

Owner's Manual & Safety Instructions

Save This Manual Keep this manual for the safety warnings and precautions, assembly, operating, inspection, maintenance and cleaning procedures. Write the product's serial number in the back of the manual near the assembly diagram (or month and year of purchase if product has no number). Keep this manual and the receipt in a safe and dry place for future reference.

17i

CENTTECH®

63043

HEAVY DUTY 6/12 VOLT CHARGER with ENGINE START



Visit our website at: <http://www.harborfreight.com>
Email our technical support at: productsupport@harborfreight.com

When unpacking, make sure that the product is intact and undamaged. If any parts are missing or broken, please call 1-888-866-5797 as soon as possible.

Copyright© 2015 by Harbor Freight Tools®. All rights reserved.
No portion of this manual or any artwork contained herein may be reproduced in any shape or form without the express written consent of Harbor Freight Tools. Diagrams within this manual may not be drawn proportionally. Due to continuing improvements, actual product may differ slightly from the product described herein.
Tools required for assembly and service may not be included.

⚠ WARNING

**Read this material before using this product.
Failure to do so can result in serious injury.
SAVE THIS MANUAL.**



Table of Contents



Safety	2	Operation	7
Specifications	6	Maintenance	10
Assembly	6	Warranty	12

CENTTECH®

WARNING SYMBOLS AND DEFINITIONS

	This is the safety alert symbol. It is used to alert you to potential personal injury hazards. Obey all safety messages that follow this symbol to avoid possible injury or death.
⚠ DANGER	Indicates a hazardous situation which, if not avoided, will result in death or serious injury.
⚠ WARNING	Indicates a hazardous situation which, if not avoided, could result in death or serious injury.
⚠ CAUTION	Indicates a hazardous situation which, if not avoided, could result in minor or moderate injury.
NOTICE CAUTION	Addresses practices not related to personal injury.

	Canadian Standards Association
	Underwriters Laboratories, Inc.
VAC	Volts Alternating Current
A	Amperes
CCA	Cold Cranking Amps
RC	Reserve Capacity
Ah	Ampere-hours

	WARNING marking concerning Risk of Eye Injury. Wear ANSI-approved splash-resistant safety goggles.
	Read the manual before set-up and/or use.
	WARNING marking concerning Risk of Fire. Follow connection procedure.

IMPORTANT SAFETY INSTRUCTIONS

1. **SAVE THESE INSTRUCTIONS –**
This manual contains important safety and operating instructions for this battery charger.
2. Do not expose charger to rain or snow.
3. Use of an attachment not recommended or sold by the battery charger manufacturer may result in a risk of fire, electric shock, or injury to persons.
4. To reduce risk of damage to electric plug and cord, pull by plug rather than cord when disconnecting charger.
5. An extension cord should not be used unless absolutely necessary. Use of improper extension cord could result in a risk of fire and electric shock. If an extension cord must be used, make sure:
 - a. That pins on plug of extension cord are the same number, size, and shape as those of plug on charger;
 - b. That extension cord is properly wired and in good electrical condition; and
 - c. That wire size is large enough for AC ampere rating of charger as specified in Table A.
9. To reduce risk of electric shock, unplug charger from outlet before attempting any maintenance or cleaning. Turning off controls will not reduce this risk.
10. **WARNING – RISK OF EXPLOSIVE GASES.**
 - a. **WORKING IN VICINITY OF A LEAD-ACID BATTERY IS DANGEROUS. BATTERIES GENERATE EXPLOSIVE GASES DURING NORMAL BATTERY OPERATION. FOR THIS REASON, IT IS OF UTMOST IMPORTANCE THAT YOU FOLLOW THE INSTRUCTIONS EACH TIME YOU USE THE CHARGER.**
 - b. To reduce risk of battery explosion, follow these instructions and those published by battery manufacturer and manufacturer of any equipment you intend to use in vicinity of battery. Review cautionary marking on these products and on engine.

Table A: Recommended minimum AWG size for extension cords for battery chargers

AC input rating, amperes*		AWG size of cord			
		Length of cord, feet			
Equal to or greater than	But less than	25	50	100	150
8	10	18	14	12	10
10	12	16	14	10	8
12	14	16	12	10	8
14	16	16	12	10	8
16	18	14	12	8	8
18	20	14	12	8	6

* If the input rating of a charger is given in watts rather than in amperes, the corresponding ampere rating is to be determined by dividing the wattage rating by the voltage rating – for example:
1250 watts/125 volts = 10 amperes

6. Do not operate charger with damaged cord or plug – replace the cord or plug immediately.
7. Do not operate charger if it has received a sharp blow, been dropped, or otherwise damaged in any way; take it to a qualified serviceman.
8. Do not disassemble charger; take it to a qualified serviceman when service or repair is required. Incorrect reassembly may result in a risk of electric shock or fire.
11. **PERSONAL PRECAUTIONS**
 - a. Consider having someone close enough by to come to your aid when you work near a lead-acid battery.
 - b. Have plenty of fresh water and soap nearby in case battery acid contacts skin, clothing, or eyes.
 - c. Wear complete eye protection and clothing protection. Avoid touching eyes while working near battery.
 - d. If battery acid contacts skin or clothing, wash immediately with soap and water. If acid enters eye, immediately flood eye with running cold water for at least 10 minutes and get medical attention immediately.
 - e. NEVER smoke or allow a spark or flame in vicinity of battery or engine.
 - f. Be extra cautious to reduce risk of dropping a metal tool onto battery. It might spark or short-circuit battery or other electrical part that may cause explosion.
 - g. Remove personal metal items such as rings, bracelets, necklaces, and watches when working with a lead-acid battery. A lead-acid battery can produce a short-circuit current high enough to weld a ring or the like to metal, causing a severe burn.
 - h. Use charger for charging a LEAD-ACID battery only. It is not intended to supply power to a low voltage electrical system other than in a starter-motor application. Do not use battery charger for charging dry-cell batteries that are commonly used with home appliances. These batteries may burst and cause injury to persons and damage to property.
 - i. NEVER charge a frozen battery.

12. PREPARING TO CHARGE

- a. If necessary to remove battery from vehicle to charge, always remove grounded terminal from battery first. Make sure all accessories in the vehicle are off, so as not to cause an arc.
- b. Be sure area around battery is well ventilated while battery is being charged.
- c. Clean battery terminals. Be careful to keep corrosion from coming in contact with eyes.
- d. Add distilled water in each cell until battery acid reaches level specified by battery manufacturer. Do not overfill. For a battery without removable cell caps, such as valve regulated lead acid batteries, carefully follow manufacturer's recharging instructions.
- e. Study all battery manufacturer's specific precautions while charging and recommended rates of charge.
- f. Determine voltage of battery by referring to vehicle owner's manual and make sure it matches output rating of battery charger. If charger has adjustable charge rate, charge battery initially at lowest rate.

13. CHARGER LOCATION

- a. Locate charger as far away from battery as DC cables permit.
- b. Never place charger directly above battery being charged; gases from battery will corrode and damage charger.
- c. Never allow battery acid to drip on charger when reading electrolyte specific gravity or filling battery.
- d. Do not operate charger in a closed-in area or restrict ventilation in any way.
- e. Do not set a battery on top of charger.

14. DC CONNECTION PRECAUTIONS

- a. Connect and disconnect DC output clips only after setting any charger switches to "off" position and removing AC cord from electric outlet. Never allow clips to touch each other.
- b. Attach clips to battery and chassis as indicated in 15(e), 15(f), and 16(b) through 16(d).

15. FOLLOW THESE STEPS WHEN BATTERY IS INSTALLED IN VEHICLE. A SPARK NEAR BATTERY MAY CAUSE BATTERY EXPLOSION. TO REDUCE RISK OF A SPARK NEAR BATTERY:

- a. Position AC and DC cords to reduce risk of damage by hood, door, or moving engine part.
- b. Stay clear of fan blades, belts, pulleys, and other parts that can cause injury to persons.
- c. Check polarity of battery posts. POSITIVE (POS, P, +) battery post usually has larger diameter than NEGATIVE (NEG, N, -) post.

- d. Determine which post of battery is grounded (connected) to the chassis. If negative post is grounded to chassis (as in most vehicles), see (e). If positive post is grounded to the chassis, see (f).
- e. For negative-grounded vehicle, connect POSITIVE (RED) clip from battery charger to POSITIVE (POS, P, +) ungrounded post of battery. Connect NEGATIVE (BLACK) clip to vehicle chassis or engine block away from battery. Do not connect clip to carburetor, fuel lines, or sheet-metal body parts. Connect to a heavy gauge metal part of the frame or engine block.
- f. For positive-grounded vehicle, connect NEGATIVE (BLACK) clip from battery charger to NEGATIVE (NEG, N, -) ungrounded post of battery. Connect POSITIVE (RED) clip to vehicle chassis or engine block away from battery. Do not connect clip to carburetor, fuel lines, or sheet-metal body parts. Connect to a heavy gauge metal part of the frame or engine block.
- g. When disconnecting charger, turn switches to off, disconnect AC cord, remove clip from vehicle chassis, and then remove clip from battery terminal.
- h. See operating instructions for length of charge information.

16. FOLLOW THESE STEPS WHEN BATTERY IS OUTSIDE VEHICLE. A SPARK NEAR THE BATTERY MAY CAUSE BATTERY EXPLOSION. TO REDUCE RISK OF A SPARK NEAR BATTERY:

- a. Check polarity of battery posts. POSITIVE (POS, P, +) battery post usually has a larger diameter than NEGATIVE (NEG, N, -) post.
- b. Attach at least a 24-inch-long 6-gauge (AWG) insulated battery cable to NEGATIVE (NEG, N, -) battery post.
- c. Connect POSITIVE (RED) charger clip to POSITIVE (POS, P, +) post of battery.
- d. Position yourself and free end of cable as far away from battery as possible – then connect NEGATIVE (BLACK) charger clip to free end of cable.
- e. Do not face battery when making final connection.
- f. When disconnecting charger, always do so in reverse sequence of connecting procedure and break first connection while as far away from battery as practical.
- g. A marine (boat) battery must be removed and charged on shore. To charge it on board requires equipment specially designed for marine use.

17.  Wear ANSI-approved splash-resistant safety goggles and heavy-duty rubber work gloves whenever connecting, disconnecting, or working near battery. Battery acid can cause permanent blindness.
18. Do not use Start setting to charge batteries. Use to jump start only.
19. Maintain labels and nameplates on the charger. These carry important safety information. If unreadable or missing, contact Harbor Freight Tools for a replacement.
20. This product is not a toy. Keep it out of reach of children.
21. Unplug the Battery Charger from its electrical outlet before connecting its cables to a battery, or performing any inspection, maintenance, or cleaning procedures.
22. **This Charger/Starter does NOT have an automatic cut off. It is equipped with a timer. Check battery and time manually; do NOT depend solely on timer. Leaving Charger/Starter unattended can result in fire and property damage.**
23. **Use this Battery Charger with flooded lead-acid batteries only.** When charging a maintenance-free battery, always monitor the progress of the charge by viewing the ammeter. Do not overcharge a maintenance-free battery.
24. Do not attempt to charge non-rechargeable or defective batteries.
25. Do not charge more than one battery at one time.
26. Have your charger serviced by a qualified repair person using only identical replacement parts. This will ensure that the safety of the charger is maintained.
27. Do not use charger while you are tired or under the influence of drugs, alcohol or medication. A moment of inattention while operating charger may result in serious personal injury.
28. Before moving charger, disconnect power supply and battery, then allow charger to cool.
29. People with pacemakers should consult their physician(s) before use. Electromagnetic fields in close proximity to heart pacemaker could cause pacemaker interference or pacemaker failure. In addition, people with pacemakers should:
- Avoid operating alone.
 - Properly maintain and inspect to avoid electrical shock.
 - Properly ground power cord. Ground Fault Circuit Interrupter (GFCI) should also be implemented – it prevents sustained electrical shock.
30. The warnings, precautions, and instructions discussed in this instruction manual cannot cover all possible conditions and situations that may occur. It must be understood by the operator that common sense and caution are factors which cannot be built into this product, but must be supplied by the operator.



SAVE THESE INSTRUCTIONS.

Grounding and AC Power Cord Connection Instructions

Charger should be grounded to reduce risk of electric shock. Charger is equipped with an electric cord having an equipment-grounding conductor and a grounding plug. The plug must be plugged into an outlet that is properly installed and grounded in accordance with all local codes and ordinances.

DANGER – Never alter AC cord or plug provided – if it will not fit outlet, have proper outlet installed by a qualified electrician. Improper connection can result in a risk of an electric shock.

CAUTION – **Risk of Fire or Electric Shock.** Connect battery charger directly to grounding receptacle (three-prong). An adapter should not be used with battery charger.

CEN-TECH®

Specifications

Electrical Rating	120VAC / 60Hz / 9A @ 40A, 12V Setting
Charge Settings	2A, 12V 10A, 12V 40A, 12V
Starter Settings	100A, 6V 60 second maximum with 90 second minimum rest
	200A, 12V 5 second maximum with 240 second minimum rest
Battery Cables	6' 6" Red = Positive Black = Negative
Power Cord	6' 5"
Timer Settings	0-180 minutes (up to 3 hours), and continuous (HOLD)

Assembly Instructions



Read the **ENTIRE IMPORTANT SAFETY INFORMATION** section at the beginning of this manual including all text under subheadings therein before set up or use of this product.

WARNING

TO PREVENT SERIOUS INJURY: Unplug the charger, disconnect any battery, and allow charger to cool completely before assembling or making any adjustments to the charger.

1. Place the Battery Charger/Starter on its side.
2. Use two Screws to install the Mounting Foot to the front bottom of the Charger/Starter. See Figure A.
3. Slide the Wheels onto the ends of the Axle and slide an Axle Cap onto each wheel. If needed, tap on the Axle Caps with a rubber mallet.

NOTE: Verify the Hub of each Wheel is facing in.

4. Set the Axle along the bottom of the Charger/Starter and Align the Axle Brackets with the mounting holes. Once aligned, fasten the Wheel Axle into place by sliding the bracket tabs into the slots, and securing with two screws. See Figure A.
5. Stand up the Charger/Starter.
6. Remove the two top screws on each side of the Charger/Starter and set the Handle against the unit, aligning the mounting holes. See Figure B.
7. Use the Screws to mount the Handle on the sides of the Charger/Starter. See Figure B.

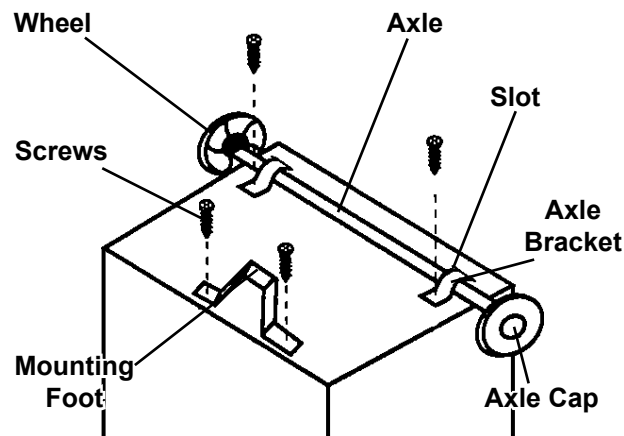

Figure A: Foot and Wheel Installation

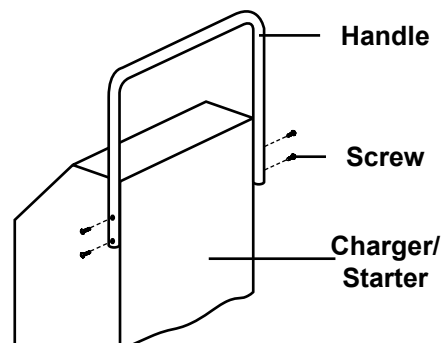

Figure B: Handle Installation

Operating Instructions



Read the **ENTIRE IMPORTANT SAFETY INFORMATION** section at the beginning of this manual including all text under subheadings therein before set up or use of this product.

WARNING

TO PREVENT SERIOUS INJURY:

Assemble charger according to Assembly Instructions before use.

DO NOT PLUG IN CHARGER UNTIL DIRECTED TO DO SO.

Controls

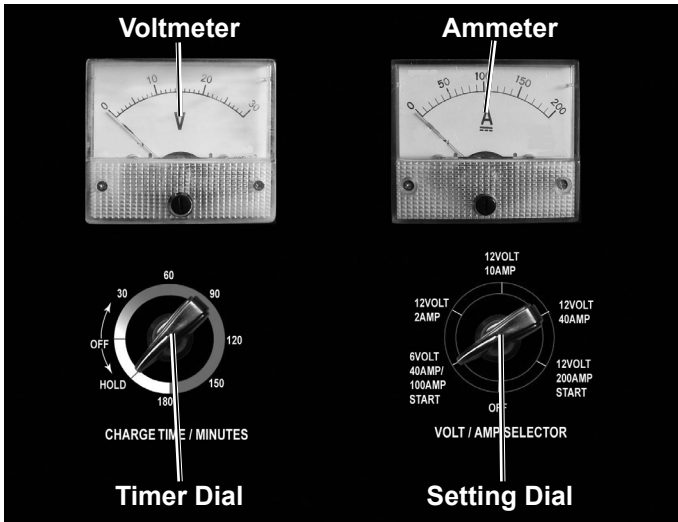

Figure E: Controls

Timer Dial: The Timer prevents over-charging while allowing a battery the needed time to obtain a satisfactory charge. To set the Timer, you must know the size of battery in ampere hours or reserve capacity in minutes, and the state of charge. The state of charge can be obtained using a battery load tester (not included). For example, the average size automotive battery at 50% charge will require 1 to 1-1/2 hours of charging at 40 amp rate to reach full charge state. For the same battery with the Timer set to maximum, overcharging will occur. *Slight* overcharging should not harm a battery that was otherwise in good condition. When the state of charge is unknown, start out with a timer setting of one hour or less.

Hold: (on Timer Dial) This sets the charger for continuous operation. Use for long-period charging, such as when the lowest charge rate is selected.

WARNING! TO PREVENT SERIOUS INJURY AND FIRE: Monitor charging and stop charge when battery is fully charged.

Setting Dial: Use this to set the voltage/ampere output.

Ammeter: The ammeter indicates amount of current measured in amperes that is drawn from battery. For example, in 40 amp charge rate a typical discharged battery will initially draw approximately 40 amps. As battery continues to charge, current will taper to 15 to 20 amps at full charge. When cranking an engine, starter motor draws up to 200 amps. The meter needle will register to extreme left side during 2 amp charge rate, indicating minimal activity because the meter doesn't have the resolution to display such low rates.

When a battery is close to being dead or has a very low charge, it will want to draw more current. When a dead or low battery is charged, the charger's ammeter will register at high end. As the battery charges, the reading will move down toward the low end, resting on zero, when battery is fully charged.

Do not depend on reading ammeter to approximate how long charging will take. Even at full charge, ammeter will still provide as much as 50% of charger's output rating. Sometimes conditions such as a cold battery, a sulfated battery, or a deeply discharged Lead Calcium battery may cause ammeter to read near a full charge when charging process is only beginning.

Note: The ammeter shows the amount of current being drawn from the charger. It does not show what the charger is capable of delivering. When the battery is fully charged and registering zero on the ammeter, a small charge will continue to move from the charger to the battery. If the charger is not disconnected from the battery, eventually heat build up will cause the battery acid to boil and overcharge the battery causing damage to the battery. Monitor battery charging progress constantly and if battery gets warm, stop charging it immediately.

Preparing to Charge

⚠️ WARNING

Use this charger only on flooded lead-acid batteries. Other batteries may be damaged or may overheat, leak, or catch fire.



TO PREVENT SERIOUS INJURY:

Wear ANSI-approved splash-resistant safety goggles and heavy-duty rubber work gloves whenever connecting, disconnecting, or working near battery.

Battery acid can cause permanent blindness.

1. If necessary to remove battery from vehicle to charge, always remove grounded terminal from battery first. Make sure all accessories in the vehicle are off, so as not to cause an arc.
2. Be sure area around battery is well ventilated while battery is being charged.
3. Clean battery terminals. Be careful to keep corrosion from coming in contact with eyes.
4. Add distilled water in each cell until battery acid reaches level specified by battery manufacturer. Do not overfill. For a battery without removable cell caps, such as valve regulated lead acid batteries, carefully follow manufacturer's recharging instructions.
5. Study all battery manufacturer's specific precautions while charging and recommended rates of charge.
6. Determine voltage of battery by referring to vehicle owner's manual and make sure it matches output rating of battery charger. If charger has adjustable charge rate, charge battery initially at lowest rate.
7. A marine (boat) battery must be removed and charged on shore. To charge it on board requires equipment specially designed for marine use.

SHORTED BATTERIES - will read on ammeter as a high end peg at beginning of charging process. If after 5-10 minutes, needle does not move off high end, the battery probably has a short circuit. Unplug charger and discontinue use. Have battery checked by a qualified technician.

COLD BATTERIES - begin charging at a low rate, increase as battery reaches a normal temperature, then rate will decrease normally.

DO NOT CHARGE A FROZEN BATTERY.

BATTERIES WITH HYDROMETER EYE:

Do not depend on hydrometer eye to determine battery charge level.

Charger Location

1. Locate charger as far away from battery as DC cables permit.
2. Never place charger directly above battery being charged; gases from battery will corrode and damage charger.
3. Never allow battery acid to drip on charger when reading electrolyte specific gravity or filling battery.
4. Do not operate charger in a closed-in area or restrict ventilation in any way.
5. Do not set a battery on top of charger.

TABLE B: CHARGING RATE/TIME

Battery Size / Rating		Charge Rate			
		Charging Time (based on battery at 50% charge)			
		2A, 12V	10A, 12V	40A, 12V	
Small batteries (Motorcycle, Garden Tractor, etc.)	6-12 Ah	3~6 hr	Do not use these rates for small batteries.		
Cars / Trucks	200-315 CCA	40-60 RC	13~20 hr	2-1/2~4 hr	1/2~3/4 hr
	315-550 CCA	60-85 RC	20~35 hr	4~7 hr	3/4~2 hr
	550-875 CCA	85-125 RC	35~55 hr	7~11 hr	2~3 hr

WARNING! TO PREVENT SERIOUS INJURY, FIRE, AND PROPERTY DAMAGE:

Monitor charging during use. This Charger/Starter is not automatic and can overcharge and damage a battery if allowed to operate for extended periods of time.

Charging Battery Installed in Vehicle

⚠️ WARNING

A SPARK NEAR BATTERY MAY CAUSE BATTERY EXPLOSION.
TO REDUCE RISK OF A SPARK NEAR BATTERY FOLLOW THESE INSTRUCTIONS EXACTLY.



TO PREVENT SERIOUS INJURY:

Wear ANSI-approved splash-resistant safety goggles and heavy-duty rubber work gloves whenever connecting, disconnecting, or working near battery.
Battery acid can cause permanent blindness.

WARNING! Do not use Start setting to charge batteries. Use to jump start only.

1. Position AC and DC cables to reduce risk of damage by hood, door, or moving engine part.
 2. Stay clear of fan blades, belts, pulleys, and other parts that can cause injury to persons.
 3. Determine which post of battery is grounded (connected) to the chassis. If negative post is grounded to chassis (as in most vehicles), see 4. If positive post is grounded to the chassis, see 5.
 4. For negative-grounded vehicle, connect POSITIVE (RED) clip from battery charger to POSITIVE (POS, P, +) ungrounded post of battery. Connect NEGATIVE (BLACK) clip to vehicle chassis or engine block away from battery. Do not connect clip to carburetor, fuel lines, or sheet-metal body parts. Connect to a heavy gauge metal part of the frame or engine block.
 5. For positive-grounded vehicle, connect NEGATIVE (BLACK) clip from battery charger to NEGATIVE (NEG, N, -) ungrounded post of battery. Connect POSITIVE (RED) clip to vehicle chassis or engine block away from battery. Do not connect clip to carburetor, fuel lines, or sheet-metal body parts. Connect to a heavy gauge metal part of the frame or engine block.
 6. Turn Timer Dial until desired time is selected. **Refer to Timer Dial on page 7.**
 7. Turn Setting Dial until desired charging function is selected. **Refer to Table B on page 8.**
- WARNING!** Do not use 6V 40A/100A Start or 12V 200A Start functions for charging.
8. After dials are set, plug in charger. Monitor the charging process.
 9. When disconnecting charger, turn switches to off, disconnect AC cord, remove clip from vehicle chassis, and then remove clip from battery terminal.
 10. After use clean, then store the charger indoors out of children's reach.

Charging Battery Outside Vehicle

⚠️ WARNING

A SPARK NEAR BATTERY MAY CAUSE BATTERY EXPLOSION.
TO REDUCE RISK OF A SPARK NEAR BATTERY FOLLOW THESE INSTRUCTIONS EXACTLY.



TO PREVENT SERIOUS INJURY:

Wear ANSI-approved splash-resistant safety goggles and heavy-duty rubber work gloves whenever connecting, disconnecting, or working near battery.
Battery acid can cause permanent blindness.

WARNING! Do not use Start setting to charge batteries. Use to jump start only.

1. Attach at least a 24-inch-long 6-gauge (AWG) insulated battery cable to NEGATIVE (NEG, N, -) battery post.
 2. Connect POSITIVE (RED) charger clip to POSITIVE (POS, P, +) post of battery.
 3. Position yourself and free end of cable as far away from battery as possible – then connect NEGATIVE (BLACK) charger clip to free end of cable.
 4. Do not face battery when making final connection.
 5. Turn Timer Dial until desired time is selected. **Refer to Timer Dial on page 7.**
 6. Turn Setting Dial until desired charging function is selected. **Refer to Table B on page 8.**
- WARNING!** Do not use 6V 40A/100A Start or 12V 200A Start functions for charging.
7. After dials are set, plug in charger. Monitor the charging process.
 8. When disconnecting charger, always do so in reverse sequence of connecting procedure and break first connection while as far away from battery as practical.
 9. After use clean, then store the charger indoors out of children's reach.

Engine Starting

NOTICE

Some vehicles with onboard computers may be damaged from the high-current starting output. Thoroughly read the vehicle service manual before using this procedure.

WARNING! Do not use Start setting to charge batteries. Use to jump start only.

Note: During extremely cold weather or when battery is severely exhausted, charge the battery for about five minutes before attempting to turn on engine.

1. Set the charge rate and timer to the OFF positions.
2. Plug the Charger AC power cord into the AC outlet.
3. Set the Volt/Amp selector to the correct setting. Make sure setting of Engine Start charge rate matches the vehicle battery.
4. For negative-grounded vehicle, connect POSITIVE (RED) clip from battery charger to POSITIVE (POS, P, +) ungrounded post of battery. Connect NEGATIVE (BLACK) clip to vehicle chassis or engine block away from battery. Do not connect clip to carburetor, fuel lines, or sheet-metal body parts. Connect to a heavy gauge metal part of the frame or engine block.
5. Position AC and DC cables to reduce risk of damage by hood, door, or moving engine part.

6. **WARNING! TO PREVENT SERIOUS INJURY, FIRE, AND DAMAGE TO STARTER AND BATTERY, follow duty cycle for each Start mode as follows:**

100A, 6V:

60 second maximum with 90 second minimum rest

200A, 12V:

5 second maximum with 240 second minimum rest

7. To start the engine, set the charge time dial to HOLD and turn ignition key. **ONLY KEEP CHARGER IN START MODE AS LONG AS THE DUTY CYCLE LISTED ABOVE ALLOWS.**

Note: If the unit beeps, the cables are reversed or touching (short-circuited) and the Engine Starter will power off. Check that cables are connected properly.

8. If engine fails to start, charge battery for an additional five minutes before attempting to start.
9. After the engine starts, move the charge rate switch to OFF and unplug the power cord from outlet before disconnecting the DC cable clamps.

Maintenance Instructions



Procedures not specifically explained in this manual must be performed only by a qualified technician.

⚠️WARNING

TO PREVENT SERIOUS INJURY: Unplug the charger, disconnect any battery, and allow charger to cool completely before performing any inspection, maintenance, or cleaning procedures.

TO PREVENT SERIOUS INJURY FROM TOOL FAILURE:

Do not use damaged equipment. If abnormal noise or vibration occurs, have the problem corrected before further use.

1. **BEFORE EACH USE**, inspect the general condition of the charger. Check for loose hardware, misalignment or binding of moving parts, cracked or broken parts, damaged electrical wiring, and any other condition that may affect its safe operation.
2. **AFTER USE**, wipe external surfaces of the tool with clean cloth.
3. **⚠️WARNING!** If the supply cord of this charger is damaged, it must be replaced only by a qualified service technician. **DO NOT OPEN CHARGER HOUSING, NO USER-SERVICEABLE PARTS INSIDE.**

Troubleshooting

Problem	Possible Causes	Likely Solutions
Ammeter display reads maximum.	Defective battery.	Check or replace battery.
No ammeter reading.	<ol style="list-style-type: none"> 1. No power to engine starter. 2. Battery cables not making connection. 3. Two-amp charge rate being used. 	<ol style="list-style-type: none"> 1. Check power and cable outlet connections. 2. Clean battery cables and reset cable clamps. 3. None, meter will not indicate at this rate.
Charging current not to full output.	<ol style="list-style-type: none"> 1. Battery is partially charged. 2. Defective battery, will not hold full charge. 	<ol style="list-style-type: none"> 1. Continue charging battery. 2. Check and/or replace battery.
Ammeter needle moves up to full charge, then drops to zero. Makes "clicking" noise.	<ol style="list-style-type: none"> 1. Reversed battery connections. 2. Battery is completely dead. 3. Defective battery. 4. Circuit breaker is cycling. 	<ol style="list-style-type: none"> 1. Double-check connection polarity. If wrong, shut off charger and correct cable lead connections. 2. Continue charging battery. Charger will continue to reset itself until the battery reaches a chargeable level. 3. Check and/or replace battery. 4. May be the wrong switch position.



Follow all safety precautions whenever diagnosing or servicing the tool. Disconnect power supply before service.

Record Product's Serial Number Here: _____

Note: If product has no serial number, record month and year of purchase instead.

Note: Some parts are listed and shown for illustration purposes only, and are not available individually as replacement parts. Internal parts are not user-serviceable and are not available.

Limited 90 Day Warranty

Harbor Freight Tools Co. makes every effort to assure that its products meet high quality and durability standards, and warrants to the original purchaser that this product is free from defects in materials and workmanship for the period of 90 days from the date of purchase. This warranty does not apply to damage due directly or indirectly, to misuse, abuse, negligence or accidents, repairs or alterations outside our facilities, criminal activity, improper installation, normal wear and tear, or to lack of maintenance. We shall in no event be liable for death, injuries to persons or property, or for incidental, contingent, special or consequential damages arising from the use of our product. Some states do not allow the exclusion or limitation of incidental or consequential damages, so the above limitation of exclusion may not apply to you. THIS WARRANTY IS EXPRESSLY IN LIEU OF ALL OTHER WARRANTIES, EXPRESS OR IMPLIED, INCLUDING THE WARRANTIES OF MERCHANTABILITY AND FITNESS.

To take advantage of this warranty, the product or part must be returned to us with transportation charges prepaid. Proof of purchase date and an explanation of the complaint must accompany the merchandise. If our inspection verifies the defect, we will either repair or replace the product at our election or we may elect to refund the purchase price if we cannot readily and quickly provide you with a replacement. We will return repaired products at our expense, but if we determine there is no defect, or that the defect resulted from causes not within the scope of our warranty, then you must bear the cost of returning the product.

This warranty gives you specific legal rights and you may also have other rights which vary from state to state.

CEN-TECH®

3491 Mission Oaks Blvd. • PO Box 6009 • Camarillo, CA 93011 • 1-888-866-5797