

Owner's Manual & Safety Instructions

Save This Manual Keep this manual for the safety warnings and precautions, assembly, operating, inspection, maintenance and cleaning procedures. Write the product's serial number in the back of the manual near the assembly diagram (or month and year of purchase if product has no number). Keep this manual and the receipt in a safe and dry place for future reference.

REV 16k

CHICAGO  **ELECTRIC**
POWER TOOLS

63118

10" 15 AMP BENCHTOP TABLE SAW



Visit our website at: <http://www.harborfreight.com>
Email our technical support at: productsupport@harborfreight.com

When unpacking, make sure that the product is intact and undamaged. If any parts are missing or broken, please call 1-888-866-5797 as soon as possible.

Copyright© 2016 by Harbor Freight Tools®. All rights reserved.
No portion of this manual or any artwork contained herein may be reproduced in any shape or form without the express written consent of Harbor Freight Tools. Diagrams within this manual may not be drawn proportionally. Due to continuing improvements, actual product may differ slightly from the product described herein.
Tools required for assembly and service may not be included.

WARNING

**Read this material before using this product.
Failure to do so can result in serious injury.
SAVE THIS MANUAL.**

Table of Contents

Safety	3	Maintenance	17
Specifications	8	Parts List and Diagram	20
Setup	8	Warranty	23
Operation	14		

SAFETY





CHICAGO ELECTRIC® POWER TOOLS

SETUP

OPERATION

MAINTENANCE

WARNING SYMBOLS AND DEFINITIONS

	This is the safety alert symbol. It is used to alert you to potential personal injury hazards. Obey all safety messages that follow this symbol to avoid possible injury or death.
	Indicates a hazardous situation which, if not avoided, will result in death or serious injury.
	Indicates a hazardous situation which, if not avoided, could result in death or serious injury.
	Indicates a hazardous situation which, if not avoided, could result in minor or moderate injury.
	Addresses practices not related to personal injury.

IMPORTANT SAFETY INFORMATION

General Tool Safety Warnings

⚠ WARNING

Read all safety warnings and instructions.

Failure to follow the warnings and instructions may result in electric shock, fire and/or serious injury.

Save all warnings and instructions for future reference.

- KEEP GUARDS IN PLACE and in working order.
- REMOVE ADJUSTING KEYS AND WRENCHES. Form habit of checking to see that keys and adjusting wrenches are removed from tool before turning it on.
- KEEP WORK AREA CLEAN. Cluttered areas and benches invite accidents.
- DON'T USE IN DANGEROUS ENVIRONMENT. Don't use power tools in damp or wet locations, or expose them to rain. Keep work area well lit.
- KEEP CHILDREN AWAY. All visitors should be kept safe distance from work area.
- MAKE WORKSHOP KID PROOF with padlocks, master switches, or by removing starter keys.
- DON'T FORCE TOOL. It will do the job better and safer at the rate for which it was designed.
- USE RIGHT TOOL. Don't force tool or attachment to do a job for which it was not designed.
- ALWAYS USE SAFETY GLASSES. Also use face or dust mask if cutting operation is dusty. Everyday eyeglasses only have impact resistant lenses, they are NOT safety glasses.
- SECURE WORK. Use clamps or a vise to hold work when practical. It's safer than using your hand and it frees both hands to operate tool.
- DON'T OVERREACH. Keep proper footing and balance at all times.
- MAINTAIN TOOLS WITH CARE. Keep tools sharp and clean for best and safest performance. Follow instructions for lubricating and changing accessories.
- DISCONNECT TOOLS before servicing; when changing accessories, such as blades, bits, cutters, and the like.
- REDUCE THE RISK OF UNINTENTIONAL STARTING. Make sure switch is in off position before plugging in.
- USE RECOMMENDED ACCESSORIES. Consult the owner's manual for recommended accessories. The use of improper accessories may cause risk of injury to persons.
- NEVER STAND ON TOOL. Serious injury could occur if the tool is tipped or if the cutting tool is unintentionally contacted.
- CHECK DAMAGED PARTS. Before further use of the tool, a guard or other part that is damaged should be carefully checked to determine that it will operate properly and perform its intended function – check for alignment of moving parts, binding of moving parts, breakage of parts, mounting, and any other conditions that may affect its operation. A guard or other part that is damaged should be properly repaired or replaced.
- DIRECTION OF FEED. Feed work into a blade or cutter against the direction of rotation of the blade or cutter only.
- NEVER LEAVE TOOL RUNNING UNATTENDED. TURN POWER OFF. Don't leave tool until it comes to a complete stop.
- USE PROPER EXTENSION CORD. Make sure your extension cord is in good condition. When using an extension cord, be sure to use one heavy enough to carry the current your product will draw. An undersized cord will cause a drop in line voltage resulting in loss of power and overheating. Table A shows the correct size to use depending on cord length and nameplate ampere rating. If in doubt, use the next heavier gauge. The smaller the gauge number, the heavier the cord.
- WEAR PROPER APPAREL. Do not wear loose clothing, gloves, neckties, rings, bracelets, or other jewelry which may get caught in moving parts. Nonslip footwear is recommended. Wear protective hair covering to contain long hair.

Table A: RECOMMENDED MINIMUM WIRE GAUGE FOR EXTENSION CORDS (120 VOLT)

NAMEPLATE AMPERES (at full load)	EXTENSION CORD LENGTH			
	25'	50'	100'	150'
0 – 6	18	16	16	14
6.1 – 10	18	16	14	12
10.1 – 12	16	16	14	12
12.1 – 16	14	12	Do not use.	

Grounding Instructions



⚠️ WARNING

TO PREVENT ELECTRIC SHOCK AND DEATH FROM INCORRECT GROUNDING WIRE CONNECTION READ AND FOLLOW THESE INSTRUCTIONS:

110-120 VAC Grounded Tools: Tools with Three Prong Plugs

1. In the event of a malfunction or breakdown, grounding provides a path of least resistance for electric current to reduce the risk of electric shock. This tool is equipped with an electric cord having an equipment-grounding conductor and a grounding plug. The plug must be plugged into a matching outlet that is properly installed and grounded in accordance with all local codes and ordinances.

2. Do not modify the plug provided – if it will not fit the outlet, have the proper outlet installed by a qualified electrician.

3. Improper connection of the equipment-grounding conductor can result in a risk of electric shock. The conductor with insulation having an outer surface that is green with or without yellow stripes is the equipment-grounding conductor. If repair or replacement of the electric cord or plug is necessary, do not connect the equipment-grounding conductor to a live terminal.

4. Check with a qualified electrician or service personnel if the grounding instructions are not completely understood, or if in doubt as to whether the tool is properly grounded.

5. Use only 3-wire extension cords that have 3-prong grounding plugs and 3-pole receptacles that accept the tool's plug.

6. Repair or replace damaged or worn cord immediately.

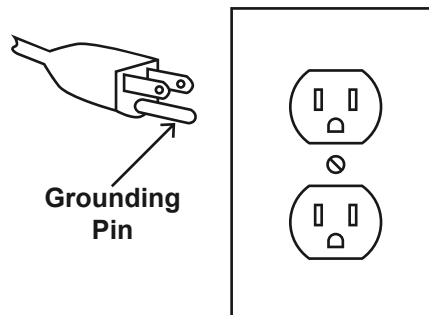

**125 VAC 3-Prong Plug and Outlet
(for up to 125 VAC and up to 15 A)**

7. This tool is intended for use on a circuit that has an outlet that looks like the one illustrated above in **125 VAC 3-Prong Plug and Outlet**. The tool has a grounding plug that looks like the plug illustrated above in **125 VAC 3-Prong Plug and Outlet**.

8. The outlet must be properly installed and grounded in accordance with all codes and ordinances.

9. Do not use an adapter to connect this tool to a different outlet.

Table Saw Safety Warnings

For Your Own Safety Read Instruction Manual Before Operating Saw

1. Wear eye protection.
2. Use saw-blade guard and spreader for every operation for which it can be used, including all through sawing.
3. Keep hands out of the line of saw blade.
4. Use an appropriate push-stick when required.
5. Know how to reduce risk of kickback.
6. Do not perform any operation freehand.
7. Never reach around or over saw blade.
8. Make sure the workpiece is supported at all times while sawing. Use a roller stand (not provided) with larger workpieces if necessary.
9. To properly understand all safety warnings, be familiar with the following safety terms and equipment:
 - a. Featherboard – A block with “fingers” that hold the workpiece against the fence while sawing.
 - b. Through-sawing – A cut made from one side of a board to the opposite side, without stopping.
 - c. Ripcut or Ripping - A cut made parallel to (along with) the grain of the wood.
 - d. Crosscut or Crosscutting - A cut made perpendicular (at a 90° angle) to the grain of the wood.
 - e. Push-stick – A narrow strip of wood or other soft material with a notch cut into one end and which is used to push short pieces of material through saws. It provides a safe distance between the hands and the cutting tool. Must be narrower than the cut width to prevent contact with the blade.
 - f. Freehand – Feeding a workpiece through the saw without using a fence or guided support to guide it. **NOT A SAFE METHOD.**
 - g. Kerf – The gap made by the saw in the workpiece.
 - h. Kickback – A sudden reaction to a pinched, bound, or misaligned blade, causing an uncontrolled workpiece to lift up and out of the saw toward the operator.
 - i. Spreader – A metal plate that follows the saw blade to keep the kerf (gap) from closing on the saw blade. Spreaders, except riving knives, must be aligned to the blade after blade adjustment to prevent binding.
 - j. Riving Knife – A spreader mounted on the same mechanism as the blade. Generally more effective than simple spreaders.
10. As noted previously, **Kickback** is a sudden reaction to a pinched, bound, or misaligned blade, causing an uncontrolled workpiece to lift up and out of the saw toward the operator. Kickback is usually a result of tool misuse and can be limited or avoided by following the precautions below:
 - Fence must be completely parallel to the saw blade.
 - Workpiece must be free from flaws (such as loose knots) and from foreign objects (such as nails and screws).
 - Support large workpieces along their entire length. Large workpieces tend to bend, grabbing the blade.
11. Do not use a dull, pitch-covered, or damaged blade.
 - Do not use fence as a guide when crosscutting.
 - Do not ripcut a twisted or warped workpiece, or workpiece without straight edge to guide along fence.
12. Maintain control of the workpiece. Do not allow the workpiece to rest against the moving blade without holding onto it.
 - If the blade binds or a cut is interrupted, turn off the power switch and hold the workpiece still until the blade stops. Correct the cause of blade binding before proceeding.
 - Before continuing an unfinished cut, center the blade in the pre-cut kerf and check that the saw teeth are not engaged into the workpiece before turning on the saw.
 - Push the wood stock past the blade prior to release.
13. Check guards for proper operation with saw disconnected from power before each use. Do not disable any guard. Do not operate saw if any movable guard does not move freely and close instantly. Make sure any movable guard does not touch the blade in all angles, depths of cut, and positions.
14. Keep the guard in place while through-sawing. Verify that the spreader lines up with the blade to prevent binding.
15. Construct an appropriate Push Stick out of wood according to the guidelines on the following page.
16. **DO NOT OPERATE WITH ANY GUARD DISABLED, DAMAGED, OR REMOVED. Moving guards must move freely and close instantly.**
17. The use of accessories or attachments not recommended by the manufacturer may result in a risk of injury to persons.

18. When servicing use only identical replacement parts.
19. Do not depress the spindle lock when starting or during operation.
20. Only use safety equipment that has been approved by an appropriate standards agency. Unapproved safety equipment may not provide adequate protection. Eye protection must be ANSI-approved and breathing protection must be NIOSH-approved for the specific hazards in the work area.
21. Stay alert, watch what you are doing and use common sense when operating a power tool. Do not use a power tool while you are tired or under the influence of drugs, alcohol or medication. A moment of inattention while operating power tools may result in serious personal injury.
22. Industrial applications must follow OSHA guidelines.
23. Maintain labels and nameplates on the tool. These carry important safety information. If unreadable or missing, contact Harbor Freight Tools for a replacement.
24. Avoid unintentional starting. Prepare to begin work before turning on the tool.
25. People with pacemakers should consult their physician(s) before use. Electromagnetic fields in close proximity to heart pacemaker could cause pacemaker interference or pacemaker failure.
26. **WARNING:** Some dust created by power sanding, sawing, grinding, drilling, and other construction activities, contains chemicals known to the State of California to cause cancer and birth defects or other reproductive harm. Some examples of these chemicals are:
 - Lead from lead-based paints
 - Crystalline silica from bricks and cement or other masonry products
 - Arsenic and chromium from chemically treated lumber
 Your risk from these exposures varies, depending on how often you do this type of work. To reduce your exposure to these chemicals: work in a well ventilated area, and work with approved safety equipment, such as those dust masks that are specially designed to filter out microscopic particles. (California Health & Safety Code § 25249.5, *et seq.*)
27. **WARNING:** The cord of this product contains lead and/or di (2-ethylhexyl) phthalate (DEHP), chemicals known to the State of California to cause cancer, and birth defects or other reproductive harm. Wash hands after handling. (California Health & Safety Code § 25249.5, *et seq.*)
28. The warnings, precautions, and instructions discussed in this instruction manual cannot cover all possible conditions and situations that may occur. It must be understood by the operator that common sense and caution are factors which cannot be built into this product, but must be supplied by the operator.

Vibration Safety

This tool vibrates during use. Repeated or long-term exposure to vibration may cause temporary or permanent physical injury, particularly to the hands, arms and shoulders. To reduce the risk of vibration-related injury:

1. Anyone using vibrating tools regularly or for an extended period should first be examined by a doctor and then have regular medical check-ups to ensure medical problems are not being caused or worsened from use. Pregnant women or people who have impaired blood circulation to the hand, past hand injuries, nervous system disorders, diabetes, or Raynaud's Disease should not use this tool. If you feel any medical or physical symptoms related to vibration (such as tingling, numbness, and white or blue fingers), seek medical advice as soon as possible.
2. Do not smoke during use. Nicotine reduces the blood supply to the hands and fingers, increasing the risk of vibration-related injury.
3. Wear suitable gloves to reduce the vibration effects on the user.
4. Use tools with the lowest vibration when there is a choice between different processes.
5. Include vibration-free periods each day of work.
6. Grip workpiece as lightly as possible (while still keeping safe control of it). Let the tool do the work.
7. To reduce vibration, maintain the tool as explained in this manual. If any abnormal vibration occurs, stop use immediately.



SAVE THESE INSTRUCTIONS.

Essential Straight Push Stick Features and Functions

Note: Straight style (traditional) stick shown. A different stick design may be used if it properly protects against all hazards.

Diagram not to scale.

- Push sticks must be made from sturdy, defect-free, plywood or normal wood to prevent unexpected breakage. Material must be at least 1/4 IN. thick, but no thicker than the finished wood.
- Inspect push stick before use and do not use a damaged or deteriorated push stick.
- Push stick dimensions will vary depending on the application and user.

Handle Notch

- Must be far enough down the stick to allow a comfortable and firm grip.
- Must be deep enough to prevent hand from slipping down the stick.
- Do not cut more than halfway into the stick to prevent weakening.
- Corners may be rounded to increase comfort.

Stick Length

- Must be long enough to keep hand clear of blade.
- At least 6" from end of handle to closest part of notch.

Notch

- Must be right (90°) angle, cut at 30°–40° from the angle of the stick to keep hands out of the line of the blade.
- The lower lip of the notch must be no longer than the workpiece is thick.

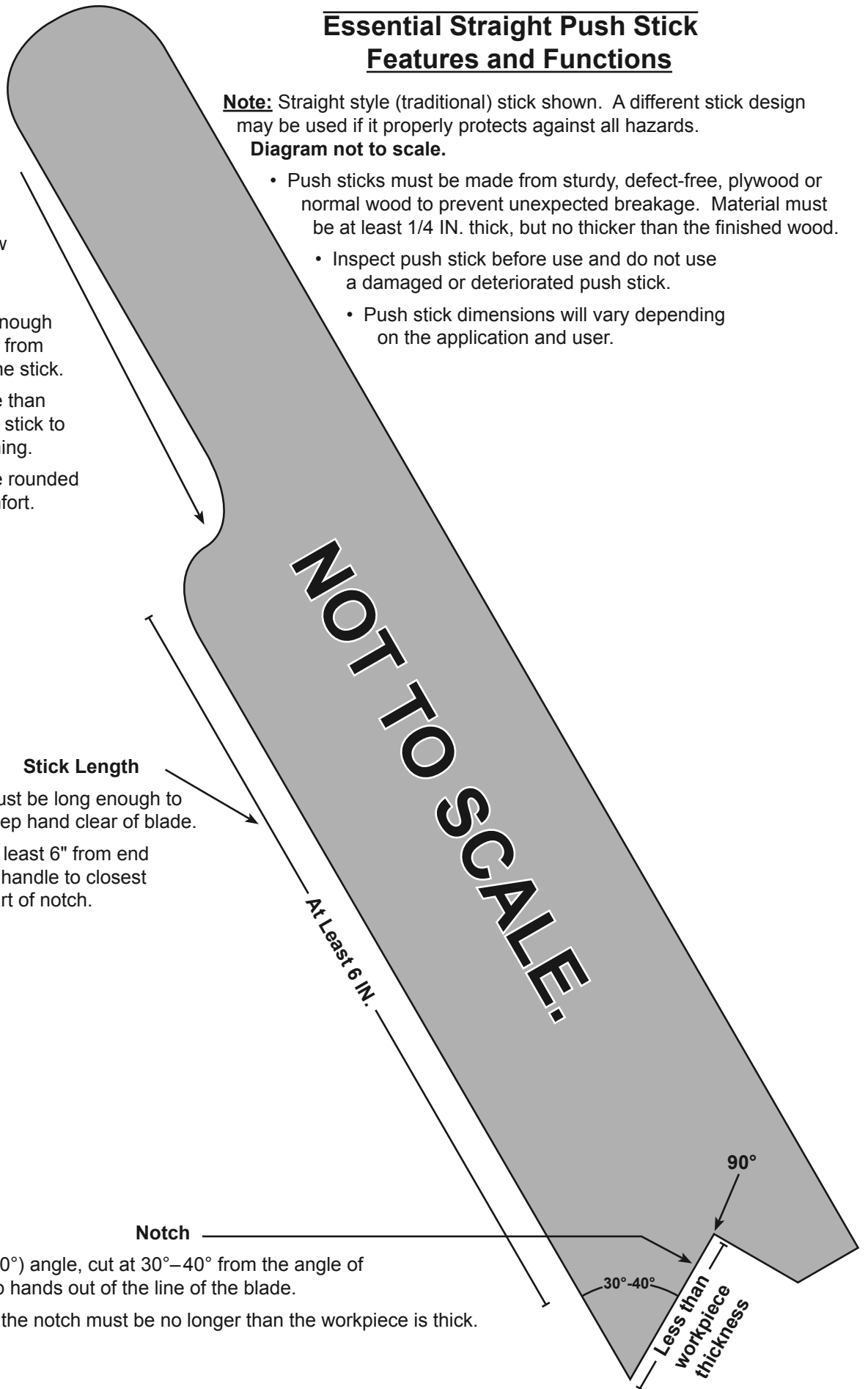

Specifications

Electrical Rating	120VAC / 60Hz / 15A
Motor No Load Speed	4800 RPM
Max. Depth Cut	3" @ 90° 2-1/2" @ 45°
Arbor Size	5/8"



SAFETY

SETUP

OPERATION

MAINTENANCE

Setup - Before Use:



Read the **ENTIRE IMPORTANT SAFETY INFORMATION** section at the beginning of this manual including all text under subheadings therein before set up or use of this product.

WARNING

TO PREVENT SERIOUS INJURY FROM ACCIDENTAL OPERATION:

Turn the Power Switch of the tool off and unplug the tool from its electrical outlet before performing any procedure in this section.

Note: For additional information regarding the parts listed in the following pages, refer to the Assembly Diagram near the end of this manual.

Mounting Table Saw

If mounting onto a metal table stand:

1. Select a table stand which will support the weight of the Table Saw. Follow the table saw stand instructions for assembly. Tighten all connections, making sure the assembled table is secure and balanced.
2. Mount the Table Saw to the top of the assembled stand using four 3/8" bolts, eight 3/8" washers and four 3/8" nuts (not included).

If mounting onto a bench or other wooden surface:

1. Select four 3/8" bolts, eight 3/8" washers, and four 3/8" nuts* (not included).

*Screws and washers may be used instead, if desired.

2. Place the Table Saw where it will be mounted. Make a mark in the center of each of the 4 mounting holes. Set the Saw aside.

WARNING! Before drilling the holes, make sure that there are no electric wires, cables, utility lines or other obstructions in the area to be drilled.

3. Drill the holes straight down, large enough to allow your mounting hardware to fit.
4. Put the Saw in place and mount using the hardware mentioned above. Tighten all hardware securely before use.

Installing Push Stick Brackets

1. Tilt saw on its side to access opening underneath the Housing (12) of the saw.
2. Use ST4.2x14 Screws (4) and Ø4 Flat Washers (3) to attach the Push Stick Clamps (13) and Push Stick Blocks (14) to the side of the Table Saw. See Figure A.

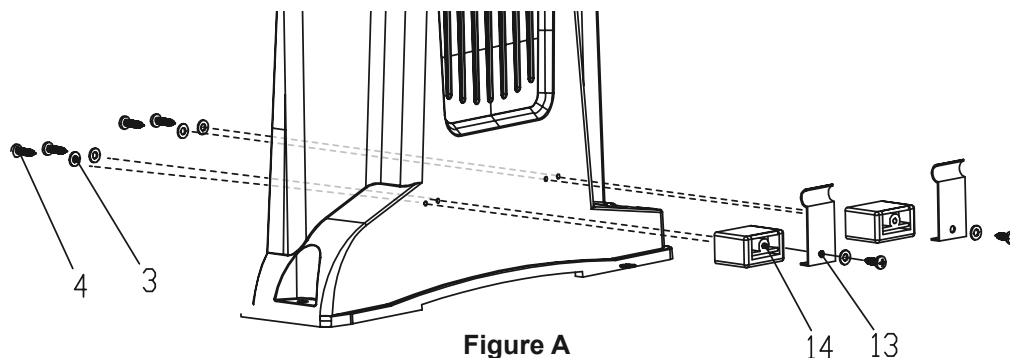

Installing Plug Holder

1. With saw still on its side find mounting hole for Plug Holder on Housing (12). Secure the Plug Block (22) to Housing using the ST4.2x14 Screws (4) and Ø4 Flat Washers (3).
2. Install Plug Clamp (21) into Plug Block using the M4x10 Bolt (19), Ø4 Spring Washer (20) and Ø4 Flat Washer (3). See Figure B.

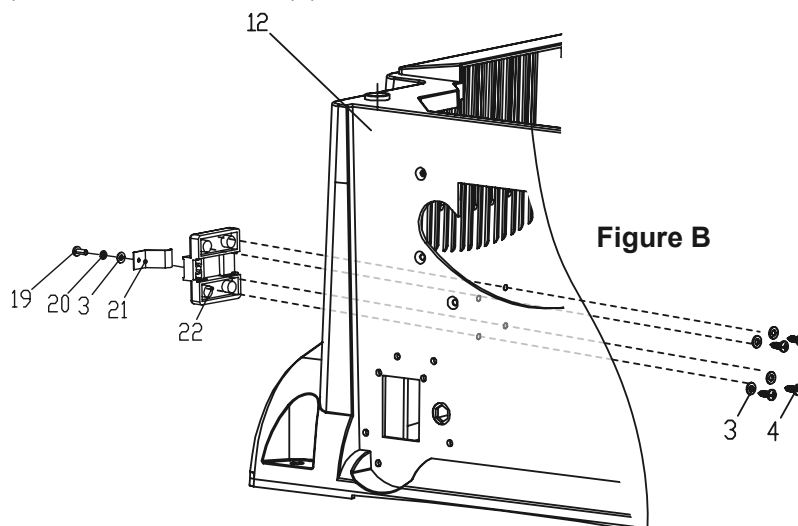

Functions

SAFETY

SETUP

OPERATION

MAINTENANCE

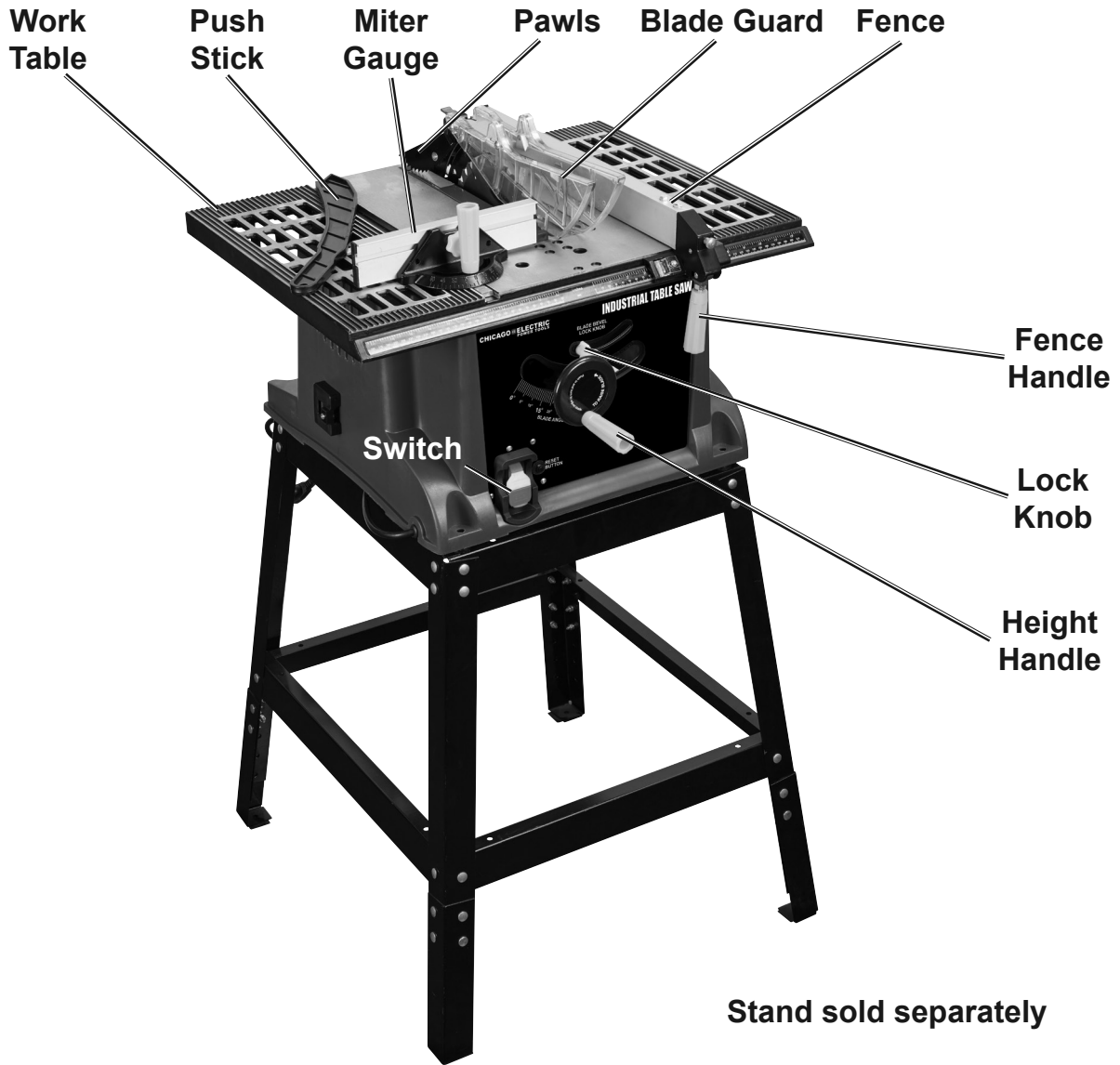

Stand sold separately

Installing/Changing Blade

⚠️ WARNING

TO PREVENT SERIOUS INJURY:

Before installing a saw blade, unplug the Table Saw and wear heavy-duty work gloves. Be very careful during blade tightening and loosening to avoid contact with the blade.

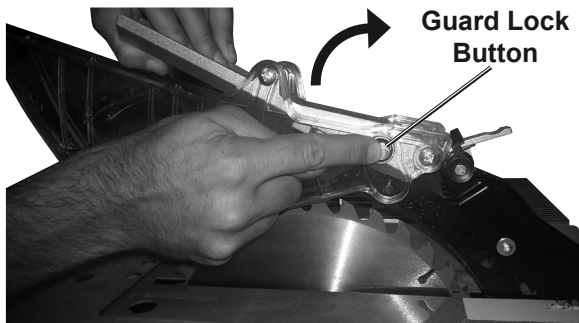

Figure C

1. Press the Guard Lock Button on the side of the Blade Guard (77) and remove the Blade Guard. Pull out the Pawl Lock Pin and remove the anti-kick Pawl assembly, exposing the Saw Blade opening.

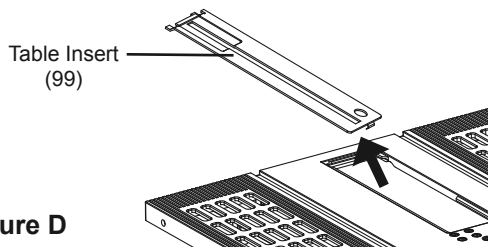

Figure D

2. Remove the Table Insert (99), using the round hole provided in the insert to grab it.

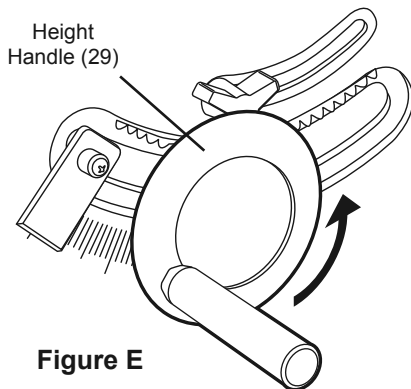

Figure E

3. Pull out and turn the Height Handle (29) counterclockwise to raise the motor to its uppermost position.

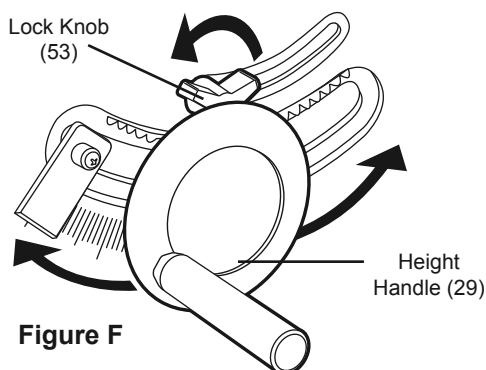

Figure F

4. Turn the Lock Knob (53) counterclockwise to loosen the tilt lock. Push the Height Handle in to engage the gears and rotate it counterclockwise to tilt the Spindle to 15 degrees. See Figure F.
5. With the Open-end Wrench (140), hold the Outer Flange (74) and use the other Open-end Wrench (141) to loosen the Blade Nut (75). Then remove the Blade Nut and Outer Flange (74) and remove old blade. See Figure G, below.

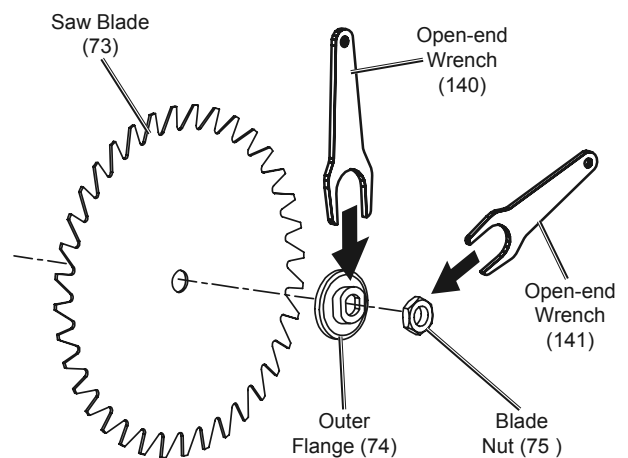

Figure G

WARNING! ONLY 10" saw blades with a 5/8" arbor, rated to at least 5,000 RPM and intended for woodcutting may be used with this Table Saw.

6. With the teeth at the top of the new Saw Blade pointing toward the front, place the Saw Blade over the Spindle. Slide the Outer Flange over the Spindle (keeping the recessed face towards the Saw Blade.)
7. Attach the Blade Nut and finger-tighten. Then use the Wrenches, one to hold the Outer Flange and the second to tighten the Nut. **CAUTION!** Do not overtighten.

NOTE: The Spindle has a normal right-hand thread and is secured when turned in a clockwise direction.

8. Once the Blade is secured, adjust the Riving Knife and install the Blade Guard.

Adjusting Riving Knife

SAFETY

SETUP

OPERATION

MAINTENANCE

WARNING TO PREVENT SERIOUS INJURY: Unplug the Table Saw before this procedure.

NOTE: The Riving Knife (88) follows the saw blade to keep the kerf (gap) from closing on the saw blade. Reposition the Riving Knife before initial use.

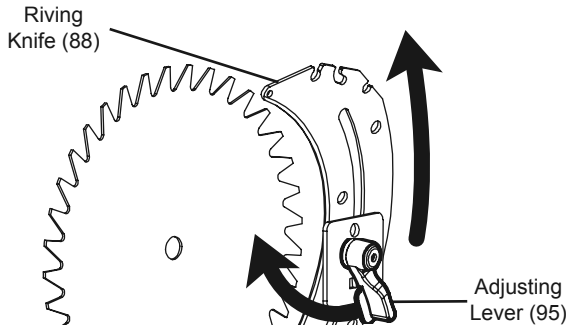

Figure H

1. With the Table Insert removed, rotate the Adjusting Lever up and pull the Riving Knife out slightly to disengage the tabs on the Connecting Bar. This will allow the Riving Knife to slide up and down.

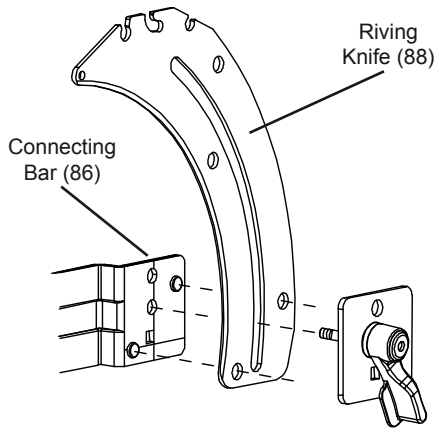

Figure I

2. Bring the Riving Knife up so that the bottom mounting holes are set against tabs on the Connecting Bar.

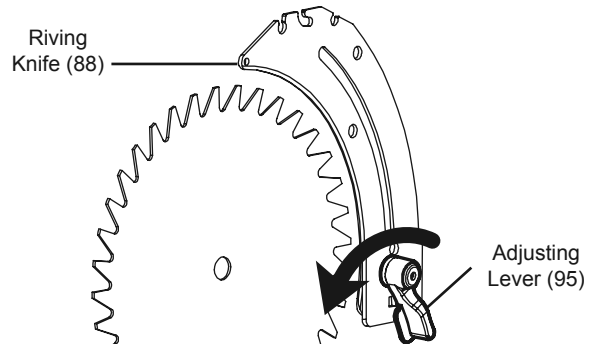

Figure J

- 3.
4. Pull the Adjusting Lever forward, locking the Riving Knife in its new position.
5. Once the Blade is installed and the Riving Knife adjusted to its working setting, replace the Table Insert.

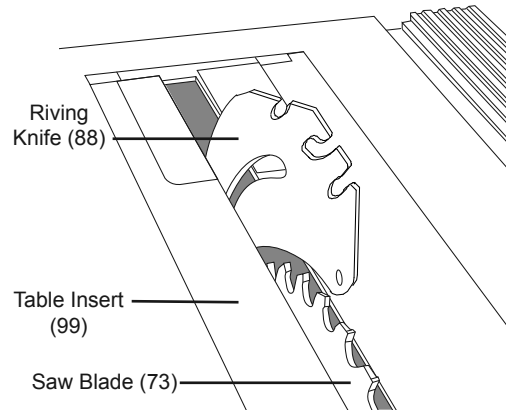

Figure K

Installing Anti-Kickback Pawls

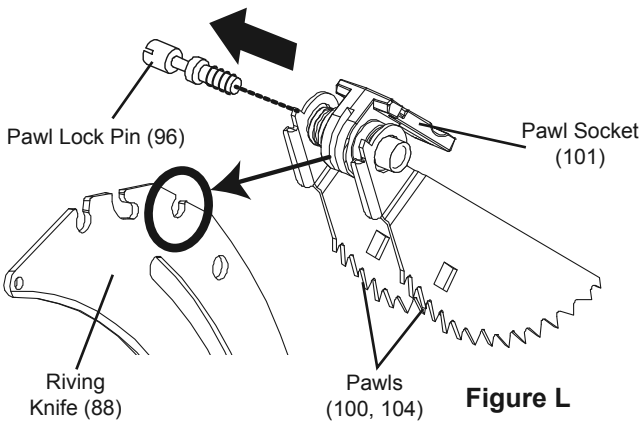

Figure L

1. Pull out the Pawl Lock Pin (96). See Figure L.
2. Set the Pawl Socket (101) onto the rear mounting hole on the top of the Riving Knife (88).
3. Pivot the Pawl Socket against the Riving Knife until the Pawl Knob snaps back into place.

Attaching Blade Guard

⚠ WARNING TO PREVENT SERIOUS INJURY: Unplug the Table Saw before this procedure. BLADE GUARD MUST BE INSTALLED BEFORE USE.



Figure M

1. Set the Blade Guard on top of the Riving Knife so that the Roller slides into the slot at the top of the Riving Knife. Push it to the back of the slot. See Figure M.

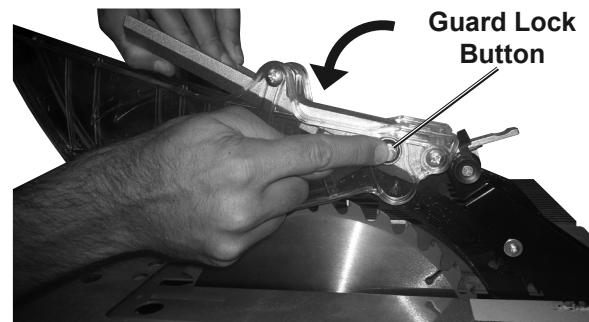

Figure N

2. Press in the Guard Lock Button and lower the Blade Guard to lock it in place. See Figure N.



Figure O

3. Make sure the Blade Guard is fully engaged, aligned properly and does not contact the Blade.

Attaching and Adjusting the Fence

WARNING! Before installing the Fence, make sure the Table Saw is disconnected from its electrical power source.

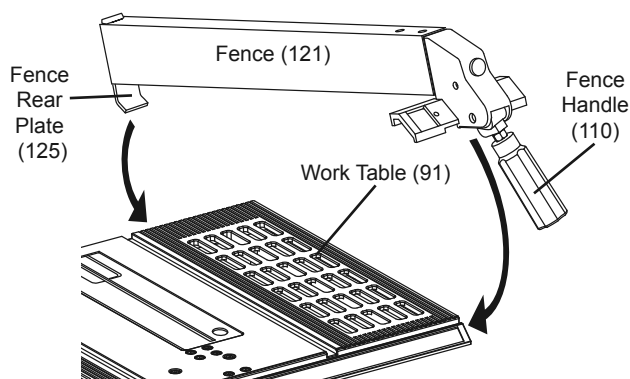

Figure P

1. To attach Fence (121) to Work Table (91), raise Fence Handle (110) and slip the Fence Rear Plate (125) over the back edge of Table. See Figure P.
2. Lower the Fence all the way onto the Table and lock in position by lowering the Fence Handle.

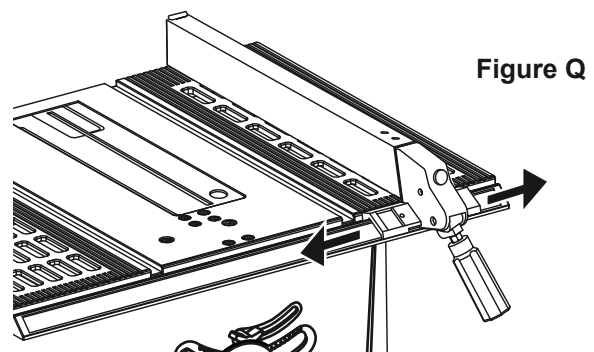

Figure Q

3. To adjust the position of the Fence, raise the Fence Handle and slide the Fence along the Work Table. Once position is adjusted, lower the Fence Handle to lock the Fence in place. See Figure Q.
4. **WARNING!** Make sure fence is perfectly parallel to the blade and completely locked in place to prevent kickback.

WARNING! Do not use fence when cutting across wood grain (crosscutting).

Operating Instructions



Read the **ENTIRE IMPORTANT SAFETY INFORMATION** section at the beginning of this manual including all text under subheadings therein before set up or use of this product.

Tool Set Up

WARNING

TO PREVENT SERIOUS INJURY FROM ACCIDENTAL OPERATION:

Turn the Power Switch of the tool off and unplug the tool from its electrical outlet before performing any procedure in this section.

TO PREVENT SERIOUS INJURY:

DO NOT OPERATE WITH ANY GUARD DISABLED, DAMAGED, OR REMOVED.

Moving guards must move freely and close instantly.

INSTALL GUARD BEFORE USE.

Raising And Lowering the Saw Blade

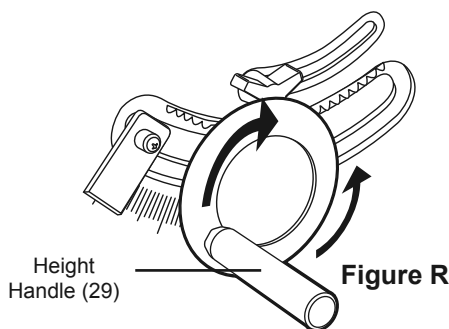

When cutting for safety, the top edge of the Saw Blade should rise no more than 1/4" above the top edge of the workpiece.

To **increase** the Blade height, turn the Control Wheel counterclockwise.

Adjusting the Saw Blade Angle

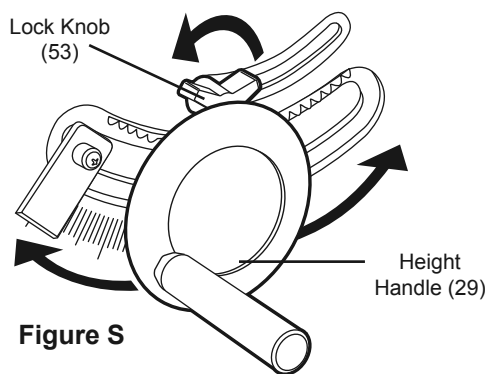

The Table Saw is capable of making cuts from 45° to 90°. It also features an *Angle Scale* and *Angle Indicator* on the front side of the unit.

1. To adjust the angle of the Saw Blade (73), unlock the Lock Knob (53) by turning it *counterclockwise*. Push the Height Handle (29) inward to engage the gear, then turn it until the red pointer indicates the desired angle.
2. When an angle is set, hold the Height Handle stationary with one hand and tighten the Lock Knob *clockwise* to lock the Saw Blade in position.

Adjusting the Width Of Cut

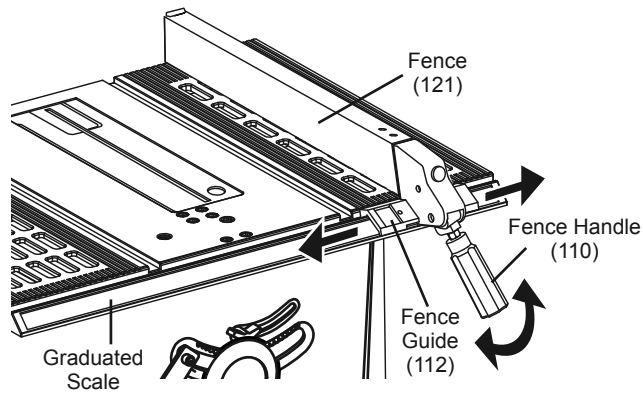

Figure T

WARNING! Do not attempt to use the fence and miter gauge at the same time.

1. The width of a cut is achieved by moving the Fence (121) to the right or left.

2. The Table Saw features a Graduated Scale on the front of the unit. The Scale's measurements are in both *inch* and *metric* increments.
3. To adjust the position of the Fence, raise the Fence Handle and slide the Fence along the Work Table. Once the position is adjusted, lower the Fence Handle to lock the Fence in place.
4. To adjust the Fence position using the workpiece and the Graduated Scale:
 - a. Place the workpiece against the Fence on the Table Saw.
 - b. Raise the Fence Handle to unlock the Fence and slide the workpiece and Fence together to the right or left until the left side of the Fence Guide (112) aligns with the desired measurement on the Graduated Scale.
 - c. Lock the Fence in place by lowering the Fence Handle (110).

Workpiece and Work Area Set Up

1. Designate a work area that is clean and well-lit. The work area must not allow access by children or pets to prevent distraction and injury.
2. Route the power cord along a safe route to reach the work area without creating a tripping hazard or exposing the power cord to possible damage. The power cord must reach the work area with enough extra length to allow free movement while working.
3. Allow room on both sides of saw for extended workpieces.
4. Use a table, stand, or other means to support extended workpieces. Mount the Saw so that the surface is level to the ground, and additional supports to provide a surface on the same level as the saw table. If the work surface and any workpiece supports are not level, and on the same level, unwanted bevel angles will appear in the cuts resulting in poor joinery.
5. Secure loose work pieces using a vise or clamps (not included) to prevent movement while working.
6. There must not be objects, such as utility lines, nearby that will present a hazard while working.

General Operating Instructions



! DANGER

SAWS CAN QUICKLY AMPUTATE FINGERS IF MISUSED.

Keep hands well clear of cutting area.

DO NOT OPERATE WITH ANY GUARD DISABLED, DAMAGED, OR REMOVED.

Moving guards must move freely and close instantly.

INSTALL GUARD BEFORE USE.

Proper Placement Of Hands During the Cutting Process

1. Review Safety warnings at the beginning of the manual before performing any cutting procedure. Keep all guards in place and in working order.
2. Do not pass hands directly over the Saw Blade (42) when cutting the workpiece. Push the workpiece into the Saw Blade using a Push-stick, push-block or by holding the workpiece against the Miter Gauge.

WARNING! SAFE CUTTING PROCEDURES VARY DEPENDING ON THE TYPE OF CUT. TO PREVENT SERIOUS INJURY FROM KICKBACK:

Use Fence for every Rip Cut (cut along with the grain).

BUT Do not use Fence for any crosscut (cut against the grain).

Rip Cuts

1. Rip cuts are straight cuts made parallel to (along with) the grain of the wood by sliding the workpiece along the Fence.
2. For pieces wider than 6" hold the workpiece, staying clear of the Saw Blade. For pieces between 2" and 6", use the included Push-stick or make a push-stick as described in the Safety section of this manual. Use a Push-block (not included) when ripping widths under 2".
2. When ripping, always use the Fence (194). This improves the accuracy of the cut, and reduces the chance for Saw Blade binding.

Crosscuts/Miter Cuts

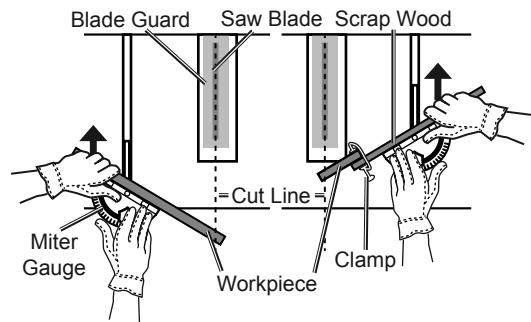

Figure U

1. Adjust the Miter Gauge to the needed angle and place it in the right or left slot on the Table.
2. Hold the workpiece against the Miter Gauge, and slide them together to make the cut. Clamp smaller pieces to a piece of scrap wood that can reach beyond the Miter Gauge and hold the scrap against the Gauge while making the cut. Keep the clamp clear of the Saw Blade.

Making a Cut

1. After adjusting the width and/or angle of the cut, plug the Table Saw into a grounded 120V outlet.
2. Insert the Switch Key and turn the Switch on.
3. At the start of the cut, the left hand holds the workpiece firmly on the Work Table (and against the Fence, if used), and the right hand, with the aid of a Push-stick, pushes the workpiece toward the turning Saw Blade. Keep both hands out of the path of the Saw Blade.
4. After the cut is under way, use the Push Stick to continue guiding the workpiece forward. Just before the cut is completed, move the left hand safely farther away from the workpiece and the Saw Blade. Continue pushing the workpiece into the Saw Blade with the Push Stick until the cut is complete.
5. Once the cut is complete, continue to maintain control of the workpiece. Turn the Switch off. Then, wait until the Saw Blade completely stops rotating before removing the workpiece.
6. To prevent accidents, turn off the Table Saw, remove the key and disconnect its power supply after use. Clean, then store the Saw indoors out of children's reach.

WARNING! Throughout the cut, keep all body parts a safe distance from the spinning Blade.

Table Saw Overload Protection

1. The Table Saw is equipped with an Overload Protector (5). If the motor shuts off or fails to start due to overloading (cutting stock too fast, using a dull Saw Blade, low voltage, using the Table Saw beyond its capacity, etc.), turn the Switch to its OFF position.
2. Let the motor cool three to five minutes before pushing the Reset button. This will reset the overload device. The motor can then be turned on again in the usual manner.

Maintenance and Servicing



Procedures not specifically explained in this manual must be performed only by a qualified technician.

WARNING

TO PREVENT SERIOUS INJURY FROM ACCIDENTAL OPERATION:
Always disconnect the Table Saw from its electrical outlet before performing any inspection, maintenance, or cleaning procedures.

TO PREVENT SERIOUS INJURY FROM TOOL FAILURE:
Do not use damaged equipment. If abnormal noise or vibration occurs, have the problem corrected before further use.

Cleaning, Maintenance, and Lubrication

1. **BEFORE EACH USE**, inspect the general condition of the tool. Check for loose screws, misalignment or binding of moving parts, cracked or broken parts, damaged electrical wiring, improper mounting of the Saw Blade (73) and any other condition that may affect its safe operation.
2. **Remove cut-off pieces and scraps from the Table before starting the Table Saw.** Switch off the tool. While the Saw Blade is completely stopped; unplug the machine, remove the Blade, and remove all debris. With a brush, soft cloth, or vacuum, remove all sawdust from the Table Saw.
Allowing sawdust, scraps, or other debris to accumulate can cause a fire, resulting in severe personal injury or property damage.
3. Do not use solvents to wipe off the Table Saw, as damage may result. If necessary, wipe with a damp cloth. You may use a mild detergent.
Do not introduce water into the electric motor through the motor vents.
4. Once clean, lubricate all moving parts with a light oil.
5. When storing, keep the Table Saw covered with a cloth cover.
6. **WARNING!** If the supply cord of this power tool is damaged, it must be replaced only by a qualified service technician.
7. Use the Adjustable Stop Bolts in the table top to adjust the zero degree and 45 degree positive stops. A 5mm hex key and a 10mm wrench (both sold separately) are required for adjustment. See Figure V.

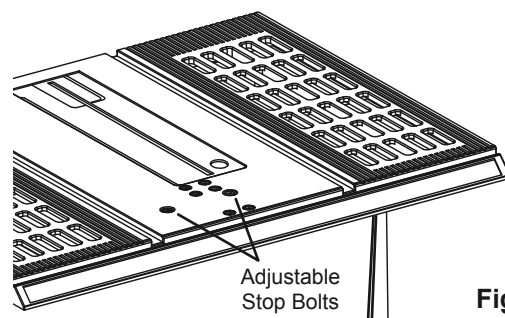

Figure V

Troubleshooting

SAFETY

SETUP

OPERATION

MAINTENANCE

Problem	Possible Causes	Likely Solutions
Motor will not start.	<ol style="list-style-type: none"> 1. Low voltage. 2. Key not installed. 3. Short circuit in line cord or plug. 4. Short circuit in motor. 5. Open circuit or loose connection in motor. 6. Incorrect fuses or circuit breakers. 7. Defective switch. 8. Defective capacitor. 9. Motor overload results in circuit breaker tripped. 	<ol style="list-style-type: none"> 1. Check power supply for proper voltage. 2. Insert Key. 3. Inspect line cord and plug for faulty insulation or shorted connection. 4. Inspect connection on motor. 5. Inspect connection on motor. 6. Replace with correct fuses or circuit breakers. 7. Replace switch. 8. Replace capacitor. 9. Turn off Table Saw and reset overload protection.
Motor stalling or failing to reach full speed.	<ol style="list-style-type: none"> 1. Power overload. 2. Low voltage from power supply. 3. Undersized line cord. 4. Motor overloaded. 5. Short circuit or loose connection in motor. 6. Incorrect fuses or circuit breakers. 7. Wood chips clogged. 	<ol style="list-style-type: none"> 1. Reduce workload on the power supply. 2. Check power supply for proper voltage. 3. Use cord of adequate size or reduce wiring length. 4. Reduce load on motor. 5. Inspect the connection in motor for loose or shorted connection. 6. Replace with correct fuses or circuit breaker. 7. Inspect chip blower assembly and fan belt. Remove excessive wood chips.
Motor overheats.	<ol style="list-style-type: none"> 1. Motor overloaded. 2. Excessive dust build-up, decreasing air circulation. 	<ol style="list-style-type: none"> 1. Reduce load on motor. Turn off machine until motor cools down. 2. Remove dust build-up.
Circuit Breaker frequently trips.	<ol style="list-style-type: none"> 1. Motor overload. 2. Inadequate circuit capacity. 3. Circuit overload. 4. Blades are dull. 	<ol style="list-style-type: none"> 1. Reduce load on motor. 2. Connect to larger circuit. 3. Disconnect other devices from circuit. 4. Sharpen or replace blades.
Does not make accurate 45° and 90° rip cuts.	<ol style="list-style-type: none"> 1. Positive stop not adjusted correctly. 2. Tilt angle pointer not set accurately. 	<ol style="list-style-type: none"> 1. Check blade with square and adjust stop. 2. Check blade with square and adjust to zero.
Workpiece pinched blade during ripping.	<ol style="list-style-type: none"> 1. Rip fence not aligned with blade. 2. Warped wood; edge against fence not straight. 	<ol style="list-style-type: none"> 1. Check and adjust rip fence. 2. Select another piece of wood.
Workpiece binds on Riving Knife.	Riving Knife not aligned correctly with blade.	Check and align Riving Knife with blade.
Saw makes unsatisfactory cuts.	<ol style="list-style-type: none"> 1. Dull blade. 2. Blade mounted backwards. 3. Gum or pitch on blade. 4. Incorrect blade for work being done. 5. Table dirty. 	<ol style="list-style-type: none"> 1. Replace blade. 2. Turn the blade around. 3. Remove blade and clean with turpentine and coarse steel wool. 4. Change the blade. 5. Clean table with turpentine and steel wool.



**Follow all safety precautions whenever diagnosing or servicing the tool.
Disconnect power supply before service.**

Problem	Possible Causes	Likely Solutions
Workpiece kicked back from blade.	<ol style="list-style-type: none"> 1. Fence out of alignment. 2. Riving Knife not aligned with blade. 3. Feeding workpiece without fence. 4. Riving Knife not in place. 5. Dull blade. 6. Letting go of workpiece before it is past blade. 7. Miter angle lock knob not tight. 	<ol style="list-style-type: none"> 1. Align fence with miter gauge slot. 2. Align Riving Knife with blade. 3. Install and use fence. 4. Install and align Riving Knife (with guard). 5. Replace blade. 6. Push material all the way past blade before releasing workpiece. 7. Tighten knob.
Blade does not raise or tilt freely.	Sawdust and dirt in tilting mechanism.	Brush or blow out loose dust and dirt.
Blade does not come up to speed. Reset trips too easily.	<ol style="list-style-type: none"> 1. Extension cord too thin or too long. 2. Low voltage. 	<ol style="list-style-type: none"> 1. Omit extension cord or replace with adequate thickness (gauge) cord. 2. Contact local electric power company.
Saw vibrates excessively.	<ol style="list-style-type: none"> 1. Saw not mounted securely to workbench. 2. Bench on uneven floor. 3. Damaged saw blade. 	<ol style="list-style-type: none"> 1. Tighten all mounting hardware. 2. Reposition on flat, level surface. 3. Replace blade.
Does not make accurate 45° and 90° crosscuts.	Miter gauge out of adjustment.	Adjust miter gauge.
 <p>Follow all safety precautions whenever diagnosing or servicing the tool. Disconnect power supply before service.</p>		

PLEASE READ THE FOLLOWING CAREFULLY

THE MANUFACTURER AND/OR DISTRIBUTOR HAS PROVIDED THE PARTS LIST AND ASSEMBLY DIAGRAM IN THIS MANUAL AS A REFERENCE TOOL ONLY. NEITHER THE MANUFACTURER OR DISTRIBUTOR MAKES ANY REPRESENTATION OR WARRANTY OF ANY KIND TO THE BUYER THAT HE OR SHE IS QUALIFIED TO MAKE ANY REPAIRS TO THE PRODUCT, OR THAT HE OR SHE IS QUALIFIED TO REPLACE ANY PARTS OF THE PRODUCT. IN FACT, THE MANUFACTURER AND/OR DISTRIBUTOR EXPRESSLY STATES THAT ALL REPAIRS AND PARTS REPLACEMENTS SHOULD BE UNDERTAKEN BY CERTIFIED AND LICENSED TECHNICIANS, AND NOT BY THE BUYER. THE BUYER ASSUMES ALL RISK AND LIABILITY ARISING OUT OF HIS OR HER REPAIRS TO THE ORIGINAL PRODUCT OR REPLACEMENT PARTS THERETO, OR ARISING OUT OF HIS OR HER INSTALLATION OF REPLACEMENT PARTS THERETO.

Record Product's Serial Number Here: _____

Note: If product has no serial number, record month and year of purchase instead.

Note: Some parts are listed and shown for illustration purposes only, and are not available individually as replacement parts.

Parts List

SAFETY

SETUP

OPERATION

MAINTENANCE

Part	Description	Qty	Part	Description	Qty	Part	Description	Qty
1	Switch (Hy18)	1	56	M6 Nut	7	111	M4×8 Cross Head Screw	1
2	Panel	1	57	M6x30 Screw	1	112	Fence Guide	1
3	Ø4 Flat Washer	15	58	Rotary Board	2	113	Ø8 Round Pin	1
4	St4.2x14 Screw	16	59	M6 T Type Screw	2	114	Ø6 Round Pin	1
5	Overload Protector	1	60	Height Bar	1	115	M6 Locknut	1
6	Gasket	1	61	Bracket Base 2	1	116	Fense Sliding Seat	1
7	Switch Box	1	63	Ø8 Flat Washer	3	117	(Big)Cam	1
8	Label	1	64	Bearing Frame	1	118	Fense Lock Before Board	1
9	Feet	4	65	M6x16 Bolt	3	119	Forward Washer Plate	1
10	M6x25 Screw	4	66	Ø6 Spring Washer	9	120	M6×10 Hexagon-Headed Bolt	2
11	Ø6 Washer	6	67	Ø4x10 Spring Pin	2	121	Fence (Aluminum Alloy)	1
12	Housing	1	68	M6x22 Bolt	4	122	Draw Bar (Fence)	1
13	Push Stick Block	2	69	M6 Double Head Screw	1	123	Back Base Plate	1
14	Block	2	70	Junction Plate	1	124	Press Spring 2	1
15	Dust Cover	1	71	Ø45 Circlip	1	125	Fence Rear Plate	1
16	Plug	1	72	Inner Flange	1	126	M6x16 Knob	1
17	Cable Sleeve	1	73	Saw Blade	1	127	Washer	2
18	Cable Clamp	1	74	Outer Flange	1	128	St3.5×6 Cross Head Screw	1
19	M4x10 Bolt	1	75	M16 Blade Nut	1	129	6×11 Round Pin	1
20	Ø4 Spring Washer	1	76	Link Bar	1	130	Square Nut	1
21	Plug Clamp	1	77	Blade Guard	1	131	Backer Cover (First)	1
22	Plug Block	1	78	Fixed Link	1	132	M6×18 Handle	1
23	M4 Nut	1	79	M5 Locknut	2	133	Miter Gauge Guide	1
24	M4x12 Screw	9	80	M5x20 Screw	2	134	Backer Cover (Second)	1
25	Dead Plate	1	81	Fixed Link Down Clamp	2	135	Aluminium Profile	1
26	M4 Locknut	9	82	Fixed Link Up Clamp	2	136	629 Bearing	1
27	Rack	1	83	M6x20 Screw	4	137	Motor Housing	1
28	M8x65 Screw	1	84	M5 Double Head Screw	1	139	Push Stick	1
29	Height Handle	1	85	M6x12 Screw	2	140	Open-End Wrench	1
30	M8 Nut	4	86	Connecting Bar	1	141	Open-End Wrench	1
31	Label	1	87	Ø3×20 Hollow Pin	1	146	M5×15 Cross Countersunk Screw	3
32	Height Knob	1	88	Riving Knife	1	147	Bearing Cap	1
33	Spring	1	89	Riving Knife Clamp	1	148	6003 Bearing	1
34	Ø2.5x22 Flexible Pin	1	90	Ø3x15 Spring Pin	1	149	Ø35 Circlip	1
35	Height Bar	1	91	Work Table	1	150	Output Shaft	1
36	Ø10 Flat Washer	3	92	Scale	1	151	Flat Key 5×5×12	1
37	M6 Nut	2	93	M6*25 Screw	2	152	Gear	1
38	Bracket Base 1	1	94	Locking Screw	1	153	Ø16 Circlip	1
39	Plate Stop	1	95	Adjusting Lever	1	154	Hk1210 Needle Roller Bearing	1
40	Slot Cover	1	96	Pawl Lock Pin	1	155	M5×30 Cross Head Screw	4
41	M5x12 Screw	1	97	Small Spring	1	156	Middle Cover	1
42	Ø5 Spring Washer	4	98	Ø12 External Plier	1	157	6202 Bearing	1
43	Ø5 Flat Washer	8	99	Table Insert	1	158	Fan Shroud	1
44	M6x85 Screw	2	100	Pawl Socket	1	159	Connecting Wire	1
45	Ø6 Flat Washer	12	101	Keep Back Socket	1	160	Brush Cover	2
46	Bushing	3	102	Pawl Plate Location Pin	2	161	Electric Brush	2
47	M6 Lock Nut	9	103	Double Twist Spring	1	162	Brush Holder	2
48	M5x14 Screw	1	104	Anti-Kickback Pawl	1	163	St4.8x65 Screw	2
49	Magnifier	1	105	Pawl Plate Guard Cap	1	164	Stator	1
50	M8 Locknut	1	106	Lid Lock	1	165	Rotor	1
51	Connecting Hook	1	107	M4×10 Cross Countersunk Screw	1	166	Ø8×100 Hollow Pin	1
52	M8x16 Screw	1	108	Table Insert Washer (Left)	1	167	M6 Locknut	6
53	Lock Knob	1	109	Table Insert Washer (Right)	1			
54	Ø6 Washer	1	110	Fence Handle	1			
55	Lock Sleeve	1						

Assembly Diagram

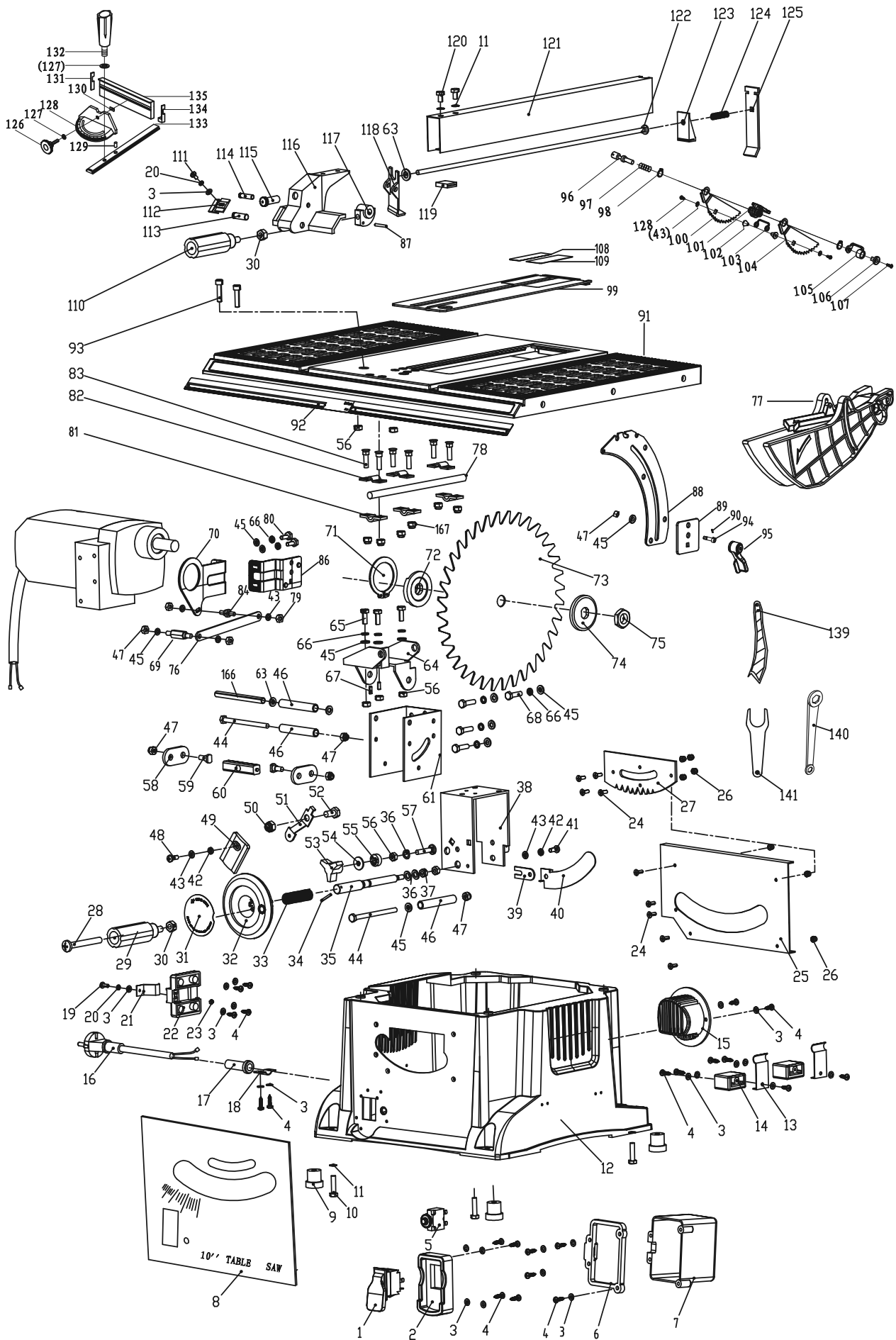

SAFETY

SETUP

OPERATION

MAINTENANCE

Assembly Diagram (continued)

SAFETY

SETUP

OPERATION

MAINTENANCE

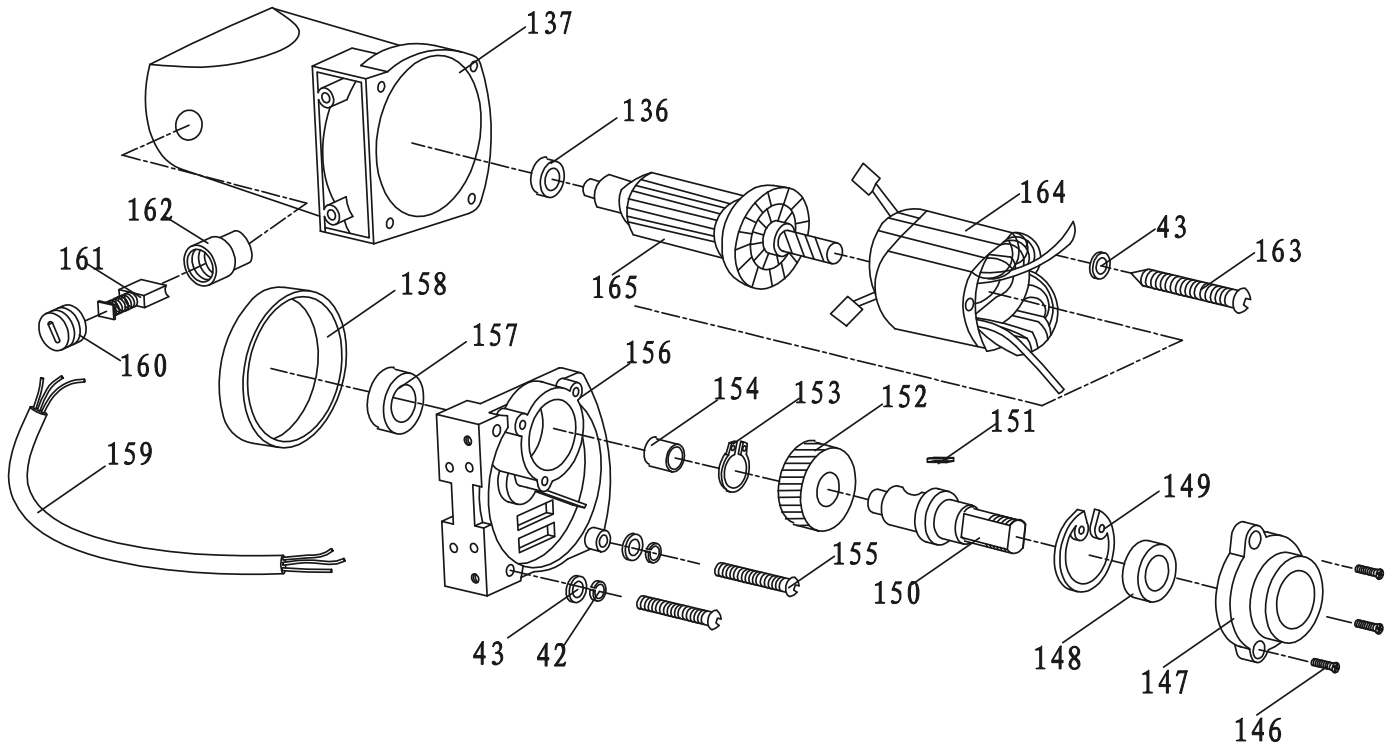

Limited 90 Day Warranty

Harbor Freight Tools Co. makes every effort to assure that its products meet high quality and durability standards, and warrants to the original purchaser that this product is free from defects in materials and workmanship for the period of 90 days from the date of purchase. This warranty does not apply to damage due directly or indirectly, to misuse, abuse, negligence or accidents, repairs or alterations outside our facilities, criminal activity, improper installation, normal wear and tear, or to lack of maintenance. We shall in no event be liable for death, injuries to persons or property, or for incidental, contingent, special or consequential damages arising from the use of our product. Some states do not allow the exclusion or limitation of incidental or consequential damages, so the above limitation of exclusion may not apply to you. THIS WARRANTY IS EXPRESSLY IN LIEU OF ALL OTHER WARRANTIES, EXPRESS OR IMPLIED, INCLUDING THE WARRANTIES OF MERCHANTABILITY AND FITNESS.

To take advantage of this warranty, the product or part must be returned to us with transportation charges prepaid. Proof of purchase date and an explanation of the complaint must accompany the merchandise. If our inspection verifies the defect, we will either repair or replace the product at our election or we may elect to refund the purchase price if we cannot readily and quickly provide you with a replacement. We will return repaired products at our expense, but if we determine there is no defect, or that the defect resulted from causes not within the scope of our warranty, then you must bear the cost of returning the product.

This warranty gives you specific legal rights and you may also have other rights which vary from state to state.

CHICAGO  ELECTRIC[®]
POWER TOOLS

3491 Mission Oaks Blvd. • PO Box 6009 • Camarillo, CA 93011 • 1-888-866-5797