

# Owner's Manual & Safety Instructions

**Save This Manual** Keep this manual for the safety warnings and precautions, assembly, operating, inspection, maintenance and cleaning procedures. Write the product's serial number in the back of the manual near the assembly diagram (or month and year of purchase if product has no number). Keep this manual and the receipt in a safe and dry place for future reference.

17j

# CreekStone™

## SUBMERSIBLE POND PUMP

63313

**264** GPH **MAXIMUM FLOW**  
**AT 0 FT**

**5.5** ft **MAXIMUM HEAD LIFT**  
**AT 0 FLOW**



Visit our website at: <http://www.harborfreight.com>  
Email our technical support at: [productsupport@harborfreight.com](mailto:productsupport@harborfreight.com)

When unpacking, make sure that the product is intact and undamaged. If any parts are missing or broken, please call 1-888-866-5797 as soon as possible.

Copyright© 2016 by Harbor Freight Tools®. All rights reserved.  
No portion of this manual or any artwork contained herein may be reproduced in any shape or form without the express written consent of Harbor Freight Tools. Diagrams within this manual may not be drawn proportionally. Due to continuing improvements, actual product may differ slightly from the product described herein.  
Tools required for assembly and service may not be included.

### **⚠ WARNING**

**Read this material before using this product.  
Failure to do so can result in serious injury.  
SAVE THIS MANUAL.**

## Before start-up, note the following:

The pump must be connected to a GFCI protected plug which has been installed according to regulations. The plug must have a supply voltage of 120VAC at 60Hz.

## CAUTION

This pump has been evaluated for use with fresh water only.

## ⚠WARNING

**IMPORTANT! For your own safety – before starting to run the pump, please have the following items checked by an expert:**

1. Risk of electric shock – This pump is supplied with a grounding conductor and grounding-type attachment plug. To reduce the risk of electric shock, be certain that it is connected only to a properly grounded, grounding-type receptacle.
2. Risk of electric shock – This pump has not been investigated for use in swimming pool areas.
3. The electrical connections must be protected from moisture.
4. If there is danger of flooding, the electrical connections must be taken to higher ground.
5. Circulation of caustic fluids, as well as the circulation of abrasive materials, must be avoided at all costs.
6. The pump must be protected from frost.
7. The pump must be protected from running dry.
8. Access by children should also be prevented with appropriate measures.
9. To reduce the risk of electric shock, use only on portable self-contained fountains.
10. **POSITION OF PUMP:**

To avoid the possibility of the pump plug or receptacle getting wet, position pump to one side of a wall mounted receptacle to prevent water from dripping onto the receptacle or plug. The user should arrange a “drip loop” in the cord connecting the pump to a receptacle.

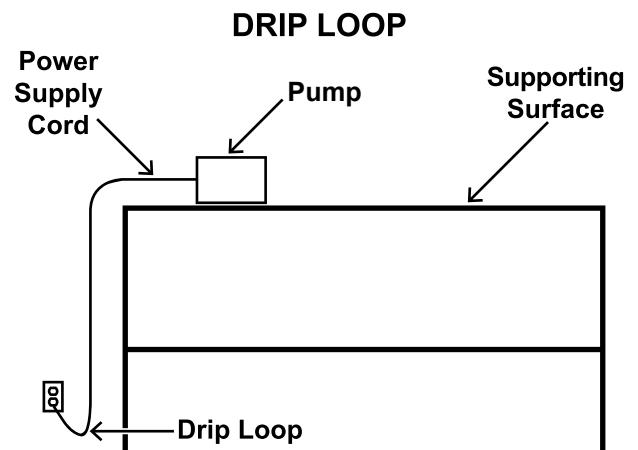

The “drip loop” is that part of the cord below the level of the receptacle, or the connector if an extension cord is used, to prevent water traveling along the cord and coming in contact with the receptacle.

11.  **To prevent death from electric shock, pump must be connected only to a GFCI protected outlet.**
12. Do not use an extension cord with this item.
13. People with pacemakers should consult their physician(s) before use. Electromagnetic fields in close proximity to heart pacemaker could cause pacemaker interference or pacemaker failure.
14. The warnings, precautions, and instructions discussed in this instruction manual cannot cover all possible conditions and situations that may occur. It must be understood by the operator that common sense and caution are factors which cannot be built into this product, but must be supplied by the operator.

## Fluid Type

The Pump is designed for use with fresh water with a maximum temperature of 77° F (25°C)—do not use for heated liquids. Do not use the pump for other fluids, especially not fuels, cleaning fluids, or other chemical products. Do not use to pump salt water, highly chlorinated water, or water with a high pH level.

## Specifications

Electrical Rating	120VAC / 60Hz / 0.23A
Power Cord Length	12'
Maximum Flow @ 0'	264 GPH
Maximum Head lift @ 0 Flow	5.5'
Discharge Port	1/2"

## Installation

The submersible motor pump must be installed in a stationary position with either:

- a. A fixed pipeline or
- b. A flexible hose pipe.

## Please note!

1. Do not install the pump by suspending it unsupported from its delivery pipe or power cord. The pump must be suspended from the handle or be placed on the bottom of the basin. To ensure that the pump works properly, keep the bottom of the fountain/water feature free from sludge and dirt of all kinds.
2. If the water level sinks too low, any sludge in the basin will dry out and stop the pump from starting. Pump will not function unless fully submerged.

## Power Supply

1. The pump is equipped with a shock-proof plug according to regulations. The pump is designed to be connected to a 120VAC, 60Hz GFCI protected socket.
2. Make sure that the socket is sufficiently secured and is in excellent condition.
3.  **WARNING: To prevent death from electric shock, pump must be connected only to a GFCI protected outlet.**

**WARNING!** If the power cord or plug is damaged, do not use the pump. The power cord or plug may only be repaired by a certified electrician.

## Areas of use

1. This pump is designed to pump fresh water only.
2. This pump is designed to be used for:  
Fresh-water aquariums and water features.
3. This pump should NOT be used for:  
Saltwater or brackish water aquariums or water features.

## Installation Instructions

1. Place the pump on the bottom of the aquarium/water feature. Suction cups must be in contact with the aquarium/fountain floor or a smooth platform.
2. Shift regulator to adjust flow rate.

## Operation

After reading these instructions, consider the following points before starting the pump:

1. Verify that the pump rests on the floor of the basin, if it is not suspended by the handle.
2. Verify that the discharge pipe is properly connected.
3. Verify that the electrical connection is 120VAC, 60Hz.
4. Verify that the electrical socket is GFCI protected and in good condition. Test GFCI protected outlet before use.
5. Verify that water and moisture cannot get near the power supply socket.
6. Verify that the pump is installed so as to prevent running dry.

## **⚠️WARNING**

**TO PREVENT SERIOUS INJURY FROM ACCIDENTAL OPERATION:**  
**Unplug the Pump from its electrical outlet before performing any inspection, maintenance, or cleaning procedures.**

If the pump is moved during operation, flush it out with clean water after every use.

## Quarterly Maintenance

The below maintenance must be performed at least once every 3 months under optimal conditions. For frequent use, or dirty areas, more frequent maintenance is required.

1. **Unplug pump from its electrical outlet before reaching into the water.** Clean sludge and debris from the bottom of the basin.
2. Clean sludge/debris from inlet screen.
3. Make sure discharge pipe is free from leaks.
4. Make sure check valve is functioning properly.
5. Manually operate flow switch to determine that pump turns on/off as intended.

## Troubleshooting

<b>Problem</b>	<b>Possible Causes</b>	<b>Possible Solutions</b>
Pump runs, but will not deliver any water.	<ol style="list-style-type: none"> <li>1. Inlet Screen and/or impeller clogged.</li> <li>2. When starting, water level may fall below the minimum required to keep Pump completely submerged.</li> <li>3. Low line voltage.</li> <li>4. Check valve (sold separately) stuck or installed backwards.</li> </ol>	<ol style="list-style-type: none"> <li>1. Remove Inlet Screen. Clean out dirt and debris from Inlet Screen and impeller. Then replace Inlet Screen.</li> <li>2. For proper operation after startup, Pump must remain completely submerged at all times.</li> <li>3. Consult an electrician.</li> <li>4. Remove and examine check valve.</li> </ol>
Pump won't start or run.	<ol style="list-style-type: none"> <li>1. Check power connections and circuits/fuses.</li> <li>2. Water level too low.</li> <li>3. Inlet Screen and/or impeller clogged.</li> <li>4. Defective motor.</li> </ol>	<ol style="list-style-type: none"> <li>1. Consult an electrician.</li> <li>2. Move Pump to a location where it is completely submerged at all times.</li> <li>3. Remove Inlet Screen. Clean out Inlet Screen and impeller. Reinstall Inlet Screen.</li> <li>4. Have a qualified service technician repair or replace.</li> </ol>
Excessive noise or vibration.	<ol style="list-style-type: none"> <li>1. Debris in impeller.</li> <li>2. Discharge hose restricted.</li> </ol>	<ol style="list-style-type: none"> <li>1. Remove Inlet Screen. Clean impeller. Reinstall Inlet Screen.</li> <li>2. Clean Pump and discharge hose.</li> </ol>
Pump starts and stops too frequently.	<ol style="list-style-type: none"> <li>1. Water temperature too high.</li> <li>2. Check valve (sold separately) stuck or installed backwards.</li> <li>3. Back flow of water from discharge hose.</li> </ol>	<ol style="list-style-type: none"> <li>1. Do not exceed 77° F (25°C) water temperature.</li> <li>2. Remove and examine check valve.</li> <li>3. Install or inspect check valve (sold separately).</li> </ol>



**Follow all safety precautions whenever diagnosing or servicing the tool.**  
**Disconnect power supply before service.**

### PLEASE READ THE FOLLOWING CAREFULLY

THE MANUFACTURER AND/OR DISTRIBUTOR HAS PROVIDED THE PARTS LIST AND ASSEMBLY DIAGRAM IN THIS MANUAL AS A REFERENCE TOOL ONLY. NEITHER THE MANUFACTURER OR DISTRIBUTOR MAKES ANY REPRESENTATION OR WARRANTY OF ANY KIND TO THE BUYER THAT HE OR SHE IS QUALIFIED TO MAKE ANY REPAIRS TO THE PRODUCT, OR THAT HE OR SHE IS QUALIFIED TO REPLACE ANY PARTS OF THE PRODUCT. IN FACT, THE MANUFACTURER AND/OR DISTRIBUTOR EXPRESSLY STATES THAT ALL REPAIRS AND PARTS REPLACEMENTS SHOULD BE UNDERTAKEN BY CERTIFIED AND LICENSED TECHNICIANS, AND NOT BY THE BUYER. THE BUYER ASSUMES ALL RISK AND LIABILITY ARISING OUT OF HIS OR HER REPAIRS TO THE ORIGINAL PRODUCT OR REPLACEMENT PARTS THERETO, OR ARISING OUT OF HIS OR HER INSTALLATION OF REPLACEMENT PARTS THERETO.

### Parts List

Part	Description	Qty.	Part	Description	Qty.
1	Front Cover	1	15	Magnet Wire	2
2	Filter	1	16	Iron Core	1
3	Water Seating	1	17	Grommet	1
4	Impeller Head	1	18	Power Cord	1
5	Impeller	1	19	Back Cover	1
6	Impeller Shaft	1	20	Plug	1
7	Sealing Ring	2	1A	Extension	1
8	Shaft Cover	2	2A	Bell Outlet	1
9	Suction Cup	4	3A	Star Outlet	1
10	Frame	1	4A	Left Adjustment Lever	1
11	Water Outlet	1	5A	Right Adjustment Lever	1
12	Pump Body	1	6A	Extension Valve	1
13	Motor	2	7A	Main Outlet	1
14	Grounded Terminal	1	8A	Lower Connector	1

**Record Product's Serial Number Here:** \_\_\_\_\_

**Note:** If product has no serial number, record month and year of purchase instead.

**Note:** Some parts are listed and shown for illustration purposes only, and are not available individually as replacement parts.



# Assembly Diagram

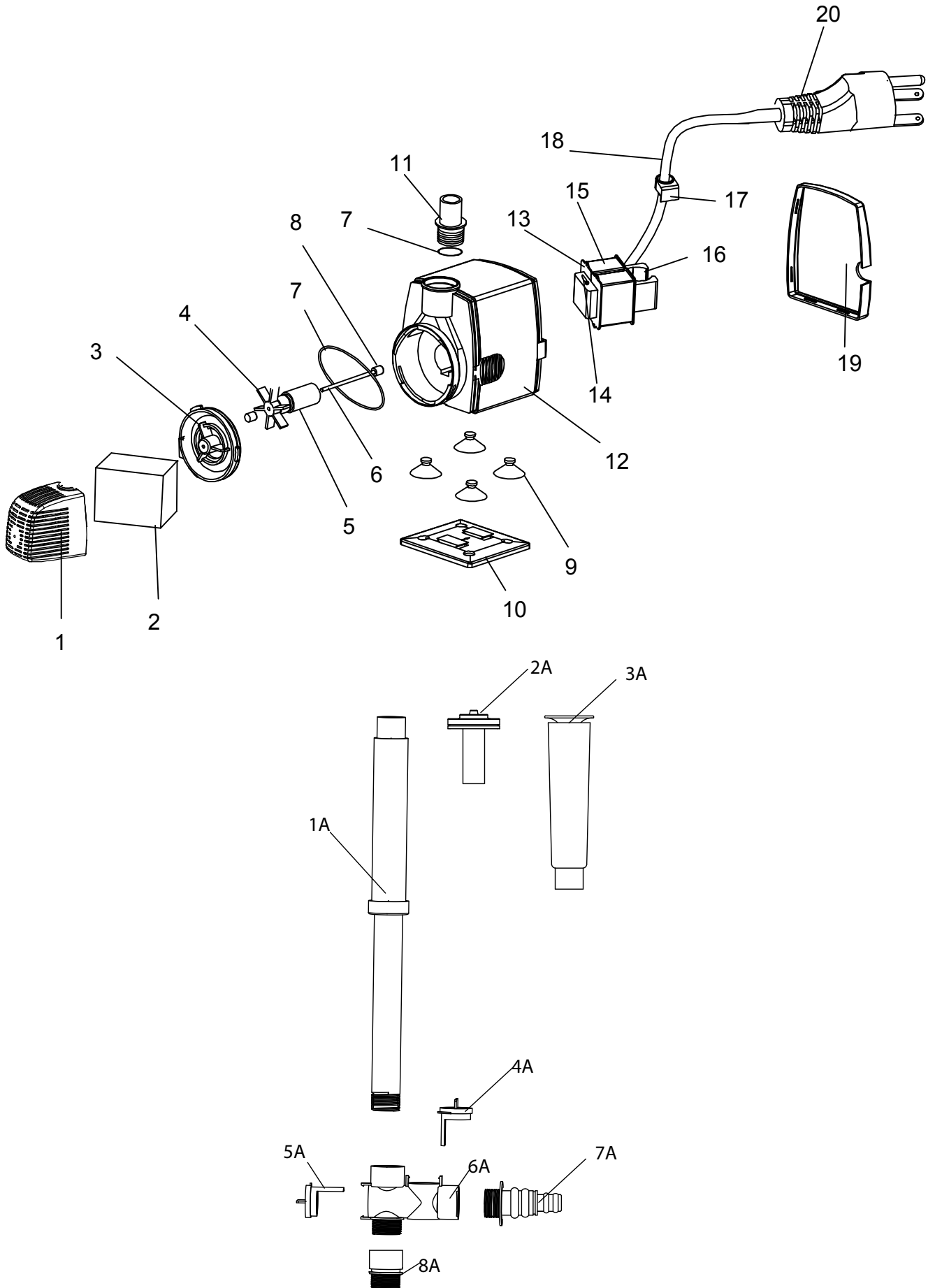

## Limited 90 Day Warranty

Harbor Freight Tools Co. makes every effort to assure that its products meet high quality and durability standards, and warrants to the original purchaser that this product is free from defects in materials and workmanship for the period of 90 days from the date of purchase. This warranty does not apply to damage due directly or indirectly, to misuse, abuse, negligence or accidents, repairs or alterations outside our facilities, criminal activity, improper installation, normal wear and tear, or to lack of maintenance. We shall in no event be liable for death, injuries to persons or property, or for incidental, contingent, special or consequential damages arising from the use of our product. Some states do not allow the exclusion or limitation of incidental or consequential damages, so the above limitation of exclusion may not apply to you. THIS WARRANTY IS EXPRESSLY IN LIEU OF ALL OTHER WARRANTIES, EXPRESS OR IMPLIED, INCLUDING THE WARRANTIES OF MERCHANTABILITY AND FITNESS.

To take advantage of this warranty, the product or part must be returned to us with transportation charges prepaid. Proof of purchase date and an explanation of the complaint must accompany the merchandise. If our inspection verifies the defect, we will either repair or replace the product at our election or we may elect to refund the purchase price if we cannot readily and quickly provide you with a replacement. We will return repaired products at our expense, but if we determine there is no defect, or that the defect resulted from causes not within the scope of our warranty, then you must bear the cost of returning the product.

This warranty gives you specific legal rights and you may also have other rights which vary from state to state.



3491 Mission Oaks Blvd. • PO Box 6009 • Camarillo, CA 93011 • 1-888-866-5797