

Owner's Manual & Safety Instructions

Save This Manual Keep this manual for the safety warnings and precautions, assembly, operating, inspection, maintenance and cleaning procedures. Write the product's serial number in the back of the manual near the assembly diagram (or month and year of purchase if product has no number). Keep this manual and the receipt in a safe and dry place for future reference.

17e

VULCAN™

150A TIG TORCH



Visit our website at: <http://www.harborfreight.com>
Email our technical support at: productsupport@harborfreight.com

63785

When unpacking, make sure that the product is intact and undamaged. If any parts are missing or broken, please call 1-888-866-5797 as soon as possible.





Copyright© 2017 by Harbor Freight Tools®. All rights reserved.

No portion of this manual or any artwork contained herein may be reproduced in any shape or form without the express written consent of Harbor Freight Tools. Diagrams within this manual may not be drawn proportionally. Due to continuing improvements, actual product may differ slightly from the product described herein. Tools required for assembly and service may not be included.

⚠ WARNING

**Read this material before using this product.
Failure to do so can result in serious injury.
SAVE THIS MANUAL.**

WARNING SYMBOLS AND DEFINITIONS

	This is the Safety alert symbol. It is used to alert you to potential personal injury hazards. Obey all Safety messages that follow this symbol to avoid possible injury or death.
	Indicates a hazardous situation which, if not avoided, will result in death or serious injury.
	Indicates a hazardous situation which, if not avoided, could result in death or serious injury.
	Indicates a hazardous situation which, if not avoided, could result in minor or moderate injury.
	Addresses practices not related to personal injury.

IMPORTANT SAFETY INFORMATION

⚠️ WARNING

Read all Safety warnings and instructions.

Failure to follow the warnings and instructions may result in electric shock, fire and/or serious injury.

Save all warnings and instructions for future reference.

General Safety

PROTECT yourself and others. Read and understand this information.

1. **Before use, read and understand manufacturer's instructions, Material Safety Data Sheets (MSDS's), employer's Safety practices, ANSI Z49.1, and welder instructions.**
2. **Keep out of reach of children.**
Keep children and bystanders away while operating.
3. **Place the welder on a stable location before use.**
If it falls while plugged in, severe injury, electric shock, or fire may result.
4. **Do not overreach.**
Keep proper footing and balance at all times.
5. **Stay alert, watch what you are doing and use common sense when operating a welder.**
Do not use a welder while you are tired or under the influence of drugs, alcohol or medication.
A moment of inattention while operating welders may result in serious personal injury.
6. **Avoid unintentional starting.** Make sure you are prepared to begin work before turning on the Welder.
7. **Never leave the Welder unattended while energized.** Turn power off if you have to leave.
8. **The warnings, precautions, and instructions discussed in this instruction manual cannot cover all possible conditions and situations that may occur.** It must be understood by the operator that common sense and caution are factors which cannot be built into this product, but must be supplied by the operator.
9. **WARNING:** This product, when used for welding, plasma cutting, soldering, or similar applications, produces chemicals known to the State of California to cause cancer and birth defects or other reproductive harm. (California Health & Safety Code § 25249.5, *et seq.*)
10. **WARNING:** The cord of this product contains lead and/or di (2-ethylhexyl) phthalate (DEHP), chemicals known to the State of California to cause cancer, and birth defects or other reproductive harm. Wash hands after handling. (California Health & Safety Code § 25249.5, *et seq.*)

11. **Exposure to welding or cutting exhaust fumes can increase the risk of developing certain cancers, such as cancer of the larynx and lung cancer.** Also, some diseases that may be linked to exposure to welding or plasma cutting exhaust fumes are:
 - Early onset of Parkinson's Disease
 - Heart disease
 - Ulcers
 - Damage to the reproductive organs
 - Inflammation of the small intestine or stomach
 - Kidney damage
 - Respiratory diseases such as emphysema, bronchitis, or pneumonia

Use natural or forced air ventilation and wear a respirator approved by NIOSH to protect against the fumes produced to reduce the risk of developing the above illnesses.
12. **Do not use near degreasing or painting operations.**
13. **Keep head out of fumes.**
Do not breathe exhaust fumes.
14. **Use enough ventilation, exhaust at arc, or both, to keep fumes and gases from breathing zone and general area.** If engineering controls are not feasible, use an approved respirator.
15. **Work in a confined area only if it is well-ventilated, or while wearing an air-supplied respirator.**
16. **Have a recognized specialist in Industrial Hygiene or Environmental Services check the operation and air quality and make recommendations for the specific welding situation.**
Follow OSHA guidelines for Permissible Exposure Limits (PEL's) and the American Conference of Governmental Industrial Hygienists recommendations for Threshold Limit Values (TLV's) for fumes and gases.
17. **Wear ANSI-approved welding eye protection featuring at least a number 10 shade lens rating.**
18. **Wear leather leggings, fire resistant shoes or boots during use.** Do not wear pants with cuffs, shirts with open pockets, or any clothing that can catch and hold molten metal or sparks.
19. **Keep clothing free of grease, oil, solvents, or any flammable substances.**
Wear dry, insulating gloves and protective clothing.
20. **Wear an approved head covering to protect the head and neck.** Use aprons, cape, sleeves, shoulder covers, and bibs designed and approved for welding and cutting procedures.
21. **Wear an approved welding jacket or long sleeves to protect forearms from radiation burns.**
22. **When welding/cutting overhead or in confined spaces, wear flame resistant ear plugs or ear muffs to keep sparks out of ears.**
23. **Turn off, disconnect power, and discharge electrode to ground before setting down torch/electrode holder and before installing TIG torch to welder.**
24. **Turn off, disconnect power, and discharge electrode to ground before setting down torch/electrode holder and before service.**
25. **Do not touch energized electrical parts.**
Wear dry, insulating gloves. Do not touch electrode holder, electrode, welding torch, or welding wire with bare hand. Do not wear wet or damaged gloves.
26. **Do not use near water or damp objects.**
27. **People with pacemakers should consult their physician(s) before use.** Electromagnetic fields in close proximity to heart pacemaker could cause pacemaker interference or pacemaker failure.
28. **Do not expose welders to rain or wet conditions.**
Water entering a welder will increase the risk of electric shock.
29. **Do not use outdoors.**
30. **Insulate yourself from the workpiece and ground.**
Use nonflammable, dry insulating material if possible, or use dry rubber mats, dry wood or plywood, or other dry insulating material large enough to cover your full area of contact with the work or ground.
31. **Clear away or protect flammable objects.**
Remove or make safe all combustible materials for a radius of 35 feet (10 meters) around the work area. Use a fire resistant material to cover or block all open doorways, windows, cracks, and other openings.
32. **Keep ABC-type fire extinguisher near work area and know how to use it.**
33. **Maintain a safe working environment.**
Keep the work area well lit.
Make sure there is adequate surrounding workspace.
Keep the work area free of obstructions, grease, oil, trash, and other debris.
34. **Do not operate welders in atmospheres containing dangerously reactive or flammable liquids, gases, vapors, or dust.**
Provide adequate ventilation in work areas to prevent accumulation of such substances.
Welders create sparks which may ignite flammable substances or make reactive fumes toxic.

35. **If working on a metal wall, ceiling, etc., prevent ignition of combustibles on the other side by moving the combustibles to a safe location.** If relocation of combustibles is not possible, designate someone to serve as a fire watch, equipped with a fire extinguisher, during the cutting process and for at least one half hour after the cutting is completed.
36. **Do not weld or cut on materials having a combustible coating or combustible internal structure, as in walls or ceilings, without an approved method for eliminating the hazard.**
37. **Do not dispose of hot slag in containers holding combustible materials.**
38. **After welding, make a thorough examination for evidence of fire.** Be aware that easily visible smoke or flame may not be present for some time after the fire has started.
39. **Do not apply heat to a container that has held an unknown substance or a combustible material whose contents, when heated, can produce flammable or explosive vapors.** Clean and purge containers before applying heat. Vent closed containers, including castings, before preheating, welding, or cutting.
40. **Unplug before maintenance.** Unplug the Welder from its electrical outlet before any inspection, maintenance, or cleaning procedures.

Gas Shielded Welding - Cylinder Safety

Cylinders can explode when damaged.

1. **Do not weld on a pressurized or closed cylinder.**
2. **Do not allow an electrode holder, electrode, welding torch, or welding wire to touch the cylinder.**
3. **Keep cylinders away from any electrical circuits, including welding circuits.**
4. **Keep protective cap in place over the valve except when the cylinder is in use.**
5. **Use only correct gas shielding equipment designed specifically for the type of welding you will do.** Maintain this equipment properly.
6. **Protect gas cylinders from heat, being struck, physical damage, slag, flames, sparks, and arcs.**
7. **Use proper procedures to move cylinders.**



SAVE THESE INSTRUCTIONS.

Specifications

Cable Length	12- 1/2'
Duty Cycle	150A @ 60% duty cycle (DC) 115A @ 60% duty cycle (AC)
Tungsten Range	0.020" - 5/32" (0.5 - 4.0mm)
Weight	5.5 lbs.
Cooling	Air cooled

TIG Setup



Read the **ENTIRE IMPORTANT SAFETY INFORMATION** section at the beginning of this manual including all text under subheadings therein before set up or use of this product.

WARNING

TO PREVENT SERIOUS INJURY FROM ACCIDENTAL OPERATION:
Turn the Power Switch off and unplug the Welder before setup.

TIG Setup

Connect DINSE

1. Determine which DINSE Connector is appropriate for your welding system. For OMNIPRO 220 and PROTIG 200 welders, use the 35-50 Connector. For PROTIG 165 welders, use the 10-25 Connector.

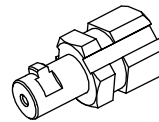

**10-25 DINSE
Connector**

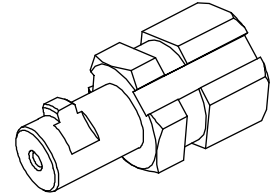

**35-50 DINSE
Connector**

2. Slide rubber sleeve on TIG Torch hose back to expose threaded tip.

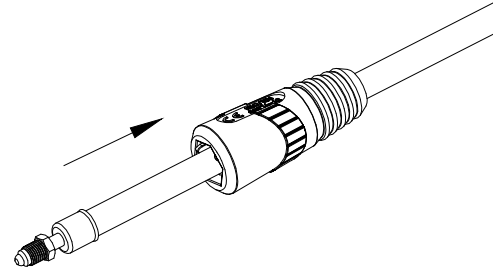

3. Screw DINSE Connector onto threaded tip of TIG Torch hose.

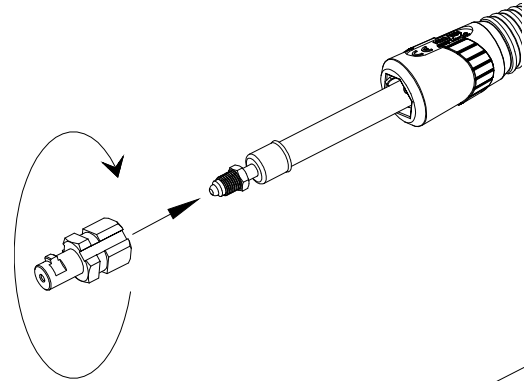

4. Position rubber sleeve so that ridges align with grooves on DINSE Connector.

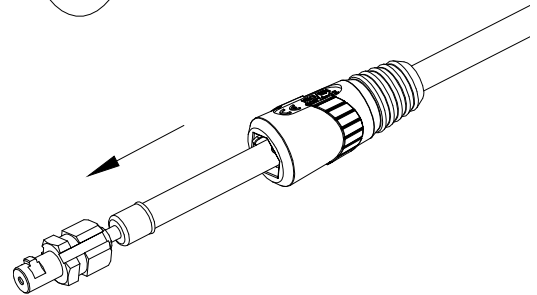

5. Slide rubber sleeve over DINSE Connector leaving only the end exposed. Apply enough force to lock rubber sleeve onto Connector.

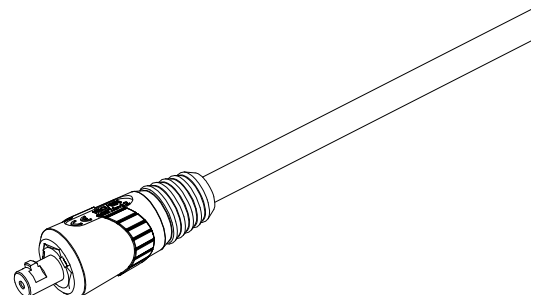

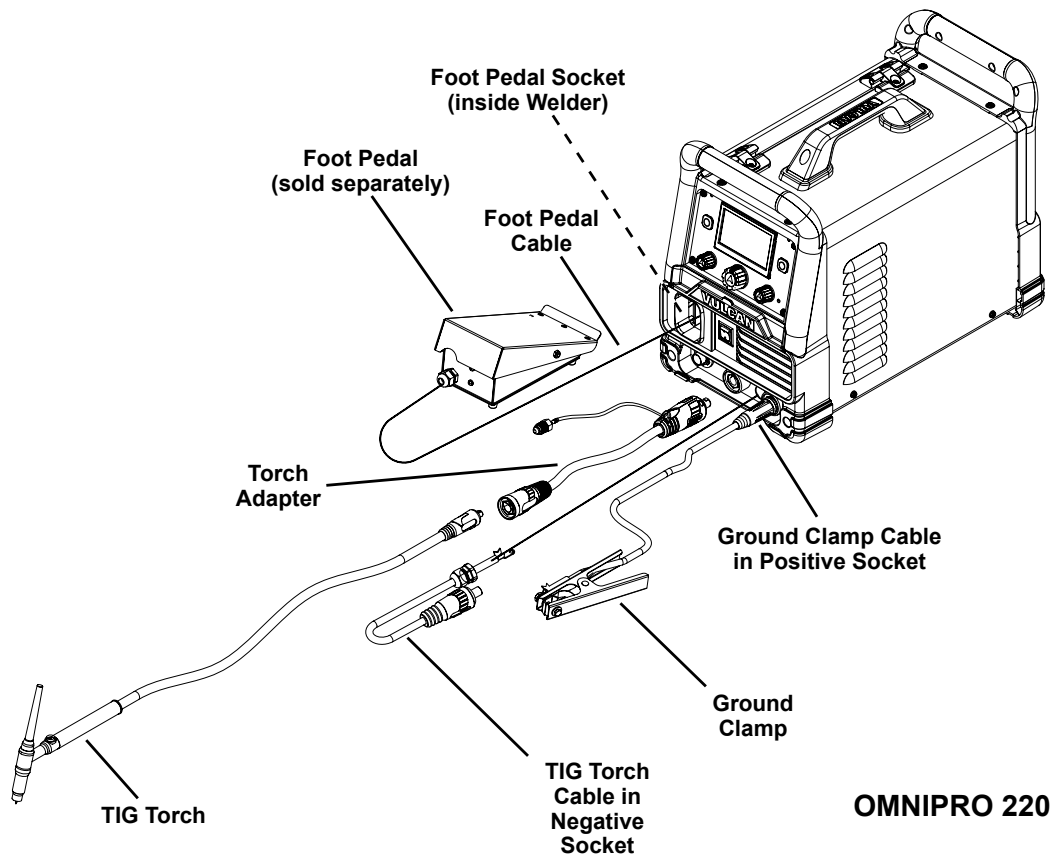

OMNIPRO 220

1. OMNIPRO 220:

- a. Plug TIG Torch Cable into Torch Adapter. Twist clockwise all the way to lock into place.
- b. Plug Torch Adapter into Negative Socket. Twist clockwise all the way to lock in place.
- c. Insert the Foot Pedal Cable, through hole on Welder front and connect to the Foot Pedal Socket inside the machine. Secure by turning collar clockwise until tight.
- d. Plug Ground Clamp cable into Positive Socket. Twist clockwise all the way to lock in place.

2. PROTIG 165 and 200:

- a. Plug Ground Clamp cable into Positive Socket. Twist clockwise all the way to lock in place.
- b. Plug TIG Torch cable into Negative Socket. Twist clockwise all the way to lock in place.
- c. Plug Foot Pedal cable into Foot Pedal Socket. Secure by turning collar clockwise until tight.

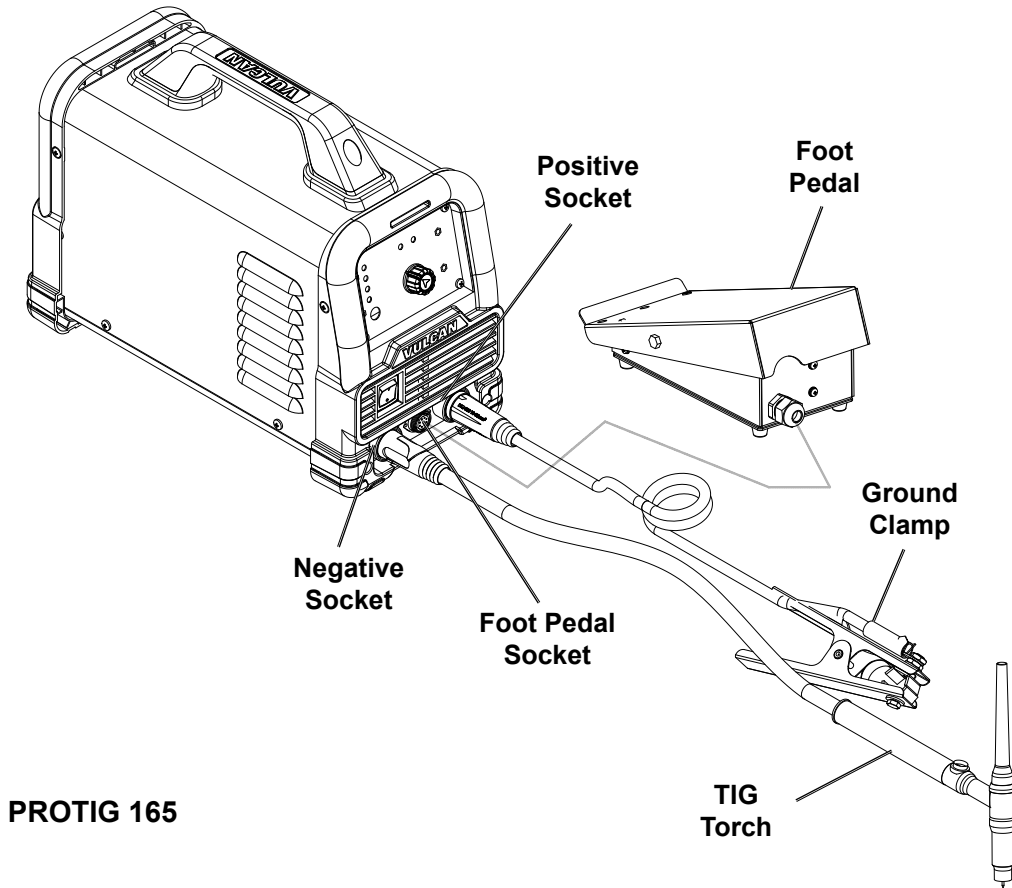

PROTIG 165

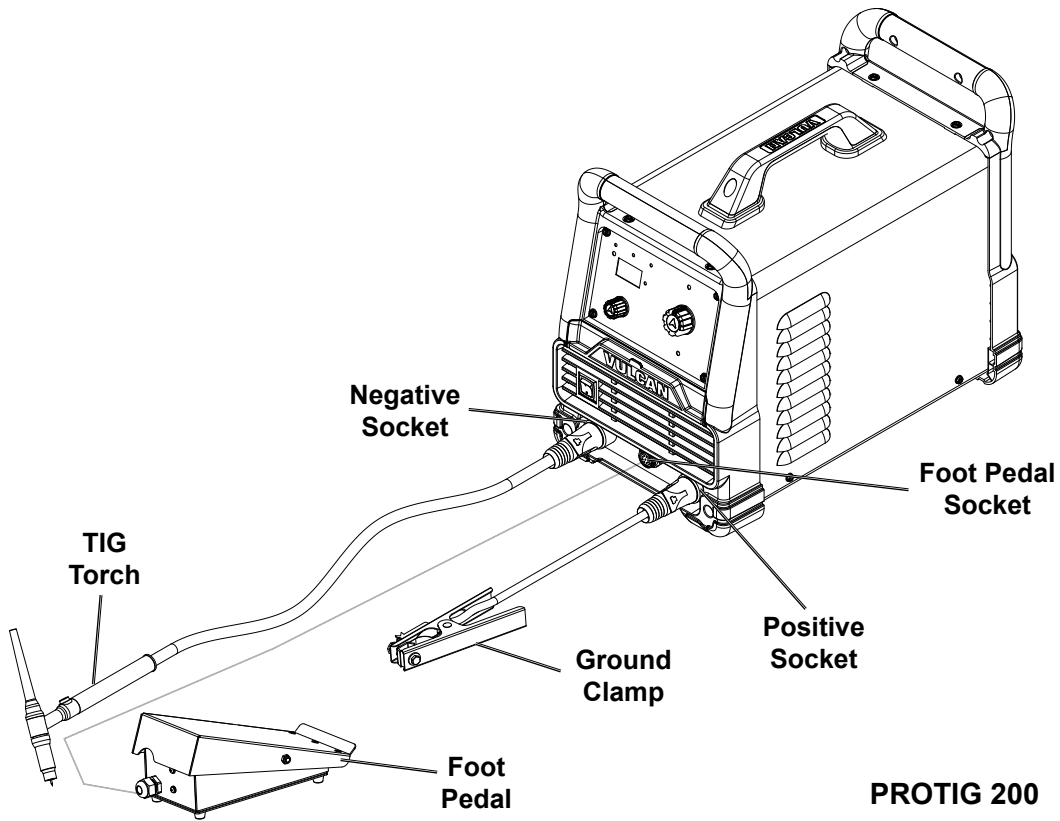

PROTIG 200

3. For connecting Shielding Gas Hose, refer to *Connect Shielding Gas* section on next page.

Connect Shielding Gas

1. With assistance, place an 100% Argon cylinder (not included) onto a cabinet or cart near the Welder and secure the cylinder in place with two straps (not included) to prevent tipping.

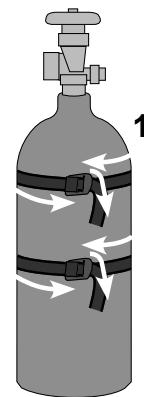

2. Remove the cylinder's cap. Stand to the side of the valve opening, then open the valve briefly to blow dust and dirt from the valve opening. Close the cylinder valve.

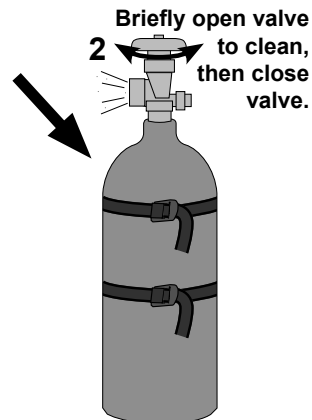

3. Locate the Regulator (included) and close its valve until it is loose, then thread Regulator onto cylinder and wrench-tighten connection.

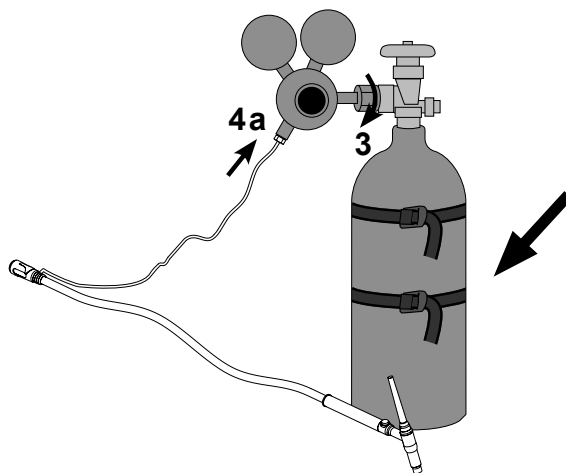

4. Connect Gas Hose.

a. **OMNIPRO 220:** Connect Shielding Gas Hose on TIG Torch Cable Connector to the Regulator's Outlet and wrench-tighten connection.

b. **PROTIG 165 and 200:** Attach the Gas Hose to the Regulator's Outlet and the Welder's Gas Inlet. Wrench-tighten both connections.

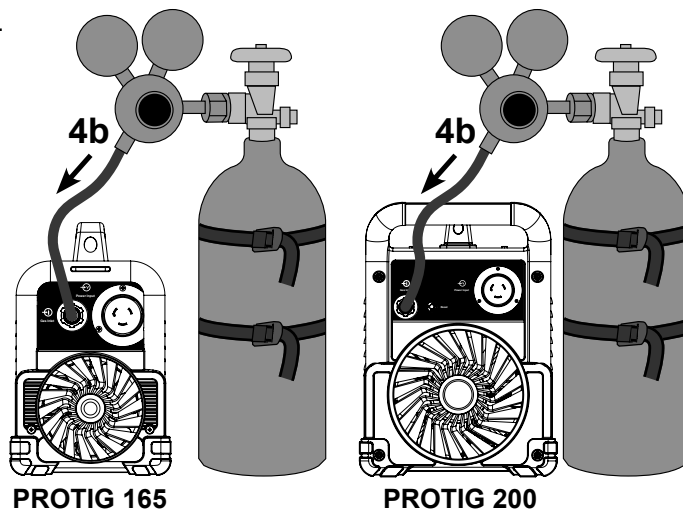

5. Open Gas Flow Valve on Torch.

Note: When using TIG Torch with OMNIPRO 220, gas flow is continuous. Close Gas Flow Valve on TIG Torch when welding is complete.

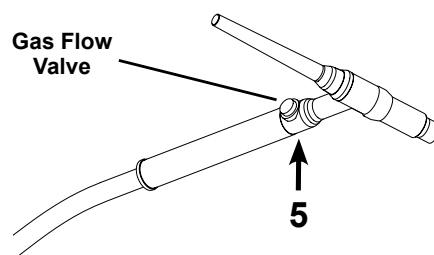

Sharpen Tungsten Electrode

To avoid Electrode contamination, dedicate a fine grit grinding wheel exclusively to Electrode grinding.

WARNING! Some Electrodes may have materials added to them that are hazardous to breathe. Wear a respirator and ANSI-approved Safety goggles when grinding an Electrode.

1. Shut off the welder and wait until Electrode and Torch have cooled enough to handle.
2. Remove Back Cap. Pull Electrode from front of Torch. (Pulling it from rear will damage Collet and create burrs on Electrode).
3. If Electrode has dulled or been otherwise contaminated, use pliers or a suitable tool to grip the Electrode above the contaminated section and snap off the end of the Electrode.

4. Lightly press Electrode tip against the surface of the grinding wheel at an angle. Rotate Electrode tip until a blunt point is formed.

Note: Grinding direction must be parallel to length of Electrode.

5. The conical portion of the ideal tip will be 2-1/2 times as long as the Electrode diameter.
6. Re-insert Electrode into Collet with tip protruding 1/8"-1/4" beyond the Ceramic Nozzle, then re-tighten the Back Cap.

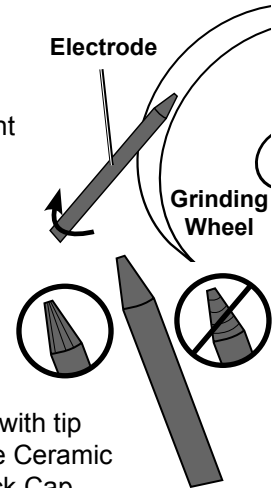

Assemble TIG Torch

1. Consult Settings Chart, on top of Welder, to determine proper Tungsten Electrode size to be used with thickness of material to be welded.
2. Match Collet and Collet Body sizes to Tungsten Electrode size.
3. Thread Collet Body into the front of the Torch.
4. Make sure Ceramic Nozzle size is appropriate for application.
5. Thread Ceramic Nozzle onto Collet Body.
6. Insert Collet into back of Torch and into Collet Body.
7. Insert Tungsten Electrode into Collet on front of Torch.

8. Lock Electrode in place with Back Cap. Electrode should protrude 1/8" to 1/4" beyond the Ceramic Nozzle.

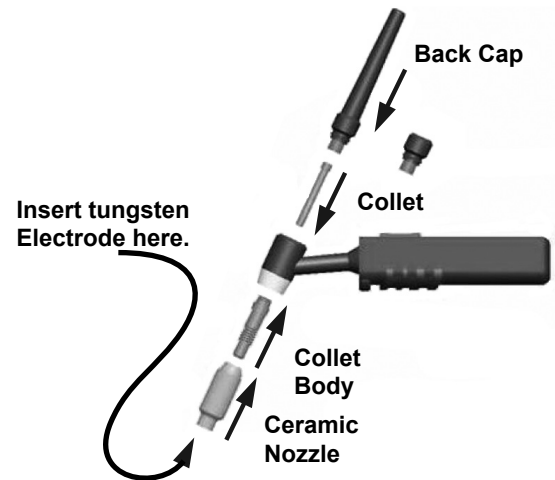

9. Refer to welder manual for instruction on basic TIG/Stick welding techniques and safety practices.

WARNING



TO PREVENT SERIOUS INJURY, FIRE AND BURNS:

Unplug the Welder, rest the tool on a heat-proof, electrically non-conductive surface, and allow all parts of the Welder to cool thoroughly before service.

1. **BEFORE EACH USE**, inspect the general condition of the Torch. Check for:
 - loose hardware
 - misalignment or binding of moving parts
 - damaged cord/electrical wiring
 - frayed or damaged cables
 - cracked or broken parts
 - any other condition that may affect its safe operation.
2. **AFTER EVERY USE**, store in a clean and dry location.

Limited 90 Day Warranty

Harbor Freight Tools Co. makes every effort to assure that its products meet high quality and durability standards, and warrants to the original purchaser that this product is free from defects in materials and workmanship for the period of 90 days from the date of purchase. This warranty does not apply to damage due directly or indirectly, to misuse, abuse, negligence or accidents, repairs or alterations outside our facilities, criminal activity, improper installation, normal wear and tear, or to lack of maintenance. We shall in no event be liable for death, injuries to persons or property, or for incidental, contingent, special or consequential damages arising from the use of our product. Some states do not allow the exclusion or limitation of incidental or consequential damages, so the above limitation of exclusion may not apply to you. THIS WARRANTY IS EXPRESSLY IN LIEU OF ALL OTHER WARRANTIES, EXPRESS OR IMPLIED, INCLUDING THE WARRANTIES OF MERCHANTABILITY AND FITNESS.

To take advantage of this warranty, the product or part must be returned to us with transportation charges prepaid. Proof of purchase date and an explanation of the complaint must accompany the merchandise. If our inspection verifies the defect, we will either repair or replace the product at our election or we may elect to refund the purchase price if we cannot readily and quickly provide you with a replacement. We will return repaired products at our expense, but if we determine there is no defect, or that the defect resulted from causes not within the scope of our warranty, then you must bear the cost of returning the product.

This warranty gives you specific legal rights and you may also have other rights which vary from state to state.

Record Product's Serial Number Here: _____

Note: If product has no serial number, record month and year of purchase instead.

Note: Other than consumables, replacement parts are not available for this item.

