

SPAREPARTSMANUAL2005

ERSATZTEILKATALOG: FAHRGESTELL + MOTOR
SPARE PARTS MANUAL: CHASSIS + ENGINE
65 SX



KTM

TELEGABEL MARZOCCHI USD 35
FRONT FORK MARZOCCHI USD 35

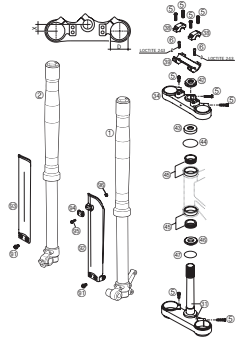

4

GABELBEINE MARZOCCHI
FORK LEGS MARZOCCHI

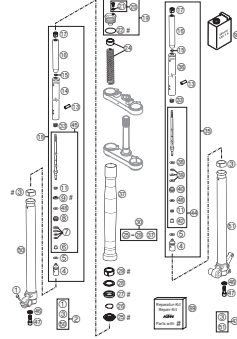

5

LENKER, ARMATUREN
HANDLEBAR, CONTROLS

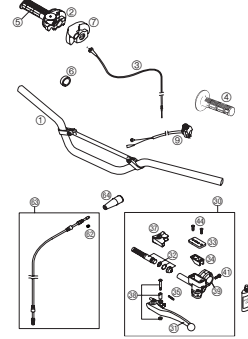

7

HANDBREMSZYLINDER FORMULA
HAND BRAKE CYLINDER FORMULA

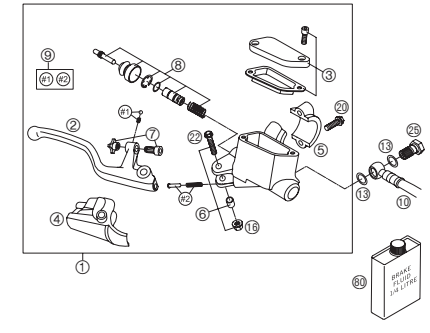

8

RAHMEN, AUSLEGER
FRAME, SUB FRAME

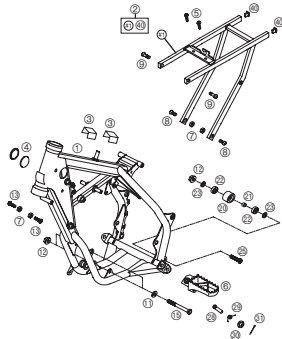

9

FUSSBREMSBETÄTIGUNG
REAR BRAKE CONTROL

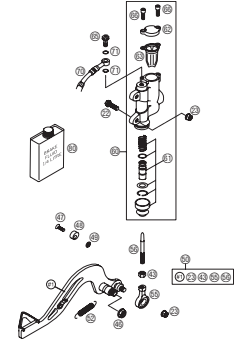

10

SCHWINGARM, FEDERBEIN
SWINGARM, MONOSHOCK

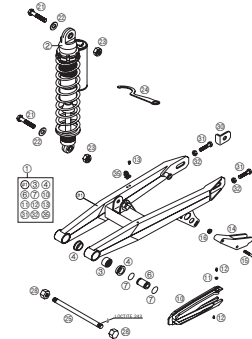

11

FEDERBEIN WP ZERLEGT
MONOSHOCK WP DISASSEMBLED

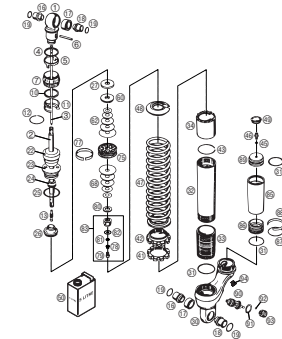

12

AUSPUFFANLAGE
EXHAUST SYSTEM

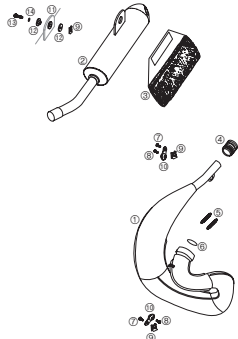

14

LUFTFILTERKASTEN
AIR FILTER BOX

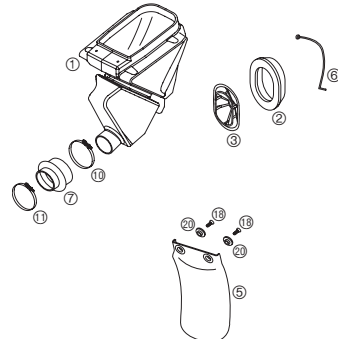

15

TANK, SITZBANK, VERKLEIDUNG
TANK, SEAT, COVER

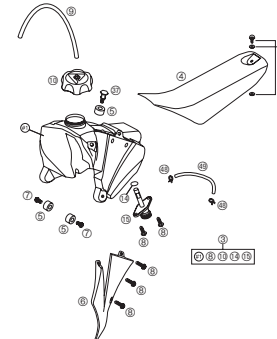

16

MASKE, KOTFLÜGEL
MASK, FENDERS

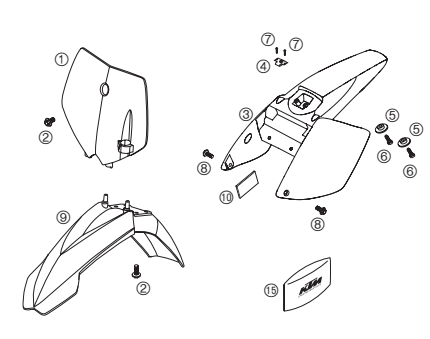

17

DEKOR
DECAL

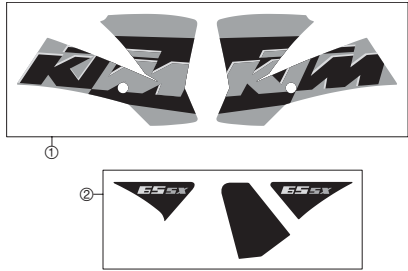

18

VORDERRAD
FRONT WHEEL

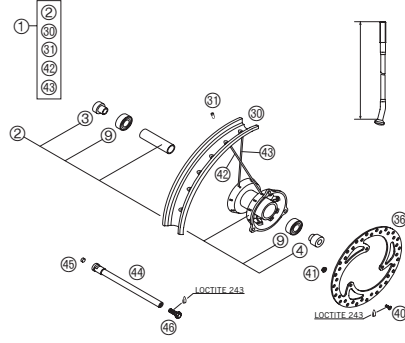

19

BREMSZANGE VORNE FORMULA
BRAKE CALIPER FRONT FORMULA

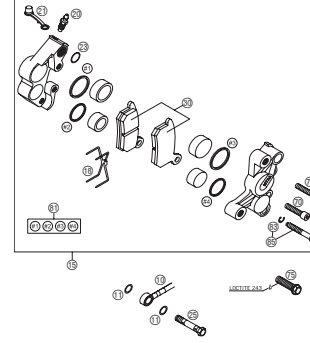

20

HINTERRAD
REAR WHEEL

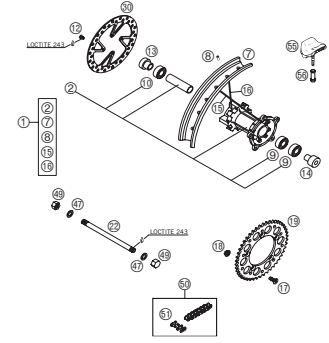

21

BREMSZANGE HINTEN FORMULA
BRAKE CALIPER REAR FORMULA

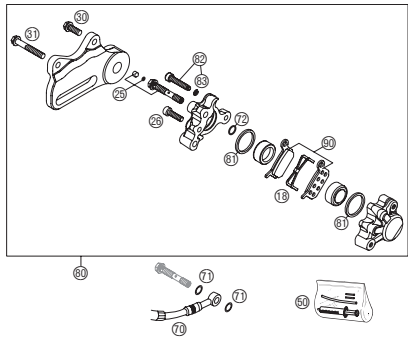

22

MOTERGEHÄUSE
ENGINE CASE

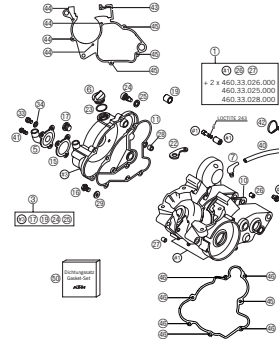

23

KURBELWELLE, KOLBEN
CRANKSHAFT, PISTON

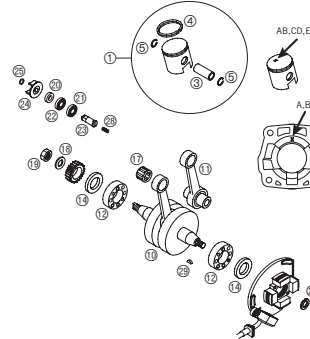

24

ZYLINDER
CYLINDER

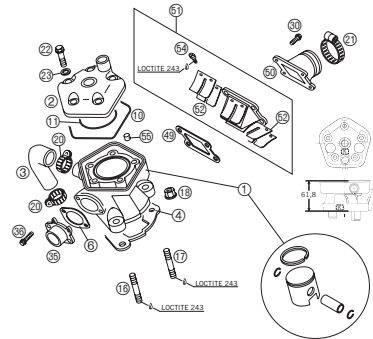

25

VERGASER MIKUNI VM24
CARBURETOR MIKUNI VM24

ACHTUNG !!
Vor dem Einbau des Vergasers, die Einstellung kontrollieren.
CAUTION !!
Before mounting the carburetor, check the jetting.

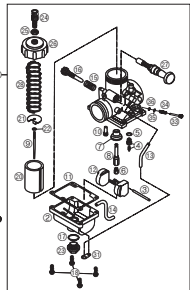

26

ZÜNDANLAGE
IGNITION SYSTEM

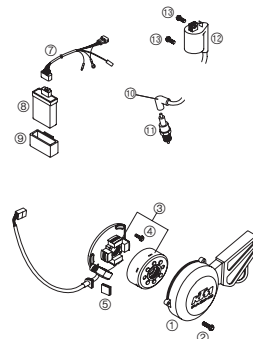

27

KUPPLUNG
CLUTCH

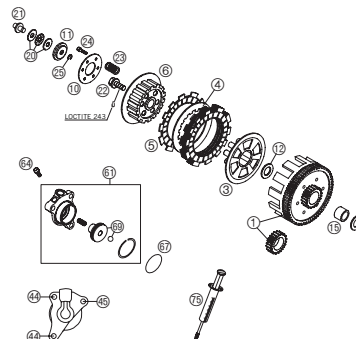

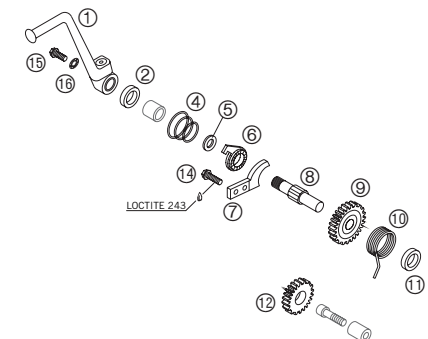

28

KICKSTARTER
KICKSTARTER

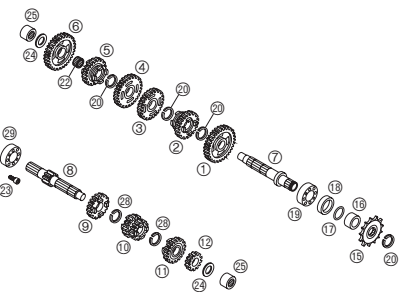
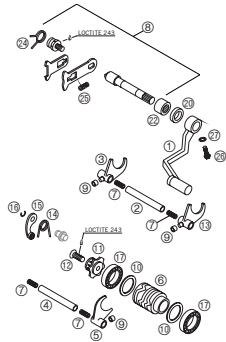
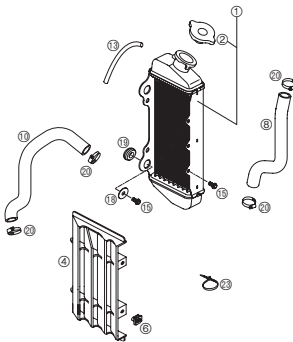
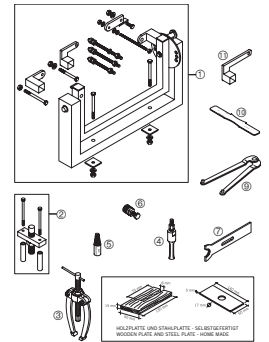

29

<p>GETRIEBE TRANSMISSION</p>  <p style="text-align: right;">30</p>	<p>SCHALTUNG SHIFTING MECHANISM</p>  <p style="text-align: right;">31</p>	<p>KÜHLSYSTEM COOLING SYSTEM</p>  <p style="text-align: right;">32</p>	<p>SPEZIALWERKZEUGE SPECIAL TOOLS</p>  <p style="text-align: right;">33</p>
<div style="display: flex; align-items: center;"> <div style="flex: 1; text-align: center;">  </div> <div style="flex: 3;"> <p>Alle enthaltenen Angaben sind unverbindlich. Die KTM-Sportmotorcycle AG behält sich insbesondere das Recht vor, technische Angaben, Preise, Farben, Formen, Materialien, Dienst- und Serviceleistungen, Konstruktionen, Ausstattungen und ähnliches ohne vorheriger Ankündigung und ohne Angabe von Gründen zu ändern bzw. ersatzlos zu streichen, sie an lokale Gegebenheiten anzupassen sowie die Fertigung eines bestimmten Modells ohne vorherige Ankündigung einzustellen. KTM übernimmt keine Haftung für Liefermöglichkeiten, Abweichungen von Abbildungen und Beschreibungen sowie Druckfehler und Irrtümer. Die abgebildeten Modelle enthalten zum Teil Sonderausstattungen, die nicht zum serienmäßigen Lieferumfang gehören. © 2004 by KTM-SPORTMOTORCYCLE AG, Mattighofen AUSTRIA; Alle Rechte vorbehalten; Nachdruck, auch auszugsweise, nur mit schriftlicher Genehmigung von KTM-SPORTMOTORCYCLE AG, Mattighofen</p> <p><i>All information contained is without obligation. KTM-Sportmotorcycle AG particularly reserves the right to modify any equipment, technical specifications, prices, colors, shapes, materials, services, service work, constructions, equipment and the like so as to adapt them to local conditions or to cancel any of the above items, all without previous announcement and without giving reasons. KTM may stop manufacturing certain models without previous notice. KTM shall not be held liable for any deviations of availability and/or ability to deliver, illustrations, descriptions, printing and/or other errors. The illustrated models partly contain extra equipment, which is not applied to standard models.</i></p> <p>© 2004 by KTM-SPORTMOTORCYCLE AG, Mattighofen AUSTRIA; All rights reserved; Reprint, also in extracts, with written allowance of KTM-SPORTMOTORCYCLE AG, Mattighofen only.</p> </div> </div>			

TELEGABEL MARZOCCHI USD 35 » FRONT FORK MARZOCCHI USD 35 65 SX / 2005

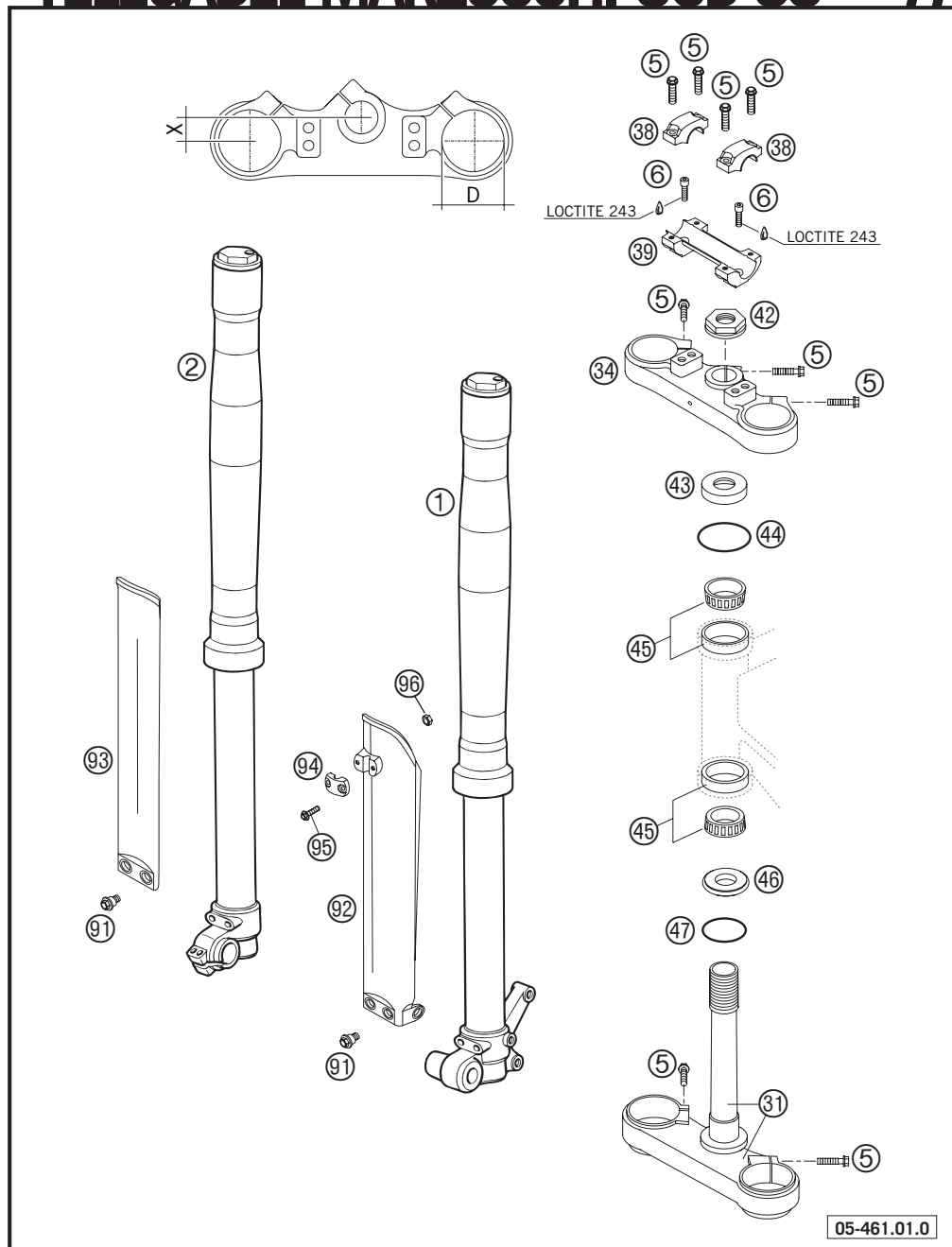

FIG	TEILNR/PARTNR	BEZEICHNUNG	DESCRIPTION	QTY
1	7631210/F	GABELBEIN LINKS USD 35	FORK LEG L/S USD 35	1
2	7631209/F	GABELBEIN RECHTS USD 35	FORK LEG R/S USD 35	1
5	0015 080303	SK.BUNDSCHRAUBE M 8X30 SW=10	HH COLLAR SCREW M 8X30 WS=10	9
6	0912 100250	ISK.SCHR.DIN6912 M10X25 10.9 S	AH SCREW DIN6912-M10X25,10.9,L	2
31	77051116	GABELBR.UNT. + GABELSCHAFTROHR	BOT.TRIPLE CLAMP + FORK TUBE	1
34	7501478	GABELBRÜCKE OBEN	TOP TRIPLE CLAMP	1
38	503.01.038.000	LENKERKLEMMBRÜCKE D=22MM 2001	HANDLEBAR CLAMP D=22MM 2001	2
39	590.01.039.000	LENKERAUFNAHME 22MM 2T 2000	HANDLEBAR SUPPORT 22MM 2T 2000	1
42	590.30.029.000	SK-MUTTER M20X1,5 SW=27 RECHTS	HH NUT M20X1,5 WS=27 RIGHT	1
43	490.01.086.000	ABDECKKAPPE	COVERING CAP	1
44	0770 021300	O-RING 40,94X2,62 NBR70	O-RING 40,94X2,62 NBR70	1
45	490.01.081.000	KEGELROLLENLAGER 32004X	TAPERED ROLLER BEARING 32004X	2
46	460.01.086.000	SCHUTZRING STEUERK. 20,1X39X5	PROTECTION RING 20,1X39X5	1
47	0770 360030	O-RING 36,00X3,00 NBR	O-RING 36,00X3,00 NBR	1
91	590.01.092.050	SONDERSCHRAUBE M6X12,5 SW=8	SPECIAL SCREW M6X12,5 WS=8	6
92	461.01.092.000	GABELSCHUTZ LINKS 65SX 2002	FORK PROTECTION L/S 65SX 2002	1
93	461.01.093.000	GABELSCHUTZ RECHTS 65SX 2002	FORK PROTECTION R/S 65SX 2002	1
94	546.01.085.000	BREMSSCHLAUCHKLEMME MARZ. '95	BRAKE HOSE CLAMP MARZOCCHI'95	1
95	0015 050163	SK.BUNDSCHRAUBE M 5X16 SW=8	HH COLLAR SCREW M 5X16 WS=8	2
96	0985 050003	SS.MUTTER DIN 985 M5	SELF LOCKING NUT DIN985-M 5	2

* NEUTEIL / NEW PART X NACH BEDARF / AS REQUIRED

GABELBEINE MARZOCCHI » FORK LEGS MARZOCCHI

65 SX / 2005

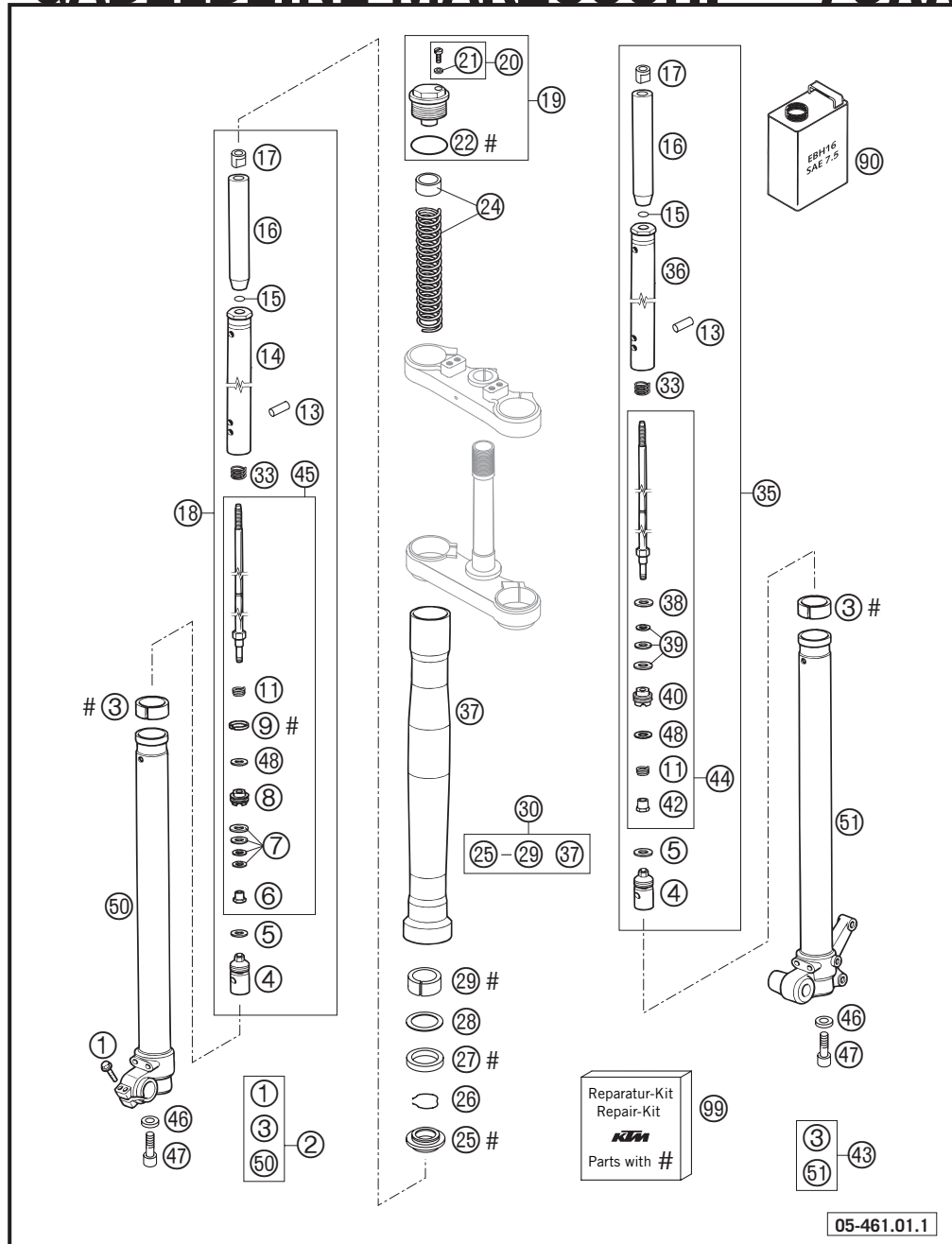

FIG	TEILNR/PARTNR	BEZEICHUNG	DESCRIPTION	QTY
1	0015 060303	SK.BUNDSCHRAUBE M 6X30 SW=8	HH COLLAR SCREW M 6X30 WS=8	2
2	7819139/C	GLEITROHR + FAUST KPL. RE.	SLIDER + AXLE CLAMP CPL. R/S	1
3	7538029	FÜHRUNGSRING D=35	GUIDE RING D=35	2
4	7717065/R	BODENVENTIL	FOOT VALVE	2
5	7528005	O-RING D=20,3	O-RING D=20,3	2
6	7521092/D	SPEZIALMUTTER M6X1 MIT ABSATZ	SPECIAL NUT M6X1 WITH STEP	1
7	7517217	KONTROLLVENTIL 22X8,1X0,1	REED VALVE 22X8,1X0,1	4
8	7530097/B	KOLBEN ZUGSTUFE D=26	PISTON REBOUND D=26	1
9	7524163	KOLBENRING D=26	PISTON RING D=26	1
11	75141087	FEDER ZUGSTUFE UNTEN	LOWER REBOUND SPRING	2
13	75321033	BOLZEN 8X30	PIN 8X30	2
14	75181140/R	ROHRKÖRPER RECHTS	TUBE BODY R/S	1
15	7523224	STOP RING 10X1	STOP RING 10X1	2
16	75181153	FÜHRUNGSBUCHSE 6,4X12X12	GUIDE BUSH 6,4X12X12	2
17	7521005	SPEZIALMUTTER	SPECIAL NUT	2
18	78031082	ZUGSTUFE KPL.	REBOUND CPL.	1
19	7701196	VERSCHLUSS KPL.	PLUG CPL.	2
20	7850208AR	LINSENSCHRAUBE M4X6	LENTIL HEAD SCREW M4X6	2
21	7528180	O-RING D=3,69; S=1,78	O-RING D=3,69; S=1,78	2
22	7528008	O-RING D=34,6; S=1,78	O-RING D=34,6; S=1,78	2
24	7850728	FEDERN + VORSPANNHÜLSEN-SET	SPRINGS + PRELOAD SLEEVES KIT	1
25	7533167	STAUBKAPPE	DUST CAP	2
26	7523236	SICHERUNGSRING D=51,5	LOCK WASHER D=51,5	2
27	7528034	DICHTRING 35X47X10	OIL SEAL 35X47X10	2
28	7539032AA	SCHEIBE 36X47X3	WASHER 36X47X3	2
29	7538038/A	FÜHRUNGSRING 35X15	GUIDE RING 35X15	2
30	7760069FN/C	AUSSENROHR KPL.	OUTER TUBE CPL.	2
33	7514077	FEDER ZUGSTUFE OBEN	TOP REBOUND SPRING	2
35	78031083	DRUCKSTUFE KPL.	COMPRESSION CPL.	1
36	75181139/R	ROHRKÖRPER LINKS	TUBE BODY L/S	1
38	7535099	DRUCKSTUFENSCHIEBE	COMPRESSION DAMPING SHIM	1
39	7517028	SCHEIBE 8,1X23X0,2	SHIM 8,1X23X0,2	1
39	7517039	SCHEIBE 8,1X22X0,2	SHIM 8,1X22X0,2	1
39	7517060	SCHEIBE 8,1X22X0,3	SHIM 8,1X22X0,3	1
40	7530090/B	KOLBEN DRUCKSTUFE D=26	PISTON COMPRESSION D=26	1

* NEUTEIL / NEW PART X NACH BEDARF / AS REQUIRED

GABELBEINE MARZOCCHI » FORK LEGS MARZOCCHI

65 SX / 2005

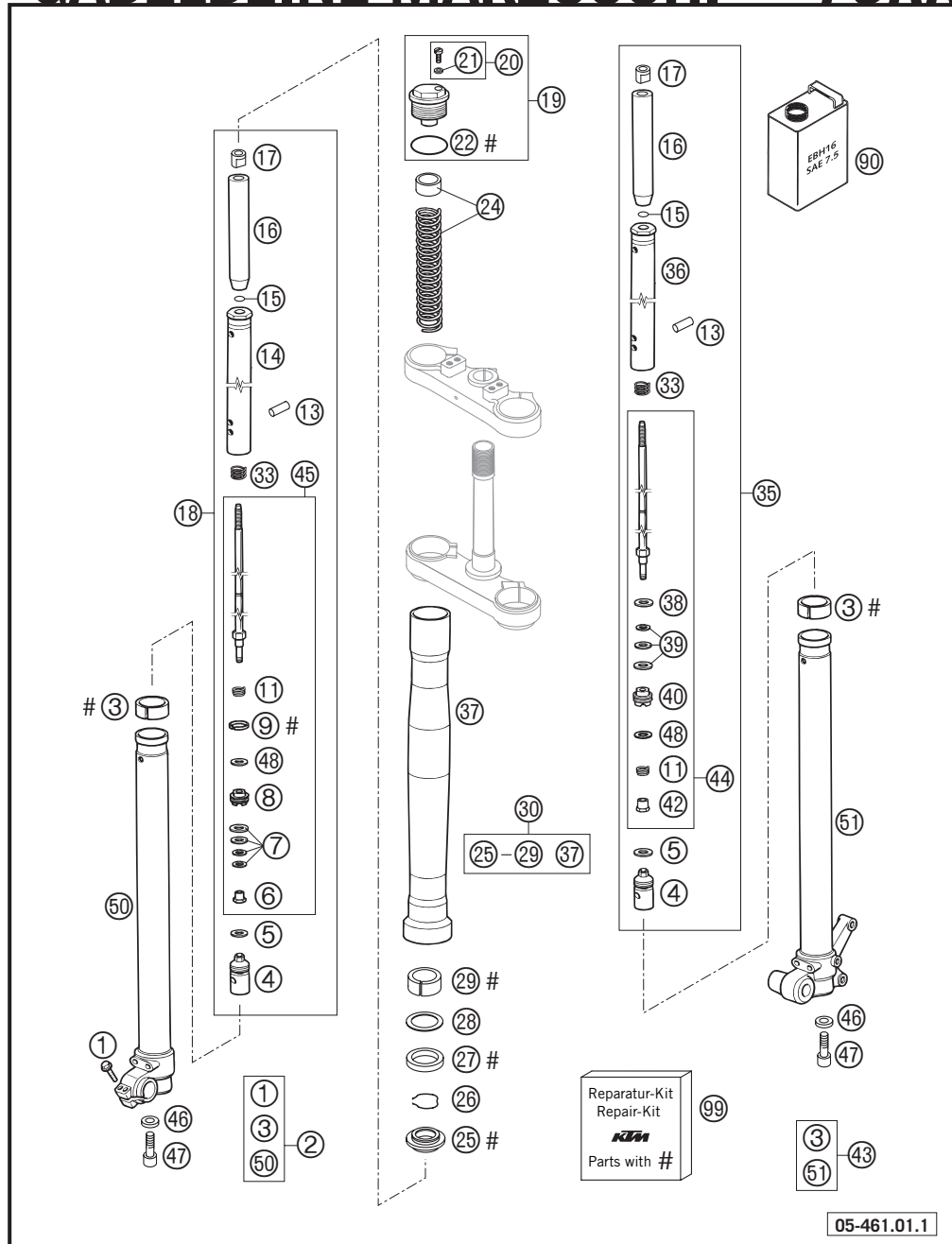
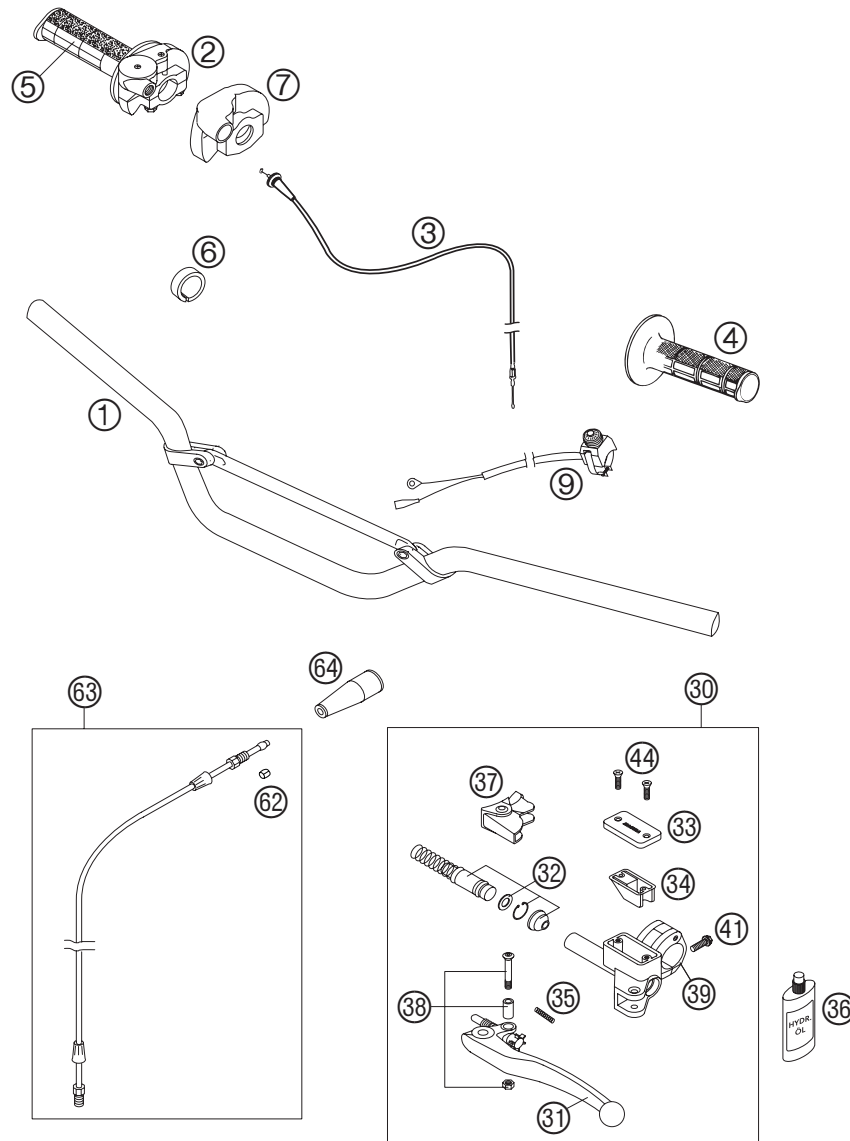

FIG	TEILNR/PARTNR	BEZEICHNUNG	DESCRIPTION	QTY
42	7521147/A	SPEZIALMUTTER M6X1 MIT ABSATZ	SPECIAL NUT M6X1 WITH STEP	1
43	7819140/C	GLEITROHR + FAUST KPL. LI.	SLIDER + AXLE CLAMP CPL. L/S	1
44	7309651/R	DRUCKSTUFENEINSATZ KPL.	COMPRESSION CARTRIDGE CPL.	1
45	7309652/R	ZUGSTUFENEINSATZ KPL.	REBOUND CARTRIDGE CPL.	1
46	7522061	SCHEIBE 8X12X1,5	SHIM 8X12X1,5	2
47	0912 080253	ISK.SCHRAUBE DIN 912 M8X25	AH SCREW DIN0912-M 8X25	2
48	7517044	SCHEIBE 8,1X23X0,3	SHIM 8,1X23X0,3	2
90	7550013	GABELÖL EBH16 SAE 7.5	FORKOIL EBH16 SAE 7.5	1
99	7850731/C	REPARATUR-KIT USD 35	REPAIR-KIT USD 35	1

05-461.01.1

03-461.01.1

* NEUTEIL / NEW PART X NACH BEDARF / AS REQUIRED



04-461.02.0

05-461.02.0

FIG	TEILNR/PARTNR	BEZEICHNUNG	DESCRIPTION	QTY
1*	461.02.001.200	LENKER 65 SX 2005	HANDLEBAR 65 SX 2005	1
2	461.02.010.000	GASDREHGRIF M.ÜBERZUG 65SX 02	THROTTLE GRIP W.COVER 65 SX 02	1
3	461.02.091.000	GASSEIL DOMINO 65 SX 2002	THROTTLE CABLE DOMINO 65 SX 02	1
4	502.02.052.000	FESTGRIF DOMINO SCHWARZ '95	FIXED GRIP DOMINO BLACK '95	1
5	502.02.003.000	DREHGRIFÜBERZUG DOMINO SCHW.	TWIST GRIP COVER DOMINO BLACK	1
6	460.02.012.000	DISTANZBÜCHSE 21,5X28X7,5	SPACER BUSHING 21,5X28X7,5	1
7	503.02.020.000	SCHUTZKAPPE DOMINO '97	PROTECTION COVER '97	1
9	503.11.089.200	KURZSCHLUSSSCHALTER 02	SHORT CIRCUIT BUTTON 02	1
30*	461.02.030.100	GEBERZYLINDER KPL. D=9MM 05	MASTER CYLINDER CPL. D=9MM 05	1
31	546.02.031.000	KUPPLUNGHEBEL KURZ KPL. 2003	CLUTCH LEVER SHORT CPL. 2003	1
31	590.02.031.000	KUPPLUNGHEBEL LANG KPL. 2003	CLUTCH LEVER LONG CPL. 2003	X
32*	590.02.032.100	REP.SATZ KOLBEN 9,0MM RAC.2004	REP.KIT PISTON 9,0MM RAC. 2004	1
33	503.02.033.100	DECKEL HYD.KUPPLUNG 2T 2000	COVER HYD.CLUTCH 2T 2000	1
34	503.02.034.000	GUMMIBALG FÜR RESERVOIR '98	RUBBER FOR RESERVOIR '98	1
35	590.02.035.000	FEDER FÜR KUPPLUNGHEBEL 03	SPRING FOR CLUTCH LEVER 03	1
36*	503.02.036.200	ÖL FÜR HYD.KUPPLUNG 75ML	OIL FOR HYD. CLUTCH 75ML	1
37	503.02.037.000	SCHUTZKAPPE FÜR HEBELGELENK'98	PROTECT.CAP FOR LEVER PERCH'98	1
38	503.02.038.000	HEBELSCHRAUBE KPL. 125-200 '98	LEVER SCREW CPL. 125-200 '98	1
39	503.02.030.150	KLEMMSCHELLE M.SPANNSTIFT 2000	CLAMP WITH PIN 2000	1
41	0015 060203	SK.BUNDSCHRAUBE M 6X20 SW=8	HH COLLAR SCREW M 6X20 WS=8	1
44	0965 040123	SENKSCHRAUBE DIN0965-M 4X12	FLAT HEAD SCREW DIN0965-M 4X12	2
62	503.32.063.050	SCHNEIDRING FÜR HYDR.LEITUNG	SELF CUTTING RING HYDR.PIPE	X
63	461.32.063.000	LEITUNGSKIT F.HYDR.KUPPL. 65SX	PIPE KIT FOR HYDR.CLUTCH 65 SX	1
64	540.02.016.000	SCHUTZKAPPE	PROTECTION CAP	1

* NEUTEIL / NEW PART X NACH BEDARF / AS REQUIRED

HANDBREMSZYLINDER FORMULA » *HAND BRAKE CYLINDER FORMULA*

65 SX / 2005

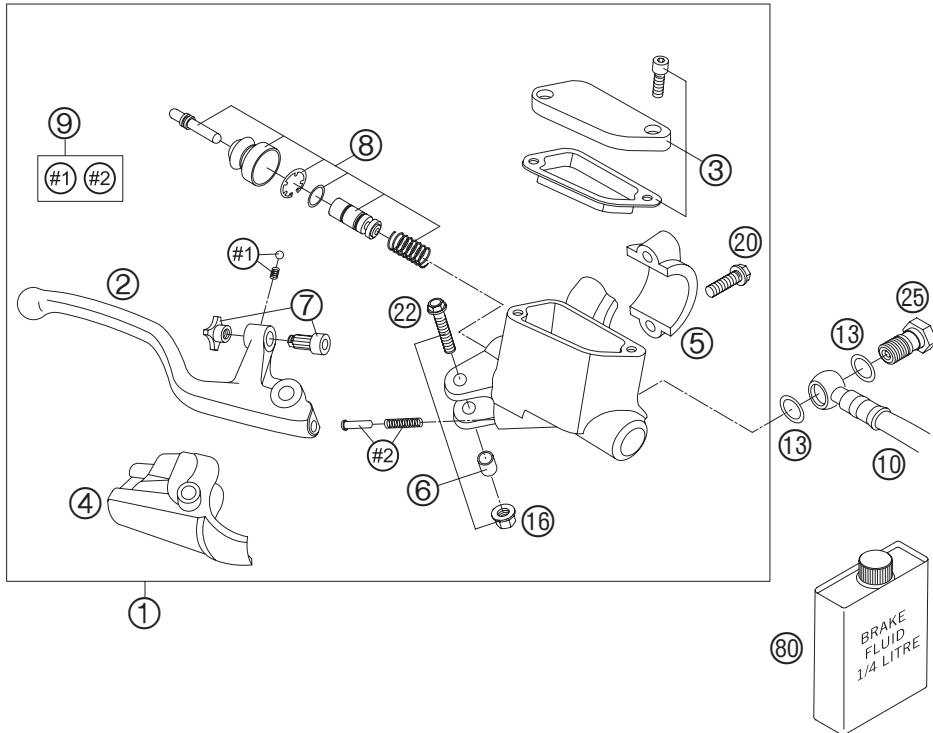

FIG	TEILNR/PARTNR	BEZEICHNUNG	DESCRIPTION	QTY
1	470.13.001.000	HANDBREMSZYLINDER KPL.85 SX 03	HAND BRAKE CYL. CPL. 85 SX 03	1
2	470.13.002.000	BREMSHEBEL LOSE 85 SX 2003	BRAKE LEVER LOOSE 85 SX 2003	1
3	470.13.003.000	ZYLINDERDECKEL KPL. VORNE 2003	CYLINDER COVER CPL. FRONT 2003	1
4	470.13.004.000	SCHUTZKAPPE 85 SX 2003	PROTECTION COVER 85 SX 2003	1
5	470.13.005.000	SHELLE FÜR BREMSZYLINDER 2003	CLAMP FOR BRAKE CYLINDER 2003	1
6	470.13.006.000	SCHRAUBE+BÜCHSE+MUTTER 03	SCREW+BUSHING+NUT 03	1
7	470.13.007.000	EINSTELLSCHRAUBE KPL. 85 SX 03	ADJUSTING SCREW CPL. 85 SX 03	1
8	470.13.008.000	REP.SATZ KOLBEN VORNE D=11MM	REP.SET PISTON FRONT D=11MM	1
9	470.13.009.000	KUGEL+FEDERN+FEDERFÜHRUNG 03	BALL+SPRING+SPRING GUIDE 03	1
10	461.13.010.100	BREMSSCHLAUCH VORNE 65 SX 2004	BRAKE HOSE FRONT 65 SX 2004	1
13	0770 080019	O-RING 8,00X1,00 EPDM	O-RING 8,00X1,00 EPDM	2
16	565.09.064.100	STOVER-FLANSCHMUTTER M6 10.9	SELF LOCKING NUT M6 10.9	1
20	0015 060203	SK.BUNDSCHRAUBE M 6X20 SW=8	HH COLLAR SCREW M 6X20 WS=8	2
22	0015 060303	SK.BUNDSCHRAUBE M 6X30 SW=8	HH COLLAR SCREW M 6X30 WS=8	1
25	470.13.025.000	HOHLSCHRAUBE BREMSZYLINDER 03	HOLLOW SCREW BRAKE CYLINDER 03	1
80	306054	BREMSFLÜSSIGKEIT DOT 5.1	BRAKE FLUID DOT 5.1	1

05-461.13.0

05-461.13.0

* NEUTEIL / NEW PART X NACH BEDARF / AS REQUIRED

RAHMEN · AUSLEGER » FRAME · SUB FRAME

65 SX / 2005

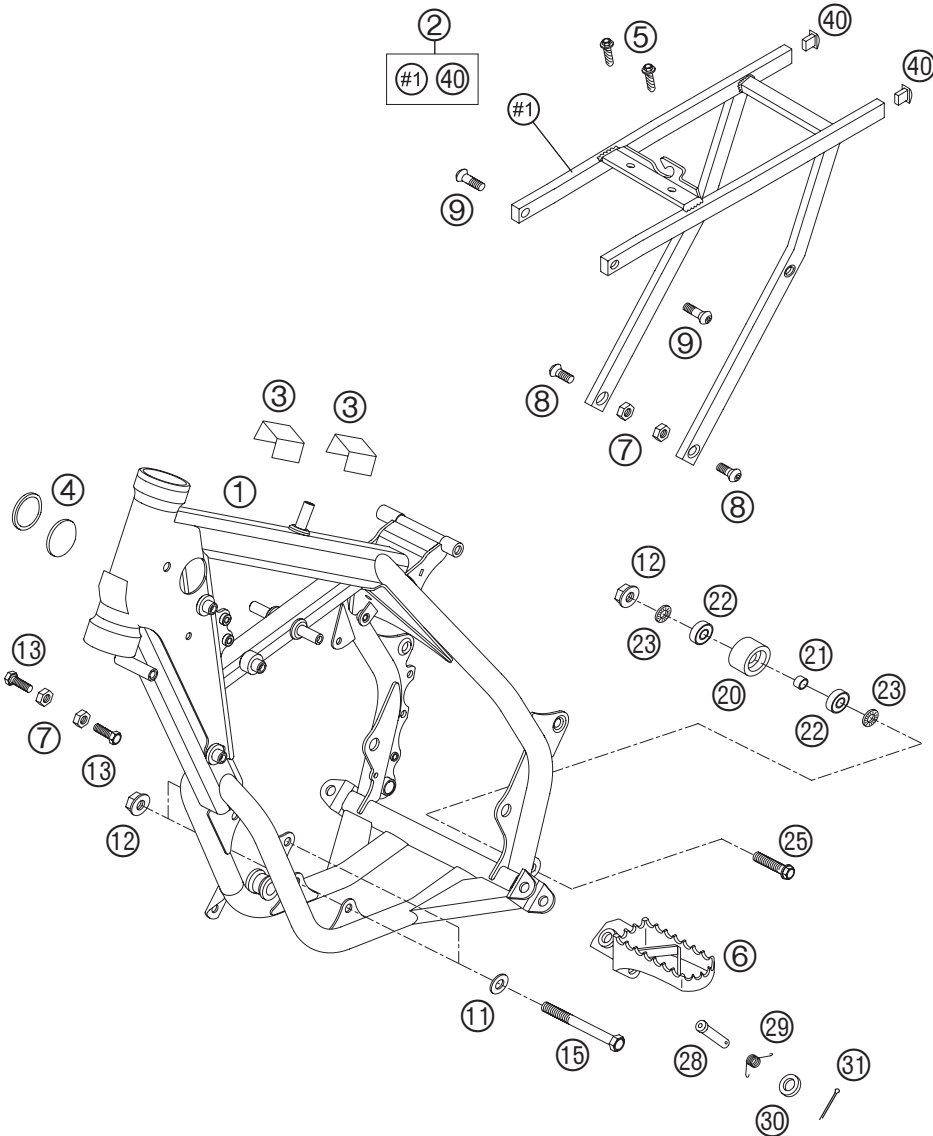

FIG	TEILNR/PARTNR	BEZEICHUNG	DESCRIPTION	QTY
1	461.03.001.100/90	RAHMEN 65 SX "MD3R" 2003	FRAME 65 SX "MD3R" 2003	1
2	461.03.002.044	AUSLEGER 65 SX 2002	SUB FRAME 65 SX 2002	1
3	587.11.054.050	METAMOLL F. BATTERIEHALTEBÜGEL	METAMOLL FOR BATTERY BRACKET	2
4	546.06.004.000	VERSCHLUSSKAPPE 37MM	PLUG 37MM	2
5	0017 060203	SONDERSCHRAUBE T60 6X20 SW=6	SPECIAL SCREW T60 6X20 WS=6	2
6	546.03.040.100/90	FUSSRASTE LINKS SILBER '98	FOOT PED L/S SILVER '98	1
6	546.03.140.100/90	FUSSRASTE RECHTS SILBER '98	FOOT PED R/S SILVER '98	1
7	0934 080003	SK.MUTTER DIN 934 M8	HEXAGON NUT DIN0934-M 8	4
8	546.10.052.000	KETTENRADSCHR. M8X20 ISK SW=6	SPROCKET SCREW-AH M8X20 WS=6	2
9	545.10.052.100	KETTENRADSCHR. M8X26 ISK SW=6	SPROCKET SCREW-AH M8X26 WS=6	2
11	0125 080003	UNTERLEGSCHLEIBE DIN 125 A 8,4	WASHER DIN0125-A 8,4	2
12	543.10.086.200	STOVER-FLANSCHMUTTER M8 10.9	SELF LOCKING NUT M8 10.9	3
13	590.01.037.000	ANSCHLAGSCHRAUBE M8X26 SW=10	SPECIAL SCREW M8X26 WS=10	2
15	0931 080805	SK.SCHRAUBE DIN 931 M8X80 10.9	HH SCREW DIN 931 M8X80 10.9	2
20	502.03.053.000	KETTENROLLE D=30MM	CHAIN ROLL D=30MM	1
21	740.03.021.000	BÜCHSE 8.2 X 12 X 6	BUSHING 8.2 X 12 X 6	1
22	0625 006087	RILLENKUGELLAGER 608 2RS C3	GROOVED BALL BEAR. 608 2RS C3	2
23	360.03.014.000	SCHNORR-SICHERUNGSSCHLEIBE 8MM	LOCK WASHER 8MM	2
25	0015 080353	SK.BUNDSCHRAUBE M 8X35 SW=10	HH COLLAR SCREW M 8X35 WS=10	1
28	548.03.044.000	BOLZEN FÜR FUSSRASTE 03	BOLT FOR FOOT PED 03	2
29	546.03.041.000	FUSSRASTENFEDER LINKS & RECHTS	FOOTREST SPRING L/S & R/S	2
30	0125 100003	UNTERLEGSCHLEIBE DIN 125 A 10,5	WASHER DIN0125-A10,5	2
31	0094 032253	SPLINT DIN0094-3,2X25 STAHL	PIN DIN0094-3,2X25 STEEL	2
40	503.03.002.182	EINSCHUBKAPPE SW14 99	PLUG-IN CAP SW14 99	2

05-461.03.0

05-461.03.0

* NEUTEIL / NEW PART X NACH BEDARF / AS REQUIRED

FUSSBREMSBETÄTIGUNG » REAR BRAKE CONTROL

65 SX / 2005

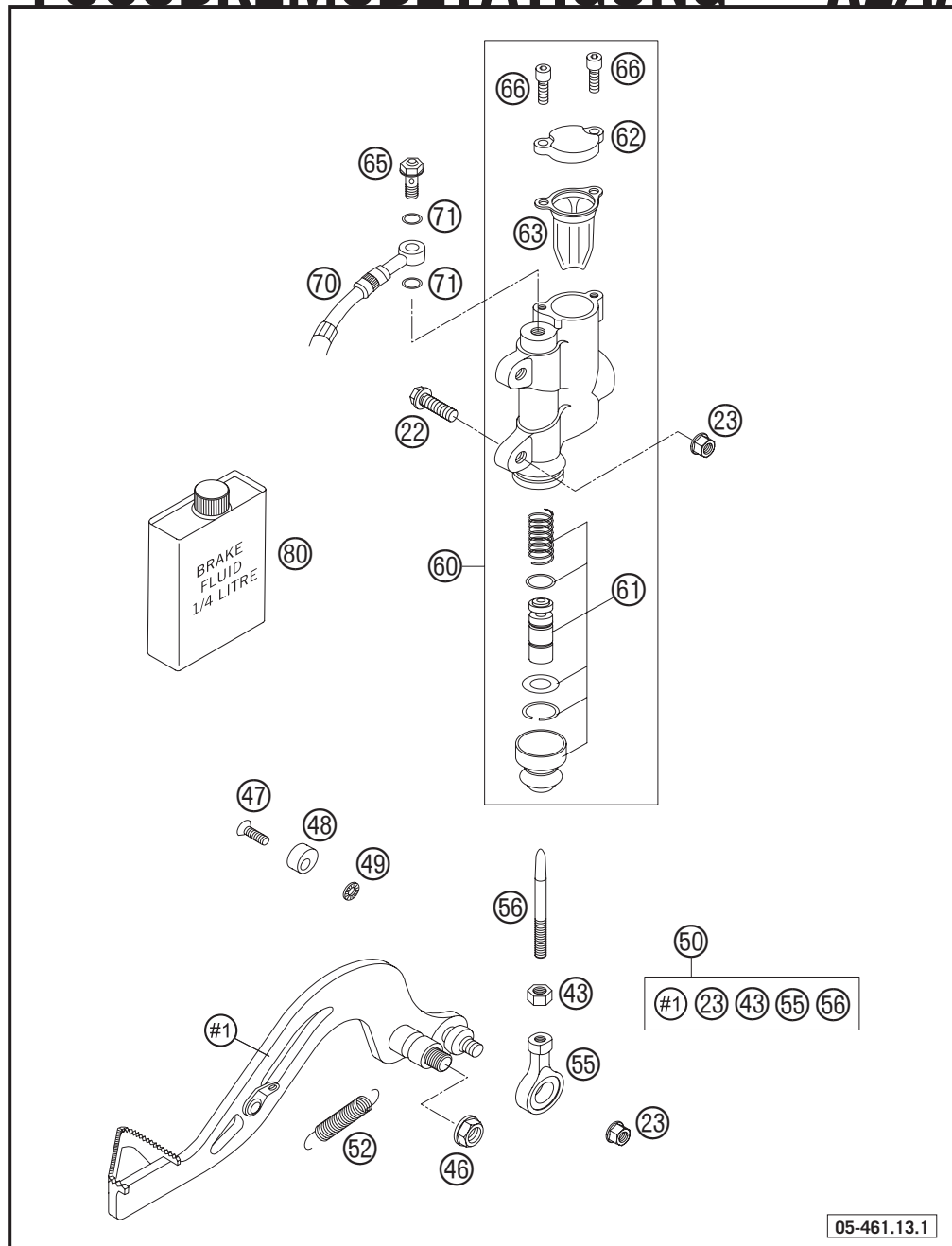

FIG	TEILNR/PARTNR	BEZEICHNUNG	DESCRIPTION	QTY
22	0015 060203	SK.BUNDSCHRAUBE M 6X20 SW=8	HH COLLAR SCREW M 6X20 WS=8	2
23	565.09.064.100	STOVER-FLANSCHMUTTER M6 10.9	SELF LOCKING NUT M6 10.9	3
43	0934 060003	SK.MUTTER DIN 934 M6	HEXAGON NUT DIN0934-M 6	1
46	543.10.086.200	STOVER-FLANSCHMUTTER M8 10.9	SELF LOCKING NUT M8 10.9	1
47	0991 060203	SENKSCHRAUBE DIN7991 M6X20 8.8	FLAT H.SCREW DIN7991-M6X20 8.8	1
48	583.03.063.000	BREMSHEBELANSCHLAG '93	BRAKE LEVER STOP '93	1
49	0797 060003	ZAHNSCHEIBE DIN6797-J 6,4	TOOTH LOCK WASH. DIN6797-A 6,4	1
50	460.03.060.233	FUSSBREMSHEBEL KPL 2000	BRAKE PEDAL LEVER CPL 2000	1
52	546.03.062.000	RÜCKZUGFEDER FÜR BREMSHEBEL	RETURN SPRING FOR BRAKE LEVER	1
55	546.03.069.000	GELENKKOPF M6 FUBBREMSHEBEL	SWIVEL HEAD M6 FOOT BRAKE LEV.	1
56	546.03.068.000	DRUCKSTANGE 250 '90	PRESSURE ROD ALU 250 '90	1
60	461.13.060.000	FUSSBREMSZYL. KPL. 50+65 04	REAR BRAKE CYL. 50+65 04	1
61	470.13.061.000	REP. SATZ KOLBEN HI. D=11 2003	REP. SET PISTON REAR D=11 2003	1
62	470.13.062.000	ZYLINDERDECKEL HINTEN 85 SX 03	CYLINDER COVER REAR 85 SX 03	1
63	470.13.063.000	DICHTUNG ZYLINDERDECKEL HI. 03	GASKET CYLINDER COVER REAR 03	1
65	461.13.325.000	HOHLSCHRAUBE M6	HOLLOW SCREW M6	1
66	0912 040103	ISK.SCHRAUBE DIN0912-M 4X10	AH.SCREW DIN0912-M 4X10	2
70	461.13.070.000	BREMSSCHLAUCH HINTEN 65 SX 04	BRAKE HOSE REAR 65 SX 04	1
71	0770 060019	O-RING 6,00X1,00	O-RING 6,00X1,00	2
80	306054	BREMSFLÜSSIGKEIT DOT 5.1	BRAKE FLUID DOT 5.1	1

05-461.13.1

05-461.13.1

* NEUTEIL / NEW PART

X NACH BEDARF / AS REQUIRED

SCHWINGARM · FEDERBEIN » SWINGARM · MONOSHOCK

65 SX / 2005

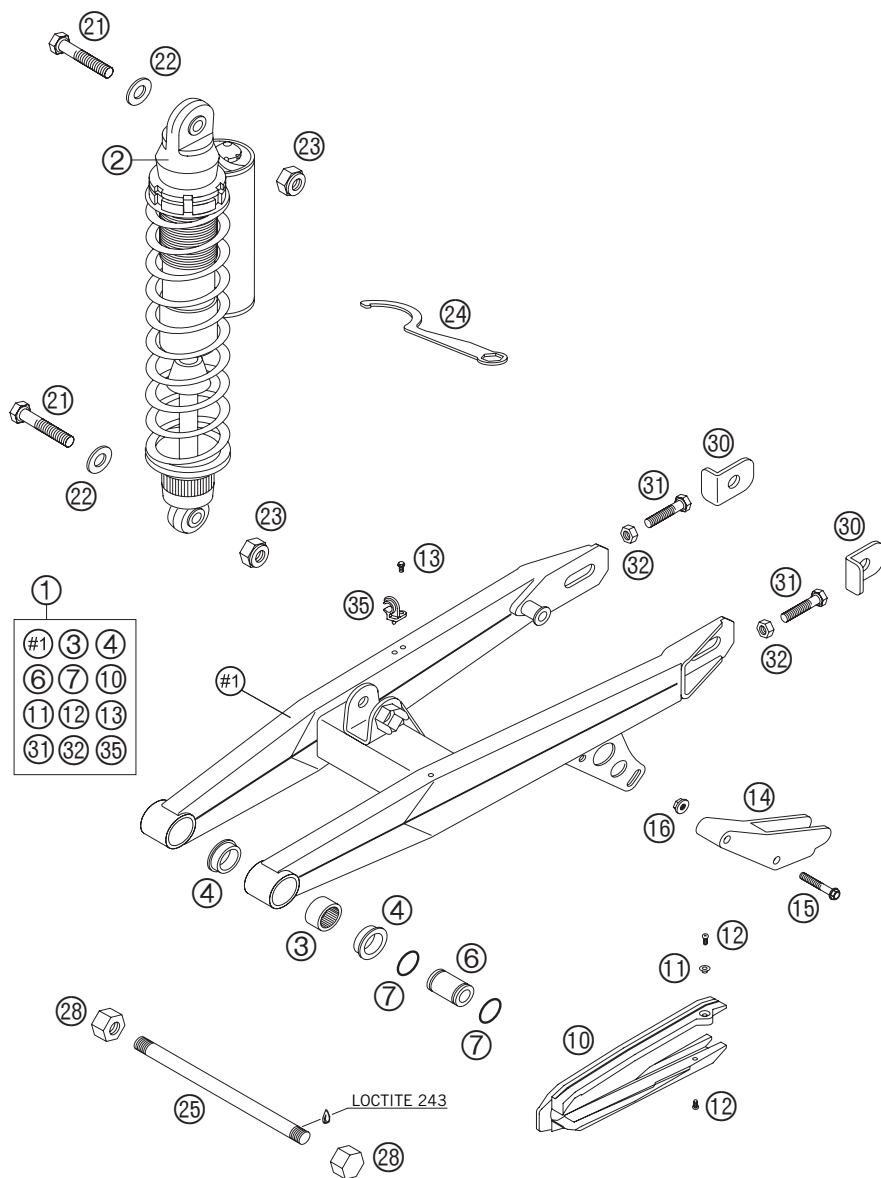

FIG	TEILNR/PARTNR	BEZEICHNUNG	DESCRIPTION	QTY
1	461.04.030.044	SCHWINGARM KPL. 65 SX 2002	SWINGARM CPL. 65 SX 2002	1
2*	0318.7A03	MONOSHOCK 65 SX 2005	MONOSHOCK 65 SX 2005	1
3	546.03.097.000	NADELHÜLSE HK 2016	NEEDLE BUSH HK 2016	2
4	460.04.030.070	DISTANZBÜCHSE 20X26X30X9,7	SPACER BUSHING 20X26X30X9,7	4
6	460.04.030.071	LAGERBÜCHSE 12X20X36,5	BUSHING BOX 12X20X36,5	2
7	0770 160021	O-RING 16,00X2,00 VITON	O-RING 16,00X2,00 VITON	4
10	461.04.066.000	KETTENGLEITSCHUTZ VO. 65SX 02	CHAIN SLID. GUARD FRO. 65SX 02	1
11	461.04.066.050	BÜCHSE F.KETTENGLEITSCHUTZ 02	BUSH FOR CHAIN SLIDER GUARD 02	1
12	0010 050103	GEW.FURCHSCHRAUBE M 5,0X10	SPECIAL SCREW M 5,0X10	2
13	0009 050103	GEW.FURCHSCHRAUBE M 5,0X10	SPECIAL SCREW M 5,0X10	2
14	460.07.066.000	KETTENFÜHRUNG HINTEN 60/65 '98	CHAIN GUIDE REAR 60/65 '98	1
15	0015 060403	SK.BUNDSCHRAUBE M 6X40 SW=8	HH COLLAR SCREW M 6X40 WS=8	2
16	565.09.064.100	STOVER-FLANSCHMUTTER M6 10.9	SELF LOCKING NUT M6 10.9	2
21	0931 100453	SK.SCHRAUBE DIN 931 M10X45	HH SCREW DIN0931-M10X45	2
22	0125 100003	UNTERLEGSCHIBE DIN 125 A 10,5	WASHER DIN0125-A10,5	2
23	543.10.086.100	SS.MUTTER M10 CU SW=14	SELF LOCKING NUT M10 CU WS=14	2
24	460.12.024.000	HAKENSCHLÜSSEL FÜR FEDERBEIN	HOOK WRENCH FOR SHOCK ABSORBER	1
25	460.04.037.000	SCHWINGARMBOLZEN 201MM M12X1	SWINGARM BOLT 201MM M12X1	1
28	0917 120103	HUTMUTTER DIN917-M12X1	NUT DIN917-M12X1	2
30	460.10.083.000	KETTENSPIANNER 60/65 '98	CHAIN ADJUSTER 60/65 '98	2
31	0933 060353	SK.SCHRAUBE DIN 933 M6X35	HH SCREW DIN0933-M 6X35	2
32	0934 060003	SK.MUTTER DIN 934 M6	HEXAGON NUT DIN0934-M 6	2
35	546.11.076.100	HALTESCHELLE FÜR BREMSSCHL.'96	RETAIN.CLAMP FOR BRAKE HOSE'96	2

05-461.04.0

05-461.04.0

* NEUTEIL / NEW PART X NACH BEDARF / AS REQUIRED

FEDERBEIN WP ZERLEGT » MONOSHOCK WP DISASSEMBLED 65 SX / 2005

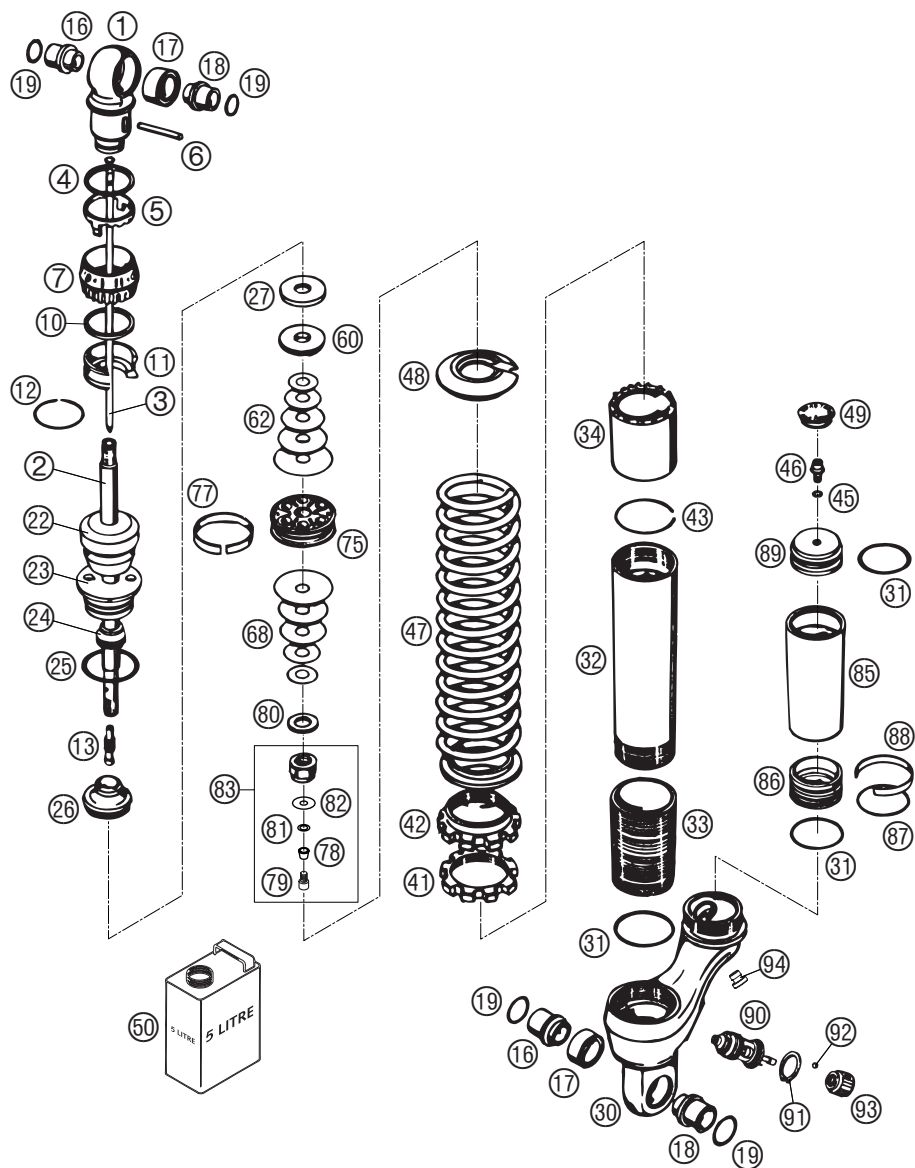

04-461.04.1

FIG	TEILNR/PARTNR	BEZEICHNUNG	DESCRIPTION	QTY
1	4681.1525	FEDERBEIN UNTERTEIL L=46	SHOCK ABS. BOTTOM L=46	1
2	3612.0586	KOLBENSTANGE D=14; L=126	PISTON ROD D=14; L=126	1
3	4681.1401S	NADEL KPL. D=4; L=142	NEEDLE CPL. D=4; L=142	1
4	4681.1222	O-RING 36X0,5	O-RING 36X0,5	1
5	4681.1263	SCHEIBE	WASHER	1
6	4681.1261	BOLZEN 4X35	PIN 4X35	1
7	4681.1262	EINSTELLSCHEIBE D=41	ADJ. KNOB D=41	1
10	4681.1221	O-RING 35X3	O-RING 35X3	1
11	4681.1367	ZWISCHENRING H=4	INTERMEDIATO RING H=4	1
12	4681.1268	SPRENGRING 22X1,2	CIRCLIP 22X1,2	1
13	4681.1259	NADELSITZ 5X17,25	NEEDLE SEAT 5X17,25	1
16	4681.1076	ADAPTER BUCHSE KGW 10X20	ADAPTOR BUSH KGW 10X20	2
17	4681.1027	LAGER KGW 1525	BUSHING KGW 1525	2
18	4681.1077	ADAPTER BUCHSE KGW 10X22	ADAPTOR BUSH KGW 10X22	2
19	4681.1050	O-RING KGW	SEAL KGW	4
22	3612.0135	GUMMIPUFFER WP65 ROT	BUMP RUBBER WP65 RED	1
23	3612.0650	SCHRAUBVERSCHLUSS M37,65 STAHL	SCREW CAP M37,65 STEEL	1
24	4681.1044	SCHMUTZABSTREIFRING 1424	DUST SEAL 1424	1
25	3612.0064	O-RING NBR 29,74X3,53	O-RING NBR 29,74X3,53	1
26	3612.0522S1	ADAPTER KPL. D=36 H=20,5	ADAPTER CPL. D=36 H=20,5	1
27	3612.0469	SCHEIBE 28,5X14X2	SHIM 28,5X14X2	1
30	3612.0726	FEDERBEINGEHÄUSE PGB KGW H=33	SHOCK ABSORB.CASE PGB KGW H=33	1
31	4054.0037	O-RING 38X2	O-RING 38X2	3
32	3612.0137	ROHR L=167	TUBE L=167	1
33	3612.0019	GEWINDEBÜCHSE L=70 SCHWARZ	THREADED BUSH L=70 BLACK	1
34	3612.0467	SCHUTZROHR L=40	PROTECTION SLEEVE L=40	1
41	3612.0015	KONTERMUTTER	COUNTERNUT	1
42	3612.0418	EINSTELLMUTTER	ADJUSTING NUT	1
43	4054.0015	SPRENGRING 38X1,5	CIRCLIP 38X1,5	1
45	4681.0893	O-RING NBR 5,28X1,78	O-RING NBR 5,28X1,78	1
46	3612.0151	VERSCHLUSSSCHRAUBE M5X6	SCREW PLUG M5X6	1
47	9301.0049	FEDER WP 40-220	SPRING WP 40-220	1
47	9301.0050	FEDER WP 45-220	SPRING WP 45-220	X
48	3612.0386	FEDERTELLER H=3; D=14,5	SPRING RET. H=3; D=14,5	1
49	4681.1208	GUMMIKAPPE "NICHT ÖFFNEN"	RUBBER CAP "DO NOT OPEN"	1
50	5018.0342S1	DÄMPFERÖL 5 LT 2003	SHOCK ABSORBER FLUID 5 LT 2003	1

05-461.04.1

* NEUTEIL / NEW PART X NACH BEDARF / AS REQUIRED

FEDERBEIN WP ZERLEGT » MONOSHOCK WP DISASSEMBLED 65 SX / 2005

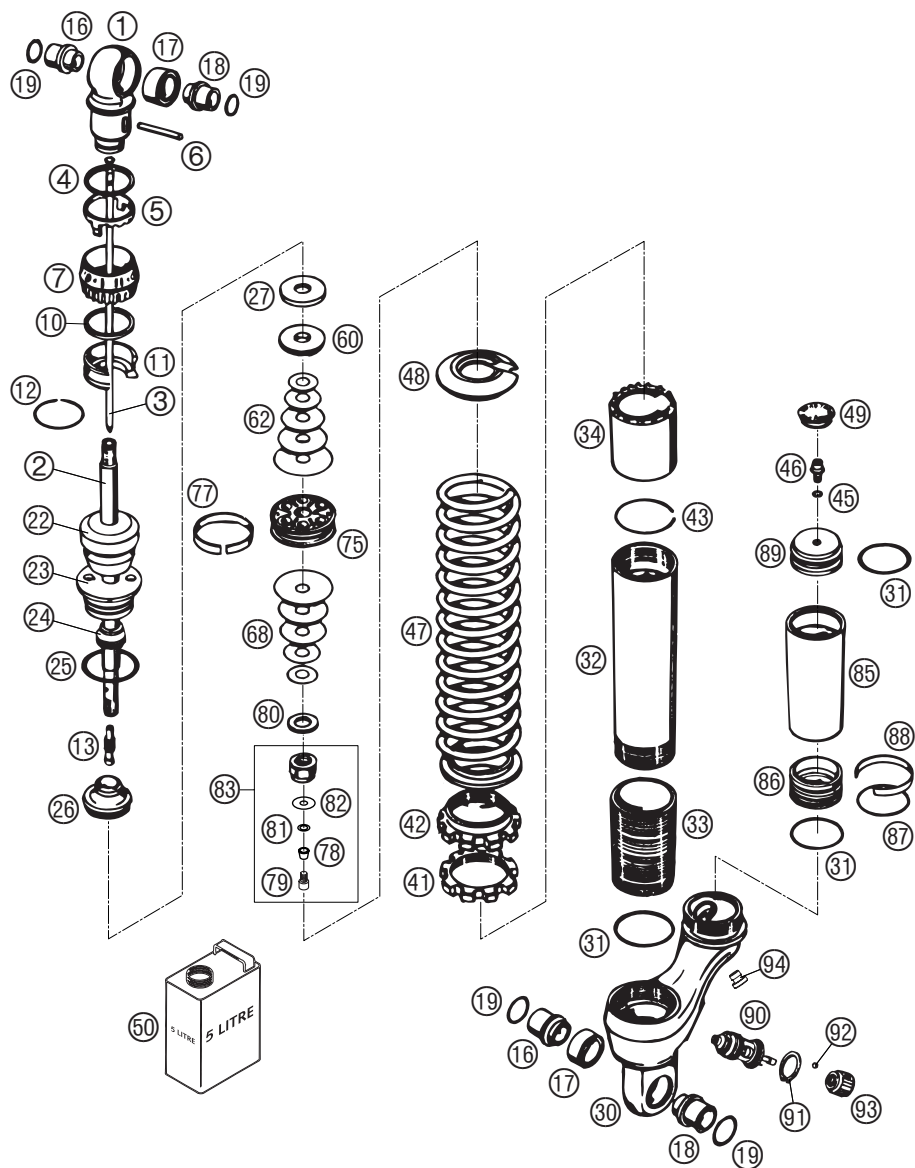

04-461.04.1

FIG	TEILNR/PARTNR	BEZEICHNUNG	DESCRIPTION	QTY
60	3612.0557	ZUGSTUFEN-BÜCHSE H=5,6	REBOUND BUSH H=5,6	1
62	3612.0312	SCHEIBE 10X16X0,30	SHIM 10X16X0,30	1
62	3612.0334	SCHEIBE 10X21X0,20	SHIM 10X21X0,20	1
62	3612.0335	SCHEIBE 10X23X0,20	SHIM 10X23X0,20	1
62	3612.0336	SCHEIBE 10X25X0,20	SHIM 10X25X0,20	1
62	3612.0337	SCHEIBE 10X27X0,20	SHIM 10X27X0,20	1
62	3612.0330	SCHEIBE 10X29X0,15	SHIM 10X29X0,15	1
62	3612.0331	SCHEIBE 10X31X0,15	SHIM 10X31X0,15	1
62	3612.0332	SCHEIBE 10X33X0,15	SHIM 10X33X0,15	1
62	3612.0329	SCHEIBE 10X27X0,15	SHIM 10X27X0,15	1
62	3612.0325	SCHEIBE 10X19X0,15	SHIM 10X19X0,15	1
62	3612.0340	SCHEIBE 10X33X0,20	SHIM 10X33X0,20	2
68	3612.0314	SCHEIBE 10X18X0,30	SHIM 10X18X0,30	1
68	3612.0342	SCHEIBE 10X21X0,25	SHIM 10X21X0,25	1
68	3612.0343	SCHEIBE 10X23X0,25	SHIM 10X23X0,25	1
68	3612.0336	SCHEIBE 10X25X0,20	SHIM 10X25X0,20	1
68	3612.0284	SCHEIBE 10X16X0,10	SHIM 10X16X0,10	1
68	3612.0335	SCHEIBE 10X23X0,20	SHIM 10X23X0,20	1
68	3612.0328	SCHEIBE 10X25X0,15	SHIM 10X25X0,15	2
75	3612.0603	KOLBEN 6+6XD=5,5/3,5 BA	PISTON 6+6XD=5,5/3,5 BA	1
77	3612.0040	KOLBENRING 8X1X108,3	PISTON RING 8X1X108,3	1
78	4681.1267	BÜCHSE 6X9X3	BUSHING 6X9X3	1
79	4681.1251	ENTLÜFTUNGSSCHRAUBE M 4X6	BLEED SCREW M 4X6	1
80	3612.0604	SCHEIBE D10XD22X2,5	SHIM D10XD22X2,5	1
81	4054.0450	SCHEIBE 6X9,5X0,3	SHIM 6X9,5X0,3	1
82	4054.0403	SCHEIBE 6X18X0,1	SHIM 6X18X0,1	4
83	3612.0605S2	KOLBENSTANGENMUTTER KPL.H=15,2	PISTON ROD NUT CPL. H=15,2	1
85	3612.0631	RESERVOIRSCHRAUBE L=98 GRAU	RESERVOIR SCREW L=98 GREY	1
86	3612.0024	TRENNKOLBEN D=42	SEPARATION PISTON D=42	1
87	3612.0466	O-RING VITON 32X5	O-RING VITON 32X5	1
88	4681.0022	KOLBENRING 3,9X1,5X124	PISTON RING 3,9X1,5X124	1
89	3612.0552	SCHRAUBE FÜR RES.KAPPE M5	SCREW FOR RESERVOIR CAP M5	1
90	4681.0850S7	CC-DRUCKSTUFENREGULIERUNG KPL.	CC-COMPRE.DAMPING CONTROL CPL.	1
91	4681.0334	SICHERUNGSSCHEIBE JV24	LOCK WASHER JV24	1
92	4681.0333	STAHLKUGEL D=4,75	STEEL-BALL D=4,75	1
93	5018.0131S	EINSTELLSCHRAUBE CC-MECH. KPL.	ADJUSTING KNOB CC-MECH. CPL.	1
94	5018.0095	ENTLÜFTUNGSSCHRAUBE R 1/8	BLEED PLUG R 1/8	1

05-461.04.1

* NEUTEIL / NEW PART X NACH BEDARF / AS REQUIRED

AUSPUFFANLAGE » EXHAUST SYSTEM

65 SX / 2005

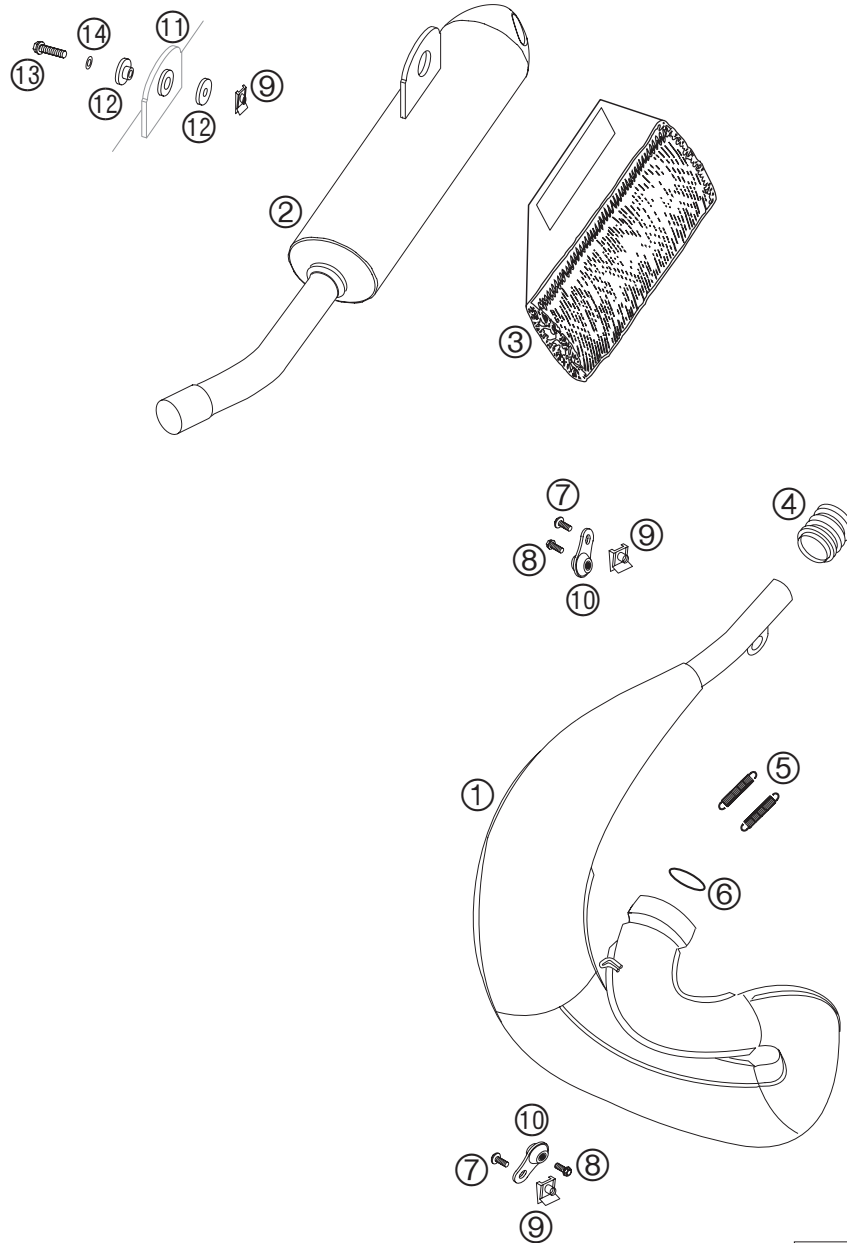

04-461.05.0

05-461.05.0

FIG	TEILNR/PARTNR	BEZEICHNUNG	DESCRIPTION	QTY
1	461.05.007.000	AUSPUFF 65 SX 2002	EXHAUST PIPE 65 SX 2002	1
2	461.05.079.000	ENDDÄMPFER 65 SX 2002	SILENCER 65 SX 2002	1
3	451.05.079.056	DÄMMSTOFF FORMTEIL 50 2002 110 GRAMM GESAMTGEWICHT	ROCKWOOL PREFORMED 50 2002 110 GRAMM TOTAL WEIGHT	1
4	546.05.057.000	GUMMIMUFFE D=21/23MM '93	RUBBER SLEEVE D=21MM/23MM '93	1
5	503.05.016.000	ZUGFEDER L=62MM ÖSEN BEWEGLICH	TEN.SPRING L=55MM EY.MOVEABLE	2
6	0770 350030	O-RING 35,00X3,00 VITON	O-RING 35,00X3,00 VITON	1
7	0014 060153	SK.BUNDSCHRAUBE M 6X15 SW=8	HH COLLAR SCREW M 6X15 WS=8	2
8	0015 060163	SK.BUNDSCHRAUBE M 6X16 SW=8	HH COLLAR SCREW M 6X16 WS=8	2
9	546.03.048.100	MEHRBEREICHBLECHMUTTER M6	RANGE CHANGE METAL NUT M6	3
10	503.05.012.000	SCHWINGELEMENT FÜR AUSPUFF	SWINGELEMENT FOR EXHAUST PIPE	2
11	546.05.068.000	DÄMPFUNGELEMENT SCHWARZ	EXHAUST BRACKET RUBBER BLACK	1
12	546.05.069.000	BÜCHSE 7,5X12X28X7,8 '96	BUSHING 7,5X12X28X7,8 '96	2
13	0015 060303	SK.BUNDSCHRAUBE M 6X30 SW=8	HH COLLAR SCREW M 6X30 WS=8	1
14	0137 060003	FEDERSCHEIBE DIN 137 B 6	SPRING WASHER DINO137-B 6	1

* NEUTEIL / NEW PART X NACH BEDARF / AS REQUIRED

LUFTFILTERKASTEN » AIR FILTER BOX

65 SX / 2005

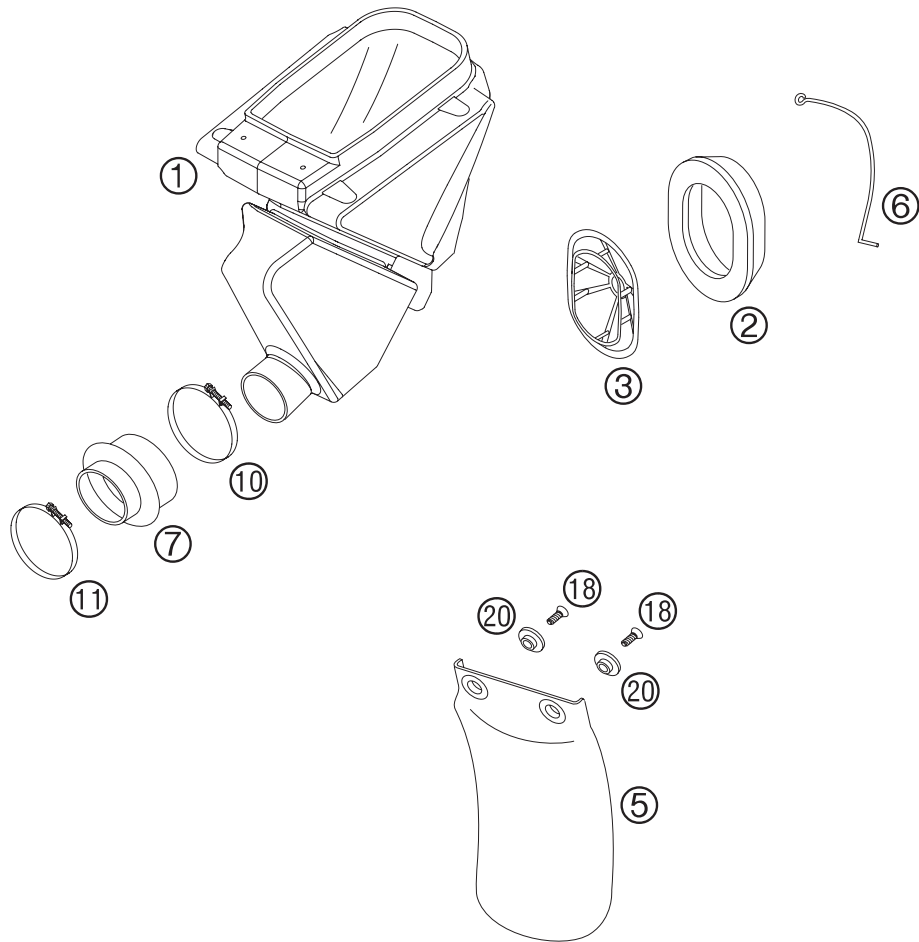

FIG	TEILNR/PARTNR	BEZEICHNUNG	DESCRIPTION	QTY
1	461.06.001.200	FILTERKASTEN INKL.AUFKLEBER 04	FILTER BOX INCL. STICKER 04	1
2	584.06.015.100	LUFTFILTER E-STARTER 98	FILTERELEMENT E-STARTER '98	1
3	584.06.016.000	FILTERTRÄGER '97	FILTER CARRIER '97	1
5	460.06.010.000	SPRITZSCHUTZ 60/65 SX '98	SPLASH PROTECTOR 60/65 SX '98	1
6	461.06.017.000	HALTEBÜGEL FÜR LUFTFILTER 2002	HOLDING HANGER FOR FILTER 2002	1
7	460.06.026.000	VERGASERMANNSCHETTE 60/65 SX	CARBURETOR CONNECTING BOOT	1
10	460.05.058.000	SCHLAUCHBINDER 40-60MM	HOSE CLAMP 40-60MM	1
11	450.07.027.000	SCHLAUCHBINDER 32-50MM B=5MM	HOSE CLAMP 32-50MM W=5MM	1
18	0017 060203	SONDERSCHRAUBE T60 6X20 SW=6	SPECIAL SCREW T60 6X20 WS=6	2
20	461.06.006.000	BÜCHSE F. SPRITZSCHUTZ 2002	BUSH FOR SPLASH PROTECTOR 2002	2

05-461.06.0

05-461.06.0

* NEUTEIL / NEW PART X NACH BEDARF / AS REQUIRED

TANK · SITZBANK · VERKLEIDUNG » TANK · SEAT · COVER

65 SX / 2005

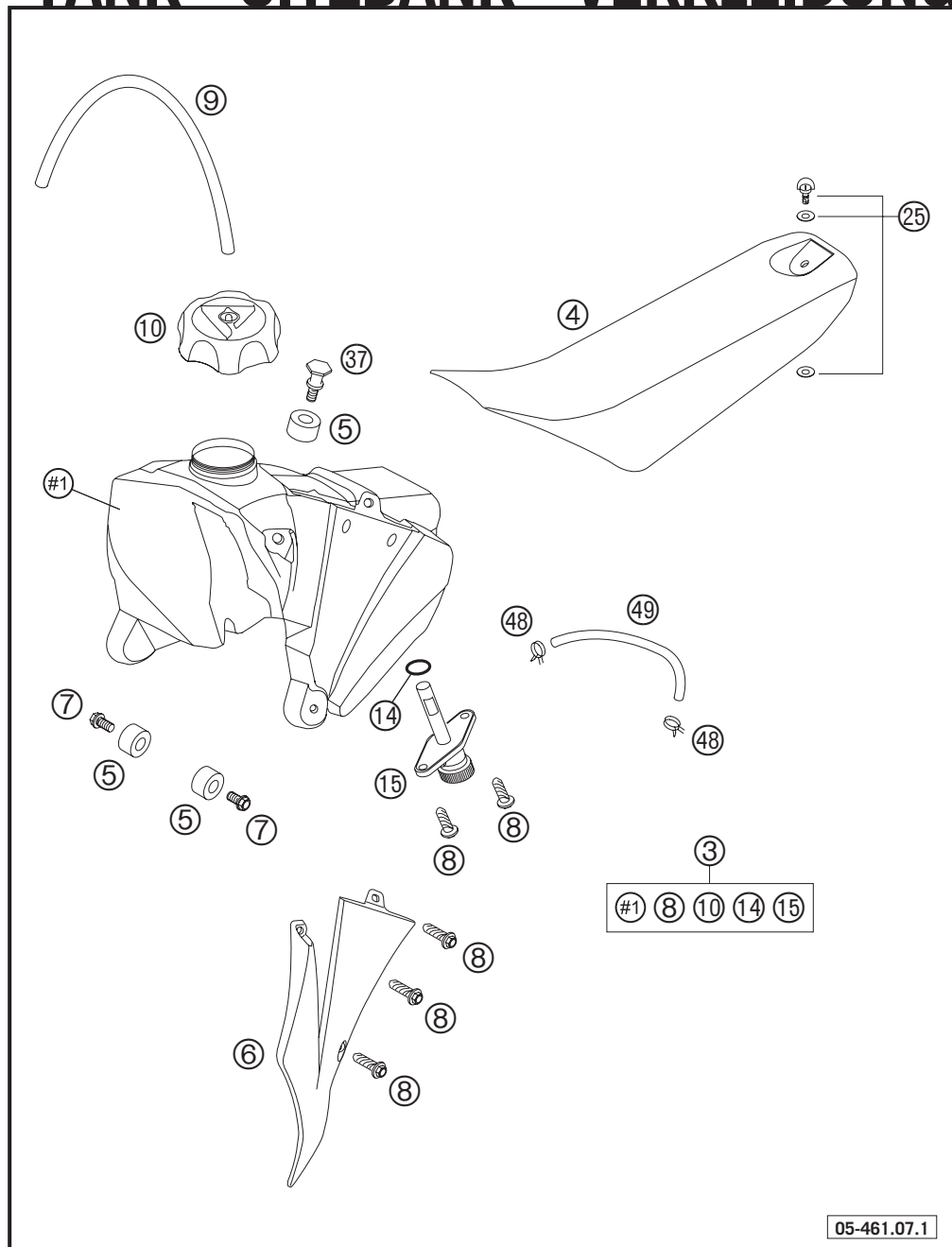

05-461.07.1

05-461.07.0

FIG	TEILNR/PARTNR	BEZEICHNUNG	DESCRIPTION	QTY
3	461.07.013.000/04	BENZINTANK KPL. 65 SX 2003	FUEL TANK CPL. 65 SX 2003	1
4*	461.07.040.200	SITZBANK 65 SX 2005	SEAT 65 SX 2005	1
5	503.07.014.000	TANKROLLE 12X26X12 '98	TANK ROLLER 12X26X12 '98	3
6	461.08.050.100/04	SPOILER LI. 65SX ORANGE 02	SPOILER L/S 65SX ORANGE 02	1
6	461.08.051.100/04	SPOILER RE. 65SX ORANGE 02	SPOILER R/S 65SX ORANGE 02	1
7	0015 060123	SK.BUNDSCHRAUBE M 6X12 SW=8	HH COLLAR SCREW M 6X12 WS=8	2
8	0017 060203	SONDERSCHRAUBE T60 6X20 SW=6	SPECIAL SCREW T60 6X20 WS=6	8
9	503.32.095.101	SCHLAUCH VINNYLAN 6X9 DVOH	TUBE VINNYLAN 6X9 DVOH	0,30
10	490.07.008.044	TANKVERSCHLUSS KPL. KLEIN	FILLER CAP CPL. SMALL	1
14	550.07.006.200	O-RING 11X1,8 NBR 70	O-RING 11X1,8 NBR 70	1
15	585.07.003.000	BENZINHAHN KPL.KLEIN RALLYE'96	FUEL COCK CPL. SMALL RALLYE'96	1
25	450.07.040.051	SCHNELLVERSCHLUSS KPL.50SXR'97	QUICK RELEASE CPL. 50 SXR '97	1
37	451.07.011.000	SITZBANKBEF.SCHRAUBE 50 2001	TANK SCREW MINI 50 2001	1
48	580.07.117.000	YDNAC-KLAMMER 10107 10MM	YDNAC-CLAMP 10107 10MM	2
49	503.07.016.000	BENZINFORMSCHLAUCH SX 2001	FUEL PREFORMED HOSE SX 2001	1

* NEUTEIL / NEW PART

X NACH BEDARF / AS REQUIRED

MASKE · KOTFLÜGEL » MASK · FENDERS

65 SX / 2005

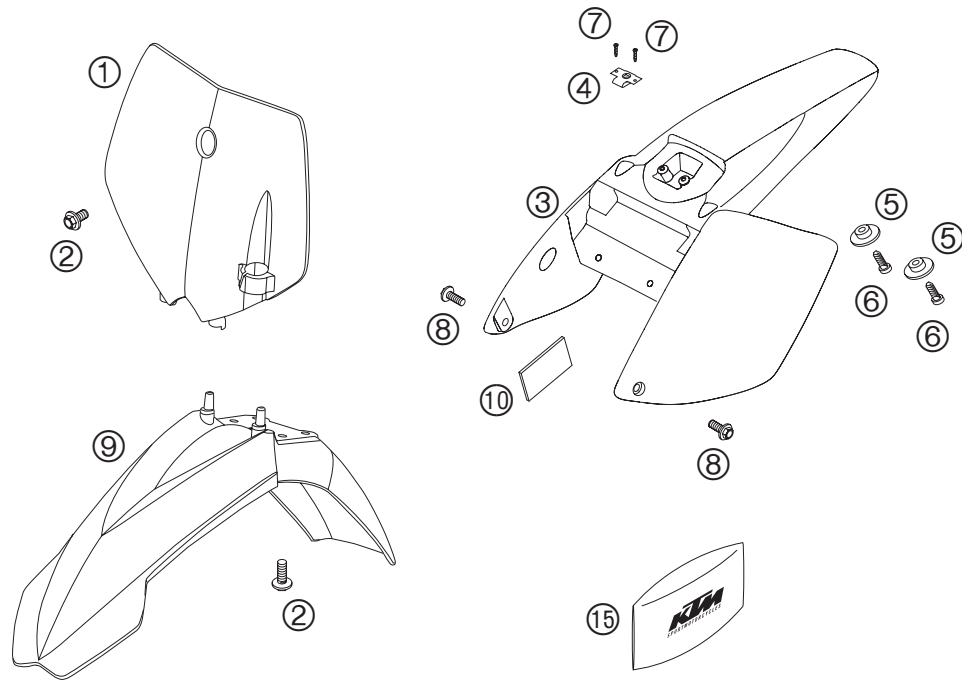

FIG	TEILNR/PARTNR	BEZEICHNUNG	DESCRIPTION	QTY
1	461.08.007.000/04	STARTNUMMERNTAFEL 65SX 2002	START NUMBER PLATE 65SX 2002	1
2	0014 060103	SK.BUNDSCHRAUBE M 6X10 SW=8	HH COLLAR SCREW M 6X10 WS=8	5
3	461.08.013.000/04	HECKTEIL 65 SX ORANGE 2003	REAR PART 65 SX ORANGE 2003	1
4	450.07.040.050	WIDERLAGER SCHNELLVERSCHLUSS	QUICK RELEASE LATCHPLATE	1
5	722.10.079.000	STÜTZSCHALE	BUCKET	2
6	0017 060203	SONDERSCHRAUBE T60 6X20 SW=6	SPECIAL SCREW T60 6X20 WS=6	2
7	0981 350163	LI.BLECHSCHR. DIN7981- 3,5X16	SHEET MET.SCR.DIN7981- 3,5X16	2
8	0014 060153	SK.BUNDSCHRAUBE M 6X15 SW=8	HH COLLAR SCREW M 6X15 WS=8	2
9	461.08.010.000/04	KOTFLÜGEL VORNE 65SX 2002	FENDER FRONT 65SX 2002	1
10*	590.03.001.099	METAMOLL 90X45X3MM 03	METAMOLL 90X45X3MM 03	1
15	450.29.099.000	BORDWERKZEUG 50 MINI, 60/65 SX	TOOL SET 50 MINI, 60/65 SX	1

05-461.08.0

05-461.08.0

* NEUTEIL / NEW PART X NACH BEDARF / AS REQUIRED

FIG	TEILNR/PARTNR	BEZEICHNUNG	DESCRIPTION	QTY
1*	461.08.099.300	SPOILERDEKOR LI.+RE. 65 SX 05	SPOILER DECAL L/S+R/S 65 SX 05	1
2	461.08.092.200	DEKORSATZ 65 SX 2004	DECAL SET 65 SX 2004	1

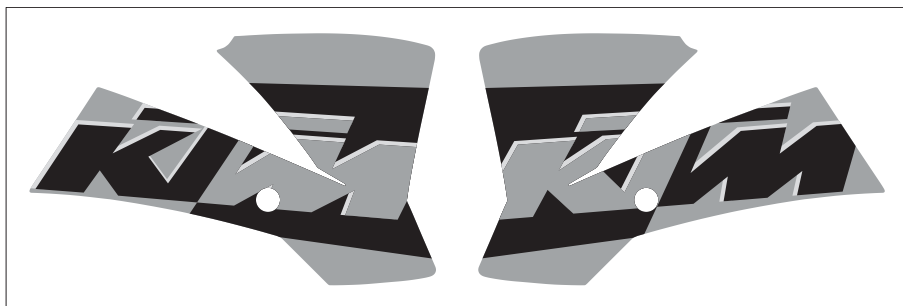

①



②

05-461.08.1

05-461.08.1

* NEUTEIL / NEW PART X NACH BEDARF / AS REQUIRED

VORDERRAD » FRONT WHEEL

65 SX / 2005

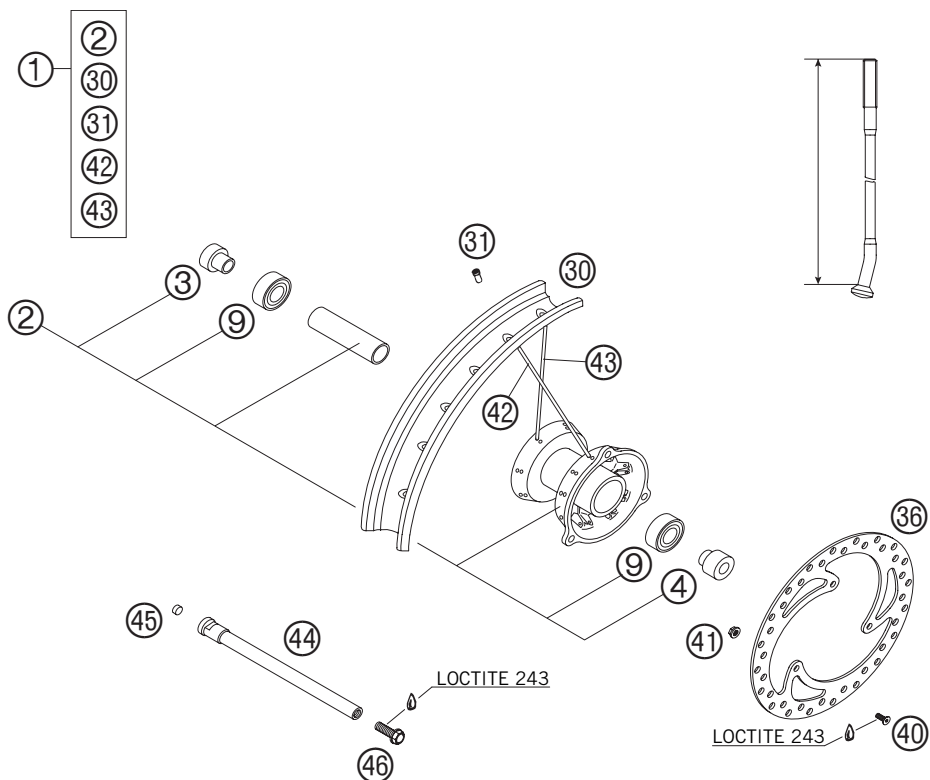

FIG	TEILNR/PARTNR	BEZEICHNUNG	DESCRIPTION	QTY
1	461.09.001.044	VORDERRAD-ET 1,6X14" ALU	FRONT WHEEL-SP 1,6X14" ALU	1
2	461.09.010.044	VORDERRADNABE KPL. SILBER 2002	FR.WHEEL HUB CPL. SILVER 2002	1
3	460.09.013.000	LAGERDISTANZ RE. 65SX 04	SPACER BUSH R/S 65SX 04	1
4	460.09.014.000	LAGERDISTANZ LI. 65SX 04	SPACER BUSH L/S 65SX 04	1
9	0625 060037	RILLENKUGELL. 6003-2RSH/C3HMTF	GR.BALL BEAR. 6003-2RSH/C3HMTF	2
30	460.09.070.000	FELGE VORNE 1,60X14" ALUMINIU.	RIM FRONT 1,6X14" ALU	1
31	460.09.072.100	SPEICHENNIPPEL M3,5 2001	SPOKE NIPPEL M3,5 2001	32
36	461.09.060.000	BREMSSCHEIBE VORNE 65 SX 2004	BRAKE DISC FRONT 65 SX 2004	1
40	0991 060163	SENKSCHRAUBE DIN7991-M 6X16	FLAT HEAD SCR. DIN7991-M 6X16	3
41	565.09.064.100	STOVER-FLANSCHMUTTER M6 10.9	SELF LOCKING NUT M6 10.9	3
42	460.09.071.000	SPEICHE M3,5X145MM	SPOKE M3,5X145MM	16
43	460.09.171.000	SPEICHE M3,5X149MM	SPOKE M3,5X149MM	16
44	461.09.081.000	STECKACHSE VORNE 65SX 2002	AXLE FRONT 65SX 2002	1
45	550.09.086.000	VERSCHLUSSPFROPFEN SFL13	PLUG SFL13	1
46	490.32.011.000	SK.BUNDSCHRAUBE M10X20 SW=17	HH COLLAR SCREW M10X20 WS=17	1

05-461.09.0

05-461.09.0

* NEUTEIL / NEW PART

X NACH BEDARF / AS REQUIRED

BREMSZANGE VORNE FORMULA » BRAKE CALIPER FRONT FORMULA

65 SX / 2005

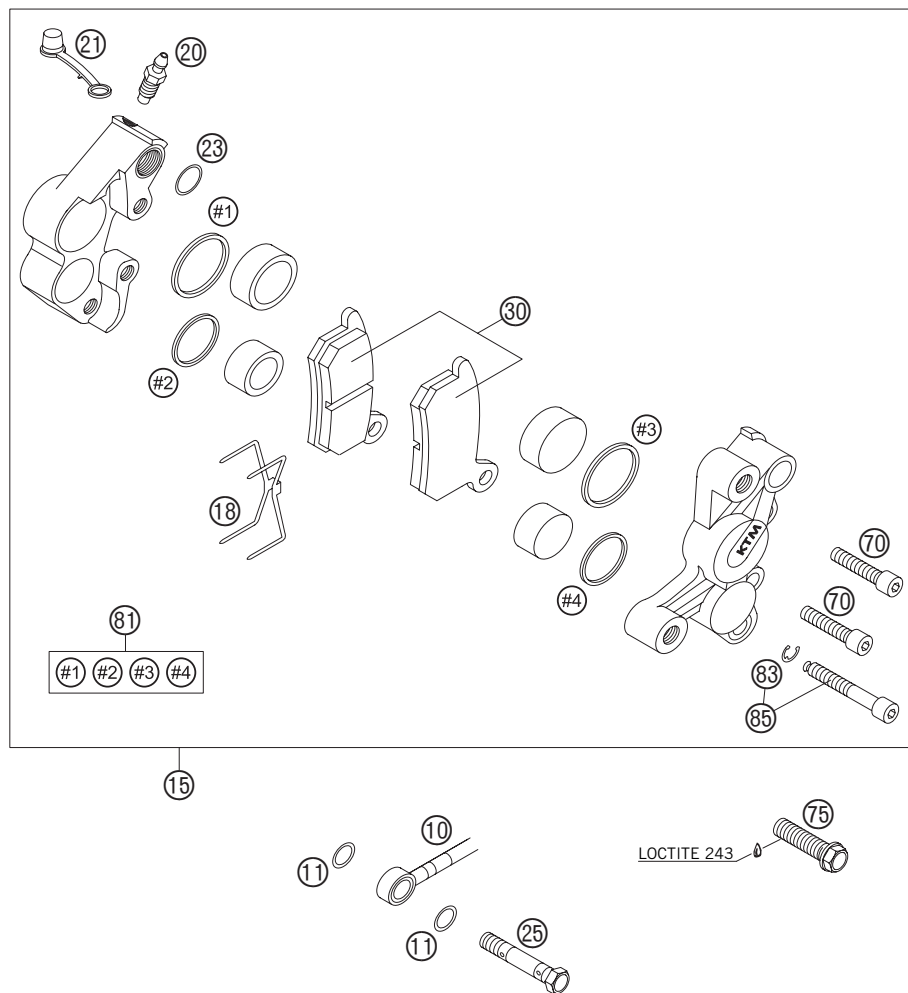

05-470.13.2

05-461.13.2

FIG	TEILNR/PARTNR	BEZEICHNUNG	DESCRIPTION	QTY
10	461.13.010.100	BREMSSCHLAUCH VORNE 65 SX 2004	BRAKE HOSE FRONT 65 SX 2004	1
11	0770 080019	O-RING 8,00X1,00 EPDM	O-RING 8,00X1,00 EPDM	2
15	470.13.015.000	BREMSZANGE VORNE KPL. 85 SX 03	BRAKE CALIPER FR. CPL.85 SX 03	1
18	461.13.018.000	HALTEFEDER 65 SX	RETAINING SPRING 65 SX	1
20	470.13.020.000	ENTLÜFTUNGSSCHRAUBE M6	BLEEDER SCREW M6	1
21	470.13.021.000	KAPPE FÜR ENTLÜFTUNGSSCHRAUBE	CAP FOR BLEEDER SCREW	1
23	0770 100019	O-RING 10X1 EPDM	O-RING 10X1 EPDM	1
25	470.13.125.000	HOHLSCHRAUBE M8X38,8	HOLLOW SCREW M8X38,8	1
30	461.13.030.000	GARN. BREMSKLÖTZE VORNE 2002	BRAKE PAD SET FRONT 2002	1
30*	470.13.090.100	GARN. BREMSKLÖTZE HINTEN 2004	BRAKE PAD SET REAR 2004	X
70	0912 060283	ISK.SCHRAUBE DIN0912-M 6X28	AH SCREW DIN0912-M 6X28	2
75	0015 080303	SK.BUNDSCHRAUBE M 8X30 SW=10	HH COLLAR SCREW M 8X30 WS=10	2
81	461.13.019.000	REP. SATZ DICHRING 2002	REPAIR KIT SEAL RING 2002	1
83	0799 040009	SICH.SCHEIBE DIN6799-RA 4,0	TAB WASHER DIN6799-RA 4,0	1
85	461.13.125.000	ISK.SCHRAUBE + S-RING 2002	AH SCREW + CIRCLIP 2002	1

* NEUTEIL / NEW PART

X NACH BEDARF / AS REQUIRED

HINTERRAD » REAR WHEEL

65 SX / 2005

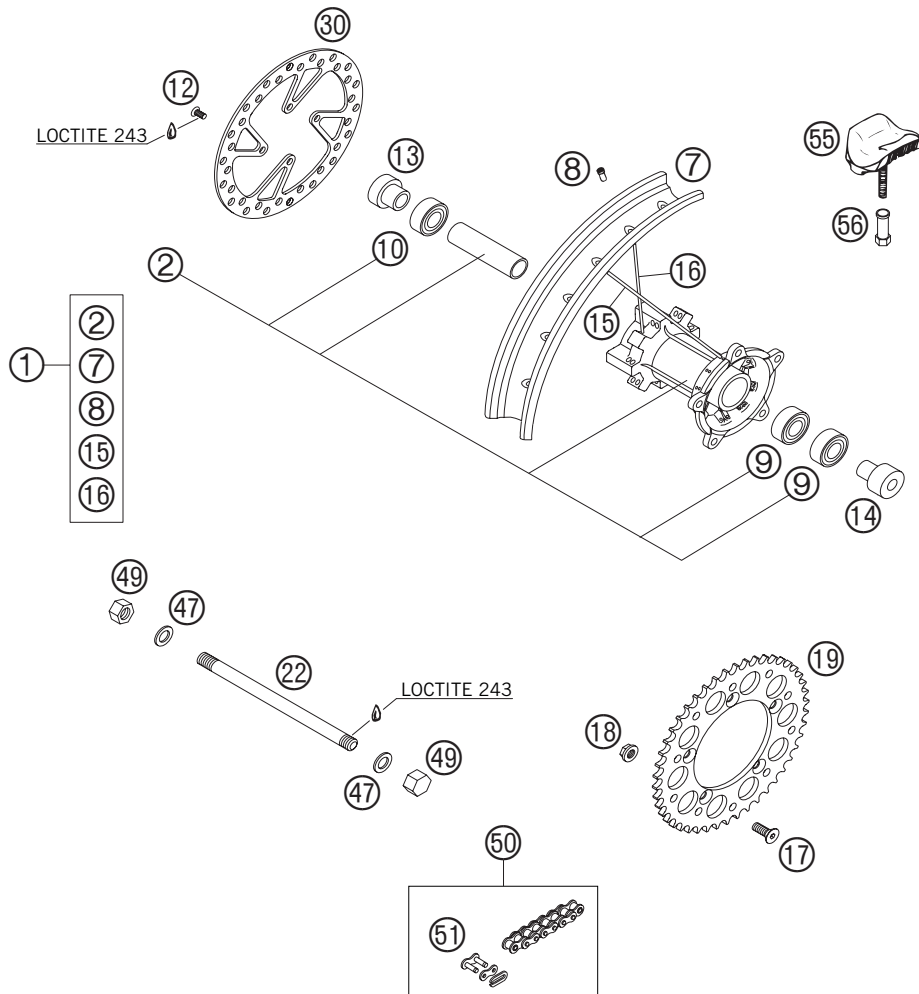

FIG	TEILNR/PARTNR	BEZEICHNUNG	DESCRIPTION	QTY
1	460.10.001.144	HINTERRAD-ET 1,6X12" ALU	REARWHEEL-SP 1,6X12" ALU	1
2	460.10.010.144	HINTERRADNABE KPL.60/65SX 2000	REAR WHEEL HUB CPL.60/65 2000	1
7	460.10.070.000	FELGE HINTEN 1,6X12" ALUMINI.	RIM REAR 1,6X12" ALU	1
8	460.09.072.100	SPEICHENNIPPEL M3,5 2001	SPOKE NIPPEL M3,5 2001	32
9	0625 060037	RILLENKUGELL. 6003-2RSH/C3HMTF	GR.BALL BEAR. 6003-2RSH/C3HMTF	2
10	0625 062032	RILLENKUGELL. 6203-2RSHC3HMTF	GR.BALL BEAR. 6203-2RSHC3HMTF	1
12	590.09.062.013	SONDERSCHRAUBE M6X13 SW=8 10.9	SPECIAL SCREW M6X13 WS=8 10.9	4
13	460.10.013.000	LAGERDISTANZ RE. SX 60/65 2000	SPACER BUSH R/S SX 60/65 2000	1
14	460.10.014.000	LAGERDISTANZ LI. SX 60/65 2000	SPACER BUSH L/S SX 60/65 2000	1
15	460.10.071.100	SPEICHE 3X140X4MM-161°	SPOKE 3X140X4MM-161°	16
16	460.10.171.100	SPEICHE 3X132X5MM-150°	SPOKE 3X132X5MM-150°	16
17	0991 080253	SENKSCHRAUBE DIN7991-M 8X25	FLAT HEAD SCREW DIN7991-M 8X25	5
18	543.10.086.200	STOVER-FLANSMUTTER M8 10.9	SELF LOCKING NUT M8 10.9	5
19	460.10.051.046	KETTENRAD 46-Z	REAR SPROCKET 46-T	X
19	460.10.051.048	KETTENRAD 48-Z	REAR SPROCKET 48-T	X
19	460.10.051.050	KETTENRAD 50-Z	REAR SPROCKET 50-T	1
22	460.10.085.100	STECKACHSE HINTEN 213MM M12X1	AXLE REAR 213MM M12X1	1
30	461.10.060.000	BREMSSCHEIBE HINTEN 65 SX 2004	BRAKE DISC REAR 65 SX 2004	1
47	0125 120003	UNTERLEGSCHIBE DIN 125 A 13	FLAT WASHER DIN0125-A13	2
49	0917 120103	HUTMUTTER DIN917-M12X1	NUT DIN917-M12X1	2
50	461.10.165.112	KETTE 1/2X1/4" MIT K. SCHLOSS	CHAIN 1/2X1/4" WITH M. LINK	1
51	461.10.166.000	KETTENSCHLOSS 1/2X1/4"	MASTER LINK 1/2X1/4"	1
55	510.09.100.100	REIFENHALTER VM1 (1,60")	RIM LOCK VM1 (1,60")	1
56	503.10.090.050	MUTTER FÜR REIFENHALTER '96	NUT FOR WHEEL HOLDER '96	1

05-461.10.0

05-461.10.0

* NEUTEIL / NEW PART X NACH BEDARF / AS REQUIRED

BREMSZANGE HINTEN FORMULA » BRAKE CALIPER REAR FORMULA

65 SX / 2005

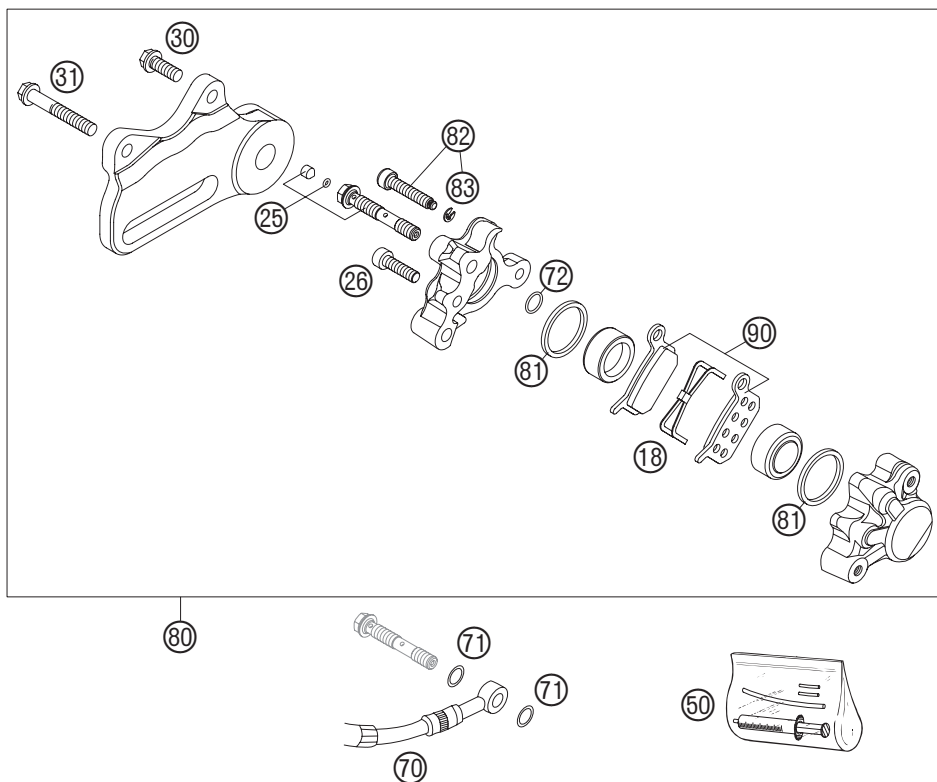

FIG	TEILNR/PARTNR	BEZEICHNUNG	DESCRIPTION	QTY
18	451.13.018.000	HALTEFEDER 50 LC	RETAINING SPRING 50 LC	1
25	461.13.225.000	HOHLSCHRAUBE KPL.	HOLLOW SCREW CPL.	1
26	0912 050163	ISK.SCHRAUBE DIN 912 M5X16	AH SCREW DIN0912-M 5X16	1
30	0015 060163	SK.BUNDSCHRAUBE M 6X16 SW=8	HH COLLAR SCREW M 6X16 WS=8	1
31	0015 060403	SK.BUNDSCHRAUBE M 6X40 SW=8	HH COLLAR SCREW M 6X40 WS=8	1
50*	451.19.050.000	ENTLÜFTUNGSSPRITZEN-SET 50-65	BLEEDER INJECTION-SET 50-65	1
70	461.13.070.000	BREMSSCHLAUCH HINTEN 65 SX 04	BRAKE HOSE REAR 65 SX 04	1
71	0770 060019	O-RING 6,00X1,00	O-RING 6,00X1,00	2
72	0770 080019	O-RING 8,00X1,00 EPDM	O-RING 8,00X1,00 EPDM	1
80	461.13.080.000	BREMSZANGE HINTEN KPL.65 SX 04	BRAKE CALIPER REAR CPL.65SX 04	1
81	0770 022020	O-RING 22X2X2 EPDM	O-RING 22X2X2 EPDM	2
82	451.13.225.000	ISK.SCHRAUBE + S-RING 50/65 04	AH SCREW + CIRCLIP 50/65 04	1
83	0799 025000	SICH.SCHEIBE DIN6799-RS 2,5	TAB WASHER DIN6799 RS2,5	1
90	451.13.030.000	GARN. BREMSKLÖTZE 50 LC 2002	BRAKE PAD SET 50 LC 2002	1

05-461.13.3

05-461.13.3

* NEUTEIL / NEW PART X NACH BEDARF / AS REQUIRED

MOTORGEHÄUSE » ENGINE CASE

65 SX / 2005

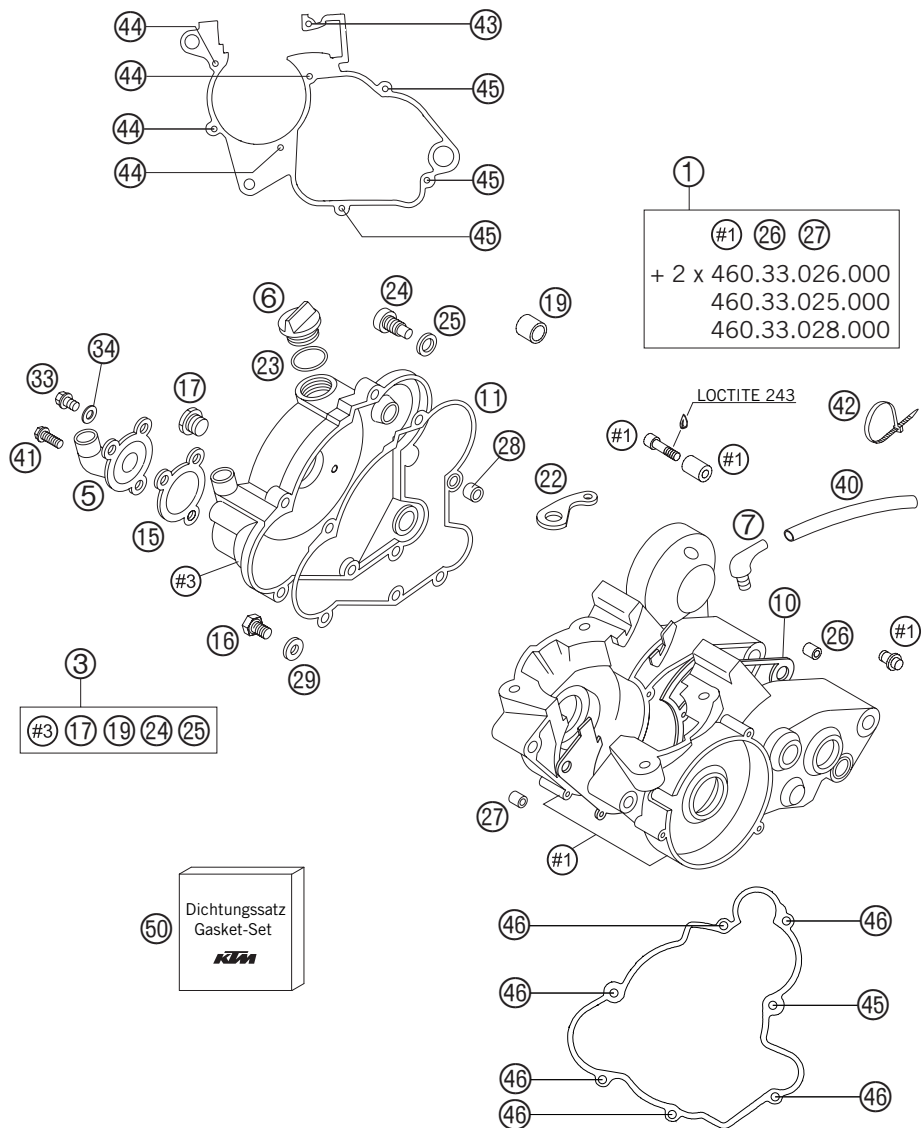

FIG	TEILNR/PARTNR	BEZEICHNUNG	DESCRIPTION	QTY
1	460.30.000.244	MOTORGEHÄUSE KPL. 65 SX 2003	ENGINE CASE CPL. 65 SX 2003	1
3	460.30.001.200	KUPPLUNGSDECKEL KPL.65 SX 2002	CLUTCH COVER CPL. 65 SX 2002	1
5	451.35.052.000	WASSERPUMPENDECKEL 50 LC 2002	WATER PUMP COVER 50 LC 2002	1
6	580.30.020.000	ÖLEINFÜLLSCHRAUBE M 24X3	PLUG M 24X3	1
7	510.30.022.000	WINKELSTÜCK 90 GRAD M10X1	ANGLE PIECE 90 DEGREE M10X1	1
10	460.30.039.000	MOTORGEHÄUSEDICHTUNG 60/65	ENGINE CASE GASKET 60/65	1
11	460.30.025.000	KUPPLUNGSDECKELDICHTUNG INNEN	CLUTCH COVER GASKET INSIDE	1
15	451.35.053.000	DICHTUNG WASSERPUMPENDECKEL 02	GASKET WATER PUMP COVER 02	1
16	460.30.021.100	ÖLABLASSSCHRAUBE M10 SW=13	OIL DRAIN PLUG M10 WS=13	1
17	490.30.095.000	ÖLSCHAUGLAS GN 540	LENS TYPE GN 540	1
19	460.33.068.000	EINPRESSBÜCHSE KICKST. 65SX	PRESS IN BUSH KICKSTARTER 65SX	1
22	460.32.059.100	AUSRÜCKHEBEL 65 SX 2002	RELEASE LEVER 65 SX 2002	1
23	0770 160030	O-RING 16,00X3,00 NBR 70	O-RING 16,00X3,00 NBR 70	1
24	460.33.067.000	SPEZIALSCHRAUBE 65 SX	SPECIAL SCREW 65 SX	1
25	460.33.067.100	SCHEIBE F. SPEZIALSCHR. 65 SX	WASHER F. SPECIAL SCREW 65 SX	1
26	460.30.023.100	PASSHÜLSE 17X15	DOWEL 17X15	1
27	460.30.023.000	PASSHÜLSE 12X14,5	DOWEL 12X14,5	1
28	460.30.024.000	PASSHÜLSE 9X15	DOWEL 9X15	1
29	0603 101420	DICHRING 10,2X14X2 MM CU 01	COPPER GASKET 10,2X14X2 MM 01	1
33	0015 060103	SK.BUNDSCHRAUBE M 6X10 SW=8	HH COLLAR SCREW M 6X10 WS=8	1
34	0603 061001	CU-DICHRING DIN7603-6X10X1	CU-SEAL RING DIN7603-6X10X1	1
40	310.07.007.001	PVC-SCHLAUCH 5 X 8 MM	PVC-HOSE 5 X 8 MM	0,22
41	0015 060163	SK.BUNDSCHRAUBE M 6X16 SW=8	HH COLLAR SCREW M 6X16 WS=8	3
42	440.11.076.100	KABELBAND 100/2,5MM SCHWARZ	CABLE TIE 100/2,5MM BLACK	X
43	0912 060404	ISK.SCHRAUBE DIN0912-M 6X40 A2	AH SCREW DIN0912-M 6X40 A2	1
44	0912 060453	ISK.SCHRAUBE DIN 912 M6X45	AH SCREW DIN0912-M 6X45	4
45	0912 060303	ISK.SCHRAUBE DIN 912 M6X30	AH SCREW DIN0912-M 6X30	4
46	0912 060253	ISK.SCHRAUBE DIN 912 M6X25	AH SCREW DIN0912-M 6X25	6
50	460.30.099.100	DICHTUNGSSATZ KPL. 65 SX 2002	GASKET SET CPL. 65 SX 2002	1

05-461.30.0

03-461.30.0

* NEUTEIL / NEW PART X NACH BEDARF / AS REQUIRED

KURBELWELLE · KOLBEN » CRANKSHAFT · PISTON

65 SX / 2005

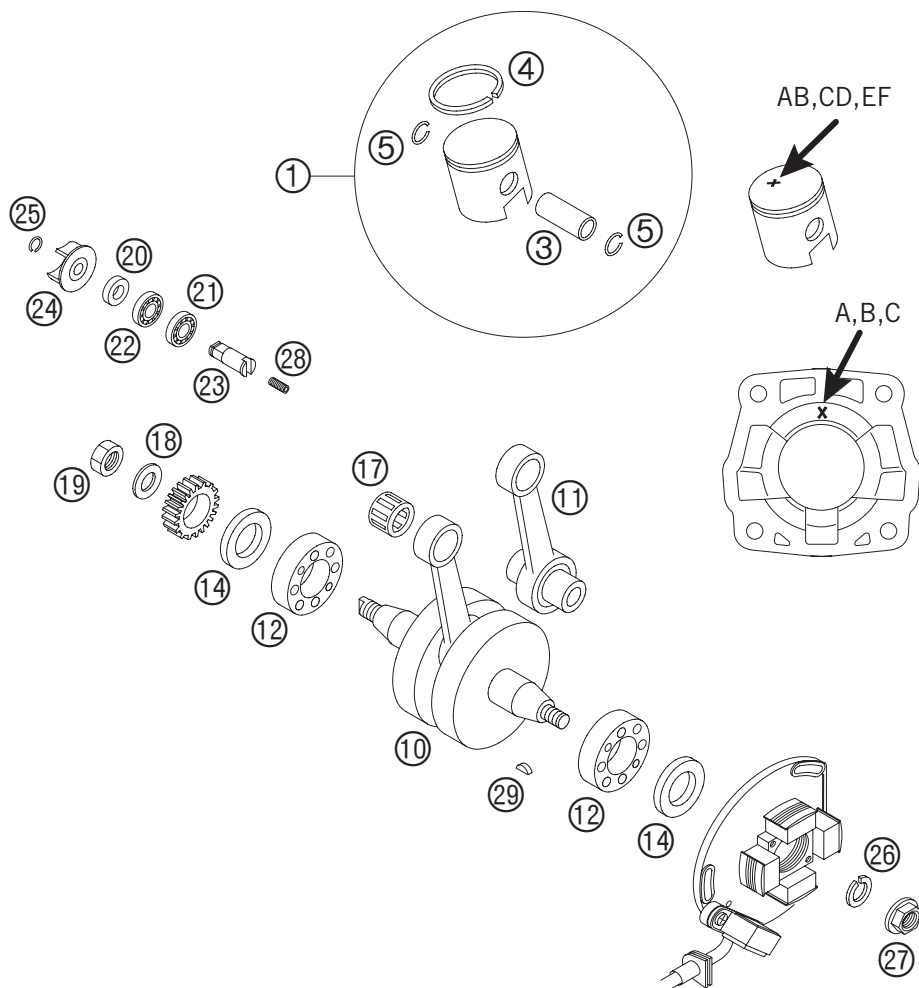

FIG	TEILNR/PARTNR	BEZEICHNUNG	DESCRIPTION	QTY
1	460.30.007.500/ A	KOLBEN KPL. 45MM "A/B" 65'98	PISTON CPL. 45MM "A/B" 65'98	X
1	460.30.007.500/ C	KOLBEN KPL. 45MM "C/D" 65'98	PISTON CPL. 45MM "C/D" 65'98	X
1	460.30.007.500/ E	KOLBEN KPL. 45MM "E/F" 65'98	PISTON CPL. 45MM "E/F" 65'98	X
3	460.30.033.000	KOLBENBOLZEN 12X38	PISTON PIN 12X38	1
4	460.30.030.500	KOLBENRING 45MM 65CCM	PISTON RING 45MM 65CCM	1
5*	451.30.074.000	KOLBENBOLZENSICHERUNG 2001	CIRCLIP 2001	2
10	460.30.018.200	KURBELWELLE KPL. HUB 40,8 2003	CRANKSHAFT CPL. STROKE 40,8 03	1
11	460.30.015.100	PLEUEL-REP.SATZ 65 SX 2003	CONN.ROD REPAIR SET 65 SX 2003	1
12	460.30.082.200	RILLENKUGELLAGER 20X52X15 NTN	GROOVED BALL BEAR.20X52X15 NTN	2
14	470.30.076.100	WELLENDICHRING 20X35X6 BTSL	SEAL SHAFT RING 20X35X6 BTSL	2
17	460.30.034.000	NADELLAGER KOLBENBOLZ.12X15X17	NEEDLE BEAR.PISTONPIN 12X15X17	1
18	460.30.078.100	SICHERUNGSSCHEIBE 14X20X1	LOCKING WASHER 14X20X1	X
19	460.30.029.100	SK-MUTTER M14X1,25X5 '99	HH-NUT M14X1,25X5 '99	1
20	460.35.056.100	WELLENDICHRING 10X18X4	SHAFT SEAL RING 10X18X4	1
21	460.35.057.000	WASSERPUMPENLAGER 10X19X5	WATER PUMP BEARING 10X19X5	1
22	460.35.058.000	WA.PU.LAGER 10X19X5 DOPPELLIP.	WA.PU.BEAR. 10X19X5 DOUBLELIP	1
23	451.35.054.000	WASSERPUMPENWELLE 50 LC 2004	WATER PUMP SHAFT 50 LC 2004	1
24	460.35.055.100	WASSERPUMPENRAD 60/65 '99	WATER PUMP WHEEL 60/65 '99	1
25	0471 090010	SICHERUNGSRING DIN0471- 9X1	CIRCLIP DIN0471- 9X1	1
26	502.30.029.012	SPERRKANTRING VSK 12	LOCKING RING VSK 12	1
27	490.30.021.000	BUNDMUTTER M12X1 RECHTS	COLLAR NUT M12X1 R/S	1
28	451.35.058.000	FEDER FÜR WASSERPUMPENWELLE 04	SPRING FOR WATER PUMP SHAFT 04	1
29	0888 030050	SCHEIBENFEDER DIN6888-3X5X13	WOODRUFF KEY DIN6888-3X5X13	1

05-461.30.1

05-461.30.1

* NEUTEIL / NEW PART X NACH BEDARF / AS REQUIRED

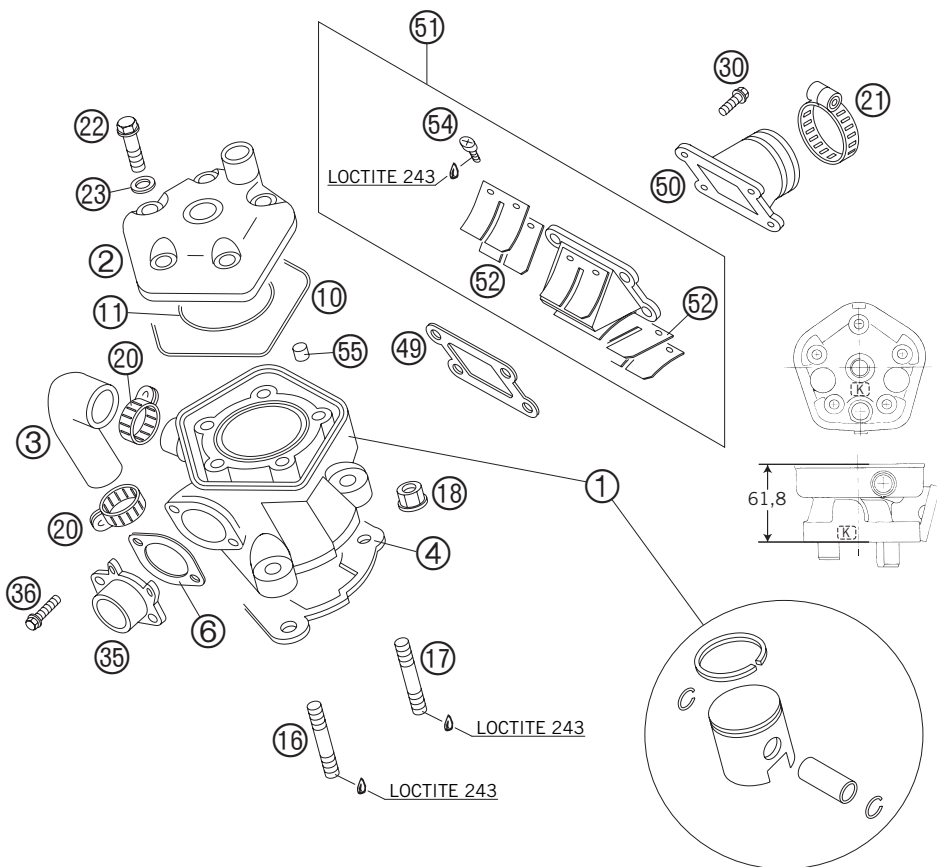

FIG	TEILNR/PARTNR	BEZEICHNUNG	DESCRIPTION	QTY
1	460.30.005.600	ZYLINDER M.KOLBEN 45MM 65SX 03	CYLINDER W.PISTON 45MM 65SX 03	1
2	460.30.006.700	ZYLINDERKOPF 65 SX 2003	CYLINDERHEAD 65 SX 2003	1
3	460.35.027.000	FORMSCHLAUCH ZYL.-KUPP.DECKEL	PRE-FORM.HOSE CYL.-CLUTCH COV.	1
4	460.30.035.020	ZYLINDERFUSSDICHTUNG 0,2 MM	CYLINDER BASE GASKET 0,2 MM	X
4	460.30.035.040	ZYLINDERFUSSDICHTUNG 0,4 MM	CYLINDER BASE GASKET 0,4 MM	X
4	460.30.035.050	ZYLINDERFUSSDICHTUNG 0,5 MM	CYLINDER BASE GASKET 0,5 MM	X
4	460.30.035.060	ZYLINDERFUSSDICHTUNG 0,6 MM	CYLINDER BASE GASKET 0,6 MM	X
6	460.30.046.000	AUSPUFFDICHTUNG 60/65 CCM	EXHAUST GASKET 60/65 CCM	1
10	460.30.037.000	O-RING 94,97X1,78	O-RING 94,97X1,78	1
11	460.30.036.000	O-RING 53,7X1,78 VITON	O-RING 53,7X1,78 VITON	1
16	460.30.043.000	STIFTSCHRAUBE M8X41	STUD M8X41	3
17	460.30.043.100	STIFTSCHRAUBE M8X44	STUD M8X44	1
18	460.30.045.000	BUNDMUTTER M8 SW=10	COLLAR NUT M8 WS=10	4
20	100.01.020.000	SCHLAUCHKLEMME GEMI 16-27	HOSE CLAMP GEMI 16-27	2
21	310.01.027.000	SCHLAUCHBINDER 32-52MM D5	HOSE CLAMP 32-52MM D5	1
22	460.30.079.100	ZYLINDERKOPFSCHR.SK-M7X38 2003	CYLINDERHEADSCR.HH-M7X38 2003	5
23	502.30.032.010	CU-DICHRING 7,3 X 12 X 0,5	CU-SEAL RING 7,3 X 12 X 0,5	5
30	0015 060203	SK.BUNDSCHRAUBE M 6X20 SW=8	HH COLLAR SCREW M 6X20 WS=8	4
35	460.36.040.100	AUSPUFFSTUTZEN 65 SX 2002	EXHAUST FLANGE 65 SX 2002	1
36	0015 060203	SK.BUNDSCHRAUBE M 6X20 SW=8	HH COLLAR SCREW M 6X20 WS=8	2
49	460.30.049.000	ANSAUGFLANSCHDICHTUNG	INTAKE VALVE GASKET	1
50	460.30.050.000	ANSAUGFLANSCH	INTAKE FLANGE	1
51	460.30.051.144	MEMBRANGEHÄUSE KPL. 65SX 2001	MEMBRANE HOUSING CPL.65SX 2001	1
52	460.30.052.000	MEMBRAN LOSE 60/65 CCM	MEMBRANE LOOSE 60/65 CCM	2
54	0985 030063	LINSENSCHRAUBE DIN7985-M 3X6	FLAT HEAD SCREW DIN7985-M 3X6	4
55	451.30.023.000	PASSHÜLSE 7X9X10	DOWEL 7X9X10	2

05-461.30.4

05-461.30.4

* NEUTEIL / NEW PART X NACH BEDARF / AS REQUIRED

VERGASER MIKUNI VM24 » CARBURETOR MIKUNI VM24

65 SX / 2005

▲ ACHTUNG !!!
Vor dem Einbau des Vergasers, Bedüsung kontrollieren.
CAUTION !!!
Before mounting the carburetor, check the jetting.

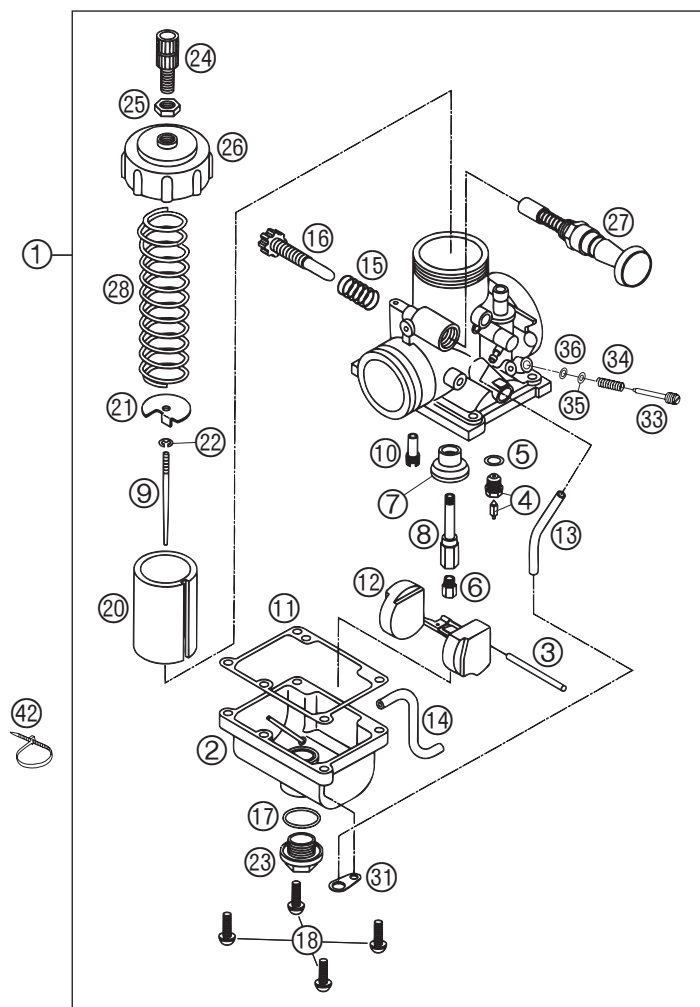

05-461.31.0

FIG	TEILNR/PARTNR	BEZEICHNUNG	DESCRIPTION	QTY
1	461.31.001.000	VERGASER MIKUNI VM24-505 2004	CARBURETOR MIKUNI VM24-505 04	1
2	460.31.011.000	SCHWIMMERGEHÄUSE 5-1 VM24	FLOAT BODY 5-1 VM24	1
3	450.31.008.000	STIFT 2,5X27	PIN 2,5X27	1
4	461.31.020.000	SCHWIMMERNADELVENTIL KPL. VM24	NEEDLE VALVE CPL. VM24	1
5	460.31.018.000	DICHTUNG NADELVENT. 9,1X12X0,5	GASKET NEEDLE VALVE 9,1X12X0,5	1
6	450.31.023.185	HAUPTDÜSE 185	MAIN JET 185	X
6	450.31.023.190	HAUPTDÜSE 190	MAIN JET 190	X
6	450.31.023.195	HAUPTDÜSE 195	MAIN JET 195	X
6	450.31.023.200	HAUPTDÜSE 200	MAIN JET 200	1
6	450.31.023.205	HAUPTDÜSE 205	MAIN JET 205	X
7	460.31.074.000	PRALLGLOCKE	BUFFLE	1
8	461.31.021.000	DÜSENSTOCK 864 0-0	NEEDLE JET 864 0-0	1
9	450.31.034.200	DÜSENNADEL MIKUNI 5114	JET NEEDLE MIKUNI 5114	1
10	450.31.007.025	LEERLAUFDÜSE 25 MIKUNI	IDLING JET 25 MIKUNI	1
11	450.31.010.100	DICHTUNG SCHWIMMERGEHÄUSE	GASKET FLOAT BOWL	1
12	460.31.009.000	SCHWIMMER VM24	FLOAT VM24	1
13	520.31.137.001	PVC-SCHLAUCH 3X5MM	PVC-HOSE 3X5MM	0,28
14	520.31.137.001	PVC-SCHLAUCH 3X5MM	PVC-HOSE 3X5MM	0,17
15	450.31.015.100	FEDER MIKUNI	SPRING MIKUNI	1
16	460.31.019.000	SCHIEBERANSCHLAGSCHRAUBE M6X30	THROTTLE VALVE SCREW M6X30	1
17	460.31.043.000	O-RING 17,5X1,4	O-RING 17,5X1,4	1
18	450.31.014.016	LINSENSCHRAUBE M4X16 (SATZ)	LINTIL HEAD SCREW M4X16 (SET)	1
20	461.31.035.000	GASSCHIEBER 1.5	THROTTLE VALVE 1.5	1
21	460.31.032.000	HALTESCHEIBE	HOLDING WASHER	1
22	450.31.045.000	KLEMMFEDER	SPRING	1
23	460.31.014.000	VERSCHLUSSSCHRAUBE M16 SW=17	PLUG SCREW M16 WS=17	1
24	570.31.525.000	STELLSCHRAUBE M6X0,75	ADJUSTMENT SCREW M6X0,75	1
25	450.31.026.000	SK-MUTTER M6X0,75	HH-NUT M6X0,75	1
26	460.31.027.000	VERGASERDECKEL VM24	CARBURETOR COVER VM24	1
27	460.31.048.044	KALTSTARTKNOPF KPL. VM24	COLD STARTER KNOB CPL. VM24	1
28	460.31.030.000	SCHIEBERFEDER VM24	THROTTLE VALVE SPRING VM24	1
31	460.31.081.000	HALTEBLECH F. ENTLÜFT.SCHLAUCH	BRACKET FOR BREATHER HOSE	1
33	461.31.017.000	EINSTELLSCHRAUBE MIKUNI	ADJUSTING SCREW MIKUNI	1
34	450.31.015.000	FEDER	SPRING	1
35	461.31.032.000	SCHEIBE EINSTELLSCHRAUBE	WASHER ADJUSTING SCREW	1
36	461.31.033.000	O-RING EINSTELLSCHRAUBE	O-RING ADJUSTING SCREW	1
42	440.11.076.100	KABELBAND 100/2,5MM SCHWARZ	CABLE TIE 100/2,5MM BLACK	X

05-461.31.0

* NEUTEIL / NEW PART X NACH BEDARF / AS REQUIRED

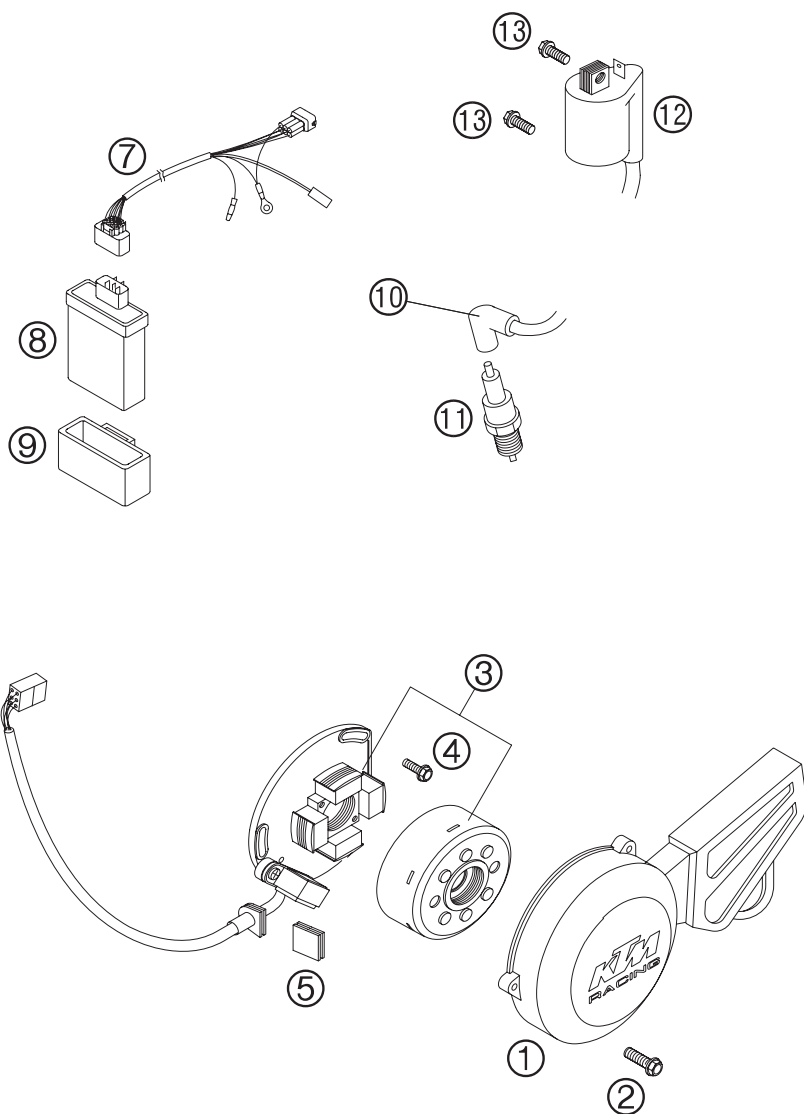

FIG	TEILNR/PARTNR	BEZEICHNUNG	DESCRIPTION	QTY
1	460.30.002.100	ZÜNDUNGSDECKEL 65 SX 2003	IGNITION COVER 65 SX 2003	1
2	0015 060203	SK.BUNDSCHRAUBE M 6X20 SW=8	HH COLLAR SCREW M 6X20 WS=8	3
3	461.39.002.100	ZÜNDANLAGE KPL. 65 SX 2003	IGNITION CPL. 65 SX 2003	1
4	0015 050163	SK.BUNDSCHRAUBE M 5X16 SW=8	HH COLLAR SCREW M 5X16 WS=8	3
5	461.39.012.000	GUMMI FÜR ZÜNDUNGSDECKEL 2003	RUBBER FOR IGNITION COVER 2003	2
7	461.39.095.000	KABELSTRANG 65 SX 2003	WIRING HARNESS 65 SX 2003	1
8	461.39.031.000	ELEKTRONIKBOX 65SX 2003	ELECTRONIC BOX 65 SX 2003	1
9	461.39.030.000	HALTEGUMMI DIGI.BOX 65SX 2003	RUBBER BR. DIGI.BOX 65SX 2003	1
10	470.39.090.000	KERZENSTECKER NGK VERSTÄRKT 04	SPARK PLUG CAP NGK REINFORC.04	1
11	543.31.093.410	ZÜNDKERZE NGK BR8ECM	SPARK PLUG NGK BR8ECM	1
12	461.39.006.100	ZÜNDSPULE KPL. 65 SX 2003	IGNITION COIL CPL. 65 SX 2003	1
13	0015 060203	SK.BUNDSCHRAUBE M 6X20 SW=8	HH COLLAR SCREW M 6X20 WS=8	2

03-461.39.0

05-461.39.0

* NEUTEIL / NEW PART X NACH BEDARF / AS REQUIRED

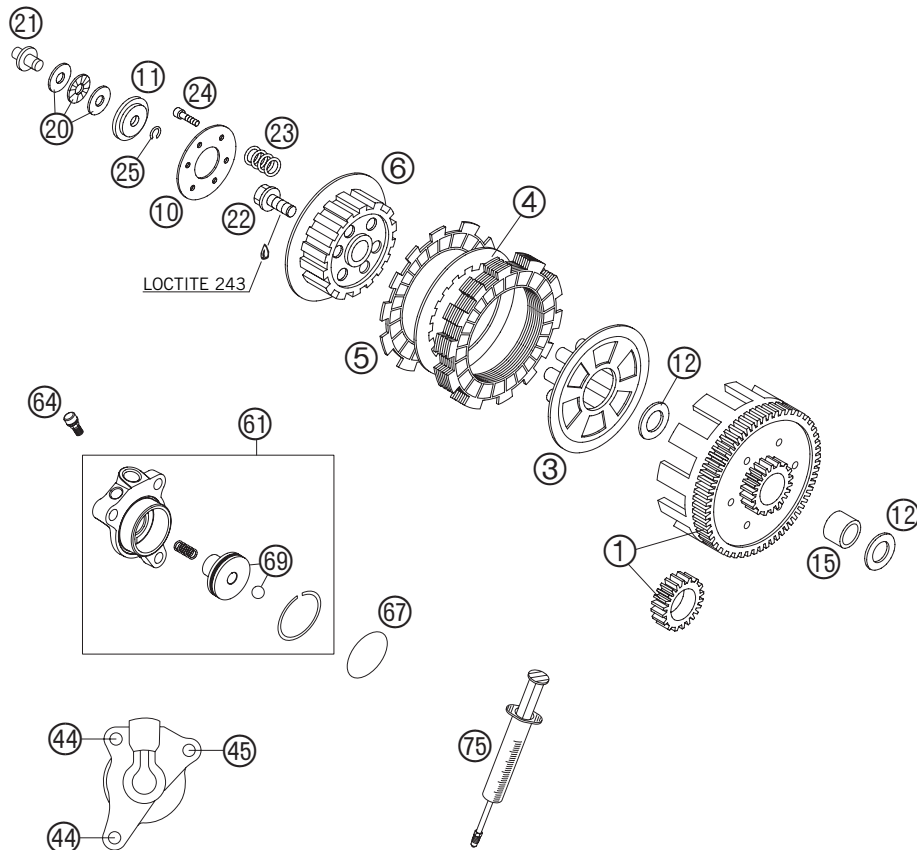

FIG	TEILNR/PARTNR	BEZEICHNUNG	DESCRIPTION	QTY
1	460.32.000.144	PRIMÄRTR.M.KUPP.KORB 23:75 '99	PRIM.DR.W.CLUTCH HUB 23:75 '99	1
3	460.32.003.000	DRUCKKAPPE 60/65 CCM '98	PRESSURE CAP 60/65 CCM '98	1
4	460.32.010.000	ZWISCHENLAMELLE STAHL	INTERMEDIATE DISK STEEL	5
5	460.32.011.000	BELAGLAMELLE	LINING DISK	6
6	460.32.002.000	MITNEHMER 60/65 CCM '98	INNER CLUTCH HUB 60/65 CCM '98	1
10	460.32.006.000	FEDERTELLER 25X63,5X2	SPRING RETAINER 25X63,5X2	1
11	460.32.008.000	TRÄGER FÜR AXIALLAGER	CARRIER FOR AXIAL BEARING	1
12	490.32.012.000	ANLAUFSCHLEIBE 17,2X30X1,5	STOP DISK 17,2X30X1,5	2
15	460.32.015.000	INNENRING 22X17X20,5	INNER RING 22X17X20,5	1
20	460.32.056.000	AXIALLAGER 6X19X2	AXIAL BEARING 6X19X2	1
21	460.32.054.100	DRUCKPILZ 65 SX 2002	PRESSURE PIECE 65 SX 2002	1
22	460.32.019.000	SK.BUNDSCHRAUBE M10X20	HH COLLAR SCREW M10X20	1
23	460.32.005.100	KUPPLUNGSFEDER VERSTÄRKT 60/65 L=27,5 D=2,1	CLUTCH SPRING REINFORCED 60/65 L=27,5 D=2,1	6
24	0991 060203	SENKSCHRAUBE DIN7991 M6X20 8.8	FLAT H.SCREW DIN7991-M6X20 8.8	6
25*	0471 006007	SICHERUNGSRING DIN0471-6X0,7	CIRCLIP DIN0471-6X0,7	1
44	0015 060163	SK.BUNDSCHRAUBE M 6X16 SW=8	HH COLLAR SCREW M 6X16 WS=8	2
45	0015 060203	SK.BUNDSCHRAUBE M 6X20 SW=8	HH COLLAR SCREW M 6X20 WS=8	1
61	590.32.061.044	NEHMERZYLINDER KPL. 2003	OUTPUT CYLINDER CPL. 2003	1
64	547.32.064.000	ENTLÜFTUNGSSCHR. MIT KAPPE	BLEEDER SCREW WITH CAP	1
67	0770 300015	O-RING 30,00X1,50 NBR 70	O-RING 30,00X1,50 NBR 70	1
69	590.32.066.000	KOLBEN MIT O-RING UND KUGEL 03	PISTON WITH O-RING AND BALL 03	1
75	503.29.050.000	ENTLÜFT.SPRITZE HYDR. KUPPLUNG	VENT INJECTION HYDR. CLUTCH	1

05-461.32.0

05-461.32.0

* NEUTEIL / NEW PART X NACH BEDARF / AS REQUIRED

KICKSTARTER » KICKSTARTER

65 SX / 2005

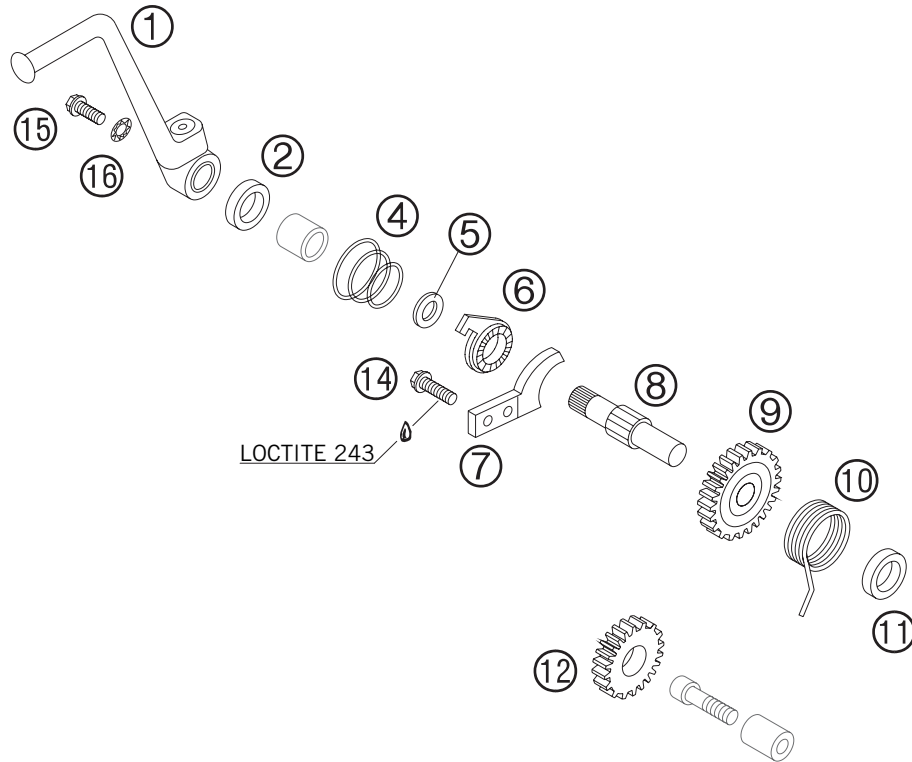

FIG	TEILNR/PARTNR	BEZEICHNUNG	DESCRIPTION	QTY
1	461.33.070.000	KICKSTARTER ALU 65 SX 2003	KICKSTARTER ALU 65 SX 2003	1
2	0760 142460	WELLENDICHTRING 14X24X6 B	SHAFT SEAL RING 14X24X6 B	1
4	460.33.056.000	SPERRADFEDER	RATCHET GEAR SPRING	1
5	460.30.078.100	SICHERUNGSSCHEIBE 14X20X1	LOCKING WASHER 14X20X1	1
6	460.33.052.000	SPERRAD	RATCHET GEAR	1
7	460.33.069.000	ANSCHLAGBLECH	STOP PLATE	1
8	460.33.050.000	KICKSTARTERWELLE	KICKSTARTER SHAFT	1
9	460.33.051.000	STARTERRAD 29-Z	STARTING GEAR 29-T	1
10	460.33.054.000	KICKSTARTERFEDER	KICKSTARTER SPRING	1
11	460.33.055.000	MITNEHMERNABE	DRIVING HUB	1
12	460.33.053.000	STARTERZWISCHENRAD 18-Z	INTERMEDIATE GEAR 18-T	1
14	0015 060203	SK.BUNDSCHRAUBE M 6X20 SW=8	HH COLLAR SCREW M 6X20 WS=8	2
15	0015 060163	SK.BUNDSCHRAUBE M 6X16 SW=8	HH COLLAR SCREW M 6X16 WS=8	1
16	0797 060003	ZAHNSCHEIBE DIN6797-J 6,4	TOOTH LOCK WASH. DIN6797-A 6,4	1

05-461.33.0

05-461.33.0

* NEUTEIL / NEW PART X NACH BEDARF / AS REQUIRED

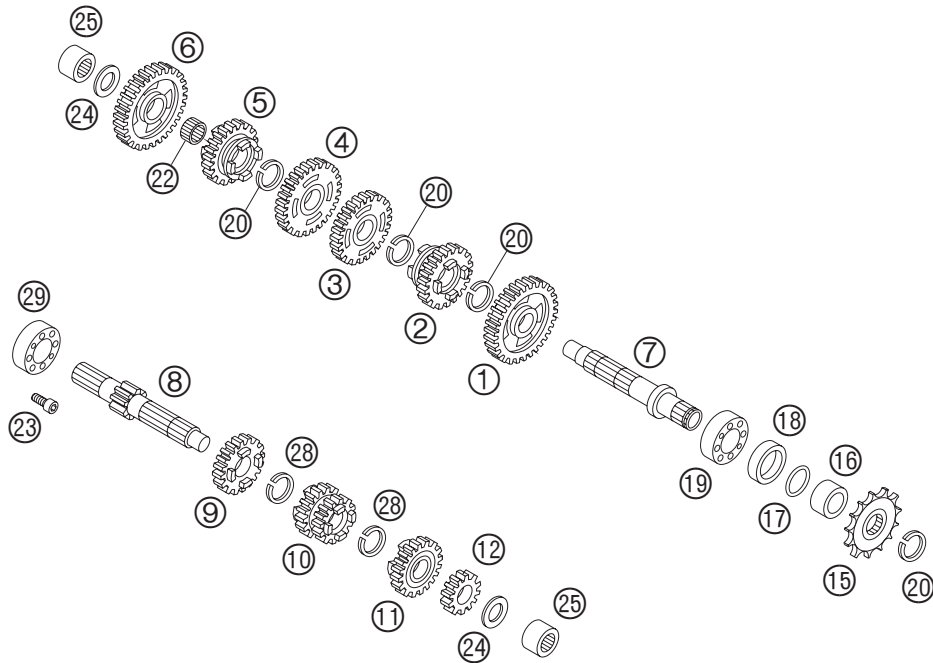

FIG	TEILNR/PARTNR	BEZEICHNUNG	DESCRIPTION	QTY
1	460.33.011.100	LOSRAD 2.GANG 65 SX 2002	IDLER GEAR 2ND GEAR 65 SX 2002	1
2	460.33.012.200	SCHIEBERAD 6.GANG 65 SX 2002	SLIDING GEAR 6TH GEAR 65 SX 02	1
3	460.33.013.100	LOSRAD 3.GANG 65 SX 2002	IDLER GEAR 3RD GEAR 65 SX 2002	1
4	460.33.014.100	LOSRAD 4.GANG 65 SX 2002	IDLER GEAR 4TH GEAR 65 SX 2002	1
5	460.33.015.200	SCHIEBERAD 5.GANG 65 SX 2002	SLIDING GEAR 5TH GEAR 65 SX 02	1
6	460.33.016.200	LOSRAD 1.GANG 65 SX 2002	IDLER GEAR 1ST GEAR 65 SX 2002	1
7	460.33.002.100	ABTRIEBSWELLE 65SX 2001	COUNTER SHAFT 65SX 2001	1
8	460.33.001.000	ANTRIEBSWELLE 13-Z	MAIN SHAFT 13-T	1
9	460.33.007.200	LOSRAD 5.GANG 65 SX 2002	IDLER GEAR 5TH GEAR 65 SX 2002	1
10	460.33.008.200	SCHIEBERAD 3./4.GANG 65SX 2002	SLIDING GEAR 3RD/4TH G.65SX 02	1
11	460.33.009.200	LOSRAD 6.GANG 65 SX 2002	IDLER GEAR 6TH GEAR 65 SX 2002	1
12	460.33.010.000	FESTRAD 2.GANG 16-Z	SOLID GEAR 2ND GEAR 16-T	1
15	460.33.029.013	KETTENRITZEL 13-Z 60/65	SPROCKET 13-T 60/65	X
15	460.33.029.014	KETTENRITZEL 14-Z 65 SX 2002	SPROCKET 14-T 65 SX 2002	1
16	460.33.030.000	DISTANZBÜCHSE KETTENRITZEL	DISTANCE BUSHING SPROCKET	1
17	460.33.031.000	O-RING 18,77X1,78	O-RING 18,77X1,78	1
18	0760 263560	WELLENDICHTRING 26X35X6	SHAFT SEAL RING 26X35X6	1
19	460.33.028.000	RILLENKUGELLAGER 20X42X12	GROOVED BALL BEARING 20X42X12	1
20	490.33.091.000	SEEGERRING AS20X1,75 DIN 471	CIRCLIP AS20X1,75	4
22	460.33.020.000	NADELKRANZ 14X18X8	NEEDLE BEARING 14X18X8	1
23	460.33.023.000	SICH.SCHRAUBE M6X10 SPEZIAL	SPECIAL SCREW M6X10	1
24	490.33.013.000	ANLAUFSCHIEBE 12,1X25X1	STOP DISK 12,1X25X1	2
25	460.33.026.000	NADELLAGER NK12/12A 12X19X12	NEEDLE BEARING NK12 12X19X12	2
28	460.33.022.000	SICHERUNGSRING SW=17X1,2	CIRCLIP WS=17X1,2	2
29	460.33.025.000	RILLENKUGELLAGER SKF98203/C3	GROOVED BALL BEAR.SKF98203/C3	1

02-461.33.4

05-461.33.4

* NEUTEIL / NEW PART X NACH BEDARF / AS REQUIRED

SCHALTUNG » SHIFTING MECHANISM

65 SX / 2005

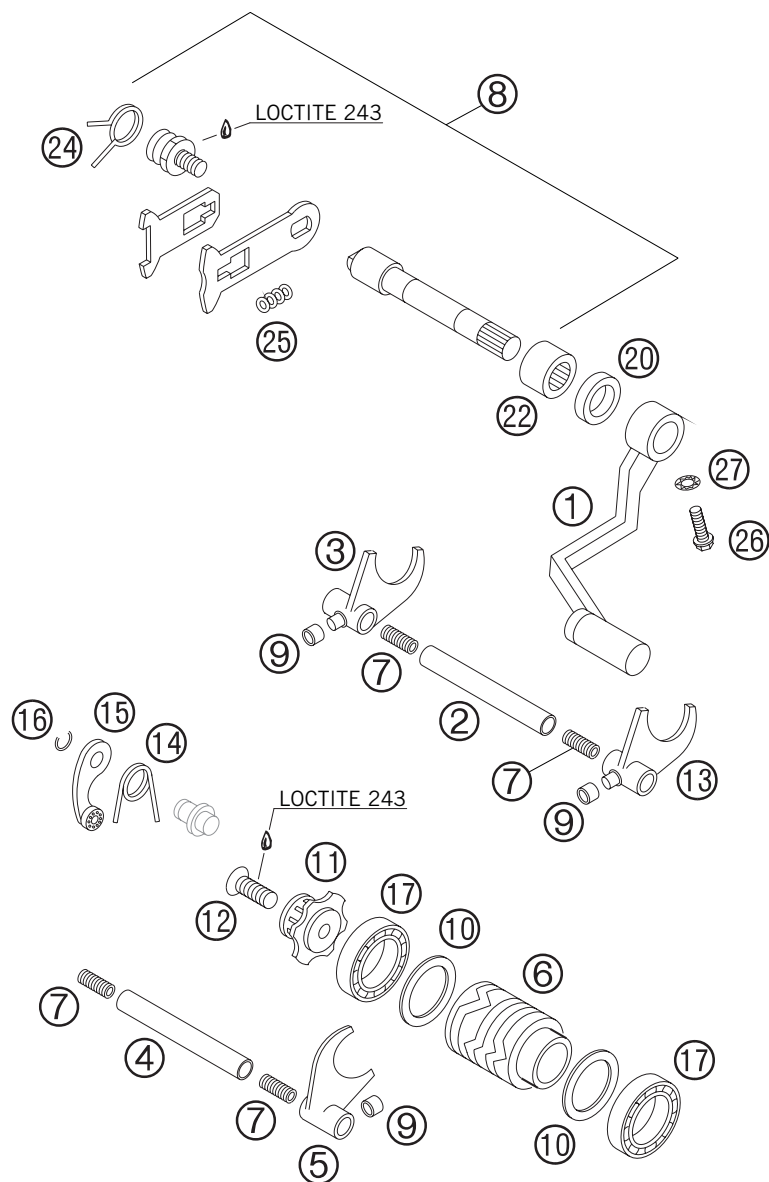

05-461.34.2

FIG	TEILNR/PARTNR	BEZEICHNUNG	DESCRIPTION	QTY
1	460.34.031.100	SCHALTHEBEL KPL. 65 SX 2001	SHIFT LEVER COL. 65 SX 2001	1
2	460.34.020.100	SCHALTSCHIENE 2001	SHIFT RAIL 2001	1
3	460.34.002.100	SCHALTGABEL ABTRIEBSWELLE RE.	SHIFT FORK COUNTERSHAFT R/S	1
4	460.34.019.100	SCHALTSCHIENE 10X72MM 2001	SHIFT RAIL 10X72MM 2001	1
5	460.34.001.100	SCHALTGABEL ANTRIEBSWELLE 2001	SHIFT FORK MAIN SHAFT 2001	1
6	460.34.012.300	SCHALTWALZE 65 SX 2001	SHIFT ROLLER 65 SX 2001	1
7	460.34.019.052	FEDER SCHALTSCHIENE 2001	SPRING SHIFT RAIL 2001	4
8	460.34.005.044	SCHALTWELLE KPL.	SHIFT SHAFT CPL.	1
9	503.34.018.100	SCHALTROLLE 6X8X5,2	SHIFTING ROLLER 6X8X5,2	3
10	460.34.091.100	DISTANZSCHEIBE-SET 2001 0,2/0,5/0,6 MM	SPACER WASHER-SET 2001 0,2/0,5/0,6 MM	1
11	460.34.015.100	SCHALTARRETIERUNG 60/65 2000	SHIFT DRUM LOCATING 60/65 2000	1
12	0991 060303	SENKSCHRAUBE DIN7991-M 6X30	FLAT HEAD SCREW DIN7991-M 6X30	1
13	460.34.002.200	SCHALTGABEL ABTR. 2.3.GANG	SHIFT FORK COUNT. 2.3.GEAR	1
14	460.34.023.100	ARRETIERHEBELFEDER 2001	LOCKING LEVER SPRING 2001	1
15	460.34.024.100	ARRETIERHEBEL KPL. 65 SX 2002	LOCKING LEVER CPL. 65 SX 2002	1
16	0471 100010	SICHERUNGSRING DIN0471-10X1	CIRCLIP DIN0471-10X1	1
17	0625 618050	RILLENKUGELLAGER 61805 C3	BALL BEARING 61805 C3	2
20	0760 122050	WELLENDICHRING 12X20X5 B	SHAFT SEAL RING 12X20X5 B	1
22	460.34.027.000	NADELLAGER 12X18X12 2002	NEEDLE BEARING 12X18X12 2002	1
24	460.34.014.000	RÜCKHOLFEDER	RETURN SPRING	1
25	460.34.009.000	DRUCKFEDER GLEITBLECH	PRESSURE SPRING SLIDER PLATE	1
26	0015 060203	SK.BUNDSCHRAUBE M 6X20 SW=8	HH COLLAR SCREW M 6X20 WS=8	1
27	0797 060003	ZAHNSCHEIBE DIN6797-J 6,4	TOOTH LOCK WASH. DIN6797-A 6,4	1

05-461.34.2

* NEUTEIL / NEW PART X NACH BEDARF / AS REQUIRED

KÜHLSYSTEM » COOLING SYSTEM

65 SX / 2005

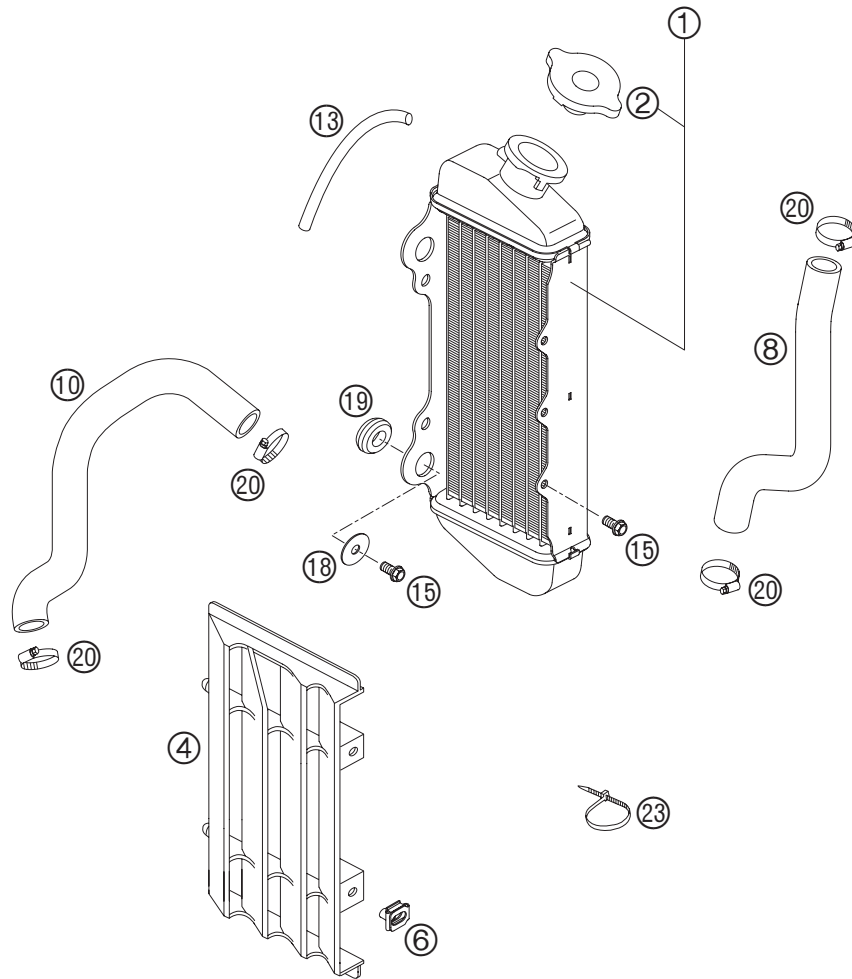

FIG	TEILNR/PARTNR	BEZEICHNUNG	DESCRIPTION	QTY
1	461.35.008.000	KÜHLER 65SX 2002	RADIATOR 65SX 2002	1
2	580.35.016.000	KÜHLERVERSCHLUSS KLEIN 1,4 BAR	RADIATOR CAP SMALL 20,3 PSI	1
4	545.35.034.000	KÜHLERSCHUTZ LI.KURZ 60165	RADIATOR PROTECTOR L/S 60165	1
6	502.35.033.300	KLIPS-MUTTERNHALTER M6 KP142	SNAP-NUT HOLDER M6 KP142	2
8	461.35.026.000	FORMSCHLAUCH ZYL.-KÜHLER 2002	PREFORMED HOSE CYL.-RADI. 2002	1
10	461.35.027.000	FORMSCHLAUCH WAPU-KÜHLER 2002	PREFORMED HOSE WAPU-RADI. 2002	1
13	310.07.107.001	PVC-SCHLAUCH 6X9 MM PER METER	PVC-HOSE 6X9 MM PER METRE	0,12
15	0015 060123	SK.BUNDSCHRAUBE M 6X12 SW=8	HH COLLAR SCREW M 6X12 WS=8	5
18	0021 060003	SCHEIBE DIN 9021 A 6,4	WASHER DIN9021-A 6,4	3
19	410.01.052.000	KABELTÜLLE D=12MM	RUBBER SLEEVE D=12MM	3
20	420.13.037.200	SCHLAUCHBINDER GEMI 12/22	HOSE CLAMP GEMI 12/22	4
23	440.11.076.200	KABELBAND 200/3,6MM SCHWARZ	CABLE TIE 200/3,6MM BLACK	X
23	440.11.076.305	KABELBAND 300/4,8MM SCHWARZ	CABLE TIE 300/4,8MM BLACK	X

05-461.35.0

05-461.35.0

* NEUTEIL / NEW PART

X NACH BEDARF / AS REQUIRED

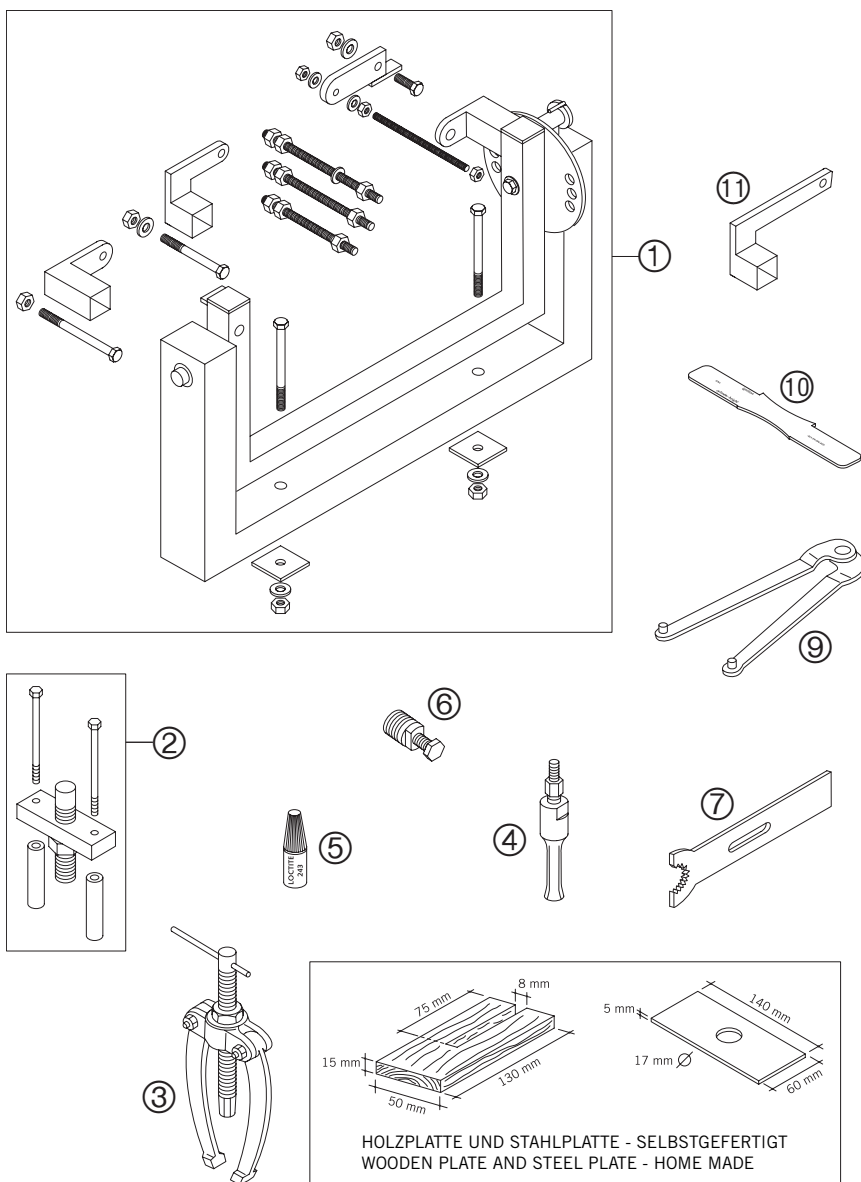

FIG	TEILNR/PARTNR	BEZEICHNUNG	DESCRIPTION	QTY
1	560.12.001.000	UNIVERSALMONTAGEBOCK '96	UNIVERSAL MOUNTING RACK '96	1
2	491.12.008.000	AUSRÜCK-EINZIEHVORRICHTUNG	MOUNTING TOOL	1
3	151.12.017.000	LAGERAUSZIEHER	BUSHING EXTRACTOR	1
4	151.12.018.000	EINSATZ 12-16 MM	INTERN.BEAR.PULLER 12-16 MM	1
5	6 899 785	LOCTITE 243 BLAU 6CCM	LOCTITE 243 BLUE 6CCM	1
6	546.29.009.044	MAGNETABZIEHER M 27X1 KOKUSAN	MAGNETIC PULLER M 27X1 KOKUSAN	1
7	490.12.004.000	HALTER FÜR PRIMÄRRAD	HOLDER FOR PRIMARY WHEEL	1
9	151.12.021.000	HALTESCHLÜSSEL FÜR SCHWUNGRAD	HOLDING WRENCH FOR ROTOR	1
10	461.29.006.100	EINSTELLEHRE 65 SX 2003	ADJUSTING PLATE 65 SX 2003	1
11	460.29.002.000	MOTORHALTER FÜR 60/65 CCM	ENGINE BRACKET FOR 60/65 CCM	1

05-461.29.0

03-461.29.0

* NEUTEIL / NEW PART X NACH BEDARF / AS REQUIRED

A large empty rectangular box with a black border, intended for taking notes.

A large empty rectangular box with a black border, intended for taking notes.

A large empty rectangular box with a black border, intended for taking notes.



KTM-Sportmotorcycle AG
A-5230 Mattighofen
www.ktm.at

KTM Group Partner



3208160



Art.Nr.: 3.208.160

4/2004

Foto: Mitterbauer