

# ASSEMBLY INSTRUCTION









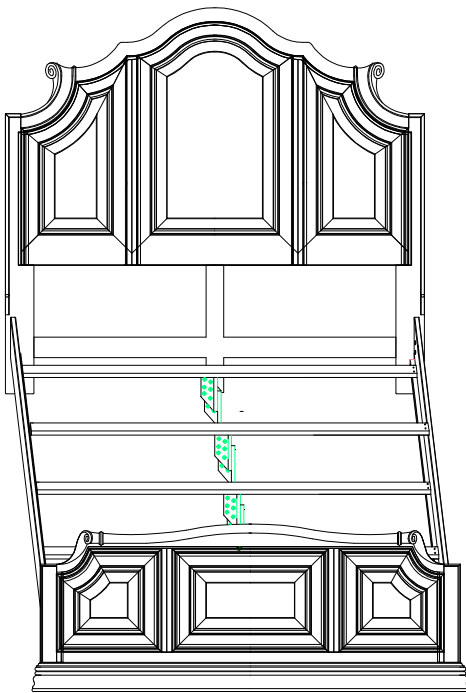



ITEM# 681-90-467 6/6 HEADBOARD

681-90-468 6/6 FOOTBOARD

681-90-469 6/6 RAILS

**Caution: Please make sure you have all the parts indicated below prior to assembly. This unit is heavy and can best be assembled with the help of two or more person.**



NO.	HARDWARE LIST		Q'TY
E		NUT	8
F		$\frac{3}{8}$ " LOCK WASHER	8
G		$\frac{3}{8}$ " FLAT WASHER	8
H		CURVED WASHER	8
I		SPANNER WRENCH	1
J		FULL THREADED BOLT	8
K		SCREW	16
R		4mm ALLEN WRENCH	1
Q		1/4" BOLT	8
V		1/4" LOCK WASHER	8
U		1/4" FLAT WASHER	8
M		5mm ALLEN WRENCH	1

## Assembly steps:

1. Insert 2 Bolts (J) into the holes of each posts on Headboard (A) and Footboard (B), attach each end of Side Rails (C) to the Bolts (J) on the posts using 2 Curved Washers (H), 2 Flat Washers (G), 2 Lock Washers (F) and 2 Nuts (E), tighten the Nuts (E) securely with Spanner (I), see Diagram 1.

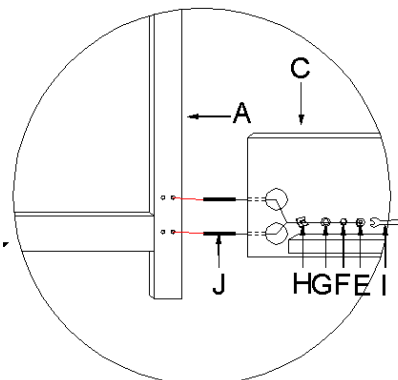

**Diagram 1**

2. Attach the Center Support (L) to the slat using 2 Bolts (Q), 2 Lock Washers (V) and 2 Flat Washers (U) securing the Bolt (Q) by Allen Wrench (R) as shown in Diagram 2.

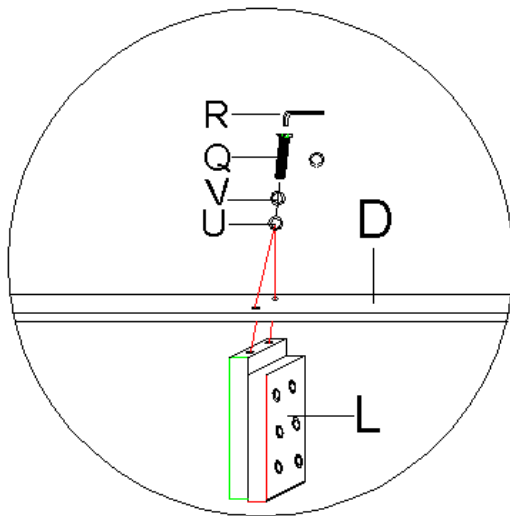

**Diagram 2**

3. Attach the Slats (D) to the Side Rails (C), align the holes pre-drilled on the slat with the holes on the cleat on the Side Rail (C), turn the Screws (K) and tighten it, see Diagram 3.

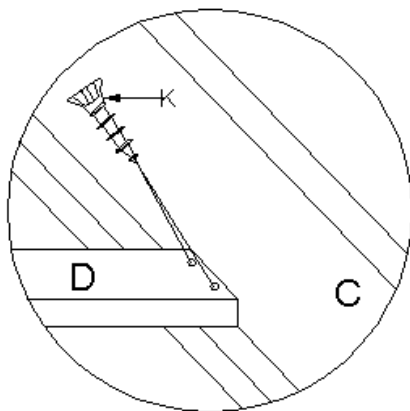

**Diagram 3**

Note: You can change the height of the slat by adjusting the height of the cleat on the side rail as shown in diagram 4, remove the Bolt (N), Lock Washer (O) and Flat Washer (P) from the cleat by turning the Bolt (N) with Allen wrench (M) in anti-clockwise direction, adjust the cleat to a desired position, and then secure the lock washer, flat washer, bolt in a clockwise direction by turning with Allen wrench.



**Diagram 4**

You can adjust the height show as in Diagram 5 to meet your need by the following steps.

1. Unscrew the bolts on the center support with Allen Wrench (R).
2. Adjust the height of the center support, align the holes on 2pcs woods and tighten them together with 2 bolts(S), 2 lock washer (V) and two flat washer (U) by turning with Allen Wrench(R) in a clockwise direction.

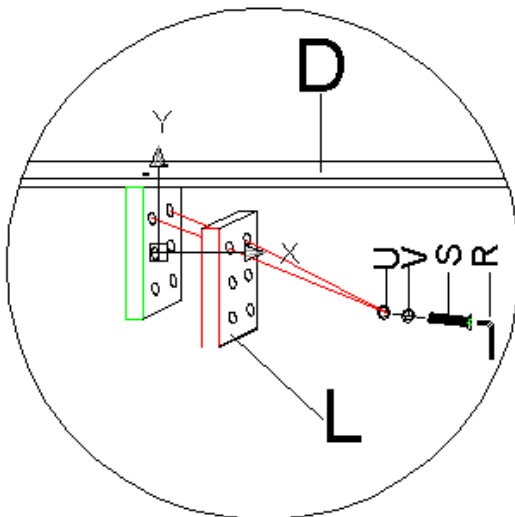

**Diagram 5**

**Cleaning Instruction:** Clean finished parts with a mild dishwashing liquid and water solution on a damp cloth. Polish the finish with soft cloth and an industry recognized furniture polish.