

Treker

4220ST & 4420ST Light Utility Vehicles



24700

700-504M **Operator's Manual**



Read the Operator's manual entirely. When you see this symbol, the subsequent instructions and warnings are serious - follow without exception. Your life and the lives of others depend on it!



© Copyright 2007 Printed 8/05/08

Cover photo may show optional equipment not supplied with standard unit.

Section 1: Introduction	1	Section 5: Options and Accessories	23
Safety First	1	Treker Options	23
Using This Manual	1	Front Bumper	23
Terminology	1	Heavy Duty Brush Guard	23
Definitions	1	Tires	23
Application	1	Treker Accessories	24
Models Covered	1	Section 6: Maintenance	25
Getting Acquainted with your Treker	1	General Maintenance	25
Owner Assistance	2	Securing Vehicle for Maintenance	25
Serial Number Plate	2	Torque Values	25
Section 2: Important Safety Information	3	Tire Maintenance	25
Look For The Safety Alert Symbol	3	Jacking the Vehicle	26
Be Aware of Signal Words	3	Shock Absorber Adjustment	26
Safe Operating Procedures	5	Electrical System	27
Personal Safety	5	Battery	27
Mechanical Safety	5	Adding Water to the Battery	28
Transporting Safety	6	Charging the Battery	28
Towing Safety	7	Jump Starting the Battery	28
Safe Load Capacities	7	Fuel System	29
Safety Decals	8	Engine Maintenance	30
Section 3: Pre-Delivery and Check List	13	General Information	30
Pre-Delivery Certificate	13	High Altitude Carburetor Kit	30
Vehicle Information	13	Drive Belt Replacement	31
Dealer Service and Inspection List	13	Driven Pulley Maintenance	31
Dealer Test Ride List	14	Engine Air Filter Maintenance	32
Dealer Delivery To Customer List	14	Engine Air Filter Handling	32
Customer Acceptance List	14	CVT Snorkel Filter Maintenance	33
Section 4: Operating Instructions	15	Exhaust System	34
Operator Responsibilities	15	Spark Arrester	34
Pre-Start Check List	15	Park Brake Adjustment	35
General Operation	15	Maintenance Schedule	36
Indicating Lights and Gauges	16	Section 7: Lubrication	37
Switches	16	Engine Oil	37
Choke	17	Case Oil	39
Floor Pedals	17	Rear Trans-axle Case	39
Shift Selector and Park Brake	17	Center Transfer Case	40
Fuel Gauge	18	Front Differential Case	40
Seat Belts	18	Brake Fluid	41
Cup Holders	18	Section 8: Seasonal Storage	42
Glove Box Enclosure	19	Section 9: Body Repair	43
Cargo Box / Flat Bed Set-Up	19	Section 10: Specifications and Capacities ..	45
Towing	20	Section 11: Features and Benefits	46
Engine Performance	20	Section 12: Troubleshooting	47
Fuel Quality	20	Section 13: Appendix	51
Incomplete Combustion	20	Torque Values Chart	51
Cold Weather Operation	20	Tire Inflation Chart	51
Traveling Tips From the Trail Masters	21	Notes	52
		Land Pride Limited Warranty	53

© Copyright 2007 All rights Reserved

Land Pride provides this publication "as is" without warranty of any kind, either expressed or implied. While every precaution has been taken in the preparation of this manual, Land Pride assumes no responsibility for errors or omissions. Neither is any liability assumed for damages resulting from the use of the information contained herein. Land Pride reserves the right to revise and improve its products as it sees fit. This publication describes the state of this product at the time of its publication, and may not reflect the product in the future. The illustrations in this manual are not intended for safe and proper assembly or disassembly of equipment. The illustrations are intended for ordering parts only.

Land Pride is a registered trademark.
 Weather Pro G is a registered trademark of Spartech Plastic
 All other brands and product names are trademarks or registered trademarks of their respective holders.

Printed in the United States of America.

Section 1: Introduction

Land Pride welcomes you to its growing family of new product owners. Treker series trucks are light utility vehicles that have been designed with care and built by skilled workers using quality materials. Proper set-up, maintenance and safe operating practices will help you get years of satisfactory use from this vehicle.

Safety First

Land Pride is fully aware of the need for safe operating procedures around all of our equipment. We hope you will make a sincere effort to put safety above all other priorities. The Trekers are designed and built for work, recreation and enjoyment; however, improper and irresponsible operation could result in serious injury or death. Since this is an off-road vehicle, operators will seldom see road safety and warning signs they are accustomed to seeing on highways and public streets. This places additional responsibility on the driver to operate this vehicle well within safe operational limits and capabilities of the unit.

This manual has been prepared to instruct you in the safe and responsible operation of your Treker. Please read and abide by all safety alert information about this vehicle. If you do not understand any part of this manual, contact your local dealer for additional information and clarification. As the operator of this piece of equipment, you are in complete control. Only you can prevent an accident from happening!

Using This Manual

- Prior to any vehicle operation it is absolutely essential that you read and comprehend each section in this manual to develop an understanding of your vehicle and safety practices. After reviewing this manual, store it in a dry and easily accessible place for future reference.
- The Operator's Section is designed to help familiarize you with safety, assembly, operation, adjustments, troubleshooting and maintenance. Read this manual and follow recommendations to help ensure safe and efficient operation.
- The information contained within this manual was current at the time of printing. Some parts may change slightly to assure you of the best performance.
- To order a new Operator's or Parts Manual contact your authorized dealer. Manuals can also be downloaded, free-of-charge from our website at www.landpride.com or printed from the Land Pride Service & Support Center by your dealer.

Terminology

Right-hand and left-hand as used in this manual are determined by facing the direction the vehicle will travel while in use unless otherwise stated.

Definitions

The following terms are used throughout this manual.

IMPORTANT: A special point of information related to its preceding topic. Land Pride's intention is that this information should be read and noted before continuing.

NOTE: A special point of information that the operator must be aware of before continuing.

Application

Models Covered

4220ST 4x2 and 4420ST 4x4

Getting Acquainted with your Treker

The Treker line of light utility vehicles is designed by Land Pride exclusively for off-road use. They are not designed for, nor are they properly equipped to be safely operated or licensed for use on public streets and highways. These vehicles are designed to carry two to three people and a limited amount of gear or cargo comfortably and safely over rough or difficult off road terrain.

The wide stance ST series is designed to carry three passengers on the bench seat and 900 lbs. of cargo in its 15.9 cu-ft. capacity dumping cargo box for a total payload capacity of 1,300 lbs. The wide stance, long wheelbase, and high payload make the ST series Trekers a strong and stable workhorse for ranches, farms, and construction sites.

The 4220ST series (4x2) is equipped with two wheel traction drive and the 4420ST series (4x4) is equipped with four wheel traction drive. Both series have an automotive steering wheel with easy handling rack-and-pinion steering, four wheeled independent suspension, McPherson Struts, large diameter hi-flotation tires, and high center-frame ground clearances that add up to excellent stability and smooth ride over tough terrain. The 4420ST series feature our Command Track four wheel drive system with over-running clutches on the front differential for unexcelled traction, easy handling and minimal disturbance to the turf. These models also feature Auto-Lock rear differentials with over-running clutches and sealed torque converters for absolute maximum traction capability in wet or slippery conditions. Seat belts for two passengers are standard. An additional seat belt may be added for the center third person.

Section 1: Introduction

Driving a Treker is as easy as driving a pickup with an automatic transmission. A simple forward and reverse shifter provides direction control. A neutral start feature and keyed 12-volt electronic ignition make for safe and easy starting. We have even provided a manual choke control with spring-loaded return for quicker cold weather starting. The infinitely variable torque converter drive system means there is no clutching; you just shift into either forward or reverse and step on the throttle pedal to go at speeds up to 25 mph. All Trekers are powered by highly reliable and proven 20 hp. Honda engines that are EPA certified and meet California Air Resources Board (CARB) certification standards.

Braking is accomplished by simply depressing the brake pedal located on the floorboard. This activates the rear hydraulic drum brakes and front mounted disc brakes.

The park brake is incorporated into the dash-mounted shifter so when you put the vehicle in park you simultaneously set the park brake. All models come with a very strong 4-post accessory bar that provides extra protection against low hanging limbs and brush as well as providing a mounting system for accessories such as windshields, canopy tops, and weather enclosures. The 4-post accessory bar also provides a mounting base for accessories such as cargo racks, gun and bow racks, back screens, tree stands, and camping or fishing gear and tool holders. A standard rear receiver enables quick installation of a hitch to pull small trailers full of supplies, tools, gear, or game.

Owner Assistance

The safety video should be viewed by the owner and the Warranty Registration card should be filled out by the dealer at the time of purchase. The owner should also receive a copy of the safety video upon purchasing the vehicle as well as have participated in a short drivers training course with the dealer. This information is necessary to provide you with quality customer service.

The parts on your Treker Light Utility Vehicle have been specially designed and should only be replaced with genuine Land Pride parts.

If customer service or repair parts are required contact a Land Pride vehicle dealer. They have trained personnel, genuine repair parts and equipment specially designed to repair Land Pride products.

Serial Number Plate

Refer to Figure 1:

Always use serial and model number when ordering parts from your Land Pride dealer. The serial-number plate is located on the driver's side just left of the rear tail light as shown in figure 1 below.



**Serial Number Plate
Figure 1**

Record your vehicle model number (4220ST or 4420ST) and serial number here for quick reference:

Model Number: _____

Serial Number: _____

Your Land Pride dealer wants you to be satisfied with your new vehicle. If you do not understand any part of this manual or are not satisfied with the service received, please take the following actions.

1. Discuss the matter with your dealership service manager. Make sure they are aware of any problems so they can assist you.
2. If you are still unsatisfied, seek out the owner or general manager of the dealership.
3. For further assistance write to:

Product Support

Land Pride Service Department
1525 East North Street
P.O. Box 5060
Salina, Ks. 67402-5060

E-mail address
lpservicedept@landpride.com

Section 2: Important Safety Information

IMPORTANT: Read and understand all pages in this manual thoroughly before operating your vehicle.

These are common practices that may or may not be applicable to the products described in this manual.

Look For The Safety Alert Symbol

The SAFETY ALERT SYMBOL indicates there is a potential hazard to personal safety involved and extra safety precaution must be taken. When you see this symbol, be alert and carefully read the message that follows it. In addition to design and configuration of equipment, hazard control and accident prevention are dependent upon the awareness, concern, prudence and proper training of personnel involved in the operation, transport, maintenance and storage of equipment.



Be Aware of Signal Words

A signal words designate a degree or level of hazard seriousness. The signal words are:

DANGER

DANGER indicates an imminently hazardous situation which, if not avoided, will result in serious or death injury. This signal word is limited to the most extreme situations, typically for vehicle components that, for functional purposes, cannot be guarded.

WARNING

WARNING indicates a potentially hazardous situation which, if not avoided, could result in death or serious injury, and includes hazards that are exposed when guards are removed. It may also be used to alert against unsafe practices.

CAUTION

CAUTION indicates a potentially hazardous situation which, if not avoided, may result in minor or moderate injury. It may also be used to alert against unsafe practices.

For Your Protection

- ▲ Thoroughly read and understand the instructions given in this manual before operation. Refer to the "Safety Label" section, read all instructions noted on the decals.
- ▲ Do not allow anyone to operate this equipment who has not fully read and comprehended this manual and who has not been properly trained in the safe operation of the equipment.

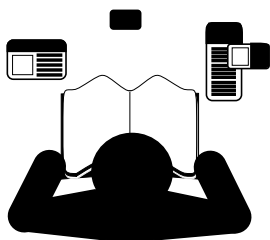

Before Operating

- ▲ This Treker Light Utility Vehicle is not to be driven on public roads.
- ▲ Do not operate this vehicle under the influence of alcohol or drugs.
- ▲ Always inspect the vehicle before operating it. See "Pre-Start Check List" on page 15.

- ▲ Do not operate this machine unless all safety shields are in place and all badly worn, broken or missing parts have been properly replaced.
- ▲ Wear appropriate protective gear and clothing such as safety helmet, goggles, gloves, coveralls, etc., when conditions warrant.
- ▲ No driver under age of 16.

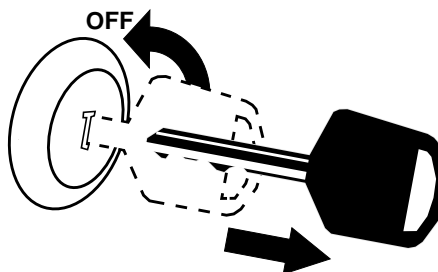

Table of Contents

Section 2: Important Safety Information

These are common practices that may or may not be applicable to the products described in this manual.

Practice Safe Maintenance

- ▲ Understand procedure before doing work. Use proper tools and equipment. Refer to this manual for additional information.
- ▲ Work in a clean, dry area.
- ▲ Place the vehicle in neutral, set parking brake, turn off engine and remove key before performing maintenance. Chock wheels if you must perform maintenance on a slope.

- ▲ Make sure all moving parts have stopped and all system pressure is relieved.
- ▲ Allow the engine to cool completely.
- ▲ Disconnect battery ground cable (-) before servicing or adjusting electrical systems or before welding.

- ▲ Inspect all parts. Make sure parts are in good condition and installed properly.
- ▲ Remove build-up of grease, oil or debris.
- ▲ Remove all tools and unused parts from the Treker before operation.

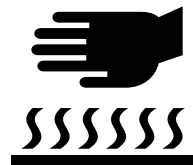
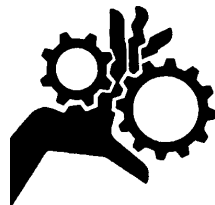
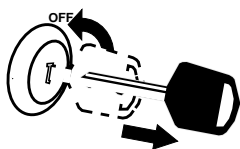

Prepare for Emergencies

- ▲ Be prepared if a fire starts.
- ▲ Keep a first aid kit and fire extinguisher handy.
- ▲ Keep emergency numbers for doctor, ambulance, hospital and fire department near phone.

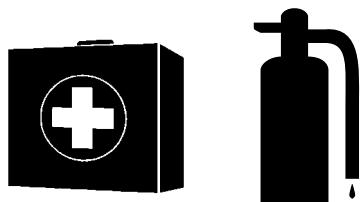

Wear Protective Equipment

- ▲ Wear protective clothing and equipment.
- ▲ Wear clothing and equipment appropriate for the job. Avoid loose-fitting clothing.
- ▲ Because prolonged exposure to loud noise can cause hearing impairment or hearing loss, it is best to wear suitable hearing protection such as earmuffs or earplugs.
- ▲ Because operating equipment safely requires your full attention, avoid wearing radio headphones while operating machinery.
- ▲ It is the discretion of the operator and passenger to wear Seat Belts when available.

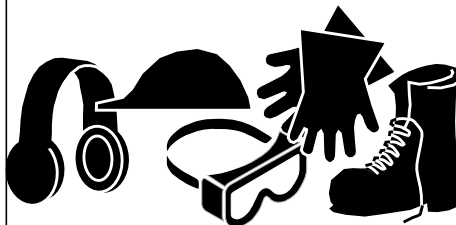

Tire Safety

Tire changing can be dangerous and should be performed by trained personnel using correct tools and equipment.

- ▲ When inflating tires, use a clip-on chuck and extension hose long enough for you to stand to one side—not in front of or over tire assembly. Use a safety cage if available.
- ▲ When removing and installing wheels, use wheel-handling equipment adequate for weight involved.



Section 2: Important Safety Information

Safe Operating Procedures

The safe operation of any machinery is a big concern to all consumers. Your Treker has been designed with many built-in safety features. However, no one should operate this vehicle before carefully reading this Operator's Manual. Also read all instructions noted on the safety decals.

Personal Safety

- ▲ Be familiar with all functions of this vehicle.
- ▲ Do not allow anyone to operate this vehicle who has not fully read and comprehended this manual and who has not been properly trained in the safe operation of this vehicle.
- ▲ Do not operate vehicle while drinking or under the influence of alcohol or drugs.
- ▲ Do not allow anyone under 16 years of age to operate this vehicle even under adult supervision.
- ▲ Do not run engine indoors except when starting engine and transporting attachment in or out of a building. Carbon monoxide gas is colorless, odorless and deadly.
- ▲ Operator must always use both hands on the steering wheel.
- ▲ Keep all bystanders away from this vehicle during operation. Keep children out of the operating area and under the watchful eye of another responsible adult.
- ▲ Riders may, without knowing it, place their foot on the accelerator pedal while bracing themselves against a rough ride. This makes it impossible to slow down the vehicle until the passenger removes his foot from the pedal. Inform passenger to keep his foot off the accelerator and always slow down before the ride gets rough.
- ▲ Operator and passenger are responsible for deciding if their situation warrants using seat belts if so equipped.
- ▲ No riders are allowed except in factory designed and supplied seating and no more than one person in a bucket seat and three people in a bench seat. Do not use cargo bed for carrying people. Maximum vehicle occupancy including driver is one person per seat position.
- ▲ Operate vehicle from driver's seat only.
- ▲ Do not leave vehicle unattended with engine running.
- ▲ Do not dismount a moving vehicle as serious injury or death could occur.
- ▲ Wear snug-fitting clothing to avoid entanglement with moving parts.
- ▲ Keep hands, feet, long hair, clothing and jewelry away from moving parts and obvious pinch points to avoid getting caught.

- ▲ Keep hands, arms, feet and all bodily appendages safely inside the confines of the vehicle. Always be aware of and avoid tree limbs and brush that have a potential of hitting and/or poking individuals riding the vehicle. Serious body harm could result.
- ▲ Some conditions may warrant extra safety gear to be worn such as safety helmets and/or goggles.
- ▲ Do not touch engine, engine exhaust pipe and/or muffler while they are hot.
- ▲ Avoid pinch point hazards. Cargo bed and seat platform hinge creating pinch points.
- ▲ Battery fumes are explosive. A spark will ignite battery fumes. Wear a face shield when charging or jumping a battery. Follow all battery safety rules outlined in this manual.
- ▲ Avoid battery acid spills. Do not get battery acid on eyes, face, or other body parts. Flush eyes and other body parts immediately with water for at least 15 minutes if battery acid has gotten on them.
- ▲ When refueling use a UL approved nonmetallic container that has no screen or filter. Set container on the ground before fueling to eliminate static discharge and do not use Methanol fuel.
- ▲ Do not smoke or use electrical devices including cell phones while refueling.
- ▲ Support this vehicle securely before working beneath. Chock wheels to prevent vehicle from rolling.

Mechanical Safety

- ▲ Do not operate a vehicle with damaged or worn parts. Repair all damages and worn parts before putting vehicle back in to service.
- ▲ Never attempt to make any adjustments while engine is running or hot. Keep clear of all rotating parts.
- ▲ Make sure engine surface, cooling fins and fan screen are clean of all debris including dirt, trash and oil.
- ▲ Always operate vehicle with drive belt enclosure installed. Do not leave pulleys and belts exposed.
- ▲ Never modify any parts on the vehicle without authorization. Unauthorized modifications will void warranty to all parts directly and indirectly affected by the modification.
- ▲ Do not use cargo tail gate as a seat.
- ▲ Do not use cargo bed as a working platform.
- ▲ The power lift is designed to dump cargo only. Do not use it to lift other objects.
- ▲ Never attempt "wheelies", jumps, or other stunts. Never drive recklessly. Always operate your vehicle at a safe speed that will allow you to maintain control.
- ▲ Do not use vehicle as an anchor device.

Section 2: Important Safety Information

- ▲ Do not mount a receiver hitch type carrier platform to the vehicle.
- ▲ Front bumper, brush guards and cargo box are not designed as pusher bars. Do not attempt to push other vehicles or implements or damage may result.
- ▲ Always maintain proper tire inflation. See "Tire Maintenance" on page 25.
- ▲ Always disconnect negative battery terminal before making adjustments to vehicle electrical system or welding on this vehicle.
- ▲ Always check wheel lug nut torque values two hours after initial operation and two hours after each tire repair or replacement. Routinely check lug nut torque every 100 hours of operation. See "Wheel Lug Nuts" on page 25.
- ▲ Do not shift trans-axle unless this vehicle is fully stopped and engine is at idle or damage may occur.
- ▲ Keep safety decals clean of dirt and grime.
- ▲ Replace all missing, illegible, or damaged safety decals. See list of safety decals in this manual.
- ▲ Do not load 4-post accessory bar with heavy equipment. Rollover could result from such loading.
- ▲ Always park on level ground, stop engine, set park brake (see "Shift Selector and Park Brake" on page 17) and remove ignition key before leaving vehicle. Chock tires if condition warrants.
- ▲ Use extreme caution when cresting hills, approaching blind corners, shrubs, trees or other obstructions that might limit visibility. Proceed slowly until you are sure trail conditions immediately ahead are safe. Use extra care when approaching obstructions that might hide children.
- ▲ Be especially observant of operating area and terrain. Watch for holes, rocks, or other hidden hazards. Do not operate vehicle near the edge of drop-offs or banks.
- ▲ Keep front wheels straight when cresting hills or going over bumps.
- ▲ Do not stop, start suddenly or over accelerate on hills. Loss of control and rollover could result.
- ▲ Use extreme caution when descending hills, running on loose slippery surfaces, or when towing at maximum capacity. Towing, braking and tractive capabilities are greatly diminished.

Transporting Safety



WARNING

Most accidents with off road vehicles occur when traveling up, down, or across the face of a slope. Refer to operation instructions and safety video for proper operation procedures.

- ▲ Use extreme caution when driving through dry grass, brush and other fire hazard materials. Never stop or park over combustible materials. Keep grass and brush from collecting on and around engine and muffler parts.
- ▲ Be aware of cargo shifting when stopping or moving. Make sure all cargo is properly secured and tied down. Injury could result from loose cargo.
- ▲ Avoid sudden stops, starts and turns.
- ▲ Always make sure vehicle pathway is clear of all objects when backing up. Know location of persons around vehicle and especially location of small children. Take extra precautions when rear view is hindered by cargo.
- ▲ Do not attach an implement, trailer or other device to the hitch that will produce negative tongue weight.
- ▲ Reduce speed and payload on hilly, rough, wet, slick or unstable ground.
- ▲ Reduce speed when loaded with cargo. Heavy cargo load takes longer to stop.
- ▲ Always make turns at a speed that will maintain control of vehicle. Never make turns at full speed. Reduce speed when turning empty and reduce speed even more when turning loaded. The heavier the cargo load, the slower the turn should be.
- ▲ The 4-post accessory bar is not a certified ROPS (Roll Over Protection System). Always avoid roll-overs.
- ▲ Avoid changing direction or making sharp steering corrections on slopes or rollover may occur.
- ▲ If this vehicle begins to tip when crossing a slope, turn front wheels downhill to regain stability and control.
- ▲ Do not operate vehicle on slopes over 15°.
- ▲ When crossing a slope on soft terrain, turn front wheels slightly uphill and maintain a constant speed to maintain a straight line of travel.
- ▲ When descending hills or slopes apply steady pressure to the foot brake to avoid potential of freewheeling or runaway.
- ▲ Never allow vehicle to coast or free wheel in neutral or loss of control may result.
- ▲ If your vehicle loses power and stops on a hill, immediately engage foot brake and back slowly down the hill maintaining a straight downhill line of travel. Do not attempt to turn vehicle sideways on the hill or a rollover could result.
- ▲ Never operate vehicle without good visibility and lighting. When traveling at night always use your headlights and reduce speed according to visibility, trail and terrain conditions.
- ▲ Do not operate this vehicle on highways, public roads, or where it may be a hazard to faster moving traffic.
- ▲ Exercise extreme caution when operating on or crossing a gravel drive, walks, or roads. stay alert for hidden hazards or traffic.

Section 2: Important Safety Information

- ▲ Avoid water crossings when possible and never cross a body of water where depth is unknown. Loss of power will occur if drive belt becomes submerged or wet. Unnecessary crossing of streams and waterways erodes shore line and damages water-born habitat. If you must cross, do it at a point where banks are not steep and proceed at a slow and steady speed. Do not travel in water that is higher than the bottom wheel lug nuts. Water higher than the bottom wheel lug nut can damage the brake system and get the drive belt wet stalling the vehicle. However, *intermittent* stream crossings where depth of water briefly comes into contact with bottom of floorboards is acceptable. See "**Going Out on the Trail**" Note 7 on page 21.
- ▲ Never use vehicle for racing and never modify engine to exceed 25 MPH vehicle speed.

Towing Safety

- ▲ Follow all towing instructions in this manual when towing the Treker behind another vehicle. Do not tow the vehicle faster than 25 MPH. See "Towing" on page 20.
- ▲ Beware, tow ropes, cables and chains can break when pulling another vehicle or object causing serious injury or death to anyone in line with the whipping action created when they break. Never jerk when pulling, always ease into a pull gently. Always stay clear of tow line. Never be in line with tow line.

Safe Load Capacities

Refer to Vehicle Specifications on page 45:

- ▲ Do not exceed total payload capacity of this vehicle.
- ▲ Do not pull a trailer or implement exceeding maximum towing capacity and/or maximum tongue weight. Loss of control may result.
- ▲ Do not exceed front cargo rack carrying capacity.
- ▲ Do not exceed rear cargo box payload capacity.

Section 2: Important Safety Information

Safety Decals

Your Treker comes equipped with all safety labels in place. They were designed to help you safely operate your implement. Read and follow their directions.

1. Keep all safety decals clean and legible.
2. Replace all damaged or missing decals. Order new safety decals through your Land Pride dealer.
3. Some new equipment installed during repair requires safety labels to be affixed to the replaced component as specified

- by Land Pride. When ordering new parts or components, also request corresponding safety decals.
4. Refer to this section for proper label placement. Install new decals as follows
 - a. Clean area on which decal is to be placed.
 - b. Spray soapy water on the surface where decal is to be placed.
 - c. Peel backing from decal. Press firmly on surface, being careful not to cause air bubbles under decal.
 - d. Squeeze out air bubbles with edge of a credit card.

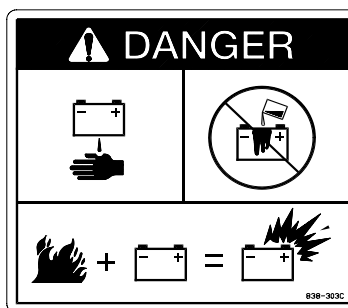

838-303C

Danger: Battery



818-543C

Danger: Guard Missing

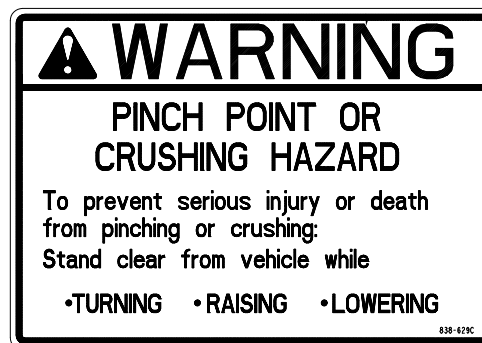

838-629C

Warning: Pinch Point or Crushing Hazard

Section 2: Important Safety Information



WARNING

- VEHICLE ROLLOVER could cause severe injury or death. This cab frame is not designed or intended to provide rollover protection.

838-532C

838-532C

Warning: Cab Rollover Protection



CAUTION

Exceeding rated current of 12V 20A can damage electrical system.

POWER SOURCE MAX. 12V 20A

838-492C

838-492C

Caution: Maximum Power Source



CAUTION

Before leaving vehicle:

- Stop engine
- Set park brake
- Remove key

818-490C

838-490C

Caution: Stop Engine

Table of Contents

Section 2: Important Safety Information

 **WARNING**

To prevent serious injury or death:

- Read and understand Operator's Manual before using and review annually.
- Do not operate without proper training or instructions.
- Operate only with guards installed and in good condition.
- Keep away from moving parts.
- NEVER operate with passenger – except in seat or seats provided (one person per seat position), passengers affect balance and steering and increase risk of losing control.
- Support vehicle securely before working beneath.
- Keep arms, legs, loose clothing and other appendages inside vehicle at all times.
- Do not operate vehicle in a dangerous manner. When ascending or descending hills – travel slowly, travel straight up and down, and avoid turning if possible.
- Use caution and slow down when approaching wet, loose, slippery surfaces or unfamiliar terrain.
- Avoid sudden stops, starts, turns or direction so as not to shift your load, endanger passengers, or lose control of the vehicle.
- Under all day or night travel conditions: operate this vehicle at speeds that will permit it to be brought to a stop in a safe manner.
- Prior to each use: inspect tires, engine oil level, brakes steering mechanism and overall vehicle condition. If any problem exists, DO NOT OPERATE vehicle until safe operation can be restored.
- DO NOT EXCEED PAYLOAD recommendations and avoid loads which can not be centered and secured.
- This vehicle is built for off-road use only at speeds NOT TO EXCEED 25 mph. Any attempt to make unauthorized modifications of the original manufacturer's design will make the modifying party immediately and totally responsible, henceforth, for meeting compliance with all applicable Federal, State and Local laws, guidelines and regulations.

Si no lee ingles, pida ayuda a alguien que si lo lea para que le traduzca las medidas de seguridad.

838-486C REV. A

838-486C

Warning: General Utility Vehicle



Section 2: Important Safety Information



⚠ WARNING
<p>OVER-LOADING can cause loss of control. Loss of control can result in severe injury or death.</p> <p>4X2 ST CURB WEIGHT: 925 LBS.</p> <p>TOTAL PAYLOAD CAPACITY: 1300 LBS <small>ACCESSORIES, PASSENGERS + CARGO</small></p> <p>TOTAL BOX PAYLOAD CAPACITY: 900 LBS</p> <p>GROSS VEHICLE WEIGHT (GVW): 2225 LBS.</p> <p>NEVER exceed the Maximum Vehicle Load Rating.</p> <p style="text-align: right;"><small>838-570C REV. C</small></p>

838-570C

Vehicle Loading Capacities, 4220ST Series

⚠ WARNING
<p>OVER-LOADING can cause loss of control. Loss of control can result in severe injury or death.</p> <p>4X4 ST CURB WEIGHT: 1050 LBS.</p> <p>TOTAL PAYLOAD CAPACITY: 1300 LBS <small>ACCESSORIES, PASSENGERS + CARGO</small></p> <p>TOTAL BOX PAYLOAD CAPACITY: 900 LBS</p> <p>GROSS VEHICLE WEIGHT (GVW): 2350 LBS.</p> <p>NEVER exceed the Maximum Vehicle Load Rating.</p> <p style="text-align: right;"><small>838-663C REV. A</small></p>

838-663C

Vehicle Loading Capacities, 4420ST Series

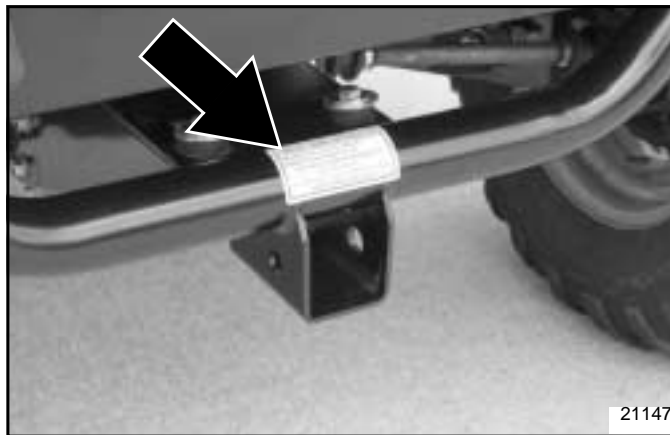

TRAILER TOWING INFORMATION
<p>MAXIMUM Towing Capacity: 1000 LBS.</p> <p>MAXIMUM Tongue Weight: 100 LBS.</p> <p style="text-align: center;">TOW LOAD AT A SPEED SLOW ENOUGH TO MAINTAIN CONTROL.</p> <p style="text-align: center;">DO NOT EXCEED TOWING CAPACITY OR TONGUE WEIGHT. DAMAGE CAN OCCUR.</p> <p style="text-align: right;"><small>838-579C</small></p>

838-579C

Trailer Towing Information

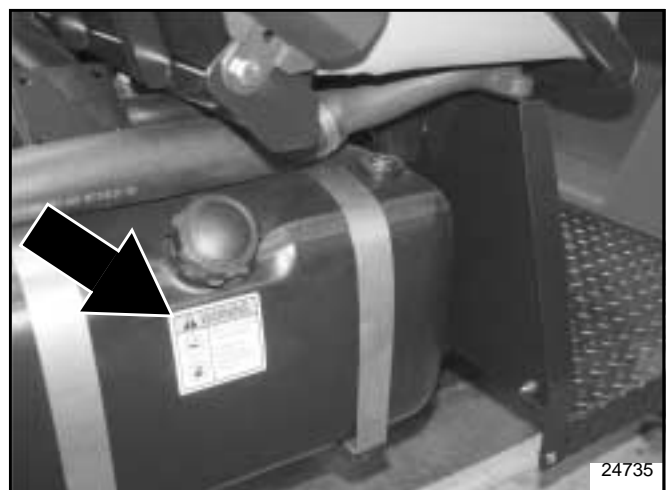

⚠ WARNING
<div style="display: flex; align-items: center;"> <div style="margin-right: 10px;">  </div> <div> <p>BEFORE FILLING TANK WITH GASOLINE.</p> <ul style="list-style-type: none"> • Let engine cool. • Gas vapors can ignite and explosion can occur. </div> </div> <p style="text-align: right;"><small>838-508C</small></p>

838-508C

Warning: Before Filling Tank with Gasoline

Table of Contents

Section 2: Important Safety Information



838-491C

Warning: Improper Use



838-489C

Warning: Rollover Hazard

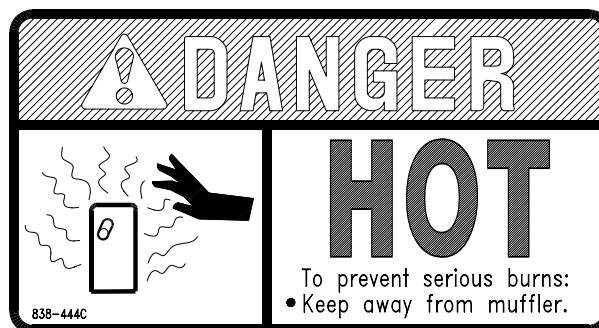

838-444C

Danger: Muffler hot



Section 3: Pre-Delivery and Check List

Each vehicle must undergo a Pre-Delivery Inspection by the Dealer. Listed below is an example of the checklist that is included with the Warranty Registration that is to be submitted to Land Pride upon Retail Sale. The Pre-Delivery Certificate and Warranty Registration must be submitted to Land Pride in order to activate the vehicle warranty.

Pre-Delivery Certificate

The dealer is required to complete Land Pride's "Certificate of Light Utility Vehicle Pre-Delivery" form before customer may take possession of vehicle. The information must be filled in and check list checked off or initialed by individuals performing the checks. Dealership's name, signatures of individuals filling in the form, seller's signature, customer's signature and signing dates are also required before the form is returned to Land Pride. Below is a list of the information found in the form that is required to be completed and checked off.

Vehicle Information

Model No. _____
Date _____
Serial No. _____
Engine Serial No. _____

Dealer Service and Inspection List

- Fully charge battery. Check battery voltage to verify that it is fully charged.
 - Connect negative battery cable. (Negative battery cable is disconnected before leaving factory and is to be disconnected after initial dealer set-up to prevent battery discharge while setting on the dealer's lot.)
 - Check tire pressure to make sure front and rear tires have a minimum of 7 psi. See "Tire Inflation Chart" on page 26.
 - Make sure wheel lug bolts/nuts are tightened to 90 Newton meters/(65ft. lbs.).
 - Check master cylinder to make sure it is filled.
 - Check engine oil level at the dipstick. Add SAE 10W30 oil if oil is below the full mark on the dipstick. Do not overfill.
 - Check engine for correct RPM. Set to factory specification if needed. (See page 45)
 - Check Tie Rods for tightness.
 - Step on foot brake to make sure there is plenty of pedal and that brakes hold pressure and do not bleed off. Add brake fluid and bleed brakes if required.
 - Make sure seats and seat belts are properly fastened to vehicle frame if so equipped.
 - Make sure all safety decals are in place.
 - Check headlights to make sure they are working and are properly mounted.
 - Check tail lights and brake lights to make sure they are working and are properly mounted.
 - Inspect air cleaner element. Make certain it is clean and in place.
 - Inspect fuel tank to make sure it is properly installed and that there are no leaks.
- NOTE:** Vehicles are shipped from the factory with about a quart of fuel in the tank.
- Check fuel level in tank. If needed, add gasoline with a fuel stabilizer to perform initial starting operations. See "Fuel System" instructions on page 29 before adding fuel.
 - Inspect fuel lines to make sure they are properly installed and that there are no leaks.
 - Check steering by executing a full lock to lock turn in each direction.
 - Check park brake to make sure it will engage, hold and release.
 - Make sure neutral start feature is working by trying to start unit while shifter is located in the forward and reverse positions.
 - Check throttle control to make sure it moves and returns freely.
 - Check choke control to make sure it moves and returns freely.
 - Check Rear Trans-axle oil level at the oil plug. Add Land Pride special formulated gear lube noted on page 39 if oil is low.
 - Check overall appearance for cleanliness and for body and molding damage.

Table of Contents

Section 3: Pre-Delivery and Check List

Dealer Test Ride List

- Check engine for starting, accelerating, running and idling smoothly.
- Check steering response. There should be no free-play.
- Check forward, neutral and reverse shifting response. Also check neutral start response.
- Check park brake to make sure it engages, holds and disengages.
- Make sure rocker switches are all working.
- Make sure throttle is responsive and returns freely.
- Make sure suspension ride is satisfactory and stable.
- Make sure there are no fuel or petroleum leaks.
- Make sure foot brake has a firm engagement and that stopping is straight.
- Make sure there are no bad rattles or vibrations.

Dealer Delivery To Customer List

- Warranty registration form is complete.
- Owner's Manual has been delivered to and reviewed by customer.
- Engine Manual has been delivered to and reviewed by customer.
- Warranty Policy limits and requirements have been explained to customer.
- Customer has reviewed safety video.
- Location and functions of vehicle controls have been explained.
- Fuel transportation and storage procedures have been explained.
- Fluid fill and lubrication points have been located and explained to customer.
- Customer has completed the driving course.
- Information on safety decals have been reviewed with customer.

Customer Acceptance List

Customer initials required where accepted as successfully completed.

- Customer has reviewed and understands Land Pride warranty policy.
- Customer has inspected the vehicle and it meets customer's satisfaction.
- Customer understands the importance of following the owner's manual instructions.
- Customer has completed the Land Pride safety training course.

Section 4: Operating Instructions

Operator Responsibilities



WARNING

It is the operator's responsibility to have read this manual thoroughly and to know how to operate this vehicle safely in all situations. See "Section 2: Important Safety Information" starting on page 3.

Pre-Start Check List

- Lubricate vehicle as indicated in "Section 7: Lubrication" starting on page 37.
- Make sure engine cooling fan screen is clean of all debris including dirt, trash and oil. Also, make sure engine surface and cooling fins are clean. See "Engine Maintenance" on page 30.
- Make sure exhaust system is clean of all dirt, trash and oil. Check spark arrester every 100 hours to make sure it is clean and in good working condition. See "Exhaust System" on page 34.
- Check tire pressure as indicated in the "Tire Inflation Chart" on page 26.
- Make sure wheel lug bolts/nuts are tightened to 65ft. lbs.
- All nuts, bolts, screws and fasteners should be checked. Refer to Torque Value Chart in "Section 13: Appendix" on page 51.
- Turn on headlights to make sure battery has a charge and electrical lighting circuit is working.
- Check tail lights and brake lights.
- Step on foot brake to make sure there is plenty of pedal and that brakes hold pressure and do not bleed off. Add brake fluid as indicated in "Brake Fluid" on page 41 and bleed brakes if required.
- Check park brake to make sure it will engage, hold and release.
- Check steering by executing a full lock to lock turn in each direction.
- Check to make sure neutral start feature is working by trying to start unit with the shift selector located in forward and reverse positions. (Unit should not start.)
- Check engine oil level at the dipstick. Add oil as indicated in "Engine Oil" on page 37 if oil is at or below the add mark on the dipstick. Do not overfill or plug fouling will occur.
- Check differential oil level at the differential oil plug. Add gear lube as indicated in "Case Oil" on page 39.
- Check fuel level to make sure there is at least 1/8 of a tank of gas prior to performing initial starting operations.
- Check air intake filtering system. Clean or replace filtering system per instructions for "Engine Air Filter Maintenance" on page 32 and "CVT Snorkel Filter Maintenance" on page 33.

- Make sure low engine idle speed is set between 1250 and 1350 rpm and that maximum engine static speed does not exceed 3800 rpm. **Modifying or adjusting carburetor to increase vehicle speed above factory set specification is a safety violation and could result in voiding the warranty.**

General Operation



DANGER

Avoid injury or death from entanglement in the rotating drive belt. All shields must be in place and secure when operating. Keep all persons away from rotating driveline.

To start the Treker, following starting procedures displayed at the gearshift lever and as noted below.

1. Set park brake and shift selector in Park.
2. Pull choke fully out and hold when engine is cold.
3. Turn ignition key fully clockwise and hold until engine starts.
4. Release ignition key to run position and choke to normal operating position immediately after engine starts.
5. Turn ignition key counterclockwise to stop engine.

Operating a Treker is as easy as operating a car with an automatic transmission. A simple forward and reverse shifter provides direction control. A neutral start feature and keyed 12 volt electronic ignition makes for safe and easy starting. A manual choke control under the seat assist quick cold weather starting. The infinitely variable torque converter drive system means there is no clutching. Shift into either forward or reverse when the vehicle is stopped and step on the throttle pedal to go at speeds up to 25 mph. Never shift while vehicle is moving. The unit will only start when shift lever is in neutral or park and dash mounted indicator light is on.

Braking is accomplished by simply depressing the brake pedal located on the floorboard. This activates the rear hydraulic drum brakes and front hydraulic disc brakes. The park brake is incorporated in the shift selector. A dash mounted park brake indicator light will remain on until park brake is disengaged.

Section 4: Operating Instructions

Indicating Lights and Gauges

Refer to Figure 4-1:

- #1 **Hour Meter:** Indicates number of hours, to the nearest 1/10 of an hour, the vehicle has run.
- #2 **Park Brake Light:** Indicates park brake is on when illuminated. Do not move vehicle with park brake light on. See note below.
- #3 **4-Wheel Drive Light:** Indicates 4-wheel drive is activated when illuminated.
- #4 **Neutral Light:** Indicates shift selector is in neutral when illuminated.

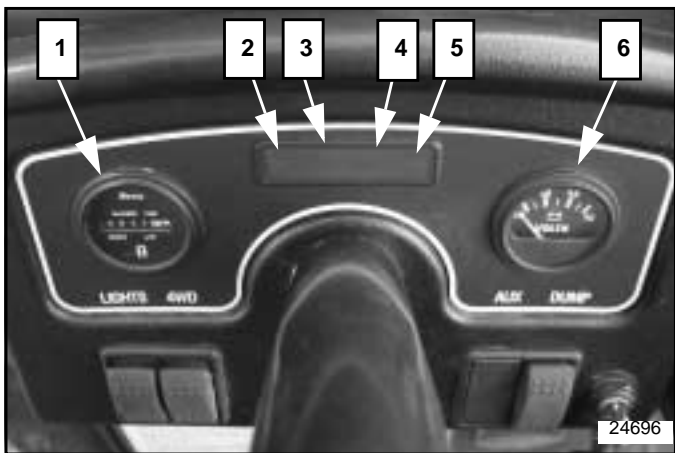

Figure 4-1

- #5 **Oil Light:** Indicates low oil pressure when illuminated. Stop engine immediately. Check oil level and add if low. See your authorized Land Pride dealer if oil light stays on and engine is full of oil. It is normal for the oil light to come on whenever the ignition switch is turned on and will stay on until engine is running.
- #6 **Volt Meter:** Indicates battery is charging. Check battery if volt meter registers a charge that is lower than normal. See your authorized Land Pride dealer if battery is good and volt meter still registers low charge.

Switches

Refer to Figure 4-2 and Figure 4-3:

- #7 **Power Plug Outlet:** Located on the dash is a power plug outlet for connecting 12 volt accessories such as a cell phone or light.
- #8 **Ignition Switch:** Starts and stops engine. Vertical position is off. Turn switch key clockwise to start engine. See "General Operation" on page 15 for correct vehicle starting procedures.
- #9 **Dump Switch:** An electric cylinder raises and lowers the cargo box. Press top of switch and hold to raise cargo box. Press bottom of switch and hold to

lower cargo box. Release switch at any position to stop cargo box. Release switch immediately if Power Bed Lift Cylinder makes a ratchet noise.

IMPORTANT: The Power Bed Lift is protected by an internal clutch in both directions and will make a loud "ratchet" noise indicating end of travel has been reached or Power Bed Lift is overloaded. Release switch immediately when this noise is heard.

- #10 **Auxiliary Switch Slot:** 12 volt on/off accessory with switch may be installed at this location.
- #11 **Light Switch:** Turns on head and tail lights. Press top of switch to turn on lights and bottom of switch to turn off lights.
- #12 **4-Wheel Drive Switch:** Engages the 4-wheel drive system. Press top of switch to engage 4-wheel drive and bottom of switch to disengage 4-wheel drive. The 4-wheel drive system should be used only when required to get through a difficult situation.

NOTE: 4x4 drive should not be engaged at transport speed or on hard surface roads.

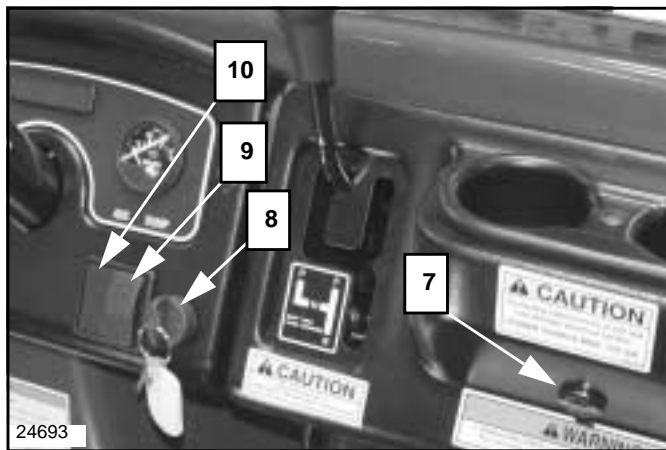

Figure 4-2

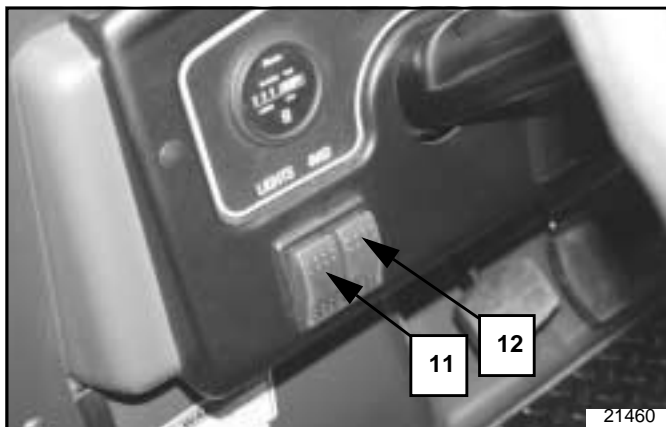

Figure 4-3

Section 4: Operating Instructions

Choke

Refer to Figure 4-4:

- #13 Choke Control:** Located under the driver's seat. Use to choke engine when starting. Pull on knob to start a cold engine. Release knob after engine has started. Do not choke an engine that is hot from operating, engine flooding may result.

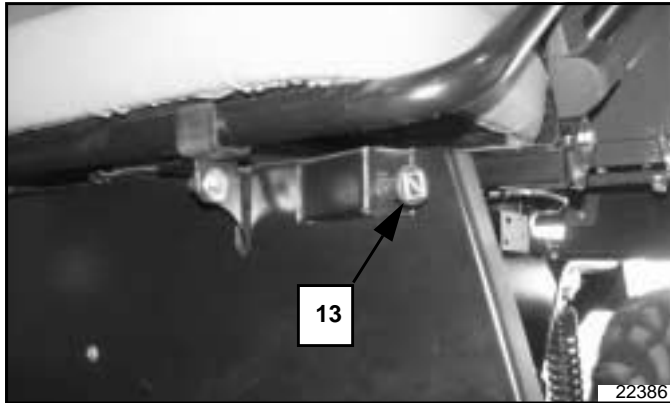

Figure 4-4

Floor Pedals

Refer to Figure 4-5:

- #14 Brake Pedal:** Applying pressure to brake pedal instead of accelerator pedal with your foot will slow down and/or stop vehicle. Riding or resting your foot on the pedal unnecessarily will wear the brakes out prematurely.
- #15 Accelerator Pedal:** Changes engine rpm and vehicle ground speed. Press down on the accelerator pedal with your foot to increase speed and let up on the pedal to decrease speed. Vehicle should not move when engine is idling. Adjust engine idle speed if vehicle moves while accelerator pedal is not being depressed.

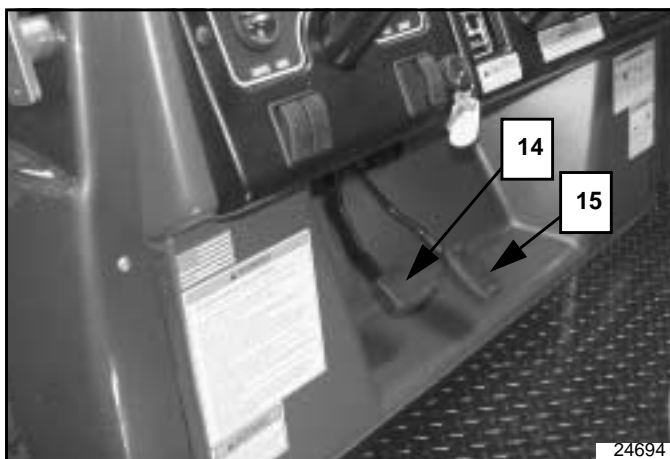
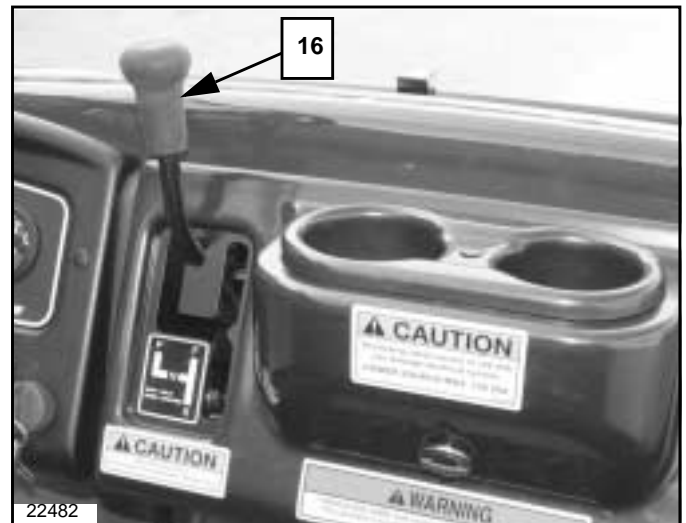

Figure 4-5

Shift Selector and Park Brake

Refer to Figure 4-6:

- #16 Shift Selector & Park Brake Control:** Sets and releases the park brake and changes trans-axle gears from neutral to forward or reverse. Always start engine in park or neutral.
- To place trans-axle in neutral from park position, move shift selector up and over to the left and then pull straight down to neutral position.
 - From neutral, move shift selector over to the right and up to place trans-axle in forward gear.
 - From neutral, move shift selector over to the right and down to place trans-axle in reverse gear.
 - Make a full stop by letting up on accelerator pedal and applying brakes before returning shift selector to park or switching from reverse to forward and forward to reverse.



Shift Selector Shown in Park
Figure 4-6

Section 4: Operating Instructions

Fuel Gauge

Refer to Figure 4-7:

#17 Fuel Gauge: The fuel gauge, located on the gas tank, displays approximately how much fuel you have in the fuel tank. Always park vehicle on level ground to get an accurate reading. The fuel tank is empty when the fuel gauge needle points to E and full when the needle points to F.

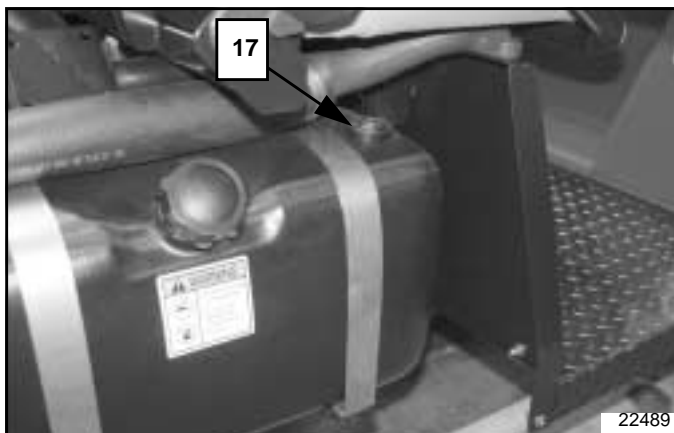

Figure 4-7

Seat Belts

WARNING

Seat belts should fit snugly and as low around the hips as possible. Wearing seat belts high around the waist greatly increases the chances of that person being injured in a dangerous situation.

WARNING

Never use a seat belt for more than one person and never buckle the seat belt to a buckle designed to receive the other seat belt.

Two seat belts are factory supplied with the bench seat. A third accessory seat belt may be added. See “Treker Accessories” on page 24. It is the responsibility of the operator and passenger to decide if their situation warrants using seat belts. Make sure seats and seat belts are properly fastened to the frame.

Seat Belt Components

Refer to Figure 4-8:

#18 Seat Belt: The seat belt is the belt that extends from the retractor when pulled across your lap to be buckled. It is located on the left side of the driver's seat and right side of the passenger's seat.

#19 Buckle: Both operator and passenger buckles are located in the middle. It secures the seat belt in place.

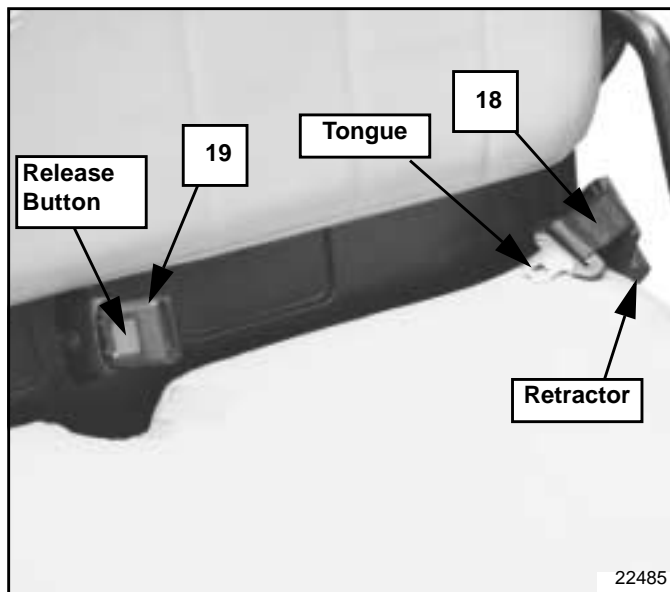

Figure 4-8

Seat Belt Operation

Pull the seat belt across your hips and insert its tongue into the buckle until you hear it snap. Release the seat belt by pressing the release button in the center of the buckle. Guide the seat belt to its original position as it retracts to keep it aligned and to prevent its tongue from striking and damaging surfaces on the vehicle.

Cup Holders

Refer to Figure 4-9:

A removable rivet secures the cup holder to the dash. The cups may be removed from the dash for cleaning.



Figure 4-9

Section 4: Operating Instructions

Glove Box Enclosure

Refer to Figure 4-10:

Unlock glove box by inserting key and rotating clockwise 90 degrees to the position shown. Rotate twist lock clockwise another 90 degrees to open. To close, push glove box lid shut. To lock while shut, rotate key 90 degrees counterclockwise and remove. Key can be removed in locked and unlocked positions.



Figure 4-10

Cargo Box / Flat Bed Set-Up



CAUTION

Always load front of cargo box first and back last. Never load back with more weight than the front.



DANGER

Make sure area behind cargo box is clear of personnel before raising the cargo box. Bodily harm can result from being pinched between cargo box and another object or from a load dumping and/or rolling onto a bystander.

The cargo box is factory standard with removable tailgate and side panels for changing cargo box into a flatbed.

Refer to Figure 4-11:

1. Remove cotter pins (#6) and flat washers (#5) from tailgate cable pins (#8). (2-places)
2. Remove 1/4"-20 hex screws (#4) and tailgate pivots (#1) from tailgate. (2-places)
3. Pull gate release lever (#7) back on both sides and remove gate (#3) from cargo box.
4. Replace flat washers (#5) and cotter pins (#6) in tailgate cable pins (#8) for storage.

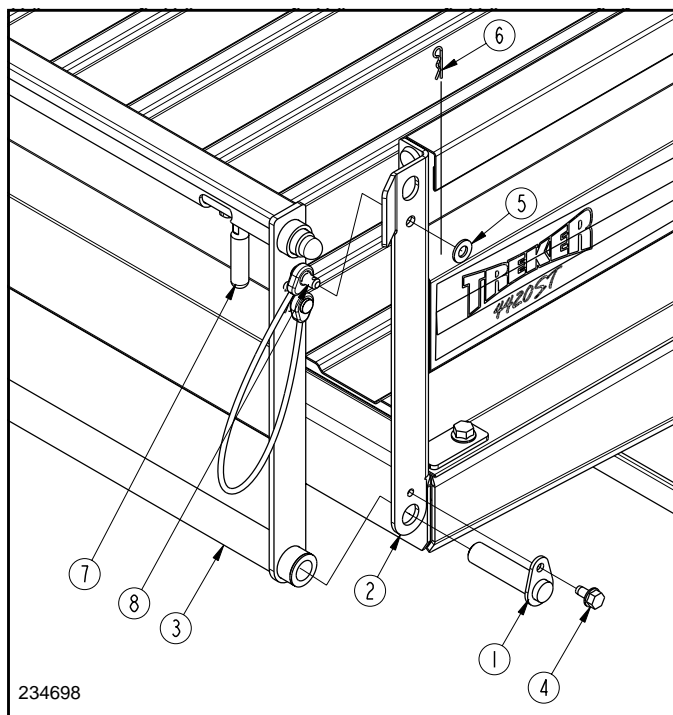

Figure 4-11

Refer to Figure 4-12:

5. Remove 5 5/16"-18 hex flange screws (#10) and right hand side panel (#9) as shown.
6. Repeat step 5 for left hand side panel.

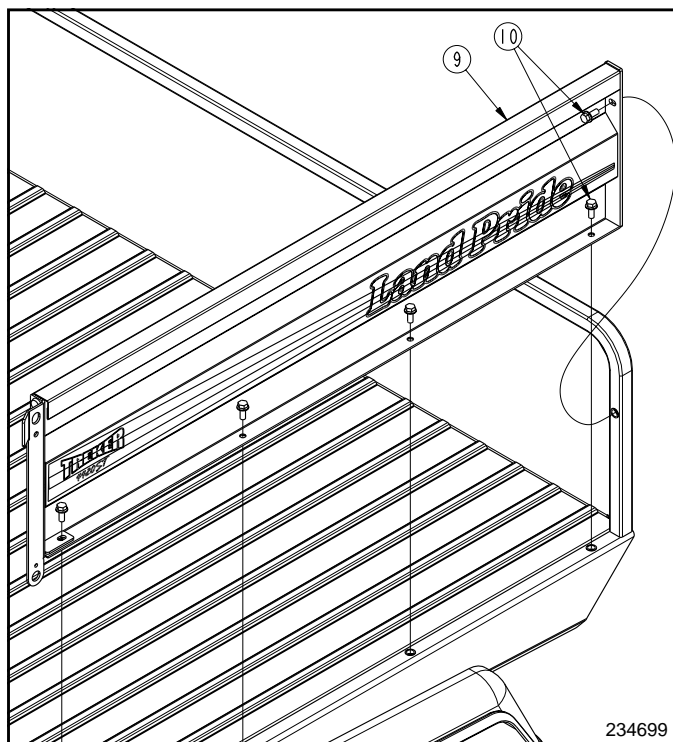

Figure 4-12

Section 4: Operating Instructions

Towing

The Treker is capable of being towed behind a tractor or another vehicle as long as certain precautions are followed:

- The ignition switch must be turned off.
- The gear selector must be placed in neutral position.
- The vehicle must be towed with a rigid tow-bar that is designed to tow the gross weight of the Treker. See "Section 10: Specifications and Capacities" on page 45 for vehicle gross weight.
- Tow-bar must be securely attached to the Treker at a location that will not damage the vehicle or come loose from the vehicle.
- Owner/user takes on all responsibility and liability resulting from attaching tow-bar to the Treker and to the vehicle towing the Treker.
- Do not allow anyone to ride in the Treker while it is being towed.
- Do not tow a trailer or vehicle behind the Treker that is being towed.
- Do not tow vehicle at speeds over 25 mph. The vehicle is designed to travel up to 25 mph. Higher speeds may result in damage to the Treker, vehicle towing the Treker and personnel.
- Slow down when turning to prevent loss of control and rollovers.
- Obey all state and local laws for towing vehicles.

Engine Performance

All small gas engines need fuel, air, and spark in exactly the right proportions in order to run properly at peak performance. Bad or stale fuel, a fouled spark plug, a wet or corroded spark plug wire, a gummed up carburetor, a wet or dirty air filter, a low oil situation, incomplete fuel combustion, carburetor icing, high oil situation (gas in the oil reservoir), and low engine temperature are all causes of small gas engine problems or diminished performance.

Fuel Quality

The normal shelf life of gasoline from the time it leaves the refinery is about 30 days. Unused gas that is stored too long can oxidize and break down causing formation of gum and varnish deposits in carburetors, needle valves, jets and venturis. This stops or chokes off flow of proper fuel/air mixture.

Draining the tank or running the engine until the tank is empty can result in dried out gaskets that, when dry, will crack and leak. Also, emptying metal fuel tanks and storage containers can result in corroded containers and contaminated fuel.

Land Pride highly recommends using a fuel stabilizer or oxygen inhibitor such as STA-BIL.

Incomplete Combustion

Incomplete combustion is when fuel is not fully burned in the engine combustion chamber. This condition can occur when an engine is started but is not allowed to run long enough to reach full operating temperature. Cold weather can accelerate this condition. Also, fouled spark plugs, wet electrical circuits and/or a plugged air filter will prevent fuel from being fully burned.

Unburned fuel pools on top of the piston and seeps down the cylinder walls into the oil reservoir. Often the oil dipstick will show an oil over-fill condition as fuel accumulates in the reservoir.

The oil reservoir filling up with gas can foul the spark plugs. If left unchecked, oil will become so diluted with gasoline that it can no longer function as a lubricant. It is extremely important to change oil and oil filter often whenever there is a high frequency of gas getting into the oil reservoir. Not changing oil and oil filter often can result in premature wear on cylinder walls and piston rings.

Also, replace fouled spark plugs, regap weak plugs, check electrical system for capability of delivering a strong spark and clean the air filter when dirty.

Cold Weather Operation

Small gasoline engines must get up to operating temperature before they will operate properly. Most air cooled engines draw a large volume of air through their intake fan. In sub-zero temperatures or freezing weather it can become almost impossible for an engine to reach normal operating temperature unless intake air is restricted or warmer air is fed into the carburetor. Land Pride offers a cold weather kit that directs air warmed from the exhaust manifold into the carburetor.

Chokes, throttle cables, and other mechanical linkages are also subject to freezing and sticking in cold weather. Products like WD-40 or dry graphite lubricants can be invaluable in keeping these items working freely. Whenever possible, park your Treker in a warm, dry environment to allow time for the linkages to dry out.

Section 4: Operating Instructions

Traveling Tips From the Trail Masters

At Land Pride we want you to get maximum working and recreational enjoyment out of your utility vehicle. If your work project or recreational adventure is going to take you on an extended ride deep into the wilderness or way out on the prairie, you'll need to seriously consider some of the following tips from experienced pros about safety, gear, clothing, supplies and driving techniques.

Preparation and Planning

Do a complete equipment check as follows:

1. Make sure you have plenty of fuel and oil to make the trip and then some.
2. Make sure your tires have proper inflation, your lug bolts are tight and that you have a spare and the tools to change, repair and inflate a tire. Consider adding a puncture sealant to your tires as a preventative measure.
3. Check for any loose or missing parts and definitely make those needed repairs before going anywhere. It is especially important that you check steering, braking, throttle, electrical and engine components thoroughly.

Plan Your Route

1. Plan your route, destination and rendezvous points before starting out.
2. Don't go it alone if at all possible. Taking someone else along reduces the potential for loss of life or major injury from inclement weather, animal attacks, or accidents. Besides, it's more fun when you have someone to share the adventure with.
3. Obtain trail or area maps of your travel routes to and from your destination. Communicate your travel plans to responsible friends and or proper authorities. Plan rendezvous points at conspicuous landmarks along your route just in case you run into unexpected trouble on the trail.
4. Make sure you take a weather radio and two-way communication devices such as cell phones or long range-two way radios. It is also good to have ground flares, a flare gun, a smoke canister, emergency strobe light, a reflecting mirror, matches for a signal fire and a compass.

Plan Your Gear

1. Check the short and long range weather forecast and take protective gear and clothing to cover all contingencies. It doesn't have to snow for you to fall victim to hypothermia or exposure. Take or wear appropriate eye and head protection, gloves, boots, a long sleeve shirt, long pants, a jacket, rain gear, dry socks and a full change of dry clothing.
2. Plan your gear and gear up for the best and worst of environmental conditions.

3. Pack a first aid kit, sunblocker, lip balm, insect repellent, personal medications, water, tarp or tent, flash light, survival knife, binoculars, camera, tool kit, rope, duct tape, tow strap, winch or come-along, eating utensils, cooking utensils and high energy trail food.
4. Tie and lash down your gear and supplies securely. Keep the bulk of the weight centered and mounted as low as possible on the vehicle in order to maintain a low center of gravity for safe and stable off-road travel.

Going Out on the Trail

1. When it's time to hit the trail "take it all in" but do it safely!
2. Make sure you brief your passenger on proper safety procedures like keeping hands, arms, feet and other bodily appendages inside the vehicle. Passengers should only be transported in factory supplied seating.
3. Operator and passenger are responsible for deciding if their situation warrants using Seat Belts.
4. Avoid operating on excessively steep hills and especially on hills that are steeper than 15 degrees. Avoid crossing slopes if possible and don't make sharp uphill steering corrections or a rollover could result. If your vehicle starts to tip over on a slope turn the front wheels quickly down hill to regain stability and control. The best way to climb most hills is to drive straight up while maintaining a steady ground speed and constant engine rpm. The best way to descend most hills is straight down while using steady pressure on the brakes without locking them up. Locking up the brakes in a steep downhill situation can result in loss of traction, steering and control. When you must cross a slope on soft terrain, keep the front wheels turned slightly uphill and maintain a constant speed and a straight line of travel.
5. Driving too fast, being inattentive and turning too sharply on slippery surfaces can result in rollovers and accidents almost quicker than any other ground condition. Snow cover, wet trails, loose gravel and frozen ground can all contribute to this dangerous condition. In these conditions maintain sharp focus on the trail ahead. Don't make sharp turns and avoid the need for hard braking if at all possible. If you do start to slide turn the front wheels in the direction of the skid to regain control.
6. Avoid paved surfaces. Land Pride vehicles are designed exclusively for off-road use only. We understand that occasionally operators have to cross public roads or right of ways to gain access to work or recreation sites, but don't get in the way of faster traffic and cross quickly and safely.
7. Land Pride Vehicles with shielded torque converters are capable of making *intermittent* stream crossings where the depth of water briefly comes into contact with the bottom of floorboards, but you must keep these considerations in mind; you must know how

Section 4: Operating Instructions

deep the water is and the strength of the current. Cross where you have a gradual incline for entry and exit and the bottom is fairly clean and free of obstacles. Maintain a slow steady speed disturbing the stream bed as little as possible. If you submerge the engine or the whole vehicle, do not attempt to start the vehicle but take it to your nearest Land Pride dealer immediately. After intermittent stream or shallow water crossings, dry out the brake linings and drive belt by slightly accelerating the engine rpm while riding the brakes momentarily until full drive power and braking are restored. You may lose forward momentum and power if water gets into the sealed torque converter and drive belt through the enclosure's vents. Always remove the CVT drain cap to drain any water that may have entered the enclosure. Replace cap once all water is drained.

8. Backing up in an off-road situation might seem a simple thing to do to a novice, but having to back down a hill is a very dangerous situation. If you are on level ground always look behind you and back up slowly. If you find yourself having to back down a hill, apply the brakes very lightly. Hard braking can cause total loss of control and a rollover situation. Try to back straight down the hill without turning. Turning in this situation can also cause a rollover.
9. Whenever possible, park your vehicle on a level surface, set the park brake by placing shift selector in (P) and remove ignition key. If you do have to park on a hillside make sure you chock the rear wheels on the downhill side to prevent a roll away. It's a good idea to keep your spare key stashed separately.
10. Never operate a vehicle under the influence of drugs or alcohol. When you're driving off-road vehicles you need to keep your senses keen and capable of quick reaction, sharp perception and good balance.
11. Working or recreation in the deep wilderness or on the prairies can be personally rewarding and very enjoyable to those who truly love and understand nature and the outdoors. Good judgement, maturity, proper preparation and planning can turn these adventures into great experiences you'll talk about for a lifetime. Share these adventures with young people whenever you can and show them how to do it properly. Don't let anyone under 16 operate this vehicle. They just aren't mature and experienced enough to take on the serious responsibility of operating a vehicle in the off-road environment without the benefit of an experienced adult with them. Remember, the only one who can prevent and avoid an accident is the operator in control and that's you!

Section 5: Options and Accessories

Treker Options

Front Bumper

Refer to Figure 5-1:

The front bumper is the most economical bumper option. It can be unbolted from the Treker to add the optional brush guard.

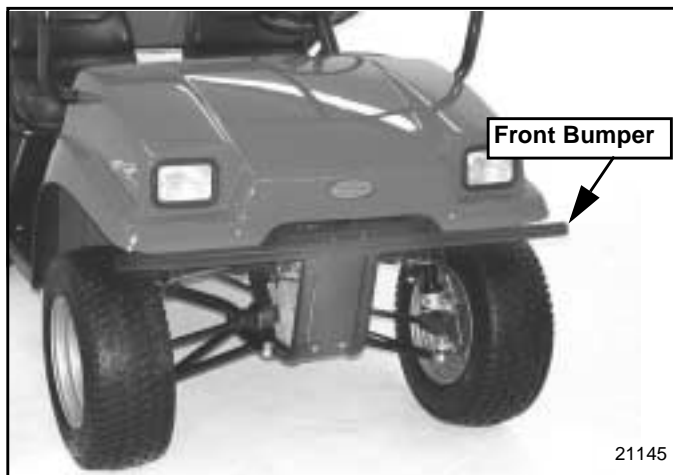

Front Bumper
Figure 5-1

Heavy Duty Brush Guard

Refer to Figure 5-2:

The Heavy Duty Brush Guard with front hitch receiver is a great option for accessories and front protection. The hitch receiver on the Heavy Duty Brush Guard is removable for adding a winch and roller fairlead accessory. The front cargo accessory rack (not shown) can be mounted to the Brush Guard.

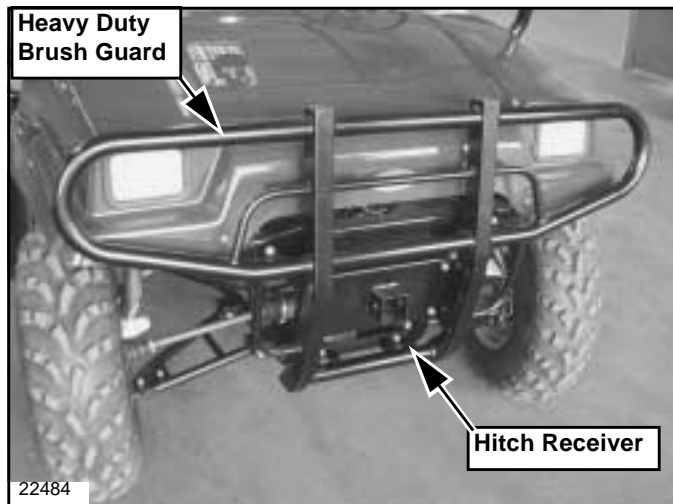

Heavy Duty Brush Guard
Figure 5-2

Tires

Refer to Figure 5-3:

There are two types of tires available for your Land Pride Treker. See Figure 5-3. The All Terrain Tire is a good tire to choose when traction is your first priority. This tire is a tough tire for going over rough terrain. It can be purchased mounted on gray rims or black rims.

The Turf Tire, mounted on gray rims, is a good selection when one wants to preserve the terrain being traveled over. Golf courses, parks and other maintained areas make the Turf Tire an excellent choice.



Figure 5-3

Section 5: Options and Accessories

Treker Accessories

A variety of accessory equipment has been designed to complement your needs and make your Land Pride Treker a very functional and useful vehicle. See your nearest Land Pride Dealer for all available accessories. Accessories available are:

- 2,000 lb. Winch
- Roller Fairlead
- Rear Tire Chains
- Front Tire chains
- Grab Light
- Vertical Gun Case
- Fifth Wheel Trailer
- Front Bumper
- Front Brush Guard
- Front Rack
- Rear hitch
- Back Screen
- Back Screen Head Rest
- Head Rest
- Mud Flaps
- 60" Snow Blade
- Canopy Top - Black
- Front Windshieldas
- Hard Cab Enclosure with Hard Doors
- Front Boot Guards
- Rear Boot Guards
- Skid Plate
- 3rd Seat Belt
- Electric Spin Spreader
- Back-up Light
- Back-up Alarm

Electric Spin Spreader

Refer to Figure 5-1:

The Land Pride Electric Spin Spreader is a highly versatile full component package designed to plant or spread seeds. It can then be used to spread prilled or granulated fertilizer, lime, gypsum, and other soil conditioning amendments at distances ranging from 4 ft. to 20 ft. The combination spin spreader/planter portion of this system can also be used in the off-season to spread sand or salt for winter icing or slick snow conditions.

The combination of maximum versatility and narrow to wide spread pattern makes the Electric Spin Spreader an excellent choice for applications in wild game food plots, hunting clubs, hunting resorts, ranches, farms, game preserves, landscaping, hobby farming, smaller nurseries, and gardens.

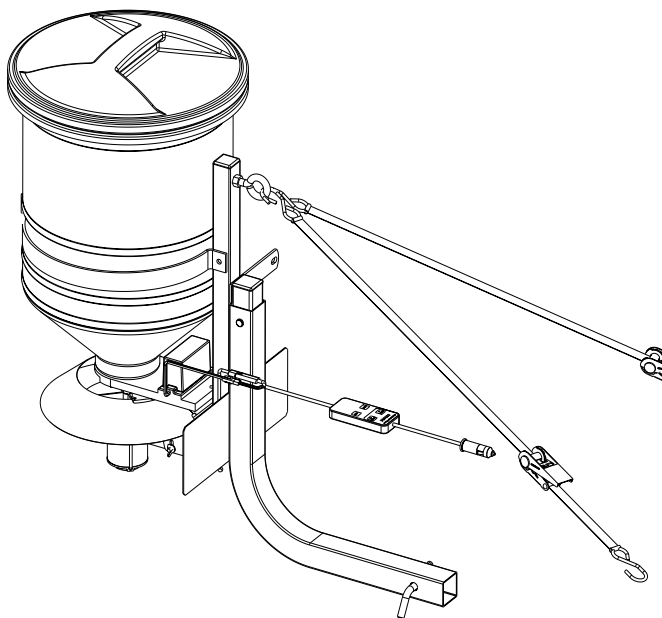

23921

Figure 5-1

The Land Pride Electric Spin Spreader can be attached to any vehicle equipped with a 2" receiver hitch and 12 volt accessory receptacle. Description and part number are listed below. See your nearest Land Pride dealer for additional information.

ELECTRIC SPIN SPREADER 701-130A



Section 6: Maintenance

General Maintenance

 **WARNING**

Read and observe all safety warnings in this manual and in the engine service manual.

 **WARNING**

Except when checking or changing components, always keep protective shields on for safety as well as for cleanliness.

 **WARNING**

Keep engine clean of oil, grease, trash and debris which can cause engine overheating, fires and belt wear. Clean only after engine has completely cooled. Wear gloves to protect hands from cuts, puncture wounds and burns.

 **WARNING**

DO NOT have engine running when servicing or making adjustments to the vehicle. Shut engine off, place transmission in park and remove ignition switch key for maximum safety.

 **DANGER**

Repairs or maintenance specifically requiring engine power should be performed by trained personnel only. Transmission gear should be set in neutral with tires properly chocked or with drive tires properly supported off the floor. Enclosed areas should be properly ventilated to prevent carbon monoxide poisoning.

 **DANGER**

Exercise extreme caution when working with and around the belt drive. Make certain the engine cannot be accidentally started. Shut engine off and remove ignition switch key for maximum safety. Repairs or maintenance requiring engine power should be performed by trained personnel only.

Regular maintenance is the best prevention for costly downtime or expensive, premature repair. The following pages contain suggested maintenance information and schedules which the operator should follow on a routine basis.

Remain alert for unusual noises; they could be signaling a problem. Visually inspect vehicle for any abnormal wear or damage. A good time to detect potential problems is while performing scheduled maintenance service. Correcting the problem as quickly as possible is the best insurance.

Some repairs require the assistance of a trained service mechanic and should not be attempted by unskilled personnel. Consult your Land Pride dealer when assistance is needed.

Securing Vehicle for Maintenance

Before servicing the vehicle the following procedure must be met to secure the vehicle:

1. Park vehicle on a level surface. **Don't work under or around a vehicle parked on an incline.**
2. Set shift selector in Park.
3. Turn ignition switch off and remove switch key.
4. Chock front and back side of the wheels not being raised off the ground when jacking a vehicle or when ground surface slopes.
5. Always use jack stands to support the vehicle when working under the vehicle.
6. Always secure cargo box in the up position when working under the cargo box.

Torque Values

Wheel Lug Nuts

 **WARNING**

Particular attention must be given to tightening the wheel lug nuts. Not torquing these items correctly may result in loss of a wheel, which can cause personal injury and damage to the vehicle.

Torque Values		
	FT -lbs.	Nm
Wheel lug nuts	65 - 75	88.14 - 101.7

Always check wheel lug nut torque values two hours after initial operation and two hours after each tire repair and/or replacement. Routinely check lug nut torque valves every 100 hours of operation. See "Maintenance Schedule" on page 36.

Engine Torques

For engine torque values, see engine owner's manual.

All Other Torques

For all other torques refer to "Torque Values Chart" page 51.

Tire Maintenance

Use only tires recommended by Land Pride.

It is important for your safety and the safety of others that the tires have correct air pressure. Check air pressure in

Section 6: Maintenance

all four tires before each use. Visually inspect tires for loss of air throughout each day of operation. See Tire Inflation Chart below for correct tire pressure.

Tire Inflation Chart	
Tire	Inflation PSI
Front Tires	7 psi*
Rear Tires	7 psi*

* Tire pressure may be increased to accommodate additional cargo load. Maximum tire pressure is noted on tire side wall.

Jacking the Vehicle



DANGER

For your safety and safety of others, a jacked vehicle must be supported properly with jack stands before working under and around it. Also the wheels on the ground must be chocked on both sides to prevent vehicle from rolling forward or backward.

IMPORTANT: Use a hydraulic jack, floor jack, or scissor type jack to lift vehicle. Do not use a handyman jack or bumper jack and don't jack against the bumper, body, front 4-wheel drive transfer case, rear trans-axle, or axles.

1. Secure vehicle for maintenance. See "**Securing Vehicle for Maintenance**" on page 25.
2. Loosen the lug nuts on a wheel being removed approximately 1/2 turn counterclockwise while it is still on the ground.
3. See important note above. Place proper jack under vehicle as follows:
 - a. **Front tires:** Refer to Figure 6-1. Place jack under body frame where the A-Frame struts attach to the body.
 - b. **Rear tires:** Refer to Figure 6-2. Center the jack under the receiver hitch.
4. Jack vehicle only high enough to do the work intended.
5. Support vehicle securely with jack stands before working under or around the vehicle.
6. Work may now be performed on the vehicle. Be sure to properly torque all bolts that were loosened. Wheel bolts should be torqued after vehicle is lowered to the ground.
7. Lower vehicle by first jacking vehicle up high enough to remove jack stands. Then carefully lower jack until vehicle is on the ground.
8. Remove wheel chocks.

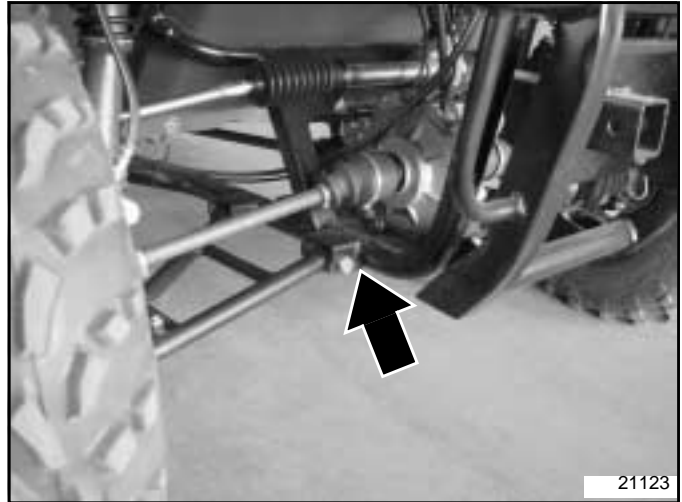

Figure 6-1



Figure 6-2

Shock Absorber Adjustment

Traveling fast or carrying heavy loads may cause shock absorbers to bottom-out making the ride rough. The mounting position of the rear shocks is adjustable to increase or decrease firmness of ride. Typically, they are set soft for slow speeds and light loads. Fast speeds and heavy loads require a firmer setting.

Adjust rear shock absorber position as follows:

1. Refer to "Jacking the Vehicle" instructions to jack vehicle up before repositioning the rear shocks.
2. Refer to Figure 6-3. Locate shock absorber's top three mounting holes.

Section 6: Maintenance

3. Remove locknut and hex bolt securing shock absorber to the vehicle frame.
4. Reposition rear shocks backwards or forwards to change load carrying capabilities as follows:
 - a. Repositioning the shock backwards increases ride firmness and load carrying capabilities.
 - b. Repositioning the shock forwards makes the ride softer.
5. Lower vehicle as outlined in the instructions for "Jacking the Vehicle" on page 26.

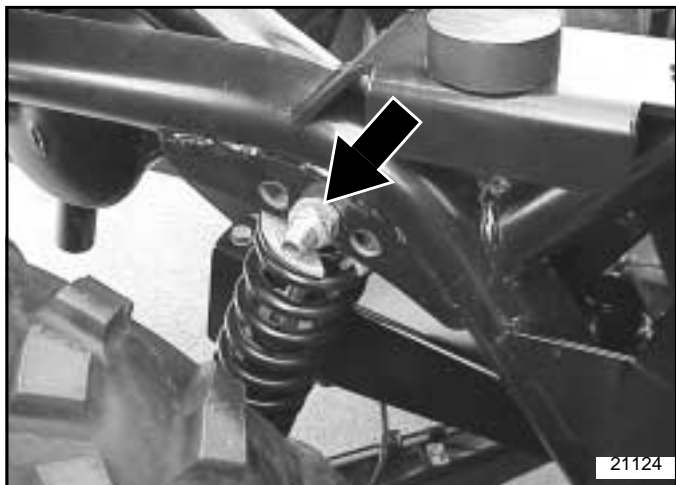

Figure 6-3

Electrical System

The electrical system is protected by fuses located in the fuse box. The fuse box lid, located on the vehicle's left side panel behind the driver's seat, is attached with Velcro. Remove lid by pulling out at the top two corners. On the lid is a diagram illustrating fuses and their locations. Fuses may be purchased through your nearest Land Pride Dealer.

Common circuit problems are shorts, corroded or dirty terminals, loose connections, defective wire insulation or broken wires. Switches, solenoids and ignition components can also not function, causing a short or open circuit.

Before attempting any fault diagnosis of the electrical system, use a test light or voltmeter to check battery voltage. If battery voltage is satisfactory, check cleanliness and tightness of terminals and ground connections. A general understanding of electrical servicing and use of basic test equipment is necessary for troubleshooting and repair.

Major overhaul or repair of starting motor and alternator should be performed by trained technicians only.

Battery

WARNING

Acid can cause serious injury to skin and eyes. Avoid skin contact with battery acid and always wear eye protection when checking the battery. Flush area with clean water and call a physician immediately. Acid will also damage clothing.

WARNING

Incorrect battery cable connections can damage vehicle's electrical system and cause battery cables to spark. Sparks around a battery can result in a battery gas explosion and personal injury.

- Always **disconnect** negative (black) battery cable before disconnecting positive (red) cable.
- Always **reconnect** positive (red) battery cable to positive (+) post before reconnecting negative (black) cable to negative (-) post.

WARNING

Keep battery terminals from touching any metal parts when removing or installing the battery. Do not allow metal tools to short between battery terminals and metal vehicle parts. Sparks can cause a battery gas explosion which will result in personal injury.

WARNING

Do not allow an open flame near the battery when charging. Hydrogen gas forms inside the battery. This gas is both toxic and flammable and may cause an explosion if exposed to a flame.

The battery is located under the seat. It may be either a maintenance-free sealed battery or a maintenance-free battery with removable vent caps. Inspect your battery and know which battery you have. Water cannot be added to sealed batteries as the vent caps are not removable.

Land Pride recommends a maintenance-free battery size BCI group U1/U1R. The battery should also have a minimum of 300 cold cranking AMPs and 375 cranking AMPs at 32°F. The battery support is designed to hold a larger automotive style battery. Simply reposition the J-hooks to the higher holes when installing a larger battery. Always follow manufacturer's maintenance, safety, storing and charging specifications.

Section 6: Maintenance

Adding Water to the Battery



Do not overfill battery with water. Electrolytes may overflow and damage paint, wiring or structure. Use soap and water to clean the battery. Be careful not to get soap and water into the battery. Use baking soda mixed in water to clean corrosion off the terminals.

There should be no need to add water throughout the normal life of a maintenance-free battery. However, abnormal electrical system conditions or high ambient temperatures may boil off more water than normal. Batteries with removable vent caps should have the water level checked in them once a year. Water level in each cell should be up to the level indicator. If not, add water. Distilled water should be used to fill each cell in the battery. However, tap water may be used if tap water is not hard or does not have high mineral or alkali content. Do not overfill. Have the charging system checked by your local Land Pride dealer if the battery requires water every few months.

Charging the Battery

Batteries that are severely discharged may not take or indicate a charge immediately. Some automatic chargers need a minimum voltage before they will start charging and some will not indicate a charging condition at the meter until the battery reaches a minimum charge. Consult your charger manual to determine how your charger works.

When recharging batteries, please follow these important safety precautions:

1. Secure vehicle for maintenance. See "**Securing Vehicle for Maintenance**" on page 25.
2. Read manufacturer's instructions for the charger.
3. Leave battery charger unplugged until its cables are connected to the battery.
4. Choose the correct battery charger to properly charge a battery.
5. Put on protective eye wear, rubber gloves, work clothes and remove all jewelry.
6. Don't charge a frozen battery. Allow battery to warm up to about 60 deg. F before charging.
7. Charge batteries in a well ventilated area.
8. Never smoke while charging a battery.
9. If applicable, remove vent caps and check battery's water level. **If water level is low**, follow instructions for "**Adding Water to the Battery**" above.
10. If applicable, reinstall vent caps before charging.
11. Set charger to 12 volts.

12. Plug in and turn on charger.
13. Don't wiggle connections to check contact while charger is turned on or plugged in.
14. Choose lowest amperage setting initially. Once charger is on and battery is charging you may want to choose a higher amp setting to reduce charging time.

Jump Starting the Battery

The battery will discharge if lights or any other electrical equipment is left on after engine has stopped running. Also, the battery will discharge if lights or power plug outlet is used over a prolong period while engine is idling.

The engine can be jump-started with a booster battery. Follow procedures listed below when jump-starting.

Prepare Vehicle to Jump-Start

1. Use only a 12-volt battery to jump-start the Treker. Higher voltages can damage starter motor and other electrical components. Do not use a 24 volt battery or two 12-volt batteries connected in series.
2. Do not disconnect a vehicle's battery that needs a jump-start. Disconnecting the battery can damage the vehicle's electrical system.
3. Park second vehicle close to the vehicle needing a boost without touching the two vehicles together. Set parking brake on both vehicles.
4. Turn off all ignition switches, electric switches, light switches and set parking brakes on both vehicles.

Connecting Jumper Cables

Refer to Figure 6-4 on page 29:

1. Inspect battery terminals for corrosion. Remove excess corrosion before connecting jumper cables.
2. Connect one end of the red jumper cable to the positive (+) terminal on the dead battery.
3. Connect the other end of the red jumper cable to the positive (+) terminal on the booster battery.
4. Connect one end of the black jumper cable to the negative (-) terminal on the booster battery.



WARNING

Make connection in step 5 below to a metal surface away from battery. Never connect to negative (-) post of dead battery or to a metal surface near the battery. Sparking near the battery can result in a battery gas explosion and personal injury.

5. Connect the other end of the black jumper cable to a metal surface on the vehicle that has the dead battery.
6. Inspect jumper cables to make certain they are not in the way of moving or rotating components. Reposition any cables that will be in the way.

Section 6: Maintenance

DANGER

Make certain everyone is clear of all moving and rotating components before starting either vehicle.

Refer to Figure 6-4:

7. Start the live vehicle and run it at a moderate speed for a few minutes to charge the dead battery.
8. After waiting a few minutes, start the dead vehicle. It should start within several tries. If vehicle does not start, then the problem might be something other than the battery.

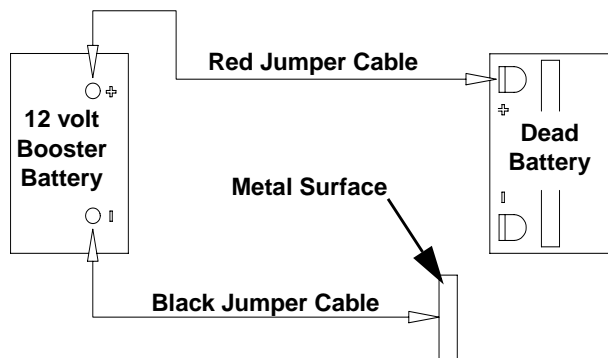

Figure 6-4

Disconnecting Jumper Cables

Refer to Figure 6-4:

1. Let both vehicles run for several minutes to charge up the dead battery before removing jumper cables.
2. Disconnect black jumper cable from the metal surface on the vehicle that had the dead battery.
3. Disconnect the other end of the black jumper cable from the negative post on the booster battery.
4. Disconnect the red jumper cable from the positive (+) post on the booster battery.
5. Disconnect the other end of the red jumper cable from the positive (+) post on the dead battery.
6. Drive the vehicle that had the dead battery for a while to recharge battery or recharge battery with a battery charger. Follow all battery charger instructions when recharging a battery with a battery charger.

Fuel System

DANGER

- Observe safe fuel handling precautions.
- Do not smoke while handling fuel.
- Do not fill tank with engine running or while engine is hot. Allow engine to cool before filling. Spilling fuel over engine, muffler, or a hot object may result in a fire or explosion.

- Allow engine to cool before servicing the fuel system.
- Clean up any gasoline spills immediately.
- Keep fuel away from open flame or spark.
- Store vehicle away from open flame or spark if there is fuel in the tank.
- Use extra caution when handling gasoline and other fuels. They are flammable and vapors are explosive. A fire or explosion from gasoline can burn you and others and can damage property.
- Refuel outdoors preferably, or in well ventilated areas.
- Never attempt to start engine when there is a strong odor of gasoline fumes present. Locate and correct cause.
- Store gasoline in an approved container and keep it out of children's reach.
- Never buy more than a 30 day supply of gasoline.
- Do not fill gasoline containers inside a vehicle, on a truck, or on a trailer. Interior carpets and plastic truck bed liners insulate container and slow loss of static charge.
- When practical, remove equipment from truck or trailer and refuel equipment with its wheels on the ground. If this is not possible, then refuel equipment on the truck or trailer using a portable container and not a gasoline dispenser nozzle. If a gasoline dispenser nozzle must be used, keep nozzle in contact with rim of fuel tank or container opening at all times until fueling is complete.
- Gasoline is harmful or fatal if swallowed.
- Long-term exposure to vapors can cause serious injury and illness.
- Avoid prolonged breathing of vapors.
- Keep face away from nozzle and gas tank opening.
- Keep gas away from eyes and skin.

The fuel tank is located behind the passengers seat. Total fuel capacity is 8 gallons.

When filling the fuel tank, set park brake, turn off engine and remove ignition key. Clean dirt from around fuel tank cap, remove cap and begin filling. When finished, screw cap back on securely and wipe up any spilled gasoline. Use regular unleaded gasoline with an octane rating of 87 or higher.

IMPORTANT: Never use methanol, gasoline containing methanol and/or gasohol containing more than 10% ethanol. These fuels can damage the vehicle's fuel system. Do not mix oil with gasoline.

Using a fuel stabilizer/conditioner in the vehicle can provide benefits such as:

1. Keeps gasoline fresh during storage of 90 days or less. Empty fuel tank for longer storage.
2. Cleans engine during operation.
3. Eliminates gum-like varnish build-up in the fuel system.

Section 6: Maintenance

IMPORTANT: Do not use fuel additives containing methanol or ethanol.

Add correct amount of gas stabilizer/conditioner to the gas. For best results, always follow manufacturer's directions when adding gas stabilizer/conditioner.

Fuel Filter Maintenance

Refer to Figure 6-5:

The fuel filter (Land Pride Part No. 831-031C) is installed in the fuel line between the fuel tank and engine. Check it every 100 hours for excessive water accumulation or sediment and replace if necessary. Otherwise replace after every 300 hours of operation or annually, whichever occurs first. Also check fuel tank and fuel line for cracks and leaks every 100 hours.

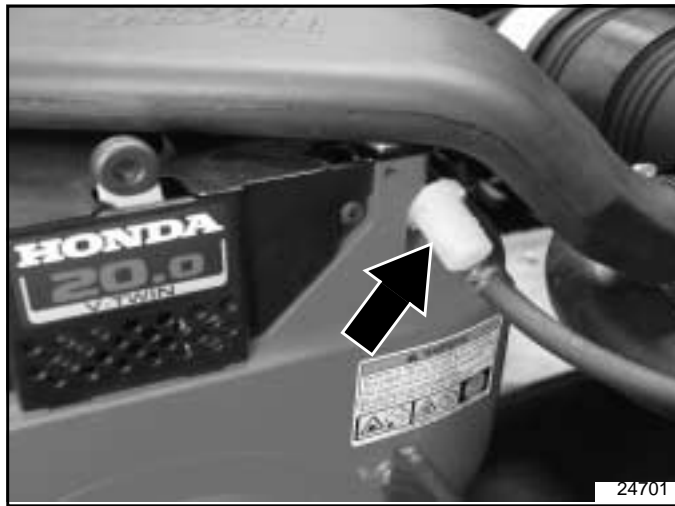

Figure 6-5

1. Secure vehicle for maintenance. See "**Securing Vehicle for Maintenance**" on page 25.
2. Following all Fuel Safety Cautions and Warnings, remove clamps securing fuel filter and remove fuel filter for inspection.
3. Check fuel filter for sediment and water accumulation. Check fuel lines for cracks and leaks.
4. Replace damaged fuel lines with new ones.
5. Replace fuel filter when sediment or excessive water is present.
6. Reattach fuel filter to fuel line with arrow on filter pointing in the same direction fuel flows in the line. Fuel flows towards the engine.
7. Install hose clamps around fuel filter.
8. Start vehicle and inspect for fuel leaks along fuel line and fuel filter.
9. Shut off vehicle. Remove blocks securing cargo box up and lower cargo box.
10. Remove wheel chocks if used.

Emptying the Fuel Tank



Never siphon a fuel tank by sucking on a hose with your mouth. Fuel vapors and gas are harmful to your lungs and can permanently damage them. Always use a siphon pump.

The fuel tank will need emptying when preparing for long term storage or replacing a damaged one.

1. Secure vehicle for maintenance. See "**Securing Vehicle for Maintenance**" on page 25.
2. Follow all Fuel Safety Cautions, Warnings and Dangers.
3. Remove gas cap and siphon fuel through fill opening with a siphon pump into an approved gas container. Make sure container or containers are capable of holding all the gas. Do not dump fuel on the ground.

Engine Maintenance

General Information

Prevent engine fires. Clean engine compartment daily. Clean cooling fan screen of all debris including dirt, trash and oil. Make sure engine surface and cooling fins are clean. Check engine compartment often for cleanliness when traveling over areas that produce high amounts of airborne combustible materials.

Detailed instructions and recommendations for break-in and regular maintenance are specified in the engine operator's manual. Engine warranty is backed by the engine manufacturer. Please refer to engine manufacturer's manual for engine servicing, lubricating oil levels, oil quality and viscosity recommendations, bolt torques, etc. Special attention should be paid to applicable data that is not duplicated here.

High Altitude Carburetor Kit

IMPORTANT: The air-fuel mixture in carburetors modified for high elevation is too lean when operating at elevations below 5,000 feet. Operating engines with modified carburetors below 5,000 feet can result in engine overheating and serious engine damage. Return carburetor to original factory specifications when operating at low elevations.

Treker vehicles shipped from the factory are stocked with carburetors designed to operate efficiently between 0 and 4,999 feet. Carburetor change over kits for different altitudes may be purchased from your nearest Land Pride Dealer as follows:

<u>Elevation</u>	<u>Carburetor Kit No.</u>
0'-4999'	99201-ZG8-1050
5,000'-7,999'	99201-ZG8-1020
8,000' & up	99201-ZG8-1000

Section 6: Maintenance

Drive Belt Replacement

Replace drive belt when it shows signs of severe cuts, tears, excessive weather checking, cracking and/or burns caused by slipping. Slight raveling of belt covering does not require belt replacement. Trim raveling with a sharp knife.

Inspect belt pulley grooves and flanges for wear. A new belt, or one in good condition, should never run against bottom of pulley groove except when engine is idling. Replace pulley when this is the case, otherwise belt will lose power and slip excessively.

Never pry a belt to get it on a pulley as this will cut or damage the belt fibers.

Keep oil and grease away from belts and never use belt dressings. Any of these will destroy the belt composition in a very short time.

CAUTION

Securely support cargo box in the up position to prevent injury when working under the cargo box.

CAUTION

Make certain to keep fingers from getting caught between belt and pulley when rotating belt over pulley.

Refer to Figure 6-6:

1. Secure vehicle for maintenance. See "**Securing Vehicle for Maintenance**" on page 25.

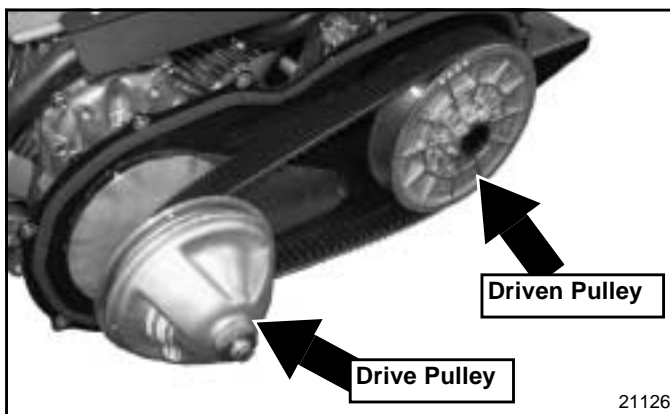

Figure 6-6

Drive Belt Replacement	
Part No.	Part Description
816-546C	Belt, CVT

2. Remove hardware securing drive belt cover and remove cover.
3. Hand squeeze the belt together between drive pulley and driven pulley to force belt into the driven pulley.

This should open driven pulley side walls allowing room to remove the belt.

4. Remove belt by rolling it off over the driven pulley and then lifting it up off the drive pulley.
5. Reinstall new belt by placing it over the drive pulley and then rolling it over the variable driven pulley.
6. Reinstall belt cover and fasteners.
7. Reconnect battery negative cable.
8. Remove blocks securing cargo box up and lower cargo box.

Driven Pulley Maintenance

Refer to Figure 6-6:

The driven pulley should be inspected for wear at the cam shoes to prevent damage to pulley and pulley compression spring.

Refer to Figure 6-7:

1. Secure vehicle for maintenance. See "**Securing Vehicle for Maintenance**" on page 25.
2. Remove screws securing drive belt cover. Pull cover back to inspect.
3. Check cam shoes on driven pulley every 100 hours or less for wear. Cam shoes should be at least 1/16" above aluminum hub when measuring parallel to the cam incline.

DANGER

Do not replace cam shoes without contacting your nearest Land Pride vehicle dealer for help. The compression spring can cause bodily injury if replacement is done incorrectly.

4. Replace all cam shoes if there is less than 1/16" clearance between aluminum housings. Make certain you contact your nearest Land Pride vehicle dealer for help when replacing them.

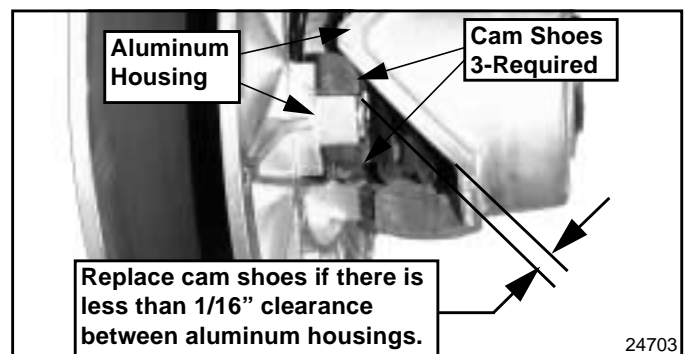

Figure 6-7

Cam Shoe Replacement	
Part No.	Part Description
6030-3001	DRIVEN PULLEY CAM SHOE (3 required)

Section 6: Maintenance

Engine Air Filter Maintenance

Refer to Figure 6-8 & Figure 6-9:

NOTE: Do not operate engine with a damaged air filter or without an air filter element. Dirt will enter engine causing dust ingested engine problems.

NOTE: Do not block air intake to air cleaner. Placing an object on the platform in front of the air intake snorkel or allowing loose clothing to drape over the snorkel could block the snorkel opening.

1. Replace filter element with Land Pride filter element No. 839-323C every 300 hours or every year, (whichever comes first). **Service more frequently when used in dusty conditions.**
2. Release retaining clips (#5) to remove canister access cover (#4) and filter element (#3). Clean canister (#2) with a damp cloth.
3. Before installing new filter element, inspect it by placing a bright light inside and rotate element slowly, looking for any holes and tears in the paper. Also check gaskets for cuts or tears. Do not attempt to use a damaged element. A damaged element will allow abrasive particles to enter the engine.
4. Install new filter element (#3) with open end first.
5. Reinstall canister access cover (#4). Make sure it seals all around canister body (#2) before tighten retaining clips (#5).
6. Check rubber burp cap (#6). Clean if plugged.
7. Check all fittings and clamps periodically for tightness. Inspect hoses for holes or cracks.
8. Periodically check engine intake hose (#1) for signs of ingested dust. Locate and repair source of ingested dirt.
9. Never operate vehicle without a filter element (#3).

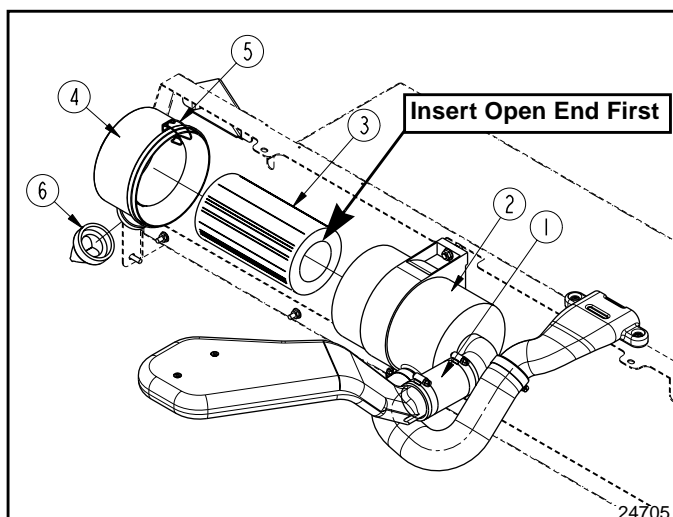
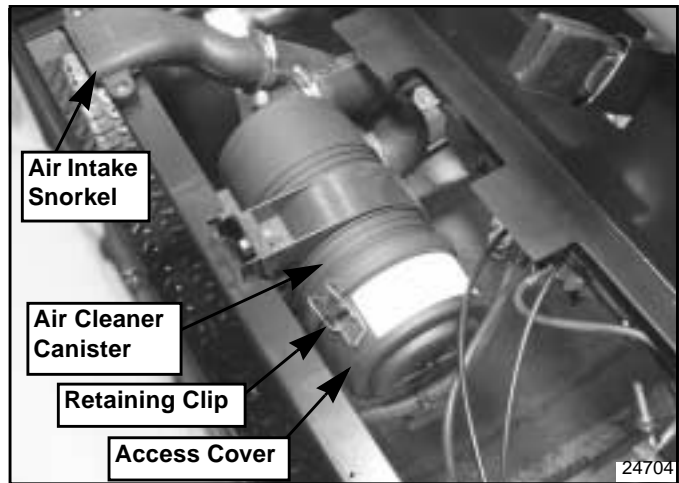

Figure 6-8



Location - Under Hinged Seat
Figure 6-9

Engine Air Filter Handling

Refer to Figure 6-8 and Figure 6-9:

A specially designed dry filter is standard equipment on the Treker and supplies clean combustion air to the engine.

Prevent costly and non-warrantable premature engine damage by maintaining the vehicle air filter properly. Many engine problems are due to improper handling of the air filter. Dust and dirt that gets past the air filter will damage engine cylinder, piston and bearings in a few hours.

Prevent costly and non-warrantable premature engine problems by avoiding the following common mishandling:

- Over servicing
- Improper installation
- Damaged air filtering system
- Incorrect air filter element

Over Servicing

Over servicing occurs when an air filter element is inspected and/or replaced too often. Dust and dirt can fall off the filter element onto the canister where it can be sucked into the intake system. Only a few grams of dirt getting into an engine during each filter inspection can prematurely produce dust ingested engine problems. A partially dirty air filter element is not harmful to the engine.

The air filter element should be changed before it becomes too dirty and restricts air flow to the engine hindering its performance. Replace air filter element immediately should this happen. Engines that do not get proper amounts of air will draw in excessive amounts of gas causing premature engine problems.

Section 6: Maintenance

The frequency of needing to change the air filter is largely determined by driving conditions. Dusty conditions will require more frequent servicing.

A dirty filter element should always be replaced with a new element. Improper cleaning procedures can get dust on the inside of the filter causing dirt ingestion and engine problems. **The air filter warranty expires upon cleaning or servicing a used filter in any manner. Land Pride does not warranty a dust ingested engine problem if a used air filter element has been cleaned or serviced in any manner.**

Improper Installation

Improper installation occurs when dust leaks past the seals. The filter element must be aligned within the canister and properly seated on both ends to prevent dirt from entering the engine.

Damaged Air Filtering System

A damaged air filtering system often occurs from mishandling the filter element and driving the vehicle in areas that could damage the canister.

Banging and/or bumping the filter element against a solid object such as a tire or blowing the element with air can damage the seals and/or force dust and dirt particles through the filter media creating a hole for dirt to pass through to the engine.

Driving the vehicle carelessly over rough terrain, jutting sticks, heavy brush and severe rocks can damage the air cleaner canister. Periodically inspect the air cleaner canister for external damage and replace if necessary.

Incorrect Air Filter Element

The air filter must remain intact to block passage of dirt and foreign particles. It must be of sufficient size and construction to withstand stresses, caused by rapid cycling of air volume demanded by the engine, without cracking or tearing under fatigue and pressure. Its filter elements must have the correct media composition, filter area, micron size and dimensions to properly filter the air of dirt while at the same time passing sufficient air to the engine.

Land Pride and the engine manufacturers have carefully selected a reliable filter designed to fit the needs of the Treker engines. Always specify a Land Pride filter part number 839-323C.

Always use genuine Land Pride filters. **Not using original equipment replacement parts is an alteration and will not be considered for warranty in the event of a dust ingested engine problem.**

CVT Snorkel Filter Maintenance

Refer to Figure 6-10:

Located under the seat on the passenger side are the engine air intake snorkel and CVT air intake snorkel. Inside the CVT snorkel is a filter element that should be inspected at every oil change.

1. Check filter element (#2) by removing it from CVT air intake snorkel (#1) and inspecting it for dirt and damage.
2. If dirty, wash filter element in warm soapy water. Rinse and let dry before reinstalling.
3. Replace with a new filter element if torn or cut.
4. Check all fittings and clamps periodically for tightness. Inspect hose for holes or cracks.

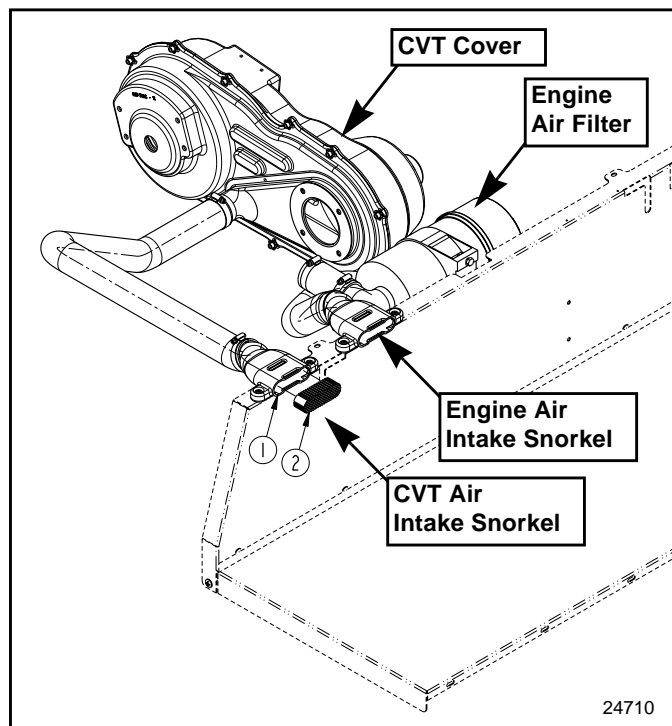

Figure 6-10

Section 6: Maintenance

Exhaust System

Prevent exhaust fires. Clean exhaust system daily while cold of all dirt and trash. Check exhaust system often for cleanliness especially while traveling over areas that produce high amounts of airborne combustible materials. Check spark arrester to make sure it is clean and in good working condition.

Spark Arrester

Refer to Figure 6-11:



DANGER

The spark arrester does not stop all fire emitting sparks from escaping the muffler. Use extreme caution when driving through dry grass, brush and other fire hazard materials. Never stop or park vehicle over combustible materials.



WARNING

The muffler is very hot and will burn upon contact. Allow time to cool before servicing the spark arrester.



CAUTION

To maintain efficiency, the spark arrester must be serviced every 100 hours.



CAUTION

Be careful not to damage spark arrester screen when cleaning.

The spark arrester is mounted on the end of the muffler tail pipe and is designed to suppress sparks from escaping the muffler while they are still glowing.

Spark Arrester Maintenance Schedule

- Inspect every 100 hours for carbon build-up and screen damage.
- Clean whenever carbon build-up is visible or whenever lost of engine power is detected.
- Replace when damaged.

Spark Arrester Maintenance Procedure

1. Remove spark arrester mounting screw (#1) and remove spark arrester (#2) from muffler exhaust pipe.
2. Remove carbon deposits from both sides of spark arrester screen with a wire bristle brush. Be careful not to damage spark arrester screen.
3. Inspect spark arrester for holes or breaks in the screen and replace if damaged.
4. Reattach spark arrester to muffler with mounting screw.

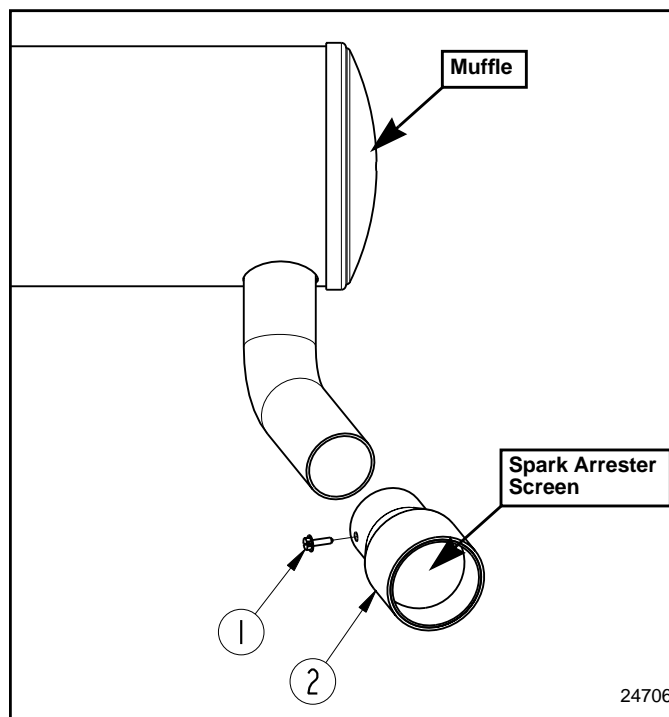

Spark Arrester
Figure 6-11

24706

Section 6: Maintenance

Park Brake Adjustment

The Park Brake Assembly is factory shimmed to the correct gap and should not require adjusting. Make adjustments only if park brake pads do not hold when shift selector is in park or if brake pads drag on the disc when out of park. Have your nearest Land Pride Service Center replace brake pads and/or shims if the following adjustments are not satisfactory.

Refer to Figure 6-13:

The park brake caliper is located on the right side of the rear trans-axle case.

IMPORTANT: If the park brake lever is not properly adjusted, the brake pads can drag resulting in excessive brake wear and decreased engine power. When adjusted properly, the park brake lever (#4) will be located in its ball detent position when shift selector is in neutral.

IMPORTANT: Make certain the wheels are chocked and the cargo box is securely supported in the up position before working on the Park Brake calipers.

1. Park vehicle on a level surface. **Don't work under or around a vehicle parked on an incline.**
2. Set shift selector in park.
3. Chock front and back of rear wheels.
4. Secure cargo box in the up position.
5. Change shift selector to neutral.
6. Turn ignition switch off and remove switch key.
7. Remove cotter pin (#1) and linchpin (#2).
8. Loosen jam nut (#3).
9. Allow park brake lever (#4) to seat itself in the ball detents.
10. Adjust yoke (#7) in or out until yoke linchpin hole aligns with brake lever (#4) linchpin hole.
11. Reinsert linchpin (#2).
12. Insert cotter pin (#1) and secure in place by bending one leg out.
13. Tighten jam nut (#3) against yoke (#7).
14. Check park brake's ability to hold and release by:
 - a. Placing shift selector in park and check to make sure brake pads (#5) are seated tight against rotary disc (#6). The vehicle should not move with shift selector in this position.
 - b. Return shift selector to neutral and check to make sure park brake pads (#5) do not make contact with rotary disc (#6).
 - c. If park brake still does not work properly, have your nearest Land Pride service center inspect the brakes before continuing to use the vehicle.
15. Set shift selector in park, lower cargo box and remove wheel chocks.

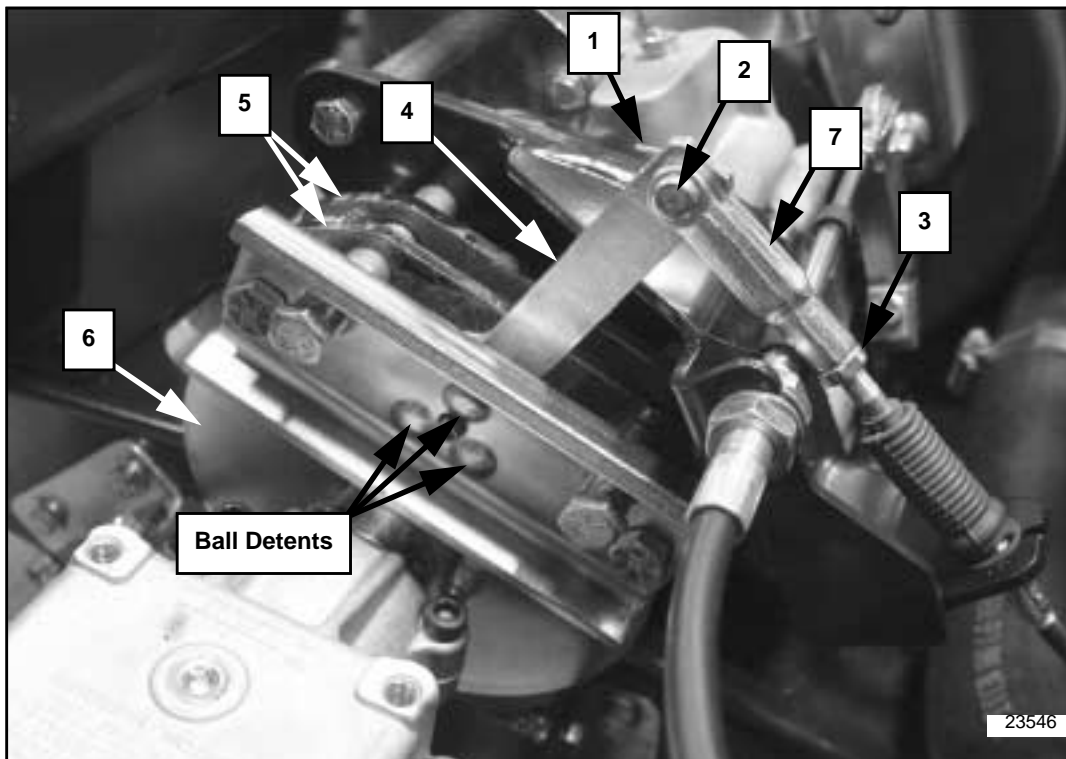

Park Brake Calipers
Figure 6-13

Table of Contents

Section 6: Maintenance

Maintenance Schedule

Maintenance Operation	Daily	Every 100 Hrs.	Every 300 Hrs.	Every 500 Hrs.	Every 6 Mos.	Every Year	Refer to Page
Check Engine Oil level (9)	X						37
Check Tire Pressure	X						25
Clean Engine and exhaust (11)	X						30 & 34
Inspect All Nuts and Bolts for Tightness	X						25
Check and Clean Area Around Engine Air Intake	X						32
Check Fuel Line Hoses, Clamps, & Tank for Leaks	X					X	30
Clean Spark Arrester (1)		X					34
Check Wheel Lug Nuts (Torque 65 to 75 Ft. lbs.) (2)		X					25
Check Master Cylinder Brake Fluid Level		X					41
Check Battery Charge and Water Level		X					27
Check In-line Fuel Filter (10)		X			X		30
Check CVT Snorkel Filter (3) & (4)		X			X		33
Change Engine Oil (3), (4) & (9)		X			X		37
Change Engine Oil Filter (3), (4) & (9)		X			X		38
Check & Regap Spark Plugs (.028 to .031 in.) (9)		X			X		
Check Rear Trans-axle Case Fluid Level (7)		X			X		39
Check Center Transfer Case Fluid Level (7)		X			X		40
Check Front Differential Case Fluid Level (7)		X			X		40
Check Driven Pulley Wear Buttons		X					31
Inspect Drum Brakes (6)			X				
Inspect Parking Brake (6)			X				
Replace Air Cleaner Filter Element (5)			X			X	32
Replace Spark Plugs (9)			X			X	
Check and Adjust engine idle Speed (6) & (9)			X			X	
Check Valve Clearance (6) & (9)			X			X	
Replace In-line Fuel Filter			X			X	30
Clean Combustion Chamber (8) & (9)				X		X	
Clean Battery and Terminals						X	27
Check Drive Belt and Pulleys						X	31

Reference Notes for above Maintenance Operation:

- (1) Clean spark arrester whenever loss of engine power is noticed or every 100 hours (whichever comes first).
- (2) Check tightness after first 2 hours of initial operation and after removal for repair and replacement.
- (3) Make first engine oil and filter change after the first month of operation or at 20 hours of operation (whichever comes first).
- (4) Service every 100 hours or 6 months (whichever comes first).
- (5) Replace air cleaner filter element if damaged, every 300 hours or ever season (whichever comes first). Replace more frequently when used in dusty conditions.
- (6) Have a Land Pride dealer perform this service every year or every 300 hours (whichever comes first).
- (7) Change every year or every 400 hours (whichever comes first). Change immediately if contaminated with water.
- (8) Have a Land Pride dealer perform this service every year or every 500 hours (whichever comes first).
- (9) See also your Honda Engine Owner's Manual.
- (10) Replace fuel filter immediately if excessive water accumulation or sediment is found.
- (11) Maker certain engine and exhaust are cool before cleaning. Check and clean engine fan cooling screen often when traveling in dirty trashy terrain.

Section 7: Lubrication

Lubrication Legend	Multi-purpose spray lube	Multi-purpose grease lube	Multi-purpose oil lube	Intervals in hours at which lubrication is required

Engine Oil

A general description for engine oil maintenance, recommendations and capacities is provided below. See Engine Operator's Manual for a detailed description.

IMPORTANT:

Running engine low on oil can cause engine damage and void engine warranty.

Overfilling engine of oil can cause loss of power, engine damage and void engine warranty.

Maintenance Schedule

- Check oil level after each use.
- Make first oil change after the first month of operation or at 20 hours of operation (whichever comes first).
- Make all subsequent oil changes every 6 months or every 100 hours of operation (whichever comes first).

Level Check

Refer to Figure 7-1:

Check engine oil daily with dipstick located at the engine left front side as follows:

1. Park vehicle on a level surface, set park brake, turn off ignition switch and remove switch key.
2. Allow enough time for engine oil to settle before checking oil level with dipstick.
3. Remove dipstick and wipe clean.
4. Fully insert dipstick and remove. Check oil level shown on dipstick.
5. If oil level on dipstick is low, remove filler cap located top of rear valve cover and fill with recommended oil. Repeat steps 2, 3 and 4 until oil level on dipstick indicates full. **Do not overfill or plug fouling and power loss will occur.**
6. Replace filler cap and dipstick.

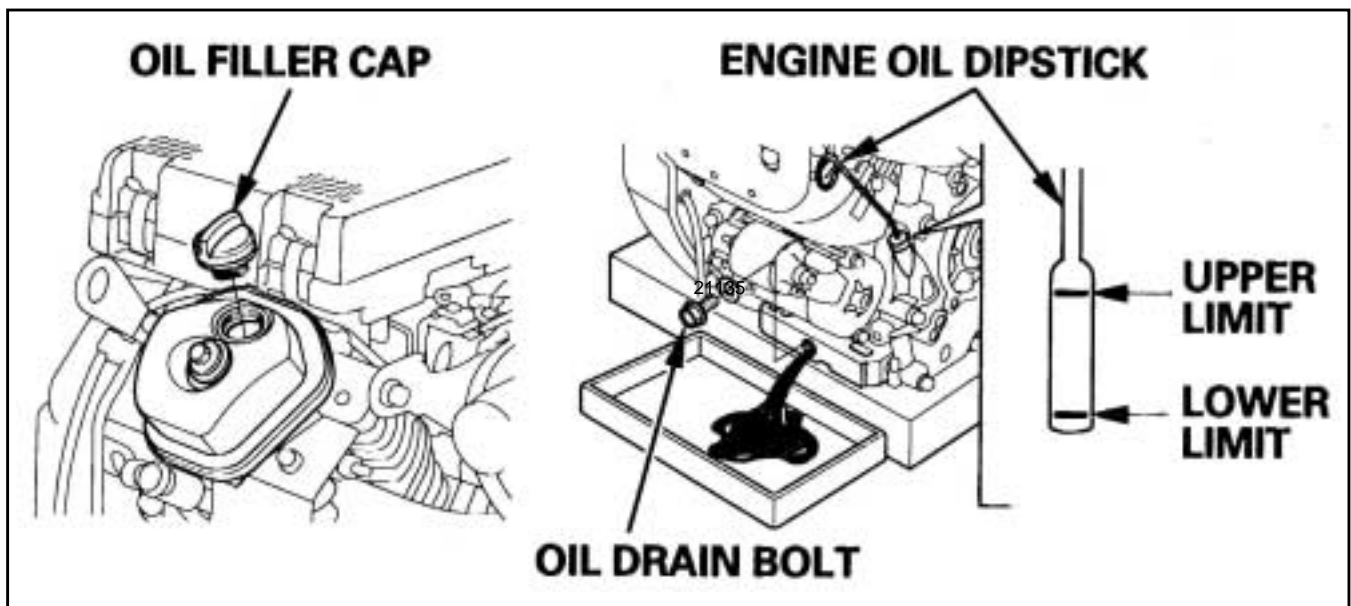

Engine Oil Fill, Drain and Check Locations
Figure 7-1

Section 7: Lubrication

Oil And Filter Change

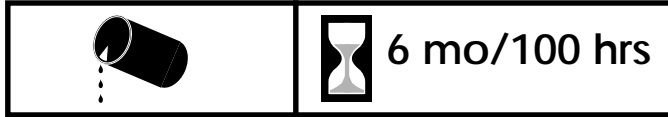

Refer to Figure 7-1 on page 37:

See also "Section 10: Specifications and Capacities" on page 45.

Filler cap location: Top of rear valve cover

Dipstick location: Front left side of engine

Drain plug location: Front bottom center of engine

Type of Lubrication: SAE 10W30

Engine Oil Capacity: 1.5 US qts. with filter replacement, 1.1 US qts. without filter replacement.

Quantity: Fill oil to upper limit mark on dipstick.

Refer to Figure 7-2 and Figure 7-3:

Warm oil drains quickly and completely. Therefore, drain used engine oil while engine is still warm as follows:

1. Park vehicle on a level surface, set park brake, turn off ignition switch and remove switch key.
2. Place a suitable container below engine to catch used oil. Remove filter access cover and drain plug to allow oil to drain out.
3. Remove oil filter with a filter wrench and let remaining oil drain out. Discard oil filter.
4. Clean engine filter base.
5. Coat new filter O-ring with clean engine oil and install filter to engine filter base.
6. Hand tighten oil filter until O-ring seats. Finish tightening by turning the filter to the specified turning angle or torque with a torque wrench.

Turning Angle: 7/8 of a turn

Torque: 22 N.m (2.2 kgf.m, 16 lb-ft)

7. Reinstall and tighten drain plug securely.
8. Dispose of used motor oil and filter in a manner that is compatible with the environment. Do not throw used oil in the trash, pour it on the ground, or down a drain.
9. Fill engine with 1.5 US quarts of 10W30 oil. Do not overfill. See "Level Check" on page 37.
10. Replace filler cap, start engine and check oil filter for leaks.
11. Stop engine and check oil level as outlined in section titled "Engine Oil Level Check" on page 37.

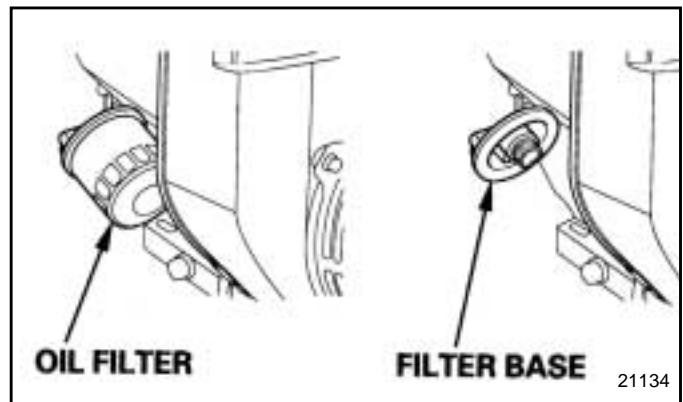

Oil Filter Location
Figure 7-2

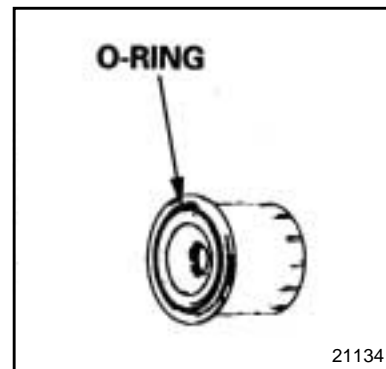

Oil Filter O-Ring
Figure 7-3

Section 7: Lubrication

Case Oil

A general description of maintenance, recommendations and capacities for the trans-axle case, center transfer case and front differential case are provided below.

Maintenance Schedule

- Check case housing for damage and possible oil leakage after each use.
- Check oil level every 6 months or every 100 hours (whichever comes first).
- Change oil once a year or every 400 hours (whichever comes first).

Level Check

Oil must be drained and refilled with proper quantities to insure correct oil level in the front differential case. Check rear trans-axle case and center transfer case oil at the fill plug with a clean rod. The rod should be long enough so that it will not fall pass the fill opening.

1. Park vehicle on a level surface, set park brake, turn off ignition switch and remove switch key.
2. Remove fill cap and measure from top of fill hole to oil level in case. This should be approximately 4 1/2" for

rear trans-axle case, 2" for center transfer case and 1/4" from bottom of fill opening for front differential case.

3. Add correct lubrication if needed. (**Don't overfill**)
4. Replace fill cap and tighten securely.

Oil Change

Warm oil drains quickly and completely. Drain used oil while it is still warm as follows:

1. Park vehicle on a level surface, set park brake, turn off ignition switch and remove switch key.
2. Place a suitable container below housing to catch used oil. Remove fill cap and drain plug.
3. Allow used oil to drain completely and then reinstall drain plug and tighten securely.
4. Dispose of used oil in a manner that is compatible with the environment. Do not throw used oil in the trash, pour it on the ground, or down a drain.
5. Fill gear cases per capacities in "Section 10: Specifications and Capacities" on page 45.
6. Replace fill cap and tighten securely.

Rear Trans-axle Case

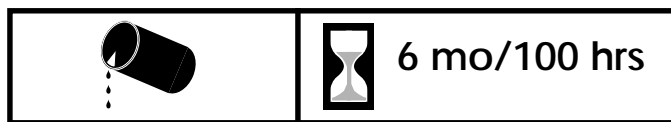

Refer to Figure 7-4 & Figure 7-5:

See also "Section 10: Specifications and Capacities" on page 45.

NOTE: Running trans-axle or driveline gearboxes low on oil can damage seals, bearings and gears voiding warranty for the trans-axle and gearboxes.

Fill cap location: Top center rear side (See Figure 7-4)

Drain plug location: At bottom left side (see Figure 7-5)

Type of lubrication: Mobil 424

Trans-axle case oil capacity: 20 oz.

Quantity: Fill to center line of output shaft.

(Approximately 4 1/2" from top of fill opening to top of oil level.)

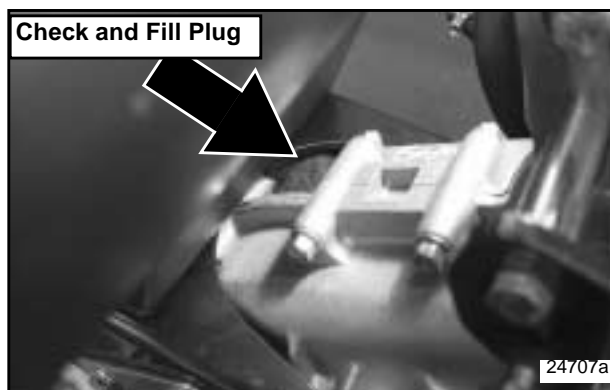

Rear Trans-axle Check and Fill Plug
Figure 7-4

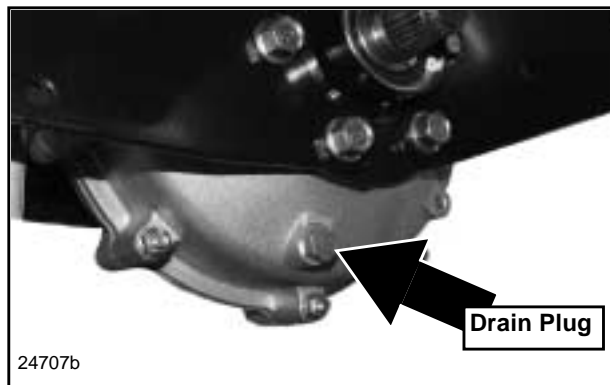

Rear Trans-axle Drain Plug
Figure 7-5

Section 7: Lubrication

Center Transfer Case

(4-Wheel Units Only)

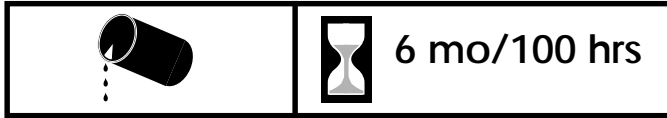

Refer to Figure 7-6:

See also "Section 10: Specifications and Capacities" on page 45.

Fill cap location: Top center (See arrow)

Drain plug location: Bottom Hex socket screw

Type of lubrication: 80/90 Gear Lube

Center transfer case oil capacity: 6 oz.

Quantity: Fill to center line of output shaft.
(Approximately 2" from top of fill opening to top of oil level.)

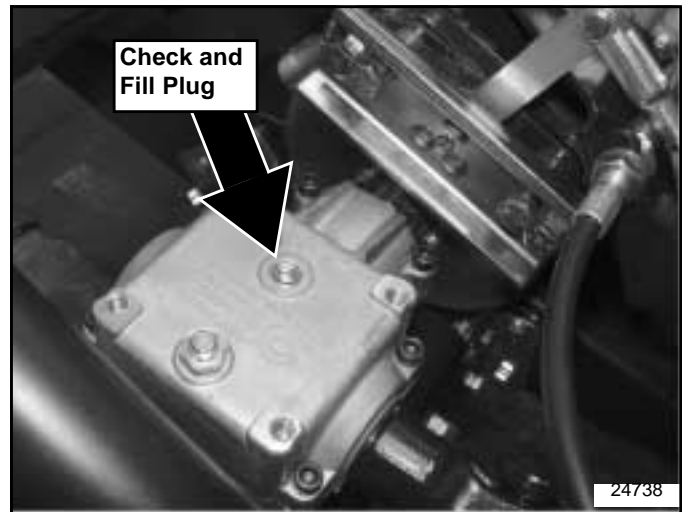

Center Transfer Case
Figure 7-6

Front Differential Case

(4-Wheel Units Only)

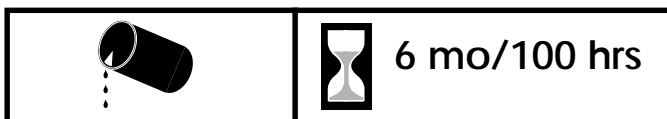

Refer to Figure 7-7:

See also "Section 10: Specifications and Capacities" on page 45.

IMPORTANT: Differential may not function properly and/or become damaged if wrong oil is installed.

Fill plug location: Left front side (See large arrow)

Drain plug location: Bottom center (see large arrow)

Type of lubrication: Mobil 424

Front differential Case oil capacity: **5 oz.**
(Approximately 1/4" from bottom of fill opening to top of fill opening.)

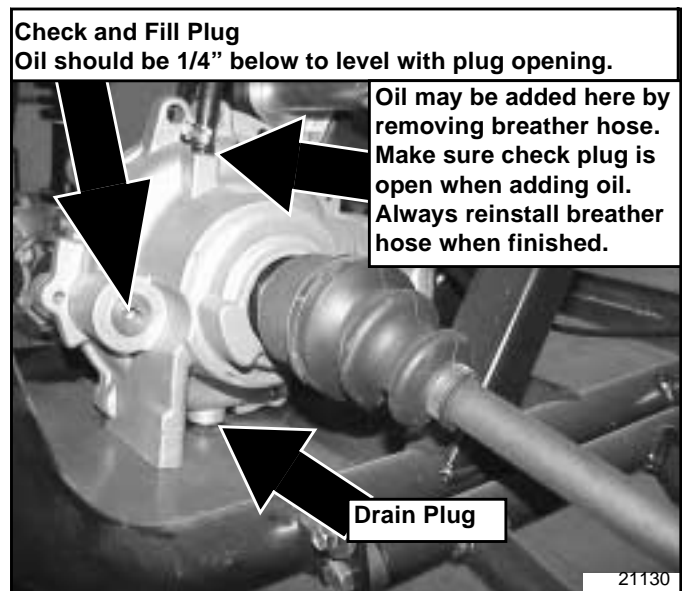

Front Differential Case
Figure 7-7

Section 7: Lubrication

Brake Fluid

Brake Fluid Maintenance Schedule

- Check fluid reservoir monthly.
- Fill reservoir immediately if low or if brakes begin to fade.

Brake Fluid Visual Check and Fill

Refer to Figure 7-8:

The master cylinder fluid reservoir is attached to the body frame under the front hood on the driver's side. Visually inspect fill line on the reservoir by turning the steering wheel to the left and looking under the driver's side wheel well. Remove cap and add DOT 3 fluid to the reservoir through the wheel well with a squeeze bottle and tube inserted into the reservoir.

Brake Fluid Type and Fill Location

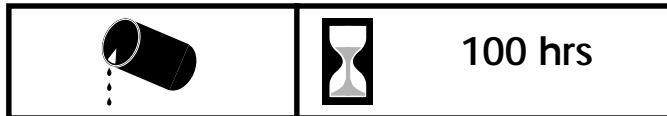

See also "Section 10: Specifications and Capacities" on page 45

Fill cap location: Located on driver's side of vehicle under front hood. (see Figure 7-8)

Type of fluid: DOT 3

Quantity: Fill to line on reservoir.

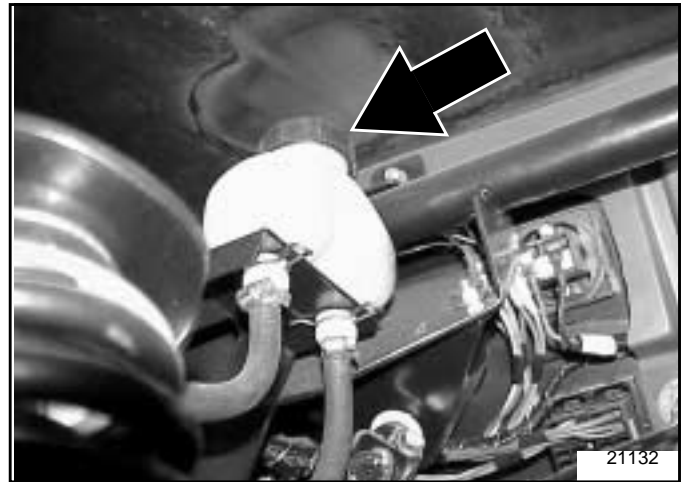

Master Cylinder Reservoir
Figure 7-8

Section 8: Seasonal Storage

Engine Preparation for Storage



Fuel vapors are flammable and explosive. Do not store a vehicle with fuel in the tank in a building where fumes can reach a spark or an open flames (i.e. plug-in sockets, light switches, light fixtures, power tools, welders, pilot lights and stoves).

Engine exhaust fumes contain carbon monoxide. Do not run a vehicle inside a building any longer than what it takes to move it. Serious illness or death may result from prolong exposure to carbon monoxide.

1. Take vehicle out of gear, set park brake and run engine outside for 15 minutes minimum. Then shut vehicle off and remove ignition key.
2. Drain oil from crankcase while engine is still warm.
3. Change oil filter. Refer to page 38.
4. Refill with fresh oil of proper viscosity. Refer to page 37.
5. Replace fuel filter if needed. Refer to page 30.
6. Prepare fuel system as follows:
 - Short term storage (90 days or less):
 - a. Siphon most of the fuel from the tank.
 - b. Add fuel stabilizer to tank per manufacturers recommendation.

IMPORTANT: Do not use fuel additives containing methanol or ethanol.

- c. Fill fuel tank with fresh fuel to prevent water condensation build-up.
- d. Run engine to circulate fresh fuel throughout engine components.

Long term storage (over 90 days):

- a. Siphon most of the fuel from the tank.
- b. Run engine until it stops from lack of fuel.

NOTE: Gasoline evaporates if left in carburetor for long periods, forming gum and varnish deposits in the carburetor. These deposits will cause engine flooding and loss of power.

- c. Remove spark plugs and pour a tablespoon of engine oil into each spark plug hole. Install plugs, but do not reconnect plug leads.
 - d. Crank engine with starter at least a dozen revolutions to distribute oil over cylinder walls and valve mechanism.
7. Clean exterior surface of engine. Spread a light film of oil over any exposed metal surfaces of engine that are subject to corrosion.

8. Clean dirt and chaff from cylinders and fins, blower housing and muffler.
9. Check oil fill cap and fuel tank cap to make certain they are securely in place.

Vehicle Storage Preparation

1. Perform separate engine preparations listed previously before storing vehicle.
2. Store vehicle in a clean, dry place.
3. Always place shift selector in park and remove ignition key before dismounting from vehicle.
4. Always allow vehicle to cool before working on or around it.
5. Remove all dirt and trash.
6. Clean and touch up all scrapes per "Section 9: Body Repair" on page 43.
7. Check thoroughly for any worn or damaged parts that need replacing including decals and order them from your Land Pride Dealer.
8. Thoroughly lubricate vehicle according to lubrication instructions. See Section 7: Lubrication, page 37.
9. Block vehicle up to take weight off the tires.

NOTE: Do not deflate tires.

10. Clean battery and battery post. Check battery electrolyte level. Protect battery from freezing temperatures. Occasionally recharging battery during storage will extend battery life.
11. Secure a waterproof cover over the vehicle if stored outside.

Vehicle Removal From Storage Preparation

1. Remove waterproof cover if used.
2. Clean vehicle, removing trash and dirt accumulation.
3. Install all safety shields and review safety precautions listed in this manual.
4. Reconnect spark plug leads to spark plugs.
5. Check engine oil level.
6. Check trans-axle oil level. If 4-wheel drive, check 4-wheel transfer case and front differential oil level.
7. Charge battery.
8. Fill fuel tank with fresh gasoline.
9. Run vehicle at half speed for 5 minutes, checking operation of steering control levers.
10. Stop engine and check for oil leaks, loose fittings and overall condition of vehicle.
11. Tighten any bolts that may have loosened.
12. Check and inflate tires to correct air pressure.



Section 9: Body Repair

Introduction

Land Pride Treker bodies are constructed of ABS with WeatherPro Gtm Color Cap. Scuffs, light scratches and deep gouges are in most situations repairable. Land Pride recommends that you use a professional body shop to restore your vehicle's body. For your consideration, we have provided below a list of recommended tools, materials and steps suggested for repairing the WeatherPro Gtm Color Cap body.

NOTE: Land Pride does not supply required tools, paint and materials needed to repair the vehicle body. All tools, paint and materials should be purchased locally.

Light Scuff

Required Tools and Materials (See note above)

- 1,000 rpm buffing tool, DeWalt #849
- Meguiars buffing compound #8432
- Meguiars polish #8232 (optional)
- Meguiars maroon cutting pad #W-7006
- Meguiars tan polishing pad #W-9006 (optional)
- Meguiars backing plate #W-64
- Soft clean cotton cloths

Steps to Repair

1. Clean entire area of repair. Clean water is fine for this purpose. **Do not use solvent** as this will damage the body surface.
2. Install cutting pad #7006 on buffer (maroon pad).
3. Spread compound on area of repair, use about as much as it takes to cover a half-dollar coin, this is a good starting point.
4. Set buffing tool to lowest possible speed on dial, do not buff at a high speed as this will heat and warp material.
5. Buff damage area until surface scuff disappears. A second and third application of compound may be required. Keep buffer moving over surface, this will help keep surface cool. Clean compound residue off surface after each buffing operation. Do not continue to buff compound until dry, or buff surface when dry. When all scuff marks have been buffed out the surface may still appear a little dull, if so, proceed to #6.
6. Install polish on surface as in step #3.
7. Spread #8232 polish on surface as in step #3.
8. Polish to a high luster or as required to match surrounding material.
9. Wipe clean with **soft clean** cloth; any dirt on cloth will mar surface.

Scratch

Required Tools and Materials (See note to left)

- 1,000 rpm buffing tool, DeWalt #849
- Meguiars buffing compound #8432
- Meguiars polish #8232 (optional)
- Meguiars maroon cutting pad #W-7006
- Meguiars tan polishing pad #W-9006 (optional)
- Meguiars backing plate #W-64
- Soft clean cotton cloths
- 3M interface sanding pad #05774
- Air Vantage finishing sander with 6-inch hook and loop pad
- 3M-P800 sanding film #00970

Steps to Repair

1. Clean entire area of repair. Clean water is fine for this purpose. **Do not use solvent** as this will damage the body surface.
2. Install interface-sanding pad onto finishing sander. Attach sanding film to Interface pad. (Take care in centering sanding pad and film on sander.)
3. Sand surface using about 45 P.S.I. air pressure at tool inlet, do not sand at a high pad speed, because speed causes the sanding film to load with dust and heats the body surface. Proper sander pad speed is based on cut, travel speed, and downward pressure applied by the operator. To clean sanding pad surface, run sander face at 90 degrees on the edge of a piece of cardboard. This cleaning operation will help keep sanding film clean and run cooler. Continue to sand surface until original scratch damage is no longer visible. Wipe surface with a cloth and then inspect to be sure the entire original scratch has been fully sanded away (very important).
4. Install cutting pad #7006 on buffer (maroon pad).
5. Spread compound #8432 on area of repair, use about as much as it takes to cover a half-dollar coin, this is a good starting point.
6. Set buffing tool to lowest possible speed on dial, do not buff at a high speed as this will heat and warp material.
7. Buff sanded area until surface scuff disappears.
8. A second and third application of compound may be required. Keep buffer moving over surface to help keep surface cool. Clean compound residue off surface after each buffing operation. Do not continue to buff compound until dry.
9. Buff surface of body when dry. When all scuff marks have been buffed out the surface may still appear a little dull, if so, proceed to #10.

Section 9: Body Repair

10. Install polishing pad #W-9006 on buffer (tan pad).
11. Spread #8232 polish on surface as in step #3.
12. Polish to a high luster or as required to match surrounding material.
13. Wipe clean with ***soft clean*** cloth; any dirt on cloth will mar surface.

Deep Gouge

Required Tools and Materials (See note on page 43)

- 1,000 rpm buffing tool, DeWalt #849
- Evercoat Body Filler Easy Sand
- Sanding Pad
- DuPont Full-Thane Primer 421-15
- DuPont 3939 Cleaner
- DuPont Sealer 42470
- DuPont Chroma Base/ Clear Coat Paint System
- HVLP Paint Sprayer

Steps to Repair

1. Sand damaged area with 500-grit paper to remove raised edges and to create abraded surface for proper adhesion.
2. Fill damaged area with Evercoat body filler (2-part system) and allow to completely dry.
3. Sand down high spots with 500-grit paper. If recesses are still visible due to filler shrinkage, apply second skim coat and again allow to dry completely, then sand surface flush with surrounding area.
4. Apply DuPont Full-Thane Primer 421-15 over body filler.
5. Once primer is completely dry, clean surface with DuPont 3939 Cleaner and again allow surface to dry completely.
6. Apply 42470 Sealer over body filler.
7. Apply color-matched paint system with HVLP paint sprayer according to supplier's recommendations to meet WeatherPro G's surface finish, i.e. DuPont's two part Base/ Clear coat system.

Table of Contents



Section 10: Specifications and Capacities

4220ST & 4420 ST Series

Engine Specifications			
Engine Model	Honda GX620K1	Lubrication	Pressurized
Engine Type	4 stroke - air cooled	Engine Oil Type	SAE 10W30
Horse Power	20	Engine Oil Capacity	1.5 US qts. with filter change 1.1 US qts. without filter change
Displacement	614 cc	Engine Idle rpm	1250 rpm min. to 1350 rpm max.
Max. Torque	32.5 lb@2500	Max. Engine Static rpm	3800 rpm to 4000 rpm max.
Cylinders	2	Cooling	Air
Valving	OHV	ACG Output	12V/20A
Fuel And Oil Specifications			
Fuel Capacity	8 gallons	Rear Trans-axle Case	Capacity: 20 oz. Type: US Mobil 424
Fuel Type	Unleaded fuel with 87 min. octane (Methanol fuel not allowed)	Center Transfer Case	Capacity: 6 oz. Type: US 80/90 gear lube
Brake Fluid	DOT 3	Front Differential Case	Capacity: 5 oz. Type: US Mobil 424
Vehicle Specifications			
Headlights	Two with standard 37.5 watt bulbs #894	4-Post Acc.Bar	Standard
Tail Lights	Two with standard bulbs #1157	Max. Speed	25 mph
Battery Type	12 volt, Size BCI, Group U1/U1R with min. 300 CCA and 375 CCA at 32°F.	Approximate Curb Weight	4220ST: 925 lbs. 4420ST: 1234 lbs.
Back-up Light/Alarm	Available as accessories	Base Unit Total Payload*	1300 lbs.
Belt Drive	Enclosed CVT (Constantly Variable Transmission)	Gross Vehicle Weight	4220ST: 2225 lbs. 4420ST: 2534 lbs.
Ignition	Keyed (Starts only in park and neutral.)	Rear Cargo Box Capacity	900 lbs.
Gear Selection	Park/Neutral/Forward/Reverse	Maximum Tongue Weight	100 lbs.
Rear Park Brake Operator	Gear selector automatically sets rear brakes when placed in park.	Max. Towing Capacity	1200 lbs.
Brake Type	Front: Hydraulic disc Rear: Hydraulic drum	Carrying Capacity of Front Optional Cargo Rack	160 lbs.
Steering Type	Rack & Pinion	Wheel Base	76"
Steering Wheel Dia.	15"	Tread Center Front	46.5"
Exhaust Protection	Spark arrestor	Tread Center Rear	47.5"
Frame Construction	Tube & channel	Width at front tires	54"
Frame. Suspension	Independent A-arms, MacPherson struts	Width at rear tires	58"
Rear Suspension	Independent trailing arms Coil/over adjustable shocks	Height	With All-Terrain tires: 71" With Turf tires: 70"
Floorboards	Steel safety plate	Length	120"
Body Cowling	ABS Composite in optional colors: Green, Red, Yellow or Camouflage	Floorboard Height	All-Terrain tires: 14" Turf tires: 13"
Front Guard	Optional bumper or brush guard	Min. Ground Clearance	9 1/2"
Rear Hitch	2" receiver	Tire Pressure	Front & Rear = 7 psi**
Front Hitch	2" receiver available with front brush guard option	Tire Type & Size (Front)	All-Terrain tread with black or gray rims: 25 x 8-12 (option) Turf tread: 23 x 8.5-12 (option)
Fenders	Front: Integral with body Rear: Mounted to cargo box	Tire Type & Size (Rear)	All-Terrain tread with black or gray rims: 25 x 11-12 (option) Turf tread: 23x10.5-12 (option)
Seating	Bench seat with two seat belts. Center 3rd seat belt available as an accessory.		

* Base unit does not include optional cargo racks.

** Tire pressure may be increased to accommodate additional cargo load. Max.tire pressure is noted on tire side wall.



Section 11: Features and Benefits

4220ST & 4420 ST Series

Features	Benefits
20hp Honda OHV V-Twin Engine	For Proven Power & Dependability.
25 MPH Top Speed	Able to go from job site to job site at a reasonable speed.
4-Wheeled Independent Suspension	For Soft Ride & Excellent Stability.
Rack & Pinion Automotive Type Steering	For Easy Handling & Quick Response.
4- Post Accessory Bar	Offers Accessory Mounting Capabilities & Added Protection from Limbs & Branches.
9 1/2" Minimum Ground Clearance	For Traversing Rough Terrain.
1,300 lb. Total Payload	For Maximum Cargo and Gear Hauling Capabilities.
4-Wheeled Automotive Style Braking	For Maximum Stopping Power & Control.
Constantly Variable Transmission	For Rapid Response & Easy Shifting.
Large Open Operators Platform	For Maximum Operator & Passenger Comfort.
8 Gallon Fuel Tank	For Extended Operating Range.
58" Overall Width at Rear Tires	For Maximum Stability.
Cargo Box with Power Lift	For added convenience and maximum productivity.
Full Bench Seat	More Spacious Seating.
Wide Range Of Accessories	To Meet Individual Customer Needs.
Enclosed CVT	For enhanced stream crossing capability.
Auto-Lock Differential	For maximum traction capability.
Overrunning Clutch	For environmental friendly traction and easy handling.
Seat Belts	For extra measure of safety.
Heavy Duty Brush Guard	For added body protection.
Front Receiver (With Heavy Duty Brush Guard Option)	For added versatility.
High Mounted Air Intake	For enhanced stream crossing capability.
Dash Mounted Cup Holders	For added convenience.
Locking Deep Well Glove Box	For added security and convenience.
Dash Mounted Shifter with Integral Park Brake	For added convenience.
Removable Cargo Box Sides	For added versatility.
Warranty	One year against manufacturing defects. Two years manufactured engine warranty.

Section 12: Troubleshooting

Symptoms	Probable Causes	Suggested Remedies
Battery is dead	Key switch is not in the off position.	Switch key to off position. Disconnect and recharge battery.
	Battery is worn out or defective.	Replace battery.
	Starter solenoid is shorted.	Replace starter solenoid.
Battery will not charge up	Battery connections are loose or corroded.	Clean and tighten battery connections.
	Battery fluid level is low.	Add distilled water to battery cell.
	Battery cell is dead.	Replace battery as soon as possible.
	Battery is worn out or defective.	
Brakes are sticking (won't release)	Master cylinder linkage is out of adjustment.	Adjust master cylinder linkage.
	Master cylinder return spring is broken.	Replace master cylinder return spring.
	Ground debris in brake linkage.	Clean debris from brake linkage.
Brakes don't function	Master cylinder oil level is low.	Add brake fluid to the master cylinder.
	Brake line is broken.	Replace brake line.
	Brake line has air in it.	Bleed brake line and add brake fluid.
	Master cylinder is defective.	Replace master cylinder.
Electrical System does not work	Electrical fuse is blown or missing.	Replace electrical fuse.
	Battery connections are loose or corroded.	Clean and tighten battery connections.
	Battery is worn out or defective.	Replace battery.
	Ignition switch is defective.	Replace ignition switch.
Engine backfires	Spark plug is fouled.	Replace or clean spark plug.
	Fuel solenoid is stuck.	See Honda Engine Manual.
	Air intake restrictor upstream of air cleaner is missing or incorrectly installed.	Replace or correctly install air intake restrictor.
	Throttle cable is defective or out of adjustment.	Clean and oil throttle cable. Replace worn or damaged cable.
Engine knocks	Engine speed is set too low.	Adjust engine idle screw.
	Fuel is stale or dirty.	Replace fuel with new fuel.
Engine overheats	Engine cooling fins are plugged.	Allow engine to cool. Clean cooling fins with high pressure air.
	Engine oil level is low.	Add specified engine oil.
	Carburetor air intake tube is plugged.	Clean air intake tube.
	Air cleaning element is plugged or missing.	Replace or clean air cleaner with air.

Table of Contents

Section 12: Troubleshooting

Symptoms	Probable Causes	Suggested Remedies
Engine loses power	Throttle cable is sticking.	Clean and oil throttle cable. Replace worn or damaged cable.
	Choke cable is sticking.	Clean and oil choke cable. Replace worn or damaged cable.
	Spark plugs are defective.	Replace spark plugs.
	Spark plugs are fouled.	Clean spark plugs or replace.
	Fuel supply is restricted.	Check for dirt in fuel tank.
	Fuel line is plugged, pinched, or kinked.	Clean or replace fuel line.
	Fuel leaks into the crankcase.	Clean or replace fouled spark plugs. Verify choke position is not stuck on.
	Engine oil level is high.	Drain excess oil, check for gas in the oil. Change if gas is present.
	Fuel octane is incorrect.	Use unleaded 87 minimum octane.
	Throttle cable is faulty or out of adjustment.	Adjust or replace throttle cable.
	Air cleaning element is plugged.	Replace or clean air cleaner with air.
	Engine is overheating.	See Symptoms for engine overheating.
Engine runs unevenly	Electrical connections are loose.	Reattach electrical connections.
	Engine cooling fins are plugged.	Allow engine to cool. Clean cooling fins with high pressure air.
	Throttle cable is sticking.	Clean and oil throttle cable. Replace worn or damaged cable.
	Choke cable is sticking.	Clean and oil choke cable. Replace worn or damaged cable.
	Fuel is stale or dirty.	Replace fuel with new fuel.
	Fuel line is plugged.	Clean fuel line.
	Fuel type is incorrect.	Use unleaded 87 minimum octane. (Methanol not allowed).
	Fuel leaks into the crankcase.	Clean or replace fouled spark plugs. Verify choke position is not stuck on.
	Spark Plug wiring is defective.	Replace spark plug wiring.
	Spark plug is defective.	Replace spark plugs.
	Spark plug is fouled.	Clean spark plugs or replace.
	Carburetor is not adjusted correctly.	Adjust carburetor.
	Air cleaner is plugged.	Replace air cleaner.
Engine starts in gear	Neutral switch is adjusted incorrectly.	Adjust neutral switch to be engaged with shift selector in neutral.
	Shifter link is out of adjustment.	With shift selector in neutral, adjust shifter link at engine to be in neutral position.

Table of Contents

Section 12: Troubleshooting

Symptoms	Probable Causes	Suggested Remedies
Engine stops running	Gas tank is empty.	Refill gas tank.
	Spark Plug wiring is defective.	Replace spark plug wiring.
	Ignition switch is defective.	Replace ignition switch.
	Battery is worn out or defective.	Replace battery.
	Crankshaft is broke.	Replace broken crankshaft.
Shift Selector is malfunctioning	Foot feed throttle spring is loose or broken.	Reattach disconnected foot feed spring. Replace defective spring.
	Throttle cable is sticking.	Clean and oil throttle cable. Replace worn or damaged cable.
	Engine idle return spring is loose or broken.	Reattach disconnected engine idle spring. Replace defective spring.
	Engine idle set too high.	Readjust engine idle. (1250 to 1350 RPM)
	Governor spring is loose or broken.	Reattach disconnected governor spring. Replace defective spring.
	Drive Clutch does not disengaged.	Clean drive clutch by blowing air through it.
	Shift selector jumps out of gear.	With shift selector in neutral, adjust shifter link at engine to be in neutral position.
Park brake doesn't work	Park brake cable is not adjusted correctly.	Adjust park brake cable at the caliper.
	Park brake cable is broken.	Replace park brake cable.
	Park brake cable is jammed with debris.	Clean debris from park brake cable.
Starter cranks slowly	Battery power is low.	Recharge battery.
	Battery connections are loose or corroded.	Clean and tighten battery connections.
	Battery is worn out or defective.	Replace battery.
	Harness connections are loose.	Reconnect harness connections.
	Harness pin connections are bent.	Straighten harness pins.
	Harness is defective.	Replace harness.
	Ignition switch is defective.	Replace ignition switch.
	Starter is defective.	Replace starter.
Engine oil is too heavy.	Replace with SAE 10W30 oil.	

Table of Contents

Section 12: Troubleshooting

Symptoms	Probable Causes	Suggested Remedies
Starter does not work	Neutral switch is not engaged.	Adjust neutral switch to be engaged with shift selector in neutral.
	Neutral switch is defective.	Replace neutral switch.
	Battery power is low.	Recharge battery.
	Battery connections are loose or corroded.	Clean and tighten battery connections.
	Battery is worn out or defective.	Replace battery.
	Harness connections are loose.	Reconnect harness connections.
	Harness pin connections are bent.	Straighten harness pins.
	Harness is defective.	Replace harness.
	Ignition switch is defective.	Replace ignition switch.
	Starter is defective.	Replace starter switch.
Steering does not track correctly	Improper tire inflation.	Inflate all tires to correct tire pressure.
	Tie rods not adjusted correctly.	Adjust front tie rods. Front tires should toe-out a total of 0" to 3/16" more at the front than at the back.
	Damaged frame steering or suspension parts.	Inspect thoroughly.
Steering play is excessive	Pinion shaft is improperly attached.	Realign pinion shaft.
	Pinion shaft is loose.	Tighten pinion shaft bolts.
	Tie rod ends are loose.	Align and tighten tie rod ends.
Vehicle speed does not reach 25 MPH	Throttle cable housing is set too close to engine preventing proper cable movement.	Reposition cable housing toward seats until all cable slack is removed between cable housing and engine.
	Carburetor is icing up.	Install cold weather kit.
Vehicle loses ground speed without loosing engine speed	Normal condition when climbing grades as the CVT will downshift automatically allowing the engine to run in it's horsepower band.	None required.
	Drive belt is wet and slips.	Rev engine in neutral for one minute.
	Drive belt is worn.	Replace drive belt.



Section 13: Appendix

Torque Values Chart													
Bolt Size (Inches) in-tpi ¹	Bolt Head Identification						Bolt Size (Metric) mm x	Bolt Head Identification					
	 Grade 2		 Grade 5		 Grade 8			 Class 5.8		 Class 8.8		 Class 10.9	
	N ·	ft-lb	N ·	ft-lb	N ·	ft-lb		N ·	ft-lb	N ·	ft-lb	N ·	ft-lb
1/4" - 20	7.4	5.6	11	8	16	12	M 5 X 0.8	4	3	6	5	9	7
1/4" - 28	8.5	6	13	10	18	14	M 6 X 1	7	5	11	8	15	11
5/16" - 18	15	11	24	17	33	25	M 8 X 1.25	17	12	26	19	36	27
5/16" - 24	17	13	26	19	37	27	M 8 X 1	18	13	28	21	39	29
3/8" - 16	27	20	42	31	59	44	M10 X 1.5	33	24	52	39	72	53
3/8" - 24	31	22	47	35	67	49	M10 X 0.75	39	29	61	45	85	62
7/16" - 14	43	32	67	49	95	70	M12 X 1.75	58	42	91	67	125	93
7/16" - 20	49	36	75	55	105	78	M12 X 1.5	60	44	95	70	130	97
1/2" - 13	66	49	105	76	145	105	M12 X 1	90	66	105	77	145	105
1/2" - 20	75	55	115	85	165	120	M14 X 2	92	68	145	105	200	150
9/16" - 12	95	70	150	110	210	155	M14 X 1.5	99	73	155	115	1215	160
9/16" - 18	105	79	165	120	235	170	M16 X 2	145	105	225	165	315	230
5/8" - 11	130	97	205	150	285	210	M16 X 1.5	155	115	240	180	335	245
5/8" - 18	150	110	230	170	325	240	M18 X 2.5	195	145	310	230	405	300
3/4" - 10	235	170	360	265	510	375	M18 X 1.5	220	165	350	260	485	355
3/4" - 16	260	190	405	295	570	420	M20 X 2.5	280	205	440	325	610	450
7/8" - 9	225	165	585	430	820	605	M20 X 1.5	310	230	650	480	900	665
7/8" - 14	250	185	640	475	905	670	M24 X 3	480	355	760	560	1050	780
1" - 8	340	250	875	645	1230	910	M24 X 2	525	390	830	610	1150	845
1" - 12	370	275	955	705	1350	995	M30 X 3.5	960	705	1510	1120	2100	1550
1-1/8" - 7	480	355	1080	795	1750	1290	M30 X 2	1060	785	1680	1240	2320	1710
1 1/8" - 12	540	395	1210	890	1960	1440	M36 X 3.5	1730	1270	2650	1950	3660	2700
1 1/4" - 7	680	500	1520	1120	2460	1820	M36 X 2	1880	1380	2960	2190	4100	3220
1 1/4" - 12	750	555	1680	1240	2730	2010	¹ in-tpi = nominal thread diameter in inches-threads per ² N·m = newton-meters ³ ft-lb= foot pounds ⁴ mm x pitch = nominal thread diameter in millimeters x						
1 3/8" - 6	890	655	1990	1470	3230	2380							
1 3/8" - 12	1010	745	2270	1670	3680	2710							
1 1/2" - 6	1180	870	2640	1950	4290	3160							
1 1/2" - 12	1330	980	2970	2190	4820	3560							

Torque tolerance + 0%, -15% of torquing values. Unless otherwise specified use torque values listed above.

Tire Inflation Chart	
Tire	Inflation PSI
Front Tires	7 psi*
Rear Tires	7 psi*

* Tire pressure may be increased to accommodate additional cargo load. Maximum tire pressure is noted on tire side wall.

Table of Contents

Section 13: Appendix

Notes

Land Pride Limited Warranty

Utility Vehicle

Land Pride, A Division of Great Plains Manufacturing, Inc., 1525 East North Street, Salina, Kansas, USA (hereinafter "Land Pride") warrants for a period of twelve (12) months from the date of initial retail purchase from an authorized Land Pride Utility Vehicle dealer that each new Land Pride Utility Vehicle shall be free, under normal use and maintenance, from any defect in material and workmanship subject to the following conditions, exclusions, obligations and limitations.

1. **Coverage** Any material or workmanship found and determined to be defective by Land Pride within the (12) twelve month warranty period shall be remedied without charge for parts or labor at any authorized Land Pride Utility Vehicle dealership.
2. **Owner's Obligations** The following obligations must be fulfilled by the owner to maintain the validity of Land Pride warranty:
 - a. The original owner must service the vehicle according to the periodic maintenance charts contained in the Operator's Manual as neglecting to do so can impede the warranty process. These inspections, maintenance services and adjustments are to be performed at the owner's expense.
 - b. The owner must present a copy of the warranty registration card or other positive proof of initial retail purchase date issued at the time of purchase, to an authorized Land Pride Utility Vehicle dealer at the time the warranty repairs are to be performed on the vehicle.
3. **Exclusions** The following are specifically excluded from this warranty:
 - a. Any Land Pride Utility Vehicle used for rental purposes.
 - b. Any Land Pride Utility Vehicle used to tow loads in excess of the maximum trailer weight specified in the Operator's Manual.
 - c. Any Land Pride Utility Vehicle used to carry loads in excess of the maximum vehicle load rating including occupants and cargo as stated in the Operator's Manual.
 - d. Any Land Pride Utility Vehicle that has been altered or modified without Land Pride's specific recommendation, approval and authorization in writing.
 - e. Any Land Pride accessories that are covered by the Land Pride Parts and Accessories Warranty Policy.
 - f. Any Land Pride Utility Vehicle that has not been completely and properly assembled and pre-delivered by an authorized Land Pride Utility Vehicle dealer.
4. **Limitations** This warranty shall not apply to or include any of the following:
 - a. Repair or replacement required as result of (I) accident, (II) misuse or neglect, (III) lack of reasonable and proper maintenance, (IV) repairs improperly performed or replacements improperly installed, (V) use of replacement parts or accessories not conforming to Land Pride specifications which adversely affect performance and/or durability, (VI) alterations or modifications not recommended or approved in writing by Land Pride and/or (VII) wear and deterioration occasioned by the use of this vehicle.
 - b. Pre-delivery, routine maintenance, service and adjustments.
 - c. Engine (Warranty is covered by the original engine manufacturer).
 - d. Tires, belts, shocks, brakes and body (Considered wear items).
5. **Limited Liability** The liability of Land Pride under the twelve (12) month warranty is limited solely to the remedying of defects in materials or workmanship by an authorized Land Pride Utility Vehicle dealer at its place of business during customary business hours. This warranty does not cover inconvenience, loss of use of the vehicle, or transportation of the vehicle to or from the Land Pride dealer. **Land Pride shall not be liable for any other expense, loss, or damage, whether direct, incidental, consequential, or exemplary arising in connection with the sale or use of or the inability to use the Land Pride Utility Vehicle for any purpose.** Some states, provinces or countries do not allow the exclusion or limitation of any incidental or consequential damages, so the above limitation or exclusion may not apply to you.
 - a. No express warranty is given by Land Pride with respect to the Land Pride Utility Vehicle except as set forth herein. Any warranty implied by law, including any warranty of merchantability or fitness for a particular purpose, is expressly limited to the twelve (12) month warranty terms set forth herein. The foregoing statements of warranty are exclusive and in lieu of all other remedies. Some states, provinces or countries do not allow limitations on how long an implied warranty lasts, so the above limitation may not apply to you.
 - b. No dealer is authorized to modify this Land Pride Utility Vehicle Warranty.
 - c. Any breach of warranty claim must be brought forth within 15 months of original sale.
6. **Legal Rights** This warranty gives you specific legal rights and you may also have other rights which vary from state, province or country.

Effective January 2, 2003



Corporate Office: P.O. Box 5060
Salina, Kansas 67402-5060 USA
www.landpride.com
