

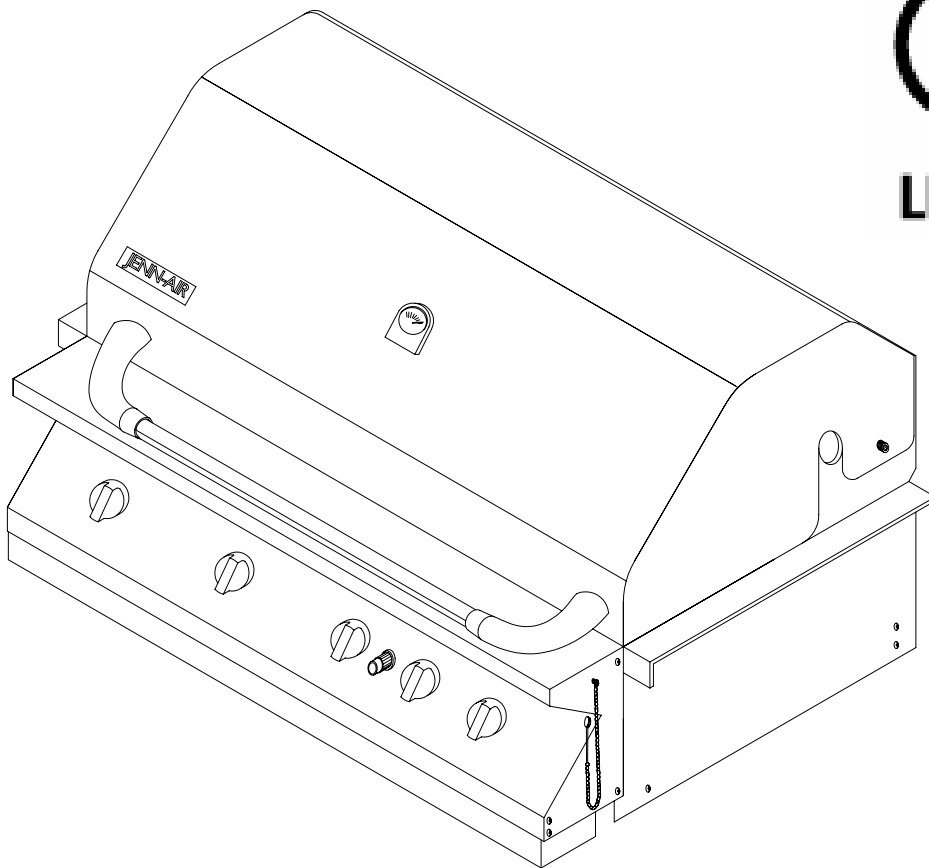

STAINLESS STEEL BUILT-IN GAS GRILL

MODEL #s: 720-0138-NG / 720-0141-LP LOWE'S ITEM #s: 168932/168931

Jenn-Air is a Trademark of the Maytag Corporation and is used under license to Lowe's Companies, Incorporated.



GAS-FIRED



**19TY
LISTED**

FOR OUTDOOR USE ONLY



**PLEASE CONTACT 1-800-554-5799 FOR ASSISTANCE
DO NOT RETURN TO PLACE OF PURCHASE**

TABLE OF CONTENTS

SECTION ONE

Important Warnings	1
Safety Instructions	2-4
Placement of the Grill	4

SECTION TWO

Model Specifications... ..	5
Island Construction	6
Front View of Opening	7
Rear View of Opening.....	8

SECTION THREE

Battery Installation	9
LP Gas Hook-up	10
Propane Tank Assembly	11
Installation of NG Regulator	12
Natural Gas Hook-up	13

SECTION FOUR

Leak Testing	14-15
Installer Final Checklist	15
Operating Instructions	16-17
Lighting Instructions	18
Easy Lighting Illustrations	19
Match Lighting the Grill	20
Care & Maintenance	21
Troubleshooting	22

SECTION FIVE

Exploded View Model 720-0138-NG	23
Parts List Model 720-0138-NG	24
Exploded View Model 720-0141-LP	25
Parts List Model 720-0141-LP	26

SECTION SIX

Grilling Hints	27-29
Grilling Recipes	30-31

SECTION SEVEN

Warranty Information	32
-----------------------------	----

IMPORTANT WARNINGS



WARNING

FOR YOUR SAFETY

If you smell gas:

1. Shut off gas to the appliance.
2. Extinguish any open flames.
3. Open the top cover or lid.
4. If the odor continues, immediately call your gas supplier or local fire department.
5. Do not store or use gasoline or other flammable vapors and liquids in the vicinity of this or any other appliance.

SAFETY INSTRUCTIONS

SAFETY SYMBOLS



WARNING

Hazardous or unsafe practices that could result in personal injury or death.



CAUTION

Hazardous or unsafe practices that could result in personal injury.

COMMON CAUTIONS AND WARNINGS



INSECT WARNING

Spiders and insects can nest inside the burners of this and other grills, which could disrupt gas flow. This dangerous condition could cause a fire behind and beneath the valve panel, damaging the grill and making it unsafe to operate.

Inspect the grill at least twice a year.



CAUTION

Remove the warming rack when using the rotisserie burner. High heat from the burner could cause the warming rack to bend.

Do not leave the grill unattended while cooking.



ELECTRICAL GROUNDING WARNING

The rotisserie motor should be plugged directly into a properly grounded receptacle.

Do not cut or remove the grounding prong from this plug.

Keep the rotisserie motor electric cord away from the heated surfaces of the grill.

When not in use, remove and store the motor in a dry location.



WARNING

Do not try lighting this appliance without first reading the "LIGHTING INSTRUCTIONS" section of this manual.

Do not use aluminum foil to line the grill racks or grill bottom. This can severely upset combustion air flow or trap excessive heat in the control area.



LP GAS CYLINDER WARNING

The LP Gas Cylinder must be fitted with an Overfill Protection Device (OPD).

For Your Safety:

1. Do not store spare LP-gas cylinders under or near this appliance.
2. Never fill the cylinder beyond 80 percent capacity.
3. If the information above is not followed exactly, a fire resulting in death or serious injury could occur.

SAFETY INSTRUCTIONS



WARNING

Do not try lighting this appliance without first reading the "LIGHTING INSTRUCTIONS" section of this manual.

TESTED IN ACCORDANCE WITH ANSI Z21.58b LATEST STANDARD and CGA 1.6b-2002 STANDARD FOR OUTDOOR COOKING GAS APPLIANCES. THIS GRILL IS FOR OUTDOOR USE ONLY.

Check your local building codes for the proper method of installation. In the absence of local codes, this unit should be installed in accordance with the National Fuel Gas Code ANSI Z223.1/NFPA 54, Storage and Handling of Liquefied Petroleum Gases, ANSI/NFPA 58 or CSA B149.1 Natural Gas and Propane Installation Code, and the National Electrical Code, ANSI/NFPA 70.



CALIFORNIA PROPOSITION 65-WARNING

The burning of gas fuel generates some byproducts, which are known by the State of California to cause cancer or reproductive harm. To minimize exposure to these substances, always operate this unit according to the care and use manual, ensuring you provide good ventilation when cooking with gas.

SAFETY PRACTICES TO AVOID PERSONAL INJURY

When properly cared for, your grill will provide safe, reliable service for many years. However, extreme care must be used as the grill produces intense heat that can increase accident potential. When using this appliance, basic safety practices must be followed, including the following:

Do not repair or replace any part of the grill unless specifically recommended in this manual. All other service should be referred to a qualified technician.

This grill is not intended to be installed in or on recreational vehicles or boats.

Children should not be left alone or unattended in an area where the grill is being used. Do not allow them to sit, stand or play in or around the grill at any time.

Do not store items of interest to children around or below the grill.

Do not permit clothing, pot holders or other flammable materials to come in contact with or too close to any grate, burner or hot surface until it has cooled. The fabric could ignite and cause personal injury.

For personal safety, wear proper apparel. Loose fitting garments or sleeves should never be worn while using this appliance. Some synthetic fabrics are highly flammable and should not be worn while cooking.

Only certain types of glass, heat-proof glass ceramic, earthenware, or other glazed utensils are suitable for grill use. These materials may break with sudden temperature changes. Use only on low or medium heat settings in accordance with the manufacturer's guidelines.

Do not heat unopened food containers. A build-up of pressure may cause the containers to burst.

Use a covered hand when opening the grill lid.

Never lean over an open grill.

When lighting a burner, pay close attention to what you are doing. Make certain you are aware of which burner you are lighting, so your body and clothing remain clear of open flames.

SAFETY INSTRUCTIONS

When using the grill, do not touch the grill rack, burner grate or immediate surroundings as these areas become extremely hot and could cause burns. Use only dry potholders. Moist or damp potholders on hot surfaces may cause steam burns. Do not use a towel or bulky cloth in place of potholders. Do not allow potholders to touch hot portions of the grill rack.

Grease is flammable. Let hot grease cool before attempting to handle it. Do not allow grease deposits to collect in the grease tray at the bottom of the grill's firebox. Clean the grease tray often.

Do not use aluminum foil to line the grill racks or grill bottom. This can severely upset combustion air flow or trap excessive heat in the control area.

For proper lighting and performance of the burners, keep the burner ports clean. It is necessary to clean them periodically for optimum performance. The burners will only operate in one position and must be mounted correctly for safe operation.

Clean the grill with caution. To avoid steam burns, do not use a wet sponge or cloth to clean the grill while it is hot. Some cleaners produce noxious fumes or can ignite if applied to a hot surface.



INSECT WARNING

Spiders and insects can nest inside the burners of this and other grills, which could disrupt gas flow. This dangerous condition could cause a fire behind and beneath the valve panel, damaging the grill and making it unsafe to operate.

Inspect the grill at least twice a year.

Turn off grill controls and make certain the grill is cool before using any type of aerosol cleaner on or around the grill. The chemical that produces the spraying action could, in the presence of heat, ignite or cause metal parts to corrode.

Do not use the grill to cook excessively fatty meats or other products which promote flare-ups.

Do not operate the grill under unprotected combustible constructions. Use only in well ventilated areas. Do not use in buildings, garages, sheds, breezeways or other such enclosed areas.

This unit is intended for outdoor use only.

Keep the areas surrounding the grill free from combustible materials and fluids, trash, and vapors such as gasoline or charcoal lighter fluid. Do not obstruct the flow of combustion and ventilation air. If the unit is stored indoors make sure it is cool.

Do not use briquettes of any kind in the grill.

The 720-0138-NG and 720-0141-LP grills are designed for optimum performance without the use of briquettes. Do not place briquettes on the flame tamers as this will block the vent to the grill burners. Adding briquettes can damage ignition components and knobs, and void the warranty.

Keep the back of the cart free and clear from debris. Keep electrical supply cords and the rotisserie motor cord away from heated areas of the grill.

Never use the grill in extremely windy conditions. If located in a consistently windy area (oceanfront, mountaintop, etc.), a windbreak will be required. Always adhere to the specified clearance.

PLACEMENT OF THE GRILL

CLEARANCE

Non-Combustible Construction

A minimum of 3 in. clearance from the back of the grill to non-combustible materials are required for the lid to open fully.



WARNING

Do not install this unit into combustible enclosures. There should be a minimum clearance of at least 24 in. from all sides to combustible materials.

LOCATION

When determining a suitable location take into account concerns such as exposure to wind, proximity to traffic paths, and keeping gas supply lines as short as possible.

Place the grill in well-ventilated areas. Never locate the grill in a building, garage, breezeway, shed or other such enclosed areas. During heavy use, the grill will produce a lot of smoke.

GRILL SPECIFICATIONS

Description	720-0138-NG and 720-0141-LP
Cutout Width	32 1/2 in. (82.55 cm)
Cutout Depth	23 in. (58.42 cm)
Cutout Height	10 1/4 in.(26.04 cm)
Gas Requirements	Natural Gas: Standard residential 1/2 in. (1.3 cm) ID gas service line. Natural gas hose/regulator assembly included with quick-connect fitting for attachment to house natural gas line.
	Liquid Propane: Supplied with hose/regulator assembly for connection to standard 5 gal, 20 lb. liquid propane gas cylinder with Type 1, QCC-1 connection.
Grill Burners	4 Cast brass main burners. Infra-red rear rotisserie burner.
BTU Ratings	Main burners 48,000 BTU/Hr. <u>Rear burners 10,000 BTU/Hr.</u> Total 58,000 BTU/Hr.
Approximate Shipping Weight	140 lbs.

GRILL SPECIFICATIONS

Description	720-0138-NG and 720-0141-LP
Cutout Width	32 1/2 in. (82.55 cm)
Cutout Depth	21 1/2 in. (54.61 cm)
Cutout Height	10 3/4 in.(27.31 cm)
Gas Requirements	Natural Gas: Standard residential 1/2 in. (1.3 cm) ID gas service line. Natural gas hose/regulator assembly included with quick-connect fitting for attachment to house natural gas line.
	Liquid Propane: Supplied with hose/regulator assembly for connection to standard 5 gal, 20 lb. liquid propane gas cylinder with Type 1, QCC-1 connection.
Grill Burners	4 Cast brass main burners. Infra-red rear rotisserie burner.
BTU Ratings	Main burners 48,000 BTU/Hr. <u>Rear burners 10,000 BTU/Hr.</u> Total 58,000 BTU/Hr.
Approximate Shipping Weight	150 lbs.

ISLAND CONSTRUCTION

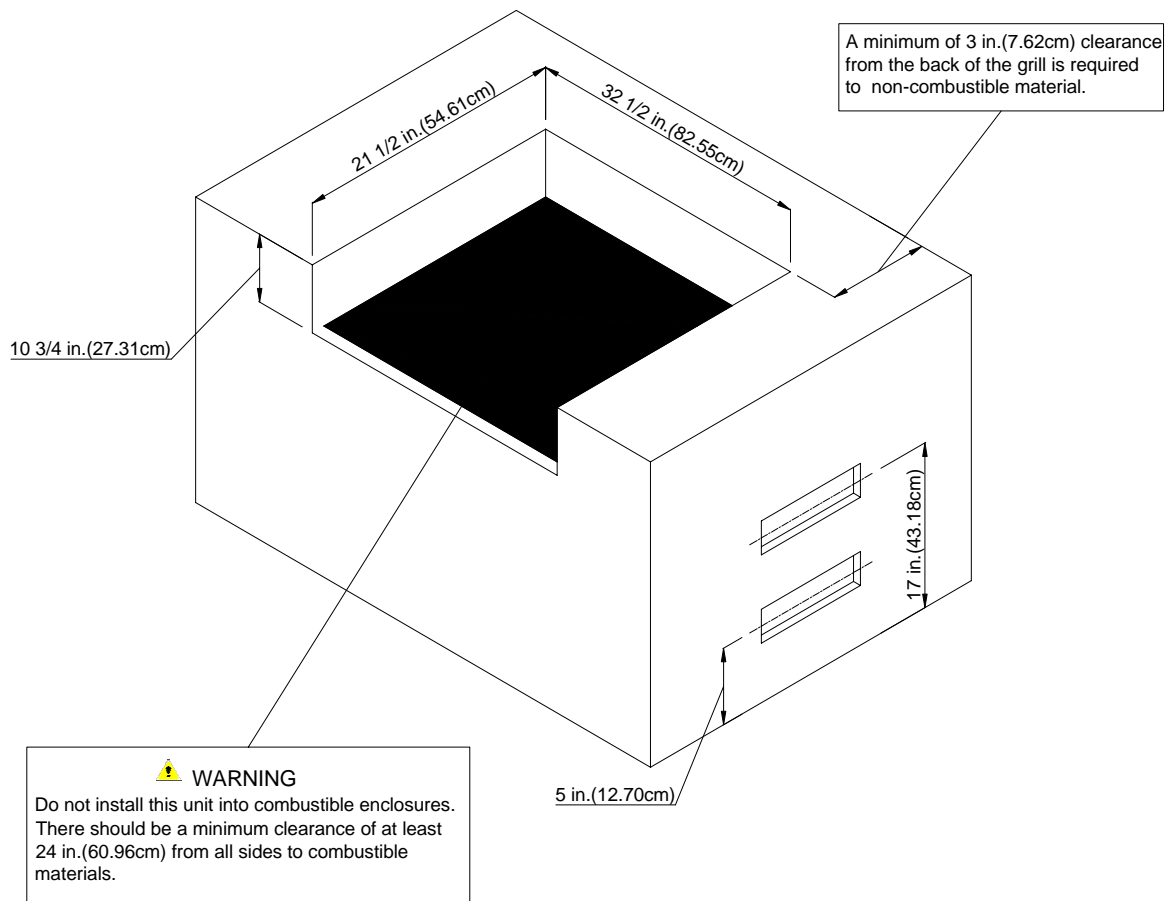

Island cutout dimensions for Jenn-Air 4 burner LP and NG built-in grills:

Width	32 1/2 in. (82.55 cm)
Depth	21 1/2 in. (54.61 cm)
Height	10 3/4 in. (27.31 cm)

SIDE VIEW FOR BUILT-IN OPENING

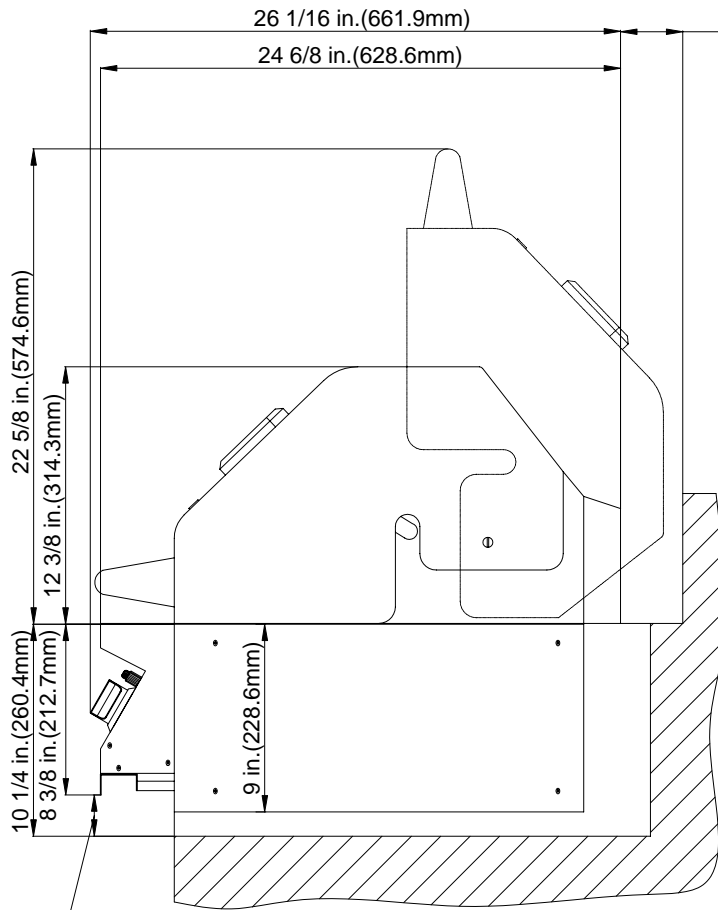

A minimum of 3 in. (76.2mm) is required between the back of the grill and any non-combustible material. A minimum of 24 in. (609.6mm) is required between the back of the grill and any combustible material.

To ensure proper combustion, 1 7/8 in. (47.6mm) space is needed between the bottom of the grease tray and the island material.

The following are minimum clearances necessary around the Jenn-Air built-in 4 burner grills (Item numbers: 168932/168931):

Rear Clearance: 3 in. to non-combustible materials
24 in. to combustible materials

Combustion gap below control panel: 1 3/4 in.

BATTERY INSTALLATION

1. To install the battery, remove the ignition button housing.
2. Insert the battery into the housing with the positive pole of the battery facing outward.
3. Replace the ignition button housing after the battery has been installed (See the image below).

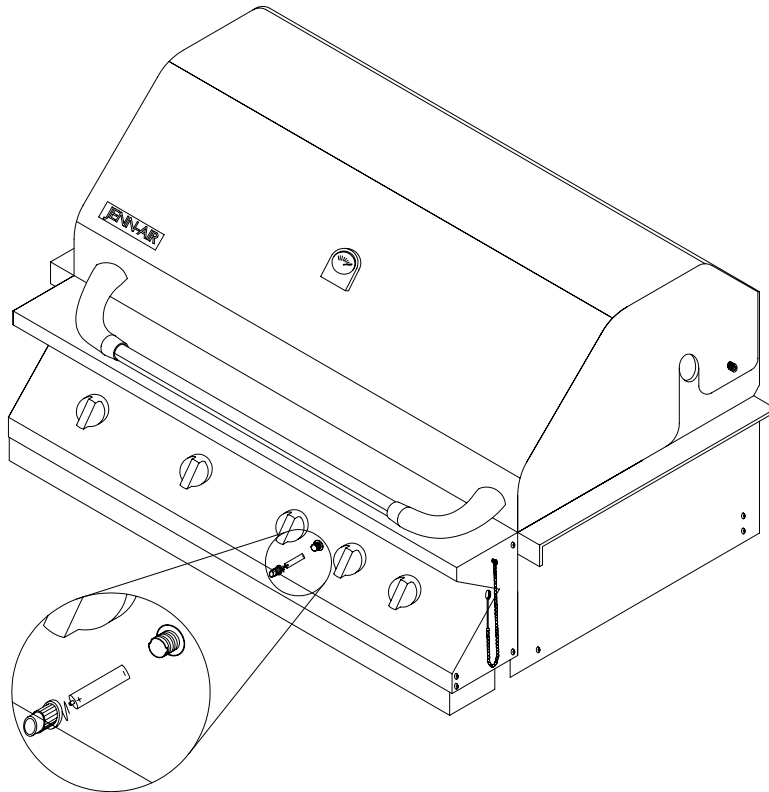

LP GAS HOOK-UP

Only the pressure regulator and hose assembly supplied with the grill should be used. Any replacement pressure regulator and hose assembly must be specified by the grill manufacturer.

This is a liquid propane configured grill. Do not attempt to use a natural gas supply.

Total gas consumption (per hour) of 720-0141-LP grill with all burners on "HI":

Main burners	48,000 BTU/Hr.
Rotisserie burner	10,000 BTU/Hr
<u>Total</u>	<u>58,000 BTU/Hr.</u>

The installation of this appliance must conform with local codes or, in the absence of local codes, to the national fuel gas code, ANSI Z223.1. Installation in Canada must be in accordance with the Standard CAN/CG A-B149.2 (installation code for gas burning appliances and equipment) and local codes.

LP GAS CYLINDER REQUIREMENTS (20lb. Cylinder)

A dented or rusty LP gas cylinder may be hazardous and should be checked by your LP supplier. Never use a cylinder with a damaged valve. The LP gas cylinder must be constructed and marked in accordance with the specifications for LP gas cylinders of the U.S. Department of Transportation (DOT), or the National Standard of Canada, CAN/CSA-B339, Cylinders, Spheres and Tubes for Transportation of Dangerous Goods; and Commission.

The 20lb. cylinder must be provided with a shut off valve terminating in an LP gas supply cylinder valve outlet specified, as applicable, for connection type QCC1 is the standard for compressed gas cylinder valve outlet and inlet connection ANSI/CGA-V-1.

The cylinder supply system must be arranged for vapor withdrawal. The cylinder must include a collar to protect the cylinder valve.

Manifold pressure: (operating): 10 in. water column (W.C.), (non-operating): 11.2 in. water column (W.C.).

The LP gas cylinder must be fitted with an Overfill Protection Device (OPD).

LP GAS HOOK-UP

Make sure the black plastic grommets on the LP cylinder valve are in place, and the hose does not come into contact with the grease tray or grill head.

LP GAS SUPPLY CYLINDER CONNECTION

Your grill is equipped with gas supply orifices for use only with liquid propane gas. It is also equipped with a high capacity hose/regulator assembly for connection to a standard 20lb. LP cylinder (18-1/4 in. high, 12-1/4 in. diameter).

To connect the L.P. gas supply cylinder:

1. The tank valve should be in the "OFF" position. If not, turn the knob clockwise until it stops.
2. Make sure the tank valve has the proper type 1 connection external male threads per ANSIZ21.81.
3. Make sure all burner valves are in the "OFF" position.
4. Inspect the valve connections, the port and regulator assembly. Look for damage or debris. Remove debris, and inspect hose for damage.
5. When connecting the regulator assembly to the tank valve, use your hand to tighten the nut clockwise until it stops. Use of a wrench may damage the quick coupling nut and result in a hazardous condition.
6. Open the tank valve fully by turning the valve counterclockwise.
7. Before lighting the grill, use a soap and water solution to check all the connections for leaks.
8. If a leak is found, turn the tank valve off and do not use the grill until a local LP gas dealer can make repairs.

 **WARNING**
Do not attempt to use damaged or obstructed equipment. See your local LP gas dealer for repair.

LP GAS SUPPLY CYLINDER DISCONNECTION

To disconnect the LP gas cylinder:

1. Turn the burner valves off and make sure the grill is cool.
2. Turn the tank valve off. (Turn clockwise to stop).
3. Detach the regulator assembly from the tank valve by turning the quick coupling nut counterclockwise.

PROPANE TANK ASSEMBLY

1. Attach the regulator to the propane tank by turning the regulator handle clockwise.
2. Turn off the LP supply at the cylinder when the grill is not in use.

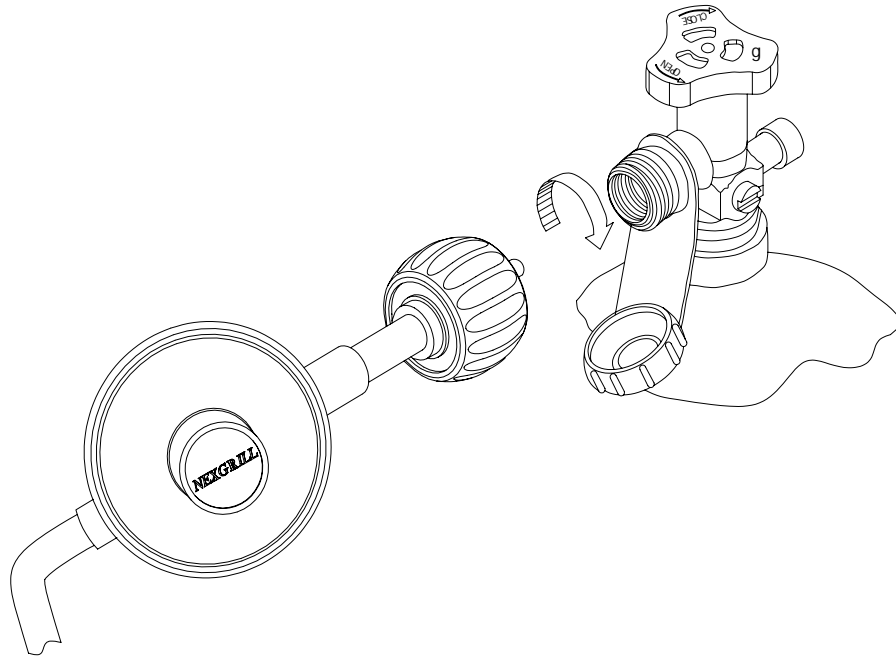

INSTALLATION OF NATURAL GAS REGULATOR

1. The Natural Gas regulator has been factory installed. Attach the PVC gas hose to the regulator (See drawing below).
2. Adjust the brass elbow so that it is pointing down.
3. Connect the other end of the PVC gas hose to the house gas line using the quick-connect fitting.

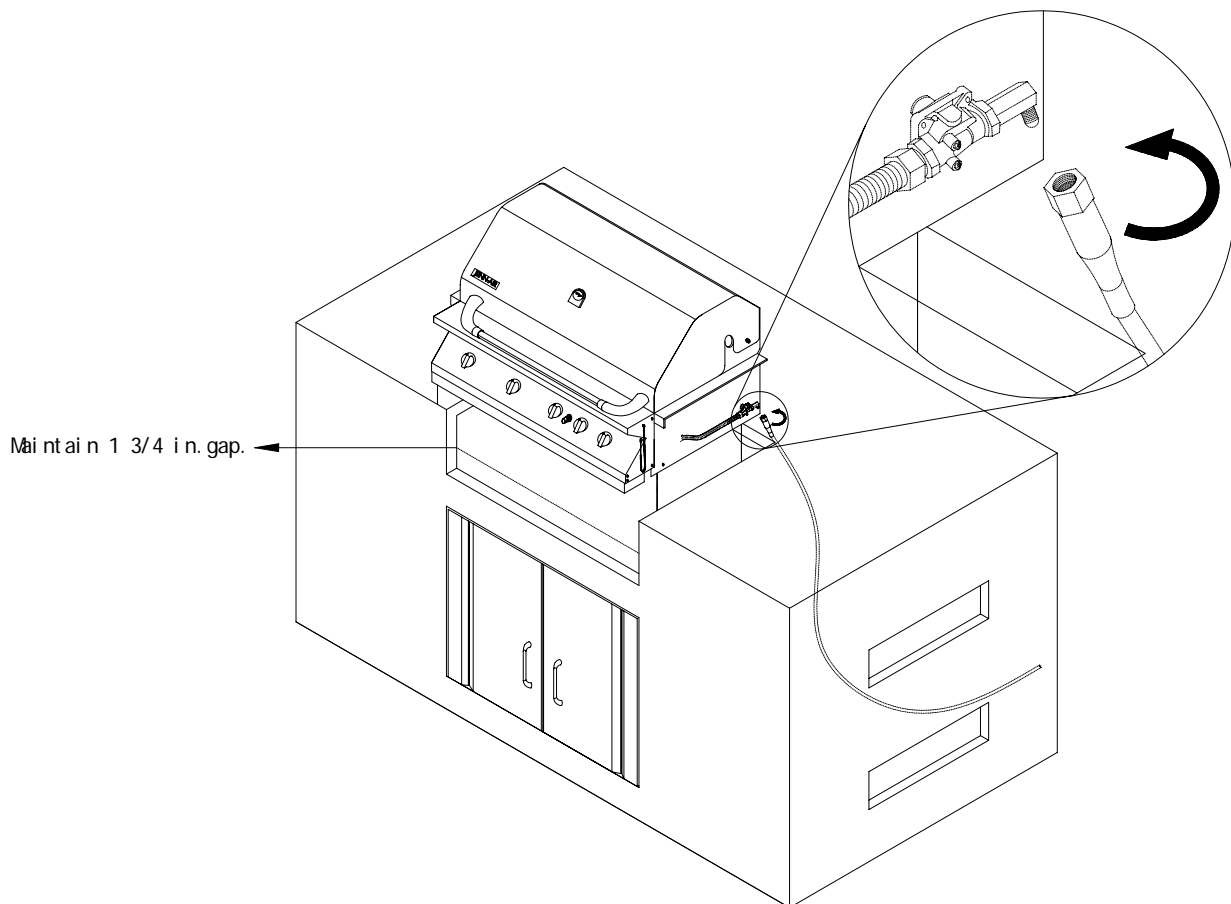

NATURAL GAS HOOK-UP

Only the pressure regulator and hose assembly supplied with the grill should be used. Any replacement pressure regulator and hose assembly must be specified by the grill manufacturer.

The installation of this appliance must conform with the local codes or, in the absence of local codes, to the national fuel gas code, ANSI Z223.1.

Total gas consumption (per hour) of the 720-0138-NG grill with all burners on the “HI” setting:

Main burners	48,000 BTU/Hr
<u>Rear Burner</u>	<u>10,000 BTU/Hr</u>
Total	58,000 BTU/Hr

LEAK TESTING

GENERAL

Although all gas connections on the grill are leak tested at the factory prior to shipment, a complete gas tightness check must be performed at the installation site. Periodically check the whole system for leaks following the procedures listed below.

If the smell of gas is detected at anytime you should immediately check the entire system for leaks.

BEFORE TESTING

Make sure all packing materials have been removed from the grill, including the burner tie-down straps.



WARNING

Do not use the grill until all connections have been checked and do not leak.

Do not smoke while leak testing.

Never leak test with an open flame.

Make a soap solution of one part liquid detergent and one part water. You will need a spray bottle, brush, or rag to apply the solution to the fittings.

TO TEST

1. Turn off all control valves, and turn on the gas supply.
2. Apply the soap solution to all pipe fittings, from the natural gas regulator and supply valve or from the LP cylinder up to and including the pipe that connects to the burners. Soap bubbles will appear where a leak is present.
3. If a leak is present, immediately turn off the gas supply and tighten the leaky fittings.
4. Turn the gas back on and recheck.
5. If gas continues to leak from any of the fittings, turn off the gas supply, and contact customer service at 1-800-554-5799.

Only those parts recommended by the manufacturer should be used on the grill. Substitutions will void the warranty.

GAS FLOW CHECK

Each grill burner is tested and adjusted at the factory prior to shipment. However, variations in the local gas supply may make it necessary to adjust the burners. The flames of the burners should be visually checked. Flames should be blue and stable with no yellow tips, excessive noise or lifting.

If any of these conditions exist, first check to see if the burner is blocked by dirt, debris, spider webs, etc.

If the burner is free of blockages, you will need to fine-tune the air/gas mixture by moving the adjustment bolt (See the image on page 15).

Remember it is better to make several minor adjustments as opposed to a single large adjustment.

It is handy to keep a spray bottle of soapy water near the shut-off valve of the gas supply line. Spray all the fittings. Bubbles indicate leaks.

Disconnected LP cylinders must have threaded valve plugs tightly installed, and must not be stored in a building, garage or any other enclosed area.

The gas must be turned off at the supply cylinder when the unit is not in use.

If the appliance is stored indoors the cylinder must be disconnected and removed from the appliance. Cylinders must be stored outdoors in a well-ventilated area out of reach of children.



WARNING

Always check for leaks after every LP tank change.

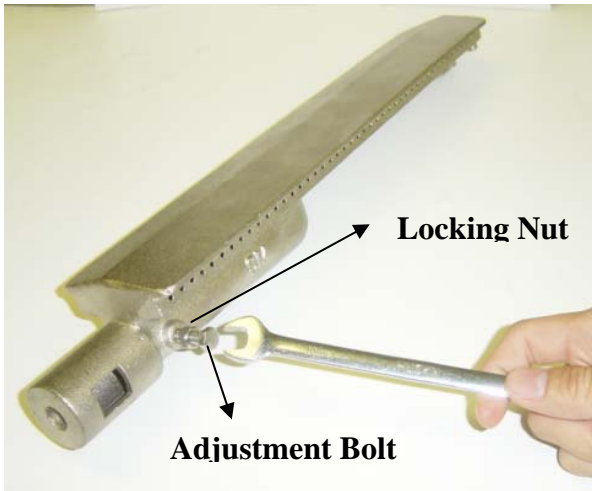

CAUTION

Burner adjustments should only be performed after the burners have cooled.

Always tighten the locking nut before relighting the burner

GAS FLOW ADJUSTMENTS

- If the flames have yellow tips, loosen the locking nut and move the bolt in a clockwise direction.
- If the flames are making excessive noise or lifting, loosen the locking nut and turn the bolt in a counter-clockwise direction.
- For questions regarding flame stability, contact customer service at 1-800-554-5799.

INSTALLER FINAL CHECK

- | | |
|--|--|
| <ul style="list-style-type: none"> <input type="checkbox"/> Specified clearance maintained 24 in. from combustible materials. <input type="checkbox"/> All internal packaging has been removed. <input type="checkbox"/> All the burners are factory installed. | <ul style="list-style-type: none"> <input type="checkbox"/> The hose and regulator are properly connected. <input type="checkbox"/> The unit has been tested and is free of leaks. <input type="checkbox"/> The gas supply shut off valve has been located. |
|--|--|

Model 720-0138-NG



WARNING

1. The outdoor cooking gas appliance and its individual shutoff valve must be disconnected from the gas supply piping system during any pressure testing of that system at test pressure in excess of ½ psi (3.5 kpa).
2. The outdoor cooking gas appliance must be isolated from the gas supply piping system by closing its individual manual shutoff valve during any pressure testing of the gas supply piping system at test pressures equal to or less ½ psi (3.5 kpa).

Model 720-0141-LP



WARNING

1. Do not store spare LP gas cylinders under or near this appliance.
2. Never fill the cylinder beyond 80 percent capacity.
3. If the information above is not followed exactly, a fire resulting in death or serious injury could occur.

OPERATING INSTRUCTIONS

GENERAL USE OF THE GRILL AND ROTISSERIE

Each main burner is rated at 12,000 BTU/Hr. The main grill burners encompass the entire cooking area and are side ported to minimize blockage from falling grease and debris. Above the burners are stainless steel flame tamers. The igniter knobs are located on the lower center portion of the valve panel. Each rotary igniter is labeled on the control panel.

USING THE GRILL

Grilling requires high heat for searing and proper browning. Most foods are cooked at a "HI" heat setting for their entire cooking time. However, when grilling large pieces of meat or poultry, it may be necessary to turn the heat to a lower setting after the initial browning. This method cooks the food thoroughly without burning the outside.

Food cooked for a long time or basted with a sugary marinade may need a lower heat setting near the end of its cooking time.

To begin:

1. Make sure the grill has been leak tested and is properly located.
2. Remove remaining packing materials.
3. Light the grill burners using the instructions on page 18.
4. Turn the control knob(s) to "HI" setting and preheat the grill for 15 minutes. The grill lid is to be closed during the appliance preheat period.
5. Place the food on the grill and cook to the desired doneness. If necessary, adjust the heat setting. The control knob may be set to any position between "HI" and "LO".



CAUTION

Do not leave the grill unattended while cooking.

The grill is designed to grill efficiently without the use of lava rocks or briquettes of any kind. Heat is radiated by the stainless steel flame tamers positioned above each burner.

USING THE ROTISSERIE BURNER

Your grill is capable of performing back burner rotisserie cooking.

Light the rear burner as described in the lighting instructions on page 18. Once lit, the rotisserie burner will reach cooking temperature in about 1 minute.

The rotisserie motor is capable of turning up to a 12lb. cut of meat or poultry. The motor slides onto the stainless steel motor mount.

The rotisserie motor must be electrically grounded in accordance with local codes or, in the absence of local codes, with the National Electrical Code, ANSI/NFPA 70.



WARNING

The rotisserie motor is equipped with a plug and should be plugged directly into a properly grounded receptacle.

Do not cut or remove the grounding prong from this plug.

Keep the rotisserie motor cord away from the heated surfaces of the grill. When not in use remove and store the motor in a dry location.

THE ROTISSERIE SKEWER

The skewer for the rotisserie should be assembled into the motor assembly by placing the pointed end into the motor, and then sliding the grooved bushing into the slot at the opposite side of the grill.

The thumbscrew for the grooved bushing should be inside the grill body.

LOADING THE ROTISSERIE SKEWER

1. Screw the bushing into the skewer rod at the opposite end from the point.
2. Slide and tighten the counter balance apparatus onto the skewer rod approximately 2-4 in. from the bushing.
3. Slide the first meat fork onto the skewer rod prongs toward the food.
4. Center the product to be cooked on the skewer, and then push the meat forks firmly together.
5. Tighten the wing nuts.
6. It may also be necessary to wrap the food with butcher's string (never use nylon or plastic string) to secure any loose portions.
7. Once the food is secure, insert the skewer into the motor.

It is normal for the skewer to flex when larger cuts of meat are being cooked. It may also be necessary to remove the cooking grids for larger cuts of meat.

If the meat scrapes on the cooking grids during any part of the rotation, the cooking grids must be removed.

Adjust the counter balance weight to balance the heavier side of the meat and avoid lopsided rotation of the rotisserie motor.

NOTE

After its first use, the stainless steel adjacent to the rotisserie burner will most likely turn dark blue. This is a normal property of the non-rusting, type stainless steel used on the grill.



CAUTION

Remove the warming rack when using the rotisserie burner. High heat from the burner may cause the warming rack to bend.

LIGHTING INSTRUCTIONS

BEFORE LIGHTING...

Inspect the gas supply piping prior to turning the gas "ON". If there is evidence of cuts, wear, or abrasion, it must be replaced prior to use.



WARNING

Do not use the grill if gas odor is present. Contact customer service at 1-800-554-5799.

Leak check the piping and regulator connections with a soap and water solution before operating the grill (see instructions on page 14).

Only the pressure regulator supplied with the unit should be used. Never substitute regulators. If a replacement is necessary, contact customer service for proper replacement 1-800-554-5799.

TO LIGHT THE GRILL BURNER

1. Make sure all knobs are in the "OFF" position, and turn on the gas supply.
2. The igniter is built into the valve. To ignite each burner simply press and turn the control knobs to the "HI" setting, you will hear the valve click as it sends a spark to the pilot flame.
3. If the burner does not light, wait 5 minutes for any excess gas to dissipate and then retry.



WARNING

While lighting, keep your face and body as far from the grill as possible.

FLAME CHARACTERISTICS

Check for proper burner flame characteristics. Each burner is adjusted prior to shipment. However, variations in the local gas supply may make minor adjustments necessary.

Burner flames should be blue and stable with no yellow tips, excessive noise, or lifting. If any of these conditions exist, contact customer service.

Yellow flames indicate insufficient air. Noisy flames or flames that lift away from the burner indicate too much air. (See the "GAS FLOW CHECK" section on page 14).

TO LIGHT THE ROTISSERIE BURNER

1. Open the lid and press the knob for about 5 seconds without turning it. This will allow time for the gas to flow into the rear burner.
2. Press the knob for 5 seconds, and then turn the knob to the "HI" setting.
3. Press the igniter button to light the rotisserie burner.
4. If the burner does not light, turn the control knob to the "OFF" position.
5. If the igniter does not function, follow the instruction above for match lighting.

Keep a spray bottle of soapy water near the gas supply valve, and check the connections before each use.

EASY LIGHTING ILLUSTRATIONS

MAIN BURNER LIGHTING ILLUSTRATION



1. Open the top cover or lid.



2. Press and turn one of the main burner knobs to the "HI" setting.



3. Several attempts may be required to light the burner. After the burner is lit, adjust the knob to the desired temperature setting.

ROTISSERIE BURNER LIGHTING ILLUSTRATION



1. Press and turn the Rotisserie knob to the "ON" setting.



2. Press the electric igniter button for 3 to 4 seconds to light the rotisserie burner.

MATCH LIGHTING THE GRILL

If the burner will not light after several attempts using the control knobs, the burner may be lit with a match.

1. If you have already attempted to light the burner with the igniter, allow 5 minutes for any accumulated gas to dissipate.
2. Insert a lit extended match or lighter through the cooking grids to the burner.
3. Press and turn the control knob to the "HI" setting. Continue pressing the knob until the burner ignites.
4. If the burner does not ignite within 4 seconds, turn the control knob to the "OFF" position. Wait 5 minutes and try again.



CAUTION

When lighting, keep your face and body as far from the grill as possible.

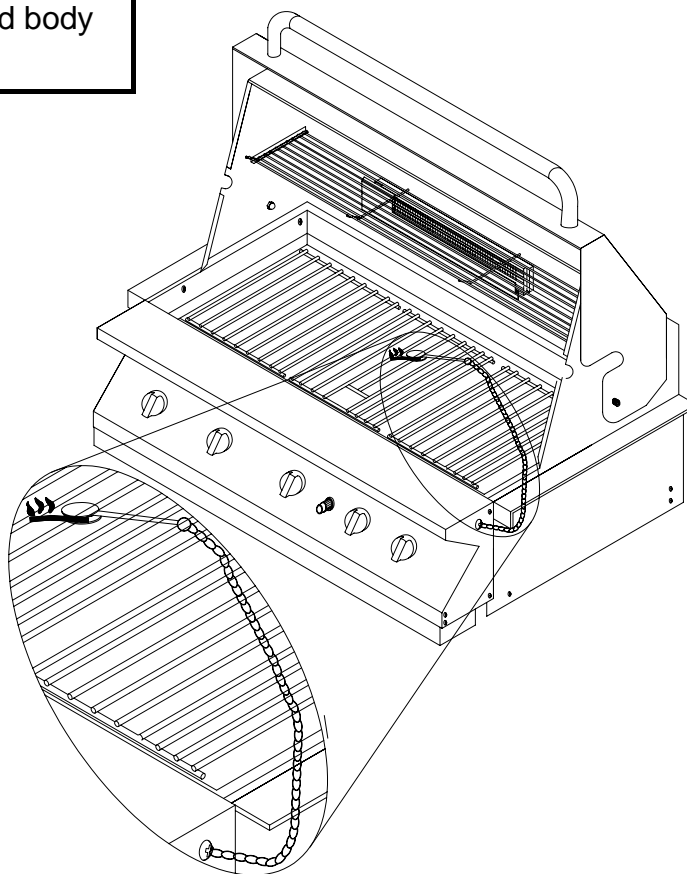

CARE & MAINTENANCE

STAINLESS STEEL

The grill is made from non-rusting and non-magnetic stainless steel. There are many different stainless steel cleaners available. Always use the mildest cleaning procedure first, scrubbing in the direction of the grain.

To touch up noticeable scratches in the stainless steel, sand very lightly with dry 100 grit emery paper in the direction of the grain.

Grease specks can gather and bake onto the surfaces of the stainless steel, giving the appearance of rust. For removal, use an abrasive pad with a stainless steel cleaner.



CAUTION

Before cleaning make sure the burners are cool, and the gas supply and knobs are in the "OFF" position.

GRILL RACK

The easiest way to clean the grill is immediately after cooking is completed, and the flame has been turned off.

Wear a barbeque mitt to protect your hand from the heat and steam.

Scrub the hot grill by dipping a bristle barbeque brush in tap water. Cleaning will be more difficult if the grill is allowed to cool.

GRILL BURNERS

Extreme care should be taken when moving a burner as it must be correctly centered on the orifice before any attempt is made to relight the grill. Frequency of cleaning will depend on how often you use the grill.

GRILL BURNER REMOVAL/INSTALLATION

The grill burners are factory installed. To remove the main burners for cleaning,

1. Locate the cotter pin at the rear of the burner on the bottom side.
2. Remove the cotter pin and lift the burner out of the fire box.
3. To reinstall the main burners, insert the burner over the valve assembly (See exploded view and parts list on pages 23 and 24).
4. Insert the back of the burner into the hole at the rear of the fire box and reinsert the cotter pin.



CAUTION

Failure to ensure proper placement of the burner over the valve assembly can cause a fire to occur behind and beneath the valve panel, thereby damaging the grill and making it unsafe to operate.

GRILL BURNER CLEANING

1. Turn off the gas supply, and make sure all the knobs are in the "OFF" position.
2. Wait for the grill to cool.
3. Clean the exterior of the burner with a wire brush. Use a metal scrapper for stubborn stains.
4. Clear clogged ports with a straightened paper clip. Never use a wooden toothpick as it may break off and clog the port.
5. If insects or other obstructions are blocking the flow of gas through the burner, call customer service at 1-800-554-5799.

GREASE TRAY CLEANING:

The grease tray should be emptied, wiped down and washed periodically in a mild detergent and warm water solution.

A small amount of sand or cat litter may be placed in the bottom of grease tray to absorb excess grease. Do not allow excess grease to accumulate and overflow out of the grease tray.

TROUBLESHOOTING



INSECT WARNING

Spiders and insects can nest in the burners of this and other grills, which could disrupt gas flow. This dangerous condition could cause a fire behind and beneath the valve panel, damaging the grill and making it unsafe to operate.

Inspect the grill at least twice a year.

WHEN TO LOOK FOR SPIDERS

You should inspect the burners twice a year or immediately after any of the following conditions occur:

1. The smell of gas in conjunction with the burner flames appearing yellow.
2. The grill does not reach temperature.
3. The grill heats unevenly.
4. The burners make popping noises.

BEFORE CALLING FOR SERVICE

If the grill does not function properly, use the checklist below before contacting your dealer for service. You may save yourself the cost of a service call.

PROBLEMS

Grill will not light when the control knob is rotated.

Burner flame is yellow or orange and the gas odor is present.

Low heat with the knob on "HI".

WHAT TO DO

- Check to see if house NG valve is open.
 - Check to see if LP tank is empty.
 - Clean wire(s) and/or electrode with rubbing alcohol and a clean swab.
 - Make sure the wire is connected to the electrode assembly.
 - Check to see if other burners operate. If so, check the gas orifice on the malfunctioning burner for an obstruction.
-
- Contact customer service at 1-800-554-5799.
-
- Check to see if the fuel hose is bent or kinked.
 - Make sure the grill area is clear of dust.
 - Check your gas supply and gas pressure.
 - If it is only one burner that appears low, make sure the orifice or burner is clean.

EXPLODED VIEW MODEL 720-0138-NG

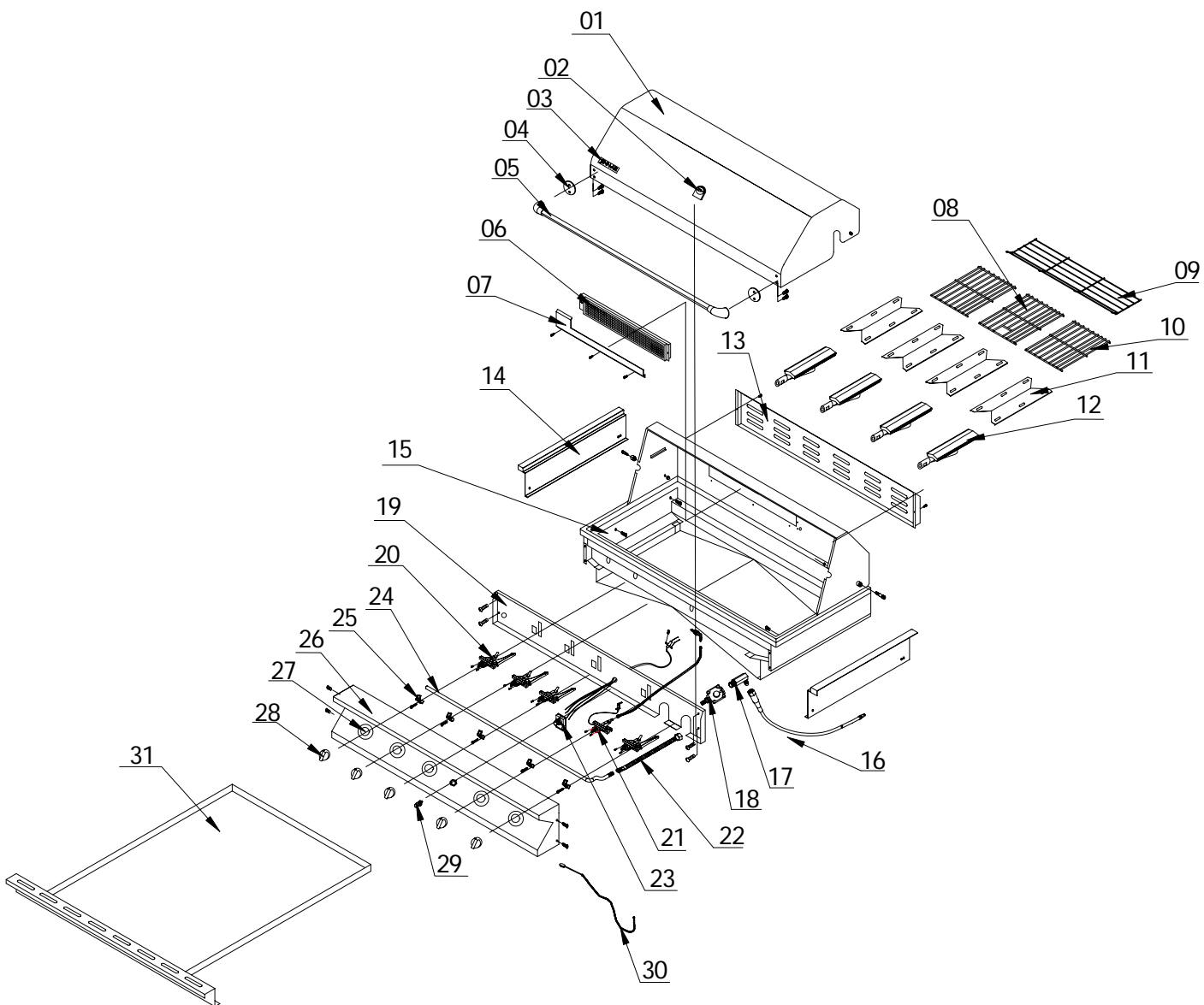

PARTS LIST

MODEL 720-0138-NG

REF#	DESCRIPTION	Q'TY	REF#	DESCRIPTION	QTY
1	Lid, Front	1	17	90 Degree Brass	1
2	Heat Indicator	1	18	Regulator, NG	1
3	Name Plate	1	19	Front Baffle, Front Burner	1
4	Heat Insulating Spacer	2	20	Gas Valve, Main Burner	4
5	Handle Assembly, Lid	1	21	Gas Valve, Infrared Burner	1
6	Infrared Burner	1	22	Gas Pipe	1
7	Gas Collector	1	23	Electronic Ignition	1
8	Cooking Grid with Hole	1	24	Manifold	1
9	Warming Rack	1	25	Manifold Retainer Bracket	5
10	Cooking Grid	2	26	Control Panel	1
11	Flame Tamer	4	27	Control Knob Seat	5
12	Main Burner	4	28	Control Knob	5
13	Rear Baffle, Rear Burner	1	29	Electronic Ignition Button	1
14	Flange	2	30	Lighting Rod	1
15	Bowl Assembly	1	31	Grease Tray	1
16	12" PVC Gas Hose	1			

EXPLODED VIEW MODEL 720-0141-LP

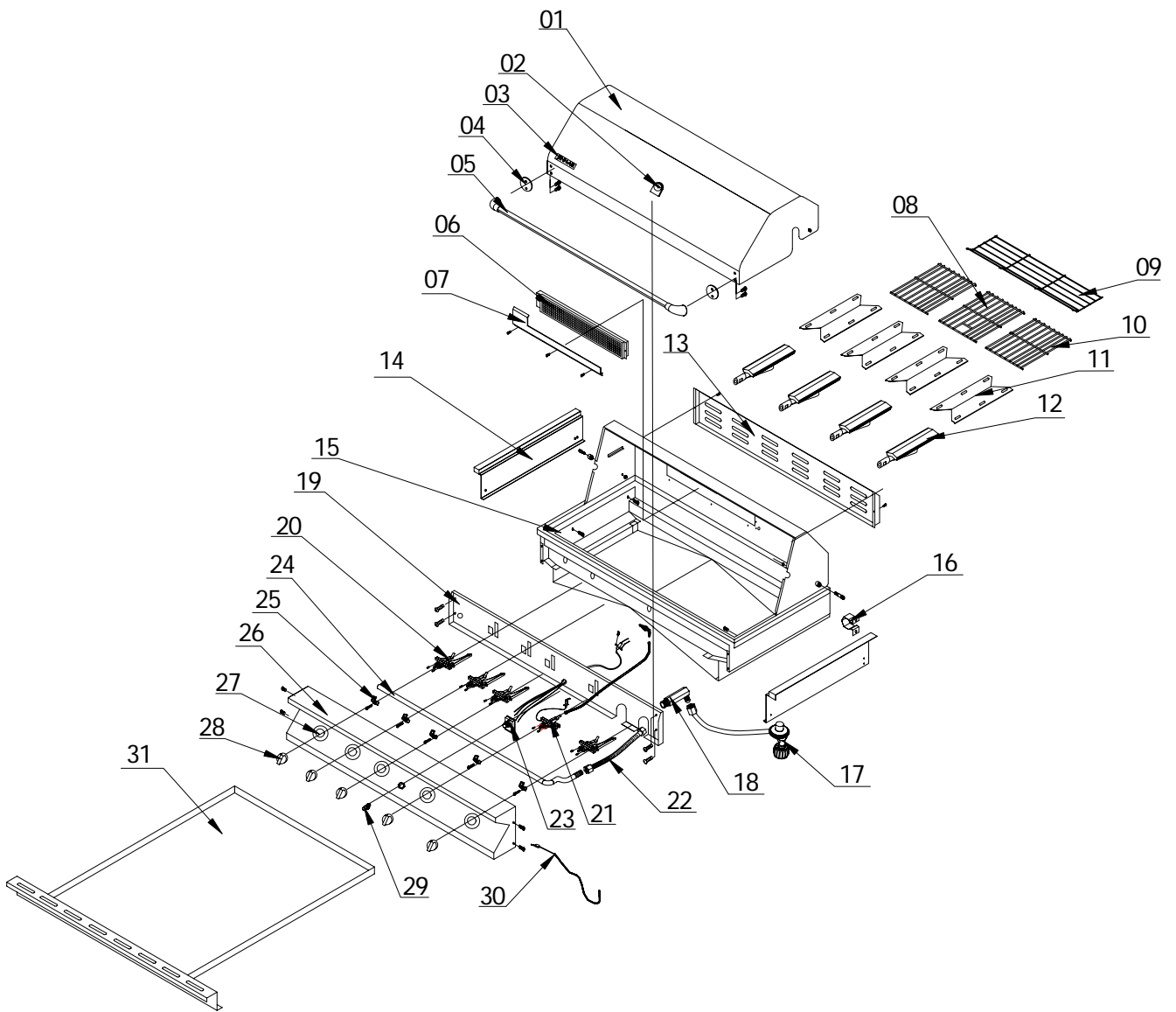

PARTS LIST

MODEL 720-0141-LP

REF#	DESCRIPTION	Q'TY	REF#	DESCRIPTION	QTY
1	Lid, Front	1	17	Regulator, LP	1
2	Heat Indicator	1	18	90 Degree Brass	1
3	Name Plate	1	19	Front Baffle, Front Burner	1
4	Heat Insulating Spacer	2	20	Gas Valve, Main Burner	4
5	Handle Assembly, Lid	1	21	Gas Valve, Infrared Burner	1
6	Infrared Burner	1	22	Gas Pipe	1
7	Gas Collector	1	23	Electronic Ignition	1
8	Cooking Grid with Hole	1	24	Manifold	1
9	Warming Rack	1	25	Manifold Retainer Bracket	5
10	Cooking Grid	2	26	Control Panel	1
11	Flame Tamer	4	27	Control Knob Seat	5
12	Main Burner	4	28	Control Knob	5
13	Rear Baffle, Rear Burner	1	29	Electronic Ignition Button	1
14	Flange	2	30	Lighting Rod	1
15	Bowl Assembly	1	31	Grease Tray	1
16	Clamp	1			

GRILLING HINTS

The preparation of meat, whether rare, medium, or well done, is affected to a large degree by the thickness of the cut.

The cooking time is affected by meat type, size, shape of the cut, the temperature of the meat when cooking begins, and the degree of preparation desired.

It is recommended that meat be defrosted overnight in a refrigerator as opposed to a microwave. This generally yields a juicier cut of meat.

Turn the meat with a spatula instead of tongs. The spatula will keep the meat whole and trap in the juices.

To get the juiciest meat, add seasoning or salt after the cooking is finished and turn the meat only once (juices are lost when the meat is turned several times). Turn the meat just after the juices begin to bubble to the surface.

Trim excess fat from the meat before cooking.

To prevent steaks or chops from curling during cooking, slit the fat around the edges at 2-inch intervals.



WARNING

Do not leave the grill unattended while cooking.

GRILL COOKING CHART

FOOD	WEIGHT OR THICKNESS	FLAME SIZE	APPROXIMATE TIME	SPECIAL INSTRUCTIONS AND TIPS
VEGETABLES				
Beets Carrots		Medium	12 to 20 minutes	Slice. Dot with butter or margarine. Wrap in heavy-duty foil. Grill, turning occasionally.
Turnips				Grill, turning once. Brush occasionally with melted butter or margarine.
Onion	1/2 inch slices	Medium	8 to 20 minutes	
Potatoes				Wrap individually in heavy-duty foil. Grill, rotating occasionally.
Sweet	Whole	Medium	40 to 60 minutes	
White	6 to 8 ounces	High	45 to 60 minutes	
Frozen				Dot with butter or margarine. Wrap in heavy-duty foil. Grill, turning occasionally.
Asparagus Broccoli Brussels Sprouts Green beans Peas		Medium	15 to 30 minutes	

FOOD	WEIGHT OR THICKNESS	FLAME SIZE	APPROXIMATE TIME	SPEICAL INSTRUCTIONS AND TIPS
French Fries		Medium	15 to 30 minutes	Place in aluminum foil pan. Grill, stirring occasionally.
MEATS BEEF				
Hamburgers	1/2 to 3/4 inch	Medium High	10 to 18 minutes 8 to 15 minutes	Grill, turning once when juices rise to the surface. Do not leave hamburgers unattended since a flare-up could occur quickly.
Tenderloin, Porterhouse, Rib eye				
Rare	1 inch 1-1/2 inch	High High	8 to 14 minutes 11 to 18 minutes	Remove excess fat from edge. Slash remaining fat at 2-inch intervals. Grill, turning once.
Medium	1 inch 1-1/2 inch	Medium to High	12 to 22 minutes 16 to 27 minutes	
Well-done	1 inch 1-1/2 inches	Medium Medium	18 to 30 minutes 16 to 35 minutes	
Lamb Chops & Steaks				
Rare	1 inch 1-1/2 inch	High High	10 to 15 minutes 14 to 18 minutes	Remove excess fat from edge. Slash remaining fat at 2-inch intervals. Grill, turning once.
Medium	1 inch 1-1/2 inch	Medium to High	13 to 20 minutes 18 to 25 minutes	Remove excess fat from edge. Slash remaining fat at 2-inch intervals. Grill, turning once. Cook well done.
Well-done	1 inch	Medium	17 to 30 minutes	
Pork Chops Well-done	1 inch 1-1/2 inches	Medium Medium	20 to 30 minutes 30 to 40 minutes	

FOOD	WEIGHT OR THICKNESS	FLAME SIZE	APPROXIMATE TIME	SPECIAL INSTRUCTIONS AND TIPS
Ribs		Medium	30 to 40 minutes	Grill, turning occasionally. During last few minutes brush with barbecue sauce, turn several times.
Pork Ham steaks (precooked)	1/2 inch slices	High	4 to 8 minutes	Remove excess fat from edge. Slash remaining fat at 2-inch intervals. Grill, turning once.
Hot dogs		Medium	5 to 10 minutes	Slit skin. Grill, turning once.
POULTRY				
Broiler/fryer	2 to 3 pounds	Low or Medium	1 to 1-1/2 hours	Place skin side up. Grill, turning and brushing frequently with melted butter, margarine, oil or marinade.
Halved or Quartered well-done Breast well-done		Medium	30 to 45 minutes	
FOOD	WEIGHT OR THICKNESS	FLAME SIZE	APPROXIMATE TIME	SPECIAL INSTRUCTIONS AND TIPS
FISH AND SEAFOOD				
Steaks				Grill, turning once. Brush with melted butter, margarine or oil to keep moist.
Halibut Salmon Swordfish	3/4 to 1 inch	Medium to High	8 to 15 minutes	
Whole Cattfish Rainbow trout	4 to 8 ounces	Medium to High	12 to 20 minutes	Grill, turning once. Brush with melted butter, margarine or oil.

GRILL RECIPES

BBQ SALMON

2 large salmon steaks
2 tbs. oil
Salt & pepper
2 oz. thin bacon slices
2 tbs. butter
1 tbs. lemon juice
Sprig of parsley
Lemon wedges

*You can substitute catfish, halibut or cod for salmon.

Preheat the BBQ

Brush the steaks with oil and season with salt and pepper. Place on BBQ grill and cook for 10 minutes, turning steaks over halfway through cooking time.

Meanwhile fry the bacon in a pan on the side burner. Drain on paper towels. Melt the butter in a small saucepan taking care not to discolor it. Arrange the fish and bacon on serving plates. Pour the butter over and sprinkle with lemon juice. Garnish with parsley sprigs and lemon wedges. Serve with boiled potatoes in butter and sprinkled with parsley.

BAKED CHILI CORN

6 medium ears corn, husked
3 tbs. butter or margarine, melted
Dash ground cumin
Dash ground coriander

About ½ hour before cooking, turn the grill on for butter. Place each ear on a heavy-duty foil. In a bowl, combine remaining ingredients. Mix well. Brush 1-1/2 tsp. butter mixture over each ear. Close foil and fold up ends to seal. Place on grill. Cook, turning packets occasionally 10 to 12 minutes or until cooked through.

TANGY SEAFOOD KABOBS

1 lb. Large shrimp, shelled & divined
¾ Lbs. Sea scallops
2/3 c. chili sauce
¼ c. cider vinegar
3 tbs. Chopped parsley
1 tbs. Vegetable oil
1 tbs. Worcestershire sauce
½ tsp. Prepared horseradish
1 clove garlic, minced
1 20 oz. Can pineapple chunks in juice drained.

In medium bowl, combine shrimp and scallops. In small bowl, combine chili sauce and next six ingredients. Pour over seafood. Toss to coat. Cover, refrigerate 2 hours.

Half-hour before cooking, turn the burner to the grill on high. Drain seafood-reserving marinade. On each of twelve 10" skewers, thread 2 shrimps and 2 scallops, alternating with pineapple chunks. Place skewers on grill. Cook 7-10 minutes, basting and turning often.

PORK CHOPS

4 pork chops
Marinade
1 large onion
2 tbs. lemon juice or vinegar
2 tbs. oil
½ tsp. freshly ground black pepper.
1 tsp. sugar
½ tps. paprika
1 clover garlic
Peel, grate onion, and add rest of the ingredients except the pork chops. Mix well. Pour over chops and marinate one hour in a cool place. Turn the BBQ grill on high. Heat 10 minutes. BBQ the chops brushing with the marinade occasionally. Serve with mixed salad, dressed with vinaigrette flavored with fresh dill.

BARBECUED POTATOES and CHEESE

1 -1/2 cups shredded cheddar cheese
1 can (10-3/4 oz.) condensed cream of mushroom soup
1/3 cup milk
2 tbs barbecue sauce
¼ tsp. oregano
¼ tsp. salt
1/8 tsp. pepper
4 cups thinly sliced potatoes (4 medium-sized potatoes)

Preheat grill. Combine cheese, condensed soup, milk, BBQ sauce, oregano, salt and pepper in a large mixing bowl. Stir in potatoes until well coated. Turn into well-buttered 1-1/2 quart rectangular baking dish. Cover dish with aluminum foil. Bake covered 25 minutes on medium with the lid of your BBQ grill closed. Remove foil and continue baking 15 minutes longer or until potatoes are tender. Let stand 5 minutes before serving.

BARBECUED LONDON BROIL

4 to 6 servings
¾ c. Italian dressing

1tsp. Worcestershire sauce
1tsp. Dry mustard
¼ tsp. Thyme, crushed
1 medium onion, sliced
1 pound flank steak, scoured
2 tbs. Butter, melted

Combine first 4 ingredients, add onion and marinade flank steak with it. Refrigerate at least 4 hours or overnight. Remove steak and grill on preheated BBQ grill. Grill 5 to 7 minutes on each side basting frequently with the marinade. In the meantime sauté onions from the marinade in butter in a skillet on grill side burner for 3 minutes. To serve, slice steak diagonally into thin slices, sprinkle onions over top. Garnish with vegetable kabobs.

VEGETABLE KABOBS

3 medium-size zucchini
12 cherry tomatoes
12 fresh mushrooms
Grated parmesan cheese

Parboil whole zucchini 5 minutes on grill side burner or until just tender. Drain and cut into ½ inch slices. Thread zucchini, tomatoes and mushrooms alternately on each of six skewers. Brush with marinade made of Italian dressing, Worcestershire sauce, mustard and thyme. Grill 5 to 7 minutes turning and basting occasionally. Sprinkle liberally with Parmesan cheese.

FAJITAS

1-1/2 lb. flank steak or boned chicken breasts
2 tbs. oil
½ cup lime juice
½ tsp. salt
½ tsp. celery salt
¼ tsp. garlic powder
½ tsp. pepper
¼ tsp. oregano
¼ tsp. cumin
Flour tortillas
Lemon

Pound flank steak to ¼ inch thickness or flatten chicken breasts. Mix oil, lime juice and seasonings in a zip lock bag. Add meat and shake bag to coat the meat. Refrigerate overnight or at least 6 to 8 hours. Wrap tortillas in foil. Remove meat from marinade. Cook on a pre-heated gas grill for 5 to 8 minutes on each side. While meat is cooking,

heat tortillas on grill. Slice meat across grain in thin slices. Place on hot platter. Squeeze lemon juice over. Wrap meat and any of the following toppings in tortillas: chopped tomatoes, guacamole, sour cream, and taco sauce.

BEEF AND LAMB KABOBS

Serve 4

½ lb. boneless sirloin or beef cut into 1" cubes
½ lb. boneless loin of lamb cut into 1" cubes
2/3 c. water, divided
¼ c. chopped onion
2 tbs. soy sauce
¼ c. vegetable oil, divided
1 tbs. dark brown sugar
1 tbs. fresh lemon juice
2 cloves garlic, minced
¼ tsp. ground cumin
¼ tsp. ground coriander
¼ tsp. ground turmeric
1/8 tsp. ground red pepper
1/8 tsp. ground ginger
1 red pepper cut into chunks
1 large banana, cut into chunks
8 small mushrooms
1/3 c. smooth peanut butter

In blender, process 1/3 c. water, onion, soy sauce, 2 tsp. oil and the next 8 ingredients until smooth. Pour over meat cubes and marinate about 4 hours, turning occasionally. Drain and reserve marinade. On to four 12" skewers alternately thread meat, pepper, banana and mushrooms. Preheat grill. Brush the kabobs with oil. Grill 7-8 minutes each side.

Bring marinade to boil on the side burner in a saucepan. Add remaining 1/3 c. water and peanut butter. Stir to blend. Heat through. If sauce gets too thick, add 1 tbs. water. Serve sauce with kabobs.

EGGPLANT CAVIAR

1 large eggplant
2 tbs. olive oil
2 tbs. wine vinegar
2 tbs. finely chopped onion
½ clove garlic, minced
1 medium tomato, chopped salt and pepper

Roast eggplant on gas grill over medium flame, turning occasionally until thoroughly cooked. This may take 30 minutes. Remove from grill and cool for handling. Strip off the skin and chop eggplant finely. Add all the seasonings. Chill thoroughly and serve on toast.

CHICKEN TANDOORI STYLE

8 large chicken thighs or drumsticks
1 c. plain nonfat yogurt
½ c. lemon juice
2 tsp. salt
½ tsp. cayenne
½ tsp. black pepper
½ tsp. crushed garlic
½ tsp. grated ginger
1 tbs. corn oil

Combine all the ingredients in a large mixing bowl and marinate the chicken for 8 hours in the refrigerator. Drain the chicken and spread on the spit running the rod on the fleshier side of the bone.

Bake using the rotisserie. Cook on medium high heat for 40 minutes basting occasionally with the remainder of the marinade mixture. Serve with sliced onions and lemon wedges.

SPARE RIBS

Marinade:
1 c. soy sauce
½ c. honey
½ c. vinegar
½ c. dry sherry
2 tsp. chopped garlic
2 tsp. sugar
1 c. water
1 chicken bouillon cube
1 can beer for basting sauce

Marinate ribs for 3 hours. Use marinade for basting by adding beer to it. Place pan under the ribs and baste frequently. To cook ribs select lean, meaty ribs and accordion pleat them with your spit. Slide four-prong meat hook down the length of spit and tighten. At the beginning of the rack and to its center, penetrate the second rib with the pointed end of the spit and push it between the meat. Skip a couple and continue the process until the entire rack is accordion pleated. Fasten the second meat hook into the rack. Turn rotisserie burner on high. Bake using the rotisserie for 50 minutes or until done.

PORK ROAST

Apple cider vinegar basting sauce:
1 c. apple cider vinegar
6 oz. water
½ stick butter
Salt, pepper, parsley and garlic seasoning
2 oz. lemon juice
10 lbs. pork roast

Time: 1-1/2 hours to 2 hours
Bring pork to room temperature before placing it on the rotisserie spit rod. Place on the rod and test for balance. Light rotisseries burner. Turn control knob to high. Use the above basting sauce for rotisserie baking

TURKEY

12 lb. turkey
Beer basting sauce:
1 can beer
12 oz. water
1 stick butter
1 tsp. salt
1 tsp. pepper
½ tsp. garlic flakes
1 tsp. parsley

Thaw the bird completely. Wash inside out. Securely tie the legs and wings before placing the turkey on the rotisserie spit rod. Light rotisseries burner. Turn to high. Combine all the ingredients for basting sauce in a shallow pan. Place it under the turkey 15 to 20 minutes. Cook for approximately 3 hours. The basting sauce combined with turkey drippings makes delicious gravy.

LIMITED WARRANTY
MODEL # 720-0138-NG/720-0141-LP
STAINLESS STEEL BUILD-IN OUTDOOR GAS GRILL

Nexgrill Industries, Inc. warrants to the original consumer/purchaser of each Jenn-Air Outdoor Gas Grill that when subject to normal residential use, it is free from defects in workmanship and materials for the periods specified below. This warranty excludes grills used in rental or commercial applications.

<u>Component</u>	<u>Warranty Period:</u>
Cast Brass Burners:	Lifetime
Stainless Steel Flame Tamer:	Lifetime
Stainless Steel Cooking Grids:	Lifetime
Valves, Nature Gas Regulator and 12 in. Gas Hose:	1 Year
Igniter and related Parts:	1 Year
All Stainless Steel Parts:	Lifetime

Our obligation under this warranty is limited to repair or replacement, at our option, of the product during the warranty period. The extent of any liability of Nexgrill Industries, Inc. under this warranty is limited to repair or replacement. This warranty does not cover normal wear of parts, discoloration of the stainless steel parts, or damage resulting from any of the following: negligent use or misuse of the product, improper use of the fuel/gas supply, use contrary to the operating instructions, or alteration by any person other than our factory service center. The warranty period is not extended by such repair or replacement.

Product repair as provided under this warranty is your exclusive remedy. Nexgrill Industries, Inc. shall not be liable for any incidental or consequential damages for breach of any express or implied warranties on its products. Except to the extent prohibited by applicable law, any implied warranty of merchantability or fitness for a particular purpose on this product is limited by the duration of the above warranty. Some states do not allow the exclusion or limitation of incidental or consequential damages, or allow limitations on how long an implied warranty lasts, so the above limitations or exclusions may not apply to you. This warranty gives you specific legal rights, and you may have other rights, which vary from state to state.

WARRANTY CLAIM PROCEDURE

If you require service or parts for your grill, please contact our Warranty Service Center for factory direct assistance. Our hours of operation are 7 AM to 6 PM PST Monday to Friday, 8 AM to 12 PM PST on Saturday. Our telephone number is 1-800-554-5799, FAX number 1-800-598-8829. Please direct all correspondence to: Nexgrill Industries, Inc. 145 Brea Canyon Road, Walnut, CA 91789, ATTN: Warranty Service Center.

*Jenn-Air is a trademark of the Maytag Corporation and is used under license to Lowe's Company Inc.