



# **757-200/300**

Airplane Characteristics for

# **Airport Planning**



THIS PAGE INTENTIONALLY LEFT BLANK

**757 AIRPLANE CHARACTERISTICS  
LIST OF ACTIVE PAGES**

Page	Date
Original	Preliminary November 1989
Rev A	Preliminary June 1999
Rev B	December 1982
Rev C	August 1985
Rev D	September 1989
Rev E	June 1999
Rev F	August 2002
1	June 1999
2	June 1999
3	June 1999
4	June 1999
5	June 1999
6	June 1999
7	June 1999
8	June 1999
9	June 1999
10	June 1999
11	June 1999
12	August 2002
13	June 1999
14	June 1999
15	June 1999
16	June 1999
17	June 1999
18	June 1999
19	June 1999
20	June 1999
21	June 1999
22	June 1999
23	June 1999
24	June 1999
25	June 1999
26	June 1999

Page	Date
27	June 1999
28	June 1999
29	June 1999
30	June 1999
31	June 1999
32	June 1999
33	June 1999
34	June 1999
35	June 1999
36	June 1999
37	August 2002
38	June 1999
39	June 1999
40	June 1999
41	June 1999
42	June 1999
43	June 1999
44	June 1999
45	June 1999
46	June 1999
47	June 1999
48	June 1999
49	June 1999
50	August 2002
51	August 2002
52	June 1999
53	June 1999
54	August 2002
55	August 2002
56	August 2002
57	August 2002
58	August 2002
59	August 2002
60	August 2002
61	August 2002
62	August 2002

Page	Date
62	August 2002
63	August 2002
64	June 1999
65	June 1999
66	June 1999
67	August 2002
68	June 1999
69	June 1999
70	June 1999
71	June 1999
72	June 1999
73	June 1999
74	June 1999
75	June 1999
76	June 1999
77	June 1999
78	June 1999
79	June 1999
80	June 1999
81	June 1999
82	June 1999
83	June 1999
84	June 1999
85	June 1999
86	June 1999
87	June 1999
88	June 1999
89	June 1999
90	June 1999
91	June 1999
92	June 1999
93	June 1999
94	June 1999
95	June 1999
96	June 1999
97	June 1999

**757 AIRPLANE CHARACTERISTICS  
LIST OF ACTIVE PAGES (CONTINUED)**

98	June 1999	134	June 1999	170	June 1999
99	June 1999	135	June 1999	171	June 1999
100	June 1999	136	June 2010	172	June 1999
101	June 1999	137	June 2010	173	June 1999
102	June 1999	138	June 2010	174	June 1999
103	June 1999	139	June 1999	3	May 2011
104	August 2002	140	June 1999		
105	June 1999	141	June 1999		
106	June 1999	142	June 1999		
107	June 1999	143	June 1999		
108	June 1999	144	June 1999		
109	June 1999	145	June 1999		
110	June 1999	146	June 1999		
111	June 1999	147	June 1999		
112	June 1999	148	June 1999		
113	June 1999	149	June 1999		
114	June 1999	150	June 1999		
115	June 1999	151	June 1999		
116	June 2010	152	June 1999		
117	June 1999	153	June 1999		
118	June 1999	154	June 1999		
119	June 2010	155	June 1999		
120	June 1999	156	June 1999		
121	June 1999	157	June 1999		
122	June 1999	158	June 1999		
123	June 1999	159	June 1999		
124	June 1999	160	June 1999		
125	June 1999	161	June 1999		
126	June 1999	162	June 1999		
127	June 1999	163	June 1999		
128	June 1999	164	June 1999		
129	June 1999	165	June 1999		
130	June 1999	166	June 1999		
131	June 1999	167	June 1999		
132	June 1999	168	June 1999		
133	June 1999	169	June 1999		

## TABLE OF CONTENTS

<u>SECTION</u>	<u>TITLE</u>	<u>PAGE</u>
1.0	SCOPE AND INTRODUCTION	1
1.1	Scope	2
1.2	Introduction	3
1.3	A Brief Description of the 757 Family of Airplanes	4
2.0	AIRPLANE DESCRIPTION	7
2.1	General Characteristics	8
2.2	General Dimensions	11
2.3	Ground Clearances	13
2.4	Interior Arrangements	15
2.5	Cabin Cross-Sections	19
2.6	Lower Cargo Compartments	20
2.7	Door Clearances	22
3.0	AIRPLANE PERFORMANCE	31
3.1	General Information	32
3.2	Payload/Range for Long-Range Cruise	33
3.3	FAA Takeoff Runway Length Requirements	38
3.4	FAA Landing Runway Length Requirements	64
4.0	GROUND MANEUVERING	69
4.1	General Information	70
4.2	Turning Radii	71
4.3	Clearance Radii	73
4.4	Visibility from Cockpit in Static Position	74
4.5	Runway and Taxiway Turn Paths	75
4.6	Runway Holding Bay	79
5.0	TERMINAL SERVICING	81
5.1	Airplane Servicing Arrangement - Typical Turnaround	83
5.2	Terminal Operations - Turnaround Station	86
5.3	Terminal Operations - En Route Station	89
5.4	Ground Servicing Connections	91
5.5	Engine Start Pneumatic Requirements - Sea Level	94
5.6	Ground Pneumatic Power Requirements	96
5.7	Conditioned Air Flow Requirements	98
5.8	Ground Towing Requirements	100

## TABLE OF CONTENTS (CONTINUED)

<u>SECTION</u>	<u>TITLE</u>	<u>PAGE</u>
6.0	JET ENGINE WAKE AND NOISE DATA	103
6.1	Jet Engine Exhaust Velocities and Temperatures	104
6.2	Airport and Community Noise	111
7.0	PAVEMENT DATA	115
7.1	General Information	116
7.2	Landing Gear Footprint	119
7.3	Maximum Pavement Loads	120
7.4	Landing Gear Loading on Pavement	121
7.5	Flexible Pavement Requirements - U.S. Army Corps of Engineers Method (S-77-1)	123
7.6	Flexible Pavement Requirements - LCN Method	125
7.7	Rigid Pavement Requirements - Portland Cement Association Design Method	128
7.8	Rigid Pavement Requirements - LCN Conversion	131
7.9	Rigid Pavement Requirements - FAA Method	134
7.10	ACN/PCN Reporting System: Flexible and Rigid Pavements	136
8.0	FUTURE 757 DERIVATIVE AIRPLANES	141
9.0	SCALED 757 DRAWINGS	143

## **1.0 SCOPE AND INTRODUCTION**

**1.1 Scope**

**1.2 Introduction**

**1.3 A Brief Description of the 757 Airplane**

## 1.0 SCOPE AND INTRODUCTION

### 1.1 Scope

This document provides, in a standardized format, airplane characteristics data for general airport planning. Since operational practices vary among airlines, specific data should be coordinated with the using airlines prior to facility design. Boeing Commercial Airplanes should be contacted for any additional information required.

Content of the document reflects the results of a coordinated effort by representatives from the following organizations:

- Aerospace Industries Association
- Airports Council International - North America
- Air Transport Association of America
- International Air Transport Association

The airport planner may also want to consider the information presented in the "CTOL Transport Aircraft, Characteristics, Trends, and Growth Projections," available from the US AIA, 1250 Eye St., Washington DC 20005, for long-range planning needs. This document is updated periodically and represents the coordinated efforts of the following organizations regarding future aircraft growth trends:

- International Coordinating Council of Aerospace Industries Associations
- Airports Council International - North America
- Air Transport Association of America
- International Air Transport Association



## **1.2 Introduction**

This document conforms to NAS 3601. It provides characteristics of the Boeing Model 757 family of airplanes for airport planners and operators, airlines, architectural and engineering consultant organizations, and other interested industry agencies. Airplane changes and available options may alter model characteristics; the data presented herein reflect typical airplanes in each model category.

For additional information contact:

Boeing Commercial Airplanes  
P.O. Box 3707  
Seattle, Washington 98124-2207  
USA

Attention: Manager, Airport Technology  
Mail Code:20-93

### 1.3 A Brief Description of the 757 Airplane

The 757 is a twin-engine, new technology jet airplane designed for low fuel burn and short-to-medium range operations. This airplane uses new aerodynamics, materials, structures, and systems to fill market requirement that cannot be efficiently provided by existing equipment or derivatives.

The 757 is a low-noise airplane powered by either Rolls-Royce RB211-535C, -535E4, or -535E4B, or the Pratt & Whitney PW2037, PW2040, or PW2043 engines. These are high-bypass-ratio engines which are efficient, reliable, and easy to maintain. The following table shows the available engine options

ENGINE MFR	MODEL	THRUST	AIRPLANE MODEL
PRATT & WHITNEY	PW2037	37,200 LB	757-200, -200PF
	PW 2040	41,700 LB	757-200,-200PF, -300
	PW 2043	43,850 LB	757-300
ROLLS ROYCE	RB211-535C	37,400 LB	757-200
	RB211-535E4	40,100 LB	757-200,-300
	RB211-535E4B	43,100 LB	757-200,-300

#### 757-200

The 757-200 family of airplanes consists of passenger and package freighter versions.

The passenger version is available in two configurations:

- The basic configuration (overwing-exit) has three LH and RH passenger doors and two LH and RH overwing exit doors.
- An optional configuration (four-door) has the same three LH and RH passenger doors but with LH and RH exit door aft of the wing, in lieu of the overwing exit doors.

In the passenger configuration, the 757-200 can typically carry 186 passengers in a six-abreast, mixed class configuration over a 2,900-nautical-mile range with full load. High gross options can increase the range to about 3,900 nautical miles. High-density seating arrangements can accommodate as many as 239 passengers in an all-economy configuration.

The 757-200 can be equipped for Extended Range Operations (EROPS) to allow extended overwater operations. Changes include a backup hydraulic motor-generator set and an auxiliary fan for equipment cooling.

## **757-200PF**

The Package Freighter (757-200PF) airplane is designed to carry an all-cargo payload. Main-deck cargo is either in cargo containers or pallets and are loaded through a large cargo door forward of left wing. The -200PF has no windows or passenger doors in the fuselage. A crew entry door is provided forward of the main deck cargo door.

## **757-300**

The 757-300 is a second-generation derivative of the 757-200 airplane. Two body extensions are added to the airplane fuselage to provide additional seating and cargo capacity. The 757-300 can typically seat 243 passengers in a dual-class arrangement or 279 passengers in an all-economy configuration. The EROPS option has been incorporated in the 757-300.

The 757 has ground service connections compatible with existing ground support equipment and no special equipment is required.

THIS PAGE INTENTIONALLY LEFT BLANK

## **2.0 AIRPLANE DESCRIPTION**

**2.1 General Characteristics**

**2.2 General Dimensions**

**2.3 Ground Clearances**

**2.4 Interior Arrangements**

**2.5 Cabin Cross Sections**

**2.6 Lower Cargo Compartments**

**2.7 Door Clearances**

## 2.0 AIRPLANE DESCRIPTION

### 2.1 General Characteristics

Maximum Design Taxi Weight (MTW). Maximum weight for ground maneuver as limited by aircraft strength and airworthiness requirements. (It includes weight of taxi and run-up fuel.)

Maximum Design Landing Weight (MLW). Maximum weight for landing as limited by aircraft strength and airworthiness requirements.

Maximum Design Takeoff Weight (MTOW). Maximum weight for takeoff as limited by aircraft strength and airworthiness requirements. (This is the maximum weight at start of the takeoff run.)

Operating Empty Weight (OEW). Weight of structure, powerplant, furnishing systems, unusable fuel and other unusable propulsion agents, and other items of equipment that are considered an integral part of a particular airplane configuration. Also included are certain standard items, personnel, equipment, and supplies necessary for full operations, excluding usable fuel and payload.

Maximum Design Zero Fuel Weight (MZFW). Maximum weight allowed before usable fuel and other specified usable agents must be loaded in defined sections of the aircraft as limited by strength and airworthiness requirements.

Maximum Pay load. Maximum design zero fuel weight minus operational empty weight.

Maximum Seating Capacity. The maximum number of passengers specifically certificated or anticipated for certification.

Maximum Cargo Volume. The maximum space available for cargo.

Usable Fuel. Fuel available for aircraft propulsion.

CHARACTERISTICS	UNITS	757-200				
MAX DESIGN TAXI WEIGHT	POUNDS	221,000	231,000	241,000	251,000	256,000
	KILOGRAMS	100,250	104,800	109,300	113,850	116,100
MAX DESIGN TAKEOFF WEIGHT	POUNDS	220,000	230,00	240,000	250,000	255,000(1)
	KILOGRAMS	99,800	104,350	108,850	113,400	115,650(1)
MAX DESIGN LANDING WEIGHT	POUNDS	198,000	198,000	198,000	198,000	210,000
	KILOGRAMS	89,800	89,800	89,800	89,800	95,250
MAX DESIGN ZERO FUEL WEIGHT	POUNDS	184,000	184,000	184,000	184,000	188,000
	KILOGRAMS	83,450	83,450	83,450	83,450	85,300
SPEC OPERATING EMPTY WEIGHT	POUNDS	134,090	125,110	132,280	136,940	136,940
	KILOGRAMS	60,800	56,750	60,000	62,100	62,100
MAX STRUCTURAL PAYLOAD	POUNDS	49,910	58,890	51,720	47,060	47,060
	KILOGRAMS	22,650	26,700	23,450	21,350	21,350
SEATING CAPACITY	TWO-CLASS	186 - 16 FIRST + 170 ECONOMY				
	ONE-CLASS	FAA EXIT LIMIT: 224 (2), 239(3)				
MAX CARGO - LOWER DECK (4)	CUBIC FEET	1,790	1,790	1,790	1,790	1,790
	CUBIC METERS	51	51	51	51	51
USABLE FUEL	US GALLONS	11276	11276	11276	11276	11276
	LITERS	42,680	42,680	42,680	42,680	42,680
	POUNDS	75,550	75,550	75,550	75,550	75,550
	KILOGRAMS	34,260	34,260	34,260	34,260	34,260

NOTES: WEIGHTS SHOWN ARE FOR TYPICAL AS-DELIVERED OR AS-OFFERED CONFIGURATIONS.  
CONSULT WITH AIRLINE FOR ACTUAL WEIGHTS.

- (1) 255,500 LB (115,900 KG) FOR AIRPORT ALTITUDES BELOW 1,500 FT.
- (2) OVERWING-EXIT CONFIGURATION AIRPLANE.
- (3) FOUR-DOOR CONFIGURATION AIRPLANE.
- (4) VOLUME IS REDUCED BY 100 CU FT (3 CU M) WITH TELESCOPING BAGGAGE SYSTEM.

### 2.1.1 GENERAL CHARACTERISTICS

MODEL 757-200 (RB211-535C, -535E4, -535E4B ENGINES)

CHARACTERISTICS	UNITS	757-200				
MAX DESIGN TAXI WEIGHT	POUNDS	221,000	231,000	241,000	251,000	256,000
	KILOGRAMS	100,250	104,800	109,300	113,850	116,100
MAX DESIGN TAKEOFF WEIGHT	POUNDS	220,000	230,00	240,000	250,000	255,000(1)
	KILOGRAMS	99,800	104,350	108,850	113,400	115,650(1)
MAX DESIGN LANDING WEIGHT	POUNDS	198,000	198,000	198,000	198,000	210,000
	KILOGRAMS	89,800	89,800	89,800	89,800	95,250
MAX DESIGN ZERO FUEL WEIGHT	POUNDS	184,000	184,000	184,000	184,000	188,000
	KILOGRAMS	83,450	83,450	83,450	83,450	85,300
SPEC OPERATING EMPTY WEIGHT	POUNDS	128,380	130,850	130,860	130,875	130,875
	KILOGRAMS	58,250	59,350	59,350	59,350	59,350
MAX STRUCTURAL PAYLOAD	POUNDS	55,620	53,140	53,140	53,125	53,125
	KILOGRAMS	25,250	24,100	24,100	24,100	25,000
SEATING CAPACITY	TWO-CLASS	186 - 16 FIRST + 170 ECONOMY				
	ONE-CLASS	FAA EXIT LIMIT: 224 (2), 239(3)				
MAX CARGO - LOWER DECK (4)	CUBIC FEET	1,790	1,790	1,790	1,790	1,790
	CUBIC METERS	51	51	51	51	51
USABLE FUEL	US GALLONS	11276	11276	11276	11276	11276
	LITERS	42,680	42,680	42,680	42,680	42,680
	POUNDS	75,550	75,550	75,550	75,550	75,550
	KILOGRAMS	34,260	34,260	34,260	34,260	34,260

NOTES: WEIGHTS SHOWN ARE FOR TYPICAL AS-DELIVERED OR AS-OFFERRED CONFIGURATIONS.

CONSULT WITH AIRLINE FOR ACTUAL WEIGHTS.

(1) 255,500 LB (115,900 KG) FOR AIRPORT ALTITUDES BELOW 1,500 FT.

(2) OVERWING-EXIT CONFIGURATION AIRPLANE.

(3) FOUR-DOOR CONFIGURATION AIRPLANE.

(4) VOLUME IS REDUCED BY 100 CU FT (3 CU M) WITH TELESCOPING BAGGAGE SYSTEM.

## 2.1.2 GENERAL CHARACTERISTICS

MODEL 757-200 (PW2037, PW2040 ENGINES)

D6-58327



CHARACTERISTICS	UNITS	757-200PF	
MAX DESIGN TAXI WEIGHT	POUNDS	251,000	256,000
	KILOGRAMS	113,850	116,100
MAX DESIGN TAKEOFF WEIGHT	POUNDS	250,000	255,000(1)
	KILOGRAMS	113,400	116,650(1)
MAX DESIGN LANDING WEIGHT	POUNDS	210,000	210,000
	KILOGRAMS	92,250	92,250
MAX DESIGN ZERO FUEL WEIGHT	POUNDS	200,000	200,000
	KILOGRAMS	90,700	90,700
SPEC OPERATING EMPTY WEIGHT	POUNDS	114,000	114,000
	KILOGRAMS	51,700	51,700
MAX STRUCTURAL PAYLOAD	POUNDS	86,000	86,000
	KILOGRAMS	39,000	39,000
MAX CARGO	CUBIC FEET	1,830	1,830
- LOWER DECK (2)	CUBIC METERS	52	52
MAX CARGO - MAIN DECK (3)	CUBIC FEET	6,600	6,600
	CUBIC METERS	187	187
USABLE FUEL	US GALLONS	11,276	11,276
	LITERS	42,680	42,680
	POUNDS	75,550	75,550
	KILOGRAMS	34,260	34,260

NOTES: WEIGHTS SHOWN ARE FOR TYPICAL AS-DELIVERED OR AS-OFFERRED CONFIGURATIONS. CONSULT WITH AIRLINE FOR ACTUAL WEIGHTS.

(1) 255,500 LB (115,900 KG) FOR AIRPORT ALTITUDES BELOW 1,500 FEET.

(2) VOLUME IS REDUCED BY 100 CU FT (3 CU M) WITH TELESCOPING BAGGAGE SYSTEM.

(3) 15 UNIT LOAD DEVICES (ULD) AT 440 CU FT (12.36 CU M) EACH.

### 2.1.3 GENERAL CHARACTERISTICS

MODEL 757-200PF

CHARACTERISTICS	UNITS	PW2040, PW 2043 ENGINES	RB211-535E4, -535E4B ENGINES
MAX DESIGN TAXI WEIGHT	POUNDS	271,000	271,000
	KILOGRAMS	122,930	122,930
MAX DESIGN TAKEOFF WEIGHT	POUNDS	270,000	270,000
	KILOGRAMS	122,470	122,470
MAX DESIGN LANDING WEIGHT	POUNDS	224,000	224,000
	KILOGRAMS	101,610	101,610
MAX DESIGN ZERO FUEL WEIGHT	POUNDS	210,000	210,000
	KILOGRAMS	95,260	95,260
SPEC OPERATING EMPTY WEIGHT (1)	POUNDS	141,800	142,350
	KILOGRAMS	64,330	64,580
MAX STRUCTURAL PAYLOAD	POUNDS	68,200	67,650
	KILOGRAMS	30,940	30,690
SEATING CAPACITY (1)	TWO-CLASS	243 - 12 FIRST + 231 ECONOMY	
	ONE-CLASS	279 ALL-ECONOMY	
MAX CARGO - LOWER DECK	CUBIC FEET	2,382 (2)	2,382 (2)
	CUBIC METERS	67.5 (2)	67.5 (2)
USABLE FUEL	US GALLONS	11,490	11,490
	LITERS	43,495	43,495
	POUNDS	76,980	79,980
	KILOGRAMS	34,930	34,930

NOTES: (1) SPEC WEIGHT FOR BASELINE CONFIGURATION OF 243 PASSENGERS.  
CONSULT WITH AIRLINE FOR SPECIFIC WEIGHTS AND CONFIGURATIONS.

(2) FWD CARGO = 1,070 CU FT (30.3 CU M).  
AFT CARGO = 1,312 CU FT (37.2 CU M).

#### 2.1.4 GENERAL CHARACTERISTICS

MODEL 757-300

D6-58327

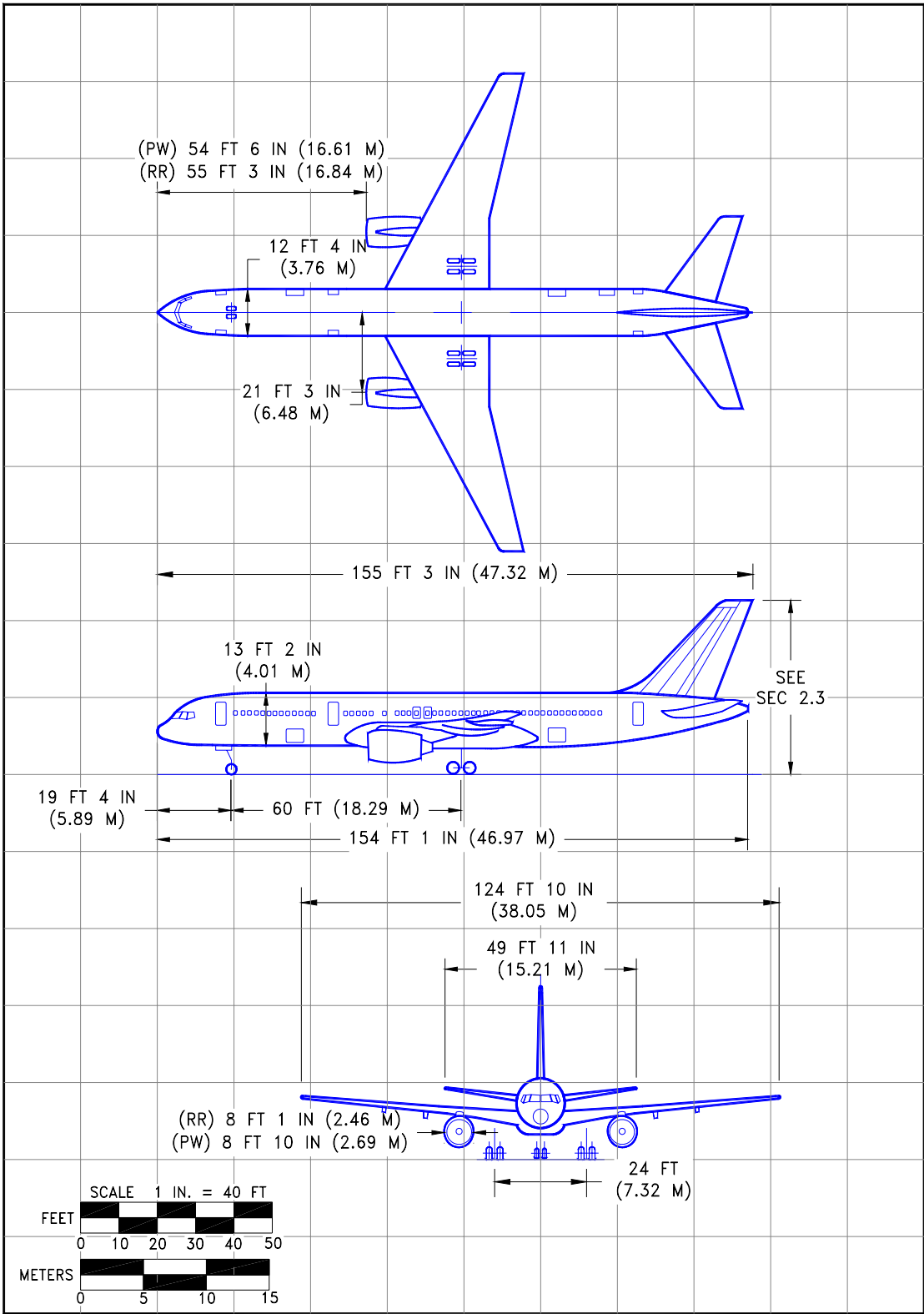

**2.2.1 GENERAL DIMENSIONS**  
 MODEL 757-200, -200PF

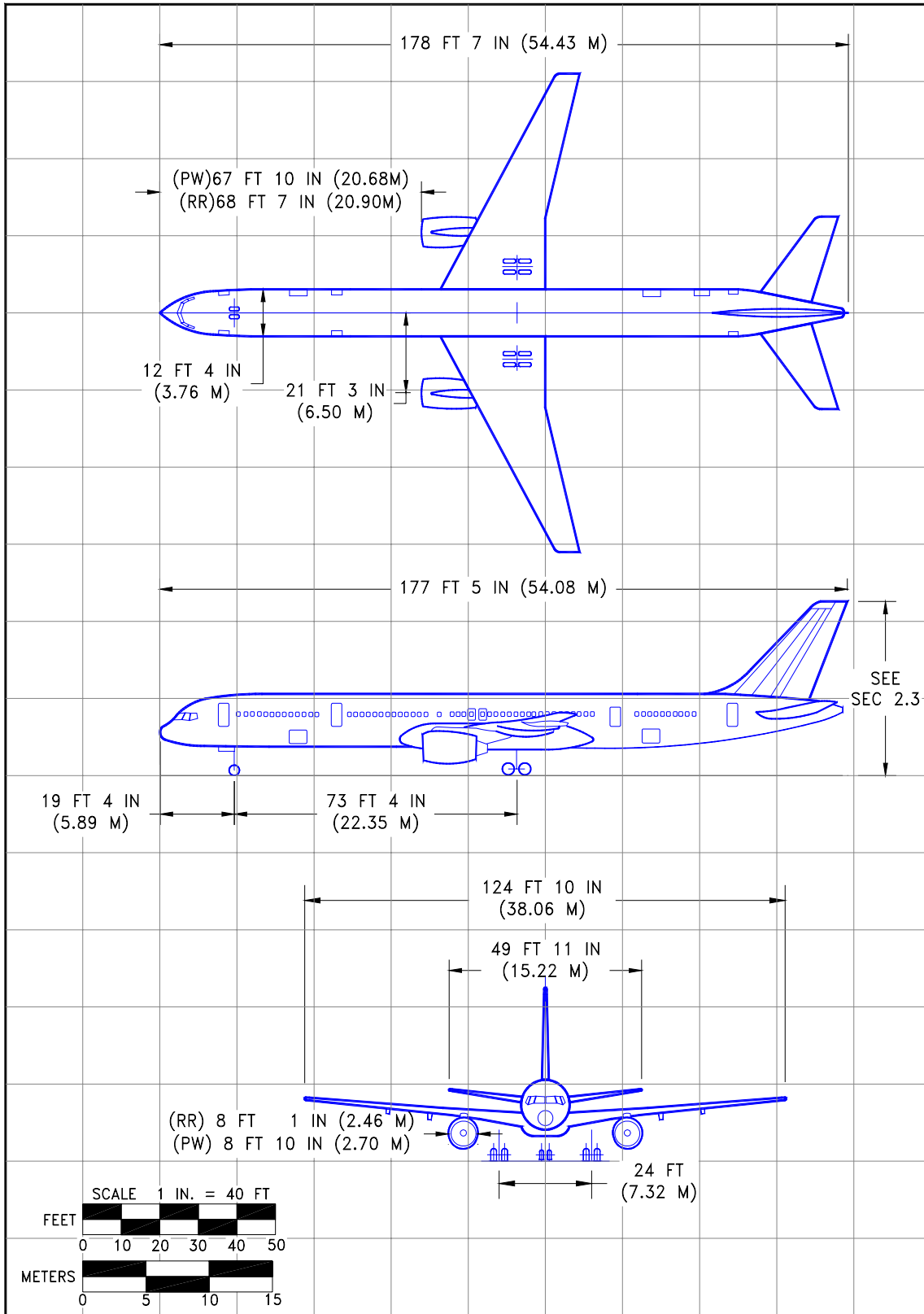

**2.2.2 GENERAL DIMENSIONS**  
*MODEL 757-300*

D6-58327

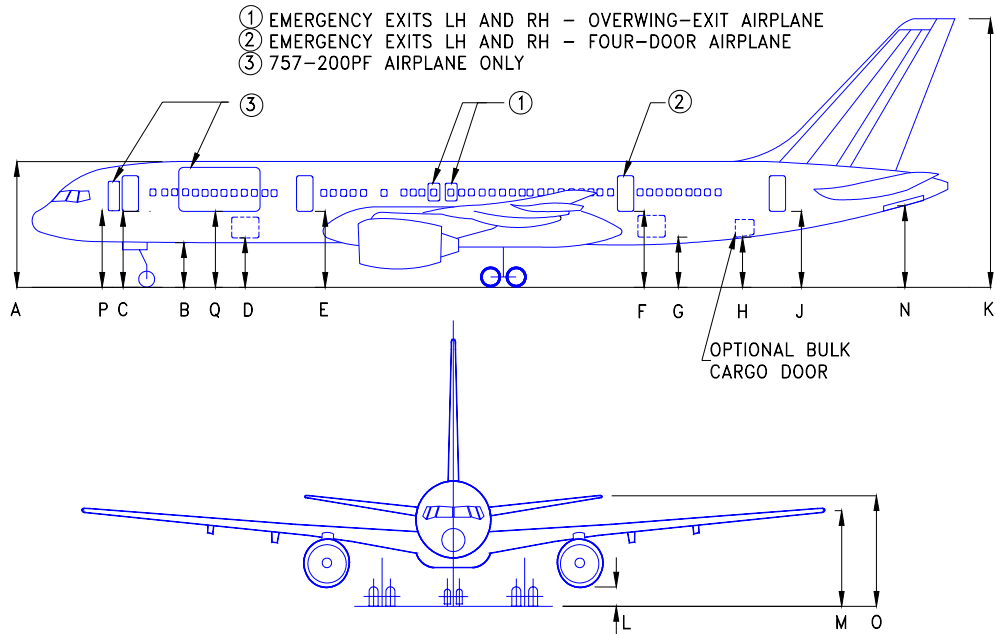

	MINIMUM*		MAXIMUM*		MODEL APPLICABILITY
	FEET - INCHES	METERS	FEET - INCHES	METERS	
A	20 - 6	6.25	21 - 2	6.45	-200, -200PF
B	7 - 4	2.24	8 - 0	2.44	-200, -200PF
C	12 - 5	3.79	13 - 2	4.01	-200
D	8 - 1	2.46	8 - 9	2.67	-200, -200PF
E	12 - 7	3.84	13 - 2	4.01	-200
F	12 - 9	3.89	13 - 3	4.04	-200
G	7 - 9	2.36	8 - 3	2.51	-200, -200PF
H	8 - 6	2.59	9 - 1	2.77	-200
J	12 - 9	3.89	13 - 7	4.14	-200
K	44 - 3	13.49	45 - 1	13.74	-200, -200PF
L	2 - 5	0.74	2 - 10	0.86	-200, -200PF
M	15 - 4	4.67	16 - 1	4.90	-200, -200PF
N	12 - 5	3.78	13 - 3	4.04	-200, -200PF
O	18 - 7	5.66	19 - 8	5.99	-200, -200PF
P	12 - 5	3.79	13 - 2	4.01	-200PF
Q	12 - 6	3.81	13 - 2	4.01	-200PF

NOTES: VERTICAL CLEARANCES SHOWN OCCUR DURING MAXIMUM VARIATIONS OF AIRPLANE ATTITUDE. COMBINATIONS OF AIRPLANE LOADING AND UNLOADING ACTIVITIES THAT PRODUCE THE GREATEST POSSIBLE VARIATIONS IN ATTITUDE WERE USED TO ESTABLISH THE VARIATIONS SHOWN.

\* NOMINAL DIMENSIONS

**2.3.1 GROUND CLEARANCES**  
 MODEL 757-200, 200PF

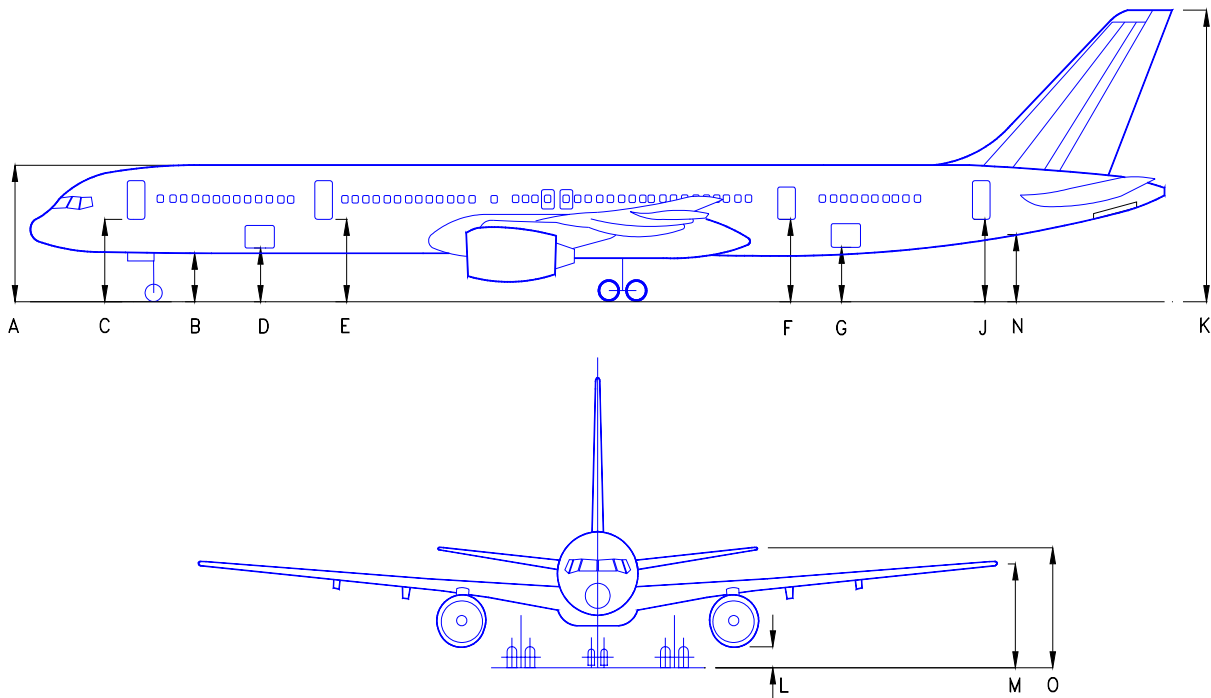

	MINIMUM*		MAXIMUM*	
	FEET - INCHES	METERS	FEET - INCHES	METERS
A	20 - 7	6.27	21 - 4	6.50
B	7 - 5	2.26	8 - 2	2.49
C	12 - 5	3.79	13 - 2	4.01
D	8 - 0	2.44	8 - 9	2.67
E	12 - 7	3.84	13 - 2	4.01
F	12 - 11	3.94	13 - 4	4.06
G	7 - 6	2.29	7 - 10	2.39
J	13 - 0	3.96	13 - 4	4.06
K	44 - 6	13.56	44 - 9	13.64
L (RB211)	3 - 0	0.91	3 - 7	1.09
L (PW2043)	2 - 8	0.81	3 - 3	0.99
M	16 - 1	4.90	16 - 6	5.03
N (TAIL SKID)	9 - 0	2.74	9 - 4	2.85
O	18 - 10	5.74	19 - 1	5.82

NOTES: VERTICAL CLEARANCES SHOWN OCCUR DURING MAXIMUM VARIATIONS OF AIRPLANE ATTITUDE. COMBINATIONS OF AIRPLANE LOADING AND UNLOADING ACTIVITIES THAT PRODUCE THE GREATEST POSSIBLE VARIATIONS IN ATTITUDE WERE USED TO ESTABLISH THE VARIATIONS SHOWN.

\* NOMINAL DIMENSIONS

### 2.3.2 GROUND CLEARANCES MODEL 757-300

D6-58327

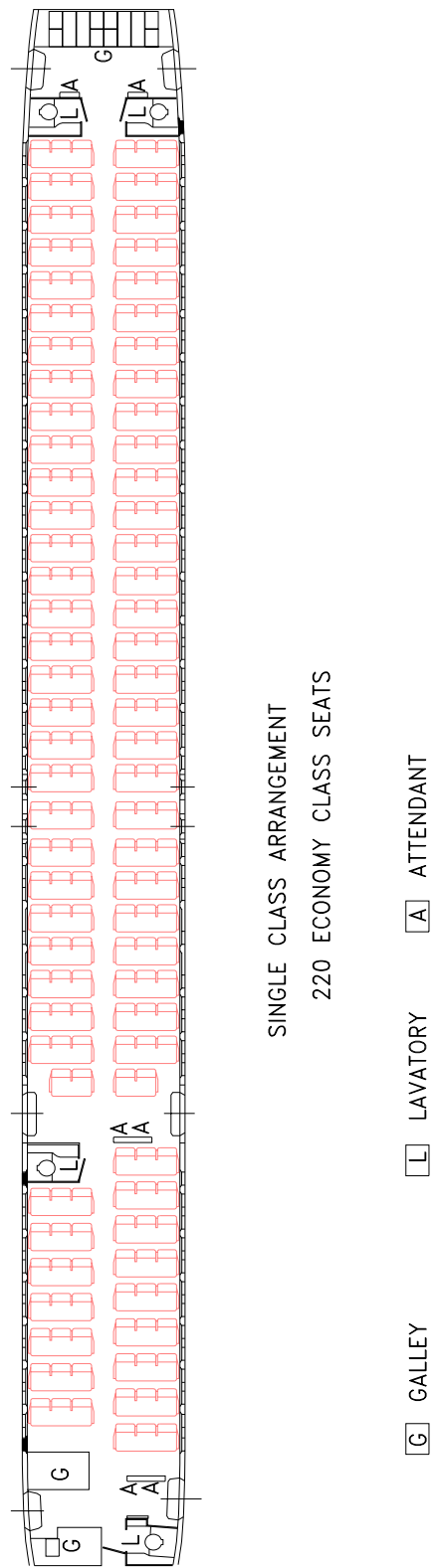
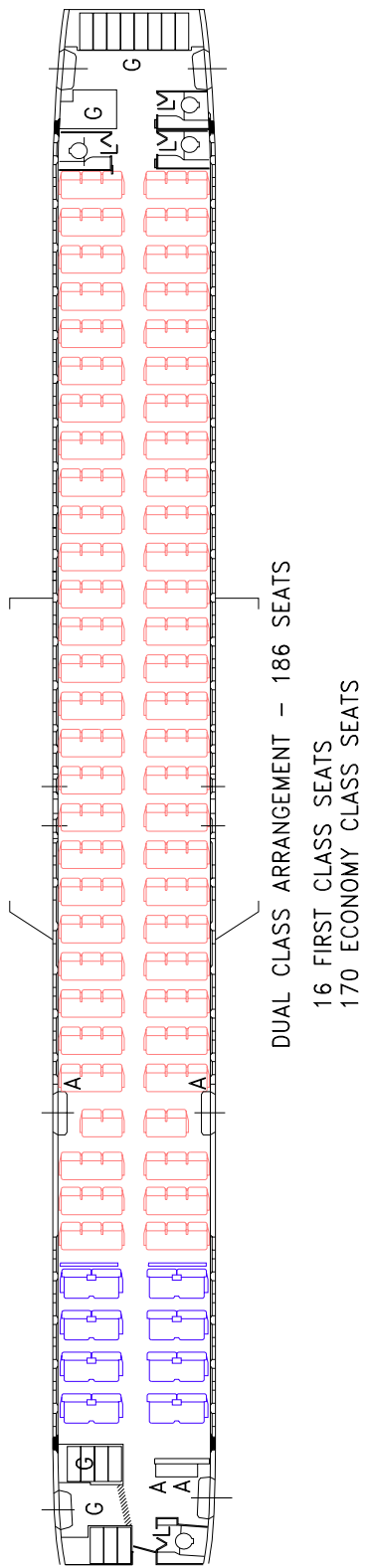

G GALLEY   
 L LAVATORY   
 A ATTENDANT

**2.4.1 INTERIOR ARRANGEMENTS - OVERWING-EXIT AIRPLANE**  
 MODEL 757-200

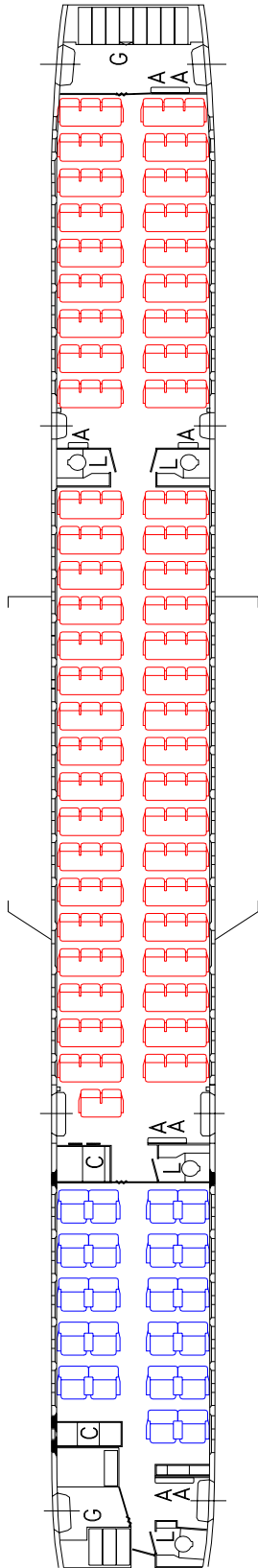

DUAL CLASS ARRANGEMENT - 180 SEATS  
 22 FIRST CLASS SEATS  
 158 ECONOMY CLASS SEATS

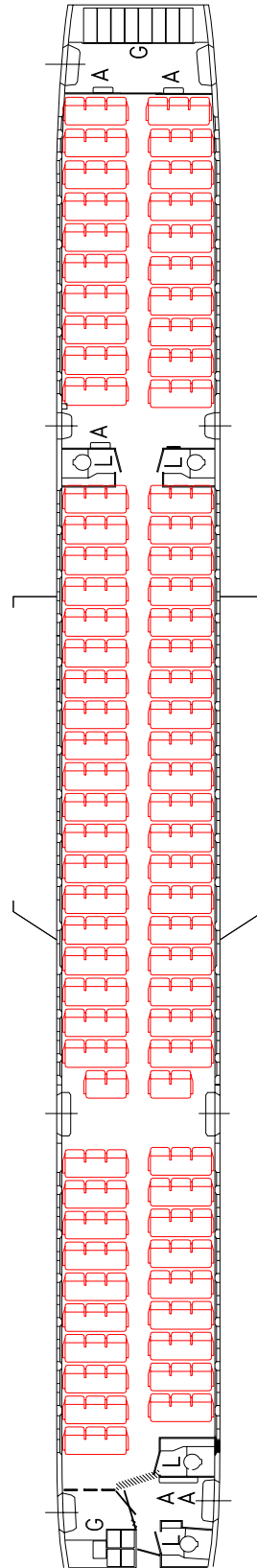

SINGLE CLASS ARRANGEMENT  
 228 ECONOMY CLASS SEATS

- G GALLEY
- L LAVATORY
- A ATTENDANT
- C CLOSET

**2.4.2 INTERIOR ARRANGEMENTS - FOUR-DOOR AIRPLANE**  
 MODEL 757-200



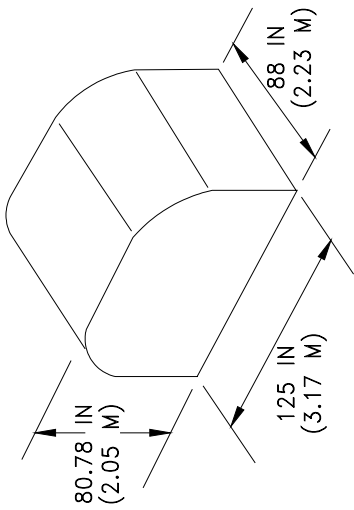

440 CU FT (12.47 CU M)  
CONTAINER

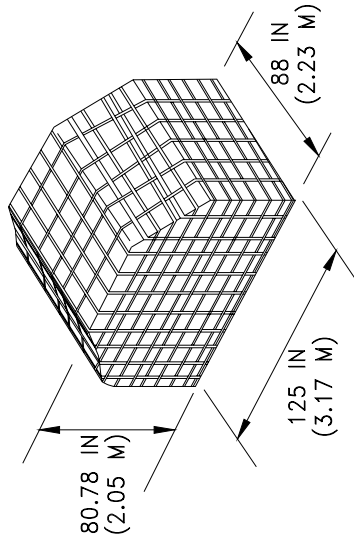

STRAPPED PALLET  
UP TO 440 CU FT

ULD DATA

15 UNIT LOAD DEVICES  
(ULD)

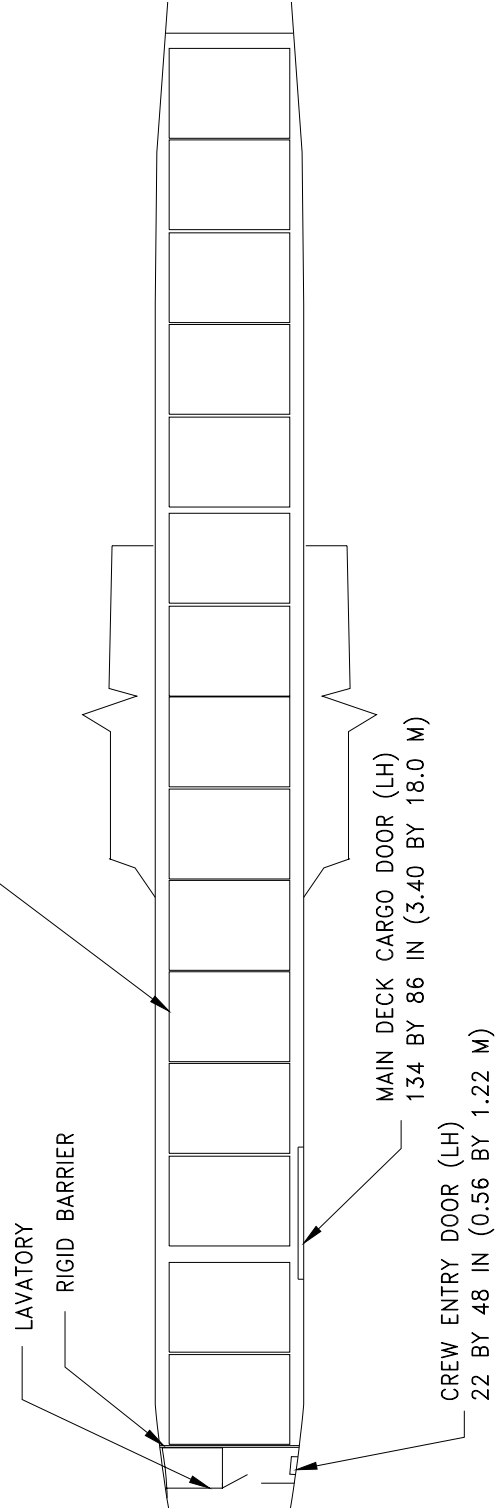

**2.4.3 INTERIOR ARRANGEMENTS - MAIN DECK CARGO**  
MODEL 757-200PF

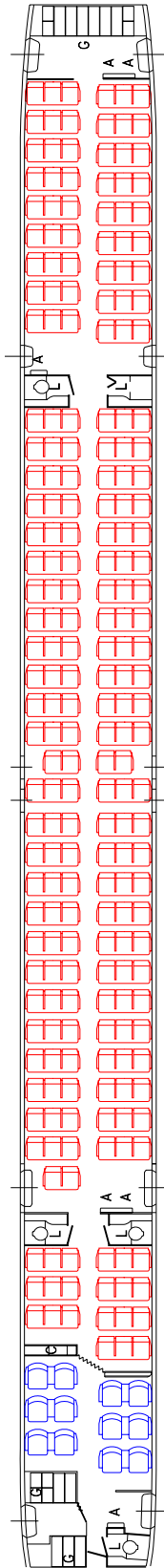

DUAL CLASS ARRANGEMENT - 243 SEATS  
 12 FIRST CLASS SEATS  
 231 ECONOMY CLASS SEATS

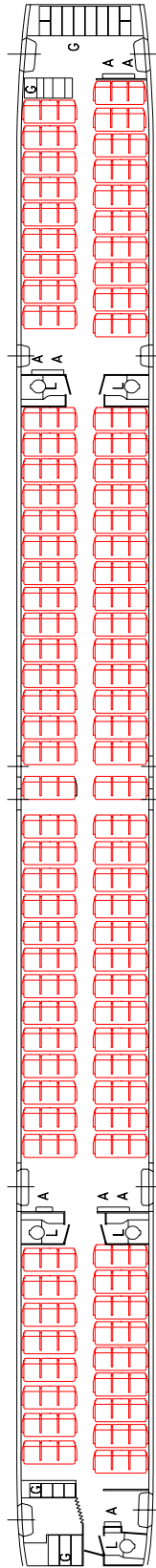

SINGLE CLASS ARRANGEMENT  
 279 ECONOMY CLASS SEATS

G GALLEY L LAVATORY A ATTENDANT

**2.4.4 INTERIOR ARRANGEMENTS**  
 MODEL 757-300

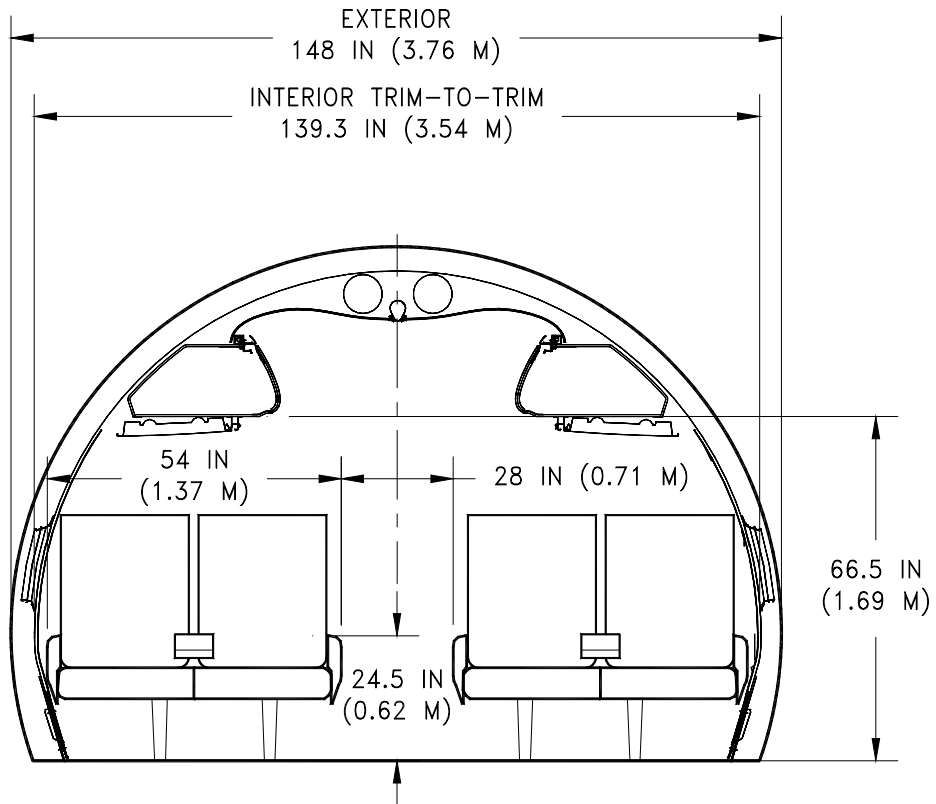

FIRST CLASS

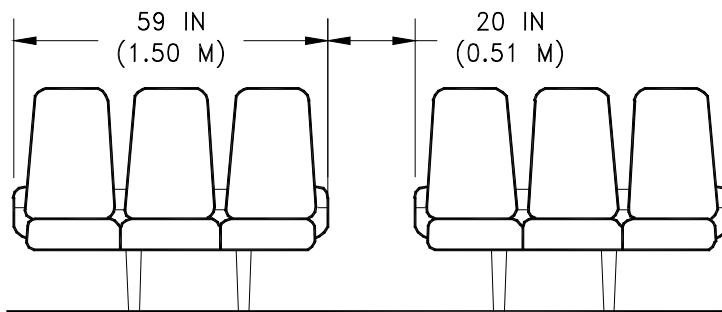

ECONOMY CLASS

**2.5 CABIN CROSS-SECTIONS**  
 MODEL 757-200, -300

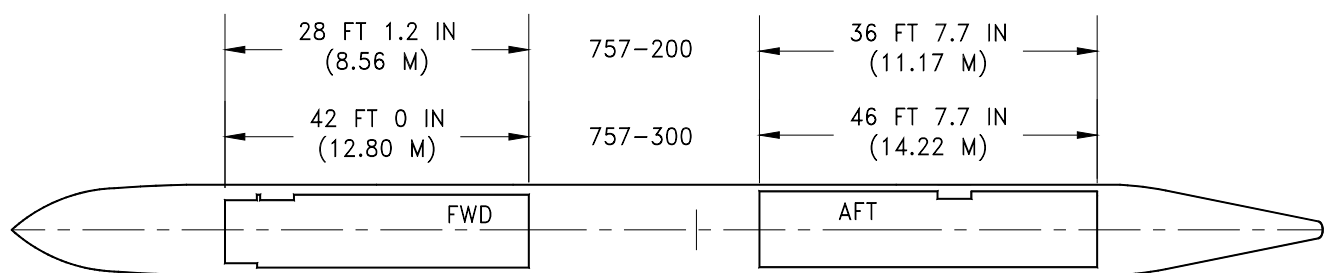
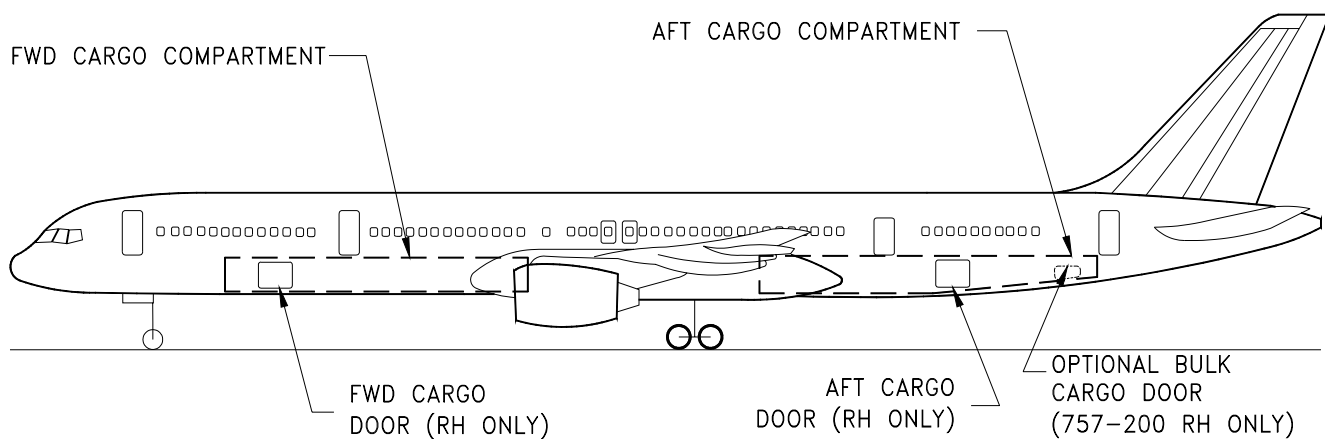

PLAN VIEW

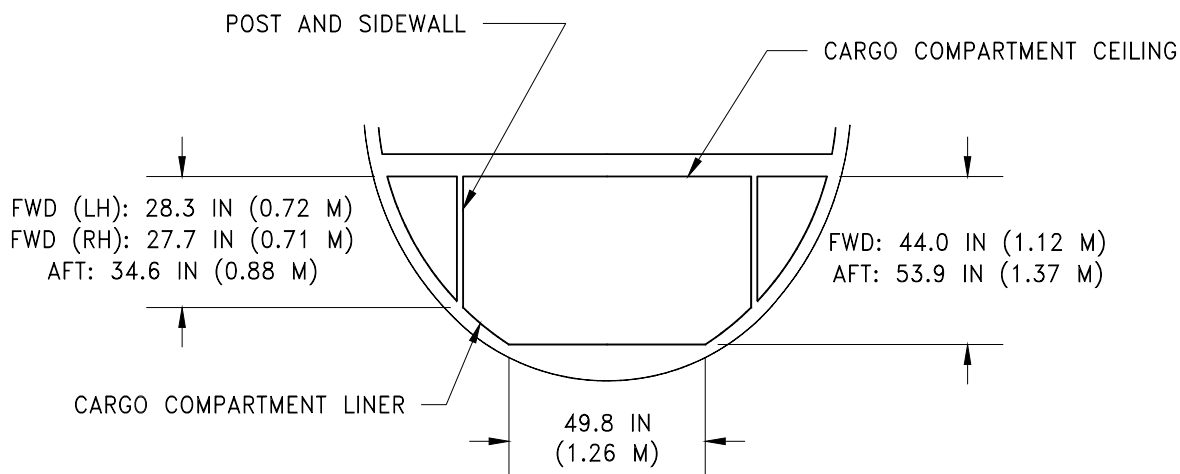

CROSS-SECTION

**2.6.1 LOWER CARGO COMPARTMENTS - BULK CARGO CAPACITIES**  
 MODEL 757-200, -300

- SYSTEM AVAILABLE IN EITHER OR BOTH CARGO COMPARTMENTS
- FORWARD CARGO COMPARTMENT USES A THREE-MODULE SYSTEM AFT OF THE CARGO DOOR
- AFT CARGO COMPARTMENT USES A TWO-MODULE SYSTEM FORWARD OF THE CARGO DOOR

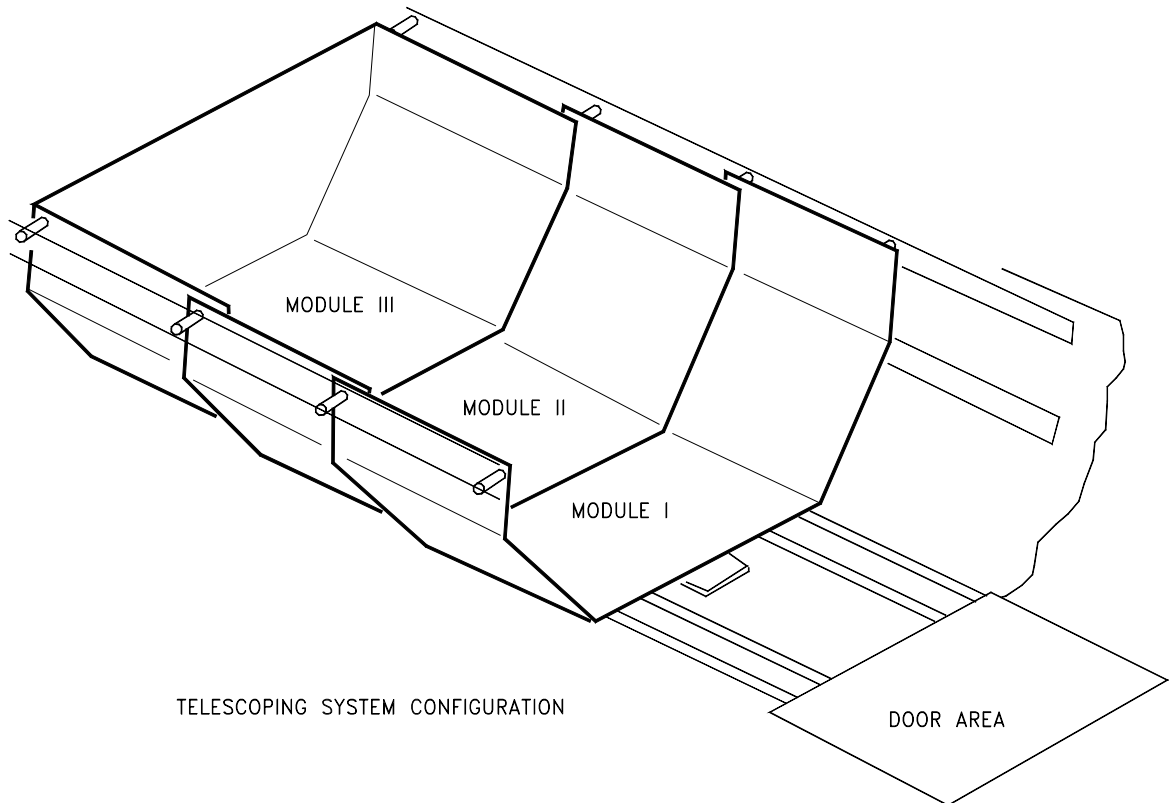

TELESCOPING SYSTEM CONFIGURATION

		BULK CARGO CAPACITIES - TELESCOPING SYSTEM				TOTAL(1)
		FWD COMPARTMENT		AFT COMPARTMENT		
		3 MODULES	ADD'L BULK	2 MODULES	ADD'L BULK	
VOLUME	CU FT	420	220	420	630	1,690
	CU M	11.9	6.2	11.9	17.8	47.8

NOTE: (1) OPTIONAL THIRD CARGO DOOR REDUCES VOLUME BY 100 CU FT

**2.6.2 LOWER CARGO COMPARTMENTS - OPTIONAL TELESCOPING BAGGAGE SYSTEM**  
 MODEL 757-200, -200PF

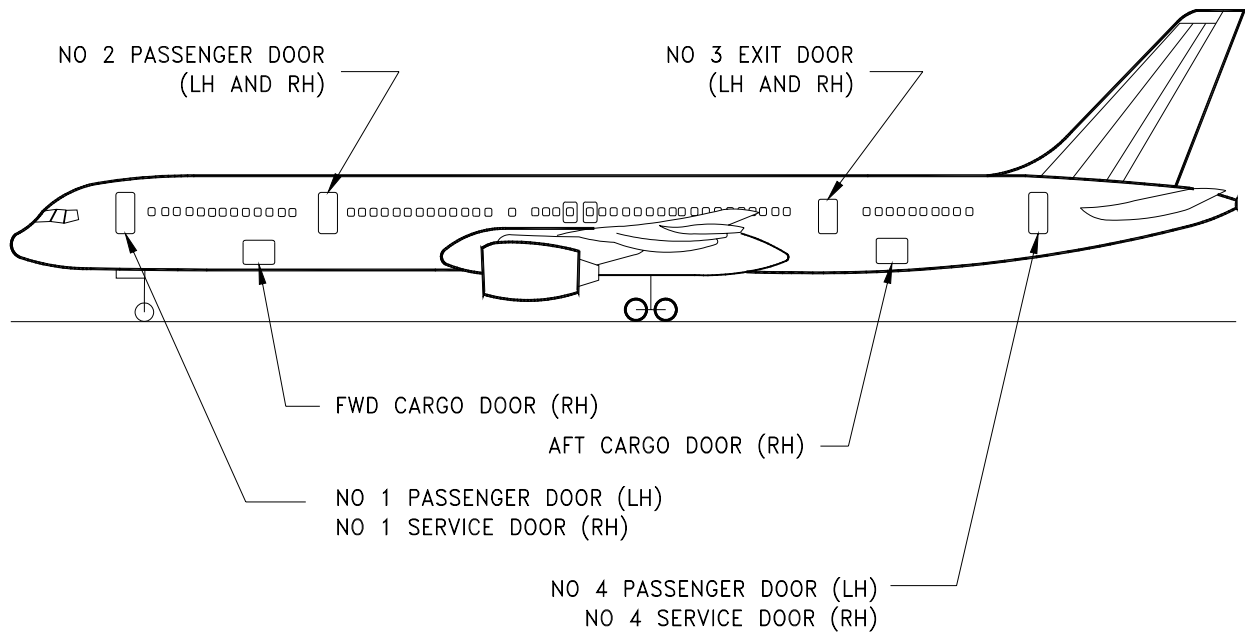

DOOR NAME	DISTANCE FROM NOSE(1) - 757-200	DISTANCE FROM NOSE(1) - 757-300	DOOR OPENING SIZE
NO. 1 PASSENGER DOOR (LH)	16 FT 7 IN (5.05 M)	16 FT 7 IN (5.05 M)	33 BY 72 IN (0.84 BY 1.83 M)
NO. 1 SERVICE DOOR (RH)	15 FT 8 IN (4.78 M)	15 FT 8 IN (4.78 M)	30 BY 65 IN (0.76 BY 1.65 M)
NO. 2 PASSENGER DOOR (LH & RH)	45 FT 11 IN (13.99 M)	45 FT 11 IN (13.99 M)	33 BY 72 IN (0.84 BY 1.83 M)
NO. 3 EXIT DOOR (LH & RH)	(N/A)	121 FT 4 IN (35.99 M)	24 BY 44 IN (0.61 BY 1.18 M)
NO. 4 PASSENGER DOOR (LH & RH)	125 FT 5 IN (38.23 M)	148 FT 9 IN (45.34 M)	30 BY 72 IN (0.76 BY 1.83 M)
FWD CARGO DOOR (RH)	35 FT 11 IN (10.95 M)	35 FT 11 IN (10.95 M)	55 BY 42.5 IN (1.40 BY 1.08 M)
AFT CARGO DOOR (RH)	104 FT 3 IN (31.78 M)	127 FT 7 IN (38.89 M)	55 BY 45 IN (1.40 BY 1.14 M)
BULK CARGO DOOR (2)	117 FT 3 IN (35.74 M)	(N/A)	48 BY 32 IN (1.22 BY 0.81 M)

NOTES (1) LONGITUDINAL DISTANCE FROM NOSE TO CENTER OF DOOR

(2) EARLY PRODUCTION 757-200 AIRPLANES ONLY

**2.7.1 DOOR CLEARANCES - PASSENGER, SERVICE, AND CARGO DOOR LOCATIONS**  
 MODEL 757-200, -300

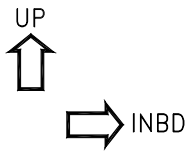
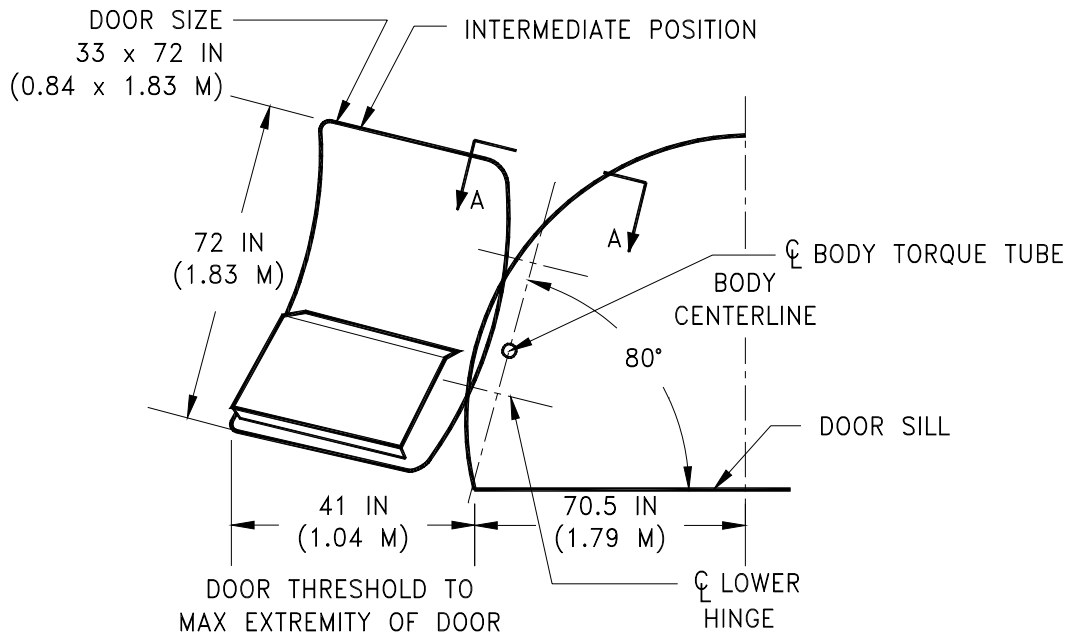
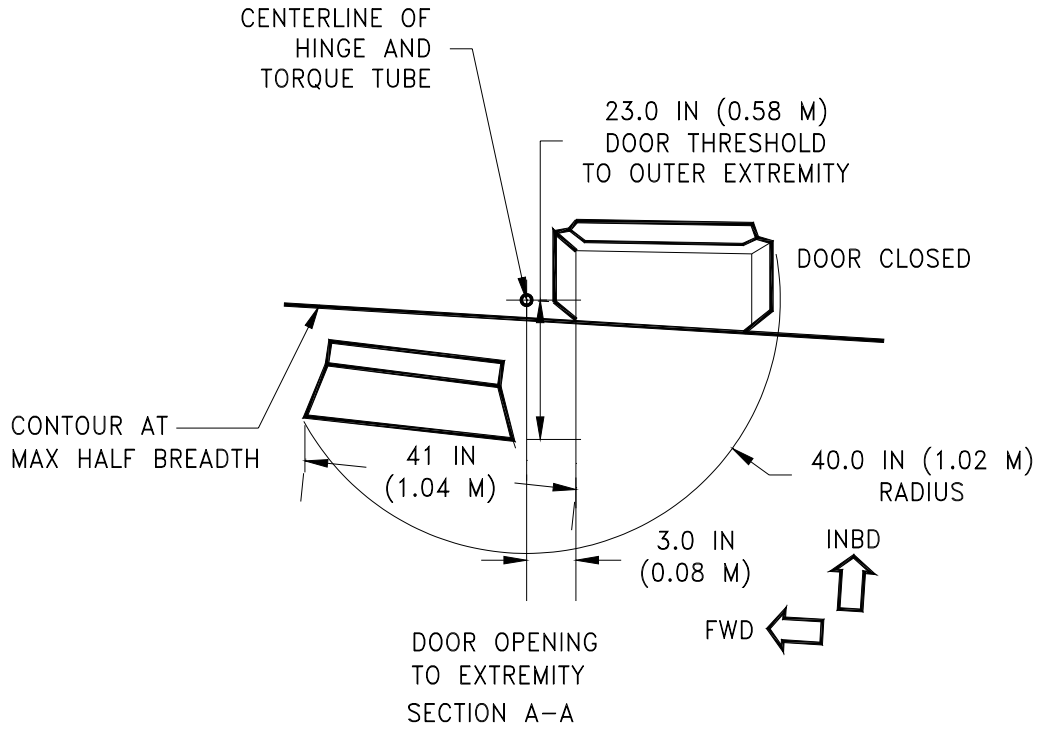

VIEW LOOKING FORWARD AT PASSENGER DOOR NO 1 (LH SHOWN)

**2.7.2 DOOR CLEARANCES - MAIN DECK DOOR NO 1**  
 MODEL 757-200, -300

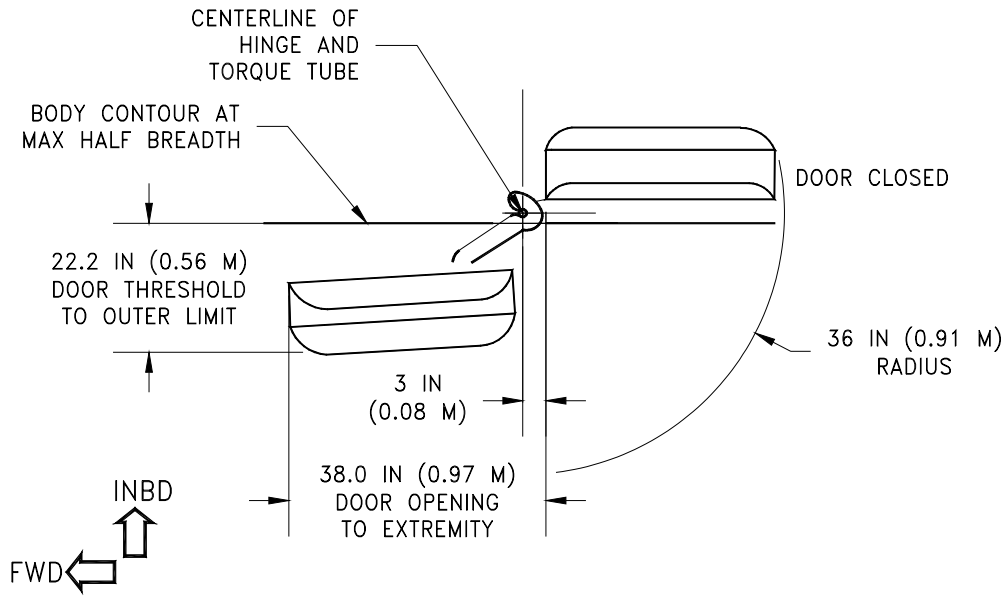

SECT A-A

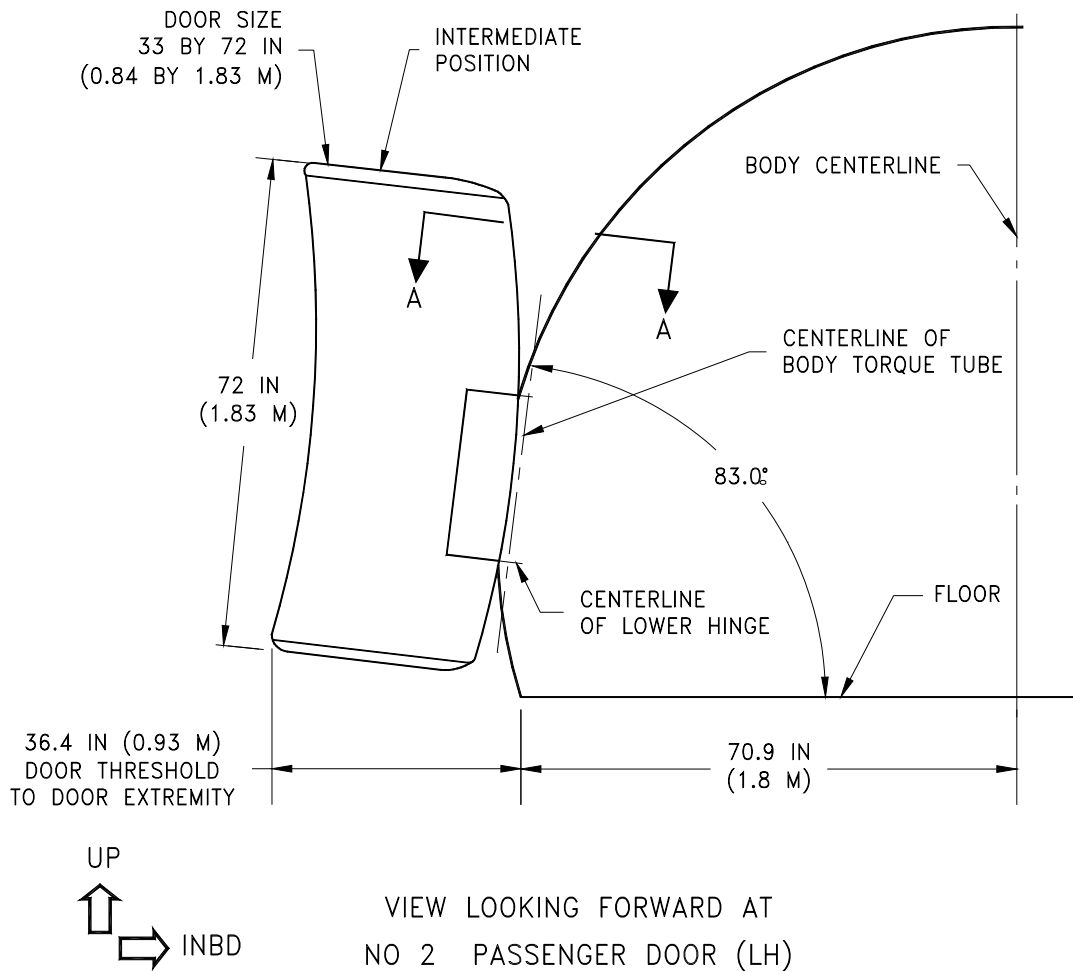

**2.7.3 DOOR CLEARANCES - MAIN DECK DOOR NO 2**  
 MODEL 757-200, -300

D6-58327



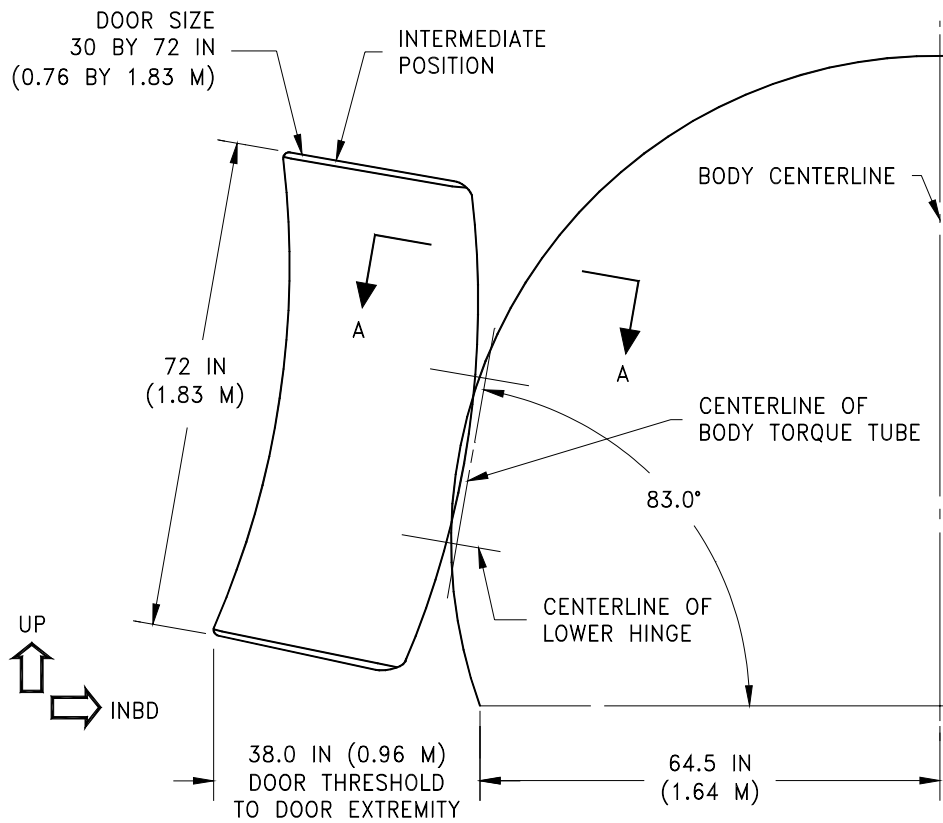
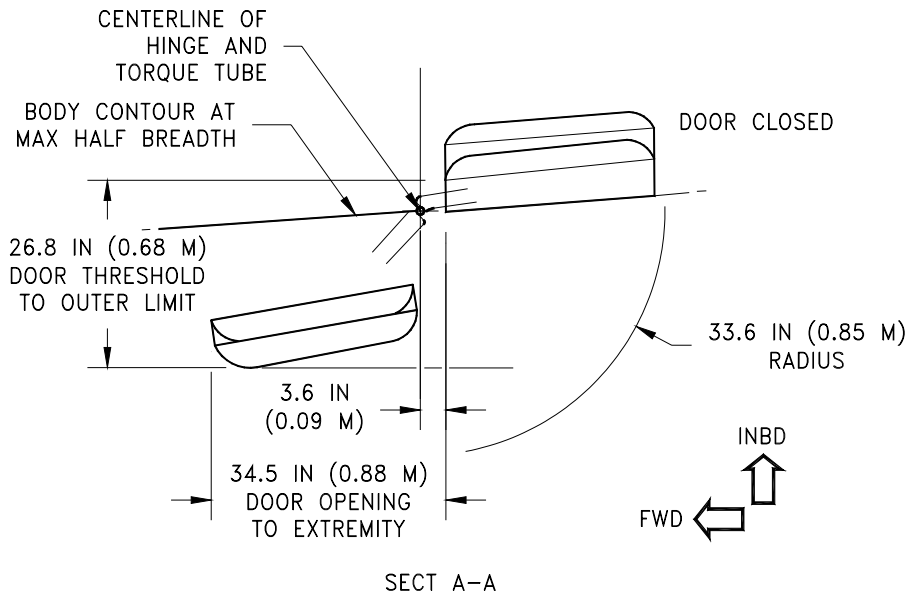

VIEW LOOKING FORWARD AT  
NO 4 PASSENGER DOOR (LH)

**2.7.4 DOOR CLEARANCES - MAIN DECK DOOR NO 4**  
MODEL 757-200, -300

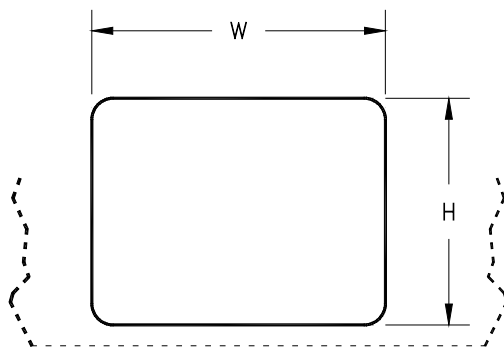
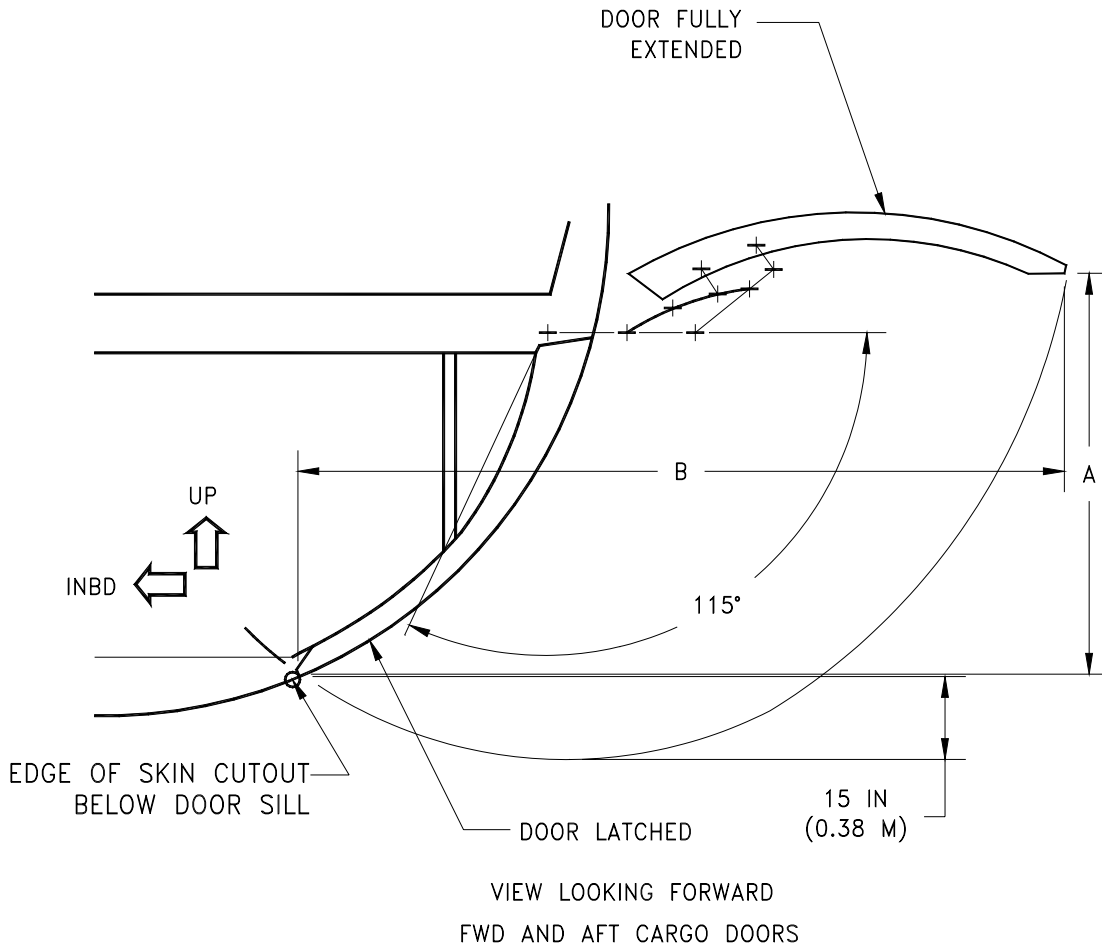

RIGHT SIDE VIEW  
FWD & AFT CARGO DOORS

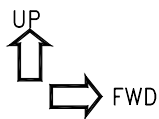

	W WIDTH	H HEIGHT	A VERTICAL	B LATERAL
FWD CARGO DOOR	55.0 IN (1.40 M)	42.5 IN (1.08 M)	57.0 IN (1.45 M)	111.1 IN (2.82 M)
AFT CARGO DOOR	55.0 IN (1.40 M)	45.0 IN (1.14 M)	61.0 IN (1.55 M)	111.3 IN (2.83 M)

**2.7.5 DOOR CLEARANCES - CARGO DOORS**  
MODEL 757-200, -300

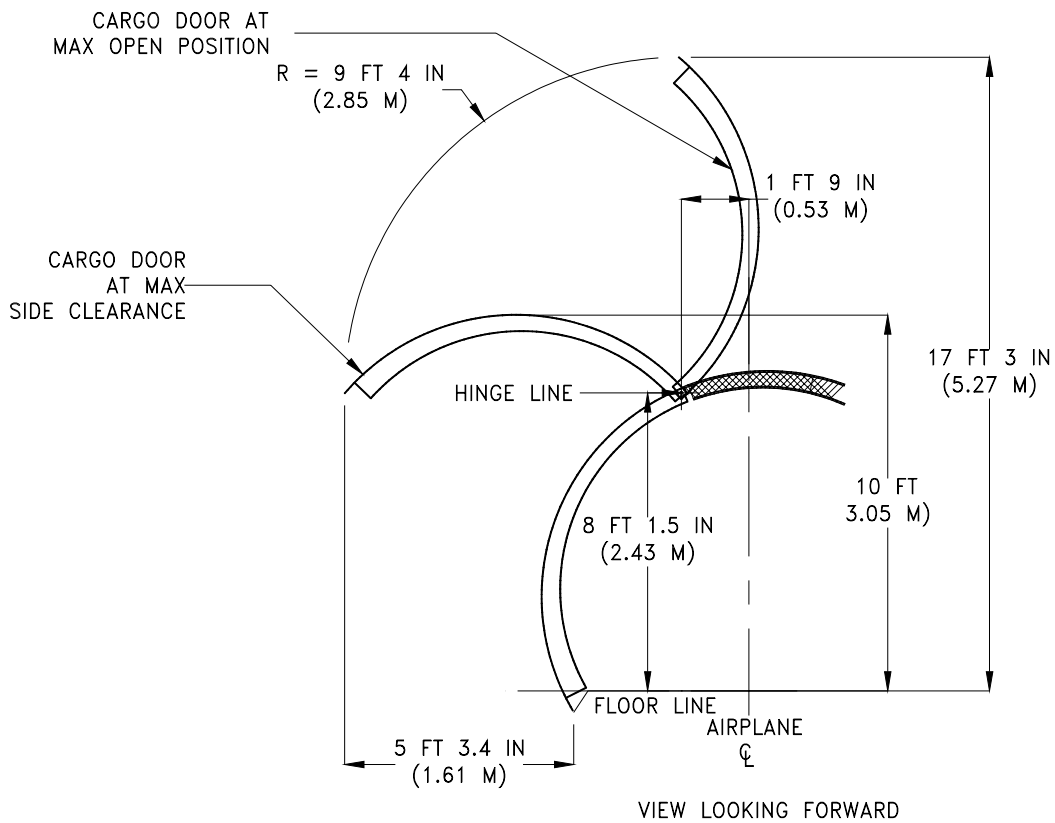
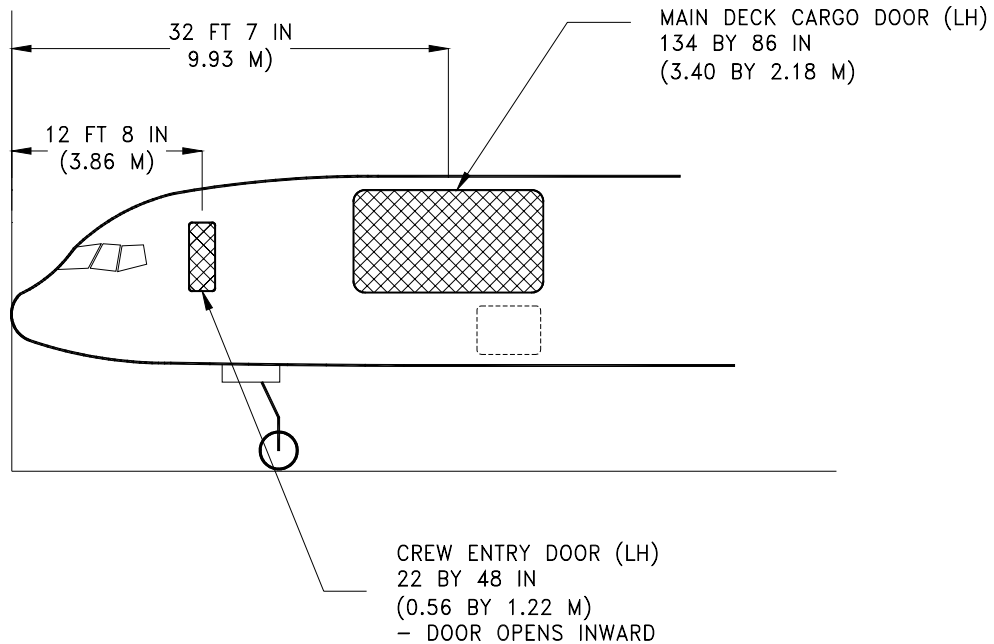

**2.7.6 DOOR CLEARANCES - MAIN DECK DOORS**  
MODEL 757-200PF

THIS PAGE INTENTIONALLY LEFT BLANK

### **3.0 AIRPLANE PERFORMANCE**

#### **3.1 General Information**

#### **3.2 Payload/Range for Long-Range Cruise**

#### **3.3 F.A.R. and J.A.R. Takeoff Runway Length Requirements**

#### **3.4 F.A.R. Landing Runway Length Requirements**

### 3.0 AIRPLANE PERFORMANCE

#### 3.1 General Information

The graphs in Section 3.2 provide information on operational empty weight (OEW) and payload, trip range, brake release gross weight, and fuel limits. To use this graph, if the trip range and zero fuel weight (OEW + payload) are known, the approximate brake release weight can be found, limited by fuel quantity.

The graphs in Section 3.3 provide information on F.A.R. takeoff runway length requirements with typical engines at different pressure altitudes. Maximum takeoff weights shown on the graphs are the heaviest for the particular airplane models with the corresponding engines. Standard day temperatures for pressure altitudes shown on the F.A.R. takeoff graphs are given below:

PRESSURE ALTITUDE		STANDARD DAY TEMP	
FEET	METERS	°F	°C
0	0	59.0	15.00
2,000	609	51.9	11.04
4,000	1,219	44.7	7.06
6,000	1,828	37.6	3.11
8,000	2,438	30.5	-0.85

Wet runway performance for the 757-300 airplane is shown in accordance with JAR-OPS 1 Subpart F, with wet runways defined in Paragraph 1.480(a)(10). Skid-resistant runways (grooved or PFC treated) per FAA or ICAO specifications exhibit runway length requirements that remove some or all of the length penalties associated with wet smooth (non-grooved) runways. Under predominantly wet conditions, the wet runway performance characteristics may be used to determine runway length requirements, if it is longer than the dry runway performance requirements. This is not required for the 757-200 airplanes.

The graphs in Section 3.4 provides information on landing runway length requirements for different airplane weights and airport altitudes. The maximum landing weights shown are the heaviest for the particular airplane model.

- NOTES:
- \* 0.80 MACH AT 35,000 AND 39,000 FT (10,668 AND 11,887 M)
  - \* ATA DOMESTIC RESERVES
  - \* STANDARD DAY
  - \* NOMINAL PERFORMANCE
  - \* CONSULT USING AIRLINE FOR SPECIFIC OPERATING PROCEDURE PRIOR TO FACILITY DESIGN

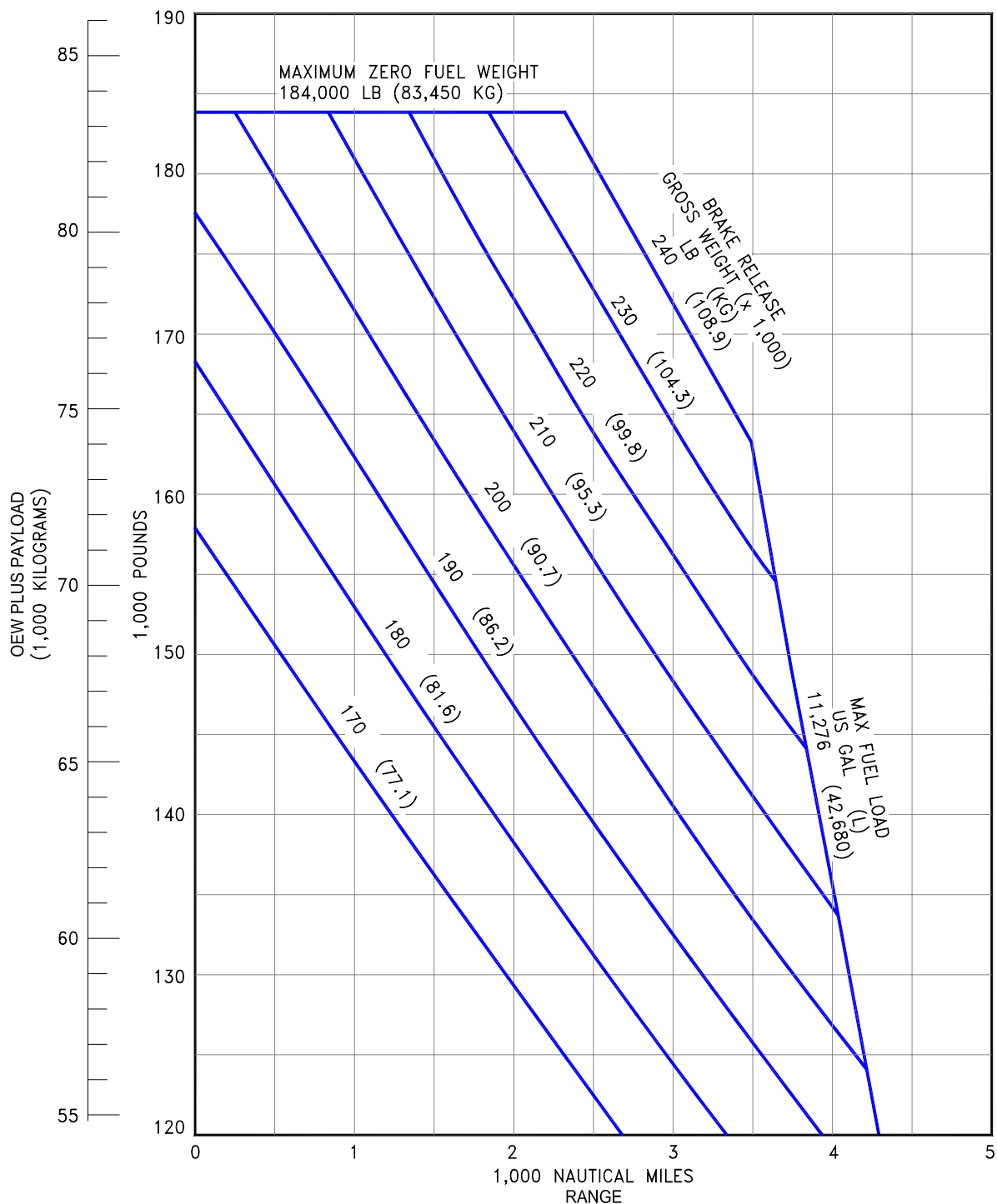

**3.2.1. PAYLOAD/RANGE FOR LONG-RANGE CRUISE**  
 MODEL 757-200 (RB211-535C ENGINES)

NOTES:

- \* 0.80 MACH AT 35,000 AND 39,000 FT (10,668 AND 11,887 M)
- \* ATA DOMESTIC RESERVES
- \* STANDARD DAY
- \* NOMINAL PERFORMANCE
- \* CONSULT USING AIRLINE FOR SPECIFIC OPERATING PROCEDURE PRIOR TO FACILITY DESIGN

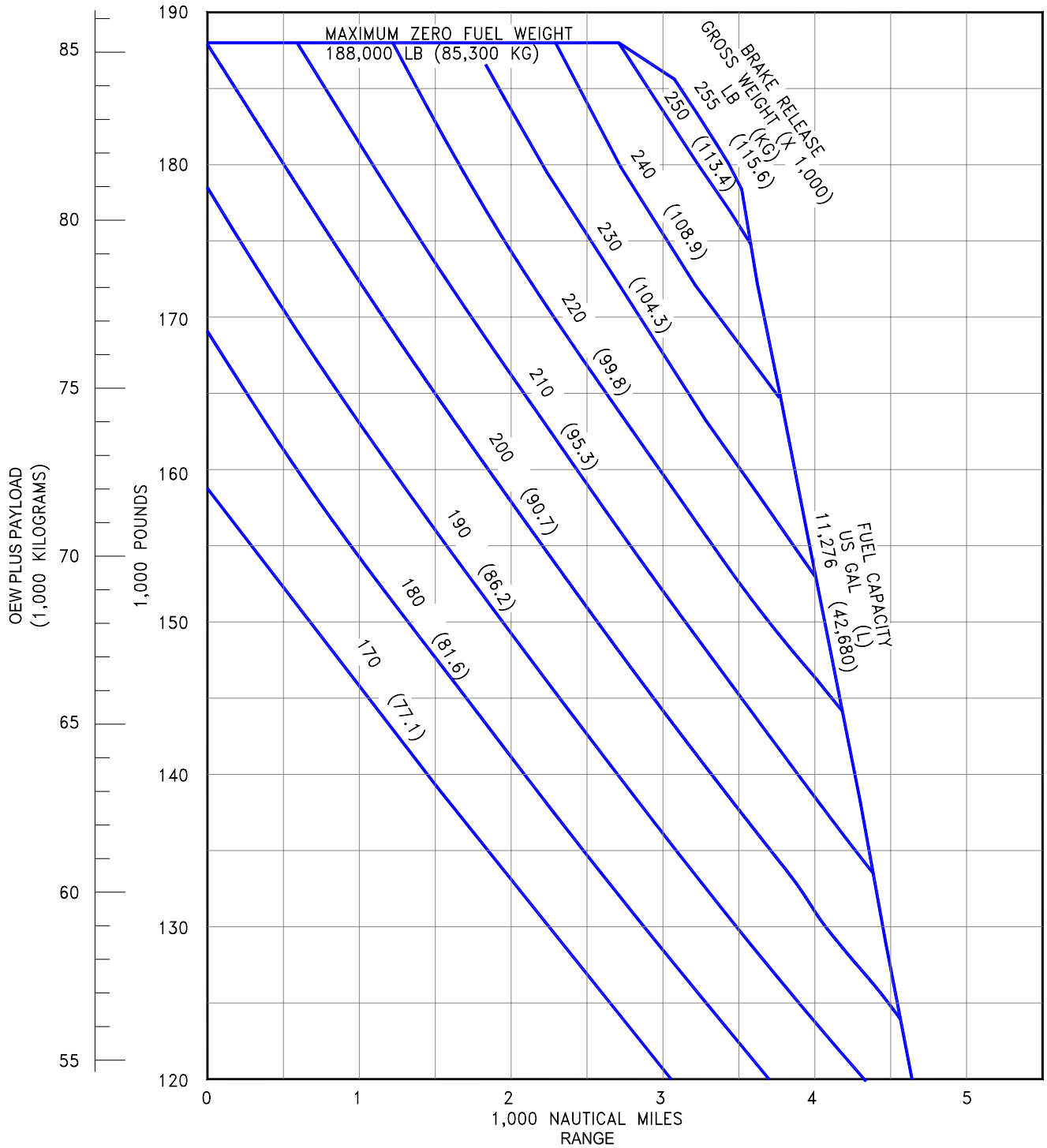

**3.2.2. PAYLOAD/RANGE FOR LONG-RANGE CRUISE**  
 MODEL 757-200 (RB211-53E4, -535E4B ENGINES)

D6-58327



NOTES:

- \* 0.80 MACH AT 35,000 AND 39,000 FT (10,668 AND 11,887 M)
- \* ATA DOMESTIC RESERVES
- \* STANDARD DAY
- \* NOMINAL PERFORMANCE
- \* CONSULT USING AIRLINE FOR SPECIFIC OPERATING PROCEDURES PRIOR TO FACILITY DESIGN

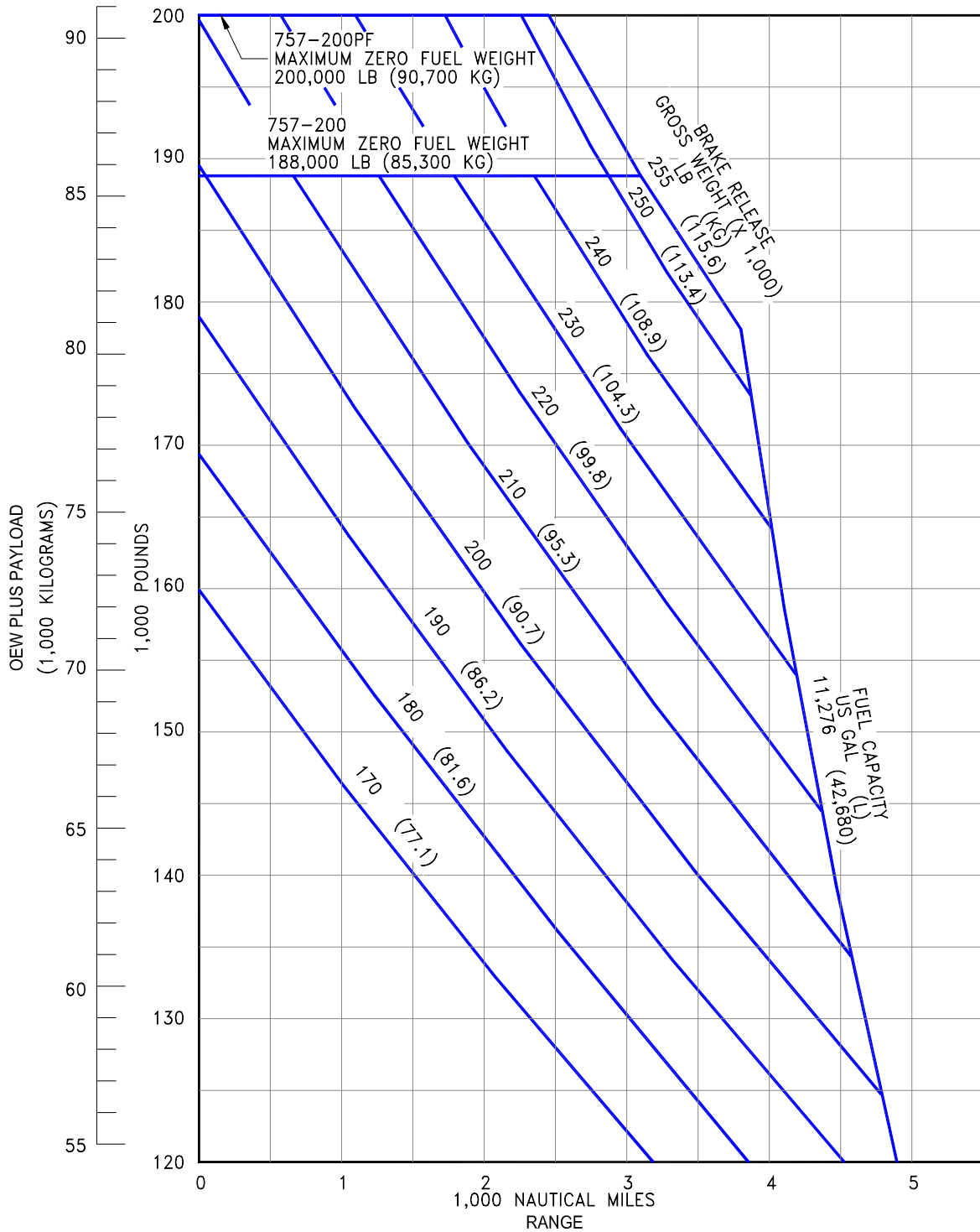

**3.2.3. PAYLOAD/RANGE FOR LONG-RANGE CRUISE**  
 MODEL 757-200, -200PF (PW2037, PW2040 ENGINES)

NOTES:

- \* 31-35-39,000 FT STEP CRUISE
- \* CRUISE MACH = 0.80
- \* STANDARD DAY
- \* 200 NMI ALTERNATE
- \* TYPICAL MISSION RESERVES
- \* NOMINAL PERFORMANCE
- \* CONSULT USING AIRLINE FOR SPECIFIC OPERATING PROCEDURE PRIOR TO FACILITY DESIGN

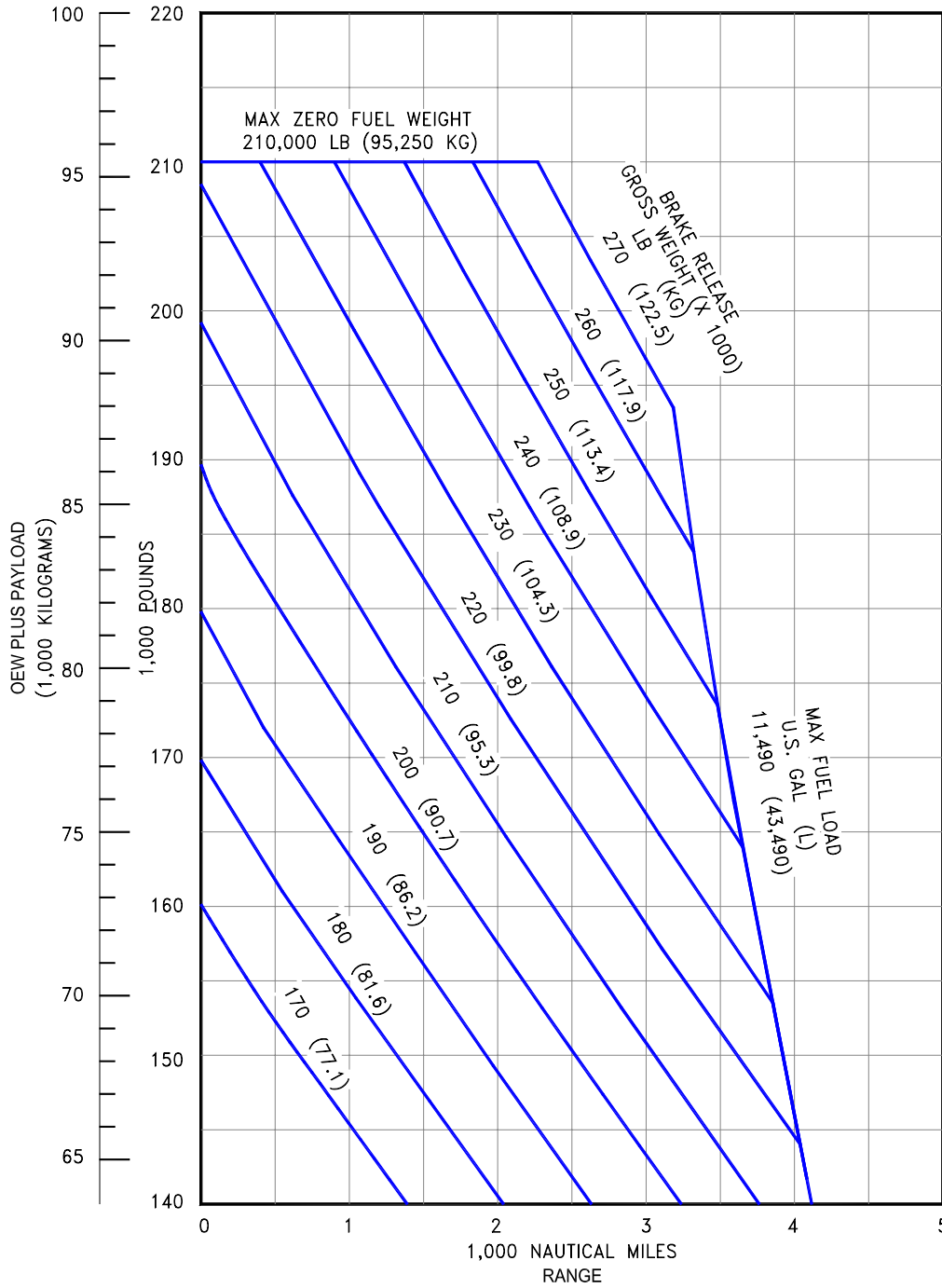

**3.2.4. PAYLOAD/RANGE FOR 0.80 MACH CRUISE**  
 MODEL 757-300 (RB211-535E4, -535E4B ENGINES)

D6-58327

NOTES:

- \* 31-35-39,000 FT STEP CRUISE
- \* CRUISE MACH = 0.80
- \* STANDARD DAY
- \* 200 NMI ALTERNATE
- \* TYPICAL MISSION RESERVES
- \* NOMINAL PERFORMANCE
- \* CONSULT USING AIRLINE FOR SPECIFIC OPERATING PROCEDURE PRIOR TO FACILITY DESIGN

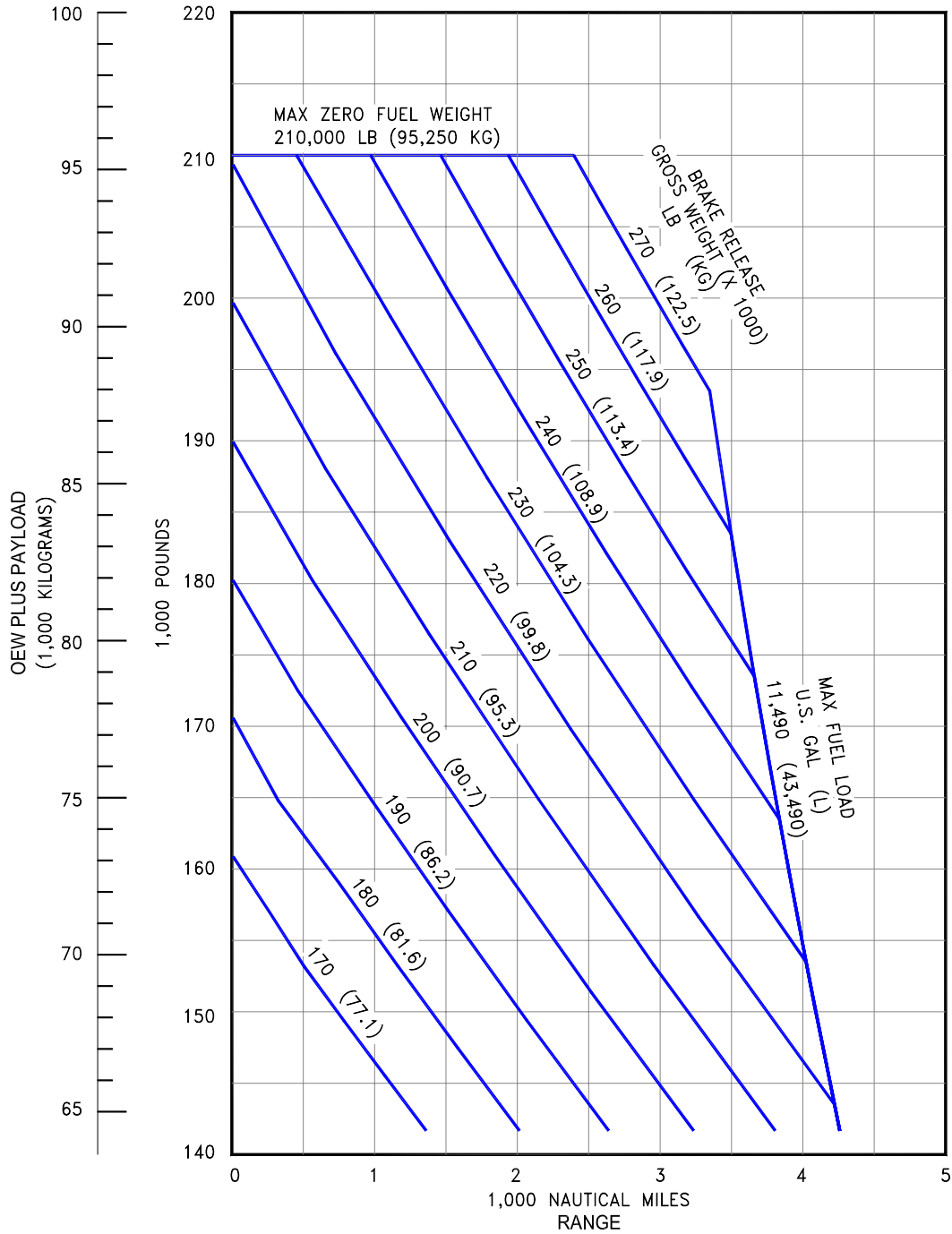

**3.2.5. PAYLOAD/RANGE FOR 0.80 MACH CRUISE**  
 MODEL 757-300 (PW2040, PW2043 ENGINES)

NOTES:

- \* RB211-535C ENGINES
- \* NO ENGINE AIRBLEED FOR AIR CONDITIONING
- \* ZERO WIND, ZERO RUNWAY GRADIENT
- \* CONSULT USING AIRLINE FOR SPECIFIC OPERATING PROCEDURE PRIOR TO FACILITY DESIGN
- \* LINEAR INTERPOLATION BETWEEN ALTITUDES INVALID
- \* LINEAR INTERPOLATION BETWEEN TEMPERATURES INVALID
- \* NOMINAL PERFORMANCE

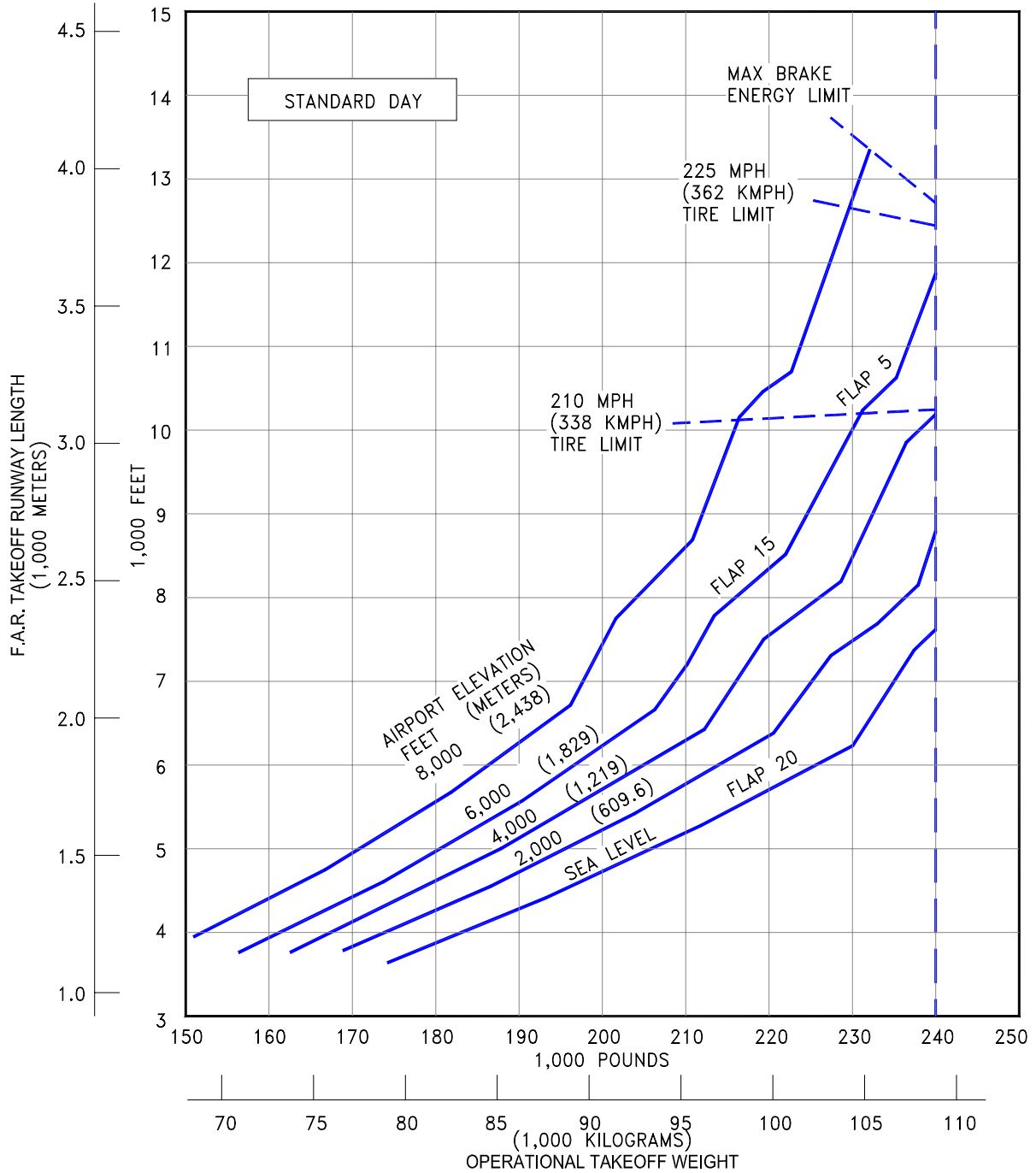

**3.3.1 F.A.R. TAKEOFF RUNWAY LENGTH REQUIREMENTS - STANDARD DAY**  
 MODEL 757-200 (RB211-535C ENGINES)

NOTES:

- \* RB211-535C ENGINES
- \* NO ENGINE AIRBLEED FOR AIR CONDITIONING
- \* ZERO WIND, ZERO RUNWAY GRADIENT
- \* CONSULT USING AIRLINE FOR SPECIFIC OPERATING PROCEDURE PRIOR TO FACILITY DESIGN
- \* LINEAR INTERPOLATION BETWEEN ALTITUDES INVALID
- \* LINEAR INTERPOLATION BETWEEN TEMPERATURES INVALID
- \* NOMINAL PERFORMANCE

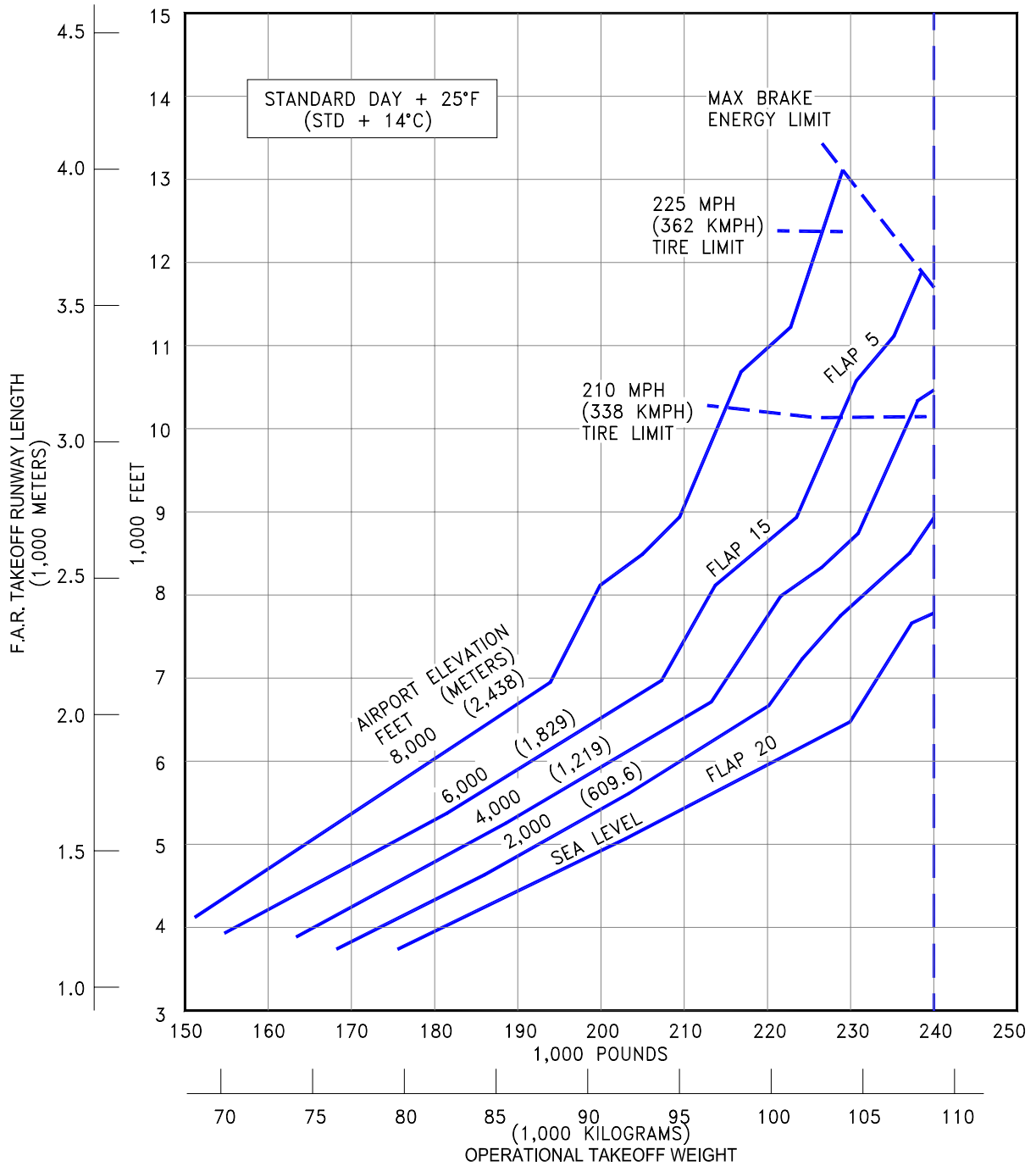

**3.3.2 F.A.R. TAKEOFF RUNWAY LENGTH REQUIREMENTS -**

**STANDARD DAY +25°F (STD + 14°C)**

MODEL 757-200 (RB211-535C ENGINES)

NOTES:

- \* RB211-535E4 ENGINES
- \* NO ENGINE AIRBLEED FOR AIR CONDITIONING
- \* ZERO WIND, ZERO RUNWAY GRADIENT
- \* CONSULT USING AIRLINE FOR SPECIFIC OPERATING PROCEDURE PRIOR TO FACILITY DESIGN
- \* LINEAR INTERPOLATION BETWEEN ALTITUDES INVALID
- \* LINEAR INTERPOLATION BETWEEN TEMPERATURES INVALID
- \* NOMINAL PERFORMANCE

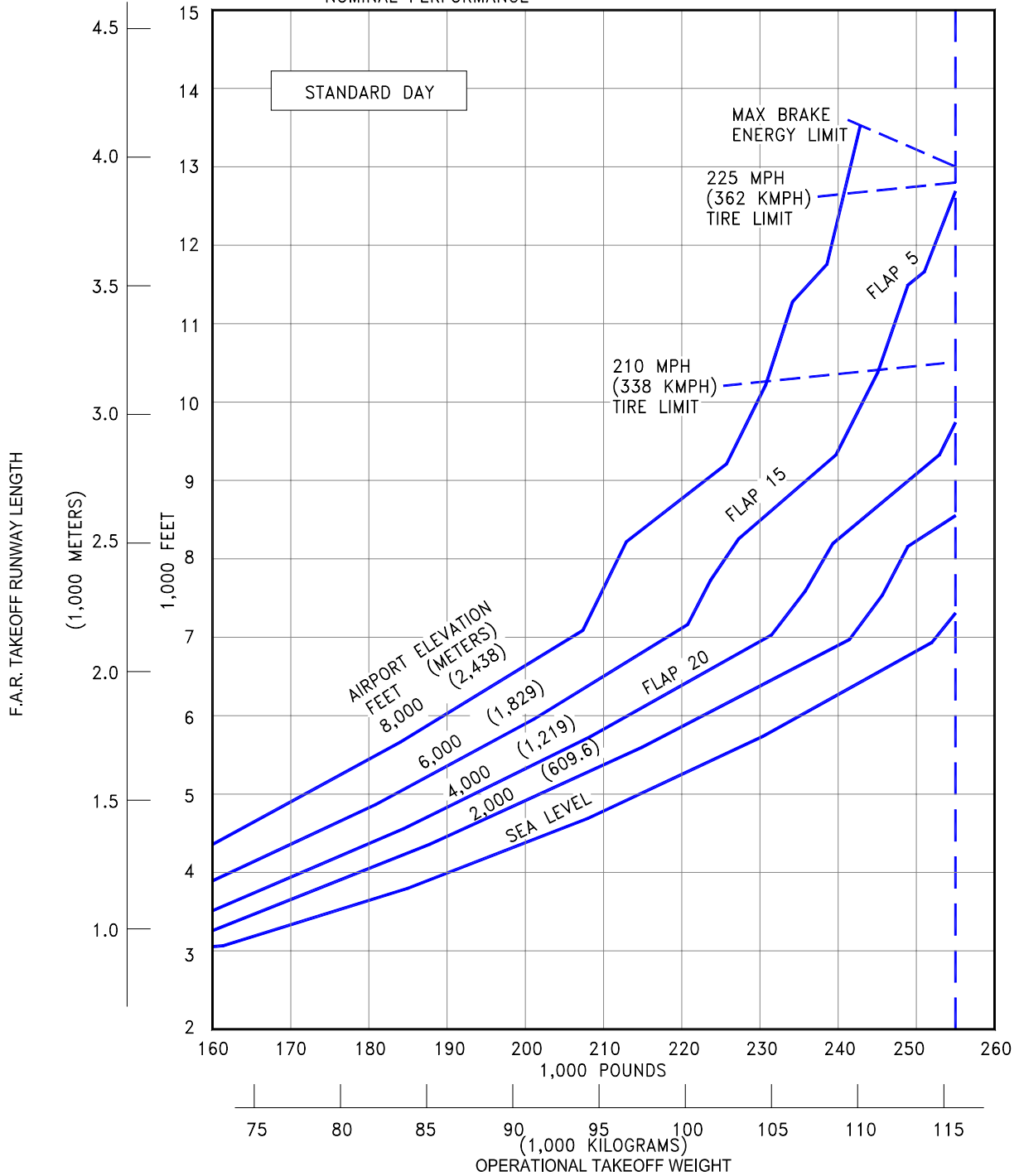

**3.3.3 F.A.R. TAKEOFF RUNWAY LENGTH REQUIREMENTS - STANDARD DAY**  
 MODEL 757-200 (RB211-535E4 ENGINES)

D6-58327

NOTES:

- \* RB211-535E4 ENGINES
- \* NO ENGINE AIRBLEED FOR AIR CONDITIONING
- \* ZERO WIND, ZERO RUNWAY GRADIENT
- \* CONSULT USING AIRLINE FOR SPECIFIC OPERATING PROCEDURE PRIOR TO FACILITY DESIGN
- \* LINEAR INTERPOLATION BETWEEN ALTITUDES INVALID
- \* LINEAR INTERPOLATION BETWEEN TEMPERATURES INVALID
- \* NOMINAL PERFORMANCE

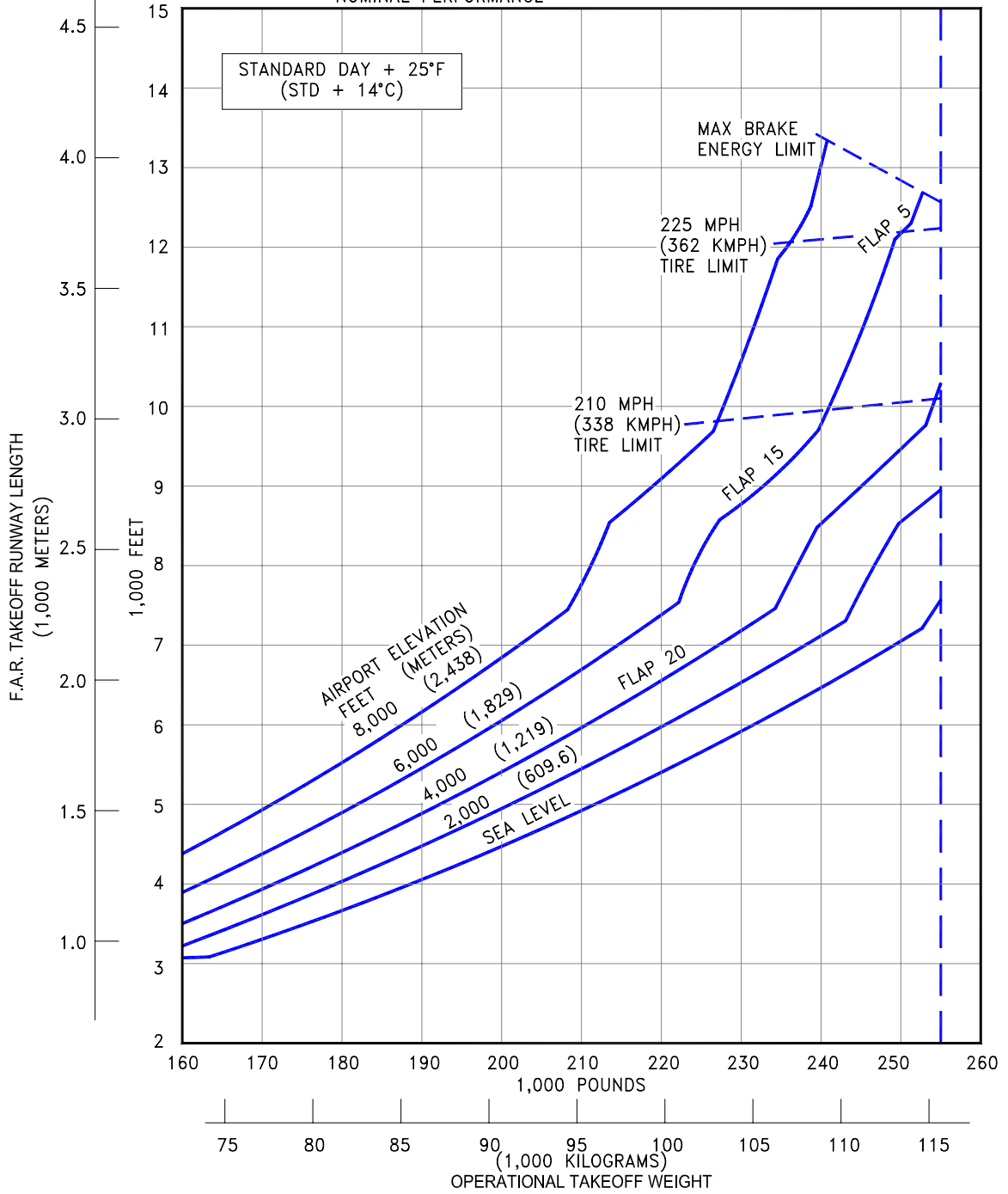

**3.3.4 F.A.R. TAKEOFF RUNWAY LENGTH REQUIREMENTS -**

**STANDARD DAY +25°F (STD + 14°C)**

MODEL 757-200 (RB211-535E4 ENGINES)

NOTES:

- \* RB211-535E4B ENGINES
- \* NO ENGINE AIRBLEED FOR AIR CONDITIONING
- \* ZERO WIND, ZERO RUNWAY GRADIENT
- \* CONSULT USING AIRLINE FOR SPECIFIC OPERATING PROCEDURE PRIOR TO FACILITY DESIGN
- \* LINEAR INTERPOLATION BETWEEN ALTITUDES INVALID
- \* LINEAR INTERPOLATION BETWEEN TEMPERATURES INVALID
- \* NOMINAL PERFORMANCE

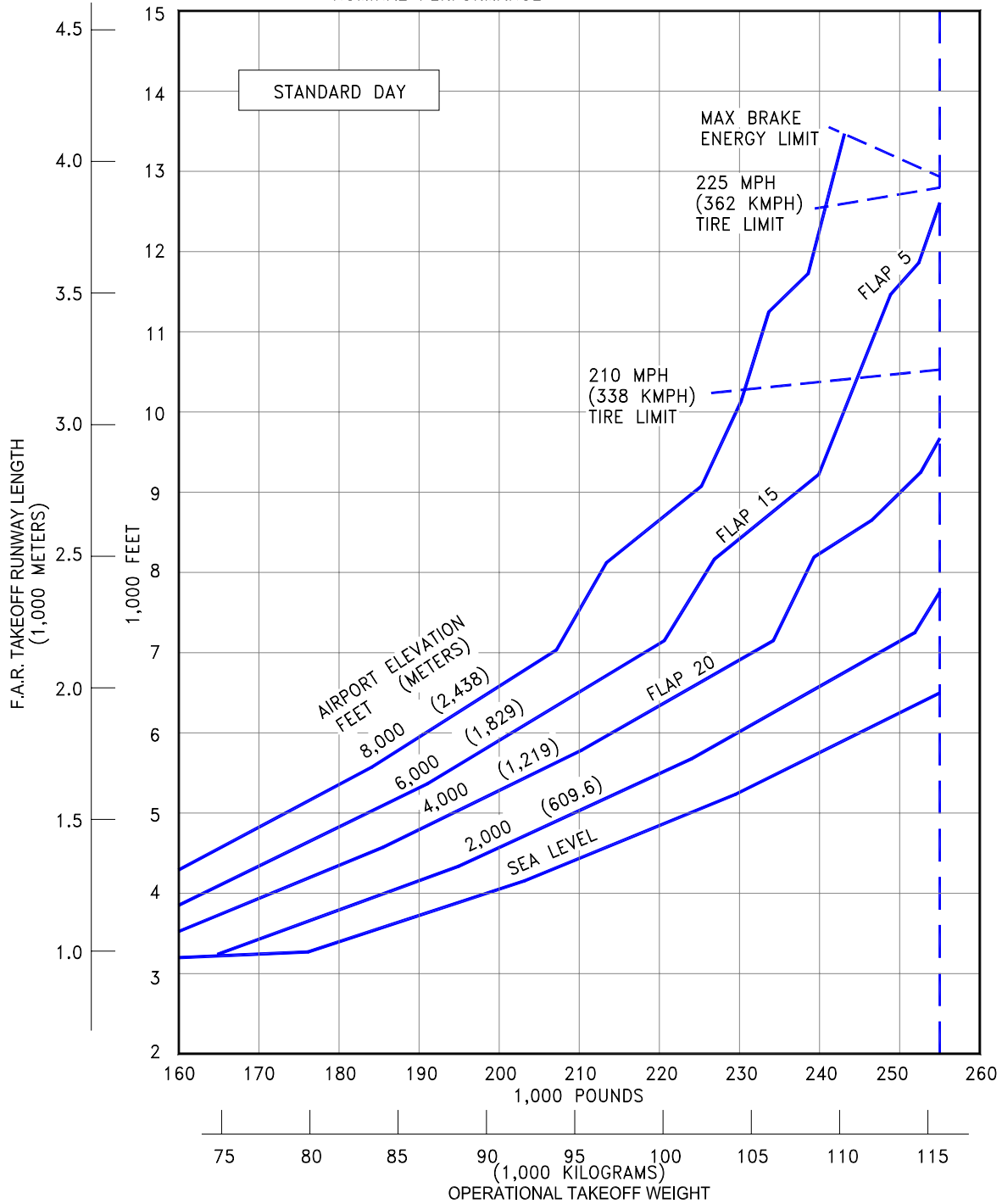

**3.3.5 F.A.R. TAKEOFF RUNWAY LENGTH REQUIREMENTS - STANDARD DAY**  
 MODEL 757-200 (RB211-535E4B ENGINES)

D6-58327



NOTES:

- \* RB211-535E4B ENGINES
- \* NO ENGINE AIRBLEED FOR AIR CONDITIONING
- \* ZERO WIND, ZERO RUNWAY GRADIENT
- \* CONSULT USING AIRLINE FOR SPECIFIC OPERATING PROCEDURE PRIOR TO FACILITY DESIGN
- \* LINEAR INTERPOLATION BETWEEN ALTITUDES INVALID
- \* LINEAR INTERPOLATION BETWEEN TEMPERATURES INVALID
- \* NOMINAL PERFORMANCE

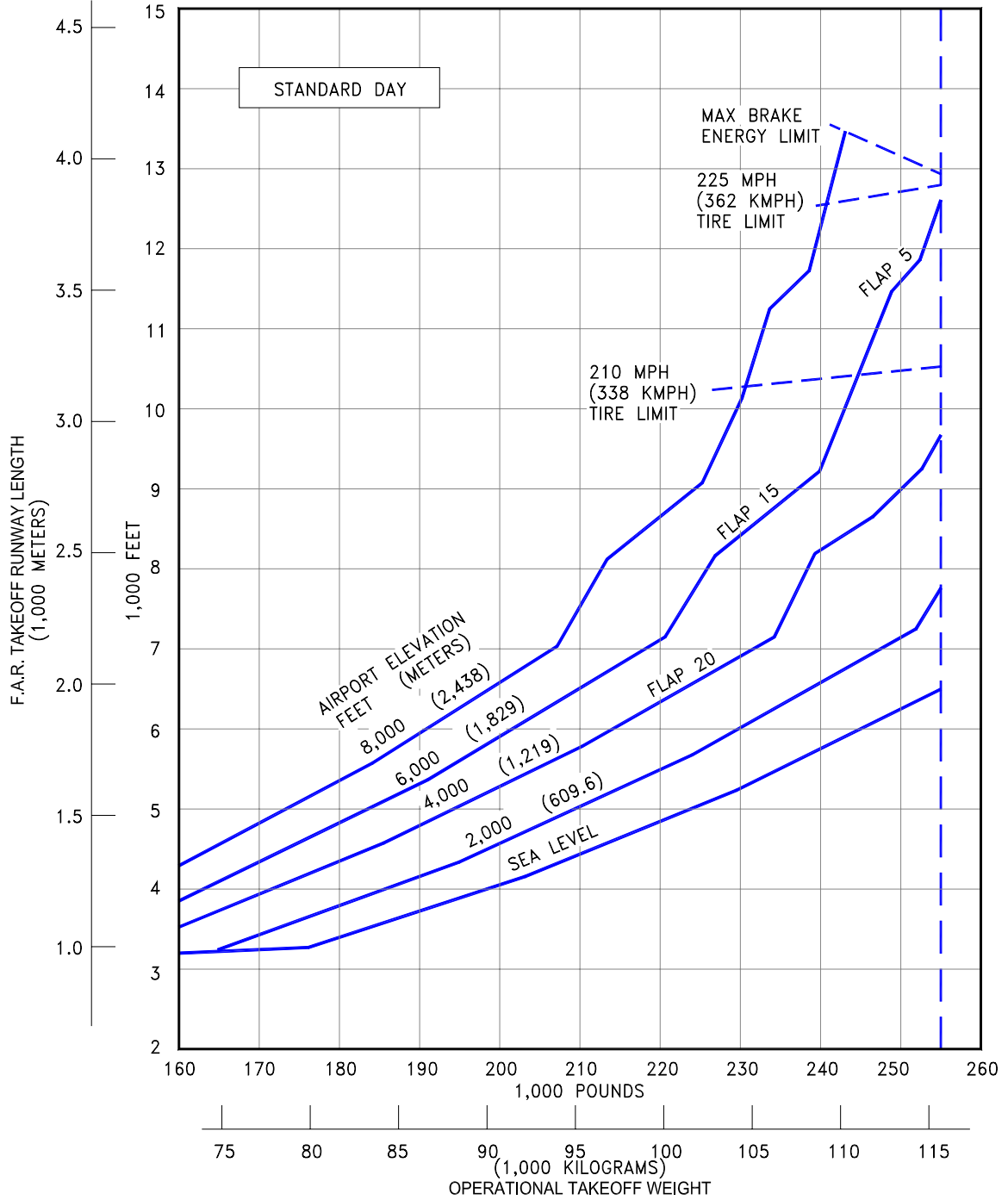

**3.3.6 F.A.R. TAKEOFF RUNWAY LENGTH REQUIREMENTS -  
STANDARD DAY +25°F (STD + 14°C)  
MODEL 757-200 (RB211-535E4B ENGINES)**

NOTES:

- \* PW2037 ENGINES
- \* NO ENGINE AIRBLEED FOR AIR CONDITIONING
- \* ZERO WIND, ZERO RUNWAY GRADIENT
- \* CONSULT USING AIRLINE FOR SPECIFIC OPERATING PROCEDURE PRIOR TO FACILITY DESIGN
- \* LINEAR INTERPOLATION BETWEEN ALTITUDES INVALID
- \* LINEAR INTERPOLATION BETWEEN TEMPERATURES INVALID
- \* NOMINAL PERFORMANCE

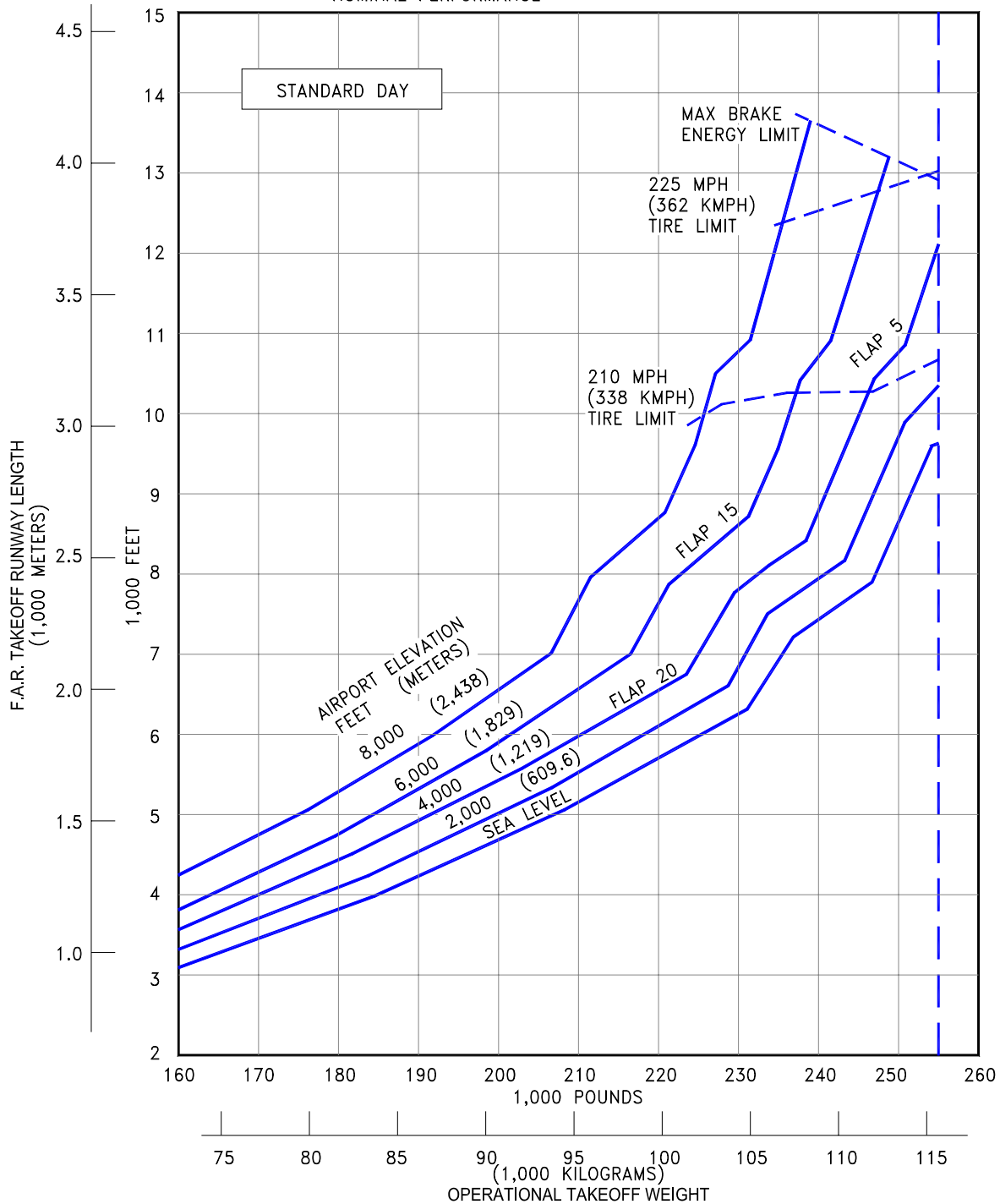

**3.3.7 F.A.R. TAKEOFF RUNWAY LENGTH REQUIREMENTS - STANDARD DAY**  
 MODEL 757-200 (PW2037 ENGINES)

D6-58327

NOTES:

- \* PW2037 ENGINES
- \* NO ENGINE AIRBLEED FOR AIR CONDITIONING
- \* ZERO WIND, ZERO RUNWAY GRADIENT
- \* CONSULT USING AIRLINE FOR SPECIFIC OPERATING PROCEDURE PRIOR TO FACILITY DESIGN
- \* LINEAR INTERPOLATION BETWEEN ALTITUDES INVALID
- \* LINEAR INTERPOLATION BETWEEN TEMPERATURES INVALID
- \* NOMINAL PERFORMANCE

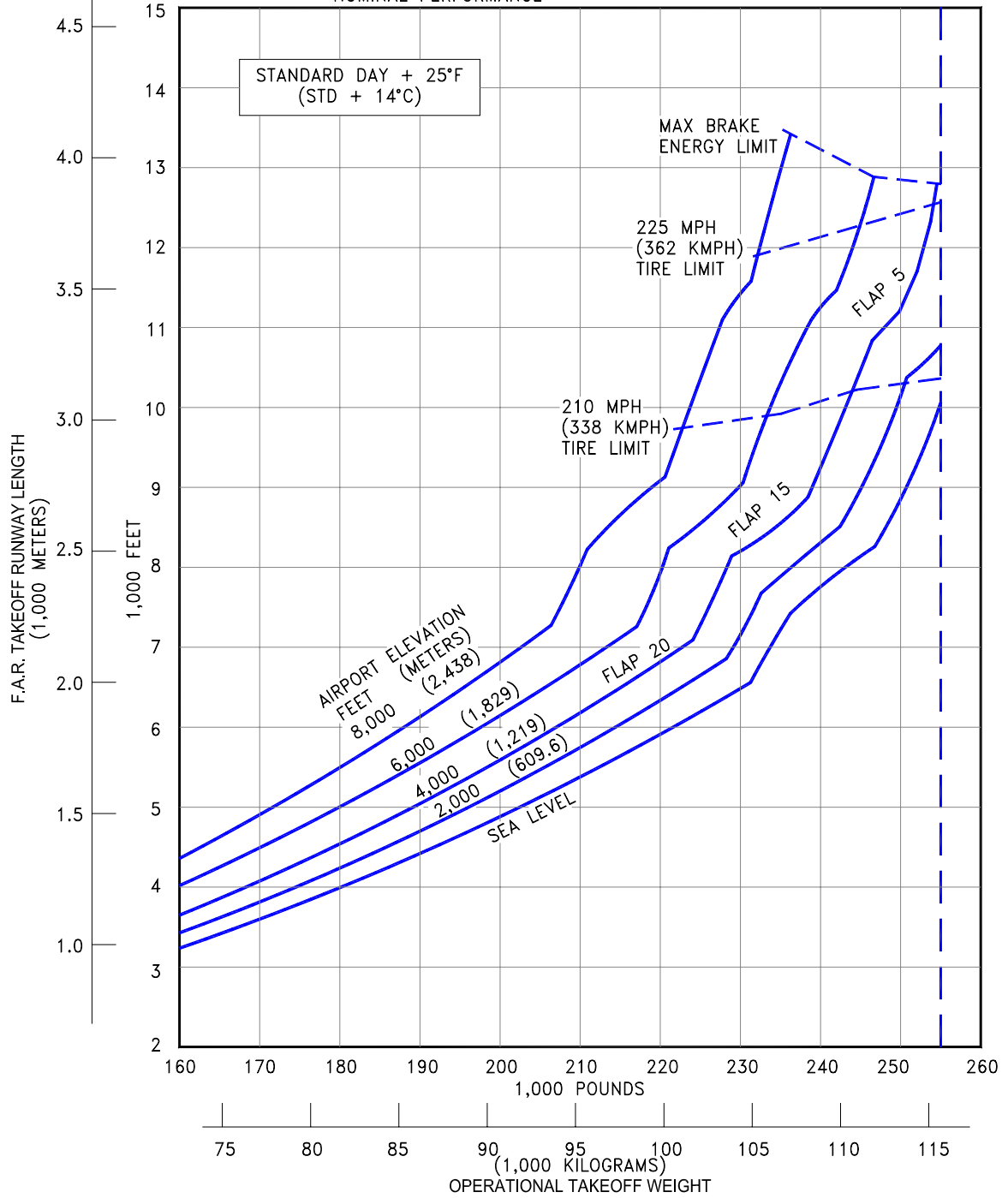

**3.3.8 F.A.R. TAKEOFF RUNWAY LENGTH REQUIREMENTS -  
STANDARD DAY +25°F (STD + 14°C)  
MODEL 757-200 (PW2037 ENGINES)**

NOTES:

- \* PW2040 ENGINES
- \* NO ENGINE AIRBLEED FOR AIR CONDITIONING
- \* ZERO WIND, ZERO RUNWAY GRADIENT
- \* CONSULT USING AIRLINE FOR SPECIFIC OPERATING PROCEDURE PRIOR TO FACILITY DESIGN
- \* LINEAR INTERPOLATION BETWEEN ALTITUDES INVALID
- \* LINEAR INTERPOLATION BETWEEN TEMPERATURES INVALID
- \* NOMINAL PERFORMANCE

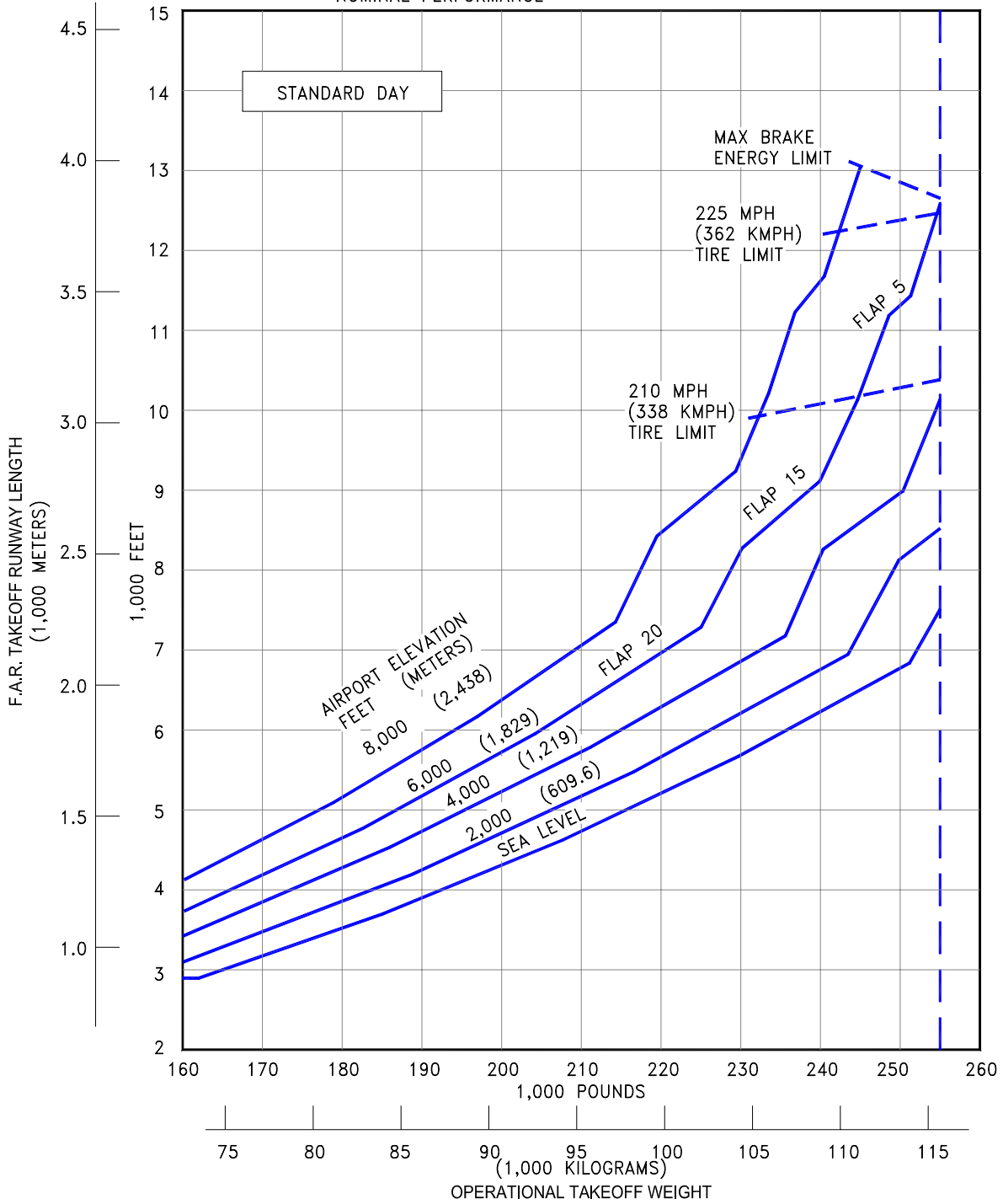

**3.3.9 F.A.R. TAKEOFF RUNWAY LENGTH REQUIREMENTS - STANDARD DAY**  
 MODEL 757-200 (PW2040 ENGINES)

NOTES:

- \* PW2040 ENGINES
- \* NO ENGINE AIRBLEED FOR AIR CONDITIONING
- \* ZERO WIND, ZERO RUNWAY GRADIENT
- \* CONSULT USING AIRLINE FOR SPECIFIC OPERATING PROCEDURE PRIOR TO FACILITY DESIGN
- \* LINEAR INTERPOLATION BETWEEN ALTITUDES INVALID
- \* LINEAR INTERPOLATION BETWEEN TEMPERATURES INVALID
- \* NOMINAL PERFORMANCE

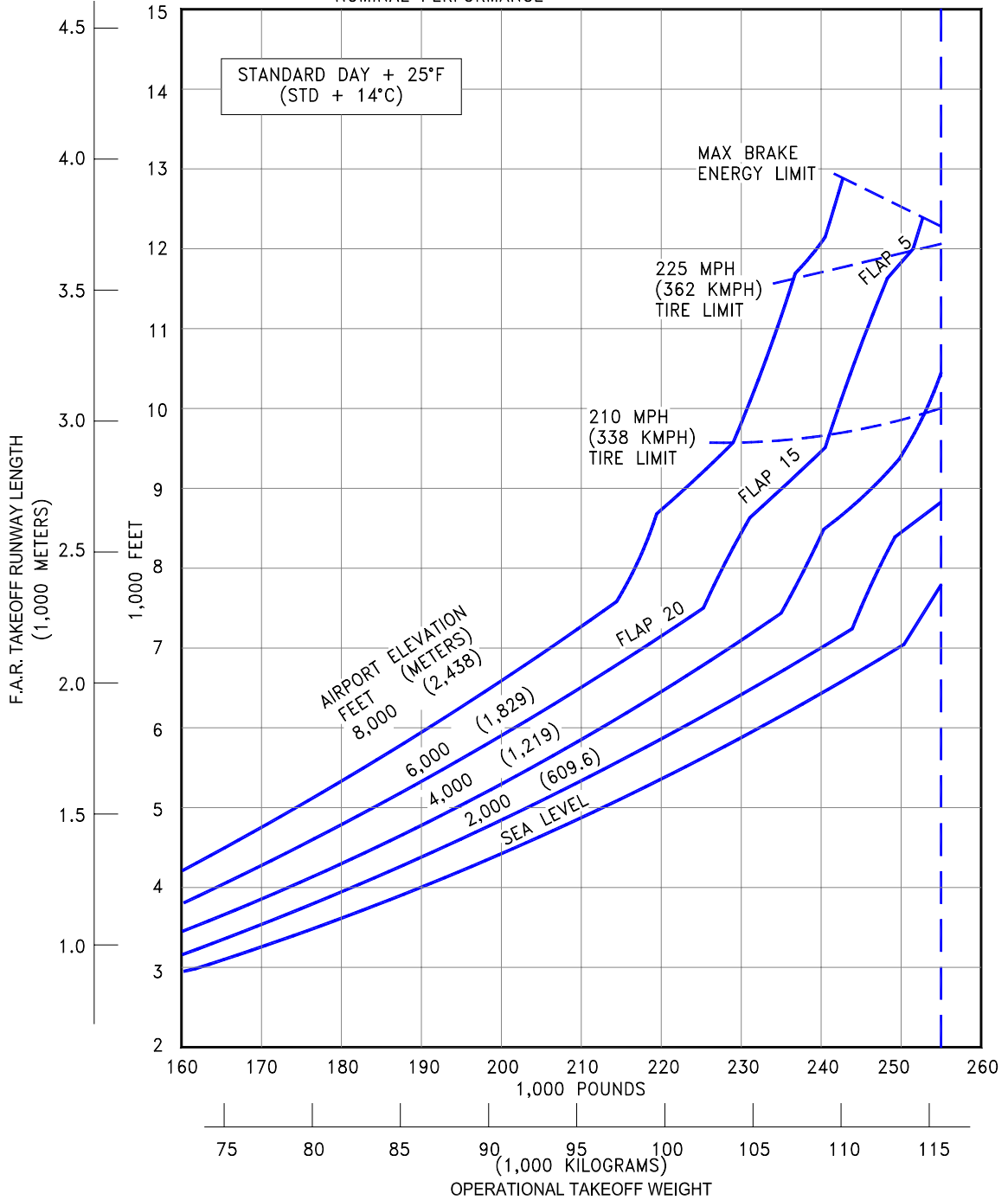

**3.3.10 F.A.R. TAKEOFF RUNWAY LENGTH REQUIREMENTS -**  
**STANDARD DAY +25°F (STD + 14°C)**  
 MODEL 757-200 (PW2040 ENGINES)

NOTES:

- \* RB211-535E4 ENGINES
- \* NO ENGINE AIRBLEED FOR AIR CONDITIONING
- \* ZERO WIND, ZERO RUNWAY GRADIENT
- \* DRY RUNWAY SURFACE
- \* CONSULT USING AIRLINE FOR SPECIFIC OPERATING PROCEDURE PRIOR TO FACILITY DESIGN
- \* LINEAR INTERPOLATION BETWEEN ALTITUDES INVALID
- \* LINEAR INTERPOLATION BETWEEN TEMPERATURES INVALID

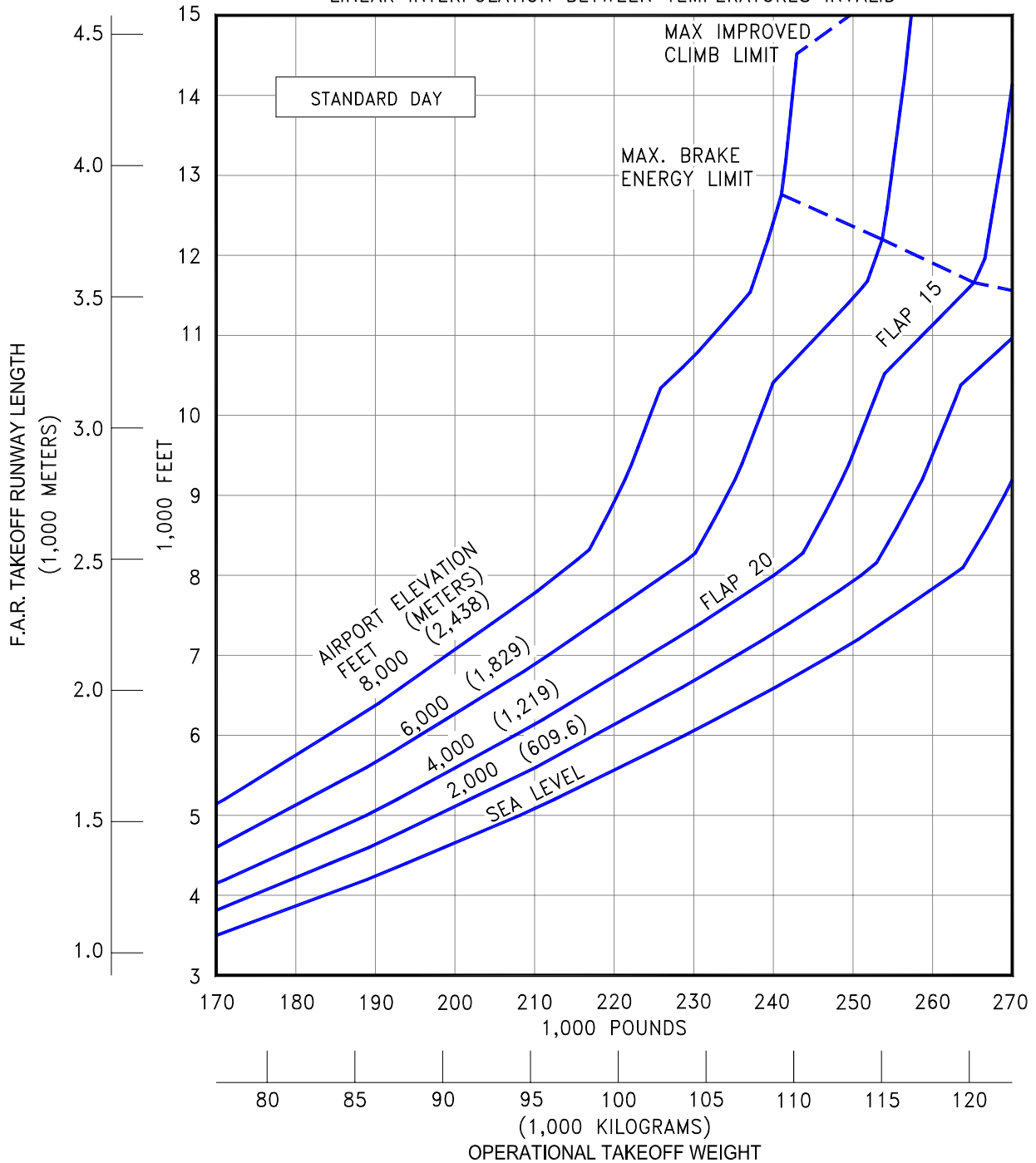

**3.3.11 F.A.R. TAKEOFF RUNWAY LENGTH REQUIREMENTS - STANDARD DAY**  
 MODEL 757-300 (RB211-535E4 ENGINES)

NOTES:

- \* RB211-535E4 ENGINES
- \* NO ENGINE AIRBLEED FOR AIR CONDITIONING
- \* ZERO WIND, ZERO RUNWAY GRADIENT
- \* DRY RUNWAY SURFACE
- \* CONSULT USING AIRLINE FOR SPECIFIC OPERATING PROCEDURE PRIOR TO FACILITY DESIGN
- \* LINEAR INTERPOLATION BETWEEN ALTITUDES INVALID
- \* LINEAR INTERPOLATION BETWEEN TEMPERATURES INVALID

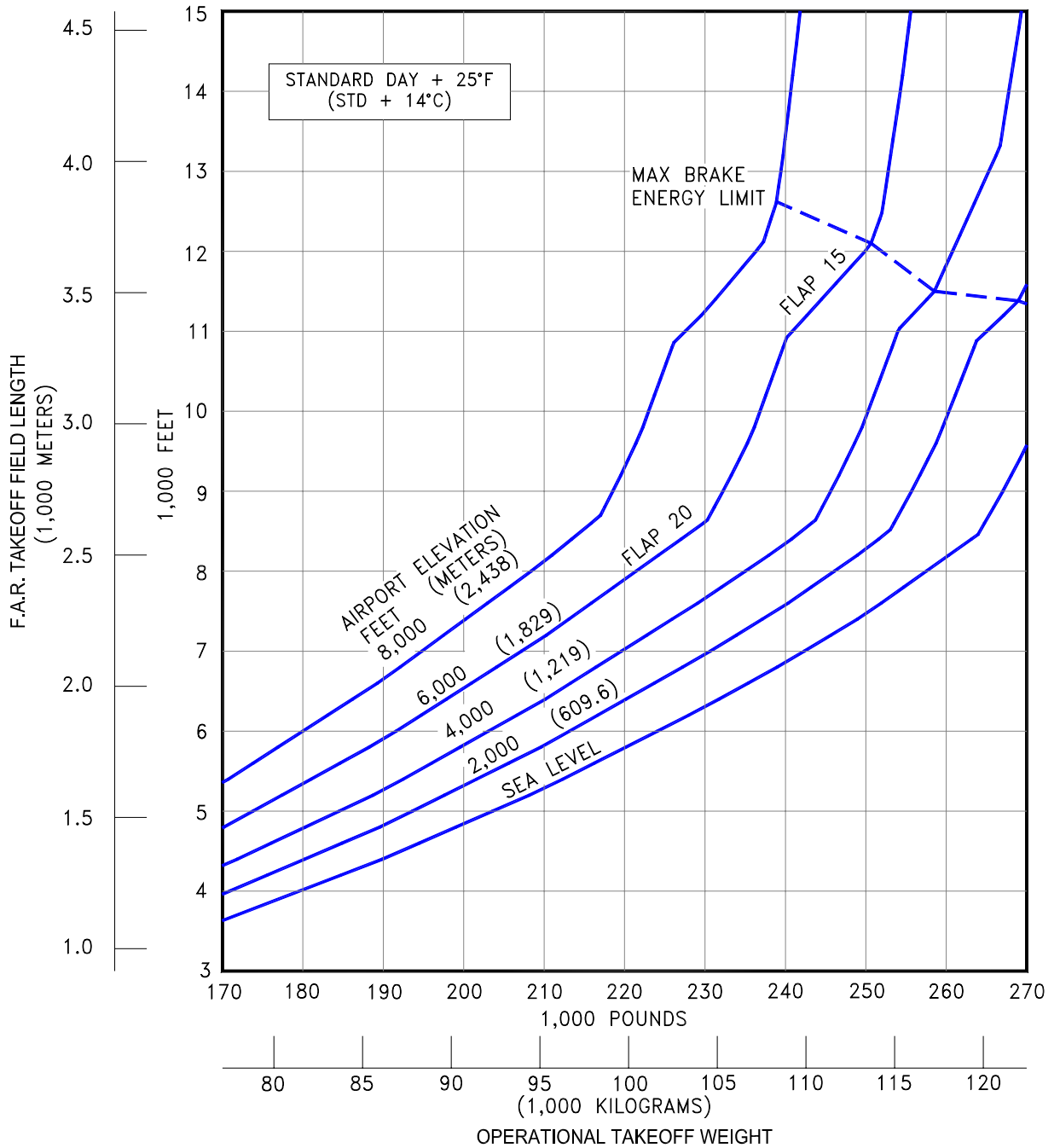

**3.3.12 F.A.R. TAKEOFF RUNWAY LENGTH REQUIREMENTS**

**STANDARD DAY +25°F (STD + 14°C)**

MODEL 757-300 (RB211-535E4 ENGINES)

NOTES:

- \* RB211-535E4 ENGINES
- \* NO ENGINE AIRBLEED FOR AIR CONDITIONING
- \* ZERO WIND, ZERO RUNWAY GRADIENT
- \* WET SMOOTH RUNWAY SURFACE
- \* CONSULT USING AIRLINE FOR SPECIFIC OPERATING PROCEDURE PRIOR TO FACILITY DESIGN
- \* LINEAR INTERPOLATION BETWEEN ALTITUDES INVALID
- \* LINEAR INTERPOLATION BETWEEN TEMPERATURES INVALID
- \* TAKEOFF PERFORMANCE IMPROVEMENTS ARE POSSIBLE USING GROOVED RUNWAY

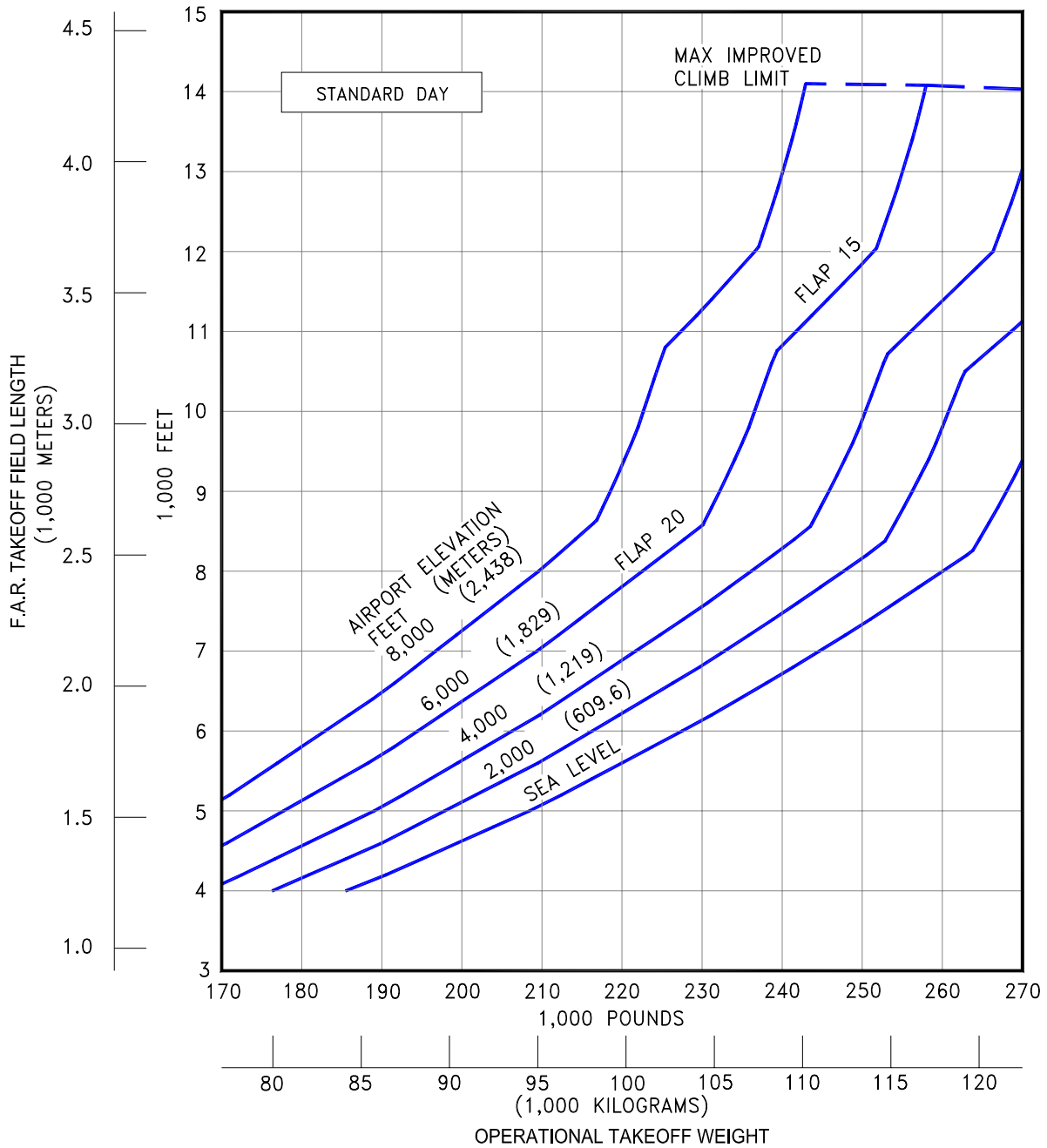

**3.3.13 J.A.R. TAKEOFF RUNWAY LENGTH REQUIREMENTS - STANDARD DAY - WET RUNWAY**  
 MODEL 757-300 (RB211-535E4 ENGINES)



NOTES:

- \* RB211-535E4 ENGINES
- \* NO ENGINE AIRBLEED FOR AIR CONDITIONING
- \* ZERO WIND, ZERO RUNWAY GRADIENT
- \* WET SMOOTH RUNWAY SURFACE
- \* CONSULT USING AIRLINE FOR SPECIFIC OPERATING PROCEDURE PRIOR TO FACILITY DESIGN
- \* LINEAR INTERPOLATION BETWEEN ALTITUDES INVALID
- \* LINEAR INTERPOLATION BETWEEN TEMPERATURES INVALID
- \* TAKEOFF PERFORMANCE IMPROVEMENTS ARE POSSIBLE USING GROOVED RUNWAY

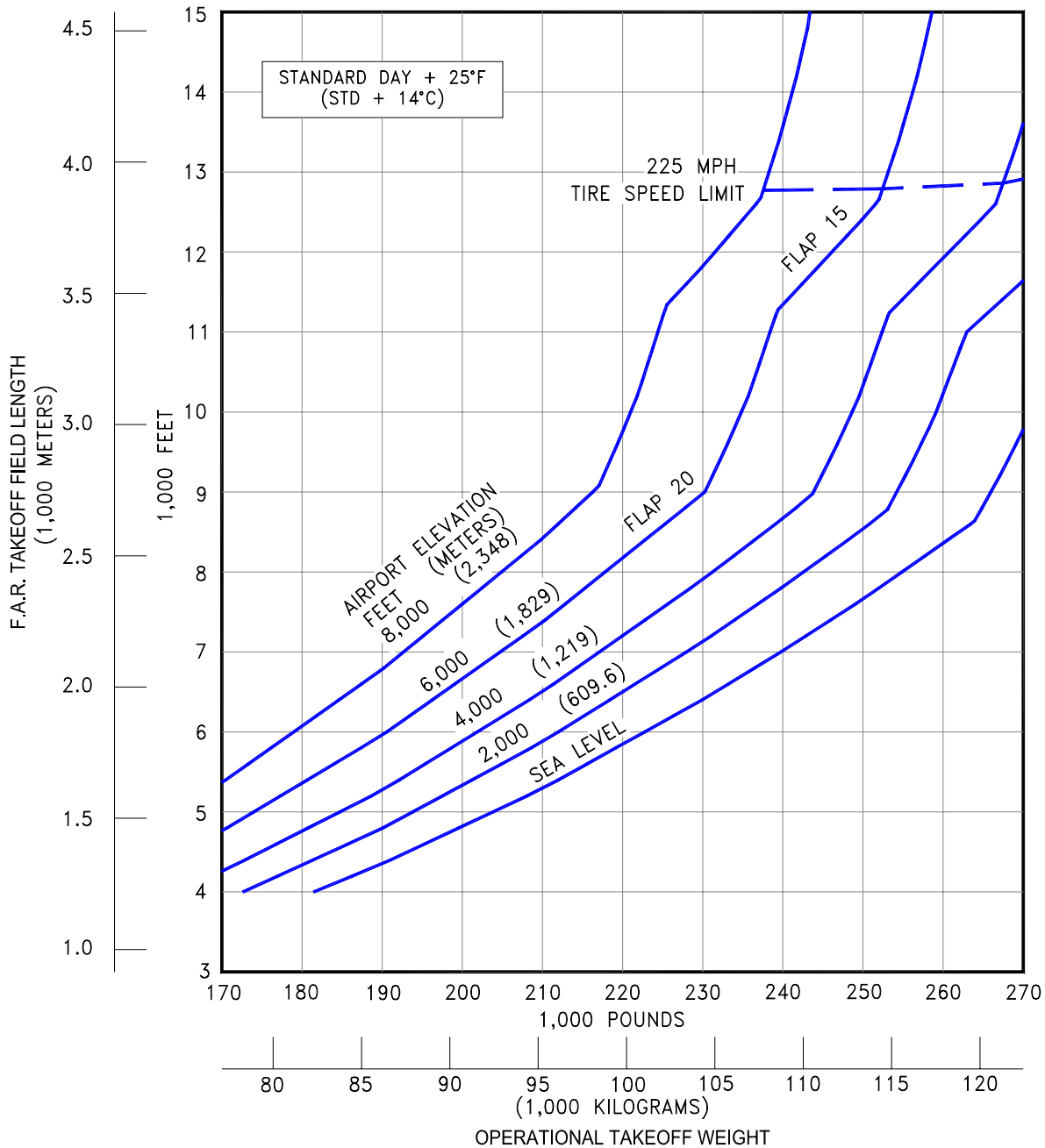

**3.3.14 J.A.R. TAKEOFF RUNWAY LENGTH REQUIREMENTS**

**STANDARD DAY +25°F (STD + 14°C) - WET RUNWAY**

MODEL 757-300 (RB211-535E4 ENGINES)

NOTES:

- \* RB211-535E4B ENGINES
- \* NO ENGINE AIRBLEED FOR AIR CONDITIONING
- \* ZERO WIND, ZERO RUNWAY GRADIENT
- \* DRY RUNWAY SURFACE
- \* CONSULT USING AIRLINE FOR SPECIFIC OPERATING PROCEDURE PRIOR TO FACILITY DESIGN
- \* LINEAR INTERPOLATION BETWEEN ALTITUDES INVALID
- \* LINEAR INTERPOLATION BETWEEN TEMPERATURES INVALID

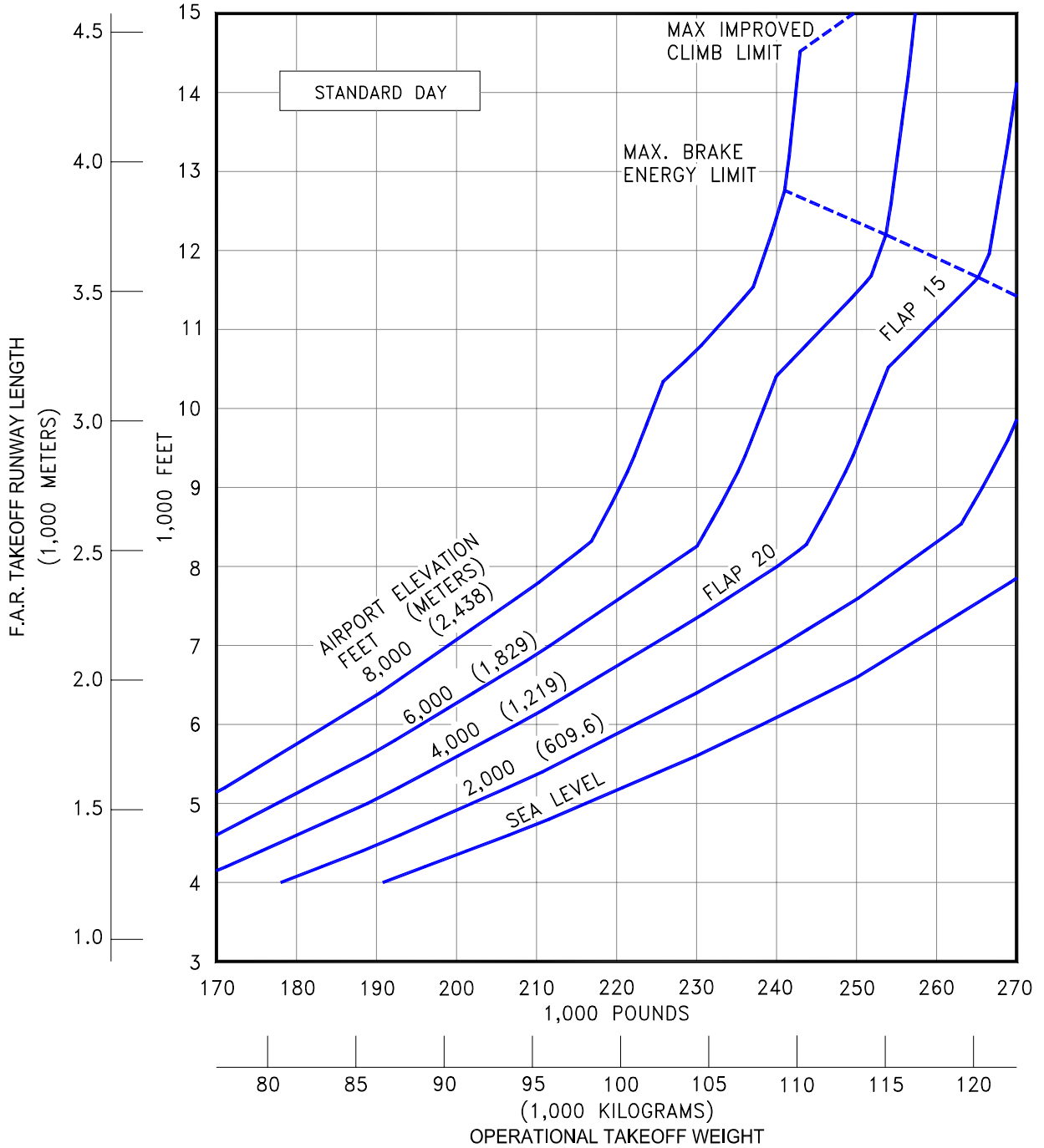

**3.3.15 F.A..R TAKEOFF RUNWAY LENGTH REQUIREMENTS - STANDARD DAY**  
 MODEL 757-300 (RB211-535E4B ENGINES)

NOTES:

- \* RB211-535E4B ENGINES
- \* NO ENGINE AIRBLEED FOR AIR CONDITIONING
- \* ZERO WIND, ZERO RUNWAY GRADIENT
- \* DRY RUNWAY SURFACE
- \* CONSULT USING AIRLINE FOR SPECIFIC OPERATING PROCEDURE PRIOR TO FACILITY DESIGN
- \* LINEAR INTERPOLATION BETWEEN ALTITUDES INVALID
- \* LINEAR INTERPOLATION BETWEEN TEMPERATURES INVALID

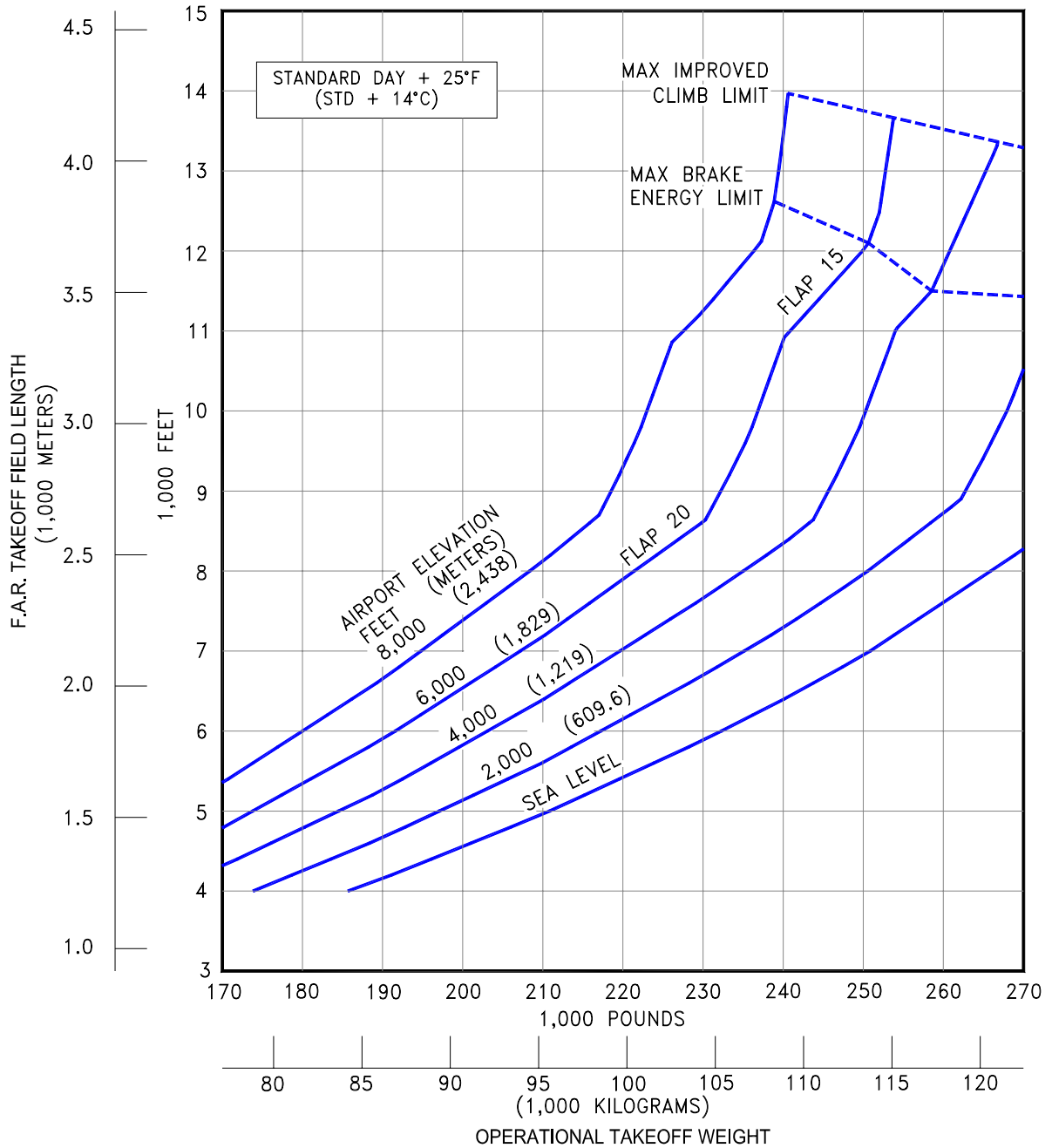

**3.3.16 F.A.R. TAKEOFF RUNWAY LENGTH REQUIREMENTS**

**STANDARD DAY +25°F (STD + 14°C)**

MODEL 757-300 (RB211-535E4B ENGINES)

- NOTES:
- \* RB211-535E4B ENGINES
  - \* NO ENGINE AIRBLEED FOR AIR CONDITIONING
  - \* ZERO WIND, ZERO RUNWAY GRADIENT
  - \* WET SMOOTH RUNWAY SURFACE
  - \* CONSULT USING AIRLINE FOR SPECIFIC OPERATING PROCEDURE PRIOR TO FACILITY DESIGN
  - \* LINEAR INTERPOLATION BETWEEN ALTITUDES INVALID
  - \* LINEAR INTERPOLATION BETWEEN TEMPERATURES INVALID
  - \* TAKEOFF PERFORMANCE IMPROVEMENTS ARE POSSIBLE USING GROOVED RUNWAY

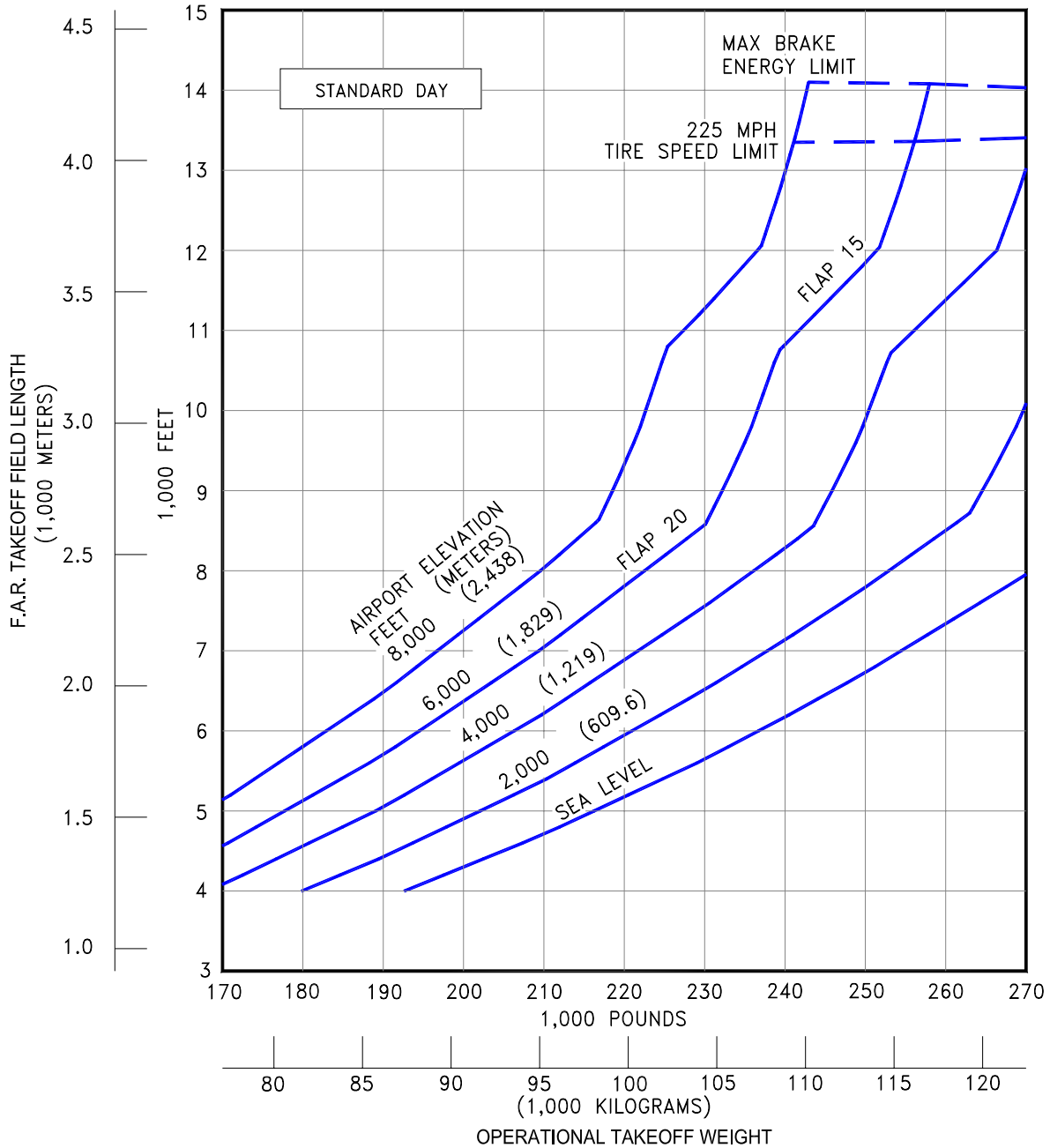

**3.3.17 J.A.R. TAKEOFF RUNWAY LENGTH REQUIREMENTS - STANDARD DAY - WET RUNWAY**  
 MODEL 757-300 (RB211-535E4B ENGINES)

NOTES:

- \* RB211-535E4B ENGINES
- \* NO ENGINE AIRBLEED FOR AIR CONDITIONING
- \* ZERO WIND, ZERO RUNWAY GRADIENT
- \* WET SMOOTH RUNWAY SURFACE
- \* CONSULT USING AIRLINE FOR SPECIFIC OPERATING PROCEDURE PRIOR TO FACILITY DESIGN
- \* LINEAR INTERPOLATION BETWEEN ALTITUDES INVALID
- \* LINEAR INTERPOLATION BETWEEN TEMPERATURES INVALID
- \* TAKEOFF PERFORMANCE IMPROVEMENTS ARE POSSIBLE USING GROOVED RUNWAY

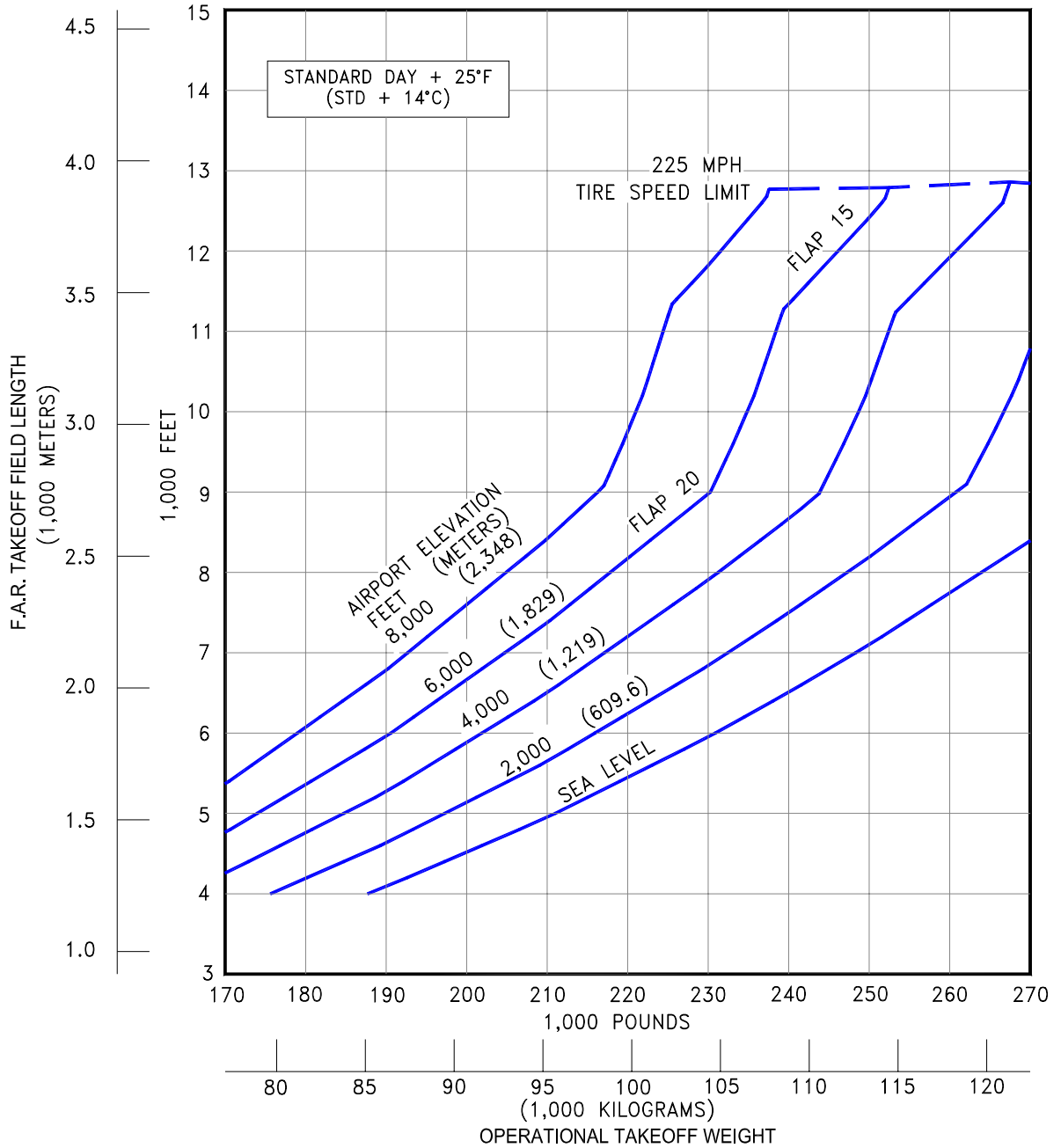

**3.3.18 J.A.R. TAKEOFF RUNWAY LENGTH REQUIREMENTS**  
**STANDARD DAY +25°F (STD + 14°C) - WET RUNWAY**  
 MODEL 757-300 (RB211-535E4B ENGINES)

NOTES:

- \* PW2040 ENGINES
- \* NO ENGINE AIRBLEED FOR AIR CONDITIONING
- \* ZERO WIND, ZERO RUNWAY GRADIENT
- \* DRY RUNWAY SURFACE
- \* CONSULT USING AIRLINE FOR SPECIFIC OPERATING PROCEDURE PRIOR TO FACILITY DESIGN
- \* LINEAR INTERPOLATION BETWEEN ALTITUDES INVALID
- \* LINEAR INTERPOLATION BETWEEN TEMPERATURES INVALID

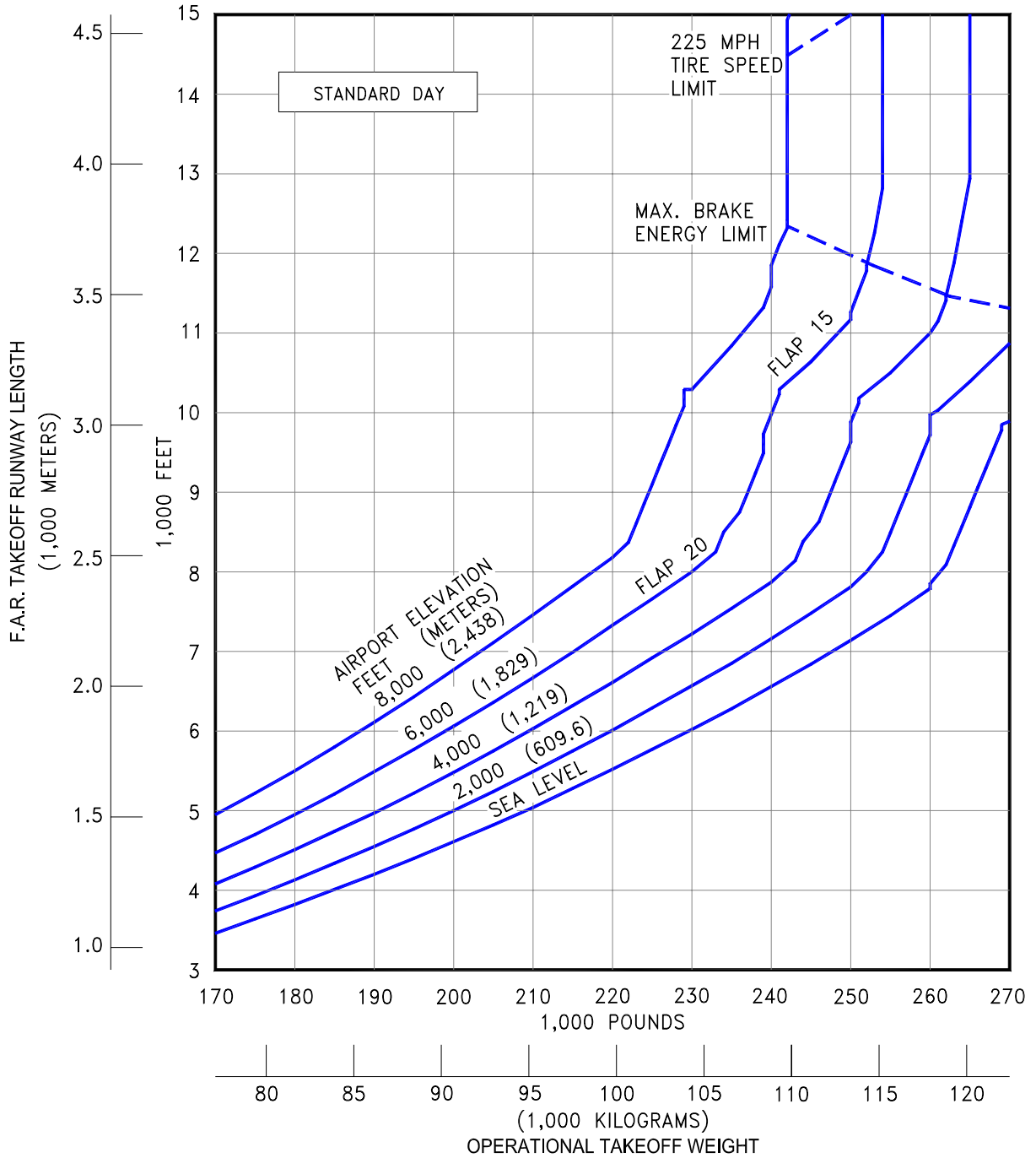

**3.3.19 F.A.R. TAKEOFF RUNWAY LENGTH REQUIREMENTS - STANDARD DAY**  
 MODEL 757-300 (PW2040 ENGINES)

D6-58327

NOTES:

- \* PW2040 ENGINES
- \* NO ENGINE AIRBLEED FOR AIR CONDITIONING
- \* ZERO WIND, ZERO RUNWAY GRADIENT
- \* DRY RUNWAY SURFACE
- \* CONSULT USING AIRLINE FOR SPECIFIC OPERATING PROCEDURE PRIOR TO FACILITY DESIGN
- \* LINEAR INTERPOLATION BETWEEN ALTITUDES INVALID
- \* LINEAR INTERPOLATION BETWEEN TEMPERATURES INVALID

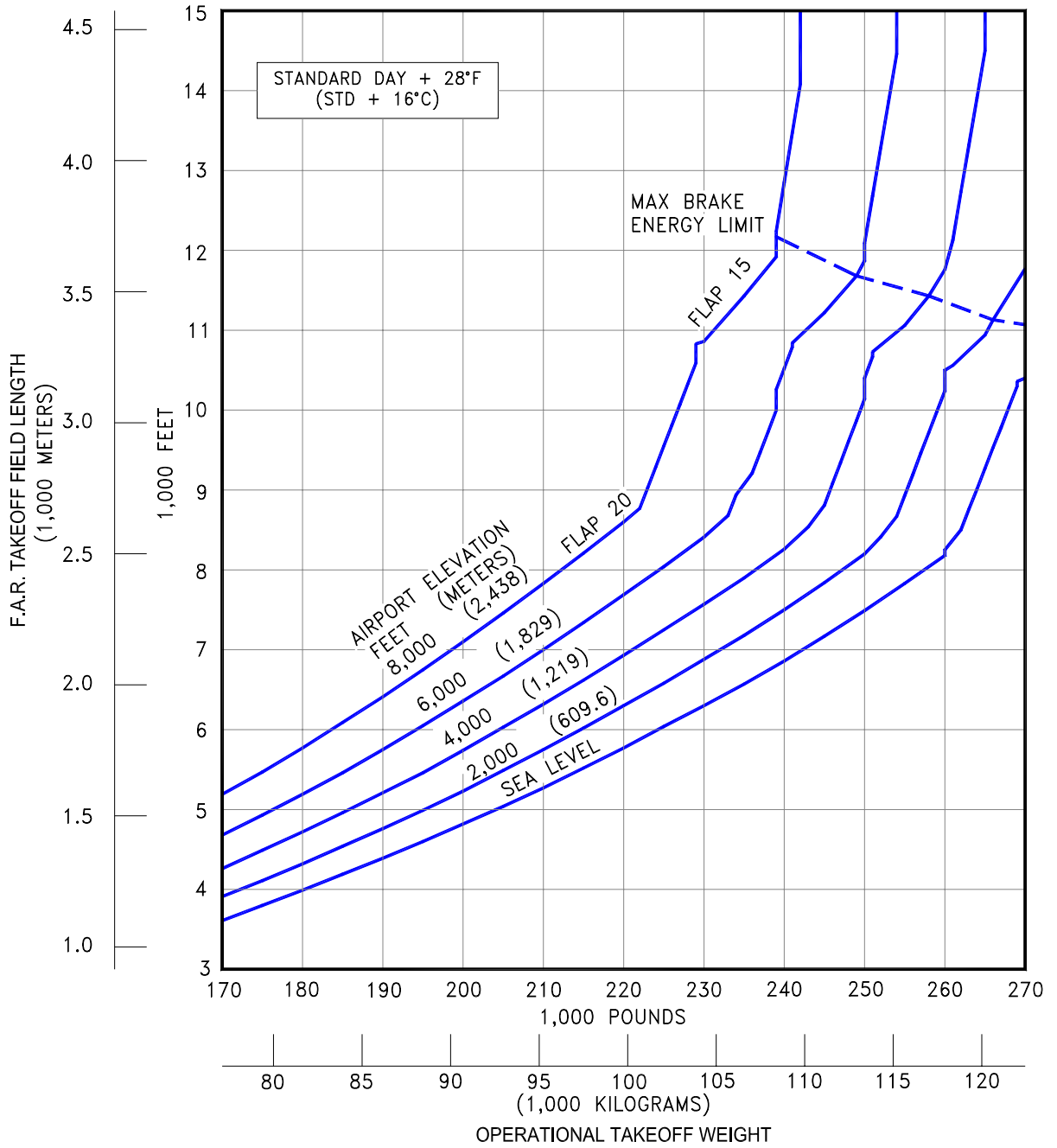

**3.3.20 F.A.R. TAKEOFF RUNWAY LENGTH REQUIREMENTS**

**STANDARD DAY +28°F (STD + 16°C)**

*MODEL 757-300 (PW2040 ENGINES)*

- NOTES:
- \* NO ENGINE AIRBLEED FOR AIR CONDITIONING
  - \* ZERO WIND, ZERO RUNWAY GRADIENT
  - \* WET SMOOTH RUNWAY SURFACE
  - \* CONSULT USING AIRLINE FOR SPECIFIC OPERATING PROCEDURE PRIOR TO FACILITY DESIGN
  - \* LINEAR INTERPOLATION BETWEEN ALTITUDES INVALID
  - \* LINEAR INTERPOLATION BETWEEN TEMPERATURES INVALID
  - \* TAKEOFF PERFORMANCE IMPROVEMENTS ARE POSSIBLE USING GROOVED RUNWAY

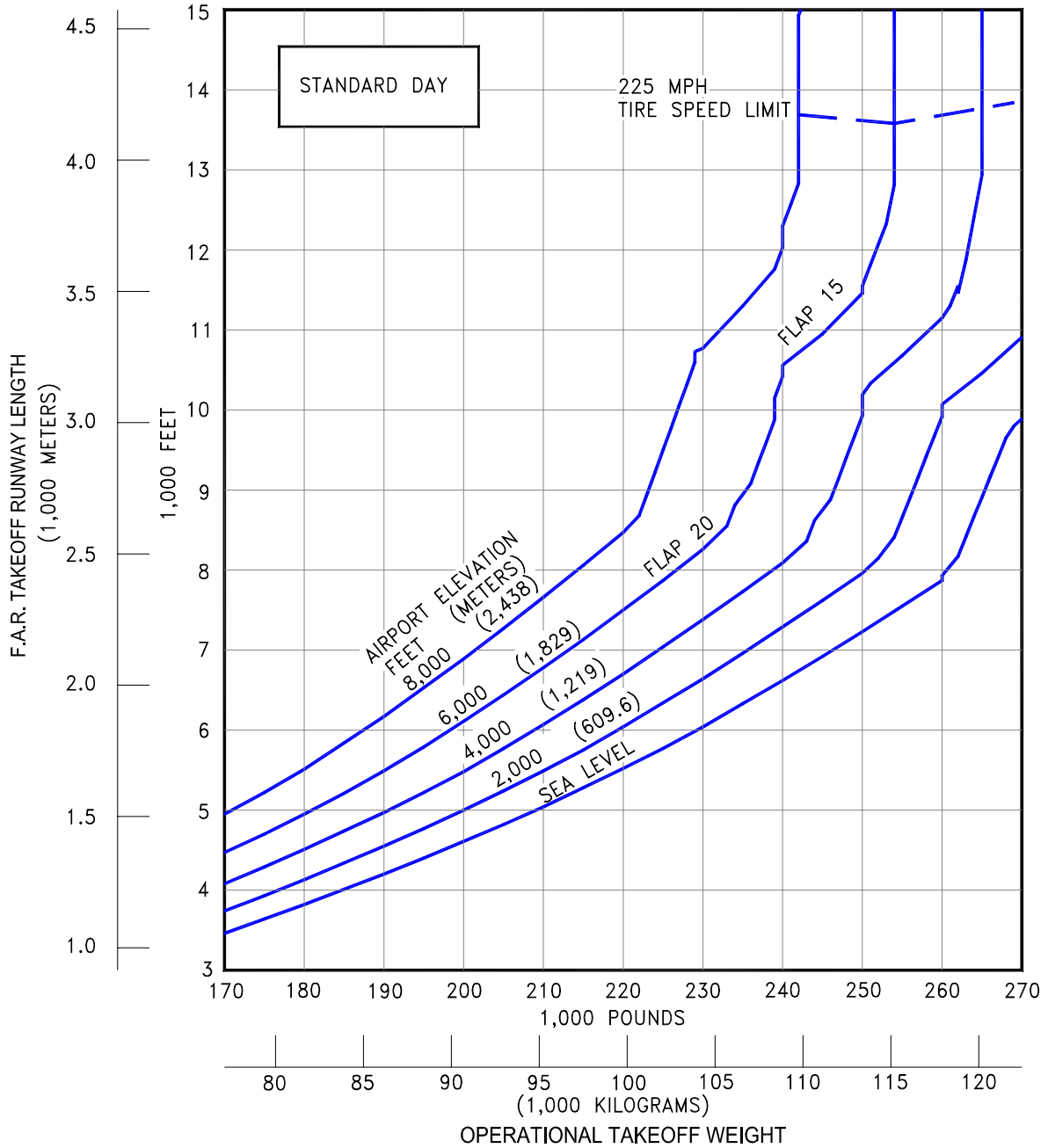

**3.3.21 J.A.R. TAKEOFF RUNWAY LENGTH REQUIREMENTS - STANDARD DAY - WET RUNWAY**  
 MODEL 757-300 (PW2040 ENGINES)



NOTES:

- \* NO ENGINE AIRBLEED FOR AIR CONDITIONING
- \* ZERO WIND, ZERO RUNWAY GRADIENT
- \* WET SMOOTH RUNWAY SURFACE
- \* CONSULT USING AIRLINE FOR SPECIFIC OPERATING PROCEDURE PRIOR TO FACILITY DESIGN
- \* LINEAR INTERPOLATION BETWEEN ALTITUDES INVALID
- \* LINEAR INTERPOLATION BETWEEN TEMPERATURES INVALID
- \* TAKEOFF PERFORMANCE IMPROVEMENTS ARE POSSIBLE USING GROOVED RUNWAY

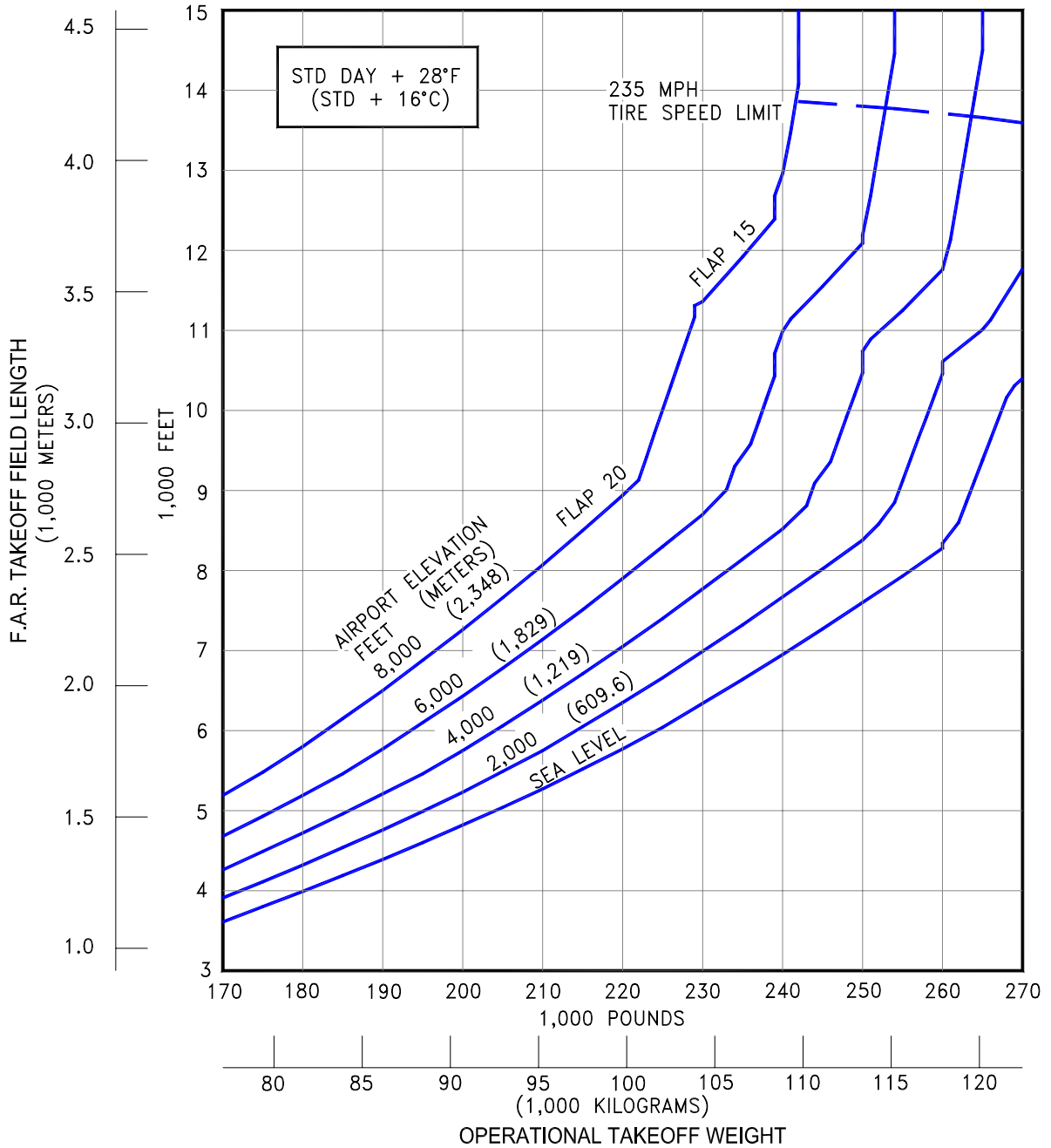

**3.3.22 J.A.R. TAKEOFF RUNWAY LENGTH REQUIREMENTS**  
**STANDARD DAY +28°F (STD + 16°C) - WET RUNWAY**  
 MODEL 757-300 (PW2040 ENGINES)

NOTES:

- \* NO ENGINE AIRBLEED FOR AIR CONDITIONING
- \* ZERO WIND, ZERO RUNWAY GRADIENT
- \* DRY RUNWAY SURFACE
- \* CONSULT USING AIRLINE FOR SPECIFIC OPERATING PROCEDURE PRIOR TO FACILITY DESIGN
- \* LINEAR INTERPOLATION BETWEEN ALTITUDES INVALID
- \* LINEAR INTERPOLATION BETWEEN TEMPERATURES INVALID

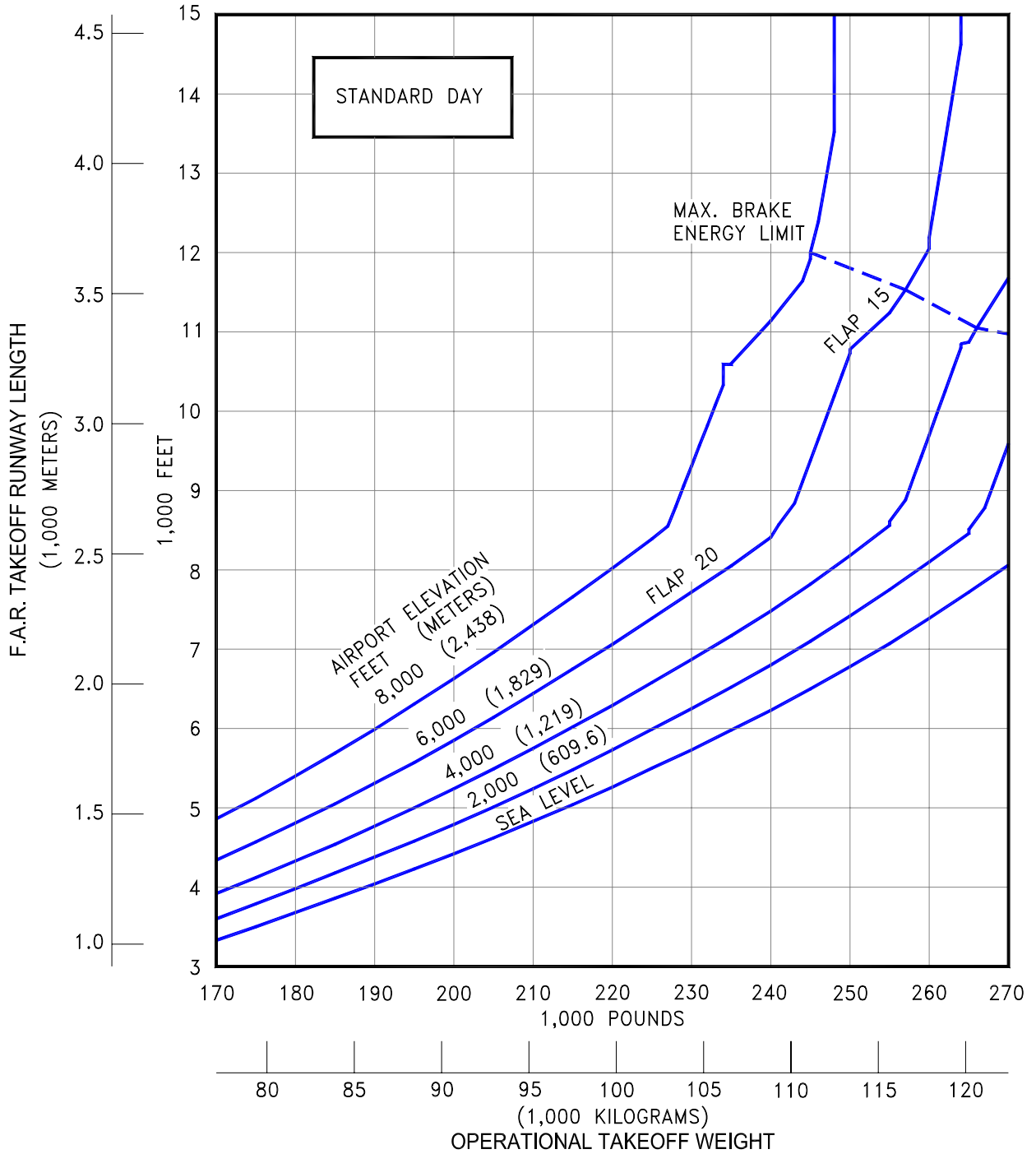

**3.3.23 F.A.R. TAKEOFF RUNWAY LENGTH REQUIREMENTS - STANDARD DAY**  
 MODEL 757-300 (PW2043 ENGINES)

NOTES:

- \* NO ENGINE AIRBLEED FOR AIR CONDITIONING
- \* ZERO WIND, ZERO RUNWAY GRADIENT
- \* DRY RUNWAY SURFACE
- \* CONSULT USING AIRLINE FOR SPECIFIC OPERATING PROCEDURE PRIOR TO FACILITY DESIGN
- \* LINEAR INTERPOLATION BETWEEN ALTITUDES INVALID
- \* LINEAR INTERPOLATION BETWEEN TEMPERATURES INVALID

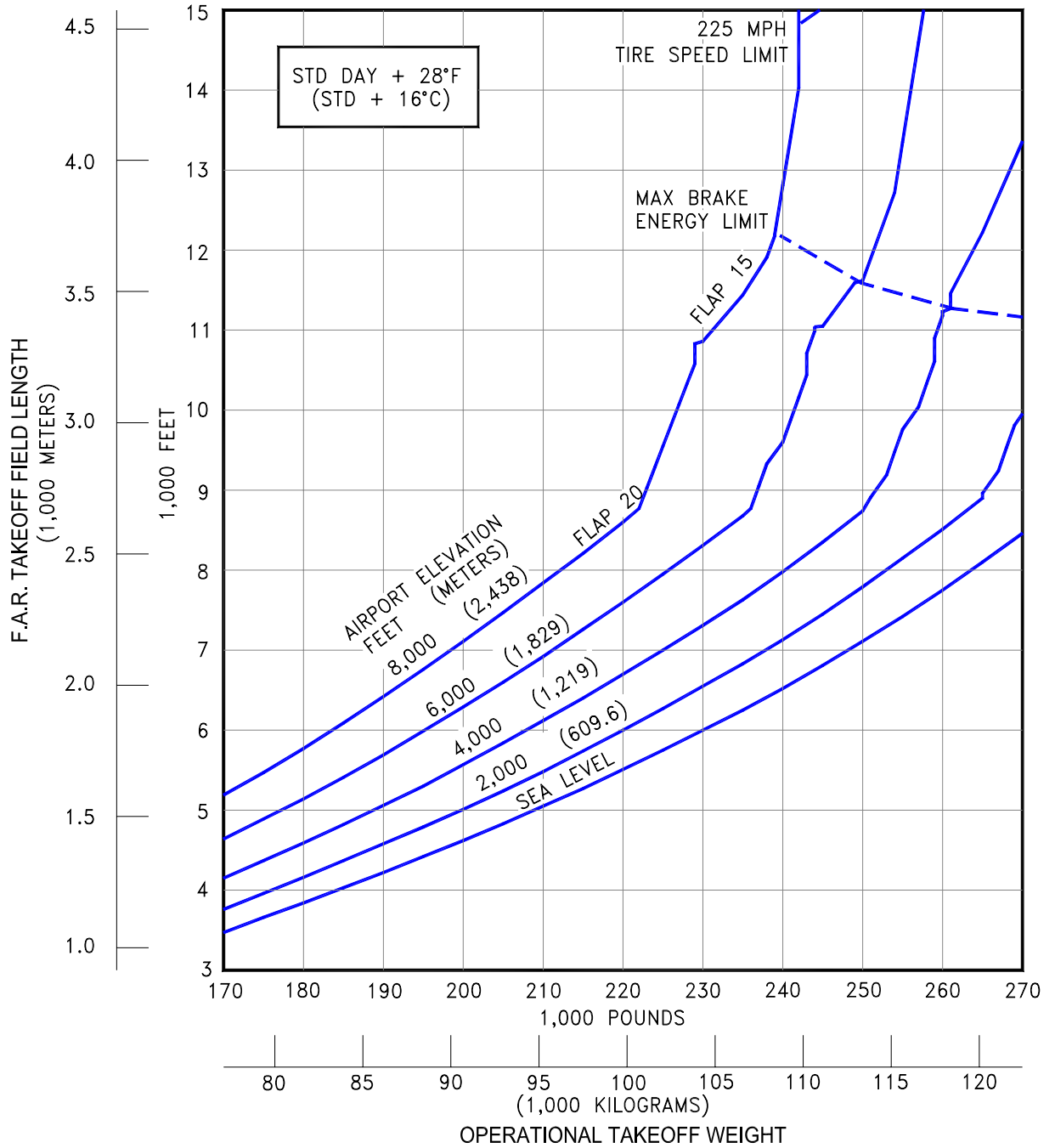

**3.3.24 F.A.R. TAKEOFF RUNWAY LENGTH REQUIREMENTS**

**STANDARD DAY +28°F (STD + 16°C)**

*MODEL 757-300 (PW2043 ENGINES)*

NOTES:

- \* NO ENGINE AIRBLEED FOR AIR CONDITIONING
- \* ZERO WIND, ZERO RUNWAY GRADIENT
- \* WET SMOOTH RUNWAY SURFACE
- \* CONSULT USING AIRLINE FOR SPECIFIC OPERATING PROCEDURE PRIOR TO FACILITY DESIGN
- \* LINEAR INTERPOLATION BETWEEN ALTITUDES INVALID
- \* LINEAR INTERPOLATION BETWEEN TEMPERATURES INVALID
- \* TAKEOFF PERFORMANCE IMPROVEMENTS ARE POSSIBLE USING GROOVED RUNWAY

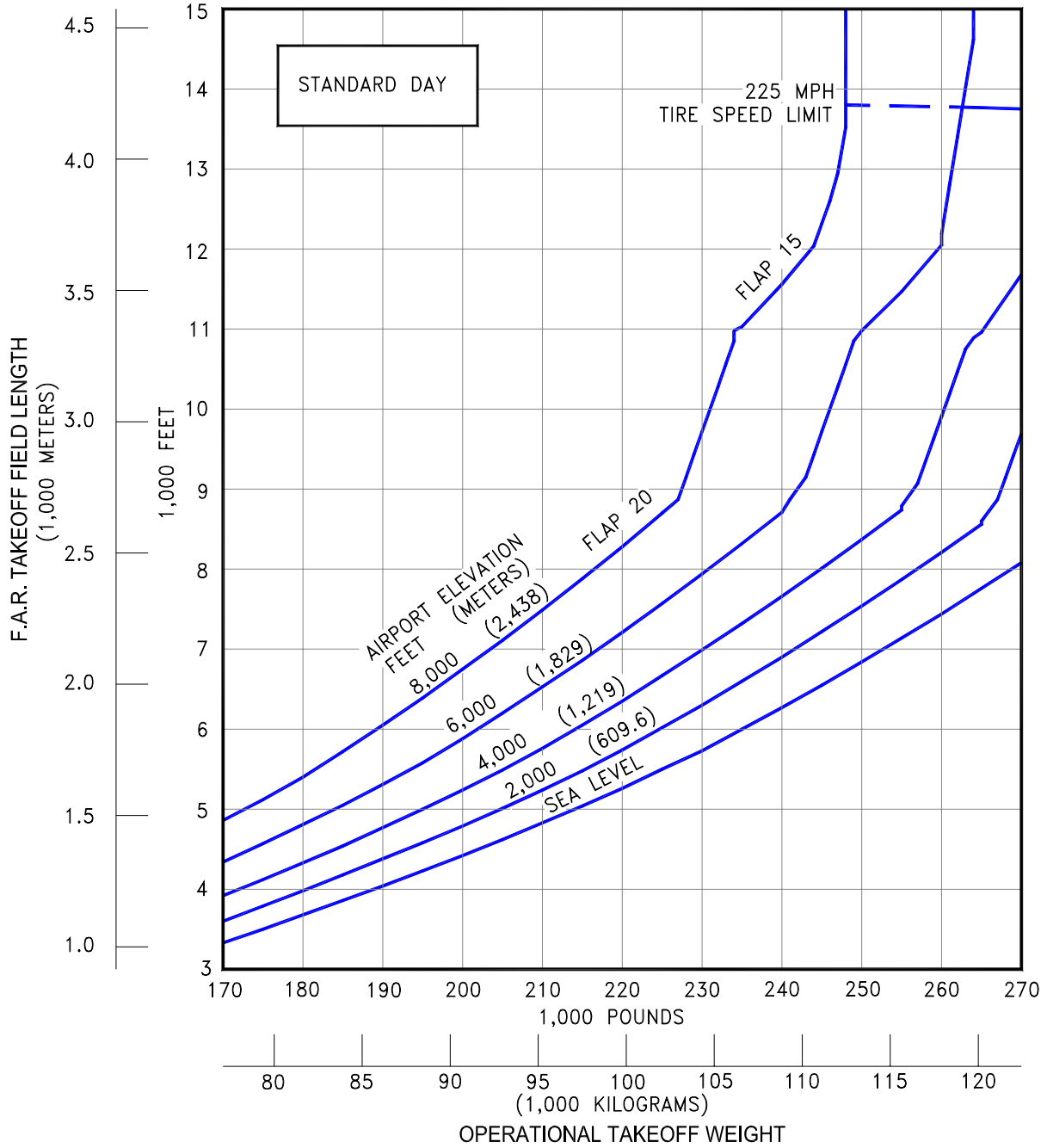

**3.3.25 J.A.R. TAKEOFF RUNWAY LENGTH REQUIREMENTS - STANDARD DAY - WET RUNWAY**  
 MODEL 757-300 (PW2043 ENGINES)

NOTES:

- \* NO ENGINE AIRBLEED FOR AIR CONDITIONING
- \* ZERO WIND, ZERO RUNWAY GRADIENT
- \* WET SMOOTH RUNWAY SURFACE
- \* CONSULT USING AIRLINE FOR SPECIFIC OPERATING PROCEDURE PRIOR TO FACILITY DESIGN
- \* LINEAR INTERPOLATION BETWEEN ALTITUDES INVALID
- \* LINEAR INTERPOLATION BETWEEN TEMPERATURES INVALID
- \* TAKEOFF PERFORMANCE IMPROVEMENTS ARE POSSIBLE USING GROOVED RUNWAY

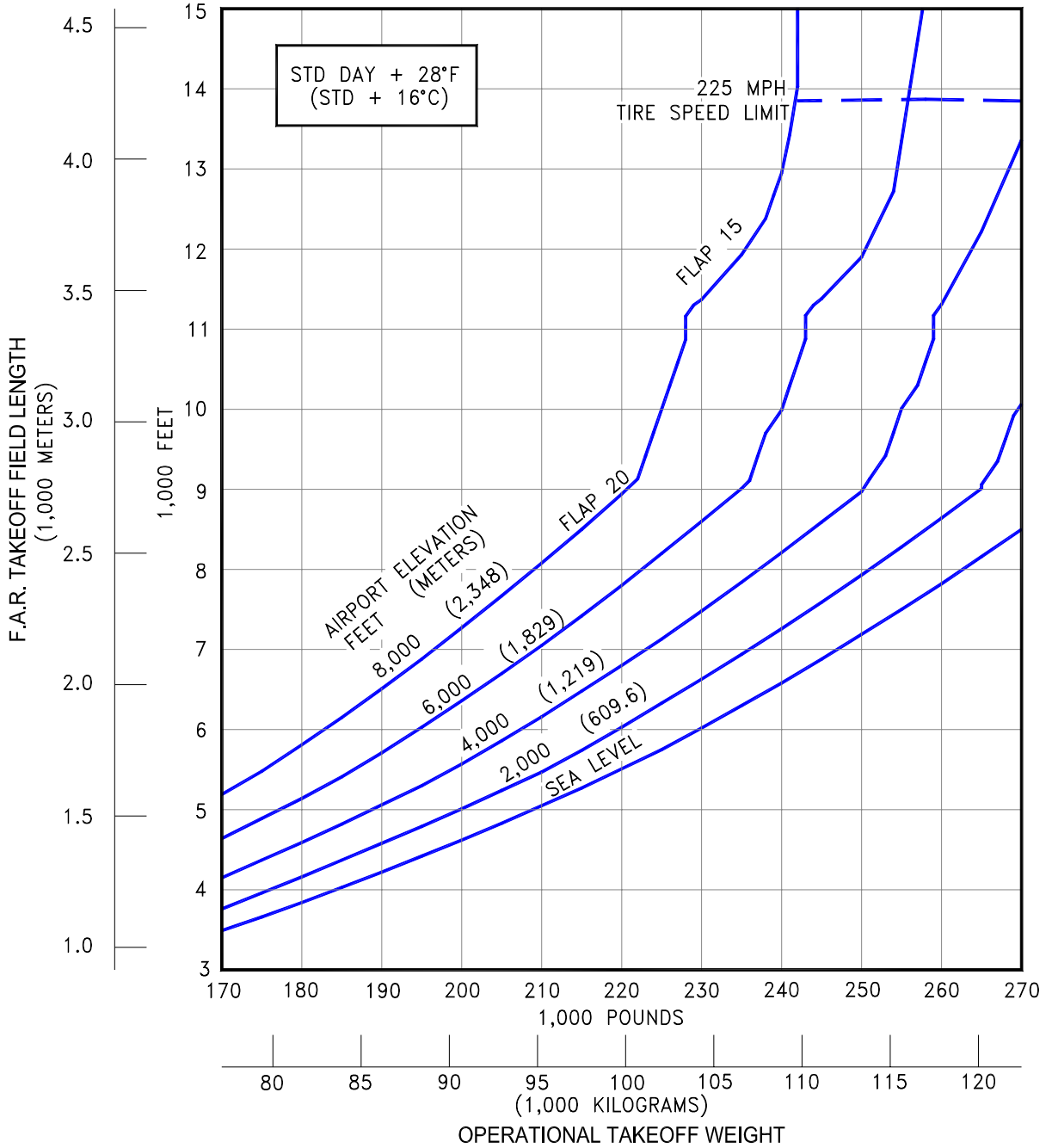

**3.3.26 J.A.R. TAKEOFF RUNWAY LENGTH REQUIREMENTS**  
**STANDARD DAY +28°F (STD + 15°C) - WET RUNWAY**  
 MODEL 757-300 (PW2043 ENGINES)

NOTES:

- \* STANDARD DAY
- \* AUTO SPOILERS OPERATIVE
- \* ANTI-SKID OPERATIVE
- \* CONSULT USING AIRLINE FOR SPECIFIC OPERATING PROCEDURE PRIOR TO FACILITY DESIGN
- \* ZERO WIND

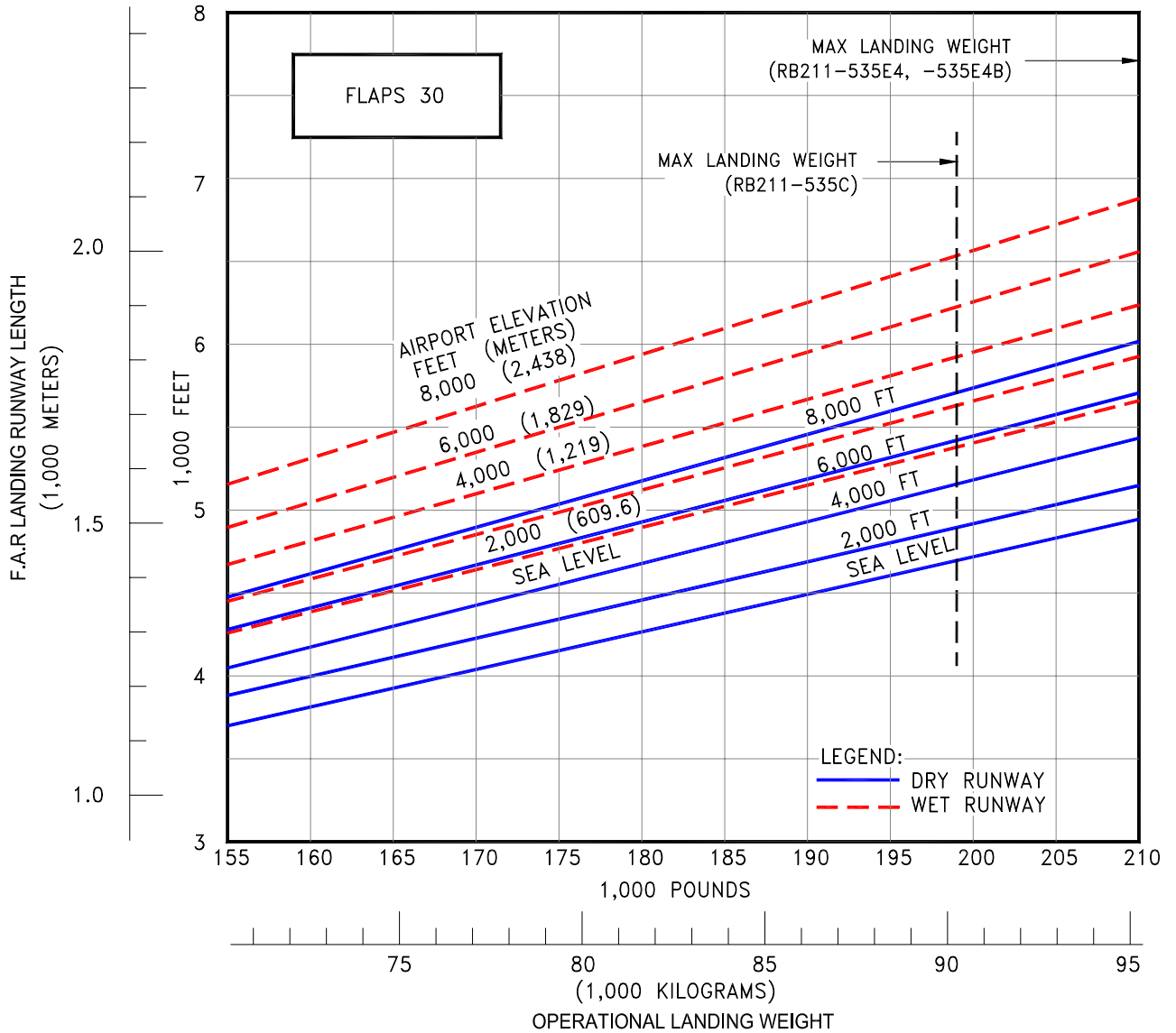

**3.4.1 F.A.R. LANDING RUNWAY LENGTH REQUIREMENTS**

MODEL 757-200 (RB211-535C, -535E4, -535E4B ENGINES)

- NOTES:  
 \* STANDARD DAY  
 \* AUTO SPOILERS OPERATIVE  
 \* ANTI-SKID OPERATIVE  
 \* CONSULT USING AIRLINE FOR SPECIFIC OPERATING PROCEDURE PRIOR TO FACILITY DESIGN  
 \* ZERO WIND

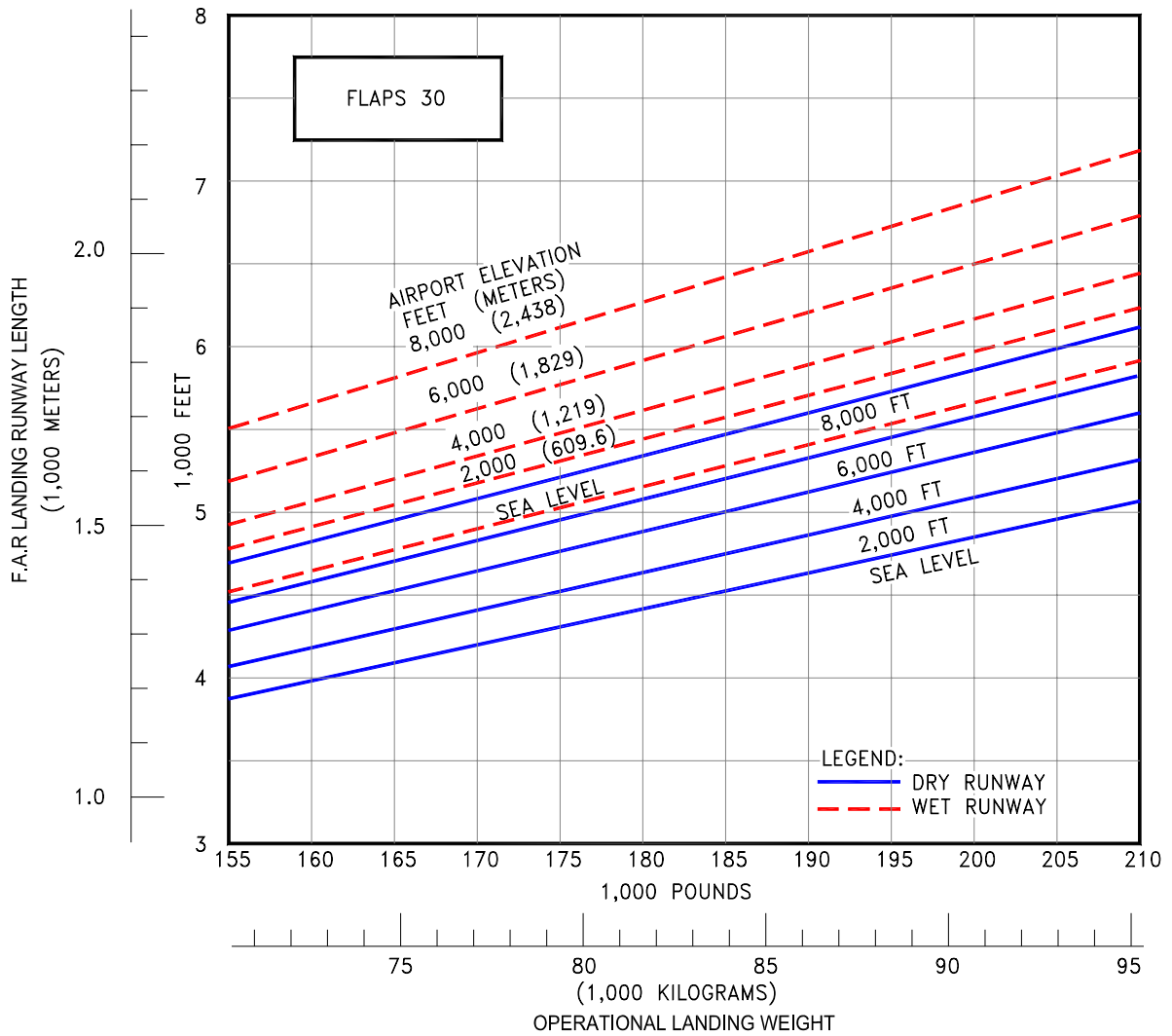

**3.4.2 F.A.R. LANDING RUNWAY LENGTH REQUIREMENTS**  
 MODEL 757-200, -200PF (PW2037, PW2040 ENGINES)

- NOTES:  
 \* STANDARD DAY  
 \* AUTO SPOILERS OPERATIVE  
 \* ANTI-SKID OPERATIVE  
 \* CONSULT USING AIRLINE FOR SPECIFIC OPERATING PROCEDURE PRIOR TO FACILITY DESIGN  
 \* ZERO WIND

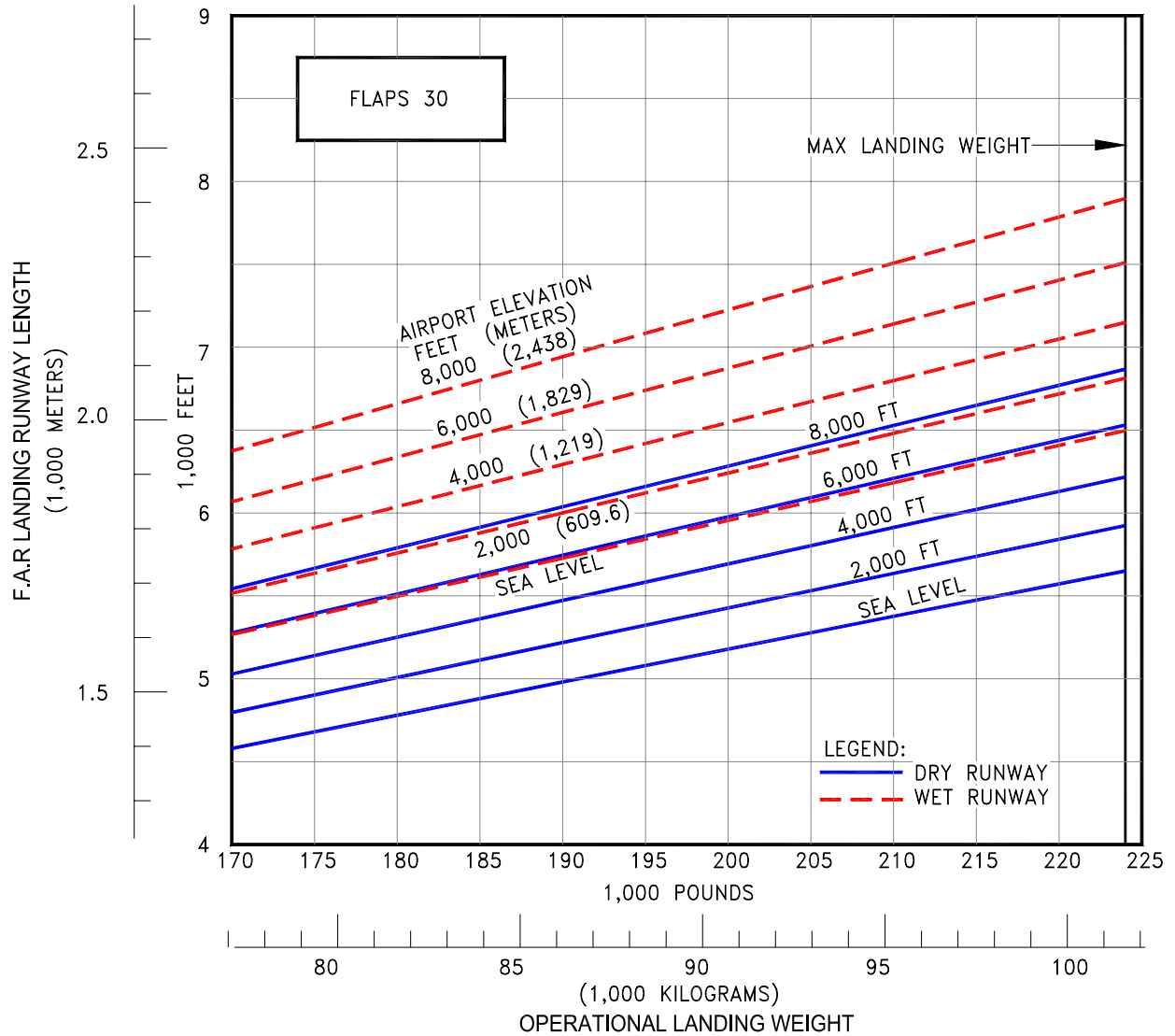

**3.4.3 F.A.R. LANDING RUNWAY LENGTH REQUIREMENTS**  
 MODEL 757-300 (RB211-535E4, -535E4B ENGINES)



- NOTES:  
 \* STANDARD DAY  
 \* AUTO SPOILERS OPERATIVE  
 \* ANTI-SKID OPERATIVE  
 \* CONSULT USING AIRLINE FOR SPECIFIC OPERATING PROCEDURE PRIOR TO FACILITY DESIGN  
 \* ZERO WIND

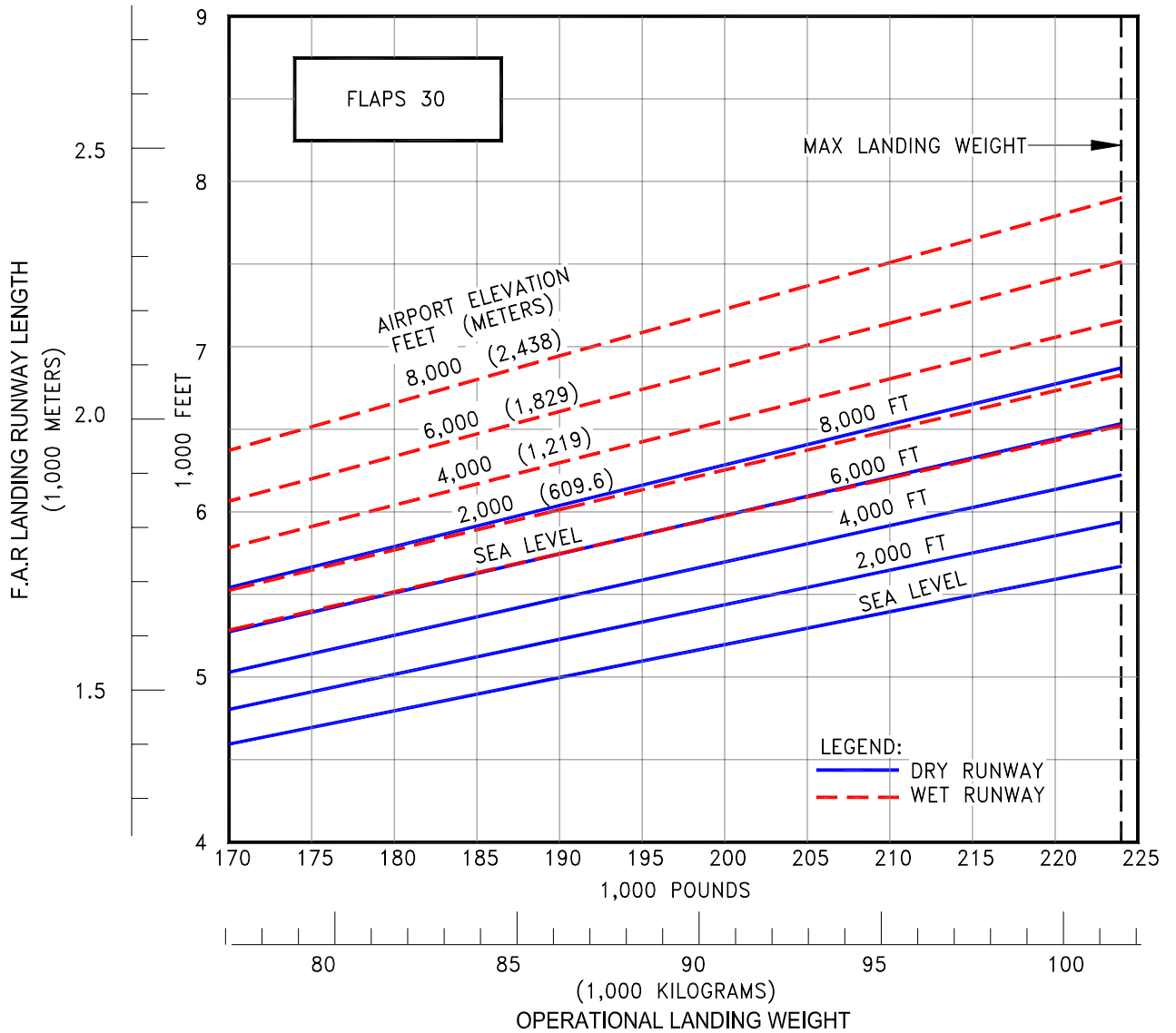

**3.4.4 F.A.R. LANDING RUNWAY LENGTH REQUIREMENTS**  
 MODEL 757-300 (PW2040, PW2043 ENGINES)

THIS PAGE INTENTIONALLY LEFT BLANK

## **4.0 GROUND MANEUVERING**

**4.1 General Information**

**4.2 Turning Radii**

**4.3 Clearance Radii**

**4.4 Visibility From Cockpit in Static Position**

**4.5 Runway and Taxiway Turn Paths**

**4.6 Runway Holding Bay**

## 4.0 GROUND MANEUVERING

### 4.1 General Information

This section provides airplane turning capability and maneuvering characteristics.

For ease of presentation, these data have been determined from the theoretical limits imposed by the geometry of the aircraft, and where noted, provide for a normal allowance for tire slippage. As such, they reflect the turning capability of the aircraft in favorable operating circumstances. These data should be used only as guidelines for the method of determination of such parameters and for the maneuvering characteristics of this aircraft.

In the ground operating mode, varying airline practices may demand that more conservative turning procedures be adopted to avoid excessive tire wear and reduce possible maintenance problems. Airline operating procedures will vary in the level of performance over a wide range of operating circumstances throughout the world. Variations from standard aircraft operating patterns may be necessary to satisfy physical constraints within the maneuvering area, such as adverse grades, limited area, or high risk of jet blast damage. For these reasons, ground maneuvering requirements should be coordinated with the using airlines prior to layout planning.

Section 4.2 shows turning radii for various nose gear steering angles. Radii for the main and nose gears are measured from the turn center to the outside of the tire.

Section 4.3 provides data on minimum width of pavement required for 180° turn.

Section 4.4 shows the pilot's visibility from the cockpit and the limits of ambinoocular vision through the windows. Ambinoocular vision is defined as the total field of vision seen simultaneously by both eyes.

Section 4.5 shows wheel paths of a 757-300 on runway to taxiway, and taxiway to taxiway turns. Wheel paths for the 757-200 would be slightly less than the 757-300 configurations.

Section 4.6 illustrates a typical runway holding bay configuration for the 757-300.

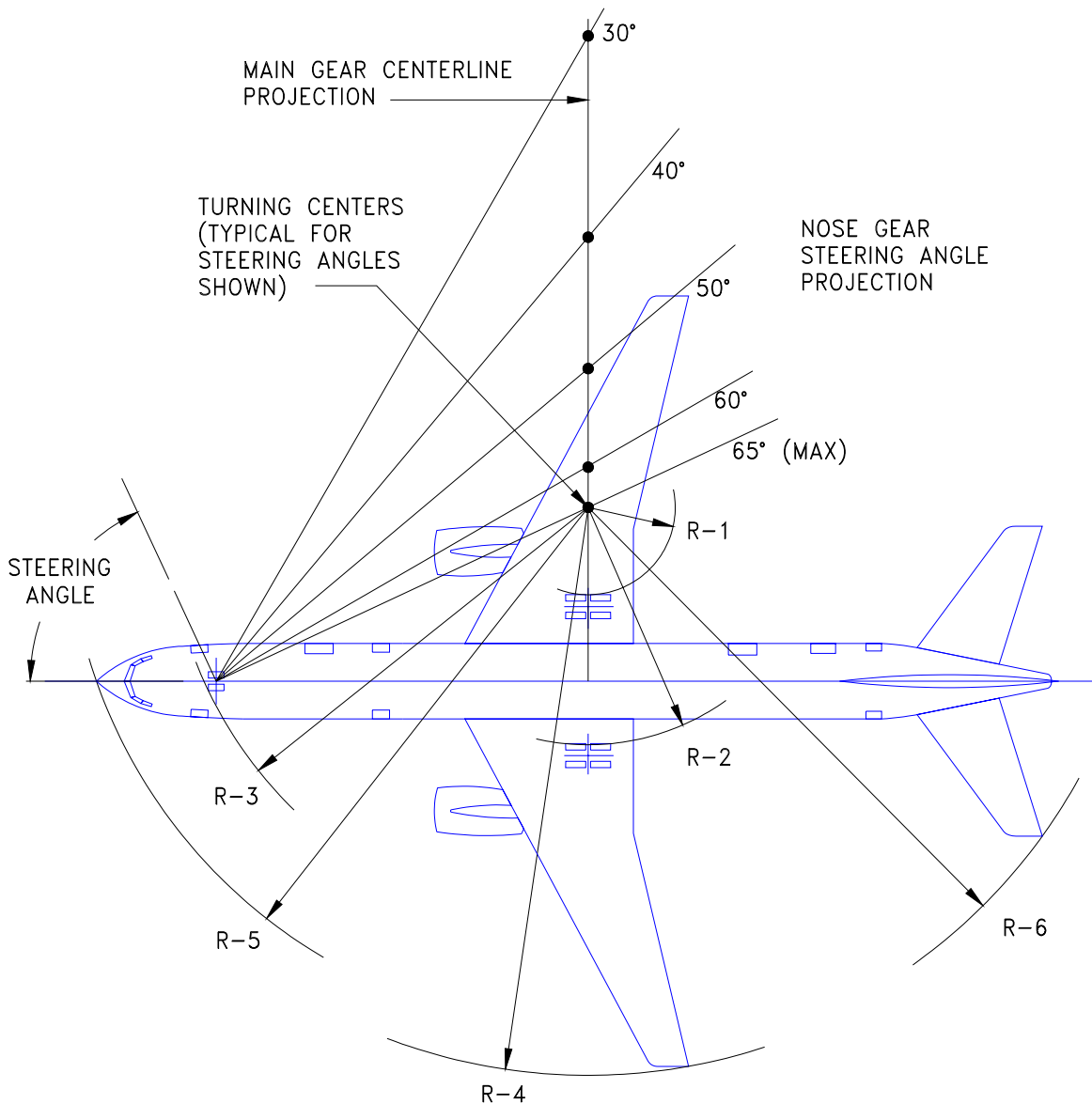

NOTES: \*ACTUAL OPERATING TURNING RADII MAY BE GREATER THAN SHOWN.  
 \* CONSULT WITH AIRLINE FOR SPECIFIC OPERATING PROCEDURE  
 \* DIMENSIONS ROUNDED TO NEAREST FOOT AND 0.1 METER.

STEERING ANGLE (DEG)	R1 INNER GEAR		R2 OUTER GEAR		R3 NOSE GEAR		R4 WING TIP		R5 NOSE		R6 TAIL	
	FT	M	FT	M	FT	M	FT	M	FT	M	FT	M
30	90	27.4	118	35.9	122	37.0	167	50.9	131	39.9	149	45.3
35	72	21.9	100	30.4	106	32.3	149	45.4	117	35.6	133	40.6
40	58	17.5	86	26.1	95	28.9	135	41.1	107	32.6	121	37.0
45	46	14.0	74	22.6	86	26.3	124	37.6	99	30.3	112	34.3
50	36	11.1	64	19.6	80	24.4	114	34.7	94	28.6	105	32.1
55	28	8.5	56	17.1	75	22.8	106	32.2	90	27.3	100	30.4
60	21	6.3	49	14.8	71	21.6	98	30.0	87	26.4	95	28.9
65 (MAX)	14	4.3	42	12.8	68	20.6	92	28.0	84	25.6	91	27.6

**4.2.1 TURNING RADII - NO SLIP ANGLE**  
 MODEL 757-200

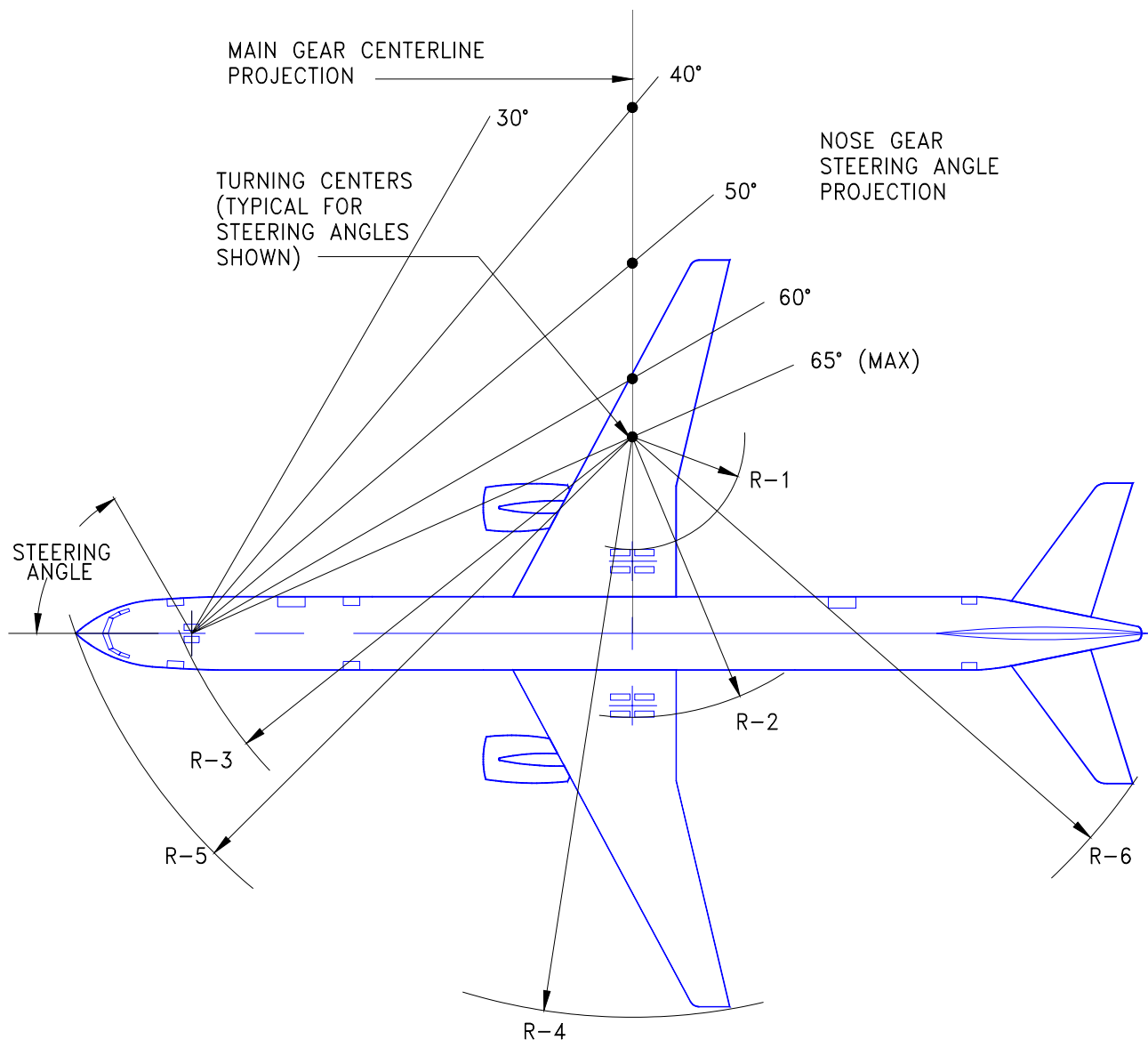

NOTES: \*ACTUAL OPERATING TURNING RADII MAY BE GREATER THAN SHOWN.  
 \* CONSULT WITH AIRLINE FOR SPECIFIC OPERATING PROCEDURE  
 \* DIMENSIONS ROUNDED TO NEAREST FOOT AND 0.1 METER.

STEERING ANGLE (DEG)	R1 INNER GEAR		R2 OUTER GEAR		R3 NOSE GEAR		R4 WING TIP		R5 NOSE		R6 TAIL	
	FT	M	FT	M	FT	M	FT	M	FT	M	FT	M
30	113	34.4	141	43.0	148	45.2	190	57.9	157	47.9	173	52.9
35	91	27.6	119	36.2	129	39.4	168	51.2	140	42.6	154	47.0
40	73	22.4	101	30.9	115	35.2	151	45.9	127	38.8	140	42.7
45	59	18.1	87	26.6	105	32.1	137	41.7	118	36.0	129	39.3
50	47	14.5	76	23.0	97	29.6	125	38.1	111	33.9	120	36.7
55	37	11.4	65	19.9	91	27.7	115	35.0	106	32.3	113	34.5
60	28	8.6	56	17.2	86	26.3	106	32.3	102	31.0	107	32.7
65 (MAX)	20	6.2	48	14.7	82	25.1	98	29.8	99	30.1	102	31.2

**4.2.2 TURNING RADII - NO SLIP ANGLE**  
 MODEL 757-300

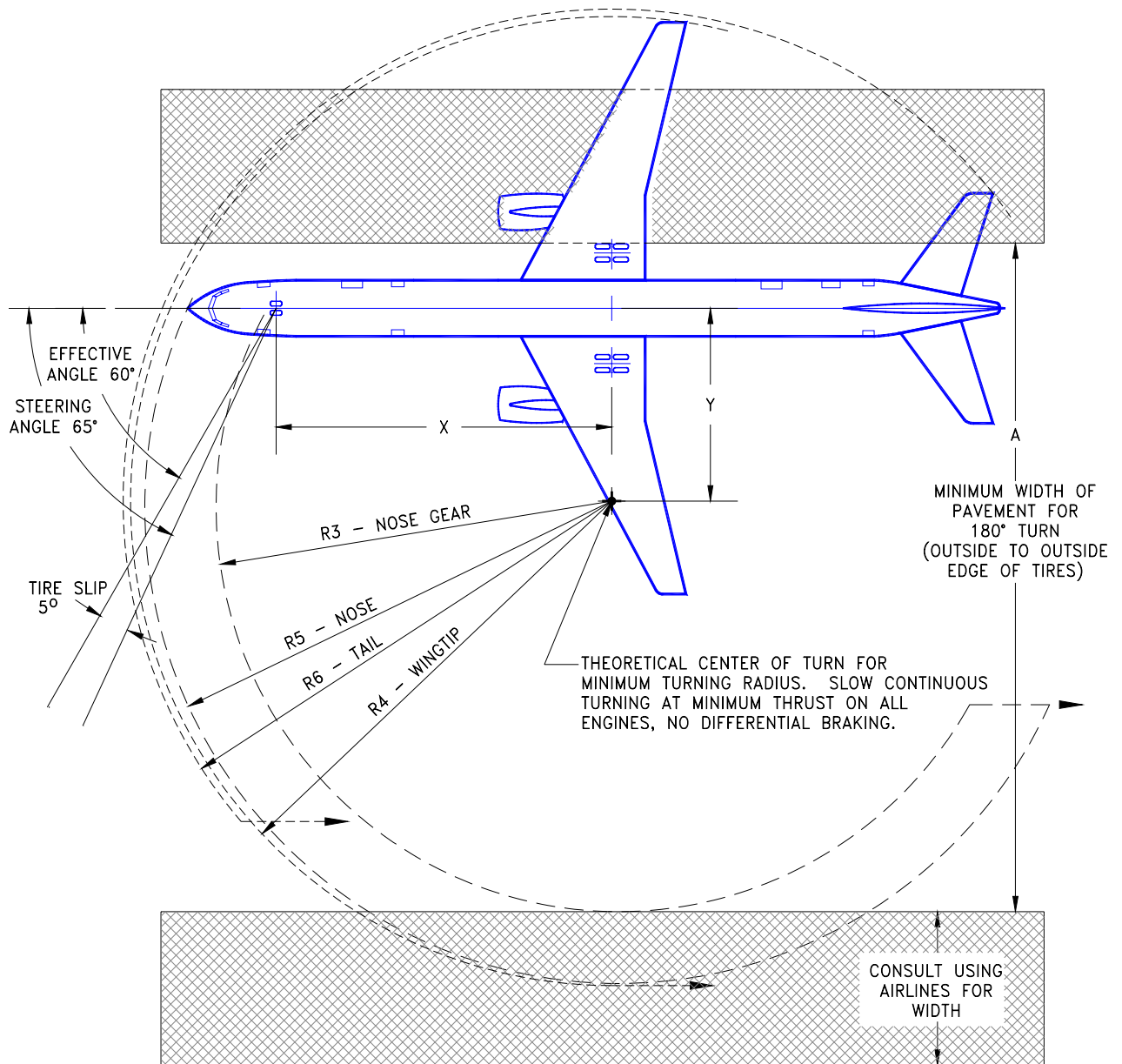

- NOTES:
- 5° TIRE SLIP ANGLE APPROXIMATE FOR 65° STEERING ANGLE.
  - CONSULT USING AIRLINE FOR SPECIFIC OPERATING PROCEDURE
  - DIMENSIONS ROUNDED TO NEAREST FOOT AND 0.10 METER.

MODEL	EFF STEERING ANGLE-DEG	X		Y		A		R3		R4		R5		R6	
		FT	M	FT	M	FT	M	FT	M	FT	M	FT	M	FT	M
757-200	60	60	18.3	35	10.5	120	36.4	71	21.6	98	30.0	87	26.4	95	28.9
757-300	60	73	22.3	42	12.9	141	43.0	86	26.3	106	32.3	102	31.0	107	32.7

**4.3 CLEARANCE RADII**  
 MODEL 757-200,-300

NOT TO BE USED  
FOR LANDING  
APPROACH VISIBILITY

NOT TO SCALE

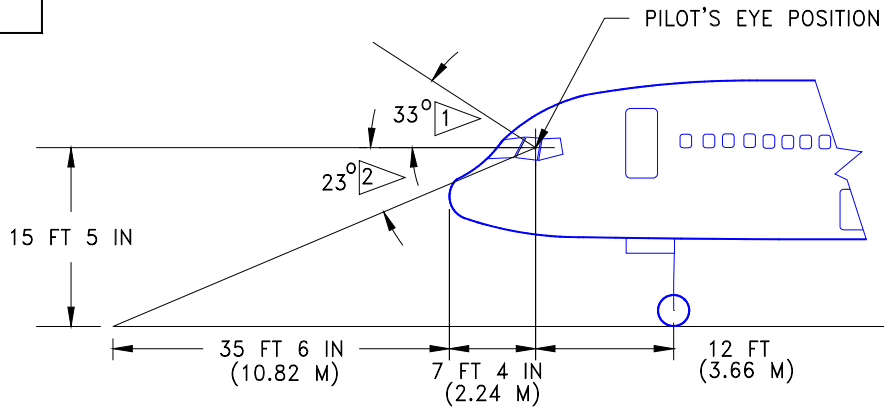

VISUAL ANGLES IN PLANE PARALLEL  
TO LONGITUDINAL AXIS THROUGH  
PILOT'S EYE POSITION

NOTE: AIRPLANE RESTS AT 3.2° NOSE-DOWN ANGLE ON RUNWAY

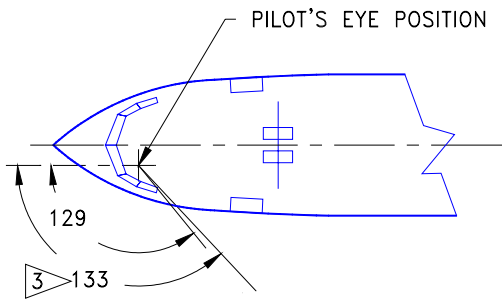

VISUAL ANGLES IN HORIZONTAL PLANE  
THROUGH PILOT'S EYE POSITION

NOTE:  
HEAD ROTATED ABOUT POINT  
3.3 IN (0,88 M) AFT OF  
PILOT'S EYE POSITION

- 1 UPWARD VISION THROUGH MAIN WINDOW
- 2 DOWNWARD VISION THROUGH MAIN WINDOW
- 3 WITH HEAD MOVED 5 IN (0.13 M) OUTBOARD  
NOTE: IF HEAD IS MOVED 2 IN (0.05 M)  
FORWARD, SO VISION WILL CLEAR  
WINDOW POST, DOWN VISION 2  
BECOMES 29° AND DOWN VISION 3  
BECOMES 35°

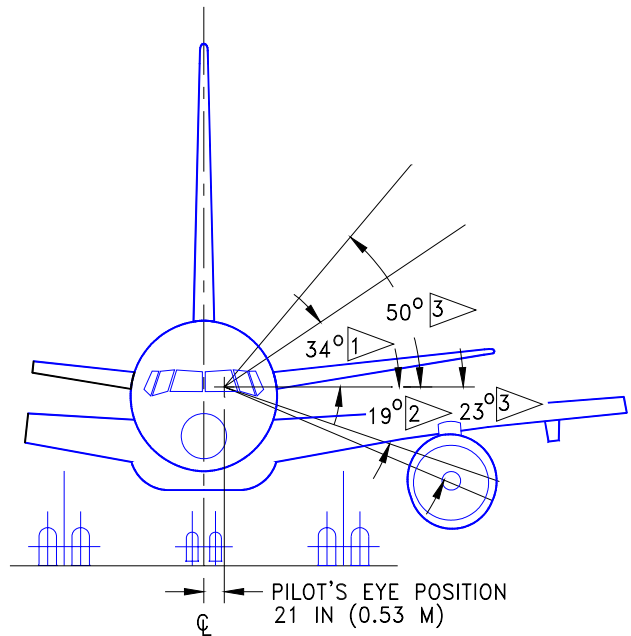

VISUAL ANGLES IN PLANE  
PERPENDICULAR TO LONGITUDINAL AXIS  
THROUGH PILOT'S EYE POSITION

#### 4.4 VISIBILITY FROM COCKPIT IN STATIC POSITION MODEL 757-200, -300



NOTE:  
 BEFORE DETERMINING THE SIZE OF THE  
 INTERSECTION FILLET, CHECK WITH THE  
 AIRLINES REGARDING THE OPERATING  
 PROCEDURES THAT THEY USE AND THE  
 AIRCRAFT TYPES THAT ARE EXPECTED  
 TO SERVE THE AIRPORT.

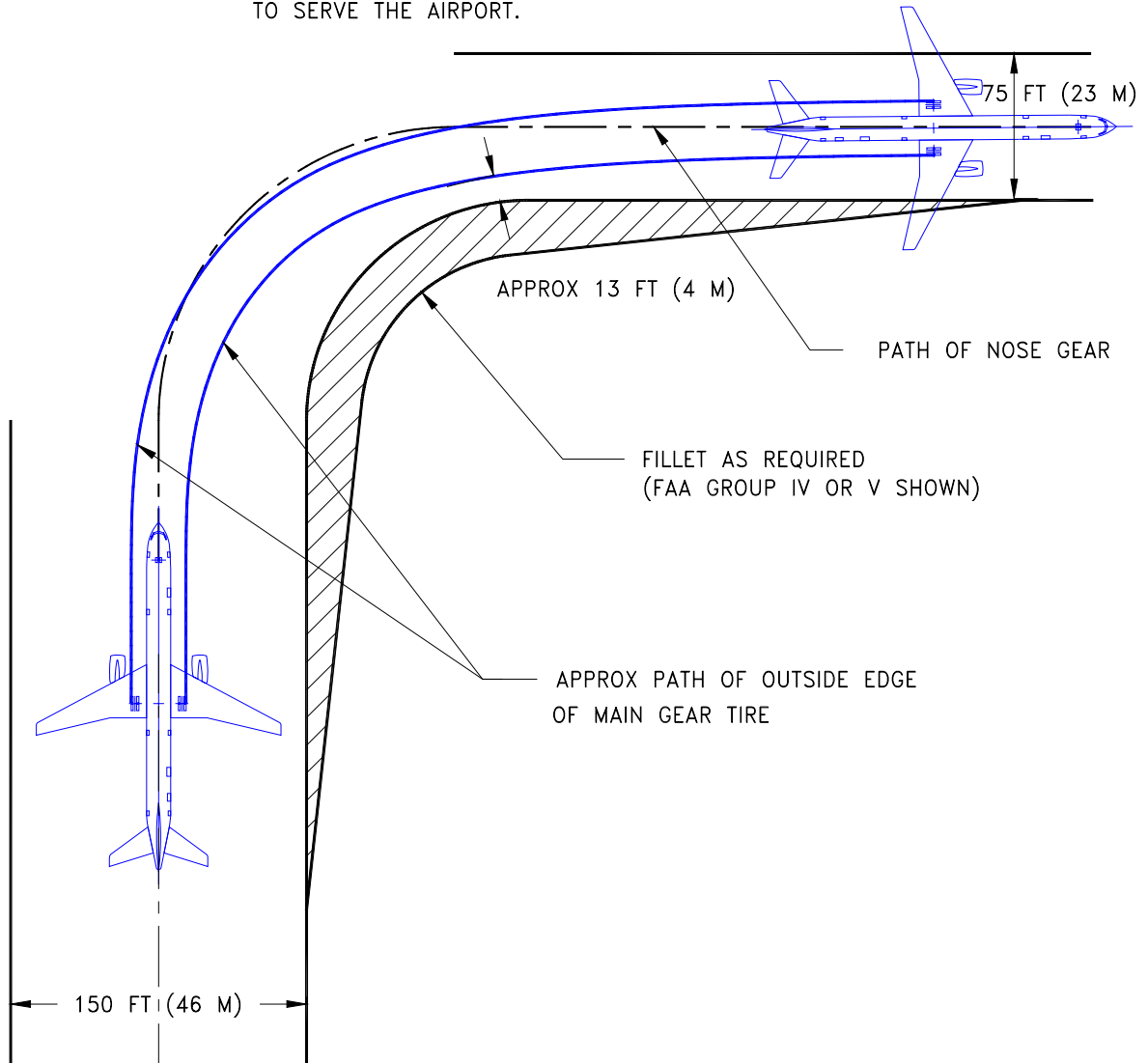

NOSE GEAR FOLLOWING CENTER LINE OF TURN

**4.5.1 RUNWAY AND TAXIWAY TURNPATHS - 90° TURN - RUNWAY-TO-TAXIWAY**  
 MODEL 757-300

NOTE:  
BEFORE DETERMINING THE SIZE OF THE  
INTERSECTION FILLET, CHECK WITH THE  
AIRLINES REGARDING THE OPERATING  
PROCEDURES THAT THEY USE AND THE  
AIRCRAFT TYPES THAT ARE EXPECTED  
TO SERVE THE AIRPORT.

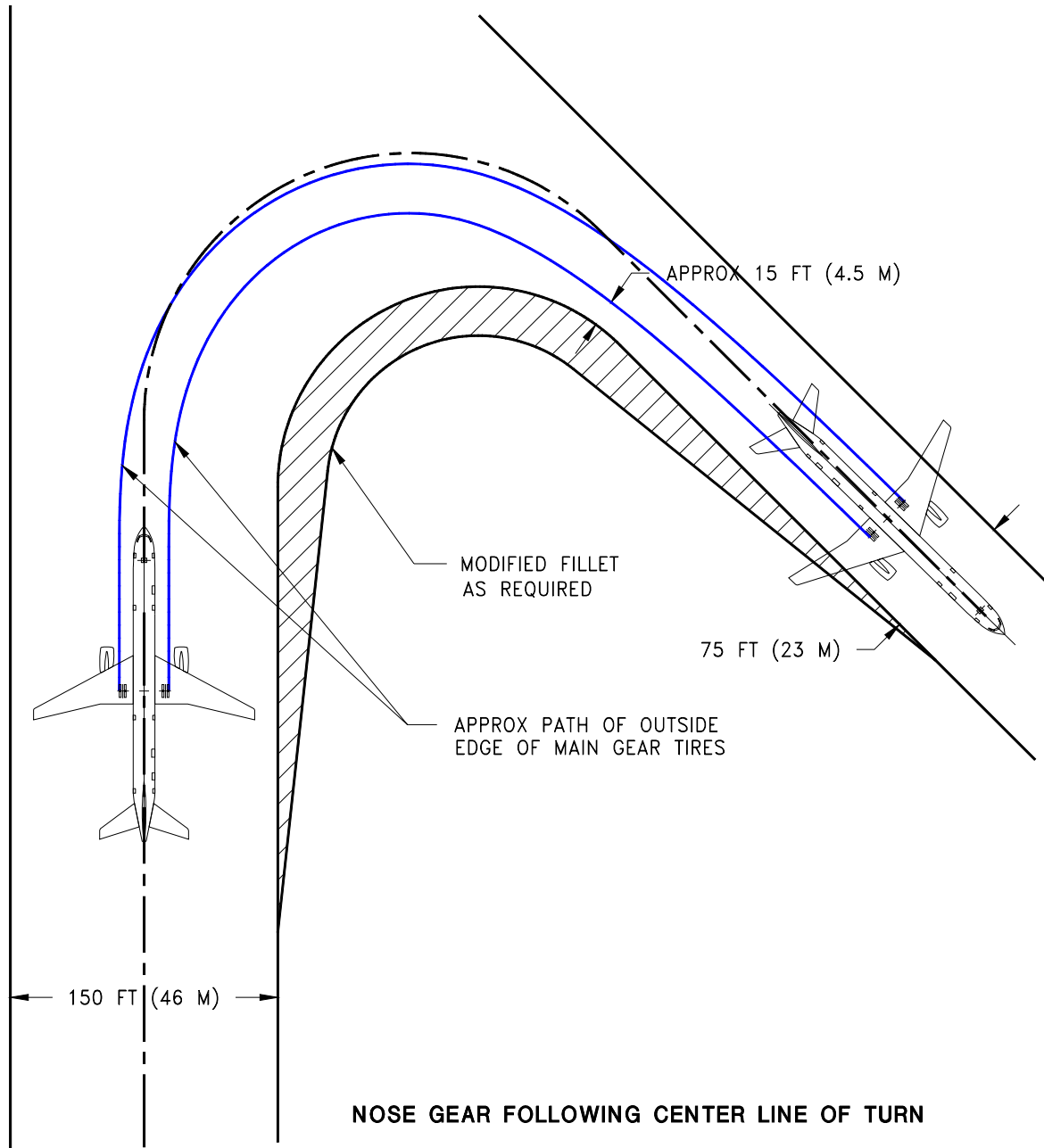

**4.5.2 RUNWAY AND TAXIWAY TURNPATHS - MORE THAN 90° TURN -  
RUNWAY-TO-TAXIWAY**  
*MODEL 757-300*

NOTE:  
BEFORE DETERMINING THE SIZE OF THE  
INTERSECTION FILLET, CHECK WITH THE  
AIRLINES REGARDING THE OPERATING  
PROCEDURES THAT THEY USE AND THE  
AIRCRAFT TYPES THAT ARE EXPECTED  
TO SERVE THE AIRPORT.

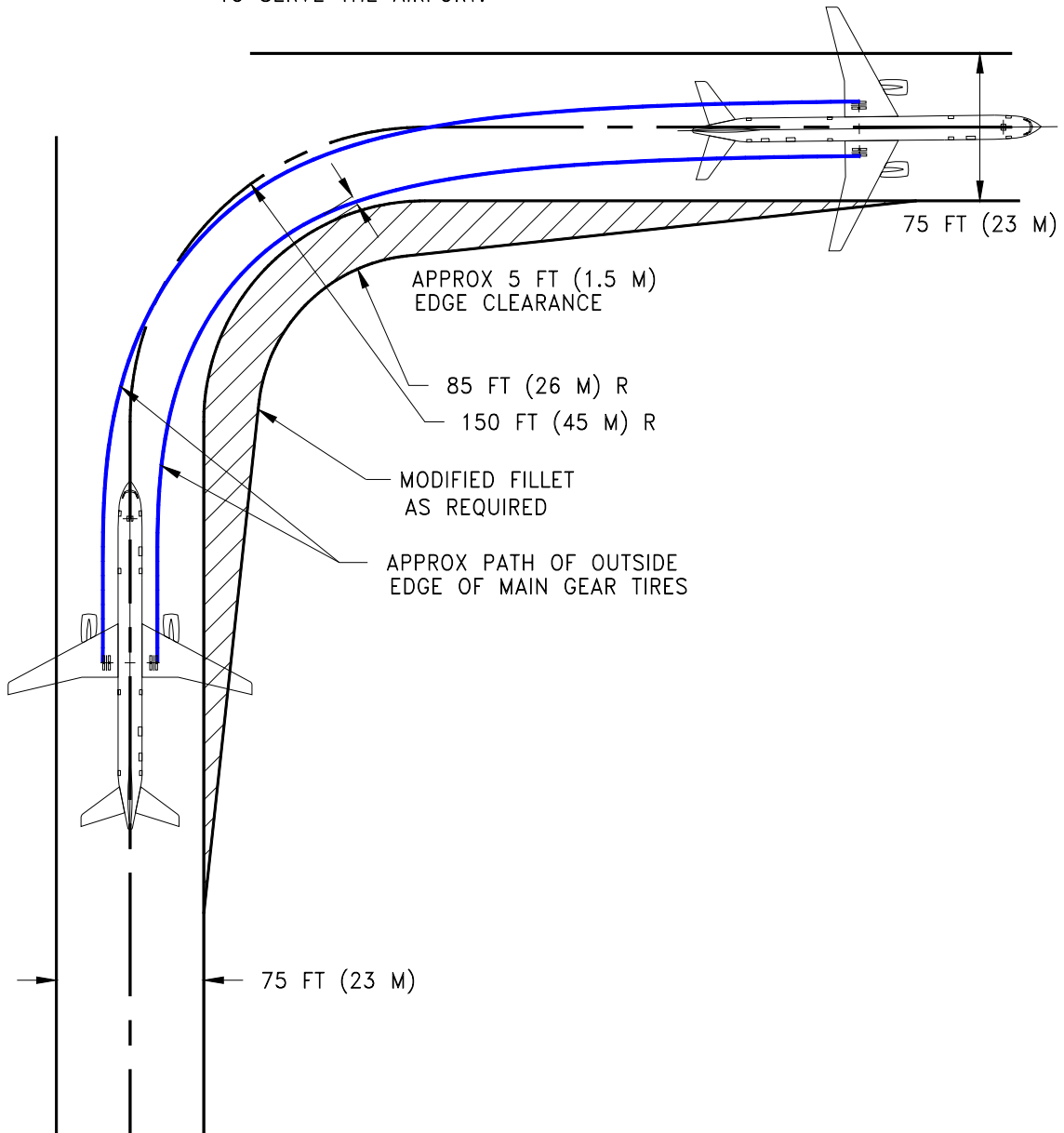

**NOSE GEAR FOLLOWING CENTER LINE OF TURN**

**4.5.3 RUNWAY AND TAXIWAY TURNPATHS - TAXIWAY-TO-TAXIWAY,  
90 DEGREES, NOSE GEAR TRACKS CENTERLINE  
MODEL 757-300**

NOTE:  
 BEFORE DETERMINING THE SIZE OF THE  
 INTERSECTION FILLET, CHECK WITH THE  
 AIRLINES REGARDING THE OPERATING  
 PROCEDURES THAT THEY USE AND THE  
 AIRCRAFT TYPES THAT ARE EXPECTED  
 TO SERVE THE AIRPORT.

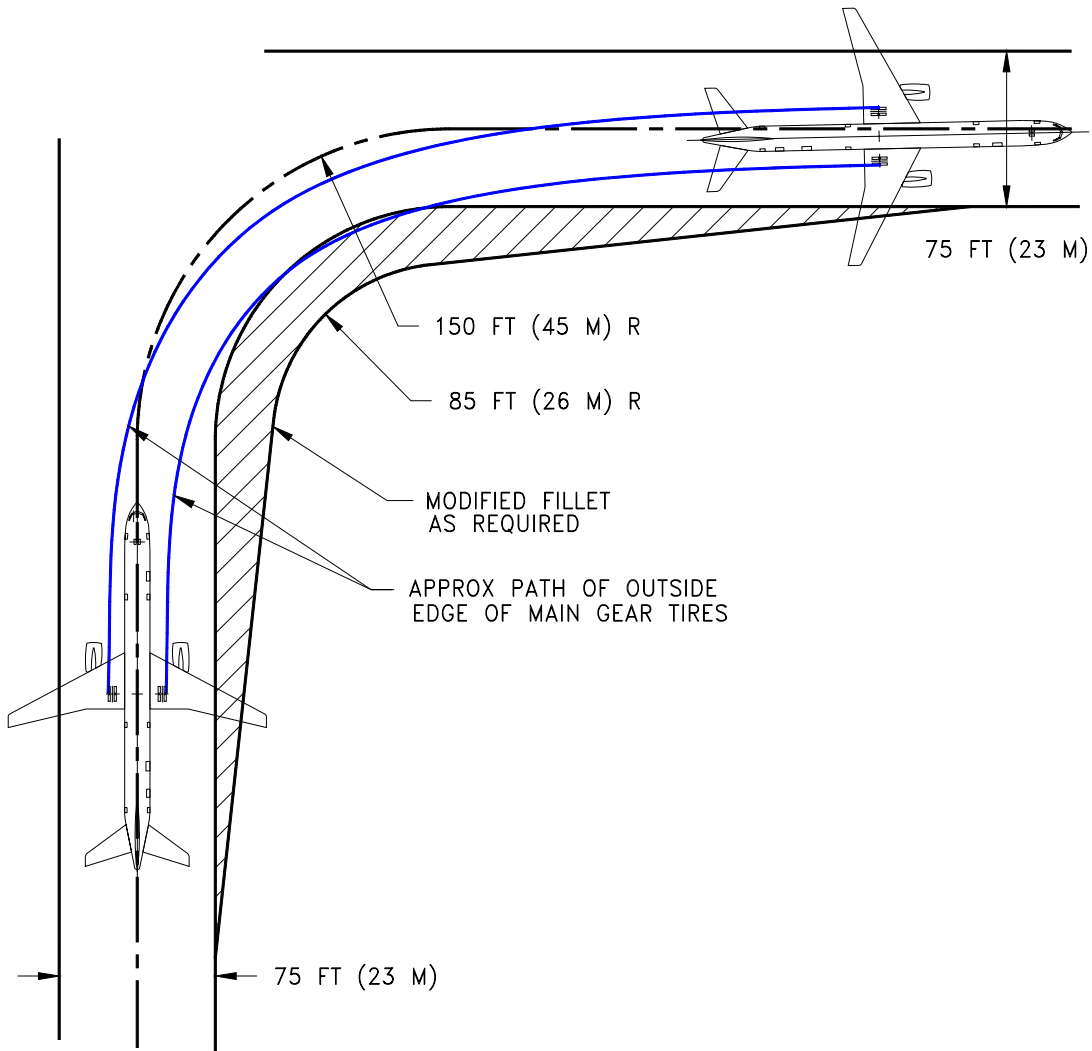

**COCKPIT FOLLOWING CENTER LINE OF TURN**

**4.5.4 RUNWAY AND TAXIWAY TURNPATHS - TAXIWAY-TO-TAXIWAY,  
 90 DEGREES, COCKPIT TRACKS CENTERLINE  
 MODEL 757-300**

D6-58327

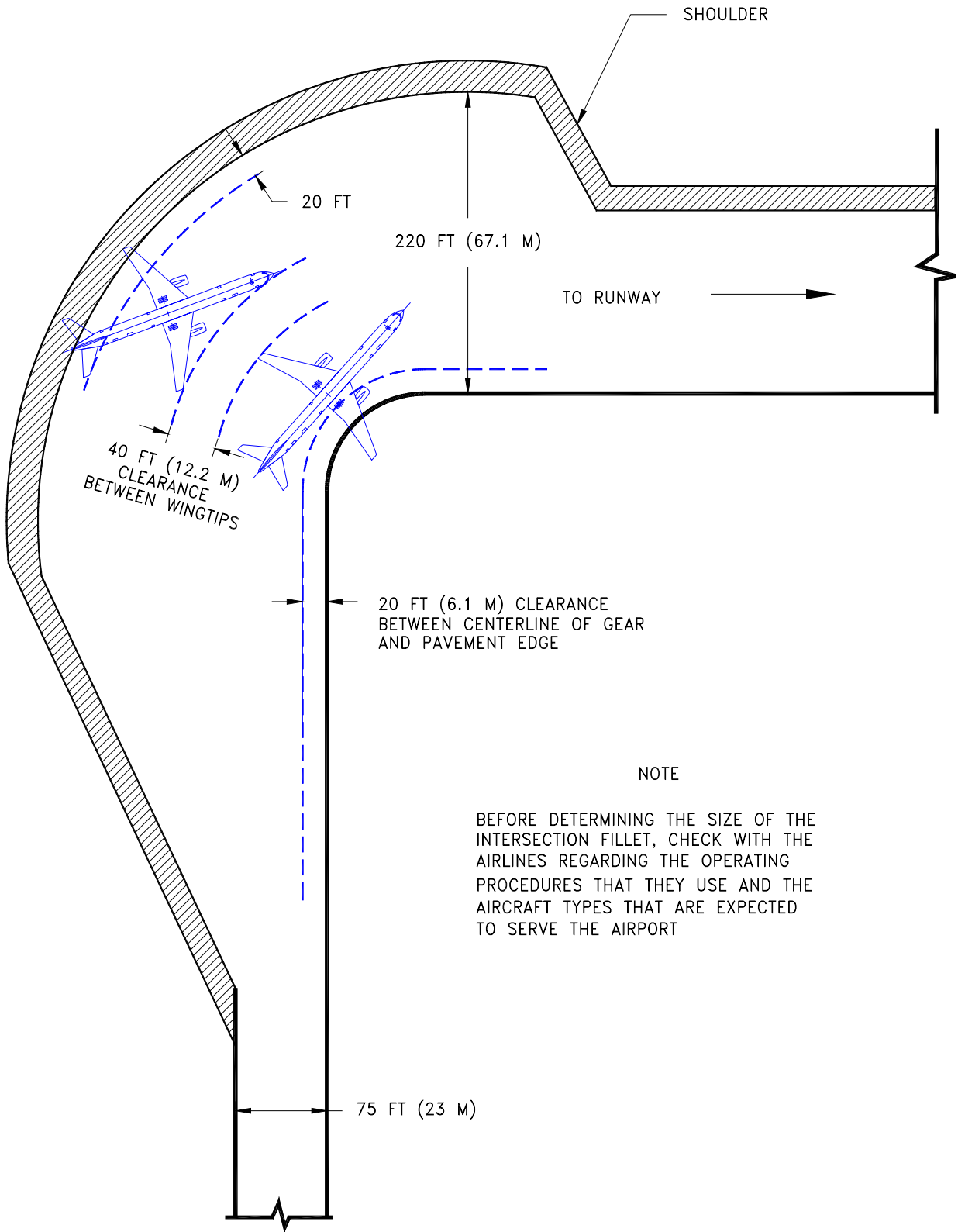

**4.6 RUNWAY HOLDING BAY**  
*MODEL 757-300*

THIS PAGE INTENTIONALLY LEFT BLANK

## **5.0 TERMINAL SERVICING**

**5.1 Airplane Servicing Arrangement - Typical Turnaround**

**5.2 Terminal Operations - Turnaround Station**

**5.3 Terminal Operations - En Route Station**

**5.4 Ground Servicing Connections**

**5.5 Engine Starting Pneumatic Requirements**

**5.6 Ground Pneumatic Power Requirements**

**5.7 Conditioned Air Requirements**

**5.8 Ground Towing Requirements**

## 5.0 TERMINAL SERVICING

During turnaround at the terminal, certain services must be performed on the aircraft, usually within a given time, to meet flight schedules. This section shows service vehicle arrangements, schedules, locations of service points, and typical service requirements. The data presented in this section reflect ideal conditions for a single airplane. Service requirements may vary according to airplane condition and airline procedure.

Section 5.1 shows typical arrangements of ground support equipment during turnaround. As noted, if the auxiliary power unit (APU) is used, the electrical, air start, and air-conditioning service vehicles would not be required. Passenger loading bridges or portable passenger stairs could be used to load or unload passengers.

Sections 5.2 and 5.3 show typical service times at the terminal. These charts give typical schedules for performing service on the airplane within a given time. Service times could be rearranged to suit availability of personnel, airplane configuration, and degree of service required.

Section 5.4 shows the locations of ground service connections in graphic and in tabular forms. Typical capacities and service requirements are shown in the tables. Services with requirements that vary with conditions are described in subsequent sections.

Section 5.5 shows typical sea level air pressure and flow requirements for starting different engines. The curves are based on an engine start time of 90 seconds.

Section 5.6 shows air conditioning requirements for heating and cooling (pull-down and pull-up) using ground conditioned air. The curves show airflow requirements to heat or cool the airplane within a given time at ambient conditions.

Section 5.7 shows air conditioning requirements for heating and cooling to maintain a constant cabin air temperature using low pressure conditioned air. This conditioned air is supplied through an 8-in ground air connection (GAC) directly to the passenger cabin, bypassing the air cycle machines.

Section 5.8 shows ground towing requirements for various ground surface conditions.



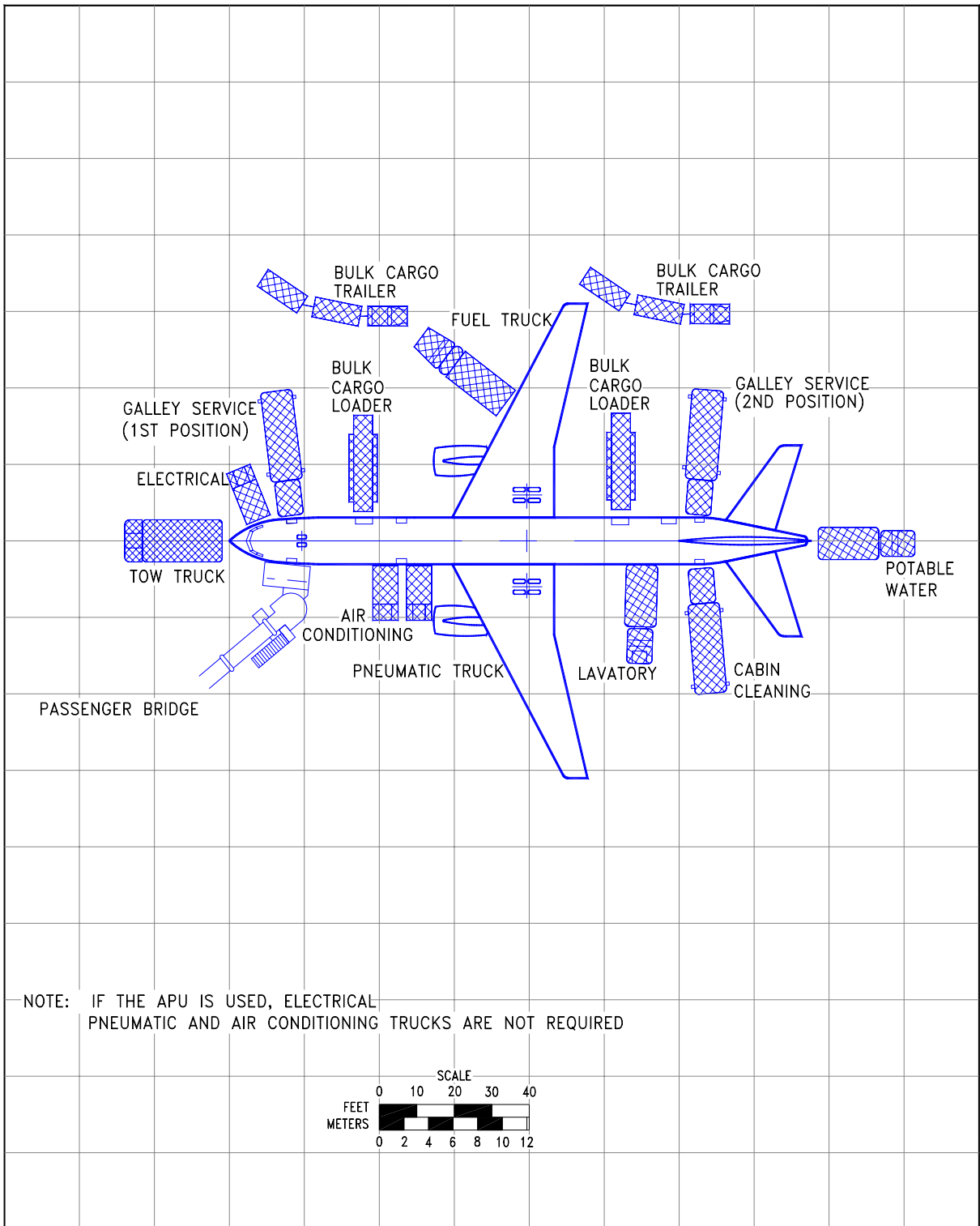

**5.1.1. AIRPLANE SERVICING ARRANGEMENT - TYPICAL TURNAROUND**  
 MODEL 757-200

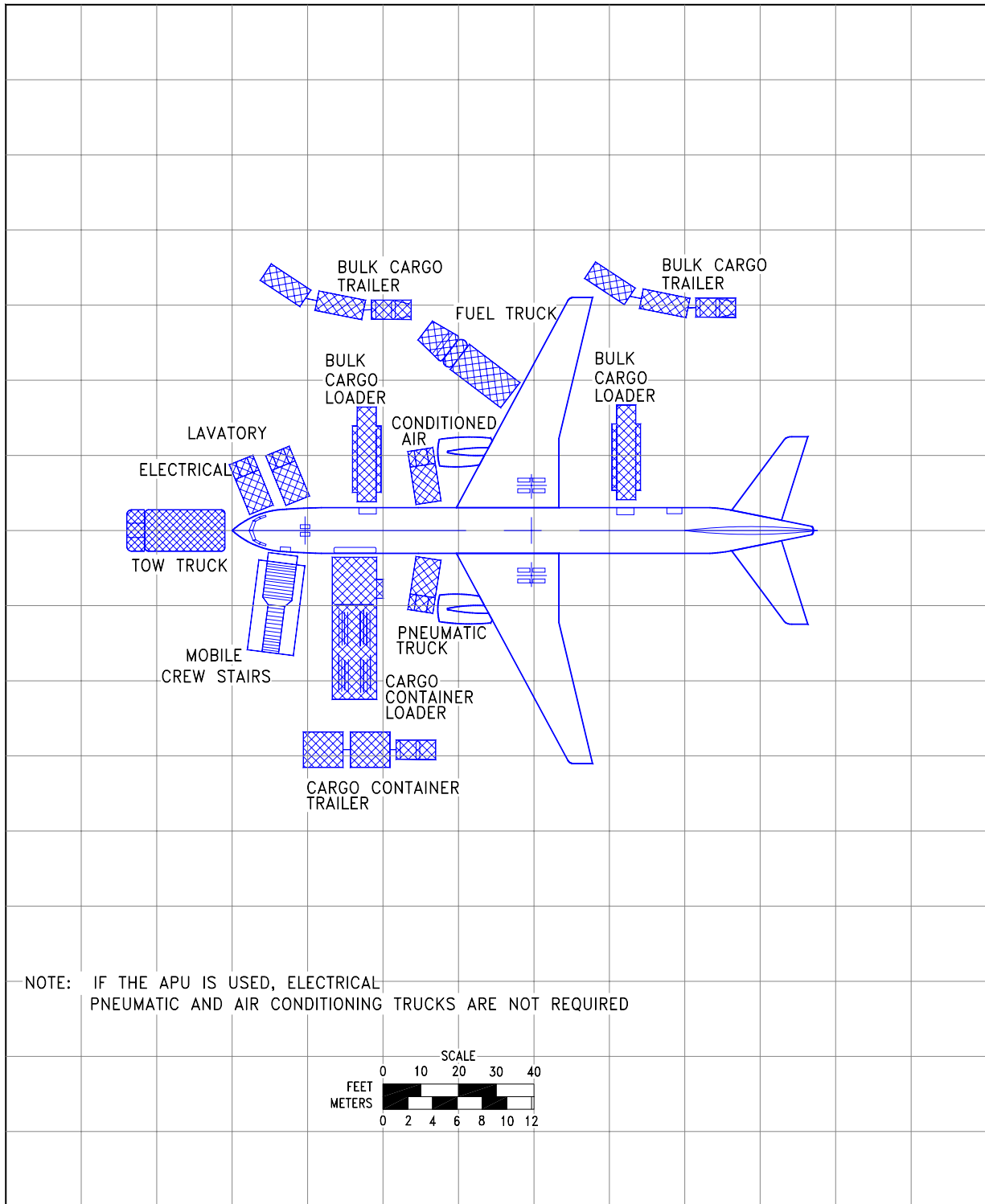

**5.1.2. AIRPLANE SERVICING ARRANGEMENT - TYPICAL TURNAROUND**  
 MODEL 757-200PF

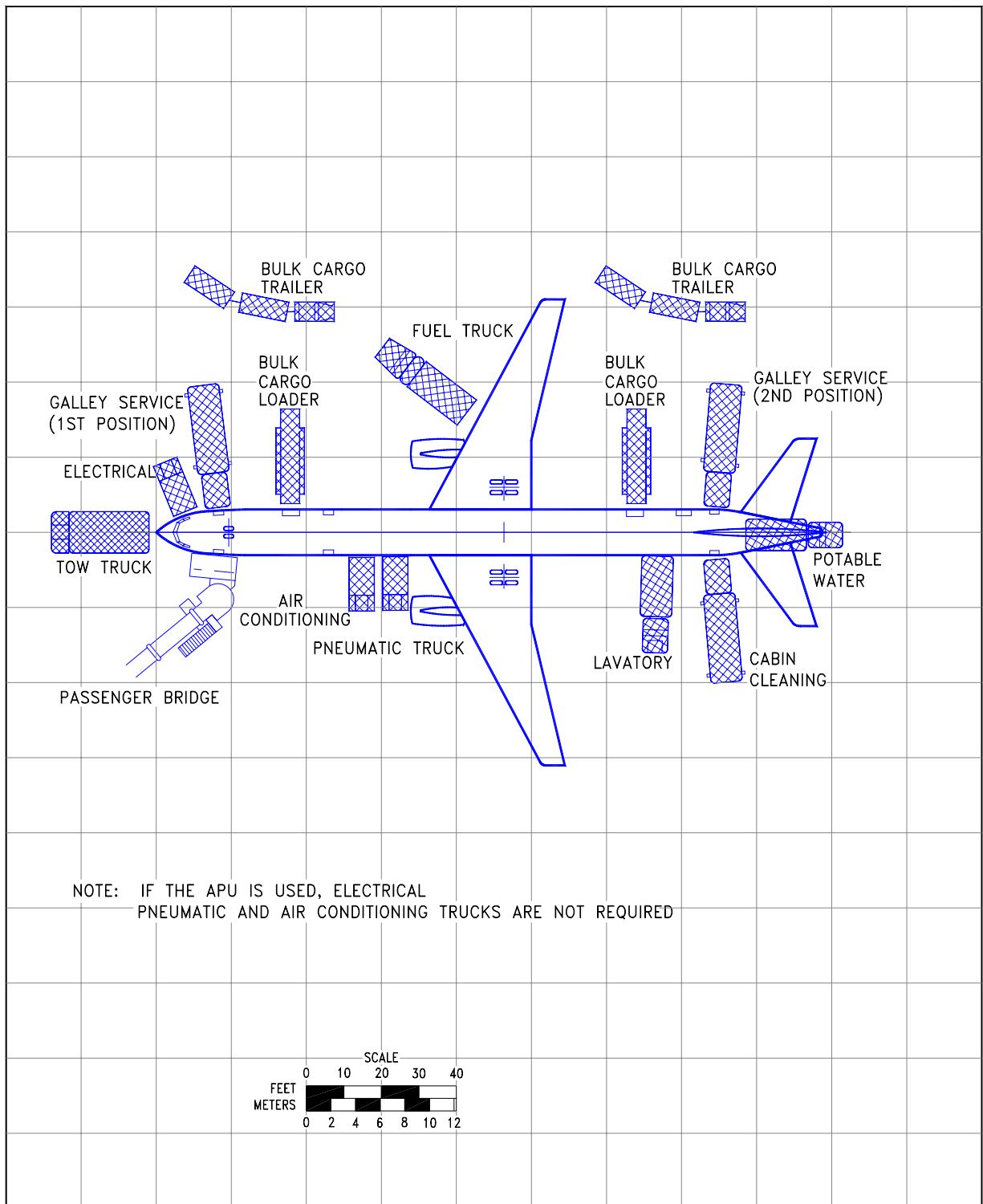

**5.1.3. AIRPLANE SERVICING ARRANGEMENT - TYPICAL TURNAROUND**  
 MODEL 757-300

**5.2.1 TERMINAL OPERATIONS - TURNAROUND STATION**  
 MODEL 757-200

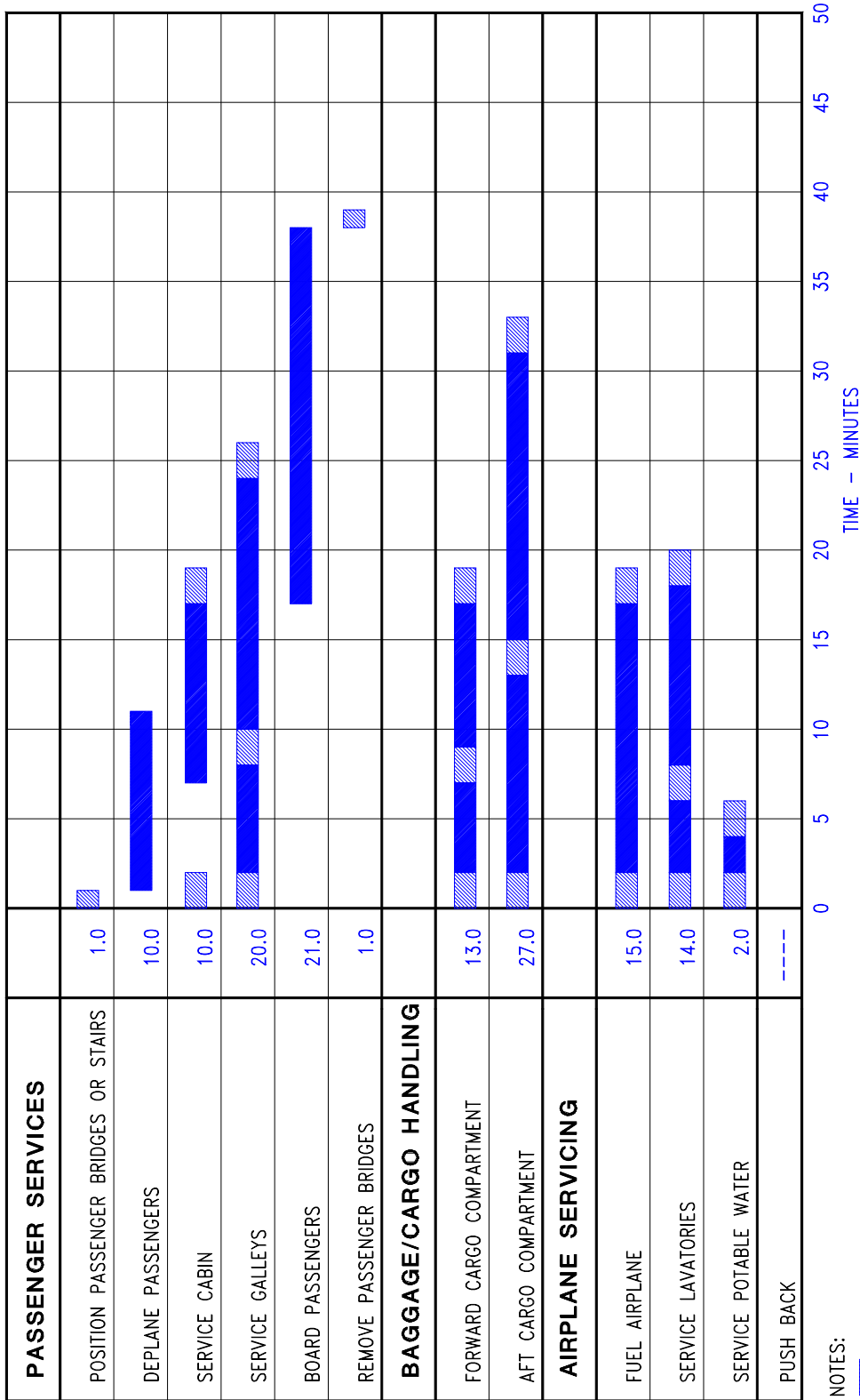

NOTES:

- MIXED CLASS 186 (16 FIRST CLASS, 170 ECONOMY CLASS) PASSENGERS
- 100 % LOAD FACTOR
- DEPLANE RATE: 18 PASSENGERS PER MINUTE
- ENPLANE RATE: 9 PASSENGERS PER MINUTE
- 100% PASSENGER, BAGGAGE, AND CARGO EXCHANGE
- FUEL: 8,175 USG (30,946 LITERS) AT 545 GAL/MIN. (2,063 LITERS/MIN)
- THIS DATA IS PROVIDED TO ILLUSTRATE THE GENERAL SCOPE AND TYPES OF TASKS INVOLVED IN TERMINAL OPERATIONS. VARYING AIRLINE PRACTICES AND OPERATING CIRCUMSTANCES WILL RESULT IN DIFFERENT SEQUENCE AND TIME INTERVALS TO ACCOMPLISH THE TASKS SHOWN. CONSULT USING AIRLINE PRIOR TO RAMP PLANNING.

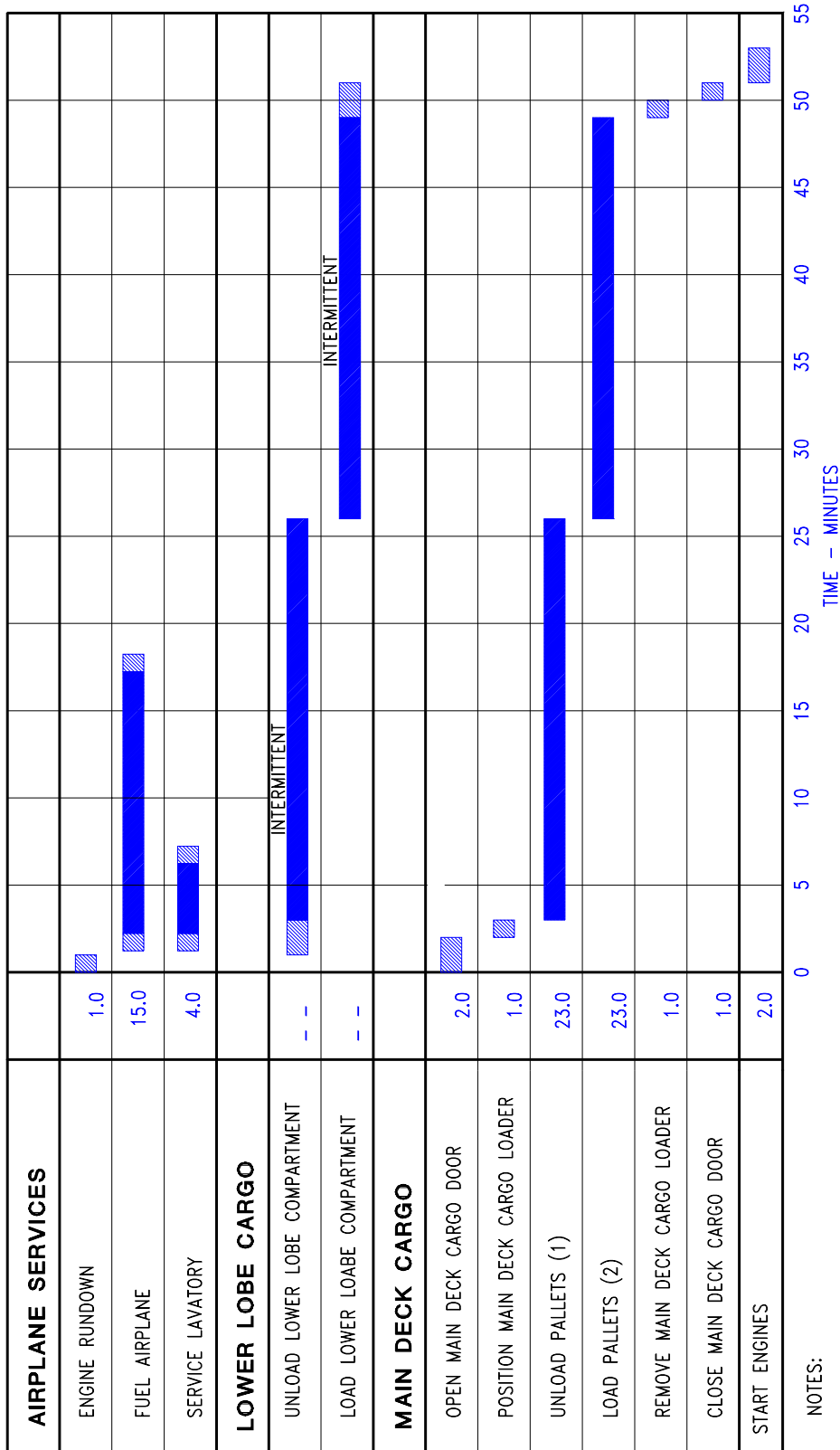

5.2.2 TERMINAL OPERATIONS - TURNAROUND STATION  
MODEL 757-200PF

**5.2.3. TERMINAL OPERATIONS - TURNAROUND STATION**  
 MODEL 757-300

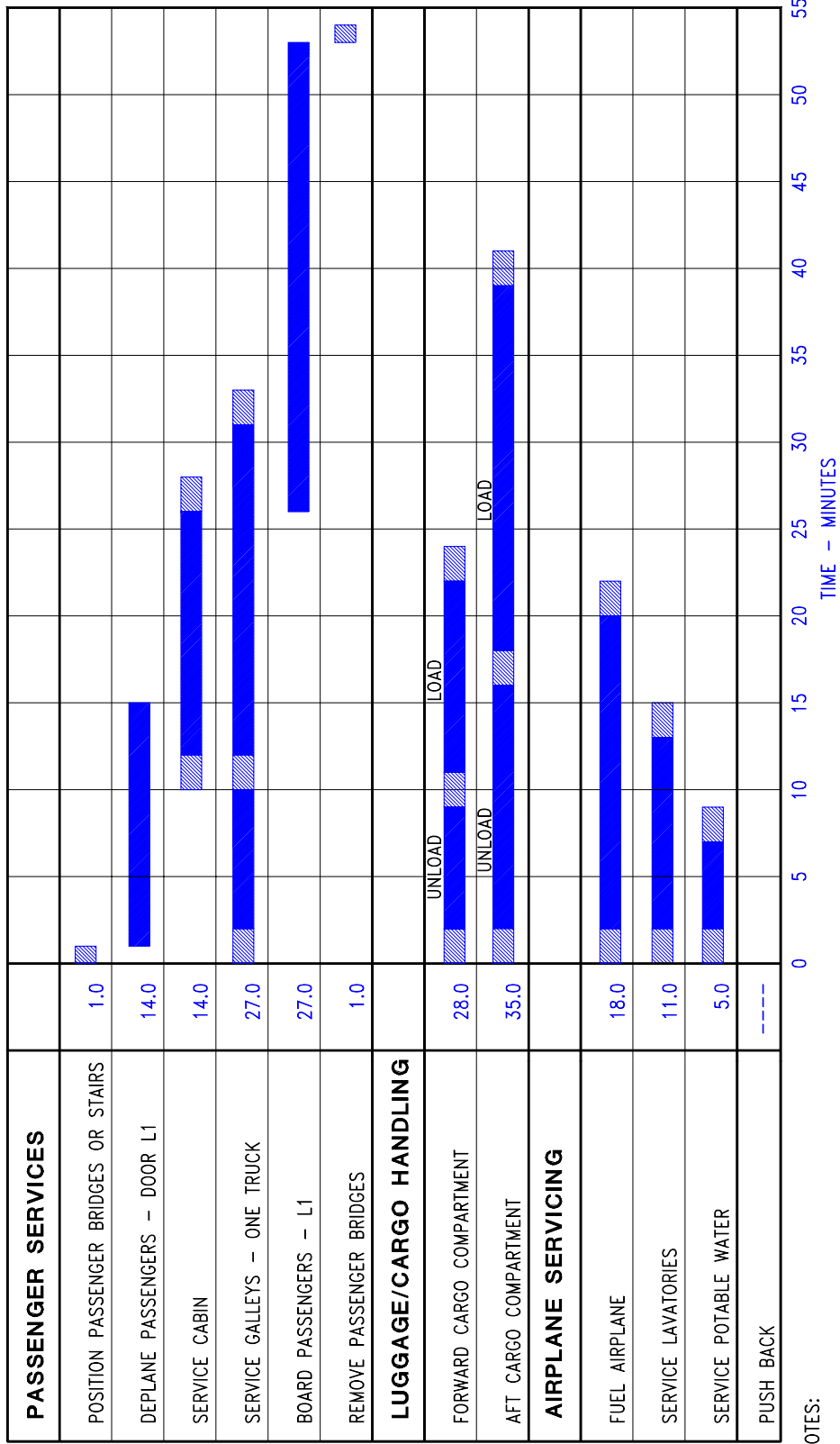

NOTES:

- ▨ POSITION/REMOVE EQUIPMENT
- 243 PASSENGERS BOARD AND DEPLANE VIA FWD LH ENTRY DOOR
- PASSENGER LOADING RATES (ONE DOOR)  
 DEPLANE RATE: 18 PASSENGERS PER MINUTE  
 ENPLANE RATE: 9 PASSENGERS PER MINUTE
- 100% LOAD FACTOR
- 100% PASSENGER AND BAGGAGE EXCHANGE, NO CARGO EXCHANGE
- BAGGAGE LOADING RATES  
 UNLOADING - 15 BAGS PER MINUTE  
 LOADING - 10 BAGS PER MINUTE
- ASSUMES MECHANIZED CARGO HANDLING EQUIPMENT (FWD AND AFT)
- FUEL: 9600 USG AT 545 GAL/MIN.
- 1.3 BAGS PER PASSENGER (4.5 CU FT)
- 83% STACKING EFFICIENCY
- 67% BAGS AFT, 33% BAGS FWD
- ONE GALLEY TRUCK USED

● THIS DATA IS PROVIDED TO ILLUSTRATE THE GENERAL SCOPE AND TASKS INVOLVED IN TERMINAL OPERATIONS. VARYING AIRLINE PRACTICES AND OPERATING CIRCUMSTANCES THROUGHOUT THE WORLD WILL RESULT IN VARYING SEQUENCES AND TIME INTERVALS TO ACCOMPLISH THE TASKS SHOWN. CONSULT USING AIRLINE PRIOR TO RAMP PLANNING

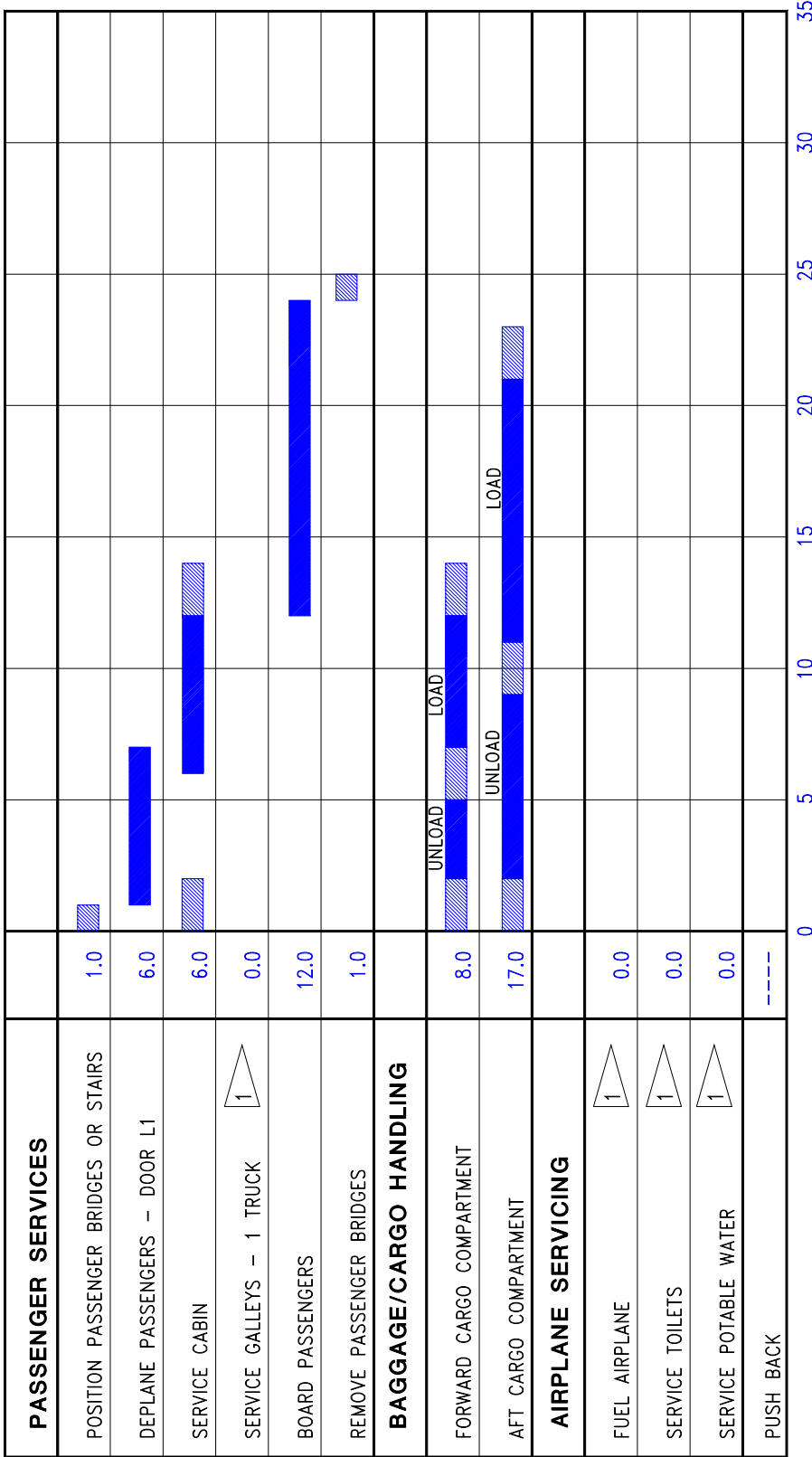

NOTES:

POSITION/REMOVE EQUIPMENT

1

NO GALLEY, FUEL, POTABLE WATER, OR LAVATORY SERVICE

- 60% PASSENGER BAGGAGE AND CARGO EXCHANGE
- 186 PASSENGERS (16 FIRST CLASS, 170 ECONOMY)
- 100% LOAD FACTOR
- 1.3 BAGS PER PASSENGER
- DEPLANE AND BOARDING TIMES BASED ON RATES OF 18 AND 9 PASSENGERS PER MINUTE RESPECTIVELY
- 67% BAGS AFT, 33% BAGS FWD

- THIS DATA IS PROVIDED TO ILLUSTRATE THE GENERAL SCOPE AND TYPES OF TASKS INVOLVED IN TERMINAL OPERATIONS. VARYING AIRLINE PRACTICES AND OPERATING CIRCUMSTANCES WILL RESULT IN DIFFERENT SEQUENCE AND TIME INTERVALS TO ACCOMPLISH THE TASKS SHOWN. GROUND OPERATION REQUIREMENTS SHOULD BE COORDINATED WITH USING AIRLINES PRIOR TO RAMP PLANNING.

5.3.1 TERMINAL OPERATIONS - EN ROUTE STATION  
MODEL 757-200

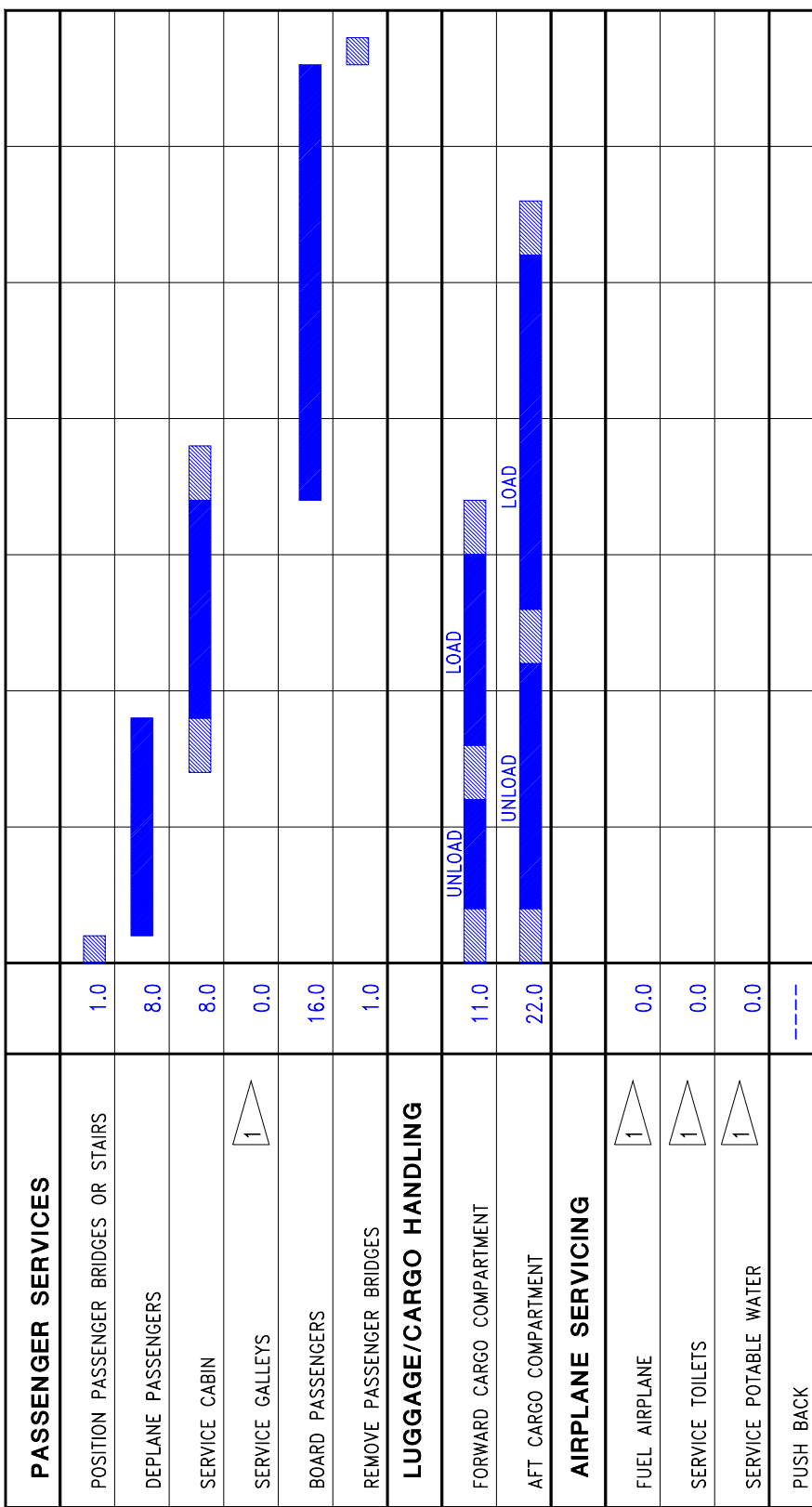

NOTES:  
 POSITION/REMOVE EQUIPMENT  
 NO GALLEY, FUEL, POTABLE WATER, OR LAVATORY SERVICE

- 60 % PASSENGERS AND CARGO EXCHANGE
- 146 PASSENGERS BOARD AND DEPLANE VIA FW LH ENTRY DOOR
- 100% LOAD FACTOR
- PASSENGER LOADING RATES (1 DOOR)  
UNLOADING – 18 PASSENGERS PER MINUTE  
LOADING – 9 PASSENGERS PER MINUTE
- BAGGAGE LOADING RATES  
UNLOADING – 15 BAGS PER MINUTE  
LOADING – 10 BAGS PER MINUTE
- 1.3 BAGS PER PASSENGER (4.5 CU FT)
- 83% STACKING EFFICIENCY
- THIS DATA IS PROVIDED TO ILLUSTRATE THE GENERAL SCOPE AND TASKS INVOLVED IN TERMINAL OPERATIONS. VARYING AIRLINE PRACTICES AND OPERATING CIRCUMSTANCES THROUGHOUT THE WORLD WILL RESULT IN DIFFERENT SEQUENCES AND TIME INTERVALS TO ACCOMPLISH THE TASKS SHOWN. CONSULT USING AIRLINE PRIOR TO RAMP PLANNING.

5.3.2 TERMINAL OPERATIONS - EN ROUTE STATION  
 MODEL 757-300



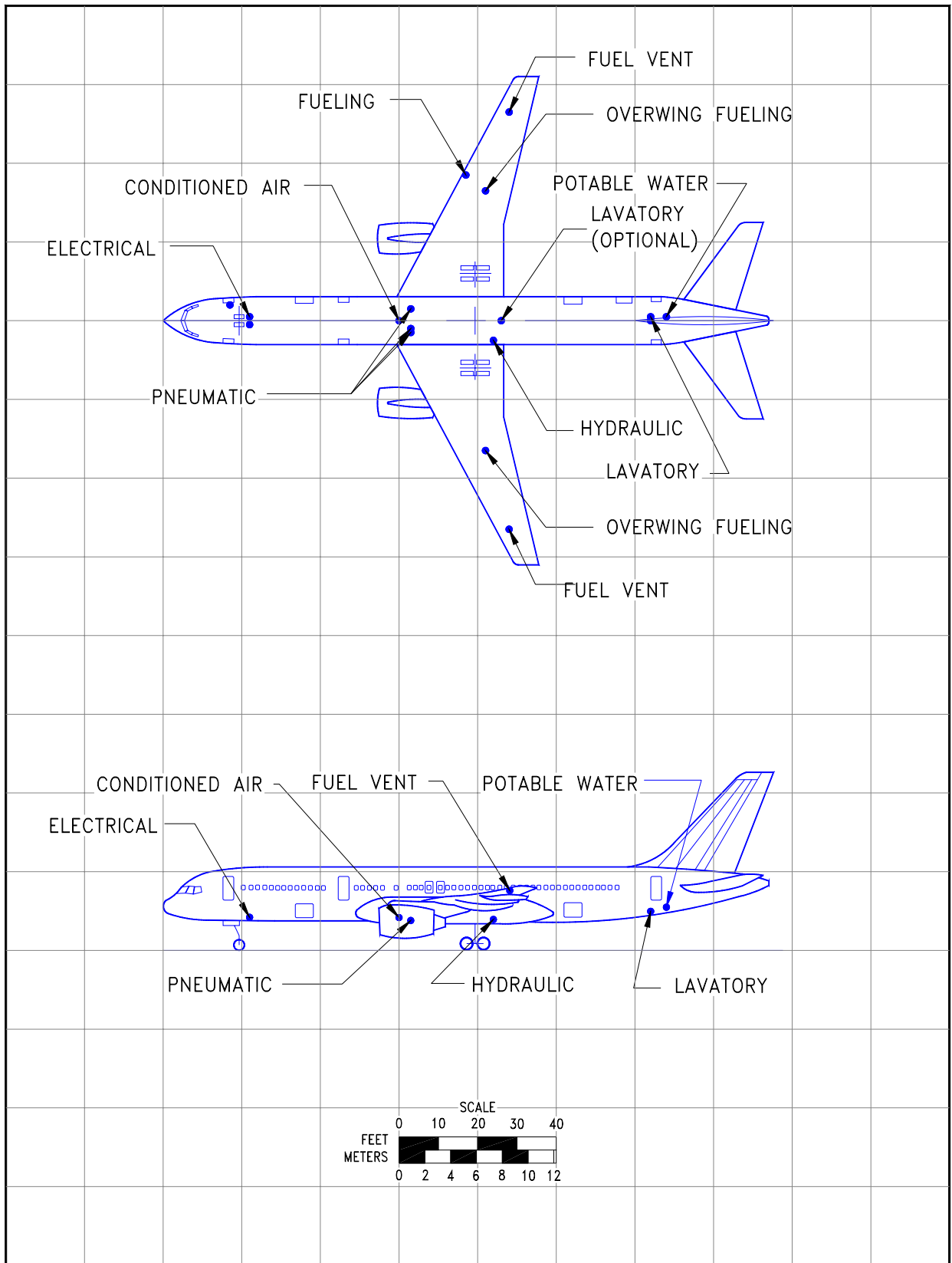

**5.4.1 GROUND SERVICING CONNECTIONS**  
*MODEL 757-200*

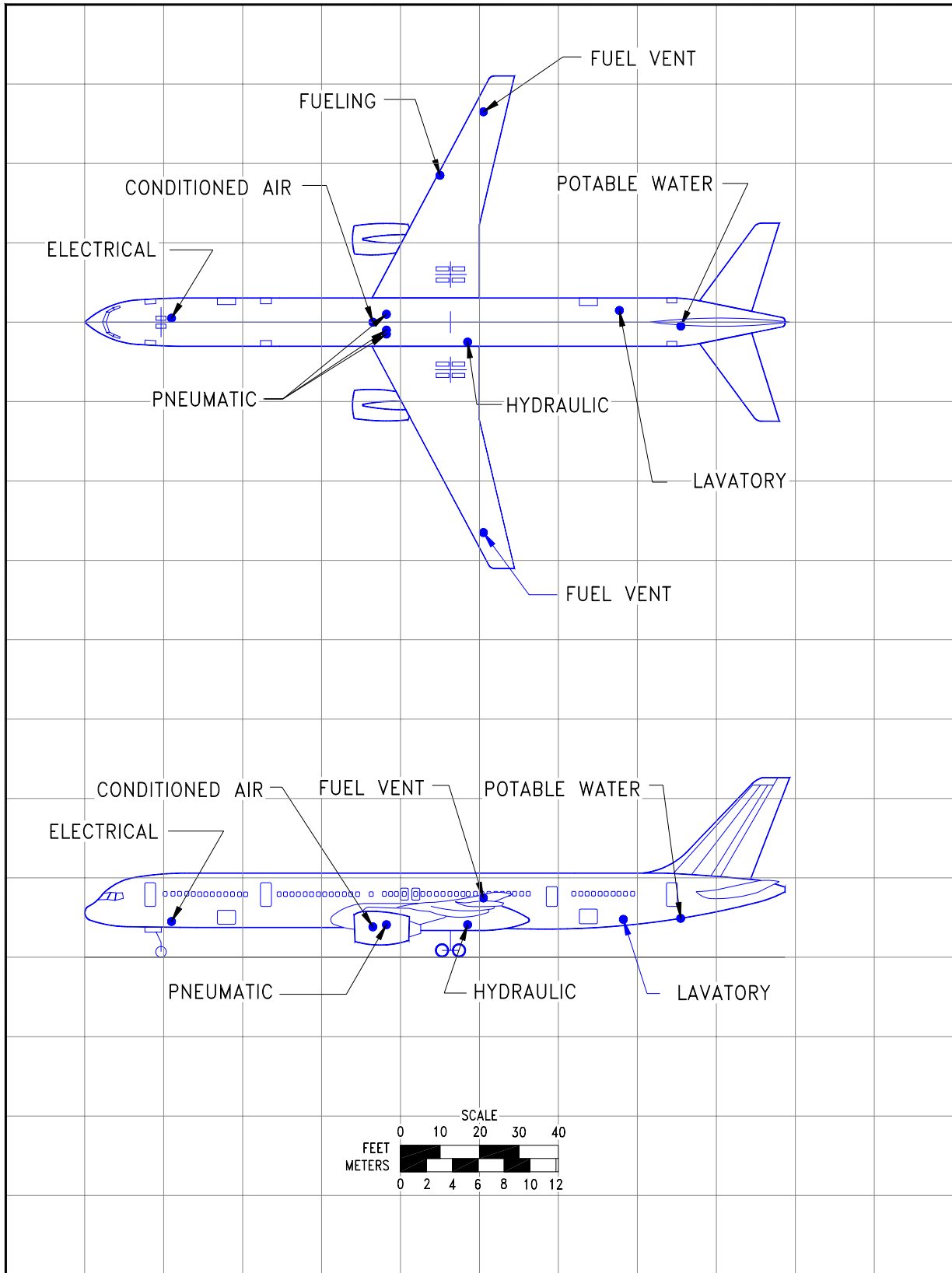

**5.4.2 GROUND SERVICING CONNECTIONS**  
 MODEL 757-300

SYSTEM	MODEL	DISTANCE AFT OF NOSE		DISTANCE FROM AIRPLANE CENTERLINE				MAX HT ABOVE GROUND	
				LH SIDE		RH SIDE			
		FT	M	FT	M	FT	M	FT	M
CONDITIONED AIR ONE 8-IN (20.3 CM) PORT	757-200	60	18.3	0	0	0	0	7	2.1
	757-300	73	22.4	0	0	0	0	7	2.1
ELECTRICAL ONE CONNECTION 90 KVA , 200/115 V AC 400 HZ, 3-PHASE EACH	757-200	22	6.6	-	-	1	0.3	8	2.4
	757-300	22	6.6	-	-	1	0.3	8	2.4
FUEL TWO UNDERWING PRESSURE CONNECTORS ON RIGHT WING (SEE SEC 2.2 FOR CAPACITIES)  TWO OVERWING GRAVITY PORTS * TOP OF THE WING  FUEL VENTS	757-200	77	23.5	-	-	37	11.3	14	4.3
	757-300	90	27.5	-	-	37	11.3	14	4.3
	757-200	82	24.9	33	10.1	33	10.1	*	*
	757-300	95	29.1	33	10.1	33	10.1	*	*
	757-200	88	26.9	53	16.3	53	16.3	15	4.6
	757-300	101	30.1	53	16.3	53	16.3	15	4.6
HYDRAULIC TOTAL SYSTEM CAPACITY = 72 GAL (273 L) FILL PRESSURE = 150 PSIG (10.55 KG/CM <sup>2</sup> )	757-200	84	25.6	5	1.5	-	-	12	3.7
	757-300	97	29.6	5	1.5	-	-	12	3.7
LAVATORY TWO CONNECTIONS - 757-200 * OVERWING EXIT AIRPLANE ** FOUR-DOOR AIRPLANE ONE SERVICE CONNECTION - 757-200PF ONE SERVICE CONNECTION - 757-300	757-200	22	6.7	1	0.3	-	-	8	2.4
		* 128	39.0	-	-	-	-	10	3.1
		** 86	26.2	0	0	0	0	7	2.1
	757-200PF	17	5.0	0	0	0	0	9	2.9
	757-300	135	41.2	1	0.3	-	-	12	3.7
PNEUMATIC THREE 3-IN(7.6-CM) PORTS (RB211) TWO 3-IN (7.6-CM) PORTS (PW) ** RB211 ENGINES ONLY	757-200	**63	19.2	2	0.6	-	-	7	2.1
		63	19.2	-	-	3	0.9	7	2.1
		63	19.2	3	0.9	-	-	7	2.1
	757-300	**76	23.3	2	0.6	-	-	7	2.1
		76	23.3	-	-	2	0.6	7	2.1
	76	23.3	3	0.9	-	-	7	2.1	
POTABLE WATER ONE SERVICE CONNECTION * OVERWING-EXIT AIRPLANE ** FOUR-DOOR AIRPLANE	757-200	* 124	37.8	1	0.3	-	-	10	3.1
		**124	37.8	0	0	0	0	10	3.1
	757-300	147	44.8	1	0.3	-	-	13	4.0

NOTE: DISTANCES ROUNDED TO THE NEAREST FOOT AND 0.1 METER.

### 5.4.3 GROUND SERVICING CONNECTIONS

MODEL 757-200, -300

- NOTES: 1. SEA LEVEL CONDITIONS  
 2. TWO GROUND CONNECTIONS (GAC) ABOVE  $-15^{\circ}\text{F}$  ( $-26^{\circ}\text{C}$ )  
 3. THREE GAC BELOW  $-15^{\circ}\text{F}$  ( $-26^{\circ}\text{C}$ )  
 4. MAXIMUM PRESSURE AT GAC 60 PSIA (4.2 KG/SQ CM A)  
 5. MAXIMUM TEMPERATURE AT GAC  $450^{\circ}\text{F}$  ( $232^{\circ}\text{C}$ )

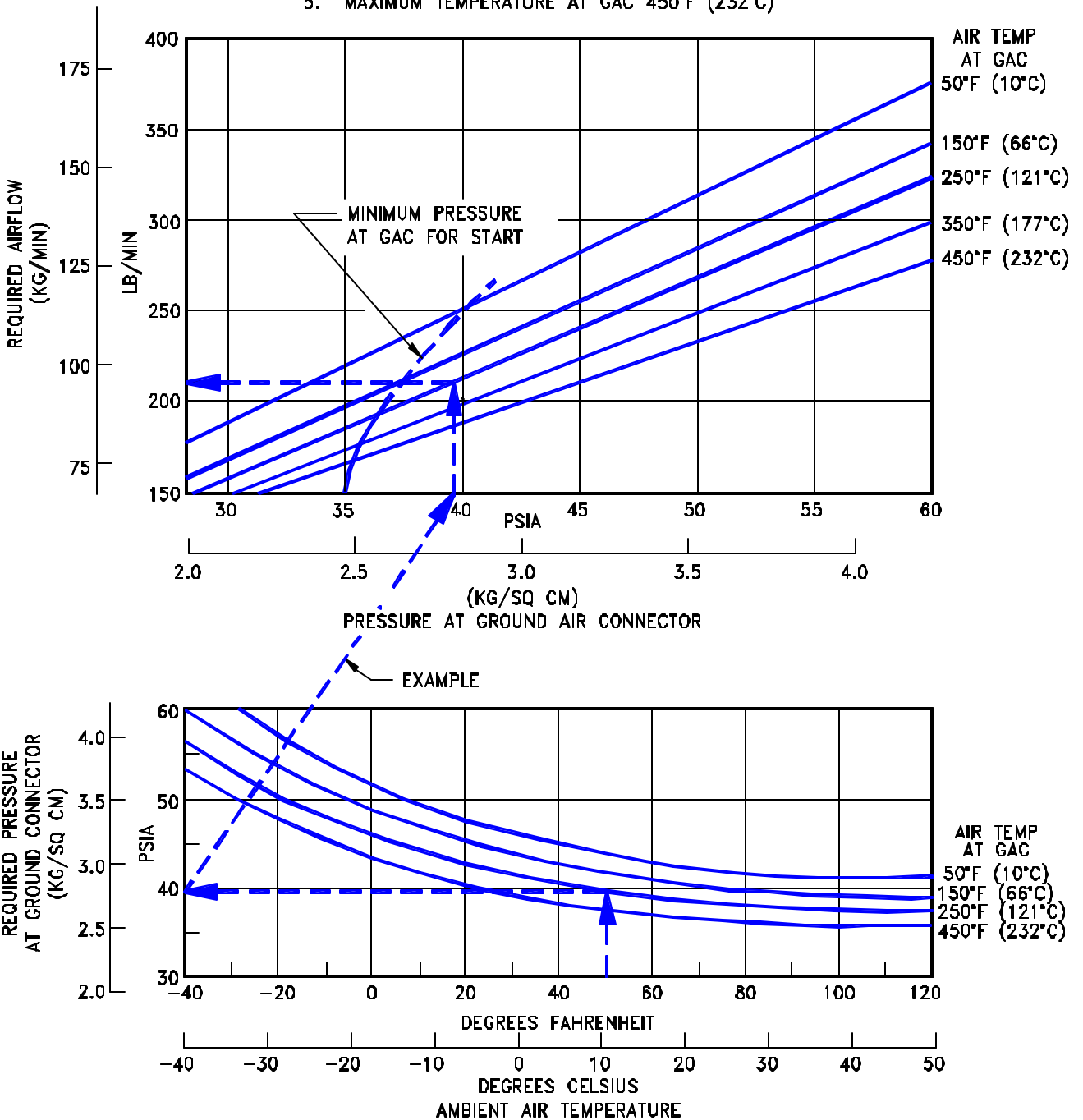

**5.5.1 ENGINE START PNEUMATIC REQUIREMENTS - SEA LEVEL**  
 MODEL 757-200, 300 (ROLLS ROYCE ENGINES)

D6-58327

- NOTES: 1. SEA LEVEL CONDITIONS  
 2. TWO GROUND AIR CONNECTIONS  
 3. MAXIMUM PRESSURE AT GAC 60 PSIA (4.2 KG/SQ CM)  
 4. MAXIMUM TEMPERATURE AT GAC 450°F (232°C)

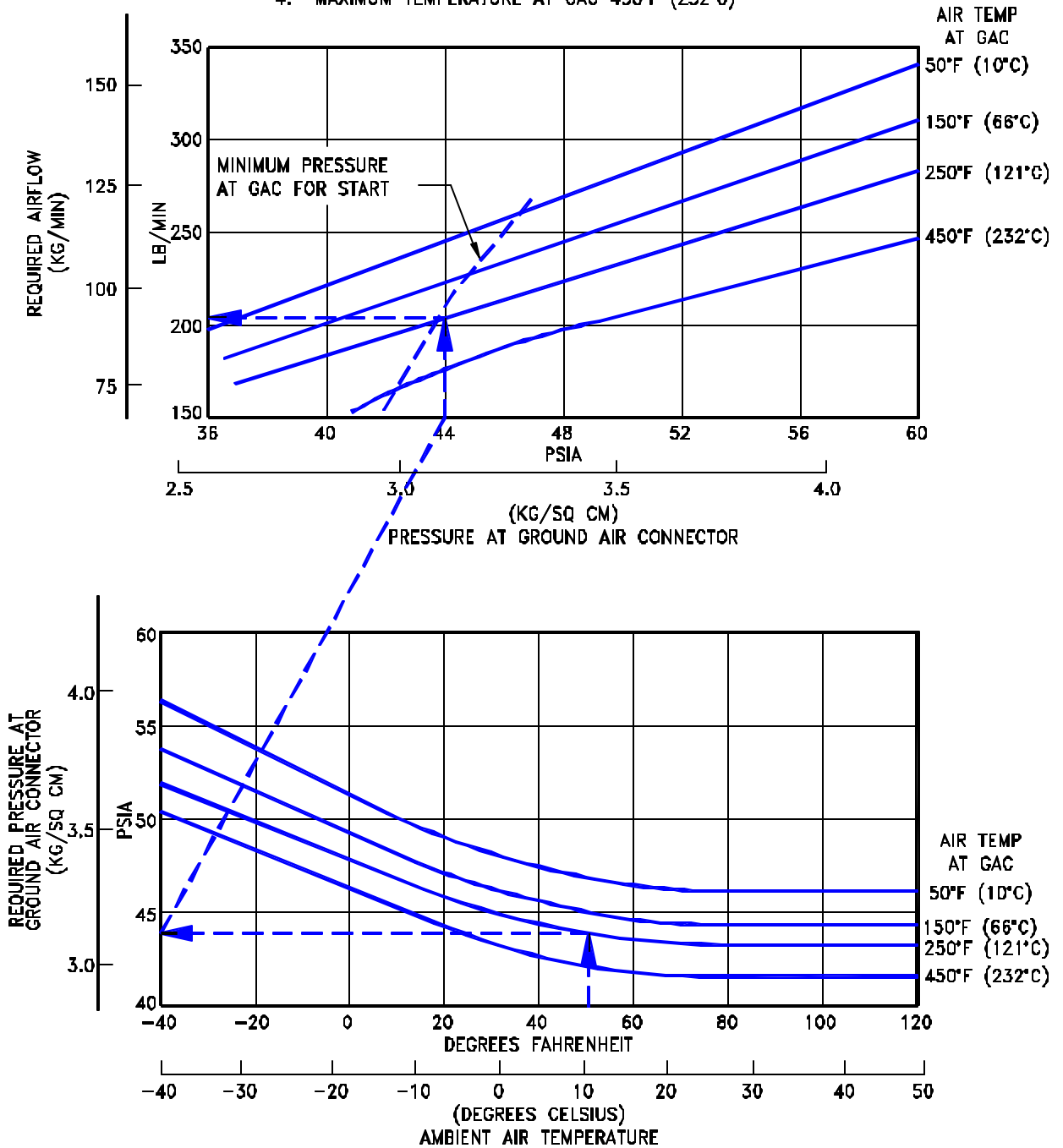

**5.5.2 ENGINE START PNEUMATIC REQUIREMENTS - SEA LEVEL**  
 MODEL 757-200, -300 (PRATT & WHITNEY ENGINES)

**HEATING (PULL-UP)**

- INITIAL CABIN TEMPERATURE: 0°F (-17.8°C)
- OUTSIDE AIR TEMPERATURE: 0°F (-17.8°C)
- NO GALLEY LOAD, ELECTRICAL LOAD, OR SOLAR LOAD
- TEMPERATURE AT GROUND AIR CONNECTION: 300°F (149°C)
- P = PRESSURE AT GROUND AIR CONNECTION, PSIG
- NO OCCUPANTS
- RH RECIRCULATING FAN MUST BE OFF DURING GROUND OPERATIONS

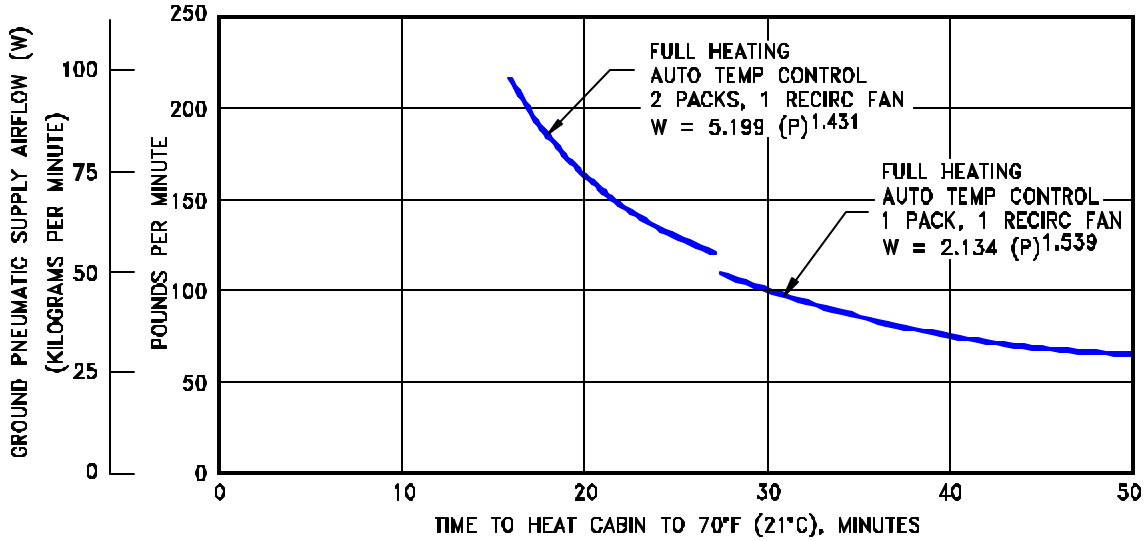

**COOLING (PULL-DOWN)**

- INITIAL CABIN TEMPERATURE: 103°F (39.5°C)
- OUTSIDE AIR TEMPERATURE: 103°F (39.5°C)
- SOLAR LOAD: 8520 BTU/HR (2145 KCAL/HR)
- NO GALLEY LOAD OR ELECTRICAL LOAD
- TEMPERATURE AT GROUND AIR CONNECTION: 450°F (232°C)
- P = PRESSURE AT GROUND AIR CONNECTION, PSIG
- NO OCCUPANTS
- RH RECIRCULATING FAN MUST BE OFF DURING GROUND OPERATIONS

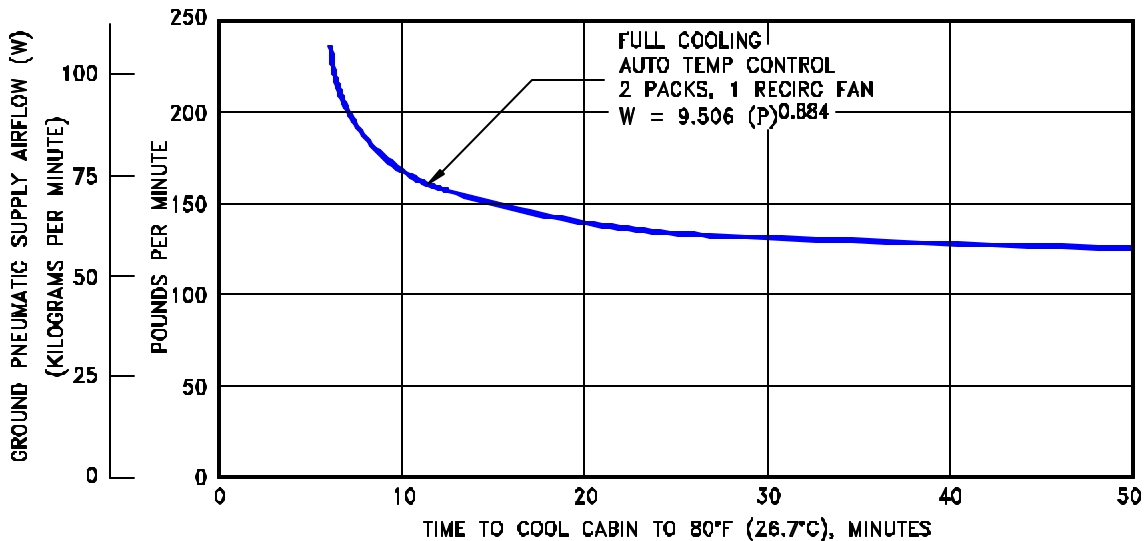

**5.6.1 GROUND PNEUMATIC POWER REQUIREMENTS - HEATING & COOLING**

MODEL 757-200

- \* AMBIENT TEMPERATURE 0°F (-17.8°C)
- \* CABIN INITIALLY AT 0°F (-17.8°C)
- \* NO OCCUPANTS OR OTHER HEAT LOADS
- \* AIR TEMPERATURES AT GROUND CONNECTION 300°F (149°C)

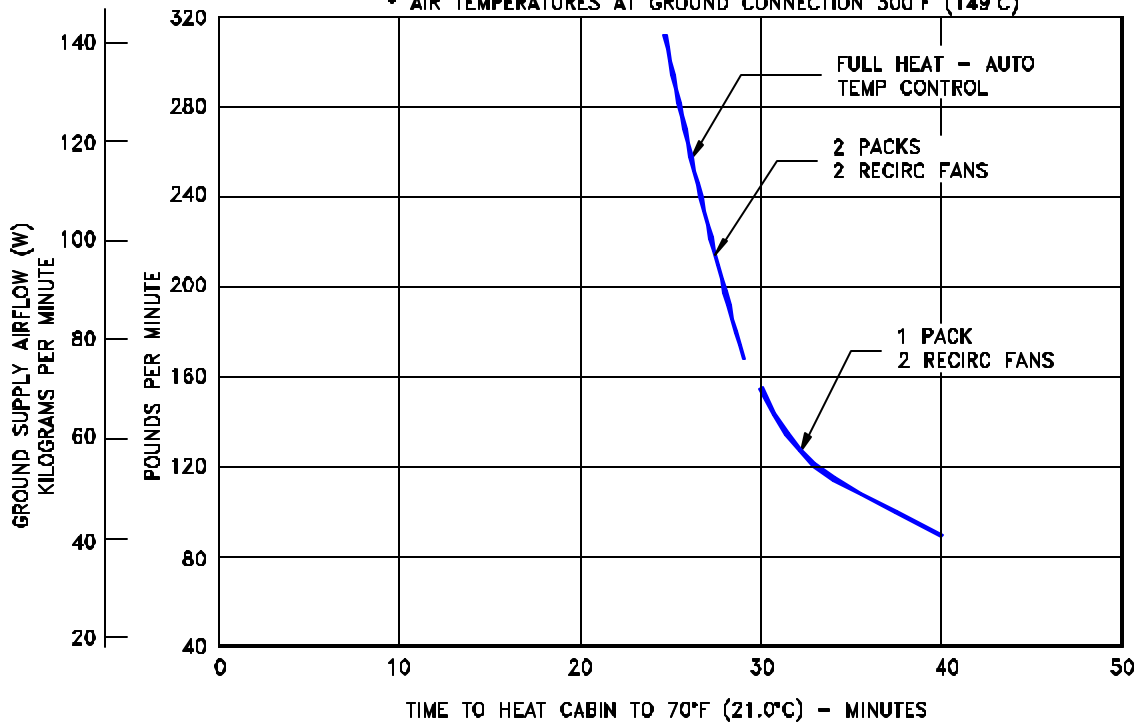

- \* CABIN INITIALLY AT 103°F (39°C)
- \* NO OCCUPANTS, NO GALLEY OR ELECTRICAL HEAT LOAD
- \* AMBIENT TEMPERATURE 103°F (39°C)
- \* AIR TEMPERATURE AT GROUND CONNECTION 450°F (232°C)

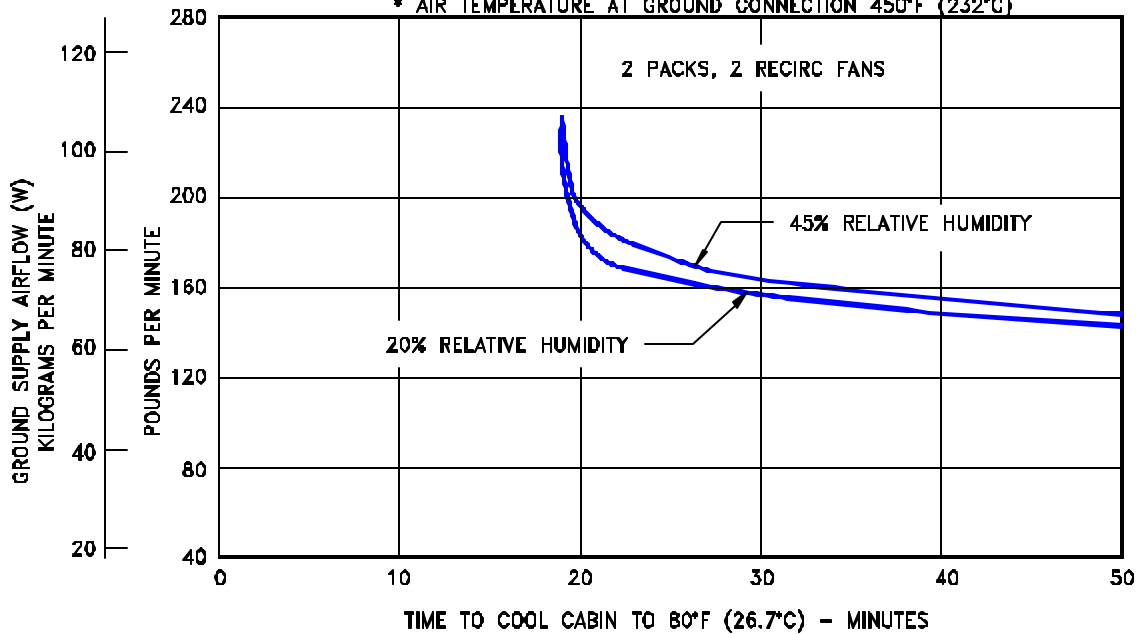

**5.6.2 GROUND PNEUMATIC POWER REQUIREMENTS - HEATING & COOLING**  
 MODEL 757-300

NOTES:

1. ALL DATA WITH LH RECIRCULATING FAN ON FOR ELECTRONIC COOLING AIRFLOW
2. GROUND OPERATION IS LIMITED TO ONE RECIRCULATING FAN OPERATION
3. MAXIMUM STATIC PRESSURE  $\Delta P_S$  AT 8-IN SUPPLY DUCT AT GROUND AIR CONNECTION (GAC) TO MIX MANIFOLD LIMITED TO 16 INCHES OF WATER.
4. MAXIMUM TEMPERATURE OF GAC SUPPLY FLOW TO MIX MANIFOLD IS 160°F

CONDITIONS	TAMB	SOLAR LOAD	ELECTRICAL LOAD	PASS	CABIN TEMPERATURE
①	103°F(39°C)	142 BTU/MIN	160 BTU/MIN	186	70°F(21°C)
②	103°F(39°C)	39 KG CAL/MIN	40 KG CAL/MIN	186	75°F(24°C)
③	103°F(39°C)	39 KG CAL/MIN	40 KG CAL/MIN	186	80°F(27°C)
④	0°F(-18°C)	0	0	0	75°F(24°C)
⑤	-20°F(-29°C)	0	0	0	75°F(24°C)
⑥	-40°F(-40°C)	0	0	0	75°F(24°C)

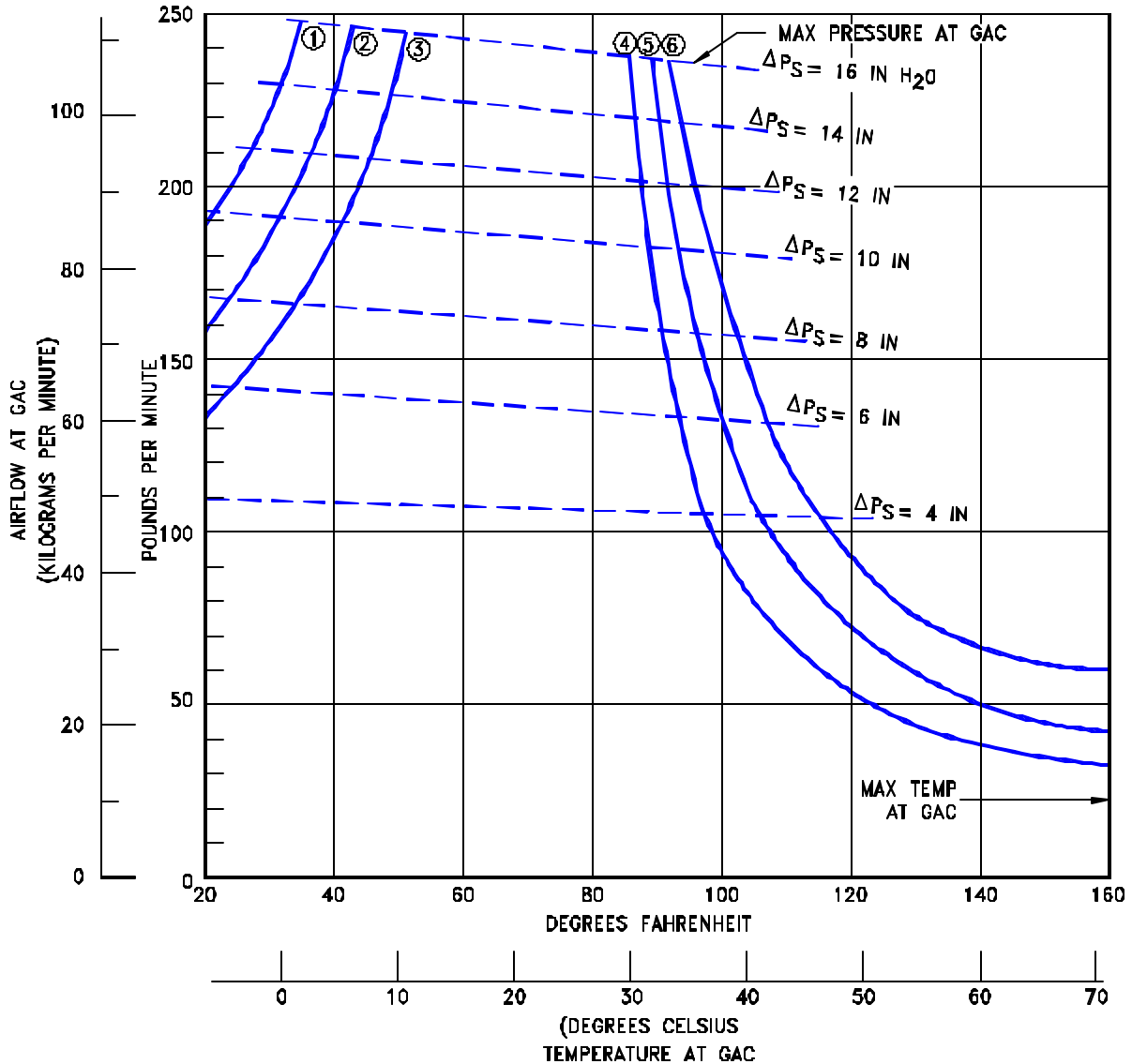

5.7.1 CONDITIONED AIR FLOW REQUIREMENTS - STEADY STATE AIRFLOW  
MODEL 757-200



**COOLING**

- \* ALL EXTERIOR DOORS AND WINDOWS CLOSED
- \* OUTSIDE AIR TEMPERATURE 103°F (39°C)
- \* FULL SOLAR LOAD AND ELECTRICAL HEAT LOADS
- \* RECIRCULATION FANS OFF
- \* CHILLERS ON
- \* 286 OCCUPANTS
- \* CABIN TEMPERATURE MAINTAINED AT 75°F (24°C)

**HEATING**

- \* ALL EXTERIOR DOORS AND WINDOWS CLOSED
- \* OUTSIDE TEMPERATURE -40°F (-40°C)
- \* NO SOLAR OR ELECTRICAL HEAT LOADS
- \* RECIRCULATION FANS OFF
- \* CHILLERS OFF
- \* NO OCCUPANTS
- \* CABIN TEMPERATURE MAINTAINED AT 75°F (24°C)

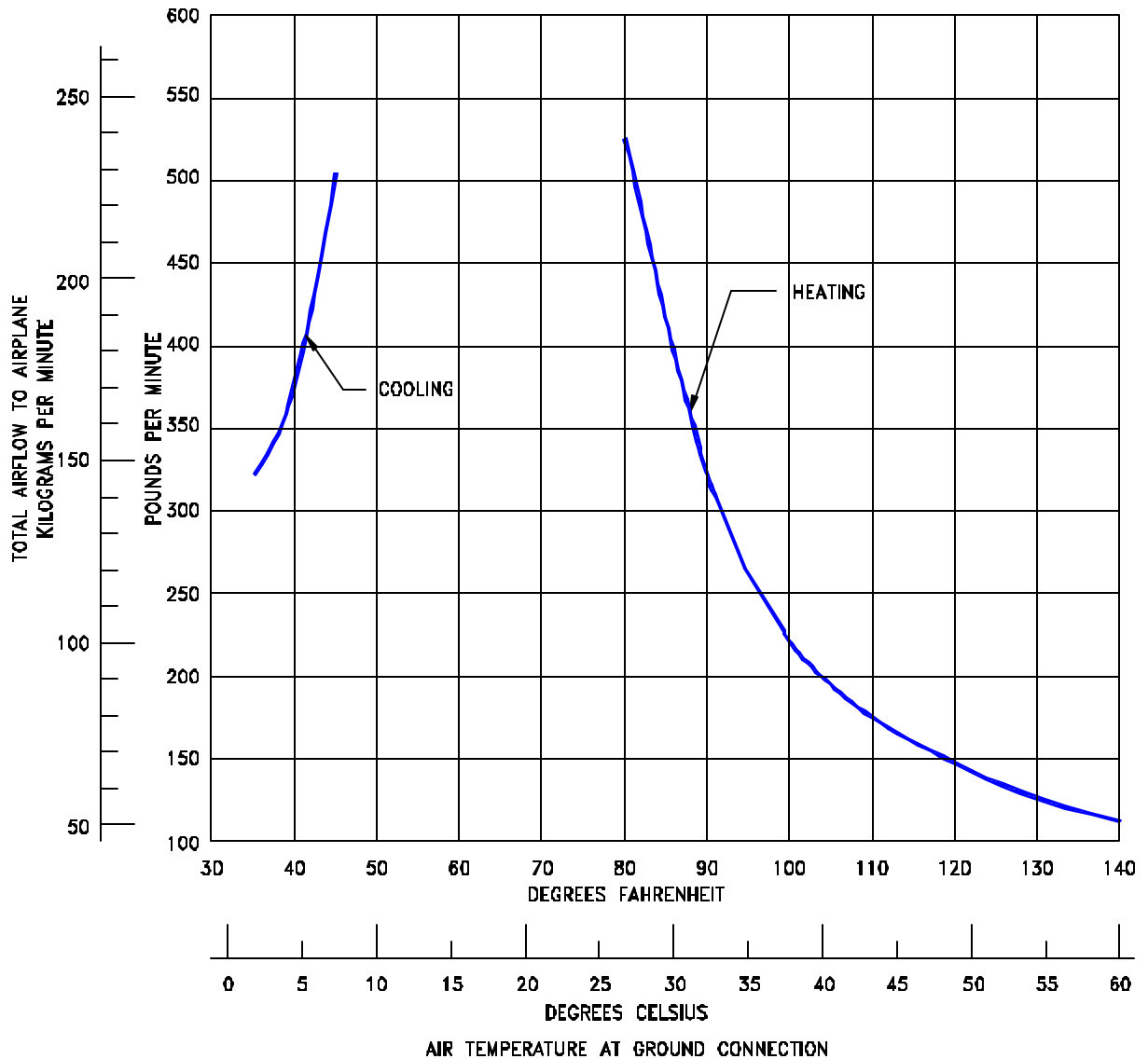

**5.7.2 CONDITIONED AIR FLOW REQUIREMENTS - STEADY STATE AIRFLOW**

MODEL 757-300

NOTES:

1. STRAIGHT-LINE TOW
2. UNUSUAL BREAKAWAY CONDITIONS NOT SHOWN
3. COEFFICIENTS OF FRICTION ( $\mu$ ) ARE ESTIMATED FOR RUBBER-TIRED TOW VEHICLES

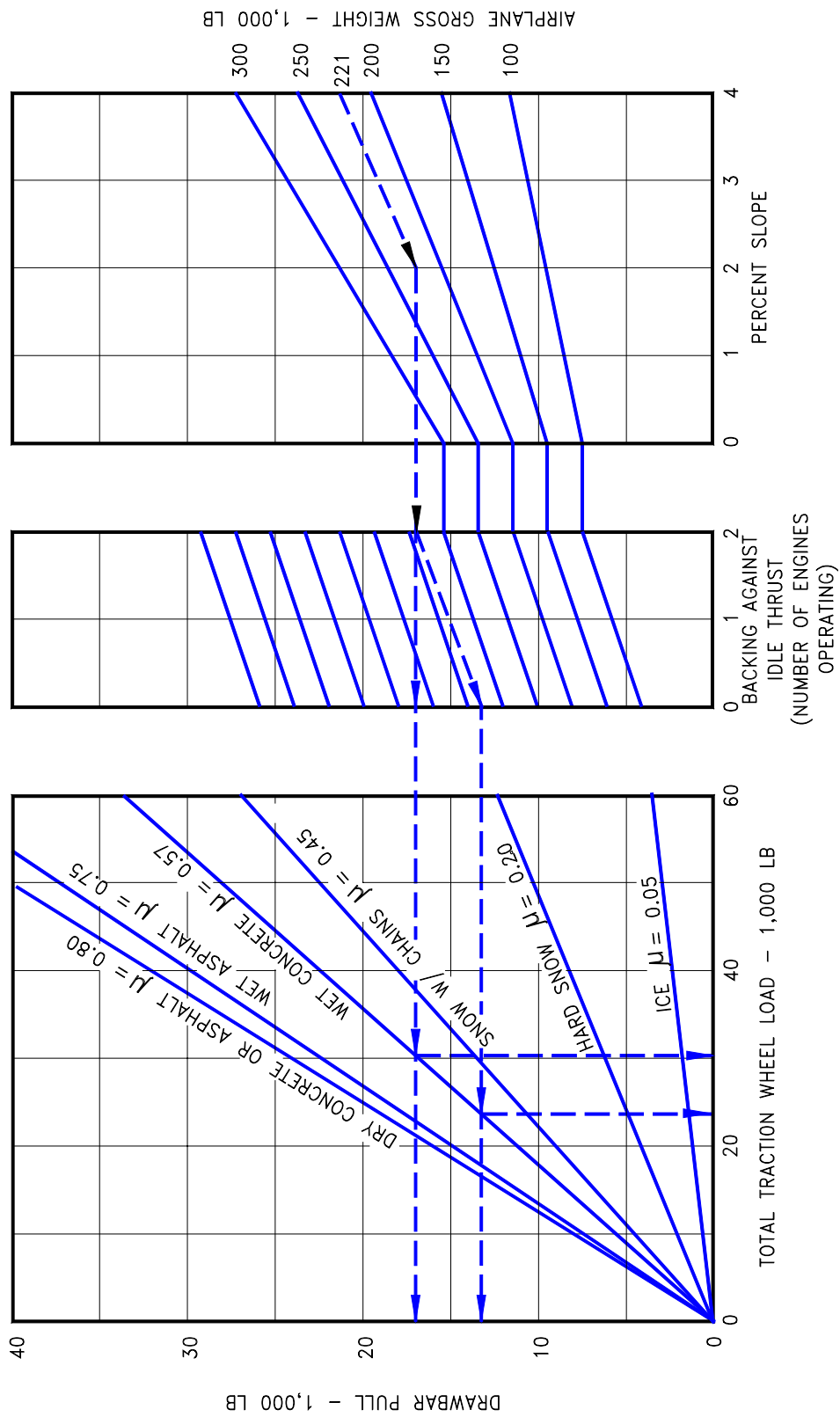

**5.8.1 GROUND TOWING REQUIREMENTS - ENGLISH UNITS**  
 MODEL 757-200, -300

D6-58327

NOTES:

STRAIGHT-LINE TOW  
 UNUSUAL BREAKAWAY CONDITIONS NOT SHOWN  
 COEFFICIENTS OF FRICTION ( $\mu$ ) ARE ESTIMATED  
 FOR RUBBER-TIRED TOW VEHICLES

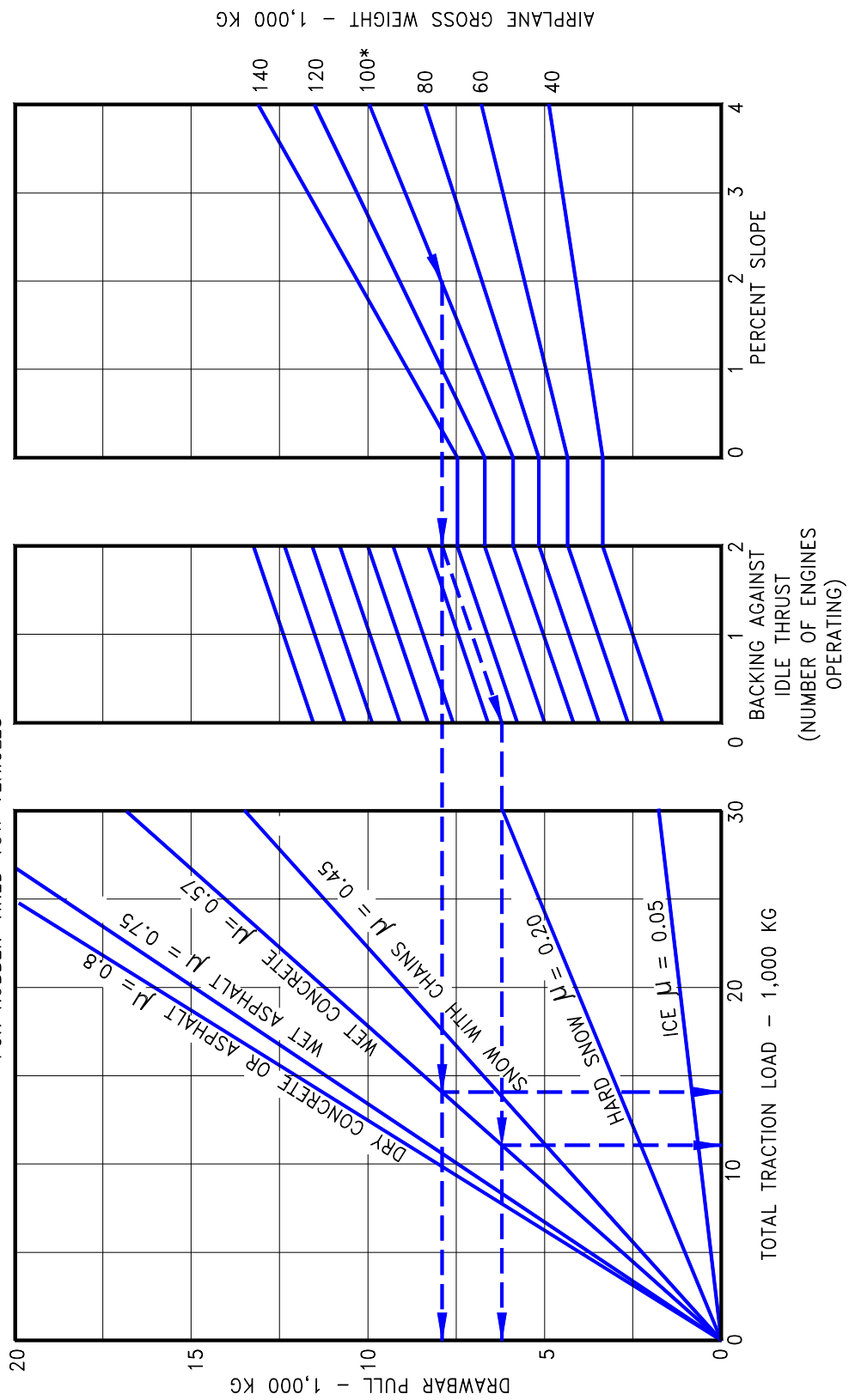

**5.8.2 GROUND TOWING REQUIREMENTS - METRIC UNITS**  
 MODEL 757-200, -300

THIS PAGE INTENTIONALLY LEFT BLANK

## **6.0 JET ENGINE WAKE AND NOISE DATA**

### **6.1 Jet Engine Exhaust Velocities and Temperatures**

### **6.2 Airport and Community Noise**

## **6.0 JET ENGINE WAKE AND NOISE DATA**

### **6.1 Jet Engine Exhaust Velocities and Temperatures**

This section shows exhaust velocity and temperature contours aft of the 757 airplane. The contours were calculated from a standard computer analysis using three-dimensional viscous flow equations with mixing of primary, fan, and free-stream flow. The presence of the ground plane is included in the calculations as well as engine tilt and toe-in. Mixing of flows from the engines is also calculated. The analysis does not include thermal buoyancy effects which tend to elevate the jet wake above the ground plane. The buoyancy effects are considered to be small relative to the longitudinal velocity and therefore are not included.

The graphs show jet wake velocity and temperature contours for a representative engine. The results are valid for sea level, static, standard day conditions. The effect of wind on jet wakes was not included. There is evidence to show that a downwind or an upwind component does not simply add or subtract from the jet wake velocity, but rather carries the whole envelope in the direction of the wind. Crosswinds may carry the jet wake contour far to the side at large distances behind the airplane.

- NOTES:
- \* SEA LEVEL
  - \* STANDARD DAY
  - \* ZERO WIND
  - \* STATIC AIRPLANE
  - \* TWO ENGINES OPERATING
  - \* 2,000 LB (910 KG) THRUST PER ENGINE

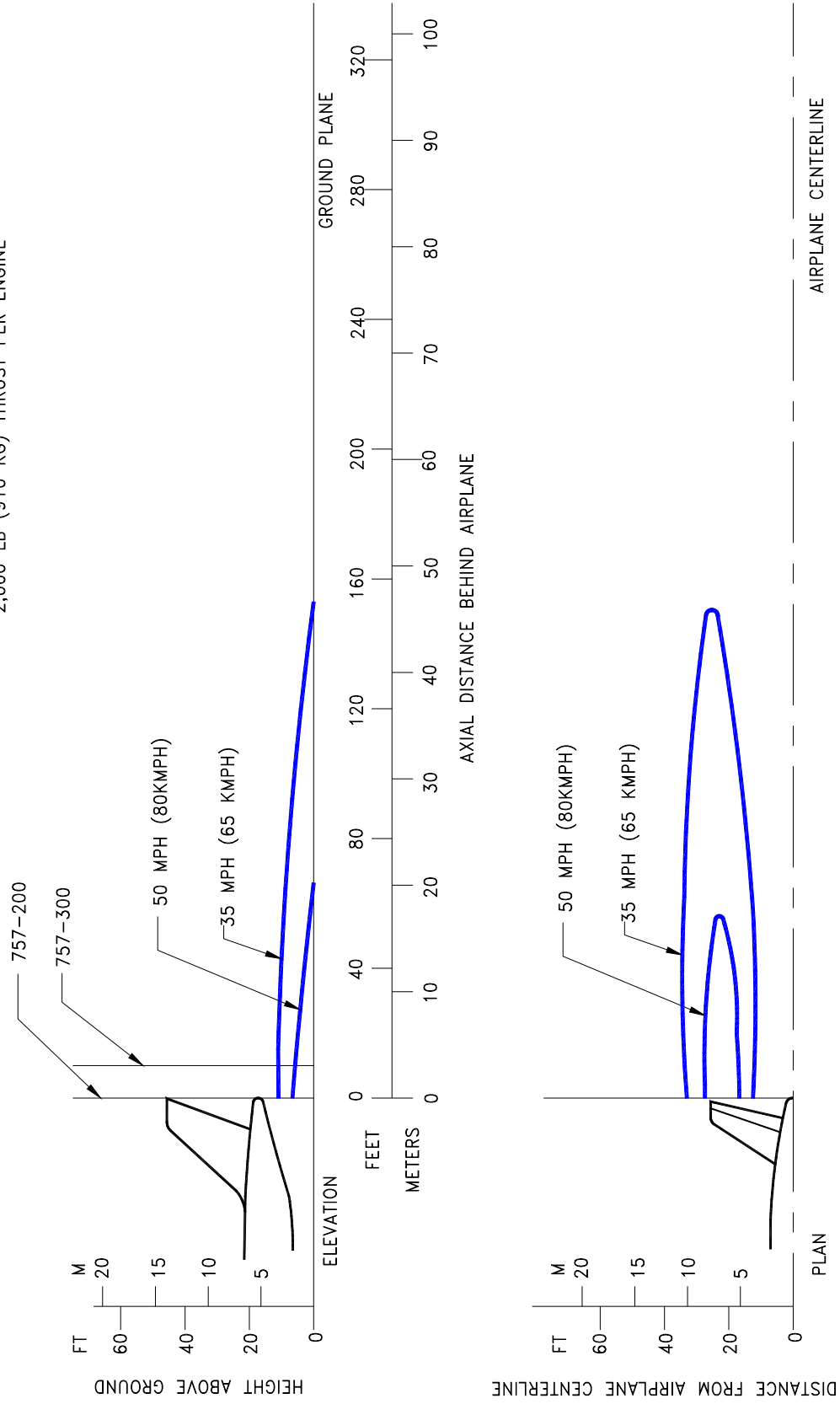

**6.1.1 PREDICTED JET ENGINE EXHAUST VELOCITY CONTOURS - IDLE THRUST**  
 MODEL 757-200, -300

- NOTES:
- \* SEA LEVEL
  - \* STANDARD DAY
  - \* ZERO WIND
  - \* STATIC AIRPLANE
  - \* TWO ENGINES OPERATING
  - \* 6000 LB (2720 KG) THRUST PER ENGINE

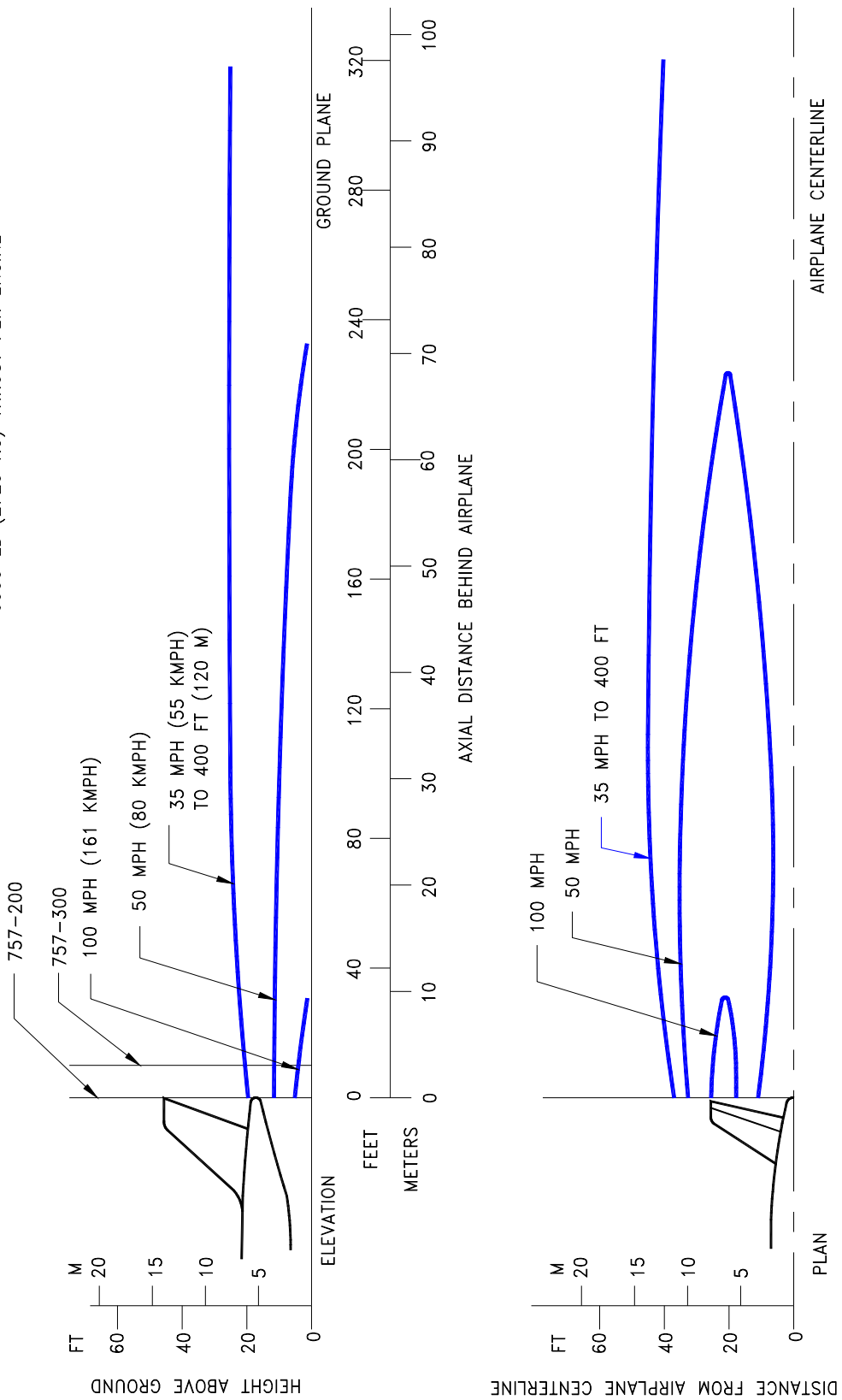

**6.1.2 PREDICTED JET ENGINE EXHAUST VELOCITY CONTOURS -  
BREAKAWAY THRUST**  
MODEL 757-200, -300



- NOTES:
- \* SEA LEVEL
  - \* STANDARD DAY
  - \* ZERO WIND
  - \* STATIC AIRPLANE
  - \* TWO ENGINES OPERATING
  - \* 35,500 LB (16,100 KG) TAKEOFF THRUST RATING PER ENGINE

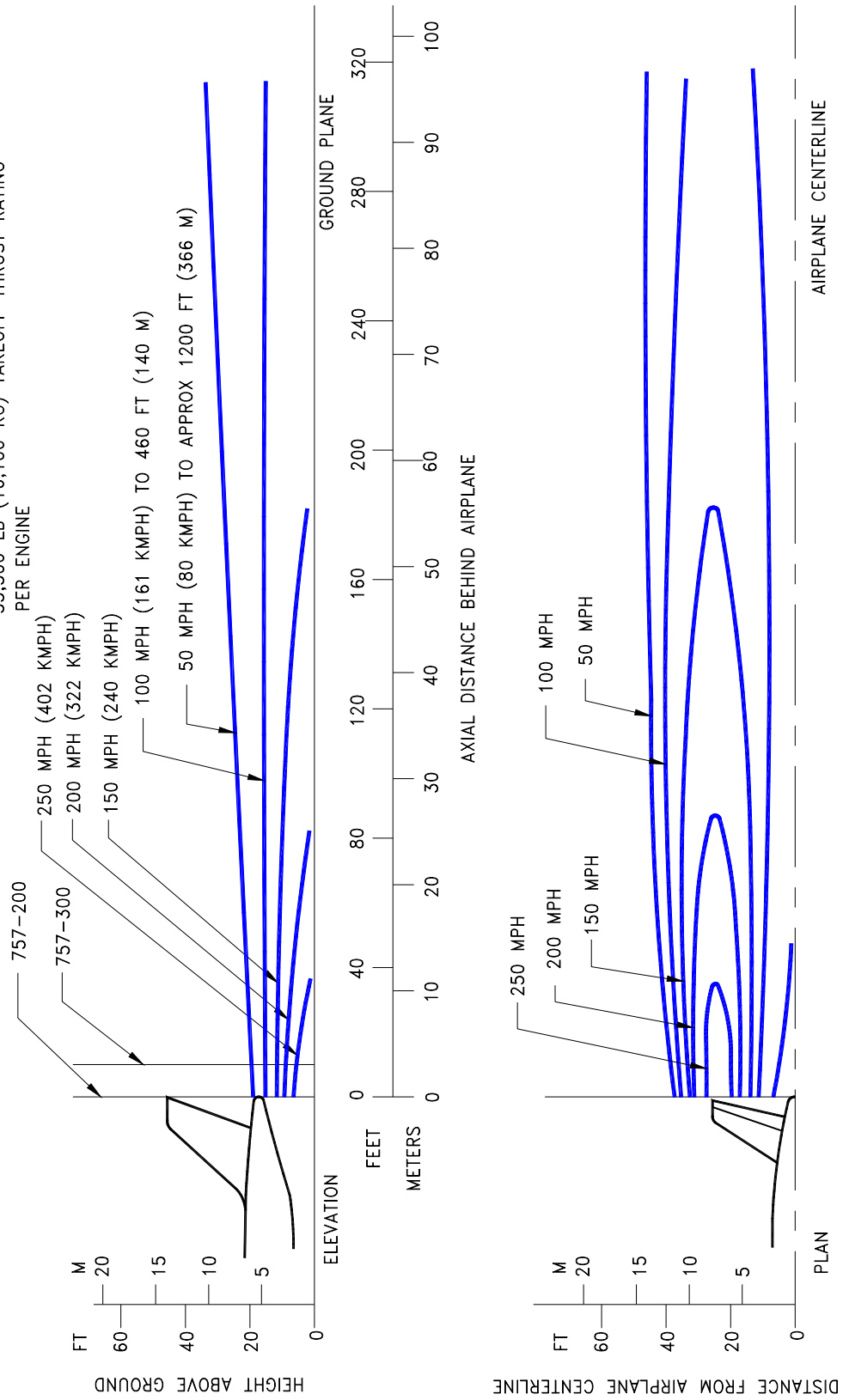

**6.1.3 PREDICTED JET ENGINE EXHAUST VELOCITY CONTOURS - TAKEOFF THRUST**  
 MODEL 757-200, -300

- NOTES:
- \* SEA LEVEL
  - \* STANDARD DAY
  - \* ZERO WIND
  - \* STATIC AIRPLANE
  - \* TWO ENGINES OPERATING
  - \* 2000 LB (910 KG) THRUST PER ENGINE

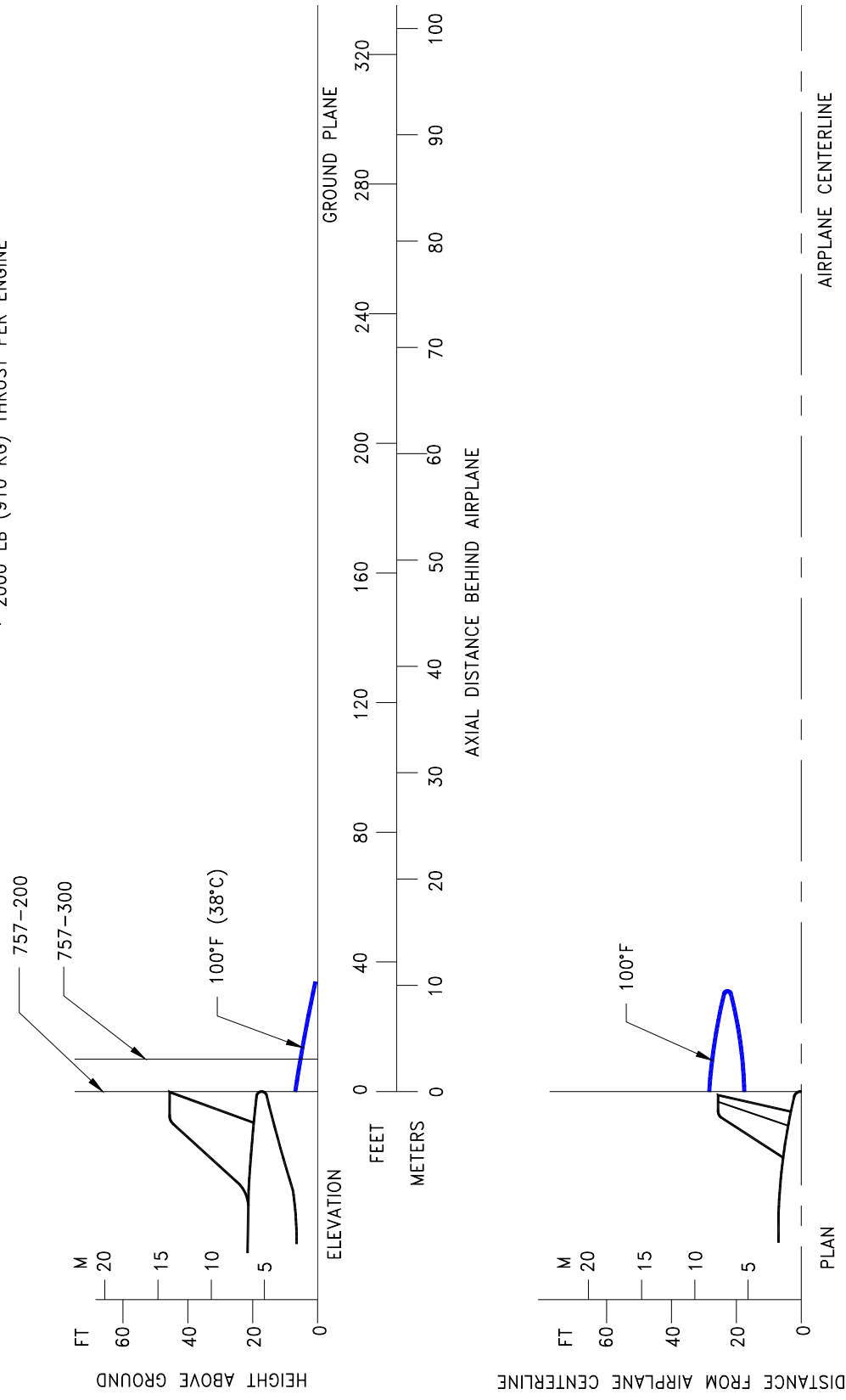

**6.1.4 PREDICTED JET ENGINE EXHAUST TEMPERATURE CONTOURS - IDLE THRUST**  
 MODEL 757-200, -300

- NOTES:
- \* SEA LEVEL
  - \* STANDARD DAY
  - \* ZERO WIND
  - \* STATIC AIRPLANE
  - \* TWO ENGINES OPERATING
  - \* 6000 LB (2720 KG) THRUST PER ENGINE

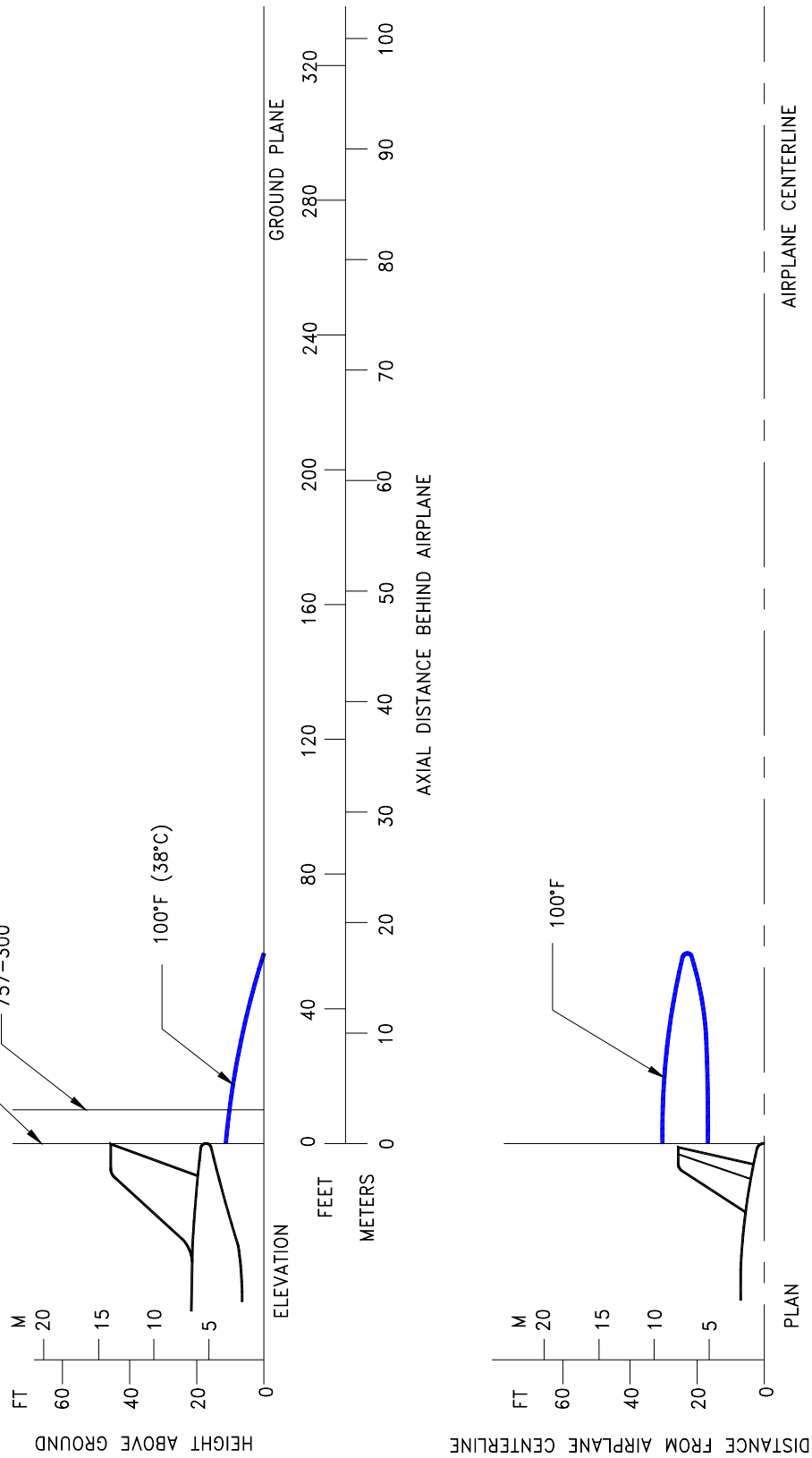

**6.1.5 PREDICTED JET ENGINE EXHAUST TEMPERATURE CONTOURS -  
BREAKAWAY THRUST**  
MODEL 757-200, -300

- NOTES:
- \* SEA LEVEL
  - \* STANDARD DAY
  - \* ZERO WIND
  - \* STATIC AIRPLANE
  - \* TWO ENGINES OPERATING
  - \* 35,500 LB (16,100 KG) TAKEOFF THRUST RATING PER ENGINE

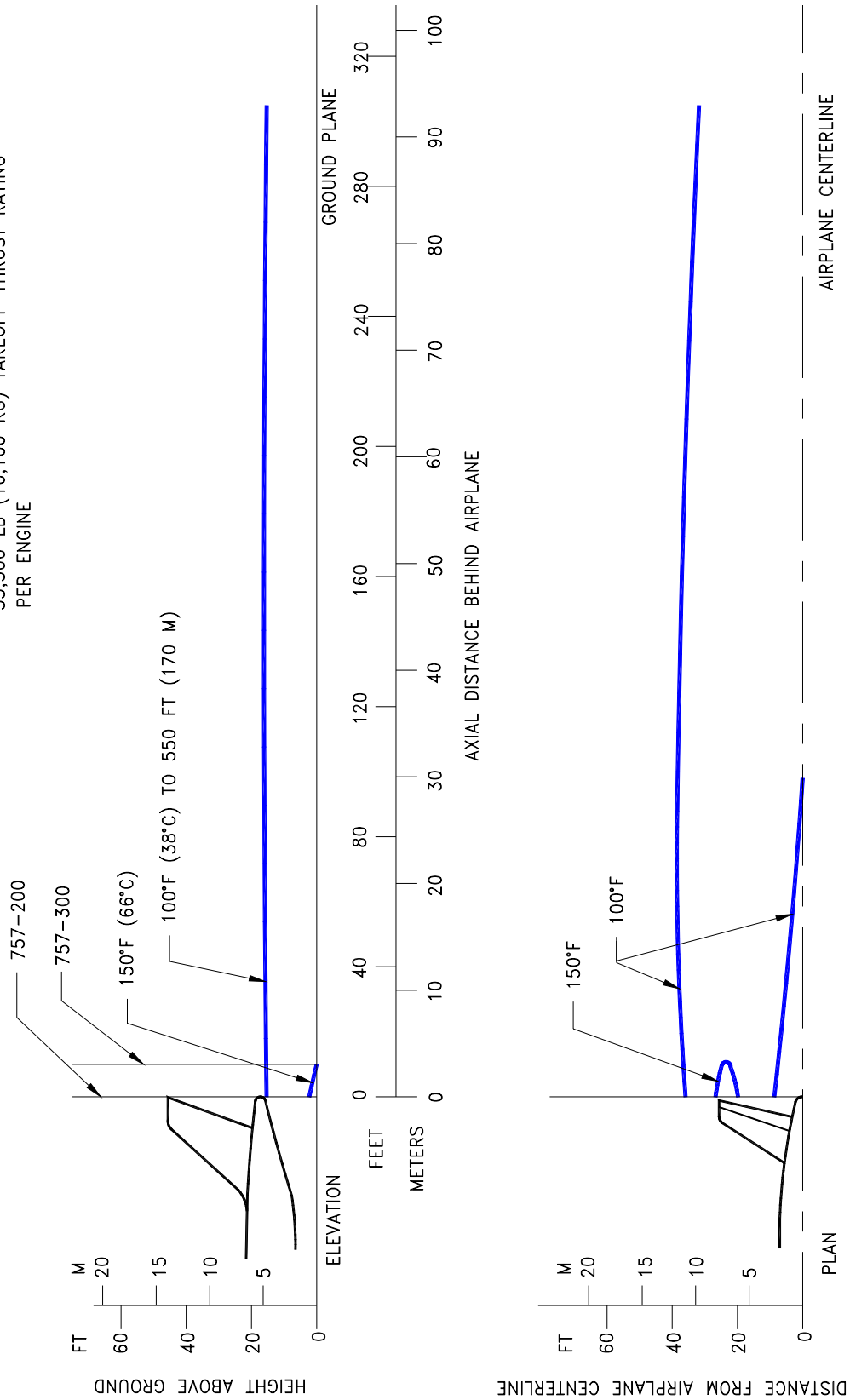

**6.1.6 PREDICTED JET ENGINE EXHAUST TEMPERATURE CONTOURS - TAKEOFF THRUST**  
 MODEL 757-200, -300

## 6.2 Airport and Community Noise

Airport noise is of major concern to the airport and community planner. The airport is a major element in the community's transportation system and, as such, is vital to its growth. However, the airport must also be a good neighbor, and this can be accomplished only with proper planning. Since aircraft noise extends beyond the boundaries of the airport, it is vital to consider the impact on surrounding communities. Many means have been devised to provide the planner with a tool to estimate the impact of airport operations. Too often they oversimplify noise to the point where the results become erroneous. Noise is not a simple subject; therefore, there are no simple answers.

The cumulative noise contour is an effective tool. However, care must be exercised to ensure that the contours, used correctly, estimate the noise resulting from aircraft operations conducted at an airport.

The size and shape of the single-event contours, which are inputs into the cumulative noise contours, are dependent upon numerous factors. They include the following:

1. Operational Factors

- (a) Aircraft Weight-Aircraft weight is dependent on distance to be traveled, en route winds, payload, and anticipated aircraft delay upon reaching the destination.
- (b) Engine Power Settings-The rates of ascent and descent and the noise levels emitted at the source are influenced by the power setting used.
- (c) Airport Altitude-Higher airport altitude will affect engine performance and thus can influence noise.

2. Atmospheric Conditions-Sound Propagation

(a) Wind-With stronger headwinds, the aircraft can take off and climb more rapidly relative to the ground. Also, winds can influence the distribution of noise in surrounding communities.

(b) Temperature and Relative Humidity-The absorption of noise in the atmosphere along the transmission path between the aircraft and the ground observer varies with both temperature and relative humidity.

3. Surface Condition-Shielding, Extra Ground Attenuation (EGA)

(a) Terrain-If the ground slopes down after takeoff or up before landing, noise will be reduced since the aircraft will be at a higher altitude above ground. Additionally, hills, shrubs, trees, and large buildings can act as sound buffers.

All these factors can alter the shape and size of the contours appreciably. To demonstrate the effect of some of these factors, estimated noise level contours for two different operating conditions are shown below. These contours reflect a given noise level upon a ground level plane at runway elevation.

Condition 1

Landing

Takeoff

Maximum Structural Landing  
Weight  
10-knot Headwind  
3° Approach  
84 °F  
Humidity 15%

Maximum Gross Takeoff Weight  
Zero Wind  
84 °F  
Humidity 15%

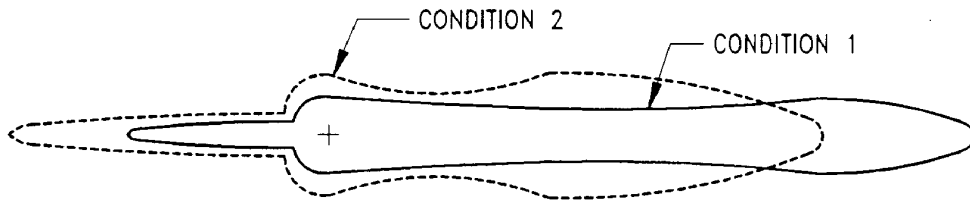

Condition 2

Landing:

Takeoff:

85% of Maximum Structural  
Landing Weight  
10-knot Headwind  
3° Approach  
59 °F  
Humidity 70%

80% of Maximum Gross Takeoff  
Weight  
10-knot Headwind  
59 °F  
Humidity 70%

As indicated from these data, the contour size varies substantially with operating and atmospheric conditions. Most aircraft operations are, of course, conducted at less than maximum gross weights because average flight distances are much shorter than maximum aircraft range capability and average load factors are less than 100%. Therefore, in developing cumulative contours for planning purposes, it is recommended that the airlines serving a particular city be contacted to provide operational information.

In addition, there are no universally accepted methods for developing aircraft noise contours or for relating the acceptability of specific zones to specific land uses. It is therefore expected that noise contour data for particular aircraft and the impact assessment methodology will be changing. To ensure that the best currently available information of this type is used in any planning study, it is recommended that it be obtained directly from the Office of Environmental Quality in the Federal Aviation Administration in Washington, D.C.

It should be noted that the contours shown herein are only for illustrating the impact of operating and atmospheric conditions and do not represent the single-event contour of the family of aircraft described in this document. It is expected that the cumulative contours will be developed as required by planners using the data and methodology applicable to their specific study.



## **7.0 PAVEMENT DATA**

- 7.1 General Information**
- 7.2 Landing Gear Footprint**
- 7.3 Maximum Pavement Loads**
- 7.4 Landing Gear Loading on Pavement**
- 7.5 Flexible Pavement Requirements - U.S. Army Corps of Engineers Method S-77-1**
- 7.6 Flexible Pavement Requirements - LCN Conversion**
- 7.7 Rigid Pavement Requirements - Portland Cement Association Design Method**
- 7.8 Rigid Pavement Requirements - LCN Conversion**
- 7.9 Rigid Pavement Requirements - FAA Method**
- 7.10 ACN/PCN Reporting System - Flexible and Rigid Pavements**

## **7.0 PAVEMENT DATA**

### **7.1 General Information**

A brief description of the pavement charts that follow will help in their use for airport planning. Each airplane configuration is depicted with a minimum range of six loads imposed on the main landing gear to aid in interpolation between the discrete values shown. All curves for any single chart represent data based on rated loads and tire pressures considered normal and acceptable by current aircraft tire manufacturer's standards. Tire pressures, where specifically designated on tables and charts, are at values obtained under loaded conditions as certificated for commercial use.

Section 7.2 presents basic data on the landing gear footprint configuration, maximum design taxi loads, and tire sizes and pressures.

Maximum pavement loads for certain critical conditions at the tire-to-ground interface are shown in Section 7.3, with the tires having equal loads on the struts.

Pavement requirements for commercial airplanes are customarily derived from the static analysis of loads imposed on the main landing gear struts. The chart in Section 7.4 is provided in order to determine these loads throughout the stability limits of the airplane at rest on the pavement. These main landing gear loads are used as the point of entry to the pavement design charts, interpolating load values where necessary.

The flexible pavement design curves (Section 7.5) are based on procedures set forth in Instruction Report No. S-77-1, "Procedures for Development of CBR Design Curves," dated June 1977, and as modified according to the methods described in ICAO Aerodrome Design Manual, Part 3, Pavements, 2<sup>nd</sup> Edition, 1983, Section 1.1 (The ACN-PCN Method), and utilizing the alpha factors approved by ICAO in October 2007. Instruction Report No. S-77-1 was prepared by the U.S. Army Corps of Engineers Waterways Experiment Station, Soils and Pavements Laboratory, Vicksburg, Mississippi. The line showing 10,000 coverages is used to calculate Aircraft Classification Number (ACN).

The following procedure is used to develop the curves, such as shown in Section 7.5:

1. Having established the scale for pavement depth at the bottom and the scale for CBR at the top, an arbitrary line is drawn representing 6,000 annual departures.
2. Values of the aircraft gross weight are then plotted.
3. Additional annual departure lines are drawn based on the load lines of the aircraft gross weights already established.
4. An additional line representing 10,000 coverages (used to calculate the flexible pavement Aircraft Classification Number) is also placed.

All Load Classification Number (LCN) curves (Sections 7.6 and 7.8) have been developed from a computer program based on data provided in International Civil Aviation Organization (ICAO) document 9157-AN/901, Aerodrome Design Manual, Part 3, "Pavements", First Edition, 1977. LCN values are shown directly for parameters of weight on main landing gear, tire pressure, and radius of relative stiffness ( $l$ ) for rigid pavement or pavement thickness or depth factor ( $h$ ) for flexible pavement.

Rigid pavement design curves (Section 7.7) have been prepared with the Westergaard equation in general accordance with the procedures outlined in the Design of Concrete Airport Pavement (1955 edition) by Robert G. Packard, published by the American Concrete Pavement Association, 3800 North Wilke Road, Arlington Heights, Illinois 60004-1268. These curves are modified to the format described in the Portland Cement Association publication XP6705-2, Computer Program for Airport Pavement Design (Program PDILB), 1968, by Robert G. Packard.

The following procedure is used to develop the rigid pavement design curves shown in Section 7.7:

1. Having established the scale for pavement thickness to the left and the scale for allowable working stress to the right, an arbitrary load line is drawn representing the main landing gear maximum weight to be shown.
2. Values of the subgrade modulus ( $k$ ) are then plotted.
3. Additional load lines for the incremental values of weight on the main landing gear are drawn on the basis of the curve for  $k = 300$ , already established.

The ACN/PCN system (Section 7.10) as referenced in ICAO Annex 14, "Aerodromes," First Edition, July 1990, provides a standardized international airplane/pavement rating system replacing the various S, T, TT, LCN, AUW, ISWL, etc., rating systems used throughout the world. ACN is the Aircraft Classification Number and PCN is the Pavement Classification Number. An aircraft having an ACN equal to or less than the PCN can operate on the pavement subject to any limitation on the tire pressure. Numerically, the ACN is two times the derived single-wheel load expressed in thousands of kilograms, where the derived single wheel load is defined as the load on a single tire inflated to 181 psi (1.25 MPa) that would have the same pavement requirements as the aircraft. Computationally, the ACN/PCN system uses the PCA program PDILB for rigid pavements and S-77-1 for flexible pavements to calculate ACN values. The method of pavement evaluation is left up to the airport with the results of their evaluation presented as follows:

PCN	PAVEMENT TYPE	SUBGRADE CATEGORY	TIRE PRESSURE CATEGORY	EVALUATION METHOD
	R = Rigid F = Flexible	A = High B = Medium C = Low D = Ultra Low	W = No Limit X = To 254 psi (1.75 MPa) Y = To 181 psi (1.25 MPa) Z = To 73 psi (0.5 MPa)	T = Technical U = Using Aircraft

Section 7.10.1 shows the aircraft ACN values for flexible pavements. The four subgrade categories are:

- Code A - High Strength - CBR 15
- Code B - Medium Strength - CBR 10
- Code C - Low Strength - CBR 6
- Code D - Ultra Low Strength - CBR 3

Section 7.10.2 shows the aircraft ACN values for rigid pavements. The four subgrade categories are:

- Code A - High Strength,  $k = 550 \text{ pci (150 MN/m}^3\text{)}$
- Code B - Medium Strength,  $k = 300 \text{ pci (80 MN/m}^3\text{)}$
- Code C - Low Strength,  $k = 150 \text{ pci (40 MN/m}^3\text{)}$
- Code D - Ultra Low Strength,  $k = 75 \text{ pci (20 MN/m}^3\text{)}$

NOT TO SCALE

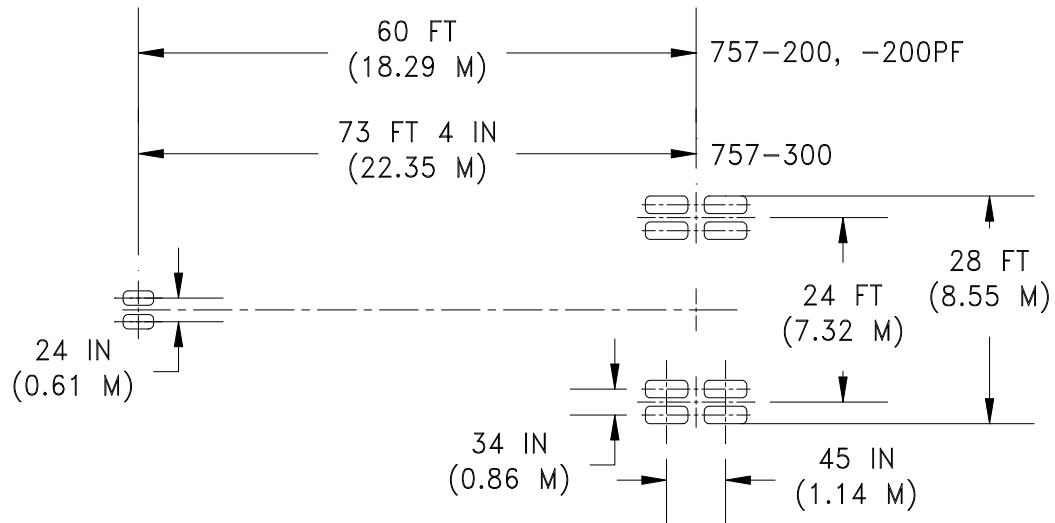

	UNITS	757-200, -200PF					757-300
MAXIMUM DESIGN TAXI WEIGHT	LB	221,000	231,000	241,000	251,000	256,000	271,000
	KG	100,250	104,800	109,300	113,850	116,100	122,920
PERCENT OF WEIGHT ON MAIN GEAR		SEE SECTION 7.4					
NOSE GEAR TIRE SIZE	IN.	H31 X 13 - 12 20 PR			H31 x 13 - 12 20 PR		
NOSE GEAR TIRE PRESSURE	PSI	150			155	136	
	KG/CM <sup>2</sup>	10.55			10.90	9.56	
MAIN GEAR TIRE SIZE	IN.	H40 X 14.5 - 19 22 PR			H40 X 14.5 24 PR	H40 x 14.5 - 19 26 PR	
MAIN GEAR TIRE PRESSURE	PSI	162	168	170	179	183	195
	KG/CM <sup>2</sup>	11.39	11.81	11.95	12.80	12.87	13.70

## 7.2 LANDING GEAR FOOTPRINT

MODEL 757-200, -200PF, -300

$V_{(NG)}$  = MAXIMUM VERTICAL NOSE GEAR GROUND LOAD AT MOST FORWARD CENTER OF GRAVITY

$V_{(MG)}$  = MAXIMUM VERTICAL MAIN GEAR GROUND LOAD AT MOST AFT CENTER OF GRAVITY

H = MAXIMUM HORIZONTAL GROUND LOAD FROM BRAKING

NOTE: ALL LOADS CALCULATED USING AIRPLANE MAXIMUM DESIGN TAXI WEIGHT

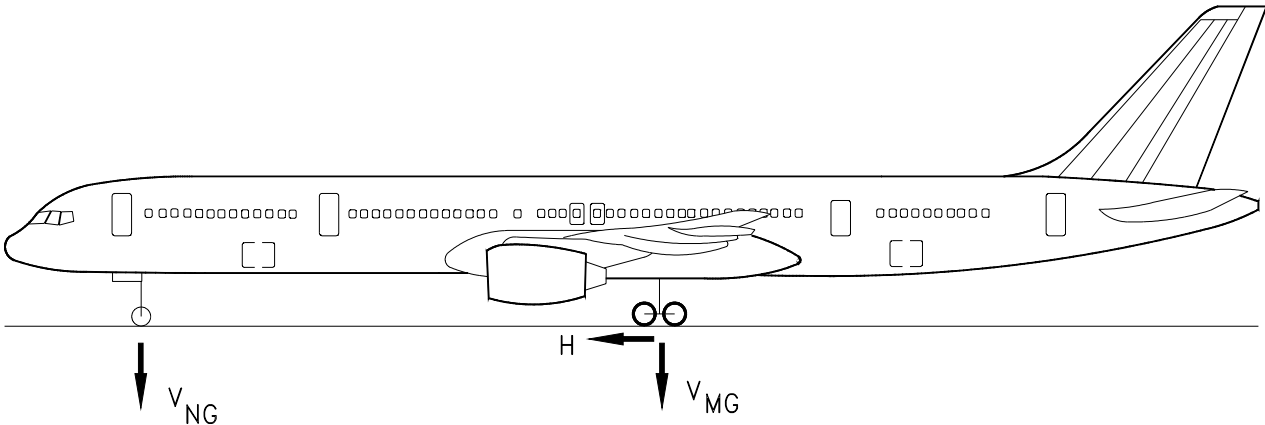

MODEL	UNIT	MAXIMUM DESIGN TAXI WEIGHT	$V_{(NG)}$		$V_{(MG)}$ PER STRUT	H PER STRUT	
			STATIC AT MOST FWD C.G.	STATIC + BRAKING 10 FT/SEC <sup>2</sup> DECEL	MAX LOAD AT STATIC AFT C.G.	STEADY BRAKING 10 FT/SEC <sup>2</sup> DECEL	AT INSTANTANEOUS BRAKING ( $u=0.8$ )
757-200,-200PF	LB	221,000	31,100	45,100	102,900	34,300	82,300
	KG	100,250	14,100	20,450	46,650	15,550	37,350
757-200,-200PF	LB	231,000	31,700	46,400	105,600	35,900	84,500
	KG	104,800	14,400	21,050	47,900	16,300	38,350
757-200,-200PF	LB	241,000	31,900	47,200	108,900	37,400	87,100
	KG	109,300	14,450	21,400	49,400	16,950	37,500
757-200,-200PF	LB	251,000	33,300	48,900	115,800	39,000	92,700
	KG	113,850	15,100	22,200	52,550	17,700	42,050
757-200,-200PF	LB	256,000	28,200	44,800	116,700	39,800	93,400
	KG	116,100	12,800	20,300	52,950	18,050	42,350
757-300	LB	271,000	28,600	42,800	125,500	42,100	100,400
	KG	122,920	12,980	19,400	56,900	19,100	45,550

### 7.3 MAXIMUM PAVEMENT LOADS

MODEL 757-200, 300

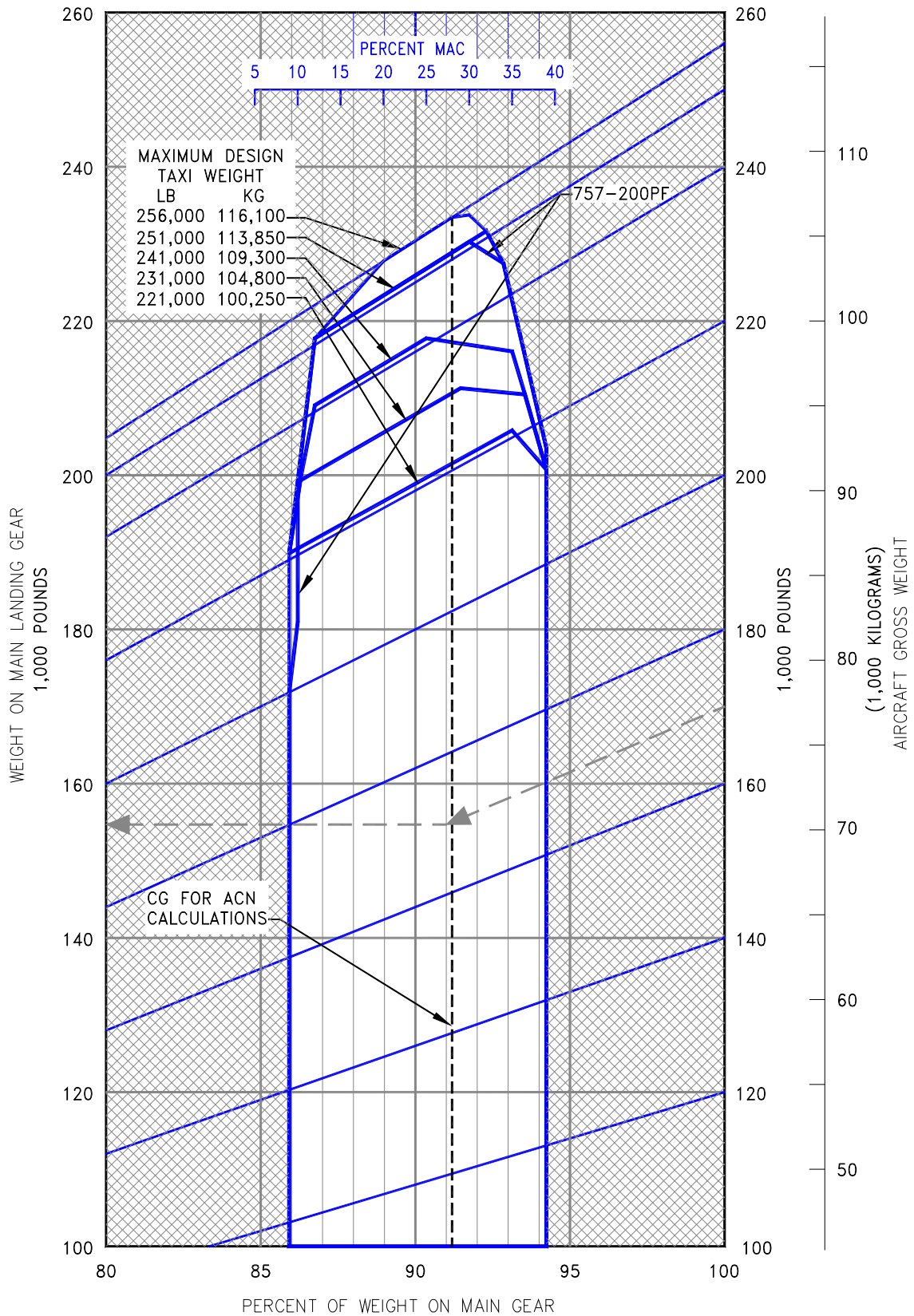

**7.4.1 LANDING GEAR LOADING ON PAVEMENT**  
 MODEL 757-200, -200PF

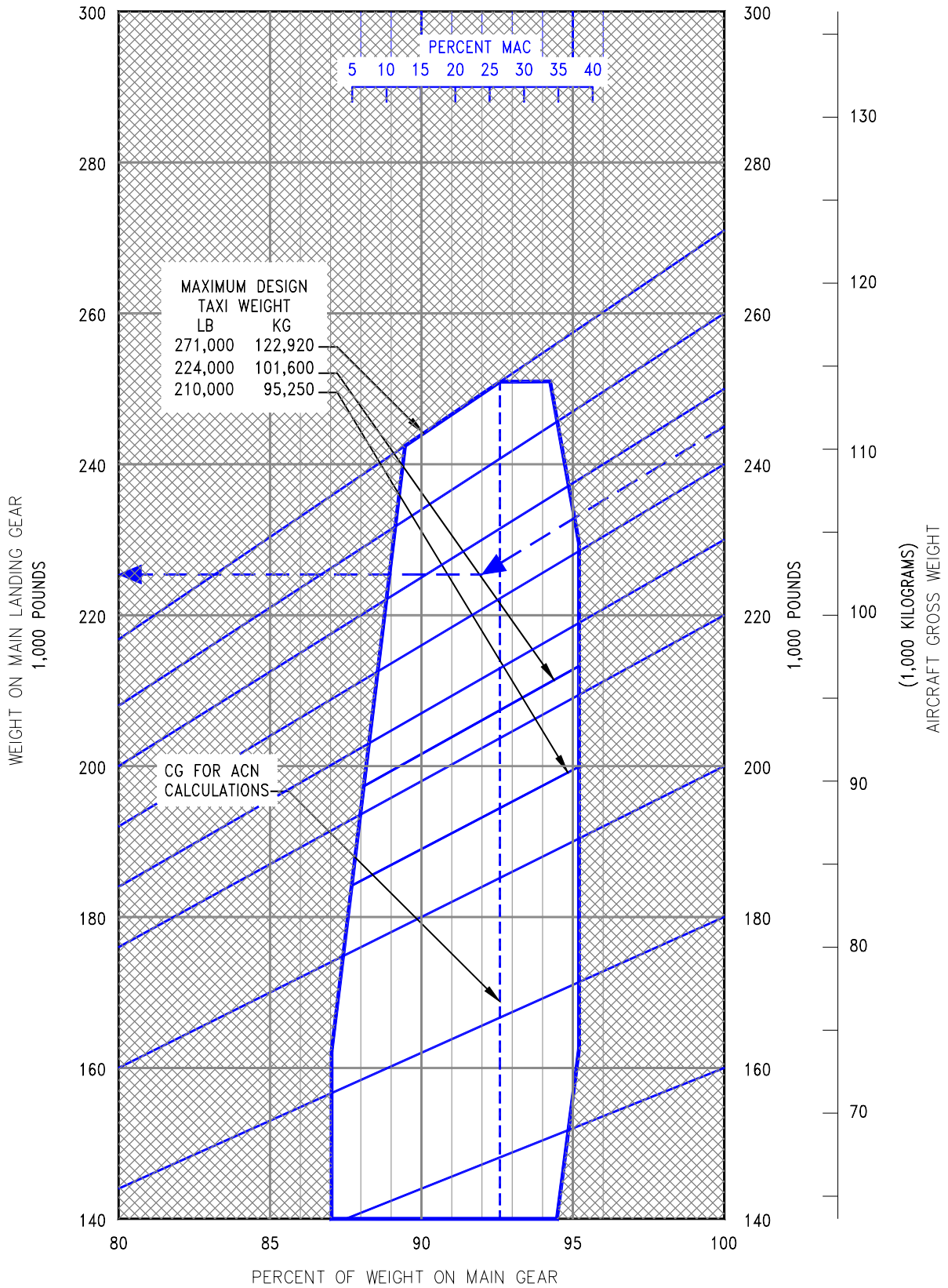

**7.4.2 LANDING GEAR LOADING ON PAVEMENT**  
MODEL 757-300

D6-58327



## **7.5 Flexible Pavement Requirements - U.S. Army Corps of Engineers Method (S-77-1)**

The following flexible-pavement design chart presents the data of six incremental main-gear loads at the minimum tire pressure required at the maximum design taxi weight.

In the example shown in the next page, for a CBR of 24.5 and an annual departure level of 6,000, the required flexible pavement thickness for an airplane with a main gear loading of 200,000 pounds is 10.7 inches.

The line showing 10,000 coverages is used for ACN calculations (see Section 7.10).

The FAA design method uses a similar procedure using total airplane weight instead of weight on the main landing gears. The equivalent main gear loads for a given airplane weight could be calculated from Section 7.4.

NOTE: TIRES - H40 x 14.5-19 , 22PR, 24PR, 26PR

CALIFORNIA BEARING RATIO, CBR

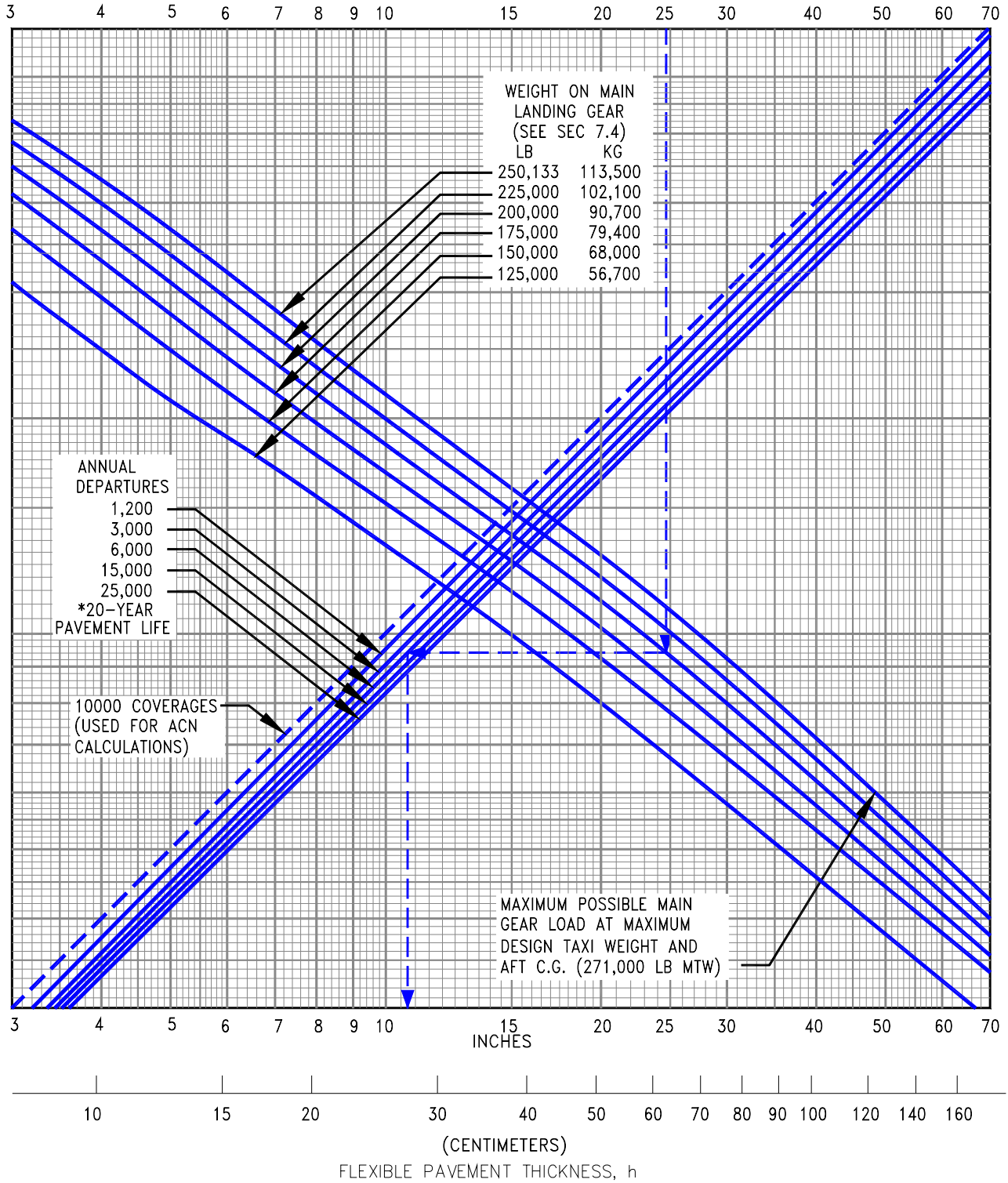

**7.5 FLEXIBLE PAVEMENT REQUIREMENTS - U.S. ARMY CORPS OF ENGINEERS DESIGN METHOD (S-77-1)**  
 MODEL 757-200, -200PF, -300

D6-58327

## 7.6 Flexible Pavement Requirements - LCN Method

To determine the airplane weight that can be accommodated on a particular flexible pavement, both the Load Classification Number (LCN) of the pavement and the thickness must be known.

In the example shown in Section 7.6.1, flexible pavement thickness is shown at 26.5 in. with an LCN of 53. For these conditions, the apparent maximum allowable weight permissible on the main landing gear of a 757-200 airplane with 162-psi main gear tires is 175,000 lb.

In Section 7.6.2, flexible pavement thickness is shown at 17 in. with an LCN of 55. For these conditions, the apparent maximum allowable weight permissible on the main landing gear of a 757-300 airplane with 195-psi main gear tires is 200,000 lb.

Note: If the resultant aircraft LCN is not more than 10% above the published pavement LCN, the bearing strength of the pavement can be considered sufficient for unlimited use by the airplane. The figure 10% has been chosen as representing the lowest degree of variation in LCN that is significant (reference: ICAO Aerodrome Manual, Part 2, "Aerodrome Physical Characteristics," Chapter 4, Paragraph 4.1.5.7v, 2nd Edition dated 1965).

NOTES:  
 \* TIRES - H40 x 14.5-19, 22PR, 24PR  
 \* EQUIVALENT SINGLE-WHEEL LOADS ARE DERIVED FROM ICAO AERODROME MANUAL, PART 2 PAR. 4.1.3, DATED 1965.

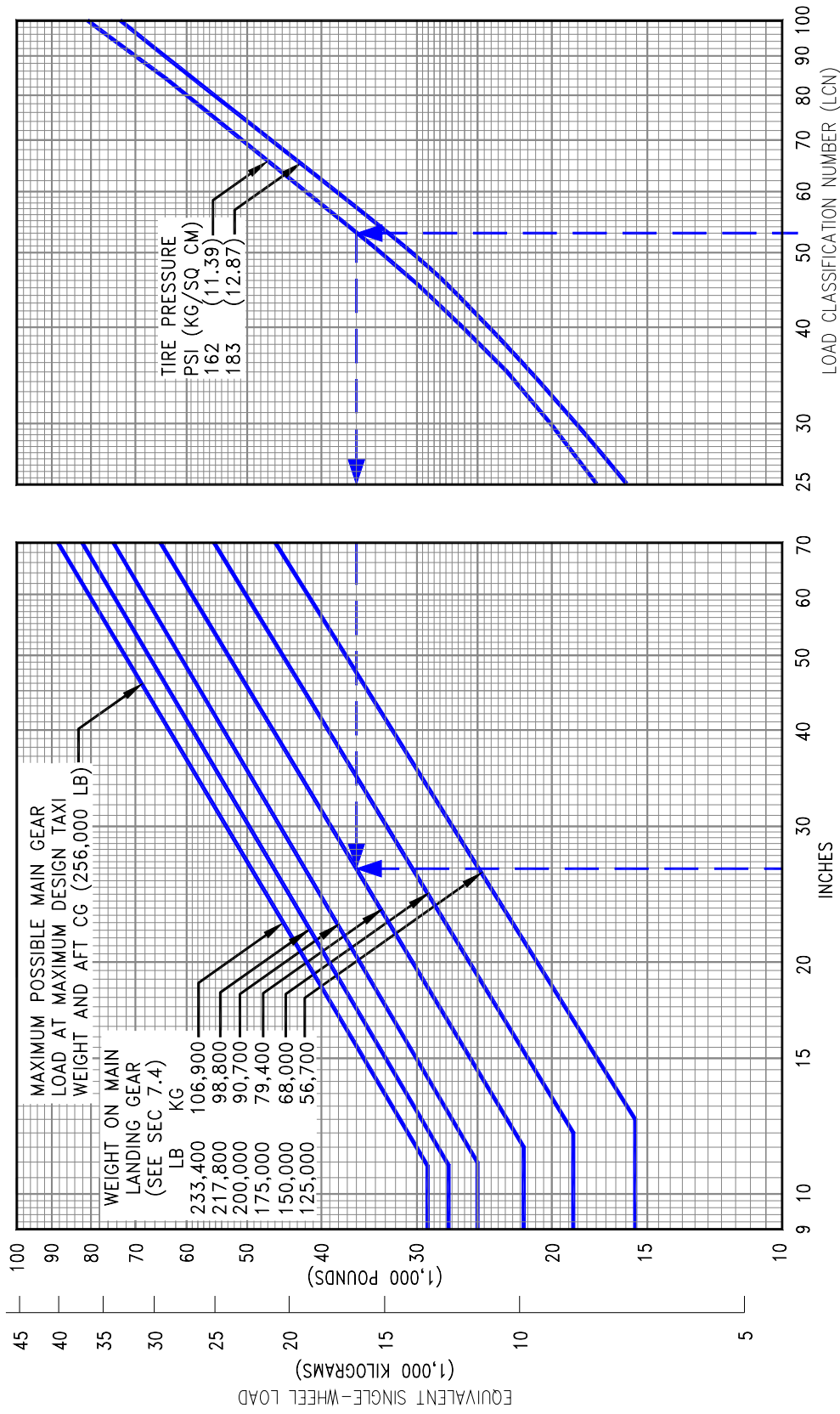

**7.6.1 FLEXIBLE PAVEMENT REQUIREMENTS - LCN METHOD**  
 MODEL 757-200, -200PF

NOTES:  
 \* TIRES - H40 x 14.5-19, 26PR  
 \* AT 195 PSI (13.70 KG/SQ CM)  
 \* EQUIVALENT SINGLE-WHEEL LOADS ARE DERIVED FROM  
 ICAO AERODROME MANUAL, PART 2 PAR. 4.1.3, DATED 1965.

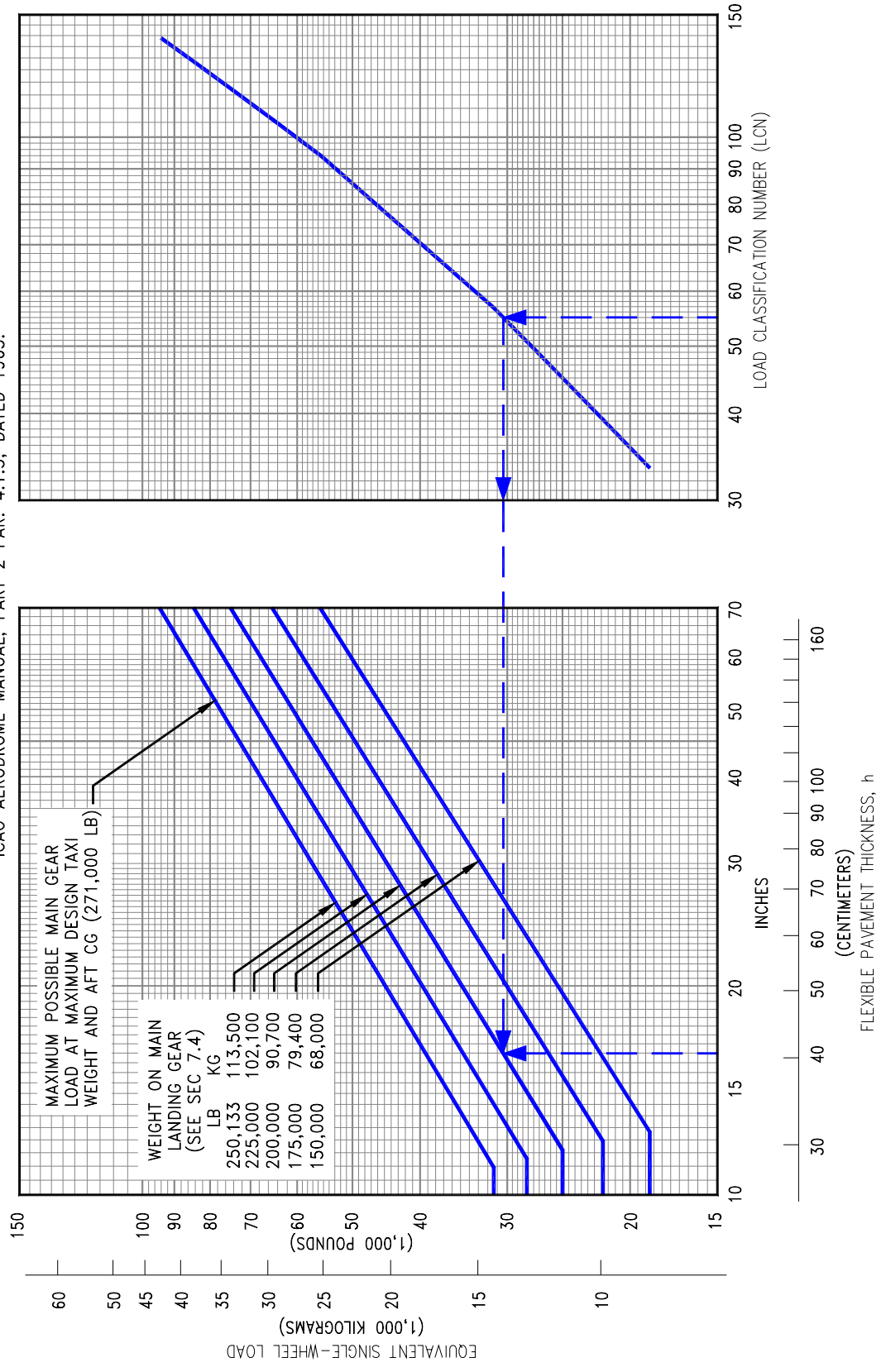

**7.6.2 FLEXIBLE PAVEMENT REQUIREMENTS - LCN METHOD**  
 MODEL 757-300

## **7.7 Rigid Pavement Requirements - Portland Cement Association Design Method**

The Portland Cement Association method of calculating rigid pavement requirements is based on the computerized version of "Design of Concrete Airport Pavement" (Portland Cement Association, 1955) as described in XP6705-2, "Computer Program for Airport Pavement Design" by Robert G. Packard, Portland Cement Association, 1968.

The following rigid pavement design chart presents the data for six incremental main gear loads at the minimum tire pressure required at the maximum design taxi weight.

In the example shown in Section 7.7.1, for an allowable working stress of 400 psi, and a subgrade strength (k) of 300, the required rigid pavement thickness for a 757-200 airplane with a main gear load of 200,000 lb, is 7.9 in.

In Section 7.7.2, for an allowable working stress of 450 psi, and a subgrade strength (k) of 300, the required rigid pavement thickness for a 757-300 airplane with a main gear load of 200,000 lb, is 8.9 in.

NOTE: TIRES - H40x14.5-19 22PR, 24PR  
 PRESSURE RANGE FROM 162 TO 170 PSI (11.39 TO 11.95 KG/SC CM)

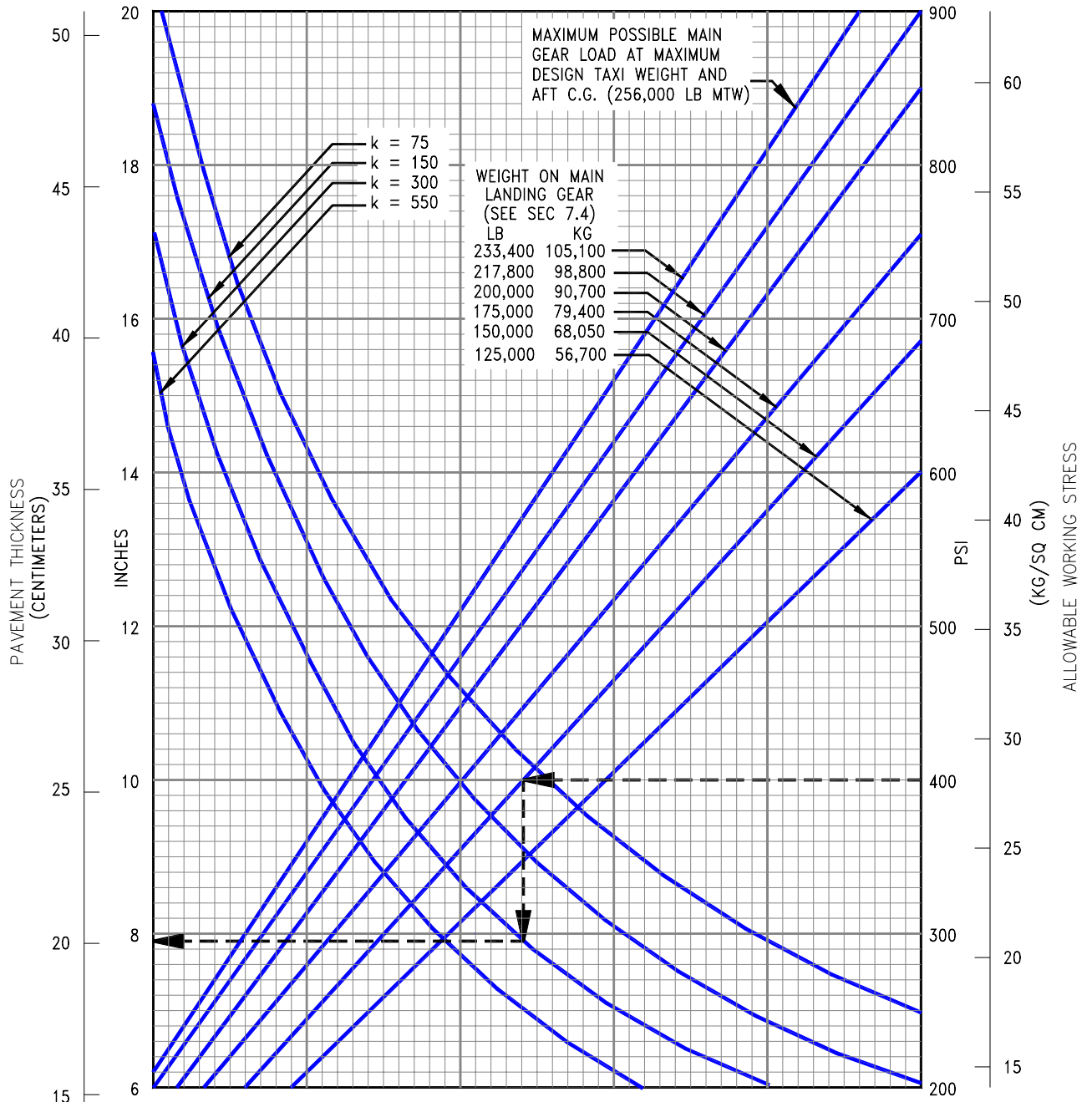

NOTE:  
 THE VALUES OBTAINED BY USING THE MAXIMUM LOAD REFERENCE LINE AND ANY VALUE OF k ARE EXACT. FOR LOADS LESS THAN MAXIMUM, THE CURVES ARE EXACT FOR k = 300 BUT DEVIATE SLIGHTLY FOR OTHER VALUES OF k.

REFERENCES:  
 "DESIGN OF CONCRETE AIRPORT PAVEMENT" AND "COMPUTER PROGRAM FOR AIRPORT PAVEMENT DESIGN - PROGRAM PDILB" PORTLAND CEMENT ASSOCIATION.

**7.7.1 RIGID PAVEMENT REQUIREMENTS - PORTLAND CEMENT ASSOCIATION DESIGN METHOD**  
 MODEL 757-200, -200PF

NOTE: TIRES - H40x14.5-19 26PR

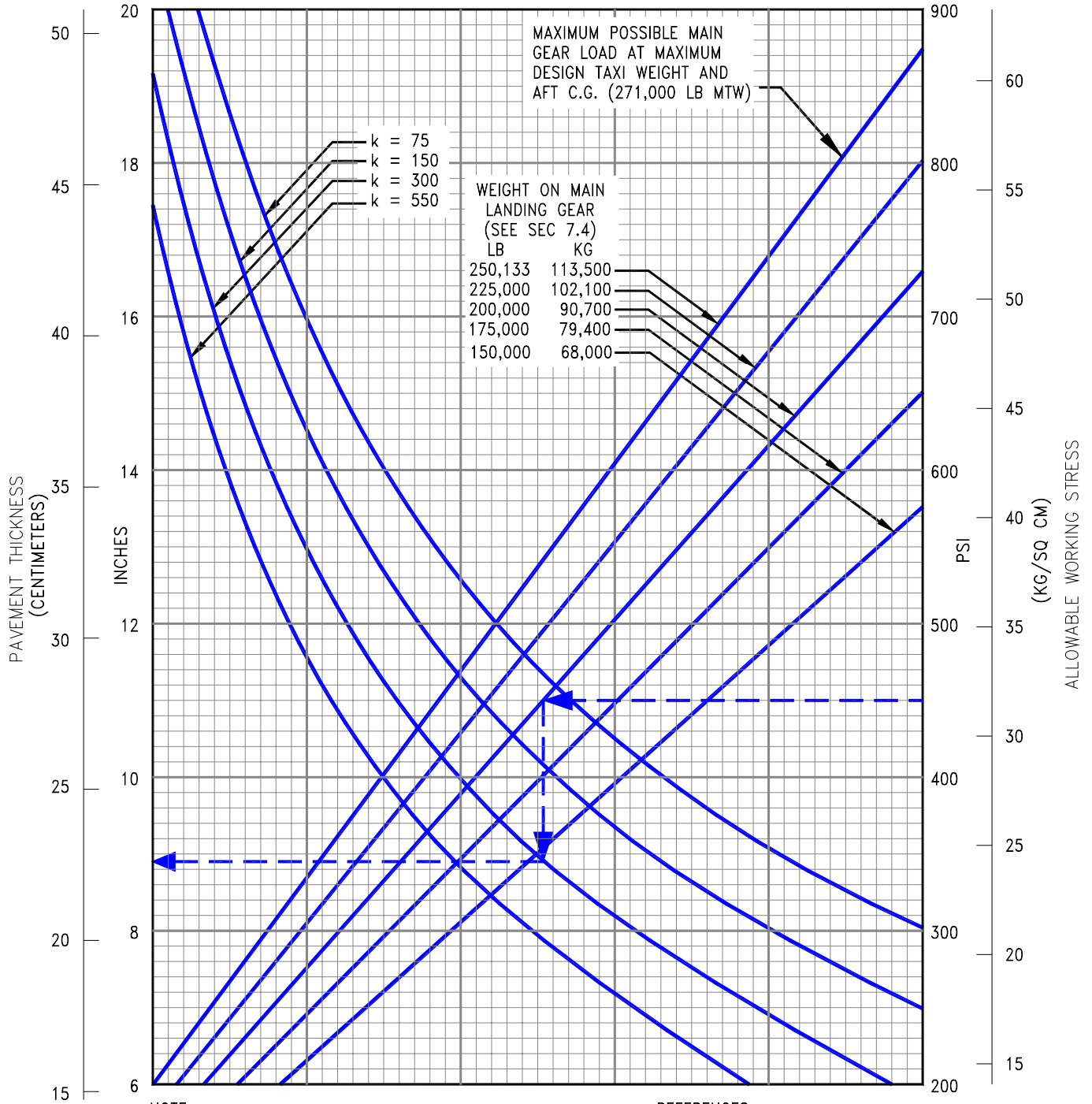

NOTE:  
 THE VALUES OBTAINED BY USING THE MAXIMUM LOAD REFERENCE LINE AND ANY VALUE OF  $k$  ARE EXACT.  
 FOR LOADS LESS THAN MAXIMUM, THE CURVES ARE EXACT FOR  $k = 300$  BUT DEVIATE SLIGHTLY FOR OTHER VALUES OF  $k$ .

REFERENCES:  
 "DESIGN OF CONCRETE AIRPORT PAVEMENT" AND "COMPUTER PROGRAM FOR AIRPORT PAVEMENT DESIGN - PROGRAM PDILB"  
 PORTLAND CEMENT ASSOCIATION.

**7.7.2 RIGID PAVEMENT REQUIREMENTS - PORTLAND CEMENT ASSOCIATION DESIGN METHOD**  
 MODEL 757-300

D6-58327



## 7.8 Rigid Pavement Requirements - LCN Conversion

To determine the airplane weight that can be accommodated on a particular rigid pavement, both the LCN of the pavement and the radius of relative stiffness ( $l$ ) of the pavement must be known.

In the example shown in Section 7.8.2, for a rigid pavement with a radius of relative stiffness of 37 with an LCN of 45, the apparent maximum allowable weight permissible on the main landing gear is 150,000 lb for an airplane with 195-psi main tires.

Note: If the resultant aircraft LCN is not more than 10% above the published pavement LCN, the bearing strength of the pavement can be considered sufficient for unlimited use by the airplane. The figure 10% has been chosen as representing the lowest degree of variation in LCN that is significant (reference: ICAO Aerodrome Manual, Part 2, "Aerodrome Physical Characteristics," Chapter 4, Paragraph 4.1.5.7v, 2nd Edition dated 1965).

RADIUS OF RELATIVE STIFFNESS ( $l$ )  
VALUES IN INCHES

$$l = \sqrt[4]{\frac{Ed^3}{12(1-\mu^2)k}} = 24.1652 \sqrt[4]{\frac{d^3}{k}}$$

WHERE: E = YOUNG'S MODULUS OF ELASTICITY =  $4 \times 10^6$  psi  
k = SUBGRADE MODULUS, LB PER CU IN  
d = RIGID PAVEMENT THICKNESS, IN  
 $\mu$  = POISSON'S RATIO = 0.15

d	k = 75	k = 100	k = 150	k = 200	k = 250	k = 300	k = 350	k = 400	k = 500	k = 550
6.0	31.48	29.29	26.47	24.63	23.30	22.26	21.42	20.71	19.59	19.13
6.5	33.42	31.10	28.11	26.16	24.74	23.63	22.74	21.99	20.80	20.31
7.0	35.33	32.88	29.71	27.65	26.15	24.99	24.04	23.25	21.99	21.47
7.5	37.21	34.63	31.29	29.12	27.54	26.31	25.32	24.49	23.16	22.61
8.0	39.06	36.35	32.84	30.56	28.91	27.62	26.57	25.70	24.31	23.73
8.5	40.87	38.04	34.37	31.99	30.25	28.90	27.81	26.90	25.44	24.84
9.0	42.66	39.70	35.88	33.39	31.57	30.17	29.03	28.07	26.55	25.93
9.5	44.43	41.35	37.36	34.77	32.88	31.42	30.23	29.24	27.65	27.00
10.0	46.17	42.97	38.83	36.13	34.17	32.65	31.41	30.38	28.73	28.06
10.5	47.89	44.57	40.27	37.48	35.44	33.87	32.58	31.52	29.81	29.10
11.0	49.59	46.15	41.70	38.81	36.70	35.07	33.74	32.63	30.86	30.14
11.5	51.27	47.72	43.12	40.12	37.95	36.26	34.89	33.74	31.91	31.16
12.0	52.94	49.26	44.51	41.43	39.18	37.43	36.02	34.83	32.94	32.17
12.5	54.58	50.80	45.90	42.71	40.40	38.60	37.14	35.92	33.97	33.17
13.0	56.21	52.31	47.27	43.99	41.60	39.75	38.25	36.99	34.98	34.16
13.5	57.83	53.81	48.63	45.25	42.80	40.89	39.34	38.05	35.99	35.14
14.0	59.43	55.30	49.97	46.50	43.98	42.02	40.43	39.10	36.98	36.11
14.5	61.01	56.78	51.30	47.74	45.15	43.14	41.51	40.15	37.97	37.07
15.0	62.58	58.24	52.62	48.97	46.32	44.25	42.58	41.18	38.95	38.03
15.5	64.14	59.69	53.93	50.19	47.47	45.35	43.64	42.21	39.92	38.98
16.0	65.69	61.13	55.23	51.40	48.61	46.45	44.69	43.22	40.88	39.92
16.5	67.22	62.55	56.52	52.60	49.75	47.53	45.73	44.23	41.83	40.85
17.0	68.74	63.97	57.80	53.79	50.87	48.61	46.77	45.23	42.78	41.77
17.5	70.25	65.38	59.07	54.97	51.99	49.68	47.80	46.23	43.72	42.69
18.0	71.75	66.77	60.34	56.15	53.10	50.74	48.82	47.22	44.65	43.60
19.0	74.72	69.54	62.83	58.47	55.30	52.84	50.84	49.17	46.50	45.41
20.0	77.65	72.26	65.30	60.77	57.47	54.91	52.83	51.10	48.33	47.19
21.0	80.55	74.96	67.73	63.03	59.61	56.95	54.80	53.00	50.13	48.95
22.0	83.41	77.62	70.14	65.27	61.73	58.98	56.75	54.88	51.91	50.68
23.0	86.23	80.25	72.51	67.48	63.82	60.98	58.67	56.74	53.67	52.40
24.0	89.03	82.85	74.86	69.67	65.89	62.95	60.57	58.58	55.41	54.10
25.0	91.80	85.43	77.19	71.84	67.94	64.91	62.46	60.41	57.13	55.78

**7.8.1 RADIUS OF RELATIVE STIFFNESS  
(REFERENCE: PORTLAND CEMENT ASSOCIATION)**

NOTES: \* TIRES - H40 x 14.5-19, 22PR, 24PR, 26PR  
 \* EQUIVALENT SINGLE-WHEEL LOADS ARE DERIVED FROM ICAO AERODROME MANUAL, PART 2 PAR 4.1.3, DATED 1965.

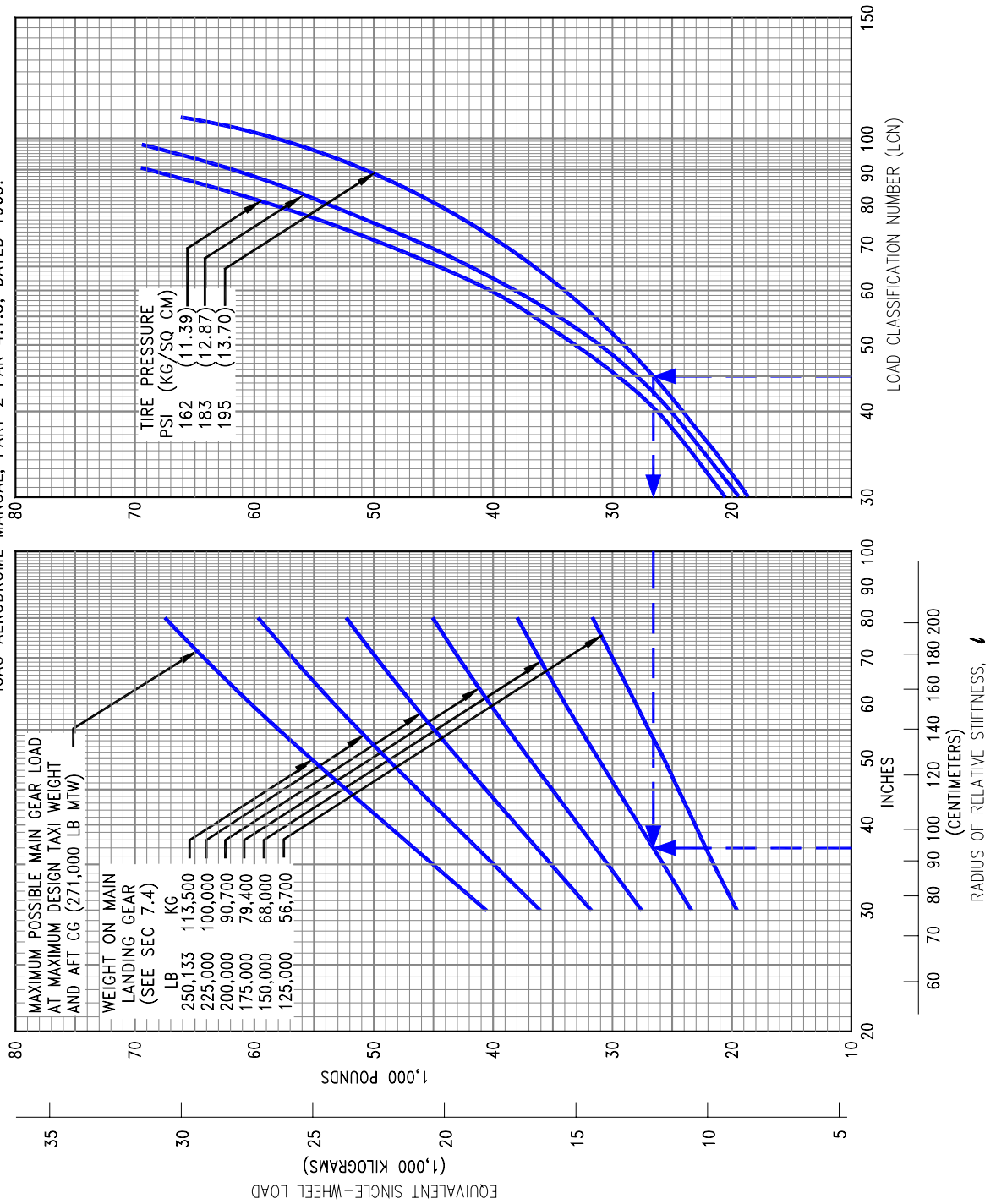

**7.8.2 RIGID PAVEMENT REQUIREMENTS - LCN CONVERSION**  
 MODEL 757-200, -200PF, 300

## **7.9 Rigid Pavement Requirements - FAA Design Method**

The following rigid-pavement design chart presents data on seven incremental main gear weights at the minimum tire pressure required at the maximum design taxi weight.

In the example shown, the pavement flexural strength is shown at 750 psi, the subgrade strength is shown at  $k = 300$ , and the annual departure level is 6,000. For these conditions, the required rigid pavement thickness for an airplane with a main gear loading of 229,000 pounds is 10 inches.

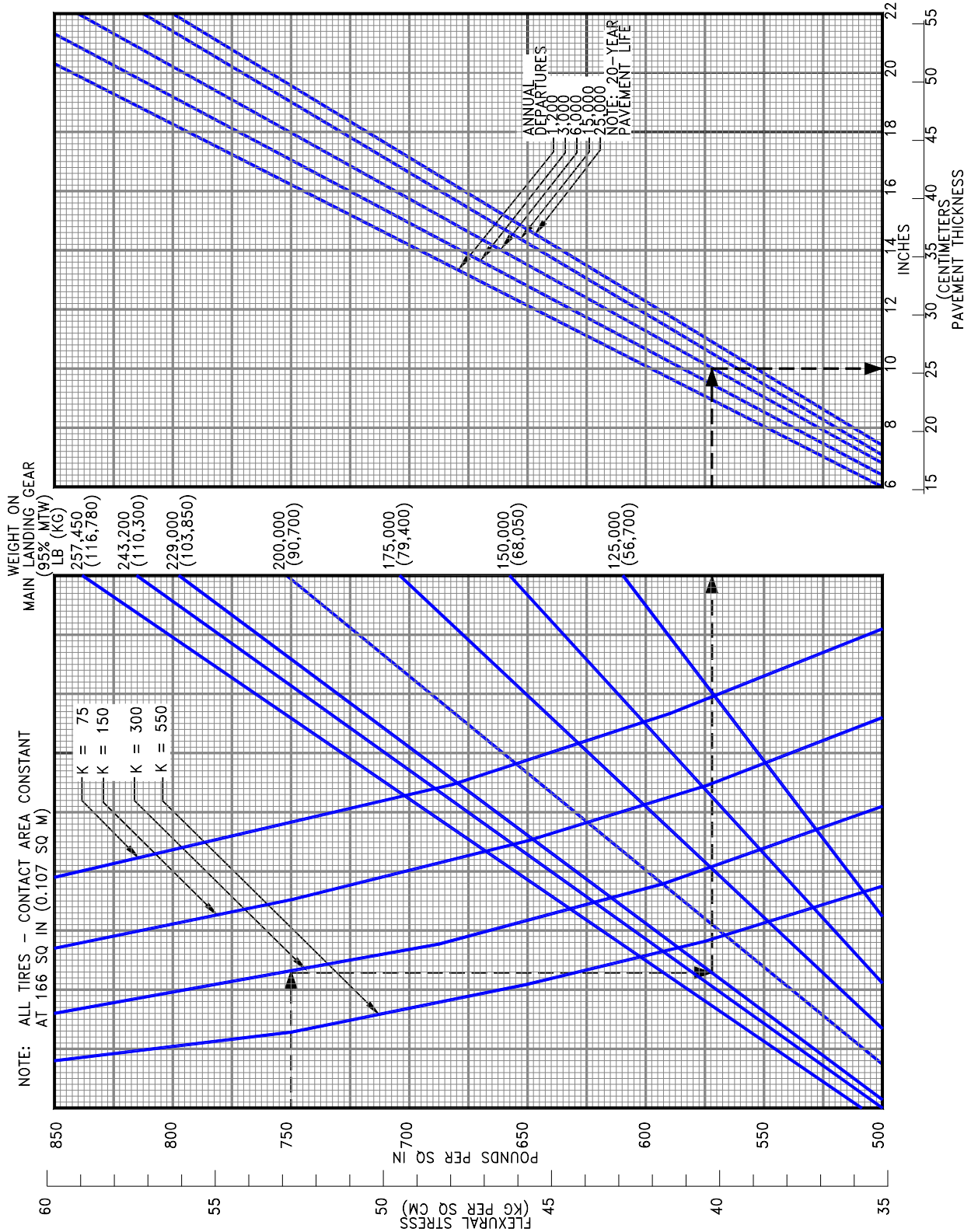

**7.9 RIGID PAVEMENT REQUIREMENTS - FAA METHOD**  
MODEL 757-200, -200PF, 300

## **7.10 ACN/PCN Reporting System: Flexible and Rigid Pavements**

To determine the ACN of an aircraft on flexible or rigid pavement, both the aircraft gross weight and the subgrade strength category must be known.

In the chart in Section 7.10.1, for 757-200 aircraft with gross weight of 208,500 lb and medium subgrade strength (Code B), the flexible pavement ACN is 24.8. In Section 7.10.3, for the same aircraft with gross weight of 190,000 lb and medium subgrade strength (Code B), the rigid pavement ACN is 26.5.

In the chart in Section 7.10.2, for 757-300 aircraft with gross weight of 230,000 lb and medium subgrade strength (Code B), the flexible pavement ACN is 29. In Section 7.10.4, for the same aircraft and gross weight and medium subgrade strength (Code B), the rigid pavement ACN is 33.2.

Note: An aircraft with an ACN equal to or less than the reported PCN can operate on that pavement subject to any limitations on the tire pressure. (Ref.: ICAO Annex 14 Aerodrome, First Edition, July 1990.)

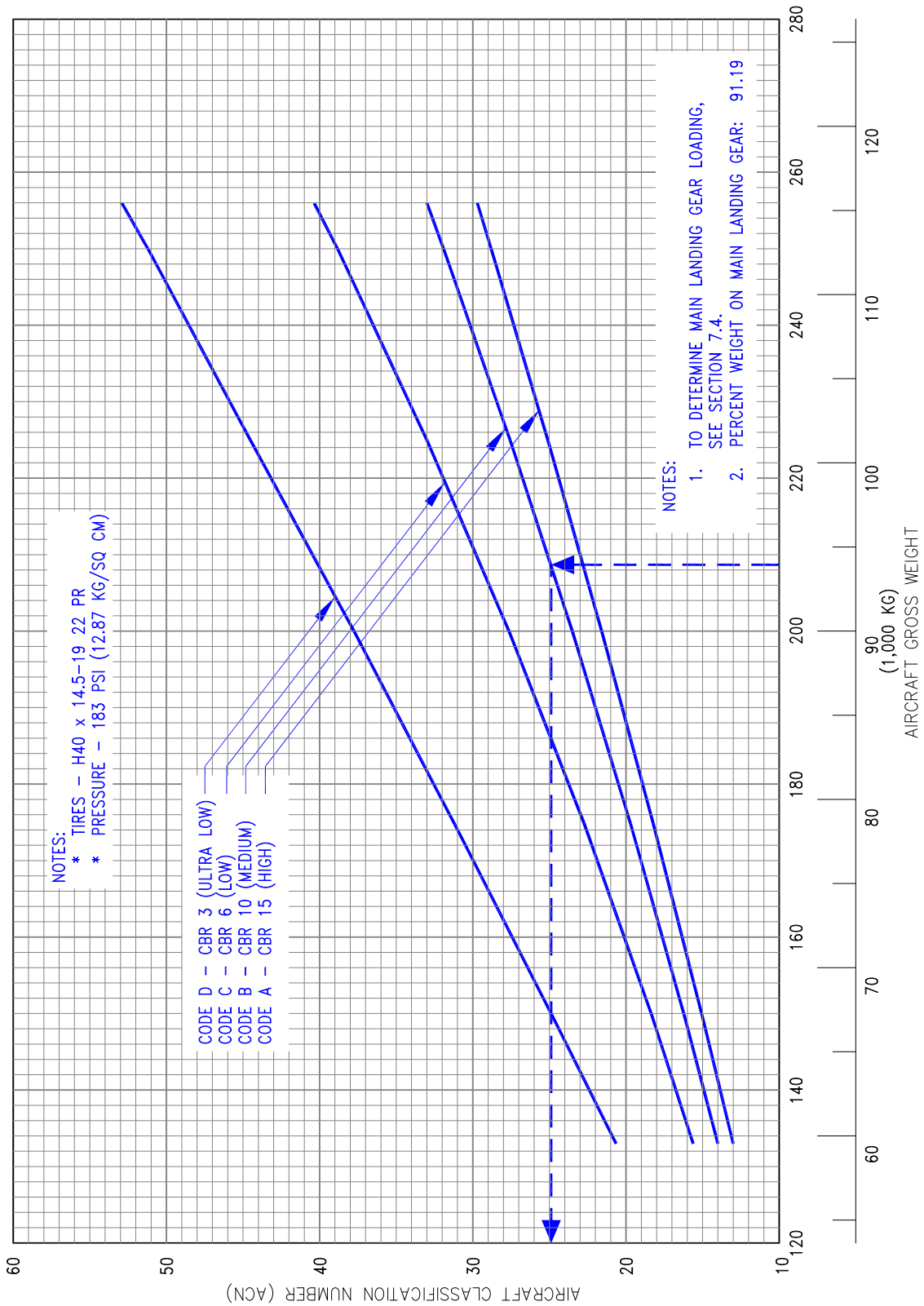

**7.10.1. AIRCRAFT CLASSIFICATION NUMBER - FLEXIBLE PAVEMENT**  
*MODEL 757-200, -200PF*

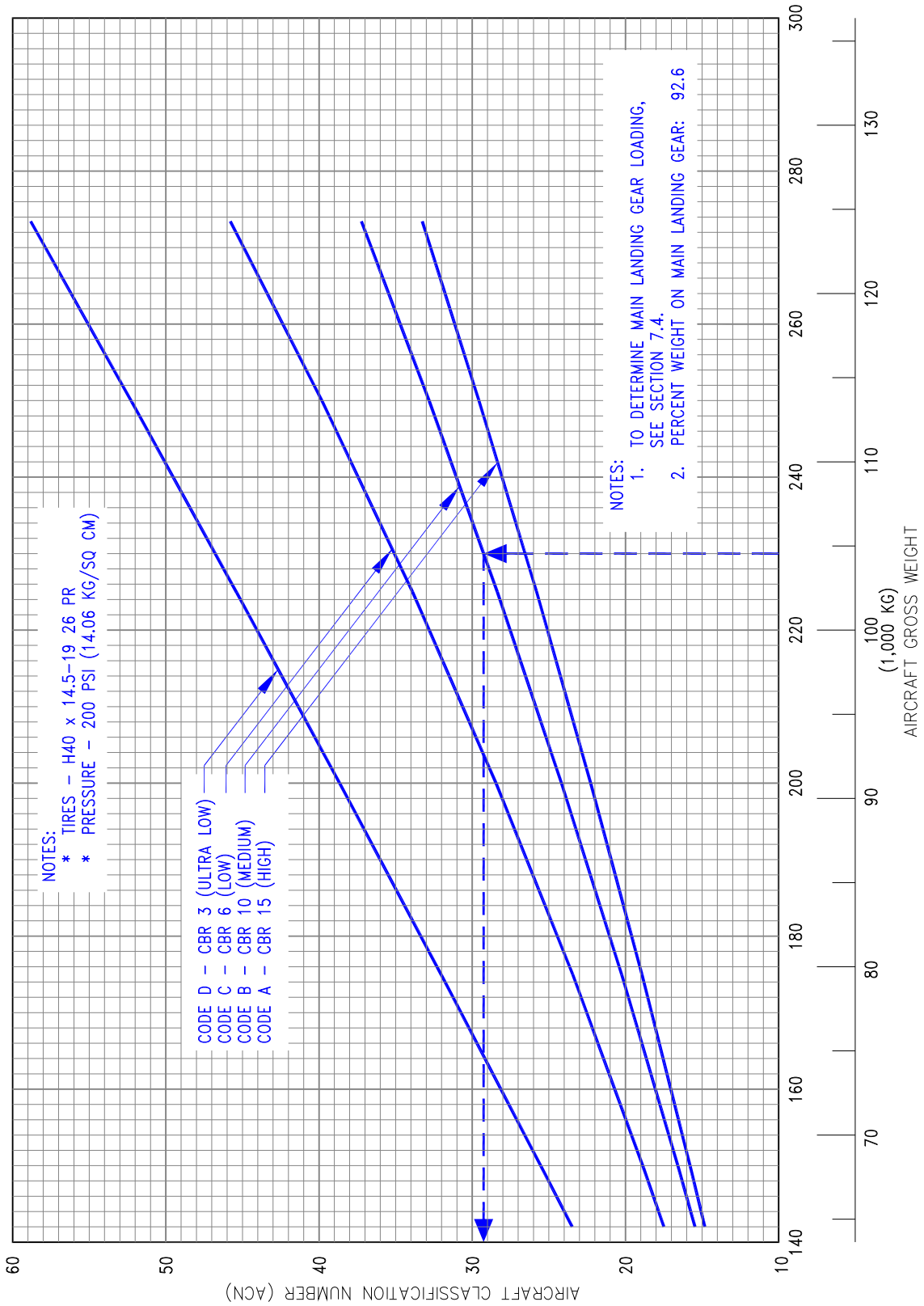

**7.10.2. AIRCRAFT CLASSIFICATION NUMBER - FLEXIBLE PAVEMENT**  
 MODEL 757-300



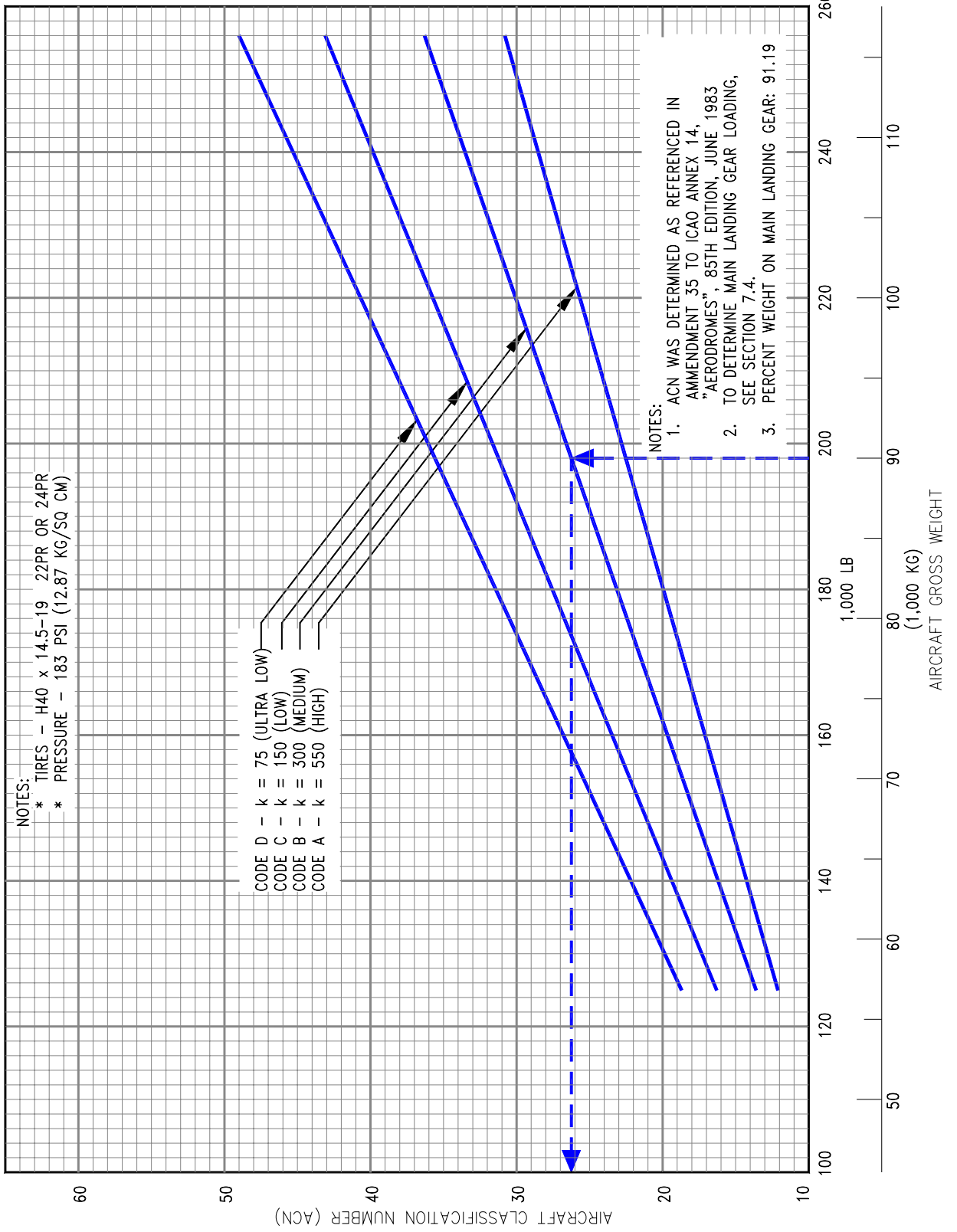

**7.10.3. AIRCRAFT CLASSIFICATION NUMBER - RIGID PAVEMENT**  
 MODEL 757-200, -200PF

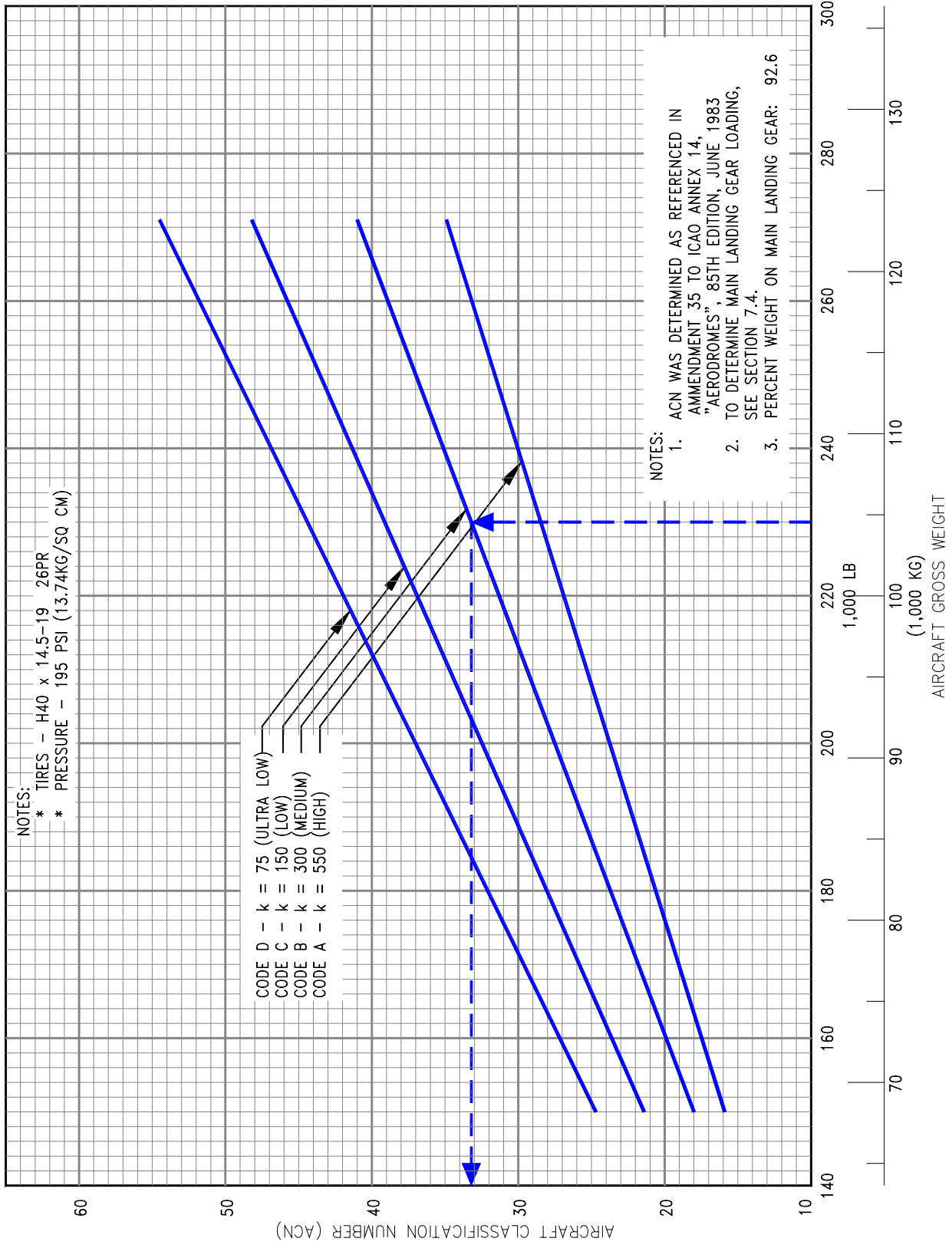

**7.10.4. AIRCRAFT CLASSIFICATION NUMBER - RIGID PAVEMENT**  
 MODEL 757-300

D6-58327

## **8.0 FUTURE 757 DERIVATIVE AIRPLANES**

## **8.0 FUTURE 757 DERIVATIVE AIRPLANES**

Several derivatives are being studied to provide additional capabilities of the 757 family of airplanes. Future growth versions could require additional passenger or cargo capacity or increased range or both. Whether these growth versions could be built would depend entirely on airline requirements. In any event, impact on airport facilities will be a consideration in the configuration and design.

## **9.0 SCALED 757 DRAWINGS**

**9.1- 9.5      Scaled Drawings , 757-200**

**9.6 - 9.10    Scaled Drawings, 757-200PF**

**9.11 - 9.15   Scaled Drawings, 757-300**

THIS PAGE INTENTIONALLY LEFT BLANK

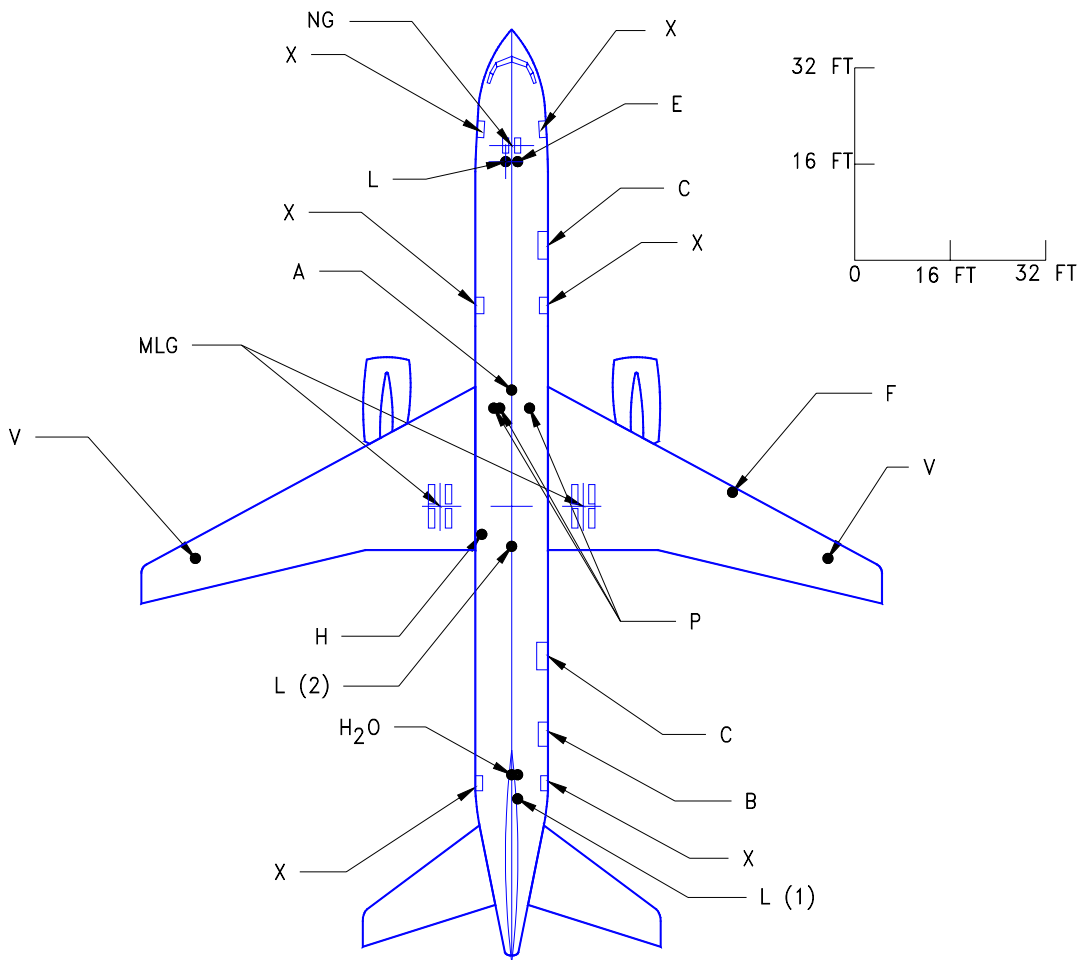

LEGEND

- A AIR CONDITIONING
- B BULK CARGO DOOR (OPTIONAL)
- C CARGO DOOR
- E ELECTRICAL
- F FUEL
- H HYDRAULIC
- H<sub>2</sub>O POTABLE WATER
- L LAVATORY
- MLG MAIN LANDING GEAR
- NG NOSE GEAR
- P PNEUMATIC
- V FUEL VENT
- X PASSENGER DOOR

NOTES:

- (1) OVERWING-EXIT AIRPLANE
- (2) FOUR-DOOR AIRPLANE

**NOTE: WHEN PRINTING THIS DRAWING, MAKE SURE TO ADJUST FOR PROPER SCALING**

**9.1.1 SCALED DRAWING - 1 IN. = 32 FT**  
 MODEL 757-200

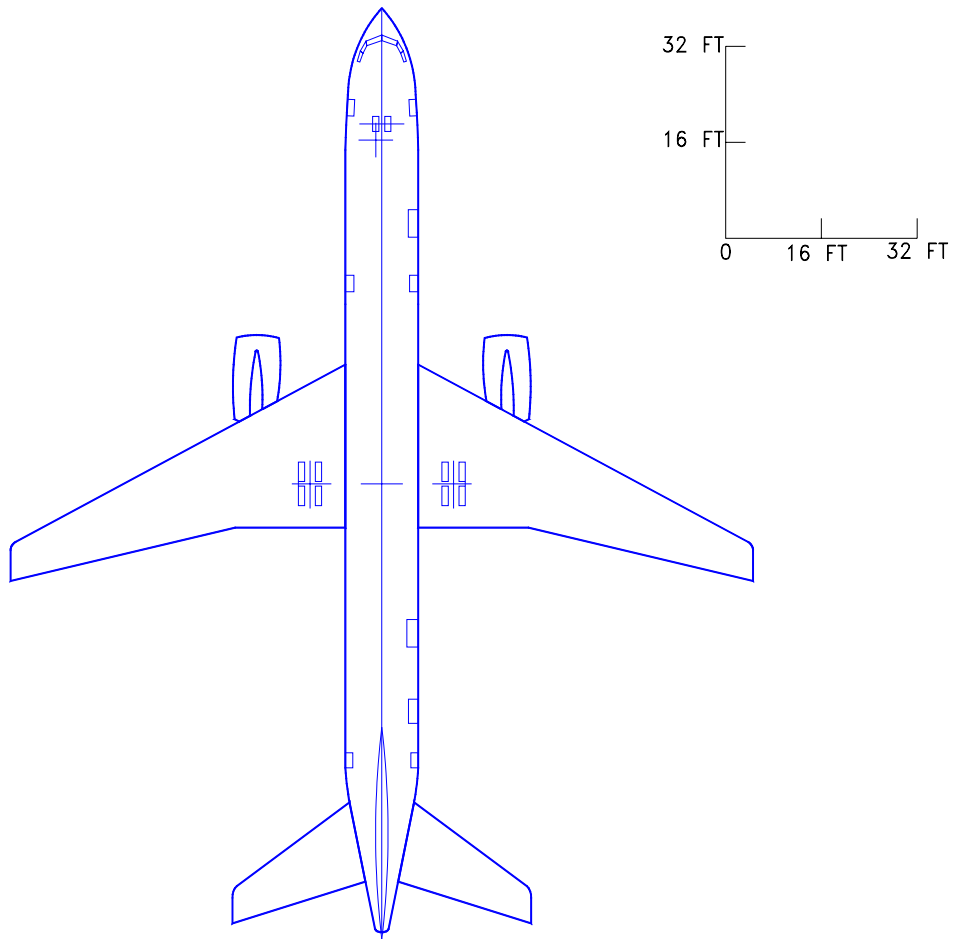

**NOTE: WHEN PRINTING THIS DRAWING, MAKE SURE TO ADJUST FOR PROPER SCALING**

**9.1.2 SCALED DRAWING - 1 IN. = 32 FT**  
*MODEL 757-200*

D6-58327



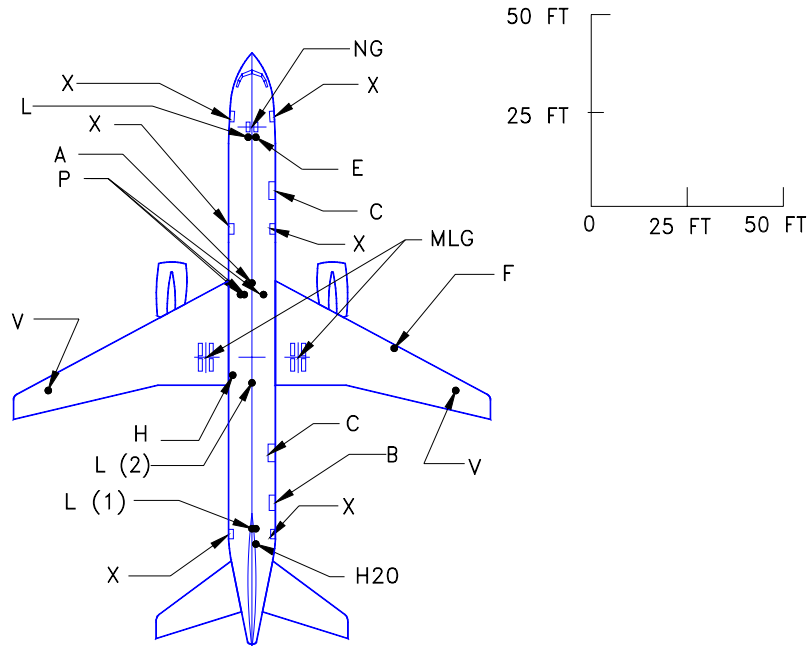

LEGEND

- A AIR CONDITIONING
- B BULK CARGO DOOR (OPTIONAL)
- C CARGO DOOR
- E ELECTRICAL
- F FUEL
- H HYDRAULIC
- H2O POTABLE WATER
- L LAVATORY
- MLG MAIN LANDING GEAR
- NG NOSE GEAR
- P PNEUMATIC
- V FUEL VENT
- X PASSENGER DOOR

NOTES:

- (1) OVERWING-EXIT AIRPLANE
- (2) FOUR-DOOR AIRPLANE

**NOTE: WHEN PRINTING THIS DRAWING, MAKE SURE TO ADJUST FOR PROPER SCALING**

**9.2.1 SCALED DRAWING - 1 IN. = 50 FT**  
*MODEL 757-200*

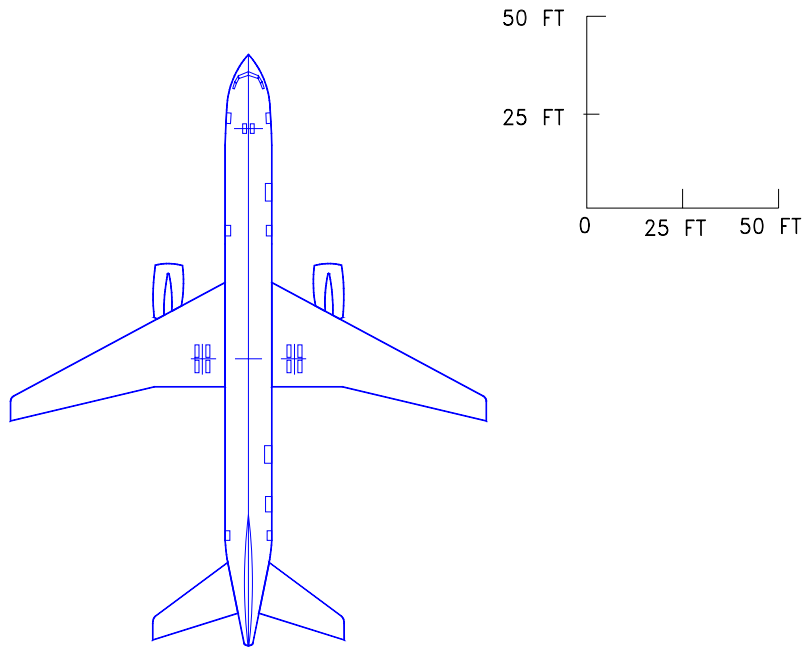

**NOTE: WHEN PRINTING THIS DRAWING, MAKE SURE TO ADJUST FOR PROPER SCALING**

**9.2.2 SCALED DRAWING - 1 IN. = 50 FT**  
*MODEL 757-200*

D6-58327

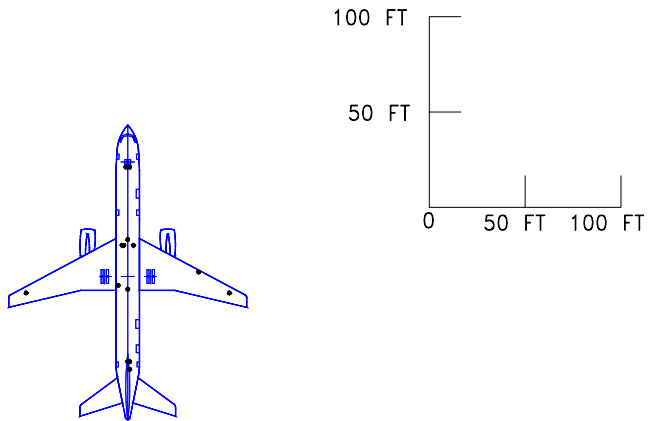

LEGEND

- A AIR CONDITIONING
- B BULK CARGO DOOR (OPTIONAL)
- C CARGO DOOR
- E ELECTRICAL
- F FUEL
- H HYDRAULIC
- H2O POTABLE WATER
- L LAVATORY
- MLG MAIN LANDING GEAR
- NG NOSE GEAR
- P PNEUMATIC
- V FUEL VENT
- X PASSENGER DOOR

NOTE:

SEE SECTION 9.1.1 FOR IDENTIFICATION OF SERVICE POINT LOCATIONS.

**NOTE: WHEN PRINTING THIS DRAWING, MAKE SURE TO ADJUST FOR PROPER SCALING**

**9.3.1 SCALED DRAWING - 1 IN. = 100 FT**  
 MODEL 757-200

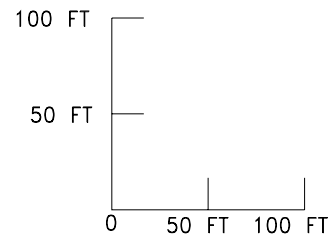
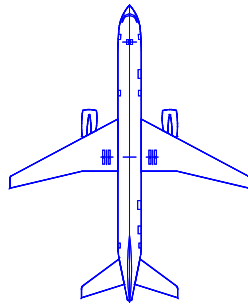

**NOTE: WHEN PRINTING THIS DRAWING, MAKE SURE TO ADJUST FOR PROPER SCALING**

**9.3.2 SCALED DRAWING - 1 IN. = 100 FT**  
*MODEL 757-200*

D6-58327

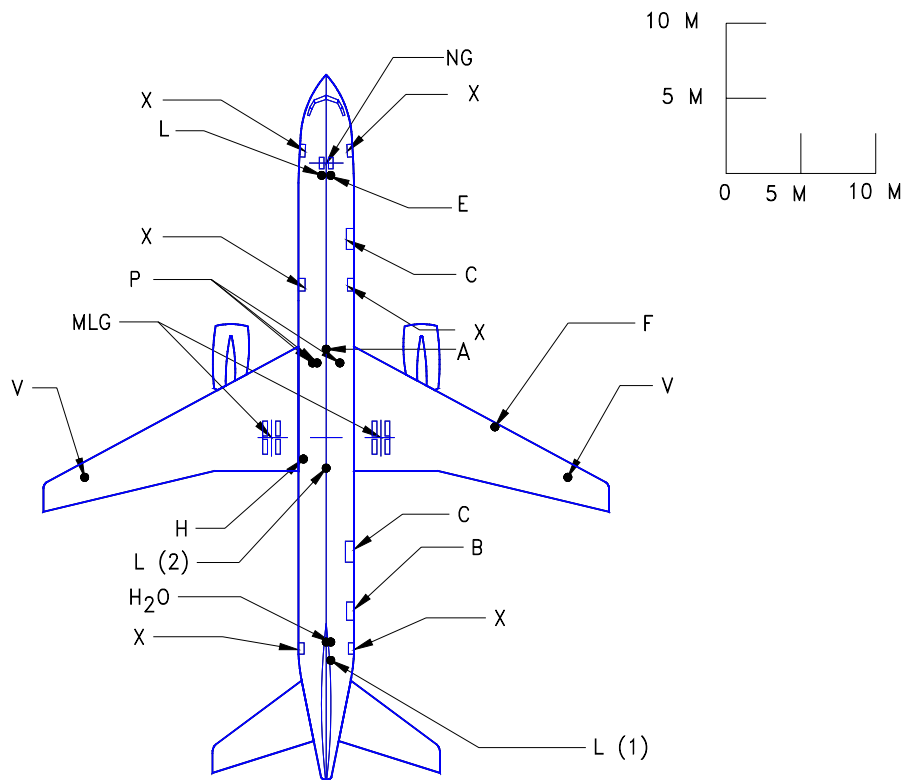

LEGEND

- A AIR CONDITIONING
- B BULK CARGO DOOR (OPTIONAL)
- C CARGO DOOR
- E ELECTRICAL
- F FUEL
- H HYDRAULIC
- H<sub>2</sub>O POTABLE WATER
- L LAVATORY
- MLG MAIN LANDING GEAR
- NG NOSE GEAR
- P PNEUMATIC
- V FUEL VENT
- X PASSENGER DOOR

NOTES:

- (1) OVERWING-EXIT AIRPLANE
- (2) FOUR-DOOR AIRPLANE

**NOTE: WHEN PRINTING THIS DRAWING, MAKE SURE TO ADJUST FOR PROPER SCALING**

**9.4.1 SCALED DRAWING - 1:500**  
 MODEL 757-200

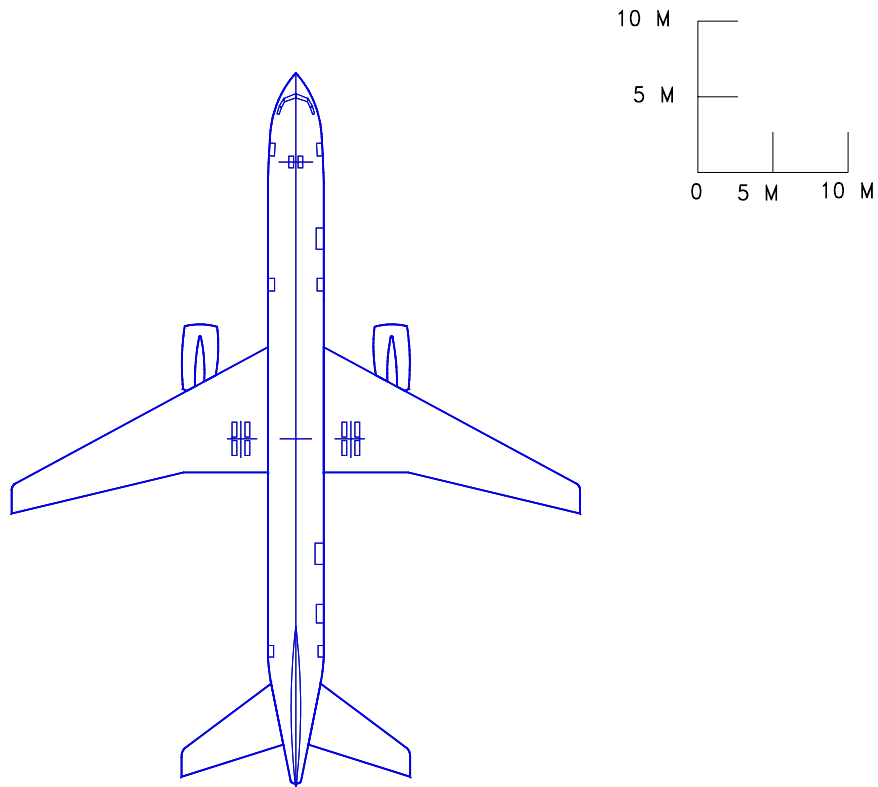

**NOTE: WHEN PRINTING THIS DRAWING, MAKE SURE TO ADJUST FOR PROPER SCALING**

**9.4.2 SCALED DRAWING - 1:500**  
*MODEL 757-200*

D6-58327

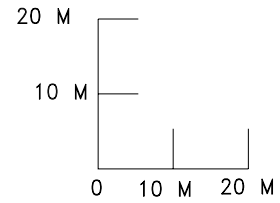
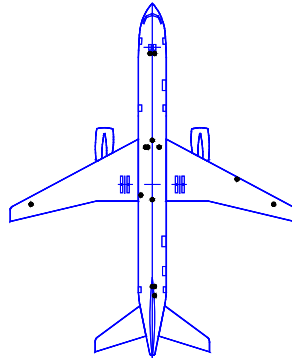

LEGEND

- A AIR CONDITIONING
- B BULK CARGO DOOR (OPTIONAL)
- C CARGO DOOR
- E ELECTRICAL
- F FUEL
- H HYDRAULIC
- H2O POTABLE WATER
- L LAVATORY
- MLG MAIN LANDING GEAR
- NG NOSE GEAR
- P PNEUMATIC
- V FUEL VENT
- X PASSENGER DOOR

NOTE:

SEE SECTION 9.1.1 FOR IDENTIFICATION OF SERVICE POINT LOCATIONS

**NOTE: WHEN PRINTING THIS DRAWING, MAKE SURE TO ADJUST FOR PROPER SCALING**

**9.5.1 SCALED DRAWING - 1:1000**  
*MODEL 757-200*

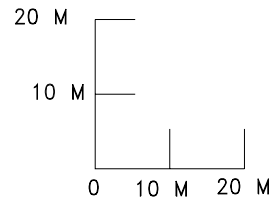
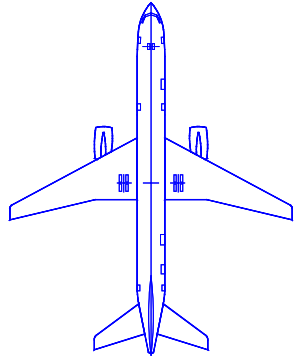

**NOTE: WHEN PRINTING THIS DRAWING, MAKE SURE TO ADJUST FOR PROPER SCALING**

**9.5.2 SCALED DRAWING - 1:1000**  
*MODEL 757-200*

D6-58327



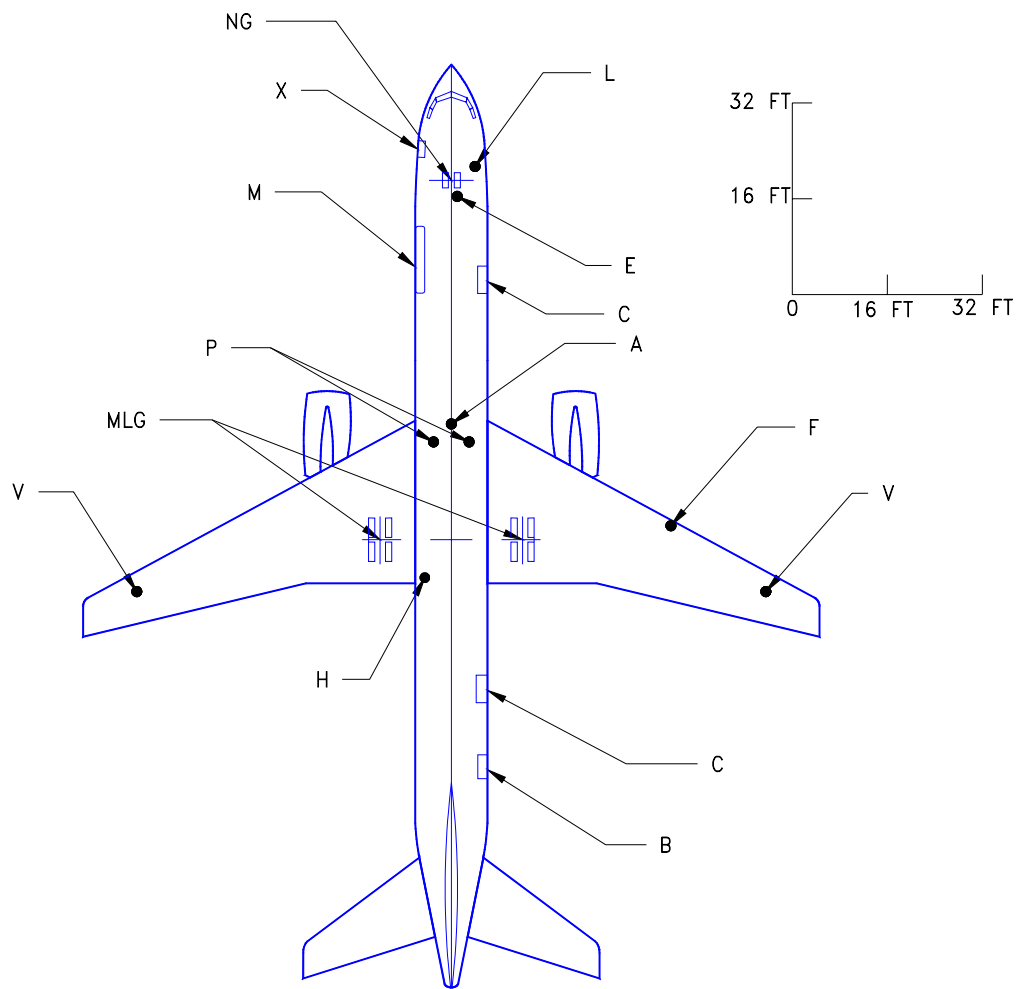

- LEGEND
- A AIR CONDITIONING
  - B BULK CARGO DOOR (OPTIONAL)
  - C CARGO DOOR
  - E ELECTRICAL
  - F FUEL
  - H HYDRAULIC
  - L LAVATORY
  - MLG MAIN LANDING GEAR
  - NG NOSE GEAR
  - P PNEUMATIC
  - V FUEL VENT
  - X PASSENGER DOOR

**NOTE: WHEN PRINTING THIS DRAWING, MAKE SURE TO ADJUST FOR PROPER SCALING**

**9.6.1 SCALED DRAWING - 1 IN. = 32 FT**  
 MODEL 757-200PF

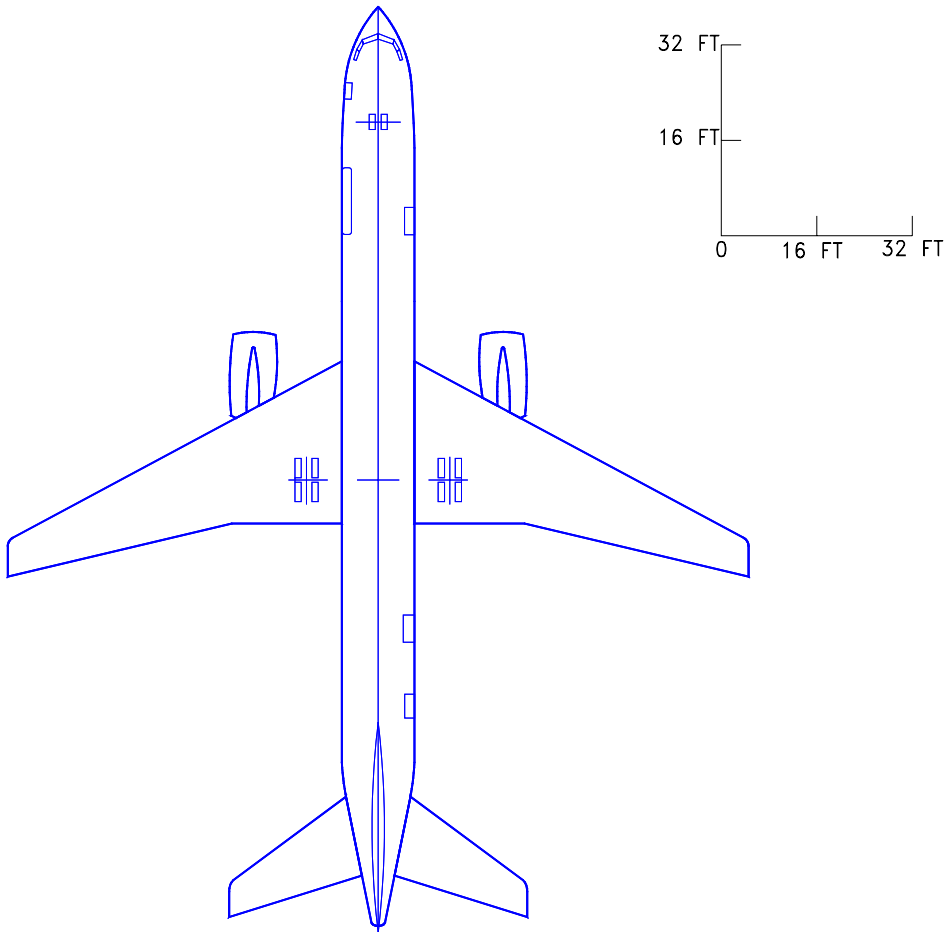

**NOTE: WHEN PRINTING THIS DRAWING, MAKE SURE TO ADJUST FOR PROPER SCALING**

**9.6.2 SCALED DRAWING - 1 IN. = 32 FT**  
*MODEL 757-200PF*

D6-58327

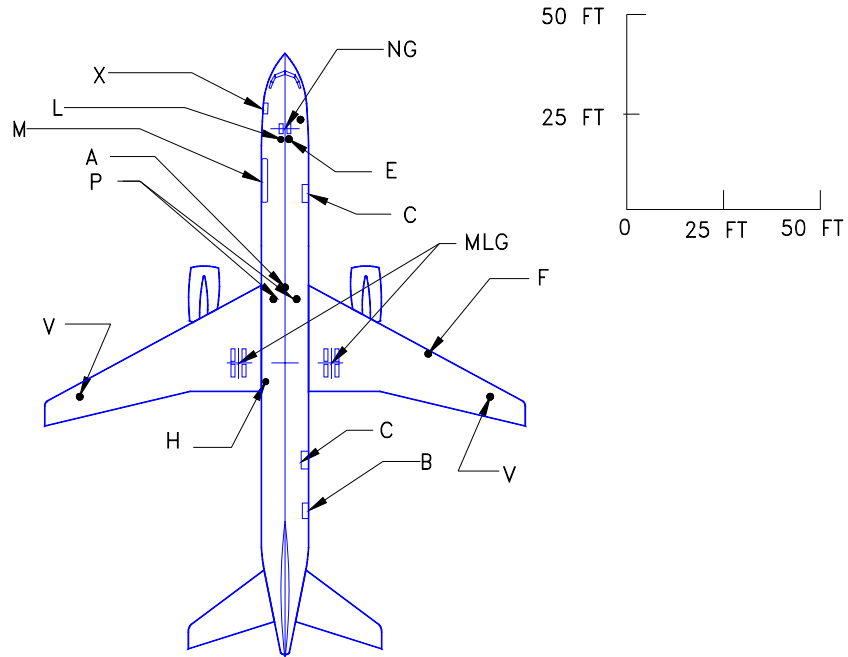

LEGEND

- A AIR CONDITIONING
- B BULK CARGO DOOR (OPTIONAL)
- C CARGO DOOR
- E ELECTRICAL
- F FUEL
- H HYDRAULIC
- L LAVATORY
- MLG MAIN LANDING GEAR
- NG NOSE GEAR
- P PNEUMATIC
- V FUEL VENT
- X PASSENGER DOOR

**NOTE: WHEN PRINTING THIS DRAWING, MAKE SURE TO ADJUST FOR PROPER SCALING**

**9.7.1 SCALED DRAWING - 1 IN. = 50 FT**  
*MODEL 757-200PF*

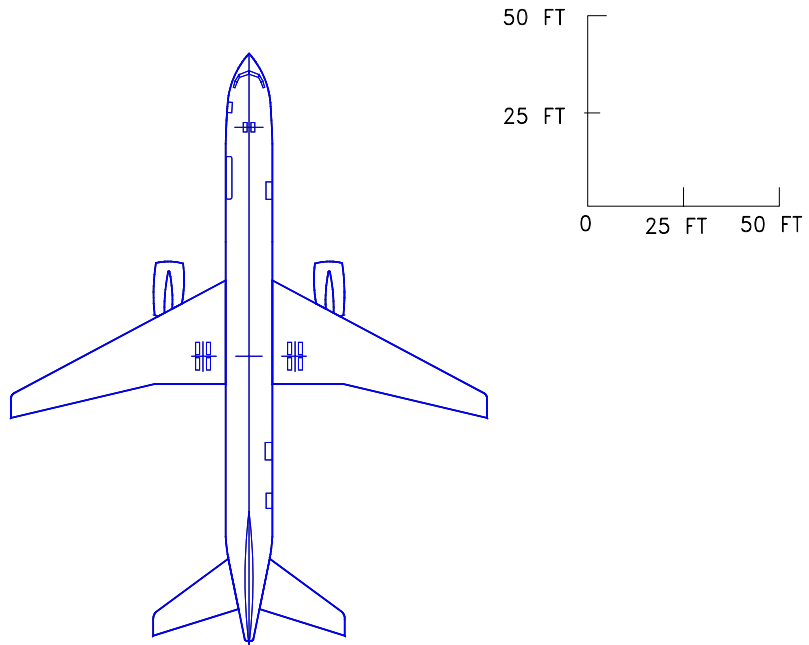

**NOTE: WHEN PRINTING THIS DRAWING, MAKE SURE TO ADJUST FOR PROPER SCALING**

**9.7.2 SCALED DRAWING - 1 IN. = 50 FT**  
*MODEL 757-200PF*

D6-58327

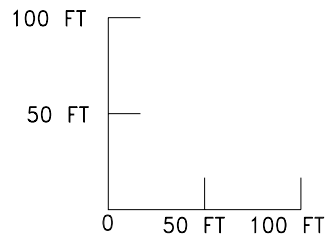
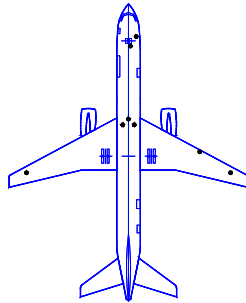

LEGEND

- A AIR CONDITIONING
- B BULK CARGO DOOR (OPTIONAL)
- C CARGO DOOR
- E ELECTRICAL
- F FUEL
- H HYDRAULIC
- L LAVATORY
- MLG MAIN LANDING GEAR
- NG NOSE GEAR
- P PNEUMATIC
- V FUEL VENT
- X PASSENGER DOOR

NOTE:

SEE SECTION 9.6.1 FOR IDENTIFICATION OF SERVICE POINT LOCATIONS.

**NOTE: WHEN PRINTING THIS DRAWING, MAKE SURE TO ADJUST FOR PROPER SCALING**

**9.8.1 SCALED DRAWING - 1 IN. = 100 FT**  
*MODEL 757-200PF*

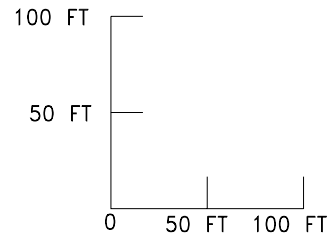
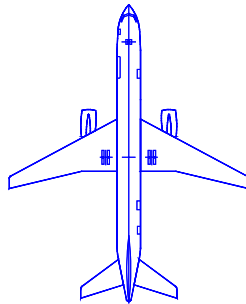

**NOTE: WHEN PRINTING THIS DRAWING, MAKE SURE TO ADJUST FOR PROPER SCALING**

**9.8.2 SCALED DRAWING - 1 IN. = 100 FT**  
*MODEL 757-200PF*

D6-58327

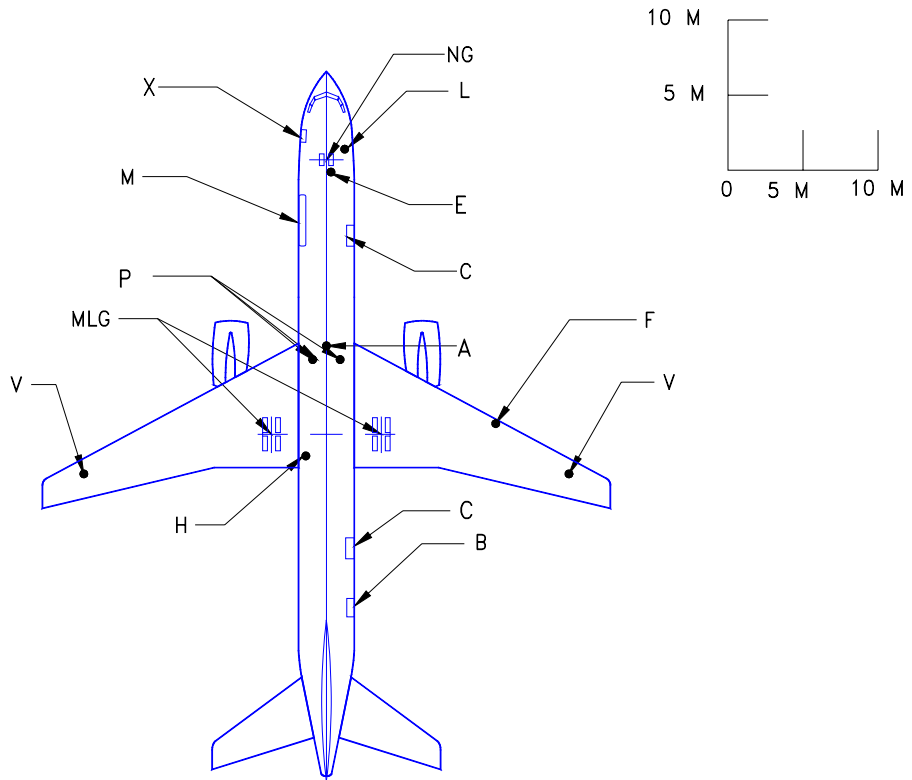

LEGEND

- A AIR CONDITIONING
- B BULK CARGO DOOR (OPTIONAL)
- C CARGO DOOR
- E ELECTRICAL
- F FUEL
- H HYDRAULIC
- L LAVATORY
- MLG MAIN LANDING GEAR
- NG NOSE GEAR
- P PNEUMATIC
- V FUEL VENT
- X PASSENGER DOOR

**NOTE: WHEN PRINTING THIS DRAWING, MAKE SURE TO ADJUST FOR PROPER SCALING**

**9.9.1 SCALED DRAWING - 1:500**  
*MODEL 757-200PF*

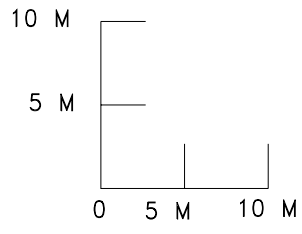
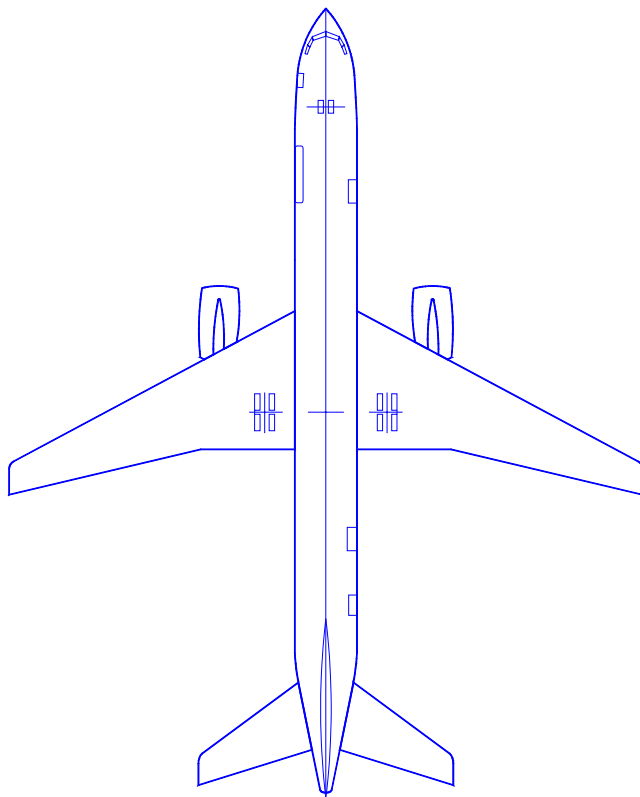

**NOTE: WHEN PRINTING THIS DRAWING, MAKE SURE TO ADJUST FOR PROPER SCALING**

**9.9.2 SCALED DRAWING - 1:500**  
*MODEL 757-200PF*

D6-58327



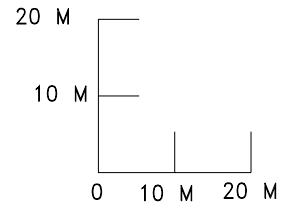
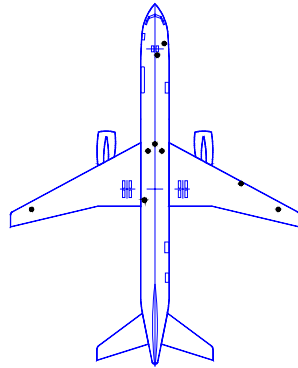

LEGEND

- A AIR CONDITIONING
- B BULK CARGO DOOR (OPTIONAL)
- C CARGO DOOR
- E ELECTRICAL
- F FUEL
- H HYDRAULIC
- L LAVATORY
- MLG MAIN LANDING GEAR
- NG NOSE GEAR
- P PNEUMATIC
- V FUEL VENT
- X PASSENGER DOOR

NOTE:

SEE SECTION 9.6.1 FOR IDENTIFICATION OF SERVICE POINT LOCATIONS

**NOTE: WHEN PRINTING THIS DRAWING, MAKE SURE TO ADJUST FOR PROPER SCALING**

**9.10.1 SCALED DRAWING - 1:1000**  
*MODEL 757-200PF*

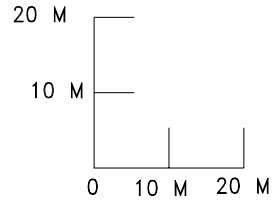
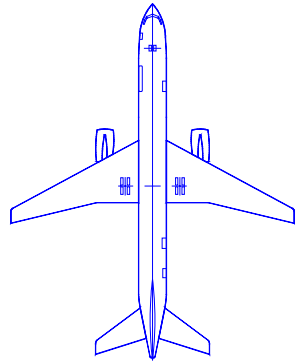

**NOTE: WHEN PRINTING THIS DRAWING, MAKE SURE TO ADJUST FOR PROPER SCALING**

**9.10.2 SCALED DRAWING - 1:1000**  
*MODEL 757-200PF*

D6-58327

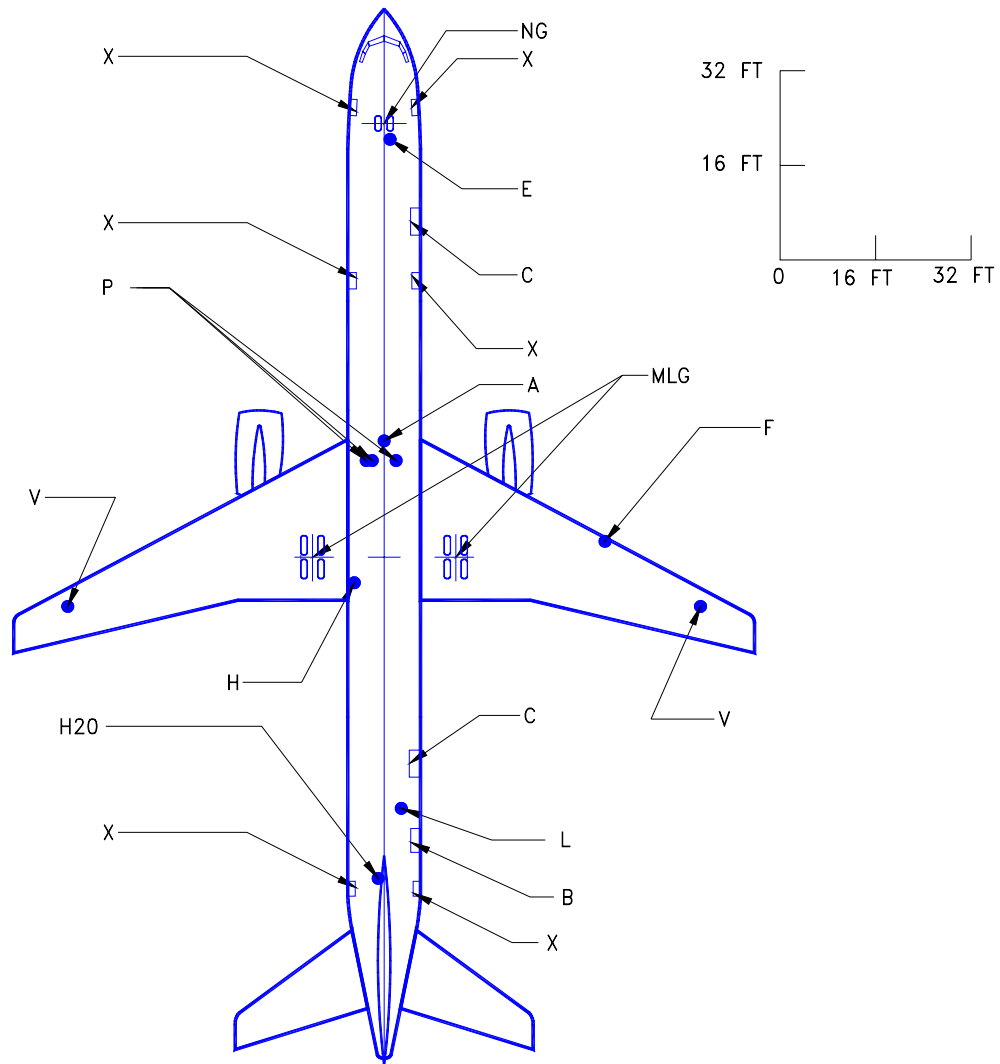

LEGEND

- A AIR CONDITIONING
- B BULK CARGO DOOR
- C CARGO DOOR
- E ELECTRICAL
- F FUEL
- H HYDRAULIC
- H2O POTABLE WATER
- L LAVATORY
- MLG MAIN LANDING GEAR
- NG NOSE GEAR
- P PNEUMATIC
- V FUEL VENT
- X PASSENGER DOOR

**NOTE: WHEN PRINTING THIS DRAWING, MAKE SURE TO ADJUST FOR PROPER SCALING**

**9.11.1 SCALED DRAWING - 1 IN. = 32 FT**  
 MODEL 757-300

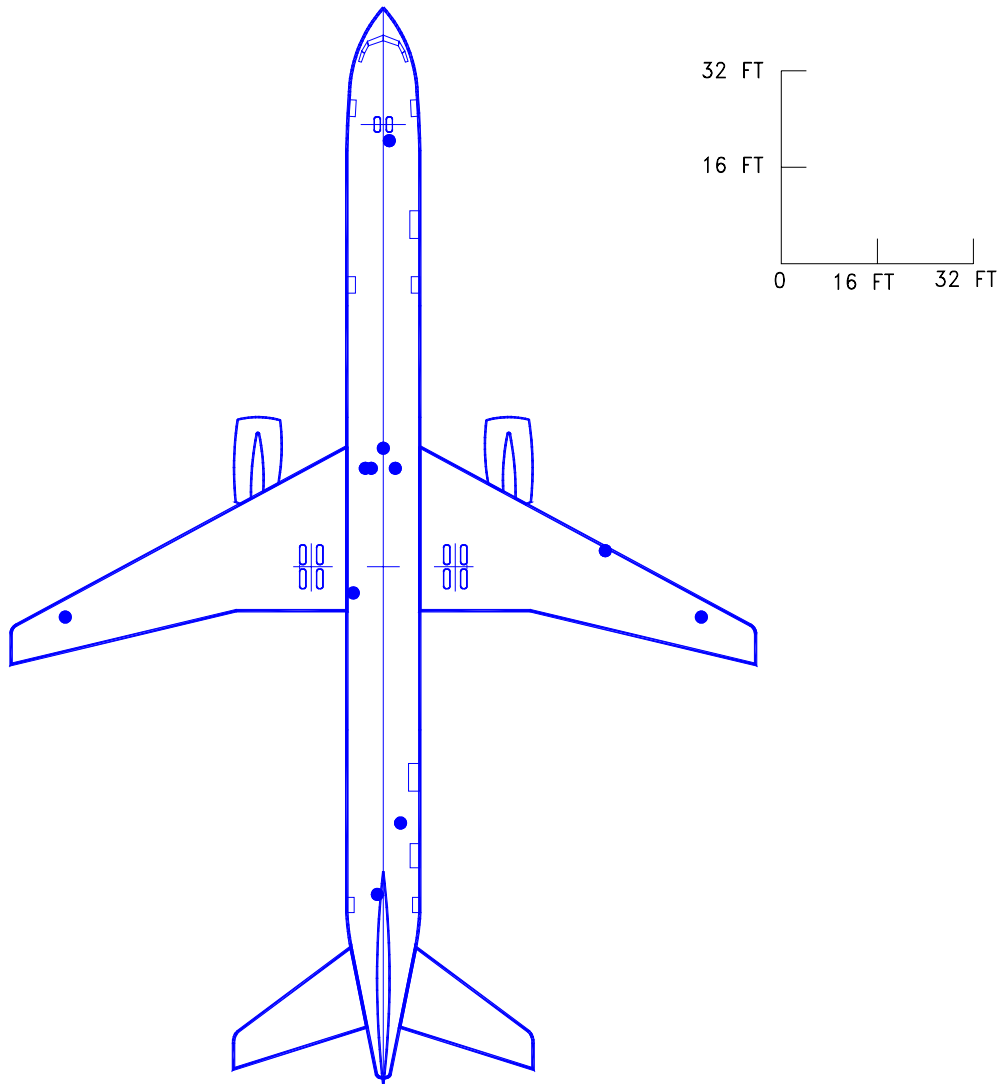

**NOTE: WHEN PRINTING THIS DRAWING, MAKE SURE TO ADJUST FOR PROPER SCALING**

**9.11.2 SCALED DRAWING - 1 IN. = 32 FT**  
*MODEL 757-300*

D6-58327

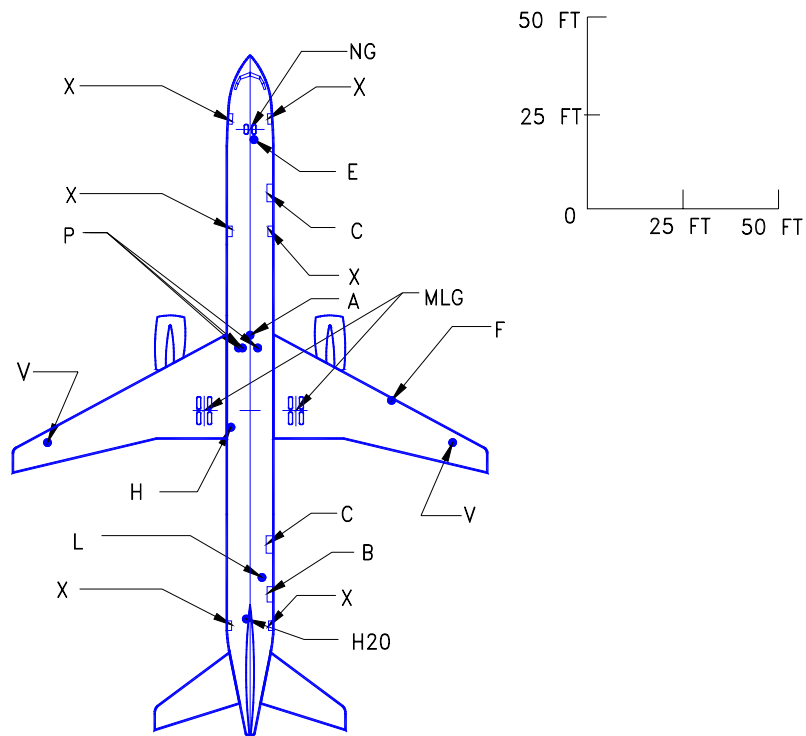

LEGEND

- A AIR CONDITIONING
- B BULK CARGO DOOR
- C CARGO DOOR
- E ELECTRICAL
- F FUEL
- H HYDRAULIC
- H2O POTABLE WATER
- L LAVATORY
- MLG MAIN LANDING GEAR
- NG NOSE GEAR
- P PNEUMATIC
- V FUEL VENT
- X PASSENGER DOOR

**NOTE: WHEN PRINTING THIS DRAWING, MAKE SURE TO ADJUST FOR PROPER SCALING**

**9.12.1 SCALED DRAWING - 1 IN. = 50 FT**  
 MODEL 757-300

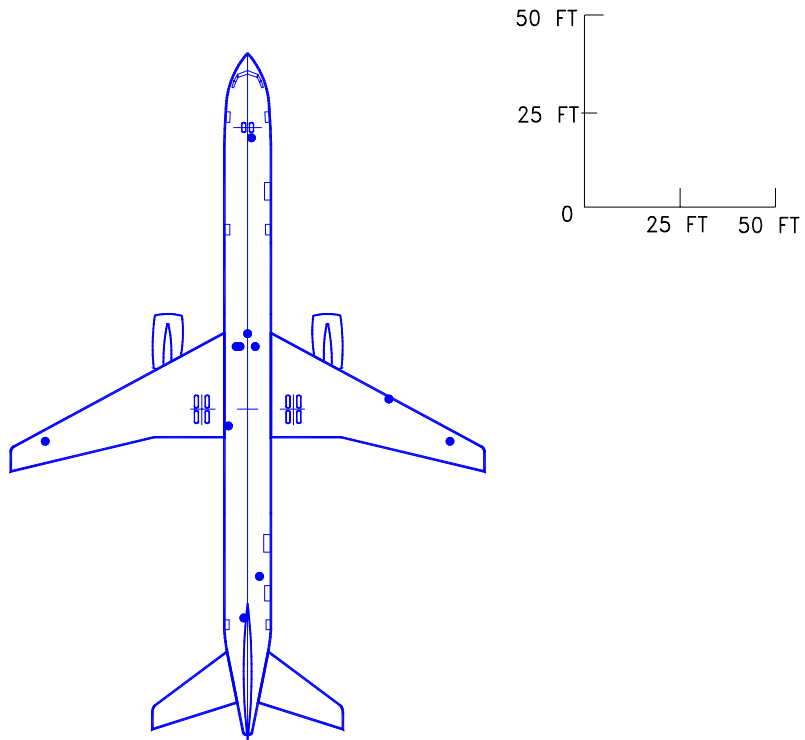

**NOTE: WHEN PRINTING THIS DRAWING, MAKE SURE TO ADJUST FOR PROPER SCALING**

**9.12.2 SCALED DRAWING - 1 IN. = 50 FT**  
*MODEL 757-300*

D6-58327

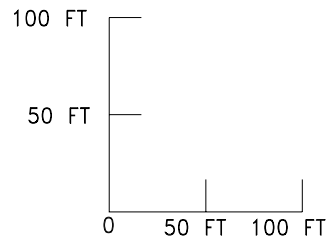
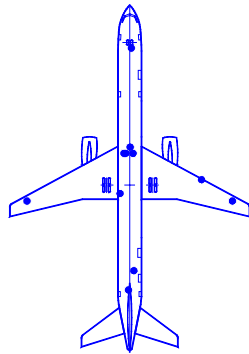

LEGEND

- A AIR CONDITIONING
- B BULK CARGO DOOR
- C CARGO DOOR
- E ELECTRICAL
- F FUEL
- H HYDRAULIC
- H2O POTABLE WATER
- L LAVATORY
- MLG MAIN LANDING GEAR
- NG NOSE GEAR
- P PNEUMATIC
- V FUEL VENT
- X PASSENGER DOOR

NOTE:

SEE SECTION 9.11.1 FOR IDENTIFICATION OF SERVICE POINT LOCATIONS

**NOTE: WHEN PRINTING THIS DRAWING, MAKE SURE TO ADJUST FOR PROPER SCALING**

**9.13.1 SCALED DRAWING - 1 IN = 100 FT**  
*MODEL 757-300*

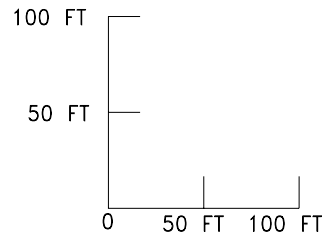
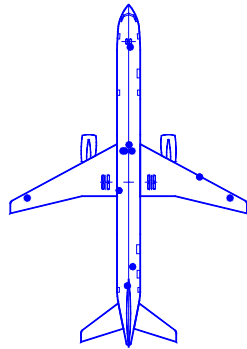

**NOTE: WHEN PRINTING THIS DRAWING, MAKE SURE TO ADJUST FOR PROPER SCALING**

**9.13.2 SCALED DRAWING - 1 IN = 100 FT**  
*MODEL 757-300*

D6-58327



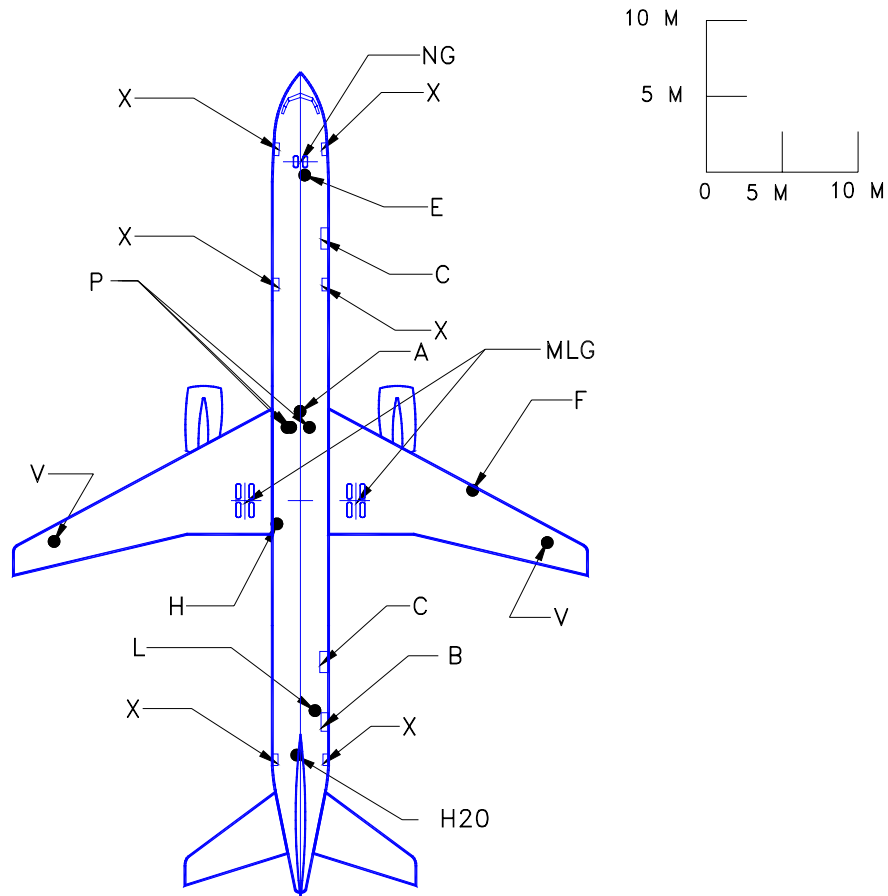

LEGEND

- A AIR CONDITIONING
- B BULK CARGO DOOR
- C CARGO DOOR
- E ELECTRICAL
- F FUEL
- H HYDRAULIC
- H2O POTABLE WATER
- L LAVATORY
- MLG MAIN LANDING GEAR
- NG NOSE GEAR
- P PNEUMATIC
- V FUEL VENT
- X PASSENGER DOOR

**NOTE: WHEN PRINTING THIS DRAWING, MAKE SURE TO ADJUST FOR PROPER SCALING**

**9.14.1 SCALED DRAWING - 1:500**  
 MODEL 757-300

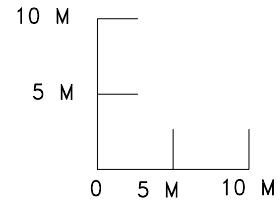
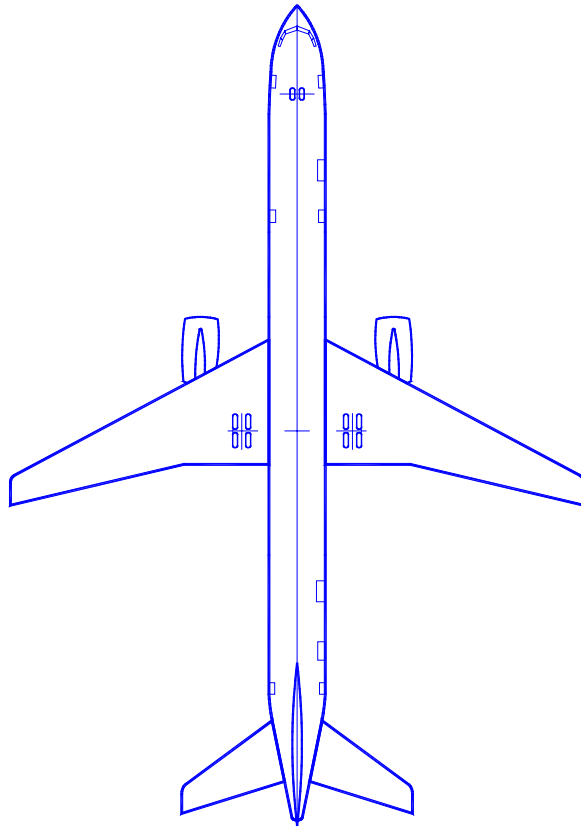

**NOTE: WHEN PRINTING THIS DRAWING, MAKE SURE TO ADJUST FOR PROPER SCALING**

**9.14.2 SCALED DRAWING - 1:500**  
*MODEL 757-300*

D6-58327

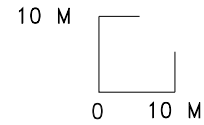
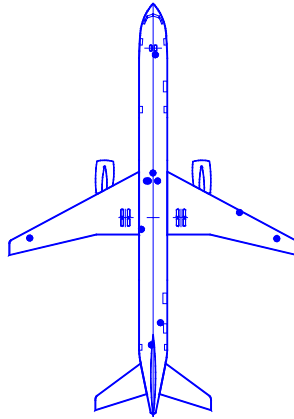

LEGEND

- A AIR CONDITIONING
- B BULK CARGO DOOR
- C CARGO DOOR
- E ELECTRICAL
- F FUEL
- H HYDRAULIC
- H2O POTABLE WATER
- L LAVATORY
- MLG MAIN LANDING GEAR
- NG NOSE GEAR
- P PNEUMATIC
- V FUEL VENT
- X PASSENGER DOOR

NOTE:

SEE SECTION 9.11.1 FOR IDENTIFICATION OF SERVICE POINT LOCATIONS

**NOTE: WHEN PRINTING THIS DRAWING, MAKE SURE TO ADJUST FOR PROPER SCALING**

**9.15.1 SCALED DRAWING - 1:1000**  
MODEL 757-300

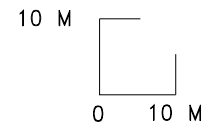
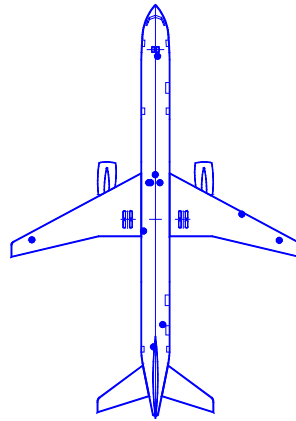

**NOTE: WHEN PRINTING THIS DRAWING, MAKE SURE TO ADJUST FOR PROPER SCALING**

**9.15.2 SCALED DRAWING - 1:1000**  
*MODEL 757-300*

D6-58327