

Frontload Washers

Metered Commercial

Installation/Operation

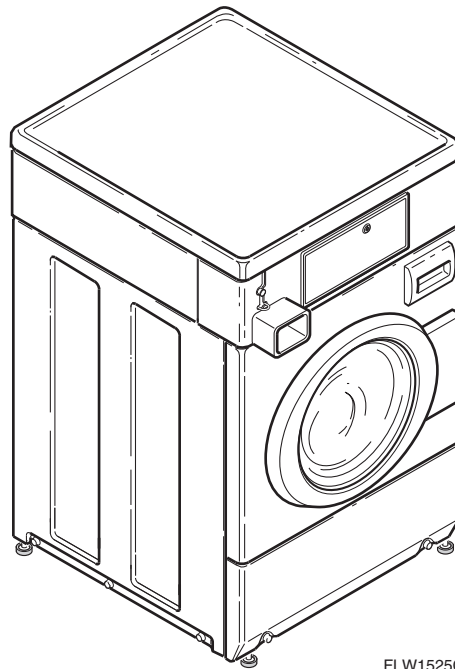

FLW1525C

Para bajar una copia de estas instrucciones en español, visite www.comlaundry.com.

Keep These Instructions for Future Reference.

(If this machine changes ownership, this manual must accompany machine.)



www.comlaundry.com

Part No. 802733R4
October 2011



WARNING

Failure to install, maintain, and/or operate this machine according to the manufacturer's instructions may result in conditions which can produce bodily injury and/or property damage.

W030

NOTE: The WARNING and IMPORTANT instructions appearing in this manual are not meant to cover all possible conditions and situations that may occur. It must be understood that common sense, caution, and carefulness are factors which cannot be built into these washers. These factors MUST BE supplied by the person(s) installing, maintaining, or operating the washer.

Always contact the distributor, service agent, or the manufacturer about any problems or conditions you do not understand.

Table of Contents

Safety Information	4
Explanation of Safety Messages.....	4
Important Safety Instructions	4
Installation	6
Dimensions and Specifications.....	6
Before You Start.....	7
Tools	7
Installing the Washer	8
Step 1: Position Washer Near Installation Area	8
Step 2: Position and Level the Washer	8
Step 3: Connect Fill Hoses.....	9
Step 4: (Non-Gravity Drain Models Only)	
Connect Drain Hose to Drain Receptacle.....	11
Step 5: (Gravity Drain Models Only)	
Connect Drain Outlet to Drain System.....	12
Step 6: Remove the Shock Sleeves and Shipping Brace	13
Step 7: Wipe Out Inside of Wash Drum	13
Step 8: (Supply Injection Models Only)	
Connect External Supplies to Washer	13
Control Function Test	14
Step 9: Plug In the Washer.....	15
Step 10: Check Installation	16
Operation	17
Operation Instructions for MDC Washers.....	17
Step 1: Load Laundry.....	17
Step 2: Close Loading Door.....	17
Step 3: Add Laundry Supplies	18
Step 4: Set Fabric Selector and Wash Temperature.....	18
Step 5: Insert Coin(s) or Card	19
Step 6: Start Washer.....	19
Indicator Lights.....	20
Operation Instructions for NetMaster Washers	21
Step 1: Load Laundry.....	21
Step 2: Close Loading Door.....	21
Step 3: Add Laundry Supplies	22
Step 4: Set Fabric Selector	22
Step 5: Set Wash Temperature.....	22
Step 6: Insert Coin(s) or Card	23
Step 7: Start Washer.....	23
Indicator Lights	23
Maintenance	25
User-Maintenance Instructions.....	25
Lubrication	25
Cold Weather Care.....	25
Care of Your Washer	25
Cleaning Glass Sealing Area	25
Replacing Hoses.....	25

© Copyright 2011, Alliance Laundry Systems LLC

All rights reserved. No part of the contents of this book may be reproduced or transmitted in any form or by any means without the expressed written consent of the publisher.

Filter Screens	25
Vacations and Extended Non-Use	25
Reinstallation of Shipping Materials	26
Cleaning Foreign Object Trap	26
Troubleshooting	27
Contact Information	29
Installer Checklist	Back Cover

Safety Information

Explanation of Safety Messages

Throughout this manual and on machine decals, you will find precautionary statements (“DANGER,” “WARNING,” and “CAUTION”) followed by specific instructions. These precautions are intended for the personal safety of the operator, user, servicer, and those maintaining the machine.

	DANGER
Indicates an imminently hazardous situation that, if not avoided, will cause severe personal injury or death.	

	WARNING
Indicates a hazardous situation that, if not avoided, could cause severe personal injury or death.	

	CAUTION
Indicates a hazardous situation that, if not avoided, may cause minor or moderate personal injury or property damage.	

Additional precautionary statements (“IMPORTANT” and “NOTE”) are followed by specific instructions.

IMPORTANTE: The word “IMPORTANT” is used to inform the reader of specific procedures where minor machine damage will occur if the procedure is not followed.

NOTA: The word “NOTE” is used to communicate installation, operation, maintenance or servicing information that is important but not hazard related.

Important Safety Instructions

(Save These Instructions)

	WARNING
To reduce the risk of fire, electric shock, serious injury or death to persons when using your washer, follow these basic precautions:	
W023	

1. Read all instructions before using the washer.
2. Install the washer according to the INSTALLATION INSTRUCTIONS. Refer to the GROUNDING INSTRUCTIONS in the INSTALLATION manual for the proper grounding of the washer. All connections for water, drain, electrical power and grounding must comply with local codes and be made by licensed personnel when required. Do not do it yourself unless you know how!
3. Do not install or store the washer where it will be exposed to water and/or weather.
4. Do not add the following substances or textiles containing traces of the following substances to the wash water: gasoline, kerosene, waxes, cooking oils, vegetable oils, machine oils, dry-cleaning solvents, flammable chemicals, thinners or other flammable or explosive substances. These substances give off vapors that could ignite, explode or cause the fabric to catch on fire by itself.
5. Under certain conditions, hydrogen gas may be produced in a hot water system that has not been used for two weeks or more. HYDROGEN GAS IS EXPLOSIVE. If the hot water system has not been used for such a period, before using a washing machine or combination washer-dryer, turn on all hot water faucets and let the water flow from each for several minutes. This will release any accumulated hydrogen gas. THE GAS IS FLAMMABLE, DO NOT SMOKE OR USE AN OPEN FLAME DURING THIS TIME.
6. To reduce the risk of an electric shock or fire, DO NOT use an extension cord or an adapter to connect the washer to the electrical power source.

7. Do not allow children to play on or in the washer. Close supervision of children is necessary when the washer is used near children. This appliance is not intended for use by persons (including children) with reduced physical, sensory or mental capabilities, or lack of experience and knowledge, unless they have been given supervision or instruction concerning the use of the appliance by a person responsible for their safety. This is a safety rule for all appliances.
8. Do not reach into the washer if the washtub is moving.
9. Never operate the washer with any guards, panels and/or parts removed or broken. DO NOT tamper with the controls or bypass any safety devices.
10. DO NOT operate individual units if they have been separated from a stack unit.
11. Use your washer only for its intended purpose, washing clothes. Always follow the fabric care instructions supplied by the garment manufacturer.
12. Always read and follow manufacturer's instructions on packages of laundry and cleaning aids. To reduce the risk of poisoning or chemical burns, keep them out of the reach of children at all times (preferably in a locked cabinet). Heed all warnings or precautions.
13. Do not use fabric softeners or products to eliminate static unless recommended by the manufacturer of the fabric softener or product.
14. Loading door MUST BE CLOSED any time the washer is to fill, tumble or spin. DO NOT bypass the loading door switch by permitting the washer to operate with the loading door open.
15. Be sure water connections have a shut-off valve and that fill hose connections are tight. CLOSE the shut-off valves at the end of each wash day.
16. Keep your washer in good condition. Bumping or dropping the washer can damage safety features. If this occurs, have your washer checked by a qualified service person.
17. Do not repair or replace any part of the washer, or attempt any servicing unless specifically recommended in the user-maintenance instructions or in published user-repair instructions that you understand and have the skills to carry out. ALWAYS disconnect the washer from electrical supply before attempting any service.
18. Disconnect the power cord by grasping the plug, not the cord. If the supply cord is damaged, it must be replaced by a special cord or assembly available from the manufacturer or its service agent.
19. Before the washer is removed from service or discarded, remove the door to the washing compartment.
20. Failure to install, maintain, and/or operate this washer according to the manufacturer's instructions may result in conditions which can produce bodily injury and/or property damage.

NOTA: The WARNING and IMPORTANT SAFETY INSTRUCTIONS appearing in this manual are not meant to cover all possible conditions and situations that may occur. Common sense, caution and care must be exercised when installing, maintaining, or operating the washer.

Always contact your dealer, distributor, service agent or the manufacturer about any problems or conditions you do not understand.

Installation

Dimensions and Specifications

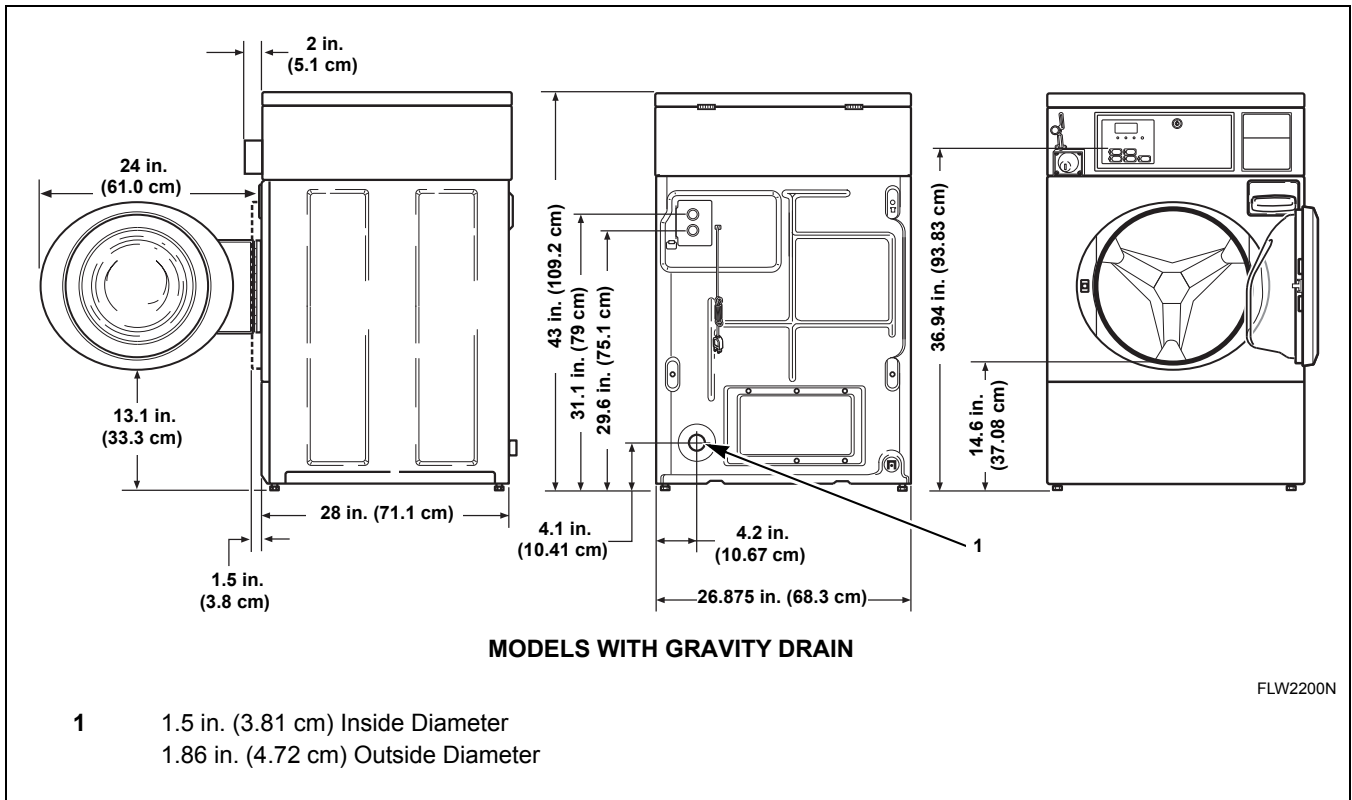
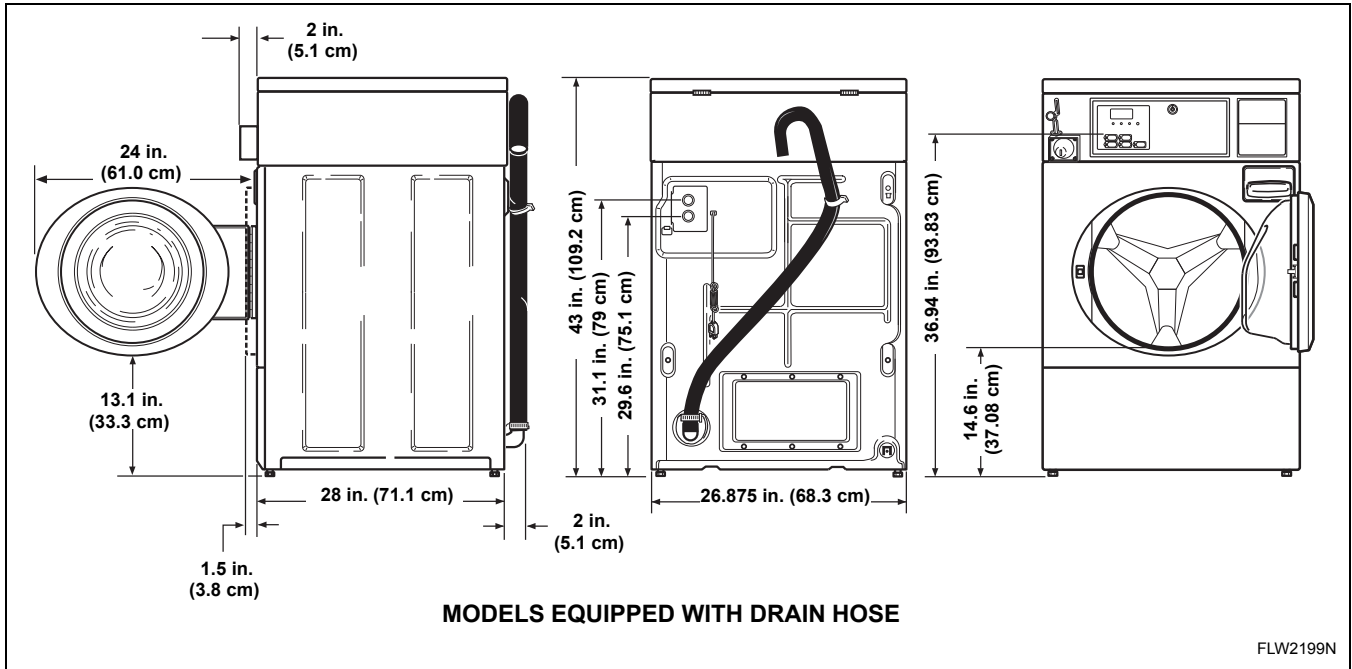

Before You Start

Tools

For most installations, the basic tools you will need are:

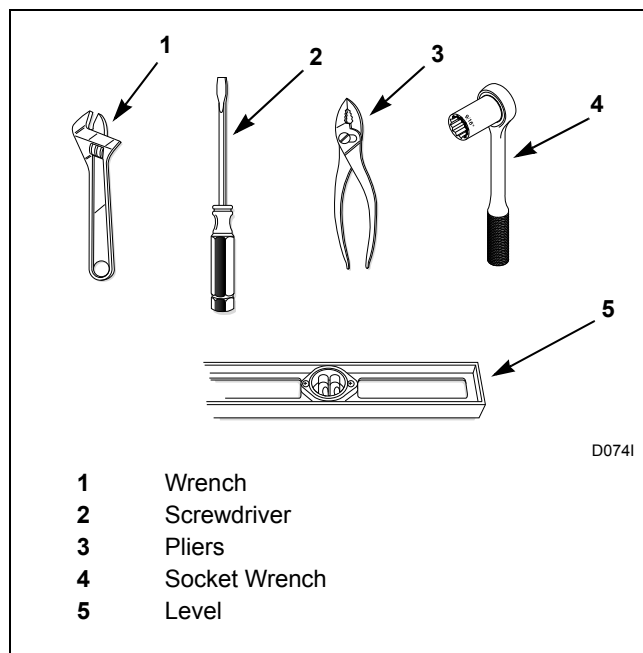

Figure 1

NOTA: An 8 in. (20.32 cm) coin drawer is required for coin operated models.

NOTA: If the washer is delivered on a cold day (below freezing), or is stored in an unheated room or area during the cold months, do not attempt to operate it until the washer has had a chance to warm up.

NOTA: Install dryer before washer. This allows room for attaching exhaust duct.

NOTA: Some moisture in the wash drum is normal. Water is used during testing at the manufacturer.

Installation

Installing the Washer

Step 1: Position Washer Near Installation Area

Move washer so that it is within 4 feet (1.2 meters) of the desired area of installation.

NOTA: For best performance and to minimize vibration or movement, install washer on a solid, sturdy and level floor. Some floors may need to be reinforced, especially on a second floor or over a basement. Do not install the washer on carpeting, soft tile, a platform or other weakly supported structures.

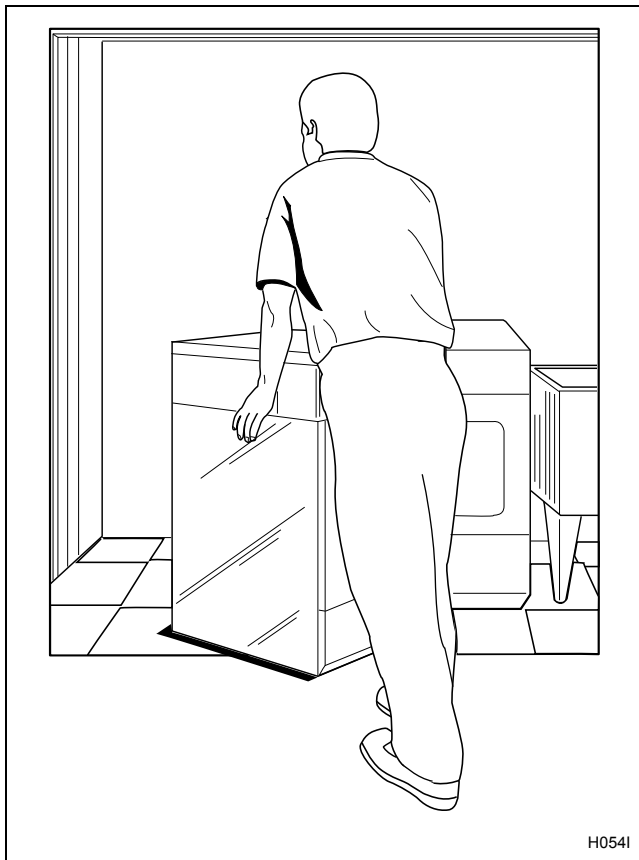

Figure 2

Step 2: Position and Level the Washer

	WARNING
<p>Washers elevated above floor level must be anchored to that elevated surface, base or platform. The material used to elevate the washer should also be anchored to the floor to ensure that the washer will not walk or that the washer can not be physically pulled, tipped or slid from its installed position. Failure to do so may result in conditions which can produce serious injury, death and/or property damage.</p>	
<small>W306</small>	

Position washer so it has sufficient clearance for installation and servicing.

NOTA: Use of the dispenser drawer or washer door as a handle in the transportation of the washer may cause damage to the dispenser or door.

Place washer in position on a solid, sturdy and level floor. Installing the washer on any type of carpeting, soft tile, a platform or other weakly supported structures is not recommended.

Place a level on the cabinet top and check if the washer is level from side to side and front to back.

NOTA: Level must rest on raised portion of top panel. Refer to *Figure 3*.

If washer is not level, tilt washer to access the front and rear leveling legs. For easier access to leveling legs, prop up washer with a wooden block. Refer to *Figure 3*. Loosen 7/8 in. locknut and adjust legs until the washer is level from side to side and front to back (using a level). Washer should not rock.

Tighten the locknuts securely against the washer base using the 7/8 in. wrench. If the locknuts are not tight, washer will move out of position during operation.

NOTA: DO NOT slide washer across floor if the leveling legs have been extended, as legs and base could become damaged.

Remove rubber feet from accessories bag and place on all four leveling legs.

Verify that unit doesn't rock.

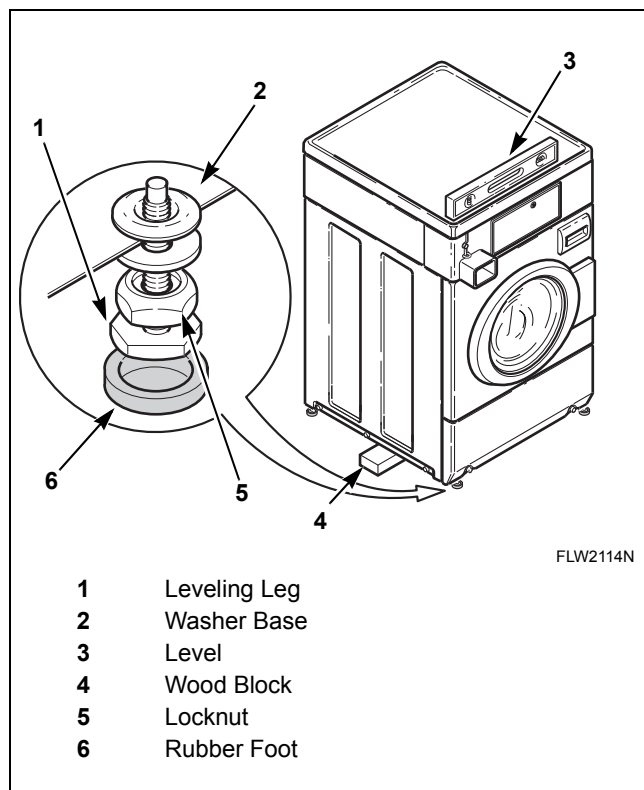

Figure 3

Step 3: Connect Fill Hoses

!

WARNING

Under certain conditions, hydrogen gas may be produced in a hot water system that has not been used for two weeks or more. HYDROGEN GAS IS EXPLOSIVE. If the hot water system has not been used for such a period and before using the washer, turn on all hot water faucets and let the water flow from each for several minutes. This will release any accumulated hydrogen gas. The gas is flammable. Do not smoke or use an open flame during this time.

W029

Water Supply

Water supply faucets must fit standard 3/4 inch (19.1 mm) female garden hose couplings. **DO NOT USE SLIP-ON OR CLAMP-ON CONNECTIONS.**

Water supply faucets should be readily accessible to permit turning them off when washer is not being used.

Recommended cold water temperature is 60° to 80° Fahrenheit (16° to 27 Celsius). Recommended maximum hot water temperature is 125° Fahrenheit (51° Celsius). Warm water is a mixture of hot and cold water. Warm water temperature is dependent upon water temperature and pressure of both the hot and cold water supply lines.

!

WARNING

To prevent personal injury, avoid contact with inlet water temperatures higher than 125° Fahrenheit (51° Celsius) and hot surfaces.

W748

Water pressure must be a minimum of 20 to a maximum of 120 pounds per square inch (138 to 827 kPa) static pressure measured at the faucet.

NOTA: Water pressure under 20 pounds per square inch (138 kPa) will cause an extended fill time in the washer and may not properly flush out the detergent dispenser.

Installation

Turn on the water supply faucets and flush the lines for approximately two minutes to remove any foreign materials that could clog the screens in the water mixing valve.

NOTA: When installing in newly constructed or renovated building, it is very important to flush the lines since build-up may have occurred during construction.

Connecting Hoses

Insert each filter screen into the end of each fill hose that will connect to the water supply faucet. The screen must be facing outward. Refer to *Figure 4*.

Insert each plain rubber washer into the other end of each fill hose that will connect to the water mixing valve at the rear of the washer. Refer to *Figure 4*.

Thread hose couplings onto valve connections finger-tight, then approximately 1/4 turn with pliers.

IMPORTANTE: DO NOT cross thread or overtighten couplings.

Turn water on and check for leaks. If leaks are found, retighten the hose couplings. Continue tightening and rechecking until no leaks are found.

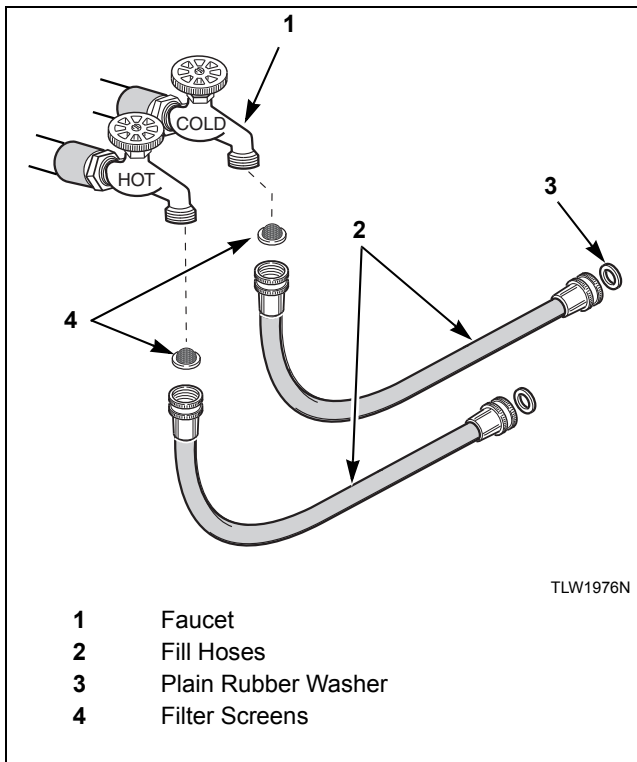

Figure 4

IMPORTANTE: Hoses and other natural rubber parts deteriorate after extended use. Hoses may develop cracks, blisters or material wear from the temperature and constant high pressure they are subjected to.

All hoses should be checked on a monthly basis for any visible signs of deterioration. Any hose showing the signs of deterioration listed above should be replaced immediately. All hoses should be replaced every five years.

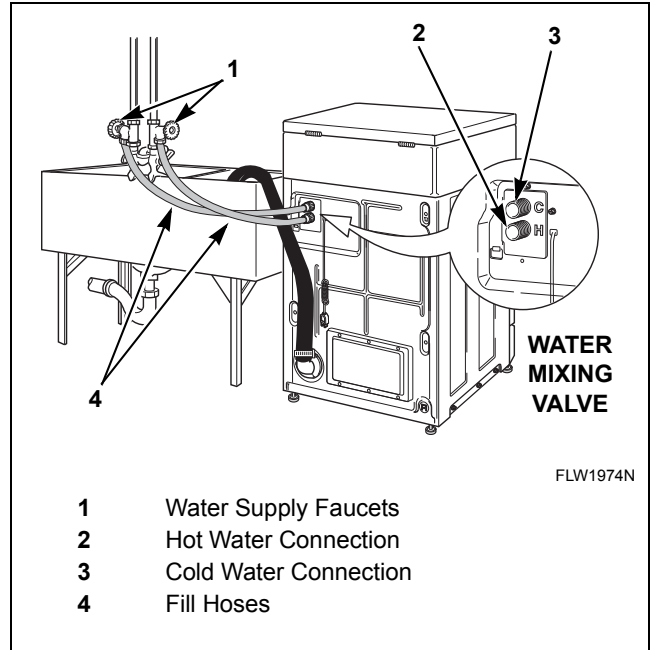

Figure 5

IMPORTANTE: Turn off water supply faucets after check-out and demonstration. Owner should turn off water supply whenever there will be an extended period of non-use.

NOTA: Longer fill hoses are available (as optional equipment at extra cost) if the hoses supplied with the washer are not long enough for the installation. Order hoses as follows:

No. 20617 Fill Hose (8 feet) (2.44 m)

No. 20618 Fill Hose (10 feet) (3.05 m)

Risers

Risers (or air cushions) may have to be installed if the pipes knock or pound when flow of water stops. The risers are more efficient when installed as close as possible to the water supply faucets (refer to *Figure 6*).

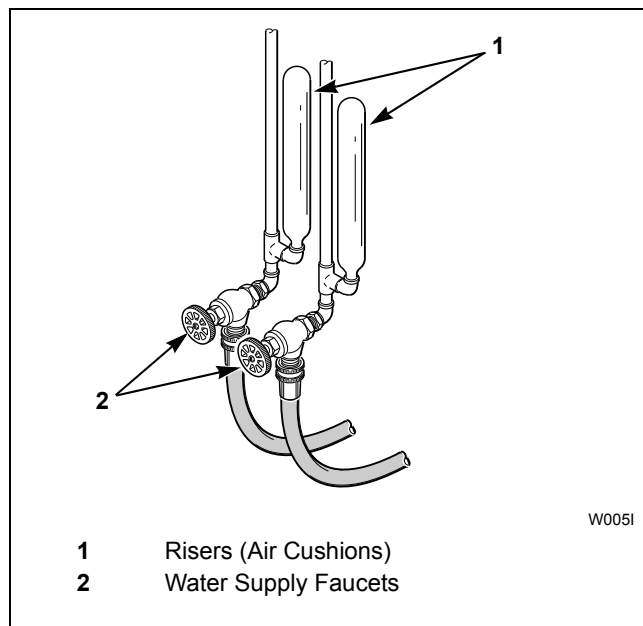

Figure 6

Step 4: (Non-Gravity Drain Models Only) Connect Drain Hose to Drain Receptacle

Remove the drain hose from its shipping position on the rear of the washer by removing the shipping tape.

IMPORTANT: Drain receptacle must be capable of handling a minimum of 1-3/8 inch (3.5 cm) outside diameter drain hose.

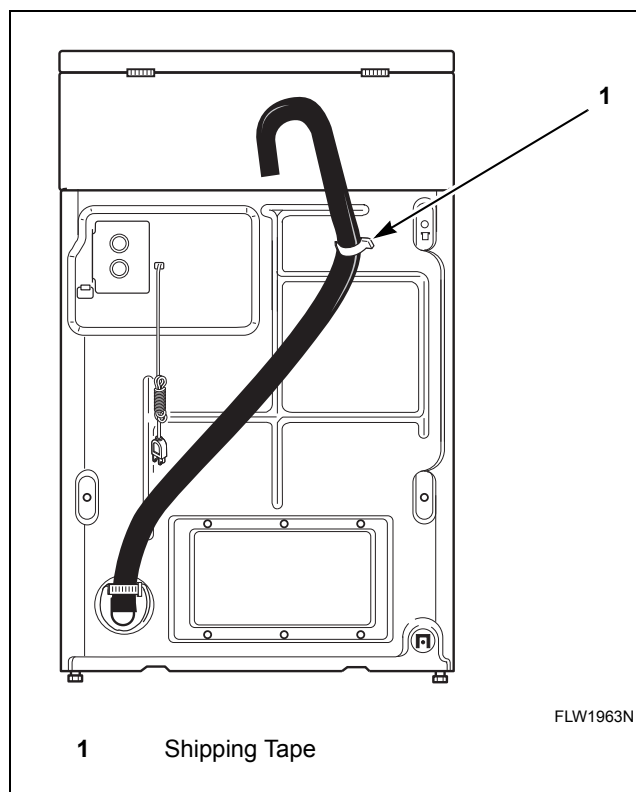

Figure 7

Installation

Standpipe Installation

Place the drain hose into the standpipe.

Remove the beaded tie-down strap from accessories bag and place around standpipe and drain hose and tighten strap to hold hose to standpipe. Refer to *Figure 8*. This will prevent the drain hose from dislodging from drain receptacle during use.

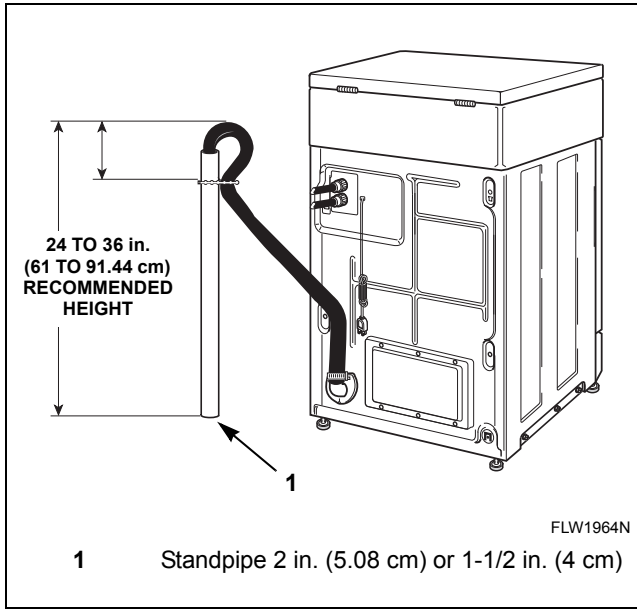

Figure 8

Step 5: (Gravity Drain Models Only) Connect Drain Outlet to Drain System

Remove drain fitting (four inches long) and hose clamp from accessories bag. Insert drain fitting into drain outlet hose. Clamp hose and fitting.

Connect the drain fitting to a vented drain system using a flexible connection (obtain locally). Inside diameter of fitting is 1.53 in. (3.89 cm) and outside diameter is 1.66 in. (4.22 cm). The drain system must be vented to prevent an air lock or siphoning.

IMPORTANT: Increasing the drain hose length, installing elbows, or causing bends will decrease drain flow rates and increase drain times, impairing machine performance.

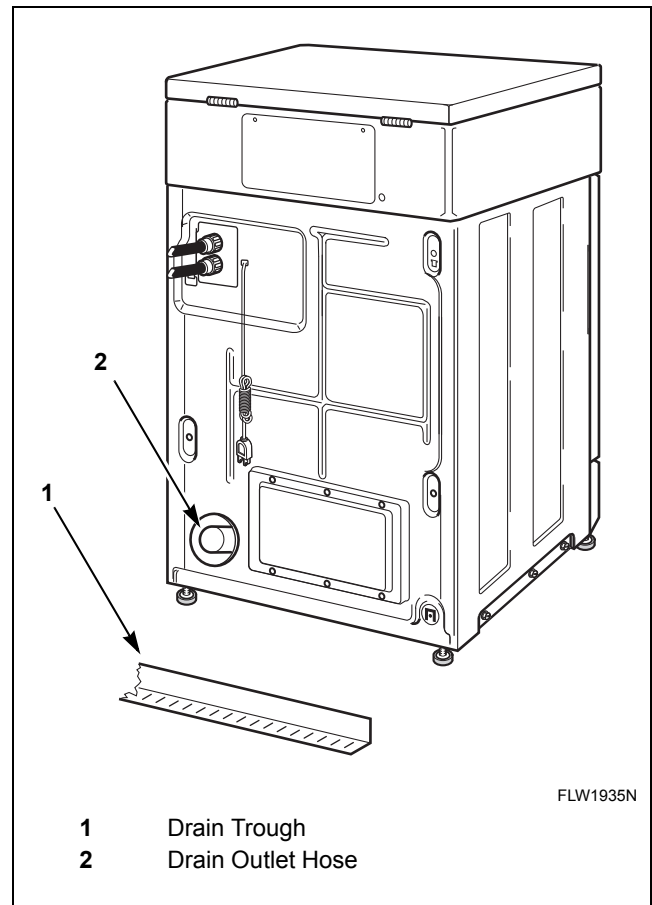

Figure 9

Step 6: Remove the Shock Sleeves and Shipping Brace

Remove front access panel by removing the two screws at the bottom of the panel.

Remove the five bolts and lockwashers from shipping brace with 9/16 in. wrench. Refer to *Figure 10*. One is holding the brace to the weight. Remove this bolt first. Four bolts are located on the washer base. Remove the two front bolts next and then the two rear bolts. Remove all four shock sleeves by pulling on the yellow rope. Remove brace and sleeves from washer.

NOTA: The shipping brace, bolts, washers and shock sleeves should be saved and MUST be reinstalled whenever the washer is moved more than four feet. Refer to *User-Maintenance* section for instructions. Do not lift or transport washer from front or without shipping materials installed.

Store the shipping materials in the accessories bag. Save materials for use whenever the washer is moved.

Reinstall front access panel.

IMPORTANTE: DO NOT tip washer more than 6 inches (152.4 mm) in any direction after shipping brace has been removed. Shock absorbers may separate and damage to washer may result. For leveling purposes, the washer may be tilted a maximum of 6 inches (152.4 mm) in any direction.

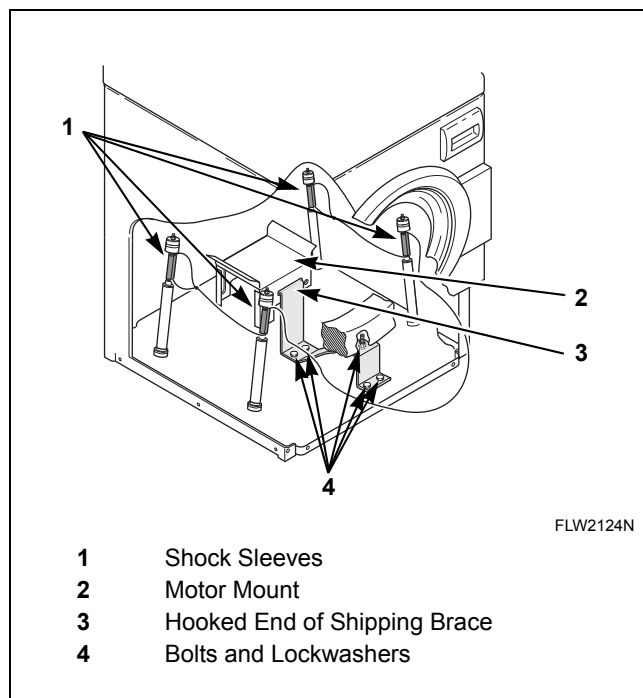

Figure 10

Step 7: Wipe Out Inside of Wash Drum

Before using washer for the first time, use an all-purpose cleaner, or a detergent and water solution, and a damp cloth to remove shipping dust from inside wash drum.

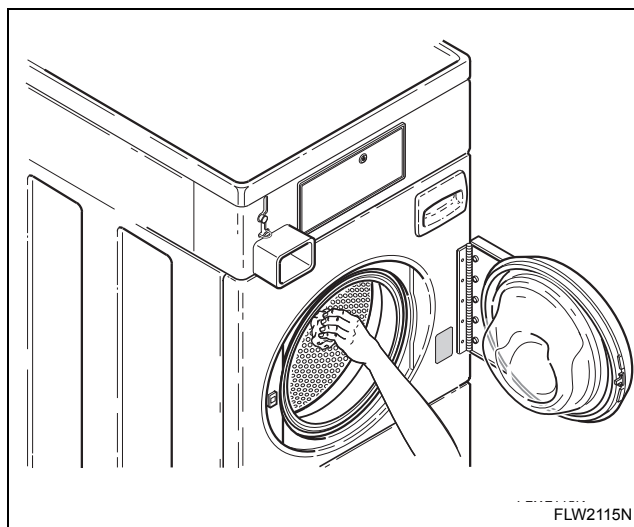

Figure 11

Step 8: (Supply Injection Models Only) Connect External Supplies to Washer

IMPORTANTE: Undiluted chemical dripping can damage the washer.

1. Remove two nozzles from accessories bag. Use either the 3/8 inch or 1/4 inch nozzles, depending on the diameter of the dispenser tubing used.
2. Attach nozzles to rear of machine. Connection point located on cabinet, above water mixing valve. Refer to *Figure 12*.
3. Connect supply hoses to nozzles and secure with hose clamps (obtain locally). Refer to *Figure 12*.

NOTA: Hoses can be connected to either nozzle.

4. Refer to supply injection system instructions and label inside washer junction box cover (*Figure 13*) for electrical connection.

Do not attempt to make supply injection electrical connections to points other than those provided specifically for that purpose by the factory.

5. Refer to supply injection system instructions for details on operation.

Installation

Supply Injection System	
Number of liquid supply connections (1–Detergent and 2–Softener)	2
Liquid supply connection size, in. (mm)	3/8 (9.52) or 1/4 (6.35)

WARNING

Wear eye and hand protection when handling chemicals; always avoid direct contact with raw chemicals. Read the manufacturer's directions for accidental contact before handling chemicals. Ensure an eye-rinse facility and an emergency shower are within easy reach. Check at regular intervals for chemical leaks.

SW016

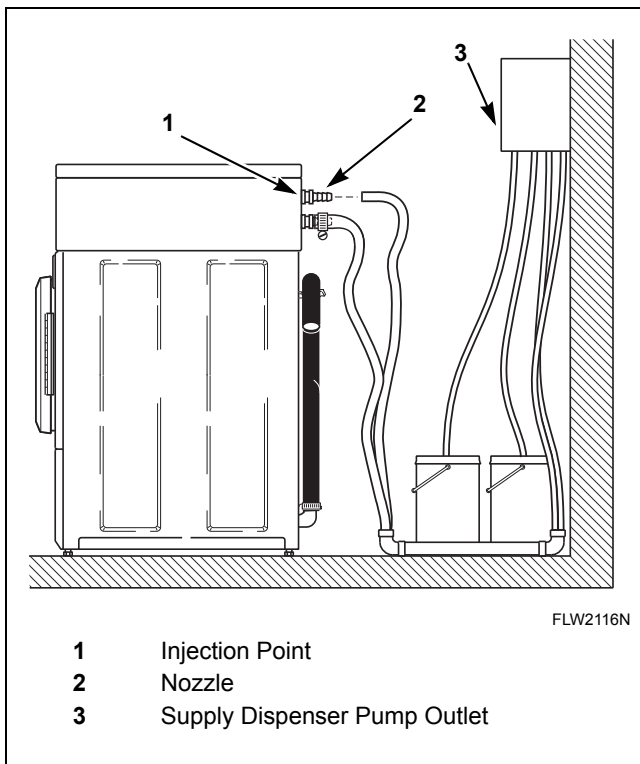

Figure 12

A junction box on the rear panel houses a terminal strip which furnishes supply output signals for the supply injection pumps. These are dry contacts. Voltage needs to be supplied. Refer to *Figure 13* for the injection interface label.

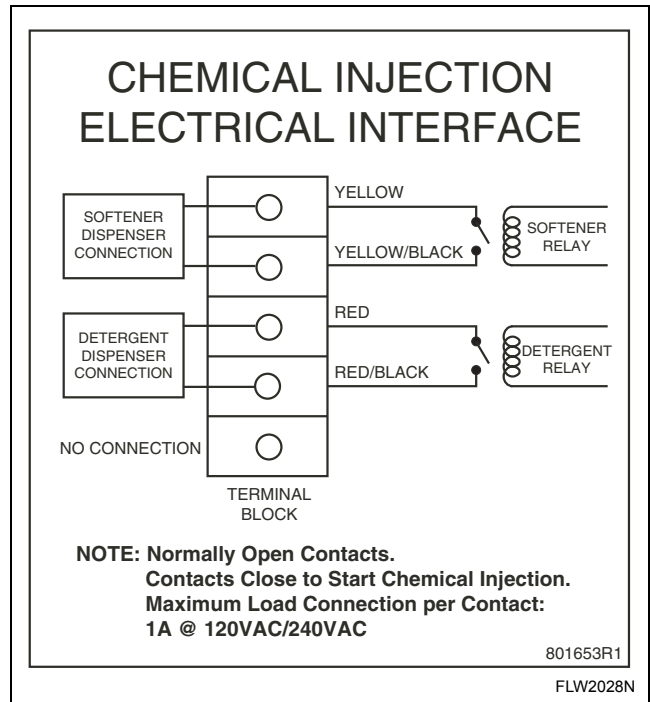

Figure 13

These terminals may be used to provide signals to the supply injection system but must not be used to provide power to the actual pump.

Any injection system pump which requires 110 VAC must be powered by a separate external power source.

Control Function Test

The washer should be cleaned after the installation is complete. A function test should then be executed on the unloaded machine:

1. Check the power supply for such characteristics as correct voltage, phase, and cycles to be certain they are correct for the washer.
2. Open manual shut-off valves to the washer.
3. Apply power to the washer.

Step 9: Plug In the Washer

Electrical Requirements

(120 Volt, 60 Hertz with 3-Prong Grounding Plug)

NOTA: The wiring diagram is located in the control cabinet.

	WARNING
<p>To reduce the risk of fire, electric shock, serious injury or death, all wiring and grounding MUST conform with the latest edition of the National Electrical Code, ANSI/NFPA No. 70, and such local regulations as might apply. It is the customer's responsibility to have the wiring, fuses and circuit breakers installed by a qualified electrician to make sure adequate electrical power is available to the washer.</p>	
	W518

When plugging in the washer:

- DO NOT overload circuits.
- DO NOT use an extension cord.
- DO NOT use an adapter.
- DO NOT operate other appliances on the same circuit. Use separately fused 15 Amp circuits.

The washer is designed to be operated on a separate branch, polarized, three-wire, effectively grounded, 120 Volt, 60 Hertz, AC (alternating current), circuit protected by a **15 ampere fuse**, equivalent fusetrone or circuit breaker.

The three-prong grounding plug on the power cord should be plugged directly into a polarized three-slot effectively grounded receptacle rated 110/120 Volts AC (alternating current) 15 Amps. Refer to *Figure 14* to determine correct polarity of the wall receptacle.

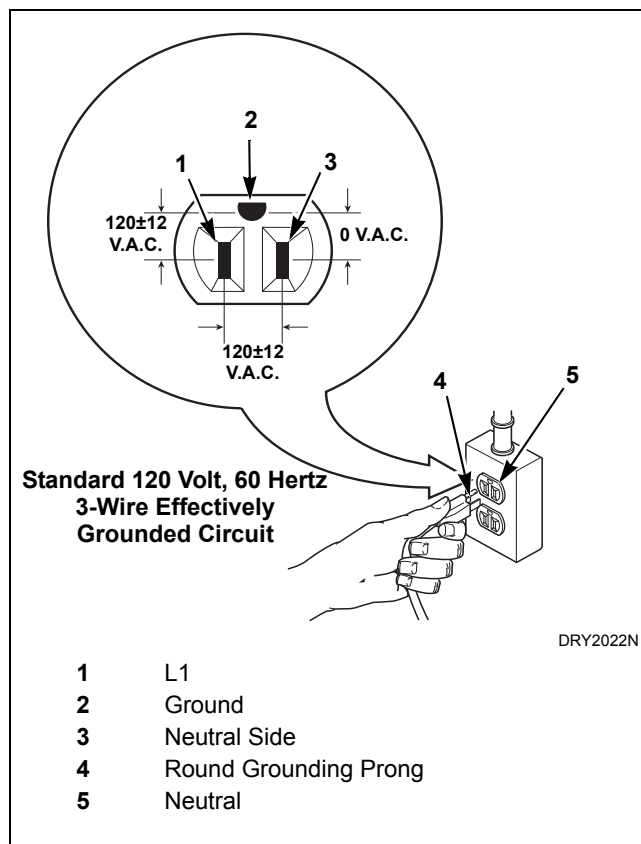



Figure 14

	WARNING
<p>To reduce the risk of an electric shock or fire, DO NOT use an extension cord or an adapter to connect the washer to the electric power source.</p>	
	W082

Installation

Grounding Instructions

The washer must be grounded. In the event of malfunction or breakdown, grounding will reduce the risk of electric shock by providing a path of least resistance for electric current.

The washer is equipped with a cord having an equipment-grounding conductor and a three-prong grounding plug. The plug must be plugged into an appropriate outlet that is properly installed and grounded in accordance with all local codes and ordinances.

	WARNING
<p>Improper connection of the equipment-grounding conductor can result in a risk of electric shock. Check with a qualified electrician or service person if you are in doubt as to whether the washer is properly grounded.</p>	
<small>W327</small>	

DO NOT modify the plug provided with the washer – if it will not fit the outlet, have a proper outlet installed by a qualified electrician.

NOTA: Have a qualified electrician check the polarity of the wall receptacle. If a voltage reading is measured other than that in *Figure 14*, the qualified electrician should correct the problem.

Step 10: Check Installation

Refer to *Installer Checklist* on the back cover of this manual and make sure that washer is installed correctly.

Run washer through one complete cycle to make sure it is operating properly.

Operation

Operation Instructions for MDC Washers

IMPORTANTE: Prior to first wash, use an all-purpose cleaner, or a detergent and water solution, and a damp cloth to remove shipping dust from inside of washtub.

IMPORTANTE: Remove all sharp objects from laundry to avoid tears and rips to items during normal machine operation.

Step 1: Load Laundry

Load items loosely into wash drum.

NOTA: Small items such as baby socks may get caught around the door. Place these articles inside a mesh garment bag.



Figure 15

When washing bulky items such as blankets and comforters, use the DELICATES COLD cycle. The cycle includes agitation and final spin speeds that maintain the load's balance and minimize wear to the articles.

Step 2: Close Loading Door

Close loading door tightly. The washer will not operate with the loading door open.

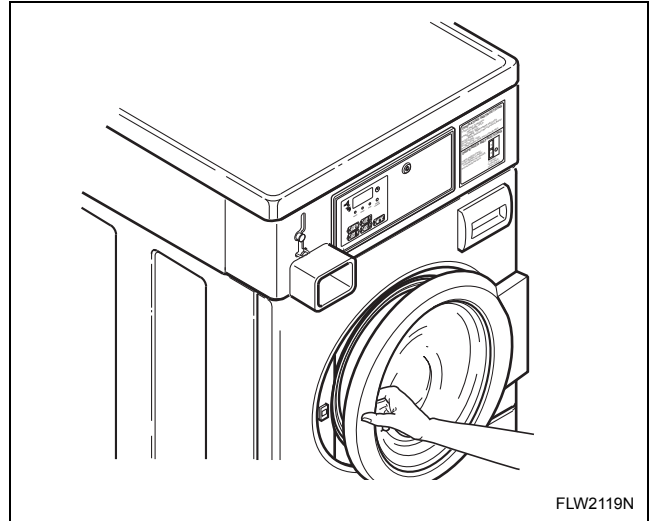

Figure 16

Operation

Step 3: Add Laundry Supplies

Open dispenser drawer. Measure and add low sudsing, high efficiency (HE) detergent (1), bleach (2) and fabric softener (3) to the dispenser drawer (refer to *Figure 17*). Close dispenser drawer.

IMPORTANTE: If using non-HE detergent, avoid oversudsing by using 1/2 of the detergent manufacturer's recommended amount.

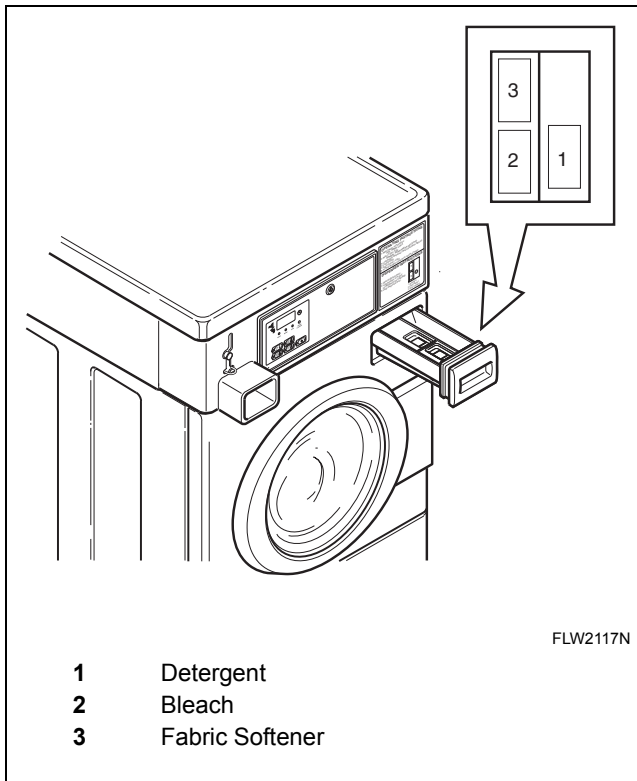



Figure 17

	CAUTION
Dispenser drawer requires a special tool for removal. Contact a service person if removal is necessary.	
W236	

Step 4: Set Fabric Selector and Wash Temperature

Push touchpad for **NORMAL/HOT**, **NORMAL/WARM**, **PERM PRESS/WARM** or **DELICATES/COLD** cycle. Light indicates selection.

NOTA: Changes can be made to Fabric Selector setting up until the first fill is complete.

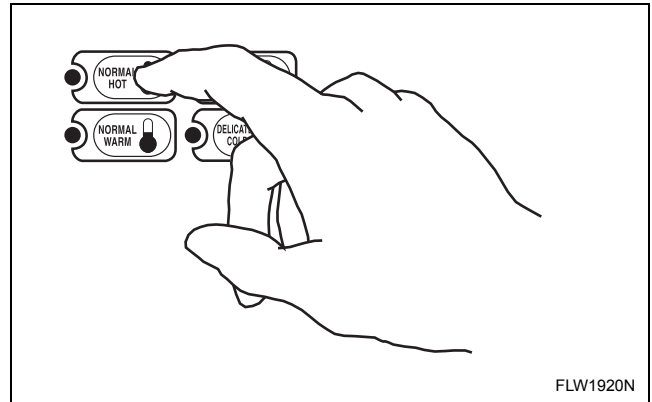

Figure 18

Step 5: Insert Coin(s) or Card

To Insert Money

Insert coin(s) in coin slot. Check pricing as seen on digital display.

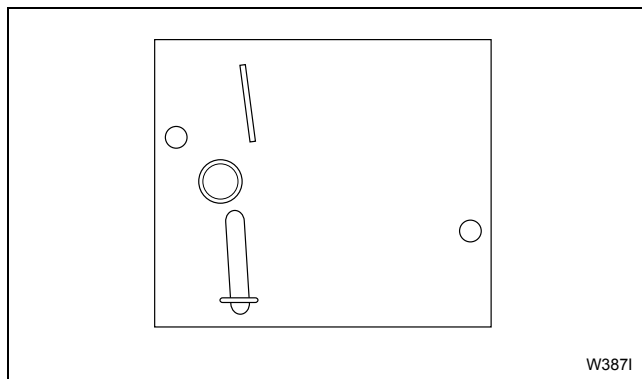

Figure 19

To Insert Card

Insert card into opening.



Figure 20

Step 6: Start Washer

After vend price has been satisfied, push the **START** pad. **DOOR MUST BE CLOSED TO START WASHER.**

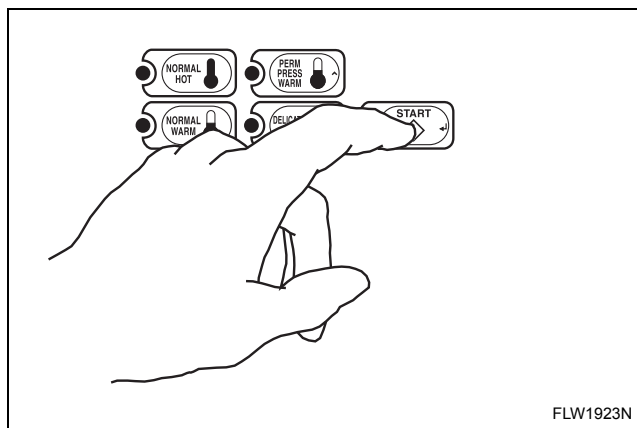

Figure 21

Operation

Indicator Lights

WASH

WASH is lit at the beginning of a wash cycle and will remain lit until the wash cycle is complete.

RINSE

RINSE is lit at the beginning of all RINSE cycles and will remain lit until the rinse cycle is complete.

SPIN

SPIN is lit for all spin cycles.

START

START flashes one second on and one second off when the full vend price has been satisfied.

DOOR LOCKED

DOOR LOCKED is lit whenever the door is locked. The door cannot be opened when this light is on.

IMPORTANTE: If washer fails to operate properly after installation, make sure electrical service and water supply faucets are turned on. Are all the controls properly set? Have a qualified service person refer to the wiring diagram (located inside of washer control cabinet) and check for broken, loose or incorrect wiring.

NOTA: Once a cycle has started, the door can only be opened by first unplugging the power cord and waiting one minute.

	WARNING
To reduce the risk of bodily injury, do not remove laundry from washer until all lights are out, and all moving parts have stopped.	
<small>W092</small>	

Operation Instructions for NetMaster Washers

IMPORTANTE: Prior to first wash, use an all-purpose cleaner, or a detergent and water solution, and a damp cloth to remove shipping dust from inside of washtub.

IMPORTANTE: Remove all sharp objects from laundry to avoid tears and rips to items during normal machine operation.

Step 1: Load Laundry

Load items loosely into wash drum.

NOTA: Small items such as baby socks may get caught around the door. Place these articles inside a mesh garment bag.



Figure 22

When washing bulky items such as blankets and comforters, use the DELICATES cycle. The cycle includes agitation and final spin speeds that maintain the load's balance and minimize wear to the articles.

Step 2: Close Loading Door

Close loading door tightly. The washer will not operate with the loading door open.

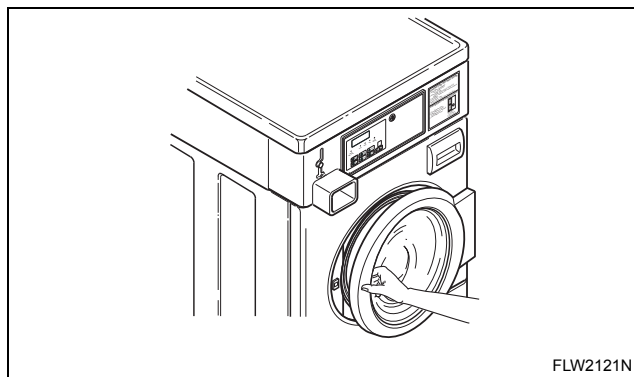

Figure 23

Operation

Step 3: Add Laundry Supplies

Open dispenser drawer. Measure and add low sudsing, high efficiency (HE) detergent (1), bleach (2) and fabric softener (3) to the dispenser drawer (refer to *Figure 24*). Close dispenser drawer.

IMPORTANTE: If using non-HE detergent, avoid oversudsing by using 1/2 of the detergent manufacturer's recommended amount.

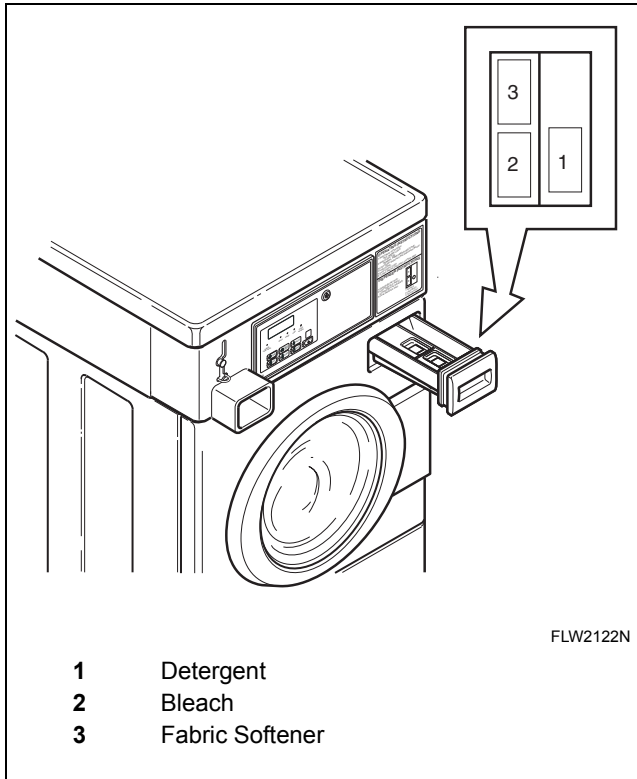

Figure 24

	CAUTION
Dispenser drawer requires a special tool for removal. Contact a service person if removal is necessary.	
W236	

Step 4: Set Fabric Selector

Push touchpad for **NORMAL**, **PERM PRESS** or **DELICATES** cycle. Light indicates selection.

NOTA: Changes can be made to Fabric Selector setting up until the first fill is complete.

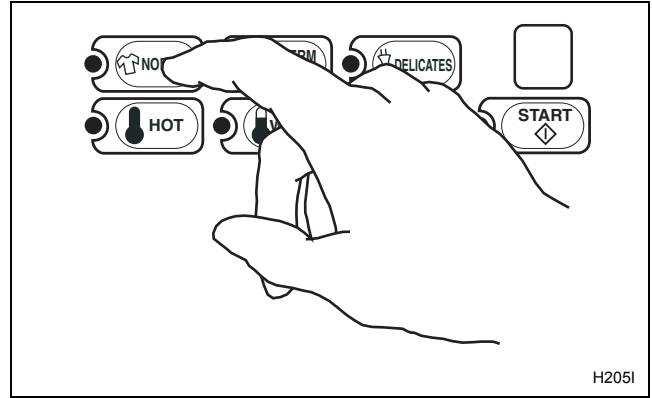

Figure 25

Step 5: Set Wash Temperature

Push touchpad for **HOT**, **WARM** or **COLD**. Light indicates selection.

NOTA: Always follow manufacturer's care labels.

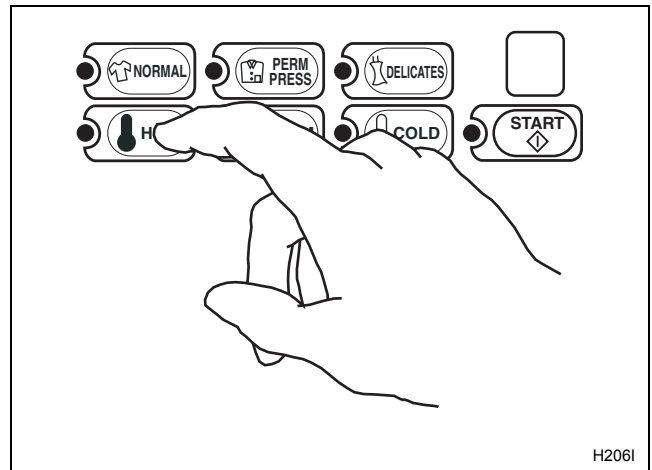

Figure 26

Step 6: Insert Coin(s) or Card

To Insert Money

Insert coin(s) in coin slot. Check pricing as seen on digital display.

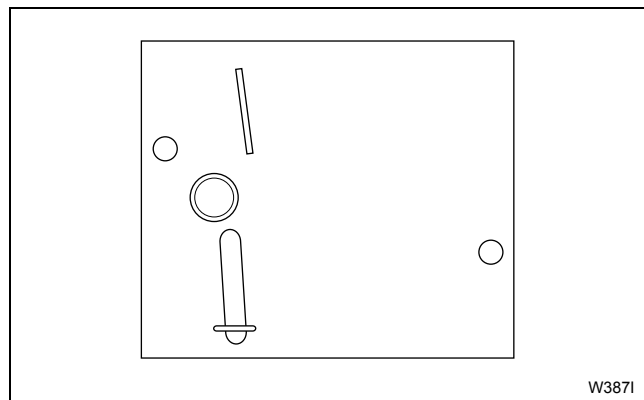

Figure 27

To Insert Card

Insert card into opening. Do not remove the card until REMOVE CARD LED is lit.

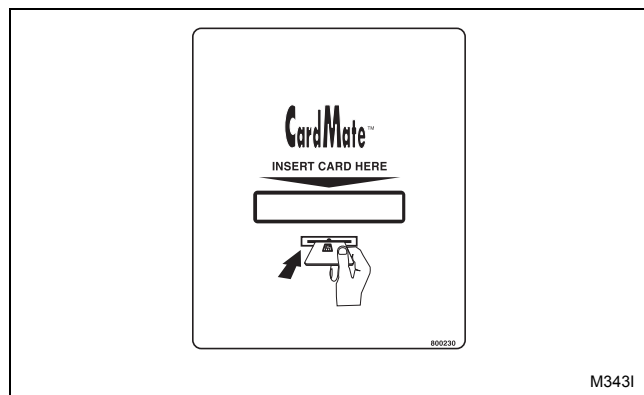

Figure 28

Step 7: Start Washer

After vend price has been satisfied, push the **START** pad. **DOOR MUST BE CLOSED TO START WASHER.**

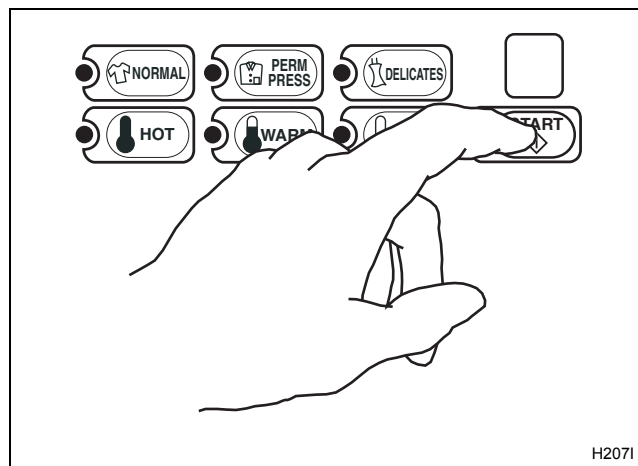

Figure 29

Indicator Lights

WASH

WASH is lit at the beginning of a wash cycle and will remain lit until the wash cycle is complete.

RINSE

RINSE is lit at the beginning of the RINSE or EXTRA RINSE cycle and will remain lit until the rinse cycle is complete.

SPIN

SPIN is lit for all spin cycles.

DOOR LOCKED

DOOR LOCKED is lit whenever the door is locked. The door cannot be opened when this light is on.

Operation

INSERT COIN/CARD

INSERT COIN/CARD is lit to prompt the user to insert coins or card to satisfy the vend price. When *INSERT COIN/CARD* is lit, the digits and decimal point show the vend price remaining to be satisfied.

REMOVE CARD (Card Models Only)

REMOVE CARD flashes after the **START** pad has been pressed and the vend has been deducted from the card.

IMPORTANTE: If washer fails to operate properly after installation, make sure electrical service and water supply faucets are turned on. Are all the controls properly set? Have a qualified service person refer to the wiring diagram (located inside of washer control cabinet) and check for broken, loose or incorrect wiring.

NOTA: Once a cycle has started, the door can only be opened by first unplugging the power cord and waiting one minute.



WARNING

To reduce the risk of bodily injury, do not remove laundry from washer until all lights are out, and all moving parts have stopped.

W092

Maintenance

User-Maintenance Instructions

Lubrication

All moving parts are sealed in a permanent supply of lubricant or are equipped with oilless bearings. Additional lubrication will not be necessary.

Do not lubricate the door hinge. If the hinge makes noise, replace the hinge.

Cold Weather Care

If the washer is delivered on a cold day (below freezing), or is stored in an unheated room or area during the cold months, do not attempt to operate it until the washer has had a chance to warm up.

Care of Your Washer

Use only a damp or sudsy cloth for cleaning the control panel. Some cleaning product sprays may harm the finish on the control panel or damage the interior.

Wipe the washer cabinet as needed. If detergent, bleach or other washing products are spilled on the cabinet, wipe immediately. Some products will cause permanent damage if spilled on the cabinet.

Do not use scouring pads or abrasive cleansers.

The wash drum will need no particular care although it may need rinsing or wiping after an unusual load has been washed.

The outside of the door window can be cleaned with household window cleaner.

Running an occasional rinse cycle with bleach will help to avoid a musty smell in the wash drum.

Cleaning Glass Sealing Area

In order to assure that the door properly seals against water leaks, the following surfaces should be wiped off periodically:

- The outside perimeter of the door glass where the seal contacts the glass
- The front surface of the door seal lip

Usually a mild soap solution will work. If there is an extreme build-up of minerals from a hard water supply, the surfaces may need to be cleaned with a lime removal chemical.

Replacing Hoses

Hoses and other natural rubber parts deteriorate after extended use. Hoses may develop cracks, blisters or material wear from the temperature and constant high pressure they are subjected to.

All hoses should be checked on a monthly basis for any visible signs of deterioration. Any hose showing the signs of deterioration listed above should be replaced immediately. All hoses should be replaced every five years.

Filter Screens

Check the filter screens in the fill hoses for debris or damage annually. Clean or replace them if necessary.

If the washer is filling with water slower than normal, check the filter screens. Clean or replace them if necessary.

Order filter screen Part No. F270300 from the nearest authorized parts distributor.

Vacations and Extended Non-Use

IMPORTANTE: To avoid possible property damage due to flooding, turn off the water supply to the washer whenever there will be an extended period of non-use.

Maintenance

Reinstallation of Shipping Materials

To prevent damage while moving the washer, the shipping materials **MUST** be reinstalled.

- Disconnect washer from electrical supply.
- While supporting the front access panel, remove two screws from the bottom edge of the panel.
- Gently lower the panel to remove it from the washer.
- Place the shock sleeves on all four shock absorbers. Refer to *Figure 30*.
- Insert hooked end of shipping brace into the open slot of the motor mount. Refer to *Figure 30*.
- Attach the brace with the five bolts and washers. Refer to *Figure 30*.
- Reinstall front access panel.

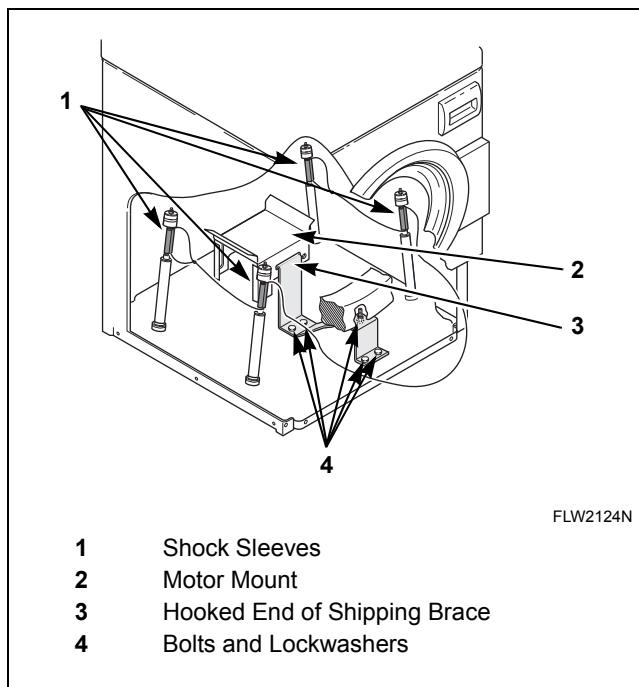

Figure 30

Refer to **Installation** section, step 6 for proper procedures whenever the washer is moved.

Cleaning Foreign Object Trap

The washer's pump has a trap that may collect foreign objects. The trap may need to be cleaned if water is draining slower than usual. To clean:

- Disconnect washer from electrical supply.
- While supporting the front access panel, remove two screws from the bottom edge of the panel.
- Gently lower the panel to remove it from the washer.

NOTA: The pump may have some water in it. Use a rag or a container to catch water. If the wash drum is full of water, use a wet/dry shop vacuum to catch the water.

- With rag or vacuum ready, unscrew the cap on the left side of the pump and remove trap.
- Clean the debris from the trap.
- Reinstall the trap and access panel.
- Reconnect washer to electrical supply.

Troubleshooting

Try these troubleshooting tips before making a service call. They may save time and money.

Washer Symptom	Possible Cause/Solution
Won't Fill	<ul style="list-style-type: none"> • Make sure power cord is plugged all the way into the electrical outlet. • Make sure hot and cold water faucets are turned on. • Make sure that the fill hoses are not kinked or twisted. • Press START keypad. • Make sure that the controls are properly set. • Make sure that the loading door is closed tightly. • Check the laundry room fuse or circuit breaker. • Clean the screens in the water mixing valve and the filter screens located at the faucet end of the fill hoses.
Won't Start	<ul style="list-style-type: none"> • Make sure loading door is closed tightly. • Press START keypad. • Make sure power cord is plugged all the way into the electrical outlet. • Check the laundry room fuse or circuit breaker. • Insert coin(s) or card. • Make sure door latch is properly adjusted relative to door lock.
Won't Spin/Tumble	<ul style="list-style-type: none"> • Make sure loading door is closed tightly. • Press START keypad. • Make sure power cord is plugged all the way into the electrical outlet. • Make sure controls are properly set. • Check the laundry room fuse or circuit breaker. • Broken drive belt. Call the service person. • Foreign object trap in pump may be clogged. Clean the trap. Refer to <i>Maintenance</i> section.
Stops/Pauses During Cycle	<ul style="list-style-type: none"> • Pauses are part of the washer's normal operation. • Wash load may be unbalanced. Washer will stop and then restart spin automatically. • Check the laundry room fuse or circuit breaker.
Won't Drain	<ul style="list-style-type: none"> • Make sure drain hose is not kinked or twisted. • Make sure drain hose is not clogged. • Make sure drain receptacle is not clogged. • Refer to the <i>Installation</i> section to make sure that the drain hose has been properly installed. • Foreign object trap in pump may be clogged. Clean the trap. Refer to <i>Maintenance</i> section.
Water Leaks	<ul style="list-style-type: none"> • Check that fill hoses are properly installed on the faucets and the washer's water mixing valve. • Check the condition of the fill hoses. Replace fill hoses every five years. • Check the condition of the rubber door gasket for tears or holes. • Make sure drain receptacle is not clogged. • Check building plumbing. • Laundry load may be oversudsing or overloaded. Make sure you are using low-sudsing, high efficiency (HE) detergent and proper load sizes. • Make sure outside perimeter of the door glass where seal contacts glass is clean.
Too Many Soap Suds	<ul style="list-style-type: none"> • Laundry load may be oversudsing. Make sure you are using low sudsing, high efficiency (HE) detergent. • Make sure you are using the amount of detergent recommended on the detergent's label. If using non-HE detergent, use only 1/2 of the detergent manufacturer's recommended amount. • Laundry load may be overloaded. Make sure you are using proper load sizes.

Troubleshooting

Washer Symptom	Possible Cause/Solution
Vibrates/Moves Slightly	<ul style="list-style-type: none">• Make sure washer is level. Uneven leveling can cause vibration.• Make sure washer is installed on a solid, sturdy and level floor. The washer should not be installed on carpeting, soft tile, a platform or other weakly supported structures.• Make sure rubber feet are installed on all four leveling legs. Refer to <i>Installation</i> section, step 5.
Is Noisy	<ul style="list-style-type: none">• Make sure washer is level. Uneven leveling can cause vibration.• Some sounds may be a part of normal operation for a frontload washer.
Load is too Wet	<ul style="list-style-type: none">• Wash load may be unbalanced. The washer may have limited the spin speed to prevent damage to the machine. Redistribute the load.• Load is too small. Add items to make full load.
Wrong Water Temperature	<ul style="list-style-type: none">• Make sure that the controls are properly set.• Check fill hoses. Make sure hot faucet hose is connected to hot mixing valve (indicated with “H” on the valve bracket) and cold faucet is connected to cold mixing valve (indicated with “C” on the valve bracket).• Make sure laundry room water heater is adjusted properly.

Contact Information

If service is required, contact the nearest Factory Authorized Service Center.

If you are unable to locate an authorized service center or are unsatisfied with the service performed on your unit, contact:

Alliance Laundry Systems
Shepard Street
P.O. Box 990
Ripon, WI 54971-0990
U.S.A.
www.comlaundry.com
Phone: (920) 748-3121

When calling or writing about your unit, PLEASE GIVE THE MODEL AND SERIAL NUMBERS. The model and serial numbers are located on the nameplate. The nameplate will be in the location shown in *Figure 31*.

Date Purchased _____

Model Number _____

Serial Number _____

Please include a copy of your bill of sale and any service receipts you have.

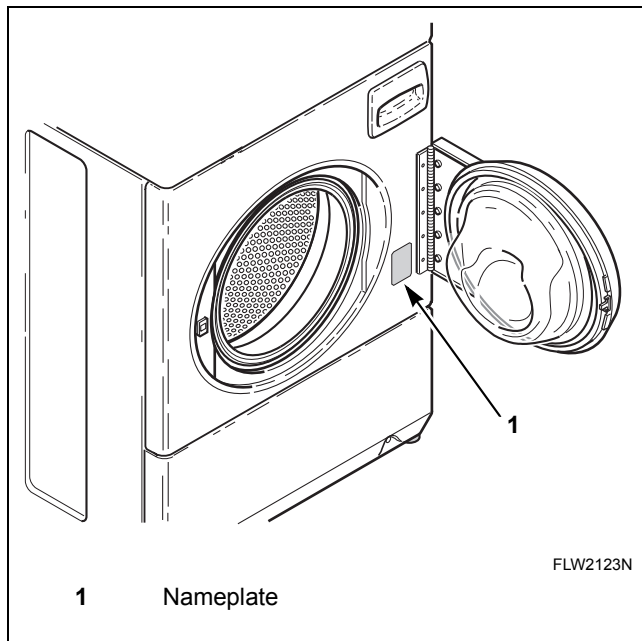

Figure 31



WARNING

To reduce the risk of serious injury or death, DO NOT repair or replace any part of the unit or attempt any servicing unless specifically recommended in the user-maintenance instructions or in published user-repair instructions that you understand and have the skills to carry out.

W329

If replacement parts are required, contact the source from where you purchased your washer or call (920) 748-3950 for the name and address of the nearest authorized parts distributor.

Installer Checklist

Fast Track for Installing the Washer

(Refer to the manual for more detailed information)

1 • Position Washer Near Installation Area.

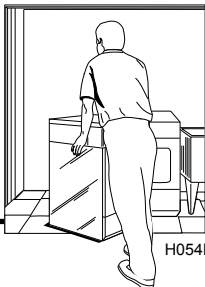

CHECK

H054IE0A

5 - (Gravity Drain Models Only)

- Connect Drain Outlet to Drain System.

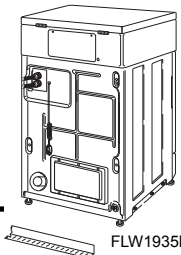

CHECK

FLW1935N

2 • Position and Level the Washer.

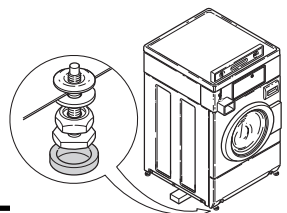

CHECK

FLW2114N

6 • Remove the Shock Sleeves and Shipping Brace.

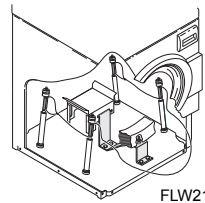

CHECK

FLW2124N

3 • Connect Fill Hoses.

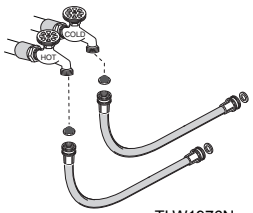

CHECK

TLW1976N

7 • Wipe Out Inside of Wash Drum.

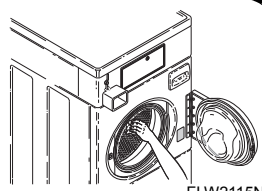

CHECK

FLW2115N

4 - (Non-Gravity Drain Models Only)

- Connect Drain Hose to Drain Receptacle.

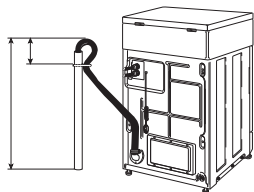

CHECK

FLW1964N

8 - (Supply Injection Models Only)

- Connect External Supplies to Washer.

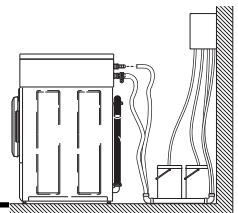

CHECK

FLW2116N

9 • Plug In the Washer.

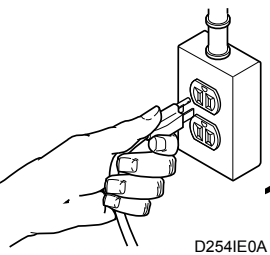

CHECK

D254IE0A