



Operator Manual

Our energy working for you.™



Generator Set with PowerCommand® 3100 Controller

DFHA (Spec A–J)
DFHB (Spec A–J)
DFHC (Spec A–J)
DFHD (Spec A–J)

Table of Contents

SECTION	TITLE	PAGE
	IMPORTANT SAFETY INSTRUCTIONS	iii
1	INTRODUCTION	
	About this Manual	1-1
	Test Equipment	1-1
	How To Obtain Service	1-1
	System Overview	1-2
	Generator Set Control Function	1-2
2	CONTROL OPERATION	
	General	2-1
	Safety Considerations	2-1
	Sequence of Operation	2-2
	PCC Power On/Standby Mode	2-2
	Front Panel	2-4
	Menu Display and Switches	2-6
	Main Menu	2-6
	Engine Menu	2-8
	Gen Menu	2-10
3	CIRCUIT BOARDS AND MODULES	
	General	3-1
	Digital Board (A32)	3-3
	Engine Interface Board (A31)	3-4
	Analog Board (A33)	3-6
	Digital Display Board (A35)	3-7
	Customer Interface Board (A34)	3-8
	PT/CT Board (A36)	3-10
	Bus PT Board (A39)	3-11
	Genset Communications Module (A41)	3-12
	Voltage Regulator Output Module (A37)	3-13
	Governor Output Module (A38)	3-14
	Master First Start Sensor	3-15
4	TROUBLESHOOTING	
	General	4-1
	Safety Considerations	4-1
	Status Indicators	4-2
	Resetting the Control	4-2
	Warning and Shutdown Codes	4-3
	PCC Oil Pressure Warning and Shutdown Limits	4-12
	Troubleshooting Procedure	4-13
	PCC Fuses	4-57
	Rack Position Fault/Test Procedure	4-58
	Load Sharing Controls Troubleshoot Procedure	4-59

SECTION	TITLE	PAGE
5	CONTROL SERVICE AND CALIBRATION	
	General	5-1
	Circuit Board Removal/Replacement	5-1
	Initial Start Setup Menu	5-4
	Adjust Menu	5-6
	Setup and Calibration Menus	5-8
	Calibration Procedure	5-28
	Engine Torque Adjustment	5-30
	Accessory Box Control Components	5-31
	Engine Sensors	5-44
	Magnetic Speed Pickup Unit (MPU) Installation	5-45
	Current Transformer (CT) Installation	5-46
	Digital Board (A32) Calibration	5-47
6	SERVICING THE GENERATOR	
	General	6-1
	Generator/PCC Control Isolation Procedure	6-2
	Testing the Generator	6-3
	Exciter Stator	6-5
	Exciter Rectifier Bridge (Rotating Rectifier Assembly)	6-6
	Exciter Rotor	6-7
	Main Rotor (Generator Field)	6-8
	Main Stator	6-9
	Testing the PMG	6-10
	Bearing Inspection/Removal/Replacement	6-11
	Generator Disassembly	6-13
	Generator Reassembly	6-22
	Aligning Generator with Engine	6-25
7	DAY TANK FUEL TRANSFER PUMP AND CONTROL	
	Operation	7-2
	Wiring Connections	7-4
	Fuel Transfer Pump Motor Connections	7-6
	Testing the Float Switch Assembly	7-7
8	INITIAL SYSTEM STARTUP	
	General	8-1
	The Startup Process	8-1
	Equipment Application Review	8-1
	Individual Generator Set Startup	8-2
	Manual System Operation	8-4
	Automatic System Operation	8-7
	Black Start Testing	8-8
	Test Reports and Acceptance	8-8
	On Site Power System Application Review (Diesel/600VAC and Lower)	8-9
9	WIRING DIAGRAMS	
	General	9-1

IMPORTANT SAFETY INSTRUCTIONS

SAVE THESE INSTRUCTIONS – This manual contains important instructions that should be followed during installation and maintenance of the generator and batteries.

Before operating the generator set (genset), read the Operator's Manual and become familiar with it and the equipment. **Safe and efficient operation can be achieved only if the equipment is properly operated and maintained.** Many accidents are caused by failure to follow fundamental rules and precautions.

The following symbols, found throughout this manual, alert you to potentially dangerous conditions to the operator, service personnel, or the equipment.

⚠ DANGER *This symbol warns of immediate hazards which will result in severe personal injury or death.*

⚠ WARNING *This symbol refers to a hazard or unsafe practice which can result in severe personal injury or death.*

⚠ CAUTION *This symbol refers to a hazard or unsafe practice which can result in personal injury or product or property damage.*

FUEL AND FUMES ARE FLAMMABLE

Fire, explosion, and personal injury or death can result from improper practices.

- DO NOT fill fuel tanks while engine is running, unless tanks are outside the engine compartment. Fuel contact with hot engine or exhaust is a potential fire hazard.
- DO NOT permit any flame, cigarette, pilot light, spark, arcing equipment, or other ignition source near the generator set or fuel tank.
- Fuel lines must be adequately secured and free of leaks. Fuel connection at the engine should be made with an approved flexible line. Do not use zinc coated or copper fuel lines with diesel fuel.
- Be sure all fuel supplies have a positive shutoff valve.
- Be sure battery area has been well-ventilated prior to servicing near it. Lead-acid batteries emit a highly explosive hydrogen gas that can be ignited by arcing, sparking, smoking, etc.

EXHAUST GASES ARE DEADLY

- Provide an adequate exhaust system to properly expel discharged gases away from enclosed or sheltered areas and areas where individuals are likely to congregate. Visually and audibly inspect the exhaust daily for leaks per the maintenance schedule. Make sure that exhaust manifolds are secured and not warped. Do not use exhaust gases to heat a compartment.
- Be sure the unit is well ventilated.
- Engine exhaust and some of its constituents are known to the state of California to cause cancer, birth defects, and other reproductive harm.

MOVING PARTS CAN CAUSE SEVERE PERSONAL INJURY OR DEATH

- Keep your hands, clothing, and jewelry away from moving parts.
- Before starting work on the generator set, disconnect battery charger from its AC source, then disconnect starting batteries, negative (-) cable first. This will prevent accidental starting.
- Make sure that fasteners on the generator set are secure. Tighten supports and clamps, keep guards in position over fans, drive belts, etc.
- Do not wear loose clothing or jewelry in the vicinity of moving parts, or while working on electrical equipment. Loose clothing and jewelry can become caught in moving parts.
- If adjustment must be made while the unit is running, use extreme caution around hot manifolds, moving parts, etc.

DO NOT OPERATE IN FLAMMABLE AND EXPLOSIVE ENVIRONMENTS

Flammable vapor can cause an engine to overspeed and become difficult to stop, resulting in possible fire, explosion, severe personal injury and death. Do not operate a genset where a flammable vapor environment can be created by fuel spill, leak, etc., unless the genset is equipped with an automatic safety device to block the air intake and stop the engine. The owners and operators of the genset are solely responsible for operating the genset safely. Contact your authorized Cummins Power Generation distributor for more information.

ELECTRICAL SHOCK CAN CAUSE SEVERE PERSONAL INJURY OR DEATH

- Remove electric power before removing protective shields or touching electrical equipment. Use rubber insulative mats placed on dry wood platforms over floors that are metal or concrete when around electrical equipment. Do not wear damp clothing (particularly wet shoes) or allow skin surface to be damp when handling electrical equipment. Do not wear jewelry. Jewelry can short out electrical contacts and cause shock or burning.
- Use extreme caution when working on electrical components. High voltages can cause injury or death. DO NOT tamper with interlocks.
- Follow all applicable state and local electrical codes. Have all electrical installations performed by a qualified licensed electrician. Tag and lock open switches to avoid accidental closure.
- DO NOT CONNECT GENERATOR SET DIRECTLY TO ANY BUILDING ELECTRICAL SYSTEM. Hazardous voltages can flow from the generator set into the utility line. This creates a potential for electrocution or property damage. Connect only through an approved isolation switch or an approved paralleling device.

GENERAL SAFETY PRECAUTIONS

- Coolants under pressure have a higher boiling point than water. DO NOT open a radiator or heat exchanger pressure cap while the engine is running. Allow the generator set to cool and bleed the system pressure first.
- Used engine oils have been identified by some state or federal agencies as causing cancer or reproductive toxicity. When checking or changing engine oil, take care not to ingest, breathe the fumes, or contact used oil.
- Keep multi-class ABC fire extinguishers handy. Class A fires involve ordinary combustible materials such as wood and cloth; Class B fires, combustible and flammable liquid fuels and gaseous fuels; Class C fires, live electrical equipment. (ref. NFPA No. 10).
- Make sure that rags are not left on or near the engine.
- Make sure generator set is mounted in a manner to prevent combustible materials from accumulating under the unit.
- Remove all unnecessary grease and oil from the unit. Accumulated grease and oil can cause overheating and engine damage which present a potential fire hazard.
- Keep the generator set and the surrounding area clean and free from obstructions. Remove any debris from the set and keep the floor clean and dry.
- Do not work on this equipment when mentally or physically fatigued, or after consuming any alcohol or drug that makes the operation of equipment unsafe.
- Substances in exhaust gases have been identified by some state or federal agencies as causing cancer or reproductive toxicity. Take care not to breathe or ingest or come into contact with exhaust gases.
- Do not store any flammable liquids, such as fuel, cleaners, oil, etc., near the generator set. A fire or explosion could result.
- Wear hearing protection when going near an operating generator set.
- To prevent serious burns, avoid contact with hot metal parts such as radiator, turbo charger and exhaust system.



CONTAINERIZED RENTAL UNITS POTENTIAL TIPPING PROBLEM

On all containerized rental equipment, there is a potential problem of having the container tip forward over the landing legs, pulling the axles off the ground when the con-

tainer is fully fueled without a semi-tractor under the king pin. Jack stands for the front of the container are required to mitigate this potential problem.

Note: The figure below shows the jack stands and their placement at the nose of the container.



Jack Stands at Nose of Container

KEEP THIS MANUAL NEAR THE GENSET FOR EASY REFERENCE





THIS PAGE LEFT INTENTIONALLY BLANK



1. Introduction

ABOUT THIS MANUAL

This manual provides troubleshooting and repair information regarding the PowerCommand® Control 3100 (PCC) and generators for the generator set (genset) models listed on the front cover. Engine service instructions are in the applicable engine service manual. Operating and maintenance instructions are in the applicable Operator's Manual.

This manual does not have instructions for servicing printed circuit board assemblies. After determining that a printed circuit board assembly is faulty, replace it. Do not repair it. Attempts to repair a printed circuit board can lead to costly damage to the equipment.

This manual contains basic (generic) wiring diagrams and schematics that are included to help in troubleshooting. Service personnel must use the actual wiring diagram and schematic shipped with each unit. The wiring diagrams and schematics that are maintained with the unit should be updated when modifications are made to the unit.

Read **Important Safety Instructions** and carefully observe all instructions and precautions in this manual.

TEST EQUIPMENT

To perform the test procedures in this manual, the following test equipment must be available

- True RMS meter for accurate measurement of small AC and DC voltages. Fluke models 87 or 8060A are good choices.
- Grounding wrist strap to prevent circuit board damage due to electrostatic discharge (ESD).
- Battery Hydrometer
- Jumper Leads
- Tachometer or Frequency Meter
- Wheatstone Bridge or Digital Ohmmeter
- Variac
- Load Test Panel
- Megger or Insulation Resistance Meter
- PCC Service Tool Kit (Harness Tool and Sensor Tool)

HOW TO OBTAIN SERVICE

Always give the complete Model, Specification and Serial number of the generator set as shown on the nameplate when seeking additional service information or replacement parts. The nameplate is located on the side of the generator output box.

⚠WARNING *Incorrect service or replacement of parts can result in severe personal injury or death, and/or equipment damage. Service personnel must be trained and experienced to perform electrical and mechanical service. Read and follow Important Safety Instructions, on pages iii and iv.*



SYSTEM OVERVIEW

The PCC is a microprocessor-based control for Onan generator sets. It provides fuel control and engine speed governing, main alternator voltage output regulation, and complete generator set control and monitoring. It also provides controls for automatic and semi-automatic synchronizing and automatic load sharing controls for both isolated bus or utility (mains) paralleling applications.

The operating software provides control of the generator set and its performance characteristics, and displays performance information on a digital display panel. It accepts menu-driven control and setup input from the push button switches on the front panel.

GENERATOR SET CONTROL FUNCTION

Figure 1-1 shows some of the control functions. A more complete block diagram is provided in Section 3. A system schematic is provided in Section 9.

The PCC monitors frequency from both the magnetic pick-up (MPU) and the main stator inputs. The control sends a low power pulse-width modulated (PWM) signal to the governor output module, which then sends an amplified signal to the engine fuel control.

The Bus PT module reduces the bus voltage to approximately 18 VAC and provides a signal to the control for reference in synchronizing the generator set to the system bus.

The external PT/CT module reduces generator voltage to approximately 18 VAC, and produces a representative AC voltage from CT output current. The voltage regulation function sends a low power PWM signal to the voltage regulator output module, which then sends an amplified signal to the exciter stator.

Oil, coolant, and exhaust temperatures are sensed by variable resistance element sensors. Oil pressure is sensed by a capacitive element active sensor.

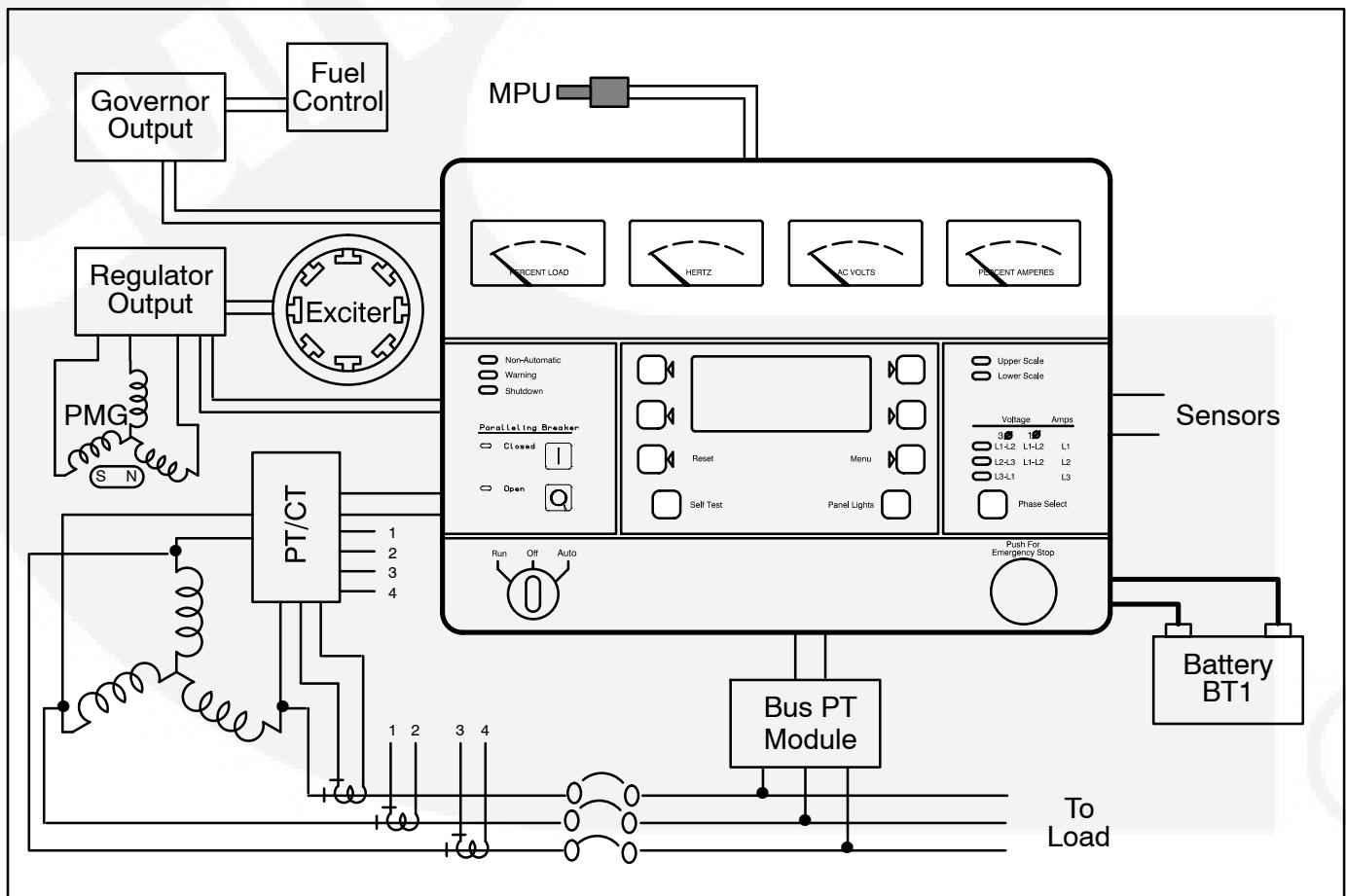

FIGURE 1-1. GENERATOR SET CONTROL FUNCTIONS

2. Control Operation

GENERAL

The following describes the function and operation of the PowerCommand generator set control. All indicators, displays, meters and control switches are located on the face of the control panel as illustrated in Figure 2-1.

The PCC control cabinet must be opened only by technically qualified personnel.

Normally, generator set configuration options are set at the factory. When a new control is installed on a generator set or when parts are replaced, the control must be configured for that generator set with the use of the “Initial Start Setup” portion of the internal software. Setup and calibration procedures are described in *Section 5*.

The automatic voltage regulator (AVR) and governor operation characteristic adjustments are also described in *Section 5*.

SAFETY CONSIDERATIONS

AC power is present when the set is running. Do not open the generator output box while the set is running.

⚠ WARNING *Contacting high voltage components can cause electrocution, resulting in severe personal injury or death. Do not open the generator output box while the set is running. Read and observe all WARNINGS and CAUTIONS in your generator set manuals.*

⚠ CAUTION *The PCC control cabinet must be opened only by technically qualified personnel. Lower level voltages (18 VAC to 24 VDC) are present in PCC control cabinet. These voltages can cause electrical shock, resulting in personal injury.*

Even with power removed, improper handling of components can cause electrostatic discharge and damage to circuit components.



SEQUENCE OF OPERATION

When the PowerCommand control is in the AUTO mode, it will cause the generator set to start on receiving a signal from a remote device. The PowerCommand control will initiate a starter cranking signal and verify that the engine is rotating. The PowerCommand control will provide sufficient fuel to the engine to accelerate to start disconnect speed. On reaching that speed, the control will ramp the generator set to rated speed and voltage.

On reaching rated speed and voltage, the PowerCommand control checks the system bus voltage. If no bus voltage is present, it will wait for a pulse from a remote Master First Start Sensor. On receiving that pulse, the control will signal the paralleling breaker to close.

If bus voltage is present, the PowerCommand control will check for proper phase rotation, adjust the generator set to the bus voltage and frequency level, and then synchronize the generator set to the system bus. When a synchronous condition is achieved, the control will send a signal to close the paralleling breaker.

When the paralleling breaker is closed, the generator set will assume its proportional share of the total load on the system bus.

PCC POWER ON / STANDBY MODE

Standby Mode

In the Standby (sleep) mode (selector switch S5 on the Digital Board is set to the right and the generator set is not running), the control's operating software is inactive and the LEDs and displays on front panel are all off.

The operating software is initialized and the front panel is turned on in response to a run signal or any

one of eight "wake up" inputs from remote sensing switches.

The wake up signals are:

- Emergency Stop
- Low Coolant Level
- Low Coolant Temperature
- Low Fuel
- Customer Fault Inputs 2 and 3
- Run Selected on Run/Off/Auto Switch
- Remote Start Signal in Auto Mode
- Self Test switch

To activate and view the menu displays, press and release the Self Test switch. The PCC will initialize the operating software and permit operation of the menu display panel. If no menu selections are made, the power to the control panel will shut down after 30 seconds.

Power On Mode

In the Power On (awake) mode (selector switch S5 on the Digital Board is set to the left), the PCC will initialize the operating software and permit operation of the menu display panel. (See Figure 3-1 for S5 location.) Power will stay on until switch (S5) is set to the Standby mode. It is recommended that switch S5 be left in the Power On mode in all applications, except those where auxiliary battery charging is not available.

⚠ CAUTION *Electrostatic discharge will damage circuit boards. Always wear a grounding wrist strap when touching or handling circuit boards or socket-mounted ICs and when disconnecting or connecting harness connectors.*



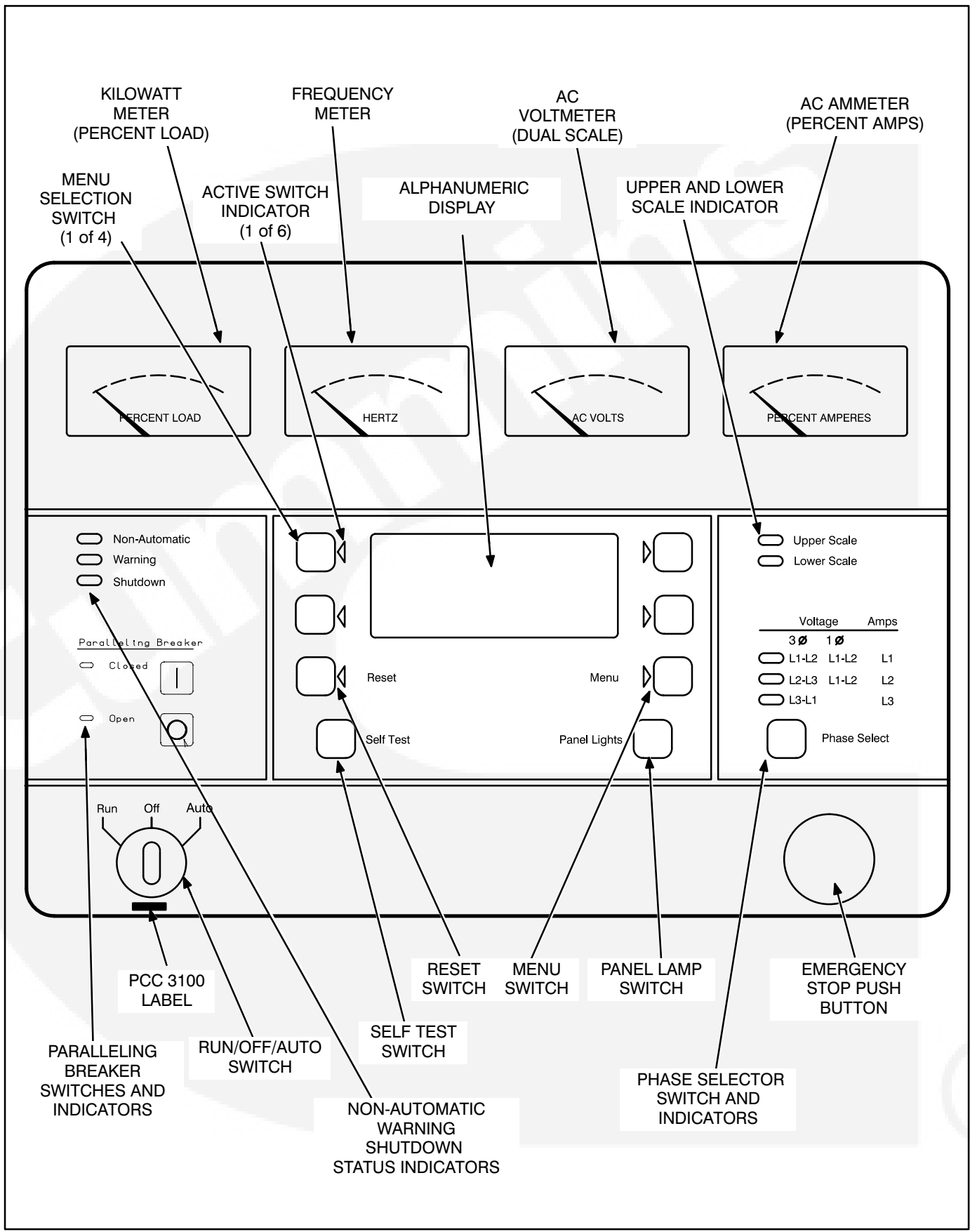

FIGURE 2-1. FRONT PANEL (PCC 3100)

FRONT PANEL

Figure 2-1 shows the features of the front panel.

AC Voltmeter: Dual scale instrument indicates AC voltage. Measurement scale in use is shown on scale indicator lamp.

AC Ammeter: Indicates current output in percent of maximum rated current. (Percent current is based on .8 PF.)

Kilowatt Meter: Indicates 3-phase AC power output as percent of rated load.

Frequency Meter: Indicates generator output frequency in hertz.

Upper and Lower Scale Indicator Lamps: Indicate AC voltmeter scale.

Digital Display: This two-line, 16-character per line alphanumeric display is used in the menu-driven operating system, in conjunction with the display menu selection switches and the Menu switch. Refer to the menu trees later in this section. The display is also used to show warning and shutdown messages.

Display Menu Selection Switches: Four momentary switches—two on each side of the digital display window—are used to step through the various menu options and to adjust generator set parameters. The green arrow adjacent to the switch is lit when the switch can be used (switch is “active”).

Menu Switch: Press this switch to return the digital display to the MAIN MENU. Refer to the menu trees later in this section.

Reset Switch: Press this switch to reset warning and shutdown messages after the condition has been corrected. To reset a shutdown message with the Reset switch, the Run/Off/Auto switch must be in the Off position.

With the Run/Off/Auto switch in the Auto mode, shutdown faults can be reset by removing the remote start input and then cycling the remote reset input.

Self Test Switch: Press and hold this switch to light all front panel LEDs and cycle through all shutdown and warning messages.

In the Standby (sleep) mode, with the generator set not running, the control's operating software is inactive and the LEDs and displays on front panel are all off.

To activate and view the menu displays without starting the generator set, press and hold the Self Test switch until the front panel LEDs light. The PCC will initialize the operating software and permit operation of the menu display panel. If no menu selections are made, a software timer will shut down the power after 30 seconds.

Panel Lights Switch: Press this switch to turn control panel illumination on and off. The illumination will shut off after about eight minutes.

Phase Selector Switch and Indicators: Press this momentary switch to select phases of generator output to be measured by the analog AC voltmeter and ammeter. LEDs indicate the selected phase.

Run/Off/Auto Switch: This switch starts and stops the set locally, or enables start/stop control of the engine from a remote location. (Ground to start.)



Emergency Stop Button: Push the switch in for emergency shutdown of the engine.

Remote Reset switch will not reset emergency stop. Can only be reset at the PCC front panel.

To reset:

1. Pull the button out or turn the switch clockwise (button with arrow) and allow it to pop out.
2. Move the Run/Off/Auto switch to Off.
3. Press the front panel Reset switch.
4. Select Run or Auto, as required.

Non-Automatic Status Indicator: This red lamp flashes continuously when the Run/Off/Auto switch is not in the Auto position.

Warning Status Indicator: This yellow lamp is lit whenever the control detects a warning condition. After the condition is corrected, warning indicators can be reset by pressing the Reset switch. (It is **not** necessary to stop the generator set.)

With the Run/Off/Auto switch in the Auto mode, warnings can also be reset by cycling the remote reset input after the condition is corrected.

Shutdown Status Indicator: This red lamp is lit whenever the control detects a shutdown condition. After the condition is corrected, shutdown indicators can be reset by turning the Run/Off/Auto switch to the Off position, and pressing the Reset switch. In Auto mode, shutdowns can be reset by removing the remote start input and then cycling the remote reset input.

Emergency Stop shutdown status (Code 102) can be reset only at the PCC front panel.

Paralleling Breaker Switches and Indicators: These two switches are used to manually open or close the paralleling breaker of the generator set. The lamps are used to indicate the opened or closed position of the paralleling breaker.

The Breaker Operation switches are operational only when the Run/Off/Auto switch is in the Run position. The breaker will close when the generator set is synchronized with the system bus, or if the system bus is de-energized.



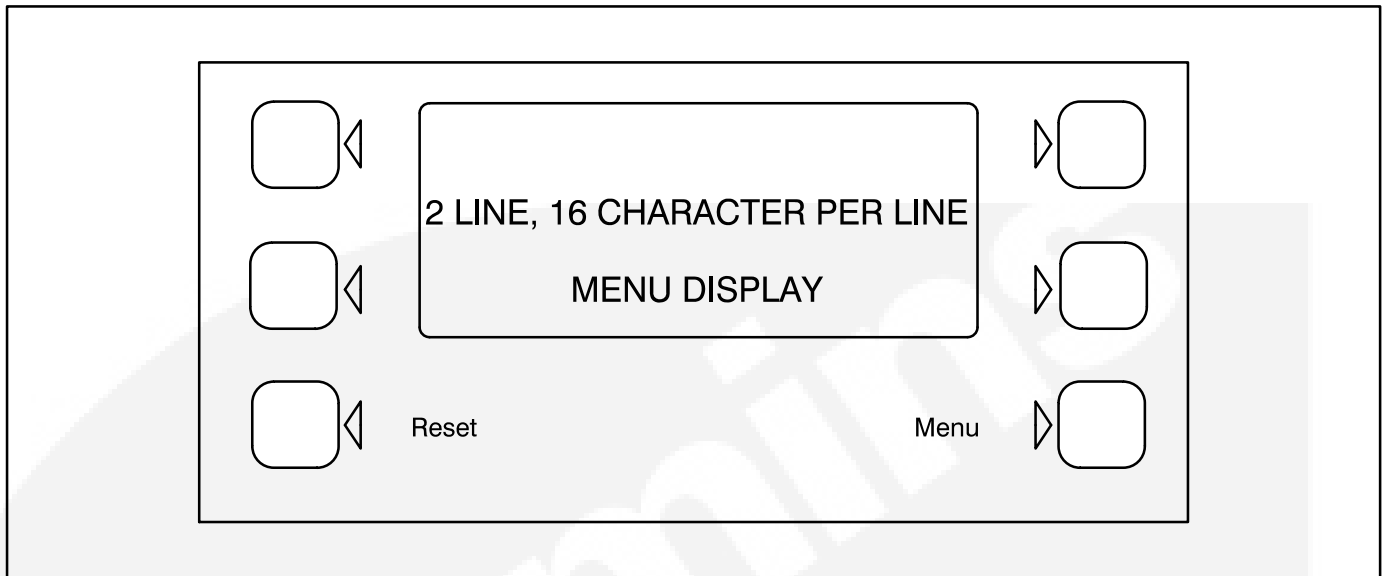

FIGURE 2-2. DIGITAL DISPLAY AND MENU SELECTION SWITCHES

MENU DISPLAY AND SWITCHES

Figure 2-2 shows the digital display and the menu selection switches. Refer to heading “*Front Panel*” which describes the menu display and switches.

In the Standby Mode, to activate and view the menu displays without starting the generator set, press and release the Self Test switch. This will initialize the PCC operating software and permit operation of the menu display panel. If no menu selections are made, a software timer will shut down the power after 30 seconds. In the Power On Mode, power is continuously supplied to the control panel. Display will always remain on.

In the digital display, the “>>” symbol indicates that selecting the adjacent button causes the operating program to branch to the next menu display—as shown in the menu diagrams.

In the digital display, the “<<” symbol indicates that selecting the adjacent button causes the operating program to go back to the previous menu display.

MAIN MENU

The facing page shows the main menu and a block representation of the available submenus.

As shown in the diagram, the main menu can branch into one of four directions.

To display engine parameters, such as oil pressure and temperature, water temperature, engine speed (RPM), and exhaust temperature, press the button next to the word “ENGINE” in the display. Refer to *ENGINE MENU* in this section.

To display generator parameters, such as volts, amps, power (kW), and frequency, press the button next to the word “GEN” in the display. Bus voltage, frequency and a digital synchroscope can also be viewed from this menu branch. Turn to the *GEN MENU* in this section.

To adjust output voltage and frequency, or start and stop delays, press the button next to the word “ADJUST” in the display. Refer to *ADJUST MENU* in *Section 5*.

To display the selected generator set model and the resident version software, press the button next to the “>>” in the display. Refer to *VERSION & DISPLAYS MENU* in *Section 5*.

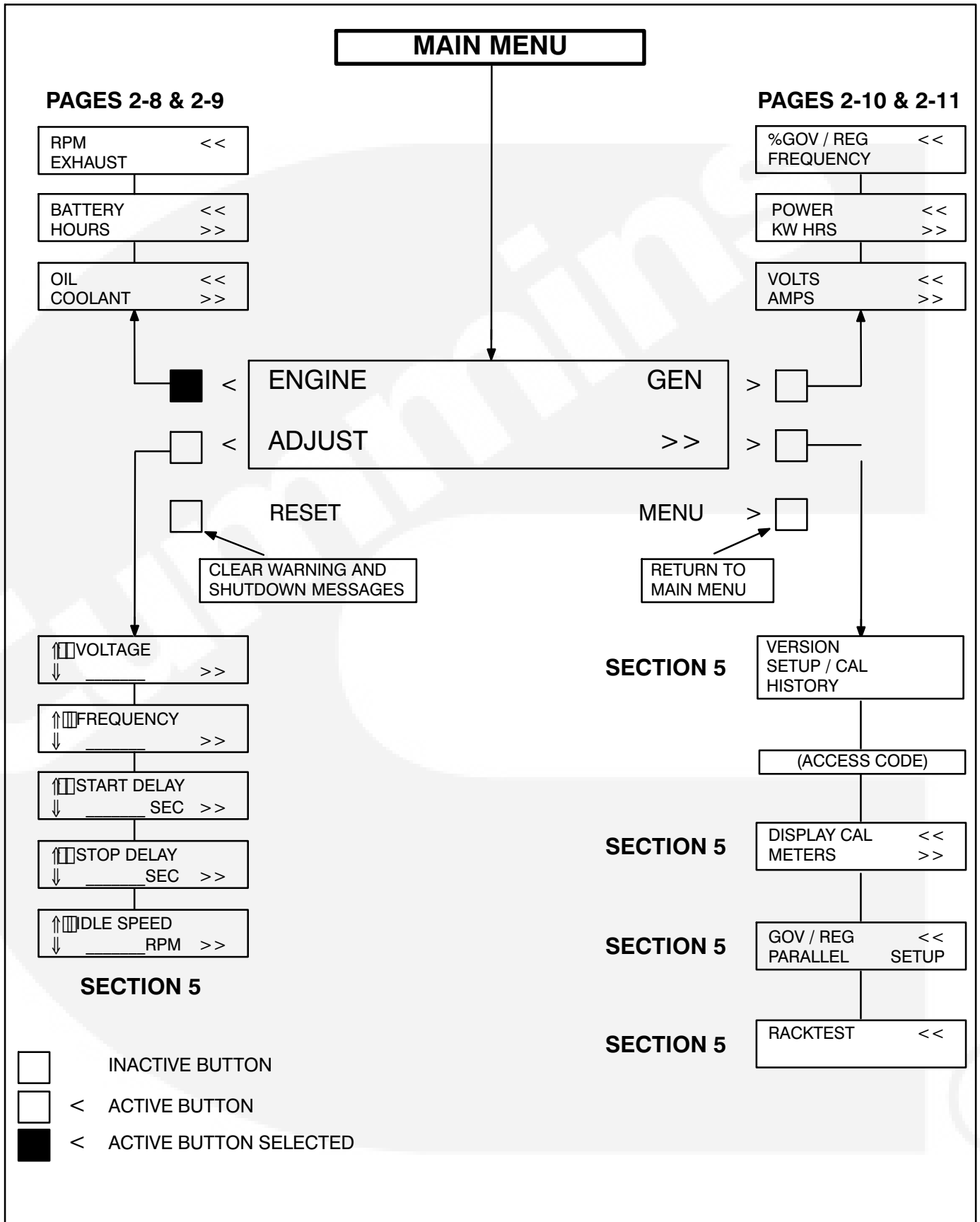

ENGINE MENU

The facing page shows a block representation of the ENGINE menu. If you press the button next to the word “ENGINE” in the display, the first ENGINE submenu will appear.

As shown in the diagram, the ENGINE menu has three submenus.

OIL/COOLANT submenu: This is the first submenu. Select OIL for a display of oil pressure and oil temperature. Select COOLANT for a display of coolant temperature. When oil or coolant parameters are displayed, pressing the button next to the “<<” will return the display (“BACK”) to the OIL/COOLANT submenu.

BATTERY/HOURS submenu: From the OIL/COOLANT submenu, press the button next to the “>>” in the display to move to the BATTERY/HOURS submenu. Select BATTERY for a display of battery voltage. Select HOURS for a display of the number of starts and the running hours. When battery or hours parameters are displayed, pressing the button next to the “<<” will return the display (“BACK”) to the BATTERY/HOURS submenu.

RPM/EXHAUST submenu: From the BATTERY/HOURS submenu, press the button next to the “>>” in the display to move to the RPM/EXHAUST submenu. Select RPM for a display of engine RPM. Select EXHAUST for a display of the (optional) exhaust temperature. When RPM or exhaust parameters are displayed, pressing the button next to the “<<” will return the display (“BACK”) to the RPM/EXHAUST submenu.



ENGINE

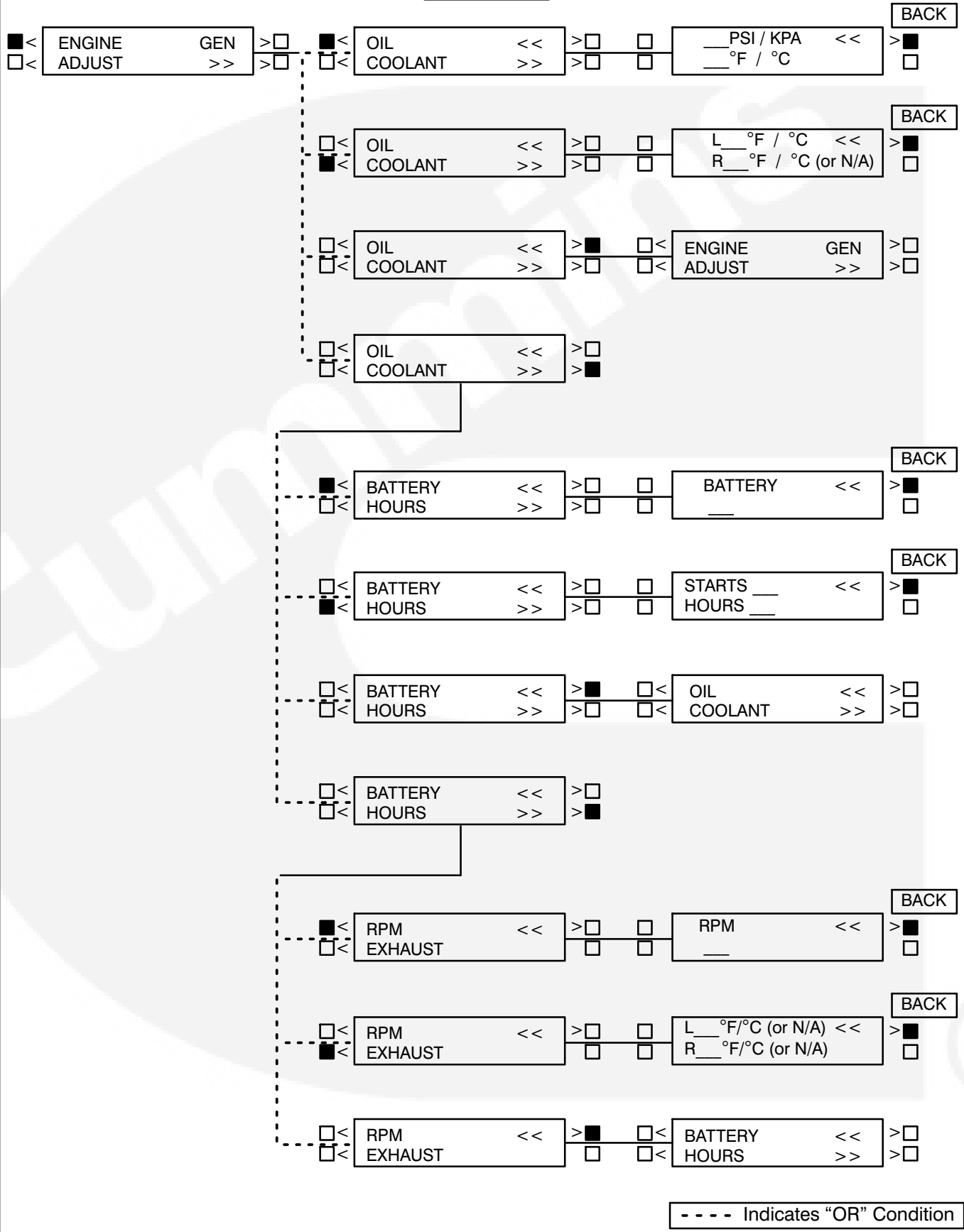

--- Indicates "OR" Condition

GEN MENU

The facing page shows a block representation of the GEN menu. If you press the button next to the word “GEN” in the display, the first GEN submenu will appear.

As shown in the diagram, the GEN menu has three submenus.

VOLTS/AMPS submenu: This is the first submenu. Select VOLTS for a display of a line-to-line or line-to-neutral selection, or for viewing of the system bus line-to-line voltage. Select line-line or line-neutral for the desired voltage display. Select AMPS for a display of L1, L2, and L3 current in amps. When voltage or current parameters are displayed, pressing the button next to the “<<” will return the display (“BACK”) to the L-L/L-N submenu.

If DELTA is selected in the Initial Start Setup submenu, when selecting VOLTS, the “line-line” or “line-neutral” submenus will not be displayed, only the L12, L23, L31 submenu will be displayed.

POWER / KW HOURS submenu: From the VOLTS/AMPS submenu, press the button next to the “>>” in the display to move to the POWER/KW HOURS submenu. Select POWER for a display of power output in kilowatts and a power factor value. Select KW HOURS for a display of kilowatt hours. When power or kW hours parameters are displayed, pressing the button next to the “<<” will re-

turn the display (“BACK”) to the POWER/KW HOURS submenu.

The PF reading will contain an asterisk if the power factor is leading (for example, *.3PF).

Beginning Version 1.06, N/A is displayed in the PF field when the generator set is not running.

%GOV/REG/FREQUENCY submenu: From the POWER/KW HOURS submenu, press the button next to the “>>” in the display to move to the %GOV/REG/FREQUENCY submenu. Select %GOV/REG for a display of voltage regulator and governor duty cycle (drive) levels in percentage of maximum. Select FREQUENCY for a display of the generator output frequency the bus frequency, or the digital synchroscope. When voltage regulator and governor or frequency parameters are displayed, pressing the button next to the “<<” will return the display (“BACK”) to the %GOV/REG/FREQUENCY submenu.

Bus Frequency (Digital Synchroscope) submenu: When the bus frequency (digital synchroscope) information is displayed, the operator can observe the generator set synchronizing with the system bus. The display indicates bus frequency and number of degrees from synchronous condition (+ indicates faster, – indicates slower). When the generator set is operating within the sync-check window, an asterisk will indicate that the paralleling breaker can be closed.



GEN

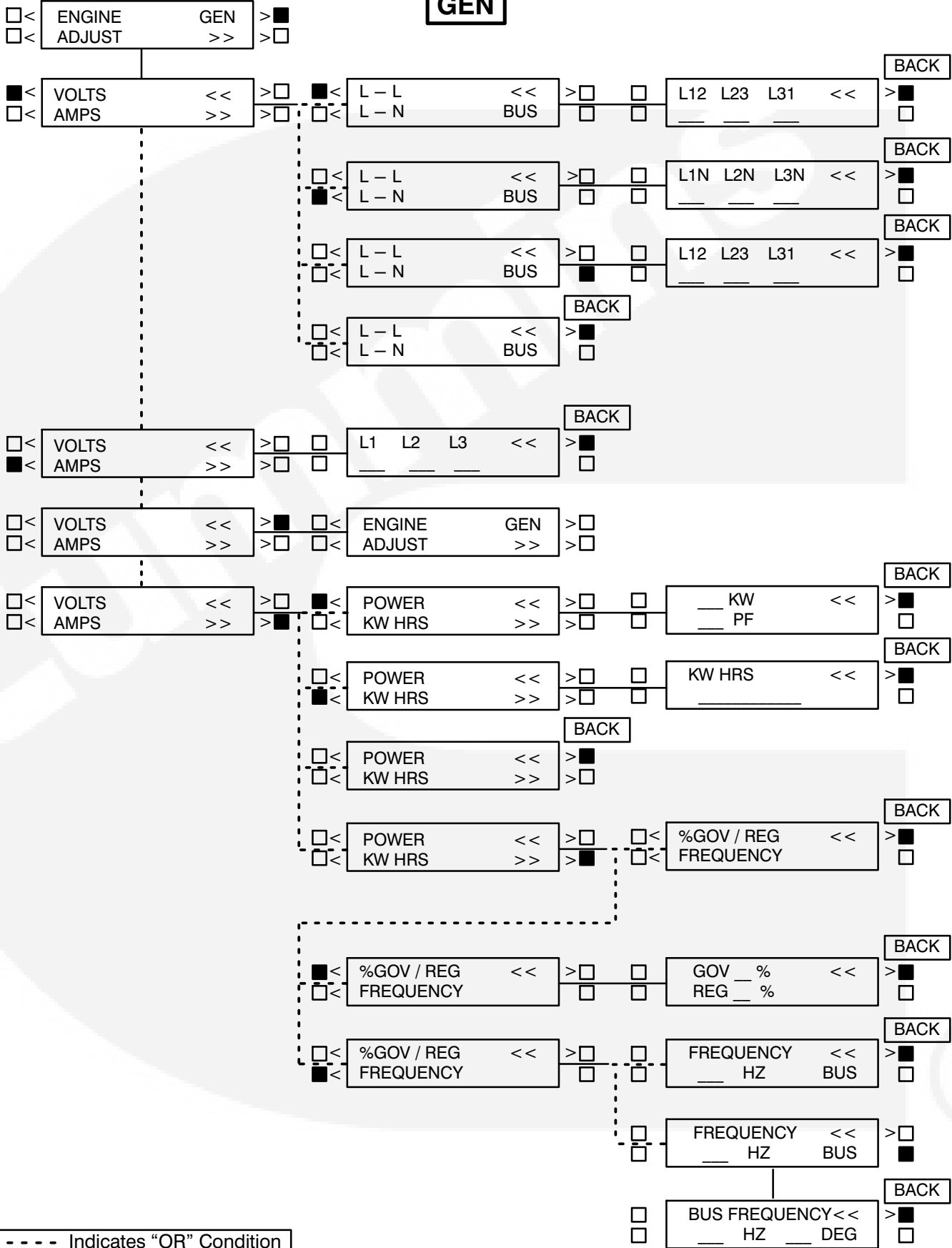

--- Indicates "OR" Condition



THIS PAGE LEFT INTENTIONALLY BLANK



3. Circuit Boards and Modules

GENERAL

This section describes the function of the PCC circuit boards and modules that are contained in the control panel (Figure 3-1) and the accessory box. The block diagram in Figure 3-2, shows both internal and external components of the PCC system.

The system schematics are provided in *Section 9* of this manual.

⚠ CAUTION *Electrostatic discharge will damage circuit boards. Always wear a grounding wrist strap when touching or handling circuit boards or socket-mounted ICs.*

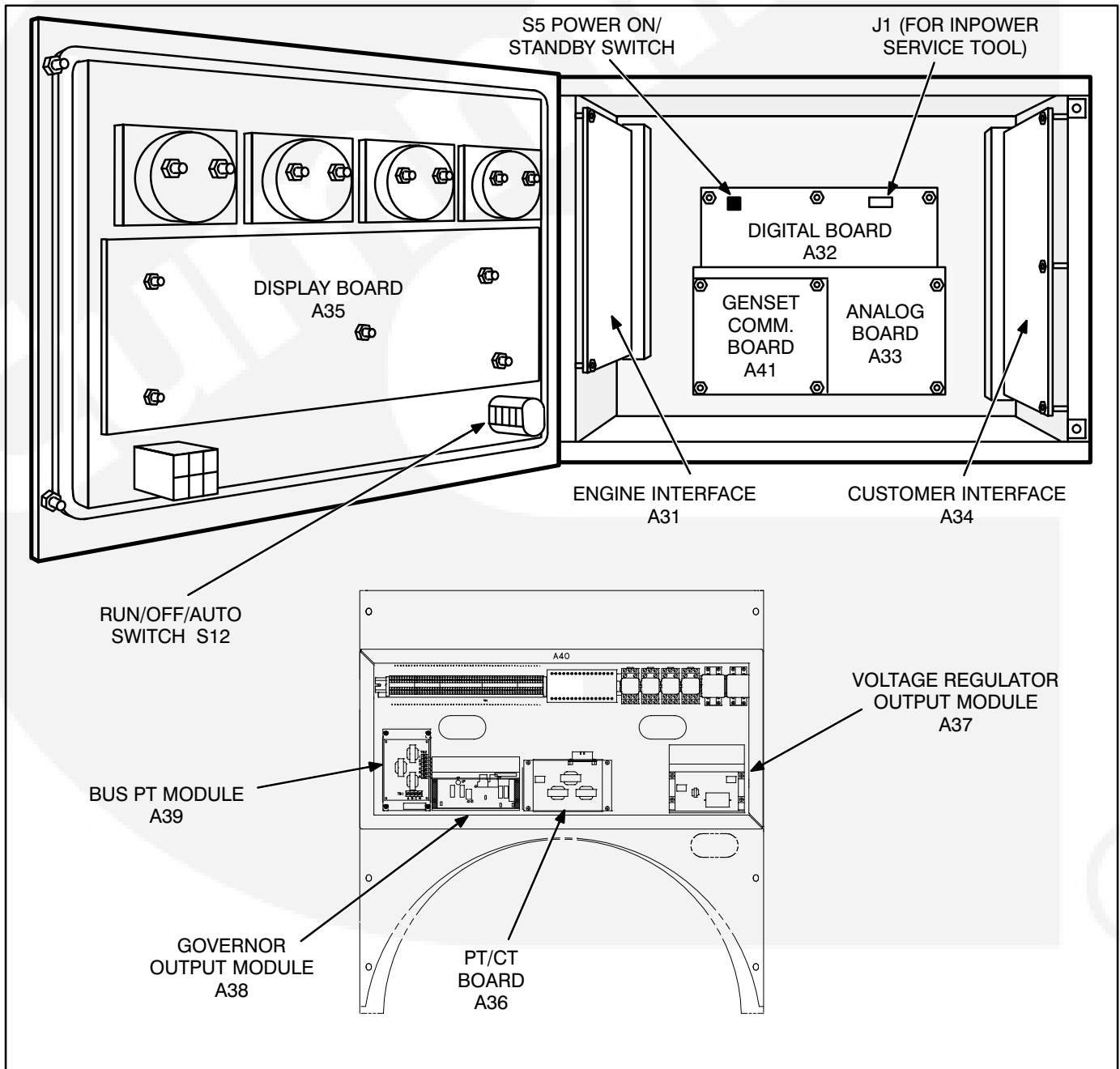

FIGURE 3-1. CIRCUIT BOARD LOCATIONS

POWERCOMMAND GENSET SYSTEM ARCHITECTURE

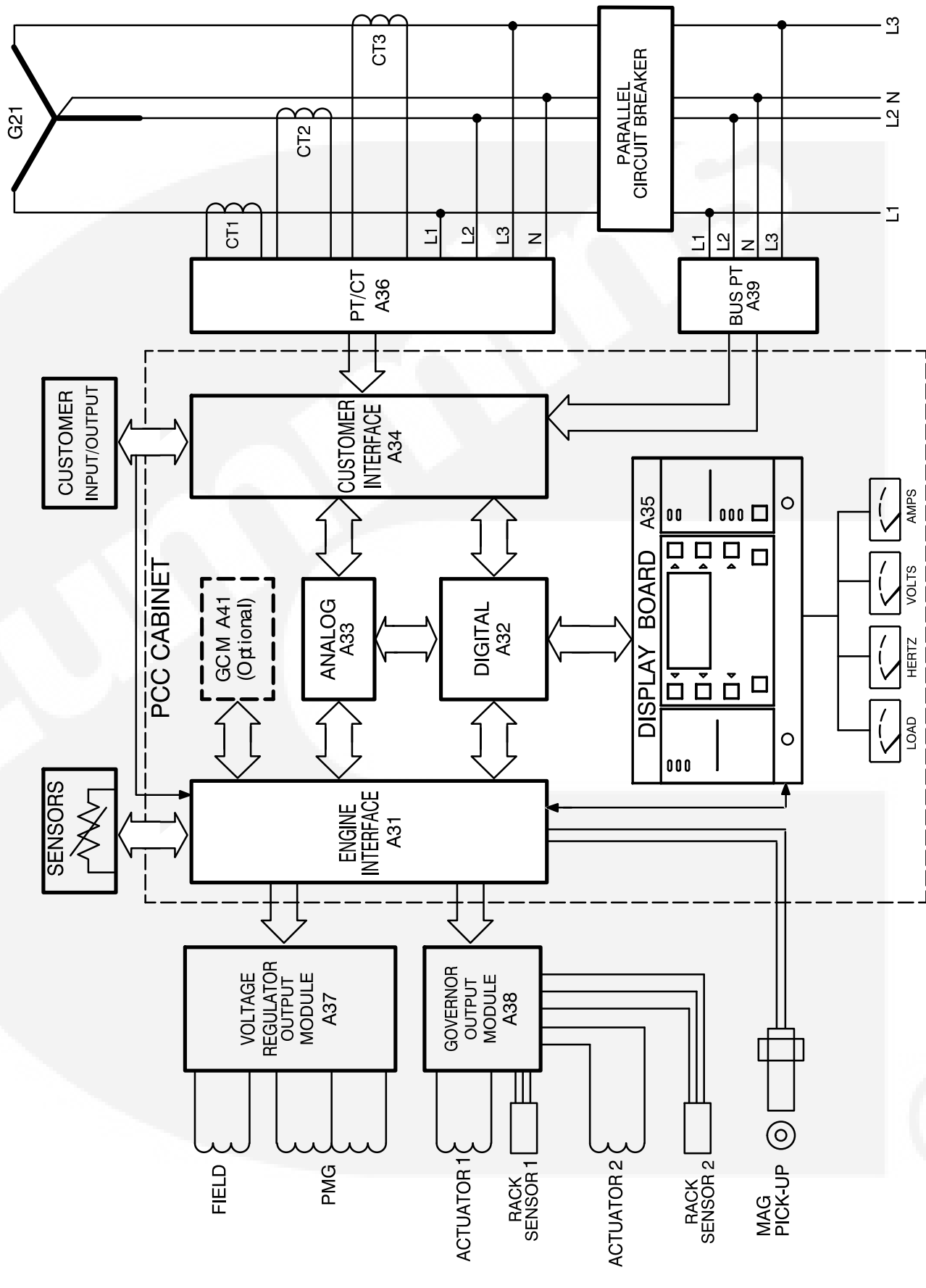

FIGURE 3-2. BLOCK DIAGRAM

DIGITAL BOARD (A32)

The digital circuit board (Figure 3-3) contains the microprocessor and the operational software for the control. It connects to all other boards inside the control. This board also provides the analog-to-digital conversions for the PCC.

Switch

S5 Slide the switch to the left to select the Power On (awake) mode. Control panel power/operating software will remain on until the switch is reset to the Standby mode. It is recommended that switch S5 be left in the Power On mode in all applications, except those where auxiliary battery charging is not available.

Slide right to put the PCC in the Standby (“sleep”) mode. In this mode, the PCC operating software will be initiated by selection of Run on the front panel, by pressing the Self Test switch, by a remote start input (in Auto mode), or by any one of several “wake-up” signals from external switches.

Connectors

The digital board has five connectors. They are:

J1 For InPower Service Tool

J2 Connects to J4 on A34 Customer Interface board

J3 Connects to J2 on A33 Analog board

J4 Connects to J1 on A31 Engine Interface board

J5 Connects to J5 on A35 Digital Display assembly

LEDs

The digital board has seven LED’s that indicate the following conditions:

DS1 Spare (Green)

DS2 Spare (Green)

DS3 +18 VDC supply OK (Green)

DS4 +5 VDC supply OK (Green)

DS5 Run (**Flashes once per second if software is running**) (Green)

DS6 +24 VDC B+ supply OK (Green)

DS7 +12 VDC supply OK (Green)

Resistors

The three resistors (R36, R37 and R38) are used to configure the digital board to the generator set model number. Refer to *Digital Board (A32) Calibration* in *Section 5*, which provides a detailed description of how to configure this board.

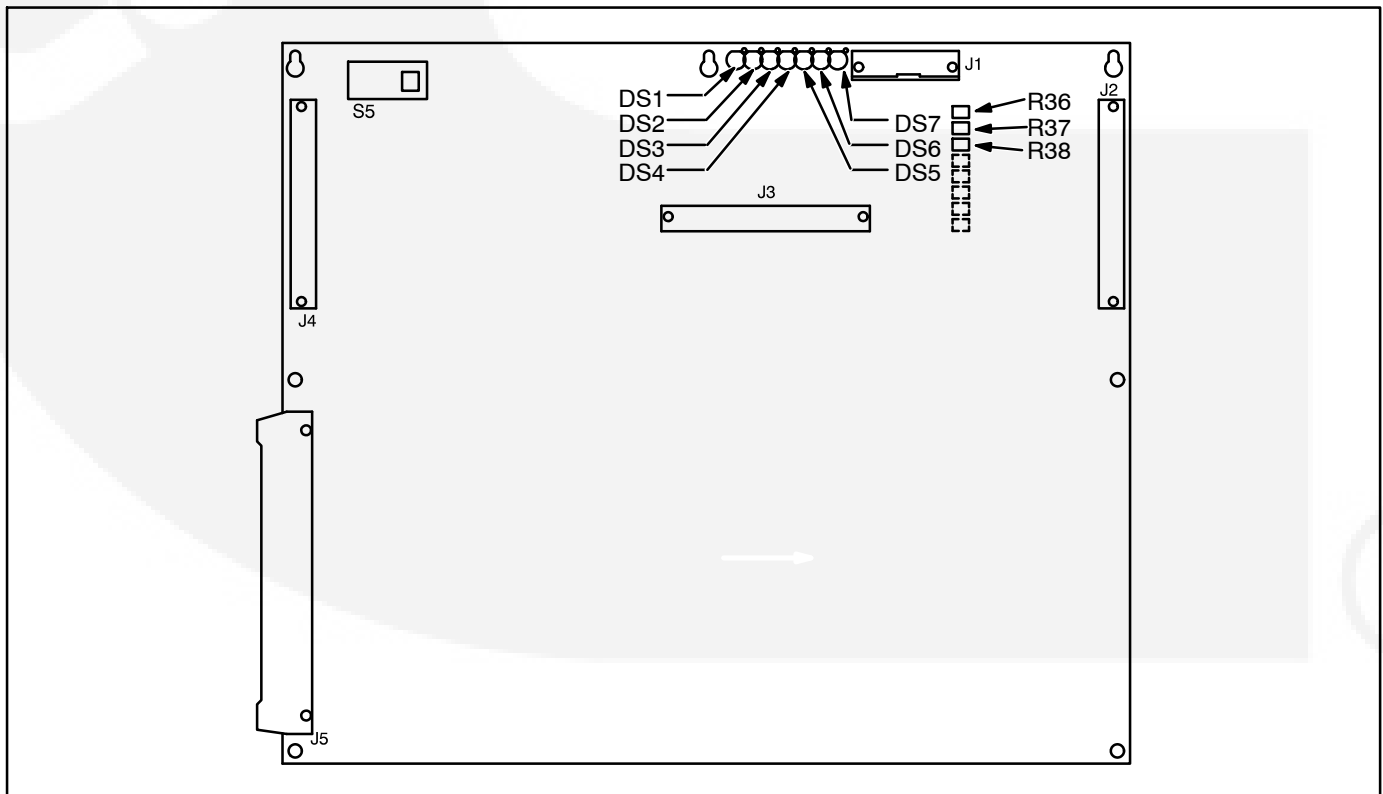

FIGURE 3-3. DIGITAL BOARD (A32)

ENGINE INTERFACE BOARD (A31)

The engine interface board (Figure 3-4) reads user control inputs, monitors engine, generator and system status, and initiates the appropriate action for normal operating and fault conditions (warning or shutdown).

This board is connected to the engine sensors, battery, starter, governor output module, voltage regulator output module, and the magnetic pick-up (MPU).

The engine interface board can also be connected to an optional network interface module for network access.

During a typical start sequence the LED's light as follows:

1. **DS11** lights when a remote run signal is received and S12 is in the Auto position, or S12 is moved to the Run position.
2. **DS12** lights when the magnetic pick-up voltage is sensed (engine is cranking). (When the engine is cranking, the mag pickup output should be a minimum of 1 volt.)
3. **DS11** extinguishes, **DS9** lights and **DS10** is dimly lit when the generator is running.

Connectors

The engine interface board has seven connectors and one terminal strip. They are:

- J1** Connects to J4 on A32 Digital board.
- J2** Connects to J1 on A33 Analog board.
- J3** Connects to display board, front panel switches and meters.

- J4** Connects to customer connections and to engine harness which includes magnetic pick-up.
- J5** Connects to engine sensors.
- J6** Connects to Genset Control module (GCM).
- J7** Connects to Genset Control module (GCM).

Fuses

The engine interface board has two replaceable fuses. They are:

- F1** Control B+ (5 Amps)
- F3** Aux. B+ (5 Amps). (Panel lamps and run/start contacts).

LED's

The engine interface board has 10 LED's that indicate the following conditions:

- DS1** Low Fuel Alarm input (Red)
- DS2** Low Coolant Level Alarm input (Red)
- DS3** Low Engine Temperature Alarm input (Red)
- DS4** S12 in Run position (Green). S12 is the Run/Off/Auto switch.
- DS5** S12 in Auto position (Green)
- DS6** Emergency Stop (Red)
- DS7** Not configured.
- DS8** Not configured.
- DS9** Automatic voltage regulator duty cycle (Green). Brighter indicates larger duty cycle.
- DS10** Governor duty cycle (Green). Brighter indicates larger duty cycle.
- DS11** Start pilot relay output (Red)
- DS12** Run pilot relay output (Red)



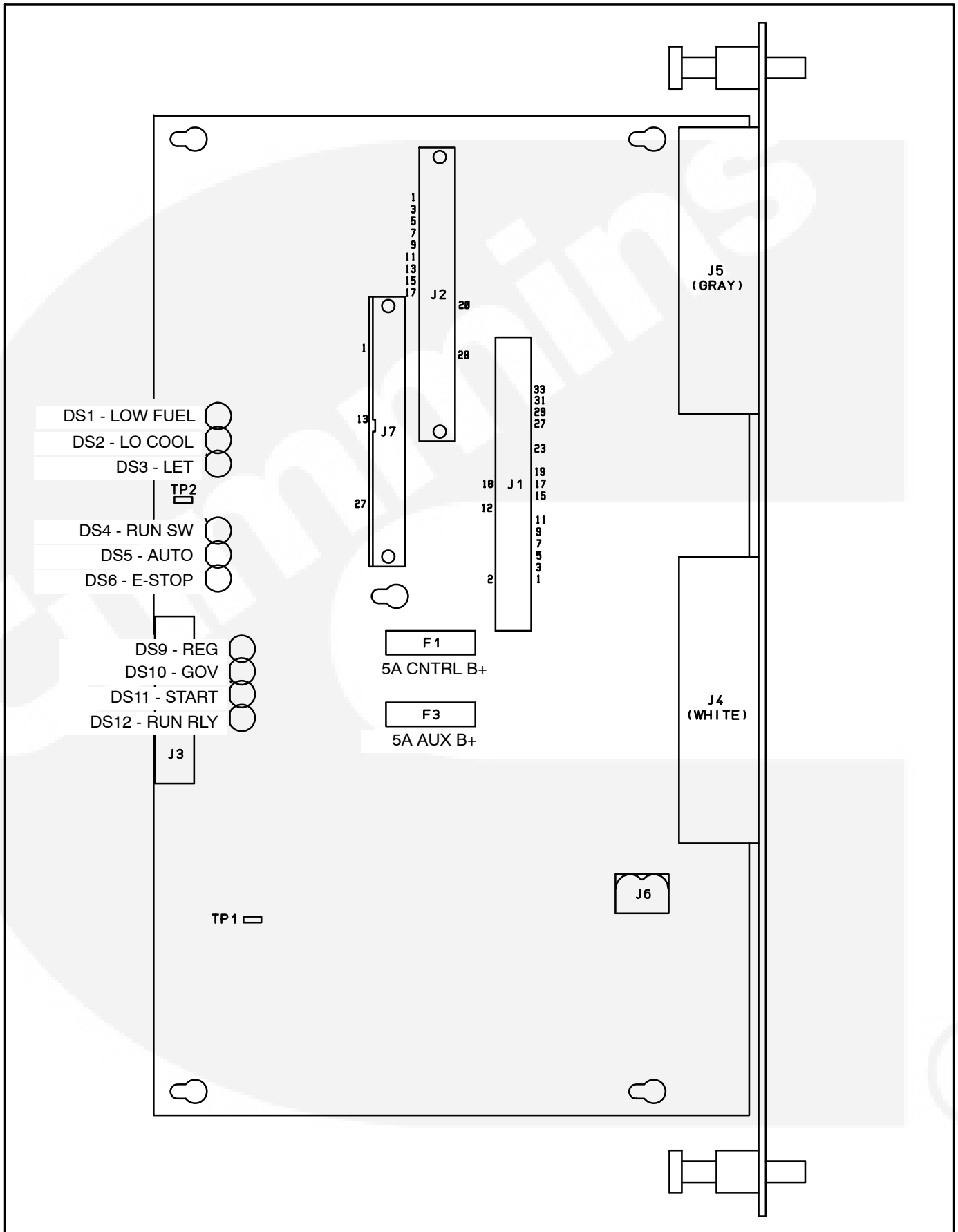

FIGURE 3-4. ENGINE INTERFACE BOARD

ANALOG BOARD (A33)

The analog board (Figure 3-5) is the only circuit board inside the control that has no LED's. There are two versions of the analog board that are used for paralleling and non-paralleling systems.

This board interprets all analog input signals and converts the analog signals to 0–5 VDC for the digital board.

Connectors

The analog board has four connectors with ribbon cables permanently soldered to them. They are:

- J1** Connects to J2 on A31 Engine Interface board
- J2** Connects to J3 on A32 Digital board
- J3** Spare analog inputs
- J4** Connects to J1 on A34 Customer Interface board

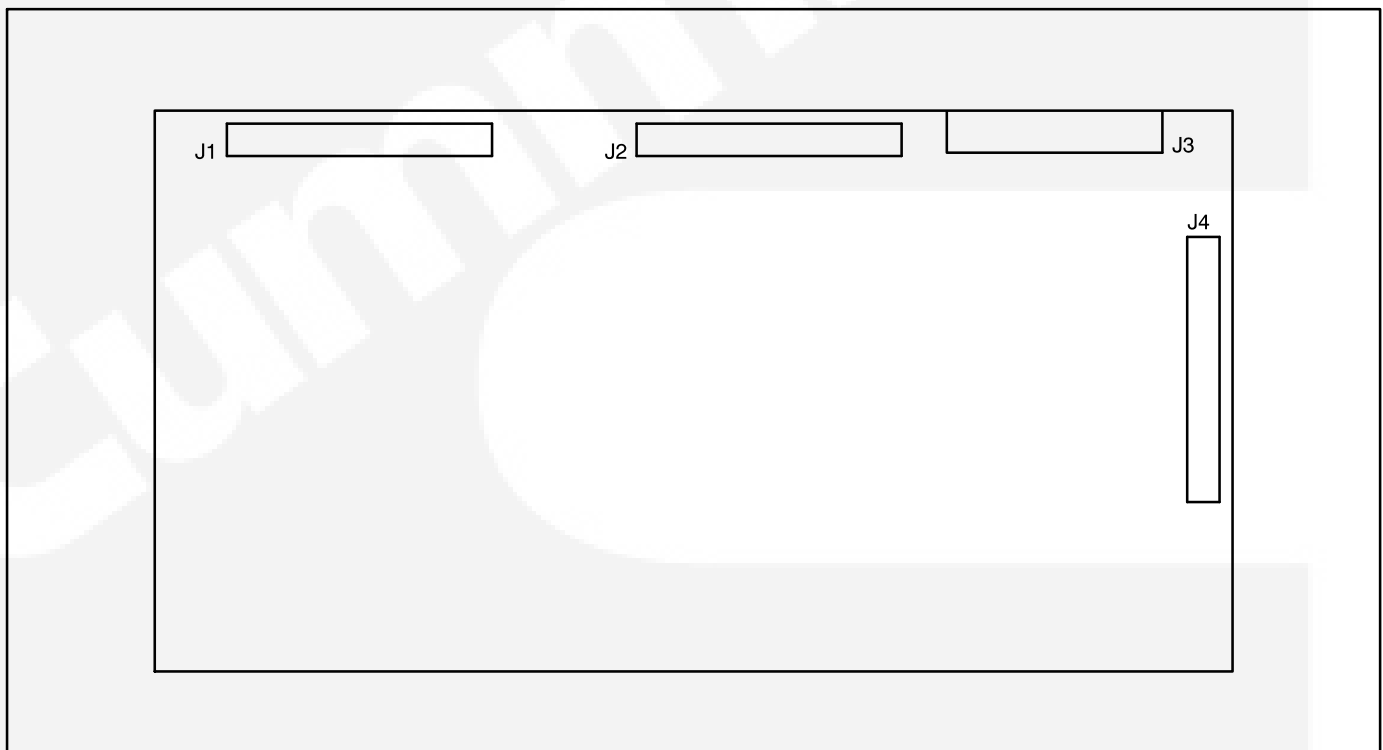

FIGURE 3-5. ANALOG BOARD

DIGITAL DISPLAY BOARD (A35)

The digital board (Figure 3-6) connects to all meters and the LED display.

Connectors

The digital board has three connectors. They are:

- J1** Connects to front panel membrane switches
- J5** Connects to J2 on A32 Digital board. (With J5 disconnected, the display will be non-functional, but the PCC will continue to operate.)
- J6** Connects to meters, Run/Off/Auto switch, J3 on A31 Engine Interface board

LEDs

The digital board has 18 LED's that are used to indicate operational status of the generator set and control panel mode/switch selections.

- DS9** Not In Auto (Red)
- DS10** Upper Scale (Green)
- DS11** Left Top Arrow (Green)

- DS12** Right Top Arrow (Green)
- DS13** Warning (Amber)
- DS14** Lower Scale (Green)
- DS15** Shutdown (Red)
- DS20** Left Bottom Arrow (Green)
- DS21** Right Bottom Arrow (Green)
- DS22** Automatic mains failure (AMF) or paralleling application only: Breaker Closed (Red)
- DS23** Phase A (Green)
- DS24** Reset Arrow (Green)
- DS25** Menu Arrow (Green)
- DS26** AMF application only: Breaker Open (Green)
- DS27** Phase B (Green)
- DS29** Phase C (Green)
- DS36** AMF application: Breaker Closed (Red) – or – paralleling application: Breaker Open (Green)
- DS37** AMF application only: Breaker Open (Green)

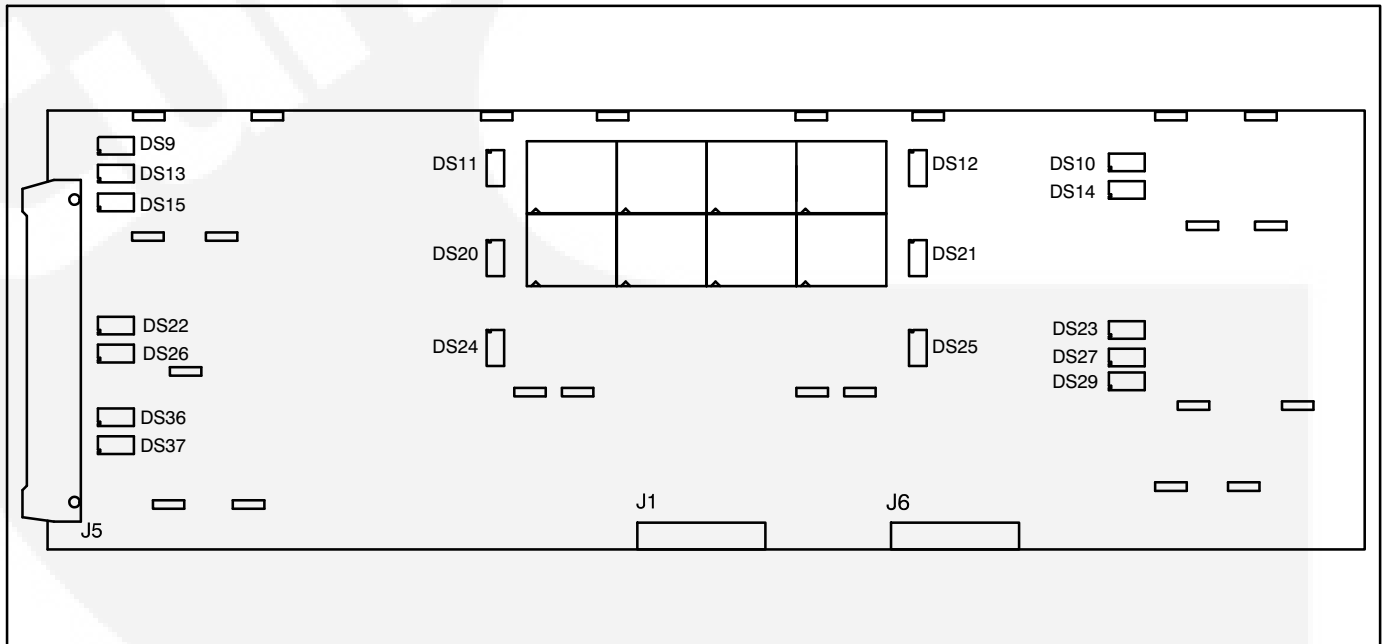

FIGURE 3-6. DIGITAL DISPLAY BOARD

CUSTOMER INTERFACE BOARD (A34)

The customer interface board (Figure 3-7) connects to the PT/CT board to bring in voltage and current. It also connects to customer inputs and outputs. Note that there are two versions of this board, for parallel and non-parallel generator sets.

Connectors

The customer interface board has five connectors. They are:

- J1** Customer connections
- J2** Customer connections
- J3** A36 PT/CT Board and customer connections
- J4** Connects to J2 on A32 Digital board
- J5** Connects to J4 on A33 Analog board

LEDs

The customer interface board has 27 LED's that indicate the following conditions:

- DS1** Master First Start Input (Green) – paralleling application only
- DS2** Pre low oil pressure output relay K14 (Red)
- DS3** Customer Fault #4 Input (Red)
- DS4** Customer Fault #1 Input (Red)
- DS5** Low oil pressure output relay K15 (Red)
- DS6** Fault Reset Input (Red)
- DS7** Engine Idle (Green)
- DS8** Paralleling Breaker Close Input (Green) [paralleling function is load demand]
- DS9** Paralleling Breaker Open Input (Green)
- DS10** Paralleling Breaker Position Input (Green)
- DS11** Customer Fault #2 input (Red)
- DS12** Low coolant output relay K17 (Red)
- DS13** Low Fuel Input (Red)
- DS14** Remote Start input (Green)
- DS15** Customer Fault #3 input (Red)
- DS16** Paralleling Breaker Control input relay energized from Digital board (Green). This output is activated to close the paralleling breaker.
- DS17** Common Alarm output relay energized from Digital board (Green)
This output is activated only on a shutdown condition.
- DS18** Spare output relay energized from Digital board (Green)
This output is activated only on a warning condition.
- DS19** Load Dump output relay energized from Digital board (Red)
If overload or underfrequency for 5 seconds, this output is activated (before shutdown).
- DS20** Ready to Load output relay energized from Digital board (Green)
This output is activated when AC voltage and frequency exceed 90% of nominal.
- DS21** Pre high engine temperature output relay K8 (Red)
- DS22** Not in auto output relay K6 (Red)
- DS23** High engine temperature output relay K9 (Red)
- DS24** Overspeed output relay K10 (Red)
- DS25** Overcrank output relay K11 (Red)
- DS26** Low engine temperature output relay K12 (Red)
- DS27** Low fuel output relay K13 (Red)



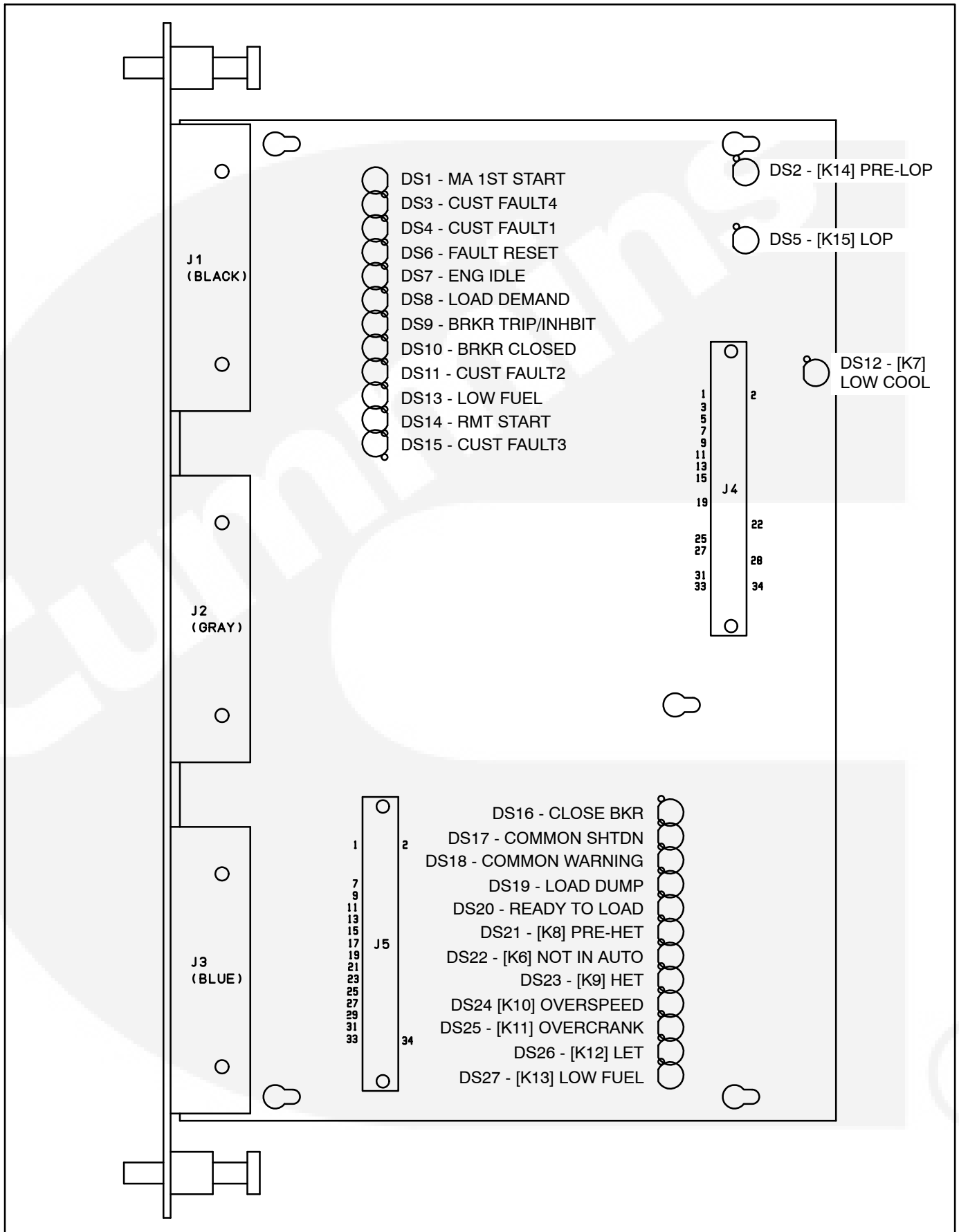

FIGURE 3-7. CUSTOMER INTERFACE BOARD

PT/CT BOARD (A36)

The PT/CT board (Figure 3-8) is mounted inside the accessory box. This board converts generator output voltage to approximately 18 VAC levels for the analog board. It also converts CT .55 amp (at full load) output to approximately 1.65 VAC (at full load) input for the analog board.

There are three versions of this board. For proper operation, the PT/CT board must be correctly matched to the generator set.

In addition, there is a specific set of CTs for each genset. For proper operation, the CTs must also be correctly matched to the genset output current.

Connectors

The PT/CT board has two connectors. They are:

- J8** Connects to J3 on A34 Customer Interface board
- J9** Connects to AC harness (generator output voltage and CTs)

J9 wiring connections:

Yellow	Gen. A In
Orange	Gen. B In
Red	Gen. C In
Brown	Gen. Common In
White	CT21 (+) In
Gray	CT21 (common) In
Grn/Ylw	CT22 (+) In
Black	CT22 (common) In
Purple	CT23 (+) In
Blue	CT23 (common) In

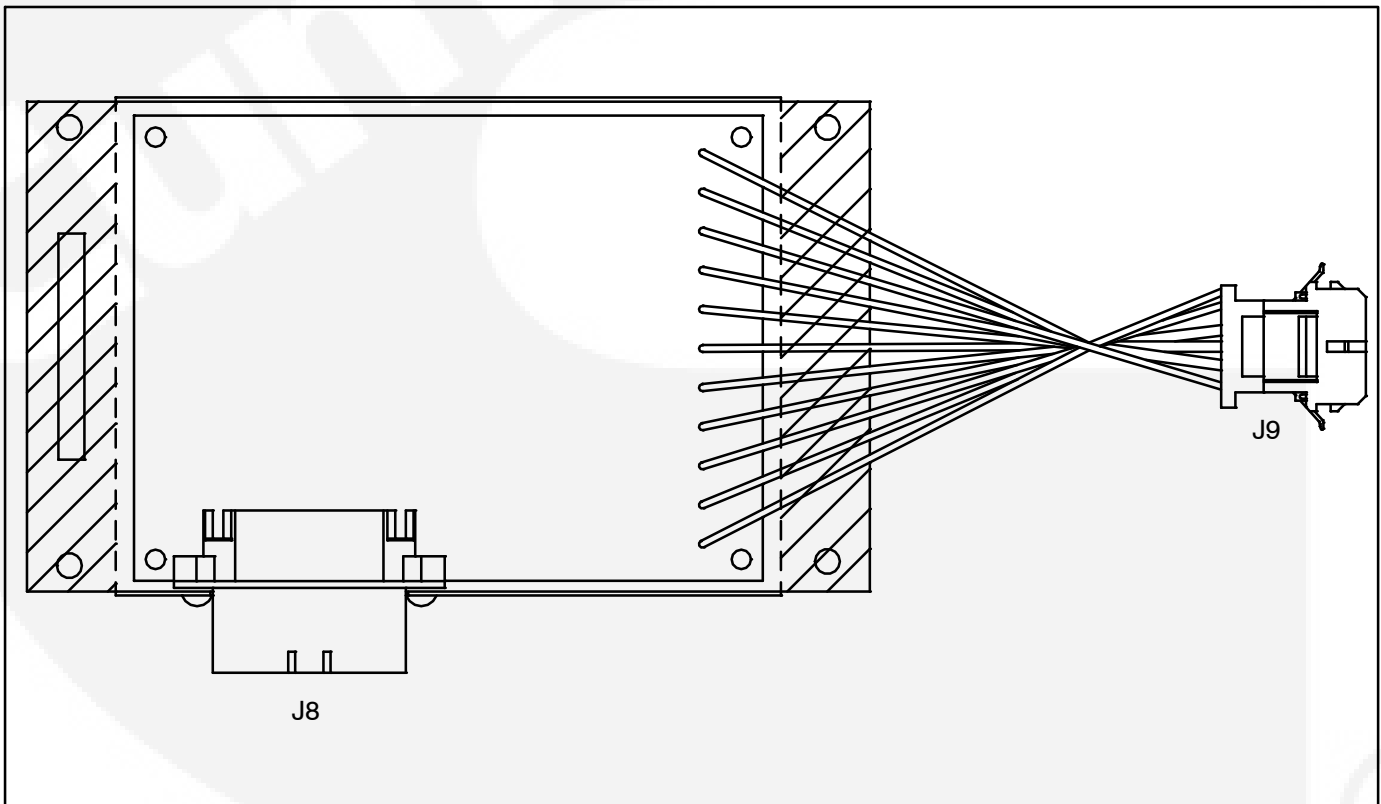

FIGURE 3-8. PT/CT BOARD

BUS PT MODULE (A39)

The bus PT module (Figure 3-9) is mounted inside the accessory box. This module converts the bus output voltage (from the load side of the paralleling breaker) to 18 VAC and provides this to the analog board. It provides a reference signal to the Power-Command Control for synchronizing the generator set output to a system bus. There are four versions of this module, for primary voltages of 69, 120, 240 or 346 volts AC line to neutral. For proper operation, the correct bus PT module must be installed in the generator set. Correct phasing is also important as the system uses the bus PT module output for both protection and control of the generator set.

Connectors

The bus PT module has two terminal blocks. They are:

TB1 Bus voltage connections.

- N bus neutral
- A bus A phase (U)
- B bus B phase (V)
- C bus C phase (W)

TB2 Bus PT output for PowerCommand control.

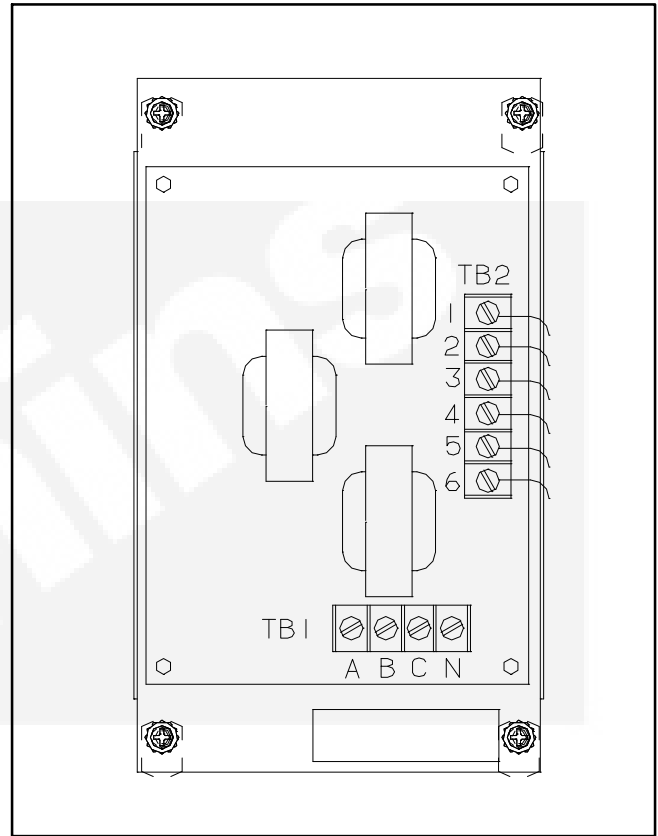

FIGURE 3-9. BUS PT MODULE



GENSET COMMUNICATIONS MODULE (A41)

The genset communications module (GCM) is required to connect the PCC to a PowerCommand (LonWorks) network, and communicate with other network modules. The GCM module is an optional feature, and it is available as a field upgrade kit for applications where the feature must be added in the field. The PC must be operating with firmware version 1.06 or later. For model DFH gensets only, firmware must be version 1.04 or later.)

The GCM provides an interface for data transfer between the PowerCommand control and other modules on the network. It communicates with the PCC through a serial port on the PCC, as well as monitoring various PCC inputs to determine the operating state of the control. For example, the GCM monitors

PCC data such as voltage, oil pressure, current, engine speed, and not in auto status; and provides that information to the network.

The GCM also facilitates remote monitoring and limited remote control of the genset that PCC controls. Outputs from the GCM can 'wake up' the PCC when needed, or issue start commands to the genset. The GCM also includes a terminate circuit for use at the end of a network data bus.

The GCM module is powered from the genset starting batteries. It is operational at all times when powered, even if the PCC is asleep.

The GCM module is mounted on stand-off mounting legs above the analog board (A33).

Refer to the Power Command Network Installation and Operator's Manual (900-0366) for information on installation and use of the GCM module.

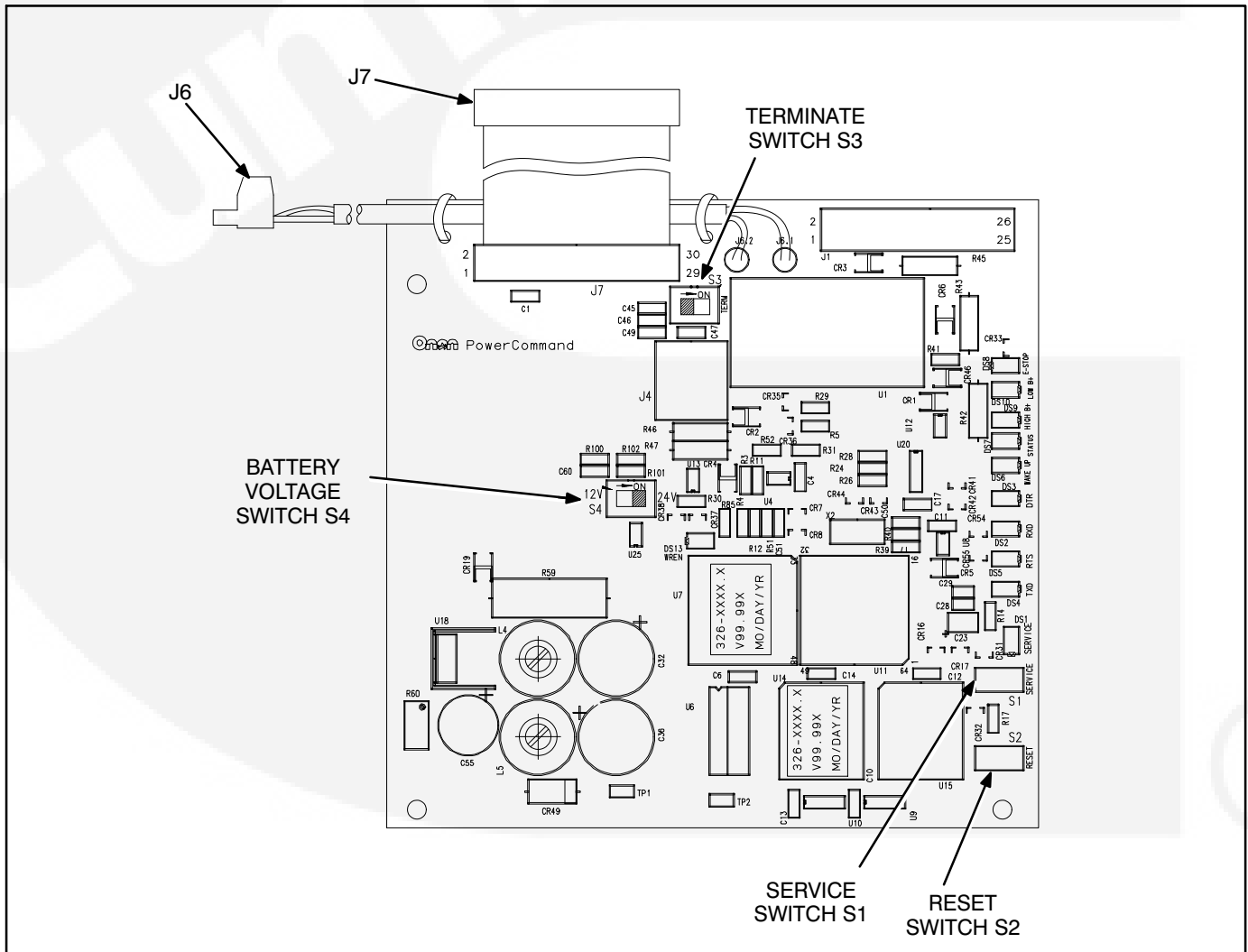

FIGURE 3-10. GENSET COMMUNICATIONS MODULE

VOLTAGE REGULATOR OUTPUT MODULE (A37)

The voltage regulator output module (Figure 3-11) is a power amplifier. This board is used to amplify the pulse-width modulated (PWM) signal from the PCC to drive the exciter windings. Power from the PMG is used by this board to amplify the PWM signal.

Connectors

The voltage regulator output module has two connectors. They are:

J7 Connects to engine harness (control)

J7 wiring connections:

Gray	Regulator Drive (+) Input
White	Regulator Drive (-) Input
Blue	B+ Input (RUN signal)
Purple	Ground Input
Grn/Yel	Start in
Black	Start solenoid

J10 Connects to engine harness (power)

J10 wiring connections:

Green	Phase A PMG power
Yellow	Phase B PMG power
Orange	Phase C PMG power
Red	X (Field +) Output
Brown	XX (Field -) Output

LEDs

The voltage regulator output module has 3 LED's that indicate the following conditions.

DS1 On when voltage regulator isolated supply is operating (Green)

DS2 Output Duty Cycle – Brighter when load increases – larger duty cycle (Amber). The duty cycle range of the PWM signal is 0 - 60%. Because the normal duty cycle is less than 10%, the output duty cycle LED, DS2 will normally be very dimly lit.

DS3 Backup start disconnect – On when start disconnect is true (Green). The backup start disconnect is initiated at about 850 RPM, when sensed PMG voltage is greater than 105 volts RMS.

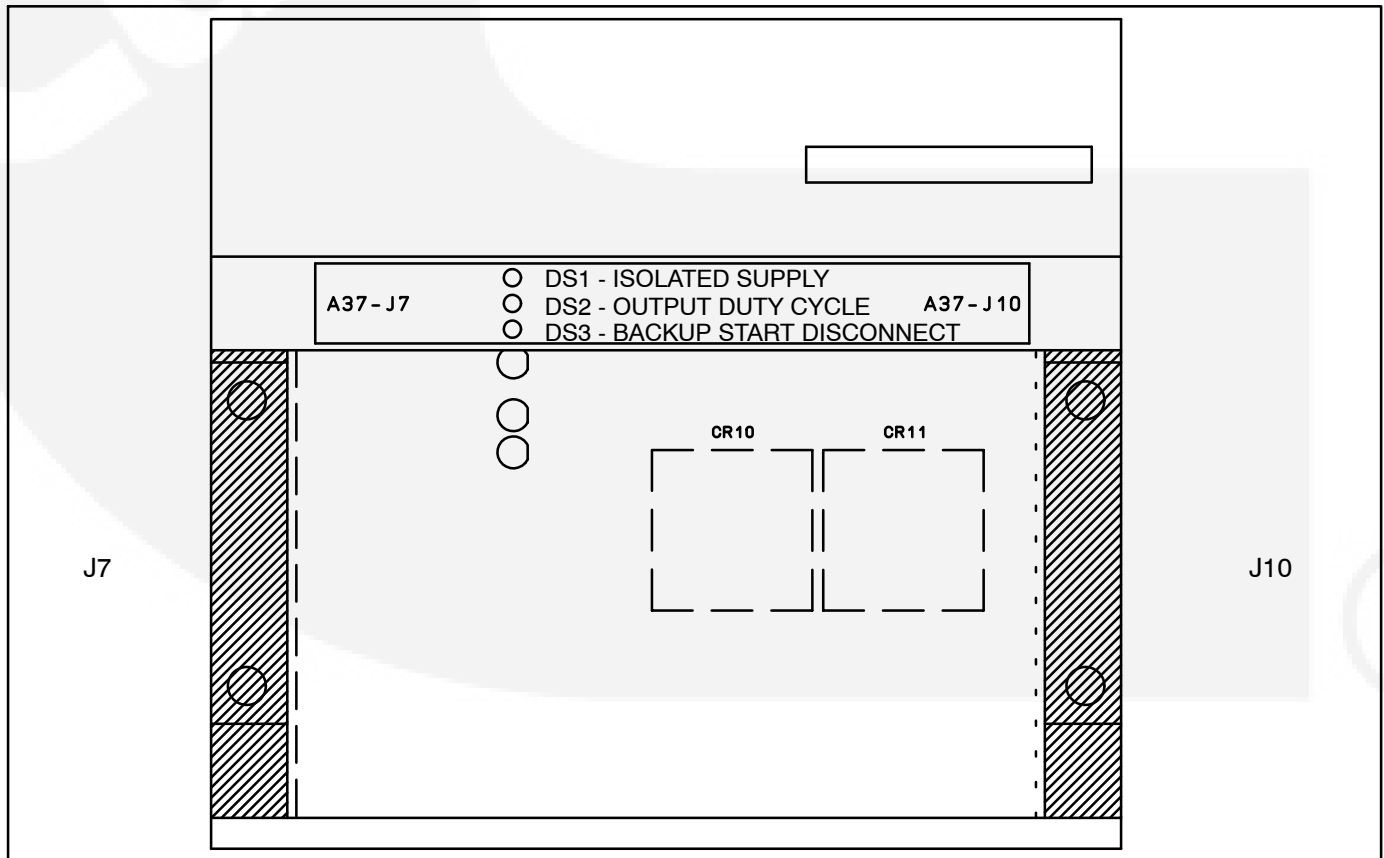

FIGURE 3-11. VOLTAGE REGULATOR OUTPUT MODULE (A37)

GOVERNOR OUTPUT MODULE (A38)

The governor output module (Figure 3-12) receives a low power, 3 kHz pulse-width modulated (PWM) command from the engine interface board (A31). This module drives the two fuel actuators (right and left) with a feed back-controlled, 200 Hz PWM power output stage. The governor module also has both right and left 0-5 volt actuator position voltages which are used for actuator diagnostics.

Connectors

The governor output module has two connectors. They are:

J6

Inputs: Run Signal, B+, Governor Command (from engine interface board)

Outputs: B+ (fused), SwB+, actuator position voltages (R, L), and Rack Position Fault

J13

Inputs: (R, L) Actuator position sensing signals

Outputs: (R, L) Actuator drive

Fuses

The governor output module has four fuses to protect it from overloads and groundfaults. They are:

- F1** Left Actuator Drive (15 Amps)
- F2** Right Actuator Drive (15 Amps)
- F3** Switched B+ (10 Amps)
- F4** B+ Fused (10 Amps)

LEDs

The governor output module has six LED's that indicate the following conditions:

- DS1** (Green) Run command signaling governor module is active.
- DS2** (Green) 5 volt power supply is active.
- DS3** (Green) Left actuator drive is active. The PCC duty cycle range is 25 - 93%. When running, the maximum duty cycle is about 63%. Note that the brighter the LED, the larger the duty cycle.
- DS4** (Green) Right actuator drive is active. See DS3 description.
- DS5** (Red) Left actuator fault indicator. If the actuator is more than 1.5 mm from its commanded position, the fault indicator will be ON. Note that the actuator has maximum range of 0 - 21mm. During transients and starting sequences, the fault indicator will become active for short (200 millisecond) periods.
- DS6** (Red) Right actuator fault indicator. See DS5 description.

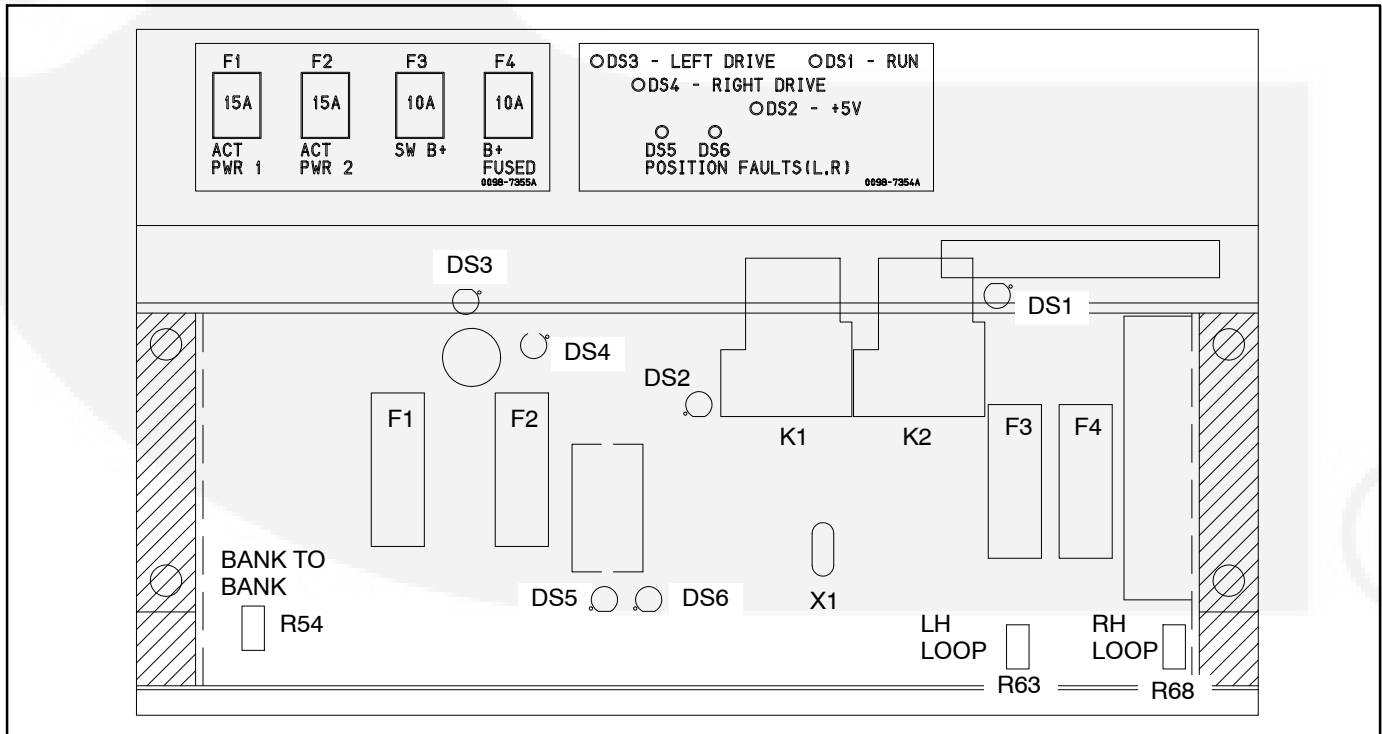

FIGURE 3-12. GOVERNOR OUTPUT MODULE (A38)

MASTER FIRST START SENSOR

The First Start Sensor System is an Onan control sub-system which is used to sense when a generator set is ready to close to a de-energized system bus and to prevent more than one generator set from closing to a dead bus on automatic system starting. The First Start Sensor System for PowerCommand generator sets is composed of control algorithms within the PowerCommand control and a Master First Start Sensor, which is usually mounted in a remote master control panel.

The sequence of operation of the control system is as follows: On a signal to start, all generator sets in a system simultaneously start, and accelerate to rated speed and voltage. The Master First Start Sensor continuously provides pulses to each PowerCommand control. When the PowerCommand control receives the pulse from the Master First Start Sensor, if it is ready to close to the bus, an interlock signal is sent to all other controls to prevent their respective paralleling breakers from closing. A close signal is then provided to the generator set paralleling breaker.





THIS PAGE LEFT INTENTIONALLY BLANK



4. Troubleshooting

GENERAL

The PowerCommand® Control 3100 (PCC) continuously monitors engine sensors for abnormal conditions, such as low oil pressure and high coolant temperature. If any of these conditions occur, the PCC will light a yellow Warning lamp or a red Shutdown lamp and display a message on the digital display panel.

In the event of a shutdown fault (red Shutdown lamp), the PCC will stop the generator set (genset) and close a set of contacts that can be wired to trip a circuit breaker. If the genset is stopped for this reason, the operator can restart the genset after making adjustments or corrections.

This section contains the following information:

- **Table 4-1:** Contains a list of all status codes, including the displayed message and status indicator. Also references the page number that contains a description of each code.
- **Table 4-2:** Describes each warning and shutdown code, warning and shutdown limits where applicable, and basic corrective actions, such as, checking fluid levels, control reset functions, battery connections, etc.
- **Table 4-3:** Lists the PCC oil pressure warning and shutdown limits.
- **Tables 4-4 through 4-36:** Provide detailed troubleshooting procedures.
- **Table 4-37:** Describes the analog circuit board inputs and outputs.
- **Table 4-38:** Describes the location and function of each fuse.

SAFETY CONSIDERATIONS

⚠ WARNING *Contacting high voltage components can cause electrocution, resulting in severe personal injury or death. Keep the output box covers in place during troubleshooting.*

High voltages are present when the genset is running. Do not open the generator output box while the genset is running.

⚠ WARNING *Ignition of explosive battery gases can cause severe personal injury or death. Arcing at battery terminals, light switch or other equipment, flame, pilot lights and sparks can ignite battery gas. Do not smoke, or switch trouble light ON or OFF near battery. Discharge static electricity from body before touching batteries by first touching a grounded metal surface.*

Ventilate battery area before working on or near battery—Wear goggles—Stop genset and disconnect charger before disconnecting battery cables—Disconnect negative (-) cable first and reconnect last.

⚠ CAUTION *Disconnect battery charger from AC source before disconnecting battery cables. Otherwise, disconnecting cables can result in voltage spikes damaging to DC control circuits of the genset.*

⚠ WARNING *Accidental starting of the generator set can cause severe personal injury or death. Prevent accidental starting by disconnecting the negative (-) cable from the battery terminal.*

When troubleshooting a generator set that is shut down, make certain the generator set cannot be accidentally restarted as follows:

1. Move the Run/Off/Auto switch on the control panel to the OFF position.
2. Turn off or remove AC power from the battery charger.
3. Remove the negative (-) battery cable from the generator set starting battery.

STATUS INDICATORS

Non-Automatic Status Indicator: This red lamp flashes continuously when the Run/Off/Auto switch is in the Off position.

Warning Status Indicator: This yellow lamp is lit whenever the control detects a warning condition. After the condition is corrected, warning indicators can be reset by pressing the Reset switch. (It is **not** necessary to stop the generator set.) In auto mode, warning indicators can also be reset by cycling the remote reset input after the condition is corrected.

Shutdown Status Indicator: This red lamp is lit whenever the control detects a shutdown condition. Shutdown faults are latched. After the condition is corrected, shutdown indicators can be reset by turning the Run/Off/Auto switch to the Off position, and pressing the Reset switch. In the Auto position, shutdown faults can be reset by removing the remote start input and then cycling the remote reset input.

Emergency Stop shutdown status (Code 102) can be reset only at the PCC front panel.

Digital Display: This two-line, 16-character per line alphanumeric display is used in the menu-driven operating system and to show shutdown and warning messages. Refer to Tables 4-1 and 4-2.

RESETTING THE CONTROL

Press the momentary **Reset Switch** to reset warning and shutdown messages after the condition has been corrected. To reset a shutdown message with the Reset switch, the Run/Off/Auto switch must be in the Off Position. **(The control cannot go into Standby (sleep) mode until all faults have been reset.)**

In Auto mode, warning indicators can also be reset by cycling the remote reset input after the condition is corrected. Shutdown faults can be reset by removing the remote start input and then cycling the remote reset input.

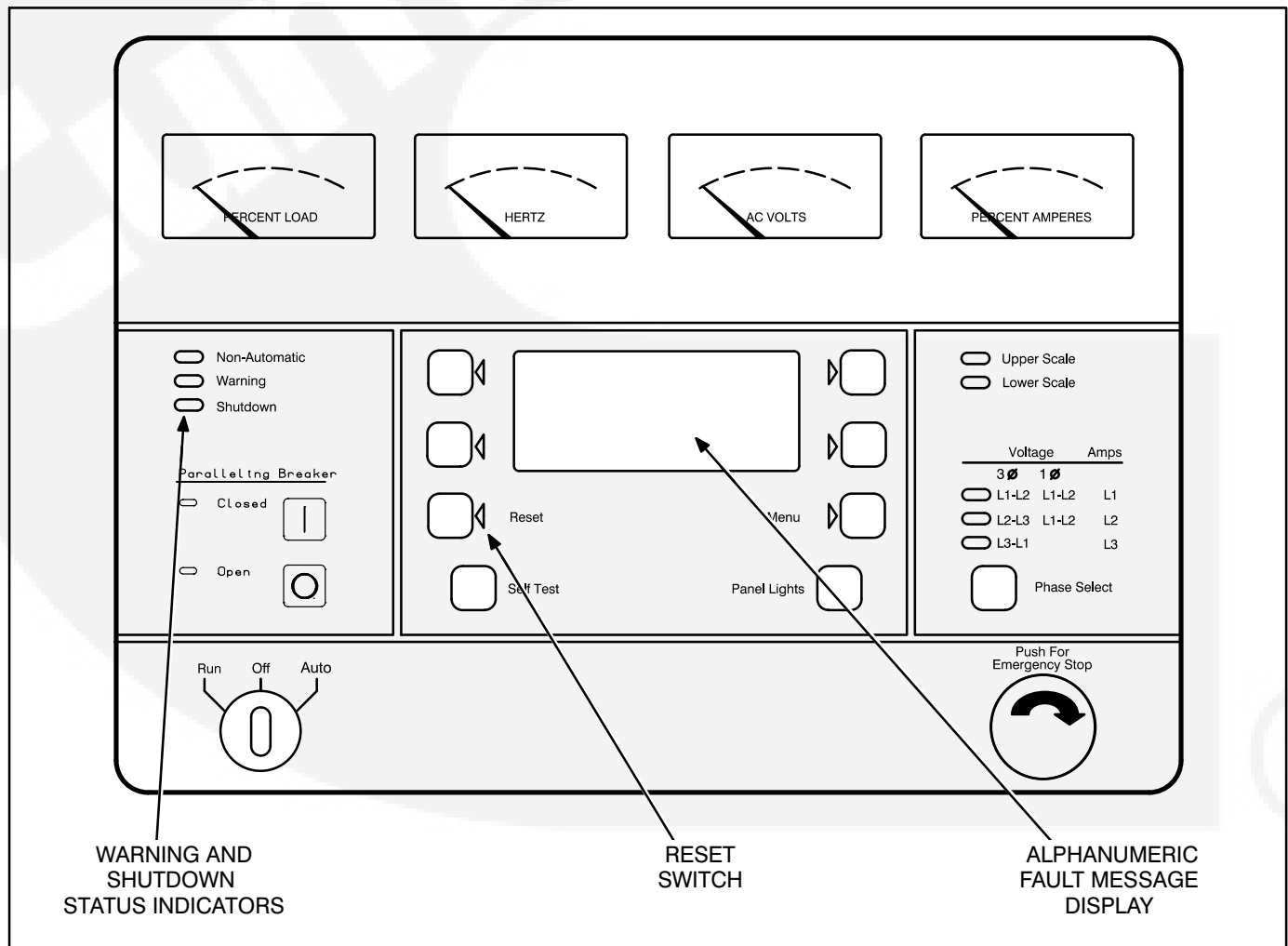

FIGURE 4-1. CONTROL PANEL (PCC 3100)

TABLE 4-1. WARNING AND SHUTDOWN CODES

CODE ...	MESSAGE	STATUS LED	BASIC CHECKS ...	TROUBLE-SHOOTING
Blank	LOAD DEMAND	none	4-5	
101	IDLE MODE	none	4-5	
102	EMERGENCY STOP	Shutdown	4-5	
200	LOW OIL PRESSURE	Warning	4-5	4-24
201	LOW OIL PRESSURE	Shutdown	4-5	4-24
204	OIL PRES SENDER	Warning	4-5	4-25
210	LOW COOLANT TEMP	Warning	4-6	4-26
211	HIGH COOLANT TEMP	Warning	4-6	4-27
212	HIGH COOLANT TEMP	Shutdown	4-6	4-27
213	COOLANT SENDER	Warning	4-6	4-25
214	LOW COOLANT LVL	Warning	4-7	4-28
215	LOW COOLANT LVL	Shutdown	4-7	4-28
220	MAG PICKUP	Shutdown	4-7	4-29
221	FAIL TO CRANK	Shutdown	4-7	4-15, 4-23
222	OVERCRANK	Shutdown	4-7	4-21
223	OVERSPEED	Shutdown	4-7	4-30
224	FAIL TO SYNCHRONIZE	Warning/Shutdown	4-8	4-31
226	FAIL TO CLOSE	Warning/Shutdown	4-8	4-33
230	LOW DC VOLTAGE	Warning	4-8	4-35
231	HIGH DC VOLTAGE	Warning	4-8	4-35
232	WEAK BATTERY	Warning	4-8	4-35
240	LOW FUEL – DAY	Warning	4-9	4-36
241	LOW FUEL	Warning	4-9	4-37
250	EEPROM ERROR	Shutdown	4-9	4-38
251	EEPROM ERROR	Warning	4-9	4-38
252	EEPROM ERROR	Warning	4-9	4-38

TABLE 4-1. WARNING AND SHUTDOWN CODES

CODE ...	MESSAGE	STATUS LED	BASIC CHECKS ...	TROUBLE-SHOOTING
260	RACK POSITION	Warning/Shutdown	4-9	4-39
261	GROUND FAULT*	Warning/Shutdown	4-9/10	4-40
262	DAY TANK*	Warning/Shutdown	4-9/10	4-40
263	HIGH GEN TEMP*	Warning/Shutdown	4-9/10	4-40
270	PHASE ROTATION	Shutdown	4-10	4-41
272	FIRST START	Warning	4-10	4-43
301	HIGH AC VOLTAGE	Shutdown	4-10	4-44
303	LOW AC VOLTAGE	Shutdown	4-10	4-47
313	UNDER FREQUENCY	Shutdown	4-10	4-49
320	OVERCURRENT	Warning	4-10	4-50
321	OVERCURRENT	Shutdown	4-11	4-50
322	SHORT CIRCUIT	Shutdown	4-11	4-50
330	OVERLOAD	Warning	4-11	4-50
335	REVERSE POWER	Shutdown	4-11	4-51
337	LOSS OF EXCITATION	Shutdown	4-12	4-52
None	INVALID SETUP	None	4-12	
None	INVALID CAL	None	4-12	

* Default message. Editable for customer site requirements. It is recommended that the bell alarm contacts of the paralleling breaker be brought back to the control and indicate "Parallel CB Trip" as one customer fault.



TABLE 4-2. WARNING AND SHUTDOWN CODES

⚠ WARNING *Hazards present in troubleshooting can cause equipment damage, severe personal injury or death. Only trained and experienced service personnel with knowledge of fuels, electricity, and machinery hazards should perform service procedures. Read Important Safety Instructions page and observe all instructions and precautions in this manual.*

SYMPTOM	CORRECTIVE ACTION
<p>MESSAGE: LOAD DEMAND</p>	<p>The PowerCommand control has received a signal to shut down from a remote device. This is a normal operation mode, which is typically used in automatic control system to minimize generator set operation hours and system fuel consumption. When the load demand signal is removed, the generator set will automatically start, synchronize, and close to the system bus.</p>
<p>MESSAGE: IDLE MODE 101 – WARNING</p>	<p>Indicates that the engine is operating in idle mode. When the genset is operating in the RUN mode, grounding the engine idle input causes generator build-up to be inhibited and the engine to be governed at 800 RPM.</p> <p>When ground is removed from this input, the genset returns to normal speed and voltage. When the engine idle function is enabled, the control automatically gensets lower oil pressure warning and shutdown trip points to reflect the lower operating speed. When the engine idle function is removed and the genset reverts to normal operating speed, the control automatically resets oil pressure warning and shutdown trip points to the normal settings.</p>
<p>Shutdown lamp lights. MESSAGE: EMERGENCY STOP 102 – SHUTDOWN</p>	<p>Indicates local or remote Emergency Stop. To reset the local/remote Emergency Stop button: Pull the button out (button with arrow – turn clockwise to allow it to pop out). Move the Run/Off/Auto switch to Off. Press the Reset switch. Select Run or Auto, as required.</p>
<p>Warning lamp lights. MESSAGE: LOW OIL PRESSURE 200 – WARNING</p>	<p>Indicates engine oil pressure has dropped to an unacceptable level. If generator is powering critical loads and cannot be shut down, wait until next shutdown period and then follow 201-SHUTDOWN procedure.</p> <p>To check oil pressure, access the Oil Pressure menu prior to clearing the fault.</p>
<p>Shutdown lamp lights. MESSAGE: LOW OIL PRESSURE 201 – SHUTDOWN</p>	<p>Indicates engine oil pressure has dropped below the shutdown trip point. Check oil level, lines and filters. If oil system is OK but oil level is low, replenish. Reset control and restart. Oil pressure limits are listed in Table 4-3.</p>
<p>Warning lamp lights. MESSAGE: OIL PRES SENDER 204 – WARNING</p>	<p>Indicates that the control has sensed that the engine oil pressure sender is out of its working range. Check that the engine oil pressure sender is properly connected.</p>

TABLE 4-2. WARNING AND SHUTDOWN CODES (CONT.)

⚠ WARNING *Hazards present in troubleshooting can cause equipment damage, severe personal injury or death. Only trained and experienced service personnel with knowledge of fuels, electricity, and machinery hazards should perform service procedures. Read Important Safety Instructions page and observe all instructions and precautions in this manual.*

SYMPTOM	CORRECTIVE ACTION
<p>Warning lamp lights. MESSAGE: LOW COOLANT TEMP 210 – WARNING Set is not operating. Warning occurs when engine coolant temperature is 70° F (21° C) or lower. NOTE: In applications where the ambient temperature falls below 40°F (4°C), Low Coolant Temp may be indicated even though the coolant heaters are operating.</p>	<p>Indicates engine coolant heater is not operating or is not circulating coolant. Check for the following conditions:</p> <ol style="list-style-type: none"> Coolant heater not connected to power supply. Check for blown fuse or disconnected heater cord and correct as required. Check for low coolant level and replenish if required. Look for possible coolant leakage points and repair as required. Open heater element. Check current draw of heater.
<p>Warning lamp lights. MESSAGE: HIGH COOLANT TEMP 211 – WARNING</p>	<p>Indicates the engine coolant temperature is getting close to the recommended maximum temperature limit: 215° F (102° C) – standby or 207° F (97° C) – prime. If generator is powering non-critical and critical loads and cannot be shut down, use the following:</p> <ol style="list-style-type: none"> Reduce load if possible by turning off non-critical loads. Check air inlets and outlets and remove any obstructions to airflow. <p>If engine can be stopped, follow HIGH COOLANT TEMP 212 – SHUTDOWN procedure.</p> <p>To check coolant temperature, access the coolant temperature menu prior to clearing the fault.</p>
<p>Shutdown lamp lights. MESSAGE: HIGH COOLANT TEMP 212 – SHUTDOWN</p>	<p>Indicates engine has overheated (coolant temperature has risen above the shutdown trip point: 223° F (106° C) – standby or 215° F (102° C) – prime. Allow engine to cool down completely before proceeding with the following checks:</p> <ol style="list-style-type: none"> Check for obstructions to cooling airflow and correct as necessary. Check fan belt and repair or tighten if necessary. Check coolant mixture. Check blower fan and circulation pumps on remote radiator installations. Reset control and restart after locating and correcting problem.
<p>Warning lamp lights. MESSAGE: COOLANT SENDER 213 – WARNING</p>	<p>Indicates that the resistance of the coolant temperature sender is out of range. Check the resistance of the sender. Resistance should be 500 to 2k ohms.</p>

TABLE 4-2. WARNING AND SHUTDOWN CODES (CONT.)

⚠ WARNING *Hazards present in troubleshooting can cause equipment damage, severe personal injury or death. Only trained and experienced service personnel with knowledge of fuels, electricity, and machinery hazards should perform service procedures. Read Important Safety Instructions page and observe all instructions and precautions in this manual.*

SYMPTOM	CORRECTIVE ACTION
<p>Shutdown lamp lights. MESSAGE: LOW COOLANT LVL 214 – WARNING or LOW COOLANT LVL 215 – SHUTDOWN</p>	<p>Indicates engine coolant level has fallen below the trip point. Allow engine to cool down completely before proceeding.</p> <ol style="list-style-type: none"> Check coolant level in both radiator and coolant recovery bottle and replenish if low. Look for possible coolant leakage points and repair if necessary. If radiator level is low and coolant bottle level is correct, defective coolant bottle hose or radiator cap. Reset control and restart after locating and correcting problem. <p>LOW COOLANT LVL Shutdown will not occur if genset is in Idle mode (low coolant warning only).</p>
<p>Shutdown lamp lights. MESSAGE: MAG PICKUP 220 – SHUTDOWN</p>	<p>Indicates mag pickup speed indication is not being sensed or does not match generator set output frequency.</p> <ol style="list-style-type: none"> Restart and check RPM on the digital display.
<p>Engine will not crank. Shutdown lamp lights. MESSAGE: FAIL TO CRANK 221 – SHUTDOWN</p>	<p>Indicates possible fault with control or starting system. Check for the following conditions:</p> <ol style="list-style-type: none"> Check fuse F3 on the Engine Interface board. Poor battery cable connections. Clean the battery cable terminals and tighten all connections. Discharged or defective battery. Recharge or replace the battery.
<p>Shutdown lamp lights. Engine stops cranking. MESSAGE: OVERCRANK 222 – SHUTDOWN</p>	<p>Indicates possible fuel system problem.</p> <ol style="list-style-type: none"> Check for empty fuel tank, fuel leaks, or plugged fuel lines and correct as required. Check for dirty fuel filter and replace if necessary. Check for dirty or plugged air filter and replace if necessary. Reset the control and restart after correcting the problem.
<p>Engine runs and then shuts down. Shutdown lamp lights. MESSAGE: OVERSPEED 223 – SHUTDOWN</p>	<p>Indicates engine has exceeded normal operating speed. (115% ±1% of nominal).</p>

TABLE 4-2. WARNING AND SHUTDOWN CODES (CONT.)

⚠ WARNING *Hazards present in troubleshooting can cause equipment damage, severe personal injury or death. Only trained and experienced service personnel with knowledge of fuels, electricity, and machinery hazards should perform service procedures. Read Important Safety Instructions page and observe all instructions and precautions in this manual.*

SYMPTOM	CORRECTIVE ACTION
<p>Warning (or Shutdown) lamp lights. MESSAGE: FAIL TO SYNCHRONIZE 224 – WARNING or FAIL TO SYNCHRONIZE 224</p>	<p>The generator set has not synchronized to the system bus within the allowable time frame.</p> <ol style="list-style-type: none"> Check the governor system stability. Adjust governing and synchronizer parameters as required. Check for fuel system problems which can cause engine instability. Synchronizing time can be improved by widening the synchronizing window and reducing the acceptance time delay.
<p>Warning lamp lights. MESSAGE: FAIL TO CLOSE 226 – SHUTDOWN</p>	<p>Indicates that the paralleling breaker has been given a signal to close, but has not closed properly.</p> <ol style="list-style-type: none"> Verify that the charging mechanism of the paralleling breaker is functioning properly. Check the close signal to the breaker. Verify that the auxiliary contact signals from the breaker to the PowerCommand control are operational.
<p>Warning lamp lights. MESSAGE: LOW DC VOLTAGE 230 – WARNING</p>	<p>Indicates battery voltage is below 10 VDC.</p> <ol style="list-style-type: none"> Discharged or defective battery. Check the battery charger fuse. Recharge or replace the battery. Poor battery cable connections. Clean the battery cable terminals and tighten all connections. Check engine DC alternator. Replace engine DC alternator if normal battery charging voltage is not obtained. Check battery charge voltage float level if applicable (raise float level).
<p>Warning lamp lights. MESSAGE: HIGH DC VOLTAGE 231 – WARNING</p>	<p>Indicates battery voltage exceeds 32 VDC.</p> <p>Check voltage float level on battery charger if applicable (lower float level).</p> <p>Check engine DC alternator. Replace engine DC alternator if normal battery charging voltage is not obtained.</p>
<p>Warning lamp lights. MESSAGE: WEAK BATTERY 232 – WARNING</p>	<p>Indicates battery voltage drops below 60% of nominal for two seconds, during starting.</p> <p>Discharged or defective battery. See Warning message 230, LOW DC VOLTAGE.</p>

TABLE 4-2. WARNING AND SHUTDOWN CODES (CONT.)

⚠ WARNING *Hazards present in troubleshooting can cause equipment damage, severe personal injury or death. Only trained and experienced service personnel with knowledge of fuels, electricity, and machinery hazards should perform service procedures. Read Important Safety Instructions page and observe all instructions and precautions in this manual.*

SYMPTOM	CORRECTIVE ACTION
<p>Warning lamp lights. MESSAGE: LOW FUEL-DAY 240 - WARNING or LOW FUEL 241 - WARNING</p>	<p>Indicates day tank fuel supply is running low. Check fuel supply and replenish as required.</p>
<p>Shutdown lamp lights. MESSAGE: EEPROM ERROR 250 - SHUTDOWN</p>	<p>Indicates PCC memory error. Data corruption of critical operating parameters.</p>
<p>Warning lamp lights. MESSAGE: EEPROM ERROR 251 - WARNING or 252 - WARNING</p>	<p>Indicates PCC memory error. Data corruption of noncritical operating parameters.</p>
<p>Shutdown lamp lights. MESSAGE: RACK POSITION 260 - WARNING</p>	<p>Indicates that one or both of the fuel racks is not at the commanded position.</p> <ol style="list-style-type: none"> a. Check fuel pump connections. b. Check left and right actuator fuses (A38-F1 & F2) on the governor output module.
<p>Shutdown lamp lights. MESSAGE: GROUND FAULT 261 - SHUTDOWN or DAY TANK 262 - SHUTDOWN or HIGH GEN TEMP 263 - SHUTDOWN</p>	<p>When any one of these customer defined inputs is closed to ground, the corresponding fault message is displayed. The nature of the fault is an optional customer selection. These fault functions can be programmed to initiate a shutdown or a warning.</p> <p>As indicated by the Shutdown lamp, a shutdown response has been pre-selected.</p> <p>Note: Customer fault messages are editable. The message displayed for the code shown (261 thru 263) may have been edited and may not appear as shown in this table.</p>

TABLE 4-2. WARNING AND SHUTDOWN CODES (CONT.)

⚠ WARNING *Hazards present in troubleshooting can cause equipment damage, severe personal injury or death. Only trained and experienced service personnel with knowledge of fuels, electricity, and machinery hazards should perform service procedures. Read Important Safety Instructions page and observe all instructions and precautions in this manual.*

SYMPTOM	CORRECTIVE ACTION
<p>Warning lamp lights. MESSAGE: GROUND FAULT 261 – WARNING or DAY TANK 262 – WARNING or HIGH GEN TEMP 263 – WARNING</p>	<p>When any one of these customer defined inputs is closed to ground, the corresponding fault message is displayed. The nature of the fault is an optional customer selection. These fault functions can be programmed to initiate a shutdown or a warning.</p> <p>As indicated by the Warning lamp, a warning response has been preselected.</p> <p>Note: Customer fault messages are editable. The message displayed for the code shown (261 thru 263) may have been edited and may not appear as shown in this table.</p>
<p>Shutdown lamp lights. MESSAGE: PHASE ROTATION 270 – SHUTDOWN</p>	<p>The phase relationship between the generator set and the system bus is not matched.</p> <ol style="list-style-type: none"> Using a phase rotation checker, verify that the generator set phase rotation matches the phase orientation of the system bus. Verify that control wiring to the bus PT module on the PowerCommand control is properly connected.
<p>Shutdown lamp lights. MESSAGE: FIRST START 272 – WARNING</p>	<p>The PowerCommand control is not receiving a proper signal from the system master first start sensor. When this occurs, the control reverts to a fallback mode in which breaker closure is automatically allowed if bus is deenergized. If bus voltage is sensed, the control will force the generator set to synchronize to the system bus before breaker close signal is initiated.</p>
<p>Shutdown lamp lights. MESSAGE: HIGH AC VOLTAGE 301 – SHUTDOWN</p>	<p>Indicates that one or more of the phase voltages has exceeded 130% of nominal, or has exceeded 110% of nominal for 10 seconds.</p>
<p>Shutdown lamp lights. MESSAGE: LOW AC VOLTAGE 303 – SHUTDOWN</p>	<p>Indicates that one or more of the phase voltages has dropped below 85% of nominal for 10 seconds.</p>
<p>Shutdown lamp lights. MESSAGE: UNDER FREQUENCY 313 – SHUTDOWN</p>	<p>Indicates that engine speed has dropped below 90% of nominal for 10 seconds. Note: Five seconds before shutdown, a Load Dump signal is initiated.</p> <p>Check fuel supply, intake air supply and load.</p>

TABLE 4-2. WARNING AND SHUTDOWN CODES (CONT.)

⚠ WARNING *Hazards present in troubleshooting can cause equipment damage, severe personal injury or death. Only trained and experienced service personnel with knowledge of fuels, electricity, and machinery hazards should perform service procedures. Read Important Safety Instructions page and observe all instructions and precautions in this manual.*

SYMPTOM	CORRECTIVE ACTION
<p>Warning lamp lights. MESSAGE: OVERCURRENT 320 – WARNING</p>	<p>Indicates that generator output current has exceeded 110% of rated for 60 seconds. Check load and load lead connections.</p>
<p>Shutdown lamp lights. MESSAGE: OVERCURRENT 321 – SHUTDOWN</p>	<p>Indicates that generator output current has exceeded 110% of rated, and that a PCC time/current calculation has initiated an overcurrent shutdown. Check load and load lead connections.</p>
<p>Shutdown lamp lights. MESSAGE: SHORT CIRCUIT 322 – SHUTDOWN</p>	<p>Indicates that generator output current has exceeded 175% of rated. Check load and load lead connections.</p>
<p>Warning lamp lights. MESSAGE: OVERLOAD 330 – WARNING</p>	<p>Indicates that three-phase power output exceeds 105% of standby (or 115% of prime) rating. After five seconds, the Load Dump output is activated. After 60 seconds, the OVERLOAD warning is activated. Check load and load lead connections.</p>
<p>Shutdown lamp lights. MESSAGE: REVERSE POWER 335 – SHUTDOWN</p>	<p>Indicates that power is flowing into the generator set, rather than out from the unit. This can be caused by engine failure, or inability to carry load, or by a number of control or interconnection problems.</p> <ol style="list-style-type: none"> a. If problem occurs at initial startup, verify connection of generator set CT's, by applying load to the generator set while it is operating alone while connected to bus. b. Verify proper connection of load sharing lines. c. Verify that the generator set is operating at the correct frequency and voltage. The no-load voltage of the generator set and other generator sets should all be the same.

TABLE 4-2. WARNING AND SHUTDOWN CODES (CONT.)

⚠ WARNING Hazards present in troubleshooting can cause equipment damage, severe personal injury or death. Only trained and experienced service personnel with knowledge of fuels, electricity, and machinery hazards should perform service procedures. Read Important Safety Instructions page and observe all instructions and precautions in this manual.

SYMPTOM	CORRECTIVE ACTION
<p>Shutdown lamp lights. MESSAGE: LOSS OF EXCITATION 337 – SHUTDOWN</p>	<p>Indicates that the alternator excitation system is improperly adjusted or has failed. Loss of Excitation failure may also be caused by operation of filters and power factor correction capacitors in the generator set loads when the kW load level on the genset is low. The capacitors in the filters and power factor correction equipment can present a leading power factor load to the generator set, which (correctly) shuts down the generator set through the loss of excitation fault. Leading power factor loads can cause the generator set to lose control of the output voltage of the genset and can cause kVar load sharing problems. Therefore, it is necessary to protect the genset from excessive leading power factor and reverse Var conditions.</p> <ol style="list-style-type: none"> Start the generator set in the RUN mode and check output voltage with both the control digital meter set and a calibrated meter. Calibrate voltage if necessary. Output voltage should be adjusted to the same level as all other generator sets at no load. Make adjustments as necessary to correct. Check load sharing lines for proper interconnections. See <i>Section 6</i> of this manual “Servicing the Generator”, Exciter Rectifier, and exciter Rotor.
<p>MESSAGE: INVALID SETUP</p>	<p>Indicates that the digital board is not properly calibrated for the generator set model. Refer to <i>Digital Board (A32) Calibration</i> in <i>Section 5</i>.</p>
<p>MESSAGE: INVALID CAL</p>	<p>Indicates that the digital board is not properly calibrated for the generator set model. Refer to <i>Digital Board (A32) Calibration</i> in <i>Section 5</i>.</p>

TABLE 4-3. PCC OIL PRESSURE WARNING & SHUTDOWN LIMITS

<p>QST30 Engine: NORM 45-65 psi (310-448 kPa), IDLE 20 psi (138 kPa)</p>		
35 psi	(241 kPa)	shutdown limit - run mode value
40 psi	(276 kPa)	warning limit - run mode value
10 psi	(69 kPa)	shutdown limit - idle mode value
15 psi	(103 kPa)	warning limit- idle mode value

To check oil pressure or engine temperature during a warning, access the oil pressure or coolant temperature menu prior to clearing the fault.

TROUBLESHOOTING PROCEDURE

The following tables are a guide to help you evaluate problems with the generator set. You can save time if you read through the manual ahead of time and understand the system.

To determine the appropriate troubleshooting procedure for the specific problem at hand, be sure to refer to the “Indicators” column provided in each troubleshooting table.

Try to think through the problem. Go over what was done during the last service call. The problem could be as simple as a loose wire, an opened fuse or a tripped circuit breaker. (Table 4-38 describes the location and function of each fuse.)

Figure 4-2 shows the location of the components within the control panel that are referenced in the

following troubleshooting procedures. Connector, LED and switch locations for each circuit board and module are provided in *Section 3*. The control wiring and circuit board connections are shown in *Section 9*.

⚠ CAUTION *Always set the Run/Off/Auto (S12) switch to the Off position and the Power On/Standby (S5) switch to the Standby position before disconnecting or connecting harness connectors. Otherwise, disconnecting the harness connectors can result in voltage spikes high enough to damage the DC control circuits of the genset.*

⚠ CAUTION *Electrostatic discharge will damage circuit boards. Always wear a grounding wrist strap when handling circuit boards or socket-mounted IC's and when disconnecting or connecting harness connectors.*



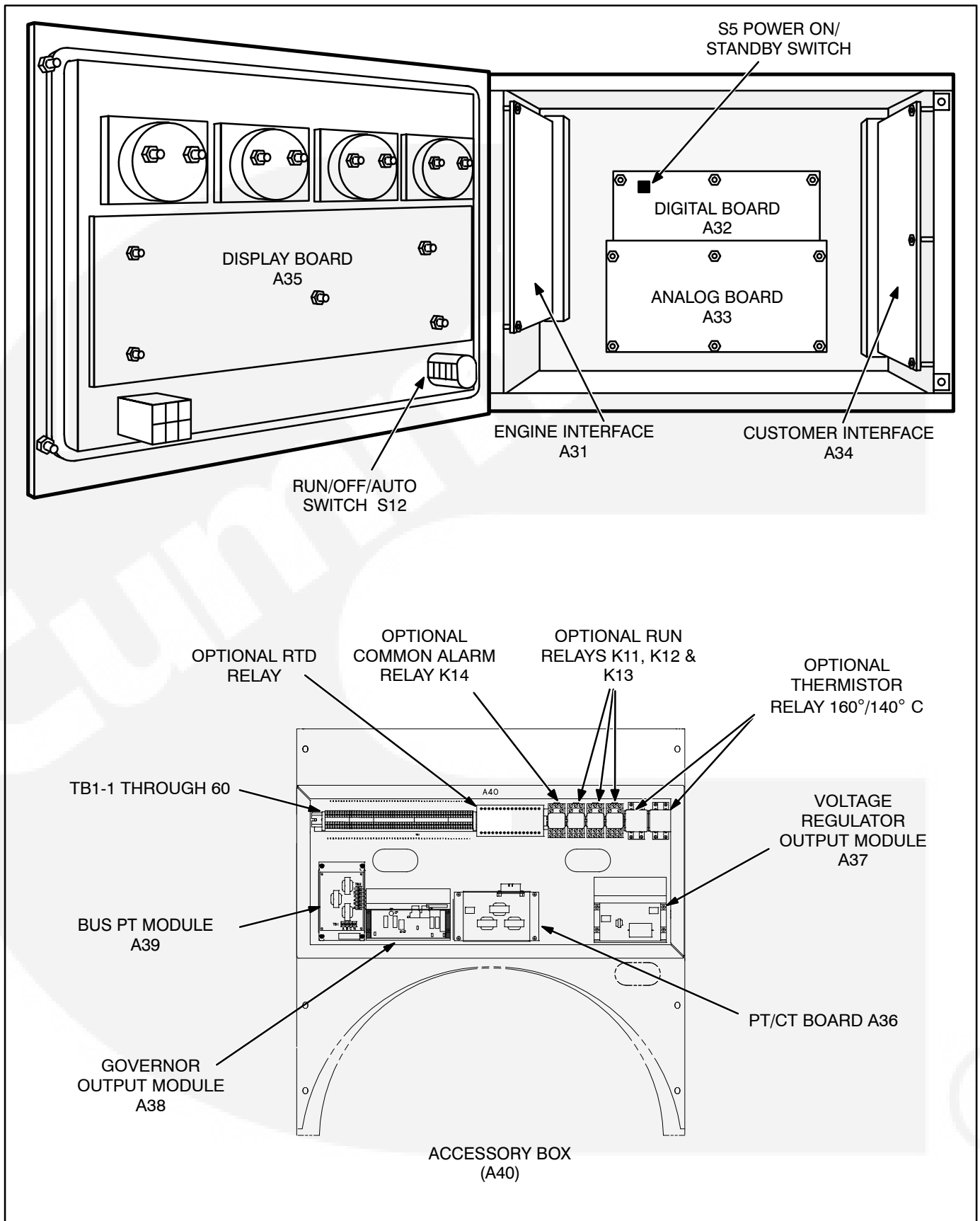

FIGURE 4-2. CIRCUIT BOARD LOCATIONS

TABLE 4-4. ENGINE DOES NOT CRANK—LOCAL OR REMOTE RUN

⚠WARNING Many troubleshooting procedures present hazards that can result in severe personal injury or death. Only trained and experienced service personnel with knowledge of fuels, electricity, and machinery hazards should perform service procedures. Review Important Safety Instructions page.

Indicator(s)	Possible Cause	Corrective Action
<p>“FAIL TO CRANK” (221) message</p> <p>Reset and attempt to start:</p> <p>Start LED DS11 on the engine interface board turns on.</p> <p>NOTE: These two indications suggest that the PCC has received a start signal and has sent a start command to the start output (J4-2) on the engine interface board.</p>	<ol style="list-style-type: none"> 1. Insufficient battery voltage. Check the following conditions: <ol style="list-style-type: none"> a. Batteries not charged. b. Battery connections loose or dirty. c. Insufficient battery charging voltage. d. Engine DC alternator could be bad. 2. Starter could be bad. 3. If there is no B+ at the starter, start solenoid K4 could be bad. 4. If there is no B+ at the start solenoid coil (K4), the backup start disconnect contacts in the regulator output module (A37) could be open (indicating that A37 is bad). 5. If there is continuity at A37 J7-5/J7-6, there may be an open between A37 and A31, an open between A37 and K4, or A31 may be bad. 6. The mag pickup signal is not being sensed. 	<ol style="list-style-type: none"> 1a. Recharge or replace the battery. Specific gravity for a fully charged battery is approximately 1.260 at 80° F (27° C). 1b. Clean and tighten or replace the battery cable connectors and cables at the battery and the set. 1c. Adjust charge rate of battery charging circuit. 1d. Replace engine DC alternator if normal battery charging voltage is not obtained. 2. Reset the control. Attempt to start, and test for B+ at the starter. If there is B+ at the starter, the starter could be bad. Test starter (see engine service manual). Replace the starter. 3. Reset the control. Attempt to start, and test for B+ into and out of start solenoid contacts. If there is B+ in, but not out, check for B+ at the start solenoid coil. If there is B+ at the coil, check ground connection. If ground connection is good, the start solenoid is bad. Replace the start solenoid. If there is B+ into and out of the start solenoid contacts, check for an open between the start solenoid contacts and the starter. If there is no B+, go to the next step. *4. Disconnect J7/P7 at the regulator output module. Test for continuity at A37 J7-5/J7-6. If there is no continuity, the regulator output module is bad. Replace A37. *5. If there is continuity at A37 J7-5/J7-6, reset the control, attempt to start, and check for B+ at A37 P7-5. If there is B+ at P7-5, there may be an open between start solenoid coil (K4) and A37. If there is no B+ at P7-5, check for B+ at J4-2 on the engine interface board (A31) while attempting to start. If there is B+ at A31 J4-2, check for an open between A37 and A31. If there is no B+ at A31 J4-2, (and DS11 is on) the engine interface board is bad. Replace A31. 6. Refer to the mag pickup shutdown message (220).
<p>*CAUTION: Wearing wrist strap, set S12 to Off and A32 S5 to Standby before connecting/disconnecting harness plugs.</p>		

TABLE 4-5. ENGINE DOES NOT CRANK—LOCAL OR REMOTE RUN

⚠WARNING Many troubleshooting procedures present hazards that can result in severe personal injury or death. Only trained and experienced service personnel with knowledge of fuels, electricity, and machinery hazards should perform service procedures. Review Important Safety Instructions page.

Indicator(s)	Possible Cause	Corrective Action
<p>“FAIL TO CRANK” (221) message</p> <p>Reset and attempt to start:</p> <p>Start LED DS11 on the engine interface board does NOT turn on.</p> <p>NOTE: These two indications suggest that the PCC has received a start signal and has NOT sent a start command to the start output (J4-2) on the engine interface board.</p>	<ol style="list-style-type: none"> 1. Fuse F3 on the engine interface board (A31) may be open, or B+ may not be getting to F3. 2. Emergency Stop switch S13 or the PCC door harness may be bad. 3. Digital board (A32) may be bad. 4. Engine interface board (A31) may be bad. 	<ol style="list-style-type: none"> *1. Install harness tool between A31 J4/P4. Reset the control. Attempt to start and check for B+ at J4-2. If no B+, remove F3 and check continuity. If open, replace the fuse with one of the same type and amp rating (5 Amps). If F3 is OK, check the B+ supply from the wiring harness. 2. To isolate: <ul style="list-style-type: none"> • Check for B+ at S13-1 and S13-2. If there is B+ at S13-2, but not at S13-1 (and S13 is NOT in the emergency stop position), then S13 is bad. Replace S13. • If there is no B+ at S13-2, disconnect J3/P3, and check for B+ at A31 J3-2. If there is no B+, replace A31. • If there is B+ at A31 J3-2, check continuity from P3-2 to P3-6. If no continuity, repair or replace as necessary. *3. Install harness tool between A32 J4/P4. Reset the control. Attempt to start, and test for ground output at A32 J4-3. If there is no ground output, A32 is bad. Replace A32. *4. If there is a ground output at A32 J4-3, and yet there is no B+ output at A31 J4-2; then A31 is bad. Replace A31.

***CAUTION:** Wearing wrist strap, set S12 to Off and A32 S5 to Standby before connecting/disconnecting harness plugs.

TABLE 4-6. ENGINE DOES NOT CRANK—REMOTE RUN

⚠WARNING *Many troubleshooting procedures present hazards that can result in severe personal injury or death. Only trained and experienced service personnel with knowledge of fuels, electricity, and machinery hazards should perform service procedures. Review Important Safety Instructions page.*

Indicator(s)	Possible Cause	Corrective Action
<p>“FAIL TO CRANK” (221) message DOES NOT appear on digital display –and: Auto LED DS5 on the engine interface board (A31) is on – RMT Start LED DS14 on the customer interface board (A34) is on –</p> <p>NOTE: This condition suggests that the PCC processor (digital board –A32) has NOT received or recognized a remote start start signal.</p>	<ol style="list-style-type: none"> 1. The Auto mode signal is not getting from engine interface board A31 to digital board A32, indicating that A31 is bad. 2. The Remote run signal is not getting from customer interface board A34 to A32, indicating that A34 is bad. 3. Digital board (A32) may be bad. 	<ol style="list-style-type: none"> *1. Install harness tool between A32 J4/P4. Check for ground output at A32 J4-18. If there is no ground output (but A31 DS5 is on) engine interface board A31 is bad. Replace A31. If there is a ground output at A31 J1-18, proceed to the next step. *2. Install harness tool between A32 J4/P4. Reset the control. Attempt to remote start, and check for ground output at A32 J2-26. If no ground output (but A34 DS14 is on) customer interface board A34 is bad. Replace A34. If there is a ground output at A32 J2-26, proceed to the next step. *3. If, when attempting remote start, there is a ground input at A32 J2-26, and a ground input at A32 J4-18—and there is no “FAIL TO CRANK” message—and the set does not crank; A32 is bad. Replace, A32.

***CAUTION:** Wearing wrist strap, set S12 to Off and A32 S5 to Standby before connecting/disconnecting harness plugs.

TABLE 4-7. ENGINE DOES NOT CRANK—REMOTE RUN

⚠WARNING *Many troubleshooting procedures present hazards that can result in severe personal injury or death. Only trained and experienced service personnel with knowledge of fuels, electricity, and machinery hazards should perform service procedures. Review Important Safety Instructions page.*

Indicator(s)	Possible Cause	Corrective Action
<p>“FAIL TO CRANK” (221) message DOES NOT appear on digital display –and: Auto LED DS5 on the engine interface board (A31) is off – RMT Start LED DS14 on the customer interface board (A34) is on –</p> <p>NOTE: This condition suggests that the engine interface board (A31) is NOT enabling the remote start logic on the digital board.</p>	<p>The Auto mode input is not getting from the Auto select switch (S12) to engine interface board A31 (indicating that S12, A31, or the harness is bad.</p> <ol style="list-style-type: none"> 1. S12 or the wiring harness may be bad. 2. Engine interface board A31 may be bad. 3. Digital board A32 may be bad. 	<ol style="list-style-type: none"> *1. Disconnect A31 J3/P3. Check continuity to ground at A31 J3-11. (J3-11 is ground out to S12. If ground is not present, replace A31. If ground is present, place S12 in Auto and check continuity from P3-11 to P3-13. If no continuity, isolate to switch or wiring harness. Repair as necessary. If there is continuity, A31 may be bad. Reconnect J3/P3. *2. Install harness tool between A32 J4/P4. Check the 16 volt (nominal) supply at A32 J4-16. If the voltage is present at A32 J4-16, and ground is present at A31 P3-13—and yet A31 DS5 is off; then A31 is bad. Replace A31. 3. If there is no +16 volt supply voltage at A32 J4-16, A32 is bad. Replace A32.

***CAUTION:** Wearing wrist strap, set S12 to Off and A32 S5 to Standby before connecting/disconnecting harness plugs.

TABLE 4-8. ENGINE DOES NOT CRANK—REMOTE RUN

⚠WARNING *Many troubleshooting procedures present hazards that can result in severe personal injury or death. Only trained and experienced service personnel with knowledge of fuels, electricity, and machinery hazards should perform service procedures. Review Important Safety Instructions page.*

Indicator(s)	Possible Cause	Corrective Action
<p>“FAIL TO CRANK” (221) message DOES NOT appear on digital display –and: Auto LED DS5 on the engine interface board (A31) is on – RMT Start LED DS14 on the customer interface board (A34) is off</p> <p>NOTE: This condition suggests that the remote start input is NOT passing through the customer interface board (A34) to enable the remote start logic on the digital board.</p>	<p>The remote start input is not getting from the remote start switch to the output of the customer interface board (A34) (indicating that the switch, A34, or the harness is bad.</p> <ol style="list-style-type: none"> 1. The remote start switch or the wiring harness may be bad. 2. Customer interface board A34 may be bad. 	<ol style="list-style-type: none"> *1. Install harness tool between A34 J1/P1. Reset the control. Attempt remote start and check for ground at A34 J1-13. If ground level is not present, isolate to the switch or the wiring harness by checking for a start signal at TB1-5. Repair as necessary. 2. If ground is present at A34 J1-13—and yet A34 DS14 is off, replace A34.

***CAUTION:** Wearing wrist strap, set S12 to Off and A32 S5 to Standby before connecting/disconnecting harness plugs.

TABLE 4-9. ENGINE DOES NOT CRANK—LOCAL RUN

⚠WARNING *Many troubleshooting procedures present hazards that can result in severe personal injury or death. Only trained and experienced service personnel with knowledge of fuels, electricity, and machinery hazards should perform service procedures. Review Important Safety Instructions page.*

Indicator(s)	Possible Cause	Corrective Action
<p>“FAIL TO CRANK” (221) message DOES NOT appear on digital display –and: Run LED DS4 on the engine interface board (A31) is off–</p> <p>NOTE: This condition suggests that the start input is NOT getting from the Run/Off/ Auto switch (S12) to the engine interface board (A31) to enable the remote start logic on the digital board.</p>	<p>The start input is not getting from the Run/ Off/ Auto select switch (S12) to A31 (indicating that S12, A31, or the harness is bad.</p> <ol style="list-style-type: none"> 1. Run/Off/ Auto select switch S12 or the wiring harness may be bad. 2. Engine interface board A31 may be bad. 3. Digital board A32 may be bad. 	<ol style="list-style-type: none"> *1. Check continuity to ground at A31 J3-11. If ground is not present, replace A31. If ground is present, place S12 in Run and check continuity from P3-11 to P3-12. If no continuity, isolate to switch or wiring harness. Repair as necessary. If there is continuity, A31 may be bad. *2. Install harness tool between A32 J4/P4. Check the 16 volt (nominal) supply at A32 J4-16. If the voltage is present at A32 J4-16, and ground is present at A31 J3-12—and yet A31 DS5 is off, replace A31. 3. If there is no +16 volt supply voltage at A32 J4-16, replace A32.

***CAUTION:** Wearing wrist strap, set S12 to Off and A32 S5 to Standby before connecting/disconnecting harness plugs.

TABLE 4-10. ENGINE CRANKS BUT DOES NOT START

⚠WARNING Many troubleshooting procedures present hazards that can result in severe personal injury or death. Only trained and experienced service personnel with knowledge of fuels, electricity, and machinery hazards should perform service procedures. Review Important Safety Instructions page.

Indicator(s)	Possible Cause	Corrective Action
<p>“OVERCRANK” (222) message</p> <p>–and</p> <p>While cranking, Run LED DS12 on the engine interface board (A31) is on.</p> <p>and</p> <p>While cranking, Run LED DS2 on the governor output module (A38) is on.</p> <p>NOTE: These indications suggest that the PCC has sent a run signal to the fuel solenoid.</p>	<p>Fuel supply or fuel delivery.</p> <ol style="list-style-type: none"> 1. Restricted fuel supply due to: <ol style="list-style-type: none"> a. Fuel level below pickup tube in tank. b. Closed shutoff valve in supply line. c. Fuel injectors clogged. d. Air in fuel system. 2. The mechanical fuel linkage could be binding, loose, or damaged. 3. Fuel solenoid (K1) on the injection pump not energized due to: <ol style="list-style-type: none"> a. Open in fuel solenoid circuit or defective governor module. b. Defective fuel solenoid. 4. Fuel tank solenoid not energized due to: <ol style="list-style-type: none"> a. Open in fuel tank solenoid circuit. b. Defective fuel tank solenoid. 5. Engine fuel injection or other engine problem. 	<ol style="list-style-type: none"> 1a. Add fuel if low. Prime the fuel system. 1b. Open any closed shutoff valve in the fuel line supplying the engine. 1c. Refer to engine service manual. 1d. Bleed air from fuel system. Refer to engine service manual. 2. Inspect the mechanical fuel linkage, and repair or replace as necessary. Follow the procedure in the engine repair manual to check the EFC for binding or damage. Disconnect the actuator connector, and connect +12 VDC from the battery to the actuator. The actuator should click upon application and removal of the voltage. If the actuator does not click, refer to the engine manual. If the actuator clicks, reconnect the wires to the actuator. 3a. Reset the control. Attempt to start and check for B+ at the K1 fuel solenoid coil on the injection pump and at output of governor module. Check continuity from J6-20 and 21 to J6-19. 3b. Check wiring continuity of fuel solenoid circuit. Test fuel solenoid. Repair or replace as necessary. 4a. Check wiring continuity of fuel tank solenoid circuit. 4b. Test fuel tank solenoid. Repair or replace as necessary. 5. Refer to the engine service manual.

***CAUTION:** Wearing wrist strap, set S12 to Off and A32 S5 to Standby before connecting/disconnecting harness plugs.

TABLE 4-11. ENGINE CRANKS BUT DOES NOT START

⚠WARNING Many troubleshooting procedures present hazards that can result in severe personal injury or death. Only trained and experienced service personnel with knowledge of fuels, electricity, and machinery hazards should perform service procedures. Review Important Safety Instructions page.

Indicator(s)	Possible Cause	Corrective Action
<p>“OVERCRANK” (222) message</p> <p>–and</p> <p>While cranking, Run LED DS12 on the engine interface board (A31) is on.</p> <p>and</p> <p>While cranking, Run LED DS2 on the governor output module (A38) is off.</p> <p>NOTE: These indications suggest that the PCC has sent a run signal to the governor module, but the signal is not getting through the governor module to the fuel solenoid.</p>	<p>The run signal is not getting through the governor module to the fuel solenoid.</p> <ol style="list-style-type: none"> 1. The run signal is not getting out of the engine interface board (A31). A31 may be bad. 2. There is an open between the engine interface board (A31) and the governor output module (A38). 3. The run signal is not getting through the governor output module (A38). A38 may be bad. 	<p>Reset the control. Attempt to start and check for B+ at A31 J4-1.</p> <ol style="list-style-type: none"> *1. Install harness tool between A31 J4/P4. Reset the control. Attempt to start and check for B+ at A31 J4-1. If there is no B+ at A31 J4-1, replace A31. *2. If there is B+ at A31 J4-1, install harness tool between A38 J6/P6. Check for B+ at A38 J6-19, while attempting to crank. If there is no B+ at A38 J6-19, isolate to connectors and wiring. Repair or replace as necessary. 3. If there is B+ at A31 J4-1, and there is B+ at A38 J6-19, check continuity from A38 J6-15 to battery ground, if not continuity replace harness, if continuity, replace A38.
<p>*CAUTION: Wearing wrist strap, set S12 to Off and A32 S5 to Standby before connecting/disconnecting harness plugs.</p>		

TABLE 4-12. ENGINE CRANKS BUT DOES NOT START

⚠WARNING Many troubleshooting procedures present hazards that can result in severe personal injury or death. Only trained and experienced service personnel with knowledge of fuels, electricity, and machinery hazards should perform service procedures. Review Important Safety Instructions page.

Indicator(s)	Possible Cause	Corrective Action
<p>“OVERCRANK” (222) message</p> <p>–and</p> <p>Run LED DS12 on the engine interface board (A31) is off.</p> <p>NOTE: These indications suggest that the PCC has NOT sent a run signal – (fuel solenoid enable signal) out to the governor module and the fuel solenoid.</p>	<p>The run signal from the digital board (A32) is not being processed by the engine interface board (A31).</p> <ol style="list-style-type: none"> 1. The run signal is not getting out of the digital board (A32). A32 may be bad. 2. The run signal is not being processed by the engine interface board (A31). A31 may be bad. 	<p>*Install harness tool between A32 J4/P4. Attempt to start and check for ground signal at A32 J4–8.</p> <ol style="list-style-type: none"> 1. If there is no ground signal at A32 J4–8, replace A32. 2. If there is a ground signal at A32 J4–8, replace A31.
<p>“FAIL TO CRANK” (221) message</p> <p>NOTE: The engine is cranking but shutting down on a 221 fault.</p>	<p>The mag pickup signal is not being sensed.</p>	<p>Refer to the mag pickup shutdown message (220).</p>

***CAUTION:** Wearing wrist strap, set S12 to Off and A32 S5 to Standby before connecting/disconnecting harness plugs.

TABLE 4-13. LOW OIL PRESSURE WARNING (200) OR SHUTDOWN (201)

⚠WARNING Many troubleshooting procedures present hazards that can result in severe personal injury or death. Only trained and experienced service personnel with knowledge of fuels, electricity, and machinery hazards should perform service procedures. Review Important Safety Instructions page.

Indicator(s)	Possible Cause	Corrective Action
<p>“LOW OIL PRESSURE” warning (200) or shutdown (201) message.</p>	<p>1. Low oil level. Clogged lines or filters.</p> <p>2a. Sender or oil pump could be bad. Or the generator set may be shutting down on another fault.</p> <p>2b. Harness or PCC circuit board could be bad.</p> <p>Isolate to the harness, engine interface board (A31), analog board (A33), or digital board (A32).</p>	<p>1. Check oil level, lines and filters. If oil system is OK but oil level is low, replenish. Oil pressure limits are listed in <i>Table 4-3</i>.</p> <p>2. Disconnect the oil pressure sender leads, and connect an oil pressure sender simulator to the harness.</p> <p>a. If the control responds to the simulator, reconnect the sender, disconnect the run signal wire at the fuel solenoid, and crank the engine. Check the oil pressure reading on the digital display.</p> <ul style="list-style-type: none"> • If the display shows an acceptable oil pressure, the problem may not be in the oil or oil sensing system. The generator set may be shutting down on another fault (out of fuel, blown governor fuse, intermittent connector). Restart the generator set and monitor the PCC display panel for other faults. • If the display does not show an acceptable oil pressure, replace the sender. If the PCC still doesn't display an oil pressure while cranking, the oil pump may be faulty. Refer to the engine service manual. <p>*b. If the control does not respond to the simulator, the PCC or the harness is bad. Install harness tool between A31 J2/P2.</p> <p>Check for +5 VDC at the sender (lead marked E1-B). If there is no 5 VDC at the sender</p> <ul style="list-style-type: none"> • Check for 5 VDC at A31 J5-18. • If yes, harness is bad. If no, check for 5 VDC at A31 J2-24. • If yes, A31 is bad. If no, A33 is bad. <p>If there is 5 VDC at the sender, use the sender simulator to generate a signal to A31 J2-23. If the pressure signal (.5 to 4.5 VDC) does not get to A31 J2-23, isolate to the harness or A31. If the pressure signal does get to A31 J2-23, refer to the analog/digital troubleshooting procedure (<i>Table 4-36a/b</i>).</p>

***CAUTION:** Wearing wrist strap, set S12 to Off and A32 S5 to Standby before connecting/disconnecting harness plugs.

TABLE 4-14. SENDER WARNINGS (204 or 213)

⚠WARNING Many troubleshooting procedures present hazards that can result in severe personal injury or death. Only trained and experienced service personnel with knowledge of fuels, electricity, and machinery hazards should perform service procedures. Review Important Safety Instructions page.

Indicator(s)	Possible Cause	Corrective Action
<p>“OIL PRESSURE SENDER” warning (204) message.</p>	<ol style="list-style-type: none"> 1. The sender connections could be bad. 2. The sender, the harness, engine interface board (A31), digital board (A32), or analog board (A33) could be faulty. 	<ol style="list-style-type: none"> 1. Check the sender connections. *2. Isolate to the sender, harness, engine interface board (A31), analog board (A33), or digital board (A32). Disconnect the oil pressure sender leads, and connect an oil pressure sender simulator to the harness. “OIL PRES SENDER” warning is displayed after the fault condition is sensed for 10 seconds. <ol style="list-style-type: none"> a. If the control responds to the simulator, replace the sender. *b. If the control does not respond to the simulator, the PCC or the harness is bad. Install harness tool between A31 J2/P2. Check for +5 VDC at the sender (lead marked E1-B). If there is no 5 VDC at the sender <ul style="list-style-type: none"> • Check for 5 VDC at A31 J5-18. • If yes, harness is bad. If no, check for 5 VDC at A31 J2-24. • If yes, A31 is bad. If no, A33 is bad. If there is 5 VDC at the sender, use the sender simulator to generate a signal to A31 J2-23. If the pressure signal (.5 to 4.5 VDC) does not get to A31 J2-23, isolate to the harness or A31. If the pressure signal does get to A31 J2-23, refer to the analog/digital troubleshooting procedure (Table 4-36a/b).
<p>“COOLANT SENDER” warning (213) message.</p>	<ol style="list-style-type: none"> 1. The sender connections could be bad. 2. The sender, the harness, engine interface board (A31), digital board (A32), or analog board (A33) could be faulty. 	<ol style="list-style-type: none"> 1. Check the sender connections. *2. Isolate to the sender, harness, engine interface board (A31), analog board (A33), or digital board (A32). Disconnect the sender, and plug in a resistive sender simulator to isolate the fault. <ol style="list-style-type: none"> a. If the control responds to the simulator, replace the sender. b. If the control does not respond to the simulator, refer to the high coolant temp troubleshooting procedure.
<p>*CAUTION: Wearing wrist strap, set S12 to Off and A32 S5 to Standby before connecting/disconnecting harness plugs.</p>		

TABLE 4-15. LOW ENGINE TEMPERATURE WARNING (210)

⚠WARNING Many troubleshooting procedures present hazards that can result in severe personal injury or death. Only trained and experienced service personnel with knowledge of fuels, electricity, and machinery hazards should perform service procedures. Review Important Safety Instructions page.

Indicator(s)	Possible Cause	Corrective Action
<p>“LOW COOLANT TEMP” warning (210) message.</p> <p>Coolant level is normal.</p> <p>Heater is OK.</p> <p>Coolant temp on front panel display is OK.</p> <p>DS3 on the engine interface board, A31, is on.</p>	<p>DS3 / A31 is on, indicating that engine interface board A31 is receiving a low coolant temp from the sender.</p> <p>The sender, the harness or A31 could be bad.</p>	<p>Isolate the source of the signal.</p> <p>Unplug the coolant temperature switch (S1) and reset the control.</p> <ol style="list-style-type: none"> 1. If the 210 warning message drops out and does not reappear, replace the sender. *2. If the 210 warning message reappears and remains after control reset, disconnect A31 J4 and check continuity from P4-13 to GND. <ul style="list-style-type: none"> • If there is continuity, replace the harness. • If there is no continuity, replace circuit board A31.
<p>“LOW COOLANT TEMP” warning (210) message.</p> <p>Coolant level is normal.</p> <p>Heater is OK.</p> <p>Coolant temp on front panel display is OK.</p> <p>DS3 on the engine interface board, A31, is off.</p>	<p>DS3 / A31 is off, indicating that engine interface board A31 is not receiving a low engine temp signal from the sender—but the 210 message indicates that A32, the digital board, is responding to a false low engine temp signal.</p> <p>A31, the engine interface board, or A32, the digital board, could be bad.</p>	<p>Isolate the source of the signal.</p> <p>Check J4-6/P4-6 on A32.</p> <ol style="list-style-type: none"> *1. Install harness tool between A32 J4/P4. 2. Open J4-6 and reset the control. <ul style="list-style-type: none"> • If fault drops out and does not return, replace A31. • If fault returns after resetting the control, replace A32.

***CAUTION:** Wearing wrist strap, set S12 to Off and A32 S5 to Standby before connecting/disconnecting harness plugs.

TABLE 4-16. HIGH ENGINE TEMPERATURE WARNING (211) OR SHUTDOWN (212)

⚠️WARNING Many troubleshooting procedures present hazards that can result in severe personal injury or death. Only trained and experienced service personnel with knowledge of fuels, electricity, and machinery hazards should perform service procedures. Review Important Safety Instructions page.

Indicator(s)	Possible Cause	Corrective Action
<p>“HIGH COOLANT TEMP” warning (211) or shutdown (212) message.</p> <p>Coolant mixture and level is normal.</p> <p>No airflow obstructions.</p> <p>Fan belt is OK.</p>	<ol style="list-style-type: none"> 1. Engine problem: <ul style="list-style-type: none"> • Coolant pump could be faulty. • Thermostat could be faulty. • There could be an obstruction in the coolant flow. • External coolant pump (with remote radiator) could be faulty. • External radiator fan motor (with remote radiator) could be faulty. 2. The generator set may have been overloaded. 3. Sender, harness or PCC circuit board could be bad. 	<ol style="list-style-type: none"> 1. Refer to the engine service manual if there are any physical indications of overheating. 2. Correct any overload condition. 3. If there are no physical indications of overheating, check to see if the PCC accurately displays ambient engine temperature. <ul style="list-style-type: none"> • If the PCC ambient coolant temperature reading is accurate, the engine may be overheating. Refer to the engine service manual. • If the PCC ambient coolant temperature reading is not accurate, isolate to the sender, harness, engine interface board (A31), analog board, or digital board. <p>Disconnect the coolant temperature sender leads, and connect an coolant temperature sender simulator to the harness.</p> <ol style="list-style-type: none"> a. If the control responds to the simulator, replace the sender. *b. If the control does not respond to the simulator, install harness tool between A31 J5/P5. Connect the coolant temperature sender simulator (and B+) to A31 J5. <ul style="list-style-type: none"> • If the control displays the correct simulated temperature, replace the harness. • If the control does not display the correct simulated temperature, install harness tool at A31 J2/P2, and open lines 18/19 (and 14/15, if applicable). Check for continuity between A31 J2-18 to 19 (for coolant temp L), and A31 J2-14 to 15 (for coolant temp R). <ul style="list-style-type: none"> • If no continuity, then A31 is bad. • If continuity is OK, then send a simulated temperature signal and measure the voltage out of A31 (A31 J2-18 to 19, and A31 J2-14 to 15). If voltage is not OK (refer to the analog board inputs and outputs, <i>Table 4-37</i>), replace A33. If voltage is OK, refer to the analog/digital troubleshooting procedure (<i>Table 4-36a/b</i>).

***CAUTION:** Wearing wrist strap, set S12 to Off and A32 S5 to Standby before connecting/disconnecting harness plugs.

TABLE 4-17. LOW COOLANT WARNING OR SHUTDOWN (214 / 215)

⚠WARNING *Many troubleshooting procedures present hazards that can result in severe personal injury or death. Only trained and experienced service personnel with knowledge of fuels, electricity, and machinery hazards should perform service procedures. Review Important Safety Instructions page.*

Indicator(s)	Possible Cause	Corrective Action
<p>“LOW COOLANT LVL” warning (214) or shutdown (215) message</p> <p>Coolant level is normal.</p> <p>DS2 on the engine interface board, A31, is on.</p>	<p>DS2 on A31 is on, indicating that A31 is receiving a low coolant signal from the sender.</p> <p>The sender, the harness or the A31 circuit board could be bad.</p>	<p>If the coolant level is normal, isolate the source of the low coolant signal. (This is a ground signal.)</p> <p>Disconnect the signal lead at the sender and reset the control.</p> <ol style="list-style-type: none"> 1. If the 215 shutdown message drops out and does not reappear, replace the sender. *2. If the 215 shutdown message reappears and remains after control reset, disconnect J4/A31 and check continuity from P4–7 to GND. <ul style="list-style-type: none"> • If there is continuity, replace the harness. • If there is no continuity, replace circuit board A31.
<p>“LOW COOLANT LVL” warning (214) or shutdown (215) message</p> <p>Coolant level is normal.</p> <p>DS2 on the engine interface board, A31, is off.</p>	<p>DS2 on A31 is off, indicating that A31 is not receiving a low coolant signal from the sender—but the 215 message indicates that A32, the digital board, is responding to a false low coolant signal.</p> <p>A31, the engine interface board, or A32, the digital board, could be bad.</p>	<p>If the coolant level is normal, isolate the source of the low coolant signal.</p> <p>Check J4–4/P4–4 on A32.</p> <ol style="list-style-type: none"> *1. Install harness tool between A32 J4/P4. 2. Open the J4-4 circuit and reset the control. <ul style="list-style-type: none"> • If the fault drops out and does not return, replace A31. • If the fault returns after resetting the control, replace A32.

***CAUTION:** Wearing wrist strap, set S12 to Off and A32 S5 to Standby before connecting/disconnecting harness plugs.

TABLE 4-18. MAG PICKUP SHUTDOWN (220)

⚠️WARNING Many troubleshooting procedures present hazards that can result in severe personal injury or death. Only trained and experienced service personnel with knowledge of fuels, electricity, and machinery hazards should perform service procedures. Review Important Safety Instructions page.

Indicator(s)	Possible Cause	Corrective Action
<p>“MAG PICKUP” shutdown message (220)</p>	<p>This indicates that the PCC is not sensing the mag pickup signal, or the mag pickup frequency does not correspond (in proportion) to the genset output frequency.</p> <ol style="list-style-type: none"> 1. The PCC may not be set for the correct generator set. 2. Loose or damaged mag pickup wire. 3. Damaged mag pickup (MPU). 4. The harness, the engine interface board (A31), the analog board (A33) or the digital board (A32) could be bad. 	<ol style="list-style-type: none"> 1. Check and correct setting if necessary. 2. Inspect the wires, and repair or replace as necessary. <p>*3/4 To isolate the problem, reset the control and attempt to start the set in idle mode.</p> <ol style="list-style-type: none"> a. If the engine displays a “FAIL TO CRANK” shutdown message, or if the engine starts and idles, but then shuts down on a MAG PICKUP fault, the MPU sender could be bad. Remove the MPU connectors and check for 3.5 to 15 VAC at the MPU while cranking. <ul style="list-style-type: none"> • If no output, check for damage or debris. Also check for improper adjustment of the MPU. (Refer to <i>Section 5</i>.) If there is still no output, replace the MPU sender. • If the MPU output is OK, install harness tool between A32 J4/P4. Check for MPU voltage at A32 J4-10 to 11, while cranking. If OK, replace A32. If not OK, use continuity checks to isolate to A31 or harness. b. If the engine starts and idles, and does not display a fault, then there could be a frequency mismatch problem. <ul style="list-style-type: none"> • Measure generator output frequency with a digital multimeter and compare to the frequency on the PCC display. • If they do match, multiply the frequency by 30 and compare this number to the RPM on the PCC display. If these are not the same, the MPU sender may be bad. Replace the MPU sender • If the multimeter and PCC frequencies do not match, there is a frequency sensing problem. Verify the accuracy of the PCC L1N voltage, and then refer to the analog/digital troubleshooting procedure (<i>Table 4-36a/b</i>).

⚠️CAUTION: Wearing wrist strap, set S12 to Off and A32 S5 to Standby before connecting/disconnecting harness plugs.

TABLE 4-19. OVERSPEED SHUTDOWN (223)

⚠WARNING Many troubleshooting procedures present hazards that can result in severe personal injury or death. Only trained and experienced service personnel with knowledge of fuels, electricity, and machinery hazards should perform service procedures. Review Important Safety Instructions page.

Indicator(s)	Possible Cause	Corrective Action
<p>“OVERSPEED” shutdown message (223)</p>	<p>1. The mechanical fuel linkage could be binding, loose, or damaged.</p> <p>2. The governor output module (A38) or the digital board (A32) could be bad.</p>	<p>1. Inspect the mechanical fuel linkage, and repair or replace as necessary.</p> <ul style="list-style-type: none"> • Follow the procedure in the engine repair manual to check the EFC for binding or damage. • Disconnect the actuator connector, and connect +12 VDC from the battery to the actuator. The actuator should click upon application and removal of the voltage. If the actuator does not click, refer to the engine manual. If the actuator clicks, reconnect the wires to the actuator. <p>*2. Reset the control, and start the set while monitoring the PCC duty cycle display.</p> <ul style="list-style-type: none"> • If the duty cycle goes high (above 40%) and the set shuts down on overspeed, replace A32. • If the duty cycle goes to zero and the set shuts down on overspeed, replace A38.

***CAUTION:** Wearing wrist strap, set S12 to Off and A32 S5 to Standby before connecting/disconnecting harness plugs.

TABLE 4-20a. FAIL TO SYNCHRONIZE (224)

⚠️WARNING Many troubleshooting procedures present hazards that can result in severe personal injury or death. Only trained and experienced service personnel with knowledge of fuels, electricity, and machinery hazards should perform service procedures. Review Important Safety Instructions page.

Indicator(s)	Possible Cause	Corrective Action
<p>“FAIL TO SYNCHRONIZE” warning (224) or shutdown (224) message.</p>	<ol style="list-style-type: none"> 1. Improper adjustment of bus or generator set voltage. 2. Generator set hunting due to improper synchronizing adjustments. 3. Unstable or hunting generator set due to governor component failure or misadjustment. <p><i>Continued On Next Page...</i></p>	<ol style="list-style-type: none"> 1. Verify that the bus voltage is within plus or minus 5% of the value which is programmed into the PowerCommand control, and verify that the generator set is operating at proper voltage and frequency. Verify that the bus PT module is properly calibrated. (Refer to <i>Digital Bus Voltage Calibration</i> in Section 5). Check the FAIL TO SYNCHRONIZE time delay. It should be set for approximately 120 seconds. Check paralleling setup adjustments, particularly PERM WIN - PHASE and PERM WIN - TIME. They are typically adjusted to 20 degrees and 0.5 seconds. 2. Check synchronizer adjustments in the PowerCommand control set-up. If you are unsure of proper adjustment procedure, returning the unit to its default values should result in proper operation. The default values are shown in the test report which is shipped with the generator set. In particular, check values for paralleling functions, governing and voltage regulation. 3. Inspect generator set governing system for evidence of binding or sticking linkages or other components which are not operating correctly. Verify that water jacket heaters are operational and properly functioning. Check and adjust governor settings as required.

***CAUTION:** Wearing wrist strap, set S12 to Off and A32 S5 to Standby before connecting/disconnecting harness plugs.

TABLE 4-20b. FAIL TO SYNCHRONIZE (224) (Continued)

⚠WARNING Many troubleshooting procedures present hazards that can result in severe personal injury or death. Only trained and experienced service personnel with knowledge of fuels, electricity, and machinery hazards should perform service procedures. Review Important Safety Instructions page.

Indicator(s)	Possible Cause	Corrective Action
<p>“FAIL TO SYNCHRONIZE” warning (224) or shutdown (224) message.</p>	<p>4. Unstable or hunting generator set due to air entrained in the fuel system.</p>	<p>4. This problem is indicated in situations where the generator set performs properly after the generator set is up and running with load, but experiences “FAIL TO SYNCHRONIZE” alarms after it has been shut down for several days. Check the generator set fuel system for leaks or cracks. If fuel filters have recently been changed, air may be trapped in the fuel filter heads. Check to be sure that there is a fuel head on the engine fuel pump. Check fuel line routing for overhead loops which could result in the trapping of air in the system if the system sits idle for some period of time. Parallel systems should use option C174, the fuel pump feature option. This feature is available as an aftermarket accessory kit.</p> <p>Note: The generator set will synchronize faster as the synchronize acceptance window is widened (i.e., the value in the PERM WIN-PHASE is increased) and as the acceptance time is minimized (the value in the PERM WIN-TIME is minimized). Caution should be taken in utility (mains) paralleling applications to avoid damage to the generator set by inappropriate setting of these parameters.</p>

*CAUTION: Wearing wrist strap, set S12 to Off and A32 S5 to Standby before connecting/disconnecting harness plugs.

TABLE 4-21a. FAIL TO CLOSE (226)

⚠WARNING Many troubleshooting procedures present hazards that can result in severe personal injury or death. Only trained and experienced service personnel with knowledge of fuels, electricity, and machinery hazards should perform service procedures. Review Important Safety Instructions page.

Indicator(s)	Possible Cause	Corrective Action
<p>“FAIL TO CLOSE” warning (226) or shutdown (226) message.</p>	<ol style="list-style-type: none"> 1. Check the paralleling breaker for indication that the breaker is tripped and locked out from a signal issued from it's internal trip unit 2. Breaker charge circuit is not operating properly. (Power circuit breakers only.) <p><i>Continued On Next Page...</i></p>	<ol style="list-style-type: none"> 1. If the breaker has tripped due to operation of it's internal trip unit, the alternator and electrical distribution system connected to the alternator should be carefully inspected for evidence of burning or tracking, which might indicate that an electrical fault has occurred. If no evidence of a fault is found, reset the trip unit and verify that the trip settings of the breaker are appropriate for the application. Reset the fault on the PowerCommand control and check the system operation to verify that the failure to close fault problem has been eliminated. 2. Check the circuit breaker status indicators and verify that the breaker status indicates that the breaker is properly charged. If it is, go on to step 3. If it is not charged, check the charge circuit for proper operation. Switch the PowerCommand control RUN/OFF/AUTO switch to OFF and then manually recharge the paralleling breaker according to the manufacturer's instructions. Switch the PowerCommand control RUN/OFF/AUTO switch back to RUN. The generator set should start and accelerate to rated speed and voltage and the operator should be able to manually control the circuit breaker from the pushbuttons on the front panel of the PowerCommand control. In most cases the breaker should automatically recharge on closing to the system bus. If this does not occur, problem may be in the control wiring to the breaker, or the control power source. <p>NOTE: Some breakers are not able to be set up to charge on closing (they will recharge on opening). If this is the case with your installation, it is critical that the generator set be allowed to operate for a cooldown period which is long enough for the breaker to completely charge before the generator set is shut down. If the generator set is shut down on a fault condition, the breaker may require manual recharge before the system can be put back into automatic operation.</p>

***CAUTION:** Wearing wrist strap, set S12 to Off and A32 S5 to Standby before connecting/disconnecting harness plugs.

TABLE 4-21b. FAIL TO CLOSE (226) (Continued)

⚠WARNING *Many troubleshooting procedures present hazards that can result in severe personal injury or death. Only trained and experienced service personnel with knowledge of fuels, electricity, and machinery hazards should perform service procedures. Review Important Safety Instructions page.*

Indicator(s)	Possible Cause	Corrective Action
<p>“FAIL TO CLOSE” warning (226) or shutdown (226) message.</p>	<p>3. Breaker close signal has been issued from the PowerCommand control, but has not reached the breaker.</p> <p>4. Breaker status (open/close) signals are not properly connected to the PowerCommand control, or are not operating properly.</p>	<p>3. Disconnect breaker control wiring and verify that the control is sending a close signal to the breaker. If the breaker signal is present at the generator set control, reconnect the control wiring at the set, verify that it is present at the breaker terminals. Note that in Onan paralleling systems, DC power for operation of the relay comes from the generator control. Verify that the 20 amp customer B+ fuse (F1 – engine harness assembly) is OK and that the pilot relay operates properly.</p> <p>4. Verify that the breaker auxiliary contact wiring is properly connected to the generator set. Verify that the breaker is sending proper condition signals to the generator set, by disconnecting the control wiring at the breaker and verifying that the breaker auxiliary contacts change state when breaker condition changes. If they are functioning properly, verify that the signals are reaching the generator set by reconnecting the wiring and the breaker and checking for condition change at the generator set control accessory box.</p>

***CAUTION:** Wearing wrist strap, set S12 to Off and A32 S5 to Standby before connecting/disconnecting harness plugs.

TABLE 4-22. DC (BATTERY) WARNINGS (230, 231, 232)

⚠WARNING Many troubleshooting procedures present hazards that can result in severe personal injury or death. Only trained and experienced service personnel with knowledge of fuels, electricity, and machinery hazards should perform service procedures. Review Important Safety Instructions page.

Indicator(s)	Possible Cause	Corrective Action
<p>“LOW DC VOLTAGE” (230) or “WEAK BATTERY” (232), warning message.</p>	<ol style="list-style-type: none"> 1. Weak or discharged battery. 2. Low electrolyte level in battery. 3. Battery connections loose or dirty. 4. Insufficient battery charging voltage. 5. Engine DC alternator could be bad. 6. If the batteries are OK, the problem may be the harness, the engine interface board (A31), the digital board (A32), or the analog board (A33). 	<ol style="list-style-type: none"> 1. Recharge or replace the battery. Specific gravity for a fully charged battery is approximately 1.260 at 80° F (27° C). 2. Replenish electrolyte and recharge battery. 3. Clean and tighten or replace the battery cable connectors and cables at the battery and the set. 4. Adjust charge rate of battery charging circuit, according to manufacturers instructions. 5. Replace engine DC alternator if normal battery charging voltage is not obtained. *6. If the battery voltage, electrolyte, and connections are OK, check the battery voltage at A31 J5-17. If the voltage is not OK (same as battery voltage), disconnect J5 and isolate to the harness or A31. If the voltage is OK, check battery voltage at A33 J1-31. If the voltage is not OK, replace A31. If the voltage at A33 J1-31 is OK, isolate to A33 or A32 using the analog input troubleshooting procedure (Table 4-36a/b).
<p>“HIGH DC VOLTAGE” (231) warning message. But battery voltage is OK.</p>	<ol style="list-style-type: none"> 1. Excessive battery charging voltage. 2. Engine DC alternator could be bad. 3. If the battery voltage is OK, the problem may be the engine interface board (A31), the digital board (A32), or the analog board (A33). 	<ol style="list-style-type: none"> 1. Adjust charge rate of battery charging circuit according to manufacturers instructions. 2. Replace engine DC alternator if normal battery charging voltage is not obtained. *3. Check the battery voltage at A31 J5-17. If the voltage is not OK (same as battery voltage), disconnect J5 and isolate to the harness or A31. If the voltage is OK, check battery voltage at A33 J1-31. If the voltage is not OK, replace A31. If the voltage at A33 J1-31 is OK, isolate to A33 or A32 using the analog input troubleshooting procedure (Table 4-36a/b).
<p>*CAUTION: Wearing wrist strap, set S12 to Off and A32 S5 to Standby before connecting/disconnecting harness plugs.</p>		

TABLE 4-23. LOW FUEL –DAY WARNING (240)

⚠WARNING Many troubleshooting procedures present hazards that can result in severe personal injury or death. Only trained and experienced service personnel with knowledge of fuels, electricity, and machinery hazards should perform service procedures. Review Important Safety Instructions page.

Indicator(s)	Possible Cause	Corrective Action
<p>“LOW FUEL–DAY” warning message (240)</p> <p>Fuel level is normal.</p> <p>DS1 on the engine interface board, A31, is on.</p>	<p>DS1 on A31 is on, indicating that A31 is receiving a low fuel signal from the sender.</p> <p>The sender, the harness or the A31 circuit board could be bad.</p>	<p>If the fuel level is normal, isolate the source of the low fuel signal.</p> <p>Disconnect the signal lead at the sender and reset the control.</p> <ol style="list-style-type: none"> 1. If the 240 message drops out and does not reappear, replace the sender. *2. If the 240 message reappears and remains after control reset, disconnect J4/A31 and check continuity from P4–14 to GND. <ul style="list-style-type: none"> • If there is continuity, replace the harness. • If there is no continuity, replace circuit board A31.
<p>“LOW FUEL–DAY” warning message (240)</p> <p>Fuel level is normal.</p> <p>DS1 (A31) and DS13 (A34) are off.</p>	<p>DS1 on A31 is off, indicating that the PCC is not receiving a low fuel signal from the sender—but the 240 message indicates that A32, the digital board, is responding to a false low fuel signal.</p> <p>A31, the engine interface board, or A32, the digital board, could be bad.</p>	<p>If the fuel level is normal, isolate the source of the low fuel signal.</p> <ol style="list-style-type: none"> *1. Install a breakout connector at A32 J4. 2. Open the J4-15 circuit and reset the control. <ul style="list-style-type: none"> • If the fault drops out and does not return, replace A31. • If the fault returns after resetting the control, go to step 3. 3. Install harness tool between A32 J2/P2. 4. Open the J2-19 circuit and reset the control. <ul style="list-style-type: none"> • If the fault drops out and does not return, replace A31. • If the fault returns after resetting the control, replace A32..

***CAUTION:** Wearing wrist strap, set S12 to Off and A32 S5 to Standby before connecting/disconnecting harness plugs.

TABLE 4-24. LOW FUEL WARNING (241)

⚠WARNING Many troubleshooting procedures present hazards that can result in severe personal injury or death. Only trained and experienced service personnel with knowledge of fuels, electricity, and machinery hazards should perform service procedures. Review Important Safety Instructions page.

Indicator(s)	Possible Cause	Corrective Action
<p>“LOW FUEL” warning message (241)</p> <p>Fuel level is normal.</p> <p>DS13 on the customer interface board, A34, is on.</p>	<p>DS13 on A34 is on, indicating that A34 is receiving a low fuel signal from the customer circuit.</p> <p>If there is no actual fault, the problem may be a short to ground in the external wiring or a bad customer interface board (A34).</p>	<p>If the fuel level is normal, isolate the source of the low fuel signal.</p> <p>Disconnect the signal lead near the control and reset the control.</p> <ol style="list-style-type: none"> 1. If the 241 message drops out and does not reappear, there is a short to ground in the external wiring or a faulty sender. *2. If the 241 message reappears and remains after control reset, disconnect J1/A34 and check continuity from P1–5 to GND. <ul style="list-style-type: none"> • If there is continuity, find and repair a short to ground in the external wiring. • If there is no continuity, replace circuit board A34.
<p>“LOW FUEL” warning message (241)</p> <p>Fuel level is normal.</p> <p>DS13 (A34) is off.</p>	<p>DS13 on A34 is off, indicating that the PCC is not receiving a low fuel signal from the sender—but the 241 message indicates that A32, the digital board, is responding to a false low fuel signal.</p> <p>A34, the customer interface board, or A32, the digital board, could be bad.</p>	<p>If the fuel level is normal, isolate the source of the low fuel signal.</p> <ol style="list-style-type: none"> *1. Install harness tool between A32 J2/P2. 2. Open the J2-19 circuit and reset the control. <ul style="list-style-type: none"> • If the fault drops out and does not return, replace A34. • If the fault returns after resetting the control, replace A32.

***CAUTION:** Wearing wrist strap, set S12 to Off and A32 S5 to Standby before connecting/disconnecting harness plugs.

TABLE 4-25. EEPROM ERROR SHUTDOWN (250) OR WARNING (251, 252)

⚠️WARNING Many troubleshooting procedures present hazards that can result in severe personal injury or death. Only trained and experienced service personnel with knowledge of fuels, electricity, and machinery hazards should perform service procedures. Review Important Safety Instructions page.

Indicator(s)	Possible Cause	Corrective Action
<p>“EEPROM ERROR” shutdown (250) message.</p>	<p>The EE memory on the digital board (A32) may be bad.</p>	<ol style="list-style-type: none"> 1. Perform the initial start setup procedure. Turn the Run/Off/Auto switch to Off and reset the control. Simultaneously press the RESET, MENU, and PHASE SELECT keys to start the setup. Select the correct values, save your choices, and attempt to start the set. 2. If the set shuts down on the same EEPROM ERROR message, replace the digital board (A32).
<p>“EEPROM ERROR” warning (251) message.</p>	<p>The EE memory on the digital board (A32) may be bad.</p>	<ol style="list-style-type: none"> 1. Perform the adjustment procedures (described in <i>Section 5</i>). Save the adjustments. Reset the control. Shut off and restart the set. 2. If the control generates the same EEPROM ERROR message, perform the calibration procedures in <i>Section 5</i>. Reset the control. Shut off and restart the set. 3. If the control generates the same EEPROM ERROR message, replace the digital board (A32).
<p>“EEPROM ERROR” warning (252) message.</p>	<p>The EE memory on the digital board (A32) may be bad.</p>	<ol style="list-style-type: none"> 1. If this message occurred during an adjustment, option selection, or calibration of the PCC, verify the values or choices selected and repeat the save operation. Reset the control. Shut off and restart the set. 2. If the control generates the same EEPROM ERROR message, replace the digital board (A32).

***CAUTION:** Wearing wrist strap, set S12 to Off and A32 S5 to Standby before connecting/disconnecting harness plugs.

TABLE 4-26. RACK POSITION WARNING (260)

⚠WARNING Many troubleshooting procedures present hazards that can result in severe personal injury or death. Only trained and experienced service personnel with knowledge of fuels, electricity, and machinery hazards should perform service procedures. Review Important Safety Instructions page.

Indicator(s)	Possible Cause	Corrective Action
<p>“RACK POSITION” warning message (260)</p>	<p>PowerCommand control fault or defective governor control circuitry.</p>	<p>Restart the generator set and monitor the fault LED's of the governor output module (A38). Refer to Section 3 for LED descriptions.</p> <ol style="list-style-type: none"> 1 LED's (DS1 through DS4 are on and DS5 and DS6 are off) do not indicate a fault, refer to “Customer Fault 261, 262 & 263 for corrective action. 2 LED's (DS5 or DS6 are on) one or more indicate a fault and the generator set shuts down after restarting – perform the <i>Rack Position Fault/Test Procedure</i> at the end of this section.

*CAUTION: Wearing wrist strap, set S12 to Off and A32 S5 to Standby before connecting/disconnecting harness plugs.

TABLE 4-27. CUSTOMER FAULTS (261, 262 or 263)

⚠WARNING Many troubleshooting procedures present hazards that can result in severe personal injury or death. Only trained and experienced service personnel with knowledge of fuels, electricity, and machinery hazards should perform service procedures. Review Important Safety Instructions page.

Indicator(s)	Possible Cause	Corrective Action																				
<p>“CUSTOMER FAULT (261, 262 or 263) message. And corresponding LED on customer interface board A34 is on.</p>	<p>If the corresponding LED on the customer interface board (A34) is on, then A34 is receiving a signal from the customer circuit. If there is no actual fault, the problem may be a short to ground in the external wiring or a bad customer interface board (A34).</p>	<p>Isolate the source of the false signal. Disconnect the signal lead near the control and reset the control.</p> <ol style="list-style-type: none"> 1. If the message drops out, there is a short to ground in the external wiring. 2. If the message remains, replace A34. 																				
<p>“CUSTOMER FAULT (261, 262 or 263) message. And corresponding LED on customer interface board A34 is off.</p>	<p>If the corresponding LED on the customer interface board (A34) is off, then A34 is not receiving a signal from the customer circuit. The message indicates that A32, the digital board, is responding to a false signal. A34, the customer interface board, or A32, the digital board, could be bad.</p>	<p>Isolate the source of the false signal. Check J2/P2 on A32.</p> <ol style="list-style-type: none"> *1. Install harness tool between A32 J2/P2. 2. Open the appropriate circuit J2-3, J2-24, J2-9, or J2-15 and reset the control. <ul style="list-style-type: none"> • If the fault does not return, replace A34. • If the fault reappears, replace A32. <table border="1" data-bbox="870 1330 1471 1549"> <thead> <tr> <th>A 34 LED</th> <th>A32 CONNECTOR</th> <th>CUSTOMER FAULT #</th> <th>FAULT CODE</th> </tr> </thead> <tbody> <tr> <td>DS4</td> <td>J2-3</td> <td>Rack Position</td> <td>260</td> </tr> <tr> <td>DS11</td> <td>J2-24</td> <td>2</td> <td>261</td> </tr> <tr> <td>DS15</td> <td>J2-9</td> <td>3</td> <td>262</td> </tr> <tr> <td>DS3</td> <td>J2-15</td> <td>4</td> <td>263</td> </tr> </tbody> </table>	A 34 LED	A32 CONNECTOR	CUSTOMER FAULT #	FAULT CODE	DS4	J2-3	Rack Position	260	DS11	J2-24	2	261	DS15	J2-9	3	262	DS3	J2-15	4	263
A 34 LED	A32 CONNECTOR	CUSTOMER FAULT #	FAULT CODE																			
DS4	J2-3	Rack Position	260																			
DS11	J2-24	2	261																			
DS15	J2-9	3	262																			
DS3	J2-15	4	263																			
<p>*CAUTION: Wearing wrist strap, set S12 to Off and A32 S5 to Standby before connecting/disconnecting harness plugs.</p>																						

TABLE 4-28a. PHASE ROTATION (270)

⚠WARNING Many troubleshooting procedures present hazards that can result in severe personal injury or death. Only trained and experienced service personnel with knowledge of fuels, electricity, and machinery hazards should perform service procedures. Review Important Safety Instructions page.

Indicator(s)	Possible Cause	Corrective Action
<p>“PHASE ROTATION” shutdown (270) message.</p>	<ol style="list-style-type: none"> 1. Single phase bus condition. 2. Generator set output power feeders are improperly connected. <p><i>Continued On Next Page...</i></p>	<ol style="list-style-type: none"> 1. Verify that bus voltage is proper and is not single phased. 2. Verify phase rotation of the generator set output relative to the system bus. Correct wiring of power output conductors if required. The phase relationship between the generator set and the system bus can be checked by either using a phase rotation checker, or by using synchronizing lamps or two voltmeters. The procedure for using voltmeters for checking phase relationship is as follows: Energize the system bus and start the generator set in question in the RUN mode, but do not close the paralleling breaker. Connect each voltmeter from the line to load side of a single phase of the paralleling breaker (see Figure 8-1). If the generator set and bus have the same phase rotation, the voltmeters should rise and fall in voltage at the same time. If they are not in phase, one will rise while the other falls.
<p>*CAUTION: Wearing wrist strap, set S12 to Off and A32 S5 to Standby before connecting/disconnecting harness plugs.</p>		

TABLE 4-28b. PHASE ROTATION (270) (Continued)

⚠WARNING Many troubleshooting procedures present hazards that can result in severe personal injury or death. Only trained and experienced service personnel with knowledge of fuels, electricity, and machinery hazards should perform service procedures. Review Important Safety Instructions page.

Indicator(s)	Possible Cause	Corrective Action
<p>“PHASE ROTATION” shutdown (270) message.</p>	<p>3. Wiring to bus PT module is not correct.</p>	<p>3. If power conductors are properly phased, check the phase rotation of the wiring to the generator set CT/PT module (A36) and Bus PT module (A39). This is done using voltmeters connected as shown in Figure 8-1. Energize the system bus and start the generator set being tested in the RUN mode. Operate the display screen on the PowerCommand control to show the digital synchroscope (bus frequency). Observe the voltmeter(s) and the synchronized indicator (*) on the PowerCommand screen. When the voltage of the meter(s) approaches zero, the * should be displayed. If the * is on when the voltmeters are reading their highest value, the Bus PT module or the genset CT/PT module is incorrectly wired. If incorrect wiring is indicated, switch off the power supply to the system bus and manually close the paralleling breaker by pushing the breaker close switch on the front of the PowerCommand control. Check the voltage between phase L1 of the generator CT/PT module (J9-4 yellow) and phase L1 of the Bus PT module (terminal TB1-1 on the module). If there is voltage difference between these points, reverse the wiring between TB1-1 and TB1-3 on the Bus PT module. Retest the system to be certain that the phase relationship problem has been corrected. If no voltage difference is sensed at the input to the CT/PT module and Bus PT module, the problem could be in the wiring between the Bus PT module and the PowerCommand control. Reverse the connections between terminals TB2-1, 2 with TB2-5, 6. Retest the system to make sure that the phase relationship problem has been corrected.</p>

***CAUTION:** Wearing wrist strap, set S12 to Off and A32 S5 to Standby before connecting/disconnecting harness plugs.

TABLE 4-29. FIRST START (272)

⚠WARNING *Many troubleshooting procedures present hazards that can result in severe personal injury or death. Only trained and experienced service personnel with knowledge of fuels, electricity, and machinery hazards should perform service procedures. Review Important Safety Instructions page.*

Indicator(s)	Possible Cause	Corrective Action
<p>“FIRST START” warning (272) message.</p>	<ol style="list-style-type: none"> 1. Master First Start Sensor has failed. 2. Interconnection between Master First Start Sensor and the PowerCommand control has failed. 	<ol style="list-style-type: none"> 1. Verify that the Master First Start Sensor is properly functioning. This can be accomplished by connecting a DC voltmeter from ground to the appropriate terminal on the Master First Start Sensor to the PowerCommand Control. The voltmeter should indicate a pulsing voltage present on the terminal. 2. Verify that the voltage pulse is present at the PowerCommand Control (terminal TB1-50). Check and repair any problems in the interconnection wiring between the generator set and the Master First Start Sensor.

***CAUTION:** Wearing wrist strap, set S12 to Off and A32 S5 to Standby before connecting/disconnecting harness plugs.

TABLE 4-30a. HIGH AC VOLTAGE SHUTDOWN (301)

⚠WARNING *Many troubleshooting procedures present hazards that can result in severe personal injury or death. Only trained and experienced service personnel with knowledge of fuels, electricity, and machinery hazards should perform service procedures. Review Important Safety Instructions page.*

Indicator(s)	Possible Cause	Corrective Action
<p>“HIGH AC VOLTAGE ” shutdown (301) message.</p> <p>(Continued)</p>	<p>1. The problem may be in the PCC, the alternator, or the interconnection between them.</p> <p>Note 1: The PCC may indicate either a low AC Voltage or High AC Voltage shutdown due to the design of the logic in the control.</p> <p>You must first determine if the output voltage the control sees is low or high.</p> <p>Note 2: Residual voltage is normally 5 to 10% of nominal output voltage. For example, a genset with a 480 volt output, will have a residual voltage of 25 to 50 VAC at normal operating speed.</p> <p>2. The problem may be the regulator module (A37), the engine interface board (A31), or the digital board (A32).</p>	<p>1. Set the display on the PCC to GEN, VOLTS, L-N.</p> <ol style="list-style-type: none"> Start the genset and observe the voltage displayed on the digital display. If all phases of voltage are balanced and not zero, but lower than normal, the alternator and the input to the PCC are OK. The problem is in the excitation circuit for the alternator. Go to step 2. If one or more phases of voltage are high or the voltages are unbalanced, the PCC is not measuring all phases of voltage and is responding to the low “average” of the three phases of voltage. Go to step 3. <p>2. With DC power to the PCC and with the set not running, check A31 DS9, the AVR duty cycle LED. this LED should be off. If it is on, go to step 2d.</p> <p>Isolate the genset output from the load. Disconnect A37 J10, and place the set in Idle mode. In Idle mode the excitation circuit is disabled. Start the set and monitor the AC output voltage with a digital multimeter.</p> <ol style="list-style-type: none"> If output voltage is greater than residual (5% of normal output), go to step 3. If output voltage stays at 0 (or residual), and DS2 on A37 is off, go to step 4. If output voltage stays at 0 (or residual), and DS2 on A37 is on, look at DS9 on A31. If DS9 on A31 is off, replace A37. If DS9 on A31 is on, connect a breakout connector at A32 J4, and open J4-2. If DS9 goes out, replace A32. If DS9 stays on replace A31.

***CAUTION: Wearing wrist strap, set S12 to Off and A32 S5 to Standby before connecting/disconnecting harness plugs.**

TABLE 4-30b. HIGH AC VOLTAGE SHUTDOWN (301) (Continued)

⚠WARNING Many troubleshooting procedures present hazards that can result in severe personal injury or death. Only trained and experienced service personnel with knowledge of fuels, electricity, and machinery hazards should perform service procedures. Review Important Safety Instructions page.

Indicator(s)	Possible Cause	Corrective Action
<p>“HIGH AC VOLTAGE ” shutdown (301) message.</p> <p>(Continued)</p>	<p>3. The problem may be the PT/CT module (A36) or the interconnecting wiring to the PT/CT module.</p> <p>NOTE: To calculate the “expected A36 output” voltage range, do the following:</p> <p>Determine the ratio between the measured voltage and the expected voltage. The output (18 VAC) of the PT/CT module will also be reduced by this ratio.</p> <p>4. The problem may be in the customer interface board (A34) or the interconnecting wiring.</p>	<p>*3. Before starting the generator set, disconnect the harness connector from the PT/CT module (A36) and connect the harness connector between A36 and its harness connector. Check the output voltage at the alternator output terminals and record the voltages.</p> <p>a. If the voltages are not balanced, go to step 5.</p> <p>b. If the voltages are balanced, calculate the expected output voltage from the PT/C module (see Note to the left). Measure and record the outputs from A36 J8 pins 6–5, 4–3, and 2–1.</p> <p>If the output voltage is proportional to the alternator output voltage the A36 module is OK. Go on to step 4.</p> <p>If the voltages are not balanced, replace A36.</p> <p>*4. Disconnect the plugs in the following steps below with the set off then start the set in the idle mode, and measure voltages with a digital multimeter.</p> <p>a. Disconnect J3/P3 (blue) and insert the harness tool. Check the voltage into the customer interface board with the harness tool at J3 terminals 4–6, 5–13, and 7–20. Remove the harness tool and reconnect J3 and P3. These voltages should be the same values measured in step 3b.</p> <p>If the voltages are balanced, continue in this step. If the voltages are unbalanced, repair the harness between the A36 module and the A34 board.</p> <p>b. Disconnect J5/P5 on the customer interface board and insert the harness tool. Check the voltage out of the customer interface board at J5 terminals 24–28, 26–28, and 30–28. These voltages should be the same values measured in step 3b.</p> <p>If the voltages are balanced, go to step 5. If the voltages are unbalanced, replace the customer interface board.</p>

***CAUTION: Wearing wrist strap, set S12 to Off and A32 S5 to Standby before connecting/disconnecting harness plugs.**

TABLE 4-30c. HIGH AC VOLTAGE SHUTDOWN (301) (Continued)

⚠WARNING Many troubleshooting procedures present hazards that can result in severe personal injury or death. Only trained and experienced service personnel with knowledge of fuels, electricity, and machinery hazards should perform service procedures. Review Important Safety Instructions page.

Indicator(s)	Possible Cause	Corrective Action
<p>“HIGH AC VOLTAGE ” shutdown (301) message.</p>	<p>5. The problem may be the analog board (A33).</p> <p>NOTE: To determine the “3-phase ave” signal voltage range for Step 3b, use the following formula:</p> <p>$V_{out \text{ 3-phase ave}} = V_{in} (2.9 \div PT) \pm 5\%$</p> <p>$V_{in}$ = Actual generator output voltage (phase-to-neutral) PT = PT primary (120, 240 or 346)</p> <p>6. The problem may be in the generator set itself.</p>	<p>*5. Using the harness tool, check the “3-phase ave” signal at A33 J2-18.</p> <p>If the voltage is within the expected range, replace A32. If the voltage is not within the expected range, replace A33. See Note.</p> <p>6. Refer to the generator servicing procedures in <i>Section 6</i>.</p>

***CAUTION:** Wearing wrist strap, set S12 to Off and A32 S5 to Standby before connecting/disconnecting harness plugs.

TABLE 4-31a. LOW AC VOLTAGE SHUTDOWN (303)

⚠️WARNING Many troubleshooting procedures present hazards that can result in severe personal injury or death. Only trained and experienced service personnel with knowledge of fuels, electricity, and machinery hazards should perform service procedures. Review Important Safety Instructions page.

Indicator(s)	Possible Cause	Corrective Action
<p>“LOW AC VOLTAGE ” shutdown (303) message.</p> <p>(Continued)</p>	<ol style="list-style-type: none"> 1. PMG or field wiring could be faulty. 2. The rotating rectifier assembly (diodes CR1 through CR6) is faulty. 3. Overload. 4. There may be a loose connector in the control loop. <p>5a. The problem may be the analog board (A33) or the digital board (A32).</p> <p>5b. The problem may be the regulator module (A37), the engine interface board (A31), or the digital board (A32).</p>	<ol style="list-style-type: none"> 1. If output voltage is low and both A37/DS2 and A31/DS10 are on, check and repair the PMG or field wiring. 2. Check each diode according to <i>Servicing the Generator</i> in <i>Section 6</i>. Service as necessary. 3. Check the load and correct any overload. 4. Check connectors J8 and J9 on A36, J3 and J5 on A34, and J7 on A37. <p>*5. Isolate the genset output from the load. Reset the control, restart the set, and measure AC output voltage with a multimeter.</p> <p>a. If output voltage is high, refer to the troubleshooting section for High AC Voltage Shutdown (301).</p> <p>If output voltage is normal, the problem must be in the voltage sensing circuitry (A32 or A33).</p> <p>Isolate, using the analog input troubleshooting procedure (<i>Table 4-36a/b</i>). Check the phase that shows a low voltage on the PCC display.</p> <p>*b. If output voltage is low, the control cannot drive the output voltage high enough. The problem could be A37, A31, or A32. Restart the set and monitor isolated B+ supply LED A37/DS1, output duty cycle LED A37/DS2, and AVR duty cycle LED A31/DS10.</p> <ul style="list-style-type: none"> • If A37/DS1 is not on, disconnect A3 J7/P7 and check for B+ at P7-1. (Control must be in Run mode for B+ reading.) • If B+ is OK to A37, replace A37. • If A37/DS1 is on, check A31/DS10 (with the set running). • If A31/DS10 is not on with set running, check for continuity: A31 J1-2 to J4-10 and A31 J1-1 to J4-11 (270 ohms). If no continuity, replace A31. • If A31 is OK, replace A32. • If A31/DS10 is on with set running and A37/DS2 is not on, check the harness. • If the harness is OK, replace A37.

***CAUTION:** Wearing wrist strap, set S12 to Off and A32 S5 to Standby before connecting/disconnecting harness plugs.

TABLE 4-31b. LOW AC VOLTAGE SHUTDOWN (303) (Continued)

⚠WARNING Many troubleshooting procedures present hazards that can result in severe personal injury or death. Only trained and experienced service personnel with knowledge of fuels, electricity, and machinery hazards should perform service procedures. Review Important Safety Instructions page.

Indicator(s)	Possible Cause	Corrective Action
<p>“LOW AC VOLTAGE ” shutdown (303) message.</p>	<p>5c. The problem may be the PT/CT module (A36), the analog board (A33), the customer interface board (A34), or the digital board (A32).</p>	<p>c. If the measured AC voltage is high, the control must have lost AC sensing. Check PTs (primary 1K–2.5K ohms; secondary 140–225 ohms), sensing harness wires, generator output connections, and the customer interface board for continuity. If these are OK, then check the analog and digital boards, using the analog input troubleshooting procedure (<i>Table 4-36a/b</i>).</p>

***CAUTION:** Wearing wrist strap, set S12 to Off and A32 S5 to Standby before connecting/disconnecting harness plugs.

TABLE 4-32. UNDER FREQUENCY SHUTDOWN (313)

⚠WARNING Many troubleshooting procedures present hazards that can result in severe personal injury or death. Only trained and experienced service personnel with knowledge of fuels, electricity, and machinery hazards should perform service procedures. Review Important Safety Instructions page.

Indicator(s)	Possible Cause	Corrective Action
<p>“UNDER FREQUENCY” shutdown (313) message.</p>	<ol style="list-style-type: none"> 1. Improper setup. 2. Overload. 3. Fuel or air delivery problem. 4. The governor output module (A38), the digital board (A32), or the engine interface board (A31) could be bad. 	<ol style="list-style-type: none"> 1. Check Initial Setup (set size) and correct, if necessary. 2. Check the load and correct any overload, if necessary. Disconnect the load. Reset the control and attempt to restart the generator set. 3. If the engine starts and runs, refer to the engine fuel/air delivery service procedures. *4. Disconnect the wire to the fuel solenoid, reset the control, and crank the set. DS2 on the governor output module A38 should light. If the duty cycle LED (DS1) on the governor output module (A38) slowly becomes bright, the governor output module(A38), the digital board (A32), and the engine interface board (A31) are functioning properly. If DS1 does not light or instantly becomes bright, A31, A32 or A38 may be bad. A38 - Crank the set, and check the governor duty cycle on the PCC display. If the duty cycle is OK (60% max), replace governor output module (A38). If the duty cycle is not OK, the digital board (A32) or the engine interface board (A31) may be bad. <ul style="list-style-type: none"> • A31 - Check for continuity: A31 J1-13 to A31 J4-19 and A31 J1-14 to A31 J4-12. If no continuity, replace A31. • A32 - If A31 is OK, replace A32

***CAUTION:** Wearing wrist strap, set S12 to Off and A32 S5 to Standby before connecting/disconnecting harness plugs.

TABLE 4-33. OVERCURRENT WARNING (320) OR SHUTDOWN (321), SHORT CIRCUIT SHUTDOWN (322), OR OVERLOAD WARNING (330)

⚠WARNING Many troubleshooting procedures present hazards that can result in severe personal injury or death. Only trained and experienced service personnel with knowledge of fuels, electricity, and machinery hazards should perform service procedures. Review Important Safety Instructions page.

Indicator(s)	Possible Cause	Corrective Action
<p>“OVER-CURRENT” warning (320) or shutdown (321), or “SHORT CIRCUIT” shutdown (322), or OVERLOAD warning (330) message.</p>	<ol style="list-style-type: none"> 1. Short or Overload. 2. Incorrect CTs or CT connections. 3. The problem may be a bad PT/CT module (A36). 4. The problem may be the customer interface board (A34) or connections. 5. The problem may be the analog board (A33) or the digital board (A32). 	<ol style="list-style-type: none"> 1. Check the load and load cables. Repair if necessary. 2. Check CTs and CT connections. Correct if necessary. Refer to <i>Current Transfer Installation</i> in Section 5. 3. Disconnect the PT/CT module and check the 3-ohm resistors (J8-15 to 14, J8-22 to 23, J8-7 to 8). Replace the module if necessary. *4. Check continuity from A36—through A34—to A33. Repair the connection or replace A34 if necessary. Refer to Section 9 for pin reference. 5. Isolate, using the analog input troubleshooting procedure (Table 4-36a/b). Check the bad phase or phases.

***CAUTION:** Wearing wrist strap, set S12 to Off and A32 S5 to Standby before connecting/disconnecting harness plugs.

TABLE 4-34. REVERSE POWER (335)

⚠WARNING Many troubleshooting procedures present hazards that can result in severe personal injury or death. Only trained and experienced service personnel with knowledge of fuels, electricity, and machinery hazards should perform service procedures. Review Important Safety Instructions page.

Indicator(s)	Possible Cause	Corrective Action
<p>“REVERSE POWER” shutdown (335) message.</p>	<ol style="list-style-type: none"> 1. If this shutdown condition occurs when a non-paralleled generator set is loaded, it indicates that the generator set output CT’s or PT’s are incorrectly installed. 2. Verify that the generator set is operating at the correct frequency and voltage. The bus voltage and frequency should be the same as the no-load generator set frequency and voltage. 3. The load sharing line connections and orientation must be correctly accomplished for proper load sharing. 4. If the alarm occurs when a large load is added or shed, dissimilar transient response of the generator sets in the system may cause the reverse power condition. 5. Reverse power alarm can also indicate that the generator set is unable to carry load properly. 	<ol style="list-style-type: none"> 1. Verify proper CT orientation, wiring and connections on the control system. Refer to <i>Current Transformer (CT) Installation</i> in <i>Section 5</i>. Make sure that the no load frequency matches the bus frequency. Check metering calibration for both generator set and bus. 2. Make adjustments as required for proper operation. 3. Verify that load sharing connections are made as noted in the drawings and that there are no damaged or disconnected wires. 4. Apply various load steps to each generator set in the system, noting the voltage and frequency dips/surges and recovery times. The generator sets should be adjusted so that transient load performance is approximately the same in all machines in the system. 5. Verify that the generator set can pick up and carry loads properly, up to the rated capacity of the machine. Inability to carry load can be related to engine misadjustments, component failures, or poor fuel quality. Check governing system for binding or sticking. Check fuel filters and fuel lines for cracks, leaks or dents. Check air cleaner(s) for obstructions.

***CAUTION:** Wearing wrist strap, set S12 to Off and A32 S5 to Standby before connecting/disconnecting harness plugs.

TABLE 4-35. LOSS OF EXCITATION (337)

⚠WARNING *Many troubleshooting procedures present hazards that can result in severe personal injury or death. Only trained and experienced service personnel with knowledge of fuels, electricity, and machinery hazards should perform service procedures. Review Important Safety Instructions page.*

Indicator(s)	Possible Cause	Corrective Action
<p>“LOSS OF EXCITATION” shutdown (337) message.</p> <p>(Continued)</p>	<ol style="list-style-type: none"> 1. Improper voltage adjustment of the generator set relative to the system bus. 2. Load sharing line mis-connection or damage. 3. If condition occurs when the generator set is lightly loaded, leading power factor loads may cause this condition. 	<ol style="list-style-type: none"> 1. Verify that the no load voltage of the generator set matches the bus voltage. Check generator set metering calibration for both generator set and bus readings. If no problems are found, check the paralleling adjustments in the Power-Command control, to see if they match the default settings in the generator set test report. 2. Verify load sharing line connections and condition. Make corrections as required. 3. Loss of Excitation failure may also be caused by operation of filters and power factor correction capacitors in the generator set loads when the kW load level on the genset is low. The capacitors in the filters and power factor correction equipment can present a leading power factor load to the generator set, which (correctly) shuts down the generator set through the loss of excitation fault. Leading power factor loads can cause the generator set to lose control of the output voltage of the genset, and can cause kVar load sharing problems, so it is necessary to protect the genset from excessive leading power factor and reverse var conditions. <p>For generator sets prior to the release of version 2.0 firmware:</p> <p>Check the load for devices which may apply leading power factor loads to the generator set. These include power factor correction capacitors, input filter and some non-linear load devices with internal voltage waveform correction provisions. These devices may need to be disconnected from the bus until other loads are added to the system.</p> <p>For generator sets with version 2.0 and higher firmware:</p> <p>If there is a loss of excitation fault that cannot be explained by genset component failures or mis-adjustments, perform the following steps:</p>

***CAUTION: Wearing wrist strap, set S12 to Off and A32 S5 to Standby before connecting/disconnecting harness plugs.**

TABLE 4-35. LOSS OF EXCITATION (337) (Continued)

⚠WARNING Many troubleshooting procedures present hazards that can result in severe personal injury or death. Only trained and experienced service personnel with knowledge of fuels, electricity, and machinery hazards should perform service procedures. Review Important Safety Instructions page.

Indicator(s)	Possible Cause	Corrective Action
<p>“LOSS OF EXCITATION” shutdown (337) message.</p>	<p>3. (continued)</p> <p>4. The generator set may be incapable of carrying full reactive load due to component failures.</p> <p>5. If transient conditions result in this alarm condition, the PowerCommand control internal set points may need adjustment.</p>	<p>a. Start the generator set and apply system loads in their normal operation sequence. Observe the output voltage, power factor, and % voltage regulation of the generator set as the loads are applied. (This may take more than one test.)</p> <p>b. If the voltage does not rise and the % voltage regulation is greater than 0 as the system loads are applied, extend the time delay on loss of excitation shutdown and repeat the load addition test.</p> <p>c. If the increase in time delay does not resolve the shutdown condition, contact the factory for the maximum permissible setting of the loss of excitation shutdown set points.</p> <p>d. If the voltage rises or the % voltage regulation value drops to 0 and does not rise as load is applied, investigate means to remove leading power factor loads from the genset bus.</p> <p>4. See section 6 of this manual, “Servicing the Generator, Exciter Rectifier and Exciter Rotor”. See also repair and diagnosis process for “Low AC Voltage” in this section.</p> <p>5. Consult factory.</p>

***CAUTION:** Wearing wrist strap, set S12 to Off and A32 S5 to Standby before connecting/disconnecting harness plugs.

TABLE 4-36a. TROUBLESHOOTING ANALOG SIGNALS BETWEEN ANALOG AND DIGITAL BOARDS

⚠WARNING *Many troubleshooting procedures present hazards that can result in severe personal injury or death. Only trained and experienced service personnel with knowledge of fuels, electricity, and machinery hazards should perform service procedures. Review Important Safety Instructions page.*

NOTE: Perform this procedure after you have isolated the problem to either the analog board (A33) or to the digital board (A32). You must have schematics and wiring diagrams to identify the various inputs and outputs.

- *1. Check that the input to the analog board is correct. There are a few signals (e.g.: 3PH Ave, Line Freq, Phase Angle 1 to 3, Lead Lag) that are derived from one or more input signals.
- 1a. To check the sensor input voltages into the analog board, connect the sender simulator and test the voltage across the + and – inputs at A33 J1 using harness tool. (This assumes that you have verified that the harness and the engine interface board is good.)
- If the input voltage to the analog board is correct (refer to Table 4-36), go to step 2.
 - If the input voltage to the analog board is incorrect, check for 12 VDC at A32 J3-20 and 5 VDC at A32 J3-12. Do this with the analog board connected to the digital (A32).
 - If the 12 VDC and 5 VDC voltages are OK, replace the analog board.
 - If the 12 VDC and 5 VDC voltages are not OK, disconnect A32 J3 and recheck for 12 VDC at A32 J3-20 and 5 VDC at A32 J3-12.
 - If the 12 VDC and 5 VDC voltages are now OK, replace the analog board.
 - If the 12 VDC and 5 VDC voltages are still not OK, replace the digital board.
- 1b. To check the AC inputs into the analog board, drive the PT/CT inputs (voltage or current) and verify that the input is correct.
- If the input to the analog board is correct, go to step 2.
 - If the input to the analog board is incorrect, disconnect the ribbon cable at A34 J5 and check the voltage at A34 J5 again (Customer Interface).
 - If the voltage is now correct, replace the analog board.
 - If the voltage is still not correct, the problem is not on the analog or digital boards.
2. If the input to the analog board is correct, determine whether the signal is multiplexed (refer to Table 4-36). If the signal is not multiplexed, go to step 2a. If the signal is multiplexed, go to step 2b.
- 2a. This step is for non-multiplexed AC signals. Drive the input to the analog board with an AC source, and test the signal level out of the analog board. You must calculate what the analog output voltage should be (Table 4-36), assuming the analog board transfer function is linear.
- If the signal level into the digital board is correct, the problem must be on the digital board. Replace the digital board.
 - If the signal level into the digital board is incorrect, remove the ribbon cable connector at A32 J3, and check the front panel digital display of the bad analog value.
 - If the display reads 0, replace the analog board.
 - If the display reads a value other than 0, replace the digital board.

***CAUTION:** Wearing wrist strap, set S12 to Off and A32 S5 to Standby before connecting/disconnecting harness plugs.

TABLE 4-36b. TROUBLESHOOTING ANALOG SIGNALS BETWEEN ANALOG AND DIGITAL BOARDS

⚠WARNING *Many troubleshooting procedures present hazards that can result in severe personal injury or death. Only trained and experienced service personnel with knowledge of fuels, electricity, and machinery hazards should perform service procedures. Review Important Safety Instructions page.*

NOTE: Perform this procedure after you have isolated the problem to either the analog board (A33) or to the digital board (A32). You must have schematics and wiring diagrams to identify the various inputs and outputs.

2b. This step is for multiplexed signals. Is more than one multiplexed signal reading bad?

- No. If the input to the analog board is correct and only one multiplexed signal is reading bad, replace the analog board.
- Yes. If more than one multiplexed signal reading is bad, remove the ribbon cable connector at A32 J3 and check the front panel digital display of the bad inputs. It should read 0 for all inputs except the temperature inputs (which should read less than 32° F or less than 0° C) and power factor (which should read "NA").

If any values read incorrectly, replace the digital board.

If they all read correctly, measure voltages on the multiplexer control lines (with A32-J3 disconnected, measure from Digital board connector J3). Voltages should be:

A32-J3-23: 3.0 ±0.25 VDC

A32-J3-24: 2.4 ±0.25 VDC

A32-J3-27: 1.4 ±0.25 VDC

A32-J3-33: 3.0 ±0.25 VDC

A32-J3-34: 3.0 ±0.25 VDC

If these control (select) line voltages are not correct, replace the digital board.

If these control (select) line voltages are correct (and the input to the analog board is correct), reconnect the ribbon cable connector (through harness tool) at A32 J3 and check the 5 VDC reference at A32 J3-12 and the 12 VDC supply at A32 J3-20.

If the 5 VDC and the 12 VDC voltages are OK, replace the analog board.

If the 5 VDC and the 12 VDC voltages are not OK, disconnect A32 J3 and check the voltages again (measured from Digital board side).

If the 5 VDC and the 12 VDC voltages are OK with A32 J3 disconnected, replace the analog board.

If the 5 VDC and the 12 VDC voltages are not OK with A32 J3 disconnected, replace the digital board.

***CAUTION:** Wearing wrist strap, set S12 to Off and A32 S5 to Standby before connecting/disconnecting harness plugs.

TABLE 4-37. ANALOG CIRCUIT BOARD (A33) INPUTS AND OUTPUTS

Input Name	Input Connection	Input Signal Range	Output Name ¹	Output Connection ²	Output Signal Range
L1 (0 to nominal)	J4-24 to J4-28	0 to 18 VAC	L10 (ACH1)	J2-4	0 to 3.0 VDC
L2 (0 to nominal)	J4-26 to J4-28	0 to 18 VAC	L20 (ACH2)	J2-13	0 to 3.0 VDC
L3 (0 to nominal)	J4-37 to J4-28	0 to 18 VAC	L30 (ACH3)	J2-1	0 to 3.0 VDC
			3PH ave (ACH0)	J2-18	0 to 2.9 VDC
			Line freq. (HS1.1)	J2-21	0-5V sq wave @ L1 Hz
CT21 (0 to full load)	J4-33 to J4-34	0 to 1.65 VAC	C1 fltrd (ACH4)	J2-3	0 to 1.0 VDC
CT22 (0 to full load)	J4-32 to J4-34	0 to 1.65 VAC	C2 fltrd (ACH5)	J2-9	0 to 1.0 VDC
CT23 (0 to full load)	J4-31 to J4-34	0 to 1.65 VAC	C3 fltrd (ACH6)	J2-17	0 to 1.0 VDC
			C1 (ACH7)	J2-7	0 to 1.0 VDC
			C2 (ACH7)	J2-7	0 to 1.0 VDC
			C3 (ACH7)	J2-7	0 to 1.0 VDC
(1 to 0.8 pf)			Phase angle 1 (ACH7) ³	J2-7	0 to 1.0 VDC
(1 to 0.8 pf)			Phase angle 2 (ACH7) ³	J2-7	0 to 1.0 VDC
(1 to 0.8 pf)			Phase angle 3 (ACH7) ³	J2-7	0 to 1.0 VDC
(L1 vs CT21)			Lead lag (P2A.1) ³	J2-29	0 or 5 VDC (digital)
Bus L1 (0 to nominal) ⁶	J4-15 to J4-18	0 to 18 VAC	Bus L1 (ACH7)	J2-7	0 to 3.0 VDC
Bus L2 (0 to nominal) ⁶	J4-16 to J4-18	0 to 18 VAC	Bus L2 (ACH7)	J2-7	0 to 3.0 VDC
Bus L3 (0 to nominal) ⁶	J4-17 to J4-18	0 to 18 VAC	Bus L3 (ACH7)	J2-7	0 to 3.0 VDC
			Bus freq (HS1.3)	J2-22	0-5V sq wave @ Bus L1 Hz
			Phase rot (P2A.0) ⁵	J2-26	0 or 5 VDC (digital)
			Bus/gen phase dif (ACH7) ⁵	J2-7	0 to 5.0 VDC
			Bus/gen phase (HS1.2) ⁵	J2-19	0-5V 120 Hz 0 to 100% DC
			Synch (ACH7) ⁵	J2-7	
Battery voltage	J1-31 (+) to J1-30(-)	0 to 32 VDC	Battery voltage (ACH7)	J2-7	0 to 2.9 VDC
Oil press (0 to 100 psi)	(See note ⁴)	0.5 to 4.5 VDC	Oil press (ACH7)	J2-7	0.5 to 4.5 VDC
H ₂ O 1 (6 to 230° F)	J1-19/20 to J1-17/18	700 to 1800 Ω	H ₂ O 1 (ACH7)	J2-7	1.4 to 3.7 VDC
H ₂ O 2 (6 to 230° F)	J1-15/16 to J1-14/15	700 to 1800 Ω	H ₂ O 2 (ACH7)	J2-7	1.4 to 3.7 VDC
Oil temp (6 to 230° F)	J1-11/12 to J1-9/10	700 to 1800 Ω	Oil temp (ACH7)	J2-7	1.4 to 3.7 VDC
Exh temp 1 (32 to 1471° F)	J1-7/8 to J1-5/6	100 to 376 Ω	Exh temp 1 (ACH7)	J2-7	0.8 to 3.0 VDC
Exh temp 2 (32 to 1471° F)	J1-3/4 to J1-1/2	100 to 376 Ω	Exh temp 2 (ACH7)	J2-7	0.8 to 3.0 VDC

Notes:

1. All output signals on ACH7 are multiplexed.
2. All output voltages on A33 J2 are referenced to ground (J2-15 and J2-16).
3. Must have L1, L2, L3, CT21, CT22, and CT23 for these phase angle outputs.
4. J1-24 (5VDC), J1-23 (signal), J1-18 (return).
5. Must have L1, L2, L3, Bus L1, Bus L2, and Bus L3 for these outputs.
6. L1, L2, and L3 can be 0 to 180° out of phase with Bus L1, Bus L2, and Bus L3, respectively.

TABLE 4-38. PCC FUSES

LOCATION	REFERENCE DESIGNATION	RATING	FUNCTION
Engine Interface	A31-F1	5 Amp	PCC control B+
Engine Interface	A31-F3	5 Amp	Auxiliary B+ (for panel lights, run and start relays)
Governor Output Module	A38-F4	10 Amp	Network B+ (to TB1 customer terminal block)
Governor Output Module	A38-F3	10 Amp	Switched B+ (to TB1 customer terminal block)
Governor Output Module	A38-F1	15 Amp	Left actuator
Governor Output Module	A38-F2	15 Amp	Right actuator
TB-Bat (Engine Harness Assembly)	F1	20 Amp	Customer B+ (to TB1 customer terminal block)



RACK POSITION FAULT/TEST PROCEDURE

The rack position fault/test procedure is a troubleshooting tool for the Rack Position (260) warning message. This test will isolate the fault to one of these components; fuel pump, governor output module (A38), or the PowerCommand control.

Use a calibrated RMS multimeter for accurate measurements. Fluke models 87 or 8060A are good choices.

1. Move the Run/Off/Auto switch to the Off position.
2. At the engine interface board (A31), place a jumper wire from A31-TP1 to A31-TP2 (see Figure 3-4 for test point location).
3. Select RACK TEST from the Setup Menu (page 5-17) to initiate the fuel rack test. This will apply power to the governor output module.
4. Are A38 DS1 (RUN) and A38 DS2 (VCC) LED's on?
Yes: Go to next step.
No: Possible control problem. Remove jumper wires (Step 2). Restart set and follow proper troubleshooting procedure.
5. Are fuses A38 F1 and F2 blown?
Yes: Replace blown fuse and restart set.
No: Go to next step.
6. Move both racks from 0mm to 19mm from the "POS MM" menu (see Setup Menu). Periodi-

cally read the DC voltages from J11-B (left position voltage) to J11-A and J11-C (right position voltage) to J11-A. (J11 engine harness connector is located at the bottom of the accessory box.)

7. Do these voltages correspond to the voltage on the display ($\pm .25$ VDC) ?
Yes: Test OK. Restart set and monitor A38-DS5 (left position fault) and A38-DS6 (right position fault).
No: Go to next step.
 8. Are both left and right voltages out of tolerance?
Yes: Possible control or governor output module problem. Check PWM signal (refer to Step 4 of error Code 313 in Troubleshooting section).
No: Go to next step.
 9. Move the racks to 0mm from the "POS MM" menu. Monitor the position voltage of the side that has the incorrect voltage.
 10. Disconnect the fuel pump connector at the fuel pump. Does the voltage rise up from approximately $1.3 \pm .25$ VDC to $4.5 \pm .25$ VDC ?
Yes: Replace defective fuel pump (refer to engine service manual).
No: Replace defective governor output module.
- Engine Torque Adjustment procedure must be performed after replacement of fuel pump or governor output module. Refer to Section 5.**

LOAD SHARING CONTROLS TROUBLESHOOT PROCEDURE

The generator set load sharing settings in the PowerCommand control are factory set and normally do not require adjustment. The controls are designed to cause generator sets in the paralleling system to share load proportionally, based on the standby ratings of the generator sets in the system.

When the system is operating normally, the generator sets in an isolated bus (not utility/mains paralleled) paralleling system will share both real (kW) and reactive (amps) load equally, within plus or minus 5%. For example, if two 1000 kW generator sets are paralleled and serving a 2000 kW load, the generator sets should each carry between 950 and 1050 kW.

In actual practice, load sharing may be much more precise than plus or minus 5%, but you should not be concerned about operational problems unless the load sharing is in error by more than 5%. If dissimilar generator sets are used in a system, there may be load sharing inequities for a short time when loads are applied, but the steady state load sharing should perform to the plus or minus 5% standard.

If the generator set is paralleled to a utility (mains) grid, the amount of load on the generator set is programmed into the control in the setup mode or set from a remote device. It is NOT a function of the load sharing control system. See *Section 5* for more information on load sharing set-up functions, and utility (mains) paralleling set-up.

If the generator set is not sharing load properly, the following procedure can be used to diagnose and solve the problem:

1. The no load speed and voltage of the generator set must be the same as the system bus. Measure the bus voltage and frequency, and the generator set voltage and frequency with a true RMS digital meter. Calibrate the voltage and current sensing circuits of the control, and make required adjustments to voltage and frequency to match bus conditions. Adjusting the voltage and frequency after the generator set is paralleled to the bus will cause load sharing to be unequal between generator sets.
2. Check to make sure that the load sharing control wiring is properly connected.
3. Check to make sure that each generator set in the system is capable of carrying its rated load.
4. Fine adjustment to the amount of load carried by each generator set can be made by adjusting the KW BALANCE and KVAR BALANCE settings under the paralleling setup menu (*Section 5*).
5. If the generator sets share load approximately equally, but there is an oscillating load circulating between the generator sets, the governor gain may be set too high. Reduce the governor gain (see *Setup Menu, Section 5*).
6. Consult factory for any other load sharing problems.





THIS PAGE LEFT INTENTIONALLY BLANK



5. Control Service and Calibration

GENERAL

This section contains circuit board removal and replacement procedures, calibration procedures for the generator set control and test procedures for the generator and engine components. Refer to the figures included with this information and also the *Wiring Diagrams* section when instructed.

Before servicing the PCC, it is recommended that all settings be recorded. This will make sure of correct and complete readjustment of the PCC in the event that all previous entries are lost during servicing.

CIRCUIT BOARD REMOVAL/REPLACEMENT

No special tools (other than a grounding wrist strap) are required to remove a circuit board from inside the control panel or the accessory box.

There are several circuit boards, that when replaced, require you to recalibrate the control panel functions. Table 5-1 lists the circuit boards and the appropriate procedure to perform to recalibrate the control panel. The circuit board locations are shown in Figure 5-1.

Before you attempt to remove a circuit board, read the *Circuit Board Removal Safety Precautions* in this section.

TABLE 5-1. CONTROL PANEL RECALIBRATION

CIRCUIT BOARD/ DEVICE	ADJUSTMENT	PROCEDURE / PAGE
Analog Board (A33)	1. Voltage, Current and PF. 2. Coolant Temperature L & R	<i>Setup and Calibration Menus</i> (Page 5-8)
Digital Board (A32)	Must recalibrate all values, starting with the <i>Initial Start Setup</i> procedure.	1. <i>Initial Start Setup</i> (Page 5-4). 2. <i>Adjust Menu</i> (Page 5-6). 3. <i>Setup and Calibration Menus</i> (Page 5-8).
PT/CT Board (A36)	Voltage, Current and PF.	<i>Setup and Calibration Menus</i> (Page 5-8)
Governor Output Module (A38)	Torque Adjustment % DC	<i>Engine Torque Adjustment</i> (Page 5-30)
Fuel Pump	Torque Adjustment % DC	<i>Engine Torque Adjustment</i> (Page 5-30)

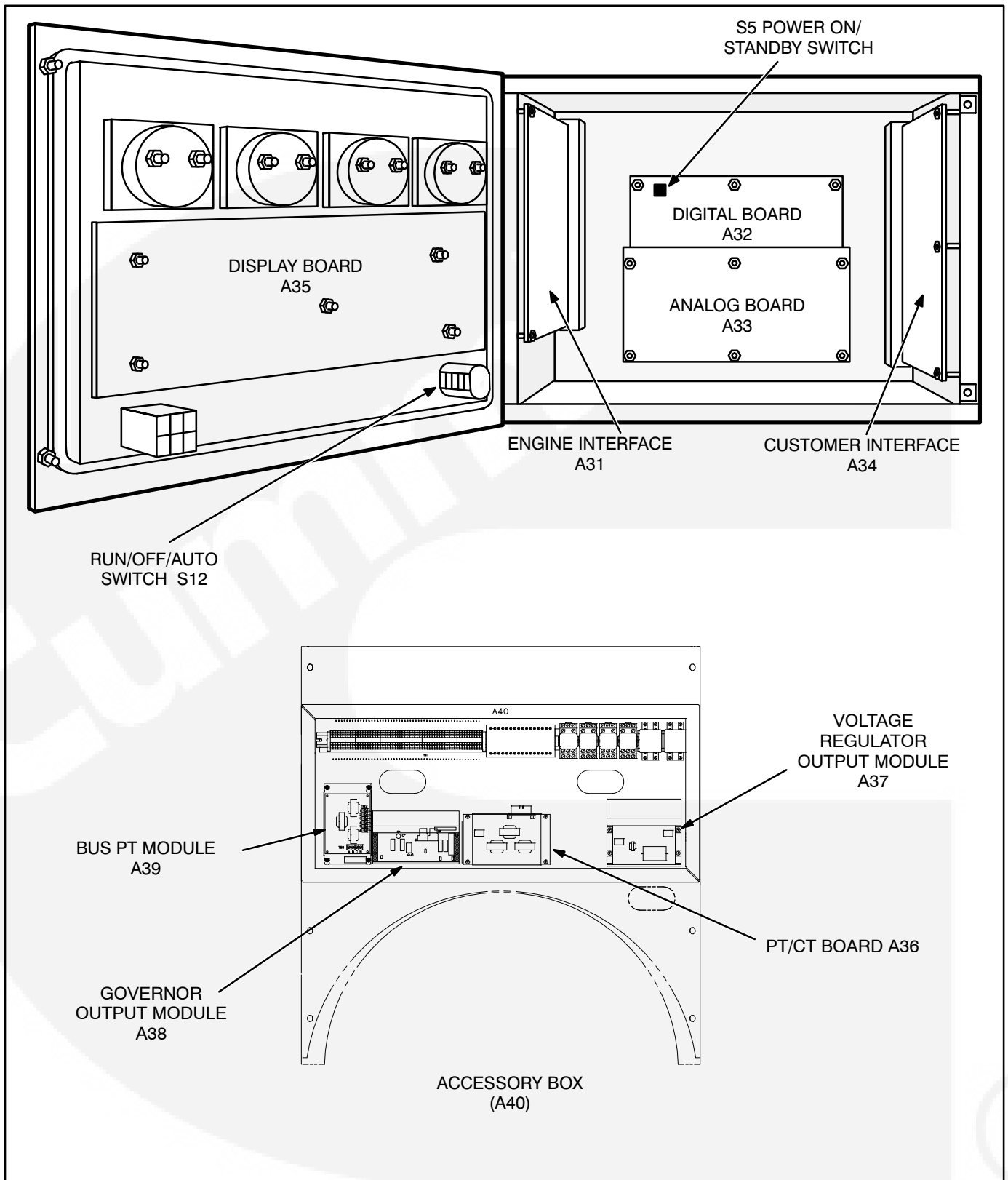

FIGURE 5-1. CIRCUIT BOARD LOCATIONS

Circuit Board Removal Safety Precautions

To prevent circuit board damage due to electrostatic discharge (ESD), a grounding wrist strap must be worn when handling circuit boards or socket-mounted IC's. (The wrist strap **does not** provide a direct short to ground, but is typically rated at approximately 1 megohm to ground.)

Attach the clip to a non-painted surface of the control box and place the strap around your wrist before handling a circuit board.

CAUTION *Electrostatic discharge will damage circuit boards. Always wear a grounding wrist strap when handling circuit boards or socket-mounted IC's.*

Turn off or remove AC power from the battery charger and then remove the negative (-) battery cable from the set starting battery. This is to make sure that the set will not start while working on it and to avoid circuit board damage, caused by voltage spikes when removing and replacing circuit board connectors.

WARNING *Ignition of explosive battery gases can cause severe personal injury or death. Arcing at battery terminals, light switch or other equipment, flame, pilot lights and sparks can ignite battery gas. Do not smoke, or switch trouble light ON or OFF near battery. Discharge static electricity from body before touching batteries by first touching a grounded metal surface.*

Ventilate battery area before working on or near battery—Wear goggles—Stop genset and disconnect charger before disconnecting battery cables—Disconnect negative (-) cable first and reconnect last.

CAUTION *Disconnect battery charger from AC source before disconnecting battery cables. Otherwise, disconnecting cables can result in voltage spikes damaging to DC control circuits of the set.*

WARNING *Accidental starting of the generator set can cause severe personal injury or death. Prevent accidental starting by disconnecting the negative (-) cable from the battery terminal.*

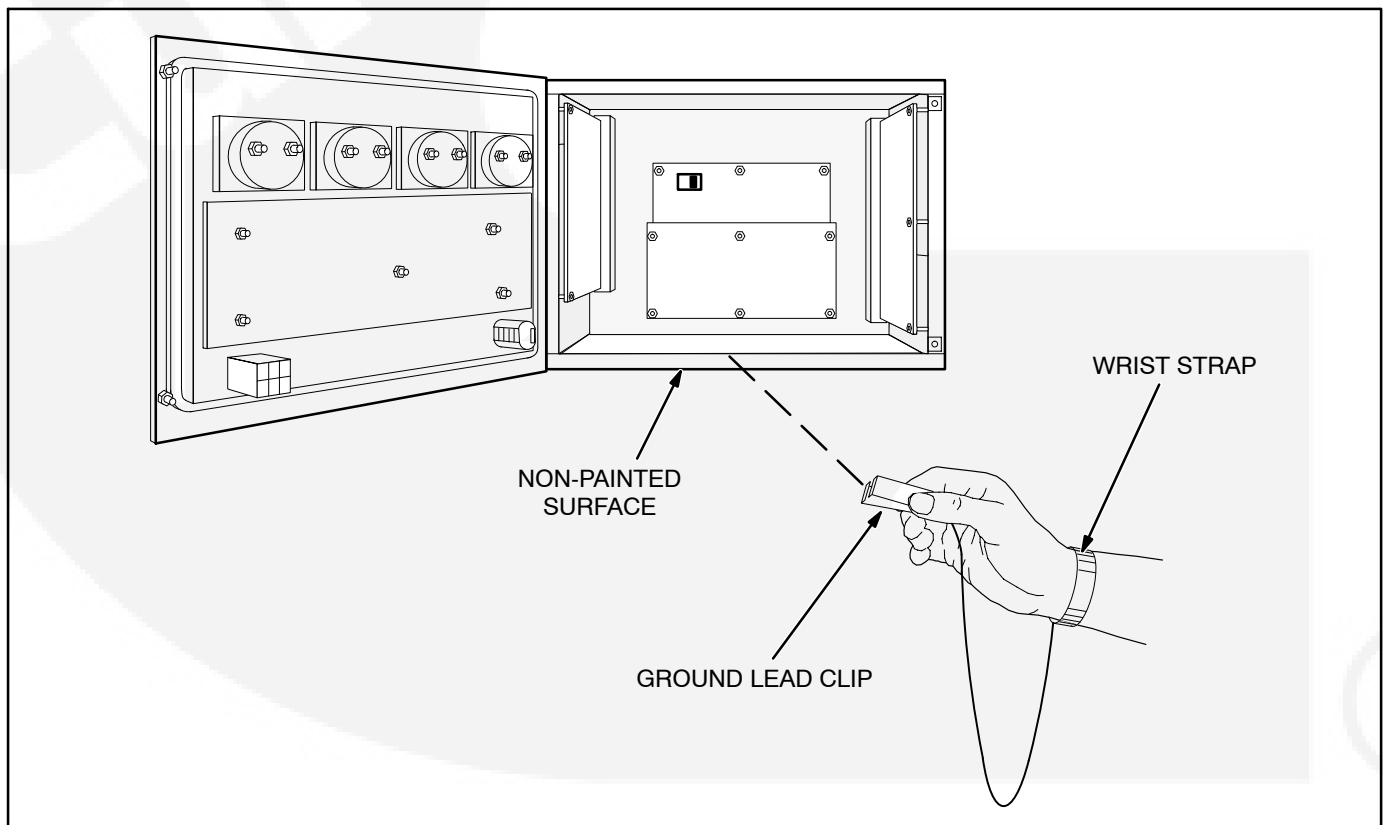

FIGURE 5-2. WRIST STRAP

INITIAL START SETUP MENU

The facing page shows a block representation of the INITIAL START SETUP menu.

CAUTION *Selecting this menu resets all operating parameters to the default values for the selected set. All previously selected setup and adjustment settings will be lost. Therefore, this procedure must be performed by technically qualified personnel only.*

This menu appears on the digital display when the PCC has not been set up for use with a generator set during factory test, or the digital board was replaced in the PCC.

When this display is showing, you must go through the Initial Start Setup menu to select the operating parameters for the generator set. These include whether the set will be used for Prime Power or Standby use, the Model Number of the generator set, and its operating frequency and output voltage. These choices must be saved into the PCC's read-only memory before the PCC will accept changes made to other menus.

If the PCC is already set up to operate with a specific generator set, this menu will not appear when power is applied. To reset the control and display the Initial Start Setup menu, you can press RESET, MENU, and PHASE SELECT buttons at the same time.

If you choose to do this, the governor/regulator adjustments and the setup options will be reset to the default settings (including the editable customer fault messages). Display calibrations (volts, amps, PF and coolant temperature) are retained (not reset). To make sure correct and complete readjustment of the PCC, it is suggested that all settings be recorded before you perform the reset function.

CAUTION *Improper setup, calibration, or adjustments can cause equipment malfunction or damage. Setup, calibration, and adjustment must be performed by technically qualified personnel only.*

STANDBY/PRIME submenu: Use the buttons next to the “↑↓” symbols to toggle the standby/prime option. Press the button next to the “>>” in the display to move to the model select submenu.

MODEL select submenu: Use the buttons next to the “↑” and “↓” symbols to select the correct generator set model number, frequency and power rating.

VOLTAGE SELECT submenu: Use the buttons next to the “↑” and “↓” symbols to select the correct generator set nominal line-to-line output voltage.

DELTA / WYE submenu: Use the buttons next to the “↑” and “↓” symbols to select the delta or wye option.

SAVE submenu: From the model select submenu, press the button next to the “>>” in the display to move to the SAVE submenu. Select SAVE to save your changes. The MAIN MENU will then be displayed.

If “INVALID SETUP” or “INVALID CAL” is displayed after saving your changes, refer to *Digital Board (A32) Calibration* at the end of this section.

INITIAL START SETUP

(It can be invoked by simultaneously pressing the Reset, Menu, and Phase Select keys.)

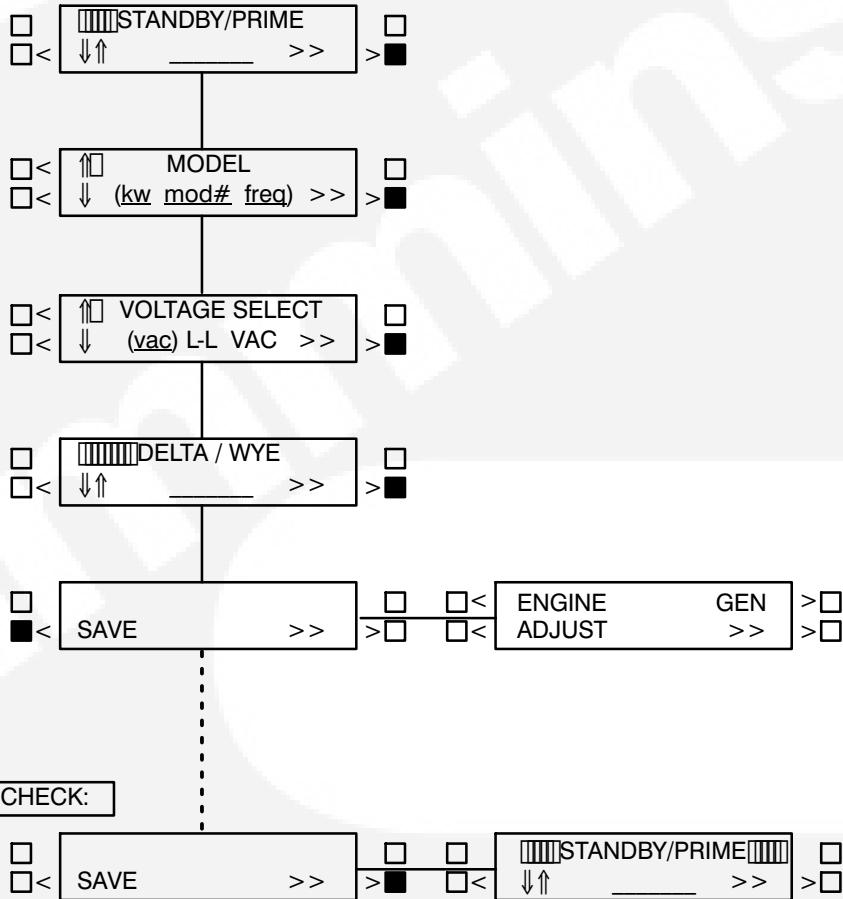

TO LOOP BACK & CHECK:

- - - - Indicates "OR" Condition

ADJUST MENU

The ADJUST submenus permit adjustment of the output voltage and frequency and the start and stop delay times of the generator set.

The complete calibration procedure is described in the *Calibration Procedure* in this section.

The facing page shows a block representation of the ADJUST menu. If you press the button next to the word "ADJUST" in the Main menu, the VOLTAGE ADJUST submenu will appear.

As shown in the diagram, the ADJUST menu has five submenus, including a save/exit procedure.

Voltage and frequency can be adjusted only when the generator set is running under normal operating parameters (not in idle mode). For example, if voltage adjustment is selected when the set is in Idle mode or not running, the digital display will be:

“↑	VOLTAGE ”
“↓	N/A >>”

VOLTAGE submenu: This is the first submenu. Use the buttons next to the “↑” and “↓” symbols to adjust output voltage $\pm 5\%$.

FREQUENCY submenu: From the VOLTAGE submenu, press the button next to the “>>” in the display to move to the FREQUENCY submenu. Use the buttons next to the “↑” and “↓” symbols to adjust output frequency $\pm 5\%$.

START DELAY submenu: This delay applies only to remote starting in the Auto mode. From the FREQUENCY submenu, press the button next to the “>>” in the display to move to the START DELAY submenu. Use the buttons next to the “↑” and “↓” symbols to set the start delay. The start delay adjustment range is 0 to 300 seconds.

STOP DELAY submenu: This delay applies only to remote stopping in the Auto mode. From the START DELAY submenu, press the button next to the “>>” in the display to move to the STOP DELAY submenu. Use the buttons next to the “↑” and “↓” symbols to set the stop delay. The stop delay adjustment range is 0 to 600 seconds.

IDLE SPEED submenu: From the STOP DELAY submenu, press the button next to the “>>” in the display to move to the IDLE SPEED submenu. Use the buttons next to the “↑” and “↓” symbols to set the idle speed. The idle speed adjustment range is 800 RPM ± 100 RPM. (Default value is 800 RPM.)

The idle speed can be adjusted only when the generator set is running in the idle mode. When not in idle mode, N/A is displayed in RPM field.

SAVE/EXIT submenu: From the STOP DELAY submenu, press the button next to the “>>” in the display to move to the SAVE/EXIT submenu. Select SAVE to save your changes. At the CHANGES SAVED submenu, select EXIT to return to the main menu.

If you select SAVE, the adjustments will be retained after shutdown, and will be in effect when the set is restarted. If you select EXIT without saving first, the adjustments will remain in effect until the generator set is shut down, but will be reset (and will not be in effect) when the set is restarted.

ADJUST

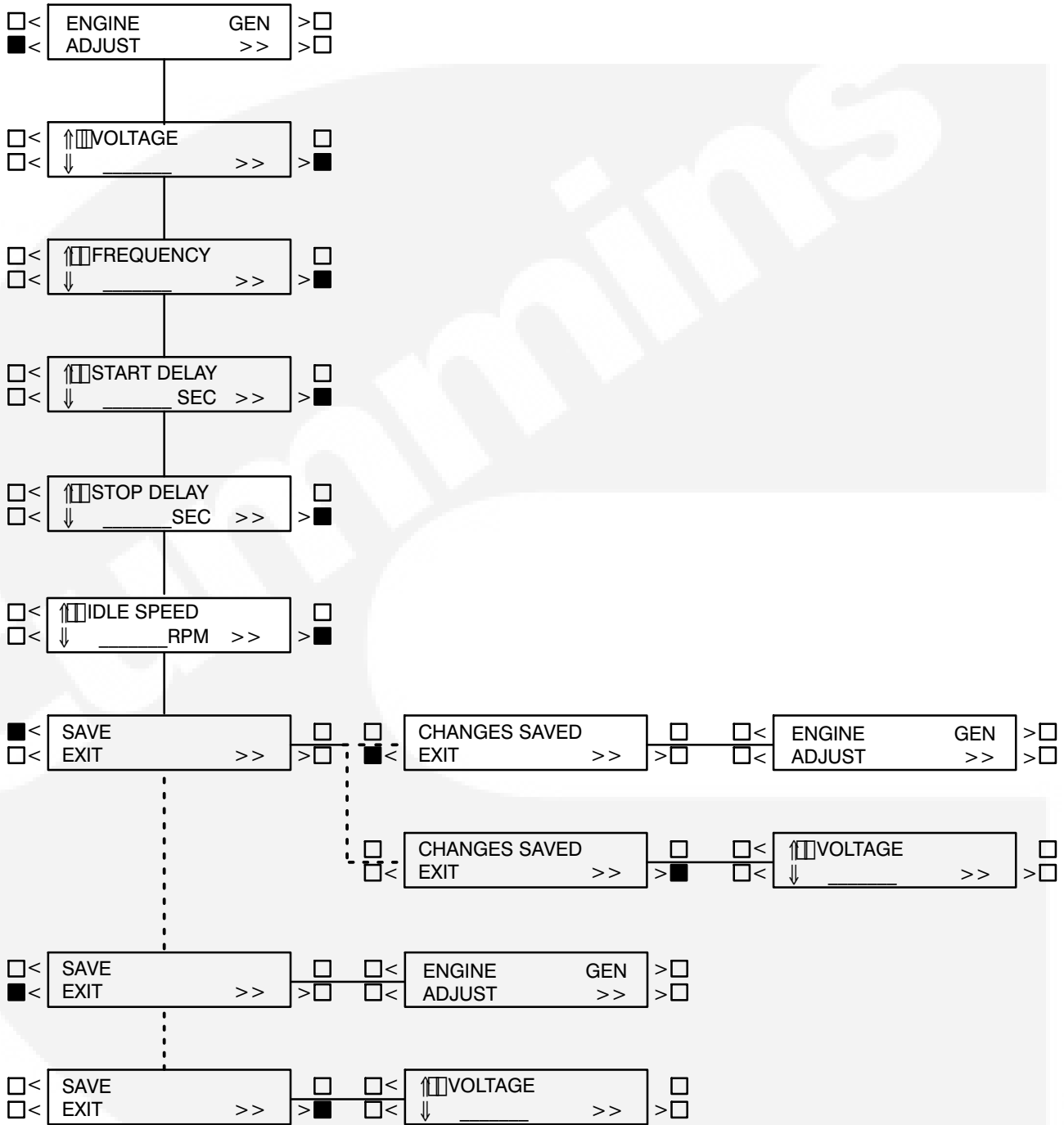

- - - Indicates "OR" Condition

SETUP AND CALIBRATION MENUS

The setup and calibration menus allow you to calibrate the PCC with the reading from a calibrated meter. There are four setup and calibration menus that are selectable from the SETUP/CAL menu:

- VERSION AND DISPLAYS
- METERS
- GOVERNOR/REGULATOR
- SETUP

These four menus are intended for qualified service personnel only. For this reason, a three-digit access code must be entered before you can proceed to those menus.

ENTER CODE submenu:

The access code for your PCC is: **5 7 4**.

To enter the code:

1. Press the button next to the “↑” to increment the first digit.
2. Press the button next to the “>>” to select the second digit.
3. Press the button next to the “↑” to increment the second digit.
4. Press the button next to the “>>” to select the third digit.
5. Press the button next to the “↑” to increment the third digit.
6. Press the button next to the “>>” to proceed to the DISPLAYS/METERS submenu. (Provided, of course, that you have correctly entered the access code.)

The following sub-sections describe how to select and make changes to the setup and calibration menus and save the changes made to these menus.

Version Menu

The VERSION menu allows you to verify the model number and frequency of the generator set, the date and version of the operating software and generator set configuration options. From the VERSION menu you can also review a History file, that can contain up to 20 error messages.

The complete calibration procedure is described in the *Calibration Procedure* in this section.

The facing page shows a block representation of the VERSION submenu. If you press the button next to the “>>” in the Main menu display, the VERSION/SETUP/CAL menu will appear.

⚠ CAUTION *Improper calibration or adjustment of the PowerCommand control can cause equipment malfunction or damage. Calibration and adjustment must be performed by technically qualified personnel only.*

VERSION submenu: If you select VERSION, the display will show the generator set model number, frequency, and kW rating, and the date and version of the operating software.

To display the generator set configuration options, press the button next to the “>>” in the submenu that displays the model number, frequency and etc. This menu provides the following information:

- Generator set voltage
- WYE or DELTA
- Standby or Prime
- Parallel or Single

HISTORY: From the VERSION, SETUP/CAL menu, press the button next to the “>>” in the display to move to the HISTORY submenu. Press the button next to “HISTORY” to display the last (latest) recorded error message.

The software will record (save) up to 20 error messages. The last error detected will always be displayed first. As each new error is detected, the oldest error recorded after 20 will be deleted.

To view the generator set runtime at which the error occurred and to scroll through the remaining recorded errors, press the button next to the “>>” in the error message menu to display the RUNTIME, NEWER/OLDER menu.

The buttons next to NEWER and OLDER are used to scroll up and down through the error messages. For example, pressing OLDER will display the next oldest recorded error message. When pressing NEWER and the last (newest) error message is displayed, or OLDER and oldest error is displayed, the display will return to the HISTORY menu.

VERSION MENUS

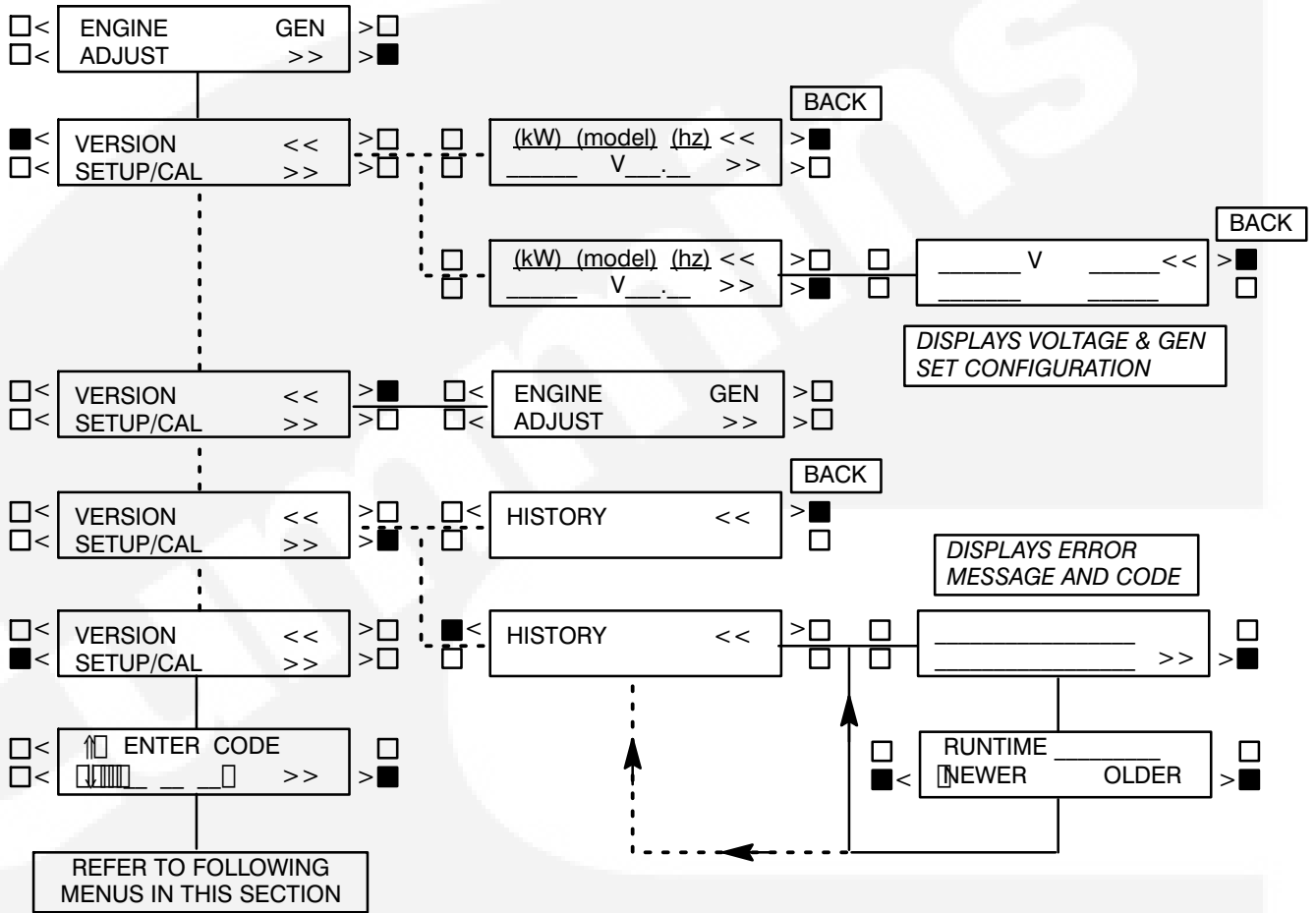

- - - Indicates "OR" Condition

Displays Menu

The DISPLAYS submenus permit calibration of the digital voltage, current, power factor (PF) and coolant temperature displays. Calibration is accomplished by using this section of the menu software to adjust the display so that it matches the reading taken on an accurate, recently calibrated meter.

The complete calibration procedure is described in the *Calibration Procedure* in this section.

The facing page shows a block representation of the DISPLAYS submenus, which is the first of four SETUP/CAL menus. If you press the button next to the ">>" in the Main menu display, the VERSION/SETUP/CAL menu will appear.

⚠ CAUTION *Improper calibration or adjustment of the PowerCommand control can cause equipment malfunction or damage. Calibration and adjustment must be performed by technically qualified personnel only.*

DISPLAYS submenus: The DISPLAYS submenus are intended for qualified service personnel only. For this reason, a three-digit access code must be entered before you can proceed to those menus.

Select SETUP/CAL. The display will show the ENTER CODE submenu. Enter access code (574) as previously described in this section.

Select DISPLAYS to proceed to the DISPLAYS submenus. Use the buttons next to the "↑" and "↓" sym-

bols to calibrate the selected voltage, current, PF or coolant temperature reading. Press the button next to the ">>" in the display to move to the next adjustment.

"VOLTS L12," "VOLTS L23," and "VOLTS L31" refer to voltages measured from L1 to L2, L2 to L3, and L3 to L1, respectively. Note that the system includes bus voltage reading provisions ("BUS VOLTS L12," "BUS VOLTS L23," and "BUS VOLTS L31"), which must be calibrated separately from the generator set voltage settings.

"PF1, PF2 and PF3" will display N/A when the generator set is not running.

"COOLANT TEMP R" will display "N/A" if the genset has only one sensor. To calibrate coolant temperature display, a precision resistor (provided in the engine sensor tool) must be temporarily substituted for the temperature sender. Refer to *Calibration Procedure* in this section.

SAVE/EXIT submenu: From the AMPS L3 submenu, press the button next to the ">>" in the display to move to the SAVE/EXIT submenu. Select SAVE to save your changes. At the CHANGES SAVED submenu, select EXIT to return to the DISPLAYS/METERS submenu.

If you select SAVE, the adjustments will be retained after shutdown, and will be in effect when the set is restarted. If you select EXIT without saving first, the adjustments will remain in effect until the genset is shut down, but will be reset (and will not be in effect) when the set is restarted.



DISPLAYS MENU

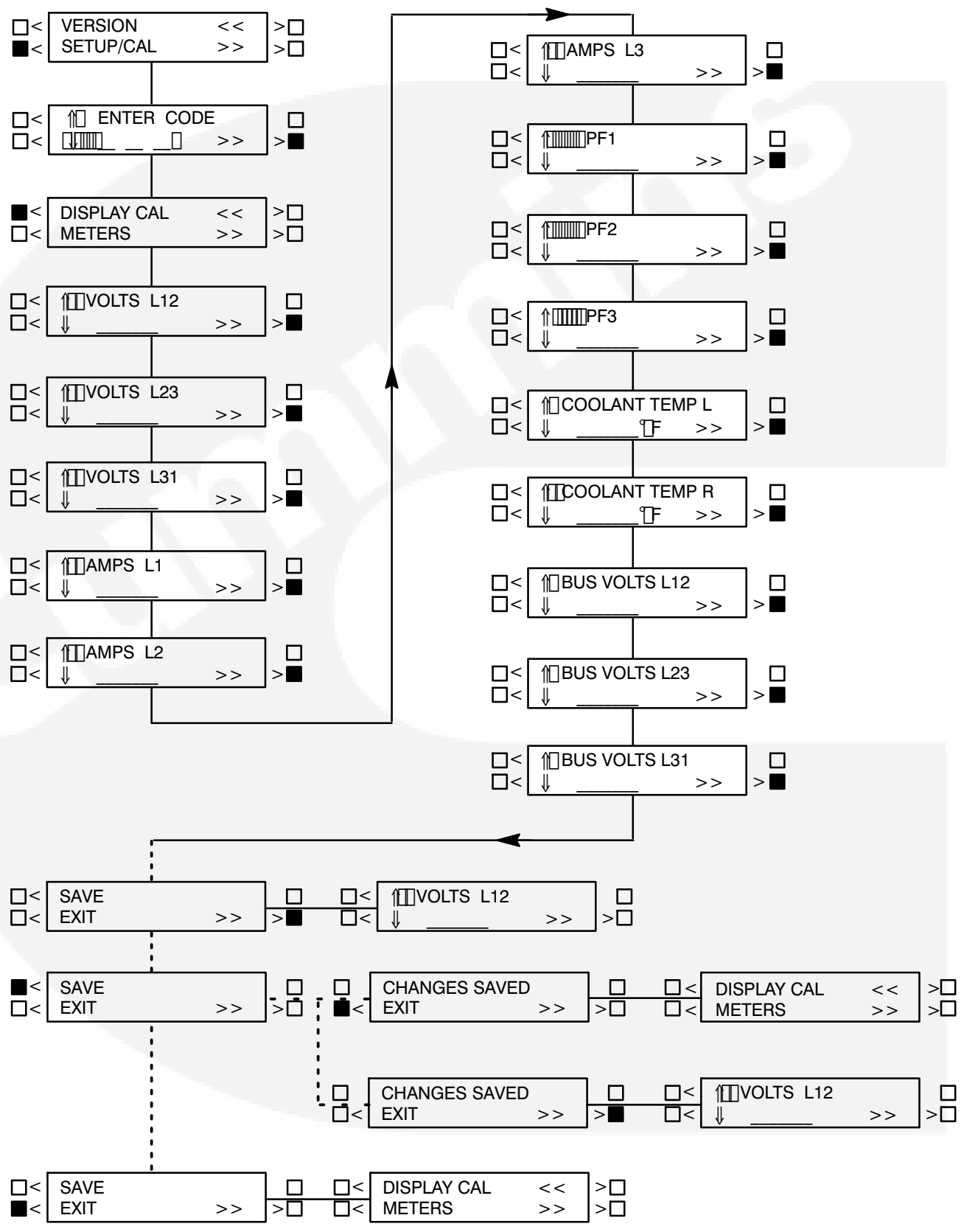

- - - Indicates "OR" Condition

Meters Menu

The METERS submenus permit calibration of the control's analog meters to match the calibrated digital values. (Calibrate the digital display before calibrating the analog meters.) This calibration is accomplished by using this section of the menu software to adjust the selected meter reading so that it matches the reading provided on the digital display.

The complete calibration procedure is described in the *Calibration Procedure* in this section.

The facing page shows a block representation of the METERS submenus, which is the second of four SETUP/CAL menus. If you press the button next to the ">>" in the Main menu display, the VERSION/SETUP/CAL submenu will appear.

⚠ CAUTION *Improper calibration or adjustment of the PowerCommand control can cause equipment malfunction or damage. Calibration and adjustment must be performed by technically qualified personnel only.*

METERS submenu: The METERS submenus are intended for qualified service personnel only. For this reason, a three-digit access code must be entered before you can proceed to those menus.

Select SETUP/CAL. The display will show the ENTER CODE submenu. Enter access code (574) as previously described in this section.

Select METERS to proceed to the METERS submenus. Use the buttons next to the "↑" and "↓" symbols to calibrate the selected meter to match the "CAL TO:" value provided on the digital display. Press the button next to the ">>" in the display to move to the next calibration.

"VOLT METER" and "% AMPERES" calibration reference the phase that is indicated on the phase selection LED's.

NOTE: The % AMPERES meter scale is based on a 0.8 power factor. (100% of rated current is full load current at 0.8 PF.)

SAVE/EXIT submenu: From the HERTZ submenu, press the button next to the ">>" in the display to move to the SAVE/EXIT submenu. Select SAVE to save your changes. At the CHANGES SAVED submenu, select EXIT to return to the DISPLAYS/METERS submenu.

If you select SAVE, the adjustments will be retained after shutdown, and will be in effect when the set is restarted. If you select EXIT without saving first, the adjustments will remain in effect until the generator set is shut down, but will be reset (and will not be in effect) when the set is restarted.



METERS MENU

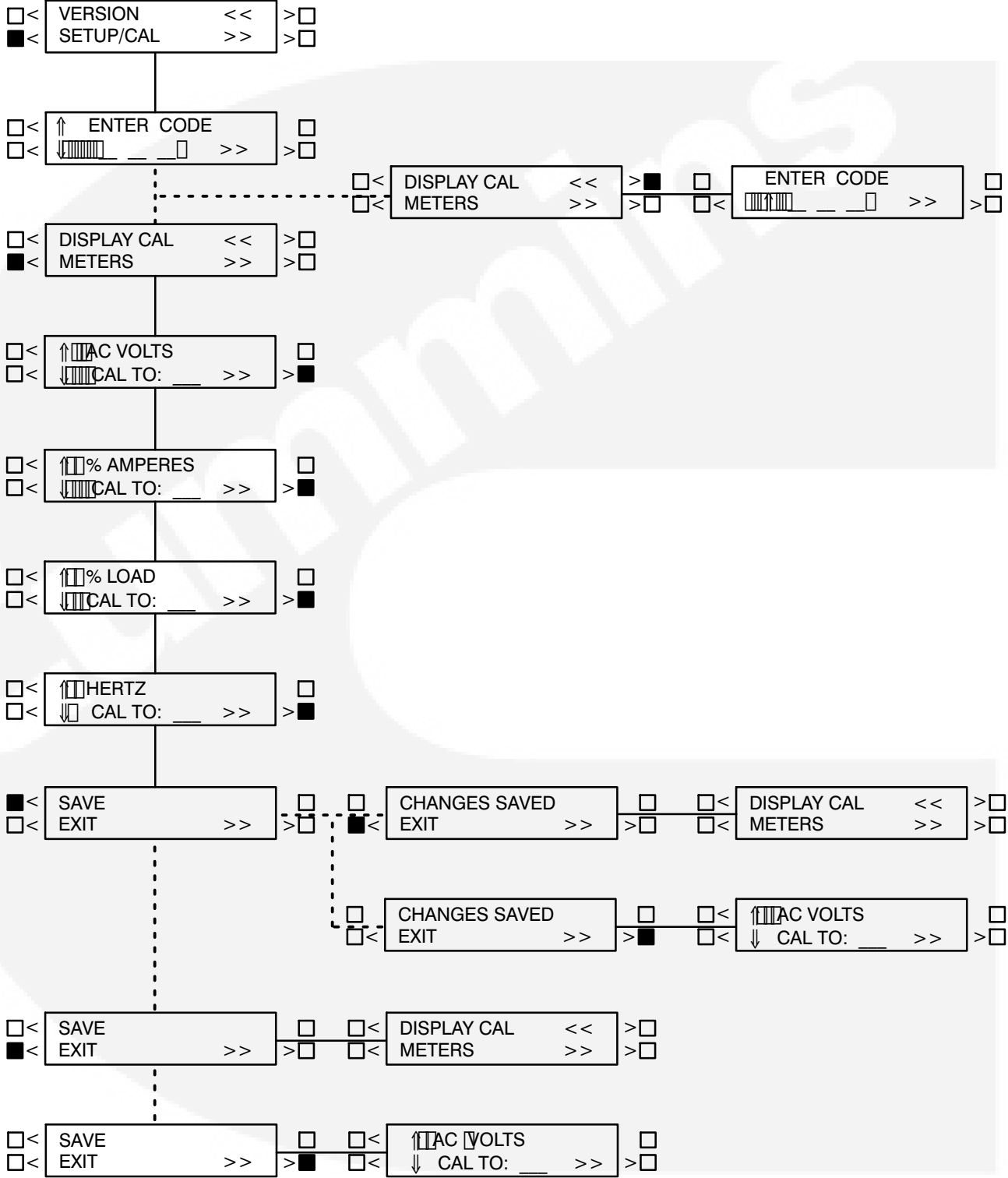

- - - Indicates "OR" Condition

Governor / Regulator Menu

The GOV/REG submenus permit adjustment of voltage regulator and governor parameters.

All GOV/REG menu values, except for REG VHZ and GOV RAMP, will display “100%”. The expression “100%” represents the factory setting (default value) for the selected set. When increasing or decreasing the value, you are increasing or decreasing from the factory default value. (For example, entering “200%” will double the value; “50%” will decrease the value by one half.)

Default values are preset by the factory. Due to site variables, the default values may need to be adjusted to attain peak performance.

The facing page shows a block representation of the GOV/REG submenus, which is the third of four SETUP/CAL menus. If you press the button next to the “>>” in the Main menu display, the VERSION/SETUP/CAL submenu will appear.

⚠ CAUTION *Improper calibration or adjustment of the PowerCommand control can cause equipment malfunction or damage. Calibration and adjustment must be performed by technically qualified personnel only.*

GOV/REG submenu: The GOV/REG submenus are intended for qualified service personnel only. For this reason, a three-digit access code must be entered before you can proceed to those menus.

Select SETUP/CAL. The display will show the ENTER CODE submenu. Enter the access code (574) as previously described in this section.

From the DISPLAYS/METERS submenu, press the button next to the “>>” in the display to move to the GOV/REG/SETUP submenu. Select GOV/REG to proceed to the GOV/REG submenus.

Use the buttons next to the “↑” and “↓” symbols to adjust the selected governor and regulator parameters. Press the button next to the “>>” in the display to move to the next adjustment.

GOV GAIN: If the gain adjustment is set too high, engine speed will “hunt” or oscillate. If gain is set too low, the engine will respond too slowly to changes in load—overspeed may result.

For paralleling applications, the default value for governor gain is 70.

GOV INTEGRAL: If this adjustment is set too low, the engine will respond too slowly to changes in load. If it is set too high, engine response will be unstable.

GOV RAMP: This adjustment sets the time for the engine to ramp to full operating speed. This adjustment applies only to set start up and does not affect the transient response. (Adjustable range: 0 through 10 seconds.)

REG GAIN: If the gain adjustment is set too high, output voltage will be unstable. If gain is set too low, the output voltage will respond sluggishly to changes in load—overshoot may result.

REG INTEGRAL: If this adjustment is set too low, the output voltage will respond sluggishly to changes in load, resulting in a droop-type response. If it is set too high, output voltage will be unstable.

REG VHZ: This underfrequency roll-off adjustment controls how much excitation is reduced in response to underfrequency. If the value is set too low, excitation will be cut too fast, and the voltage will drop too much. If set too high, the generator set may not be able to pick up rated load in one step. (Adjustable range: 1 through 50; normal range 7 through 21.)

SAVE/EXIT submenu: From the REG VHZ submenu, press the button next to the “>>” in the display to move to the SAVE/EXIT submenu. Select SAVE to save your changes. At the CHANGES SAVED submenu, select EXIT to return to the DISPLAYS/METERS submenu.

If you select SAVE, the adjustments will be retained after shutdown, and will be in effect when the set is restarted. If you select EXIT without saving first, the adjustments will remain in effect until the generator set is shut down, but will be reset (and will not be in effect) when the set is restarted.

GOVERNOR/REGULATOR MENU

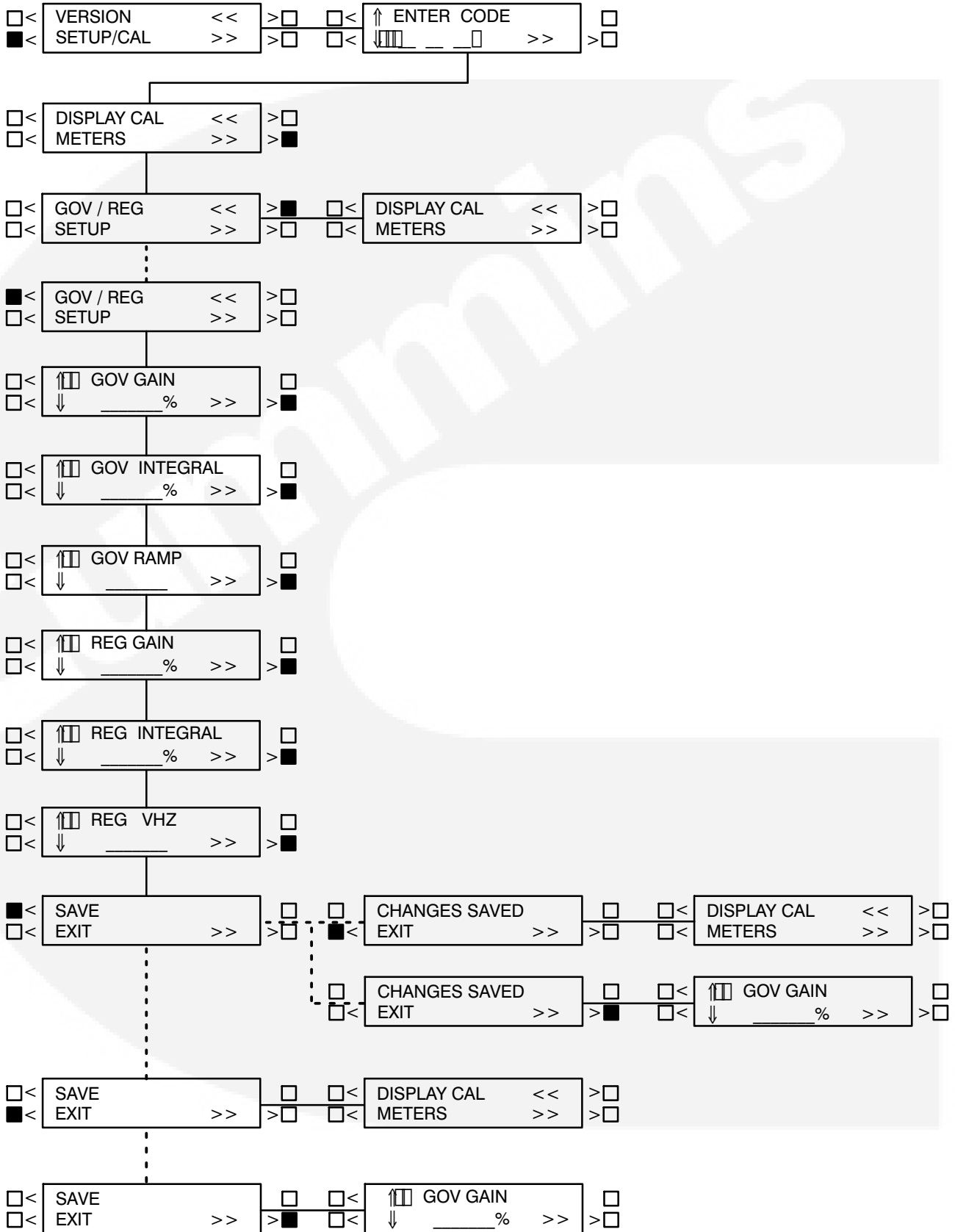

- - - - Indicates "OR" Condition

Setup Menu

The SETUP submenus permit selection of several configuration and operation options. Setup option defaults are listed in Table 5-2.

TABLE 5-2. SETUP DEFAULTS

SELECTION	DEFAULT
CYCLE CRANK	ON
SYSTEM OF UNITS	IMPERIAL
*RACK POSITION (CF1)	WARN
*GRND FAULT (CF2)	WARN
*DAY TANK (CF3)	WARN
*HIGH GEN TEMP (CF4)	WARN
EGT L	NO
EGT R	NO
LOW COOLANT	SHTD
LANGUAGE	ENGLISH

* Default display messages for customer faults (CF) 1 through 4. To change the customer fault message(s) or select the desired fault condition (WARN or SHTD), refer to heading *Edit Customer Fault Messages*.

The facing page shows a block representation of the SETUP submenus, which is the fourth of four SETUP/CAL menus. If you press the button next to the ">>" in the Main menu display, the VERSION/SETUP/CAL submenu will appear.

⚠ CAUTION *Improper calibration or adjustment of the PowerCommand control can cause equipment malfunction or damage. Calibration and adjustment must be performed by technically qualified personnel only.*

SETUP submenu: The SETUP submenus are intended for qualified service personnel only. For this reason, a three-digit access code must be entered before you can proceed to those menus.

Select SETUP/CAL. The display will show the ENTER CODE submenu. Enter the access code (574) as previously described in this section.

From the DISPLAYS/METERS submenu, press the button next to the ">>" in the display to move to the GOV/REG/SETUP submenu. Select SETUP to proceed to the SETUP submenus or ">>" to proceed to the RACK TEST submenus.

Use the buttons next to the "↑↓" symbols to toggle the setup options. Press the button next to the ">>" in the display to move to the next adjustment.

If the cycle cranking option is selected, the menu will prompt for the selection of cycle number (3, 4, or 5) and crank and rest times (7 to 20 seconds).

An in-line engine that has the EGT (exhaust gas temp.) option, select "YES" for EGT L and "NO" for EGT R.

RACK TEST submenu: The RACK TEST submenu is used to initiate the rack position diagnostic test. This test is used to determine if the PCC is properly controlling the rack position of the actuators. To initiate this test, the Run/Off/Auto switch must be set to the Off position.

When exiting this test or if the Run/Off/Auto switch is moved to either the Run or Auto position, the PCC software will re-initialize the governor duty cycle to 2 (0%) and allow the engine starting sequence to proceed as normal.

To perform the rack test, refer to the *Rack Position Fault/Test Procedure* in Section 4.

TORQUE ADJ %DC submenu: This submenu is used to adjust the engine torque through the digital display to compensate for engine/electronic variations. If the generator set is not providing the name plate kilowatt rating, the torque limit can be adjusted at this menu. Refer to *Engine Torque Adjustment* in this section for a detailed description of how to perform this adjustment.

SETUP MENU

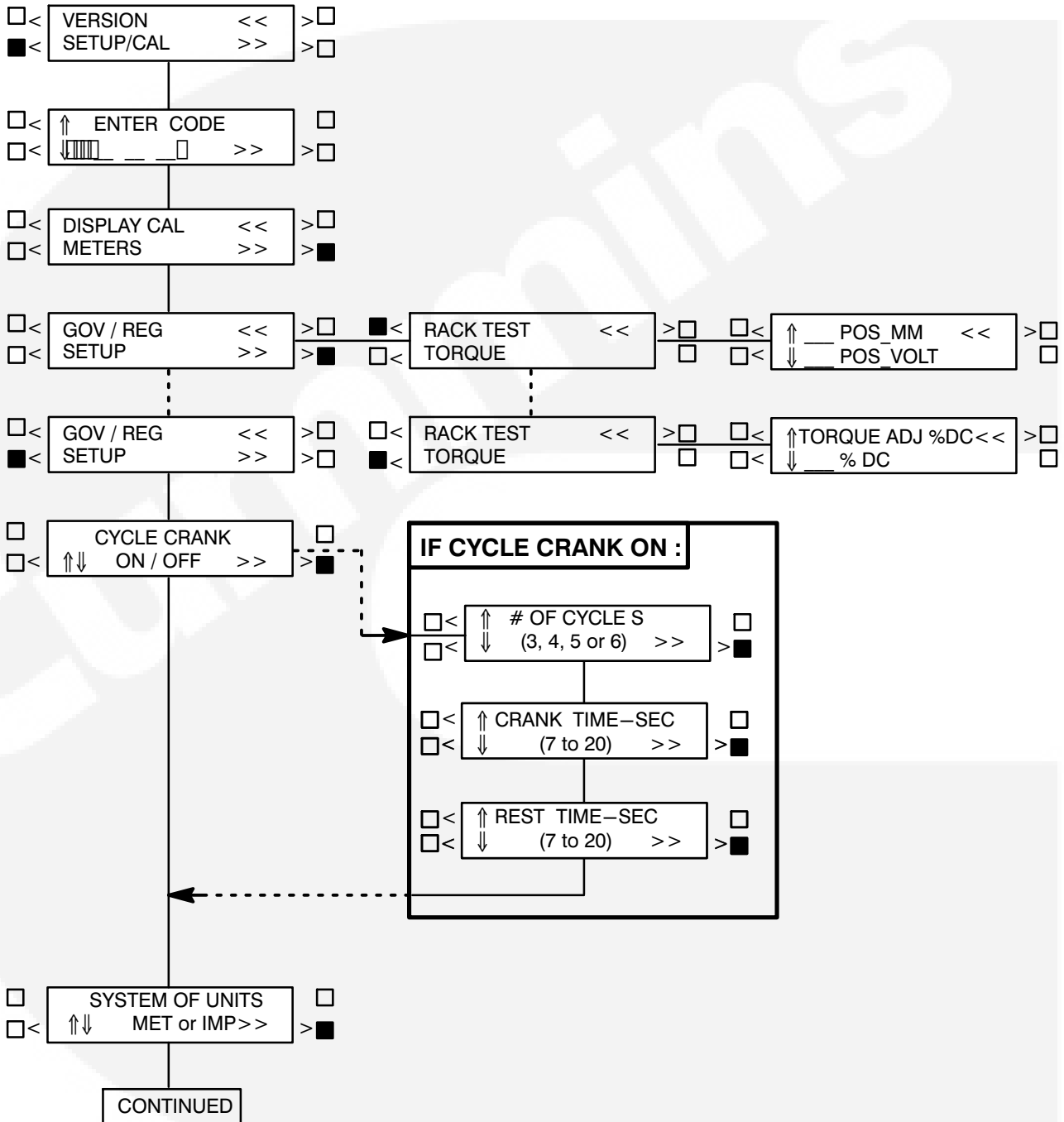

----- Indicates "OR" Condition

Setup Menu (Cont.)

Edit Customer Fault Message(s): The four customer fault messages shown in Table 5-2 are editable. *Customer Fault 1 is reserved for the RACK POSITION fault. Do not modify this fault name or change the fault condition (WARN to SHTD).*

To enter the desired customer fault message, press the button next to the ">>" in the display to display the customer fault message to be changed, Customer Fault 2, 3 or 4.

Press the upper-left button by the display to select the desired character. Press the upper-right button to move the cursor to the next character to be changed. (Holding this button down will return the cursor to the first position.) The message can be up

to 16 characters. The fault code number will remain the same, this code cannot be edited.

If these messages are changed, you should note these changes in the *Troubleshooting* section of the Operator's manual for this generator set.

SAVE/EXIT submenu: From the LANGUAGE submenu, press the button next to the ">>" in the display to move to the SAVE/EXIT submenu. Select SAVE to save your changes. At the CHANGES SAVED submenu, select EXIT to return to the DISPLAYS/METERS submenu.

If you select SAVE, the adjustments will be retained after shutdown, and will be in effect when the set is restarted. If you select EXIT without saving first, the adjustments will remain in effect until the generator set is shut down, but will be reset (and will not be in effect) when the set is restarted.



SETUP MENU (Cont.)

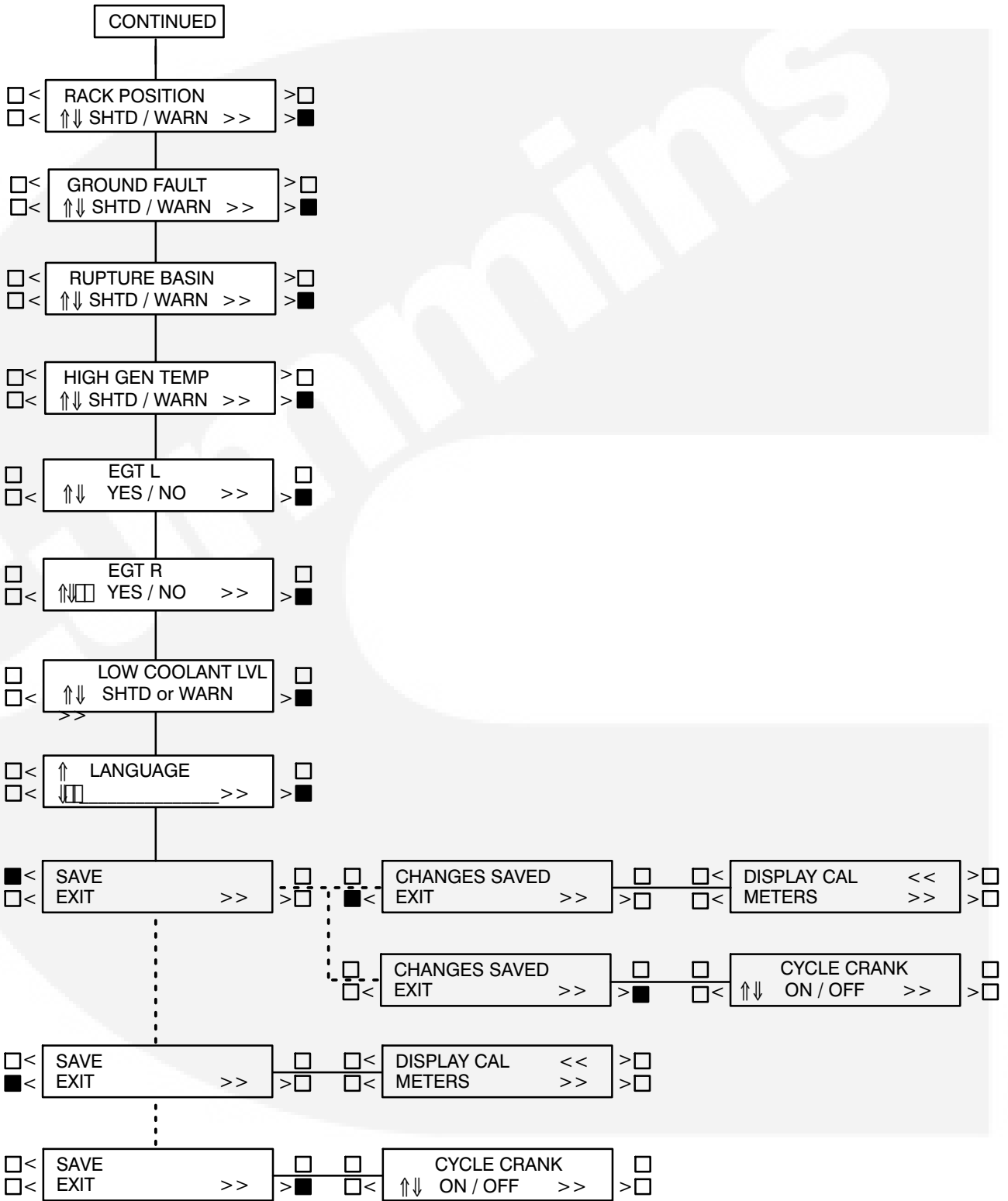

- - - Indicates "OR" Condition

Paralleling Setup Menu

The PARALLELING SETUP submenus adjust the control parameters for generator set protection, synchronizing and load sharing for both isolated bus and utility (mains) paralleling applications. Utility (mains) parallel applications may require adjustment of both the “isolated bus” and “utility” branch submenus.

The sync check (permissive) function is operational in both automatic and manual (RUN) modes. The control will make sure that the generator set is at proper voltage, within the defined sync check window for the defined period of time and that phase rotation is correct. When all criteria are met, the paralleling breaker is closed automatically by the control (auto mode), or by operation of the breaker close switch by the operator (run mode).

The synchronizing function of the PowerCommand control is enabled when the control has brought the generator set to rated speed and voltage, and has sensed that bus voltage is available. The control automatically adjusts the generator set speed and voltage to match the bus frequency and voltage. The control can force the generator set to match a bus voltage and frequency in a range of minus 40% to plus 10% of normal bus conditions. When the paralleling breaker has closed, the control will bring the generator set back to normal voltage and frequency.

When the generator set is paralleled to another generator set, the control provides automatic load sharing functions for both real (kW) and reactive (kVAR) loads. Load sharing is proportional between generator sets based on their standby ratings. If two generator sets of different sizes are paralleled, they will assume the same percentage of the system load automatically. This can easily be verified on the analog % Load meters on the front of the PowerCommand control panel.

When the utility paralleling mode is enabled and the generator set paralleling breaker is closed, the generator set will assume load based on external analog input signal. The input signal must be calibrated from 0–5 VDC. When the signal is at 0.5 to 1 VDC, the control will operate the generator at no load in parallel with the utility (mains) source. At 4.5 VDC and greater, the control will operate the generator

set at 110% of the generator set base load setting. When the load govern signal is between 1 VDC and 4.5 VDC the control will operate the generator set at a load level which is determined by a linear relationship between the kW reference and the load govern signal.

ISOLATED BUS ADJUSTMENTS

SYNC TIME LIMIT: This parameter adjusts the time delay in seconds before the Fail To Synchronize alarm will operate.

– **PWR LIMIT (%):** Adjusts the reverse power set point. For PowerCommand generator sets, a typical set point is 10-15%.

– **PWR LIMIT (TIME):** Adjusts the reverse power function time delay. A typical time delay which is suitable for PowerCommand generator sets is 3 seconds.

Lower reverse power set points can result in nuisance reverse power shutdown faults.

PERM WIN-PHASE: Adjusts the width of the permissive (sync-check) acceptance window. The adjustment range is from five to twenty electrical degrees. Recommended set point is 20 degrees for isolated bus applications, and 15 degrees for utility (mains) paralleling applications.

PERM WIN-TIME: Adjusts the time period (in seconds) for which the generator set must be synchronized with the system bus, before a breaker close signal is issued by the PowerCommand control. Available range is 0.5 to 5 seconds. Recommended value for PowerCommand generator sets is 0.5 seconds for isolated bus applications.

Adjusting the control for a smaller sync-check window or longer time delay will cause synchronizing time to be extended.

SYNC GAIN: The sync gain adjustment controls how quickly the governor will respond to try to minimize the bus/generator phase difference. Increasing the gain speeds up the response. If the gain is too high instability can result.

SYNC INTEGRAL: The sync integral adjustment controls the rate at which the governor will be adjusted to try to minimize the bus/generator phase difference. The lower the number the slower the response.

PARALLELING SETUP MENU

< VERSION << >
 < SETUP/CAL >> >

< ↑ ENTER CODE >
 < ▯▯▯▯▯ _ _ _ ▯ >> >

< DISPLAY CAL << >
 < METERS >> >

< GOV / REG << >
 < PARALLEL SETUP >> >

< ISO BUS << >
 < UTILITY >> >

B (CONTINUED)

< ISO BUS << >
 < UTILITY >> >

< ↑ SYNC TIME LMT >
 < ▯▯ 120 >> >

< ↑ -PWR LMT (%) >
 < ▯▯ 10 >> >

< ↑ -PWR LMT (TIME) >
 < ▯▯ 3 >> >

< ↑ PERM WIN-PHASE >
 < ▯▯ 20 >> >

< ↑ PERM WIN-TIME >
 < ▯▯ .5 >> >

< ↑ SYNC GAIN >
 < ▯▯ 95 >> >

< ↑ SYNC INTEGRAL >
 < ▯▯ 12 >> >

A (CONTINUED)

--- Indicates "OR" Condition

ISOLATED BUS ADJUSTMENTS (Cont.) (A)

KW BALANCE: This function adjusts the kW load sharing function of the generator set. Before adjusting this value, all generator set calibrations should be performed. If the total load on the system is not shared proportionately, the kW Balance can be used to adjust the generator set for more precise load sharing. Increasing the kW Balance value will cause the generator set to reduce the percentage of the total kW load on that set.

KVAR BALANCE: This function adjusts the kVAR load sharing function of the generator set. Before adjusting this value, all generator set calibrations should be performed. If the total load on the system is not shared proportionately, the kVAR balance can be used to adjust the generator set for more precise load sharing. Increasing the kVAR balance value will cause the generator set to reduce the percentage of the total kVAR load on that set.

KW GAIN: Adjusts the rate of change of kW load on the generator set. With a constant load on the system, if the generator set load is constantly changing, reduce the gain adjustment on the generator set. This also allows modification of the rate of load assumption on transient load change.

KVAR GAIN: Adjusts the rate of change of kVAR load on the generator set. With a constant load on the system, if the generator set load is constantly changing, reduce the gain adjustment on the gener-

ator set. This also allows modification of the rate of load assumption on transient load change.

1ST START FAIL: Time delay in seconds after a signal from the first start master is not sensed by the PCC that a FIRST START FAIL warning is displayed.

RAMP UNLD TIME: When a load demand stop input is sensed the load is ramped down from the present load level on the set to the ramp unload level in the time specified in seconds.

RAMP UNLD LEVEL: The load demand ramp unload function will ramp the load down from the present level on the set to this level before opening the set circuit breaker. Value shown is in % of genset standby rating.

RAMP LOAD TIME: When the load demand stop signal is removed the load is ramped from 0kW to the load share level in the specified time after the circuit breaker closes.

LOSS FIELD (LOSS OF EXCITATION) TIME and LEVEL: Adjusts the time delay on the Loss of Excitation fault. Generator sets with version 1.07 and higher (9-26-96 and later) firmware may be adjusted for time delay on this condition. the default value is 2 seconds.

Generator sets with version 2.0 and higher firmware allow adjustment of both time delay and reverse VAR set point. Default values are 10 seconds and 20%.



PARALLELING SETUP MENU (Cont.)

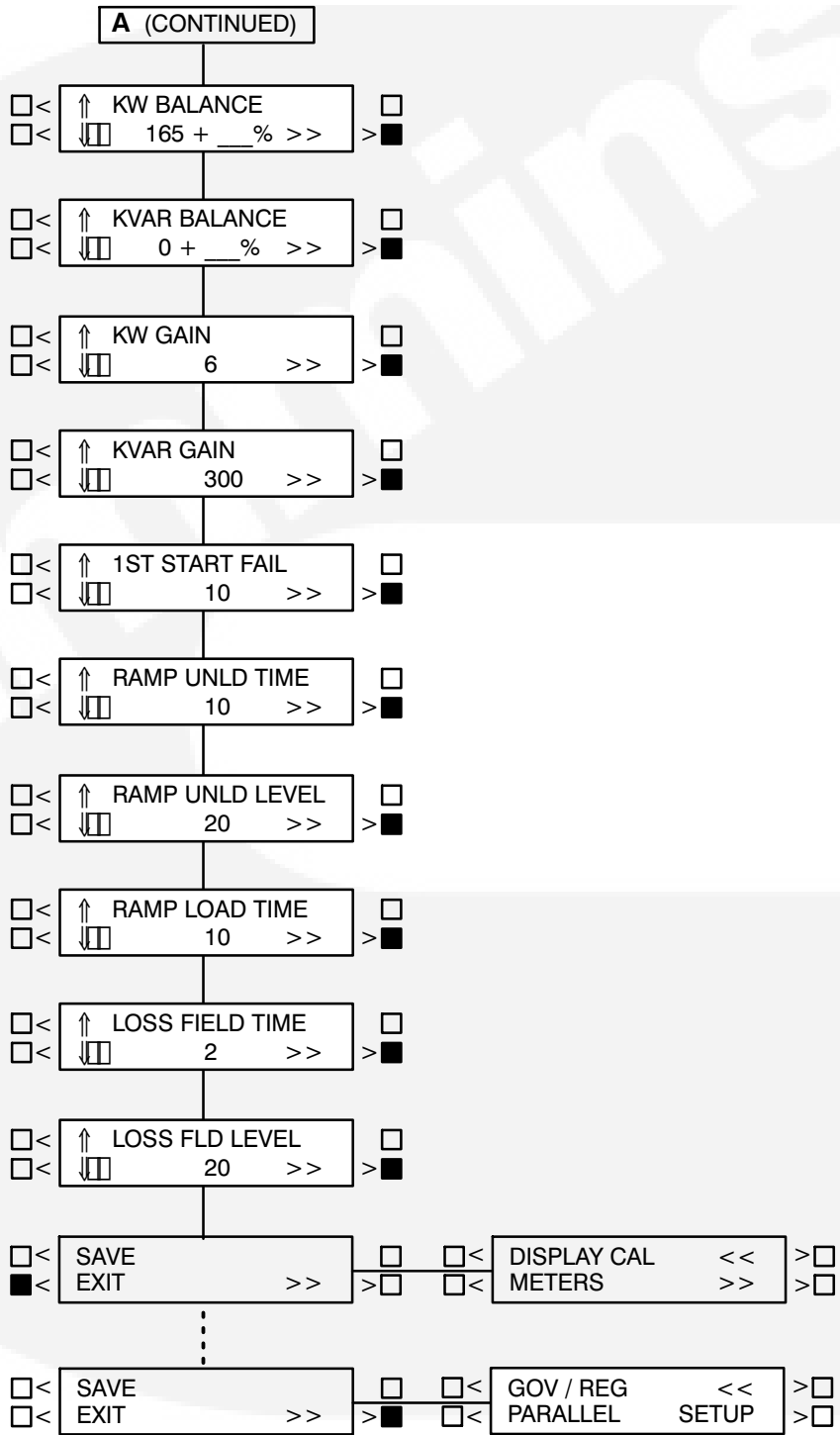

- - - - Indicates "OR" Condition

UTILITY (MAINS) ADJUSTMENTS (B)

BASE LOAD (%): Controls the maximum kW load level that the generator set will operate at when paralleled with the utility (mains). The value shown indicates the steady state load on the generator as a percent of the generator set standby rating.

Check generator set ratings for maximum load level at which the generator set should operate when paralleled with the utility (mains). Extended operation at load levels in excess of the generator set rating can cause abnormal engine wear or premature engine failure.

PF LEVEL: Adjusts the power factor that the generator set will run at when paralleled to the utility (mains). Recommended setting is 1.0.

KW GOVERN GAIN: Controls the rate that the generator set kW load is increased after the generator set has closed to the system bus when utility (mains) paralleled. Decreasing this value will result in slower loading of the generator set.

KW INTEGRAL: The kW integral adjustment is used to control the response of the generator set to large load changes when utility (mains) paralleled. Use of a higher integral value will result in slower response, and reduced kW overshoot on load assumption or rejection, especially on large system load changes. Decreased integral values will also result in slower load acquisition and rejection.

KVAR GOVERN GAIN: Controls the rate that the generator set kVAR load is increased after the gen-

erator set has closed to the system bus when utility (mains) paralleled. Decreasing this value will result in slower loading of the generator set.

KVAR INTEGRAL: The kVAR integral adjustment is used to control the response of the generator set to large load changes when utility (mains) paralleled. Use of a higher integral value will result in slower response and reduced kVAR overshoot on load assumption or rejection, especially on large system load changes. Decreased integral values will also result in slower load acquisition and rejection.

RAMP LOAD TIME: This is the ramp time from present set load to level determined by the load set analog input. This is active when the control first enters the load govern mode.

RAMP UNLD TIME: This is the ramp time from present set load to the 0 kW. This ramp is active when the load set analog input is less than 0.5 volts.

MULTIPLE/SINGLE: This selection modifies the sequence of operation and functions of the inputs and outputs of the control on TB1 to allow for application of the control in multiple generator set applications ("Multiple" selection), where generator sets are paralleled to each other and may also be paralleled to a utility (mains) service; or for applications where a single generator set is used with a breaker pair for closed transition power transfer functions ("Single" selection). See *Table 5-3* for a description of the operation and use of TB1-51 input.



Multiple – In the MULTIPLE configuration, the control is set up for proper operation in a system where the gensets are configured similar to that shown in Figure 5-3 or 5-4. In these illustrations, 52-Gn are the paralleling circuit breakers and 52-Fn are feeder circuit breakers that provide generator set power to load transfer devices. 52-U is a utility (mains) circuit breaker and 52-GM is a generator bus main breaker. 52-U and 52-GM provide power transfer func-

tions in the system.

Upon receiving a start signal, the gensets automatically start, select one generator set in the system to be the first one to close to the bus using the First Start Sensor system, synchronize, and load share. Upon receiving a signal to the control that the generator sets are closed to the utility (mains), the generator sets automatically ramp to their preset base load level.

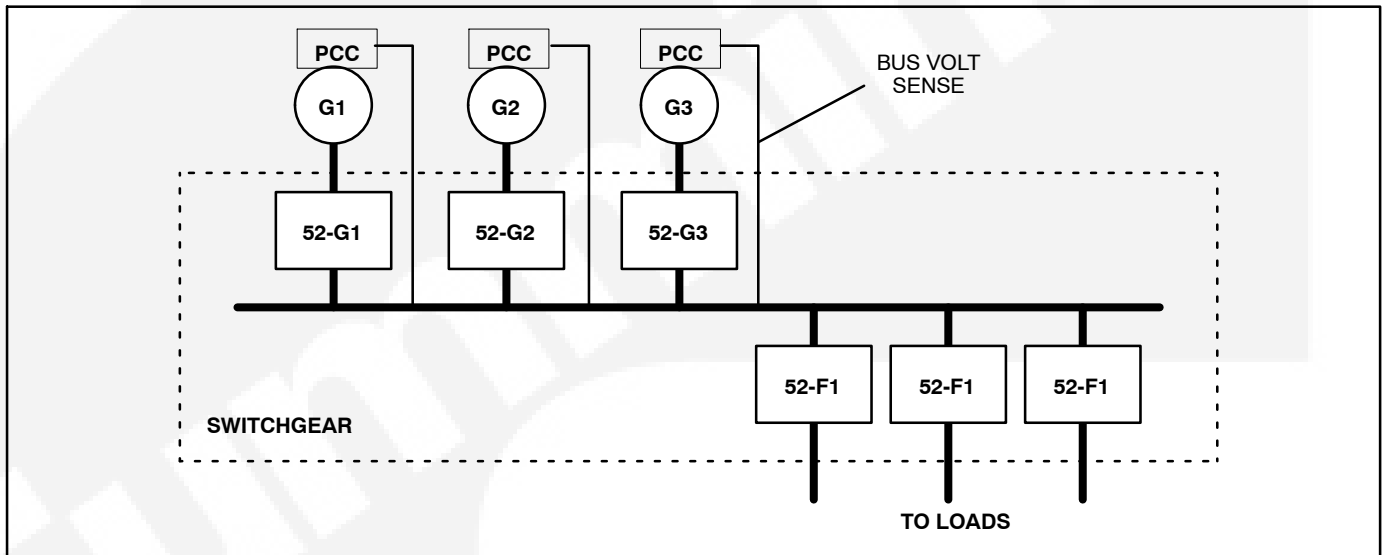

FIGURE 5-3. TYPICAL MULTIPLE CONFIGURATION

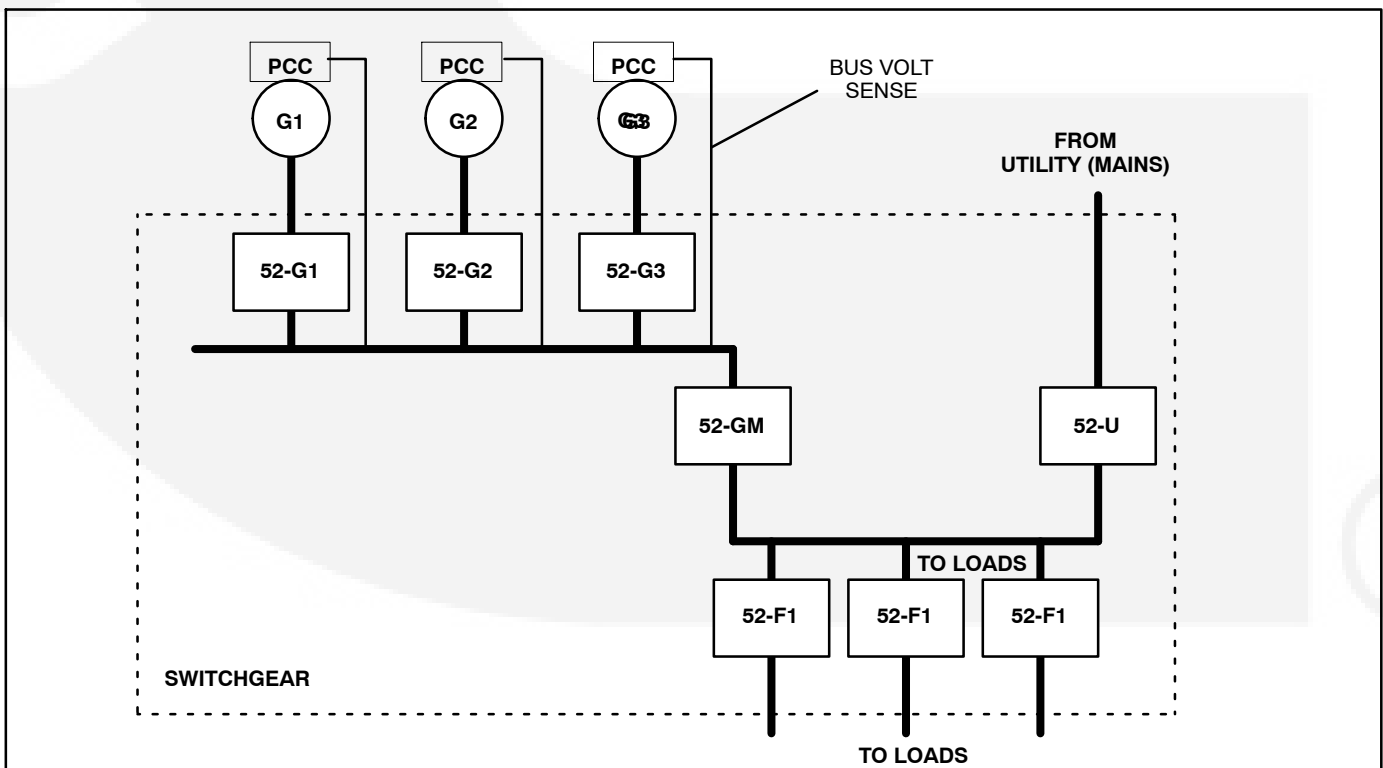

FIGURE 5-4. TYPICAL MULTIPLE CONFIGURATION

Single – The SINGLE configuration (limited to ONLY the electrical configuration shown in Figure 5-5) allows for incorporation of a single PowerCommand generator set in a power system that provides load transfer functions and various utility paralleling functions. In the SINGLE configuration, PowerCommand provides all the generator set control functions including synchronizing, load govern (import/export control and var/PF control), and genset breaker control functions; equipment provided by others provides utility (mains) breaker control, utility source sensing, and other functions.

The PCC monitors the position of the generator set breaker (52-G1) and the utility (mains) breaker (52-U). In a black start condition, the generator set receives a start signal from a remote device. If the PCC senses no voltage available on the bus voltage connection and the utility (mains) breaker is open, it closes the generator set breaker.

When utility (mains) power returns, the remote device turns on the synchronizer in the PCC, the PCC synchronizes the genset-to-utility (mains) service, and the remote device closes the utility (mains) breaker (52-U). When the PCC senses that 52-U is closed, it checks the voltage on the external load set terminals (TB1-59 and 60) and ramps to the commanded load level. The remote device control system determines when to open the genset breaker by removing the start signal from the genset control. When it is removed, the genset ramps down to zero load and opens the genset breaker (52-G1).

If the generator set receives a start signal when the utility (mains) service is available, the generator set starts and accelerates to rated voltage and frequency. It automatically synchronizes and closes its breaker. When the generator breaker is closed, the generator set ramps to the load level commanded by the signal on the external load set terminals (TB1-59 and 60).

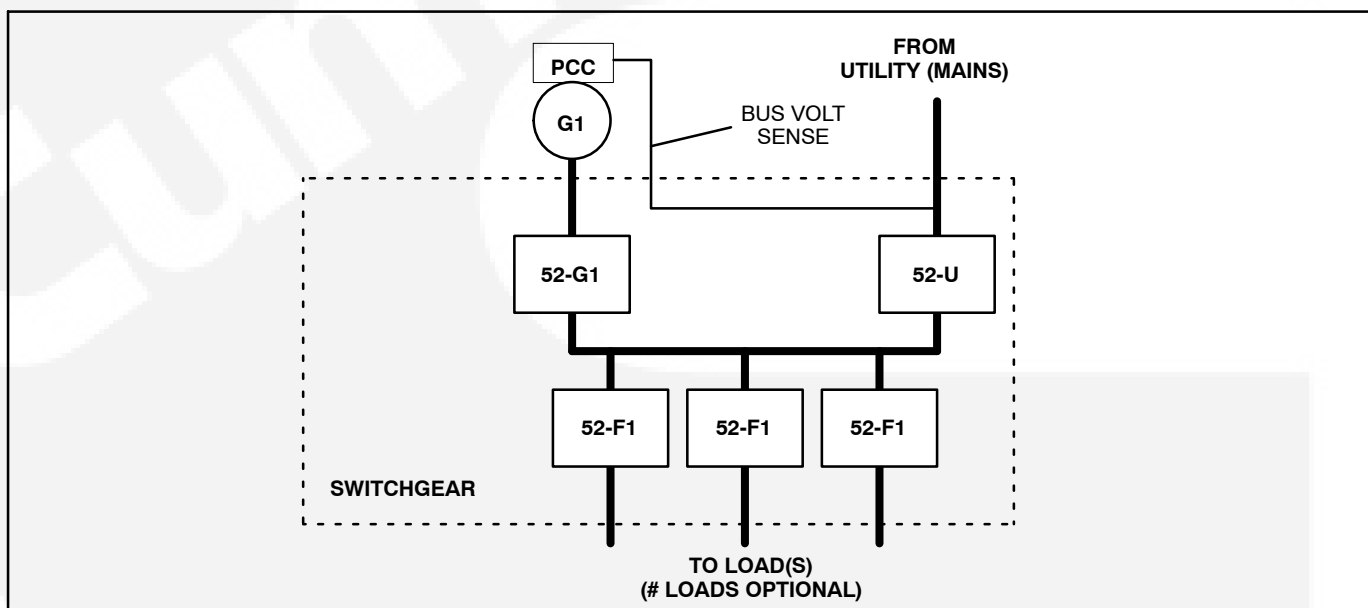
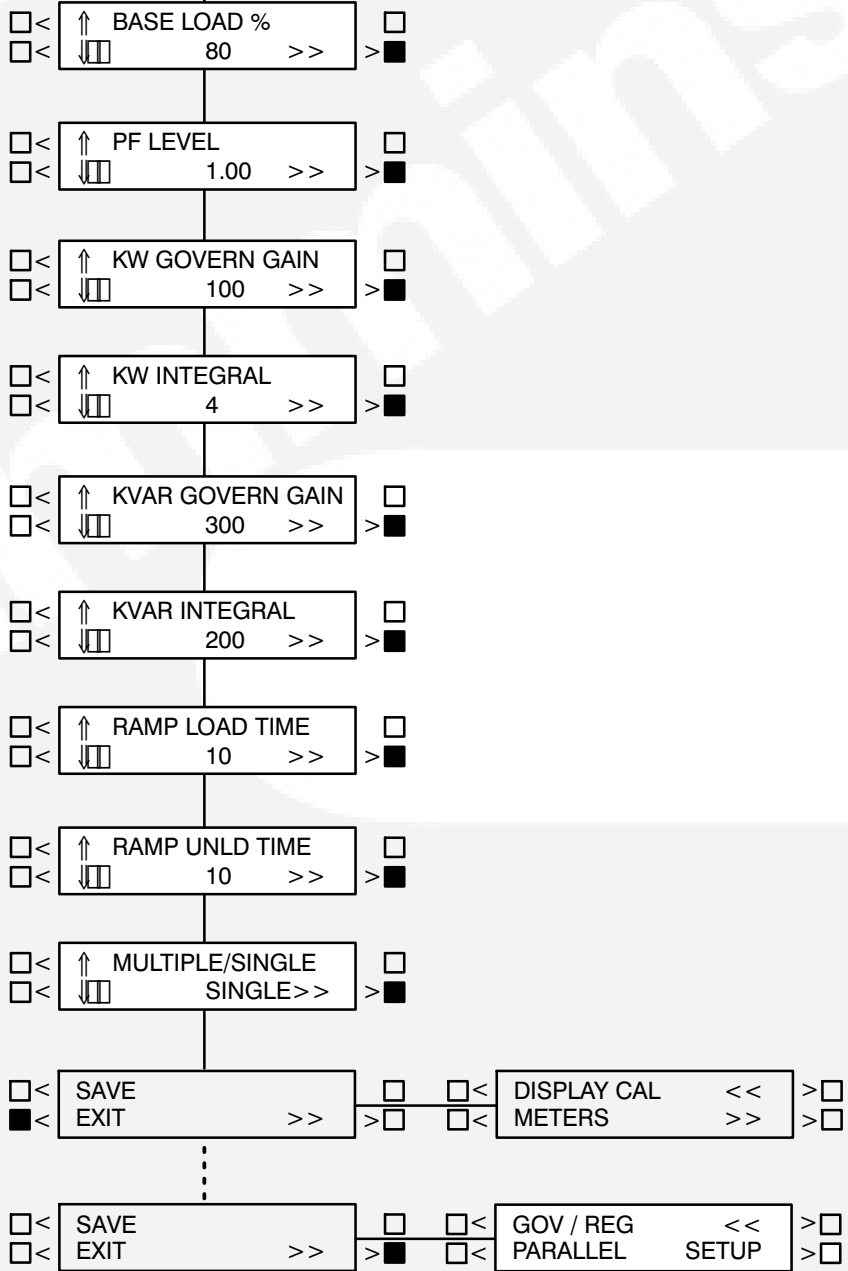

FIGURE 5-5. UTILITY-SINGLE CONFIGURATION

PARALLELING SETUP MENU (Cont.)

B (CONTINUED)



--- Indicates "OR" Condition

CALIBRATION PROCEDURE

⚠ WARNING *Contacting high voltage components can cause electrocution, resulting in severe personal injury or death. Calibration and adjustment must be performed by technically qualified personnel only. Read and observe all WARNINGS and CAUTIONS in your generator set manuals.*

⚠ CAUTION *Improper calibration or adjustment of the PowerCommand control can cause equipment malfunction or damage. Calibration and adjustment must be performed by technically qualified personnel only.*

The calibration procedure is divided into 7 subsections, with the subsections arranged in a specified order. If two or more of the following subsections are required to calibrate the PCC, they must be completed in the order shown.

When removing and replacing a defective circuit board, you may have to perform one or more of the following subsections. Table 5-1 (Control Panel Recalibration) provides a list of the circuit boards that require calibration when replaced and the calibration procedure(s) that must be performed.

Use a calibrated RMS multimeter for accurate measurements. Fluke models 87 or 8060A are good choices.

Initial Start Setup

1. Refer to Page 5-4, which describes how and when you should perform this procedure.

To verify if the PCC is set to operate with a specific generator set, refer to the *VERSION* menu (Page 5-9). This menu will show the generator set model number, frequency, and kW rating. If any of these values are incorrect, you must perform the Initial Start Setup procedure.

Voltage and Frequency Adjustment

2. With the generator set OFF, attach a calibrated frequency/voltmeter to the AC output from L1 to L2.
3. Select *ADJUST* from the Main Menu (page 5-7) to display the *VOLTAGE* adjust menu.
4. Start the generator set and allow the generator set to reach normal operating speed.

5. Adjust *VOLTAGE* (generator set output voltage) so that the calibrated voltmeter reads the desired voltage. (Use a calibrated voltmeter because the value displayed on the PCC digital display may not be calibrated at this time; therefore, its accuracy is unknown.)
6. Select the Frequency adjust menu.
7. Verify that the frequency displayed on the calibrated meter is the desired frequency. If not, adjust to the desired frequency. (Note: If the frequency reading on the digital display is not the same as frequency shown on calibrated meter, there is an equipment malfunction.)
8. If no frequency or voltage adjustment was made, select EXIT. If an adjustment was made, SAVE, then EXIT.

Digital Voltage Display Calibration

The paralleling bus must be de-energized while voltage calibrations are performed. If this is not possible, disconnect and isolate bus voltage inputs to the Bus PT Module (A39) before attempting voltage calibration.

9. Select ">>" from the Main Menu (Page 5-9). From this menu proceed to the *VOLTS L12* menu (Page 5-11).
10. With the generator set OFF, attach a calibrated frequency/voltmeter to the AC output from L1 to L2.
11. Start the generator set and allow it to reach normal operating speed.
12. Calibrate voltage reading for *VOLTS L12* so that the reading on the digital display agrees with the calibrated voltmeter.
13. Shut the generator set OFF.
14. Repeat steps 10 through 13 for L23 and L31. (In step 10 attach meter to the AC output from L2 to L3 to calibrate *VOLTS L23* and then L3 to L1 to calibrate *VOLTS L31*.)
15. If no calibration was made, select EXIT. If a calibration was made, SAVE, then EXIT.

Digital Ammeter Display Calibration

16. Select ">>" from the Main Menu (Page 5-9). From this menu proceed to the *AMPS L1* menu (Page 5-11).
17. With the generator set OFF, attach a calibrated ammeter to L1.

18. Start the generator set and allow it to reach normal operating speed.
19. Load the generator set to maximum rated kVA at rated voltage.
20. Calibrate the reading for *AMPS L1* so that the reading on the digital display agrees with calibrated ammeter.
21. Repeat steps 17 through 20 for *L2* and *L3*. (In step 17, attach meter to *L2* to calibrate *AMPS L2* and then *L3* to calibrate *AMPS L3*.)
22. If no calibration was made, select EXIT. If a calibration was made, SAVE, then EXIT.

Digital Power Factor Display Calibration

Power factor calibration is not required except in applications requiring a higher accuracy than $\pm 5\%$. If the $\pm 5\%$ accuracy is not acceptable, further calibration will require reactive load sufficient to reach 0.8 PF at rated load, and calibrated instruments with $\pm 1\%$ accuracy or better. Typical load rack instruments are not accurate enough to perform this procedure.

23. Select ">>" from the Main Menu (Page 5-9). From this menu proceed to the *PF1* menu (Page 5-11).
24. With the generator set OFF, attach the power factor meter to *L1*.
25. Start the generator set and allow it to reach normal operating speed.
26. Load the generator set to maximum rated kVA at rated voltage.
27. Calibrate the reading for *PF1* so that the reading on the digital display agrees with power factor meter.
28. Repeat steps 24 through 27 for *L2* and *L3*. (In step 24, attach meter to *L2* to calibrate *PF2* and then *L3* to calibrate *PF3*.)
29. If no calibration was made, select EXIT. If a calibration was made, SAVE, then EXIT.

Digital Coolant Temperature Display Calibration

An engine sensor calibration tool is required to perform this procedure.

30. With the generator set OFF, replace the coolant temperature sender with the precision resistor provided in the calibration tool.
31. Select ">>" from the Main Menu (Page 5-9). From this menu proceed to the *COOLANT TEMP L* menu (5-11).

32. Calibrate the temperature reading to match the temperature indicated on the calibration tool.
33. Repeat step 32 for *COOLANT TEMP R* if the engine uses two sensors.
34. If no calibration was made, select EXIT. If a calibration was made, SAVE, then EXIT.

Digital Bus Voltage Calibration

35. Select ">>" from the Main Menu (Page 5-9). From this menu proceed to the *Bus Volts L12* menu (Page 5-11).
36. With the genset OFF, attach a calibrated frequency/voltmeter to the alternator AC output from *L1* to *L2*.

The paralleling bus must be de-energized while voltage calibrations are performed. If this is not possible, disconnect and isolate bus voltage inputs to the Bus PT Module (A39) before attempting voltage calibration.

37. Start the genset and allow it to reach normal operating speed and voltage.
38. Push the breaker close switch on the front of the PowerCommand control and verify that the paralleling breaker has closed by observing the closed lamp on the control panel and physical check of the breaker.
39. Calibrate the voltage reading for *Bus Volts L12* so that the reading on the digital display matches the reading on the calibrated meter.
40. Shut the generator set OFF.
41. Repeat steps 36 through 40 for *Bus Volts L23* and *Bus Volts L31*.
42. If no calibration was made, select EXIT. If a calibration was made, SAVE, then EXIT.

Analog meter calibration

43. Select ">>" from the Main Menu (Page 5-9). From this menu proceed to the *A-C VOLTS ADJ TO* menu (Page 5-13).
44. Start the generator set and allow the generator set to reach normal operating speed.
45. Calibrate the analog Voltmeter to the digitally displayed value.
46. Calibrate the analog % Amps meter to the digitally displayed value.
47. Calibrate the analog % Load meter to the digitally displayed value.
48. Calibrate the analog Frequency meter to the digitally displayed value.
49. SAVE, then EXIT.

ENGINE TORQUE ADJUSTMENT

The engine torque fuel limit is set in the PowerCommand control. This limit is adjustable (0% to +1% of duty cycle units, which corresponds approximately to 0% to +2% engine horsepower) through the digital display to compensate for engine/electronic variation. If the generator set is not providing the nameplate kilowatt rating, the torque limit can be adjusted with the following procedure.

1. Select ">>" from the Main Menu (Page 5-9). From this menu proceed to the *Torque Adjust %DC* menu (Page 5-17).

2. Start the generator set and allow it to reach normal operating speed.
3. Load the generator set to maximum rated kVA at rated voltage.
4. Adjust the torque limit up or down to achieve the proper generator set frequency, under maximum load.

If you select SAVE, the adjustments will be retained after shutdown, and will be in effect when the set is restarted. If you select EXIT without saving first, the adjustments will remain in effect until the generator set is shut down, but will be reset (and will not be in effect) when the set is restarted.



ACCESSORY BOX CONTROL COMPONENTS

The generator set accessory box (Figure 5-6) which is located on the backside of the control housing, contains components that provide connection

points for remote control and monitor options. The set can be equipped with one or more of the following components (customer terminal block TB1 is standard). Refer to Page 9-6 for typical connections to TB1.

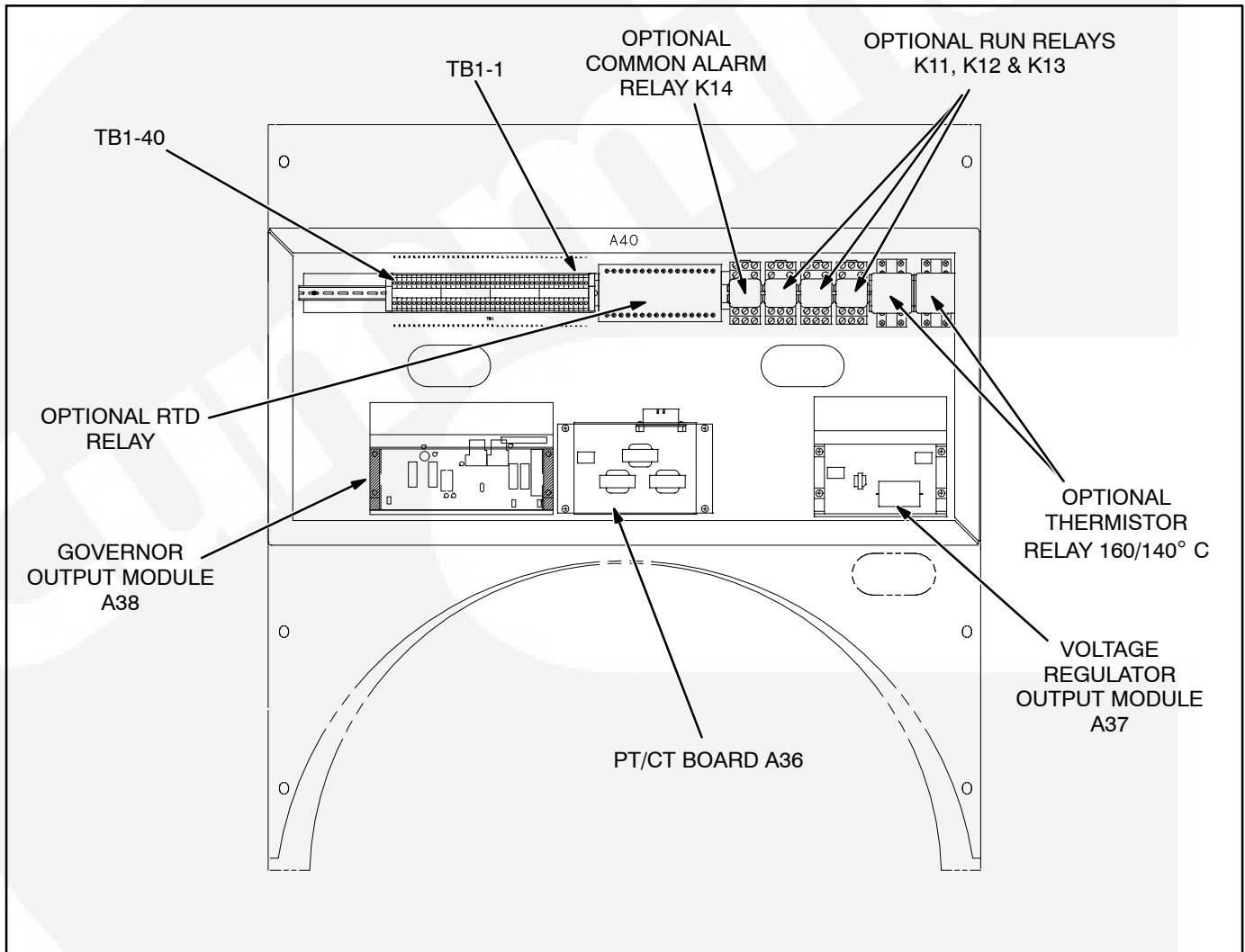

FIGURE 5-6. ACCESSORY BOX COMPONENTS

TABLE 5-3. A39/A40 TB1 CUSTOMER INPUTS

A39/A40 TB1 TERMINAL #	FUNCTION	DESCRIPTION
A39	1, 2, 3, 4	Bus PT Input (On Bus PT Module)
A40	5	Remote Start
	6	Remote Emergency Stop
	16 – 19	Customer Fault
	20	Fault Reset
	21	Engine Idle
	22	Low Fuel
	35	Rupture Basin Alarm
	41, 42	Common Alarm Warning
	46	Utility Parallel Signal
	47	Utility Parallel Signal
	50	Master First Start/Synchronizer Enable
CONTINUED		

TABLE 5-3. A39/A40 TB1 CUSTOMER INPUTS (Cont.)

A39/A40 TB1 TERMINAL #		FUNCTION	DESCRIPTION
A40	51	Load Demand	Close to ground to initiate load demand mode in PowerCommand control. (Select "Multiple" in Paralleling Setup Menu to enable load demand mode.)
	51	Utility Single Verify	For single generator set utility (mains) applications ("SINGLE" selected in the Paralleling Setup Menu), this terminal must be connected [strapped] to ground to enable breaker closure. (Version 1.07, beginning 9-26-96 only.)
	52	Breaker Open / Inhibit	Close to ground to manually open the paralleling breaker or inhibit breaker closure.
	53	Breaker Position	Close to ground to indicate breaker closed.
	54, 55	kVAR Load Share	Load Sharing Lines. Connect to load sharing lines in other generator sets in the system.
	56, 57	kW Load Share	Load Sharing Lines. Connect to load sharing lines in other generator sets in the system.
	59, 60	External Load Set	Analog 0 – 5 VDC input to control kW load level on generator set when the generator set is paralleled to utility.

Remote Start: When the Run/Off/Auto switch is in the Auto position, grounding this input initiates the engine cranking and start sequence. This circuit must be opened to permit resetting a shutdown condition with the Reset input.

Low Fuel: Grounding this input actuates the Low Fuel warning. This input can be connected to a local day tank or to a main fuel tank that is located on site. When the switch grounds this designated input, the input will "wake up" the control, if it is not operating, and then initiate the fault.

Customer Fault Inputs 1 through 4: Grounding any one of these inputs activates the corresponding warning or shutdown sequence. Warning or shutdown status is selected in the setup menu.

External sensing equipment must be connected to the designated digital input.

The four customer fault messages can be separately edited in the setup menu to display any desired message. This allows each customer "default" fault

message to be customized to represent the type of device that is attached to the fault input.

Customer Fault 1 (A40 TB1-16) is reserved for the RACK POSITION fault. Do not modify this fault name or change the fault condition (Warning to Shutdown).

The "default" message that is displayed, when ground is applied to the input, is as follows:

- Fault 1 = RACK POSITION
- Fault 2 = GRND FAULT
- Fault 3 = DAY TANK
- Fault 4 = HIGH GEN TEMP

If Fault 2 or 3 input is grounded, the control will "wake up" if it is not operating, and then initiate the fault.

Fault Reset: When the Run/Off/Auto switch is in the Auto position and the remote start switch is open, grounding this input resets any warning and latched shutdown fault (except Emergency Stop, which must be reset at the front panel.)

Engine Idle: When the set is operating in the RUN mode, grounding this input causes generator build up to be inhibited and the engine to be governed at 800 RPM. When ground is removed from this input, the set returns to normal speed and voltage.

Engine idle operation is applicable only in the RUN mode. The PCC operating program does not permit engine idle operation when the set is operating in AUTO mode.

When the engine idle function is enabled, the control automatically sets lower oil pressure warning and shutdown trip points to reflect the lower operating speed. When the engine idle function is removed and the set reverts to normal operating speed, the control automatically resets oil pressure warning and shutdown trip points to the normal settings.

Remote Emergency Stop: Grounding this input causes an immediate shutdown. Emergency stop must be reset at the front panel.

Master First Start/Synchronizer Enable: This input is received from a Master First Start Sensor, which is mounted remotely from the PowerCommand control. The input is a pulsed signal which is used by the PowerCommand control to enable safe closing of the paralleling breaker when the system bus is de-energized. The control will receive a pulse from the Master First Start Sensor approximately once per second. If the PowerCommand control does not receive a pulse within the programmable time delay (default is 10 seconds), the FIRST START warning is displayed by the control and a backup system is enabled by the control.

When the system is set up for paralleling a single generator set with a utility (mains) bus, this input is

used to enable the synchronizer in the PowerCommand control. (See Paralleling Setup Menu, path B.) A 24VDC signal applied to the terminal will cause the generator set to synchronize with the voltage reference signal applied to the bus PT module (A39).

All PCC's in a system should be programmed to a different first start fail time. This will help prevent simultaneous closure of breakers in the event of a failure of the master first start module

Load Demand: On receipt of a signal on the Load Demand terminals (normally open, close to ground), the generator set will ramp down to a minimum load level and the paralleling breaker will open. The generator set will run for a cool-down period and shut down. LOAD DEMAND SHUTDOWN will be displayed on the PowerCommand panel.

When the Load Demand input is removed, the generator set will start, synchronize and close to the system bus and accept its proportional share of the total load on the bus.

The Load Demand function of the PowerCommand control is only active when the RUN/OFF/AUTO switch is in the AUTO position and "PARALLEL" is selected in the Paralleling Setup Menu.

Utility Single Verify: For single generator set utility (mains) applications, this input must be strapped to ground before the generator set breaker will close when the utility breaker is opened.

The Load Demand function of the PowerCommand control is only active when the RUN/OFF/AUTO switch is in the AUTO position and "SINGLE" is selected in the Paralleling Setup Menu.

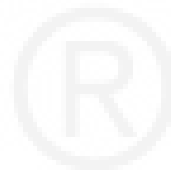

Utility (Mains) Parallel Input: Closure of a normally open contact to ground on terminal 47 and applying a 24VDC signal to terminal 46 will cause the PowerCommand control to begin operation in a utility (mains) paralleling mode. The ground signal is usually applied by operation of auxiliary contacts in the utility paralleling breaker. In this operation mode, the control will ignore inputs from the load sharing lines and operate at the load level which is determined by the magnitude of the Load Govern signal and the base load adjustment in the control setup.

Load Govern: This input is enabled when the control has received a utility (mains) parallel input. A 0–5V signal applied to terminals 59 and 60 will direct the control to operate the genset at a fraction of the preset base load (%). Operating load level is determined by the formula:

$$31.4 * (\text{Load Set Voltage} - 1) = \% \text{ kW load}$$

For Load Set Voltage of 1.0 volts and lower, the genset will ramp to no load. For Load Set Voltage levels 4.5 volts and higher, the genset will be controlled to the preset base load.

A change in the Load Set Voltage will cause the genset to ramp to the new commanded kW level. Ramp rate is controlled by Ramp Load Time and Ramp Unload Time. (See *Utility (Mains) Adjustments* elsewhere in this section.) In the load govern state, kVar load is always a function of the preset power factor and the % kW load.

Parallel Breaker Open/Close Inhibit: This function is operational only when the RUN/OFF/AUTO switch is in the AUTO position. Closing a normally open contact to ground on this contact will cause the paralleling breaker to open if it is closed, or prevent it from closing if it is open. Removing the ground signal will cause the PowerCommand control to return to normal operation.



Operating PowerCommand in Droop Mode

The PowerCommand control is designed to operate isochronously (with no intended droop) so that voltage and frequency are as constant as possible when the generator set is paralleled to other PowerCommand generator sets. In certain situations, however, such as paralleling with other generators that are operating in droop mode, it may be necessary to operate the control in a droop mode for frequency, voltage, or both.

Note that when the generator set is paralleled to a utility (mains) service it is recommended that the control be operated in its utility parallel mode, rather than in droop, even if other generator sets in the system operate in droop for that function. The droop mode in PowerCommand will only work when all the other generator sets in the system are operating in droop and the system bus voltage and frequency change with load.

PowerCommand controls that are set up to operate in droop mode must include the paralleling option (H532). The generator set should be set up for multiple unit paralleling, but load sharing interconnecting wiring is not used. Connect a 5K resistor across terminal A40-TB1-54 and 55 (KVAR) to cause voltage to droop. A 5K resistor across terminal A40-TB1-56 and 57 (KW) will cause frequency to droop. Resistors can be used on one or both of the load sharing terminal connections, depending on the needs of the application.

Complete all start up procedures as described in *Section 8* of this manual up to the point that you are ready to make load sharing adjustments. To set the

governor and voltage regulation system droop level:

1. Set the no load speed and voltage at the desired level. Bus must be de-energized when this setting is made, or disconnect Bus PT module.
2. Apply 100% load to the generator set, and adjust the KW load sharing gain to obtain the desired full load operating frequency. Adjust the KVAR load sharing gain to obtain the desired full load operating voltage. Refer to Figure 5-7 for typical gain settings for specific droop levels.
3. Repeat the process for other generator sets in the system.
4. When initial settings have been made, test the system with all available load, and verify that the generator sets share load approximately equally at no load and maximum available load.

Proper adjustment of load sharing in droop operation requires use of both real and reactive load banks. It is possible that precise load sharing will not be possible with all generator sets in the system at all load levels, due to the non-linearity of the droop characteristic of some generator sets. In that case, it is generally best to set up the system so that available load is equally shared at the maximum load level expected on the system. Note also that the synchronizer is active and functional in PowerCommand even when the system is set up for droop load sharing. Manual paralleling and system synchronizing should be performed by the PowerCommand control. It is recommended that paralleling breakers be electrically operated by the PowerCommand control.



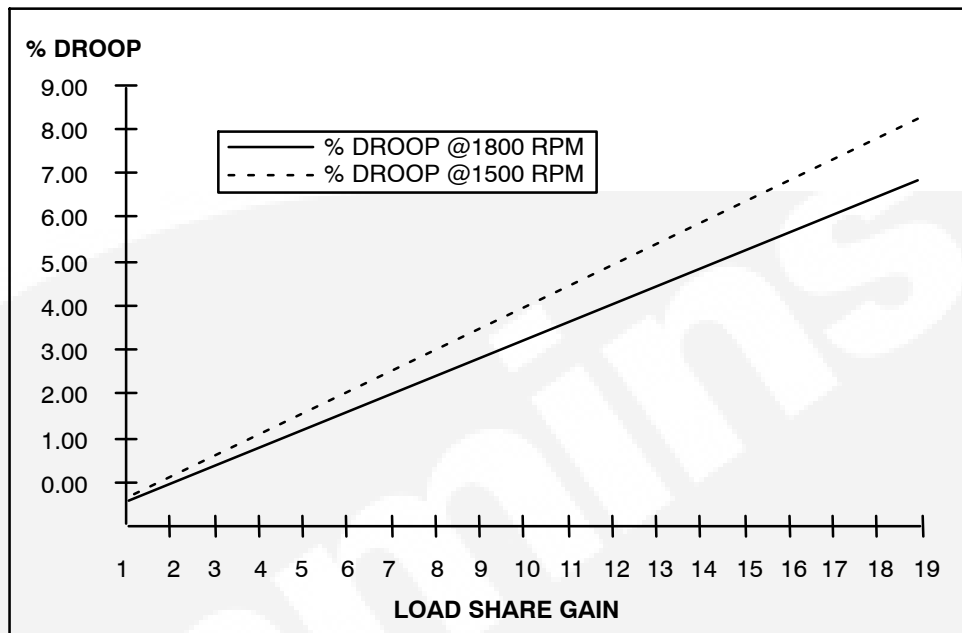

FIGURE 5-7. PERCENT SPEED DROOP VERSUS KW LOAD SHARE GAIN



TB1 Customer Outputs

Refer to Page 9-9 for typical connections to TB1.

TABLE 5-4. TB1 CUSTOMER OUTPUTS

TB1 TERMINAL #	FUNCTION	DESCRIPTION
1	B+ Auxiliary Power	24 VDC control power supply, fused at 20 amps.
2	Switched B+ Auxiliary Power	24 VDC control power available when genset is running, fused at 10 amps.
3, 4	Ground	
7, 8, 9	Common Shutdown	Form C contact set to indicate to a remote device that a generator set shutdown fault has occurred.
10, 11 N-K20	Parallel Breaker Close Signal	Normally open contact which closes to close a remote paralleling breaker.
14, 15	Network Data	Terminations for network data twisted pair, operational when generator set is equipped with generator control module (GCM).
23-32, 33	NFPA Fault Contacts	Normally open contact which closes to indicate that a specific fault has occurred in the generator set. Common is terminal 33.
38, 40	Ready to Load	Indicates that the generator set is at rated frequency and voltage and is ready to accept load. Normally open contact between 38 and 40, which is common.
39, 40	Load Dump	Normally open contact which closes to indicate that the generator set is overloaded.
41, 42	Common Warning	Normally open contact that closes to indicate a warning condition on the generator set.
43, 44	Common Warning	Normally closed contact that opens to indicate a warning condition on the generator set
48, 49 N-K21	Parallel Breaker Open Signal	Normally closed contact which opens to close the paralleling breaker.

Paralleling Breaker Control: Contacts are provided to allow the PowerCommand control to operate a remote paralleling circuit breaker. A normally open contact will close to signal the paralleling breaker to close. A normally closed contact will open to open the paralleling breaker.

When the RUN/OFF/AUTO switch is in the RUN position the breaker signals will be initiated on operation of the paralleling breaker control switches on the front panel of the PowerCommand control. The breaker control switches on the front panel of the control are not operational in other control operation modes.

When the RUN/OFF/AUTO switch is in the AUTO position, the PowerCommand control will automatically close the paralleling breaker if the system bus is de-energized and the master first start sensor pulse is received, or if synchronous condition with the bus is achieved.

Warning Alarm: One set of normally open (NO) and one set of normally closed (NC), rated for 2 amps at 30 VDC. Any warning causes the warning alarm relay (labeled Spare Relay on Customer Interface board) to be energized. This output is often used to energize an audible alarm.

Common Alarm: One set of form-C contacts, rated for 2 amps at 30 VDC. Any shutdown causes the common alarm relay to be energized. This output is often used to energize an audible alarm.

Load Dump: One set of normally open (NO) contacts, rated for 2 amps at 30 VDC. If an overload occurs which causes generator set frequency to drop more than 3 hertz below nominal for more than 3 seconds, or a load of more than 105% of the standby rating is applied to the generator set for more than 60 seconds, the normally open load dump contacts are closed. This relay is energized before shutdown (for overload or underfrequency) occurs.

Ready To Load: One set of normally open (NO) contacts, rated for 2 amps at 30 VDC. This output is activated whenever AC voltage and frequency exceed 90% of nominal.

Switched B+: This is a fused 10 amp, 24 volt switched output. This output is activated by the run pilot signal, at the governor output module. (Fuse is located on Governor Output Module.)

B+: This is a fused 20 amp, 24 volt output. (Fuse is located on TB-BAT terminal block of the engine harness.)



Run Relays (K11, K12, 13)

The optional run relays are rail mounted inside the accessory box (Figure 5-6). The rail mount allows you to easily remove and replace the snap-on relays. The generator set can be equipped with one, two or three run relays.

The three-pole, double-throw run relays (Figure 5-8) are used to control auxiliary equipment such as

fans, pumps and motorized air dampers. The run relays are energized when the generator set reaches operating speed.

The contacts are rated:

- 10 amps at 28 VDC or 120 VAC, 80%PF
- 6 amps at 240 VAC, 80%PF
- 3 amps at 480/600 VAC, 80%PF

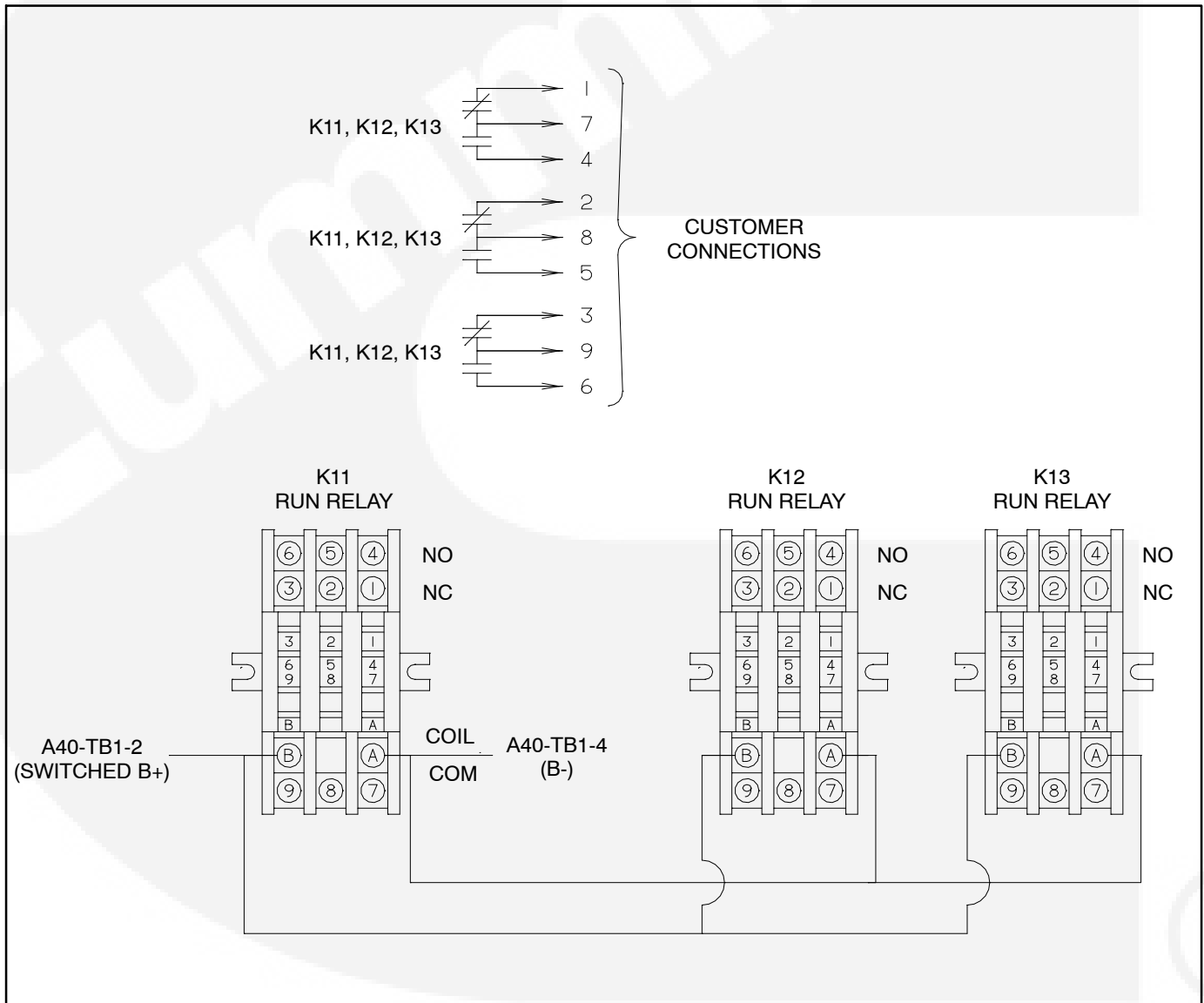

FIGURE 5-8. OPTIONAL RUN RELAYS (K11, K12, K13)

Shutdown Alarm Relay (K14)

The optional shutdown alarm relay is rail mounted inside the accessory box (Figure 5-6). The rail mount allows you to easily remove and replace the snap-on relay.

The three-pole, double-throw shutdown alarm relay (Figure 5-9) is often used to energize warning de-

vices such as audible alarms. Any generator set shutdown will energize the alarm relay.

The contacts are rated:

- 10 amps at 28 VDC or 120 VAC, 80%PF
- 6 amps at 240 VAC, 80%PF
- 3 amps at 480/600 VAC, 80%PF

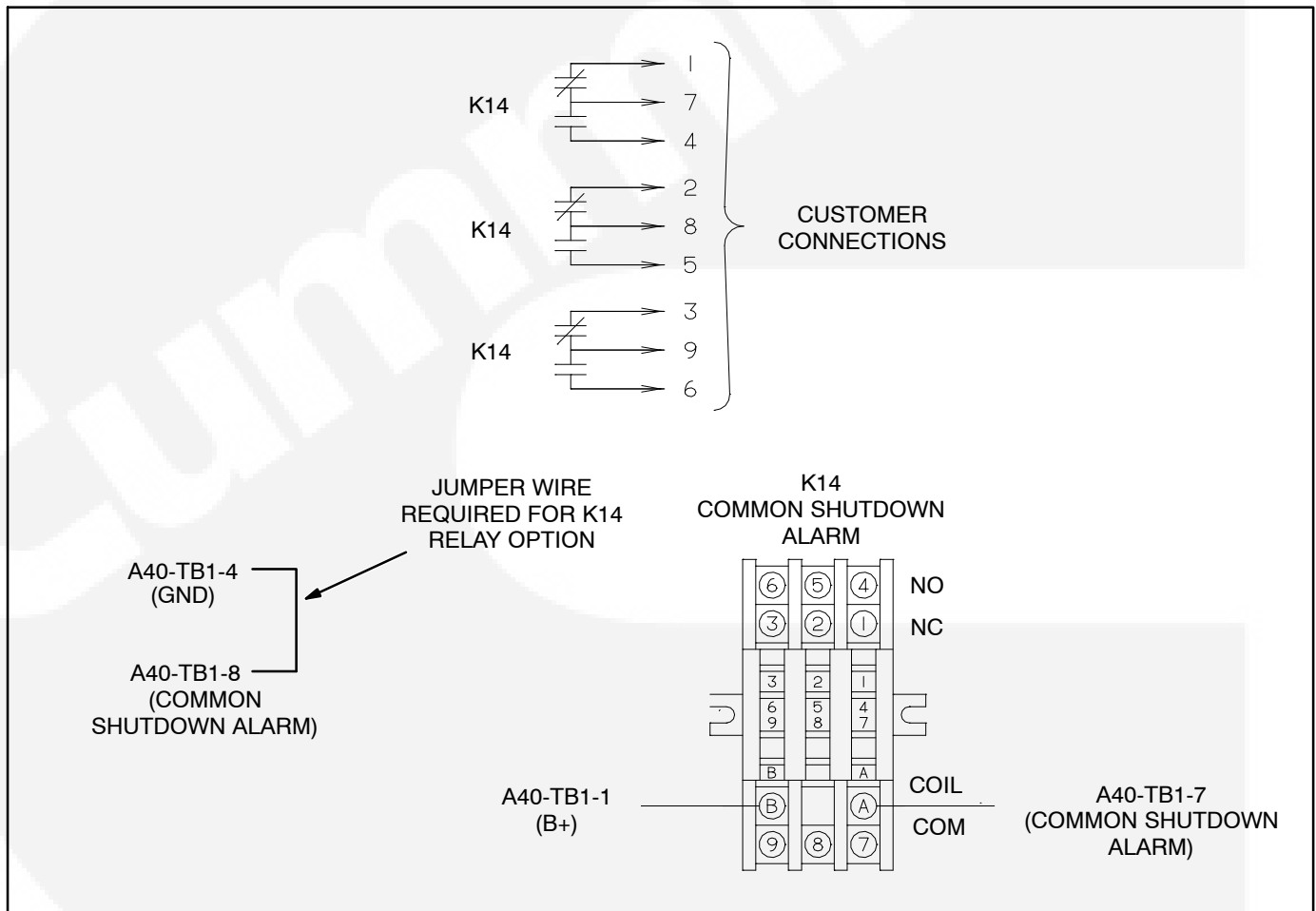

FIGURE 5-9. OPTIONAL SHUTDOWN ALARM RELAY (K14)

RTD Relay (Optional)

The optional RTD relay is rail mounted inside the accessory box (Figure 5-6). This relay is used to monitor six separate temperature zones in the generator windings using resistive temperature detectors (RTDs). The relay determines the sensed temperature and acts to isolate, alarm, or initiate corrective action.

The RTD relay (Figure 5-10) compares the six inputs to the predetermined setpoint (temperature setpoint is factory adjusted). If one or more of the inputs exceed the setpoint, the output relay is energized. LED's indicate the state of the output relay (green for normal, red for tripped). Additional red

LED's are used to indicate which inputs exceed the setpoint.

The relay terminals 11, 12 and 14 are for customer connection. These terminals can be attached to any one of the four Customer Fault inputs on TB1 to provide a warning/shutdown condition or to other customer warning devices. (Refer to *Setup Menu* in Section 7, which describes how to modify the customer fault message and to select a warning or shutdown condition.)

The contacts are rated:

- 240 VAC, 5 amps non-inductive
- 24 VDC, 25 amps resistive

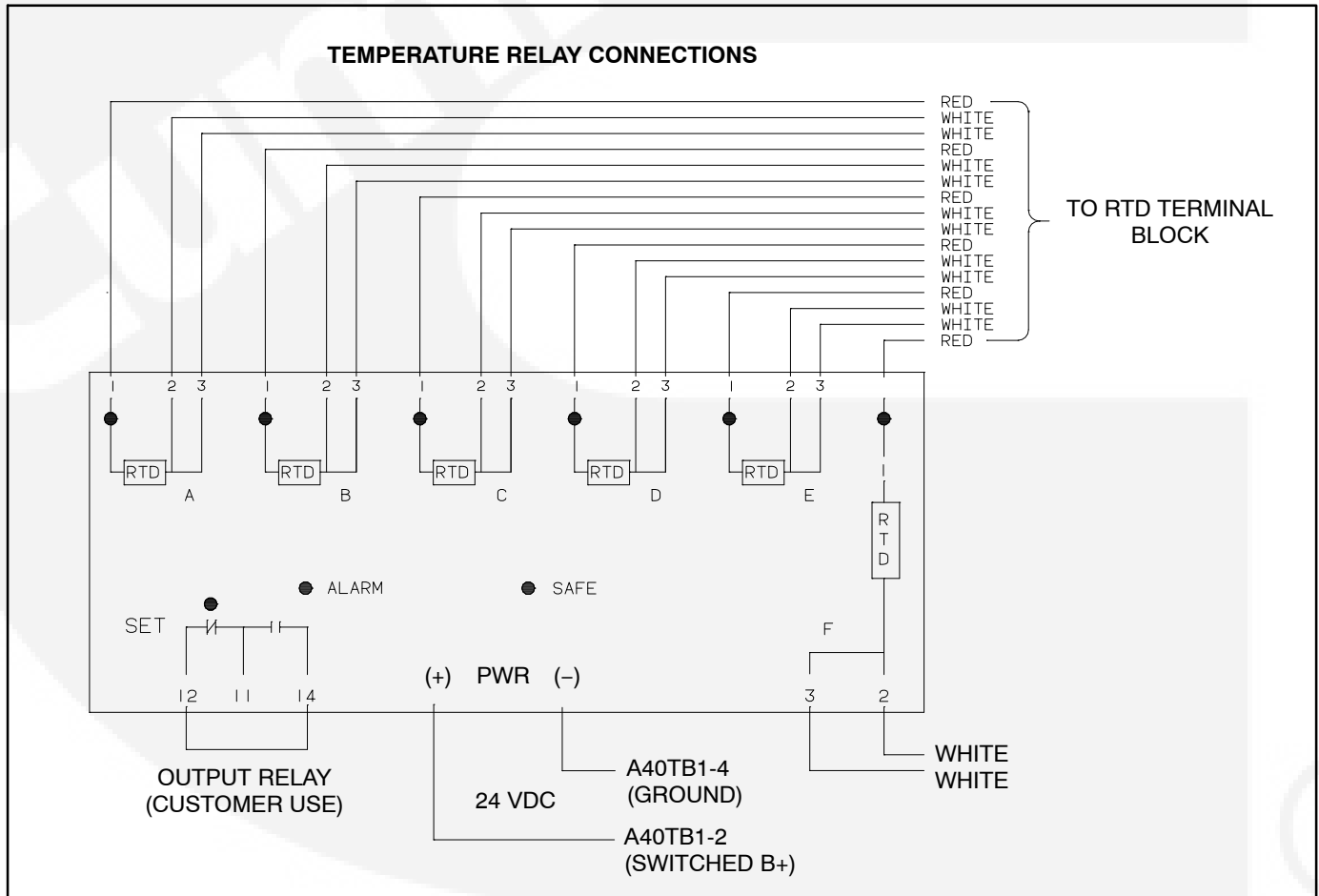

FIGURE 5-10. RTD RELAY (OPTIONAL)

Thermistor Relay (Optional)

The optional thermistor relays are rail mounted inside the accessory box (Figure 5-6). Each relay monitors three thermistors (one per phase) that are connected in series inside the generator. One series or chain of thermistors are rated at 140° C and the other at 160° C. The 140° C relay is commonly used in a pre-alarm circuit and the 160° C relay in a shut-down circuit. The relay will energize (trip)

when the thermistor chain resistance reaches 3000 ±500 ohms.

The relay terminals 1, 2 and 3 are for customer connection and are normally connected to a breaker shunt trip or a load shed circuit (Figure 5-11).

The contacts are rated:

- 3 amps at 250 VAC
- 1 amp at 480 VAC

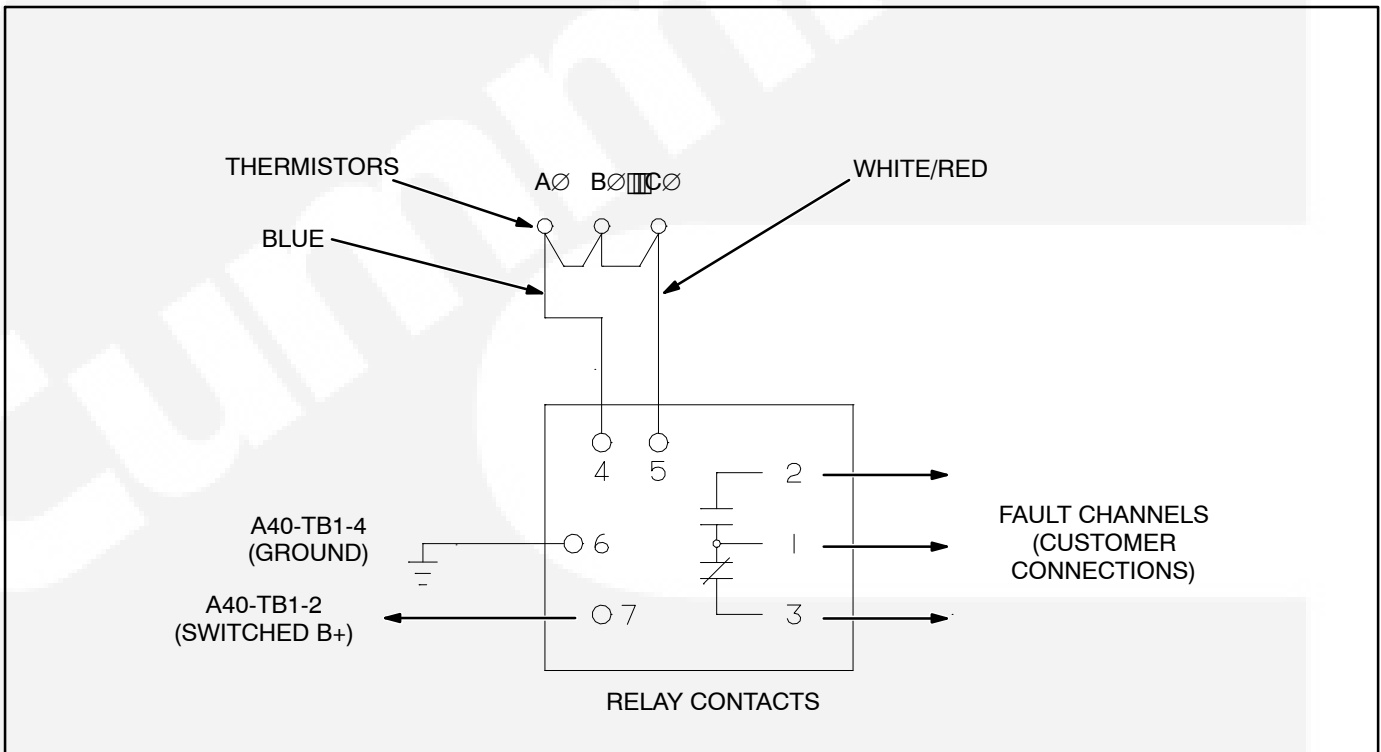

FIGURE 5-11. THERMISTOR RELAY (OPTIONAL)

ENGINE SENSORS

Figures 5-12 shows the locations of the oil and coolant temperature and oil pressure senders to which

the PCC responds. The switches function by closing the fault or warning circuit to the engine chassis ground (battery negative [-]). The low coolant level switch has its own ground wire.

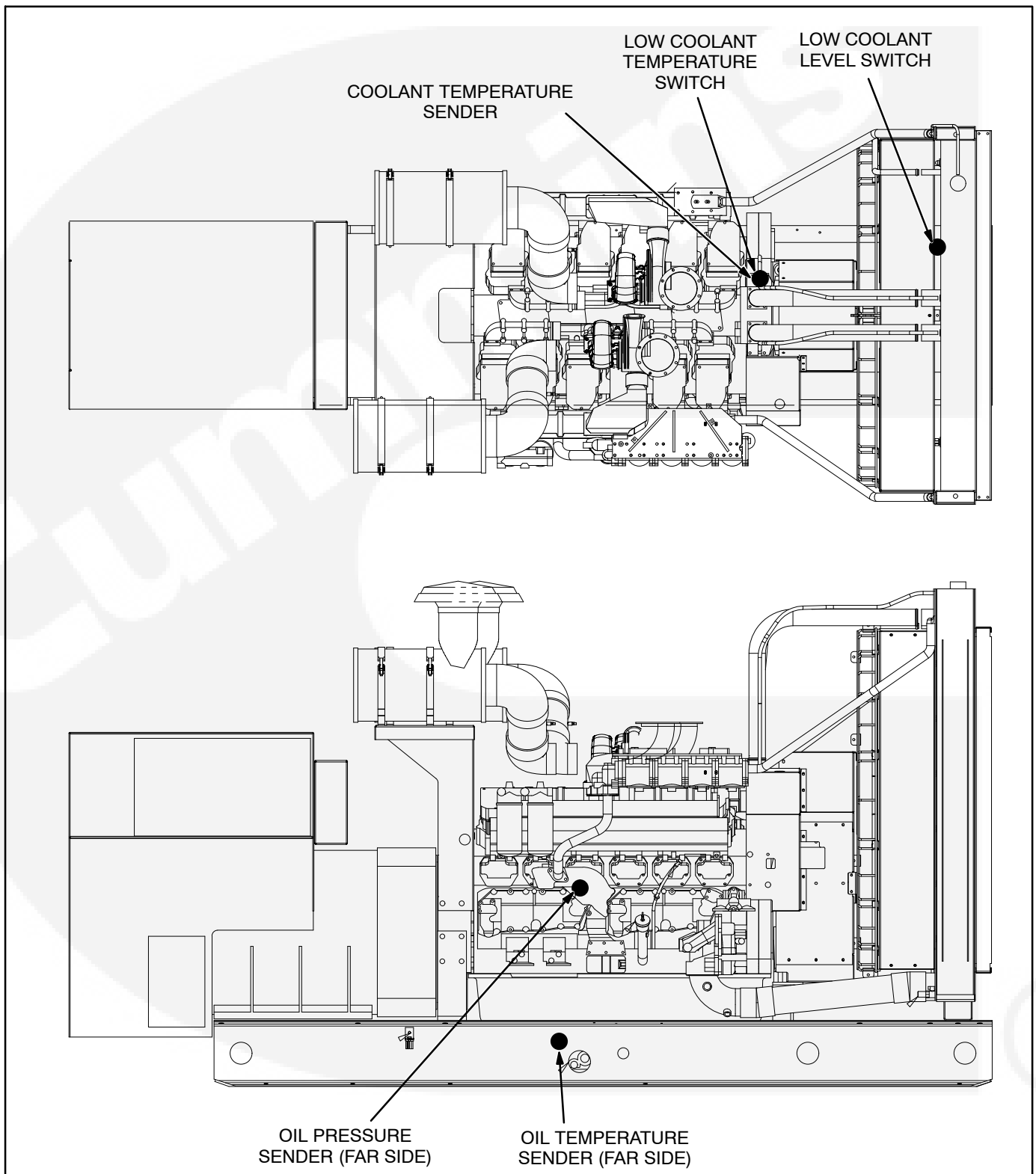

FIGURE 5-12. ENGINE SENSOR LOCATIONS

MAGNETIC SPEED PICKUP UNIT (MPU) INSTALLATION

To install the MPU sensor, bar the engine until a gear tooth on the flywheel lines up in the center of the mounting hole. Thread the sensor in gently by hand until it just touches the gear tooth. Back it out one quarter turn and set the locknut.

⚠ CAUTION *Do not use fan blade to bar over engine. That can damage blades and cause property damage and personal injury.*

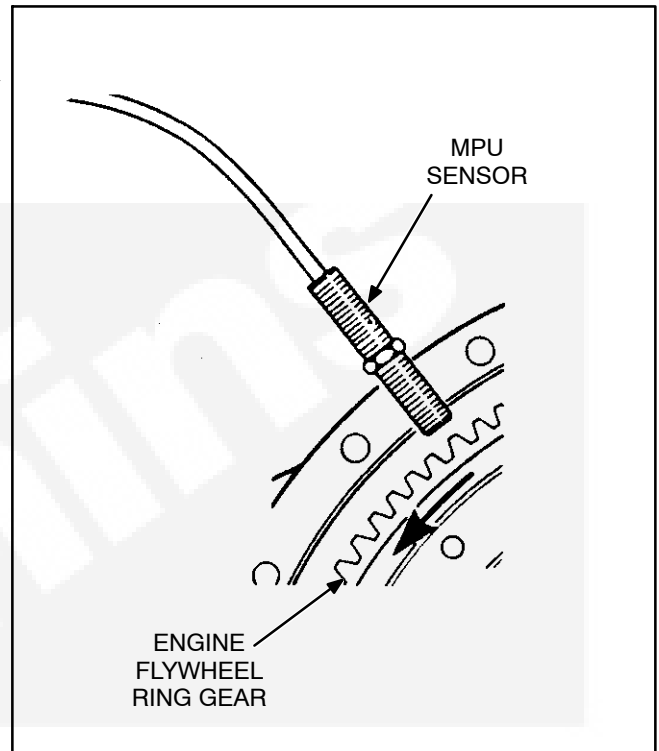

FIGURE 5-13. MPU SENSOR

CURRENT TRANSFORMER (CT) INSTALLATION

Current transformers (CT's) are required on generator sets that contain AC meters. The CT's must be installed as noted in the following *CT Installation Requirements*. Improper installation of CT's will cause a "335 Reverse Power" shutdown error.

Refer to the Reconnection Diagram to identify the output leads/phase that must be routed through each CT, and also appropriate transformer post selection for meter sensing leads. The transformers are labeled CT21, CT22 and CT23 on the reconnection wiring diagram. (The Reconnection Diagram is located on the upper side cover of the control housing.)

CT Installation Requirements

- A. The CT has a dot on one side. This dot must be facing toward the generator (conventional current flowing into the dot). A dot is also used to indicate pin 1 of the CT.
- B. CT21 – U load leads (A phase)
CT22 – V load leads (B phase)
CT23 – W load leads (C phase)
- C. Route the appropriate leads through each CT.
 - 6 lead generator sets – generator output leads are routed through the CT's.
 - 12 lead generator sets – load wires are routed through the CT's.
- D. Reconnectable generator sets (12 leads) have dual secondary CT's (3 pins). The CT secondary wire marked 1 is connected to pin 1 of the CT. CT secondary wire marked 2/3 is connected to pin 2 for high voltage generator sets or to pin 3 for low voltage generator sets. (Refer to Reconnection Diagram.)
Non-reconnectable generator sets (6 leads) have single secondary CT's (2 pins).
 - The lead from CT terminal #1 connects to the metering circuitry.
 - The lead from CT terminal #2/3 connects to ground.



DIGITAL BOARD (A32) CALIBRATION

The digital board (Figure 5-14) contains three resistors that are used to calibrate the digital board for different generator set models. One of these resistors may need to be removed in order to calibrate/initialize the PowerCommand control to the generator set model. Table 5-5 provides the necessary information to determine which resistor that may need to be cut to select the desired generator set model.

To find the exact genset model, spec. level and engine rating, refer to the engine data tag on the left bank intake manifold.

After the appropriate resistor selection is made, the PowerCommand control must be re-initialized. Refer to *Initial Start Setup Menu* in this section to initialize the PowerCommand control. When the initial setup save button is pushed, the PowerCommand control will compare the calibration selection (cut

resistor) to the initial setup and perform one of the following:

1. If the model numbers corresponding to the cut resistor and the initial setup are compatible, according to Table 5-5, the calibration is validated. The control will store the appropriate information based on calibration and initial setup data in EEPROM. The initial setup is now complete and the control can start the engine.
2. If the model number corresponding to the cut resistor and the initial setup are not compatible the control will display the fault “**INVALID SETUP**” (fault code 401). No initial setup data is saved and the control will not leave the initial setup menu until this fault condition is corrected.
3. If the control senses that more than one resistor has been cut, the control will display the fault “**INVALID CAL**” (fault code 402). No initial setup data is saved and the control will not leave the initial setup menu until this fault condition is corrected.

TABLE 5-5. DIGITAL BOARD (A32) CALIBRATION

STANDBY MODEL NUMBERS	ENGINE RATING	EPROM KIT P/N		RESISTOR REMOVED
		SINGLE	PARALLEL	
1000DFHD-60/900DFHD-50	QST30-G4	0300-4721-04	0300-4721-16	R38
1000DFHD-60/900DFHD-50	QST30-G5-NR1	0300-4721-04	0300-4721-16	R38
900DFHC-60/800DFHC-50 SPEC A-C	QST30-G3	0300-4721-35	0300-4721-40	NONE
900DFHC-60/800DFHC-50 SPEC D	QST30-G3	0300-4721-35	0300-4721-40	R38
800DFHB-60/700DFHB-50 SPEC A-D	QST30-G2	0300-4721-04	0300-4721-16	R36
800DFHB-60/700DFHB-50 SPEC E	QST30-G2	0300-4721-35	0300-4721-40	R37
800DFHB-60/700DFHB-50 SPEC E	QST30-G2-NR1	0300-4721-35	0300-4721-40	R37 & R38
750DFHA-60/620DFHA-50 SPEC A-D	QST30-G1	0300-4721-04	0300-4721-16	NONE
750DFHA-60/620DFHA-50 SPEC E	QST30-G1	0300-4721-35	0300-4721-40	R36
750DFHA-60/620DFHA-50 SPEC E	QST30-G1-NR1	0300-4721-35	0300-4721-40	R36 & R37

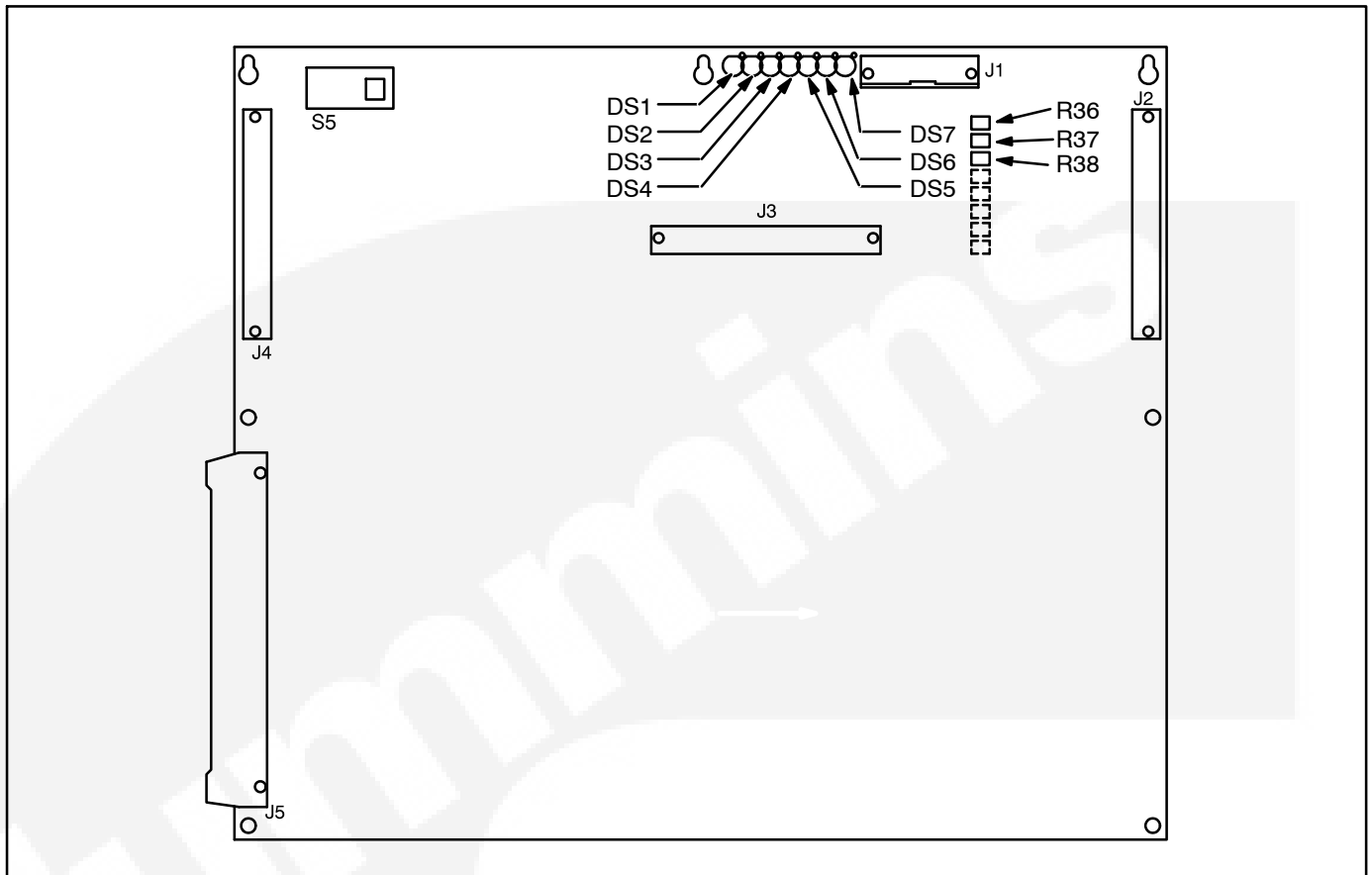

FIGURE 5-14. DIGITAL BOARD (A32)

6. Servicing the Generator

GENERAL

This section describes how to isolate a high AC voltage fault to the PCC control circuitry or generator, and the procedures to test, disassemble and reassemble the generator (Figure 6-1).

⚠️WARNING *Incorrect service or replacement of parts can result in severe personal injury or death, and/or equipment damage. Service personnel must be trained and experienced to perform electrical and mechanical service.*

⚠️WARNING **HAZARDOUS VOLTAGE.** *The PCC1301 control box must be opened only by technically qualified personnel. Voltages of up to 600 VAC are present in the PCC box. These voltages can cause electrical shock, resulting in personal injury.*

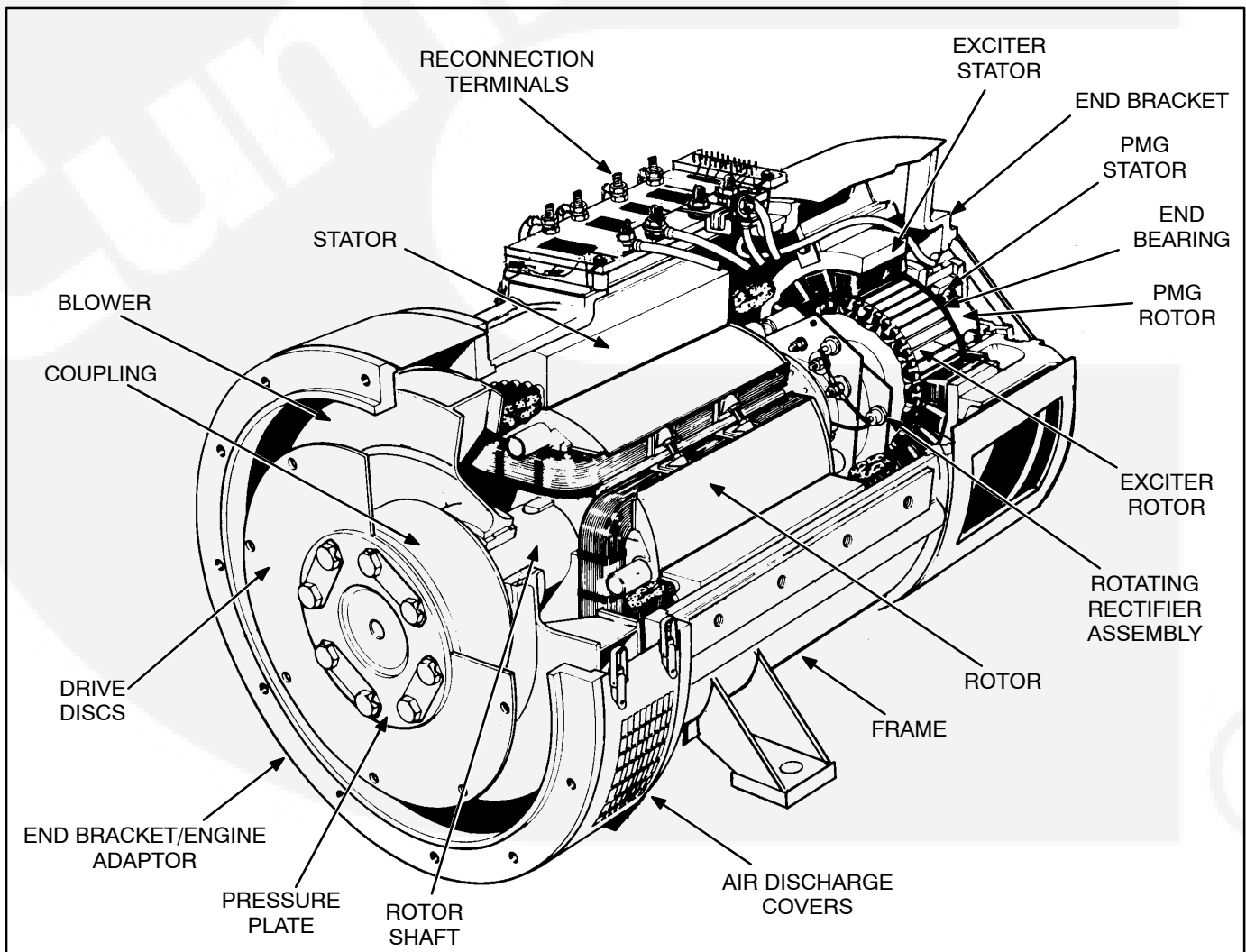

FIGURE 6-1. TYPICAL GENERATOR

GENERATOR/PCC CONTROL ISOLATION PROCEDURE

The following procedure is used to determine if the generator or the PCC control circuitry is causing a high AC voltage shutdown fault.

1. Throw the line circuit breaker **OFF** and shut down the set.

⚠ CAUTION *This test involves unregulated excitation of the generator. To prevent damage to the generator due to overcurrent, make sure that all loads have been disconnected and that all faults have been cleared from the power output terminals of the generator.*

2. Remove the housing cover of the accessory box and remove plug P10 from connector J10 of the voltage regulator output module (A37). See Figure 3-9.
3. Prepare to measure output voltage across the generator terminals while the set is running.
4. Bring two jumpers from a 12 volt battery for connection to the **X** (Field +) and **XX** (Field -) pins of plug P10.

X = Red wire of P10-6

XX = Brown wire of P10-3

Connect the jumper from the positive (+) post of the battery to the **X** pin (red wire) of P10-6. Be prepared to connect the jumper from the negative (-) post of the battery to the **XX** pin (brown wire) of P10-3. If one of the 12 volt cranking batteries is used, bring the jumpers from the battery connected on the grounded

side of the system to avoid inadvertently imposing 24 volts on the system.

5. Check polarity again. Polarity must be correct or this test will be inconclusive because the induced and residual magnetic polarities in the exciter stator will be opposed.

⚠ WARNING **HAZARDOUS VOLTAGE.** *Touching uninsulated high voltage parts inside the control box can result in severe personal injury or death. Measurements and adjustments must be done with care to avoid touching hazardous voltage parts.*

For your protection, stand on a clean dry wooden platform or clean rubber insulating mat, make sure your clothing and shoes are dry, remove jewelry and use tools with insulated handles.

6. Start the set and connect the jumper from the battery negative (-) terminal to the **XX** lead.
7. The generator circuitry is probably okay if rated output voltage or higher is obtained and the voltages for all phases are balanced when the exciter is powered by a 12 volt battery. Refer to *Section 4* to troubleshoot the PCC control circuitry. (Normal excitation voltage ranges from approximately 10 VDC at no-load to approximately 40 VDC at full-load.)
8. If the voltages are unbalanced, troubleshoot the main stator first. If the voltages are uniformly low, troubleshoot the exciter and field circuits first. Perform the *Winding Resistance Test* procedure for the desired windings as noted in this section.



TESTING THE GENERATOR

These tests can be performed without removing the generator. Before starting tests, disconnect the negative (-) cable from the battery to make sure the engine will not start while performing these tests.

⚠ WARNING *Ignition of explosive battery gases can cause severe personal injury or death. Arcing at battery terminals, light switch or other equipment, flame, pilot lights and sparks can ignite battery gas. Do not smoke, or switch trouble light ON or OFF near battery. Discharge static electricity from body before touching batteries by first touching a grounded metal surface.*

Ventilate battery area before working on or near battery—Wear goggles—Stop genset and disconnect charger before disconnecting battery cables—Disconnect negative (-) cable first and reconnect last.

⚠ CAUTION *Disconnect battery charger from AC source before disconnecting battery cables. Otherwise, disconnecting cables can result in voltage spikes damaging to DC control circuits of the set.*

⚠ WARNING *Accidental starting of the generator set can cause severe personal injury or death. Prevent accidental starting by disconnecting the negative (-) cable from the battery terminal.*

Insulation Resistance Testing

The insulation resistance test should be performed before the initial start-up of the generator set or when low insulation is suspected, e.g. damp or wet windings.

A 500 VAC megger is recommended for insulation testing. A test consists of applying the test potential between the winding and ground (winding laminations).

The highest resistance values shown in Table 6-1 should be obtained for a new generator with dry windings. For a set that has been in service, the resistance reading should not be less than the lower value shown.

If low readings are obtained, the cause should be investigated and corrected before the generator set is returned to service.

If moisture is determined to be the cause of low test readings, a winding drying process will be required.

1. Disconnect plug **J10** from the voltage regulator output stage module.
2. Disconnect the AC control input leads from the generator output terminals. The AC control leads are marked 5, 6, 7 and 8. Refer to the appropriate *Reconnection Diagram* in *Section 8*.
3. If the RTD (resistive thermal device) option is installed, ground all six RTD temperature leads. Each RTD has three leads, one red and two white leads. Total of 18 leads must be grounded.
4. Perform the *Insulation Resistance Test* procedure for the desired windings as noted in this section.

TABLE 6-1. GENERATOR INSULATION RESISTANCE

FRAME SIZE	GENERATOR VOLTAGE	MEGGER VDC SETTING	MINIMUM RESISTANCE (MEG)			
			MAIN STATOR	MAIN ROTOR	PMG	EXCITER STATOR
P7	600 VAC or less	500	10.0 – 1.0	10.0 – 1.0	10.0 – 1.0	10.0 – 1.0
HC6	600 VAC or less	500	5.0 – 1.0	5.0 – 1.0	5.0 – 1.0	5.0 – 1.0

Drying the Windings

If low readings are obtained and moisture is determined to be the problem, the windings should be dried out and the test repeated. Use the generator heaters or blow warm air through the generator with a fan. A more effective way is to use a bolted 3-phase short across the generator terminals. This procedure must be done as described or equipment damage can result. To do this:

1. Bolt the generator three phase output terminals together. See the reconnection diagrams in *Section 8*.
2. Remove the housing cover of the accessory box and remove plug P10 from connector J10 of the voltage regulator output module (A37). See Figure 3-11.

3. Connect the positive and negative leads of a variable 12 VDC source to P10 as follows:
Positive lead – Red wire of P10-6 (X)
Negative lead – Brown wire of P10-3 (XX)

⚠ CAUTION *Voltage must begin at zero volts and be gradually increased or equipment damage will result. The current will increase rapidly and it must be monitored to prevent exceeding the generator rating.*

4. Attach a clamp-on ammeter to the generator leads to measure generator current, adjust the 12 VDC source for zero voltage, start the set and very slowly increase the excitation voltage. Obtain the highest current possible without exceeding generator rating.
5. Run the genset for approximately one hour, then repeat the insulation resistance tests. If further drying time is indicated, continue the drying process.



EXCITER STATOR

Testing Winding Resistance: Measure winding resistance with a Wheatstone bridge or digital ohmmeter. Replace the stator if winding resistance is not as specified by Table 6-2.

Before performing the following insulation resistance test, refer to the *Insulation Resistance Test* procedure at the beginning of this section.

Testing Winding Insulation Resistance: Disconnect exciter stator leads **F1** and **F2** from their connectors in the AC generator wiring harness and isolate them from ground.

Connect the megger between one of the leads and ground and conduct the test as instructed under *Insulation Resistance testing*.

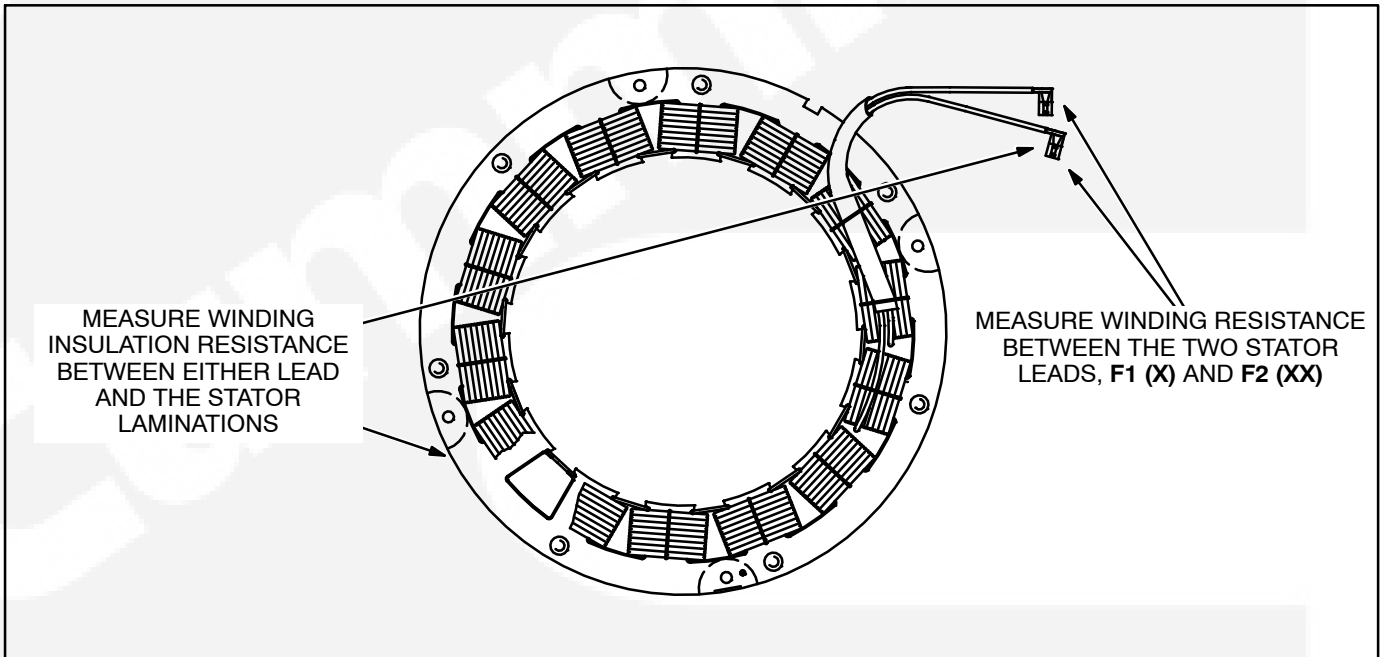

FIGURE 6-2. TESTING THE EXCITER STATOR

TABLE 6-2. WINDING RESISTANCE VALUES*

FRAME SIZE	EXCITER STATOR	EXCITER ROTOR	MAIN ROTOR	MAIN STATOR			
				WINDING 11	WINDING 12	WINDING 17	WINDING 07
P7B	17.5	0.048	1.67	N/A	0.0016	N/A	0.0026
P7C	17.5	0.048	1.85	N/A	0.00126	N/A	0.002
6G	17	0.158	1.44	0.0037	0.0148	N/A	0.011
6H	17	0.158	1.54	0.0027	0.0108	N/A	0.0072
6J	17	0.158	1.73	0.0024	0.0096	N/A	0.006
6K	17	0.158	1.95	0.0019	0.0076	N/A	0.0052

* Resistance figures are approximates, at 68° F (20°C) ± 10%.

EXCITER RECTIFIER BRIDGE (ROTATING RECTIFIER ASSEMBLY)

The exciter rectifier bridge is mounted on the exciter rotor, inboard, facing the main rotor. It consists of a positive plate and a negative plate, split diametrically. Each carries three diodes, three terminal posts for connecting exciter rotor leads to the diode pigtailed and a terminal for the main rotor (generator field) lead. A surge suppresser is connected across the two plates to prevent transient voltages that could damage the diodes.

Testing Diodes: Disconnect the diode pigtailed from the terminal posts. Using an ohmmeter, measure electrical resistance between each diode pigtail and the plate on which the diode is mounted. Reverse the meter test probes and repeat the tests. The electrical resistance across each diode should be high in one direction and low in the other. If the resistance is high or low in both directions, replace the diode.

Replacing Diodes: Make sure the replacement diode is of the correct polarity. Disconnect the pigtail from the terminal post and unscrew the old diode. Apply heat-sink compound under the head of the diode. Make sure the compound does not get on the threads. Torque the diodes to 36 to 42 in-lbs (4 to 4.8 N•m) and the pigtail terminals to 24 in-lbs (2.7 N•m) when reassembling.

Surge Suppressor Testing and Replacement: Remove the suppresser. Replace the suppresser if it appears to have overheated or if ohmmeter readings indicate less than infinite resistance (end of scale) in both directions. Torque the terminals to 24 in-lbs (2.7 N•m) when reassembling.

CAUTION Layers of dust can cause diodes to overheat and fail. Brush dust off regularly.

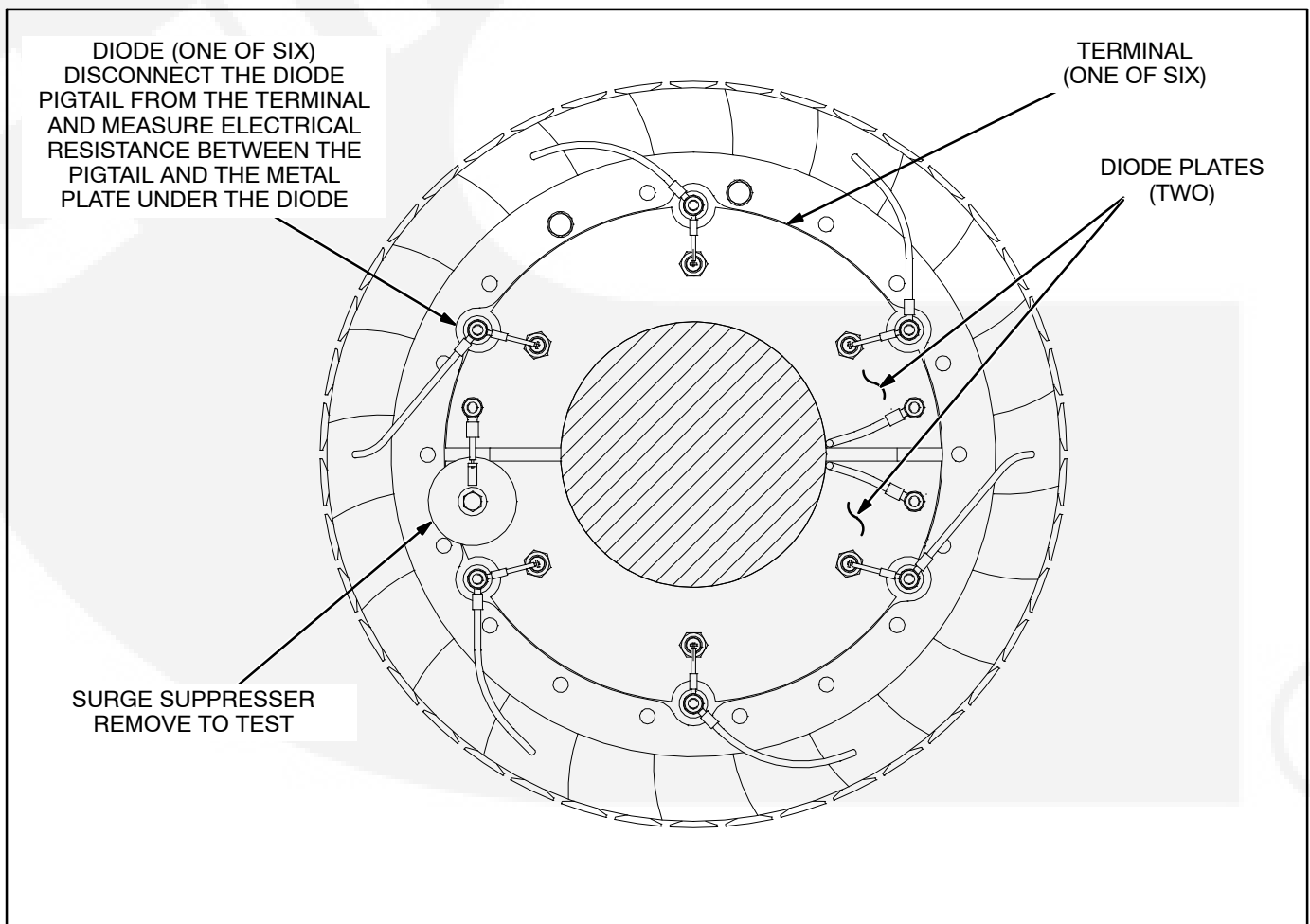

FIGURE 6-3. TESTING THE ROTATING RECTIFIER ASSEMBLY

EXCITER ROTOR

Testing Winding Resistance: Disconnect the six rotor winding leads from the terminal posts on the rectifier assembly. With a Wheatstone bridge, measure electrical resistance across each pair of rotor windings: **U** (CR1 or CR4) and **V** (CR2 or CR5), **V** (CR2 or CR5) and **W** (CR3 or CR6), **W** (CR3 or CR6) and **U** (CR1 or CR4). See the winding schematic. Replace the whole rotor shaft assembly if the resistance of any winding is not as specified in Table 6-2.

Before performing the following insulation resistance test, refer to the *Insulation Resistance Test* procedure at the beginning of this section.

Testing Winding Insulation Resistance: Disconnect all six exciter rotor leads from diode terminals CR1 through CR6 and isolate them from ground.

Connect the megger between one of the leads and ground and conduct the test as instructed under *Insulation Resistance testing*.

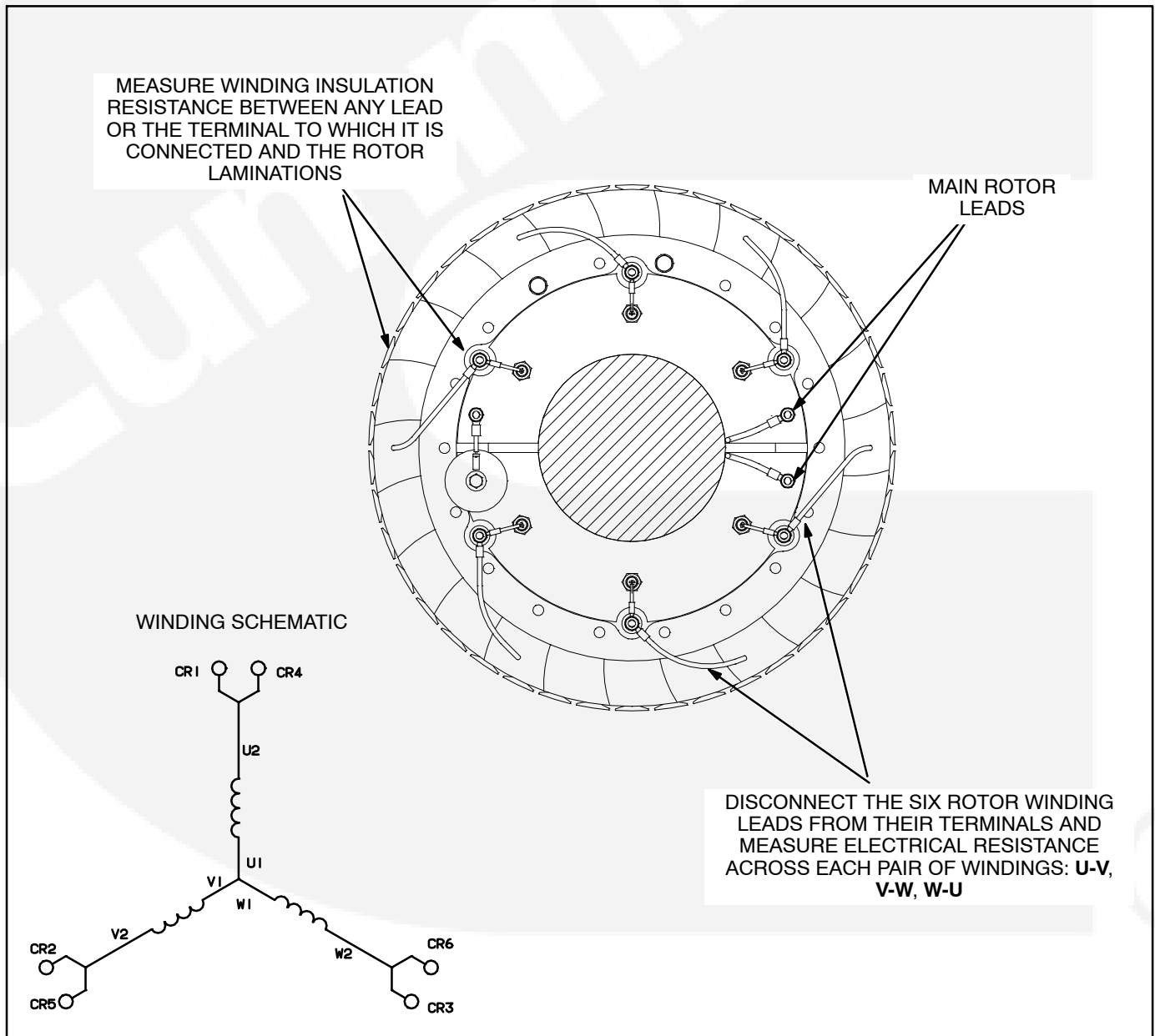

FIGURE 6-4. TESTING THE EXCITER ROTOR

MAIN ROTOR (GENERATOR FIELD)

Testing Winding Resistance: Disconnect the two leads of the main rotor from the terminals on the rotating rectifier assembly. See Figure 6-5. Measure electrical resistance between the two leads with a Wheatstone bridge or digital ohmmeter. Replace the rotor if the resistance is not as specified in Table 6-2. Connect the rotor leads and torque the terminals to 23 in-lbs (3.3 N•m) when reassembling.

Before performing the following insulation resistance test, refer to the *Insulation Resistance Test* procedure at the beginning of this section.

Insulation Resistance and PI Test: Disconnect the main rotor and voltage suppressor leads from terminals **F1+** and **F2-** on the rotating rectifier assemblies and isolate them from ground. Tag and mark each lead with its terminal number (**F1+** or **F2-**).

Connect the megger between one of the rotor leads and ground and conduct the test as instructed under *Insulation Resistance testing*.

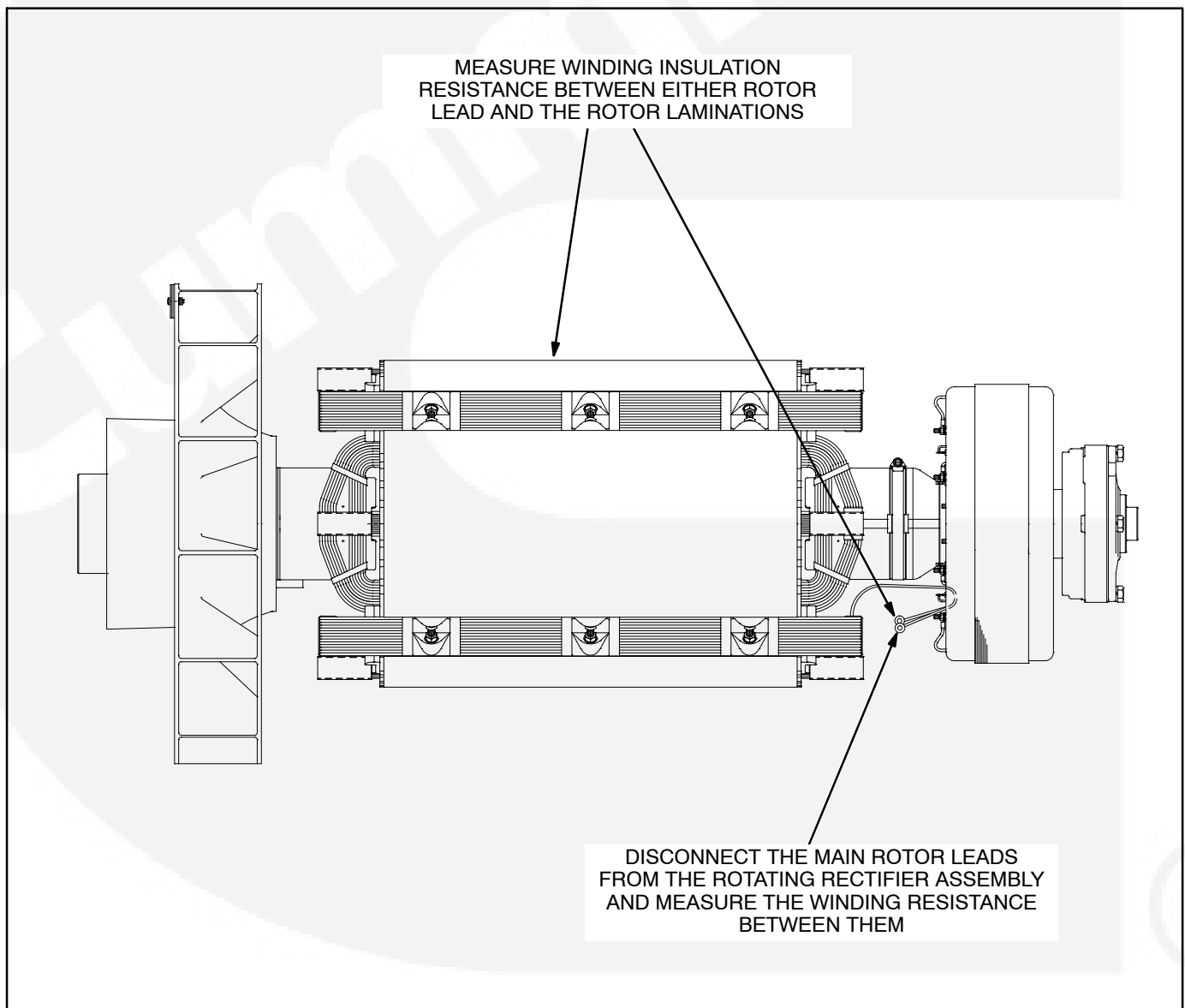

FIGURE 6-5. TESTING THE MAIN ROTOR

MAIN STATOR

Testing Main Stator Winding Resistance: Disconnect all stator leads from the terminals to which they are connected. Using a Wheatstone bridge having at least 0.001 ohm precision, measure electrical resistance across each pair of stator leads: **U1-U2, V1-V2, W1-W2, U5-U6, V5-V6** and **W5-W6**. Replace the stator if the resistance of any winding is not as specified in Table 6-2.

Before performing the following insulation resistance test, refer to the *Insulation Resistance Test* procedure at the beginning of this section.

Insulation Resistance and PI Test: Remove and separate all leads of the generator from the generator load terminal block. Number of neutral leads (three or six) to remove will vary between low and medium voltage generators.

Connect the megger between one phase of the stator and ground while grounding the other two phases and conduct the test as instructed under *Insulation Resistance testing*.

Repeat this step in turn for the other two phases.

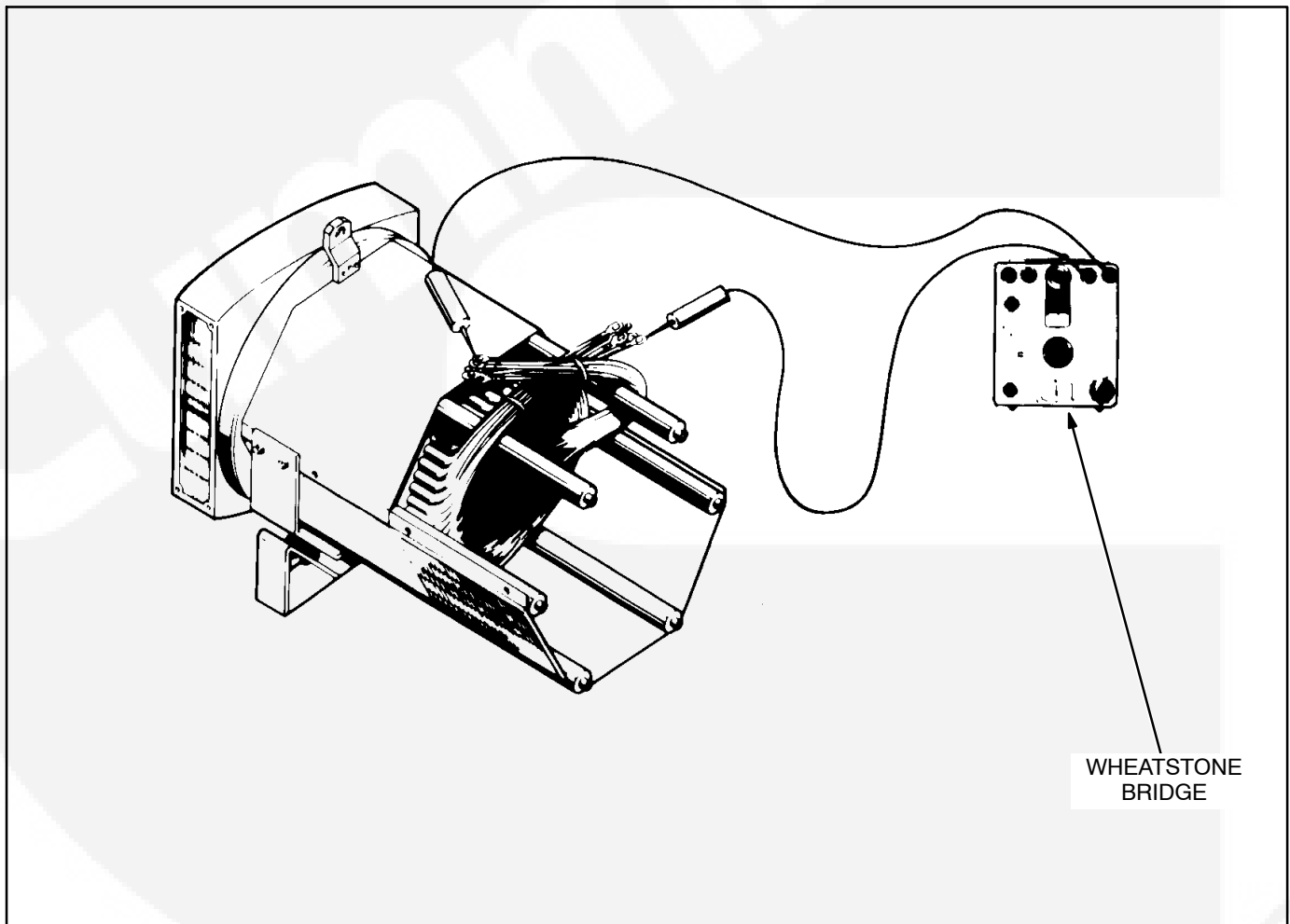

FIGURE 6-6. TESTING THE GENERATOR STATOR

TESTING THE PMG

⚠WARNING **HAZARDOUS VOLTAGE.** *Touching uninsulated high voltage parts inside the control box can result in severe personal injury or death. Measurements and adjustments must be done with care to avoid touching hazardous voltage parts.*

For your protection, stand on a clean dry wooden platform or clean rubber insulating mat, make sure your clothing and shoes are dry, remove jewelry and use tools with insulated handles.

1. Disconnect plug **J10** from the voltage regulator output stage module.
2. Start the engine at the set and let the speed stabilize.
3. Measure voltage across lead pairs **J10-1 & J10-4**, **J10-4 & J10-5**, and **J10-5 & J10-1**. Voltage should be at least 150 VAC for 50 Hz sets and at least 180 VAC for 60 Hz sets, and should be approximately the same for each set of leads. If the voltages are low or uneven, check all the leads and connections between the voltage regulator output stage module and the PMG and repair as necessary before disassembling the PMG.
4. Stop the set and measure electrical resistance across lead pairs **J10-1 & J10-4**, **J10-4 & J10-5**, and **J10-5 & J10-1** with a Wheatstone bridge or digital ohmmeter. The resistance should be $2.6 \pm 10\%$ ohms for frame size P7 and HC6.

BEARING

INSPECTION/REMOVAL/REPLACEMENT

The end bearing is enclosed in a pre-packed machined cartridge.

Bearing Inspection: If a situation occurs which allows an opportunity to visually inspect the end bearing with it installed, check the color of the grease. The color of the grease is the only indication that can be used to determine if the bearing is defective.

New grease is a whitish-beige color but some mild discoloration will occur with use. If the grease shows signs of gross discoloration, the bearing should be replaced.

Bearing Removal: The bearing is press fitted onto the shaft and can be removed with standard workshop tools (i.e., two or three legged manual or hydraulic bearing pullers). The bearing should only be removed for replacement (bearing is destroyed during removal and must be replaced).

The end bearing is enclosed in a pre-packed cartridge housing and must only be dismantled as necessary for relubrication, replacement, or when a major overhaul is carried out on the generator set.

P7 Bearing Removal

1. Remove the endbracket (complete steps 1 through 16 of the *Main Stator and Rotor Removal (P7)* procedure.
2. Remove the four screws holding bearing cap.
3. Remove cap.
4. Remove circlip.
5. Remove bearing cartridge housing complete with bearing.

P7 Bearing Replacement

The instruction sheet provided with the bearing kit is required to complete the following procedure.

P7 generator component parts cannot be ordered from Cummins. Refer to the Newage nameplate and supply all available information. Contact your nearest Newage distributor for assistance in ordering component parts.

1. Lift slightly on end of rotor shaft and install wooden shims to hold rotor on center with stator.
2. Install bearing onto rotor shaft. Refer to bearing kit instruction sheet.
3. Install two threaded studs into end bearing cartridge to aid subsequent procedures. Position the end bearing cartridge assembly close to proper position for hole alignment with endbracket.
4. Install endbracket to the stator frame using the proper screws and lock washers, but do not tighten securely as yet.
5. Insert and start the threads of the bearing cartridge fasteners, and remove threaded alignment studs, through the endbracket into the cartridge housing.
6. Lift slightly on endbracket and remove wooden shims holding rotor on center with stator.
7. Securely tighten the endbracket fasteners.
8. Tighten the bearing cartridge fasteners to 4.5 ft-lbs. (6 N•m) torque.
9. Install the PMG assembly. Refer to *Permanent Magnet (PMG) Installation* procedure.

P7 Bearing Lubrication

A grease fitting is provided to allow re-greasing of the bearing with a grease gun (see *Operator's manual* for grease quantities/type, maintenance intervals, and procedure).

HC6 Bearing Removal

1. Remove the endbracket (complete steps 1 through 16 of the *Main Stator and Rotor Removal (P7)* procedure).
2. Remove the four screws holding bearing cap
3. Remove cap.
4. Remove circlip.
5. Remove bearing cartridge housing complete with bearing.

HC6 Bearing Replacement

When replacing bearing onto rotor shaft, be sure to apply pressing force to the inner face of the bearing only.

HC6 Bearing Lubrication

Bearing Lubrication: When re-lubricating or replacing the bearing, review the following.

- Recommended Lubricant: Lithium based grease, Mobilux No. 2 or Shell Alvania R3.
- Temperature Range: -22°F to +248°F (-30°C to +120°C).
- Quantity: 2.74 oz. (81 ml). The grease should be equally divided between the bearing, the bearing cap cavity, and the bearing cartridge cavity.



GENERATOR DISASSEMBLY

The following procedures provide information for removal and reassembly of the generator PMG exciter, control housing, and stator/rotor assemblies. Be sure to read through this section first, before performing procedures listed, to determine the steps most appropriate for the service attention required.

Two types of generators (P7 or HC6) are used with these generator set models. The major difference between these two generators is the lifting eye locations on the generator and the type of control housing. The control housing for the HC6 generator is shown in Figure 6-7 and the control housing for the P7 generator is shown in Figure 6-8. In the following procedures, if the step only applies to a particular control housing or generator, it will be noted at the beginning of the step (e.g., *HC6 control housing*, *P7 generator*, etc.)

Permanent Magnet (PMG) Removal

⚠ WARNING *Ignition of explosive battery gases can cause severe personal injury or death. Arcing at battery terminals, light switch or other equipment, flame, pilot lights and sparks can ignite battery gas. Do not smoke, or switch trouble light ON or OFF near battery. Discharge static electricity from body before touching batteries by first touching a grounded metal surface.*

Ventilate battery area before working on or near battery—Wear goggles—Stop genset and disconnect charger before disconnecting battery cables—Disconnect negative (-) cable first and reconnect last.

⚠ CAUTION *Disconnect battery charger from AC source before disconnecting battery cables. Otherwise, disconnecting cables can result in voltage spikes damaging to DC control circuits of the set.*

⚠ WARNING *Accidental starting of the generator set can cause severe personal injury or death. Prevent accidental starting by disconnecting the negative (-) cable from the battery terminal.*

1. Disconnect the negative (-) battery cable to prevent accidental starting of the generator set while servicing.
2. *HC6 Control Housing:* Remove the control housing grille and access covers (see Figure 6-7).
3. Remove the three M5X12mm capscrews and lockwashers from the PMG cover, and remove cover.
4. Disconnect the PMG wiring harness connector.
5. Remove the four bolts and clamps retaining the exciter stator housing to the endbracket.
6. Tap the stator housing out of its spigot, and carefully remove from generator endbracket.

The highly magnetic rotor will attract the stator core; care must be taken to avoid any contact which may damage the windings.

7. Remove the hex head through-bolt from the rotor shaft and firmly pull the complete rotor assembly from its location. Keep the rotor clean by avoiding contact with metal dust or particles.

⚠ CAUTION *The rotor assembly must not be dismantled, or the magnetic properties will be destroyed.*

Permanent Magnet (PMG) Installation

1. Install the complete rotor assembly to the end of the main rotor shaft using the hex head through-bolt. Keep the rotor clean by avoiding contact with metal dust or particles.
2. Carefully locate the stator housing to position on the generator endbracket. Fasten in place using the 4 bolts and clamps, and tighten securely.

The highly magnetic rotor will attract the stator core, care must be taken to avoid any contact which may damage the windings.

3. Connect the PMG wiring harness connector.
4. Install the PMG assembly cover using the three M5x12mm capscrews and lockwashers, and tighten securely.
5. *HC6 Control Housing:* Install the control housing grille and access covers (see Figure 6-7).

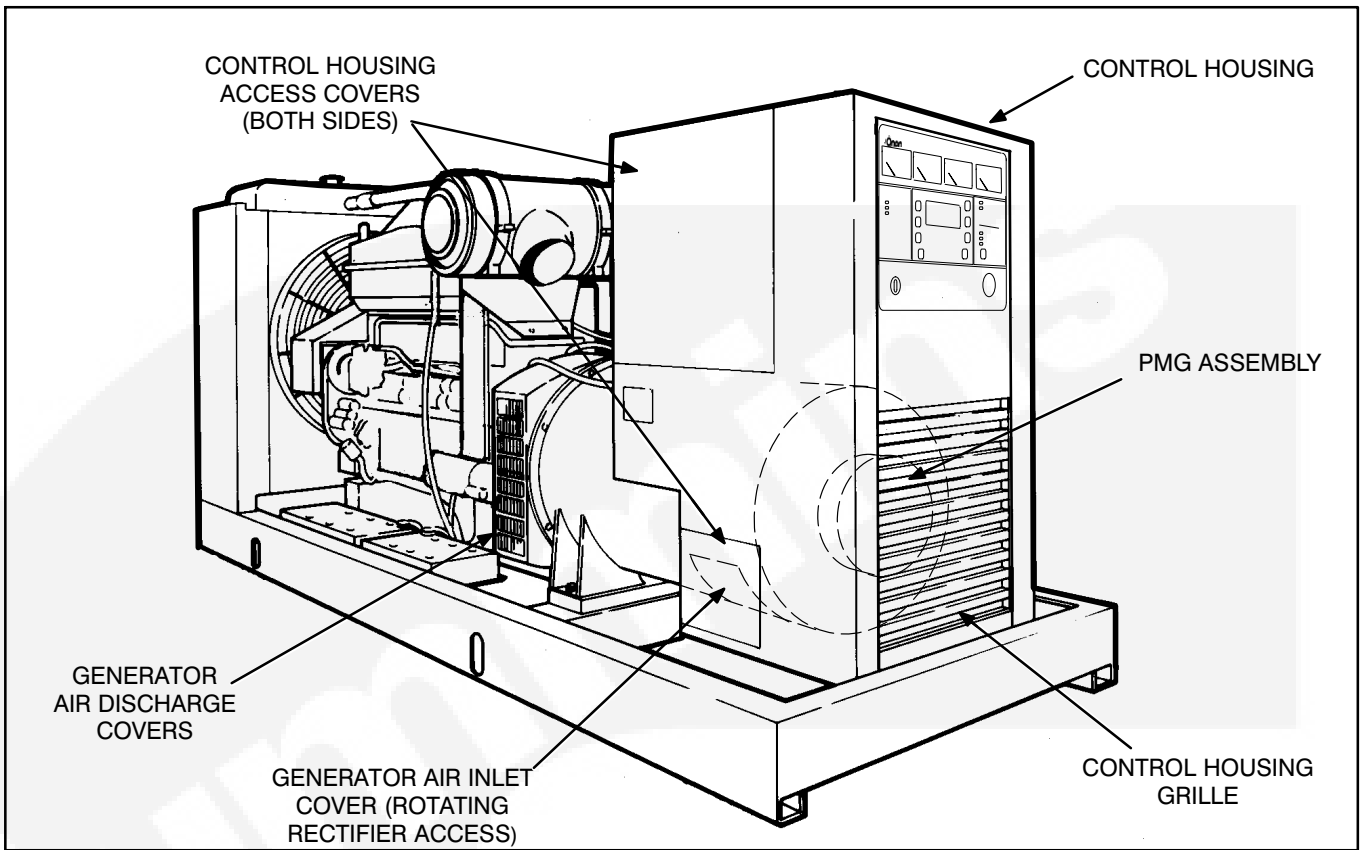

FIGURE 6-7. HC6 GENERATOR AND CONTROL HOUSING ASSEMBLY

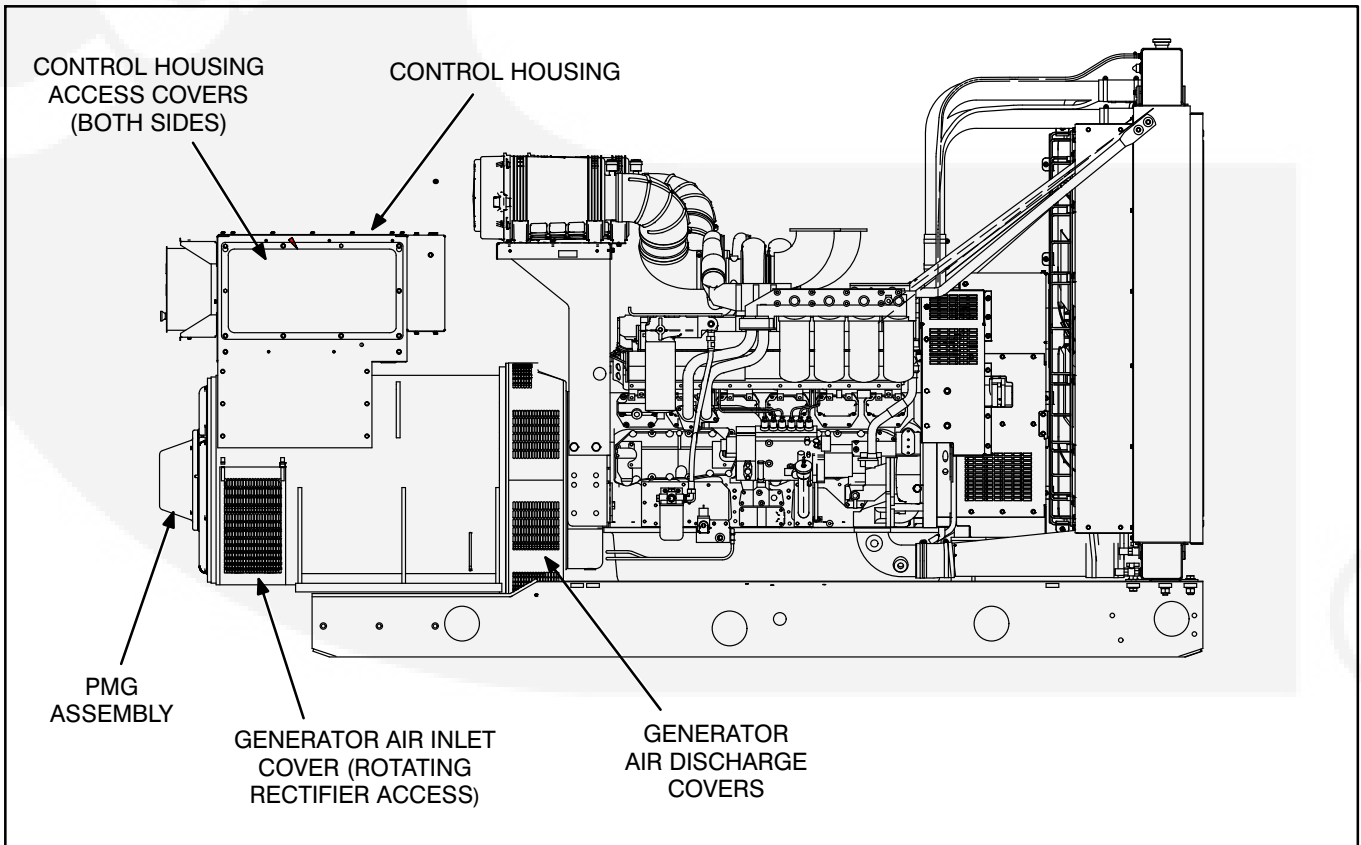

FIGURE 6-8. P7 GENERATOR AND CONTROL HOUSING ASSEMBLY

Main Stator and Rotor Removal

1. Remove the PMG, refer to *Permanent Magnet PMG Removal*, earlier this section.
2. Remove the air inlet and discharge panels and access covers from control housing and generator (see Figure 6-7 or 6-8).
3. Disconnect all load wires from the reconnection terminal block assembly. If equipped with the circuit breaker option, disconnect load wires from circuit breaker. Check that all leads are labeled to ease reassembly.
4. Disconnect the remote control wiring and conduit from the accessory box. For reconnections later, make sure each wire is clearly marked to indicate the correct terminal.
5. Disconnect the engine harness connectors and remove harness assembly from the control housing:
 - P4 and P5 from the back side of the control panel box.
 - PMG2 through PMG4, F1 and F2 generator leads located inside the control housing assembly.
 - P6 (Governor Output Module), P7 and P10 (Voltage Regulator Output Module) and J12 (from P12 of the rail assembly), located inside the accessory box.
6. Use a hoist or similar lifting device to support the control housing assembly (see Figure 6-9).

⚠WARNING To prevent personal injury, use adequate lifting devices to support heavy components. Keep hands and feet clear while lifting.

7. HC6 Control Housing Removal:

- a. Loosen the fasteners that secure the control housing side and bottom panels to generator. Make sure that hoisting device is controlling weight of control housing assembly.

- b. Remove control housing fasteners, and remove the control housing assembly from the generator. Replace panel fasteners to their respectable positions for safe keeping, and tighten finger-tight.
- c. Remove control housing mounting brackets from both sides of generator, and assemble lifting eyes to generator.

8. P7 Control Housing Removal:

- a. Loosen the fasteners that secure the control housing side panels to generator. Make sure that hoisting device is controlling weight of control housing assembly.
- b. Remove control housing fasteners, and remove the control housing assembly from the generator. Replace panel fasteners to their respectable positions for safe keeping, and tighten finger-tight.

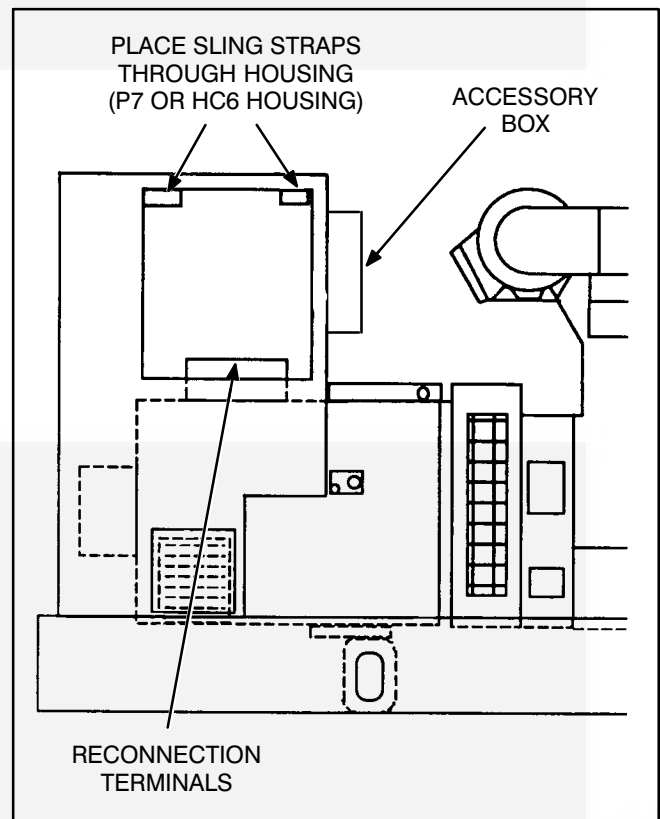

FIGURE 6-9. REMOVING CONTROL HOUSING

- Remove as necessary, air intake components to engine that may interfere with disassembly and reassembly of generator.

CAUTION Do not use fan blade to bar over engine. That can damage blades and cause property damage and personal injury.

- Crank or bar the engine/generator to position the rotor such that a full pole face is at the bottom of the main stator core. Proper positioning can be viewed through the generator access openings. Refer to engine service manual for proper cranking or barring procedure.

To remove the stator and rotor at the same time, refer to step 28. To remove the stator and rotor individually, continue with step 11.

- Remove the four bolts retaining the bearing cartridge housing in the endbracket (outer four bolts).
- Remove the eight bolts holding the endbracket to the generator housing.
- Insert two bolts (M10) in the two holes provided for “jacking” purposes, on the endbracket center line. Screw bolts in until endbracket spigot is clear of locating recess.
- Carefully tap the whole assembly off the bearing cartridge housing, ensuring the endbracket is supported to prevent the exciter stator from damaging the windings on the exciter rotor.

WARNING To prevent personal injury, use adequate lifting devices to support heavy components. Keep hands and feet clear while lifting.

- The exciter stator is now accessible for inspection and removal from endbracket/engine adaptor.
- The end bearing can now be removed if required. Refer to *Bearing Inspection/Removal/Replacement* in this section.
- Remove the fasteners from the two generator mounting feet brackets.
- Attach cables of lifting device to generator lifting points (Figures 6-10 or 6-11).

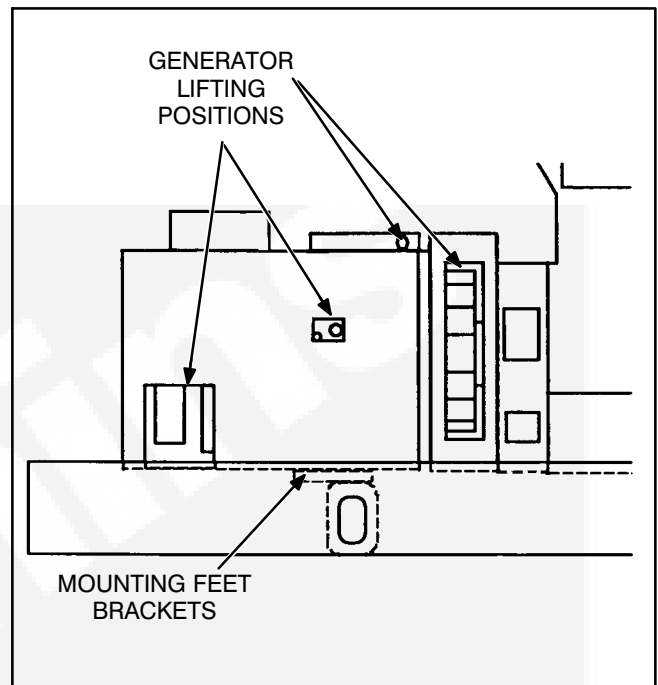

FIGURE 6-10. HC6 GENERATOR LIFTING POSITIONS

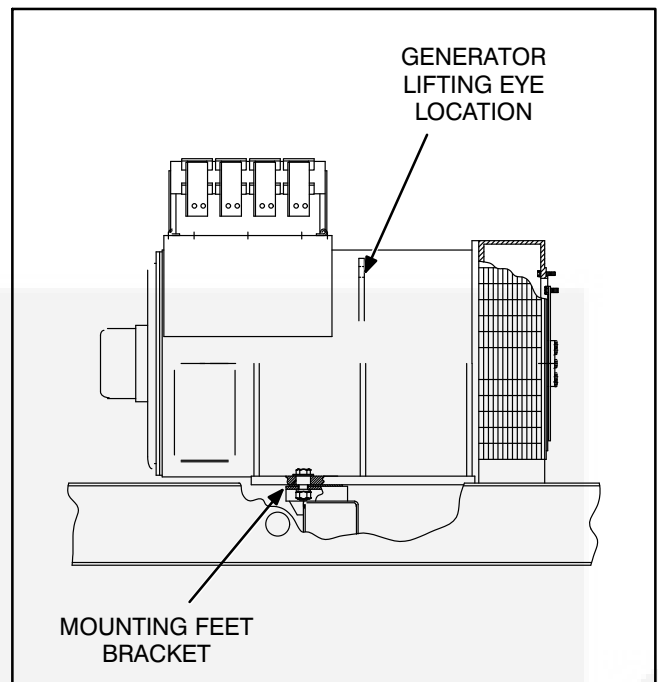

FIGURE 6-11. P7 LIFTING POSITION

19. Using an adequate lifting device, lift the generator (at lifting eyes provided, and main stator housing) until the mounting feet brackets are clear of the frame member (see Figure 6-12 or 6-13).

20. Disconnect the grounding strap from the fly-wheel housing.
21. Using a forklift, position a lifting bar of the forklift (inside and in line with the generator) under the rotor shaft. Lift the rotor shaft slightly so that rotor is not resting on inside of stator assembly. See Figure 6-12 or 6-13.

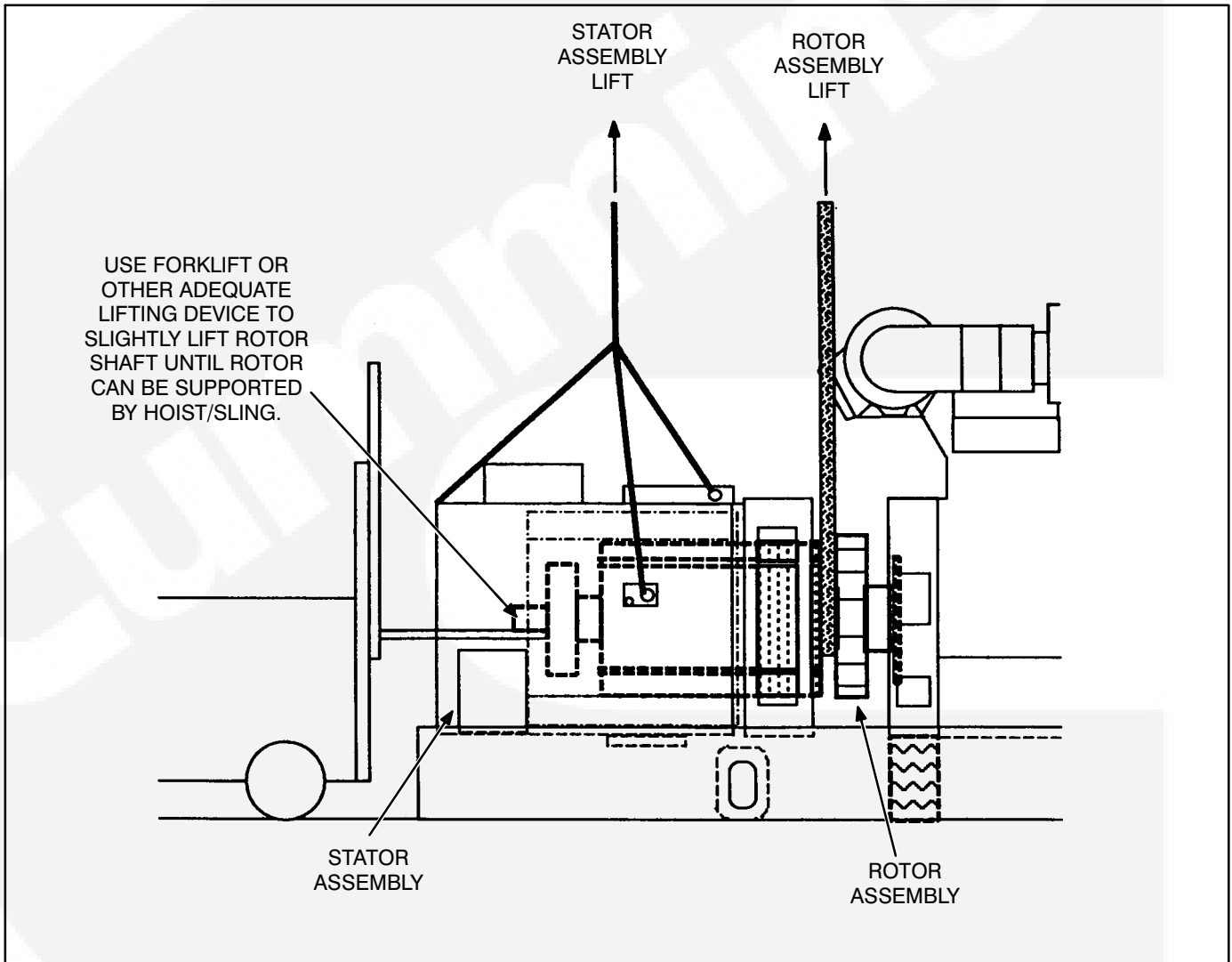

FIGURE 6-12. REMOVING HC6 STATOR ASSEMBLY

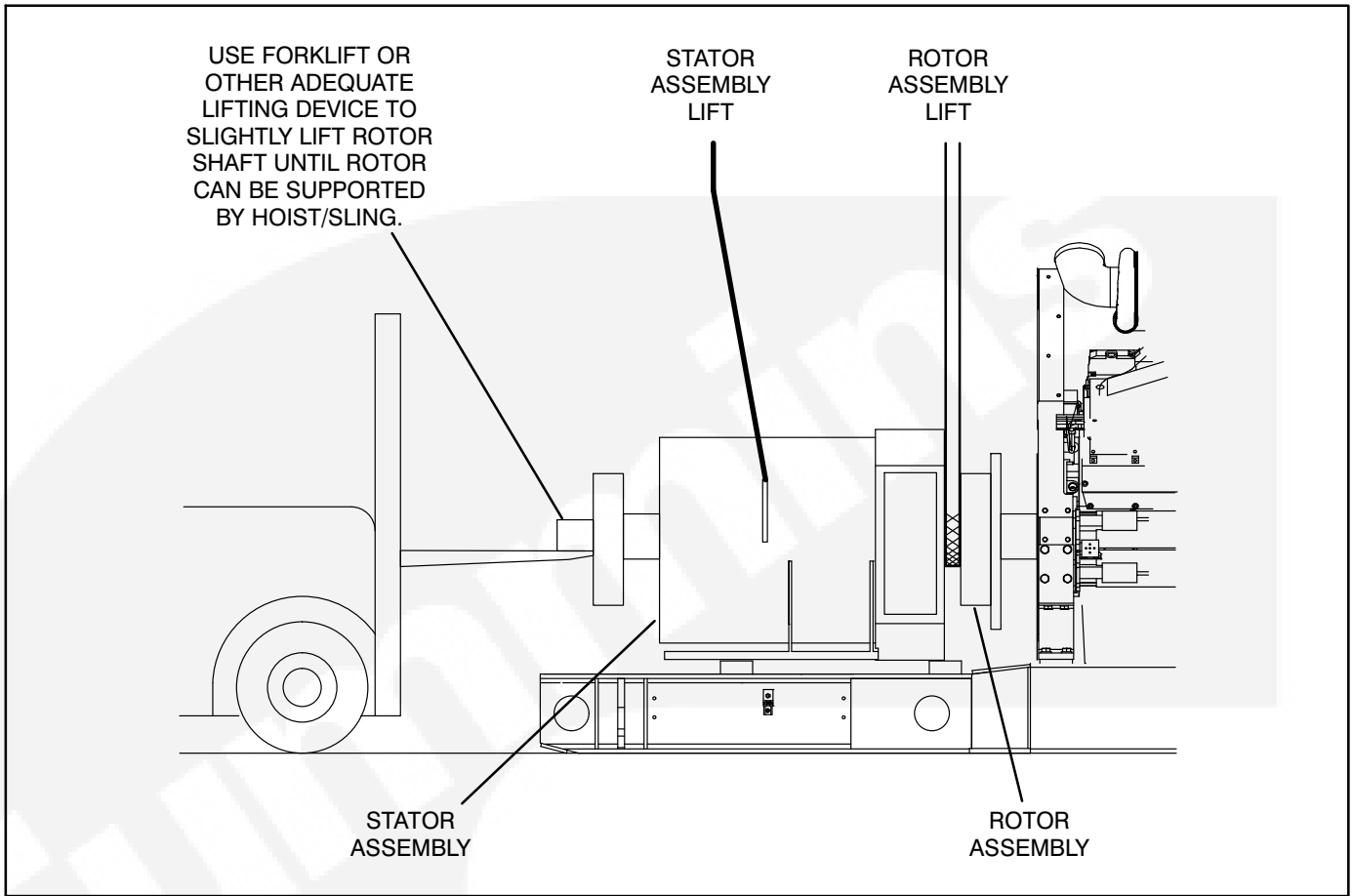

FIGURE 6-13. REMOVING P7 STATOR ASSEMBLY



22. Verify that the stator is adequately supported and then carefully remove the capscrews from the stator attachment ring.

⚠ WARNING *To prevent personal injury, use adequate lifting devices to support heavy components. Keep hands and feet clear while lifting.*

⚠ CAUTION *Improper stator assembly rigging and handling can result in damage to stator and rotor assemblies. Lifting eyes may not be at center-of-gravity position of stator assembly. Therefore, lifting and moving the stator assembly alone, by hoisting at lifting eyes only, presents the hazard of load imbalance; allowing one end to drop and other end to rise. Make sure the stator is adequately hooked/strapped to maintain level control of stator assembly while lifting and moving.*

23. Being careful not to drag the windings on the rotor, move the stator assembly sufficiently away from engine to sling and support the rotor assembly. Do not allow rotor assembly to hang on engine flywheel.

⚠ CAUTION *Drive disc damage can be caused by allowing the rotor assembly to hang on flywheel. Use adequate hoist and sling to support the rotor assembly.*

24. Reposition or add hoist and sling support for the main rotor, and remove the forklift. See Figure 6-14, Rotor Lift detail.

⚠ WARNING *To prevent personal injury, use adequate lifting devices to support heavy components. Keep hands and feet clear while lifting.*

25. Remove the stator assembly, being careful not to drag the windings on the rotor. Place stator assembly away from the chassis in the horizontal position.

26. Using the hoist and sling to support the rotor, carefully remove the capscrews and flat washers that secure the drive discs to the engine flywheel.

⚠ WARNING *To prevent personal injury, use adequate lifting devices to support heavy components. Keep hands and feet clear while lifting.*

27. Remove the rotor assembly and place it on wood blocks in the horizontal position. To avoid possible distortion, do not allow the drive discs and fan to rest on anything.



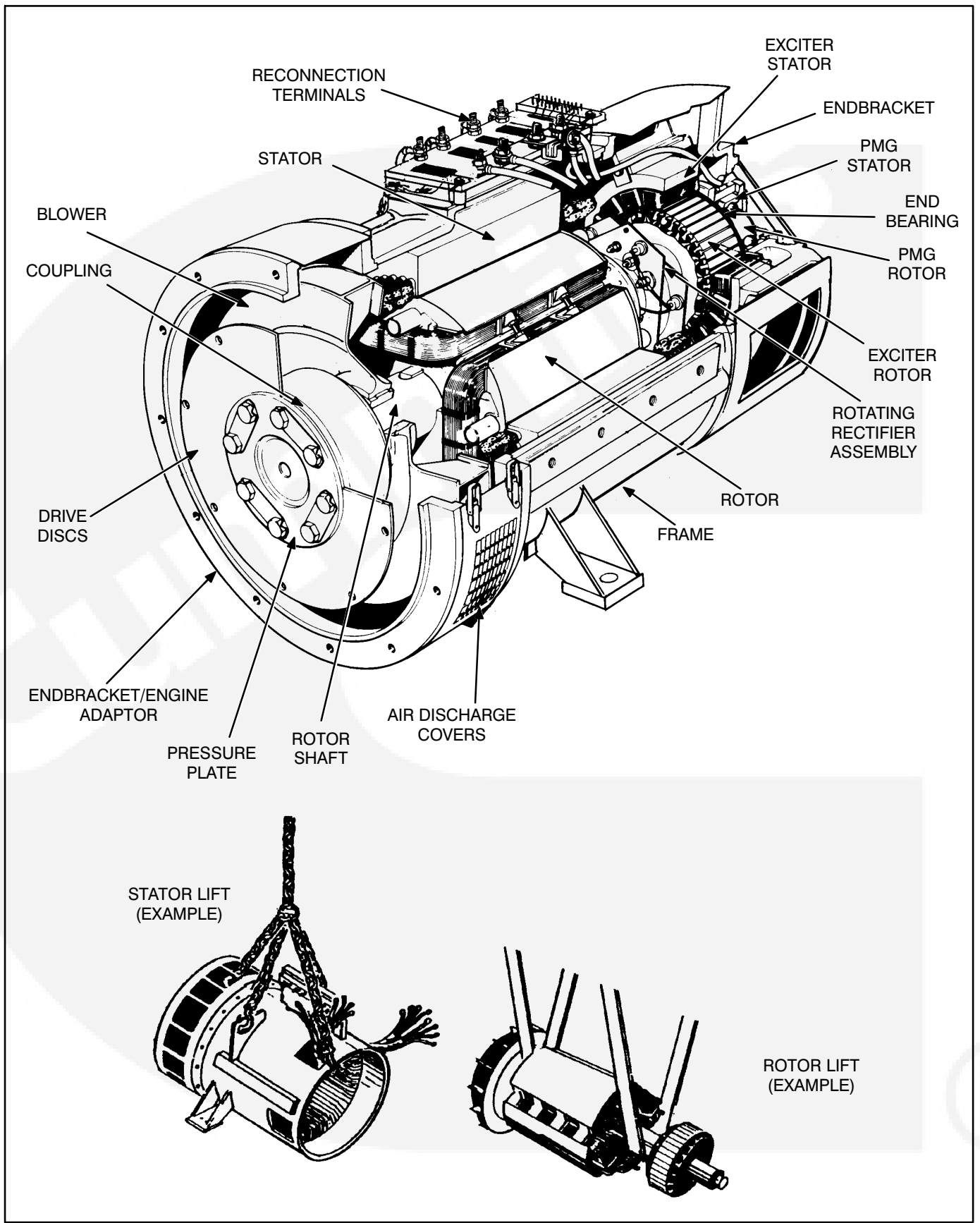

FIGURE 6-14. TYPICAL GENERATOR ASSEMBLY

Generator Assembly Removal

28. Remove the fasteners from the two generator mounting feet brackets.
29. Attach cables of lifting device to generator lifting points (Figures 6-10 or 6-11).
30. Using an adequate lifting device, lift the generator (at lifting eyes provided, and main stator housing) until the mounting feet brackets are clear of the frame member.
31. Disconnect the grounding strap from the flywheel housing.
32. Carefully remove the capscrews and flat washers that secure the drive discs to the engine flywheel.
33. Verify that the generator assembly is adequately supported. Carefully remove the capscrews securing the engine adaptor endbracket to the engine flywheel housing.

⚠WARNING *To prevent personal injury, use adequate lifting devices to support heavy components. Keep hands and feet clear while lifting.*

⚠CAUTION *Improper generator assembly rigging and handling can result in damage to stator and rotor assemblies. Lifting eyes may not be at center-of-gravity position of stator assembly. Therefore, lifting and moving the generator by hoisting at lifting eyes only, presents the hazard of load imbalance; allowing one end to drop and other end to rise. Make sure the generator is adequately hooked/strapped to maintain level control of assembly while lifting and moving.*

34. Remove the generator assembly away from engine. Place generator assembly on floor with a piece of wood beneath the stator housing (toward PMG end) to allow for endbracket removal, if desired.



GENERATOR REASSEMBLY

Generator reassembly is the reverse of disassembly procedure.

To assemble the stator and rotor at the same time, continue with step 1. To assemble the stator and rotor individually, skip to step 16.

1. Using an adequate lifting device, locate the generator assembly into position near the engine flywheel housing. Align the holes of the rotor drive discs with the holes of the engine flywheel. Install the capscrews and flat washers that secure the drive discs to the engine flywheel, hand tighten.

⚠WARNING *To prevent personal injury, use adequate lifting devices to support heavy components. Keep hands and feet clear while lifting.*

⚠CAUTION *Improper generator assembly rigging and handling can result in damage to stator and rotor assemblies. Lifting eyes may not be at center-of-gravity position of stator assembly. Therefore, lifting and moving the generator by hoisting at lifting eyes only, presents the hazard of load imbalance; allowing one end to drop and other end to rise. Make sure the generator is adequately hooked/strapped to maintain level control of assembly while lifting and moving.*

2. Align the holes of the engine adaptor endbracket with the holes in the flywheel housing and install the capscrews and lock washers. Tighten fasteners to 95–105 ft-lbs. (129–142 N•m).
3. Secure the rotor assembly to the flywheel. Tighten fasteners to 150–180 ft-lbs. (204–245N•m).

4. Connect the grounding strap to the flywheel housing using a capscrew and EIT locking washer; and tighten securely.
5. Install the mounting feet bracket fasteners; and tighten securely.

If endbracket has been removed, continue with step 6, otherwise skip to step 15.

6. Lift slightly on end of rotor shaft and install wooden shims to hold rotor on center with stator.
7. If removed, install end bearing. Refer to *Bearing Inspection/Removal/Replacement* procedure in this section.
8. Install two threaded studs into end bearing cartridge to aid subsequent procedures. Position the end bearing cartridge assembly close to proper position for hole alignment with endbracket.
9. Assemble exciter stator, if removed, to inside of endbracket. Tighten fasteners to 4.5 ft-lbs. (6 N•m) torque.
10. Install endbracket to the stator frame using the proper capscrews and lock washers, but do not tighten securely as yet.
11. Insert and start the threads of the bearing cartridge fasteners, and remove threaded alignment studs, through the endbracket into the cartridge housing.
12. Lift slightly on endbracket and remove wooden shims holding rotor on center with stator.
13. Securely tighten the endbracket fasteners.
14. Tighten the bearing cartridge fasteners to 4.5 ft-lbs. (6 N•m) torque.



15. Install the PMG assembly, if removed. Refer to *Permanent Magnet (PMG) Installation*.

Perform the 'Aligning Generator with Engine' procedures, later in this section, then return to the following steps.

To assemble the control housing, skip to step 35.

To assemble the stator and rotor individually begin here.

16. If removed, replace exciter rotor and rotating rectifier assembly to main rotor shaft. Reconnect main rotor wire leads to positive and negative terminals of rectifier assembly.
17. If removed, install the drive disk spacer, drive disc and pressure plate on the rotor shaft. Install the cap screws and flat washers and tighten to 607 ft-lbs. (822 N•m).
18. Using a hoist and sling to support the rotor, align the holes in the drive disc with the corresponding holes in the flywheel.

⚠ WARNING *To prevent personal injury, use adequate lifting devices to support heavy components. Keep hands and feet clear while lifting.*

19. Secure the rotor assembly drive disc to the flywheel using appropriate capscrews and flat washers. Tighten fasteners to 150–180 ft-lbs. (204–245N•m) Do not allow rotor assembly to hang on engine flywheel.

⚠ CAUTION *Drive disc damage can be caused by allowing the rotor assembly to hang on flywheel. Use adequate hoist and sling to support the rotor assembly.*

20. Reassemble engine adaptor endbracket to stator frame if removed. Using an adequate lifting device, carefully move the stator into position over the rotor assembly, being careful not to drag the windings on the rotor.

⚠ WARNING *To prevent personal injury, use adequate lifting devices to support heavy components. Keep hands and feet clear while lifting.*

⚠ CAUTION *Improper stator assembly rigging and handling can result in damage to stator and rotor assemblies. Lifting eyes may not be at center-of-gravity position of stator assembly. Therefore, lifting and moving the stator assembly alone, by hoisting at lifting eyes only, presents the hazard of load imbalance; allowing one end to drop and other end to rise. Make sure the stator is adequately hooked/strapped to maintain level control of stator assembly while lifting and moving.*

21. Using a forklift, position a lifting bar of the forklift (inside and inline with the generator) under the rotor shaft. Lift the rotor shaft slightly so that rotor is not resting on inside of stator assembly.
22. Remove the hoist/sling support of the rotor assembly. Align the holes of the engine adaptor endbracket with the holes in the flywheel housing and install the capscrews and lock washers. Tighten fasteners to 95–105 ft-lbs. (129–142 N•m).



23. Connect the grounding strap to the flywheel housing using a capscrew and EIT locking washer; and tighten securely.
24. Install the mounting feet bracket fasteners; and tighten securely.
25. Lift slightly on end of rotor shaft and install wooden shims to hold rotor on center with stator.
26. If removed, install end bearing. Refer to *Bearing Inspection/Removal/Replacement* procedure in this section.
27. Install two threaded studs into end bearing cartridge to aid subsequent procedures. Position the end bearing cartridge assembly close to proper position for hole alignment with endbracket.
28. Assemble exciter stator, if removed, to inside of endbracket. Tighten fasteners to 4.5 ft-lbs. (6 N•m) torque.
29. Install endbracket to the stator frame using the proper capscrews and lock washers, but do not tighten securely as yet.
30. Insert and start the threads of the bearing cartridge fasteners, and remove threaded alignment studs, through the endbracket into the cartridge housing.
31. Lift slightly on endbracket and remove wooden shims holding rotor on center with stator.
32. Securely tighten the endbracket fasteners.
33. Tighten the bearing cartridge fasteners to 4.5 ft-lbs. (6 N•m) torque.
34. Install the PMG assembly, if removed. Refer to *Permanent Magnet (PMG) Installation*.

Perform the 'Aligning Generator with Engine' procedures, later in this section, then return to step 35.

35. *HC6 Control Housing*: Remove generator lifting eyes. Reassemble control housing mounting brackets to sides of generator and fasten securely.

⚠WARNING *To prevent personal injury, use adequate lifting devices to support heavy components. Keep hands and feet clear while lifting.*

36. Use an adequate lifting device to lift the control housing in position for mounting to the stator frame. Replace the capscrews and lock washers and tighten to 20 ft-lbs. (27 N•m) torque.
37. Connect all control wires and generator leads using the proper generator set AC and DC wiring diagram/schematic.
38. Reassemble any engine air intake components removed during generator disassembly.
39. Reassemble the covers over the generator air discharge openings and fasten securely.
40. Refer to *Permanent Magnet (PMG) Installation* procedure in this section.
41. If equipped with the circuit breaker option, reconnect load wires to circuit breaker. Reconnect all lead wires to the terminal block assembly using proper reconnection diagram in *Section 9*.
42. Verify that all connections are proper and secure and then install the air inlet panel and access covers to control housing.
43. Connect the negative (-) battery cable and test the generator set for operation.



ALIGNING GENERATOR WITH ENGINE

Proper alignment of the generator and engine assemblies is necessary to avoid premature wear and improper operation of the genset. Review the following alignment conditions and procedures for aligning the generator assembly to engine flywheel housing.

Angular Misalignment: Is the result of the generator bearing center axis not aligning with axis of the engine crankshaft. This condition creates an angle between the generator shaft axis and the crankshaft axis. The cause of this type of misalignment is usually shimming error.

Axial Misalignment: Is the result of the generator shaft axis not aligning with engine crankshaft axis. The tolerances in the bolted flywheel and drive disc connection may add up to displace the generator axially relative to the crankshaft axis.

Misalignment Symptoms: If the assembly is allowed to run under these conditions, the discs must

flex in alternate directions twice for each engine revolution. It is important to minimize the amount of disc flexing since, if it is excessive, the drive disc will crack. Although perfect bearing alignment is desirable, it is more important to keep disc deflection to the minimum possible. This procedure assumes that the pilot bore of the drive discs are in the exact center and the flywheel counterbore (pilot) has no practical runout. Under these conditions, perfect Angular alignment will be attained when no deflection of the disks is measured.

Excessive Axial misalignment will cause more generator vibration than Angular misalignment.

Axial misalignment needs to be checked only when an objectionable vibration is present.

Either type of misalignment may be present in a generator set assembly, with angular misalignment being the most common problem. Angular alignment may also be effected by set installation conditions and/or mishandling during shipping of the genset.



Angular Alignment Procedure

⚠️WARNING *Accidental starting of the generator set during this procedure presents the hazard of severe personal injury or death. Make sure to disconnect the negative (-) battery cable(s) before beginning.*

Fasten a dial indicator to either the generator shaft or the cooling fan with the sensing point resting on the capscrew head or the flat surface of the drive

disc at the bolt circle diameter, see Figure 6-15. Bar the engine over in a clockwise rotation as viewed from engine flywheel. Do not allow it to roll back on compression at the end of the travel of each reading. It is unnecessary to zero the indicator since the total indicator reading (T.I.R.) of the deflection measurement to the bolt heads is what is required. T.I.R. will be the sum of the maximum positive and negative dial indicator readings as the engine completes one revolution.

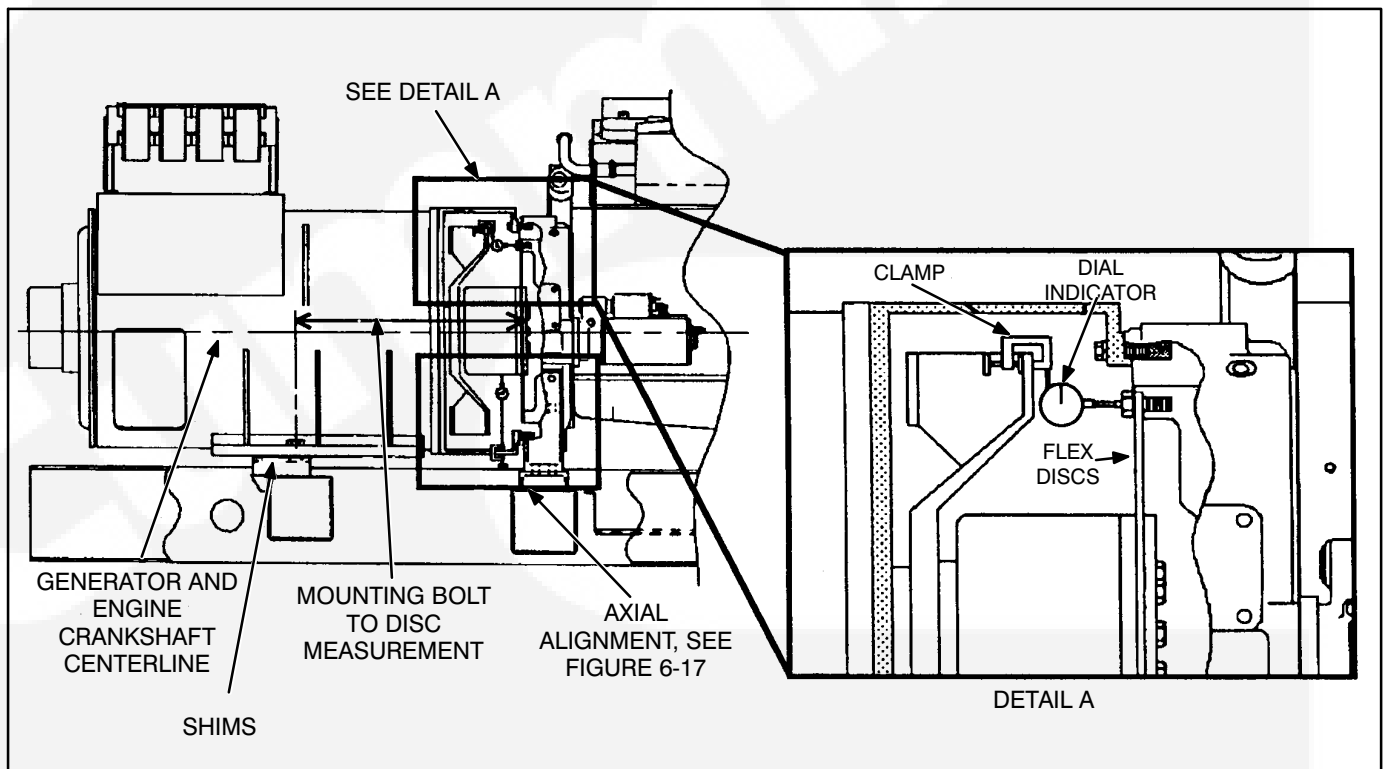

FIGURE 6-15. ANGULAR ALIGNMENT MEASUREMENT

Sample Generator Runout Readings

When taking the deflection readings described, make a diagram similar to the example shown in Figure 6-16, where a total indicator reading of $.025''$. (The highest positive value of $+.010''$ and the largest negative value of $-.015''$.) The indicator is closer to the top and further away at the bottom. This example indicates that the generator bearing is high. Since the side readings are equal, the generator is centered side to side. To lower the generator, remove equal shims from under both generator mounting feet. To approximate the amount of shims to remove or add:

1. Measure the distance between the center of the generator shaft to the point the indicator is measuring at. (For example; a SAE 18 Disc coupling distance is $10.7''$).

2. Measure the distance from the generator side of the flex discs to the center of the generator mounting bolt, refer to Figure 6-15. (For example; a HC6 Frame's distance is $28.4''$.)
3. Compare the distance measured in steps 1 and 2. ($28.4''$ vs $10.7''$ or a 2.65 to 1 ratio.) Multiply this ratio times one half the T.I.R. (In our example, $.025''$ divided by 2 is $.0125''$. This, times 2.65 equals $.033''$. Therefore, remove $.033''$ of shims from under both mounting feet.)

In general, the T.I.R. should not be more than $.001''$ for each inch of radius (center of shaft to indicator axis). If we use our example of $10.7''$, then the maximum T.I.R. would be $.011''$. This would only require a correction of $.014''$ from the T.I.R. of $.025''$. (A reading of $+.002$ at the top and $-.009$ at the bottom would fall within the satisfactory range.)

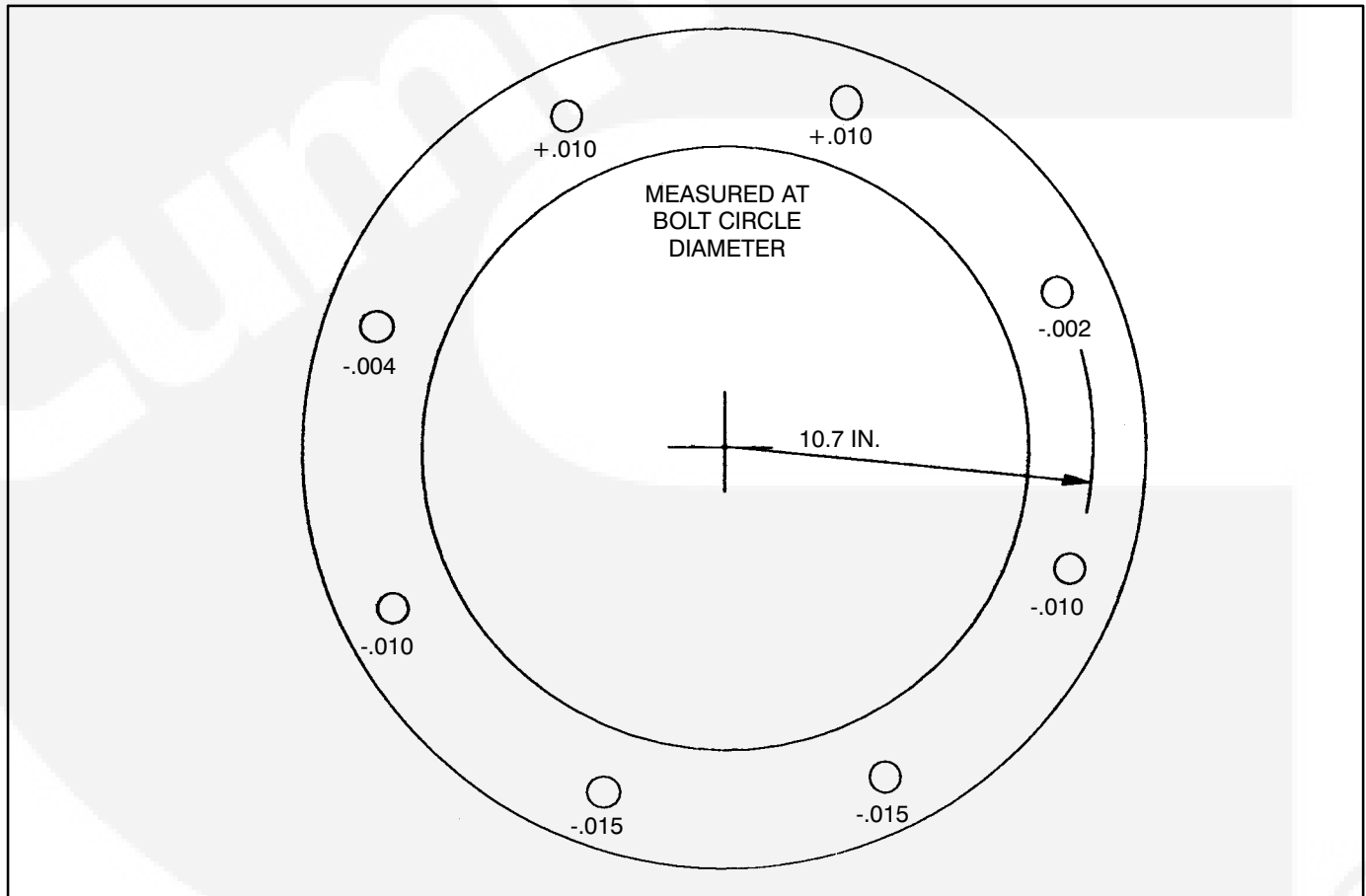

FIGURE 6-16. ANGULAR ALIGNMENT MEASUREMENT READINGS (Example)

HC6 Axial Alignment Procedure

Axial misalignment needs to be checked only when an objectionable vibration is present.

If excessive vibration remains after the angular alignment, check for concentric alignment of the generator shaft/engine crankshaft axes.

Fasten dial indicator holding device to skid base, engine block, or generator shell with a magnetic base or clamp and position so the sensor point of indicator rests on the generator shaft hub, see Figure 6-15. Bar the engine over in a clockwise rotation as viewed from engine flywheel, through a couple of rotations. Record indicator readings in eight equally spaced points around the shaft diameter. This will provide a T.I.R. for Axial shaft misalignment.

The maximum allowable T.I.R. runout is subjective, the optimal T.I.R. for runout would be .000", however, that may not be attainable. The recommendation of this procedure will be to reduce the measured T.I.R. runout by one half. Specific out-of-tolerance runout levels are difficult to establish due to the

varying surface quality of the generator shaft's drive disc mountain hub.

The goal of the Axial realignment is to reduce the vibration level of the genset while it is operating. A small improvement in the T.I.R. runout may have dramatic effects in the mechanically measured or physically observed vibration levels.

To correct for an out of tolerance T.I.R. indication, remove the capscrews connecting drive discs and flywheel. Mark the drive discs and flywheel with respect to each other. Rotate either the engine or generator so that drive discs holes are repositioned 180 degrees from their original location. Put the drive discs capscrews back in and retorque. Recheck shaft alignment as before. If shaft T.I.R. runout remains unchanged then the discs should be rotated to either 30, 60, or 90 degrees from original location to correct the out of tolerance condition. If the T.I.R. does not improve after repositioning, a closer inspection of the flywheel pilot and drive disc runouts is required. This will help determine the cause of the Axial misalignment.

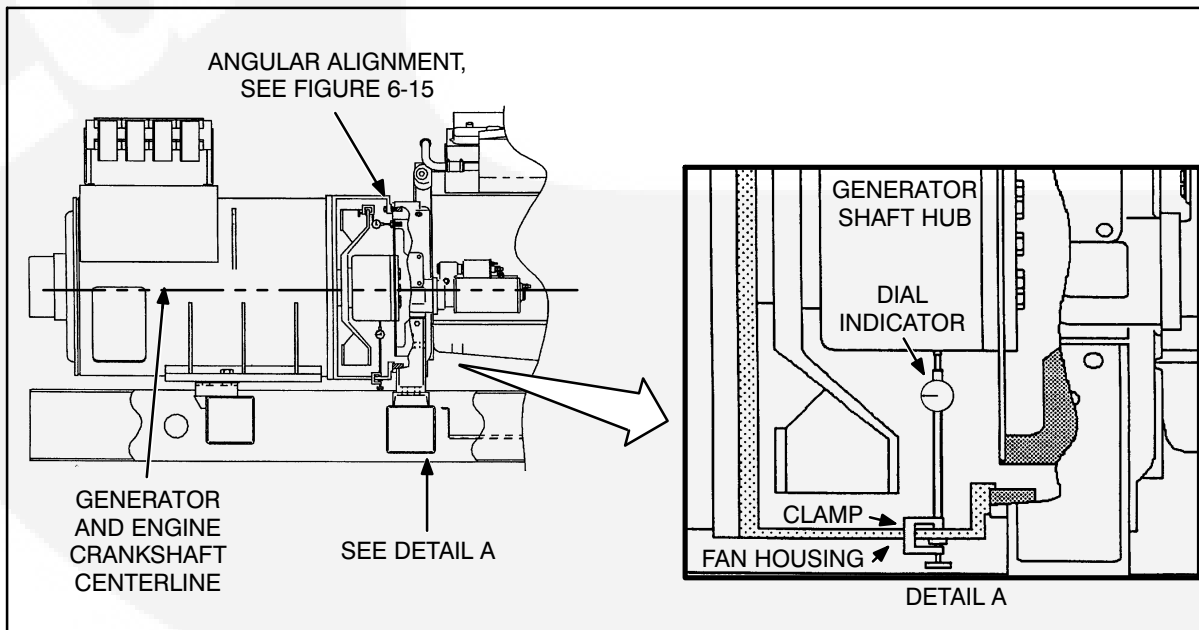

FIGURE 6-17. HC6 AXIAL ALIGNMENT MEASUREMENT

P7 Axial Alignment Procedure

Axial misalignment needs to be checked only when an objectionable vibration is present.

If excessive vibration remains after the angular alignment, concentric alignment of the generator shaft/engine crankshaft axes may be at fault.

The goal of the axial realignment is to reduce the vibration level of the genset while it is operating. A small improvement in the axial alignment may have dramatic effects in the measured or physically observed vibration levels.

To correct for possible axial misalignment, remove the capscrews connecting drive discs and flywheel. Mark the drive discs and flywheel with respect to each other. Rotate either the engine or generator so that drive discs holes are repositioned two bolt holes from their original location. Put the drive discs capscrews back in and retorque. Recheck/record vibration levels as before. Repeat this test until the drive discs holes are repositioned 180 degrees from their original location.

Review vibration data and position drive disc in lowest recorded level location.





THIS PAGE LEFT INTENTIONALLY BLANK



7. Day Tank Fuel Transfer Pump and Control

A fuel transfer pump and control are available when a sub-base or in-skid day tank are provided. The automatic control operates the fuel pump to maintain a reservoir of fuel in the day tank.

⚠️WARNING Diesel fuel is highly combustible. Improper installation of this kit can lead to spill-

age of large quantities of fuel and loss of life and property if the fuel is accidentally ignited. Installation and service must be performed by qualified persons in accordance with the applicable codes, including environmental regulations.

Do not smoke near fuel and keep flames, sparks and other sources of ignition well away.

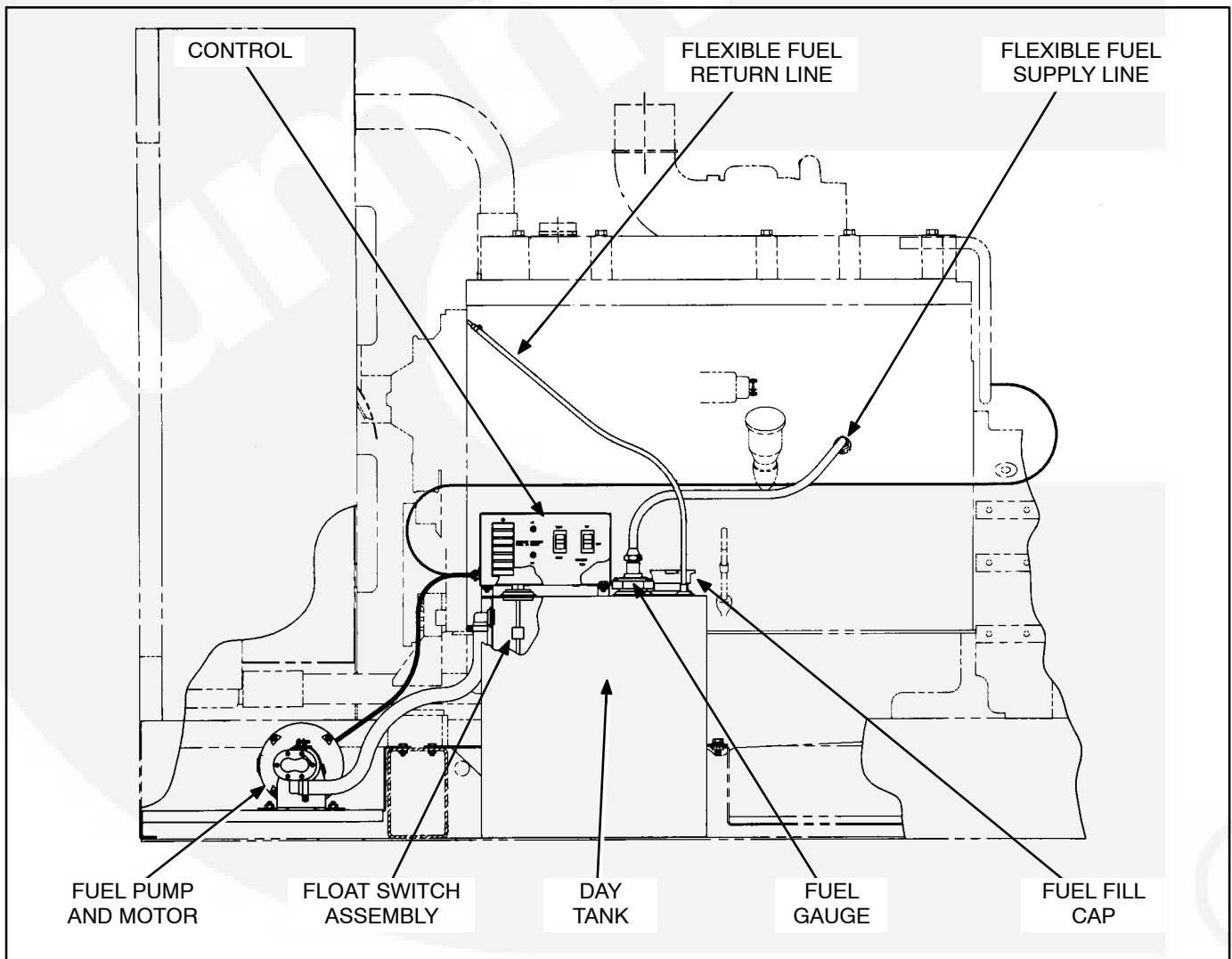

FIGURE 7-1. TYPICAL IN-SKID DAY TANK INSTALLATION

OPERATION

1. Push the control switch to the **ON** position for automatic operation. The green **SYSTEM READY** light will come on and the pump will fill the tank if AC power is available for pumping and DC power is available for the internal logic circuits. The level of fuel in the tank will be automatically kept between a set of pump-on and pump-off float switches.

When filling an empty tank, the red LO SHUTDOWN and LO FUEL lights will come on when the control switch is pushed to the ON position. This is normal. Push the panel RESET switch to turn off the red lights after the tank has been filled.

If the SYSTEM READY light does not come on, check for correct AC and DC power connections. See Wiring Connections and Fuel Pump Motor Connections below.

2. The green **PUMP ON** light indicates when the pump is running. It will come on and go off as fuel is pumped to maintain the proper level in the tank.
3. Push the control switch to the **EMERGENCY RUN** position (momentary contact) to pump

fuel into the tank if the control fails to operate the pump automatically.

The green PUMP ON light does not come on when the switch is in the EMERGENCY RUN position.

4. The red lights indicate fault conditions and the need for service. The control panel includes the following lights:

- A. **HI FUEL:** The fuel in the tank has reached an abnormally high level, indicating possible failure of the pump-off float switch. The high-fuel float switch takes over as the automatic pump-off switch. The **HI FUEL** light stays on. The light can be **RESET** with the panel switch when the fuel level drops to normal, but will come back on again during the next pumping cycle if the fault remains.

⚠ WARNING *Continued operation with a HI FUEL fault present can lead to spillage of large quantities of fuel if the high-fuel float switch fails. Spilled fuel can cause loss of life and property if it is accidentally ignited, or environmental damage.*

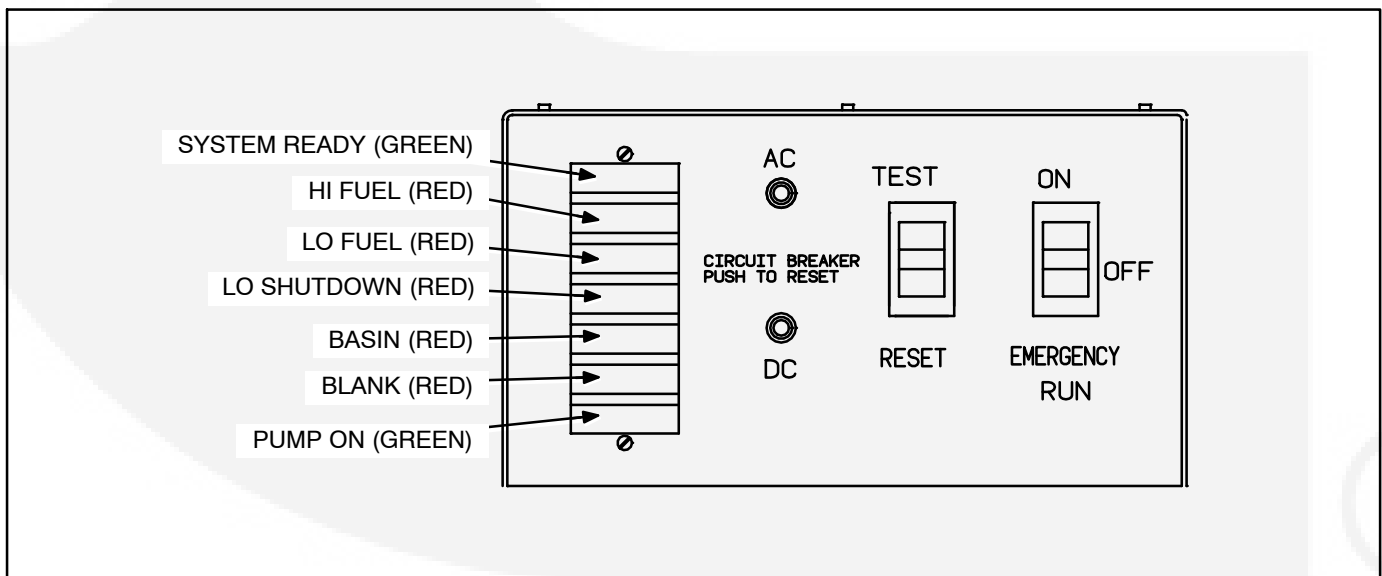

FIGURE 7-2. FUEL PUMP CONTROL PANEL

B. **LO FUEL:** The fuel in the tank has dropped to an abnormally low level, indicating possible failure of the pump-on float switch. The lo-fuel float switch takes over as the automatic pump-on switch. The **LO FUEL** light stays on. The light can be **RESET** with the panel switch when the fuel level rises to normal, but will come back on again during the next pumping cycle if the fault remains.

C. **LO SHUTDOWN:** The fuel has dropped to a level near the bottom of the tank, indicating an empty main fuel tank, pump failure or possible failure of both the pump-on and low-fuel level float switches. Further operation will allow air to enter the engine fuel unit, causing shutdown and the necessity to bleed the fuel unit to start up the engine again. Connections should have been made to Terminals **TB1-14** and **TB1-15** to shut down the engine automatically (to ground one of four customer fault inputs on terminals **A40-TB1-16, 17, 18, or 19**). If the light comes on, check the fuel level in the main fuel tank and fill it if necessary. As

the day tank is refilling, **RESET** the light with the panel switch.

To restore engine operation following this fault, both the pump control and the PCC have to be RESET.

D. **BASIN:** Fuel has overflowed into the rupture basin (if provided), indicating possible failure of both the pump-off and hi-fuel level float switches, or a leak in the day tank. **RESET** the control after the fuel in the basin has been safely disposed of and the cause of the overflow corrected.

E. **BLANK:** For customer use.

The control fault circuits will trip and latch, requiring RESET, even if AC power is lost.

5. Press the **TEST** switch to test the indicator lights and pump operating circuits. Replace any light that does not come on. The pump will stop automatically after it has filled the tank to the normal pump-off fuel level.
6. Press the reset button of the **AC** or **DC** circuit breaker if either has tripped.



WIRING CONNECTIONS

See *Day Tank Pump Control Wiring* diagram in *Section 8* when making connections at the control box terminal board. The following should be noted.

1. The control can be powered by 120 VAC or 240 VAC. The control is set up at the factory for connection to 240 VAC.

To convert the day tank controller from 240 VAC to 120 VAC, perform the following steps.

- A. Remove the two jumpers between terminals **TB1-6** and **TB1-7** in the control box and connect one between terminals **TB1-5** and **TB1-6** and the other between terminals **TB1-7** and **TB1-8**.
- B. Move selector switch **S103** on the control PCB to the up position for 120V.
- C. If the control is equipped with a transformer, remove the two jumpers between terminals **H2** and **H3** and connect one between **H1** and **H3** and the other between **H2** and **H4**.

To convert the day tank controller from 120 VAC to 240 VAC, perform the following steps.

- A. Remove the jumpers between terminals **TB1-5** and **TB1-6**, and **TB1-7** and **TB1-8** in the control box and connect the two jumpers between terminals **TB1-6** and **TB1-7**.
- B. Move selector switch **S103** on the control PCB to the down position for 240 VAC.

- C. If the control is equipped with a transformer, remove the jumpers between terminals **H1** and **H3**, and **H2** and **H4** and connect the two jumpers between **H2** and **H3**.
2. Attach a tag to the control box indicating the supply voltage.
 3. If a two lead wiring harness is provided, the control does not include a power transformer. To provide 24 VDC for the control circuit, connect terminal **TB1-19** to the positive (+) terminal of the 24 V starter motor solenoid and terminal **TB-20** to the negative (-) terminal.
 4. To immediately shut down the engine when the **LO SHUTDOWN** light comes on, connect terminal **TB1-14** to a good grounding point on the engine block and terminal **TB1-15** to terminal **A40-TB2-16, 17, 18, or 19** (Customer Fault inputs). The customer fault input selected, must be set for a shutdown operation (refer to *SET-UP MENU* in Section 5).
 5. Terminals **TB1-10** through **TB1-17** and **TB2-23** through **TB2-27** are available for connections to remote annunciators or to any one of the four customer fault inputs of the PCC.
 6. Terminal **TB2-22** is available for connection of a grounding signal to activate the blank red light.
 7. Terminals **TB1-8** and **TB1-5** are available for connection of a 120 or 240 VAC electric fuel shutoff valve rated not more than 0.5 amps. The voltage rating of the valve must correspond with the voltage utilized for the pump. See Item 2 above.

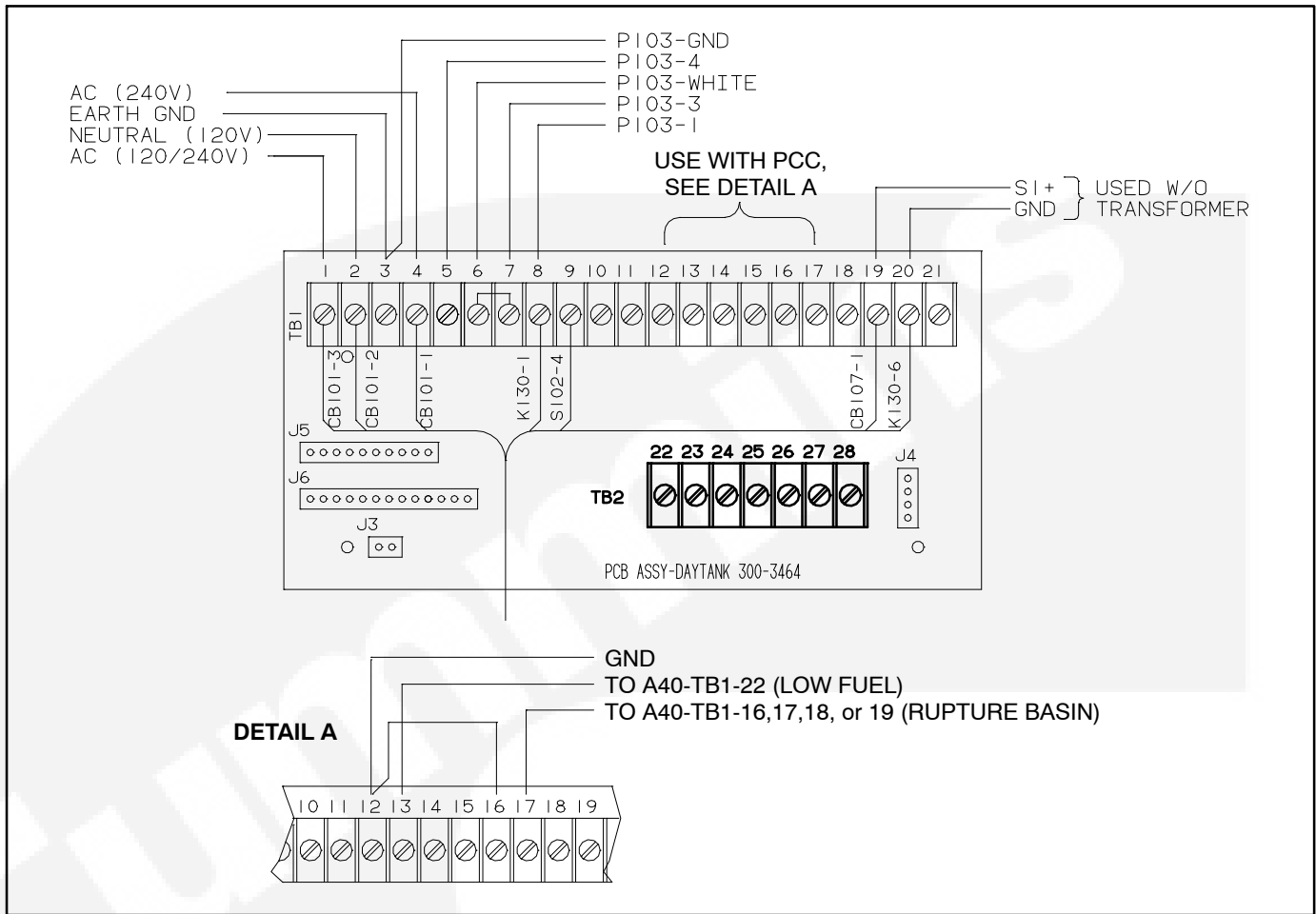

FIGURE 7-3. FUEL PUMP CONTROL TERMINAL BOARD

FUEL TRANSFER PUMP MOTOR CONNECTIONS

Connect a replacement fuel transfer pump motor as follows.

1. Remove the end bell cover for access to the motor wiring terminals.
2. Disconnect the brown lead from motor terminal **P103-3** and connect it to terminal **P103-6**. (Terminal **P103-6** is an insulated receptacle for securing the end of the lead so that it cannot move and touch the motor frame or a live terminal and cause a short circuit.)
3. Disconnect the red lead from motor terminal **P103-2**. It will be connected to the piggy-back terminal on the lead connected at motor terminal **P103-3**.
4. Cut the white lead from its ring connector at motor terminal **P103-4**. Strip 1/2 inch (12 mm) of insulation from the end of the white motor lead for splicing to the wire harness lead marked **P103-WHITE**.
5. Connect each lead of the five-lead wiring harness to the motor terminal or lead marked on it.
6. Connect the red motor lead to the piggy-back terminal at motor terminal **P103-3**.
7. Secure the end bell cover.

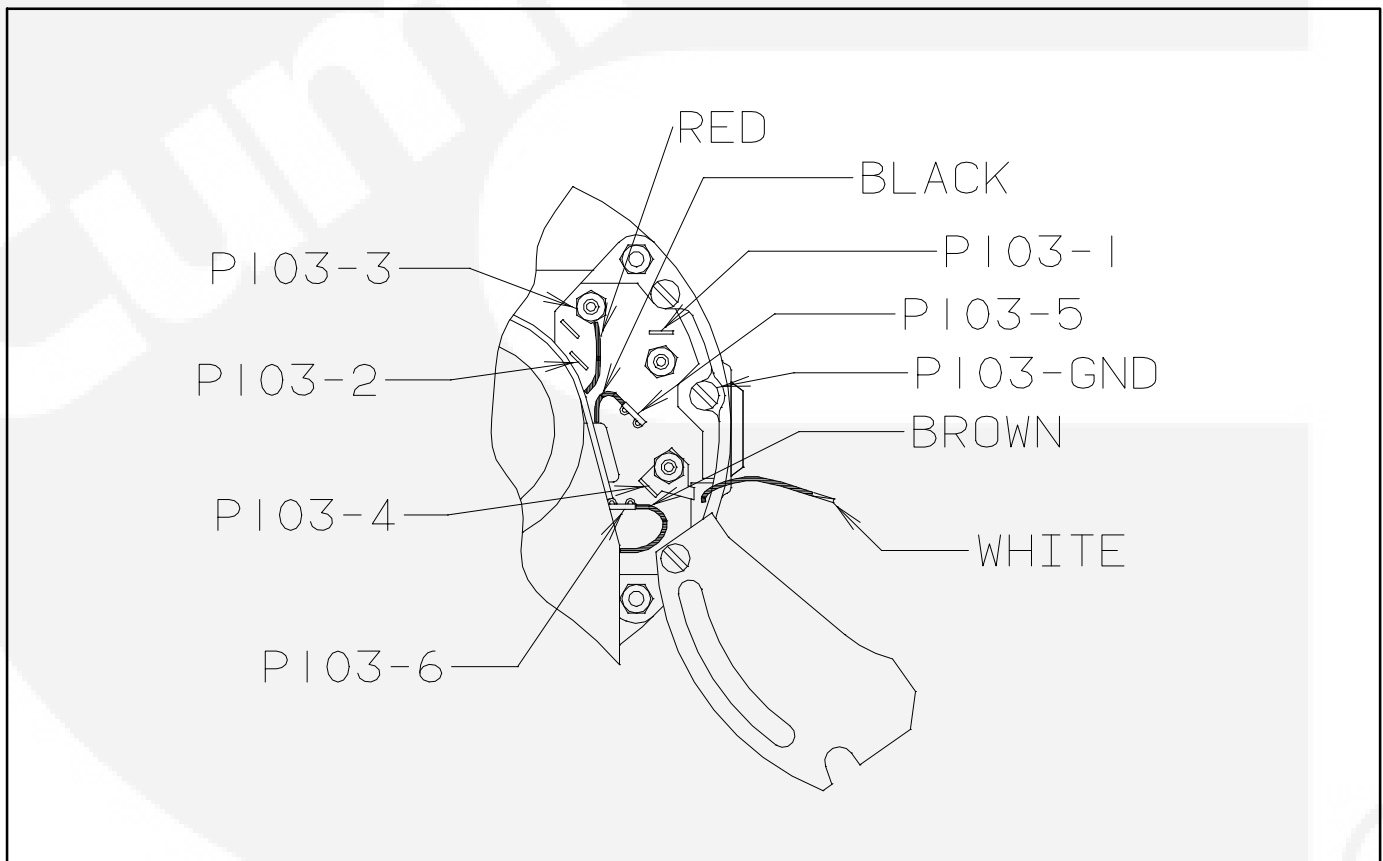

FIGURE 7-4. FUEL TRANSFER PUMP MOTOR CONNECTIONS

TESTING THE FLOAT SWITCH ASSEMBLY

The float switch assembly consists of 5 switches. Each switch has a pair of color coded leads connected to a common jack.

To test the float switches, remove the fuel pump control cover, disconnect the wiring jack and unscrew the assembly from the top of the day tank. Test as follows:

1. With an ohmmeter, test for electrical continuity (switch closed) between each pair of colored leads, while holding the assembly vertical. Replace the assembly if any switch is open (all the readings should be zero).
2. Lift each float, in turn, to 1/8 inch (3 mm) below the C-clip stop above it (use a feeler gauge) and test for electrical continuity. Replace the assembly if any switch does not open (all the readings should be infinity).
3. Use pipe thread sealant when replacing the assembly.

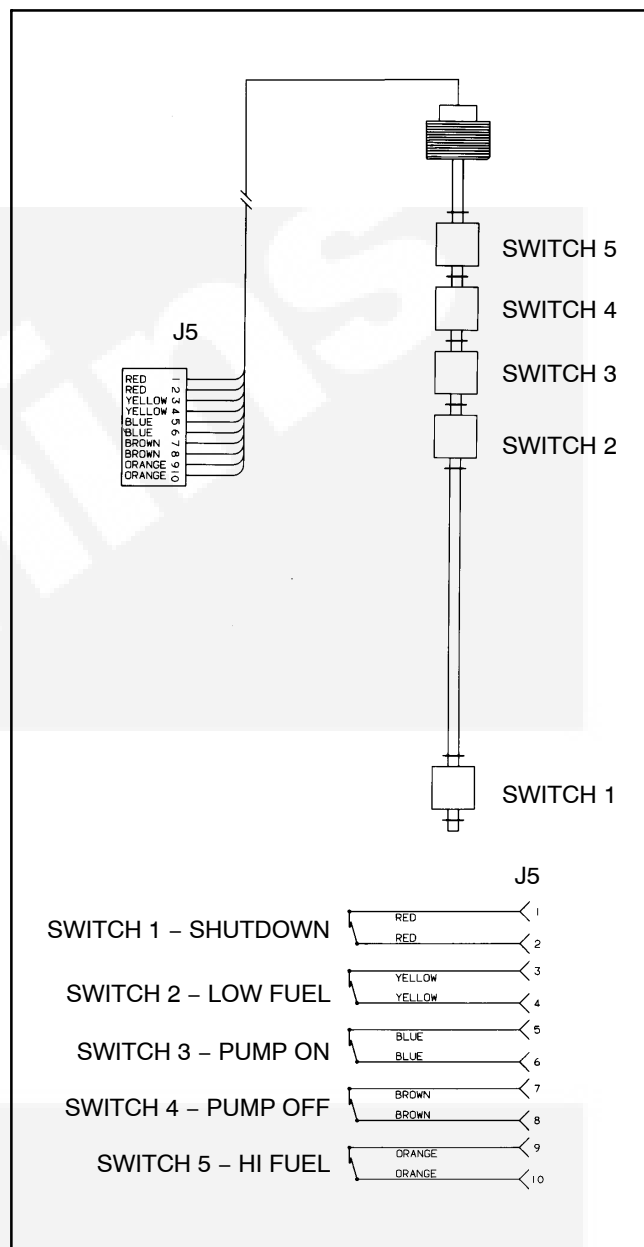

FIGURE 7-5. FLOAT SWITCH ASSEMBLY



THIS PAGE LEFT INTENTIONALLY BLANK



8. Initial System Startup

GENERAL

⚠ DANGER *Do not perform any procedure in this section on medium voltage (601 through 15,000 volts) generator sets. Special equipment and training is required to work on or around medium voltage equipment. Operation and maintenance must be done only by persons trained and qualified to work on such devices. Improper use or procedures will result in severe personal injury or death.*

This section describes a process which can be used in the initial startup and test of generator sets which are paralleled using PowerCommand Digital Paralleling controls. PowerCommand Digital Paralleling systems have many functions which are common to traditional paralleling systems, but they are completely different in the way that these functions are supplied in the system. The intent of this section is to provide you with guidance in the initial running of the equipment, so that you can perform this function with as safe and efficient procedures as possible.

⚠ DANGER *The accessory box of the PowerCommand Control contains high voltages when the generator set is running. It can be energized from the system bus and contain high voltages even when the generator set is not running. Contacting these high voltage components will cause severe injury or death. Do not attempt to service, operate or adjust the control unless you have been trained in proper service techniques.*

THE STARTUP PROCESS

The startup process described in this section is typical for paralleling systems which utilize PowerCommand Digital Paralleling equipment. Every paralleling system is different in its design and application, so portions of the recommended procedures may be inappropriate for your application, or some pro-

cedures may be needed which are not described in this section. Use your experience as the best guide for enhancing these general guidelines to provide the best process for the specific site which you are servicing.

In general, the startup process contains these major steps:

- Installation design review, including mechanical and electrical support systems for the generator sets and paralleling equipment.
- Individual generator set preparation, operation and performance review.
- Manual system operation.
- Automatic system operation and adjustments.
- Black start testing of system.
- Customer acceptance testing.
- Customer training.
- Issuing an installation report showing the work done, system performance and customer acceptance.

EQUIPMENT APPLICATION REVIEW

The purpose of the equipment application review is to visually inspect the installation to confirm that the equipment has been installed within specified parameters and that the equipment can be started as specified. Cummins technical application manuals *T-030 Liquid-Cooled Generator Sets* and *T-016 Paralleling and Paralleling Switchgear* provide guidance in evaluating installation requirements. It is recommended that you use an installation review report form, included at the end of this section, to avoid missing any major points in the equipment review and simplify reporting of problem areas to the installer or customer.

The system startup process should not proceed until the inspection and review are complete and all issues resolved.

INDIVIDUAL GENERATOR SET STARTUP

The generator set should be properly serviced, with proper levels of coolant and lubricants in the system. Care should be taken to remove all shipping blocks and braces from the equipment. Complete all pre-start service and checks as for a standard non-paralleled generator set.

Equipment needed to perform the startup:

- Two properly calibrated hand-held digital meters.
- Be certain that the meters are rated for use on a circuit operating at proper voltage.**
- Phase rotation meter.
 - PowerCommand service tool kit.
 - Individual generator set and system drawings, specific to the project being installed. Operator's manual, including PC program documentation, if available.

A two channel strip chart recorder with voltage and frequency modules is helpful, but not required for the startup.

Operate the generator set RUN/OFF/AUTO switch to the OFF position. Connect the generator set starting and control batteries at their proper locations and verify that no fuses are blown (indicating improper connections in the system). Verify that the stationary battery chargers are properly installed and wired and turn them on.

If the system includes a master control panel, verify that control power is present in the master control and operate the system mode select switch to the manual operation position, so that the system does not inadvertently receive a start signal. If the system includes a touchscreen, PLC bridge/MUX or network interconnections, verify that these are all functional.

Check the settings of the paralleling control functions. Typical values for these functions are shown in Table 8-1. If the generator set was tested in parallel at the factory, do not modify these adjustments at this time. Check the factory test report to verify that the settings of the control match the test report.

For paralleling applications, the default value of the governor gain should be set to 70. See *Section 5 – Governor/Regulator* menu for more information. Generator sets that are shipped from the factory without Cummins parallel gear are set up as single units. For multiple unit paralleling applications you must reconfigure the control. See *Section 5 – Paralleling Setup* menu.

TABLE 8-1. TYPICAL PARALLEL SET-UP PARAMETERS

FUNCTION	TYPICAL SETTING
ISOLATED BUS PARAMETERS	
SYNC TIME LIMIT	120 seconds
- PWR LIMIT	10 percent
- PWR LIMIT (TIME)	3 seconds
PERM WIN-PHASE	± 20 degrees (ISO bus) ± 15 degrees (utility)
PERM WIN-TIME	0.5 seconds
SYNC GAIN	95
SYNC INTEGRAL	12
KW BALANCE	165
KVAR BALANCE	0
KW GAIN	6
KVAR GAIN	300
1ST START FAIL	10 seconds
RAMP UNLD TIME	30 seconds
RAMP UNLD LEVEL	20 percent
RAMP LOAD TIME	30 seconds
LOSS FIELD TIME	2 seconds
UTILITY PARAMETERS	
BASE LOAD %	80 percent
PF LEVEL	1.00
KW GOVERN GAIN	100
KW INTEGRAL	4
KVAR GOVERN GAIN	300
KVAR INTEGRAL	200
RAMP LOAD TIME	10 seconds
RAMP UNLD TIME	10 seconds

Connect a jumper to the idle terminals of the generator set in the accessory box, so that it will start and run initially at idle speed.

Verify that starting the generator set and energizing the system bus will not cause hazards to other persons working in the vicinity of the equipment, or directly on the equipment or anything electrically connected to the equipment. Notify responsible persons in the building that the equipment may be energized and operating at any time.

Start the generator set by operating the RUN/OFF/AUTO switch to the RUN position. The generator set should start and accelerate to idle speed. An idle mode alarm should appear on the generator set digital display panel. Allow the generator set to run at idle, taking care to note unusual noises or vibration from the engine or alternator, leaking fluids or exhaust connections. Run the generator set at idle until the coolant temperature is greater than 100 degrees F (40 degrees C) Make any corrections necessary prior to continuing with the startup process.

Stop the generator set and remove the idle speed jumper from the accessory box interconnection terminal block. Start the generator set by operating the RUN/OFF/AUTO switch to the RUN position and observe it accelerating to rated frequency and voltage. Calibrate and adjust all generator set metering (if necessary) using the hand-held digital meter and the procedure in *Section 5* of this manual. Adjust the generator set to proper voltage and frequency. Record the values of voltage and frequency so that all units can be adjusted to the same values. Remember to save all changes and adjustments prior to switching off the generator set.

Make sure that the paralleling breaker is charged and ready to close (power circuit breakers only) and that the paralleling bus is de-energized. If the breaker is not charged, manually charge the breaker. Manually close the paralleling breaker for the generator set. Most paralleling breakers will automatically re-charge on closing (power circuit breakers only). When the charging cycle is complete, electrically open the breaker using the breaker open control switch on the front of the PowerCommand control. Close the breaker using the breaker close

switch on the front of the PowerCommand control. Verify proper functioning of the breaker open and close lamps on the PowerCommand Control and proper operation of the manual breaker control switches on the PowerCommand control.

⚠ DANGER *Use extreme caution when performing phase relationship testing. The system is energized and dangerous voltages are present in many locations. Contact with energized parts will cause serious injury or death. Do not attempt these tests unless you have proper equipment for testing and are trained in its safe use.*

Verify that the phase rotation of the generator set matches the phase rotation of the utility service at each transfer switch or breaker power transfer pair. Correct generator set phase rotation to match utility condition, if required, by reversing the phase L1 (A or U) and L2 (C or W) connections on the generator set output.

Note: *The purpose of this procedure is to make sure that the generator set output matches the bus phase relationship. Later in the startup process the wiring and interconnection of the bus and generator set PT modules will be verified. Note that the PT/CT module phases must be matched to the generator set phase changes, or a FAIL TO SYNCHRONIZE alarm will occur.*

If a master control is used in the system, make sure that the main bus metering is functioning and properly calibrated.

Using the load bank or available load on the system, check the generator set load carrying ability and the transient performance of the generator set. Adjust as necessary for proper generator set operation. Disconnect the load from the system.

Make sure that all alarm and shutdown circuits in the generator set are functioning properly. Shut down the generator set by switching the RUN/OFF/AUTO switch to OFF.

Repeat the process described in this section for each generator set in the system before moving on to the next step of the startup process.

MANUAL SYSTEM OPERATION

Once all generator sets in the system have been successfully run individually, the generator sets are ready for verification of manual paralleling capability.

Make sure that all generator set RUN/OFF/AUTO control switches are placed in the OFF position and that the master control switch (if used) is also in the manual mode position.

Operate the control switch of one generator set to the RUN position and allow the generator set to start and accelerate to rated speed and voltage. Manually close the paralleling breaker on this generator set by pushing the breaker close pushbutton on the front face of the PowerCommand control. Allow the generator set to run at no load for the first phase of the manual paralleling test.

⚠ DANGER *Use extreme caution when performing phase relationship testing. The system is energized and dangerous voltages are present in many locations. Contact with energized parts will cause serious injury or death. Do not attempt these tests unless you have proper equipment for testing and are trained in its safe use.*

Check the phase relationship of the generator set output to its Bus PT module. The voltage difference between the L1 phase on the input to the Bus PT board and the generator set PT/CT board should be zero. Repeat this process for each generator set in the system.

Make sure that all generator set RUN/OFF/AUTO control switches are placed in the OFF position and that the master control switch (if used) is also in the manual mode position.

Operate the control switch of one generator set to the RUN position and allow the generator set to start and accelerate to rated speed and voltage. Manually close the paralleling breaker on this gen-

erator set by pushing the breaker close pushbutton on the front face of the PowerCommand control. Check the phase relationship of the generator set which is closed to the bus, with each individual generator set. This can be accomplished by starting the second generator set in the system by operating the RUN/OFF/AUTO control switch to the RUN position and allow the generator set to start and accelerate to rated speed and voltage. When generator set frequency and voltage have stabilized, operate the display screen of the PowerCommand control to the voltage and frequency screens and use the digital display to verify that the generator set voltage and frequency matches the bus voltage and frequency.

Switch the display screen to the digital synchroscope (bus frequency) screen and observe the control phase relationship between the generator set and the bus. When the phase relationship of the oncoming generator set is within the acceptance parameters programmed into the control, an asterisk (*) will be displayed on the screen next to the phase difference display.

When the asterisk is displayed on the control panel, check the phase relationship between the generator set and the bus. With the hand-held digital voltmeter, check the voltage from the line side to the load side for each phase of the open paralleling breaker on two phases simultaneously (Figure 8-1). If the phase relationship is proper, the voltage across the breaker (with the breaker open) should be zero, or nearly zero on both phases when the "synchronized" indicator lamp is on. The voltage of the two meters should rise and fall at approximately the same time.

Note: If the generator set output phase rotation matches the bus and a PHASE ROTATION warning appears when you attempt to close the paralleling breaker, you should check the generator set and Bus PT boards for proper wiring and interconnection. Both the primary and secondary wiring in the Bus PT board should be checked. See Table 4-28.

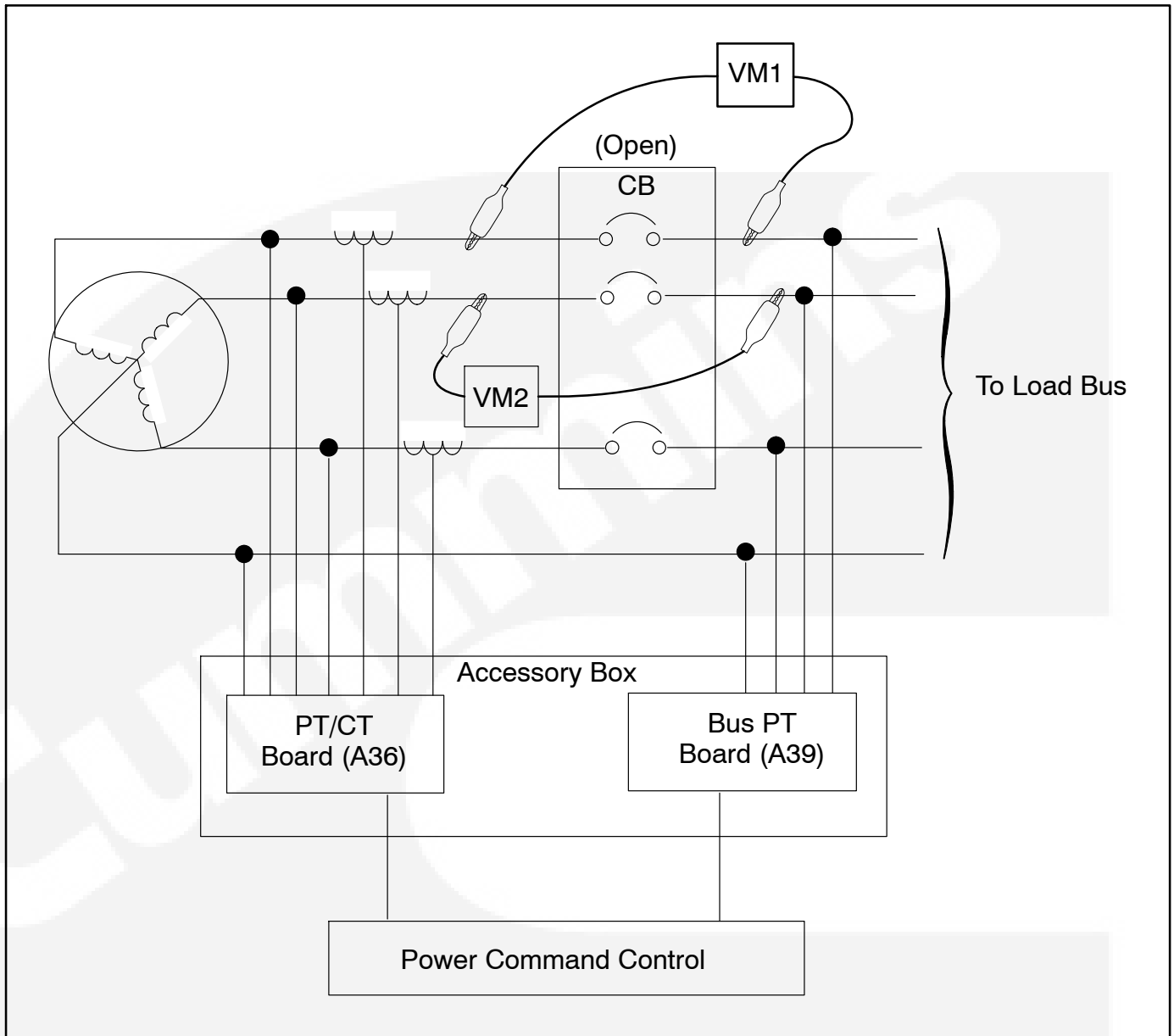

FIGURE 8-1. CHECKING PHASE RELATIONSHIP BETWEEN GENERATOR SET AND SYSTEM BUS

Note: For applications where a wye connected generator set is paralleled to a delta connected bus, the generator neutral bus must be floating and the neutral connection to the bus PT module must not be used.



Make sure that the “charged” flag is present on the paralleling breaker and push the breaker close pushbutton on the PowerCommand Control to manually close the oncoming set paralleling breaker and paralleling the generator set to the system bus.

Note: The breaker close function operates through a permissive relay function in the PowerCommand Control, so the paralleling breaker will not close unless the generator set is properly synchronized with the system bus.

Perform the phase rotation verification on each generator set in the system, prior to attempting to close it to the live parallel bus for the first time.

When all generator sets have been closed to the bus, observe the voltage, frequency, amp load and kilowatt load on each generator set metering set. The metering should indicate identical voltage and frequency readings on all generator sets in the system. Amp and kilowatt readings should all be zero. With no load on the system, a positive amp load reading on generator sets indicates a voltage difference between the generator sets in the system. A

positive kilowatt reading on any generator set indicates a frequency misadjustment on at least one generator set. Perform adjustments necessary to eliminate circulating currents and kilowatt loads. Save the generator set adjustments made prior to switching off the generator set.

With all generator sets running in parallel in manual (RUN) mode, apply available load to the system. Observe load sharing levels on the generator sets. The units should share load proportionally. (The %load and %amps meters on the PowerCommand control should all read within plus or minus 5% of each other.)

Adjust load sharing parameters within control system to achieve proper load sharing. Save all changes.

If possible, operate the system at various load levels and verify proper operation at each level.

Remove all load from the system and return the generator sets to their normal automatic mode by placing the RUN/OFF/AUTO switch in the AUTO position.



AUTOMATIC SYSTEM OPERATION

If the system includes a master control panel, move the mode selection switch on that panel to the full automatic position. Operate the test switch to cause the system to automatically start and parallel all generator sets.

The generator sets should automatically start, accelerate to rated speed and voltage, synchronize and parallel on the system bus. As the generator sets synchronize and close to the system bus, observe the operation of the load adding (priority) control relays in the master control. (If load add control relays are provided.) Observe and record the time to synchronize for each generator set.

With all the generator sets running and closed to the system bus, apply load to the running generator sets, but at a low enough level that all the generator sets need not be running in order to carry the bus load. On one generator set, ground the Load Demand contact in the accessory box. The following sequence should then occur:

- The "LOAD DEMAND" shutdown message should be displayed on the PowerCommand digital display panel.
- The load should ramp down on the generator set to its minimum set point level.
- The generator set paralleling breaker should open.

- The generator should run for its normal cool-down period and then shut down.

When the unit has shut down, remove the ground signal on the Load Demand termination point. The generator set should start, build up to rated frequency and voltage, synchronize and parallel to the system bus. When it has closed to the bus, it should ramp up to its proportional share of the total bus load.

Repeat the load demand test for each of the generator sets in the system.

Switch off the test switch in the master control. All the paralleling breakers should simultaneously open and the generator sets should run for a cool-down period and shut down.

Simulate a remote start in the master control. The generator sets should automatically start, accelerate to rated speed and voltage, synchronize and parallel on the system bus. Remove the remote start jumper on the master control. The generator set paralleling breakers should all open and the generator sets should run for a cooldown period and shut down.

At this point the various control functions of the master control can be tested and verified. Consult the project drawings and specifications or approved submittal documents for details on master control functions and requirements.



BLACK START TESTING

The black start testing process is designed to demonstrate that the entire on-site power system is installed correctly and that system support equipment, such as day tanks, fuel pumps, or supplemental ventilation equipment, is designed and installed correctly. It is primarily used in applications where the paralleling system is intended to provide emergency power in the event of a normal utility (mains) power failure. The black start testing process is performed after the entire on-site power system is installed. This testing process is often performed in conjunction with the customer approval testing, since it may be disruptive to the operation of the facility and demand special arrangements to avoid potentially dangerous or costly power failures in the facility.

The specific details of this testing process are very dependent on the design of the electrical and mechanical systems of the facility. In general the steps in this process are as follows:

- A power failure is simulated in the facility by opening the main power feeder in the building. It is desirable to do this to be certain that critical loads such as fuel pumps are fed from both the generator and utility (mains) bus.
- The generator sets start and parallel. The time required for the generator sets to start and parallel should be recorded and noted on the final test report for the system.
- Observe operation of all power transfer devices, noting the time required to transfer.
- The generator sets should be run in parallel with all available load in the building, at a minimum of approximately 30% of their standby KW rating. The duration of the test should be sufficient for the generator sets to reach their normal operating temperatures. The load demand system (if provided in the system master control) should be shut down until all generator sets in the system have reached normal operation temperatures and their operation tempera-

tures have stabilized. During this process, data should be gathered to demonstrate the load applied and the operational performance of the system. It is customary to document the generator set performance during this period, by recording all values on all meters and engine monitors every 15 minutes.

- When all required customer testing and verifications have been performed, return the system to normal power by restoring utility (mains) power at the point where it was disconnected.
- Verify that the generator sets and power transfer devices all return to their normal ready-to-start states.

TEST REPORTS AND ACCEPTANCE

The technician performing the system startup should issue a start up and test report to document the work performed and demonstrate that the system is functional and operational. The exact requirements of this report will vary depending on customer requirements, but should include, as a minimum:

- The application and review and evaluation. A copy of the site review checklist performed at the start of the testing process might be included to document this step of the process.
- A copy of the startup check list (a typical check list is included at the end of this section), documenting the functions tested and that each function performed properly.
- Test data sheets documenting results of load testing.
- List of all the settings of each generator set control.
- Black start test results.
- Certification that the system is operational and ready to run.
- It is customary for an owner's representative to review and sign all test documents, indicating acceptance of the test data and system performance.

ON SITE POWER SYSTEM APPLICATION REVIEW (DIESEL/600VAC AND LOWER)

Date: _____ Location: _____

Owner/Operator: _____

Generator Set Model: _____ Serial Number: _____

Transfer Switch Model: _____ Serial Number: _____

Project/Order Number: _____

Review Performed By: _____

Mounting/Noise/Isolation

- Flexible power output conduit, supported by bldg.
 - Isolators/pad (integral to set)
 - Isolators/pad (external to set)
 - Isolators/spring-pad, adjusted correctly
 - Flexible stainless steel exhaust connection
 - Flexible fuel lines (supply & return), secured
 - Flexible power output conduit, supported by bldg.
 - Flexible auxiliary power connections
 - Flexible control connections
 - Flexible exhaust air duct
 - Seismic restraints (where required)
 - Provisions for draining oil/coolant
 - Clearance around genset (3ft/1 meter min.)
 - Fire alarm provisions
 - System covers/shields all in place
- Heat sources in room insulated
 - Recirculation of radiator exhaust air unlikely
 - Access door to room opens in (or vented)
 - Vent dampers powered from emergency power supply
 - Direction of prevailing winds

Fuel System

- Piping is not galvanized or copper
- Manual shut-off valve
- Solenoid valve on fuel supply, power from set
- Fuel returns to main tank
- Fuel line size adequate
- Fuel line high loops
- Day tank/vent at highest point
- Day tank/location below return lines
- Day tank/strainer-filter
- Day tank/level alarms
- Main fuel tank below set
- Fuel transfer pump/power from genset
- Main fuel tank above set
- Solenoid valve
- Sub-base tank
- Level gage
- Vent

Exhaust

- Silencer close to genset
- Exhaust connections sealed
- Exhaust insulated
- Proper personnel protection provided
- Exhaust run slopes away from genset
- Condensate trap with valve on exhaust silencer
- Provisions for thermal expansion
- Raincap/birdscreen on exterior of building
- Exhaust thimble
- Correct pipe size, supported by building
- Facility vent air intake, windows, doors not close to exhaust outlet
- No combustible materials, or fire system components near uninsulated pipe

Cooling System

- Filled with soft water/E.G./DCA mixture
- Jacket water heater provided
- Valves to isolate jacket water heater
- Power supply to heater from normal power

Ventilation System

- Inlet air duct properly sized (approx. 1.5x radiator)
- Exhaust air duct properly sized (effective open area not less than radiator area)

Electrical System

- Control connections isolated from power
- Control connections use stranded wire
- Conductor size OK (power & control)
- Proper battery size/filled with electrolyte
- Battery rack isolated from floor
- Battery charger/power from utility
- Start signal wired to ATS
- Generator frame grounded (bonded)
- Neutral connection (where/how)
- Power/control conductors torqued
- Wiring accuracy/matches drawings

Other

- Oil installed in engine
- Posted operating instructions
- Generator/ATS manuals, drawings provided
- Generator room/control boxes cleaned



THIS PAGE LEFT INTENTIONALLY BLANK



9. Wiring Diagrams

GENERAL

This section consists of the schematic and connection wiring diagrams referenced in the text. The following drawings are included.

- Page 9-2 and 9-3, AC Reconnect Wiring Diagram
- Page 9-4, Block Diagram (12 Lead)
- Page 9-5, Block Diagram (6 Lead)
- Page 9-6, Customer Connections
- Page 9-7, Engine Interface Board (A31)
- Page 9-8, Digital board (A32)
- Page 9-9, Analog board (A33)
- Page 9-10, Customer Interface Board (A34)
- Page 9-11, Display Board (A35)
- Page 9-12, PC/CT Board (A36)
- Page 9-13, Voltage Regulator Output Module (A37)
- Page 9-14, Governor Output Board (A38)
- Page 9-15, PT/CT Wiring Harness
- Page 9-16, Engine Wiring Harness
- Page 9-17, Accessory Box Interconnection Harness Diagram
- Page 9-18, Day Tank Pump Control Wiring
- Page 9-19 Accessory Interconnect Diagram
- Page 9-20, Sequence of Operation (Local Start and Run)
- Page 9-21, Sequence of Operation (Local Stop)
- Page 9-22, Sequence of Operation (Local Emergency Stop)



THIS PAGE LEFT INTENTIONALLY BLANK



SC, CC, HC GENERATORS

3 PHASE RECONNECTABLE

THIS IS A REPRESENTATIVE (GENERIC) SCHEMATIC/WIRING DIAGRAM. FOR TROUBLESHOOTING, REFER TO THE WIRING DIAGRAM PACKAGE THAT WAS INCLUDED WITH YOUR GENSET.

NOTES:

1. UVW PHASE SEQUENCE WITH C.W. ROTATION FACING DRIVE END.
2. TIE BACK UNUSED LEADS.
3. WHEN RECONNECTING GENERATOR LEADS, BOLTS SHOULD BE TORQUED AT 68±6 FT-LBS. FOR FRAMES 5, 6 AND 7.
4. WHEN RECONNECTING GENERATOR LEADS, BOLTS SHOULD BE TORQUED AT 22±2 FT-LBS. FOR FRAMES 4.
5. NEUTRAL FLOATED FOR DELTA CONFIGURATION. TIE LEAD 5 BACK INTO HARNESS.

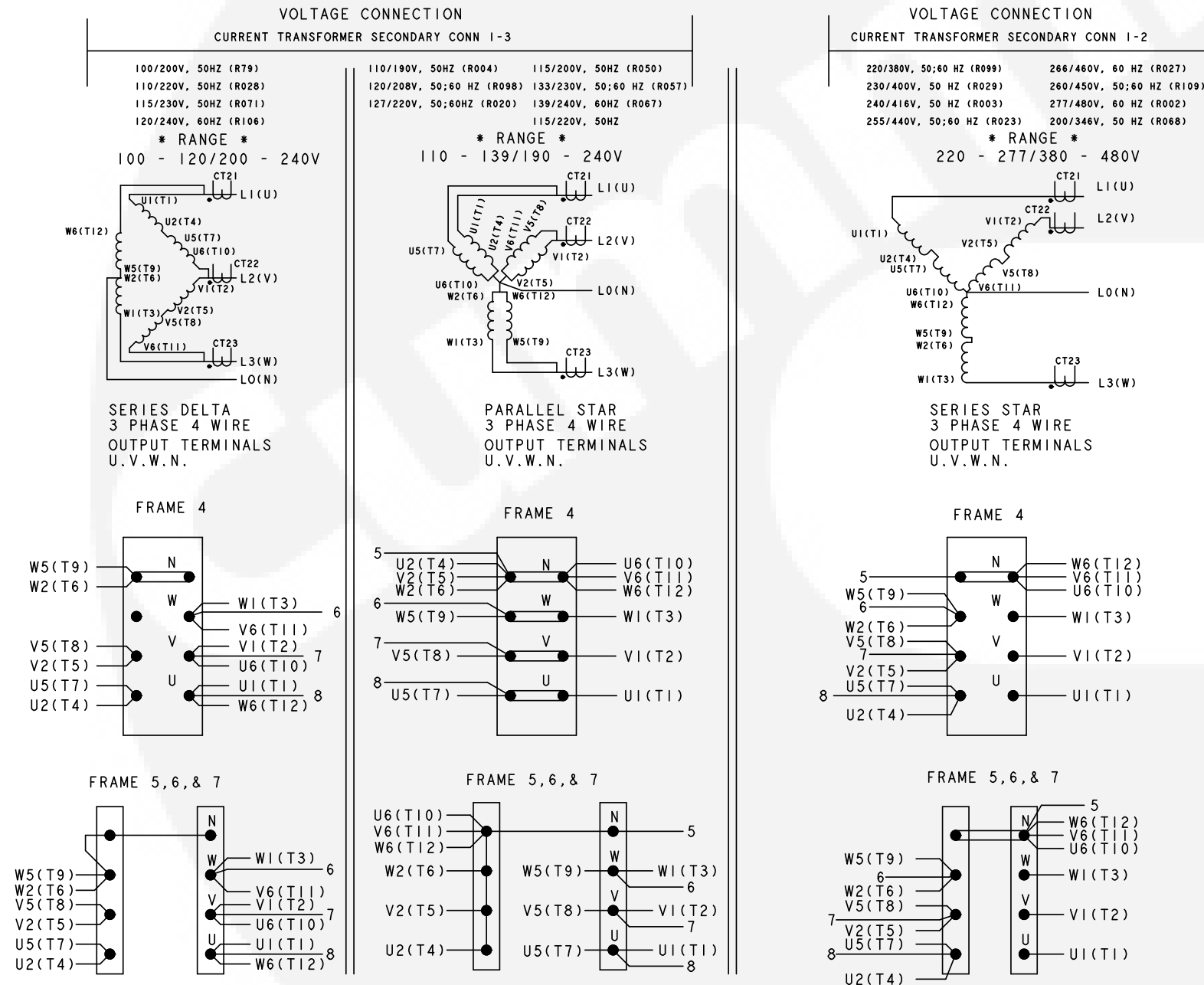

PC CONTROL

No. 625-3100 sh1 of 2
Rev. H Sys:CADAM
Modified 2/2011

THIS IS A REPRESENTATIVE (GENERIC) SCHEMATIC/WIRING DIAGRAM. FOR TROUBLESHOOTING, REFER TO THE WIRING DIAGRAM PACKAGE THAT WAS INCLUDED WITH YOUR GENSET.

SC, CC, HC GENERATORS

3 PHASE NON-RECONNECTABLE

MEDIUM VOLTAGE

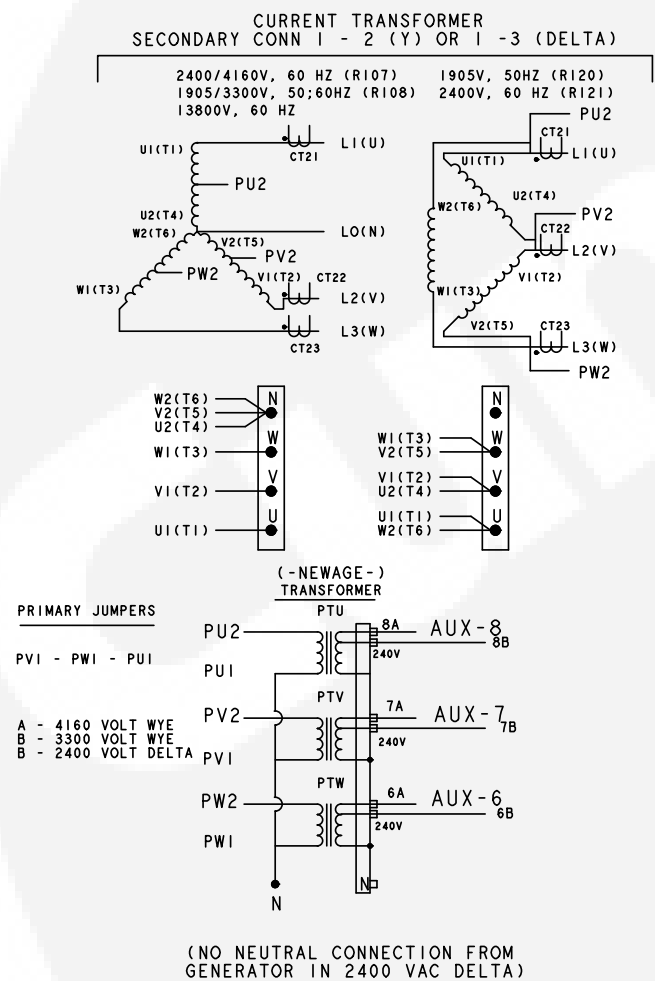

CURRENT TRANSFORMER SECONDARY CONN 1 - 2

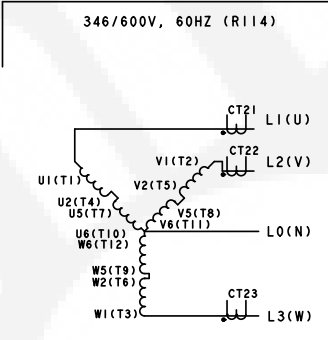

FRAME 4, 5, & 6

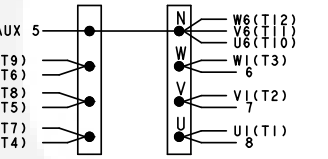

CURRENT TRANSFORMER SECONDARY CONN 1 - 2

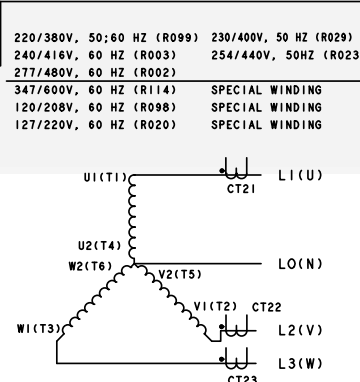

FRAME 5, 6, & 7

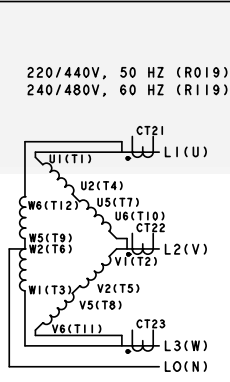
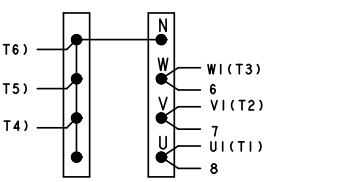

FRAME 5, 6, & 7

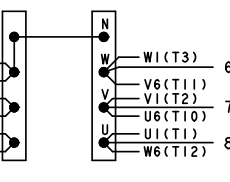

FRAME 4

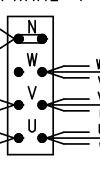

PC CONTROL

No. 625-3100 sh 2 of 2
Rev. H Sys:CADAM
Modified 2/2011

CUSTOMER CONNECTIONS(SEE SHEET 3)

ANNUNCIATOR CUSTOMER CONNECTIONS(SEE SHEET 3)

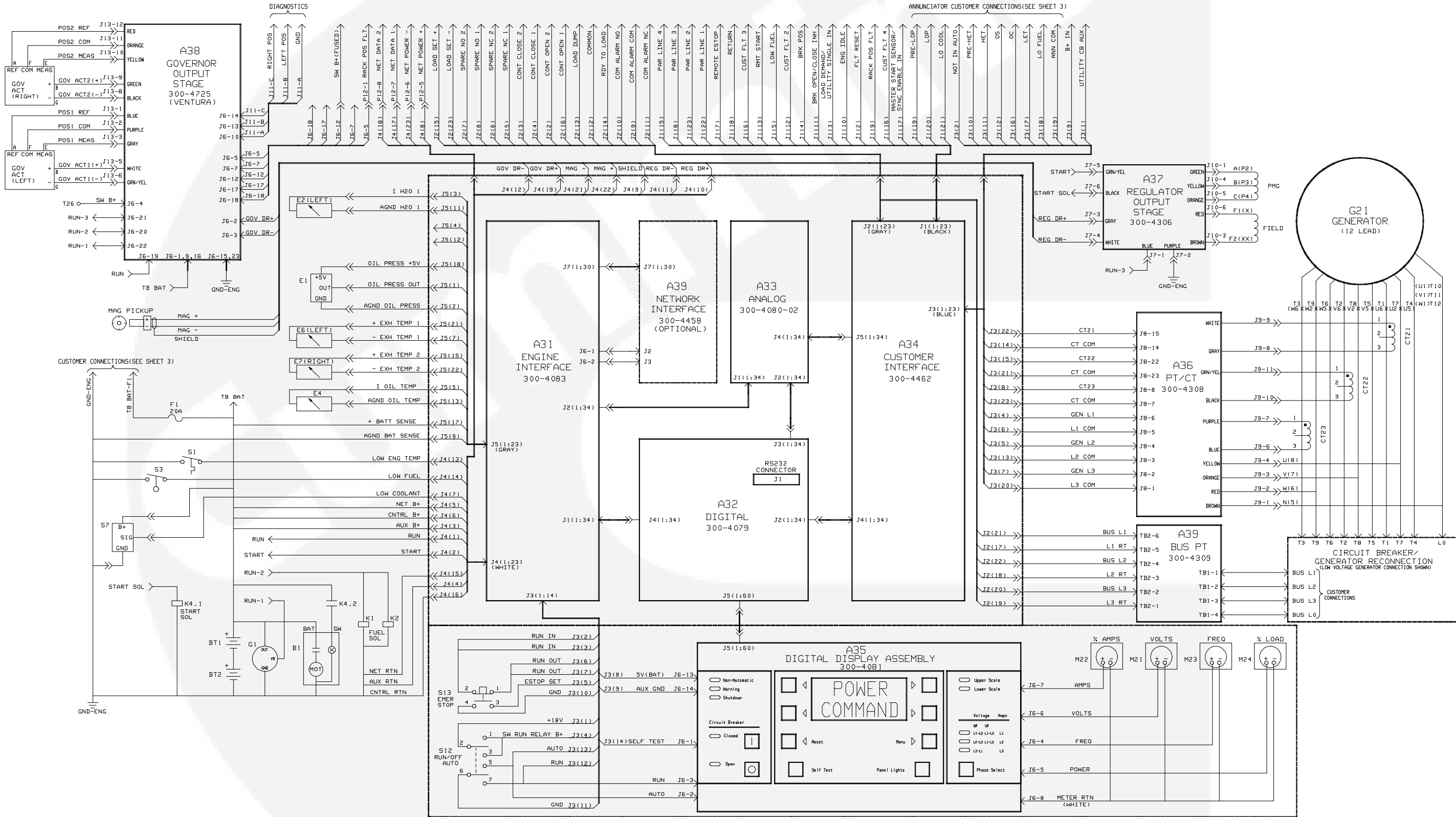

No. 612-6701 sh 1of3
 Rev. B Sys: HP
 Modified 12/1996

BLOCK DIAGRAM (12 LEAD)

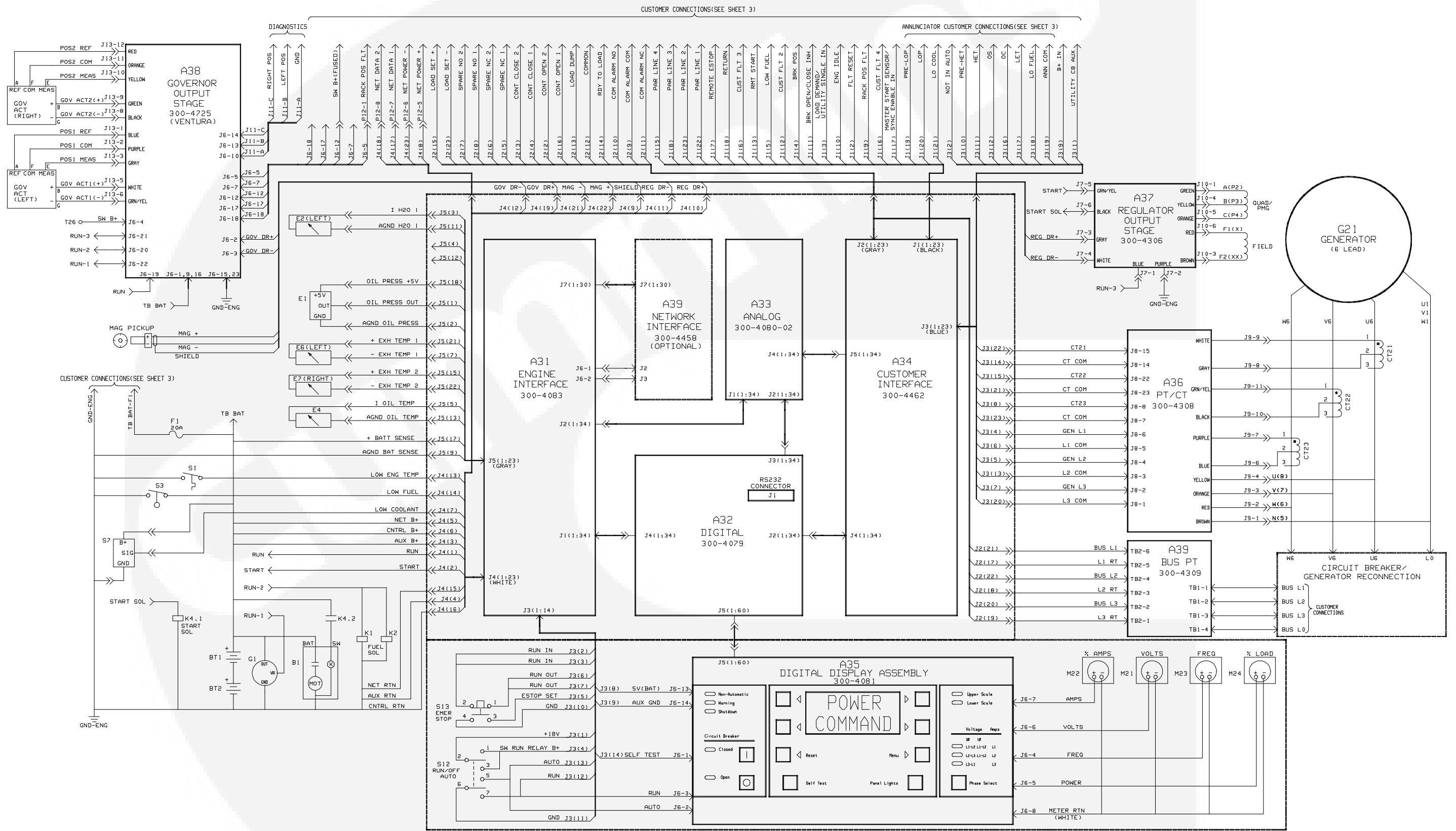

BLOCK DIAGRAM (6 LEAD)

No. 612-6701 sh 2of 3
 Rev. B Sys: HP
 Modified 12/1996

CUSTOMER TERMINAL BLOCK (PARALLELING)

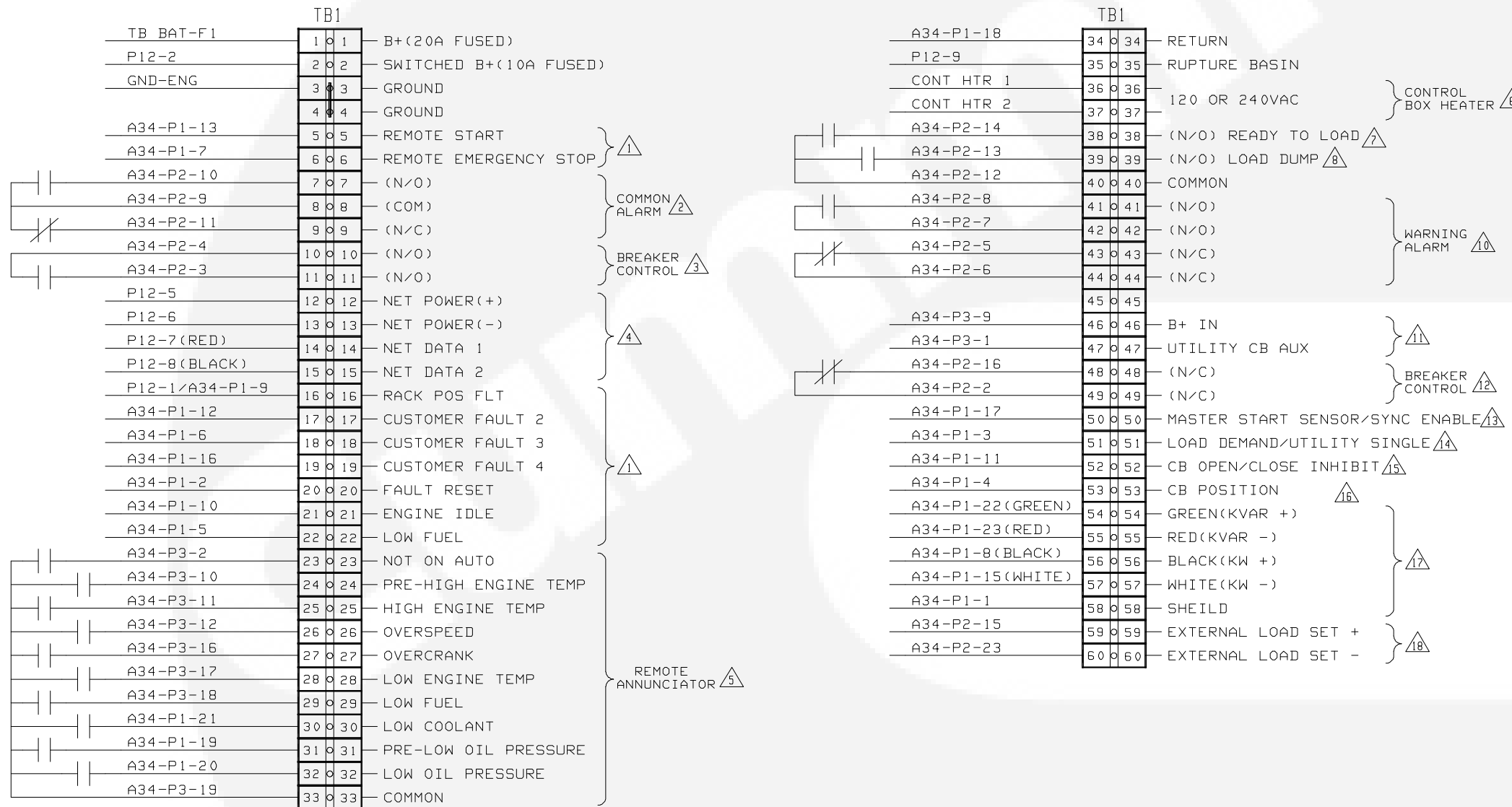

NOTES:

- 1 APPLY A GROUND TO ACTIVATE INPUT. CUSTOMER FAULT 2 AND CUSTOMER FAULT 3 "WAKE UP" CONTROL. USE COPPER STRANDED WIRE. 20 GA FOR RUNS LESS THAN 1000 FT. 18 GA FOR RUNS FROM 1000 TO 2000 FT. (LESS THAN 50mA CURRENT)
- 2 2A @ 30VDC RELAY CONTACTS. THIS RELAY PICKS UP ON SHUTDOWNS ONLY.
- 3 5A @ 30VDC RELAY CONTACTS. THIS RELAY PICKS UP TO CLOSE THE BREAKER AND DROPS OUT TO OPEN THE BREAKER.
- 4 REFER TO ONAN 900-0366 POWER COMMAND NETWORK AND OPERATION MANUAL FOR INTERCONNECTION INSTRUCTIONS (OPTIONAL PCC NETWORK INTERFACE MODULE).
- 5 1A @ 30VDC ISOLATED RELAY CONTACTS. THESE RELAYS PICKS UP ON THE GIVEN FAULT.
- 6 120VAC OR 240VAC @ 50 WATTS (OPTIONAL).
- 7 2A @ 30VDC ISOLATED RELAY CONTACTS. THIS RELAY PICKS UP WHEN GENERATOR AC VOLTAGE AND FREQUENCY EXCEED 90% OF NOMINAL.
- 8 2A @ 30VDC RELAY CONTACTS. THIS RELAY PICKS UP IF AN OVERLOAD OR UNDER-FREQUENCY CONDITION OCCURS.
- 9 TERMINAL BLOCK RATING
20A, 600V
22 TO 12 GA WIRE
TORQUE TERMINAL SCREWS TO 7 IN-LBS (0.8 NM)
- 10 5A @ 30VDC RELAY CONTACTS. THIS RELAY PICKS UP WHEN A WARNING CONDITION OCCURS.
- 11 APPLY B+ TO B+ AND A GROUND TO CIRCUIT BREAKER AUXILIARY TO INDICATE A UTILITY BREAKER CLOSURE (LESS THAN 50mA).
- 12 5A @ 30VDC RELAY CONTACTS. THIS RELAY PICKS UP TO CLOSE AND DROPS OUT TO OPEN THE GENERATOR CIRCUIT BREAKER.
- 13 PULSED INPUT TO ENABLE GENSER AS FIRST ON LINE FOR MULTIPLE UNITS. IN SINGLE/UTILITY PARALLEL MODE, APPLY 24VDC TO ENABLE SYNCHRONIZER.
- 14 IN MULTIPLE UNIT OPERATION MODE APPLY GROUND TO CAUSE LOAD DEMAND STOP. IN SINGLE MODE, GROUND TERMINAL TO ENABLE BREAKER CLOSURE.
- 15 APPLY A GROUND TO REMOTELY OPEN OR INHIBIT CLOSURE OF THE GENERATOR CIRCUIT BREAKER WHEN PCC IS IN AUTO MODE (LESS THAN 50mA).
- 16 APPLY A GROUND TO INDICATE GENERATOR CIRCUIT BREAKER IS CLOSED (LESS THAN 50mA).
- 17 PARALLEL LOAD SHARE LINES (0 - 1mA). USE 4 CONDUCTOR SHIELDED CABLE, 18 GA STRANDED. MAXIMUM RUN 500 FT.
- 18 ANALOG 0-5VDC INPUTS TO CONTROL GENERATOR LOAD IN UTILITY PARALLELING MODE.

No. 612-6701 sh 3of3
Rev. B Sys: hp
Modified 12/1996

THIS IS A REPRESENTATIVE (GENERIC) SCHEMATIC/WIRING DIAGRAM. FOR TROUBLESHOOTING, REFER TO THE WIRING DIAGRAM PACKAGE THAT WAS INCLUDED WITH YOUR GENSET.

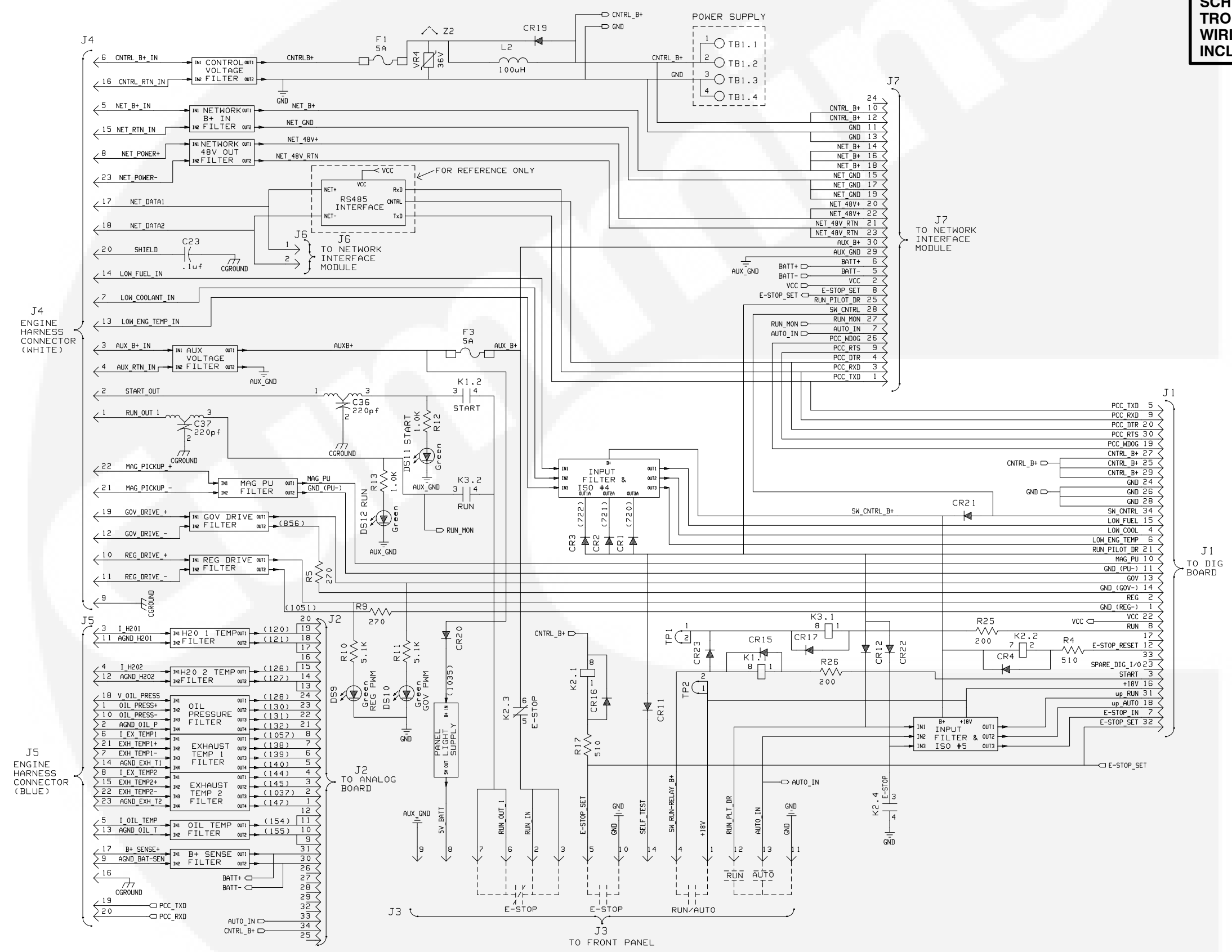

ENGINE INTERFACE BOARD (31)

NO. 300-4819 sht 1 of 4
REV. B
MODIFIED 8/2008

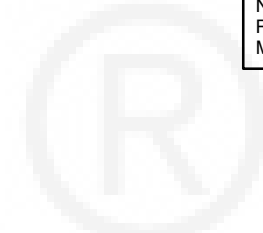

THIS IS A REPRESENTATIVE (GENERIC) SCHEMATIC/WIRING DIAGRAM. FOR TROUBLESHOOTING, REFER TO THE WIRING DIAGRAM PACKAGE THAT WAS INCLUDED WITH YOUR GENSET.

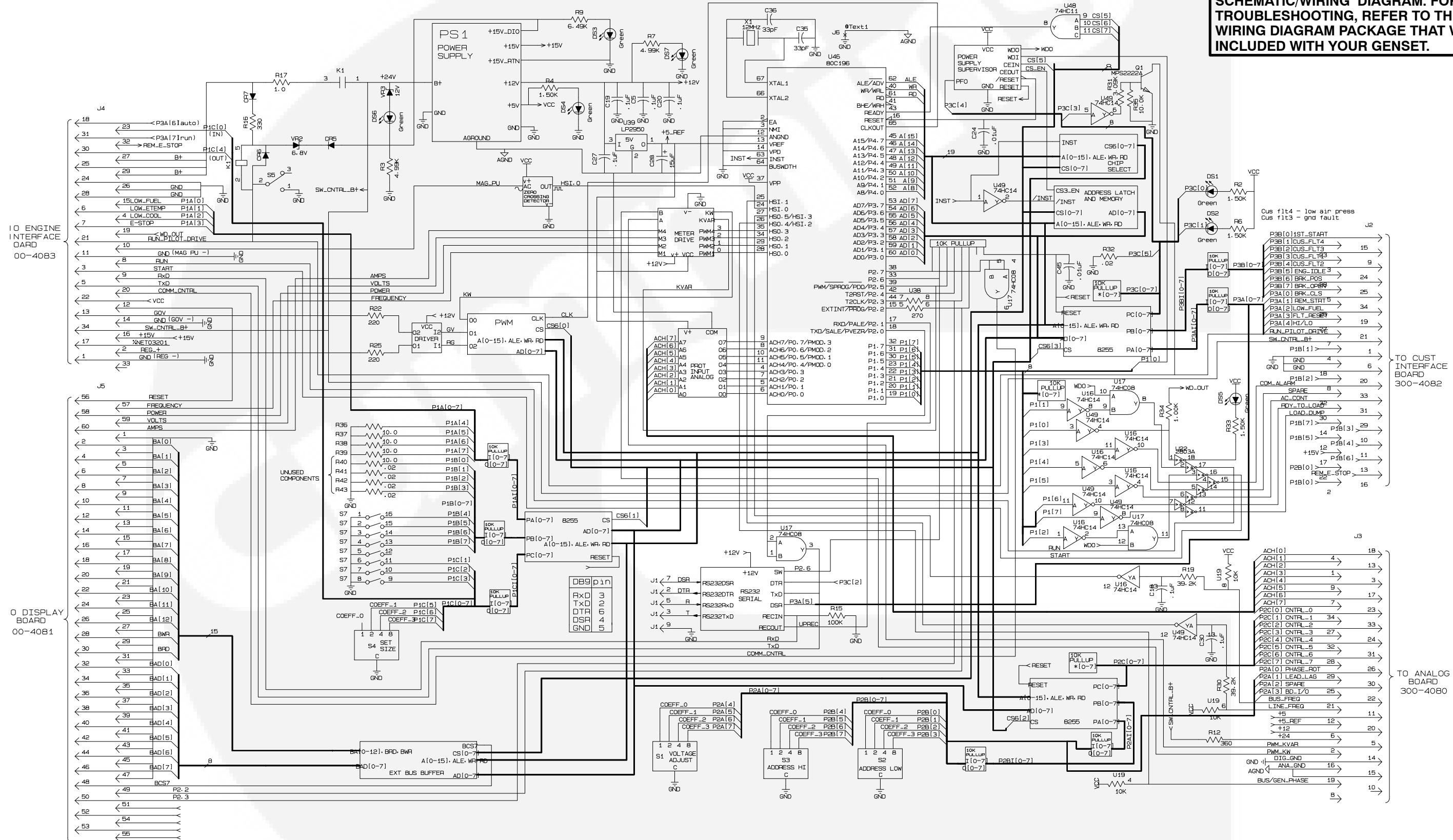

NO. 300-4079
REV. N
MODIFIED 4/2006

THIS IS A REPRESENTATIVE (GENERIC) SCHEMATIC/WIRING DIAGRAM. FOR TROUBLESHOOTING, REFER TO THE WIRING DIAGRAM PACKAGE THAT WAS INCLUDED WITH YOUR GENSET.

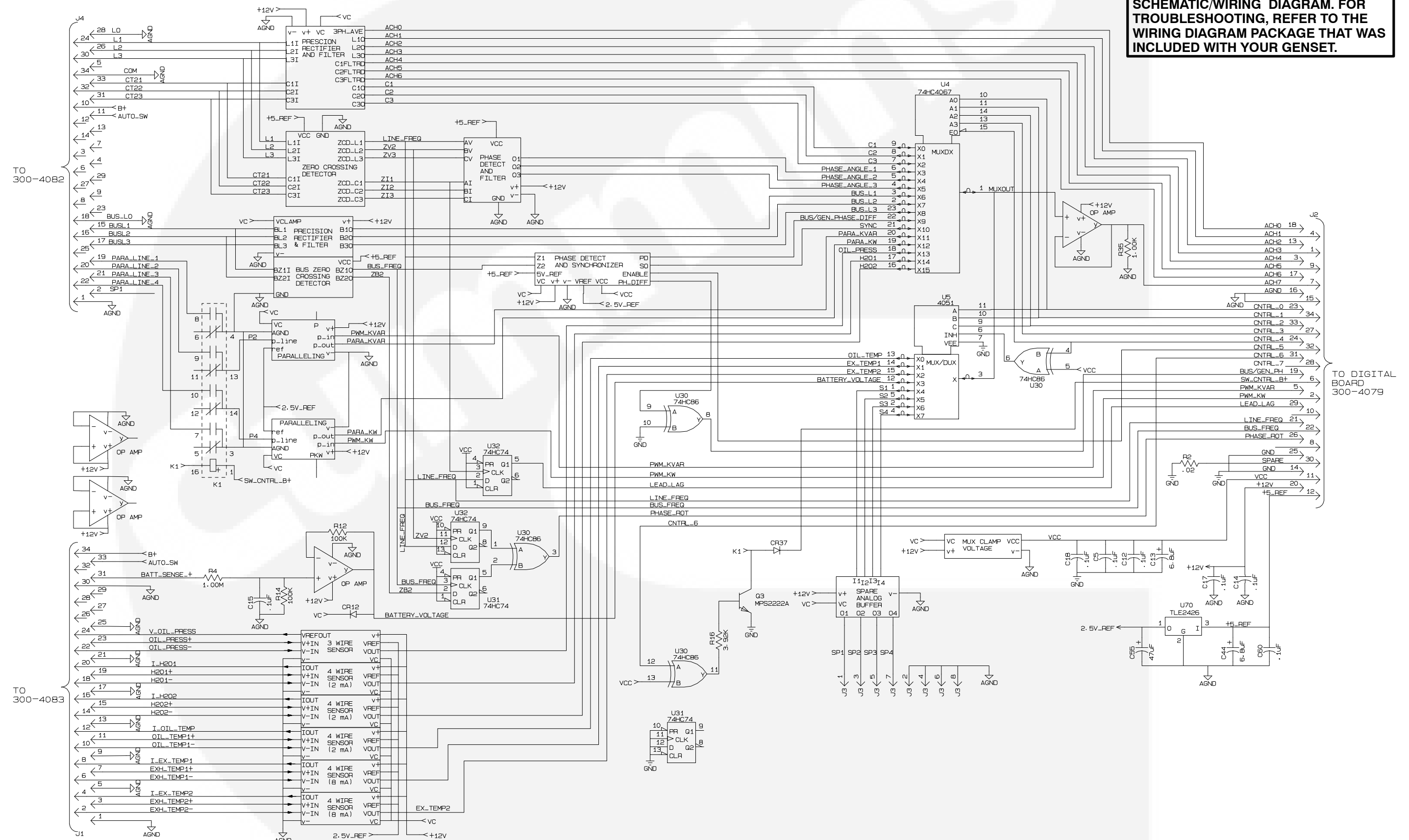

ANALOG BOARD (A33)

NO. 300-4080
REV.e
MODIFIED 11/2000

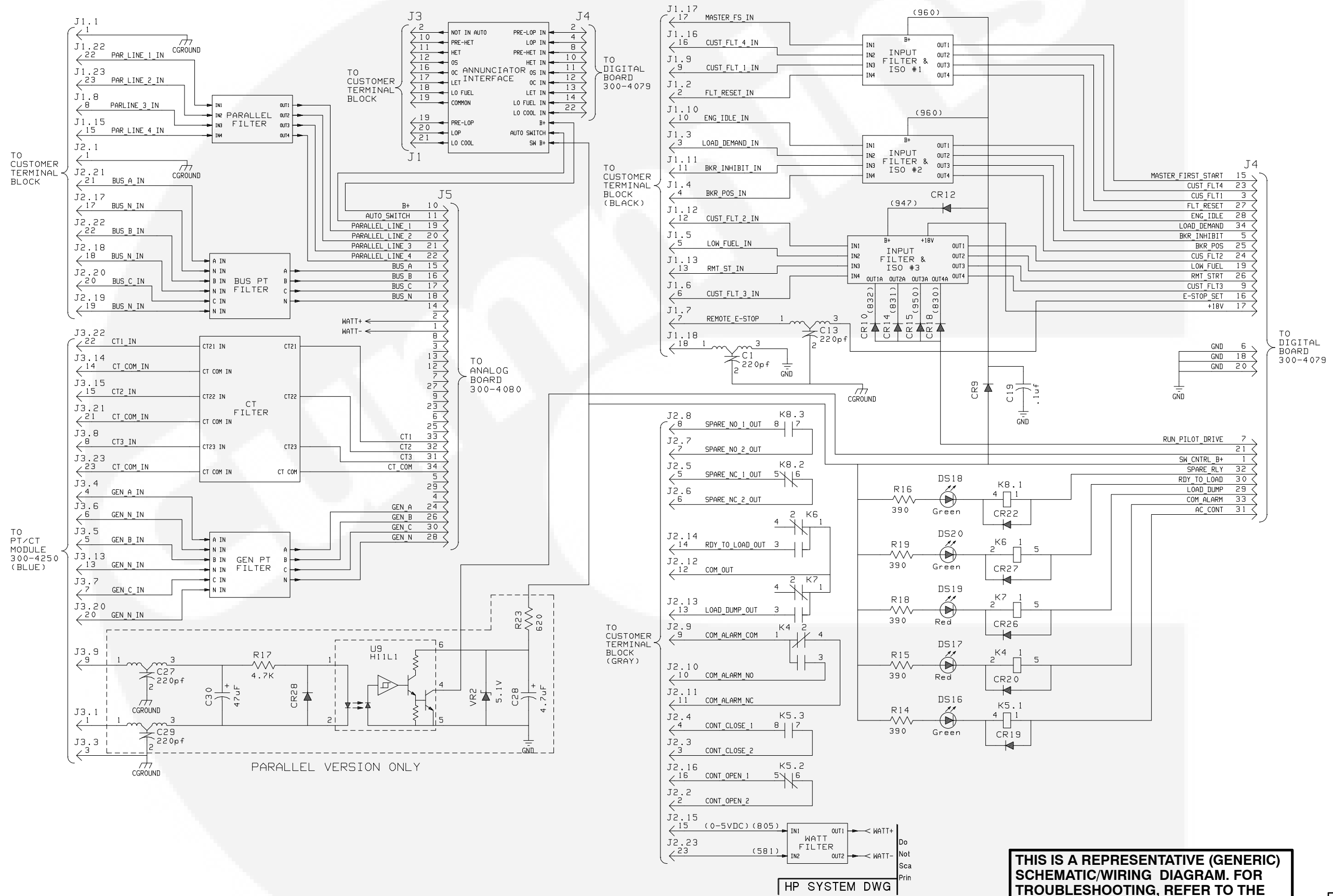

THIS IS A REPRESENTATIVE (GENERIC) SCHEMATIC/WIRING DIAGRAM. FOR TROUBLESHOOTING, REFER TO THE WIRING DIAGRAM PACKAGE THAT WAS INCLUDED WITH YOUR GENSET.

NO. 300-4462 sh1
REV. J
MODIFIED 8/2008

THIS IS A REPRESENTATIVE (GENERIC) SCHEMATIC/WIRING DIAGRAM. FOR TROUBLESHOOTING, REFER TO THE WIRING DIAGRAM PACKAGE THAT WAS INCLUDED WITH YOUR GENSET.

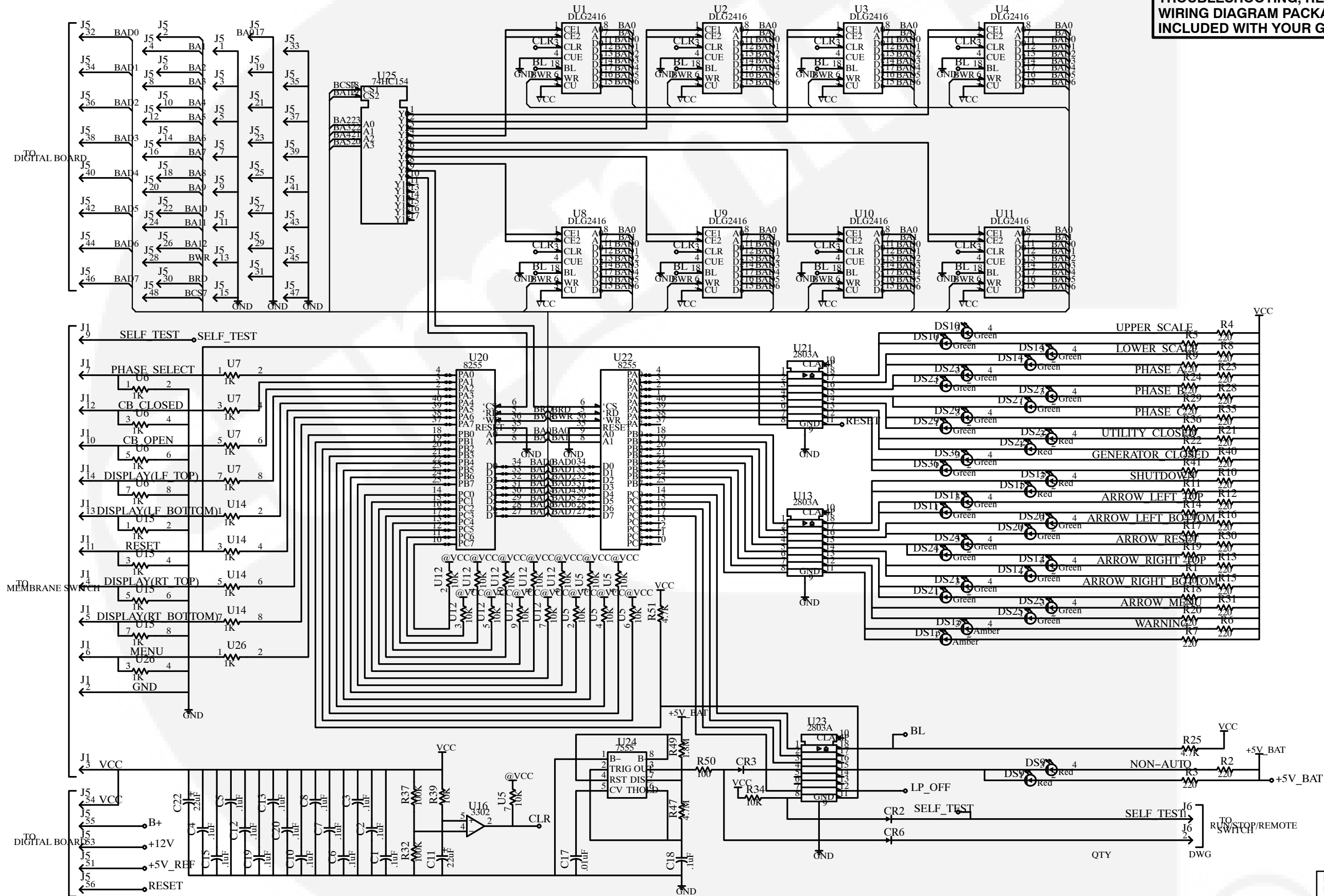

DISPLAY BOARD (A35)

THIS IS A REPRESENTATIVE (GENERIC) SCHEMATIC/WIRING DIAGRAM. FOR TROUBLESHOOTING, REFER TO THE WIRING DIAGRAM PACKAGE THAT WAS INCLUDED WITH YOUR GENSET.

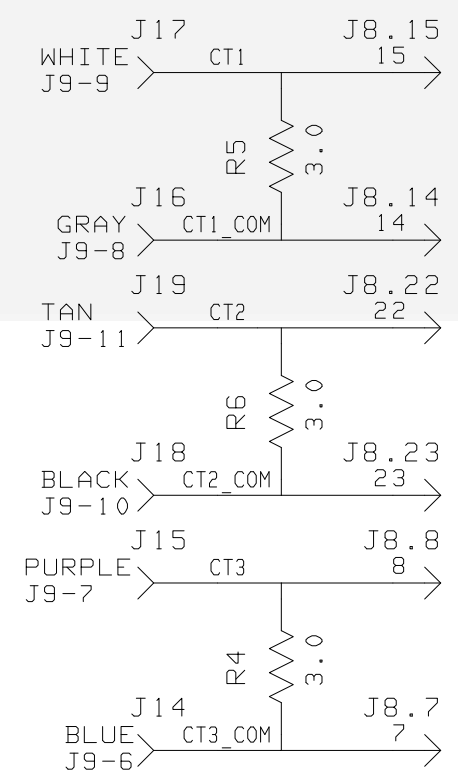
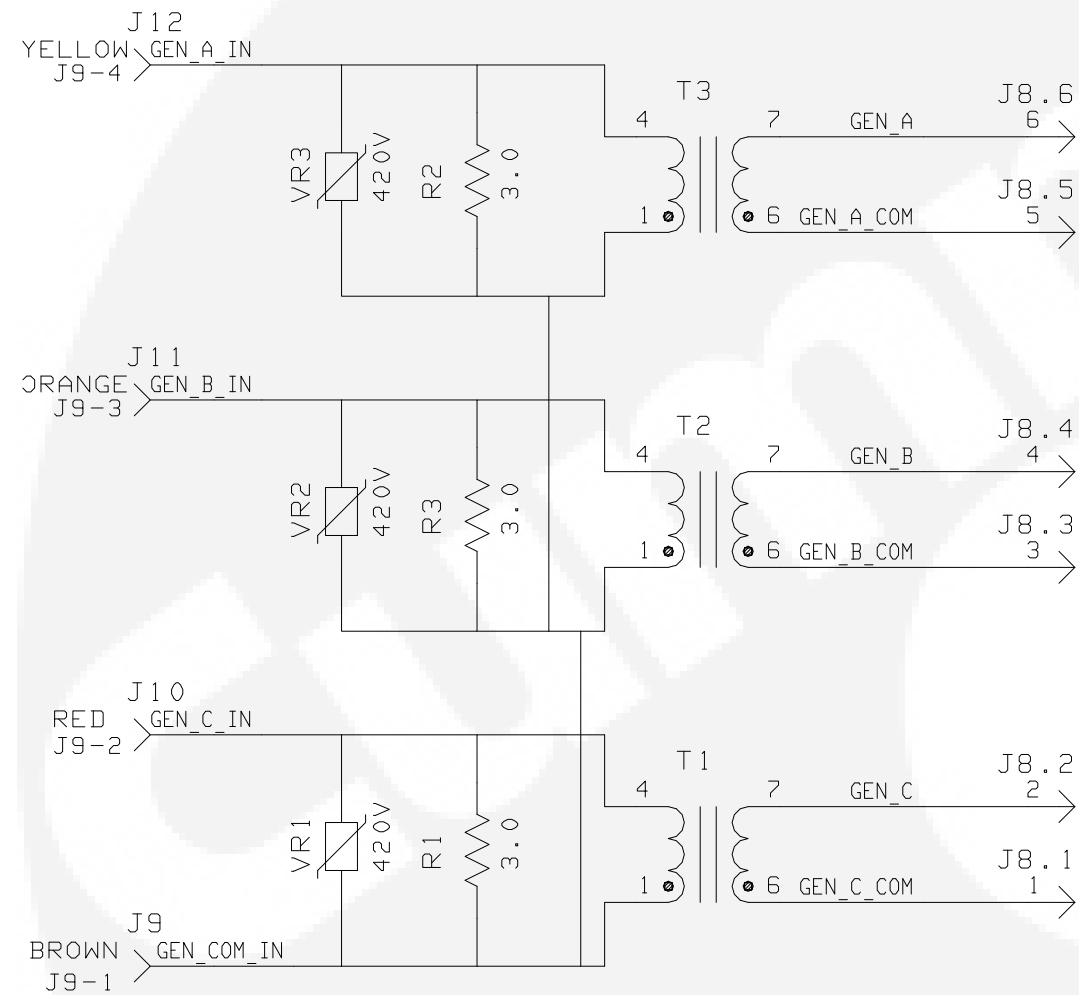

PT VOLTAGE TABLE			
ASSY DWG NO.	GEN		R1,R2,R3 Value
	PRI	SEC	
300-4250-01	120V	18V	51k ohms
300-4250-02	240V	18V	51k ohms
300-4250-03	346V	18V	110k ohms

NO. 300-4250 sh1
REV. C SYS. HP
MODIFIED 1/24/95

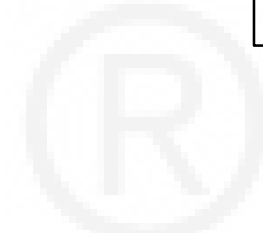

THIS IS A REPRESENTATIVE (GENERIC) SCHEMATIC/WIRING DIAGRAM. FOR TROUBLESHOOTING, REFER TO THE WIRING DIAGRAM PACKAGE THAT WAS INCLUDED WITH YOUR GENSET.

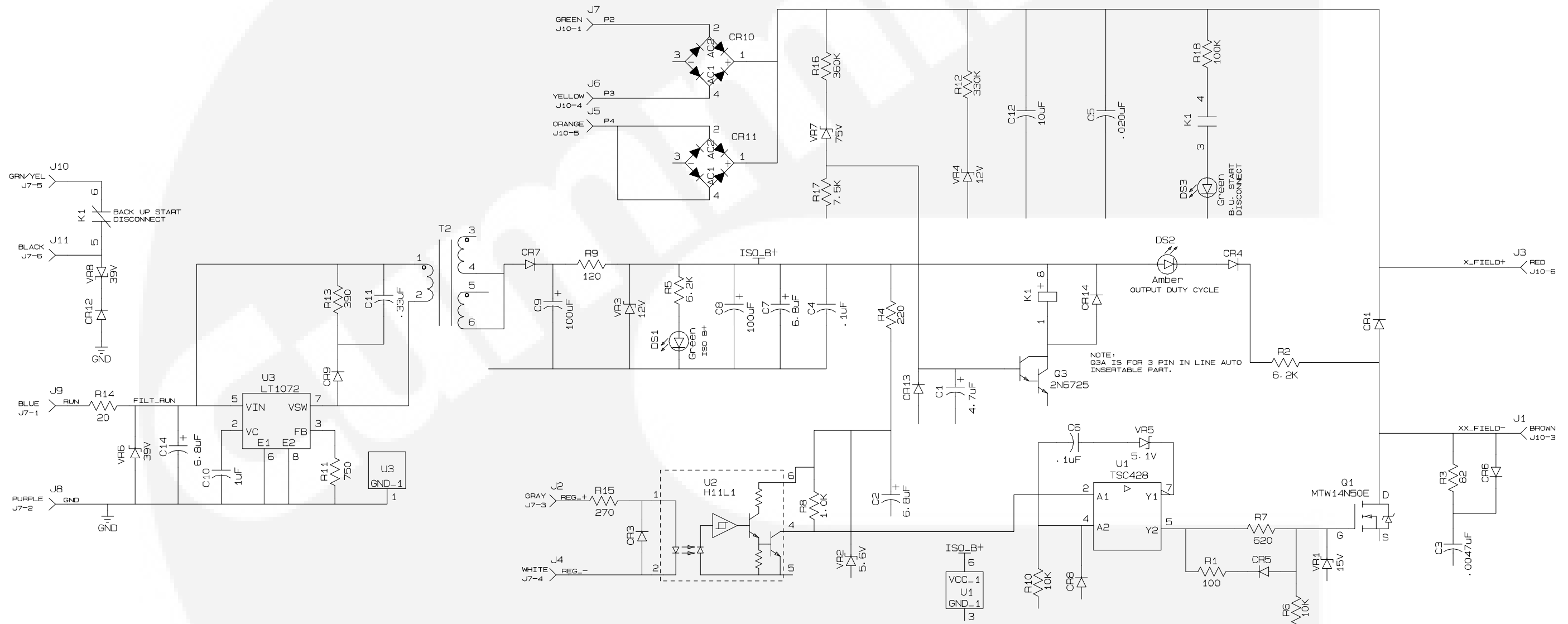

VOLTAGE REGULATOR OUTPUT MODULE (A37)

NO. 300-4085 sh1
REV. L
MODIFIED 10/2002

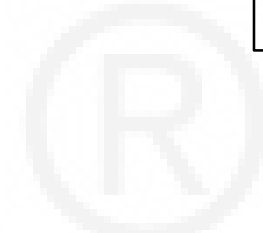

THIS IS A REPRESENTATIVE (GENERIC) SCHEMATIC/WIRING DIAGRAM. FOR TROUBLESHOOTING, REFER TO THE WIRING DIAGRAM PACKAGE THAT WAS INCLUDED WITH YOUR GENSET.

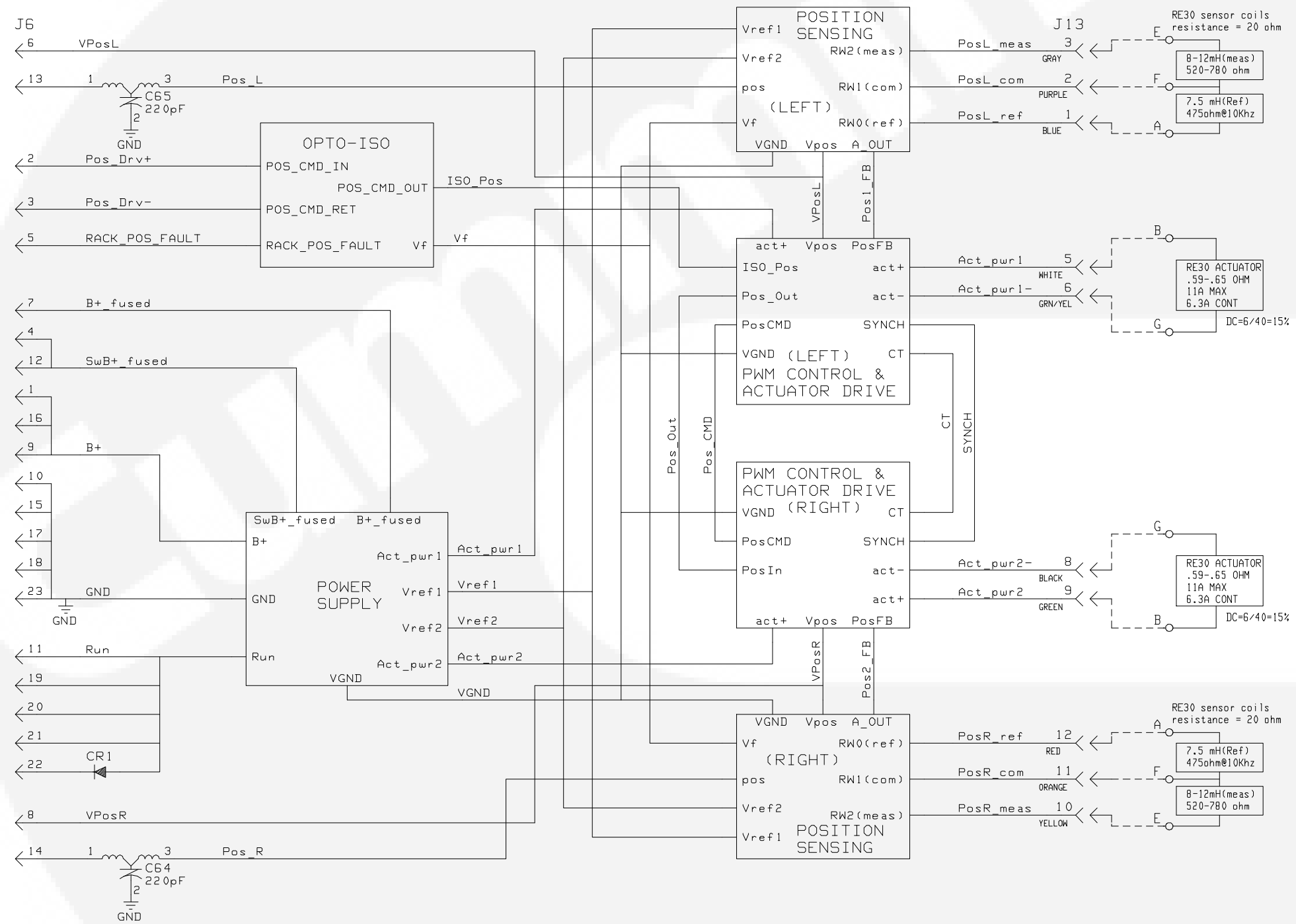

THIS IS A REPRESENTATIVE (GENERIC) SCHEMATIC/WIRING DIAGRAM. FOR TROUBLESHOOTING, REFER TO THE WIRING DIAGRAM PACKAGE THAT WAS INCLUDED WITH YOUR GENSET.

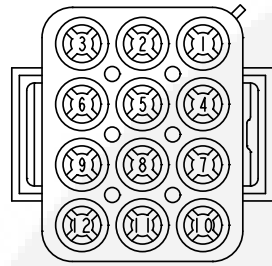

VIEW **A-A**
SCALE: NONE

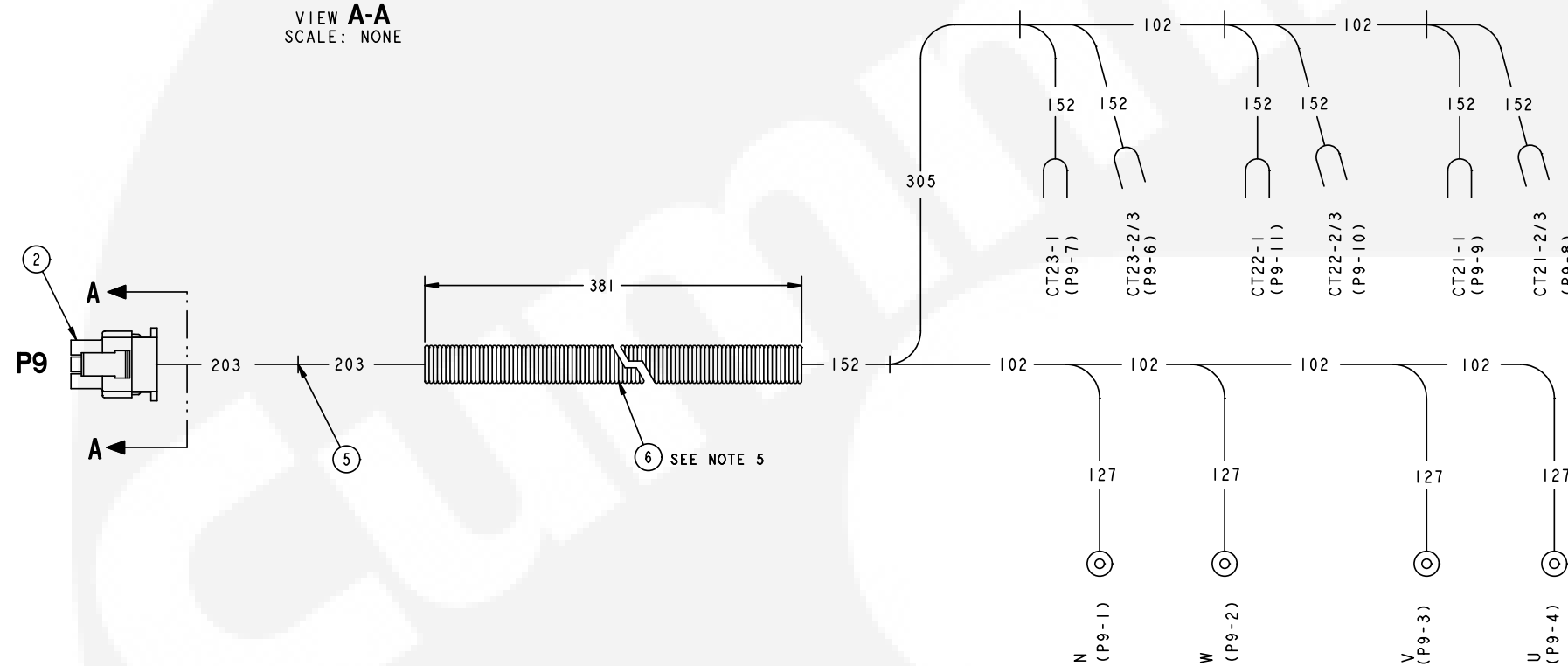

NOTES:

- WIRES SHALL BE MARKED WITH BOTH STATION NUMBERS LISTED IN TABULATION. MARKINGS SHALL APPEAR A MAXIMUM OF 75 mm FROM EACH END.
- PLACE CABLE TIES (ITEM 5) WHERE SHOWN. WHERE NOT SHOWN EVERY 203 mm.
- ALL DIMENSIONS ARE IN MILLIMETERS.
- TOL: UP TO 208 ± 6.4
208 TO 516 ± 13
516 & LONGER ± 25
- TY-RAP ENDS AND CENTER OF CONVOLUTED TUBING WITH CABLE TIES (ITEM 5).
- IF A VALUE OF 0 (ZERO) IS USED IN THE BILL OF MATERIAL, THE QUANTITY OF THE AFFECTED ITEMS SHALL BE DERIVED FROM THE DRAWING REQUIREMENTS.
- HARNESS MUST BE PROCURED FROM A SUPPLIER QUALIFIED AS A UL RECOGNIZED HARNESS MANUFACTURER CATEGORY (ZPFW2). PACKAGING OR PARTS TO BE MARKED IN ACCORDANCE WITH REQUIREMENTS SPECIFIED BY SUPPLIERS UL PROGRAM.

LEAD TABULATION						
DASH NO.	WIRE ITEM NO.	LUG ITEM NO.	FROM STATION	TO STATION	LUG ITEM NO.	WIRE COLOR
-01	8	3	A36-P9-11	CT22-1	4	PURPLE
-02	9	3	A36-P9-10	CT22-2/3	4	GRAY
-03	10	3	A36-P9-9	CT21-1	4	PINK
-04	9	3	A36-P9-8	CT21-2/3	4	GRAY
-05	11	3	A36-P9-7	CT23-1	4	ORANGE
-06	9	3	A36-P9-6	CT23-2/3	4	GRAY
-07	14	3	A36-P9-4	U	7	BLACK
-08	12	3	A36-P9-3	V	7	RED
-09	13	3	A36-P9-2	W	7	DARK BLUE
-10	1	3	A36-P9-1	N	7	WHITE

FRAME 4 THRU 7

NO. 338-3019 sh1
REV. T
MODIFIED 9/2011

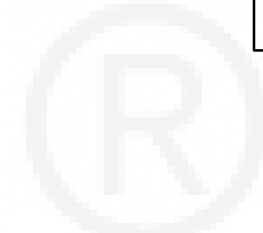

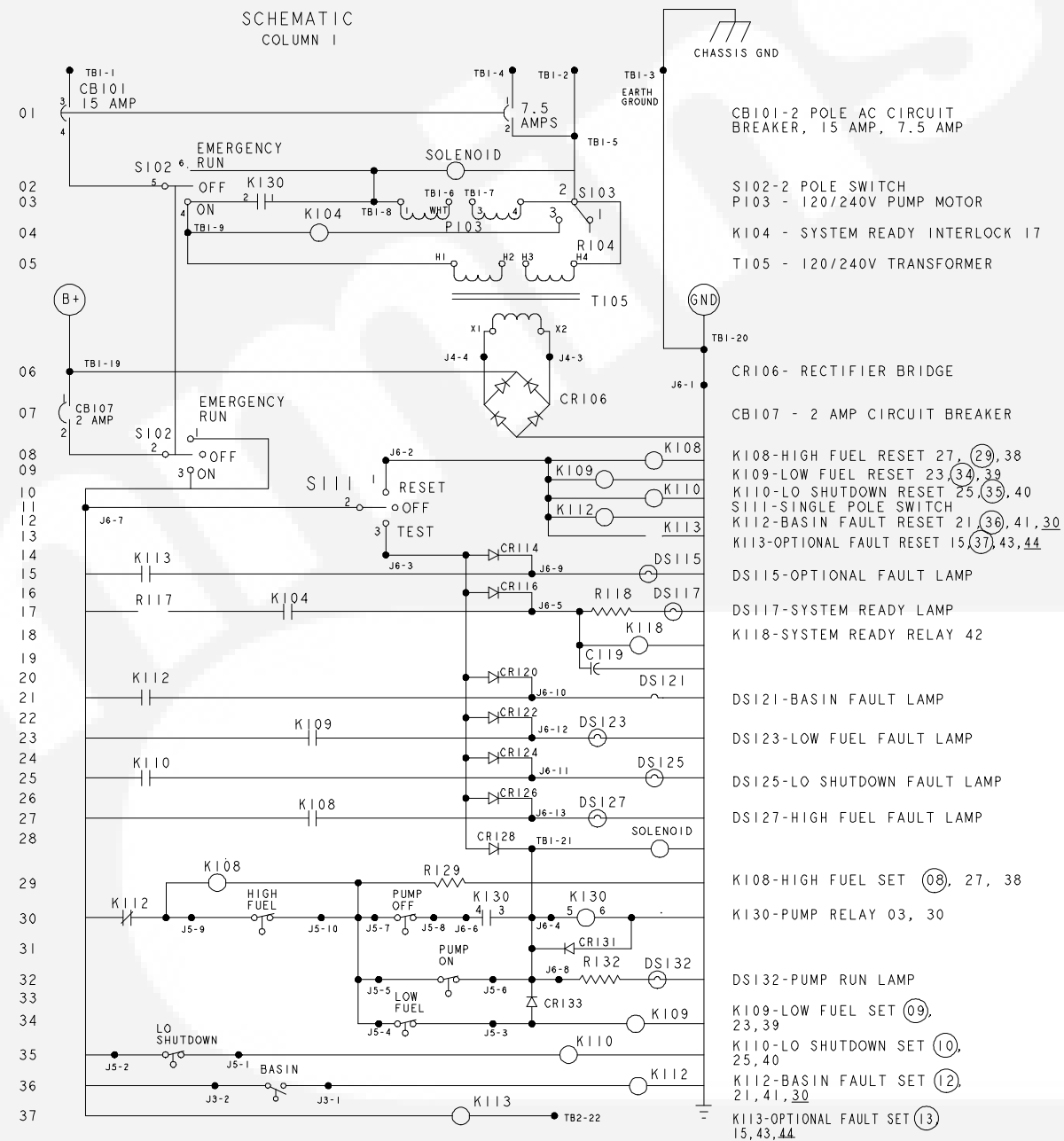
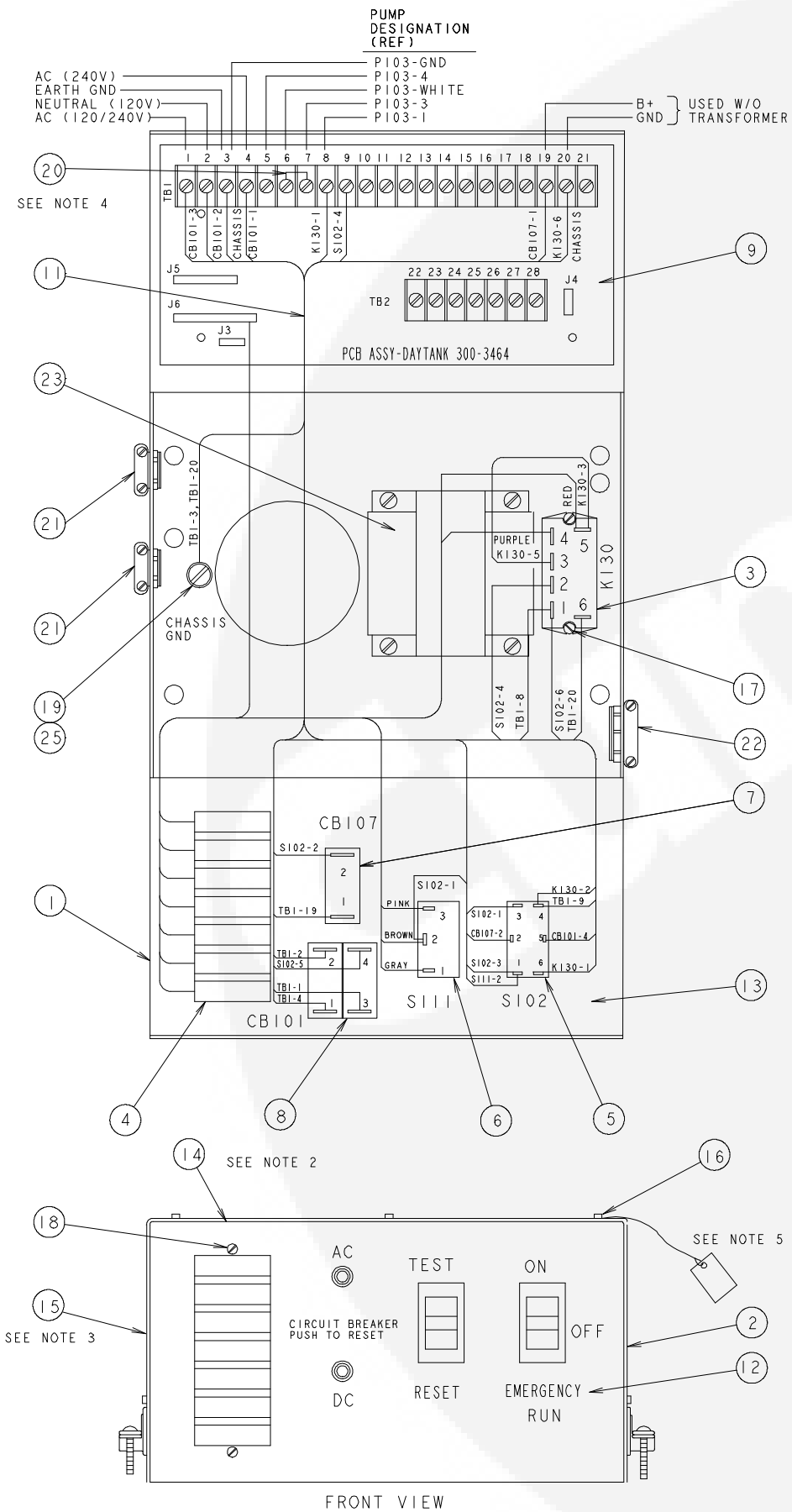

- NOTES:
- SCHEMATIC KEY:
EACH COMPONENT IS LOCATED BY PART NUMBER. ON THE RIGHT HAND SIDE, A DESCRIPTION IS GIVEN OF THE PART AND ITS FUNCTIONAL LOCATIONS.
 - SILKSCREEN ONAN #98-5955 OF CIRCUIT SCHEMATIC LOCATED ON THE INSIDE TOP OF THE COVER.
 - TWO TERMINAL JUMPERS ARE SUPPLIED BETWEEN TERMINALS 6 & 7 WITH THE FACTORY SUPPLIED 240 AC CONNECTION. FOR 120 VAC FIELD OPERATION PLACE ONE JUMPER BETWEEN TERMINALS 5 & 6 AND THE SECOND JUMPER BETWEEN 7 AND 8. CHANGE JUMPERS ON TRANSFORMER IF EQUIPPED. SEE SILKSCREEN ONAN #98-5954 ON THE INSIDE OF THE COVER FOR FULL 120/240 CONVERSION INSTRUCTIONS.
 - PIGGYBACK TERMINALS S111-2, S102-1, AND S102-4 SHOULD BE ASSEMBLED WITH THE INSULATED FASTON TO THE OUTSIDE OF THE SWITCH TO PROVIDE THE MAXIMUM AMOUNT OF ELECTRICAL PROTECTION.
 - A TAG SHOULD BE PLACED ON CONTROL INDICATING VOLTAGE THE CONTROL IS WIRED TO.
- K 1 12 - BASIN FAULT RESET 21, 41, (36), 30
- LINE 12
- COLUMN 1
- RELAY
- N/C CONTACTS ON LINE 30
- RELAY SET COIL ON LINE 36
- N/O CONTACTS ON LINES 21 AND 41
- WRITTEN DESCRIPTION

38	TBI-10	K108	TBI-11	HIGH FUEL FAULT CONTACTS
39	TBI-12	K109	TBI-13	LOW FUEL FAULT CONTACTS
40	TBI-14	K110	TBI-15	LOW SHUTDOWN FAULT CONTACTS
41	TBI-16	K112	TBI-17	BASIN FAULT CONTACTS
42	TB2-26	K118	TB2-27	SYSTEM READY CONTACTS
43	TB2-23	K113	TB2-24	OPTIONAL FAULT CONTACTS
44		K113	TB2-25	

NO. 625-2141
REV. R
MODIFIED 3/2006

ONAN/CUMMINS GENERATOR SET WITH PCC CONTROL

OT & BT 2 WIRE START UTILITY TO GENSET

THIS IS A REPRESENTATIVE (GENERIC) SCHEMATIC/WIRING DIAGRAM. FOR TROUBLESHOOTING, REFER TO THE WIRING DIAGRAM PACKAGE THAT WAS INCLUDED WITH YOUR GENSET.

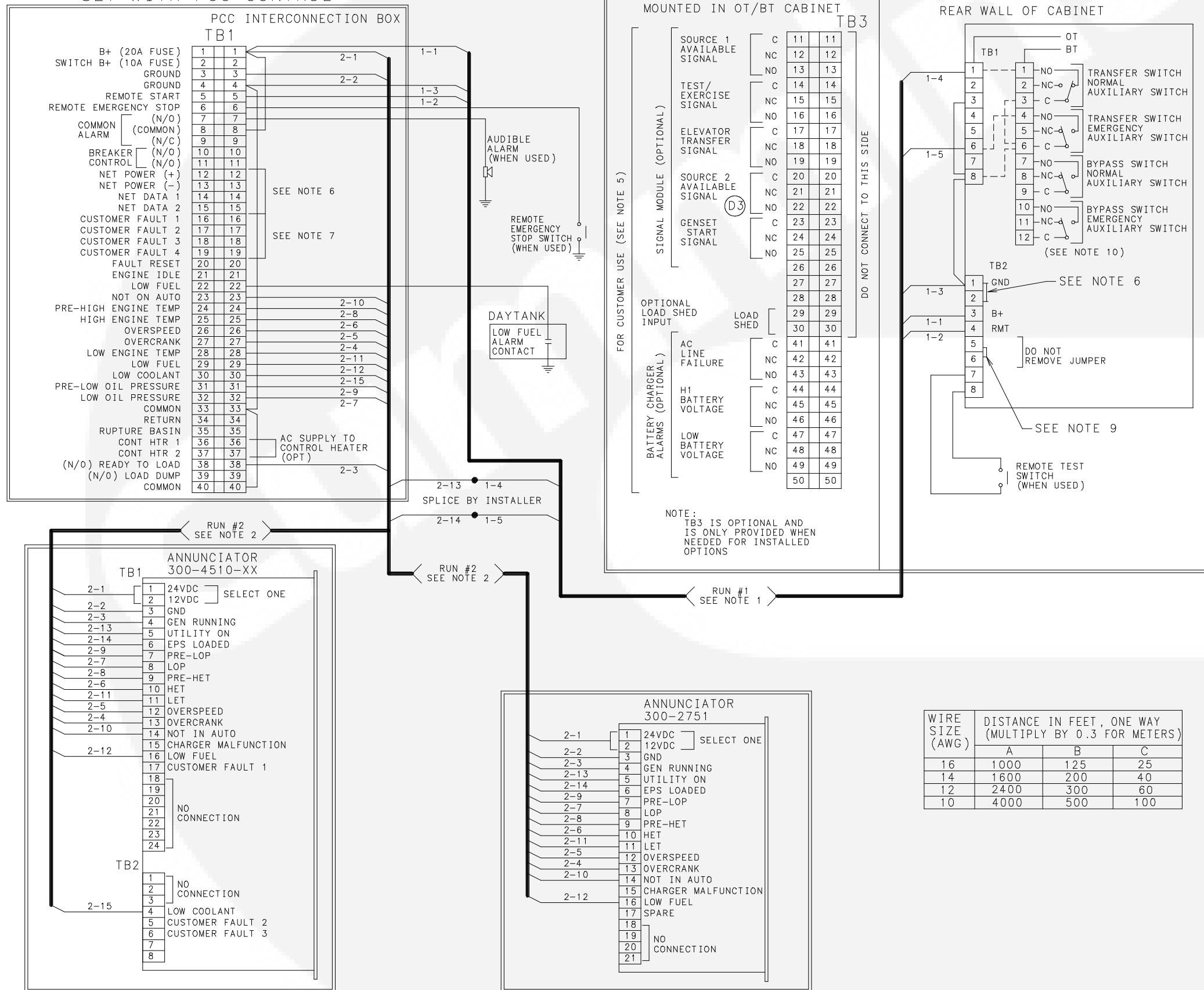

- NOTES:
1. WIRE SIZES MUST BE AS FOLLOWS:
 RUN #1-GENSET TO TRANSFER SWITCH-LEAD SIZE MUST BE INCREASED IF A BATTERY CHARGER IS INSTALLED IN THE SWITCH.
 WITH NO BATT CHARGER-LEADS 1-1, -2, -3, -4, -5 USE COL. A.
 WITH 2 AMP CHARGER-LEADS 1-1 & 1-3, USE COL. B
 WITH 10 AMP CHARGER-LEADS 1-1 & 1-3, USE COL. C
 2. RUN #2-GENSET TO ANNUNCIATOR-ALL LEADS, USE COL. A
 3. FOR MULTIPLE TRANSFER SWITCHES, DUPLICATE RUN #1 FOR EACH SWITCH. DAISY CHAIN CONNECTION IS ACCEPTABLE PROVIDED WIRE SIZE & DISTANCE TO THE LAST SWITCH MEET THE SPECS IN NOTE 1.
 - 4.
 5. CONTACTS RATED: 4 AMPS AT 30 VDC OR 120V MAX.
 6. REFER TO ONAN 900-0366 POWER COMMAND NETWORK & OPERATION MANUAL. FOR WIRING INSTRUCTIONS.
 7. INPUTS FOR CUSTOMER FAULTS. GROUNDED SIGNAL REQUIRED TO ACTIVATE INPUT (MAX 50 MA.)
 8. INSTALL JUMPER BETWEEN TB2-1 & TB2-2. FOR SETS WITH PCC CONTROL.
 9. WHEN CONNECTING A REMOTE SIGNAL TO THE TRANSFER INHIBIT CIRCUIT. THE INSTALLER MUST USE A TWISTED PAIR OF WIRES WITH A SHIELDED GROUND.
 10. TRANSFER SWITCH SHOWN CLOSED TO NORMAL BYPASS SWITCH SHOWN NEUTRAL POSITION.

WIRE SIZE (AWG)	DISTANCE IN FEET, ONE WAY (MULTIPLY BY 0.3 FOR METERS)		
	A	B	C
16	1000	125	25
14	1600	200	40
12	2400	300	60
10	4000	500	100

ACCESSORY INTERCONNECT DIAGRAM

NO.630-1345 sh1
 REV.j
 MODIFIED 11/1996

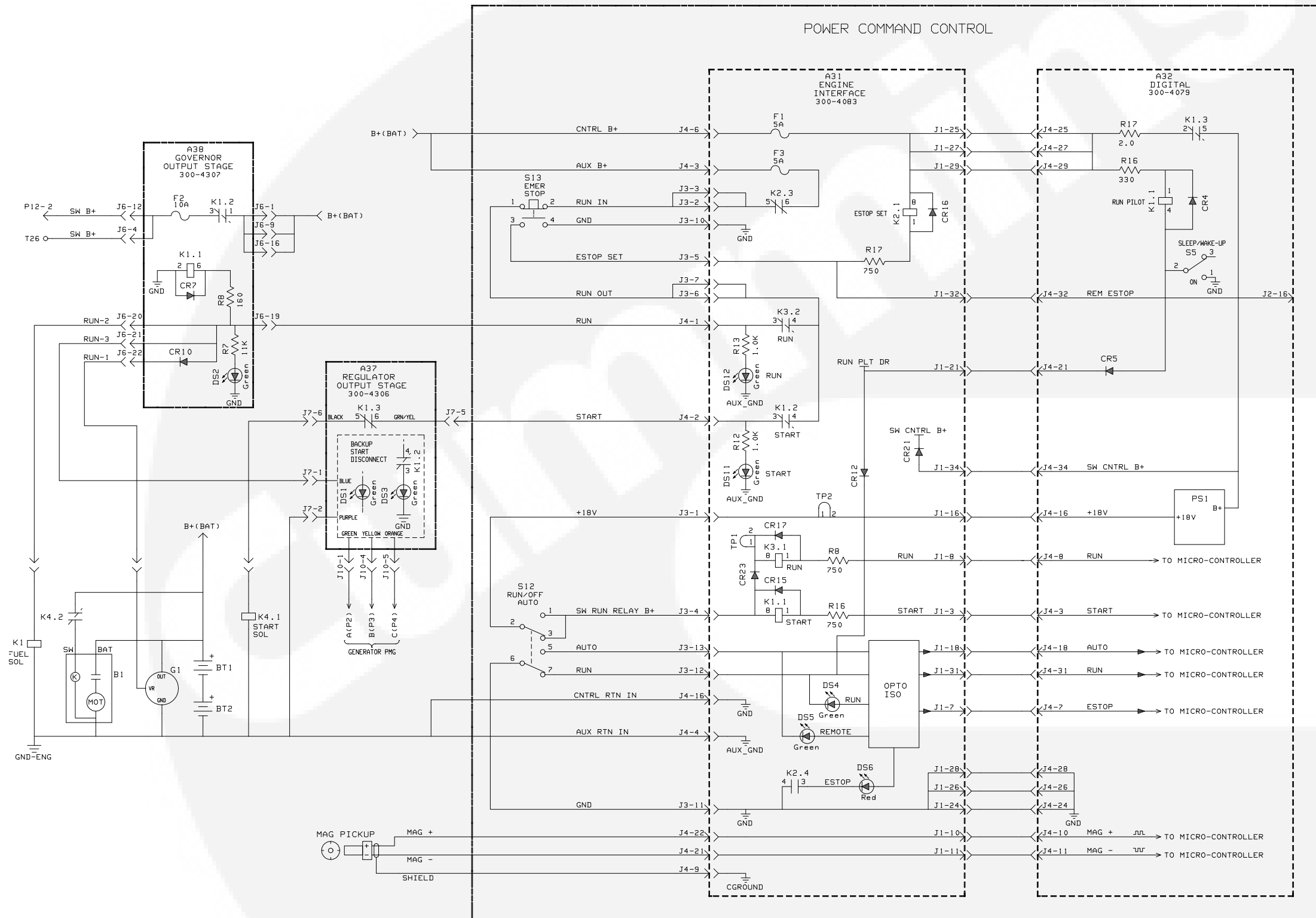

- NOTES:
- THE FOLLOWING IS THE SEQUENCE OF EVENTS FOR LOCAL START AND RUN.
1. S12 IS SET TO THE RUN POSITION.
 2. RUN PILOT RELAY K1 ON DIGITAL BOARD (A32) IS ENERGIZED.
 3. B+ IS NOW APPLIED TO THE POWER SUPPLY SECTION OF ENGINE INTERFACE BOARD (A31) AND THE DIGITAL BOARD (A32).
 4. RUN LED DS4 ON ENGINE INTERFACE BOARD (A31) IS ON.
 5. THE DIGITAL BOARD INITIATES A START DRIVE.
 6. START RELAY K1 ON ENGINE INTERFACE BOARD (A31) IS ENERGIZED.
 7. B+ IS NOW APPLIED TO THE STARTER SOLENOID.
 8. ENGINE WOULD CRANK.
 9. THE DIGITAL BOARD (A32) MONITORS THE MAG PICKUP AND INITIATES A RUN DRIVE.
 10. RUN RELAY K3 ON ENGINE INTERFACE BOARD (A31) IS ENERGIZED.
 11. B+ IS NOW APPLIED TO THE FUEL SOLENOID, ALTERNATOR G1, REGULATOR OUTPUT STAGE (A37).
 12. LEDES DS1 ON REGULATOR OUTPUT STAGE (A37) AND DS2 ON GOVERNOR OUTPUT STAGE (A38) ARE ON.
 13. RELAY K1 ON THE GOVERNOR OUTPUT STAGE (A38) IS ENERGIZED.
 14. SW B+ IS NOW APPLIED TO TERMINAL 26 AND CUSTOMER CONNECTIONS.
 15. ENGINE WOULD RUN.
 16. THE DIGITAL BOARD (A32) MONITORS THE MAG PICKUP AND WHEN THE ENGINE REACHES 475 RPM THE START DRIVE IS REMOVED.
 17. START RELAY K1 ON ENGINE INTERFACE BOARD (A31) IS DE-ENERGIZED, REMOVING B+ TO THE STARTER SOLENOID. RELAY CONTACT K1.2 IS OPEN, START LED DS11 IS OFF.
 18. WHEN PMG OUTPUT REACHES 105VAC (850 RPM), BACK-UP START DISCONNECT RELAY K1 ON REGULATOR OUTPUT STAGE (A37) IS ENERGIZED, RELAY CONTACT K1.3 IS OPEN, BACK-UP START DISCONNECT LED DS3 IS ON.

No. 612-6679 sh 1 of 2
 Rev. B Sys: HP
 Modified 11/21/95

SEQUENCE OF OPERATION (LOCAL START AND RUN)

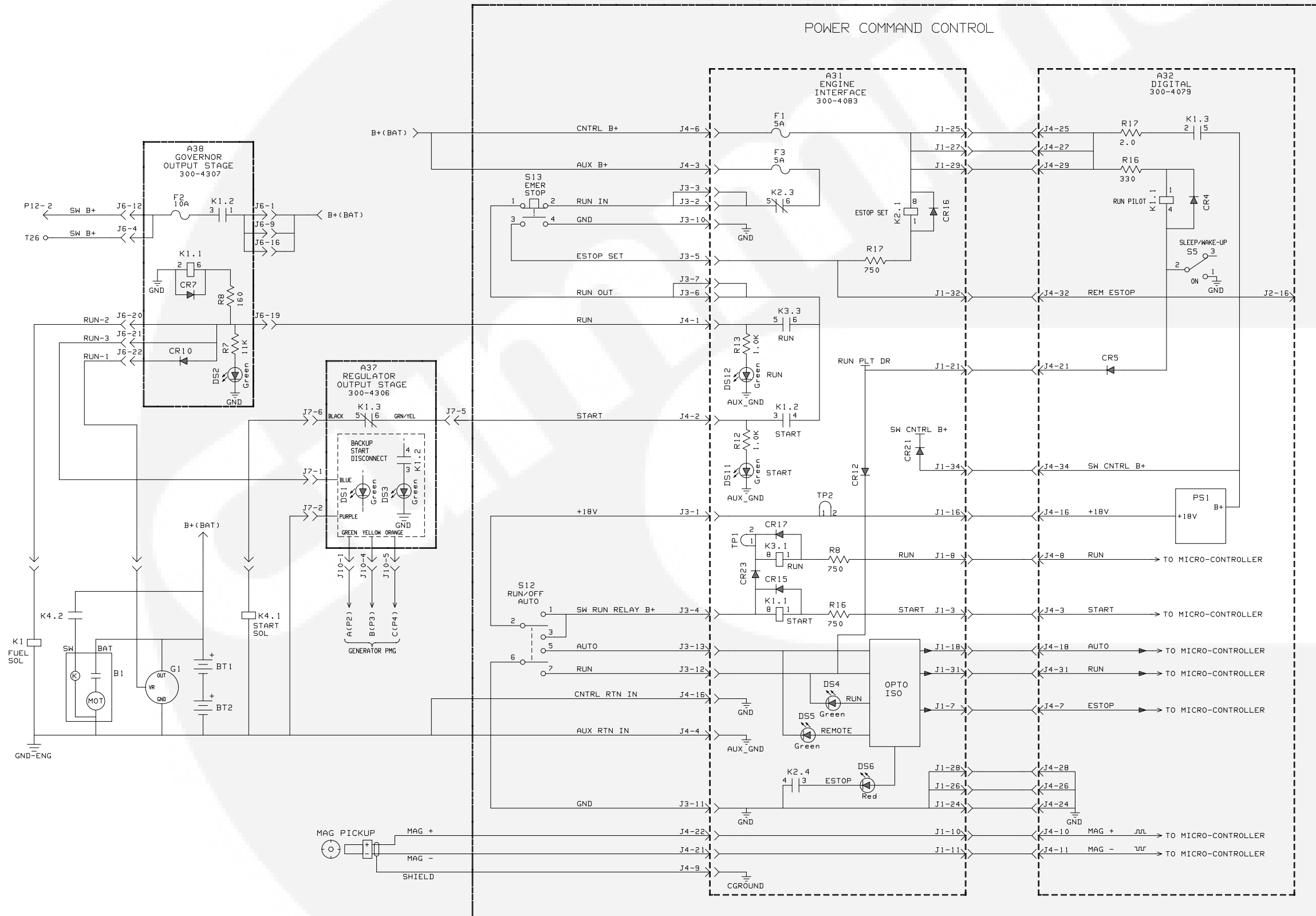

- NOTES:
1. S12 IS SET TO THE OFF POSITION.
 2. RUN PILOT RELAY K1 ON DIGITAL BOARD (A32) IS DE-ENERGIZED.

SEQUENCE OF OPERATION (LOCAL STOP)

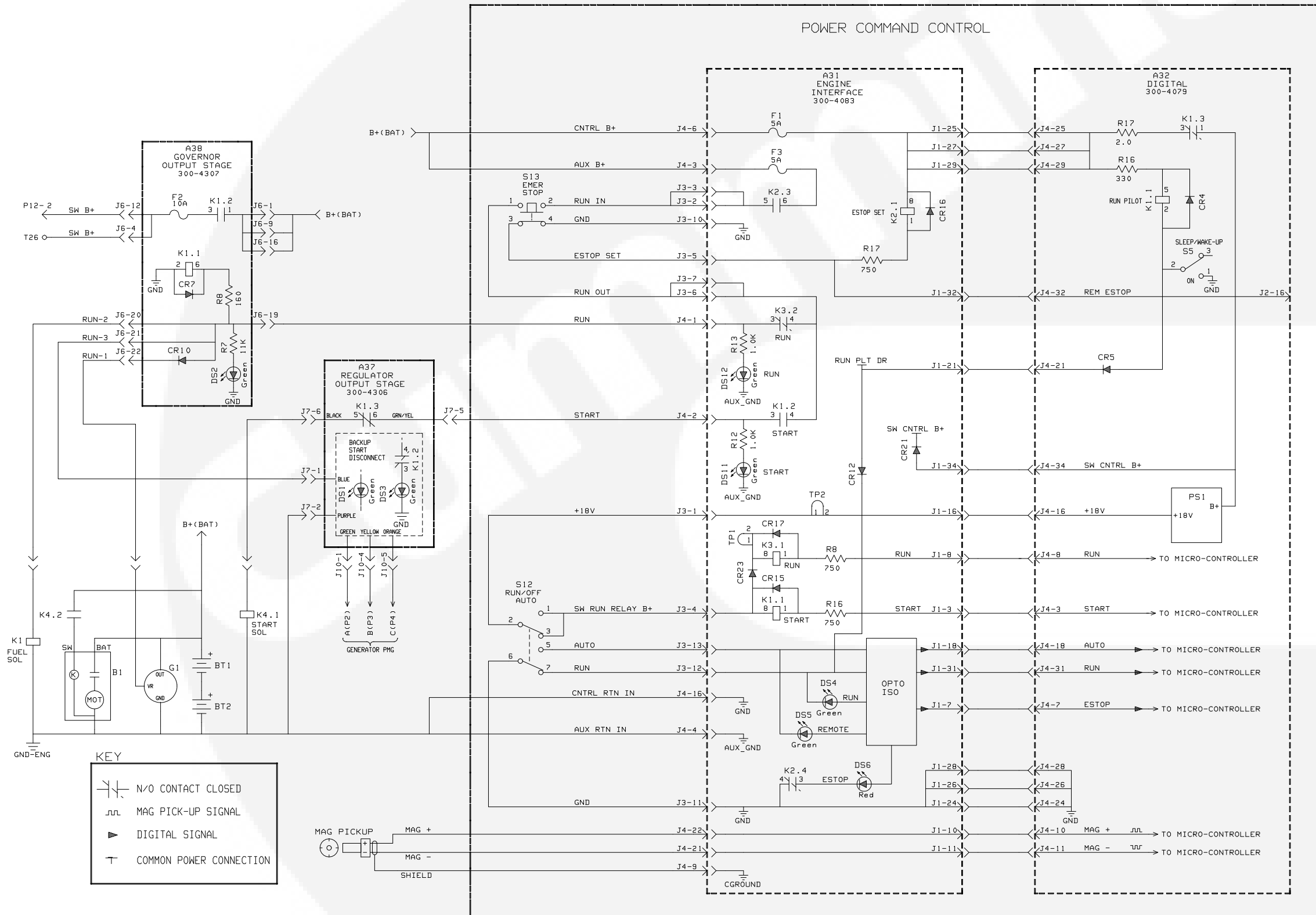

NOTES:

THE FOLLOWING IS THE SEQUENCE OF EVENTS FOR LOCAL EMERGENCY STOP.

1. S13 IS SET TO THE EMERGENCY STOP POSITION.
2. B+ IS NOW REMOVED FROM THE FUEL SOLENOID, THE GOVERNOR OUTPUT STAGE (A38) AND THE REGULATOR OUTPUT STAGE (A37). RUN LED DS12 ON INTERFACE BOARD (A31) IS OFF. LED DS2 ON GOVERNOR OUTPUT STAGE (A38) IS OFF. LED DS1 ON REGULATOR OUTPUT STAGE (A37) IS OFF.
3. RELAY K1 ON THE GOVERNOR OUTPUT STAGE (A38) IS DE-ENERGIZED.
4. SW B+ IS NOW REMOVED FROM TERMINAL 26 AND CUSTOMER CONNECTIONS.
5. EMERGENCY STOP RELAY K2 (SET) ON THE ENGINE INTERFACE BOARD (A31) IS ENERGIZED AND LATCHED.
6. RELAY CONTACT K2.3 ON THE ENGINE INTERFACE BOARD (A31) IS NOW OPEN, REMOVING B+ TO THE EMERGENCY STOP SWITCH (S13).
7. RELAY CONTACT K2.4 ON THE ENGINE INTERFACE BOARD (A31) IS NOW CLOSED, GROUNDING THE ESTOP LINE TO THE DIGITAL BOARD (A32).
8. ESTOP LED DS6 ON ENGINE INTERFACE BOARD (A31) IS ON.
9. THE ENGINE WOULD STOP RUNNING.

NO.612-6680 sh10f1
REV. A
MODIFIED 8/25/94

SEQUENCE OF OPERATION (LOCAL EMERGENCY STOP)

Cummins Power Generation

1400 73rd Ave. NE
Minneapolis, MN 55432 USA

Phone 1 763 574 5000

Toll-free 1 800 888 6626

Fax 1 763 574 5298

Email ask.powergen@cummins.com

www.cumminspower.com

Cummins®, the "C" logo, and "Our energy working for you." are trademarks of Cummins Inc.

©2011 Cummins Power Generation, Inc. All rights reserved.

