

**ELECTRIC GENERATING SET  
TRAINING MANUAL  
FOR**

**RECREATIONAL VEHICLES**



### **Onan Plant**

The main offices, engineering, and the 500,000 square foot manufacturing plant are located in the suburb of Fridley on the north side of Minneapolis. The move to this facility was commenced in October of 1968 and completed in the spring of 1969. The facility covers almost 15 acres and employs approximately 1600 people at this time.



### **Aerial View**

This aerial view of the Onan facility shows how the three-story administration building, the engineering building and the manufacturing plant are all interconnected. The physical design of the structure also represents the organizational design of the corporation: administration, engineering and manufacturing are all working together to provide top quality products and service to Onan customers.



### **Onan Plant**

This Onan manufacturing plant is located in Huntsville, Alabama. Production at the plant was started in late 1974. The plant contains 465,390 square feet of floor space which covers almost 11 acres and employs approximately 450 people at this time. One unique aspect is the fact that the Onan Jet Star can taxi right up to the front door from the Madison county airport complex.

*Hook up to the  
ONAN Power Line*

These powerful, compact, little green machines have been precision-engineered and built with extra care to make you feel at home on the road . . . wherever you go. They reflect the quality and dependability built into every Onan product. It's just another way of saying that the people at Onan are continually striving to provide you with first class power units and controls.



#### **RV Sales and Service**

Onan has approximately 1300 sales offices and service centers conveniently located throughout the United States and Canada providing effective assistance to the Recreational Vehicle owner.



*. . . Dreaming of the relaxing things  
in life. . . .*

**A little  
green  
goes a  
long way.**

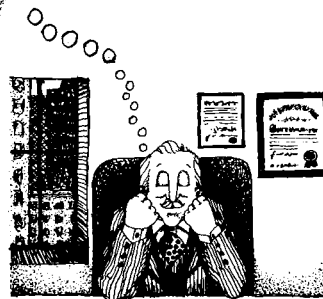

. . . Made a Reality by One of the  
**Many Onan** Electric Generating Sets  
 for Recreational Vehicles



**TABLE OF CONTENTS**

<b>Safety Precautions</b> .....	3
<b>General Description</b> .....	4
<b>Installation Checks</b> .....	10
<b>Preventive Maintenance</b> .....	24
<b>Adjustments</b> .....	43
<b>Troubleshooting</b> .....	59
<b>Controls</b> .....	69

# SAFETY PRECAUTIONS

The following symbols in this manual signal potentially dangerous conditions to the operator or equipment. Read this manual carefully. Know when these conditions can exist. Then, take necessary steps to protect personnel as well as equipment.

**WARNING** Onan uses this symbol throughout this manual to warn of possible serious personal injury.

**CAUTION** This symbol refers to possible equipment damage.

Fuels, electrical equipment, batteries, exhaust gases and moving parts present potential hazards that could result in serious, personal injury. Take care in following these recommended procedures.

- **Use Extreme Caution Near Gasoline. A constant potential explosive or fire hazard exists.**

Do not fill fuel tank near unit with engine running. Do not smoke or use open flame near the unit or the fuel tank.

Be sure all fuel supplies have a positive shutoff valve.

Fuel lines must be of steel piping, adequately secured and free of leaks. Use a flexible section of fuel line between generator set and stationary fuel line in the vehicle. This flexible section must be 100% NON-METALLIC to prevent electrical currents from using it as a conductor.

Have a fire extinguisher nearby. Be sure extinguisher is properly maintained and be familiar with its proper use. Extinguishers rated ABC by the NFPA are appropriate for all applications. Consult the local fire department for the correct type of extinguisher for various applications.

- **Guard Against Electric Shock**

Remove electric power before removing protective shields or touching electrical equipment. Use rubber insulative mats placed on dry wood platforms over floors that are metal or concrete when around electrical equipment. Do not wear damp clothing (particularly wet shoes) or allow skin surfaces to be damp when handling electrical equipment.

Always use an appropriately sized, approved double-throw transfer switch with any standby generator set. DO NOT PLUG PORTABLE OR STANDBY SETS DIRECTLY INTO A HOUSE

RECEPTACLE TO PROVIDE EMERGENCY POWER. It is possible for current to flow from generator into the utility line. This creates extreme hazards to anyone working on lines to restore power.

Jewelry is a good conductor of electricity and should be removed when working on electrical equipment.

Use extreme caution when working on electrical components. High voltages cause injury or death.

Follow all state and local electrical codes. Have all electrical installations performed by a qualified licensed electrician.

- **Do Not Smoke While Servicing Batteries**

Lead acid batteries emit a highly explosive hydrogen gas that can be ignited by electrical arcing or by smoking.

- **Exhaust Gases Are Toxic**

Provide an adequate exhaust system to properly expel discharged gases. Check exhaust system regularly for leaks. Ensure that exhaust manifolds are secure and not warped.

Be sure the unit is well ventilated.

- **Keep The Unit And Surrounding Area Clean**

Remove all oil deposits. Remove all unnecessary grease and oil from the unit. Accumulated grease and oil can cause overheating and subsequent engine damage and may present a potential fire hazard.

Do NOT store anything in the generator compartment such as oil cans, oily rags, chains, wooden blocks etc. A fire could result or the generator set operation may be adversely affected. Keep the floor clean and dry.

- **Protect Against Moving Parts**

Avoid moving parts of the unit. Loose jackets, shirts or sleeves should not be permitted because of the danger of becoming caught in moving parts.

Make sure all nuts and bolts are secure. Keep power shields and guards in position.

If adjustments *must* be made while the unit is running, use extreme caution around hot manifolds, moving parts, etc.

Do not work on this equipment when mentally or physically fatigued.

# General Description

## CURRENT MODELS

### RV SERIES 3.0 AJ — 3,000 WATTS

The new 3.0 AJ RV set has a four-cycle, single cylinder, 3600 rpm engine. The two-pole revolving armature generator is inherently regulated and produces 3,000 watts of power at a current rating of 25 amperes at 120 volts AC. This compact, lightweight model is ideal for type "C" mini-motor home applications. This model is also UL Listed and CSA Certified.

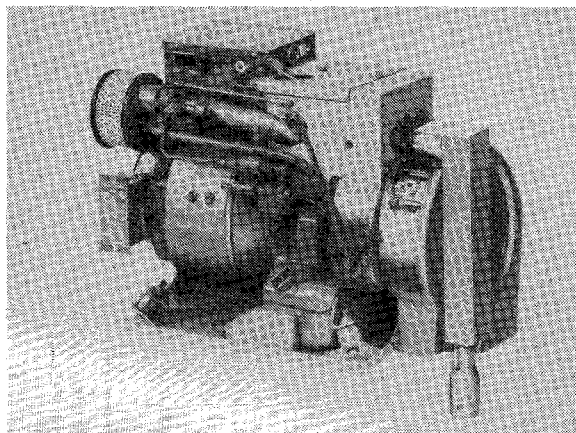

MODEL NUMBER	ELECTRICAL DETAILS					
	WATTS	VOLTS	AMP	HERTZ	PHASE	WIRE
3.0AJ-1R/16017P	3000	120	25	60	1	2

### RV SERIES 4.0 BFA — 4,000 WATTS

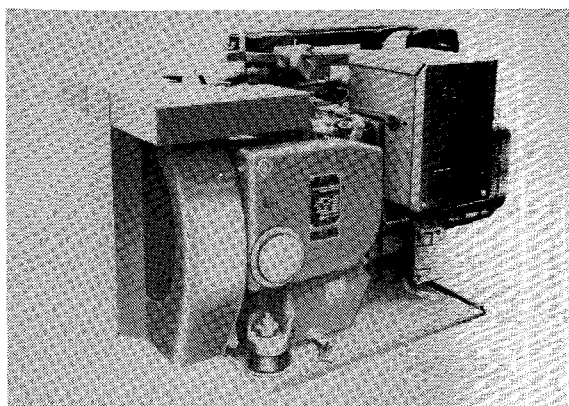

The new 4 kW set supersedes the 4.0 BF model. It has a four-cycle, twin cylinder, horizontally opposed 1800 rpm Onan model B43-GA016 engine. This model is UL listed and CSA certified and features built-in, 30 amp circuit breaker protection. The electrical characteristics are shown below.

MODEL NUMBER	ELECTRICAL DETAILS					
	WATTS	VOLTS	AMP	HERTZ	PHASE	WIRE
4.0BFA-1R/16004A	4000	120	33.3	60	1	4

## RV SERIES 5.0 BGA — 5,000 WATTS

The completely new 5 kW set supersedes the 5.0 CCK models. It has a four-cycle, twin cylinder, horizontally opposed 1800 rpm Onan model B48-GA018 engine. The set is also UL listed and CSA certified and features built-in, 40 amp circuit breaker protection. The electrical characteristics are shown below.

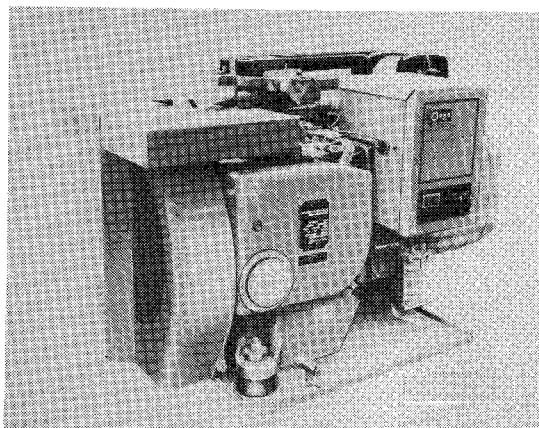

MODEL NUMBER	ELECTRICAL DETAILS					
	WATTS	VOLTS	AMP	HERTZ	PHASE	WIRE
5.0BGA-3CR/16004A	5000	120	41.6	60	1	4

## RV SERIES 6.5 NH — 6,500 WATTS

The new 6.5 NH is a 4-cycle, air cooled, horizontally opposed 2-cylinder design. The four-pole revolving armature rotates at 1800 rpm to provide 6500 watts of RV electric power. The electrical characteristics are shown below. This model is UL Listed and CSA Certified and features built-in 50 amp circuit breaker protection.

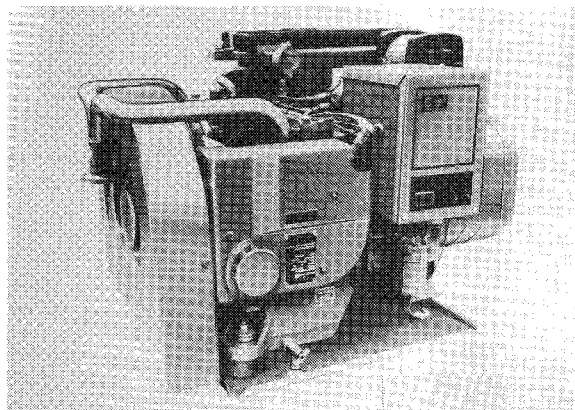

MODEL NUMBER	ELECTRICAL DETAILS					
	WATTS	VOLTS	AMP	HERTZ	PHASE	WIRE
6.5NH-3CR/16004	6500	120/240	54.2/27.1	60	1	4

# General Description

## OLDER MODELS

### RV SERIES 2.5AJ — 2,500 WATTS

The 2.5AJ has a four-cycle, single cylinder 3600 rpm engine. The two-pole, revolving armature generator is inherently regulated. This generator set is ideal for application in chopped vans and mini-homes.

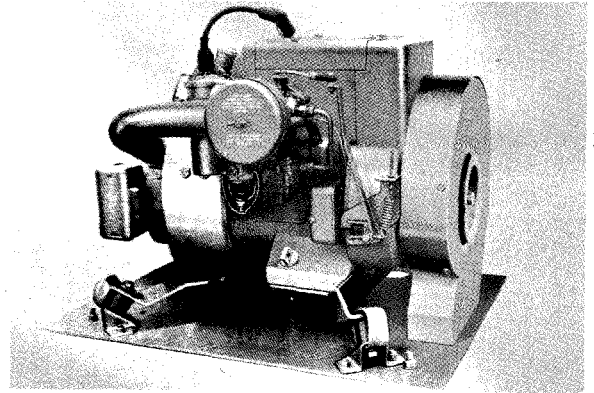

MODEL NUMBER	ELECTRICAL DETAILS					
	WATTS	VOLTS	AMP	HERTZ	PHASE	WIRE
2.5AJ-1E/12006	2500	120	20.8	60	1	2

### RV SERIES 2.5 LK — 2,500 WATTS

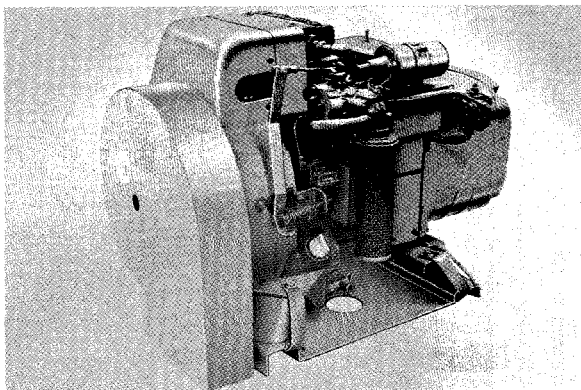

The LK produces 2500 watts of electric power. The LK has a four-cycle single cylinder 1800 rpm engine. The four-pole revolving armature generator is inherently regulated.

MODEL NUMBER	ELECTRICAL DETAILS					
	WATTS	VOLTS	AMP	HERTZ	PHASE	WIRE
2.5LK-3CR/12006	2500	120/240	20.8/10.4	60	1	4



## RV SERIES 2.7AJ—2,750 WATTS

The 2.7 AJ has a four-cycle, single cylinder, 3600 rpm engine. The two-pole revolving armature generator is inherently regulated. This generator set was replaced by the 3.0 AJ set for 1978.

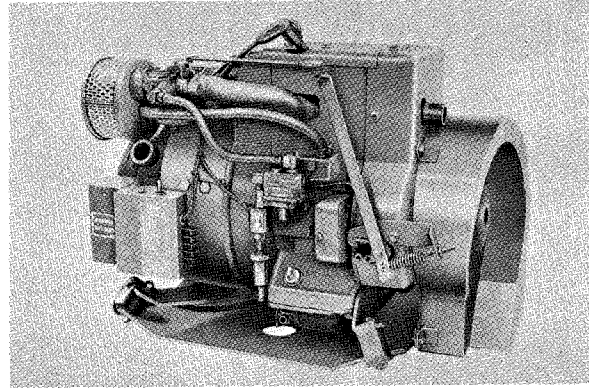

MODEL NUMBER	ELECTRICAL DETAILS					
	WATTS	VOLTS	AMP	HERTZ	PHASE	WIRE
2.7AJ-1R/12020	2750	120	22.9	60	1	2

## RV SERIES 4.0BF—4,000 WATTS

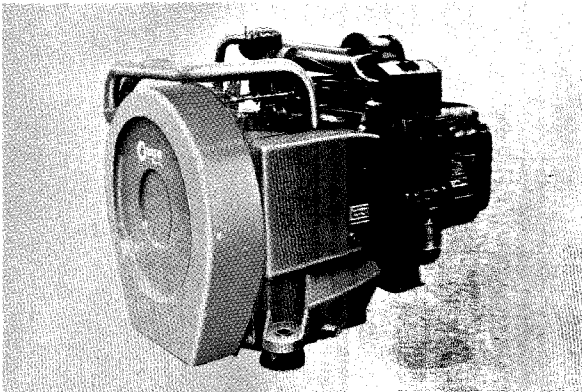

The 4.0 BF is a four-cycle, twin cylinder, horizontally opposed 1800 rpm engine. The unit features include vacu-flow cooling electric starting, and built-in battery charging system. The four-pole revolving armature generator is self-excited and inherently regulated. This unit was replaced by the 4.0 BFA set for 1978.

MODEL NUMBER	ELECTRICAL DETAILS					
	WATTS	VOLTS	AMP	HERTZ	PHASE	WIRE
4.0BF-3CR/16000*	4000	120/240	33.3/16.6	60	1	4
4.0BF-3CR/16002						

\* - Includes fixed mounting plate.

**RV SERIES 4.0 AND 5.0 CCK — 4000 OR 5000 WATTS**

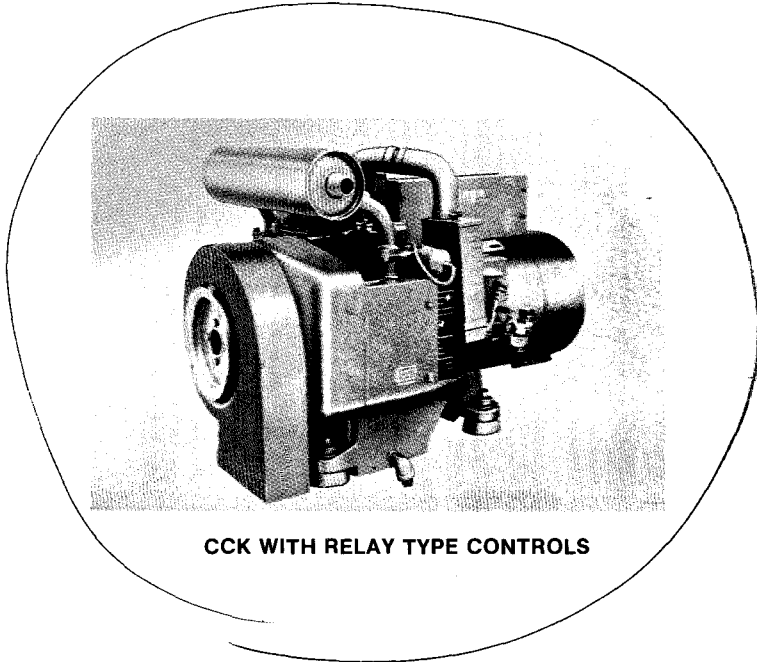

**CCK WITH RELAY TYPE CONTROLS**

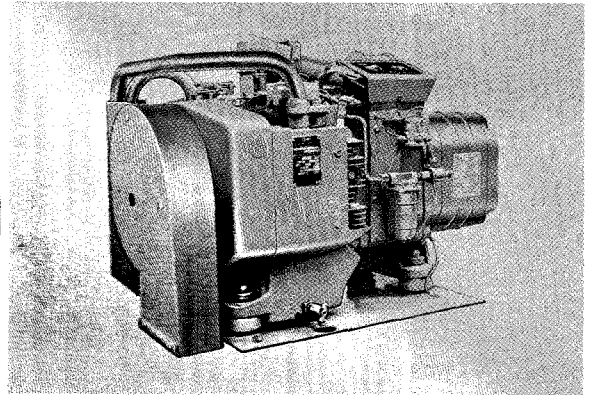

**CCK WITH SOLID STATE CONTROLS**

The 4.0 and 5.0CCK look identical: both have four-cycle engines with two horizontally opposed cylinders. The four-pole, revolving armature generator on both units is self-excited

and inherently regulated. The major difference between the 4.0 CCK and the 5.0 CCK is in their electrical characteristics as shown below. These CCK models are no longer in production.

MODEL NUMBER	ELECTRICAL DETAILS					
	WATTS	VOLTS	AMP	HERTZ	PHASE	WIRE
4.0CCK-3CR/12000	4000	120/240	33.3/16.7	60	1	4
5.0CCK-3CR/12000	5000	120/240	41.6/20.8	60	1	4

## RV SERIES 6.5 NH — 6,500 WATTS

The 6.5 NH is a 4-cycle, air cooled, horizontally opposed 2-cylinder design. The four-pole revolving armature rotates at 1800 rpm to provide 6500 watts of RV electric power. The electrical characteristics are shown below.

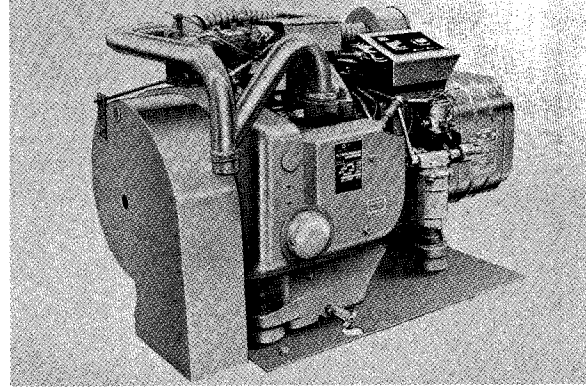

MODEL NUMBER	ELECTRICAL DETAILS					
	WATTS	VOLTS	AMP	HERTZ	PHASE	WIRE
6.5NH-3CR/12000	6500	120/240	54.2/27.1	60	1	4

## RV SERIES POWER DRAWER 6.0 NH — 6,000 WATTS

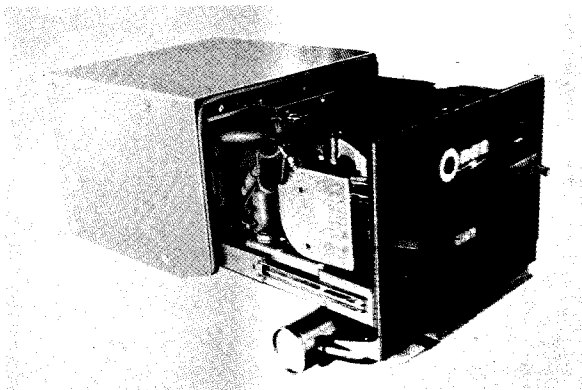

The 6.0 NH Power Drawer has a four-cycle, air cooled, L-Head engine. The four-pole revolving armature rotates at 1800 rpm to provide 6000 watts of RV electric power. The electrical characteristics are as follows:

MODEL NUMBER	ELECTRICAL DETAILS					
	WATTS	VOLTS	AMP	HERTZ	PHASE	WIRE
6.0NH-1R/9000	6000	120	50.0	60	1	4

# Installation Checks

To verify the proper installation of an RV generator set, check the following:

- Compartment Size
- Ventilation
- Mounting
- Fuel Supply
- Exhaust System
- Battery Connection
- Load Wire Connections

**WARNING** The primary installation requirement is safety. Be sure installation meets all applicable code requirements, i.e., ANSI, NFPA, California State Codes, etc.



4000 watt

**POWER REQUIREMENTS FOR APPLIANCES**

<b>Appliance or Tool</b>	<b>Approximate Running Wattage*</b>
Refrigerator .....	600-1000
Electric broom .....	200-500
Coffee percolator .....	550-700
Electric frying pan .....	1000-1350
Hair dryer .....	350-500
Electric stove (per element) .....	350-1000
Electric iron .....	500-1200
Radio .....	50-200
Electric water heater .....	1000-1500
Space heater .....	1000-1500
Electric blanket .....	50-200
Television .....	200-600
Electric drill .....	250-750
Battery charger .....	Up to 800
Electric water pump .....	500-600
Air Conditioner .....	1400-2200
Converter .....	300-350
Microwave oven .....	700-1500

\* - Starting wattages for motors can be three to four times more than the approximate running wattages.

**Power Requirements**

This table lists the power requirements for some of the tools and appliances used in an RV. Determine the load placed on the generating set. Overloading can cause engine and generator problems and customer dissatisfaction with the unit.

**CAUTION**

Do not overload the generator set. Continuous overloading may cause high operating temperatures that can damage the windings.

**WARNING**

**TO PREVENT FIRE OR ACCIDENT HAZARD . . . THIS UNIT MUST BE INSTALLED ACCORDING TO THE MANUFACTURER'S DETAILED INSTALLATION PROCEDURES OBSERVING ALL MINIMUM CLEARANCES.**

**TO AVOID POSSIBLE PERSONAL INJURY OR EQUIPMENT DAMAGE, ANY INSTALLATION AND ALL SERVICE MUST BE PERFORMED BY QUALIFIED PERSONNEL.**

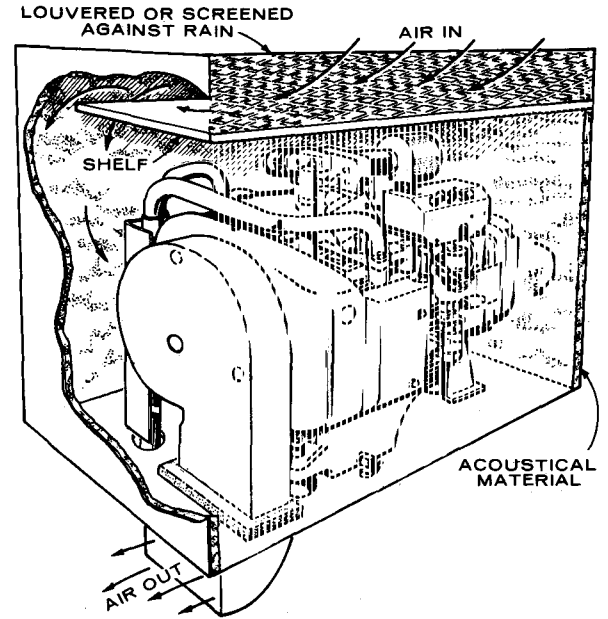
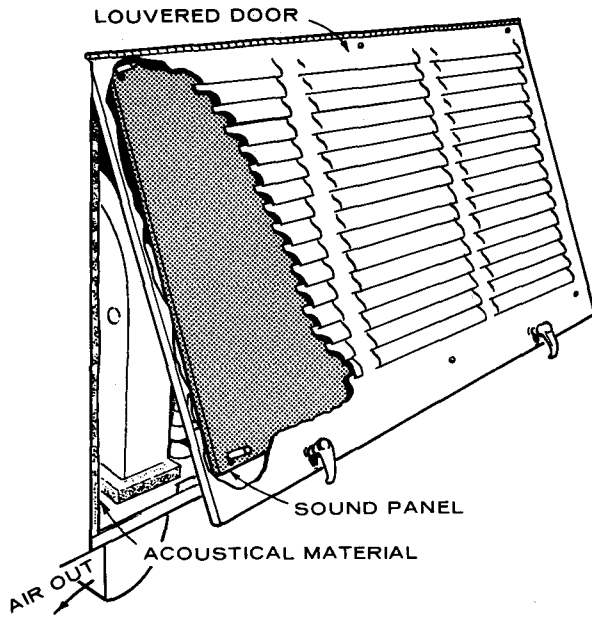

### Ventilation

One of the most important installation considerations is ventilation. Generator cooling, engine cooling and engine combustion require adequate air inlet and outlet vents. High compartment temperatures can damage the engine and generator affecting service life and ability of the unit to carry the applied load.

#### **WARNING**

The ventilation system should provide a constant flow of air to expel any accumulation of fuel vapor while the vehicle is in transit. Separate installation area or compartment from living quarters by a vapor-tight wall to prevent entrance of noxious fumes to interior.

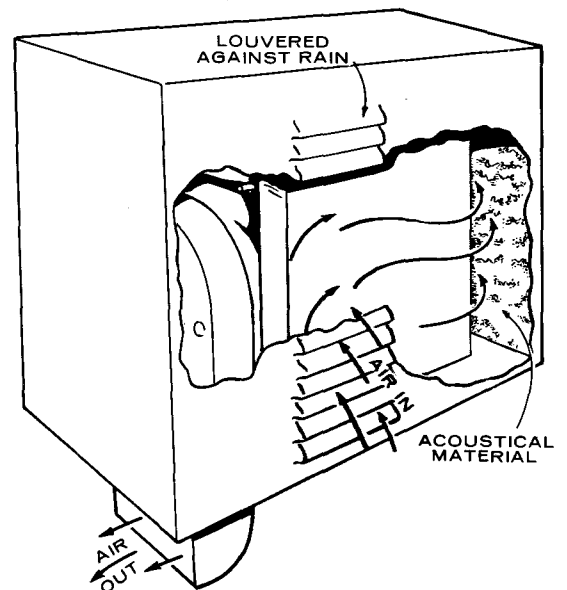
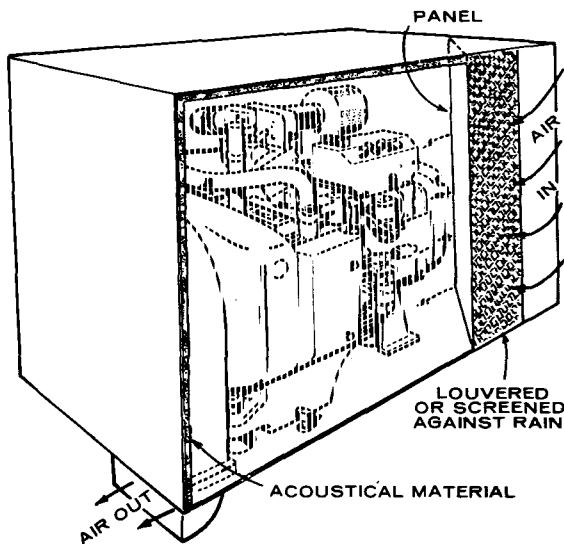

### Vacu-Flo Cooling

All Onan RV generating sets use Vacu-Flo cooling: a centrifugal fan in a scroll housing on the engine end draws air from the generator end of the compartment, through the generator and over the cooling surfaces of the engine. Then, the heated air is discharged out through the Vacu-Flo discharge opening. Install a deflector to eliminate dust, dirt or other foreign matter from being stirred up and pulled into the generator.

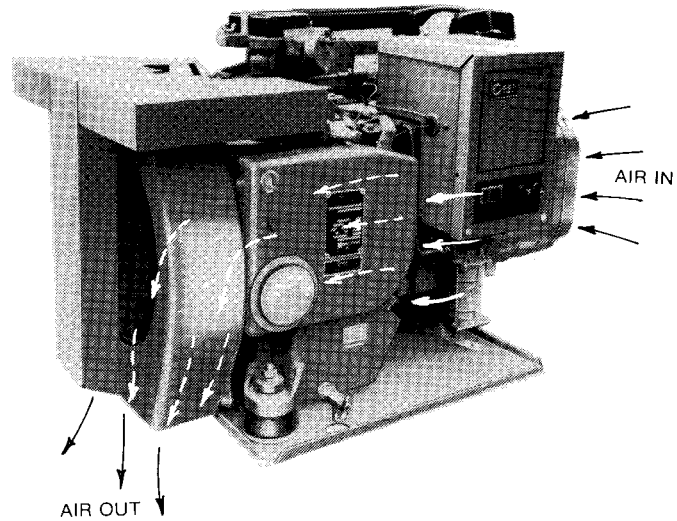

### Ventilation

The biggest enemy of electric generating sets installed in motor homes is excessive heat. Make sure the sets air inlet and outlet are not plugged with dust, dirt, bugs, leaves or anything that could restrict cooling air.

**WARNING** Do not use discharged Vacu-Flo air for heating because it may contain carbon monoxide and other poisonous gases.

**WARNING** Do not use flammable material directly above or around the electric generating set compartment. Heat transferred through the sheet metal compartment structure or other material can be HOT enough to discolor, char or ignite fiberboard, seat cushions, etc. Use of asbestos or other noncombustible temperature insulating material in high temperature areas may be necessary.

---

Notes:

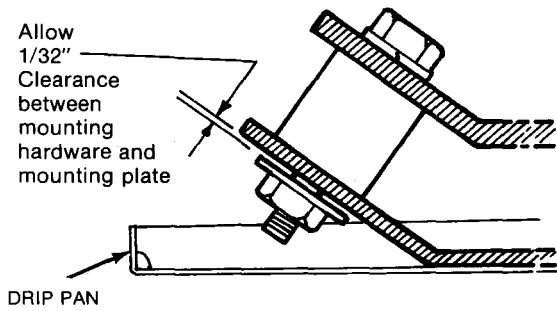

**3.0AJ-1R 16017P**

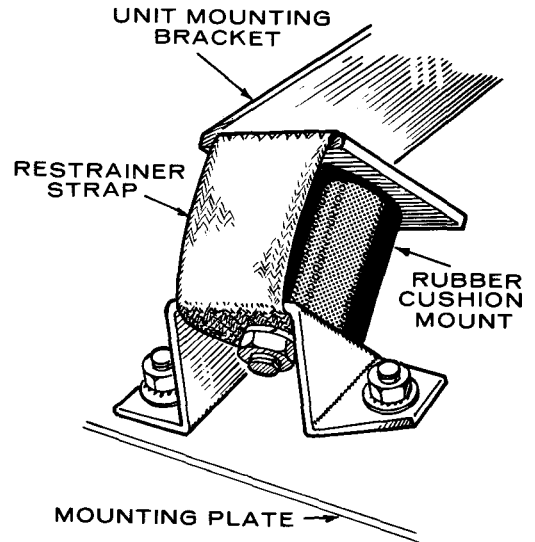

B99

**2.5AJ-1E/12006 FOCALIZED MOUNT**

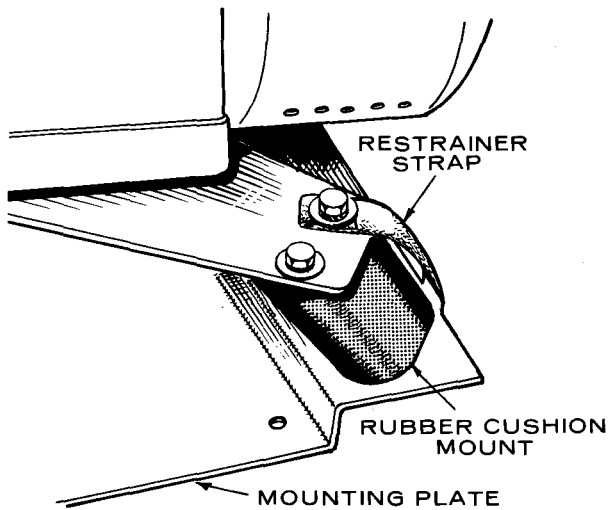

**2.5LK-1R/12006 FOCALIZED MOUNT**

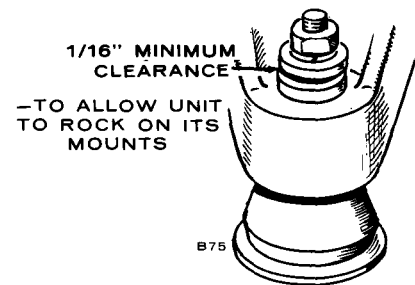

B75

**TWIN CYLINDER MODELS**

**Vibration Isolators**

All Onan RV models have rubber vibration isolators that are a "through bolt" type which prevent the units from breaking loose if the mounts are damaged.



**Use only the vibration isolators provided with the electric generating set, as they are designed to support unit's weight.**



### **Install Isolators**

Install the cone shaped vibration isolators as shown. Allow 1/16-inch (1.59 mm) minimum clearance between the snubber and the flat washer providing the generator sets with freedom of movement to eliminate vibration.

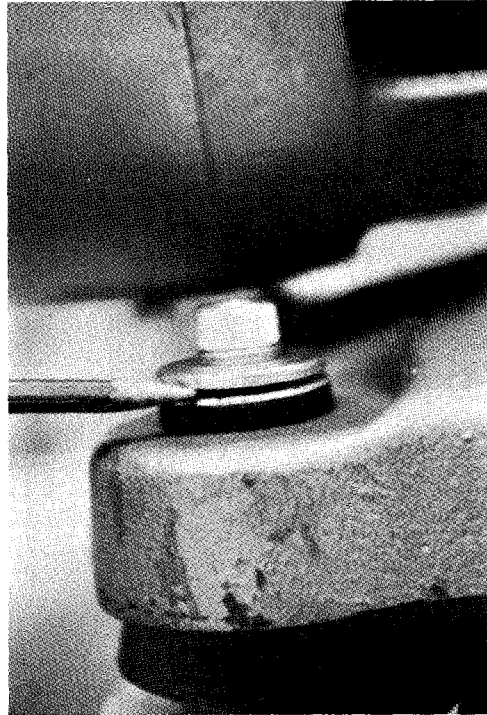

For additional information on installation, contact your Onan Service Representative or request specific installation guide for your model generator set. The installation guide number is listed on your Operator's Manual for each model.

---

### **Notes:**

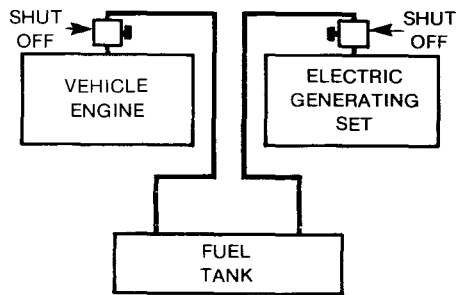

Operating the generator set from a tee in the main fuel line can cause erratic operation when vehicle is operated at highway speeds. The sets fuel pump has neither the capacity nor the power to overcome the draw of vehicle engine fuel pump.

**WARNING** Leakage of gasoline in or around the compartment is a serious fire hazard. The ventilation system should provide a constant flow of air to expel any accumulation of fuel vapor while the vehicle is in transit. Compartments must be vapor tight to the interior to keep fumes from within the vehicle.

## Fuel Supply

When the generator set shares the supply tank of the vehicle, be sure the fuel lines from the tank to the generating set are large enough to supply an adequate amount of fuel to the set. Check all fuel connections, valves, sediment bowls and filters to be sure there are no air leaks that could cause fuel failure and subsequent shut-down.

**WARNING** Fuel lines must be of steel piping, adequately secured and free of leaks. A flexible section of fuel line must be used between the generating set and stationary fuel line in the vehicle. This flexible section must be 100% NON-METALLIC to prevent electrical currents from using it as a conductor.

**WARNING** Do not tie electrical wiring to fuel line because any short or arcing could cause an explosion.

Keep the fuel lines away from hot engine or exhaust areas to reduce the chance of vapor lock.

## WARNING

### ENGINE EXHAUST GAS (CARBON MONOXIDE) IS DEADLY!

Carbon monoxide is an odorless, colorless gas formed by incomplete combustion of hydrocarbon fuels. Carbon monoxide is a dangerous gas that can cause unconsciousness and is potentially lethal. Some of the symptoms or signs of carbon monoxide inhalation are:

- Dizziness
- Intense Headache
- Weakness and Sleepiness
- Vomiting
- Muscular Twitching
- Throbbing in Temples

If you experience any of the above symptoms, get out into fresh air immediately.

The best protection against carbon monoxide inhalation is a regular inspection of the complete exhaust system. If you notice a change in the sound or appearance of exhaust system, shut the unit down immediately and have it inspected and repaired at once by a competent mechanic.

## Exhaust System

Be sure the construction of the exhaust system prevents damage from leaks or vibration. Use automotive exhaust hangers and connections under the vehicle. Be sure the exhaust outlet terminates aft of the set compartment and the exhaust pipe extends to the perimeter of the vehicle.

**WARNING** Plan the exhaust system carefully. Exhaust gases are deadly!

**CAUTION** Do not connect the electric generating set exhaust to the vehicle exhaust system. Water vapor from one engine can damage the other engine.

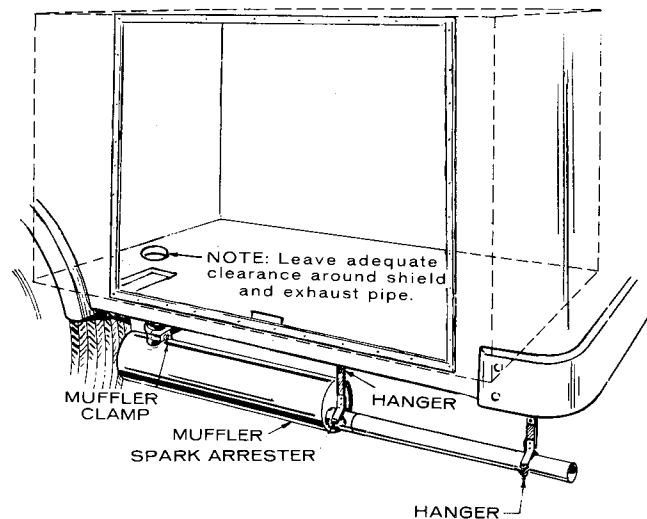

## Exhaust Spark Arresters

Exhaust spark arresters are necessary for SAFE OPERATION. All require periodic clean-out (every 50 to 100 operating hours) to maintain maximum efficiency. Some state and federal parks require them. To clean spark arrester, remove pipe plug in bottom of muffler. Run set for 5 minutes. Replace plug. Onan sets are equipped with mufflers using an integral spin-out type spark arrester.

**WARNING** Do not install the exhaust outlet closer than 3 feet (1 m) from the gasoline filler spout. Exhaust gases contain DEADLY carbon monoxide.

**WARNING** Check exhaust system every 8 hours of operation for leaks.

**CAUTION** If using tail pipe deflector, be sure it is large enough to prevent excessive back pressure. All exhaust pipe should extend beyond the rear of the vehicle.

**WARNING** Do not terminate exhaust under vehicle, as carbon monoxide gas is poisonous. Direct exhaust gases away from window and door openings.

**IMPORTANT:** Certain states (particularly California) have state ordinances pertaining to the type and usage of exhaust muffler/spark arresters on internal combustion engines or engine driven equipment when used in a recreational vehicle such as electric generating sets. Be sure your installation meets all Federal, State and local codes pertaining to your unit. Failure to provide and maintain a spark arrester may be in violation of the law.

**WARNING** All exhaust shielding supplied with unit MUST be properly installed to prevent overheating of compartment walls or the possibility of fire.

### Battery Selection

Determine battery size by the amount of "surge" power required to start the generating set. Select a battery that is at least as large as that specified by Onan.

Locate battery as close as possible to starter and charging system. Keep the battery well charged and clean. Keep terminals clean and free of corrosion.

**WARNING** Do not locate battery in same compartment as generating set to avoid a potential fire hazard. Onan recommends using a separate battery for operation of the generator set in addition to the regular vehicle starting battery.

### BATTERY CABLE RECOMMENDATIONS

*CABLE LENGTH IN FEET (metres)	CABLE SIZE
0-10 (0-3)	2
11-15 (3-4.5)	0
16-20 (4.5-6)	000

\* - Distance from battery to set.

Onan recommends one 12-volt, 74 amp hour battery for all RV generator sets. In colder temperature applications (0° to 32°F), one 12-volt, 92 amp hour battery is recommended for all units. For sub-zero operation, Onan recommends one 12-volt, 105 amp or larger capacity battery.

### Check Cable Size

After checking the battery for the correct size and capacity, check the battery cables. The distance from the battery to the generator determines the size of the battery cable as indicated in this table. If cables are undersize, starting problems may develop.

**WARNING** Do NOT use maintenance-free, unvented batteries with these generator sets. Malfunction of the starting-charging system can produce high charging currents, causing excessive gassing. An unvented battery can build up sufficient pressure to explode.

---

**Notes:**

### Negative Battery Connection

Connect the negative cable to the designated point on the generator set. Use shakeproof washers between the cable lug and the connection point. If possible, make connections directly from the generator to the battery. Battery ground connection can be made to the vehicle chassis.

**WARNING** Be sure to make a good ground connection. Generator must be effectively bonded to recreational vehicle chassis for proper operation. Vehicle chassis (frame) ground and the battery and generator set ground should all be electrically connected to be at 0 ground potential. All Onan units are designated for negative ground application.

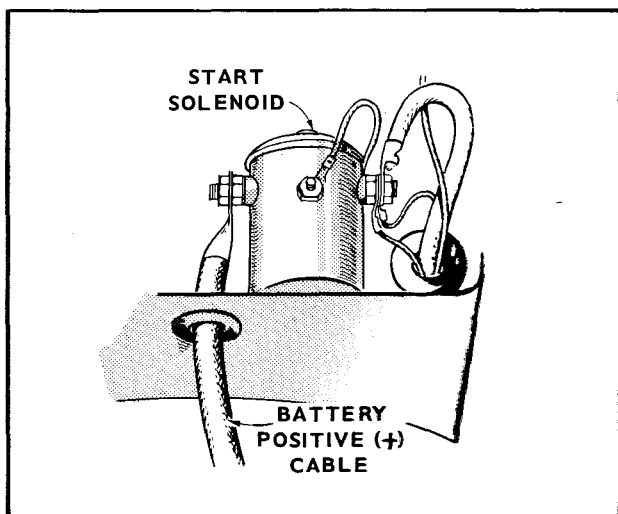
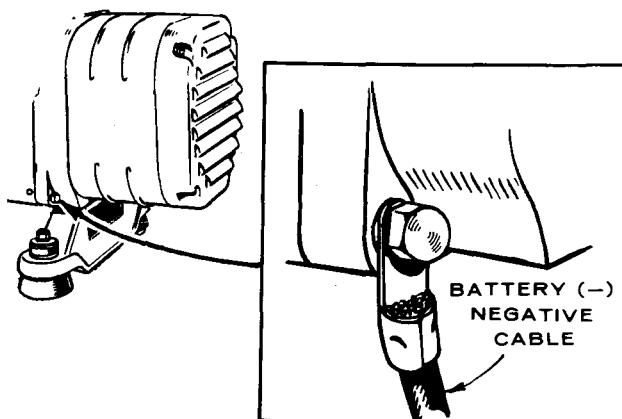

### Positive Connections

Connect the B+ cable to the start solenoid. Use this point to measure the available voltage at the generator for cranking and during cranking.

Notes:

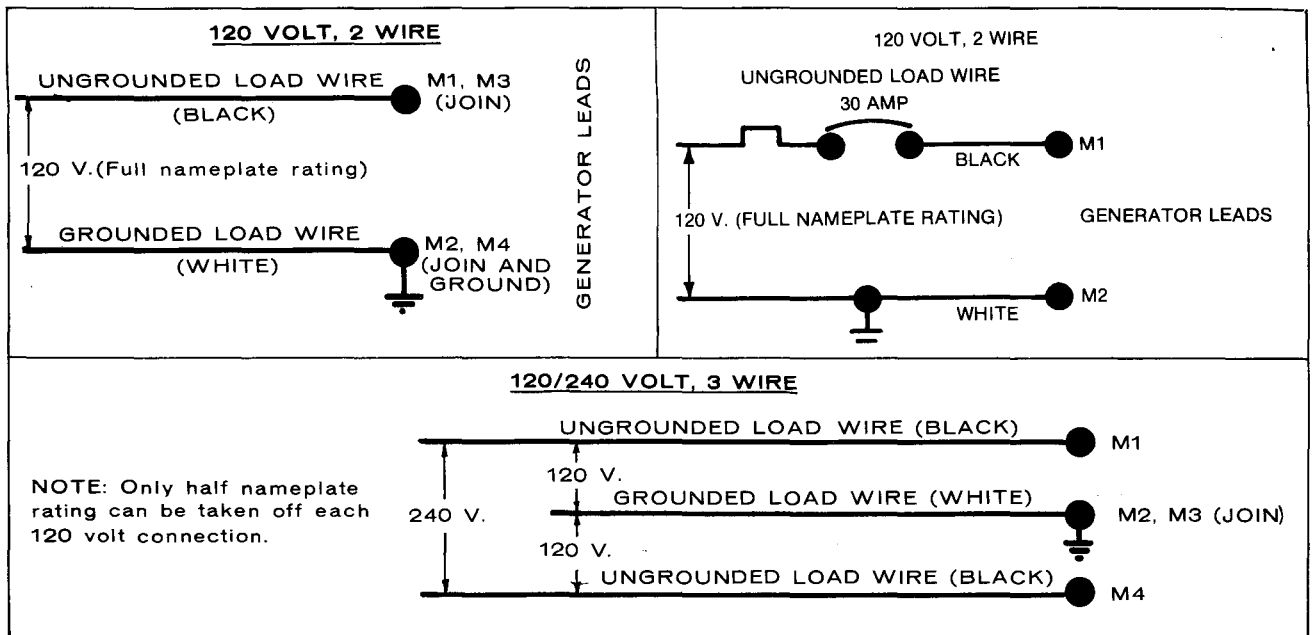

### Load Wire Connections

Most motor home generating sets are 120-volt, two-wire units. However, 120/240 dual voltage units are available. Many units can be reconnected to any of the voltage configurations. Be sure the generator is correctly connected to supply the voltage requirements of the motor home. See Operator's Manual.

Observe all applicable electric code requirements.

**WARNING** To prevent noxious gases from entering vehicle interior, seal any openings made in the set's compartment for conduit, wiring, etc.

Notes:

## SUMMARY OF GENERATOR SET INSTALLATION DETAILS

### IMPORTANT SAFETY PRECAUTIONS

**CAUTION** Air flow is restricted if insulation extends into minimum clearance around the generating set (1 inch). Insulation must be of a material that does not support combustion.

**CAUTION** For proper vibration isolation do not compress isolators (not applicable for 2.5 AJ and 2.5 LK). Leave approximately 1/16-inch clearance between top snubber washers.

**WARNING** Do not tie electrical wiring to fuel line as this could produce arcing and subsequent fire hazard.

**CAUTION** Solid metal conductors can develop metal fatigue and break. Use only stranded wire in compartment.

**WARNING** Never use discharged cooling air for heating because it may contain poisonous gases.

**CAUTION** Onan does not recommend battery sharing. The Onan charging system will not be damaged, but the vehicle's system could be.

**WARNING** Do not use insulation on the bottom of the compartment. Oil and/or gasoline present a potential fire hazard.

**CAUTION** Do not use a sheet metal base or thin plate without a frame to adequately support the unit.

**WARNING** Do not terminate exhaust under vehicle. Exhaust gases are deadly. Plan exhaust systems carefully. Extend exhaust beyond rear of vehicle.

**CAUTION** Do not connect generating set exhaust to vehicle exhaust system. Water vapor from one engine can damage the other engine.

**WARNING** Do not locate battery in generating set compartment. Buildup of hydrogen gas in compartment could cause explosion.

**WARNING** DO NOT DISCONNECT BATTERY CABLES FROM BATTERY WHILE GENERATOR SET IS CRANKING OR RUNNING; SPARKS MAY CAUSE AN EXPLOSION.

**WARNING** Do not terminate exhaust under vehicle, as carbon monoxide gas is poisonous. Direct exhaust gases away from window and door openings.

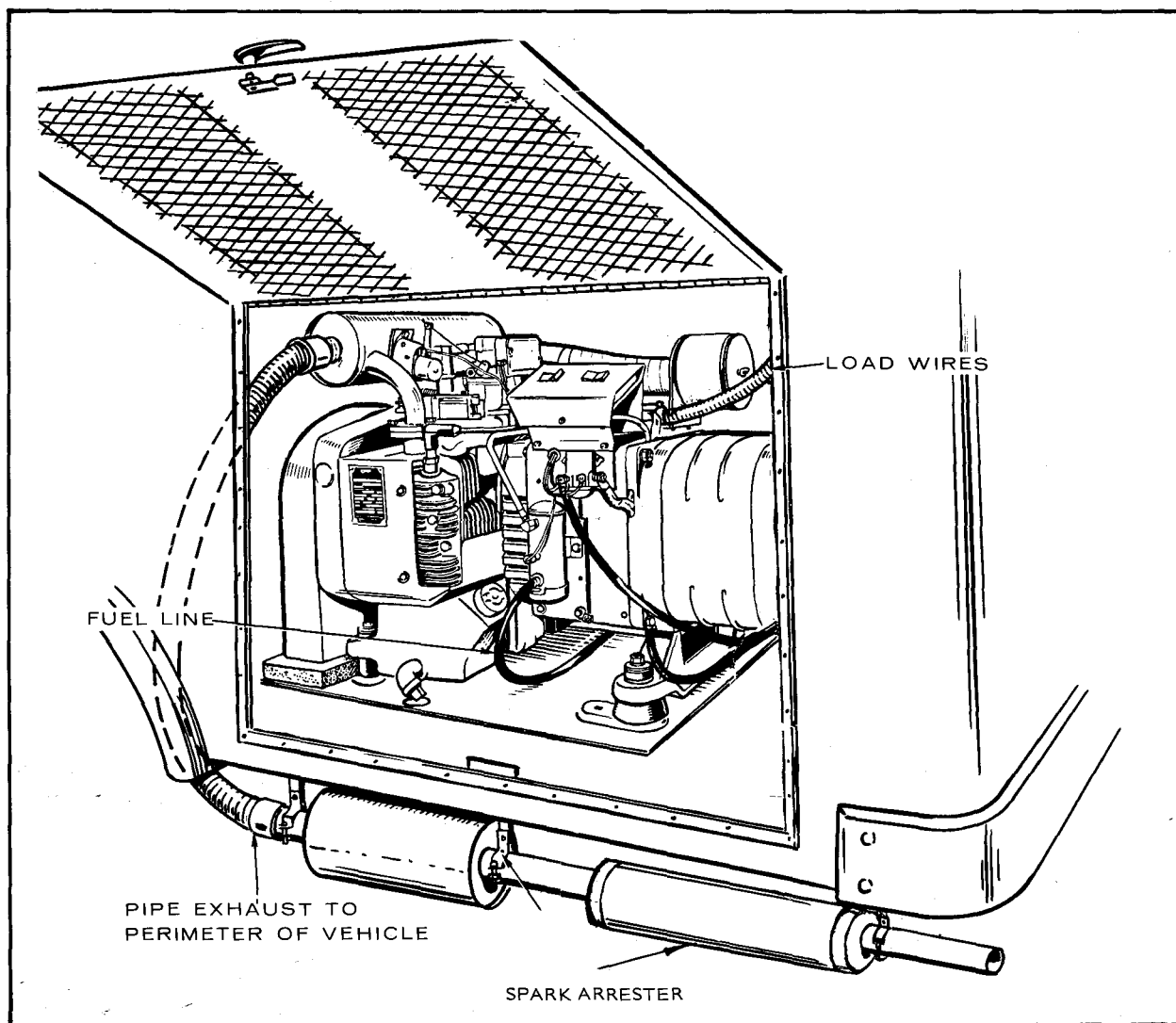

### Earlier Installations

Earlier installations have unit-mounted exhaust muffler systems with a flexible line to the muffler. Watch for leaks or breaks in the line. These installations can be converted to the new system for service convenience and noise reduction.



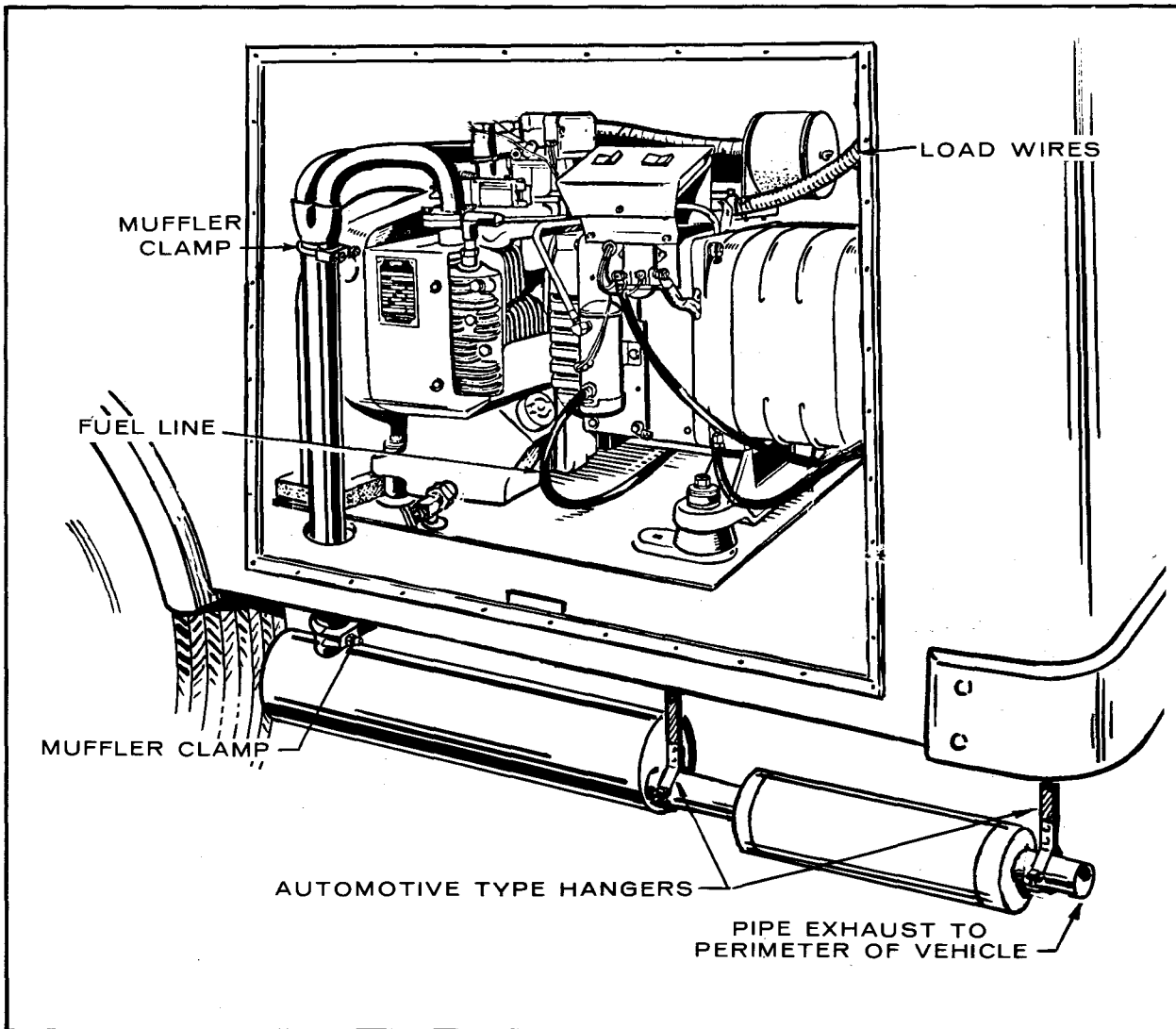

### Later Installations

Later installations have right- or left-hand exhaust manifolds and have a short exhaust pipe into the muffler. The Onan muffler lowers compartment temperature and reduces engine exhaust noise to below industry's suggested minimum limits. As required in some camps and parks, spark arresters are available to catch carbon particles from exhaust. Onan sets use mufflers with integral spin-out type exhaust spark arresters. Current models have a center down exhaust system.

Removing a pipe plug from the arrester and operating the electric set (at a convenient time and place) cleans out the deposits.

**This arrester does not plug up when the holding chamber is full and does not cause harmful high exhaust back pressure.**

### Spin-Out Spark Arrester (Optional)

The spin-out spark arrester attaches to the muffler. It removes carbon particles from the generator set exhaust by centrifugal force, catching the particles in a holding chamber.

When full, particles pass through the arrester. Clean the arrester every 50 to 100 hours of operation.

---

# Preventive Maintenance

To achieve efficient generator operation and promote long life for the unit, it is important to keep the unit clean and to perform the service

items listed on the generator end band or cylinder shroud at the indicated hours-of-operation.

## Keep Unit Clean

Cleanliness of the generating set and the compartment directly reflects the total operating efficiency of the unit. Consider the road conditions under which the unit has been operating.

- Keep cooling system clean.
- Service air cleaner as required by road conditions.
- Change crankcase oil and filter more frequently when operating the generating set in dusty or dirty conditions.
- Keep governor and choke linkage clean.

### CAUTION

On Power Drawer units, clean sand and dirt from slide rails with an air hose. NEVER OIL SLIDE RAILS.

- Clean bottom of housing and inlet duct as necessary.
- Check air outlet screen for obstructions.
- Blow out the unit and the compartment with clean, dry, compressed air not to exceed 35 psi (242 kPa).

### WARNING

Before beginning any maintenance work on the engine, generator, control panel or associated wiring, disconnect the battery. Failure to do so could result in damage to the unit or serious personal injury in the event of inadvertent starting.

### WARNING

Always allow generator set to cool off before performing any maintenance or installation work on the set. Working on a hot set could cause severe burns.

# Periodic Maintenance Schedule

Regularly scheduled maintenance is the key to lower operating cost and longer service life for the set. The following schedule should be used as a guide. Actual operating conditions under which the set operates should be the determining factor in establishing a maintenance schedule. Periodically inspect the generating

set and it's components and clean or replace as is necessary. Remember—100 hours of generator set operation at 1800 rpm is equivalent to the running time necessary for your motor home to travel 4,000 miles at 40 mph.

SERVICE THESE ITEMS	AFTER EACH CYCLE OF INDICATED HOURS				
	8	50	100	200	400
General Inspection	x1				
Check Oil Level	x				
Check Battery Electrolyte Level		x			
Change Crankcase Oil			x2		
Check Spark Plugs			x4		
Check Breaker Points			x3		
Clean Breather Valve			x		
Clean Governor Linkage			x		
Service Air Cleaner (Oil Bath)			x2		
Replace Air Cleaner Element (Dry)				x2	
Clean Cooling Fins				x2	
Change Oil Filter (If Used)				x2	
Replace Breaker Points				x4	
Clean Crankcase Breather				x	
Remove Carbon Deposits from Heads				x	
Adjust Tappets					x
Replace Fuel Filter (If Used)					x4
Clean Carburetor					x
Check Generator Brushes (Replace if Necessary)	As Required				

x1 - With set running, visually and audibly check exhaust system for leaks.

x2 - Perform more often in extremely dusty conditions.

x3 - Replace if necessary.

x4 - Replace annually or prior to storage.

**NOTE: ON 3600 RPM MODELS, REDUCE HOURLY INTERVALS BY ONE-HALF.**

**WARNING** All exhaust system connections **MUST** be checked regularly for any leaks and tightened as necessary. Do **NOT** terminate exhaust pipe under vehicle or near any window or door openings. Inspect the vapor tight seals around all openings made in the set's compartment for wiring, conduit, etc., to prevent entrance of any noxious fumes to motor home interior.

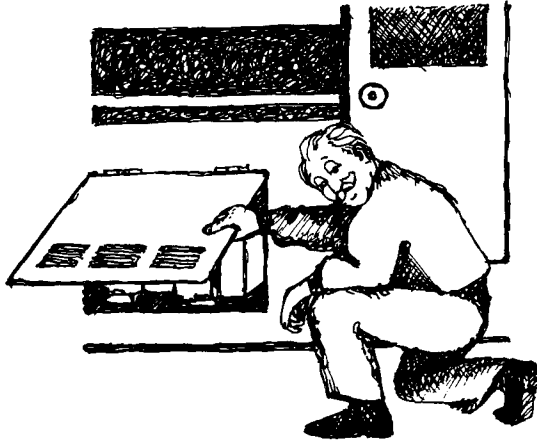

### Visual Inspection

Visually inspect the general appearance of the generating set. Look for any broken or damaged parts and be sure all connections are secure.

**WARNING** Do NOT store anything in the generator compartment such as oil cans, oily rags, chains, wooden blocks, etc. A fire could result or the generator set operation may be adversely affected. Keep the floor clean and dry.

SPECIFIC GRAVITY READING SHOULD BE 1.260 at 80° F (26° C)

B45

- 12-VOLT NEGATIVE GROUND
- BATTERY MUST BE CONNECTED AT ALL TIMES UNIT IS RUNNING
- CHECK SPECIFIC GRAVITY
- KEEP WATER TO PROPER LEVEL
- BATTERY CABLES TIGHT - TERMINALS CLEAN

### Battery Care

To increase battery life, a number of routine checks and some preventive maintenance should be performed.

1. Keep the battery case clean and dry.
2. Make sure the battery cable connections are clean and tight. Use a terminal puller when removing cables for any reason.
3. Coat the battery terminals with a mineral grease or petroleum jelly to reduce corrosion and oxidation.
4. Identify each battery cable to be positive or negative before making any connection. Always connect the ground (negative) cable last.
5. Maintain the electrolyte level by adding water (drinking quality or better) as needed for filling to split level marker. The water ingredient of the electrolyte evaporates, but the sulphuric acid ingredient remains. Therefore, add water, not electrolyte.
6. Avoid overcharging when recharging. Stop the boost charge when the specific gravity is 1.260 and the electrolyte is 80°F (26.7°C).



Charging system tests require a **fully charged battery** for accuracy in isolating component **malfunctions**.

### Recommended Fuels

Use clean, fresh, unleaded or regular grade gasoline. Do not use highly leaded premium fuels. Using unleaded gasoline results in less maintenance.

Use regular gasoline for the first 25 hours to allow the rings to seat well for best performance. Then use unleaded gasoline thereafter.

If regular gasoline is used continually, carbon and lead deposits must be removed from the cylinder heads as required because of engine power loss. Unleaded gasoline may be used safely after lead deposits have been removed.

**CAUTION** If lead deposits accumulate, loss of engine power will result. Remove cylinder heads—clean out lead! If lead deposits are not removed, preignition could occur with damage resulting to the engine.

**WARNING** To avoid a possible explosion never fill the fuel tank when the generator set engine is running.

### RECOMMENDED FUELS

- NON-LEADED GASOLINE IF AVAILABLE
- CLEAN FRESH "REGULAR" GRADE GASOLINE
- DO NOT USE HIGHLY LEADED PREMIUM (ETHYL) GRADES

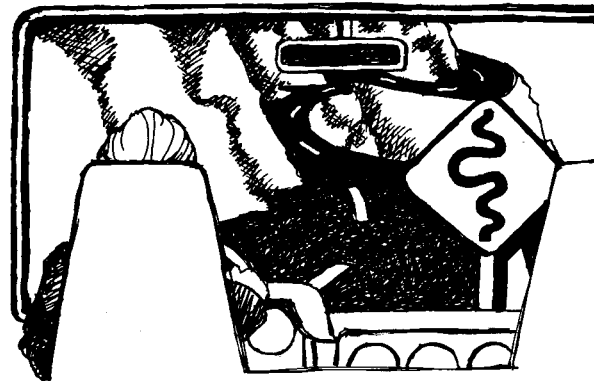

---

Notes:

## Lubricating Oil

The American Petroleum Institute, the Society of Automotive Engineers and the American Society for Testing Materials class oils according to the service for which they are designed. Onan recommends using SE or SE/CC oil, viscosity to be determined by the ambient temperature where the generating set is operating.

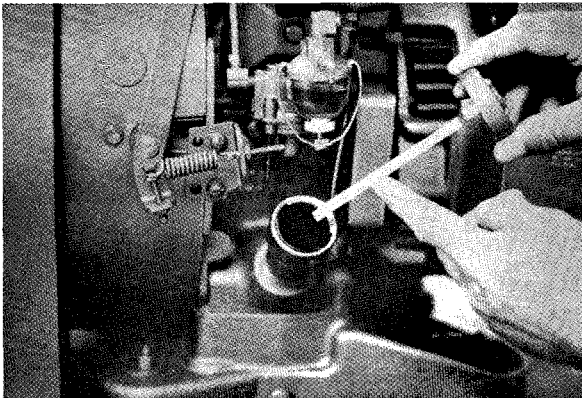
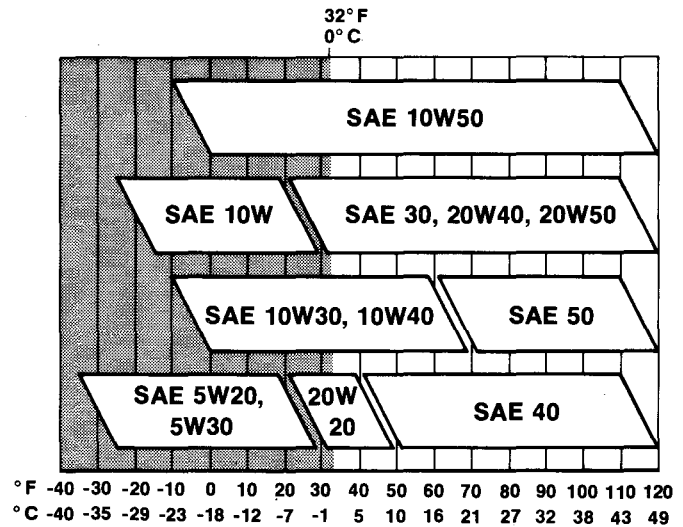

### **WARNING**

**Do NOT check oil while the generator set is operating.**

Hot oil could cause burns by blowing out of oil fill tube due to crankcase pressure.

### Check Oil Level

Prior to starting the generating set or each eight hours of operation, check the oil level to be sure the crankcase is properly filled. When adding oil, always use a good quality name brand oil that meets service designations SE or SE/CC.

Use of the same grade and quality oil as that used in your recreational vehicle engine is acceptable as long as unit is serviced regularly and oil meets API designation SE or SE/CC. Other factors (primarily temperature) should also be considered when selecting appropriate engine oil.

1. Avoid mixing different brands of oil.
2. If mixing oils of different brands is unavoidable, only one brand of detergent oil should be used. The other brand(s) should be non-detergent.
3. Do not use oils claiming "superior life" until rings are well broken in.
4. Beware of low quality multi-viscosity oils:
  - a. their viscosity improver may break down rapidly, leaving only the lighter viscosity base to protect your engine.
  - b. 5W and 10W oils, while they may pass the SAE viscosity requirement (at 0°F), may "congeal" at slightly colder temperatures, causing abnormally low cranking speeds and possible bearing damage on start-up.

### Change Oil

Change oil every 100 hours under normal operating conditions. When the generating set is operating in extremely dusty or dirty conditions, change oil every 50 hours or sooner.

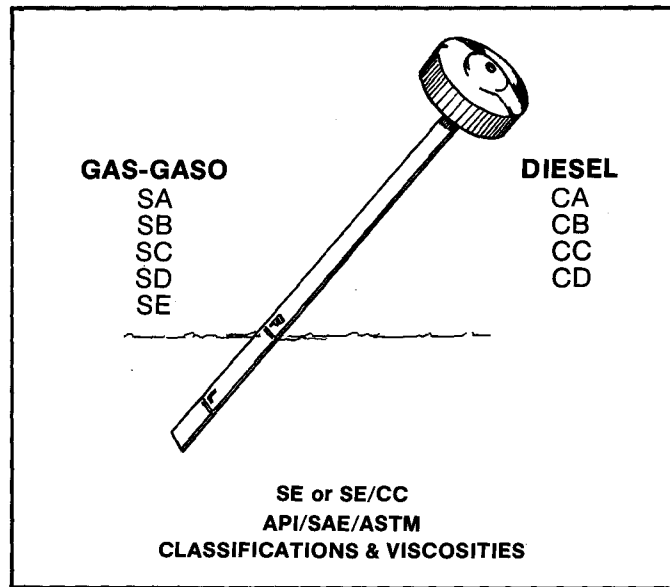

### Change Oil Filter

If the engine is equipped with an oil filter, change the filter every 200 hours of operation or every other oil change. Be sure to replace the foam strip around the filter.

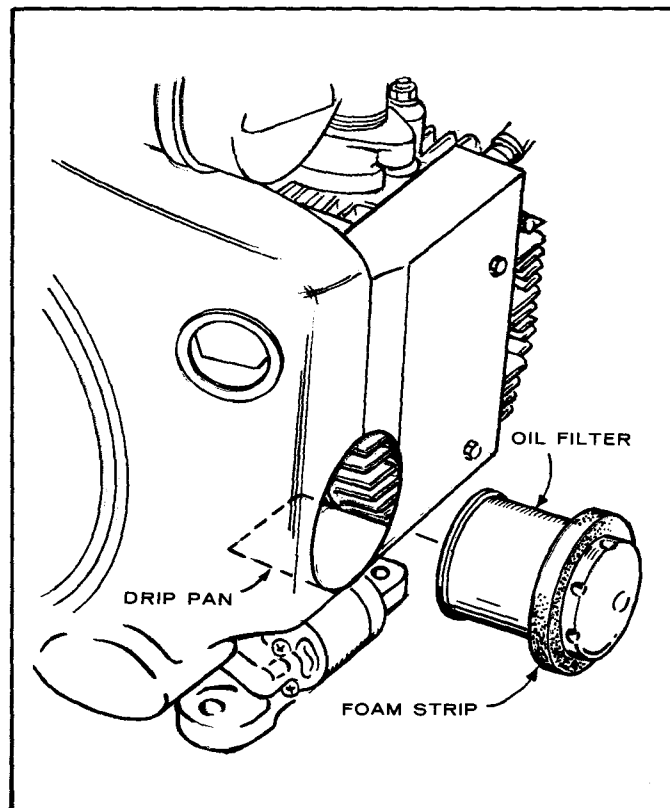

# AIR CLEANERS

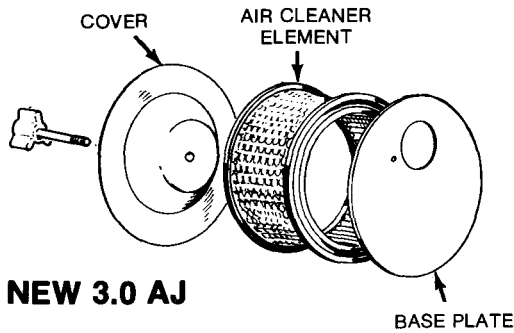
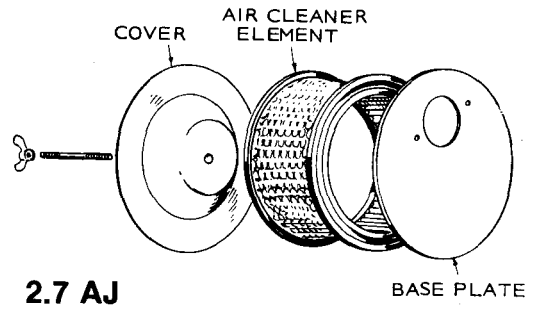
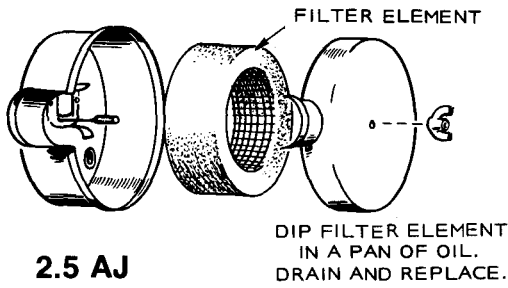

## POWER DRAWER

BF  
NH  
LK

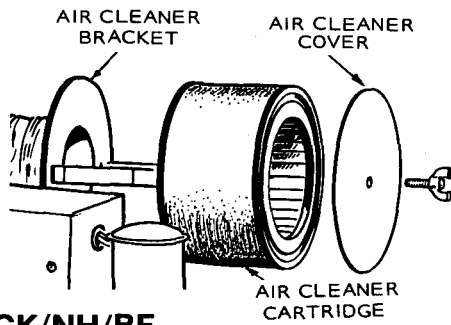
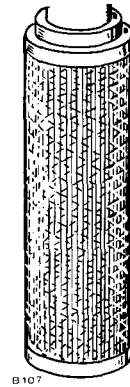

## CCK/NH/BF OLDER MODELS

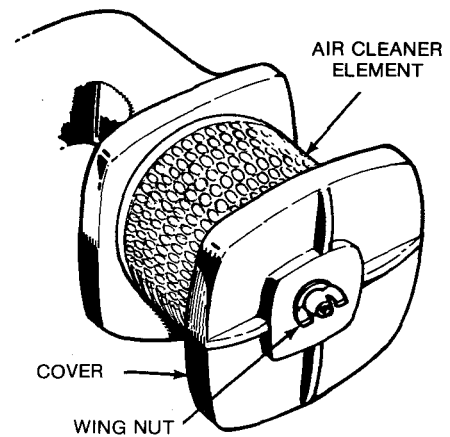
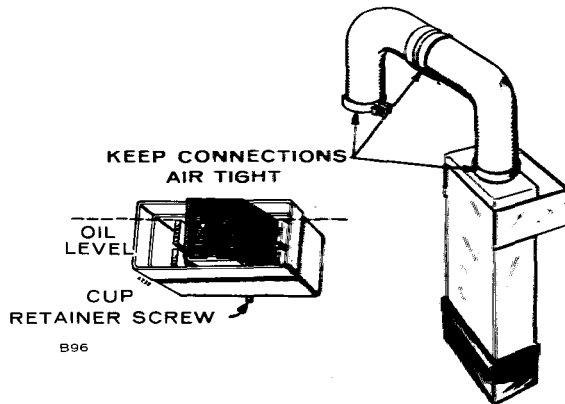

## NEW BFA, BGA and NH (Spec K)



### **Air Cleaner Maintenance**

Air cleaner design varies with the model of generating set. Generally, check the air cleaner every 100 hours of operation or more often when operating in extremely dusty conditions. A plugged air cleaner restricts intake air causing poor engine operation and excessive fuel consumption.

- Clean the sump on the oil bath air cleaner and add new oil at each oil change.
- Clean the paper element at each oil change by gently tapping against a flat surface removing dust and dirt accumulation. If compressed air is used to remove the dirt, it must not exceed 35 psi (242 kPa).
- The AJ and some CCK elements should be washed in a detergent, dipped in oil and squeezed out before replacement.

Replace the long thin element of the BF and NH Power Drawers® each 200 hours; replace the round element with the sleeve every 500 hours. Consult the owners manual of the specific model.



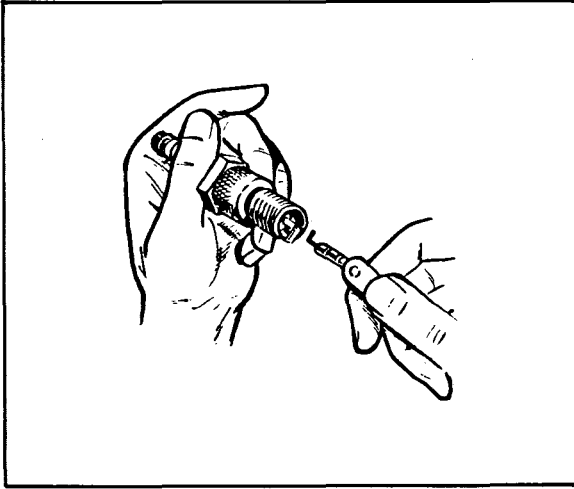

### **Check Spark Plugs**

Replace spark plugs after each 200 hours of operation. Spark plug gap should be .025 inch (.635 mm) for the AJ, LK, CCK, BF, BFA, BGA and 6.5 NH; .020 inch (.508 mm) for the 4.0 BF and 6.0 NH Power Drawer models. Check the conditions of the old plugs.

- Black deposits indicate a rich mixture.
- Wet plugs indicate misfiring.
- Badly or frequently fouled plugs indicate the need for major tune up.
- Yellow plugs indicate bad gasoline.

Badly leaded plugs cause misfiring, poor operation or stopping when a load is applied.

---

**Notes:**

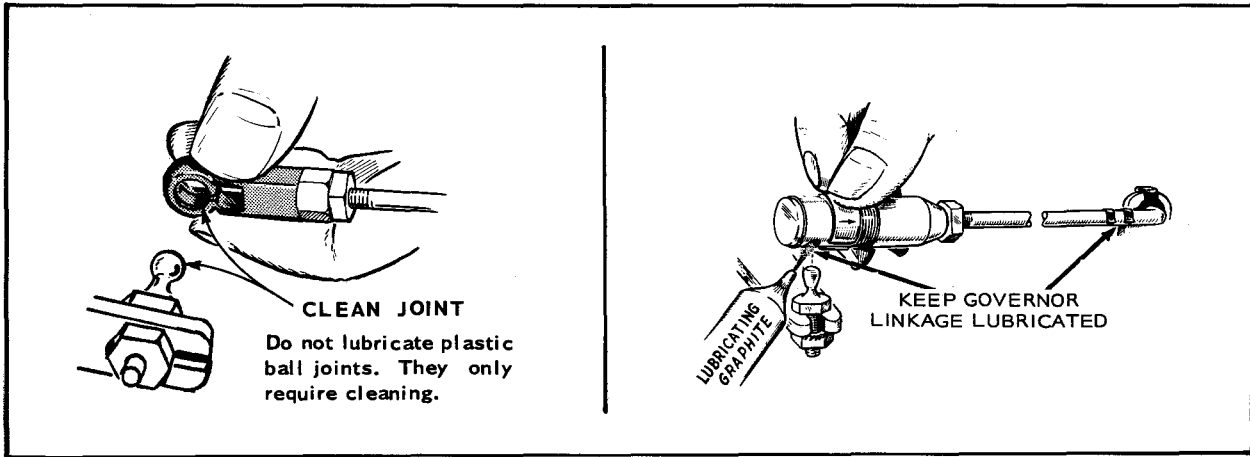

### Clean Governor Linkage

The governor linkage on Onan engines has one of two kinds of ball joints: plastic or steel. Clean all joints every 100 hours of operation.

- The plastic joint requires cleaning only. Do not lubricate!
- Clean the steel joint and apply a graphite lubricant.

---

### Notes:

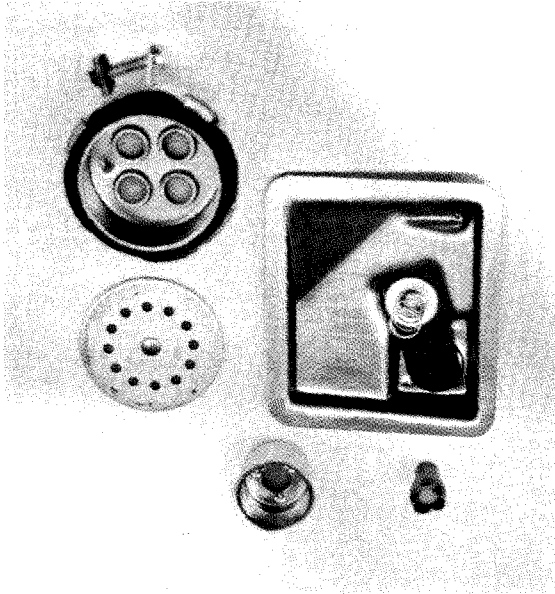

### Clean Crankcase Breather

The crankcase breather prevents pressure from building up in the crankcase but maintains a vacuum in the crankcase to reduce oil leaks. A sticky breather valve can cause oil leaks, high oil consumption, rough idling, reduced engine power and a rapid formation of sludge and varnish within the engine. Every 100 hours of operation, clean the breather valve in a suitable solvent. Dry and reinstall.

Lift off the rubber breather cap and carefully pry valve from cap. Wash and rinse the whole valve in a suitable solvent. Dry the valve and re-insert. Be sure the valve flapper is toward the engine.

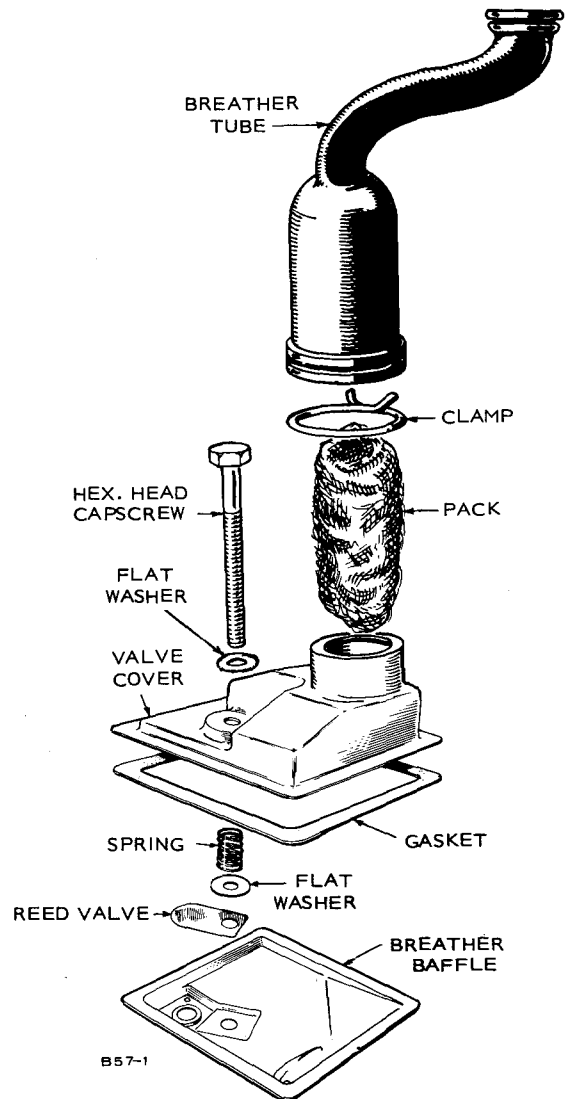
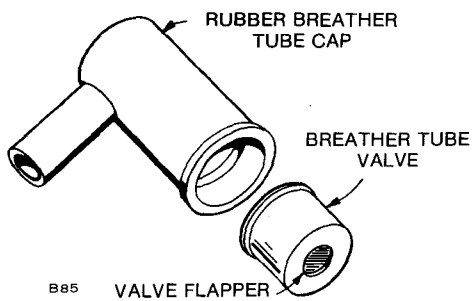

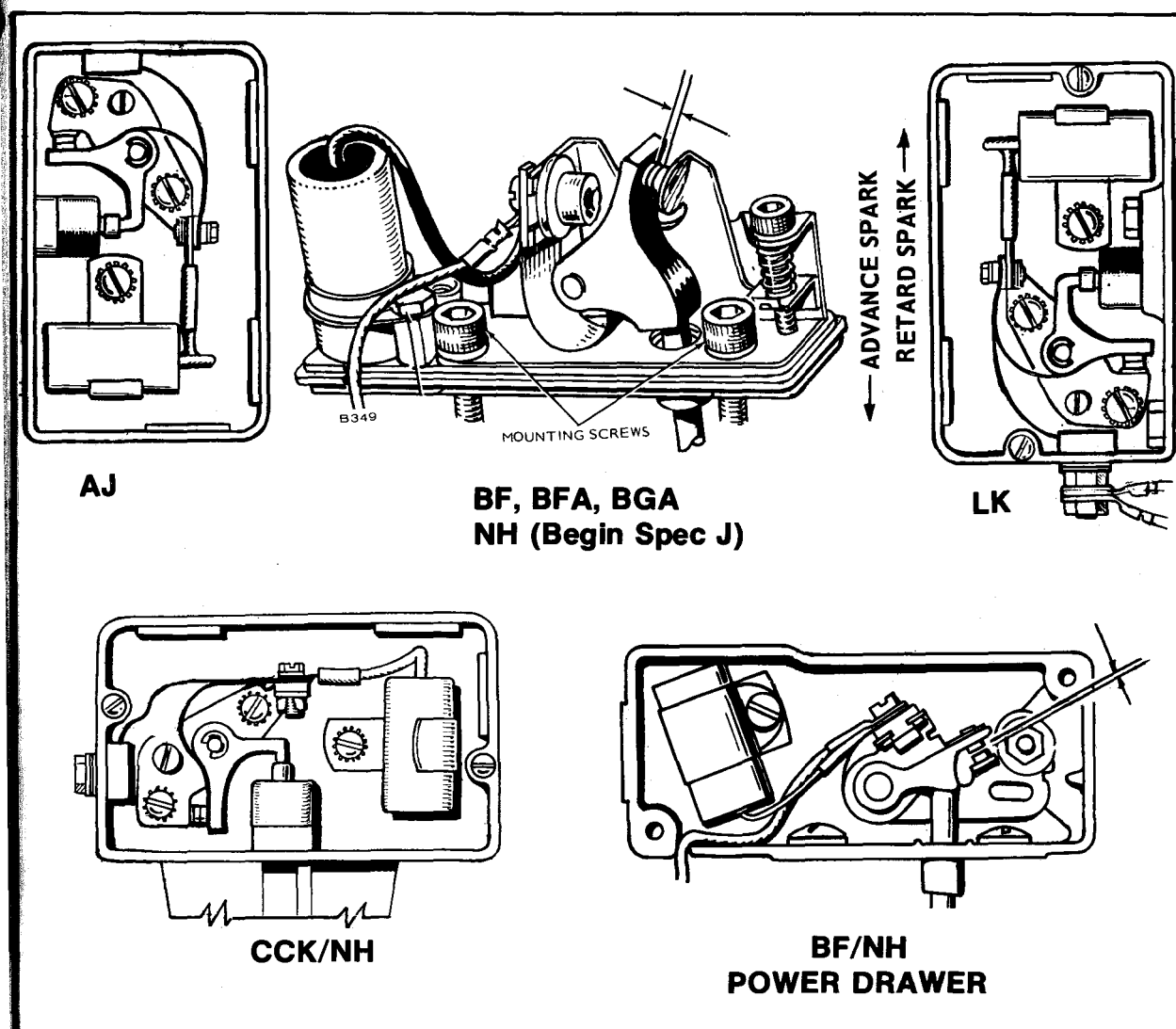

### Set Point Gap

To set the point gap, turn the engine crankshaft with rotation until the maximum breaker point gap is obtained. Turn the cam screw until the proper gap is as indicated in this table. Be sure to measure the gap with a clean feeler gauge; dirt or other accumulations on the gauge can adhere to the breaker points causing ignition failure. If the points become pitted or badly burned, replace according to the instructions given in the appropriate operator's manual.

MODEL	POINT GAP
AJ	.022" (0.56 mm)
LK	.020" (.508 mm)
CCK	.020" (.508 mm)
NH (Prior to Spec J)	.020" (.508 mm)
BF (Power Drawer)	.025" (.635 mm)
BF, BFA and BGA	.021" (0.53 mm)
NH (Begin Spec J)	.016" (0.41 mm)

# IGNITION TIMING

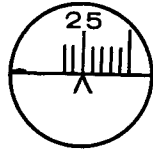

AJ

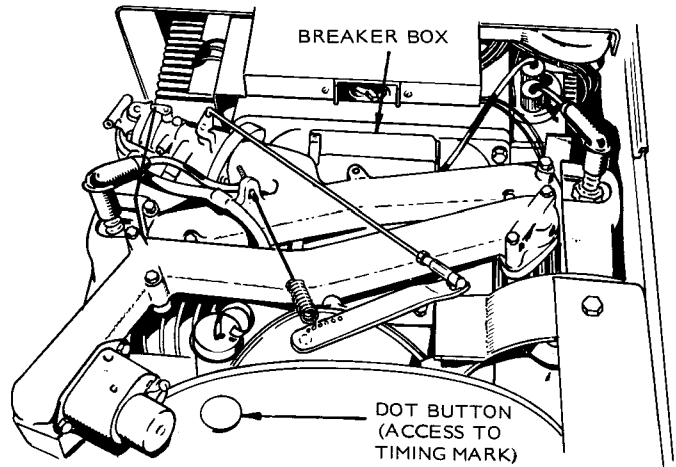

4.0BF

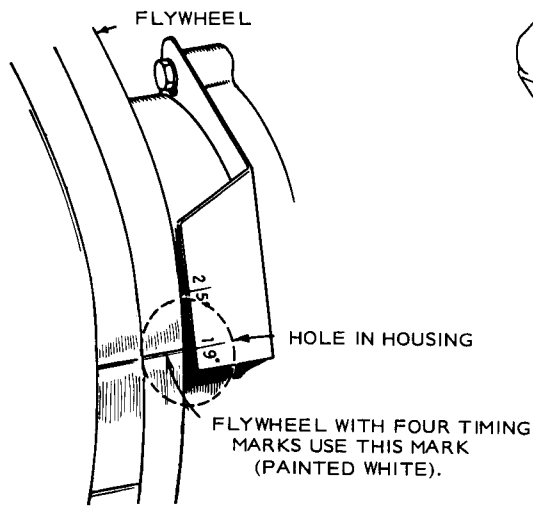

LK

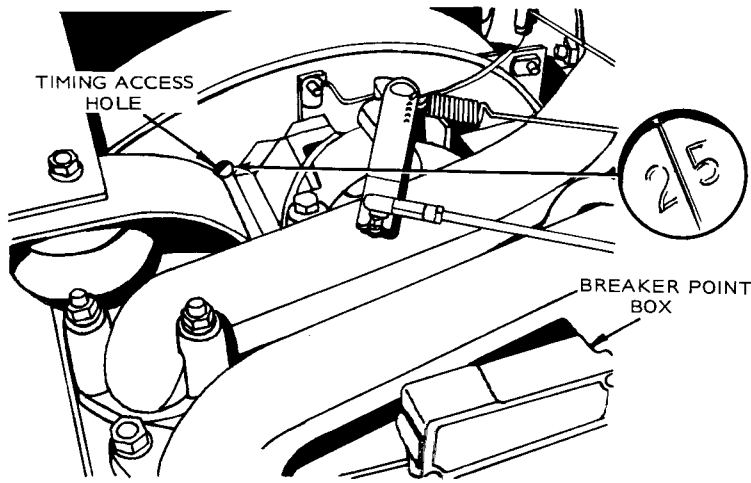
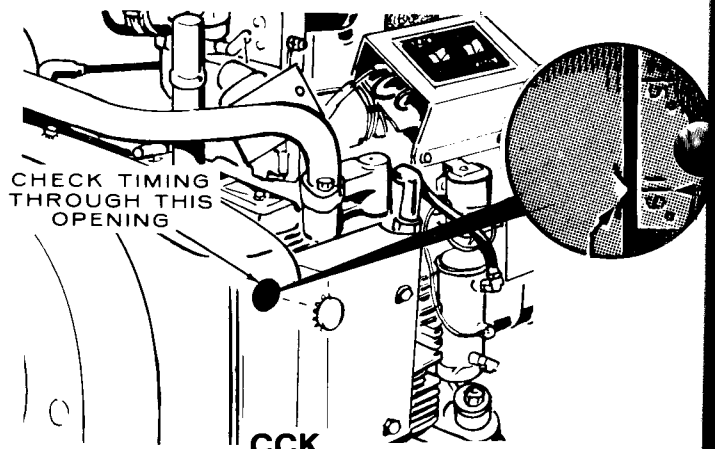

6.0NH

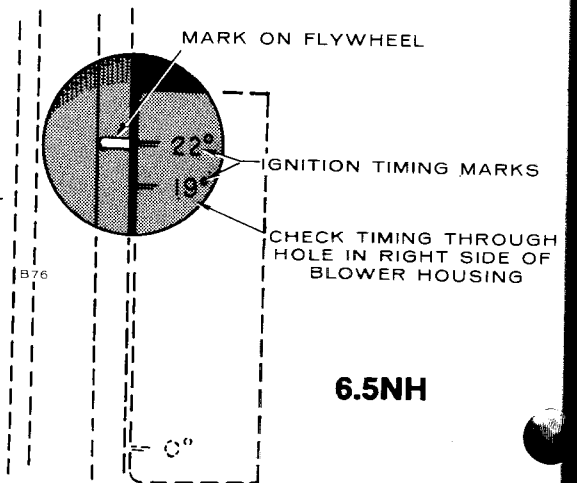

6.5NH

### Check Ignition Timing

**Static Timing:** Connect a continuity indicator across the ignition breaker points. Turn the crankshaft against rotation until the points close. Then, slowly turn the crankshaft in the direction of rotation. The lamp should go out just as the points break and the timing marks align. Correct timing is as indicated in this table. If the timing marks do not align, move the breaker box on all units except 4.0BF and 6.0NH Power Drawer models. The breaker box on these units does not move. Instead, change the point gap to correct the timing. Retarded timing reduces the load carrying ability of the generating set.

TIMING	
MODEL	DEGREES
2.5 AJ	25
2.7 and 3.0 AJ	22
LK	19
CCK	19
BF, BFA, BGA	21
6.0 NH	25
6.5 NH	22

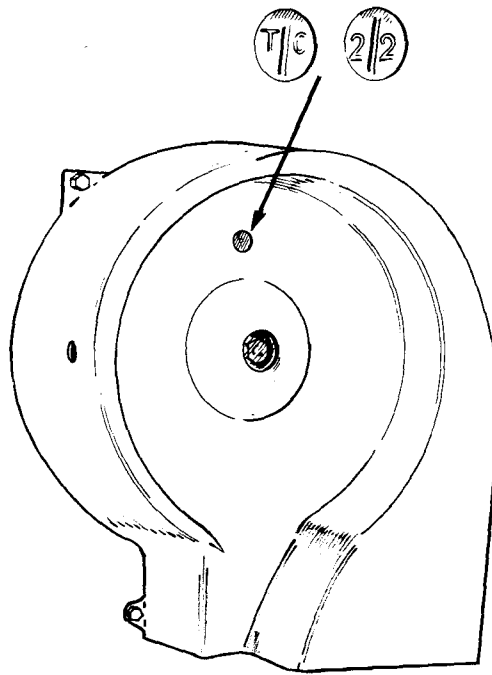

3.0AJ

Notes:

## Top Adjust Points

1. Remove both spark plugs and rotate flywheel TC mark to align with 25°BTC mark on timing cover. Then rotate it another 90 degrees clockwise to ensure points are fully open.
2. Remove breaker box cover, one screw.
3. Unplug coil wire from (+) terminal on coil.
4. Remove screw (A) and condenser from base plate.
5. Loosen terminal screw (B) and detach condenser lead and coil lead.
6. Loosen two Allen head mounting screws (C) and lift point assembly off of engine.
7. Replace breaker point assembly with new unit; reconnect new condenser lead and coil lead on terminal and tighten screw (A). Fasten condenser to base plate using screw (B).
8. Reinstall breaker point assembly on engine; tighten both mounting screws (C); attach coil wire on coil at (+) terminal.
9. Using Allen wrench at screw (D), adjust point gap at .021 inch (0.53 mm) using a clean, flat thickness gauge.

**NOTE: SETTING THE POINT GAP ALSO ADJUSTS ENGINE TIMING ACCURATELY.**

10. Replace breaker box cover and spark plugs.

**If desirable, check ignition timing with a 12 volt test light or continuity tester.**

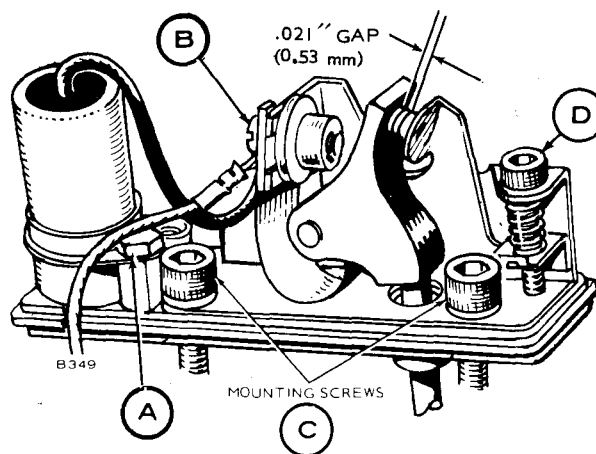



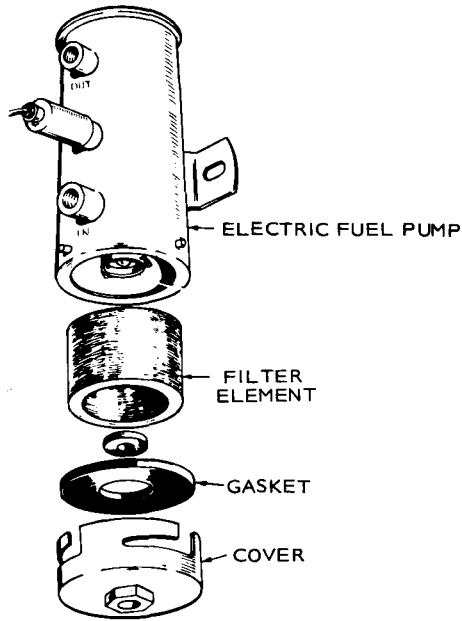

### Electric Fuel Pump

Many RV generator sets use an electric fuel pump. Service of the fuel pump is limited to cleaning the filter. Every 500 hours, drain the fuel pump and check the filter element. Turn the hex nut on the base of the pump to gain access to the filter element. If the element appears dirty, replace it. Be sure to replace gaskets when reassembling. Earlier models may have external fuel shutoff solenoid.

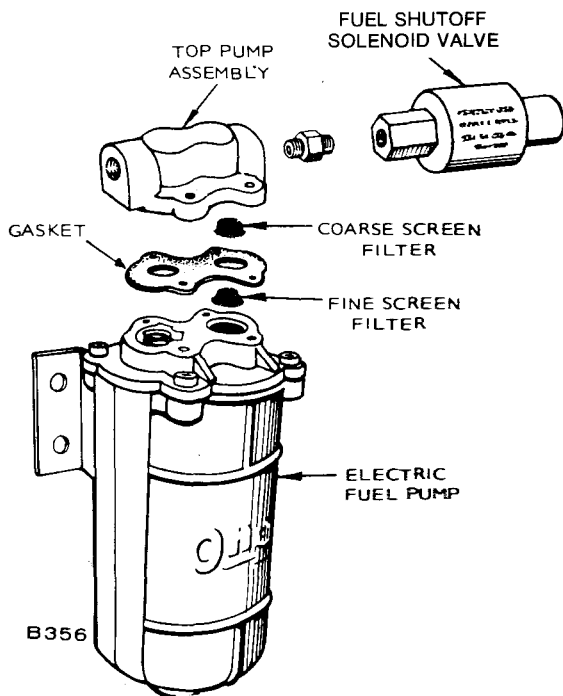

### Onan Electric Fuel Pump

Every 100 operating hours or sooner, clean the filters. To gain access to the filters in the Onan fuel pump, remove the four top Phillips head screws and lift off the top filter assembly. Clean the two screen filters, reinstall and remount the top filter assembly. Be sure the gasket is in place.

**Clean Generator**

Clean the generator every 500 hours of operation or sooner depending on road conditions. Remove the generator end band and blow the accumulated dust and dirt from the brushes and windings with clean, dry compressed air. This assures adequate cooling air and free brush movement.

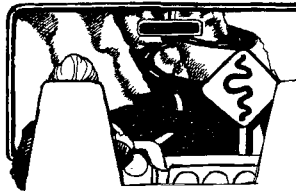
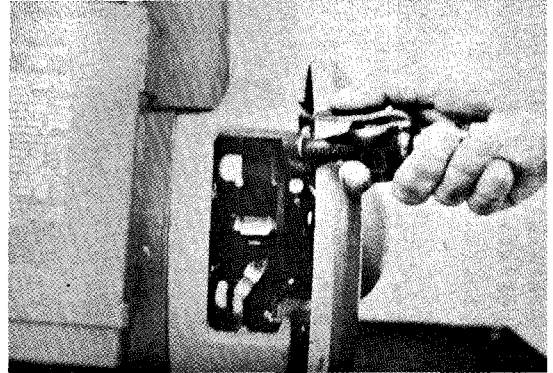

**CAUTION** Do not use compressed air that exceeds 35 psi (242 kPa) or damage to generator components could occur.

**Check Generator Brushes**

Every 500 hours of operation check the generator brushes. Pull on the brush lead to be sure the brush is free and to remove any accumulated dirt from the brush boxes. Be sure the brush springs are supplying sufficient pressure on the brushes to maintain good brush-to-commutator contact. Brushes must have 50% contact with the slip rings to be effective. Be sure the brush face is not glazed. Replace generator brushes when worn to the length here indicated. Check condition of slip rings and commutator.

**MEASURE FROM TOP FACE OF BRUSH BLOCK TO TOP OF BRUSH**

	DC	AC
NEW	5/8" (15.9 mm)	11/16" (17.5 mm)
1/2 WEAR	13/16" (20.6 mm)	7/8" (22.0 mm)
REPLACE	1" (25.4 mm)	1-1/16" (26.9 mm)

INSTALL BRUSHES WITH BEVELLED TOP SLANTING DOWN TOWARD SPRING HOLDER

TO REMOVE BRUSH SPRING PRESS SPRING HOLDER DOWN AND OUT AS SHOWN IN BROKEN LINES.

Replace when worn to 5/8" (15.9 mm)



### HOT WEATHER OPERATION

When operating temperatures are above 75° F (24° C):

- Keep ignition timing properly adjusted.
- Keep cooling fins clean/free of obstructions.
- Air flow to and from generator set must be unobstructed.
- Use proper grade and weight of oil.
- Check oil level each 8 hours of operation.
- Check battery water level more frequently than the 50-hour battery check at normal temperatures.
- High temperatures can cause vapor lock.
- Use lead free, regular grade gasoline.
- Air housings should be properly installed and undamaged.
- Vacu-Flo cooling is excellent for closed area installation but must be provided with sufficient air intake opening.
- Generally, keep the unit as clean as possible.



### COLD WEATHER OPERATION

When operating temperatures are below 30° F (0° C):

- Use proper grade and weight of oil for colder temperatures.
- Change oil only when the engine is warm.
- Use proper grade and weight of oil for colder temperatures.
- Change oil only when the engine is warm.
- If engine is filled with summer oil - refer to oil recommendations in the operator's manual and change to the weight listed for the ambient temperatures expected.
- Keep fuel system clean.
- Use fresh gasoline: keep tank full to prevent condensation in tank and lines.
- Keep battery in fully charged condition; booster charge if in low condition.

### Out-Of-Service Protection

If the generating set will be out of service for more than 60 days, corrosion damage to the engine and control components could occur. To assure engine and generator preservation over an extended period of time, perform these steps:

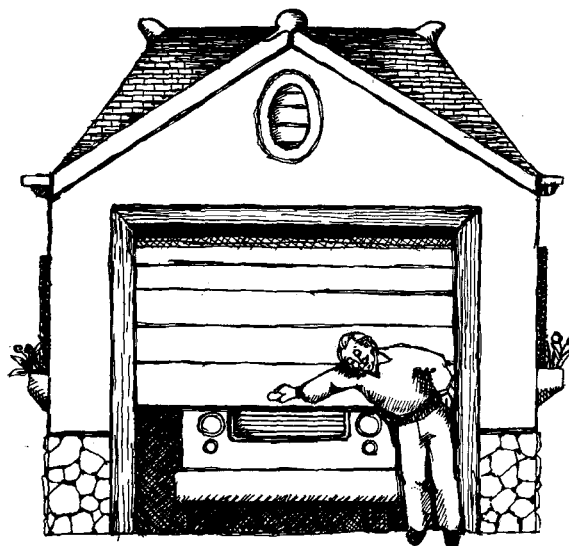

#### OUT-OF-SERVICE PROTECTION

If the generator set is out of service for more than 60 days, perform the following:

- Run the set until it reaches normal operating temperature.
- Turn off fuel supply and run the engine until it stops.
- Drain oil from warm engine.
- Refill crankcase with fresh oil—attach tag indicating oil viscosity used.
- Remove spark plug(s)—place inhibitor oil in cylinder(s)—rotate crankshaft a few times—reinstall spark plug(s).
- Service air cleaner using same oil as crankcase.
- Clean governor linkage and wrap with clean cloth.
- Plug exhaust outlet and fuel inlet fitting.
- Wipe off entire unit—coat rustable parts with a light film of oil or grease.
- Remove battery—store separately following standard battery storage procedures.

#### RETURNING THE UNIT TO SERVICE

- Remove the cover and all protective wrapping. Wipe the oil film off all exposed engine parts. Remove the plug from the exhaust outlet.
- Visually inspect the unit for any damage. Check to be sure the carburetor and governor linkage are free. Remove the generator end bell band and check to be sure the brushes work freely in their holders.
- Check the tag to ensure oil of the proper brand and grade has been installed. Check the oil level.
- Install the battery (be sure battery is fully charged), observing proper polarity. Ground is negative.
- Remove spark plugs, clean and gap. Turn the engine over by hand several times. Reinstall spark plugs.
- Turn on fuel, disconnect electric fuel pump lead and electric fuel solenoid shut-off lead if unit is so equipped. Jumper the fuel pump and electric fuel solenoid shut-off leads to the battery to prime the unit. Use the hand primer lever on units with mechanical pumps. Reconnect the leads.
- Remove all load and start the generator set at the unit. Initial start may be slow due to oil or rust inhibitor in the cylinders. Excessive smoke and rough operation will occur until the oil or rust inhibitor is burned off.
- Apply a 50% load after the set runs smooth. Allow the generator set to warm up (1 hour) with the load connected. Check speed and voltage.
- Unit is now ready for service.

# Adjustments

If an RV generating set fails to achieve or retain its rated voltage, check the following and adjust if necessary:

- Carburetor
- Choke
- Governor

A major cause for carburetor maladjustment is dirt. When preventive maintenance is not performed at the recommended hours-of-operation, dust and dirt can enter the carburetor resulting in wear of the needles and seats.

An excessive change in the ambient temperature calls for a choke adjustment to maintain the proper air-to-fuel ratio required for starting and running.

Make governor adjustments concurrent with carburetor adjustments.

Excessive starting and stopping with short running periods can cause the battery to lose some of its charge. On units with adjustable high charge rates, adjust to compensate.

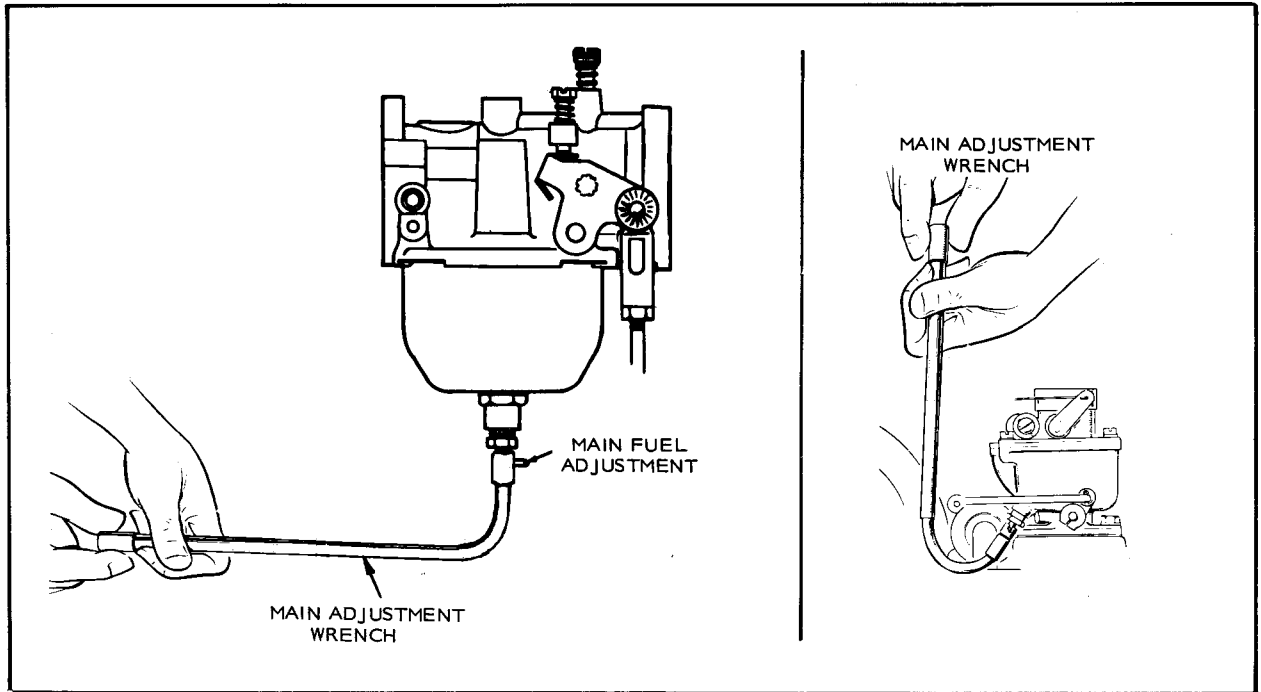

### Carburetor Adjusting Wrenches

Use a carburetor adjusting wrench to simplify main jet adjustments. It eliminates burns from a hot manifold or exhaust pipe. Depending on the design of the carburetor and the installation, use either Onan number 420-0294 or 420-0169. Refer to Onan Tool Catalog #900-0019.

---

### Notes:

### Preliminary Carburetor Adjustment

Use this table when making preliminary carburetor adjustments on any of the RV model generating sets. Refer to appropriate Operator's Manual for each model for detailed carburetor adjustment procedures.

UNIT	TURNS OPEN	
	MAIN	IDLE
AJ	1-1/4	1-1/4
LK	1-1/2	1-1/2
CCK	1-1/2	1-1/2
NH (Prior to Spec J)	1-1/2	1-1/2
BF	1-1/2	1-1/2
BFA	1-1/2	3/4
BGA	1-1/2	3/4
NH (Begin Spec J)	1-1/2	3/4

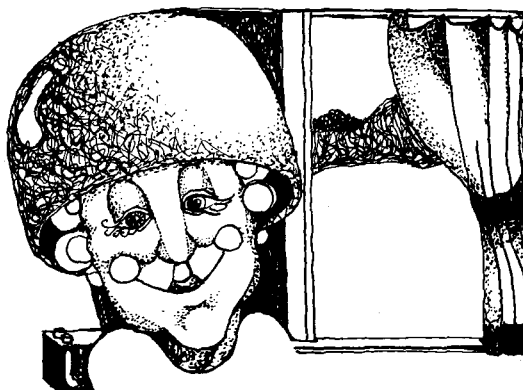

---

**Notes:**

# RV CARBURETORS

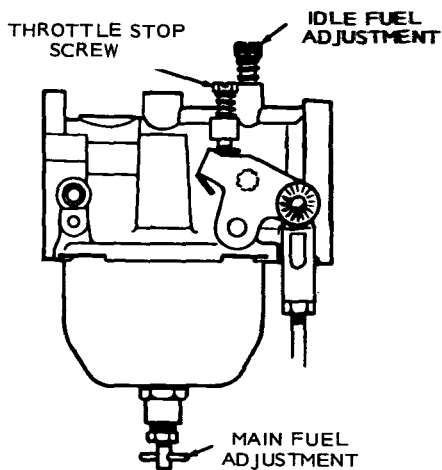

**6.5 NH (Older Models)**

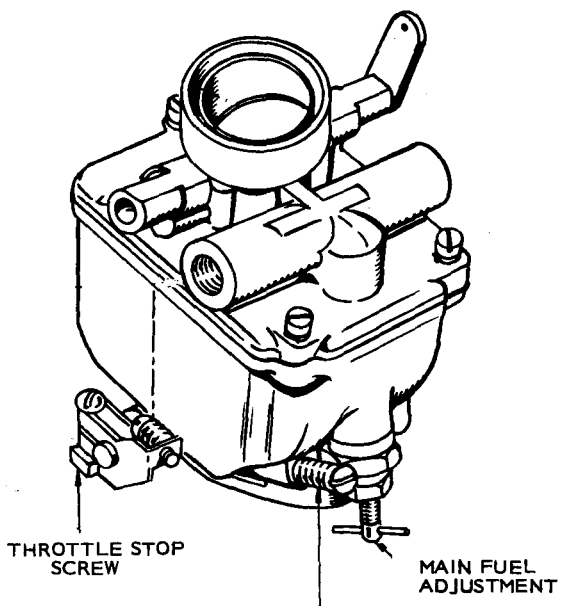

**CCK/BF**

IDLE FUEL ADJUSTMENT

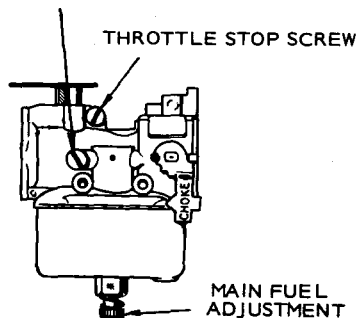

**AJ/LK**

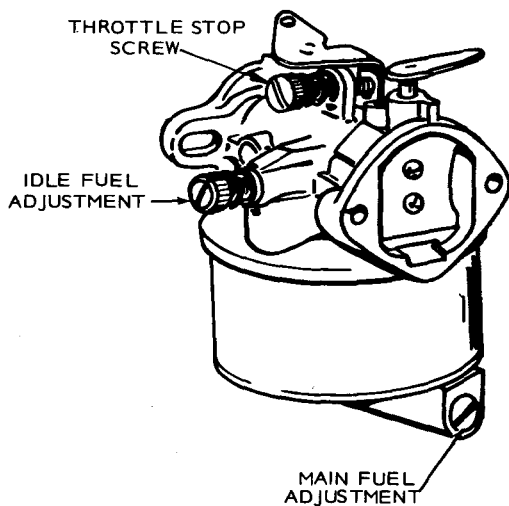

**BF/NH  
POWER DRAWER**

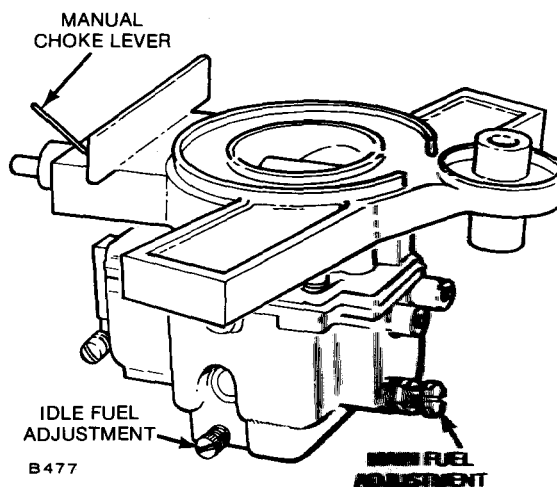

**BFA, BGA AND NH (Engle Spec J)**



### **Carburetor Adjustments**

Though design may vary, carburetor adjustments are similar on all RV generating sets.

**Throttle Stop:** Remove all AC load. Connect a voltmeter to the AC leads or plug the meter into one of the set's receptacles (if available). Hold the governor arm to minimum speed and adjust the stop screw so the voltmeter indicates 75-80 volts.

**Idle Adjustment:** Leave the voltmeter connected as for the throttle stop adjustment. Hold the governor arm against the throttle stop and turn the idle jet in until voltage drops. Then, turn it out until the highest voltage is obtained. Release the governor arm. The engine should accelerate to governed speed and become stable.

**Main Adjustment:** Connect the AC leads to a suitable load test panel or connect appliances obtaining a full load condition on the generating set. With a rated load applied, adjust the main jet to achieve the highest voltage. Remove the connected load and hold the governor arm to minimum speed. Release the governor arm and observe acceleration. If surging occurs at governed speed, open the main jet slightly. However, do not exceed one-half turn beyond the full load point. If surging continues, adjust the governor sensitivity.

---

**Notes:**

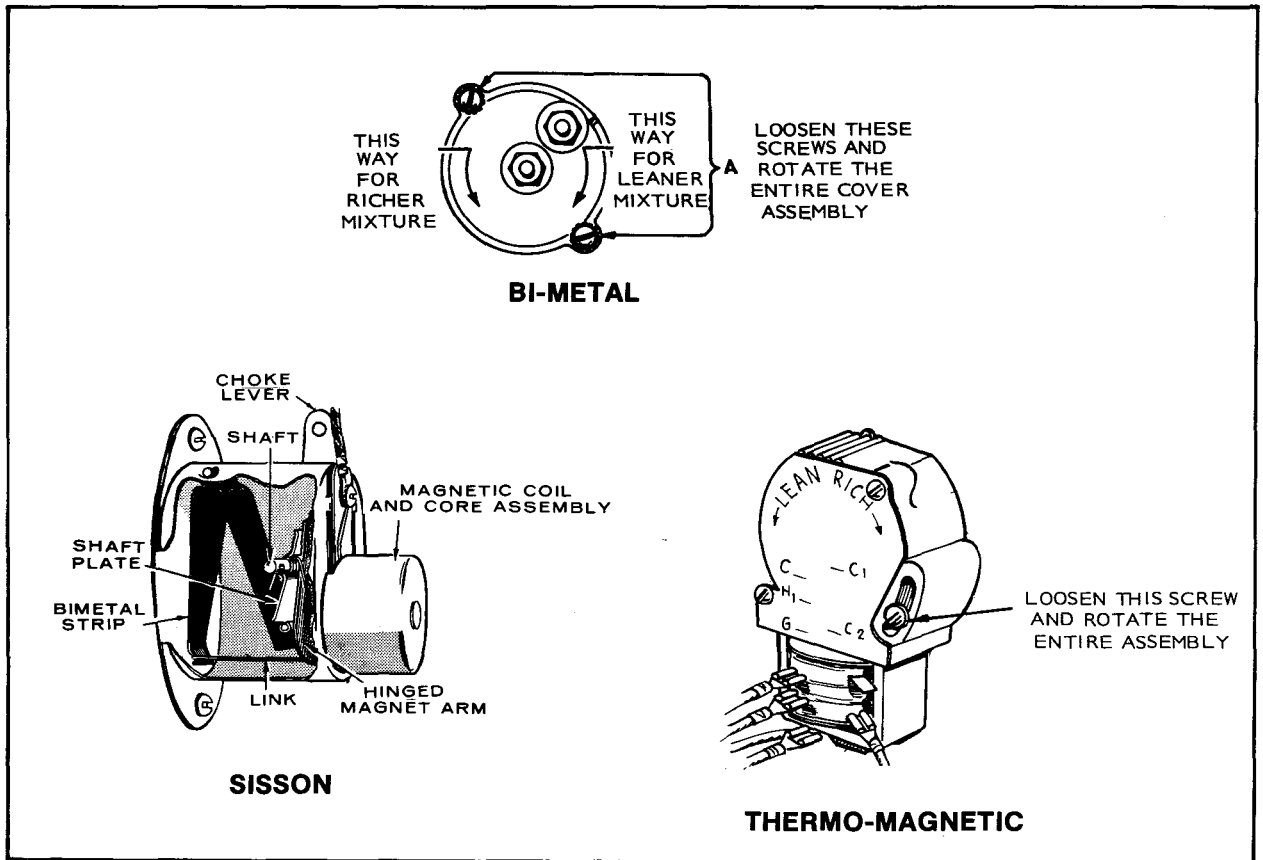

## Chokes

Onan equips their generating sets with one of three kinds of chokes: electric bi-metal, Sisson and thermo-magnetic. All chokes perform the same function—control the amount of air intake to the carburetor venturi. When the engine is first started, the choke is closed but gradually opens as the engine warms up. Rough operation of a cold engine indicates the need of choke adjustment.

- Loosen the two screws on the electric choke and turn to obtain smooth operation of a cold engine.
- Adjust the Sisson choke by loosening the screw holding the choke wire and repositioning it to obtain smooth cold engine operation.
- Adjust the thermo-magnetic choke by loosening the screw and rotating the entire assembly to obtain smooth cold engine operation.

**If the engine starts and runs roughly after a minute or two of operation, the choke is set too rich. If the engine starts, and assuming that fuel, ignition and compression are adequate, but the engine sputters or stops before it warms up, the choke is set too lean.**

## Governor

The governor system automatically regulates engine speed regardless of load conditions; the engine speed, in turn, determines the voltage and frequency of the generator current. Onan uses variations of the standard flyball governor: the 1800 RPM units use a 10-ball governor and the 3600 RPM units use a 5-ball governor. Perform governor adjustments concurrent with carburetor adjustments. Use test meter #420-0335.

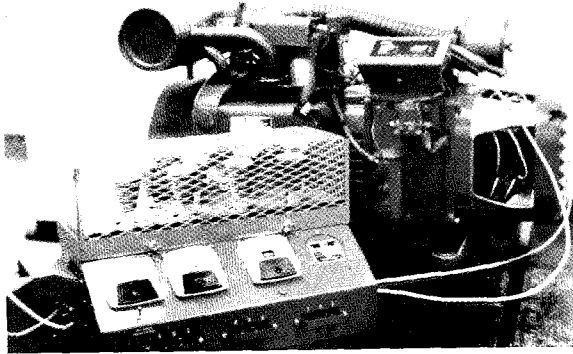
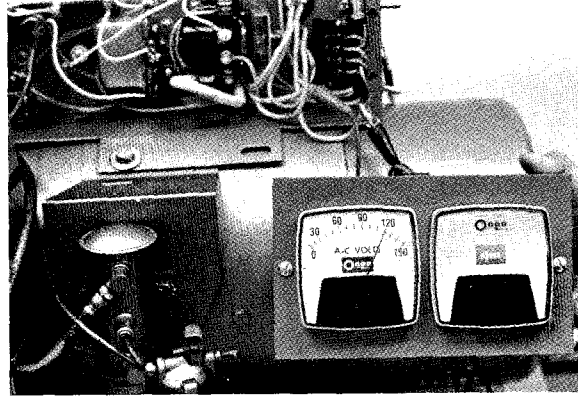

## Onan Load Test Panel

Use the Onan load test panel #300-0608 for governor and carburetor adjusting in the shop.

## Frequency Ranges

When making governor adjustments, use this table as a guide to determine the proper frequency ranges from no load to full load operation. The frequency spread can be reduced as long as no surging develops.

UNIT	NO LOAD FREQUENCY	FULL LOAD FREQUENCY
2.7 AJ	62	59
3.0 AJ	63	57
BF (Power Drawer Unit)	63	59
BF, BFA, BGA	63	59
CCK	61	59
LK	62	59
NH (Early Models)	61	59
NH (Begin Spec J)	63	59
NH (Power Drawer Unit)	63	59.5

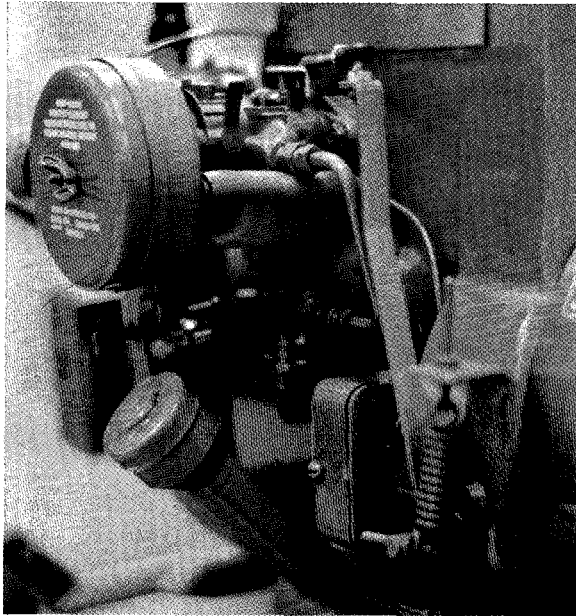

## 2.5 AJ Governor

The design of the engine dictates the location of the governor linkage. On single cylinder engines such as the AJ, the governor runs from the camshaft, up the side of the engine to the top-mounted carburetor throttle plate. The governor mounts on the *left* side of the AJ engine readily accessible for adjustment.

## 2.7 AJ Governor Adjustment

Start the unit and adjust speed to a frequency of 62 Hertz with no load on the generating set. Adjust the carburetor, then adjust the sensitivity to obtain a 3-Hertz (or less if possible) spread from no load to full load.

**Speed adjustment is necessary after sensitivity adjustment on all governors.**

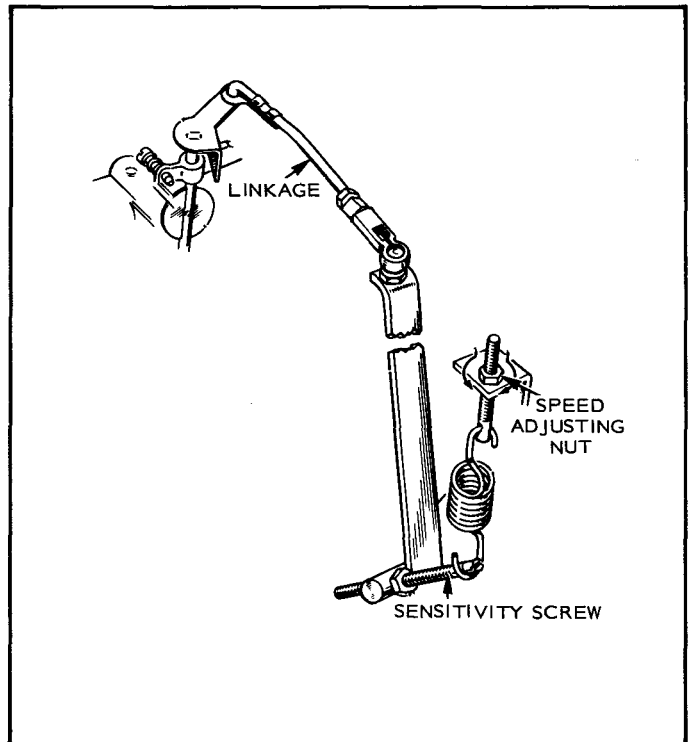

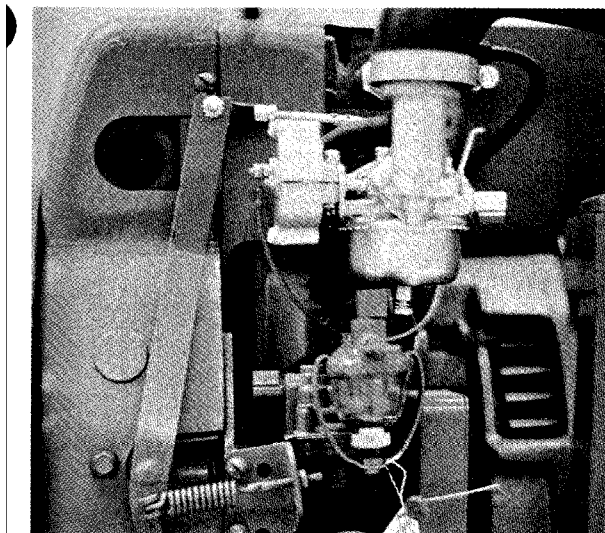

### LK Governor

As with the AJ, the LK governor extends vertically from the camshaft to the carburetor throttle plate on the right side of the engine where all components are easily serviced.

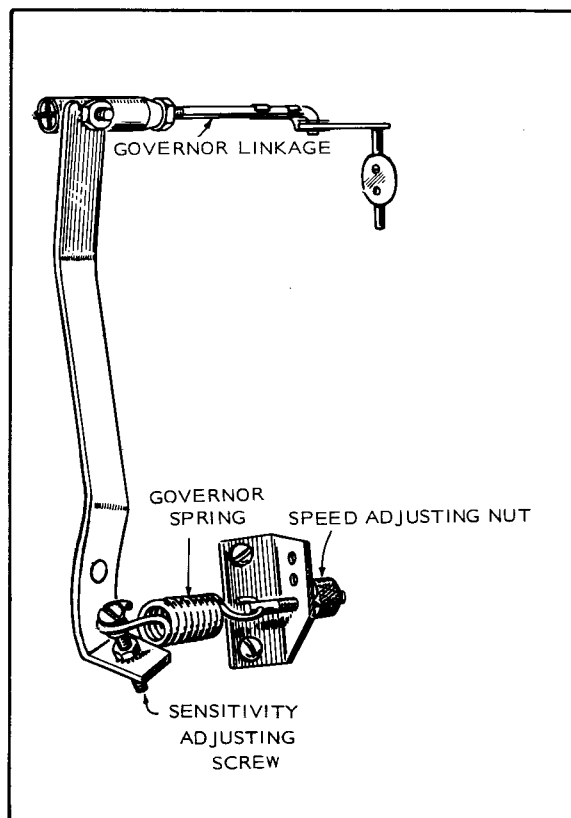

### LK Governor Adjustment

Adjust the speed nut to produce 62 Hertz at no load. Adjust the carburetor, then set the governor sensitivity for a 3-Hertz spread from no load to full load.

**Speed Adjustment is necessary after sensitivity adjustment on all governors.**

---

### Notes:

### CCK Governor With Booster

The CCK model uses the standard flyball governor system and a vacuum booster that aids in maintaining rpm when the set is operated at higher load levels.

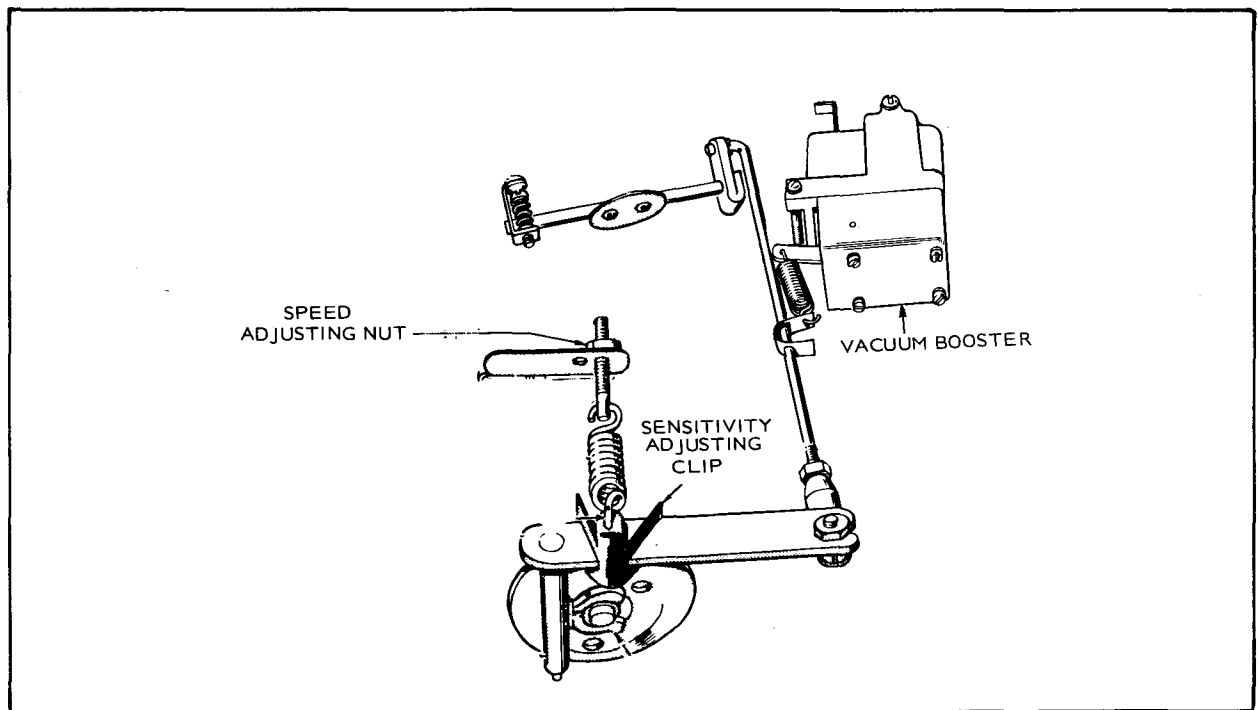
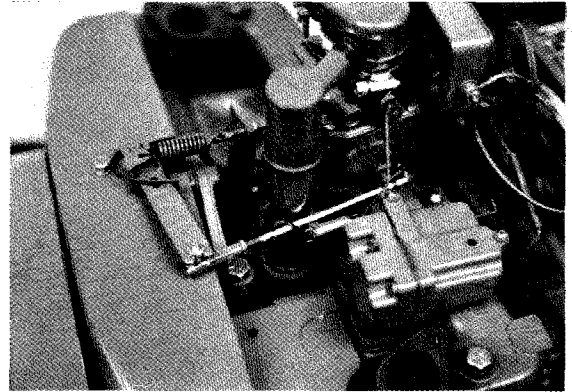

### CCK Governor Adjustment

Adjust no-load speed to 61 Hertz. Adjust the sensitivity adjusting clip to produce a 2-Hertz change from no-load to full-load. Then, applying a full load to the generating set, adjust the vacuum booster to produce a fixed frequency or a slight increase. Vacuum booster spring should be free of any tension when the generator set is not under load and engine is operating at rated speed.

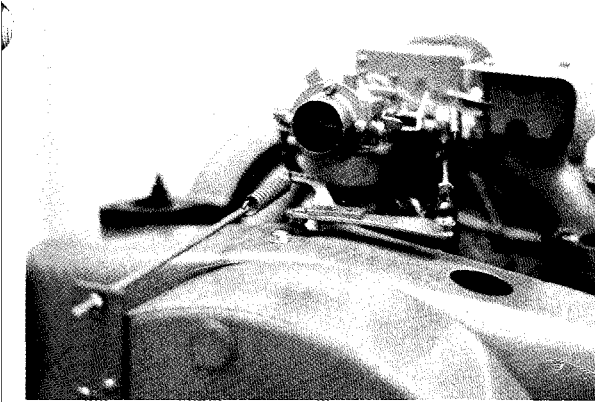

A binding in the bearings of the governor shaft, in the ball joint, or in the carburetor throttle assembly will cause erratic governor action or alternate increase and decrease in speed (hunting). A lean carburetor adjustment may also cause hunting. Springs of all kinds have a tendency to lose their calibrated tension through fatigue after long usage.

**Linkage:** The engine starts at wide open throttle. The length of the linkage connecting the governor arm to the throttle shaft assembly is adjusted by rotating the ball joint.

### 6.5 NH Governor (Earlier Models)

The standard 6.5 NH governor is slightly different in appearance from the other RV governors but functions the same.

### BFA, BGA and NH Governor

Engine speed determines the output voltage and current frequency of the generator. By increasing the engine speed, generator voltage and frequency are increased, and by decreasing the engine speed, generator voltage and frequency are decreased. An accurate voltmeter or frequency meter (preferably both) should be connected to the generator output in order to correctly adjust the governor. A small speed drop not noticeable without instruments will result in an objectionable voltage drop. The engine speed can be checked with a tachometer.

VOLTAGE CHART FOR CHECKING GOVERNOR REGULATION	120 VOLT 1 PHASE 2 WIRE
MAXIMUM NO-LOAD VOLTAGE	132
MINIMUM FULL-LOAD VOLTAGE	108

SPEED CHART FOR CHECKING GOVERNOR REGULATION	
MAXIMUM NO-LOAD SPEED (RPM)	1890
HERTZ (CURRENT FREQUENCY)	63
MINIMUM FULL-LOAD SPEED (RPM)	1770
HERTZ	59

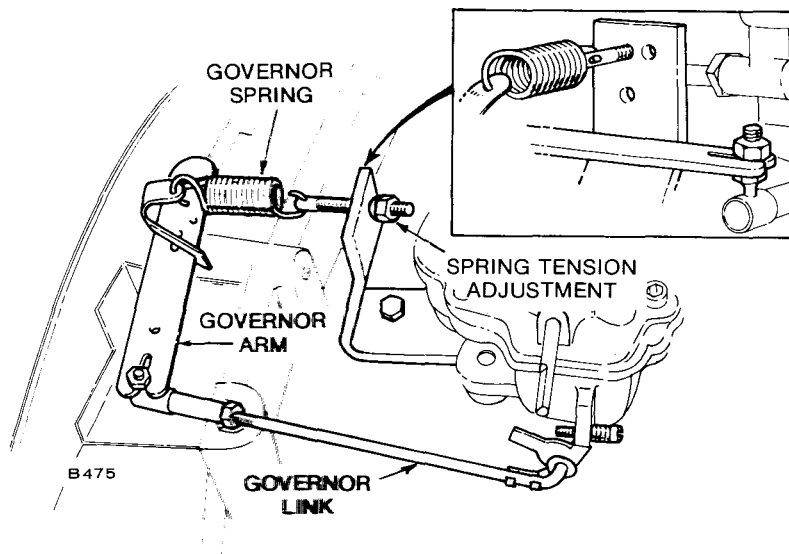

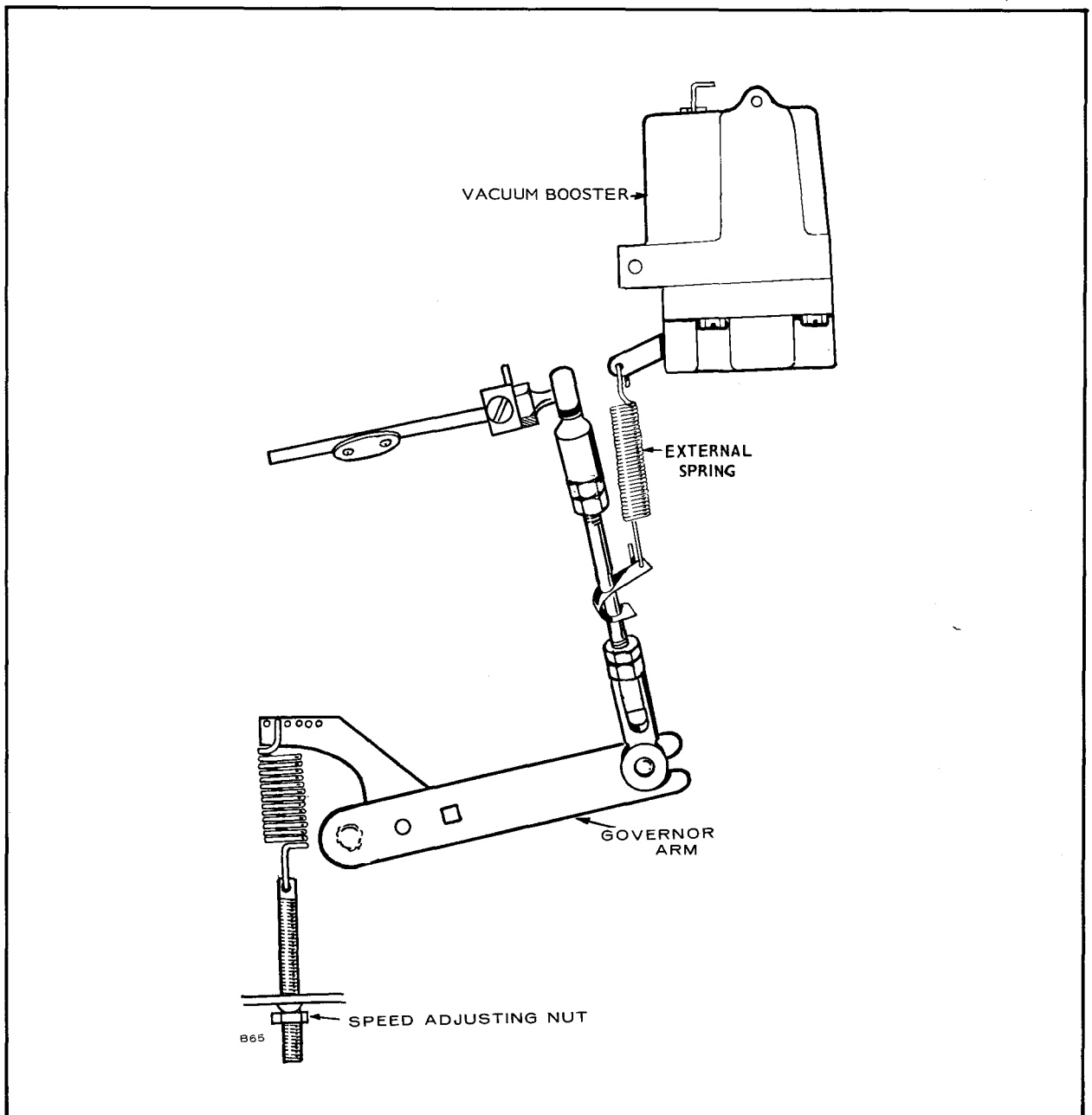

### 6.5 Governor Adjustment (Earlier Models)

Adjust speed at no load to 61 Hertz. Adjust the sensitivity by gradually applying a full load to obtain 59 Hertz. Position the governor spring in a hole closer to the governor shaft to increase sensitivity. Adjust the vacuum booster to obtain the most satisfactory full-load Hertz. Vacuum booster spring should be free of any tension when the generator set is not under load and engine is operating at rated speed.



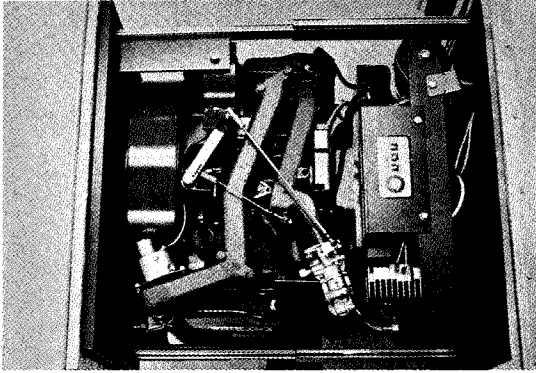

#### 4.0 BF and 6.0 NH Governors

The 4.0 BF and 6.0 NH RV generating sets employ the same governor design.

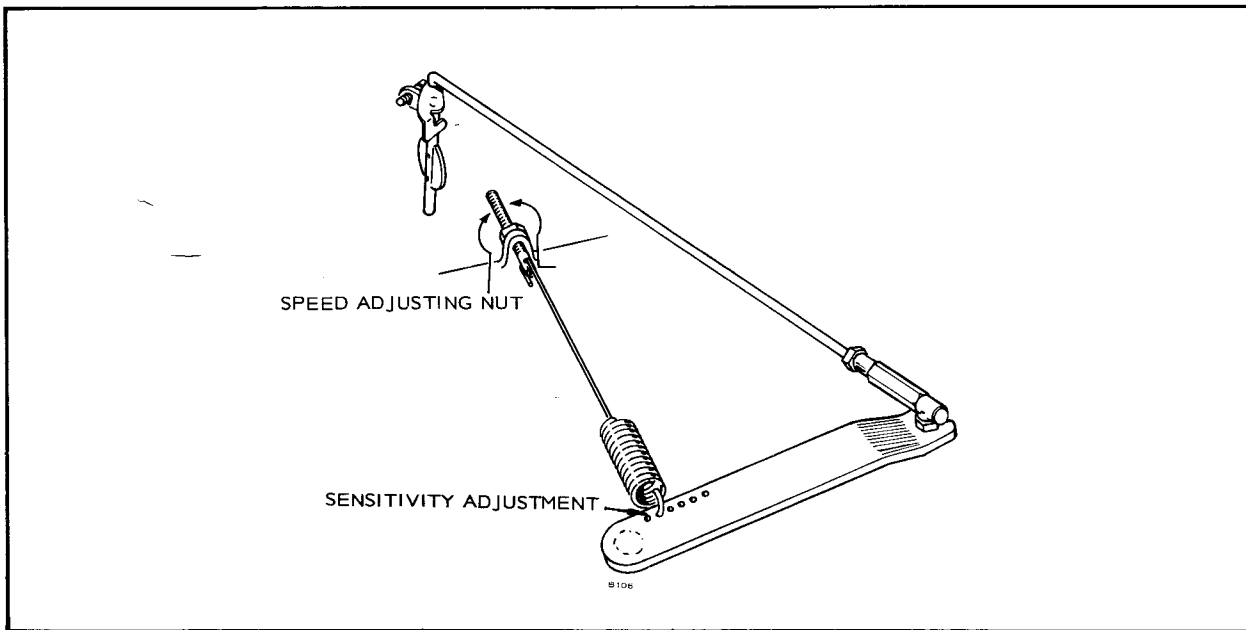

#### 4.0 BF and 6.0 NH Governor Adjustment

Adjust speed at no load to **63 Hertz**. Adjust the sensitivity by gradually applying a full load **to obtain 59 Hertz**. Position the governor spring in a hole **closer to the governor shaft** to increase sensitivity.

### 3.0 AJ Governor Adjustments

The governor controls engine speed by opening or closing the throttle according to the load taken off the set. The engine speed also determines voltage and frequency of the generator current. Before readjusting the governor linkage, check for binding at the linkage or throttle.

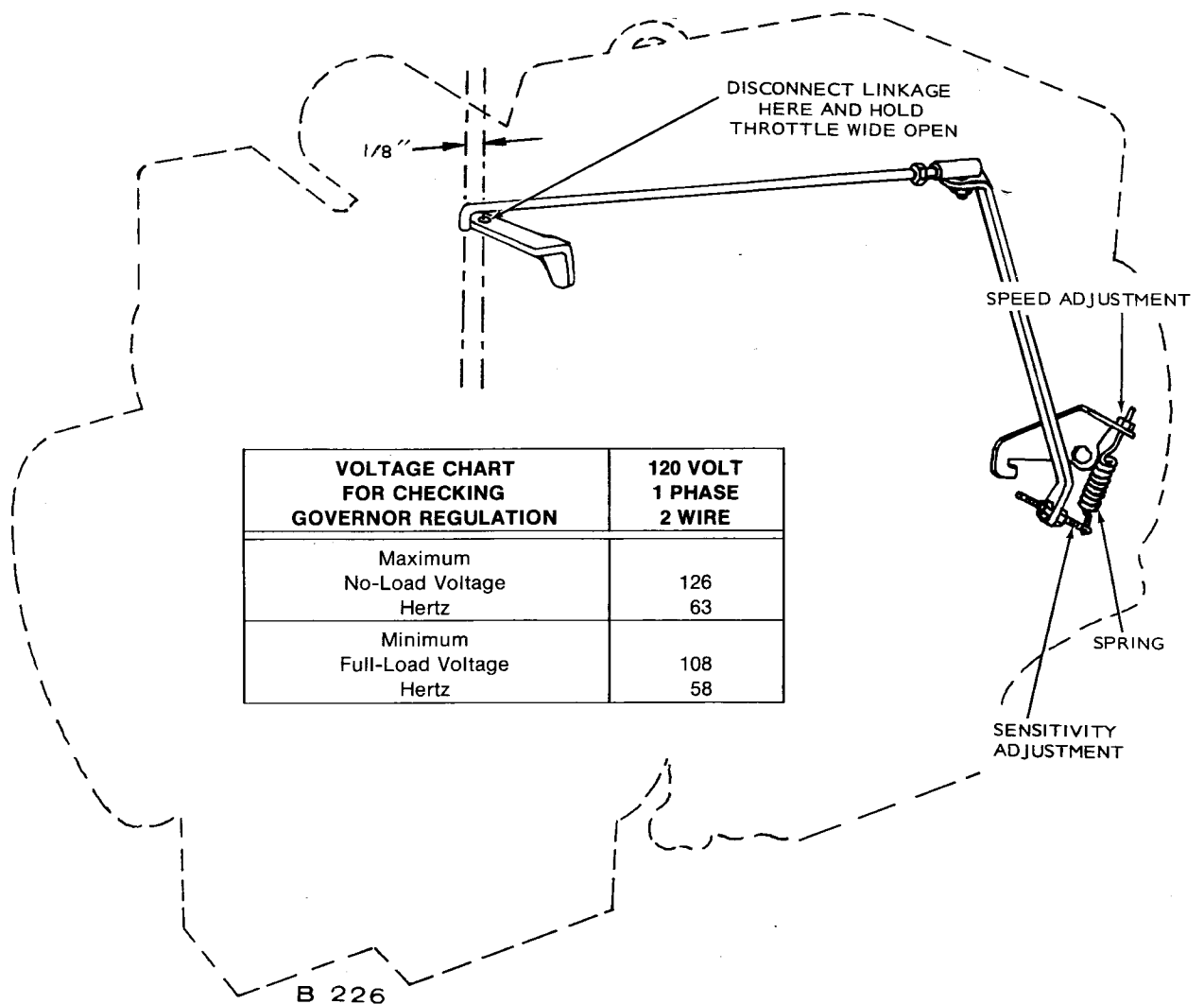

### Vacuum Booster

The vacuum speed booster is a separate auxiliary device that supplements governor action. As the generator load increases, the booster helps the governor by producing a slight increase in engine speed. This results in nearly a constant output voltage.

**Vacuum Booster Adjustment:** Adjust the booster after satisfactory performance under various load conditions has been obtained by governor adjustments without the booster. Connect the booster external spring to the bracket on the governor link. With the unit operating at no load, slide the bracket on the governor link just to the position where there is no tension on the external spring. Apply full load and observe the action of the booster. To increase or decrease response, change the cotter pin to another hole in the return spring

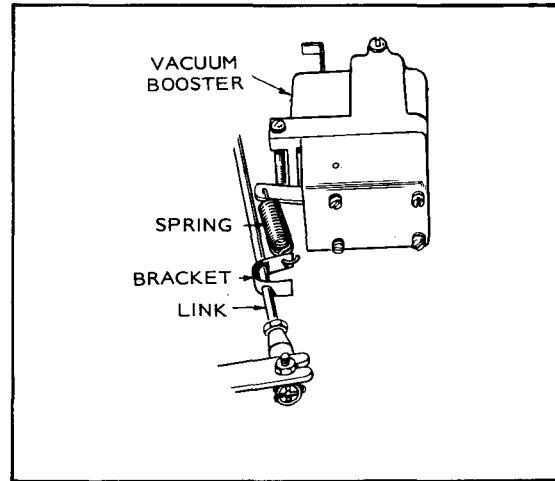

strap. The booster is correctly adjusted when the speed does not drop more than 4 cycles with a sudden load application and recovers rapidly. Tighten the hold-down screws of the booster at each tune-up.

---

### Notes:

### Sensitivity Adjustment

After adjusting the carburetor and the governor, adjust the governor sensitivity. Sensitivity affects the rpm from no load to full load. Moving the governor spring closer to the shaft makes the governor more sensitive to load change and decreases the speed change from no load to full load. Observing a frequency meter, adjust the sensitivity for as close a cycle range as possible without hunting. Check frequency table.

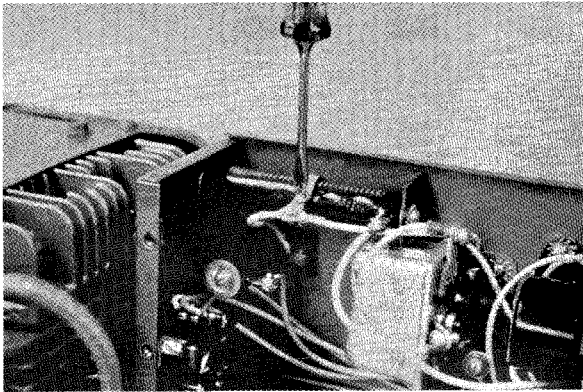
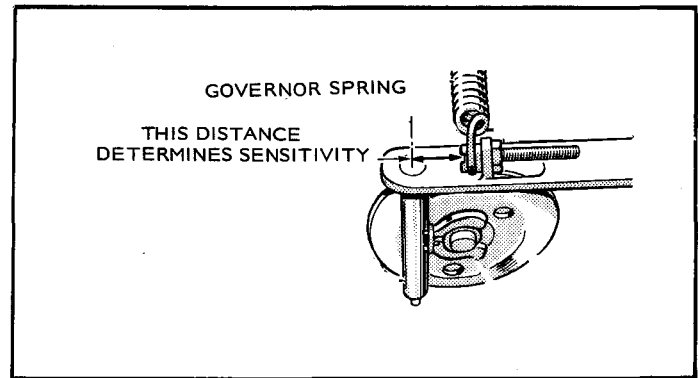

### High Charge Rate (Older Models)

The high charge rate is adjustable on many of the controls. The factory setting is 7.5 amps on high charge. To adjust the high charge rate on standard controls stop the generating set. Loosen the band screw and slide the band toward the end of the control to reduce the rate or towards the center of the control to increase the rate. Measure positive voltage at start solenoid to ground. Voltage should be 14.3 to 14.7 volts. Solid state controls have fixed charged rates—both high and low.

---

**Notes:**

# Troubleshooting

The following are the most common problems that occur with an RV electric generating set.

- Engine will not crank
- Engine cranks but will not start
- Engine overheats
- Engine misfires
- Engine stops
- No voltage output
- Low output voltage

When troubleshooting an RV set, consider the problem, then check the most probable causes first, as presented on the following two pages.

The remainder of this section describes troubleshooting of the controls with separate wiring diagrams of the various controls.

---

**Notes:**

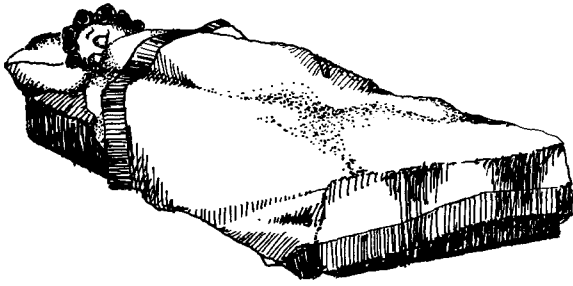

### ENGINE WILL NOT CRANK

- Battery Connections
- Generator Ground Cable
- Battery Condition
- Start Solenoid Bad
- Correct Generator DC Brushes
- Engine Seized
- Cranking Motor Bad
- Generator Output AC Wires Connected Wrong
- Faulty Control Board Contacts

### ENGINE CRANKS BUT WILL NOT START

- No Fuel in Tank
- Air Leak in Fuel System
- Electric Fuel Pump Failed
- No Ignition Power
- Spark Plugs Fouled
- Choke Stuck (Closed or Open)
- Faulty Start Solenoid
- Fuse Out of PC Board
- Faulty Disconnect Circuit
- Faulty Control Board Contacts
- Faulty Relay

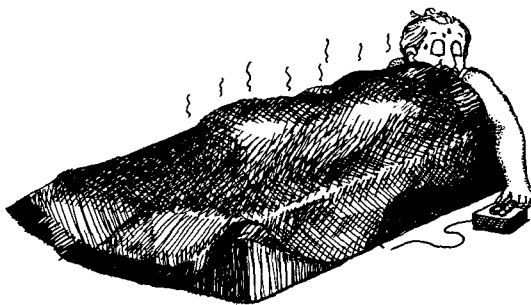

### ENGINE OVERHEATS

- Ignition Timing Wrong
- Lean Fuel Mixture
- Poor Air Circulation
- Dirty or Oily Cooling Fins
- Oil Too Light or Diluted
- Low Oil Level
- Generator Overloaded
- Faulty Exhaust System

## ENGINE MISFIRES

- Incorrect Ignition Timing
- Wrong Spark Plug Gap or Fouled Plugs
- Worn Points or Improper Gap Setting
- Bad Ignition Coil or Condenser
- Lean Fuel Mixture
- Rich Fuel Mixture or Choke Stuck
- Dirty Carburetor
- Dirty Air Cleaner
- Faulty Plug Wires.

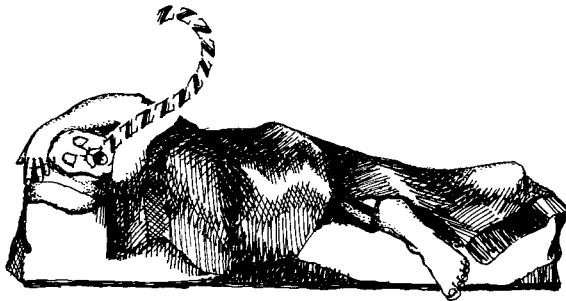

## ENGINE STOPS

- Burned Points
- No Fuel in Tank
- Engine Flooded
- Dirty Carburetor
- Defective Fuel Pump
- Generator DC Brushes Defective
- Faulty Alternator
- Faulty LOP Switch
- Low Oil
- Fuse Out
- Fouled Spark Plugs

## LOW OR NO OUTPUT VOLTAGE

- Brushes Stuck
- Open Field Circuit
- Open AC Coil
- Circuit Breaker Tripped
- Diode in Bridge Shorted
- Reactor Open
- AC Output Wires Not Connected at Brushes
- Brushes Too Short
- Field Blocking Diode Open.
- Bad Battery, Poor Connections or Battery Cables Too Small.

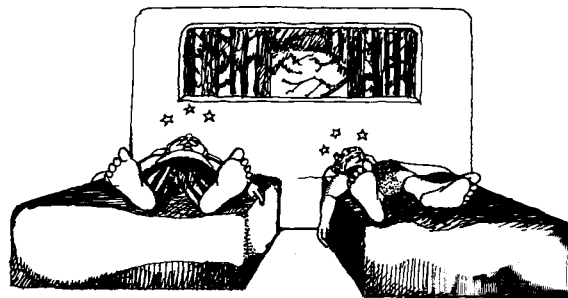

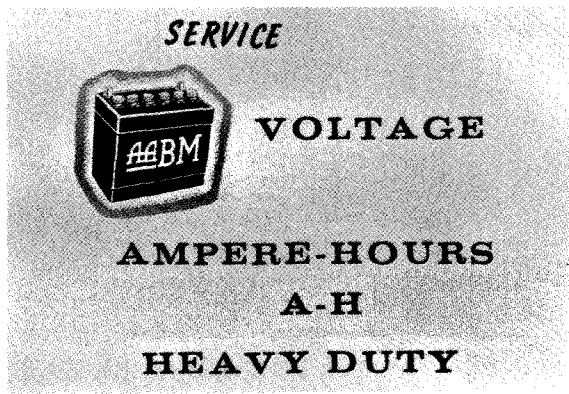

### Check Battery

When troubleshooting an RV electric generating set, first check the battery. Be sure it is of adequate size and at optimum charge to ensure satisfactory operation for the specific installation. Be sure the location of the battery does not interfere with the airflow to and from the unit. Check for proper battery connections and cleanliness of the battery terminals.

### Negative Battery Connection

Check the negative battery connection. Be sure the shakeproof washer is in place and the connection is tight at the generator set and battery. The vehicle chassis frame can be used as a ground for the battery and the generator set, if the cable is of sufficient size and secured properly.

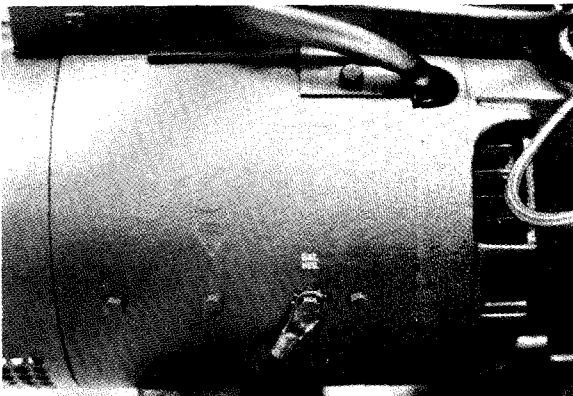

**OLDER MODELS**

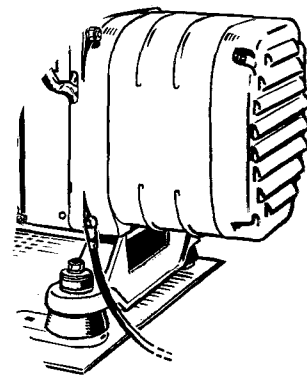

**CURRENT MODELS**



### Check Positive Connection

Battery positive connects to the start solenoid. When the solenoid is located inside the control box, be sure the control cable runs through the center of the grommeted hole in the box.

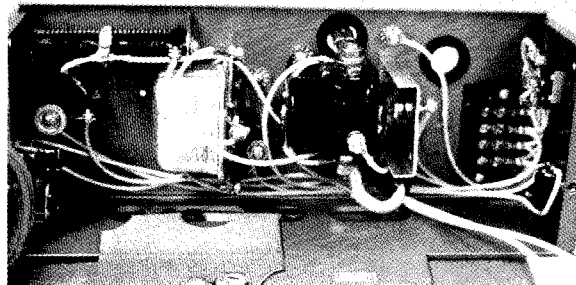

### Check Battery Voltage

Checking DC voltage at the control provides a battery voltage check.

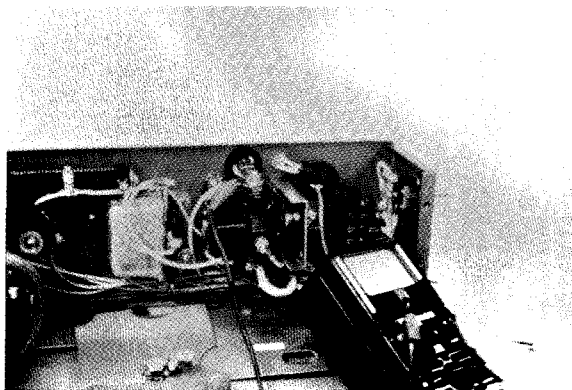

### Check Cranking Voltage

Be sure there is sufficient voltage to supply cranking power for the unit. To measure voltage, energize the start solenoid. Low voltage indicates a bad battery, poor battery connections or battery cables that are too small.

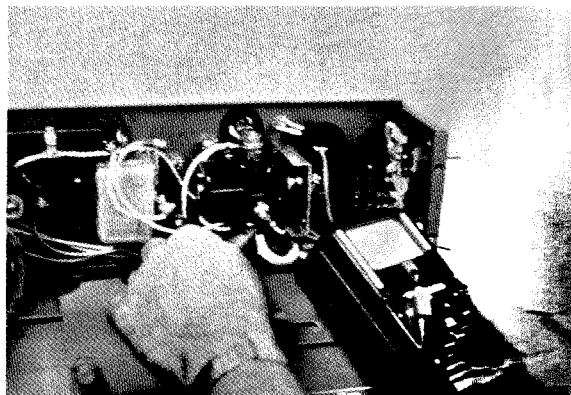

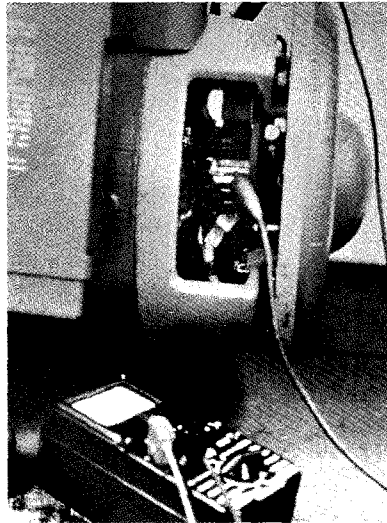

### Check DC Voltage

Place the Start switch in the Start position and observe the DC voltage produced at the generator. Normal starting voltage is approximately 7.5 volts. Sufficient DC voltage ensures that adequate cranking and excitation voltage is being supplied and that the generator is producing rated voltage. Otherwise, a bad battery, bad battery connections or ground connection, or insufficient cable size is indicated.



### Relay Type Control Switches

The standard control has a Start/Stop switch and a Hand Crank/Electric Start switch. To supply ignition power when the battery is low, place the Hand Crank switch on the Hand Crank position (this bypasses the "Stop" relay contacts). Start the generating set with a pull rope (if available). To stop the set, the Hand Crank switch must be in the Electric Start position breaking the ignition circuit.

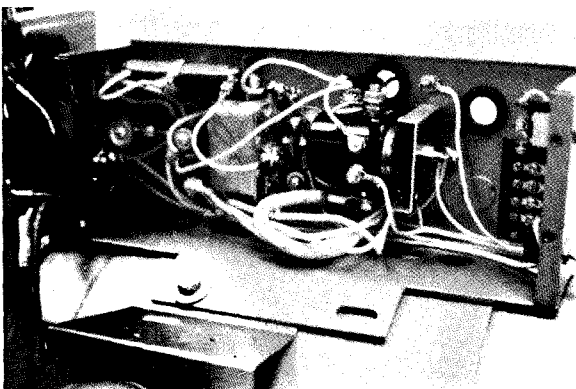

### Relay Type Control Components

The components of the standard control, pictured here, are from right to left:

- Remote connection terminal block
- Battery charge diode
- Start solenoid
- Stopping resistor
- Two-step charging resistor
- Ignition resistor
- Adjustable high charge resistor
- Low charge resistor
- Stop (ignition) relay.

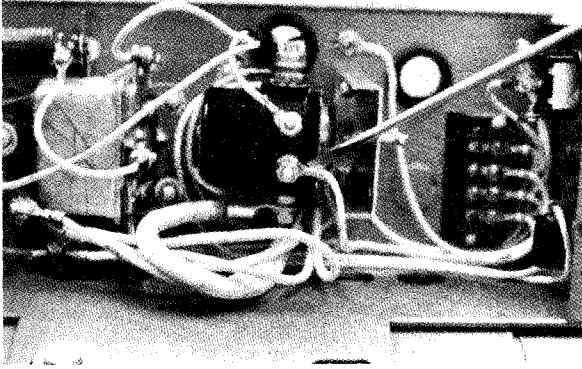

### Ground Coil Terminal (Std)

Placing the Start switch in the Start position grounds terminal #3 on the terminal block and the coil terminal of the start solenoid. If the start solenoid does not energize with an audible click and the generator receives no voltage, the start switch may be faulty. Check the Start switch by grounding the coil terminal of the start solenoid on standard generating sets.

### Jumper B+ Terminal

On solid state controls, jumper from the B+ terminal to the coil terminal. If the generating set does not crank, replace the solenoid, after checking with a voltmeter.

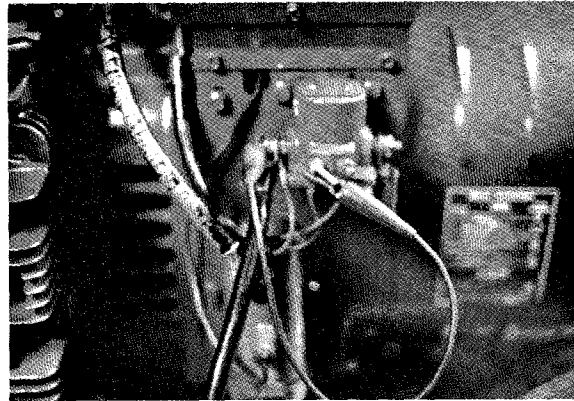

### Solid State Voltages

This table specifies the number of volts present at each terminal.

SOLID STATE VOLTAGES ENGINE RUNNING	
TERMINAL NO.	VOLTAGE
1	10
2	28
3	10
4	10
5	13
6	13
7	14
8	14
9	0
10	28
11	10
12	10
13	0 (GND)
14	10
15	13
16	0
17	13
18	13

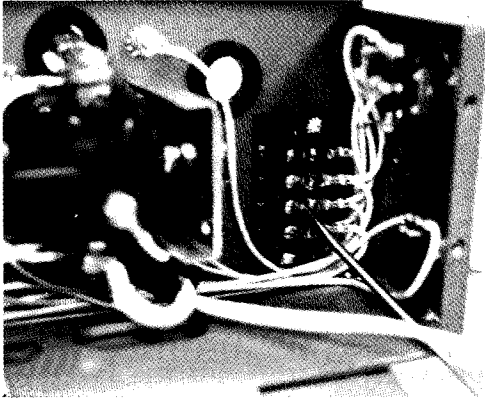

### **Start/Stop Switch Faulty (Std)**

If the start solenoid energizes when the coil terminal is grounded but will not energize when the Start switch is actuated, ground terminal #3. If the solenoid then energizes, the Start/Stop switch is faulty and must be replaced.

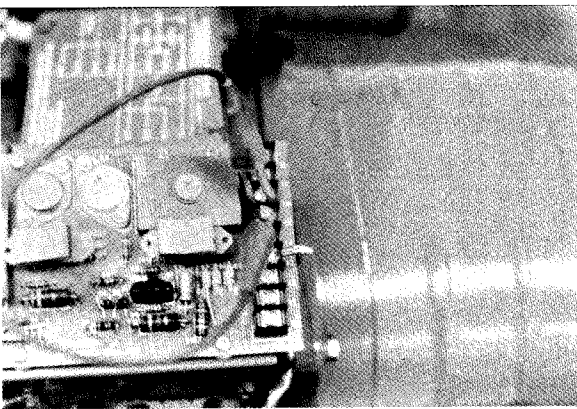

### **Check Start/Stop Switch (Std Solid State)**

On the standard solid state, jumper terminals #15 and #16 to check the Start/Stop switch.

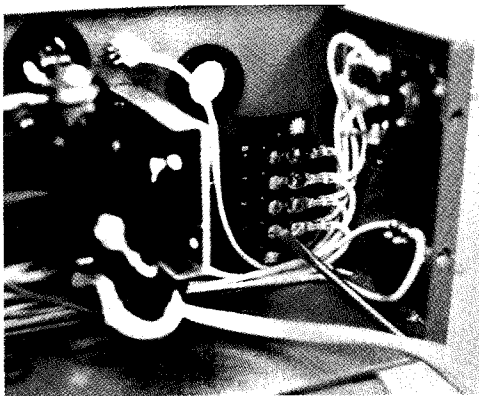

### **Start/Stop Switch Faulty (Solid State)**

If placing the Start/Stop switch in the Stop position does not stop the generating set, ground terminal #2. Should the remote wire to terminal #2 be grounded in the vehicle, the generating set will crank but will not start. Remove any remote wires from terminal #2 to check stopping. If the generating set stops, the Start/Stop switch is faulty and requires replacement.

### Electric Start Switch Position

The Hand Crank/Electric Start switch must be in the Electric Start position to stop the set with the Start/Stop switch. In the Hand Crank position, the stopping circuit is bypassed and ignition is not interrupted for stopping.

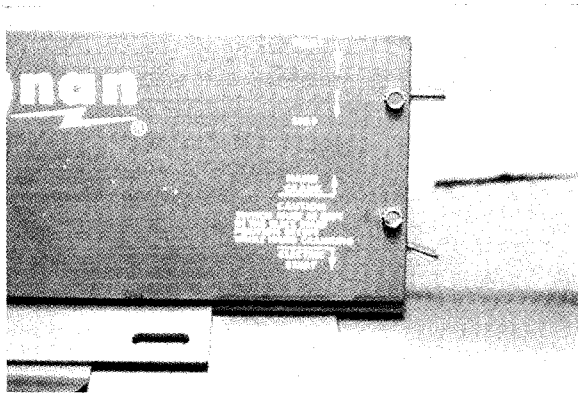

### Power Drawer Tests

Start and stopping tests on the power drawer control are the same as on the standard control: Ground terminal #3 to start and terminal #2 to stop.

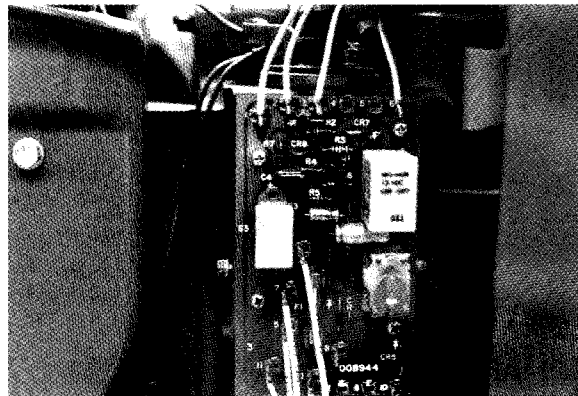

### Check Stopping (Std Solid State)

To check stopping with the standard solid state control, jumper terminal #14 to #13 (terminal #13 is ground).

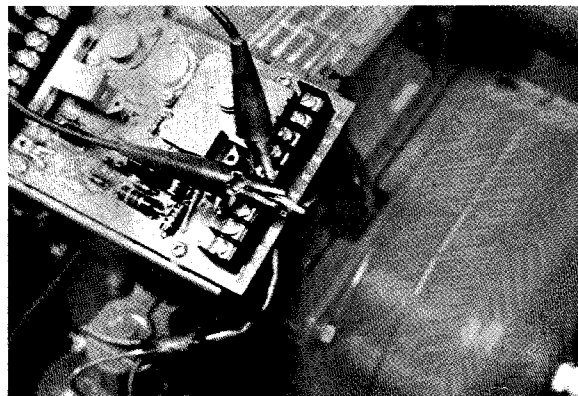

### Check Low Charge Resistor

If the stop relay (ignition relay) does not energize, the low charge resistor may be defective. Check the resistor; if it is lumpy, it has burnt out. A grounded running time meter can be the cause.

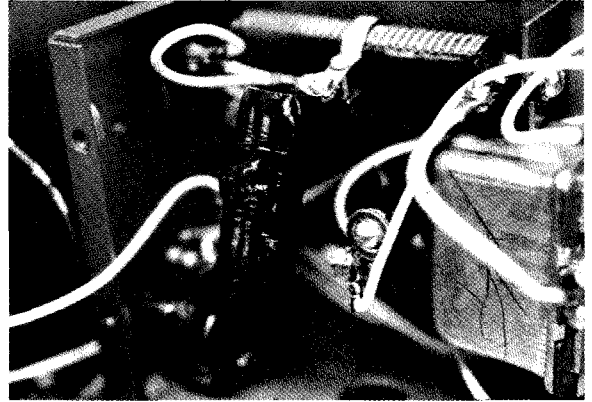

### Fuel Solenoid (Early Models)

This solenoid is a positive fuel shutoff valve that prevents fuel from flowing into the carburetor after set shutdown. It connects to the ignition power terminal. This in turn prevents the possibility of a pressurized fuel system forcing fuel into the generating set engine after it is shut down.

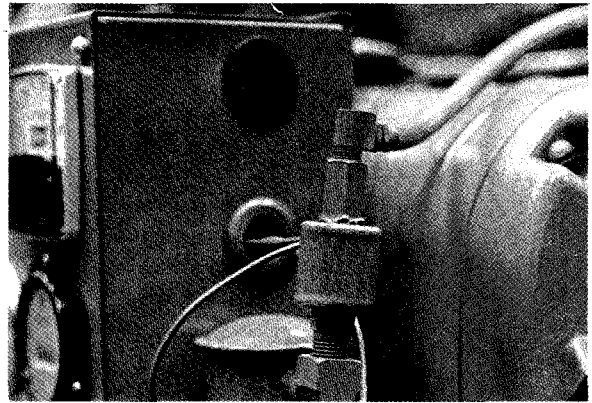

### Fuel Solenoid (Current Models)

BFA, BGA and NH (Spec K) sets use an electric fuel pump with a built in internal fuel shut-off device. 3.0 AJ sets use an external device (shown below) which functions the same as earlier models.

**CAUTION** When removing or replacing fuel solenoid, always use wrench on hex (A), Figure 9. Do not exert turning force on B because solenoid will be damaged internally.

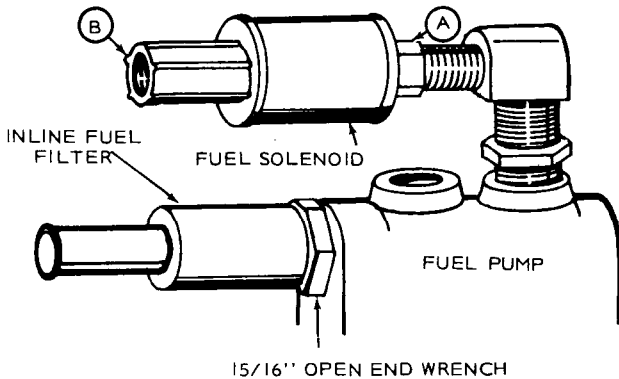

### EARLY MODELS

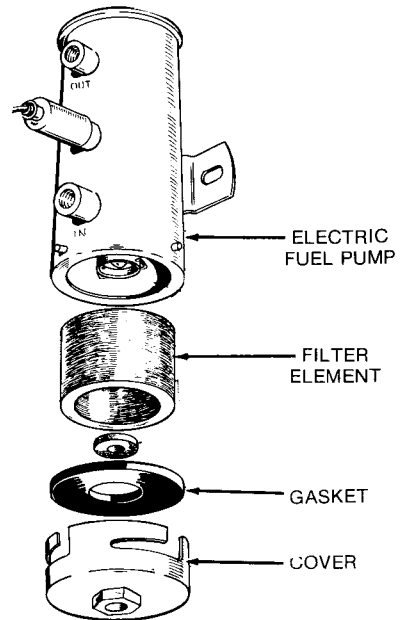

### CURRENT MODELS

# CONTROL—OPERATING SEQUENCE FOR BF “RV” MOTOR HOME CONTROL #611-1127

## Starting Circuit

A1 is the generator set control assembly. Optional items are A2, the deluxe remote control which has a running time meter and battery condition indicator. A3 is a standard remote control utilizing only a generator run indicating light and the start-stop switch.

The control is the standard three wire type. Starting is done by grounding terminal 3 and stopping by grounding terminal 2. Terminal 1 connects directly to a ground point. A fuse is placed in line with terminal 5 and 6 to protect the circuits in the event of a fault between the standard control and a deluxe or standard remote control located in another area. F1 and F2 are 5 amp fuses.

Placing S1 in the start position permits a current flow from battery to the B+ terminal of the solenoid, through the solenoid to terminal 3, to the start switch to terminal 1 and to ground. This causes the coil on relay K1 to energize closing the high current contacts within it and the auxiliary contacts. When the high current contacts close, the battery is connected to the cranking windings of the generator producing a motor effect which cranks the engine. At the same time a circuit is established through the auxiliary contacts to terminal 6 of the control, to the plus side of the ignition coil, through it to the breaker points to ground establishing ignition circuit. Beginning with Spec “B” models the auxiliary contacts on the start solenoid K1 were eliminated and replaced by a separate crank ignition relay K2. With the Start switch S1 in the start position, relay K2 (crank ignition) energizes to supply ignition current during the cranking period ONLY. When running, ignition current is supplied through the battery charging resistor R1 and fuse F2. Refer to schematic #611-1127. All other circuits in this control function the same as Spec “A” models. Refer to schematic #611-1123. In addition, power is supplied to the fuel solenoid (E4 on Spec “A” models and E5 on Spec “B” and later models) causing it to open and allowing fuel to the carburetor, by energizing the fuel pump (E5 on Spec “A” models and E4 on Spec “B” and later models). A running time meter is energized to provide a continuous record of hours of operation.

When the engine starts and reaches governed speed; releasing the start switch allows it to go to the center off position breaking the K1 and K2 coil circuit. This breaks the starting circuit and start ignition circuit.

A low oil pressure cutout switch (S3) is placed in the breaker point side of the ignition coil. In the event of a low oil pressure condition it would close grounding the breaker point side of the ignition coil thus cutting off ignition power and shutting the engine down.

## Ignition Circuit

When the engine starts and accelerates to governed speed, the battery charging circuit is energized through resistor R1, to CR1 to the battery, charging it. Also, from R1, power is supplied to fuel pump and ignition coil to maintain these devices in operation.

## Stopping Circuit

Placing switch S1 in the stop position places a ground on the breaker point side of the ignition coil preventing a make and break of ignition circuit thus eliminating the spark at the plugs shutting the engine down. Start and stop can be readily accomplished at the engine control, the deluxe remote control or the standard remote control.

## Troubleshooting

Failure of battery charge resistor R1 or loss of connections in the charging circuit will cause an ignition failure and engine shutdown.

Should the start solenoid (K1) fail to close when the start switch (S1) is placed in the correct position, a fast check can be made to determine if it's a faulty solenoid or switch. Place a wire jumper on the F terminal of K1 to a good ground point. If the solenoid now energizes the fault is in the start switch or its circuit. If starting is not accomplished through one of the remote switches, a fast check can be made through the use of a jumper by grounding terminal 3 at the engine control or at the remote control to determine complete circuit. If the starting is accomplished in this manner but not through the switch, it indicates a faulty switch. Stop circuit can be tested

in the same way by jumpering from terminal 2 of the standard control or the deluxe or standard remote control.

On Spec "B" models (Schematic 611-1127) Crank Ignition relay K2 operation can be tested by checking voltage from relay terminal 4 to ground while cranking unit. Battery voltage should appear at this terminal (4). If not, check for voltage at relay terminals 1 and 2 of K2. If battery voltage is present at terminals 1 and 2 of K2, but not at terminal 4 of K2, replace relay K2. If not voltage appears at terminals 1 and 2 on relay K2 while cranking, check wiring between Start solenoid K1 and Crank Ignition Relay K2.

A fuel pump (E4) and fuel solenoid (E5) can be tested for operation by placing a jumper from B+ out of the battery to the plus side of the ignition coil (T1). If the fuel solenoid (E5) is good, a click should be heard when this jumper is connected. A chattering of the fuel pump should indicate it is functioning.

If the unit cranks but will not start, and battery voltage is present at the plus terminal of the ignition coil (T1), disconnect the lead to the low oil pressure switch (S3) to be sure it is not remaining closed due to a fault.



REF. DES.	PART. NO.	QTY.	DESCRIPTION
A1	300-1570 D	1	CONTROL ASSY -01,-05
A2	300-1437 D	1	CONTROL ASSY -02
A3	300-1515 D	1	CONTROL ASSY -03
	300-1533 D	1	CONTROL ASSY -04
ALL PART NOS BELOW ARE REF. ONLY			
A2	300-0986 B	1	DELUXE REMOTE CONTROL
A3	300-0985 B	1	STANDARD REMOTE CONTROL
B1		1	BATTERY 12V
C1		1	CAPACITOR
E1	305-0235 A	1	RECTIFIER
E2		2	CHOKE -ONAN
E3		2	SPARK PLUG
E4		1	FUEL PUMP
E5		1	SOLENOID - FUEL (WHEN USED)
F1,2	321-0174 -	2	FUSE (5 AMP, 32V)
G1		1	GENERATOR
K1	307-1498 B	1	SOLENOID - START
K2	309-1575 P	1	RELAY -IGNITION
RI	353-0057 A	1	RESISTOR-FIXED (BF)
S1	353-0060 A	1	RESISTOR-FIXED (NH&CK)
S2		1	SWITCH-START-STOP
S3		1	BREAKER & CAP ASSY
S4	309-0237 P	1	SWITCH-LOW OIL PRESS
T1		1	SWITCH-HIGH AIR TEMP
TI		1	COIL-IGNITION
W1	338-0958 B	1	WIRING HARNESS (CONN - REMOTE)
W2	338-0959 C	1	WIRING HARNESS (CABLE - REMOTE CONTROL) (10 FEET LONG)
W3	338-0960 C	1	WIRING HARNESS (CABLE - REMOTE CONTROL) (30 FEET LONG)
OPTION			

NOTE:  
 ⑤ 1. K2 OLD RELAY CONNECTIONS ARE 1,2,3 & 4.  
 #1 WOULD BE THE SAME AS #85  
 #2 WOULD BE THE SAME AS #30  
 #3 WOULD BE THE SAME AS #86  
 #4 WOULD BE THE SAME AS #87

**BF "RV" BEGIN SPEC B**  
**611-1127**

SCHEMATIC

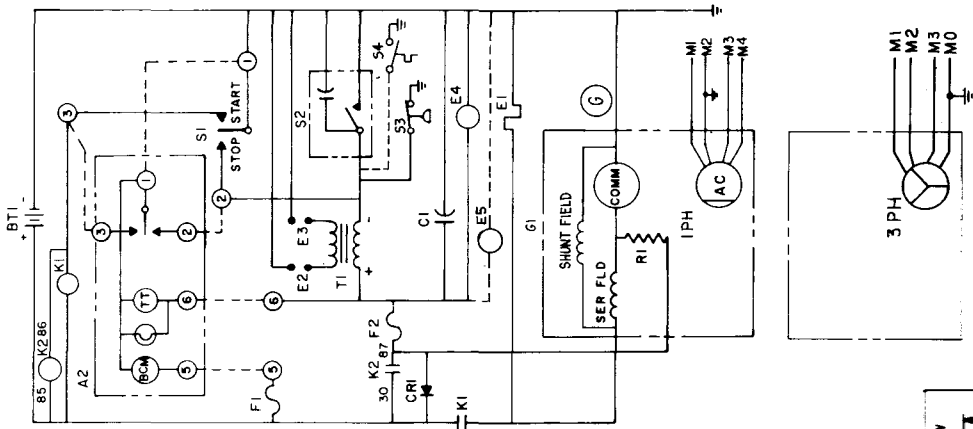

WIRING DIAGRAM

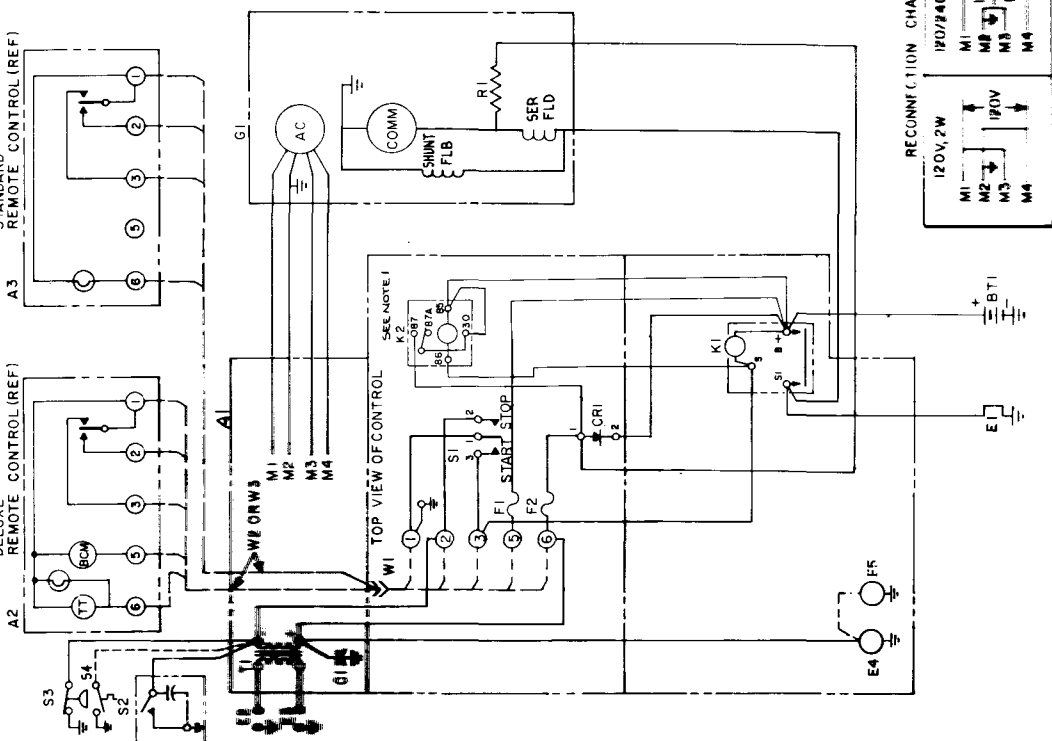

## **CONTROL—OPERATING SEQUENCE FOR BFA (SPEC A) BGA (SPEC A) AND NH (SPEC K) MOTOR HOME UNITS - SCHEMATIC #611-1135**

This control is very similar to the 611-1127 RV controls in operation except for changes to the Starting-Ignition and low oil pressure (LOPKO) circuits. All current twin cylinder RV motor home units listed above use the 611-1135 control.

### **Starting, Stopping, Ignition and Lopko Circuits**

When the start switch (S1) is placed in the start position, relay K2 (Crank Ignition) energizes to supply ignition current during the cranking period ONLY. When running, ignition current is supplied through K3 (Ignition Run) relay. All other circuitry in this control functions the same as described in the 611-1127 control theory of operation except for the low oil pressure circuit operation. S3 (low oil pressure switch), closes when oil pressure reaches 8-10 lbs during cranking. The generator supplies current through

dropping resistor R1 to relay K3 (Ignition Run) through the LOPKO switch (S3) to ground to keep K3 energized. K3 contacts complete the running ignition circuit. Placing start-stop switch (S1) in the stop position grounds power to K3. K3 de-energizes and its contacts open breaking the ignition circuit.

In the event of a low oil pressure condition (below 10 lbs when running), S3 will open, interrupting current through K3 and shutting down the set.

When the engine starts and accelerates to governed speed, the battery charging circuit is energized through resistor R1, through CR1 to the battery, charging it. Power is also supplied from R1 to the fuel pump and ignition coil through F2 to maintain these devices in operation.

## **CONTROL—OPERATING SEQUENCE FOR 3.0AJ “RV” MOTOR HOME UNIT (BEGIN SPEC P) - SCHEMATIC #611-1140**

This control functions the same as the 611-1135 control used on the twin cylinder sets except that this unit is a single cylinder.

When the engine starts and reaches governed speed; releasing the start switch (S1) allows it to go to the center off position breaking the K1 and K2 coil circuits. This breaks the starting and ignition circuits.

WIRING DIAGRAM

SCHEMATIC

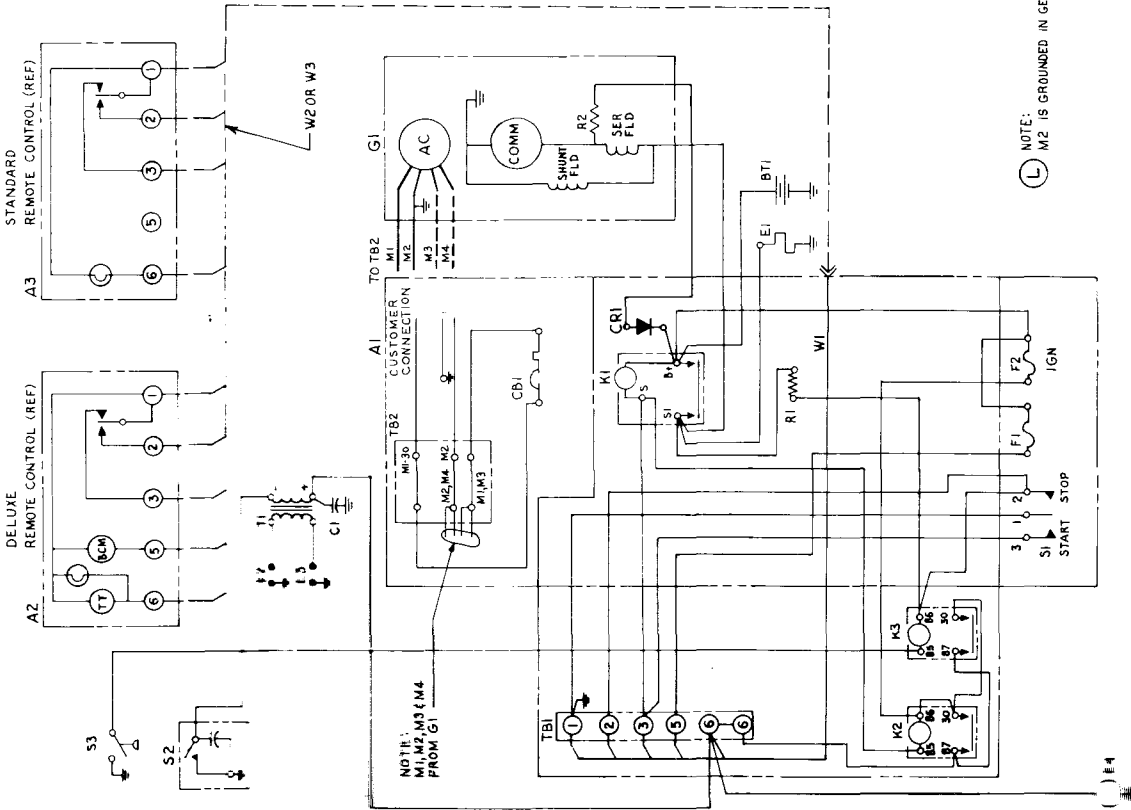

REF DES	PART NO	QTY	DESCRIPTION
A1	300-1601 D	1	CONTROL ASSY (-01) 30AMP
	300-1602 D	1	CONTROL ASSY (-02) 40AMP
	300-1603 D	1	CONTROL ASSY (-03) 50 AMP
ALL PART NOS LISTED BELOW ARE REF ONLY			
A2	300-0965 B	1	DELUXE REMOTE CONTROL
A3	300-0965 B	1	STANDARD REMOTE CONTROL
B1	312-0050 A	1	BATTERY - 12V
C1	357-0030 P	1	RECTIFIER (BATT. CHARGING)
E1		1	CHOKE - ONAN
E2		2	SPARK - PLUG
E4	148-1542	1	FUEL PUMP
F1	321-0175 P	2	FUSE HOLDER
	321-0174	2	FUSE - 5 AMP 32V
G1		1	GENERATOR
K1	307-1498 B	1	START SOLENOID
K2	307-1975 P	1	RELAY - CRANK IGNITION
K3	307-1975 P	1	RELAY - RUN IGNITION
R1	304-0431 P	1	RESISTOR - 150 OHM 5W
R2			RESISTOR
S1	308-0383 A	1	SWITCH - START STOP
S2		1	SWITCH - BREAKER & GAP ASSY
S3	166-0643 C	1	SWITCH - LOW OIL PRESS
T1		1	COIL - IGNITION
TB1	332-0699 A	1	TERMINAL BLOCK
TB2	332-0254 A	1	TERMINAL BOARD
	98-3331 B	1	SILKSCREEN - WD (REF)
CB1	320-0544 C	1	CIRCUIT BREAKER 30 AMP (-01)
	320-0547 C	1	CIRCUIT BREAKER 40AMP (-02)
	320-0548 C	1	CIRCUIT BREAKER 50AMP (-03)
W1	338-1073 C	1	WIRING HARNESS (CONN-REMOTE)
W2	338-1080 C	1	WIRING HARNESS (CABLE-REMOTE)
W3	338-1081 C	1	WIRING HARNESS (CABLE-REMOTE CONTROL) (30 FEET LONG)

4.0 BFA

5.0 BGA, 6.5 NH

RECONNECTION CHART

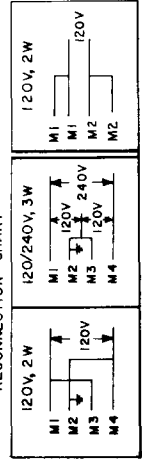

NOTE: M2 IS GROUNDED IN GENERATOR



(L) E4

(L) E4

(L) E4

(L) E4

(L) E4

(L) E4

(L) E4

(L) E4

(L) E4

(L) E4

(L) E4

(L) E4

(L) E4

(L) E4

(L) E4

(L) E4

(L) E4

(L) E4

(L) E4

(L) E4

(L) E4

(L) E4

(L) E4

BFA, BGA  
AND NH  
RV SETS  
611-1135

611-1140

WIRING DIAGRAM

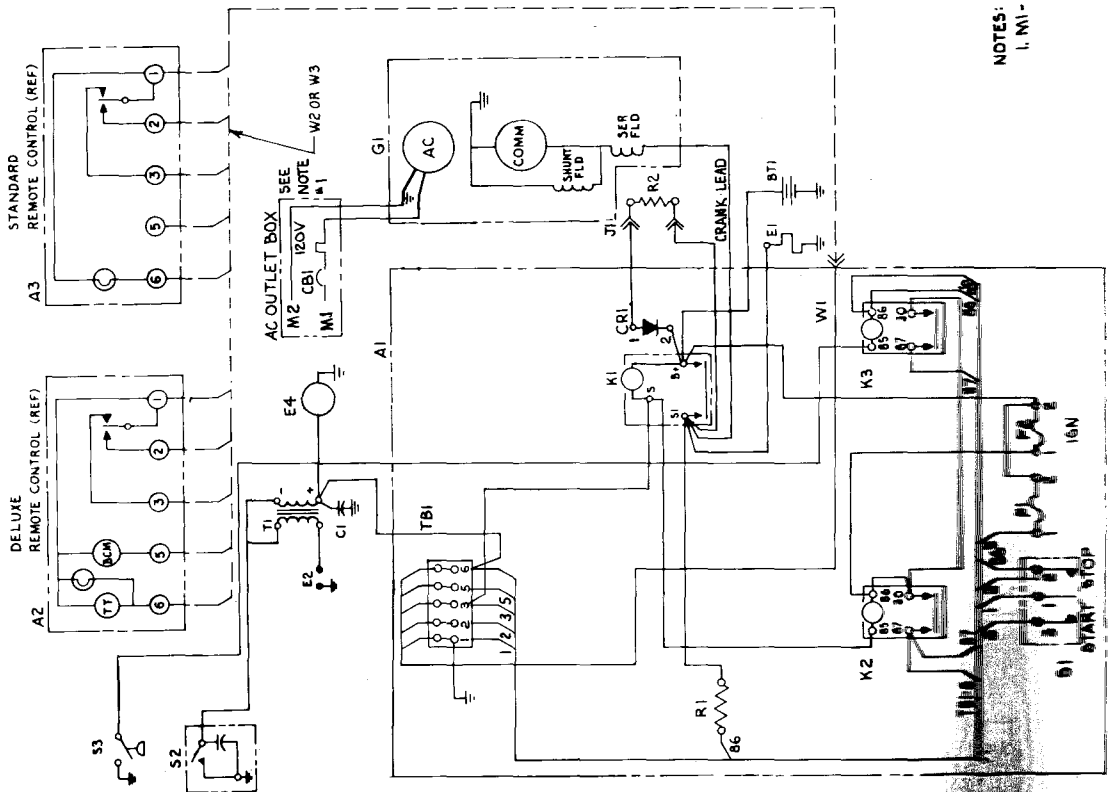

NOTES:  
1. M1 - BLACK, M2 - WHITE

SCHEMATIC

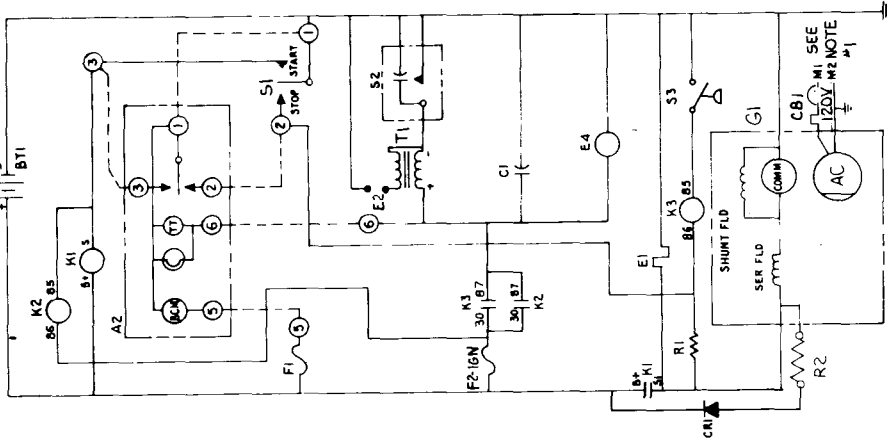

PARTS LIST			
REF DES	PART NO	QTY	DESCRIPTION
A1	300-1584	C	CONTROL ASSY
ALL PART NOS LISTED BELOW ARE REF ONLY			
A2	300-0986	P	DELUXE REMOTE CONTROL
A3	300-0885	B	STANDARD REMOTE CONTROL
BT1	312-0850	A	BATTERY
C1	357-0050	P	CAPACITOR
CBI	320-0544	C	RECTIFIER (BATT. CHARGING)
E1		I	90AMP CIRCUIT BRK
E2		I	CHOKE - OHM
E4	307-1302	A	SOLENOID FUEL SHUT OFF
F1	321-0115	P	FUSE HOLDER
F2	321-0114	P	FUSE - 5 AMP 32V
G1	307-1408	B	GENERATOR
K1	307-1575	P	START SOLENOID
K2	307-1575	P	RELAY - CRANK IGNITION
K3	307-1575	P	RELAY - RUN IGNITION
R1	304-0735	P	RESISTOR - 175 OHM 5W
R2	353-0050		RESISTOR - 10 OHM 45W
S1	308-0283	A	SWITCH - START, STOP
S2		I	SWITCH - BREAKER & CAP ASSY
S3	166-0278	C	SWITCH - LOW OIL PRESS
T1		I	COIL - IGNITION
TB1	332-0604	A	TERMINAL BLOCK
	96-3358	A	SILVERSCREEN - WD
J1	508-0200	A	BUSHING - TERMINAL
W1	338-1111	C	WIRING HARNESS (LOW-REMOTE)
W2	338-1080	C	WIRING HARNESS (CABLE-REMOTE CONTROL) (10 FEET LONG)
W3	338-108	C	WIRING HARNESS (CABLE-REMOTE CONTROL) (30 FEET LONG)

WHEN USED

3.0AJ RV SET  
(Begin Spec P)

611-1140

# AJ, BFA, BGA AND NH CONTROL TROUBLESHOOTING

PROBLEM	PROBABLE CAUSE	REMEDY
FAILS TO CRANK	1. Bad Battery Connection	1. Clean and tighten all battery and cable connections.
	2. Low Battery	2A. Check specific gravity. Recharge or replace battery if necessary. 2B. Reverse current diode (CR1) may be shorted or open causing a drain on the battery. R2 may be open.
	3. Faulty Start Solenoid (K1)	3. Check start solenoid "S" terminal voltage to ground. When battery voltage is present at start solenoid "B+" terminal then battery voltage should also appear at "S" terminal; if not, replace start solenoid.
	4. Faulty Start Switch	4. Jumper switch (TB1 #3 terminal) to ground. If <i>Solenoid Energizes, Replace Switch.</i>
CRANKS SLOWLY	1. Bad Battery Connection	1. See 1 above (FAILS TO CRANK)
	2. Low Battery	2. See 2 above (FAILS TO CRANK)
CRANKS BUT WON'T START	1. Blown Fuse (F2)	1. Replace fuse (F2) on control.
	2. Faulty Fuel Solenoid Or Fuel Pump  On later models, fuel solenoid is an integral part of fuel pump.	2. Fuel solenoid must open during cranking and running. Check by removing steel line from carburetor and crank engine. If fuel solenoid is open, fuel will pulsate out of this line. If it does not, the fuel solenoid and fuel pump must be checked separately to determine defective part.  <b>WARNING</b> Use extreme care for this test. Direct fuel flow into a suitable container and make sure area is well ventilated to prevent accumulation of gasoline fumes.
	3. Faulty Ignition	3. Check to see if points open and close during cranking. If they do not open and close, adjust and set points. Plug and plug wires must be in good condition. Voltage at ignition coil negative terminal (-) must alternate from +12 volts to zero volts as points open and close during engine cranking.
	4. Inoperative Choke	4. With engine not running, check choke vane movement by pushing choke lever arm. Choke must be in closed position with cold engine, and must be free to move against bimetal spring. As engine warms up, bi-metal spring relaxes and allows choke vane to open fully. The lever will pulsate as engine warms up. See ADJUSTMENT section.
	5. Faulty Crank Ignition Relay (K2)	5. Check voltage from relay terminal "87" to ground while cranking unit. Battery voltage should appear at this terminal. If not check for voltage at relay terminals "86" and "30". If battery voltage is present at terminals "86" and "30", but not at 87, jumper terminal 85 to ground, if no voltage is present, replace relay. If no voltage appears at terminals 86 and 30 on relay while cranking, check wiring between start solenoid (K1) and crank ignition relay (K2).
UNIT STARTS, BUT STOPS IMMEDIATELY AFTER RELEASING START SWITCH S1	1. Resistor R1 may be open. 2. S3 Low oil pressure switch may be defective. 3. Run Ignition Relay K3. 4. Low Oil Level.	1. Check voltage on both sides of R1. With set running voltage should be 24-32 volts DC on generator side. K3 side should be 8-16 volts. 2. Check S3. Switch should close with set running at 10 lbs. minimum oil pressure. Check by jumpering (K3) terminal #85 to ground while cranking. 3. Check voltage at terminal #86 of K3. Should be 8-16 volts depending on load. 4. Check oil level. If low or empty, refill to proper level.
UNITS RUNS THEN STOPS	1. Low Oil Level	1. See 4 above.
UNITS RUNS BUT SURGES	1. Stuck Choke	1. See 4 above (CRANKS BUT WON'T START)
	2. Governor Not Adjusted Properly	2. Readjust governor.
UNITS STOPS	1. Faulty Ignition	1. See 3 above (CRANKS BUT WON'T START)
	2. Out of Fuel	2. Refill fuel tank.
	3. Low Oil Level	3. See 1 above
REMOTE RUNNING TIME METER OR GENERATOR LAMP INOPERATIVE	1. Blown Fuse (F1)	1. Replace F1 fuse on control.

## CONTROL—OPERATING SEQUENCE FOR 2.5AJ MOTOR HOME UNITS 605-0110

### Starting Circuit

The ignition and start switch (308-0140) is a 3-position switch—START, RUN, and STOP. With the switch in the Start position, a circuit is completed from the battery positive terminal to the start solenoid (307-1031) B+, to the start switch, through it to the start solenoid coil, to ground. The start solenoid energizes and connects the battery to the cranking windings of the generator. The generator acts as a DC motor to crank the engine for starting. A circuit is also completed through the start switch to the ignition coil, to the breaker points, to ground. This supplies ignition power. A momentary contact switch (308-0097), when operated, breaks the circuit to the low oil pressure switch to prevent grounding the ignition circuit.

### Engine Starting and Running

The generator turns the engine and with fuel and ignition supplied, will start. When the engine starts it accelerates to governed speed. The start switch is then released and being spring loaded, it returns to the "Run" position. The start solenoid de-energizes and the battery is disconnected from the cranking circuit. The start switch, being in the "Run" position, maintains the ignition circuit on.

### Battery Charging Circuit

The battery charging circuit is from the generator cranking windings to the S1 terminal of the start solenoid, to the reverse current diode (305-0235) to the charge resistor (353-0028) to the B+ terminal of the start solenoid, to the battery. The battery charging circuit also supplies ignition current during "Run" condition.

### Stopping

Placing the start-ignition switch in the "Off" position, opens the circuit to the ignition coil and the engine stops.

### Low Oil Pressure Shutdown

If the oil level drops to a dangerous level, the low oil pressure switch (309-0237) will close and ground the ignition circuit, stopping the engine.

### Preparation

Before starting the generating set, **check** the engine for correct type and **quantity of oil**. Check fuel line to engine and be **sure there are no leaks**. Also check exhaust system **for leaks**. Use one 12-volt 92-Amp hour **battery** and connect positive (+) to **appropriate start solenoid terminal** and negative (-) to **good ground point**.

# 605A110

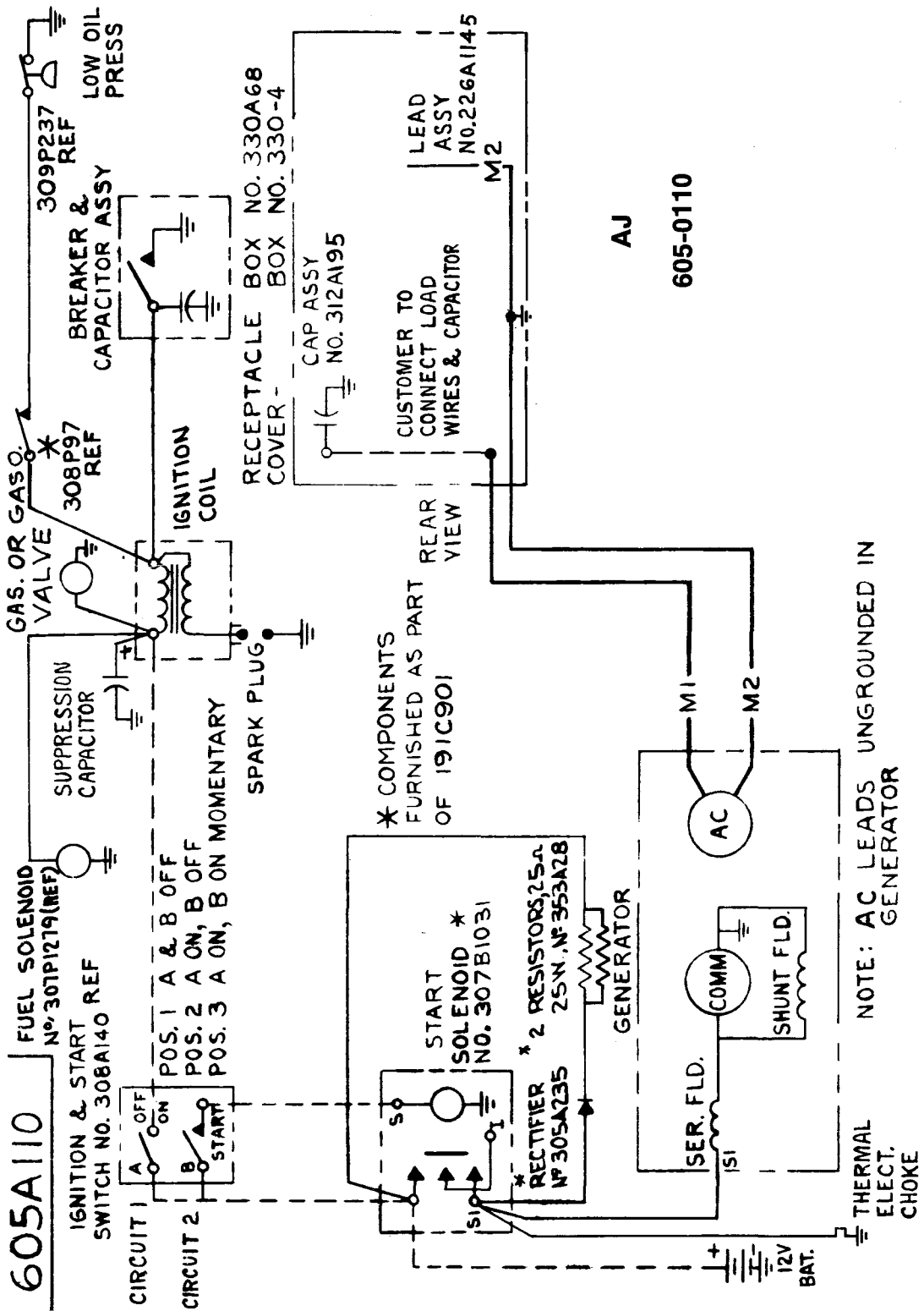

## CONTROL—OPERATING SEQUENCE FOR 2.7 kW AJ CONTROL #611-1106

### Starting Circuit

Pushing start switch S3 to the right allows battery current to flow through start solenoid K1; start switch S3, to negative battery terminal (ground). K1 start solenoid main contacts close, supplying current to the choke E1 and generator. This causes the generator to act as a direct current motor and cranks the engine. K1 start solenoid (I terminal) ignition contacts close supplying current to ignition coil T1 and fuel solenoid K2. When engine starts, release the start switch.

### Engine Stopping

To stop engine, push start-stop switch S3 to the left. This disables the points and prevents ignition.

### Low Oil Pressure Shutdown (LOPKO)

The low oil pressure switch S2 opens to allow the ignition system to operate if sufficient oil pressure (5 to 7 lbs.) is available during cranking and running. The low oil pressure switch S2 closes on loss of oil pressure to ground the ignition points and stop the engine.

### Choke Circuit

The choke heater element E1 connects to generator DC output. When the engine is running the DC output from the generator energizes the heater, which in turn relaxes the bi-metal spring to open the choke vane in the carburetor. This takes several minutes before the choke vane is fully open.

### Battery Charging Circuit

The charge rate is approximately one ampere and is fixed by the value of resistor R1 in series with diode CR1. The generator current flows through the resistor R1, diode CR1 and charges the battery. The diode CR1 polarity prevents the battery from discharging into the ignition and generator.

### Emergency Start-Stop Operation

In an emergency situation, the control box can be by-passed to start or stop the unit. To start, use a 12-inch lead to jumper start solenoid K1-S terminal to ground momentarily. After engine starts, remove jumper. To stop, use the same jumper to connect the point box terminal to ground. Remove after engine stops.

### Remote Start-Stop Switch

This switch can be connected to terminals 1 and 3 for starting and terminals 1 and 2 for stopping. This may be a single pole double throw switch momentary, either direction, rated at 5 amperes. This switch can be remotely connected with up to 100 feet of #18 gauge wire.

### Battery Condition Meter

A battery condition meter can be connected to terminals 1 (-) and 5 (+). Terminal 5 is battery positive up to 15 volts.

### Running Time Meter

A remote running time meter can be connected to terminals 1 ( $\frac{\perp}{-}$ ) and 6 (+) to indicate the total running time of the engine generator set.



WIRING DIAGRAM

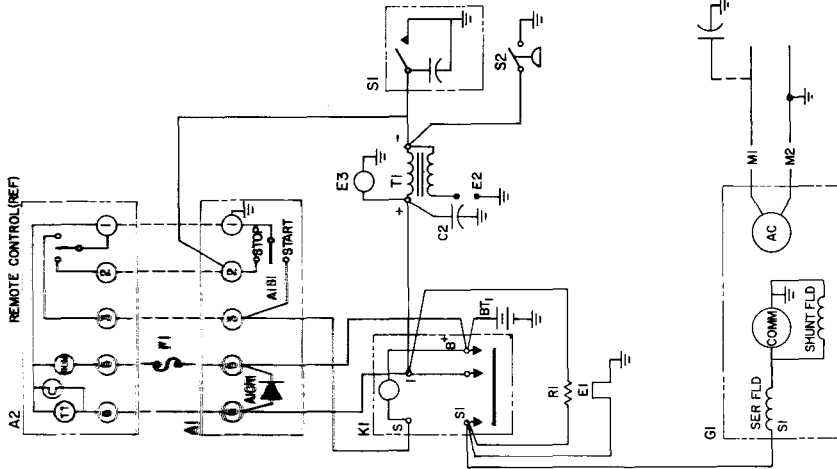

CAPACITOR MOUNTED IN A1 (E)

SCHEMATIC

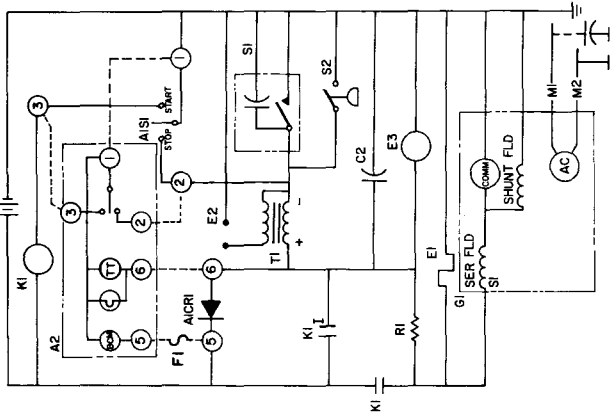

NOTE:  
1. FUSE (5 AMP) TO BE SUPPLIED BY CUSTOMER TO PROTECT AGAINST ACCIDENTAL GROUNDING

REF. DES.	DESCRIPTION
A1	CONTROL ASSY - GEN SET
A1CIRI	DIODE ASSY (REF)
A1SI	SWITCH-TOGGLE (REF)
BT1	BATTERY-2V
C2	CAPACITOR
E1	CHARGE OHMM
E2	SPARK PLUG
E3	SOLENOID-FUEL (REF)
G1	GENERATOR
K1	SOLENOID-START
R1	RESISTOR ASSY (REF) ID ± 5% OHMS 45W
S1	BREAKER & CAP ASSY
S2	SWITCH-LOW OIL PRESS (REF)
T1	COIL-IGNITION
F1	
A2	DELUXE REMOTE CONTROL (REF)
	STANDARD REMOTE CONTROL (REF)

2.7 AJ  
611-1106

## **CONTROL—OPERATING SEQUENCE FOR STANDARD CCK CONTROL 611-0176 AND STANDARD LK CONTROL**

### **Starting Circuit**

One end of the start solenoid operating coil is connected internally to the battery terminal. The other end of the coil is connected to terminal 3 of the control block. From terminal 3, a wire connects to the start side of the start-stop switch. When the switch is placed in the start position, current from the battery positive terminal flows through the start solenoid to terminal 3, to the start-stop switch, to ground and back to the battery. This energizes the start solenoid, closing the high current contacts within the solenoid. Battery current flows through these closed contacts to the series field (cranking windings) through it to the shunt field and the armature. This causes the generator to act as a direct current motor and cranks the engine.

### **Ignition Circuit**

When the start solenoid closes, current flows from the S1 terminal to the 1-ohm, 25-watt resistor, to the generator side of the reverse current relay, to the 30-ohm, 5-watt resistor, to the upper portion of the start-stop switch to the coil of the stop relay, to ground. The ignition (stop) relay energizes, closing its contacts and supplying ignition current to the coil. Current from the battery flows through the ammeter to the contacts of the stop relay, to the Hytempco resistor (1.72-ohm, 25-watt) to the coil, through the ignition breaker points to ground.

### **Engine Starting**

With the generator acting as a motor and cranking the engine and with ignition current supplied; if fuel is available at the carburetor, the engine will start.

### **Voltage Build-Up and Start-Disconnect**

When the engine starts, it accelerates to governed speed. The armature rotating in the magnetic field produced by residual magnetism has a voltage produced in its windings. This voltage is applied to the shunt field

causing an electro magnetic field to be produced. This electro magnetic field combines with the residual magnetic field and produces an overall strong field and an increase in armature voltage. This voltage increases to approximately 18 volts. This direct current is then used for excitation and to supply battery charging current. This voltage is also used to operate a start-disconnect relay on some engine controls or the start switch is released and it returns to its center "OFF" position and breaks the start solenoid coil circuit.

### **Battery Charging**

The direct current voltage produced by the DC windings of the armature causes a current through the series field to the S1 terminal of the start solenoid to the two charge resistors. One is the fixed value low charge resistor, and the other is the adjustable rate high charge resistor. Battery charging current flows from the low charge resistor to the generator terminal of the reverse current relay. From this terminal current also flows up to the 30-ohm, 5-watt resistor and supplies the current to maintain the stop relay coil energized and its contacts closed to supply ignition current.

Battery charging current also flows to the adjustable resistor and to the normally closed contacts of the two step voltage regulator, through the contacts to a terminal point and down to the generator terminal of the reverse current relay. Current through the series coil and shunt coil cause the reverse current relay to close. The contacts closing complete the battery charging circuit through that relay to the charge ammeter, through it to the battery terminal on the start solenoid and to the battery. This provides battery charging current. If the battery is in a low charge state, the charging current will be in the area of 7.5-amperes until the battery has returned to a near normal charge state. When this happens, the battery voltage and generator voltage are quite close and the two step voltage regulator coil energizes causing its contacts to open. This coil remains energized while the generator is running. The battery charging current drops to approximately 2.5-amperes when the two step voltage regulator operates. This removes the adjustable charge resistor from the circuit.



611C176

- 5CCK-1R/1A
- 3CCK-2R/1A
- 4CCK-1R/1F
- 4CCK-2R/1F
- 4CCK-51R/1A
- 4CCK-52R/1A
- 305CCK-1R/1A
- 305CCK-2R/1A
- 305CCK-51R/1A
- 305CCK-52R/1A
- 5CCK-1RV/1ZB2C
- 4CCK-1RV/4Z2BF

LOW OIL PRESS. SW. MOMENTARY CONTACT SW. N°309-97 (WHEN USED)

HIGH AIR TEMP. CUTOFF SW. N°309-92 (WHEN USED)

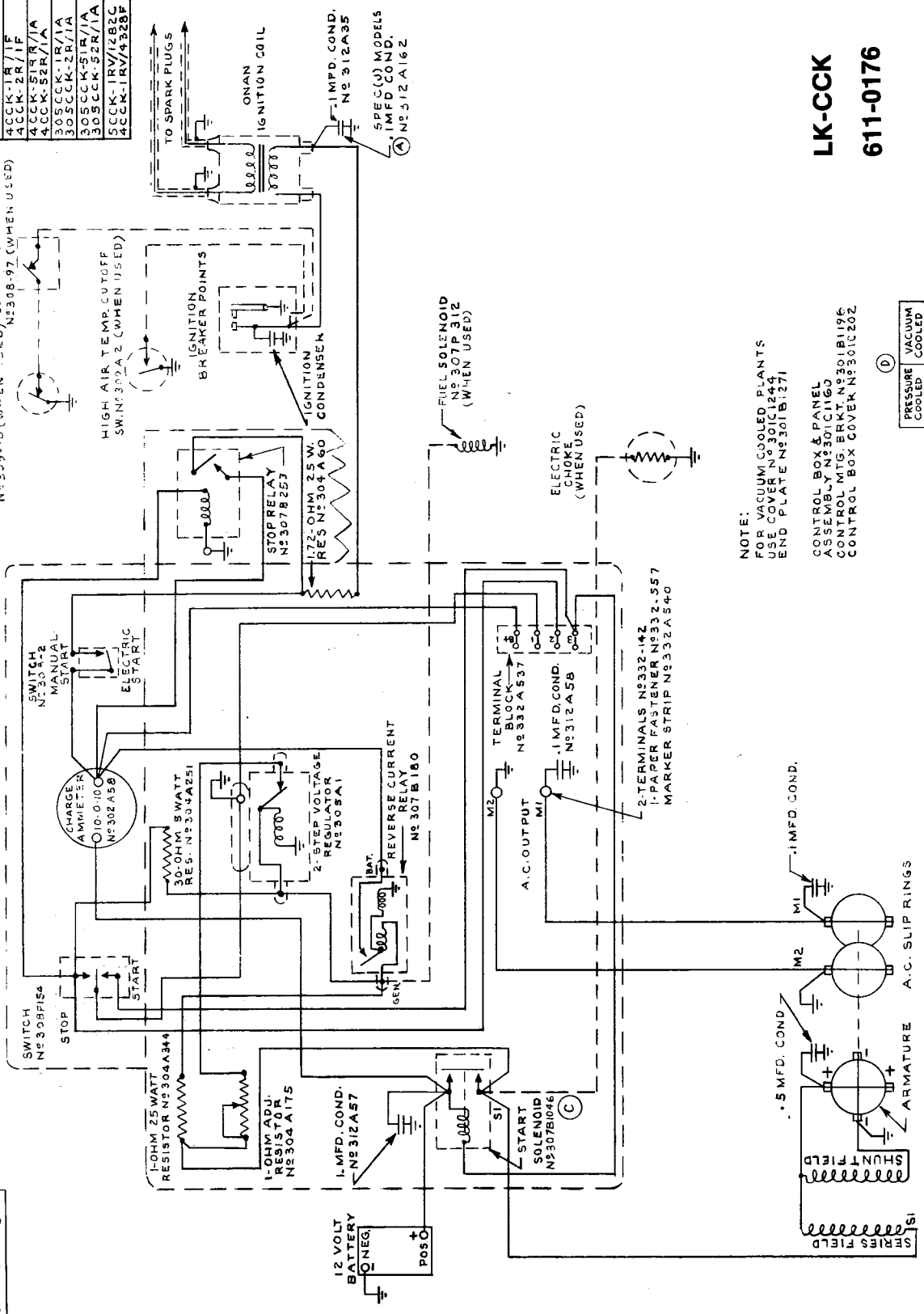

NOTE:  
 FOR VACUUM-COOLED PLANTS  
 USE COVER PLATE N°301B127  
 END PLATE N°301B1271

CONTROL BOX & PANEL  
 ASSEMBLY N°301C1160  
 CONTROL MTG. BRKT. N°301B1196  
 CONTROL BOX COVER N°301C202

(D)

PRESSURE COOLED	VACUUM COOLED
-01	-02

LK-CCK  
 611-0176

### **Set Stopping**

To stop the set, move the switch handle to the stop position. This "shorts out" the power to the stop (ignition) relay coil, causing it to de-energize and its contacts to open, breaking the ignition circuit.

### **Electric—Hand Crank Switch**

The manual start-electric start switch makes starting with a pull rope or recoil starter easier. When the switch is in the manual start position, it parallels the contacts of the stop relay and supplies ignition current directly to the ignition coil without the stop relay being energized. The set cannot be electrically stopped with this switch in the manual start position.

### **Easy Checks**

Grounding terminal 3, on the terminal block with a jumper, will energize the start solenoid and supply current to the generator. With fuel supplied to the engine, the unit should start. Grounding terminal 2, at this block, will stop the set. These are easy checks to determine if control components are operating.

When the set starts, observe the ammeter to check the charge rate. It should be in the area of 7.5-amperes. If it is indicating approximately 5 amperes, this indicates the low charge rate resistor has burned out. If it is indicating 2.5-amperes, then the high charge resistor is burned out. The ammeter should drop to an indication of approximately 2.5-amperes after a short period of time. If it drops to 0, it indicates an open low charge resistor.

Should problems be experienced with the fuel solenoid failing to energize, remove the lead from the generator terminal of the reverse current relay and place it on the supply side of the Hytempco ignition resistor (1.72-ohm, 25-watt). This will assure higher pick up voltage.

The control used on the "LK" series of sets for mobile applications, wiring diagram 610-0266, is the same as the 611-0176 "CCK" control; with the exception that the Hytempco ignition resistor is not used on "LK" series controls. The mobile "LK" uses a 12-volt ignition coil.

## **CONTROL—OPERATING SEQUENCE FOR CCK MOTOR HOME CONTROL 611-0914 AND LK MOTOR HOME CONTROL 610-0313**

### **Starting Circuit**

One end of the start solenoid operating coil is connected internally to the battery terminal. The other end of the coil is connected to terminal 3 of the control block. From terminal 3, a wire connects to the start side of the start-stop switch (S1). When the switch is placed in the start position, current from the battery positive flows through the start solenoid coil to terminal 3, to the start-stop switch (S1), to ground and back to the battery. This energizes the start solenoid closing the high current contacts within the solenoid. Battery current flows through these closed contacts to the series field (cranking winding) through it to the shunt field and the armature. This current flows through the shunt field and the armature to ground. This causes the generator to act as a direct current motor and cranks the engine.

### **Ignition Circuit**

When the start solenoid relay closes, current flows from the S1 terminal to the 1-ohm, 25-watt resistor, to the battery side of the 2-step voltage regulator, to the 30-ohm, 5-watt resistor (R3), to the stop side of the start-stop switch (S1), to the coil of the stop relay (K2) and to ground. This relay energizes, closing its contacts and supplying ignition current to the coil. Current from the battery flows to B+ on terminal block, to the contacts of the stop relay (K2), to the ignition coil, through the ignition breaker points to ground. On 'CCK' units, ignition current passes through a Hytempco resistor (1.72 ohms, 25 watt [RT1]) before the ignition coil.

### **Engine Starting**

With the generator acting as a motor and cranking the engine and with ignition current supplied; if fuel is available at the carburetor, the engine will start.

### **Voltage Build-up and Start Disconnect**

When the engine starts, it accelerates to governed speed. The armature rotating in the magnetic field produced by residual

magnetism has a voltage produced in its windings. This voltage is applied to the shunt field causing an electro-magnetic field to be produced. This electro-magnetic field combines with the residual magnetic field and produces an over-all strong field and an increase in armature voltage. This voltage increases to approximately 18 volts. This direct current is then used for excitation and to supply battery charging current. This voltage is also used to operate a start-disconnect relay on some engine controls or the start switch is released and it returns to the center "OFF" position and breaks the start solenoid coil circuit.

### **Battery Charging**

The direct current voltage produced by the DC windings of the armature causes a current through the series field to the S1 terminal of the start solenoid relay, to the two charge resistors (R1 and R2). One is the fixed value low charge resistor and the other is the adjustable rate high charge resistor. Battery charging current flows from R1 to the battery terminal of the 2-step voltage regulator relay. From this terminal current also flows up to the 30 ohm, 5 watt resistor (R3) and supplies the current to maintain the stop relay coil (K2) energized and its contacts closed to supply ignition current.

Battery charging current also flows to the adjustable resistor (R2) and to the normally closed contacts of the two step voltage regulator, through the contacts to the battery terminal and to CR1 charge diode, through it to the battery terminal on the start solenoid relay and to the battery. This provides battery charging currents. If the battery is in a low charge state, the charging current will be in the area of 7.5-amperes until the battery has returned to a near normal charge state. When this happens, the battery voltage and generator voltage are quite close and the two-step voltage regulator coil energizes, causing its contacts to open. This coil remains energized while the generator is running. The battery charging current drops to approximately 2.5-amperes when the two-step voltage regulator operates. This removes the adjustable resistor from the circuit.

INSIDE VIEW OF CONTROL BOX

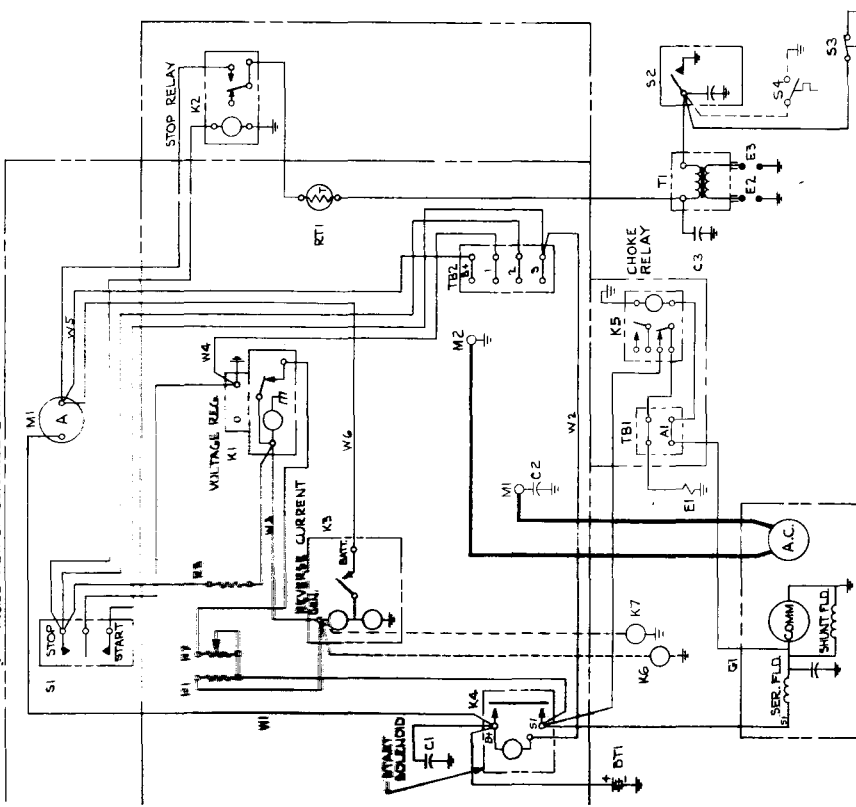

NOTE: UNGROUNDED A.C. LEADS  
HAVE CAPACITOR TO  
GROUND IN GENERATOR.

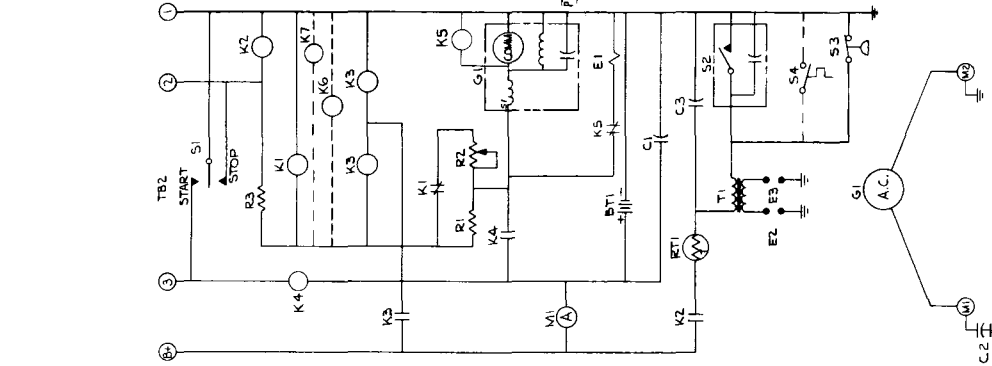

REF. DES.	QUANTITY	DESCRIPTION
C1		CAPACITOR ASSY 1.0 MFD
C2		CAPACITOR ASSY 0.1 MFD
K1		RELAY-2 STEP VOLTAGE RELYR
K2		RELAY & LEAD ASSY
K3		RELAY-STOP
K4		RELAY-REVERSE CURRENT
K5		RELAY-START SOLENOID
K6		RELAY & BOX ASSY
K7		RELAY-CHOKE
TB1		TERMINAL BLOCK
M1		RELAY & TERM BOX
M2		AMMETER-CHARGE 10-0-10
R1		RESISTORS & LEAD ASSY
R2		RESISTOR-1 OHM 25 W
R3		RESISTOR-1 OHM 50 W ADJ
R4		RESISTOR & LEAD ASSY
R5		RESISTOR-ATTENED 1.72 OHM 25 W
S1		SWITCH-STOP-START
S2		SWITCH-STOP-START
S3		RESISTOR-30 OHM 5 W
S4		MARKER STRIP
T1		TERMINAL
T2		TERMINAL
T3		TERMINAL
T4		TERMINAL
T5		TERMINAL
T6		TERMINAL
T7		TERMINAL
T8		TERMINAL
T9		TERMINAL
T10		TERMINAL
T11		TERMINAL
T12		TERMINAL
T13		TERMINAL
T14		TERMINAL
T15		TERMINAL
T16		TERMINAL
T17		TERMINAL
T18		TERMINAL
T19		TERMINAL
T20		TERMINAL
T21		TERMINAL
T22		TERMINAL
T23		TERMINAL
T24		TERMINAL
T25		TERMINAL
T26		TERMINAL
T27		TERMINAL
T28		TERMINAL
T29		TERMINAL
T30		TERMINAL
T31		TERMINAL
T32		TERMINAL
T33		TERMINAL
T34		TERMINAL
T35		TERMINAL
T36		TERMINAL
T37		TERMINAL
T38		TERMINAL
T39		TERMINAL
T40		TERMINAL
T41		TERMINAL
T42		TERMINAL
T43		TERMINAL
T44		TERMINAL
T45		TERMINAL
T46		TERMINAL
T47		TERMINAL
T48		TERMINAL
T49		TERMINAL
T50		TERMINAL
T51		TERMINAL
T52		TERMINAL
T53		TERMINAL
T54		TERMINAL
T55		TERMINAL
T56		TERMINAL
T57		TERMINAL
T58		TERMINAL
T59		TERMINAL
T60		TERMINAL
T61		TERMINAL
T62		TERMINAL
T63		TERMINAL
T64		TERMINAL
T65		TERMINAL
T66		TERMINAL
T67		TERMINAL
T68		TERMINAL
T69		TERMINAL
T70		TERMINAL
T71		TERMINAL
T72		TERMINAL
T73		TERMINAL
T74		TERMINAL
T75		TERMINAL
T76		TERMINAL
T77		TERMINAL
T78		TERMINAL
T79		TERMINAL
T80		TERMINAL
T81		TERMINAL
T82		TERMINAL
T83		TERMINAL
T84		TERMINAL
T85		TERMINAL
T86		TERMINAL
T87		TERMINAL
T88		TERMINAL
T89		TERMINAL
T90		TERMINAL
T91		TERMINAL
T92		TERMINAL
T93		TERMINAL
T94		TERMINAL
T95		TERMINAL
T96		TERMINAL
T97		TERMINAL
T98		TERMINAL
T99		TERMINAL
T100		TERMINAL

\* WHEN USED

**CCK**  
**6111-0914**

610C313

WIRING DIAGRAM  
INSIDE VIEW OF BOX  
TOP

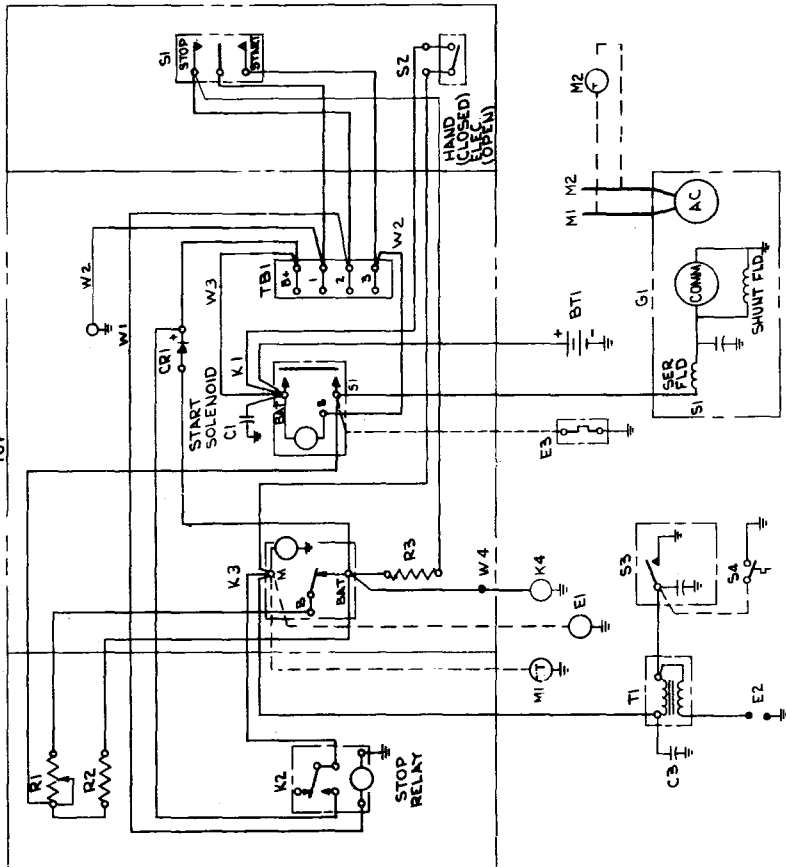

NOTE:  
M2 IS GROUNDING AC LEAD  
M1 HAS A .1 MFD CAPACITOR TO  
GROUND IN GENERATOR

SCHEMATIC

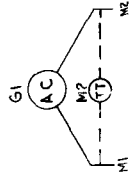
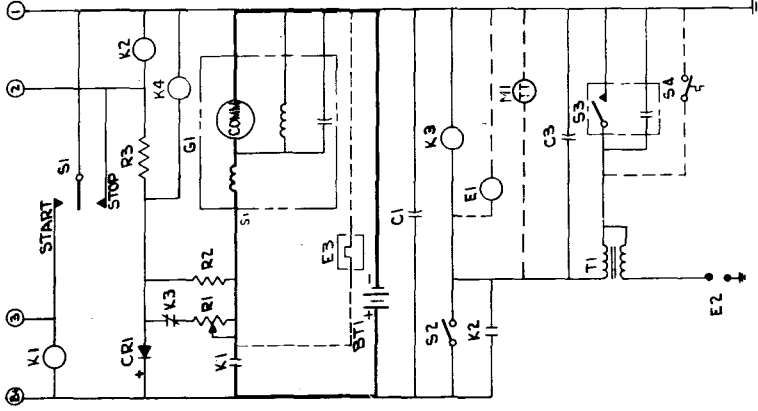

REF. DES.	PARTS LIST	DESCRIPTION
C1	CAPACITOR ASSY	
C2	DIODE ASSY	
C3	DIODE-REVERSE CURRENT	
K1	HEAT SHIELD	
K2	RELAY-START SOLENOID	
K3	RELAY-STOP	
R1	RESISTOR-ADJ. 1 OHM 50 W	
R2	RESISTOR-FIXED 1 OHM 25 W	
S1	SWITCH ASSY-RMT START	
S2	RESISTOR 30 OHM 5 W	
S3	SWITCH & LEAD ASSY	
S4	SWITCH (HAND/LEET START)	
T1	TERMINAL BLOCK	
T2	MARKER STRIP	
W1	LEAD ASSY 18	
W2	LEAD ASSY 8	
W3	LEAD ASSY 12	
W4	LEAD ASSY 22	
	CONTROL BOX	
	COVER	
	SILKSREEN	
	TERMINAL	
	BROOMET	
	-GEN (REF)	
BT1	BATTERY-12 VOLT	
C3	CAPACITOR 0.1 MFD	
E1	FUEL PUMP	
E2	SPARK PLUG	
E3	CHONE-ELECT	
G1	GENERATOR	
S3	BREAKER & CAP ASSEMBLY	
S4	SWITCH-HIGH AIR TEMP	
T1	IGNITION COIL (OHMM)	
K4	SOLENOID-FUEL (GAS)	
M1	METER-RUNNING TIME, 12 VDC	
M2	METER-RUNNING TIME, AC	

LK

610-0313



## Set Stopping

To stop the set, move the switch handle to the stop position. This “shorts out” the power to the stop relay (K2—ignition relay) coil causing it to de-energize and its contacts to open, breaking the ignition circuit.

## Electric—Hand Crank Switch

The manual start—electric start switch (S2) makes starting with a pull rope or recoil starter easier. When the switch is in the manual start position, it parallels the contacts of the stop relay (K2) and supplies ignition current directly to the ignition coil without the stop relay (K2) being energized. The set cannot be stopped electrically with this switch in the manual start position.

## Easy Checks

Grounding terminal 3 on the terminal block (TB1), with a jumper, will energize the start solenoid and supply current to the generator. With fuel supplied to the engine, the unit should start. Grounding terminal 2 at this block, will stop the set. These are easy checks to make to determine if control components are operating. Placing switch S2 in the hand crank position, bypasses stop relay K2.

**The control used on the “CCK” motor home applications is the same as the control used on the “LK” motor home applications with two exceptions!**

1. The Hytempco ignition resistor (RT1) is only used on “CCK” series units.

2. The electrical schematic component designation for a similar component performing the same electrical function, may vary between the two controls.

**EXAMPLE:** Start solenoid relay is (K4) in the “CCK” control #611-0914; and (K1) in the “LK” control #610-0313. The part number (3071046) is the same for both as is the electrical function. This is only one example and there are a few others.

## TYPICAL WIRING DIAGRAM 611-1086

### Starting and Ignition

Switch A1S2 is a rocker type switch. Pressing this to the start position closes it. Battery currents are supplied through the hand crank-electric start switch A1S1, through diode CR1, through switch A1S1 to the primary of the ignition coil T1, to the breaker points to ground and back to the battery. (The ignition coil requires about 4 volts minimum to operate.)

The fuel pump and fuel solenoid are energized at the same time as the ignition circuit. From a connection point at the coil primary, currents flow to the fuel pump (E1) fuel solenoid (K-2) to ground and back to the battery. (The fuel pump requires 5.5 volts minimum to operate.)

When A1S2 is closed currents are also supplied from the battery, through the switch, through transistor A1Q2 to the coil of Relay K1 (start solenoid) to ground and back to the battery. (Relay K1 requires 4.5 volts minimum to operate.) Relay K1 energizes and its contacts close connecting the battery to the generator. (Generator requires 7.0 volts or more to crank.) If the battery has sufficient capacity, the generator cranks the engine. If proper coil voltage and fuel are available, the engine starts and accelerates to governed speed. Relay K1 also energizes the choke coil (E-4 sisson choke) to close the choke.

### Start Disconnect

When the engine starts, generator DC voltage is supplied to charge resistor G1R1 through both sections—3.8 ohms and 8.3 ohms. When this voltage reaches the same value as battery voltage, both sides of A1CR5 are at the same potential. This causes CR5 to stop conducting and shuts off transistor A1Q2. This de-energizes the start solenoid (K1) and breaks the starting circuit.

At the same time ignition currents are supplied from the generator, through the charge resistor (G1R1) to CR2 diode, to the ignition coil, fuel pump and fuel solenoid (K2).

### Battery Charging

There are two steps of battery charging—either a high or low rate. The high rate is transistor controlled and the low rate is a fixed 1.56-ampere steady rate. The low charge circuit is continuous from A1 of the generator, through the 8.3 ohm side of G1R1 charge resistor,

through CR3 and to the battery. This circuit supplies the ignition, fuel pump and fuel solenoid currents also.

The high charge circuit is through the 3.8 ohm side of the G1R1 charge resistor through Q1 resistor, through CR3 diode and to the battery. This circuit supplies about 3.7-amperes charge current. The high and low charge circuits combined provide about 5.26-amperes during high charge periods.

### High Charge Circuit Control

Q4 and Q5 form a trigger circuit to control Q3 and then Q1. R5 and R8 form a voltage divider and control the trigger point of Q5. Q5 turns off at about 13 volts and on at about 15 volts.

Because the battery voltage drops when cranking, the high charge circuit turns on. The high charge circuit turns off when normal battery voltage is reached. Whenever battery voltage drops below 13 volts, the high charge circuit turns back on.

When battery voltage drops to about 13 volts, Q5 turns off, Q4 turns on and turns Q3 on. Q3 turns Q1 on and the high charge circuit is re-energized and the battery receives higher charge currents.

When the battery voltage comes up to about 15 volts, Q5 turns on, Q4 turns off which turns Q3 off. Q3 turns Q1 off and opens the high charge circuit.

### Stopping

The generating set stops when switch A1S2 is pushed to the stop position. This switch grounds out the point side of the coil preventing a make and break of the ignition primary, cutting off spark to the plugs. At the same time the battery is prevented from discharging through the generator by CR3 diode.

### Miscellaneous

Terminal 17 and 18 are ammeter connection points. Remove jumper (W1) when connecting ammeter.

Terminal 12 is for the LOP indicating light.

Terminal 11 is for the HET indicating light.

Terminal 10 is for the generator run indicating light and RTM (running time meter).

WIRING DIAGRAM

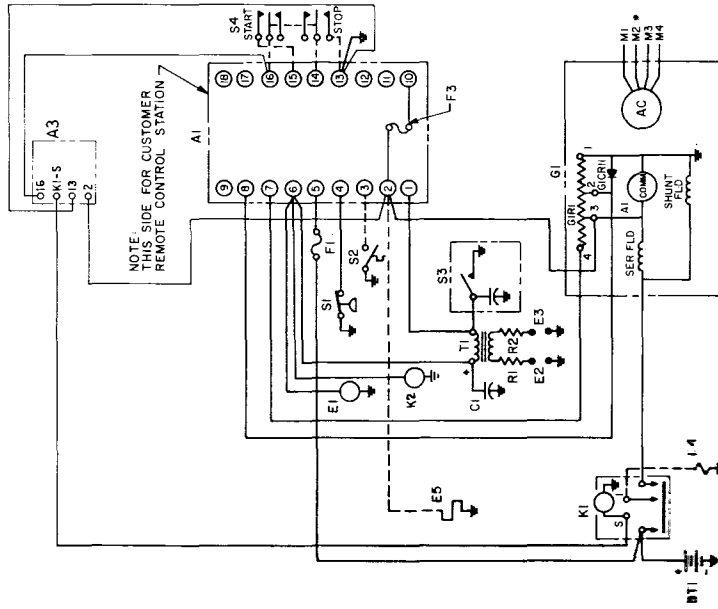

SCHEMATIC

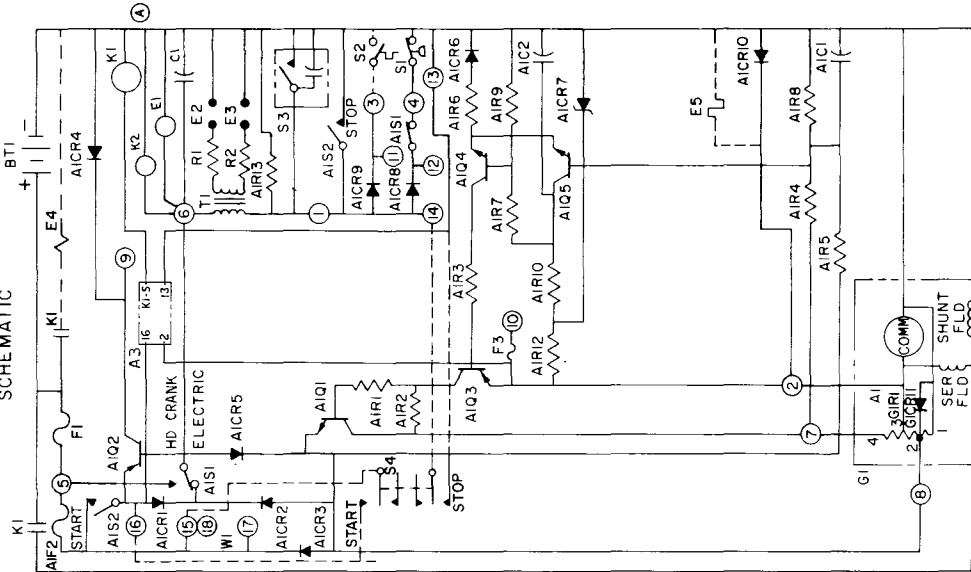

DASH NO	CHOKE	MODEL	WIRING HARNESS	CONTROL ASSY
-01	SISSION CHOKE	CCK,NH	338D640	300D1000
-02	ONAN CHOKE	CCK	338D691	300D1000
-03	NO CHOKE	GAS CARB	338D0774	300D1108
-04	NO CHOKE	HATKO GAS	338D0775	300D1108
-05	SISSION CHOKE	HATKO	338D0778	300D1000

RECONNECTION CHART

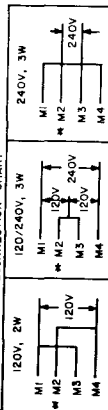

\* GROUNDED AC LEAD

REF. DES.	DESCRIPTION
A1	CONTROL ASSY
A2	CONTROL-GEN SET ASSY
A3	CONTROL-START ADAPTER (4 TO 3 WIRE)
S4	SWITCH-START STOP (CUSTOMER REMOTE)
W1	WIRING HARNESS
F3	HOLDER ASSY - FUSE
FUSE	CONTROL - DISC ADPTR
A3	CONTROL - DISC ADPTR
PARTS LIST ENG GEN (REF)	
BT1	BATTERY-12 VDC
C1	CAPACITOR-0.1 MFD
E1	PUMP-FUEL (WHEN USED)
E2,E3	SPARK PLUG
E4	IGNITION (WHEN USED)
E5	CHOLE-ONAN (WHEN USED)
G1	GENERATOR
DIODE-3A	DIODE-3A
RESISTOR	RESISTOR
K1R1	RELAY-START SOLENOID
F1	HOLDER ASSY - FUSE
K2	SOLENOID - FUSE
R1	LEAD ASSY-HI TENSION
R2	LEAD ASSY-HI TENSION
RT1	RESISTOR-HYDRO-1.7Ω, 25W
S1	SWITCH-LOW OIL PRESS
S2	SWITCH-HIGH AIR TEMP (WHEN USED)
S3	BREAKER & CAP ASSY
S4	SWITCH-REMOTE START STOP
T1	COIL-IGNITION

STANDARD CONTROL  
611-1086

# SCHEMATIC

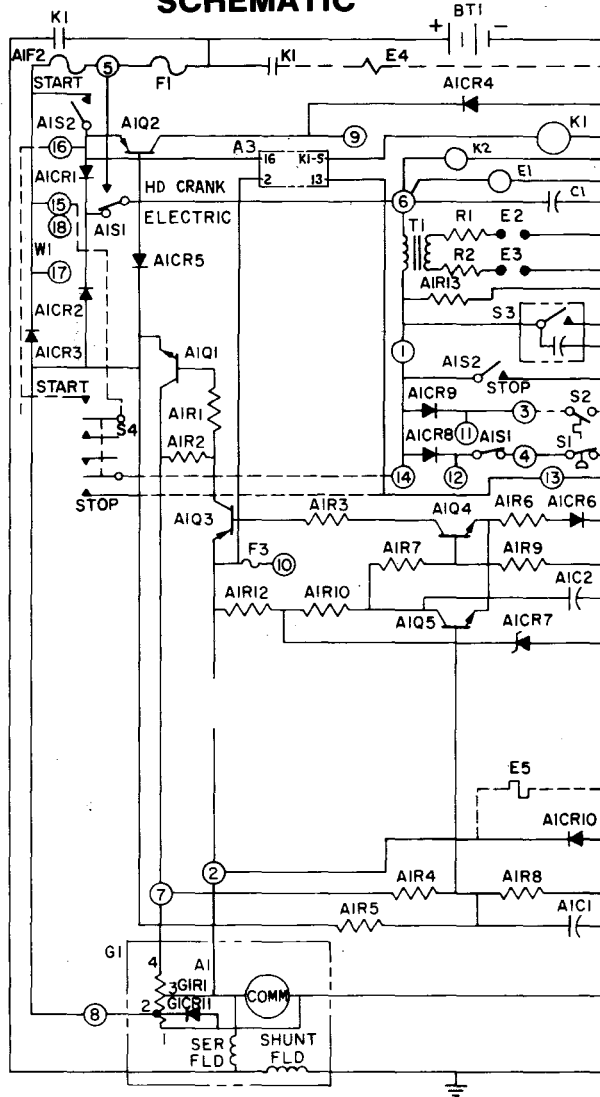

611-1086

SOLID STATE CONTROL

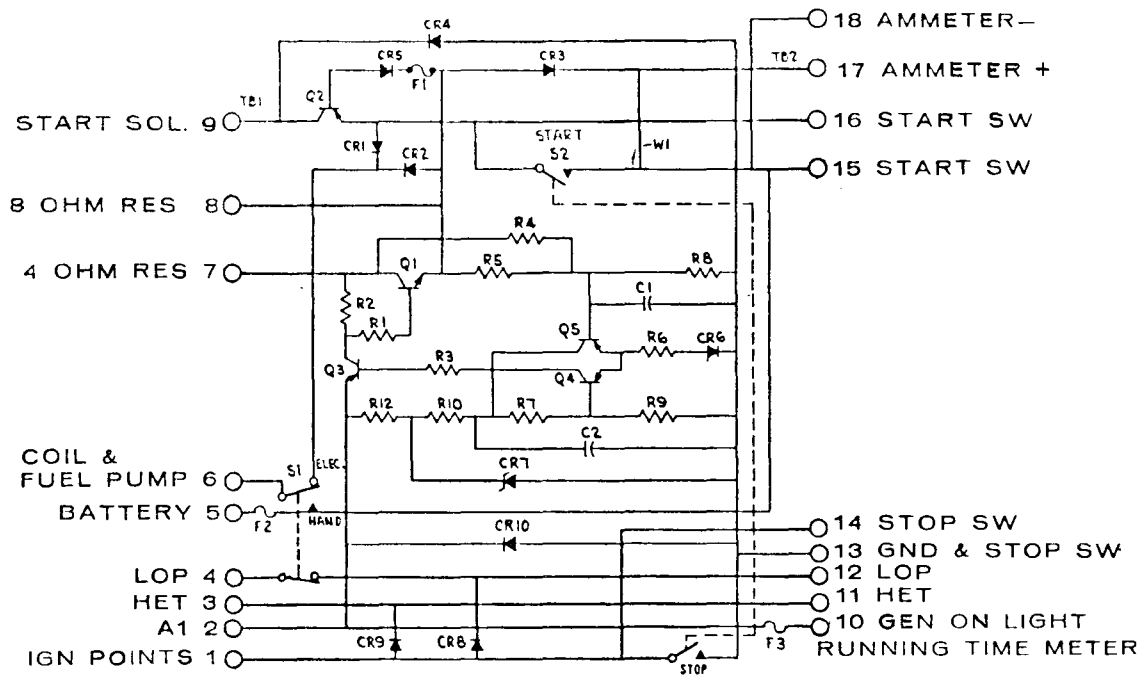

**CONNECT SOLID STATE**

**Notes:**

## **CONTROL—OPERATING SEQUENCE FOR POWER DRAWER MODELS BF and NH 611-1094**

### **Starting and Ignition Circuit**

Pushing start switch S3 allows battery current to flow through the start solenoid K1, K2 contacts and start switch S3 to negative battery terminal (ground). K1 start solenoid contacts close supplying current to starter motor, choke E1 and ignition (stop) relay K3. K3 relay contacts close and supply power to the ignition coil and electric fuel pump. The engine cranks and with fuel and ignition supplied, the engine starts.

### **Low Oil Pressure Shutdown (LOPKO)**

This control has a built-in time delay of 2 to 4 seconds for a low oil pressure shutdown. If a low oil pressure condition occurs, the low oil pressure switch S2 closes to charge capacitor C3 through resistor R3. When the voltage on capacitor C3 matches the voltage of the voltage divider circuit R5 and R6, unijunction transistor Q1 "turns on" to trigger CR8. CR8 turns on to de-energize stop relay K3. K2 contacts open as the engine stops and CR8 turns off.

### **Start Disconnect Circuit**

When the starting rpm increases, the alternator produces a voltage great enough to energize the start-disconnect relay K2. K2 relay contacts close to hold ignition relay K3 energized, and the normally closed contacts of the start-disconnect relay K2 open to de-energize start solenoid K1. K3 ignition relay contacts maintain current to the ignition coil and electric fuel pump to keep the engine running.

### **Battery Voltage Sensing**

The battery voltage sensing portion of the voltage regulator determines whether to allow the voltage regulator to turn "on" or "off" by the charge condition of the battery. To check charging, connect a DC voltmeter from B+ of the regulator to ground. A reading of 14.1 to 14.5 volts indicates charge circuit good.

### **Set Stopping**

Pushing stop switch S3 shorts out stop relay K3. K3 stop relay de-energizes and its contacts open to remove power from the electric fuel pump and ignition coil. Resistor R2 prevents a short circuit of the supply to stop relay K3 during the time the stop switch S3 is held closed as the engine slows to a stop.

WIRING DIAGRAM

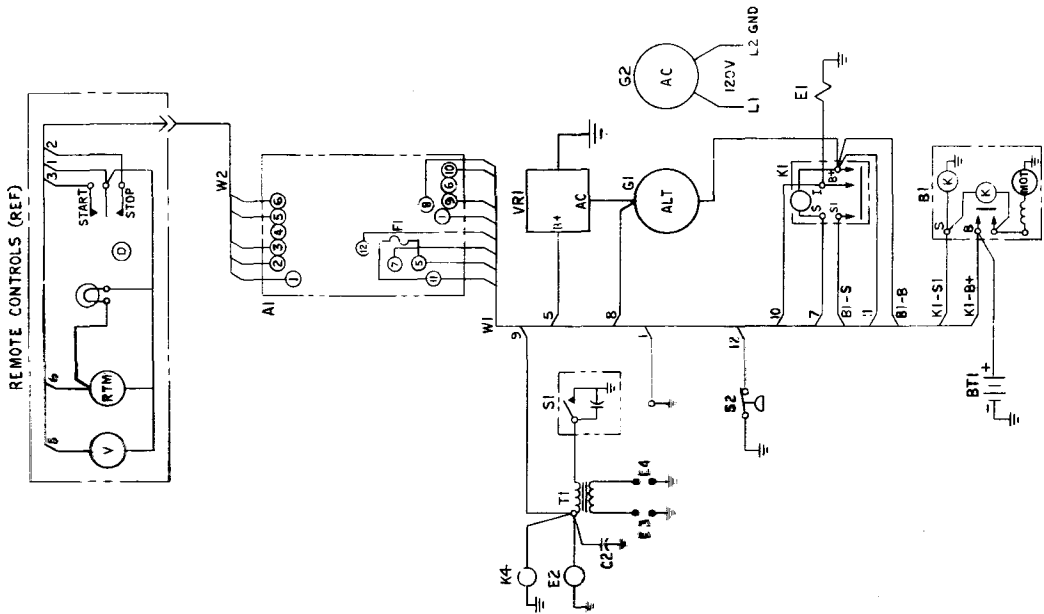

SCHEMATIC

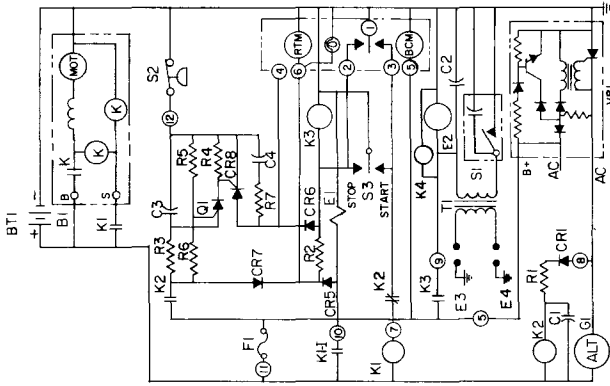

REF. DES.	PARTS LIST	DESCRIPTION
A1		CONTROL ASSY-BEN SET
B1		CONTROL-HOT HOME
BT1		STARTER-SOLENOID SHIFT
BT1		BATTERY-12 VOLT
C2		CAPACITOR
E1		CHOKE
E7		FUEL PUMP
E3.4		SPARK PLUG
G1		ALTERNATOR
G7		GENERATOR
K1		-SOLENOID-START
S1		BREAKER & CAP ASSY
S2		SWITCH-LOW OIL PRESS
K4		SOLENOID-FUEL
I1		COIL-IGNITION
VR1		VOLTAGE REGULATOR
W1		WIRING HARNESS-BEN SET
W2		WIRING HARNESS-PEROTE

BF  
NH  
POWER DRAWER  
611-1094

NOTE:  
1. MIN START DISCONNECT-675 RPM.

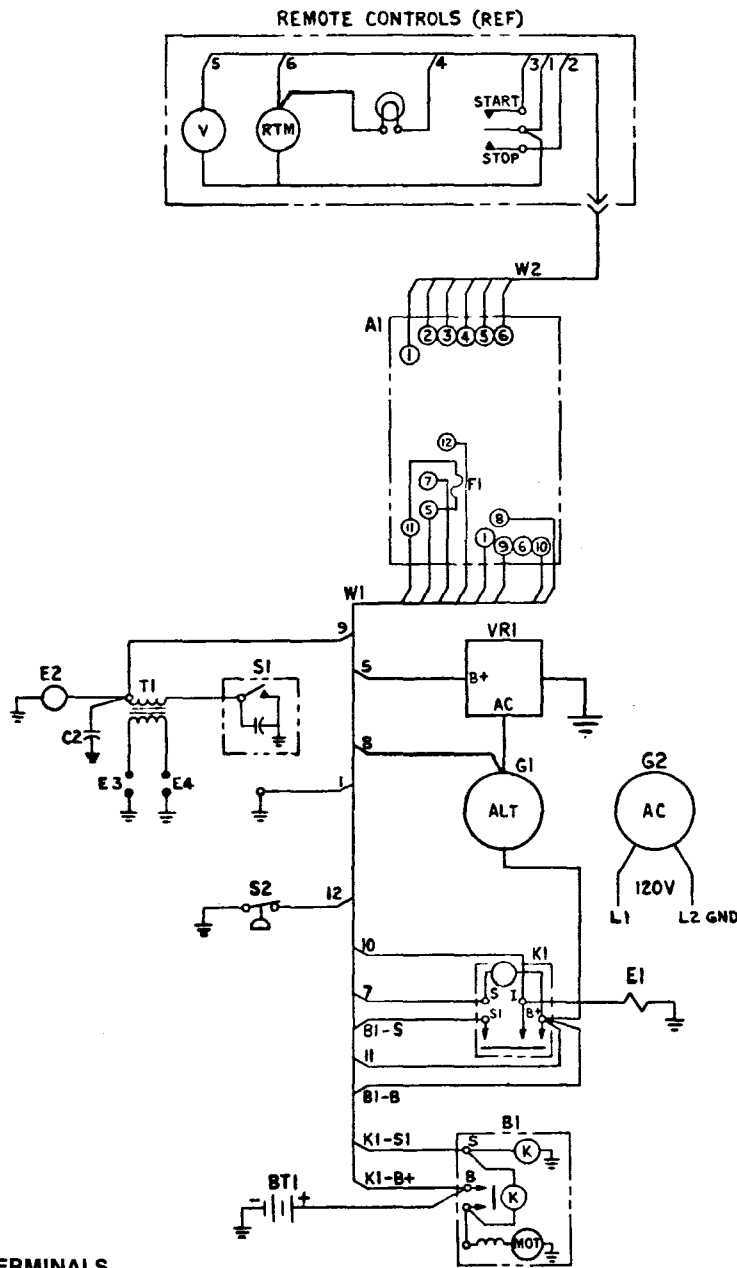

**TOP TERMINALS**

Not Running:  
Terminal 3 & 5 = 12-Volts  
All Others = 0-Volts

Running:  
Terminal 1 = 0-Volts  
Terminal 2 = 10-Volts  
Terminal 3 = 0-Volts  
Terminal 4 = 10-Volts  
Terminal 5 = 12-Volts  
Terminal 6 = 12-Volts

**BOTTOM TERMINALS**

Not Running:  
Terminals 7, 8 & 11 = 12-Volts  
All Others = 0-Volts

Running:  
Terminal 1 = 0-Volts  
Terminal 5 = 12-Volts  
Terminal 6 = 12-Volts  
Terminal 7 = 12-Volts  
Terminal 8 = 15-Volts  
Terminal 9 = 12-Volts  
Terminal 10 = 0-Volts  
Terminal 11 = 12-Volts  
Terminal 12 = 3.5-Volts

**611 - 1094**

**BF/NH  
WIRING DIAGRAM**



### REMEMBER!!

- Check the RV electric generating set for a safe and proper installation.
- Be sure all connections are clean and tight.
- Inform the customer of the importance of preventive maintenance.
- Check the following service items:
  - Oil in crankcase?
  - Extra oil for filter?
  - Air filter clean?
  - Battery properly connected?
  - Fuel lines tight?
  - Engine properly timed?
  - Rated voltage being produced?



### DO'S

**Do** keep your generator set clean; wipe dirt and grime off with a cloth, especially around and between cooling fins. Blow off the generator and engine with an air hose when you stop for gas.

**Do** turn off all lights, appliances, etc., before starting engine.

**Do** have the carburetor adjusted before using gen. set in high altitudes.

**Do** have a running-time meter installed for convenience in determining servicing frequency.

**Do** check the air cleaner periodically and clean it by tapping on a flat surface. *Never* wash it in solvents or blow it out **with an air hose!**

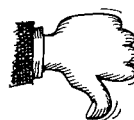

### DON'TS

**Don't** overload your generator set; total wattage of all lights and appliances used at any one time must not exceed the rated wattage of the generator set. Flickering lights indicate overloading.

**Don't** attempt to adjust the carburetor, governor, choke, etc., unless you are qualified to do so.

**Don't** obstruct the exhaust/air-intake with furniture, clothing, etc.

**Don't** connect the muffler to your vehicle's muffler.

**Don't** run the generator set for long periods of time with no lights or appliances turned on; this wastes gas, overheats the engine, and may cause it to misfire.



### **In case of trouble . . .**

- Is there gasoline in the tank?
- Check battery connections to be sure they're clean and tight.
- Check to see if oil level is near full mark (not over).
- Check for oil or gasoline leaks.
- Check for loose or broken electrical wires.
- Make sure your power consumption doesn't exceed wattage rating on generator set nameplate.

Onan Parts and Service centers are widespread throughout the U.S.A. Should you need help, just look in the Yellow Pages under Generators—Electric—Onan.

### **End of Session**

When the electric generating set is correctly serviced and maintained, it provides many hours of safe and efficient operation. Service and maintenance includes following the proper adjustment and testing procedures and repairing or replacing any necessary parts.

**When an RV customer comes to you for help, provide him with top quality Onan service to put him. . .**



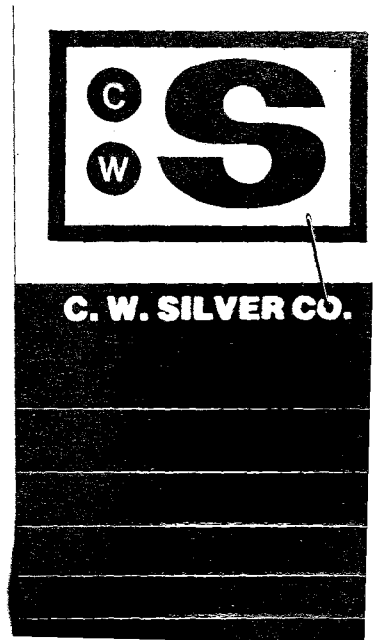

PRICE \$2.00 each

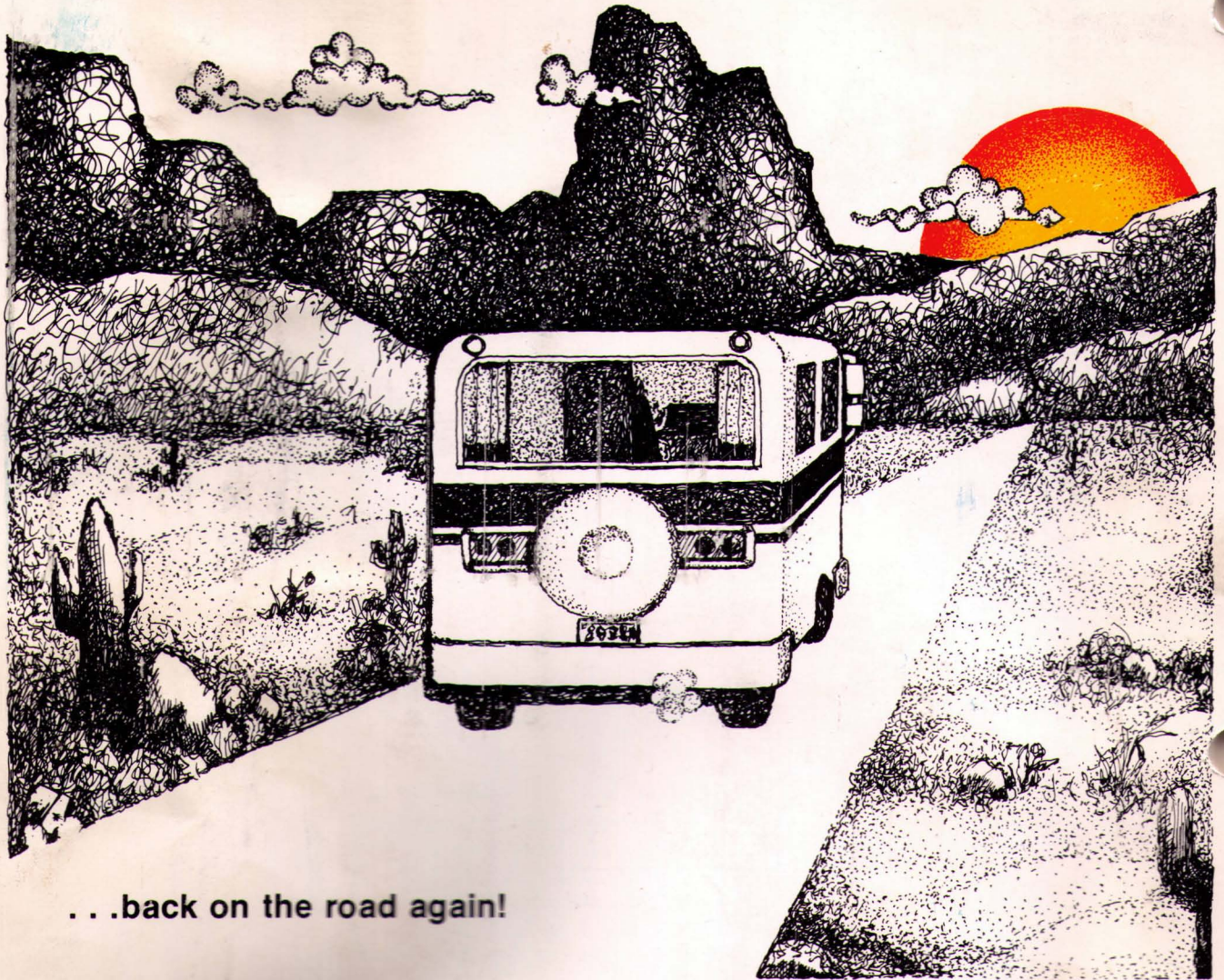

...back on the road again!

**ONAN** 1400 73RD AVENUE N.E. • MINNEAPOLIS, MINNESOTA 55432  
A DIVISION OF ONAN CORPORATION

932-0402



FEBRUARY 1978