

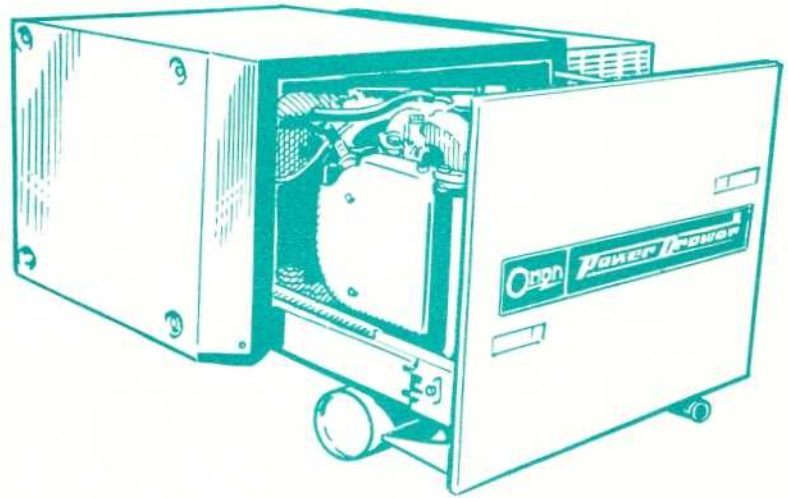

OPERATORS MANUAL AND PARTS CATALOG



“POWER DRAWER”

NH SERIES



6000 WATT CAPACITY

RV ELECTRIC POWER PLANT

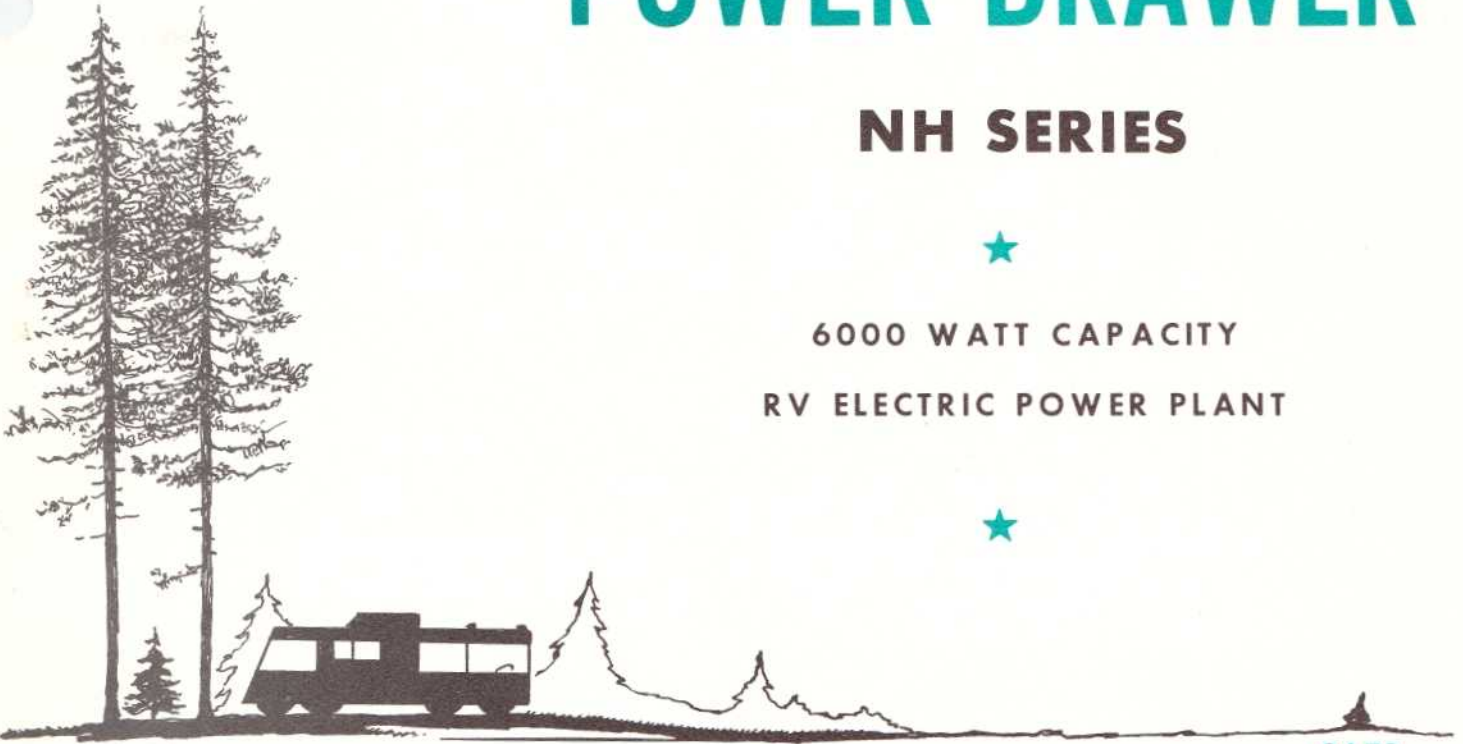

940-0315

6A73

TO THE OWNER

Welcome to the growing family of *Onan Power*....We are proud to have you as a customer.

Read this manual carefully and observe all safety rules within. Operating instructions, adjustments and periodic maintenance procedures are given so that you....the owner, can keep your unit running like new and expect many years of dependable service from it. Remember....any machine, regardless of design or type, will perform only in relation to the services it receives.

If your plant needs special attention, ask your Onan dealer for assistance; the Onan Parts and Service Organization has been factory-trained to provide up-to-date know-how for keeping your power plant "on the road".

TABLE OF CONTENTS

General Information	2
Specifications	4
Installation	5
Control System Troubleshooting	11
Operation	12
Adjustments	14
Maintenance	17
Engine Troubleshooting Guide	20
Parts Catalog	21

GENERAL INFORMATION

YOUR MANUAL

This manual contains instructions to properly install, operate and maintain your "Power Drawer" electric generating plant. When ordering parts or requesting information always supply the complete MODEL and SPECIFICATION as shown on the Onan nameplate (see "MODEL DESIGNATION" following). This information is necessary to identify your plant among the many models manufactured by Onan.



Onan uses this symbol throughout the text to warn of possible equipment damage.



This symbol is used to warn of any possible personal injury.

MODEL DESIGNATION

The following typical model number is broken down into code segments used by Onan.

6.0	NH	-	1	R	9500	A
1	2		3	4	5	6

1. Indicates kilowatt rating.
2. Series identification.
3. Voltage code of the generator, 1 = 120 volts.
4. Method of starting: R - remote electric starting.
5. Factory code for designating optional equipment, if any.
6. Specification letter which advances when the factory makes production modifications.

Please Return Warranty Card Attached to Unit.

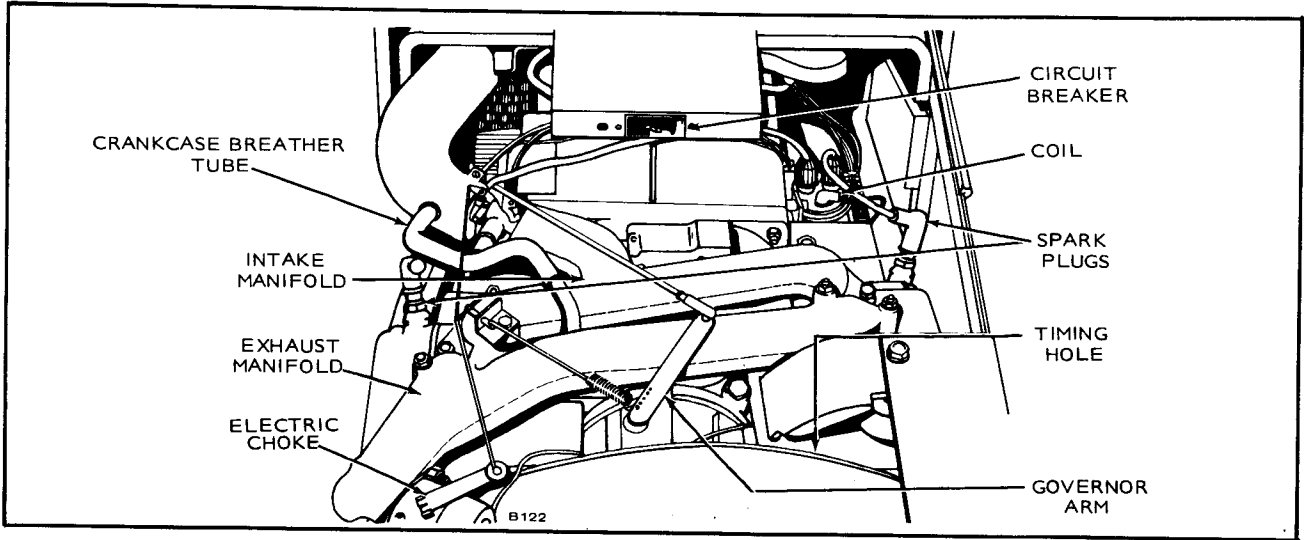

TOP VIEW

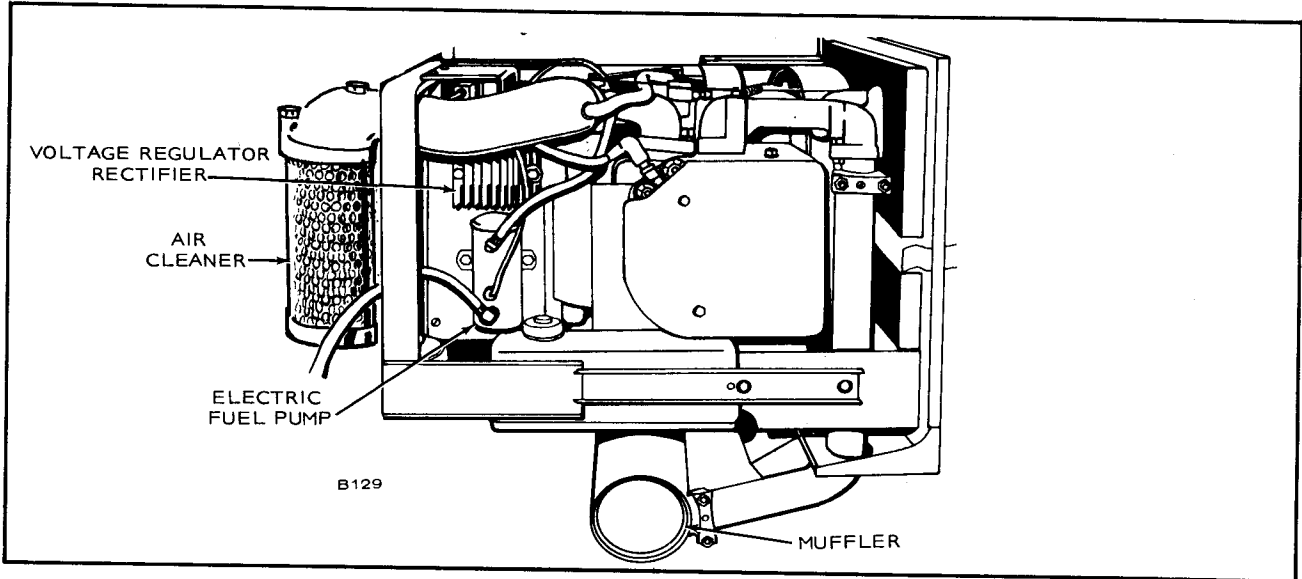

LEFT SIDE

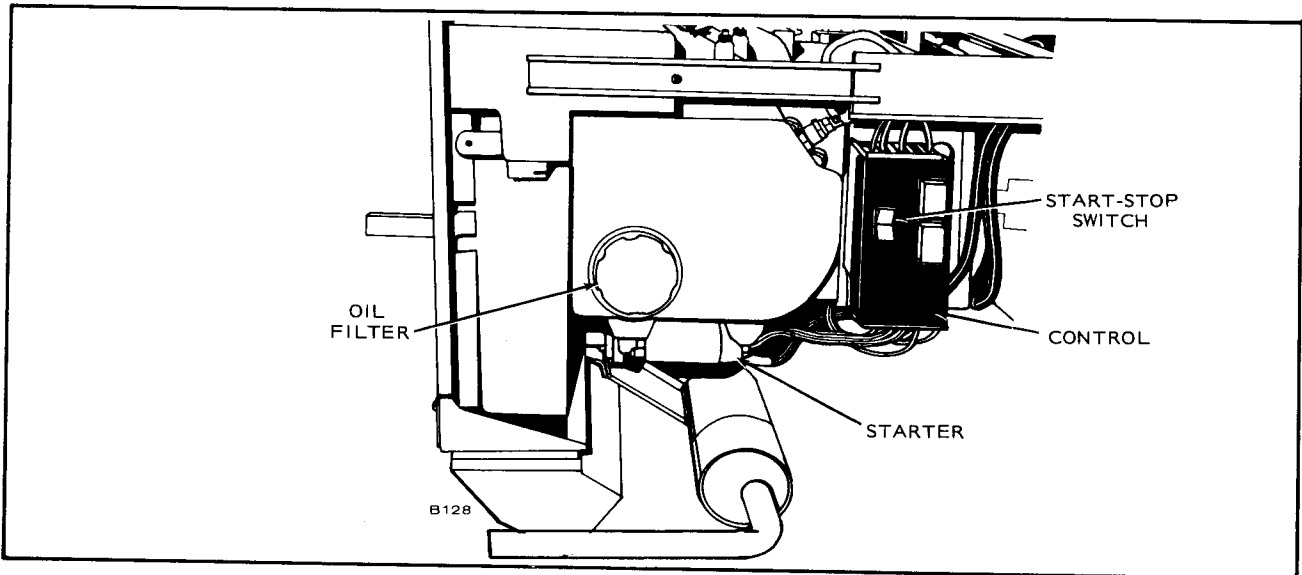

RIGHT SIDE

SPECIFICATIONS

ENGINE

Manufacturer	Onan
Design	Four Cycle, Air Cooled, L Head
Fuel	Gasoline *
Fuel Pump	12 Volt, Electric
Cylinders	Two
Bore	3-9/16 inch
Stroke	3 inch
Oil Capacity	4 quarts
(With Filter Change)	4-1/2 quarts
Battery Voltage	12 Volt
Battery Size (Above 0° F. Operation)	45 Amp/Hr. Min.
Battery Charging System	10 Ampere, Flywheel Alternator
Starting System	Solenoid Shift

GENERATOR

Manufacturer	Onan
Design	Revolving Armature, Four Pole, 1800 rpm
60 Hertz Recreational Vehicle Rating	6000 Watts (6KW)
Voltage	120 Volts
Current Rating	50 Amperes
Phase	Single
Wire	Two

PROTECTION

Generator	50 Ampere Circuit Breaker
Control (Remote Wiring)	5 Ampere Fuse

TUNE-UP SPECIFICATIONS

Spark Plug Gap020 inch
Breaker Point Gap (Full Separation)020 inch
Ignition Timing (Engine Running or Static) **	25° BTC
Tappet Adjustment (Engine Cold)	
Intake003 inch
Exhaust012 inch

* - Onan recommends using non-leaded or low-lead regular grade gasoline.

** - Ignition timing is 25° BTC when point gap is set at .020. Timing can be checked with timing light through 1/2 inch diameter hole in upper rear portion of Blower Scroll. 25° timing is indicated when line on blower wheel is centered in 1/2 inch diameter hole.

INSTALLATION

For the most efficient operation and ease of servicing, this power plant must be installed properly. Since all factors (electrical, fuel, etc.) must be considered before actual installation, read this entire section before installing.

COMPARTMENT LOCATION

The surrounding area of the installation must have provisions for a supporting frame if there isn't a floor or base already existing. Before deciding on the exact location for the compartment, keep in mind the area required for fuel and electrical connections at the rear of compartment.

1. Choose area with the best possible mounting supports.
2. Installation area must be separated from living quarters by vapor-tight walls.

MOUNTING

Mounting hole dimensions are shown in outline drawing, shipped loose with unit. Use 3/8-16 UNC-2B cap screws with grounding (star) washers for securing plant housing to recreational vehicle. If split locking washers or other methods are used, electrically bond the unit to chassis with an 8 gauge wire jumper.

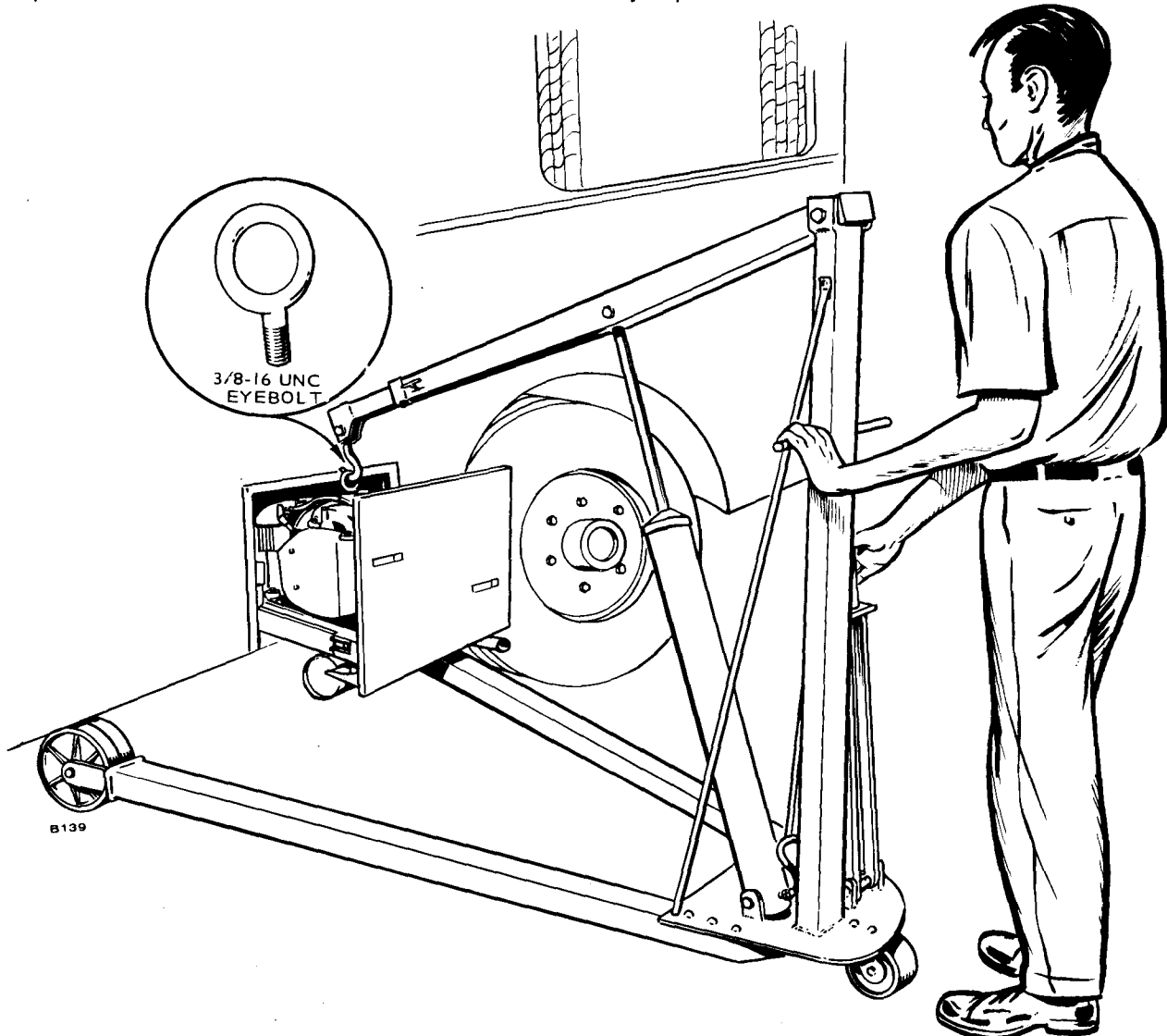

FIGURE 1. POWER PLANT INSTALLATION

1. Electric plant and battery should be mounted to withstand vibration and shock, for over-the-road conditions.
2. Channel, box or angle iron can be used for the supporting frame.
3. Plant must be properly grounded to vehicle frame.

CAUTION Don't use a sheet metal base or thin plate without a supporting frame.

A 3/8-16 threaded hole in intake manifold provides for a lifting eye. Use this as a lifting point when installing in vehicle. Pull unit out far enough to use lifting eye before hoisting (Figure 1).

WARNING Personal injury may result if unit is opened all the way without being secured.

BATTERY

If operating the recreational vehicle in ambient temperatures above 0° F and battery is kept charged by frequent running of the electric power plant, a single, 12 volt battery of 45 amp/hr capacity minimum is sufficient.

Connect the battery positive cable to (+) lug and battery negative cable to (-) lug. Battery connection lugs are located on rear of housing as shown in Figure 2. Use sufficiently sized battery cables according to the length of their run as shown in Table below.

FUEL LINE

The rear of the compartment (Figure 2) provides a 1/8 NPTF fuel connection.

1. Use annealed copper or seamless steel tubing and flared connections.
2. Keep fuel lines away from exhaust areas.
3. Use nonferrous metal straps without sharp edges to secure fuel lines.

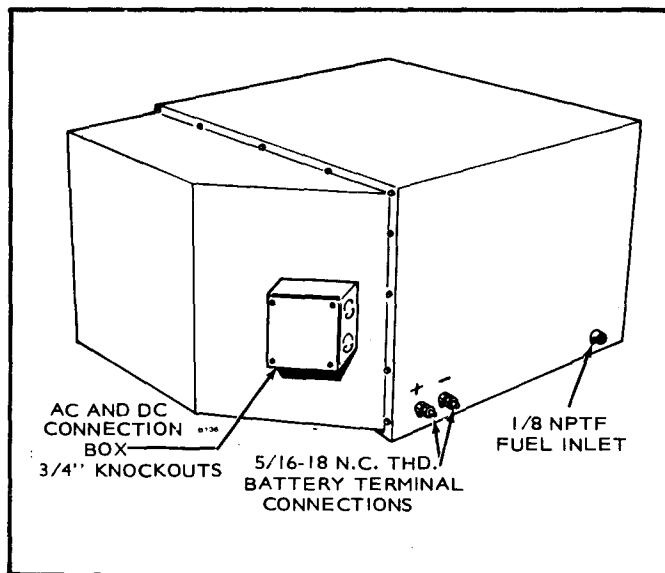

FIGURE 2. EXTERNAL CONNECTIONS

RECOMMENDED BATTERY CABLES

CABLE LENGTH IN FEET *	CABLE SIZE
0 - 8	2
8 - 11	1
11 - 14	0
14 - 17	00
17 - 20	000
20 - 24	0000

* - Distance from battery to plant.

Fuel line from rear of compartment to power plant is flexible to allow movement when plant is pulled out on its rails. Check lines and fittings periodically to ensure against fuel leaks.

SHARING FUEL TANK SUPPLY

If the electric power plant has to be connected to the vehicle supply tank, do not tee off the vehicle supply line unless absolutely necessary. Teed lines often result with the more powerful vehicle fuel pump starving the electric plant when both are running. If the electric plant gets its fuel from the vehicle tank, it is usually done either of two ways:

1. Installing a new outlet in the fuel tank. If the fuel tank has an unused outlet, use it. See Figure 3.
2. Installing a special fitting at the tank outlet so two dip tubes can be fitted in the tank (Figure 4).

Make generating plant pickup tube (within fuel tank) shorter than vehicle pickup tube to prevent generating plant from using up all the fuel when vehicle is stationary, thereby preventing the starting of vehicle engine.

Installing a second dip tube in the original fuel tank outlet is possible if the tank outlet fitting is large enough to accommodate two dip tubes. The required fittings can be made by a machine stop. A separate fuel outlet from the tank means removing the tank to braze or weld a new fitting in place.

WARNING Attempting to weld on a fuel tank, empty or not, is dangerous!

USING VEHICLE TANK AND SHARING FUEL LINE

If a tee in the main vehicle fuel line is the only solution, locate it as near as possible to the fuel tanks. Some manufacturers use this system exclusively but they design the complete fuel system around the combined fuel draw requirements of both electric plant and vehicle engines.

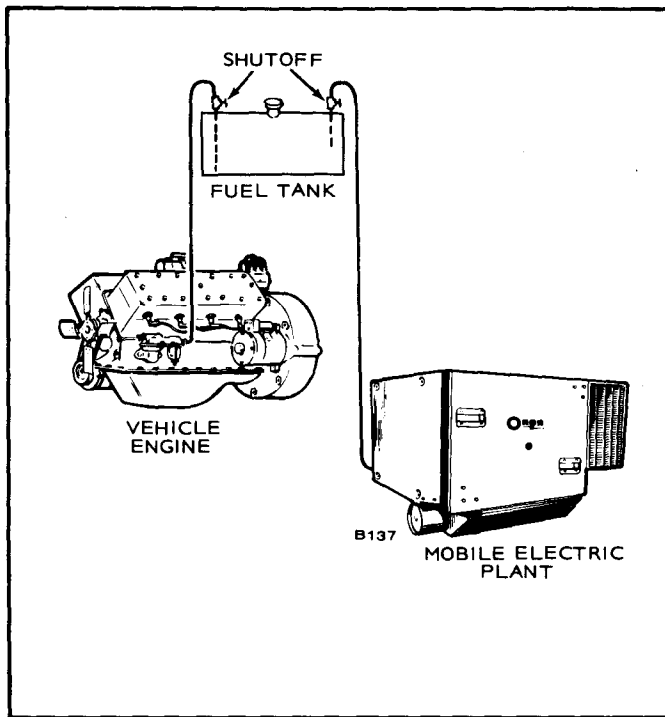

FIGURE 3. SINGLE TANK FUEL SYSTEM

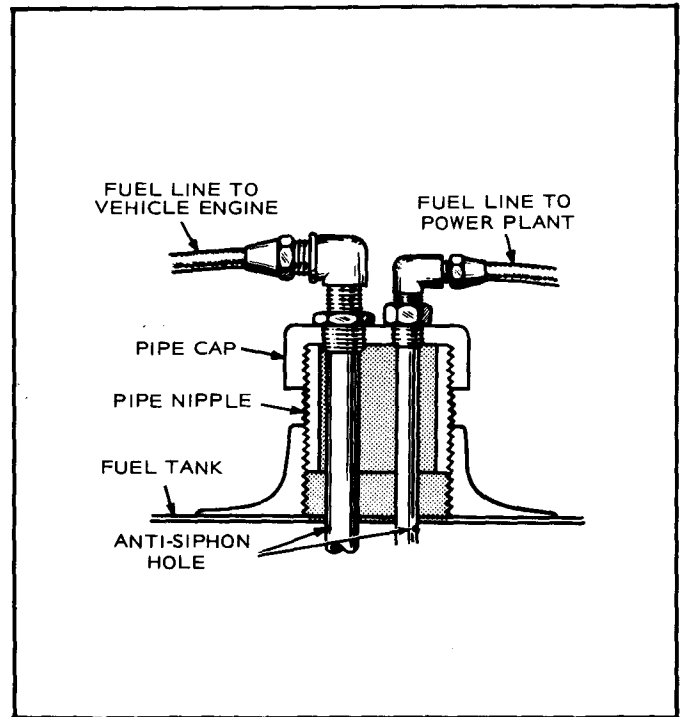

FIGURE 4. INSTALLATION OF SECOND DIP TUBE IN TANK OUTLET

Operating the electric plant from a tee in the main fuel line can cause erratic operation. The plant's fuel pump has neither the capacity nor the power to overcome the draw of vehicle engine fuel pump.

To determine if the plant will starve for fuel, test the unit after installation, first with the plant and vehicle engines running under load, then with the plant running alone. If the plant starves with the vehicle engine running under heavy load and high temperatures, the difficulty can sometimes be corrected by installing larger fuel lines between the tank and tee.

FUEL FILTERS

Some Onan electric plants with Bendix electric fuel pumps have phenolic filters in the base of the pump. Additional filters in the fuel line are unnecessary unless unusual operating conditions exist.

LOAD CONNECTIONS

1. Plant load wires L¹ and L² terminate within the junction box. L¹ is the "hot" wire and L² is grounded. Connect and join wires within this junction box in an approved manner.
2. Wires must be adequate size, properly insulated and supported.
3. Mount switches and controls securely to prevent damage from vibration and road shocks. All

switches must be vibration proof to prevent accidental opening or closing while the vehicle is in motion.

4. All wiring must meet applicable local electrical codes. Have a qualified electrician install and inspect the wiring.

Onan recommends using multistrand wire, enclosed in flexible metal conduit ("Greenfield"), as feeder conductors, from electric plant to vehicle distribution box. Many installers use multistrand wire throughout the vehicle to reduce danger of breakage from vibration. Check your local codes.

PROTECTION

A circuit breaker is installed on top of unit to protect generator from overloading and to protect feeder conductors between electric plant and vehicle distribution box.

EXHAUST

Observe the following when connecting exhaust system to muffler.

1. Use automotive type connections and clamps.
2. Terminate exhaust outlet at perimeter of vehicle so DEADLY exhaust fumes will not enter vehicle.

CAUTION Don't connect plant exhaust to vehicle exhaust system.

REMOTE CONTROLS

Onan has two optional remote control stations designed specifically for the "Power Drawer" electric power plant. One, Model 300-0985 includes a start-stop switch and indicator light. The other one, model 300-0986 includes a start-stop switch with indicator light, a running time meter, and a battery condition meter. Figures 5-8 show proper wiring for both.

Installing Onan Remote Switch

1. Cut hole in motor home panel (Figure 5) to accommodate switch.
2. Open the electric plant compartment and thread leads (#18 wire or larger) from the compartment (cut small hole if needed) into the inside of motor home; run lead ends from inside through hole cut in panel. Caulk or seal any openings made in the compartment for cable entrance to prevent outside air from entering motor home.
3. Connect leads from printed circuit board terminals to remote control terminals as shown in Figure 6.

Terminal numbers are stamped on the back of remote panel. Figure 6 schematic shows actual layout of terminals looking at the rear of remote control switch.

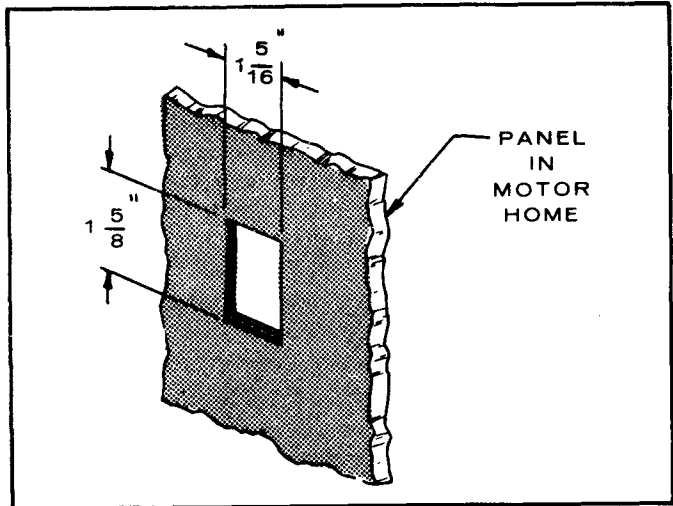

FIGURE 5. MOTOR HOME CUTOUT

4. Insert remote control into cutout and secure with #5 wood screws included with switch.

WARNING To prevent poisonous gases from entering the interior of motor home, seal any openings made in the plant compartment for the lead wires.

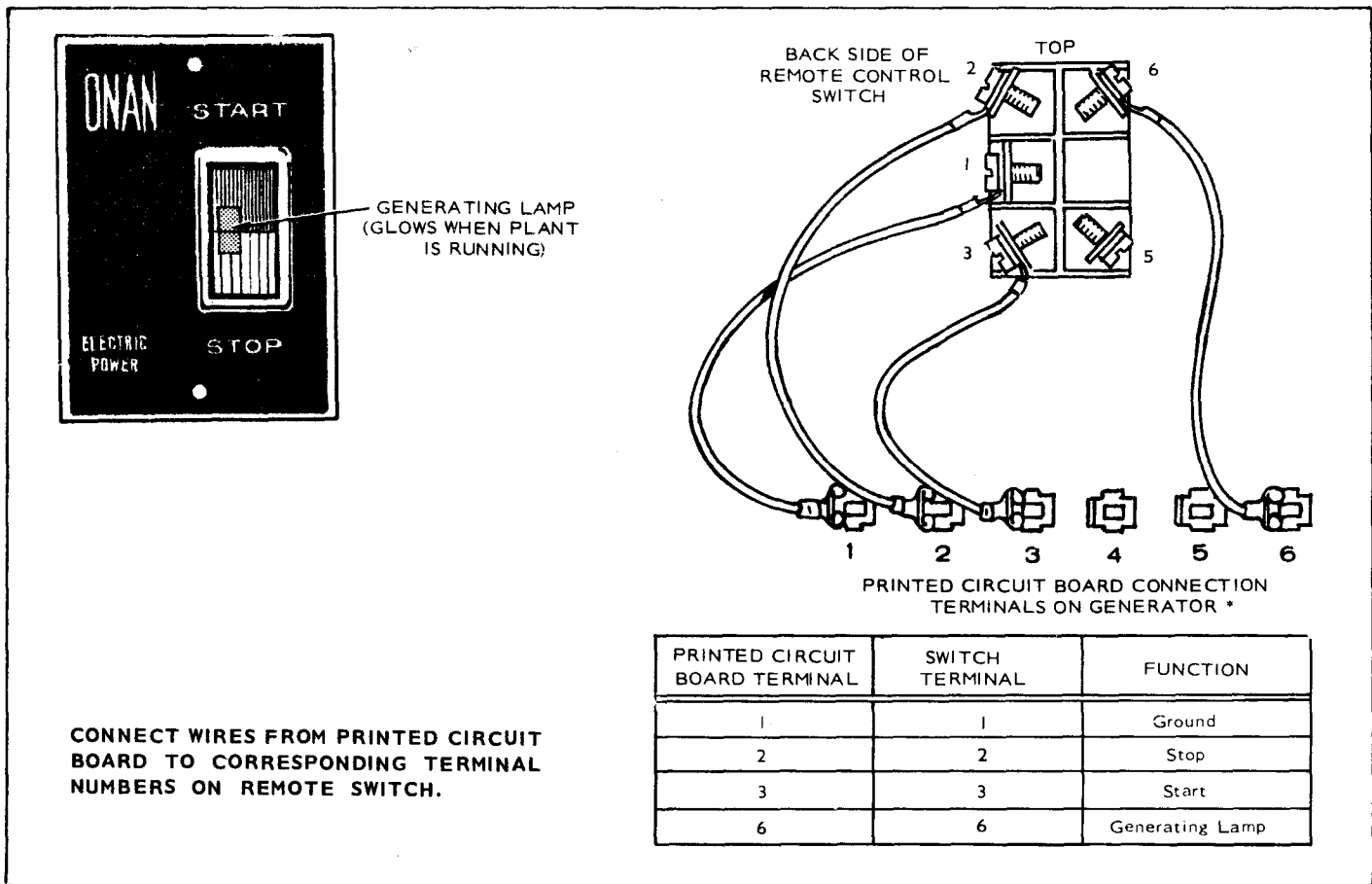

FIGURE 6. REMOTE CONTROL SWITCH (300-0985)

Installing Onan Deluxe Remote Control

1. To measure wall cutout for remote control panel, see Figure 7.
2. Open the electric plant compartment. Connect #18 wire or larger to the printed circuit board on the generator as shown in Figure 8. Thread these leads through the plant compartment to the inside of the motor home. (If necessary, cut a small hole in the compartment for these leads.) Run the lead ends from inside the motor home through the wall cutout.
3. Connect the leads to the remote control terminals as illustrated in Figure 8.

Terminal numbers are stamped on the back of the remote control panel.

4. Insert the remote control switch into the wall cutout and secure with #5 wood screws (shipped with the assembly).

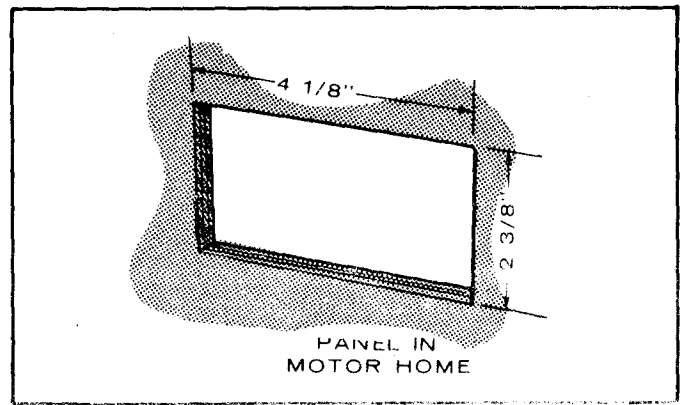

FIGURE 7. MOTOR HOME CUTOUT

WARNING To prevent noxious gases from entering the interior of the motor home, seal any openings made in the plant compartment for the lead wires.

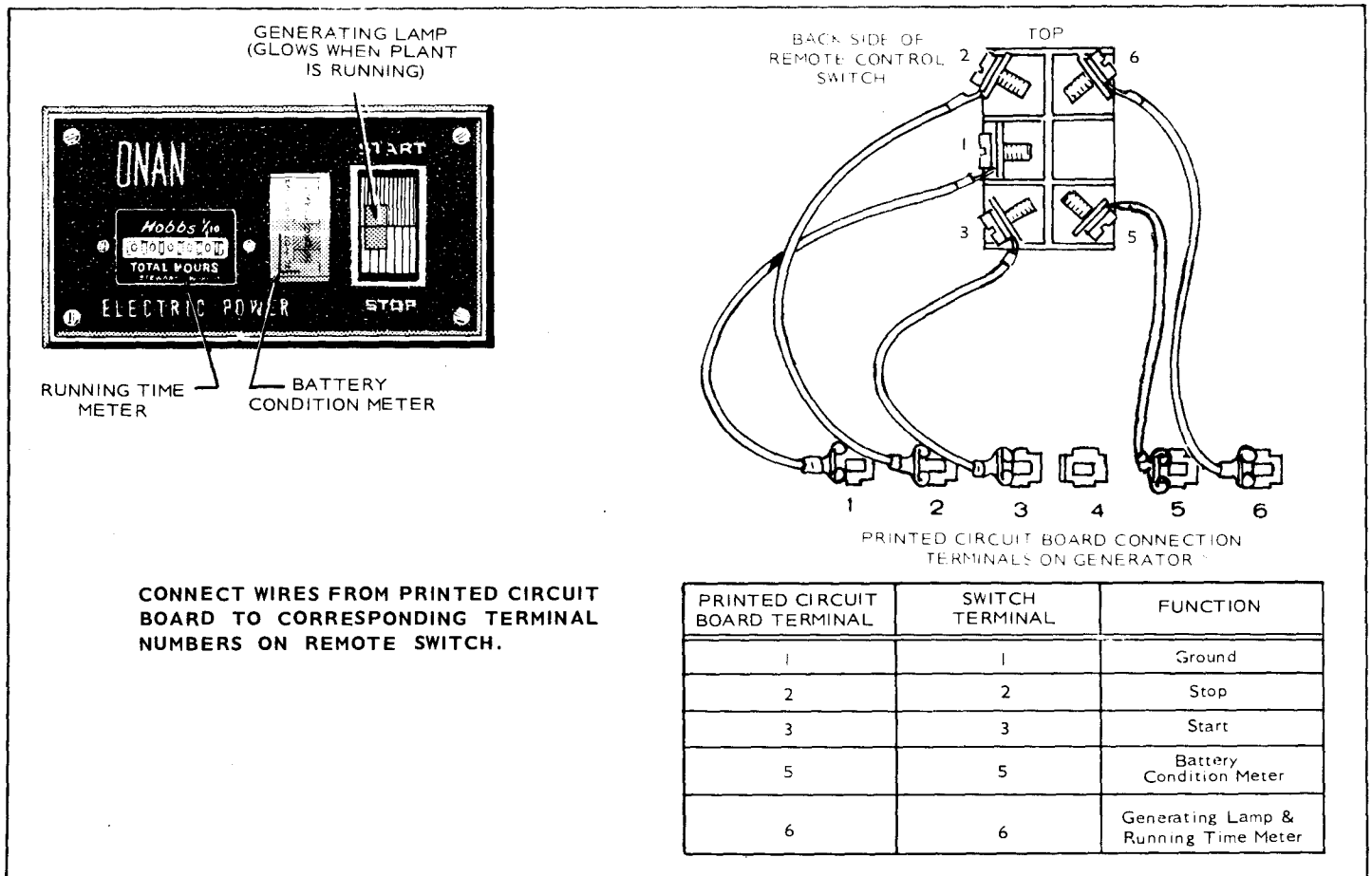

FIGURE 8. DELUXE REMOTE CONTROL (300-0986)

The following can be used if individual owners intend to install their own switches-indicators. Do not exceed any load ratings.

Remote Start-Stop Switch: A remote start-stop switch can be connected to terminals 1 and 3 for start and terminals 1 and 2 for stop. This requires a single pole, double throw (momentary closed) switch rated at 5 amperes, such as Onan No. 308-0341. Use No. 18 wire or larger with this switch (up to 100 feet).

Remote Voltmeter: A voltmeter can be connected to terminals 1 (-) and 5 (+). Terminal 5 is battery positive. This voltmeter will read the battery voltage which is approximately 13 volts when fully charged.

Running Time Meter: A 0-40 volt running time meter, such as Onan No. 302-0885, can be connected to terminals 1 (-) and 6 (+) to indicate the total running time of the power plant. These terminals are rated 12 volts and a maximum load of 1 ampere.

Remote Low Oil Pressure Lamp: A remote low oil pressure lamp can be connected to terminals 5 and 4. This lamp, lighted by a low oil pressure condition, remains lighted until the stop button is pushed or the battery supply is disconnected. Check oil level and refill to proper level. Maximum allowable lamp current is 0.5 ampere.

FUSE PROTECTION

A 5 amp fuse is installed on control board to protect the board from shorts in the remote wiring. If fuse is blown it can be replaced (after correcting trouble) by removing cover on control and replacing with an identical 5 ampere fuse.

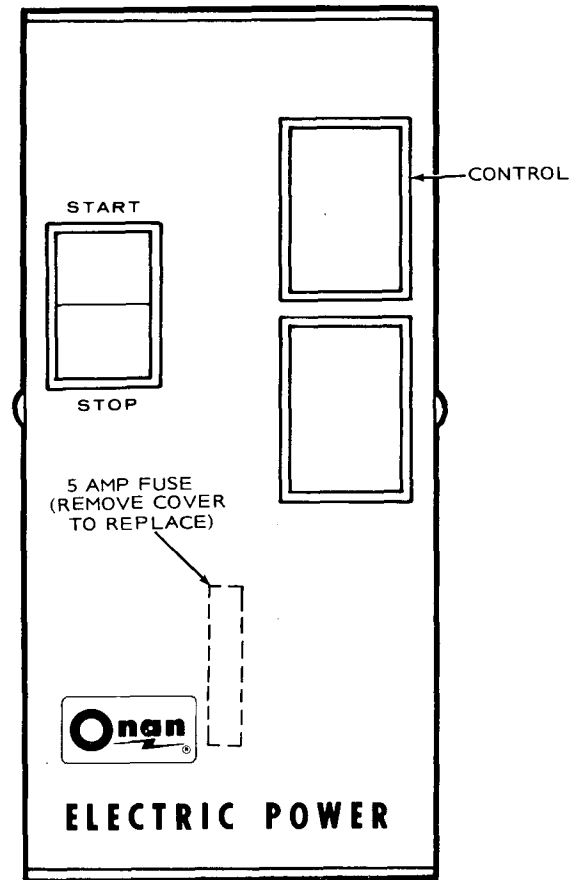

B134

FIGURE 9. FUSE LOCATION

SCHEMATIC

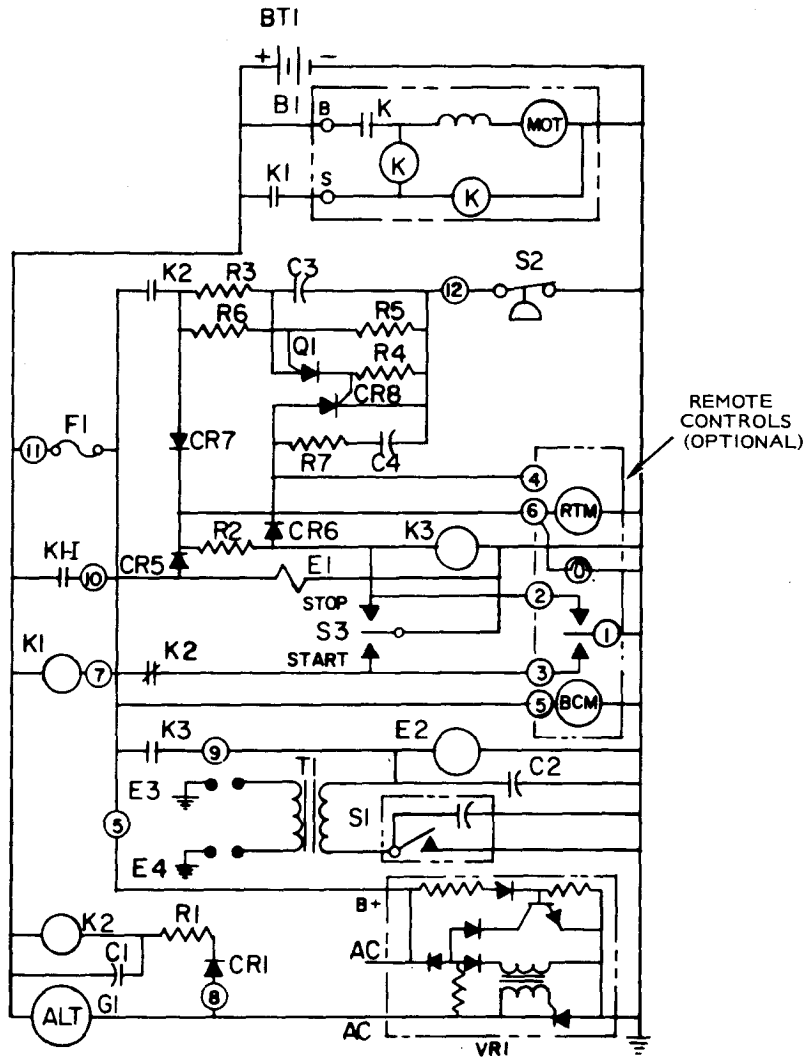

- BT1... Battery
- B1... Starter
- E1... Electric Choke
- E2... Fuel Pump
- E3, E4... Spark Plugs
- F1... 5 amp. Fuse
- G1... Alternator
- K1... Start Solenoid
- S1... Breaker Box
- S2... Low Oil Pressure Switch
- S3... Start-Stop Switch
- T1... Ignition Coil
- VR1... Voltage Regulator
- BCM... Battery Condition Meter (Opt.)

CONTROL SYSTEM TROUBLESHOOTING GUIDE

NOTE: Use the schematic wiring diagram (shown on left) to help trace problems.

CONTROL SYSTEM TROUBLESHOOTING GUIDE	
CONDITION	PROBABLE CAUSE
• Cranks Slowly	Bad Battery Connection
• Cranks - No Start	Low Battery - BT1
• Fails to Crank	Faulty Starter - B1
• Runs 3 - 4 Seconds	Faulty Start Solenoid - K1
• Runs and Surges	Faulty Alternator - G1
• Fails to Run	Faulty Ign. - T1 Coil, S1 Points
• Does Not Stop	Faulty Fuel Pump - E2
• No Stop in Low Oil	Faulty LOP Switch - S2
• Low Charging	Faulty Choke - E1
	Grounded LOP Circuit
	Low or No Fuel
	Low Oil Level
	Faulty Regulator - VR1
	Printed Circuit Board Faults
	Fuse Out - F1
	Faulty Disconnect Circuit
	Faulty Stop Switch - S3
	Faulty Contacts - K2
	Faulty Relay - K3
	Faulty LOP Circuit

OPERATION

BEFORE STARTING

Power Plant Access: The power plant is mounted on slides and can be pulled out like a drawer for ease in servicing the unit (Figure 9A). To slide out the unit, depress the buttons on the two latches. A safety latch (located on right side near the top), just inside of front panel, must be pressed to allow unit to slide all the way out. This safety latch also prevents unit from accidental opening when driving.

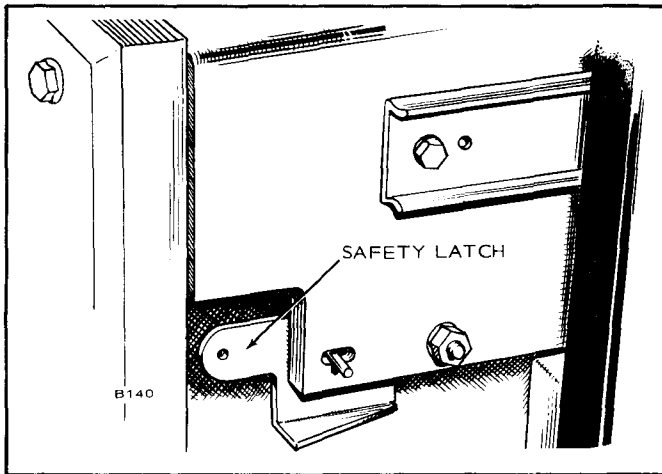

FIGURE 9A. PLANT ACCESS

Crankcase Oil: Be sure the crankcase has been filled with oil to the "FULL" mark on the oil level indicator (when plant is level). Do *NOT* overfill. Oil capacity is 4 quarts (4½ with filter). Use a good quality oil with the API (American Petroleum Institute) designation SE or SE/CC. Do not use an oil with the designation CD unless it is also designated SE and the oil manufacturer certifies it will perform satisfactorily in gasoline engines. Use the following chart as a guide for the proper oil according to temperature ranges.

Fill engine with oil through dipstick tube on left side of unit.

TEMPERATURE	RECOMMENDED OIL
Above 30° F	SAE 30 or 10W40
Between 0° F & 30° F	SAE 5W30 or 10W40
Below 0° F	SAE 5W30

Recommended Fuel: Use clean, fresh, no lead or low lead gasoline. Regular grade gasoline may also be used but do not use highly leaded premium types of fuel.

For new engines, the most satisfactory results are obtained by using nonleaded gasoline. For older engines that have previously used leaded gasoline, heads must be taken off and all lead deposits removed from engine before switching to nonleaded gasoline.

CAUTION If lead deposits are not removed from engine before switching from leaded to nonleaded gasoline, preignition could occur causing severe damage to the engine.

STARTING AND STOPPING

Push start switch to crank the engine. Release the switch after the engine starts. Allow the plant to warm up before applying a load.

CAUTION Do not operate starter more than 30 seconds or serious damage may result.

To stop, press the start-stop switch to the stop position. If the plant has been running with a full load connected, disconnect the load and allow plant to run for a few minutes before pushing stop switch.

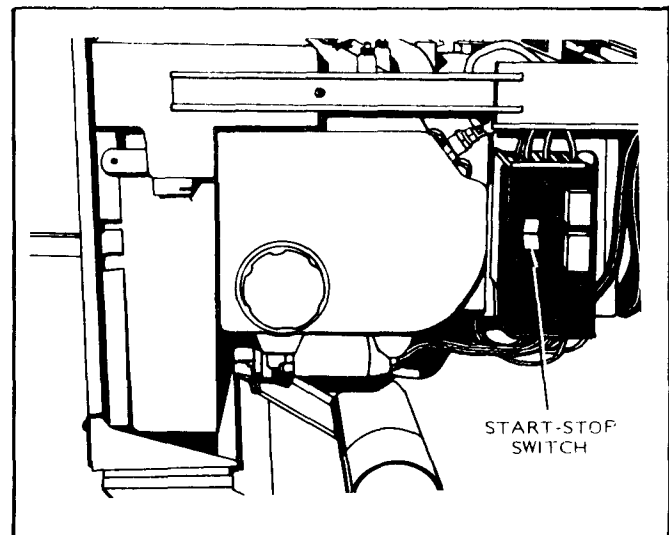

FIGURE 10. PLANT MOUNTED START-STOP SWITCH

Automatic Choke: An electric choke provides proper choking for starting and running the plant.

APPLYING LOAD (Break-In)

When applying the load to a new or reconditioned plant, it should be applied gradually in about four steps; each step of not less than 30 minutes running time. Start with 1/4 load, then 1/2, 3/4 and full load.

BATTERY CHARGING

The battery charge rate is controlled by a charge regulator. The regulator is set to allow the proper rate of charge at operating speed.

ELECTRICAL OUTPUT

The plant's output is taken from a 120 volt AC receptacle, through the wiring in the distribution box. The wiring provides for 120 volts, with the total load not to exceed 50 amperes.

CAUTION Do not install any outlets between generator and distribution panel.

PROTECTION

The circuit breaker, on top of the unit, will trip when the demand for electricity in amperes exceeds the power plant's capabilities. If the circuit breaker does trip, remove part of the electrical load and reset the breaker.

POWER REQUIREMENTS FOR APPLIANCES

APPLIANCE OR TOOL	APPROXIMATE RUNNING* WATTAGE
Refrigerator	600-1000
Electric broom	200-500
Coffee percolator	550-700
Electric frying pan	1000-1350
Hair dryer	350-500
Electric stove (per element)	350-1000
Electric iron	500-1200
Radio	50-200
Electric water heater	1000-1500
Space heater	1000-1500
Electric blanket	50-200
Television	200-600
Electric drill	250-750
Battery Charger	Up to 800
Electric water pump	500-600
Air Conditioner	600-2000
Converter	300-350

* - Starting wattages for motors can be three to four times more than the approximate running wattages.

HIGH TEMPERATURES

1. See that nothing obstructs air flow to and from the power plant.
2. Keep cooling fins clean. Air housings should be properly installed and undamaged.

LOW TEMPERATURES

1. Use correct SAE No. oil for temperature conditions. Change oil only when engine is warm.
2. Use fresh fuel. Protect against moisture condensation by keeping tank full.
3. Keep fuel system clean and batteries in a well charged condition.

WARNING Do not use discharged air from blower scroll for compartment heating. Poisonous gas fumes may be present.

DUST AND DIRT

1. Keep unit clean. Keep cooling system clean.
2. Service air cleaner as frequently as required by road conditions.
3. Change crankcase oil.
4. Keep governor and choke linkage clean.
5. Clean sand and dirt from slide rails with an air hose as necessary.

CAUTION Never oil slide rails, dust and dirt will build up faster.

6. Clean out bottom of housing and inlet duct as necessary.

OUT-OF-SERVICE PROTECTION

Protect a unit that will be out-of-service for more than 30 days as follows:

1. Run unit until thoroughly warm.
2. Turn off fuel supply and run until unit stops.
3. Drain oil from oil base while still warm. Refill and attach a warning tag stating oil viscosity used.
4. Remove each spark plug. Pour one ounce (two tablespoons) of rust inhibitor (or SAE #50 oil) into each cylinder. Crank engine slowly (by hand) several times. Install spark plug.
5. Service air cleaner.
6. Clean governor linkage and protect by wrapping with a clean cloth.
7. Plug exhaust outlet to prevent entrance of moisture, dirt, bugs, etc.
8. Wipe entire unit. Coat rustable parts with a light film of grease or oil.
9. Disconnect battery and follow standard battery storage procedure.

ADJUSTMENTS

BREAKER POINTS

To maintain maximum efficiency from the unit, inspect the breaker points every 100 hours of operation. Change if points are pitted. Proceed as follows:

1. Remove the two screws and the cover on the breaker box.
2. Remove the two spark plugs so engine can be easily rotated by hand. Check condition of spark plugs at this time.
3. Remove mounting screw (A) and pull the points out of the box just far enough so screw (B) can be removed and leads disconnected.
4. Remove screw (C) and replace condenser with a new one.
5. Replace points with a new set but do not completely tighten mounting screw (A).
6. Rotate the engine clockwise (facing flywheel) until the 25° BTC mark on flywheel aligns with 1/2 inch hole in rear of blower scroll. Turn another 1/4 turn (90°) to ensure points are fully open.
7. Using a screwdriver inserted in notch (D) on the right side of points, turn points until gap measures .020 inch with a flat thickness gauge. (Be sure feeler is clean.) Tighten mounting screw and recheck gap.
8. Timing can be checked with a timing light, however, this is not usually necessary. 25° BTC timing is indicated when notch on flywheel is centered in inspection hole on rear of scroll. Timing light can be connected to either spark plug.

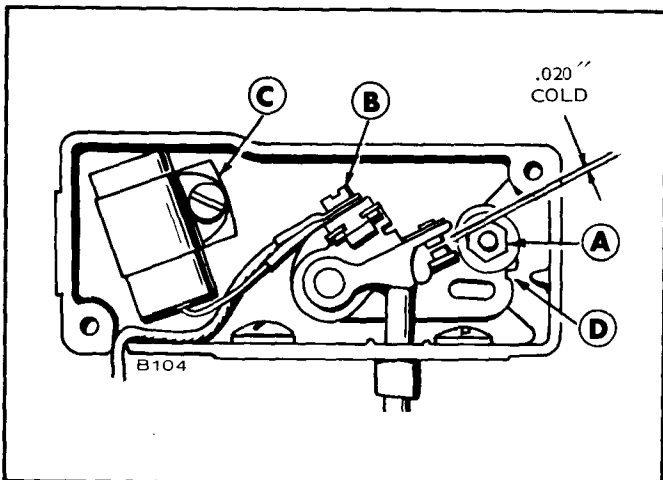

FIGURE 11. BREAKER POINT BOX

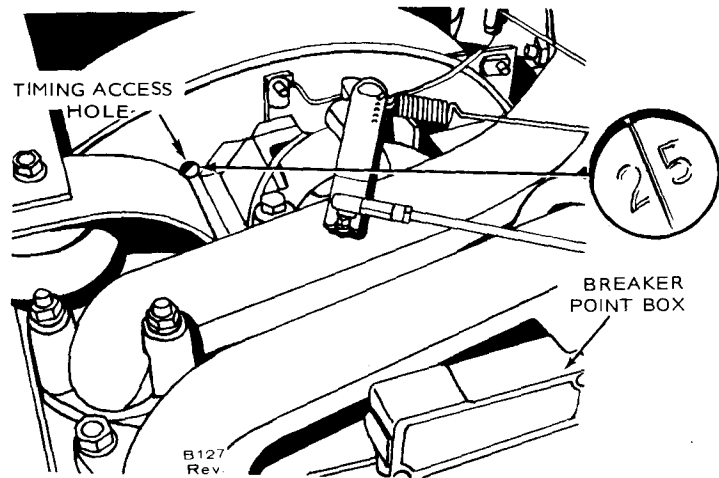

FIGURE 12. TIMING HOLE

CARBURETOR

The carburetor has a main fuel (power) adjustment and an idle fuel adjustment. The main adjustment affects operation under heavy load conditions. Idle adjustment affects operation under light or no load conditions. Under normal circumstances, factory carburetor adjustments should not be disturbed. Normal settings are 1-1/4 turn open for main fuel jet and one turn open for idle fuel jet.

CAUTION Forcing the needle against its seat will damage it. The needle does not completely shut off fuel when turned fully in.

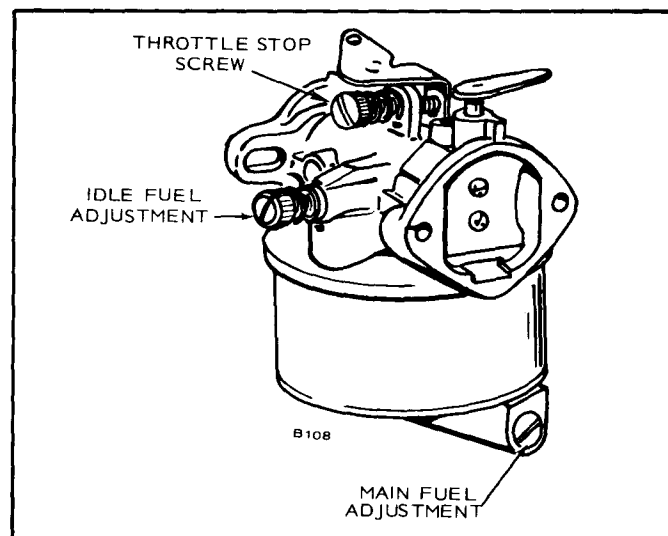

FIGURE 13. CARBURETOR ADJUSTMENTS

Before final adjustment, allow the engine to warm up. Make the idle adjustment under no load. Open the main jet until the engine runs smooth under acceleration with no load. Slightly more fuel may be needed (open about 1/4 turn further) when sudden load is applied or if operating in very cold weather.

Set the throttle stop screw (located on carburetor throttle lever) with no load connected and while running at a low speed setting. Turn the screw to give approximately 1/32 inch clearance between the screw and pin.

If the engine develops a "hunting" condition (alternate increase and decrease of engine speed), try correcting by opening the main adjustment needle a little more. Do not open more than 1/2 turn beyond the maximum power point.

GOVERNOR ADJUSTMENTS (Figure 14)

Before making governor adjustments, run the unit about 15 minutes under light load to reach normal operating temperature. (If governor is completely out of adjustment, make a preliminary adjustment at no load to first attain a safe voltage operating range).

Engine speed determines the output voltage and current frequency of the generator. By increasing the engine speed, generator voltage and frequency are increased, and by decreasing the engine speed, generator voltage and frequency are decreased. An accurate voltmeter or frequency meter (preferably both) should be connected to the generator output in order to correctly adjust the governor. A small speed drop not noticeable without instruments will result in an objectionable voltage drop. The engine speed can be checked with a tachometer.

A binding in the bearings of the governor shaft, in the ball joint, or in the carburetor throttle assembly will cause erratic governor action or alternate increase and decrease in speed (hunting). A lean carburetor adjustment may also cause hunting. Springs of all kinds have a tendency to lose their calibrated tension through fatigue after long usage. If all governor and carburetor adjustments are properly made, and the governor action is still erratic, replacing the spring with a new one and resetting the adjustments will usually correct the trouble.

1. Adjust the carburetor idle needle with no load connected.
2. Adjust the carburetor main jet for the best fuel mixture while operating the set with a full rated load connected.
3. Adjust the length of the governor linkage and check linkage and throttle shaft for binding or excessive looseness.
4. Adjust the governor spring tension for rated speed at no load operation.
5. Adjust the governor sensitivity.
6. Recheck the speed adjustment.
7. Set the carburetor throttle stop screw.

Linkage: The engine starts at wide open throttle. The length of the linkage connecting the governor arm to the throttle shaft and lever is adjusted by rotating the ball joint. Adjust this length so that with the engine stopped and tension on the governor spring, the stop on the carburetor throttle lever just contacts the underside of the carburetor bowl. This setting allows immediate control by the governor after starting. It also synchronizes travel of the governor arm and the throttle shaft.

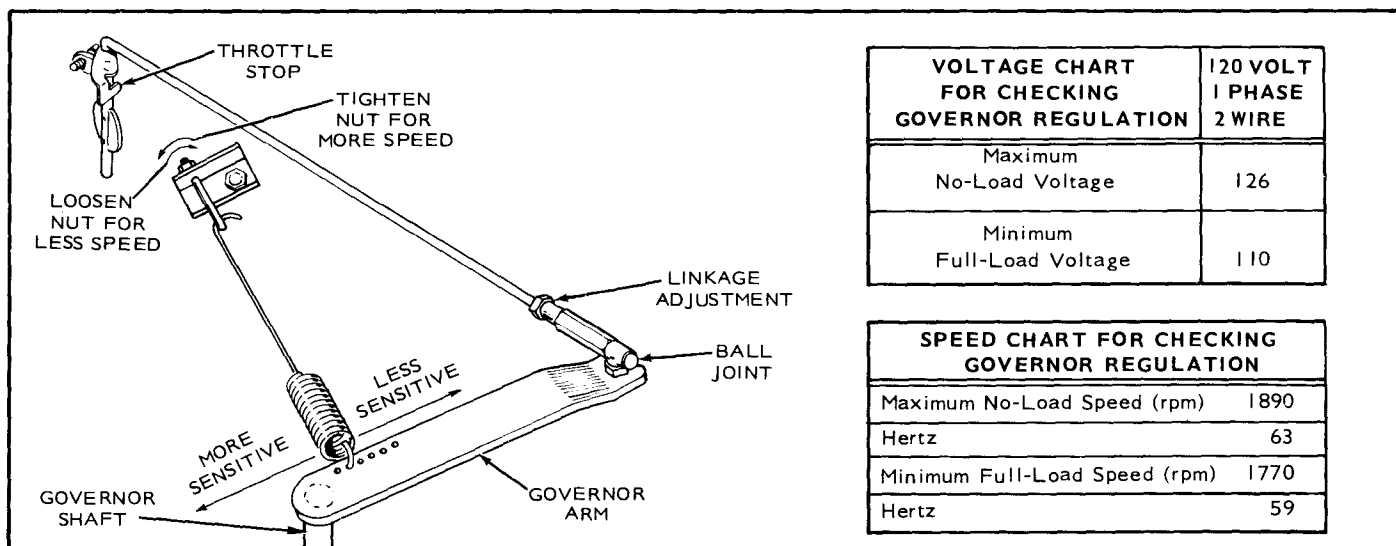

FIGURE 14. GOVERNOR ADJUSTMENTS

Speed Adjustment: With the warmed-up unit operating at no load, adjust the tension of the governor spring. Refer to *Voltage Chart* and the *Speed Chart*. Turn the speed adjusting nut to obtain a voltage and speed reading within the limits shown.

Sensitivity Adjustment: Refer to the *Governor Adjustment* illustration, and to the *Voltage* and *Speed Charts*. Check the voltage and speed, first with no load connected and again with a full load. Adjust the sensitivity to give the closest regulation (least speed and voltage difference between no load and full load) without causing a hunting condition.

To increase sensitivity (closer regulation), shift the spring toward the governor shaft.

An adjustment for too much sensitivity will cause alternate increase and decrease of engine speed (hunting).

To decrease sensitivity, shift the spring toward the outer end of the governor arm. Too little sensitivity will result in too much difference in speed between no load and full load conditions.

Any change in the sensitivity adjustment usually requires a compensating speed (spring tension) adjustment.

MAINTENANCE

Regularly scheduled maintenance is the key to lower operating costs and longer service life for the unit. The following schedule can be used as a guide. However, actual operating conditions under which a unit is run should be the determining factor in establishing a maintenance schedule. When operating in very dusty or dirty conditions, some of the service periods may have to be reduced. Check the condition of the crankcase oil, the filters, etc. frequently until the proper service time periods can be established.

For any abnormalities in operation, unusual noises from engine or accessories, loss of power, overheating, etc., contact your nearest dealer.

PERIODIC MAINTENANCE SCHEDULE

SERVICE THESE ITEMS	AFTER EACH CYCLE OF INDICATED HOURS					
	8	50	100	200	400	1000
General Inspection	x					
Check Oil Level	x					
Check Battery		x				
Change Crankcase Oil			x1			
Check Air Cleaner			x1			
Check Breaker Points			x3			
Check Spark Plugs			x4			
Change Oil Filter				x1		
Clean Cooling Fins				x1		
Clean Crankcase Breather				x2		
Replace Breaker Points				x2		
Fuel Filter					x3	
Adjust Tappets					x2	
Replace Air Cleaner					x1	
Remove Carbon From Heads					x2	
Check Generator Brushes (For Sticking)		x5				
Complete Reconditioning (If Required)						x2
Check Generator Brushes (For Wear)						x2

- x1 - Perform more often in extremely dusty conditions.
- x2 - For detailed maintenance, contact your dealer.
- x3 - Replace if necessary.
- x4 - Replace at beginning of season.
- x5 - Check at this time (or sooner) if operating vehicle in extremely dusty conditions.

OIL LEVEL

Check the oil level daily or at least every eight hours of operating time. Check more often on a new unit as oil consumption is higher until piston rings seat properly.

OIL CHANGE

Initial oil change should be made after the first 25 hours of operation; change every 100 hours after that. If operating in extremely dusty or cold weather conditions, change oil more frequently.

The engine's oil capacity is 4 quarts, 4-1/2 quarts if replacing oil filter. Do not mix brands nor grades of motor oil. Use a good quality oil with the designation SE/CC (former designation was MS, MS/DG). If necessary to add oil between changes, use the same brand and grade of oil already used.

The oil drain plug is located on the bottom side of engine oil base. Plant must be pulled out on its slide rails to gain access.

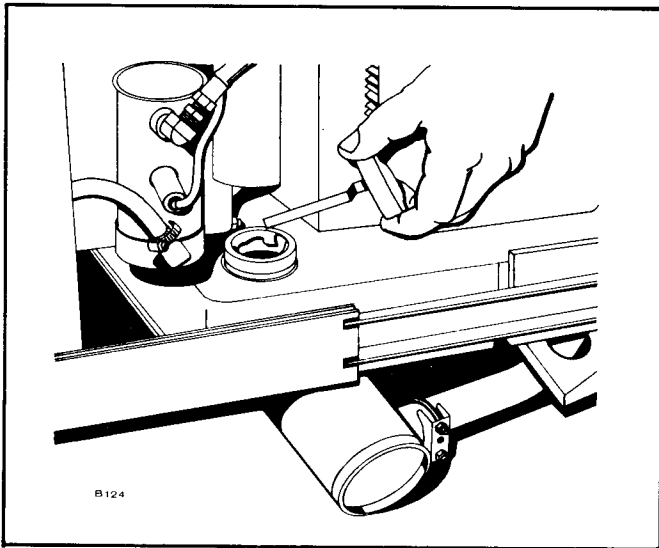

FIGURE 15. DIPSTICK AND OIL FILL

OIL FILTER

Change the crankcase oil filter every 200 hours; change more often in extremely dusty conditions. The filter is located on the right side of engine (facing compartment). Remove by turning counterclockwise with a filter wrench. Before installing new filter, coat the gasket on the filter's base with a light film of new oil. Install by turning clockwise until a light friction is noted, then turn an additional 1/2 turn.

CAUTION Do not overtighten filter as damage may occur to rubber gasket which will cause filter to leak. Be sure to install sealing ring around filter; this ring is an air seal to prevent cooling air loss.

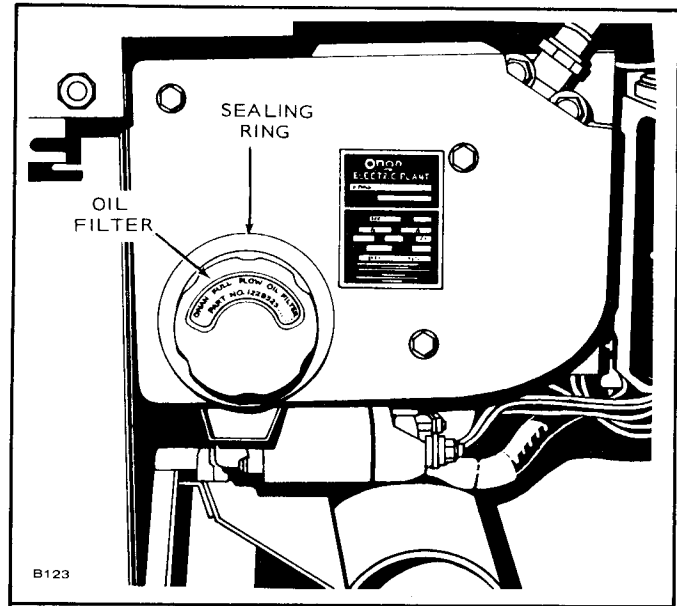

FIGURE 16. OIL FILTER LOCATION

AIR CLEANER ELEMENT

Check element every 100 hours. Loosen wing nut to remove. Clean by tapping base lightly on a flat surface. Replace element at least every 400 operating hours; clean or replace more often in dusty conditions.

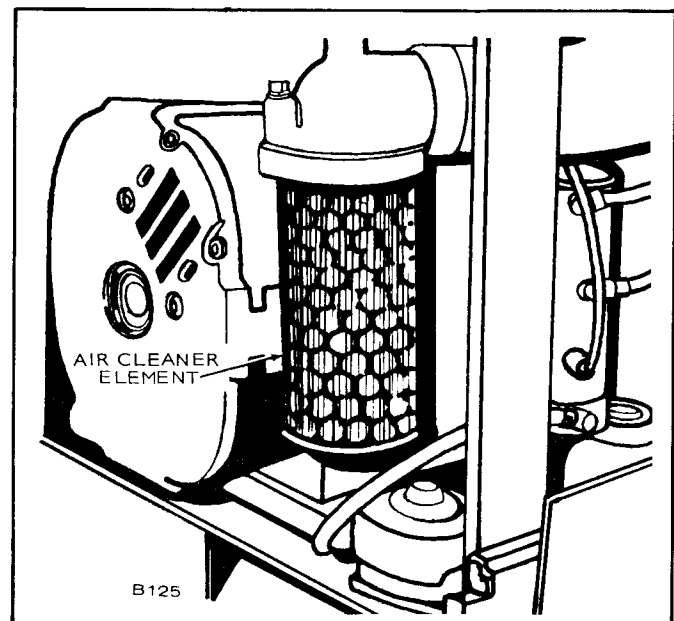

FIGURE 17. AIR CLEANER LOCATION

SPARK PLUGS

Check, clean and reset spark plugs every 100 operating hours. Replace spark plugs that show signs of fouling or electrode erosion. It is recommended that spark plugs be replaced at the beginning of each new season (once a year).

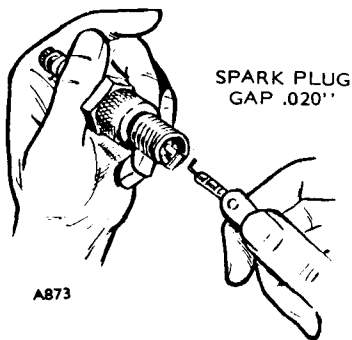

FIGURE 18. SPARK PLUG GAP

COOLING SYSTEM

The power plant is cooled by a flywheel blower fan which pulls air through the generator and over the cylinders and cooling fins. The air path is directed by sheet metal shrouds and plates. These shrouds and plates must always be installed properly so unit does not overheat.

Check and clean (if necessary) the cooling fins at least every 200 hours of operation. Remove any dust, dirt or oil which may have accumulated. Check compartment air inlet and power plant air outlet for buildup of dirt, etc.

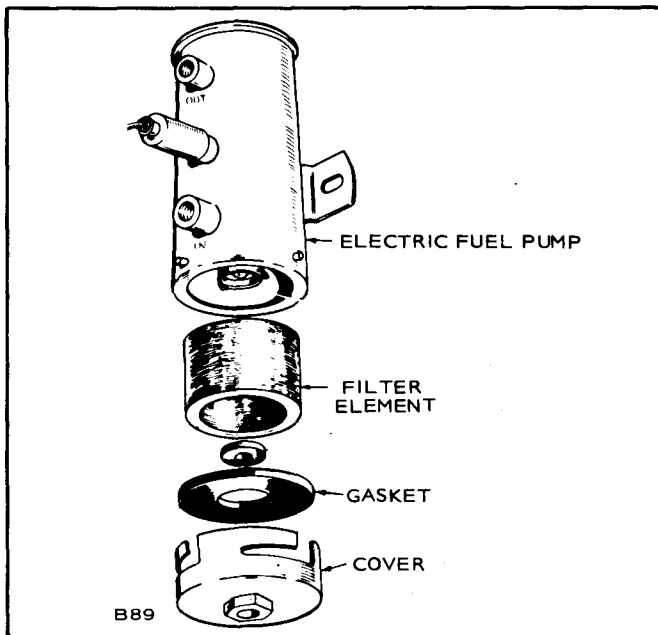

FIGURE 19. FUEL PUMP FILTER ELEMENT

FUEL PUMP FILTER ELEMENT

Every 400 hours or sooner, drain fuel pump and check filter element. Remove fuel pump mounting screws and turn off hex nut on base of pump. If element appears dirty, replace with a new one. Be sure to replace gaskets when reassembling.

Some models may not use a filter element.

CARBURETOR BOWL

Remove carburetor bowl from carburetor every 400 hours and clean screen in solvent. Blow out with low pressure, compressed air and reassemble, making sure gaskets are in place. Replace with new gaskets if necessary, a leaky or broken gasket can cause starting problems.

GOVERNOR

The governor controls the engine speed by opening or closing the throttle according to the load taken off the plant. Every 50 hours check governor linkage for freedom of movement through its entire travel. Clean and lubricate ball joint with lubricating graphite.

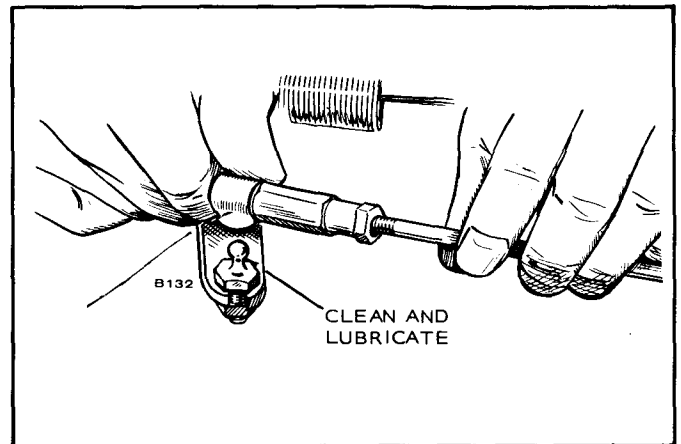

FIGURE 20. GOVERNOR LINKAGE

BATTERY INSPECTION

Check battery cells with a hydrometer. The specific gravity reading should be approximately 1.280 at 80° F.

If one or more cells are low on water, add distilled water and recharge.

Keep the battery case clean and dry. An accumulation of moisture will lead to a more rapid discharge and battery failure.

Keep the battery terminals clean and tight. After making connections, coat the terminals with a light application of petroleum jelly or grease to retard corrosion.

ENGINE TROUBLESHOOTING GUIDE

TROUBLE															GASOLINE ENGINE TROUBLESHOOTING GUIDE																					
Backfire at Carburetor	Bearing Wear	Black Exhaust	Blue Exhaust	Burned Valves	Connecting Rod Wear	Crankshaft Slowly	Cylinder Wear	Engine Stops	Failure to Start	Governor Hunting	High Oil Pressure	Low Oil Pressure	Loss of Coolant	Mechanical Noises	Misfiring	Overheating (Water Cooled)	Overheating (Air Cooled)	Piston Wear	Poor Compression	Ring Wear	Sticking Valves	CAUSE														
																						STARTING SYSTEM														
																						Loose or Corroded Battery Connection														
																						Low or Discharged Battery														
																						Faulty Starter														
																						Faulty Start Solenoid														
																						IGNITION SYSTEM														
																						Ignition Timing Wrong														
																						Wrong Spark Plug Gap														
																						Worn Points or Improper Gap Setting														
																						Bad Ignition Coil or Condenser														
																						Faulty Spark Plug Wires														
																						FUEL SYSTEM														
																						Out of Fuel - Check														
																						Lean Fuel Mixture - Readjust														
																						Rich Fuel Mixture or Choke Stuck														
																						Engine Flooded														
																						Poor Quality Fuel														
																						Dirty Carburetor														
																						Dirty Air Cleaner														
																						Dirty Fuel Filter														
																						Defective Fuel Pump														
																						INTERNAL ENGINE														
																						Wrong Valve Clearance														
																						Broken Valve Spring														
																						Valve or Valve Seal Leaking														
																						Piston Rings Worn or Broken														
																						Wrong Bearing Clearance														
																						COOLING SYSTEM (AIR COOLED)														
																						Poor Air Circulation														
																						Dirty or Oily Cooling Fins														
																						Blown Head Gasket														
																						COOLING SYSTEM (WATER COOLED)														
																						Insufficient Coolant														
																						Faulty Thermostat														
																						Worn Water Pump or Pump Seal														
																						Water Passages Restricted														
																						Defective Gaskets														
																						Blown Head Gasket														
																						LUBRICATION SYSTEM														
																						Defective Oil Gauge														
																						Relief Valve Stuck														
																						Faulty Oil Pump														
																						Dirty Oil or Filter														
																						Oil Too Light or Diluted														
																						Oil Level Low														
																						Oil Too Heavy														
																						Dirty Crankcase Breather Valve														
																						THROTTLE AND GOVERNOR														
																						Linkage Out of Adjustment														
																						Linkage Worn or Disconnected														
																						Governor Spring Sensitivity Too Great														
																						Linkage Binding														

PARTS CATALOG

INSTRUCTIONS FOR ORDERING REPAIR PARTS

For parts or service, contact the dealer from whom you purchased this equipment or refer to your Nearest Authorized Onan Parts and Service Center.

To avoid errors or delay in filling your parts order, please furnish all information requested.

Always refer to the nameplate on your unit:

1. Always give the MODEL and SPEC NO. and SERIAL NO.

The image shows a rectangular nameplate form for an Onan Electric Plant. At the top, the Onan logo is centered above the text "ELECTRIC PLANT". Below this, there are two blank lines for "MODEL AND SPEC. NO." and "SERIAL NO.". A bolded section reads "IMPORTANT - ALWAYS GIVE ABOVE NOS WHEN ORDERING PARTS". The form contains several fields for technical specifications: "A.C. VOLTS" and "PH", "K.V.A." and "WATTS", "P.F." and "CY", "D.C. VOLTS" and "AMPS", and another "WATTS" field. Below these are fields for "GEN DATA", "R.P.M.", and "BAT". At the bottom, it states "MANUFACTURED BY ONAN", "DIVISION OF STUDEBAKER CORPORATION", "MINNEAPOLIS MINNESOTA", "MADE IN U.S.A.", and "FOR ELECT. EQUIPMENT ONLY". A small number "97A444" is visible at the very bottom.

For handy reference, insert YOUR power plant nameplate information in the spaces above.

2. Do not order by reference number or group number, always use part number and description.
3. Give the part number, description and quantity needed of each item. If an older part cannot be identified, return the part prepaid to your dealer or nearest AUTHORIZED SERVICE STATION. Print your name and address plainly on the package. Write a letter to the same address stating the reason for returning the part.
4. State definite shipping instructions. Any claim for loss or damage to your unit in transit should be filed promptly against the transportation company making the delivery. Shipments are complete unless the packing list indicates items are back ordered.

Prices are purposely omitted from this Parts Catalog due to the confusion resulting from fluctuating costs, import duties, sales taxes, exchange rates, etc.

For current parts prices, consult your Onan Dealer, Distributor or Parts and Service Center.

“En esta lista de partes los precios se omiten de proposito, ya que bastante confusion resulto de fluctuaciones de los precios, derechos aduanales, impuestos de venta, cambios extranjeros, etc.”

Consiga los precios vigentes de su distribuidor de productos “ONAN”.

This catalog applies to the 6.0NH power plant for recreational vehicles. Parts are arranged in groups of related items. Each illustrated part is identified by a reference number corresponding to the same reference number following the illustration. Parts illustrations are typical. Unless otherwise mentioned in the description, parts are interchangeable between models. Right and left plant sides are determined by facing the engine end (front) of the power plant.

The Specification Letter advances (A to B, B to C, etc.) with manufacturing changes.

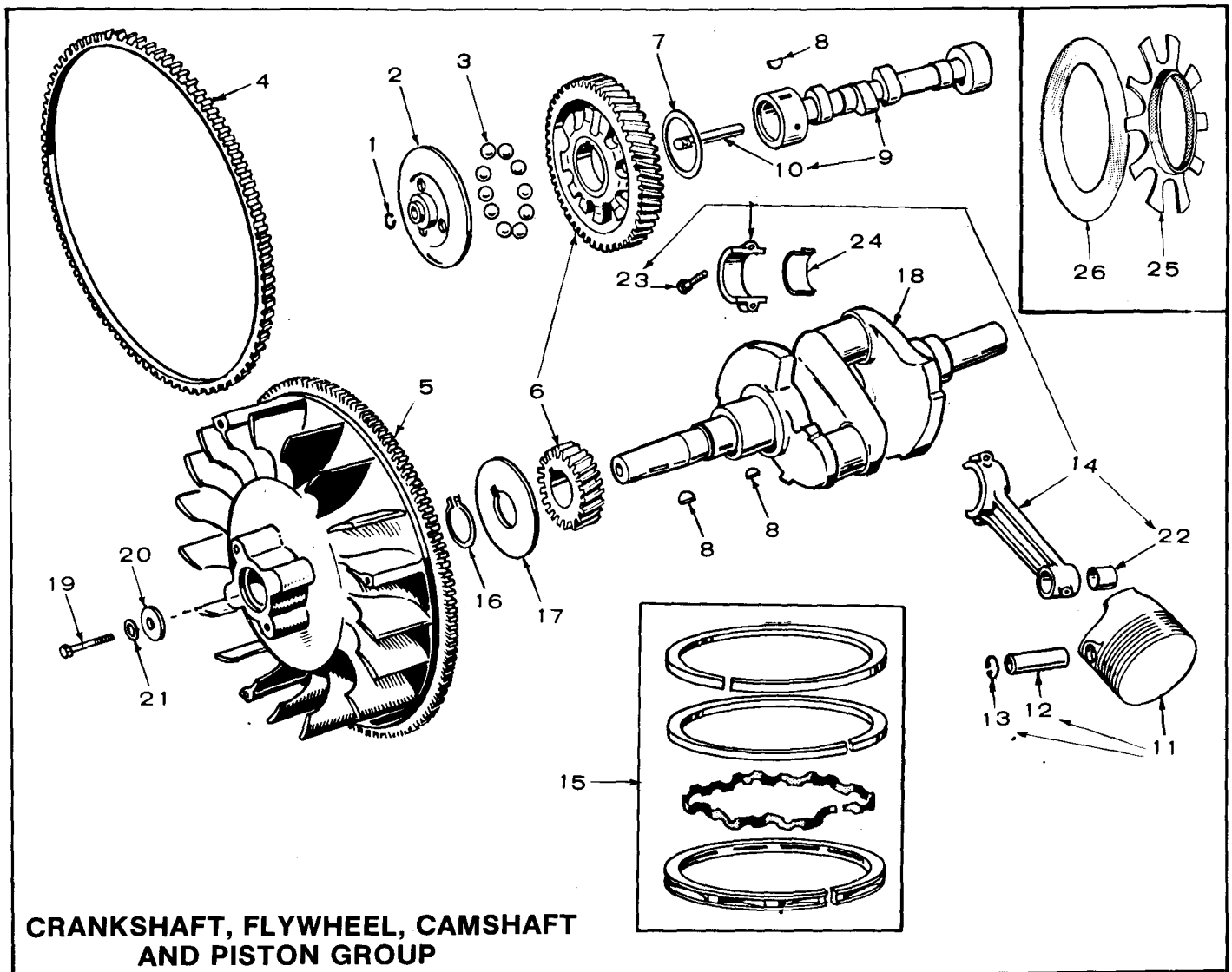

CRANKSHAFT, FLYWHEEL, CAMSHAFT AND PISTON GROUP

REF. NO.	PART NO.	QTY. USED	PART DESCRIPTION
1	150-0078	1	Ring, Camshaft Center Pin
2	150-0612	1	Cup, Governor
3	510-0015	10	Ball, Fly - Governor
4	134-0673	1	Gear, Ring - Flywheel
5	134-2603	1	Flywheel (Includes Ring Gear and Magnet Ring)
6	105-0353	1	Gear Set, Timing (Includes Camshaft and Crankshaft Gears)
7	105-0004	1	Washer, Camshaft Gear Thrust
8	KEY		
	515-0001	1	Camshaft Gear Mounting
	515-0001	1	Crankshaft Gear Mounting
	515-0002	1	Flywheel Mounting
9	105-0382	1	Camshaft (Includes Center Pin)
10	150-0075	1	Pin, Camshaft Center
11	PISTON AND PIN (INCLUDES RETAINING RINGS)		
	112-0111	2	Standard
	112-0111-05	2	.005" Oversize
	112-0111-10	2	.010" Oversize
	112-0111-20	2	.020" Oversize
	112-0111-30	2	.030" Oversize
	112-0111-40	2	.040" Oversize
12	112-0112	2	Pin, Piston
13	518-0294	4	Ring, Piston Pin Retaining
14	114-0203	2	Rod Assembly (Includes Bushing and Bolts)

REF. NO.	PART NO.	QTY. USED	PART DESCRIPTION
15	RING SET, PISTON		
	113-0165	2	Standard
	113-0165-05	2	.005" Oversize
	113-0165-10	2	.010" Oversize
	113-0165-20	2	.020" Oversize
	113-0165-30	2	.030" Oversize
	113-0165-40	2	.040" Oversize
16	518-0014	1	Lock, Crankshaft Gear Washer
17	104-0043	1	Washer, Crankshaft Gear Retaining
18	104-0843	1	Crankshaft
19	104-0170	1	Screw, Hex Cap - Flywheel Mounting (7/16-14 x 4")
20	526-0185	1	Washer, Flat - Flywheel Mounting
21	850-0055	1	Washer, Lock - Flywheel Mounting
22	114-0036	2	Bushing, Piston Pin - Connecting Rod
23	805-0010	4	Bolt, Place - Connecting Rod Cap
24	BEARING HALF, CONNECTING ROD		
	114-0188	4	Standard
	114-0188-02	4	.002" Undersize
	114-0188-10	4	.010" Undersize
	114-0188-20	4	.020" Undersize
	114-0188-30	4	.030" Undersize
25	150-1257	1	Spacer, Governor Fly Ball
26	150-0077	1	Plate, Governor Fly Ball

CYLINDER BLOCK GROUP

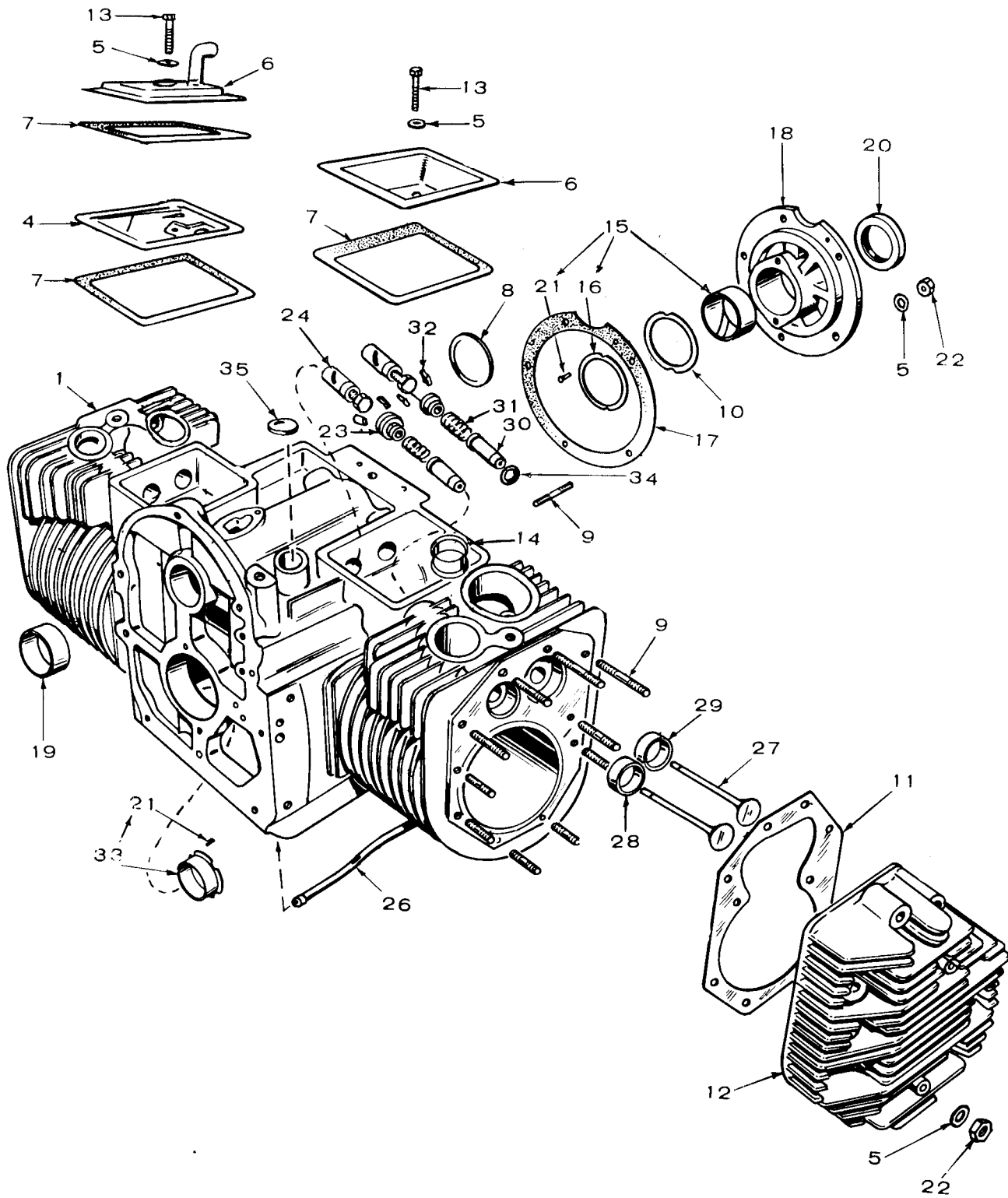

REF. NO.	PART NO.	QTY. USED	PART DESCRIPTION
1	110-1976	1	Block Assembly, Cylinder (Includes parts marked * Plus Intake and Exhaust Manifold Studs)
4	123-1215	1	Baffle, Assembly Breather
5	WASHER, FLAT 526-0063	2	Valve Compartment Cover (1/4" - Copper)
	526-0250	20	Cylinder Head Studs (3/8" - Steel)
	526-0251	5	*Rear Bearing Plate Mounting (3/8" - Steel)
6	COVER, VALVE COMPARTMENT 110-1969	1	Cover with Tube for Breather Hose (L.H.)
	110-1624	1	Cover without Tube for Breather Hose (R.H.)
7	110-1720	3	Gasket, Valve Cover
8	517-0048	1	*Plug, Camshaft Expansion
9	STUD 520-0715	8	*Cylinder Head (3/8 x 2-3/4")
	520-0716	4	*Cylinder Head (3/8 x 2-1/2")
	520-0717	8	*Cylinder Head (3/8 x 1-7/8")
	520-0736	5	*Rear Bearing Plate Mounting (3/8 x 1-21/32")
10	104-0776	As Req.	*Shim, Rear Bearing Plate (.005")
11	110-1731	2	Gasket, Cylinder Head
12	HEAD, CYLINDER 110-1905	1	Right Side (#2 Cylinder)
	110-1906	1	Left Side (#1 Cylinder)
13	SCREW, HEX CAP 800-0013	1	Valve Cover Mounting (1/4-20 x 2") (L.H.)
	800-0009	1	Valve Cover Mounting (1/4-20 x 1-3/4") (R.H.)
14	154-1424	2	Insert, Exhaust Port
15	BEARING, CRANKSHAFT - REAR 101-0420	1	*Standard
	101-0420-02	1	.002" Undersize
	101-0420-10	1	.010" Undersize
	101-0420-20	1	.020" Undersize
	101-0420-30	1	.030" Undersize
16	104-0575	2	*Washer, Crankshaft Bearing Thrust

REF. NO.	PART NO.	QTY. USED	PART DESCRIPTION
17	101-0415	1	*Gasket, Bearing Plate
18	101-0407	1	*Plate, Rear Bearing (Excludes Bearing)
19	101-0405	2	Bearing, Camshaft (Precision)
20	509-0041	1	*Seal, Bearing Plate
21	517-0072	4	*Pin, Main Bearing Stop
22	NUT, HEX 104-0091	20	Cylinder Head (3/8-24)
	104-0091	4	Rear Bearing Plate (3/8-24)
23	110-0904	4	Rotor Cap, Valve Spring
24	TAPPET, VALVE 115-0006	4	Standard
	115-0006-05	4	.005" Oversize
26	120-0680	1	*Tube, Crankcase Oil
27	VALVE 110-1756	2	Intake
	110-1719	2	Exhaust
28	INSERT, VALVE SEAT - EXHAUST 110-1716	2	*Standard
	110-1716-02	2	.002" Oversize
	110-1716-05	2	.005" Oversize
	110-1716-10	2	.010" Oversize
	110-1716-25	2	.025" Oversize
29	INSERT, VALVE SEAT - INTAKE 110-1933	2	*Standard
	110-1933-02	2	.002" Oversize
	110-1933-05	2	.005" Oversize
	110-1933-10	2	.010" Oversize
	110-1933-25	2	.025" Oversize
30	110-1939	4	*Guide, Valve
31	110-0539	4	Spring, Valve
32	110-0639	8	Lock, Valve and Spring Retainer
33	BEARING, CRANKSHAFT - FRONT 101-0432	1	*Standard
	101-0432-02	1	.002" Undersize
	101-0432-10	1	.010" Undersize
	101-0432-20	1	.020" Undersize
	101-0432-30	1	.030" Undersize
34	110-0068	2	*Gasket, Valve Guide (Intake)
35	517-0103	1	*Plug, Core Hole

* - Included in 110-1976 Cylinder Block Assembly.

OIL SYSTEM GROUP

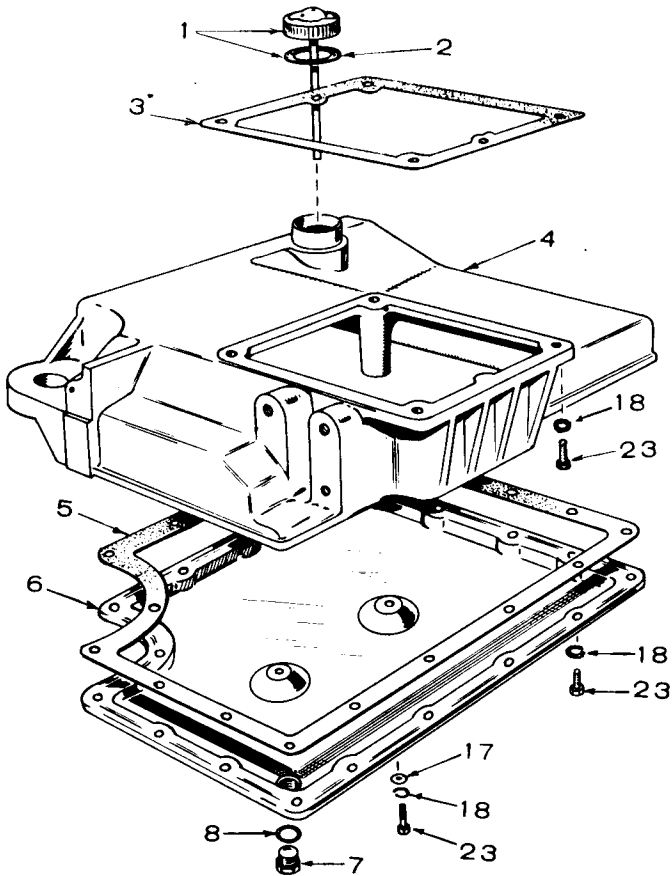

REF. NO.	PART NO.	QTY. USED	PART DESCRIPTION
1	123-1166	1	Cap and Indicator - Oil Fill (Includes Gasket)
2	123-0191	1	Gasket, Oil Fill Cap and Indicator
3	102-0646	1	Gasket, Oil Base Mounting
4	102-0728	1	Base, Oil
5	102-0734	1	Gasket, Oil Pan
6	102-0738	1	Pan, Oil
7	102-0737	1	Plug, Oil Drain
8	102-0739	1	Gasket, Oil Drain Plug
9	120-0140	1	Spring, Oil By-Pass Valve
10	120-0398	1	Valve, Oil By-Pass
11	120-0491	1	Pump, Oil - Complete (NOTE: Internal parts not sold separately)
12	120-0161	1	Gasket Kit, Oil Pump
13	120-0716	1	Intake, Oil Pump (Includes Cup, Screen and Pipe)
14	122-0362	1	Adapter, Oil Filter
15	122-0321	1	Gasket, Oil Filter Adapter
16	520-0824	2	Stud, Oil Filter Adapter and Mounting Foot
17	WASHER, FLAT 526-0065	2	Oil Filter Adapter Mounting, Copper (5/16")
	526-0066	1	Oil By-Pass Valve, Copper (3/8")
	526-0066	2	Oil Base Mounting, Copper (3/8")
18	WASHER, LOCK 850-0050	2	Oil Base Mounting (3/8")
	850-0040	2	Oil Pump Mounting (1/4")
	850-0040	19	Oil Pan Mounting (1/4")
19	122-0323	1	Filter, Oil - Spin-On
20	309-0237	1	Switch, Low Oil Pressure
21	122-0347	1	Seal, Oil Filter - Air
22	110-0445	2	Nut, Oil Filter Adapter Mounting (5/16-18)
23	SCREW, HEX CAP 815-0290	18	Oil Pan Mounting (1/4-20 x 5/8")
	800-0007	2	Oil Pump Mounting (1/4-20 x 1")
	800-0539	2	Oil Base Mounting (3/8-16 x 4")
	102-0455	2	Oil Base Mounting (3/8-16 x 1-1/4")
	801-0050	1	Oil By-Pass Valve (3/8-24 x 1")

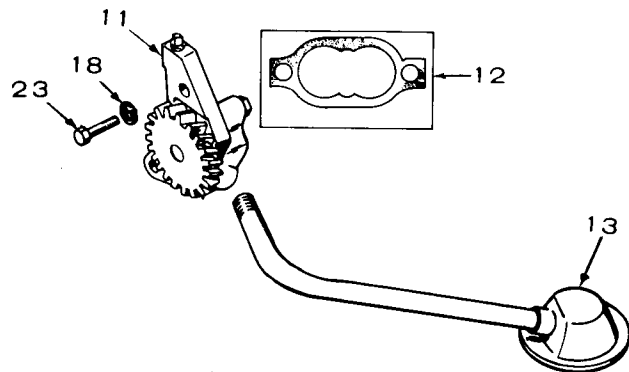
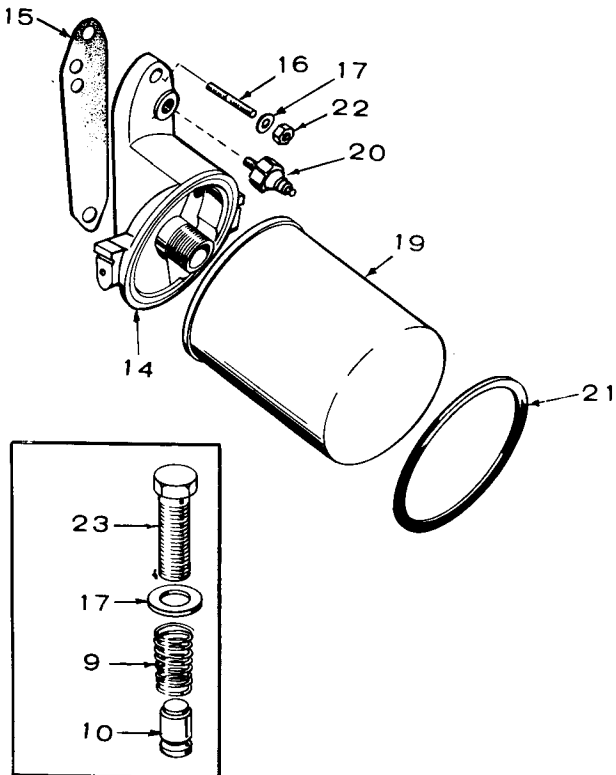

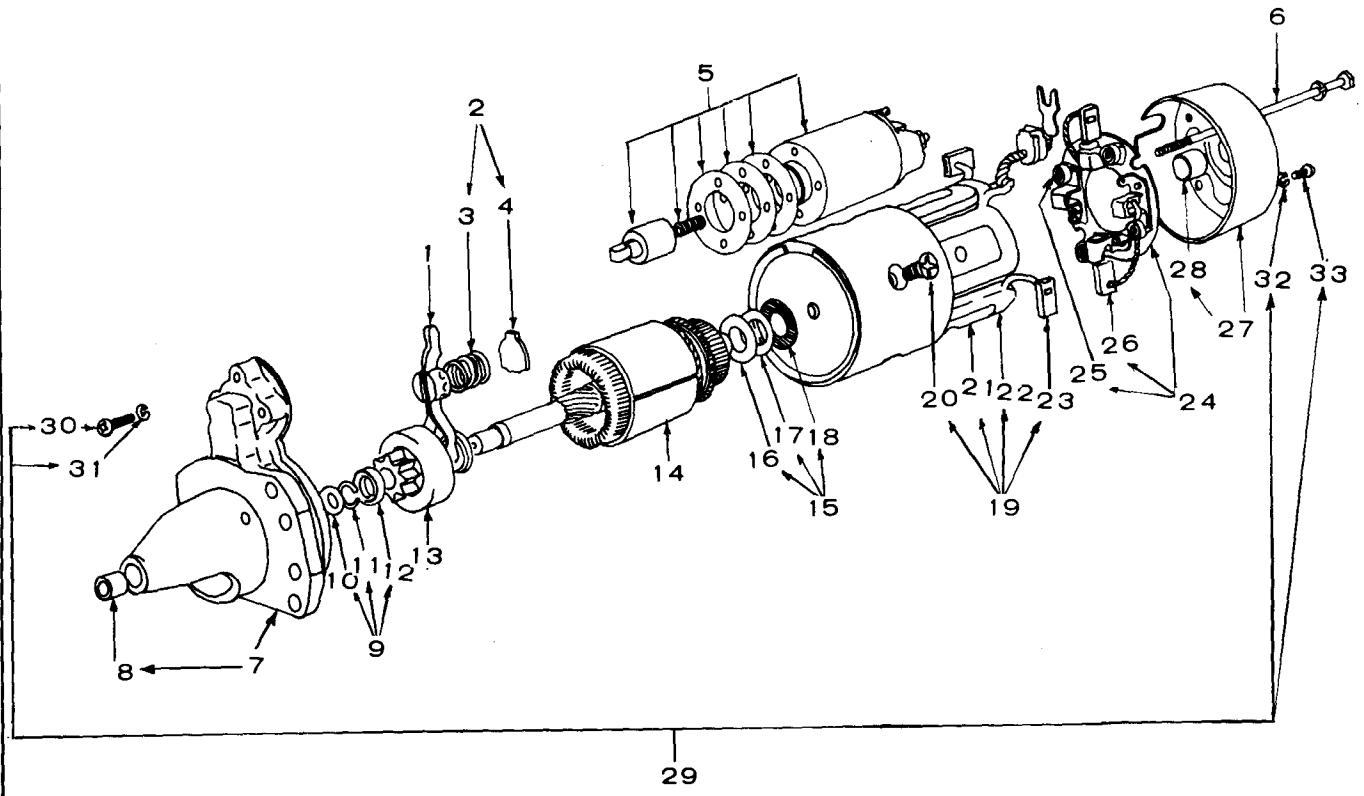

STARTING MOTOR PARTS GROUP

REF. NO.	PART NO.	QTY. USED	PART DESCRIPTION
	191-0922	1	Motor, Starting
1	191-0983	1	Lever Assembly
2	191-0984	1	Spring Set
3	191-0985	1	Spring, Lever
4	191-0986	1	Packing
5	191-0987	1	Switch Assembly
6	191-0988	2	Bolt, Through
7	191-0989	1	Bracket Assembly, Front (Includes Bearing)
8	191-0990	1	Bearing, Front
9	191-0991	1	Stopper Set, Pinion (Includes Washer, Ring and Stopper)
10	191-0992	1	Washer, Flat
11	191-0993	1	Ring, Retaining
12	191-0994	1	Stopper, Pinion
13	191-0995	1	Clutch Assembly
14	191-0996	1	Armature
15	191-0997	1	Washer Set (Includes 2 plain and 1 insulated Washer)
16	191-0998	1	Washer, Plain
17	191-0999	1	Washer, Plain
18	191-1000	1	Washer, Insulating

REF. NO.	PART NO.	QTY. USED	PART DESCRIPTION
19	191-1001	1	Field Coil Set (Includes Pole Shoes, Field Coil Brushes and Screws)
20	191-1002	4	Screw, Flat Head
21	191-1003	4	Pole, Shoe
22	191-1004	1	Coil, Field
23	191-1005	2	Brush (+)
24	191-1006	1	Holder Assembly, Brush (Includes Brushes and Springs)
25	191-1007	4	Spring, Brush
26	191-1008	2	Brush (-)
27	191-1009	1	Bracket Assembly, Rear (Includes Bearing)
28	191-1010	1	Bearing, Rear
29	191-1011	1	Screw Set (Includes Parts Marked *)
30	191-1012	3	*Screw, Machine - Pan Head
31	191-1013	5	*Washer, Lock
32	191-1014	2	*Washer, Lock
33	191-1015	2	*Screw, Machine - Pan Head

* - Parts contained in 191-1011 Screw Set.

IGNITION GROUP

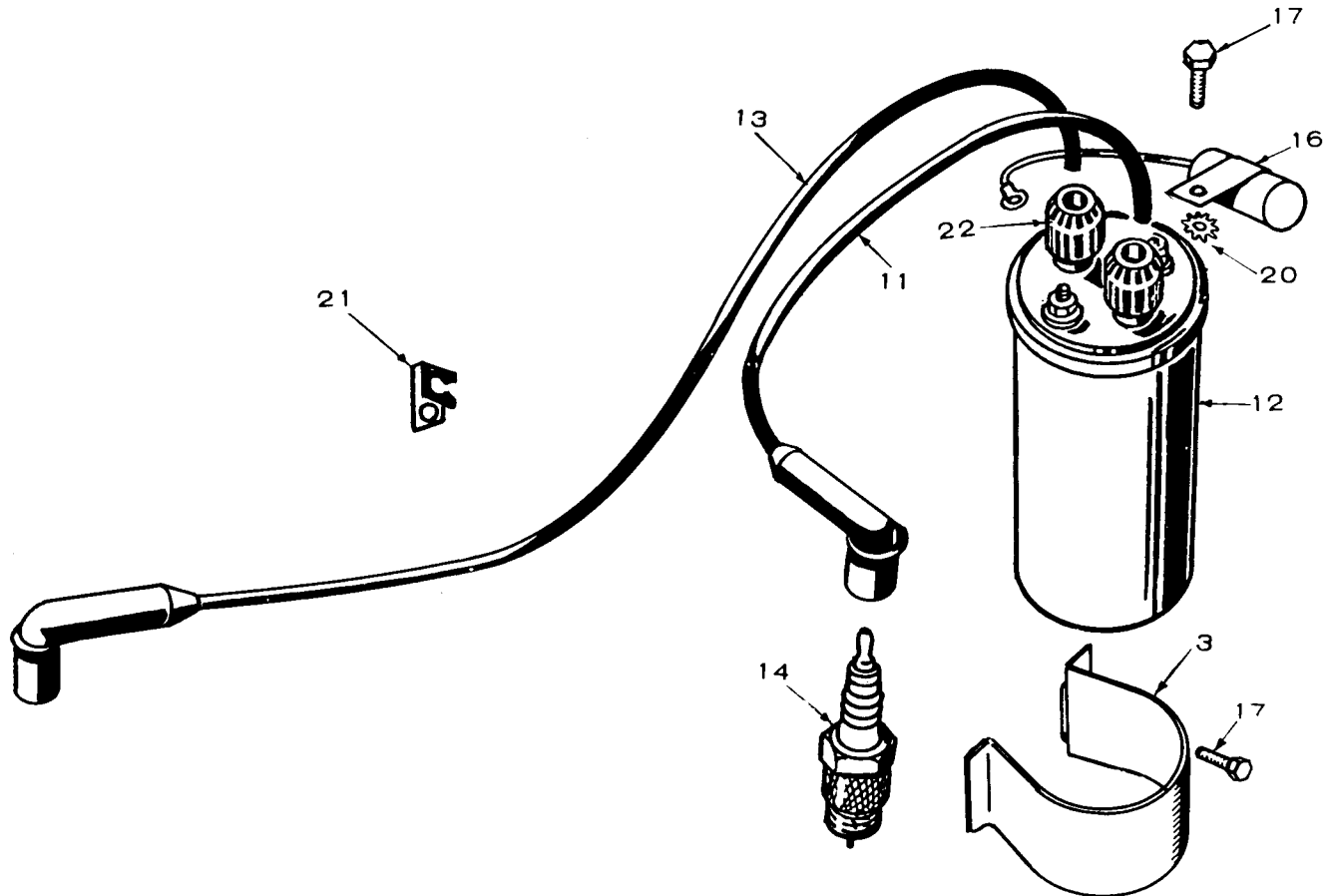
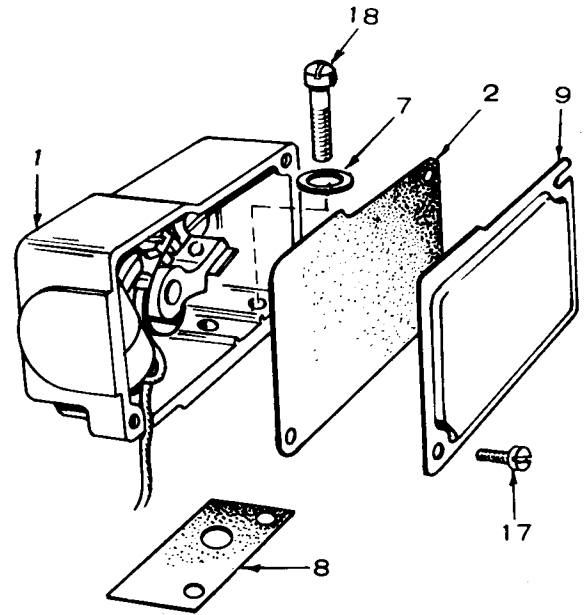
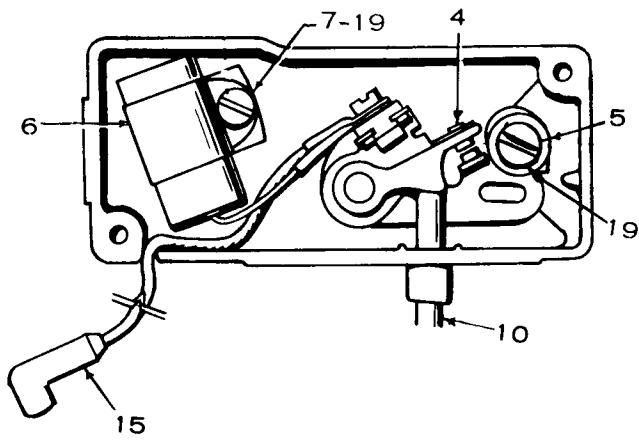

REF. NO.	PART NO.	QTY. USED	PART DESCRIPTION
1	160-1158	1	Box Assembly, Breaker (Includes parts marked *)
2	160-1148	1	*Gasket, Breaker Box Cover
3	166-0603	1	Clamp, Coil Mounting
4	160-1154	1	*Point Set, Breaker
5	870-0221	1	*Nut, Hex with External Shakeproof Washer - Point Set Mounting (#8-32)
6	312-0069	1	Condenser, Breaker Points
7	850-0025	1	*Washer, Lock Condenser Mounting (#8)
8	160-1150	1	Gasket, Breaker Box Mounting
9	160-1149	1	*Cover, Breaker Box
10	160-1151	1	Plunger
11	167-1461	1	Cable, Spark Plug (8-1/2")
12	166-0535	1	Coil, Ignition
13	167-1548	1	Cable, Spark Plug (21")
14	167-0245	2	Plug, Spark
15	336-2132	1	*Lead Assembly, Points to Coil
16	312-0017	1	Condenser, Ignition

REF. NO.	PART NO.	QTY. USED	PART DESCRIPTION
17	SCREW, HEX CAP 815-0352	2	*Breaker Box Cover Mounting (#8-32 x 3/8")
	815-0350	1	Condenser Mounting (#10-32 x 3/8")
	815-0179	1	Coil Clamp Mounting (#10-32 x 3/8")
18	815-0373	2	Screw, Fillister Phillips Head - Breaker Box Mounting (1/4-20 x 5/8")
19	SCREW, SLOTTED PAN HEAD 815-0358	1	Condenser Mounting (#8-32 x 3/8")
	815-0046	1	Breaker Points Mounting (#8-32 x 3/8")
20	856-0003	1	Washer, Shakeproof - Condenser Mounting (#10)
21	167-0188	1	Support, Spark Plug Cable
22	166-0604	2	Cap, Ignition Coil (Part of Coil)

* - Included in 160-1158 Breaker Box Assembly.

GEAR COVER GROUP

REF. NO.	PART NO.	QTY. USED	PART DESCRIPTION
1	103-0418	1	Cover Assembly, Gear (Includes parts marked *)
2	510-0013	1	*Bearing, Governor Shaft (Upper)
3	150-1381	1	*Shaft and Arm Assembly - Governor
4	150-1187	1	*Yoke, Governor Shaft
5	815-0046	2	*Screw, Yoke Retaining
6	516-0130	1	*Pin, Governor Cup Stop
7	509-0008	1	*Seal, Oil - Governor Shaft
8	510-0014	1	*Ball, Bearing - Governor Shaft
9	509-0040	1	*Seal, Gear Cover
10	103-0408	1	Gasket, Gear Cover Mounting
11	516-0011	2	Pin, Gear Cover (5/16 x 1-1/8")
12	510-0008	1	*Bearing, Governor Shaft (Lower)
13	526-0065	5	Washer, Flat - Gear Cover Mounting (5/16" Copper)
14	SCREW, HEX CAP - GEAR COVER MOUNTING		
	800-0032	4	5/16-18 x 1-3/4"
	800-0034	1	5/16-18 x 2-1/4"

* - Included in 103-0418 Gear Cover Assembly.

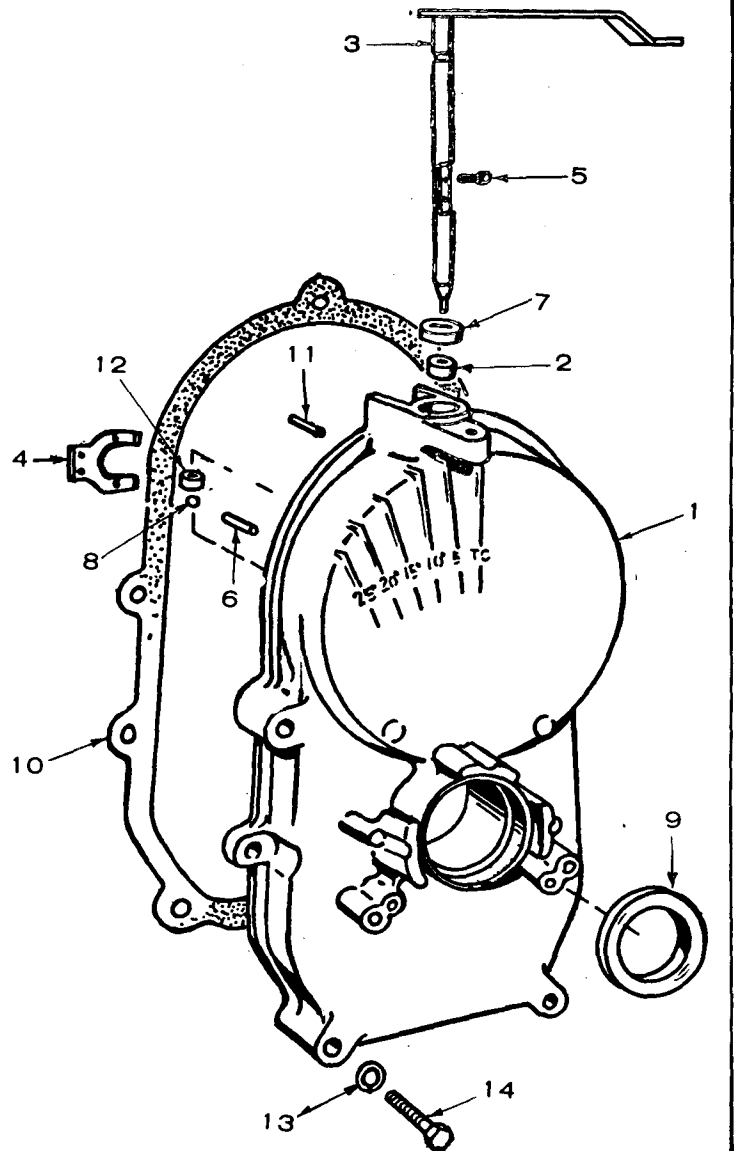

FUEL SYSTEM GROUP

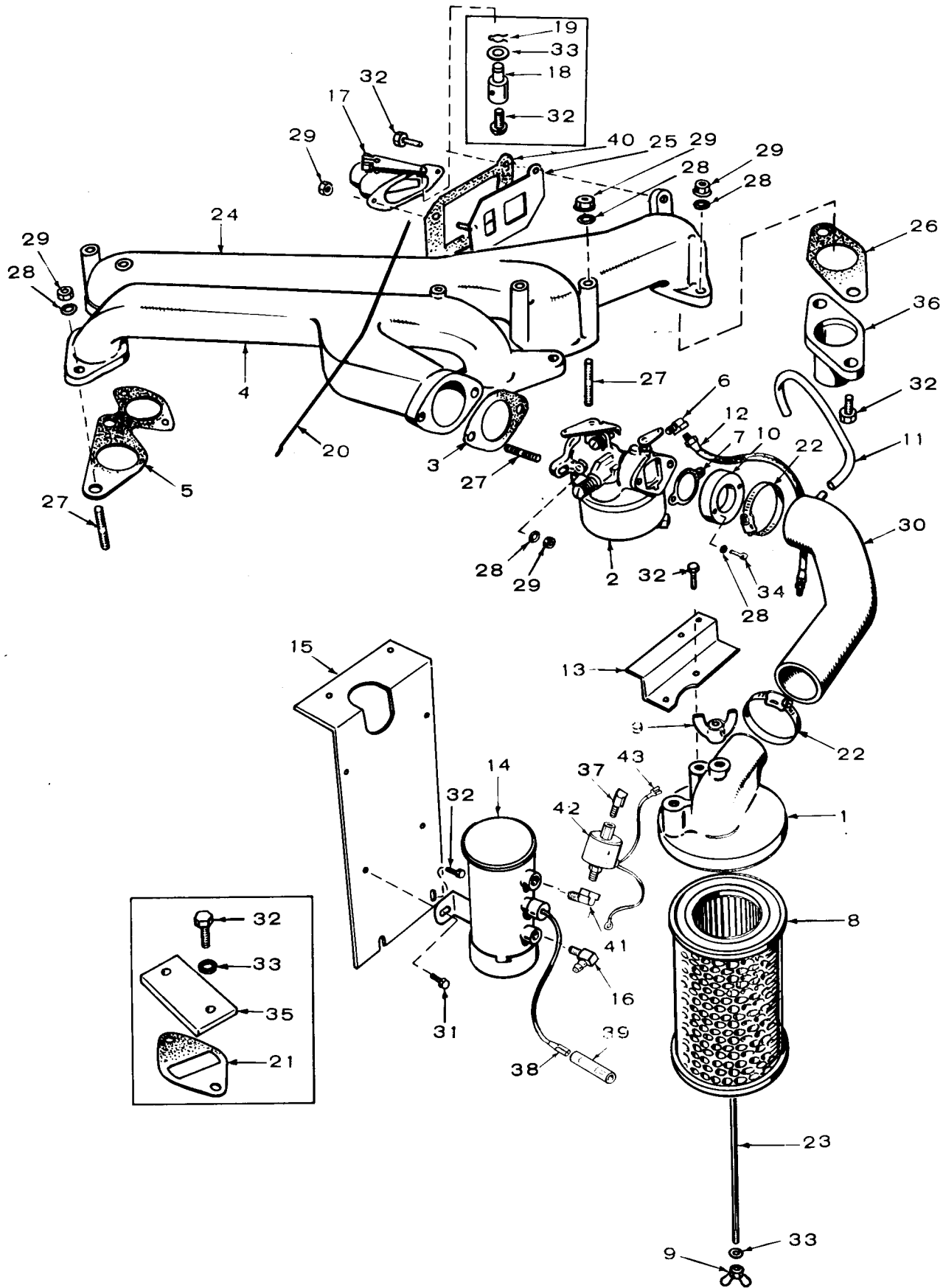

REF. NO.	PART NO.	QTY. USED	PART DESCRIPTION
1	140-1225	1	Adapter, Air Cleaner
2	146-0188	1	Carburetor
3	141-0078	1	Gasket, Carburetor Mounting
4	154-1547	1	Manifold, Intake
5	154-1555	2	Gasket, Intake and Exhaust Manifold
6	502-0020	1	Elbow, Carburetor Inlet
7	145-0111	1	Gasket, Air Cleaner Adapter
8	140-1229	1	Element, Air Cleaner
9	865-0006	2	Nut, Wing - Air Cleaner
10	145-0444	1	Adapter, Carburetor to Inlet Hose
11	503-0672	1	Hose, Breather
12	501-0003	1	Line, Flex - Fuel
13	140-1226	1	Bracket, Air Cleaner Mounting
14	149-0650	1	Pump, Fuel
15	149-1316	1	Bracket, Fuel Pump and Regulator Mounting
16	502-0313	1	Elbow, Fuel Pump Inlet
17	153-0223	1	Choke, Sisson
18	152-0155	1	Swivel, Choke Linkage
19	516-0059	1	Pin, Cotter - Choke Swivel
20	153-0455	1	Linkage, Choke
21	149-0003	1	Gasket, Fuel Pump Hole Cover
22	503-0365	2	Clamp, Air Inlet Hose
23	520-0821	1	Bolt, Air Cleaner Mounting
24	154-1532	1	Manifold, Exhaust
25	153-0452	1	Plate, Choke Mounting
26	154-1383	1	Gasket, Exhaust Manifold
27	STUD		
	520-0819	4	Intake Manifold Mounting
	520-0326	2	Carburetor Mounting
	520-0818	4	Exhaust Manifold Mounting
28	WASHER, LOCK		
	850-0045	2	Exhaust Flange to Manifold (5/16")
	850-0040	2	Carburetor Mounting (1/4")
	850-0050	4	Intake Manifold Mounting (3/8")
	850-0045	4	Exhaust Manifold Mounting (5/16")
29	NUT, HEX		
	862-0015	2	Exhaust Tube to Manifold (5/16-18)

REF. NO.	PART NO.	QTY. USED	PART DESCRIPTION
	104-0091	4	Intake Manifold Mounting (3/8-24)
	110-0445	4	Exhaust Manifold Mounting (5/16-24)
	115-0025	2	Carburetor Mounting (1/4-28)
	870-0212	2	Choke Mounting (1/4-20) - Self Locking
30	503-0671	1	Hose Air Inlet
31	821-0009	2	Screw, Self Locking - Fuel Pump Mounting (1/4-20 x 3/8")
32	SCREW, HEX CAP		
	815-0261	4	Fuel Pump and Regulator Bracket Mounting (#10-32 x 5/16")
	815-0381	1	Choke Swivel (#8-32 x 5/16")
	800-0003	2	Fuel Pump Hole Cover Mounting (1/4-20 x 1/2")
	821-0010	2	Choke Plate Mounting (1/4-20 x 1/2") - Self Locking
	800-0030	2	Exhaust Flange to Manifold (5/16-18 x 1-1/4")
	821-0010	2	Air Cleaner Adapter to Bracket (1/4-20 x 1/2") - Self Locking
33	WASHER, FLAT		
	526-0015	1	Choke Swivel
	526-0052	1	Air Cleaner Mounting
	526-0063	2	Fuel Pump Hole Cover Mounting
34	815-0105	2	Screw, Fillister Head - Air Cleaner Adapter Mounting (#8-32 x 7/8")
35	149-0136	1	Cover, Fuel Pump Hole in Cylinder Block
36	154-1580	1	Flange, Exhaust Outlet
37	502-0002	1	Elbow, Fuel Filter Outlet
38	332-0529	1	Terminal, Fuel Pump Lead
39	332-0556	1	Connector, Fuel Pump Lead
40	153-0026	1	Gasket, Choke Mounting
41	502-0099	1	Elbow, Reducer - Fuel Pump Outlet
42	307-1279	1	Solenoid Valve, Fuel
43	332-1477	1	Terminal, Flat - Fuel Valve

FUEL PUMP PARTS GROUP

REF. NO.	PART NO.	QTY. USED	PART DESCRIPTION
	149-0650	1	Pump, Fuel
1	149-1453	1	Cover
2	149-1446	1	Gasket, Cover
3	149-1447	1	Magnet
4	149-1445	1	Filter
5	149-1448	1	Retainer, Cup and Plunger
6	149-1449	1	Washer, Cup Gasket
7	149-1450	1	Gasket, Spring Cup
8	149-1451	1	Spring Cup and Valve
9	149-0767	1	Spring, Plunger Return
10	149-1452	1	Plunger

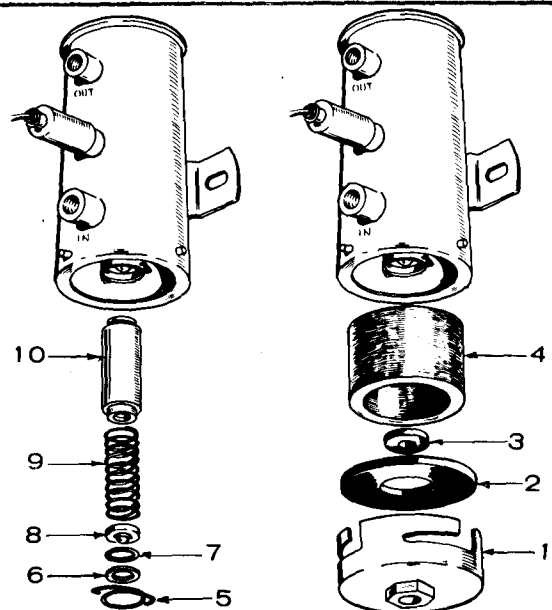

GOVERNOR, STARTER, CHARGING ALTERNATOR AND BLOWER HOUSING GROUP

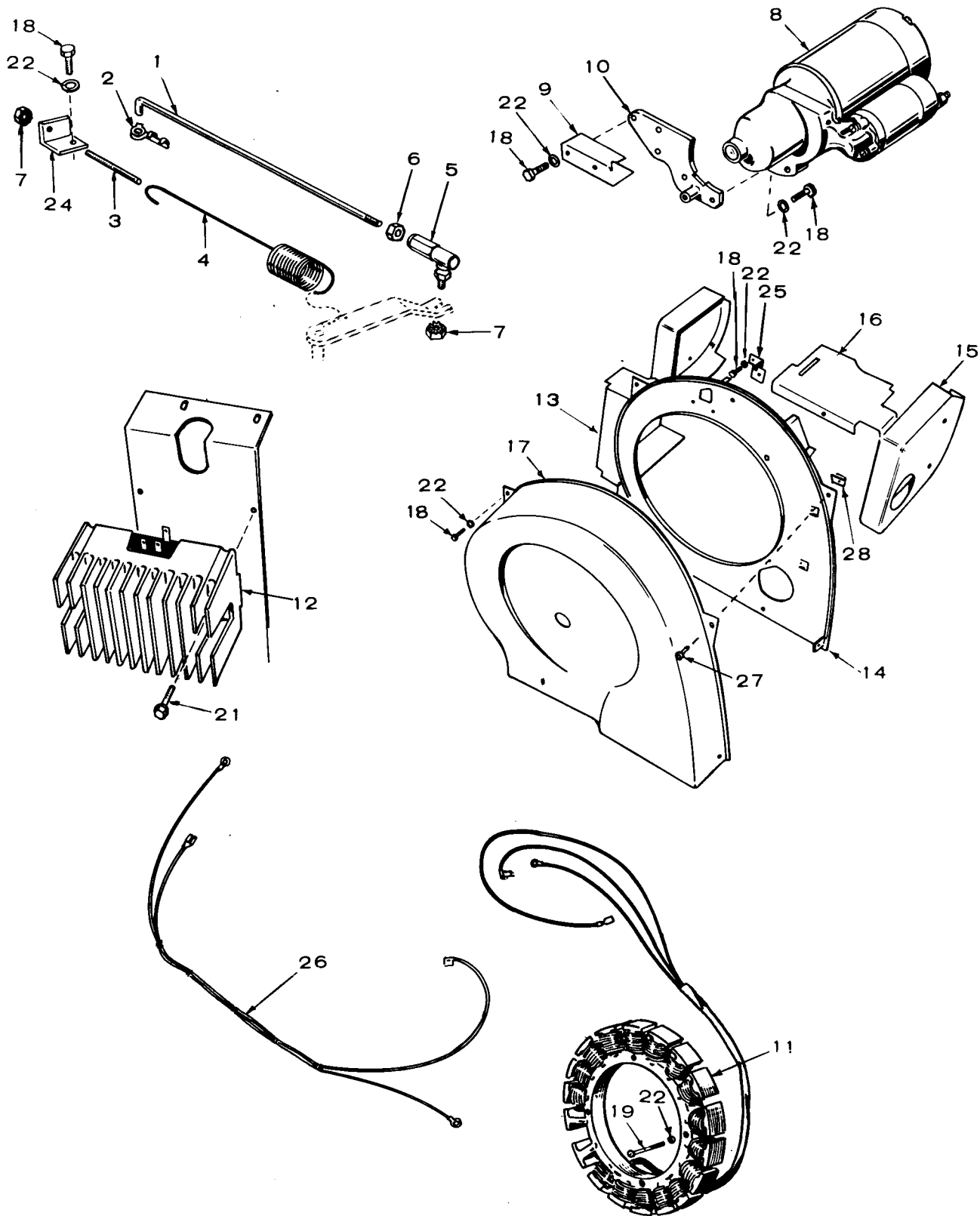

<u>REF. NO.</u>	<u>PART NO.</u>	<u>QTY. USED</u>	<u>PART DESCRIPTION</u>
1	150-1382	1	Rod, Governor Control
2	518-0004	1	Clip, Governor Control Rod
3	150-0096	1	Stud, Governor Adjusting
4	150-1376	1	Spring, Governor
5	150-0639	1	Joint, Ball - Governor
6	870-0188	1	Palnut, Governor Rod
7	870-0131	2	Nut, Keps - Governor Ball Joint and Adjusting Stud
8	191-0922	1	Motor, Starting (NOTE: For Components - see separate group)
9	134-2607	1	Bracket, Muffler and Starting Motor Baffle
10	191-0929	1	Bracket, Starting Motor Mounting
11	191-0931	1	Stator, Charging Alternator
12	191-0886	1	Regulator, 12 Volt
13	134-2598	1	Housing, Cylinder Air - Left Side
14	134-2612	1	Scroll, Blower Housing
15	134-2597	1	Housing, Cylinder Air - Right Side
16	134-2601	1	Baffle, Cylinder Air - Right Side
17	134-2595	1	Cover, Blower Housing Scroll
18	SCREW, HEX CAP 815-0261	6	Cylinder Air Housing Mounting (1/4-20 x 7/16")
	800-0003	2	Scroll Cover Mounting (1/4-20 x 1/2")

<u>REF. NO.</u>	<u>PART NO.</u>	<u>QTY. USED</u>	<u>PART DESCRIPTION</u>
	800-0004	1	Governor Bracket Mounting (1/4-20 x 5/8")
	800-0051	3	Starting Motor Bracket Mounting (3/8-16 x 1-1/4")
	800-0051	2	Starting Motor to Bracket (3/8-16 x 1/4")
19	813-0108	2	Screw, Round Head - Stator Mounting (#10-32 x 1-1/2")
21	821-0018	2	Screw, Self Locking - Regulator Mounting (1/4-20 x 5/8")
22	WASHER, LOCK 850-0050	2	Starting Motor to Bracket (3/8")
	850-0050	3	Starting Motor Bracket Mounting (3/8")
	850-0030	3	Stator Mounting (#10)
	850-0040	2	Scroll Cover Mounting (1/4")
	850-0040	1	Governor Bracket Mounting (1/4")
24	150-1388	1	Bracket Governor Spring Adjusting
25	134-2596	1	Bracket, Scroll Mounting
26	338-0709	1	Harness Wiring Alternator
27	809-0059	2	Screw, Sheet Metal - Scroll Cover Mounting (1/4 x 1/2")
28	870-0106	2	Nut, Speed - Scroll Cover Mounting

CHASSIS GROUP

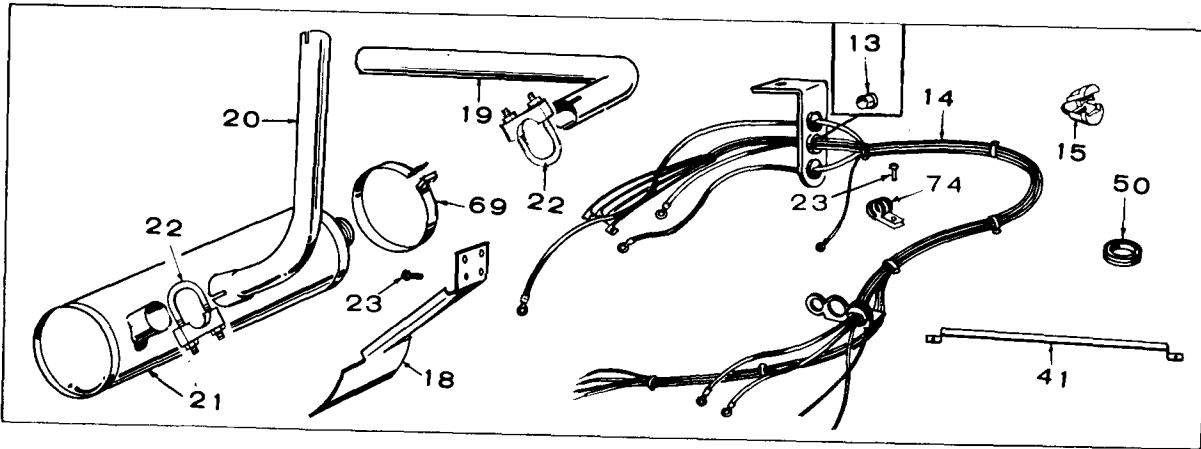
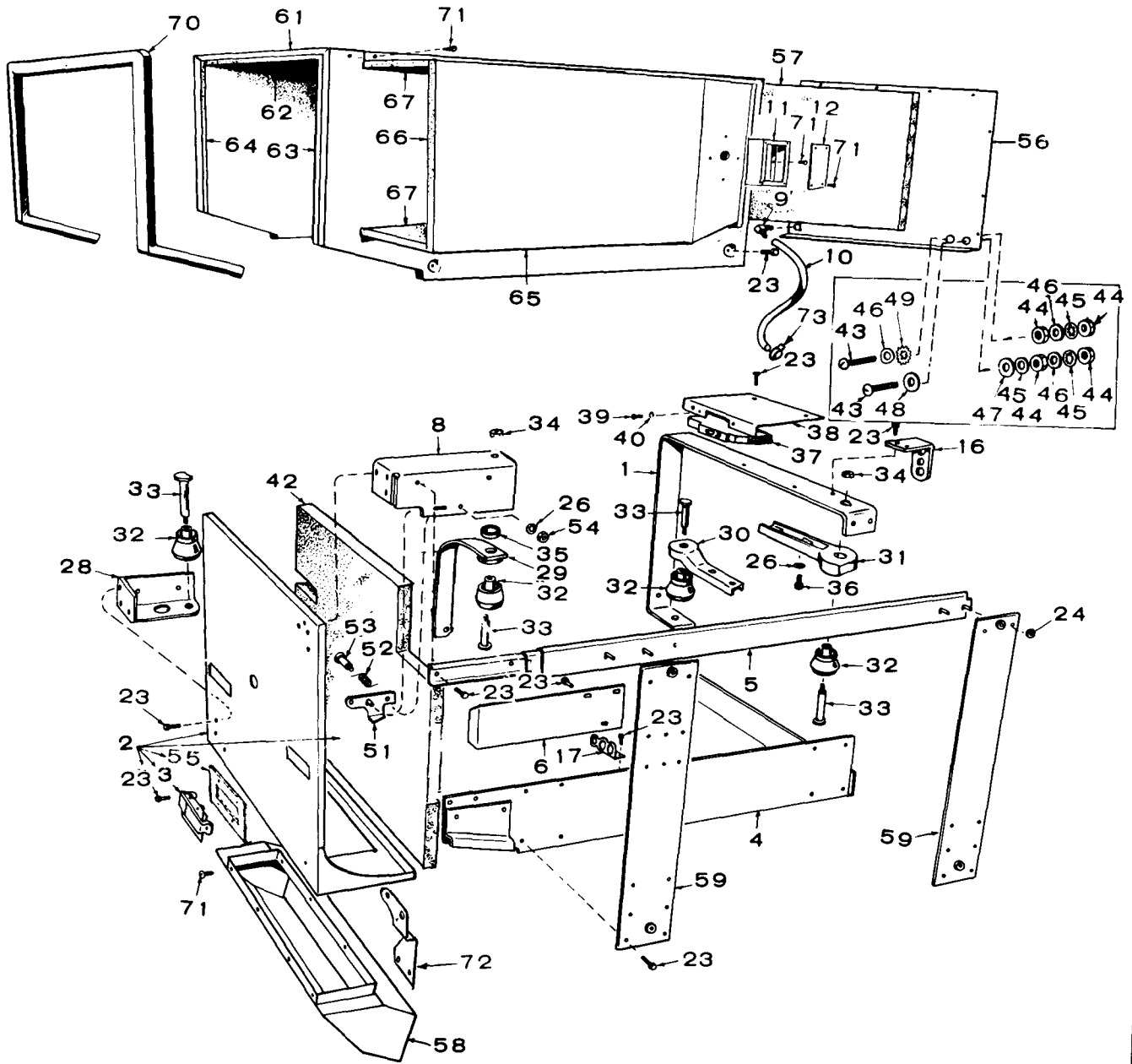

<u>REF. NO.</u>	<u>PART NO.</u>	<u>QTY. USED</u>	<u>PART DESCRIPTION</u>	<u>REF. NO.</u>	<u>PART NO.</u>	<u>QTY. USED</u>	<u>PART DESCRIPTION</u>
1	405-2073	1	Yoke, Generator Support	39	812-0059	2	Screw, Round Head - Circuit Breaker Mounting (#6-32 x 1/4")
2	405-2070	1	Door, Slide Out (Includes Latches and Insulation)	40	850-0020	2	Washer, Lock - Circuit Breaker Mounting (#6)
3	406-0372	2	Latch, Door	41	405-2007	1	Bracket, Fuel Line Return
4	405-2046	1	Base, Mounting	42	405-2071	1	Insulation, Door
5	405-2074	2	Slide	43	810-0181	2	Screw, Round Head Brass - Battery Cable Terminal (5/16-18 x 1-1/4")
6	405-2075	2	Bracket, Latch Strike	44	871-0025	4	Nut, Hex Brass - Battery Cable Terminals (5/16-18)
8	403-1032	1	Bracket, Engine Mounting	45	854-0017	3	Washer, Internal Shakeproof - Battery Cable Terminals (5/16")
9	502-0313	1	Connector Elbow - Fuel Line	46	526-0054	3	Washer, Flat - Battery Cable Terminals (5/16")
10	503-0687	1	Hose, Fuel	47	508-0019	1	Washer, Fibre - Battery Cable Terminals (5/16")
11	301-3639	1	Box, Junction	48	508-0181	1	Washer, Fibre - Battery Cable Terminals (5/16")
12	301-3640	1	Cover, Junction Box	49	856-0008	2	Washer, External - Internal Shakeproof - Battery Cable Terminals (5/16")
13	331-0102	1	Bushing (Part of Wiring Harness)	50	508-0008	1	Grommet, Battery Cable Through Pan
14	338-0711	1	Harness, Wiring - Chassis	51	405-2008	1	Lever, Safety Latch
15	508-0179	4	Relief, Strain (Part of Wiring Harness)	52	405-2081	1	Spring, Safety Stop Latch
16	301-3612	1	Bracket, Harness Mounting (Part of Wiring Harness)	53	150-1146	1	Screw, Lever Engage
17	301-3613	1	Bracket, Harness Mounting (Part of Wiring Harness)	54	115-0025	1	Nut, Hex - Safety Latch (1/4-28)
18	155-1238	1	Bracket, Muffler Hanger	55	405-2076	2	Spacer, Door Latch Mounting
19	155-1265	1	Tube, Exhaust Extension	56	405-2063	1	Panel, Rear Housing (Includes Insulation)
20	155-1260	1	Tube, Exhaust	57	405-2065	1	Insulation, Rear Panel
21	155-1222	1	Muffler, Exhaust	58	405-2089	1	Duct, Exhaust Air
22	155-1015	3	Clamp, Exhaust	59	405-2051	4	Bracket, Hanger
23	SCREW, HEX CAP			61	405-2058	1	Cover, Generator Set (Includes Insulation)
	815-0261	6	Striker Catch Mounting (1/4-20 x 1/2")	62	405-2060	1	Insulation, Cover Top
	815-0261	16	Hanger Bracket Mounting (1/4-20 x 1/2")	63	405-2062	1	Insulation, Cover Right Side
	815-0261	6	Door Mounting (1/4-20 x 1/2")	64	405-2061	1	Insulation, Cover Left Side
	815-0261	3	Wiring Harness Brackets Mounting (1/4-20 x 1/2")	65	405-2053	1	Duct Assembly (Includes Insulation)
	815-0261	2	Circuit Breaker Bracket Mounting (1/4-20 x 1/2")	66	405-2055	1	Insulation, Duct (Side)
	815-0261	2	Muffler Bracket Mounting (1/4-20 x 1/2")	67	405-2056	2	Insulation, Duct (Top and Bottom)
	815-0376	8	Door Latch Mounting (#10-32 x 3/4")	69	503-0681	2	Clamp, Muffler
	815-0261	2	Harness Clamp Mounting (1/4-20 x 1/2")	70	SEAL, WEATHER PROOF	1	Door (Order 65" of Bulk Seal Number 895-150)
	815-0261	8	Cover, Mounting (1/4-20 x 1/2")			1	Bottom Panel (Order 29" of Bulk Seal Number 895-0151)
24	870-0212	9	Nut, Self Locking - Slide Rail Mounting (1/4-20)	71	SCREW, SHEET METAL		
26	WASHER, LOCK			815-0335	10	Duct Assembly Mounting (#10)	
	850-0050	4	Generator Support Mounting (3/8")	815-0335	10	Back Panel Mounting (#10)	
	850-0038	1	Safety Latch Mounting (1/4")	815-0335	8	Outlet Duct Mounting (#10)	
28	403-1033	1	Bracket, Engine End - Left Side	815-0335	4	Outlet Box Mounting (#10)	
29	403-1022	1	Foot Assembly, Engine Mounting - Right Side	809-0044	4	Outlet Box Cover Mounting (#10)	
30	232-2363	1	Support Generator - Right Side	72	155-1269	1	Bracket, Muffler Mounting
31	232-2364	1	Support Generator - Left Side	73	503-0685	2	Clamp, Fuel Line
32	402-0284	4	Cushion, Mount	74	CLAMP, HARNESS		
33	402-0412	4	Bolt, Cushion Mounting	332-1553	1	1"	
34	870-0281	4	Nut, Self Locking - Cushion Mounting	332-1554	1	1/2"	
35	402-0413	1	Spacer, Cushion Mounting - Engine End - Right Side				
36	800-0051	4	Screw, Hex Cap - Generator Support (3/8-16 x 1-1/4")				
37	320-0052	1	Breaker, Circuit				
38	405-2003	1	Bracket, Circuit Breaker Mounting				

CONTROL GROUP

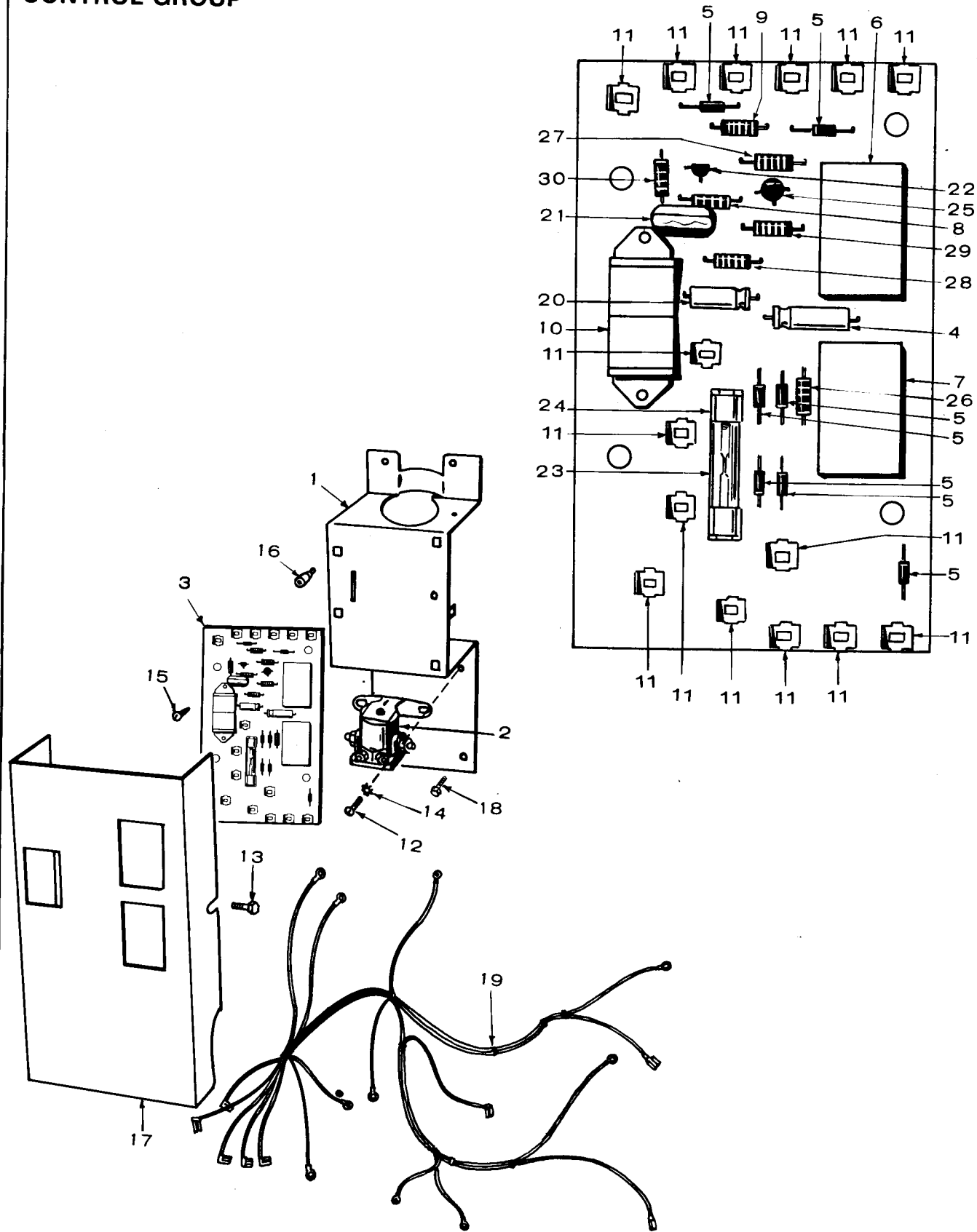

<u>REF. NO.</u>	<u>PART NO.</u>	<u>QTY. USED</u>	<u>PART DESCRIPTION</u>
1	301-3596	1	Bracket, Control and Coil Mounting
2	307-0845	1	Relay - Start Solenoid
3	300-0944	1	Control Assembly (Includes Parts Marked *)
4	356-0058	1	*Capacitor (100 Mfd. 25 VDC)
5	357-0004	7	*Rectifier, Silicon
6	307-1197	1	*Relay, Start Disconnect
7	307-1196	1	*Relay, Engine Stop
8	350-0524	1	*Resistor (100-Ohm, 1/2 Watt)
9	350-0526	1	*Resistor (330-Ohm, 1/2 Watt)
10	308-0320	1	*Switch
11	332-1511	15	*Tab, Stake
12	821-0009	2	Screw, Self Locking - Start Solenoid Mounting (1/4-20 x 3/8")
13	815-0379	2	Screw, Hex Head - Control Cover Mounting (#10 x 1/2")
15	815-0382	4	Screw, Sheet Metal - Control to Bracket (#8 x 1")

<u>REF. NO.</u>	<u>PART NO.</u>	<u>QTY. USED</u>	<u>PART DESCRIPTION</u>
16	870-0280	4	Nut, Insulating - Control to Bracket
17	301-3597	1	Cover, Control
18	815-0261	4	Screw, Control Bracket Mounting - Hex Cap (#10-32 x 5/16")
19	338-0697	1	Harness, Wiring - Control to Engine
20	356-0046	1	*Capacitor (5 Mfd., 25 Volt)
21	355-0025	1	*Capacitor (.1 Mfd., 100 Volt)
22	364-0011	1	*Rectifier, Gate Control (8 Amp., 30 Volt)
23	321-0181	1	*Fuse, 5 Amp
24	321-0163	2	*Clip, Fuse Holder
25	361-0006	1	*Transistor, Unijunction
26	350-0370	1	*Resistor (200-Ohm, 1/2 Watt)
27	350-0568	1	*Resistor (470 K Ohm, 1/2 Watt)
28	350-0421	1	*Resistor (27 K Ohm, 1/2 Watt)
29	350-0416	1	*Resistor (16 K Ohm, 1/2 Watt)
30	350-0325	1	*Resistor (2.7-Ohm, 1/2 Watt)

* - Parts Included in the 300-0944 Control Assembly.

CARBURETOR PARTS GROUP

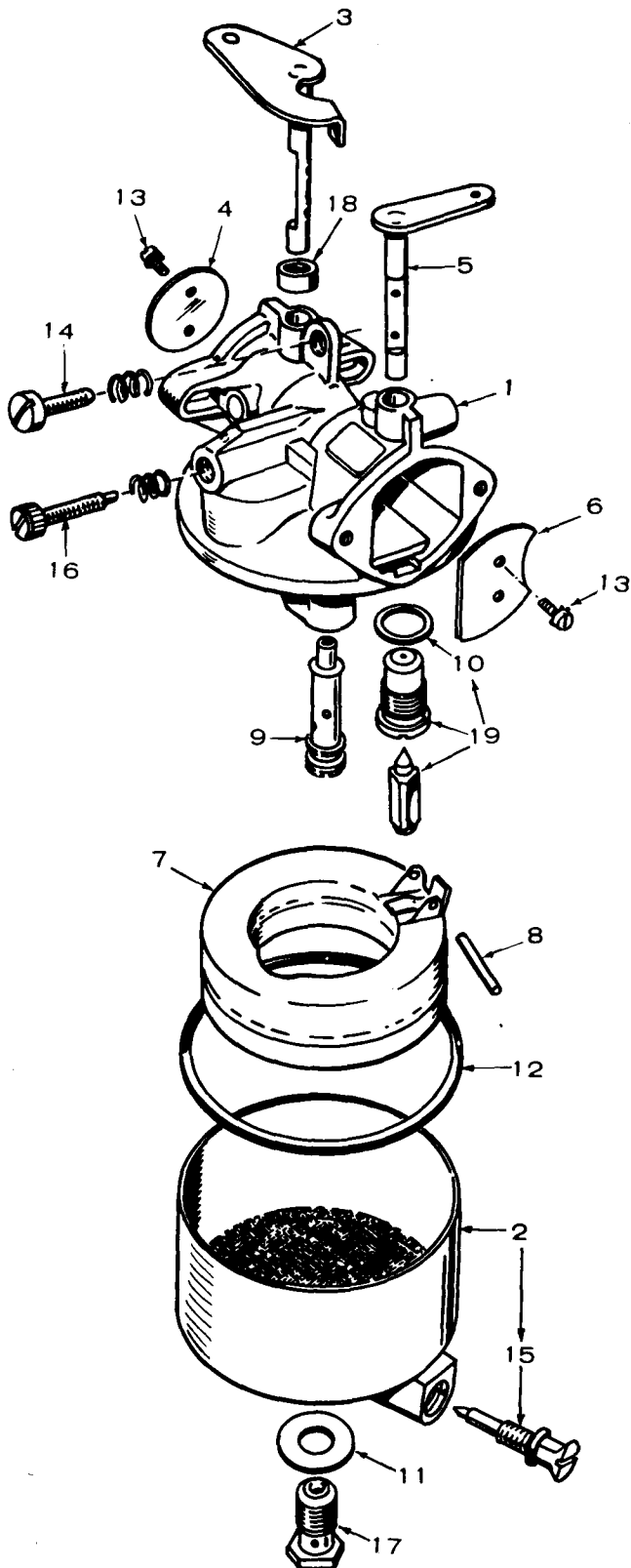

<u>REF. NO.</u>	<u>PART NO.</u>	<u>QTY. USED</u>	<u>PART DESCRIPTION</u>
	146-0188	1	Carburetor Assembly (Complete)
1	146-0189	1	Body, Carburetor
2	146-0171	1	Bowl Assembly (Includes Power Needle and Screen)
3	146-0172	1	Shaft, Throttle
4	146-0173	1	Valve, Throttle
5	146-0174	1	Shaft, Choke
6	146-0175	1	Valve, Choke
7	146-0176	1	Float Assembly
8	146-0111	1	•Shaft, Float
9	146-0190	1	Nozzle
10	146-0182	1	*Gasket, Valve Seat
11	146-0183	2	*Gasket, Bowl Nut
12	146-0184	1	*Gasket, Body to Bowl
13	146-0142	4	Screw and Washer Assembly
14	146-0186	1	Spring and Screw, Adjusting
15	146-0187	1	•Needle Assembly - Power
16	146-0116	1	•Needle Assembly - Idle
17	146-0177	1	Retainer, Bowl
18	146-0178	1	Seal, Throttle Shaft
19	146-0179	1	•Float, Valve Seat and Gasket Assembly
	141-0078	1	*Gasket, Mounting Flange
	146-0185	1	•Kit, Gasket (Includes Parts Marked *)
	146-0180	1	*Kit, Repair (Includes Parts Marked •)

* - Parts contained in the 146-0185 Gasket Kit.
 • - Parts contained in the 146-0180 Repair Kit.

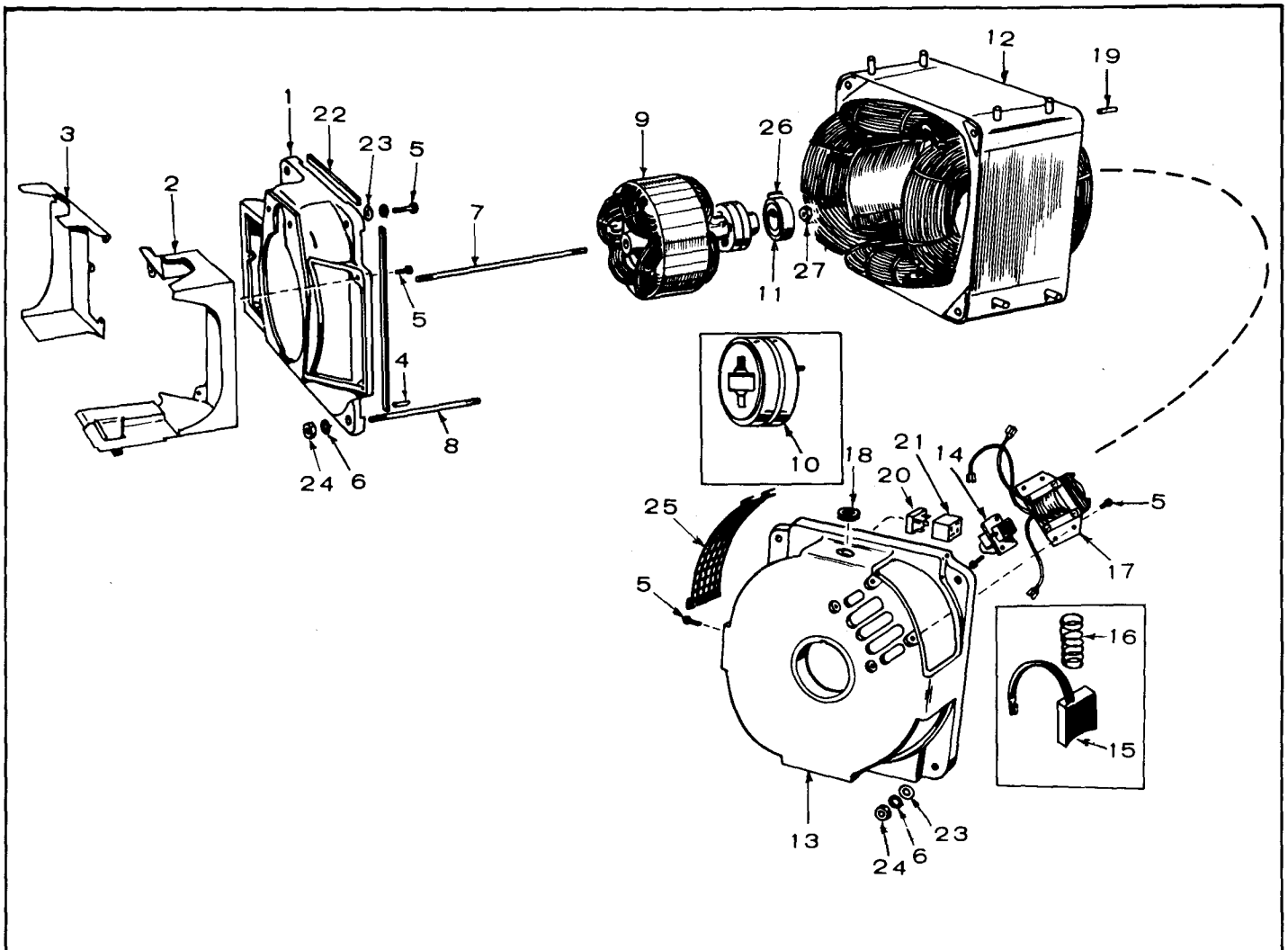

GENERATOR GROUP

REF. NO.	PART NO.	QTY. USED	PART DESCRIPTION	REF. NO.	PART NO.	QTY. USED	PART DESCRIPTION
1	231-0162	1	Adapter, Control	10	204-0115	1	Ring, Collector
2	134-2626	1	Duct, Generator Air, Starter Baffle and Oil Filter Drain (Right Side)	11	510-0047	1	Bearing, Ball
3	134-2600	1	Duct, Generator Air (Left Side)	12	220-1858	1	Frame and Stator, Wound
4	516-0182	4	Pin, Roll - Generator Adapter	13	211-0224	1	Bell, End
5	SCREW, HEX HEAD			14	212-0351	2	Block Assembly (Includes Brushes and Springs)
	815-0340	6	Air Duct Mounting (#10-32 x 3/8")	15	214-0096	4	Brush
	800-0050	4	Adapter Mounting (3/8-16 x 1-1/4")	16	212-1232	4	Spring, Brush
	815-0359	4	Brush Block Mounting (#10-32 x 7/8")	17	315-0378	1	Reactor, Compounding
	815-0374	1	Rectifier Mounting (#8-32 x 1-1/4")	18	508-0178	1	Grommet, Output Leads
	815-0359	4	Reactor Mounting (#10-32 x 7/8")	19	516-0182	4	Pin, Roll - End Bell
6	850-0045	8	Washer, Lock - Generator Through Stud (5/16")	20	305-0519	1	Plug, Rectifier Bridge
7	520-0784	1	Stud, Rotor Through	21	305-0517	1	Bridge, Rectifier
8	520-0730	4	Stud, Generator Mounting	22	232-2368	4	Seal, Generator to Adapter
9	201-1987	1	Armature Assembly, Wound (Includes Bearing and Collector Ring)	23	WASHER, FLAT		
					526-0115	4	Generator Through Stud
					526-0066	4	Adapter Mounting
				24	862-0015	8	Nut, Hex - Generator Through Stud
				25	234-0461	3	Screen, End Bell
				26	232-0596	1	Clip, Generator Bearing Stop
				27	870-0273	1	Nut, Rotor Through Stud

SERVICE KITS

168-0127	1	Gasket Kit, Carbon Removal
168-0125	1	Gasket Kit, Engine
522-0270	1	Overhaul Kit

CUSTOMER SERVICES

OWNER'S WARRANTY SERVICE -
ENGINE DRIVEN ELECTRIC GENERATOR SETS,
SEPARATE GENERATORS, INDUSTRIAL ENGINES

QUALITY OF PRODUCT

Onan products are engineered and designed to perform as stated on product nameplate and published specification. With proper installation and operation, regular maintenance and periodic repair service, the equipment will provide reliable service.

GENERAL WARRANTY PRACTICES

All Onan-manufactured engine-driven electric generator sets, separate generators, and industrial engines are sold with a full one-year warranty. This warranty is issued only to the original user and promises satisfactory performance of the product when properly installed, serviced, and operated under normal conditions, according to the manufacturer's instructions. The text of the Onan published warranty appears in the Onan Operator's Manual sent with the product.

Warranty Registration: A Warranty Registration card accompanies each Onan Product. This card must be properly filled out and returned to the Onan Factory in order to qualify for warranty consideration as covered in this bulletin. When requesting warranty repair work you must provide the purchase date, Onan model, and serial number of the equipment.

Warranty Authorization: Warranty service must be performed by Onan Factory or Onan Authorized Distributors or their Approved and Registered Service Dealers. A complete listing of these Onan Authorized Parts and Service Centers is provided in our brochure F-115, a copy of which is supplied with each Onan Product. These Onan Authorized Service Centers have trained service personnel, parts stock, and the necessary facilities and tools for the service and repair of Onan equipment.

Material Allowances: Onan will allow credit or furnish free of charge to the Onan Authorized Service Station or his Approved Service Dealer, all genuine Onan parts used in a warranty repair of these products which fail to perform as warranted.

Labor Allowance: Onan will allow warranty repair credit to the Onan Authorized Parts and Service Center and his Approved Dealer at straight time labor when the cause of failure is determined to be defective material or factory workmanship. This labor allowance will be based on the factory's standard time schedule of published flat rate labor allowances, or, otherwise a time judged reasonable by the factory. Repair work not covered by warranty will be charged to the owner. The Onan's Warranty practice does not provide for allowance of expenses such as start-up charges, communication charges, transportation charges, travel time and/or mileage, unit removal or installation expense, cost of fuel, oil, normal maintenance adjustments, tune-up adjustments or parts maintenance items, and does not cover incidental or consequential damages.

Administration: Warranty of Onan Products is administered through Onan Authorized Distributors in whose territory the equipment is located. These Distributors and their Approved or Registered Onan Service Dealers are authorized to make settlement of all customer warranty claims within the limits of the manufacturer's warranty policy as described herein.

Onan reserves the right to change warranty practices without prior notice.

MAINTENANCE

A Planned Preventive Maintenance Program is extremely important if you are to receive efficient operation and long service life from your Onan unit. Neglecting routine maintenance can result in premature failure or permanent damage to your equipment. The Onan Operator's Manual sent with the product contains recommended maintenance schedules and procedures.

Maintenance is divided into two categories:

- 1. Operator Maintenance performed by the operator.
- 2. Critical Maintenance performed only by qualified service personnel.

Regular maintenance will help you avoid sudden and costly repairs in the future. Adequate evidence of this scheduled maintenance must be offered when applying for a warranty claim.

INSTALLATION

Installation is extremely important and all Onan Products should be installed in accordance with the manufacturer's recommendations. If the owner experiences any difficulty with such items as mounting, ventilation, exhaust location, fuel lines, wiring, etc., he should immediately contact the company from whom he purchased the equipment so that corrective action can be taken. Although the Onan Authorized Distributor and his Approved or Registered Service Dealers may be able to remedy certain installation difficulties, such repair work is not considered Onan warranty and there will be a charge for this service.

Onan
Minneapolis, Minnesota 55432

MSS-22B
Replaces 23B054 and MSS-22A
Rev. 7-2-73

Power on Demand
*for the **Fun** Things in Life*

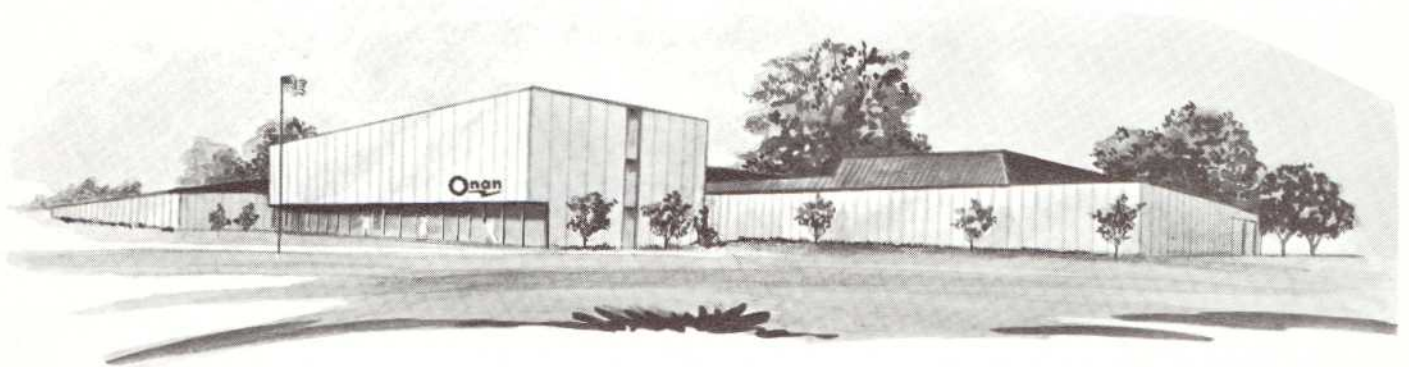

ONAN

1400 73RD AVENUE N.E. • MINNEAPOLIS, MINNESOTA 55432

A DIVISION OF ONAN CORPORATION

