

**OPERATOR'S MANUAL
AND
PARTS CATALOG**

FOR
TRACTOR DRIVE ALTERNATOR

UF

SERIES

15.0UF-3S/104

15.0UF-3S/153

INTRODUCTION

THIS OPERATOR'S MANUAL CONTAINS INFORMATION PERTAINING TO THE OPERATION AND MAINTENANCE OF YOUR UNIT.

WE SUGGEST YOU KEEP THE MANUAL AND THE WIRING DIAGRAM WHICH ACCOMPANIES EVERY UNIT AND REFER TO IT WHEN MAKING EQUIPMENT ADJUSTMENTS OR ORDERING PARTS. ADDITIONAL COPIES ARE AVAILABLE FOR A NOMINAL CHARGE FROM YOUR DISTRIBUTOR.

WHEN ORDERING PARTS, REMEMBER TO INCLUDE THE MODEL, SPECIFICATION LETTER, AND SERIAL NUMBER LOCATED ON THE UNIT NAMEPLATE. THIS IS ESSENTIAL TO ENSURE THE CORRECT PART IS SHIPPED TO YOU.

FOR REPAIR SERVICE, CONTACT YOUR AUTHORIZED SERVICE REPRESENTATIVE.

WARNING

TO AVOID POSSIBLE PERSONAL INJURY OR EQUIPMENT DAMAGE, A QUALIFIED ELECTRICIAN OR AN AUTHORIZED SERVICE REPRESENTATIVE MUST PERFORM INSTALLATION AND ALL SERVICE.

Important Safety Precautions

Read and observe these safety precautions when using or working on electric generators, engines and related equipment. Also read and follow the literature provided with the equipment.

Proper operation and maintenance are critical to performance and safety. Electricity, fuel, exhaust, moving parts and batteries present hazards that can cause severe personal injury or death.

FUEL, ENGINE OIL, AND FUMES ARE FLAMMABLE AND TOXIC

Fire, explosion, and personal injury can result from improper practices.

- Used engine oil, and benzene and lead, found in some gasoline, have been identified by government agencies as causing cancer or reproductive toxicity. When checking, draining or adding fuel or oil, do not ingest, breathe the fumes, or contact gasoline or used oil.
- Do not fill tanks with engine running. Do not smoke around the area. Wipe up oil or fuel spills. Do not leave rags in engine compartment or on equipment. Keep this and surrounding area clean.
- Inspect fuel system before each operation and periodically while running.
- Equip fuel supply with a positive fuel shutoff.
- Do not store or transport equipment with fuel in tank.
- Keep an ABC-rated fire extinguisher available near equipment and adjacent areas for use on all types of fires except alcohol.
- Unless provided with equipment or noted otherwise in installation manual, fuel lines must be copper or steel, secured, free of leaks and separated or shielded from electrical wiring.
- Use approved, non-conductive flexible fuel hose for fuel connections. Do not use copper tubing as a flexible connection. It will work-harden and break.

EXHAUST GAS IS DEADLY

- Engine exhaust contains carbon monoxide (CO), an odorless, invisible, poisonous gas. Learn the symptoms of CO poisoning.
- Never sleep in a vessel, vehicle, or room with a genset or engine running unless the area is equipped with an operating CO detector with an audible alarm.
- Each time the engine or genset is started, or at least every day, thoroughly inspect the exhaust system. Shut down the unit and repair leaks immediately.

- Warning: Engine exhaust is known to the State of California to cause cancer, birth defects and other reproductive harm.

Make sure exhaust is properly ventilated.

- Vessel bilge must have an operating power exhaust.
- Vehicle exhaust system must extend beyond vehicle perimeter and not near windows, doors or vents.
- Do not use engine or genset cooling air to heat an area.
- Do not operate engine/genset in enclosed area without ample fresh air ventilation.
- Expel exhaust away from enclosed, sheltered, or occupied areas.
- Make sure exhaust system components are securely fastened and not warped.

MOVING PARTS CAN CAUSE SEVERE PERSONAL INJURY OR DEATH

- Do not remove any guards or covers with the equipment running.
- Keep hands, clothing, hair, and jewelry away from moving parts.
- Before performing any maintenance, disconnect battery (negative [-] cable first) to prevent accidental starting.
- Make sure fasteners and joints are secure. Tighten supports and clamps, keep guards in position over fans, drive belts, etc.
- If adjustments must be made while equipment is running, use extreme caution around hot manifolds and moving parts, etc. Wear safety glasses and protective clothing.

BATTERY GAS IS EXPLOSIVE

- Wear safety glasses and do not smoke while servicing batteries.
- Always disconnect battery negative (-) lead first and reconnect it last. Make sure you connect battery correctly. A direct short across battery terminals can cause an explosion. Do not smoke while servicing batteries. Hydrogen gas given off during charging is explosive.
- Do not disconnect or connect battery cables if fuel vapors are present. Ventilate the area thoroughly.

DO NOT OPERATE IN FLAMMABLE AND EXPLOSIVE ENVIRONMENTS

Flammable vapor can be ignited by equipment operation or cause a diesel engine to overspeed and become difficult to stop, resulting in possible fire, explosion, severe personal injury and death. **Do not operate diesel equipment where a flammable vapor environment can be created by fuel spill, leak, etc., unless equipped with an automatic safety device to block the air intake and stop the engine.**

HOT COOLANT CAN CAUSE SEVERE PERSONAL INJURY

- Hot coolant is under pressure. Do not loosen the coolant pressure cap while the engine is hot. Let the engine cool before opening the pressure cap.

ELECTRICAL SHOCK CAN CAUSE SEVERE PERSONAL INJURY OR DEATH

- Do not service control panel or engine with unit running. High voltages are present. Work that must be done while unit is running should be done only by qualified service personnel.
- Do not connect the generator set to the public utility or to any other electrical power system. Electrocutation can occur at a remote site where line or equipment repairs are being made. An approved transfer switch must be used if more than one power source is connected.
- Disconnect starting battery (negative [-] cable first) before removing protective shields or touching electrical equipment. Use insulative mats placed on dry wood platforms. Do not wear jewelry, damp clothing or allow skin surface to be damp when handling electrical equipment.
- Use insulated tools. Do not tamper with interlocks.
- Follow all applicable state and local electrical codes. Have all electrical installations performed by a qualified licensed electrician. Tag open switches to avoid accidental closure.
- With transfer switches, keep cabinet closed and locked. Only authorized personnel should have cabinet or operational keys. Due to serious shock hazard from high voltages within cabinet, all service and adjustments must be performed by an electrician or authorized service representative.

If the cabinet must be opened for any reason:

1. Move genset operation switch or Stop/Auto/Handcrank switch (whichever applies) to Stop.
2. Disconnect genset batteries (negative [-] lead first).
3. Remove AC power to automatic transfer switch. If instructions require otherwise, use extreme caution due to shock hazard.

MEDIUM VOLTAGE GENERATOR SETS (601V TO 15kV)

- Medium voltage acts differently than low voltage. Special equipment and training are required to work on or around medium voltage equipment. Operation and maintenance must be done only by persons trained and qualified to work on such devices. Improper use or procedures will result in severe personal injury or death.
- Do not work on energized equipment. Unauthorized personnel must not be permitted near energized equipment. Induced voltage remains even after equipment is disconnected from the power source. Plan maintenance with authorized personnel so equipment can be de-energized and safely grounded.

GENERAL SAFETY PRECAUTIONS

- Do not work on equipment when mentally or physically fatigued or after consuming alcohol or drugs.
- Carefully follow all applicable local, state and federal codes.
- Never step on equipment (as when entering or leaving the engine compartment). It can stress and break unit components, possibly resulting in dangerous operating conditions from leaking fuel, leaking exhaust fumes, etc.
- Keep equipment and area clean. Oil, grease, dirt, or stowed gear can cause fire or damage equipment by restricting airflow.
- Equipment owners and operators are solely responsible for operating equipment safely. Contact your authorized Onan/Cummins dealer or distributor for more information.

KEEP THIS DOCUMENT NEAR EQUIPMENT FOR EASY REFERENCE.

TRACTOR DRIVE ALTERNATOR

UF

SERIES

15.0UF-3S/104

15.0UF-3S/153

TITLE	PAGE
General Information	2
Specifications	3
Installation Considerations	4
Operation	6
Service and Maintenance	7
Parts Catalog.....	11

SAFETY PRECAUTIONS

Investigation of thousands of accidents shows that careless use of machinery causes nearly 1/3 of all accidents. Study the following safety precautions carefully and insist that they be followed by those working with you and for you.

Clothing worn by the operator should be fairly tight and belted. Loose jackets, shirts, or sleeves should not be permitted because of the danger of getting into moving parts.

Do not allow anyone to operate the alternator without proper instructions.

Be sure power shields and guards are in place and secured before starting work.

Before lubricating alternator always:

1. Disengage all power
2. Shut off engine, and then
3. Wait until rotor stops

It is a good practice to have a fire extinguisher nearby. Be sure that the extinguisher is properly maintained and be familiar with its proper use.

Be sure engine is in a well ventilated area.

Keep arms, legs, feet and other parts out from underneath alternator when it is being raised by eyebolt.

Make certain only a qualified electrician does the electrical installations.

When working around electrical equipment, move slowly.

Do not lunge after falling tools.

Stop all power, and ground all high voltage points before touching wires.

Make certain that power cannot be accidentally restored.

Do not work on underground electrical equipment.

Do not examine live equipment when mentally or physically fatigued.

Do not touch electrical equipment while standing on metal floors, damp concrete or other well grounded surfaces.

Do not handle electrical equipment while wearing damp clothing (particularly wet shoes) or while skin surfaces are damp.

Be extra cautious when working with alternator during a rain.

Do not take unnecessary risks.

Do not work alone.

Read the operator's manual.

GENERAL INFORMATION

This manual contains installation and operation instructions as well as pertinent information required for maintenance, adjustment and repair of your alternator. Keep this book handy so it can be referred to when necessary.

The 15 KW, UF alternator is gear driven by a standard tractor PTO. It comes complete with a lifting eye, mounting feet, mounted gear box with splined shaft, PTO guard and a side mounted control box.

The alternator is a revolving armature, 3600 rpm, 2-pole unit with rectifier excitation. This eliminates the need for a commutator or commutator brushes. Output voltage is inherently regulated to produce a non-fluctuating source of electrical power. The alternator is completely wired internally and connected to the output receptacles. No further wiring is required nor recommended.

The side mounted control box contains a voltmeter; two 70 ampere circuit breakers for alternator protection; one 240 volt, 50 ampere, 3 blade range receptacle; one 120/240 volt, 60 ampere full output receptacle (3 blade with grounding post); and one duplex 120 volt, 15 ampere (fused) receptacle (see Figure 1). An auxiliary field timer switch is also provided which can be manually set for time intervals up to five minutes to provide added field strength when required for starting larger electric motors.

CAUTION This alternator cannot be belt driven.

TUMBLING ROD (Optional)

A shielded tumbling rod is available for coupling the alternator to your tractor. Operating length is 36 inches to 52 inches. Tumbling rod 190-0305 features a six spline shaft fitting at both ends and is used with Model 15.0UF-3S/153. Tumbling rod 190-0248 has a 1-1/4 inch diameter at the generator end and fits 1-3/8 inch splined PTO at tractor end. Use with Model 15.0UF-3S/104.

WARNING Onan uses this symbol throughout the text to warn of possible injury or death.

CAUTION This symbol is used to warn of possible equipment damage.

How to interpret MODEL and SPEC NUMBER.

15.0 UF - 3S / 153 E
1 2 3 4 5

1. Kilowatt rating of unit.
2. Factory code for series identification.
3. Combines with number 1 and 2 to identify model.
4. Factory code for designating optional equipment.
5. Specification letter (advances when factory makes production modifications).

SPECIFICATIONS

Watts	15,000 @ 1.0 PF
Volts	120/240
Phase	1
Hertz	60
Current (Amperes).....	63
Wire	3
Alternator Speed (rpm)	3600
Tractor PTO Speed (rpm)	520
Gear Ratio	6.9 to 1
Minimum Horsepower Required, Driving Source.....	30
Gear Box Oil Capacity, Pints	1-1/2
Recommended SAE Lubricant.....	90
Weight (Approximate)	300

NOTE: 15.0UF-3S/153 has six spline 1-3/8 inch shaft.
15.0UF-3S/104 has 1-1/4 inch stub shaft.

INSTALLATION CONSIDERATIONS

Consider the following before installing the alternator.

- Location
- Mounting the Alternator
- Installing the Load Transfer Switch
- Power Return Signal

LOCATION

The proper location of the alternator includes good ventilation, convenience to driving power, good operating conditions and servicing convenience.

Ventilation

The alternator creates considerable heat when operating under load conditions.

CAUTION

Overheating of the alternator can result in poor voltage regulation, alternator damage or failure.

Through proper ventilation, the heat generated by the alternator is dissipated. If the alternator is installed inside a small room or compartment, provide a vent for exhausting heated air. Heated air is discharged through the drive shaft end of the alternator.

Convenience to Driving Power

Locate the alternator for easy connection to the tractor. Align the power take-off to the alternator. Stay within the limits of the tumbling rod.

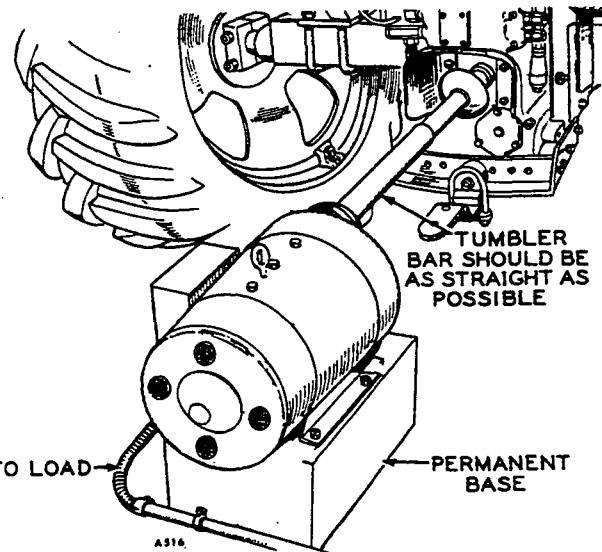

FIGURE 2. TRACTOR CONNECTION

Operating Conditions

Avoid extremely dusty or damp conditions. Protect the alternator against the weather by covering it or moving it to the inside of a building.

Servicing Convenience

Allow at least 24 inches of space on all sides of the alternator for convenient servicing.

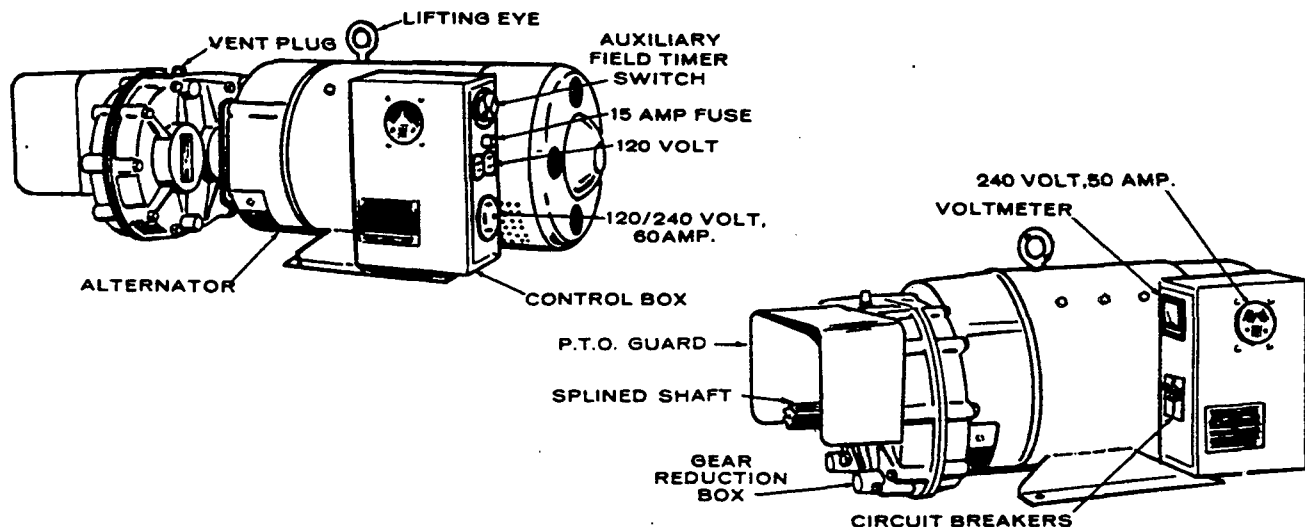

FIGURE 1. ALTERNATOR DESCRIPTION

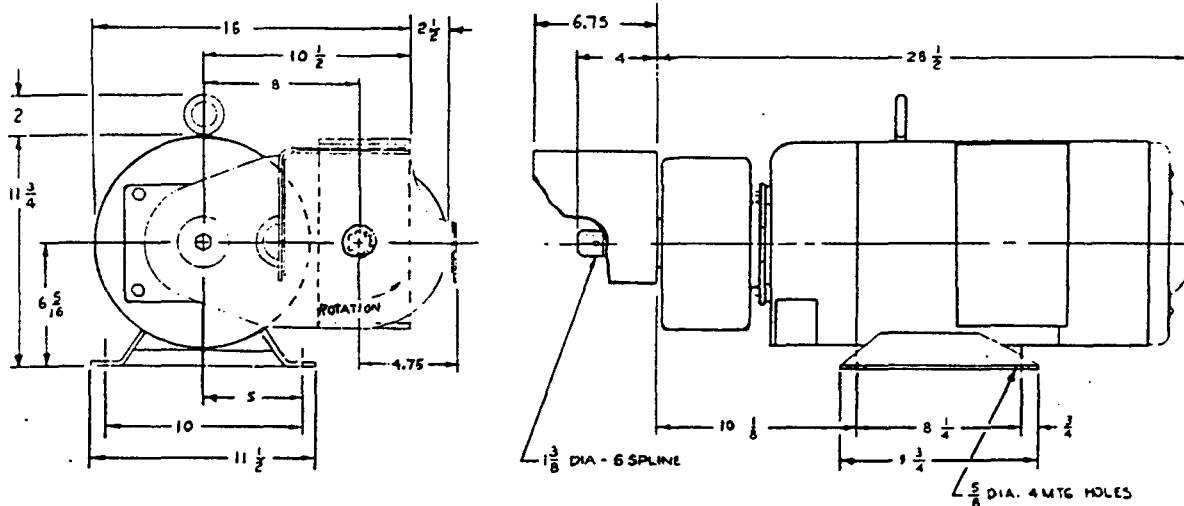

FIGURE 3. OUTLINE INSTALLATION

Wiring Convenience

Install the alternator as close to the load transfer switch as possible. Do not move the load transfer switch to the alternator. Refer to the paragraph entitled *Installing the Load Transfer Switch*.

disconnected from the main source of power, and then connected to the tractor alternator. Using the load transfer switch makes it impossible to connect the alternator to the main source of power.

MOUNTING THE ALTERNATOR

Provide a substantial mounting base of concrete, wood or steel and use large bolts. The surface of the mounting base should be flat so that the alternator mounting brackets will not be sprung when tightening into place. It should be possible to turn the shaft by hand after the alternator is bolted down.

CAUTION To develop 15 KW requires 30 to 35 horsepower at the power take-off. The torque will flip the alternator over unless secured to a strong substructure. A narrow (30 inch) trailer is not suitable for operation. A 40 inch hub to hub minimum measurement is required.

POWER RETURN SIGNAL

When the alternator is used for emergency applications, a pilot light or alarm signal should be installed to indicate when the power is restored and the alternator can be disconnected. A signal light can be connected across the regular power line, just ahead of the load transfer switch. Install an on-off switch and a fuse for the signal light. When a power outage occurs, snap the signal switch to the ON position before putting the alternator into operation. When the normal power returns, the signal will operate and the alternator can then be disconnected.

Be sure that the alternator is properly aligned with the driving mechanism and that it will stay in alignment.

INSTALLING THE LOAD TRANSFER SWITCH

Before the alternator can be used for emergency purposes, a **DOUBLE-THROW LOAD TRANSFER SWITCH MUST BE INSTALLED**. The switch must have an ampere rating large enough to carry the total load when the main source of power is in use. Follow the local electrical code.

The load transfer switch should always be installed close to the main line switch, and between the main line switch and the load. When properly installed, the load transfer switch in one position will connect the electrical load to the highline. When the load transfer switch is thrown to the other position, the load is first

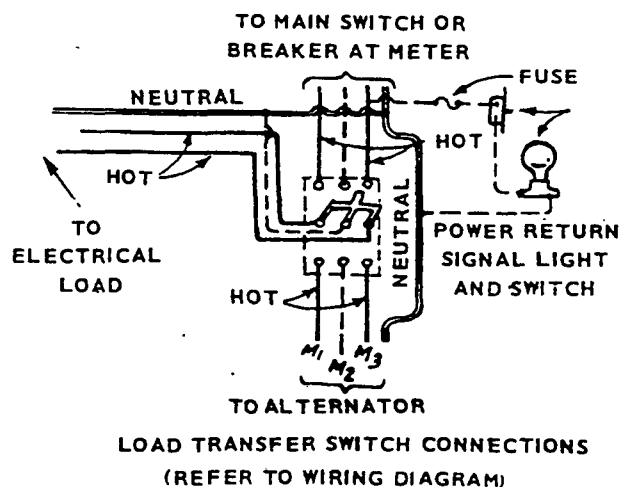

FIGURE 4. LOAD TRANSFER SWITCH

OPERATION

STARTING

Before engaging power take-off, proceed as follows in the order shown.

1. Alternator circuit breakers must be in the OFF position.
2. Connect power leads between the alternator and load transfer switch.
3. Throw transfer switch to connect load to alternator.
4. Engage power take-off and bring speed to 520 RPM. The alternator speed at this time will be 3600 RPM (60 hertz). The voltmeter on the alternator control box will read approximately 250 volts. On later models, a green segment on the voltmeter scale indicates the correct operating range.
5. Snap both alternator circuit breakers to the ON position. See Notes A and B following.

OPERATING

Voltage will decrease or drop, as the alternator warms up even when constant speed is maintained. This is normal. However, if the power drops below the recommended operating voltage (230-240 volts) it will be necessary to increase the tractor PTO speed to compensate. Also, avoid over-voltage to prevent damage to electrical equipment and/or the alternator. Reduce voltage by decreasing PTO speed.

NOTE A: Keep the alternator load within its nameplate rating. If the alternator is seriously overloaded, the circuit breakers will automatically trip, disconnecting the entire electrical load. Reduce the load before throwing the circuit breakers back to the ON position.

NOTE B: Motors require four to five times more current for starting than running. If several motors start simultaneously, the total electrical load may overload the alternator causing the circuit breakers to open and disconnect the circuit. To avoid this, always start larger horsepower motors one at a time. Your alternator is equipped with an auxiliary field timer switch, which when actuated, will connect an auxiliary winding for supplying added field strength for starting motors rated at 3HP or larger. Set the timer at one minute or longer for proper timer operation. At the end of the pre-

set time, the switch cuts out and the motor runs on normal current. For additional information on motor starting and current requirements, write for Onan Technical Bulletin T-009.

CAUTION If the tractor engine horsepower is less than 2 horsepower per kilowatt load, care should be exercised in disconnecting large loads. Governor speed changes can cause high voltage surges which could damage electrical equipment of lesser current draw than that which is removed from the line.

TIPS ON OPERATION

Total the wattage requirements of all the equipment that could be operating simultaneously during a power outage. This can be done by taking the information either from the typical wattage requirement guide shown below, or by taking the information from the nameplate on the equipment itself.

Start motors one at a time, beginning with the largest one. Then, after all motors are running, there will be extra power for other less critical equipment such as a television, air conditioner, etc. See Note B.

Check the motor nameplates for the horsepower rating of essential equipment: oil burner pump, furnace blower motor, circulating heater, electric milking machine, milk pump, barn cleaner, feed conveyor, silage unloader, chick brooder, sump pump, well pump, poultry house ventilating fan, freezer, refrigerator, washing machine, etc.

TYPICAL WATTAGE REQUIREMENTS

MOTORS* (Capacitor Type)	WATTS REQUIRED	
	START	RUN
½ horsepower	2800	550
¾ horsepower	4300	775
1 horsepower	5500	1000
2 horsepower	7130	1960
3 horsepower	10350	2970
5 horsepower	16660	3500
7-½ horsepower	23000	5250

* - Repulsion — induction motors require less starting wattage. Split phase motors require slightly more starting wattage.

SERVICE AND MAINTENANCE

Follow a definite schedule of inspection and servicing. Make a good visual check before, while and after alternator is operating; look for loose or broken leads and bad connections.

Internal alternator parts should be examined periodically. Remove end bell cover and inspect brushes, springs, bearings, etc.

GEAR BOX LUBRICATION

Use only SAE 90 multi-purpose gear lubricant. Drain the gear box after the first 100 hours of operation and refill with fresh lubricant of the recommended grade. Repeat this procedure every six months thereafter, or every 100 hours.

Maintain the proper oil level between changes. Overfilling will cause foaming, which can lead to an oil leak due to overheating. Remove the filler plug on top of the case and the oil level plug from the face of the gear case. Fill the case until the oil just begins to flow from the oil level plug hole. Gear box holds 1-1/2 pints U.S. measure. Replace both plugs. See Figure 5.

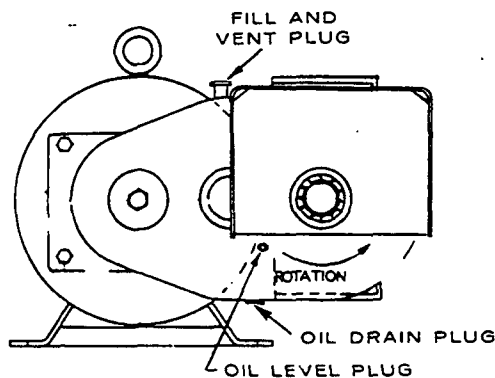

FIGURE 5. GEAR BOX LUBRICATION

TUMBLING ROD

Grease the universal joints at least every 25 operating hours. Under adverse conditions, grease the joints as required, possibly every 4 to 8 hours. Never operate the alternator with the shield removed from the tumbling rod.

SLIP RINGS

Slip rings must be clean and free of scratches and burrs (do not remove the dark brown film). If necessary to use an abrasive on the slip rings, use No. 240 sandpaper, never emery cloth or other conducting abrasives.

BEARINGS

The ball bearings are double-sealed and prelubricated. Due to oxidation of the grease, the outer alternator bearing, opposite gear box, should be replaced every five years.

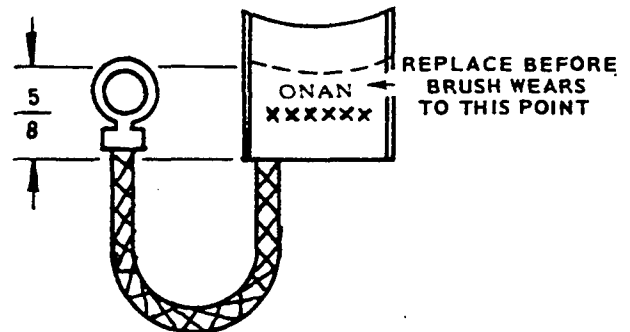

FIGURE 6. BRUSH REPLACEMENT

BRUSHES

Replace the brushes when they wear to about 5/8 inch in length. Order replacement brushes by part number, never by description: similar brushes in appearance may have different electrical characteristics.

CAUTION If brushes are not replaced by the time they wear past the stamped Onan name and number, severe damage to the slip rings will take place.

INSTALL BRUSHES WITH BEVELED TOP SLANTING DOWN TOWARD SPRING HOLDER

TO REMOVE BRUSH SPRING, PRESS SPRING HOLDER DOWN AND OUT AS SHOWN IN BROKEN LINES.

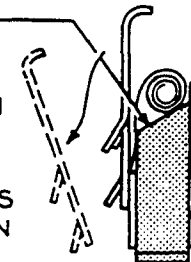
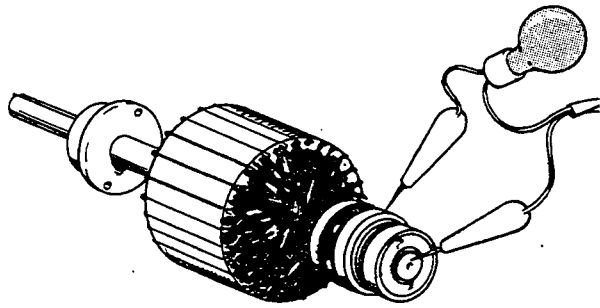

FIGURE 7. BRUSH REMOVAL



TESTING FOR GROUNDED
ARMATURE - IF GOOD SHOULD
NOT LIGHT

FIGURE 8. ARMATURE GROUNDED

ARMATURE GROUNDED

See that all brushes are lifted high in their holders. Use a continuity type test lamp set (Figure 8). Place one test prod on one of the slip rings and one other prod on a bare clean part of the alternator frame or armature shaft. The prods must make good electrical contact. The test lamp set should not light. If it does light up, the slip ring is grounded. Test all of the slip rings in the same manner. If the armature tests grounded, replace with a new one.

ARMATURE OPEN

Use a continuity type test lamp. See Figure 9.

1. Test between the two slip rings nearest the windings.
2. Test between the two slip rings nearest the bearing.
3. Test between the two outer slip rings.

In each of the above combinations the test lamp should glow. If the test lamp does not glow, an open armature is indicated.

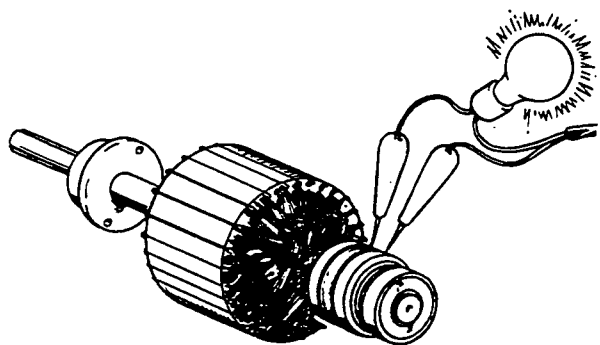

TESTING FOR OPEN
ARMATURE - IF GOOD
SHOULD LIGHT

FIGURE 9. ARMATURE OPEN

ARMATURE, SHORT CIRCUIT

To test for a short circuit, use an armature growler (Figure 10). Place the armature in the growler which is connected to alternating current. Hold a steel knife blade (or old hacksaw blade) 1/4 inch from the armature laminations. If the steel blade is attracted to any magnetized armature laminations, either the armature windings or collector rings are short circuited. A piece of foreign material between the collector rings could be responsible. Do not test for magnetism at just one point of the armature laminations, but test all of the laminations from one side over to the other side (along the dotted line in illustration). After testing in one position, revolve the armature about 1/8 turn and test for magnetism in the new position. Continue the turn and test until the armature has been tested completely around.

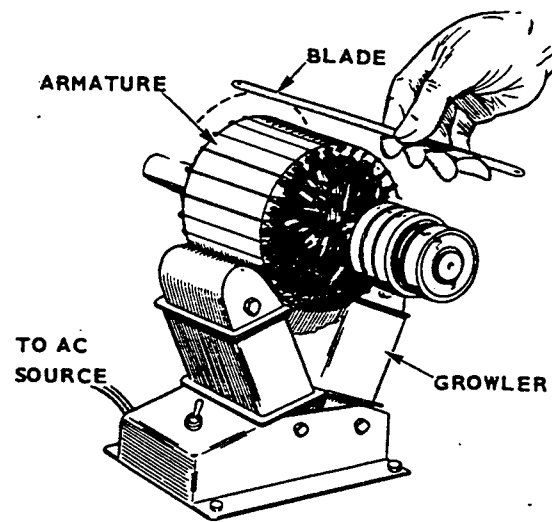

FIGURE 10. ARMATURE SHORTED

FIELD WINDINGS, OPEN CIRCUIT

A test lamp set can be used to test field windings for an open circuit. Place one test prod on one of the terminal ends of the field windings and the other test prod on the other terminal end of the winding. The test lamp should light. If it does not, an open circuit is indicated. Check carefully to see that the open circuit is not at the terminal leads or a loose terminal. An open circuit due to a broken lead or loose terminal is easily repaired. An open circuit within a coil requires replacement of the set of coils.

INSPECTING AND CLEANING DIODES (Rectifiers)

When inspecting the diodes, make sure they are kept free of dust, dirt and grease. Excessive foreign matter on these diodes causes overheating and eventual diode failure. Blow out the diode assembly periodically. Use filtered, compressed air.

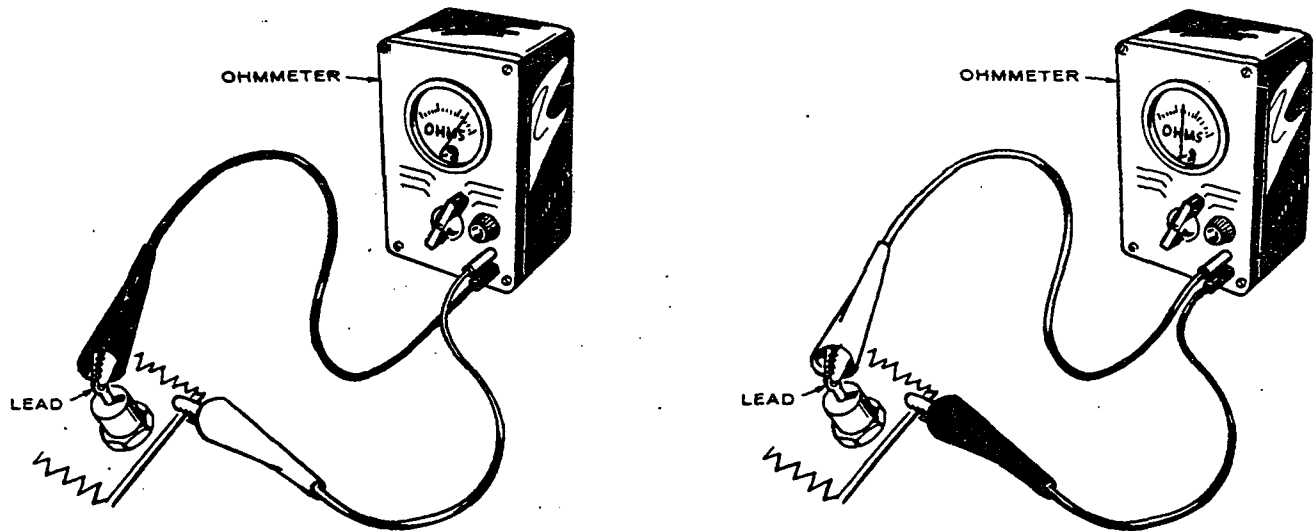

GOOD DIODE WILL HAVE HIGH RESISTANCE READING IN ONE DIRECTION AND LOW READING WHEN OHMMETER LEADS ARE REVERSED.

FIGURE 11. TESTING DIODES

Also check to see that the diodes are securely mounted and the lead wires are tight and in good condition.

TESTING DIODES

Faulty diodes (either shorted or open) will cause abnormal alternator operation. Check these individual diodes as follows:

1. Remove sheet metal end cover and band from end of the alternator.
2. Isolate each of the diodes before proceeding by disconnecting one end from its connection point.
3. To check, use an ohmmeter to measure the resistance in the individual diode (Figure 11). Reverse the ohmmeter leads and repeat resistance measurement. A good diode should have a high resistance value for one measurement and a low measurement when leads are reversed. If diode is not in good condition, replace with one known to be in good condition.

REPLACEMENT OF DIODES

When replacing defective diodes, follow these steps:

1. Unsolder lead wires from the diode terminal.
2. Use proper size wrenches to hold the body of the diode while removing nut attaching the diode to the heat sink (bracket).
3. Push the diode free of its mounting hole in the heat sink.
4. Be sure to install the new diode in the same position (or direction) as the defective diode.

These parts have directional arrows marked on them for this reason.

5. Insert new diode into its mounting hole in the heat sink or bracket, making sure heat sink surface is clean. Using nut and washer provided, secure diode, being careful not to allow it to turn while tightening nut. Tighten finger-tight plus 1/4 turn or 30 in-lb.
6. Connect lead wires to appropriate terminals.
7. Solder the lead wires removed from defective diode to terminal of the new diode.

CAUTION

Excessive heat can damage a diode. Use caution when soldering lead wires.

8. Replace access cover.

ALTERNATOR TROUBLESHOOTING GUIDE

NATURE OF TROUBLE	PROBABLE CAUSE	REMEDY
Arcing or poor contact at alternator brushes	<ol style="list-style-type: none"> 1. Brushes not seated properly 2. Alternator heavily overloaded 3. Brushes binding in holder 4. Brush tension insufficient 5. Brushes worn too short 6. Brush tension unequal 7. Wrong type brush 	<ol style="list-style-type: none"> 1. Sand brush to proper contour 2. If AC amperage is more than stated on the nameplate remove part of load 3. Clean each brush and holder 4. Replace brush springs 5. Replace brushes 6. Replace weak brush springs 7. Replace with correct type brush and spring
Alternator overheats	<ol style="list-style-type: none"> 1. Windings and parts covered with dirt and oil 2. Overloaded 3. Short circuit or grounded circuit in the field winding or armature winding 4. Air intake is restricted or incoming air is too hot 	<ol style="list-style-type: none"> 1. Clean alternator 2. Check load 3. Replace defective parts 4. Take necessary steps to allow for proper cooling
Noisy alternator	<ol style="list-style-type: none"> 1. Alternator loose on base 2. Defective bearings or gears 3. Field pole rubbing armature 4. Loose gearbox bolts 	<ol style="list-style-type: none"> 1. Tighten mounting bolts 2. Replace. Check alignment 3. Tighten field poles to frame 4. Retorque
Alternator runs but does not produce current	<ol style="list-style-type: none"> 1. Rectifier failed 2. Open, short or grounded circuit in alternator 3. Alternator leads broken or loose 	<ol style="list-style-type: none"> 1. Replace rectifier 2. Test windings and repair or replace defective parts 3. Tighten connections and replace broken leads
Low voltage output of alternator	<ol style="list-style-type: none"> 1. Tractor governor set at wrong speed 2. External short circuit on line 3. Open circuit of shunt field winding 4. Short circuit of winding in the field or armature 	<ol style="list-style-type: none"> 1. Reset governor for correct speed (520 RPM) 2. Test alternator with line wires disconnected 3. Make proper connections 4. Replace defective part
Flash over between rings	<ol style="list-style-type: none"> 1. Poor maintenance — dirt, oil, cleaning solvent residues 2. Excessive humidity or water condensation 3. Poor shielding from environment 	<ol style="list-style-type: none"> 1. Damage can't be repaired, must be replaced
Slip rings out of round	<ol style="list-style-type: none"> 1. Loose brushes or guides 	<ol style="list-style-type: none"> 1. Turn smooth on lathe or replace
Raw copper shows up on intermittent points on slip rings	<ol style="list-style-type: none"> 1. Rings out of round 2. Not enough cooling air 3. Overloaded 4. Wrong brush grade 	<ol style="list-style-type: none"> 1. Turn smooth on lathe or replace 2. Correct situation 3. Remove part of load 4. Replace with correct type brushes
Raw copper shows up continuously around slip rings	<ol style="list-style-type: none"> 1. Low humidity 2. High altitude 3. Dust and dirt 	<ol style="list-style-type: none"> 1. Turn smooth on lathe or replace

PARTS CATALOG

For parts or service, contact the dealer from whom you purchased this equipment or refer to your Nearest Authorized Parts and Service Center.

To avoid errors or delay in filling your parts order, please furnish all information requested.

Always give the MODEL and SPEC NO. and SERIAL NO.

MODEL		
SERIAL		
ALWAYS MENTION MODEL & SERIAL No.		
AC VOLTS	KVA	KW
AMPS	PF	CYCLES
PH	RPM	
EXCITER DC VOLTS	AMPS	
GENERATOR ONLY OF THIS GENERATING PLANT MANUFACTURED BY ONAN		
MINNEAPOLIS, MINNESOTA, U.S.A. FOR ELECTRICAL EQUIPMENT ONLY		

IMPORTANT: CHECK NAMEPLATE ON GEARBOX FOR CORRECT MANUFACTURER'S NAME.

**GEAR DRIVE GROUP -
MFG.-
APEX INDUSTRIES**

NOTE: Order parts from Apex Industries, Waterville, Minnesota.

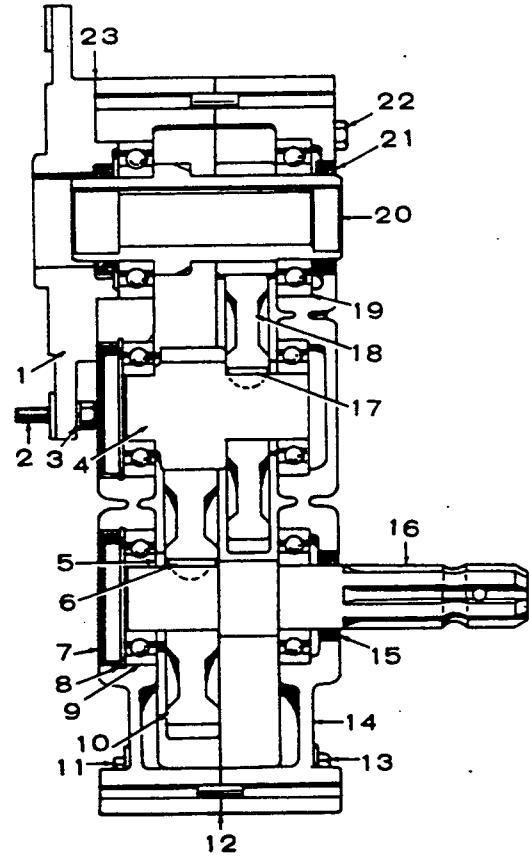
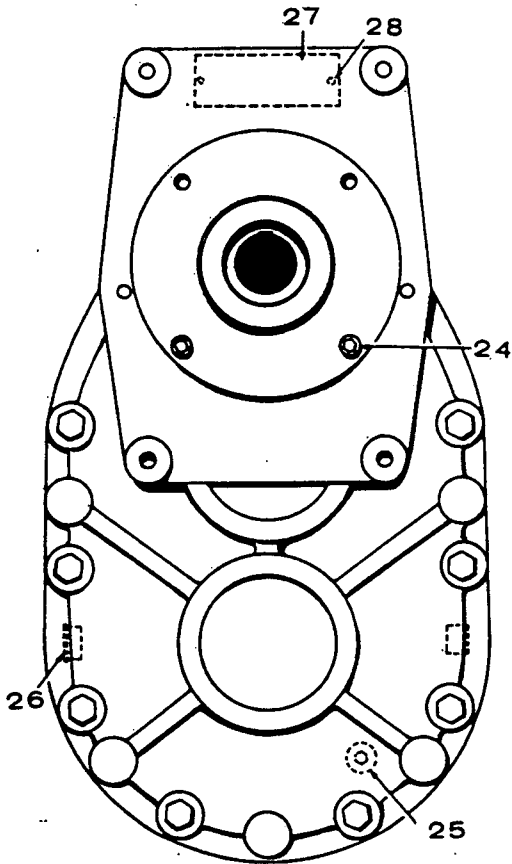

REF. NO.	PART NO.	QTY. USED	PART DESCRIPTION
	190-0294	1	Gear Drive Box (Complete Splined Shaft)
1	50046	1	Flange, Mounting
2	10178	2	Screw, Cap
3	10018	2	Washer, Lock
4	30073	1	Shaft & Gear, Idler (LH)
5	20100	2	Washer, Spacer
6	10035	1	Key, Woodruff
7	20098	2	Cover, Dust
8	10179	2	Ring, Retaining
9	10173	4	Bearing, Ball
10	40037	1	Gear, Right Hand
11	10181	8	Screw, Cap
12	50051	1	Gasket
13	10094	8	Nut
14	50047	1	Case, Sub Assembly

REF. NO.	PART NO.	QTY. USED	PART DESCRIPTION
15	10206	1	Seal
16	30072	1	Shaft, Input
17	10180	1	Key, Woodruff
18	40038	1	Gear, Left Hand
19	10207	2	Bearing, Ball
20	30074	1	Gear, Pinion (RH)
21	10209	2	Seal
22	10177	4	Screw, Cap
23	20108	As Req.	Shim (.005)
24	10175	2	Screw, Socket Head Cap
25	10166	2	Plug, Oil Level Check Pipe
26	10176	1	Plug, Cap (3/8)
27	20020	1	Plate, Name
28	10024	2	Screw, Drive

NOTE: Order Replacement Parts from Apex Industries.

**GEAR DRIVE GROUP
MFG.-
VON RUDEN CO.**

<u>REF. NO.</u>	<u>PART NO.</u>	<u>QTY. USED</u>	<u>PART DESCRIPTION</u>
	190-0294	1	Gear Drive Box (Complete Splined Shaft)
1	190-0358	1	Case
2	190-0359	1	Case
3	190-0280	1	Gasket
4	190-0360	1	Plate, End
5	190-0361	As Req.	Shim Set
6	190-0362	2	Bearing, Ball
7	190-0363	1	Plate, Open End
8	190-0279	2	Seal, Oil
9	190-0365	1	Shaft, Gear
10	190-0366	1	Gear
11	190-0367	4	Bearing
12	190-0368	1	Gear & Shaft, Idler
13	190-0369	1	Shaft, Splined
14	190-0371	1	Seal, Oil
15	190-0372	1	Gear
16	190-0373	12	Nut
17	190-0374	12	Bolt
18	190-0375	2	Key, Woodruff
19	190-0376	4	Screw, Cap
20	190-0377	1	Plug, Drain
21	190-0378	1	Plug, Check
22	190-0379	2	Washer, Lock
23	190-0380	6	Screw, Cap
24	190-0381	2	Bushing, Line Up

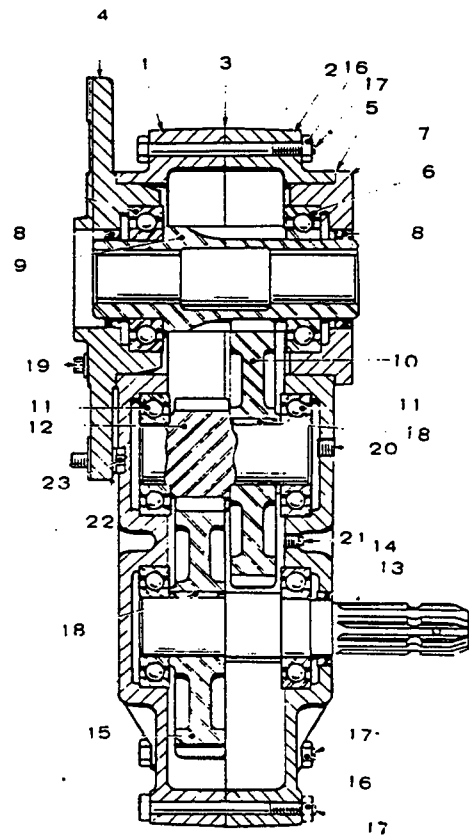

NOTE: Order Replacement Parts from your nearest Onan Distributor.

GENERATOR GROUP

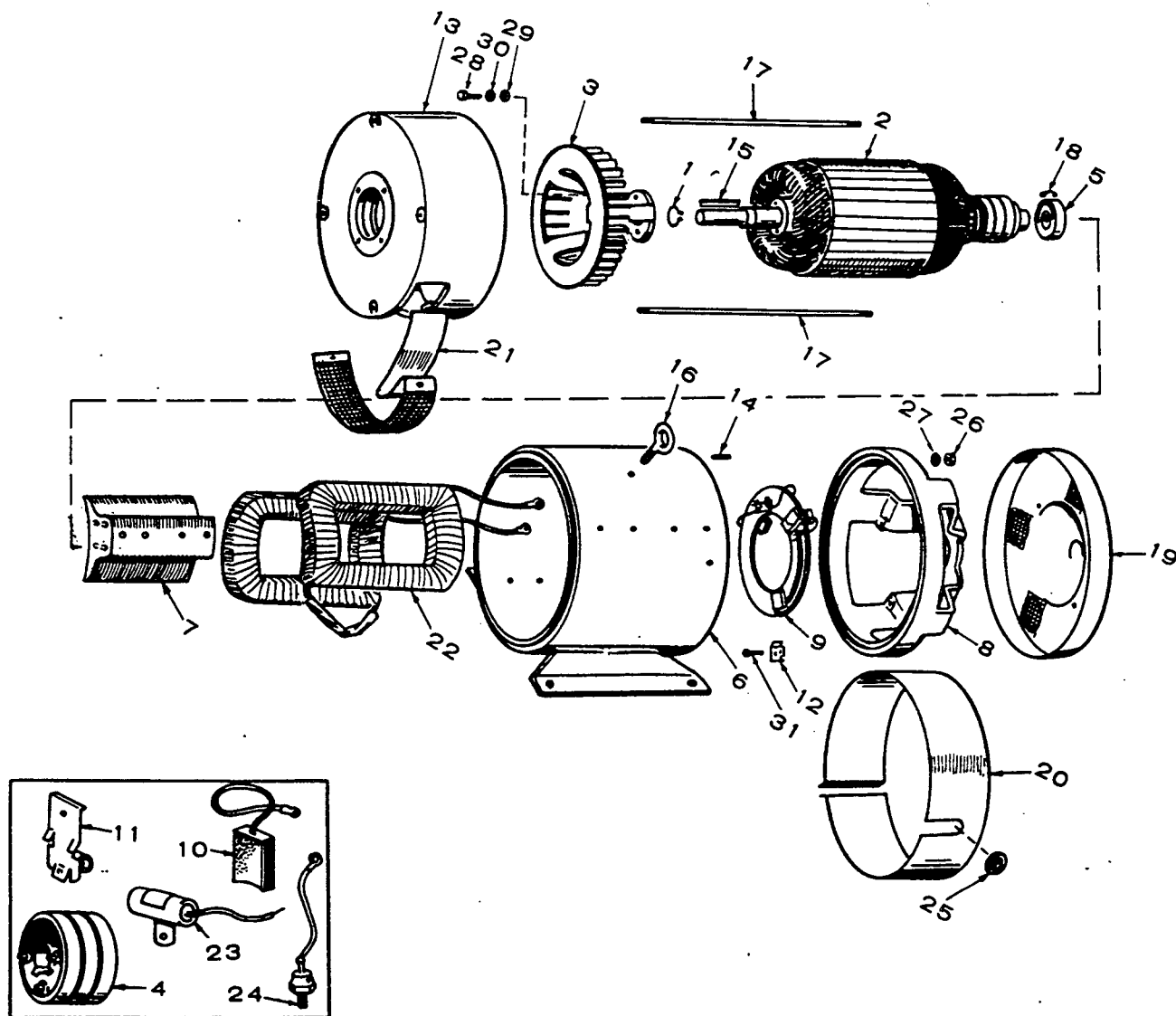

REF. NO.	PART NO.	QTY. USED	PART DESCRIPTION	REF. NO.	PART NO.	QTY. USED	PART DESCRIPTION
1	518-0014	1	Ring, Retaining	17	520-0498	2	Stud, Generator Through
2	201-1444	1	Armature	18	232-0596	1	Clip, Bearing
3	205-0060	1	Blower	19	211-0114	1	Cover, End Bell
4	204-0010	1	Ring, Collector	20	234-0065	1	Band, End Bell
5	510-0047	1	Bearing	21	234-0077	1	Scroll and Screen, Blower
6	210-1898	1	Frame	22	222-1674	1	Coil Set, Field
7	221-0154	2	Shoe, Pole	23	312-0058	2	Condenser, 1-Mfd.
8	211-0097	1	Bell, End (Bearing Rig End)	24	305-0448	2	Rectifier
9	212-0343	1	Rig Assembly, Brush	25	508-0001	1	Grommet, Rubber
10	214-0056	6	Brush	26	862-0015	2	Nut, Hex (5/16-18)
11	212-1105	6	Spring, Brush	27	850-0045	2	Washer, Lock (5/16)
12	212-1214	4	Clamp, Brush Rig	28	800-0007	3	Screw (1/4-20 x 1") - Blower Mounting
13	211-0188	1	Bell, End (Drive End)	29	526-0018	3	Washer, Flat (1/4)
14	PIN, END BELL ALIGN			30	850-0040	3	Washer, Lock (1/4)
	516-0103	1	Brush Rig End (Roll Pin)	31	800-0003	4	Screw (1/4-20 x 1/2") - Clamp Mounting
	516-0176	2	Drive End (Drive Pin)				
15	515-0108	1	Key, Armature Shaft Drive				
16	403-0095	1	Bolt, Eye - Lifting				

CONTROL GROUP

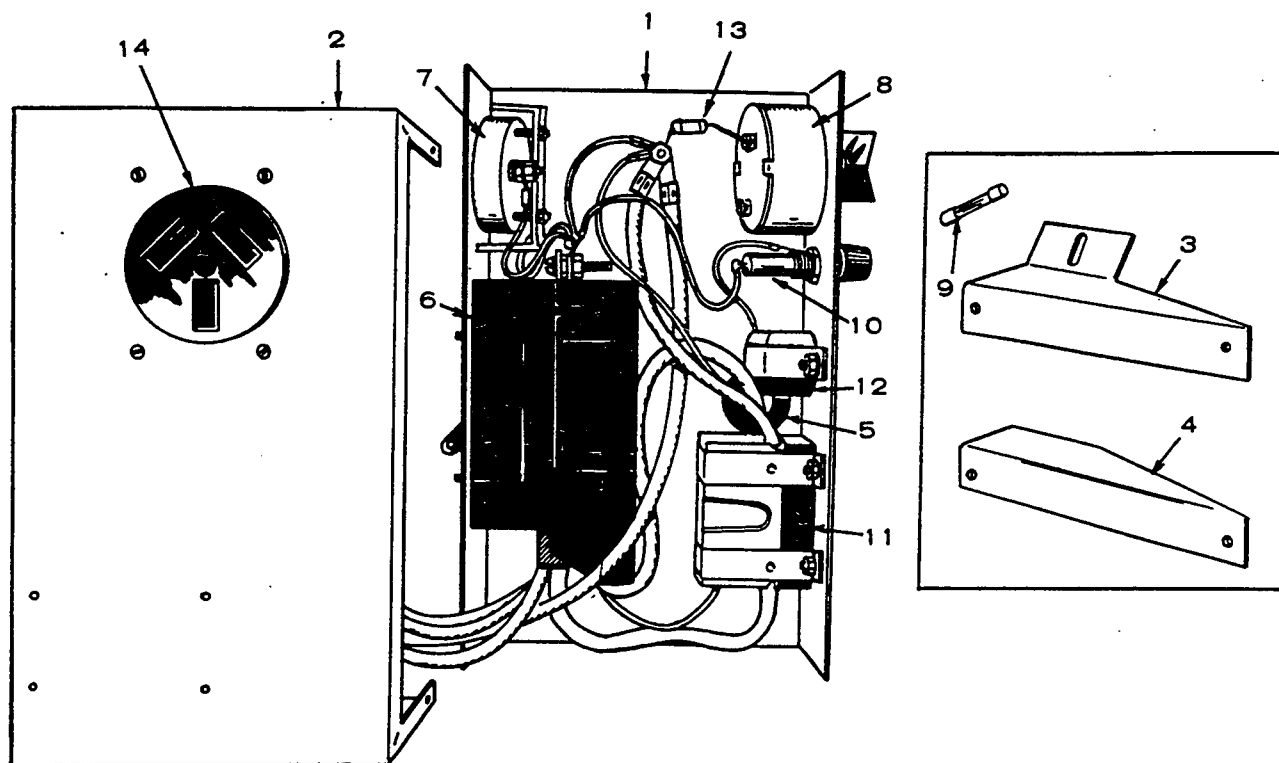

REF. NO.	PART NO.	QTY. USED	PART DESCRIPTION
1	301-2892	1	Box, Control
2	301-2893	1	Cover, Control Box
3	301-1540	1	Bracket, Mounting (Upper) (Early Models only)
4	301-1541	1	Bracket, Mounting (Lower) (Early Models only)
5	508-0001	1	Grommet, Rubber
6	320-0148	2	Breaker, Circuit
7	302-0665	1	Voltmeter, AC (0-300)
8	308-0252	1	Switch, Time (5 Minute)
9	321-0138	1	Fuse (15 Ampere)
10	321-0104	1	Holder, Fuse
11	323-0635	1	Receptacle, Output
12	323-0184	1	Receptacle, Duplex
13	305-0240	1	Rectifier
14	323-0894	1	Receptacle, 50 Amp.

GEAR DRIVE GROUP

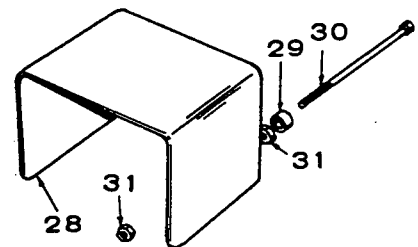
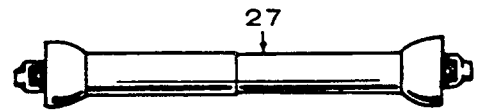
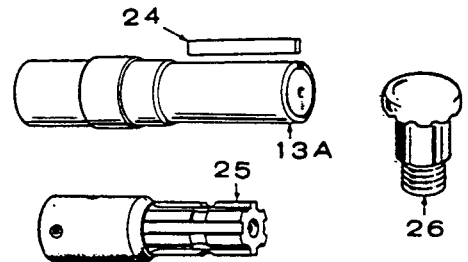
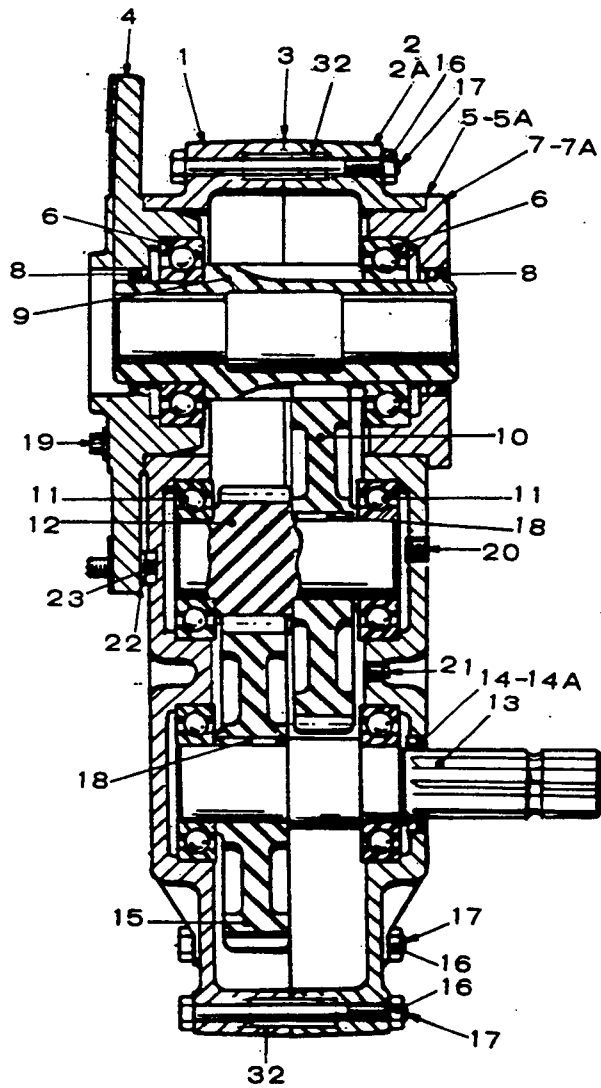

REF. NO.	PART NO.	QTY. USED	PART DESCRIPTION	REF. NO.	PART NO.	QTY. USED	PART DESCRIPTION
	190-0294	1	Gear Drive Box, Complete - Splined Shaft	14A	190-0278	1	Seal, Oil - For 190-0275 Gear Drive Box (Early Models only)
	190-0275	1	Gear Drive Box, Complete - Round Shaft (Keyed) (Early Models Only)	15	190-0372	1	Gear
1	190-0358	1	Case	16	190-0373	12	Nut
2	190-0359	1	Case - For 190-0294 Gear Drive Box	17	190-0374	12	Bolt
2A	190-0382	1	Case - For 190-0275 Gear Drive Box (Early Models Only)	18	190-0375	2	Key, Woodruff
3	190-0280	1	Gasket	19	190-0376	4	Screw, Cap
4	190-0360	1	Plate, End	20	190-0377	1	Plug, Drain
5	190-0361	As Req.	Shim Set	21	190-0378	1	Plug, Check
6	190-0362	2	Bearing, Ball	22	190-0379	2	Washer, Lock
7	190-0363	1	Plate, Open End - For 190-0294 Gear Drive Box	23	190-0380	6	Screw, Cap
7A	190-0364	1	Plate, Open End - For 190-0275 Gear Drive Box (Early Models only)	24	515-0103	1	Key, Input Shaft - For 190-0275 Gear Drive Box (Early Models only)
8	190-0279	2	Seal, Oil	25	190-0295	1	Adapter, Round Shaft (1-1/4" Round Shaft to 1-3/8" Splined Shaft) - For 190-0275 Gear Drive Box (Early Models only)
9	190-0365	1	Shaft and Gear	26	518-0275	1	Plug, Vent
10	190-0366	1	Gear	27	ROD, TUMBLING		
11	190-0367	4	Bearing		190-0305	1	Splined Both Ends (1-3/8")
12	190-0368	1	Gear and Shaft, Idler		190-0248	1	Splined (1-3/8") One End & Round Shaft (Keyed - 1-1/4") Other End (Early Models only)
13	190-0369	1	Shaft, Splined - For 190-0294 Gear Drive Box	28	190-0318	1	Guard, P.T.O.
13A	190-0370	1	Shaft, Round (Keyed) - For 190-0275 Gear Drive Box (Early Models only)	29	190-0317	4	Spacer, Guard Mounting
14	190-0371	1	Seal, Oil - For 190-0294 Gear Drive Box	30	800-0043	4	Screw (5/16-18 x 5") - Guard Mounting
				31	870-0257	8	Nut, Hex (Self-Locking, 5/16-18) - Guard Mounting
				32	190-0381	2	Bushing, Lineup