



**TeleVideo®**

VT100.net



# Operator's Manual Model 950



## CONTENTS

Paragraph	Page	Paragraph	Page
<b>CHAPTER 1 GENERAL INFORMATION</b>			
1.1	1-1	3.3.1	3-9
1.1.1	1-1	3.3.2	3-11
1.1.2	1-1	3.3.3	3-11
1.1.3	1-1	3.3.4	3-12
1.1.4	1-1	3.3.5	3-12
1.1.5	1-1	3.3.6	3-12
1.1.6	1-1	3.4	3-12
1.2	1-1	3.5	3-13
1.2.1	1-1	3.6	3-13
1.2.2	1-1	3.7	3-13
1.3	1-1	3.8	3-14
1.4	1-2	3.8.1	3-14
1.5	1-2	3.8.2	3-14
1.6	1-2	3.8.3	3-14
1.7	1-2	3.9	3-14
		3.10	3-14
		3.10.1	3-14
		3.10.2	3-14
		3.10.3	3-15
		3.10.4	3-15
		3.10.5	3-15
		3.11	3-15
		3.12	3-15
		3.13	3-15
		3.14	3-16
		3.15	3-16
		3.15.1	3-16
		3.15.2	3-16
		3.15.3	3-17
		3.15.4	3-17
		3.15.5	3-19
		3.15.6	3-19
		3.15.7	3-21
		3.15.8	3-21
		3.15.9	3-22
		3.15.10	3-22
		3.15.11	3-22
		3.15.12	3-22
		3.15.13	3-22
		3.15.14	3-22
		3.15.15	3-24
		3.15.16	3-24
		3.15.17	3-24
		3.15.18	3-24
<b>CHAPTER 2 INSTALLATION</b>			
2.1	2-4		
2.2	2-4		
2.2.1	2-4		
2.2.2	2-4		
2.2.3	2-4		
2.2.4	2-4		
2.2.5	2-4		
2.3	2-4		
2.4	2-4		
2.5	2-6		
<b>CHAPTER 3 OPERATION</b>			
3.1	3-8		
3.2	3-8		
3.2.1	3-8		
3.2.2	3-8		
3.2.3	3-8		
3.3	3-8		

Contents (continued)

Paragraph	Page	Paragraph	Page
3.15.19	Video Display Control . . . . . 3-24	5.5	MAIN INTERFACE PORT . . . . . 5-35
3.15.20	Reference Tables . . . . . 3-24	5.6	PRINTER PORT INTERFACE . . . . . 5-35
		5.7	DISPLAY GENERATOR . . . . . 6-36
		5.8	VIDEO MODULE AND SCREEN . . . . . 6-36
		5.9	POWER SUPPLY . . . . . 6-36
<b>CHAPTER 4 PERFORMANCE VERIFICATION</b>			
4.1	INTRODUCTION . . . . . 4-34		
4.2	SELF-TEST 1 . . . . . 4-34		
4.3	SELF-TEST 2 . . . . . 4-34		
<b>CHAPTER 5 FUNCTIONAL DESCRIPTION</b>			
5.1	INTRODUCTION . . . . . 5-35		
5.2	TERMINAL OVERVIEW . . . . . 5-35		
5.3	DISPLAY PROCESSOR . . . . . 5-35		
5.4	KEYBOARD AND KEYBOARD INTERFACE CIRCUITS . . . . . 5-35		
<b>CHAPTER 6 OPERATOR MAINTENANCE</b>			
		6.1	INTRODUCTION . . . . . 6-36
		6.2	PERIODIC MAINTENANCE . . . . . 6-36
		6.2.1	Cleaning . . . . . 6-36
		6.2.2	Inspection . . . . . 6-36
		6.3	TROUBLESHOOTING . . . . . 6-37
		6.4	REPAIR . . . . . 6-37
		6.4.1	Line Fuse . . . . . 6-37
		6.4.2	Power Supply Fuses . . . . . 6-37

**List of Illustrations**

**List of Tables**

Figure	Page	Table	Page
2-1	Terminal Cabinet Receiving Inspection	1-1	Specifications
2-2	115/230 V Select Switch	2-1	Host Interface Connector Configuration
2-3	Host Interface Connector Configuration for Current Loop	2-2	Printer Connector Configuration
2-4	Baud Rate, Word Length, and Stop Bit Settings	3-1	Monitor Mode Control Characters
2-5	Operating Mode Switch Settings	3-2	USASCII Chart
3-1	Model 950 Rear Panel Controls and Connectors	3-3	Model 950 Cursor Addressing Codes
3-2	Model 950 Communications Modes	3-4	Model 950 Control and Escape Codes
3-3	Model 950 Screen Display	3-5	Alpha-Numeric Key Hex Codes
3-4	Model 950 Keyboard	3-6	Cursor Control and Edit Key Hex Codes
3-5	Model 950 Video Attributes	3-7	Function Key Default Hex Codes
3-6	Model 950 Special Graphics Characters	3-8	Local Only Keys
4-1	Self Test 1 Screen Display	3-9	Key Action Modifiers
5-1	Model 950 Simplified Block Diagram	6-1	Model 950 Troubleshooting Check List
6-1	Keyboard Assembly Bottom		
6-2	Power Supply Fuses		



# Chapter 1

## GENERAL INFORMATION

### 1.1 INTRODUCTION

This manual is a reference guide for the TeleVideo Model 950 Video Display Terminal operator. The information presented in this manual will enable a Model 950 user to install, operate, program, and service the Video Display Terminal. The manual contains the following chapters:

- Chapter 1. General Information
- Chapter 2. Installation
- Chapter 3. Operation
- Chapter 4. Performance Verification
- Chapter 5. Functional Description
- Chapter 6. Maintenance

The following paragraphs describe the contents and scope of these chapters.

#### 1.1.1 General Information

The General Information describes the Model 950 Video Display Terminal, its features, and its applications. In addition, it provides general safety precautions, lists documents related to the terminal, and lists the terminal's mechanical and electrical specifications.

#### 1.1.2 Installation

The Installation chapter provides detailed procedures for unpacking and inspecting the Video Display Terminal, interconnecting it to a host computer, and setting up operating parameters. It also includes procedures for installation checks.

#### 1.1.3 Operation

The Operation chapter contains detailed procedures for operating the Model 950. It includes instructions for turning the terminal on and off and controlling and programming its many special features.

#### 1.1.4 Performance Verification

The Performance Verification chapter contains procedures for checking the terminal in all its operational modes using the self-test feature.

#### 1.1.5 Functional Description

The Functional Description chapter describes the overall functional operation of the terminal based on a system simplified block diagram. It also describes the functional operation of the major circuits in the terminal, also based upon simplified diagrams. The information contained in this chapter provides the Model 950 user with an overall perspective of the terminal hardware.

#### 1.1.6 Maintenance

The Maintenance chapter provides preventive maintenance instructions and simplified procedures for troubleshooting terminal faults. It also contains procedures for repairs most terminal users can make.

### 1.2 PRODUCT DESCRIPTION

The TeleVideo Model 950 Video Display Terminal is a

compact state-of-the-art "smart" terminal that provides high level performance at low cost. This terminal is compatible with most host computers and finds a wide variety of applications in the end user environment. Standard features include editing capabilities, protected field, addressable cursor, line and character insert/delete, upper and lower case characters, and tabbing. In addition, the Model 950 provides the following standard features:

- Split screen with line lock
- Etched CRT face to reduce glare
- Programmable function keys (11 keys with 22 functions)
- 15 special graphics characters
- On-screen status (25th line)
- Buffered auxiliary port
- 14 x 10 character resolution
- Attractive cabinet styling
- Detached keyboard
- Light weight for portability
- Typewriter-styled keyboard
- Dedicated editing keys
- Maximum serviceability
- Self test

#### 1.2.1 Additional OEM Features

The Model 950 provides the original equipment manufacturer with several customizing features that include

- Easy keyboard reconfiguration
- Easy character reconfiguration
- Reconfigurable firmware for Escape sequence changes
- Readily adaptable to packaging changes
- Easily repainted keyboard and CRT bezels, and cabinet
- Easily replaced CRT's with differing phosphors
- Accepts a variety of CRT color filters
- Maximum serviceability

#### 1.2.2 Options

The Model 950 may be ordered with several options that enhance its already comprehensive list of features. These options, available at additional cost, include

- 48 line memory that can be organized by the user in either one 48-line page or two 24-line pages
- 96 line memory that can be organized by the user in one 96-line page, two 48-line pages, or four 24-line pages
- Integral modem/dialer

### 1.3 SAFETY PRECAUTIONS

As with any electronic equipment, precautions consistent with all standard safety practices must be taken while servicing the Model 950 Video Display Terminal. Any servicing that requires opening the cabinet must be performed by qualified service personnel. Prior to inspection or service, power must be disconnected.

Notices are included throughout this manual to alert the reader to problem areas or situations that could cause personnel injury, loss of data, or hardware damage.

A **WARNING** statement precedes the text of a procedure

that, if not strictly observed, could result in injury or death.

A **CAUTION** statement precedes the text of a procedure that, if not strictly followed could result in the loss of data or damage to or destruction of equipment hardware or software.

A **NOTE** statement highlights essential operating or maintenance procedures, conditions, or clarifying facts. **NOTES** also provide information that helps the user understand a concept or the completion of a procedure.

The following are general safety precautions that are not related to any specific procedure and, therefore, do not appear elsewhere in this manual. Personnel must heed these warnings during installation and maintenance.

### **WARNING**

#### **Keep Away From Live Circuits**

Always observe safety precautions. Observe all the **CAUTIONS** and **WARNINGS** in this manual when working inside the terminal cabinet. Under certain conditions, dangerous potentials may exist when the power is off because of charges retained by the cathode ray tube (CRT) and capacitors. To avoid injury, always remove power and discharge them to ground before touching them.

#### **Do Not Service Or Adjust Alone**

Never reach into the terminal enclosure unless someone capable of giving aid is present.

The following **WARNING** applies to any service inside the terminal cabinet. It appears elsewhere in the text of this manual and is introduced here for emphasis:

### **WARNING**

Hazardous voltages are exposed in the cabinet. Use extreme caution when servicing either the power supply, the cathode ray tube, or any area where power terminals are exposed.

### **1.4 RELATED DOCUMENTATION**

This manual provides only that information necessary for terminal installation, operation, and user maintenance. Other documents that may be helpful to the Model 950 user include:

- Operators Reference Handbook for Models -912B, 912C, -920B, and -920C, TeleVideo No. B300001-001
- Model 950 Video Display Terminal Service Manual, TeleVideo No. B300002-002
- Models 912B, 912C, 920B, and 920C Maintenance Manual, TeleVideo No. B300001-002
- TeleVideo Commercial Price List
- Model 950 Customizing Instructions
- Televideo Spares Price List
- TeleVideo Model 950 data sheets

These documents may be obtained from Televideo Inc., 1170 Morse Avenue, Sunnyvale, California 94086.

### **1.5 SPECIFICATIONS**

The mechanical, electrical, and environmental characteristics of the Model 950 are listed in Table 1-1.

### **1.6 LIMITED AND EXTENDED WARRANTY**

TeleVideo warrants that its products will be free from defects in material and workmanship for a period of 6 months from the date of shipment from the factory. If a terminal is received that has been damaged in shipment, contact the carrier and process a claim (Refer to paragraph 2.2).

TeleVideo offers, at additional cost, an Extended Warranty Contract that warrants the Model 950 against defects in material and workmanship for up to 1 year beyond the standard 6 month warranty. To be effective, this Extended Warranty must be purchased prior to the expiration date of the standard warranty. The Extended Warranty may be renewed for an additional year at the current purchase price. For current Extended Warranty Contract prices, contact your authorized TeleVideo dealer or write to TeleVideo, Inc., at 1170 Morse Avenue, Sunnyvale, California, 94086, attention Manager Customer Service.

### **1.7 MANUFACTURER AND AUTHORIZED DEALER SERVICES**

TeleVideo offers service to the end users of its products that include:

1. Authorized Dealer Repair
2. Factory Repair
3. User Replaceable Spare Parts
4. Service Documentation

If you experience technical problems with a Model 950 call your TeleVideo Authorized Dealer.

If the terminal should fail during the standard warranty period, contact your local Authorized Dealer for assistance. If your dealer finds that the repairs require returning the terminal to the factory, a Return Material Authorization number will be issued. Use this number to identify the terminal in all correspondence regarding the repairs.

The terminal will be shipped to TeleVideo at the owner's expense. Once the terminal is repaired, TeleVideo will return it to its owner at no charge via UPS surface. Any other shipping arrangements, such as air express, will be at the owner's expense. Normal repairs require two days plus transit time.

For out-of-warranty repairs, the same procedure must be followed. The terminal owner is responsible for all shipping charges and must issue a purchase order or other written authorization for repair charges.

#### **NOTE**

Include a detailed description of the symptoms of the terminal malfunction when returning it for repairs. Also include the name and telephone number of a responsible technical person that TeleVideo may call in the event of any questions.

If for any reason you are dissatisfied with either the product or the service, please call the Manager of Customer Service, TeleVideo, Inc.

**Table 1-1 Specifications**

Display format	24 lines x 80 characters 25th status line
Character format	14 x 10 dot resolution with lower case descenders
Character set	128 character ASCII (96 alphanumeric + 32 control) 15 special graphics
Cursor control	Dedicated keys for left, right, up, down, home, carriage return, line feed, tab, back tab
Communications interface	RS-232C, 20mA current loop and optional originate/auto-dial modem
Communication modes	Half duplex or full duplex (keyboard selectable), 10- or 11- bit word
Baud rates	Switch selectable: 50, 75, 110, 135, 150, 300, 600 1200, 1800, 2400, 3600, 4800, 7200, 9600, and 19,200
Parity	Odd, even, no parity, mark, and space (switch and keyboard selectable)
Word structure	7 or 8 data bits, 1 or 2 stop bits
Screen attributes	Dual intensity with protected fields, reverse video, underline, blink and blank plus combinations
Cursor attributes	Programmable for reverse block, blinking reverse block, or not displayed, underline, or blinking underline
Editing	Line insertion/delete; Line or page edit; character insertion/delete line lock; Line scrolling, smooth scrolling, or no scroll, or insert mode
Auxiliary port	Printer RS-232C, bi-directional, page print, buffered transparent, buffered with screen copy (Transparent requires 48 or 96 line memory)
Communication protocol	XON, XOFF, DTR
Primary power	115 Vac, 60 Hz/230 Vac, 50 Hz; 6 5W
Cabinet dimensions	16.50" (41.9 cm) x 14.00" (35.6 cm) x 14.25" (36.2 cm)
Keyboard dimensions	16.50" (41.9 cm) x 7.50" (19.0 cm) x 3.00" (7.6 cm)
Cabinet weight	30 lbs. (13.6 kg)
Keyboard weight	4.5 lbs. (2.3 kg)
Ambient operating temperature	32° F (0° C) to 122° F (50° C)
Relative humidity (operating)	10% - 95% non-condensing
Storage temperature	-40° F (-40° C) to 149° F (65° C)
Relative humidity (non-operating)	No restrictions

## Chapter 2 INSTALLATION

### 2.1 INTRODUCTION

This chapter contains procedures for installing the Model 950 Video Display Terminal. It includes instructions for unpacking and inspecting, and procedures for setup and for interconnecting the terminal to a host computer.

### 2.2 UNPACKING AND RECEIVING INSPECTION

When a Model 950 Video Display Terminal is delivered by a transfer company, it must be carefully inspected (inside the shipping container, as well as out) for damage before taking it to the installation site. If the terminal is to be reshipped, it must be repacked in a manner that will prevent any damage while in transit.

#### 2.2.1 Shipping Damage Inspection

Prior to accepting delivery of the Model 950 Video Display Terminal from the carrier, carefully inspect the shipping container for obvious damage. If damage is found, note it on the waybill and require the delivery agent to sign the waybill. Notify the transfer company immediately and submit a damage report to the carrier, your dealer, and to TeleVideo, Inc. If no exterior damage exists, unpack the terminal and inspect for hidden damage.

#### 2.2.2 Model 950 Unpacking

The Model 950 is shipped with the cabinet, keyboard, and Operator's Instruction Manual in the same shipping container. The container and packing consists of a sturdy cardboard box and preformed styrofoam inserts.

Unpack the terminal from the shipping container with care; avoid using sharp instruments to open the container. TeleVideo recommends saving all packing materials for possible use in reshipping the terminal.

If hidden damage is found, immediately notify the transfer company of the damage. Save all packing materials for the transfer company's inspection, file a damage report with the carrier, and notify your dealer and TeleVideo, Inc. of the damage. Since Model 950 terms of sale are F.O.B. TeleVideo Inc., Sunnyvale, California, TeleVideo is not responsible for any damage incurred during shipment, nor will TeleVideo repair this damage under warranty. All repairs for shipping damage will be billed. Prompt notification of damage will ensure claim validity and will help expedite payment for necessary repairs by the transfer company or its insurance agent.

#### 2.2.3 Enclosed Documents

A Model 950 Operator's Instruction Manual is shipped with the Model 950 to provide operating and applications information, installation instructions, and service information to the end user.

#### 2.2.4 Inspection Procedures

After unpacking the Model 950, inspect it thoroughly for damage hidden by the packaging and for loose components or fittings, as follows:

### WARNING

The coating on the inside of cathod ray tubes is poisonous. Wear heavy rubber gloves or use tongs (or a similar tool) to pick up broken CRT fragments.

1. Remove the keyboard and video display covers (see Figure 2-1).
2. Inspect the keyboard and the display cabinet interior for shipping damage.
3. Examine cable harnesses for stress, loose or broken wires, or broken cable ties.
4. Examine internally mounted components for loose or missing hardware.
5. Tighten all loose hardware.
6. Clean the cabinet interior by removing loose debris.
7. Replace the keyboard and video display covers.

#### 2.2.5 Reshipping Procedures:

Should the Model 950 be reshipped to a distant location, whether for reinstallation at a new site or for return to the factory for repair, proceed as follows:

1. Remove the keyboard and video display cabinet covers.
2. Check the integrity of the cabling and the security of internal mounting hardware.
3. Repack the terminal in the original TeleVideo shipping container or other suitable materials.

### 2.3 SITE PREPARATION

The Model 950 requires 115 Vac 60 Hz or 230 Vac 50 Hz and 65 watts of power. A flat, level, mounting area is required. The installation site should have this power in the immediate vicinity (in the U.S., a NEMA standard 5-15R, 3-prong receptacle). The cabinet requires an area 17.25" (43.8cm) high x 20.13" (51.1cm) wide x 24.06" (61.1cm) deep. These dimensions allow 4 inches (10.2cm) for ventilation clearance.

### 2.4 INSTALLATION AND SETUP PROCEDURE

Installation and setup of the terminal consists of configuring for 115 Vac or 230 Vac operation, configuring and installing the host and printer connectors, and setting up the various operating parameter switches. These procedures should be performed only by technically qualified personnel. To connect and set up the terminal for operation, proceed as follows:

1. As required for international applications, cut off the US-style plug on the power cord and install a connector that will mate to local power receptacles. The power cord wires are color-coded as follows:
  - Green = earth ground
  - Black = primary power (hot)
  - White = primary power return (neutral)
2. Set the power select switch to 115V or 230V (remove and reinstall the switch blocking strip as necessary. (see Figure 2-2).
3. Configure the main interface connector according to Table 2-1.

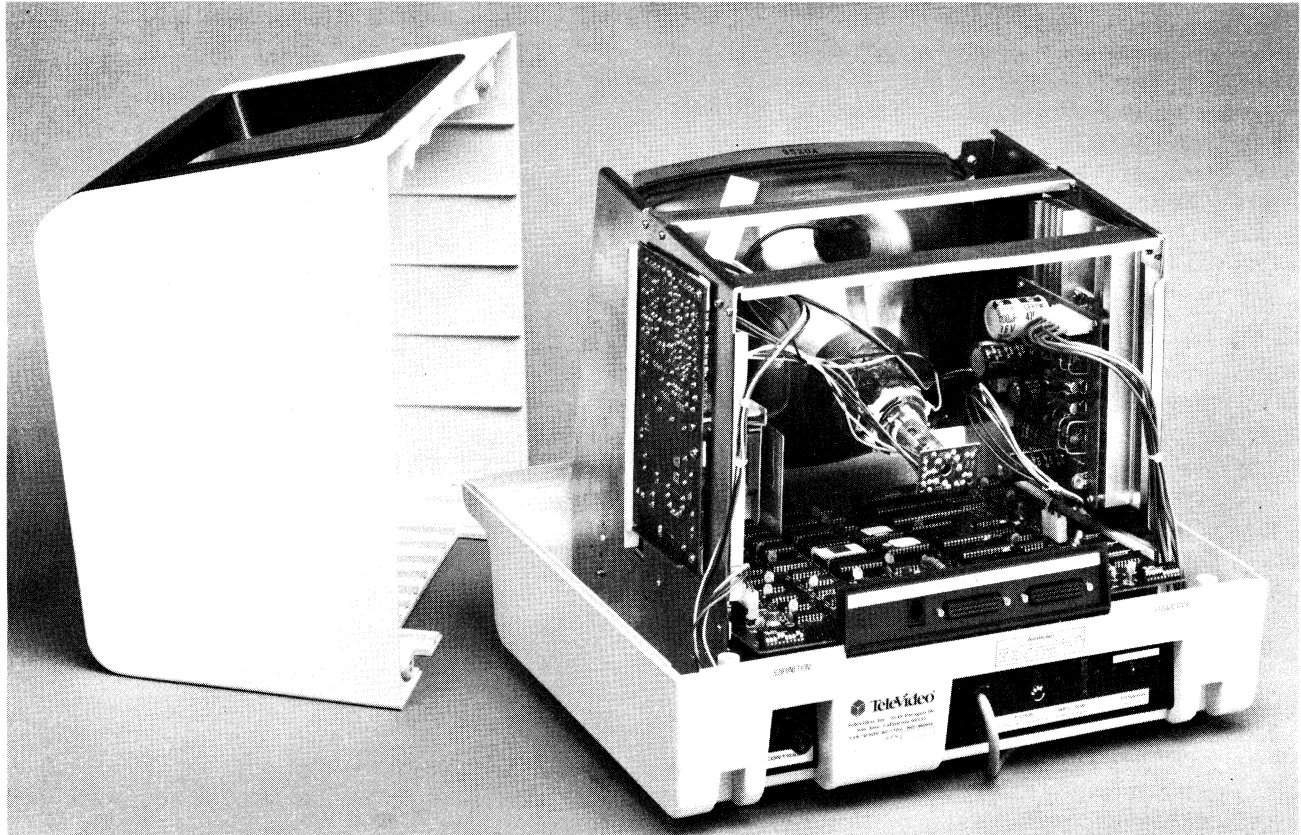

Terminal cover removed for inspection.



Keyboard cover removed for inspection.

**Figure 2-1 Terminal Cabinet Receiving Inspection**

4. Configure the host interface connector with active/passive current loop connectors as required for the loop option (see Figure 2-3).
5. As required, configure the printer interface connector according to Table 2-2.
6. Set the desired baud rate, word length, and stop bits on S1 (see Figure 2-4).
7. Set the desired operating modes and parity on S2 (see Figure 2-5).
8. Connect the host cable to the **RS-232C** connector on the cabinet rear panel.
9. As required, connect the printer cable to the **PRINTER** connector on the cabinet rear panel.
10. Connect the terminal to primary power.

### 2.5 INSTALLATION CHECKS

Before turning the terminal on for normal operation for the first time after installation, check each of the following:

1. Correct power plug installed for wall outlet?
2. Power selector switch set for local power? (see Figure 2-2)
3. Main interface cable to host computer properly wired and plugged in? (see Table 2-1)
4. Current loop jumpers installed, if needed? (see Table 2-3)
5. Printer interface connector plugged in, if needed? (see Table 2-2)
6. Baud rate set? Stop bits? Word Length? Printer baud rate? (see Figure 2-4)
7. Desired operating modes set: key click, 50/60 Hz, duplex/block/local, black-on-white/white-on-black, parity, cursor display, local or duplex edit? (see Figure 2-5)
8. Terminal plugged in to primary power?

**Table 2-1 Host Interface Connector Configuration**

PIN No.	SIGNAL NAME
1	Frame Ground
2	Transmit Data Output
3	Receive Data Input
4	Request To Send Output
5	Clear To Send Input
6	Data Set Ready Input (opt.)
7	Signal Ground
8	Carrier Detect Input
20	Data Terminal Ready Output
9	20 mA source (+12V, no load)
14	20 mA source (+12V, no load)
10	Detected current loop data
25	Current Loop +, Transmit*
13	Current Loop -, Transmit*
12	Current Loop +, Receive*
24	Current Loop -, Receive*

\*Refer to Figure 2-3 for connector configuration.

**Table 2-2 Printer Connector Configuration.**

PIN No.	SIGNAL NAME
1	Protect Ground
2	Transmit Data
3	Receive Data
4	Request To Send
5	Clear To Send
6	Data Set Ready
7	Signal Ground
8	Data Carrier Detect
20	Data Terminal Ready

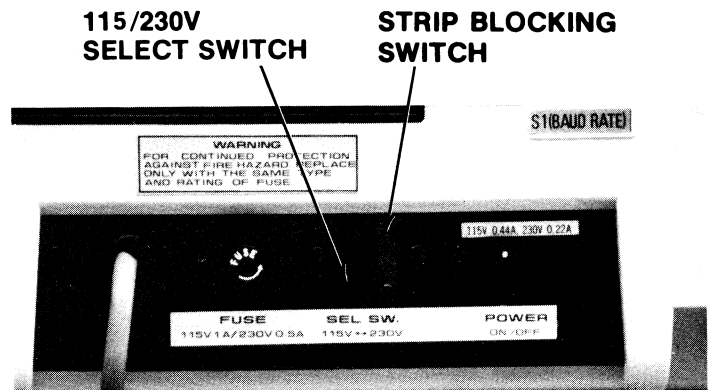

**Figure 2-2 115/230V Select Switch**

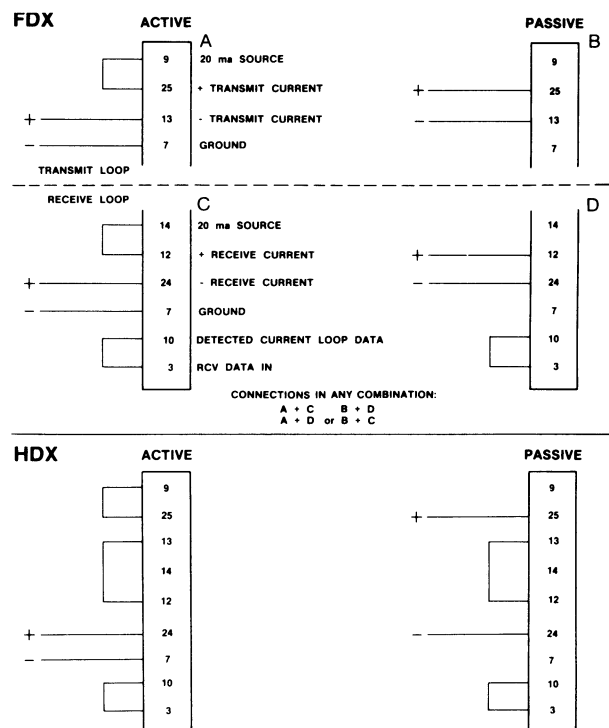

**Figure 2-3 Host Interface Connector Configuration for Current Loop**

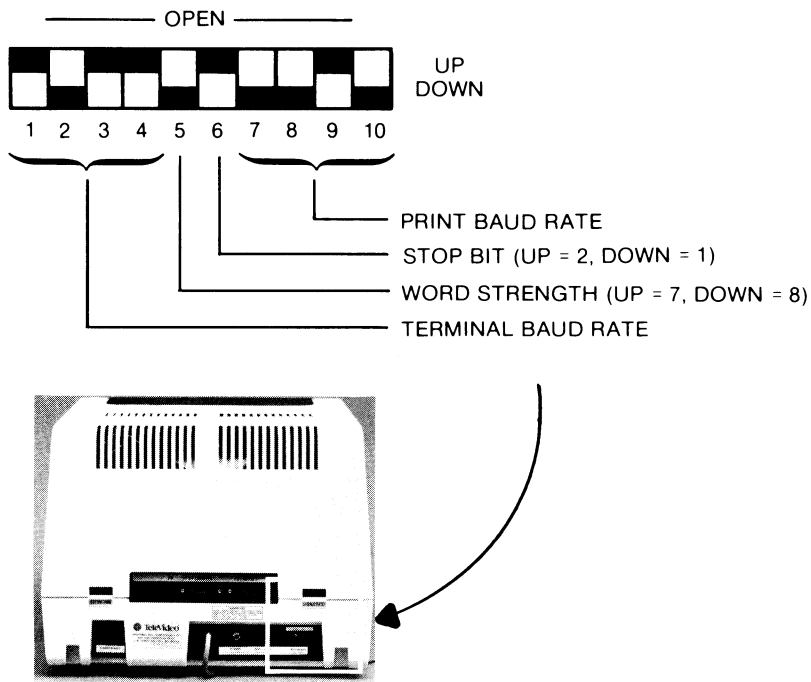

SWITCHES				BAUD RATE
7	8	9	10	PRINTER
1	2	3	4	TERMINAL
0	0	0	0	9600
1	0	0	0	50
0	1	0	0	75
1	1	0	0	110
0	0	1	0	135
1	0	1	0	150
0	1	1	0	300
1	1	1	0	600
0	0	0	1	1200
1	0	0	1	1800
0	1	0	1	2400
1	1	0	1	3600
0	0	1	1	4800
1	0	1	1	7200
0	1	1	1	9600
1	1	1	1	19200

0 = DOWN  
1 = UP

Figure 2-4 Baud Rate, Word Length, and Stop Bit Settings

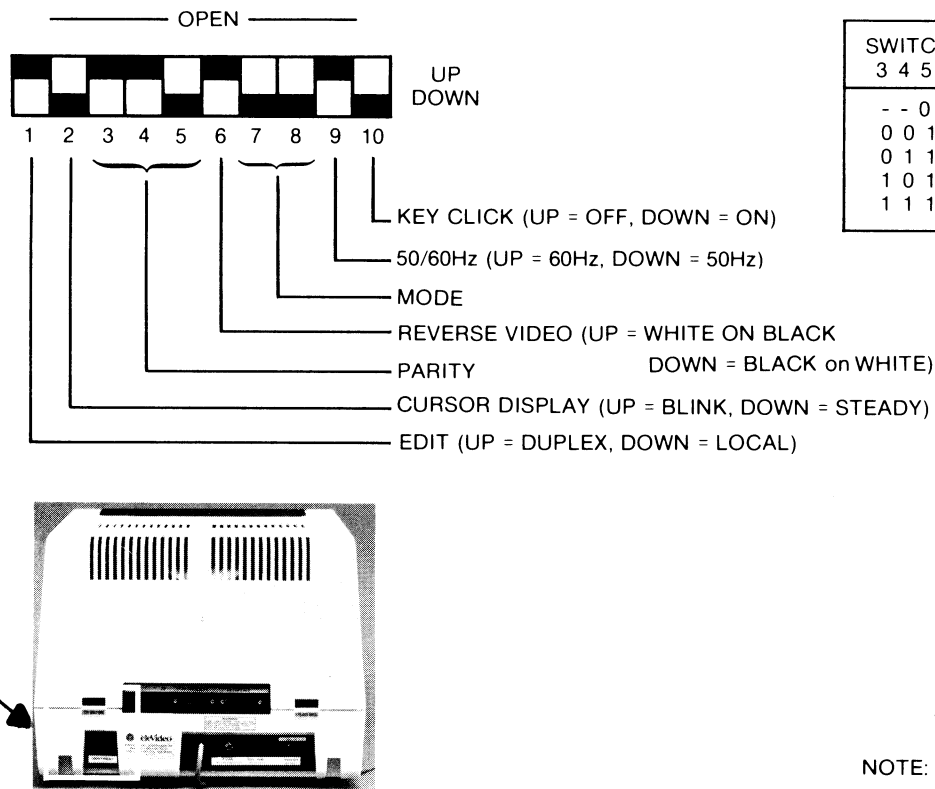

SWITCH 3 4 5	PARITY
- - 0	NO
0 0 1	ODD (RECV and XMIT)
0 1 1	EVEN (RECV and XMIT)
1 0 1	MARK (Xmit parity disabled)
1 1 1	SPACE (Xmit parity disabled)

SWITCH 7 8	MODE
0 0	HALF DUPLEX
0 1	FULL DUPLEX
1 0	BLOCK
1 1	LOCAL

NOTE: Set 50/60Hz the same as the power line frequency to avoid display flicker

Figure 2-5 Operating Mode Switch Settings

## Chapter 3 OPERATION

### 3.1 INTRODUCTION

This chapter describes the Model 950 keyboard. It also provides power-on procedures and instructions for normal operation. For the programmer, this chapter includes complete information on Escape and Control Code sequences, graphics character generation, and special feature control. As a reference aid to experienced programmers, all tables pertinent to operation are at the end of this chapter.

#### NOTE

All Escape and Control Code sequences are shown with a space between each character. *These spaces are not part of the code sequence.* The spaces are included for clarity only.

### 3.2 REAR PANEL CONTROLS AND CONNECTORS /TURN-ON/TURN-OFF PROCEDURE.

The following paragraphs describe the location and function of the controls and connectors on the Model 950 rear panel, and provide procedures for turning the terminal on and off.

#### 3.2.1 Rear Panel Controls and Connectors.

The controls on the Model 950 rear panel (see Figure 3-1)

are the **POWER** switch, the **CONTRAST** control, and the **BAUD RATE** and **FUNCTION** setup switches. The rear panel connectors are the main interface port (**P3 RS-232C**) and the printer port (**P4 PRINTER**) and keyboard connector **P1**. The **FUSE** holder contains a fuse that protects the internal circuitry against shorts.

#### 3.2.2 Turn On Procedure.

To turn on the Model 950, proceed as follows:

1. Push the end of the rocker power switch marked with a white dot. The terminal bell will beep within 1 second indicating that power is on.
2. After 10 to 15 seconds, the cursor will appear in the upper left corner of the screen, and the status line will appear across the bottom of the screen on line 25.
3. Adjust the **CONTRAST** control for the desired screen intensity.
4. Follow the sign-on protocol required by your system.

#### 3.2.3 Turn Off Procedure.

To turn off the terminal, proceed as follows:

1. Follow the sign-off (or equivalent) protocol required by your system.
2. Push the unmarked end of the rocker power switch.

### 3.3 DESCRIPTIONS OF KEYBOARD MODES AND FUNCTIONS.

The Model 950 Video Display Terminal consists of a video display processor that receives input from a host



Figure 3-1 Model 950 Rear Panel Controls and Connectors



computer and a keyboard for presentation on a CRT screen. Data is input to the processor in serial through RS-232C standard ports. The keyboard although laid out like a standard typewriter, contains additional keys for communicating with a computer. Unlike a typewriter (where pressing a key results directly in a typed character), the Model 950 keyboard *transmits* a code (American Standard Code for Information Interchange, ASCII) to the display processor for action. Depending on the terminal's communication mode, the processor either sends the typed character directly to the screen or transmits it to the host for action.

**NOTE**

*What the host computer sends back to the Model 950 (if anything) depends entirely on the application program in use. Refer to your application program user documentation for complete information.*

The Model 950 may be set to one of four transmission modes. In the Local mode (see Figure 3-2), the display processor sends keyboard entries directly to the screen for presentation (characters) or for control. The Block mode sends keyboard entries to the screen, and when the operator chooses, it sends the entries as a block of text to the host computer. The Half Duplex mode sends keyboard entries to the screen and to the host at the same time. The Full Duplex mode sends keyboard entries to the host only; if the host is programmed to act upon a code received from a keyboard entry, it may send the result back to the terminal. For example if the *A* is pressed on the keyboard, the host will probably send the character *A* back to the terminal's display processor for writing on the screen.

The Model 950 displays data entered from the keyboard or from a host computer into the terminal on an 80 column by 24 line screen (see Figure 3-3). A 25th line at the bottom of the display presents terminal status and user messages. Data entered into the terminal is organized in pages of 24 lines (or optional 48-line or 96-line pages). These pages may be flipped through with the linefeed function (using Auto Page) or a page selection control sequence.

A printer with an RS-232C serial data port may be connected to the Model 950 to print page data stored in memory or to print data sent from the host.

The controls of the Model 950 consist of the keyboard for normal operation (see Figure 3-4) and setup switches at the rear panel for configuration (see Figure 2-5). The keyboard consists of six functional areas: the alpha-numeric keys, the editing and cursor control keys (local or duplex operation), the function keys (local or duplex operation), the *SET-UP/NO SCROLL* key (a unique function—local operation only), Local Escape and shift Break (local operation only), the *BREAK* key (Full Duplex only), and the key modifiers.

**3.3.1 Alpha-Numeric Keys.**

The alpha-numeric key group (see Figure 3-4) contains all the "typewriter" letter, number, and symbol keys on the keyboard. This group also contains the carriage

*RETURN, LINEFEED, ENTER, LOC ESC/ESC, and DEL* keys. All alpha-numeric keys repeat when pressed for more than 1/2 second.

The **RETURN** and **ENTER** keys perform the same function. They send the *ASCII* code for a carriage return (CR) to the display processor. Depending on the terminal's communication mode, the code causes the processor to transmit a CR to the host and the cursor to be moved to column 1 of the current line.

**NOTE**

The Model 950 features a wraparound function, which eliminates the need to manually enter a carriage return and a line-feed at the end of each 80-character line.

The **LINEFEED** key sends an *ASCII* code for a linefeed (LF) to the display processor. Depending on the terminal's communication mode, the code causes the processor to transmit an LF code to the host and/or the cursor to be moved down one line on the screen.

The **ESC** key sends an *ASCII* code for Escape to the display processor. The key is generally used to momentarily leave (escape) an application program in order to use a special feature or function.

When pressed, **ESC** causes the next control character entered to be displayed on the screen. For example, pressing **ESC CTRL A** causes **S<sub>H</sub>** to be displayed.

When pressed in combination with **SHIFT**, the key operates only locally to invoke the terminal's functions and special features. It causes the next character entered to be interpreted as a command. For example, pressing **SHIFT LOC ESC <** turns keyclick off and pressing **SHIFT LOCK ESC >** turns keyclick on.

The **DEL** key sends an *ASCII DEL* character to the display processor, and depending on the terminal's communication mode, the processor retransmits an *ASCII DEL* code to the host.

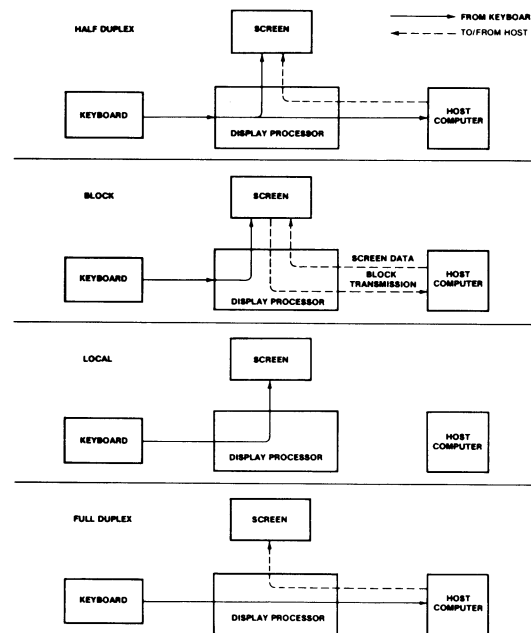

Figure 3-2 Model 950 Communications Modes



### 3.3.2 Editing and Cursor Control Keys

The cursor control keys (**↑**, **↓**, **←**, **→**, **BACKSPACE**, and **HOME**) normally control cursor movement on the screen. The editing keys (see Figure 3-3) control insert and delete characters and lines and clear functions. The **PRINT** and **SEND** keys control data transmission from the screen to the printer or host computer.

When set to the Local Edit mode (paragraph 3.10.1), the keys affect *only* the current page. They are not transmitted to the host. When set to the Duplex Edit mode, the keys operate in the same mode as the alpha-numeric keys by transmitting their associated control code or escape sequence and/or perform their action locally. The editing and cursor control keys are:

1. **TAB** and **BACK TAB**
2. **CHAR INSERT** and **CHAR DELETE**
3. **LINE INSERT** and **LINE DELETE**
4. **LINE ERASE** and **PAGE ERASE**
5. **BACKSPACE**, **HOME**, **↑**, **↓**, **←**, and **→**.
6. **CLEAR SPACE**.
7. **SEND** and **PRINT**.

All keys except **LINE ERASE**, **PAGE ERASE**, **CLEAR SPACE**, **HOME**, **SEND**, and **PRINT** repeat when pressed for more than ½ second.

a. **Tab Control Keys.** **TAB** (ESC i) and **BACK TAB** (ESC I) move the cursor forward or backward to typewriter tabs (Protect mode off) or to the next start or previous start of an unprotected field (Protect mode on).

b. **Character Insert Keys.** **CHAR INSERT** (ESC Q) enters the insert character (refer to paragraph 3.15.13) at the cursor position, causing all succeeding characters to shift one position to the right. If the terminal is set to the Edit Line mode (EDTL — wraparound turned off), characters shifted off screen to the right are lost. If the terminal is set to the Edit Page mode (EDTP — wraparound turned on — refer to paragraph 3.10.1), characters shifted beyond column 80 are moved to the first column of the next line. When **CHAR INSERT** is pressed at the same time as **SHIFT**, the Insert mode (ESC q) is turned on (INSL or INSP on the status line).

c. **Character Delete Key.** **CHAR DELETE** (ESC W) deletes the character at the cursor position and causes all succeeding characters to shift one position to the left. If the terminal is set to the Edit Line mode (EDTL — wraparound turned off), the character position at the end of the line is replaced with the insert character. If the terminal is set to the Edit Page mode (EDTP — wraparound turned on), characters from the first column of the next line are shifted into the last positions on the current line.

When **CHAR DELETE** is pressed at the same time as **SHIFT**, the Insert mode (ESC r) is turned off (**EDTL** or **EDTP** on the status line).

d. **Line Insert and Delete Keys.** The **LINE INSERT** (ESC E) key creates an entire line of insert characters on the cursor line. The data on the cursor line and all following lines shift down one line (the last line of the page is lost). **LINE DELETE** (ESC R) causes the entire line at the cursor position to be deleted. All the following lines shift up one line.

When **LINE INSERT** or **DEL** is pressed at the same time as **SHIFT**, Edit page (refer to paragraph 3.10) is turned on (ESC N) or off (ESC O), respectively.

e. **Line Erase and Page Erase Keys.** **LINE ERASE** (ESC T) and **PAGE ERASE** (ESC Y) replace the unprotected data (from the cursor the end of the line or page) with the insert character of the proper intensity.

When the keys are pressed at the same time as **SHIFT**, they cause a line erase to nulls (ESC t) or a page erase to nulls (ESC y).

f. **Cursor Control Keys.** When set to the Local mode, the **BACKSPACE**, **↑**, **↓**, **←**, and **→** keys move the cursor in the directions indicated on the key cap. **HOME** moves the cursor to the first unprotected position on the current page.

g. **Clear Space Key.** **CLEAR SPACE** (CTRL Z) replaces all unprotected characters on a page with insert characters. When pressed at the same time as **SHIFT** (ESC \*), it clears the entire page to nulls and turns off the Protect and Half Intensity modes.

h. **Print Key.** **PRINT** causes all data on a page from the home position to the cursor position (not just the screen) to be output through the terminal printer port. The data is output with a CR, LF, and null automatically inserted at the end of each 80-column line (**PRT 0**) or, when **PRINT** is pressed at the same time as **SHIFT**, without the CR, LF, or null (**PRT 1**). **PRINT** operates either as a local function or as a duplex function (like the edit keys).

When the terminal is outputting data through the printer port, **PRT 0**, **PRT 1**, **PRT 2**, **PRT 3**, or **BDIR** (bidirectional) appears on the Status Line. **PRT 2** indicates the Transparent Print mode, in which data output from the host is sent to the printer port and to the screen. **PRT 3** indicates that data output from the host is sent directly to the printer, bypassing the screen. **BDIR** turns on two-way communication through the printer port to allow conversation between a printer with a keyboard (a KSR device) and the host. **PRT 2**, **PRT 3**, and **BDIR** are print modes generally turned on by the host (through preprogramming), although they may be turned on at the keyboard.

#### CAUTION

If the terminal is set to **PRT 2** by the host, pressing **PRINT** or **SHIFT PRINT** cancels **PRT 2** (**PRT 3** is not affected). This could interrupt the host output to the printer at the wrong moment, resulting in a loss of data.

i. **Send Key.** Data may be sent to a host from the Model 950 by several methods in order to conform to the editing mode of the terminal. These methods are single character, line, and page. In addition, either all data or only unprotected data can be selected for transmission. The method used depends on the terminal's setup for the system it is in (refer to paragraph 3.15.6b for programming information).

### 3.3.3 Function Keys

The function keys (see Figure 3-4), **F1** through **F11** (refer

to Figure 3-1), are user defined. When pressed, the keys cause the processor to send a user-defined code to the screen, to the host, or to both, depending on whether the key was set up for Local or Duplex mode. For example, the user-defined code may consist of a frequently used Escape or Control code sequence in a text editing application. Up to 22 codes may be defined—two per key. Pressing *SHIFT* at the same time as a function key transmits the second code on the key.

The *FUNCT* key transmits a user-selected character bracketed by Control A (SOH) and a Carriage Return (CR). For example, if a Control A C CR sequence is required for a special operation in a text editing program, pressing *FUNCT* and *C* at the same time transmits CONTROL A C CR to the host automatically.

### 3.3.4 SET-UP/NO SCROLL Key

The *SET-UP/NO SCROLL* key (see Figure 3-4) provides control of two independent functions of the Model 950: stopping screen updating during normal operation and manually setting the operating characteristics of the terminal.

a. No Scroll Function. During normal operation, the No-Scroll function of the *SET-UP/NO SCROLL* key is active. When pressed, the terminal stops updating the screen. When pressed again, the terminal starts updating the screen. If the receive buffer fills up while update is disabled, X-OFF will be sent to the host computer, causing it to stop sending data. When update is re-enabled, the buffer will empty, causing X-ON to be sent and data to be transmitted by the host.

b. Setup Function. The *SET-UP/NO SCROLL* key is used to manually set the terminal's operating characteristics. The setup function is enabled by pressing *SHIFT* and *SET-UP/NO SCROLL* at the same time. The characteristics are as follows:

1. Edit mode—Provides for text to be changed on a line (*EDTL*) or page (*EDTP*) basis.
2. Insert mode—Provides for text to be inserted on a line (*INSL*) or page (*INSP*) basis.
3. Keyboard lock (*KLOK*)—When on, deactivates the keyboard (except for the *SET-UP*, *LOCK ESC*, *BREAK*, and function keys).
4. Protect mode (*PROT*)—Causes all half-intensity characters to be protected from change.
5. Half Intensity (*H.I.*) mode—Causes all subsequently entered characters to be displayed at half intensity.
6. Transmission mode—Local (*LOC*), Block (*BLK*), Half-Duplex (*HDX*), and Full-Duplex (*FDX*). Refer to paragraph 3.3.
7. Terminal operating baud rate (same selections as in Table 1-1).

The status of these characteristics is displayed on the Status Line (line 25).

### 3.3.5 BREAK Key

The *BREAK* key (see Figure 3-4) causes the Model 950 to transmit a 250-ms break pulse to the host. The effect of this signal depends on the operating program.

When pressed at the same time as *SHIFT*, *BREAK* performs a limited terminal reset by clearing the function in progress. It turns off the Print mode if on, turns off Half Intensity and Protect modes, and sounds the bell tone to indicate the reset.

### 3.3.6 Key Action Modifiers

The control keys of the Model 950 (see Figure 3-4) are conventional and include control (*CTRL*), *SHIFT*, and *ALPHA LOCK*. These keys by themselves have no effect on the terminal or host; however, when they are used in combination with other keys, they change (or modify) the code sent to the terminal processor for the key pressed.

a. Control Key. The *CTRL* key modifies the code sent by another key. When pressed *at the same time* as another key, the keyboard sends a unique code. The control key combinations are used for special functions of the Model 950 and/or of the application program of the host. For example, a *CTRL G* key combination sounds the Model 950 bell. The Model 950 control codes either duplicate existing dedicated keys on the keyboard or control functions normally controlled by the host, such as turning on the bidirectional printer port (refer to paragraph 3.15.5) or sounding the bell.

b. SHIFT Key. The *SHIFT* key functions similar to the *CTRL* key by modifying the code sent by another key pressed at the same time. The most familiar use of this key is to produce upper case characters on the screen. However, it is also used in combination with the dedicated keys of the terminal for special functions. For example, pressing *SHIFT* and *SET-UP* together enables or disables the setup mode of the terminal (refer to paragraph 3.4).

c. ALPHA LOCK Key. The *ALPHA LOCK* key locks the *SHIFT* keys so that all alpha keys transmit codes for upper-case characters. The key is pressed to lock and pressed again to release.

## 3.4 KEYBOARD SETUP PROCEDURE

When the Model 950 is first turned on, it reads setup default values (from rear panel switches *S1* and *S2*—refer to paragraph 2-4) and displays some of them on the Status Line (see Figure 3-3). In some cases, the operator may reset these values locally (the values may be set by the host computer—refer to paragraph 3.15.13 and 3.15.14). To set these values, proceed as follows:

1. Push *SHIFT* and *SET-UP* at the same time. The cursor will immediately appear in the eight block (*EDTL*) on the Status Line.
2. Press *T* to toggle through the editing controls (*EDTL*, *EDTP*, *INSP*, and *INSL*) to the desired selection.
3. Press *→* to move the cursor to the next Status Line block.
4. Press *T* to lock the keyboard (*KLOK*). The keyboard should be locked when the terminal is to be left on and unattended for short periods of time.)
5. Move the cursor to the next Status Line block and press *T* for the Protect mode.
6. Move the cursor to the next Status Line block and press *T* for the Half Intensity (H.I.) mode.

7. Move the cursor to the next block and toggle through the operating mode controls (**LOC**, **BLOCK**, **HDX**, and **FDX**) to the desired selection.
8. If the terminal is to operate temporarily at a baud rate different from the default value set on the setup switches (refer to paragraph 2.4), move the cursor to the next setup block and press **T** to toggle through the baud rates to the desired value.
9. Press **SHIFT** and **SET-UP** at the same time to leave the Setup Mode and return to normal operation.

### 3.5 USER LINE PROGRAMMING.

The Model 950 provides a line that may be programmed with user data. When displayed, it replaces the Status Line on line 25 (see Figure 3-4). The line may be loaded with up to 80 characters. Both the Status and User Lines may be transmitted to the host.

To load the User Line and send the Status Line or the User Line to the host, proceed as follows:

1. Press **ESC**, then press **g** to display the User Line.
2. Press **ESC**, then press **f**.
3. Enter up to 80 characters of text. The message will appear on the User Line as it is entered.
4. Press **RETURN** to terminate the user message.
5. To send the User Line message to the host, press **ESC**, then press **Z** and **0** in sequence.
6. To redisplay the Status Line on line 25, press **ESC**, then **h**.
7. To send the Status Line to the host, press **ESC**, then press **Z** and **I** sequentially.

### 3.6 FUNCTION KEY PROGRAMMING

The memory assigned to the function keys can hold up to 256 bytes (or characters) *total*. For each message entered, an extra character byte is added by the Model 950 processor for control purposes. The number of characters that may be entered per key equals 256 bytes minus the number of keys programmed minus the total bytes for all keys already programmed. For example, if three keys have already been programmed with four characters each, then the next key may be programmed with up to 240 characters; that is

- 256 bytes
- 3 bytes (extra characters) for keys already programmed
- 1 bytes (extra character) new key
- 12 bytes total already programmed
- = 240 bytes left that may be programmed.

When the terminal is first turned on, the function keys are programmed with default messages set to Full Duplex mode. These default message codes are as follows:

KEY	CODE	SHIFTED CODE
F1	CTRL A @ CR	CTRL A \ CR
F2	CTRL A A CR	CTRL A a CR
F3	CTRL A B CR	CTRL A b CR
F4	CTRL A C CR	CTRL A c CR
F5	CTRL A D CR	CTRL A d CR
F6	CTRL A E CR	CTRL A e CR
F7	CTRL A F CR	CTRL A f CR
F8	CTRL A G CR	CTRL A g CR
F9	CTRL A H CR	CTRL A h CR
F10	CTRL A I CR	CTRL A i CR
F11	CTRL A J CR	CTRL A j CR

To program the function keys, use the following dialogue:

**ESC**<sub>1</sub> **p**<sub>1</sub> **p**<sub>2</sub> message **CTRL Y**

where **p**<sub>1</sub> is the number of the function key. The values of **p**<sub>1</sub> are as follows:

KEY	NORMAL	SHIFTED
F1	1	<
F2	2	=
F3	3	>
F4	4	?
F5	5	@
F6	6	A
F7	7	B
F8	8	C
F9	9	D
F10	:	E
F11	;	F

and where **p**<sub>2</sub> is a 1 (send to a host—**FDX**), 2 (send to screen—**LOC**), or 3 (send to host and to screen—**HDX**).

#### NOTE

For revision 1.0 firmware, function keys must be programmed in sequential ascending order.

Because control, escape, cursor position, and similar function keys are not normally stored, a **CTRL P** imbedded in the *text* of the function key message may be used to store the next character entered. For example, if the desired message is (spaces are for clarity only, do not include them when entering command sequences):

**ESC A CTRL Y B C CTRL P**

precede it with **ESC**<sub>1</sub> the key number, and the transmission mode (see above), then enter it as

**ESC A CTRL P CTRL Y B C CTRL P CTRL P**

and then complete the load sequence with the **CTRL Y** load terminator.

Once the function keys have been programmed, just press the desired key (for the first message programmed) or the desired key and **SHIFT** at the same time (for the second message programmed).

### 3.7 CURSOR ATTRIBUTES

The cursor display may appear any one of five ways. To set the cursor display, enter the control code for the desired attribute. Type the code in the exact sequence shown below (do not enter the spaces between the characters; spaces are for clarity only):

ATTRIBUTE	CODE
Not displayed	ESC . 0
Blinking block	ESC . 1
Steady block	ESC . 2
Blinking underline	ESC . 3
Steady underline	ESC . 4

### 3.8 USING TABS.

The Model 950 uses two types of tabs: typewriter tabs that move the cursor anywhere tabs are set and field tabs that move the cursor across protected fields.

#### 3.8.1 Typewriter Tabs

Typewriter tabs may be set anywhere on the Model 950 page. When the page is set for normal video (*PROT* off), the tabs act like typewriter tabs, advancing the cursor to the next tab position. Each time *TAB* is pressed the cursor advances to the next tab; each time *BACK TAB* is pressed, the cursor backs to the previous tab. If the cursor is beyond the last tab set on a line, pressing *TAB* has no effect. When the cursor is at the first tab on a line, pressing *BACK TAB* moves it to the first column of the line.

#### 3.8.2 Field Tabs

Tabs may be set protected (*PROT* on) to act on a field basis. The cursor will not move to previously set typewriter tab columns. Pressing *TAB* moves the cursor to the first unprotected character position following the next protected field. If Auto page is off (refer to paragraph 3.15.10) and no *unprotected character* follows, the cursor moves to the first unprotected character on the *same page*. If Auto Page is on and there is no following *unprotected character*, the cursor moves to the first unprotected character of the *next page*. If the next page contains no protected fields, the cursor moves to the Home position (line 1, column 1) on that page.

#### 3.8.3 Tab Operations

To move the cursor forward to a tab position, press *TAB* (CTRL I); to move the cursor back to a previous position, press *BACK TAB* (ESC I).

To set or clear the tabs, enter the code for the desired operation. Type the code in the exact sequence shown below (do not enter spaces between characters; spaces are for clarity only):

OPERATION	CODE
Tab set	ESC 1
Clear tab at cursor	ESC 2
Clear all tabs	ESC 3

### 3.9 OTHER MODE CONTROLS

During normal operation of the Model 950, several functions may be controlled with code sequences. These functions include keyclick, Conversation/Block mode changes, and reverse video. To change these functions, type their codes in the exact sequence shown below (do not enter spaces between characters; spaces are for clarity only):

Normal video (white on black)	ESC d
Reverse video (black on white)	ESC b
Keyclick on	ESC <
Keyclick off	ESC >
Conversation mode on	ESC C
Block mode on	ESC B
Set Half duplex (HDX)	ESC D H
Set Full duplex (FDX)	ESC D F

### 3.10 TEXT/DATA CONTROL MODES.

For normal operation, the Model 950 provides several methods for controlling text or data entry. These methods are Edit modes for changing text, Insert modes for modifying text, Print mode for sending text to the terminal printer port, Send mode for transmitting selected data to the host, and function key message transmissions for sending preprogrammed messages to the host. Each of these modes is described in the following paragraphs.

#### 3.10.1 Editing Text

Edit mode (Insert mode off) is the most common operating mode for entering text on the screen. The Edit Page (EDTP) mode or Edit Line (EDTL) mode, which should be set by the application program, allows text to be edited or added after initial text entry. Any text entered replaces characters already on the screen.

#### NOTE

When entering text, the wraparound feature of the Model 950 eliminates the need to press *RETURN* and *LINEFEED* at the end of a line. It automatically advances the cursor to column 1 of the next line when entered characters reach column 80. A CR and an LF need only be entered when the end of a line is before the last column. If double-spaced lines are desired, *LINEFEED* must be pressed *twice*.

After the initial setup, Edit modes may be changed without re-entering the setup mode. To enter an Edit mode, type its code in the exact sequence shown below (do not enter spaces between characters; spaces are for clarity only):

EDIT MODE	CODE
Local Edit	ESC k
Duplex Edit	ESC 1
Set Page Edit	ESC N
Clear Page Edit	ESC O

These modes operate in addition to the dedicated editing keys (refer to paragraph 3.3.2).

#### 3.10.2 Inserting Text

The Insert mode allows text to be inserted on a line basis or a page basis into text previously entered. Additions are entered by setting the cursor at the insertion point and typing in the text. Existing text shifts to the right as the new text is entered. Insert mode is entered or cleared either by going to the Setup mode (paragraph 3.4) or by typing one of the following control sequences (do not type the spaces in the sequence; spaces are for clarity only):

OPERATION	CODE
Set insert	ESC q
Clear insert	ESC r

When the terminal is operated in the Insert Line and Edit Line modes, any character typed causes the cursor and all data to the right of the cursor (within the line or field) to move one column to the right. The character typed (inserted) is displayed in the cursor position before the insert; the last character in the line or field will be lost.

When the terminal is operated in the Edit Page and Insert Page modes, the last character in each line following the cursor is shifted to the first position of the next line. This shifting process continues until the end of the page is reached and the last character is lost. Nulls and spaces are characters for editing purposes.

### 3.10.3 Print Control

The terminal will send data from the screen to an auxiliary printer when *PRINT* is pressed.

#### CAUTION

Pressing *PRINT* or *SHIFT PRINT* while the host is outputting data to the printer in Transparent Print mode (*PRT 2*) cancels *PRT 2* and may result in the loss of data. (*PRT 3* is not affected by pressing *PRINT*.)

To send all the data on a page, including a carriage return, a linefeed, and a null at the end of each line, press *PRINT*. To send all the data on a page without a carriage return, linefeed, or a null at the end of each line, press *SHIFT* and *PRINT* at the same time.

### 3.10.4 Send Function

Once data or text has been entered and edited, it may be transmitted to the host by either pressing *SEND* for a pre-programmed transmit method or by entering a control sequence to send specific data. The manner in which the *SEND* key has been preprogrammed depends on the Model 950 setup for the system in which it is installed. Consult system documents for its configuration (also refer to paragraph 3.15.6 for programming information).

To send the host specific data, type the code in the exact sequence shown below (do not enter the spaces between the characters; spaces are for clarity only):

<b>SEND DATA</b>	<b>CODE</b>
Send line unprotected (from start of line to cursor)	ESC 4
Send page unprotected (from Home to cursor)	ESC 5
Send line all (from start of line to cursor)	ESC 6
Send message unprotected (STX to ETX)	ESC S
Send message all (STX to ETX)	ESC s
Send programmed transmission sequence (refer to paragraph 3.15.6)	SEND

Data other than text may also be sent to the host; however, control sequences must be used. Pressing *SEND* will not send the data. The transmit commands for other than text data follow. Type the code in the exact sequence shown below (do not enter the spaces between the characters; spaces are for clarity only):

<b>SEND DATA</b>	<b>CODE</b>
Terminal type	ESC M
User line	ESC Z 0
Status line	ESC Z 1
Page, Row, Column, and Carriage Return	ESC /
Row, Column, and Carriage Return	ESC ?

#### NOTE

When the terminal is sending data to the host, the host's data echo-back mode (echoplex) should be turned off. Turning off echoplex applies to all transmission modes: Block, Half Duplex, and Full Duplex.

### 3.10.5 Function Keys

As described in paragraph 3.6, the function keys may be user programmed. To use one of these keys in normal operation, press the key for the first message, or press *SHIFT* and the key at the same time for the second message.

### 3.11 OPERATING IN BLOCK MODE

Most normal applications of the Model 950 consist of entering text or data, changing or adding to data sent to the terminal by a host computer, sending screen data to a printer, and sending data to the host computer.

Operating the Model 950 in the Block mode generally consists of entering or changing text locally. In this mode, the terminal processor sends the results to the screen. When the operator is satisfied with the results of the text/data entry or change, the text/data may then be sent to a printer or the host. To operate the Model 950 in the Block mode, proceed as follows:

1. As required by your host computer's application program, respond to any prompts.
2. Set the terminal to the Block mode either by changing it using the Setup mode (refer to paragraph 3.4) or by entering *ESC B* (refer to paragraph 3.9).
3. Enter text or data.

Refer to the following paragraphs for detailed descriptions of the use of the editing, text insertion, print and send operations of the terminal.

### 3.12 OPERATING IN LOCAL MODE

Operating in the Local mode causes the Model 950 to perform in the same manner as when it is in the Block mode, except that no communications with the host are possible. Local mode turns off host port P3 on the terminal. If data transmission to the host is desired after the data is entered, set the terminal to Block mode and press *SEND* or use a send data control sequence.

### 3.13 OPERATING IN HALF DUPLEX MODE

When the Model 950 is set to the Half Duplex mode, it sends entered text and data to the screen and allows the control of this information similar to Block Mode. However, the terminal is also sending the text and data to the host. The host will act on the entered data, text, and control commands only as programmed to do so by its appli-



cation program. Refer to the application program user documentation for further information.

### 3.14 OPERATING IN FULL DUPLEX MODE

As described in paragraph 3.3, when operating in Full Duplex mode, all Model 950 operations capable of duplex operation (that is, all operations except Setup, Local Edit, and No-Scroll) are sent to the host computer. What the host sends back to the Model 950 (if anything) and the action it takes on data, text, or command sequences sent to it depends on the application program in use. Refer to the application program user documentation for complete information.

### 3.15 PROGRAMMER'S NOTES AND INFORMATION

The following paragraphs provide the programmer with information on using the Model 950 functions and special features. These functions and features are the following:

- Communications modes and word structure
- Editing and cursor control
- Protect mode
- Tab programming
- Print function programming
- Send function programming
- Video attributes
- Special graphics
- Page control
- Clear function Monitor mode
- Insert character loading
- Main port programming
- Printer port programming
- X-ON, X-OFF control
- User ROM
- Line lock
- Wraparound feature
- Video display control.

Unless otherwise specified in the text, all control code sequences are transmitted from the host to the Model 950 to elicit the response associated with the code.

#### 3.15.1 Communications Mode and Word Structure

The terminal communicates with a host in Half Duplex, Full Duplex, or Block modes (refer to paragraph 3.3). Although the Model 950 communicates using USASCII (or ASCII as used here) with 7-bit serial data words, it carries eight bits in memory for each character position on the screen—seven bits for character identification and an eighth bit as a character-protect flag. During asynchronous transmission, each character is transmitted as an independent message with a start bit, one or two stop bits, and a parity bit (if used). Generally, baud rates 110 and lower use two stop bits, and rates 150 and higher use one stop bit.

#### NOTE

If eight data bits are selected, bit 8 = 0. If parity is used for error detection, it follows the character. Normally, even parity is used for asynchronous transmission, and odd parity is used for synchronous

transmission. Even parity adds a 0 or 1 to the character to make the total number even. The data receiver checks this sum for an indication of a data error.

#### 3.15.2 Editing and Cursor Control

The editing and cursor control key operation is described in paragraph 3.3.2. Escape and Control sequences may be sent from the host to perform the various editing and cursor functions.

a. **Cursor Control.** The cursor control code sequences and a description of the functions follows:

- **Cursor up (CTRL K)**—Moves the cursor up one line until it encounters the top of the screen. If the cursor is not on the first line of the page, the display will roll down one line each time until the cursor reaches the top of the page. Once it reaches the top of the page, further receipt of the code has no effect.
- **Cursor down (CTRL V)**—Moves the cursor down one line. If the cursor is on the bottom line of the screen, the display will roll up one line. If the cursor is on the bottom line of the page, the code has no effect.
- **Cursor left (CTRL H)**—Same as **BACKSPACE**. Moves the cursor left to the next unprotected position on the page. If the cursor is currently in the first column of the line, it will move to the last column of the preceding line or to that line. If Auto Page is off and the cursor is currently at the Home position or the first unprotected position on the page, the code has no effect.
- If Auto Page is on and the cursor is at the Home position or the first unprotected position on the page, the cursor will move to the end of the preceding page or to the last position of the last unprotected field of the preceding page. If the current page is page 0, the code has no effect.
- **Cursor right (CTRL L)**—Moves the cursor right one column; if at column 80, it moves the cursor to the first column of the next line. With Auto Page off and the Protect mode off, it will cause a scroll if the cursor is at column 80 of the last line. With Auto Page on and the cursor at the last unprotected position on the page, the cursor will advance to the first unprotected position of the next page. If the page was the last, the cursor will advance to Home of the first page. With Auto Page off, the Protect mode on, and the cursor at the last unprotected position on the page, the cursor will move to the first unprotected position of the current page.
- **Carriage return (CTRL M)**—Moves the cursor left to column 1 of the current line.
- **Cursor Home (CTRL A)**—Moves the cursor to the first unprotected character on the page.
- **New line (CTRL \_\_\_\_\_)**—Causes the terminal to perform a carriage return and a linefeed.



### b. Cursor Position Programming.

To control the cursor position from the host, send the Escape sequences

ESC = p<sub>2</sub> p<sub>3</sub>            where p<sub>1</sub> = the desired page  
ESC — p<sub>1</sub> p<sub>2</sub> p<sub>3</sub>        number 0 through 3  
                                 p<sub>2</sub> = the desired row (line)  
                                 p<sub>3</sub> = desired column

according to the addressable cursor chart (refer to Table 3-1).

c. Smooth Scroll. The Model 950 provides a smooth scroll feature that prevents display jitter as text lines are scrolled up or down. The feature also allows displayed text to be read as it is scrolled. The smooth scroll control code sequences and a description of their function follow:

Smooth scroll on (ESC 8)—Causes the screen to scroll smoothly at a rate of six data rows per second.

Smooth scroll off (ESC 9)—Causes screen data to scroll as fast as it is received.

d. Normal And Reverse Linefeed. The linefeed control code sequences and a description of their functions follow:

#### CAUTION

Linefeeds received by the Model 950 under certain conditions may result in the loss of data. Read the following control code explanations carefully.

- Linefeed (CTRL, J or LINE FEED)—With Auto Page and the Protect mode off, a linefeed advances the cursor to the next line on the page. If the cursor is at the bottom of the screen, linefeeds cause the display to roll up one line for each linefeed. If the cursor is also at the bottom of the page, a linefeed causes a new line of data to appear at the bottom of the screen and results in the loss of the top line of data on the page. The new line contains the insert character (normally spaces, but may be programmed to be any other character. Refer to paragraph 3.15.13).

With the Protect mode off or on and Auto Page on, linefeed advances the cursor to the next line on the page. When it reaches the bottom of the page, it advances to the first line of the next page. When it reaches the last line of the last page, it advances to the first line of page 0.

With the Protect mode on and Auto Page off, the cursor advances to the top of the current page when it reaches the bottom of the page.

- Reverse linefeed (ESC j)—Moves the cursor up one line for each reverse linefeed received. If the Protect mode is on and Auto Page is off, the cursor stops when it reaches the top line of the page. If Auto Page is on and the Protect mode is on or off, the cursor moves to the last line of the previous page when it reaches the first line of the current page. If the cursor is at line 1 of page 0, it will not move.

If the Protect mode and Auto Page are off, the screen will scroll down one line when the cursor reaches the top line of the screen. If the cursor is also at the top of the page, the page will scroll down one line, causing a

new line of data to appear at line 1 of the screen and deleting the last line of the current page. The data will consist of insert characters.

e. Editing Control. The editing control sequences and a description of their functions follows:

#### CAUTION

Use of the Model 950 editing commands may result in the loss of data. Read the following explanations of the editing control functions carefully.

Set Local Edit mode (ESC k)—Sets the edit keys (*CHAR INSERT, CHAR DELETE, LINE ERASE, PAGE ERASE, SEND, PRINT, LINE INSERT, LINE DELETE, CLEAR, BACKSPACE, ↑, ↓, ←, →, TAB, and BACK TAB*) for local operation only. These keys will affect data in the terminal; no characters associated with the keys will be transmitted to the host. All other keys operate normally.

- Set Duplex Edit mode (ESC l)—Sets the edit keys (see above) to operate in the mode set for the alpha-numeric keys. For example, if the terminal is set for Half-Duplex operation (refer to paragraph 3.2), the alpha-numeric keys operate in Half Duplex mode, and the edit keys operate in Half Duplex mode.

- Set page edit (ESC N)—Enables the wraparound feature for character insert, character delete, and insert modes. When a character is inserted in a line, the character in column 80 moves to column 1 in the next line. If each line contains 80 characters, this control causes a ripple effect, resulting in the loss of the character in column 80 of the last line of the page. When deleting a character, the character in column 1 of each line moves to column 80 of the previous line. Column 80 of the last line then contains an insert character EDTP or INSP will be indicated on the status line.

#### NOTE

The Protect mode will always turn the Edit Page mode off.

- Clear page edit (ESC O)—Clears the Edit Page mode. When Edit Page is cleared, character insert affects only the cursor line; no wraparound occurs. An inserted character causes each character in the line after the insertion to move right one column; the character at column 80 is then lost. For a character delete, the last character on the line (at column 80) becomes an insert character. EDTL or INSL will be indicated on the status line.

- Character insert (ESC Q)—Causes the character at the cursor to move right one column and enters an insert character at the cursor position. If the terminal is set to Edit Page, the character at column 80 wraps to column 1 of the next line (as described above). If the terminal is set to Edit Line, the character at column 80 is lost. If the Protect mode is on, this control will turn off Edit Page. A character insert will insert from the cursor position to the end of the line or to the first protected field.

- Character delete (ESC W)—Deletes the character

at the cursor position and moves all following characters left one position. At the end of the delete function, an insert character is written into the last position on the line. If Edit Page is set, the character in column 1 of the next line moves back to column 80 of the previous line (as described above). The last position on the page is loaded with an insert character. If Protect mode is on, character delete operates only in the Edit Line mode from the cursor position to the end of the unprotected field or line.

- Set insert mode (ESC q)—Sets automatic character insertion. This mode operates like Character Insert (above), except that a typed alpha-numeric character is automatically inserted on the screen at the cursor position. This causes all characters to the right of the cursor to move one column to the right. If Edit Page is set, the character in column 80 moves to column 1 of the next line. The character at the end of the line or at the end of the page is lost. INSL or INSP will be indicated on the Status Line.
- Clear insert mode (ESC r)—Clears the Insert mode. EDTL or EDTP will be indicated on the status line.
- Line insert (ESC E)—With the Protect mode off, inserts a line consisting of insert characters at the cursor position. This causes the cursor to move to the start of the new line and all following lines to move down one line, resulting in the loss of the last line on the page. If the Protect mode is on, a line insert command has no effect.
- Line delete (ESC R)—When the Protect mode is off (has no effect when Protect mode is on), deletes the line at the cursor position, and all following lines move up one line. Also causes the cursor to move to column 1 of the line and insert characters to load into the last line of the page.
- Erase to end of line (ESC T)—Erases all unprotected characters from the cursor to the end of the line (or field, if in the Protect mode) and replaces them with insert characters. If Half Intensity is on, H.I. insert characters replace the erased characters.
- Erase to end of line with nulls (ESC t)—Erases all characters from the cursor position to the end of the line or the end of an unprotected field and replaces them with null characters. If Half Intensity is on, the erased characters are replaced with half-intensity null characters.
- Erase to end of page (ESC Y)—Replaces unprotected characters from the cursor position to the end of the page with insert characters. If Half Intensity is on, erased characters will be replaced with half-intensity insert characters.
- Erase to end of page with nulls (ESC y)—Erases all unprotected characters from the cursor position to the end of the page and replaces them with null characters. If Half Intensity is on, erased characters are replaced with half-intensity null characters.

### 3.15.3 Protect Mode

The Model 950 features a Protect mode in which defined screen/page areas may be set to prevent data entries by

the system operator. This feature is particularly useful for setting up forms on the screen for purchasing or accounting or similar applications. When the terminal is in the Protect mode, only unprotected fields may be accessed for data entry or change. The mode operates in conjunction with Half Intensity; when the Protect mode is enabled, all half-intensity, attribute and graphic characters are protected characters. The control code sequences and a description of the Protect mode functions follows:

- Protect mode on (ESC &)—Turns on the Protect mode. Indicated on the status line by *PROT*. Causes half-intensity, graphic, and attribute characters to be protected from overwriting or erasure. *PROT* will be indicated on the Status Line.
- Protect mode off (ESC ')—Turns off the Protect mode. Indicated on the Status Line by *PROT* being replaced by spaces.
- Write Protect on (ESC )—Turns on the Write Protect mode (also called Half Intensity). Until the mode is reset, each character entered is displayed at half intensity. Indicated on the Status line by *H.I.*
- Write Protect off (ESC )—Turns off the Write Protect mode (resets Write Protect). All characters entered are displayed at full intensity. Indicated on the status line by *H.I.* not being present.

### 3.15.4 Tab Programming

As briefly described in paragraph 3.8.3, the cursor may be moved on the screen to preset typewriter-style tabs or to field tabs if the Protect mode is set. The control code sequences and a description of the tab operations follows:

- Set tab (ESC 1)—When the Model 950 is set to the Protect mode, the code generates a vertical column of half intensity spaces from the cursor position down to the first write-protected character or to the end of the page, whichever is first. When the Protect mode is off, the code sets a typewriter-style column tab.
- Clear tab (ESC 2)—Clears the typewriter tab at the cursor column. The code has no effect when the Protect mode is set.
- Clear all tabs (ESC 3)—Clears all the typewriter-style tabs set on a page. The code has no effect when the Protect mode is set.
- Tab (protect and unprotect — CTRL I)—When the Protect mode is off, the code causes the cursor to advance through the next typewriter-style tab set. If no tabs are set, the code has no effect and the cursor will not move. When the Protect mode is set, the cursor is moved to the first unprotected character following the next protected field.

If Auto Page is off and there are no following unprotected fields, the cursor moves to the first character of the first unprotected field at the top of the page. If there are no characters on the page, the cursor will move to Home position.

If Auto Page is on and no unprotected field follows, the cursor will advance to the first unprotected character on the next page. If no unprotected field exists on the next page, the cursor moves to Home position on that page.

- **Field Tab (Protect only—ESC i)**—With the Protect mode set, the cursor moves exactly as described for CTRL 1, above. With the Protect mode off, this code has no effect.

- **Back tab (ESC I)**—When the Protect mode is off, the code causes the cursor to back to the previous tab position set. If no tabs are set or if the cursor is on the first tab position on the page, Back Tab moves the cursor to the first column on the line.

If the Protect mode is set and Auto Page is off, Back Tab moves the cursor back to the start of the first preceding unprotected field. If no preceding positions exist, the cursor will not move.

If Auto Page and the Protect mode are on and the cursor is in the first unprotected position on the page, the cursor backs to the start of the last unprotected field on the previous page.

If the cursor is at the first unprotected position on page 0, the code has no effect. If no protected fields exist on a page, Home position is considered the start of an unprotected field.

### 3.15.5 Print Function Programming

The Model 950 printer port may be set for terminal page date transmittal, data transmittal from the host, or two-way communications between a KSR-type printer and the host. If during a print operation (PRT 0—PRT 3) the device connected to the printer port cannot accept any more data, the device may signal the terminal to stop sending data by setting P4-20 to  $-12$  Vdc or by sending X-OFF (DC3) on P4-2. The device may then request the transmission of more data by setting P4-20 to  $+12$  Vdc or by sending X-ON (DC1) on P4-2.

The print function control sequences and their descriptions follow:

- **Page print (ESC P)**—Sends page data from Home through the cursor position to the printer port and advances the page number by 1. Data entry on the advanced page may continue while the previous page is printing. This print mode prints page data exactly as entered plus line delimiters (a carriage return and a linefeed) at the end of each line. Control characters are also sent to the printer port as are a carriage return and a linefeed at the end of the transmitted data. The terminal transmits an ACK to the host indicating that all print data has been output to the printer port.

- **Unformatted print (ESC L)**—Sends page data from Home through the cursor position to the printer port and advances the page number by 1. Data entry on the advanced page may continue while the previous page is printing. This print mode prints only the data on the page. Control characters on the page are transmitted to the printer exactly as they are read, including nulls, spaces, and rubout characters. The terminal transmits an ACK to the host at the end, indicating that all print data has been output to the print port.

- **Buffer print on (ESC `)**—Sends all subsequent data received by the terminal (including control and escape characters) to output to the printer port. No

screen updating occurs while the mode is active. If the print buffer fills, the terminal sends secondary X-OFF to the host. When the buffer empties, the terminal transmits secondary X-ON to the host, indicating that it may resume sending print data to the Model 950. The secondary X-OFF/X-ON sequence continues so long as the buffer fills and empties.

- The X-ON/X-OFF feature allows communicating with the host at a high baud rate and outputting data to a printer port device at a low baud rate. The operator may continue entering data on the terminal while the print buffer empties. When the buffer is empty, the terminal sends the secondary X-ON to the host. The host responds with another burst of print data to fill the buffer.

If the secondary X-OFF is ignored or missed by the host, print data is put into the receive buffer until it, too, is full, at which time the terminal then sends X-OFF to the host. Filling both the print buffer and the receive buffer stores of up to 512 characters in both buffers. However, the operator will not be able to enter additional data on the screen (nothing will happen when the keys are pressed).

- **Buffer print off (ESC a)**—Turns off the buffer print. Data remaining in the buffers will continue to be sent to the printer port until the print buffer empties.

- **Copy print mode on (ESC @)**—Causes all subsequent data received by the terminal to be sent to the screen and to the device connected to the printer port at selected printer baud rate. Print buffer control is identical to the Print Buffer mode.

- **Copy print mode off (ESC A)**—Turns off the Copy Print mode. Screen updating continues normally; data remaining in the print buffer continues to be outputted to the printer port until the buffer is empty.

- **Enable bidirectional port (CTRL R)**—Functionally connects P3 RS-232C and P4 PRINTER in parallel. The function allows a device connected to the printer port (such as a KSR printer) to communicate directly with the host while allowing screen update to continue.

- **Disable bidirectional port (CTRL T)**—Functionally disconnects P3 RS-232C from P4 PRINTER and prevents direct communication between the host and the print port device.

### 3.15.6 Send Function Programming

The *SEND* key may be programmed to transmit line or page data. The key operates both unshifted and shifted for transmittal of two character Escape sequences. Transmission of text data by the *SEND* key may include the use of embedded delimiters that define fields, ends of lines, and the end of text.

a. **Delimiter Programming.** To program delimiters, enter the following code in the exact sequence shown below (do not enter the spaces between the characters; spaces are for clarity only):

ESC x n p<sub>2</sub> p<sub>3</sub> Set Send delimiters, where n =  
 0 for delimit field code to p<sub>1</sub> p<sub>2</sub>  
 1 for delimit line code to p<sub>1</sub> p<sub>2</sub>  
 2 for delimit start protect field to p<sub>1</sub> p<sub>2</sub>  
 3 for delimit end protect field to p<sub>1</sub> p<sub>2</sub>  
 4 for delimit end of text to p<sub>1</sub>  
 p<sub>2</sub>. Where p<sub>1</sub> p<sub>2</sub> each = and  
 standard ASCII or control  
 character.

If no delimiter is desired, program p<sub>2</sub> and p<sub>3</sub> as nulls. For example, to eliminate the field delimiter during send, enter

ESC x 0 Null Null

When the Model 950 is turned on, the delimiter default values are as follows:

DELIMITER	CODE
Field	p <sub>1</sub> = FS, p <sub>2</sub> = null
Line	p <sub>1</sub> = US, p <sub>2</sub> = null
Start-protected field	p <sub>1</sub> = ESC, p <sub>2</sub> = )
End-protected field	p <sub>1</sub> = ESC, p <sub>2</sub> = (
End of text	p <sub>1</sub> = Carriage return, p <sub>2</sub> = null.

b. **Loading the SEND Key.** To load the *SEND* key, enter the following code in the exact sequence shown below (do not enter the spaces between the characters; spaces are for clarity only):

ESC 0 p<sub>1</sub> p<sub>2</sub> where p<sub>1</sub> = 0 for Shift  
**SEND**  
 and 1 for unshifted  
**SEND.**  
 and where p<sub>2</sub> =  
 4 to program ESC 4  
 5 to program ESC 5  
 6 to program ESC 6  
 7 to program ESC 7  
 S to program ESC S  
 s to program ESC s.

When the Model 950 is turned on, the *SEND* key is loaded with the default values of ESC 7 for unshifted and ESC 6 for shifted. The *SEND* key escape codes and a description of their functions follow:

- Send line unprotected (ESC 4)—Sends all unprotected data on a line from column 1 through the cursor position. The code also sends field delimiters in place of protected fields and an end-of-text character at the end of the send transmission.
- Send page unprotected (ESC 5)—Sends all the unprotected data on page from Home through the cursor position. It sends field delimiters in place of protected fields. The code also sends a line delimiter at the end of a line and an end-of-text character at the end of the send transmission.
- Send line all (ESC 6)—Sends all data from the first column through the cursor position. It also sends the start-protected field and end-protected field delimiters at the start and end, respectively, of each

protected field. If the character at the cursor position is protected, the terminal sends an end-protected field to the host. The code sends the end-of-text character at the end of the send transmission.

- Send page all (ESC 7)—Sends all data on the page from Home through the cursor position. It also sends the start-protected field and end-protected field delimiters at the start and end, respectively, of each protected field. If the character at the cursor position is protected, the terminal sends an end-protected field delimiter to the host. This code also sends the end-of-text character at the end of the send transmission.
- Send message unprotected (ESC S)—Sends all unprotected data bracketed by the STX and ETX codes displayed on a page. After the data is sent, the terminal positions the cursor at the ETX code. If the page contains no STX codes, transmission begins from Home. If the page contains no ETX code, the terminal sends to the end of the page and positions the cursor at Home after the data is sent. If the page contains neither an STX nor an ETX code, the entire page will be sent. The code sends field delimiters in place of protected fields. It also sends line delimiters at the end of each line and an end-of-text delimiter at the end of the send transmission.
- Send message all (ESC s)—Operates in the same manner as ESC S, except that protected fields delimited by start-protected field and end-protected field are also transmitted.

c. **Send Terminal ID.** The Model 950 may be commanded to send the host its identification, which includes the software level and the number of pages in its memory. To command the terminal to send its ID, enter

ESC M

For example, the terminal will send 1.0,3CR to indicate that it has software version 1.0 and 96 lines of memory. It then sends a carriage return (CR) as a terminator. A 0 sent indicates a 24-line memory, and a 1 indicates a 48-line memory.

d. **Send User Line.** The Model 950 may be commanded to send the data loaded into its User Line by entering

ESC Z 0

The terminal will send the User Line data, followed by a carriage return, to the host.

e. **Send Status Line.** The Model 950 may be commanded to send Status Line information to the host by entering

ESC Z 1

The terminal will send the Status Line data, followed by a carriage return, to the host.

f. **Send Cursor Position.** The Model 950 may be commanded to send the current cursor position to the host. The cursor position may be sent as page, row, and column, or as just row and column. In either case, the position information will be automatically followed with a carriage return. The Escape code sequences and a description of their functions follow:

- Send cursor row and column (ESC ?)—Sends the cursor's current line (row) and column position as

specified in the cursor addressing table.

- Send cursor page, row, and column (ESC /)—Sends the cursor's current page, line, and column position. 0 is sent for page zero, 1 for page one, 2 for page two, and so forth. Row and column are sent as specified in the cursor addressing table.

### 3.15.7 Video Attributes

The Model 950 screen attributes (see Figure 3-5) may be controlled to provide reverse video, dual intensity, underline, blink, blank, and protected fields in several combinations. The attributes are implemented with an ESC G sequence followed by a parameter. The attribute characters normally are displayed as a space on the screen. They also appear as a half intensity space on a black-on-white background. For the video attributes, enter the following codes in the exact sequence shown below (do not enter the spaces between the characters; spaces are for clarity only):

Normal (white on black)	ESC G 0
Blank	ESC G 1
Blink	ESC G 2
Blank	ESC G 3
Reverse (black on white)	ESC G 4
Reverse, blank	ESC G 5
Reverse, blink	ESC G 6
Reverse, blank	ESC G 7
Underline	ESC G 8
Underline, blank	ESC G 9
Underline, blink	ESC G :
Underline, blank	ESC G ;
Underline, reverse	ESC G <
Underline, reverse blank	ESC G =
Underline, reverse blink	ESC G >
Underline, reverse blank	ESC G ?

When used in combination with *PROT* and *H.I.*, these attributes may be used to set up protected fields.

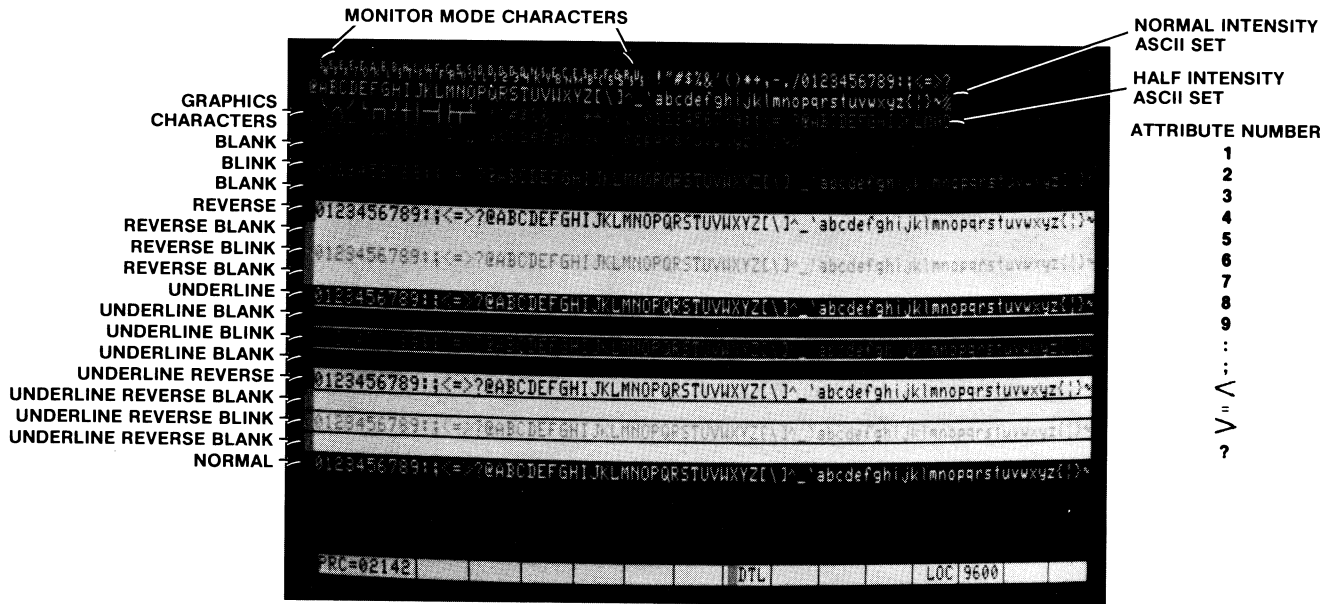

Figure 3-5 Model 950 Video Attributes

### 3.15.8 Special Graphics.

The Model 950 provides a special graphics feature (see Figure 3-6) that converts any alpha-numeric character received to 1 of 15 graphic characters. The terminal does not distinguish between shifted and unshifted alpha-numeric characters. (For example, *A* and *a* produce the same graphic character.) The graphics mode status is indicated in the status line with *GRPH* for on and a space

or *H.I.* (if Half Intensity was previously set) in the same position for off. To control the graphics mode, use the following code sequence:

Graphics on           ESC \$  
Graphics off         ESC %

Refer to Figure 3-6 for the graphics characters and their corresponding alpha-numeric characters.

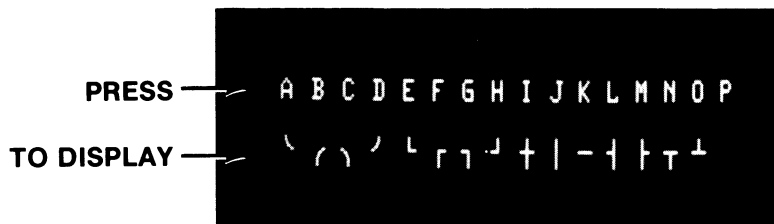

Figure 3-6 Model 950 Special Graphics Characters

### 3.15.9 Page Control

The Model 950 holds up to 96 lines (optional) in memory, which may be divided into four 24-line pages (standard), two 48-line pages, or a single 96-line page. These pages may be incremented forward or backward one page at a time. When incremented or decremented, the cursor assumes the last position previously occupied on that page. To control the paging functions, enter the following codes in the exact sequence shown below (do not enter the spaces between the characters; spaces are for clarity only):

Set lines per page	ESC \ p <sub>1</sub> where p <sub>1</sub> = 1 for 24 2 for 48 3 for 96
Advance page	ESC K
Back page	ESC J
Print page and display next page.	ESC P or ESC L
Auto Page on	ESC v
Auto Page off	ESC w

### 3.15.10 Clear Function.

The Model 950 clear function is used in one of four ways to clear data from screen memory and/or host memory. The clear function Escape codes and a description of their functions follow:

- Clear unprotected to nulls (ESC :)—Clears all unprotected data on the page to the null character (or Half-Intensity nulls if set).
- Clear unprotected to insert character (ESC ; or ESC + or CTRL Z)—Clears all unprotected data on the page to the insert character. The insert character is a space by default, although it may be programmed to be another character (refer to paragraph 3.15.13). If Half Intensity (H.I.) is set, the screen will be cleared to half-intensity insert characters.
- Clear page to half intensity spaces (ESC ,)—Clears all unprotected data on the page to half-intensity spaces.
- Clear all to null (ESC \*)—Clears all data on the page to nulls and resets the Half Intensity and Protect mode.

### 3.15.11 Monitor Mode

The Model 950 provides a Monitor mode for displaying all characters received from the host or entered on the keyboard, including Escape and Control sequences (refer to Table 3-1). The Escape and Control sequences on the screen will provide visual cues in long program routines. To control the Monitor mode, use the following code sequences:

Set Monitor Mode	ESC U
Clear Monitor Mode	ESC u or ESC X.

### 3.15.12 Insert Character Loading

Several editing, erase, and clear functions (in addition to scroll and reverse scroll) cause certain areas of the page to be replaced with a predefined character. When the terminal is turned on, the insert character is defined as a space (ASCII 20<sub>16</sub>). During normal operation, the insert character may be redefined to be any ACSII character

(for example, a null or an underline) with the following sequence:

ESC e p where p = the character.

### 3.15.13 Main Port Programming.

The default operating parameters of the host RS-232C port are set on *SI* on the terminal rear panel (refer to paragraph 2.4). The terminal processor reads the parameters once when the Model 950 is turned on. The parameters may, however, be changed with Escape sequences after power up. To change the parameters, enter

ESC { p<sub>1</sub> p<sub>2</sub> p<sub>3</sub> p<sub>4</sub> where p<sub>1</sub> = baud rate  
p<sub>2</sub> = number of stop bits  
p<sub>3</sub> = parity  
p<sub>4</sub> = word length.

To specify parameter p<sub>1</sub> (baud rate), enter:

0 for 9600 baud	8 for 1200 baud
1 for 50 baud	9 for 1800 baud
2 for 75 baud	: for 2400 baud
3 for 110 baud	; for 3600 baud
4 for 135 baud	< for 4800 baud
5 for 150 baud	= for 7200 baud
6 for 300 baud	> for 9600 baud
7 for 600 baud	? for 19200 baud.

To specify parameter p<sub>2</sub> (number of stop bits), enter

0 for 1 stop bit  
1 for 2 stop bits.

To specify parameter p<sub>3</sub> (parity), enter

0 for parity disabled, parity ignored  
1 for odd parity, receive and transmit  
3 for even parity, receive and transmit  
5 for mark parity, transmit parity check disabled  
7 for space parity, transmit parity check disabled.

To specify parameter p<sub>4</sub> (word length), enter

0 for 8 bits  
1 for 7 bits.

For example, to set the baud rate to 4800, the number of stop bits to 1, parity to even, and word length to 7, enter

ESC { < 131 where < = 4800 baud  
1 = 2 stop bits  
3 = even parity  
1 = 7-bit word length.

### 3.15.14 Printer Port Programming

The default operating parameters of the printer RS-232C port (like the host port parameters) are set on *SI* on the terminal rear panel (refer to paragraph 2.4). The terminal processor reads the parameters once when the Model 950 is turned on. However, the parameters may be changed with Escape sequences after power up. To change these parameters, enter

ESC { p<sub>1</sub> p<sub>2</sub> p<sub>3</sub> p<sub>4</sub> where p<sub>1</sub> = baud rate  
p<sub>2</sub> = number of stop bits  
p<sub>3</sub> = parity  
p<sub>4</sub> = word length.

The parameter codes for the printer port are identical to

**Table 3-1 Monitor Mode Control Characters.**

CODE	ASCII	HEX	SCREEN CHARACTER
^ @	NULL	00	none
^A	SOH	01	S
^A	STX	02	S H
^B	ETX	03	S X
^D	EDT	04	E X
^E	ENQ	05	E T
^F	ACK	06	E Q
^G	BEL	07	A K
^H	BS	08	B L
^I	HT	09	B S
^J	LF	0A	H T
^K	VT	0B	L F
^L	FF	0C	V T
^M	CR	0D	F F
^N	SO	0E	C R
^O	SI	0F	S O
^P	DLE	10	S I
^Q	DC1	11	D L
^R	DC2	12	D 1
^S	DC3	13	D 2
^T	DC4	14	D 3
^U	NAK	15	D 4
^V	SYN	16	N A K
^W	ETB	17	S Y
^X	CAN	18	E B
^Y	EM	19	C N
^Z	SUB	1A	E M
ESC	ESC	1B	S B
^ \	FS	1C	E C
^J	GS	1D	F S
^A	RS	1E	G S
^ _	US	1F	R S
DEL	DEL	7F	U S
			⋄

NOTE: indicates CONTROL, except for the ASCII character GS, where indicates CONTROL.

the codes used for the host port (refer to paragraph 3.15.14).

### 3.15.15 X-ON, X-OFF Control

The Model 950 automatically transmits *X-OFF* to the host, which requests the host to stop sending data when the terminal's receive buffer is almost full (less than 16 characters). When the data in the buffers is processed (output to the screen or to the printer buffer), the Model 950 automatically transmits *X-ON* to the host, which indicates that the host may resume sending data to the terminal (refer to paragraph 3.15.5). The *X-ON*, *X-OFF* feature may be enabled or disabled with the following Control sequences:

Enable X-ON, X-OFF CTRL 0  
 Disable X-ON, X-OFF CTRL N

### 3.15.16 User ROM.

The Model 950 allows the user to install custom programs contained in *ROM* (refer to the Model 950 Customizing Instructions). To command the terminal to execute the program, enter

ESC z p                      where p = an optional parameter defined in the user's ROM.

If the user *ROM* is not installed, the command will be ignored.

### 3.15.17 Line Lock.

The Model 950 features a line lock function that locks the line at the cursor position into screen memory. The line remains locked until cleared. The line also remains fixed in position, on the screen regardless of the action of the remainder of the screen data (such as scrolling). Multiple lines may be locked in any order or sequence;

however, no more than 23 of the 24 lines on a page may be locked. Once the line lock function is cleared, scrolling will cause all lines on the page to scroll normally. The line lock function may be used to set up a stationary data field while other screen data scrolls past. It may also be used to perform block moves of text. To control the line lock function, use the following code sequences:

Enable Line Lock        ESC ! 1  
 Disable Line Lock      ESC ! 2

### 3.15.18 Wraparound Feature

The Model 950 contains a wraparound feature, in which entered text automatically advances to column 1 of the next line when column 80 of the previous line is reached. Because of this feature, the first LF entered after wrapping past column 80 (but before any text is entered) will be ignored by the terminal. Ignoring this LF prevents a double linefeed when the terminal receives 80 characters, CR, LF, 80 characters, CR, LF, and so forth.

### 3.15.19 Video Display Control

The Model 950 features a video display control function that turns the screen on or off. The function may be used to blank the screen while the host is building a form or writing a long data list. To control the video display in this manner, use the following codes:

Screen on                      ESC n  
 Screen blank                ESC o

### 3.15.20 Reference Tables

Following this paragraph, in order, are Table 3-2, Model 950 US ASCII Chart; Table 3-3, Model 950 Cursor Addressing Codes; and Table 3-4, Model 950 Control Codes. Also included are Tables 3-5 through 3-9, which provide the hex codes associated with each key of the Model 950.

Table 3-2 US ASCII Chart

Bits		Column	Row	0 0	0 0 1	0 1 0	0 1 1	1 0 0	1 0 1	1 1 0	1 1 1
b7	b6	b5	b4	b3	b2	b1					
0	0	0	0	0	0	0	0	NUL	DLE	SP	0
0	0	0	0	1	0	0	1	SOH	DC1	!	1
0	0	0	1	0	0	0	1	STX	DC2	"	2
0	0	0	1	1	0	0	1	ETX	DC3	#	3
0	1	0	0	0	0	0	1	EOT	DC4	\$	4
0	1	0	0	1	0	0	1	ENQ	NAK	%	5
0	1	1	0	0	0	0	1	ACK	SYN†	&	6
0	1	1	1	0	0	0	1	BEL	ETB	'	7
1	0	0	0	0	0	0	1	BS←	CAN	(	8
1	0	0	0	1	0	0	1	SKIP HT	EM	)	9
1	0	1	0	0	0	0	1	LF	SUB	*	:
1	0	1	1	0	0	0	1	VT↑	ESC	+	;
1	1	0	0	0	0	0	1	FF→	FS	,	<
1	1	0	0	1	0	0	1	CR	GS	-	=
1	1	1	0	0	0	0	1	SO	HOME RS	.	>
1	1	1	1	0	0	0	1	SI	NEW LINE US	/	?
											O
											-
											o
											DEL RUB



**Table 3-3 Model 950 Cursor Addressing Codes**

CURSOR POSITIONING					
POSITION X or Y	ASCII CODE Transmitted	POSITION X or Y	ASCII CODE Transmitted	POSITION X or Y	ASCII CODE Transmitted
1	Space	33	@	65	`
2	!	34	A	66	a
3	"	35	B	67	b
4	#	36	C	68	c
5	\$	37	D	69	d
6	%	38	E	70	e
7	&	39	F	71	f
8	'	40	G	72	g
9	(	41	H	73	h
10	)	42	I	74	i
11	*	43	J	75	j
12	+	44	K	76	k
13	/	45	L	77	l
14	-	46	M	78	m
15	.	47	N	79	n
16	/	48	O	80	o
17	0	49	P	81	p
18	1	50	Q	82	q
19	2	51	R	83	r
20	3	52	S	84	s
21	4	53	T	85	t
22	5	54	U	86	u
23	6	55	V	87	v
24	7	56	W	88	w
25	8	57	X	89	x
26	9	58	Y	90	y
27	:	59	Z	91	z
28	;	60	[	92	{
29	<	61	\	93	
30	=	62	]	94	}
31	>	63	^	95	~
32	?	64	-	96	DEL/RUB

Current Page: Transmit ESC = YX (Y = 1 - 96; X = 1 - 80)

Direct Page: Transmit ESC - PYX (P = 0, 1, 2, or 3)

Example: ESC - 1% @ positions cursor on Page 1, Line 6, and Column 33.

Table 3-4 Model 950 Control and Escape Codes

CODE	FUNCTION
CTRL G	250 ms bell tone
CTRL H, BS, ←	Backspace, cursor left
CTRL I, TAB	Tab (column or field)
CTRL J, LF	Line feed
CTRL K, ↑	Cursor up
CTRL L, →	Cursor right
CTRL M, RET	Carriage return
CTRL N	Disable X-ON/X-OFF to host
CTRL O	Enable X-ON/X-OFF to host
CTRL P	Store next (used by load Function key only)
CTRL Q	X-ON when received from <b>PRINTER P4</b> , enables transmission to <b>P4</b> . X-ON will be transmitted (when previously enabled by CTRL O) to the host to signal buffer ready.
CTRL R	Turn on Bi-directional port.
CTRL S	X-OFF when received from <b>P4</b> will disable transmission to <b>P4</b>
CTRL T	Turn off bi-directional port.
CTRL V, ↓	Cursor down.
CTRL Y	End message (used by load Function key only).
CTRL Z, CLEAR SPACE	Clear to unprotected spaces.
ESC	Lead-in character for multiple character commands.
CTRL \	FS delimiter transmitted by send.
CTRL ^, HOME	Moves cursor to Home position.
CTRL _	New line. US delimiter transmitted by Send.
ESC ! 1	Linelock line at cursor position.
ESC ! 2	Clear all linelock lines on current page.
ESC "	Unlock keyboard.
ESC #	Lock keyboard. Function keys still transmit. To unlock keyboard, Host sends ESC " to terminal. In local operation, use Set-up Mode.
ESC \$	Graphics Mode on.
ESC %	Graphics Mode off.
ESC &	Protect Mode on.
ESC '	Protect Mode off.
ESC (	Write Protect off (normal intensity).
ESC )	Write Protect on (half intensity).
ESC +	Clear unprotected characters to insert character (default is a space character).
ESC ,	Clear to half intensity space.
ESC - $P_1 P_2 P_3$	Load cursor page, row, and column. Move cursor to $P_1 P_2 P_3$ , where: $P_1$ = 0, 1, 2, or 3 for page select $P_2$ = Space DEL of ASCII Code for row $P_3$ = Space DEL of ASCII Code for column

**Table 3-4 Model 950 Control and Escape Codes (continued)**

CODE	FUNCTION
ESC . <i>n</i>	Set cursor attribute, where: <i>n</i> = 0 for no cursor displayed <i>n</i> = 1 for blinking <i>n</i> = 2 steady block <i>n</i> = 3 blinking underline <i>n</i> = 4 steady underline.
ESC /	Transmit cursor location (page, row, and column) and CR according to ASCII Code opposite to load page, row, and column.
ESC 0 <i>p</i> <sub>1</sub> <i>p</i> <sub>2</sub>	Program SEND key, where: <i>p</i> <sub>1</sub> = 0 for shift SEND key = 1 for normal SEND key. <i>p</i> <sub>2</sub> = 4 for program to ESC 4 = 5 for program to ESC 5 = 6 for program to ESC 6 = 7 for program to ESC 7 = S for program to ESC S = s for program to ESC s. Default for SEND = ESC 7; default for SHIFT SEND = ESC 6.
ESC 1	Set tab.
ESC 2	Clear tab at cursor column.
ESC 3	Clear all column tabs.
ESC 4	Send unprotected data on line up to and including the cursor position. Send FS code on protected field. Send CR at the end of Send.
ESC 5	Send unprotected data on page from Home up to and including cursor position. Send FS code on protected field. Send US code at the end of a line. Send CR code at the end of Send.
ESC 6	Send all data on line up to and including cursor position. Send the code ESC 1 (initially ESC) at the beginning of a protected field. Send the code ESC 2 (initially ESC ( )) at the end of a protected field or, if necessary, at the end of data. Send CR at the end of Send.
ESC 7	Send all data on page up to and including cursor. Send ESC 1 code (initially ESC) at the beginning of a protected field. Snd ESC 2 code (initially ESC ( )) at the beginning of a protected field or at the end of data. Send US code (initially IF) at the end of a line. Send CR at the end of Send.
ESC :	Clear unprotected data on page to null.
ESC ;	Clear unprotected data to insert character (initially SPACE).

Table 3-4 Model 950 Control and Escape Codes (continued)

CODE	FUNCTION
ESC <	Key click off.
ESC ≥	Key click on.
ESC = p <sub>1</sub> p <sub>2</sub>	Load cursor row and column on same page. p <sub>1</sub> = sp DEL of ASCII code for row. p <sub>2</sub> = sp DEL of ASCII code for column. If p <sub>1</sub> is greater than page size, cursor row will be bottom line of page
ESC ?	Transmit cursor position (row and column) and CR to host. Opposite of ESC = (i.e., transmit same code).
ESC @	Copy print mode on.
ESC A	Copy print mode off.
ESC B	Block mode on.
ESC C	Block mode off (conversation mode).
ESC D or H	Set half duplex (HDX).
ESC D or F	Set full duplex (FDX).
ESC E	Line insert.
ESC G p	Set video attribute, where p = 0 for normal 1 for blank 2 for blink 3 for blank 4 for reverse 5 for reverse blank 6 for reverse blink 7 for reverse blank 8 for underline 9 for underline blank : for underline blink ; for underline blank for underline reverse = underline reverse blank for underline reverse blink ? for underline reverse blank
ESC I	Back tab.
ESC J	Back page.
ESC K	Advance page.
ESC L	Unformatted print. Print the page plus display next page while printing. Transmit ACK when printing is done.
ESC M	Transmit terminal ID to host.
ESC N	Clear page edit (set line edit).
ESC O	Clear page edit (set line edit).
ESC P	Print page and display next page. Transmit ACK when printing is done.
ESC Q	Character insert.
ESC R	Line delete.

**Table 3-4 Model 950 Control and Escape Codes (continued)**

CODE	FUNCTION
ESC S	Send message unprotected only.
ESC T	Erase to end of line with insert character (initially Space).
ESC U	Set Monitor Mode
ESC W	Character delete.
ESC X	Clear Monitor Mode.
ESC Y	Replace characters from the cursor to the end of the page with insert character.
ESC Z <i>n</i>	When <i>n</i> = 0, transmit user line to host.
	When <i>n</i> = 1, transmit status line to host.
ESC \ <i>n</i>	Set page size, where <i>n</i> =
	1 for 24 line page
	2 for 48 line page
	3 for 96 line page.
ESC `	Buffer print on.
ESC a	Buffer print off.
ESC b	Video set for black characters on a white.
ESC d	Video set for white characters on black.
ESC e <i>n</i>	Load <i>n</i> to insert character.
ESC f text CR	Load user line with up to 80 characters.
ESC g	Display user line on line 25.
ESC h	Display status line on line 25.
ESC i	Tab (protect and unprotect).
ESC j	Reverse line feed.
ESC l	Duplex edit mode.
ESC q	Set Insert Mode.
ESC r	Clear Insert Mode.
ESC s	Send message all.
ESC t	Erase from cursor position to end of line with nulls.
ESC u	Clear Monitor Mode.
ESC v	Auto Page on.
ESC w	Auto page off.
ESC x <i>n p<sub>1</sub> p<sub>2</sub></i>	Set Send delimiters, where <i>n</i> = 0 for delimit field code to <i>p<sub>1</sub> p<sub>2</sub></i> 1 for delimit line code to <i>p<sub>1</sub> p<sub>2</sub></i> 2 for delimit start protect field to <i>p<sub>1</sub> p<sub>2</sub></i> 3 for delimit end protect field to <i>p<sub>1</sub> p<sub>2</sub></i> 4 for delimit end of text to <i>p<sub>1</sub> p<sub>2</sub></i>  default field code = 001C default line code = 001F default start field code = 1B29 default end protect field = 1B28 default end of text code = 0D

**Table 3-4 Model 950 Control and Escape Codes (continued)**

CODE	FUNCTION
ESC y	Erase from cursor to end of page with nulls.
ESC z p	Go to program contained in User PROM where <i>p</i> = an optional parameter defined in the User PROM.
ESC { p <sub>1</sub> p <sub>2</sub> p <sub>3</sub> p <sub>4</sub>	Set Main (modem) port baud rate, stop bits, parity, word length.
ESC ; p <sub>1</sub> p <sub>2</sub>	text Load function keys where p <sub>1</sub> = 1 through 9 and ; and ; for key 1 - 11 and <, =, >, ?, @, and A through F for keys 1 - 11 shifted.d.
CNTL Y	p <sub>2</sub> = 1 for FDX, 2 for HDX, and 3 for LOC.
ESC } p <sub>1</sub> p <sub>2</sub> p <sub>3</sub> p <sub>4</sub>	Set printer port baud rate, stop bits, parity, and word length.

**Table 3-5 Alpha Numeric Key Hex Codes.**

CHARACTER	UNSHIFT	ALPHA LOCK	SHIFT	CTRL
A	61	41	41	01
B	62	42	42	02
C	63	43	43	03
D	64	44	44	04
E	65	45	45	05
F	66	46	46	06
G	67	47	47	07
H	68	48	48	08
I	69	49	49	09
J	6A	4A	4A	0A
K	6B	4B	4B	0B
L	6C	4C	4C	0C
M	6D	4D	4D	0D
N	6E	4E	4E	0E
O	6F	4F	4F	0F
P	70	50	50	10
Q	71	51	51	11
R	72	52	52	12
S	73	53	53	13
T	74	54	54	14
U	75	55	55	15
V	76	56	56	16
W	77	57	57	17
X	78	58	58	18
Y	79	59	59	19
Z	7A	5A	5A	1A

Table 3-5 Alpha Numeric Key Hex Codes (continued)

CHARACTER	UNSHIFT	ALPHA LOCK	SHIFT	CTRL
1 !	31	31	21	00
2 @	32	32	40	00
3 #	33	33	23	00
4 \$	34	34	24	00
5 %	35	35	25	00
6	36	36	5E	1E
7 &	37	37	26	00
8 *	38	38	2A	00
9 (	39	39	28	00
0 )	30	30	29	00
—	2D	2D	5F	1F
\	5C	5C	7C	1C
{}	7B	7B	7D	00
[]	5B	5B	5D	1D
::	3B	3B	3A	00
;"	27	27	22	00
.<	2C	2C	3C	00
.>	2E	2E	3E	00
/?	2F	2F	3F	00
~	60	60	7E	00
9	39	39	39	39
8	38	38	38	38
7	37	37	37	37
6	36	36	36	36
5	35	35	35	35
4	34	34	34	34
3	33	33	33	33
2	32	32	32	32
1	31	31	31	31
0	30	30	30	30
.<	2C	2C	2C	2C
.>	2E	2E	2E	2E
-	2D	2D	2D	2D
SPACE BAR	20	20	20	20
LINE FEED	0A	0A	0A	0A
RETURN	0D	0D	0D	0D
ENTER	0D	0D	0D	0D
DEL	7F	7F	7F	7F
ESC	1B	1B	LOCAL	LOCAL

NOTE: The Alpha Numeric keys operate in Block, Local, Half Duplex and Full Duplex Modes.

**Table 3-6 Cursor Control and Edit Key Hex Codes.**

CHARACTER	UNSHIFT	SHIFT
BACKSPACE	08	08
TAB	09	09
BACKTAB	1B 49	1B 49
PRINT	1B 50	1B 4C
HOME	1E	1E
↓	16	0A
↑	0B	1B 6A
←	08	08
→	0C	0C
LINE INS	1B 45	1B 4E
LINE DEL	1B 52	1B 4F
CHAR INS	1B 51	1B 71
CHAR DEL	1B 57	1B 72
LINE ERASE	1B 54	1B 74
PAGE ERASE	1B 59	1B 79
SEND	1B 37	1B 36
CLEAR SPACE	1A	1B 2A

**NOTES:**

1. These keys operate the same as the alpha numeric keys or operate in Local Mode only if Local Edit is set.
2. The SEND key is programmable; hex codes given are default values.

**Table 3-7 Function Key Default Hex Codes.**

KEY	UNSHIFT	SHIFT
F1	01 40 0D	01 60 0D
F2	01 41 0D	01 61 0D
F3	01 62 0D	01 62 0D
F4	01 43 0D	01 63 0D
F5	01 44 0D	01 64 0D
F6	01 45 0D	01 65 0D
F7	01 46 0D	01 66 0D
F8	01 47 0D	01 67 0D
F9	01 48 0D	01 68 0D
F10	01 49 0D	01 69 0D
F11	01 4A 0D	01 6A 0D

NOTE: The Function keys are loaded with the default values listed when the terminal is turned on.



**Table 3-8 Local Only Keys**

<b>KEY</b>	<b>FUNCTION</b>
SETUP/NO SCROLL	Enables and disables screen update (toggle action).
Shift SETUP/NO SCROLL	Provides entry to and exit from set-up mode.
Shift ESC	Provides entry to local Escape sequence (local action only).
Shift BREAK	Terminal reset (partial reset only - refer to paragraph 3.2.5).
BREAK	Causes a 250 msec space to be sent to the host.

NOTE: The BREAK key, when pressed unshifted, performs a unique function. As such, it operates neither locally nor in duplex. The key is listed in this table arbitrarily for the sake of categorization.

**Table 3-9 Key Action Modifiers**

<b>KEY</b>	<b>FUNCTION</b>
CRTL	When pressed with alpha numeric keys, causes a control character.
SHIFT	When pressed with another key, it generates an upper case or legend character.
ALPHA LOCK	When down, it causes all letter keys to generate upper case characters.
FUNCT	When pressed with alpha numeric keys, it causes a 3 characters sequence to be transmitted to the host: the first and third characters are always SOH and CR (01 <sub>16</sub> and 0D <sub>16</sub> ). The second character is a normal, shifted, or CTRL modified alpha numeric character.

## Chapter 4

### PERFORMANCE VERIFICATION

#### 4.1 INTRODUCTION.

This chapter contains procedures for verifying the performance of the Model 950 Video Display Terminal. These procedures provide steps for implementing two self-tests contained in the terminal ROM.

#### 4.2 SELF-TEST 1.

Self-Test 1 checks the video attribute functions and the display of the terminal. To run this test, proceed as follows:

1. Enter Setup mode (press *SHIFT* and *SET-UP/NO SCROLL* at the same time; refer to paragraph 3.5).
2. Press 1.

Twenty lines containing all the characters and attributes of the Model 950 will immediately appear on the screen (see Figure 4-1). This test checks character generation, the display RAM circuits (generally), the display processor, and the screen circuits. If any of the video attributes or display functions are inoperative, refer the problem to qualified service personnel.

#### 4.3 SELF-TEST 2.

Self-Test 2 checks the main and printer ports' communications by running four pattern tests. These patterns include

- 55<sub>16</sub> from P3 to P4 (Test 1)
- AA<sub>16</sub> from P3 to P4 (Test 2)
- 55<sub>16</sub> from P4 to P3 (Test 3)
- 2A<sub>16</sub> from P4 to P3 (Test 4).

To run this test, proceed as follows:

1. On the rear panel, connect P3-2 to P4-2 and P3-3 to P4-3. If necessary, use a prefabricated test cable with RS 232C 25-pin male connectors at either end.
2. Set both ports to the same baud rate (refer to paragraph 2.4 or paragraphs 3.15.14 and 3.15.15).
3. Enter the Setup mode (refer to paragraph 4.2, step 1).
4. Press 2.

A test pass or fail indicator will appear in line 1 on the screen at the end of the test. The failure indicator is *FAIL* ×, where × = the test number (1, 2, 3, or 4). If any Self-Test 2 results are unsatisfactory (that is, fail), recheck the cable connection and the baud rates set, then rerun the test. If the problem persists, refer it to qualified service personnel.

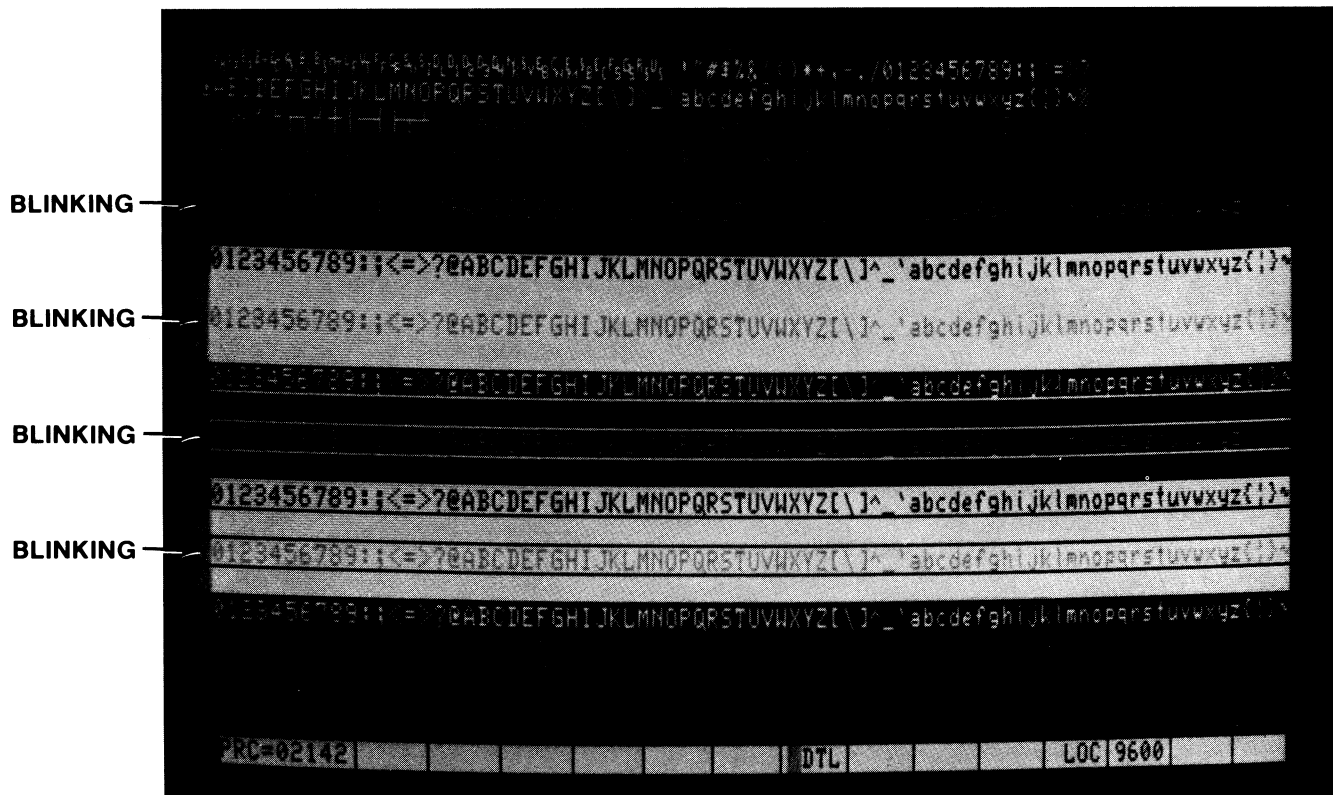

Figure 4-1 Self-Test 1 Screen Display

## Chapter 5

### FUNCTIONAL DESCRIPTION

#### 5.1 INTRODUCTION.

This chapter contains an overall functional description of the Model 950 terminal. The description is based on a simplified block diagram. The description is written to provide the advanced systems user with a general understanding of the operation of the Model 950 in terms of its hardware major circuits.

#### 5.2 TERMINAL OVERVIEW.

The Model 950 hardware consists of the following nine major circuit areas (see Figure 5-1):

Display processor	Printer port interface circuits
Display generator	Keyboard interface circuits
Video Module	Keyboard circuits
Screen	Power supply.
Main port interface circuits	

These circuits are described in the following paragraphs.

#### 5.3 DISPLAY PROCESSOR.

The display processor is the main controller of the Model 950. It contains the microprocessor central processing unit (CPU) and most of the terminal memory. The CPU responds to input either from the host or from the keyboard by instructions from ROM in the terminal and then performing the action indicated by the instruction.

The memory in the display processor consists of both Read Only Memory (ROM) and Random Access Memory (RAM). The ROM contains the program instruc-

tions for controlling the CPU; the RAM provides the CPU with temporary storage space for computation variables.

The display processor contains the system clock circuits for timing all the functions of the terminal. It also contains input/output drivers for handling data to and from the host (main) and the printer ports.

#### 5.4 KEYBOARD AND KEYBOARD INTERFACE CIRCUITS.

The keyboard is a device for transmitting serial data to the display processor. Each of the keys are switches. When closed, these switches are sensed by circuits that send a code (that corresponds to the key pressed) to the display processor. Keyboard interface circuits convert the keyboard serial data to parallel for input to the display processor circuits.

#### 5.5 MAIN INTERFACE PORT.

The main interface port, consisting of P3 and interface circuits, receives and transmits serial RS-232C data between the host computer and the display processor. This port may be connected either directly to a local computer (as in an application dedicated to a microcomputer system) or to a modem for communicating with a distant computer. The interface circuits convert the input serial data to parallel for application to the display processor; these circuits convert output data from parallel to serial RS-232C format for transmission to the host.

#### 5.6 PRINTER PORT INTERFACE.

The printer port interface, consisting of P4 and interface circuits, performs the identical function for the printer

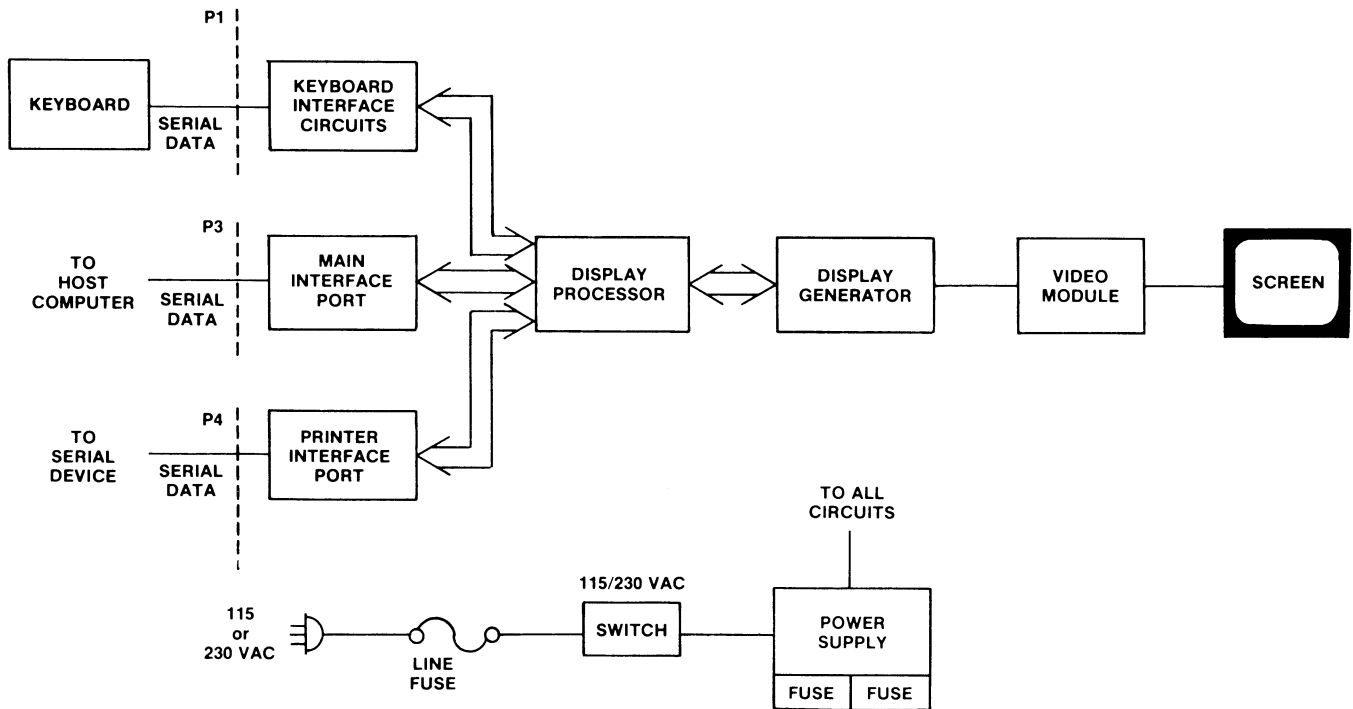

Figure 5-1 Model 950 Simplified Block Diagram

## OPERATOR MAINTENANCE

port as the main interface port does for the main port. Normally, the interface circuits convert parallel data to serial RS-232C format for output only because the port may be primarily used for connecting a printer. However, if a KSR printer or another terminal is connected to the port, the port may be operated bidirectionally (refer to paragraph 3.15.5).

**5.7 DISPLAY GENERATOR.**

The display generator contains the character generator, attribute logic, and video RAM circuits. The character generator produces a dot pattern used to modulate the intensity of the screen raster to produce characters. They attribute logic controls and keep track of the various video attributes set for screen characters (refer to paragraph 3.15.8). The video RAM circuits store all characters written on the screen.

**5.8 VIDEO MODULE AND SCREEN.**

The video module contains horizontal, vertical, and intensity modulation circuits for producing a television-type display on the screen. These circuits generate a conventional interlaced raster display. Character signals received from the display generator cause intensified dots to appear at precise intervals on a raster line. These dots, when combined with other dots on other raster lines above and/or below a given line, produce characters.

The screen is a standard video monitor CRT and a P4 phosphor. Its electron beam is driven horizontally in the conventional manner magnetically using a deflection yoke and flyback transformer.

**5.9 POWER SUPPLY.**

The Model 950 contains a single power supply that provides dc operating voltages to all circuits within the Model 950. The supply contains two 3AG type fuses that are user replaceable. A power transformer, mounted separately, steps down the ac supply voltage to provide the supply with the required input voltages. The *115V/230V* power select switch (see Figure 2-2) selects between input voltage taps on the transformer for 115 Vac or 230 Vac operation.

**6.1 INTRODUCTION.**

This chapter provides the end user with instructions for cleaning and inspecting the Model 950 terminal (periodic maintenance). It also contains procedures for troubleshooting minor problems.

**6.2 PERIODIC MAINTENANCE.**

Periodic maintenance for the Model 950 consists of cleaning the exterior of the unit and checking the terminal and keyboard cabinets for signs of damage or excessive wear. The Model 950 should be checked at the start of each day it will be in use.

**6.2.1 Cleaning.**

To clean the Model 950 cabinet exterior, proceed as follows:

**CAUTION**

To maintain the beauty of the Model 950 cabinet, do not use solvent-based cleaners or abrasive cleansers for cleaning.

1. To clean the terminal, use a soft, lint-free cloth and a commercial detergent (such as 409), to remove smudges, fingerprints, and other similar oily dirt.
2. To clean the keyboard of dust, simply vacuum using a soft brush attachment. If the keyboard contains a coffee or soft drink spill, disassemble it (see Figure 2-1), and clean it with a soft cloth and water. Dry thoroughly!

**6.2.2 Inspection**

To check the Model 950 cabinet and keyboard for damage or excessive wear, proceed as follows:

1. Inspect the keyboard cabinet for cracks or breaks. Check the bezel on customized units for paint damage (peeling, cracking, or severe scratches).
2. Check each key for free movement.
3. Check the rubber feet on the bottom of the keyboard assembly (see Figure 6-1) to ensure that they

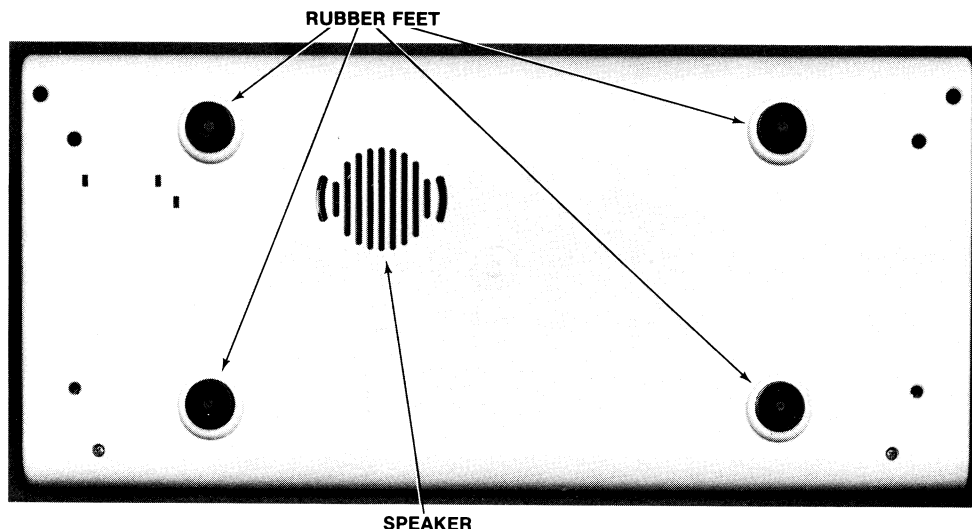

Figure 6-1 Keyboard Assembly Bottom

are still glued in place. If they are loose, reglue them with a quality contact cement.

4. Inspect the keyboard connecting cable for tight kinks indicating excessive stress. Kinks may also indicate broken wires inside. Check the cable connector (at the rear of the terminal cabinet) for damage.
5. Inspect the terminal cabinet for cracks or breaks. Check the screen bezel on customized units for paint damage (peeling, cracking, or severe scratches.)
6. Inspect the main port and printer port connectors for damage. Inspect the interface cable connectors for damage (such as bent pins). Check the interface cables for kinks or other signs of excessive stress (such as stretching).
7. Refer any damage to the Model 950 to a qualified service technician.

### 6.3 TROUBLESHOOTING

The Model 950 is a high-quality video display terminal, built to exacting performance specifications. However, as with the best of products, the terminal may occasionally malfunction. Most problems can easily be corrected by the user. Table 6-1 provides a troubleshooting check list that will help locate most installation and operation faults. If this table does not help locate the cause of a problem, call a qualified service technician for assistance.

### 6.4 REPAIR.

Model 950 operator repair is limited to changing the line fuse and the two internal power supply fuses.

#### 6.4.1 Line Fuse.

To change the line fuse, proceed as follows:

### WARNING

To avoid electrical shock, disconnect the Model 950 power cord before changing the line fuse.

1. Disconnect the Model 950 power cord from primary power.
2. Remove the fuse holder (see Figure 3-1) by unscrewing it counterclockwise.
3. Remove the blown fuse and replace it with a 3AG, 1 amp slo blo, 250V or a 0.5 Amp, 250 V fuse for 220 Vac applications instantaneous (fast blow) fuse.
4. Install the fuse in the reverse order of steps 1 through 3.

#### 6.4.2 Power Supply Fuses.

The Model 950 power supply fuses are installed in fuse clips on the power supply assembly inside the terminal. To replace either of these fuses, proceed as follows:

### WARNING

Hazardous voltages are exposed in the cabinet. Turn off the power switch and disconnect power before opening the Model 950 cabinet.

1. Disconnect the terminal power cord from primary power.
2. Turn the terminal upside down and set it on a soft surface to prevent marring the cabinet. Remove the four cross-tip screws that hold the cabinet cover on the terminal.
3. Turn the terminal right side up and lift off the cabinet cover.
4. Remove the blown fuse from its fuse clip (see Figure 6-2).
5. Replace the blown fuse with a 3AB, 3 amp, 125V fuse.
6. Reinstall the terminal cover and secure it with the four screws.

Table 6-1 Model 950 Troubleshooting Check List

CHECK	REFER TO PARA.
1. Plugged into primary power and that correct power is selected?	2.4
2. Keyboard is plugged in.	
3. Main port (P3) interface cable is plugged in?	2.4
4. Printer port (P4) interface cable is plugged in?	2.4
5. <b>CONTRAST</b> control is set at desired level?	3.2.7
6. Baud rate, stop bits, parity, and bits per word are set? (Incorrectly set parameters may cause incorrect data or @ to frequently appear on the screen.)	2.4 3.15.14 3.15.15
7. Check that fuses are intact?	6.3
8. Check main port (P3) interface cable connector pins: <ul style="list-style-type: none"> <li>• 5, 6, and 8 must be driven by +12 Vdc or not connected at all for normal operation.</li> <li>• 1 and 7 must be grounded.</li> <li>• 3 must be connected to the host transmitter.</li> <li>• 2 must be connected to the host receiver.</li> </ul>	2.4
9. Check other host requirements (such as CR and LF commands for data entry).	
10. Check printer port (P4) interface cable connector pins: <ul style="list-style-type: none"> <li>• 4 and 20 must be driven by +12 Vdc or not connected at all for normal operation.</li> <li>• 3 must be connected to printer data input.</li> <li>• 2 must be connected to printer data output for operation with X-ON/X-OFF control.</li> </ul>	2.4
11. Check other printer port device requirements.	

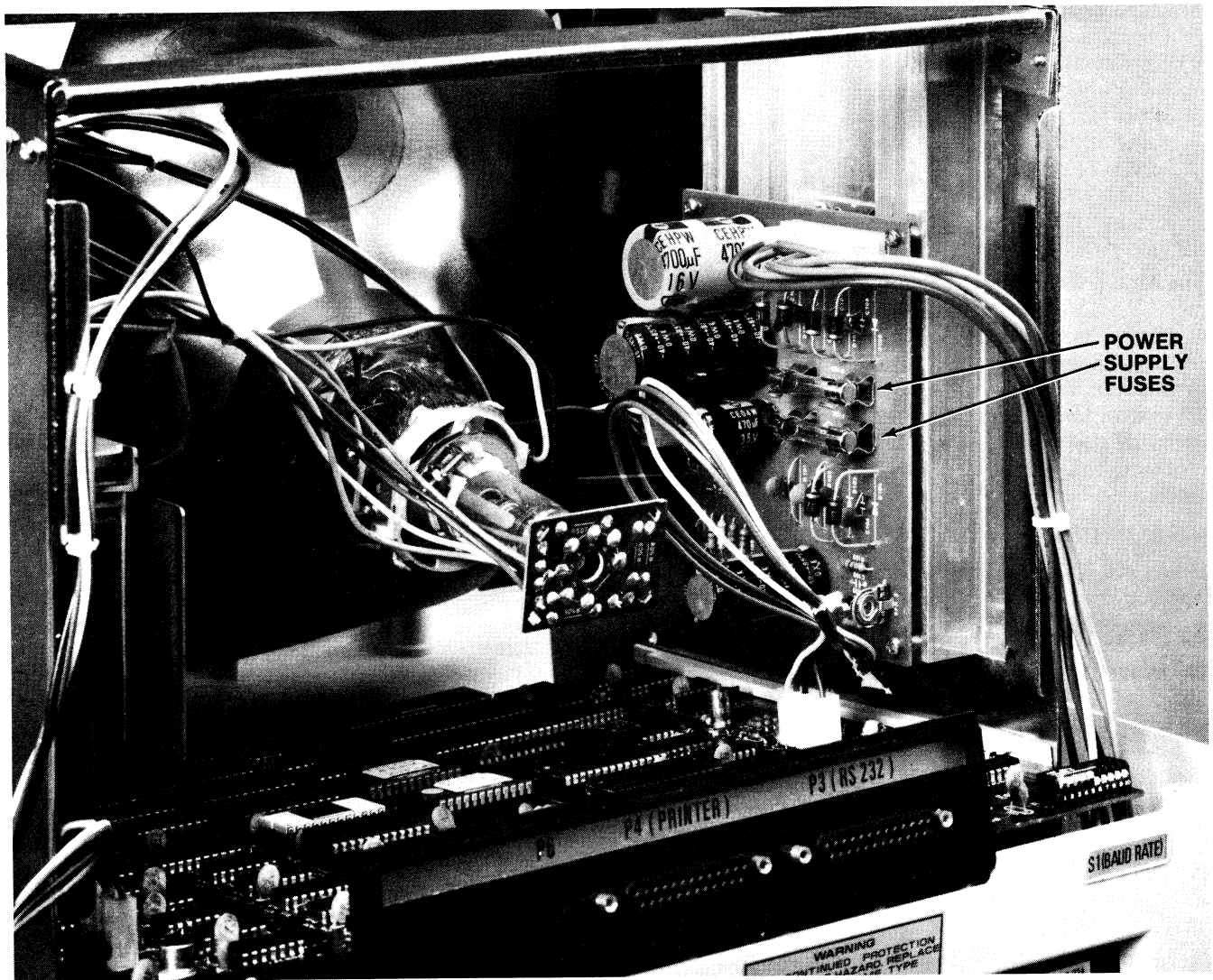

Figure 6-2 Power Supply Fuses

# CONTROL CODES

Function	Sequence
Bell	CTRL/G
Cursor Left	BACKSPACE, ←, CTRL/H
Tab	TAB, CTRL/I
Linefeed	LINEFEED, CTRL/J
Cursor up	↑, CTRL/K
Cursor right	→, CTRL/L
Carriage return	ENTER, RETURN, CTRL/M
Disable buffer control	CTRL/N
Enable buffer control	CTRL/O
Enable bidirectional port	CTRL/R
Disable bidirectional port	CTRL/T
Cursor down	↓, CTRL/V
Clear unprotected to Blank character	CLEARSPACE, CTRL/Z
Home cursor	HOME, CTRL/A
Newline	CTRL/_
Escape leadin	ESC
Linelock line	ESC !1
Remove linelock entire page	ESC !2
Unlock keyboard	ESC "
Lock keyboard	ESC #
Graphics mode on	ESC \$
Graphics mode off	ESC %
Protect mode on	ESC &
Protect mode off	ESC '
Write protect (half intensity) off	ESC (
Write protect (half intensity) on	ESC )
Clear all to nulls	ESC *
Clear unprotected to Blank character	ESC +
Clear all to half intensity Blank character	ESC ,
Address cursor, page, row, column	ESC -nnn
Set cursor attributes	ESC . n
Read cursor, page, row, column	ESC /
Program send key	ESC Øn
Set column tab	ESC 1
Clear column tab	ESC 2
Clear all column tabs	ESC 3
Send line unprotect only	ESC 4
Send page unprotect only	ESC 5
Send line all	ESC 6
Send page all	ESC 7
Smooth Scroll	ESC 8
Scroll	ESC 9
Clear unprotected to null	ESC :
Clear unprotected to Blank character	ESC ;
Keyclick off	ESC <
Address cursor row column	ESC = nn
Keyclick on	ESC >
Read cursor row column	ESC ?
Copy print mode on	ESC @
Copy print mode off	ESC A
Block mode on	ESC B
Conversation mode on	ESC C
Set HDX	ESC DH
Set FDX	ESC DF
Line insert	LINE INSERT, ESC E

Function	Sequence
Load status message	ESC F [TEXT] CR
Set video attribute	ESC G n
Back tab	BACKTAB, ESC I
Back page	ESC J
Advance page	ESC K
Unformatted print	ESC L
Transmit Terminal Type	ESC M
Set page EDIT	ESC N
Clear page EDIT	ESC O
Print	PRINT, ESC P
Character insert	CHAR INSERT, ESC Q
Line delete	LINE DELETE, ESC R
Send message unprotect	ESC S
Erase EOL with Blank	LINE ERASE, ESC T
Monitor mode on	ESC U
Character delete	CHAR DELETE, ESC W
Monitor mode off	ESC X
Erase EOP with Blank	PAGE ERASE, ESC Y
Transmit user line	ESC Z0
Transmit status line	ESC Z1
Write at hidden cursor	ESC [
Set lines per page	ESC \ n
Write at normal cursor	ESC ]
Buffer print on	ESC ^
Buffer print off	ESC a
Reverse background (white background)	ESC b
Normal background	ESC d
Load Blank character	ESC e n
Load user line	ESC f [TEXT] CR
Display user line	ESC g
Display status line	ESC h
Field tab	ESC i
Reverse line feed	ESC j
Local edit keys	ESC k
Duplex edit keys	ESC l
Set insert mode	ESC q
Clear insert mode	ESC r
Send message all	ESC s
Erase EOL with nulls	SHIFT/LINE ERASE, ESC t
Monitor mode off	ESC u
Auto page on	ESC v
Auto page off	ESC w
Program send delimiters	ESC x nnn
Erase EOP with nulls	SHIFT/PAGE ERASE, ESC y
User ROM	ESC z, p
Configure main port	ESC { nnnn
Load Function keys	ESC p1, p2[TEXT] CTRL/Y
Configure print port	ESC } nnnn

**Warning:** This equipment generates, uses, and can radiate radio frequency energy and if not installed and used in accordance with the instruction manual, may cause interference to radio communications. As temporarily permitted by regulation it has not been tested for compliance with the limits for Class A computing devices pursuant to Subpart J of Part 15 of FCC Rules, which are designed to provide reasonable protection against such interference. Operation of this equipment in a residential area is likely to cause interference in which case the user at his own expense will be required to take whatever measures may be required to correct the interference."



**TeleVideo, Inc., 1170 Morse Avenue, Sunnyvale, CA 94086**  
**Phone: (408) 745-7760, Cable: "TVI VIDEO", TWX 910-338-7633 "TVI VIDEO"**

**Printed in U.S.A.**