



sitrans p

DS III-SERIES

Transmitters for pressure,
differential pressure and flow, level,
absolute pressure from pressure series
7MF4*33-...

SIEMENS

SITRANS P, DS III series 7MF4*33-...

Edition 10/2003

Instruction Manual

Transmitters for pressure, differential pressure and flow, filling level, absolute pressure from differential pressure series, absolute pressure from pressure series, series DS III

Contains the functions of performance stage 2

Edition of operating manual	Firmware identification License plate	System integration	Installation path PDM
02	FW: 11.02.02, FW: 11.02.03, FW: 11.02.04	PDM V.5.02 + SP1; Dev. R.2 DD Rev.1	SITRANS P DSIII
03	FW: 11.03.03, FW 11.03.04, FW: 11.03.05	PDM V.5.20; Dev. R.3 DD Rev.1 *)	SITRANS P DSIII.2
04	FW: 11.03.03, FW 11.03.04, FW: 11.03.05	PDM V.5.20; Dev. R.3 DD Rev.1 *)	SITRANS P DSIII.2
05	FW: 11.03.03, FW 11.03.04, FW: 11.03.05, FW 11.03.06	PDM V.5.20; Dev. R.3 DD Rev.1 *)	SITRANS P DSIII.2

Table 1 History of this instruction manual

*) PDM V.5.02 + SPx (SITRANS P DSIII) not released

Contents

Classification of safety-related notices	7
General information	8
1 Contents	3
2 Technical description	11
2.1 Application range	11
2.1.1 Pressure	12
2.1.2 Differential pressure and flow	12
2.1.3 Filling level	13
2.1.4 Absolute pressure	13
2.1.5 Parameterization of the output variable	13
2.2 Design and functional principle	14
2.2.1 Design	14
2.2.2 Mode of operation	16
2.2.2.1 Mode of operation of the electronics	17
2.2.2.2 Pressure	18
2.2.2.3 Differential pressure and flow	18
2.2.2.4 Filling level	19
2.2.2.5 Absolute pressure from the differential pressure series	19
2.2.2.6 Absolute pressure from the pressure series	20
3 System integration	21
3.1 System configuration	21
3.2 SIMATIC PDM	22
4 Local operation and display	23
4.1 General operating instructions	23
4.1.1 Digital display	24
4.1.2 Measured value representation	24
4.1.3 Unit display/bargraph	25

4.1.4	Error signaling	26
4.1.5	Signal range	27
4.1.6	Mode display	28
4.2	Operation with the keyboard	28
4.2.1	Cancel keyboard disable and write protection	30
4.2.2	Set/adjust start of scale, full scale	30
4.2.2.1	Theoretical relationships	30
4.2.2.2	Practical application	33
4.2.3	Electric damping	35
4.2.4	Blind setting of start of scale and full scale	35
4.2.4.1	Theoretical relationships	35
4.2.4.2	Practical application	37
4.2.5	Zero adjustment (position correction)	38
4.2.6	Current transmitter	39
4.2.7	Failure current	39
4.2.8	Key and/or function disable	40
4.2.9	Flow measurement (only differential pressure)	41
4.2.10	Measured value display	44
4.2.11	Selection of the physical unit	46
5	Local operation without display or with activated keylock	47
5.1	Set start of scale, full scale	47
6	Functions/Operation via HART	49
6.1	Measuring point data	49
6.2	Measuring operation	49
6.3	Selection of measurement type	50
6.3.1	The measurement type switch	50
6.3.2	The variable mapper	50
6.3.3	Pressure measurement type	51
6.3.4	The user-specific characteristic	52
6.3.5	"Filling level" measurement type	52
6.3.6	"Flow" measurement type	54
6.3.7	"User" measurement type	56
6.3.8	"Status" measured value	58
6.3.9	Analog output	61
6.3.10	Scaling the LCD display value	62
6.4	Setting start of scale, full scale	63
6.5	Blind setting of start of scale and full scale	63
6.6	Zero adjustment (position correction)	64
6.7	Electric damping	64
6.8	Fast measured value acquisition (fast response mode)	64
6.9	Current transmitter	65
6.10	Fault current	65
6.11	Setting the current limits	65
6.12	Disabling of input keys and write protection	66
6.13	Measured value display	67
6.14	Selection of the physical unit	67
6.15	Display/bargraph	68
6.16	Sensor adjustment	68
6.16.1	Trimming the lower sensor adjustment point	68

6.16.2	Trimming the upper sensor adjustment point	69
6.17	Current transmitter adjustment	69
6.18	Factory calibration	71
6.19	Static configuration data	71
6.20	Flow measurement (only differential pressure)	72
6.21	Diagnostic functions	72
6.21.1	Operating hours counter	73
6.21.2	Calibration timer/service timer	73
6.21.3	Slave pointer	74
6.21.4	Limit value components	75
6.21.4.1	Monitoring the current saturation	75
6.22	Simulation	76
6.22.1	Simulation as a fixed value	77
6.22.2	Simulation with a ramp function	77
6.23	Limit transmitter	78
7	Modular design	81
8	Installation	83
8.1	Installation (except filling level)	84
8.1.1	Mounting without mounting bracket	85
8.1.2	Mounting with mounting bracket	85
8.2	Mounting "filling level"	87
8.2.1	Installation	87
8.2.2	Connecting the low pressure line	88
8.3	Rotating the measuring cell in relation to the housing	90
8.4	Electrical connection	91
8.4.1	Connection to screw terminals	92
8.4.2	Connection with plug	94
8.5	Turn digital display	94
9	Commissioning	95
9.1	Pressure, absolute pressure from differential pressure series and absolute pressure from pressure series 96	
9.1.1	Measuring gases	96
9.1.2	Measuring vapor and liquid	97
9.2	Differential pressure and flow	98
9.2.1	Measuring gases	99
9.2.2	Measuring liquids	100
9.2.3	Measuring vapor	101
10	Technical data	103
10.1	Measuring spans/medium pressure limits and overload limits	108
10.1.1	Pressure	108
10.1.2	Differential pressure and flow	108
10.1.3	Absolute pressure from the pressure series	109
10.1.4	Absolute pressure from the differential pressure series	109
10.1.5	Filling level	110
10.2	Dimensions	110

11	Care and maintenance	115
12	Ordering data	117
12.1	Ordering data for standard device	118
12.2	Ordering data for accessories	128
12.3	Accessories	132
13	Certificates	133
14	Index	135
14.1	"HAND-HELD operating structure HART"	139
15	Appendix	139
15.1	Pressure equipment directive (DGRL)	142

Classification of safety-related notices

This manual contains notices which you should observe to ensure your own personal safety, as well as to protect the product and connected equipment. These notices are highlighted in the manual by a warning triangle and are marked as follows according to the level of danger:



DANGER

indicates an imminently hazardous situation which, if not avoided, **will** result in death or serious injury.



WARNING

indicates a potentially hazardous situation which, if not avoided, **could** result in death or serious injury.



CAUTION

used with the safety alert symbol indicates a potentially hazardous situation which, if not avoided, **may** result in minor or moderate injury.

CAUTION

used without the safety alert symbol indicates a potentially hazardous situation which, if not avoided, may result in property damage.

NOTICE

indicates a potential situation which, if not avoided, may result in an undesirable result or state.



NOTE

highlights important information on the product, using the product, or part of the documentation that is of particular importance and that will be of benefit to the user.

Copyright © Siemens AG 2000 All rights reserved

The reproduction, transmission or use of this document or its contents is not permitted without express written authority. Offenders will be liable for damages. All rights, including rights created by patent grant or registration of a utility model or design, are reserved.

Siemens AG
Bereich Automatisierungs- und Antriebstechnik
Geschäftsgebiet Process Instrumentation
D-76181 Karlsruhe

Disclaimer of Liability

We have checked the contents of this manual for agreement with the hardware and software described. Since deviations cannot be precluded entirely, we cannot guarantee full agreement. However, the data in this manual are reviewed regularly and any necessary corrections included in subsequent editions. Suggestions for improvement are welcomed.

© Siemens AG 2000
Technical data subject to change.

General information

This device has left the factory in a perfect condition as regards safety. The notes and warnings in these Operating Instructions must be observed by the user if this state is to be maintained and hazard-free operation of the device assured.



NOTE

Dear customer,

For reasons of clarity the manual does not contain detailed information about all types of products and cannot take into account every conceivable case of installation, operation or maintenance.

If you require further information or should problems occur which are not sufficiently explained in this manual, you can consult your local Siemens branch to obtain the necessary information.

May we also draw your attention to the fact that the contents of the manual are not part of a previous or existing agreement, approval or legal relationship or an amendment thereof. All obligations of the Siemens AG result from the contract of purchase which also contains the full and solely valid warranty agreement. These contractual warranty conditions are neither extended nor restricted by the contents of the manual.

The contents reflect the technical state at the time of going to print. They are subject to technical modifications in the course of further development.



WARNING

Explosion-proof devices may only be opened when the power is off.

Intrinsically safe devices lose their license as soon as they are operated on circuits which do not meet the test requirements valid in your country.

The device may be operated with high pressure and corrosive and dangerous media. Therefore serious injuries and/or considerable material damage cannot be ruled out in the event of improper handling of the device.

The perfect and safe operation of this equipment is conditional upon proper transport, proper storage, installation and assembly as well as on careful operation and commissioning.

The equipment may only be used for the purposes specified in the instruction manual.

Exclusion of liability

All modifications to the device are the sole responsibility of the user unless these are expressly mentioned in the instruction manual.

Qualified personnel

are persons familiar with the installation, assembly, commissioning and operation of the product and who have the appropriate qualifications for their activities such as:

- training or instruction or authorization to operate and maintain devices/systems according to the standard of safety technology for electrical circuits, high pressures and corrosive and dangerous media.
- for explosion-proof equipment: training or instruction according or authorization to perform work on electrical circuits for systems where there is a risk of explosion
- training or instruction according to the standards of safety engineering in the care and use of suitable safety equipment

CAUTION

Modules which are sensitive to electrostatic charge may be destroyed by voltages which are far below the human level of perception. These voltages occur already when you touch a component or electrical connections of a module without first discharging yourself electrostatically. The damage incurred by a module as a result of an overvoltage is not usually immediately perceptible but only becomes noticeable after a long time in operation.

Trade marks

SIMATIC®, SIPART®, SIREC®, SITRANS® are registered trademarks of Siemens AG.

The other designations in this manual may be trade marks the use of which by third persons for their own purposes might infringe proprietor rights.

Technical description

1



NOTE

The transmitter must warm up for about 5 minutes after switching on the power in order to obtain stable measured values.

1.1 Application range

The SITRANS P, DS III series transmitter measures the pressure, the differential pressure, the absolute pressure or the filling level of non-corrosive and corrosive gases, vapors and liquids depending on the version. Other measuring variables such as volume, mass, volume flow and mass flow can be derived from the "pressure" variable by parameter specifications. The output signal is a load-independent direct current of 4 to 20 mA.

Transmitter designs with intrinsic safety or explosion protection can be installed in hazardous areas. The devices have EC test certification and fulfil the appropriate harmonized European standards of CENELEC.

The transmitters are available with remote seals of different designs for special applications, e.g. measuring high viscous substances.

The transmitter can be parameterized locally with three input keys or externally via HART. The following table describes the basic parameters. Other parameters are accessible via HART for special applications.

Parameter	Parameterization by input keys	Parameterization by HART
Start of scale	yes	yes
Full scale	yes	yes
Electric damping	yes	yes
Blind setting of start of scale	yes	yes
Blind setting of full scale	yes	yes
Zero adjustment (position correction)	yes	yes
Current transmitter	yes	yes
Fault current	yes	yes
Keyboard disable and write protection	yes	yes, except cancel write protection
Type of unit, unit	yes	yes
Characteristic (lin., squ.)	yes *)	yes *)
User-spec. characteristic	no	yes
Diagnostic function	no	yes

Table 2 Basic parameters

*) differential pressure only

 Basic variables

You will find a description of the listed parameters in Chapter 3, pg. 23 and Chapter 5.2, pg. 49.

1.1.1 Pressure

This version of the device measures the pressure of non-corrosive and corrosive as well as critical gases, vapors and liquids. Measuring spans between 0.01 mbar and 400 bar are possible.

1.1.2 Differential pressure and flow

This version of the device is used to measure

- the differential pressure, e.g. the active pressure,
- of a small positive or negative excess pressure,
- of the flow $q \sim \sqrt{\Delta p}$ (together with a flow control valve)

non-corrosive and corrosive and critical gases, vapors and liquids. Measuring spans between 1 mbar and 30 bar are possible.

1.1.3 Filling level

This version of the device with mounting flange measures the filling level of non-corrosive and corrosive as well as critical liquids in open and closed containers. Measuring spans between 25 mbar and 5 bar are possible. The nominal diameter of the mounting flange is DN 80 or DN100 or 3 or 4 inch.

In the filling level measurement on an open container the low pressure connection of the measuring cell remains open (measurement "compared to atmospheric"), in the measurement on a closed container this connection is usually connected to the vessel to compensate the static pressure.

The wetted parts are made of different materials (Chapter 9, pg. 103) according to the required corrosion resistance.

1.1.4 Absolute pressure

This version of the device measures the pressure of non-corrosive and corrosive as well as critical gases, vapors and liquids.

There are two series: one "differential pressure" series and one "pressure" series. The "differential pressure series" is characterized by a high overload capacity.

Measuring spans between 8.3 mbar and 30 bar are possible.

1.1.5 Parameterization of the output variable

In addition to the standard pressure measurement, all transmitter versions support your respective measuring application by providing three software-based measuring blocks for the types of measurement "filling level", "flow" or a user-specific "characteristic". These blocks give you the possibility of setting every version of the transmitter exactly to suit your requirements, for example by converting the measuring variable "pressure" into another variable such as "mass", "volume", "mass flow", "volume flow" etc.

A measuring mode switch is used to select which block is to be activated additionally. If no block is selected, the "pressure" measurement type remains active. All active device variables are available through SIMATIC PDM or the Handheld Communicator (Chapter 5.3.2, pg. 50).

You will find information about parameterization of these blocks only in Chapter 5, pg. 49 "Functions and operations via HART".

NOTE



It is not possible to set the measurement type switch with the input keys!

1.2 Design and functional principle

The SITRANS P, DS III series transmitter is ready for operation immediately after installation (Chapter 7, pg. 83). The determinable span range corresponds to the specification on the rating plate (Figure 1, pg. 14). If a customized setting is made at the factor, the start of scale and full scale are specified on the measuring point plate.

If necessary the parameters can also be changed during commissioning (Chapter 8, pg. 95) by simple operating procedures.

1.2.1 Design

The device consists of different components depending on what the customer has specified in the order. The possible variants are listed in Chapter 11, pg. 117.

The rating plate (Figure 1 and Figure 4, pg. 16) with the order number is on the side of the housing. You can determine the optional constructional details and the possible measuring range (physical properties of the built-in sensor element) with the specified number and specifications in Chapter 11, pg. 117.

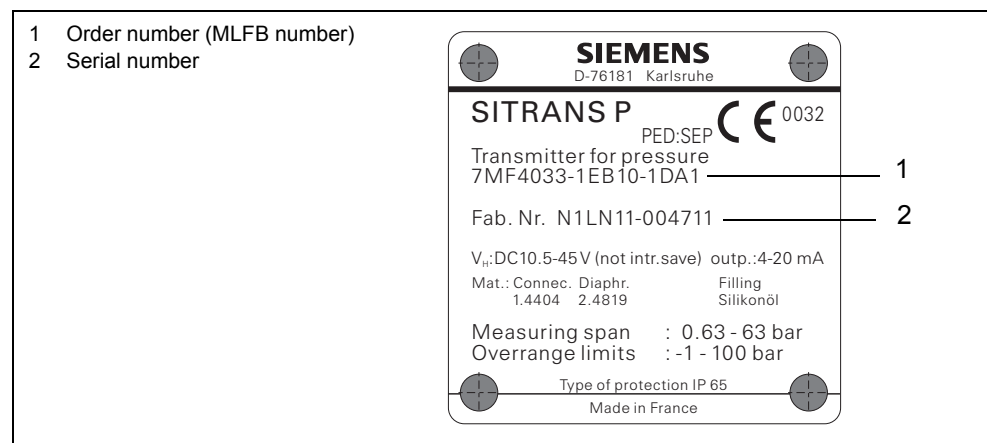

Figure 1 Example of a rating plate

Opposite it is the license plate (Figure 2 and Figure 4, pg. 16). This contains information about the hardware and firmware versions among other things.

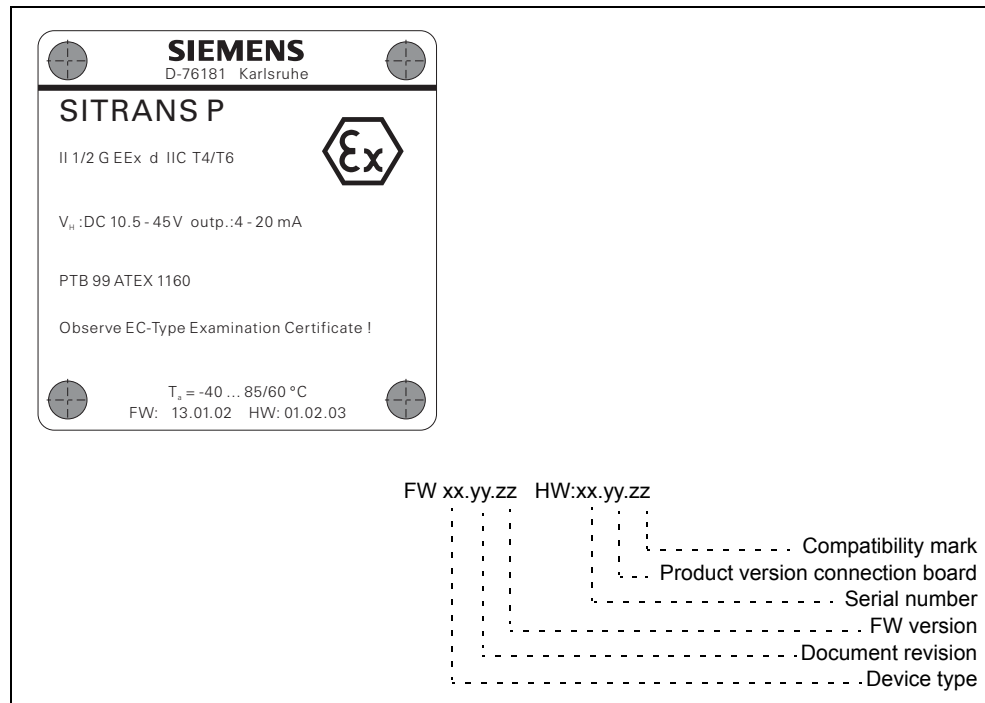

Figure 2 Example of a license plate

The electronics housing is made of diecast aluminum or stainless steel precision casting. There is an unscrewable, round cover on the front and rear. The front cover (4, Figure 3, pg. 16) can be designed as a window in order to be able to read measured values directly from the digital display. The inlet (2, Figure 3, pg. 16) to the electrical connection box is located on the side, either left or right. The opening which is not used is sealed by a blanking plug (e.g. 5, Figure 4, pg. 16). The PE conductor terminal (2, Figure 4, pg. 16) is mounted at the front of the housing.

The electrical connection box is accessible for power supply and screen when the rear cover (1, Figure 4, pg. 16) is removed. The bottom part of the housing contains the measuring cell with process connection (8, Figure 3, pg. 16). This is secured turning by a locking screw (7, Figure 3, pg. 16). The modular concept of the SITRANS P, DS III series allows the measuring cell and electronics to be exchanged as required.

At the top of the housing you can see a plastic cover (3, Figure 3, pg. 16) which can be opened. The input keyboard is beneath this.

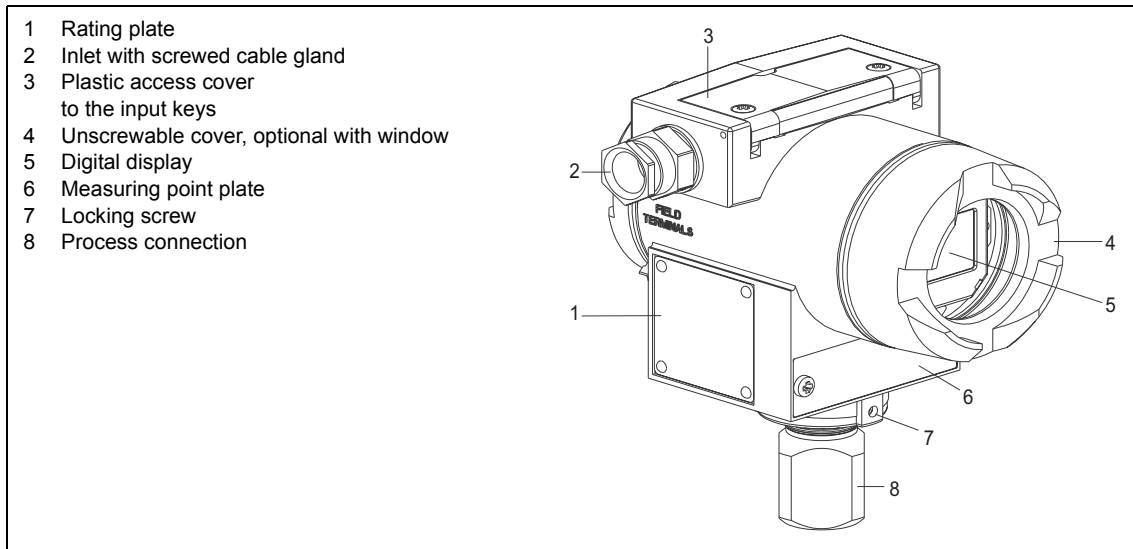

Figure 3 Front view of transmitter SITRANS P, DS III series, pressure series

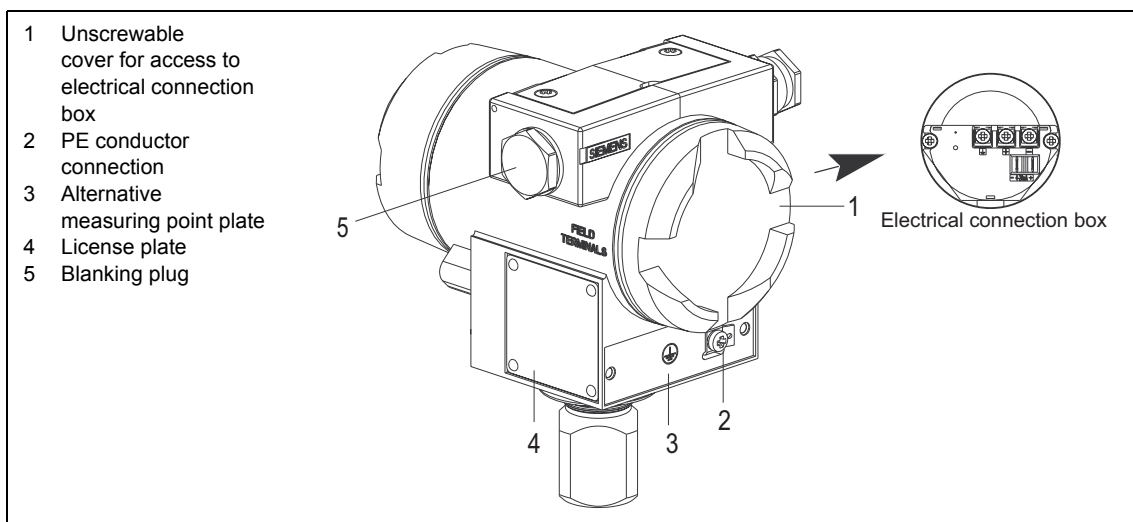

Figure 4 Rear view of device Transmitter SITRANS P, DS III series, pressure series

1.2.2 Mode of operation

This chapter describes how the transmitter operates and what protection and safety measures you need to observe. First of all the electronics are described on a functional diagram level, then the sensors used for the individual measuring modes in the various device versions.

The process variable to be measured is referred to generally in the sections which follow as the input variable.

1.2.2.1 Mode of operation of the electronics

The sensor signal is amplified by an instrument amplifier (2) and converted into a digital signal in an analog-digital converter (3). This is evaluated in a microprocessor, its linearity and temperature behavior scaled according to the set measurement type. The corrected signal is converted into the output current 4 – 20 mA in a digital-analog converter (5). A diode circuit (10) provides reverse polarity protection. An external display (voltage drop < 0.5 V) can also be connected here. The measuring cell-specific data of the electronics and the data for transmitter parameterization are stored in two non-volatile memories (6).

You can parameterize function of the "pressure" type of measurement directly at the measuring point with the three input keys (8) and view measuring results, error messages and modes of operation on the digital display (9). The HART modem (7) enables parameterization by a protocol according to HART specifications.

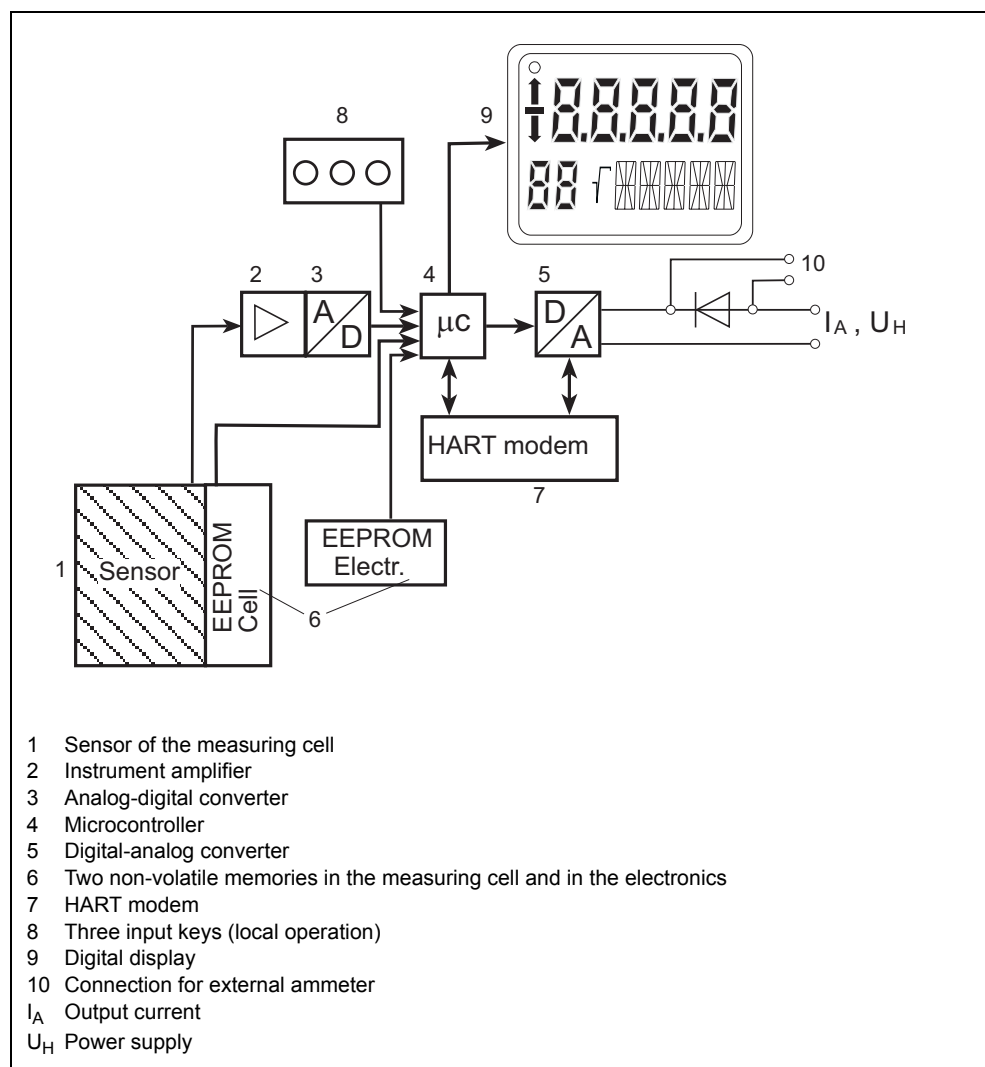

Figure 5 Principle representation of the transmitter SITRANS P, DS III series, electronics

1.2.2.2 Pressure

The pressure p_e is fed in through the process connection (3, Figure 6, pg. 18) of the measuring cell (2). It is passed further through the seal diaphragm (4) and the filling liquid (5) to the silicon pressure sensor (6) and its measuring diaphragm flexes as a result. Four piezo-resistors in bridge circuit doped in the measuring diaphragm change their resistance as a result. The change in resistance causes a bridge output voltage proportional to the input pressure.

The transmitters with measuring spans ≤ 63 bar measure the input pressure compared with atmospheric, those with measuring spans ≥ 160 bar compared with a vacuum.



CAUTION

If the measuring signal fails due to a sensor break, the isolating diaphragms may also be destroyed. In this case, process medium may leak from the threaded collar of the device in pressure transmitters with relative pressure cell (≤ 63 bar).

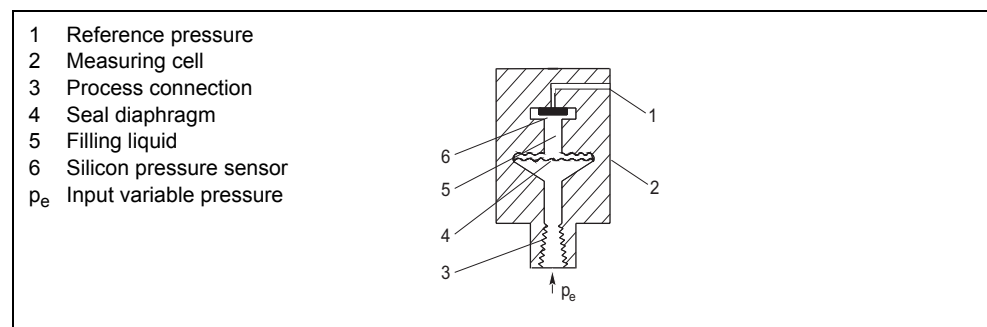

Figure 6 Pressure measuring cell, functional diagram

1.2.2.3 Differential pressure and flow

The differential pressure is transmitted via the seal diaphragms (7, Figure 7, pg. 18) and the filling liquid to the silicon pressure sensor (5). On exceeding the measuring limits, the overload diaphragm (6) flexes until one of the seal diaphragms (7) comes into contact with the body of the measuring cell (4) and protects the silicon pressure sensor (5) against overloading. The seal diaphragm is deflected by the resulting differential pressure. Four piezo-resistors in bridge circuit doped in the measuring diaphragm change their resistance as a result. The change in resistance causes a bridge output voltage proportional to the differential pressure.

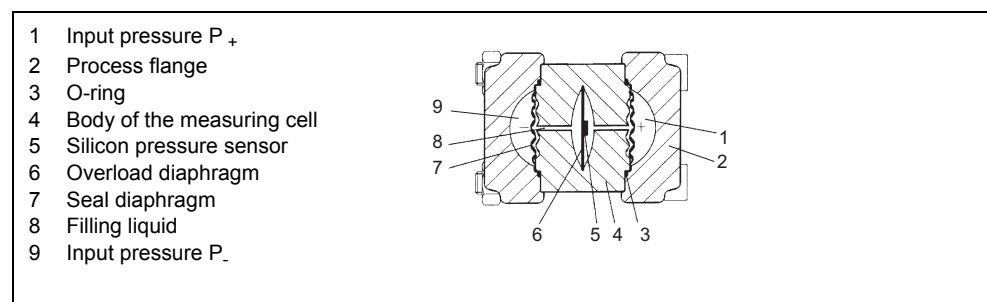

Figure 7 Measuring cell for differential pressure and flow, functional diagram

1.2.2.4 Filling level

The input pressure (hydrostatic pressure) acts through the seal diaphragm (10, Figure 8, pg. 19) at the mounting flange hydraulically on the measuring cell. The differential pressure applied at the measuring cell is transmitted via the seal diaphragms (6) and the filling liquid (7) to the silicon pressure sensor (3). On exceeding the measuring limits, the overload diaphragm (5) is deflected until one of the seal diaphragms (6) comes into contact with the body of the measuring cell (4) and protects the silicon pressure sensor (3) against overloading. The measuring diaphragm is flexed by the differential pressure. Four piezo-resistors in bridge circuit doped in the measuring diaphragm change their resistance as a result. The change in resistance causes a bridge output voltage proportional to the differential pressure.

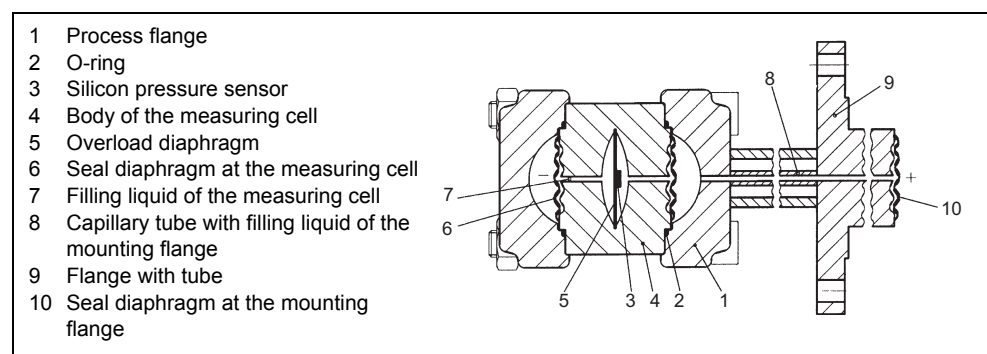

Figure 8 Measuring cell for filling level, functional diagram

1.2.2.5 Absolute pressure from the differential pressure series

The absolute pressure is transmitted via the seal diaphragm (6, Figure 9, pg. 19) and the filling liquid (7) to the silicon pressure sensor (3). On exceeding the measuring limits, the overload diaphragm (5) is deflected until the seal diaphragm (6) comes into contact with the body of the measuring cell (4) and protects the silicon pressure sensor (3) against overloading. The pressure difference between the input pressure (p_e) and the reference pressure (8) on the low pressure side of the measuring cell flexes the measuring diaphragm. Four piezo-resistors in bridge circuit doped in the measuring diaphragm change their resistance as a result. The change in resistance causes a bridge output voltage proportional to the absolute pressure.

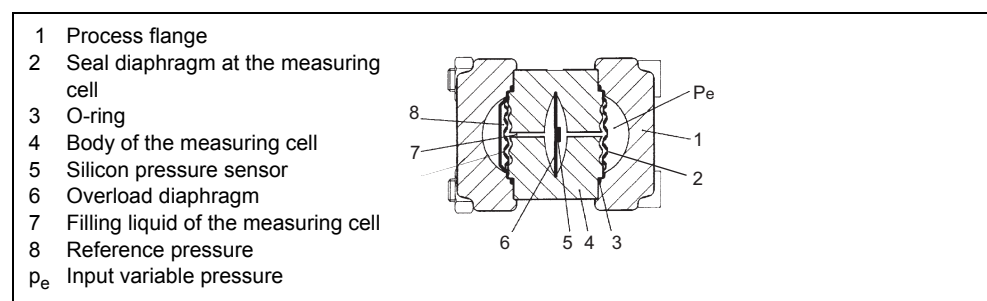

Figure 9 Measuring cell for absolute pressure, functional diagram

1.2.2.6 Absolute pressure from the pressure series

The pressure is transmitted via the seal diaphragm (3, Figure 10, pg. 20) and the filling liquid (4) to the absolute pressure sensor (5) and flexes its measuring diaphragm. Four piezo-resistors in bridge circuit doped in the measuring diaphragm change their resistance as a result. The change in resistance causes a bridge output voltage proportional to the input pressure.

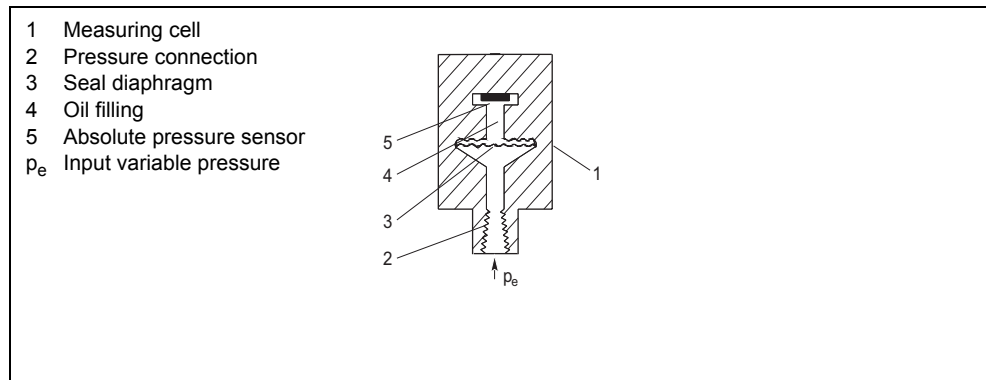

Figure 10 Measuring cell for absolute pressure from pressure series, functional diagram

2.1 System configuration

The SITRANS P, DS III series transmitter can be used in a number of system configurations. as a stand-alone version, supplied with the necessary power and as part of a complex system environment e.g. SIMATIC S7.

All basic settings (Table 4, pg. 29) can be made directly on the device with three input keys. The full scope of communication is available via HART (online parameterization).

Communication via the HART interface can take place optionally with:

- HART-Communicator (memory in the handheld ≥ 4 MB)
- HART modem with following PC/laptop on which suitable software such as SIMATIC PDM is available
- a HART-capable control system (e.g. SIMATIC S7 with ET 200M)

NOTICE

By parameterization of the transmitter the display and measuring output can be set so that the real process pressure is not reproduced. As an inspection, the basic parameters (Table 2, pg. 12) should be checked before commissioning.

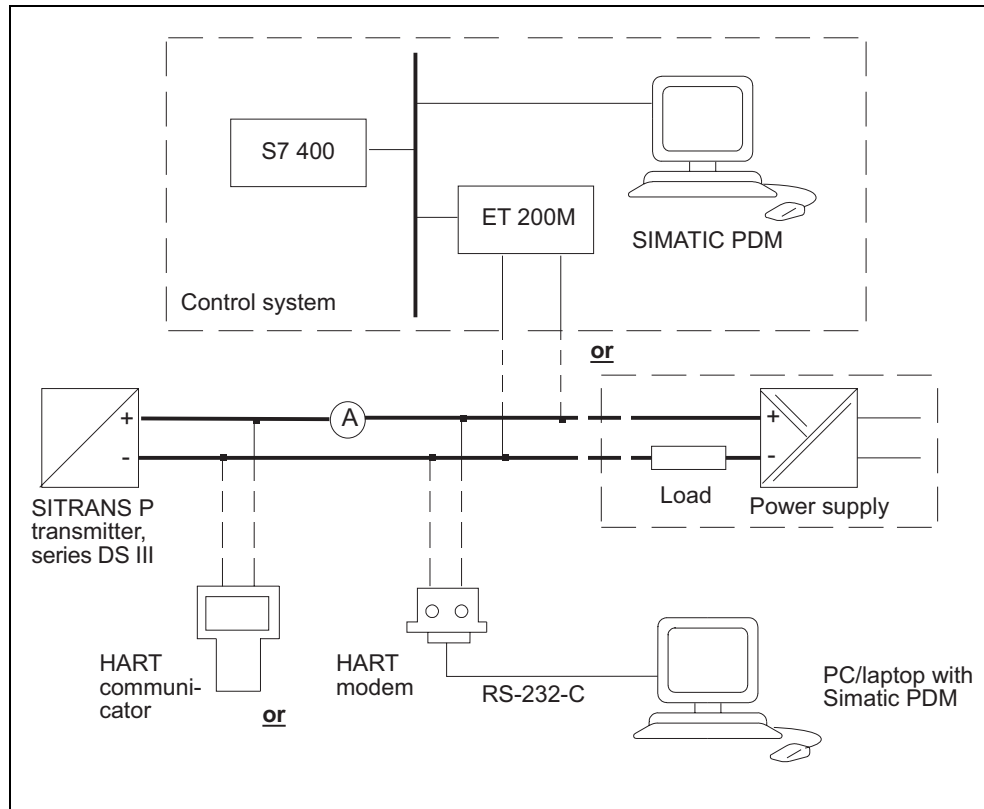

Figure 11 Possible system configurations

2.2 SIMATIC PDM

SIMATIC PDM is a software package for configuring, parameterizing, commissioning, diagnosing and maintaining SITRANS P, DS III series and other process devices.

SIMATIC PDM contains a simple process monitoring of the process values, alarms and status signals of the device.

There are two versions which run under Windows NT or Windows 95/98.

- SIMATIC PDM (stand-alone)
- SIMATIC PDM Integrated

Further information on request or in the Internet under www.fielddevices.com.

Local operation and display

3

3.1 General operating instructions

You operate the device with the keys [M], [↑] and [↓] (Figure 16, pg. 28). These are accessible when you loosen the two screws of the protective cover (3, Figure 4, pg. 16) and lift it up. The cover must be closed again after operation.

The device is normally in the measured value display mode. You can then select an option with the [M] key and change a value with [↑] and [↓]. You accept the selected option or changed value by pressing the [M] key again. Exceptions to this procedure are described in the explanations of the individual device functions.

It generally applies that:

- Numerical values are always set from the least significant digit still displayed. In the case of an overflow in the key repetition mode it switches to the next significant digit and only this continues to be counted. This procedure serves for fast rough setting over a wide numeric range. For fine setting you have to release the desired key ([↑] or [↓]) and press it again. Exceeding of the upper or lower measured value limits are shown on the display with ↑ or ↓
- The keylock must be released for keyboard operation.
- When you operate the transmitter locally, write accesses via HART are refused during this time – it is possible to read data, e.g. measured values, at any time.

NOTES



- If more than 2 minutes have passed since last pressing a key, the setting is saved and the measured value display reappears automatically.
 - If the device is delivered with a dummy cover, the operating instructions apply in Chapter 4, pg. 47
-

NOTICE

By parameterization of the transmitter the display and measuring output can be set so that the real process pressure is not reproduced. The basic parameters (Table 2, pg. 12) should be checked before commissioning as an inspection.

3.1.1 Digital display

A plug-in standard display is used for local display of the measured value (1, Figure 12, pg. 24) with unit (2), sign (6), status (5, 7) and mode (4). The root sign (3) is used for the device variants "differential pressure and flow". Active communication, e.g. with a HART Communicator, is displayed by flashing of the communication indicator (8).

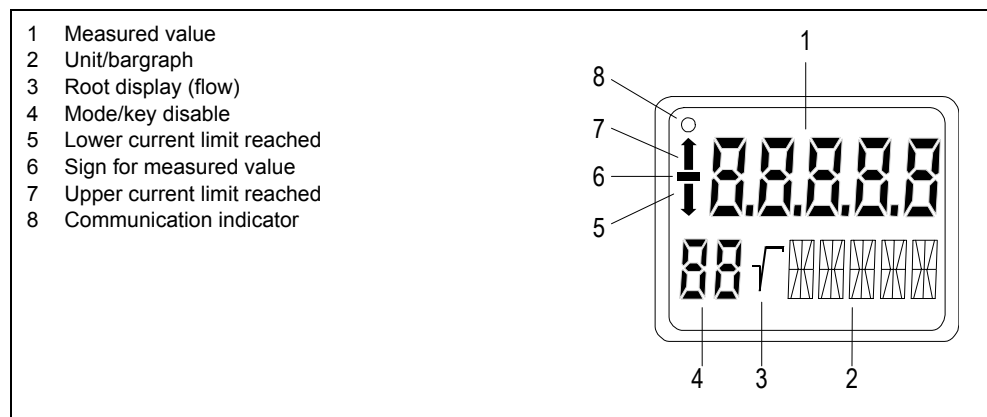

Figure 12 Structure of the digital display

3.1.2 Measured value representation

In the measured value representation, the current output by the transmitter, the percentage measured value of the respective set measurement type (filling level, flow etc.) value related to the set range or the measured value in a selectable physical unit are shown depending on the customer setting.

Status display

Operating mode	↑ (7, Figure 12, pg. 24)	↓ (5, Figure 12, pg. 24)
Mode 2 (set MA*)	on exceeding the upper current limit value	on dropping below the lower current limit value
Mode 3 (set ME*)	on exceeding the upper current limit value	on dropping below the lower current limit value
Mode 4 (set damping)	on exceeding the upper damping value ¹⁾	on dropping below the lower damping value ¹⁾
Mode 5 (set MA blind)	on exceeding the upper sensor limit ¹⁾	on dropping below the lower sensor limit ¹⁾
Mode 6 (set ME blind)	on exceeding the upper sensor limit ¹⁾	on dropping below the lower sensor limit ¹⁾
Mode 7 (position correction)	on exceeding the max. span by more than 5 %, on exceeding the upper current limit	on dropping below the lower current limit
Mode 12 (root application point)	on exceeding the root application point of 15 %	on dropping below the root application point of 5 %
Keyboard operation (mode 2, 3, 5, 6)	if the span to be set becomes greater than the maximum span	if the span to be set becomes smaller than the minimum span
Normal operation	Current exceeds the upper saturation limit Pressure exceeds the upper sensor limit	Current drops below the lower saturation limit. Pressure drops below the lower sensor limit.

Table 3 Meaning of the arrow indicators

¹⁾ For "pressure" device variable

* MA = start of scale, ME = full scale

Communication indicator

- HART communication active.

3.1.3 Unit display/bargraph

The unit display consists of five 14-segment fields to represent the type of unit as a percentage, physical unit or current value. A bargraph which represents the percentage pressure value in the range from 0 to 100% can be displayed alternately with the unit. The "bargraph" function is switched off in the standard setting. A bargraph can be displayed alternately with the unit which represents the percentage measured

value in the range from 0 to 100 %. The bargraph function is switched off in the standard setting.

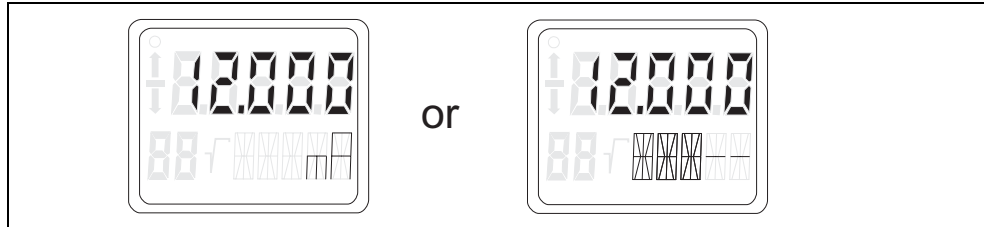

Figure 13 Examples of measured value display in "Current" and "Bargraph" display types.

The following two messages can appear as moving text in the bottom line of the display. They have no influence on the current output.

Moving text	Explanations
DIAGNOSTIC WARNING	Is displayed whenever an event parameterized by the user is to be signaled by a warning, e.g.: limit reached/event counter for limits exceeded, calibration time expired, current saturation reached. It also appears when the status of a device variable becomes "UNCERTAIN" (see Table 15, pg. 60).
SIMULATION	Is displayed whenever simulation of a pressure or temperature value is active.

3.1.4 Error signaling

If hardware or software errors or diagnostic alarms occur in the transmitter, the Error message appears in the measured value display.

A message text runs through the unit display indicating the type of error. This diagnostic information is also available via HART.

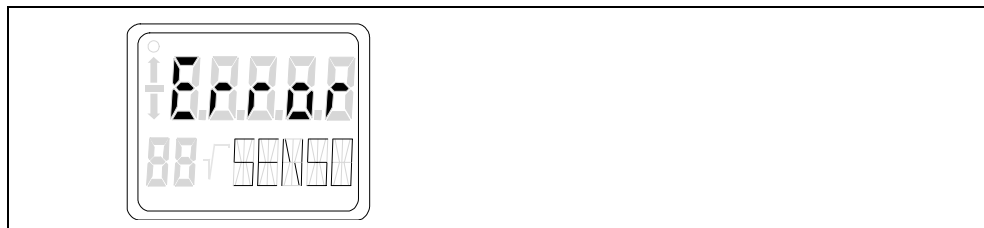

Figure 14 Error message, example "Senso(r)"

The following messages can appear as moving text in the bottom line of the display

Moving text	Explanations
HARDWARE FIRM-WARE ALARM	Contains hardware errors, such as incorrect checksum, incorrect EEPROM data, EEPROM defective, RAM error, inconsistent data, EEPROMS not initialized etc.
DIAGNOSTIC ALARM	Is displayed whenever an event parameterized by the user is to be signaled by an alarm, e.g.: limit reached/event counter for limits exceeded, calibration time expired, current saturation reached. It also appears when the status of a device variable becomes "BAD" (see Table 15, pg. 60).
SENSOR BREAK	Appears in case of sensor break

3.1.5 Signal range

The output signal is divided into defined areas (Figure 18, pg. 31).

The transmitter converts the device variable which is to be output as PV (Primary Variable) into an output current which is normally in the range from 4 mA (start of scale) to 20 mA (full scale).

Measured values below and above the range limits are displayed correctly when the measuring limits are exceeded. The "UNDER" message or "OVER" message for the selected unit appears alternately in place of the bargraph. The possible overflow range can be set via HART. If the upper or lower range limits are exceeded, the output current remains constant. "↑" or "↓" appears on the digital display. See also NAMUR recommendation NE43 "Signal level unification for failure information from digital transmitters with analogue output signal" from 18.01.94.



NOTE

The setting of the overflow range and fault current range can be selected freely by HART (Chapter 5, pg. 49, "Functions/Operation by HART"). Useful setting possibilities are shown in Figure 34, pg. 66.

3.1.6 Mode display

The currently selected mode is shown in the mode display. In the following example (Figure 15, pg. 28) a damping of 0.2 s has been set in mode 4.

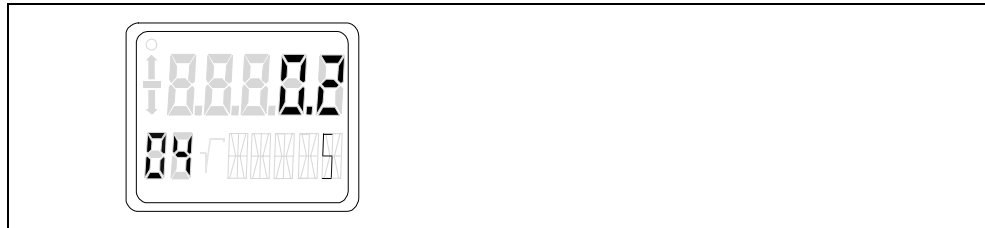

Figure 15 Example of a mode display

3.2 Operation with the keyboard

The transmitter can be parameterized locally with the keyboard (Figure 16, pg. 28). You can select and execute all the functions described in the Table 4 with settable modes (M-key). These are available in an extended scope of functions via HART (Chapter 5, pg. 49).

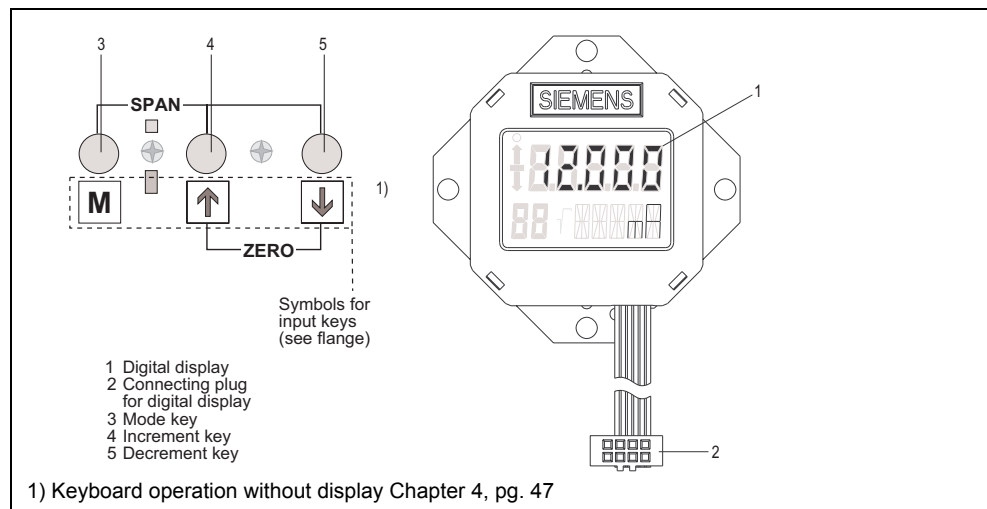

Figure 16 Position of the keyboard (three input keys) and digital display

Function	Mode	Key function			Display, explanations	Chap.	
	M ¹⁾	[↑]	[↓]	[↑] and [↓]			
Measured value					Output current in mA or measured value depending on the set measurement type in the appropriate unit or in %	3.2.10, pg. 44	
Error display					Error, if transmitter disturbed Moving text indicating reason for disturbance	3.2.7, pg. 39	
Start of scale ³⁾	2	Current greater	Current smaller	Set to 4 mA	Output current in mA ³⁾	3.2.2, pg. 30	
Full scale ³⁾	3	Current greater	Current smaller	Set to 20 mA	Output current in mA ³⁾	3.2.2, pg. 30	
Electric damping	4	Damping greater	Damping smaller	Set to 0	Time constant T ₆₃ in s Parameter range: 0.0...100.0	3.2.3, pg. 35	
Start of scale "Blind setting"	5	Pressure greater	Pressure smaller	Set to start of scale 0	Start of scale in the selected unit of pressure	3.2.4, pg. 35	
Full scale "Blind setting"	6	Pressure greater	Pressure smaller	Set to upper measuring limit	Full scale in the selected unit of pressure	3.2.4, pg. 35	
Zero adjustment (position correction) ²⁾	7	Correction value greater	Correction value smaller	Execute	Vent transmitter (pressure, differential pressure, flow, filling level) or evacuate (absolute pressure, < 0.1 % of the measuring span) (start of scale remains unaffected) measured value in unit of pressure	3.2.5, pg. 38	
Current transmitter	8	Current greater	Current smaller	Switch on	Const. output current in mA 3.6 - 4.0 - 12.0 - 20.0 or 22.8 switch off by [M]-key	3.2.6, pg. 39	
Output current in the event of an error	9	Change between the two values		lower fault current	Selected output current Possible: fault current limits set by user	3.2.7, pg. 39	
Keys and/or function disable	10	Change between the five functions		--	0 = none LA = all disabled LO = all disabled except start of scale LS = all disabled except start of scale and full scale L = write protection Operation via HART not possible.	3.2.8, pg. 40	
Characteristic, differential pressure only	11	Change between the four functions		linear	lin = linear srlin = square rooting (linear up to application point) sroff = square rooting (switched off up to application point) srlin 2 = square rooting (linear up to application point 10 %)	3.2.9, pg. 41	
Application point of the square rooting characteristic, differential pressure only	12	greater	smaller	10 % flow	Parameter range 5 to 15 % flow	3.2.9, pg. 41	
Measured value display	13	Select from three possibilities				Display type (input value), % value or output current in mA	3.2.10, pg. 44
Unit	14	Select according to Table 7, pg. 44		resp. 1 st value from table 6 to 12	Physical unit	3.2.11, pg. 46	

Table 4 Summary of operating functions with keys

- 1) Change mode by pressing the [M] key
- 2) NOTICE: The start of scale is in a vacuum in absolute pressure transmitters! The Zero adjustment in ventilated transmitters leads to misadjustments!
- 3) Only possible in the "pressure" measurement type

The operations of the device necessary for parameterization are described in detail in Chapter 3.2.2, pg. 30 to Chapter 3.2.11, pg. 46.

3.2.1 Cancel keyboard disable and write protection

You can cancel a set keyboard disable (LA, LO, LS) or a write protection for HART (L) with the input keys. To do this, press the [M] key for 5 s.

Another keyboard disable (LL) is possible in HART (Table 16, pg. 66)

3.2.2 Set/adjust start of scale, full scale

In the "pressure" measurement type you can set or adjust the start of scale and full scale here with the input keys. Modes 2 and 3 from Table 4, "Summary of operating functions with keys," pg. 29 are available for this. The appropriate keyboard inputs allow rising or falling characteristic curves. If the transmitter is not in the "pressure" measurement type, this mode is skipped in the local operation.

3.2.2.1 Theoretical relationships

Setting

In setting, a desired start of scale and/or a desired full scale is assigned to the standard current values (4 mA/20 mA). Prerequisites: Two reference pressures (p_{r1} , p_{r2}) provided by the process or generated by a pressure transmitter. After setting, the measuring span specified on the measuring point plate may no longer match the setting.

A turn-down up to a maximum 1:100 (span ratio = r, turn down) can be reached depending on the series and measuring range.

NOTE



The measuring span is **not** changed by setting the start of scale. By setting the full scale the start of scale remains **unchanged**, you should therefore set the start of scale first, then the full scale.

The relationship between the measured pressure and the generated output current is linear (exception: square rooting characteristic in differential pressure transmitters). You can calculate the output current with the following equation (Figure 17, pg. 31).

I = output current
 p = pressure
 MA = start of scale
 ME = full scale

$$I = \frac{P - MA}{ME - MA} * 16 \text{ mA} + 4 \text{ mA}$$

Figure 17 Equation for calculating the current

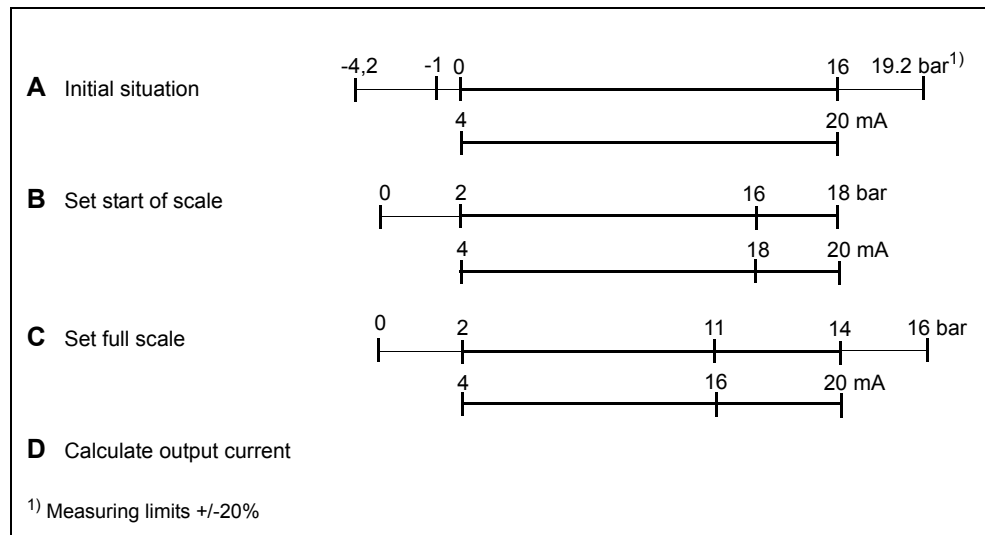

Figure 18 Example, set start of scale and full scale, calculate output current

Explanations to the example (Figure 18, pg. 31):

- A: Given a transmitter with a measuring span of 0 to 16 bar and the measuring limits of -1 and 10 bar. Set to a measuring span of 2 to 14 bar.
- B: Apply 2 bar process pressure. Set the device to mode 2 with the mode key [M]. The display shows the set mode at the bottom left. Set the start of scale by pressing the [↑] and [↓] keys on the value for about two seconds. An output current of 4 mA is then generated at 2 bar input pressure.
- C: Apply 14 bar process pressure. Set the device to mode 3 with the mode key [M]. The full scale is set by pressing the [↑] and [↓] keys on the value for about 2 seconds. An output current of 20 mA is then generated at 14 bar input pressure.
- D: You can calculate the output current for any input pressure with the specified equation (Figure 17, pg. 31).



NOTE

If the given measuring limits are exceeded or dropped below of during adjustment, the adjustment function is not performed but the old value is retained. If the zero point is increased greatly, the full scale may have to be reduced so that it is still within the permissible range after the zero point has been increased. This adjustment function is only possible in the "pressure" measurement type.

Adjusting using a reference pressure

When adjusting, you can assign the start of scale and/or the full scale to any desired current value using **one** reference pressure. This function is particularly suitable if the pressures necessary for start of scale and full scale are unavailable. After adjusting, the measuring range specified on the measuring point plate may no longer match the setting.

Requirements: Applied pressure (reference pressure), the set start of scale and full scale are known.

Using the following equation (Figure 19, pg. 32) you can calculate the current to be adjusted for the desired start of scale and full scale.

1)	current to be set at MA_{nom}	$I = \frac{p_{ref} - MA_{nom}}{ME_{act} - MA_{act}} * 16 \text{ mA} + 4 \text{ mA}$
1)	current to be set at ME_{nom}	$I = \frac{p_{ref} - MA_{nom}}{ME_{nom} - MA_{nom}} * 16 \text{ mA} + 4 \text{ mA}$
I = output current p_{ref} = applied reference pressure		ME_{act} = old full scale MA_{act} = old start of scale ME_{nom} = new full scale MA_{nom} = new start of scale
¹⁾ To calculate the output currents when setting start of scale and full scale, the reference pressure must be selected so that a value between 4 and 20 mA is obtained for the current.		

Figure 19 Equations for calculating current (set start of scale, full scale)

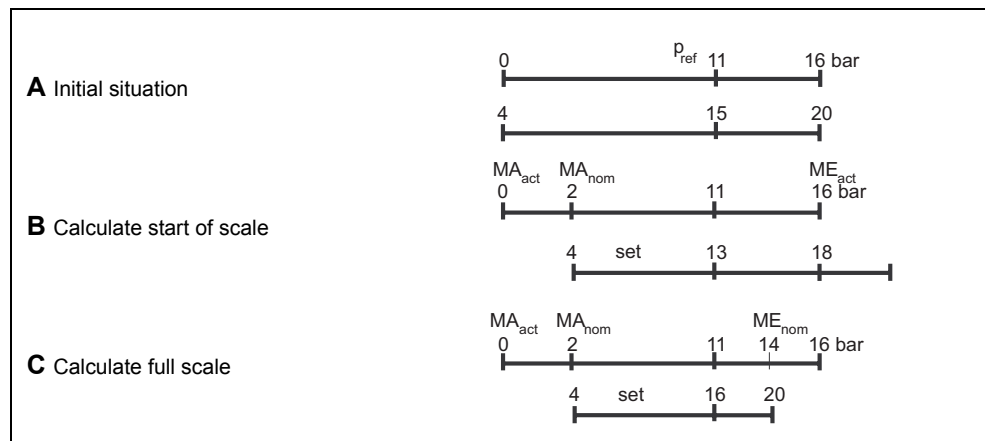

Figure 20 Example, set start of scale and full scale

Explanations to the example (Figure 20, pg. 33):

- A: Given a transmitter with a measuring span of 0 to 16 bar. Adjust to a measuring span of 2 to 14 bar. A reference pressure of 11 bar is available.
- B: Set the device to mode 2 with the [M] key. Using the equations (Figure 19, pg. 32) first calculate the current to be adjusted for the desired start of scale (2 bar) at the applied reference pressure and then adjust it with the [↑] or [↓] (13 mA) keys.
- C: Set the device to mode 3 with the [M] key. Using the equations (Figure 19, pg. 32) first calculate the current to be adjusted for the desired full scale (14 bar) at the applied reference pressure and then adjust it with the [↑] or [↓] (16 mA) keys.



NOTE

If the given measuring limits are exceeded or dropped below by more than 20% during setting, the setting function is not executed but the old value retained. In the case of a strong increase in the zero point, the full scale may therefore have to be reduced to such an extent that it is still within the permissible range after increasing the zero point. This setting function is only possible in the "Pressure" measurement type.

3.2.2.2 Practical application

Set start of scale and full scale

The device sets the output current for the start of scale to 4 mA and the full scale to 20 mA when the input keys are pressed according to the following instructions.

This is how to set the start of scale:

- Apply reference pressure
- Set mode 2
- Set start of scale to 4 mA with [↑] and [↓]
- Save with [M]

This is how to set the full scale:

- Apply reference pressure
- Set mode 3
- Set full scale to 20 mA with [↑] and [↓]
- Save with [M]

Set start of scale and full scale

If the output current is not set but adjusted continuously, you have to calculate the currents to be adjusted mathematically (Chapter 3.2.2.1, pg. 30). It is possible to make an adjustment for the start of scale, the full scale or both values one after the other.



WARNING

Only certified ammeters suitable for the transmitter may be used in intrinsically safe circuits.

The housing cover may only be unscrewed from "explosion-proof" transmitters in hazardous areas in the powerless state.

If the transmitter is used as category 1 / 2 equipment, please observe the EC type test certificate or the test certificate valid for your country.

This is how to set the start of scale:

- Apply reference pressure
- Set mode 2
- Set the output current of the start of scale with [↑] or [↓]
- Save with [M]

This is how to set the full scale:

- Apply reference pressure
- Set mode 3
- Set the output current of the full scale with [↑] or [↓]
- Save with [M]

3.2.3 Electric damping

You can set the time constant of the electric damping in steps of 0.1 s between 0 and 100 s with the input keyboard or set to 0 s. This damping acts additionally to the device-internal basic damping.

You can set or adjust the electrical damping in this way:

- Set mode 4
- Adjust the desired damping with [↑] or [↓]
- Set damping to 0 s with [↑] and [↓] pressed simultaneously
- Save with [M]

3.2.4 Blind setting of start of scale and full scale

In modes 5 and 6 you can set/adjust the start of scale/full scale with the input keys and without applying pressure. It is also possible to change between rising and falling characteristics here.



NOTE

Please note that changes in modes 5 and 6 only affect the pressure scaling. The scaling for filling level, flow or user-specific characteristic remain unaffected. Therefore only pressure values and pressure units are displayed in these modes.

3.2.4.1 Theoretical relationships

First select the desired physical unit. Then you can set/adjust two pressure values with the [↑] and [↓] keys and save them in the device. These theoretical pressure values are assigned to the standard current values 4 mA and 20 mA. After adjusting, the measuring span specified on the measuring point plate may no longer match the setting.

A turn-down up to a maximum 1:100 (span ratio = r, turn down) can be reached depending on the series and measuring range.

The relationship between the measured pressure and the generated output current is linear (exception: square rooting characteristic in differential pressure transmitters).

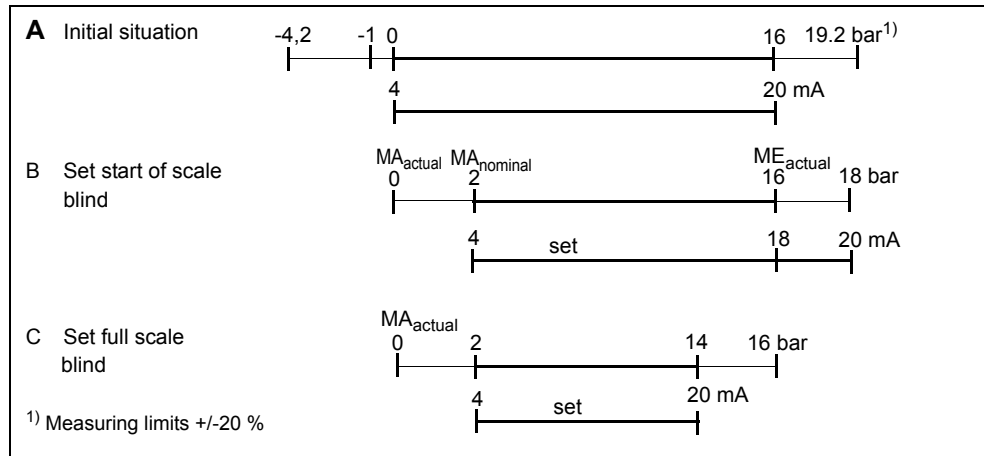

Figure 21 Example, adjusting start of scale and full scale without pressure applied

Explanations to the example (Figure 21, pg. 36):

- A: Given a transmitter with a measuring span of 0 to 16 bar Adjust it to a measuring span of 2 to 14 bar without applying pressure.
- B: Set the device to mode 5 with the mode key [M]. Set the start of scale to 2 bar by pressing the [↑] and [↓] keys. If 2 bar input pressure are applied later, an output current of 4 mA is generated.
- C: Set the device to mode 6 with the mode key [M]. Set the full scale to 14 bar by pressing the [↑] or [↓] keys. If 14 bar input pressure are applied later, an output current of 20 mA is generated.

NOTE



If the given measuring limits are exceeded or dropped below by more than 20%, the resulting current cannot be set beyond these limits. In the case of a strong increase in the zero point, the full scale may therefore have to be reduced to such an extent that it is still within the permissible range after increasing the zero point.

3.2.4.2 Practical application

Set start of scale and full scale (blind)

The device sets the start of scale to the lower and the full scale to the upper sensor limit when you operate the keys as follows:

This is how to set the start of scale (blind):

- Set mode 5
- Press [↑] and [↓] simultaneously and hold for 2 s. The start of scale is set to the lower sensor limit.

This is how to set the full scale (blind):

- Set mode 6
- Press [↑] and [↓] simultaneously and hold for 2 s. The full scale is set to the upper sensor limit.



NOTE

If the given measuring limits are exceeded or dropped below by more than 20%, the resulting current cannot be set beyond these limits. In the case of a strong increase in the zero point, the full scale may therefore have to be reduced to such an extent that it is still within the permissible range after increasing the zero point.

Adjusting start of scale and full scale (blind):

If the pressure for the start of scale and full scale is not to be set but adjusted continuously, you have to operate the keys as follows:

This is how to adjust the start of scale (blind):

- Set mode 5
- Adjust the pressure value of the start of scale with [↑] or [↓]
- Save with [M]

This is how to adjust the full scale (blind):

- Set mode 6
- Adjust the pressure value of the full scale with [↑] or [↓]
- Save with [M]



NOTE

If the given measuring limits are exceeded or dropped below by more than 20%, the resulting current cannot be set beyond these limits. In the case of a strong increase in the zero point, the full scale may therefore have to be reduced to such an extent that it is still within the permissible range after increasing the zero point.

3.2.5 Zero adjustment (position correction)

The zero error resulting from the installation position can be corrected by a zero adjustment. Depending on the device version, the procedure is as follows:

Absolute pressure device (Abs):

Apply a known reference pressure within the measuring limits and adjust any offset by displaying this reference pressure in Mode 7.

- Apply reference pressure
- Set Mode 7
- Set the reference pressure in the display using [↑] or [↓]
- Save with [M]

Relative pressure device (Gauge):

Ventilate the device and correct the offset by setting the zero point in Mode 7.

- Ventilate pressure transmitter
- Set Mode 7
- Set the zero point by pressing [↑] and [↓] simultaneously
- Save with [M]

The total of all zero corrections is displayed in SIMATIC PDM or on the Handheld Communicator.

3.2.6 Current transmitter

You can switch the transmitter to constant current mode with the [M] key. In this case the current no longer corresponds to the process variable. The following output currents can be set independently of the input pressure. Intermediate values can also be set via HART (Chapter 5.9, pg. 65).

- 3.6 mA
- 4.0 mA
- 12.0 mA
- 20.0 mA
- 22.8 mA

You cancel the current transmitter function again with the [M] key.

This is how to set the constant current:

- Set mode 8
- Activate constant current with [↑] and [↓] simultaneously
- Activate constant current with [↑] or [↓]
- Turn off constant current with [M]
- Exit constant current mode with [M]

3.2.7 Failure current

In mode 9, select whether the upper or lower fault current is to be output in the event of a fault or an alarm. The default is the lower fault current. The value of the upper and lower current can be altered via HART (Chapter 5.10, pg. 65). Here the default values are 3.6 mA and 22.8 mA.

You can set or adjust the fault current in this way:

- Set mode 9
- Select the fault current with [↑] or [↓]
- Set to lower fault current with [↑] and [↓] pressed simultaneously
- Save fault current with [M]



NOTE

If a current saturation alarm is active (Chapter 5.21.4, pg. 75) the setting of the failure current may deviate from the setting you have made here.

Fault currents can be caused by:

- HW/FW alarm (also Chapter 5.10, pg. 65)
- Diagnostic alarm (also Chapter 5.21, pg. 72)
- Sensor break
- Measured value status "BAD"

See also NAMUR recommendation NE43 "Signal level unification for failure information from digital transmitters with analogue output signal" from 18.01.94.

3.2.8 Key and/or function disable

In mode 10 you can disable several functions which are generally possible with keyboard operation. In addition you can activate a write protection to protect the saved parameters. The following settings are possible:

Symbol	Explanations
0	No disable
LA	Input keys disabled, operation via HART possible. Input key function "Release keyboard disable" (Chapter 3.2.1, pg. 30)
LO	Input keys partly disabled, only start of scale can be set (Chapter 4, pg. 47), operation via HART possible. Input key function "Release keyboard disable" (Chapter 3.2.1, pg. 30)
LS	Input keys partly displayed, only start of scale and full scale can be set (Chapter 4, pg. 47), operation via HART possible. Input key function "Release keyboard disable" (Chapter 3.2.1, pg. 30)
L	Write protection, operation by HART not possible. Input key function "Release write protection" (Chapter 3.2.1, pg. 30)

Table 5 Meaning of the mode displays

If the disable modes LS or LO are active, the keyboard operation works as described in Chapter 4, pg. 47. Another keyboard disable (LL) is possible in HART (Table 16, pg. 66)

NOTE



If the LO or LS disable is selected, it is recommended to select the measured value display "Current" in "mA" or "%" first in mode 13. Otherwise a change in the output variable is not detected when pressing the [↑] and [↓] key.

This is how you set the key disable and write protection:

- Set mode 10
- Select the disable mode with [↑] and [↓]
- Save disable mode with [M]



NOTE

When delivered with a blanking cover, the disable mode LS is active, i.e. only zero and span can be changed (Chapter 4, pg. 47). If you operate the device permanently with a blanking cover, make sure the disable mode LS remains set.

3.2.9 Flow measurement (only differential pressure)

You can select the characteristic of the output current as follows:

- linear ("lin") proportional to differential pressure
- square rooting ("sroff") proportional to the flow, switched off up to the application point
- square rooting ("srlin") proportional to the flow, linear up to application point.
- square rooting ("srlin2") proportional to the flow, two-stage linear up to the application point.

Variable application point

Below the application point of the square rooting characteristic curve, the output current can either be output linearly or set to zero. for the functions "srlin" and "sroff"

Fixed application point

The function "srlin2" has a fixed defined application point of 10 %. The range in front contains two linear characteristic curve sections. The first section runs from zero to 0.6% of the output value and 0.6% of the pressure value. The second section runs with a steep gradient up to the root application point at 10% of the output value and 1 % of the pressure value (Figure 22, pg. 43).

You can set or adjust the type of characteristic in this way:

- Set mode 11
- Select the characteristic type with [↑] or [↓]
- Set characteristic to "linear" with [↑] and [↓] pressed simultaneously.
- Save with [M]

You can set or adjust the root application point in this way (does not apply for "srln2"):

- Set mode 12
- Select the application point between 5 and 15 % with [↑] or [↓]
- Set application point to 10% with [↑] and [↓] pressed simultaneously.
- Save with [M]



NOTE

If the measurement type "linear" or "srln2" is set in mode 11, mode 12 cannot be selected.

If the input pressure is selected as a display in mode 13 and the square rooting characteristic in mode 11, the differential pressure corresponding to the flow and the root sign are displayed.

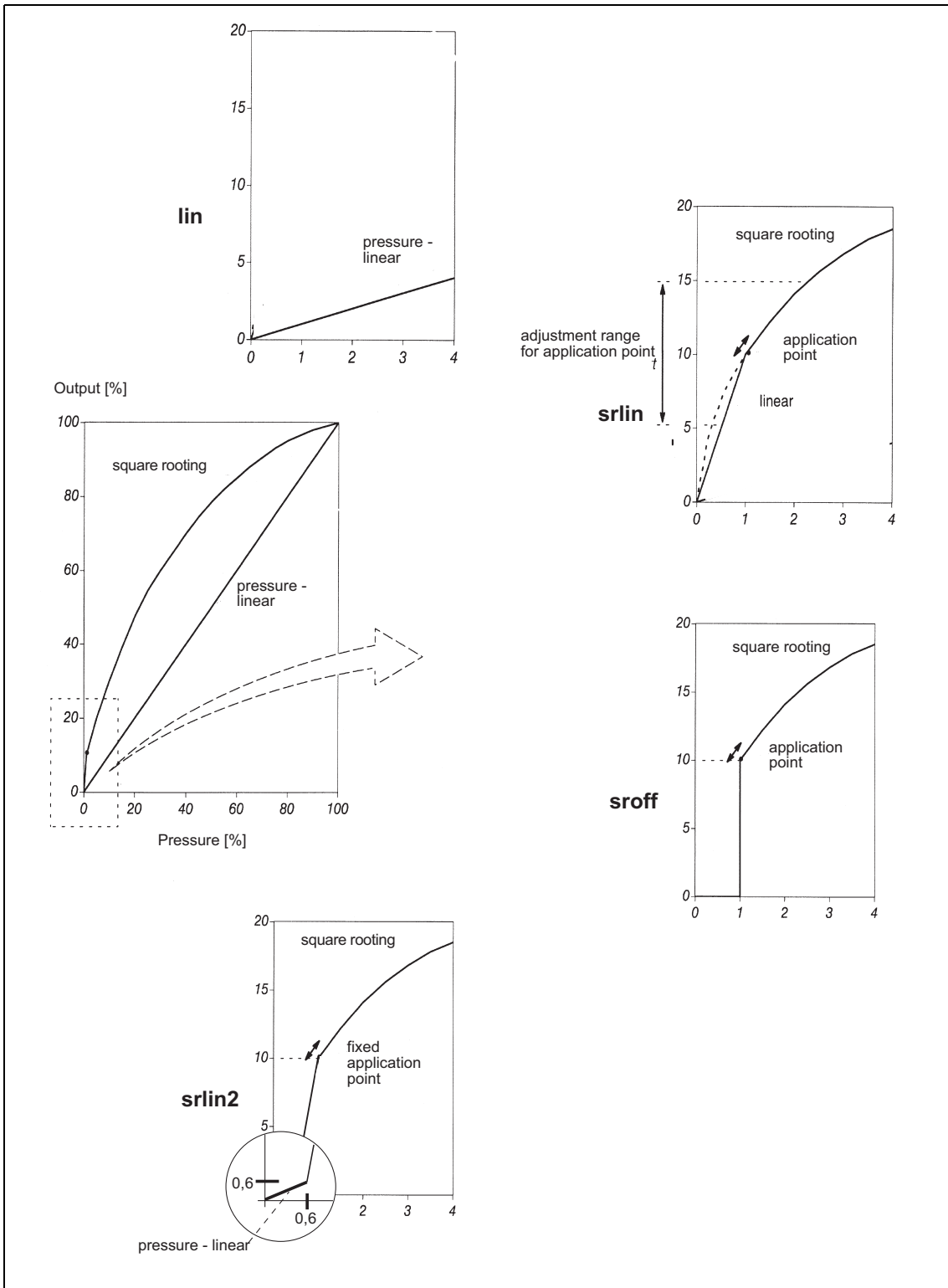

Figure 22 Characteristics and application point of the square rooting characteristic

3.2.10 Measured value display

In mode 13 you can set one of three display types with the input keys.

- Display in mA
- Display in % (of the set measuring range)
- Display the selected measurement type (Table 6, pg. 44)

The respective selection of the unit (according to Table 7, pg. 44 to Table 13, pg. 46) is selected in mode 14. This is how to set the display type:

- Set mode 13
- Select the display type (Table 6) with [↑] and [↓]
- Save with [M]

DV No.	Measured value display	LCD 7-segment display
0	Pressure	P
1	Electronics temperature	ε-EL
2	Sensor temperature	ε-SE
3	Pressure value of trim functions	P-UNC
4	Filling level	LEVEL
5	Mass	MASS
6	Volume	Uo I
7	Mass flow	m-FLo
8	Volume flow	U-FLo
9	User	CUSE I

Table 6 Possible measurement type display in mode 13

Units for pressure	Display
mbar	mbar
bar	bar
mm water column (20°C / 68°F)	inH2O
inches water column (20°C / 68°F)	inHG
feet water column (20°C / 68°F)	FTH2O
mm mercury column	mmH2O
inches mercury column	in_HG
inches water column (4°C / 39°F)	i4H2O
mm water column (4°C / 39°F)	m4H2O
Psi	PSi
Pa	Pa
KPa ²	KPa
MPa	MPa

Table 7 Available units for pressure

Units for pressure	Display
g/cm ²	Gcm2
Kg/cm ²	KGcm2
Torr	TORR
ATM	ATM

Table 7 Available units for pressure

Units for volume	Display
m ³	m3
liters	L
hectoliter	HL
US gallons	Gal
Imp. gallons	imGal
British barrel	bbl

Table 8 Available units for volume

Units for volume	Display
British barrel liquid	bblli
bushels	buShl
yard ³	Yd3
feet ³	FT3
inch ³	in3
standard l	STdl
standard m ³	STdm3
standard feet ³	STFT3

Table 8 Available units for volume

Units for mass	Display
Grams	G
kilograms	KG
tons	T
pounds	lb
short tons	Ston
long tons	lton
ounces	OZ

Table 9 Available units mass

Units for volume flow	Display
m ³ / second	m3/S
m ³ / minute	m3/M
m ³ / hour	m3/H
m ³ / day	m3/D
liters / second	L/S
liters / minute	L/M
liters / hour	L/H
million liters / day	ml/ D
feet ³ / second	FT3/S
feet ³ / minute	FT3/M
feet ³ / hour	FT3/H
feet ³ / day	FT3/D
gallons / second	Gal/S
gallons / minute	Gal/M
gallons / hour	Gal/H
gallons / day	Gal/D

Table 10 Available units for volume flow

Units for volume flow	Display
million gallons / day	MGI/D
Imp. gallons / second	iGL/S
Imp. gallons / minute	iGL/M
Imp. gallons / hour	iGL/H
Imp. gallons / day	iGL/D
standard m ³ / hour	Sm3/H
standard l / hour	STl/H
standard feet ³ / minute	SFT3M
British Barrel liquid / second	bbli/S
British Barrel liquid / minute	bbli/M
British Barrel liquid / hour	bbli/H
British barrel liquid / day	bbli/D

Table 10 Available units for volume flow

Units for mass flow	Display
g / s	G_S
g / min	G_MIN
g / h	G_H
Kg / s	KG/S
Kg / min	KG/M
Kg / h	KG/H
Kg / d	KG/D
T / min	T/M
T / h	T/H
T / d	T/D
pounds / s	lb/S
pounds / min	lb/M
pounds / h	lb/H
pounds / d	lb/D
short tons / min	ShT/M
short tons / h	ShT/H
short tons / d	ShT/D
long tons / h	IT/H
long tons / d	IT/D

Table 11 Available units for mass flow

Units for filling level	Display
feet	FT
inch	inch
m	m
cm	cm
mm	mm

Table 12 Available units for filling level

Units for temperature	Display
° Celsius	° / C
° Fahrenheit	° / F
Kelvin	K
Rankine	R

Table 13 Available units for temperature

3.2.11 Selection of the physical unit

In mode 14 you can select a desired unit **for the display** (Table 7, pg. 44 to Table 13, pg. 46) from a list with the input keys. The unit set via HART is not influenced by this (Chapter 5.14, pg. 67). The choice of unit depends on the set measurement type, i.e. in the "pressure" measurement type only pressure units, in the "filling level" measurement type only filling level units are offered etc. (Chapter 5.3, pg. 50).

You can set or adjust the fault current in this way:

- Set mode 14
- Select the unit with [↑] or [↓]
- Set the unit to the first table value of Table 7 to Table 13 (corresponding to measurement type/PV) with [↑] and [↓] pressed simultaneously
- Save with [M]

The displayed measured value is converted respectively to the new unit. If the display capacity of the digital display is exceeded, the "9.9.9.9" appears in the display.

In the measuring mode the selected unit is only visible in the display if you have selected the display of a physical unit in mode 13. Otherwise "mA" or "%" is displayed.

Local operation without display or with activated keylock

4

If the digital display has been removed or the keyboard is locked or partially locked (as-delivered state in devices with a cover without window, also Chapter 3.2.8, pg. 40), restricted operation with the keyboard is still possible. In addition to the "Cancel keyboard disable and write protection" function with the [M]-key (also Chapter 3.2.1, pg. 30), you can also set or adjust the start of scale and full scale. The different modes can no longer be selected. Please note that the transmitter must be in the "pressure" measurement type if you want to change start of scale and full scale.

4.1 Set start of scale, full scale

The differences between **set** and **adjust** start of scale/full scale have already been described in Chapter 3.2.2.1, pg. 30. The same conditions and mathematical relationships apply as for operating the display.

The SITRANS P, DS III series transmitter sets the output current for the start of scale to 4 mA and the full scale to 20 mA when the input keys are pressed according to the following instructions. An ammeter is not required.

This is how to **set** the start of scale:

- Apply reference pressure corresponding to the start of scale
- Press [↑] and [↓] simultaneously so that the start of scale is set to 4 mA and saved

This is how to **set** the full scale:

- Apply reference pressure corresponding to the full scale
- Press and hold [M]
- Press [↑] and [↓] simultaneously in addition so that the full scale is set to 20 mA and saved

If the output current is not set but adjusted continuously, you have to calculate the currents to be adjusted mathematically (Chapter 3.2.2.1, pg. 30). It is possible to make an adjustment for the start of scale, the full scale or both values one after the other.

1. Clean the casing so that no dirt can penetrate
2. Unscrew the cover from the electrical connection box (Figure 4, pg. 16).
3. Connect the DC ammeter to the test plug (Figure 51, pg. 93)

This is how to **set** the start of scale:

- Apply reference pressure
- Set the output current of the start of scale with [↑] or [↓]
- The set output current is saved automatically when you release the key

This is how to **set** the full scale:

- Apply reference pressure
- Press and hold [M]
- Set the output current of the full scale with [↑] or [↓]
- The set output current is saved automatically when you release the key



WARNING

Only certified ammeters suiting the transmitter may be used in intrinsically safe circuits.

In hazardous areas the housing cover may only be removed from transmitters with "explosion-proof" type of protection when no power is connected.

If the transmitter is to be used as category 1 / 2 equipment, please observe the EC sample test certificate or the test certificate valid in your country.

Functions/Operation via HART

5

For operation via HART it is necessary to use a HART Communicator (see the table in the appendix) or a PC software such as SIMATIC PDM. Please consult the appropriate operating instructions or online help to find out how to operate this tool. The full scope of functions of the SITRANS P, DS III series is available via the HART communication.

5.1 Measuring point data

Information about the measuring point, date etc. can be stored in freely writable fields.

Field	Explanations
Measuring position descriptor	eight characters
Date	Day:Month:Year
Description	16 characters
Message	32 characters
Serial number	Integer number
Long measuring point name	32 characters
Freely writable material parameters	21 x 16 characters

Table 14 Measuring point data

5.2 Measuring operation

In measuring mode the process variables pressure and temperature and derived from this, filling level, volume, mass, volume flow, mass flow and the user-specific characteristic are provided as digital information via the HART interface.

The HART communication is signaled using the communication character (Figure 12, pg. 24).

Further information about the measured value display in Chapter 3.1.1, pg. 24.

5.3 Selection of measurement type

You can adapt the SITRANS P, DS III series to your respective measurement task by setting a few parameters. The four selectable software blocks "pressure", "filling level", "flow" and a freely parameterizable "characteristic" provide support. Every measurement type (measurement block) is permanently assigned one or more result variables (in Figure 23, pg. 51 with device variables). You can display these variables in SIMATIC PDM or in the Handheld Communicator.

5.3.1 The measurement type switch

The device variables "pressure", "sensor temperature", "electronics temperature" and "untrimmed pressure" are always active and are therefore always displayed. All others then contain a valid measured value when the appropriate block is activated **and** parameterized. The inactive variables have the status "CONSTANT" (Chapter 5.3.8, pg. 58 "Measured value status"). One of the other three blocks can be activated by the measurement type switch in addition to the "pressure" block. In this case it has to be given valid parameters. This does not mean that this block automatically influences the current output (4 to 20 mA). To do this, the appropriate device variable must be switched via a so-called "Mapper" to the PV (Primary Variable) (Figure 24, pg. 53 "Measurement type filling level").

5.3.2 The variable mapper

In the SITRANS P, DS III series the dynamic variable which determines the behavior of the current output is always called PV (Primary Variable). Under the "Mapper" you have to select which device variable is to be switched to the PV among other things. The variable selected under SIMATIC PDM or in the Handheld Communicator as PV is scaled again in the analog output stage (Chapter 5.3.9, pg. 61) to a start of scale and a full scale value. These two values then correspond to the current values 4 and 20 mA.

These start of scale and full scale values are defaulted with the limits of the new device variables immediately after switching over the PV with the "Mapper". These limits are specified within the individual block functions.

The dynamic variables PV, SV, TV, and QV (primary, secondary, tertiary, quarter-nary variable) can be switched with any active device variables. The following measurement type examples are conceivable starting with a 4 bar pressure transmitter.

5.3.3 Pressure measurement type

The pressure measurement type contains the sensor trim function and is always active as a standard measurement type. If the measurement type switch is set to "Off", no further measuring variables are derived from the "pressure" measuring variable. Except for the first four, all other device variables are marked inactive and receive the "CONSTANT" status (Chapter 5.3.8, pg. 58 "Measured value status"). These four variables are mapped through to the dynamic variables PV, SV, TV and QV.

Switching of an inactive device variable to the Primary Variable (PV) generates an error message because the variable does not contain any valid measured value at this time. This message is displayed in SIMATIC PDM or the Handheld Communicator.

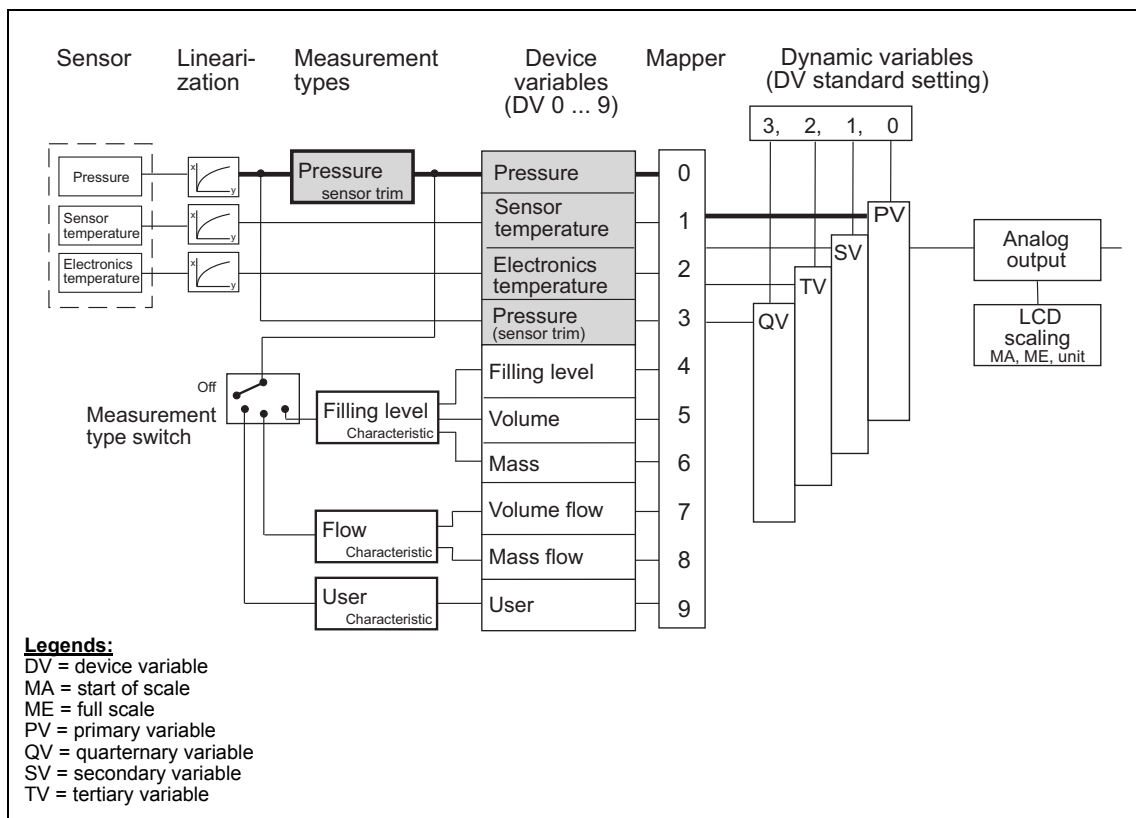

Figure 23 Pressure measurement type

5.3.4 The user-specific characteristic

The user-specific "characteristic" is permanently active as an identical function in the three following blocks (filling level, flow and user), i.e. it always provides a result for the following function and thus influences the measured value status of the device variable concerned (Chapter 5.3.8, pg. 58 "Measured value status").

In the device SITRANS P, DS III series the characteristic curve vertex points are only stored once in the non-volatile memory. Therefore you usually have to adapt the characteristic curve when you change the measurement type.

The characteristic function expects at least two and at the maximum 30 characteristic curve vertex points as input parameters which are entered as value pairs x;y (in percent). The values for the x coordinates are only accepted by the device when they run monotonously. The y coordinates cannot be monotonous on the other hand. However, the parameterizing device sends a warning which you the user must heed and acknowledge. The output of the characteristic curve is not stored explicitly in a device variable but is connected directly to the input of the next function block. The value pairs 0 %;0 % and 100 %;100 % are set as standard values. In principle, rising and falling characteristics can be parameterized. However, with respect to the device variable status (Chapter 5.3.2, pg. 50) rising characteristics are to be preferred because otherwise the meanings of "HIGH LIMIT" and "LOW LIMIT" are switched.

5.3.5 "Filling level" measurement type

When you have parameterized the measurement type "Filling level", the device variables "Filling level", "Volume" and "Mass" are activated. They are all derived from the measured pressure. The filling level block here stands for a number of permanently wired functions which you have to give suitable parameters. Only then do you obtain a usefully informative measured value for the three device variables (Figure 24, pg. 53).

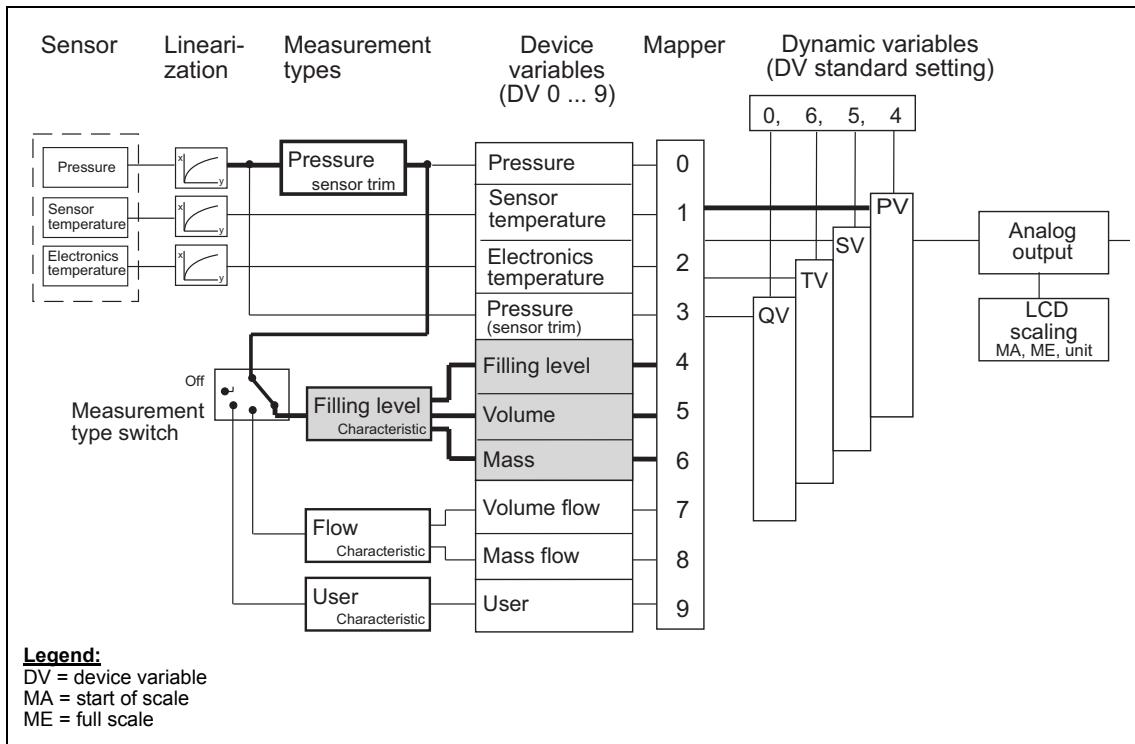

Figure 24 "Filling level" measurement type

The first function "Input scaling pressure" determines the pressure range with which the following functions operate equally in all three blocks. In the best case this range corresponds to the sensor limits of the transmitter which are assumed to be 0 and 4 bar for all blocks in a calculation example. However, you can also set a reduction of 1:2 for example. This means that 50 % of the rated measuring range, here 2 bar, already controls the following characteristic 100 % (Figure 25, pg. 54).

With the "Output scaling filling level" you determine the measuring limits for the filling level measurement type with a unit from the filling level range (Figure 23, pg. 51). The parameterization should be 10 and 20 m in the example. At 0 bar process pressure 10 m are then displayed in DV4 and 20 m at 2 bar. The values for start of scale and full scale which act on the analog output are parameterized in the analog output block. (Chapter 5.3.9, pg. 61 Analog output").

For the user-specific "characteristic" the 2 value pairs 0 %;0 % and 100 %;100 % are parameterized in the example which also corresponds to the standard setting. This means that the measured value can be passed through from the pressure scaling 1:1 in this example.

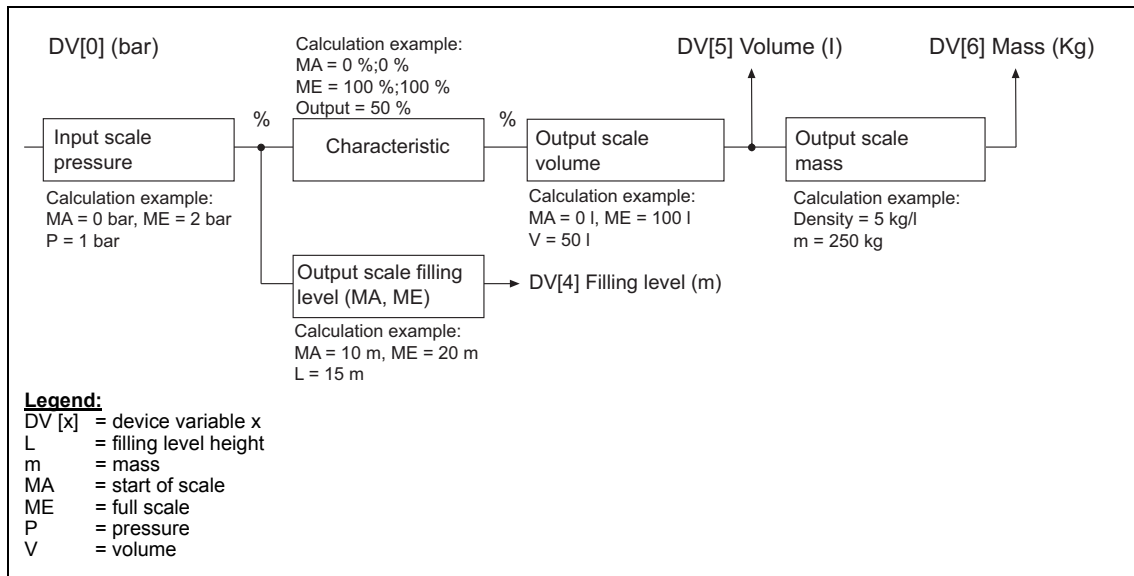

Figure 25 Functions of the filling level block

The "Output scaling volume" must be assigned a unit from the volume range (Figure 23, pg. 51) as well as the measuring limits for the device variable "Volume". The output of the characteristic acts here directly on the input of the volume scaling. In an example for the measuring limits of 0 and 100 l a volume of 50 l is given at a process pressure of 1 bar.

In addition the device variable for the mass is automatically activated by the "filling level" parameterization. If you have not yet parameterized a value for the density, the output value of 1 kg/l is defaulted. With a value of 5 kg/l a value for the mass of 250 kg is given for the device variable "Mass" in the example.

NOTE



The range limits must be adapted when the density is changed.

All parameterizations for the filling level block can be made in SIMATIC PDM or the Handheld Communicator by activating the filling level measurement type there. Exceeding of the measuring limits of +/- 20% is also permitted here. Values above or below are rejected by the device.

5.3.6 "Flow" measurement type

With activation of the "Flow" measurement type only two other device variables, volume flow and mass flow, are active (Figure 26, pg. 55). If another block was active beforehand, the device variables concerned become inactive and receive the "CONSTANT" status (Chapter 5.3.8, pg. 58 "Measured value status"). The flow block

also stands for a number of functions which you have to parameterize with SIMATIC PDM or the Handheld Communicator according to your application.

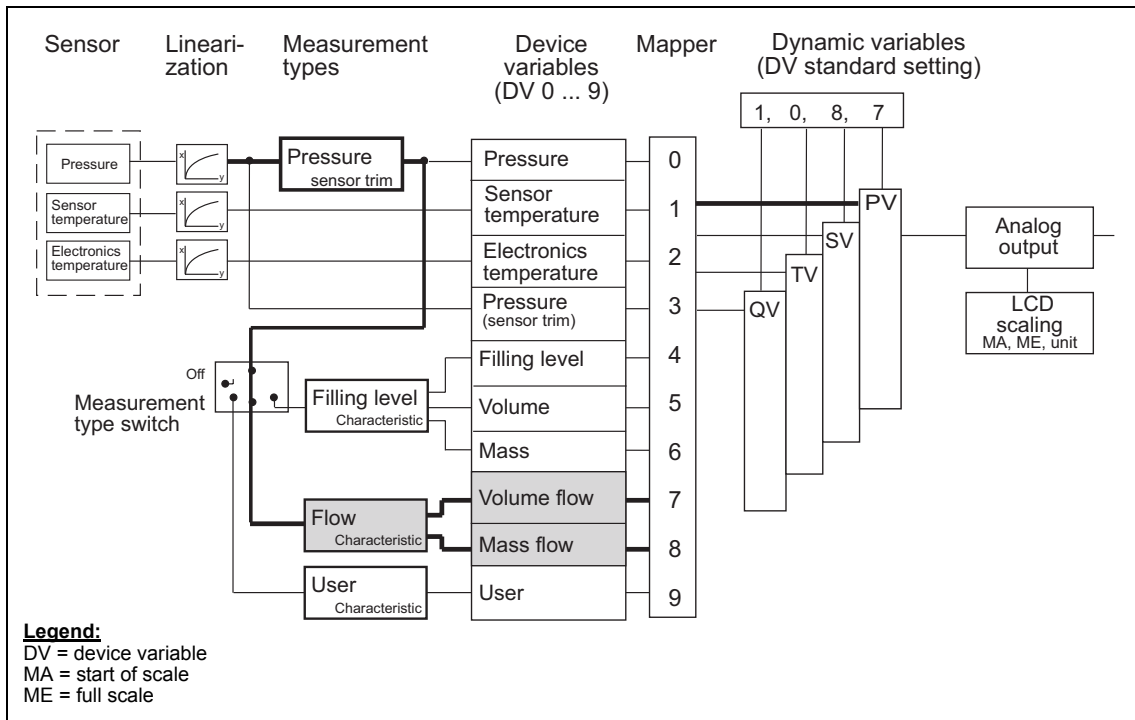

Figure 26 "Flow" measurement type

The function "input scaling pressure" determines the pressure range from 0 to 2 bar which is interpreted by the following square rooting function as 0 and 100 %. A process pressure of 0.5 bar is assumed in the example (Figure 27, pg. 56).

In the "flow" measurement type a square rooting characteristic "srln2" is run through as a standard with a fixed root application point of 10 %. At an applied process pressure of 0.5 bar, the input value for the "square rooting function" in the calculation example is at about 25 % and the output value therefore at about 50%.

NOTE



When using the flow block, other square rooting characteristics may have to be switched off (Figure 32, pg. 62).

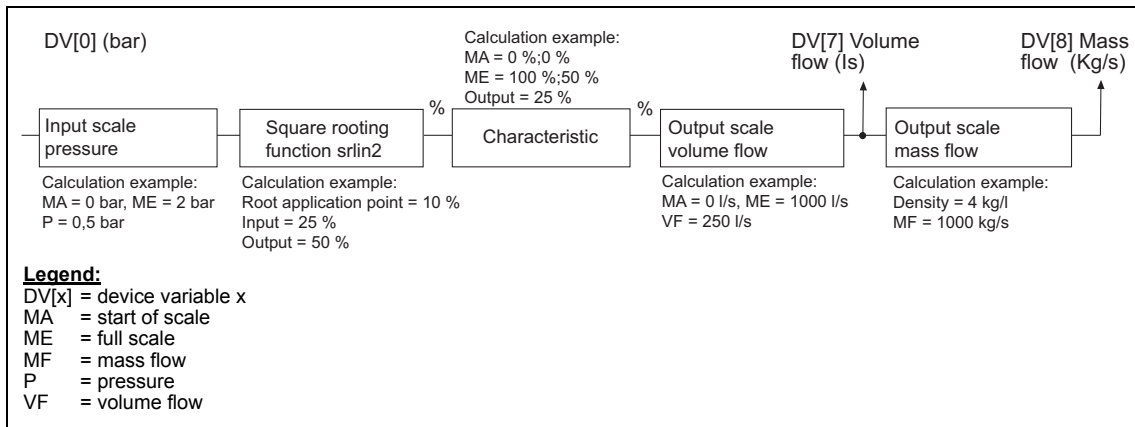

Figure 27 Functions of the flow block

For the user-specific "characteristic" the two value pairs 0 %;0 % and 100 %;50 % are parameterized in the example. This corresponds to a halving of the input value for all output values.

The output scaling "Volume flow" must be given a unit from the range volume flow (Figure 27, pg. 56) and the measuring limits for the device variable volume flow. 0 l/s and 1000 l/s are defined as the lower and upper measuring limits in the calculation example. With an applied process pressure of 0.5 bar, 250 l/s is available as a measured value at the output of the "volume flow" function.

The device variable "mass flow" is also activated automatically with parameterization of the "flow" block. If you have not yet parameterized a value for the density, the output value of 1 kg/l is defaulted. With a value of 4 kg/l a value for the mass of 1000 kg/s is given for the device variable "mass flow" in the example. The entered density value is only used for calculating the mass flow and has no influence on the aperture calculation to be made by the user.

The parameterization for the "flow" block can be done very compact in an online dialog in SIMATIC PDM or the Handheld Communicator. Here you can collect all the values in a menu and transfer them all to the device at once.

5.3.7 "User" measurement type

The "User" measurement type (Figure 28, pg. 57) is the easiest of the three function blocks which you can select with the measurement type switch. Here only one other device variable "User" is activated in addition to the four standard device variables. The variables "Filling level", "Volume", "Mass", "Volume flow" and "Mass flow" are marked inactive and receive the "CONSTANT" status (Chapter 5.3.8, pg. 58 "Measured value status").

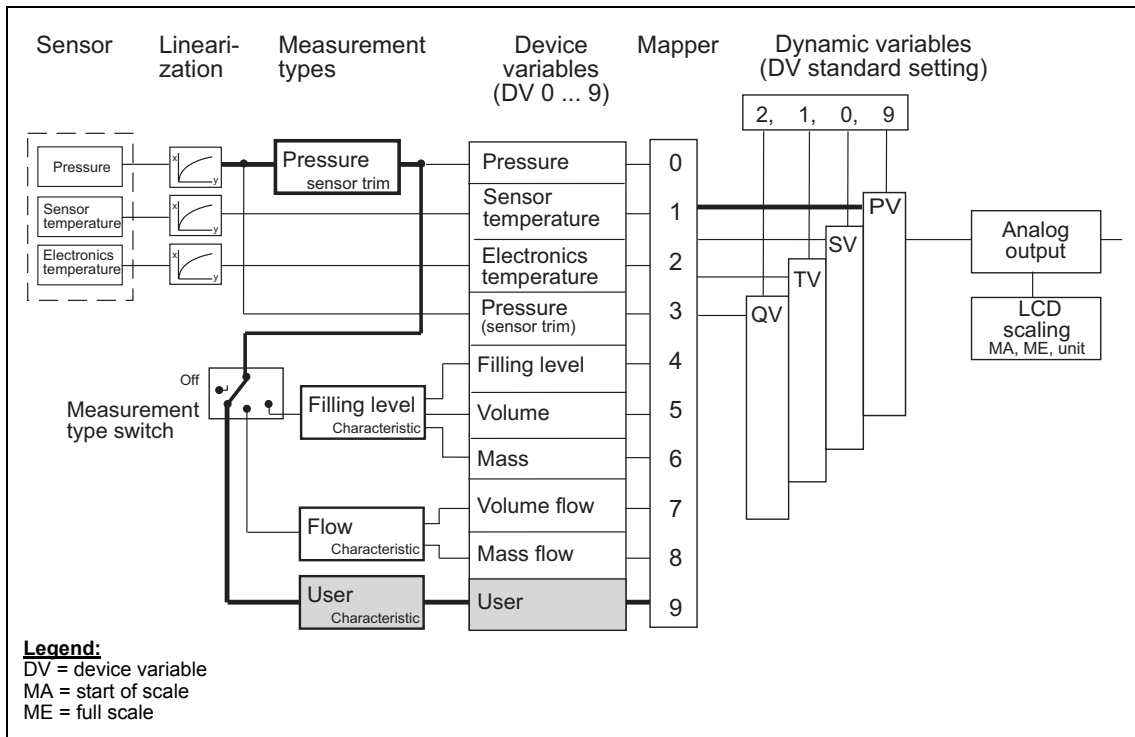

Figure 28 "User" measurement type

The first function "Input scaling pressure" also determines the pressure range here with which the user-specific characteristic operates. In the best case this range corresponds to the sensor limits. 0 and 2 bar are assumed in the calculation example. At a process pressure of 0.5 bar an input value of 25 % is available at the "characteristic" (Figure 29, pg. 57).

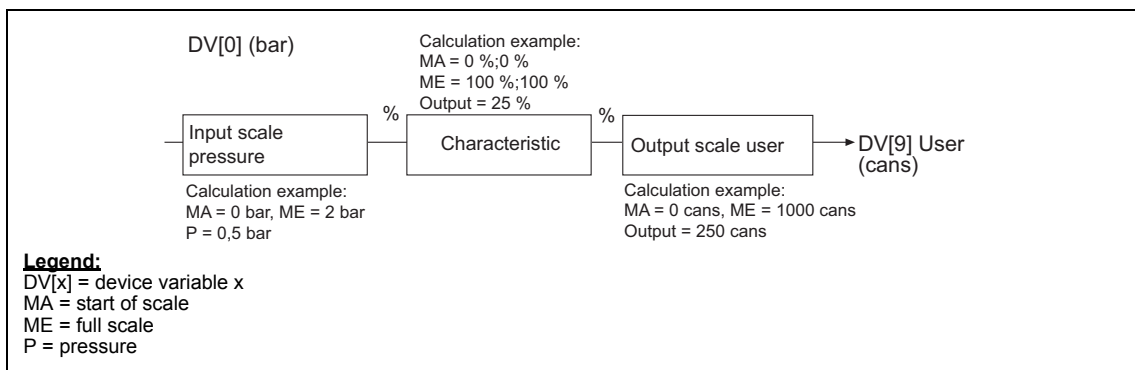

Figure 29 Functions of the user block

For the user-specific "characteristic" the 2 value pairs 0 %;0 % and 100 %;100 % are parameterized in the example. Here any curve shapes can be calculated using 30 vertex points and entered in the device by SIMATIC PDM or the Handheld Communicator. The value at the input of the characteristic is passed through 1:1 to the output in the calculation example.

A number of filled cans should be set for the output scaling. Here, five characters can be assigned for any unit. (Not to be confused with the freely parameterizable display unit, Chapter 5.3.10, pg. 62). With a start of scale of 0 cans and a full scale of 1000 cans, a value of 250 cans is obtained in the example at a process pressure of 0.5 bar for the device variable "User".

5.3.8 "Status" measured value

In order to be able to make a statement about the quality of measured values, every device variable has been assigned a status byte. This status byte can assume the statuses BAD, GOOD, MANUAL, UNCERTAIN. The identifications CONSTANT, HIGH LIMIT or LOW LIMIT are additionally possible. A master diagnostic program can display and evaluate these statuses.

In trouble-free measurement mode, the measured value statuses of all active device variables are GOOD. All inactive ones have the CONSTANT / BAD status. If a pressure value exceeds or drops below the sensor limits of the device by more than 20 %, the corresponding measured value and the derived variables are UNCERTAIN. A measured value becomes BAD on the other hand if a variable with a BAD status was the initial value for the calculation. The basic measured values pressure and temperature are BAD if for example the AD converter is not working or the linearization values in the EEPROM are faulty. The same applies when exceeding the two end points of the user-specific characteristic for the status of the device variables of the following function. The identifications HIGH LIMIT and LOW LIMIT are assigned when the A/D converter is over or undermodulated.

Up to FW 11.03.05, over or under modulation of the A/D converter leads to classification of the status as "BAD"; from 11.03.06 only the status "UNCERTAIN" is signaled.

If the status of a device variable right at the front of a block in the processing sequence changes (e.g. pressure), all variables ensuing from it assume the same status. In the following example, the "pressure" variable has BAD status. Since the measurement type switch is set to "USER" the "User" device variable is also assigned the BAD status (Figure 30, pg. 59).

The reasons for a change in status of a device variable are summarized in Table 15, pg. 60. If there are several reasons for a change in status, MANUAL always has top priority. BAD is second highest and UNCERTAIN third highest priority.

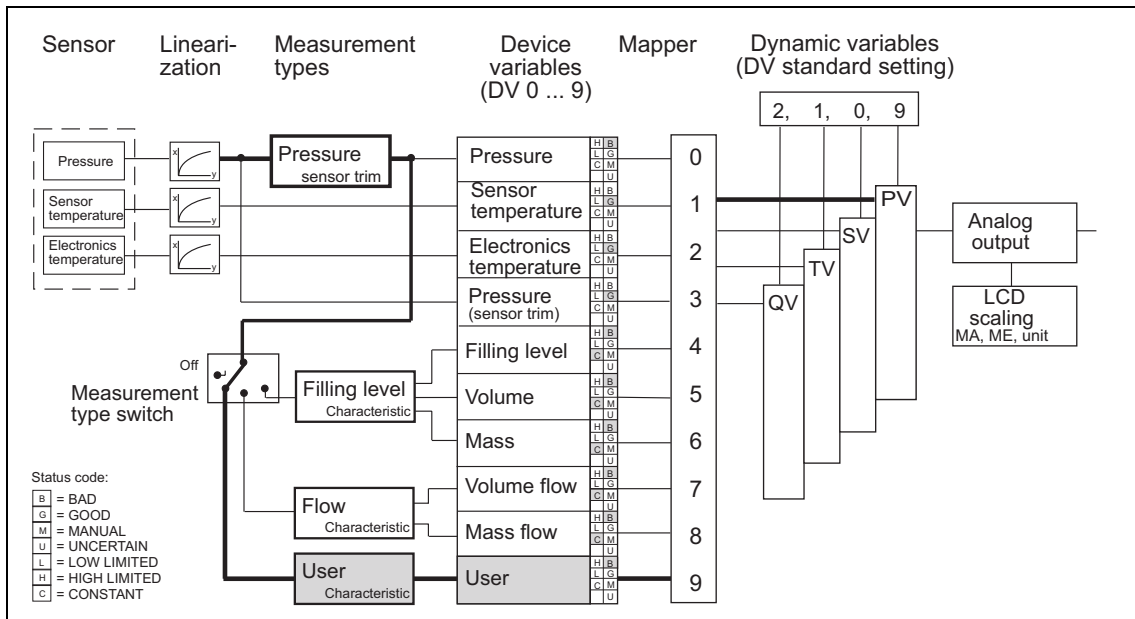

Figure 30 Dependence "Device statuses"

	BAD	MANUAL	UNCERTAIN	CONSTANT	HIGH LIMIT	LOW LIMIT
PRESSURE (DV0)	DV3=BAD, error in linearization	When DV0 is simulated	DV3 = UNCERTAIN	-	DV3 = HIGH LIMIT	DV3 = LOW LIMIT
Se.- Temp. (DV1)	DV2 = BAD, A/D converter over/undermodulated, error in linearization	When DV1 is simulated	DV1 more than 20% outside the sensor limits, DV2= UNCERTAIN, DV2 = MANUAL	-	AD converter overmodulates	AD converter undermodulates
El.-Temp. (DV2)	A/D converter over/undermodulated, error in linearization	When DV2 is simulated	DV2 more than 20% outside the sensor limits	-	AD converter overmodulates	AD converter undermodulates
Pressure untrimmed (DV3)	A/D converter over/undermodulated ¹⁾ , sensor break DV1, DV2=BAD, error in linearization	-	A/D converter over/undermodulated ²⁾ , DV3 more than 20% outside the sensor limits, DV2 = MANUAL ²⁾	-	AD converter overmodulates	AD converter undermodulates
Filling level (DV4)	If DV0 = BAD,	When DV0 is simulated	DV0 = UNCERTAIN	DV inactive	DV0 = HIGH LIMIT	DV0 = LOW LIMIT
Volume (DV5)	DV0 = BAD, Faulty characteristic	When DV0 is simulated	DV0 = UNCERTAIN Input value outside the specified characteristic range	Faulty characteristic, DV inactive	DV4 = HIGH LIMIT, Characteristic curve at maximum value with gradient 0	DV4 = LOW LIMIT, Characteristic curve at minimum value with gradient 0
Mass (DV 6)	DV5 = BAD	When DV0 is simulated	DV5=UNCERTAIN	DV inactive, DV5=CONSTANT	DV5 = HIGH LIMIT,	DV5 = LOW LIMIT
Volume flow (DV7)	DV0 = BAD, faulty characteristic	When DV0 is simulated	DV0=UNCERTAIN, Input value outside the specified characteristic-range	Faulty characteristic, DV inactive	DV0 = HIGH LIMIT, Characteristic curve at maximum value with gradient 0	DV0 = LOW LIMIT, Characteristic curve at minimum value with gradient 0
Mass flow (DV 8)	DV7 = BAD	When DV0 is simulated	DV7=UNCERTAIN	DV7 = CONSTANT	DV7 = HIGH LIMIT	DV7 = LOW LIMIT
User (DV 9)	DV0 = BAD, Faulty characteristic	When DV0 is simulated	DV0=UNCERTAIN, Input value outside the specified characteristic-range	Faulty characteristic, DV inactive	DV0 = HIGH LIMIT, Characteristic curve at maximum value with gradient 0	DV0 = LOW LIMIT, Characteristic curve at minimum value with gradient 0

Table 15 Events which lead to a change in status

¹⁾ For FW: 11.03.03, FW: 11.03.04 and FW: 11.03.05

²⁾ From FW: 11.03.06

The meanings of "HIGH LIMIT" and "LOW LIMIT" are switched when falling characteristics are used in the blocks. When falling and rising characteristics are mixed the meanings are switched every time a falling characteristic is crossed.

5.3.9 Analog output

The analog output block converts the value provided by the dynamic variable PV into a current value of 4 to 20 mA. By actuating the measurement type switch you determine the start of scale and full scale which are to correspond to the current values 4 and 20 mA here automatically in advance. The limits of the corresponding device variables as you have entered them in the parameterization of your measurement type are used for scaling the analog output (Figure 31, pg. 61 "Analog output"). This means that with a "Filling level" device variable as the Primary Variable (PV), 10 m would correspond to the value for 4 mA and 20 m to the value for 20 mA. You can change this presetting again in the analog output block by restricting the range of the device variable "Filling level" for scaling of the output current to 12 to 18 m for example (Figure 32, pg. 62). This reduction has no influence on the previous block scaling. In this case a current of 4 mA is output at a measured height of 12 m and a current of 20 mA at 18 m.

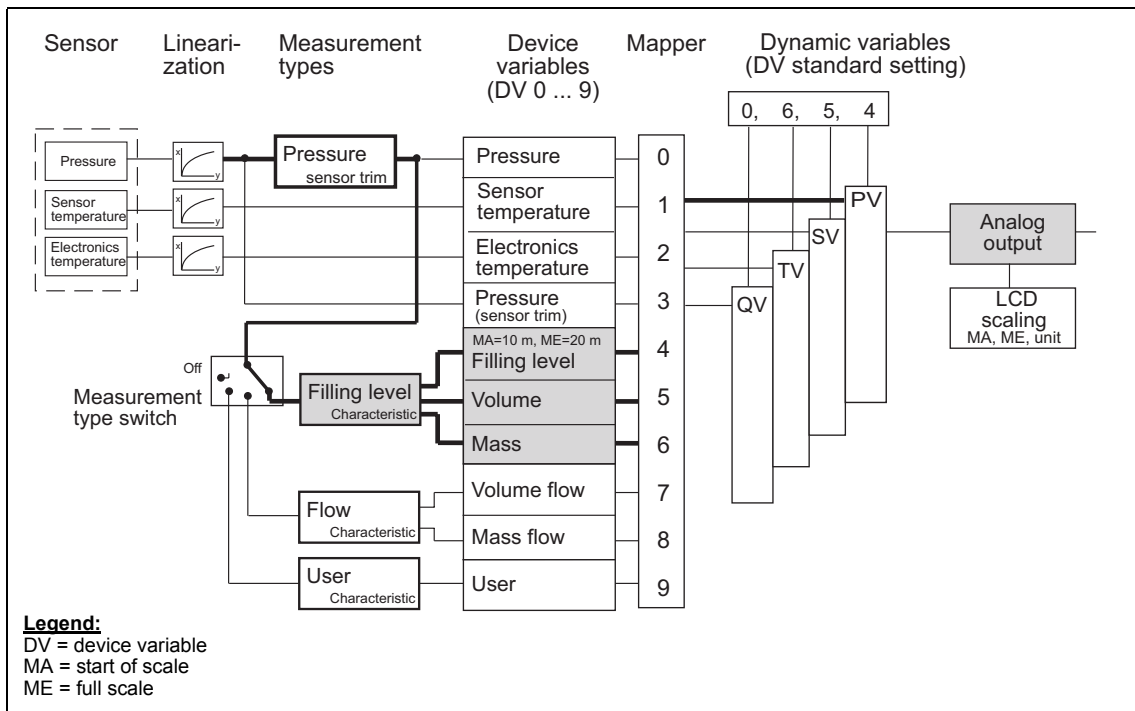

Figure 31 Scaling "Analog output"

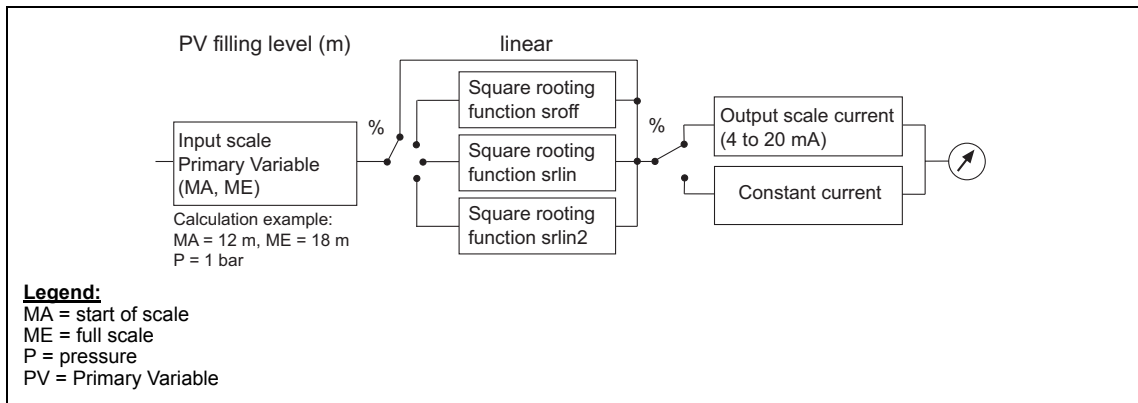

Figure 32 Analog output block



NOTE

If, the values in the parameterization of the analog output for start of scale and full scale are more than 20% below or above the limits of the set PV (by the Mapper), these values are rejected by the device. The previously parameterized values are retained. The minimum span (ME-MA) may not be dropped below of either. A selection of square rooting functions is only available in the "pressure" measurement type. The square rooting function "srlin2" is fixed in the "flow" measurement type.

5.3.10 Scaling the LCD display value

Regardless of the choice of measurement type switch, the PV (Primary Variable) and the determined display unit, you can scale the value to be shown in the display freely and assign it any unit of 5 characters. Use the LCD settings item in SIMATIC PDM or in the Handheld Communicator for this.

The basis for this scaling is the percentage value of the PV (SIMATIC PDM: set output scaling PV) which also serves for scaling the current output. After selecting the LCD settings menu item you have to enter a start of scale value, a full scale value and a unit string. In the example in the filling level measurement type a start of scale 0 m³/h and a full scale 10 m³/h are assumed. At a process pressure of 0.4 bar, 2 m³/h are displayed.

This choice of display has the highest priority of all possibilities. It is not possible to switch to %, mA or another unit in this status. You have to switch the LCD scaling back off for this (Figure 33, pg. 63).

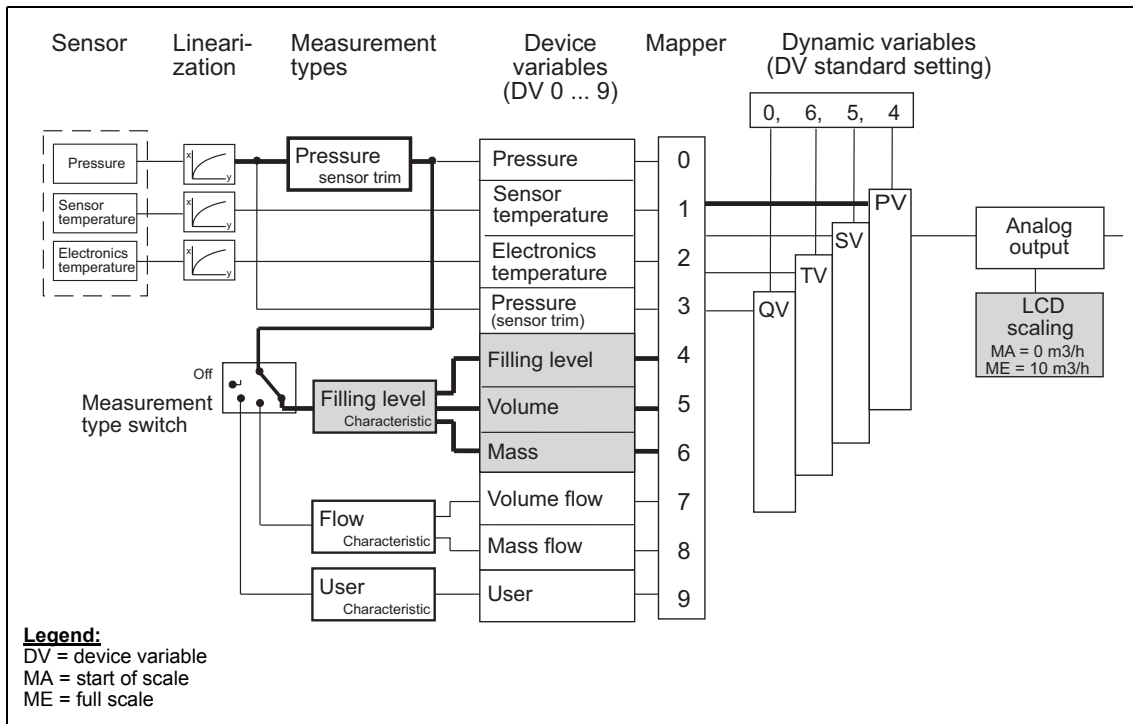

Figure 33 Free LCD scaling

5.4 Setting start of scale, full scale

You can set start of scale and full scale via HART. You can implement rising or falling characteristics with this function (also Chapter 3.2.2, pg. 30).

The pressure unit can be set independently **for the display and the HART communication**.

5.5 Blind setting of start of scale and full scale

The start of scale and full scale can be set without applying a reference pressure. Both values are freely selectable within the sensor limits. The maximum turn down is 1:100 depending on the series and measuring range.

5.6 Zero adjustment (position correction)

You can correct the zero error resulting from the installation position with a zero adjustment. To do this, ventilate the device (pressure, differential pressure, flow, filling level) or evacuate it (absolute pressure, <0.1 ‰ of the measuring span). Then carry out zero adjustment using SIMATIC PDM or the HART Communicator. If no vacuum is available, carry out a lower sensor trim at a known reference pressure (see Chapter 5.16, pg. 68).



CAUTION!

The start of scale is in a vacuum in absolute pressure transmitters! The zero adjustment in ventilated transmitters leads to misadjustments!



NOTE

The useful measuring range is reduced by the pre-pressure. Example: At a pre-pressure of 100 mbar the useful measuring range of a 1 bar transmitter is reduced to 0 to 0.9 bar.

5.7 Electric damping

You can adjust the time constant of the electric damping within a range of 0 to 100 s. It always affects the "pressure" device variable (DV0) and thus the derived measured values.

5.8 Fast measured value acquisition (fast response mode)

This mode is designed exclusively for special applications such as fast acquisition of pressure jumps, e. g. pressure drop in the event of a burst pipe. Here, the internal measured value acquisition is accelerated at the cost of accuracy. You get an increased low-frequency noise of the measured value. For this reason, good accuracy can only be achieved when setting to maximum measuring span.

5.9 Current transmitter

The transmitter can be switched to constant current operation for test purposes. In this case the current no longer corresponds to the process variable. A "C" appears in the mode indicator of the digital display.

5.10 Fault current

With this function you can adjust the value of the lower (< 4 mA) and upper (> 20 mA) fault current (Figure 34, pg. 66). Both indicate a hardware/firmware error, a sensor break or reaching an alarm limit (diagnostic alarm). In this case "Error" appears in the digital display (Chapter 3.1.4, pg. 26). You can obtain a detailed list from SIMATIC PDM or the HART Communicator. See also NAMUR recommendation NE43 "Standardization of the signal level for failure information of digital transmitters with analog output signal" of 18.01.94.

5.11 Setting the current limits

The value of the upper and lower fault current and the upper and lower limit of the linear modulation range are freely selectable within the given limits of the current modulation range (Figure 34, pg. 66).

The specified accuracy of the current output signal only applies within the current limits 4 to 20 mA.

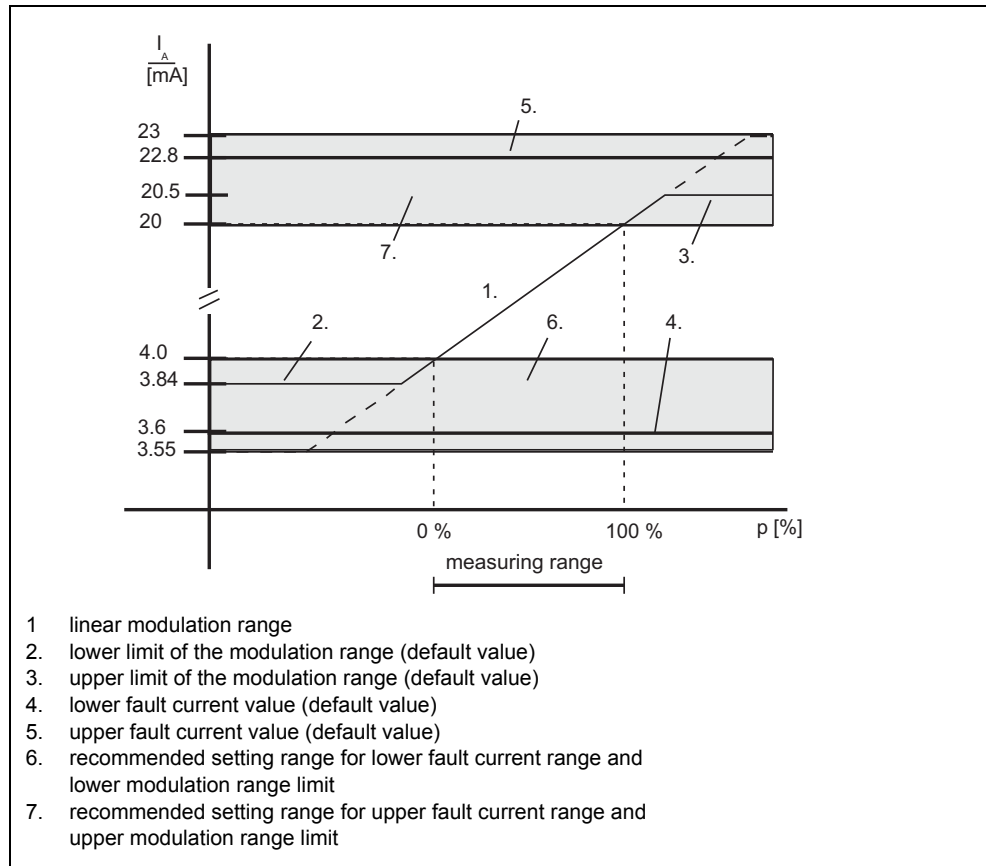

Figure 34 Current limits

5.12 Disabling of input keys and write protection

With this function you can disable the input keys or activate a write protection to protect the saved parameters. The following settings are possible:

Device display	Explanations
	No disable
LA	Input keys disabled, operation via HART possible
LO	Input keys partly disabled, only start of scale can be set, operation via HART possible
LS	Input keys partly disabled, only start of scale and full scale can be set, operation via HART possible
L	Write protection, operation via HART no longer possible, input key function only "Cancel write protection" (Chapter 3.2.1, pg. 30)
LL	Input keys fully disabled. The disable can only be released via HART

Table 16 Input key disable and write protection

For operating the device keyboard with activated write protection see also Chapter 3.2.8, pg. 40.

5.13 Measured value display

You can set one of three possibilities for the device display with this function:

- Display in mA
- Display in % (of the set measuring range)
- Display in a physical unit, e.g., l, m³/h etc.

If the Primary Variable is mapped to the device variable "pressure" (Chapter 5.3.3, pg. 51), you can add a suffix ABS (A) or GAUGE (G) to the displayed pressure unit depending on whether you are using an absolute pressure transmitter or a relative pressure transmitter. Select the absolute or gauge option under the "pressure display type" menu item. Two display possibilities exist. An "A" or a "G" is suffixed to a unit length less than 5 characters. For a unit length = 5 characters the words GAUGE or ABS flash alternately with the pressure unit.



Example of pressure unit with 3 characters

Example of alternation with pressure unit with 5 characters



NOTE

The change in the display from ABS to GAUGE does not change the physical reference pressure of the transmitter but only the form of the display.

5.14 Selection of the physical unit

With this function you can select a desired unit of pressure (see also Table 7, pg. 44) from a list of defined units. Only the units of the device variables which were mapped as PV (Primary Variable) are available.

The unit can be set independently for the display and the HART communication. You can couple the setting of both units optionally.

5.15 Display/bargraph

Here you can switch on the "Bargraph" function which is displayed in alternation with the unit display. The "bargraph" factory setting is "off".

5.16 Sensor adjustment

With the sensor adjustment it is possible to set the characteristic of the transmitter at two adjustment points. The results are then correct measured values at the adjustment points. The adjustment points are freely selectable within the nominal range.

Devices not turned down at the factory are adjusted at 0 bar and the upper nominal range limit, devices turned down at the factory at the lower and upper limit of the set pressure measuring range.

Application examples

1. The typical measured value of a not turned down device (e.g. 63 bar) is 50 bar. In order to achieve the greatest possible accuracy for this value you can make the upper sensor adjustment at 50 bar.
2. A 63 bar transmitter is turned down to 4 to 7 bar. You achieve the greatest possible accuracy when you select the lower sensor adjustment point at 4 bar and the upper one at 7 bar.
3. At 20 mbar (Abs), a 250 mbar absolute pressure transmitter displays 25 mbar. A reference pressure of 100 mbar is available. Zero adjustment can be achieved by carrying out a lower sensor trim at 100 mbar.



NOTE

The accuracy of the measuring equipment should be three times greater than that of the transmitter.

5.16.1 Trimming the lower sensor adjustment point

The pressure at which the lower sensor adjustment is to be made is applied to the transmitter. With SIMATIC PDM or the HART Communicator you instruct the transmitter to accept this pressure. This represents an offset shift of the characteristic (1., Figure 35, pg. 69).

5.16.2 Trimming the upper sensor adjustment point

The pressure at which the upper sensor adjustment is to be made is applied to the transmitter. With SIMATIC PDM or the HART Communicator you instruct the transmitter to accept this pressure. This corrects the characteristic slope (2., Figure 35, pg. 69). The lower sensor adjustment point is not affected. The upper adjustment point must be greater than the lower adjustment point.

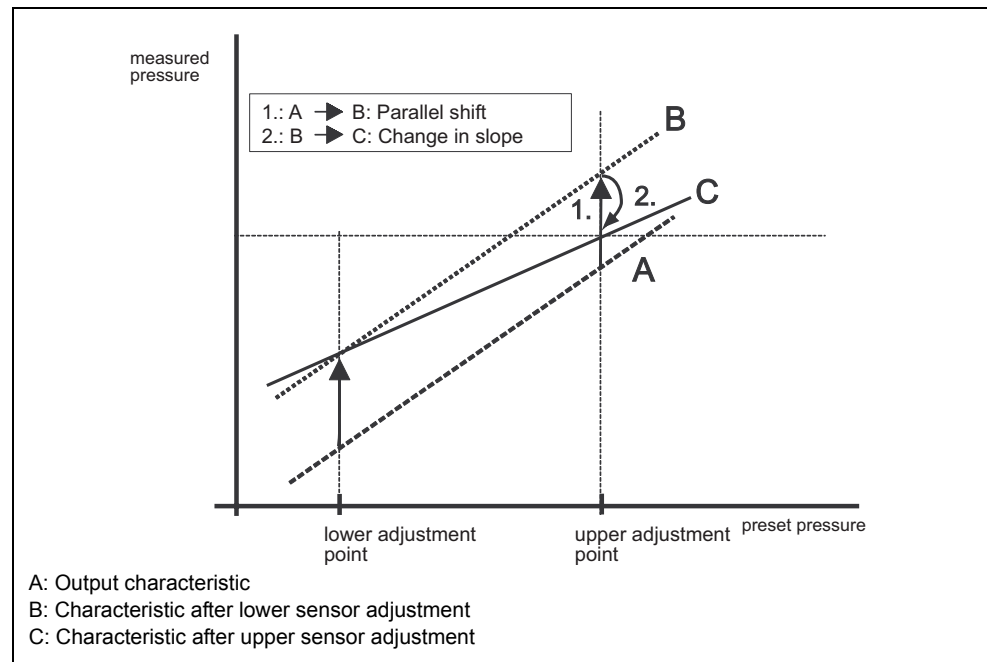

Figure 35 Sensor adjustment

5.17 Current transmitter adjustment

You can adjust the current output by the transmitter independently of the pressure measuring circuit. This function is suitable for compensating inaccuracies in the operating sequence following the transmitter.

Application example

The current should be measured as a voltage drop from 1 to 5 V at a resistance of $250 \Omega \pm 5\%$. To compensate the tolerance of the resistor, set the current transmitter so that the voltage drop at 4 mA is exactly 1 V and at 20 mA exactly 5 V.



NOTE

The accuracy of the measuring equipment should be three times greater than that of the transmitter.

1. Adjustment at 4 mA:
 Instruct the transmitter to output 4 mA under menu item Current transmitter adjustment. Read the measured value from the ammeter and enter it for example via SIMATIC PDM. The transmitter uses this value for offset correction of the current.
2. Adjustment at 20 mA:
 Instruct the transmitter to output 20 mA under menu item Current transmitter adjustment. Read the measured value from the ammeter and enter it for example via SIMATIC PDM. The transmitter uses this value for slope correction of the current. This does not alter the value for 4 mA.

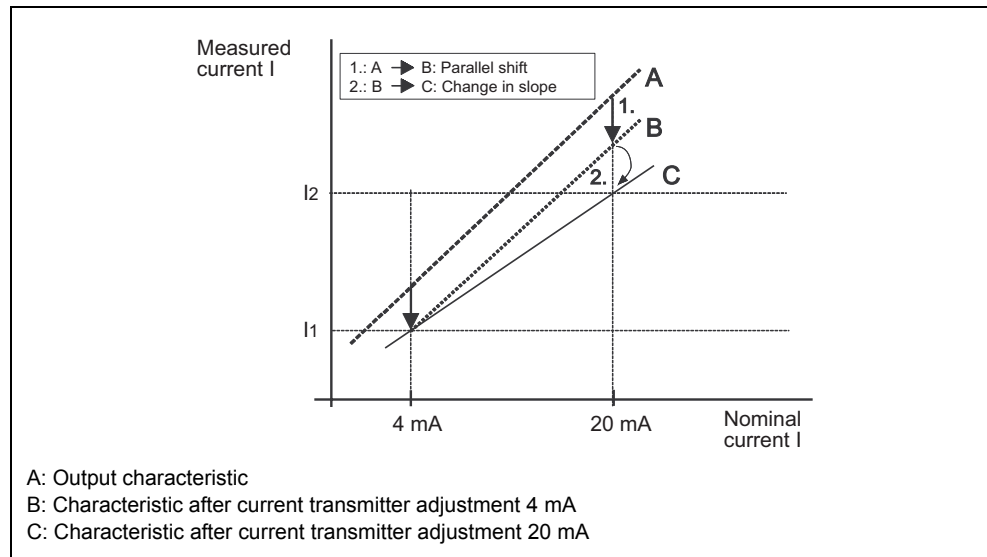

Figure 36 Current transmitter adjustment

5.18 Factory calibration

You can return the transmitter to its original state with the factory calibration. You can select the scope of the recovered parameters in a menu with SIMATIC PDM or the HART Communicator in four steps:

1. Cancellation of the current adjustment
2. Cancellation of the sensor zero adjustment (position correction)
3. Cancellation of the pressure corrections (zero adjustment and sensor adjustment)
4. Cancellation of all parameters relevant to measured value processing such as start of scale, full scale, electric damping, display unit, current adjustment, zero adjustment (position correction), sensor adjustment, measuring speed, alarm current limits, alarm setting, overflow ranges of the current.
5. Reset the variable mapper This causes the following setting:
 PV= pressure, SV= sensor temp., TV= electronics temp., QV= unlinearized pressure

Legend:

PV	Primary Variable,
SV	Secondary Variable
TV	Tertiary Variable
QV	Quarternary Variable

5.19 Static configuration data

Under another menu item in the appropriate operating program you can read and write a series of sensor-specific material data. These values are not contained in the "Factory calibration" function, i.e. changes in the device remain permanently stored.

List of adjustable material parameters: flange type, flange material, vent valve material, remote seal type, filling medium, O-ring material, remote seal, seal diaphragm material, number of remote seals, sensor filling medium, sensor seal diaphragm material, transmitter version, housing material, tube length, process connection, electrical connection, process flange screw material, position vent valve.

You can enter a freely selectable designation under the "Special" option for a series of these material data. This applies for the parameters process connection, flange type, pressure cap screws, O-ring material, bleed valve material, bleed valve position, pressure regulator type, pressure regulator, diaphragm material, pressure regulator filling medium. 16 characters per entry are possible.

5.20 Flow measurement (only differential pressure)

For the "Pressure differential and flow" transmitter type you can select the characteristic curve of the output current without actuating the measurement type switch:

- linear "lin" (proportional to the differential pressure)
- square rooting ("sroff") proportional to the flow, switched off up to the application point
- square rooting ("srlin") proportional to the flow, linear up to the application point
- square rooting ("srlin2") proportional to the flow, two-stage linear up to the application point

Variable application point

Below the application point of the square rooting characteristic curve, the output current can either be output linearly or set to zero.

Fixed application point

The function "srlin2" has a fixed defined application point of 10 %. The range in front contains two linear characteristic curve sections. The first section runs from zero to 0.6% of the output value and 0.6% of the pressure value. The second section runs with a steep gradient up to the root application point at 10% of the output value and 1 % of the pressure value (Figure 22, pg. 43).

5.21 Diagnostic functions

Communication with the HART interface enables activation and evaluation of numerous diagnostic functions from a central control station or locally. The simulation of pressure and temperature measured values and a limit value monitoring of all device variables is possible in addition to calibration/service timers, slave pointers and limit value monitoring components.

The diagnostic concept of the SITRANS P, DS III series is conceived such that a (diagnostic) warning and a (diagnostic) alarm can be parameterized for diagnostic functions which serve for monitoring limit values (e.g. monitoring of current saturation).

- **Diagnostic warning:** The device transmits the diagnostic event that has occurred via HART. The current output value remains unaffected. The moving text "Diagnostic Warning" appears in the display alternately with the unit.

- **Diagnostic alarm:** The device goes into the fault current state. The messages "ERROR" and as a moving text "Diagnostic Warning" or "Diagnostic Alarm" appear in the display. The diagnostic event is provided additionally via HART.

The standard setting for all warnings and alarms is off. You can set either only the diagnostic warning or diagnostic alarm and warning optionally. To do this use the HART Communicator or SIMATIC PDM. See the foldout for operation of the HART Communicator in the appendix or the help functions of the SIMATIC PDM software for the necessary steps.

5.21.1 Operating hours counter

Operating hours counters for the electronics and the sensor can be read out via HART (PDM or Communicator). The counters are activated the first time the transmitter is started. If the device is disconnected from its power supply the counter readings are stored automatically in the non-volatile memories. It can therefore access the latest counter readings the next time it is restarted. The operating hours counters cannot be reset.

5.21.2 Calibration timer/service timer

You can wind up a two-stage timer to ensure regular calibration of the electronics and for service work on the sensor. A calibration or service warning appears after a first time expires. On expiry of a second time set as a time difference, a diagnostic alarm is signaled and a fault current is output (Chapter 5.10, pg. 65).

You must acknowledge the warnings and alarms to perform the calibration work. Then you can reset the timers and switch off the monitoring function. The calibration intervals for the electronics are given by the following equation:

$$\text{Calibration interval} = \frac{(\text{necessary accuracy} - \text{probable total error})}{\text{stability/month}}$$

The following applies for operation/acknowledgement of the warnings and alarms in SIMATIC PDM and in the Handheld Communicator.

The following applies for as long as the warning/alarm limit is not reached:

- "Reset" resets the timer and starts again with counter reading 0. The monitor remains active.
- "Acknowledge" has no effect, the timer continues running and the monitor remains active.
- "Reset and deactivate" stops the timer, resets it and deactivates the monitor.

The following applies when the warning/alarm is reached:

- "Acknowledge" resets the warning/alarm message but allows the timer to continue running. No new alarm and no new warning are possible in this status because the time limits remain exceeded.
- "Reset" resets the warning/alarm message as well as the timer. At the same time the alarm or warning is acknowledged. The timer starts again immediately at zero and responds again the next time the warning/alarm limits are exceeded. The next calibration interval is therefore immediately active.
- "Reset and deactivate W/A" resets the warning/alarm message and the timer and deactivates the timer.

5.21.3 Slave pointer

This device offers three pairs of slave pointers with which you can monitor three measuring variables pressure, sensor temperature and electronics temperature for negative and positive peak values. Per measured value a resettable slave pointer saves the maximum and minimum peak values long-term in the two non-volatile memories. The values are then reavailable after restarting the device. The slave pointers are also updated during a simulation (Chapter 5.22, pg. 76).

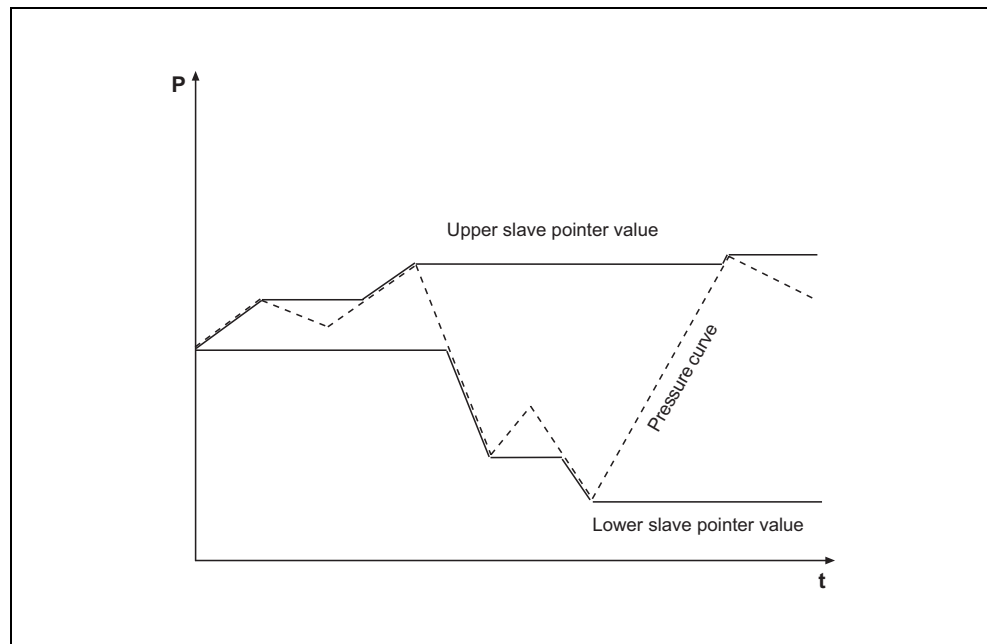

Figure 37 Principle representation of slave pointers with pressure as an example

5.21.4 Limit value components

The diagnostic functions of this device offer you the possibility of monitoring measured values in parameterizable limits and having their violation reported by a warning (via HART communication) or a fault current (analog) of a superior level.

5.21.4.1 Monitoring the current saturation

You can monitor the current output in the saturation range with a simple limit value component. This component is parameterized and activated via HART (PDM or Communicator). For this you have to parameterize two times. The first of these determines how long the current output may be in saturation (response time) before an alarm is triggered and the device outputs its set fault current. The second time (hold time) determines the duration of the alarm.

In the first example (Figure 38 and Figure 39) the response time begins at time t_1 when the current reaches the parameterized saturation limit for the first time. At t_2 the response time ends and the hold time begins. The alarm is canceled immediately when the parameterized hold time has already expired (t_3) and the current does not drop back below the saturation limit before this.

In the second example the duration of current saturation is shorter than the response time (t_1, t_2). In this case the device does not go into the "fault current" state.

In the third example the current only drops below the lower saturation limit for a short time. The fault current is not switched off until the end of the hold time (t_3).

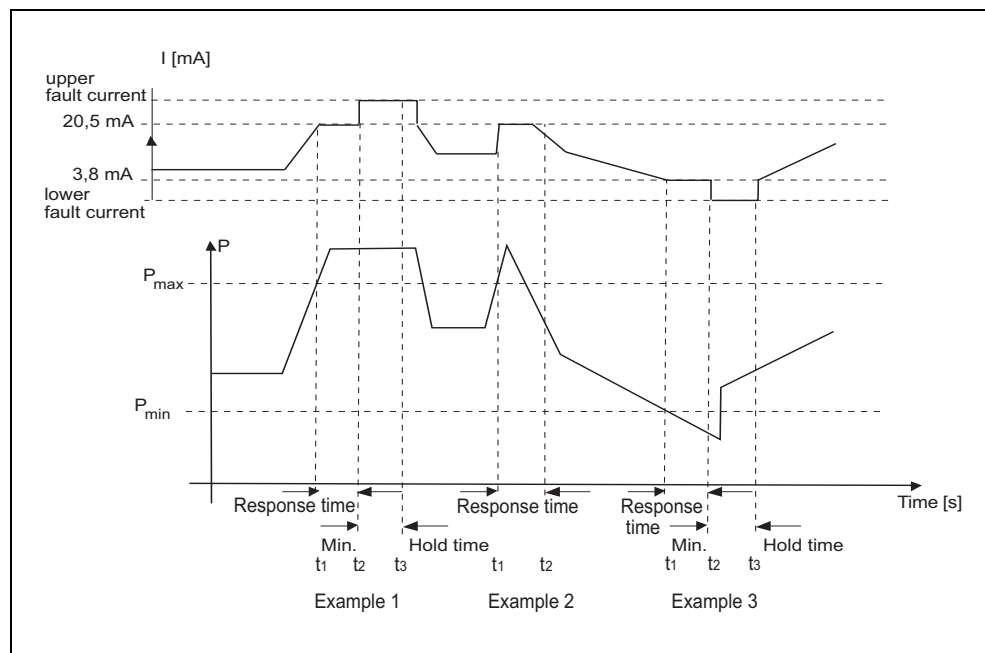

Figure 38 Three examples of the saturation monitoring with saturated alarm value

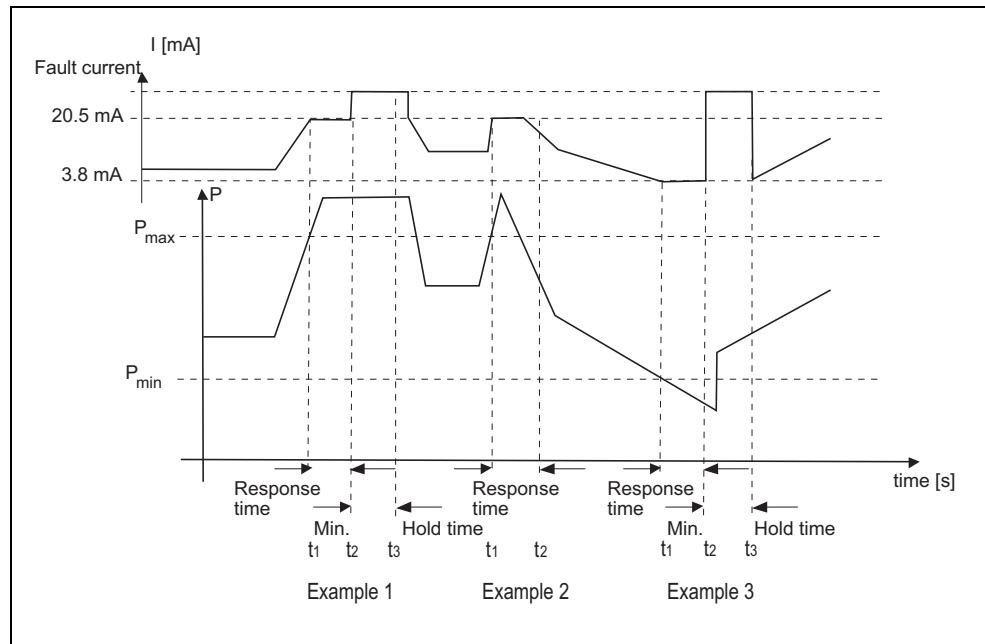

Figure 39 Three examples of the saturation monitoring with activate alarm value top

The fault current direction which is to be selected for a current saturation alarm can be parameterized to suit your requirements. The following settings are possible under the current saturation menu:

Active alarm value	The settings under the current alarm type menu item apply.
Inverse alarm value	The inverse settings under the current alarm type menu item apply.
Saturated alarm value	The fault current is output in the direction of current saturation.
Inverse saturated alarm value	The fault current is output in the opposite direction to current saturation.

5.22 Simulation

With the "Simulation" diagnostic function you can receive and process (simulated) measuring data locally or in a central station without an applied process pressure or temperature value. You can therefore run individual processes "cold" and thus simulate process states. In addition you can check the line from the control station to the individual transmitters by applying simulation values.

The value to be simulated can be preset as a fixed value or in the form of a ramp function. The simulation of pressure and temperature values is handled identically in

parameterization and function so that only the general simulation methods "fixed value" and "ramp function" are explained below.

For security reasons all the simulation data are only kept in the RAM. This means any simulation which may be activated is switched off when the device is restarted. You can simulate the pressure and both temperature values. You must note that changing the temperatures by simulation has no effect on the measured pressure value.

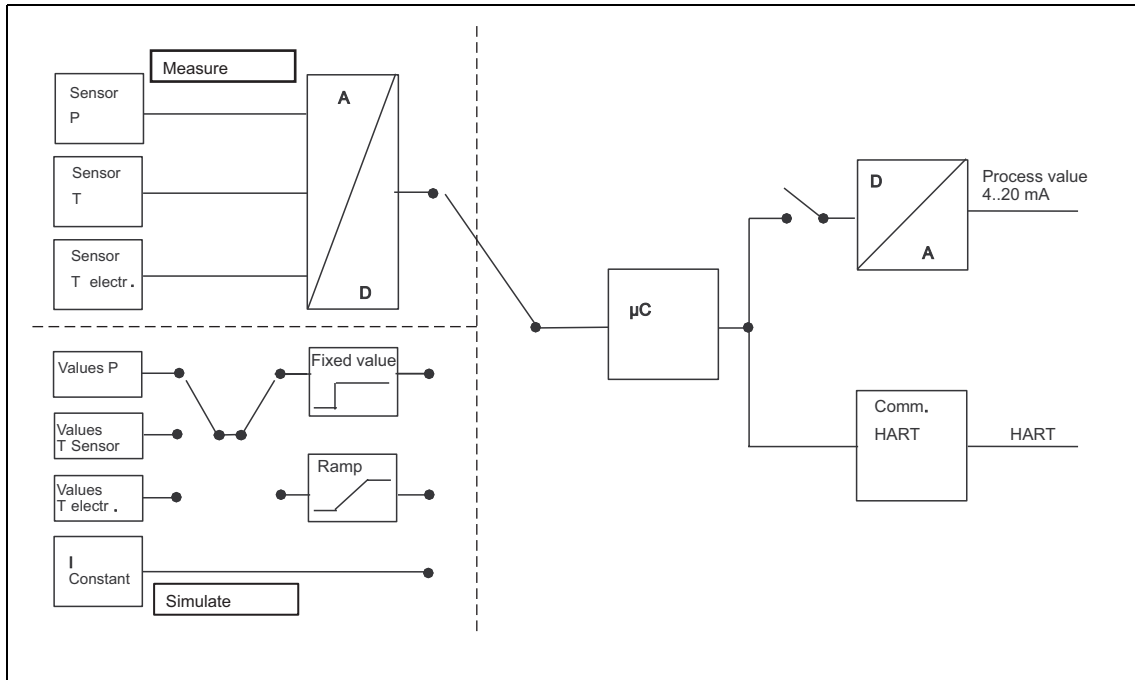

Figure 40 Principle circuit diagram simulation

5.22.1 Simulation as a fixed value

Under consideration of the physical unit you can parameterize a fixed simulation value for all three possible simulation lines. You can simulate the pressure and both temperature values simultaneously. As long as the pressure simulation is switched on, the transmitter does not react to changes in the process pressure. The current output value is set according to the pressure default. Simulation of the temperature values has no influence on the current output. It can only be observed through the HART communication interface.

5.22.2 Simulation with a ramp function

As a second possibility you can also parameterize a ramp function in addition to the settable fixed values for all three simulation lines. A settable start and end value determines the respective limits between which the simulation values move with a

rising and falling tendency. The step width can also be calculated with the settable number of steps. The rise speed of the ramp is determined by the duration of the individual ramp steps.

$$\text{Step width} = \frac{\text{end value} - \text{start value}}{\text{number of steps}}$$

5.23 Limit transmitter

You can activate up to three limit transmitters to monitor any device variables. The limit transmitter monitors a value for an upper and lower limit and sends a diagnostic warning or a diagnostic alarm when this limit is exceeded. To do this, select the menu item "Limit transmitter" in SIMATIC PDM or in the Handheld Communicator. You can parameterize the following values for each of the three limit transmitters:

Monitoring variable	A list of the active device variables is offered here. This list depends on the set measurement type (Chapter 5.3, pg. 50).
Limit monitoring warning/alarm	Here you select whether a warning or an alarm + warning is to be activated when a limit is exceeded.
Limit monitoring up/down	Here you determine whether a device variable is to be monitored for the upper limit, the lower limit or both.
Upper limit	Upper limit in the device variable unit
Lower limit	Lower limit in the device variable unit
Hysteresis	Switching threshold for flutter suppression in the case of small changes in pressure
Response time	The time which must elapse after exceeding the limit before this is registered.
Hold time	The time for which a limit alarm / warning persists even when the causal event no longer exists.

Table 17 Parameter of the limit transmitter

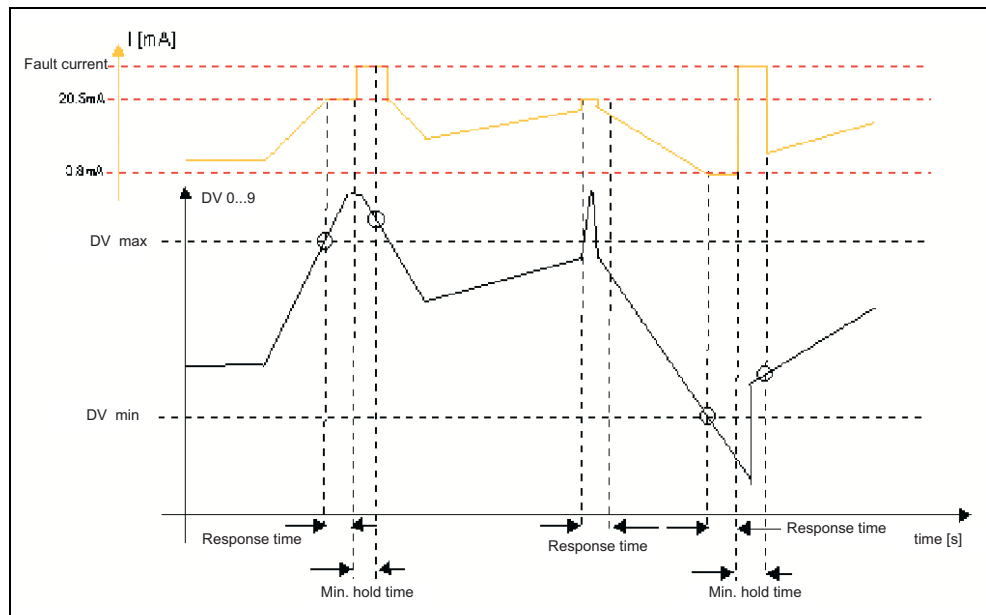

Figure 41 Trigger thresholds of the limit transmitter

You can count the number of times every limit transmitter exceeds the limit by activating an event counter which totalizes the exceeding of the upper and lower limits separately. After a certain number of exceedings which you can also parameterize, a diagnostic warning or / and a diagnostic alarm can be triggered. You can parameterize the following values for the event counter.

Event counter up	Here you determine whether a warning or an alarm + warning is to be triggered when the reference value is exceeded.
Event counter down	Here you determine whether a warning or an alarm + warning is to be triggered when the reference value is dropped below.
Reference value up	Here you determine the number of exceedings at which an alarm + warning or a warning is to be triggered.
Reference value down	Here you determine the number of times dropped below at which an alarm + warning or a warning is to be triggered.
Limit monitoring warning/alarm up	Here you select whether a warning or an alarm + warning is to be activated when the event counter is exceeded.
Limit monitoring warning/alarm down	Here you select whether a warning or an alarm + warning is to be activated when the event counter is dropped below.
Reset event counter up	Here you reset the up counter to 0. A new event is only possible after resetting the counter.
Reset event counter down	Here you reset the down counter to 0. A new event is only possible after resetting the counter.
Acknowledge warning/alarm	Here you can acknowledge every warning/alarm individually.

Table 18 Parameter of the event counter

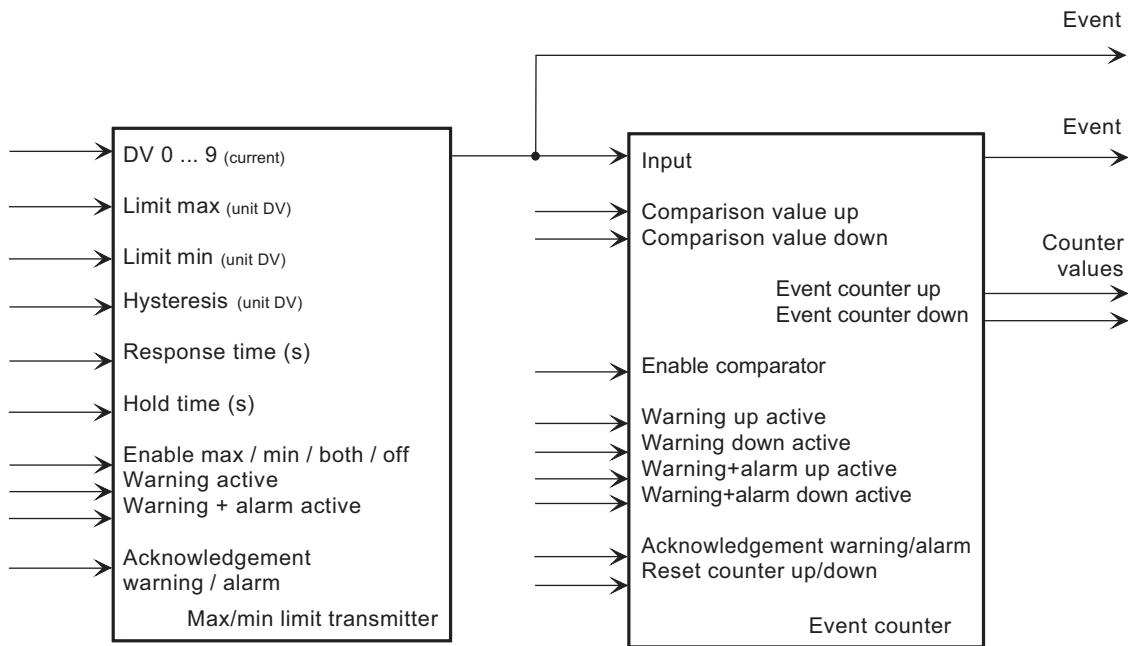

Figure 42 Limit transmitter and event counter

The messages of the limit transmitter and the event counter can be acknowledged separately. You can start a new monitoring interval by resetting the event counter.



WARNING

This device has a modular structure. This gives you the possibility of replacing various parts with original spares. In the case of replacement, please observe the instructions enclosed with the components to be replaced.

This applies particularly to devices used in hazardous areas.

Relationships

The two single components *measuring cell* and *electronics* both have a non-volatile memory (EEPROM). Each contains a data structure which is permanently assigned to the measuring cell or the electronics. Measuring cell data (e. g.: measuring range, measuring cell material, oil filling etc.) are stored in the measuring cell's EEPROM. Data of the electronics (e.g.: turn-down, electric damping etc.) are in the electronics's EEPROM. This ensures that the data relevant to the remaining component are retained when the electronics are exchanged.

Before replacing components you can set, via HART, whether the common measuring range settings are to be taken from the measuring cell or the electronics after the exchange or whether standard parameters should be set. The measuring accuracy in the specified measuring limits (with reduction 1:1) may be reduced in unfavorable cases by the temperature error.

In the course of further development, extended functions may be implemented in the measuring cell or electronics. This is identified by a changed firmware version (FW). The firmware version has no influence on the exchangeability. However, the scope of functions is restricted to the function of the respective older component.

If the combination of certain firmware versions of the measuring cell and the electronics is not possible for technical reasons, the device detects this and goes into the "fault current" state. This information is also provided via the HART interface.

The installation cases described below are typical examples. Different types of installation may be possible depending on the system configuration.



WARNING

Protection against incorrect use of the measuring device:
It must be particularly ensured that the selected materials of the process-wetted parts of the measuring device are suitable for the process media used. Failure to observe this precaution could endanger life and limb and the environment.



CAUTION

At surface temperatures $> 70\text{ °C}$ a touch protection should be provided. The touch protection must be designed so that the max. permissible ambient temperature of the device is not exceeded.

CAUTION

The device may only be used within the medium pressure limits and voltage limits specified on the rating plate depending on the explosion protection type with which the device is operated.

NOTICE

External loads may not be applied to the transmitter.



WARNING

Devices with "explosion-proof" protection may only be opened when the power has been disconnected.

Notes for the operation of the intrinsically safe version in hazardous areas:

Operation is only permissible on certified intrinsically safe circuits- The transmitter corresponds to category 1 / 2 and may be mounted in zone 0.

The EC type test certificate applies for installation of the device in the walls of vessels and pipes in which explosive gas/air or vapor/air mixtures occur only under atmospheric conditions (pressure: 0.8 bar to 1.1 bar; temperature: -20 °C to +60 °C). The permissible range of the ambient temperature is -40 °C to +85 °C, in hazardous areas -40 °C up to a maximum +85 °C (at T4).

The owner may use the device under non-atmospheric conditions outside the limits specified in the EC type test certificate (or the test certificate valid in his country) on his own responsibility if additional safety precautions have been taken according to the conditions of application (explosive mixture). The limits specified in the general technical data must be observed in any case.

Installation in Zone 0 makes additional demands:

The installation must be sufficiently tight (IP67 according to EN 60 529). A threaded connection of industrial standard (e.g. DIN, NPT) is suitable for example.

When operating with intrinsically safe feeding devices of category "ia" the explosion protection does not depend on the chemical resistance of the isolating diaphragm.

In operation with intrinsically safe feeding units of category "ib" or devices of the explosion-proof version "Ex d" and simultaneous use in Zone 0, the explosion protection of the transmitter depends on the tightness of the sensor diaphragm. The transmitter may only be used under these operating conditions for those combustible gases and liquids for which the diaphragms have sufficient resistance to chemicals and corrosion.

7.1 Installation (except filling level)

The transmitter can be arranged above or below the pressure tapping point.

When measuring gases we recommend installing the transmitter **above** the pressure tapping point and laying the pressure line with a constant downward gradient to the pressure tapping point so that condensation which forms can drain into the main line and the measured value is not falsified (recommended installation Chapter 8.1, pg. 96).

When measuring vapors and liquids the transmitter should be installed **below** the pressure tapping point and the pressure line should have a constant upward gradient so that gas entrapped in the main line can escape (recommended installation Chapter 8.1, pg. 97).

The installation point should be easily accessible, if possible in the vicinity of the measuring point and should not be exposed to strong vibration. The permissible ambient temperature limits (Chapter 9, pg. 103 for further information) may not be exceeded. Protect the transmitter from direct radiation of heat.

The desired operating data must be compared with the values specified on the device's rating plate before installation.

The housing may only be opened for maintenance, local operation or electrical installation.

Suitable tools must be used for connecting the transmitter on the pressure side. Do not rotate on the housing!

Observe the installation instructions on the housing!

7.1.1 Mounting without mounting bracket

The transmitter may be mounted directly at the process connection.

7.1.2 Mounting with mounting bracket

The mounting bracket is fastened

- to a wall or a mounting rack with two screws
or
- with a pipe bracket to a horizontal or vertical mounting pipe (Ø 50 to 60 mm)

The transmitter is fixed to the mounting bracket with two screws (enclosed).

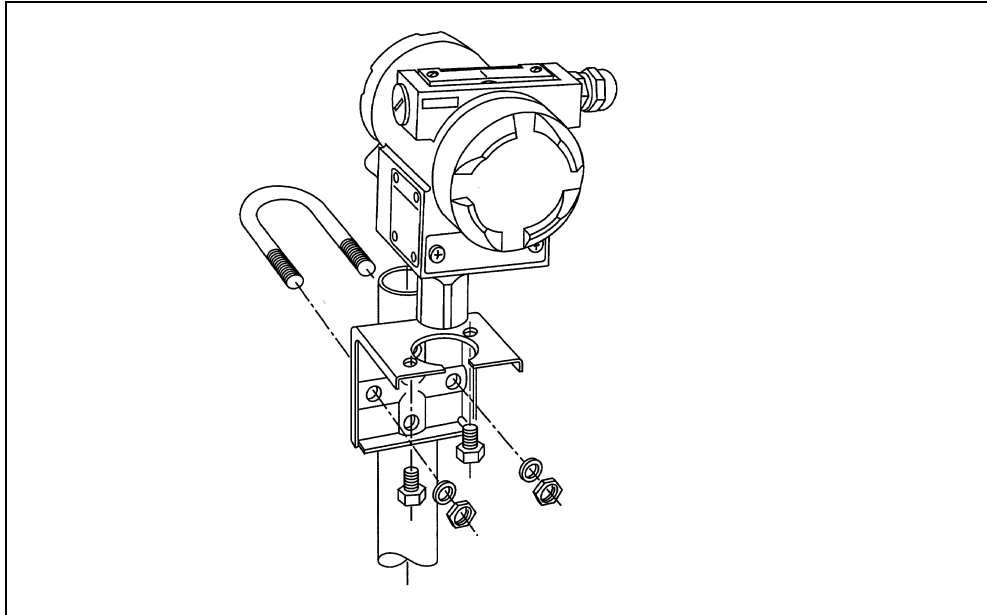

Figure 43 Mounting the SITRANS P, DS III series transmitter with mounting bracket

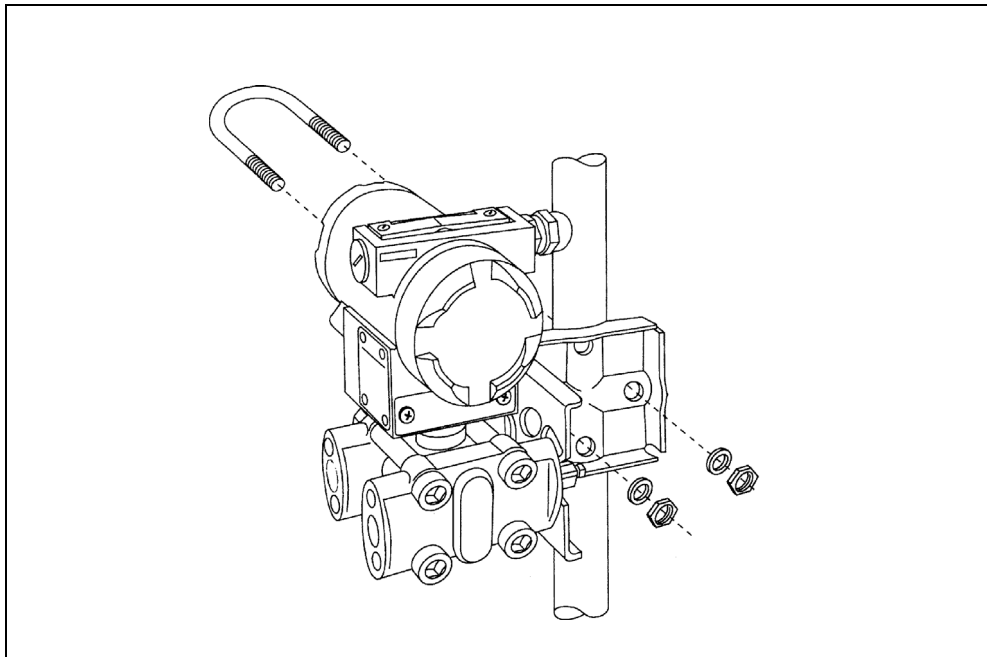

Figure 44 Mounting the SITRANS P, DS III series transmitter with mounting bracket (example differential pressure, horizontal active pressure lines)

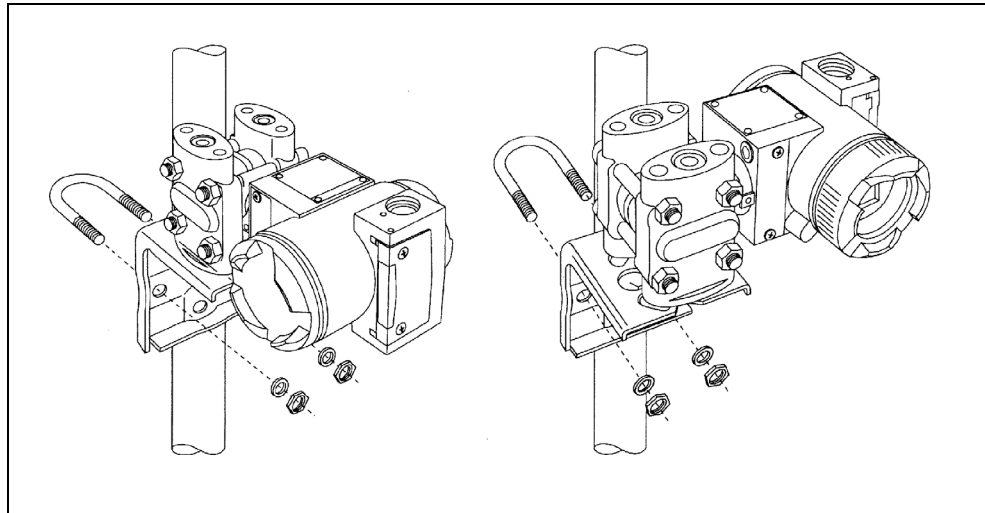

Figure 45 Mounting the SITRANS P, DS III series transmitter with mounting bracket (example differential pressure, vertical active pressure lines)

7.2 Mounting "filling level"

7.2.1 Installation

Before installing, check whether the transmitter satisfies the operating conditions (material, sensor length, measuring span).

The installation location must be easily accessible and free from vibration. The permissible ambient temperatures may not be exceeded. Protect the transmitter from heat radiation, rapid temperature fluctuations, heavy soiling and mechanical damage.

The height at which the container flange for mounting the transmitter (measuring point) must be chosen so that the lowest liquid level to be measured is always above the flange or at its top edge.

1. Screw the flange of the transmitter (dimensions Figure 61, pg. 113) after fitting a seal (e.g. flat sealing ring DIN 2690) to the counterflange of the vessel (seal and screws are not included in the delivery). The seal must be central and may not restrict the mobility of the flanges seal diaphragm at any point.
2. Observe the installation position!

7.2.2 Connecting the low pressure line

No line is necessary when measuring on the open container (Figure 46, pg. 88) because the low pressure chamber is connected to the atmosphere. The open connecting pipe should point downwards to prevent dirt getting in.

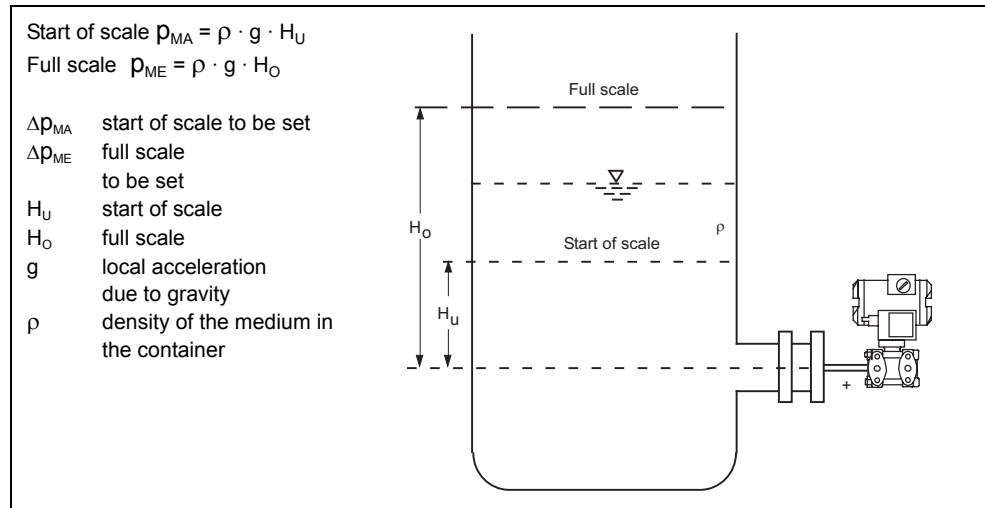

Figure 46 Measuring setup on the open container

When measuring on the closed container without or with only slight condensation (Figure 47, pg. 89) the low pressure line remains unfilled. The line must be laid so that no condensate sacks can form, you may have to install a condensation vessel.

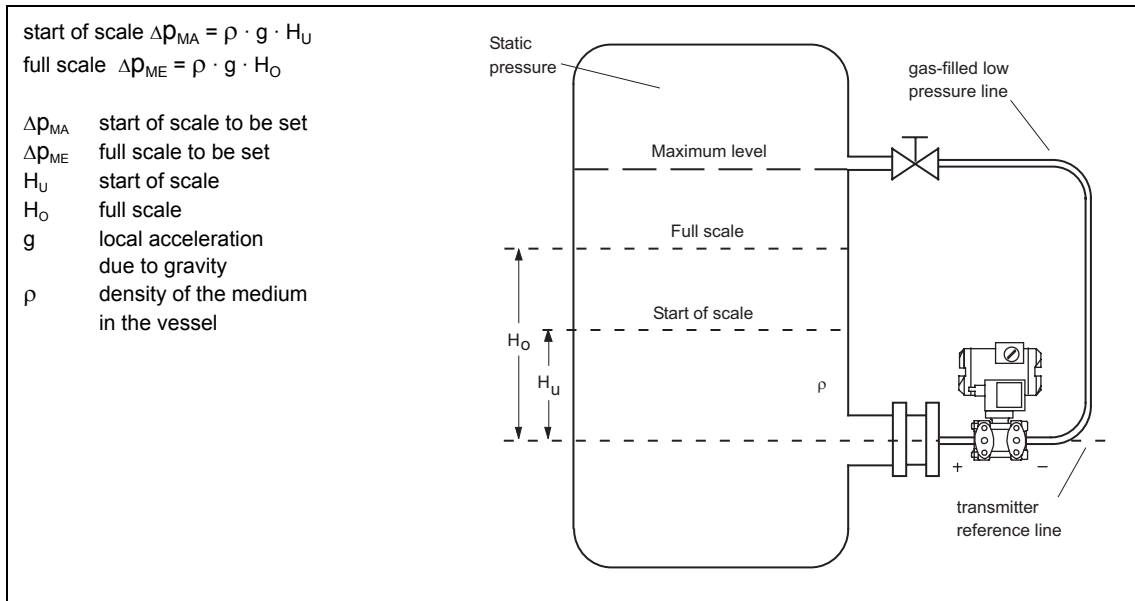

Figure 47 Measuring set up on the closed container (no or only slight condensation escape)

When measuring on the closed container with strong condensation formation (Figure 48, pg. 89), the low pressure line must be filled (usually with medium condensate) and a calibration vessel must be installed. The device can be shut off for example by a double valve manifold 7MF9001-2.

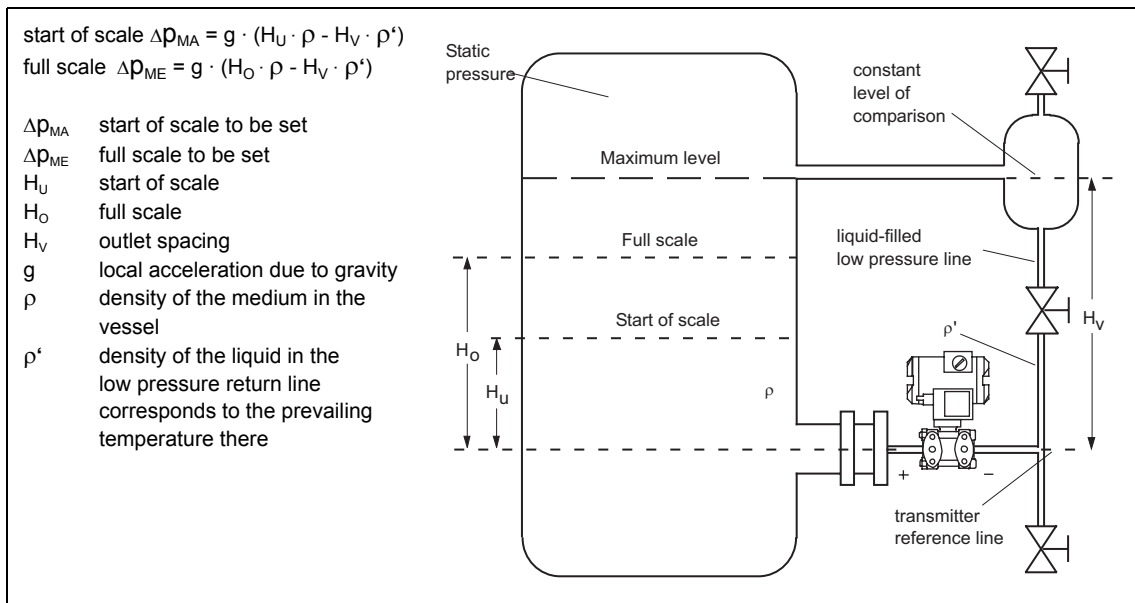

Figure 48 Measuring setup on the closed container (strong condensation formation)

The process connection on the low pressure side is a female thread $1/4$ -18 NPT or an oval flange.

The line for the low pressure must be made of 12 mm x 1.5 mm seamless steel pipe. See Figure 47, pg. 89 and Figure 48, pg. 89 for shutoff valves.

7.3 Rotating the measuring cell in relation to the housing

If necessary, you can rotate the electronics housing in relation to the measuring cell in the SITRANS P, DS III series transmitter so that the digital display (in housing covers with a window) is visible and access to the input keys and the current connection for an external measuring instrument is possible.

Only a limited rotation is permitted! The range of rotation (1, Figure 49, pg. 90) is marked at the base of the electronics housing, there is an orientation mark (3) on the neck of the measuring cell which must stay within the marked area when rotating.

1. Loosen the locking screw ((2), hexagon socket head 2.5 mm).
2. Rotate the electronics housing in relation to the measuring cell (only within the marked area)
3. Tighten the locking screw (torque: 3.4 to 3.6 Nm).

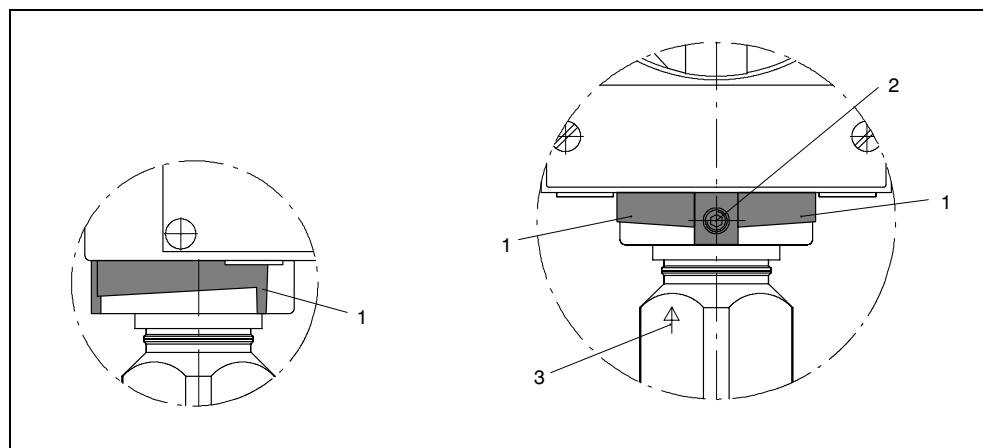

Figure 49 Range of rotation of the measuring cell (in pressure and absolute pressure transmitters of the pressure series)

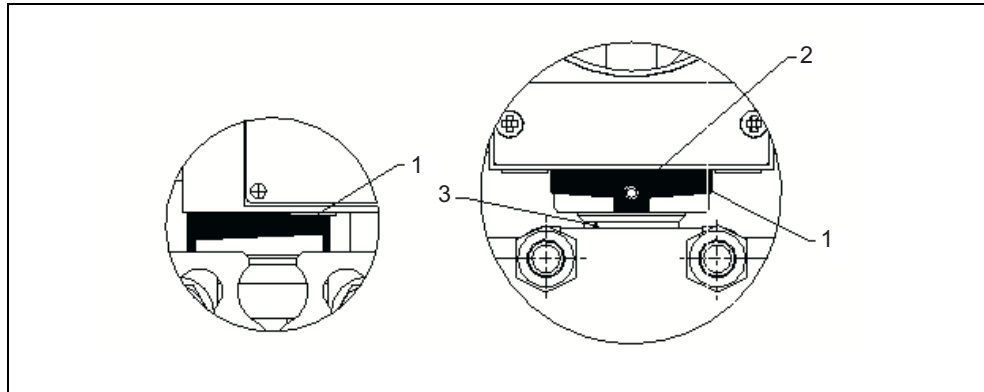

Figure 50 Range of rotation of the measuring cell (in differential pressure and flow and absolute pressure transmitters from the differential pressure and filling level series)



NOTE

The range of rotation must be observed, otherwise destruction of the electrical connections of the measuring cell cannot be ruled out.

7.4 Electrical connection



WARNING

The regulations of the test certificate valid for your country must be observed. The national regulations and laws for hazardous areas valid for your country must be observed for the electrical installation. In Germany these are for example:

- Working reliability regulations
- the regulations for installing electrical equipment in hazardous areas
DIN EN 60079-14 (formerly VDE 0165, T1)

You are recommended to check whether the existing power supply, insofar as this is required, matches the one specified on the rating plate and complies with the test certificate valid for your country. Sealing caps in the cable inlets should be replaced by suitable screwed glands or blanking plugs which must be certified accordingly for "explosion-proof" transmitters!



NOTE

To improve interference it is recommended to:

- lay signal cables separately from cables with voltages >60 V.
 - use cables with twisted wires.
 - avoid the vicinity of large electrical installations or use shielded cables.
 - use shielded cables to guarantee the full specification according to HART.
 - use a load of at least 230 ohms in the signal circuit to guarantee error-free communication. When using feed separators for SMART transmitters, e.g. Siemens 7NG4021, a load is already built into the device.
 - Only use cables with a diameter of 6 to 12 mm in the standard screwed glands M20x1.5 and 1/2-14" NPT for reasons of tightness (IP degree of protection).
 - In devices with "n" type of protection (Zone 2) only use cables with a diameter of 8 to 12 mm or a suitable screwed gland for a smaller diameter for reasons of tensile strength.
-

7.4.1 Connection to screw terminals

Connect the transmitter as follows:

1. Unscrew the cover of the connection box (marked "FIELD TERMINALS" on the housing).
2. Insert the connecting cable through the cable gland.
3. Connect the wires to the "+" and "-" terminals (Figure 51, pg. 93) and observe the polarity!
4. Connect the screen to the screen screw if necessary.
5. Screw on the housing cover.

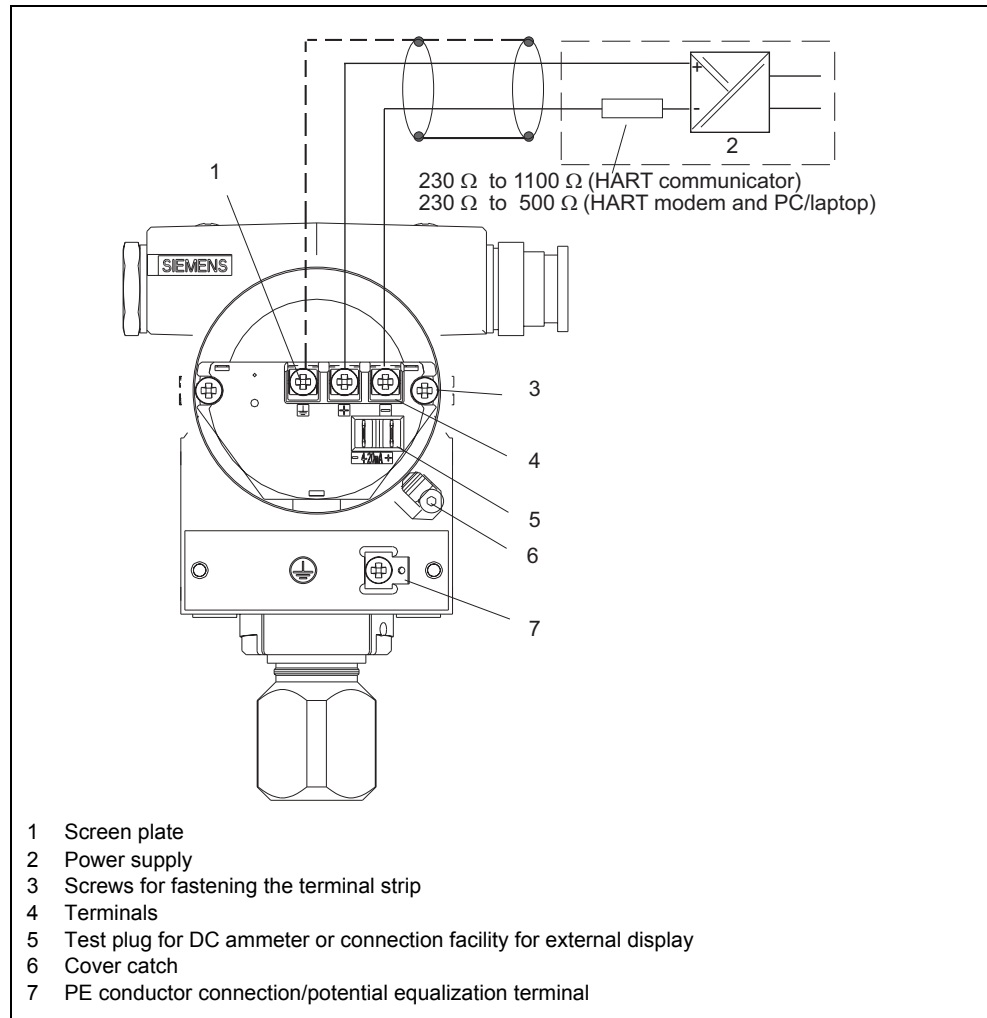

Figure 51 Electrical connection, schematic diagram



WARNING

In explosion-proof transmitters the housing cover must be screwed on tightly and secured with the cover catch.

7.4.2 Connection with plug

(not for "explosion-proof" degree of protection)

The contact parts for the coupling socket are enclosed packed in a bag.

1. Push the sleeve and screwed gland onto the cable.
2. Insulate the cable ends approx. 8 mm.
3. Crimp or solder the contact parts to the cable ends.
4. Assemble the coupling socket.



Figure 52 Connect with plug (Han 7D / Han 8U)

7.5 Turn digital display

If the device cannot be operated in a vertical position you can turn the digital display to make it easier to read. To do this, proceed as follows:

1. Unscrew the cover from the electronics housing.
2. Unscrew the digital display. Depending on the position of the transmitter you can screw it back in four different positions (rotated by $\pm 90^\circ$ or $\pm 180^\circ$ possible).
3. Screw on the housing cover.



WARNING

Explosion-proof devices may only be opened with the power off.

The operating data must match the values specified on the rating plate.
The transmitter is in operation when the power supply is switched on.



WARNING

Only certified ammeters which suit the transmitter may be used in intrinsically safe circuits.

In hazardous areas, the housign covers may only be unscrewed from transmitters with the "explosion-proof" type of protection when power is disconnected. If the transmitter is to be used as category 1/2 equipment, please observe the design sample test certificate or the test certificate valid for your country.

The following applies for equipment with protection type "intrinsically safe" and "explosion proof" (EEx ia + EEx d): The inapplicable protection type must be permanently deleted from the rating plate before commissioning.

The "intrinsically safe" protection type is no longer effective in the case of improper feeding.

The following commissioning cases are typical examples. Different arrangements may be advisable depending on the system configuration.

8.1 Pressure, absolute pressure from differential pressure series and absolute pressure from pressure series



WARNING

Wrong or improper operation of the shutoff fittings (Figure 53, pg. 97ff) may result in serious injury or considerable material damage

The transmitter may not be bled when using toxic media.

8.1.1 Measuring gases

Operate the shutoff fittings in the following order:

Initial position: all shutoff fittings closed

1. Open the shutoff valve Figure 53, pg. 97, 2B).
2. Apply pressure corresponding to the start of scale through the test connection of the shutoff fitting (2) to the transmitter.
3. Check the start of scale and correct it if necessary.
4. Close the shutoff valve (2B).
5. Open the shutoff valve (4) on the pressure tap.
6. Open the shutoff valve (2A).

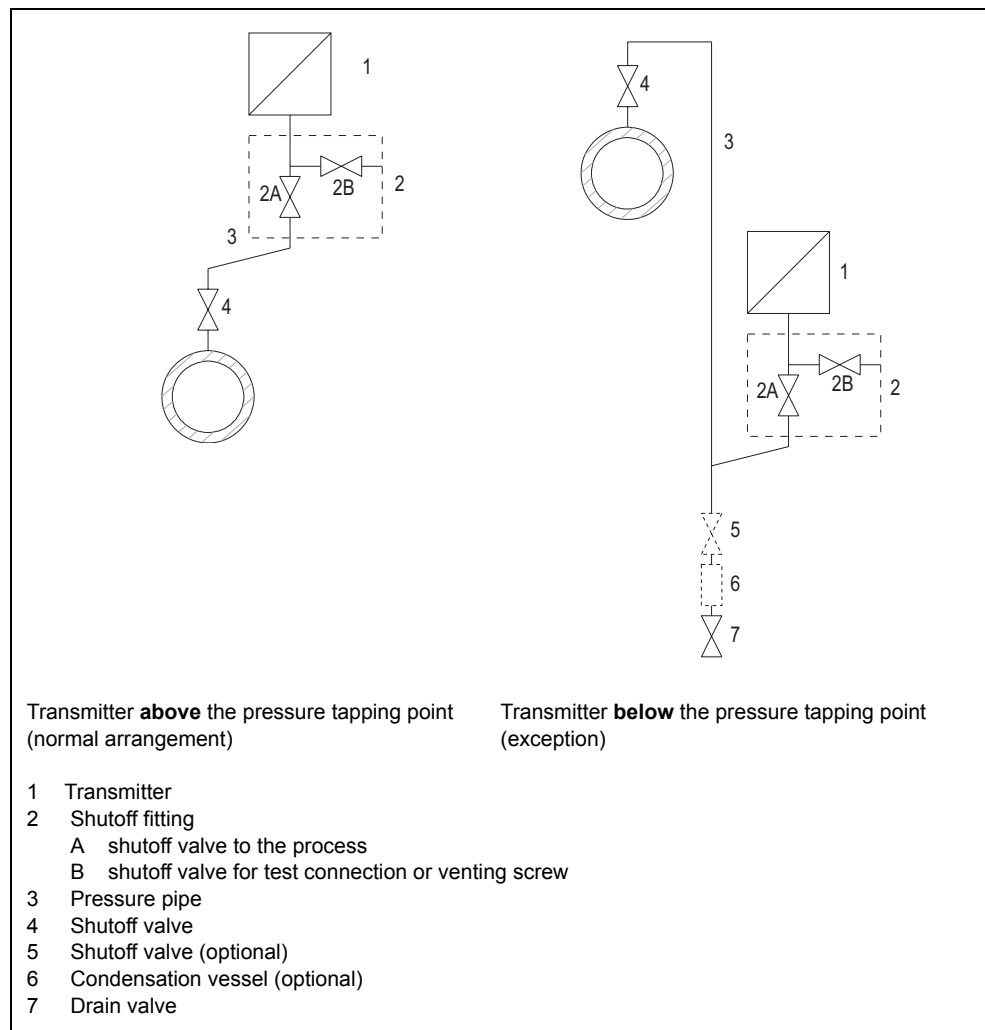

Figure 53 Measuring gases

8.1.2 Measuring vapor and liquid

Operate the shutoff fittings in the following order:

Initial position: all valves closed

1. Open the shutoff valve (Figure 54, pg. 98, 2B).
2. Apply pressure corresponding to the start of scale through the test connection of the shutoff fitting (2) to the transmitter.
3. Check the start of scale and correct it if necessary.
4. Close the shutoff valve (2B).
5. Open the shutoff valve (4) on the pressure tap.
6. Open the shutoff valve (2A).

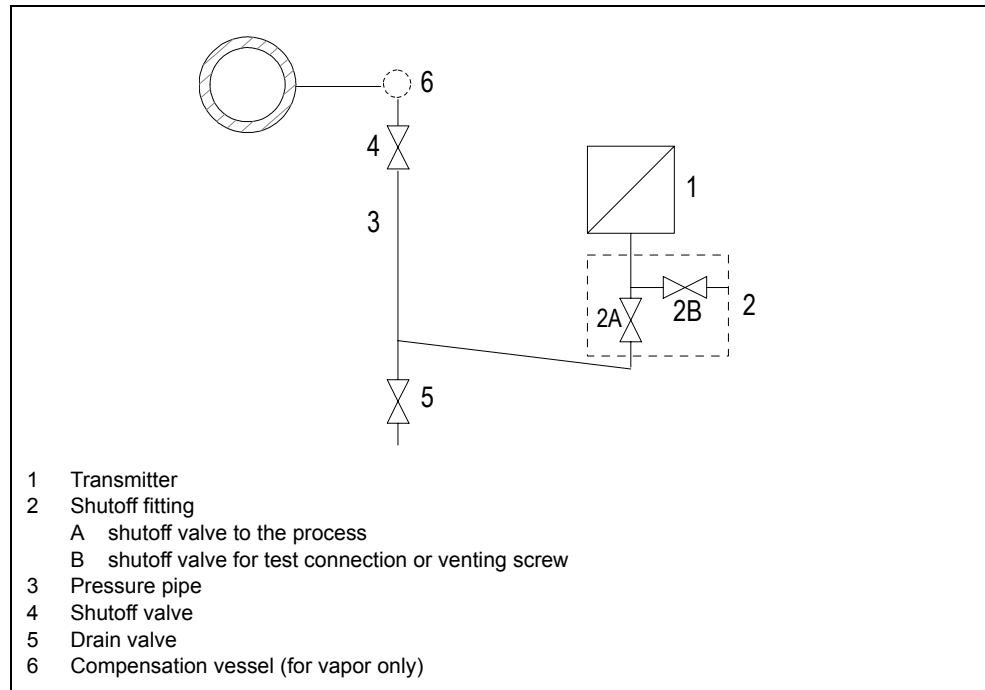

Figure 54 Measuring vapor

8.2 Differential pressure and flow



WARNING

- If the vent valve and/or the sealing screw are missing or are not tight enough and/or
- if the valves are operated wrongly or improperly, serious injury or considerable material damage may result.

In the case of hot media the individual operating steps must be performed in rapid succession. Otherwise the valves and the transmitter may be heated up impermissibly leading to damage.

8.2.1 Measuring gases

Operate the shutoff fittings in the following order:

Initial position: all valves closed

1. Open both shutoff valves (5) at the pressure taps.
2. Open the compensation valve (2).
3. Open the active pressure valve (3A or 3B).
4. Check and correct zero (4 mA) if necessary at start of scale 0 mbar.
5. Close the compensation valve (2).
6. Open the other active pressure valve (3B or 3A).

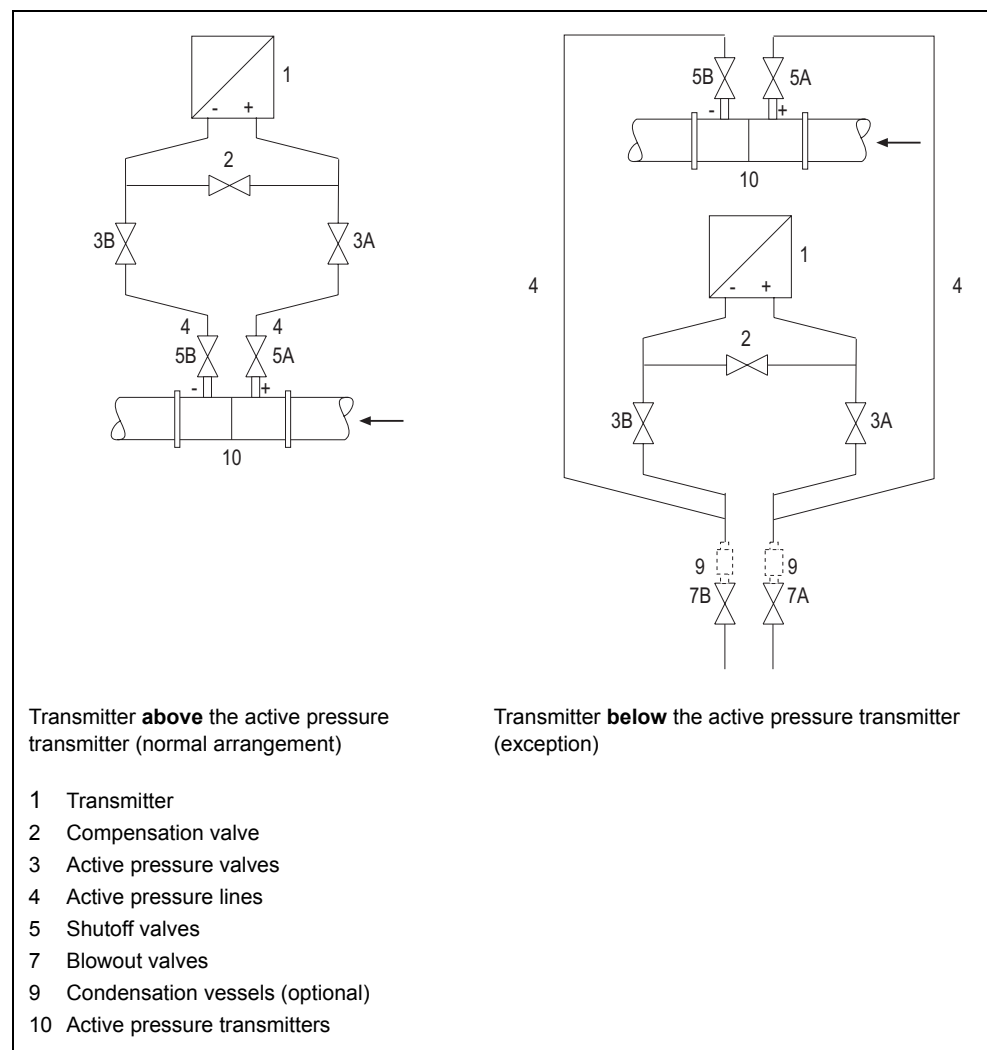

Figure 55 Measuring gases

8.2.2 Measuring liquids

Operate the shutoff fittings in the following order:

Initial position: all valves closed

1. Open both shutoff valves (5) at the pressure taps.
2. Open the compensation valve (2).
3. In the **transmitter below the active pressure transmitter** open both blowout valves (7) one after the other, in the **transmitter above the active pressure transmitter** open both vent valves (8) slightly until air-free liquid emerges.
4. Close both blowout valves (7) or vent valves (8).
5. Open the active pressure valve (3A) and the vent valve at the high pressure chamber of the transmitter (1) slightly until air-free liquid emerges.
6. Close the vent valve.
7. Open the vent valve at the low pressure chamber of the transmitter (1) slightly until air-free liquid emerges.
8. Close the active pressure valve (2).
9. Open the active pressure valve (3B) slightly until air-free liquid emerges, then close it.
10. Close the vent valve at the low pressure chamber (1).
11. Open the active pressure valve (3A) by $\frac{1}{2}$ turns.
12. Check and correct zero (4 mA) if necessary at start of scale 0 bar.
13. Close the compensation valve (2).
14. Open the active pressure valves (3A or 3B) fully.

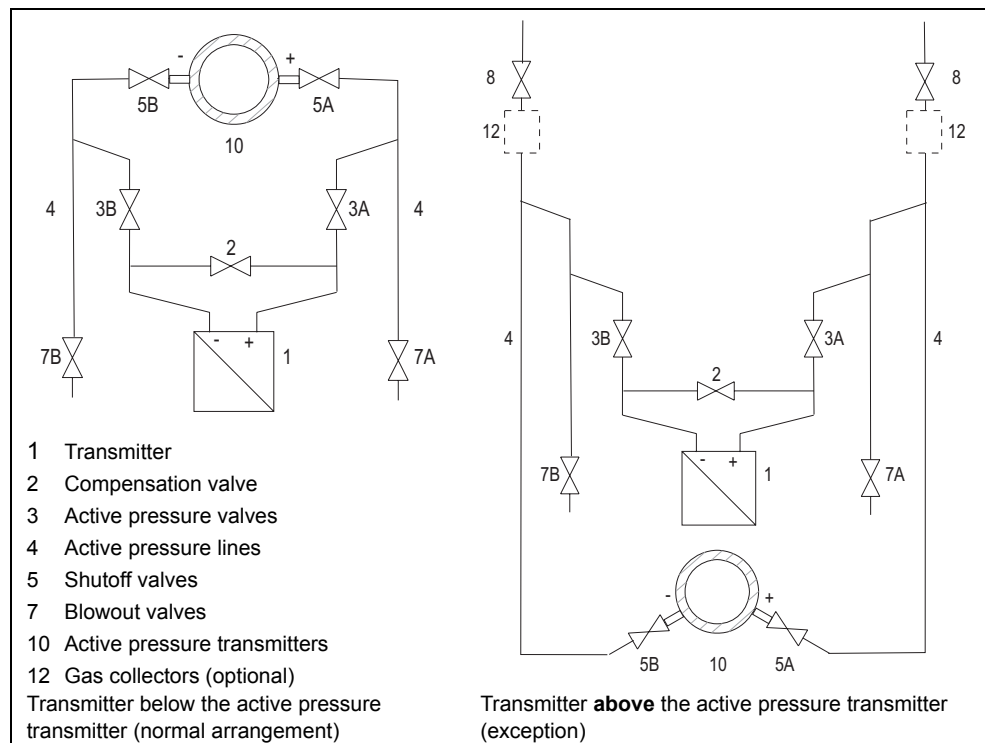

Figure 56 Measuring liquids

**WARNING**

The transmitter may not be bled when toxic media are used.

8.2.3 Measuring vapor

Operate the shutoff fittings in the following order:

Initial position: all valves closed

1. Open both shutoff valves Figure 57, pg. 101, 5 at the pressure taps.
2. Open the compensation valve (2).
3. Wait until the vapor in the active pressure lines (4) and in the compensation vessels (13) has condensed.
4. Open the active pressure valve (3A) and the vent valve at the high pressure chamber of the transmitter (1) slightly until air-free condensate emerges.
5. Close the vent valve.
6. Open the vent valve at the low pressure chamber of the transmitter (1) slightly until air-free condensate emerges.
7. Close the active pressure valve (3A).
8. Open the active pressure valve (3B) slightly until air-free condensate emerges, then close it.
9. Close the vent valve at the low pressure chamber (1).
10. Open the active pressure valve (3A) by $\frac{1}{2}$ turns.
11. Check and correct zero (4 mA) if necessary at start of scale 0 bar.
12. Close the compensation valve (2).
13. Open the active pressure valves (3A and 3B) fully.

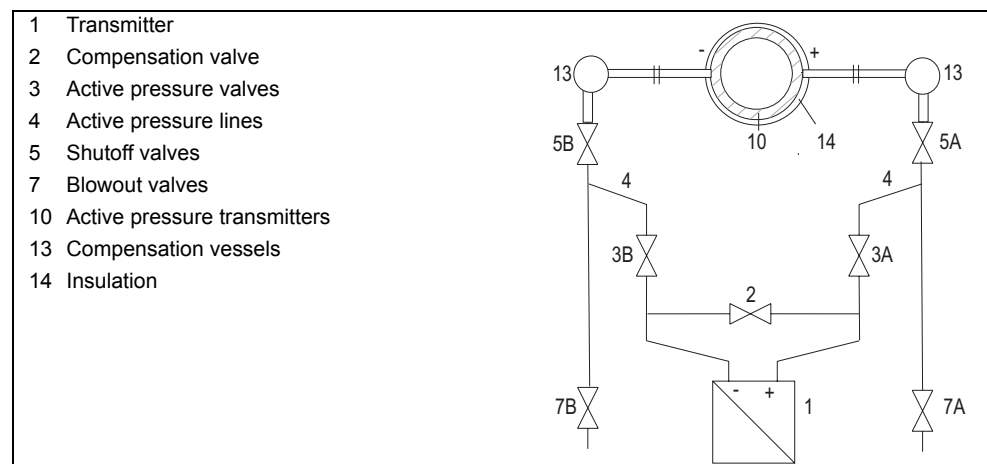

Figure 57 Measuring vapor



CAUTION

The measuring result is only error-free when the active pressure lines (4) contain equally high condensate columns of equal temperature. Zero adjustment must be repeated if these conditions are satisfied.

If the compensation valve (2) is opened when the shutoff valves (5) and active pressure valves (3) are open simultaneously, the transmitter (1) may be damaged by flowing vapors!

Technical data

9

SITRANS P, DS III series, for	Pressure 7MF4033	Absolute pressure		Differential pressure and flow 7MF4433/ 7MF4533	Level 7MF4633
		Pressure trans- mitter series 7MF4233	Diff. pressure transmitter series 7MF4333		
Application	See page 11				
Mode of operation	See page 16				
Measuring principle	Piezo-resistive				
Input					
Measured variable	Pressure	Absolute pressure		Differential pressure and flow	Level
Measuring range					
• Span (continuously adjustable)	0.01 to 400 bar (0.145 to 5802 psi)	8.3 mbar to 30 bar (0.12 to 435 psi)	8.3 mbar to 160 bar (0.12 to 2320 psi)	1 mbar to 20 mbar (0.0145 to 0.29 psi) 1 mbar to 30 bar (0.0145 to 435 psi) 2.5 mbar to 30 bar (0.036 to 435 psi)	25 mbar to 5 bar (0.36 to 72.5 psi)
- Nominal pressure PN 32 (MWP 464 psi)					
- Nominal pressure PN 160 (MWP 2320 psi)					
- Nominal pressure PN 420 (MWP 6092 psi)					
• Lower measuring limit					
- Measuring cell with silicone oil filling	30 mbar (0.44 psi) (absolute)	0 mbar (0 psi) (absolute)		-100% ¹⁾ of max. span or 30 mbar (0.44 psi) (absolute)	-100% of max. span or 30 mbar (0.44 psi) (abs.) depend- ing on mounting flange
- Measuring cell with inert filling liquid					
For process temperature -20 °C < ϑ ≤ 60 °C (-4 °F < ϑ ≤ +140 °F)	30 mbar (0.44 psi) (absolute)			-100% ¹⁾ of max. span or 30 mbar (0.44 psi) (absolu- te)	
For process temperature +60 °C < ϑ ≤ 100 °C (max. +85 °C for 30-bar measuring cell) (140 °F < ϑ ≤ 212 °C (max. +185 °F for 435 psi measuring cell))	30 mbar (abs.) + 20 mbar (abs.) · (ϑ - 60 °C)/°C (0.44 psi (abs.) + 0.29 psi (abs.) · (ϑ - 108 °F)/°F)			• -100% ¹⁾ of max. span or • 0 mbar (abs.) + 20 mbar (abs.) x (ϑ - 60 °C)/°C • (0.44 psi (abs.) + 0.29 psi (abs.) · (ϑ - 108 °F)/°F)	
• Upper measuring limit	100% of max. span (max. 160 bar (2320 psi) with oxygen measurement and inert filling liquid)				100% of max. span
• Start-of-scale (continuously adjustable)	Between the measuring limits				
Output					
Output signal	4 to 20 mA				
• Lower limit (continuously adjustable)	3.55 mA, factory-set to 3.84 mA				
• Upper limit (continuously adjustable)	23.0 mA, factory-set to 20.5 mA or optional 22.0 mA				
• Ripple (without HART communication)	$I_{pp} \leq 0.5\%$ of max. output current				
• Electric damping					
- Adjustable time constant (T_{63})	0 to 100 s in steps of 0.1 s, factory-set to 0.1 s				
• Current transmitter	Adjustable from 3.55 to 23 mA				
• Signal on alarm	Adjustable from 3.55 to 23 mA				
Load					
• Without HART communication	$R_B \leq (U_{i1} - 10.5 \text{ V}) / 0.023 \text{ A}$ in Ω , U_{i1} : power supply in V				
• With HART communication	$R_B = 230$ to 500Ω (HART communicator) / 230 to 1100Ω (SIMATIC PDM)				
Characteristic	Linear rising or falling or square-rooted, rising				

¹⁾ -33% for 30-bar (435 psi) measuring cell

SITRANS P, DS III series, for	Pressure 7MF4033	Absolute pressure Pressure trans- mitter series 7MF4233	Diff. pressure transmitter series 7MF4333	Differential pressure and flow 7MF4433/ 7MF4533	Level 7MF4633
Accuracy	Increasing characteristic, start-of-scale value 0 bar (0 psi), stainless steel seal diaphragm (with level: mounting flange without tube), silicone oil filling and room temperature (25 °C (77 °F)) r = max. span/set span = span ratio				
Reference conditions					
Error in measurement with fixed-point setting (including hysteresis and repeatability)					
- Linear characteristic					
r ≤ 10	≤ (0.0029 · r + 0.071)%			≤ 0.15%	
10 < r ≤ 30	≤ (0.0045 · r + 0.071)%			≤ 0.3%	
30 < r ≤ 100	≤ (0.005 · r + 0.05 %)			≤ (0.005 · r + 0.05%)	≤ (0.0075 · r + 0.075%)
- Square-root characteristic					
Flow > 50%				≤ 0.1% at r ≤ 10 ≤ 0.2% at 10 < r ≤ 30	
Flow 25 to 50%				≤ 0.2% at r ≤ 10 ≤ 0.4% at 10 < r ≤ 30	
• Repeatability	Included in error in measurement				
• Hysteresis	Included in error in measurement				
Response time (T ₆₃ , without electric damping)	Approx. 0.2 s	Approx. 0.2 s		Approx. 0.2 s, approx. 0.3 s with 20- and 60-mbar (0.29 and 0.87 psi) measuring cells	Approx. 0.2 s
Long-term drift (change in temperature ±30 °C (±54 °F))	≤ (0.25 · r)% per 5 years	≤ (0.2 · r)% per year		≤ (0.25 · r)% per 5 years, max. static pressure 70 bar (1015 psi)	
- 20-mbar (0.29 psi) measuring cell				≤ (0.2 · r)% per year	
Ambient temperature effect					
• At -10 to +60 °C (14 to 140 °F)	≤ (0.1 · r + 0.2)% ¹⁾				
- 250-mbar (3.63 psi) measuring cell				≤ (0.5 · r + 0.2) ²⁾ %	
- 600-mbar (8.7 psi) measuring cell				≤ (0.3 · r + 0.2) ²⁾ %	
- 1,600- and 5,000-mbar (23.2 and 72.5 psi) measuring cells				≤ (0.25 · r + 0.2) ²⁾ %	
• At -40 to -10 °C and +60 to +85 °C (-40 to +14 °F and 140 to 185 °F)	≤ (0.1 · r + 0.15)% / 10 K ¹⁾ (≤ (0.1 · r + 0.15)% / 18 °F) ¹⁾				
- 250-mbar (3.63 psi) measuring cell				≤ (0.25 · r + 0.15) ³⁾ % / 10 K (≤ (0.25 · r + 0.15) ³⁾ % / 18 °F)	
- 600-mbar(8.7 psi) measuring cell				≤ (0.15 · r + 0.15) ³⁾ % / 10 K (≤ (0.15 · r + 0.15) ³⁾ % / 18 °F)	
- 1,600- and 5,000-mbar (23.2 and 72.5 psi) measuring cells				≤ (0.12 · r + 0.15) ³⁾ % / 10 K (≤ (0.12 · r + 0.15) ³⁾ % / 18 °F)	
Influence of static pressure					
• On start-of-scale				≤ (0.15 · r)% per 100 bar (1450 psi)	
- 20-mbar (0.29 psi) measuring cell				≤ (0.15 · r)% per 32 bar (464 psi)	
- 250-mbar (3.63 psi) measuring cell				≤ (0.3 · r)% per nominal pressure (PN (MWP))	
- 600-mbar (8.7 psi) measuring cell				≤ (0.15 · r)% per nominal pressure (PN (MWP))	
- 1,600- and 5,000-mbar (23.2 and 72.5 psi) measuring cells				≤ (0.1 · r)% per nominal pressure (PN (MWP))	

¹⁾ Twice the value with 20-mbar (0.29 psi) measuring cell.

²⁾ 0.4 instead of 0.2 for 10 < r ≤ 30.

³⁾ Twice the value for 10 < r ≤ 30.

SITRANS P, DS III series, for	Absolute pressure		Differential pressure and flow 7MF4433/ 7MF4533	Level 7MF4633
	Pressure 7MF4033	Pressure trans- mitter series 7MF4233		
<ul style="list-style-type: none"> On span - 20-mbar (0.29 psi) measuring cell 			<ul style="list-style-type: none"> ≤ 0.2% per 100 bar (1450 psi) ≤ 0.2% per 32 bar (464 psi) 	≤ (0.1 · r)% per nominal pressure (PN (MWP))
Influence of mounting position	≤ 0.05 mbar (0.000725 psi) per 10° inclination (can be corrected using zero correction)	≤ 0.7 mbar (0.001015 psi) per 10° inclination (can be corrected using zero correction)		Dependent on filling liquid in mounting flange
Influence of power supply	0.005% per 1 V change in voltage			
Rated operating conditions				
Installation conditions				
<ul style="list-style-type: none"> Installation instructions 	Process connection pointing vertically downwards		Any mounting position	Defined by flange
Ambient conditions				
<ul style="list-style-type: none"> Ambient temperature (observe temperature class in potentially explosive atmospheres) - Measuring cell with silicone oil filling 30-bar (435 psi) measuring cell - Measuring cell with inert filling liquid - Digital display 				
			-40 to +85 °C (-40 to +185 °F)	
			-40 to +85 °C (-40 to +185 °F) (-20 to +85 °C (-4 to +185 °F) with 7MF4533)	
			-20 to +85 °C (-4 to +185 °F)	
			-30 to +85 °C (-22 to +185 °F)	
<ul style="list-style-type: none"> Ambient temperature limits Storage temperature 			See ambient temperature	
<ul style="list-style-type: none"> Climate class - Condensation 			Permissible	
<ul style="list-style-type: none"> Degree of protection (to EN 60 529) 			IP 65	
<ul style="list-style-type: none"> Electromagnetic compatibility - Emitted interference - Noise immunity 			To EN 50 081-1 To EN 50 082-2 and NAMUR NE 21	
Medium conditions				
<ul style="list-style-type: none"> Process temperature - Measuring cell with silicone oil filling 30-bar (435 psi) measuring cell - Measuring cell with inert filling liquid 30-bar (435 psi) measuring cell 				High-press. side: s. mounting flange Low-press. side: -40 to +100 °C
			-40 to +100 °C (-40 to +212 °F)	
			-40 to +85 °C (-40 to +185 °F) (-20 to +85 °C (-4 to +185 °F) for 7MF4533)	
			-20 to +100 °C (-4 to +212 °F)	
			-20 to +85 °C (-4 to +185 °F)	
<ul style="list-style-type: none"> Process temperature limits Maximum working pressure 			See process temperature	Nominal pressure (PN (MWP))
			See page 108	
Design				
Weight (without options)	Approx. 1.5 kg (3.3 lb)		Approx. 4.5 kg (9.9 lb)	
<ul style="list-style-type: none"> To DIN (transmitter with mounting flange, without tube) To ANSI (transmitter with mounting flange, without tube) 				Approx. 11 to 13 kg (24.2 to 28.7 lb) Approx. 11 to 18 kg (24.2 to 39.7 lb)
Dimensions	See Fig. 58	See Fig. 159	See Fig. 60	See Fig. 61

SITRANS P, DS III series, for	Pressure	Absolute pressure		Differential pressure and flow	Level
	7MF4033	Pressure transmitter series 7MF4233	Diff. pressure transmitter series 7MF4333	7MF4433/ 7MF4533	7MF4633
Design (continued)					
Material					
• Wetted parts materials					
- Connection shank	Stainless steel, mat. No. 1.4401 or Hastelloy C4, mat. No. 2.4610				
- Oval flange	Stainless steel, mat. No. 1.4401				
- Seal diaphragm	Stainless steel, mat. No. 1.4404/316L or Hastelloy C276, mat. No. 2.4819		Stainless steel, mat. No. 1.4404/316L, Hastelloy C276, mat. No. 2.4819, Monel, mat. No. 2.4360, tantalum or gold		
- Process flanges and sealing screw			Stainless steel, mat. No. 1.4408 up to PN 160 (MWP 2320 psi), mat. No. 1.4571/316Ti for PN 420 (MWP 6092 psi), Hastelloy C4, mat. No. 2.4610 or Monel, mat. No. 2.4360		
- O-ring			FPM (Viton) or as option: PTFE, FEP, FEPM and NBR		
- High-pressure side					
Seal diaphragm of mounting flange					Stainl. st., mat. No. 1.4571/316Ti, Monel 400, mat. No. 2.4360, Hastelloy B2, mat. No. 2.4617, Hastelloy C276, mat. No. 2.4819, Hastelloy C4, mat. No. 2.4610, tantalum, PTFE, ECTFE
Sealing face					Smooth to DIN 2526 form D or ANSI B16.5 RF for stainl. steel, mat. No. 1.4571/316Ti, DIN 2526 form E or ANSI B16.5 RFSF for other materials
- Sealing material in the process flanges					Viton
For standard applications					Copper
For vacuum appl. of mounting flange					
- Low-pressure side					
Seal diaphragm					Stainless steel, mat. No. 1.4404/316L
Process flanges and sealing screw					Stainless steel, mat. No. 1.4408
O-ring					FPM (Viton)
• Non-wetted parts materials					
- Electronics housing	Die-cast aluminium, low in copper, GD-ALSi 12, or stainless steel precision casting, polyester-based lacquer, stainless steel rating plate				
- Process flange screws			Steel, galvanized and yellow-passivized, or stainless steel		
- Mounting bracket (option)	Steel, galvanized and yellow-passivized, or stainless steel				
Measuring cell filling	Silicone oil or inert filling liquid (max. 160 bar (2320 psi) with oxygen measurement)				Silicone oil
• Filling liquid of mounting flange					Silicone oil or other material
Process connection	Connection shank G½A to DIN 16 288, female thread ½ - 14 NPT or oval flange (PN 160 (MWP 2320 psi)) with mounting thread M10 or 7/16-20 UNF		Female thread ¼ - 18 NPT and flange connection to DIN 19 213 with mounting thread M10 (M12 for PN 420 (MWP 6092 psi)) or 7/16-20 UNF		
• High-pressure side					Flange to DIN and ANSI
• Low-pressure side					Female thread ¼ - 18 NPT and flange connection to DIN 19 213 with mounting thread M10 or 7/16-20 UNF
Electrical connection	Screw terminals, cable inlet via screwed gland Pg 13.5 (adapter), M20 x 1.5 or ½ - 14 NPT, or Han 7D/Han 8U plug				

SITRANS P, DS III series, for	Pressure 7MF4033	Absolute pressure		Differential pressure and flow 7MF4433/ 7MF4533	Level 7MF4633
		Pressure transmitter series 7MF4233	Diff. pressure transmitter series 7MF4333		
Displays and controls					
Input keys	3 for local programming directly on transmitter				
Digital display	Built-in, cover with window (option)				
Power supply (U_H)					
Terminal voltage on transmitter	DC 10.5 to 45 V and DC 10.5 to 30 V in intrinsically-safe mode				
Ripple	$U_{pp} \leq 0.2$ V (47 to 125 Hz)				
Noise	$U_{rms} \leq 1.2$ mV (0.5 to 10 kHz)				
Certificates and approvals					
Classification according to pressure equipment directive (DGRL 97/23/EC):	7MF4033, 7MF4233, 7MF4333, 7MF4433, 7MF4633 For gases of fluid group 1 and liquids of fluid 1; complies with requirements of article 3, paragraph 3 (sound engineering practice)				
	7MF4533 For gases of fluid group 1 and liquids of fluid group 1; complies with basic safety requirements of article 3, paragraph 1 (appendix 1); assigned to category III, conformity evaluation module H by the TÜV Nord				
Explosion protection					
• Intrinsic safety "i"	PTB 99 ATEX 2122				
- Identification	II 1/2 G EEx ia IIC/IIB T4 / T5 / T6; EEx ib IIC/IIB T4 / T5 / T6				
- Permissible ambient temperature	-40 to +85 °C (-40 to +185 °F) temperature class T4, +70 °C (158 °F) temperature class T5, +60 °C (140 °F) temperature class T6				
- Connection	To certified intrinsically-safe circuits with maximum values: $U_i = 30$ V, $I_i = 100$ mA, $P_i = 750$ mW, $R_i = 300$ Ω				
- Effective internal inductance/capacitance	$L_i = 0.4$ mH / $C_i = 6$ nF				
• Explosion-proof "d"	PTB 99 ATEX 1160				
- Identification	II 1/2 G EEx d IIC T4 / T6				
- Permissible ambient temperature	-40 to +85 °C (-40 to +185 °F) temperature class T4, +60 °C (140 °F) temperature class T6				
- Connection	To circuits with values: $U_H =$ DC 10.5 to 45 V				
• Type of protection "n" (zone 2)	TÜV 01 ATEX 1696 X				
- Identification	II 3 G EEx nA L IIC T4 / T5 / T6				
- Permissible ambient temperature	-40 to +85 °C (-40 to +185 °F) temperature class T4, +70 °C (158 °F) temperature class T5, +60 °C (140 °F) temperature class T6				
- Connection	To circuits with values: $U_H =$ DC 10.5 to 45 V				
• Explosion protection to FM	Certificate of Compliance 3008490				
- Identification (XP/DIP) or (IS); (NI)	CL I, DIV 1, GP ABCD T4 to T6; CL II, DIV 1, GP EFG; CL III; CL I, ZN 0/1 AEx ia IIC T4...T6; CL I, DIV 2, GP ABCD T4...T6; CL II, DIV 2, GP FG; CL III				
- Permissible ambient temperature	Ta = T4: -40 to 85 °C (-40 to +185 °F); T5: -40 to 70 °F (-40 to 158 °F); T6: -40 to 60 °C (-40 to 140 °F)				
- Entity parameters	According to control drawing A5E00072770A: $U_i = 30$ V, $I_i = 100$ mA, $P_i = 750$ mW, $R_i = 300$ Ω , $L_i = 0.4$ mH, $C_i = 6$ nF				
• Explosion protection to CSA	Certificate of Compliance 1153651				
- Identification (XP/DIP) or (IS)	CL I, DIV 1, GP ABCD T4toT6; CL II, DIV 1, GP EFG; CL III; Ex ia IIC T4...T6; CL I, DIV 2, GP ABCD T4...T6; CL II, DIV 2, GP FG; CL III				
- Permissible ambient temperature	Ta = T4: -40 to 85 °C (-40 to +185 °F); T5: -40 to 70 °F (-40 to 158 °F); T6: -40 to 60 °C (-40 to 140 °F)				
- Entity parameters	According to control drawing A5E00072770A: $U_i = 30$ V, $I_i = 100$ mA, $P_i = 750$ mW, $R_i = 300$ Ω , $L_i = 0.4$ mH, $C_i = 6$ nF				
Communication					
Load when connecting a					
• HART communicator	230 to 1100 Ω				
• HART modem	230 to 500 Ω				
Cable	2-wire screened: ≤ 3.0 km (1.86 miles), multi-core screened: ≤ 1.5 km (0.93 miles)				
Protocol	HART, version 5.x				
PC/laptop requirements	IBM-compatible, main memory > 32 Mbyte, hard disk > 70 Mbyte, RS 232 interface, VGA graphics				
Software for PC/laptop	Windows 95 / 98 / NT 4.0 and SIMATIC PDM				

9.1 Measuring spans/medium pressure limits and overload limits

9.1.1 Pressure

Measuring span continuously adjustable	max. perm. operating pressure $p_S^*)$	max. perm. test pressure $**)$
0,01 to 1 bar = 1 kPa to 100,0 kPa	4 bar	6 bar
0,04 to 4 bar = 4 kPa to 400,0 kPa	7 bar	10 bar
0,16 to 16 bar = 16 kPa to 1,6 MPa	21 bar	32 bar
0,63 to 63 bar = 63 kPa to 6,3 MPa	67 bar	100 bar
1,60 to 160 bar = 160 kPa to 16,0 MPa	167 bar	250 bar
4,00 to 400 bar ¹⁾ = 400 kPa to 40,0 MPa ¹⁾	400 bar	600 bar

¹⁾ for oxygen measurement max. 160 bar

^{*)} according to 97/23/EC pressure transmitter regulation

^{**)} according to DIN 16086

9.1.2 Differential pressure and flow

Nominal pressure	Measuring span continuously adjustable
PN 32 ³⁾	1.0 to 20 mbar = 0.10 to 2 kPa
PN 160	1.0 to 60 mbar = 0.10 to 6 kPa
PN 160	1.0 to 20 mbar = 0.10 to 2 kPa
or	1.0 to 60 mbar = 0.10 to 6 kPa
PN 420 ¹⁾²⁾	2.5 to 250 mbar = 0.25 to 25 kPa
	6.0 to 600 mbar = 0.60 to 60 kPa
	16.0 to 1,600 mbar = 1.60 to 160 kPa
	50.0 to 5,000 mbar = 5.00 to 500 kPa
	300.0 to 30,000 mbar = 30.00 to 3,000 kPa

¹⁾ for oxygen measurement max. 160 bar

²⁾ measuring cell filling only silicone oil

³⁾ not suitable for remote seal mounting

9.1.3 Absolute pressure from the pressure series

Measuring span	max. perm. operating pressure $p_s^*)$	max. perm. test pressure $^{**)}$
8.30 to 250 mbar = 0.83 to 25.0 kPa	1.5 bar	6 bar
43.30 to 1300 mbar = 43.33 to 160.0 kPa	2.6 bar	10 bar
166.60 to 5000 mbar = 16.60 to 500.0 kPa	10 bar	30 bar
1,000.00 to 30000 mbar = 100.00 to 3,000.0 kPa	45 bar	100 bar

*) according to 97/23/EC pressure transmitter regulation

***) according to DIN 16086

NOTE on 250 mbar cell



See below.

9.1.4 Absolute pressure from the differential pressure series

Measuring span continuously adjustable	Overload limits
8.3 to 250 mbar = 0.83 to 25.0 kPa	32 bar
43.3 to 1,300 mbar = 43.33 to 160.0 kPa	32 bar
166.6 to 5,000 mbar = 16.60 to 500.0 kPa	32 bar
1,000 to 30,000 mbar = 100.00 to 3,000.0 kPa	160 bar
5,300 to 100,000 mbar = 530.00 to 10,000.0 kPa	160 bar

NOTE on 250 mbar cell



This measuring cell is designed for operation within the measuring limits 0 mbar (absolute) to 250 mbar (absolute). When storing under normal ambient pressure of about 1000 mbar (absolute), the measuring cell is in the overload state. An overload error may occur in this. The overload error disappears in operation within the measuring limits. Then the transmitter operates again within its specification, the start of scale may have to be readjusted.

In pressure measurements with repeated exceeding of the measuring limits (e.g. batch processes with transitions between vacuum and ventilation) a measuring cell with a maximum range of 1300 mbar should be selected to avoid overloading.

9.1.5 Filling level

Measuring span continuously adjustable				Nominal pressure		
25	to	250 mbar	=	2.50	to 25.0 kPa	PN 16 or PN 40
25	to	600 mbar	=	2.50	to 60.0 kPa	
53	to	1,600 mbar	=	5.30	to 160.0 kPa	
160	to	5,000 mbar	=	16.00	to 500.0 kPa	

9.2 Dimensions

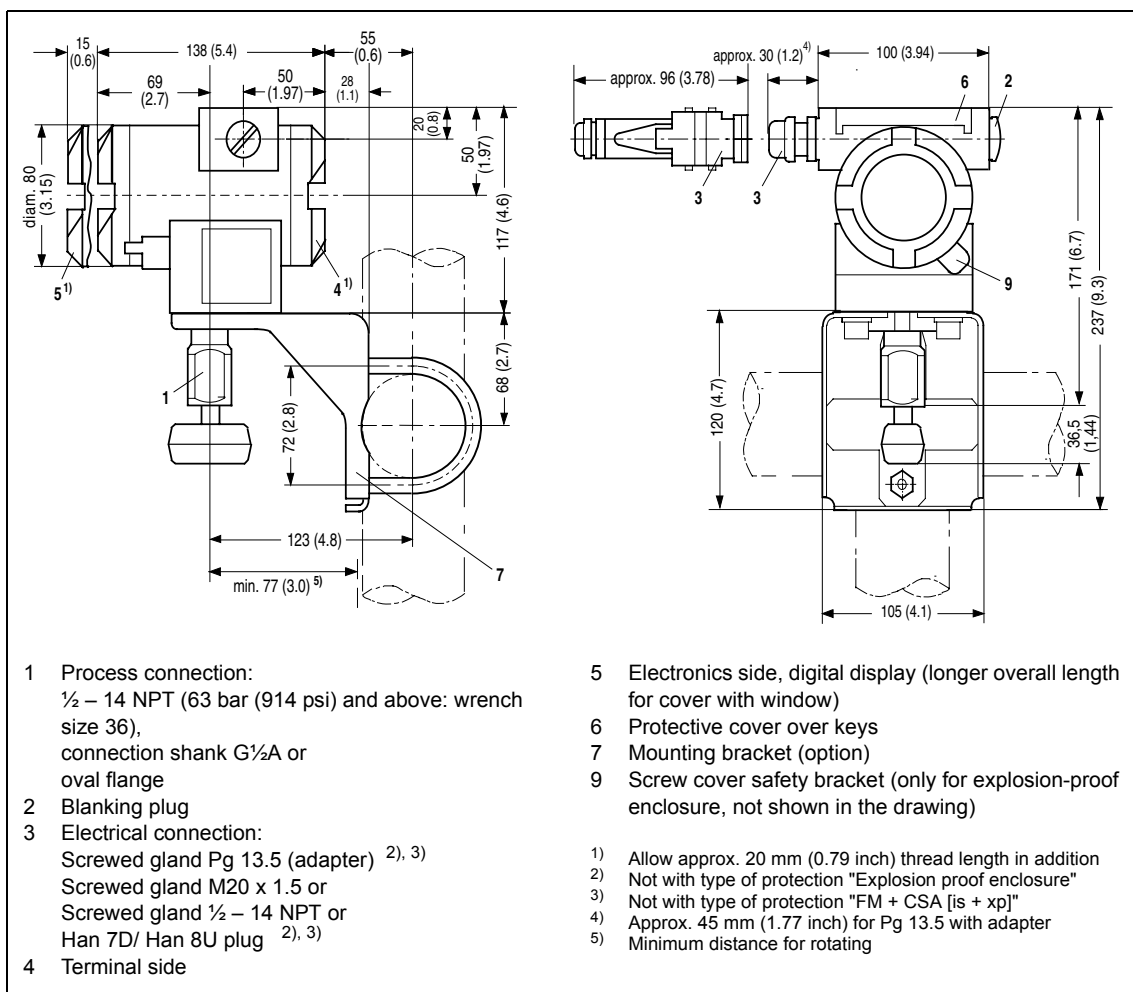

Figure 58 DS III series for pressure and absolute pressure from pressure transmitters series, dimensions in mm (inches)

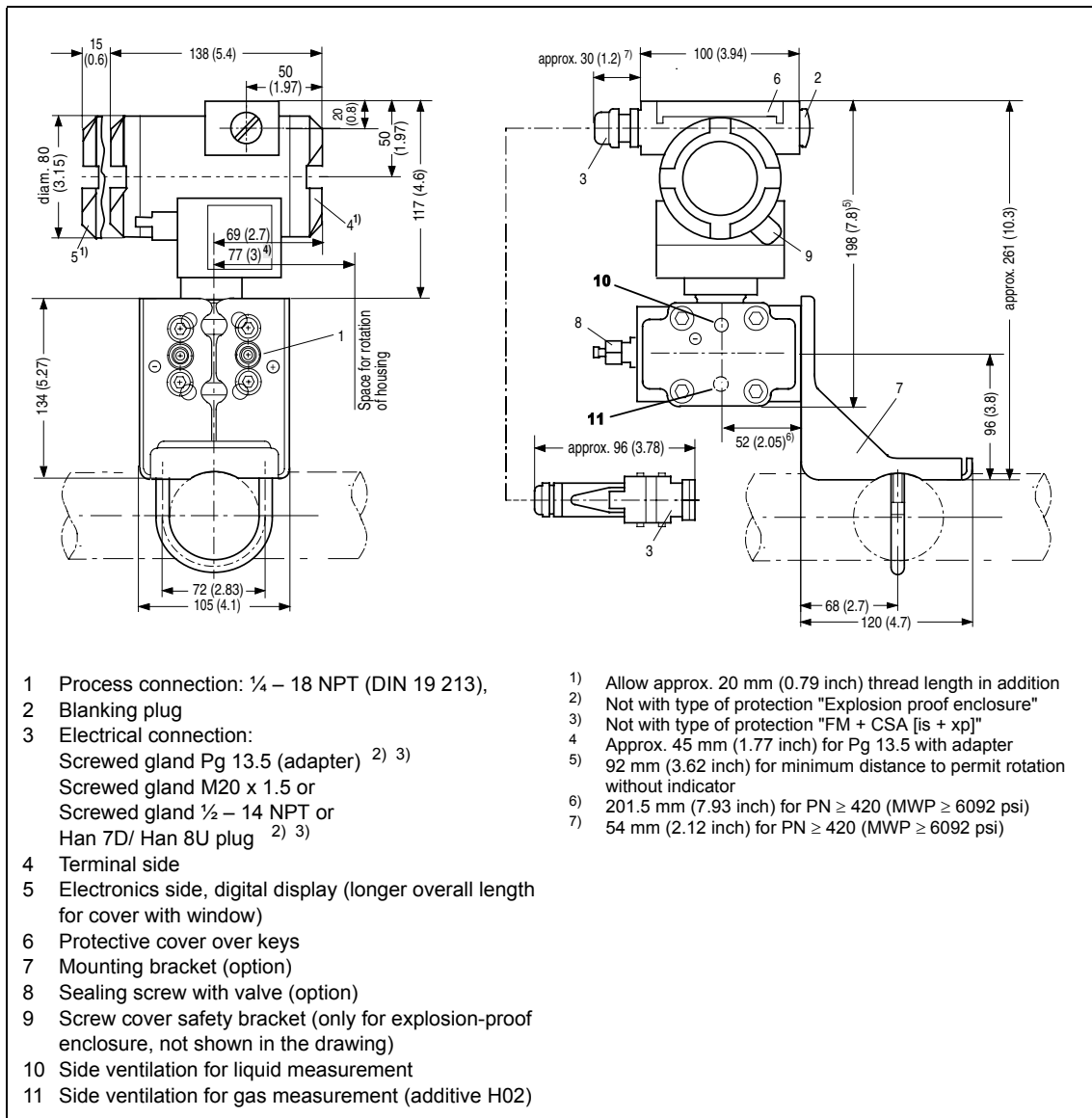

Figure 59 DS III series for differential pressure and flow as absolute pressure from differential pressure transmitter series, dimensions in mm (inches)

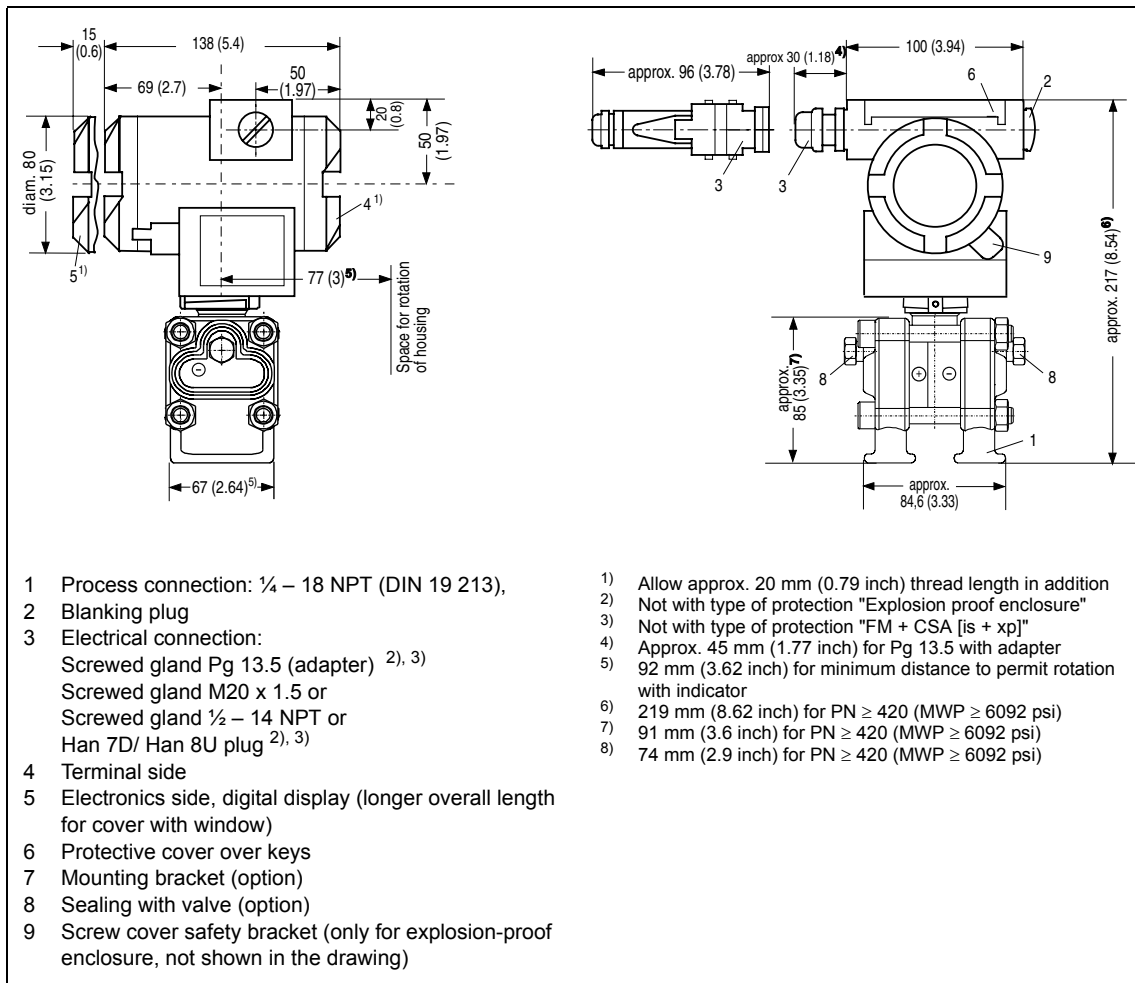

Figure 60 DS III series for differential pressure and flow as well as process covers for vertical differential pressure lines (order using Order code "H03"), dimensions in mm (inches)

A special half flange is available for better reading of the SITRANS P, DS III series transmitter's digital display. It is a particular advantage when mounting the transmitter on a valve manifold with vertical active pressure lines.

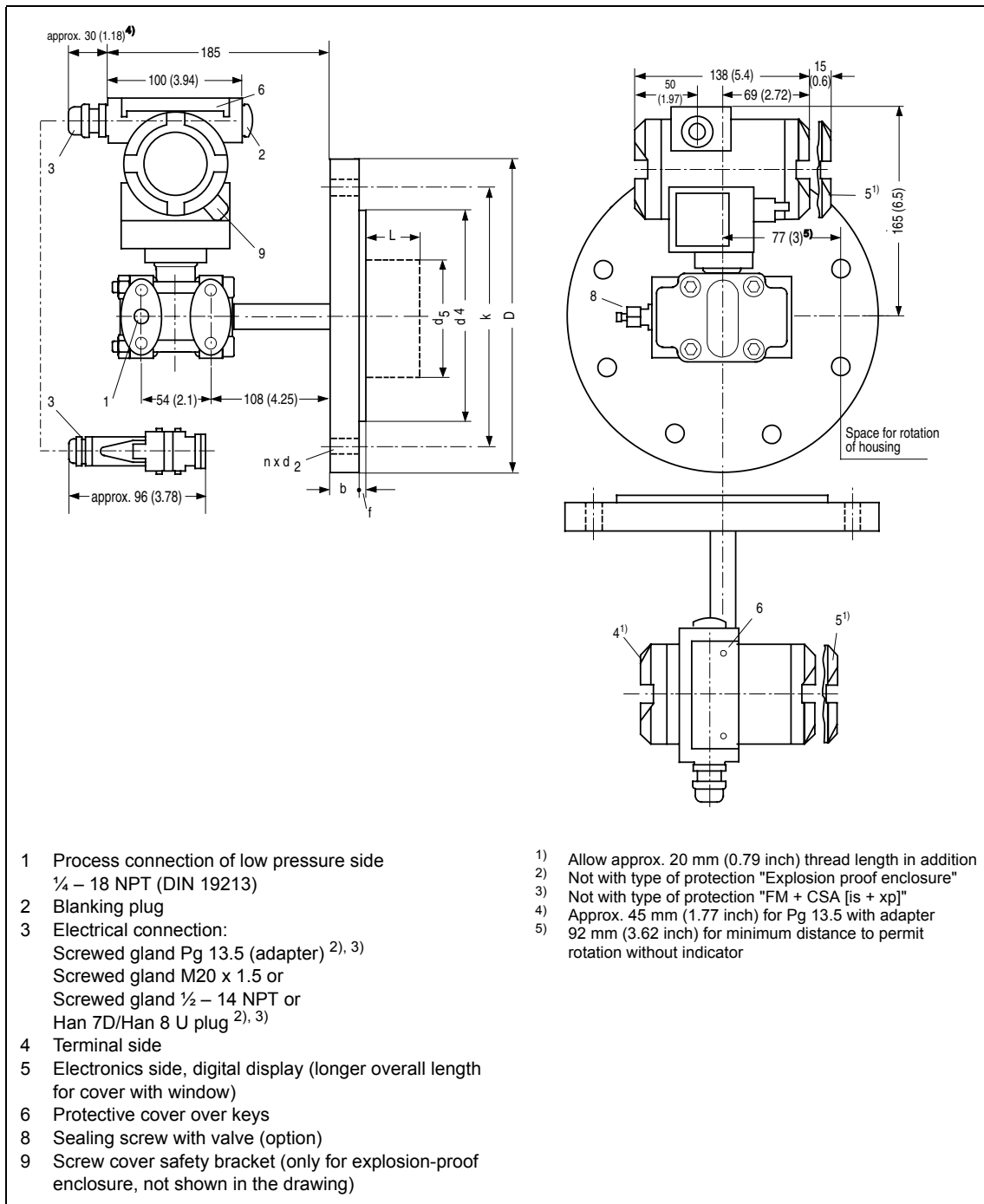

Figure 61 DS III series for level (transmitter including mounting flange), dimensions in mm (inches)

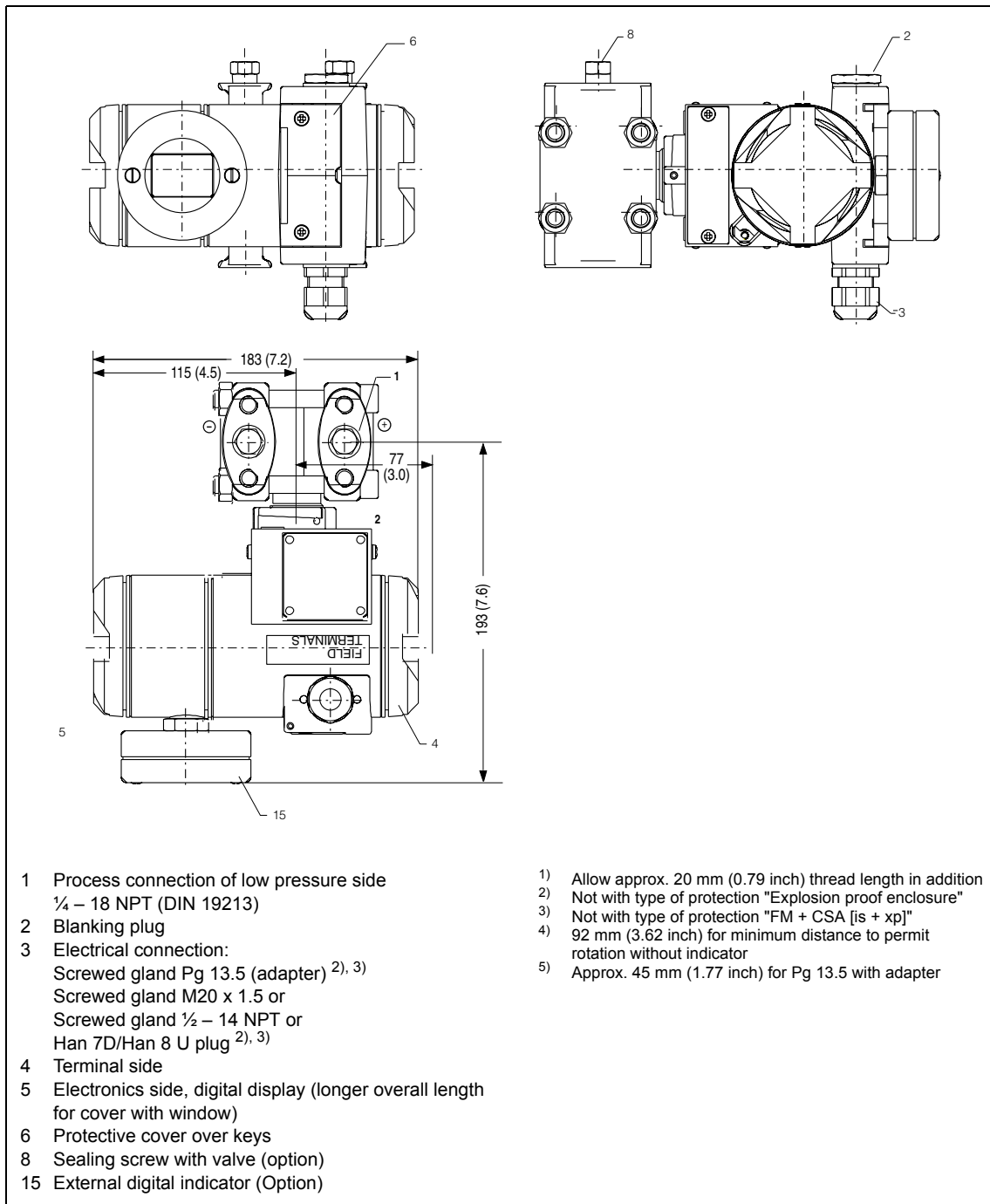

Figure 62 DS III series for differential pressure and flow as well as digital display beside input keys (order using Order code "D27"), dimensions in mm (inches)

Check the device's start of scale from time to time.

In the event of a fault decide:

- whether the internal self-test has detected a fault, e.g. sensor break, HW/FW error etc.
Displays:
 - digital display: display "ERROR" and moving error text
 - analog output: factory setting Failure current 3.6 mA or 22.8 mA or depending on the parameterization
 - HART: detailed error list for display in the HART Communicator or SIMATIC PDM
- serious hardware error the processor is not working
Displays:
 - digital display: no defined display
 - analog output: failure current < 3.6 mA

In the event of a fault you can exchange the electronics as described in Chapter 6, pg. 81 under consideration of the warnings.

Ordering data

11

See following pages.

Ordering data		Order No.	Ordering data	Order code
SITRANS P transmitter for absolute pressure, from pressure transmitter series, two-wire system, DS III series		7MF4233- ■■■■■-■■■■■	Further designs	
Meas. cell filling Meas. cell cleaning		↑↑↑↑↑↑↑↑	Please add "Z" to Order No. and specify Order code(s).	
Silicone oil	Normal	1	Transmitter with mounting bracket made of	
Inert liquid	Grease-free	3	• Steel	A01
Span		D	• Stainless steel	A02
8.3 to 250 mbar	(0.12 to 3.63 psi)	F	Han 7D plug (metal, gray)	A30
43 to 1,300 mbar	(0.62 to 18.9 psi)	G	Han 8U plug (instead of Han 7D)	A31
160 to 5,000 mbar	(2.32 to 72.5 psi)	H	Rating plate inscription (instead of German)	
1 to 30 bar	(14.5 to 435 psi)		• English	B11
Wetted parts materials		A	• French	B12
Seal diaphragm	Process connection	B	• Spanish	B13
Stainless steel	Stainless steel	C	• Italian	B14
Hastelloy	Stainless steel	Y	English rating plate, pressure units in inH ₂ O or psi	B21
Hastelloy	Hastelloy	0	Manufacturer's test certificate M to DIN 55 350, Part 18 and to ISO 8402	C11
Version for remote seal ¹⁾		1	Acceptance test certificate B to EN 10 204-3.1 B	C12
Process connection		0	Factory certificate to EN 10 204-2.2	C14
• Connection shank G½A		1	Setting of upper limit of output signal to 22.0 mA	D05
• Female thread ½ - 14 NPT		2	Acid gas version to NACE (only together with seal diaphragm made of Hastelloy)	D07
• Oval flange made of stainless steel, max. span 160 bar (2320 psi)		3	IP 68 (not together with Han 7D/Han 8U plug, Pg 13.5 screwed gland)	D12
- Mounting thread 7/16 - 20 UNF			Digital indicator beside control keys (only with transmitter 7MF4233-■■■■■0-■A■6 or 7MF4233-■■■■■0-■A■7-Z, Y21 or Y22 + Y01)	D27
- Mounting thread M10			Use in or on zone 1D/2D (only together with basic device with type of protection "Intrinsically-safe")	E01
Non-wetted parts materials		0	Use in zone 0 (basic unit EEx ia)	E02
• Housing made of die-cast aluminium		3	Oxygen application (max. 160 bar (2320 psi) with oxygen measurement and inert filling liquid)	E10
• Housing stainl. steel precision casting			Additional information	
Design			Please add "Z" to Order No. and specify Order code(s) and plain text.	
• Standard version			Measuring range to be set, specify in plain text:	
• International version, English label inscriptions, documentation in 5 languages on CD			Y01: ... to ... mbar, bar, kPa, MPa, psi, ...	Y01
Explosion protection		A	Measuring-point number/identification (max. 16 characters), specify in plain text: Y15:	Y15
• Without explosion protection		B	Measuring-point text (max. 27 characters), specify in plain text: Y16:	Y16
• With explosion protection (CENELEC)		D	Entry of HART address (TAG) (max. 8 characters), specify in plain text: Y17:	Y17
Type of protection:		P	Setting for digital display in pressure units, specify in plain text (standard setting: mA):	
- "Intrinsic safety" (EEx ia)		E	Y21: mbar, bar, kPa, MPa, psi, ...	Y21
- "Explosion-proof" (EEx d) ²⁾		N	(see "Additional information" on page 118 for pressure dimensions selectable for "Y21")	
- "Intrinsic safety and explosion-proof" (EEx ia and EEx d) ²⁾		C	Setting for digital display in non-pressure units, specify in plain text:	
- "n" (zone 2)			Y22: to l/min, m³/h, m, USgpm, ...	Y22 + Y01
• With explosion protection (FM + CSA)			(specification of measuring range in pressure units (Y01) is essential)	
- intrinsic safe and explosion-proof (is + xp) ²⁾				
Electrical connection/cable inlet		A		
• Screwed gland Pg 13.5 ³⁾		B		
• Screwed gland M20 x 1.5		C		
• Screwed gland ½ - 14 NPT		D		
• Han 7D plug ³⁾				
Indicator				
• Without indicator (digital display hidden, setting: mA)				
• With indicator (digital display visible, setting: mA)		1		
• With indicator (digital display visible, setting as specified, Order code Y21 or Y22 required)		6		
		7		

Only the settings for "Y01", "Y21", "Y22" and "D05" can be made in the factory.

Example for ordering: see page 118

Scope of delivery: Transmitter as ordered (Instruction Manual is extra ordering item (see accessories on page 132)).

¹⁾ Version 7MF4233-1DY... only up to max. span 200 mbar (2.9 psi)

²⁾ Without cable gland.

³⁾ Not together with type of protection "Explosion-proof".

Ordering data	Order No.	Ordering data	Order code																																																																												
<p>SITRANS P transmitter for absolute pressure, from differential pressure transmitter series, two-wire system, DS III series</p> <p>Meas. cell filling Meas. cell cleaning</p> <table border="1"> <tr> <td>Silicone oil</td> <td>Normal</td> </tr> <tr> <td>Inert liquid</td> <td>Grease-free</td> </tr> </table> <p>Span</p> <table border="1"> <tr> <td>8.3 to 250 mbar</td> <td>(0.12 to 3.63 psi)</td> </tr> <tr> <td>43 to 1,300 mbar</td> <td>(0.62 to 18.9 psi)</td> </tr> <tr> <td>160 to 5,000 mbar</td> <td>(2.32 to 72.5 psi)</td> </tr> <tr> <td>1.0 to 30 bar</td> <td>(14.5 to 435 psi)</td> </tr> <tr> <td>5.3 to 100 bar</td> <td>(76.9 to 1,450 psi)</td> </tr> </table> <p>Wetted parts materials</p> <table border="1"> <tr> <th>Seal diaphragm</th> <th>Parts of meas. cell</th> </tr> <tr> <td>Stainless steel</td> <td>Stainless steel</td> </tr> <tr> <td>Hastelloy</td> <td>Stainless steel</td> </tr> <tr> <td>Hastelloy</td> <td>Hastelloy</td> </tr> <tr> <td>Tantalum</td> <td>Tantalum</td> </tr> <tr> <td>Monel</td> <td>Monel</td> </tr> <tr> <td>Gold</td> <td>Gold</td> </tr> <tr> <td colspan="2">Version for remote seal 1)</td> </tr> </table> <p>Process connection</p> <p>Female thread 1/4 - 18 NPT with flange connection to DIN 19 213</p> <ul style="list-style-type: none"> With sealing screw opposite process connection <ul style="list-style-type: none"> - Mounting thread M10 - Mounting thread 7/16 - 20 UNF Sealing screw on side of process flanges 2) <ul style="list-style-type: none"> - Mounting thread M10 - Mounting thread 7/16 - 20 UNF <p>Non-wetted parts materials</p> <table border="1"> <tr> <th>Process flange</th> <th>Electronics housing screws</th> </tr> <tr> <td>Stainless steel</td> <td>Die-cast aluminium</td> </tr> <tr> <td>Stainless steel</td> <td>Stain. steel prec. cast.</td> </tr> </table> <p>Design</p> <ul style="list-style-type: none"> Standard version International version, English label inscriptions, documentation in 5 languages on CD <p>Explosion protection</p> <ul style="list-style-type: none"> Without explosion protection With explosion protection (CENELEC) <ul style="list-style-type: none"> Type of protection: <ul style="list-style-type: none"> - "Intrinsic safety" (EEx ia) - "Explosion-proof" (EEx d) 3) - "Intrinsic safety and explosion-proof" (EEx ia +EEx d) 3) - "n" (zone 2) With explosion protection (FM + CSA) <ul style="list-style-type: none"> - intrinsic safe and explosion-proof (is + xp) 3) 5) <p>Electrical connection/cable inlet</p> <ul style="list-style-type: none"> Screwed gland Pg 13.5 4) Screwed gland M20 x 1.5 Screwed gland 1/2 - 14 NPT Han 7D plug 4) <p>Indicator</p> <ul style="list-style-type: none"> Without indicator (digital display hidden, setting: mA) With Indicator (digital display visible, setting: mA) With indicator (digital display visible, setting as specified, Order code Y21 or Y22 required) 	Silicone oil	Normal	Inert liquid	Grease-free	8.3 to 250 mbar	(0.12 to 3.63 psi)	43 to 1,300 mbar	(0.62 to 18.9 psi)	160 to 5,000 mbar	(2.32 to 72.5 psi)	1.0 to 30 bar	(14.5 to 435 psi)	5.3 to 100 bar	(76.9 to 1,450 psi)	Seal diaphragm	Parts of meas. cell	Stainless steel	Stainless steel	Hastelloy	Stainless steel	Hastelloy	Hastelloy	Tantalum	Tantalum	Monel	Monel	Gold	Gold	Version for remote seal 1)		Process flange	Electronics housing screws	Stainless steel	Die-cast aluminium	Stainless steel	Stain. steel prec. cast.	<p>7MF4333- ■ ■ ■ ■ ■ - ■ ■ ■ ■ ■</p> <p>↑ ↑ ↑ ↑ ↑ ↑ ↑ ↑</p> <p>1 3</p> <p>D F G H K E</p> <p>A B C E H L Y</p> <p>0 2 4 6</p> <p>2 3</p> <p>1 2</p> <p>A B D P E N C</p> <p>A B C D</p> <p>1 6 7</p>	<p>Further designs</p> <p>Please add "Z" to Order No. and specify Order code(s).</p> <table border="1"> <tr> <td>Transmitter with mounting bracket made of <ul style="list-style-type: none"> • Steel • Stainless steel </td> <td>A01 A02</td> </tr> <tr> <td>Instead of FPM (Viton), process flange O-ring made of: <ul style="list-style-type: none"> • PTFE (Teflon) • FEP (with silicone core, approved for food) • FFFPM (Kalrez) • NBR (Buna N) </td> <td>A20 A21 A22 A23</td> </tr> <tr> <td>Han 7D plug (metal, gray)</td> <td>A30</td> </tr> <tr> <td>Han 8U plug (instead of Han 7D)</td> <td>A31</td> </tr> <tr> <td>Sealing screws (1/4 - 18 NPT) with valve in material of process flange</td> <td>A40</td> </tr> <tr> <td>Rating plate inscription (instead of German) <ul style="list-style-type: none"> • English • French • Spanish • Italian </td> <td>B11 B12 B13 B14</td> </tr> <tr> <td>English rating plate, pressure units in inH₂O or psi</td> <td>B21</td> </tr> <tr> <td>Manufacturer's test certificate M to DIN 55 350, Part 18 and to ISO 8402</td> <td>C11</td> </tr> <tr> <td>Acceptance test certificate B to EN 10 204-3.1 B</td> <td>C12</td> </tr> <tr> <td>Factory certificate to EN 10 204-2.2</td> <td>C14</td> </tr> <tr> <td>Setting of upper limit of output signal to 22.0 mA</td> <td>D05</td> </tr> <tr> <td>Acid gas version to NACE (only together with seal diaphragm made of Hastelloy)</td> <td>D07</td> </tr> <tr> <td>IP 68 (not together with Han 7D/Han 8U plug, Pg 13.5 screwed gland)</td> <td>D12</td> </tr> <tr> <td>Digital indicator beside control keys (only with transmitter 7MF4333-■ ■ ■ ■ 2-■ ■ ■ 6 or 7MF4333-■ ■ ■ ■ 2-■ ■ ■ 7-Z, Y21 or Y22 + Y01)</td> <td>D27</td> </tr> <tr> <td>Use in or on zone 1D/2D (only together with basic device with type of protection "Intrinsically-safe")</td> <td>E01</td> </tr> <tr> <td>Use in zone 0 (basic unit EEx ia)</td> <td>E02</td> </tr> <tr> <td>Oxygen application (max. 160 bar (2320 psi) with oxygen measurement and inert filling liquid)</td> <td>E10</td> </tr> <tr> <td>Interchanging of process connection side</td> <td>H01</td> </tr> <tr> <td>Vent on side for gas measurements</td> <td>H02</td> </tr> <tr> <td>Process flange made of: <ul style="list-style-type: none"> • Hastelloy • Monel • Stainless steel with PVDF insert (max. PN 10 (MWP 145 psi), max. temperature of medium 90 °C (194 °F)) </td> <td>K01 K02 K04</td> </tr> </table>	Transmitter with mounting bracket made of <ul style="list-style-type: none"> • Steel • Stainless steel 	A01 A02	Instead of FPM (Viton), process flange O-ring made of: <ul style="list-style-type: none"> • PTFE (Teflon) • FEP (with silicone core, approved for food) • FFFPM (Kalrez) • NBR (Buna N) 	A20 A21 A22 A23	Han 7D plug (metal, gray)	A30	Han 8U plug (instead of Han 7D)	A31	Sealing screws (1/4 - 18 NPT) with valve in material of process flange	A40	Rating plate inscription (instead of German) <ul style="list-style-type: none"> • English • French • Spanish • Italian 	B11 B12 B13 B14	English rating plate, pressure units in inH ₂ O or psi	B21	Manufacturer's test certificate M to DIN 55 350, Part 18 and to ISO 8402	C11	Acceptance test certificate B to EN 10 204-3.1 B	C12	Factory certificate to EN 10 204-2.2	C14	Setting of upper limit of output signal to 22.0 mA	D05	Acid gas version to NACE (only together with seal diaphragm made of Hastelloy)	D07	IP 68 (not together with Han 7D/Han 8U plug, Pg 13.5 screwed gland)	D12	Digital indicator beside control keys (only with transmitter 7MF4333-■ ■ ■ ■ 2-■ ■ ■ 6 or 7MF4333-■ ■ ■ ■ 2-■ ■ ■ 7-Z, Y21 or Y22 + Y01)	D27	Use in or on zone 1D/2D (only together with basic device with type of protection "Intrinsically-safe")	E01	Use in zone 0 (basic unit EEx ia)	E02	Oxygen application (max. 160 bar (2320 psi) with oxygen measurement and inert filling liquid)	E10	Interchanging of process connection side	H01	Vent on side for gas measurements	H02	Process flange made of: <ul style="list-style-type: none"> • Hastelloy • Monel • Stainless steel with PVDF insert (max. PN 10 (MWP 145 psi), max. temperature of medium 90 °C (194 °F)) 	K01 K02 K04	
Silicone oil	Normal																																																																														
Inert liquid	Grease-free																																																																														
8.3 to 250 mbar	(0.12 to 3.63 psi)																																																																														
43 to 1,300 mbar	(0.62 to 18.9 psi)																																																																														
160 to 5,000 mbar	(2.32 to 72.5 psi)																																																																														
1.0 to 30 bar	(14.5 to 435 psi)																																																																														
5.3 to 100 bar	(76.9 to 1,450 psi)																																																																														
Seal diaphragm	Parts of meas. cell																																																																														
Stainless steel	Stainless steel																																																																														
Hastelloy	Stainless steel																																																																														
Hastelloy	Hastelloy																																																																														
Tantalum	Tantalum																																																																														
Monel	Monel																																																																														
Gold	Gold																																																																														
Version for remote seal 1)																																																																															
Process flange	Electronics housing screws																																																																														
Stainless steel	Die-cast aluminium																																																																														
Stainless steel	Stain. steel prec. cast.																																																																														
Transmitter with mounting bracket made of <ul style="list-style-type: none"> • Steel • Stainless steel 	A01 A02																																																																														
Instead of FPM (Viton), process flange O-ring made of: <ul style="list-style-type: none"> • PTFE (Teflon) • FEP (with silicone core, approved for food) • FFFPM (Kalrez) • NBR (Buna N) 	A20 A21 A22 A23																																																																														
Han 7D plug (metal, gray)	A30																																																																														
Han 8U plug (instead of Han 7D)	A31																																																																														
Sealing screws (1/4 - 18 NPT) with valve in material of process flange	A40																																																																														
Rating plate inscription (instead of German) <ul style="list-style-type: none"> • English • French • Spanish • Italian 	B11 B12 B13 B14																																																																														
English rating plate, pressure units in inH ₂ O or psi	B21																																																																														
Manufacturer's test certificate M to DIN 55 350, Part 18 and to ISO 8402	C11																																																																														
Acceptance test certificate B to EN 10 204-3.1 B	C12																																																																														
Factory certificate to EN 10 204-2.2	C14																																																																														
Setting of upper limit of output signal to 22.0 mA	D05																																																																														
Acid gas version to NACE (only together with seal diaphragm made of Hastelloy)	D07																																																																														
IP 68 (not together with Han 7D/Han 8U plug, Pg 13.5 screwed gland)	D12																																																																														
Digital indicator beside control keys (only with transmitter 7MF4333-■ ■ ■ ■ 2-■ ■ ■ 6 or 7MF4333-■ ■ ■ ■ 2-■ ■ ■ 7-Z, Y21 or Y22 + Y01)	D27																																																																														
Use in or on zone 1D/2D (only together with basic device with type of protection "Intrinsically-safe")	E01																																																																														
Use in zone 0 (basic unit EEx ia)	E02																																																																														
Oxygen application (max. 160 bar (2320 psi) with oxygen measurement and inert filling liquid)	E10																																																																														
Interchanging of process connection side	H01																																																																														
Vent on side for gas measurements	H02																																																																														
Process flange made of: <ul style="list-style-type: none"> • Hastelloy • Monel • Stainless steel with PVDF insert (max. PN 10 (MWP 145 psi), max. temperature of medium 90 °C (194 °F)) 	K01 K02 K04																																																																														

1) Version 7MF4333-1DY... only up to max. span 200 mbar (2.9 psi).
 2) Not for measuring cells 5.3 to 160 bar (76.9 to 2320 psi).
 3) Without cable gland.
 4) Not together with type of protection "Explosion-proof".
 5) Only together with seal diaphragm made of stainless steel or Hastelloy.

Ordering data	Order code
Additional information Please add "Z" to Order No. and specify Order code(s) and plain text.	
Measuring range to be set, specify in plain text: Y01: ... to ... mbar, bar, kPa, MPa, psi, ...	Y01
Measuring-point number/identification (max. 16 characters), specify in plain text: Y15:	Y15
Measuring-point text (max. 27 characters), specify in plain text: Y16:	Y16
Entry of HART address (TAG) (max. 8 characters), specify in plain text: Y17:	Y17
Setting for digital display in pressure units, specify in plain text (standard setting: mA): Y21: mbar, bar, kPa, MPa, psi, ... (see "Additional information" on page 118 for pressure dimensions selectable for "Y21")	Y21
Setting for digital display in non-pressure units, specify in plain text: Y22: to l/min, m³/h, m, USgpm, ... (specification of measuring range in pressure units (Y01) is essential)	Y22 + Y01

Only the settings for "Y01", "Y21", "Y22" and "D05" can be made in the factory.

Example for ordering: see page 118.

Scope of delivery: Transmitter as ordered (Instruction Manual is extra ordering item (see accessories on page 132)).

Ordering data	Order No.	Ordering data	Order code
SITRANS P transmitter for differential pressure and flow, two-wire system, DS III series, PN 32/160 (MWP 464/2320 psi)	7MF4433- 	Further designs Please add "Z" to Order No. and specify Order code(s).	
Meas. cell filling Meas. cell cleaning Silicone oil Normal Inert liquid Grease-free		Transmitter with mounting bracket made of • Steel • Stainless steel	A01 A02
PN 32 (MWP 464 psi), span 1 to 20 mbar ¹⁾ (0.0145 to 0.29 psi) PN 160 (MWP 2320 psi), span 1 to 60 mbar (0.0145 to 0.87 psi) 2.5 to 250 mbar (0.036 to 3.63 psi) 6 to 600 mbar (0.087 to 8.70 psi) 16 to 1,600 mbar (0.232 to 23.2 psi) 50 to 5,000 mbar (0.725 to 72.5 psi) 0.3 to 30 bar (4.35 to 435 psi)		Instead of FPM (Viton), process flange O-ring made of: • PTFE (Teflon) • FEP (with silicone core, approved for food) • FFFPM (Kalrez) • NBR (Buna N)	A20 A21 A22 A23
Wetted parts materials (process flange made of stainless steel) Seal diaphragm Parts of meas. cell Stainless steel Stainless steel Hastelloy Stainless steel Hastelloy Hastelloy Tantalum ²⁾ Tantalum Monel ²⁾ Monel Gold ²⁾ Gold Version for remote seal		Han 7D plug (metal, gray) Han 8U plug (instead of Han 7D)	A30 A31
Process connection Female thread 1/4 - 18 NPT with flange connection to DIN 19 213 • Sealing screw opposite process conn. - Mounting thread M10 - Mounting thread 7/16 - 20 UNF • Sealing screw on side of process flanges - Mounting thread M10 - Mounting thread 7/16 - 20 UNF		Sealing screws (1/4 - 18 NPT) with valve in material of process flange Rating plate inscription (instead of German) • English • French • Spanish • Italian English rating plate, pressure units in inH ₂ O or psi	A40 B11 B12 B13 B14 B21
Non-wetted parts materials Process flange Electronics housing screws Stainless steel Die-cast aluminium Stainless steel Stain. steel prec. cast.		Manufacturer's test certificate M to DIN 55 350, Part 18 and to ISO 8402 Acceptance test certificate B to EN 10 204-3.1 B Factory cert. to EN 10 204-2.2 Setting of upper limit of output signal to 22.0 mA Acid gas version to NACE (only together with seal diaphragm made of Hastelloy)	C11 C12 C14 D05 D07
Design • Standard version • International version, English label inscriptions, documentation in 5 languages on CD		IP 68 (not together with Han 7D/Han 8U plug, Pg 13.5 screwed gland) Digital indicator beside control keys (only with transmitter 7MF4433-■■■■■2-■A■6 or 7MF4433-■■■■■2-■A■7-Z, Y21 or Y22 + Y01)	D12 D27
Explosion protection • Without explosion protection • With explosion protection (CENELEC) Type of protection: - "Intrinsic safety" (EEx ia) - "Explosion-proof" (EEx d) ³⁾ - "Intrinsic safety and explosion-proof" (EEx ia + EEx d) ³⁾ - "n" (zone 2) • With explosion protection (FM + CSA) - intrinsic safe and explosion-proof (is + xp) ^{3) 5)}		Use in or on zone 1D/2D (only together with basic device with type of protection "Intrinsically-safe") Use in zone 0 (basic unit EEx ia) Over-filling safety device for flammable and non-flammable liquids (max. PN 32 (MWP 464 psi)) (basic unit EEx ia) nach WHG und VbF Oxygen application (max. 160 bar (2320 psi) with oxygen measurement and inert filling liquid)	E01 E02 E08 E10
Electrical connection/cable inlet • Screwed gland Pg 13.5 ⁴⁾ • Screwed gland M20 x 1.5 • Screwed gland 1/2 - 14 NPT • Han 7D plug ⁴⁾		Interchanging of process connection side Vent on side for gas measurements Stainless steel process flanges for vertical differential pressure lines (not together with K01, K02 and K04) ¹⁾	H01 H02 H03
Indicator • Without indicator (hidden, setting: mA) • With indicator (digital display visible, setting: mA) • With indicator (digital display visible, setting as specified, Order code Y21 or Y22 required)		Process flange made of Hastelloy Process flange made of Monel Process flange made of stainless steel with PVDF insert (max. PN 10 (MWP 145 psi), max. temperature of medium 90 °C (194 °F))	K01 K02 K04

¹⁾ Not suitable for connection of remote seal.
²⁾ Only together with max. spans 250, 1600, 5000 and 30000 mbar (3.63, 23.2, 72.5 and 435 psi).
³⁾ Without cable gland.
⁴⁾ Not together with type of protection "Explosion-proof".
⁵⁾ Only together with seal diaphragm made of stainless steel or Hastelloy.

Ordering data	Order code
Additional information	
Please add "Z" to Order No. and specify Order code(s) and plain text.	
Measuring range to be set, specify in plain text:	
• With linear characteristic:	
Y01: ... to ... mbar, bar, kPa, MPa, psi, ...	Y01
• With square-rooted characteristic:	
Y02: ... to ... mbar, bar, kPa, MPa, psi, ...	Y02
Measuring-point number/identification (max. 16 characters), specify in plain text:	
Y15:	Y15
Measuring-point text (max. 27 characters), specify in plain text:	
Y16:	Y16
Entry of HART address (TAG) (max. 8 characters), specify in plain text:	
Y17:	Y17
Setting for digital display in pressure units, specify in plain text (standard setting: mA):	
Y21: mbar, bar, kPa, MPa, psi, ...	Y21
(see "Additional information" on page 118 for pressure dimensions selectable for "Y21")	
Setting for digital display in non-pressure units, specify in plain text:	
Y22: to l/min, m³/h, m, USgpm, ...	Y22¹) +
(specification of measuring range in pressure units (Y01 or Y02) is essential)	Y01 or Y02

Only the settings for "Y01", "Y02", "Y21", "Y22" and "D05" can be made in factory.

Example for ordering: see page 118.

Scope of delivery: Transmitter as ordered (Instruction Manual is extra ordering item (see accessories on page 132)).

Ordering data	Order No.
SITRANS P transmitter for differential pressure and flow, two-wire system, DS III series, PN 420 (MWP 6092 psi)	7MF4533- 1 ■■■■■-■■■■■
Span 2.5 to 250 mbar (0.036 to 3.63 psi) 6 to 600 mbar (0.087 to 8.7 psi) 16 to 1,600 mbar (0.23 to 23.2 psi) 50 to 5,000 mbar (0.73 to 72.5 psi) 0.3 to 30 bar (4.35 to 435 psi)	↑ D E F G H
Wetted parts materials (process flange made of stainless steel) Seal diaphragm Parts of meas. cell Stainless steel Stainless steel Hastelloy Stainless steel Gold ¹⁾ Gold	↑ A B L
Process connection Female thread 1/4 - 18 NPT and flange connection to DIN 19213 • Sealing screw opposite process connection - Mounting thread M12 - Mounting thread 7/16 - 20 UNF • Sealing screw on side of process flanges - Mounting thread M12 - Mounting thread 7/16 - 20 UNF	1 3 5 7
Non-wetted parts materials Process flange Electronics housing screws Stainless steel Die-cast aluminium Stainless steel Stain. steel prec. cast.	2 3
Design • Standard version • International version, English label inscriptions, documentation in 5 languages on CD	1 2
Explosion protection • Without explosion protection • With explosion protection (CENELEC) Type of protection: - "Intrinsic safety" (EEx ia) - "Explosion-proof" (EEx d) ²⁾ - "Intrinsic safety and explosion-proof" (EEx ia + EEx d) ²⁾ - "n" (zone 2) • With explosion protection (FM + CSA) - intrinsic safe and explosion-proof (is + xp) ^{2) 4)}	A B D P E N C
Electrical connection/cable inlet • Screwed gland Pg 13.5 ³⁾ • Screwed gland M20 x 1.5 • Screwed gland 1/2 - 14 NPT • Han 7D plug ³⁾	A B C D
Indicator • Without indicator (digital display hidden, setting: mA) • With indicator (digital display visible, setting: mA) • With indicator (digital display visible, setting as specified, Order code Y21 or Y22 required)	1 6 7

Example for ordering: see page 118.

Scope of delivery: Transmitter as ordered (Instruction Manual is extra ordering item (see accessories on page 132)).

Ordering data	Order code
Further designs Please add "Z" to Order No. and specify Order code(s).	
Transmitter with mounting bracket made of • Steel • Stainless steel	A01 A02
Instead of FPM (Viton), process flange O-ring made of: • PTFE (Teflon) • FEP (with silicone core, approved for food) • FFFPM (Kalrez) • NBR (Buna N)	A20 A21 A22 A23
Han 7D plug (metal, gray) Han 8U plug (instead of Han 7D)	A30 A31
Sealing screw (1/4 - 18 NPT) with valve in material of process flange	A40
Rating plate inscription (instead of German) • English • French • Spanish • Italian	B11 B12 B13 B14
English rating plate, pressure units in inH ₂ O or psi	B21
Manufacturer's test certificate M to DIN 55 350, Part 18 and to ISO 8402	C11
Acceptance test certificate B to EN 10 204-3.1 B Factory cert. to EN 10 204-2.2	C12 C14
Setting of upper limit of output signal to 22.0 mA	D05
Acid gas version to NACE (only together with seal diaphragm made of Hastelloy)	D07
IP 68 (not together with Han 7D/Han 8U plug, Pg 13.5 screwed gland)	D12
Use in or on zone 1D/2D (only together with basic device with type of protection "Intrinsically-safe")	E01
Use in zone 0 (basic unit EEx ia)	E02
Digital indicator beside control keys (only with transmitter 7MF4533-■■■■■2-■■■A■6 or 7MF4533-■■■■■2-■A■7-Z, Y21 or Y22 + Y01)	D27
Interchanging of process connection side	H01
Stainless steel process flanges for vertical differential pressure lines	H03

¹⁾ Only together with max. spans 250, 1600, 5000 and 30000 mbar (3.63, 23.2, 72.5 and 435 psi) and process flange screws made of stainless steel.

²⁾ Without cable gland.

³⁾ Not together with type of protection "Explosion-proof".

⁴⁾ Only together with seal diaphragm made of stainless steel or Hastelloy.

Ordering data	Order code
Additional information	
Please add " Z " to Order No. and specify Order code(s) and plain text.	
Measuring range to be set, specify in plain text:	
• With linear characteristic: Y01: ... to ... mbar, bar, kPa, MPa, psi, ...	Y01
• With square-rooted characteristic: Y02: ... to ... mbar, bar, kPa, MPa, psi, ...	Y02
Measuring-point number/identification (max. 16 characters), specify in plain text: Y15:	Y15
Measuring-point text (max. 27 characters), specify in plain text: Y16:	Y16
Entry of HART address (TAG) (max. 8 characters), specify in plain text: Y17:	Y17
Setting for digital display in pressure units, specify in plain text (standard setting: mA): Y21: mbar, bar, kPa, MPa, psi, ... (see "Additional information" on page 118 for pressure dimensions selectable for "Y21")	Y21
Setting for digital display in non-pressure units, specify in plain text: Y22: to l/min, m³/h, m, USgpm, ... (specification of measuring range in pressure units (Y01 or Y02) is essential)	Y22 + Y01 or Y02

Only the settings for "Y01" or "Y02", "Y21", "Y22" or "D05" can be made in factory.

Ordering data	Order No.	Ordering data	Order code						
<p>SITRANS P transmitter for level, two-wire system, DS III series</p> <p>Span 25 to 250 mbar (0.36 to 3.63 psi) 25 to 600 mbar (0.36 to 8.7 psi) 53 to 1,600 mbar (0.77 to 23.2 psi) 0.16 to 5.0 bar (2.32 to 72.5 psi)</p> <p>Process connection of low-pressure side Female thread 1/4 - 18 NPT and flange connection to DIN 19213 with mounting thread</p> <ul style="list-style-type: none"> M10 7/16 - 20 UNF <p>Non-wetted parts materials</p> <table border="1"> <tr> <td>Process flange</td> <td>Electronics housing screws</td> </tr> <tr> <td>Stainless steel</td> <td>Die-cast aluminium</td> </tr> <tr> <td>Stainless steel</td> <td>Stain. steel prec. cast.</td> </tr> </table> <p>Design</p> <ul style="list-style-type: none"> Standard version International version, English label inscriptions, documentation in 5 languages on CD <p>Explosion protection</p> <ul style="list-style-type: none"> Without explosion protection With explosion protection (CENELEC) Type of protection: - "Intrinsic safety" (EEx ia) - "Explosion-proof" (EEx d) ¹⁾ - "Intrinsic safety and explosion-proof" (EEx ia + EEx d) ¹⁾ - "n" (zone 2) With explosion protection (FM + CSA) - intrinsic safe and explosion-proof (is + xp) ¹⁾ ³⁾ <p>Electrical connection/cable inlet</p> <ul style="list-style-type: none"> Screwed gland Pg 13.5 ²⁾ Screwed gland M20 x 1.5 Screwed gland 1/2 - 14 NPT Han 7D plug ²⁾ <p>Indicator</p> <ul style="list-style-type: none"> Without indicator (digital display hidden, setting: mA) With indicator (digital display visible, setting: mA) With indicator (digital display visible, setting as specified, Order code Y21 or Y22 required) 	Process flange	Electronics housing screws	Stainless steel	Die-cast aluminium	Stainless steel	Stain. steel prec. cast.	<p>7MF4633- 1 Y ■ ■ ■ - ■ ■ ■ ■</p> <p>↑ D E F G</p> <p>0 2</p> <p>2 3</p> <p>1 2</p> <p>A B D P E</p> <p>NC</p> <p>A B C D</p> <p>1 6 7</p>	<p>Further designs</p> <p>Please add "Z" to Order No. and specify Order code(s).</p> <p>Instead of FPM (Viton), process flange O-ring made of:</p> <ul style="list-style-type: none"> PTFE (Teflon) FEP (with silicone core, approved for food) FFPM (Kalrez) NBR (Buna N) <p>Han 7D plug (metal, gray) A30 Han 8U plug (instead of Han 7D) A31</p> <p>Sealing screws (1/4 - 18 NPT) with valve in material of process flange A40</p> <p>Rating plate inscription (instead of German)</p> <ul style="list-style-type: none"> English B11 French B12 Spanish B13 Italian B14 <p>English rating plate, pressure units in inH₂O or psi B21</p> <p>Manufacturer's test certificate M to DIN 55 350, Part 18 and to ISO 8402 C11 Acceptance test certificate B to EN 10 204-3.1 B C12 Factory cert. to EN 10 204-2.2 C14</p> <p>Setting of upper limit of output signal to 22.0 mA D05</p> <p>IP 68 (not together with Han 7D/Han 8U plug, Pg 13.5 screwed gland) D12</p> <p>Use in or on zone 1D/2D (only together with basic device with type of protection "Intrinsically-safe") E01 Use in zone 0 (basic unit EEx ia) E02 Over-filling safety device for flammable and non-flammable liquids (max. PN 32 (MWP 464 psi)) (basic unit EEx ia) to WHG and VbF E08</p> <p>Interchanging of process connection side H01</p> <p>Additional information</p> <p>Please add "Z" to Order No. and specify Order code(s) and plain text.</p> <p>Measuring range to be set, specify in plain text: Y01: ... to ... mbar, bar, kPa, MPa, psi, ... Y01</p> <p>Measuring-point number/identification (max. 16 characters), specify in plain text: Y15: Y15</p> <p>Measuring-point text (max. 27 characters), specify in plain text: Y16: Y16</p> <p>Entry of HART address (TAG) (max. 8 characters), specify in plain text: Y17: Y17</p> <p>Setting for digital display in pressure units, specify in plain text (standard setting: mA): Y21: mbar, bar, kPa, MPa, psi, ... Y21 (see "Additional information" on page 118 for pressure dimensions selectable for "Y21")</p> <p>Setting for digital display in non-pressure units, specify in plain text: Y22: to l/min, m³/h, m, USgpm, ... Y22⁴⁾ + Y01 (specification of measuring range in pressure units (Y01) is essential)</p>	
Process flange	Electronics housing screws								
Stainless steel	Die-cast aluminium								
Stainless steel	Stain. steel prec. cast.								
<p>Ordering note: 1st order item: Transmitter 7MF4633-... 2nd order item: Mounting flange 7MF4912-3-...</p> <p>Example for ordering: Item line 1: 7MF4633-1EY20-1AA1-Z B line: Y01 C line: Y01: 80 to 143 mbar (1.16 to 2.1 psi) Item line 2: 7MF4912-3GE01</p>									

Only the settings for "Y01", "Y21", "Y22" and "D05" can be made in the factory.

Scope of delivery: Transmitter as ordered (Instruction Manual is extra ordering item (see accessories on page 132)).

¹⁾ Without cable gland.
²⁾ Not together with type of protection "Explosion-proof".
³⁾ Only together with seal diaphragm made of stainless steel or Hastelloy.
⁴⁾ Not together with over-filling safety device for flammable and non-flammable liquids (Order code "E08")

Ordering data Order No. Order code

Mounting flange
Directly fitted onto SITRANS P transmitter for level, for

DS III series

Flange	Nom. diam.	Nom. press.
Connection to DIN 2501	DN 80	PN 40
	DN 100	PN 16 PN 40
Connection to ANSI B16.5	3 inch	class 150 class 300
	4 inch	class 150 class 300

Other version
Add Order code and plain text:
Nominal diameter: ...; Nom. pressure: ...

Wetted parts materials

- Stainless steel, mat. No. 1.4571/316Ti
 - Coated with PFA¹⁾
 - Coated with PTFE¹⁾
 - Coated with ECTFE¹⁾
- Monel 400, mat. No. 2.4360
- Hastelloy B2, mat. No. 2.4617
- Hastelloy C276, mat. No. 2.4819
- Hastelloy C4, mat. No. 2.4610
- Tantalum

Other version
Add Order code and plain text:
Wetted parts materials: ...
Sealing face: see "Technical data"

Tube length

- Without tube
- 50 mm (1.97 inch)
- 100 mm (3.94 inch)
- 150 mm (5.90 inch)
- 200 mm (7.87 inch)

Filling liquid

- Silicone oil M5
- Silicone oil M50
- High-temperature oil
- Halocarbon oil (for O₂ measurements)
- Vegetable oil
- Glycerine/water²⁾

Other version
Add Order code and plain text:
Filling liquid: ...

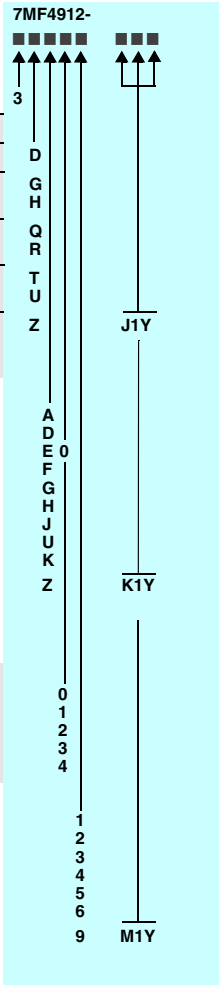

	Order code
Further designs Please add "Z" to Order No. and specify Order code(s).	
With flame flashover lock-out for mounting on zone 0 (including documentation)	A01
Manufacturer's test certificate M to DIN 55 350, Part 18, and to ISO 8402	C11
Acceptance test certificate B to EN 10 204-3.1 B	C12
Vacuum-resistant design (for use in vacuum range)	V04
Calculation of span of associated transmitter (enclose filled-in questionnaire with order)	Y05
Note: Suffix "Y01" required with transmitter!	

¹⁾ For vacuum on request.
²⁾ Not suitable for use in low-pressure range.
Example for ordering: see page 126.

11.2 Ordering data for accessories

Ordering data	Order No.	Ordering data	Order No.
<u>Spare parts</u>		<u>Spare parts (continued)</u>	
Mounting bracket and mounting parts For pressure transmitters: MK II series (7MF4010-■■■■■■-1■ C ■) MS series (7MF4013-■■■■■■-1■ C ■) and DS III (PA) series (7MF403■■■■■■-1■ C ■) For absolute pressure transmitters: DS III (PA) series (7MF423■■■■■■-1■ C ■) • Made of steel • Made of stainless steel	7MF4997-1AB 7MF4997-1AH	Mounting screws For measuring-point label for MK II, MS and DS III (PA) series, earthing and connection terminals or for digital display (50 off)	7MF4997-1CD
Mounting bracket and mounting parts For pressure transmitters: MK II series (7MF4010-■■■■■■-1■ A ■, -1■ B ■ and -1■ D ■), MS series (7MF4013-■■■■■■-1■ A ■, -1■ B ■ and -1■ D ■), DS III (PA) series (7MF403■■■■■■- 1■ A ■), -1■ B ■ and -1■ D ■), For absolute pressure transmitters: DS III (PA) series (7MF423■■■■■■-1■ A ■) -1■ B ■ and -1■ D ■), • Made of steel • Made of stainless steel	7MF4997-1AC 7MF4997-1AJ	Sealing screws (1 set = 2 off) for process flange • Stainless steel • Hastelloy	7MF4997-1CG 7MF4997-1CH
Mounting bracket and mounting parts for diff. pressure transmitters with M10 flange thread (7MF43 ■■■-... and 7MF44 ■■■-...) • Made of steel • Made of stainless steel	7MF4997-1AD 7MF4997-1AK	Vent valves complete (1 set = 2 off) • Stainless steel • Hastelloy	7MF4997-1CP 7MF4997-1CQ
Mounting bracket and mounting parts for differential pressure transmitters with M12 flange thread (7MF45 ■■■-...) • Made of steel • Made of stainless steel	7MF4997-1AE 7MF4997-1AL	Electronics for • SITRANS P, DS III series • SITRANS P, DS III PA series	7MF4997-1DK 7MF4997-1DL
Mounting bracket and mounting parts for differential pressure and absolute pressure transmitters with flange thread $\frac{1}{16}$ - 20 UNF (7MF43 ■■■-..., 7MF44 ■■■-..., MF45 ■■■-...) • Made of steel • Made of stainless steel	7MF4997-1AF 7MF4997-1AM	Connection board for • SITRANS P, DS III series • SITRANS P, DS III PA series	7MF4997-1DN 7MF4997-1DP
Cover (die-cast aluminium) without window, including gasket • For MK II, MS and DS III (PA) series	7MF4997-1BB	O-rings , for process flanges made of: • FPM (Viton) • PTFE (Teflon) • FEP (with silicone core, approved for food) • FPPM (Kalrez) • NBR (Buna N)	7MF4997-2DA 7MF4997-2DB 7MF4997-2DC 7MF4997-2DD 7MF4997-2DE
Cover (stainless steel) without window, including gasket, for DS III (PA) series	7MF4997-1BC		
Cover (die-cast aluminium) with window, including gasket • for MK II, MS and DS III (PA) series	7MF4997-1BE		
Cover (stainless steel) with window, including gasket for DS III (PA) series	7MF4997-1BF		
Analog indicator , scale 0 to 100%	7MF4997-1BN		
Analog indicator , customer-specific scale divisions as specified in plain text	7MF4997-1BP-Z Y20:		
Digital display including mounting material for MS and DS III (PA) series	7MF4997-1BR		
Measuring-point label • Without inscription (5 off) • Printed (1 off), data according to Y01 or Y02, Y15 and Y16 (see Ordering data for SITRANS P transmitters)	7MF4997-1CA 7MF4997-1CB-Z Y■■:		

Ordering data		Order No.
SITRANS P measuring cell for pressure for DS III and DS III PA series		7MF4990 - ■ ■ ■ ■ 0
Meas. cell filling	Meas. cell cleaning	
Silicone oil Inert filling liquid	Normal Grease-free	
Rated measuring range		
1 bar (14.5 psi)		
4 bar (58 psi)		
16 bar (232 psi)		
63 bar (914 psi)		
160 bar (2320 psi)		
400 bar (5802 psi)		
Wetted parts materials		
Seal diaphragm	Connection shank	
Stainless steel	Stainless steel	
Hastelloy	Hastelloy	
Process connection		
• Connection shank G½A		
• Female thread ½ - 14 NPT		
• Oval flange made of stainless steel, max. span 160 bar (2320 psi)		
- Mounting thread 1/16" - 20 UNF		
- Mounting thread M10		
Further designs		Order code
Please add "Z" to Order No. and specify Order code(s).		
Acceptance test certificate B to EN 10 204-3.1 B		C12

Ordering data		Order No.
SITRANS P measuring cell for absolute pressure (from pressure transmitter series) for DS III and DS III PA series		7MF4992 - ■ ■ ■ ■ 0
Meas. cell filling	Meas. cell cleaning	
Silicone oil Inert filling liquid	Normal Grease-free	
Rated measuring range		
250 mbar (3.63 psi)		
1,300 mbar (18.9 psi)		
5,000 mbar (72.5 psi)		
30,000 mbar (435 psi)		
Wetted parts materials		
Seal diaphragm	Connection shank	
Stainless steel	Stainless steel	
Hastelloy	Stainless steel	
Hastelloy	Hastelloy	
Process connection		
• Connection shank G½A		
• Female thread ½ - 14 NPT		
• Oval flange made of stainless steel, max. span 160 bar (2320 psi)		
- Mounting thread 1/16" - 20 UNF		
- Mounting thread M10		
Further designs		Order code
Please add "Z" to Order No. and specify Order code(s).		
Acceptance test certificate B to EN 10 204-3.1 B		C12

Ordering data		Order No.
SITRANS P measuring cell for absolute pressure (from differential pressure transmitter series) for DS III and DS III PA series		7MF4993 - ■ ■ ■ ■ ■ ↑ ↑ ↑ ↑ ↑ 1 3 D F G H K E A B C E H L 0 2 4 6 2
Meas. cell filling	Meas. cell cleaning	
Silicone oil	Normal	
Inert filling liquid	Grease-free	
Rated measuring range		
250 mbar	(3.63 psi)	
1,300 mbar	(18.9 psi)	
5,000 mbar	(72.5 psi)	
30,000 mbar	(435 psi)	
100,000 mbar	(1450 psi)	
Wetted parts materials		
Seal diaphragm	Parts of meas. cell	
Stainless steel	Stainless steel	
Hastelloy	Stainless steel	
Hastelloy	Hastelloy	
Tantalum	Tantalum	
Monel	Monel	
Gold	Gold	
Process connection		
Female thread 1/4 - 18 NPT with flange connection to DIN 19 213		
<ul style="list-style-type: none"> Vent opposite process connection - Mounting thread M10 7/16 - 20 UNF 		
<ul style="list-style-type: none"> Vent on side of process flange - Mounting thread M10 7/16 - 20 UNF 		
Non-wetted parts materials		
Process flange screws:		
<ul style="list-style-type: none"> Stainless steel 		
Further designs		Order code
Please add "Z" to Order No. and specify Order code(s).		
Instead of FPM (Viton), process flange O-ring made of:		
<ul style="list-style-type: none"> PTFE (Teflon) 	A20	
<ul style="list-style-type: none"> FEP (with silicone core, approved for food) 	A21	
<ul style="list-style-type: none"> FFPM (Kalrez) 	A22	
<ul style="list-style-type: none"> NBR (Buna N) 	A23	
Acceptance test certificate B to EN 10 204-3.1 B	C12	
Process connection G1/2A	D16	
Remote seal connection (not together with K01, K02 and K04)	D20	
Vent on side for gas measurements	H02	
Without process flanges	K00	
With process flange made of:		
<ul style="list-style-type: none"> Hastelloy 	K01	
<ul style="list-style-type: none"> Monel 	K02	
<ul style="list-style-type: none"> Stainless steel with PVDF insert (max. PN 10 (MWP 145 psi), max. temperature of medium 90 °C (194 °F)) 	K04	

¹⁾ Only together with max. span 250, 1,600, 5,000 and 30,000 mbar (3.63, 23.21, 72.5 and 435 psi).

²⁾ Not suitable for connection of remote seal.

Ordering data		Order No.
SITRANS P measuring cell for differential pressure and PN 32/160 (MWP 464/2320 psi) for DS III and DS III PA series		7MF4994 - ■ ■ ■ ■ ■ ↑ ↑ ↑ ↑ ↑ 1 3 B C D E F G H A B C E H L 0 2 4 6 2
Meas. cell filling	Meas. cell cleaning	
Silicone oil	Normal	
Inert filling liquid	Grease-free	
rated measuring range		
PN 32 (MWP 464 psi)		
20 mbar ²⁾	(0.29 psi)	
PN 160 (MWP 2320 psi)		
60 mbar	(0.87 psi)	
250 mbar	(3.63 psi)	
600 mbar	(8.7 psi)	
1,600 mbar	(23.2 psi)	
5,000 mbar	(72.5 psi)	
30,000 mbar	(435 psi)	
Wetted parts materials		
(process flanges made of stainless steel)		
Seal diaphragm	Parts of meas. cell	
Stainless steel	Stainless steel	
Hastelloy	Stainless steel	
Hastelloy	Hastelloy	
Tantalum ¹⁾	Tantalum	
Monel ¹⁾	Monel	
Gold ¹⁾	Gold	
Process connection		
Female thread 1/4 - 18 NPT with flange connection to DIN 19 213		
<ul style="list-style-type: none"> Vent opposite process connection - Mounting thread M10 7/16 - 20 UNF 		
<ul style="list-style-type: none"> Vent on side of process flange - Mounting thread M10 7/16 - 20 UNF 		
Non-wetted parts materials		
Process flange screws:		
<ul style="list-style-type: none"> Stainless steel 		
Further designs		Order code
Please add "Z" to Order No. and specify Order code(s).		
Instead of FPM (Viton), process flange O-ring made of:		
<ul style="list-style-type: none"> PTFE (Teflon) 	A20	
<ul style="list-style-type: none"> FEP (with silicone core, approved for food) 	A21	
<ul style="list-style-type: none"> FFPM (Kalrez) 	A22	
<ul style="list-style-type: none"> NBR (Buna N) 	A23	
Acceptance test certificate B to EN 10 204-3.1 B	C12	
Remote seal flanges (not together with K01, K02 and K04)	D20	
Vent on side for gas measurements	H02	
Stainless steel process flanges for vertical differential pressure lines (not together with K01, K02 or K04)	H03	
Without process flanges	K00	
With process flange made of:		
<ul style="list-style-type: none"> Hastelloy 	K01	
<ul style="list-style-type: none"> Monel 	K02	
<ul style="list-style-type: none"> Stainless steel with PVDF insert (max. PN 10 (MWP 145 psi), max. temperature of medium 90 °C (194 °F)) 	K04	

11.3 Accessories

Ordering data

Instruction Manuals

Instruction Manual for SITRANS P, DS II series

- German
- English
- French
- Spanish
- Italian

Brief instructions (Leporello) for SITRANS P, DS III series

- German/English

CD with documentation

for SITRANS P, DS III series, DS III PA, MS, MK II, MPS and Z

- German, English, French, Spanish, Italian

Instruction Manual for replacement of electronics, measuring cell and connection board

- German/English

HART communication

HART communicator

HART modem

Order No.

A5E00047090
A5E00047092
A5E00053218
A5E00053220
A5E00053219

A5E00047093

A5E00090345

A5E00078060
 (only available on the Internet)

See on the right side

7MF4997-1DA

Ordering data

HART communicator with rechargeable battery, charger for AC 230 V

Type of protection: intrinsic safety EEx ia IIC T4, with carrying case, 4 MB memory, with DDs of Siemens devices

Language

- German
- English

Loading of further device descriptions

Please specify DDs in plain text

Order No.

7MF4998-8KF

7MF4998-8KT

7MF4998-8KU

Note:

You can download the above-mentioned Instruction Manuals free-of-charge from the Internet site

www.siemens.com/fieldinstrumentation

Certificates

12

The certificates are enclosed as a collection of loose leaves in the operating manual (or on CD).

A

Adjustment 68
 Current transmitter 69
Alarm text 26
Ambient temperature 84
Analog output 50, 53, 61
Arrow
 down 27
 up 27
Assembly 84

B

Bargraph 26
Basic variables 12
Blanking plug 16
Blind setting 63
Block diagram 17, 18, 19
Bridge output voltage 18, 20

C

Calibration interval 73
Calibration timer 73
Characteristic 12, 13
Commissioning 95
Compensation valve 99, 100, 101
Configuration data 71
Connection 92
 to screw terminals 92
 with plug 94
Connection diagram 93
Constant current mode 65

Current limits 65
Current saturation 72
Current transmitter 65

D

Device variable 27, 50, 54, 58
device variable (DV) 51
Diagnostic alarm 26, 40, 65, 73, 78, 79
Diagnostic Information 26
Diagnostic warning 72, 78, 79
Differential pressure 12, 18, 29, 41, 64, 72, 91, 96, 98, 108
differential pressure 13, 24
Digital display
 Design 24
 View 28
Disable 66
Display/Bargraph 68
DV (device variable) 51
Dynamic variable (DV) 50, 61

E

Electric damping 64
Electrical connection 91
Equations
 Set start of scale, full scale 32
Error message 26
Error signaling 26
ET 200M 21
Event counter 79

F

Factory calibration 71
Failure current 65, 115
Fast measured value acquisition 64
Fast Response Mode 64
Filling level 13
Filling liquid 19
Flange 19, 87
Full scale
 adjust 30
 set 32
Functional diagram 17, 18, 19, 20

H

Hardware error 115
HART
 Communicator 21
 modem 21
Hold time 75, 78
Hysteresis 78

I

Input keys 28
Input scale 55
Input scaling 53, 57
Installation 14, 83, 84
Interference immunity 92

K

Keyboard 28
Keyboard disable 30

L

L (filling level height) 54
Lagekorrektur 64
LCD scaling 62
Limit transmitter 78
Limit value components 75
lin 41
linearization 60
Locking screw 90, 91

M

MA (start of scale) 51
Mapper 50

Mappers 71

Mass 11, 13, 49, 52, 54, 60
ME (full scale) 51
Measured value display 23, 24
Measured value status 40, 50, 51, 52, 54, 56
Measurement type 13, 24, 29, 30, 32, 33, 46, 47, 50, 51, 54
Measurement type switch 50, 51, 58
Measuring
 gases 96
 liquid 97
 vapor 97
Measuring block 50
Measuring operation 49
Measuring span 30, 32
Message
 OVER 27
 UNDER 27
Mounting bracket 85
mounting flange 13

N

Nominal width 13

O

Operation
 Key functions 29
 locally 23
Output scaling 53, 54, 56, 58
Overload capacity 13

P

Position correction 64
Position vent valve 71
Pressure equipment directive (DGRL) 142
Pressure regulator 71
Pressure simulation 77
Primary Variable 27, 71
Primary Variable (PV) 50, 51
Process connection 15, 16, 71
Process connection (figure) 16
PV (primary variable) 50

Q

Quarternary Variable 71
Quarternary Variable (QV) 50

QV (quarternary variable) 50

R

Ramp function 76
Range of rotation. 90
Rear view of device 16
Reference pressure 32
Remote seal 71
Remote seal type 71
Reponse time 75
Response time 78
Root application point 55

S

Seal diaphragm 20
Secondary Variable 71
Secondary Variable (SV) 50
Self test 115
Sensor adjustment 68
Sensor zero 64
Sensornullpunkt 64
Service timer 73
Shutoff valve 90, 96, 97, 99, 100, 101, 102
Signal range 27
SIMATIC PDM 22
SIMATIC S7 21
Simulation 74
Slave pointer 74
Slave pointer pairs 74
srln 41, 72
sroff 41, 72
Start of scale
 adjust 30, 48
 set 32

Status display 25
Step width 78
SV (secondary variable) 50
System configuration 21

T

Technical Data
 Dimensions 110
Tertiary Variable 71
Tertiary Variable (TV) 50
Test plug 93
Trimming 64
 upper sensor adjustment point 69
Trimmung 64
Turn-down 30
TV (tertiary variable) 50
Type of unit 67

U

Unit display 26
Unit of pressure 67

V

Value pairs 52, 56, 57
Vent valve 98, 100, 101
Volume 13, 49, 60
Volume flow 13, 49, 60

W

Write protection 30, 66

14.1 "HAND-HELD operating structure HART"

See next page

Appendix

Hart Handterminal
Firmware Rev. F1.6
structure of operation

*) measurement display
**) M = method

2 Online	1 (PV meas) *)		
	2 (PV) status		
	3 Module type		
	4 Identification	1 Operation Unit	1 Tag 2 Long Tag --> M **) 3 Descriptor 4 Message 5 Date
		2 Device	1 Manufacturer 2 Model 3 Device identification 4 Distributor 5 MLFB Order Number 6 Measurement type 7 Fabrication-No 8 Final assembly number 9 Sensor serial number 10 Revisions
			1 MLFB Order No --> M
			1 Universal rev. 2 Field device rev. 3 Software rev. 4 Hardware rev.
		3 Basic Parameters	1 Pressure unit 2 LSL (Lower Sensor Limit) 3 USL (Upper Sensor Limit) 4 Minimum Span 5 LRV (Lower Range Value) 6 URV (Upper Range Value) 7 Pressure damping 8 Pressure xfer function
			xfer = transfer
	5 Config Inp/Outp	1 Quick-Setup & Meas.	1 PV, Current, Status
		2 Meas.Val. & Status	1 Pressure Values 2 Temperature Values 3 Level, Vol, Mass Values (shown if valid items) 4 Vol-, Mass- & Flow (shown if valid items) 5 Appl & Stat (shown if valid items)
			1 Pressure 2 Pres status 3 Untrimmed pressure 4 Untrimmed pres status 1 Sens-Temp 2 Sens-Temp status 3 Electr-Temp 4 Electr-Temp status 1 Level 2 Level status 3 Volume 4 Volume status 5 Mass 6 Mass status 1 Vol-Flow 2 Vol-Flow status 3 Mass-Flow 4 Mass-Flow status 1 Customer 2 Customer Status
		3 Quick-Setup	1 Tag 2 Ext TAG --> M 3 PV is 4 (PV) unit 5 Position correction 6 LRV 7 URV 8 Pressure damping 9 Pressure xfer function
			1 Position corr --> M
		2 Input	1 Config Pres/Temp
			1 Pressure sensor 2 Temperature sensor 3 Pres units see --> 4 Temp units see -->
			1 Pressure 2 Untrimmed pres 3 Pressure units 1 Sens-Temp 2 Electr-Temp 3 Temp units 1 Pressure sensor 1 Temperature sensor
			1 Pres abs/rel 2 Pressure unit 3 Untrimmed pres unit 1 Sens-Temp unit 2 Electr-Temp unit
			1 Process variables 2 AO 3 AO 4 (SV measurement) 5 (TV measurement) 6 (QV measurement)
		1 (PV measurement) 2 (PV) %range 3 AO 4 (SV measurement) 5 (TV measurement) 6 (QV measurement)	
		1 measurement 2 PV is 3 SV is 4 TV is 5 QV is	
		6 (measurement) config e.g. Level	1 Input scaling 2 Level scaling e.g. Level scaling 3 Volume scaling
		1 Pres abs/rel 2 Pressure unit 3 Input LRV 4 Input URV 1 Level unit 2 Level LRV 3 Level URV 1 Volume unit 2 Vol LRV 3 Vol URV 2 Density unit 3 Density 3 Mass unit	
		6 (measurement) config e.g. Flow	1 Input scaling 2 Flow scaling
		1 Pres abs/rel 2 Pressure unit 3 Input LRV 4 Input URV 1 Vol flow unit 2 Vol flow LRV 3 Vol flow URV 2 Density unit 3 Density 3 Mass flow unit	
		6 (measurement) config e.g. Customer	1 Input scaling 3 Customer scaling
		1 Pres abs/rel 2 Pressure unit 3 Input LRV 4 Input URV 1 Cust unit (5 Ch) 2 Cust LRV 3 Cust URV	
		7 Unser linearization if Level, Flow or Customer this is valid - otherwise not	1 Special Curve status --> 2 No curve points 3 Setup special char --> M 4 Display special char --> M
		4 Meas.Limits & Span	1 Module range 2 Active Device Variables
			1 Pressure 2 Sens-Temp 3 Electr-Temp 4 Untrimmed Pres 5 Level
			1 Pressure unit 2 Pres USL 3 Pres LSL 4 Tripoint sum 5 Pres min span 1 Sens-Temp unit 2 Sens-Temp USL 3 Sens-Temp LSL 4 Sens-Temp min span 1 Electr-Temp unit 2 Electr-Temp USL 3 Electr-Temp LSL 4 Electr-Temp min span 1 Untrimmed Pres unit 2 Untrimmed Pres USL 3 Untrimmed Pres LSL 4 Untr Pres min span 1 Level unit 2 Level USL 3 Level LSL 4 Level min span
			additional if measurement is mapped to level

		additional if measurement is mapped to level	6 Volume	1 Volume unit 2 Volume USL 3 Volume LSL 4 Volume min.span
		additional if measurement is mapped to level	7 Mass	1 Mass unit 2 Mass USL 3 Mass LSL 4 Mass min span
		additional if measurement is mapped to flow	5 Vol-Flow	1 Vol-Flow unit 2 Vol-Flow USL 3 Vol-Flow LSL 4 Vol-Flow min.span
		additional if measurement is mapped to flow	6 Mass-Flow	1 Mass-Flow unit 2 Mass-Flow USL 3 Mass-Flow LSL 4 Mass-Flow min span
		additional if measurement is mapped to customer	5 Customer	1 (PV) unit 2 Customer USL 3 Customer LSL 4 Customer min. span
3 Output	1 Analog output	1 Analog output 2 Percent range 3 Zero and Span 4 Pres xfer function 5 Startpoint square root	1 Zero/Span set 2 Out Scaling PV 3 Out Scaling PV 4 Out Scaling PV 5 Out Scaling PV 6 Current Limits 7 Alarms	1 Apply values >1 2 Out Scaling PV >2 1 Unit 2 LRV 3 URV 4 LSL 5 USL 1 Apply values -> M 1 Lower AO Limit 2 Upper AO Limit 1 AO Alarm Type 2 Alarm LRV 3 Alarm URV
	2 Sensor trim points	1 Lower sensor trim point 2 Upper sensor trim point		
	3 HART output	1 Polling address 2 Num request preambles 3 Num response preambles		
4 Local meter	1 Meter type			
	2 Unit tracking			
	3 Local Display unit			
	4 LCD Settings	1 LCD Scaling, if On:	2 LCD Unit 3 LCD LRV 4 LCD URV	
	5 Bargraph			
	6 Access Control	1 Lokal keys control mode 2 Write protect 3 Set write protect -> M		
5 Mech. Construction Mech = mechanical	1 No of electronic changes			
	2 Design	1 Sensor 2 Remote Seal 3 Process Connection 4 Electronic Connection	1 Fill fluid 2 Isolation material 3 O ring material 4 Module range 1 Number remote seal (RS) 2 RS type 3 RS isolator material 4 RS fill fluid 5 Extension length 6 Extension type 7 Capillar length	
	3 Process Connection	1 Process Connection 2 Drain/Vent / plug mat 3 Drain/Vent / plug pos 4 Process flange bolt 5 Flange type 6 Flange material		
	4 Electronic Connection	1 Elect housing material 2 Elect connection		
7 Diagnosis/Service	1 Status	1 Status summary 2 Extended device status 3 Simulation status 4 HardwFirmw status 5 Diag Alarm Status 6 Diag Warn Status	1 Status group 2 2 Status group 3 3 Status group 4 4 Status group 5 1 Status group 15 2 Status group 16 1 Status group 19 2 Status group 20	
	2 Device	1 Selftest/Reset 2 Sensor trim 3 Simulation/Test 4 Access Control	1 Selftest -> M 2 Display Test -> M 3 Master reset -> M 4 Changes Config 1 Restore mfr trims -> M 2 Sensor trim 3 Trim analog output 4 Position correction 1 Loop test -> M 2 Inputs -> M 1 Local keys control mode 2 Write protect 3 Set write protect -> M	1 Config changed counter mfr = manufacturer 1 Sensor trim points 2 Sensor trim 3 Trimpoint summary 1 DIA trim -> M 2 Scaled DIA trim -> M 1 Position corr. -> M Simulation AO Simulation Fixed / Ramp
	3 Diagnostic settings	1 W/A time unit 2 Calib interval 3 Service interval 4 AO saturation 5 Limiter setup	1 W/A = warning/alarm 2 Calib status 2 W/A acknowledge -> M 3 Calib timer 4 Calib warning 5 Calib alarm 6 W/A activation 1 Service status 2 W/A acknowledge -> M 3 Service timer 4 Service warning 5 Service alarm 6 W/A activation 1 AO alarm type 2 Saturation alarm 3 Alarm duration 4 Alarm activation 1 Display limiter -> M 2 Setup limiter -> M 3 Limiter status -> M 4 Limiter Ack W/A -> M 5 CmpCnt Ack W/A -> M 6 Reset counter. -> M	1 Calib time 2 Reset timer -> M 1 Service time 2 Reset timer -> M Ack = acknowledge CmpCnt = Comparison Counter
	4 View	1 Operating hours 3 Min/Max pointer	1 Operating hours Eleidr 2 Operating hours Sensor 1 Pressure pointer 2 Elect-Temp pointer 3 Sens-Temp pointer	1 Pres max 2 Pres min 3 Reset pointer -> M 1 Electr-Temp max 2 Electr- Temp min 3 Reset pointer -> M 1 Sens-Temp max 2 Sens-Temp min 3 Reset pointer -> M
6 Certif & Approv Certif=Certification Approv=Approval	1 Explos_Protection	Explos = Explosion		

14.2 Pressure equipment directive (DGRL)

Design, dimensioning, testing and production are monitored to Module H (exhaustive quality assurance) by the TÜV North as the named authority.

General

The pressure equipment directive **97/23/EC** applies to the alignment of the statutory orders of the European member states for pressure equipment. Such equipment in the sense of the directive includes vessels, pipelines and accessories with a maximum permissible pressure of more than **0.5 bar** above atmospheric.

The pressure equipment directive can be used starting November 29, 1999, and is compulsory starting May 29, 2002.

Division according to the danger potential

Equipment is divided in line with the pressure equipment directive according to the danger potential (medium/pressure/volume/nominal diameter) into the categories I to IV or Article 3 Paragraph 3.

The following criteria are decisive for assessment of the danger potential, and are also shown in Diagrams 1 to 4 and 6 to 9:

• Fluid group	Group 1 or 2
• Aggregate state	Liquid or gaseous
• Type of pressurized equipment	
- Vessel	Product of pressure and volume (PS * V [bar·L])
- Pipeline	Nominal diameter, pressure or product of pressure and nominal diameter (PS * DN)

Fuelled pressure equipment or equipment heated in another manner are shown separately in Diagram 5.

Note:

Liquids according to Article 3 are those liquids whose steam pressure is **not** more than **0.5 bar** above standard atmospheric pressure (1013 mbar) at the maximum permissible temperature.

The **maximum permissible temperature** for the used liquids is the maximum process temperature which can occur, as defined by the user. This must be within the limits defined for the equipment.



Division of media (liquid/gaseous) into the fluid groups

Fluids are divided according to Article 9 into the following fluid groups:

Group 1			
	Potentially explosive R phrases: e.g.: 2, 3 (1, 4, 5, 6, 9, 16, 18, 19, 44)		Highly toxic R phrases: e.g.: 26, 27, 28, 39 (32)
	Highly flammable R phrases: e.g.: 12 (17)		Toxic R phrases: e.g.: 23, 24, 25 (29, 31)
	Readily flammable R phrases: e.g.: 11, 15, 17 (10, 30)		Fire stimulating R phrases: e.g.: 7, 8, 9 (14, 15, 19)

Flammable if the maximum permissible temperature is above the flash point.

Group 2

All fluids not belonging to Group 1.

Also applies to fluids which are e.g. dangerous to the environment, corrosive, dangerous to health, irritant or carcinogenic (if not highly toxic).

Conformity rating

Pressure equipment of categories I to IV must comply with the safety requirements of the directive and be assigned the CE symbol.

They must comply with a conformity rating procedure according to Appendix III of the directive.

Pressure equipment according to Article 3 Paragraph 3 must be designed and manufactured in agreement with the sound engineering practice SEP applying in a member country, and must not be assigned a CE symbol (CE symbols from other directives are not affected).

Siemens has carried out a conformity rating, assigned a CE symbol, and issued a declaration of conformity for its products (providing the equipment is not within the context of Article 3 Paragraph 3).

Supervision of the design, dimensioning, testing and manufacture is carried out according to module H (comprehensive quality assurance) by the TÜV Nord (Northern Technical Inspectorate) as the specified office.

Notes:

- Equipment designed for media with a high danger potential (e.g. gases of fluid group 1) may also be used for media with a lower danger potential (e.g. gases of fluid group 2, or liquids of fluid groups 1 and 2).
- The pressure equipment directive according to Article 1 Paragraph 1 does not apply to equipment such as e.g. mobile offshore plants, ships, aircraft, water supply and waste water networks, nuclear plants, rockets and pipelines outside industrial plants.

Diagrams

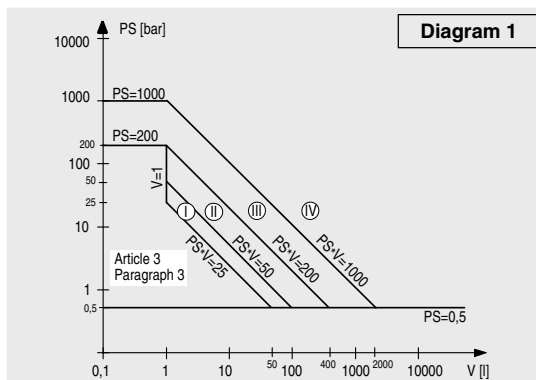

- Gases of fluid group 1
- Vessels according to Article 3 Number 1.1 Letter a) First dash
- Exception: unstable gases belonging to Categories I and II must be included in Category III.

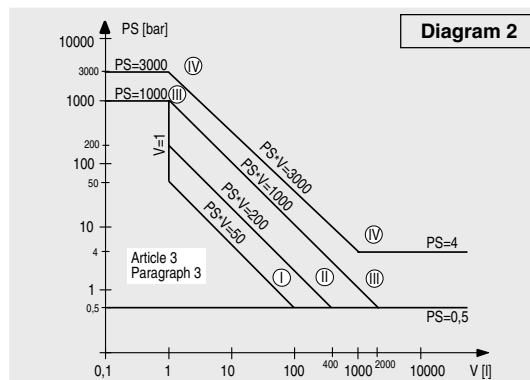

- Gases of fluid group 2
- Vessels according to Article 3 Number 1.1 Letter a) Second dash
- Exception: fire extinguishers and bottles for breathing apparatus: at least Category III.

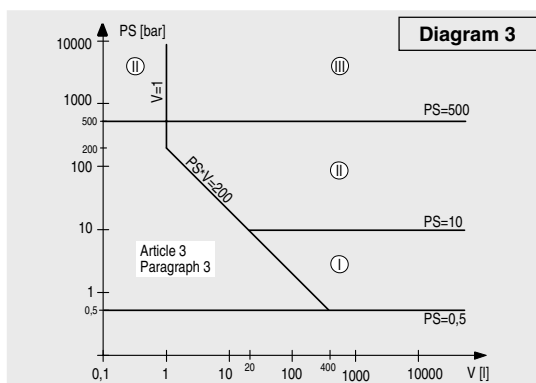

- Liquids of fluid group 1
- Vessels according to Article 3 Number 1.1 Letter b) First dash

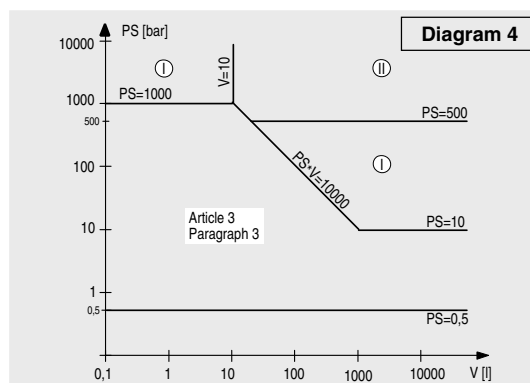

- Liquids of fluid group 2
- Vessels according to Article 3 Number 1.1 Letter b) Second dash
- Exception: modules for producing warm water

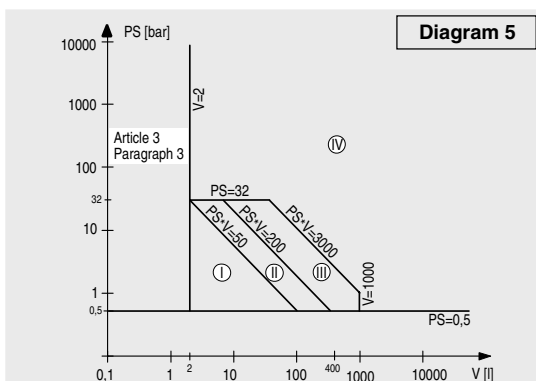

- Fuelled pressure equipment or equipment heated in another manner above 110 °C and liable to overheating.
- Vessel according to Article 3 Number 1.2
- Exception: pressure cooker, test procedure at least according to Category III.

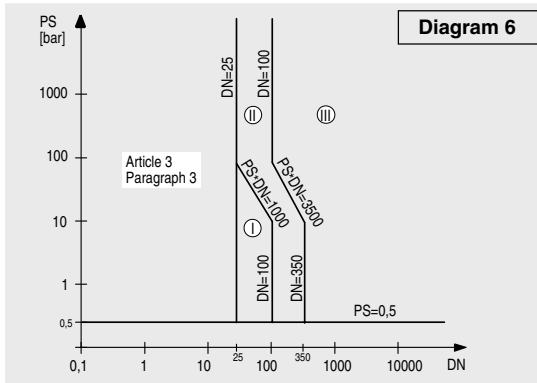

- Gases of fluid group 1
- Pipelines according to Article 3 Number 1.3 Letter a) First dash
- Exception: unstable gases belonging to Categories I and II must be included in Category III.

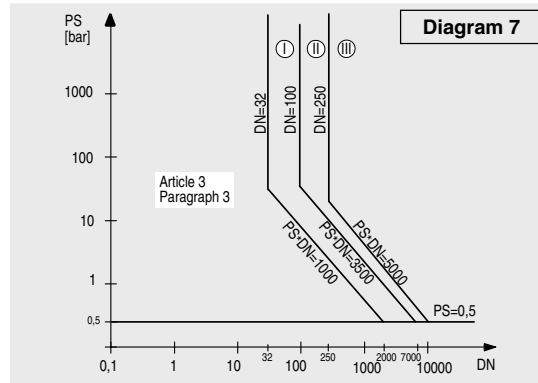

- Gases of fluid group 2
- Pipelines according to Article 3 Number 1.3 Letter a) Second dash
- Exception: liquids at temperatures > 350 °C belonging to Category II must be included in Category III.

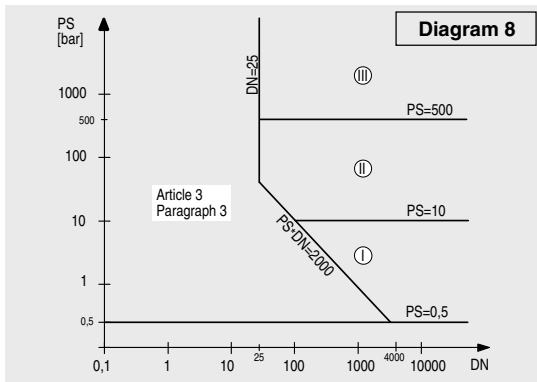

- Liquids of fluid group 1
- Pipelines according to Article 3 Number 1.3 Letter b) First dash

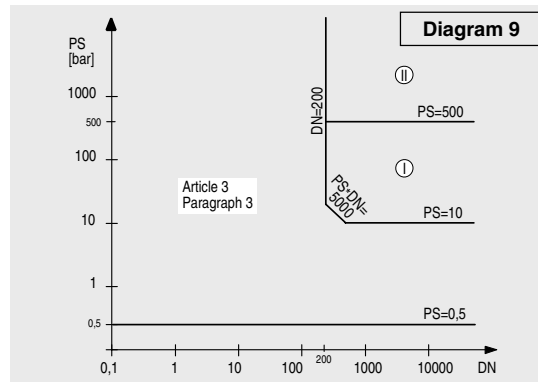

- Liquids of fluid group 2
- Pipelines according to Article 3 Number 1.3 Letter b) Second dash



1P A5E00047092

Siemens AG

Bereich Automation and Drives
Geschäftsgebiet Process Instrumentation and Analytics
D-76181 Karlsruhe