

SERVICE MANUAL

MODEL : ABR521

SERVICE MANUAL

VCR+DVD RECORDER

MODEL : ABR521

Allegro®

SECTION 1

SUMMARY

CONTENTS

PRODUCT SAFETY SERVICING GUIDELINES FOR VIDEO PRODUCTS	1-2
SERVICING PRECAUTIONS	1-3
THE STEPS FOR CHANGE THE OPTION CODE	1-4
UP-DATING PROGRAM	1-5
SPECIFICATIONS	1-7

PRODUCT SAFETY SERVICING GUIDELINES FOR VIDEO PRODUCTS

IMPORTANT SAFETY NOTICE

This manual was prepared for use only by properly trained audio-video service technicians.

When servicing this product, under no circumstances should the original design be modified or altered without permission from ALLEGRO Electronics Corporation. All components should be replaced only with types identical to those in the original circuit and their physical location, wiring and lead dress must conform to original layout upon completion of repairs.

Special components are also used to prevent x-radiation, shock and fire hazard. These components are indicated by the letter "x" included in their component designators and are required to maintain safe performance. No deviations are allowed without prior approval by ALLEGRO Electronics Corporation.

Circuit diagrams may occasionally differ from the actual circuit used. This way, implementation of the latest safety and performance improvement changes into the set is not delayed until the new service literature is printed.

CAUTION: Do not attempt to modify this product in any way. Never perform customized installations without manufacturer's approval. Unauthorized modifications will not only void the warranty, but may lead to property damage or user injury.

Service work should be performed only after you are thoroughly familiar with these safety checks and servicing guidelines.

GRAPHIC SYMBOLS



The exclamation point within an equilateral triangle is intended to alert the service personnel to important safety information in the service literature.



The lightning flash with arrowhead symbol within an equilateral triangle is intended to alert the service personnel to the presence of noninsulated "dangerous voltage" that may be of sufficient magnitude to constitute a risk of electric shock.



The pictorial representation of a fuse and its rating within an equilateral triangle is intended to convey to the service personnel the following fuse replacement caution notice:

CAUTION: FOR CONTINUED PROTECTION AGAINST RISK OF FIRE, REPLACE ALL FUSES WITH THE SAME TYPE AND RATING AS MARKED NEAR EACH FUSE.

SERVICE INFORMATION

While servicing, use an isolation transformer for protection from AC line shock. After the original service problem has been corrected, make a check of the following:

FIRE AND SHOCK HAZARD

1. Be sure that all components are positioned to avoid a possibility of adjacent component shorts. This is especially important on items transported to and from the repair shop.
2. Verify that all protective devices such as insulators, barriers, covers, shields, strain reliefs, power supply cords, and other hardware have been reinstalled per the original design. Be sure that the safety purpose of the polarized line plug has not been defeated.
3. Soldering must be inspected to discover possible cold solder joints, solder splashes, or sharp solder points. Be certain to remove all loose foreign particles.
4. Check for physical evidence of damage or deterioration to parts and components, for frayed leads or damaged insulation (including the AC cord), and replace if necessary.
5. No lead or component should touch a high current device or a resistor rated at 1 watt or more. Lead tension around protruding metal surfaces must be avoided.
6. After reassembly of the set, always perform an AC leakage test on all exposed metallic parts of the cabinet (the channel selector knobs, antenna terminals, handle and screws) to be sure that set is safe to operate without danger of electrical shock. **DO NOT USE A LINE ISOLATION TRANSFORMER DURING THIS TEST.** Use an AC voltmeter having 5000 ohms per volt or more sensitivity in the following manner: Connect a 1500 ohm, 10 watt resistor, paralleled by a .15 mfd 150V AC type capacitor between a known good earth ground water pipe, conduit, etc.) and the exposed metallic parts, one at a time. Measure the AC voltage across the combination of 1500 ohm resistor and .15 mfd capacitor. Reverse the AC plug by using a non-polarized adaptor and repeat AC voltage measurements for each exposed metallic part. Voltage measured must not exceed 0.75 volts RMS. This corresponds to 0.5 milliamp AC. Any value exceeding this limit constitutes a potential shock hazard and must be corrected immediately.

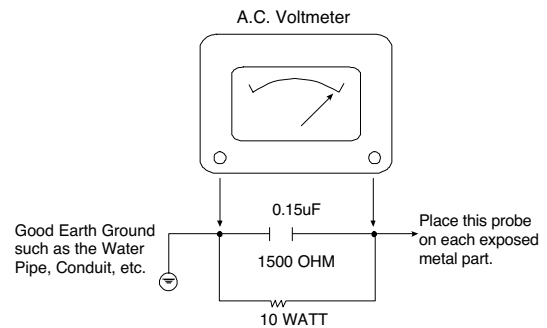

TIPS ON PROPER INSTALLATION

1. Never install any receiver in a closed-in recess, cubbyhole, or closely fitting shelf space over, or close to, a heat duct, or in the path of heated air flow.
2. Avoid conditions of high humidity such as: outdoor patio installations where dew is a factor, near steam radiators where steam leakage is a factor, etc.
3. Avoid placement where draperies may obstruct venting. The customer should also avoid the use of decorative scarves or other coverings that might obstruct ventilation.
4. Wall- and shelf-mounted installations using a commercial mounting kit must follow the factory-approved mounting instructions. A product mounted to a shelf or platform must retain its original feet (or the equivalent thickness in spacers) to provide adequate air flow across the bottom. Bolts or screws used for fasteners must not touch any parts or wiring. Perform leakage tests on customized installations.
5. Caution customers against mounting a product on a sloping shelf or in a tilted position, unless the receiver is properly secured.
6. A product on a roll-about cart should be stable in its mounting to the cart. Caution the customer on the hazards of trying to roll a cart with small casters across thresholds or deep pile carpets.
7. Caution customers against using extension cords. Explain that a forest of extensions, sprouting from a single outlet, can lead to disastrous consequences to home and family.

SERVICING PRECAUTIONS

CAUTION: Before servicing the VCR + DVD RECORDER covered by this service data and its supplements and addends, read and follow the SAFETY PRECAUTIONS. NOTE: if unforeseen circumstances create conflict between the following servicing precautions and any of the safety precautions in this publications, always follow the safety precautions.

Remember Safety First:

General Servicing Precautions

1. Always unplug the VCR + DVD RECORDER AC power cord from the AC power source before:
 - (1) Removing or reinstalling any component, circuit board, module, or any other assembly.
 - (2) Disconnecting or reconnecting any internal electrical plug or other electrical connection.
 - (3) Connecting a test substitute in parallel with an electrolytic capacitor.
Caution: A wrong part substitution or incorrect polarity installation of electrolytic capacitors may result in an explosion hazard.
2. Do not spray chemicals on or near this VCR + DVD RECORDER or any of its assemblies.
3. Unless specified otherwise in this service data, clean electrical contacts by applying an appropriate contact cleaning solution to the contacts with a pipe cleaner, cotton-tipped swab, or comparable soft applicator. Unless specified otherwise in this service data, lubrication of contacts is not required.
4. Do not defeat any plug/socket B+ voltage interlocks with which instruments covered by this service manual might be equipped.
5. Do not apply AC power to this VCR + DVD RECORDER and / or any of its electrical assemblies unless all solid-state device heat sinks are correctly installed.
6. Always connect the test instrument ground lead to an appropriate ground before connecting the test instrument positive lead. Always remove the test instrument ground lead last.

Insulation Checking Procedure

Disconnect the attachment plug from the AC outlet and turn the power on. Connect an insulation resistance meter (500V) to the blades of the attachment plug. The insulation resistance between each blade of the attachment plug and accessible conductive parts (Note 1) should be more than 1M-ohm.

Note 1: Accessible Conductive Parts include Metal panels, Input terminals, Earphone jacks, etc.

Electrostatically Sensitive (ES) Devices

Some semiconductor (solid state) devices can be damaged easily by static electricity. Such components commonly are called Electrostatically Sensitive (ES) Devices. Examples of typical ES devices are integrated circuits and some field effect transistors and semiconductor chip components.

The following techniques should be used to help reduce the incidence of component damage caused by static electricity.

1. Immediately before handling any semiconductor component or semiconductor-equipped assembly, drain off any electrostatic charge on your body by touching a known earth ground. Alternatively, obtain and wear a commercially available discharging wrist strap device, which should be removed for potential shock reasons prior to applying power to the unit under test.
2. After removing an electrical assembly equipped with ES devices, place the assembly on a conductive surface such as aluminum foil, to prevent electrostatic charge buildup or exposure of the assembly.
3. Use only a grounded-tip soldering iron to solder or unsolder ES devices.
4. Use only an anti-static solder removal device. Some solder removal devices not classified as "anti-static" can generate electrical charges sufficient to damage ES devices.
5. Do not use freon-propelled chemicals. These can generate an electrical charge sufficient to damage ES devices.
6. Do not remove a replacement ES device from its protective package until immediately before you are ready to install it. (Most replacement ES devices are packaged with leads electrically shorted together by conductive foam, aluminum foil, or comparable conductive material).
7. Immediately before removing the protective material from the leads of a replacement ES device, touch the protective material to the chassis or circuit assembly into which the device will be installed.

Caution: Be sure no power is applied to the chassis or circuit, and observe all other safety precautions.

8. Minimize bodily motions when handling unpackaged replacement ES devices. (Normally harmless motion such as the brushing together of your clothes fabric or the lifting of your foot from a carpeted floor can generate static electricity sufficient to damage an ES device.)

THE STEPS FOR CHANGE THE OPTION CODE

Note : This procedure must be done when IC304(On digital Board) or Digital Boardassy

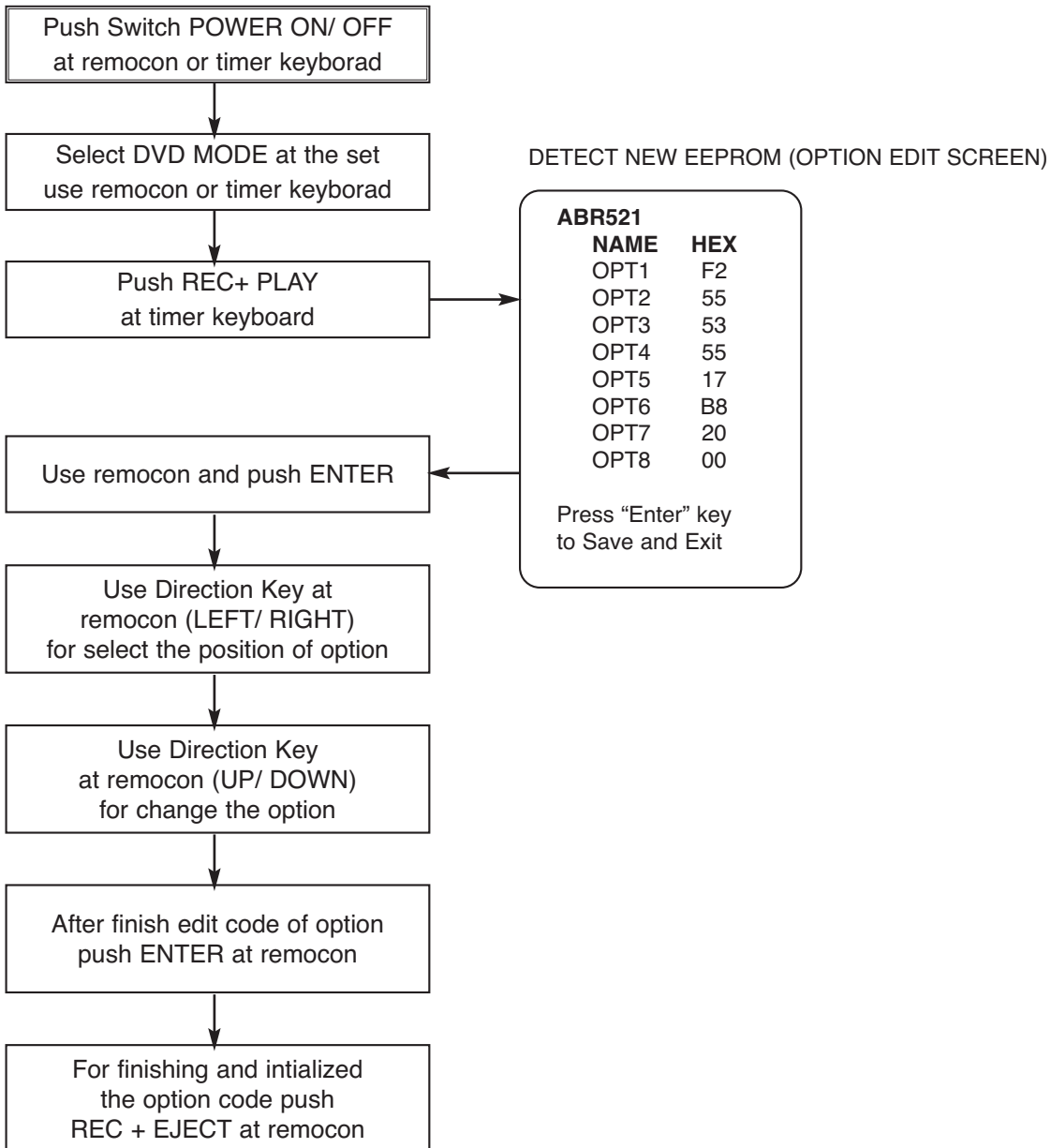

UP-DATING PROGRAM

BURNING DISC

- For up-dating the DVD program using the disc, it must burning the disc which include the DVD software.
- For recorder combi set which using the disc downloader program are DVD Program and Loader Program.
- In 2nd generation for recorder combi can download the DVD program and Loader program one by one, or all together.

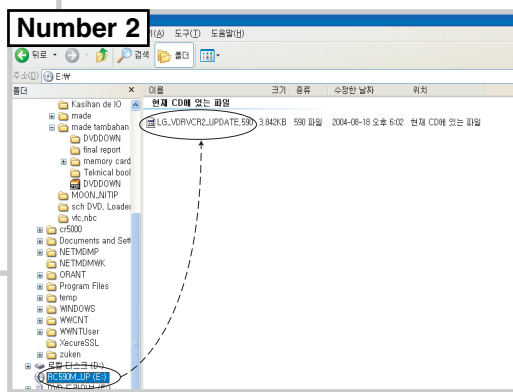
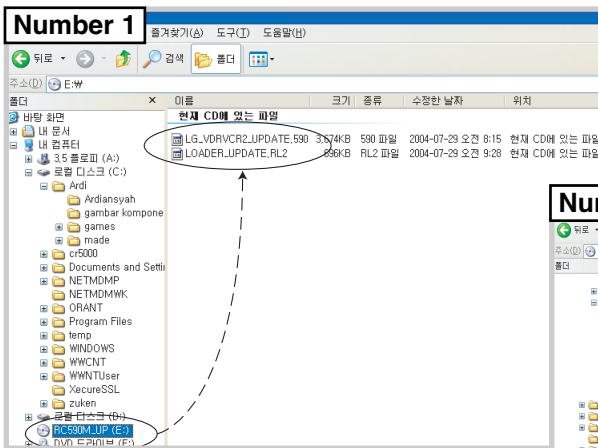

- * There is two way to format disc DVD Program
1. DVD and LOADER program format in one disc
 2. Only DVD program format in one disc

- If you format like number 1 you'll see capture like (figure 1)
- And you have three choice:
 1. Main. It's mean if you chose this it'll up-dating only DVD prgram.
 2. Loader. It's mean if you chose this it'll up-dating only Loader program.
 3. ALL. It's mean if you chose this it'll up-dating DVD and Loader program.



- If you format like number 2 you'll not see capture like figure 1 that give you choices, you have no choice only update DVD program

DVD UPGRADE INSTRUCTION

FORMAT NO 1

1. Press POWER KEY to turn on.
2. After booting, insert the upgrade disc, and you will see message like [FIGURE 1]
3. Press “REC” key (front or remote) 3 times and you will see as [FIGURE 2] with remote Chose one of them then Press enter
4. For update both of them [MAIN & LOADER] we chose “ALL” and first you will see [FIGURE 3] DVD update → Check the “Current Version” and “New CD Write Version” and press “REC” key.
5. The DVD update will be on progress. And when finish update MAIN Version it’s automatically continue to Update Loader Version and You will see [FIGURE 4]
6. The LOADER update will be on progress. And tray will open.
7. Remove the disc and wait until finish
8. The tray will be close and open automatically after completing “UNDER UPDATE” 100%
9. Turn off the unit
10. Turn on again the unit is operation with new software

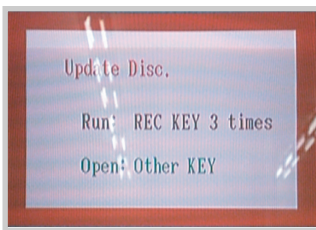

[FIGURE 1]

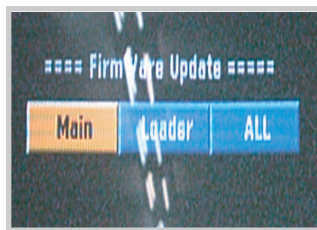

[FIGURE 2]

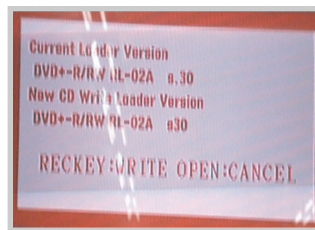

[FIGURE 3]

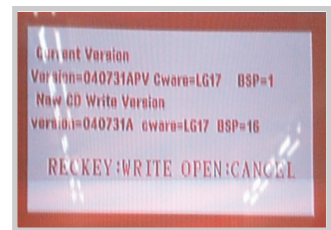

[FIGURE 4]

FORMAT NO 2

1. Press POWER KEY to turn on.
2. After booting, insert the upgrade disc, and you will see message like [FIGURE 1]
3. Press “REC” key (front or remote) 3 times
4. The DVD update will be on progress. → Check the “Current Version” and “New CD Write Version “ and Press “REC” key once more
5. The tray will be open automatically after completing “UNDER UPDATE” 100%
6. Remove the disc and Turn off the unit
7. Turn on again the unit is operation with new software

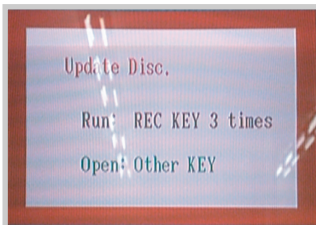

[FIGURE 1]

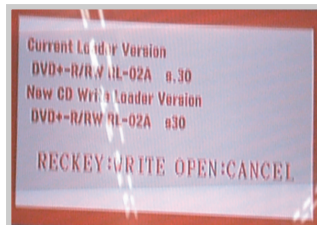

[FIGURE 2]

SPECIFICATIONS

General

Power requirements	AC 120V, 60 Hz
Power consumption	35W
Dimensions (approx.)	430 X 78.5 X 354 mm (w x h x d)
Mass (approx.)	5.7 kg
Operating temperature	5°C to 35°C
Operating humidity	5 % to 90 %
Television system	NTSC color system
Recording format	NTSC

System

Laser	Semiconductor laser, wavelength 650 nm
Video head system	Double azimuth 4 heads, helical scanning
Signal system	NTSC

Recording

Recording format	DVD+RW/+R Video format
Recordable discs	DVD-ReWritable, DVD-Recordable, DVD+ReWritable, DVD+Recordable
Recordable time	Approx. 1 hour (XP mode), 2 hours (SP mode), 4 hours (LP mode), 6 hours (EP mode)

Video recording format

Sampling frequency	27MHz
Compression format	MPEG 2

Audio recording format

Sampling frequency	48kHz
Compression format	Dolby Digital

Playback

Frequency response	DVD (PCM 48 kHz): 8 Hz to 22 kHz, CD: 8 Hz to 20 kHz DVD (PCM 96 kHz): 8 Hz to 44 kHz
Harmonic distortion	Less than 0.008% (AUDIO OUT connector)
Dynamic range	More than 95 dB (AUDIO OUT connector)

Inputs

RF IN	RF input, 75 ohms
VIDEO IN	1.0 Vp-p 75 ohms, sync negative, RCA jack
AUDIO IN	0 dBm more than 47 kohms, RCA jack (L, R)
DV IN	4 pin (i.LINK/IEEE 1394 standard)
S-VIDEO IN	(Y) 1.0 V (p-p), 75 Ω, negative sync, Mini DIN 4-pin x 1 (C) 0.3 V (p-p) 75 Ω

Outputs

S-VIDEO OUT	(Y) 1.0 V (p-p), 75 Ω, negative sync, Mini DIN 4-pin x 1 (C) 0.3 V (p-p) 75 Ω
COMPONENT VIDEO OUT	(Y) 1.0 V (p-p), 75 Ω, negative sync, RCA jack x 1 (Pb)/(Pr) 0.7 V (p-p), 75 Ω, RCA jack x 2
Audio output (digital audio)	0.5 V (p-p), 75 Ω, RCA jack x 1
Audio output (analog audio)	2.0 Vrms (1 KHz, 0 dB), 600 Ω, RCA jack (L, R) x 1

* Design and specifications are subject to change without notice.

* Manufactured under license from Dolby Laboratories. "Dolby", "Pro Logic" and the double-D symbol are trademarks of Dolby Laboratories.

* DTS and DTS Digital Out are registered trademarks of Digital Theater Systems, Inc.

SECTION 2
EXPLODED VIEWS
CONTENTS

EXPLODED VIEWS2-2

- 1. Cabinet and Main Frame Section2-2**
- 2. Deck Mechanism Section (RL-05)2-3**
- 3. Packing Accessory Section2-4**

EXPLODED VIEWS

1. Cabinet and Main Frame Section

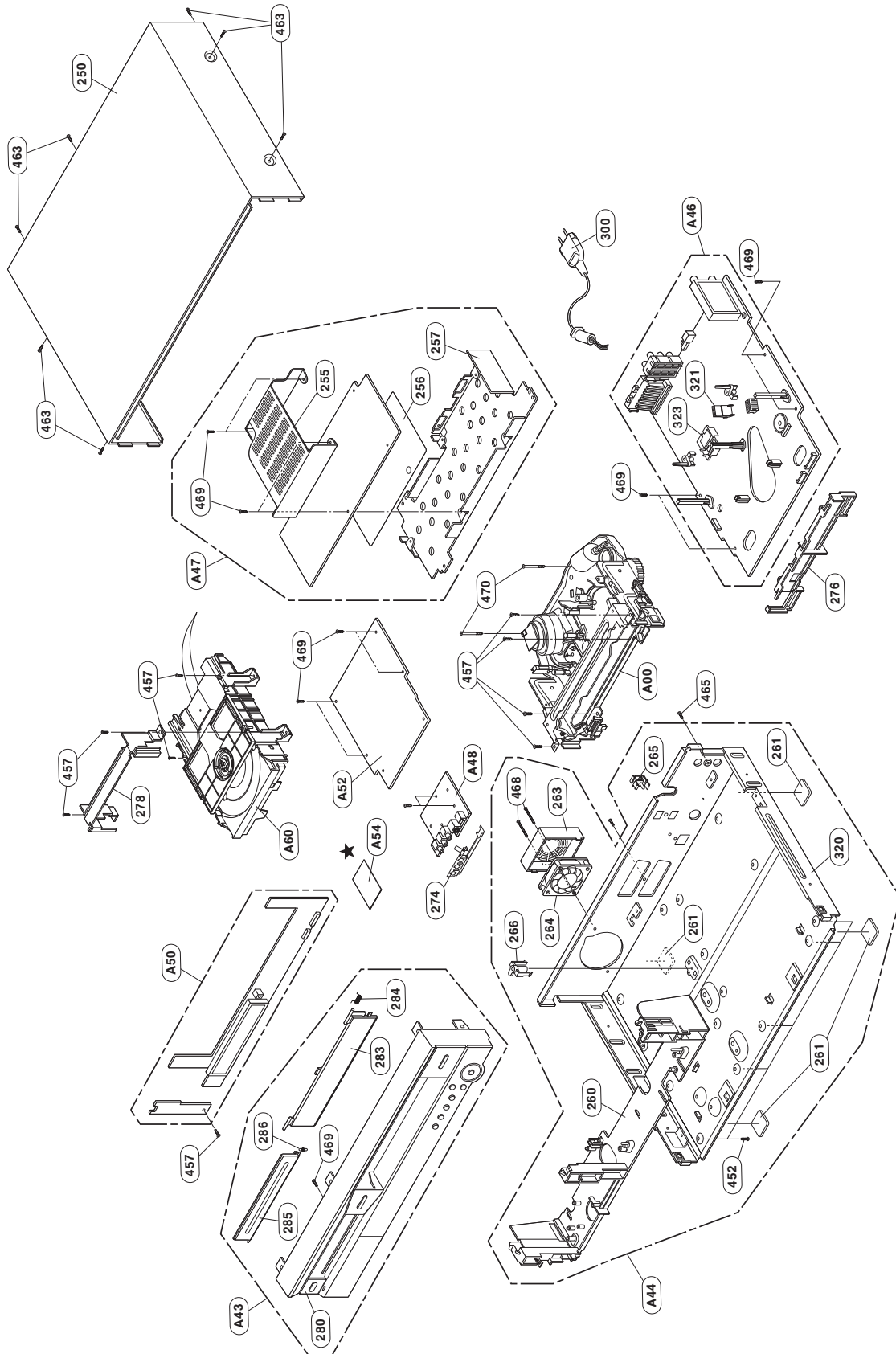

2. Deck Mechanism Section (RL-05)

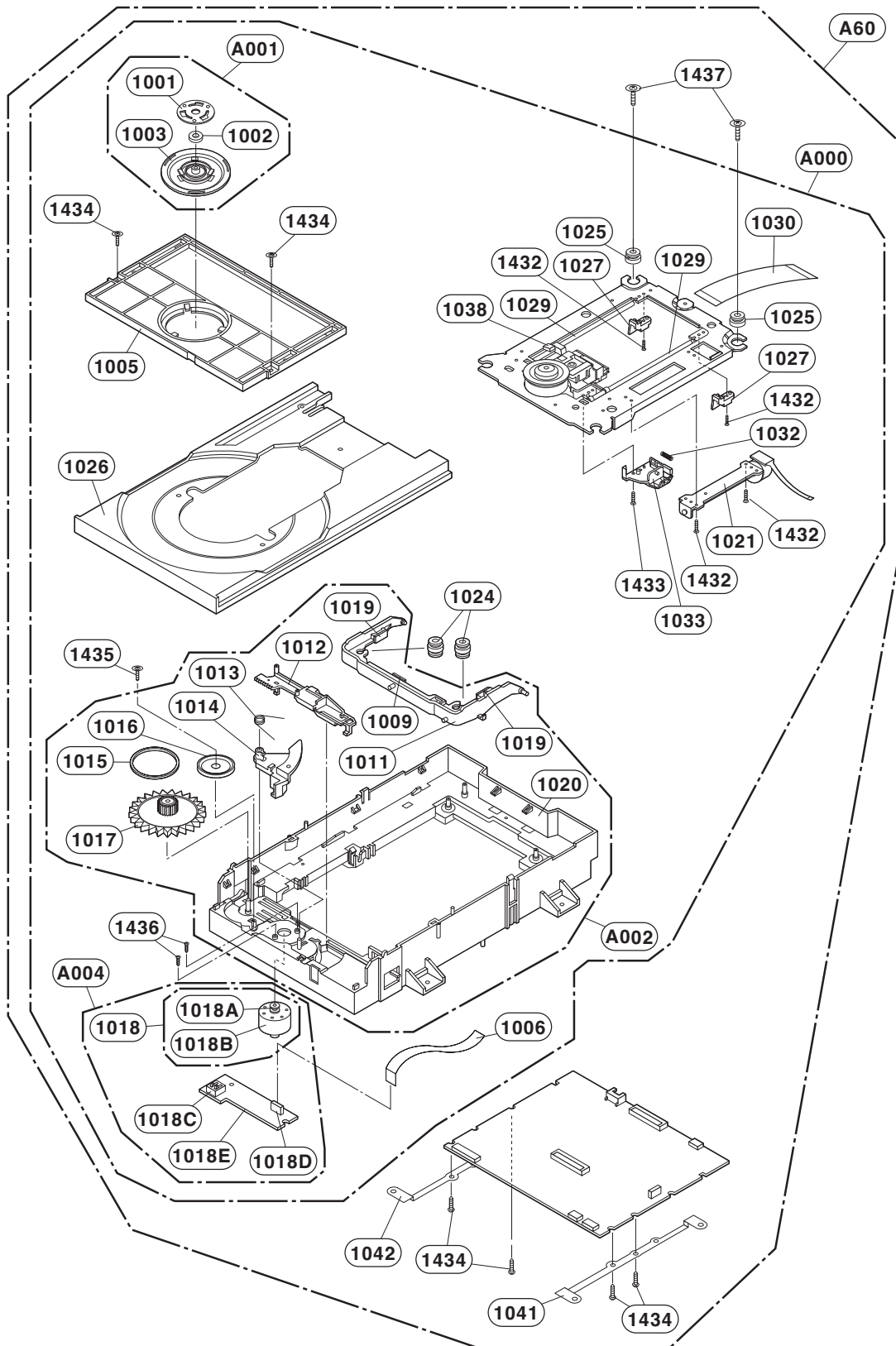

3. Packing Accessory Section

★OPTIONAL PARTS

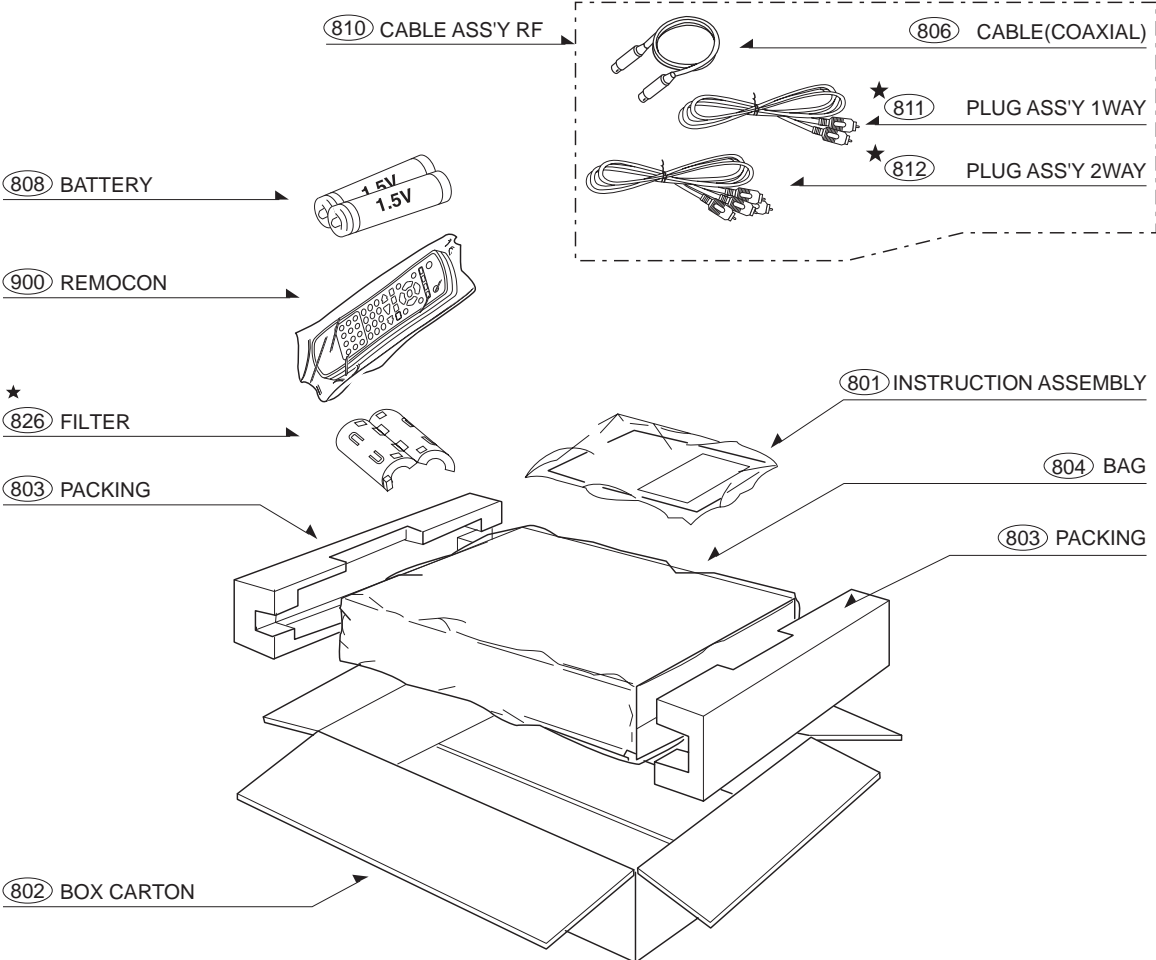

SECTION 3 ELECTRICAL CONTENTS

<p>OVERALL WIRING DIAGRAM.....3-2</p> <p>VCR PART</p> <p>ELECTRICAL ADJUSTMENT PROCEDURES.....3-3</p> <p>VCR ELECTRICAL TROUBLESHOOTING GUIDE.....3-4</p> <p style="padding-left: 20px;">1. POWER(SMPS) CIRCUIT3-4</p> <p style="padding-left: 20px;">2. SYSTEM/KEY CIRCUIT3-7</p> <p style="padding-left: 20px;">3. SERVO CIRCUIT.....3-8</p> <p style="padding-left: 20px;">4. Y/C CIRCUIT.....3-11</p> <p style="padding-left: 20px;">5. HI-FI CIRCUIT3-15</p> <p style="padding-left: 20px;">6. TUNER/IF CIRCUIT3-18</p> <p>BLOCK DIAGRAMS.....3-20</p> <p style="padding-left: 20px;">1. POWER(SMPS) BLOCK DIAGRAM.....3-20</p> <p style="padding-left: 20px;">2. AVCP BLOCK DIAGRAM3-22</p> <p style="padding-left: 20px;">3. SYSTEM BLOCK DIAGRAM3-24</p> <p style="padding-left: 20px;">4. JACK BLOCK DIAGRAM3-26</p> <p style="padding-left: 20px;">5. STUNER/MTZ BLOCK DIAGRAM.....3-28</p> <p style="padding-left: 20px;">6. AVCP BLOCK DIAGRAM3-30</p> <p>CIRCUIT DIAGRAMS.....3-32</p> <p style="padding-left: 20px;">1. POWER(SMPS) CIRCUIT DIAGRAM3-32</p> <p style="padding-left: 20px;">2. TU/IF CIRCUIT DIAGRAM3-34</p> <p style="padding-left: 20px;">3. A/V CIRCUIT DIAGRAM.....3-36</p> <p style="padding-left: 20px;">4. HI-FI CIRCUIT DIAGRAM3-38</p> <p style="padding-left: 20px;">5. SYSTEM CIRCUIT DIAGRAM.....3-40</p> <p style="padding-left: 20px;">6. JACK CIRCUIT DIAGRAM3-42</p> <p style="padding-left: 20px;">7. TIMER CIRCUIT DIAGRAM(2 TOOL)3-44</p> <p style="padding-left: 20px;">8. TIMER CIRCUIT DIAGRAM(3 TOOL, 8 TOOL) ..3-46</p> <p style="padding-left: 20px;">9. TIMER CIRCUIT DIAGRAM(4 TOOL)3-48</p> <p style="padding-left: 20px;">10. TIMER CIRCUIT DIAGRAM(6 TOOL)3-50</p> <p style="padding-left: 20px;">11. TIMER CIRCUIT DIAGRAM(7 TOOL)5-52</p> <p style="padding-left: 40px;">• WAVEFORMS3-54</p> <p style="padding-left: 40px;">• CIRCUIT VOLTAGE CHART3-56</p> <p>PRINTED CIRCUIT DIAGRAMS.....3-58</p> <p style="padding-left: 20px;">1. VCR P.C.BOARD3-58</p> <p style="padding-left: 20px;">2. SMPS P.C.BOARD3-60</p> <p style="padding-left: 20px;">3. JACK P.C.BOARD3-62</p> <p style="padding-left: 20px;">4. KEY P.C.BOARD3-64</p> <p style="padding-left: 20px;">5. TIMER P.C.BOARD3-64</p>	<p>VDR PART</p> <p>VDR ELECTRICAL TROUBLESHOOTING GUIDE.....3-66</p> <p style="padding-left: 20px;">1. POWER(SMPS) CIRCUIT3-66</p> <p style="padding-left: 20px;">2. NO COMPONENT VIDEO SIGNAL WHEN PLAYING DISC.....3-68</p> <p style="padding-left: 20px;">3. NO COMPOSITE / S-VIDEO SIGNAL WHEN PLAYING DISC.....3-69</p> <p style="padding-left: 20px;">4. NO TV, EXTERNAL INPUT VIDEO SIGNAL.....3-70</p> <p style="padding-left: 20px;">5. WHEN PLAYING DISC, NO AUDIO OUTPUT3-71</p> <p style="padding-left: 20px;">6. NO TUNER AUDIO OUTPUT3-71</p> <p style="padding-left: 20px;">7. NO OPTICAL / DIGITAL OUTPUT3-71</p> <p style="padding-left: 20px;">8. NO EXTERNAL INPUT 1, 2 AUDIO3-72</p> <p style="padding-left: 20px;">9. NO EXTERNAL INPUT 3 AUDIO3-72</p> <p>BLOCK DIAGRAMS.....3-73</p> <p style="padding-left: 20px;">1. VDR SET TOTAL BLOCK DIAGRAM.....3-73</p> <p style="padding-left: 20px;">2. VDR MAIN H/ W BLOCK DIAGRAM.....3-74</p> <p style="padding-left: 20px;">3. POWER BLOCK DIAGRAM3-75</p> <p style="padding-left: 20px;">4. AUDIO IN/ OUT BLOCK DIAGRAM3-76</p> <p style="padding-left: 20px;">5. CPU & CONTROL REGISTER BLOCK DIAGRAM.....3-77</p> <p style="padding-left: 20px;">6. VIDEO IN/ OUT BLOCK DIAGRAM3-78</p> <p style="padding-left: 20px;">7. DV 1394 IN/OUT BLOCK DIAGRAM3-79</p> <p style="padding-left: 20px;">8. MEMORY CARD IN/ OUT BLOCK DIAGRAM.....3-80</p> <p>CIRCUIT DIAGRAMS.....3-81</p> <p style="padding-left: 20px;">1. BGA 308P CIRCUIT DIAGRAM.....3-81</p> <p style="padding-left: 20px;">2. DDR & B TO B CONNECTOR CIRCUIT DIAGRAM3-83</p> <p style="padding-left: 20px;">3. POWER, FLASH, CONNECTOR CIRCUIT DIAGRAM3-85</p> <p style="padding-left: 20px;">4. RST, CONTROL/STATUS_REG., ATAPI, HOST_CPLD, LATCH CIRCUIT DIAGRAM3-87</p> <p style="padding-left: 20px;">5. VIDEO_IN, VIDEO_OUT CIRCUIT DIAGRAM.....3-89</p> <p style="padding-left: 20px;">6. DV1394, HDMI CIRCUIT DIAGRAM3-91</p> <p style="padding-left: 20px;">7. AUDIO IN/OUT CIRCUIT DIAGRAM3-93</p> <p style="padding-left: 40px;">• WAVEFORMS3-95</p> <p style="padding-left: 40px;">• CIRCUIT VOLTAGE CHART3-97</p> <p>PRINTED CIRCUIT DIAGRAMS.....3-99</p> <p style="padding-left: 20px;">1. VDR P.C.BOARD(TOP VIEW)3-99</p> <p style="padding-left: 20px;">2. VDR P.C.BOARD(BOTTOM VIEW).....3-101</p>
--	---

OVERALL WIRING DIAGRAMS

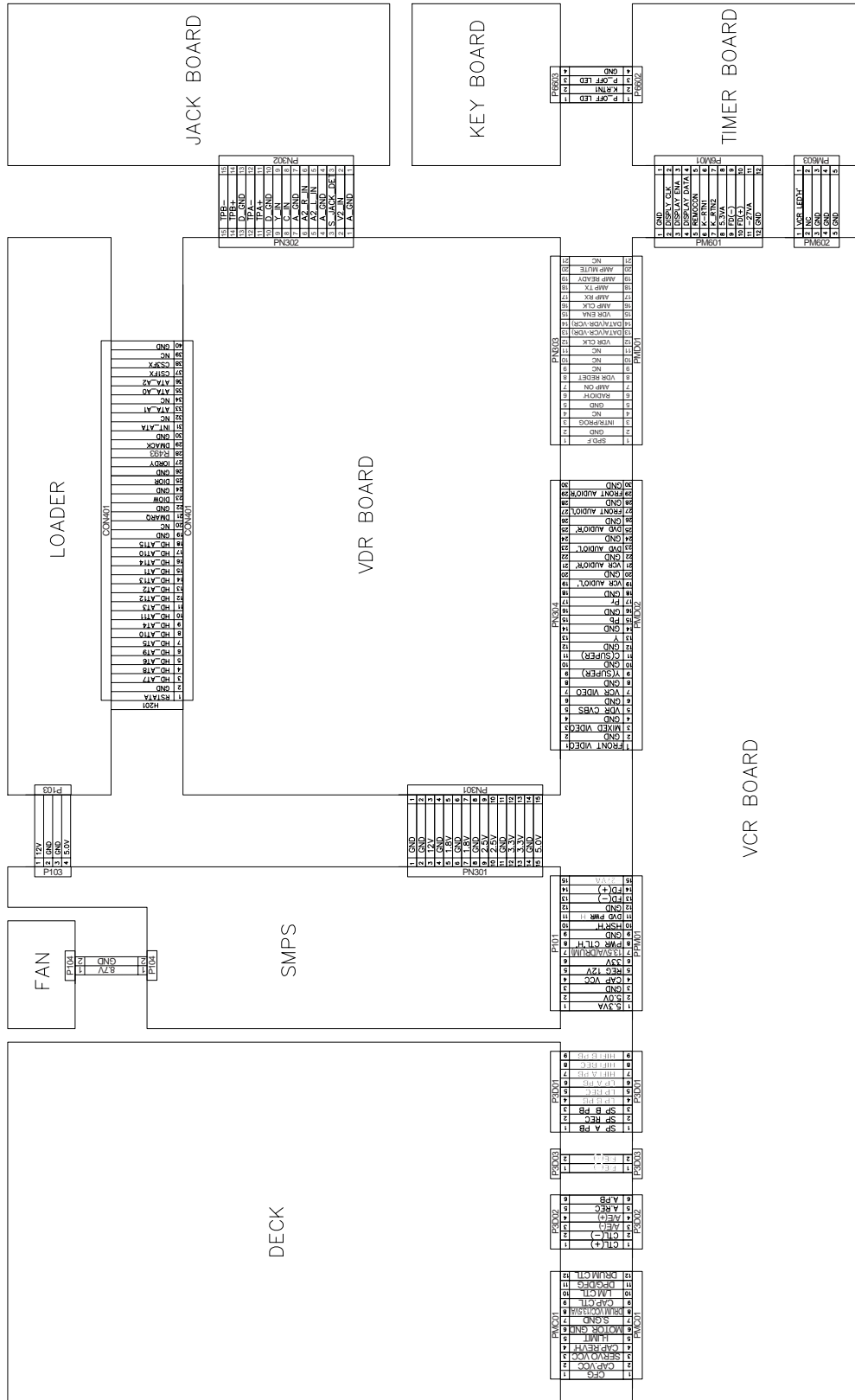

VCR PART

ELECTRICAL ADJUSTMENT PROCEDURES

1. Servo Adjustment

1) PG Adjustment

- Test Equipment
- a) OSCILLOSCOPE : NTSC SP TEST TAPE

• Adjustment And Specification

MODE	MEASUREMENT POINT	ADJUSTMENT POINT	SPECIFICATION
PLAY	V.Out H/SW(TP)	R/C TRK JIG KEY	$6.5 \pm 0.5H$

• Adjustment Procedure

- a) Insert the SP Test Tape and play.
- b) Connect the CH1 of the oscilloscope to the H/SW and CH2 to the "VCR VIDEO" TP for the VCR.
- c) Trigger the mixed Combo Video Signal of CH2 to the CH1 H/SW, and then check the distance (time difference), which is from the selected A(B) Head point of the H/SW signal to the starting point of the vertical synchronized signal, to $6.5H \pm 0.5H$ ($416\mu s$, $1H=64\mu s$).

• PG Adjustment Method

- a-1) Playback the SP standard tape
- b-2) Wait for 3seconds with F/P "REC" key and "PLAY" key pressed at the same time. < Digitron[- -] >
- c-3) Repeat the above step(No.b-2), then it finishes the PG adjusting automatically. < Digitron[PG] >
- d-4) Stop the playback, then it goes out of PG adjusting mode after many the PG data.

• CONNECTION

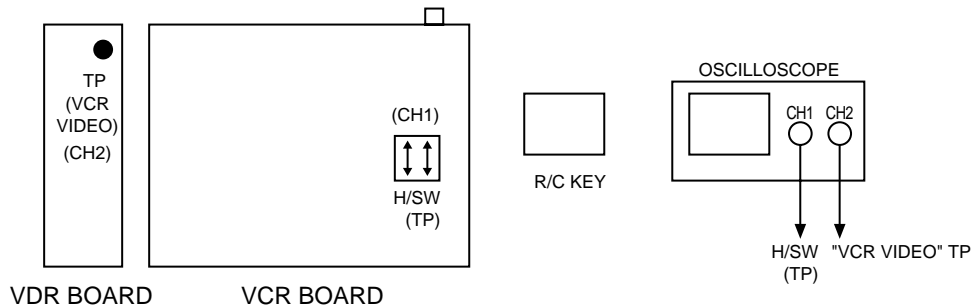

• WAVEFORM

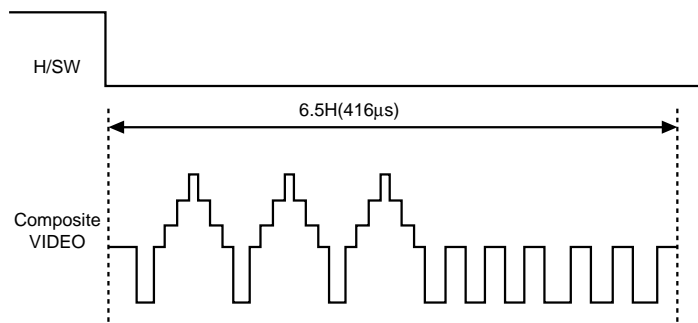

VCR ELECTRICAL TROUBLESHOOTING GUIDE

1. Power(SMPS) CIRCUIT

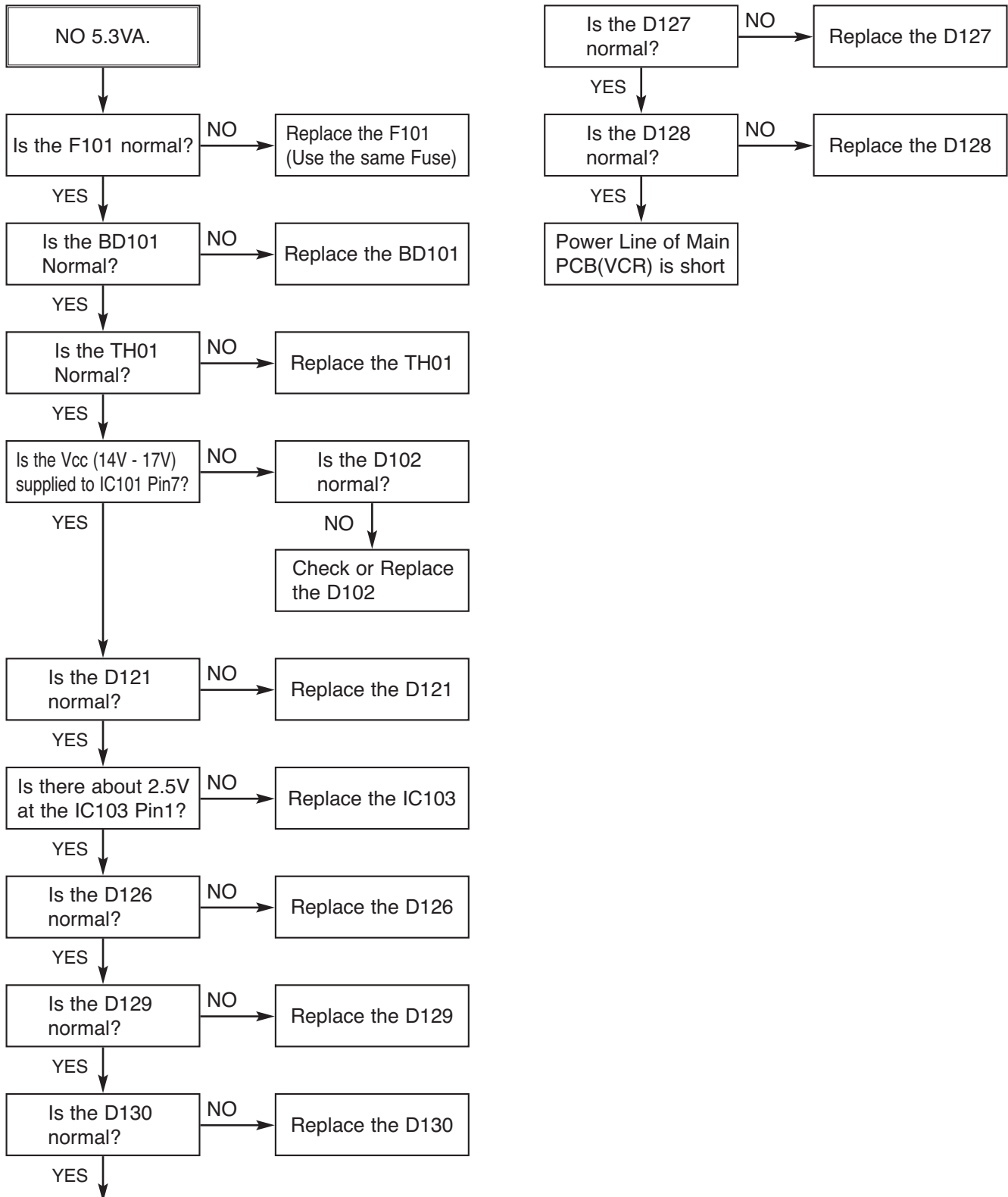

VCR ELECTRICAL TROUBLESHOOTING GUIDE

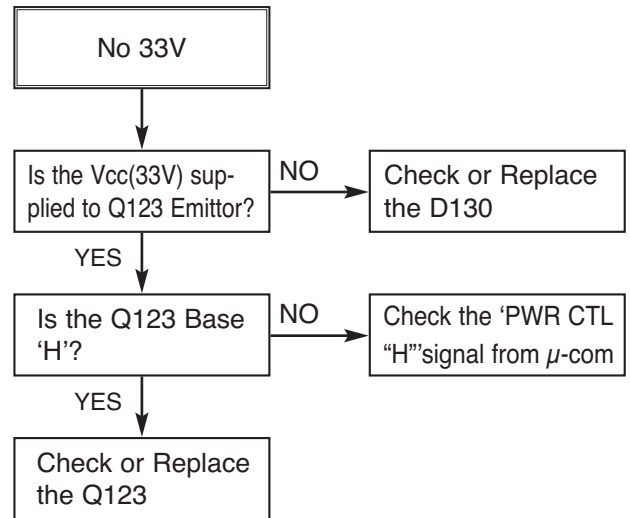
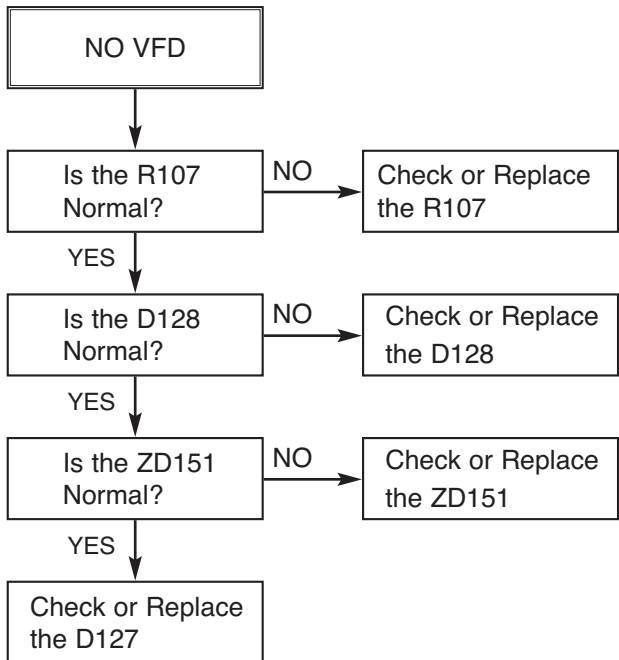
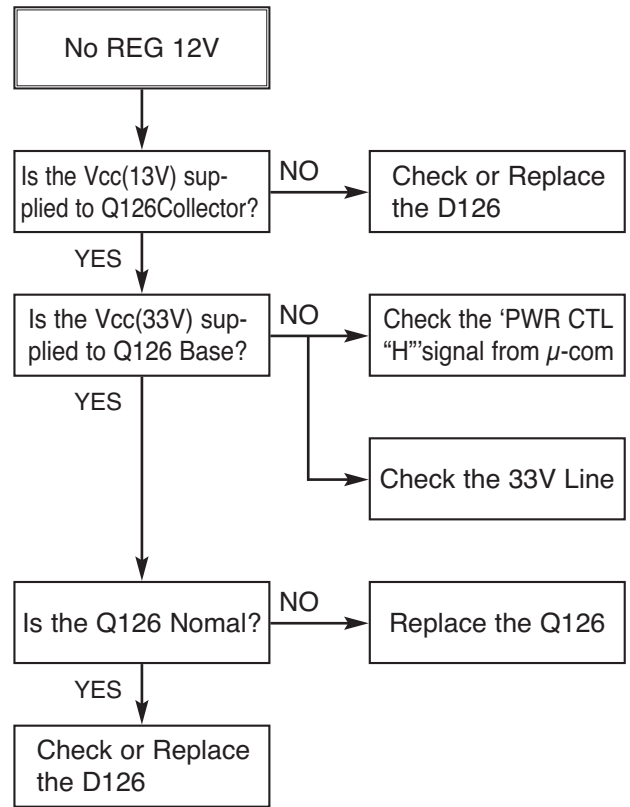
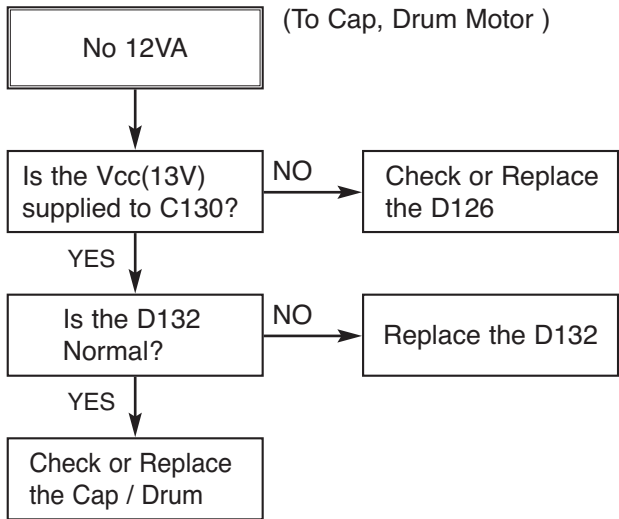

VCR ELECTRICAL TROUBLESHOOTING GUIDE

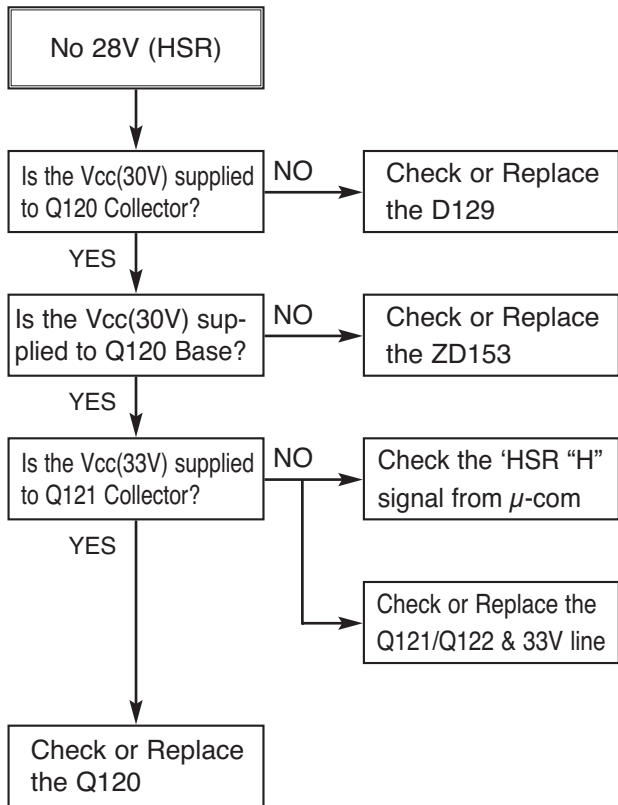

VCR ELECTRICAL TROUBLESHOOTING GUIDE

2. SYSTEM/KEY CIRCUIT

(1) AUTO STOP

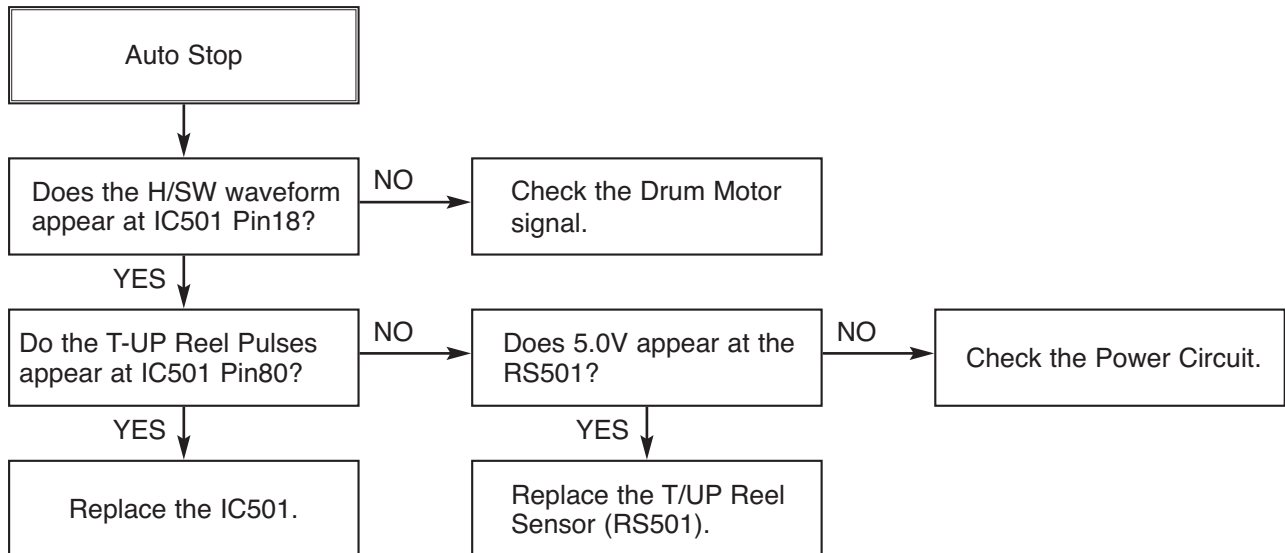

Note : Auto stop can occur because Grease or Oil has dried up

(2) The unstable loading of a Cassette tape

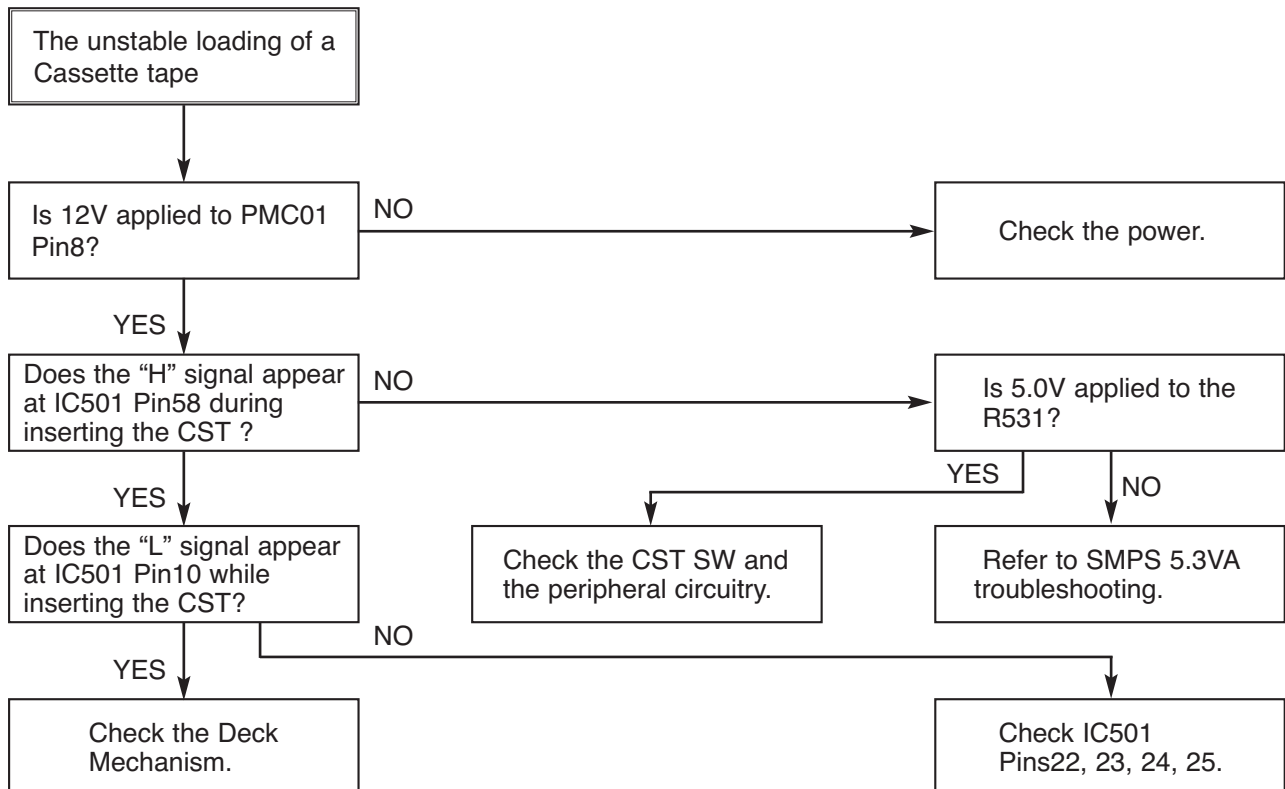

VCR ELECTRICAL TROUBLESHOOTING GUIDE

3. SERVO CIRCUIT

(1) Unstable Video in PB MODE

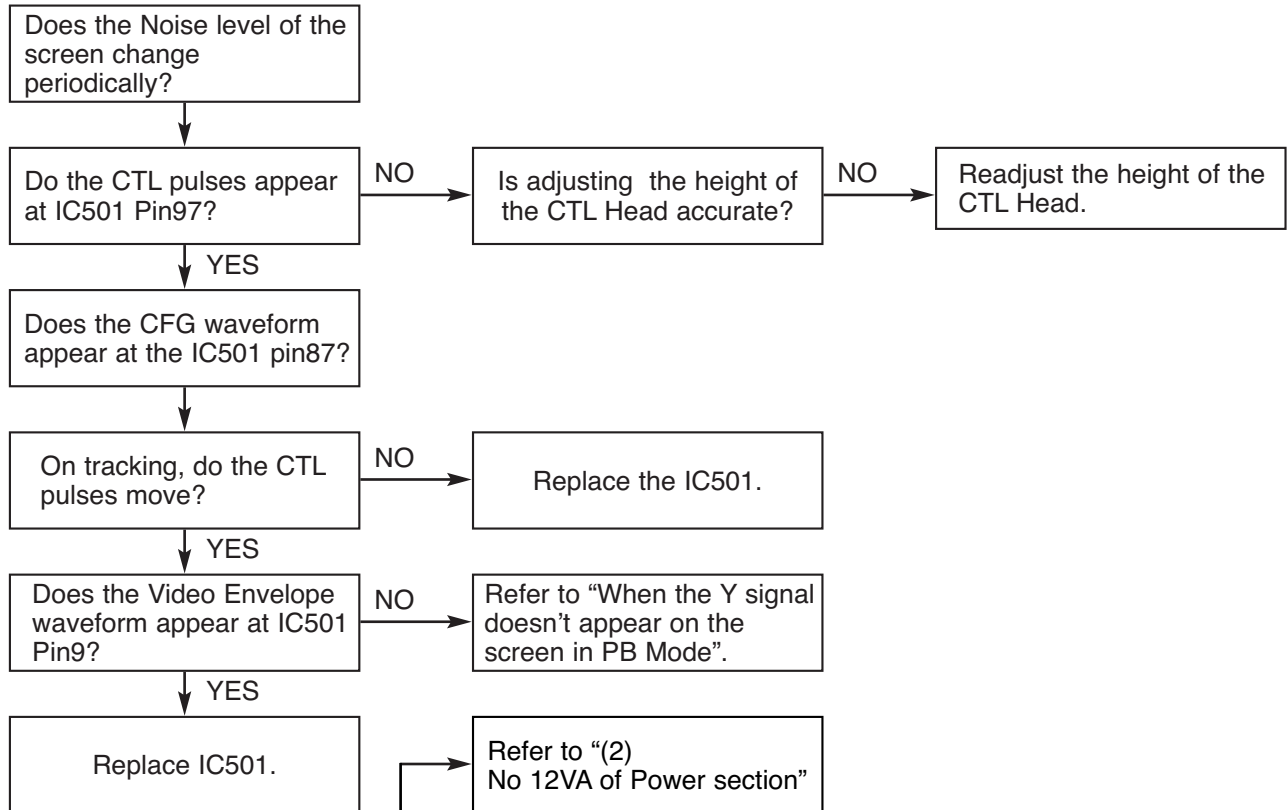

(2) When the Drum Motor doesn't run.

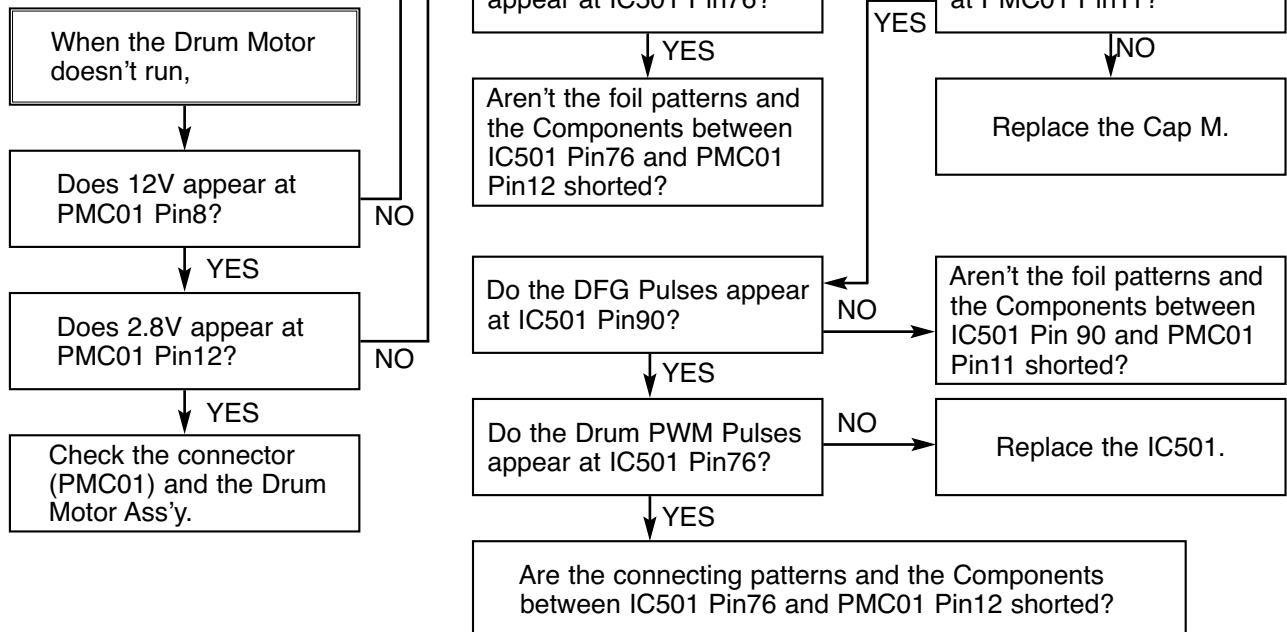

VCR ELECTRICAL TROUBLESHOOTING GUIDE

(3) When the Capstan Motor doesn't run,

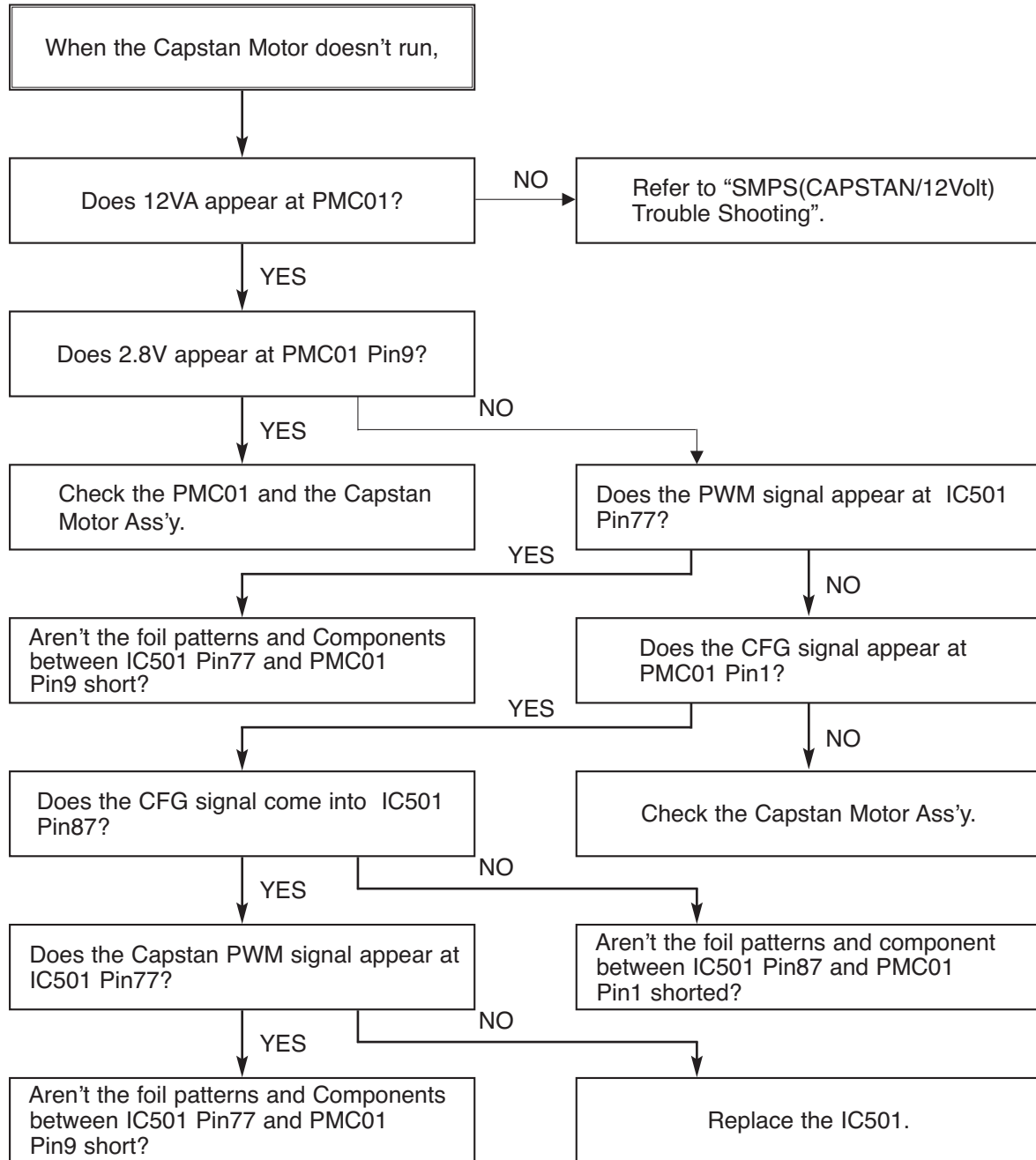

VCR ELECTRICAL TROUBLESHOOTING GUIDE

(4) Keys do not work

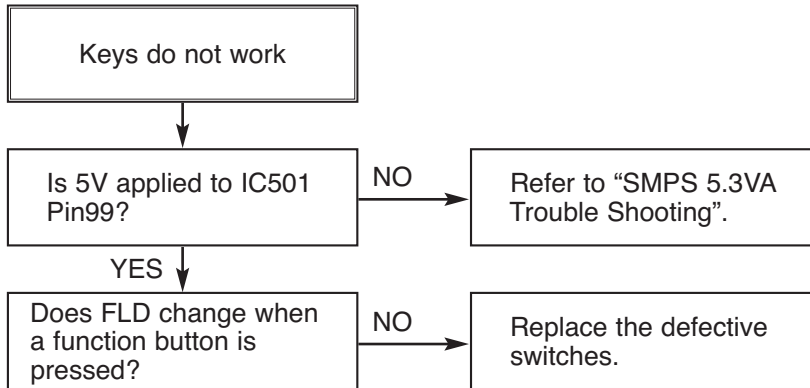

VCR ELECTRICAL TROUBLESHOOTING GUIDE

4. Y/C CIRCUIT

(1) No Video in EE Mode,

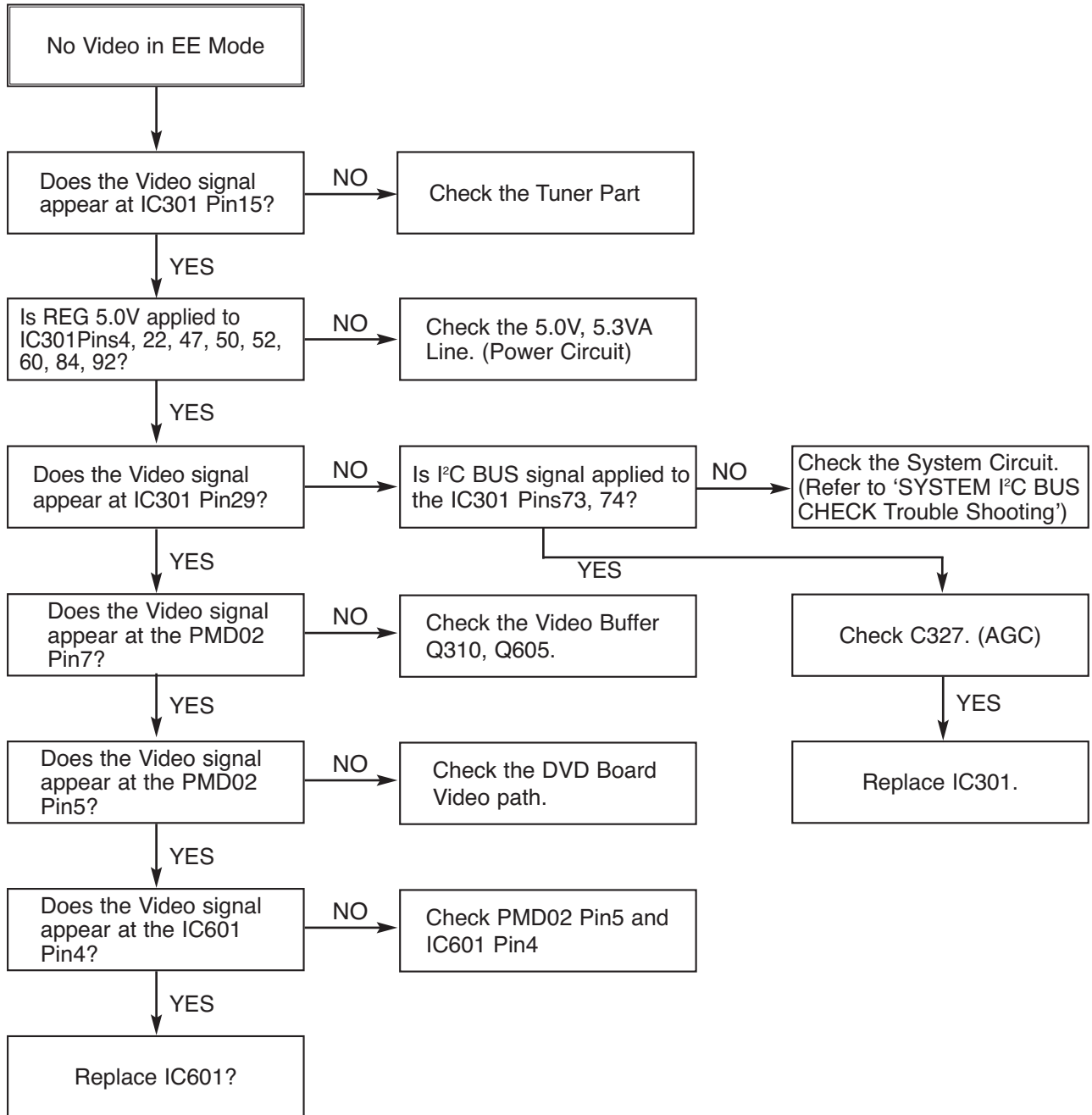

VCR ELECTRICAL TROUBLESHOOTING GUIDE

(2) When the Y(Luminance) signal doesn't appear on the screen in PB Mode,

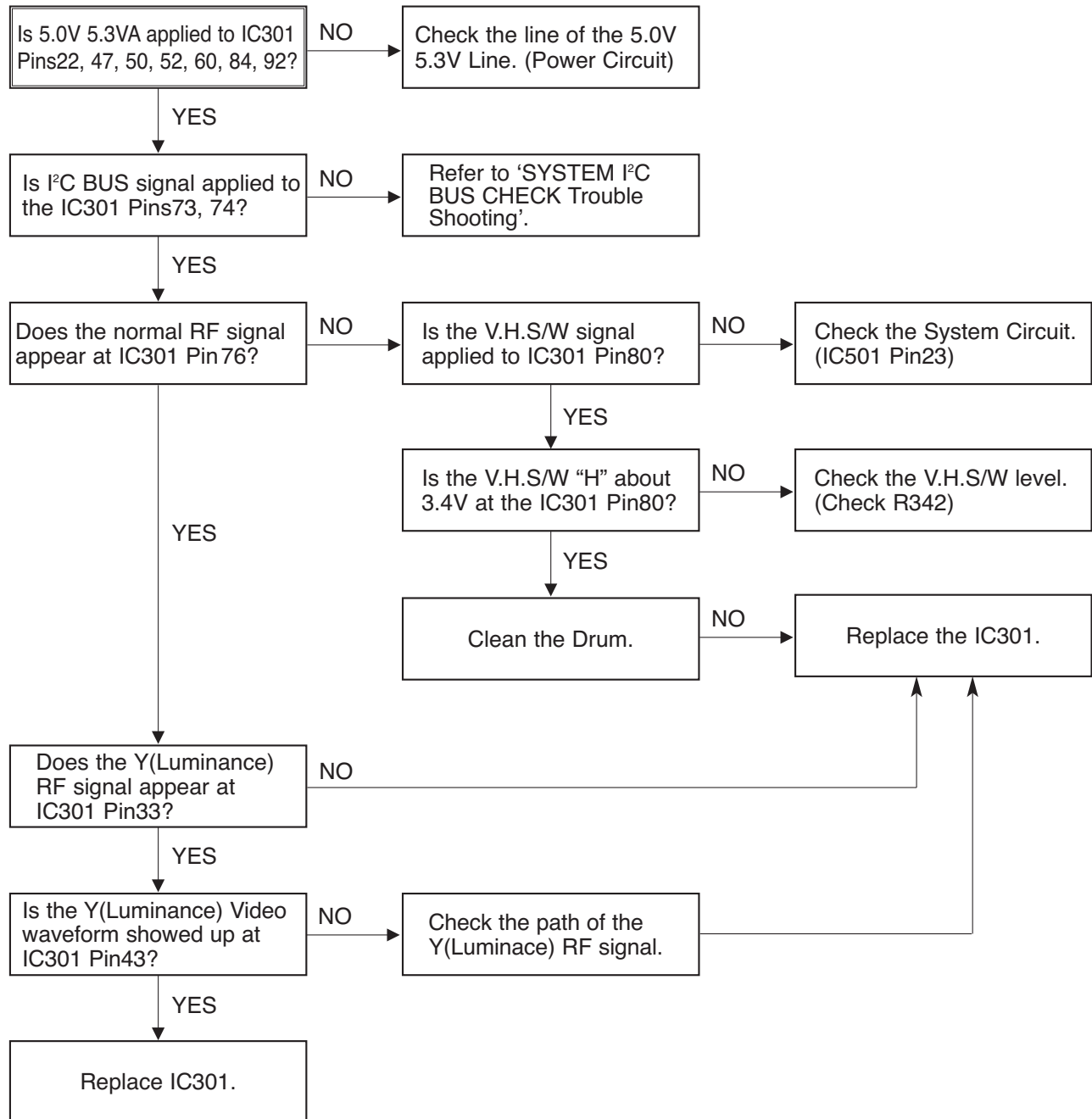

VCR ELECTRICAL TROUBLESHOOTING GUIDE

(3) When the C(Color) signal doesn't appear on the screen in PB Mode,

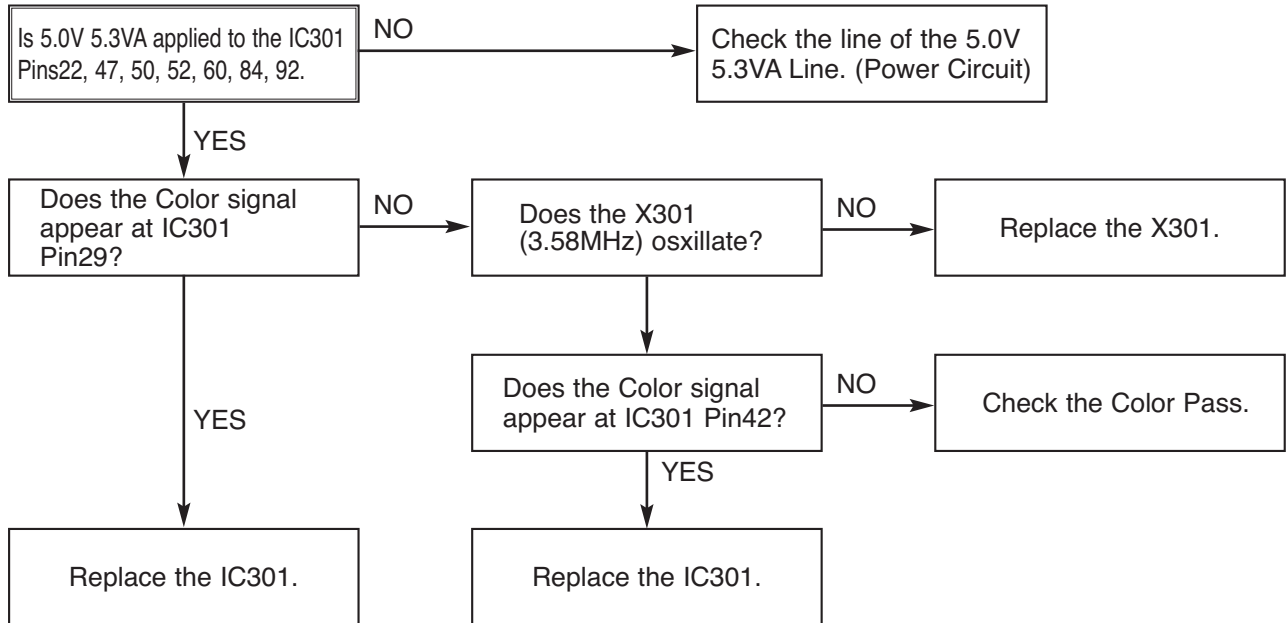

VCR ELECTRICAL TROUBLESHOOTING GUIDE

(4) When the Video signal doesn't appear on the screen in REC Mode,

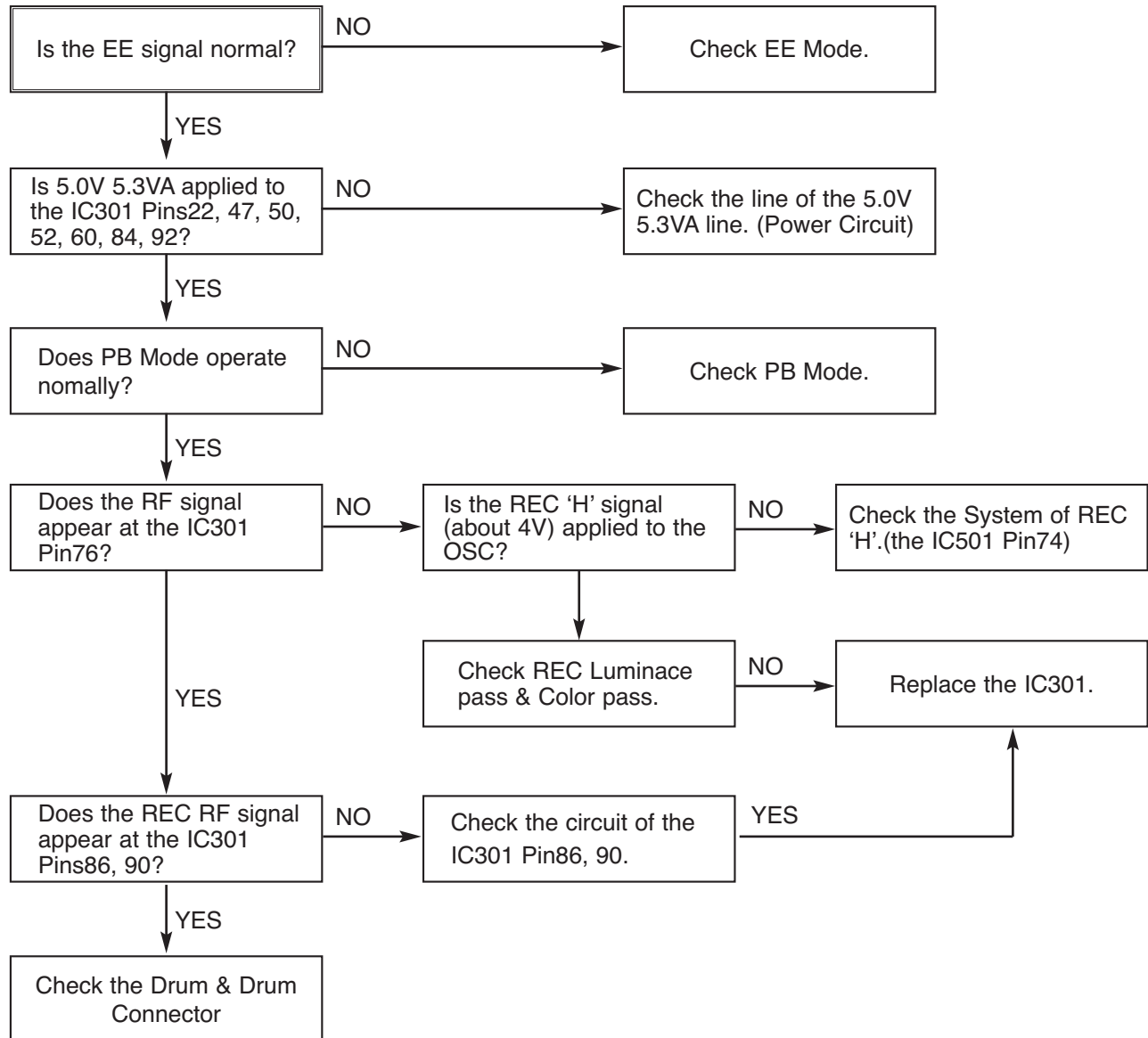

VCR ELECTRICAL TROUBLESHOOTING GUIDE

5. Hi-Fi CIRCUIT

(1) No Sound(EE Mode)

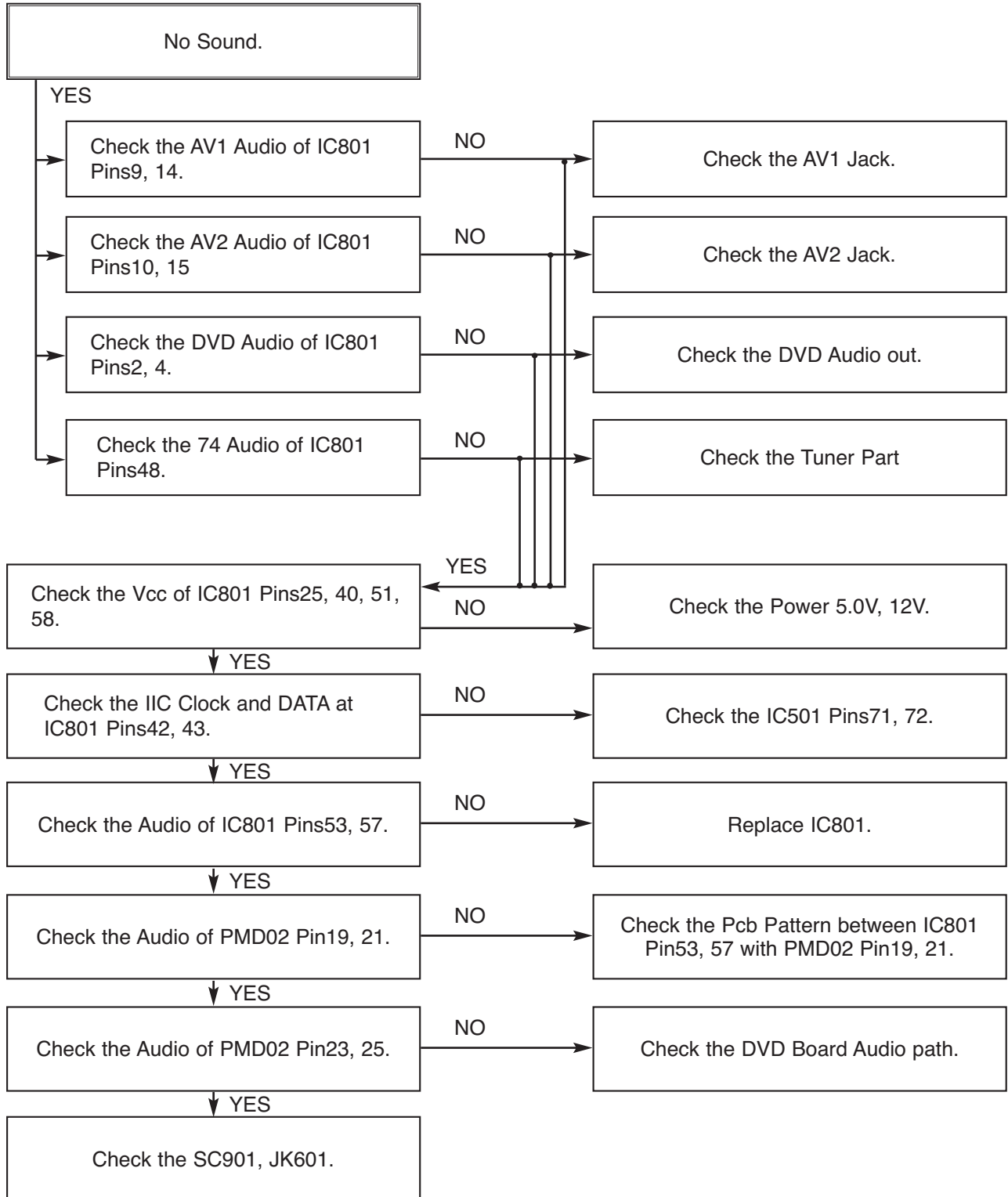

VCR ELECTRICAL TROUBLESHOOTING GUIDE

(2) Hi-Fi Playback

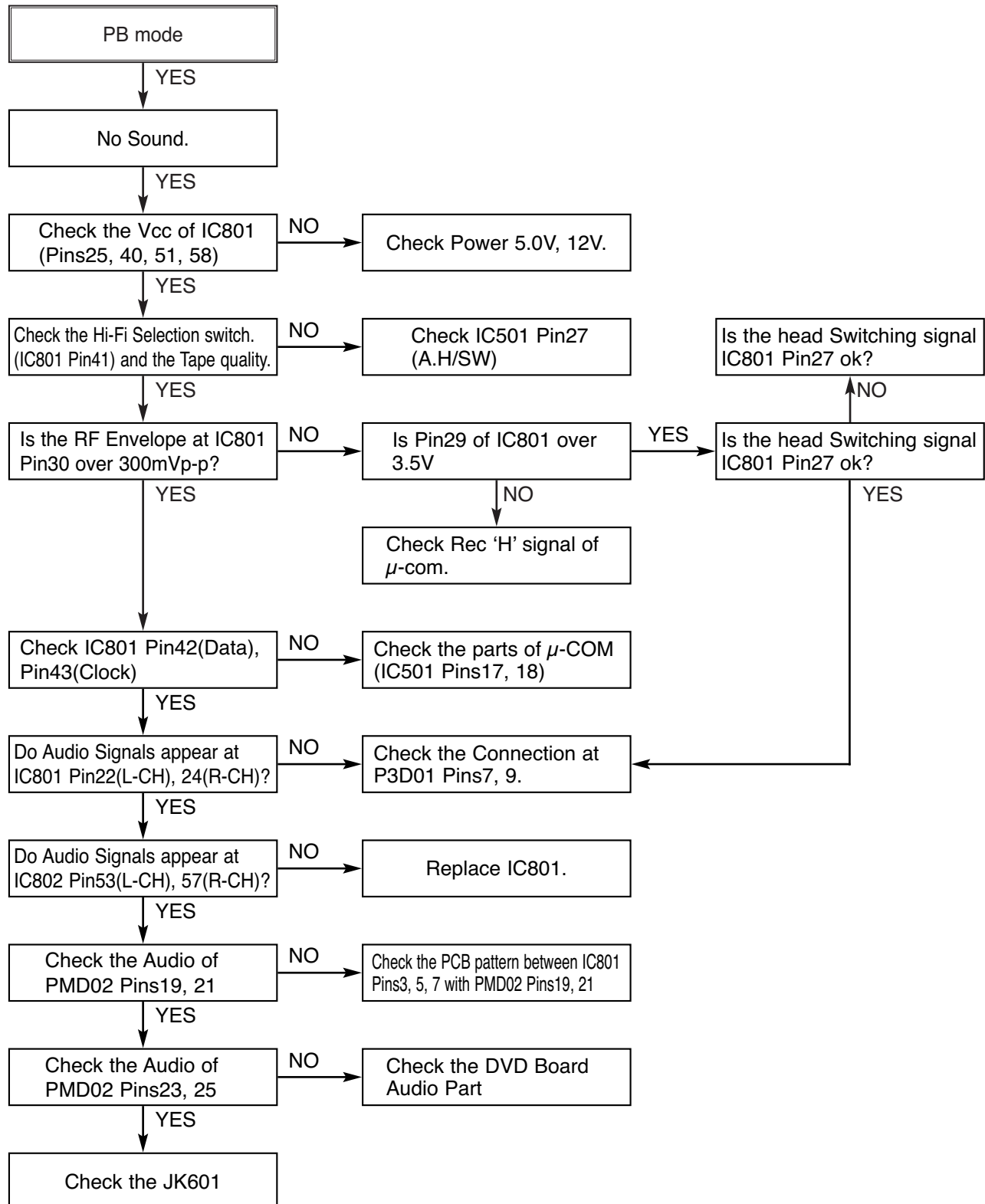

VCR ELECTRICAL TROUBLESHOOTING GUIDE

(3)

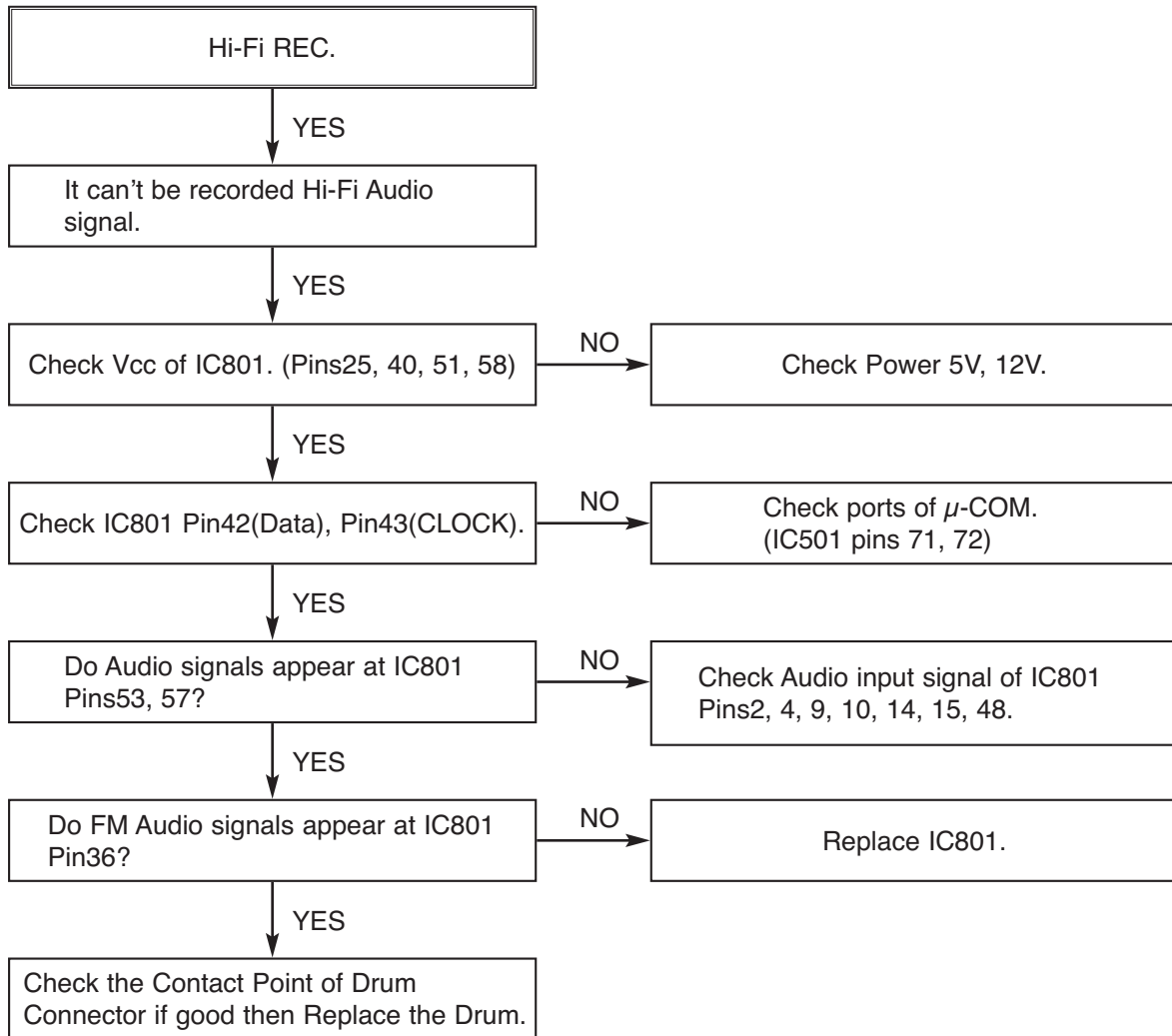

VCR ELECTRICAL TROUBLESHOOTING GUIDE

7. Tuner/IF CIRCUIT

(A)

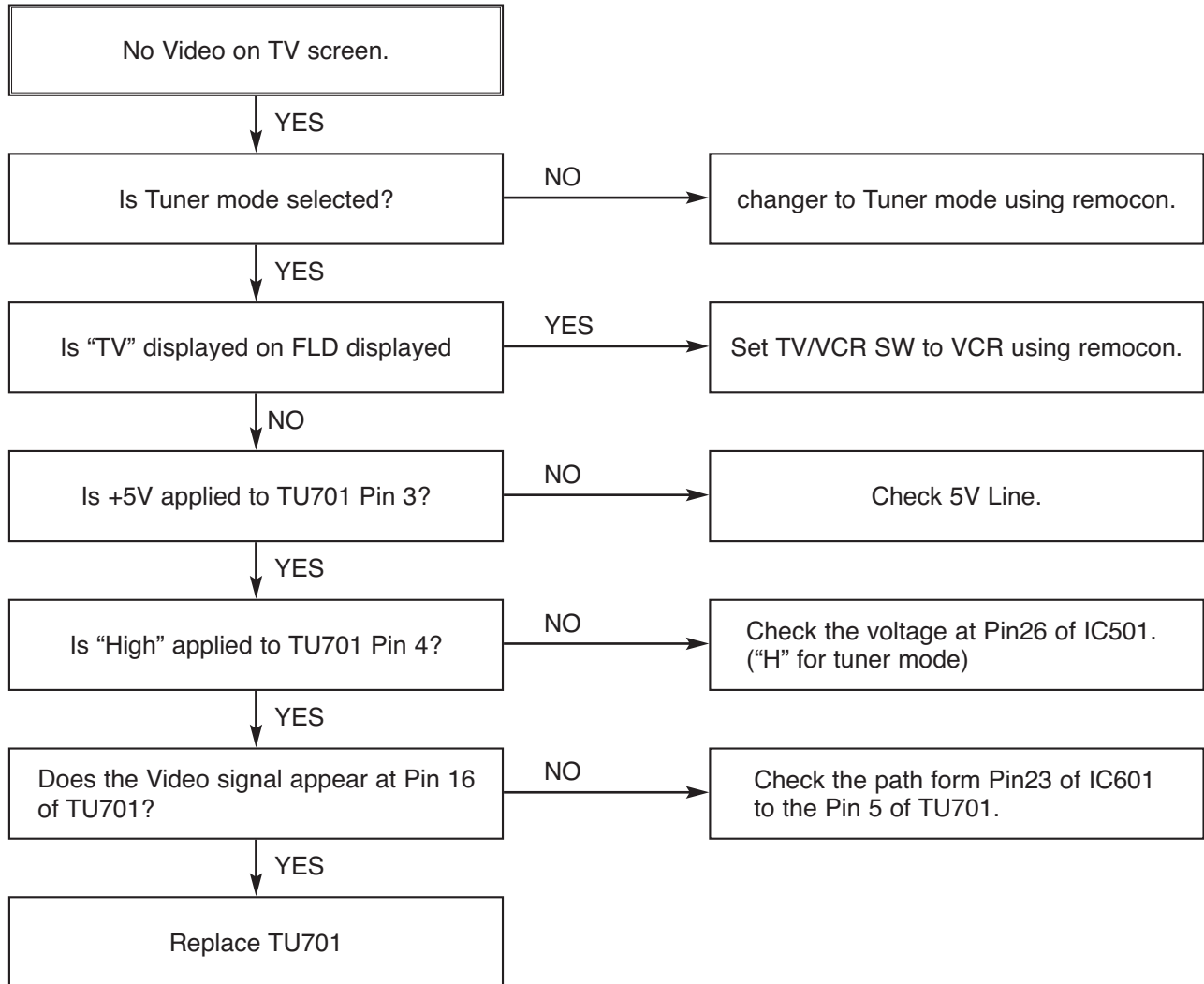

VCR ELECTRICAL TROUBLESHOOTING GUIDE

(B)

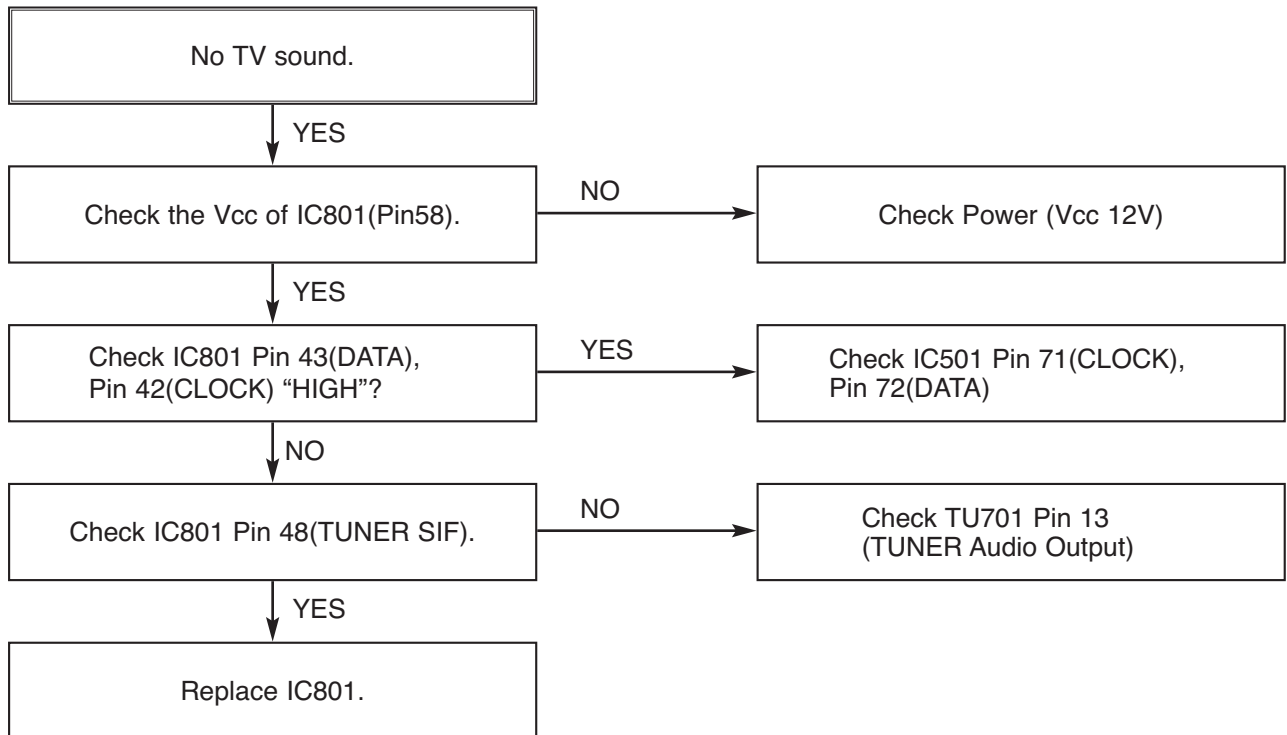

BLOCK DIAGRAMS

1. POWER(SMPS) BLOCK DIAGRAM

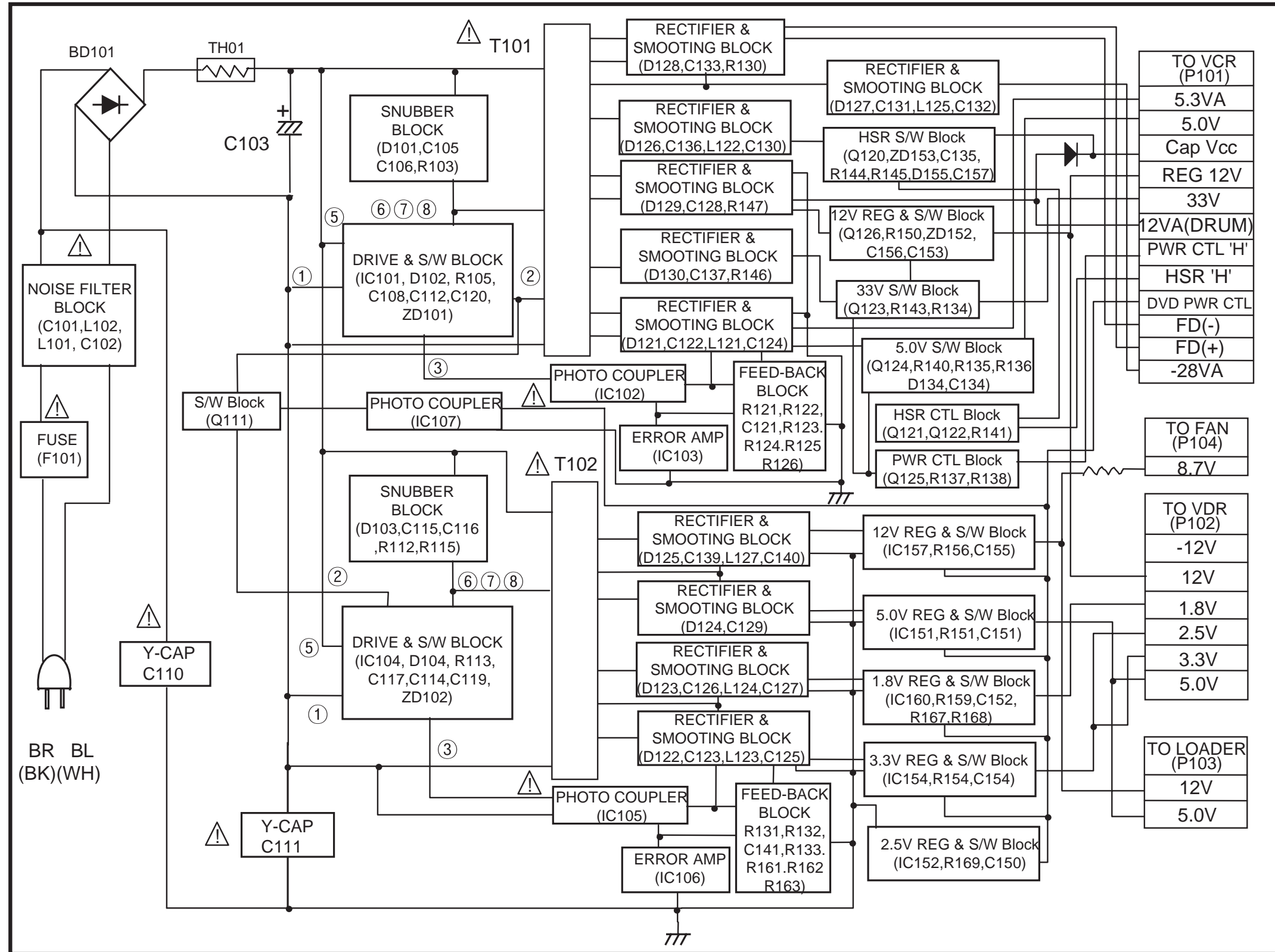

4. JACK BLOCK DIAGRAM

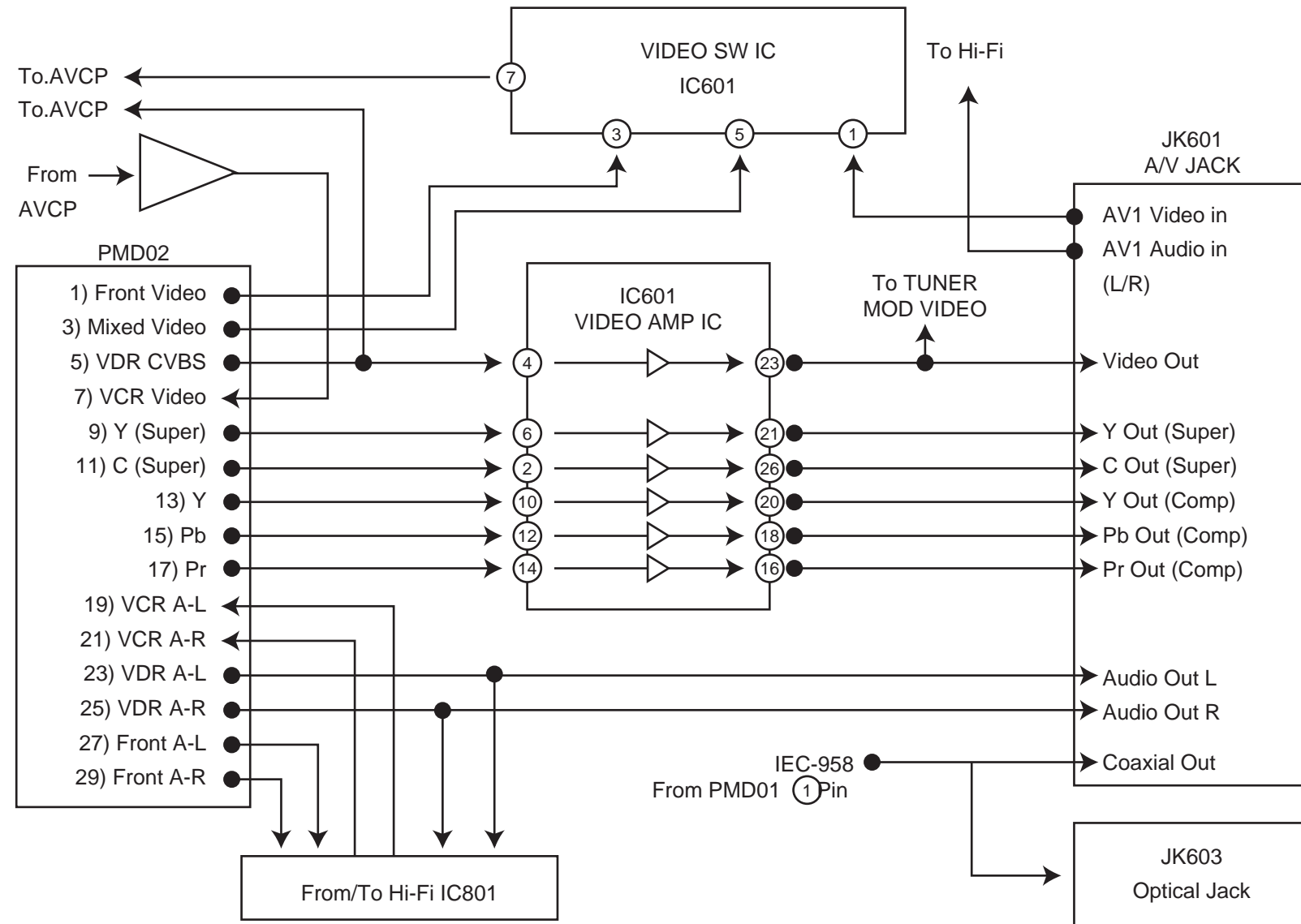

LGXBR446 (LGEUS)

5. STUNER/MTZ BLOCK DIAGRAM

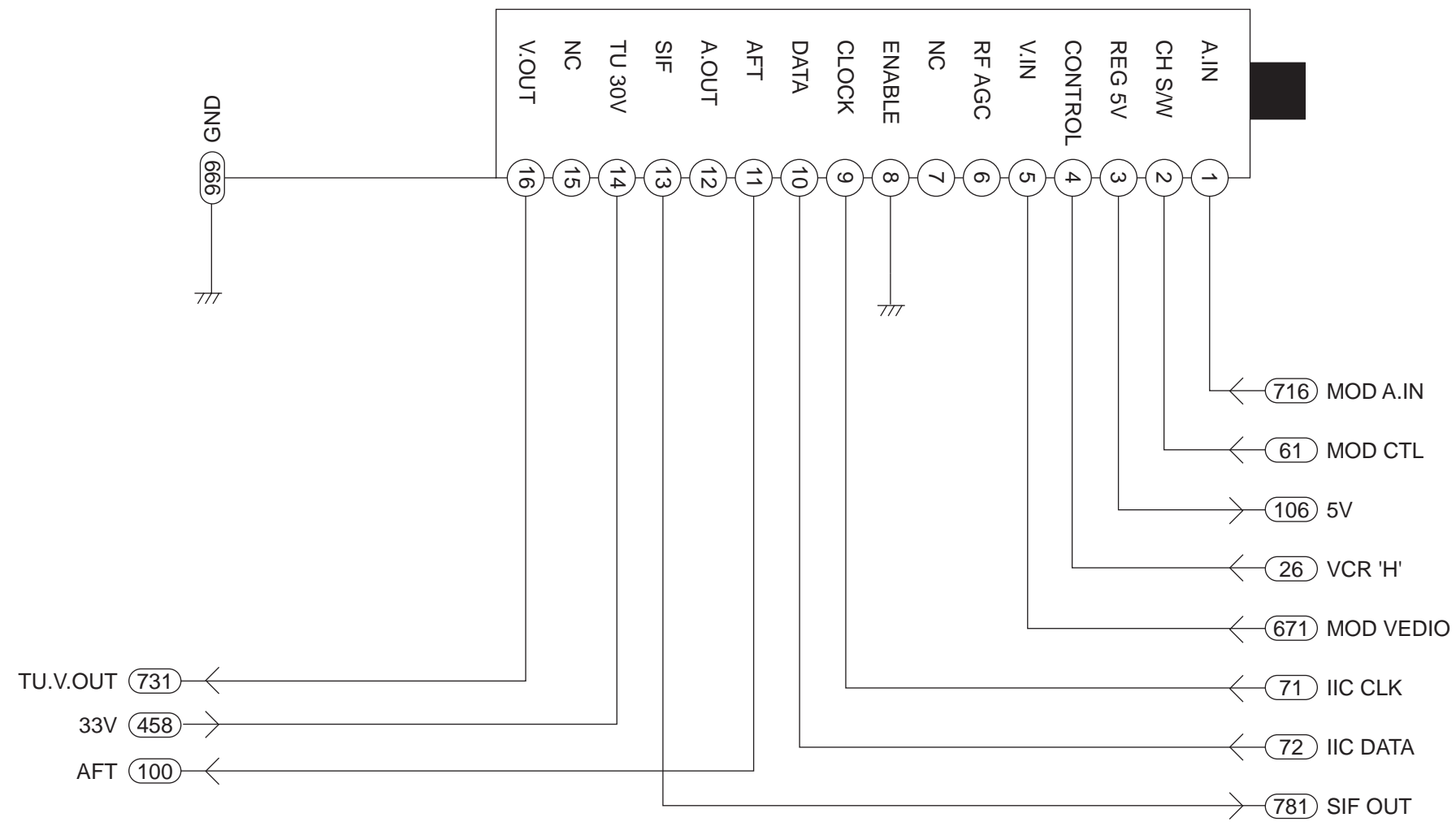

LGXBR446 (LGEUS)

6. AVCP BLOCK DIAGRAM

1) EE Mode

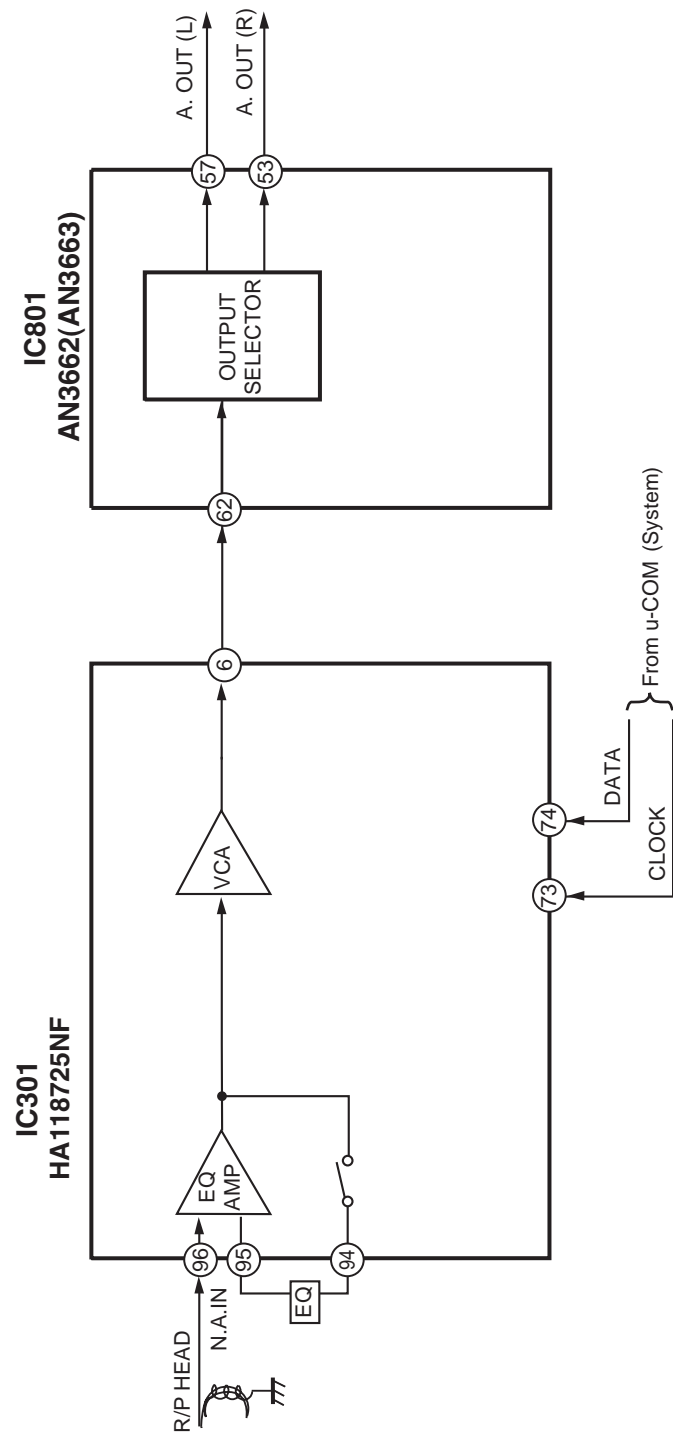

2) PB Mode

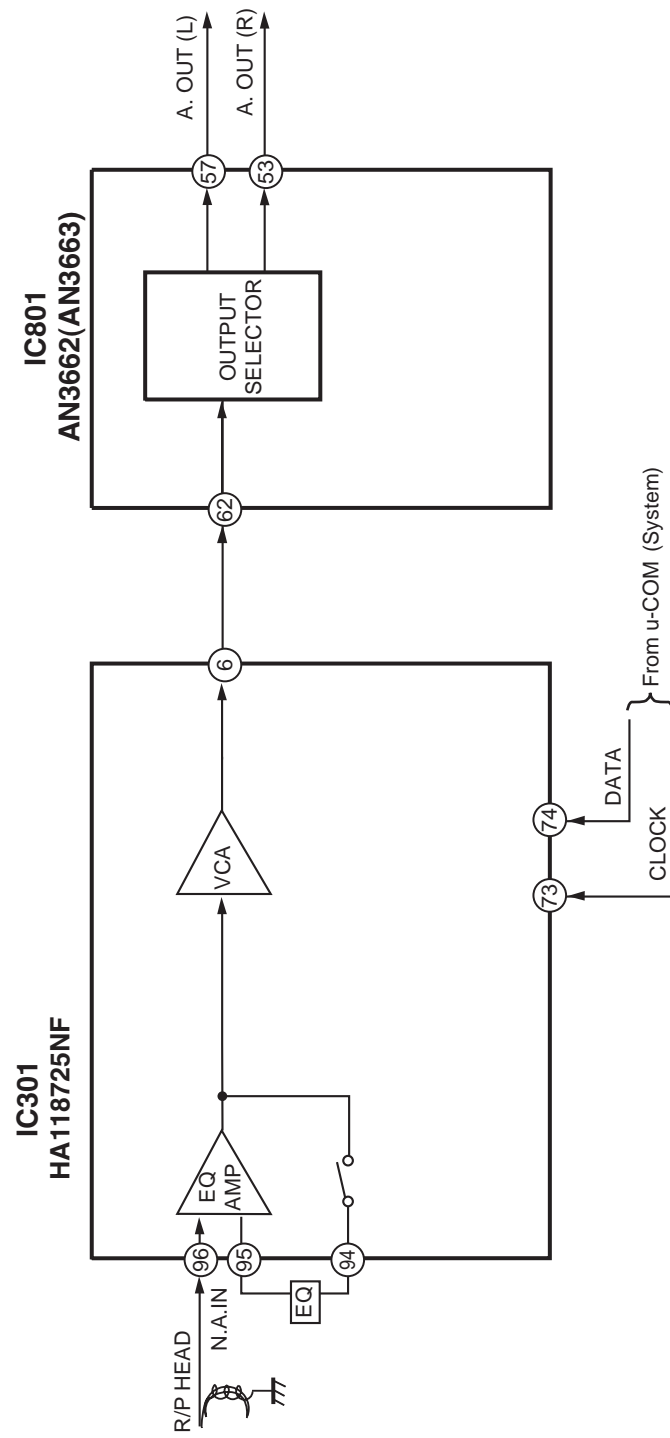

3) REC Mode

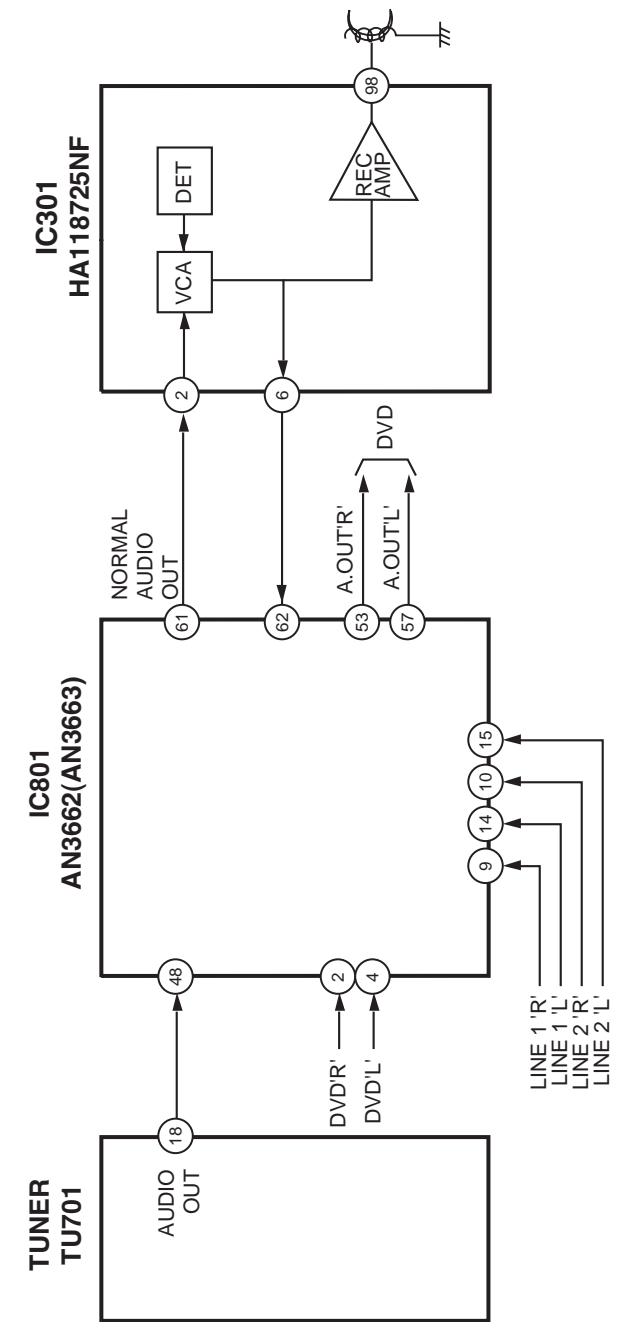

CIRCUIT DIAGRAMS

1. POWER(SMPS) CIRCUIT DIAGRAM

IMPORTANT SAFETY NOTICE

WHEN SERVICING THIS CHASSIS, UNDER NO CIRCUMSTANCES SHOULD THE ORIGINAL DESIGN BE MODIFIED OR ALTERED WITHOUT PERMISSION FROM THE ALLEGRO ELECTRONICS CORPORATION. ALL COMPONENTS SHOULD BE REPLACED ONLY WITH TYPES IDENTICAL TO THOSE IN THE ORIGINAL

CIRCUIT. SPECIAL COMPONENTS ARE SHADED ON THE SCHEMATIC FOR EASY IDENTIFICATION. THIS CIRCUIT DIAGRAM MAY OCCASIONALLY DIFFER FROM THE ACTUAL CIRCUIT USED. THIS WAY, IMPLEMENTATION OF THE LATEST SAFETY AND PERFORMANCE IMPROVEMENT CHANGES INTO THE SET IS NOT DELAYED UNTIL THE NEW SERVICE LITERATURE IS PRINTED.

NOTE :

1. Shaded (■) parts are critical for safety. Replace only with specified part number.
2. Voltages are DC-measured with a digital voltmeter during Play mode.

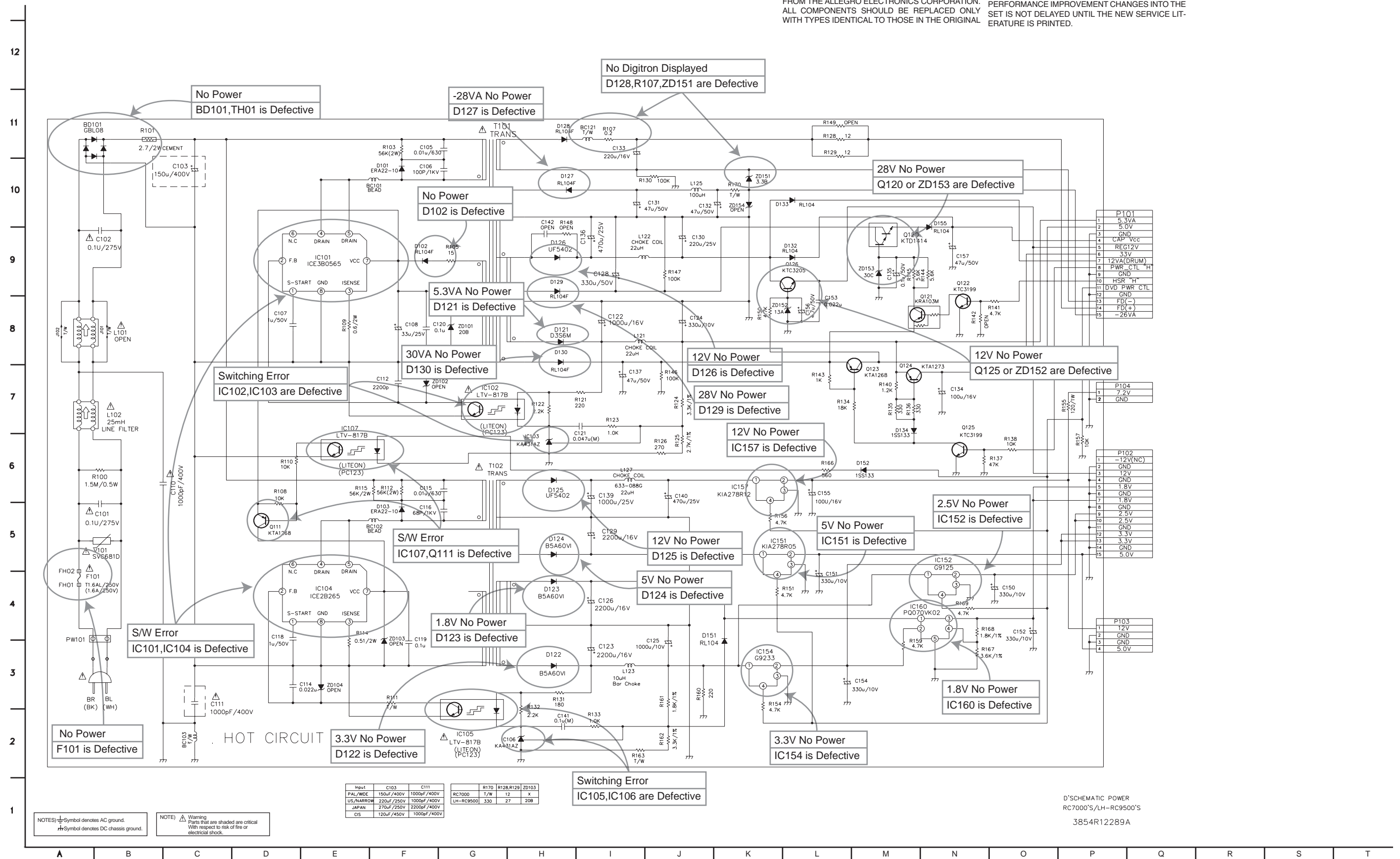

D'SCHEMATIC POWER
RC7000'S/LH-RC9500'S
3854R12289A

2. TUNER CIRCUIT DIAGRAM

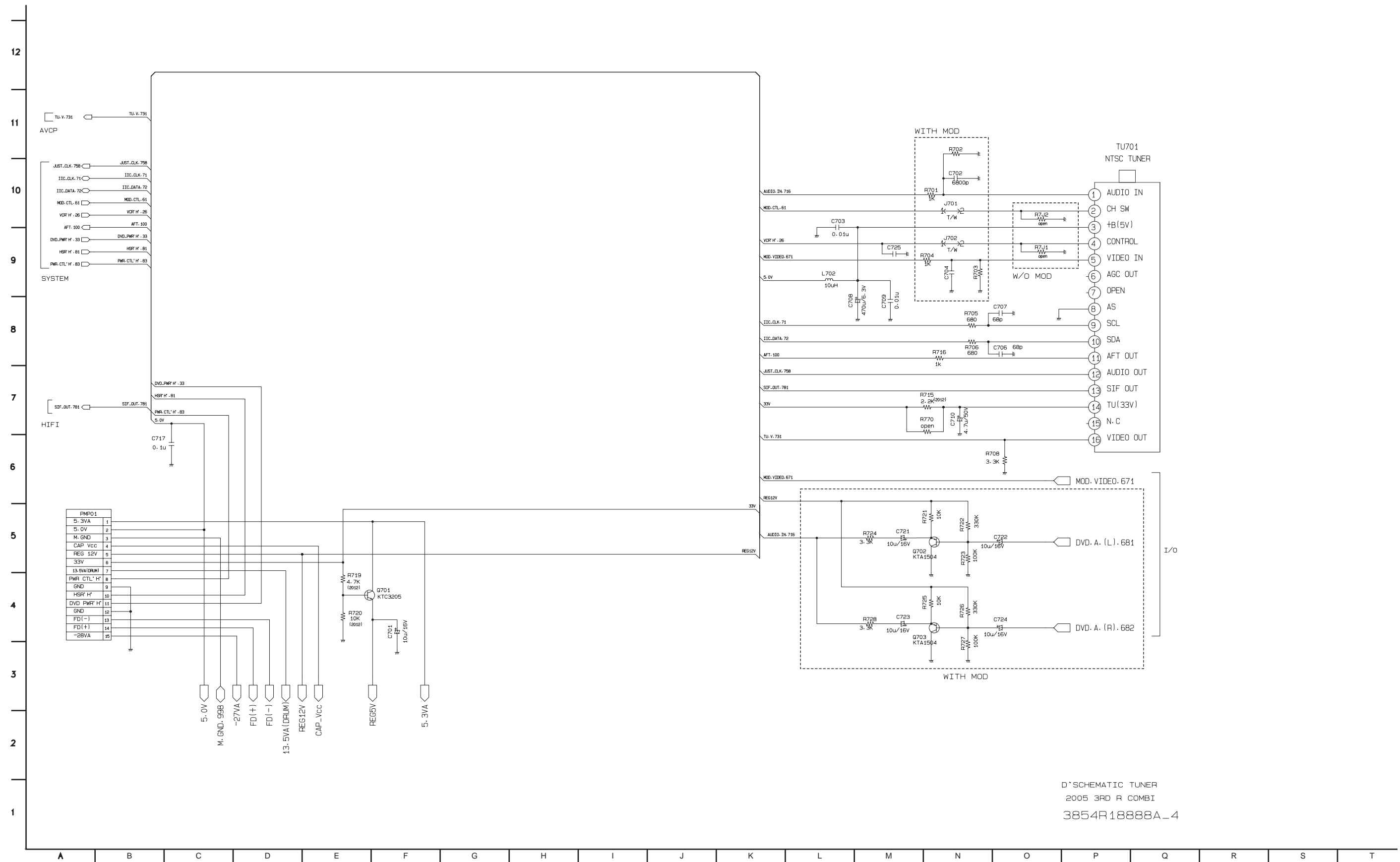

D'SCHEMATIC TUNER
2005 3RD R COMBI
3854R18888A_4

3. A/V CIRCUIT DIAGRAM

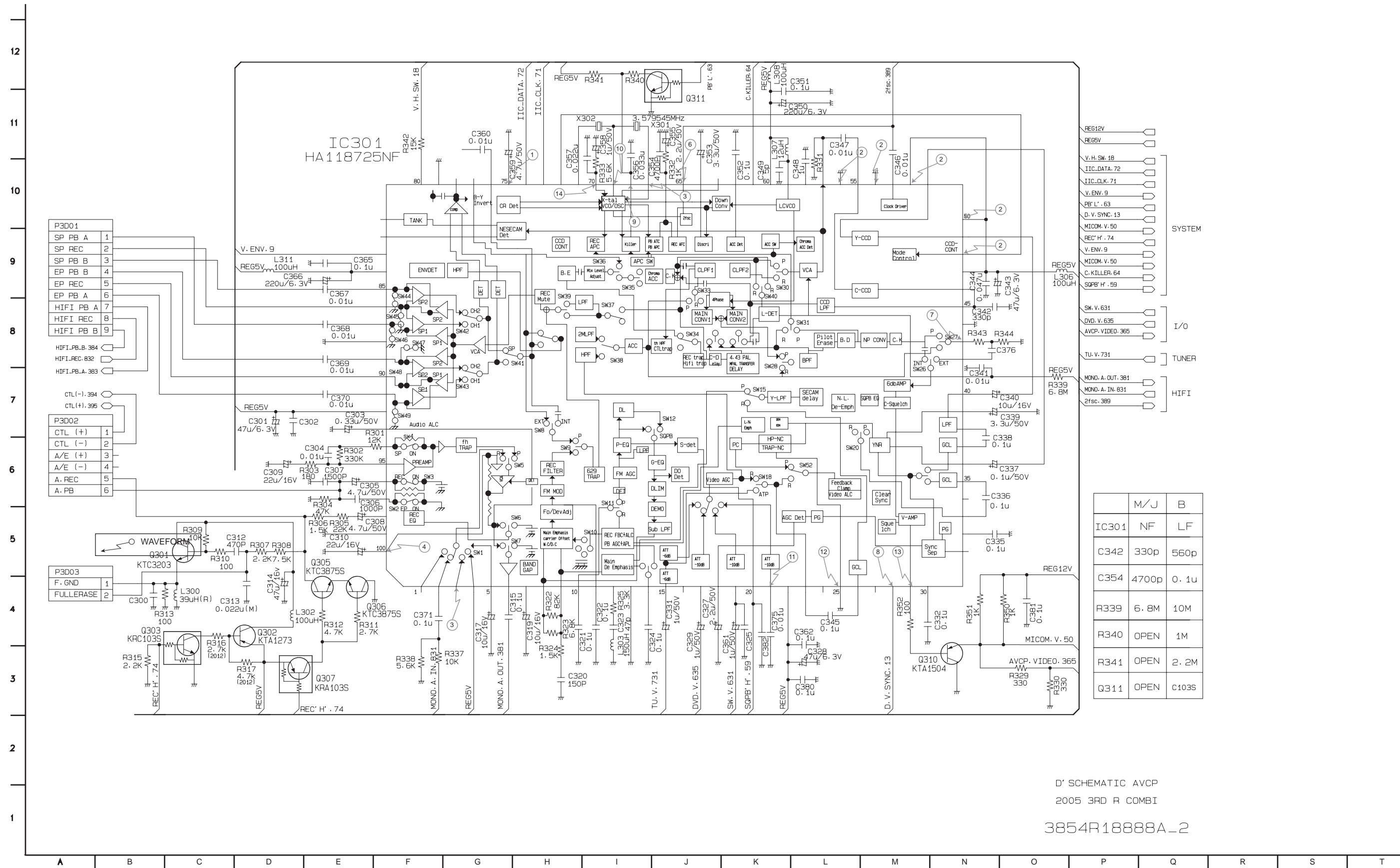

D' SCHEMATIC AVCP
 2005 3RD R COMBI
 3854R18888A_2

4. HI-FI CIRCUIT DIAGRAM

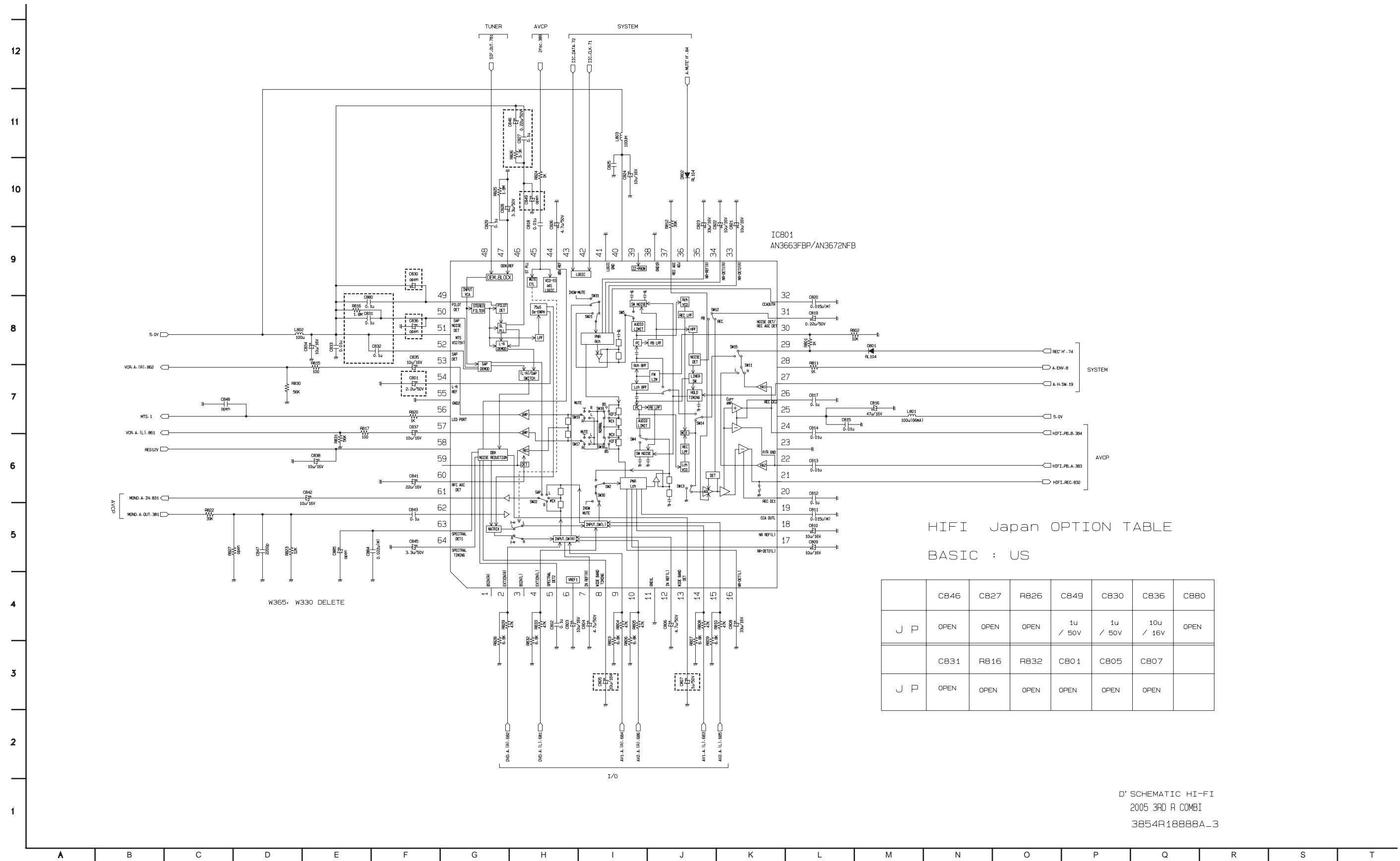

HIFI Japan OPTION TABLE
BASIC : US

	C846	C827	R826	C849	C830	C836	C880
J P	OPEN	OPEN	OPEN	1u / 50V	1u / 50V	10u / 16V	OPEN
	C831	R816	R832	C801	C805	C807	
J P	OPEN	OPEN	OPEN	OPEN	OPEN	OPEN	

D' SCHEMATIC HI-FI
2005 3RD R COMBI
3854R18888A_3

5. SYSTEM CIRCUIT DIAGRAM

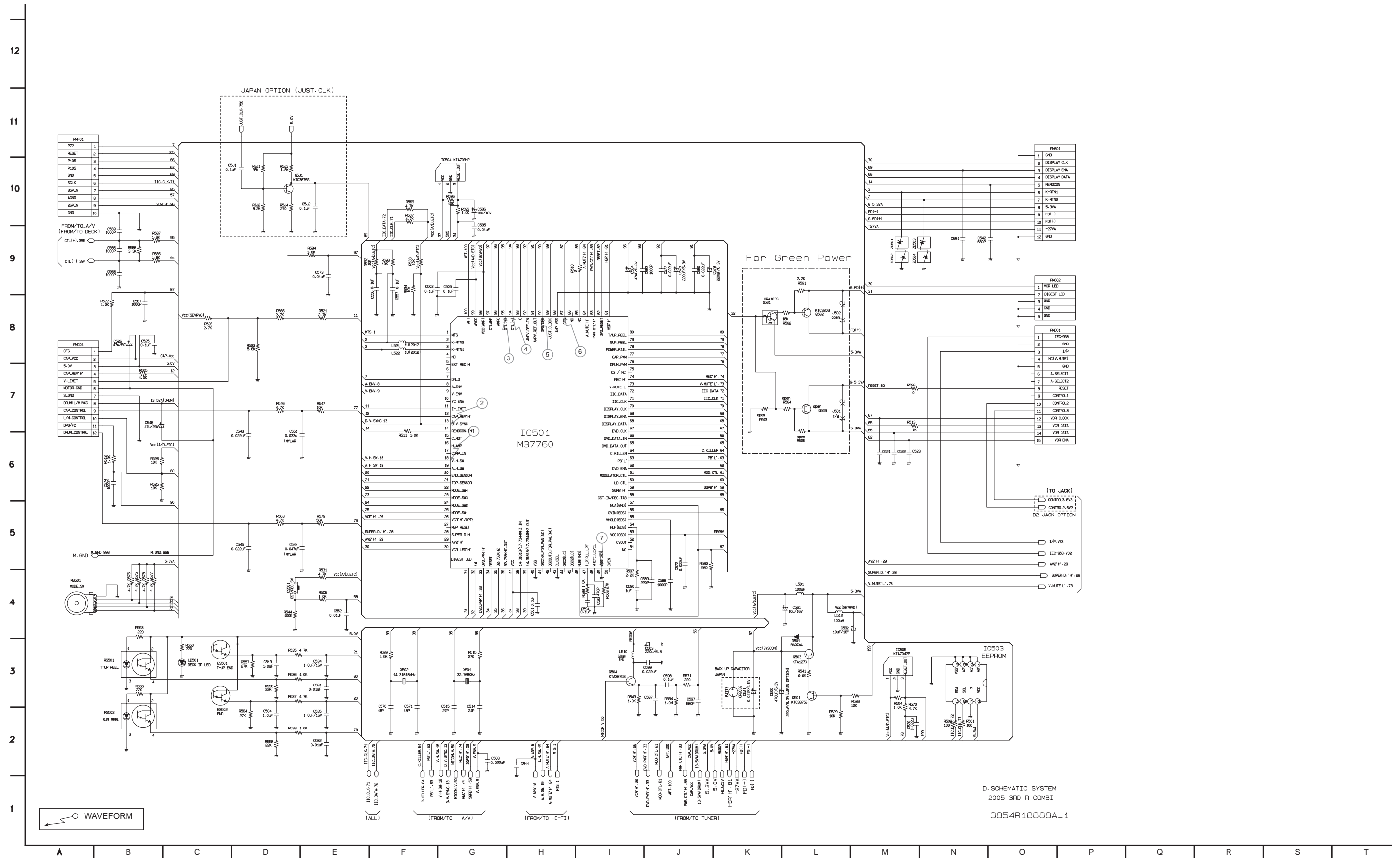

D. SCHEMATIC SYSTEM
2005 3RD R COMBI
3B54R18888A-1

7. TIMER CIRCUIT DIAGRAM(2 TOOL)

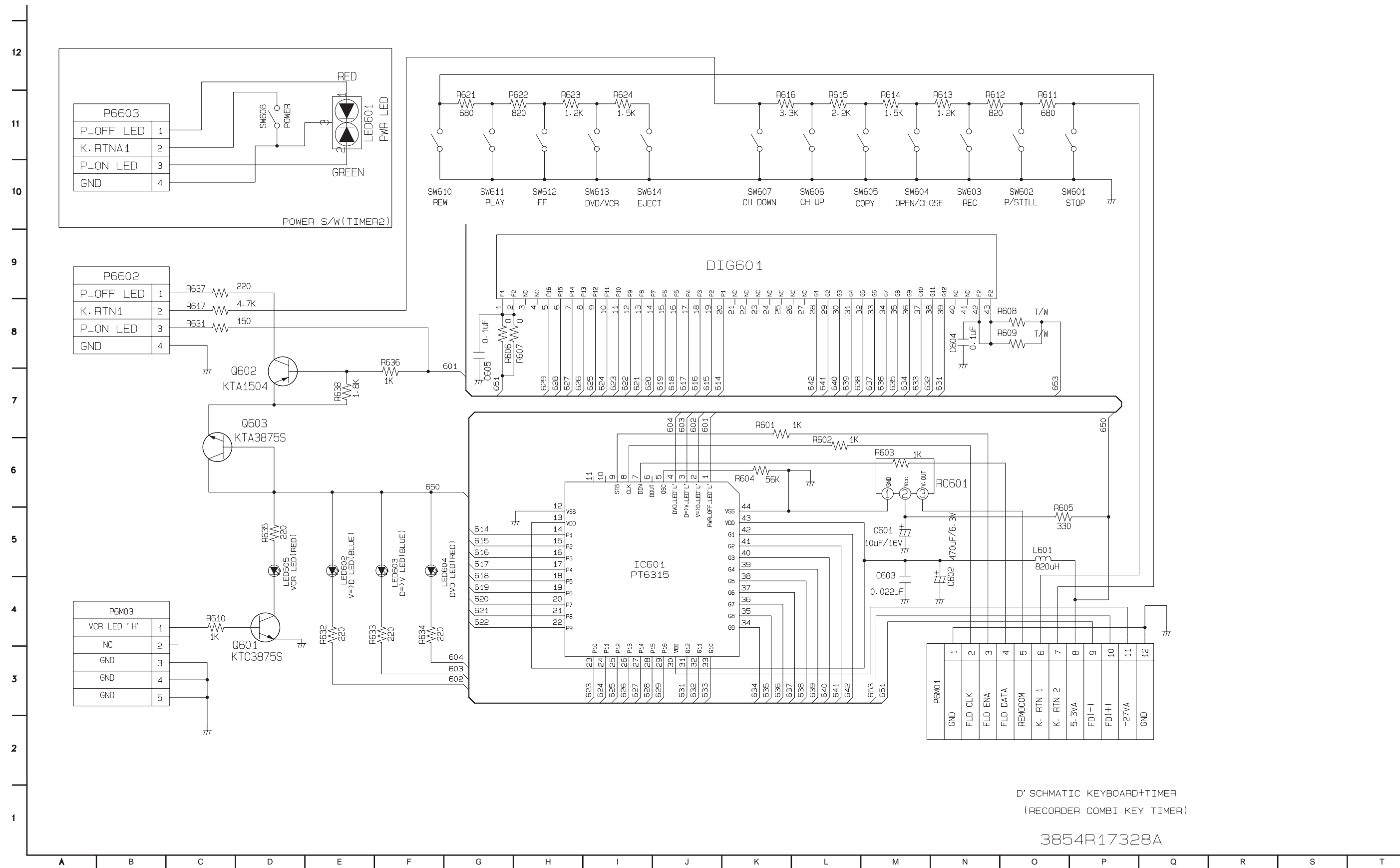

D' SCHMATIC KEYBOARD+TIMER
(RECORDER COMBI KEY TIMER)

3854R17328A

8. TIMER CIRCUIT DIAGRAM(3 TOOL, 8 TOOL)

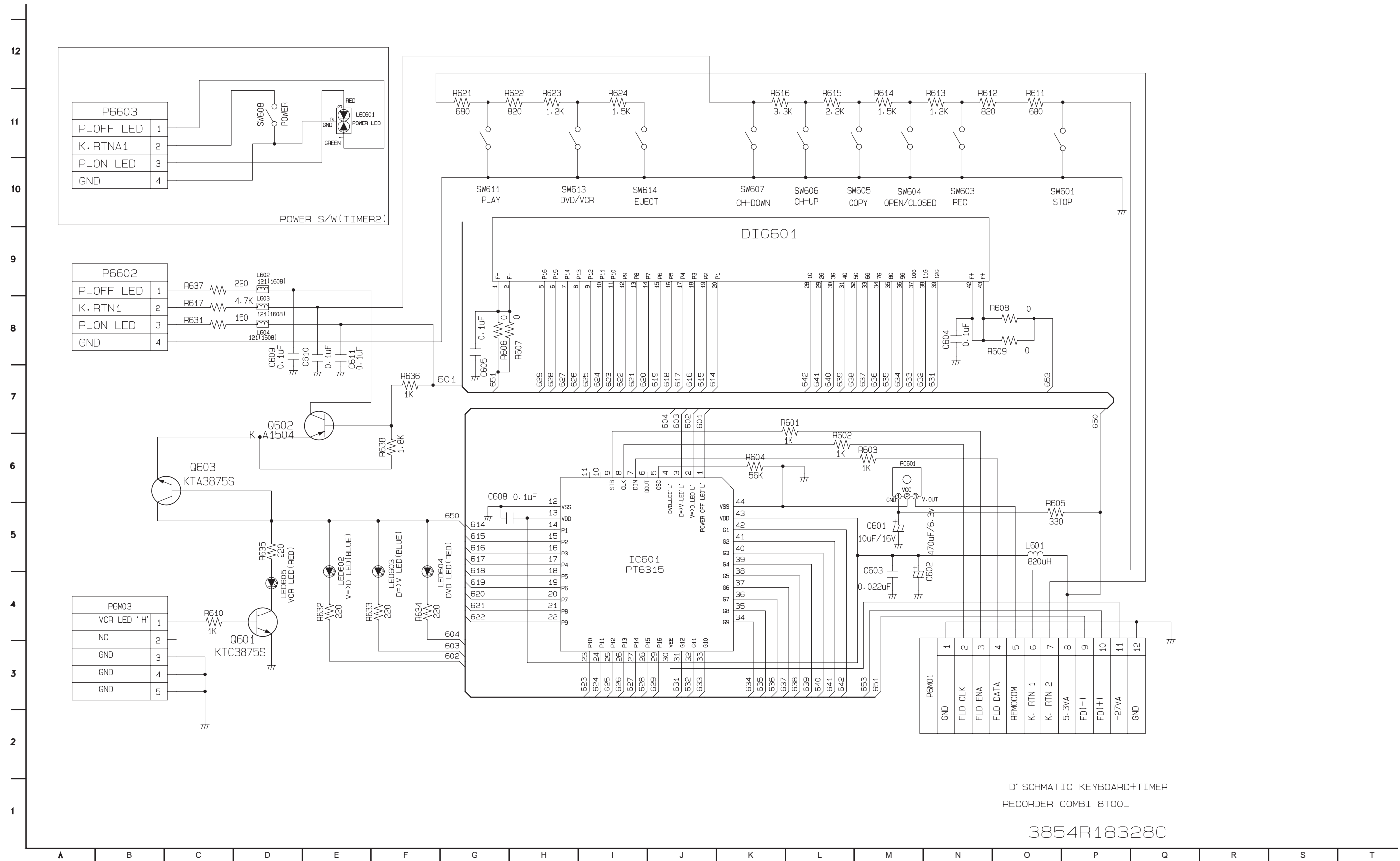

D' SCHMATIC KEYBOARD+TIMER
RECORDER COMBI 8TOOL

3854R18328C

9. TIMER CIRCUIT DIAGRAM(4 TOOL)

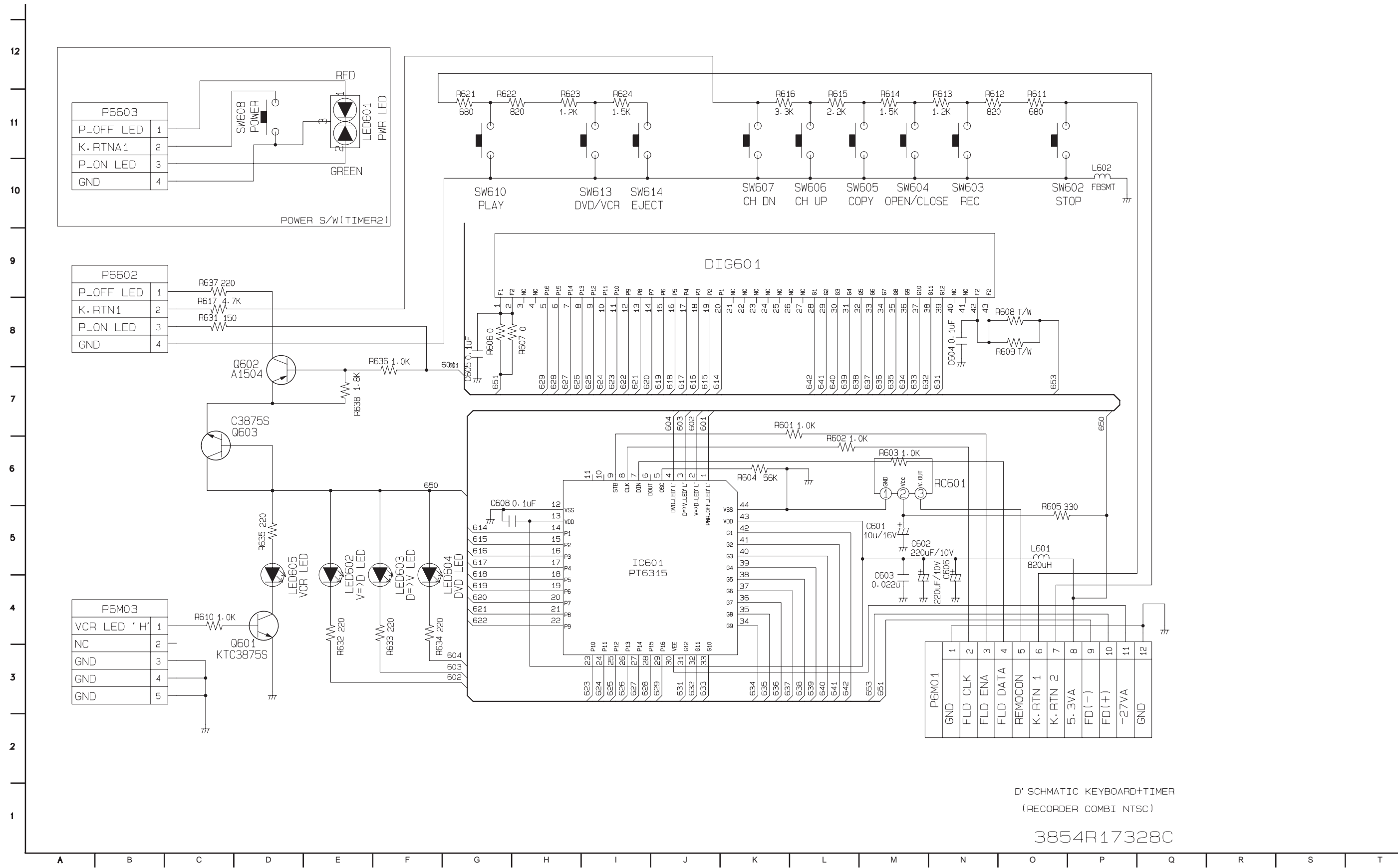

10. TIMER CIRCUIT DIAGRAM(6 TOOL)

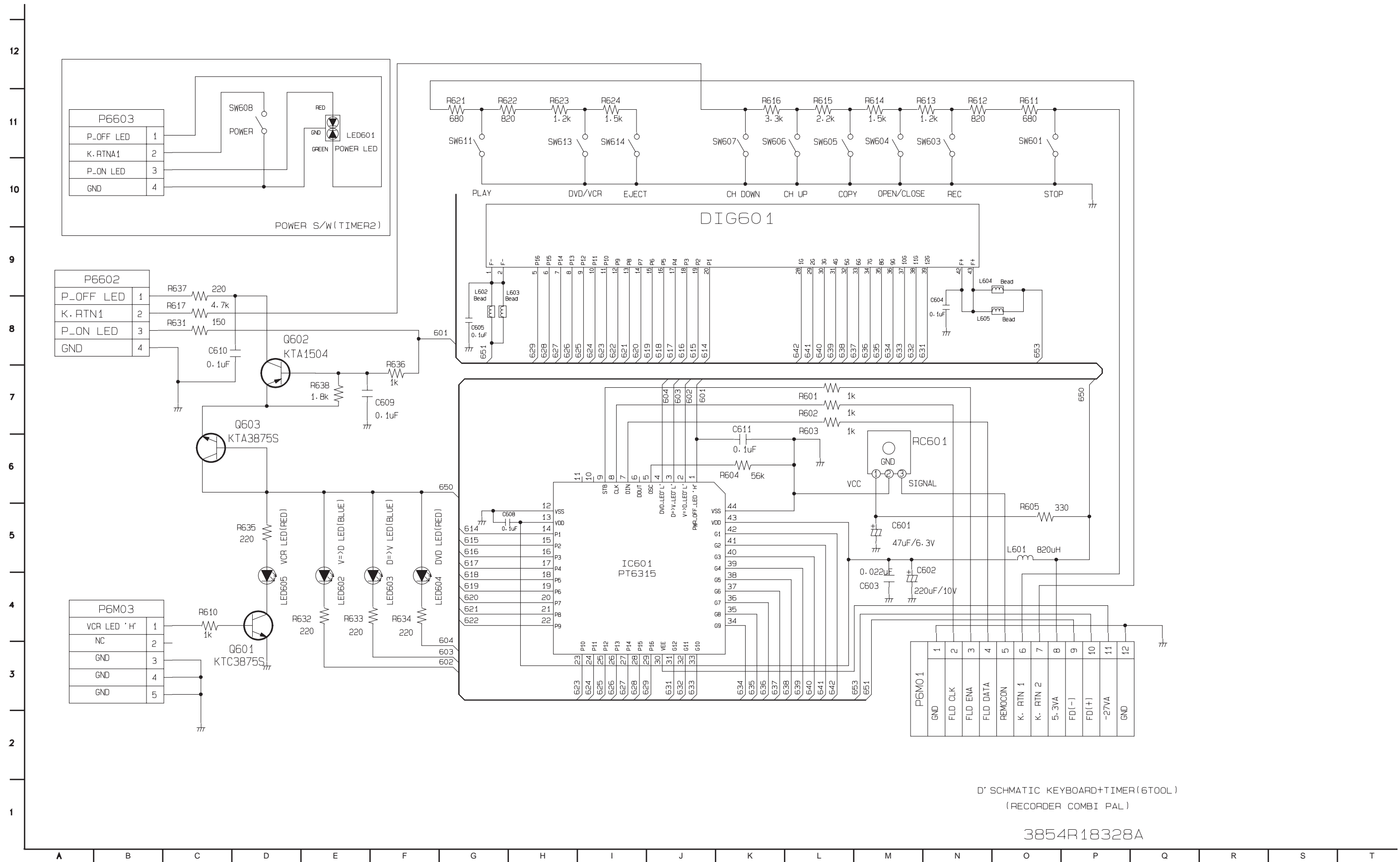

D' SCHMATIC KEYBOARD+TIMER(6TOOL)
(RECORDER COMBI PAL)

3854R18328A

11. TIMER CIRCUIT DIAGRAM(7 TOOL)

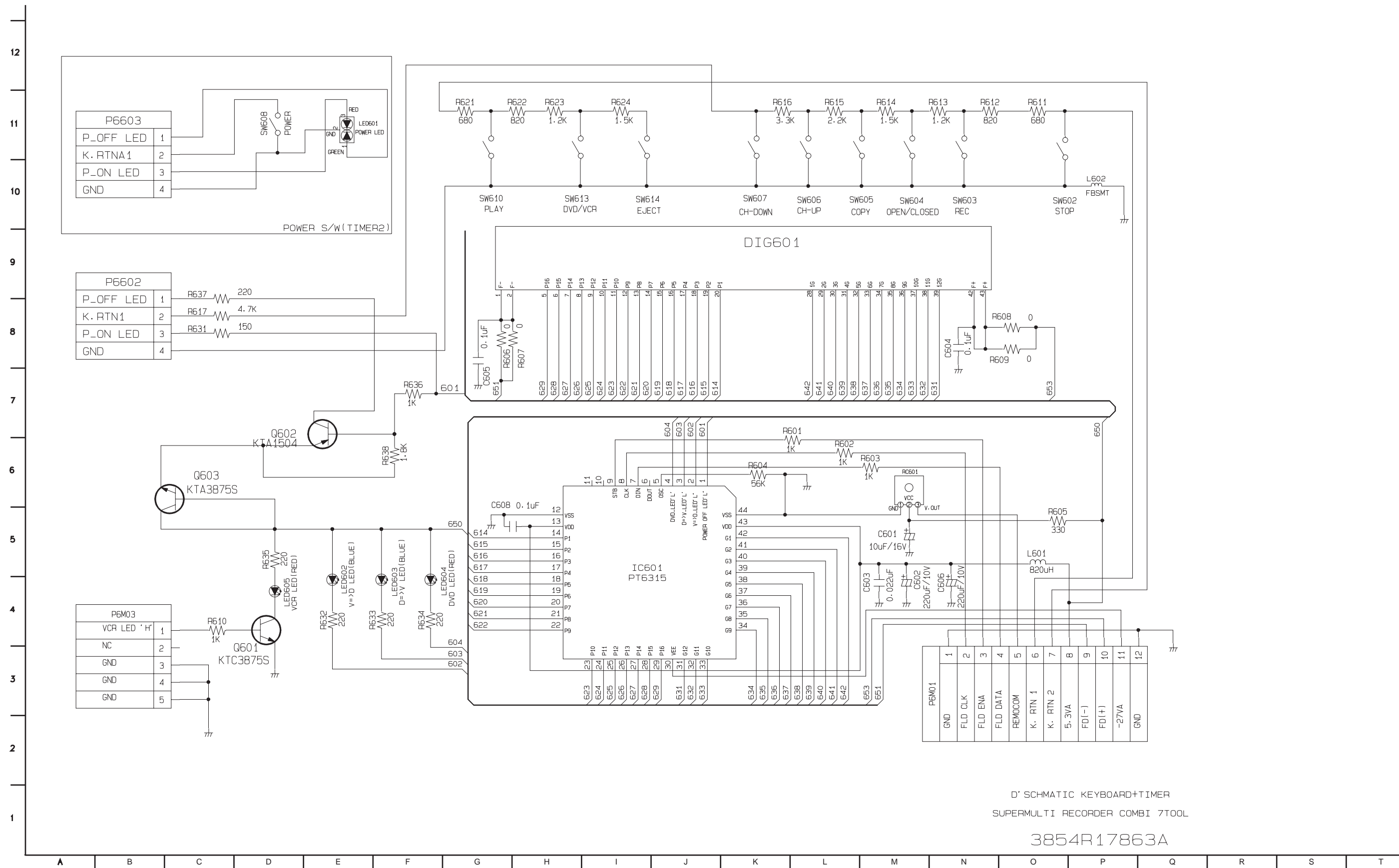

D' SCHMATIC KEYBOARD+TIMER
SUPERMULTI RECORDER COMBI 7TOOL

3854R17863A

WAVEFORMS

◆ IC301 Oscilloscope Waveform

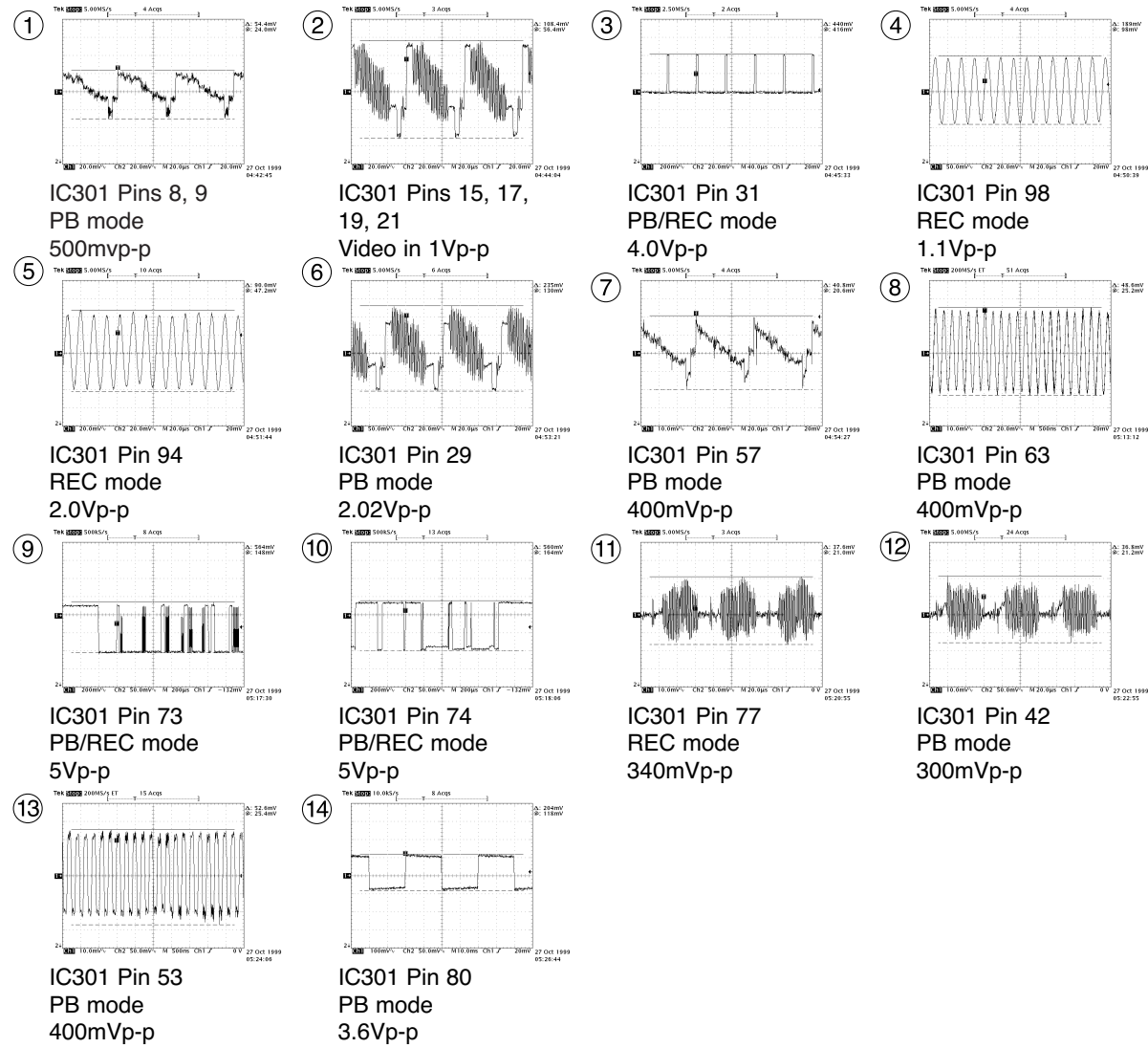

◆ IC501 Waveform Photographs

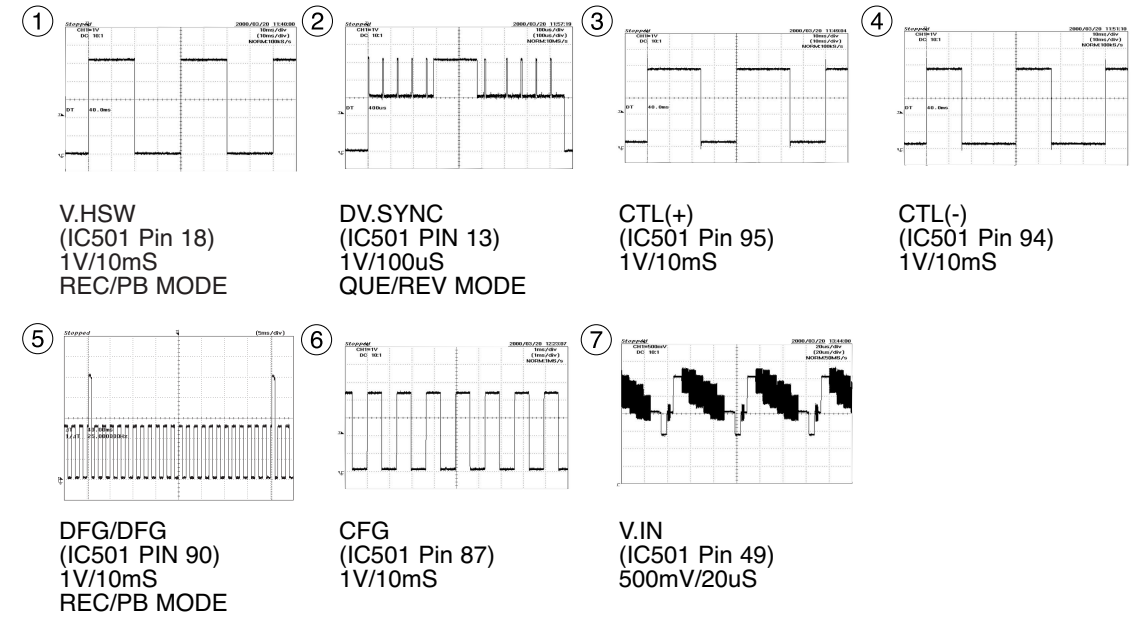

• CIRCUIT VOLTAGE CHART

MODE PIN NO.	EE	PLAY
IC 301		
1	0.06	0.06
2	0.06	0.06
3	0.06	0.06
4	0.35	0.37
5	2.35	2.09
6	2.58	2.55
7	2.83	2.83
8	1.84	1.24
9	1.84	1.23
10	2.41	1.89
11	2.61	3.00
12	1.60	0.56
13	0.00	0.00
14	2.80	2.26
15	2.80	2.38
16	0.18	1.91
17	2.79	2.80
18	1.76	1.91
19	2.80	2.80
20	0.02	0.00
21	2.80	2.80
22	5.08	5.12
23	2.32	2.34
24	0.18	0.57
25	2.12	2.12
26	3.00	2.80
27	0.18	0.45
28	0.15	0.15
29	2.48	2.46
30	2.80	2.91
31	0.37	0.37
32	2.31	2.79
33	2.09	2.13
34	1.76	1.85
35	3.03	3.07
36	2.32	2.35
37	3.03	3.06
38	2.15	2.20
39	1.42	1.45
40	2.08	2.12
41	3.01	2.55
42	1.98	1.97
43	2.05	2.05
44	0.00	0.00
45	3.13	3.15
46	3.13	3.15
47	5.03	5.07
48	0.14	0.14
49	3.17	3.19
50	5.03	5.07
51	2.05	2.07
52	5.03	5.07
53	2.62	2.64
54	0.00	0.00

MODE PIN NO.	EE	PLAY
55	2.07	2.09
56	0.00	0.00
57	2.18	2.18
58	2.34	2.34
59	4.94	4.97
60	4.94	4.97
61	0.02	0.02
62	2.28	2.21
63	2.23	2.23
64	2.94	2.95
65	2.26	2.26
66	2.95	2.96
67	2.19	2.18
68	1.28	1.24
69	1.96	1.96
70	2.71	1.42
71	2.19	2.19
72	0.14	0.14
73	5.20	5.21
74	5.20	5.21
75	2.76	2.79
76	2.25	2.17
77	2.84	2.84
78	0.02	0.03
79	0.00	0.00
80	2.54	2.53
81	4.85	4.84
82	4.15	4.15
83	0.00	2.53
84	5.07	5.10
85	2.46	2.30
86	2.54	2.30
87	2.45	2.30
88	0.00	0.00
89	2.48	2.30
90	2.52	2.30
91	2.48	2.30
92	5.08	5.11
93	0.52	0.51
94	2.53	2.54
95	2.53	2.52
96	2.53	2.50
97	0.01	0.01
98	2.27	2.55
99	0.00	0.00
100	2.58	2.55
IC 501		
1	0	0
2	4.52	4.82
3	4.84	4.84v
4	4.64	4.58v
5	4.56	4.56v
6	80m	60m
7	0	0
8	4.98	4.98

MODE PIN NO.	EE	PLAY
9	4.98	5.30
10	4.8	4.80v
11	4.82	4.82
12	4.72v	4.82
13	4.92	4.92
14	5.02	5.02
15	0	0
16	4.98v	4.98
17	5.04	5.04
18	4.98v	9.98
19	2.46v	2.46
20	3.36V	3.36
21	0	0
22	0	0
23	4.96v	4.96v
24	120mv	140m
25	4.94	4.94
26	4.92v	4.92v
27	20m	20mv
28	5.02	5.02v
29	4.98v	4.98
30	4.84v	4.84
31	5.00v	5.00v
32	0	0
33	4.98	4.94
34	0	5.00v
35	5.02	100m
36	3.16	3.12v
37	5.7v	Da/Clk(5.5)
38	0	5.7v
39	520m	0
40	4.84	520m
41	4.83	Da/Clk(5.62)
42	4.86v	4.86v
43	0	0
44	5.02	5.0v
45	0	0
46	3.94	3.94v
47	2.88	2.88v
48	0	0
49	0.98	2.94
50	1.84	1.94v
51	0.98	4.78
52	3.28	3.28v
53	2.38	2.38v
54	2.52	2.54v
55	1.88	1.88
56	0	0
57	0	0
58	120m	120m
59	4.92v	4.92v
60	4.92v	4.92v
61	0	0
62	4.82	4.82v
63	3.98	3.98v

MODE PIN NO.	EE	PLAY
64	0	0
65	2.36	2.36v
66	0	0
67	4.68	9.68v
68	0	0
69	2.48	2.48v
70	2.48	2.48
71	0	0
72	2.48	4.98
73	4.92	4.92v
74	0	0
75	2.52	2.42
76	2.42	2.48
77	80m	80m
78	0	0
79	4.02v	4.96v
80	4.96v	4.96
81	2.8	280m
82	1v	2.62v
83	120m	3.24v
84	0	1.96
85	0	0
86	4.98	4.9v
87	4.98	4.98
88	5.0v	5.0v
89	0	0
90	4.88	4.88v
91	0	0
92	0	0
93	5.04v	5.04v
94	4.88	0
95	4.98	4.98
96	0	0
97	0	0
98	4.98	4.98
99	20m	4.98v
100	0	0
IC 751		
1	4.88	4.88v
2	1.46	1.48
3	1.38	1.38
4	0	0
5	2.26v	2.24
6	2.38	0
7	0	0
8	0	0
9	0	0
10	0	0
11	0	5.0v
12	5.0v	5.0
13	5.0v	0
14	0	0
15	0	0
16	0	0
17	0	0

MODE PIN NO.	EE	PLAY
18	0	0
19	4.88	4.88
20	0	0
21	0	0
22	0	0
23	0	0
24	0	0
25	0	0
26	0	0
27	0	0
28	0	0
29	0	0
30	2.96v	3.98
31	2.96	3.98
32	0	0
33	4.88v	4.88
34	3.64v	3.58v
35	0	0
36	2.62v	2.58
37	0	0
38	0	0
39	0	0
40	2.54v	2.54
41	2.54	2.56
42	2.48	2.48
43	2.3v	2.34
44	0	0
IC 7V1		
1	0	0
2	0	0
3	0	142M
4	DA/CL(5.34)	DA/CL(5.34)
5	DA/CL(5.34)	DA/CL(5.34)
6	0	0
7	DA/CL(5.34)	DA/CL(5.34)
8	0	0
9	DA/CL(5.34)	DA/CL(5.34)
10	DA/CL(5.34)	DA/CL(5.34)
11	0	41M
12	DA/CL(2.82)	DA/CL(2.82)
13	0	0
14	DA/CL(2.82)	DA/CL(62M)
15	2.89	1.41
16	1.53	950M
17	DA/CL(1.14)	DA/CL(810M)
18	0	0
19	5.26	5.24
20	5.26	5.24
IC 801		
1	3.28	3.24
2	3.28v	3.28
3	3.32	3.26
4	3.28	3.92
5	3.28	3.92
6	3.28	3.26

MODE PIN NO.	EE	PLAY
7	3.28v	3.74
8	3.28	3.24
9	3.28v	3.24
10	3.28	3.24
11	3.28v	3.26
12	0	0
13	3.78	4.52
14	0	0
15	0	640m
16	5.82	6.64
17	5.28v	6.68
18	0	620m
19	6.28	6.66
20	6.28	6.72
21	4.46v	4.42
22	3.28	4.02
23	3.62	3.68
24	3.74	4.12
25	3.74	3.76
26	0.1	640m
27	0	0
28	3.7v	3.68
29	3.66	3.64
30	0.7	680m
31	3.72	3.72v
32	3.74v	4.08
33	3.62	3.68
34	13.4v	13.32
35	580m	520m
36	0	520m
37	580m	520m
38	0	0
39	0	20m
40	4.7	4.76
41	0v	1.68
42	5.0v	5.04m
43	50.v	4.96
44	20m	3.38
IC 901		
1	4.76	4.68
2	2.02v	2.24
3	4.88	4.88
4	1.64	1.78
5	4.72	4.78
6	1.88	1.88
7	0	0
8	2.26	2.18
9	0	0
10	1.64v	1.72
11	0	0
12	1.92v	2.08
13	4.86	4.82
14	1.92v	2.08
15	0	2.31
16	2.26v	2.64

MODE PIN NO.	EE	PLAY
17	0	0
18	2.28	2.74
19	0	0
20	2.56v	2.58
21	2.64v	2.68
22	0	0
23	2.56v	2.92
24	0	0
25	0	0
26	2.52v	2.98
27	20m	0
28	4.72	4.68
IC 901		
1	2.51	2.51
2	2.39	2.39
3	3.54	3.53
4	2.57	2.56
5	1.52	1.34
6	0.43	3.68
7	1.3m	0
8	1.2m	0
9	3.04	3.03
10	2.52	2.52
11	2	2.05
12	3.22	1.97
13	3.99	3.99
14	2.5	2.495
15	3.11	1.93
16	3.2	3.18
17	27.4m	4.11
18	112.1m	3.35
19	2.27	2.26
20	1.99	2.12
21	2.31	2.37
22	0.78	0.81
23	5.02	5.01
24	5.02	5
25	2.44	2.27
26	2.44	2.26
27	2.82	2.85
28	181.5m	187.4m
29	371.6m	212.2m
30	2.08	2.08
IC 302		
1	3	2.99
2	36.3m	38.1m
3	3.04	3.04
4	6.4m	39.1m
5	3.04	3.04
6	5.02	5.03
7	2.24	2.23
8	0	0
IC 804		
1	6.71	6.66
2	5.05	5.05

MODE PIN NO.	EE	PLAY
3	6.02	5.96
4	0	0
5	6	5.96
6	5.99	5.94
7	22.3m	21.3m
8	6.68	6.65
9	6.7	6.67
10	1.1m	0
11	6.71	6.68
12	5.04	5.05
13	12.03	11.99
14	6.7	6.7
15	0	0
16	6.73	6.69
IC 902		
1	1.3	1.3
2	4.9	4.9
3	1.66	1.56
4	0	0
5	0	0
6	4.9	4.9
7	1.7	

2. SMPS P.C.BOARD

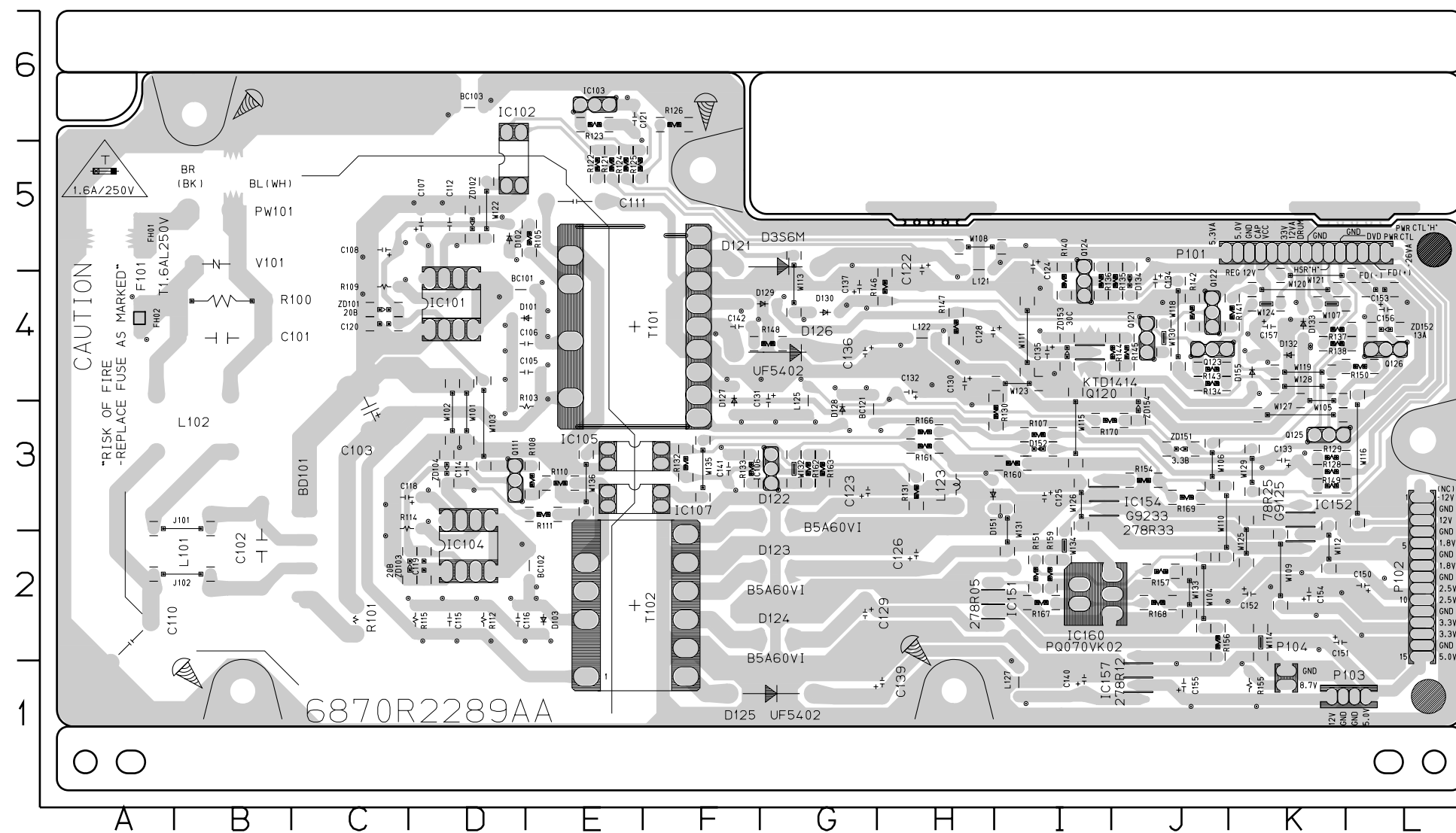

LOCATION GUIDE

BC101	D4	C152	K2	L121	H5	R135	J4
BC102	E2	C153	L4	L122	H4	R136	I4
BC103	D6	C154	K2	L123	H3	R137	K4
BC121	G3	C155	J1	L125	G3	R138	K4
BD101	C2	C156	L4	L127	I1	R140	I4
C101	B4	C157	K4	P101	J5	R141	K4
C102	B2	D101	E4	P102	L3	R142	J4
C103	C3	D102	D5	P103	K1	R143	J4
C105	E4	D103	E2	P104	K1	R144	J4
C106	E4	D121	G5	PW101	B5	R145	J4
C107	D5	D122	G3	Q111	D3	R146	H4
C108	C5	D123	G2	Q120	I4	R147	H4
C110	A2	D124	G2	Q121	J4	R148	G4
C111	E5	D125	G1	Q122	J4	R149	K3
C112	D5	D126	G4	Q123	J4	R150	L4
C114	D3	D127	F3	Q124	I4	R151	I2
C115	D2	D128	G3	Q125	K3	R154	J3
C116	D2	D129	G4	Q126	L4	R155	K1
C118	C3	D130	G4	R100	B4	R156	J2
C119	D2	D132	K4	R101	C2	R157	J2
C120	C4	D133	K4	R103	E3	R159	I2
C121	E6	D134	J4	R105	E5	R160	I3
C122	H5	D151	H3	R107	I3	R161	H3
C123	G3	D152	I3	R108	E3	R162	G3
C124	I5	D155	K4	R109	C4	R163	G3
C125	I3	FH01	A5	R110	E3	R166	H3
C126	H2	FH02	A4	R111	E3	R167	I2
C128	H4	IC101	D4	R112	D2	R168	J2
C129	G2	IC102	D6	R114	C3	R169	J3
C130	H4	IC103	E6	R115	D2	R170	I3
C131	G3	IC104	D3	R121	E5	T101	E4
C132	H4	IC105	F3	R122	E5	T102	E2
C133	K3	IC106	G3	R123	E6	V101	B5
C134	J4	IC107	F3	R124	E5	ZD101	C4
C135	I4	IC151	H2	R125	E5	ZD102	D5
C136	G4	IC152	K2	R126	F6	ZD103	D2
C137	G4	IC154	I3	R128	K3	ZD104	D3
C139	H1	IC157	J1	R129	K3	ZD151	J3
C140	I1	IC160	I2	R130	I3	ZD152	L4
C141	F3	J101	B3	R131	H3	ZD153	I4
C142	F4	J102	B2	R132	F3	ZD154	J3
C150	L2	L101	B2	R133	F3		
C151	K2	L102	B3	R134	J4		

3. JACK P.C.BOARD

(2 TOOL, 3 TOOL)

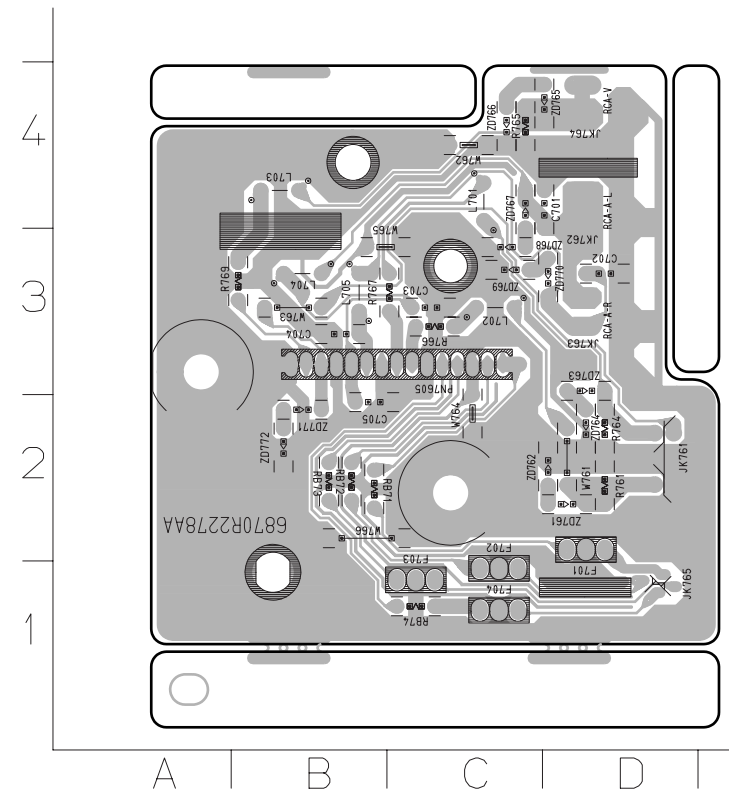

LOCATION GUIDE

C701	D4	R764	D2
C702	D3	R765	C4
C703	C3	R766	C3
C704	B3	R767	C3
C705	B2	R769	B3
F701	D2	RB71	B2
F702	C1	RB72	B2
F703	C1	RB73	B2
F704	C1	RB74	C1
JK761	E2	ZD761	D2
JK762	D4	ZD762	D2
JK763	D3	ZD763	D3
JK764	D4	ZD764	D2
JK765	D1	ZD765	D4
L701	C4	ZD766	C4
L702	C3	ZD767	C4
L703	B4	ZD768	C3
L704	B3	ZD769	C3
L705	B3	ZD770	D3
PN7605	B3	ZD771	B2
R761	D2	ZD772	B2

(6 TOOL)

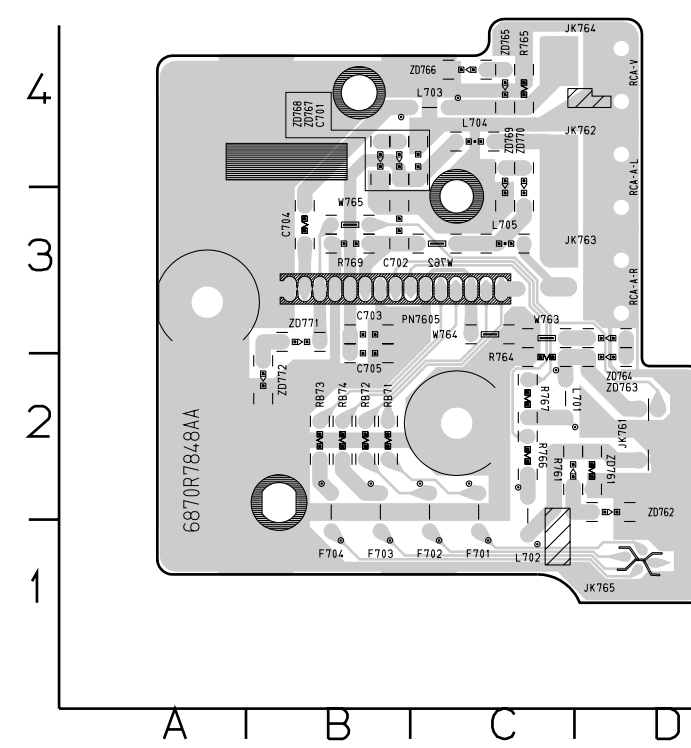

LOCATION GUIDE

C701	C4	R764	C2
C702	B3	R765	C4
C703	B3	R766	C2
C704	B3	R767	C2
C705	B2	R769	B3
F701	C2	RB71	B2
F702	C2	RB72	B2
F703	B2	RB73	B2
F704	B2	RB74	B2
JK761	D2	ZD761	C2
JK762	D4	ZD762	D2
JK763	D3	ZD763	D2
JK764	D4	ZD764	D3
JK765	D1	ZD765	C4
L701	C2	ZD766	C4
L702	C2	ZD767	B4
L703	C4	ZD768	B4
L704	C4	ZD769	C3
L705	C3	ZD770	C3
PN7605	B3	ZD771	B3
R761	D2	ZD772	B2

(4 TOOL, 8 TOOL)

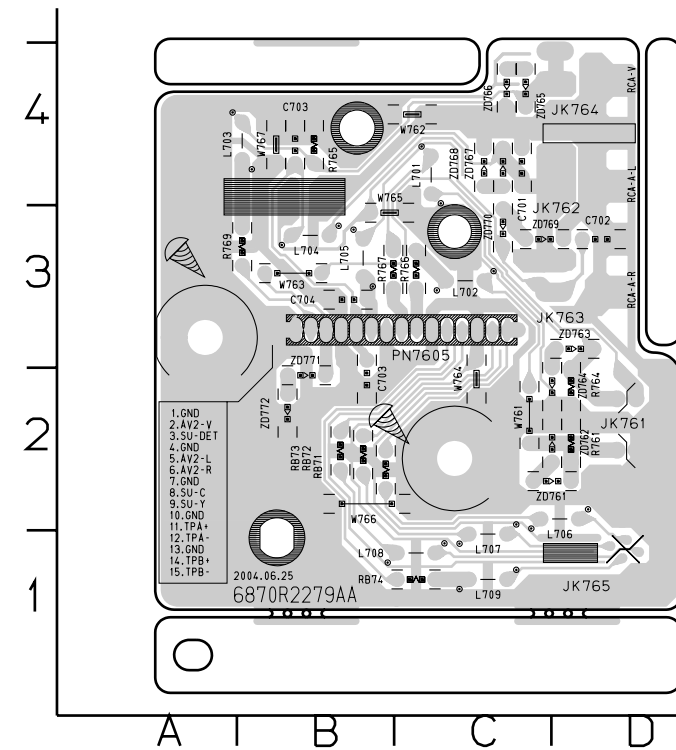

LOCATION GUIDE

C701	C4	R764	D2
C702	D3	R765	B4
C703	B4	R766	C3
C704	B3	R767	B3
C705	B2	R769	B3
JK761	D2	RB71	B2
JK762	D4	RB72	B2
JK763	D3	RB73	B2
JK764	D4	RB74	C1
JK765	D1	ZD761	D2
L701	C4	ZD762	D2
L702	C3	ZD763	D3
L703	B4	ZD764	D2
L704	B3	ZD765	C4
L705	B3	ZD766	C4
L706	D2	ZD767	C4
L707	C1	ZD768	C4
L708	C1	ZD769	C3
L709	C1	ZD770	C3
PN7605	B3	ZD771	B2
R761	D2	ZD772	B2

5. KEY P.C.BOARD

(2 TOOL)

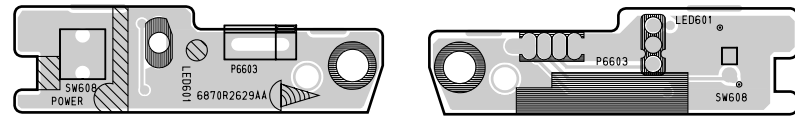

(3 TOOL)

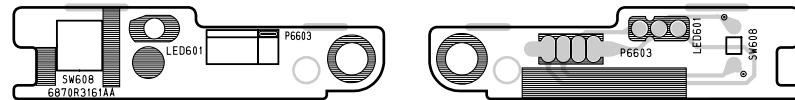

(4 TOOL)

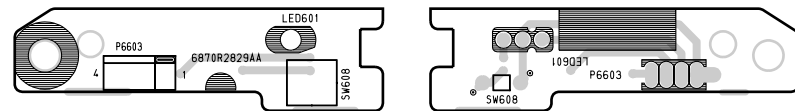

(6 TOOL)

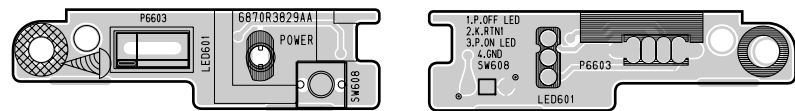

(7 TOOL)

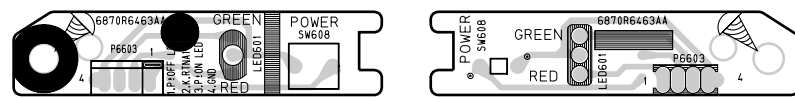

(8 TOOL)

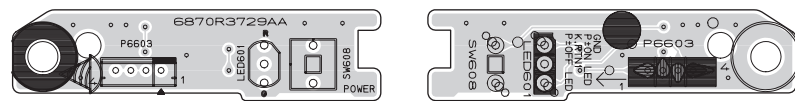

6. Timer P.C.BOARD

(2 TOOL)

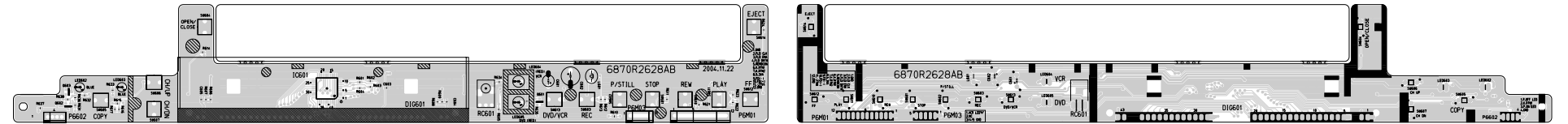

(3 TOOL)

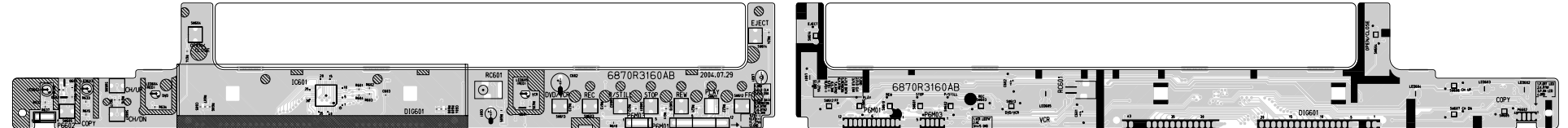

(4 TOOL)

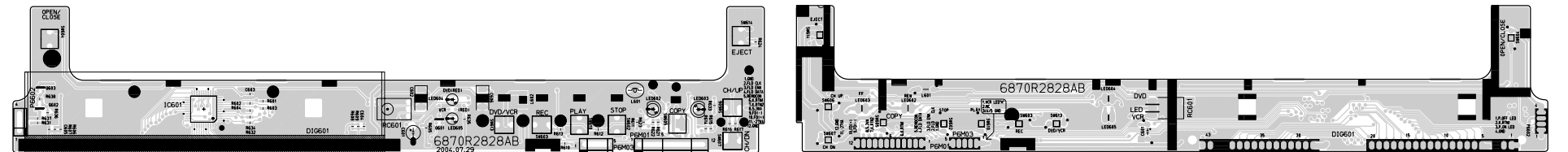

(6 TOOL)

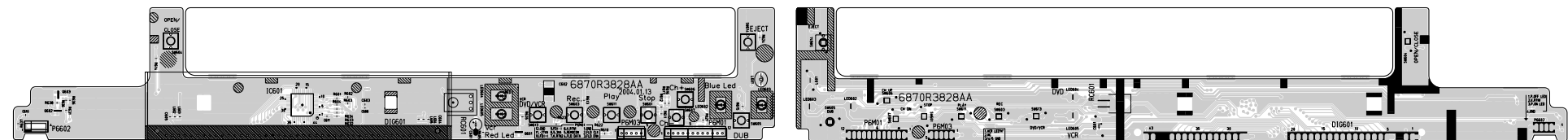

(7 TOOL)

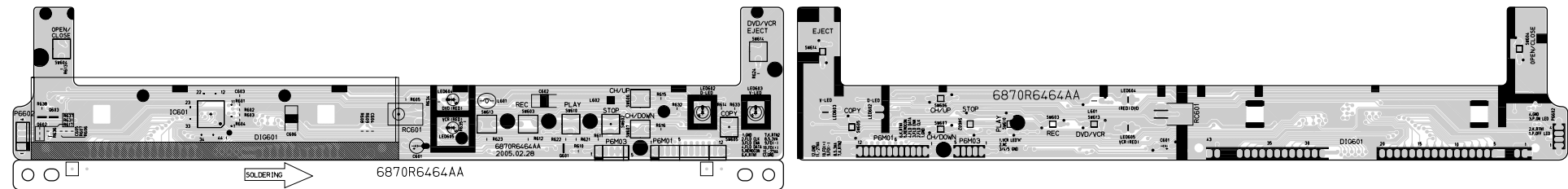

(8 TOOL)

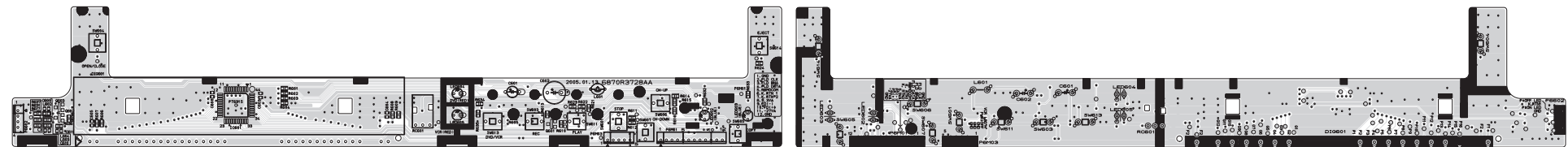

VDR PART

VDR ELECTRICAL TROUBLESHOOTING GUIDE

1. Power(SMPS) CIRCUIT

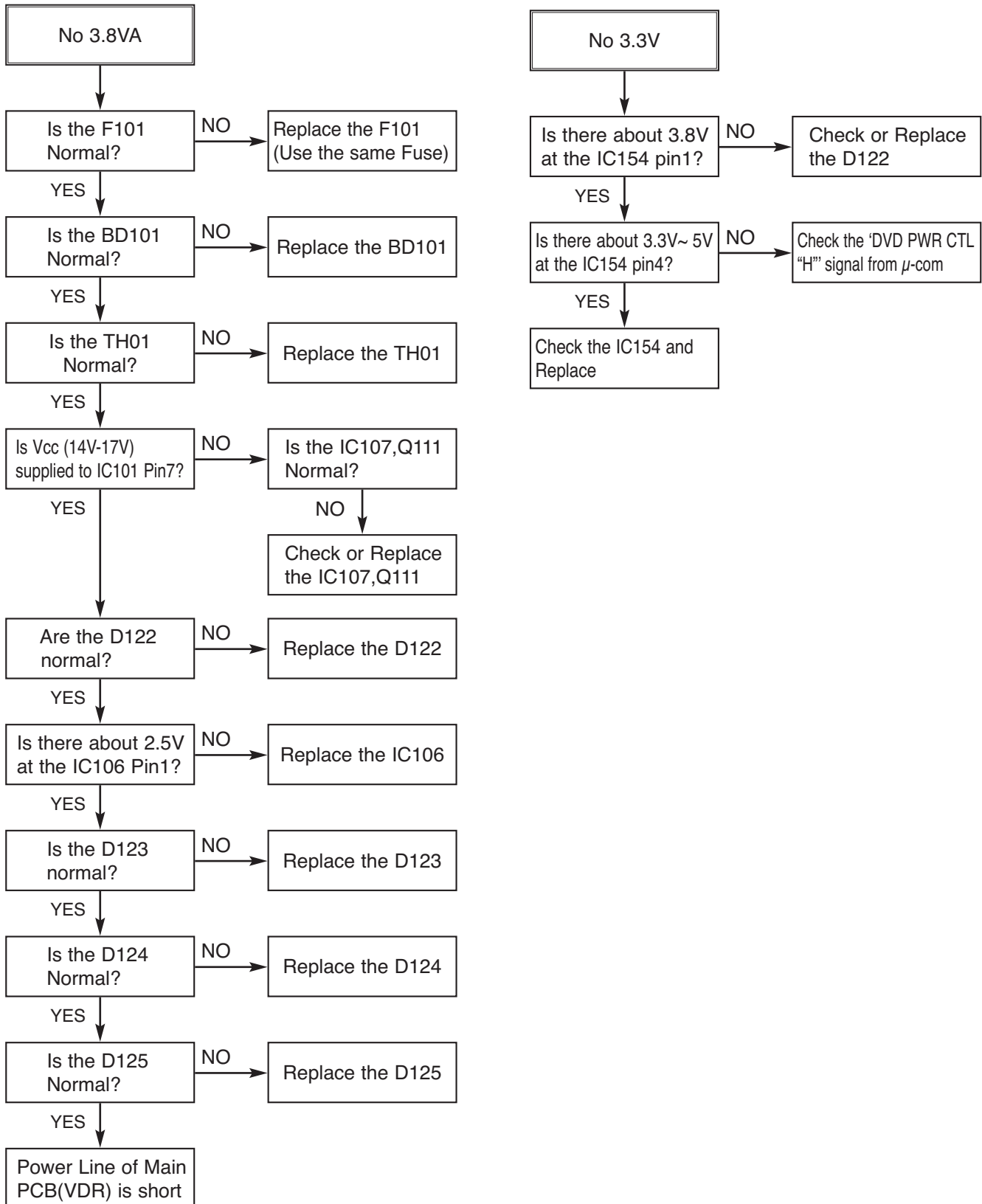

VDR ELECTRICAL TROUBLESHOOTING GUIDE

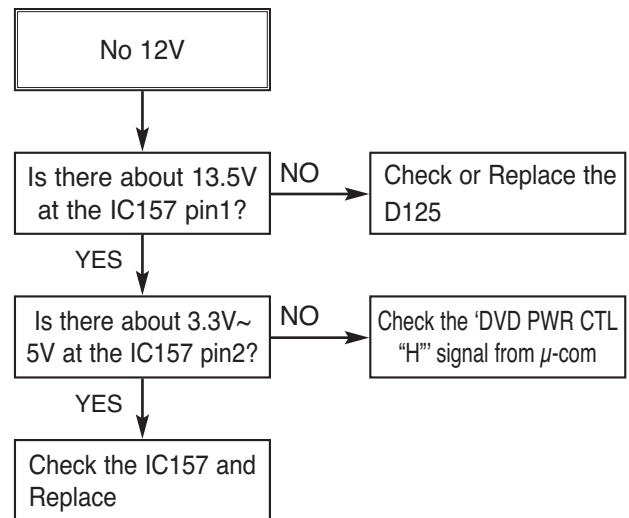
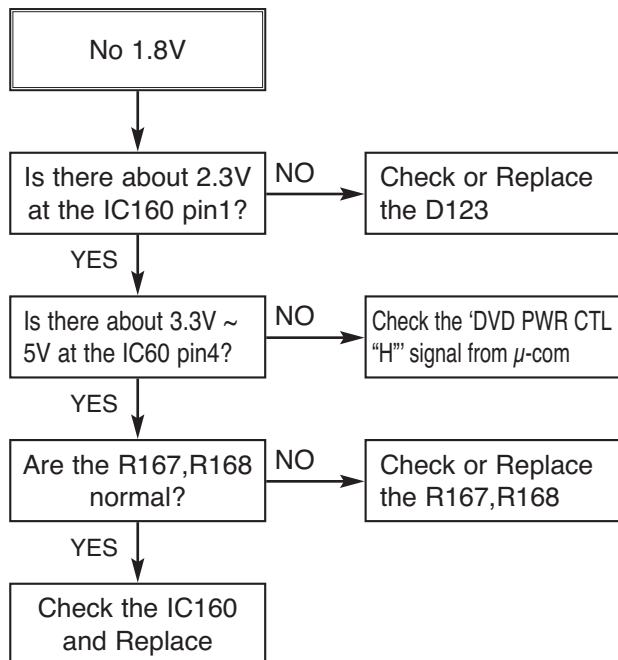
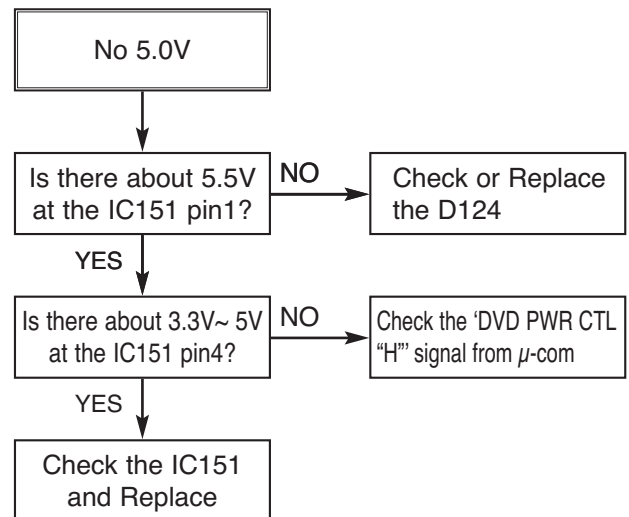
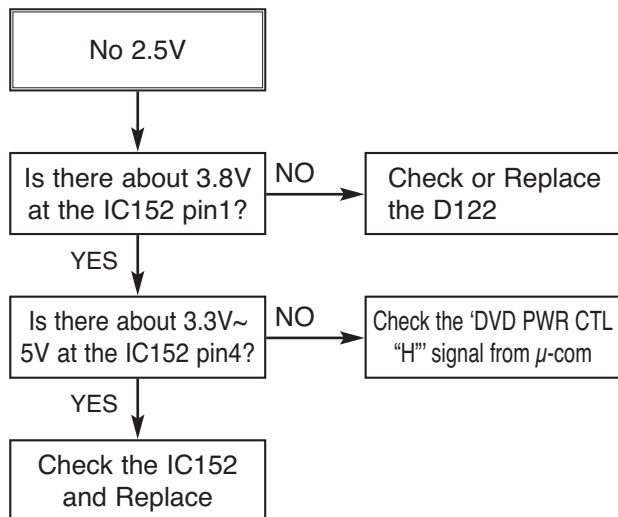

VDR ELECTRICAL TROUBLESHOOTING GUIDE

2. No Component video signal when playing DISC

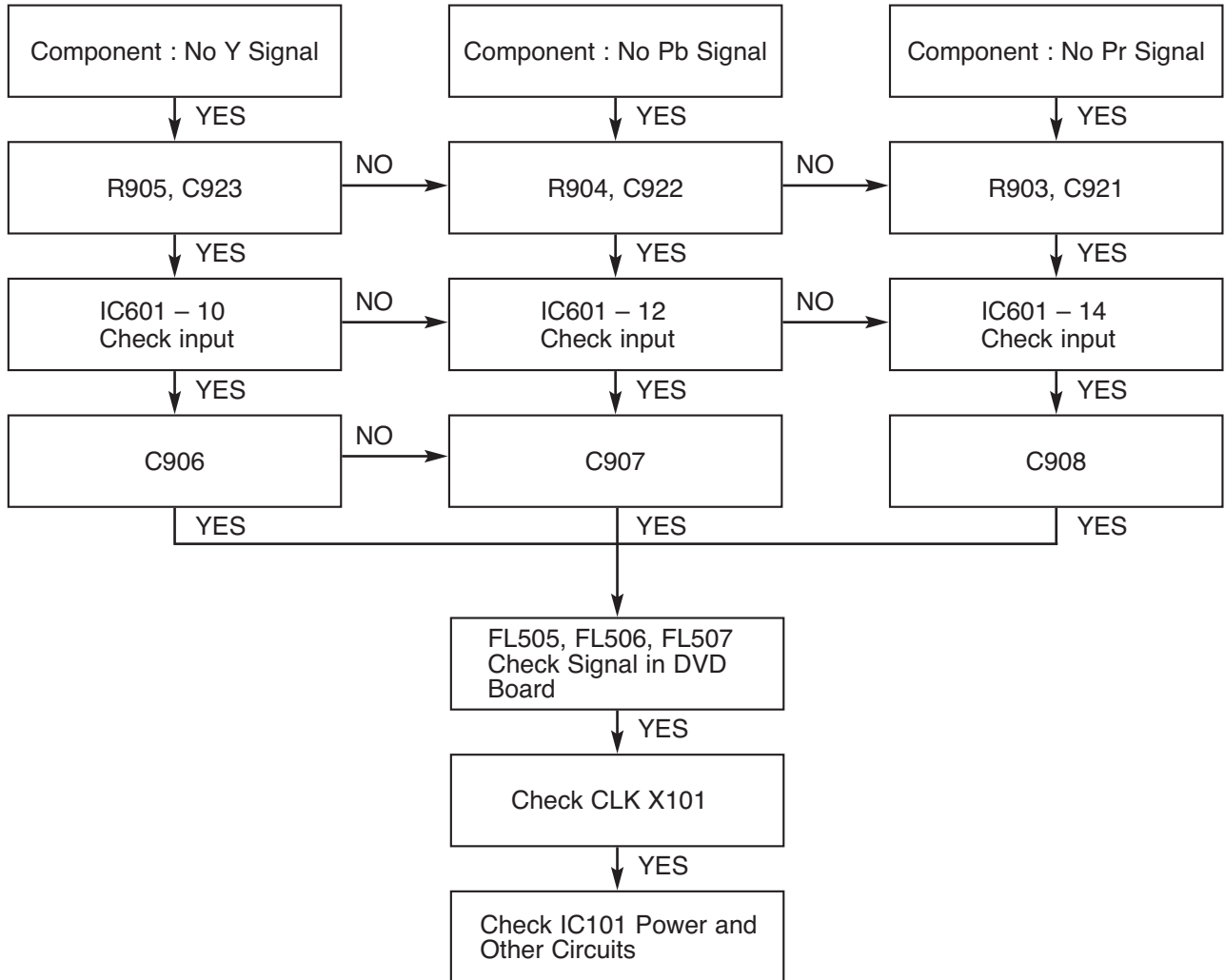

VDR ELECTRICAL TROUBLESHOOTING GUIDE

3. No COMPOSITE / S-VIDEO signal when playing DISC

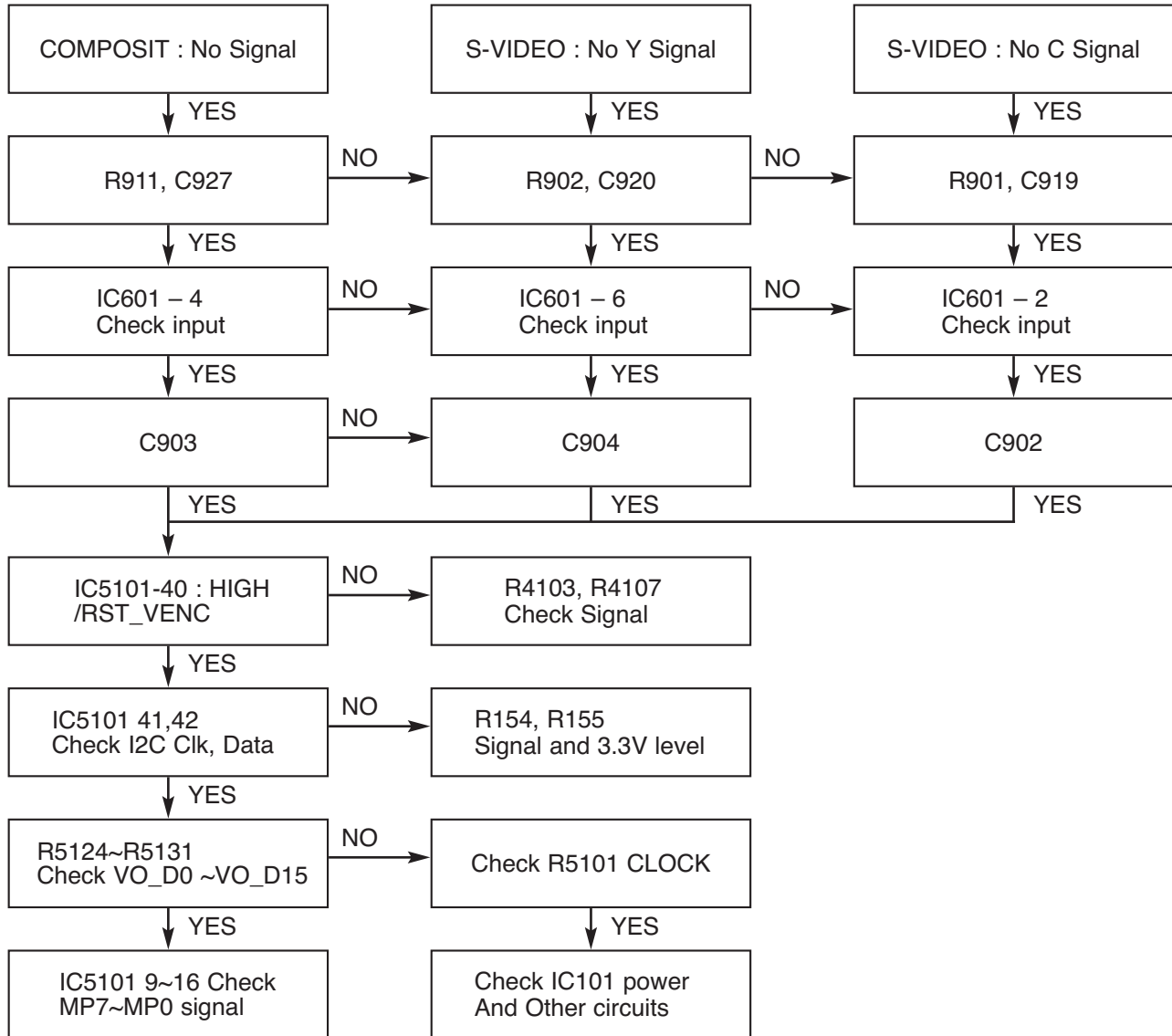

VDR ELECTRICAL TROUBLESHOOTING GUIDE

4. No TV, External Input video signal

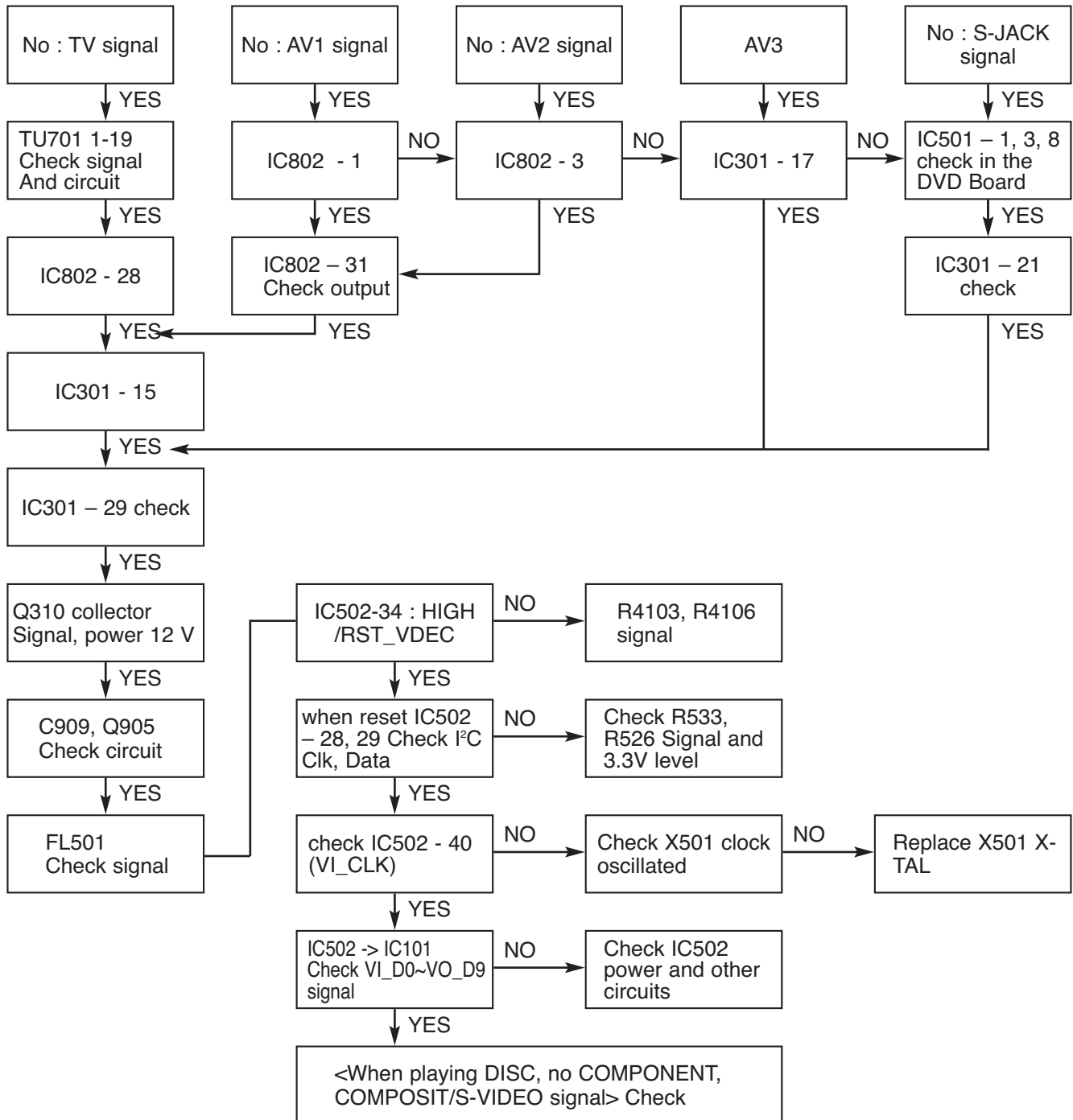

VDR ELECTRICAL TROUBLESHOOTING GUIDE

5. When playing DISC, no audio output

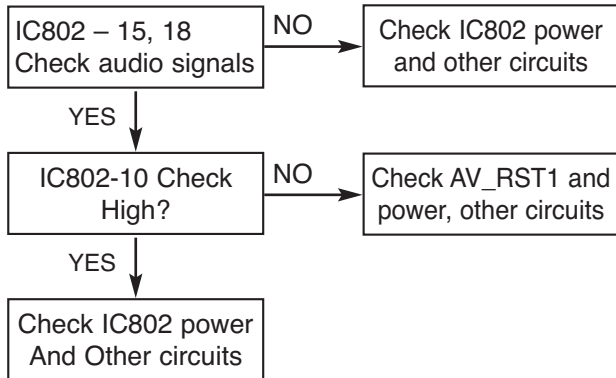

7. No OPTICAL / DIGITAL output

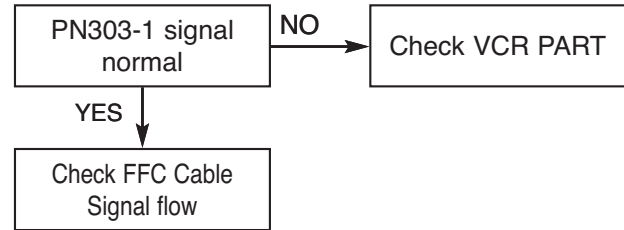

6. No TUNER audio output

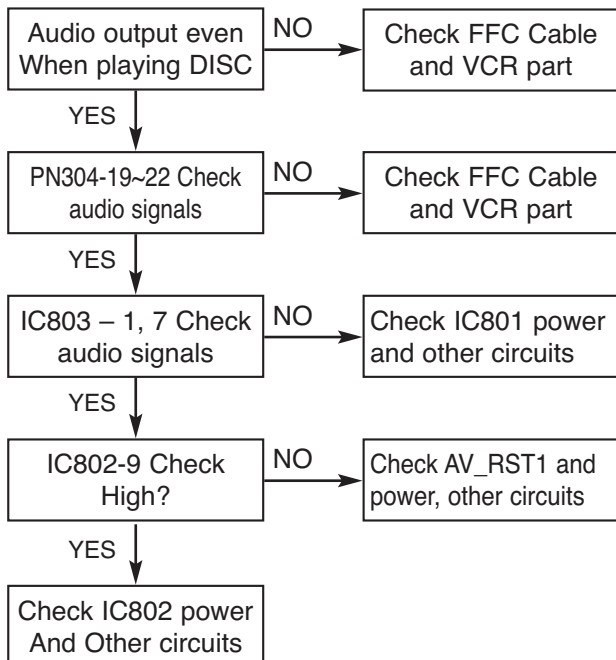

VDR ELECTRICAL TROUBLESHOOTING GUIDE

8. No External Input 1, 2 audio

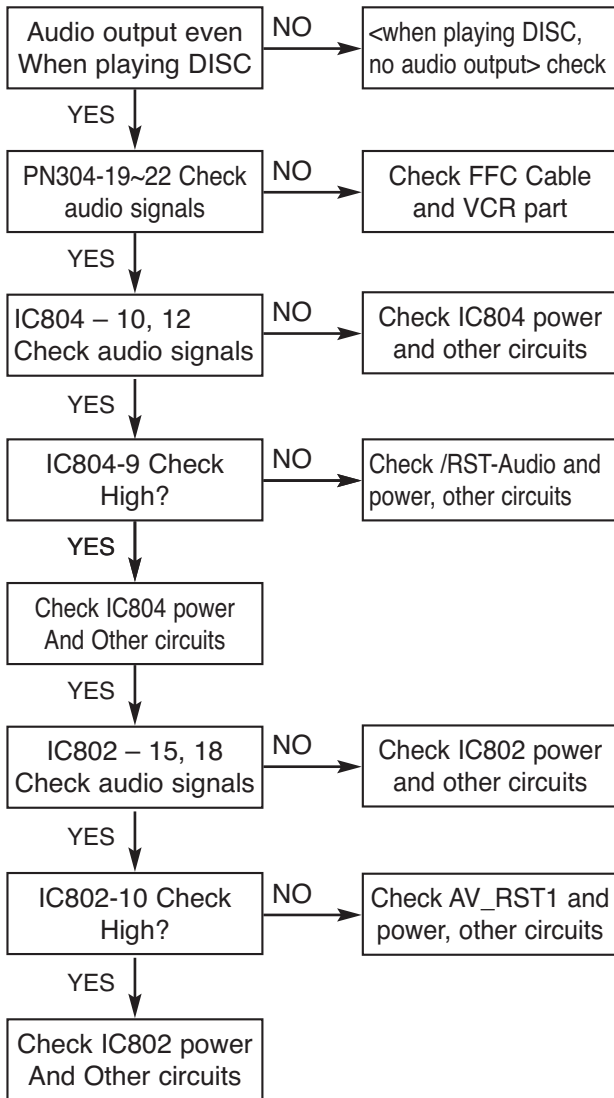

9. No External Input 3 audio

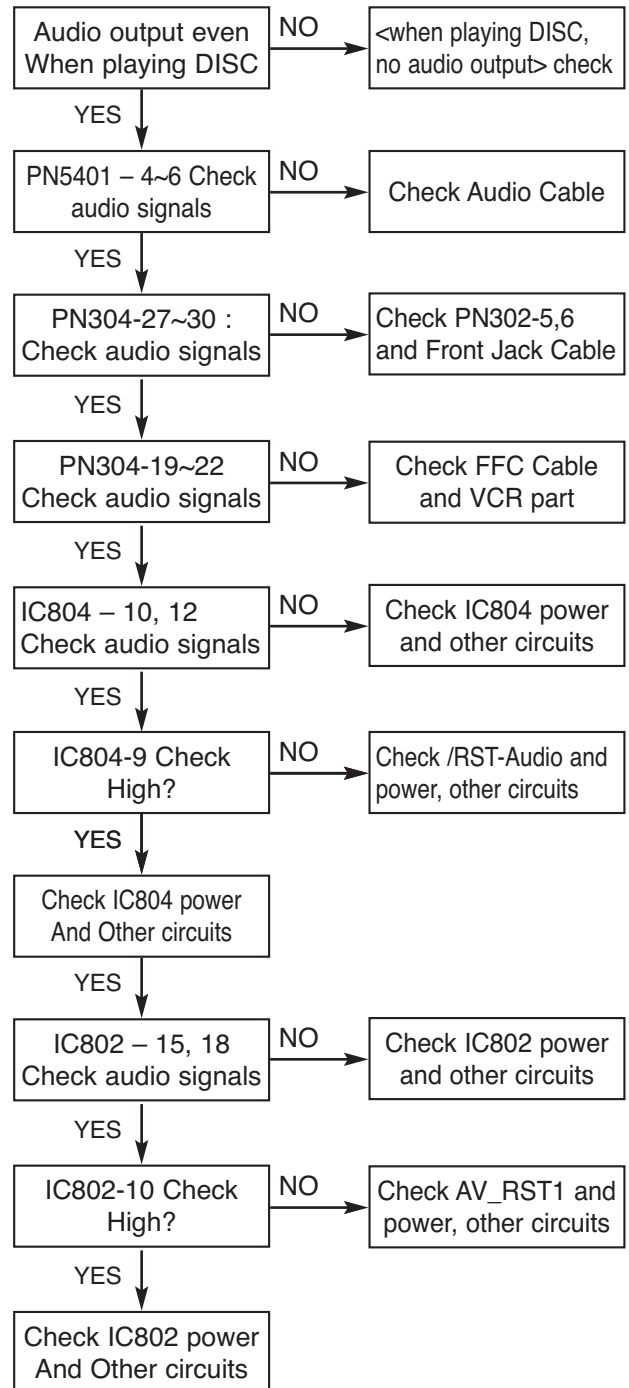

BLOCK DIAGRAMS

1. VDR SET TOTAL BLOCK DIAGRAM

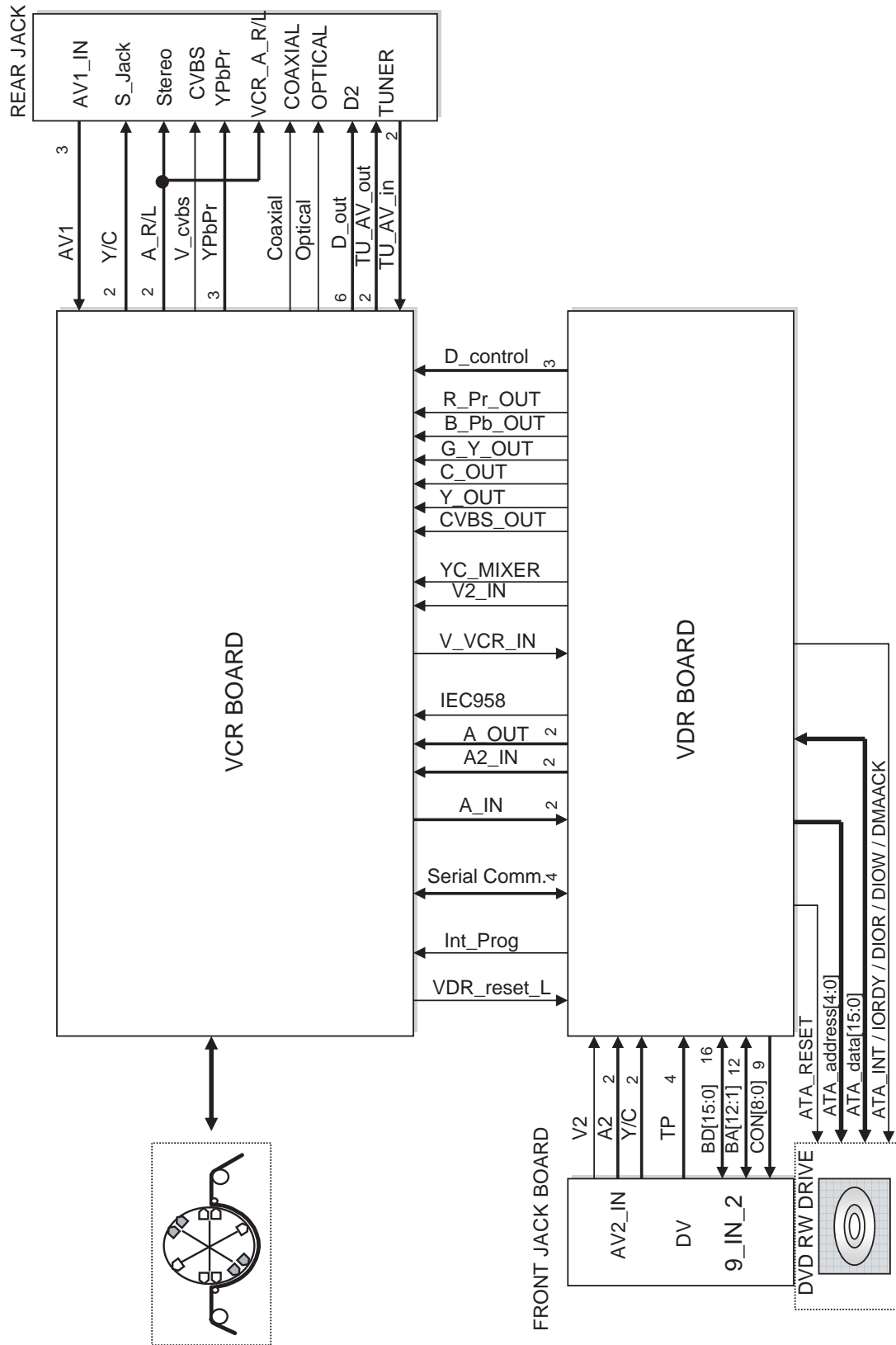

2. VDR MAIN H/ W BLOCK DIAGRAM

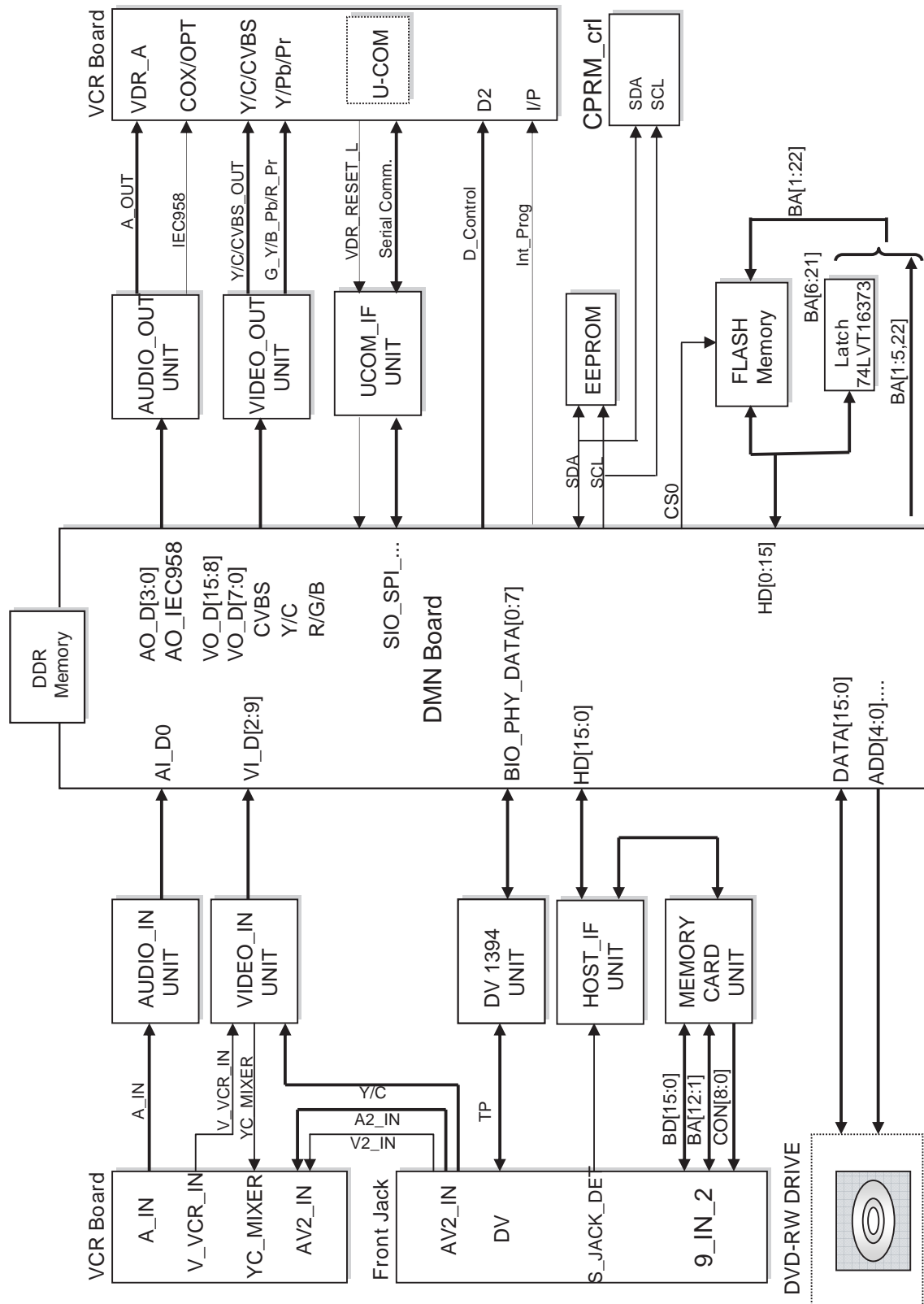

3. POWER BLOCK DIAGRAM

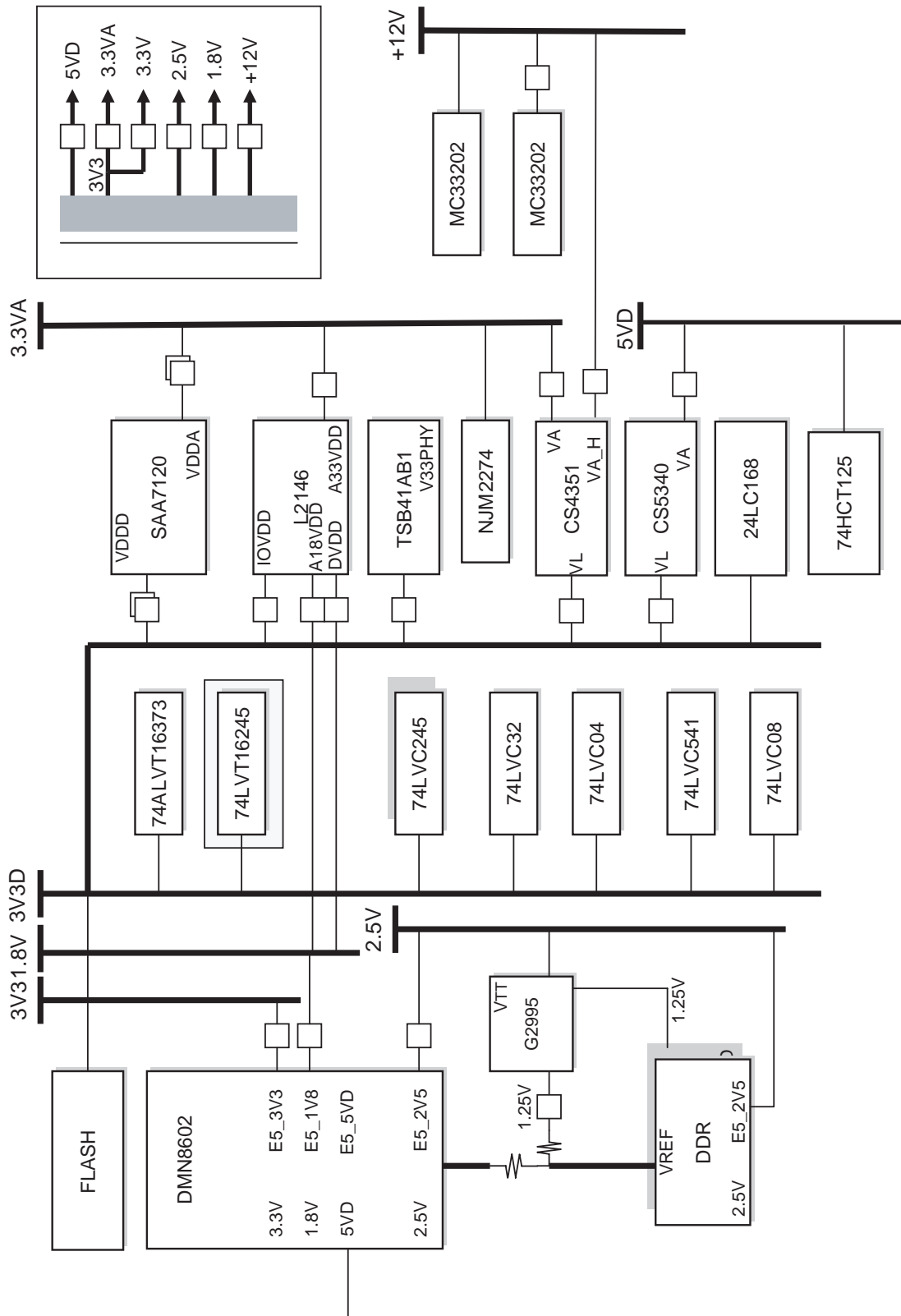

4. AUDIO IN/ OUT BLOCK DIAGRAM

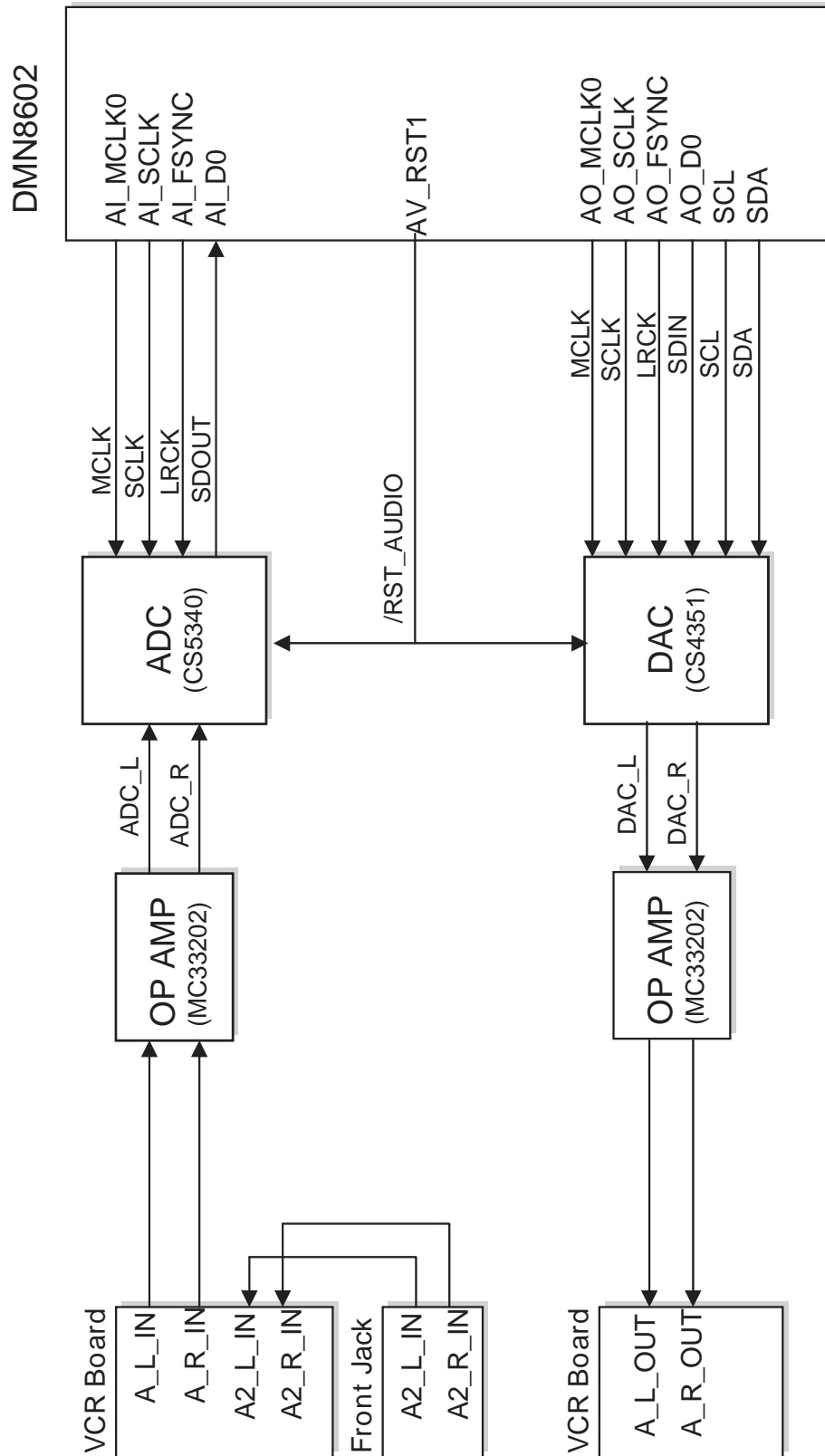

5. CPU & CONTROL REGISTER BLOCK DIAGRAM

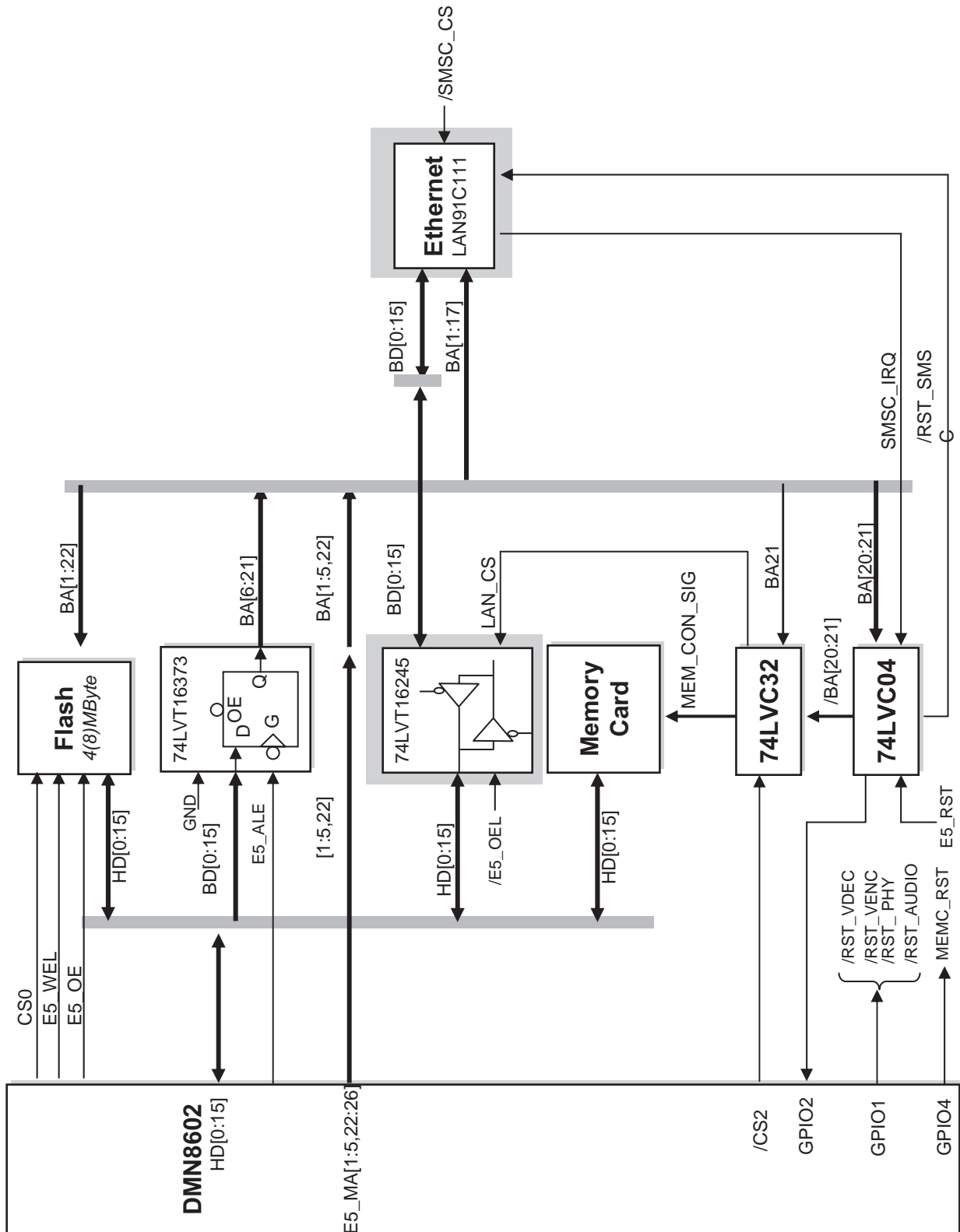

6. VIDEO IN/ OUT BLOCK DIAGRAM

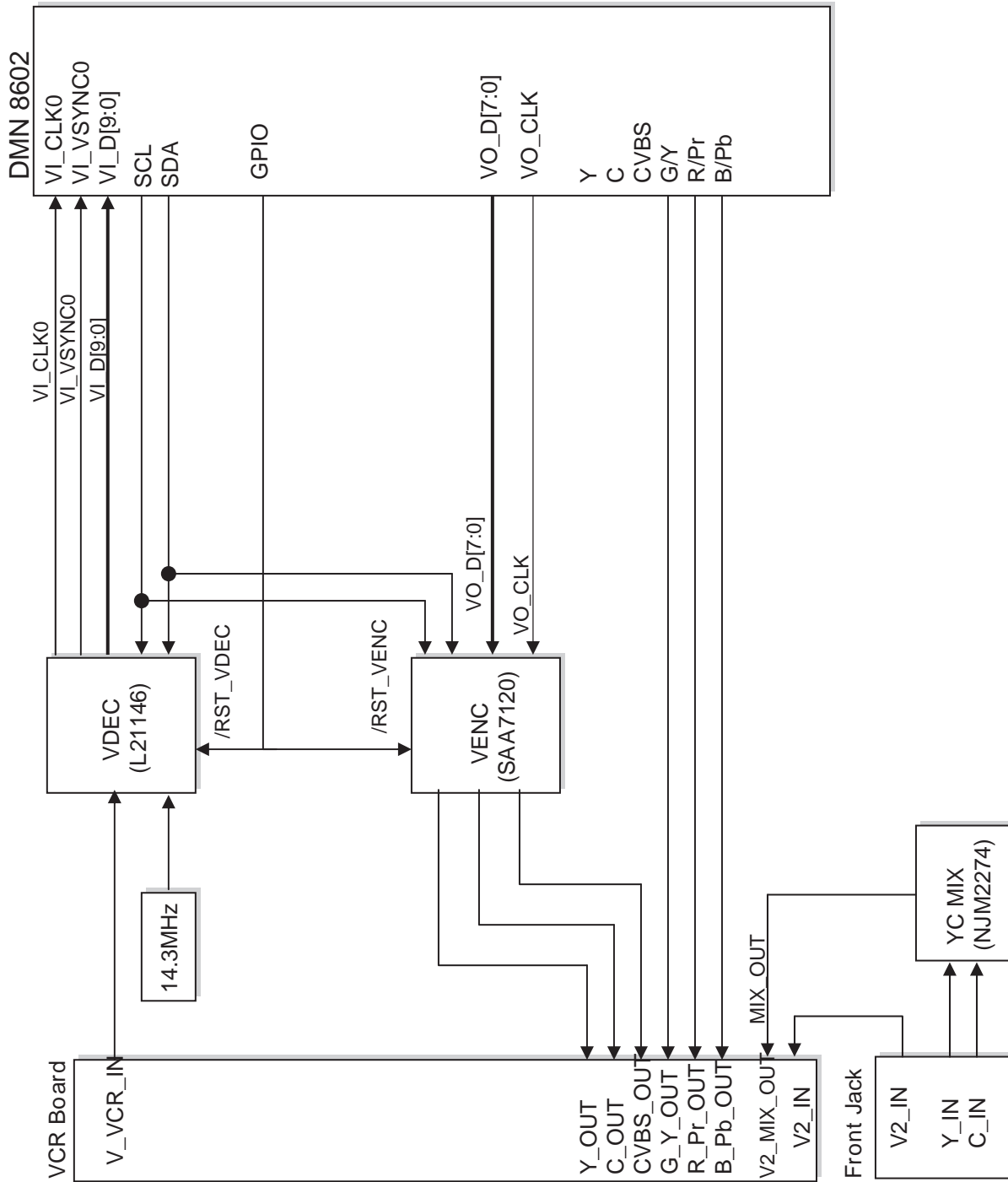

7. DV 1394 IN/OUT BLOCK DIAGRAM

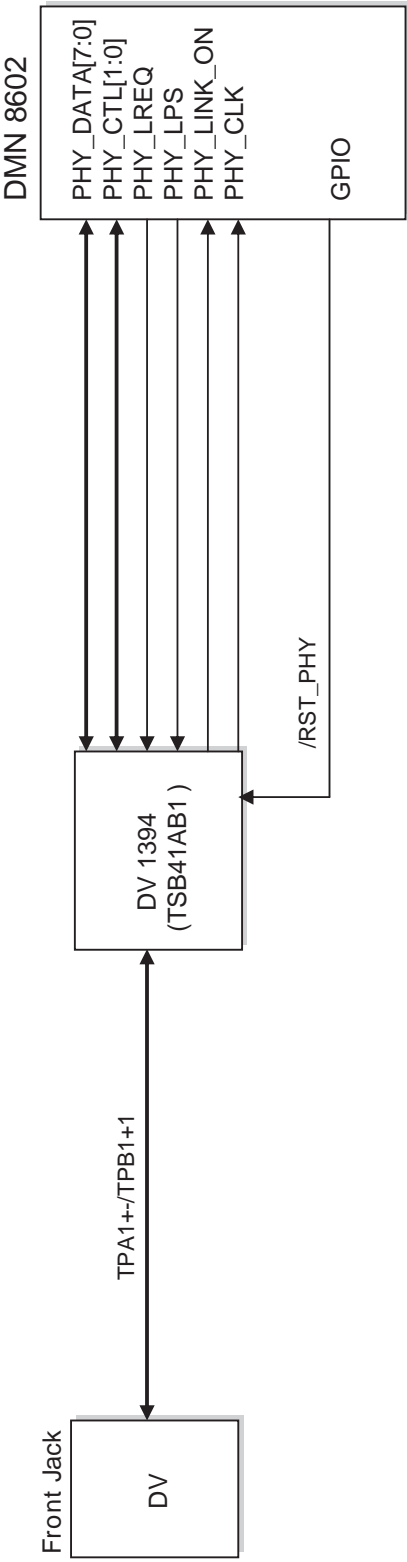

8. MEMORY CARD IN/ OUT BLOCK DIAGRAM

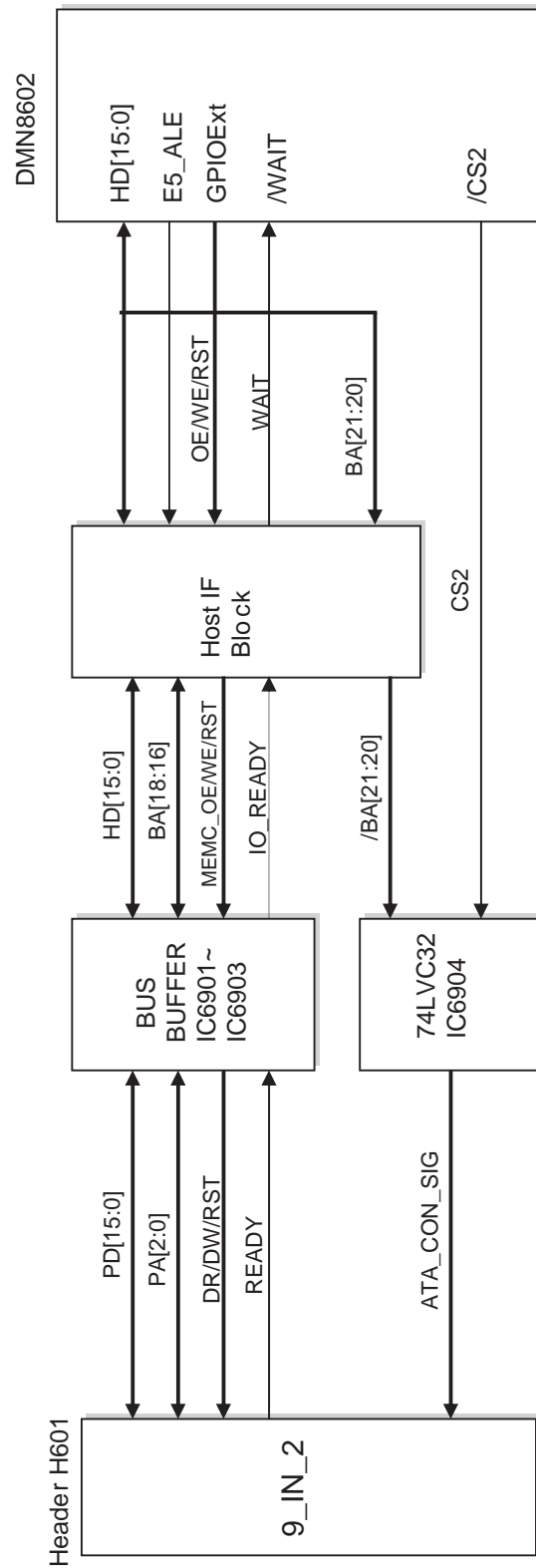

MEMO

A series of horizontal dotted lines for writing.

2. DDR & B TO B CONNECTOR CIRCUIT DIAGRAM

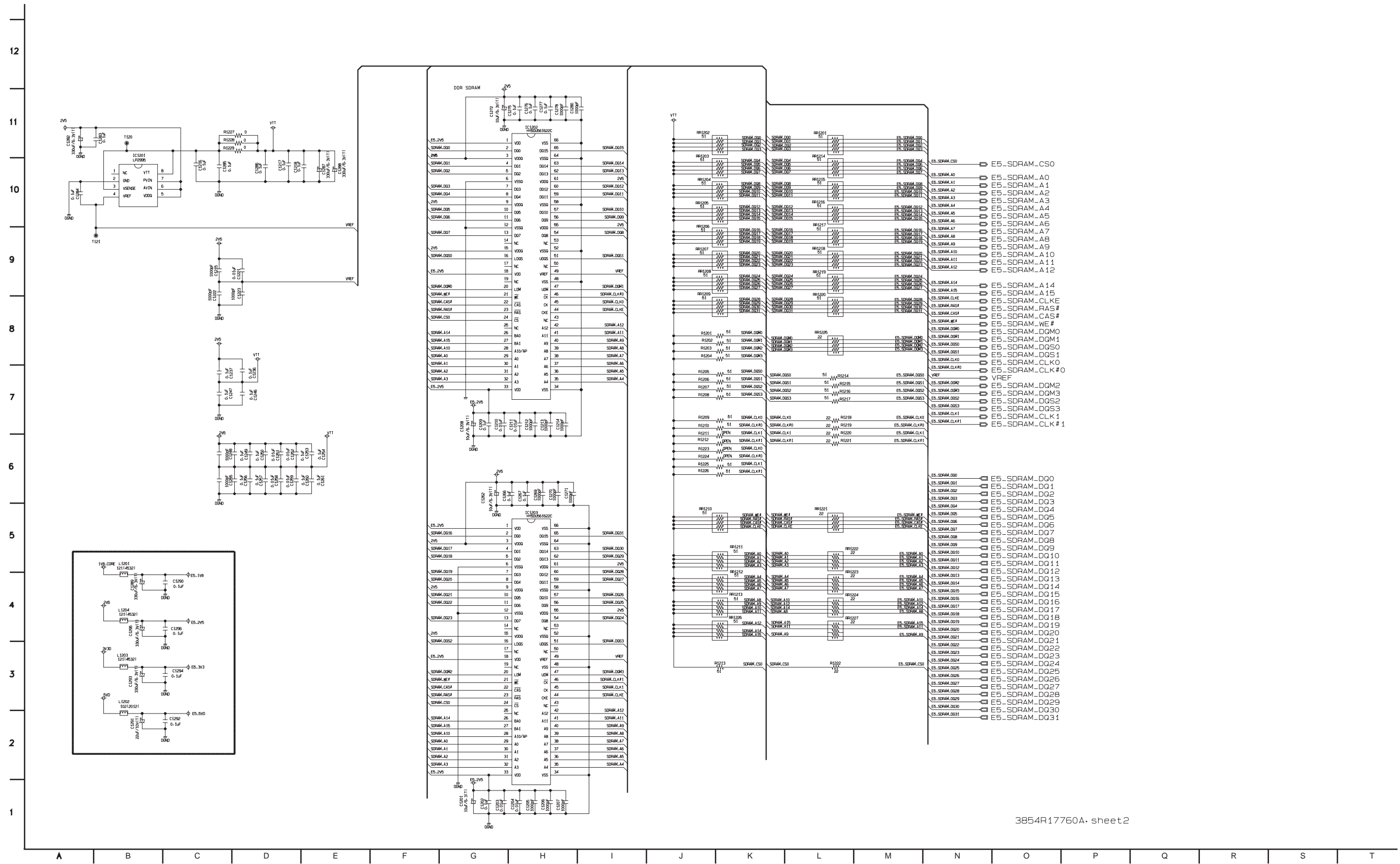

4. RST, CONTROL/STATUS_REG., ATAPI, HOST_CPLD, LATCH CIRCUIT DIAGRAM

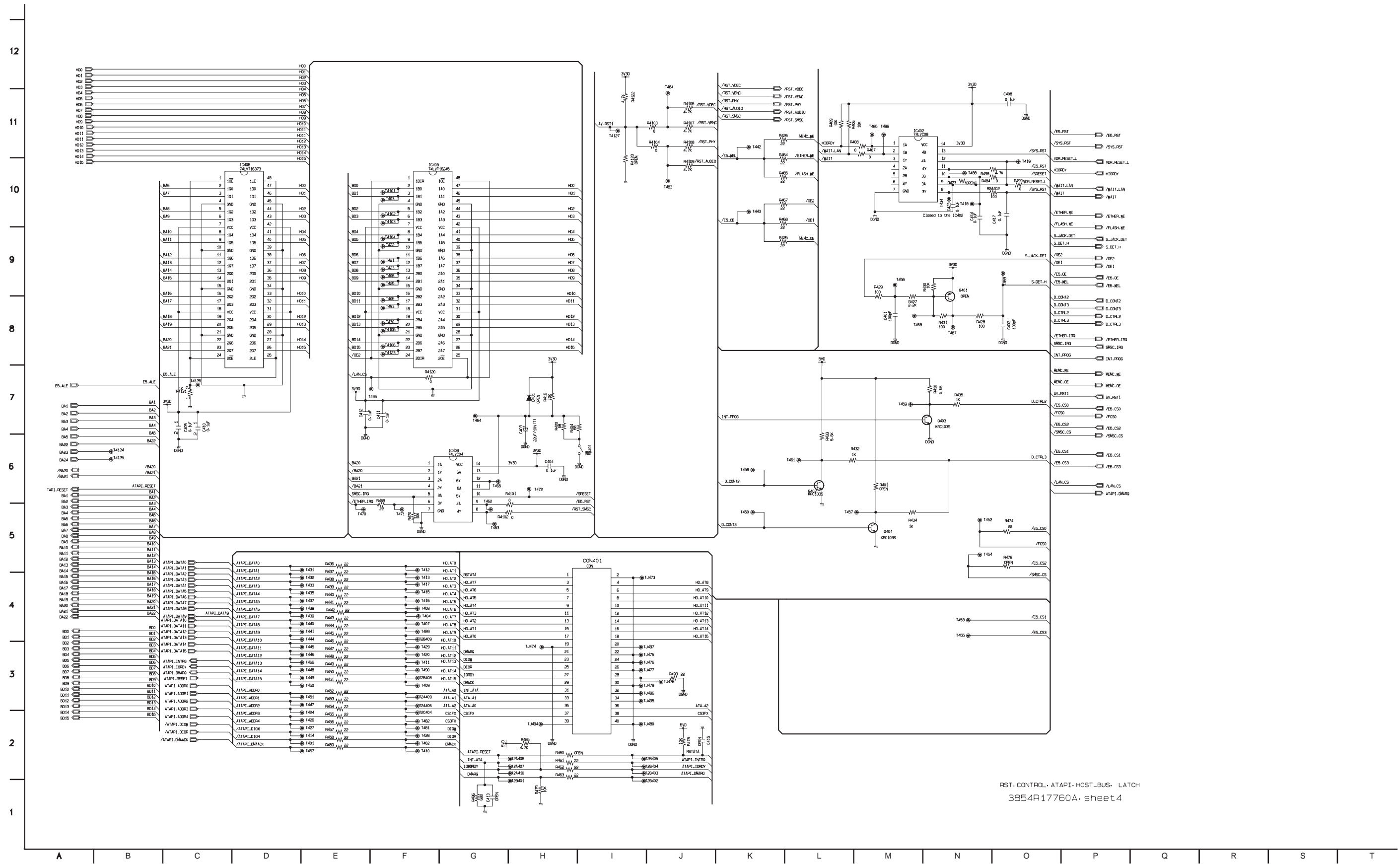

RST, CONTROL, ATAPI, HOST_BUS, LATCH
3854R17760A, sheet 4

5. VIDEO_IN, VIDEO_OUT CIRCUIT DIAGRAM

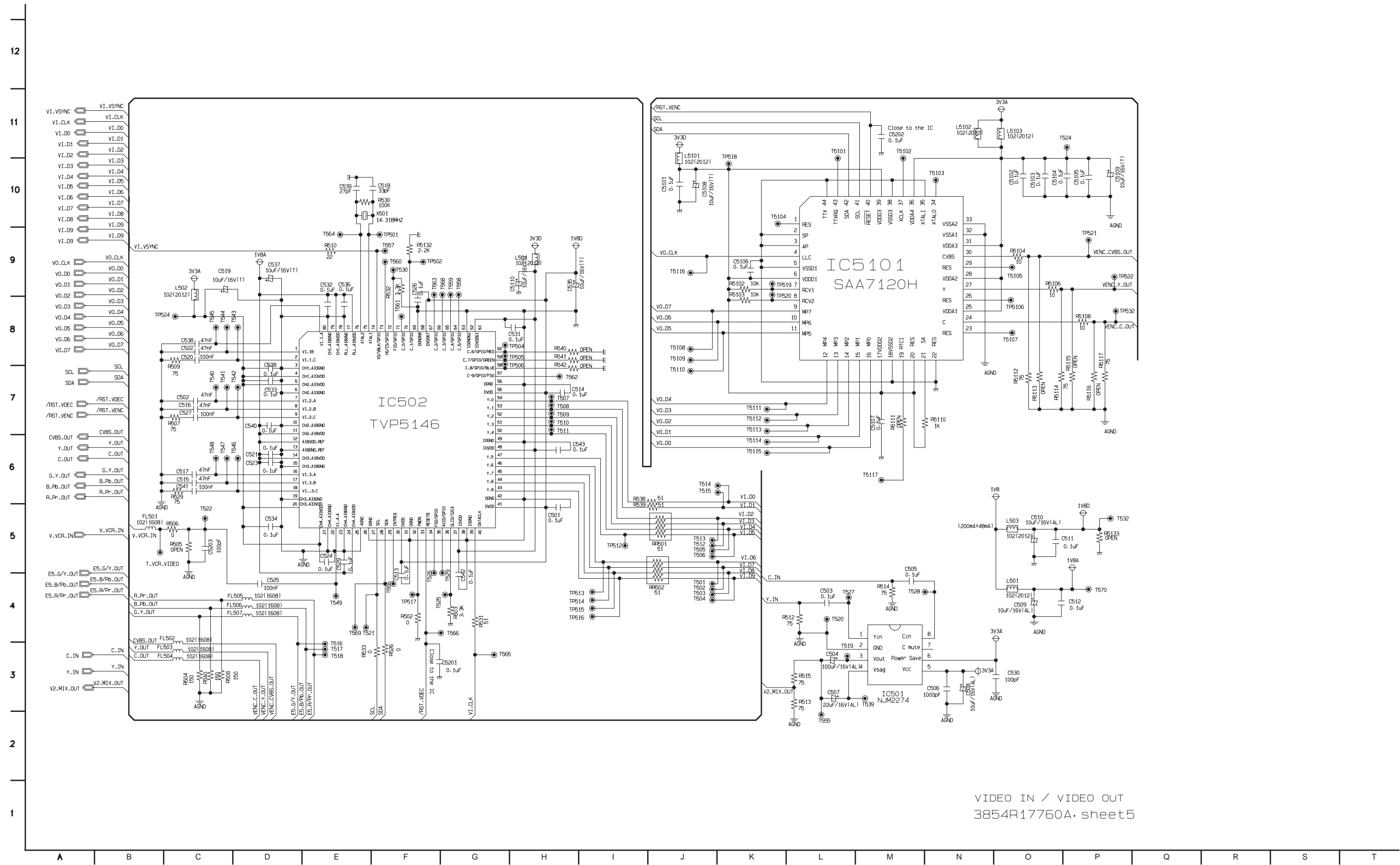

VIDEO IN / VIDEO OUT
3854R17760A, sheet5

7. AUDIO IN/OUT CIRCUIT DIAGRAM

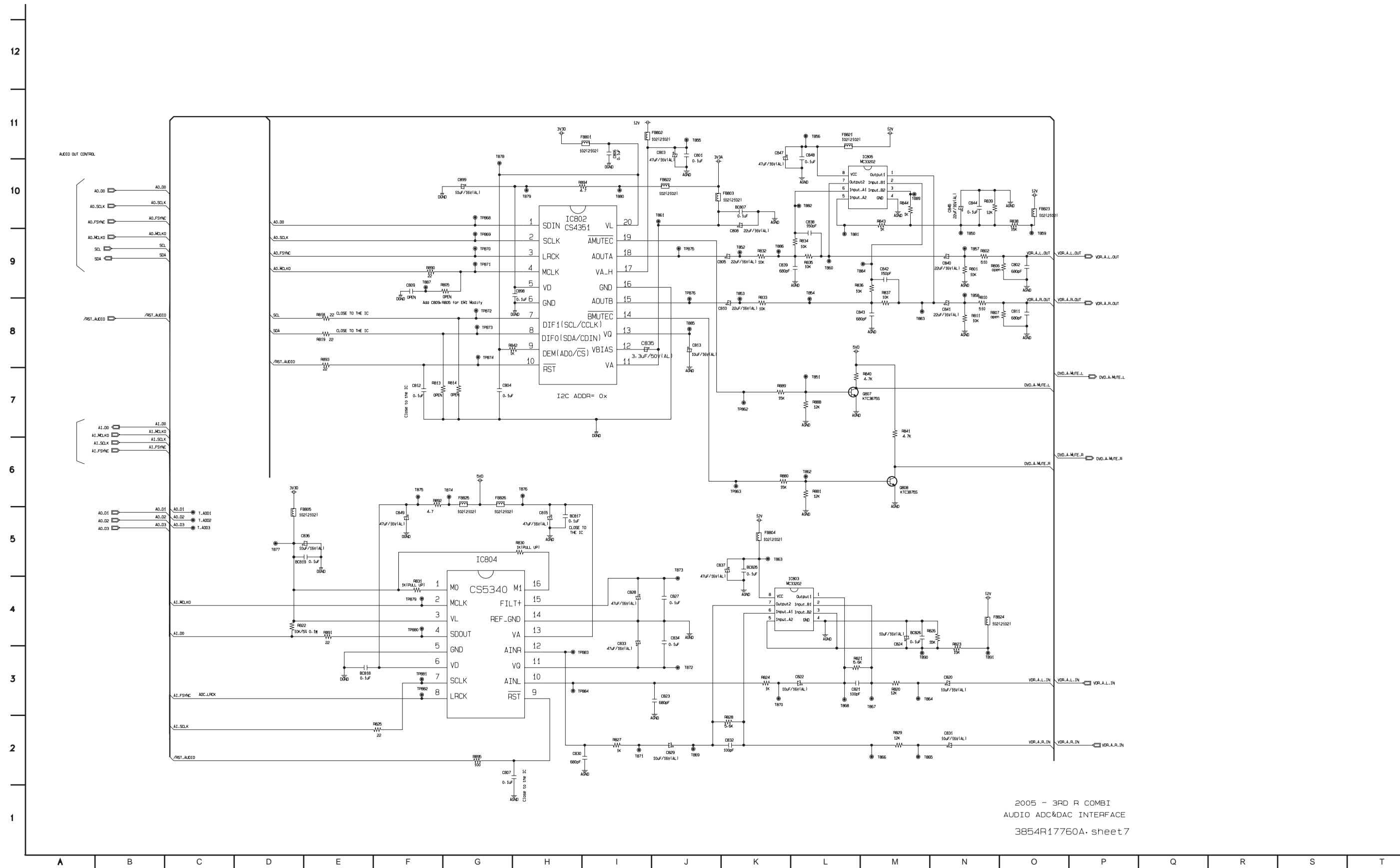

• WAVEFORMS

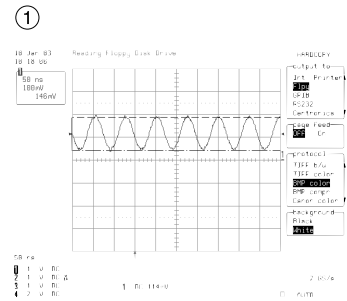

X101
13.5MHz

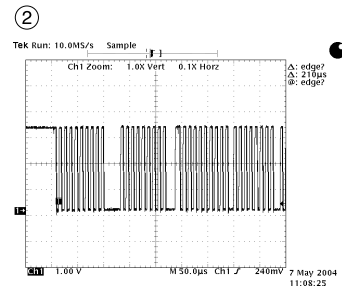

IC5101
PIN42
SDA

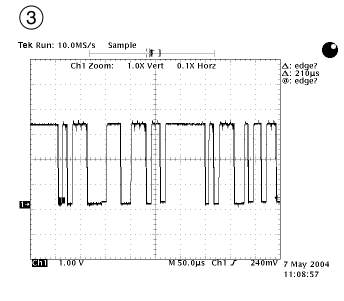

IC502
PIN29
SDA

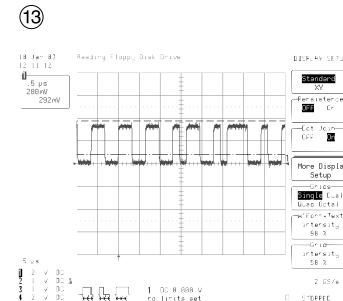

PN303
PIN1
IEC958

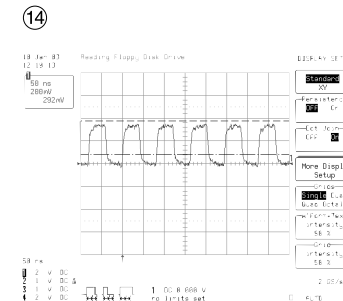

IC802
PIN4
ADAC_MCLK

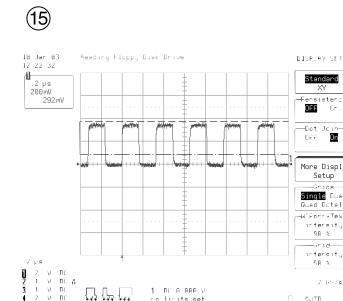

IC802
PIN2
ADAC_SCLK

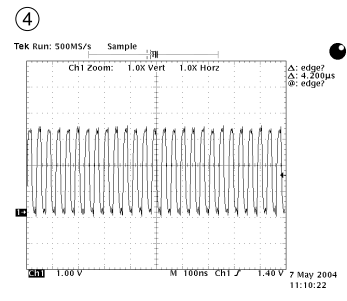

IC502
PIN40
VI_CLK

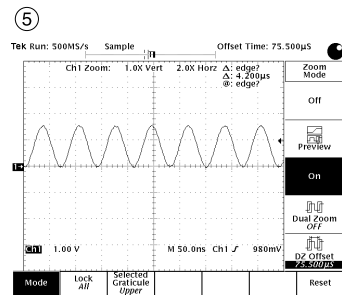

IC502
PIN74
14.318MHz

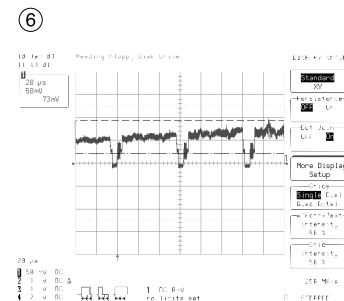

PN304
PIN5
CVBS_OUT

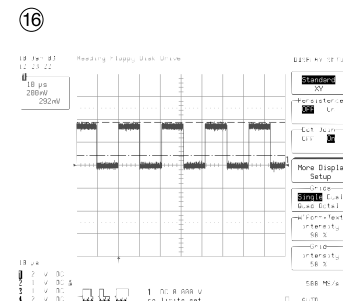

IC802
PIN3
ADAC_LRCK

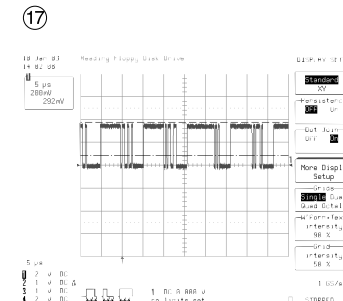

IC804
PIN4
ADC_SDATA(AI_D0)

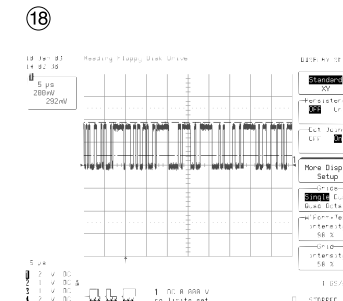

IC802
PIN1
DAC_SDATA(AO_D0)

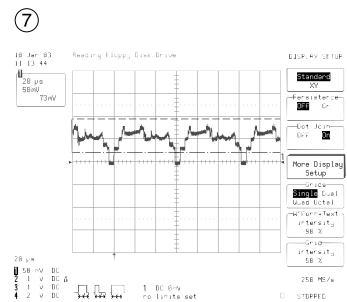

PN304
PIN9
Y_OUT

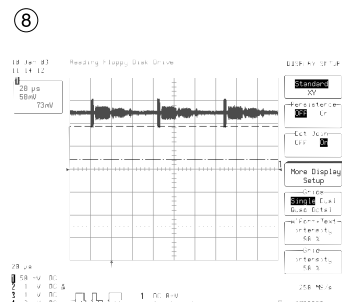

PN304
PIN11
C_OUT

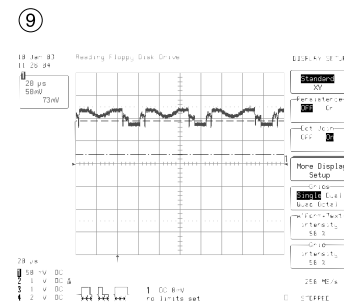

PN304
PIN17
R_Pr_OUT

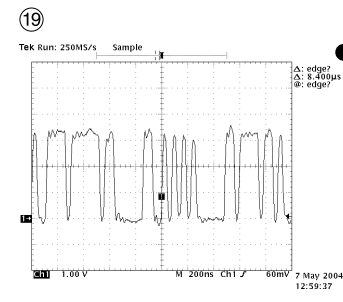

IC502
PIN53
VI_D1

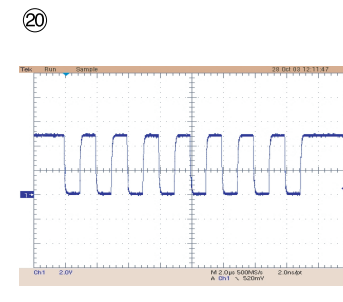

PN7401
PIN 12
VDR_CLK

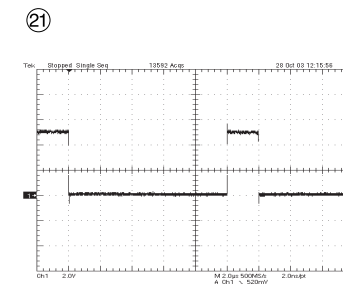

PN7401
PIN 13
VDR_DIN

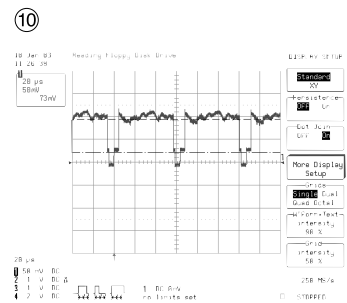

PN304
PIN13
G_Y_OUT

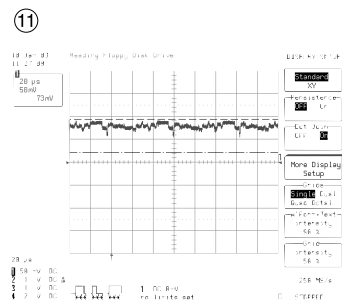

PN304
PIN15
B_Pb_OUT

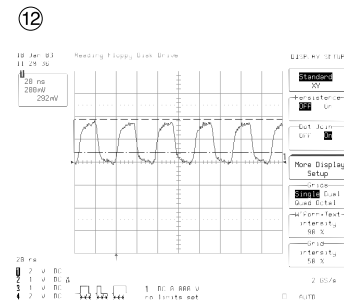

IC5101
PIN4
VO_CLK

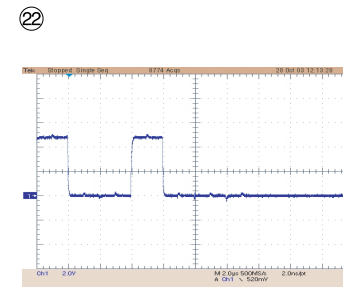

PN7401
PIN 14
VDR_DOUT

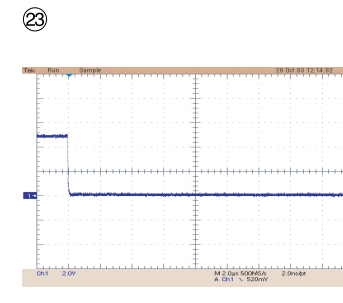

PN7401
PIN 15
VDR_ENB

• CIRCUIT VOLTAGE CHART

MODE PIN NO.	EE	PB	REC
IC 1201			
1	0	0	0
2	0	0	0
3	1.02	1.02	1.23
4	1.02	1.01	1.23
5	2.37	2.48	2.47
6	2.34	2.48	2.47
7	2.34	2.48	2.47
8	1.08	1.22	1.22
IC 302			
1	0	0	0
2	3.14	3.29	3.27
3	4.88	4.96	4.96
4	0	0	0
5	0	0	0
6	4.88	0.01	0.01
7	0	0	0
8	4.94	3.97	3.97
9	3.22	2.64	2.64
10	0	0	0
11	4.88	4.2	4.2
12	4.96	4.3	4.3
13	0	0	0
14	4.84	4.97	4.97
IC 402			
1	3.14v	3.29	3.29
2	3.14v	3.32	3.32
3	3.14v	3.29	3.29
4	0.04	0.04	0
5	0	0.04	0
6	0	0	0
7	0	0	0
8	3.14	3.29	3.29
9	3.14	5.09	5.9
10	3.14	3.29	3.29
11	3.14	3.29	3.29
12	4.98	5.09	5.09
13	3.14	3.29	3.29
14	3.14	3.29	3.29
IC 405			
1	3.28	3.28	3.29
2	3.31	0.19	0.19
3	3.22	0.19	0.19
4	0	0	0
5	0.19	0.19	0.19
6	0.19	0.19	0.19
7	3.29	3.29	3.29
8	0.19	0.19	0.19
9	0.19	0.19	0.19
10	0	0	0
11	0.19	0.19	0.19
12	0.19	0.19	0.19
13	0.19	0.19	0.19
14	3.31	0.19	0.19
15	0	0	0

MODE PIN NO.	EE	PB	REC
16	0.19	0.19	0.19
17	0.19	0.19	0.19
18	3.29	3.29	3.29
19	0.19	0.19	0.19
20	0	0.19	0.19
21	0	0	0
22	0.19	0.19	0.19
23	0	0.19	0.19
24	3.28	3.29	3.29
25	3.29	3.29	3.29
26	0	0	0
27	0	0	0
28	0	0	0
29	0	0	0
30	0	0	0
31	3.29	3.29	3.29
32	0	0	0
33	0	0	0
34	0	0	0
35	0	0	0
36	0	0	0
37	0	0	0
38	0	0	0
39	0	0	0
40	0	0	0
41	0	0	0
42	3.29	3.28	3.29
43	0	0	0
44	0	0	0
45	0	0	0
46	0	2.92	0
47	0	2.92	0
48	3.29	3.29	3.29
IC 406			
1	0	0	0
2	0	0.04	0.04
3	0	0.04	0.04
4	0	0	0
5	0	3.29	3.29
6	0	3.29	3.29
7	3.14	3.29	3.29
8	0	0.04	0.04
9	0	0.04	0.04
10	0	0	0
11	0	0.04	0.04
12	0	0.04	0.04
13	0	0.04	0.04
14	0	0.04	0.04
15	0	0	0
16	0	0.04	0.04
17	0	0.04	0.04
18	0	3.29	3.29
19	0	0.04	0.04
20	0	0.04	0.04
21	0	0	0

MODE PIN NO.	EE	PB	REC
22	0	0.04	0.04
23	0	3.29	3.29
24	0	0	0
25	0	0.01	0.01
26	0	0	0
270	0	0	0
28	0	0	0
29	0	0	0
30	0	0	0
31	0	3.29	3.29
32	0	0	0
33	0	0	0
34	0	0	0
35	0	0	0
36	0	0	0
37	0	0	0
38	0	0	0
39	0	0	0
40	0	0	0
41	0	0	0
42	3.16	3.29	3.29
43	0	0	0
44	0	0	0
45	0	0	0
46	0	0	0
47	0	0	0
48	0	0	0.01
IC 502			
1	0	0.001	0.001
2	0	0.002	0.004
3	0	0	0
4	3.22	3.256	3.255
5	3.22	3.256	3.255
6	0	0	0
7	0	0.002	0.002
8	0	0.001	0.002
9	0	0.001	0.002
10	0	0	0
11	1.78v	1.854	1.851
12	1.78	1.854	1.851
13	0	0	0
14	1.78	1.854	1.851
15	0	0	0
16	0	0.002	0.002
17	0	0.001	0
18	0	0.002	0.002
19	0	0	0
20	3.22	3.255	3.255
21	3.22	3.255	3.255
22	0	0	0
23	1.08	0.17	0.17
24	0.	0	0
25	1.78	1.852	1.848
26	0	0	0
27	0	0	0

MODE PIN NO.	EE	PB	REC
28	3.24	3.254	3.253
29	3.22	3.255	3.25
30	0	0.954	0.978
31	1.7	1.855	1.852
32	0	0	0
33	0	0	0
34	3.22	3.254	3.252
35	0	1.029	0.964
36	0	1.029	0.522
37	0	0	0
38	3.24	3.252	3.252
39	0	0	0
40	2.54	1.566	1.566
41	1.78	1.855	1.854
42	90m	0	0
43	3.08	1.642	1.642
44	2.88	1.643	0.199
45	2.88	0.399	0.405
46	2.92	1.299	1.303
47	2.68	0.369	0.37
48	3.24	3.252	0.252
49	0	0	0
50	2.64	0.372	0.376
51	2.64	0.369	0.379
52	2.64	0.382	0.372
53	2.64	0.392	0.397
54	2.64	1.855	0.382
55	1.28	0.39	1.852
56	20m	1.855	0
57	3.24	0	0.866
58	0	1.059	0.7
59	0	1.056	0.759
60	0	1.05	0.716
61	3.24	3.253	3.252
62	0	0	0.099
63	0	0.944	1.004
64	0	0.965	0.669
65	0	0.879	0.93
66	0	0.943	1.034
67	1.78	1.856	1.852
68	0	0	0
69	0	0	0
70	3.18	1.022	1.054
71	0	1.53	1.53
72	0	2.942	2.942
73	0.8m	0.082	0.082
74	0.8m	0.082	0.861
75	0	0.792	0.672
76	1.78	1.852	1.848
77	0	0	0
78	1.78	1.853	1.849
79	0	0	0
80	0	0.001	0.003
IC 501			
1	1.32	1.322	1.325

MODE PIN NO.	EE	PB	REC
2	0	0.004	0.006
3	32m	0.314	0.321
4	0	0.397	0.402
5	3.22	3.091	3.224
6	3.24	3.079	3.204
7	0	0.007	0.006
8	1.36	1.423	1.422
IC 5101			
1	0	20mv	1.122
2	0	0.005	0.01
3	0	0.004	0.009
4	2.04	1.628	1.616
5	0	0.006	0.008
6	3.21	3.232	3.186
7	3.18	3.206	3.16
8	3.18	3.229	3.183
9	3.22	1.57	1.812
10	2.82	0.969	1.068
11	2.82	1.316	0.996
12	2.88	1.381	1.492
13	2.9	0.982	1.152
14	3.26	1.25	1.092
15	3.26	1.232	1.07
16	2.96	1.206	1.111
17	3.22	3.246	3.183
18	0	0.006	0.005
19	0	0.262	0.18
20	3.24	3.247	3.192
21	3.24	3.246	3.19
22	0	0.006	0.007
23	0	0.006	0.008
24	1.06	0.941	0.943
25	3.24	3.215	3.19
26	0	0.006	0.008
27	1.08	0.827	0.91
28	2.24	3.216	3.197
29	0	0.006	0.019
30	0	0.796	0.872
31	3.22	3.216	3.194
32	0	0.006	0.006
33	0	0.007	0.008
34	3.24	3.185	3.165
35	0	0.006	0.007
36	3.24	3.207	3.19
37	0	0.009	0.01
38	0	0.006	0.007
39	3.234	3.204	3.188
40	3.24	3.212	3.199
41	3.24	3.21	3.197
42	3.24	3.209	3.195
43	20m	0.009	0.011
44	20m	0.005	0.007
IC 802			
1	3.24	3.12	2.52
2	23.24	3.12	2.5

MODE PIN NO.	EE	PB	REC
3	3.24	3.18	1.68
4	2.24	2.82	1.64
5	3.16	3.14	1.65
6	0	0	1.64
7	3.24	3.24	1.64
8	3.22	3.24	0
9	3.22	3.24	4.94
10	3.22	3.24	4.94
11	3.24	3.24	3.25
12	1.22	1.12	3.25
13	12.2v	3.36	0.01
14	14.2v	1.2	3.25
15	4.28	0	2.42
16	0	14.2	2.49
17	14.2v	12.1	2.41
18	4.34	4.34	2.41
19	14.2	12.2	2.48
20	3.21	3.22	4.95
21	0	0	0.01
22	4.79	4.78	4.79
23	4.91	4.91	4.91
24	2.52	2.51	2.51
25	2.42	2.41	2.41
26	2.42	2.41	2.41
27	2.52	2.52	2.51
28	4.89	4.88	4.89
IC601	EE	NO Conn.	REC
1	2.64	2.64	1.62
2	3.42	3.52	1.06
3	3.42	3.48	0.01
4	3.54	3.58	0.5
5	3.56	3.62	0.5
6	0	0	0.02
7	0	0	0.02
8	0	0	0.02
9	0	0	0.02
10	0	0	0.02
11	0	0	0.02
12	0	0	0
13	3.26	3.27	3.26
14	0	0	0
15	0	0	0
1	60	0	0
17	0	0	0
18	0	0	0
19	3.04	3.24	3.23
20	3.04	3.26	3.11
21	3.04	3.26	3.26
22	3.04	3.2	3.25
23	0	0	0
24	0	0	0
25	3.24	3.24	3.26
26	0	0	0
27	0	0	1.83
28	0	0	1.83

2. VDR P.C.BOARD (BOTTOM VIEW)

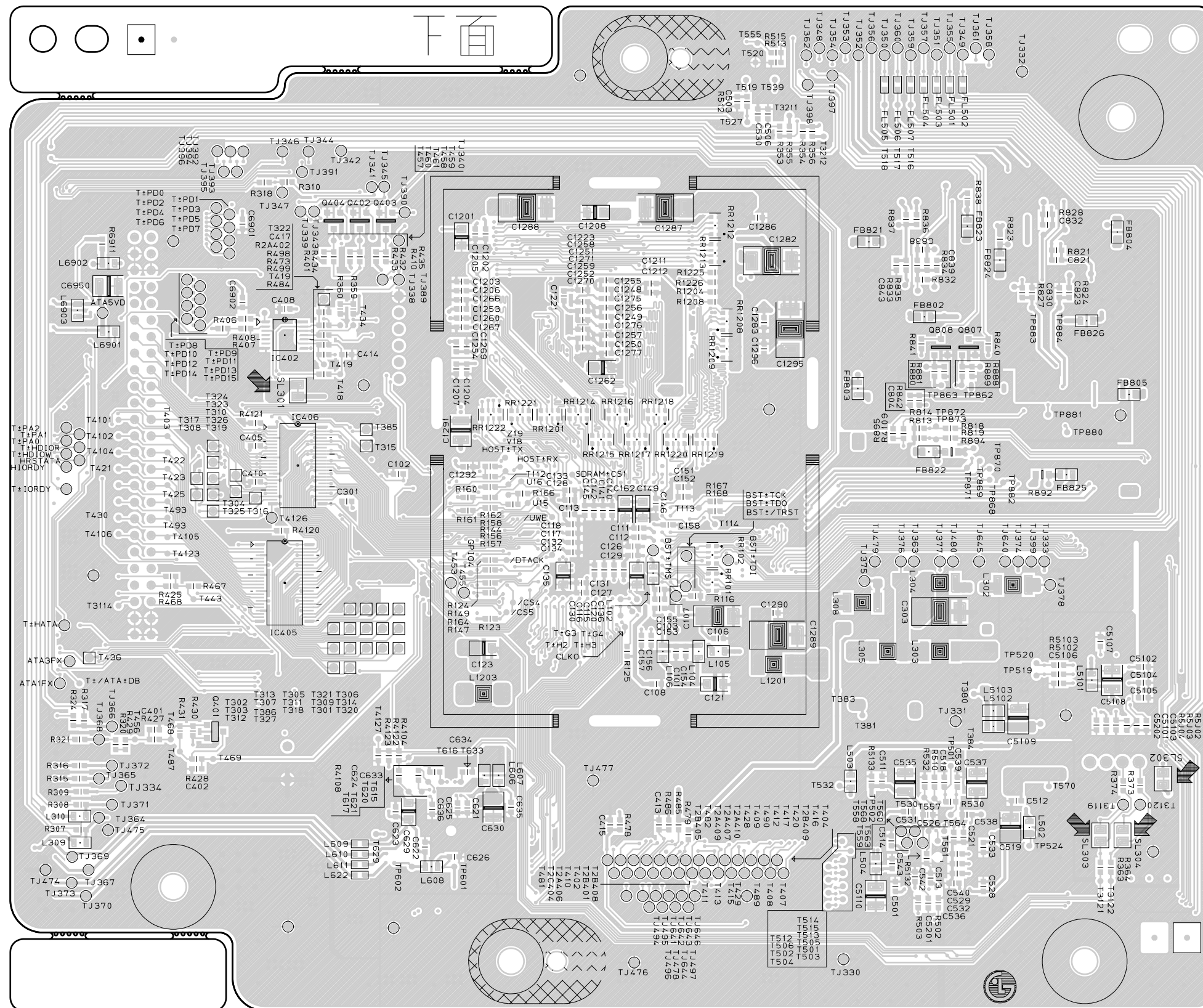

SECTION 4 MECHANISM OF VCR PART(D-37)

CONTENTS

DECK

MECHANISM PARTS LOCATIONS

- Top View4-1
- Bottom View4-1

DISASSEMBLY AND ASSEMBLY OF DECK MECHANISM

1. Disassembly of Drum assembly4-2
2. Disassembly of Plate top disassembly 4-4
3. Holder Assembly CST4-4
4. Disassembly of Gear Assembly
Rack F/L4-4
5. Opener Door4-4
6. Arm Assembly F/L4-4
7. Lever Assembly S/W4-4
8. Motor Assembly L/D4-5
9. Gear Wheel4-5
10. Arm Assembly Cleaner4-5
11. Head F/E4-5
12. Base Assembly A/C Head4-5
13. Brake Assembly T4-6
14. Arm Assembly Tension4-6
15. Reel S / Reel T4-6
16. Base Assembly P44-7
17. Opener Lid4-7
18. Arm Assembly Pinch4-7
19. Arm T/up4-7
20. Supporter, Capstan4-8
21. Belt Capstan/Motor Capstan4-8
22. Lever F/R4-8
23. Clutch Assembly D374-8
24. Gear Drive/Gear Cam4-9
25. Gear Sector4-9
26. Brake Assembly Capstan4-9
27. Plate Slider4-9
28. Lever Tension4-9
29. Lever Spring4-9
30. Lever Brake4-9
31. Gear Assembly P2/Gear Assembly P3 ...4-10
32. Base Assembly P2/Base Assembly P3 ...4-10
33. Base Loading4-10
34. Base Tension4-11
35. Arm Assembly Idler Jog4-11

DECK MECHANISM ADJUSTMENT

- Fixtures and tools for service4-12
- 1. Mechanism Assembly Mode Check4-13
- 2. Previous Preparation for
Deck Adjustment4-14
- 3. Torque Measuring4-14
- 4. Guide Roller Height Adjustment4-15
 - 4-1. Prior Adjustment4-15
 - 4-2. Fine Adjustment4-15
- 5. Audio/Control (A/C) Head Adjustment4-16
 - 5-1. Prior Adjustment4-16
 - 5-2. Tape Path Check between Pinch
Roller and Take-up Guide4-17
 - 5-3. Fine Adjustment
(Azimuth Adjustment)4-17
- 6. X-distance Adjustment4-17
- 7. Adjustment after Drum Assembly
(Video Heads)4-18
- 8. Tachometer Adjustment of
Deck Assembly4-18
 - 8-1. Check of Audio, RF Normalization
Time (Locking Time) in Play after
CUE or REV4-18
 - 8-2. Check of Tape Curl and
Jam Status4-18

PROTECTION, MAINTENANCE AND CHECK OF VIDEO FUNCTION

1. Checking Points before Repair4-19
2. Essential Check and Repair4-20
3. Regular Check and Repair4-20
4. Tools for Check and Repair4-20
5. Maintenance Process4-20
 - 5-1. Removal of Foreign Materials4-20
 - 5-2. Grease Application4-21

TROUBLESHOOTING GUIDE

1. Deck Mechanism4-23
2. Front Loading Mechanism4-26

EXPLODED VIEWS

1. Front Loading Mechanism Section4-28
2. Moving Mechanism Section(1)4-29
3. Moving Mechanism Section(2)4-30

DECK MECHANISM PARTS LOCATIONS

• Top View

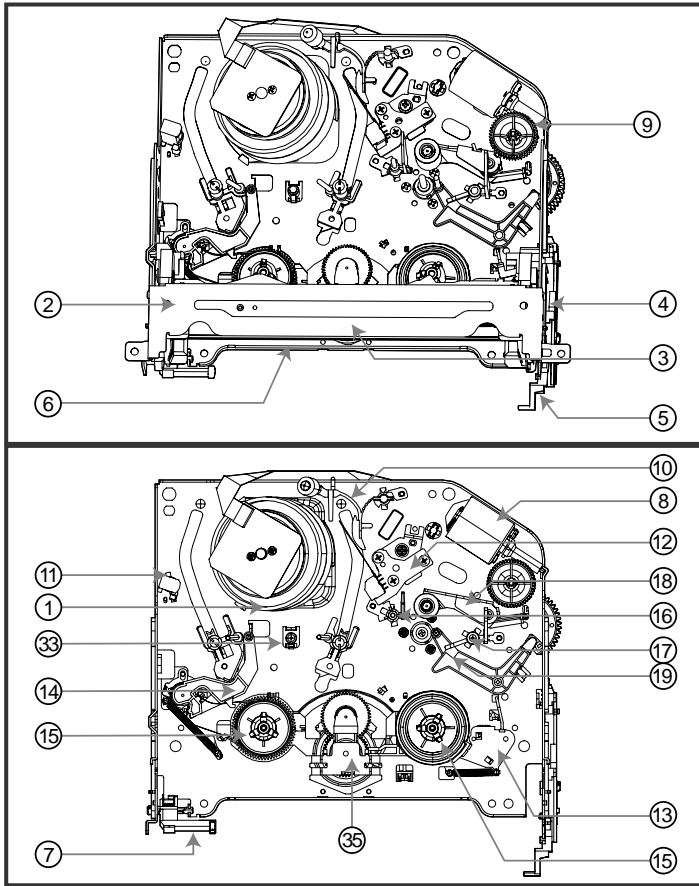

• Bottom View

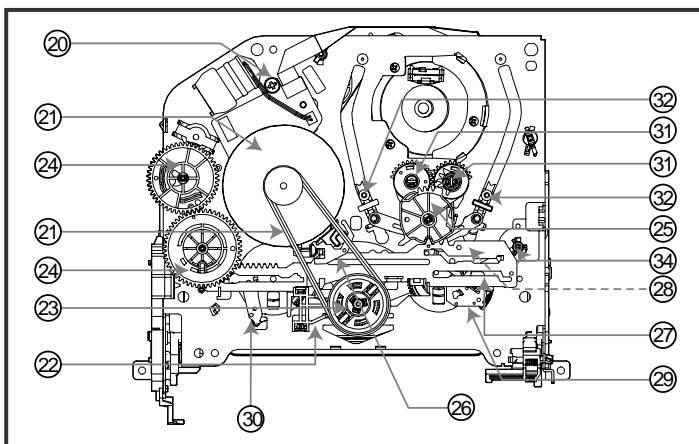

Starting No.	Procedure	Part	Fixing Type	Ref. Drawings	Position
	1	Drum Assembly	3 screws	A-1	T
	2	Plate Top	2 hooks	A-2	T
2	3	Holder Assembly CST	6 chasses	A-2	T
2,3	4	Gear Assembly Rack F/L	1 hook	A-2	T
2,3,4	5	Opener Door	Chassis Hole	A-2	T
2,3,4,5	6	Arm Assembly F/L	Chassis Hole	A-2	T
	7	Lever Assembly S/W	Chassis Hole, 1 hook	A-2	T
	8	Motor Assembly L/D	1 screw	A-3	T
	9	Gear Wheel	2 hooks	A-3	T
	10	Arm Assembly Cleaner	Chassis Embossing	A-3	T
	11	Head F/E	Chassis Embossing	A-3	T
	12	Base Assembly A/C Head	1 screw	A-3	T
2,3	13	Brake Assembly T	1 hook	A-4	T
2,3	14	Arm Assembly Tension	1 hook	A-4	T
2,3,13,14	15	Reel S / Reel T	Shaft	A-4	T
	16	Base Assembly P4	Chassis Embossing	A-5	T
	17	Opener Lid	Chassis Embossing	A-5	T
17	18	Arm Assembly Pinch	Shaft	A-5	T
17	19	Arm T/up	1 hook	A-5	T
	20	Supporter, capstan	Chassis Hole	A-6	B
17,18	21	Belt Capstan/Motor Capstar	3 screws	A-6	B
	22	Lever F/R	Locking Tab	A-6	B
21, 22	23	Clutch Assembly D37	Washer	A-6	B
	24	Gear Drive/Gear Cam	Washer/Hook	A-7	B
	25	Gear Sector	Hook	A-7	B
21	26	Brake Assembly Capstan	Chassis Hole	A-7	B
21,22,23, 24,25,26	27	Plate Slider	Chassis Guide	A-7	B
21,22,23, 24,25,26,27	28	Lever Tension	1 Hook	A7	B
21,22,23, 24,25,26,27	29	Lever Spring	1 Hook	A-7	B
21,22,23, 24,25,26,27	30	Lever Brake	1 Hook	A-7	B
25	31	Gear Assembly P2/ Gear Assembly P3	Bass	A-8	B
2, 3, 14, 25, 31	32	Base Assembly P2 /Base Assembly P3	6 Chasses	A-8	B
25, 31	33	Base Loading	3 Hooks	A-8	B
2,3,14	34	Base Tension	Chassis Embossing	A-9	T
	35	Arm Assembly Idler Jog	Locking Tab	A-9	T

T:Top, B:Bottom

NOTE : When reassembling, perform the procedure in the reverse order.

- (1) When reassembling, confirm Mechanism and Mode Switch Alignment Position
- (2) When disassembling, the Parts in the "Starting No." column should be removed first."

DISASSEMBLY AND ASSEMBLY OF DECK MECHANISM

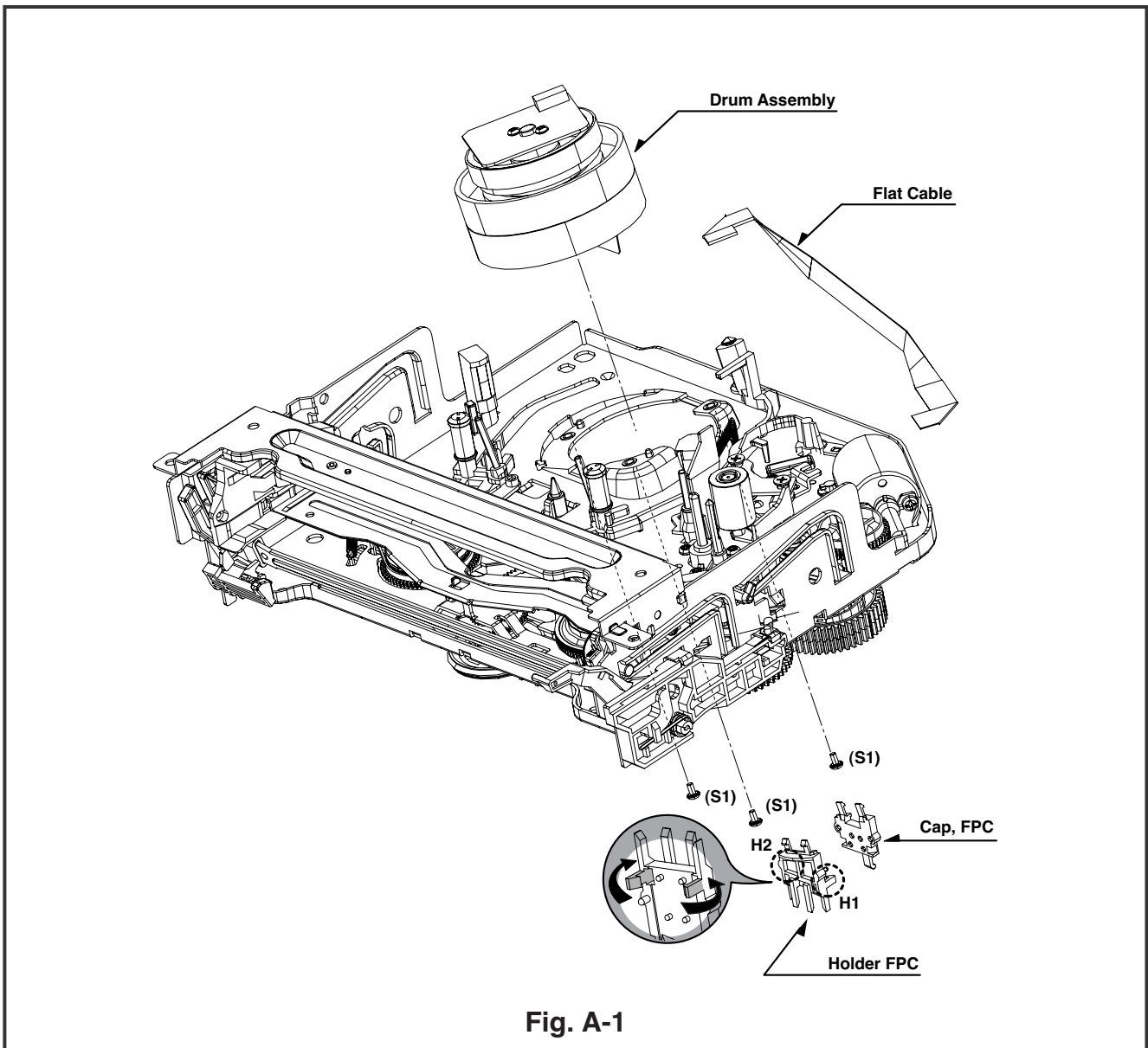
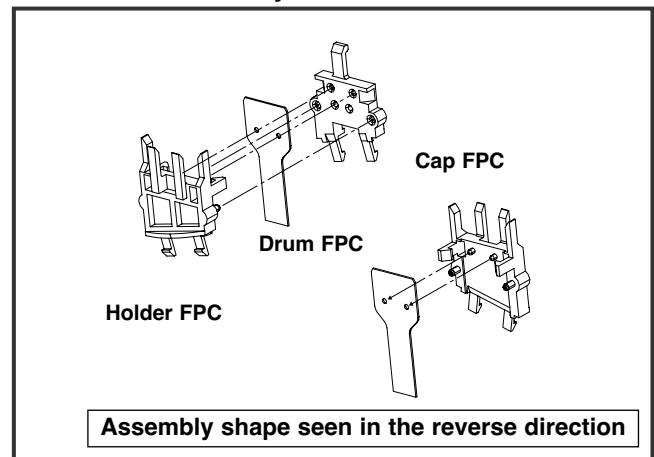

Fig. A-1

1. Disassembly of Drum Assembly (Figure A-1)

- 1) Separate the flat cable from the Drum FPC and the Capstan Motor.
- 2) Release 3 screws (S1) on the bottom side of the chassis, and separate the drum assembly.
- 3) Release the hooks (H1, H2) and separate both the holder FPC and the Cap FPC (disassemble if necessary).

Cautions in assembly of FPC



DISASSEMBLY AND ASSEMBLY OF DECK MECHANISM

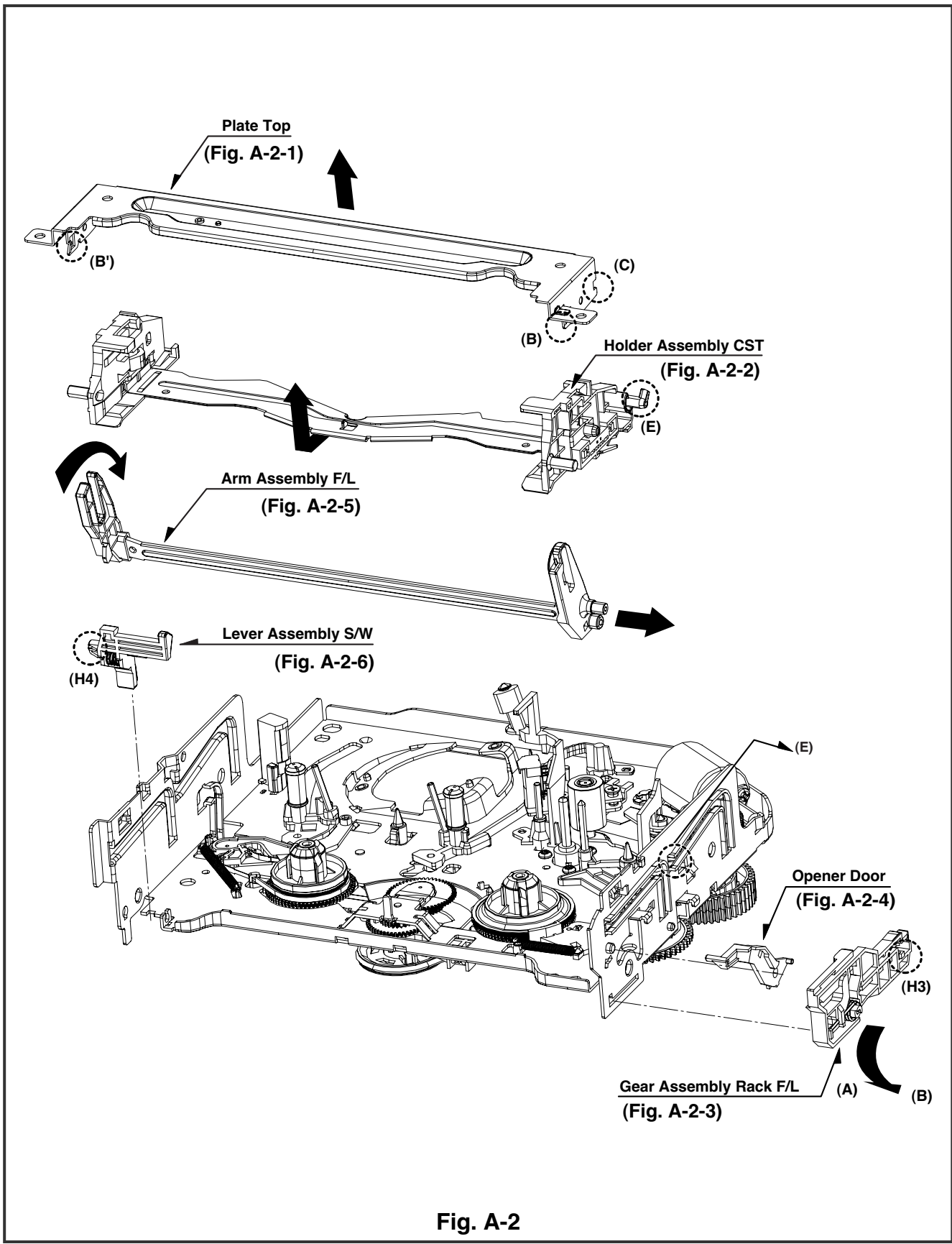

Fig. A-2

DISASSEMBLY AND ASSEMBLY OF DECK MECHANISM

2. Disassembly of Plate Top (Fig. A-2-1)

- 1) Separate the right part while leaning back the (B) part of the plate top toward the arrow direction.
- 2) Separate the left part while leaning back the (B') part of the plate top toward the arrow direction.
(Tool used: Tool such as (-) driver, auger, etc with pointed or flat end)

CAUTIONS

Assemble while pressing the (C), (C') part after corresponding them as in drawing.

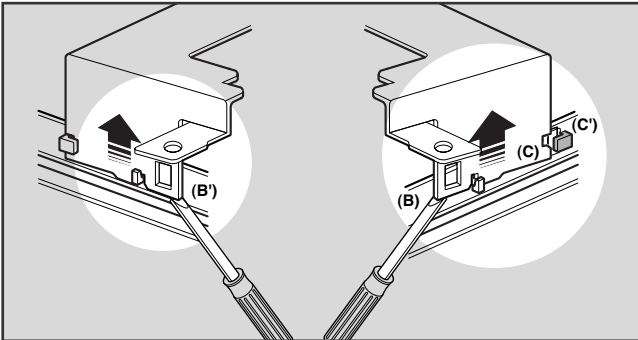

3. Holder Assembly CST (Fig. A-2-2)

- 1) Firstly separate the left part from the groove on the (D) part of chassis while moving the holder assembly CST toward the arrow direction.

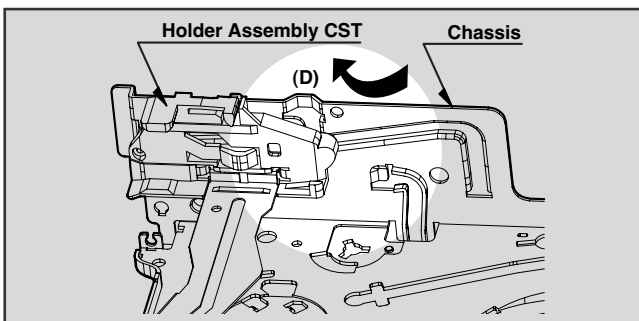

- 2) Separate the right part from each groove of chassis

CAUTIONS

Assemble by inserting the left part after firstly inserting the (E) part of the holder assembly CST into the groove on the (E') part of chassis.

4. Disassembly of Gear Assembly Rack F/L (Fig. A-2-3)

- 1) Separate the hook (H3) while leaning ahead the hook (3) after moving the gear assembly rack F/L toward the arrow (A) direction.
- 2) Separate the gear assembly rack F/L toward the arrow (B) direction.

CAUTIONS

For the assembly, correspond the gear part of gear assembly rack F/L to the gear drive.

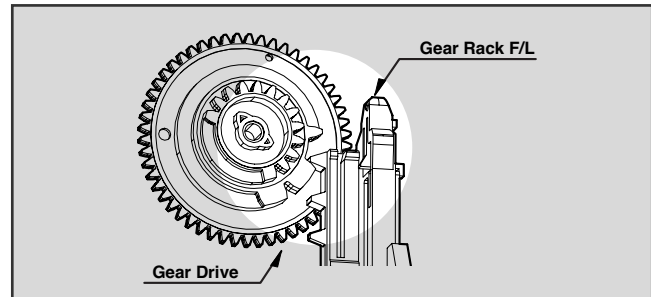

5. Opener Door (Fig. A-2-4)

- 1) Separate the opener door ahead from the guide hole of chassis while turning it clockwise.

6. Arm Assembly F/L (Fig. A-2-5)

- 1) Firstly separate the left part of the arm assembly F/L from the groove of chassis while pushing the arm assembly F/L toward the arrow direction.
- 2) Separate the right part from the groove of chassis.

7. Lever Assembly S/W (Fig. A-2-6)

- 1) Separate the lever assembly S/W while pushing it toward the arrow direction after removing the hook (4) on the left side of chassis.

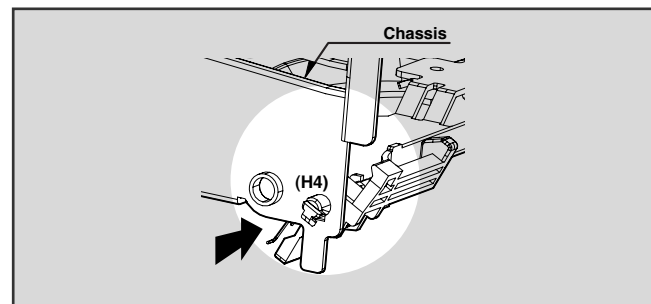

DISASSEMBLY AND ASSEMBLY OF DECK MECHANISM

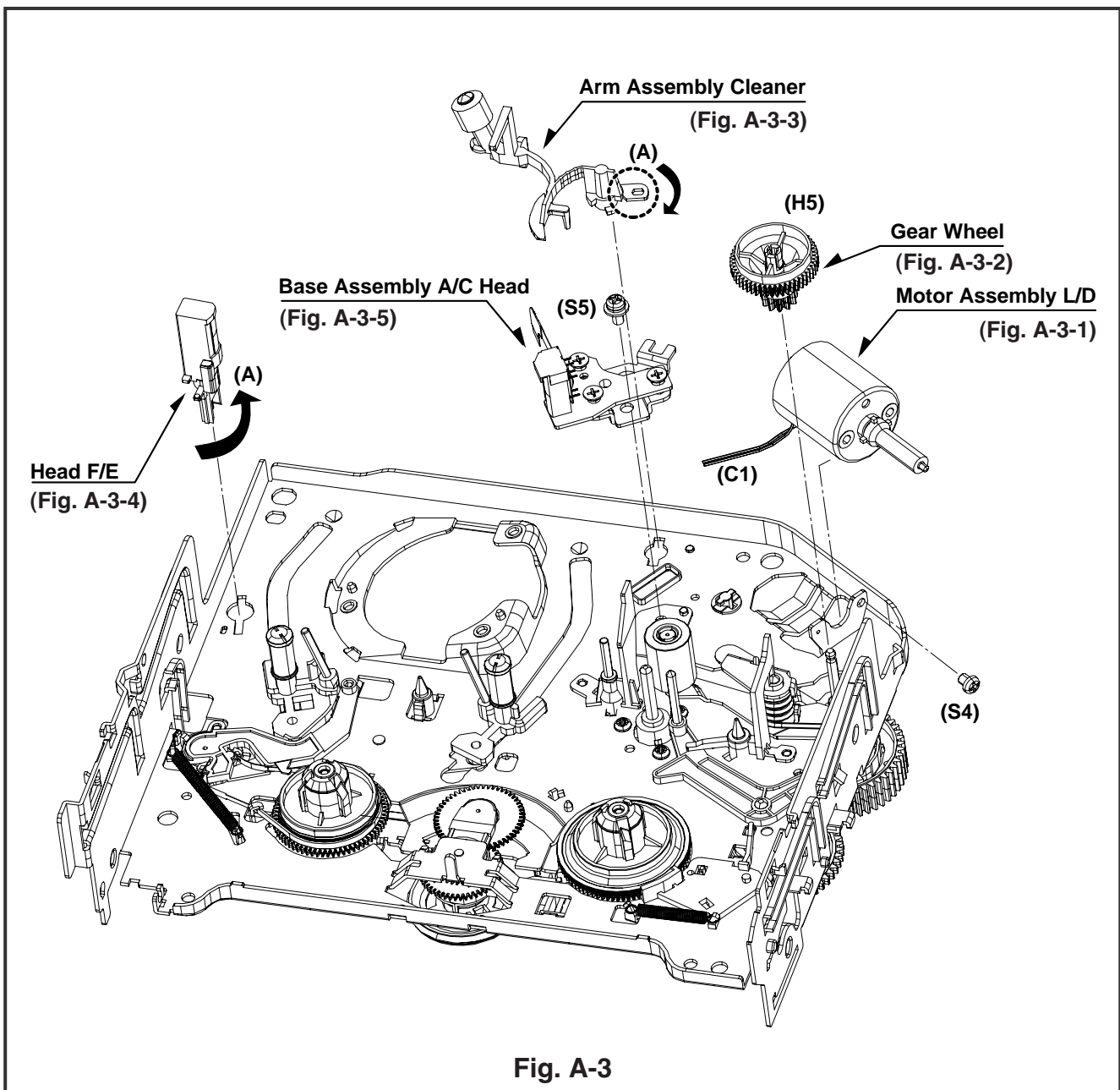

Fig. A-3

8. Motor Assembly L/D (Fig. A-3-1)

- 1) Take the connector (C1) connected to the Capstan motor PCB out.
- 2) Remove a screw (S4) of the chassis (S4) and step backward, and disassemble it while holding it up.

9. Gear Wheel (Fig. A-3-2)

- 1) Release the hook (H5) of the gear wheel and disassemble it upward.

10. Arm Assembly Cleaner (Fig. A-3-3)

- 1) Separate the (A) part of Fig. A-3-1 from the embossing of chassis, and hold it up while turning it anti-clockwise.

11. Head F/E (Fig. A-3-4)

- 1) Separate the (A) part of the head F/E from the embossing of chassis, and hold it up while turning it anti-clockwise.

12. Base Assembly A/C Head (Fig. A-3-5)

- 1) Release a screw (S5) and disassemble while holding it up.

DISASSEMBLY AND ASSEMBLY OF DECK MECHANISM

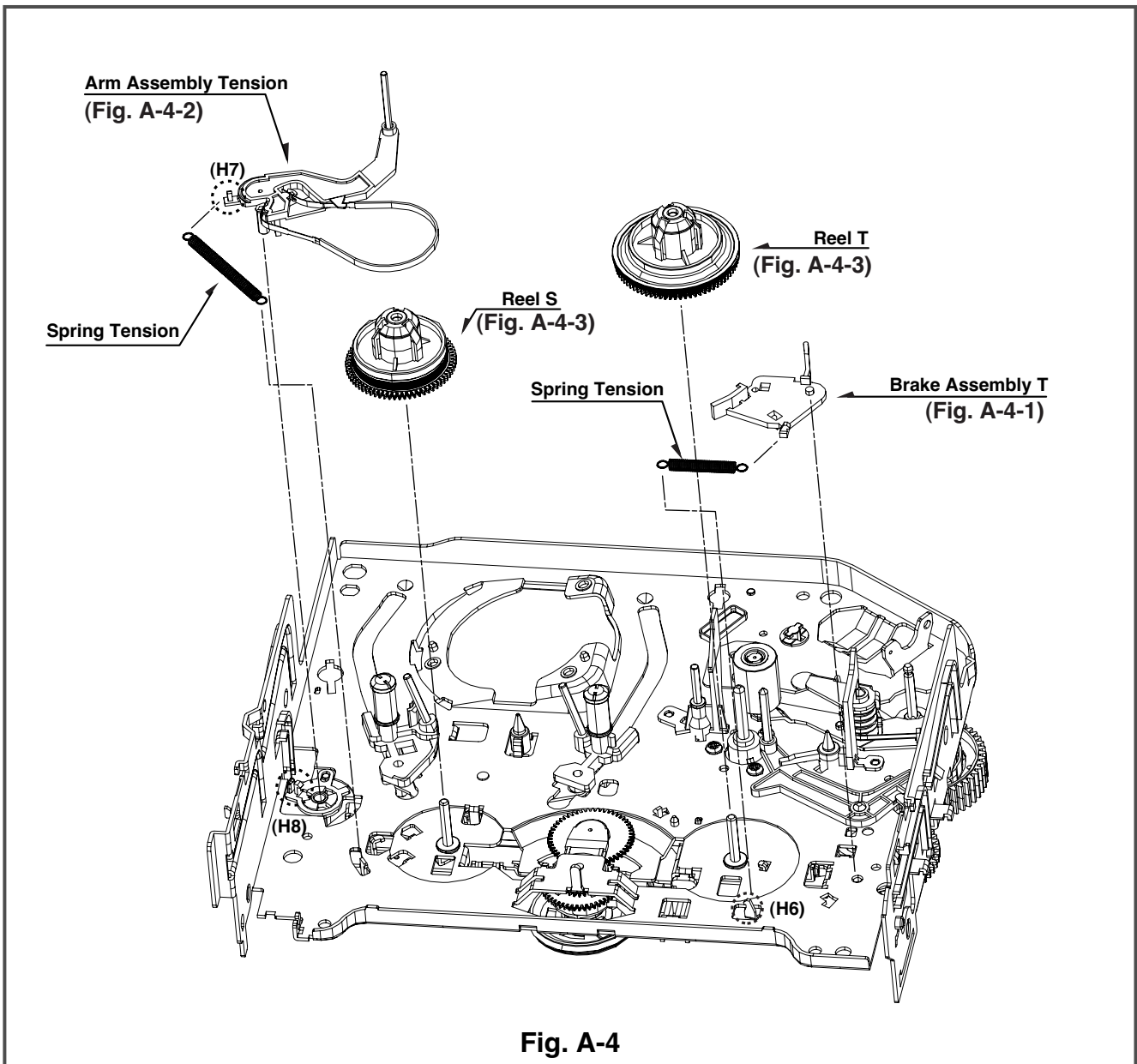

Fig. A-4

13. Brake Assembly T (Fig. A-4-1)

- 1) Release the spring tension from the lever spring hook (H6).
- 2) Disassemble the brake assembly T while holding it upward.

14. Arm Assembly Tension (Fig. A-4-2)

- 1) Release the spring tension the hook (H7) from the arm assembly tension.
- 2) After releasing the hook (H8) of the base tension, separate it while holding it up.

CAUTIONS

Spring used for both brake assembly T and arm assembly tension is used (2EA used).

15. Reel S/Reel T (Fig. A-4-3)

- 1) Disassemble the reel S/ reel T while holding it up (comparison between Reel S and Reel T)

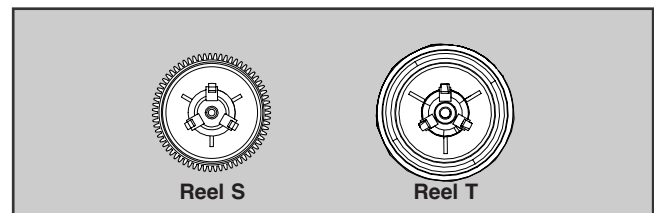

DISASSEMBLY AND ASSEMBLY OF DECK MECHANISM

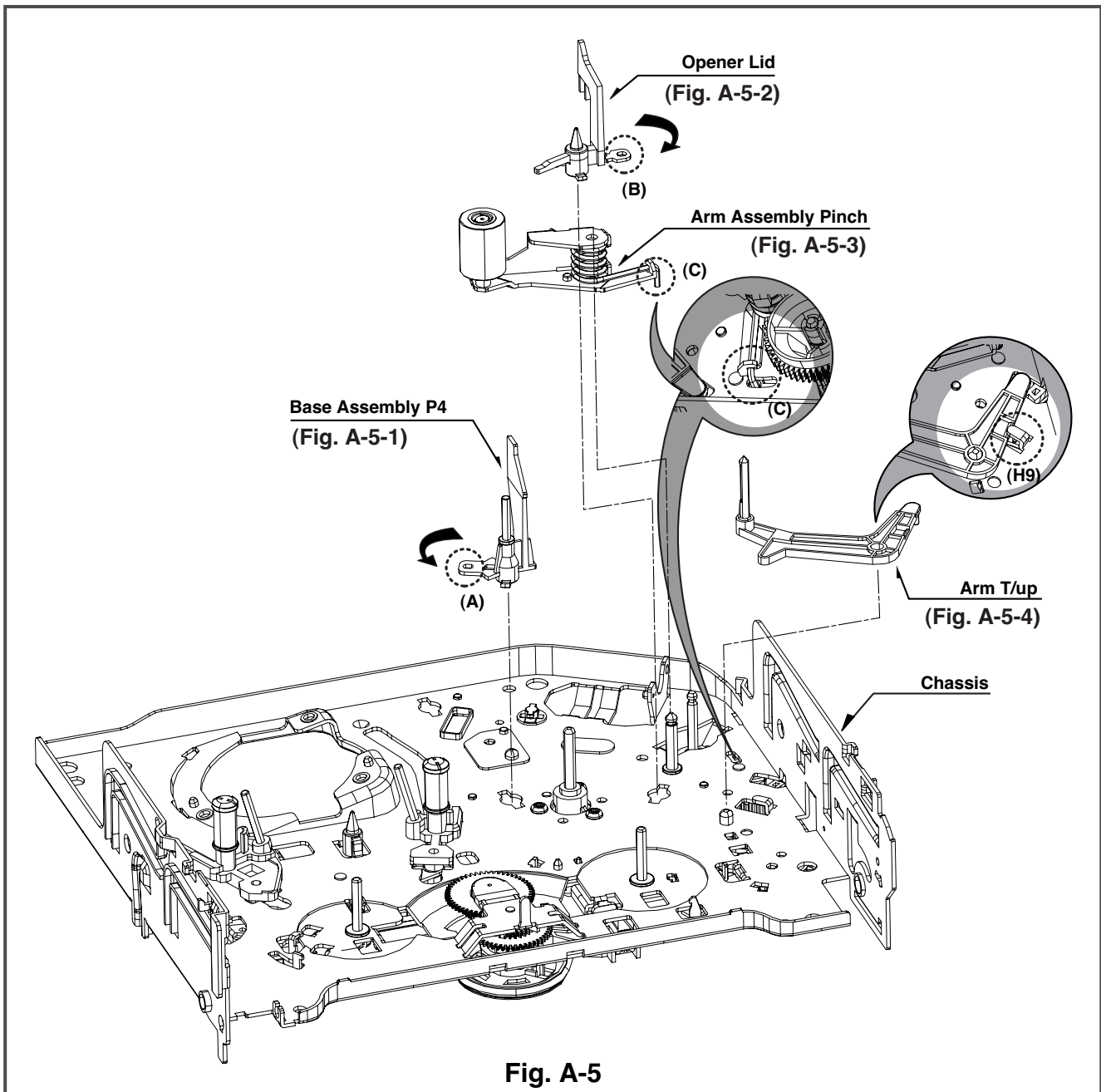

Fig. A-5

16. Base Assembly P4 (Fig. A-5-1)

- 1) Release the (A) part of the base assembly P4 from the embossing of chassis.
- 2) Hold the base assembly P4 up while turning it anti-clockwise.

17. Opener Lid (Fig. A-5-2)

- 1) Release the (B) part of the opener lid from the embossing of chassis.
- 2) Disassemble the opener lid upward while turning it anti-clockwise.

18. Arm Assembly Pinch (Fig. A-5-3)

- 1) Hold the arm assembly pinch up.

19. Arm T/up (Fig. A-5-4)

- 1) Turn the arm T/up to release the anchor jaw (H9) part of chassis and then hold it upward.

CAUTIONS

For the assembly, check the (C) part of the arm assembly pinch is assembled as in drawing.

- REVERSE THE MECHANISM.

DISASSEMBLY AND ASSEMBLY OF DECK MECHANISM

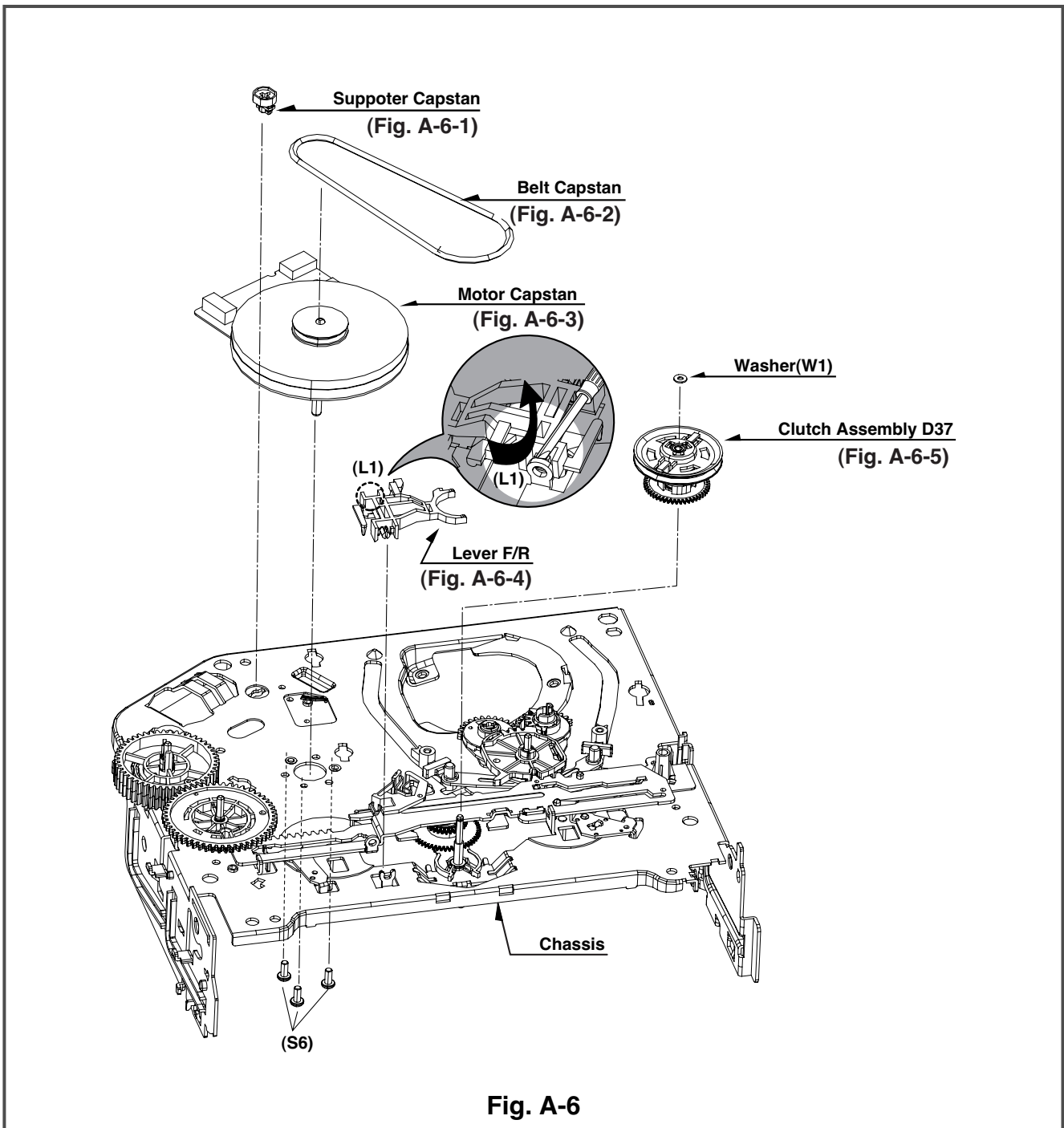

Fig. A-6

20. Supporter, Capstan (Fig. A-6-1)

- 1) Turn the supporter and Capstan by 90 deg. clockwise with a driver for disassembly.

21. Belt Capstan (Fig. A-6-2) / Motor Capstan (Fig. A-6-3)

- 1) Separate the belt Capstan.
- 2) Undo 3 screws (S6) on the bottom side of chassis and disassemble it upward.

22. Lever F/R (Fig. A-6-4)

- 1) Release the locking tab (L1) and then disassemble it upward.

23. Clutch Assembly D37 (Fig. A-6-5)

- 1) Remove the washer (W1) and then disassemble it upward.

DISASSEMBLY AND ASSEMBLY OF DECK MECHANISM

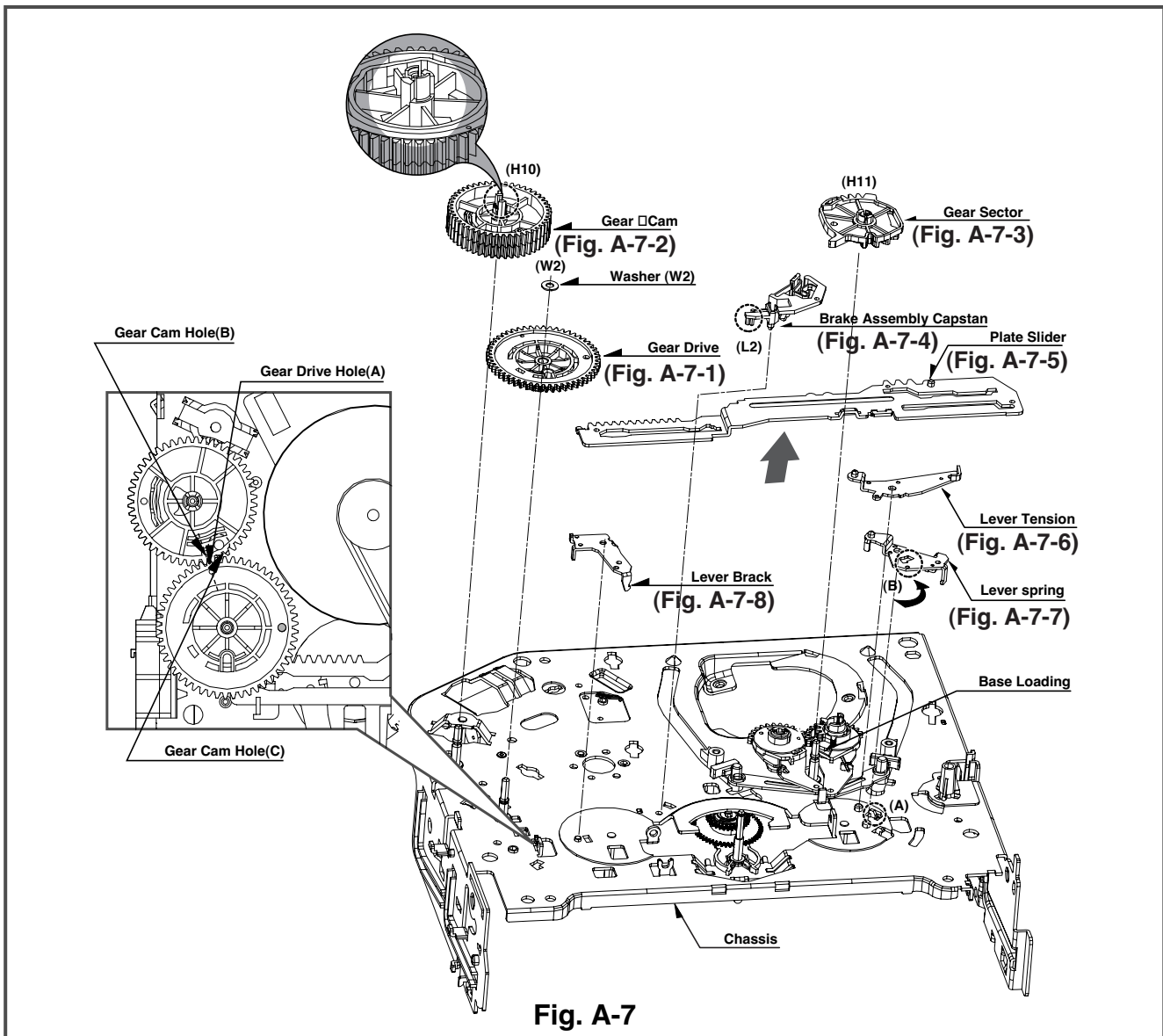

Fig. A-7

24. Gear Drive (Fig. A-7-1)/ Gear Cam (Fig. A-7-2)

- 1) Remove the washer (W2) and then disassemble the gear drive.
- 2) Release the hook (H10) of the gear cam and then disassemble it upward.

CAUTIONS

For the assembly, adjust both the gear driver hole (A) and the gear cam hole (B) straightly and then correspond the gear cam hole (C) to the chassis hole.

25. Gear Sector (Fig. A-7-3)

- 1) Release the hook (H11) of the gear sector and then hold the gear sector upward.

26. Brake Assembly Capstan (Fig. A-7-4)

- 1) Release the locking tab (L2) on the bottom side of the plate slider and then disassemble it upward.

27. Plate Slider (Fig. A-7-5)

- 1) Disassemble the plate slider while holding it up.

28. Lever Tension (Fig. A-7-6)

- 1) Release the lever tension from the guide (A) of chassis while turning it anti-clockwise.
- 2) Disassemble the lever tension while holding it up.

29. Lever Spring (Fig. A-7-7)

- 1) Release the (B) part of the lever spring from the guide (A) of chassis while turning it anti-clockwise.
- 2) Disassemble the lever tension while holding it up.

30. Lever Brake (Fig. A-7-8)

- 1) Disassemble the lever brake while holding it up.

DECK MECHANISM DISASSEMBLY

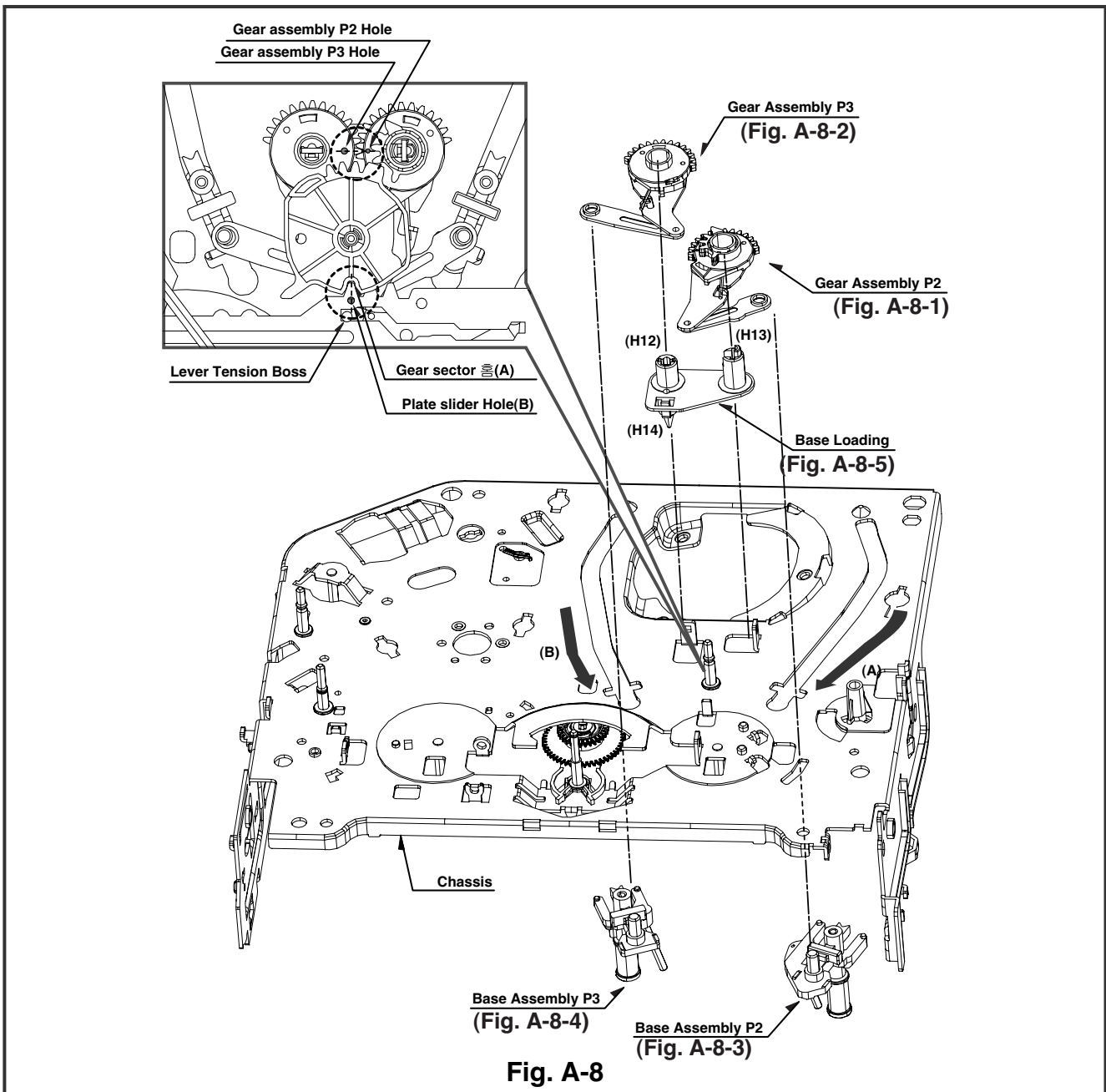

Fig. A-8

31. Gear Assembly P2 (Fig. A-8-1)/ Gear Assembly P3 (Fig. A-8-2)

- 1) Hold the gear assembly P2 upward.
- 2) Hold the gear assembly P3 upward.

CAUTIONS

For the assembly, check the holes of both the gear assembly P2 and the P3 are adjusted straightly, and then correspond the gear section groove (A) to the plate slider hole (B).

32. Base Assembly P2 (Fig. A-8-3)/ Base Assembly P3 (Fig. A-8-4)

- 1) Disassemble the base assembly P2 downward while moving it toward the arrow (A) direction along with the guide hole of chassis.
- 2) Disassemble the base assembly P2 downward while moving it toward the arrow (B) direction along with the guide hole of chassis.

33. Base Loading (Fig. A-8-5)

- 1) Release 3 hooks (H12, 13, 14) of the base loading, and then disassemble them upward.
- Reverse the mechanism.

DISASSEMBLY AND ASSEMBLY OF DECK MECHANISM

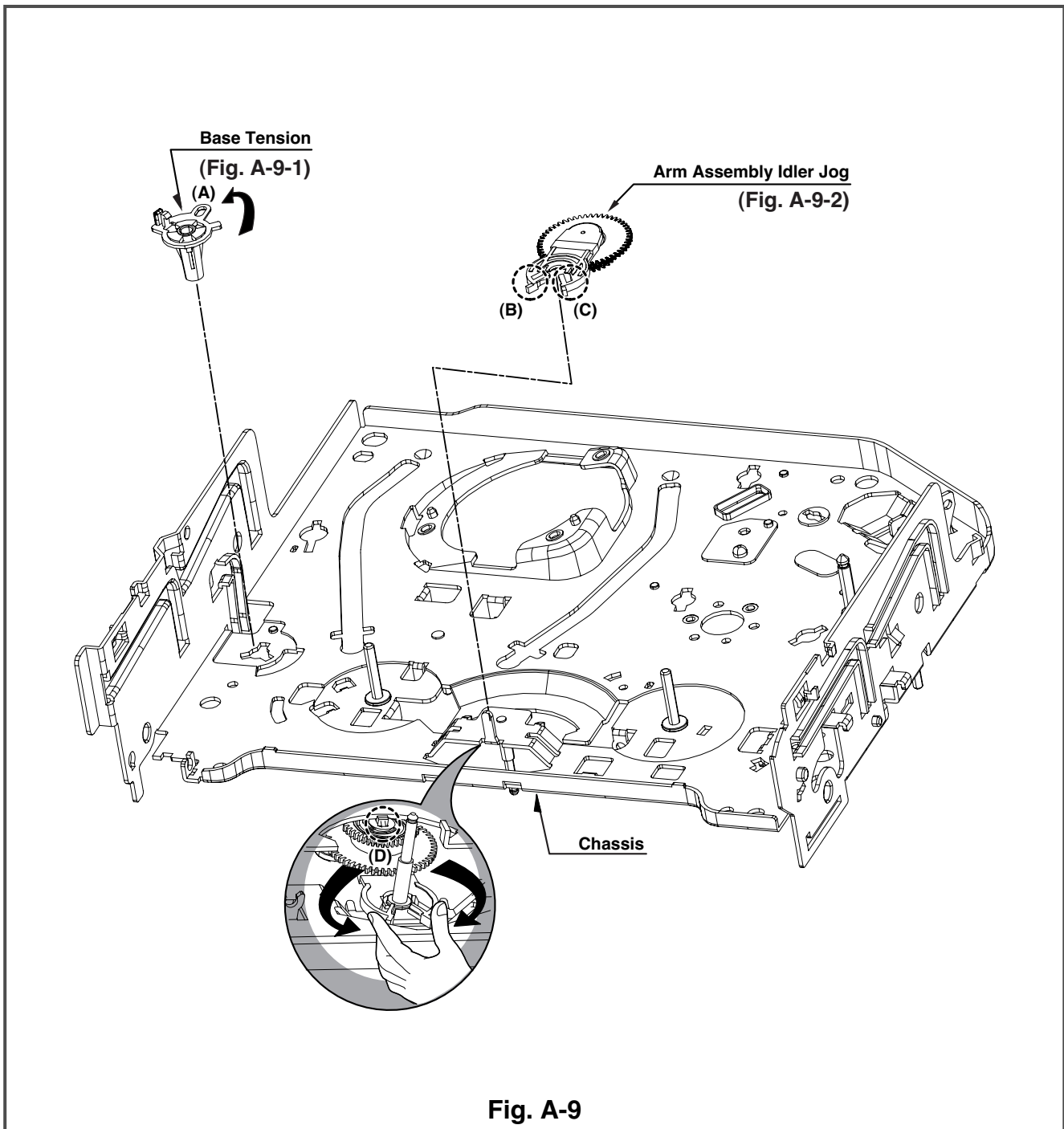

Fig. A-9

34. Base Tension (Fig. A-9-1)

- 1) Release the (A) part of the base tension from the embossing of chassis.
- 2) Hold the base tension upward while turning it anti-clockwise.

35. Arm assembly Idler Jog (Fig. A-9-2)

- 1) Push both (B), (C) parts in Fig. A-9-2 toward the arrow direction.
- 2) Disassemble the arm assembly idler upward.

CAUTIONS

Take care to ensure that the (D) part in the drawing is not hung to chassis in disassembly.

DECK MECHANISM ADJUSTMENT

• Fixtures and Tools for Service

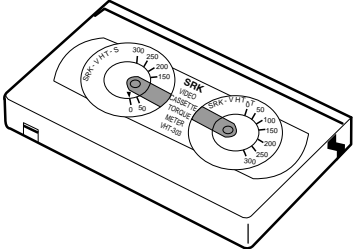
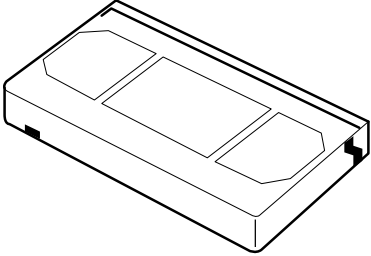
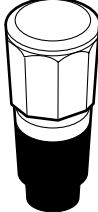
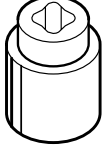
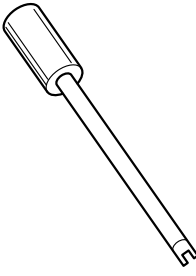
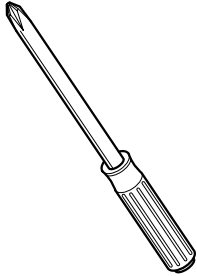
<p>1. Cassette Torque Meter SRK-VHT-303(Not SVC part) Part No:D00-D006</p>  A rectangular cassette torque meter with two circular gauges on top. Each gauge has a scale from 0 to 300 and a needle. The text 'SRK VHT-303 TORQUE METER' is visible on the device.	<p>2. Alignment tape Part No NTSC:DTN-0001 PAL:DTN-0002</p>  A rectangular alignment tape with a central slot and two smaller rectangular sections on either side.	<p>3. Torque gauge 600g.Cm ATG Part No:D00-D002</p>  A cylindrical torque gauge with a hexagonal top and a black base.
<p>4. Torque gauge adaptor Part No:D09-R001</p>  A small cylindrical adaptor with a central hole and a small protrusion on top.	<p>5. Post height adjusting driver Part No:DTL-0005</p>  A long, thin driver with a cylindrical handle and a small hook-like tip.	<p>6. + Type driver (ø5)</p>  A standard Phillips (+) type screwdriver with a textured handle.

DECK MECHANISM ADJUSTMENT

1. Mechanism Assembly Mode Check

Purpose of adjustment : To make tools normally operate by positioning tools accurately.

Fixtures and tools used	VCR (VCP) status	Checking Position
• Blank Tape (empty tape)	• Eject Mode (with cassette withdrawn)	• Mechanism and Mode Switch
<p>1) Turn the VCR on and take the tape out by pressing the eject button.</p> <p>2) Separate both top cover and plate top, and check both the hole (A) of gear cam and the hole (A') of chassis correspond (Fig. C-2).</p> <p>3) If it is done as in the paragraph 2): Turn the gear cam as in No.2) after mantling the motor assembly L/D.</p> <p>4) Undo the screw fixing the deck and the main frame, and separate the deck assembly. Check both the hole (A) of gear cam and the hole (A') of chassis correspond (Fig. C-1).</p> <p>5) Check the mode S/W on the main P.C. board locates at a proper position as in (B) of the Fig. (C-1).</p> <p>6) Connect the deck to the main P.C. board and perform all types of test.</p>		

CHECK DIAGRAM

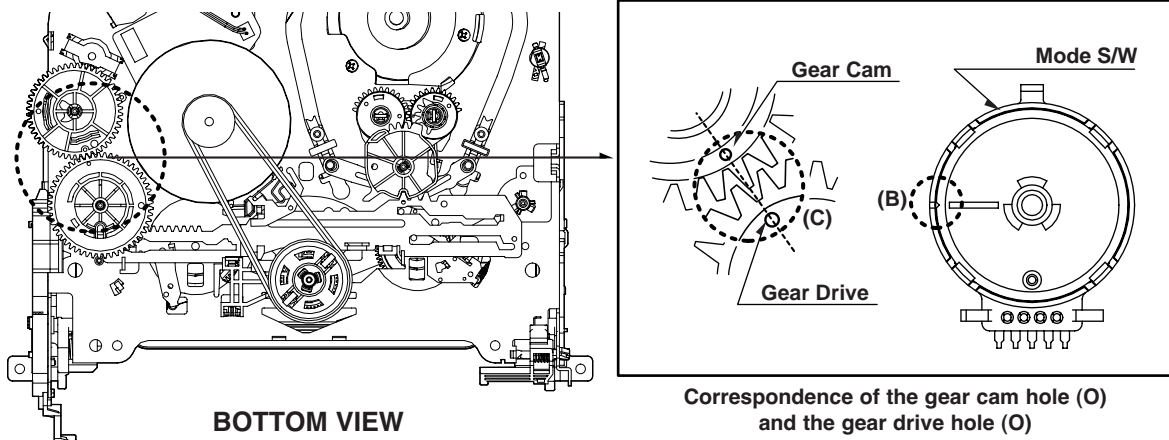

Fig. C-1

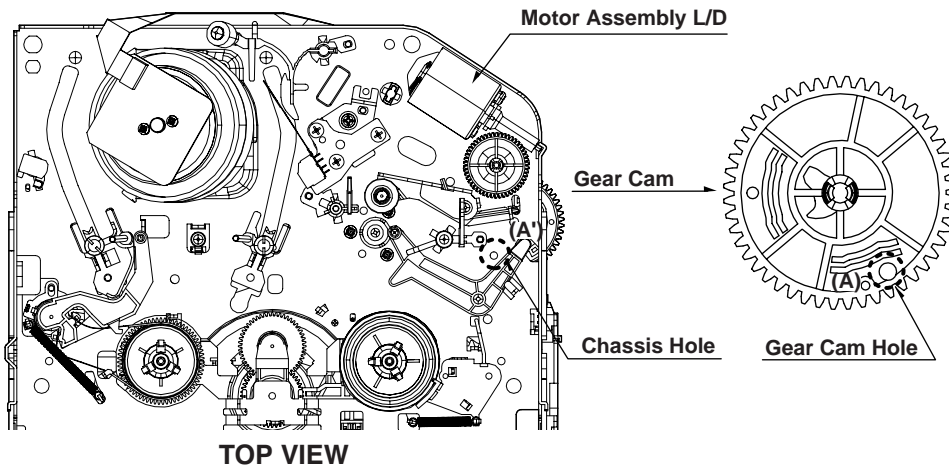

Fig. C-2

DECK MECHANISM ADJUSTMENT

2. Previous Preparation for Deck Adjustment

(Preparation to load the VCR (VCP) with cassette tape not inserted)

- 1) Take the power cord from the consent.
- 2) Separate the top cover and the plate assembly top.
- 3) Insert the power cord into again.
- 4) Turn the VCR (VCP) on and load the cassette while pushing the lever stopper of the holder assembly CST backward. In this case, clog both holes on the housing rail part of chassis to prevent detection of the end sensor.

If doing so, proceeding to the stop mode is done. In this status, input signals of all modes can be received. However, operation of the Rewind and the Review is impossible since the take-up reel remains at stop status and so cannot detect the reel pulse (however, possible for several seconds).

3. Torque Measuring

Purpose of Measuring : To measure and check the reel torque on the take-up part and the supply part that performs basic operation of the VCR (VCP) for smoothly forwarding the tape.
Measure and check followings when the tape is not smoothly wound or the tape velocity is abnormally proceeded:

Fixtures and tools used	VCR (VCP) status	Measuring method
<ul style="list-style-type: none"> • Torque Gauge (600 g.cm ATG) • Torque Gauge Adaptor • Cassette Torque Meter SRK-VHT-303 	<ul style="list-style-type: none"> • Play (FF) or Review (REW) Mode 	<ul style="list-style-type: none"> • Try to operate the VCR (VCP) per mode with the tape not inserted (See '2. Prior Preparation for Deck Adjustment). • Measure after adhering and fixing the torque gauge adaptor to the torque gauge (Fig. C-3-1) • Read scale of the supply or take-up part of the cassette torque meter (Fig. C-3-2).

Item	Mode	Instruments	Reel Measured	Measuring Value
Fast forward Torque	Fast Forward	Torque Gauge	Take-Up Reel	More than 400g°cm
Rewind Torque	Rewind	Torque Gauge	Supply Reel	More than 400g°cm
Play Take-Up Torque	Play	VHT-303	Take-Up Reel	40~100g°cm
Review Torque	Review	VHT-303	Supply Reel	120~210g°cm

NOTE

Adhere the torque gauge adaptor to the torque gauge for measuring the value.

• Torque Gauge (600g.cm ATG)

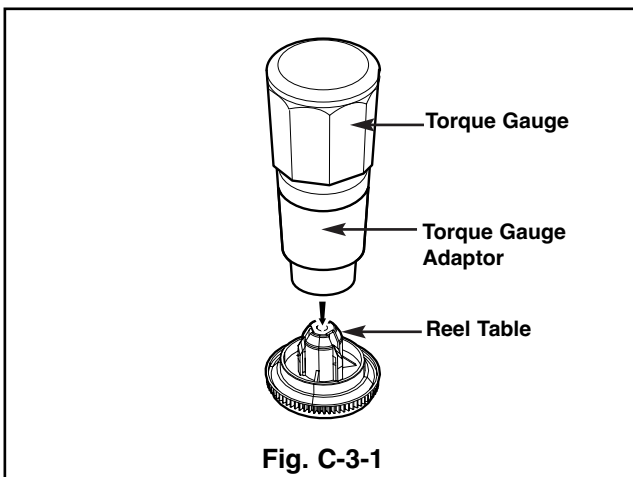

Fig. C-3-1

• Cassette Torque Meter (SRK-VHT-303)

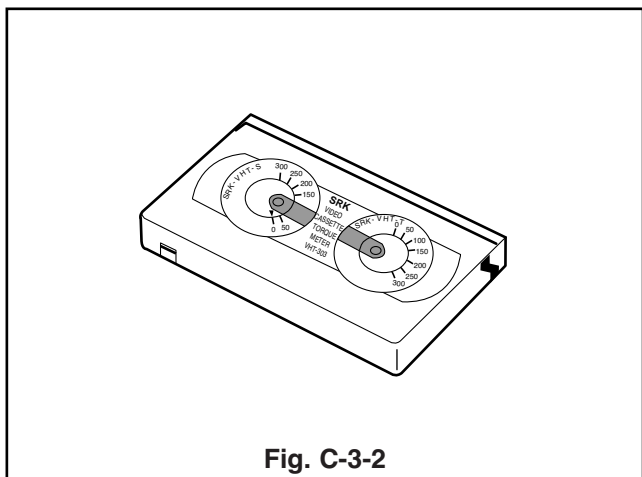

Fig. C-3-2

DECK MECHANISM ADJUSTMENT

4. Guide Roller Height Adjustment

Purpose of adjustment : To ensure that the bottom surface of the tape can travel along with the tape lead line of the lower drum by constantly and adjusting and maintaining the height of the tape.

4-1. Prior Adjustment

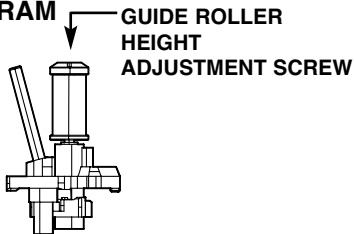
Fixtures and tools used	VCR (VCP) status	Adjustment position
<ul style="list-style-type: none"> • Post Height Adjusting Driver 	<ul style="list-style-type: none"> • Play or Review Mode 	<ul style="list-style-type: none"> • The guide roller height adjusting screw on the supply guide roller and the take-up guide roller
Adjustment Procedure 1) Travel the tape and check the bottom surface of the tape travels along with the guide line of the lower drum. 2) If the tape travels toward the lower part of guide line on the lower drum, turn the guide roller height adjusting screw to the left 3) If it travels to the upper part, turn it to the right. 4) Adjust the height of the guide roller to ensure that the tape is guided on the guide line of the lower drum at the inlet/outlet of the drum. (Fig. C-4-1)		ADJUSTMENT DIAGRAM  Fig. C-4-1

4-2. Fine Adjustment

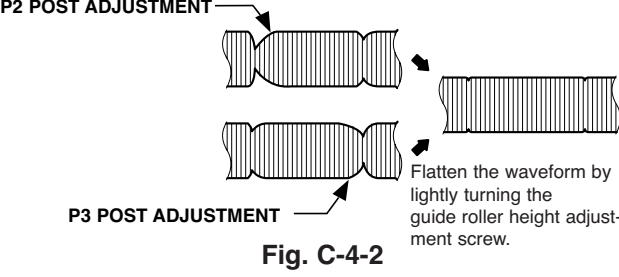
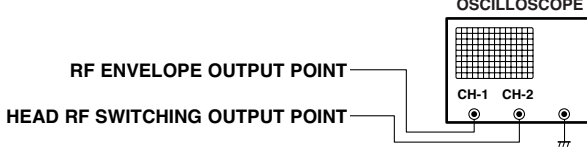
Fixtures and tools used	Measuring tools and connection position	VCR (VCP) status	Adjustment position
<ul style="list-style-type: none"> • Oscilloscope • Standard test tape • Post height adjusting driver 	<ul style="list-style-type: none"> • CH-1: PB RF Envelope • CH-2: NTSC : SW 30Hz PAL : SW 25Hz • Head switching output point • RF Envelope output point 	<ul style="list-style-type: none"> • Play the standard test tape. 	<ul style="list-style-type: none"> • Guide roller height adjusting screw
1) Play the standard test tape after connecting the probe of oscilloscope to the RF envelope output point and the head switching output point. 2) Tracking control (playback) : Locate it at the center (Set the RF output to the maximum value via the tracking control when such adjustment is completed after the drum assembly is replaced.) 3) Height adjusting screw: Flatten the RF waveform. (Fig. C-4-2) 4) Move the tracking control (playback) to the right/left. (Fig. C-4-3) 5) Check the start and the end of the RF output reduction width are constant.		Waveform  Fig. C-4-2	
CAUTIONS There must exist no crumpling and folding of the tape due to excess adjustment or insufficient adjustment.		Connection Diagram 	

DECK MECHANISM ADJUSTMENT

5. Audio/Control (A/C) Head Adjustment

Purpose of adjustment : To ensure that audio and control signals can be recorded and played according to the contract tract by constantly maintaining distance between tape and head, and tape tension between the P3 post and the P4 post.

5-1. Prior Adjustment (performed only when no audio output appears in play of the standard test tape)

Fixtures and tools used	VCR (VCP) status	Adjustment position
<ul style="list-style-type: none"> Blank Tape (Empty Tape) Driver (+) Type $\phi 5$ 	<ul style="list-style-type: none"> Play the blank tape (empty tape). 	<ul style="list-style-type: none"> Tilt adjusting screw (C) Height adjusting screw (B) Azimuth adjusting screw (A)

Adjustment Procedure/Adjustment Diagrams

- Basically use the A/C head assembly adjusted as in SPEC.
- Check there is crumpling and folding of the tape around the A/C head. If it is, Turn and adjust the tilt adjusting screw to ensure that the tape corresponds to the bottom guide of the P4, and recheck the tape path after proceeding play for 4-5 seconds.

- Where the tape bottom is not equal to Fig. C-5-3, Adjust the height by using the height adjusting screw (B) and then readjust it by using the tilt adjusting screw (C).

CAUTIONS

Always check the height of the A/C head since most ideal height of A/C head can be obtained when the bottom part of the tape is away 0.2 ~ 0.25mm from the bottom part of the A/C head.

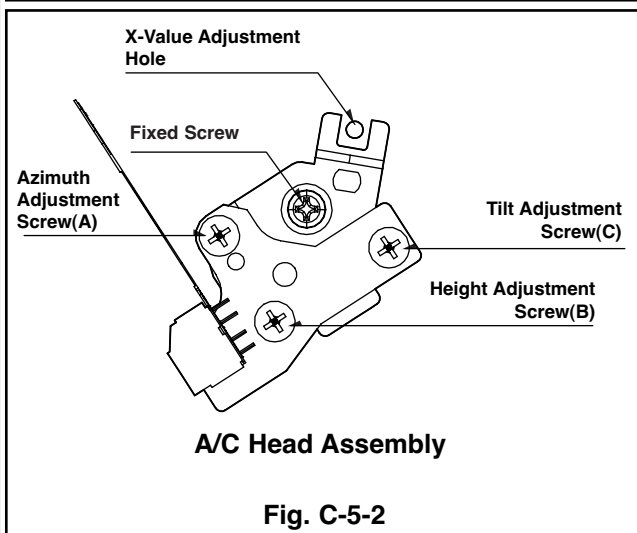
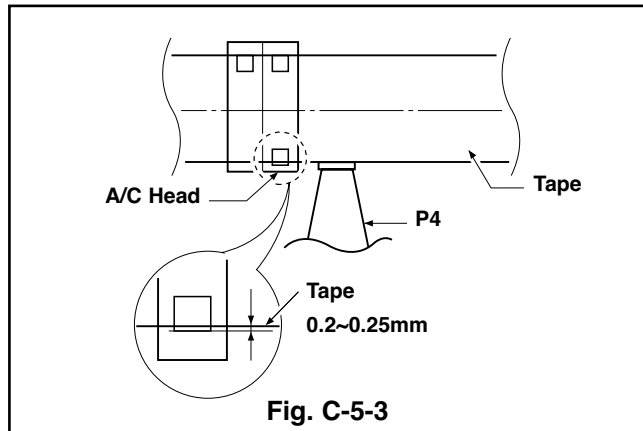
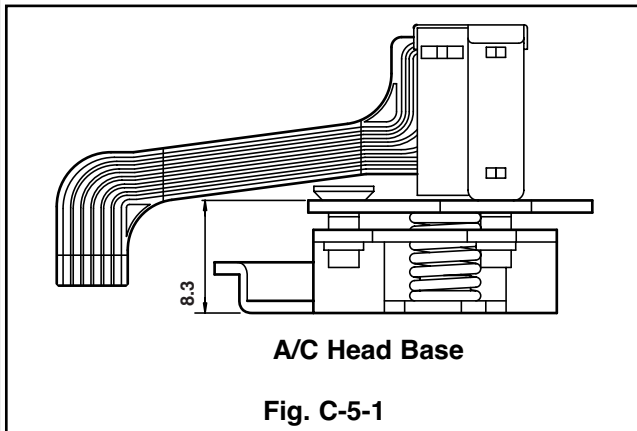

DECK MECHANISM ADJUSTMENT

5-2. Tape Path Check between Pinch Roller and Take up Guide (Check in the Rev Mode)

- 1) Check the tape pass status between the pinch roller and the take-up guide. (Check there is crumpling of the tape pass and folding of the take-up guide.)
 - (1) When holding of the take-up guide bottom occurs
Turn the tilt adjusting screw (C) clockwise and travel it stably to ensure there is no crumbling or folding of the tape.
 - (2) When holding of the take-up guide top occurs
Turn the tilt adjusting screw (C) anti-clockwise and

travel it stably to ensure there is no crumbling or folding of the tape.

- 2) Check there is folding of the tape at the bottom or top of the take-up guide in cutting-off the REV mode

CAUTIONS

If the RF waveform is changed after adjusting the A/C head, perform fine adjustment to ensure the RF waveform is flattened.

5-3. Fine Adjustment (Azimuth Adjustment)

Fixtures and tools used	Connection position	VCR (VCP) status	Adjustment position
<ul style="list-style-type: none"> • Oscilloscope • Standard test tape (only for SP) • Driver (+) Type Ø 4 	<ul style="list-style-type: none"> • Audio Output Jack 	<ul style="list-style-type: none"> • Play the standard test Tape, 1KHz, 7KHz. 	<ul style="list-style-type: none"> • Azimuth Adjusting Screw (A) • Height Adjusting Screw (B)
Adjustment Procedure <ol style="list-style-type: none"> 1) Connect the probe of Oscilloscope to the audio output jack. 2) Ensure that Audio 1KHz, 7KHz output is flattened at the maximization point by adjusting the Azimuth adjusting screw (A). 			

6. X-distance Adjustment

Purpose of adjustment : To maintain compatibility with other VCR (VCP).			
Fixtures and tools used	Connection position	VCR (VCP) status	Adjustment position
<ul style="list-style-type: none"> • Oscilloscope • Standard test tape (only for SP) • Driver (+) Type Ø 4 	<ul style="list-style-type: none"> • CH-1: PB RF Envelope • CH-2: NTSC ; SW 30Hz PAL:SW 25Hz • Head switching output point • RF Envelope output point 	<ul style="list-style-type: none"> • Play the standard test tape. 	
Adjustment Procedure <ol style="list-style-type: none"> 1) After releasing the auto tracking, lightly turn the fixing screw. Turn the (+) type driver (Ø 3 ~ Ø 4) on the X-distance adjusting hole to the right or left. Adjust the RF envelope level to the maximum point and then fix the fixing screws. 2) For the 31mm head, adjust it with the SP tape recorded in the width of 31mm since the head travels on the tape track only for SP with the width of 58mm. 	Connection Diagram		

DECK MECHANISM ADJUSTMENT

7. Adjustment after Drum Assembly (Video Heads)

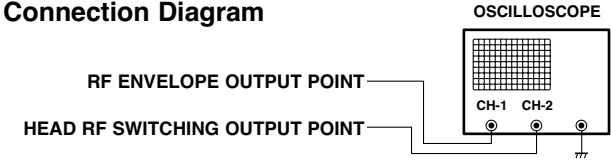
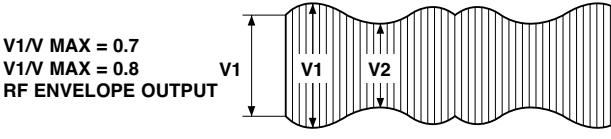
Purpose of adjustment : To adjust and stabilize the height change, X-distance change, etc depending on the guide roller after assembling the drum.			
Fixtures and tools used	Connection position	VCR (VCP) status	Adjustment position
<ul style="list-style-type: none"> • Oscilloscope • Standard test tape (only for SP) • Post Height Adjusting Driver • Driver (+) Type Ø 5 	<ul style="list-style-type: none"> • CH-1: PB RF Envelope • CH-2: NTSC : SW 30Hz PAL:SW 25Hz • Head switching output point • RF Envelope output point 	<ul style="list-style-type: none"> • Play the blank tape. • Play the standard test tape. 	<ul style="list-style-type: none"> • Fine adjustment of guide roller • Switching Point • Tracking Preset • X-distance
Checking/Adjustment Procedure <ol style="list-style-type: none"> 1) Play the blank tape (empty tape) and check whether the guide roller crumbles or wrinkles the tape and adjust it if necessary. 2) Check that the RF envelope output waveform is flat, and adjust the height of the guide roller while playing the standard test tape. 3) Adjust the switching point. 4) Check the RF envelope output is the maximum when the tracking control locates at the center. If not maximum, set up to ensure that RF envelope output becomes the maximum by turning the (+) type driver (Ø 3 ~ Ø 4) on the base A/C groove. 		Connection Diagram  Waveform  <p>V1/V MAX = 0.7 V1/V MAX = 0.8 RF ENVELOPE OUTPUT</p>	

8. Check of Traveling Device after Deck Assembly

8-1. Audio, RF Normalization Time (Locking Time) Check in Play after CUE or REV

Fixtures and tools used	Measuring standard	Connection position	VCR (VCP) status
<ul style="list-style-type: none"> • Oscilloscope • 6H 3KHz Color Bar Standard Test tape • Stop Watch 	<ul style="list-style-type: none"> • RF Locking Time: Within 5 seconds • Audio Locking Time : Within 10 seconds 	<ul style="list-style-type: none"> • CH-1: PB RF Envelope • CH-2: Audio output • RF Envelope output point • Audio output jack 	<ul style="list-style-type: none"> • Play the 6H 3KHz Color Bar Standard Test tape.
Checking Procedure <ol style="list-style-type: none"> 1) Check that locking time of the RF and Audio waveform is fallen within the measuring standard in conversion of the play mode from the CUE or the REV mode. 		<ol style="list-style-type: none"> 2) Readjust the paragraph 5 and 6 if it deviates from the standard. 	

8-2. Check of Tape Curl and Jam Status

Fixtures and tools used	Fixtures and tools used	Fixtures and tools used
<ul style="list-style-type: none"> • T-160 Tape • T-120 Tape 	<ul style="list-style-type: none"> • There must be no jam or curl at the first, middle and end position of tape. 	<ul style="list-style-type: none"> • Travel the tape at the position of its first and end.
Checking Procedure <ol style="list-style-type: none"> 1) Check there is no abnormality of every traveling post status. 2) There must be no abnormal operation of the counter in 		<ol style="list-style-type: none"> occurrence of folding of the bottom tape. There must be not abnormality of audio signal in damage of the top tape. 3) If there is abnormality, readjust the adjustment paragraph 4 and 5.

PROTECTION, MAINTENANCE AND CHECK OF VIDEO FUNCTION

1. Checking Points prior to Repair

Following abnormal phenomena may be repaired by removal of foreign materials and oil supply. Check oiling is required at the checking set or cleaning status is complete. Determine that necessity of checking and repair the set exists after checking the using period of the set together with the user. In this case, followings must be checked:

Phenomena	Checking Points and Cause	Replacement
Color beat	Pollution of Full-Erase Head	○
S/N, Color Faded	Pollution of Video Head	○
Horizontal, Vertical Jitte	Pollution of Video Head or Tape Transport System	○
Poor Sound, Low Sound	Pollution of Audio/Control Head	○
No tape wound or tape wound loosely, FF or REW impossible, or slow turning	Pollution of Pinch Roller or Belt Capstan	○
Tape loosely wound in REV or Unloading	Deterioration of Clutch Assembly D37 Torque	○
	Pollution of Drum and Traveling Device	Fig. C-9-3

F/E Head

Video Head

A/C Head

Pinch Roller

Belt Capstan

Clutch Assembly A37

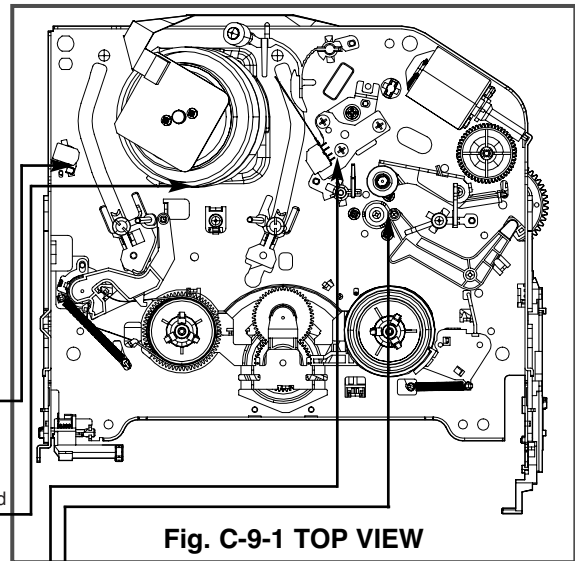

Fig. C-9-1 TOP VIEW

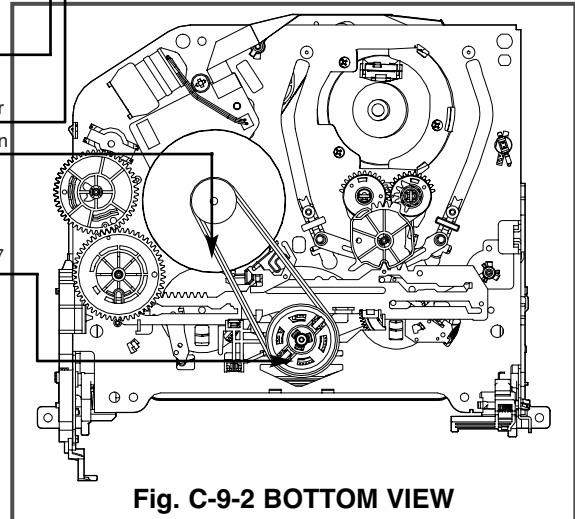

Fig. C-9-2 BOTTOM VIEW

CAUTIONS

If operation of the position with (O) mark is abnormal even after removing cause, replace it with substitute product since it shows damage or wearing.

* No. (1) ~ (12) shows sequence that the tape moves from the supply reel to the take-up reel.)

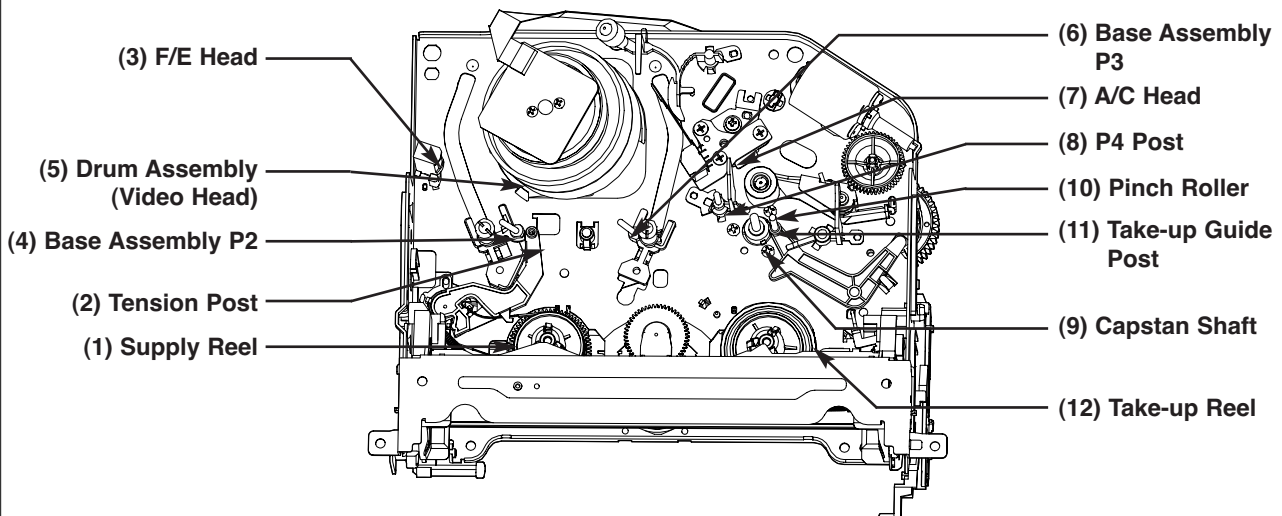

Fig. C-9-3 Tape Transport System

PROTECTION, MAINTENANCE AND CHECK OF VIDEO FUNCTION

2. Essential Check and Repair

Recording density of the video is far higher than the audio. Therefore video parts are very precise so as to allow only error of 1/1000mm or so in order to maintain compatibility with other videos.

If one of these parts is polluted or old, same phenomena will appear as they are damaged.

To maintain clear screen, regular check, replacement of old and damaged parts and oil supply, etc are essential.

3. Regular Check and Repair

Check and repair schedule is not constant since they vary depending on method that the consumer uses video and environment where the video is installed at.

However, for the video used by common household, good screen will be maintained if regular check and repair per 1,000 hour is performed. The following chart shows relationship between using time and checking time:

Table 1

Time Requiring Checking \ Average hours used per day	About 1 year	About 18 months	About 3 years
One hour	[Bar spanning all three columns]		
Two hours	[Bar spanning first two columns]		
Three hours	[Bar spanning first column]		

4. Tools for Check and Repair

- (1) Grease: Floil G-3114 (KANTO) or equivalent grease (Green)
- (2) Grease: Kanto G-754, PL-433 (Yellow)
- (3) Alcohol (Isopropyl Alcohol)
- (4) Cleaning Patch (cloth)

5. Maintenance Process

5-1) Removal of Foreign Material

- (1) Removal of foreign material from video head (Fig. C-9-4)
Firstly try to use a cleaning tape.

Use a cleaning patch if foreign materials are not removed with the cleaning tape due to severe dirty of the head. Soak the cleaning patch in alcohol and put it to the head tip. Smoothly turn the drum (turning cylinder) to the right or left (In this case, the cleaning patch must not be moved vertically).

After completely drying the head, test the traveling status of the tape.

If alcohol (Isopropyl Alcohol) remains at the video head, the tape may be damaged when this solution touches with the head surface.

Never use a cloth bar (commercial sale)

- (2) Wipe the tape transport system and the drive system with the cleaning patch soaked in alcohol (Isopropyl Alcohol) when removing foreign materials from them.
 - 1) The part touched with the traveling tape is called as tape transport system. The drive system consists of parts to travel the tape.
 - 2) Care must be exercised so that unreasonable force to change the pattern will be applied to the tape transport system during removal of foreign materials.

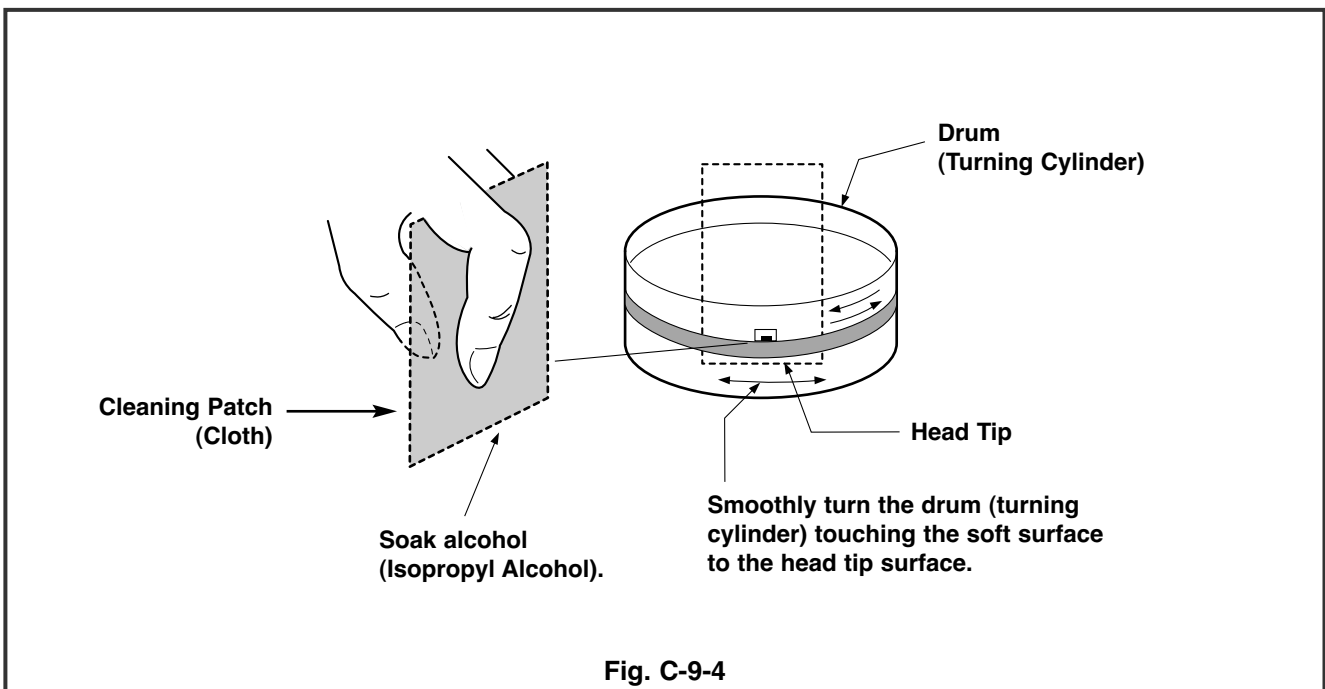

Fig. C-9-4

PROTECTION, MAINTENANCE AND CHECK OF VIDEO FUNCTION

5-2) Grease Applications

(1) Grease Application Method

Apply grease by using a cloth swab or brush. Care must be exercised so that excess quantity should not be used. If the excessive quantity is applied, wipe it with the gauze soaked in alcohol (Isopropyl Alcohol).

NOTE: POSITION OF GREASE APPLICATION

- | | |
|--|----------------------------------|
| (1) Inner Side Surface and Top Surface of Loading Path | (4) Gear Wheel Shaft |
| (2) Stable Adhesion Part of Base P2, P3 | (5) Reel S. T. Shaft |
| (3) Arm Pinch Shaft | (1) (2) (3) (4): KG-684G (Green) |
| | (5): PL-433 (Yellow) |

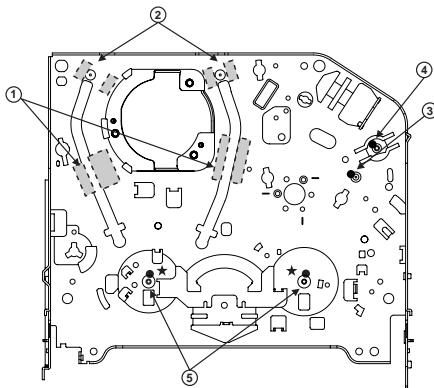

Chassis (TOP)

Gear Part

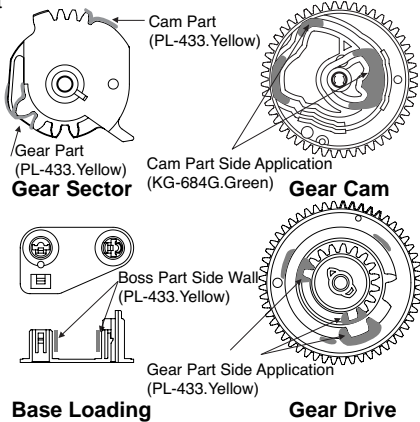

(2) Regular Grease Application

Apply grease to the designated application position every 500 hour.

- | | |
|--|--|
| (1) Inner Side Surface and Top Surface of Loading Path | (6) Guide Part on the Plate Slider Side Wall (Left) |
| (2) Stable Adhesion Part of Base P2, P3 Coil | (7) Guide Part on the Plate Slider Side Wall (Right) |
| (3) Gear Cam Shaft | (1) (2) (3) (4) (5) (6) (7): KG-684G (Green) |
| (4) Gear Drive Shaft | |
| (5) Clutch Shaft Groove | |

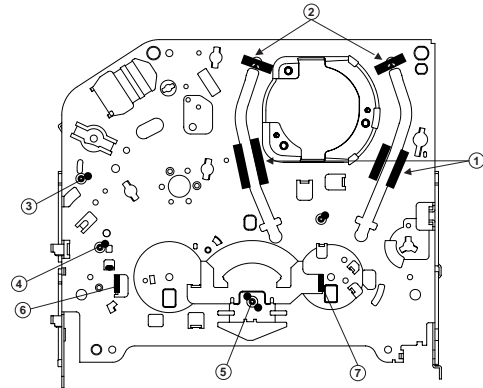

Chassis (Bottom)

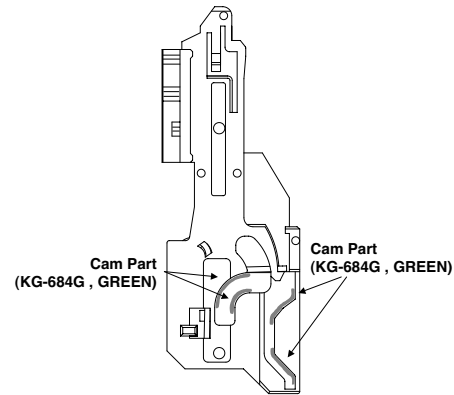

Gear Rack F/L

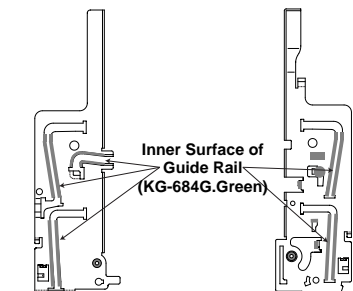

Chassis (L)

Chassis (R)

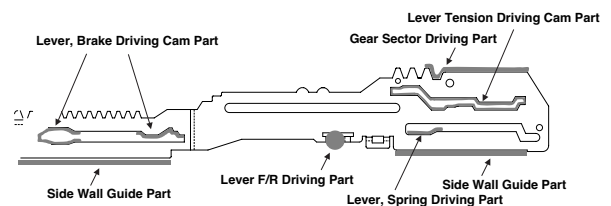
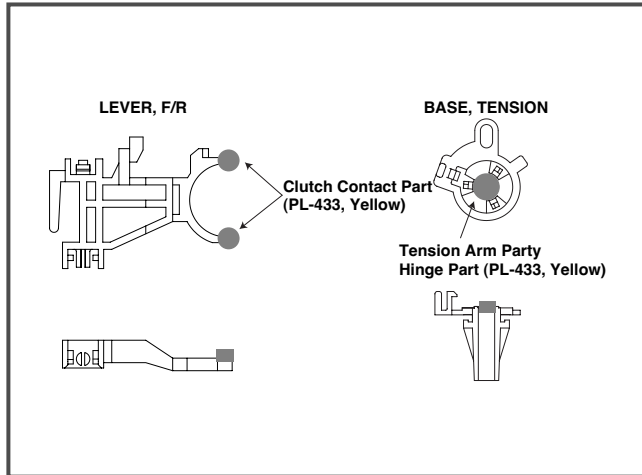

Plate Slider

PROTECTION, MAINTENANCE AND CHECK OF VIDEO FUNCTION

Lever, F/R, Base, Tension



GEAR AY, P2 & P3

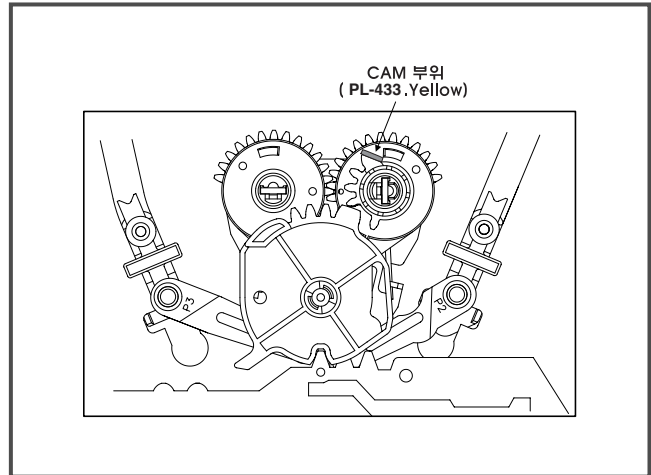

MECHANISM TROUBLESHOOTING GUIDE

1. Deck Mechanism

A.

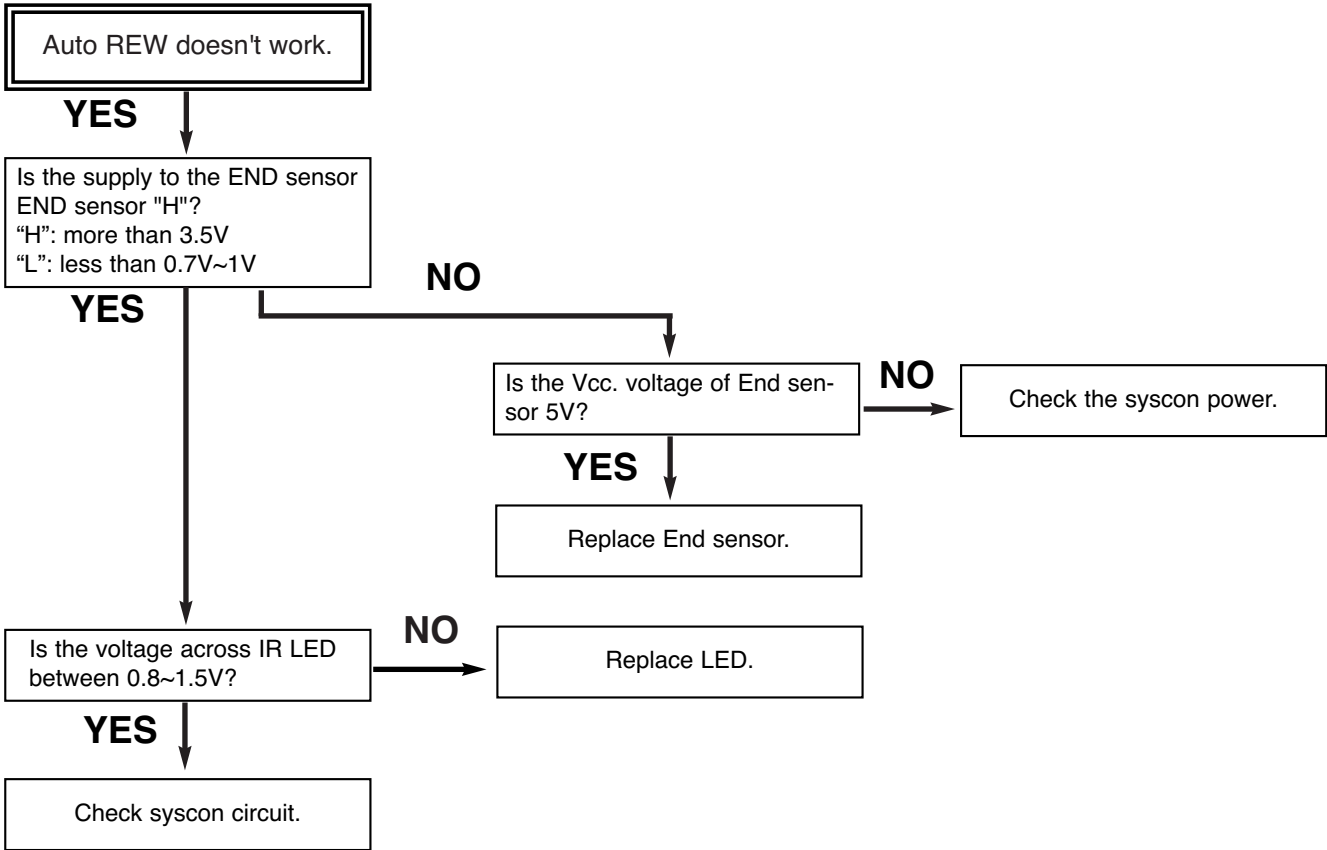

B.

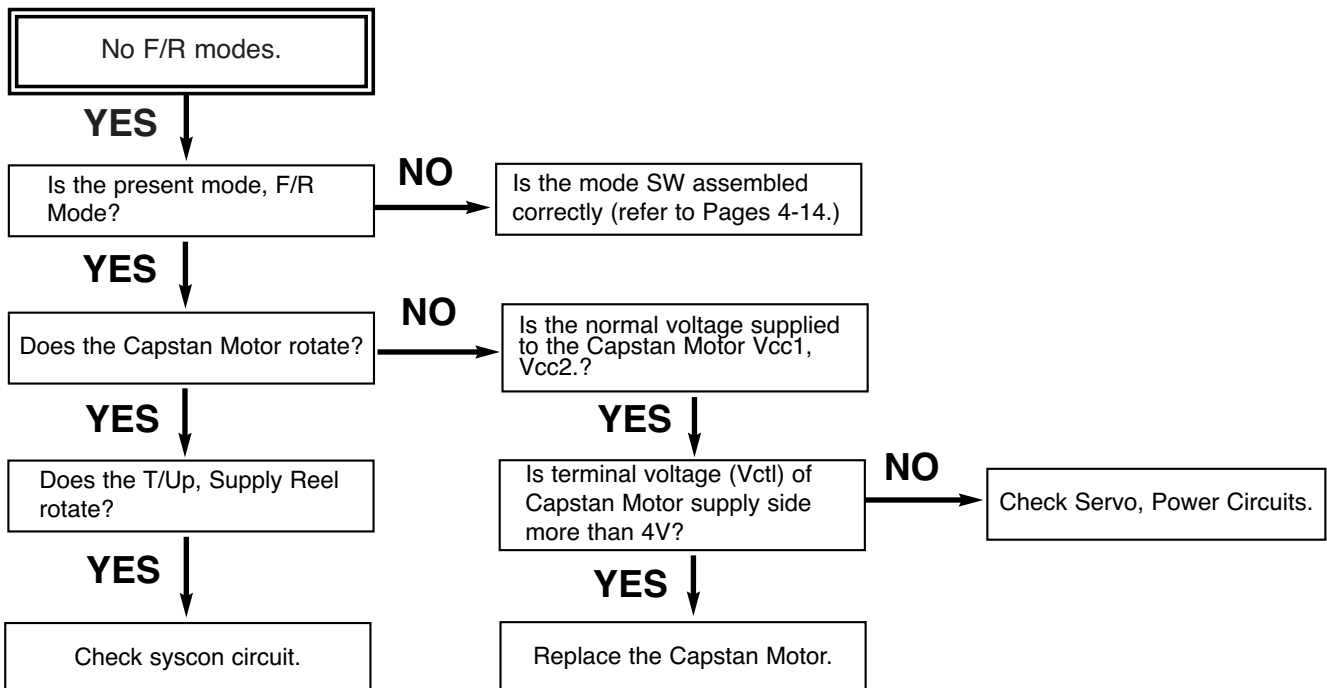

MECHANISM TROUBLESHOOTING GUIDE

C.

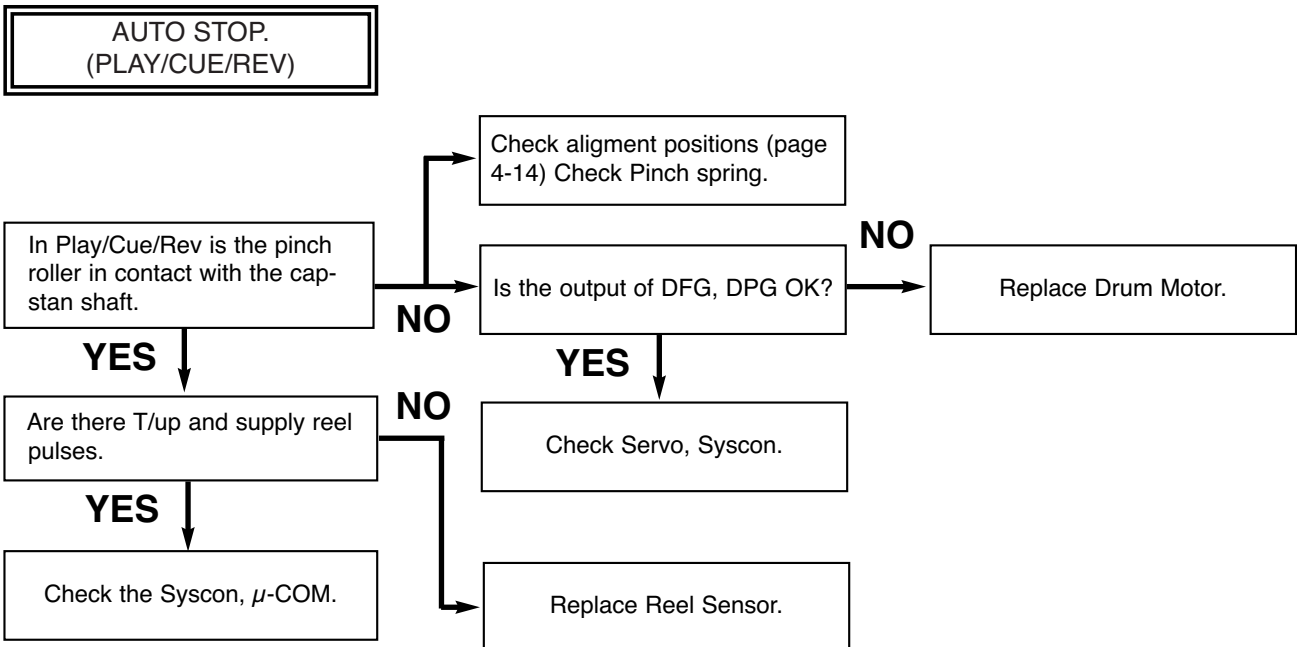

D.

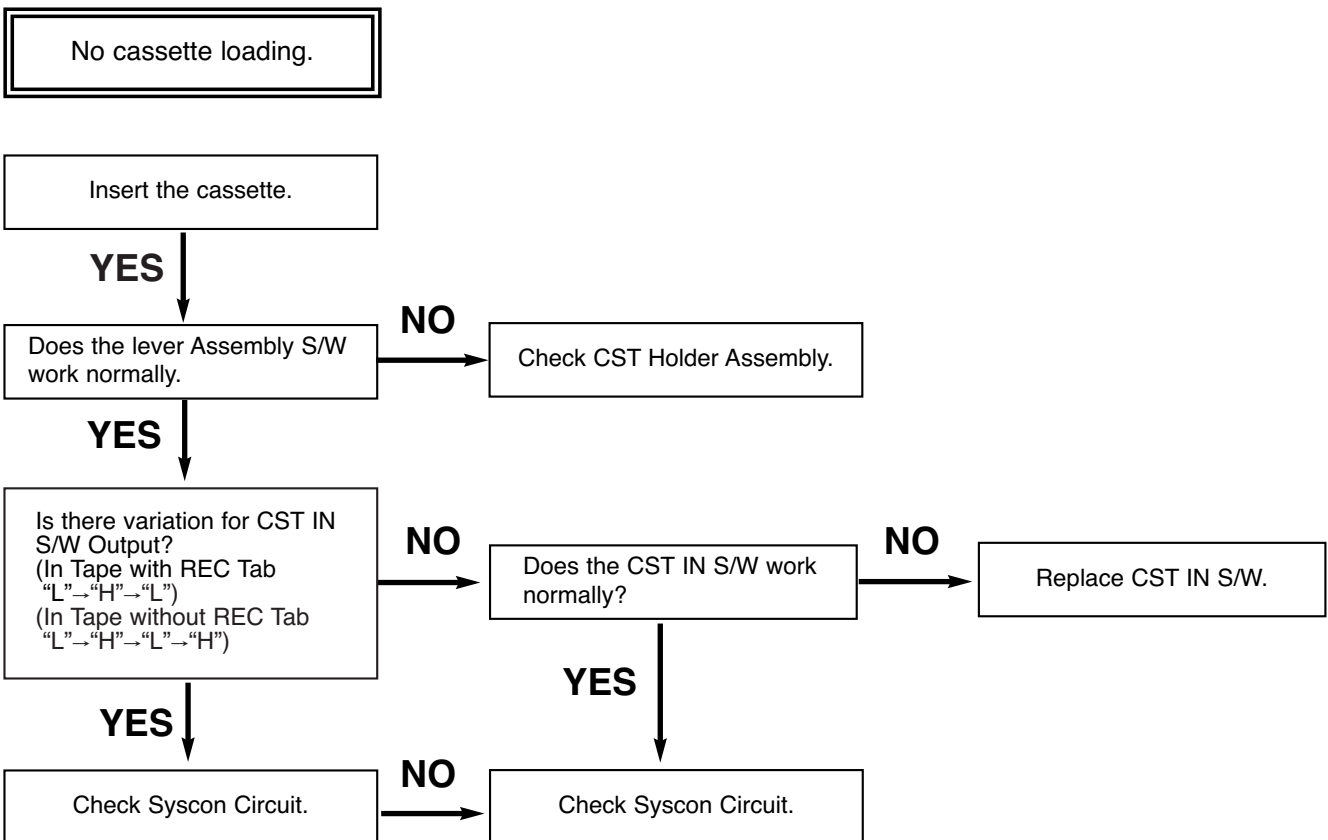

MECHANISM TROUBLESHOOTING GUIDE

E.

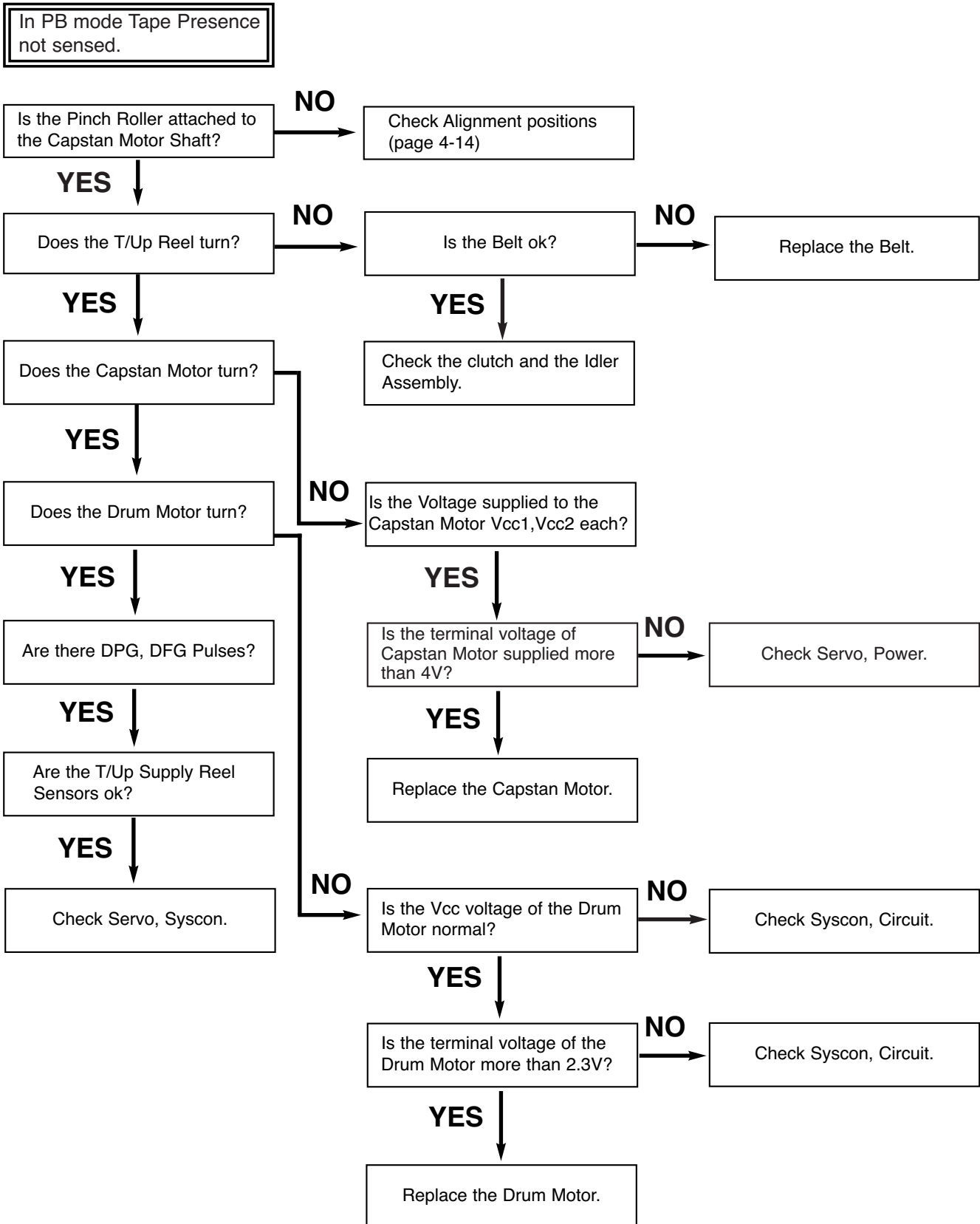

MECHANISM TROUBLESHOOTING GUIDE

2. Front Loading Mechanism

A.

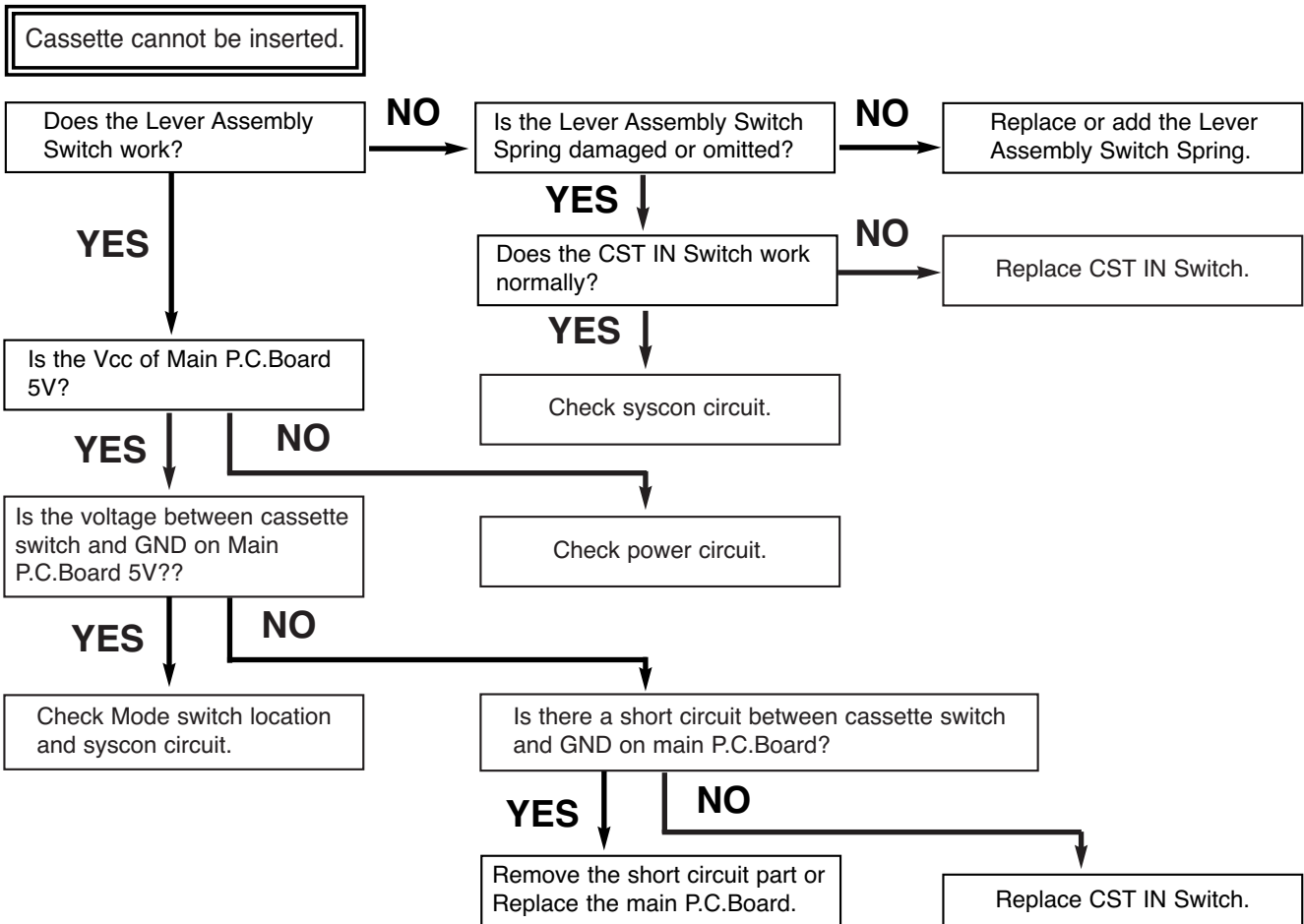

B.

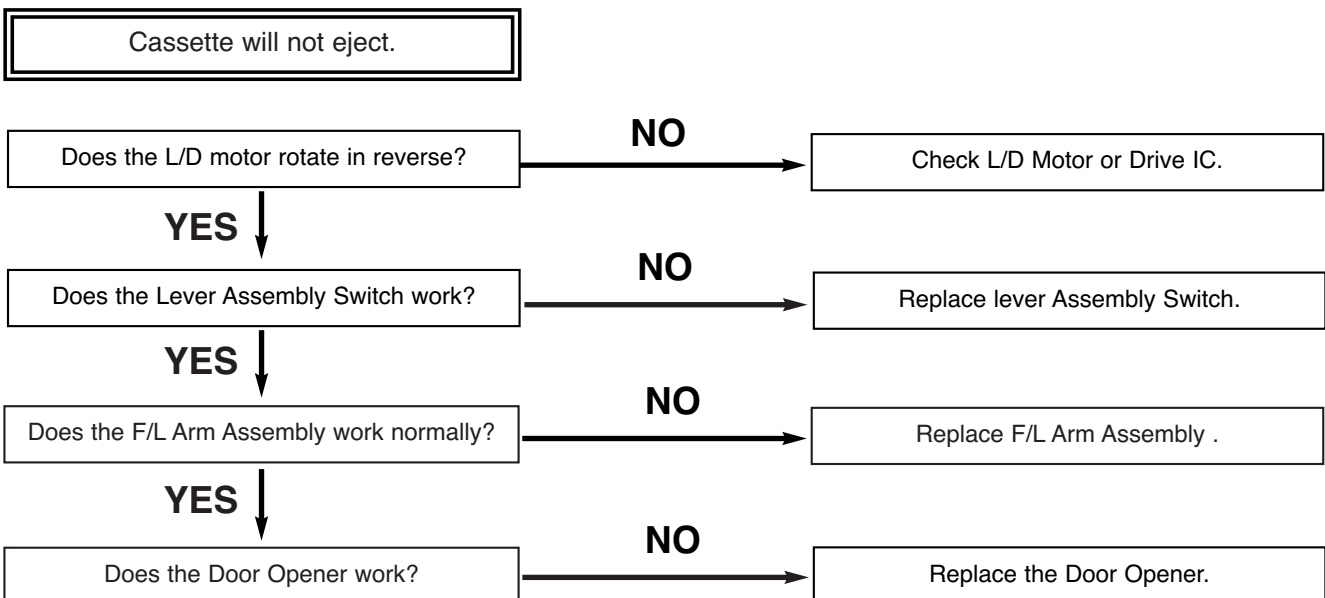

MECHANISM TROUBLESHOOTING GUIDE

C.

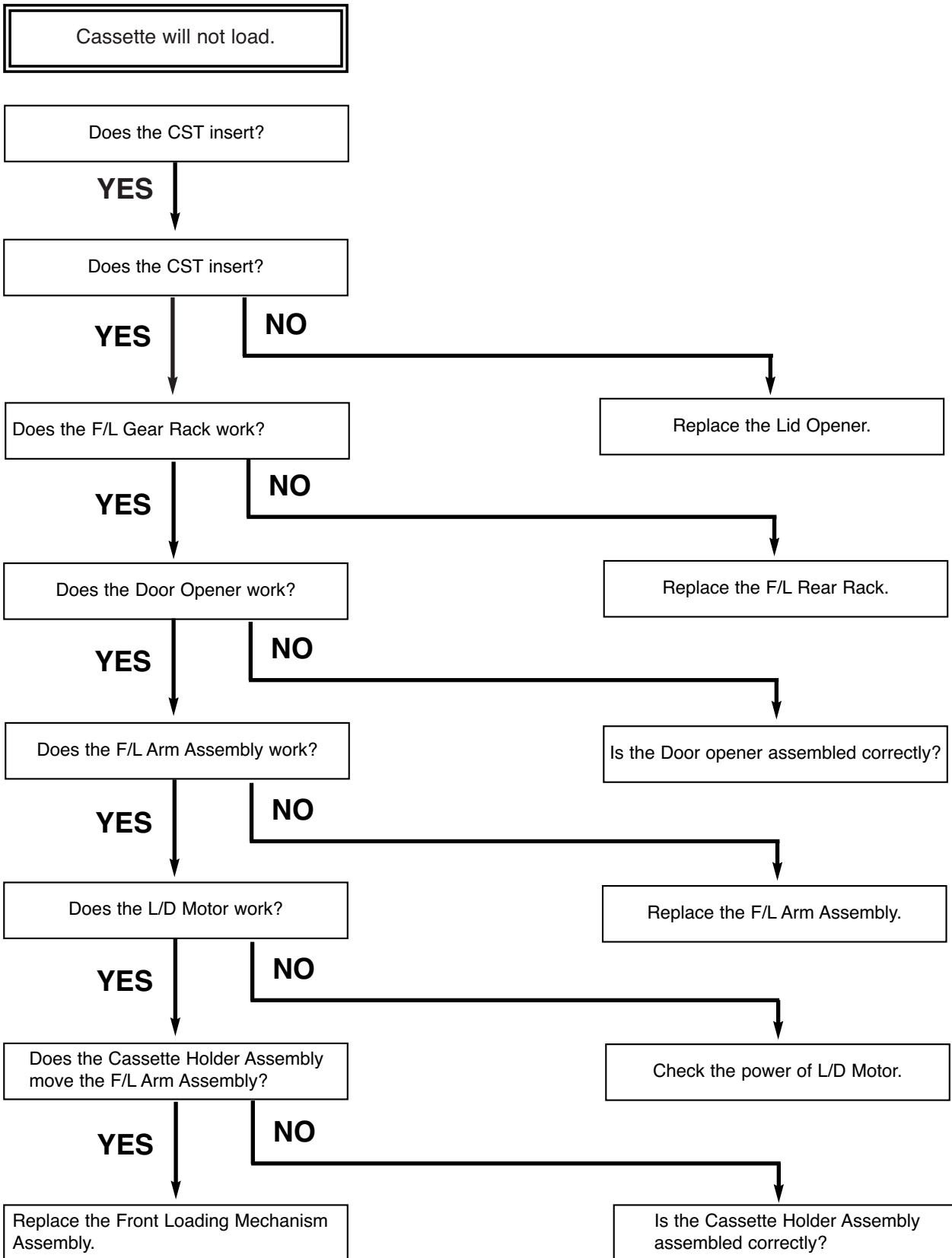

EXPLODED VIEWS

1. Front Loading Mechanism Section

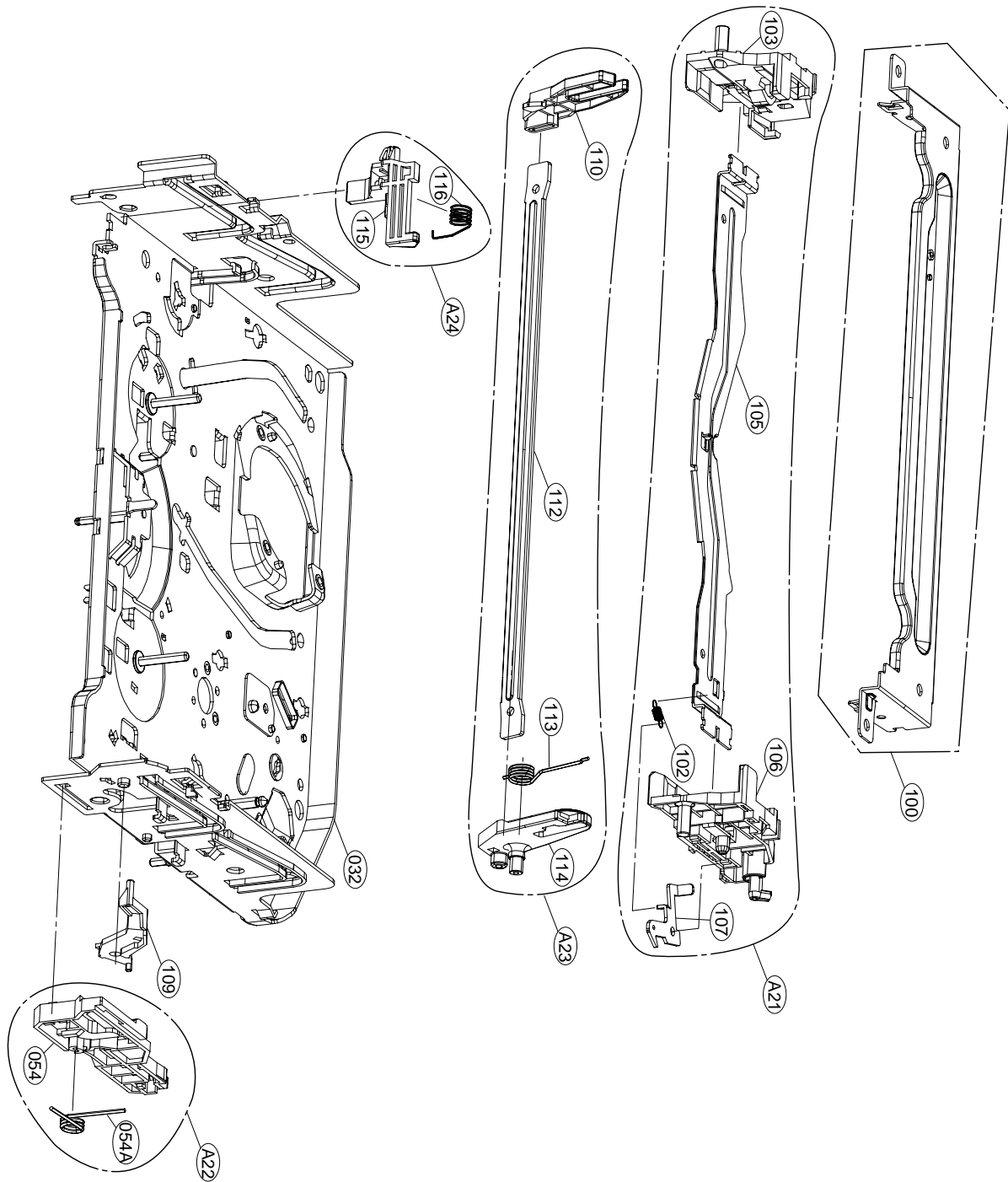

EXPLODED VIEWS

3. Moving Mechanism Section (2)

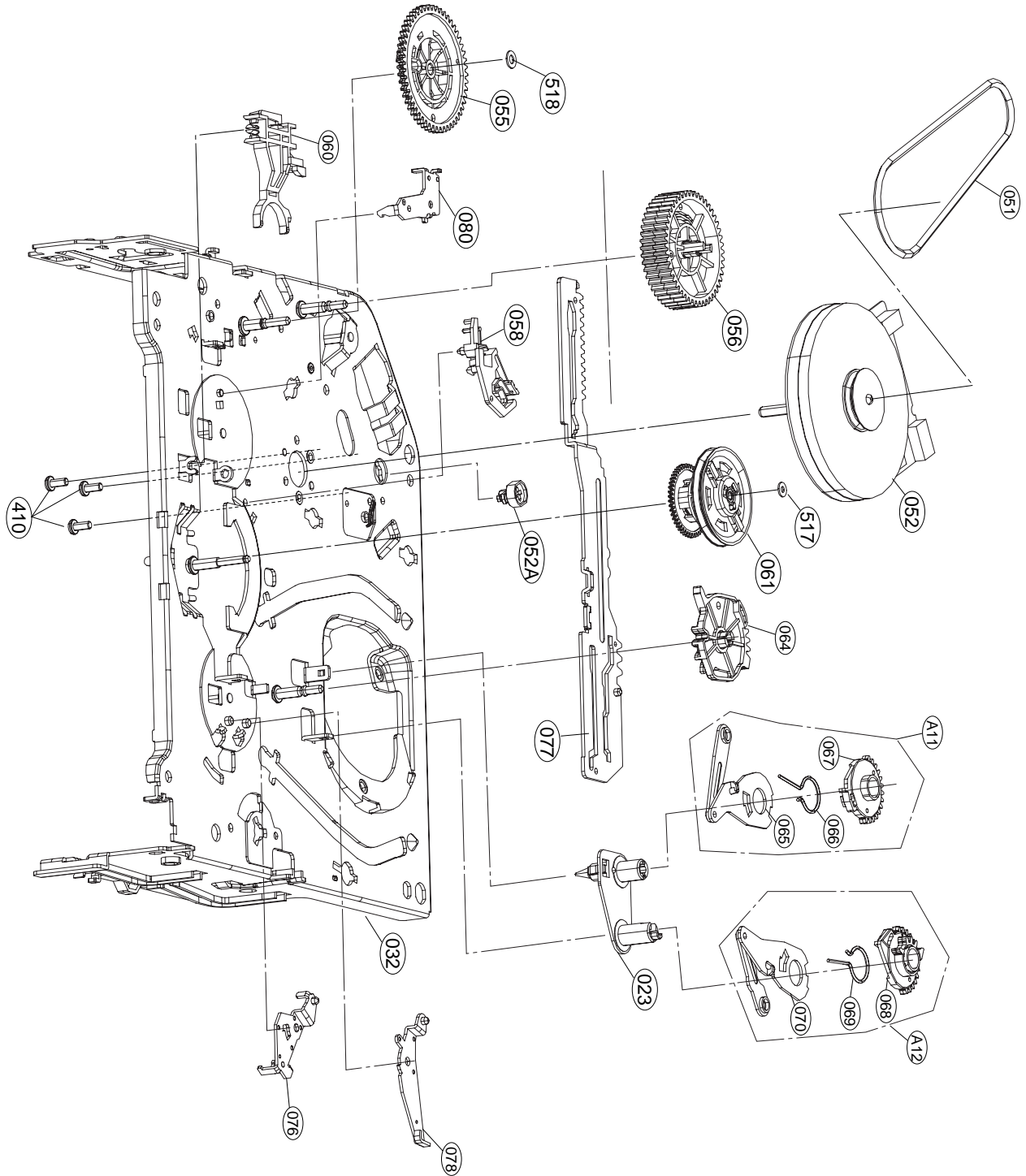

SECTION 5

RL-05 LOADER PART

CONTENTS

ELECTRICAL TROUBLESHOOTING GUIDE	5-2
WAVEFORMS	5-16
1. POWER & RESET SIGNAL	5-16
2. MAIN CLOCK1 FOR IC202 (16.9MHZ)	5-16
3. SDRAM CLOCK	5-17
4. TRAY OPEN/CLOSE SIGNAL 1	5-17
5. TRAY OPEN/CLOSE SIGNAL 2	5-18
6. SLED MOVE SIGNAL 1	5-18
7. SLED MOVE SIGNAL 2	5-19
8. FOCUS SEARCH SIGNAL	5-19
9. LASER TURN ON SIGNAL	5-20
10. DISC TYPE JUDGEMENT WAVEFORM (CD SERIES)	5-21
11. DISC TYPE JUDGEMENT WAVEFORM (CD&CD-R)	5-21
12. DISC TYPE JUDGEMENT WAVEFORM (CD-RW)	5-22
13. DISC TYPE JUDGEMENT WAVEFORM (DVD SERIES)	5-22
14. DISC TYPE JUDGEMENT WAVEFORM (DVD_SINGLE&R)	5-23
15. DISC TYPE JUDGEMENT WAVEFORM (DVD_DUAL)	5-23
16. DISC TYPE JUDGEMENT WAVEFORM (DVDRW)	5-24
17. SPINDLE WAVEFORM1	5-24
18. SPINDLE WAVEFORM2	5-25
19. FOCUS ON SIGNAL(CD)	5-25
20. FOCUS ON SIGNAL(CD))	5-26
21. FOCUS ON SIGNAL(DVD)	5-26
22. FOCUS ON SIGNAL (DVD)	5-27
23. TRACK OFF SIGNAL(CD)	5-27
24. TRACK OFF SIGNAL(DVD)	5-28
25. TILT DRIVER SIGNAL(DISC READING)	5-28
26. RF WAVEFORM(DVD)	5-29
27. RF WAVEFORM(CD)	5-29
28. WOBBLE(DVD-R/RW)_READING	5-30
29. WOBBLE(DVD+R/RW)_READING&WRITING =>X1 SPEED	5-30
30. LD ENABLE(DVD)	5-31
31. LD ENABLE(CD)	5-31
32. LASER POWER(READING)_DVD+RW	5-32
33. LASER POWER(ERASE)_DVD+RW	5-32
34. LASER POWER(WRITING)_INITIAL STATE	5-33
35. LASER POWER(WRITING)_PROCESSING	5-33
THE DIFFERENCE OF DVD-R/RW, DVD+R/RW DISCS AND DVD-ROM	5-34
1. RECORDING LAYER	5-34
2. DISC SPECIFICATION	5-35
3. DISC MATERIALS	5-34
4. ORGANIZATION OF THE INNER DRIVE AREA, OUTER DRIVE AREA, LEAD-IN ZONE AND LEAD-OUT ZONE	5-39
5. ALPC(AUTOMATIC LASER POWER CONTROL) CIRCUIT	5-43
HOW TO USE TEST TOOL	5-44
BLOCK DIAGRAMS	5-51
1. OVERALL BLOCK DIAGRAM	5-51
2. DSP BLOCK DIAGRAM	5-52
3. μ -COM BLOCK DIAGRAM	5-53
4. RF BLOCK DIAGRAM	5-54
CIRCUIT DIAGRAMS	5-55
1. RF1 CIRCUIT DIAGRAM	5-55
2. DSP CIRCUIT DIAGRAM	5-57
3. μ -COM CIRCUIT DIAGRAM	5-59
CIRCUIT VOLTAGE CHART	5-61
PRINTED CIRCUIT DIAGRAMS	5-63
1. MAIN P.C.BOARD	5-63
2. MAIN P.C.BOARD	5-65

ELECTRICAL TROUBLESHOOTING GUIDE

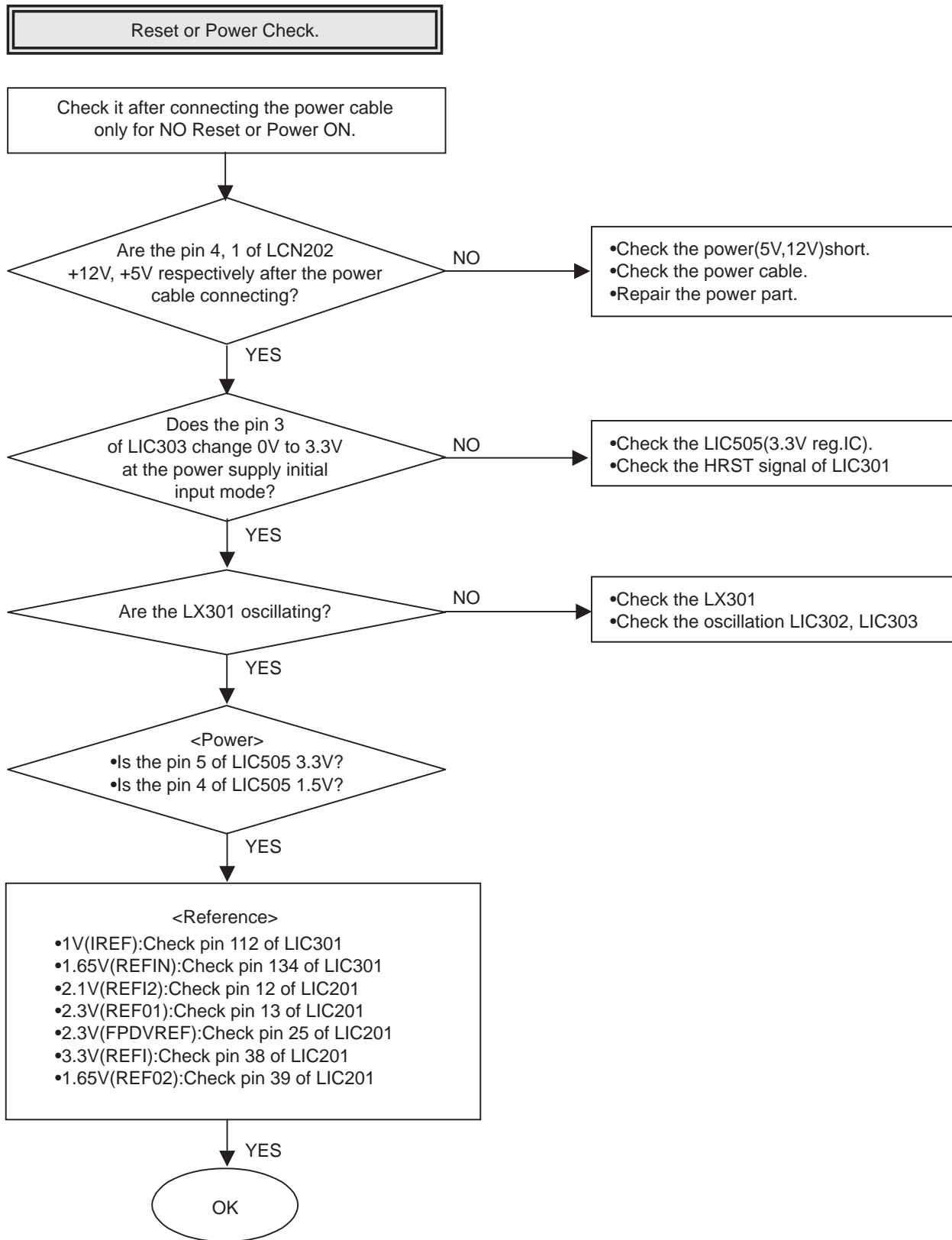

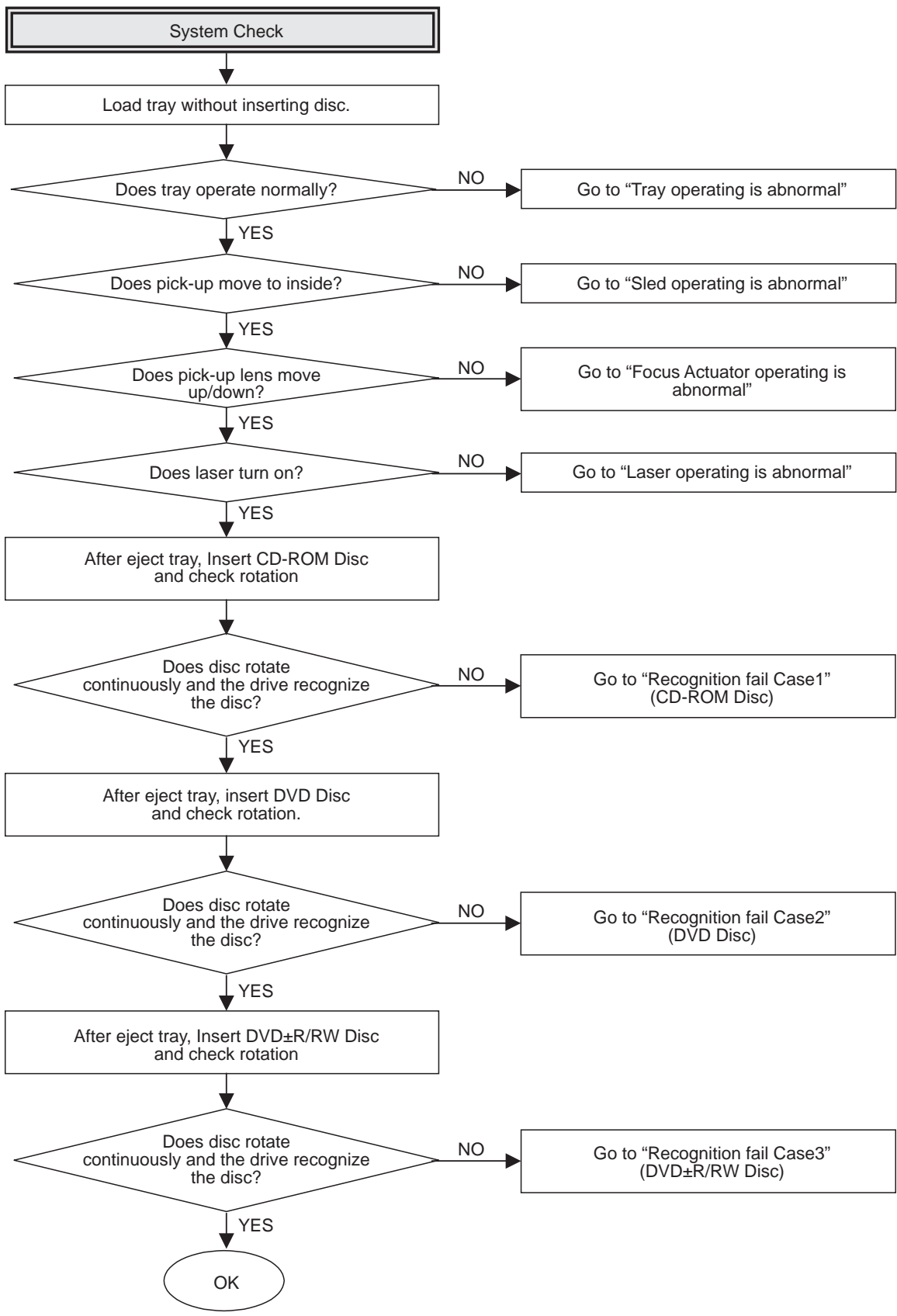

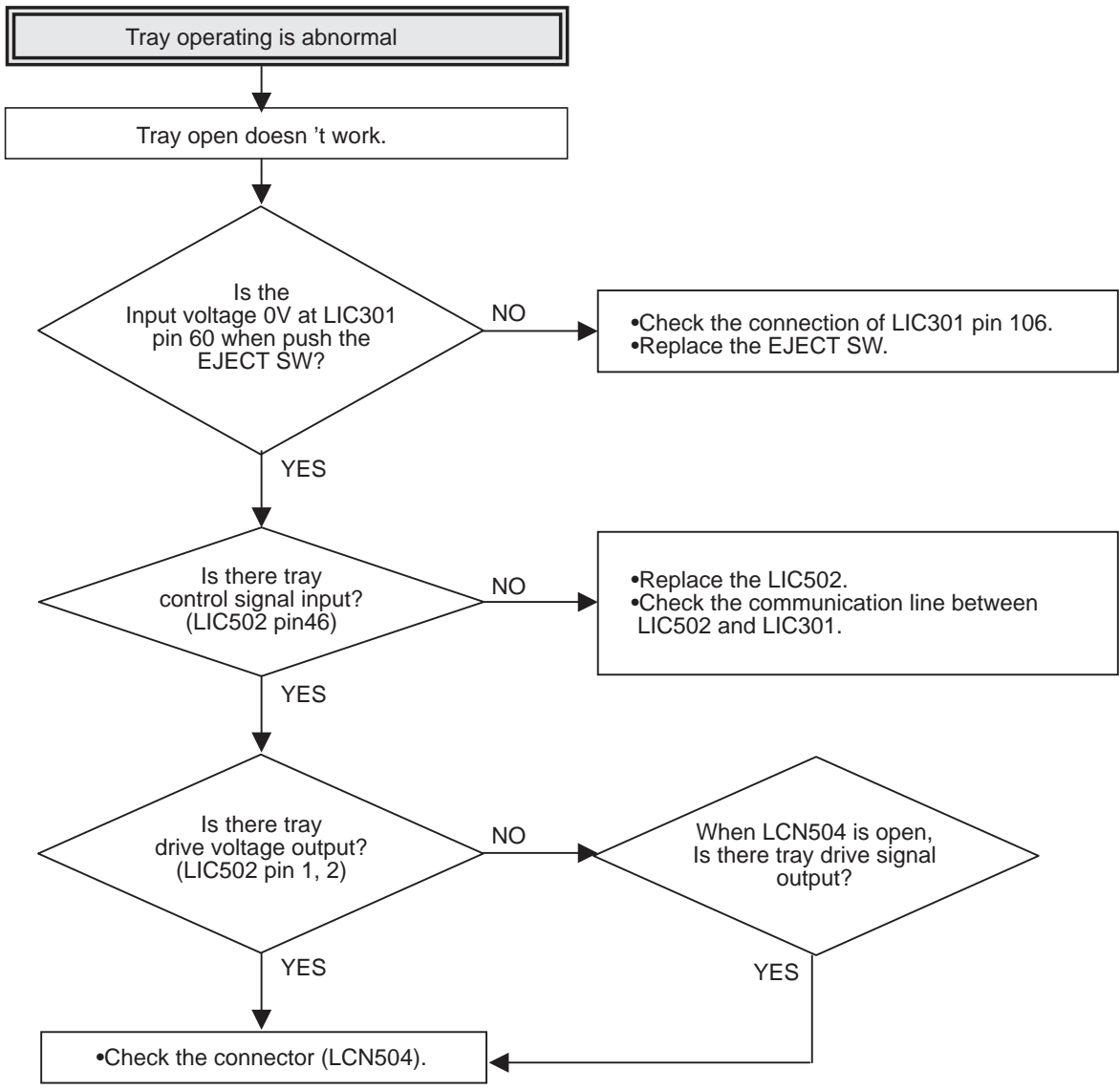

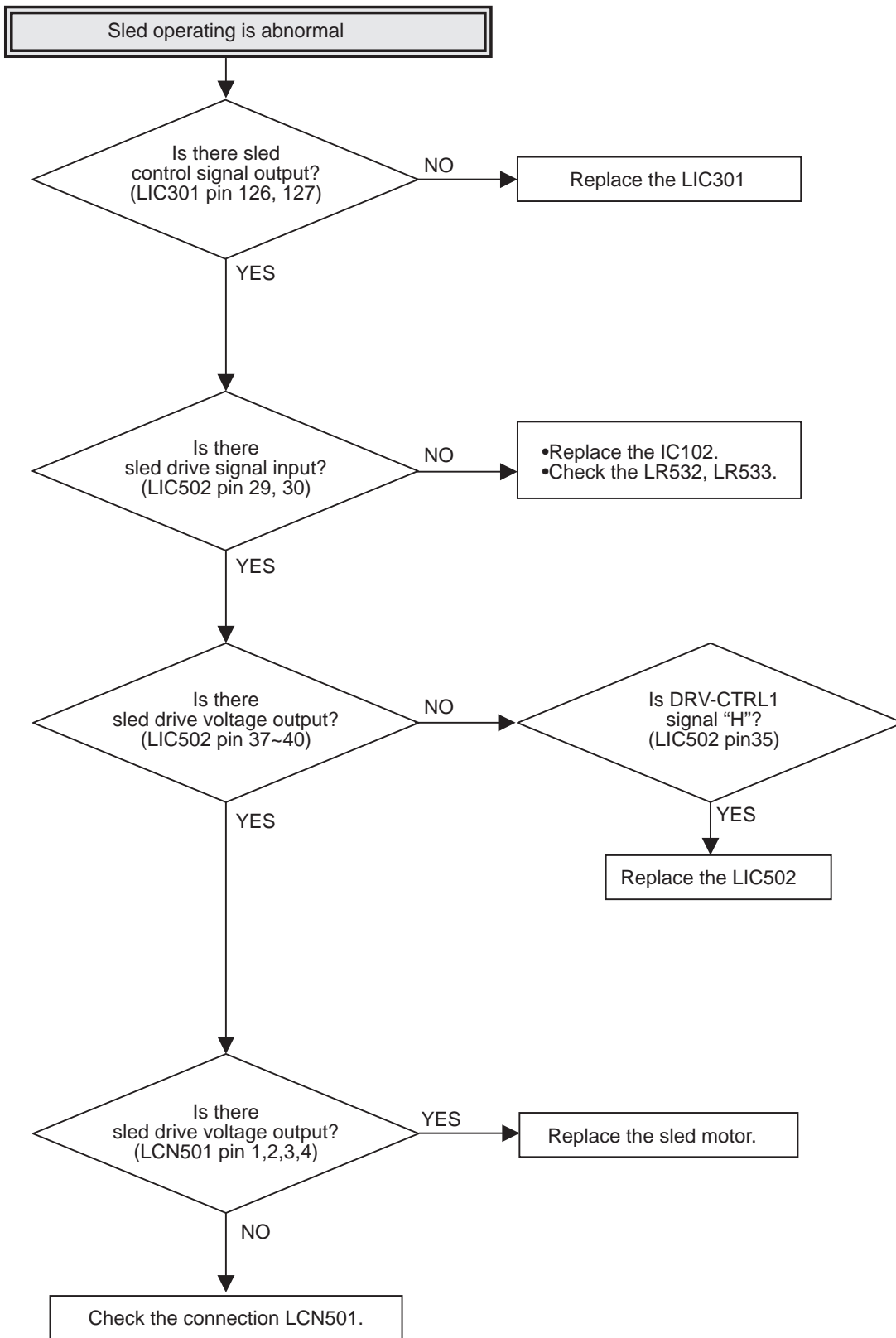

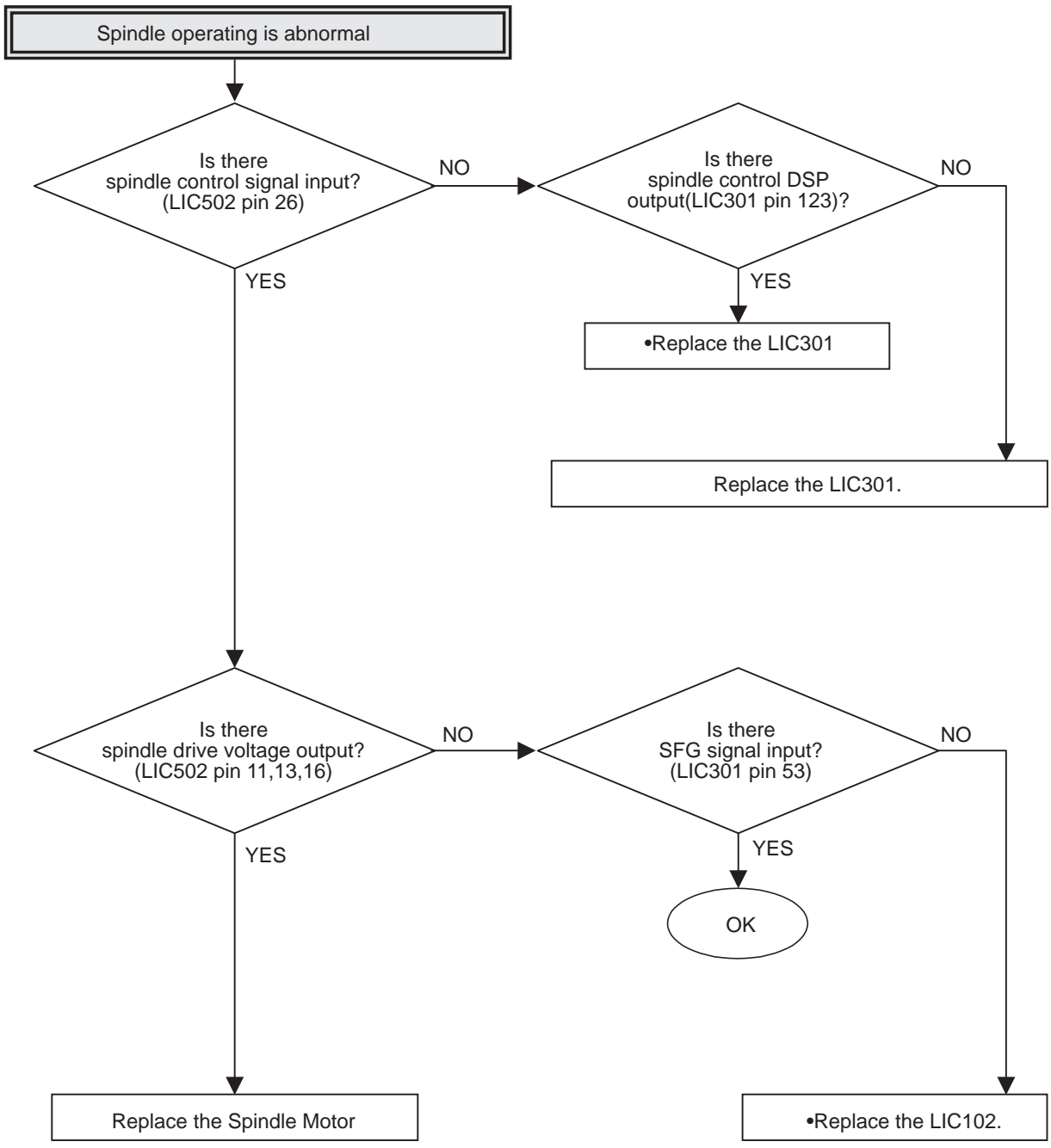

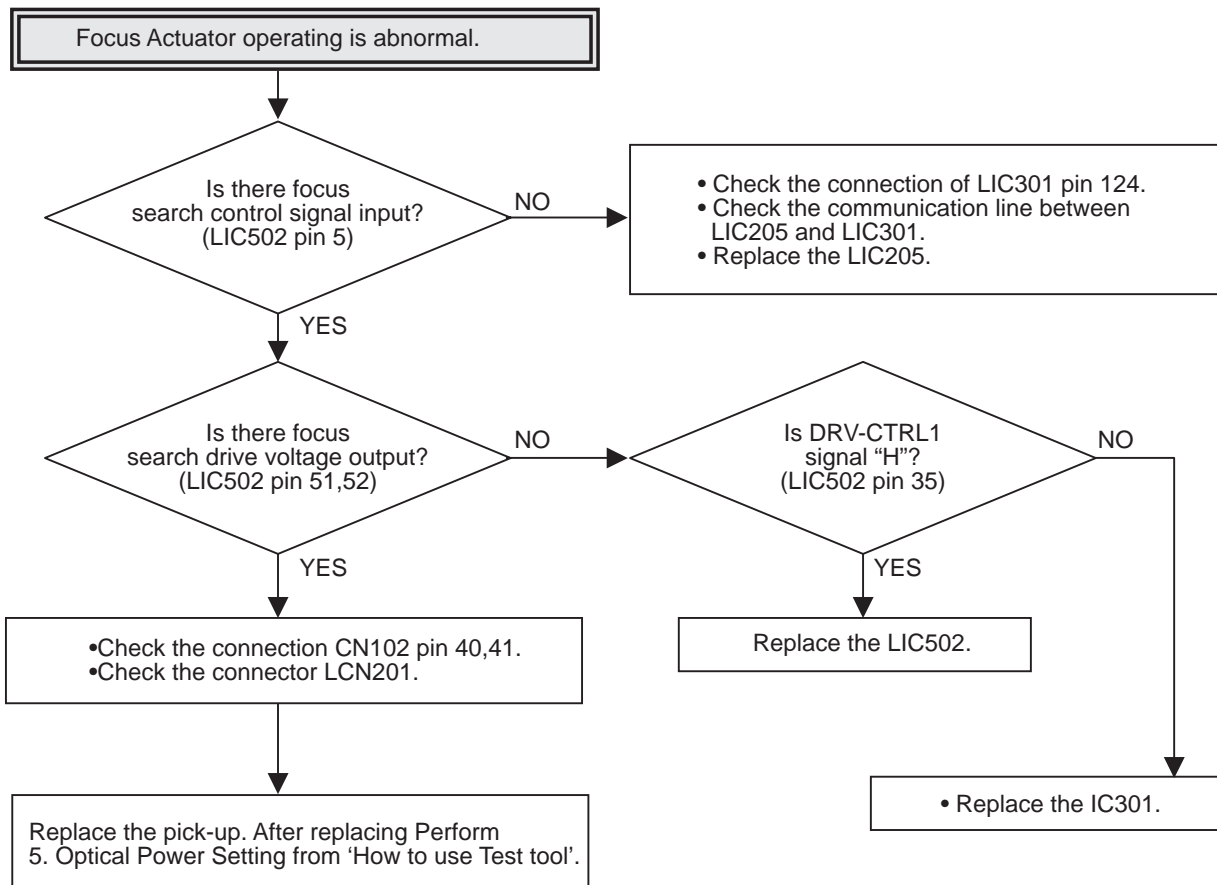
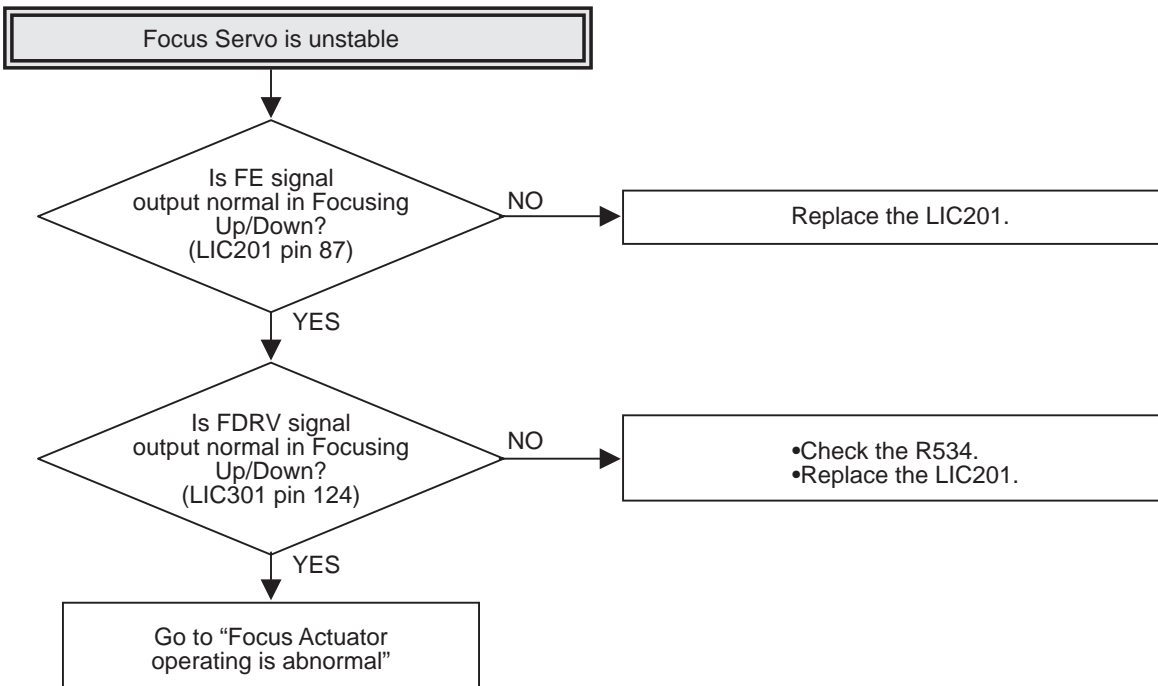

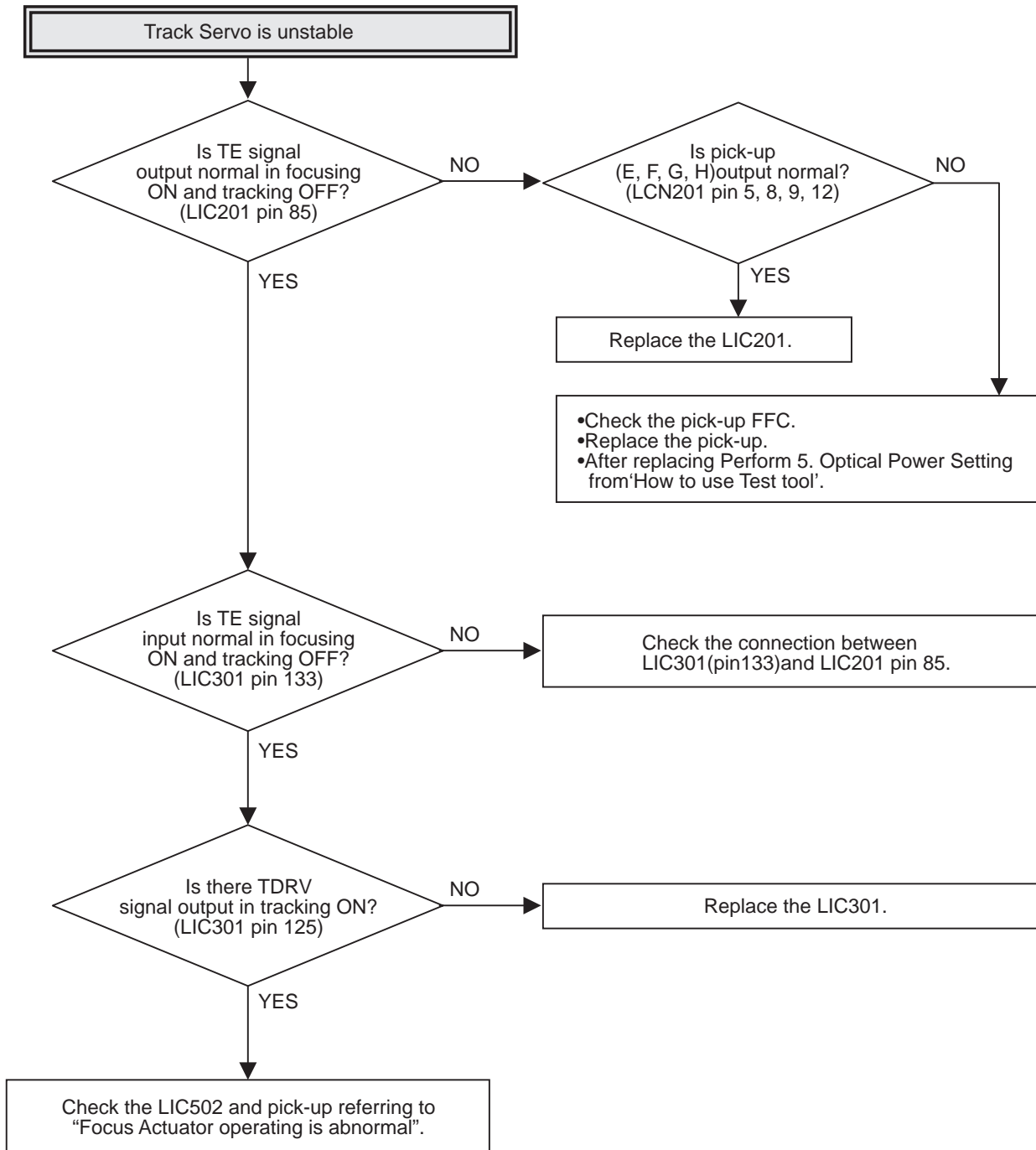

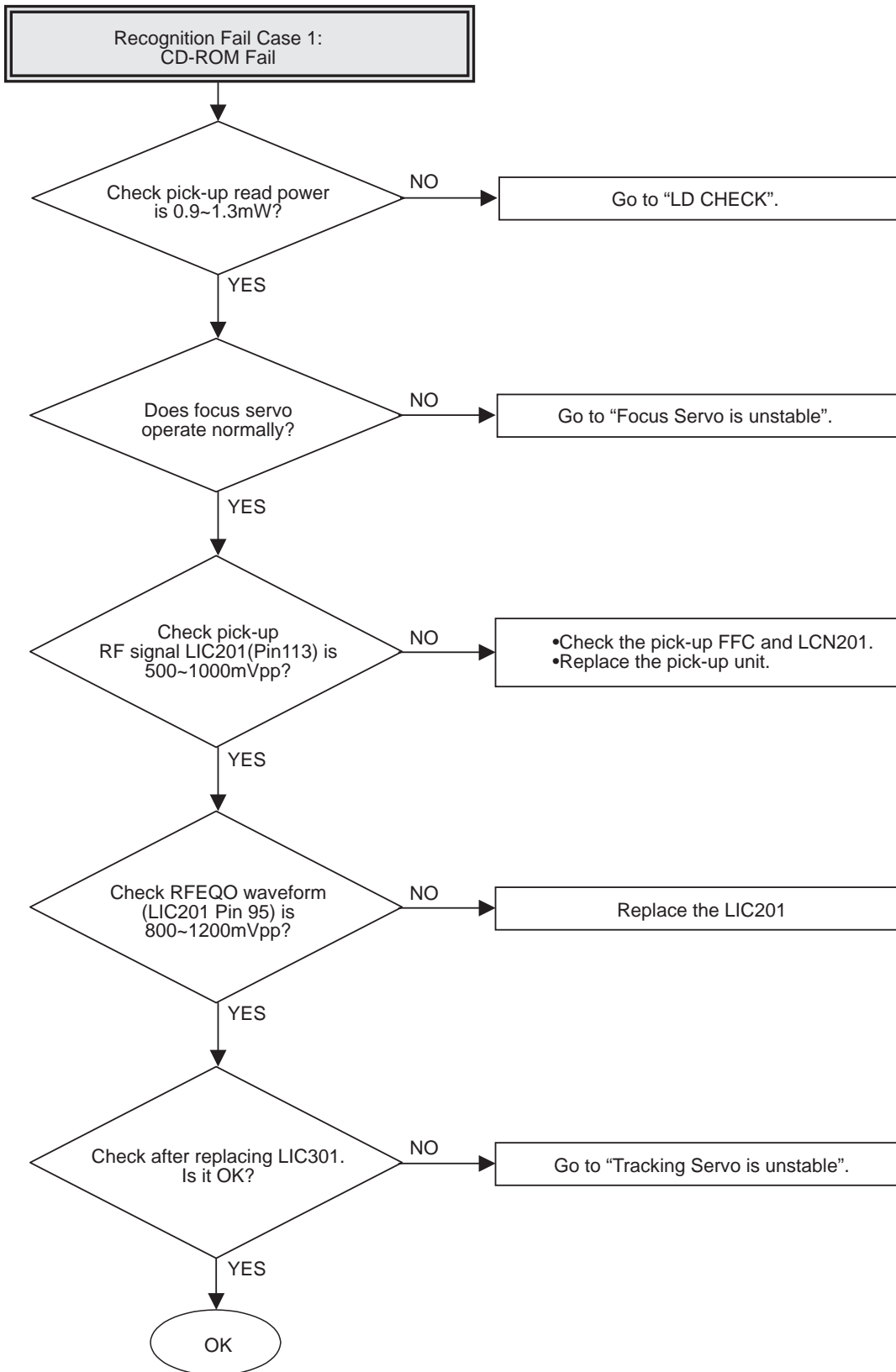

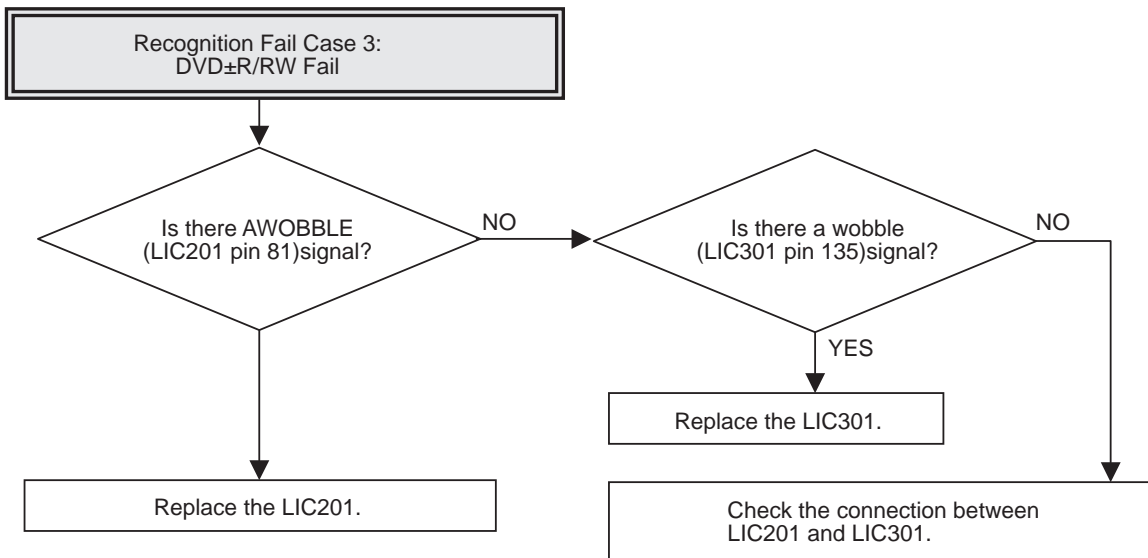
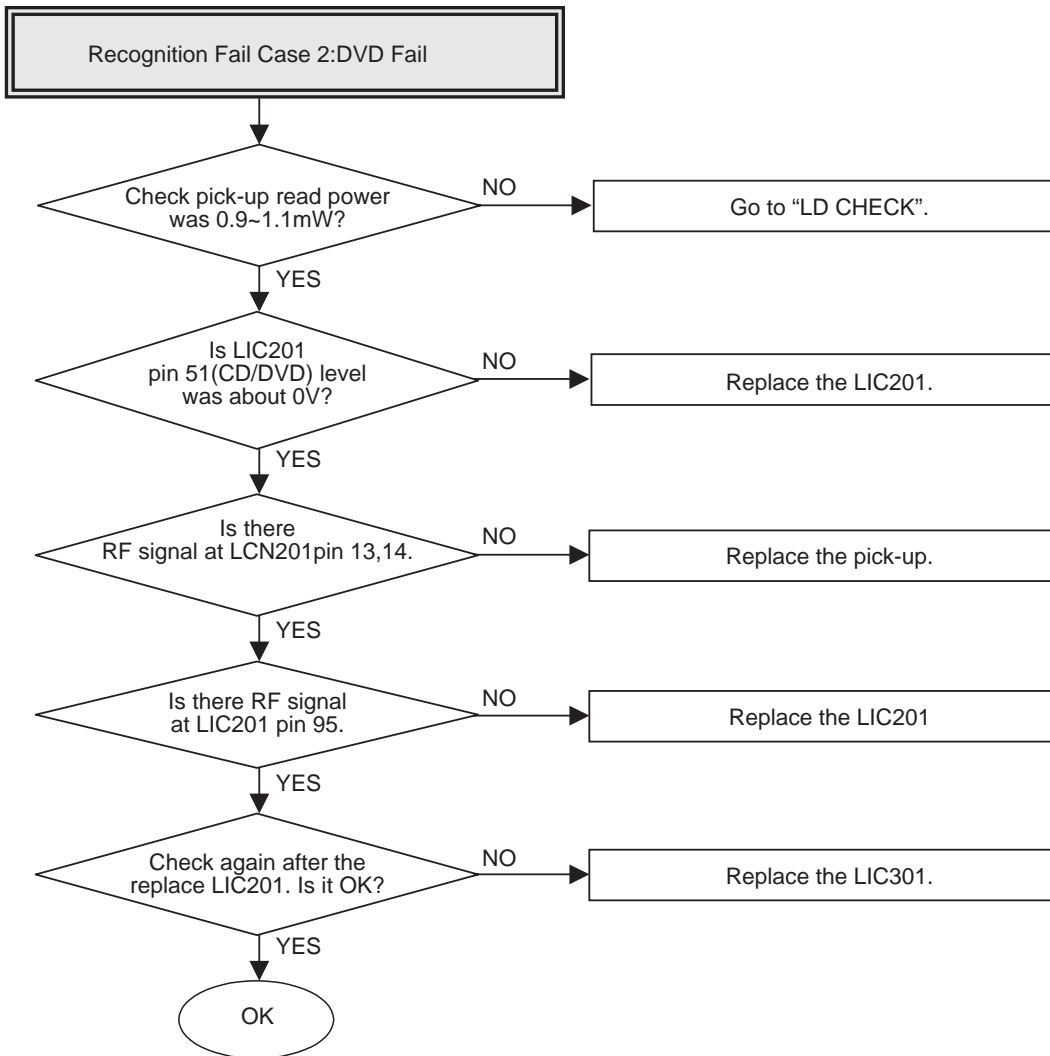

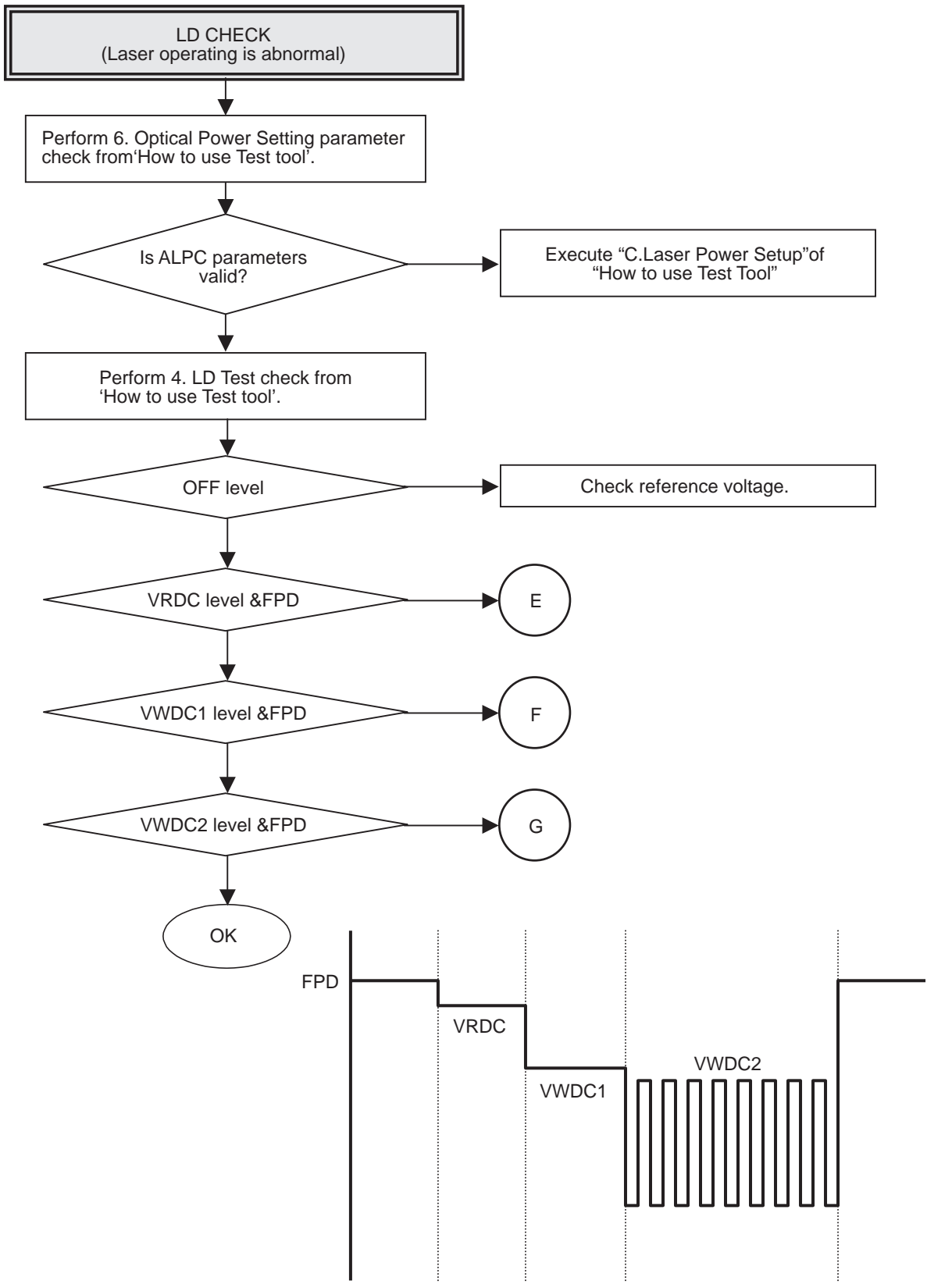

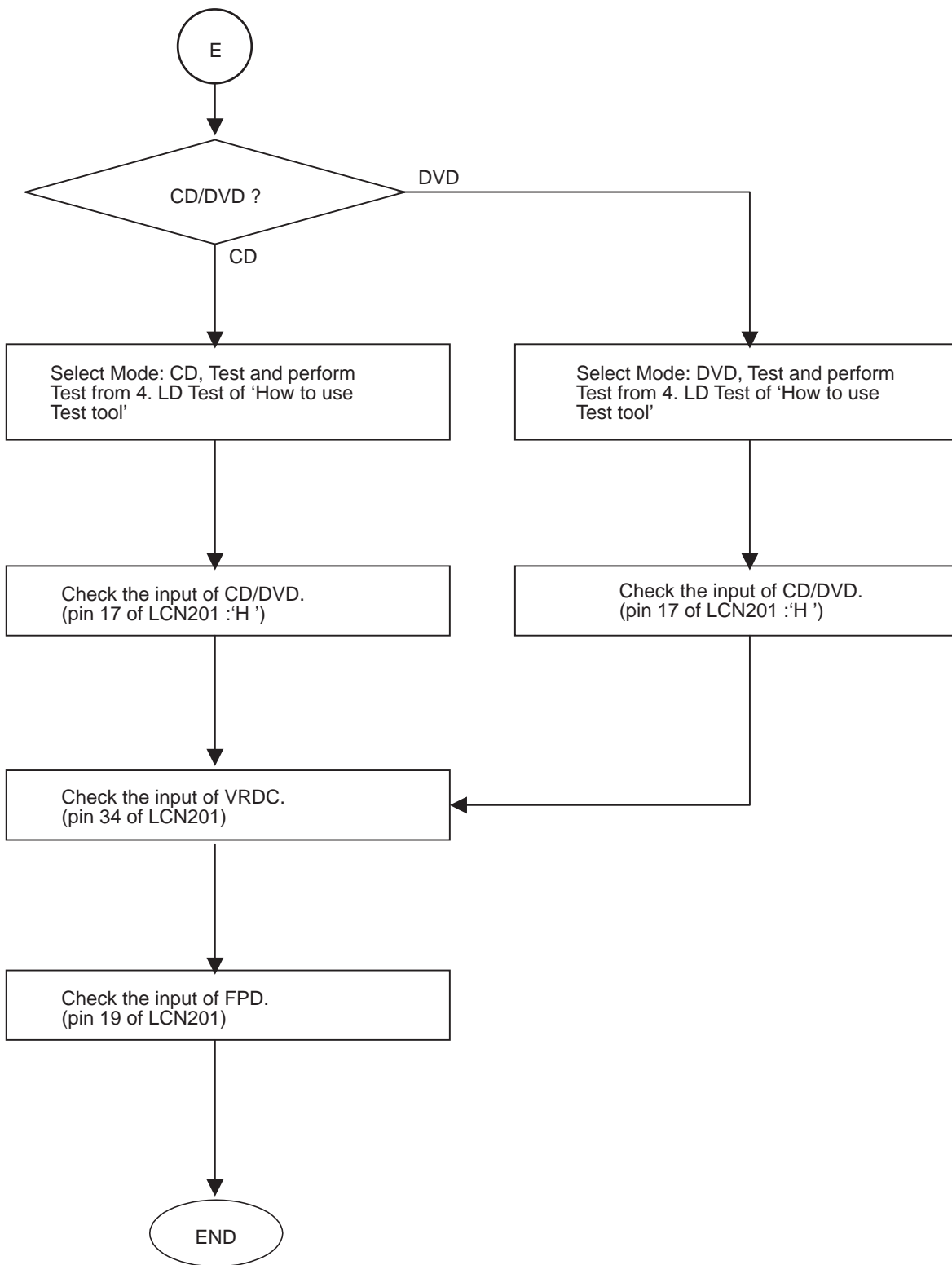

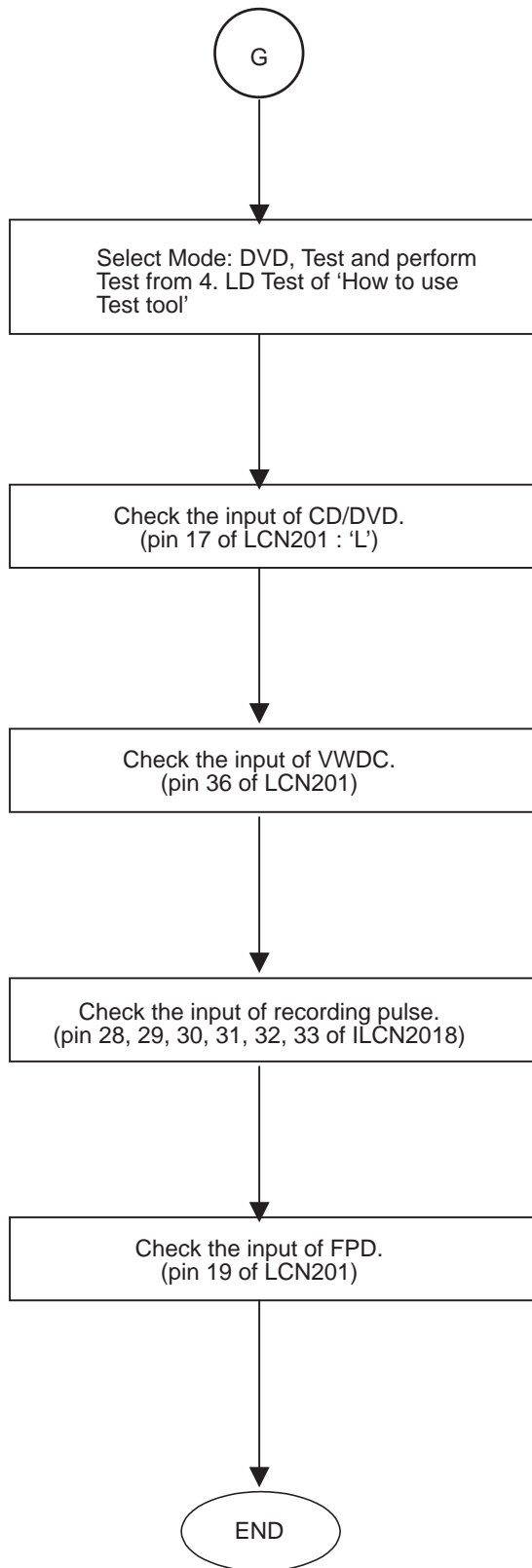
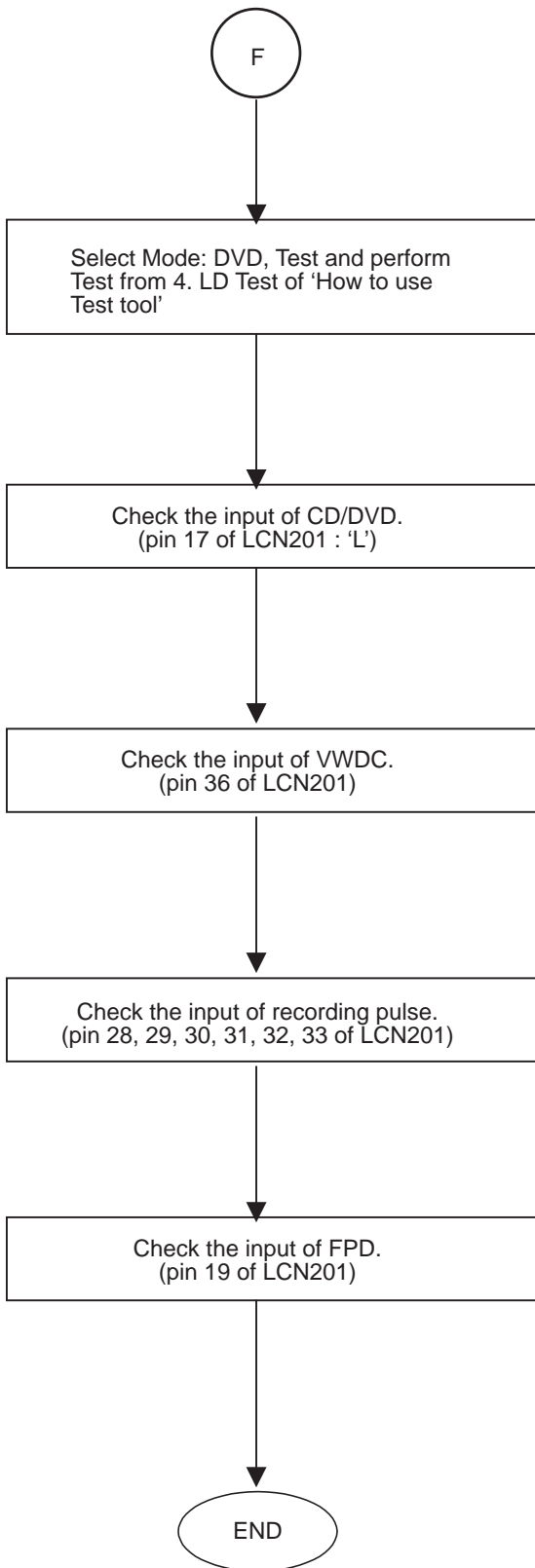

In case of writing fail.

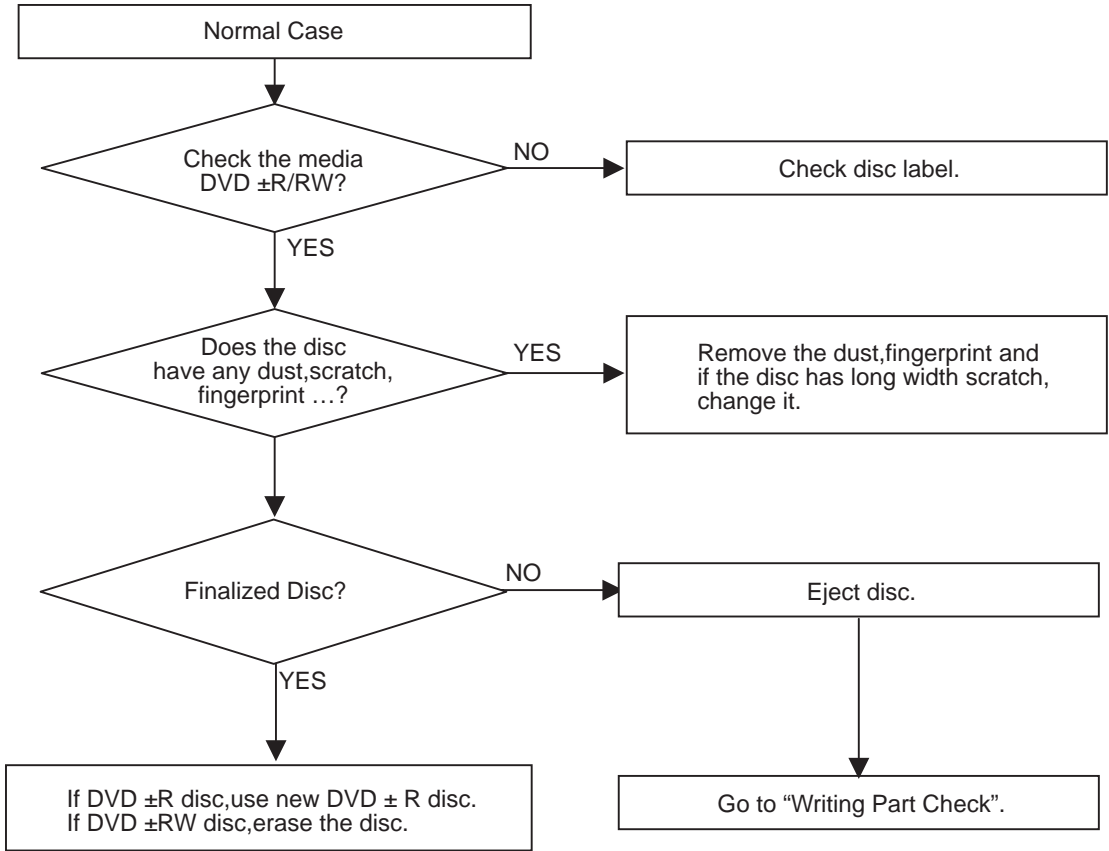

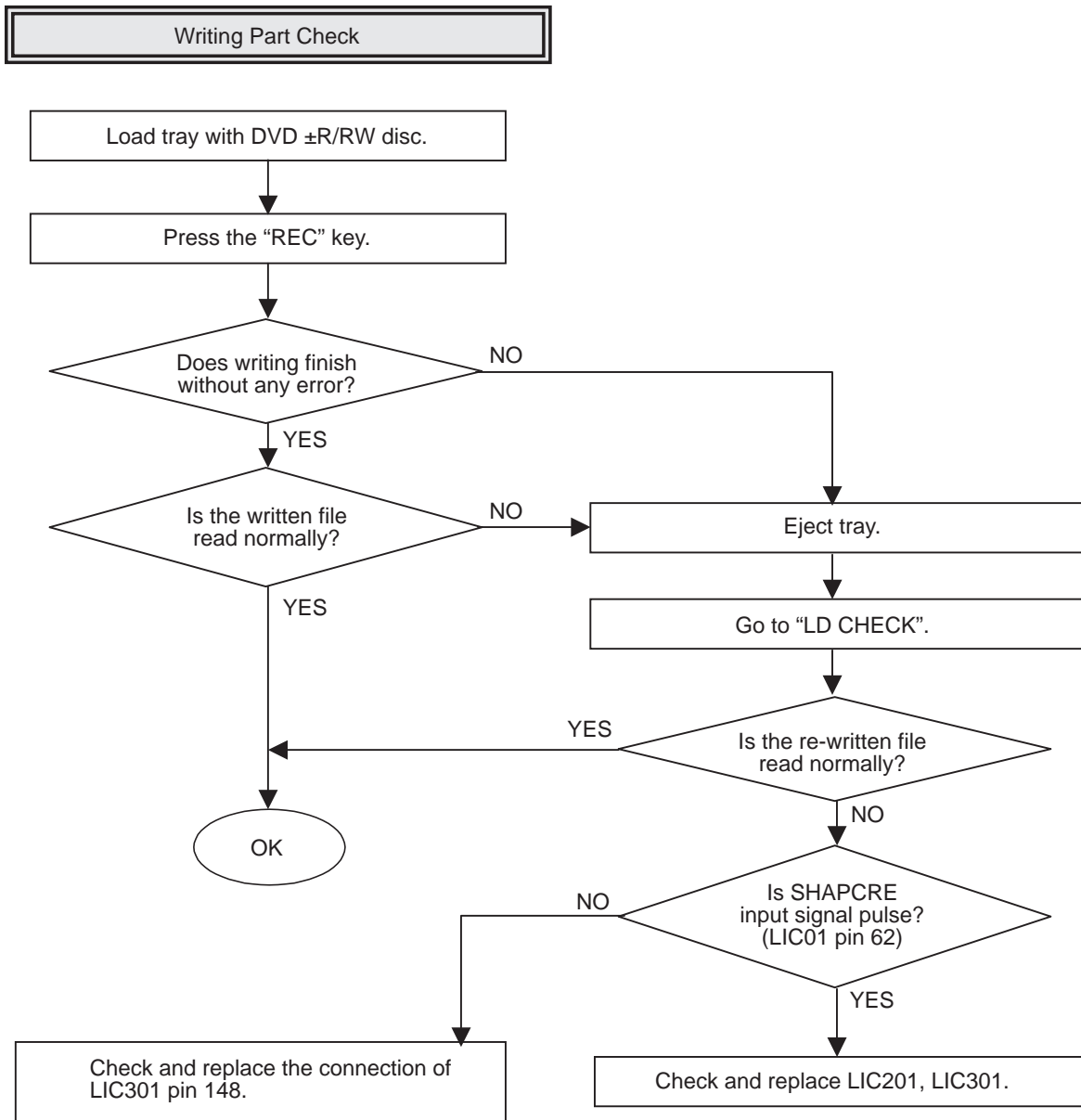

WAVEFORMS

1. POWER & RESET Signal

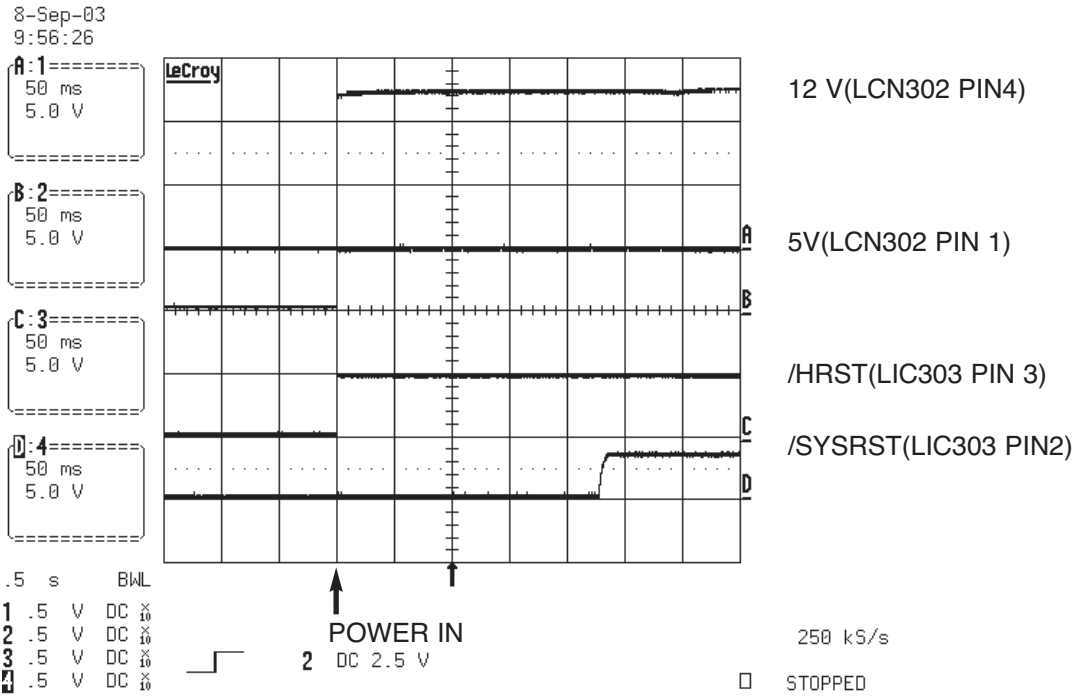

2. Main Clock1 for IC202 (16.9MHz)

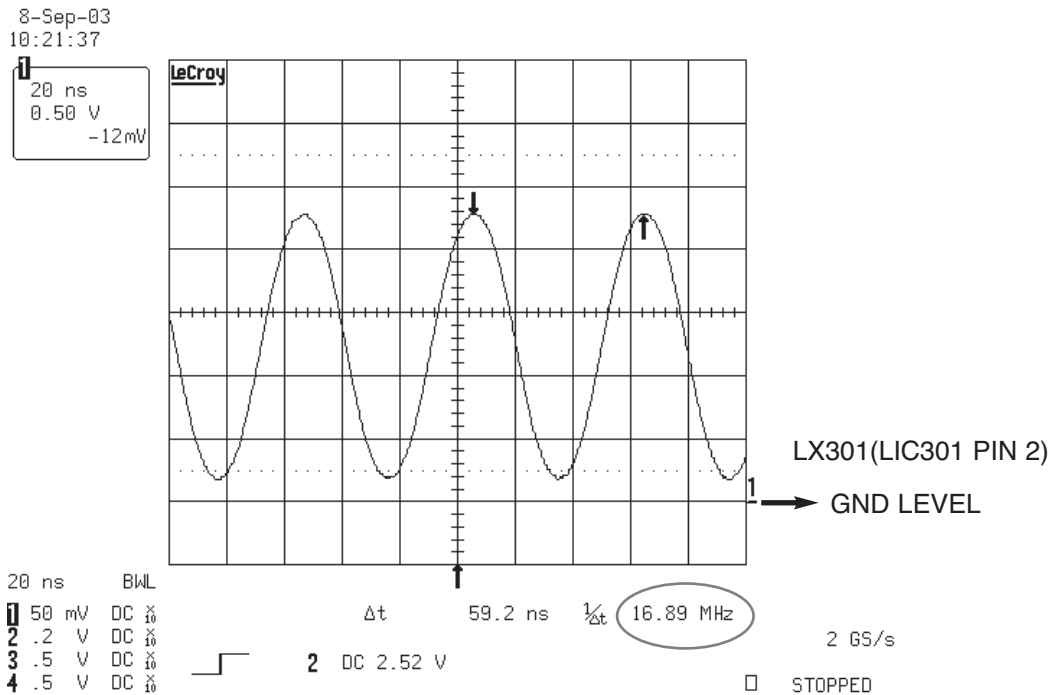

3. SDRAM Clock

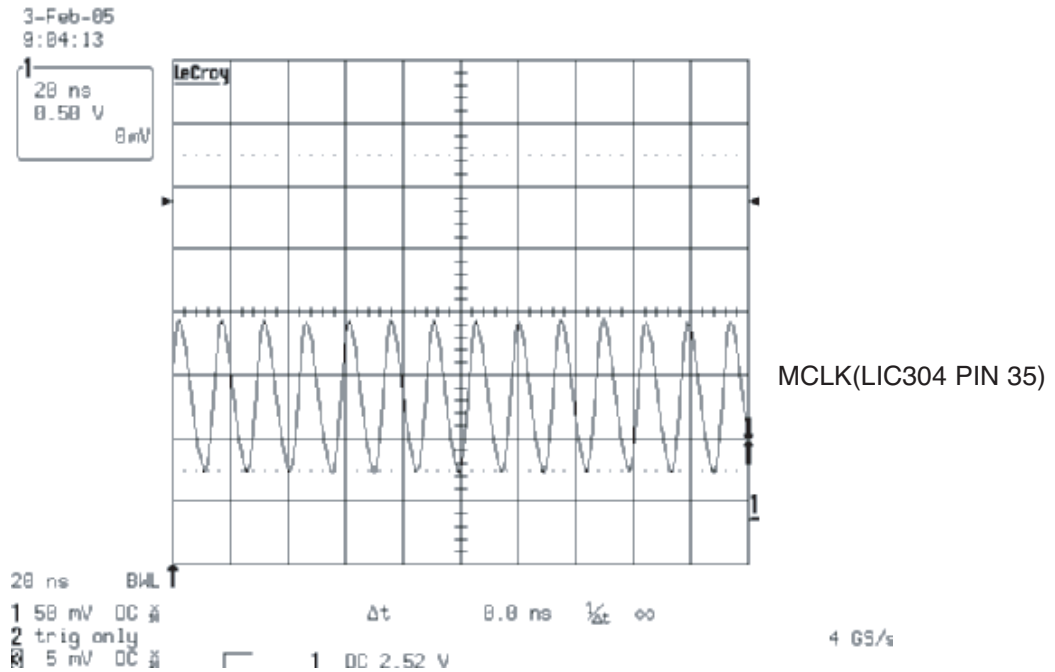

4. TRAY OPEN/CLOSE SIGNAL 1

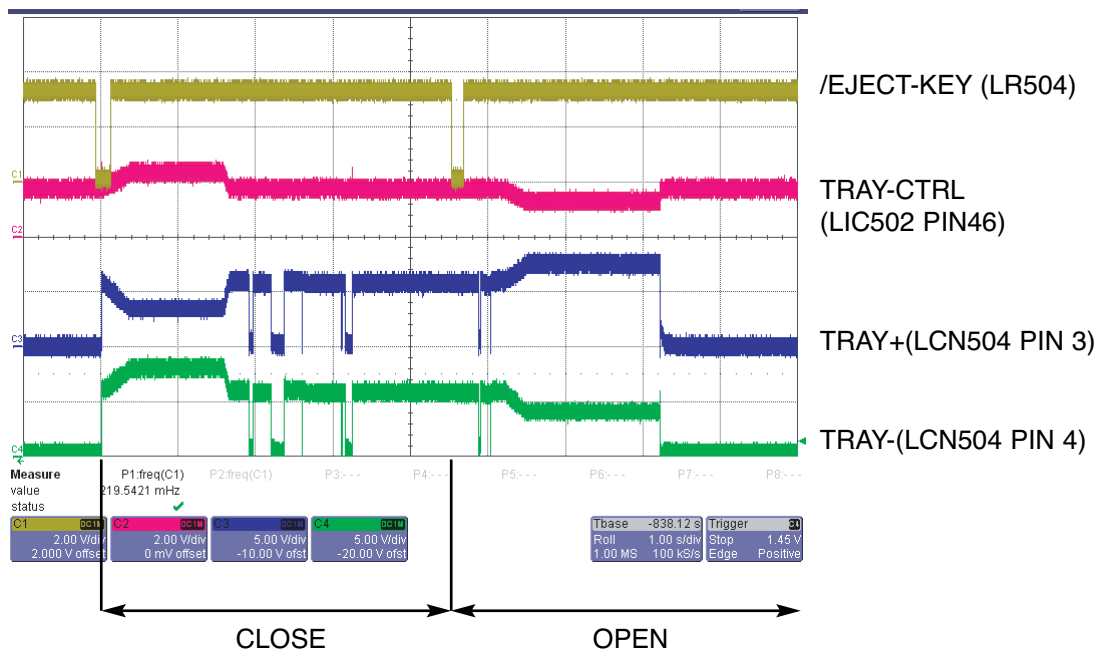

5. TRAY OPEN/CLOSE SIGNAL 2

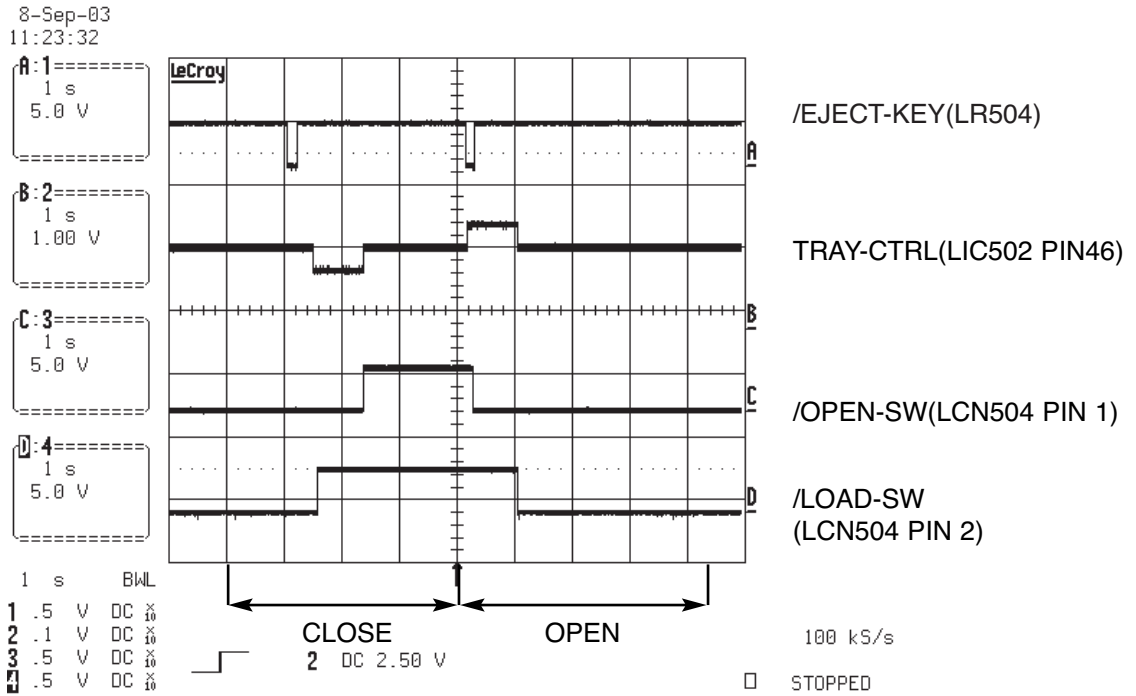

6. SLED MOVE SIGNAL 1

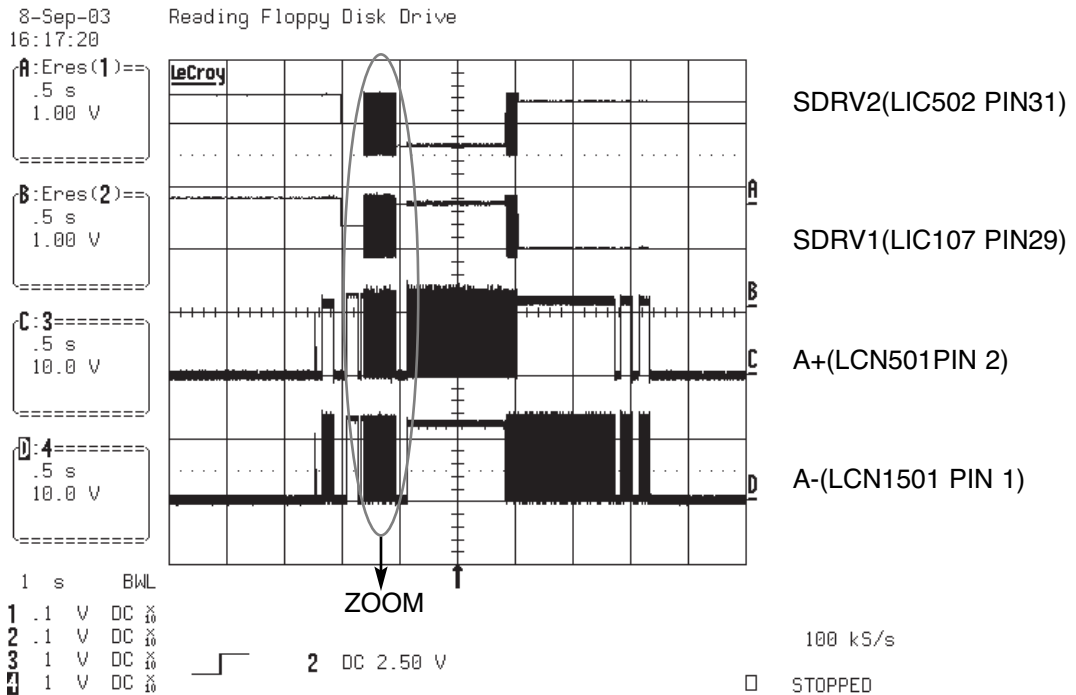

7. SLED MOVE SIGNAL 2

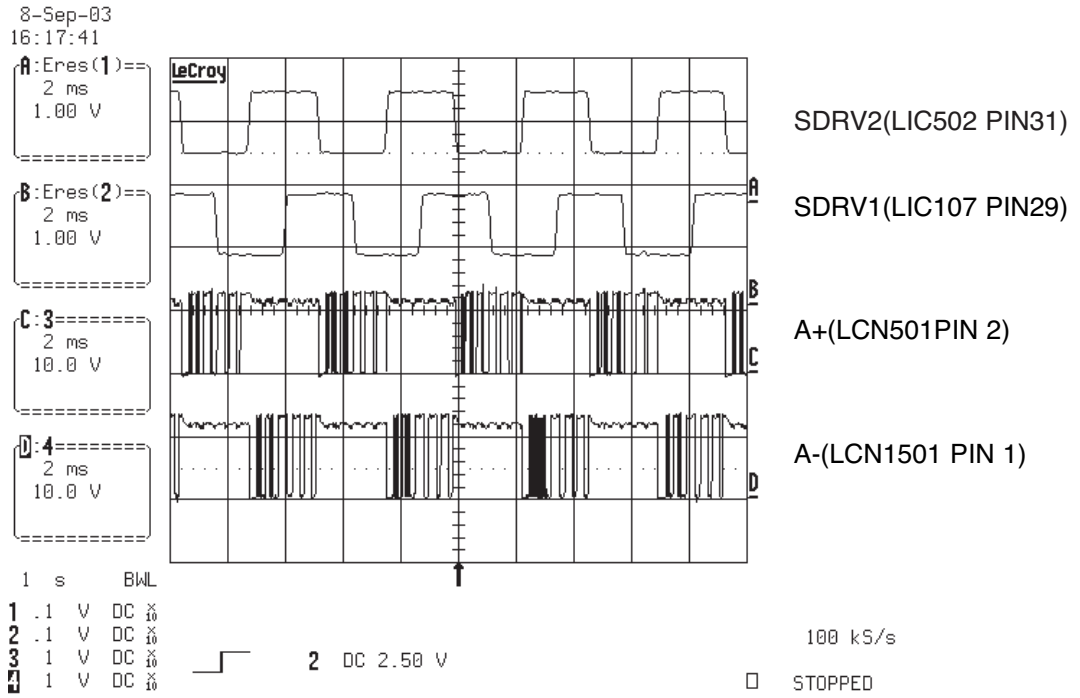

8. FOCUS SEARCH SIGNAL

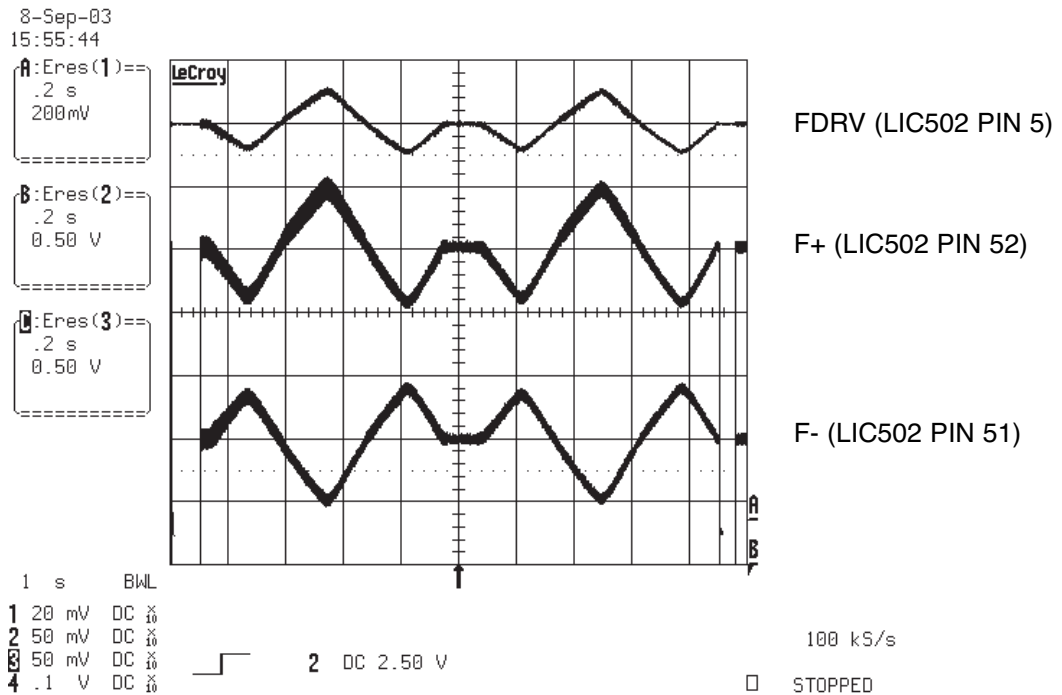

9. LASER TURN ON SIGNAL

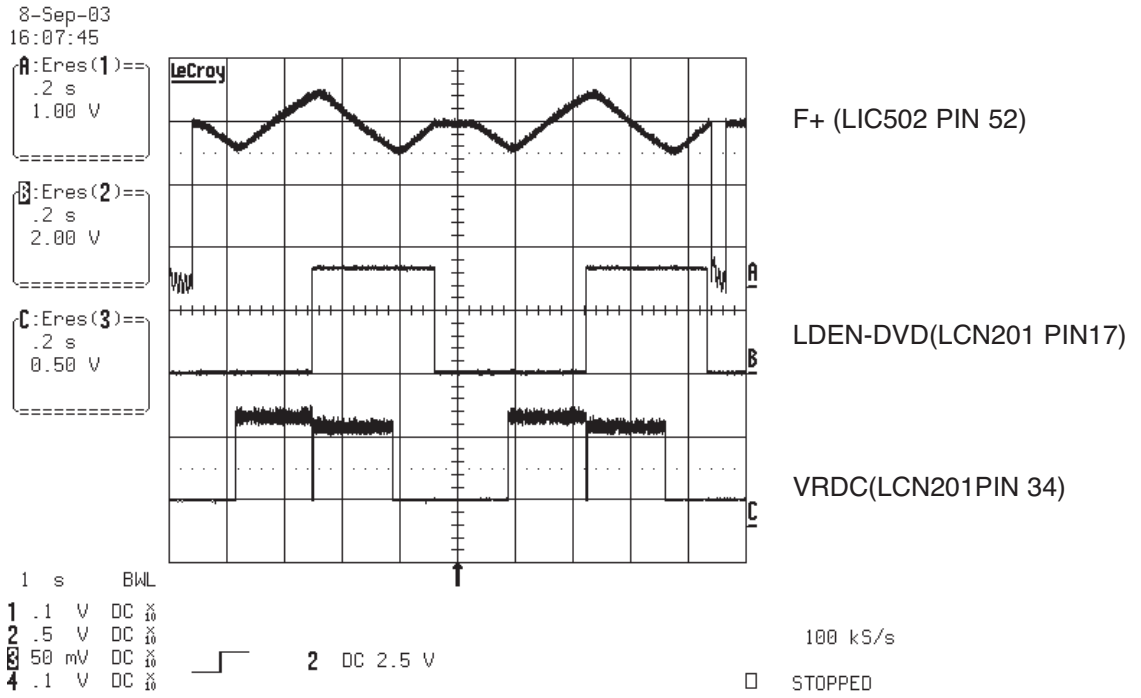

10. DISC TYPE JUDGEMENT WAVEFORM (CD SERIES)

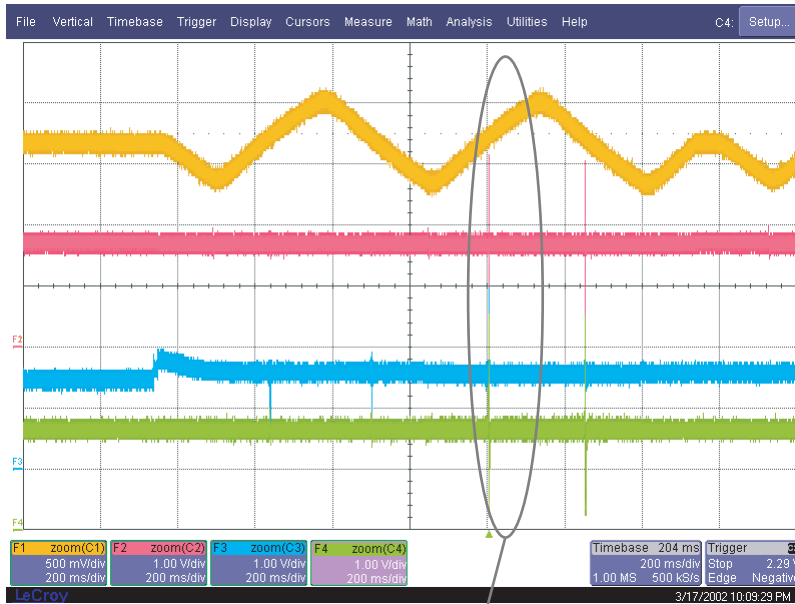

FDRV(LIC502 PIN 5)

FE(LIC201 PIN87)

TE(LIC201 PIN85)

RF(LIC201 PIN 113)

11. DISC TYPE JUDGEMENT WAVEFORM (CD&CD-R)

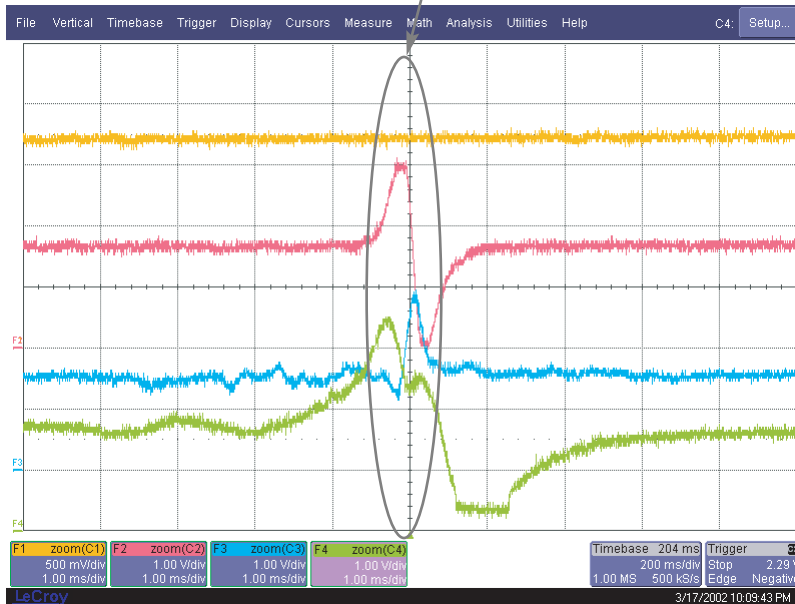

FDRV(LIC502 PIN 5)

FE(LIC201 PIN87)

TE(LIC201 PIN85)

RF(LIC201 PIN 113)

12. DISC TYPE JUDGEMENT WAVEFORM (CD-RW)

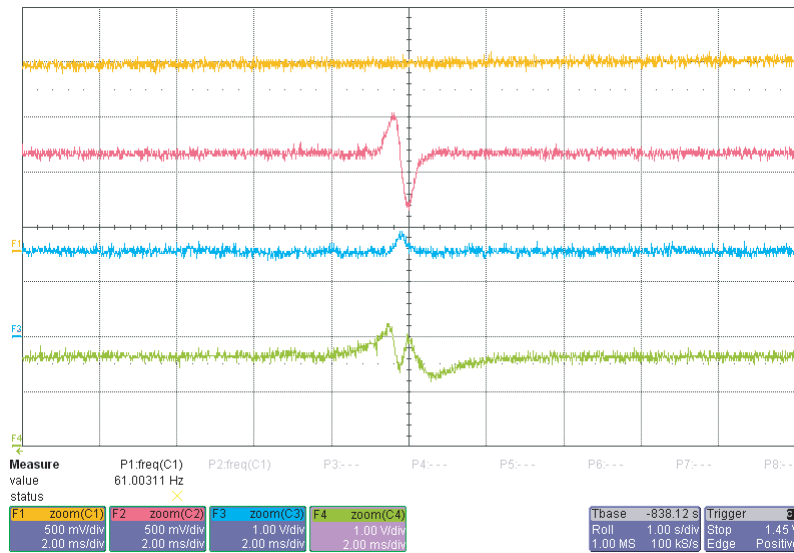

FDRV(LIC502 PIN 5)

FE(LIC201 PIN87)

TE(LIC201 PIN85)

RF(LIC201PIN 113)

13. DISC TYPE JUDGEMENT WAVEFORM (DVD SERIES)



FDRV(LIC502 PIN 5)

FE(LIC201 PIN87)

TE(LIC201 PIN85)

RF(LIC201PIN 113)

14. DISC TYPE JUDGEMENT WAVEFORM (DVD_SINGLE&R)

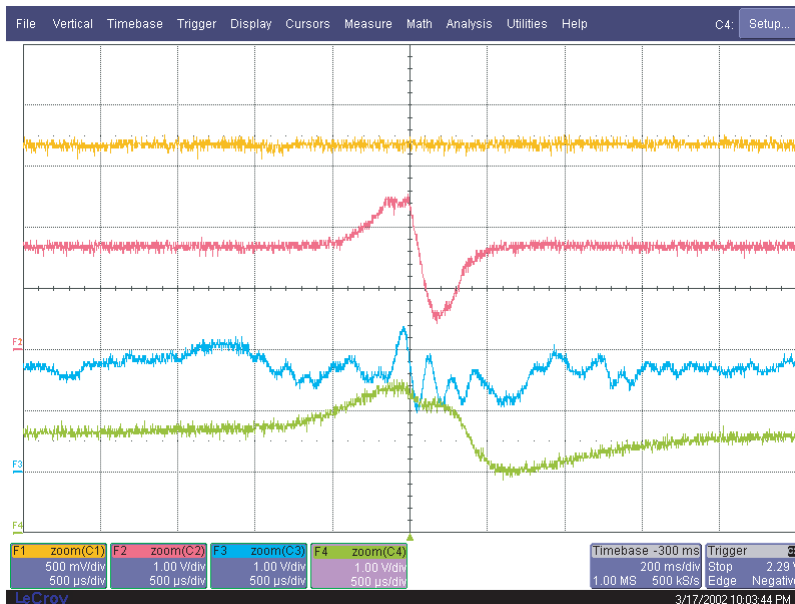

FDRV(LIC502 PIN 5)

FE(LIC201 PIN87)

TE(LIC201 PIN85)

RF(LIC201PIN 113)

15. DISC TYPE JUDGEMENT WAVEFORM (DVD_DUAL)

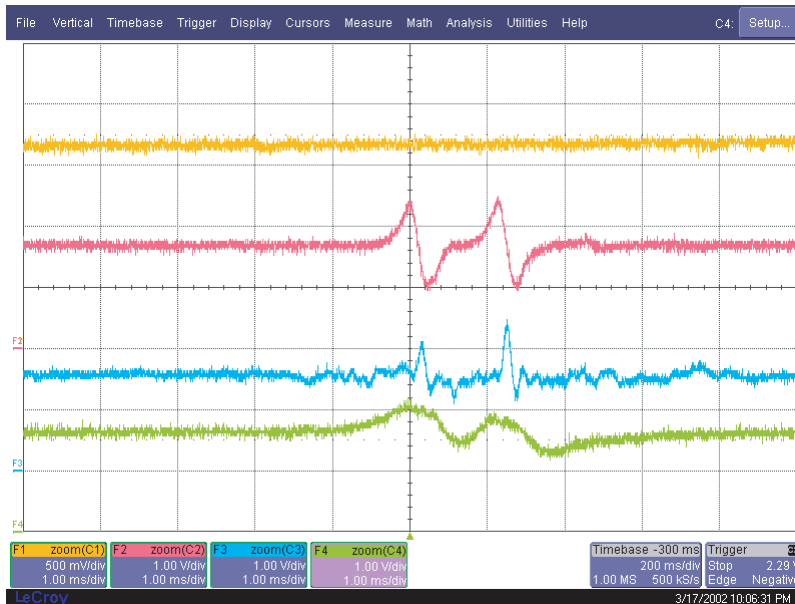

FDRV(LIC502 PIN 5)

FE(LIC201 PIN87)

TE(LIC201 PIN85)

RF(LIC201PIN 113)

16. DISC TYPE JUDGEMENT WAVEFORM (DVDRW)

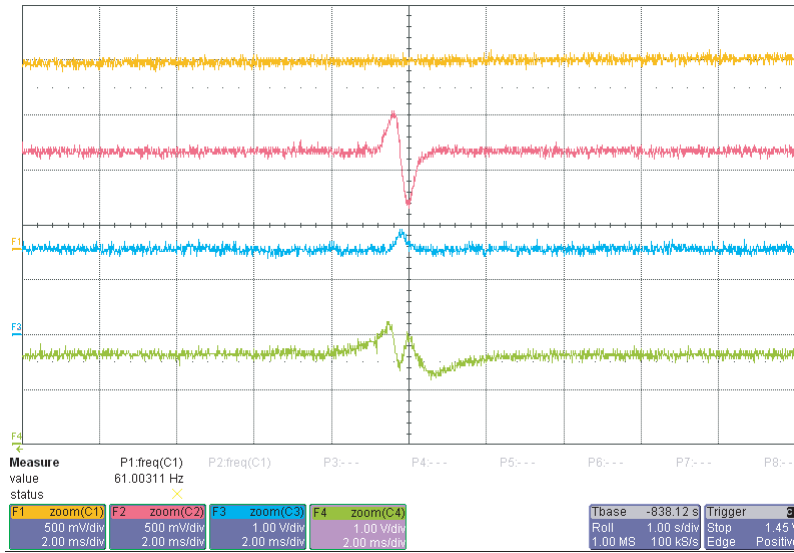

FDRV(LIC502 PIN 5)

FE(LIC201 PIN87)

TE(LIC201 PIN85)

RF(LIC201PIN 113)

17. SPINDLE WAVEFORM1

8-Sep-03
16:58:06

A: Eres(1) ==
.2 s
1.00 V

B: Eres(2) ==
.2 s
1.00 V

C: Eres(3) ==
.2 s
2.00 V

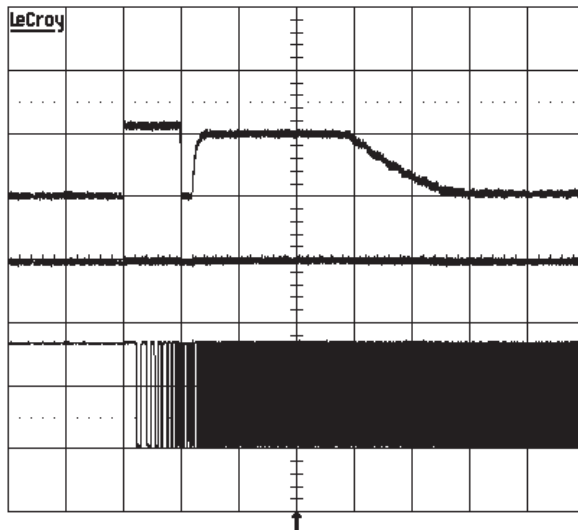

MDRV (LIC502 PIN 26)

REFOUT (LIC502 PIN 42)

SFG((LIC502 PIN43)

1 s BWL
1 .1 V DC $\frac{\infty}{10}$
2 .1 V DC $\frac{\infty}{10}$
3 .2 V DC $\frac{\infty}{10}$
4 .5 V DC $\frac{\infty}{10}$

2 DC 2.50 V

100 kS/s

STOPPED

18. SPINDLE WAVEFORM2

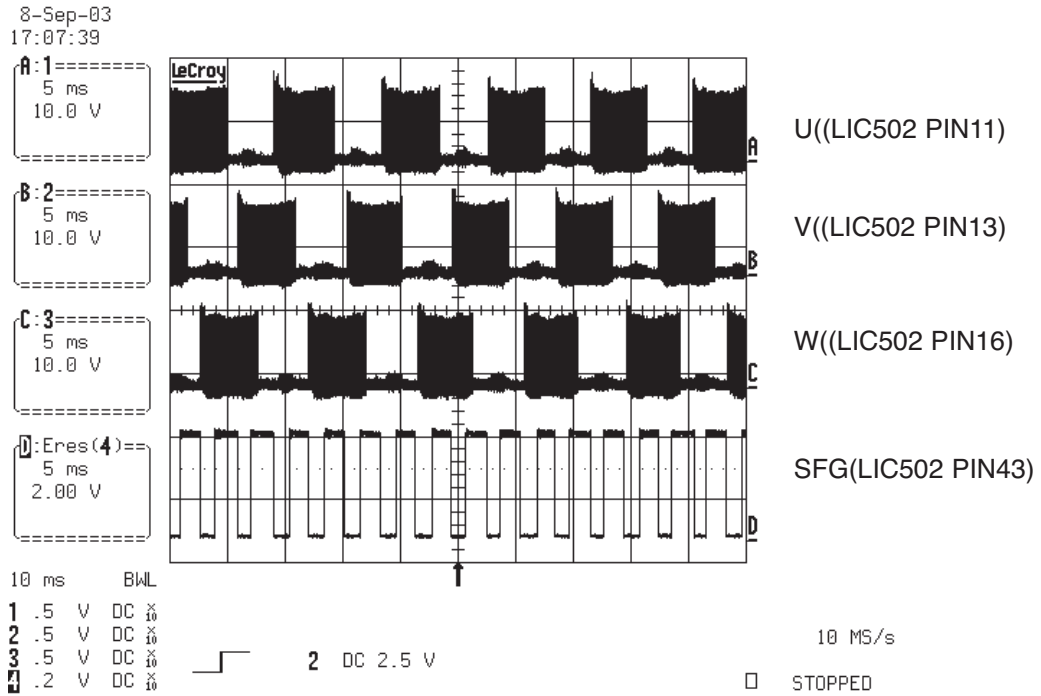

19. FOCUS ON SIGNAL(CD)

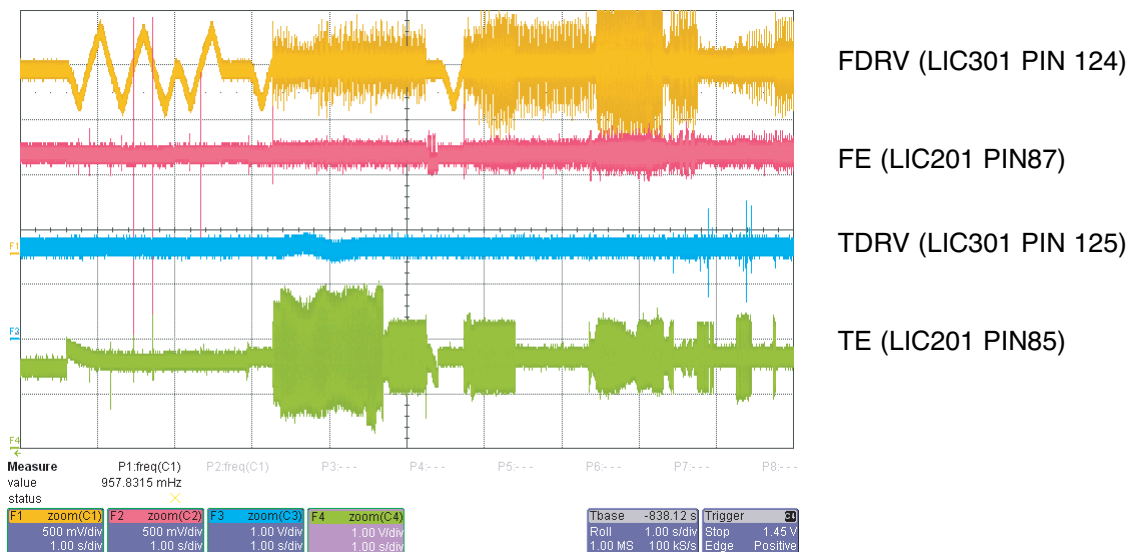

20. FOCUS ON SIGNAL(CD)

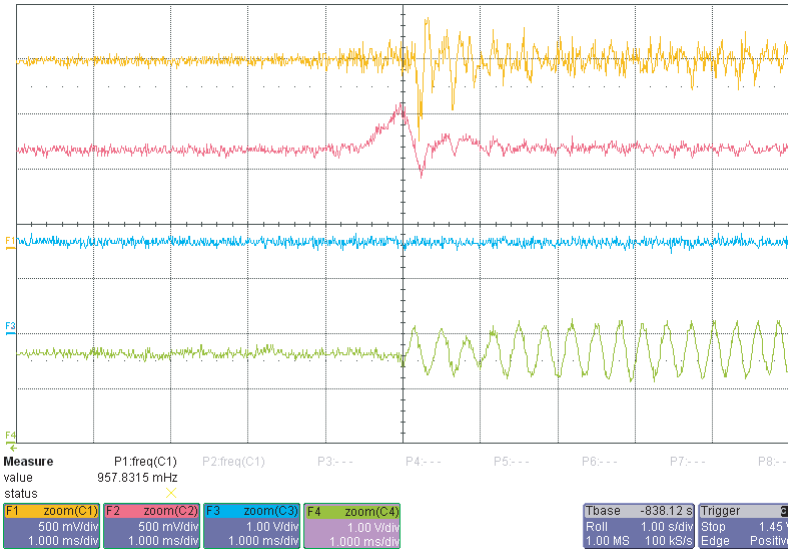

FDRV (LIC301 PIN 124)

FE (LIC201 PIN87)

TDRV (LIC301 PIN 125)

TE (LIC201 PIN85)

21. FOCUS ON SIGNAL(DVD)

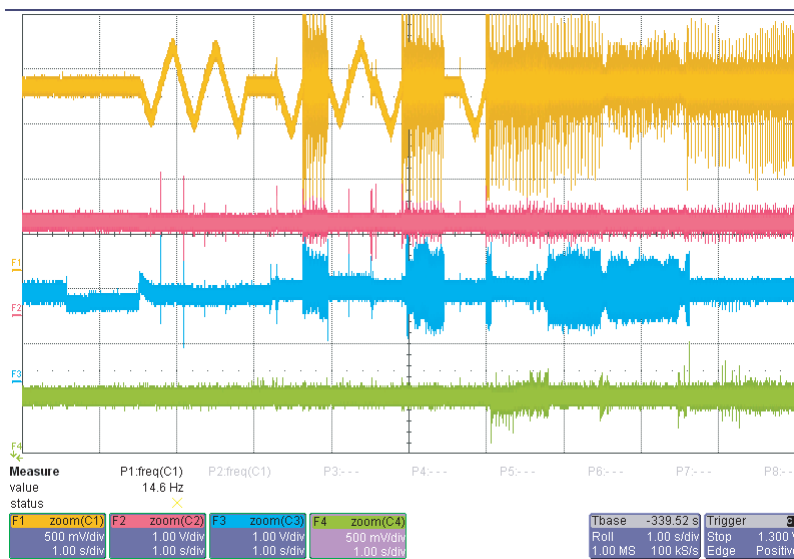

FDRV (LIC301 PIN 124)

FE (LIC201 PIN87)

TDRV (LIC301 PIN 125)

TE (LIC201 PIN85)

22. FOCUS ON SIGNAL (DVD)

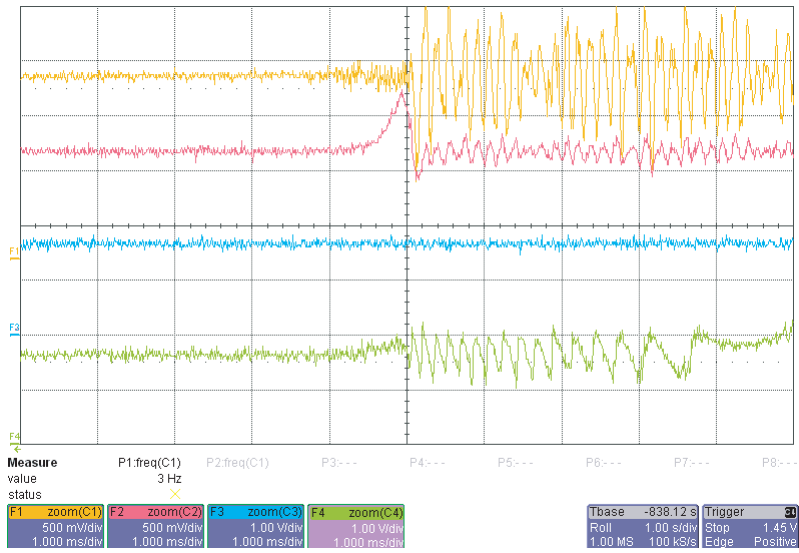

FDRV (LIC301 PIN 124)

FE (LIC201 PIN87)

TDRV (LIC301 PIN 125)

TE (LIC201 PIN85)

23. TRACK OFF SIGNAL(CD)

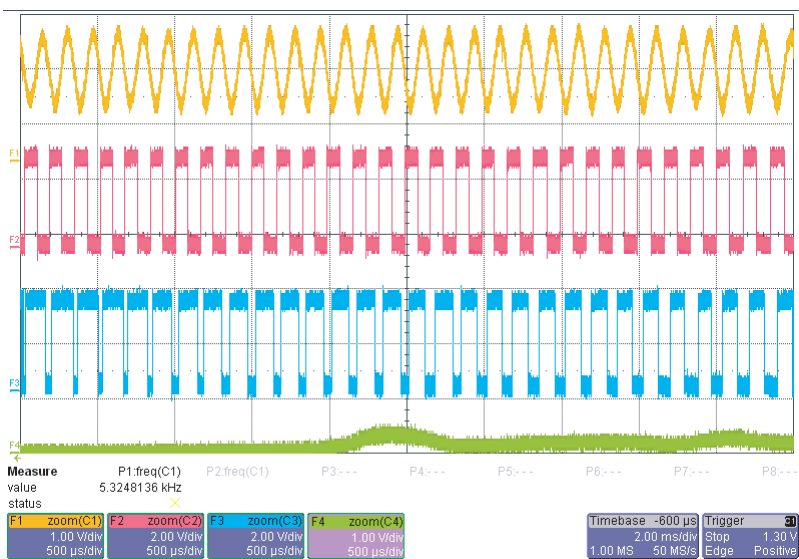

TE (LIC106 PIN85)

TZC(LIC106 PIN74)

MIRRBCA(LIC106 PIN77)

24. TRACK OFF SIGNAL(DVD)

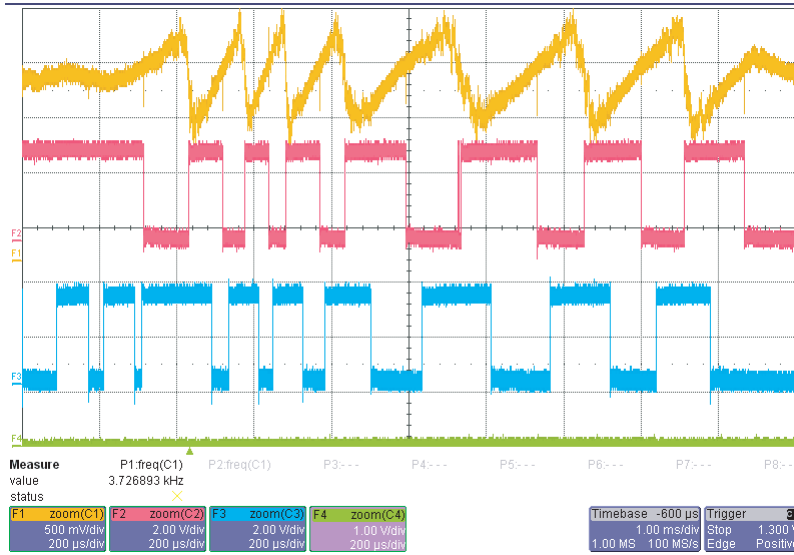

TE (LIC106 PIN85)

TZC(LIC106 PIN74)

MIRRBCA(LIC106 PIN77)

25. Tilt Driver signal(Disc reading)

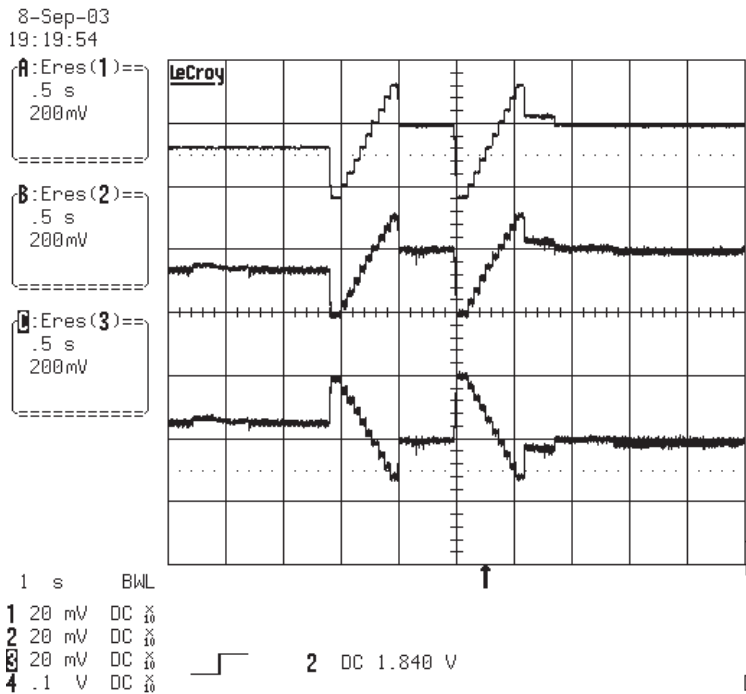

TILTDRV(LIC502 PIN47)

TILT+(LIC502 PIN50)

TILT-(LIC502 PIN49)

26. RF WAVEFORM(DVD)

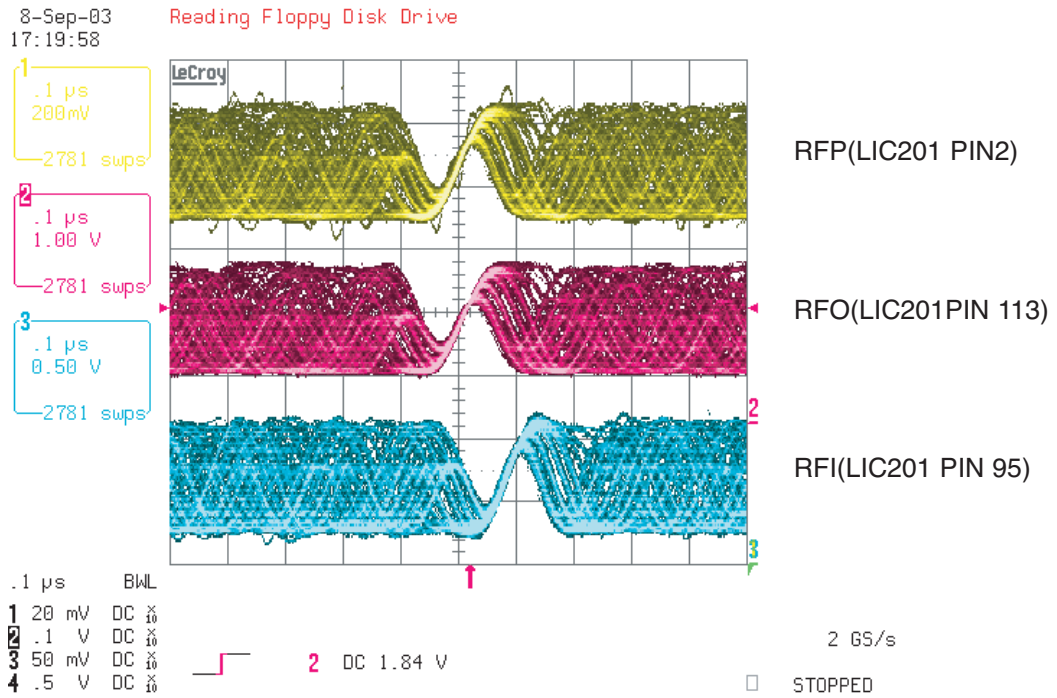

27. RF WAVEFORM(CD)

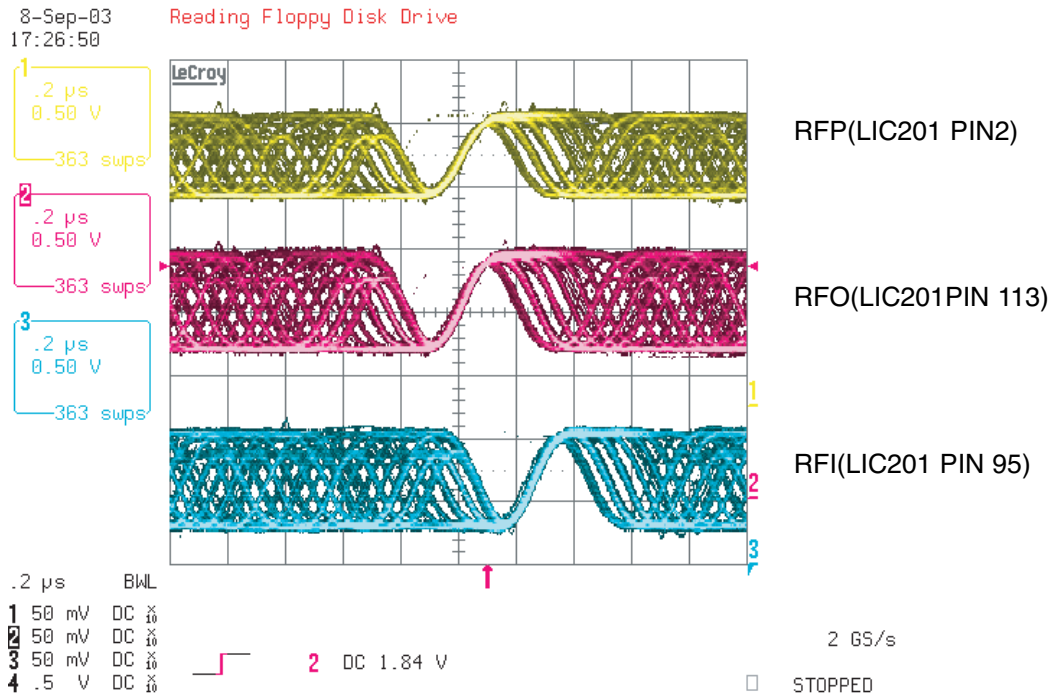

28. WOBBLE(DVD-R/RW)_READING

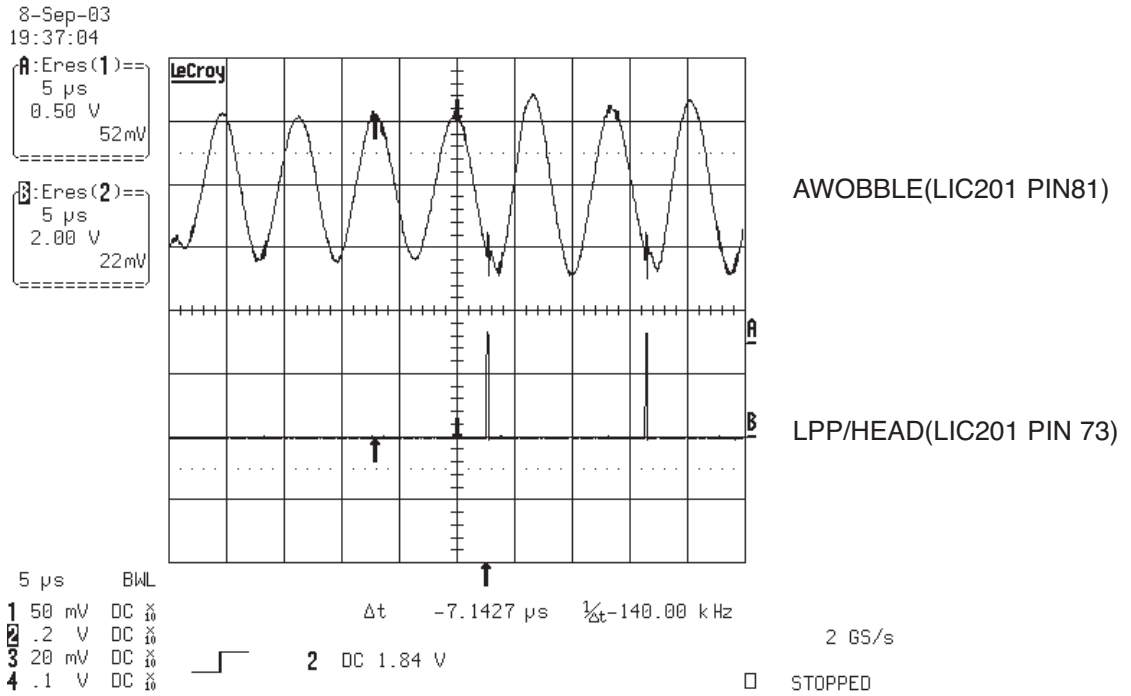

29. WOBBLE(DVD+R/RW)_READING& WRITING => X1 SPEED

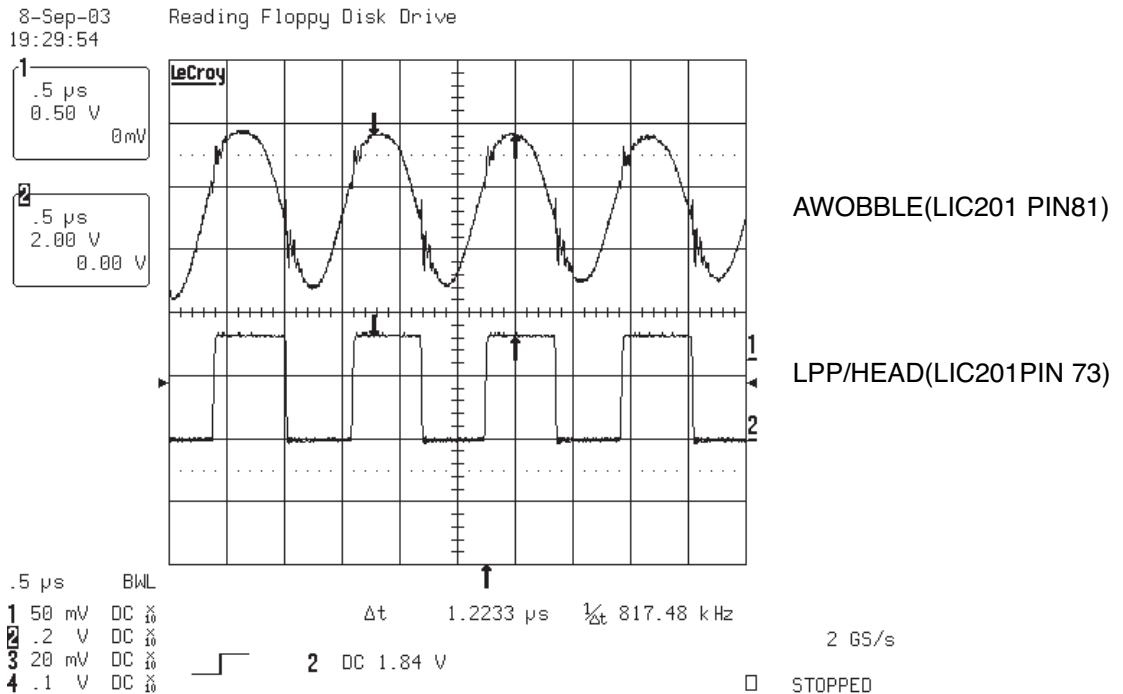

30. LD Enable(DVD)

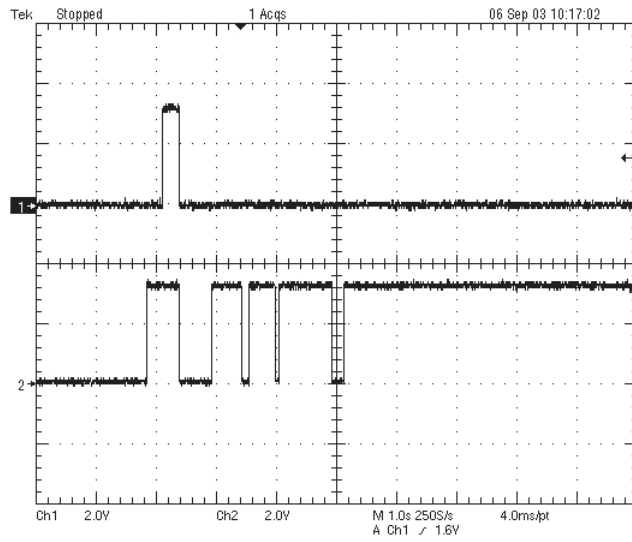

CD/DVD(LCN201 PIN 17)

LDEN(LCN PIN 38)

31. LD Enable(CD)

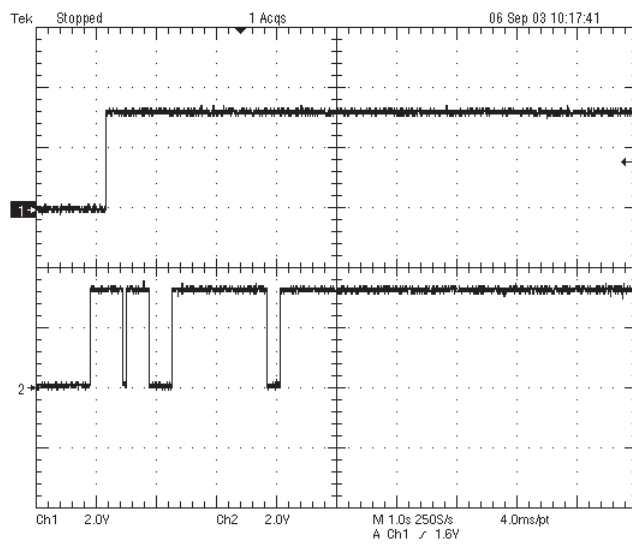

CD/DVD(LCN201 PIN 17)

LDEN(LCN102 PIN 38)

32. Laser Power(reading) _ DVD+RW

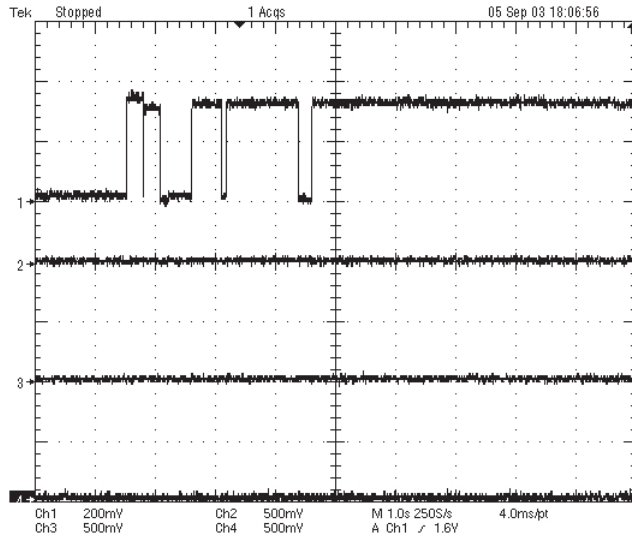

VRDC(LCN201 PIN 34)

VWDC(LCN201 PIN 36)

VWDC2(LCN201 PIN 35)

OPCTRG(LIC301 PIN 151)

33. Laser Power(Erase) _ DVD+RW

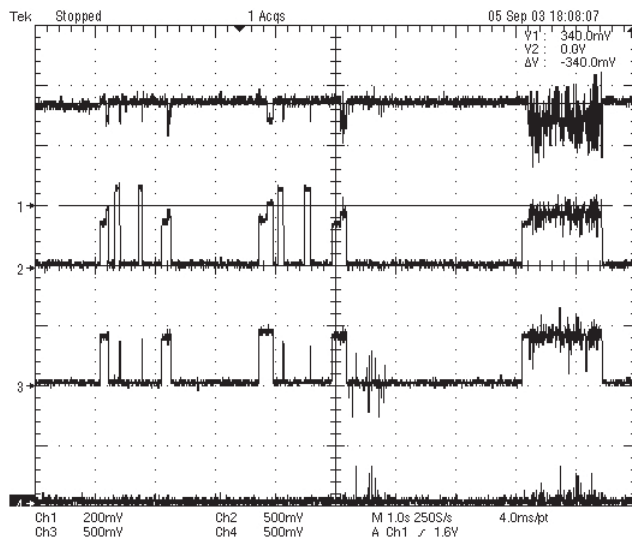

VRDC(LCN201 PIN 34)

VWDC(LCN201 PIN 36)

VWDC2(LCN201 PIN 35)

OPCTRG(LIC301 PIN 151)

34. Laser Power(Writing) _ initial state

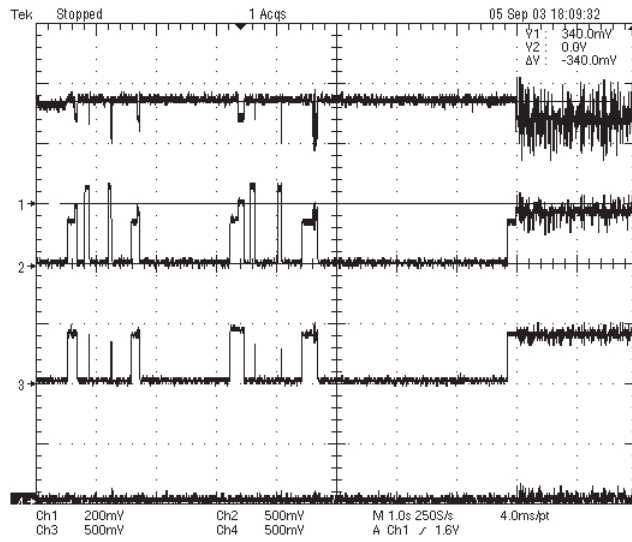

VRDC(LCN201 PIN 34)

VWDC(LCN201 PIN 36)

VWDC2(LCN102 PIN 35)

OPCTRG(LIC301 PIN 151)

35.Laser Power(Writing)_Processing

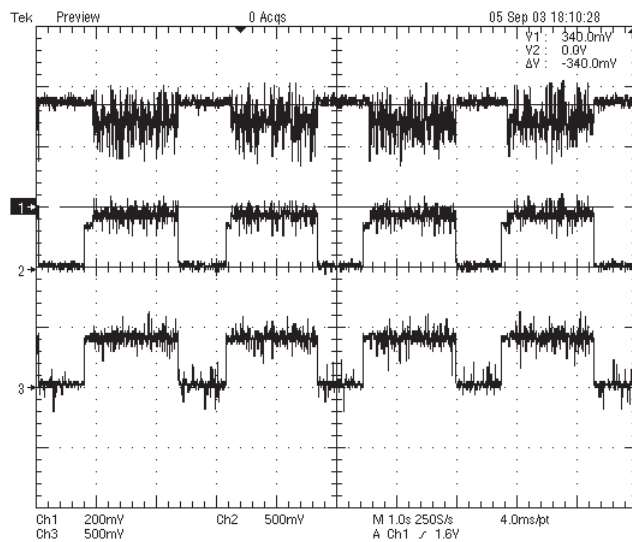

VRDC(LCN201 PIN 34)

VWDC(LCN201 PIN 36)

VWDC2(LCN201 PIN 35)

The difference of DVD-R/RW, DVD+R/RW discs and DVD-ROM

1. Recording Layer

- DVD-ROM (Read Only Disc)

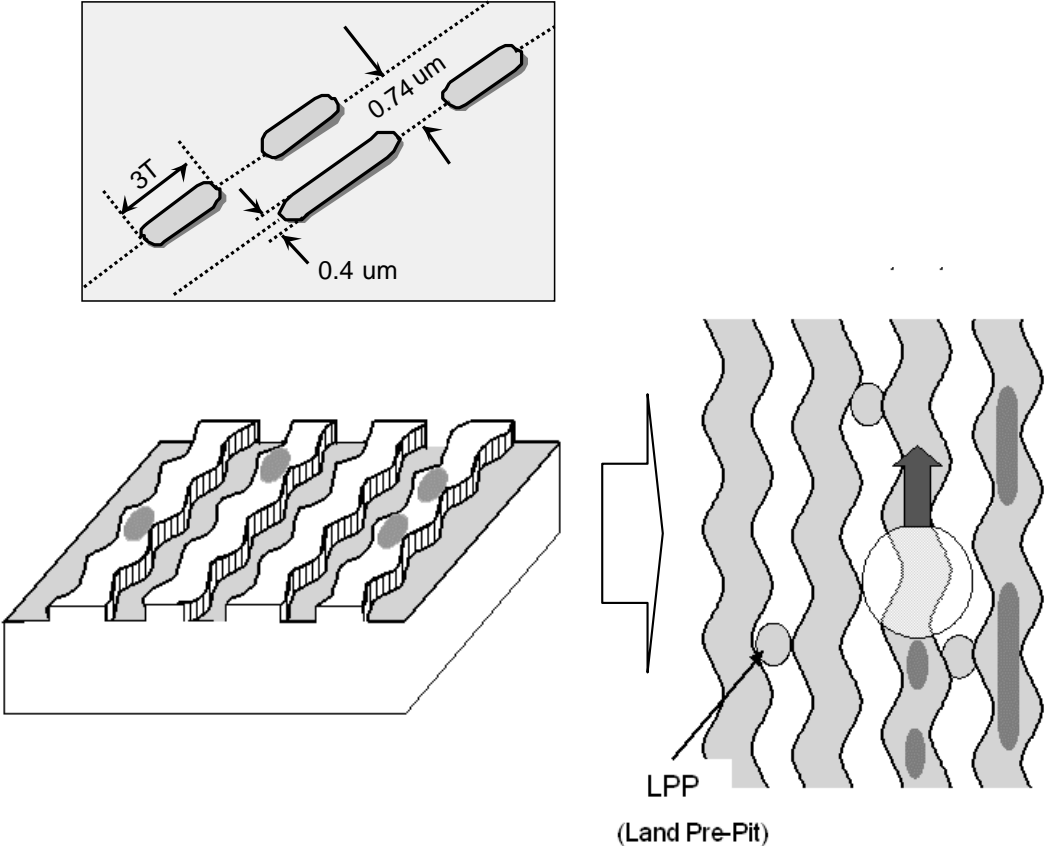

- DVD+R/RW Disc

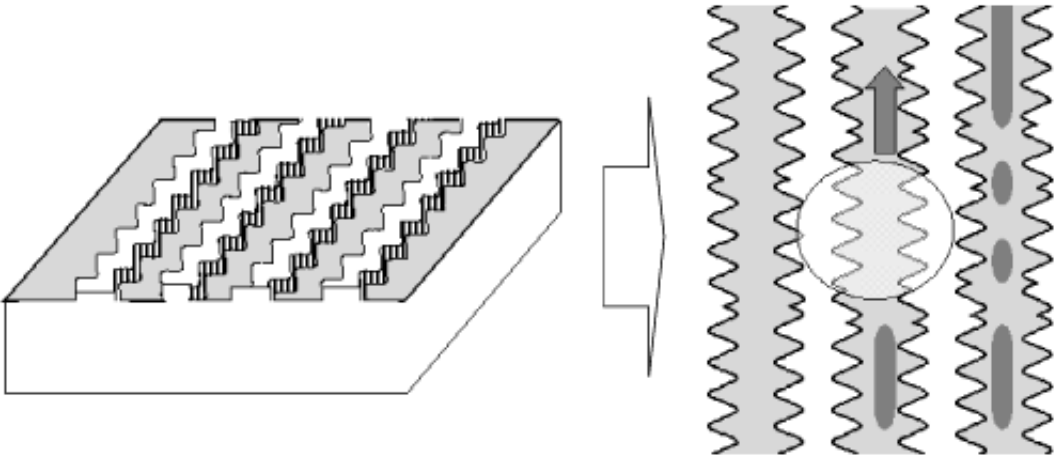

2. Disc Specification

	DVD-ROM		DVD-R	DVD-RW	DVD+R	DVD+RW
	Single-Layer	Dual-Layer				
Media Type	Read Only	Read Only	Dye	Phase change	Dye	Phase change
User data capacity	4.7GB	8.54GB	4.7GB	4.7GB	4.7GB	4.7GB
Wavelength	650nm	650nm	650nm	650nm	650nm	650nm
Reflectivity	45~85%	18~30nm	45~85%	18~30%	45~85%	18~30nm
Track pitch	0.74 μ m	0.74 μ m	0.74 μ m	0.74 μ m	0.74 μ m	0.74 μ m
Minimum pit length	0.4 μ m	0.4 μ m	0.4 μ m	0.4 μ m	0.4 μ m	0.4 μ m
Modulation	>0.6	>0.6	>0.6	>0.6	>0.6	>0.6
Channel bit-rate	26.16MHz	26.16MHz	26.16MHz	26.16MHz	26.16MHz	26.16MHz
Wobble Frequency	–	–	140KHz	140KHz	817.4KHz	817.4KHz
Addressing	26.16MHz	26.16MHz	Wobble & LPP	Wobble & LPP	Wobble(ADIP)	Wobble(ADIP)
Read Power (mW)					0.7 \pm 0.1	0.7 \pm 0.1
Write Power (mW)	–					
Jitter	<8%	<8%	<8%	<8%	<9%	<9%

3. Disc Materials

1) DVD-ROM

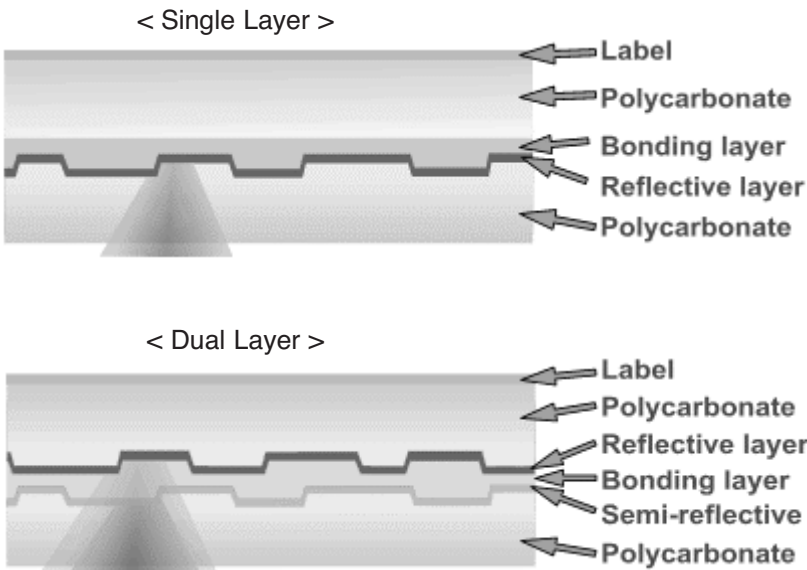

2) Recording format using organic dye material (DVD-R / DVD+R)

The format that records data through the creation of recorded marks by changing the organic dye material with a laser beam.

► Disc structure

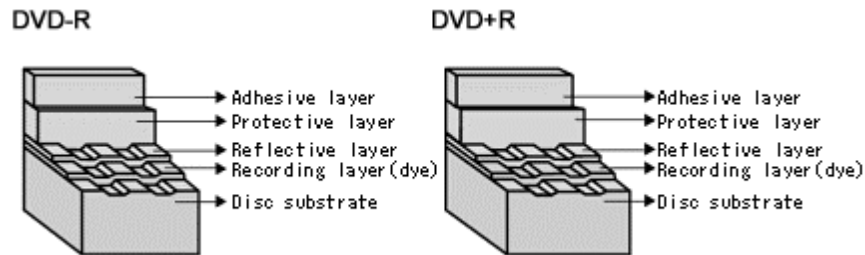

► Recording principles

[Recording]

Recording is done by changing the organic dye layer and the substrate with a laser. When a strong laser is applied to a disc, the temperature of the organic dye material goes up, the dye is decomposed and the substrate changes at the same time. At this time, a durable bit is created as is the case with a CD-ROM.

[Playback]

Signals are read with the differences of the reflection of a laser from pits.

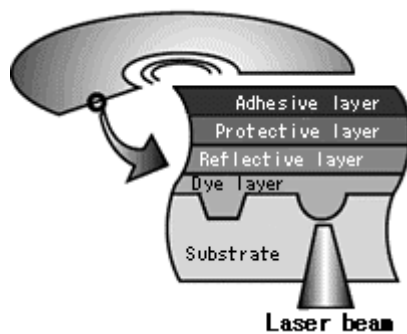

3) Recording format using phase-change recording material (DVD-RW / DVD+RW)

- Data is recorded by changing the recording layer from the amorphous status to the crystalline status, and played back by reading the difference of the reflection coefficient.

Amorphous: Non-crystalline.

► Disc structure

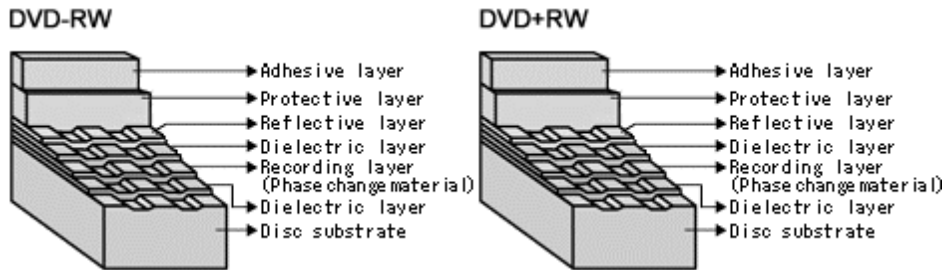

► Recording principles

[Recording]

When a high-power laser is applied to the recording material, it melts and then becomes amorphous with a low reflection coefficient when it quickly cools off. When a mid-power laser is applied to heat gradually the recording material and then gradually cools it off, it becomes crystal with a high reflection coefficient.

[Playback]

A low-power laser is used for playback. The amount of reflected light depends on the status (amorphous or crystalline) of the recording material. This is detected by an optical sensor.

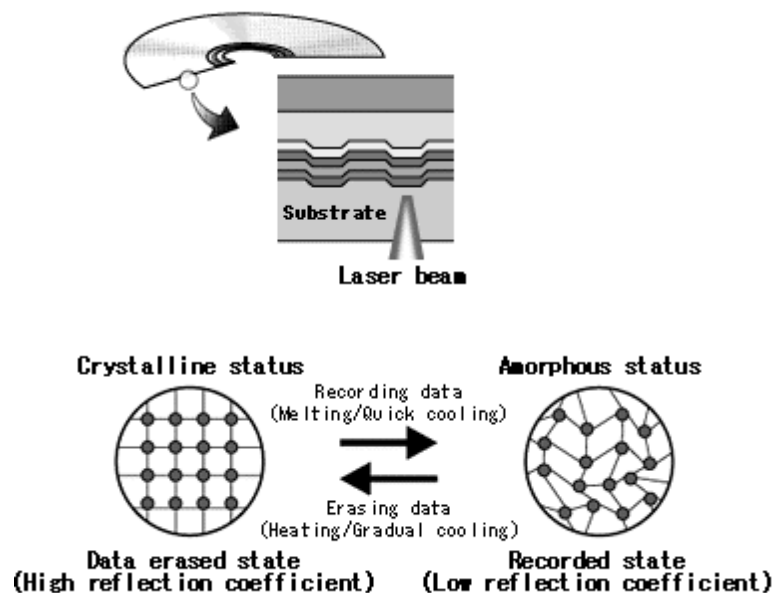

To make recordings, it is necessary to modulate the write pulse, which is called "Write Strategy".

There can be many types in Write Strategy. Typically Write Strategy for DVD \pm R has NMP(Non Multi-Pulse) type and MP(Multi-Pulse) type. In NMP type each single mark is created by subsequent separated short pulses. In MP type each single mark is created by one continuous pulse.

Write Strategy for DVD \pm RW has Type 1 and Type2. In Type 1 the mark with nT width is created by one top pulse and $(n-2)$ multi-pulses. Thus mark $3T$ is made by one top pulse and one multi-pulse. In Type 2 the mark with nT width is created by one top pulse and $(n-3)$ multi-pulses. Thus mark $3T$ is made by one top pulse only.

RL-02A uses MP type Write Strategy for DVD \pm R and Type 1 for DVD \pm RW as shown below.

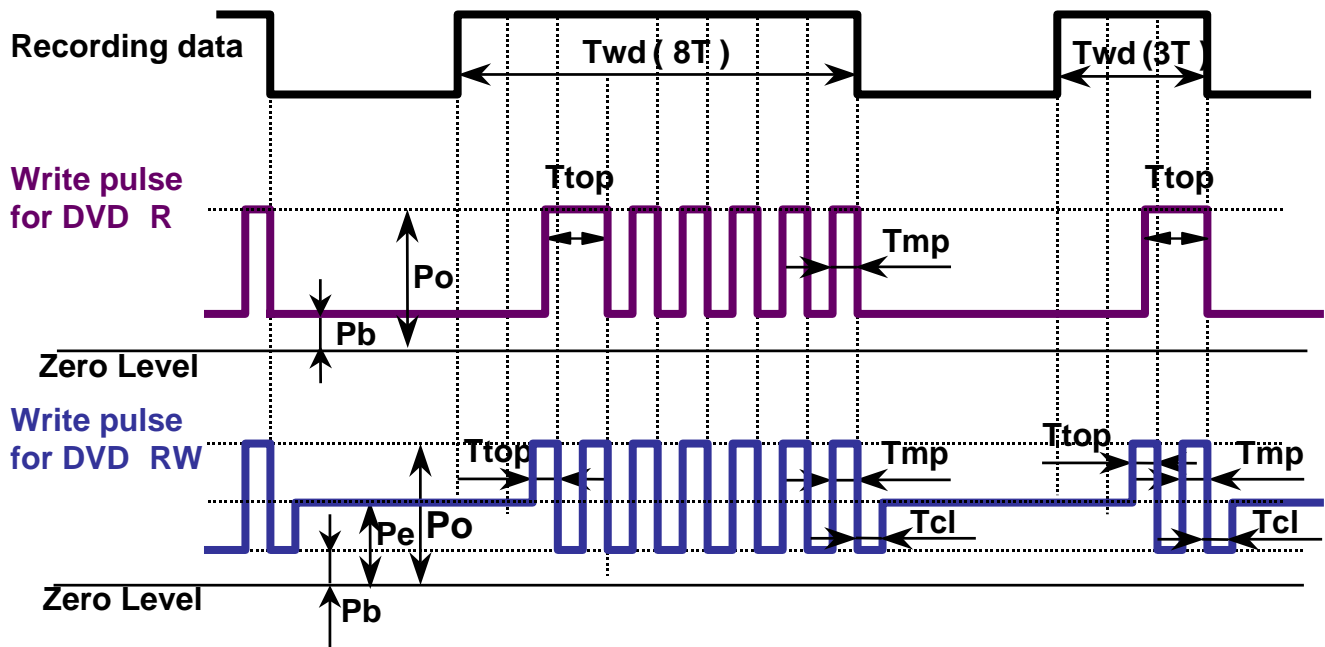

P_o :Write Power (Peak Power)
 P_e :Erase Power
 P_b :Bias Power

4. Organization of the Inner Drive Area, Outer Drive Area, Lead-in Zone and Lead-out Zone

1) Layout of DVD-ROM disc

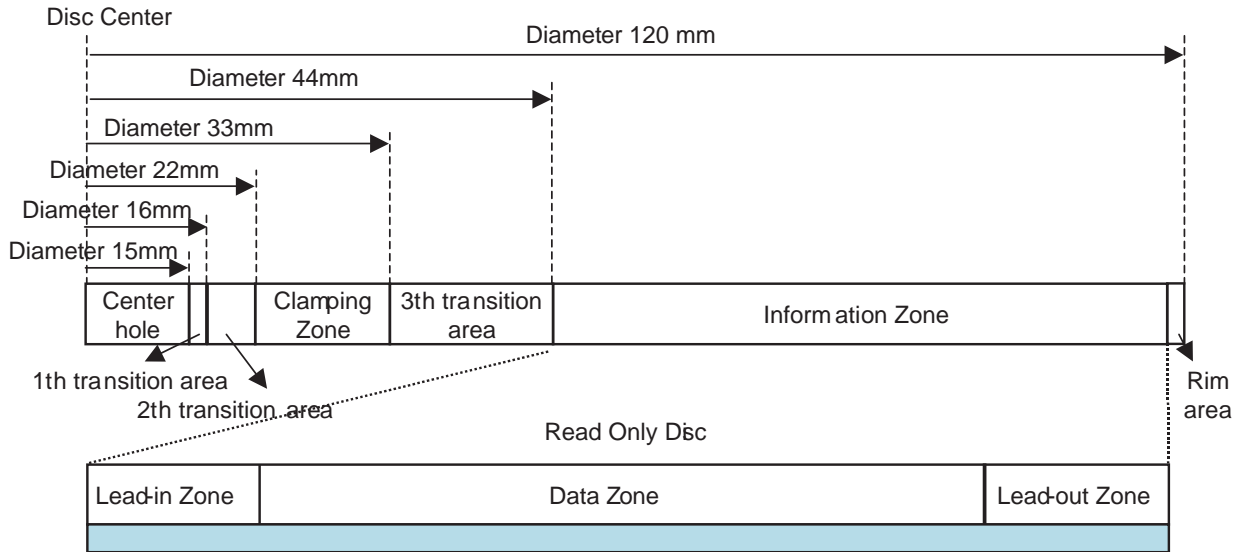

2) Layout of DVD+R disc

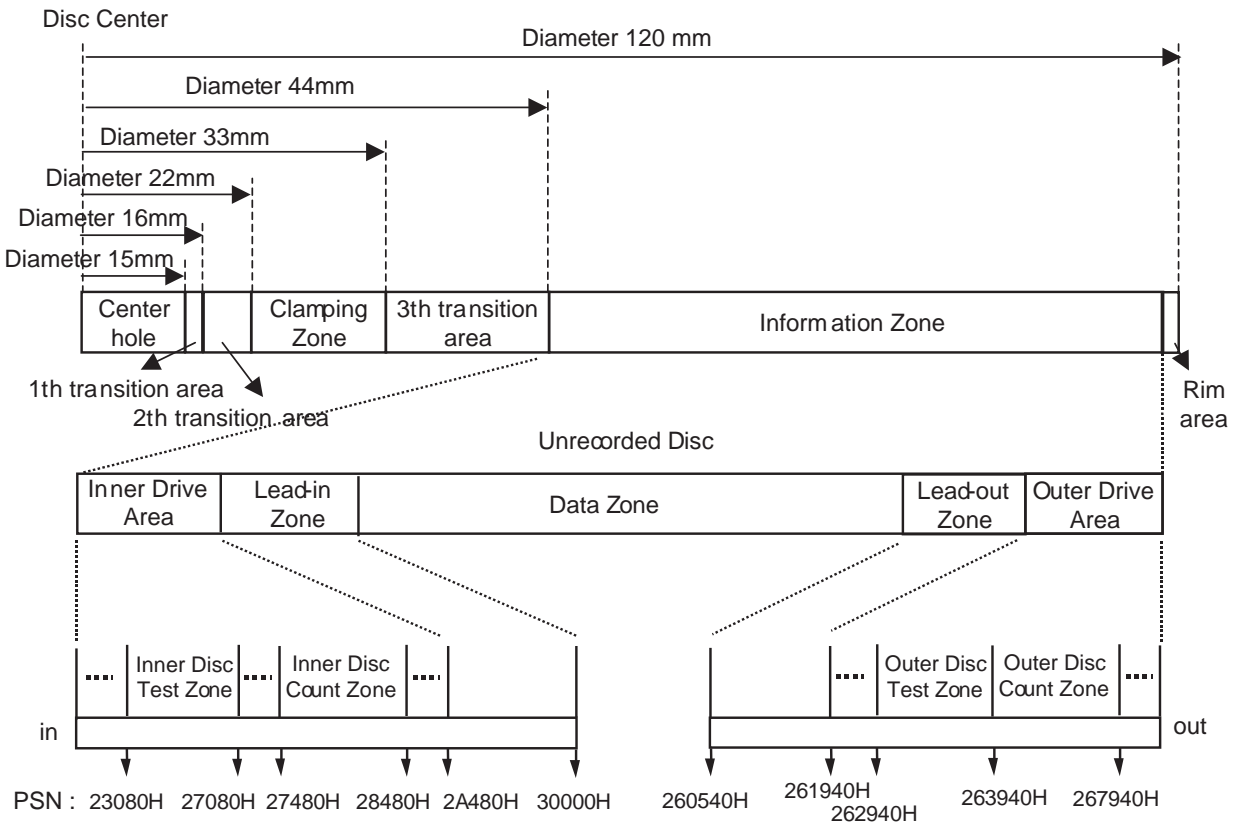

Inner Disc Test Zone : for performing OPC procedures.

Inner Disc Count Zone : For counting the number of OPC algorithm performed in IDT Zone.

Outer Disc Test Zone : for performing OPC procedures.

Outer Disc Count Zone : For counting the number of OPC algorithm performed in IDT Zone.

3) Layout of DVD+RW disc

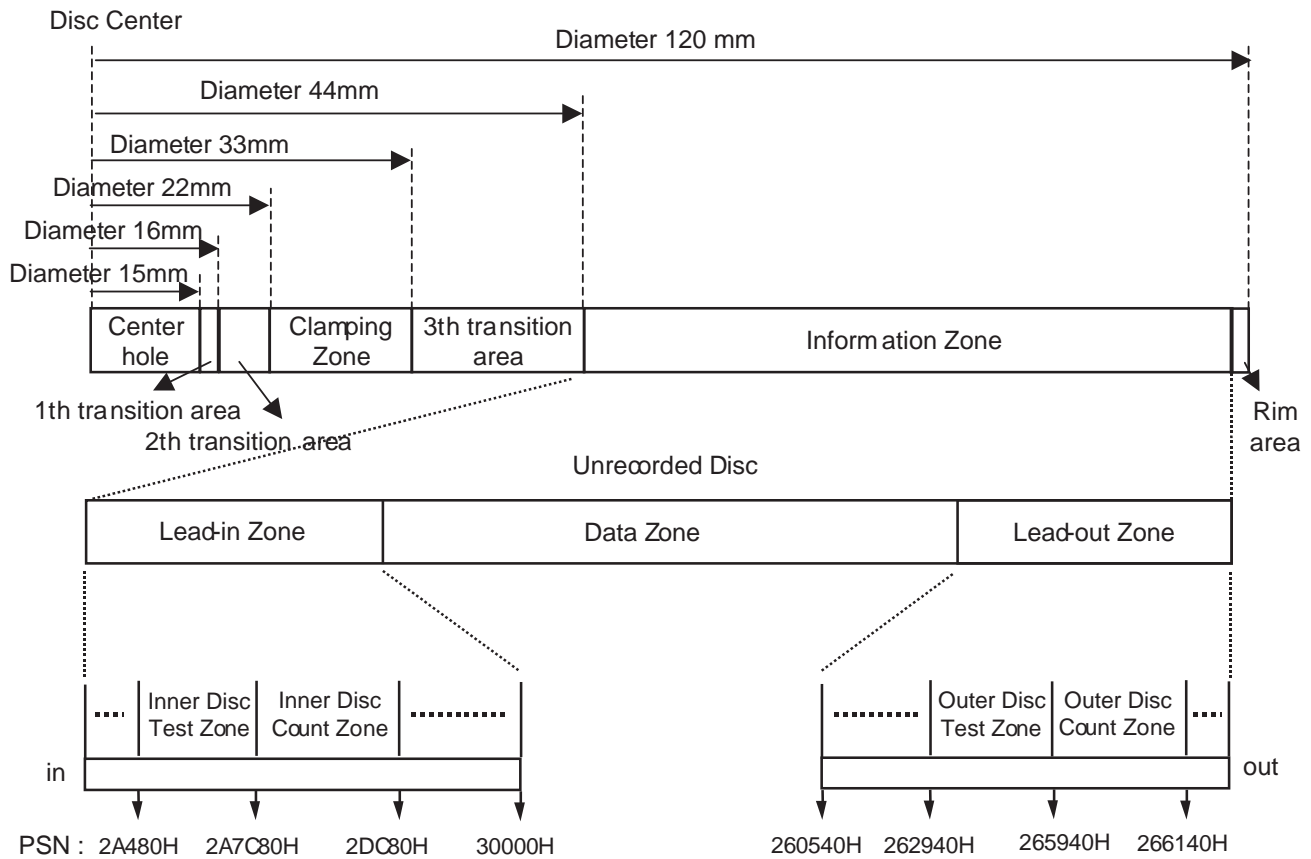

Inner Disc Test Zone : for performing OPC procedures.

Inner Disc Count Zone : For counting the number of OPC algorithm performed in IDT Zone.

Outer Disc Test Zone : for performing OPC procedures.

Outer Disc Count Zone : For counting the number of OPC algorithm performed in IDT Zone.

4) Layout of DVD-R/RW disc

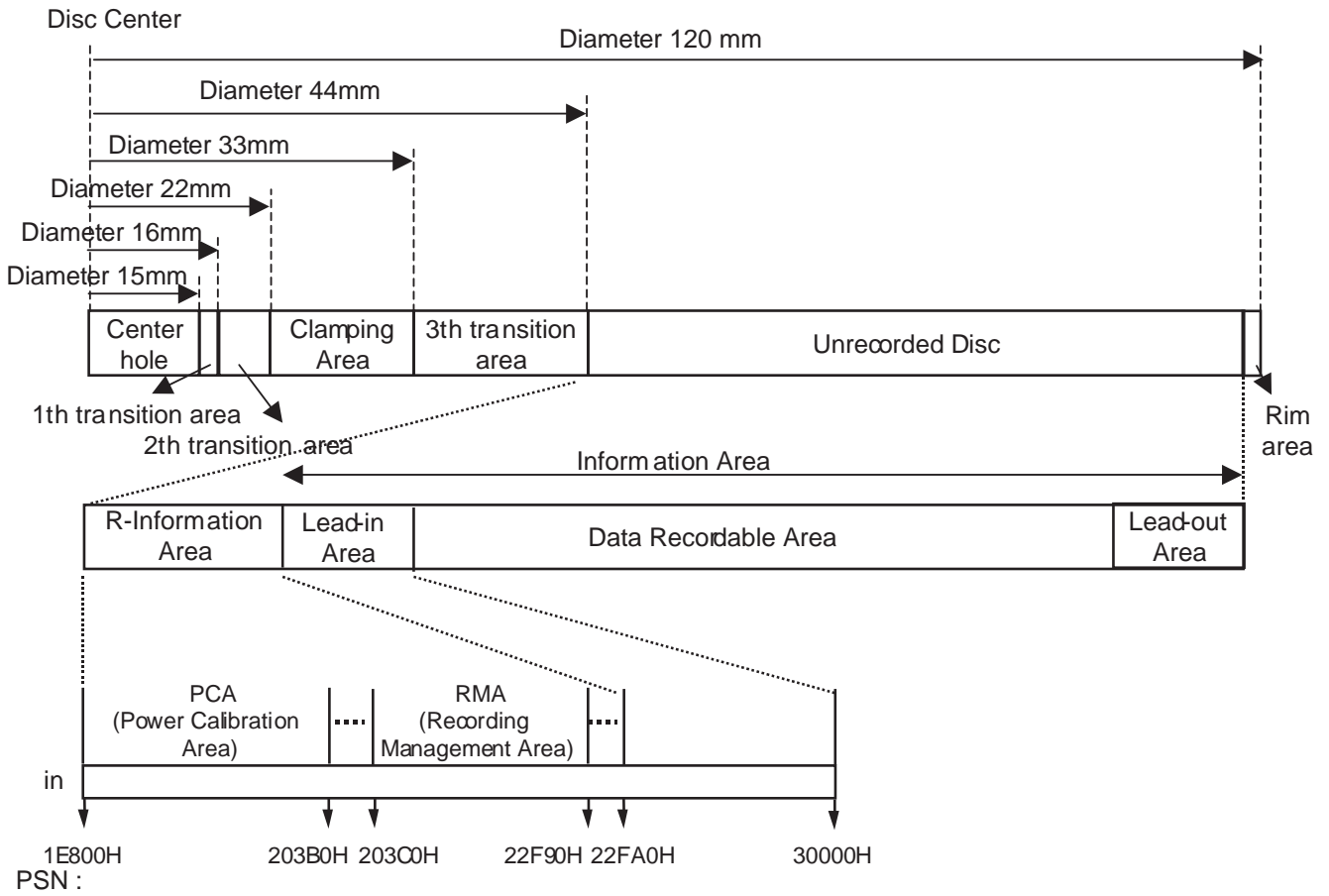

5. ALPC(Automatic Laser Power Control) Circuit

1) Block Diagram

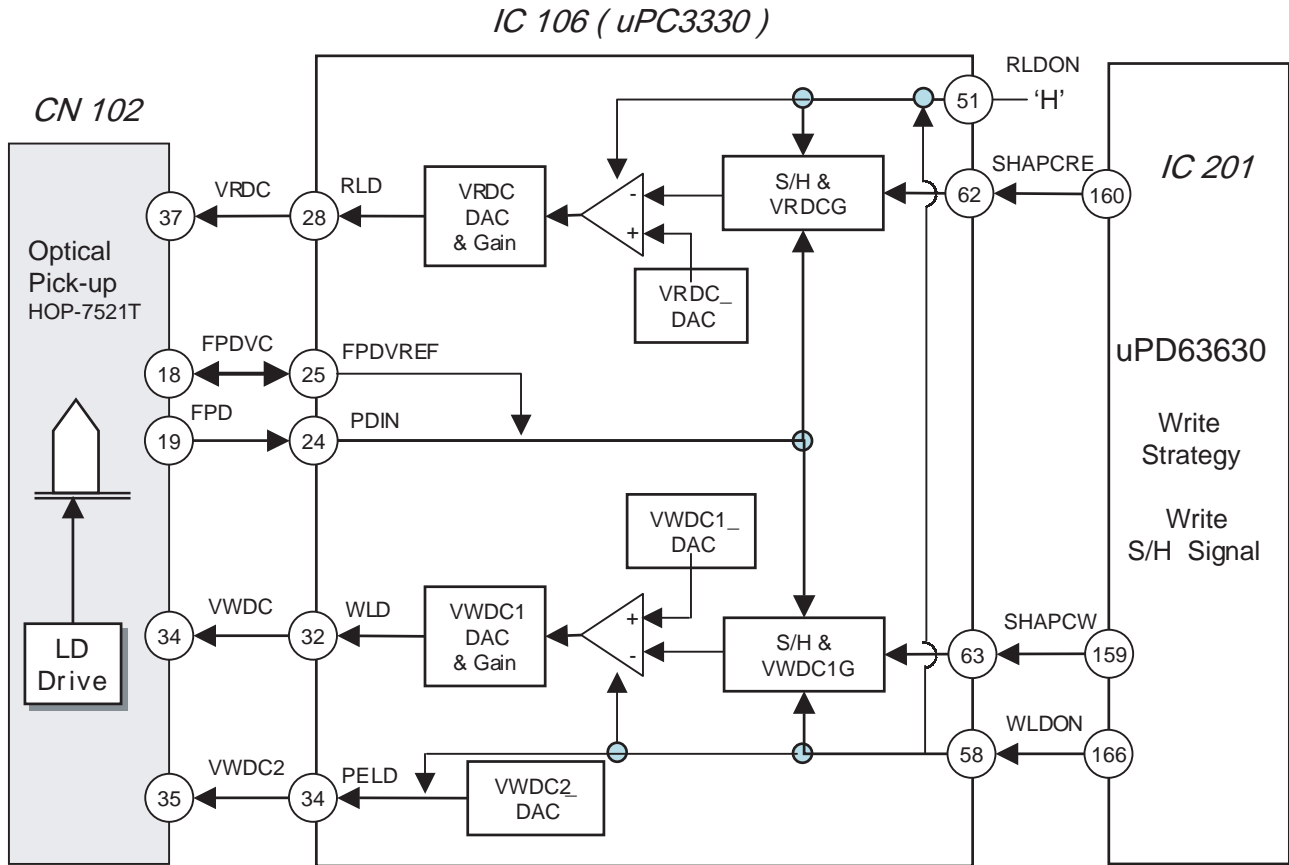

2) ALPC(Automatic Laser Power Control) Circuit Operation

ALPC function in CD-R/RW,DVD+R/RW analog front-end is for constant power level control purpose.

Based on the accurate power sensor(FPD) in OPU, ALPC feedback loop maintains constant power level against laser diode's temperature variation.

There are two power control loops in uPC3330, which are used with different combination for different applications. Generally, the first ALPC loop is used for read-power control. The 2nd ALPC loop is used for write(erase) power control for CD-R/RW and DVD+R/RW disc.

Owing to the small signal level in read-power control mode, the first ALPC loop amplifies the FPD signal to enhance the accuracy of read power control. The built-in 10-bit DAC(VRDC_DAC) is used to set the read power level.

Moreover, the 2nd ALPC loop is used for high power control. The built-in 10-bit DAC(VWDC1_DAC) is used to set the wanted power level.

And the register VWDC1G is employed to adjust the gain of FPD signal.

The following potentiometers(VRDC_DAC, VWDC1_DAC, and VWDC2_DAC) and amplifiers (VRDCG and VWDC1G) are used to set the wanted levels of the output pins RLD, WLD, and PELD

How to use test tool

1. ALPC Measurement System Configuration

In order to measure and adjust DVD RW optical power, The following measurement equipments are needed.

- ◆ Compulsory equipment
 - ① Optical Power meter & Sensor (ADVANTEST, TQ8210/Q82017A or equivalent)
 - ② Personal Computer (Pentium 3, 500MHz Above, , RAM:64M Above, Win98 Above)
 - ③ Adjustment Program (Dragon or ALPC) for SVC, ALPC Program recommended
- ◆ FI optional equipment
 - ① USB-ATAPI Interface (needed when using USB Port from the laptop computer without ATAPI interface or a desktop computer)
 - ② Connector-ATAPI Interface Board (Part Mo:6881R-7677A) (needed when ATAPI is not attached to Loader)

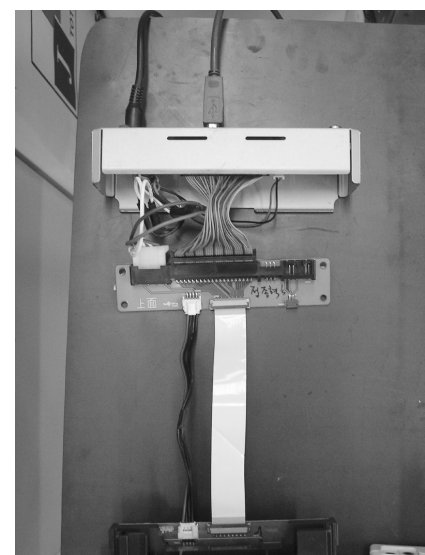
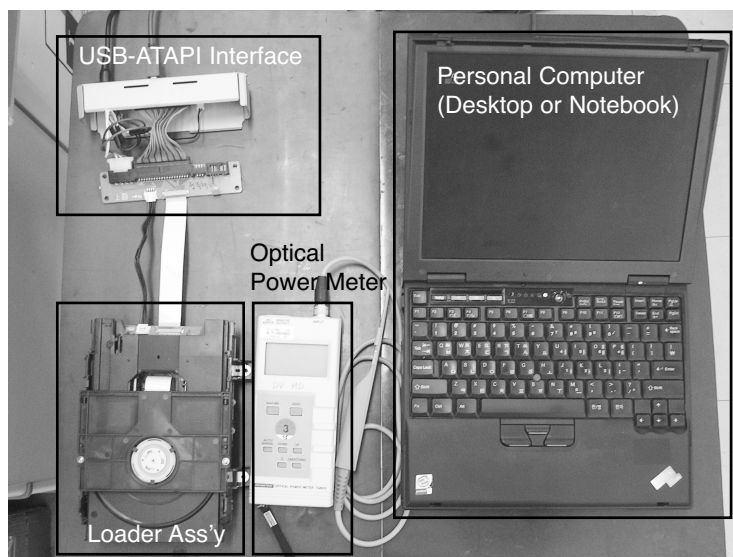

2. ALPC Program Configuration

ALPC Program consists of total 4 files.

ALPC.exe
LgBada.dll
modelnm.txt
WNASPI32.DLL

These 4 files should be located in one directory.
ALPC.exe is a program execution file.
modelnm.txt is a configuration file.

Determine how to connect

The following contents are included when you open "modelnm.txt" file.

The following contents are included when you open LGE connect=0

connect=0 is the item which you can determine whether you use Serial or ATAPI.

0 : ATAPI
1 : Serial

Thus, select connect=0 to use ATAPI, or select connect=1 to use Serial, then save the file.
(For SVC, ATAPI setting is recommended.)

3. Running ALPC Program

When running ALPC.exe file, the following screen appears.

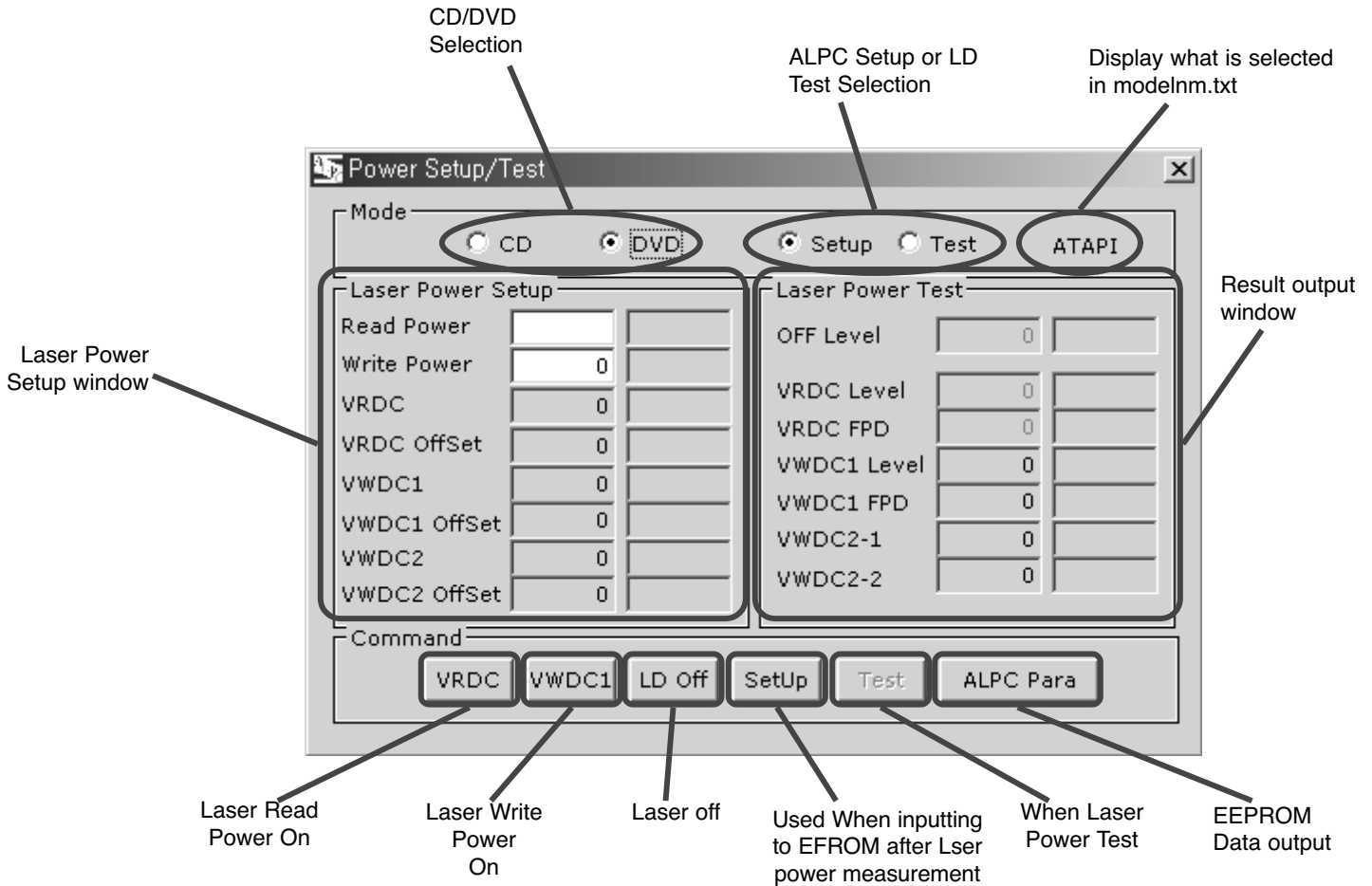

4 LD Test

* Test DVD LD

- ① Select DVD mode
- ② Select Test mode
- ③ Click

* Test DVD CD

- ① Select CD mode
- ② Select Test mode
- ③ Click

Section	Off	VRDC	VR_FPD	VWDC1	VW_FPD	VW2-1	VW2-2
CD	2.4±0.08	0.53±0.22	0.02±0.01				
DVD	2.4±0.08	0.7±0.2	0.04±0.01	0.43±0.05	0.2±0.02	0.08±0.02	0.2±0.03

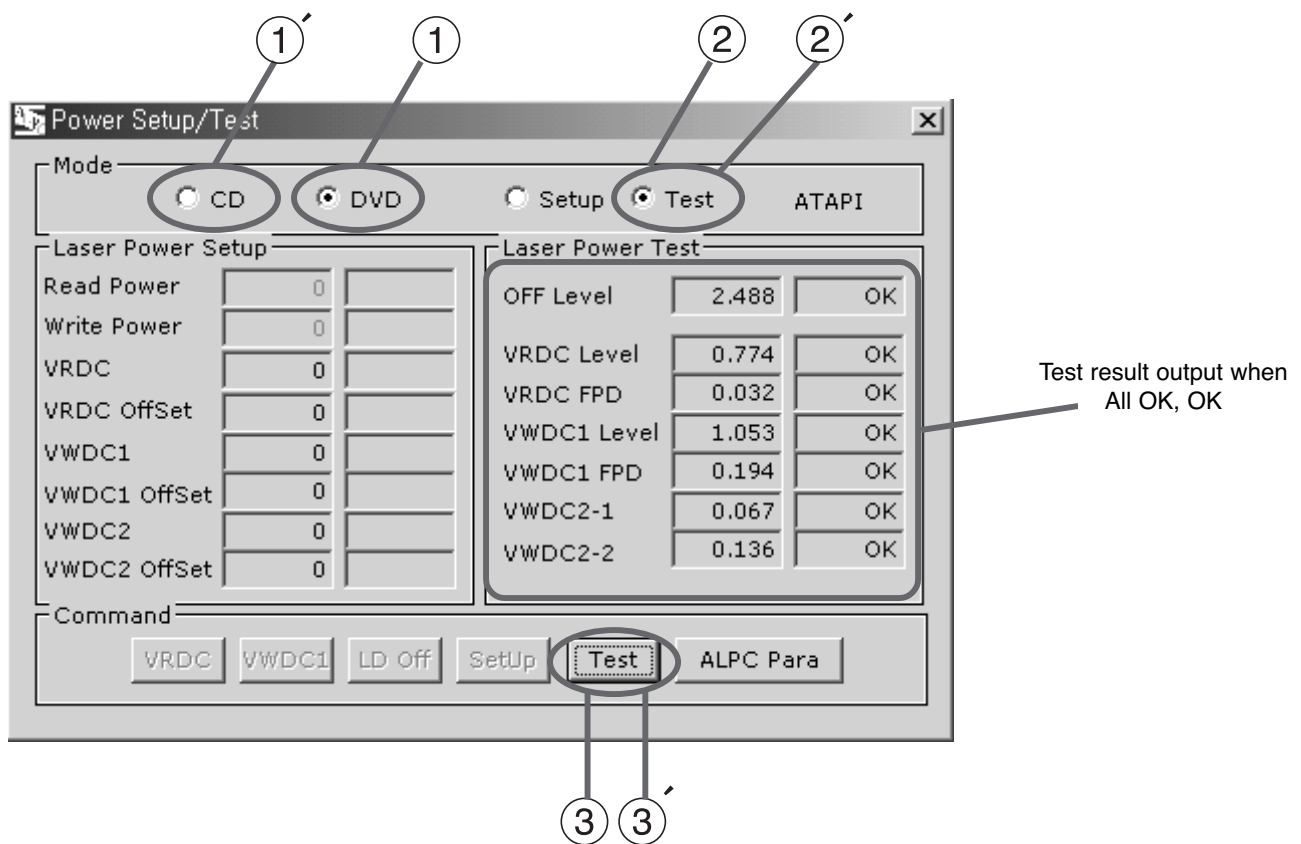

Specification can be changed according to pick-up type, circuit, program, and chipset.
 If specification is changed, program can be sent by supervisor.
 Specification above is temporary reference.

5. Optical Power Setting

When replacing Travers ass'y including Pick-up or Loader PCB, Optical Power Setting should be performed for Pick-up and Loading PCB's matching.

① DVD LD optical Power Setting

- Select DVD and Setup mode
- Push **VRDC**. (Read Power On. Strong Red light can be seen from pick up optical lens.)
- Measure optical power.
- Write measurement value in Read Power.
- Push **VWDC1**. (Write power On.) (Caution) Light is very strong. Never look at the light directly.
- Measure optical power
- Write measurement value in Read Power and push LD off **LD OFF**.
- Push **Setup**. (Measurement value is inputted to EEPROM)

② DVD LD optical Power Setting

- Select CD and Setup mode
- Push **VRDC**. (Read Power On. Weak Red light can be seen from pick up optical lens.)
- Measure optical power.
- Write measurement value in Read Power.
- Push **VWDC1**. (Write power On. Weak Red light can be seen.)
- Measure optical power and push LD off **LD OFF**.
- Write measurement value in Read Power.
- Push **Setup**. (Measurement value is inputted to EEPROM)

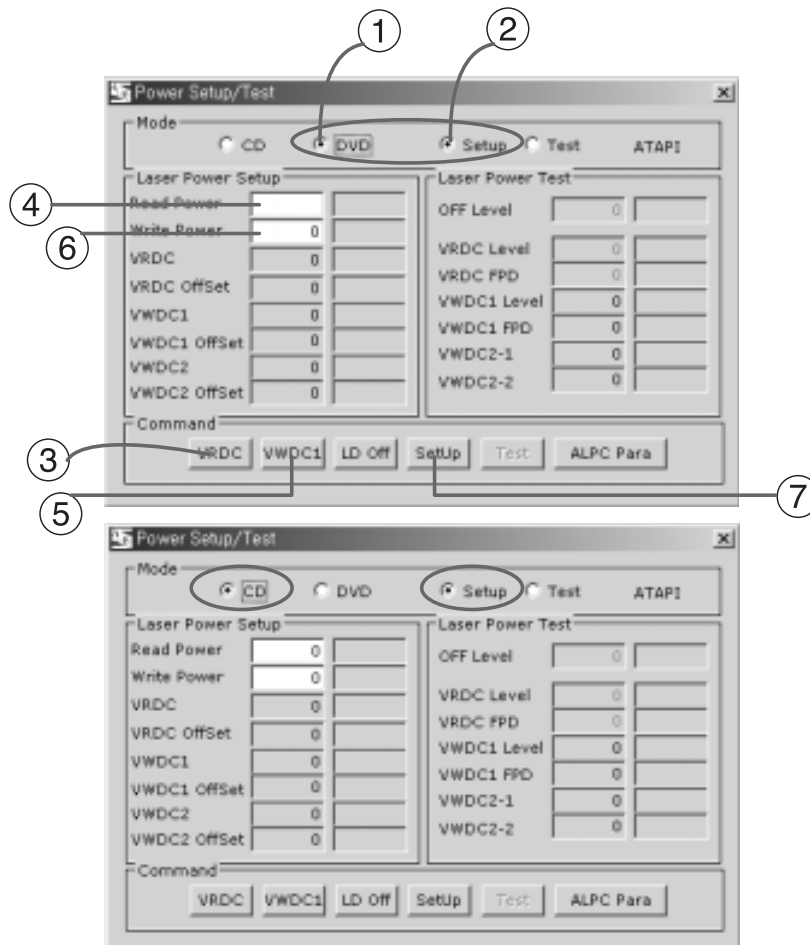

6. Optical Power Setting Parameter Check

Use when defective happens even though LD test result is normal.

When defective can be found but power test result is OK, You need to check current settings whether they are proper or not. In this case, Pressing **ALPC Para** will display ALPC Parameter Info window and show current optical power settings recorded in EEPROM(IC302).

Write down these settings on the paper, perform optical power setting and press **ALPC Para** again, then new optical power settings will appear. Compare these two parameters. If there is a big difference, optical power setting may have been wrong at first or pick-up optical output may have been changed. If pick-up is normal, problem can be solved by resetting optical power without replacing pick-up.

In order to remove previous ALPC Parameter from ALPC Parameter Info, press **Reset** at the bottom of ALPC Parameter Info window.

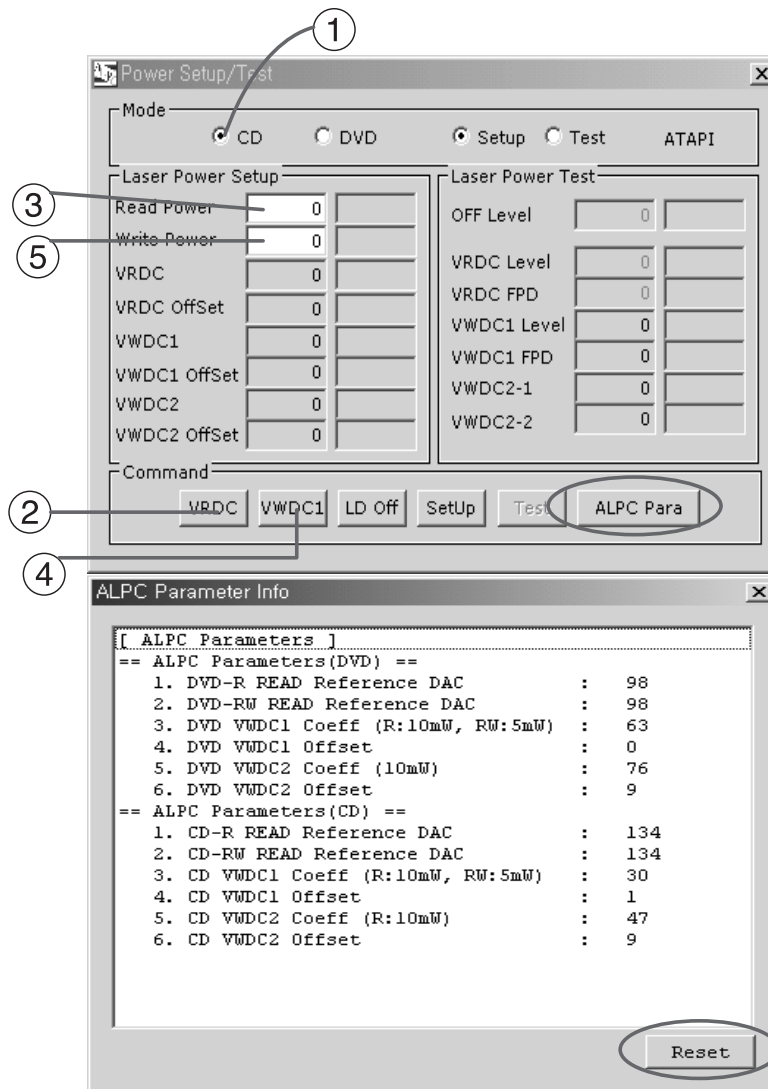

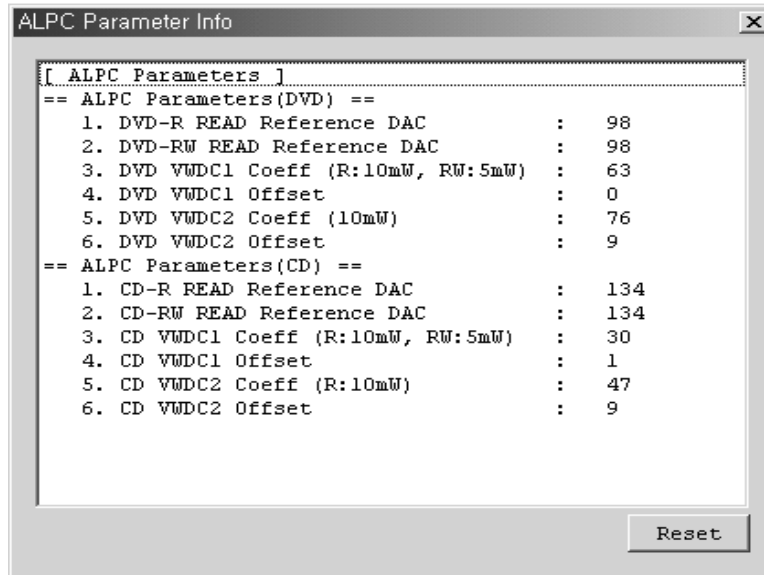

[VALID ALPC Parameters]

<CD>

- 1) CD-R READ Reference DAC : 70 ~ 100
- 2) CD-RW READ Reference DAC : 70 ~ 100

<DVD>

- 1) DVD-R READ Reference DAC : 42 ~ 107
- 2) DVD-RW READ Reference DAC : 42 ~ 107
- 3) VWDC1 : 35 ~ 65
- 4) VWDC1 Offset : 0 ~ 6
- 5) VWDC2 : 20 ~ 43
- 6) VWDC2 Offset : 0 ~ 10

Appendix. How to measure optical power

Optical power measurement is measuring actual optical power coming out from an object lens with LD turned on. thus, In order to measure optical power, LD should be turned on and environment need to be dark enough.

If necessary, Cover the top side of the sensor with black paper or hand when measuring.

Generally, fluorescent light is about $50 \mu\text{W}$, sun light is about 100 mW . so, If this is ignored, optical power setting may not be set correctly.

Optical power measurement procedure

1. Adjust optical power meter's λ (wave length) to DVD. (Generally 660 nm)
2. Turn DVD LD on.
3. Place sensor less than 3mm apart from pick-up object lens, perpendicular to lens.
Adjust position so that the center of object lens match to \square mark on the sensor.
4. Read monitor's value. (Read Maximum value as moving position slightly)
(Check working unit. Unit should be mW . When LD is dead, μW or nW unit may not be read correctly.)
5. Multiply monitor's value by 100, round off to the nearest integer, then write constant part.
6. Adjust optical power meter's λ (wave length) to CD. (Generally 780 nm)
7. Turn CD LD on.
8. Repeat step 3~5 above.



BLOCK DIAGRAMS

1. OVERALL BLOCK DIAGRAM

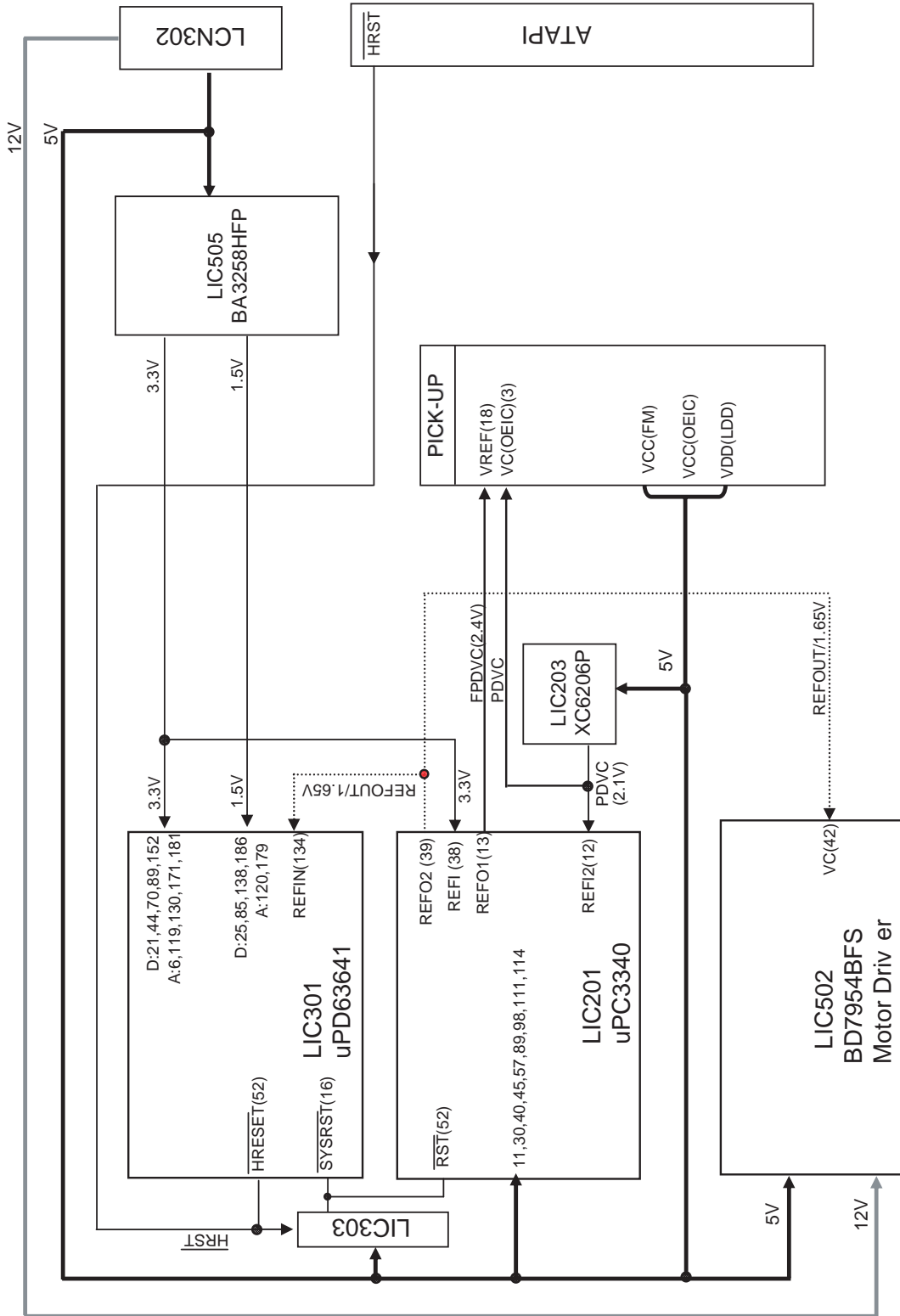

2. DSP BLOCK DIAGRAM

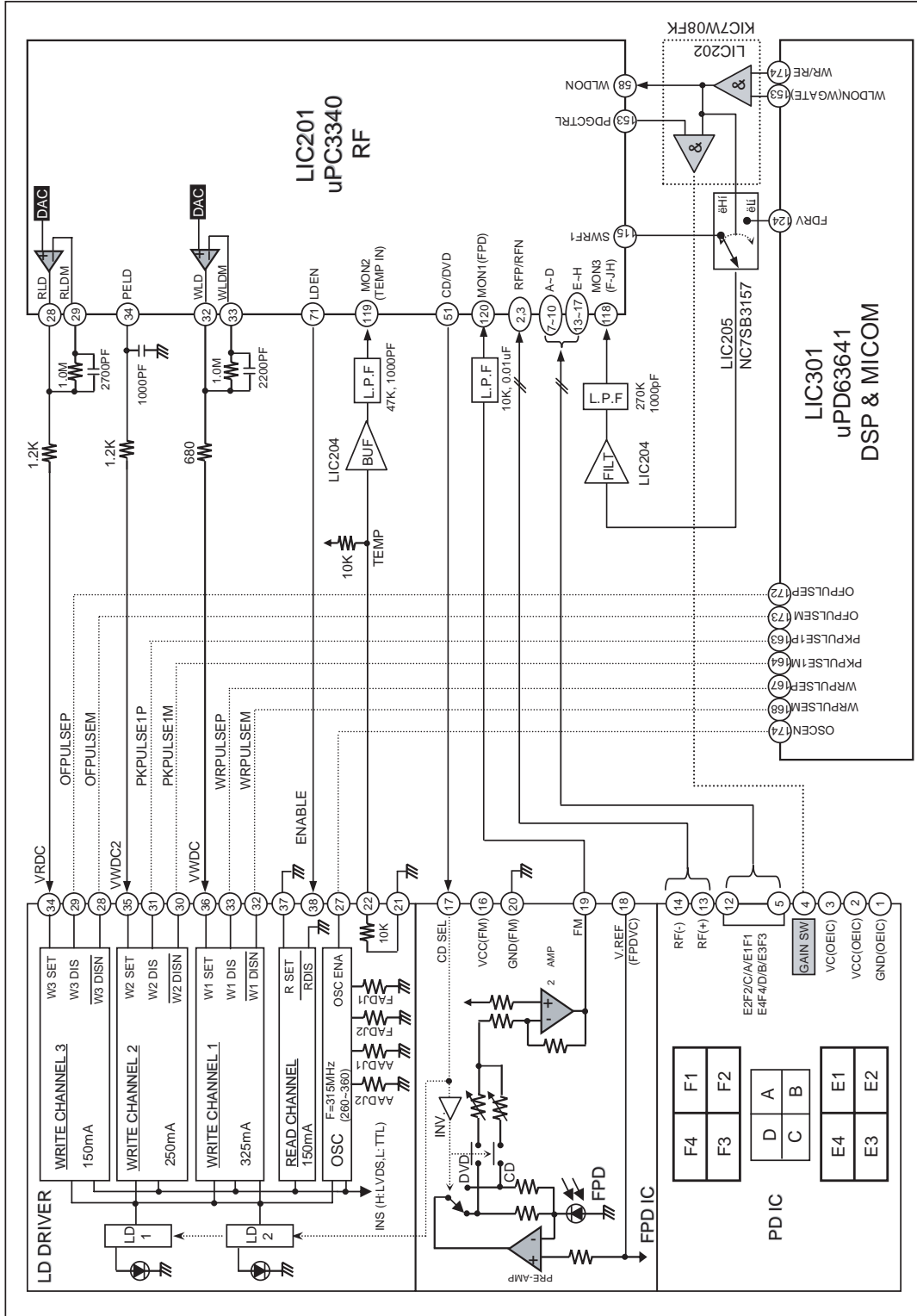

3. μ -COM BLOCK DIAGRAM

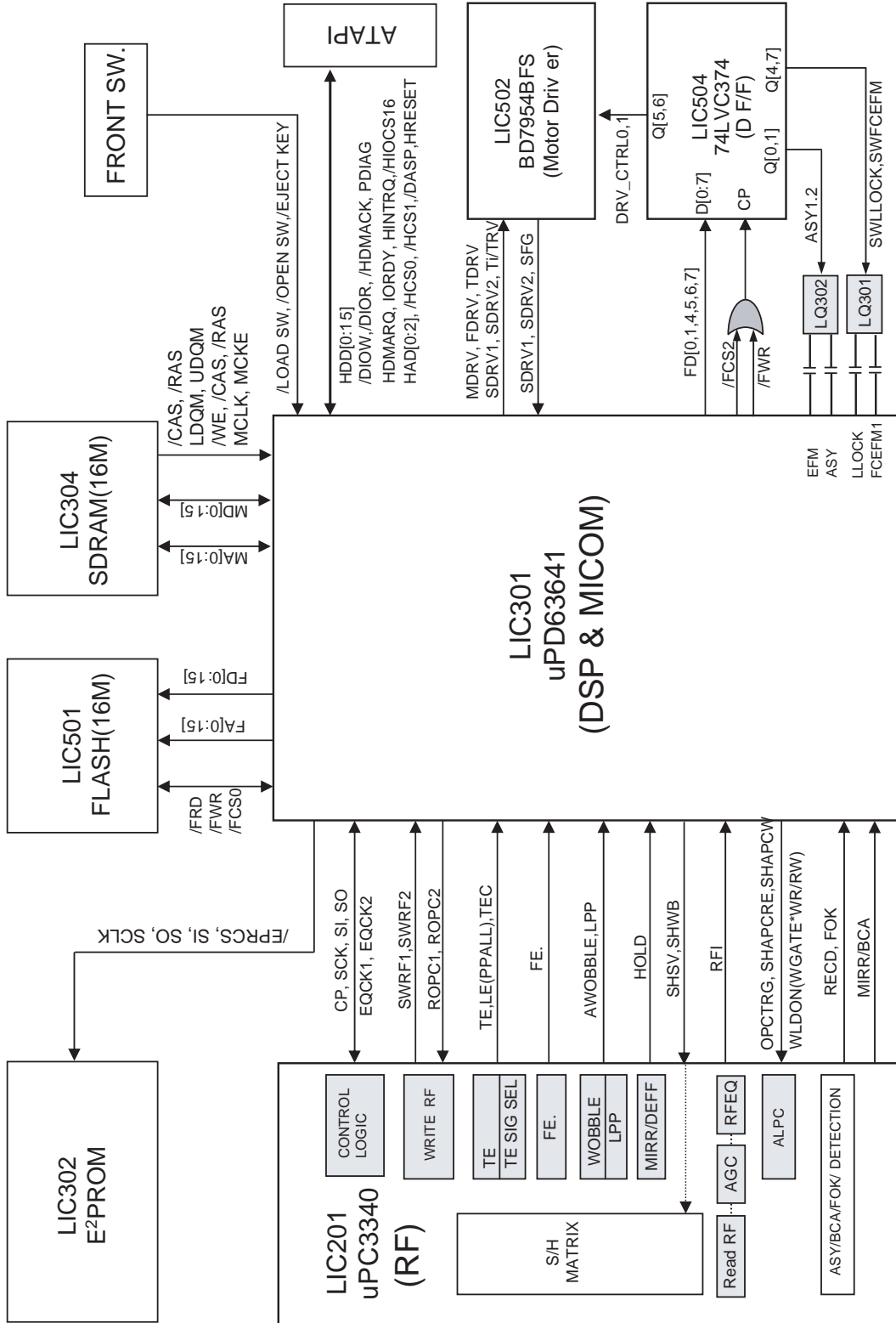

4. RF BLOCK DIAGRAM

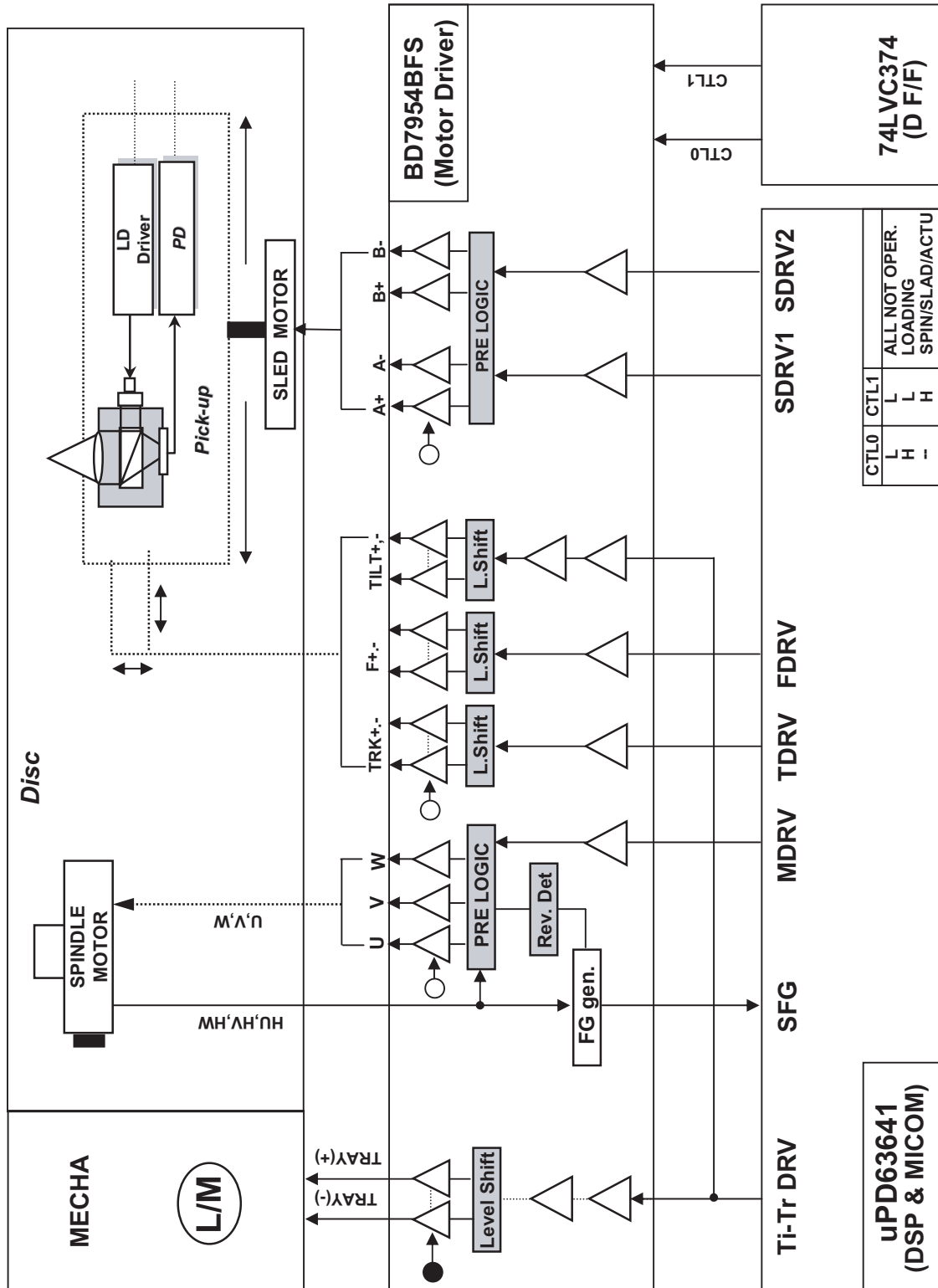

CIRCUIT DIAGRAMS

1. RF CIRCUIT DIAGRAM

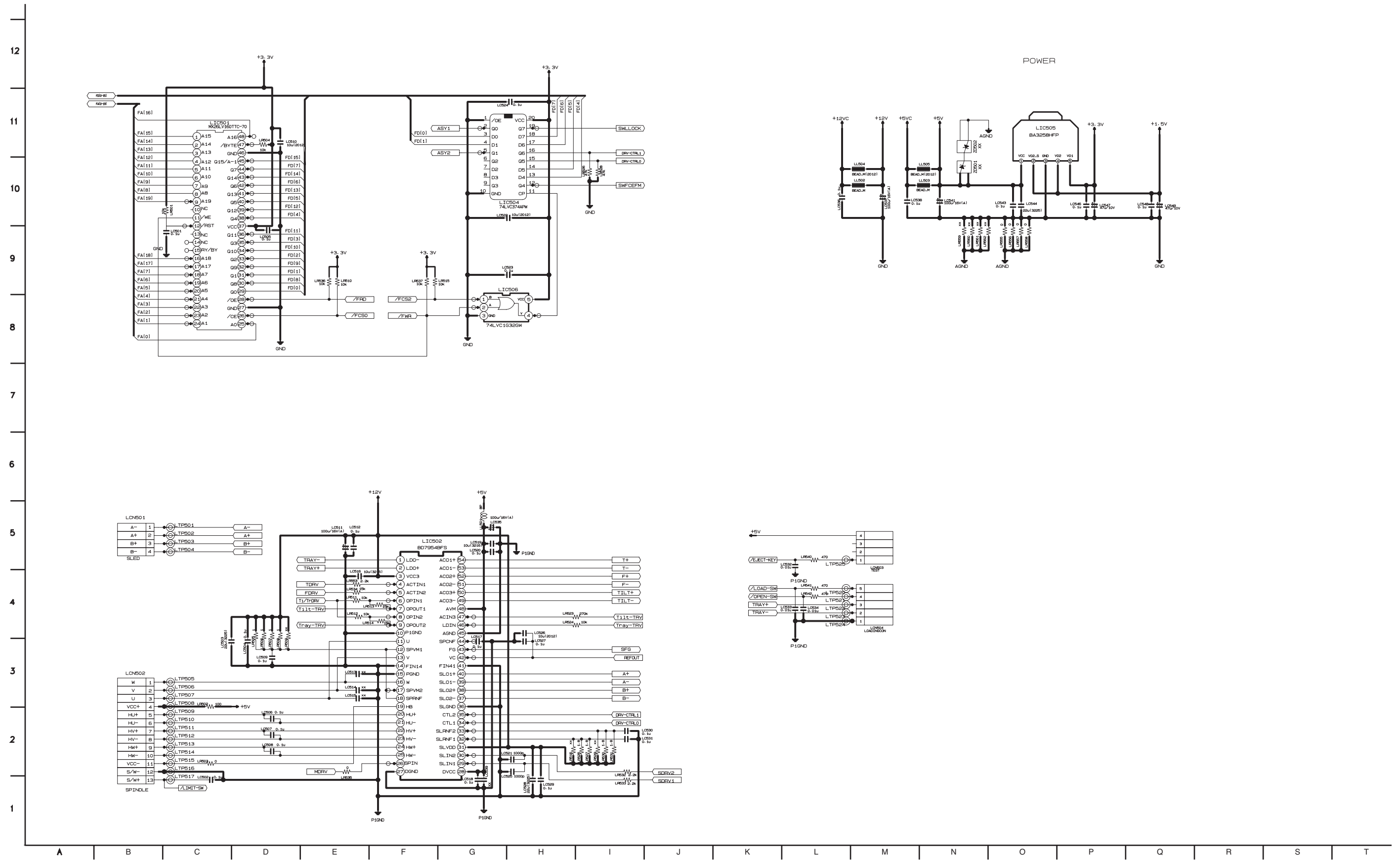

2. DSP CIRCUIT DIAGRAM

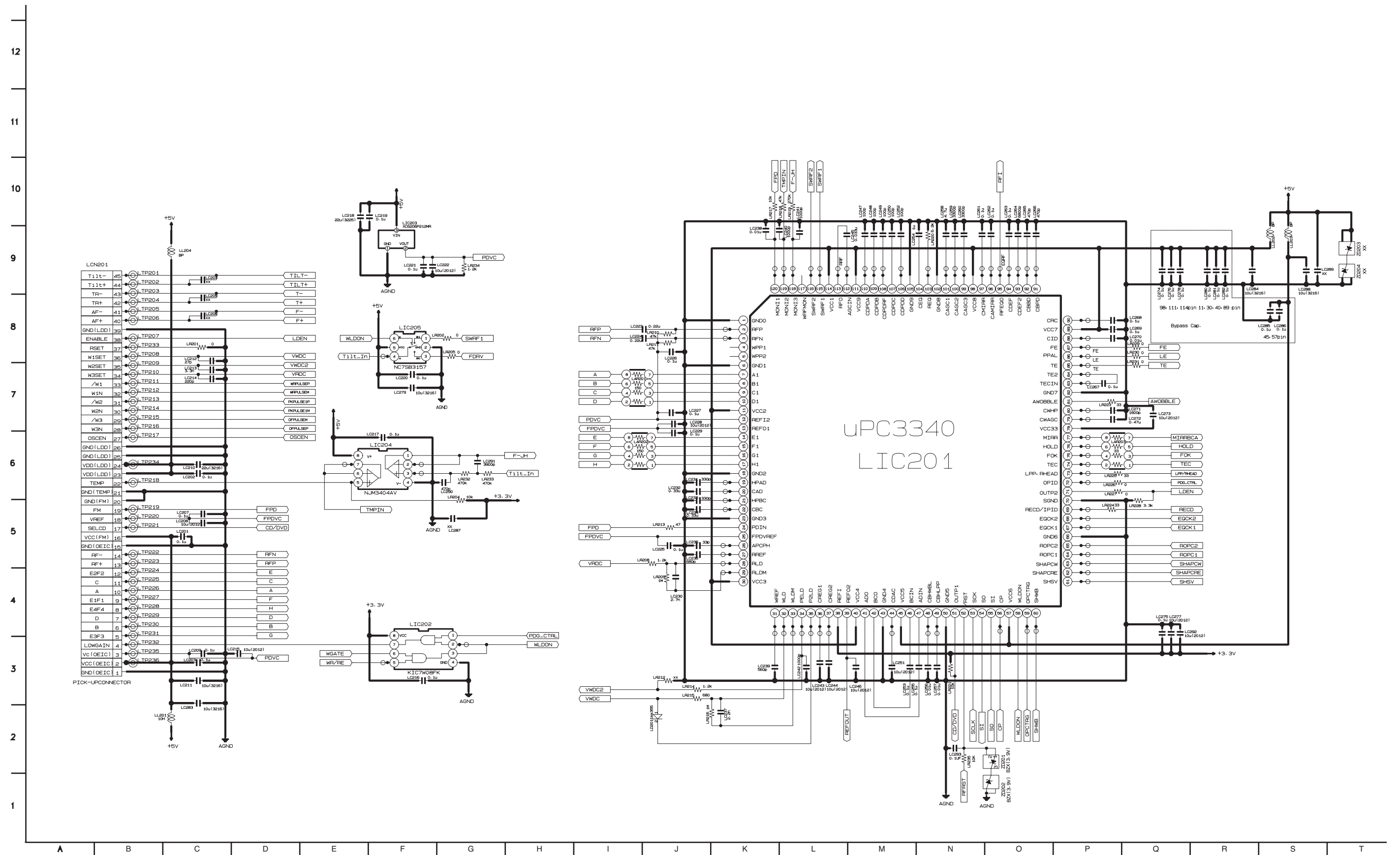

PRINTED CIRCUIT DIAGRAMS

1. MAIN P.C.BOARD

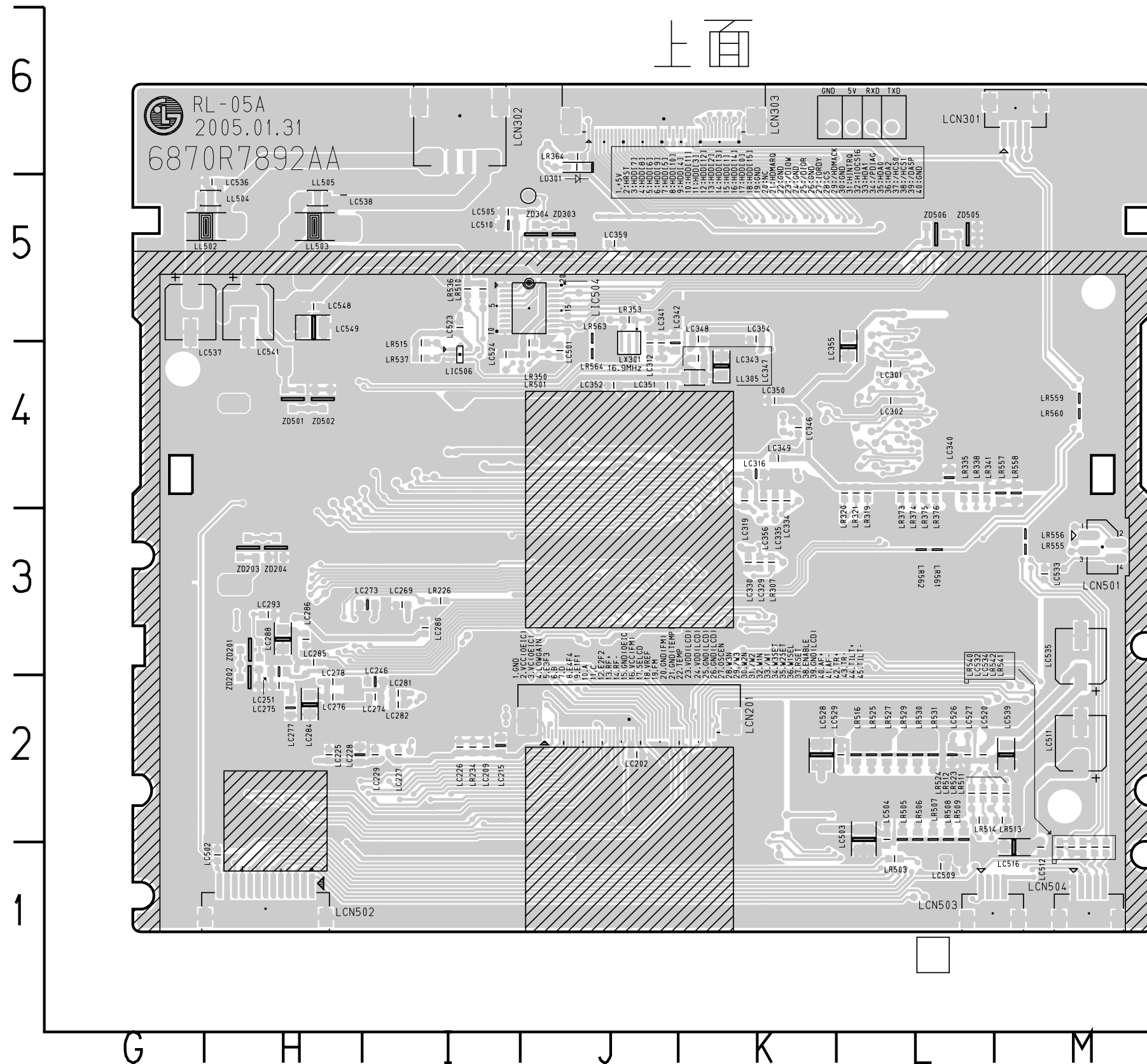

LOCATION GUIDE

LC202	J2	LC343	K4	LC541	H5	LICT318L4	LICT559L2	LR513	M2	
LC209	I2	LC346	K4	LC548	H5	LICT319L4	LICT561L2	LR514	L2	
LC215	I2	LC347	K4	LC549	H5	LICT321L4	LICT563L2	LR515	I4	
LC225	H2	LC348	K5	LCN201	J2	LICT324L4	LICT566I4	LR516	L2	
LC226	I2	LC349	K4	LCN301	M6	LICT325L4	LICT567I4	LR523	M2	
LC227	I2	LC350	K4	LCN302	I6	LICT328L4	LICT568J5	LR524	L2	
LC228	H2	LC351	J4	LCN303	J6	LICT329L4	LL305	K4	LR525	L2
LC229	I2	LC352	J4	LCN501	M3	LICT330K4	LL502	H5	LR527	L2
LC246	I2	LC354	K5	LCN502	H1	LICT331K4	LL503	H5	LR529	L2
LC251	H3	LC355	L4	LCN503	L1	LICT332L4	LL504	H5	LR530	L2
LC269	I3	LC356	K4	LCN504	M1	LICT333L4	LL505	H5	LR531	L2
LC273	I3	LC359	J5	LD301	J6	LICT335K4	LR226	I3	LR536	I5
LC274	I2	LC501	J4	LIC504	J5	LICT336L4	LR234	I2	LR537	I4
LC275	H2	LC502	H1	LIC506	I4	LICT337K1	LR307	K3	LR540	M1
LC276	H2	LC503	L2	LICT202J3		LICT339K2	LR319	L4	LR541	M1
LC277	H2	LC504	L2	LICT203I2		LICT353K3	LR320	L4	LR542	M1
LC278	H2	LC505	I5	LICT211 I2		LICT354K3	LR321	L4	LR555	M3
LC280	I3	LC509	L1	LICT238H3		LICT361K4	LR335	L4	LR556	M3
LC281	I2	LC510	I5	LICT247I3		LICT362K3	LR338	L4	LR557	M4
LC282	I2	LC511	M2	LICT265I3		LICT364K3	LR341	L4	LR558	M4
LC284	H2	LC512	M1	LICT277H3		LICT370J4	LR350	J4	LR559	M4
LC285	H3	LC516	M1	LICT301L4		LICT374J5	LR353	J5	LR560	M4
LC286	H3	LC520	L2	LICT302L5		LICT378J5	LR364	J6	LR561	L3
LC288	H3	LC523	I5	LICT303L5		LICT383J5	LR373	L4	LR562	L3
LC293	H3	LC524	I4	LICT304L4		LICT501J4	LR374	L4	LR563	J5
LC301	L4	LC526	L2	LICT305L4		LICT502I4	LR375	L4	LR564	J4
LC302	L4	LC527	L2	LICT306L4		LICT505L1	LR376	L4	LX301	J4
LC312	J4	LC528	K2	LICT307L4		LICT516L2	LR501	J4	ZD201	H3
LC316	K4	LC529	L2	LICT308L4		LICT517L2	LR503	L1	ZD202	H2
LC319	K4	LC532	M1	LICT309L4		LICT526J4	LR505	L2	ZD203	H3
LC329	K3	LC533	M3	LICT310L4		LICT539J5	LR506	L2	ZD204	H3
LC330	K3	LC534	M1	LICT311K4		LICT541J5	LR507	L2	ZD303	J5
LC334	K4	LC535	M3	LICT312L4		LICT543J5	LR508	L2	ZD304	J5
LC335	K4	LC536	H5	LICT313L4		LICT545J5	LR509	L2	ZD501	H4
LC340	L4	LC537	G5	LICT314L4		LICT554I5	LR510	I5	ZD502	H4
LC341	J4	LC538	H5	LICT315L4		LICT555I5	LR511	M2	ZD505	L5
LC342	J4	LC539	M2	LICT316L4		LICT558M2	LR512	L2	ZD506	L5

