

AUTOBOX[®] (ABX-3L) & CONTROL BOX (CBX-ABX) USER MANUAL

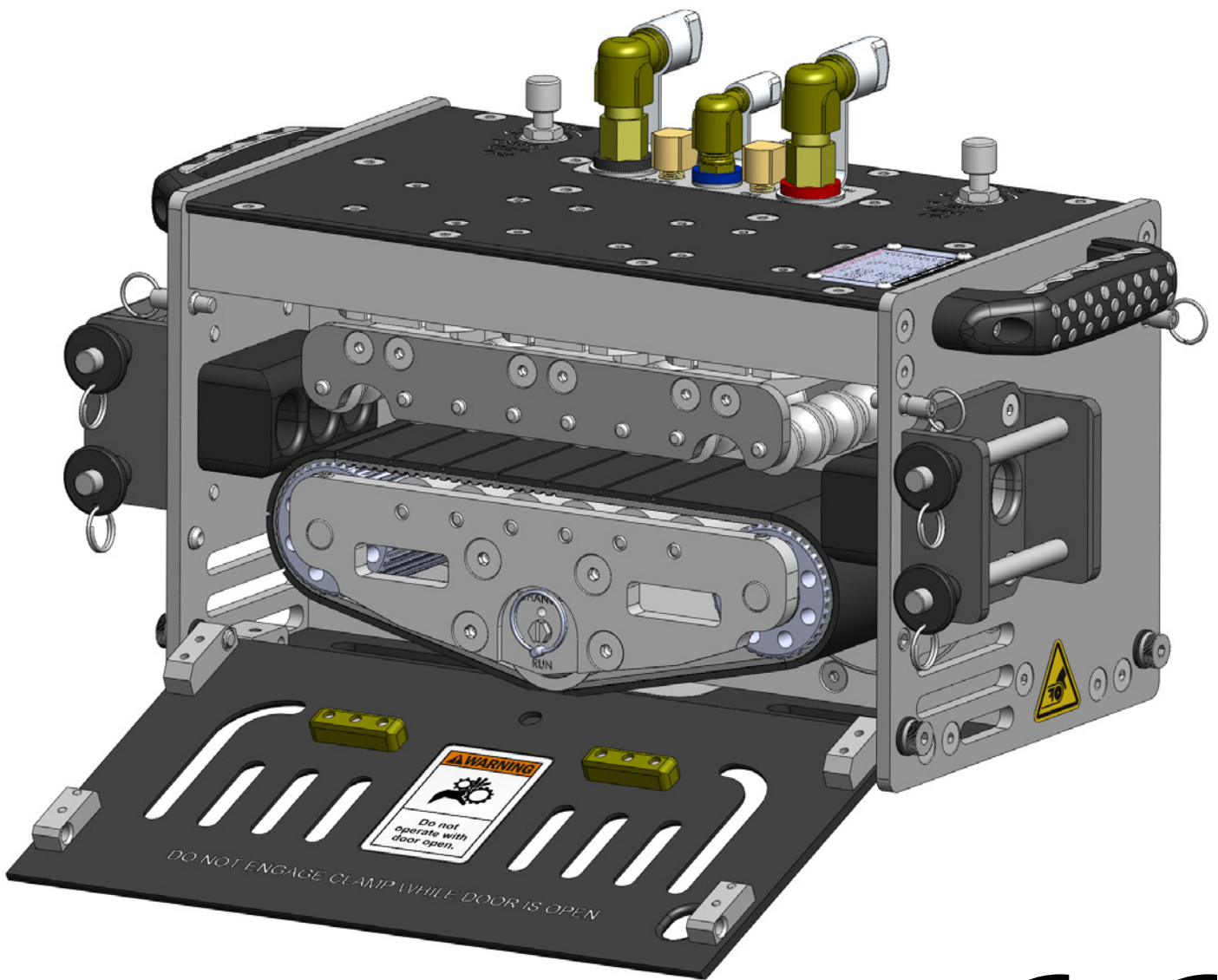

TABLE OF CONTENTS

MANUFACTURER'S INFORMATION	3
SPECIFICATIONS	3
DESCRIPTION OF EQUIPMENT AND INTENDED USE	3
KEY FEATURES.....	3
CE DECLARATION OF INCORPORATION	4
WARNING AND SAFETY INSTRUCTIONS	5
OPERATOR TRAINING.....	5
PERSONAL PROTECTIVE EQUIPMENT REQUIREMENTS.....	5
SAFETY LABEL DEFINITIONS.....	5
PRE-RUN SAFETY CHECK	6
SYSTEM ASSEMBLY - OVERVIEW	7
LIGHTWEIGHT POSITIONER - OVERVIEW	8
LIGHTWEIGHT POSITIONER CLAMP SELECTION.....	9
LIGHTWEIGHT POSITIONER SET-UP.....	10
GUIDE ASSEMBLY - OVERVIEW	12
GUIDE ASSEMBLY SET-UP	13
GUIDE ASSEMBLY TO LIGHTWEIGHT POSITIONER SET UP.....	14
AUTOBOX® (ABX-3L) HOSE TRACTOR - OVERVIEW	15
AUTOBOX® (ABX-3L) HOSE TRACTOR DRIVE BELT.....	15
AUTOBOX® (ABX-3L) HOSE TRACTOR TO GUIDE ASSEMBLY	16
CONTROL BOX - OVERVIEW	17
CONTROL BOX SET-UP.....	18
CONTROL BOX AIR SUPPLY FITTING	19
CONTROL BOX TO AUTOBOX® (ABX-3L) HOSE TRACTOR ASSEMBLY.....	20
OPERATION	21
AUTOBOX® (ABX-3L) HOSE TRACTOR DOORS AND PINS.....	21
COLLET INSERTION, HOSE, AND HOSE STOP INSTALLATION.....	22
CONTROL BOX AND HIGH PRESSURE HOSE.....	23
TEST RUN, AND RUN PROCEDURES AND HOSE CLAMP	24
MAINTENANCE AND STORAGE, TRANSPORTATION, AND HANDLING	25
ABX-3L BELT REPLACEMENT INSTRUCTIONS	26
PARTS DIAGRAMS	27
ABX-3L ACCESSORY OVERVIEW	43
TERMS AND CONDITIONS	44
WARRANTY INFORMATION	45

StoneAge Inc.
 466 S. Skylane Drive
 Durango, CO 81303, USA
 Phone: 970-259-2869
 Toll Free: 866-795-1586
 www.stoneagetools.com

StoneAge Europe
 Unit 2, Britannia Business Centre
 Britannia Way
 Malvern WR14 1GZ
 United Kingdom
 Phone: +44 (0) 1684 892065

This manual must be used in accordance with all applicable national laws. The manual shall be regarded as a part of the machine and shall be kept for reference until the final dismantling of the machine, as defined by applicable national law(s).

SPECIFICATIONS

AUTOBOX® (ABX-3L) Hose Tractor Weight:
 AUTOBOX® (ABX-3L) Hose Tractor Size:

Maximum Feed Rate (dependent upon application and hose size):
 Minimum Feed Rate (dependent upon application and hose size):
 Maximum Push/Pull Force:
 Minimum Push/Pull Force:
 Manway Access:
 Lightweight Positioner Weight:

HI-Viz Guide Assembly Weight:
 Pitch Adjustment Range (Triple):
 Pitch Adjustment Range (Dual):
 Control Box Weight:
 Maximum Air Consumption:
 Maximum Air Supply Pressure:
 System Operating Pressure:
 Recommended Operational Temperature Range:

DESCRIPTION OF EQUIPMENT AND INTENDED USE

The AUTOBOX® ABX-3L base system consists of a Hose Tractor, Control Box, Guide Assembly, and Lightweight Positioner. There are several accessories available to optimize the use of the system for specific tube cleaning applications. These accessories include Hose Containment, Fin-Fan Kit, and the Autostroke.

This system was developed for "Hands Free" heat exchanger tube cleaning applications. It is recommended it be used with the StoneAge® Banshee line of self-rotary waterblast tools.

The AUTOBOX® ABX-3L system was designed to accommodate up to three simultaneous flex lances ranging in size from 3/2 to 8/4 matched with the appropriate BN 9.5, BN13, BN15, or BN18 size Banshee.

The tractor utilizes a heavy-duty synchronous belt with a durable polyurethane cover to control the rate at which the hoses and Banshee tools are advanced or retracted inside the tubes.

The guide assembly provides anti-withdrawal protection, and precise tube pitch adjustment.

The lightweight positioner can be mounted to a variety of heat exchanger tube bundles and has pneumatic powered horizontal and vertical drives.

The control box is small and lightweight with an emphasis on ergonomics. The AUTOBOX® ABX-3L system was designed with simplicity, lightweight components, durability, and reliability in mind. It can be easily carried to the job site and setup in minutes.

49 lbs (22 kg) AUTOBOX® (ABX-3L) box only
 8.3 in. Wide x 8.2 in. Tall x 16.9 in. Long
 (211 mm Wide x 208 mm Tall x 429 mm Long)
 3.0 ft/sec (914 mm/sec)
 0.3 ft/sec (8 mm/sec)
 150 lbs (50 lbs per lance) (68 kg, 23 kg per lance)
 15 lbs (5 lbs per lance) (7 kg, (2 kg per lance)
 18 in. (457 mm)
 120 lbs (54.4 kg) (Includes 6ft rails, horiz. and vert. idler carriages, and 4 clamps)
 9.5 lbs (4 kg) with Guide Tubes 6 lbs (3 kg) without Guide Tubes
 5/8 - 2.5 in. (16 mm- 64 mm)
 5/8 - 5 in. (16 mm- 127 mm)
 48 lbs (22 kg) (Includes Control Box, FRL, and stand)
 50 cfm at 100 psi (85 m3/h at 0.70 MPa)
 125 psi (0.86 MPa)
 100 psi (0.70 MPa)
 -20 °F to 140 °F (-29 °C to 60 °C)

KEY FEATURES:

AUTOBOX® (ABX-3L) Hose Tractor

- Heavy-duty 75mm wide drive belt with steel tension members
- Drive belt has durable polyurethane cover to ensure traction in all operation conditions
- Can run any hose size from 3/2 to 8/4 without any component changes.
- Lightweight and compact design
- Can be used in triple, dual, or single lance applications
- Quick pin attachment to guide assembly
- Hinged side doors for easy access to belt and drive components
- Independent forward/reverse speed controls

Control Box (CB-ABX-3L)

- Small, lightweight, ergonomic design that includes a portable stand and filter-regulator-lubricator assembly
- Tractor controls: forward/reverse hose feed, feed motor pressure selector (number of hoses plus high/med/low selection), and clamp pressure
- Positioner controls: left/right and up/down
- Pneumatic dump control switch

Guide Assembly (ABX-301)

- Compact and lightweight design
- Turn knob control provides precise pitch adjustment
- Quick change guide tubes
- 17-4 SS hose stop collets

Lightweight Positioner (LWP-500)

- Modular, lightweight design
- Quick install drive carriages
- Utilizes 2.5 in. (6 mm) box rail
- Stainless Steel air motors
- Variety of clamp and bolt-on attachment options are available

**CE DECLARATION OF INCORPORATION
OF PARTLY COMPLETED MACHINERY**

We: StoneAge, Inc. 466 South Skylane Drive Durango, CO 81303, USA

Declare that this “partly completed machinery” supplied with this declaration:

Equipment: AUTOBOX® Hose Tractor

Model name: ABX-3L is in accordance with the following Directives: and

- is designed and manufactured solely as a non-functional component to be incorporated into a machine requiring completion;
- must not be put into service within the European Community (“EC”) until the final machinery into which it is to be incorporated has been declared in conformity with the Machinery Directive and all other applicable EC Directives; and
- is designed and manufactured to comply with the 2006/42/EC Essential Health and Safety Requirements of the Machinery Directives and the relevant parts of the following specifications:
EN ISO 12100:2010 Safety of machinery - General principles for design - Risk assessment and risk reduction

We hereby declare that the equipment named above has been tested and found to comply with the relevant sections of the above referenced specifications and directives.

Date 10/20/2016

StoneAge Europe
Unit 2, Britannia Business Centre
Britannia Way
Malvern WR14 1GZ
United Kingdom

The Technical File for the AUTOBOX® Hose Tractor (ABX-3L) is maintained at: StoneAge, Inc. 466 South Skylane Drive, Durango, CO 81303, USA



WARNING AND SAFETY INSTRUCTIONS

OPERATOR TRAINING

Managers, Supervisors, and Operators MUST be trained in Health and Safety Awareness of High-pressure Water Jetting and hold a copy the Water Jetting Association (WJA) Code of Practice, or equivalent (see www.waterjetting.org.uk).

Operators MUST be trained to identify and understand all applicable standards for the equipment supplied. Operators should be trained in manual handling techniques to prevent bodily injury.

StoneAge has designed and manufactured this equipment considering all hazards associated with its operation. StoneAge assessed these risks and incorporated safety features in the design. StoneAge **WILL NOT** accept responsibility for the results of misuse.

IT IS THE RESPONSIBILITY OF THE INSTALLER/OPERATOR to conduct a job specific risk assessment prior to use. Job specific risk assessment MUST be repeated for each different set up, material, and location.

The risk assessment MUST conform to the Health and Safety at Work Act 1974 and other relevant Health and Safety legislation.

PERSONAL PROTECTIVE EQUIPMENT REQUIREMENTS

Use of Personal Protective Equipment (PPE) is dependent on the working pressure of water and the cleaning application. Managers, Supervisors, and Operators MUST carry out a job specific risk assessment to define the exact requirements for PPE. See Protective Equipment for Personnel (Section 6) of WJTA-IMCA's Recommended Practices For The Use Of High-pressure Waterjetting Equipment for additional information.

Hygiene - Operators are advised to wash thoroughly after all waterjetting operations to remove any waterblast residue which may contain traces of harmful substances.

First aid provision - users MUST be provided with suitable first aid facilities at the operation site.

SAFETY LABEL DEFINITIONS

The AUTOBOX® (ABX-3L) Hose Tractor has the potential to cause serious injury if fingers, hair, or clothing become caught between the hose rollers or drive belts. Be sure to head the Hand Entanglement Roller Labels.

DO NOT OPERATE WITH THE DOORS OPEN. ENSURE THAT ALL FOUR DOOR PINS ARE SECURED PRIOR TO OPERATION.

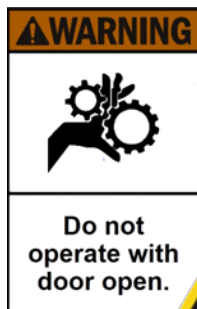

Operators MUST read, understand, and follow the Operational and Training Requirements (Section 7.0) of WJTA-IMCA's Recommended Practices For The Use Of High-pressure Water jetting Equipment, or equivalent.

Operators MUST read, understand, and follow the Warnings, Safety Information, Assembly, Installation, Connection, Operation, Transport, Handling, Storage, and Maintenance Instructions detailed in this manual.

The risk assessment MUST consider potential material or substance hazards including:

- Aerosols
- Biological and microbiological (viral or bacterial) agents
- Combustible materials
- Dusts
- Explosion
- Fibers
- Flammable substances
- Fluids
- Fumes
- Gases
- Mists
- Oxidizing Agents

PPE may include:

- **Eye protection:** Full face visor
- **Foot protection:** Kevlar® brand or steel toe capped, waterproof, non-slip safety boots
- **Hand protection:** Waterproof gloves
- **Ear protection:** Ear protection for a minimum of 85 dBA
- **Head protection:** Hard hat that accepts a full face visor and ear protection
- **Body protection:** Multi-layer waterproof clothing approved for waterjetting
- **Hose protection:** Hose shroud
- **Respiratory protection:** May be required; refer to job specific risk assessment

Maximum operating air pressure is 100 psi (0.7 MPa). Never exceed 125 psi (0.86 MPa) supply pressure. Exceeding 125 psi (0.86 MPa) supply pressure may result in injury to the Operator and/or damage to the equipment.

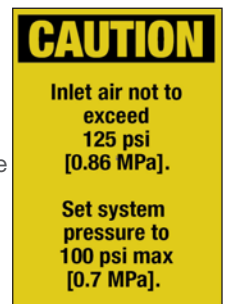

▲WARNING

Operations with this equipment can be potentially hazardous. Caution MUST be exercised prior to and during machine and water jet tool use. Please read and follow all of these instructions, in addition to the guidelines in the WJTA Recommended Practices handbook, available online at www.wjta.org. Deviating from safety instructions and recommended practices can lead to severe injury and/or death.

- Do not exceed the maximum operating pressure specified for any component in a system.
- The immediate work area MUST be marked off to keep out untrained persons.
- Inspect the equipment for visible signs of deterioration, damage, and improper assembly. Do not operate if damaged, until repaired.
- Make sure all threaded connections are tight and free of leaks.
- Users of the AUTOBOX® (ABX-3L) Hose Tractor MUST be trained and/or experienced in the use and application of high pressure technology and cleaning, as well as all associated safety measures, according to the WJTA Recommended Practices for the use of High pressure Water jetting Equipment.
- The Lightweight Positioner must be securely fastened to the tube bundle, and the Guide Assembly and Tractor must be securely fastened to the Lightweight Positioner prior to operation.
- An anti-withdrawal device (back-out preventer) MUST be used at all times. The back-out prevention device is the Hose Stop Collet located within the Hose Guide Assembly. StoneAge offers several different size Hose Stop Collets. The Collet Size Reference guide is located on the Hose Guide Assembly.
- The Control Box should be located in a safe location where the Operator has good visibility of the tool entering the exchanger tubes. The AUTOBOX® (ABX-3L) Hose Tractor and Control Box MUST be supervised at all times and should never be left unattended.
- Do not fully release the hose clamp (decreasing pressure to zero) during operation, or the AUTOBOX® (ABX-3L) Hose Tractor will release the hose and may create a dangerous runaway hose condition, which can result in severe injury and/or death.
- Always de-energize the system before opening the door to service or replace any parts. Failure to do so can result in severe injury and/or death.
- When moving the AUTOBOX® (ABX-3L) Hose Tractor lift with care to prevent bodily injury.
- Do not operate the AUTOBOX® (ABX-3L) Hose Tractor while either side door is open.

PRE-RUN SAFETY CHECK

Refer to WJTA-IMCA's, Recommended Practices For The Use Of High pressure Waterjetting Equipment and/or The Water Jetting Association's, WJA Code of Practice for additional safety information.

- Complete a job specific risk assessment and act on the resulting actions.
- Adhere to all site specific safety procedures.
- Ensure the waterblasting zone is properly barricaded and that warning signs are posted.
- Ensure the work place is free of unnecessary objects (e.g. loose parts, hoses, tools).
- Ensure all Operators are using the correct Personal Protective Equipment (PPE).
- Check that the air hoses are properly connected and tight.
- Check all hoses, lances, and accessories for damage prior to use. Do not use damaged items. Only high quality hoses intended for waterblast applications should be used as high pressure hoses.
- Check all high pressure threaded connections for tightness.
- ****Ensure that an anti-withdrawal device (back-out preventer), whip checks (hose whips), and the appropriate hose stop collet are installed and set up properly. They must be verified, secured, tested, and performance confirmed before operating at high pressure.****
- Ensure the doors of the AUTOBOX® (ABX-3L) Hose Tractor are closed and securely latched.
- Test the Control Box before operating the AUTOBOX® (ABX-3L) Hose Tractor with high pressure water to verify the control valves move the hose in the intended direction, and that the high pressure dump valve and hose clamp are working properly.
- Ensure that Operators never connect, disconnect, or tighten hoses, adapters, or accessories with the high pressure water pump unit running.
- Ensure no personnel are in the hydroblasting zone.

**AUTOBOX® (ABX-3L) HOSE TRACTOR,
LIGHTWEIGHT POSITIONER, GUIDE ASSEMBLY,
AND CONTROL BOX SYSTEM ASSEMBLY**

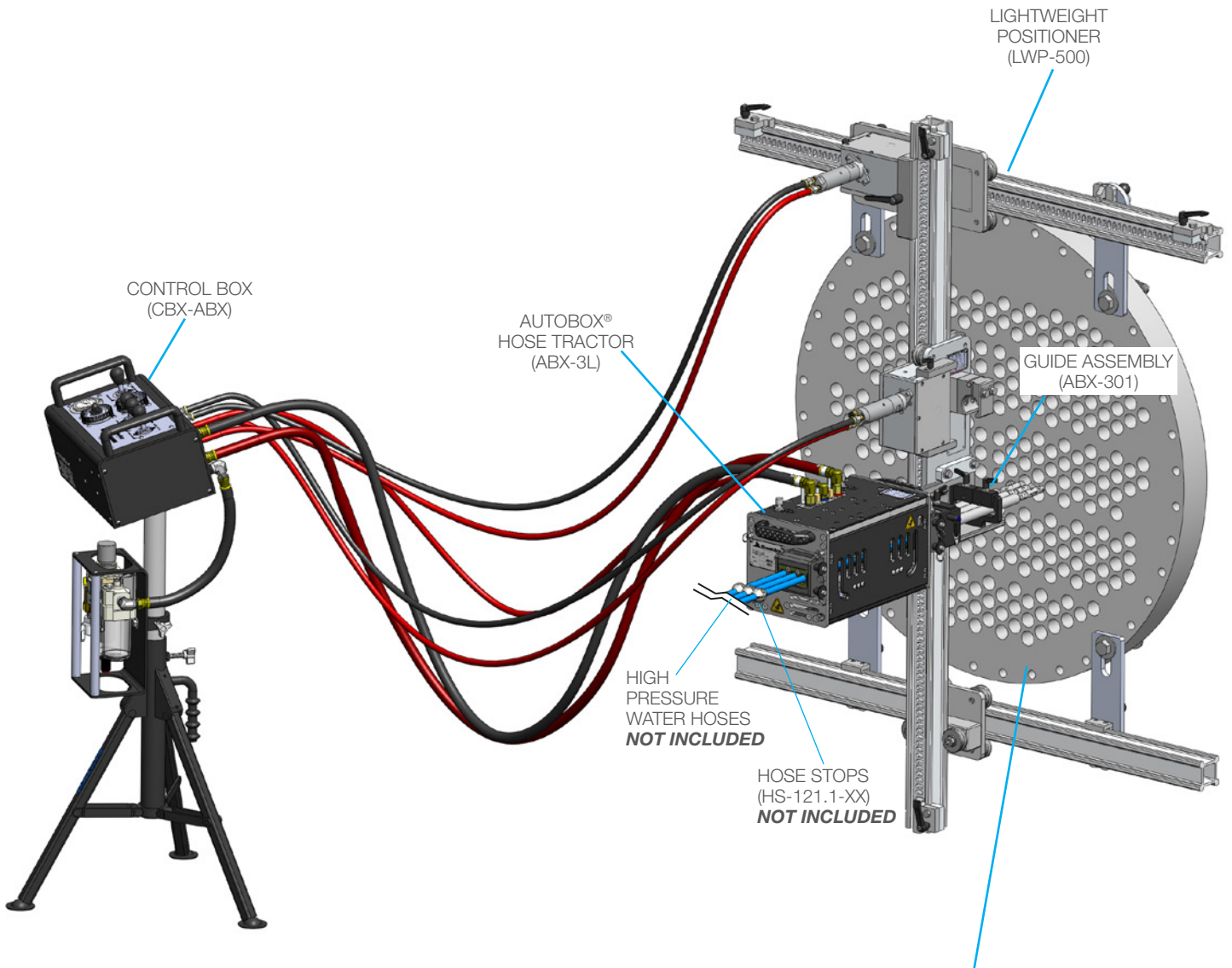

NOTICE

Heat exchanger tube bundle face, shown for graphic representation only. NOT included in assembly.

LIGHTWEIGHT POSITIONER - OVERVIEW

LIGHTWEIGHT POSITIONER AND ACCESSORIES

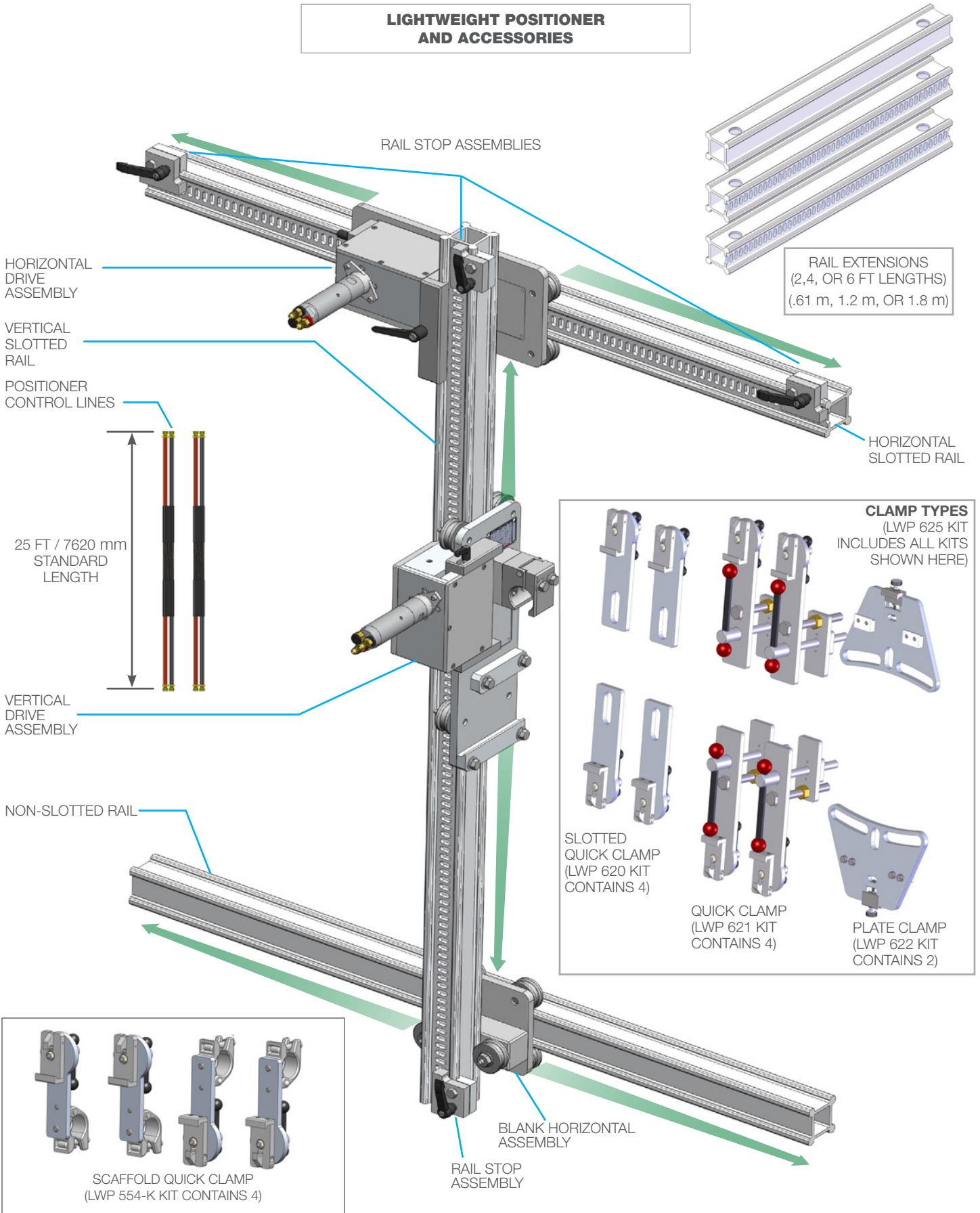

CLAMP SELECTION is dependent upon the heat exchanger geometry, bolt holes, hole spacing, and flange accessibility.

QUICK CLAMPS (LWP 518) are for use with heat exchanger flanges that provide a robust clamping surface or if flange holes are inaccessible. Align clamps on the surface of the flange to maximize flange engagement to clamps. (Figure 1)

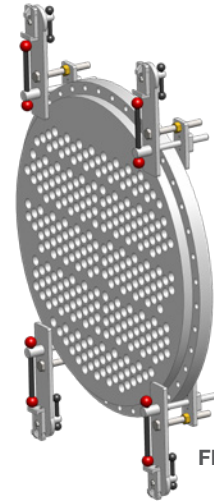
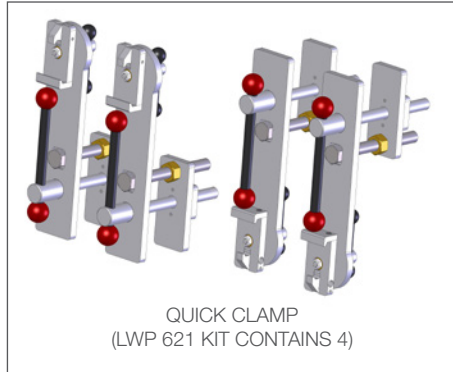

FIGURE 1

SLOTTED QUICK (LWP 552) AND PLATE CLAMPS (LWP 519) are for use with heat exchanger flanges that have easily accessible bolt holes. Use quick clamps or plate clamps, depending on the spacing of the hole pattern. (Figures 1 & 3)

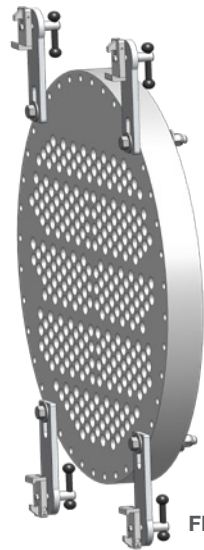

FIGURE 2

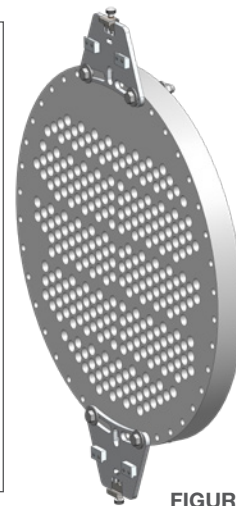
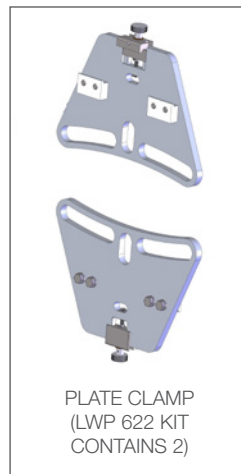

FIGURE 3

SCAFFOLD QUICK CLAMPS (LWP 554) are for use with scaffolding in situations where there may be no way to clamp directly onto the heat exchanger. (Figure 4)

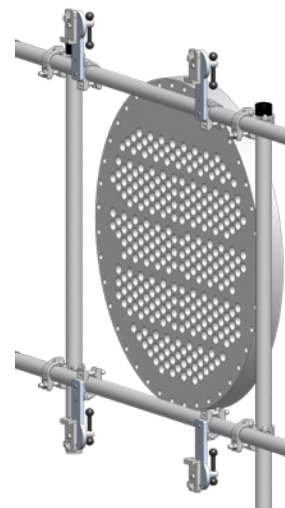
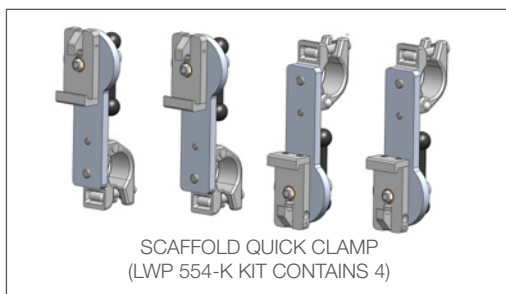

FIGURE 4

LIGHTWEIGHT POSITIONER SET-UP

LIGHTWEIGHT POSITIONER STEP BY STEP SET-UP

1. Mount the appropriate frame **Positioner Clamps** to the tube bundle as shown on the previous page. (Shown in Figure 1 with Slotted Quick Clamps) Positioner Clamps should be aligned horizontally with the direction of the tube rows. **(Figure 1)**

NOTICE

Heat exchanger tube bundle face, shown for graphic representation only. NOT included in assembly.

2. Insert the **Top Rail (slots facing out)** into the upper mounting brackets. If the rail is not closely aligned with the tube rows, loosen one of the upper mounting brackets and adjust until the top rail is parallel with the horizontal tube rows. Tighten the clamps securing the rail to the mounting brackets. Ensure upper mounting brackets are securely clamped or bolted to the tube bundle flange. **(Figure 2)**

3. Insert the **Lower Rail (non-slotted)** into the lower mounting brackets. It is not critical that this rail is aligned as precisely as the top rail, but it should be close to parallel with the top rail for best performance. Tighten the clamps securing the rail to the mounting brackets. Ensure lower mounting brackets are securely clamped or bolted to the tube bundle flange. **(Figure 3)**

4. Loosen the **Quick Adjust Handle** and pull the gearbox away from the carriage plate. This will allow the **Horizontal Drive Carriage** to slide onto the rail without pneumatic power, to rotate the drive. Center the carriage on the top rail and push the gearbox back toward the carriage plate. This will engage the gear into the rail slots. Verify the gear is engaging the slots correctly and tighten the quick adjust handle. **(Figure 4)**

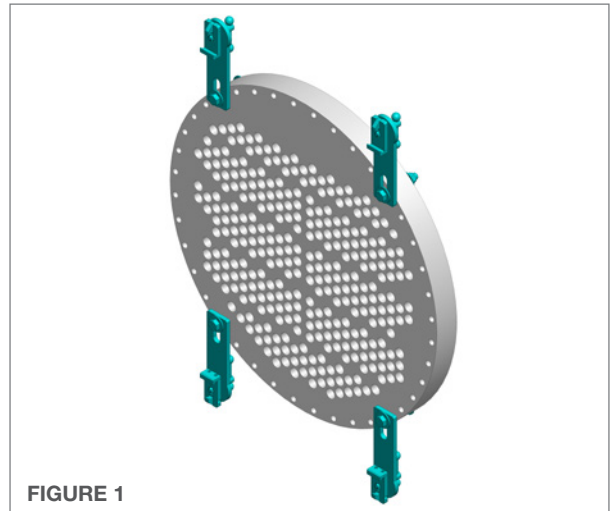

FIGURE 1

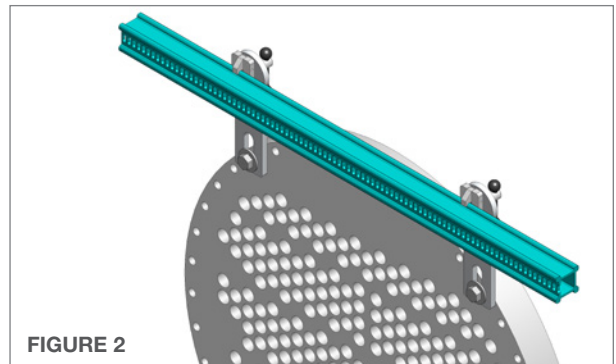

FIGURE 2

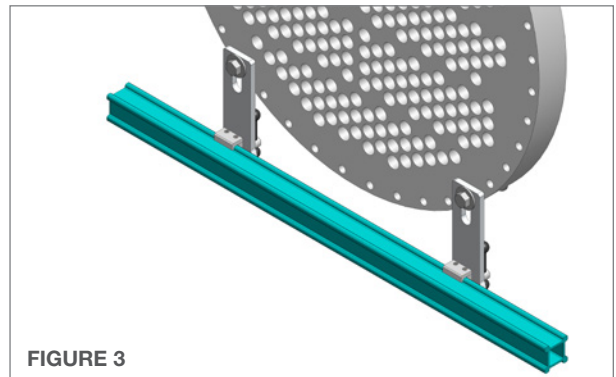

FIGURE 3

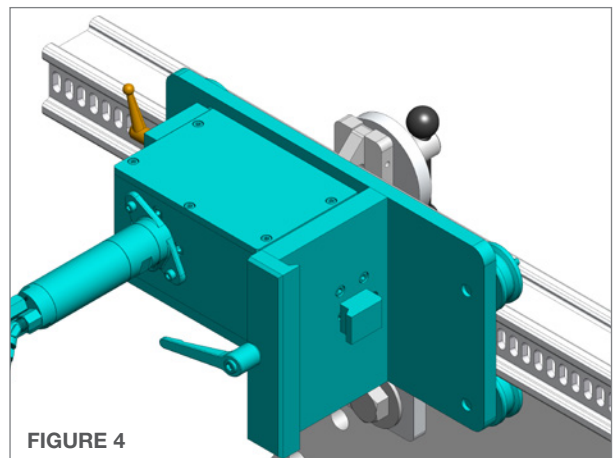

FIGURE 4

- Slide the **Idler Carriage** onto the Lower Non-Slotted Rail. **(Figure 5)**

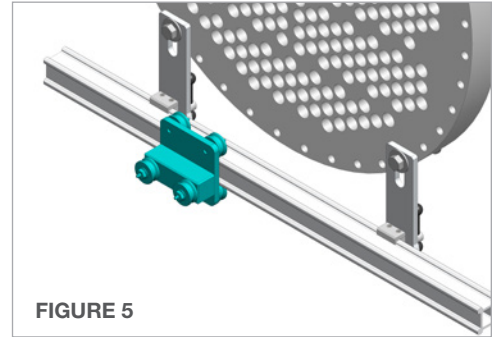

FIGURE 5

- Loosen the **Large Adjustable Handle** for the Vertical Rail Clamp. Align the Idler Carriage with the vertical rail clamp on the horizontal carriage. Install the **Vertical Rail** with **(slots facing out)** down through the horizontal carriage clamp and between the rollers on the idler carriage. Adjust the position of the vertical rail as required and secure the clamp on the horizontal carriage by tightening the large adjustable handle. **(Figure 6)**

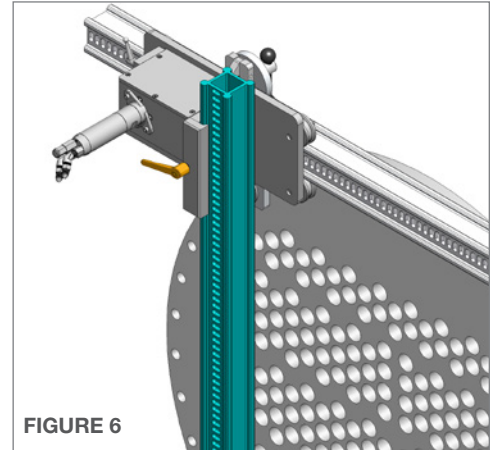

FIGURE 6

- Loosen the **Quick Adjust Handle** and pull the gearbox away from the carriage plate. This will allow the **Vertical Drive Carriage** to slide onto the rail without pneumatic power to rotate the drive. Center the carriage on the vertical rail and push the gearbox back toward the carriage plate. This will engage the gear into the rail slots. Verify the gear is engaging the slots correctly and tighten the quick adjust handle. **(Figure 7)**

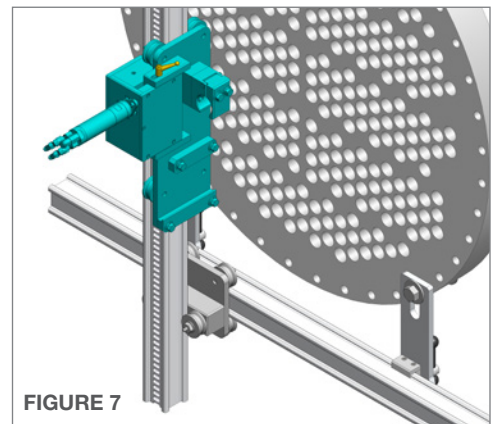

FIGURE 7

- Install the four **Rail Stops** at both ends of the top, slotted, horizontal rail, and both ends of the vertical slotted rail. **(Figure 8)**

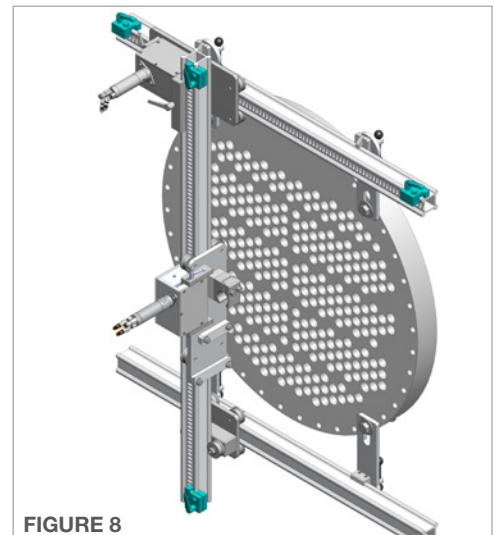

FIGURE 8

NOTICE

Verify the mounting brackets and rail clamps are securely tightened, and the drive carriages are securely engaged, and the adjustable handles are tightened.

CAUTION

Never loosen the vertical gearbox once the guide assembly and tractor are installed, as it may result in the carriage falling vertically down. This may cause damage to the equipment and/or injury.

HOSE GUIDE ASSEMBLY - OVERVIEW

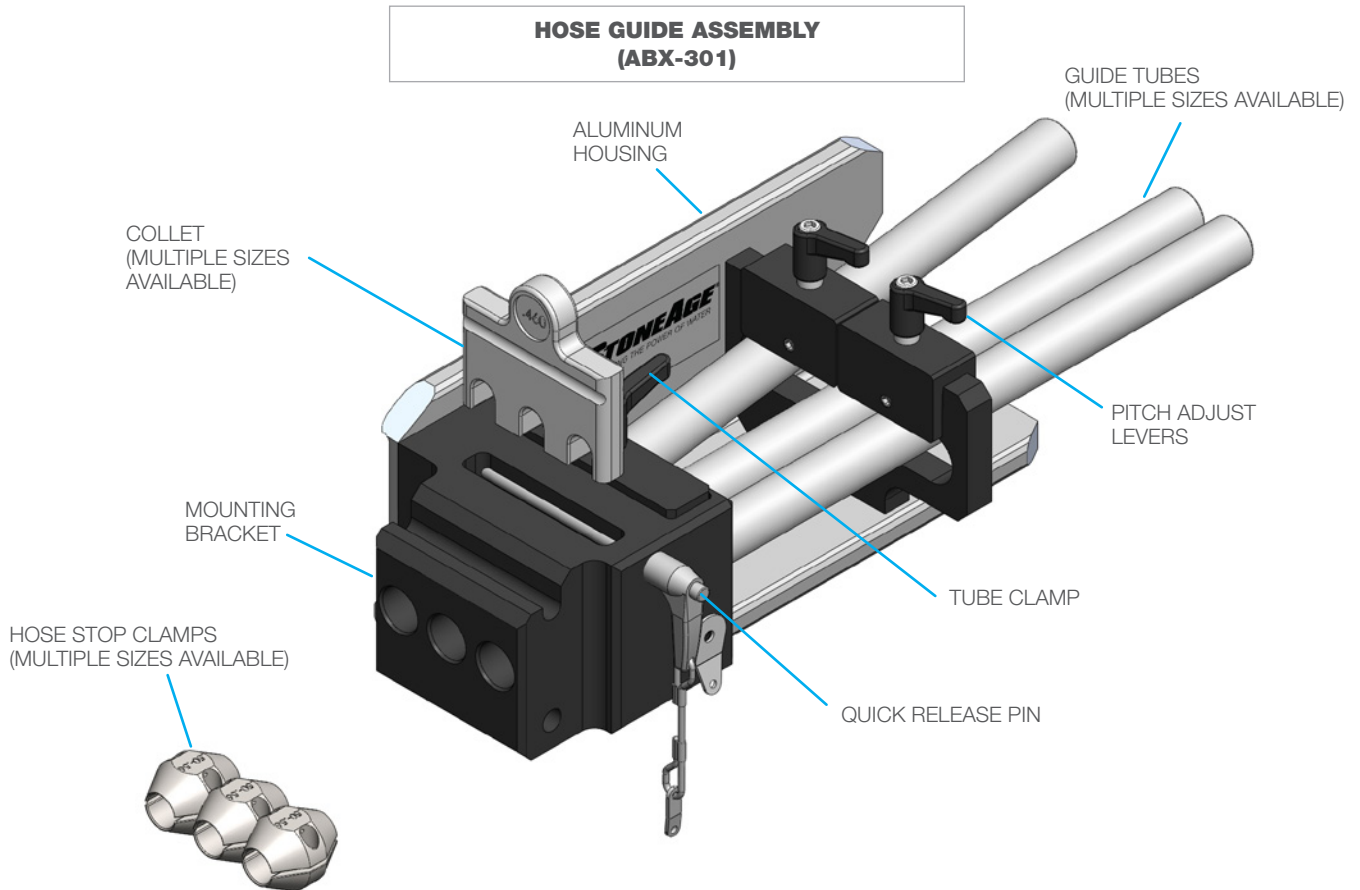

StoneAge (SA) PART NUMBER COLLET AND HOSE STOP REFERENCE CHART

HOSE O.D.	SPIR STAR	PARKER	COLLET SIZE	COLLET PART NUMBER	HOSE STOP SIZE	HOSE STOP PART NUMBER
.27-.41 in (7 mm - 10 mm)	3/2	2240D-02	.297 in. / 7.5 mm	ABX 171-297	.27-.34 / 7-9 mm	HS 121-27-34
	3/4, 4/2	2240D-025, 2440D-02	.328 in. / 8.3 mm	ABX 171-328	.27-.34 / 7-9 mm	HS 121-27-34
	3/6, 5/2	2240D-03	.406 in. / 10.3 mm	ABX 171-406	.34-.42 / 9-11 mm	HS 121-34-42
.44-.50 in (11 mm - 13 mm)	4/4	2448D-025	.438 in. / 11.1 mm	ABX 171-438	.34-.42 / 9-11 mm	HS 121-34-42
	4/6, 5/4, 6/2	2240D-04	.460 in. / 11.7 mm	ABX 171-460	.42-.50 / 11-13 mm	HS 121-42-50
		2640D-025 2740D-025	.484 in. / 12.3 mm	ABX 171-484	.42-.50 / 11-13 mm	HS 121-42-50
	6/4	2440D-04	.516 in. / 13.1 mm	ABX 171-516	.50-.56 / 13-14 mm	HS 121-50-56
.52-.61 in (13 mm - 16 mm)	5/6, 8/2	2240D-05, 2740D-03	.547 in. / 13.9 mm	ABX 171-547	.50-.56 / 13-14 mm	HS 121-50-56
	5/6H, 8/4		.594 in. / 15.1 mm	ABX 171-594	.56-.61 / 14-16 mm	HS 121-56-61
		2440D-05	.625 in. / 15.9 mm	ABX 171-625	.56-.61 / 14-16 mm	HS 121-56-61

StoneAge (SA) PART NUMBER GUIDE TUBE REFERENCE CHART

GUIDE TUBE	BANSHEE	INSIDE DIAMETER, LENGTH
ABX 115-12	BN9.5	.459 in / 11.7 mm, 12.5 in. / 318 mm
ABX 115-36	BN9.5	.459 in / 11.7 mm, 36 in. / 914 mm
ABX 116-12	BN13	.546 in / 13.9 mm, 12.5 in. / 318 mm
ABX 116-36	BN13	.546 in / 13.9 mm, 36 in. / 914 mm
ABX 117-12	BN15	.674 in / 17.1 mm, 12.5 in. / 318 mm
ABX 117-36	BN15	.674 in / 17.1 mm, 36 in. / 914 mm
ABX 119-12	BN18	.745 in / 18.9 mm, 12.5 in. / 318 mm
ABX 119-36	BN18	.745 in / 18.9 mm, 36 in. / 914 mm

*OPTIONAL ABX 140-XX GUIDE TUBE ANTI-TWIST CLAMPS

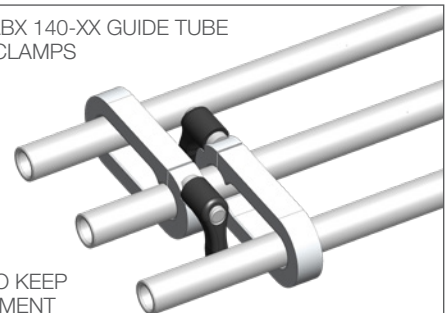

DESIGNED TO KEEP PITCH ALIGNMENT BETWEEN LONGER GUIDE TUBES

SEE "PART DIAGRAM" PAGES FOR SIZING.

HOSE GUIDE ASSEMBLY

- Select the appropriate Guide Tube size and length for the application from the chart at the bottom of the previous page.
 - The length of the Guide Tubes for an exchanger bundle with no channel head is 12.5 in. (318 mm).
 - A deeper channel head will require extended Guide Tubes. The depth of the channel head added to the 12.5 in. (318 mm) length will give the desired tube length.
 - Longer guide tubes are available if required for use with channel heads.

NOTICE

The Banshee tool should not have excessive clearance if the correct length Guide Tube size is used.

- To remove the existing Guide Tubes, loosen the Tube Clamp Lever and the two Pitch Adjust Levers, located on top of the Guide Assembly.
- After selecting the appropriate Guide Tubes, install the Guide Tubes into the Guide Assembly.
- Secure the Guide Tubes by tightening the Tube Clamp Lever and Pitch Adjust Levers, when the desired pitch has been set.
- Select the appropriate Collet and Hose Stops from the chart on the previous page and reserve them for future Hose and Collet installation instructions in this manual.

WARNING

Appropriate size Collet selection is **CRITICAL** to ensuring proper backout prevention of the tool. Use the chart on the previous page to select the proper Collet and Hose Stop sizes per hose diameter. Always confirm backout prevention performance before operating the system at high pressure.

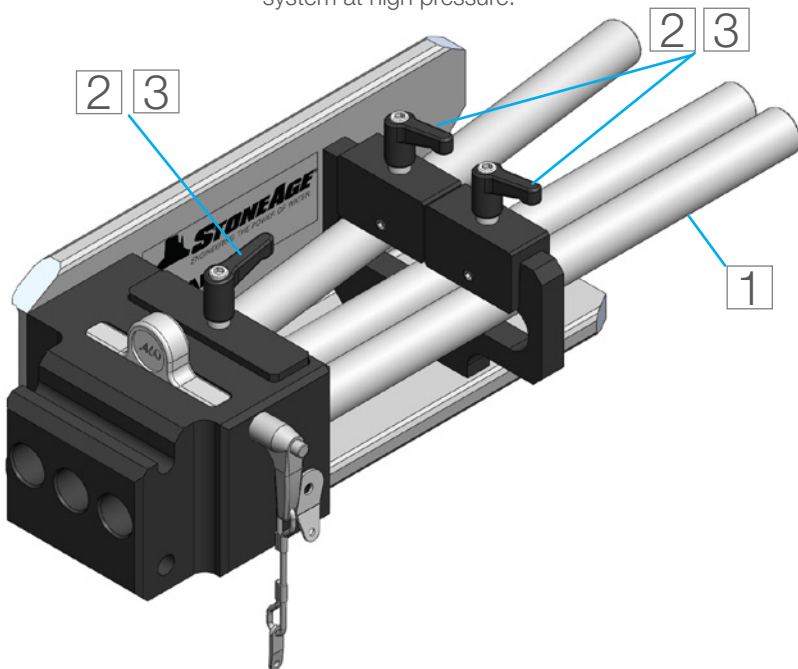

SINGLE OR DUAL HOSE LOADING

The AUTOBOX® (ABX-3L) Hose Tractor can be used as a Single or Dual Lance tool. The diagrams below show which Guide Tubes to load for each quantity for best performance.

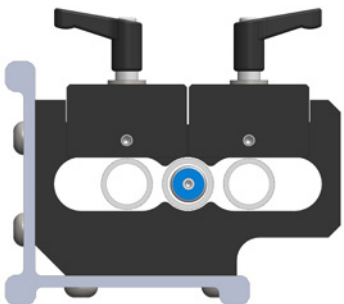

SINGLE HOSE LOAD

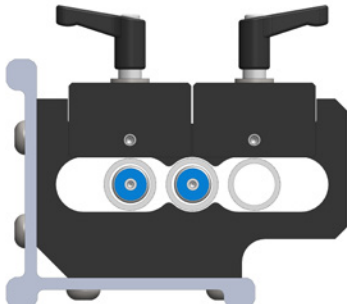

DUAL HOSE LOAD
1.25 INCH PITCH OR SMALLER
(1 INCH OD TUBES OR SMALLER)

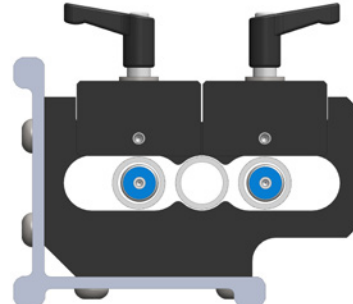

DUAL HOSE LOAD LARGE PITCH
1.25 INCH PITCH OR LARGER

HOSE GUIDE ASSEMBLY TO LIGHTWEIGHT POSITIONER SET UP

ATTACH GUIDE ASSEMBLY TO LIGHTWEIGHT POSITIONER

1. Using a 9/16 in. wrench, loosen all four rail clamp bolts located on the vertical carriage. Install the Guide Assembly into the rail clamps and adjust position until the Guide Tubes are approximately 1/2 in. (13 mm) away from the tube sheet face. Tighten the four rail clamp bolts.
2. Loosen the Pitch Adjustment Levers and adjust the guide tubes until they are in line with pitch of the tubes in the bundle.
3. Tighten Tube Clamp and Pitch Adjustment Levers until tubes are secured in position.

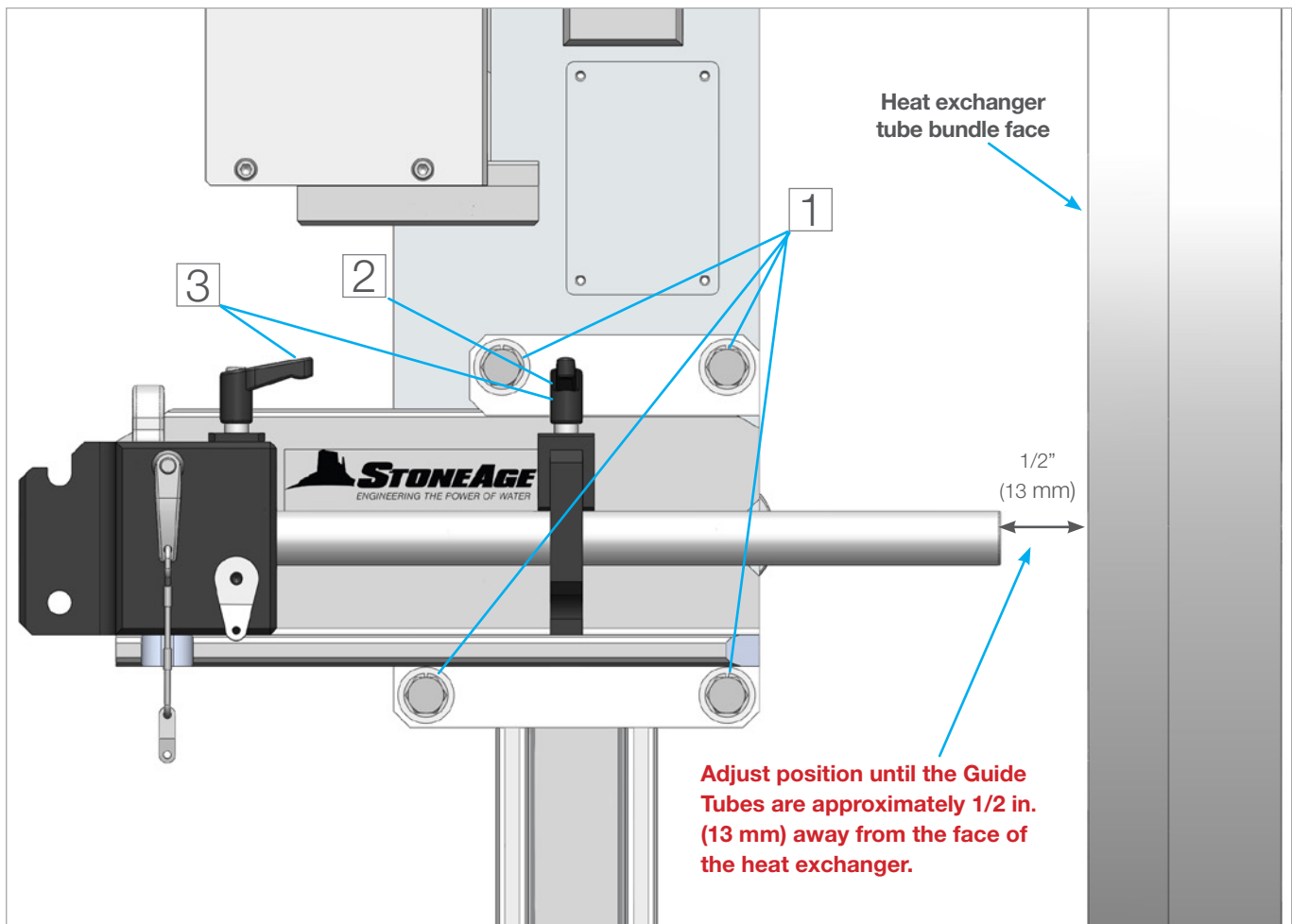

**AUTOBOX® HOSE TRACTOR
(ABX-3L)**

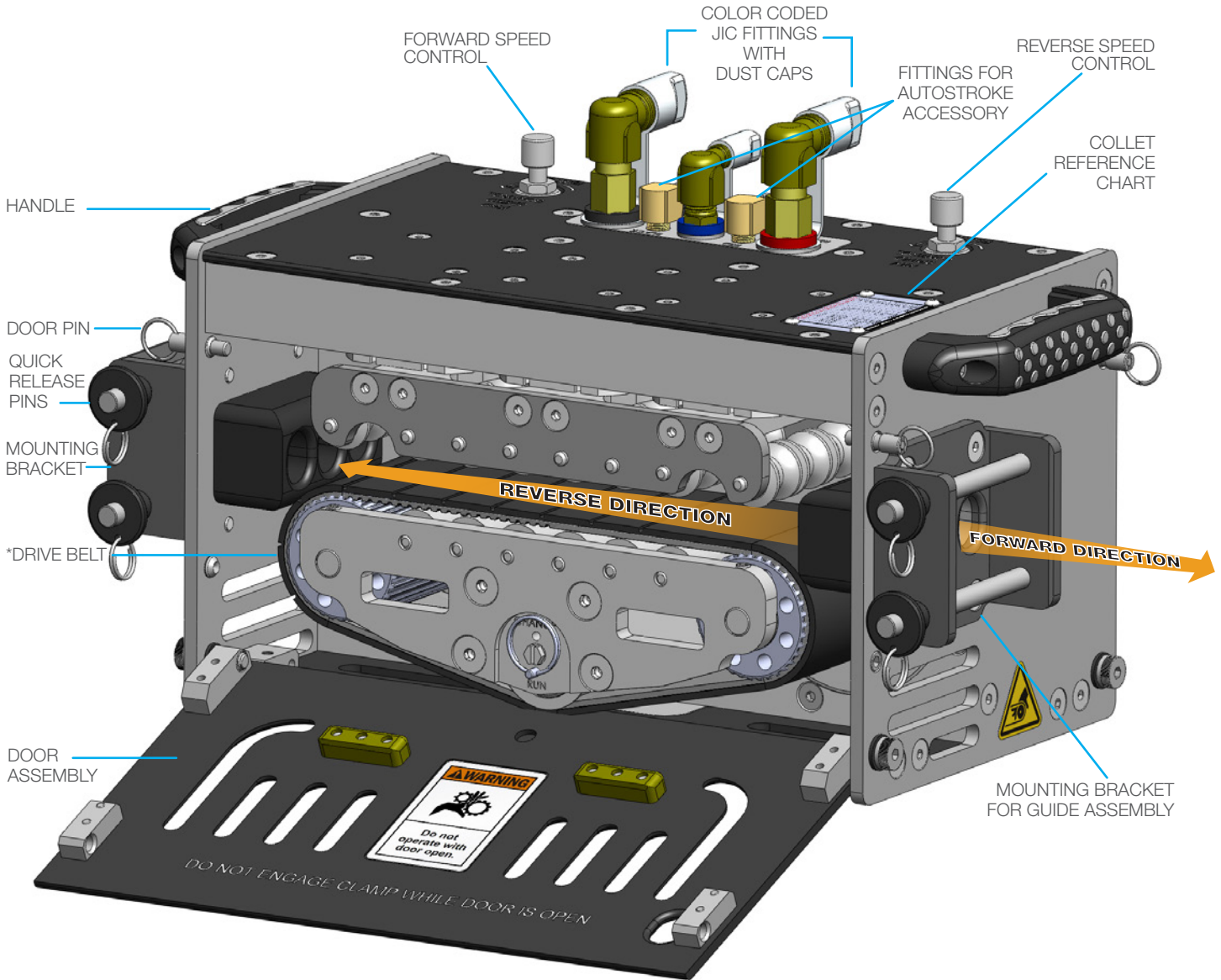

*ABX 305-80 BELT 80A 25MM (INCLUDED)
 ABX 305-70 BELT 70A 10MM (SOLD SEPARATELY)
 FOR OILY CONDITIONS

PNEUMATIC SUPPLY LINES (CB 370-25)

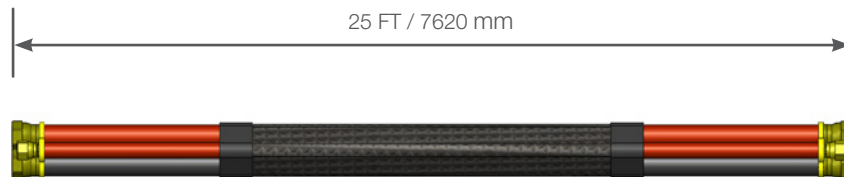

ABX-3L HOSE TRACTOR TO GUIDE ASSEMBLY

ATTACH AUTOBOX® (ABX-3L) HOSE TRACTOR TO GUIDE ASSEMBLY

1. Remove the lower quick release pin from the AUTOBOX® (ABX-3L) Hose Tractor.
2. Slide the mounting bracket over the block on the Guide Assembly and lay the pin onto the top slot on the Guide Assembly block.
3. Install the lower pin through the mounting bracket on the Hose Tractor and the block on the Guide Assembly.

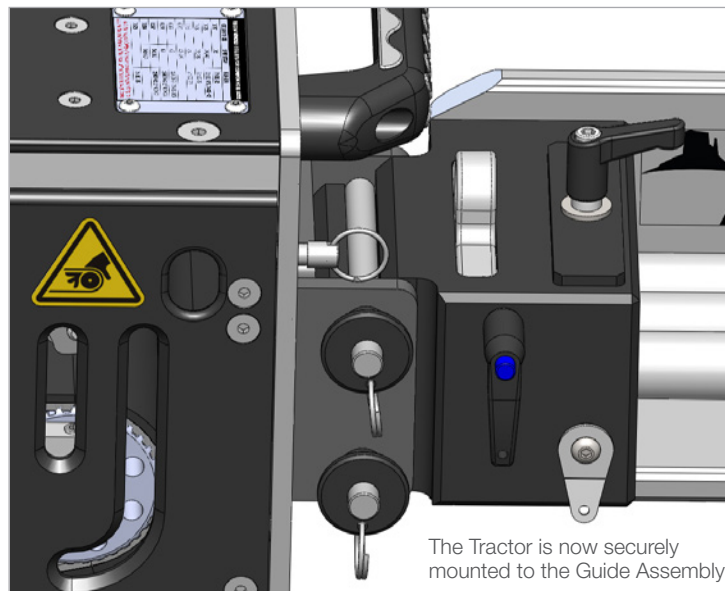
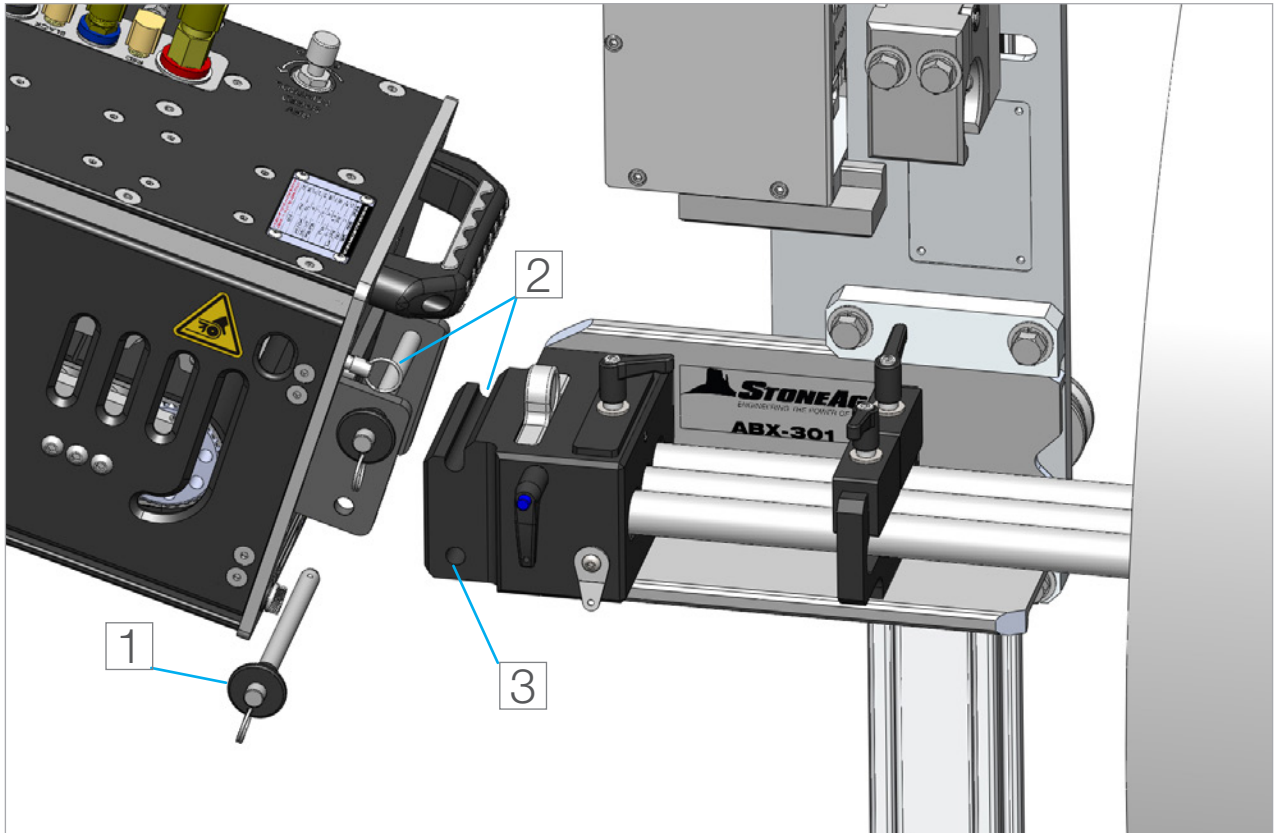

**CONTROL BOX
TOP VIEW**



**CONTROL BOX
FRONT VIEW**

**CONTROL BOX
BACK VIEW**

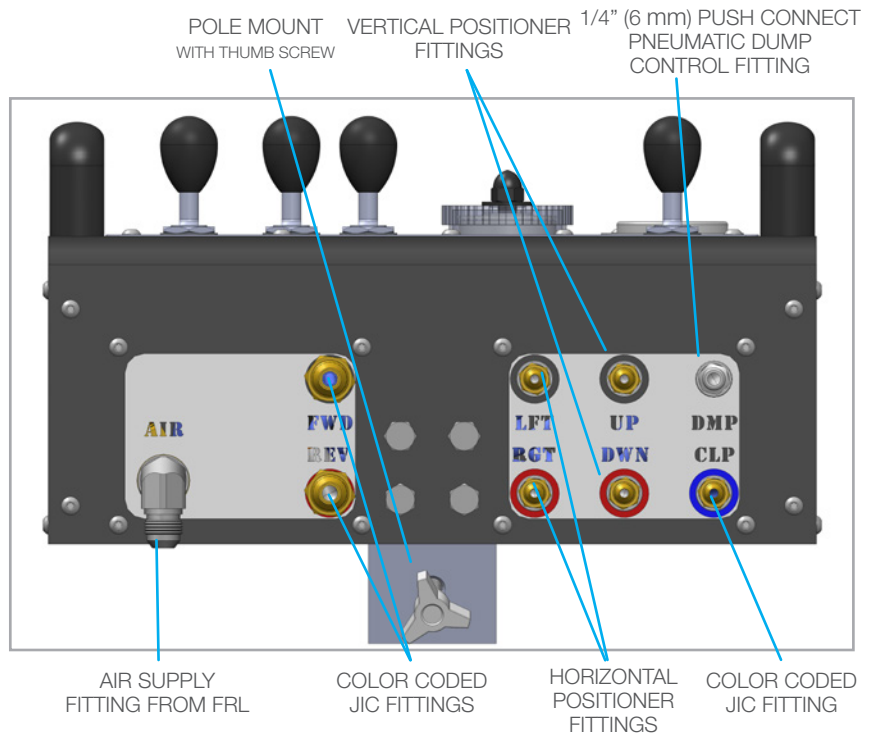
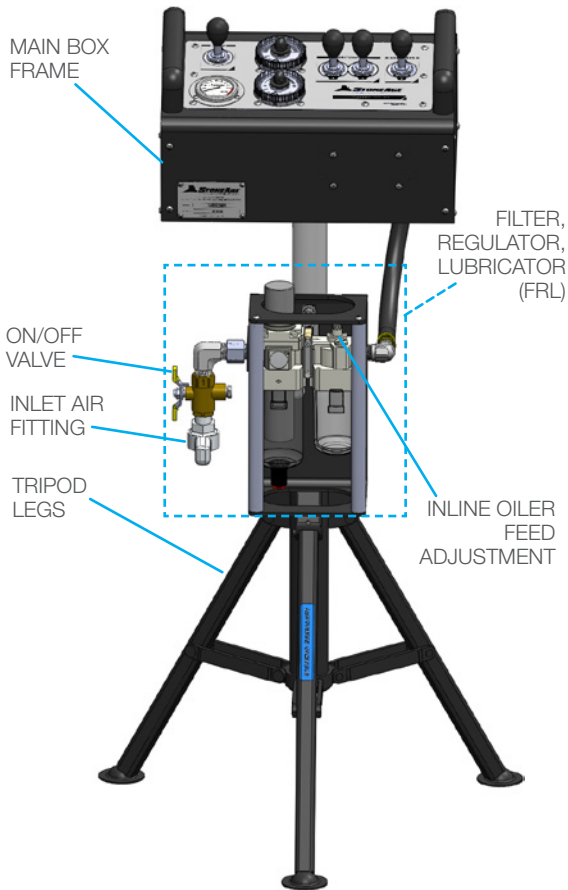

CONTROL BOX SET-UP

ASSEMBLE CONTROL BOX, FRL, AND TRIPOD BASE

1. Setup the tripod base in a location with good visibility to the bundle face, but at a safe distance away from high pressure nozzle waterblast zone.
2. Slide the vertical tube into the tripod base. Secure with the supplied thumbscrew knob.
3. Slide the Filter, Regulator, Lubricator (FRL) assembly over the vertical tube down to the tripod base. Secure with the supplied thumbscrew knob.
4. Slide the Control Box over the vertical tube. The Control Box has a stop that keeps it located at the top of the vertical tube. Secure with the supplied thumbscrew knob.
5. Install and tighten the short 1/2 in. (13 mm) I.D. hose between the FRL and the Control Box.

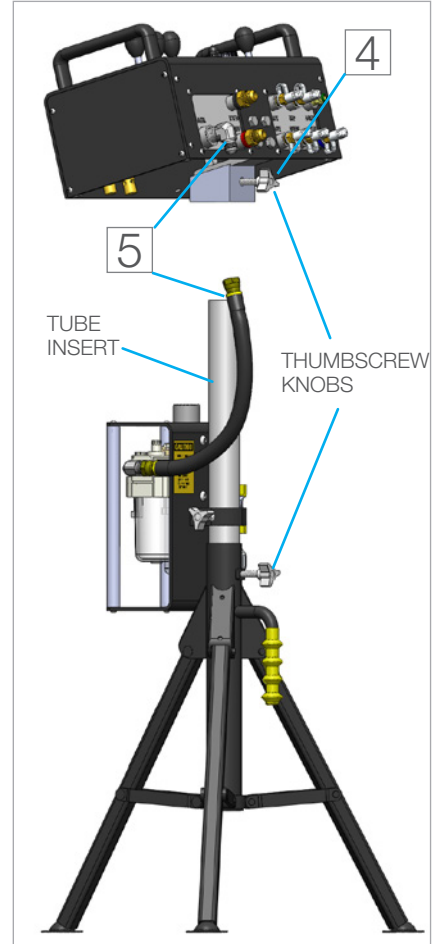
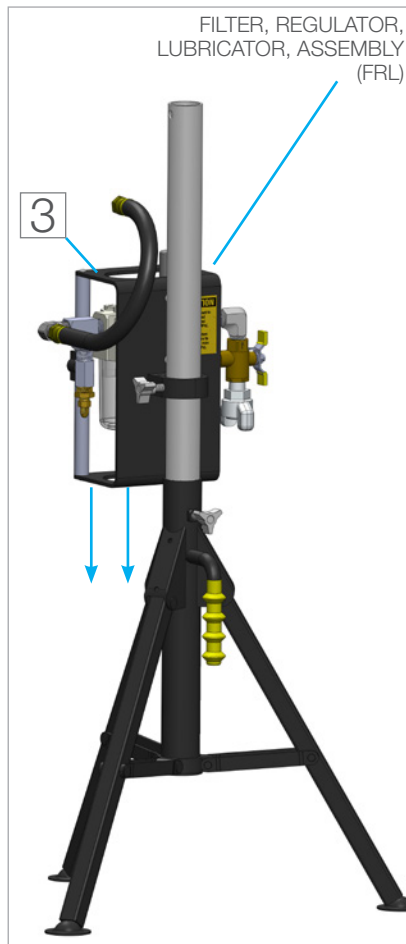
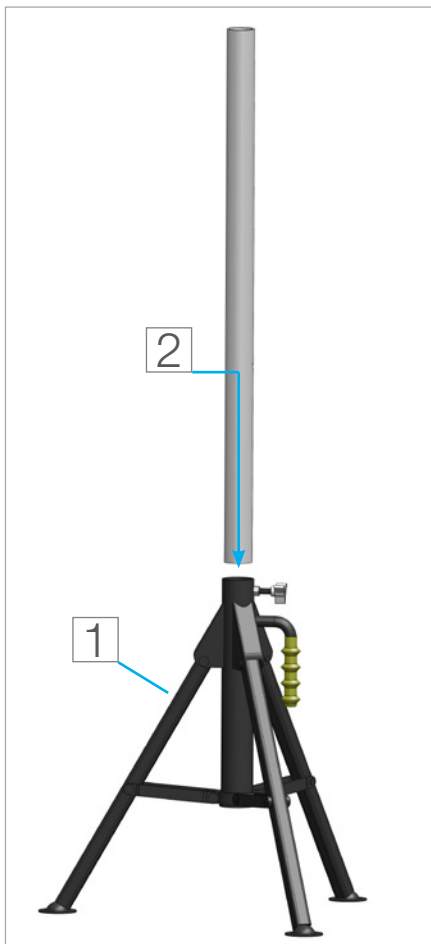
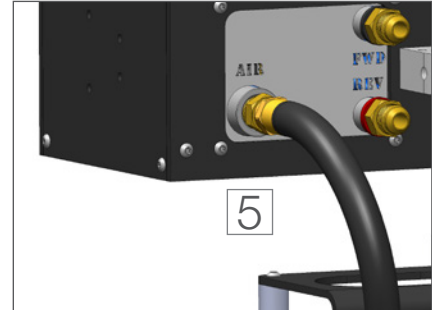

AIR SUPPLY AND LUBRICATOR SETTING

1. The Control Box is supplied with a twist claw style inlet coupling (Chicago style) located on the side of the FRL Assembly. Connect a compatible compressed air line (not included) according to the Manufacturer's instructions.
2. Using the regulator adjust the operating air pressure to 100 psi (0.7 MPa) for the application.

⚠ WARNING

Maximum operating air pressure is 100 psi (0.7 MPa). Never exceed 125 psi (0.86 MPa) supply pressure. Exceeding 125 psi (0.86 MPa) supply pressure may result in injury to the Operator and/or damage to the equipment.

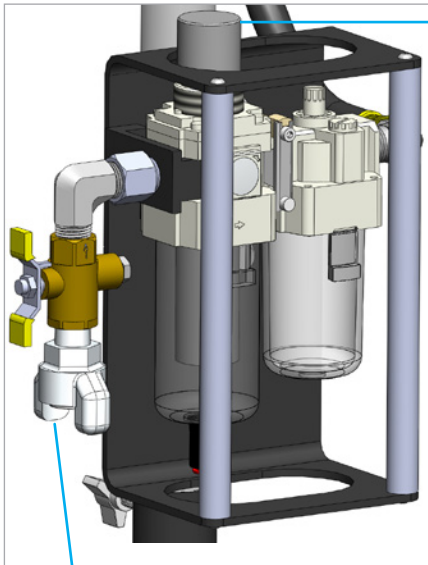

REGULATOR
ADJUSTING KNOB

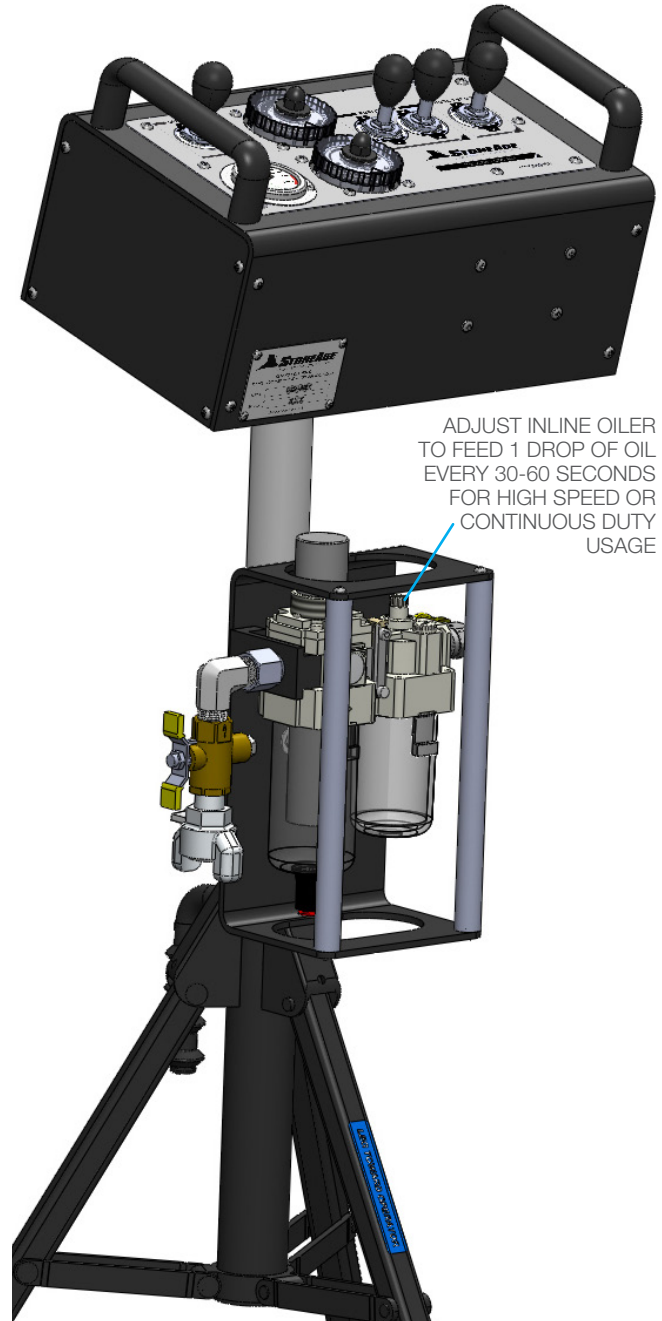

ADJUST INLINE OILER
TO FEED 1 DROP OF OIL
EVERY 30-60 SECONDS
FOR HIGH SPEED OR
CONTINUOUS DUTY
USAGE

AIR SUPPLY FITTING

A universal **AIR SUPPLY FITTING** (Chicago style) is located on the FRL. Connect a compatible compressed air line (not included) according to the Manufacturer's instructions.

PNEUMATIC DUMP CONTROL FITTING AND LINE

A **MOMENTARY PNEUMATIC DUMP CONTROL** is located on the Control Box panel and can be set up to control an air actuated dump valve. To utilize the toggle, the end user will need to install 1/4 in. O.D. tubing (not included) between the **PNEUMATIC DUMP CONTROL FITTING** and the pneumatic dump valve.

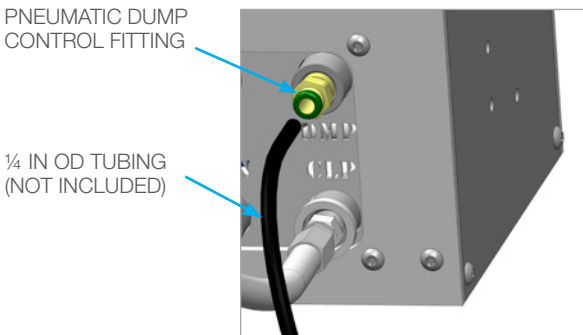

PNEUMATIC DUMP
CONTROL FITTING

1/4 IN OD TUBING
(NOT INCLUDED)

CONTROL BOX REAR VIEW

CONTROL BOX TO AUTOBOX® (ABX-3L) HOSE TRACTOR ASSEMBLY

PNEUMATIC SUPPLY LINE CONNECTIONS

1. Remove the dust caps from the Joint Industry Council (JIC) fittings of the Control Box and the AUTOBOX® (ABX-3L) Hose Tractor.
2. Connect the AUTOBOX® (ABX-3L) Hose Tractor to the Control Box with two 1/2 in. (13 mm) JIC hoses and one 1/4 in. JIC hose. Verify the Control Box rotates the Belt in the appropriate direction and that the clamp functions correctly.
3. Connect the horizontal positioner drive air motor to the Control Box with two 1/4 in. JIC hoses. Verify the Control Box moves the horizontal carriage in the appropriate direction.



4. Connect the vertical positioner drive air motor to the Control Box with two 1/4 in. JIC hoses. Verify the Control Box moves the vertical carriage in the appropriate direction.
5. Test the Control Box before operating the AUTOBOX® (ABX-3L) Hose Tractor with high pressure water to verify the control valves move the hose in the intended direction, and that the dump valve is working properly.

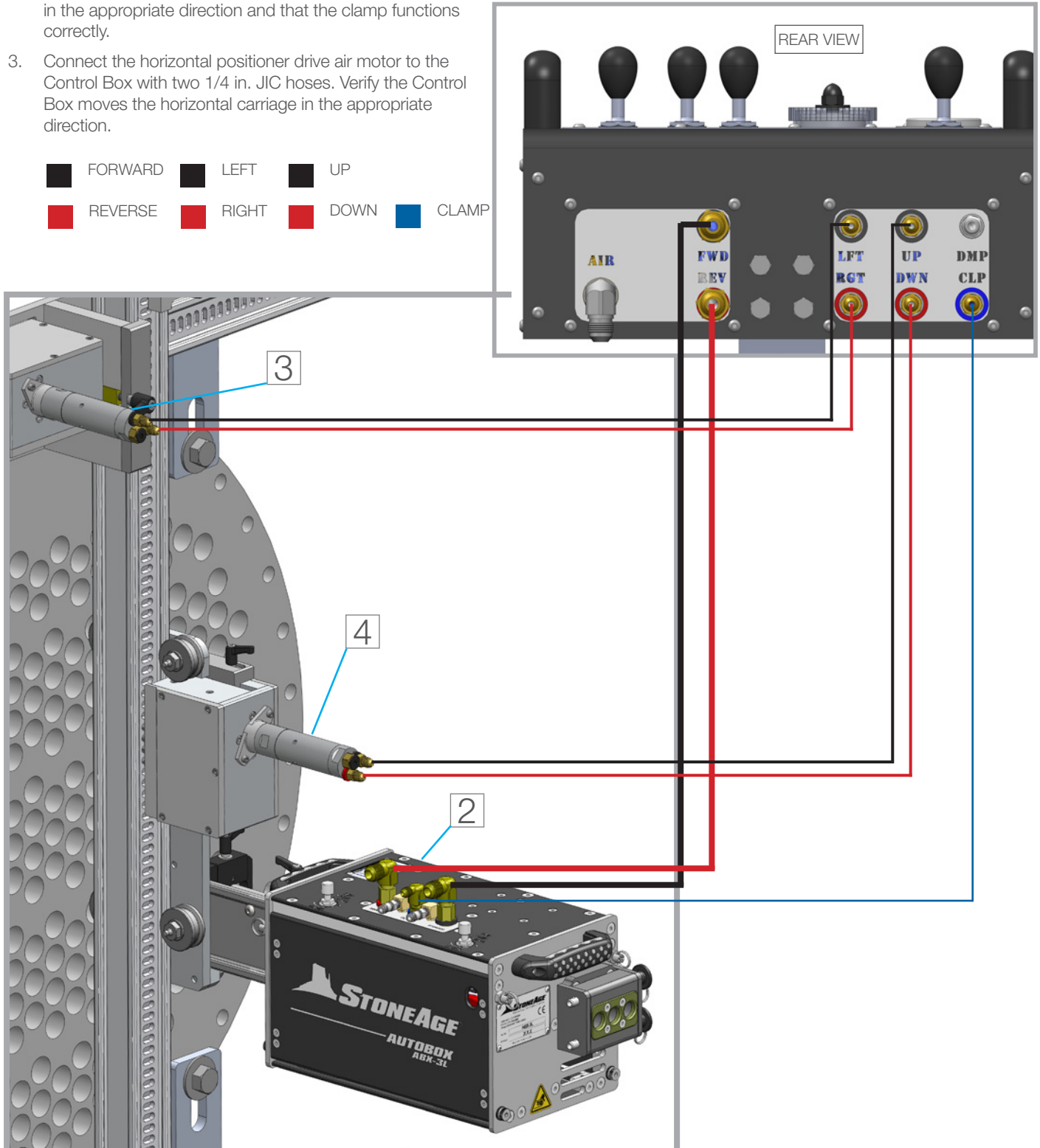

DOOR

Always run the AUTOBOX® (ABX-3L) Hose Tractor with the doors closed and locked.

DOOR PIN

The Door Pin is a spring plunger with a pull ring. To unlock the door, pull and twist the pull ring. To close and lock the door, pull and twist the pull ring, then release it into the groove of the pin. Verify the pin engages the door fully.

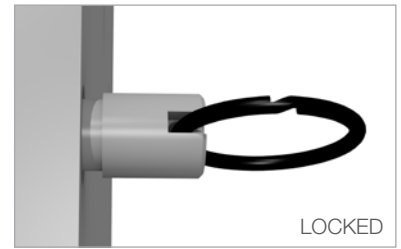

CAUTION

Make sure to lock both doors on each side of the Hose Tractor before operating AUTOBOX® (ABX-3L) Hose Tractor.

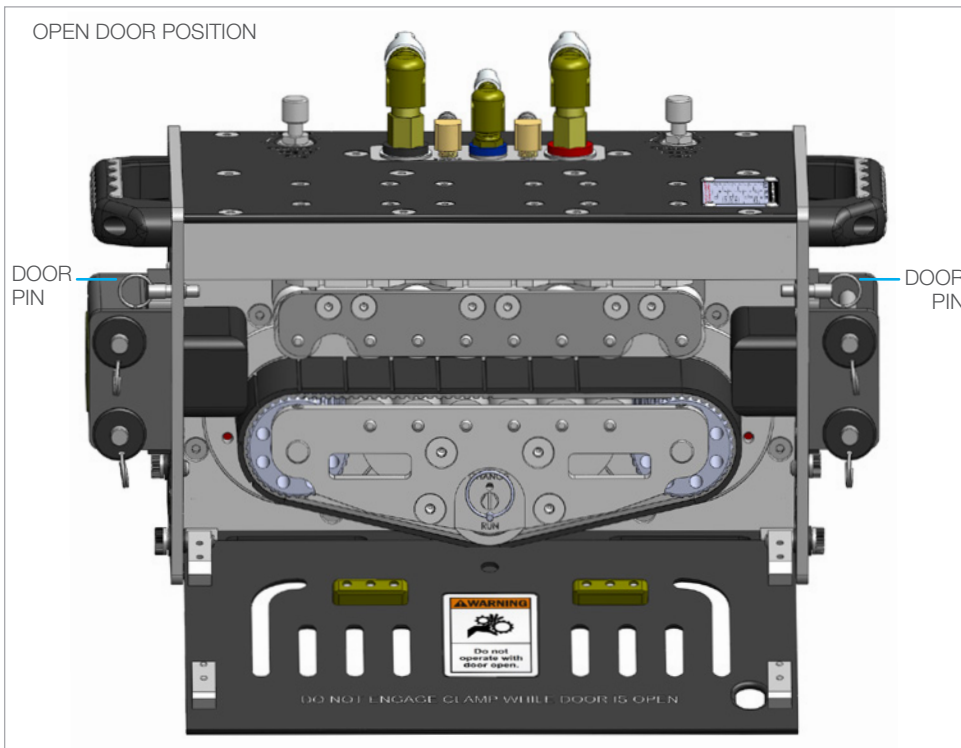

OPERATION

COLLET INSERTION, HOSE, AND HOSE STOP INSTALLATION

1. Remove Quick Release Pin and pull out existing Collet. Select the appropriate Collet size for the diameter of the hoses. (See the "Recommended Collets For Common Hose Sizes" plaque on the top plate of the AUTOBOX® (ABX-3L) Hose Tractor.) **(Figure 1)**

⚠ WARNING

Appropriate size Collet selection is **CRITICAL** to ensuring proper anti-withdrawal prevention of the tool. See "Recommended Collets For Common Hose Sizes" plaque on the top plate of the ABX-3L Tractor or the side of the vertical carriage on the Lightweight Positioner.

2. The **HOSE CLAMP PRESSURE REGULATOR** on the Control Box **MUST** be turned to zero pressure to open the door for easy hose installation. **(Figure 2)**
3. Insert the hoses, equipped with the waterblast tools, into the mounting bracket on the side of the AUTOBOX® (ABX-3L) Hose Tractor until they engage the Drive Belt. Slightly increase the pressure on the **HOSE CLAMP PRESSURE REGULATOR** to extend the clamp rollers and clamp the hoses. **(Figure 3)**
4. When the waterjet tools pass the Collet slot, install the Collet and quick release pin. **(Figure 4)**

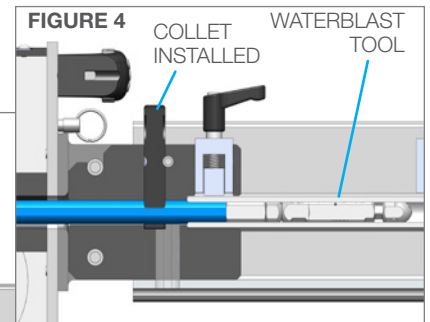
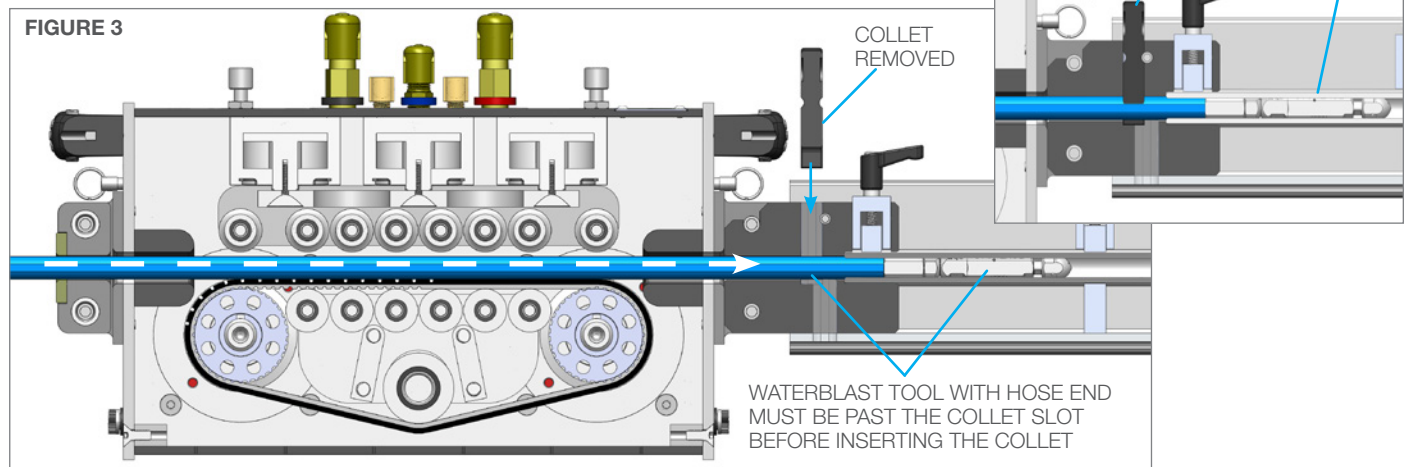
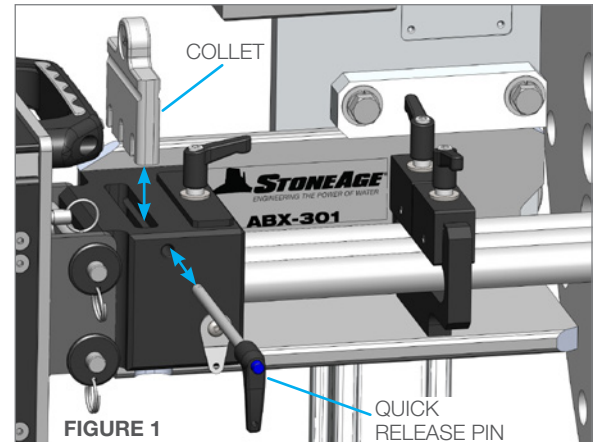

5. Pull on the hoses from the back of the AUTOBOX® (ABX-3L) Hose Tractor to ensure that the Collet does not allow the waterblast tool back out of the Guide or Hose Tractor. **(Figure 5)**
6. To install hose stops, push waterblast tools through the exchanger until the tips are 1-2" (25-51 mm) past the end of the tube bundle. Loosely install the stop, then push toward the mounting bracket and tighten in place. **(Figure 5)**

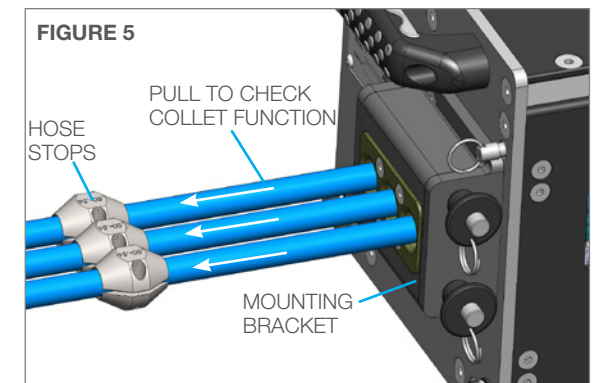

CONTROL BOX

- The **HOSE FEED LEVER** will move the hose in the forward (feeding) and reverse (retracting) directions. The **OFF** position is at the spring centered middle position and will stop the Drive Belt from turning. The speed controls are located on the AUTOBOX® (ABX-3L) Hose Tractor. Speed is independently adjustable for Forward/Reverse. Minimum speed is .3ft/sec (91 mm/sec). Maximum speed is 3.0ft/sec (914 mm/sec).
- To use the **MOMENTARY PNEUMATIC DUMP CONTROL**, hold it in the Forward/UP position to route the high-pressure water to the tool. Release the knob to divert the high-pressure water away from the tool.
- To de-energize the system, release the **HOSE FEED LEVER** and the **MOMENTARY PNEUMATIC DUMP CONTROL**. This will stop the Drive Belt from moving and reroute the high-pressure water away from the AUTOBOX® (ABX-3L) Hose Tractor.
- The **UP / DOWN POSITIONER LEVER**, will move the positioner carriage up and down the vertical rail. Let go of the lever to stop the movement and it will automatically return to the neutral position.
- The **LEFT / RIGHT POSITIONER CONTROL**, will move to positioner carriage side to side along the horizontal rail. Let go of the lever to stop the movement and it will automatically return to the neutral position.
- The **NUMBER OF HOSE DIAL** controls the ability to vary the feed motor pressure for 1, 2, or 3 hose operation and is unrelated to Hose Clamp Pressure. The AUTOBOX® (ABX-3L) Hose Tractor uses two Globe air motors are capable of delivering twice as much feed force compared to the ABX-2L. Match the number on the dial with the number of hoses being fed through the AUTOBOX® (ABX-3L) Hose Tractor. There are high and low intermediate indicators located between hose setting numbers. If there is hesitation in feeding or perceived low power due to the weight of the hose or the addition of a Hose Containment System, turn the knob up to the next higher setting. **DO NOT** set the Number Of Hose Dial to 2 or 3 when operating only one hose. This will cause excessive wear on the hose from too much power. The Autostroke accessory requires the Number Of Hose Dial to be set at a minimum of 1.5 or higher, this range is shown on the knob.
- The **HOSE CLAMP PRESSURE REGULATOR** controls the drive belt traction. It is recommended to operate the clamp pressure as low as possible without excessive slippage. Optimal clamp pressure is achieved when the Drive Belt slips at a slow rate of speed after hitting the hose stops (forward) or the Collet engages the hose crimp (reverse). It is recommended to use hoses supplied with the secondary crimp so the (anti-withdrawal protection) Collet does not impact the pressure containing crimp. Clamp force will not damage hoses. Proper clamp force will provide good control of the hose in forward and reverse directions, and will keep the hose running through the Drive Belt. Proper clamp force will also increase the life of the Drive Belt and High Pressure Hoses.

**CLAMP PRESSURE MUST NOT EXCEED;
100 PSI for 3 Hoses, 66 PSI for 2 Hoses, and 33 PSI for 1 Hose**

- Use the **HOSE CLAMP PRESSURE GAUGE** to record desired pressure for future use and to monitor pressure during operation.

NOTICE

Test the Control Box before operating the AUTOBOX® (ABX-3L) Hose Tractor with high-pressure water to verify the control valves move the hose in the intended direction, and that the dump valve is working properly

HIGH-PRESSURE HOSE

- The AUTOBOX® (ABX-3L) Hose Tractor is designed to be used with Parker Pro-Lance® and/or Spir Star Blast-Pro® hose ends. Standard hose ends may not fit into Hose Tractor and/or Guide Tubes. **NOTE: MAXIMUM hose end diameter must NOT exceed .74 in. (19 mm)**
- Only high quality hoses intended for waterblast applications should be used as high-pressure hoses. Pressure rating of high-pressure hoses **MUST NEVER** be exceeded.

NOTICE

Do not use a shrouded hose or hose with a steel protective cover. This will cause severe damage to the Drive Belt and Idlers.

- Verify that the high-pressure hose is properly installed in the back-out preventer. Operate the high-pressure hose and waterjet tool at full pressure to test the clamp force. Proper clamp force will provide good control of the hose in forward and reverse directions, and keep the hoses synchronized at full retract and full extend positions.
- The AUTOBOX® (ABX-3L) Hose Tractor **MUST** be supervised at all times.
- **HOSE LENGTHS** The ABX-3L has a variety of accessories that will require additional hose length to be considered in addition to the tube bundle length. This should be verified prior to ordering high pressure hose for each job. The chart below shows the actual length of each configuration and recommended additional length necessary to keep the assembly from lifting off the ground during operation. Provide the tube bundle length and use the chart to follow the calculation below to determine the total hose length.

$$(\text{Tube Bundle Length in inches / mm}) + (\text{Actual Length of Configuration in inches / mm}) + (\text{Recommended Additional Connection Length in / mm}) = \text{Total Hose Length in inches / mm}$$

ACCESSORY CONFIGURATIONS	ACTUAL LENGTH OF CONFIGURATION	RECOMMENDED ADDITIONAL CONNECTION LENGTH
ABX-3L, Hose Guide, and Lightweight Positioner	32.9 in / 836 mm	39 in / 991 mm
ABX-3L, Hose Guide, Lightweight Positioner, and HCS	145.0 in / 3683 mm	39 in / 991 mm
ABX-3L, Fin Fan Guide, Snout	138 in / 3505 mm	39 in / 991 mm
ABX-3L, Fin Fan Guide, Snout, and HCS	165 in / 4191 mm	39 in / 991 mm

For example: The hose length equation for a 20ft (6096 mm) tube bundle with ABX-3L, Hose Guide, and Lightweight Positioner would be;

STANDARD: (20ft x 12 in/ft) + 32.9 in + 39 in = **311.9 in.**

METRIC: 6096 mm + 836 mm + 991 mm = **7922 mm**

OPERATION

TEST RUN PROCEDURE

- Perform the **PRE-RUN SAFETY CHECK (SEE PAGE 6)**.
- Ensure appropriate Collet is installed and set initial hose clamp pressure to 20-30psi (.14-.20 MPa)
- Operate the high-pressure hose and waterjet tool at full pressure to test the clamp force. Optimal clamp force will provide good control of the hose in forward and reverse directions, and will vary by application.
- Adjust the hose feed speed controls. Proper forward and reverse speeds will vary, depending on the type of material being removed and the tube size. Adjustment of the hose feed speed controls may be necessary during operation in order to optimize cleaning and overall productivity.
- Operate the high-pressure water at full pressure and use the **MOMENTARY PNEUMATIC DUMP CONTROL** to verify that the dump valve is working properly.

RUN PROCEDURE

- After assembling and verifying, the AUTOBOX® (ABX-3L) Hose Tractor system is ready for operation.
- Once all hose connections have been secured and verified, it is recommended to flush the hoses and verify the dump valve is working properly before installing the Banshee tools.
- After flushing the hoses, install the Banshee tools and insert both tools into the back of the AUTOBOX® (ABX-3L) Hose Tractor. It may be necessary to twist the hoses slightly as the tools and hose ends are manually pushed through the Idlers and Guides.
- Once the Banshees are inside the Guide Tubes, install the Collet (anti-withdrawal protection). **The appropriate Collet must be verified, installed, secured, tested, and performance confirmed before operating at high pressure.**
- Adjust the initial clamp pressure to 20-30 psi. (.14-.20 MPa). Align the Guide Tubes with an open set of tubes in the heat exchanger bundle.
- Feed forward and advance the hoses into the tube bundle at low pressure and wait for the tools to exit the far side of the heat exchanger.
- Set the forward hose stops in the desired position to ensure the entire tube is cleaned, but that the hose crimp does not fully exit the tube.
- Retract the hoses into the Guide Tubes.
- Close the dump and gradually increase the pump to the desired operating pressure.
- Feed forward and advance the hoses into the tube bundle. Dump and make any desired changes to forward and/or reverse operating speeds.
- If the Drive Belt is slipping excessively, increase the clamp pressure. It is recommended to operate the clamp pressure as low as possible without excessive slippage. Optimal clamp pressure is achieved when the Drive Belt slips at a slow rate of speed after hitting the hose stops (forward) or the Collet engages the hose crimp (reverse). It is recommended to use hoses supplied with the secondary crimp so the (anti-withdrawal protection) Collet does not impact the pressure containing crimp. Operating at high clamp pressures will reduce Belt life.

CLAMP PRESSURE MUST NOT EXCEED; 100 PSI for 3 Hoses, 66 PSI for 2 Hoses, and 33 PSI for 1 Hose

- Operate the left/right and up/down positioner functions to begin high pressure cleaning at the preferred location on the tube bundle.
- Always align the Guide Tubes as closely as possible with the heat exchanger tubes before advancing the hoses
- When operating the AUTOBOX® (ABX-3L), an obstacle or restriction within a heat exchanger tube may be encountered. When this occurs, the AUTOBOX® (ABX-3L) is designed to slow and stall the air drive motor, stopping the advancement of the hose, lance, and Banshee tool. The operator should stop forward feed and reverse the lance feed direction, backing the tool away from the obstruction. Repeat the back and forth operation, until the resistance or obstruction is cleared via the cleaning action of Banshee tool at the end of the hose. The AUTOBOX® (ABX-3L) is not designed for continuous high speed slippage. If excessive slippage occurs, gradually increase the clamp force using the **HOSE CLAMP PRESSURE REGULATOR** on the Control Box.

▲WARNING

Do not fully release the hose clamp (decreasing pressure to zero) during operation, or the AUTOBOX® (ABX-3L) Hose Tractor will release the hose and may create a dangerous runaway hose condition, which can result in severe injury and/or death.

Crush Hazard. Keep hands, hair, and clothing clear of all moving parts. Contact with moving parts can result in severe injury.

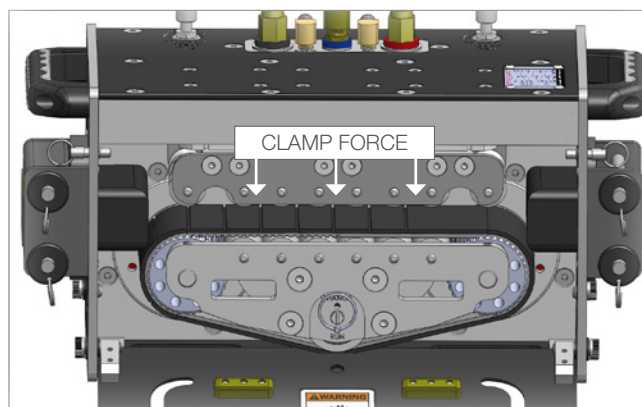

ABX-3L AND LWP-500 MAINTENANCE

Maintenance Item	Frequency	Maintenance Required
Forward, reverse, and clamp fittings	Before each use	Inspect threads on fittings for wear or damage.
Lubricant level of Filter, Regulator, Lubricator	Before each use	For average conditions, the use of high quality SAE #10 (S.U.V. 150-200 SEC @ 100°F) oil is recommended. Other lubricants, as specified by the maker of the equipment to be lubricated, may be used if not heavier than SAE #40 (S.U.V. 800 SEC @100°F).
Drive Belt (See Belt Replacement instructions in this manual)	After each use	The Belts are very durable and should last several hundred hours. However, it is recommended to inspect the Belt for wear and/or cracks at the completion of each job. Replacement is required when the Belt is damaged. NOTICE Operation with a severely damaged belt will result in excessive damage to the Idler rollers and drive sprockets.
All components the hoses pass through	After each use	Most wear parts are made from durable materials and should have a very long life. However, as wear occurs the rounded edges could become sharp and damage hoses. Any components showing excessive wear should be replaced.
FWD, REV, LFT, RGT, UP, DOWN fittings	After each use	Apply a small amount of air tool oil directly into FWD, REV, LFT, RGT, UP, DOWN fittings. Then, briefly operate the controls at slow speed for a short duration in each direction to coat the interior parts of the motor. Install the dust caps onto all fittings to keep moisture and dirt out. NOTICE Do not add oil to the Clamp (CLP) fitting, as oil may accumulate in the air cylinders and prevent them from fully retracting.
ABX-3L (Inside)	After each use	When storing the unit, use compressed air to blow out any residual remove debris and moisture. Use mild, soapy, low pressure, water to clean the machine in order to remove corrosive materials. DO NOT SPRAY WATER INTO OR SUBMERGE, THE AIR MOTOR HOUSING OR BREATHER.
Lubricant level of Filter, Regulator, Lubricator	Cessation of oil dripping through the sight dome	If both air and oil are kept clean, and the oil level is never allowed below end of tube in the bowl, the lubricator should provide long periods of unattended service. Cessation of oil dripping through the sight dome, irrespective of knob adjustment, is an indication that cleaning is necessary. To clean, it is not necessary to remove lubricator from the line. Depressurize and disassemble. In most instances, cleaning is needed only in the oil metering area. Pull off adjusting knob, unscrew sight dome assembly, remove inner drip spout and clean with household soap. PLASTIC BOWLS AND SIGHT DOME MUST BE CLEANED WITH HOUSEHOLD SOAP ONLY.
Lubricant level of Filter, Regulator, Lubricator	Intermittent Adjustments	The adjustment knob is factory set so that, when turned fully clockwise, no oil is delivered to the venturi for atomization, and the equipment is not being lubricated. To adjust the oil drip rate, turn on the air, start flow and set knob to obtain the desired drip rate, which is visible through the sight dome. As a start, one to two drops per minute is suggested, correct lubrication is a matter of experience and demand. Clockwise rotation of knob decreases oil feed rate. To check lubrication, hold thumbnail or a mirror near the equipment exhaust. A heavy film indicates over-lubrication and the drip rate should be reduced by turning knob to a lower setting.

Contact StoneAge for Safety Data Sheets for material usage, a complete list of spare part numbers, and service instructions for the AUTOBOX® (ABX-3L) Hose Tractor and Control Box.

STORAGE, TRANSPORTATION, AND HANDLING

The AUTOBOX® (ABX-3L) Hose Tractor is shipped in a custom wooden crate and should be stored upright in the same crate between jobs. When moving the AUTOBOX® (ABX-3L) Hose Tractor, lift with care to prevent bodily injury.

ABX-3L HOSE TRACTOR - DRIVE BELT REPLACEMENT

⚠ WARNING

Always de-energize the system before servicing or replacing any parts. Failure to do so can result in severe injury and/or death. Keep hands, hair, and clothing clear of rotating parts.

TO REPLACE THE BELT:

1. Pull out the Quick Release Pin on the front of the ABX 310 Belt Track Drive Assembly.
2. Use a flat head screwdriver to rotate the Eccentric Shaft 180° in either direction. This will release tension on the Drive Belt Assembly.
3. Install pin into the "CHANGE" position so it does not get misplaced, and to ensure the tension idler is in the correct position before removing the belt.
4. Place thumbs on the on top of the belt into the notches of the Outer Clamp Plate. Place fingers under the Drive Belt and light squeeze in the shape of the tensioned Drive Belt. Then pull the Dive Belt out from the ABX-3L Tractor.
5. Slide the old Drive Belt off and discard. Slide the new Drive Belt on in a similar manner.
6. Rotate the Eccentric Shaft 180° in either direction to properly tension the Drive Belt.
7. Move the Quick Release Pin to the "RUN" position.

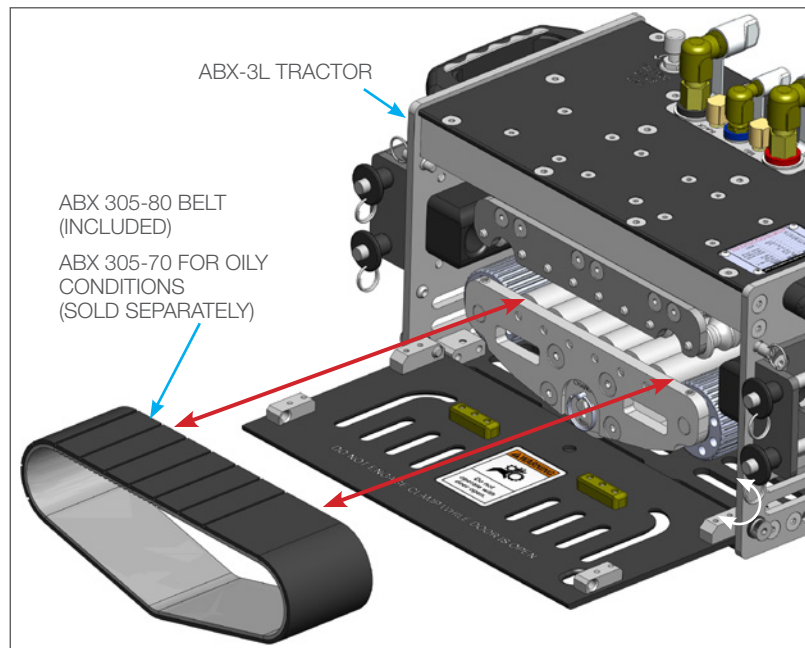
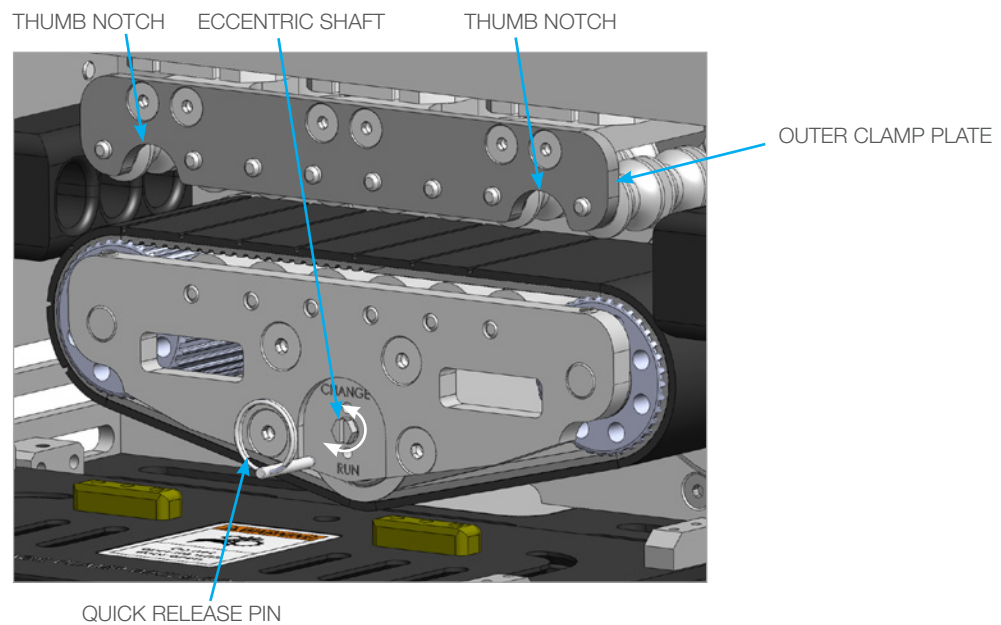

AUTOBOX® (ABX-3L) HOSE TRACTOR

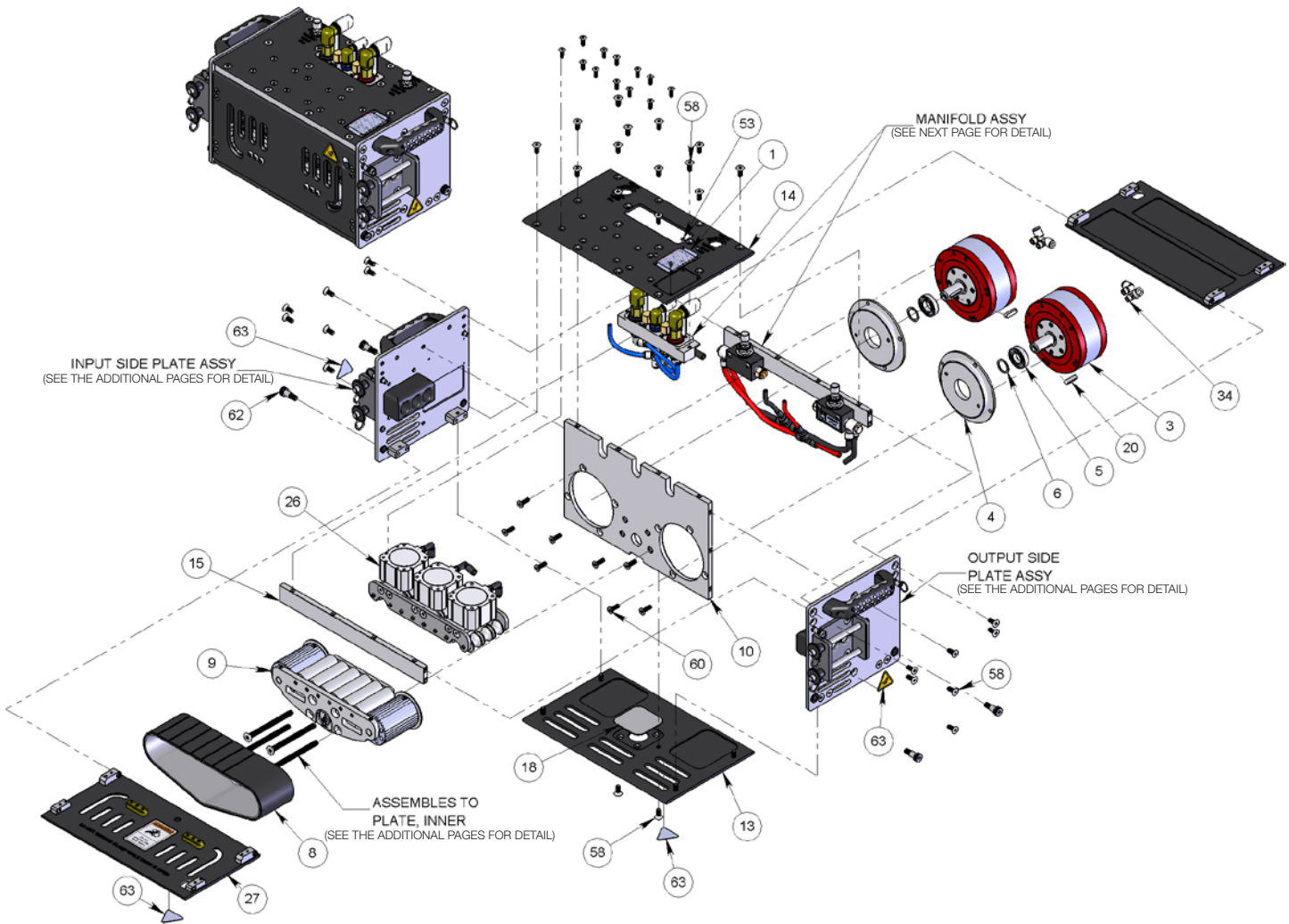

8 ABX 305-80 BELT 80A 25MM (INCLUDED)
ABX 305-70 BELT 70A 10MM (SOLD SEPARATELY)
FOR OILY CONDITIONS

#	PART NUMBER	QTY.			
1	ABX 139 COLLET REFERENCE PLATE	1	18	ABX 348 COVER	1
3	ABX 250 AIR MOTOR, GLOBE	2	20	ABX 353 KEY, MODIFIED	2
4	ABX 252 PLATE, AIR MOTOR BEARING	2	26	ABX 360 BELT TRACK DRIVE ASSY TOP	1
5	ABX 257 BEARING 19MM X 37MM X 9MM	2	27	ABX 370 DOOR ASSY	1
6	ABX 258 SHIM WASHER	4	34	ABX 391 FTG, ELBOW 90 DEG P2 BSPT X 8MM PL	4
8	ABX 305-80 BELT 80A 25MM SIPE	1	53	GSB 313-0075 BHCS 6-32 X .188 LG SS	8
9	ABX 310 BELT TRACK DRIVE ASSY BOTTOM	1	58	GSF 325-025 FHCS .25-20 X .63 LG SS	42
10	ABX 340 PLATE, INNER	1	60	GSF 3M6-20-1.00 FHCS M6X1.00X20 SS	8
13	ABX 343 PLATE, BOTTOM	1	62	GSSH 0375-0500-SS SHOULDER SCREW	4
14	ABX 344 PLATE, TOP	1	63	PL 162 WARNING DECAL, PINCH POINT	4
15	ABX 345 STIFFENER, TOP PLATE	1			

PARTS DIAGRAM

AUTOBOX® (ABX-3L) HOSE TRACTOR MANIFOLD ASSEMBLY

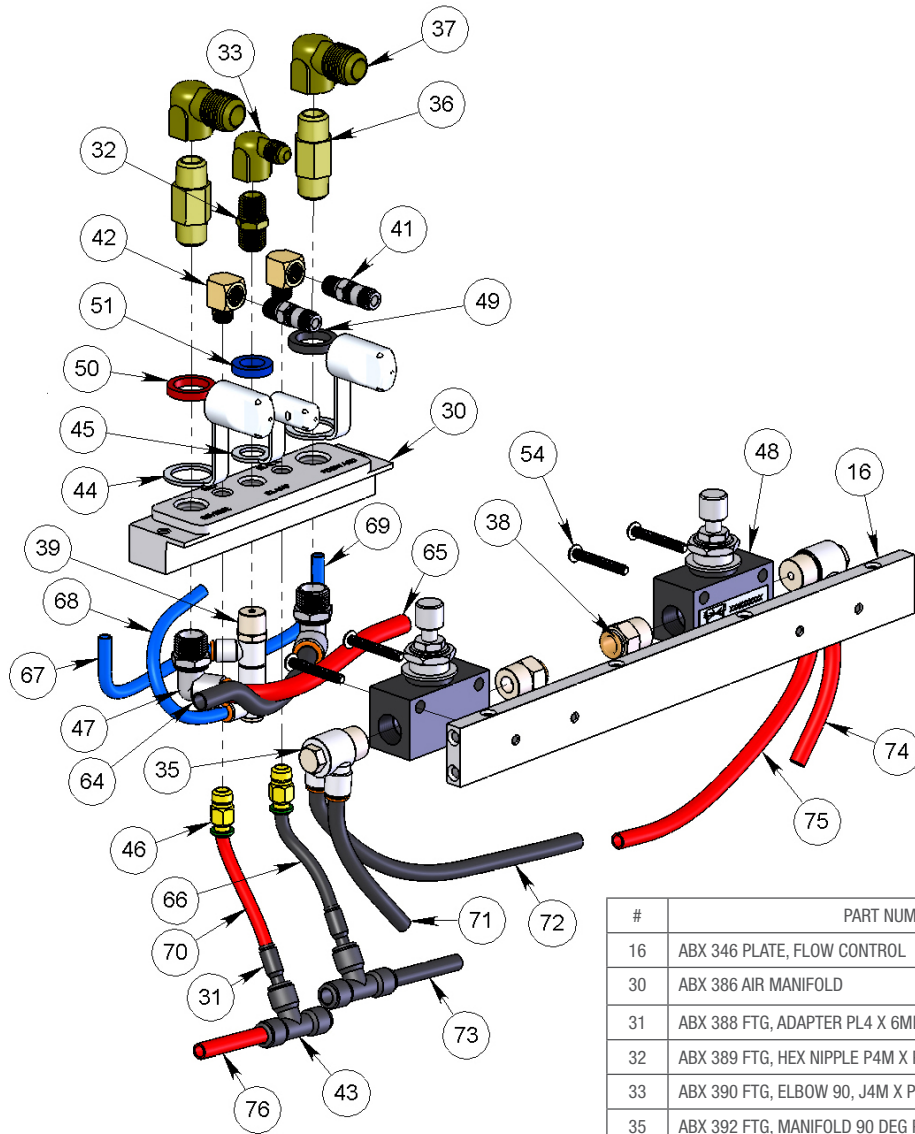

TUBING PART NUMBERS				
#	PART NUMBER	MATERIAL	QTY.	LENGTH
64	TUBE 1 PL6 BK	GPTB 0375-PUR95A-BK	1	4.5 IN
65	TUBE 1 PL6 RD	GPTB 0375-PUR95A-RD	1	5.5 IN
66	TUBE 1 PL4 BK	GPTB 0250-PUR95A-BK	1	3.5 IN
67	TUBE 1 PL4 BL	GPTB 0250-PUR95A-BL	1	4.5 IN
68	TUBE 2 PL4 BL	GPTB 0250-PUR95A-BL	1	5 IN
69	TUBE 3 PL4 BL	GPTB 0250-PUR95A-BL	1	4.5 IN
70	TUBE 1 PL4 RD	GPTB 0250-PUR95A-RD	1	3.5 IN
71	TUBE 1 M8 BK	GPTB 8MM-PUR95A-BK	1	4 IN
72	TUBE 2 M8 BK	GPTB 8MM-PUR95A-BK	1	8.5 IN
73	TUBE 3 M8 BK	GPTB 8MM-PUR95A-BK	1	3 IN
74	TUBE 1 M8 RD	GPTB 8MM-PUR95A-RD	1	4 IN
75	TUBE 2 M8 RD	GPTB 8MM-PUR95A-RD	1	8.5 IN
76	TUBE 3 M8 RD	GPTB 8MM-PUR95A-RD	1	3 IN

#	PART NUMBER	QTY.
16	ABX 346 PLATE, FLOW CONTROL	1
30	ABX 386 AIR MANIFOLD	1
31	ABX 388 FTG, ADAPTER PL4 X 6MM STEM	2
32	ABX 389 FTG, HEX NIPPLE P4M X P4M	1
33	ABX 390 FTG, ELBOW 90, J4M X P4F	1
35	ABX 392 FTG, MANIFOLD 90 DEG P6M 2X PL5	2
36	ABX 394 FTG, INLINE FILTER .375 NPT NIPPLE	2
37	ABX 396 FTG, ELBOW 90, J8M X P6F	2
38	ABX 397 FTG, STRAIGHT ADAPTER, PL6 X P6M	2
39	ABX 399 FTG, MANIFOLD 90 DEG P4M 3XPL4	1
41	AST 278 FTG, QUICK DISCONNECT P2M	2
42	AST 279 FTG, ELBOW BRASS P2M P2F	2
43	AST 282 FTG, REDUCING TEE 8MM PL X 6MM PL	2
44	BR 167 90° DUST CAP (FOR ABX-3L)	2
45	BR 168 90° DUST CAP, J4 (FOR ABX-3L)	1
46	BRUD 432 FITTING, P2M PL4F - PARKER # W68PL-4-2	2
47	CB 352 FTG P6PL6 SWIVEL ELBOW	2
48	CB 528 P6 FLOW CONTROL VALVE ABX	2
49	GP 011-BK BLACK ID BAND MED	1
50	GP 011-R RED ID BAND MED	1
51	GP 013-B BLUE ID BAND, SM	1
54	GSB 319-055 BHCS .19-24 X 1.38 LG SS	4

AUTOBOX® (ABX-3L) HOSE TRACTOR
INSIDE, OUTSIDE, AND TOP PLATE ASSEMBLIES

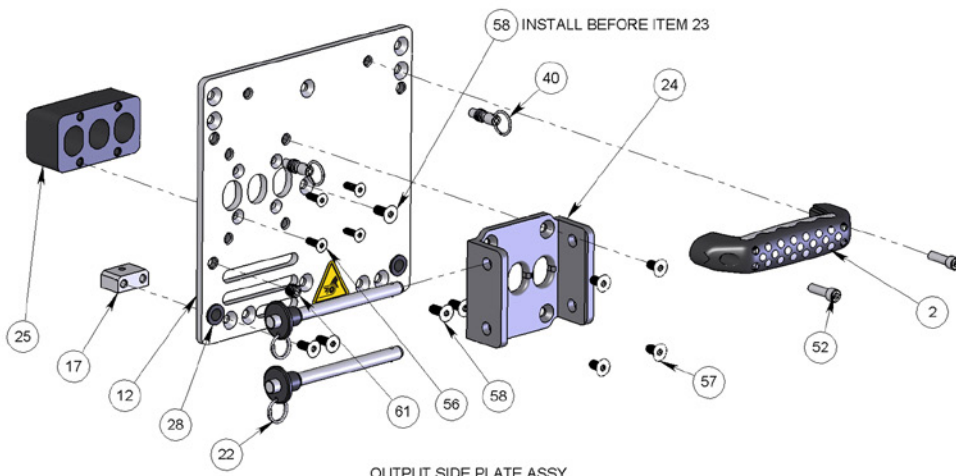
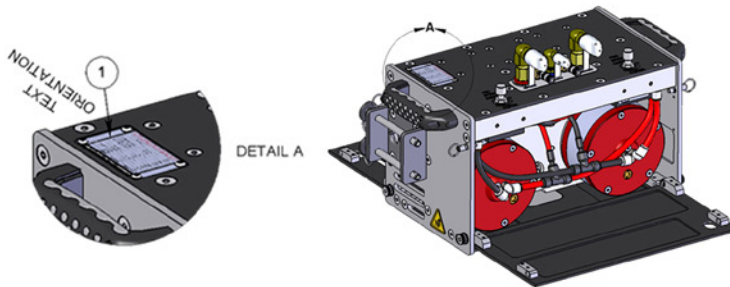
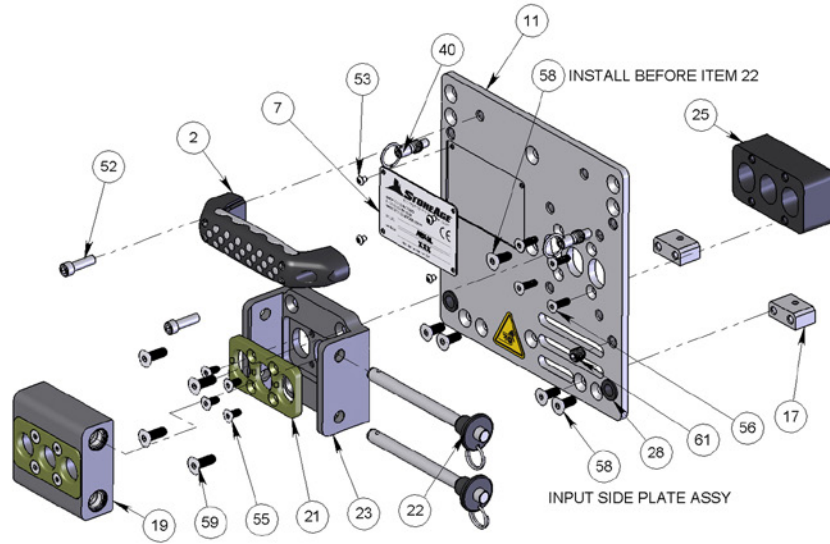

#	PART NUMBER	QTY.
1	ABX 139 COLLET REFERENCE PLATE	1
2	ABX 215 PULL HANDLE RUBBER GRIP GREY	2
7	ABX 303 CE SERIAL PLATE	1
11	ABX 341 SIDE PLATE INLET	1
12	ABX 342 SIDE PLATE OUTLET	1
17	ABX 347 BLOCK, SUPPORT	4
18	ABX 348 COVER	1

#	PART NUMBER	QTY.
19	ABX 350 REAR MOUNT INSIDE ASSY	1
21	ABX 355 HOSE GUIDE PLATE, INNER	1
22	ABX 356 QUICK PIN 17-4 SS .38 X 3.75	4
23	ABX 357 MOUNTING BRACKET, INLET	1
24	ABX 358 MOUNTING BRACKET, OUTLET	1
25	ABX 359 HOSE GUIDE BLOCK, INNER	2
28	ABX 375 BUSHING, PEEK .375 ID X .375 LG	4
40	ABX 566 SPRING PLUNGER, PULL RING LOCKING	4

#	PART NUMBER	QTY.
52	GS 325-035 SHCS .25-20 X 0.88 SS	4
53	GSB 313-0075 BHCS 6-32 X .188 LG SS	8
55	GSF 319-0175 FHCS .19-24 X .44 LG SS	4
56	GSF 319-025 FHCS .19-24 X .63 LG SS	20
57	GSF 325-02 FHCS .25-20 X .50 LG SS	4
58	GSF 325-025 FHCS .25-20 X .63 LG SS	42
59	GSF 325-03 FHCS .25-20 X .75 LG SS	4
61	GSS 337-16-37CU SET SCREW (TB 047.1)	2

PARTS DIAGRAM

AUTOBOX® (ABX 310) BELT TRACK DRIVE ASSEMBLY

NOTE:

1. APPLY BLUE LOCTITE® 242 TO ALL THREADED HARDWARE.
2. BLUE GOOP IS A SWAGELOCK® BRAND ANTI-SEIZE AN EQUIVALENT ALTERNATIVE IS ACCEPTABLE.

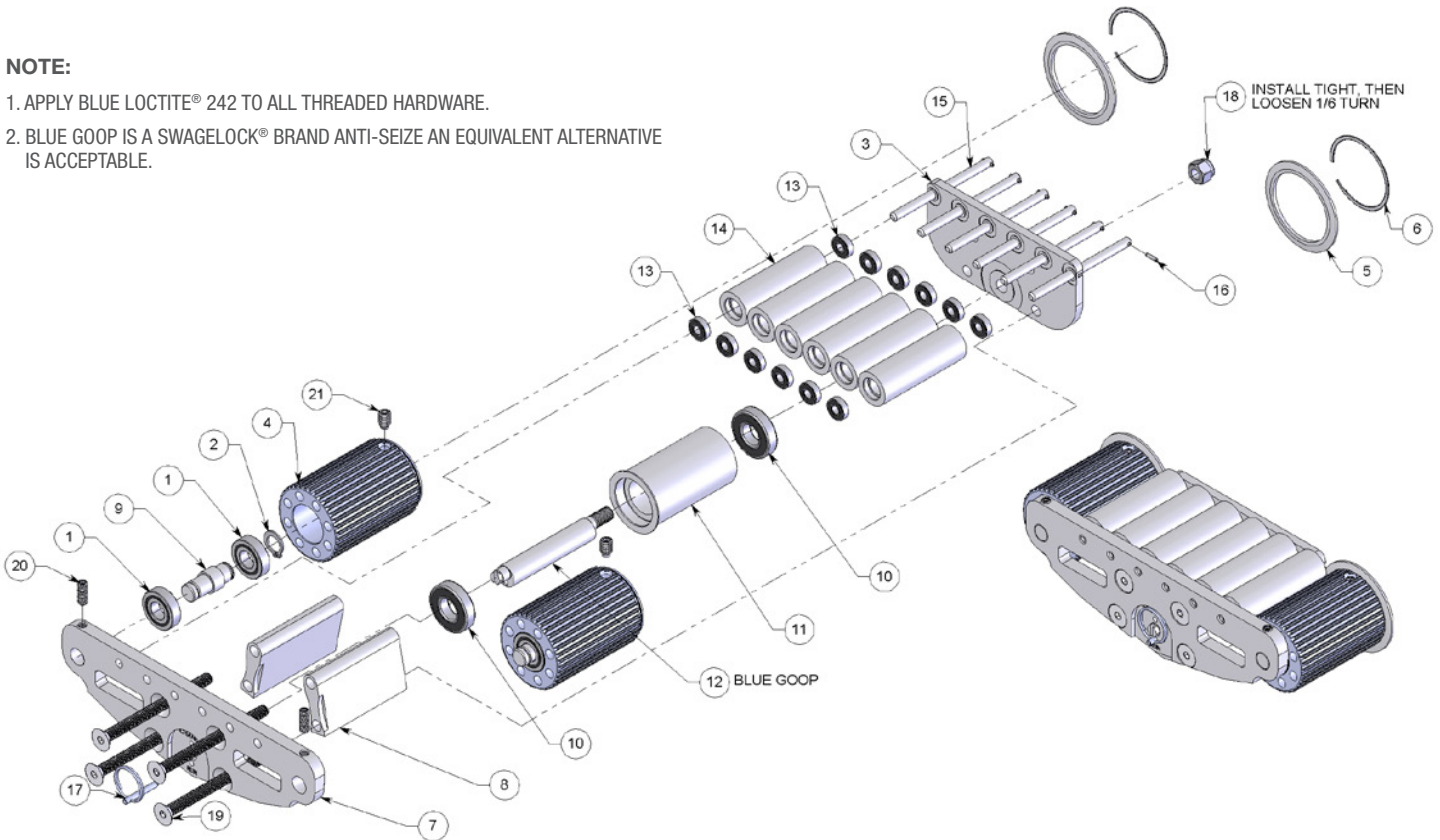

#	PART NUMBER	QTY.
1	ABX 228 BEARING .500 ID X 1.125 OD SEALED PERMALUBE	4
2	ABX 267 RETAINING RING, SL EXTERNAL SS	2
3	ABX 311 PLATE, BELT INNER	1
4	ABX 314 DRIVE SPROCKET 36T-AT5	2
5	ABX 315 SPROCKET FLANGE	2
6	ABX 316 RETAINING RING, FLANGE 2.00 EXT LIGHT DUTY	2
7	ABX 317 PLATE, SIDE	1
8	ABX 318 BLOCK, BELT DRIVE	2
9	ABX 320 STUB SHAFT, DRIVE ROLLER	2
10	ABX 322 BEARING R10, PERMALUBE	2

11	ABX 323 IDLER, TENSIONING	1
12	ABX 324 ECCENTRIC SHAFT	1
13	ABX 326 R4 PERMA LUBE BEARING	12
14	ABX 327 ROLLER, BELT	6
15	ABX 330 SHAFT, IDLER	6
16	ABX 332 SPRING PIN, .094 X .375	6
17	ABX 333 QUICK RELEASE PIN .156 X .8 LG	1
18	GN 337-L NYLOK NUT SS	1
19	GSF 331-16 FHCS .31-18 X 4.00 LG SS	4
20	GSS 325-20-75CO SET SCREW, CONE PT .25-20 X .75 LG SS	2
21	GSS 331-18-50DP SET SCREW	2

AUTOBOX® (ABX 360)
BELT TRACK DRIVE ASSEMBLY

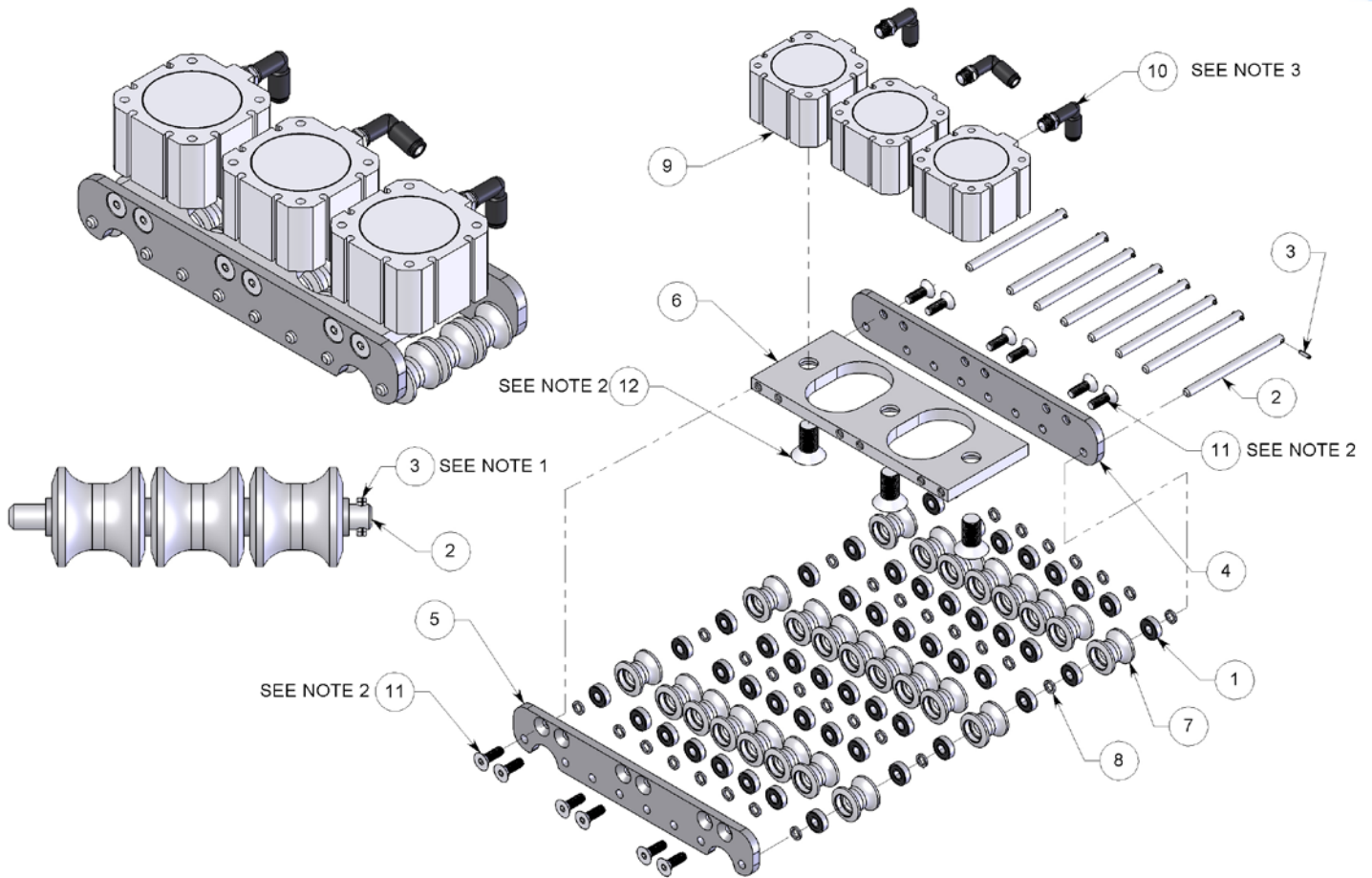

NOTE:

- 1. CENTER PIN WHEN INSTALLING SHAFT
- 2. APPLY BLUE LOCTITE® 242 TO ALL THREADED HARDWARE.
- 2. APPLY TEFLON TAPE OR EQUIVALENT TO THREADS OF ALL PNEUMATIC FITTINGS.

#	PART NUMBER	QTY.
1	ABX 326 R4 PERMA LUBE BEARING	48
2	ABX 330 SHAFT, IDLER	8
3	ABX 332 SPRING PIN, .094 X .375	8
4	ABX 361 PLATE, CLAMP INSIDE	1
5	ABX 362 PLATE, CLAMP OUTSIDE	1
6	ABX 364 PLATE, CLAMP	1
7	ABX 366 ROLLER, HOSE	24
8	ABX 367 SHIM WASHER	32
9	ABX 385 SMC AIR CYL NCQ8A200-062S	3
10	ABX 387 FTG, SWIVEL ELBOW 90 P2M PL4	3
11	GSF 325-03 FHCS .25-20 X .75 LG SS	12
12	GSF 350-04-20 FHCS .50-20 X 1.00 LG SS	3

PARTS DIAGRAM

AUTOBOX® (ABX 370) DOOR ASSEMBLY

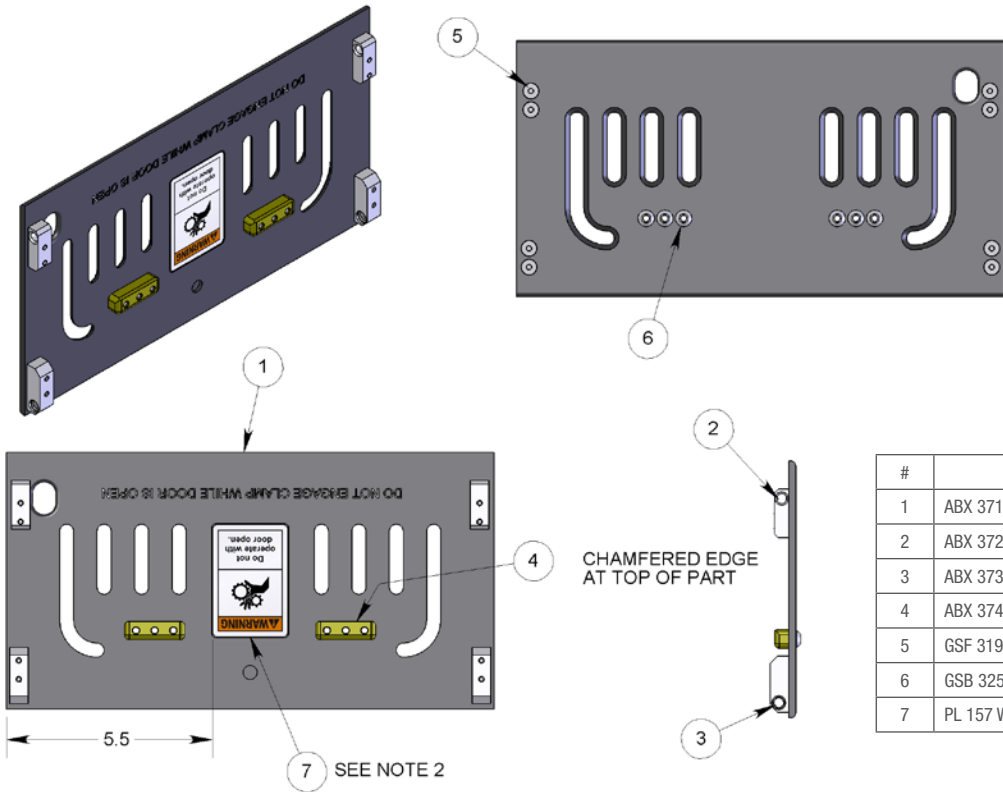

#	PART NUMBER	QTY.
1	ABX 371 DOOR	1
2	ABX 372 PIN PLATE, DOOR	2
3	ABX 373 PIVOT PLATE, DOOR	2
4	ABX 374 PLATE, WEDGE	2
5	GSF 319-0225 FHCS .19-24 X .56 LG SS	8
6	GSB 325-02 BHCS .25-20 X .50 LG SS	6
7	PL 157 WARNING DOOR OPEN	1

AUTOBOX® (ABX 380) GUARD ASSEMBLY

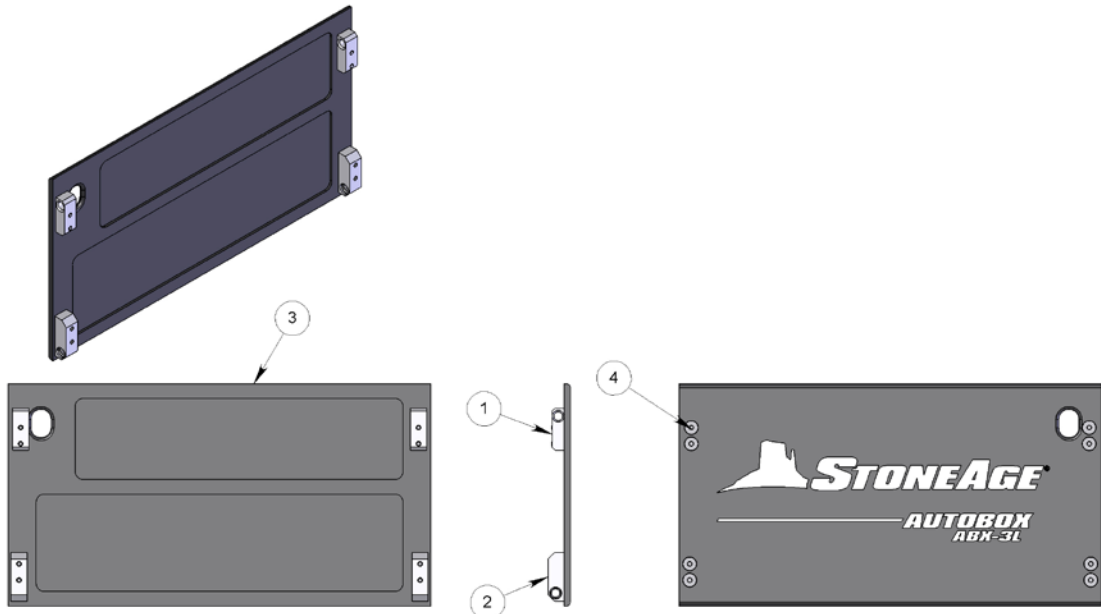

#	PART NUMBER	QTY.
1	ABX 372 PIN PLATE, DOOR	2
2	ABX 373 PIVOT PLATE, DOOR	2
3	ABX 381 GUARD	1
4	GSF 319-0225 FHCS .19-24 X .56 LG SS	8

AUTOBOX® (ABX-301)
GUIDE ASSEMBLY

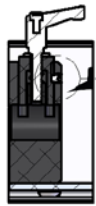

SECTION A-A

RECESSED SLOT

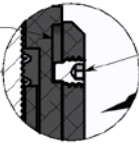

DETAIL B
SCALE 1 : 1
TYP 3 PLACES

AFTER CLAMP BAR IS INSTALLED AND SPRINGS ARE COMPRESSED SUFFICIENTLY, THE NOSE OF THE SET SCREW WILL BE ABLE TO DESCEND INTO THE RECESSED SLOT. THREAD IN SET SCREW UNTIL NOSE BOTTOMS-OUT IN SLOT, THEN BACK OUT 1/4 TURN. ASSURE TO USE BLUE LOCTITE ON SET SCREWS.

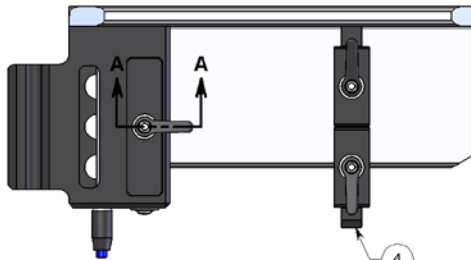

4
10 4X, BLUE LOCTITE

6X, BLUE LOCTITE



LANYARD NOT SHOWN
9 BLUE LOCTITE

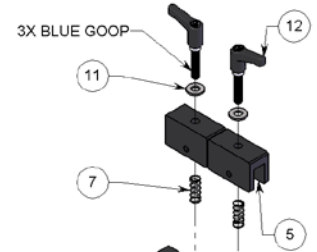

3X BLUE GOOP

3X, BLUE LOCTITE 8

(BLUE GOOP ON ALL HANDLE THREADS)

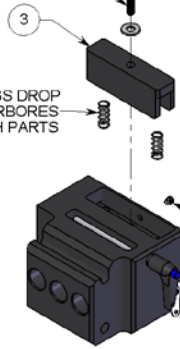

ASSURE SPRINGS DROP INTO COUNTERBORES OF BOTH PARTS

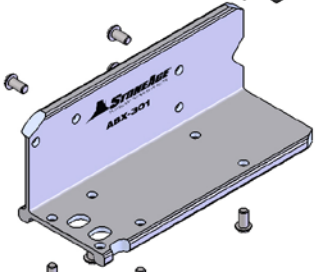

(BLUE LOCTITE ON ALL SCREWS)

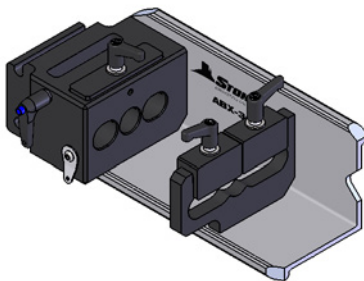

NOTE:

1. BLUE GOOP IS A SWAGelok® BRAND ANTI-SEIZE AN EQUIVALENT ALTERNATIVE I ACCEPTABLE.
2. BLUE LOCTITE 242® OR EQUIVALENT.
3. COLLET AND GUIDE TUBE SIZES WILL NEED TO BE CHOSEN AND PURCHASED SEPARATELY BY THE CUSTOMER AT TIME OF ORDER.

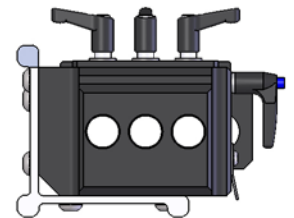

#	PART NUMBER	QTY
1	ABX 175 BOX SECTION, HIGH-VISIBILITY	1
2	ABX 176 3L GUIDE MOUNTING BLOCK, CLAMPING	1
3	ABX 177 REAR CLAMP CHANNEL	1
4	ABX 178 PITCH CLAMP PLATE	1
5	ABX 179 PITCH CLAMP CHANNEL, HALF	2
6	ABX 181 PIN, QR, .250 DIA X 4.00 L, WITH LANYARD	1
7	ABX 182 SPRING, COMPRESSION	4
8	ABX 183 SCREW, SET, EXTENDED POINT	3
9	GSB 319-015 SCREW, BHSC, #10-24 UNC X 0.375L	1
10	GSB 331-025 SCREW, BHSC, 5/16-18 UNC X 0.625L	10
11	GW 325-F WASHER, FLAT, 1/4", STAINLESS	3
12	SRT 557 ADJUSTABLE HANDLE .25-20 X 1.19	3

PARTS DIAGRAM

AUTOBOX® ABX-3L HOSE GUIDE ASSEMBLY ACCESSORIES

GUIDE TUBES, COLLETS, ANTI-TWIST CLAMPS AND HOSE STOPS

ABX GUIDE TUBES
ABX 11X-XX

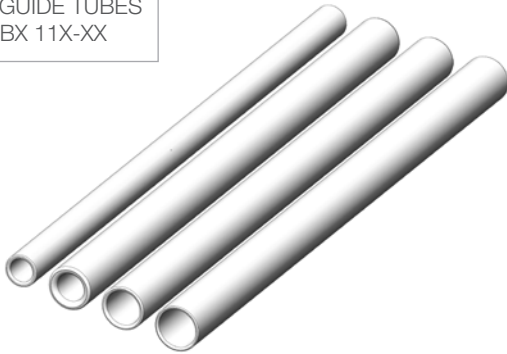

StoneAge (SA) PART NUMBER GUIDE TUBE REFERENCE CHART

GUIDE TUBE	BANSHEE	INSIDE DIAMETER, LENGTH	QTY
ABX 115-12	BN9.5	.459 in / 12 mm, 12.5 in. / 318 mm	3
ABX 115-36	BN9.5	.459 in / 12 mm, 36 in. / 914 mm	3
ABX 116-12	BN13	.546 in / 14 mm, 12.5 in. / 318 mm	3
ABX 116-36	BN13	.546 in / 14 mm, 36 in. / 914 mm	3
ABX 117-12	BN15	.674 in / 17 mm, 12.5 in. / 318 mm	3
ABX 117-36	BN15	.674 in / 17 mm, 36 in. / 914 mm	3
ABX 119-12	BN18	.745 in / 19 mm, 12.5 in. / 318 mm	3
ABX 119-36	BN18	.745 in / 19 mm, 36 in. / 914 mm	3

HOSE STOP COLLETS
ABX 171-XX

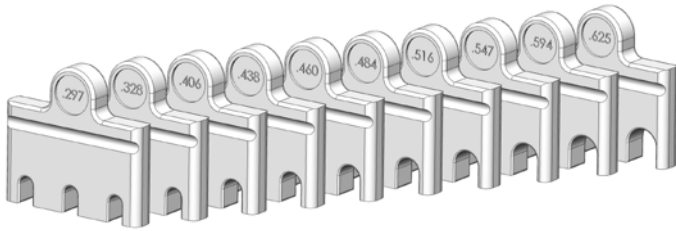

StoneAge (SA) PART NUMBER COLLET REFERENCE CHART

PART NUMBER	DESCRIPTION	QTY
ABX 171-297	HOSE STOP COLLET .297 in. / 8 mm	1
ABX 171-328	HOSE STOP COLLET .328 in. / 8 mm	1
ABX 171-406	HOSE STOP COLLET .406 in. / 10 mm	1
ABX 171-438	HOSE STOP COLLET .438 in. / 11 mm	1
ABX 171-460	HOSE STOP COLLET .460 in. / 12 mm	1
ABX 171-484	HOSE STOP COLLET .484 in. / 12 mm	1
ABX 171-516	HOSE STOP COLLET .516 in. / 13 mm	1
ABX 171-547	HOSE STOP COLLET .547 in. / 14 mm	1
ABX 171-594	HOSE STOP COLLET .594 in. / 15 mm	1
ABX 171-625	HOSE STOP COLLET .625 in. / 16 mm	1

GUIDE TUBE
ANTI-TWIST CLAMPS
ABX 140-XX



StoneAge (SA) PART NUMBER ANTI-TWIST CLAMP
REFERENCE CHART

PART NUMBER	DESCRIPTION	QTY
ABX 140-625	GUIDE TUBE ANIT-TWIST CLAMP .625	2
ABX 140-840	GUIDE TUBE ANIT-TWIST CLAMP .840	2
ABX 140-875	GUIDE TUBE ANIT-TWIST CLAMP .875	2

HOSE STOP CLAMPS
HS 121-XX-XX



StoneAge (SA) PART NUMBER HOSE STOP REFERENCE CHART

PART NUMBER	DESCRIPTION	QTY
HS 121-27-34	HOSE STOP CLAMP ASSEMBLY, .27-34	3
HS 121-34-42	HOSE STOP CLAMP ASSEMBLY, .34-42	3
HS 121-42-50	HOSE STOP CLAMP ASSEMBLY, .42-50	3
HS 121-50-56	HOSE STOP CLAMP ASSEMBLY, .50-56	3
HS 121-56-61	HOSE STOP CLAMP ASSEMBLY, .56-61	3

**LIGHTWEIGHT POSITIONER ASSEMBLY
(LWP-500-XX-V2)**

NOT INCLUDED IN PACKAGE, SEE LWP-500-V2 MANUAL FOR MORE DETAILS

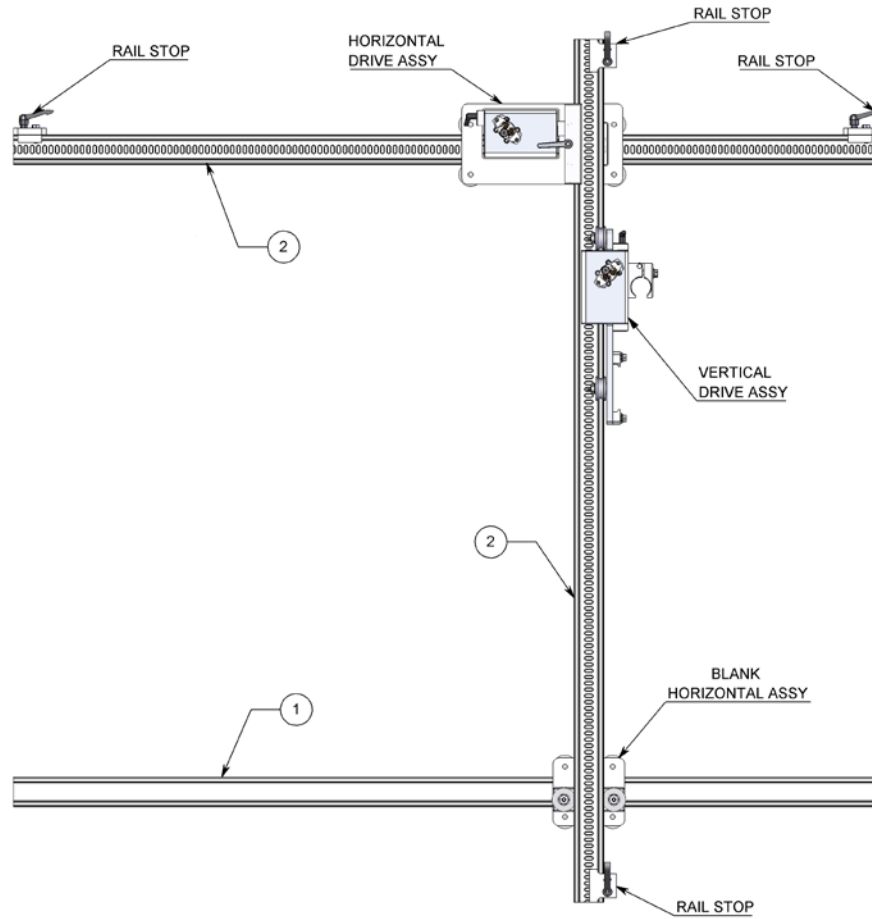

#	DESCRIPTION	QTY
1	BR 002-XX-001 2.5 BOX RAIL EXTRUSION	1
2	BU 002-XX-001 2.5 BOX RAIL EXTRUSION, SLOTTED	2
3	LWP-500.1 LIGHTWEIGHT POSITIONER PARTS (SEE BELOW)	1

LWP-500.1 LIGHTWEIGHT POSITIONER PARTS

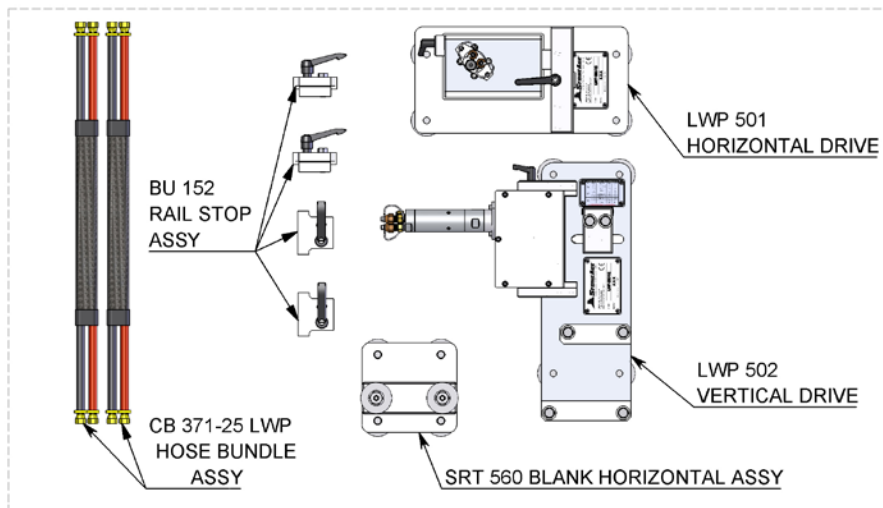

AUTOBOX® (CBX-ABX)
CONTROL BOX

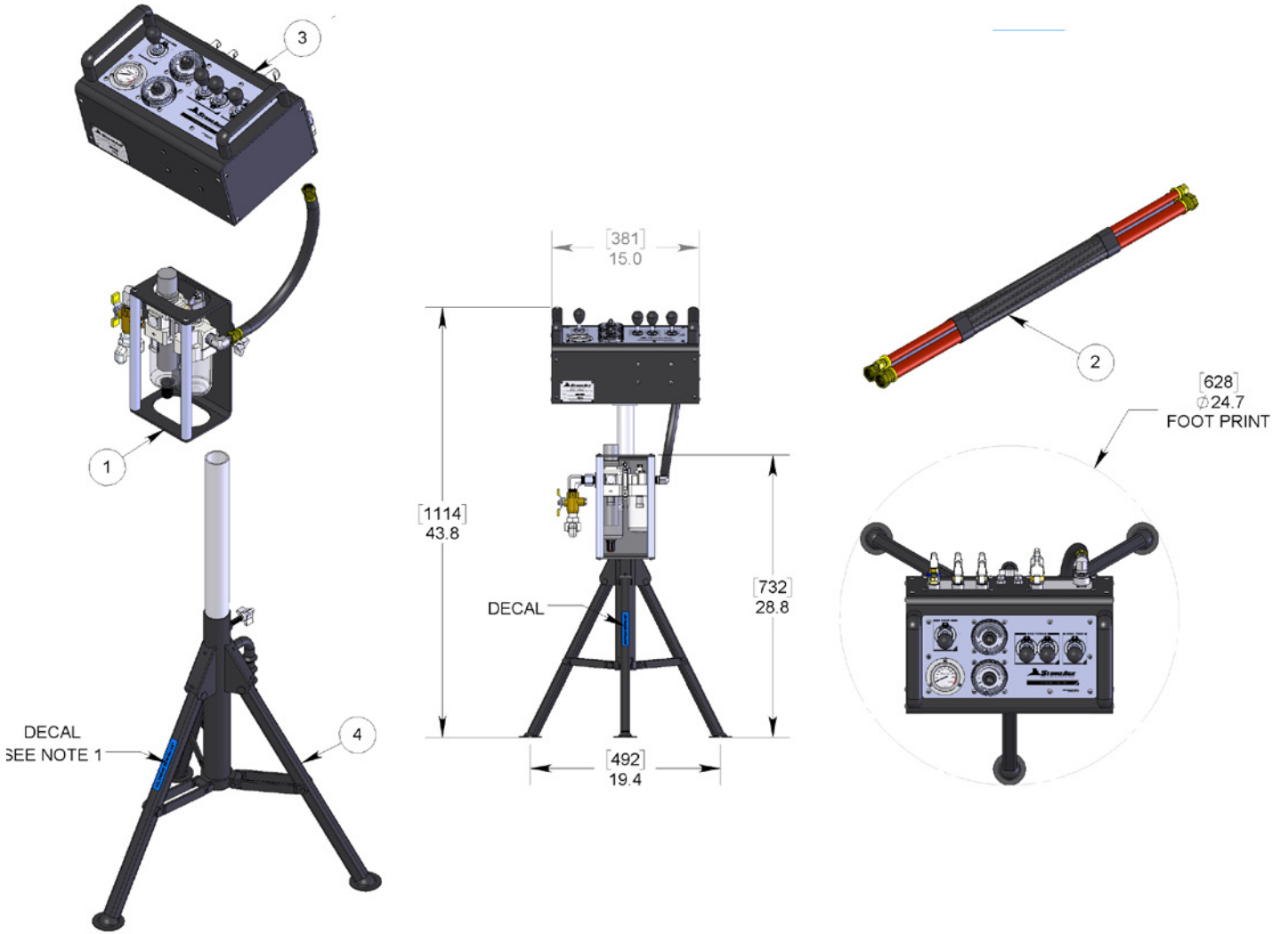

NOTES:

1. ALIGN FRL ASSY AND CONTROL BOX WITH DECAL ON FRONT LEG AS SHOWN.

#	PART NUMBER	QTY.
1	CB 310 FRL ASSEMBLY	1
2	CB 370-25 ABX HOSE BUNDLE ASSEMBLY	1
3	CBX 300 CONTROL BOX ASSEMBLY	1
4	CBX 301 CB STAND ASSEMBLY	1

**AUTOBOX® (CBX 300)
CONTROL BOX ASSEMBLY**
(CONTINUED ON NEXT PAGE)

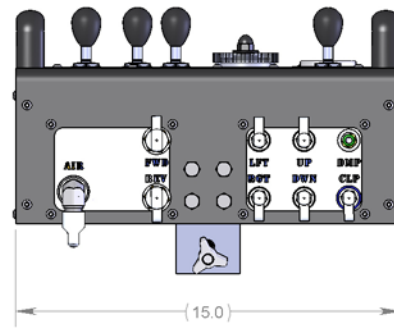
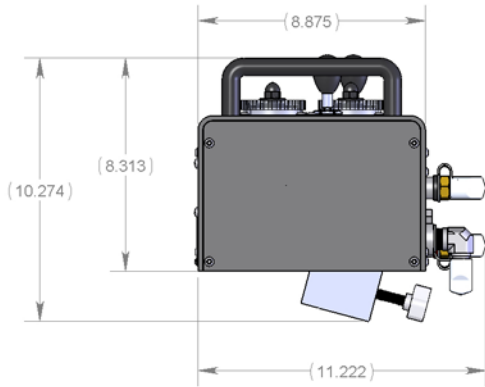
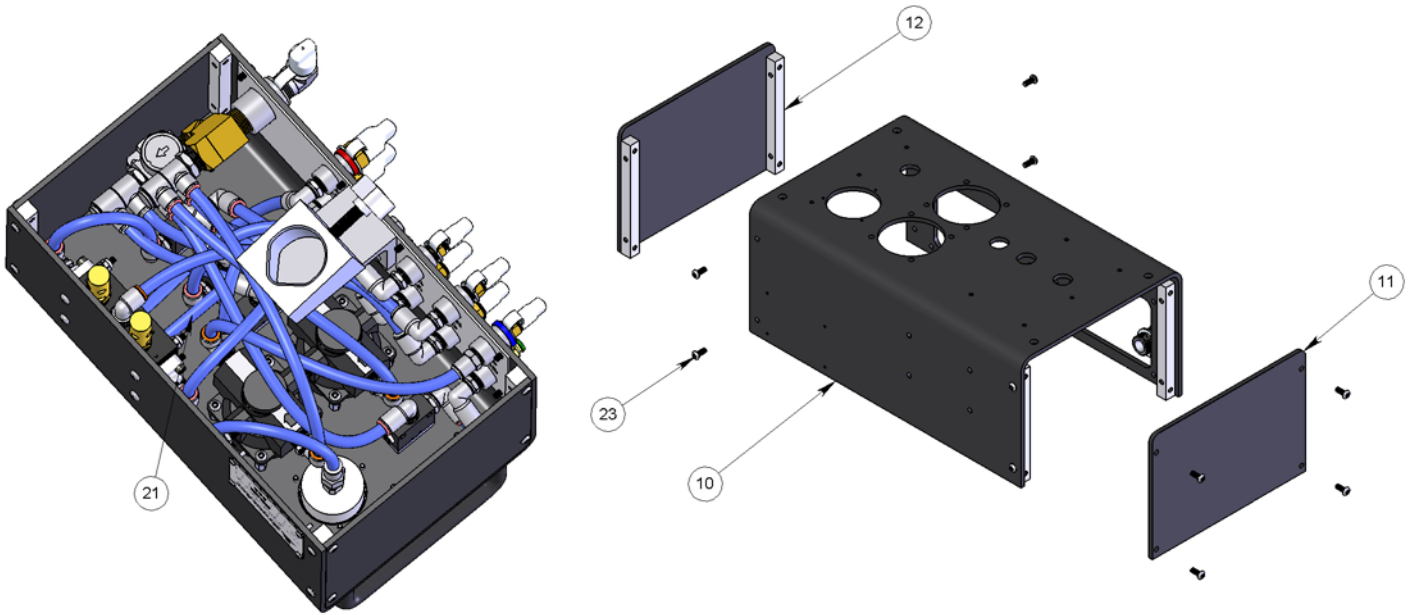

#	PART NUMBER	QTY.
10	CBX 321 FRAME	1
11	CBX 322 SIDE PLATE	2
12	CBX 323 BRACE REAR	4
21	GPTB 0375-PUR95A-BL	8FT
23	GTB 319-02-32 BHTS .19-32 X .50 LG TORX-SS	40

PARTS DIAGRAM

AUTOBOX® (CBX 300) CONTROL BOX ASSEMBLY (CONTINUED)

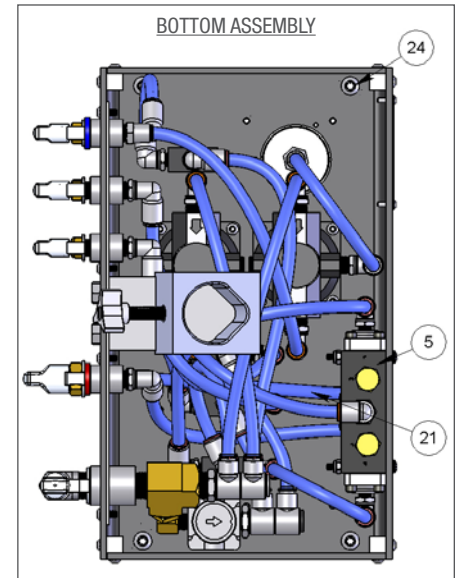
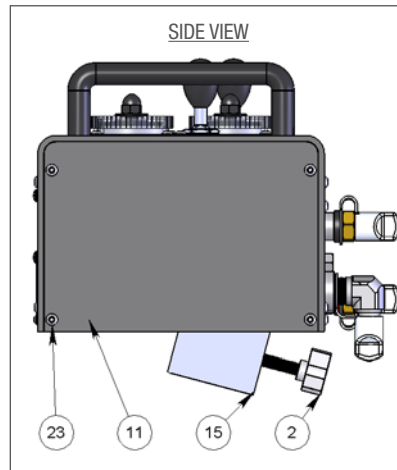
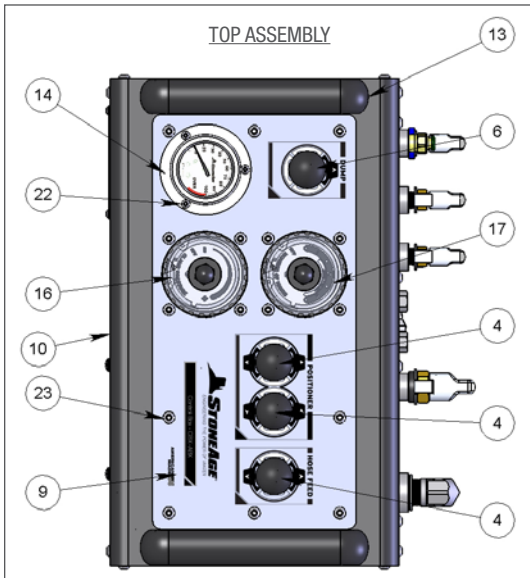
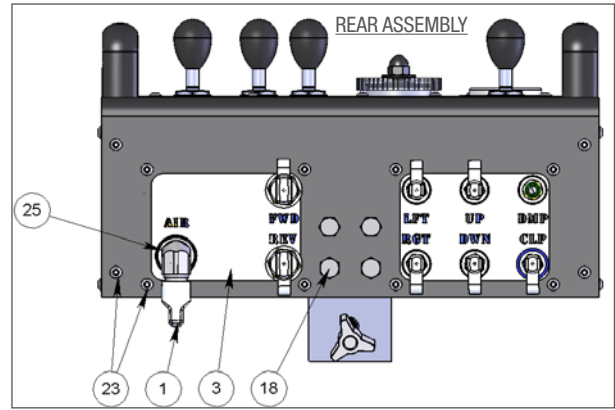
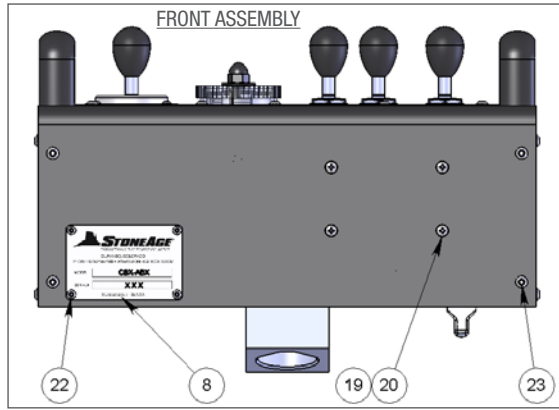

#	PART NUMBER	QTY.
1	BR 167 90° DUST CAP (FOR ABX-3L)	1
2	CB 314 3-LOBE KNOB	1
3	CB 327-001 COUPLER PLATE, REAR ASSEMBLY	1
4	CB 333-HD PNEUM3WAYASSY	3
5	CB 334 RY3 AAA PILOTED SPOOL VALVE ASSY	1
6	CB 337-HD PNEUM3WAYASSY - DUMP	1
7	CB 349 FTG P4F PL6 STRAIGHT	1
8	CBX 314 SERIAL PLATE	1
9	CBX 320 GRAPHIC OVERLAY	1
13	CBX 325 HANDLE TOP	2

14	CBX 326 GAUGE, CUSTOM	1
15	CBX 331 POLE MOUNT WELDMENT	1
16	CBX 335 CLAMP, REG ASSY	1
17	CBX 336 NUMBER, REG ASSY	1
18	GB 337-03 BOLT, HEX .37-16 X .75 SS	4
19	GN 319-L NYLOK NUT SS (HC 025.1)	4
20	GPH 319-08 PHPMS 10-24 X 2.00 SS	4
22	GSB 313-02 BHCS 6-32 X .50 LG SS	7
24	GTB 331-025 BHTS .31-18 X .63 LG TORX-SS	4
25	HRS 573 FITTING 90 DEG P8J8	1

AUTOBOX® (CB 327-001)
COUPLER PLATE, REAR ASSEMBLY

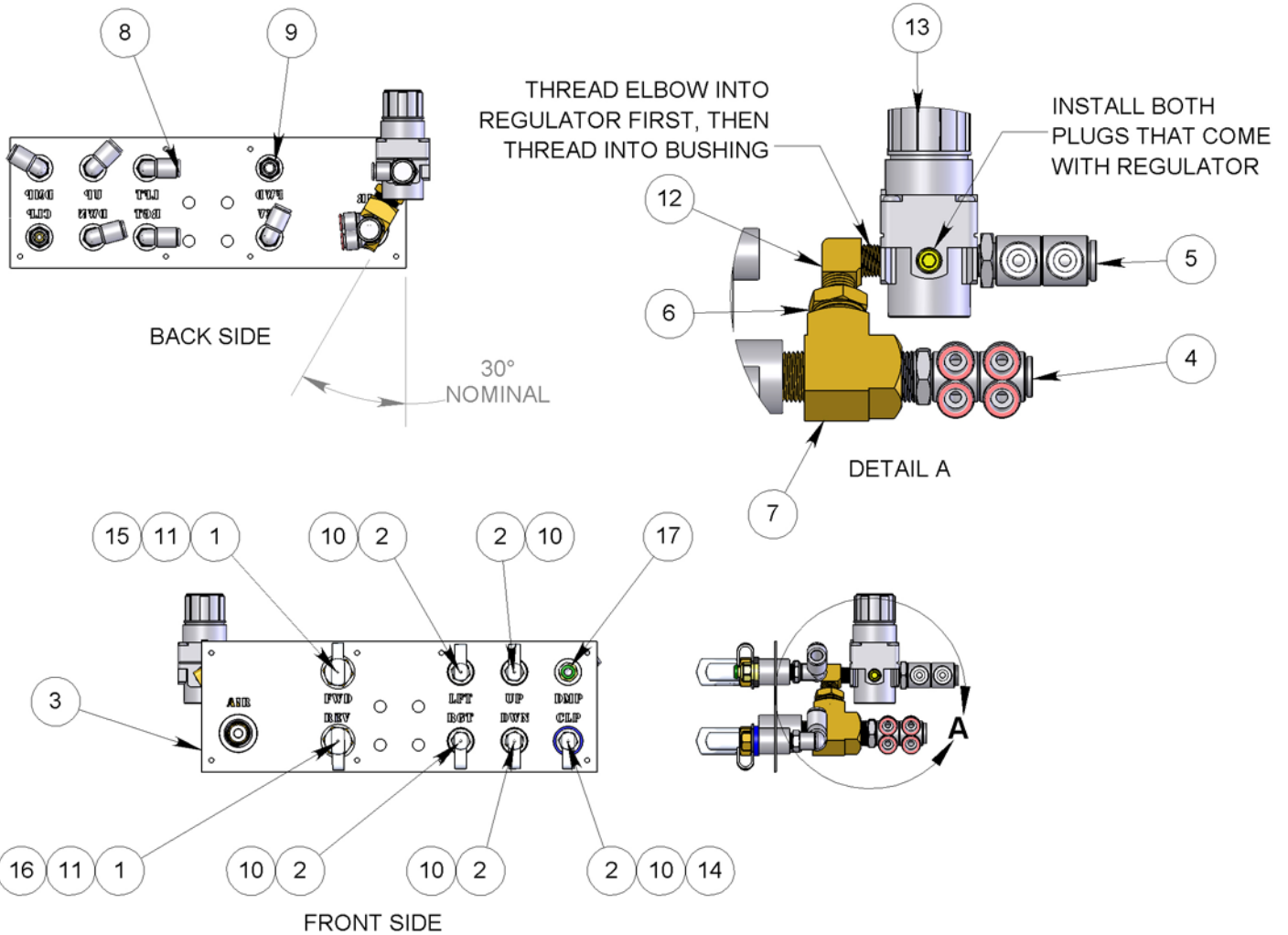

#	PART NUMBER	QTY.	#	PART NUMBER	QTY.
1	BR 167 DUST CAP	2	9	CB 354 FTG P4PL6 STRAIGHT	2
2	BR 168 DUST CAP, J4	5	10	CB 356 FTG P4J4 BRASS MALE TO MALE	5
3	CB 327.1-001 COUPLER PLATE, REAR WELDMENT	1	11	CB 357 FTG P4J8 BRASS MALE TO MALE	2
4	CB 330 P8PL6 4-WAY MANIFOLD	1	12	CB 365 FTG P4P4 ELBOW	1
5	CB 339 P4P6 MANIFOLD 2-WAY	1	13	CB 704 PRESSURE REGULATOR, 60 PSI	1
6	CB 343 FTG P8P4 BUSHING	1	14	GP 011-B BLUE ID BAND MED	1
7	CB 346 FTG P8 T-FITTING	1	15	GP 011-BK BLACK ID BAND MED	1
8	CB 351 FTG P4PL6 SWIVEL ELBOW	6	16	GP 011-R RED ID BAND MED	1
			17	SM 309 FITTING, BUSHING P4M PL4	1

PARTS DIAGRAM

AUTOBOX® (CB 301) CB STAND ASSEMBLY



#	PART NUMBER	QTY.
1	CB 303 MTG POLE	1
2	CB 314 3-LOBE KNOB	1

AUTOBOX® (CB 370-25) CONTROL LINE ASSEMBLY

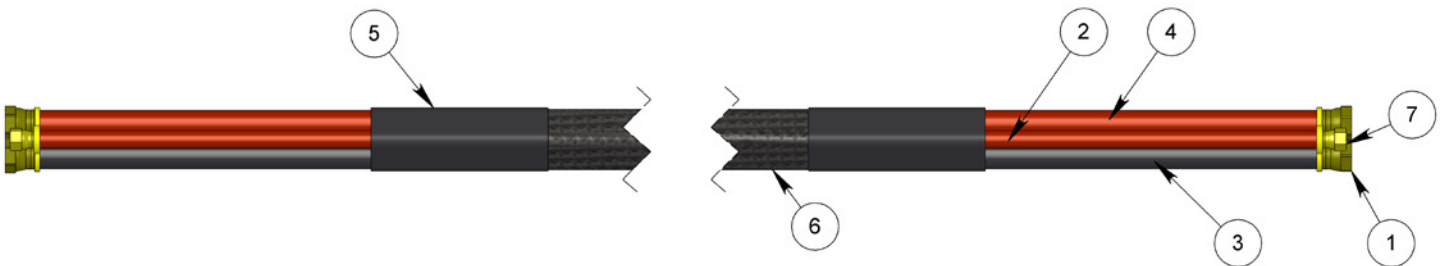

#	PART NUMBER	QTY.	UNITS
1	GP 053 1/2" PUSH-ON BRASS HOSE FITTING 1/2" JIC	4	
2	GPHO 0250-RUB-RD 1/4" ID X 1/2" OD PUSH-ON AIR HOSE, BUNA-N/PVC, 250 PSI, RED	1	25'
3	GPHO 0500-RUB-BK 1/2" ID X 3/4" OD PUSH-ON AIR HOSE, BUNA-N/PVC, 250 PSI, BLACK	1	25'
4	GPHO 0500-RUB-RD 1/2" ID X 3/4" OD PUSH-ON AIR HOSE, BUNA-N/PVC, 250 PSI, RED	1	25'
5	GPHS 2000-OLE-A-BK 2.00 DIA HEAVY DUTY MOISTURE SEAL HEAT-SHRINK	2	5"
6	GPSL 1750-NYL-G-BK 1.75 DIA BRAIDED EXPANDABLE HEAVY DUTY NYLON	1	24'
7	SRT 122 1/4" PUSH-ON BRASS HOSE FITTING 1/4" JIC	2	

AUTOBOX® (CB 310)
FRL ASSEMBLY

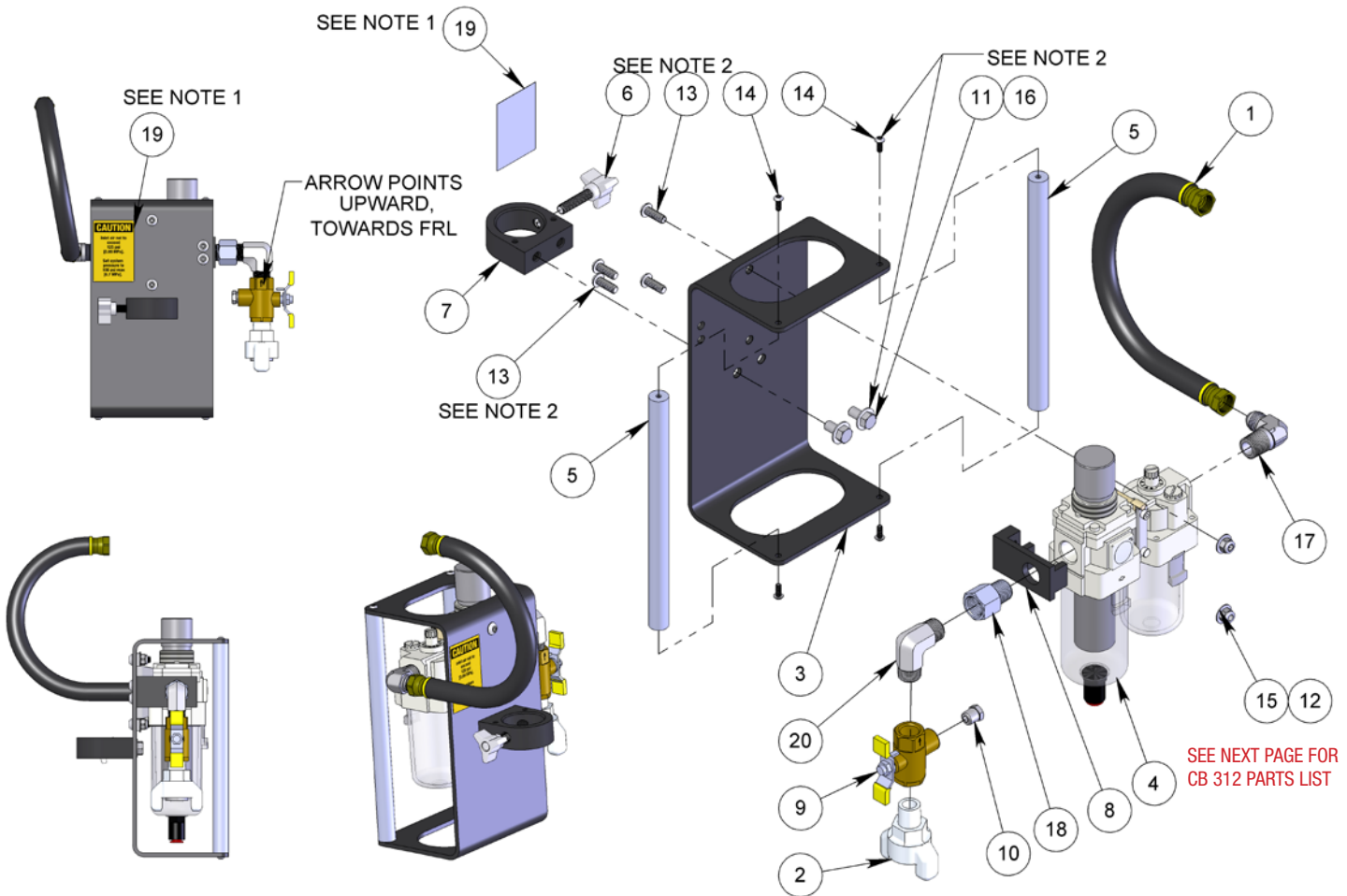

NOTES:

1. CLEAN ALL DEBRIS & OILS BEFORE INSTALLING. INSTALL AT APPROXIMATE ORIENTATION AND LOCATION & AT ROOM TEMP.
2. APPLY BLUE LOCTITE (PN: 242 OR EQUIVALENT) TO ALL STRAIGHT THREADED FASTENERS.
3. APPLY THREAD SEALANT (LOCTITE 567 OR EQUIVALENT) TO ALL TAPERED THREADS.
4. ADD BLUE GOOP WHICH IS A SWAGELOK BRAN ANTI-SEIZE TO ALL OTHER THREADED HARDWARE OR AN EQUIVALENT ALTERNATIVE IS ACCEPTABLE.

#	PART NUMBER	QTY.
1	CB 052-14 HOSE ASSY (FOR CB ABX)	1
2	CB 114 INLET FITTING	1
3	CB 311 FRL FRAME	1
4	CB 312 GEN3 FILTER-REGULATOR-LUBRICATOR WITH GEN2 CLAMP	1
5	CB 313 ROD	2
6	CB 314 3-LOBE KNOB	1
7	CB 328-001 POLE MOUNT	1
8	CB 395 FRL BRACKET	1
9	CB 792 VALVE, AUTODRAIN, P8	1
10	CB 793 BREATHER, SINTERED BRONZE, P4	1

11	GB 337-03 BOLT, HEX .37-16 X .75 SS	2
12	GN 331-L NYLOK NUT SS	2
13	GSB 331-035 BHCS .31-18 X .88 LG SS	4
14	GTB 319-02-32 BHTS .19-32 X .50 LG TORX-SS	4
15	GW 331-F FLAT WASHER SS	2
16	GW 337-F FLAT WASHER SS	2
17	HRS 573 FITTING 90 DEG P8J8	1
18	ML 077-P8 BUSHING	1
19	PL 156-125 CAUTION INLET AIR, 125PSI MAX	1
20	SBT 292.1 FTG 90° ELBOW P8MP8M	1

PARTS DIAGRAM

AUTOBOX® (CB 312)
GEN 3 FILTER, REGULATOR, LUBRICATOR WITH GEN 2 CLAMP

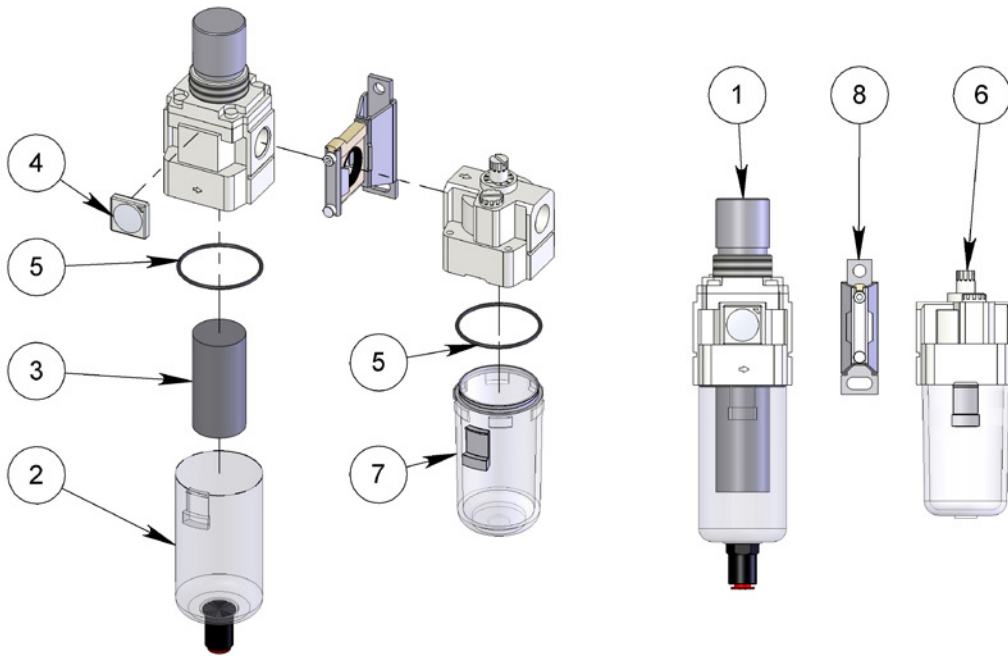
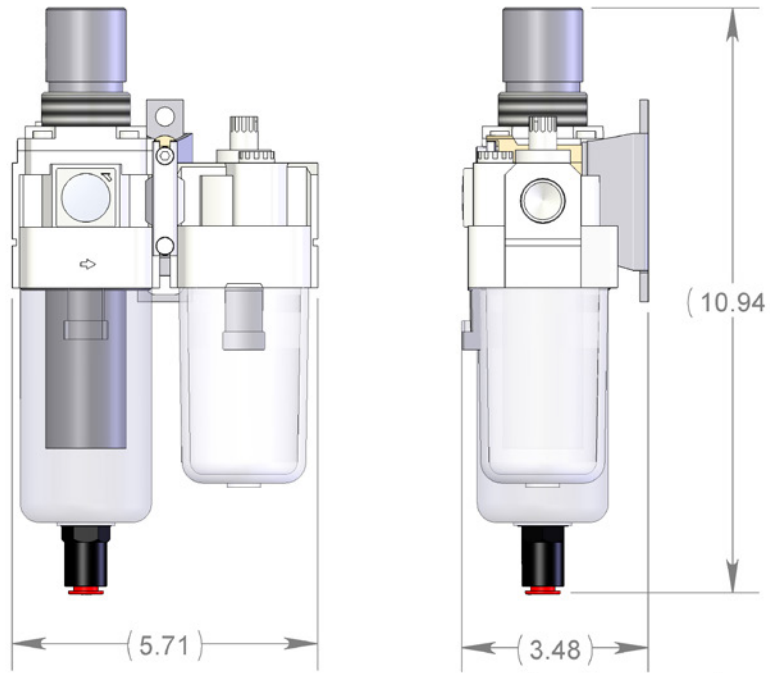

#	PART NUMBER	QTY.
1	CB 312.1 FILTER REGULATOR ASSEMBLY	1
2	CB 312.1.1 FILTER REGULATOR BOWL	1
3	CB 312.1.6 FILTER	1
4	CB 312.1.7 GAUGE WITH LENS	1
5	CB 312.1.8 ORING	2
6	CB 312.2 LUBRICATOR ASSEMBLY	1
7	CB 312.2.2 LUBRICATOR BOWL	1
8	CB 312.3 SPACER W BRACKET	1

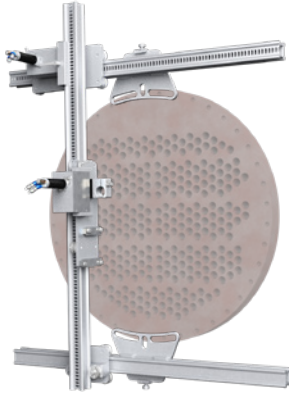

1 LWP-500 POSITIONER

- With its multiple mounting options, the LWP-100 positioner can adapt to almost any heat exchanger.
- Two high-powered pneumatic motors provide fast, precise positioning.
- Entire unit can be set up and operated with a single operator and minimal hand tools.
- Anodized aluminum rails provide maximum chemical and corrosion resistance.



2 AST-200 AUTOSTROKE – AUTOMATIC BLOCKAGE SENSOR

- Maximizes head life and cleaning efficiency by automatically detecting blockages and methodically working through the obstruction
- Easily installs in-line to your pneumatic lines.
- The perfect complement to your ABX-3L system.

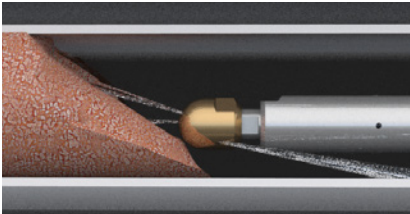

HEAD CONTACTS BLOCKAGE AND STOPS ROTATING

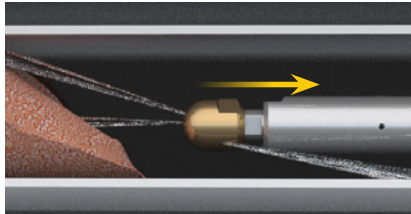

AUTOSTROKE 'SENSES' BLOCKAGE AND PULLS HOSE BACK SLIGHTLY TO REGAIN HEAD ROTATION

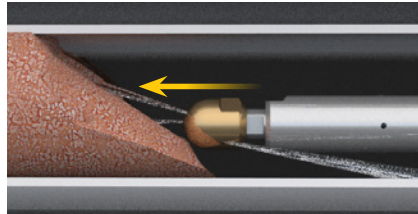

HEAD REGAINS NORMAL ROTATION AND HOSE FEED CONTINUES



3 HCS-2L AND HCS-3L – HOSE CONTAINMENT SYSTEMS

- Holds a variety of hose diameters.
- Built-in backout prevention for improved job site safety.
- Keeps job site clear of trip hazards.
- Helps manage hoses for easy transport and storage.
- Greatly extends hose life.

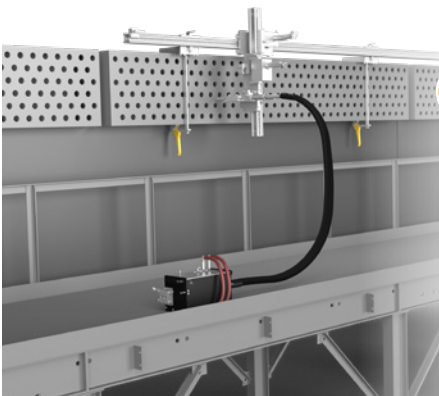

4 FF-200 AND FF-300 FIN FAN ATTACHMENTS

- Allows the ABX-3L to be operated in confined walkways to access Fin-Fan exchangers.
- Adjustable pitch. Run two or three lances.
- Customized lengths available.
- Scaffold attachment available.

TERMS AND CONDITIONS

1. Acceptance of Terms and Conditions. Receipt of these Terms and Conditions of Sale ("Terms and Conditions") shall operate as the acceptance by StoneAge, Inc. ("Seller") of the order submitted by the purchaser ("Buyer"). Such acceptance is made expressly conditional on assent by Buyer to these Terms and Conditions. Such assent shall be deemed to have been given unless written notice of objection to any of these Terms and Conditions (including inconsistencies between Buyer's purchase order and this acceptance) is given by Buyer to Seller promptly on receipt hereof.

Seller desires to provide Buyer with prompt and efficient service. However, to individually negotiate the terms of each sales contract would substantially impair Seller's ability to provide such service. Accordingly, the product(s) furnished by Seller are sold only according to the terms and conditions stated herein and with the terms and conditions stated in any effective StoneAge Dealer Agreement or StoneAge Reseller Agreement, if applicable. Notwithstanding any terms and conditions on Buyer's order, Seller's performance of any contract is expressly made conditional on Buyer's agreement to these Terms and Conditions unless otherwise specifically agreed to in writing by Seller. In the absence of such agreement, commencement of performance, shipment and/or delivery shall be for Buyer's convenience only and shall not be deemed or construed to be an acceptance of Buyer's terms and conditions.

2. Payment/Prices. Unless other arrangements have been made in writing between Seller and Buyer, payment for the product(s) shall be made upon receipt of invoice. The prices shown on the face hereof are those currently in effect. Prices invoiced shall be per pricelist in effect at the time of shipment. Prices are subject to increase for inclusion of any and all taxes which are applicable and which arise from the sale, delivery or use of the product(s), and the collection of which Seller is or may be responsible to provide to any governmental authority, unless acceptable exemption certificates are provided by Buyer in accordance with applicable law. Buyer shall pay all charges for transportation and delivery and all excise, order, occupation, use or similar taxes, duties, levies, charges or surcharges applicable to the product(s) being purchased, whether now in effect or hereafter imposed by any governmental authority, foreign or domestic.

3. Warranty. SELLER MAKES NO WARRANTIES OR REPRESENTATIONS AS TO THE PERFORMANCE OF ANY PRODUCT EXCEPT AS SET FORTH IN THE STONEAGE LIMITED WARRANTY PROVIDED WITH THE PRODUCT.

4. Delivery. Seller is not obligated to make delivery by a specified date, but will always use its best efforts to make delivery within the time requested. The proposed shipment date is an estimate. Seller will notify Buyer promptly of any material delay and will specify the revised delivery date as soon as practicable. UNDER NO CIRCUMSTANCES SHALL SELLER HAVE ANY LIABILITY WHATSOEVER FOR LOSS OF USE OR FOR ANY DIRECT OR CONSEQUENTIAL DAMAGES RESULTING FROM DELAY REGARDLESS OF THE REASON(S).

All product(s) will be shipped F.O.B. point of origin, unless specifically agreed otherwise, and Buyer shall pay all shipping costs and insurance costs from that point. Seller, in its sole discretion, will determine and arrange the means and manner of transportation of the product(s). Buyer shall bear all risk of loss commencing with the shipment or distribution of the product(s) from Seller's warehouse. Order shortages or errors must be reported within fifteen (15) business days from receipt of shipment to secure adjustment. No product(s) may be returned without securing written approval from Seller.

5. Modification. These Terms and Conditions are intended by Seller and Buyer to constitute a final, complete and exclusive expression of agreement relating to the subject matter hereof and cannot be supplemented or amended without Seller's prior written approval.

6. Omission. Seller's waiver of any breach or Seller's failure to enforce any of these Terms and Conditions at any time, shall not in any way affect, limit or waive Seller's right thereafter to enforce and compel strict compliance with every term and condition hereof.

7. Severability. If any provision of these Terms and Conditions is held to be invalid or unenforceable, such invalidity or unenforceability shall not affect the validity or enforceability of the other portions hereof.

8. Disputes. Seller and Buyer shall attempt in good faith to promptly resolve any dispute arising under these Terms and Conditions by negotiations between representatives who have authority to settle the controversy. If unsuccessful, Seller and Buyer shall further attempt in good faith to settle the dispute by nonbinding third-party mediation, with fees and expenses of such mediation apportioned equally to each side. Any dispute not so resolved by negotiation or mediation may then be submitted to a court of competent jurisdiction in accordance with the terms hereof. These procedures are the exclusive procedures for the resolution of all such disputes between the Seller and Buyer.

9. Governing Law. All sales, agreements for sale, offers to sell, proposals, acknowledgments and contracts of sale, including, but not limited to, purchase orders accepted by Seller, shall be considered a contract under the laws of the State of Colorado and the rights and duties of all persons, and the construction and effect of all provisions hereof shall be governed by and construed according to the laws of such state.

10. Jurisdiction and Venue. Seller and Buyer agree that the state or federal courts located within the City and County of Denver, Colorado shall have sole and exclusive jurisdiction over any litigation concerning any dispute arising under these Terms and Conditions not otherwise resolved pursuant to Section 9 as well as any alleged defects of any Products or damages sustained as a result of such alleged defects. Seller and Buyer further agree that should any litigation be commenced in connection with such a dispute, it shall only be commenced in such courts. Seller and Buyer agree to the exclusive jurisdiction of such courts and neither will raise any objection to the jurisdiction and venue of such courts, including as a result of inconvenience.

11. Attorney's Fees. If any litigation is commenced between Seller and Buyer, or their personal representatives, concerning any provision hereof, the party prevailing in the litigation shall be entitled, in addition to such other relief that is granted, to a reasonable sum as and for their attorneys' fees and costs in such litigation or mediation.

STONEAGE TRADEMARK LIST

View the list of StoneAge's trademarks and service marks and learn how the trademarks should be used. Use of StoneAge trademarks may be prohibited, unless expressly authorized.

<http://www.StoneAgetools.com/trademark-list/>

STONEAGE PATENT DATA

View the list of StoneAge's current U.S. patent numbers and descriptions.

<http://www.sapatents.com>

STONEAGE TERMS AND WARRANTY

View StoneAge's Terms and Warranty Conditions online.

<http://www.stoneagetools.com/terms>

<http://www.stoneagetools.com/warranty>

Warranties set forth herein extend only to End-Users, meaning customers acquiring, or that have previously acquired, a product manufactured by StoneAge ("Product") for their own use and not for resale, either directly from StoneAge Inc. ("StoneAge") or from a StoneAge Authorized Dealer or Reseller ("Dealer"). No warranty of any kind or nature is made by StoneAge beyond those expressly stated herein.

1. LIMITED WARRANTY PERIOD. Subject to the limitations and conditions hereinafter set forth, StoneAge warrants its Product to be free from defects in workmanship and material for a period of one (1) year from the date of purchase by the End-User, provided that the end of the limited warranty period shall not be later than eighteen (18) months from the date of shipment of the Product to the Dealer or the End-User by StoneAge ("Limited Warranty Period"). All replacement parts which are furnished under this Limited Warranty and properly installed shall be warranted to the same extent as the original Product under this Limited Warranty if, and only if, the original parts were found to be defective within the original Limited Warranty Period covering the original Product. Replacement parts are warranted for the remainder of the original Limited Warranty Period. This Limited Warranty does not cover any component part of any Product not manufactured by StoneAge. Any such component part is subject exclusively to the component manufacturer's warranty terms and conditions.

2. LIMITED WARRANTY COVERAGE. StoneAge's sole obligation under this Limited Warranty shall be, at StoneAge's option and upon StoneAge's inspection, to repair, replace or issue a credit for any Product which is determined by StoneAge to be defective in material or workmanship. StoneAge reserves the right to examine the alleged defective Product to determine whether this Limited Warranty is applicable, and final determination of limited warranty coverage lies solely with StoneAge. No statement or recommendation made by a StoneAge representative, Dealer or agent to End-User shall constitute a warranty by StoneAge or a waiver or modification to any of the provisions hereof or create any liability for StoneAge.

3. WARRANTY SERVICE PROVIDERS. Service and repair of the Product is to be performed only by StoneAge authorized service representatives, including Dealers who are authorized repair centers, with StoneAge approved parts. Information about StoneAge authorized service representatives can be obtained through the StoneAge website at www.stoneagetools.com/ service. Unauthorized service, repair or modification of the Product or use of parts not approved by StoneAge will void this Limited Warranty. StoneAge reserves the right to change or improve the material and design of the Product at any time without notice to End-User, and StoneAge is not obligated to make the same improvements during warranty service to any Product previously manufactured.

4. WARRANTY EXCLUSIONS. This Limited Warranty does not cover, and StoneAge shall not be responsible for the following, or damage caused by the following: (1) any Product that has been altered or modified in any way not approved by StoneAge in advance in writing; (2) any Product that has been operated under more severe conditions or beyond the rated capacity specified for that Product; (3) depreciation or damage caused by normal wear and tear, failure to follow operation or installation instructions, misuse, negligence or lack of proper protection during storage; (4) exposure to fire, moisture, water intrusion, electrical stress, insects, explosions, extraordinary weather and/or environmental conditions including, but not limited to lightning, natural disasters, storms, windstorms, hail, earthquakes, acts of God or any other force majeure event; (5) damage to any Product caused by any attempt to repair, replace, or service the Product by persons other than StoneAge authorized service representatives; (6) costs of normal maintenance parts and services; (7) damage sustained during unloading, shipment or transit of the Product; or (8) failure to perform the recommended periodic maintenance procedures listed in the Operator's Manual accompanying the Product.

5. REQUIRED WARRANTY PROCEDURES. To be eligible for warranty service, the End-User must: (1) report the Product defect to the entity where the Product was purchased (i.e. StoneAge or the Dealer) within the Limited Warranty Period specified in this Limited Warranty; (2) submit the original invoice to establish ownership and date of purchase; and (3) make the Product available to a StoneAge authorized service representative for inspection to

determine eligibility for coverage under this Limited Warranty. This Limited Warranty shall not extend to any person or entity who fails to provide proof of original purchase from StoneAge or a Dealer. No Product may be returned for credit or adjustment without prior written permission from StoneAge.

6. DISCLAIMER OF IMPLIED WARRANTIES AND OTHER REMEDIES. EXCEPT AS EXPRESSLY STATED HEREIN (AND TO THE FULLEST EXTENT ALLOWED UNDER APPLICABLE LAW), STONEAGE HEREBY DISCLAIMS ALL OTHER WARRANTIES, EXPRESS OR IMPLIED, INCLUDING WITHOUT LIMITATION ALL IMPLIED WARRANTIES OF MERCHANTABILITY OR FITNESS FOR A PARTICULAR PURPOSE, AND ANY AND ALL WARRANTIES, REPRESENTATIONS OR PROMISES AS TO THE QUALITY, PERFORMANCE OR FREEDOM FROM DEFECT OF THE PRODUCT COVERED BY THIS LIMITED WARRANTY. STONEAGE FURTHER DISCLAIMS ALL IMPLIED INDEMNITIES.

7. LIMITATION OF LIABILITY. End-User specifically acknowledges that the Product may be operated at high speeds and/or pressures, and that as such it may be inherently dangerous if not used correctly. End-User shall familiarize itself with all operation materials provided by StoneAge and shall at all times use and require its agents, employees and contractors to use all necessary and appropriate safety devices, guards and proper safe operating procedures. In no event shall StoneAge be responsible for any injuries to persons or property caused directly or indirectly by the operation of the Product if End-User or any agent, employee, or contractor of End-User: (1) fails to use all necessary and appropriate safety devices, guards and proper safe operating procedures; (2) fails to maintain in good working order such safety devices and guards; (3) alters or modifies the Product in any way not approved by StoneAge in advance in writing; (4) allows the Product to be operated under more severe conditions or beyond the rated capacity specified for the Product; or (5) otherwise negligently operates the Product. End-User shall indemnify and hold StoneAge harmless from any and all liability or obligation incurred by or against StoneAge, including costs and attorneys' fees, to or by any person so injured.

TO THE FULL EXTENT ALLOWED BY APPLICABLE LAW, STONEAGE SHALL NOT BE LIABLE FOR ANY INDIRECT, SPECIAL, INCIDENTAL, CONSEQUENTIAL, OR PUNITIVE DAMAGES (INCLUDING WITHOUT LIMITATION, LOSS OF PROFITS, LOSS OF GOODWILL, DIMINUTION OF VALUE, WORK STOPPAGE, INTERRUPTION OF BUSINESS, RENTAL OF SUBSTITUTE PRODUCT, OR OTHER COMMERCIAL LOSS EVEN TO THE EXTENT SUCH DAMAGES WOULD CONSTITUTE DIRECT DAMAGES), WITH RESPECT TO THE COVERED STONEAGE PRODUCT, OR OTHERWISE IN CONNECTION WITH THIS LIMITED WARRANTY, REGARDLESS OF WHETHER STONEAGE HAS BEEN ADVISED OF THE POSSIBILITY OF SUCH DAMAGES.

IT IS UNDERSTOOD THAT STONEAGE'S LIABILITY, WHETHER IN CONTRACT, IN TORT, UNDER ANY WARRANTY, IN NEGLIGENCE, OR OTHERWISE SHALL NOT EXCEED THE AMOUNT OF THE PURCHASE PRICE PAID BY THE END-USER FOR THE PRODUCT. STONEAGE'S MAXIMUM LIABILITY SHALL NOT EXCEED, AND END-USER'S REMEDY IS LIMITED TO EITHER (1) REPAIR OR REPLACEMENT OF THE DEFECTIVE WORKMANSHIP OR MATERIAL OR, AT STONEAGE'S OPTION, (2) REFUND OF THE PURCHASE PRICE, OR (3) ISSUANCE OF A CREDIT FOR THE PURCHASE PRICE, AND SUCH REMEDIES SHALL BE END-USER'S ENTIRE AND EXCLUSIVE REMEDY.

YOU, THE END-USER, UNDERSTAND AND EXPRESSLY AGREE THAT THE FOREGOING LIMITATIONS ON LIABILITY ARE PART OF THE CONSIDERATION IN THE PRICE OF THE STONEAGE PRODUCT YOU PURCHASED.

Some jurisdictions do not allow the limitation or exclusion of liability for certain damages, so the above limitations and exclusions may not apply to you. This Limited Warranty gives you specific legal rights, and you may also have other rights which vary from jurisdiction to jurisdiction. If any provisions of this Limited Warranty is held to be invalid or unenforceable, such invalidity or unenforceability shall not affect the validity or enforceability of the other portions hereof.

This page is intentionally left blank.

This page is intentionally left blank.



1-866-795-1586 • www.STONEAGETOOLS.com

© 2015 StoneAge, Inc. All Rights Reserved