

# SDA

## 500/600

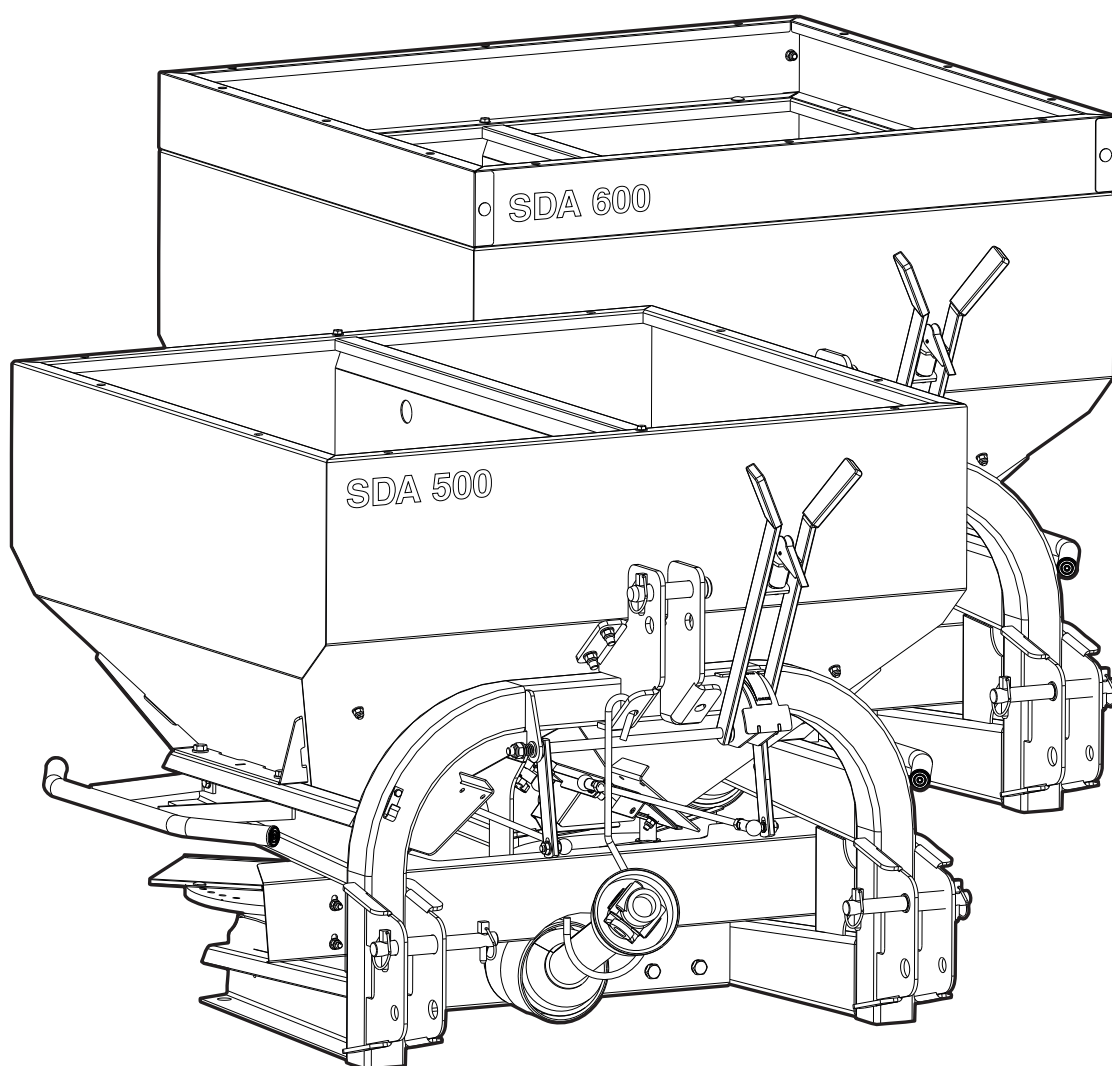

## USER AND MAINTENANCE MANUAL

**IMPORTANT! Carefully read this manual before using the machine.**

**AGREX S.p.A.**

Via Balla, 55/57 - Loc. Taggi di Sotto - 35010 Villafranca Padovana (PD)

Tel. +39 049 50 00 000 - Fax. +39 049 90 75 524

e-mail: [info@agrex.com](mailto:info@agrex.com) - web site: [www.agrex.com](http://www.agrex.com)



# SUMMARY

<b>1</b>	<b>SECTION – GENERALITY.....</b>	<b>5</b>
1.1	PRESENTATION .....	5
1.1.1	<i>Who the manual is intended for.....</i>	5
1.2	CONDITION OF GUARANTEE .....	6
1.2.1	<i>Voidance of the guarantee .....</i>	6
1.3	CUSTOMER SERVICE .....	7
<b>2</b>	<b>SECTION – GENERAL FEATURES.....</b>	<b>8</b>
2.1	MACHINE MARKINGS .....	8
2.1.1	<i>Spreader description.....</i>	9
2.1.2	<i>Scheduled use.....</i>	10
2.1.3	<i>Non-scheduled use.....</i>	10
2.2	CONTROL DEVICES .....	10
2.3	TECHNICAL DATA.....	11
2.4	STANDARDS APPLIED .....	11
<b>3</b>	<b>SECTION – SAFETY AND ACCIDENT PREVENTION .....</b>	<b>12</b>
3.1	SAFETY.....	12
3.1.1	<i>General safety rules.....</i>	13
3.1.2	<i>Safety signs .....</i>	14
3.2	SAFETY DEVICES.....	16
3.3	NOISE HAZARD .....	16
3.4	DUST HAZARD .....	16
3.5	CLOTHING .....	16
3.6	ECOLOGY AND POLLUTION .....	16
3.7	SAFE USE .....	17
<b>4</b>	<b>SECTION - HANDLING AND INSTALLATION .....</b>	<b>19</b>
4.1.1	<i>Assembly of hopper extensions.....</i>	19
4.2	HANDLING .....	20
4.3	HITCHING .....	20
4.4	PRELIMINARY CLEANING .....	22
4.5	GENERAL INSPECTION .....	22
<b>5</b>	<b>SECTION – USE .....</b>	<b>23</b>
5.1	PRIOR TO USE .....	23
5.2	STARTING UP .....	23
5.3	ADJUSTMENTS .....	23
5.3.1	<i>Product spreading adjustment.....</i>	23
5.3.2	<i>Spreading width adjustment.....</i>	24
5.3.3	<i>Spreading patterns.....</i>	25
5.3.4	<i>Loading the machine's hopper.....</i>	26
5.3.5	<i>Distribution.....</i>	26
5.3.6	<i>Driving technique suggestions.....</i>	26
5.3.7	<i>Late top-spreading.....</i>	26
5.3.8	<i>Side spreading conveyor (optional).....</i>	27
<b>6</b>	<b>SECTION – MAINTENANCE .....</b>	<b>28</b>
6.1	ROUTINE MAINTENANCE .....	28
6.1.1	<i>Daily cleaning .....</i>	28
6.1.2	<i>General checks.....</i>	28
6.1.4	<i>Spreading paddle assembly/disassembly.....</i>	28
6.2	EXTRA MAINTENANCE.....	29

6.3	TO KEEP IN MOTHBALL .....	29
6.4	RE-START.....	30
6.5	DISMANTLING THE MACHINE .....	30
<b>7</b>	<b>SECTION – SPARE PARTS .....</b>	<b>31</b>

**8 ANNEX A - STABILITY OF THE TRACTOR DISTRIBUTOR COMBINATION**

**SPREADING TABLES**

## 1 SECTION – Generality

---

### 1.1 Presentation

This manual gives information, instructions and everything else you will need to understand, correctly operate and perform routine maintenance on spreaders mod. «**SDA**», hereinafter also referred to as the machine, and of all the accessories produced by **AGREX Spa of Villafranca Padovana (Padua) Italy**, hereinafter also referred to as the Manufacturer.

You will not find a complete description of the various parts, or a detailed explanation of how they work herein. Nonetheless, you will find all the information you will usually need to operate the machine safely and to look after it properly.

Compliance with the instructions herein, together with careful, meticulous maintenance, is the only way to assure proper operation, lasting service and economic running of the machine.

Failure to comply with the provisions herein, negligent operation, incorrect use of the machine or performance of unauthorized changes may lead to the Manufacturer declaring its warranty covering the machine void.

**THE MANUFACTURER ALSO DECLINES ANY RESPONSIBILITY FOR DAMAGES AS A RESULT OF THE ABOVE-MENTIONED ACTIONS OR FOLLOWING FAILURE TO COMPLY WITH THE INSTRUCTIONS HEREIN.**

For any repairs or overhauls entailing operations of some complexity, you must contact an authorized Customer Support Centre with specialized personnel, or the actual Manufacturer, who will be glad, in any case, to assure prompt, accurate technical servicing and anything else required to restore the machine to full working order.



This manual is an integral part of the machine and must be kept with the machine at all times, even when it is moved or sold. It must be kept in a safe place where personnel in charge of work on the machine know where to find it. Said personnel must look after it and keep it intact for future reference for the entire duration of the machine's service life.

If it is damaged or misplaced, you must ask the Manufacturer for a copy without delay.

#### 1.1.1 Who the manual is intended for

---

This manual is an essential tool for personnel who, in their various capacities, are somehow involved with the machine.

The various job profiles are given below:

**USER:** A user is the person, or body, or company who has purchased or hired the plant and who intends to use it for its intended purposes. They are responsible for the machine and for the training of anyone involved with it.

**OPERATOR:** skilled technical personnel sent by AGREX S.p.A. to install the machine and train operators. Technicians are able to perform operations of a complex nature on the plant, or any work in unusual situations.

## 1.2 Condition of guarantee

- The seller guarantees that the parts of the product are new, designed and manufactured so as to meet the specific technical characteristics of the product itself.
- The guarantee period is 12 months (twelve months) if the purchaser is a judicial entity (so-called "B to B sale", i.e. "business to business") or 24 months (twenty-four months) if the purchaser is a consumer (so-called "B to C sale" ). The guarantee takes effect starting from the date of delivery of the product and, more specifically, from the date of the signature of the test certificate, if the machine has been tested, or from the date of the shipping document, in all other cases. In "B to B" sales, the guarantee period may not in any case exceed 18 months from the date the machinery is shipped.
- At the moment of delivery, the purchaser is required to check that the machine is in good condition and complete with all its parts.
- If the product has damage or defects which occurred during the guarantee period, the purchaser is required to inform the seller, in writing, of the existence and the extent of said damage or defects no later than 5 (five) days from the moment they are discovered, in "B to B" sales.
- The guarantee provides exclusively the right to free replacement or repair of the defective parts, which will be considered as such after careful examination by the seller's technical department. Shipping costs shall be at the expense of the seller, who shall select the method of shipment based on his own unquestionable judgment.
- Replacement or repair of parts covered by the guarantee shall not in any case extend the terms thereof.
- Under no circumstances shall the purchaser be entitled to the repair of the machinery or of the single components if full payment of the agreed amount has not been made.

### 1.2.1 Voidance of the guarantee

---

- This guarantee shall automatically be voided if the product undergoes interventions, modifications, or is used by technicians or staff who are not authorized in writing by the seller.
- This guarantee does not cover the replacement of the parts that are subject to normal wear and spare parts. Any additional costs, such as travel expenses, shipping and/or labour costs, are not covered by said guarantee.
- The guarantee shall not in any circumstance include loss of profits or any direct or indirect consequence thereof.
- The guarantee is automatically voided (in addition to the provisions in the supply contract) if:
  - a) non-original spare parts are used;
  - b) the damage is attributable to an erroneous operation performed by the purchaser and/or his personnel;
  - c) the damage is caused by insufficient maintenance;
  - d) the user carries out repairs at his discretion without the consensus of the manufacturer;
  - e) the instructions included in this manual are not carried out;
  - f) exceptional event;
  - also
  - g) THE REMOVAL OF THE SAFETY DEVICES WITH WHICH THE MACHINE IS EQUIPPED WILL AUTOMATICALLY VOID THE GUARANTEE AND RELIEVE THE MANUFACTURER OR ANY LIABILITY.

The retailer shall not be liable for damage due to negligence, carelessness, poor utilization and improper use of the machine and all of its parts that are subject to normal wear during operation, lack of skill and care-

lessness of the purchaser or his employees and/or of the final client/user and/or his employees, to unacceptable overloads, to inadequate means and/or operating materials, to defects of the foundations and structures of the building (if the machinery requires certain characteristics of the place in which it is to be located and installed, to inadequate means and/or materials of operation and to any other activity which is extraneous or not compliant with normal use of the product or to its specific technical characteristics or damage caused by modifications and/or repairs, replacements of single components, maintenance carried out by personnel not authorized in writing by the seller or any circumstance independent of the seller, as well as negligence or lack of skill in assembly by the purchaser and/or the final client/user.

### 1.3 Customer service



**PERFORMING REPAIRS, WORK OR CHANGES OF ANY KIND OTHER THAN THOSE INDICATED HEREIN IS STRICTLY PROHIBITED.**

Requests for servicing must be forwarded straight to the Technical Servicing Centre authorized by **AGREX SPA**, which will send skilled personnel and provide any necessary information and explanation.

When applying, remember to quote:

- Machine type
- Serial number and year of manufacture
- Type of problem encountered

## 2 SECTION – General features

### 2.1 Machine markings

Each machine features an identification plate (Pic. 1), whose data are given below:

- (A) MANUFACTURER
- (B) ABSORBED POWER
- (C) MAXIMUM LOADING
- (D) WEIGHT WHEN EMPTY
- (E) MODEL
- (F) SERIAL NUMBER
- (G) YEAR OF MANUFACTURE

		(A) <b>AGREX S.p.a.</b> <b>35010 VILAFRANCA</b> <b>PADOVA - ITALY</b>
○	<b>POTENZA MAX</b> MAX POWER	<b>CARICO MAX</b> MAX LOAD
KW	(B)	Kg. (C)
V.	A.	Kg. (D)
TIPO TYPE	(E)	MATR. R.N. (F)
<b>ANNO DI FABBR. - YEAR OF PROD.</b>		(G)



Picture 1

Removing, replacing or in any way altering the identification plates on the machine or any accessories it comes with is strictly prohibited.

The machine is supplied with:

- «Operation and maintenance manual»
- «Manufacturer's declaration of conformity»



### 2.1.1 Spreader description

The spreader consists of:

- 1- Frame
- 2- Gear box
- 3- Hopper
- 4- Hydraulic control

The SDA series spreaders have been conceived to spread different types of fertilizers, as well as seeds, salt and granulated materials in general.

**It is strictly forbidden to spread iron pieces, stones, gravel, glass and similar materials as they may injure people and cause damages.**

- The fertilizer spreader is equipped with a regulation system that allows carrying out a spreading that varies from 6 to 18 meters.
- The system that controls the fertilizer spreading is composed by an adjustable lock gate that assures the best accuracy in the spreading and in the dosing also with superconcentrated products and seeds.
- **Easy to charge:** the models SDA 500 and , SDA 600 are 94 cm and 104 cm high respectively.
- **Highest safety standards:** all rotating and transmission parts are protected by guards and protection devices in compliance with CE provisions.
- **Simple design and functioning:** : acting on the hydraulic control (or on the mechanical levers it is possible to obtain three types of spreading: at 180 degrees, or at 90 degrees only on the right side or 90 degrees only on the left side.

**A single worker can do himself all the necessary operations by himself**



Picture 2

### 2.1.2 Scheduled use

---

The machine has been built in conformity with European Union standards given in directive 2006/42/EC as described in the manufacturer's declaration supplied with each machine.

The machine is designed to be used ideally for sowing and fertilising of gardens, sports fields and small green areas.

The following can be spread:

- **solid mineral fertilisers in granular or powder form**
- **seeds**
- **salt and sand**

The machine should be carried and driven by tractors or self-propelled machines with a power suitable to the spreader weight when it is completely full.

The machine must be operated only outdoors and when visibility is sufficient to see where the product is being spread.

The machine is designed for professional use and the operators in charge must be certified fit and be able to read and understand the contents of this manual.

Operators must also use the machine in compliance with the current regulations concerning safety, conditions for use and characteristics of the machine.

### 2.1.3 Non-scheduled use

---

NEVER spread materials not specified in this manual: this would affect the safety of the machine users and persons working nearby.

NEVER disable the machine safety devices or remove the danger notices.

NEVER allow the machine to be used by disabled persons or children.

DO NOT transport people or animals during work and when moving the machinery from one place to another.

**Consequently, the manufacturer shall NOT BE held responsible for any damage to equipment or property or bodily injury as a result of its improper use or any use other than that for which the machine is intended.**

## 2.2 Control devices

In order to open and close the hopper discharging gates, it is necessary to act on the OPEN and CLOSE mechanical levers which are positioned on the spreader front (or, on the model with hydraulic system, operate on the OPEN CLOSE tractor hydraulic circuit)

Moreover, for the spreading regulation the machine is complete of:

- **Product quantity regulation levers:** positioned on the rear of the spreader. The product quantity setting is facilitated by the graduated scale. By moving the gate towards the higher values the quantity of product flow increases, vice-versa, by moving the gate towards the lower values the quantity of product flow decreases.
- **Adjustable spreading vanes:** they are positioned on the spreading discs and allow to adjust the width and the spreading uniformity.

## 2.3 Technical data

Model	SDA 500	SDA 600
Capacity (l)	500	600
Maximum loading (kg)	800	800
Weight when empty (kg)	154	163
Spreading width (m)	6 – 18	6 – 18
A Length (cm)	112	112
B Width (cm)	110	110
C Height (cm)	94	104
Tractor power required (HP)	50 – 80	50 – 80

Chart 1

Max P.T.O. speed: 540 rpm

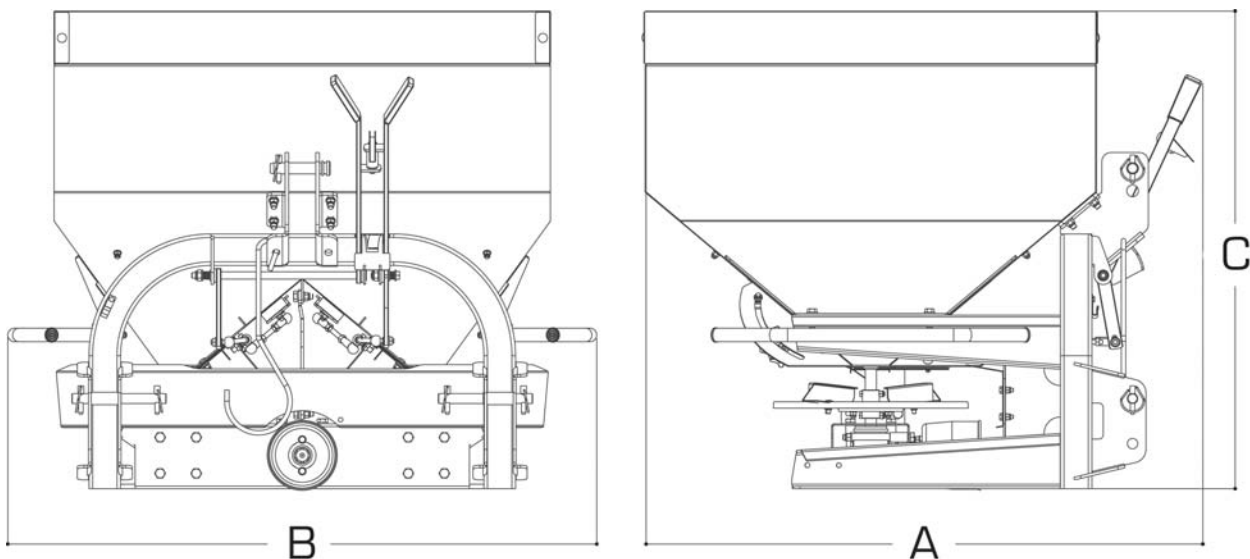

Picture 3

## 2.4 Standards applied

The machine has been designed and produced in conformity with the provisions of directive 98/37/EC, namely all moving parts have been made harmless by using guards, barriers and safety systems.

The machine has also been designed to the following directives and standards:

**EN 14017:2005 +A2:2009** Agricultural and forestry machinery – Solid fertilizer distributors – Safety (2005)

**EN ISO 4254-1:2009** Agricultural machinery -- Safety -- Part 1: General requirements

**ISO 11684:1995** Tractors, machinery for agriculture and forestry, powered lawn and garden equipment - Safety signs and hazard pictorials - General principles. (1995)

## 3 SECTION – Safety and accident prevention

### 3.1 Safety

The user must instruct personnel as to risks deriving from accidents, devices installed for the purpose of operator safety, and general safety rules provided for by directives and legislation in the country where the machine is being used.

Operator safety is one of the primary concerns of any machine manufacturer. When producing a new machine, every effort is made to allow for all potential hazardous situations and, of course, to adopt appropriate safety devices.

Nonetheless, the level of accidents caused by careless and inexperienced use of various machines is still very high.

Lack of attention, thoughtlessness and overconfidence often lead to accidents, as can fatigue and drowsiness.

Hence this manual must be read very carefully, concentrating in particular on the section on safety rules.



**WARNING**

**The Manufacturer declines all responsibility for failure to comply with safety and accident-prevention regulations provided for by legislation, and with the provisions herein**



**DANGER**

**WATCH OUT FOR THIS SYMBOL IN THE MANUAL: IT INDICATES A HAZARDOUS SITUATION.**

Depending on the danger involved, this symbol may have one of three meanings:



**DANGER**

The “**DANGER**” label indicates the highest level of danger and is intended to warn you that if the operations described are not performed properly, they will result in serious injury, death or long-term health risks.



**WARNING**

The “**WARNING**” label warns you that if the operations described are not performed properly, they may result in serious injury, death or long-term health risks.



**CAUTION**

The “**CAUTION**” label warns you that if the operations described are not performed properly, they may result in damage to the machine and/or injury.

**IN ACCORDANCE WITH OF THE DIRECTIVE 98/37/CE NOTE THE FOLLOWING CONVENTIONS:**

**DANGER ZONE:** Any area inside and/or near a machine that potentially compromises the safety or health of any exposed person there.

**EXPOSED PERSON:** Any person with all or part of his/her body inside a danger zone

**OPERATOR:** The person(s) in charge of installing, running, adjusting, servicing, cleaning, repairing and transporting a machine.

**3.1.1 General safety rules**

---



Failure to comply with the provisions of “**Section 3 - Safety and accident prevention**” and any tampering with safety devices shall relieve the Manufacturer of any responsibility in case of accident, damage or malfunctioning of the machine.

**GENERAL WARNINGS:**

- The user undertakes to entrust the machine only to qualified and suitably trained personnel.
- The user is required to take all necessary measures to ensure that unauthorized personnel have not access to the machine.
- The user undertakes to suitably instruct his personnel on the application and observance of safety rules. For this reason, he undertakes to ensure that all persons receive directions for using the machine and safety rules appropriate to their tasks.
- The user must contact the Manufacturer to report any defects or malfunctions detected in safety systems, as well as any situation presumed to be dangerous.
- The user at all times, must use personal protective gear provided for by legislation, and follow the instructions herein.
- The user must comply with all safety symbols and warnings applied on the machine.
- The user must not take their own initiative to perform operations or work outside their area of competence.
- The user are required to report to their superior any problems or hazardous situation encountered to their superiors.
- The machine has been tested only with the equipment supplied only. Fitting parts of different makes or making changes may alter the machine's characteristics and hence compromise its safe operation. Consequently, the Manufacturer declines any responsibility for any damage that might derive from use of non-original parts.

- The machine must be used only for the purpose for which it has been designed alone.
- The machine must not be run with safety devices removed.

### 3.1.2 Safety signs

The machine has been produced adopting every possible safety standard to assure operator safety.

Nonetheless, the machine may present further residual hazards that cannot be eliminated altogether under certain conditions of use.

The safety symbols (pictograms) applied on various points of the plant are intended to draw the user's attention and warn him/her of danger: consequently, it is necessary to know the meaning of said symbols and to memory them. Any symbols that have been damaged, misplaced or belong to parts that have been changed must be replaced with other original symbols, requesting them to from the Manufacturer, and must be applied in exactly the same place.



**KEEP ADHESIVES CLEAN, AND REPLACE THEM AS SOON AS THEY START PEELING OFF OR ARE DAMAGED.**

Referring to figure read the following descriptions carefully, committing their meanings to memory.

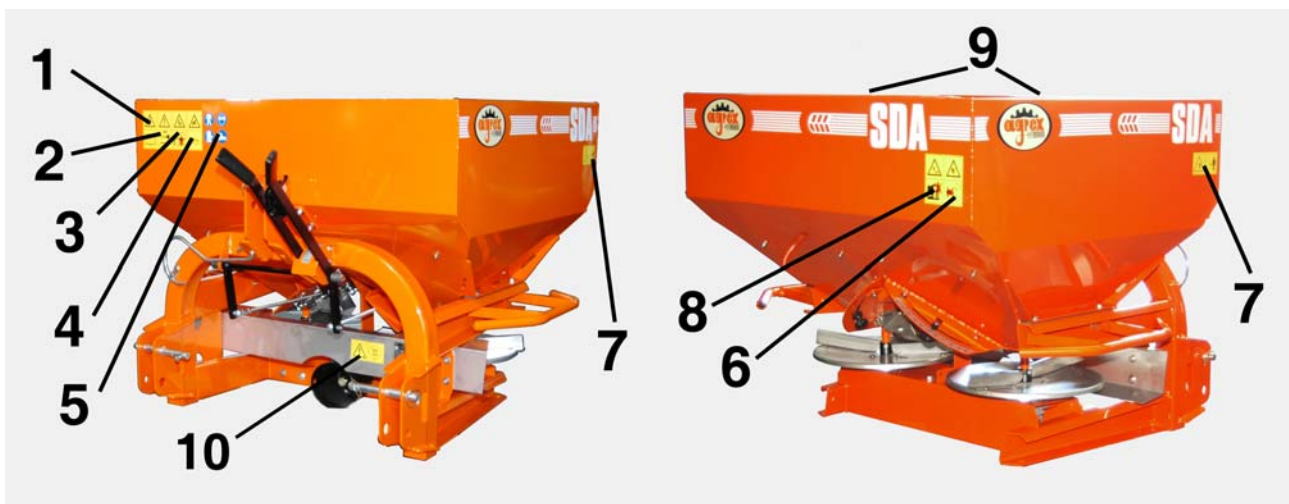

Picture 4



1



2



3



4



5



6



7



8



9



10

1. Warning! Risk of crushing; do not stand between the machine and the tractor.
2. Warning! Risk of injury by pressurised liquids; read the Operation and Maintenance Manual before proceeding to operations on the machine.
3. Warning! Read the Operation and Maintenance Manual carefully.
4. Warning! Before performing any maintenance operations, remove the tractor's ignition key and read the Operation and Maintenance Manual.
5. Always wear a work suit, safety gloves and safety shoes. Always wear safety goggles during machine loading and maintenance operations.
6. Warning! Distribution parts in movement; never enter the hopper while the machine is running.
7. Warning! Keep a safe distance from the machine; risk of sprayed product.
8. Warning! Risk of falling, do not mount the machine for purposes of transportation.
9. This indicates the coupling point to be used for machine lifting.
10. Warning! Never exceed a value of 540 rpm in the power takeoff.

### 3.2 Safety devices

The machine features **GUARDS**: Stationary devices that prevent direct contact with moving parts or any other hazardous part of the machine. Said guards can be removed only with the aid of special tools. When the machine is operating, said devices must be fitted correctly.

**CONSEQUENTLY, THE MANUFACTURER DECLINES ALL RESPONSIBILITY FOR ANY DAMAGE RESULTING FROM TAMPERING WITH GUARDS AND SAFETY DEVICES.**

### 3.3 Noise hazard

Sound level (airborne noise) measured from one metre away with the machine running was as follows:

Sound pressure at the operator's position measured according to EN ISO 4254-1:2009 Standard - Appendix B.

$$L_{pA} = 84.7 \text{ dB(A)}$$

### 3.4 Dust hazard



**When spreading powder fertilisers, dust can form in the air especially when it is windy. You are therefore advised to wear a mask to protect the respiratory system.**

Fertilisers in general can irritate the skin and eyes: contact the supplier for information on the personal protection measures to be adopted.

### 3.5 Clothing



Wear suitable clothing. Avoid baggy, loose-fitting clothing: It might get caught up in moving parts. Long hair should be tied back. Operators should not carry scissors or sharp tools in their pockets.

During maintenance and repair work, workers are required to wear protective clothing, cut-proof gloves, and non-slip boots with reinforced

### 3.6 Ecology and pollution



- Comply with laws in force in the country where the machine is being used regarding use and disposal of products employed in cleaning and servicing the machine, and comply with the instructions issued by the manufacturers of said products.



- Dispose of any special waste by handing waste materials in to suitably authorized firms, and demand a receipt attesting the disposal.
- Dispose of any packaging left over from the machine's transport in conformity with the regulations in force.
- If the machine is to be dismantled, comply with the pollution-prevention regulations provided for by the country it is used in, exercising particular care when it comes to lubricants and electric components.
- Collect all spent products from the hydraulic circuits in appropriate containers. Deliver all spent oil recovered to authorised collection centres (spent oil consortiums).

### 3.7 Safe use



#### Safety standards: HOW TO AVOID ACCIDENTS

- **To avoid accidents, pay close attention to the warning notices affixed on the machine and read this guide carefully.**
- **The use of the spreader is restricted to the functions, for which it has been designed and which are described in the present guide. The manufacturer will not be held responsible for any damages to things or injuries to people caused by a wrong use of the spreader.**
- Before starting the spreader, make sure all protection devices and guards are mounted correctly.
- Make sure no bystanders (especially children) or animals are in the working area. This is extremely important when the spreader is being used near public or easily accessible roads.
- Minors (under 18) are not allowed to operate the spreader.
- The spreader can be used with every kind of tractor of suitable power, whose couplings are compatible with those of the spreader and which is equipped with all P.T.O. and cardan shaft protection devices.
- Before connecting the P.T.O., make sure the revolution number of the tractor corresponds to that of the spreader. In any case, **never exceed 540 rpm.**
- It is strictly forbidden to spread iron pieces, stones, gravel, glass and similar materials as they may injure people and cause damages to things.
- Never load the hopper with wet products as they may obstruct the outlets.
- During work, wear close-fitting and laced-up garments, heavy safety shoes, and safety gloves and mask especially while spreading powdery fertilizers in windy weather.
- After using the spreader, turn the engine off, apply the handbrake, lower the spreader to the ground, disengage the P.T.O. and, if the hopper is still partially full, even the product up in order to avoid accidental tipplings.
- Do not carry out any maintenance or cleaning operation while the spreader is connected to the 3-point hitch of the tractor.
- It is strictly forbidden to transport persons while the spreader is in operation or during transfers.
- During transfers, make sure the P.T.O. is disengaged.

- When travelling on public roads, connect the spreader to the tractor as described on the present guide. A wrong connection may alter the vehicle stability. It is necessary to abide by the national traffic code.
- We remind you that a careful operator is the best insurance against accidents.
- The area the machine is used in should be considered a «**DANGER ZONE**», especially for anybody not trained in its use.
- Be careful of people and animals in the machine operating range: this is important when working on land or roads open to the public.
- When people are «exposed», i.e. are in the «**DANGER ZONE**», the operator must stop the machine instantly, and possibly have the person removed.
- Whilst the machine is operating, operators must be in a position where they have full control of the machine so that they can take immediate action at any time and in any event.
- Check periodically the machine as a whole, and its safety devices, at regular intervals to ensure they are intact.
- If safety guards are removed, make sure they are refitted properly before using the machine again..
- Maintenance or repair work must be performed by personnel qualified for the specific tasks.
- At the end of maintenance and repair work, before re-using the machine the technical manager must ensure that the work has been completed and that the protections have been re-fitted.
- Transport of persons or animals during work and when moving the machine from one place to another is strictly forbidden.
- Regularly check the condition of the protections for the cardan shaft, bearing in mind that only cardan shafts with protections in good condition must be used.
- Never enter the hopper with the fertilizer spreading devices in motion.
- In order to avoid the formation of lumps of fertilizer and the clogging of the hopper, do not spread fertilizer on extremely humid or rainy days (if necessary, use the hopper-cover tarpaulin provided as an optional). Whenever clogging occurs, immediately switch off the machine to avoid damaging the fertilizer spreading devices. Remove lumps of fertilizer only after first switching off the tractor. Wear personal protective equipment (safety gloves, goggles) during machine cleaning operations.
- Use cranes with adequate load capacity to load fertilizer sacks weighing more than 30 kg.

## 4 SECTION - Handling and installation



The fertiliser spreader and accessories are generally partially fitted at the factory and shipped in cardboard packaging or on pallet. To complete assembly, follow the instructions given in this manual.

In some cases, depending on customer requirements, the machine is delivered fully assembled.

Upon receipt of the goods, carefully check to ensure that no damage has occurred during transport.

### 4.1.1 Assembly of hopper extensions



**Before proceeding to hopper extension assembly/disassembly, uncouple the fertilizer spreader from the tractor and make sure that the fertilizer spreader is parked on solid, level ground.**

**Wear safety gloves and safety shoes for all the operations below.**

Proceed as follows to assemble hopper extensions:

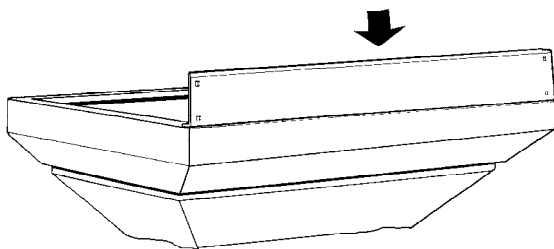

**1.** Fasten the longer lifting panel to the front part of the fertilizer spreader. Do not tighten the fixing screws all the way at this point.

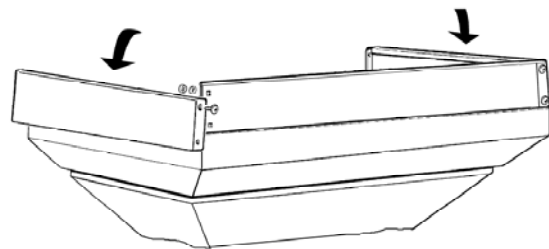

**2.** Fasten the two lateral panels

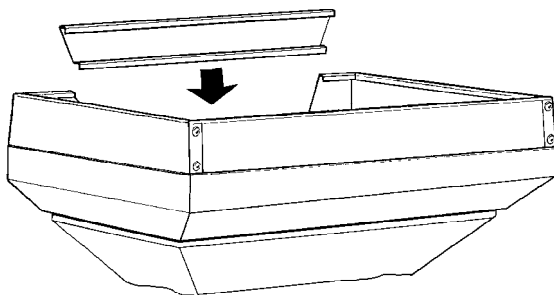

**3.** Fasten the rear lifting panel.

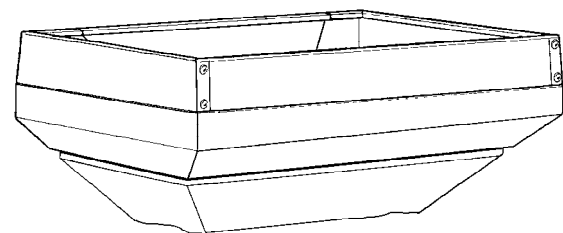

**4.** Tighten all screws in order to solidly connect the hopper extension to the standard hopper.

## 4.2 Handling

Use only appropriate fork-lifts with adequate capacity for the handling of the material.

Lift the machine using the indicated lifting points (see picture 5).



**Lift the machine only when the hopper is empty.**

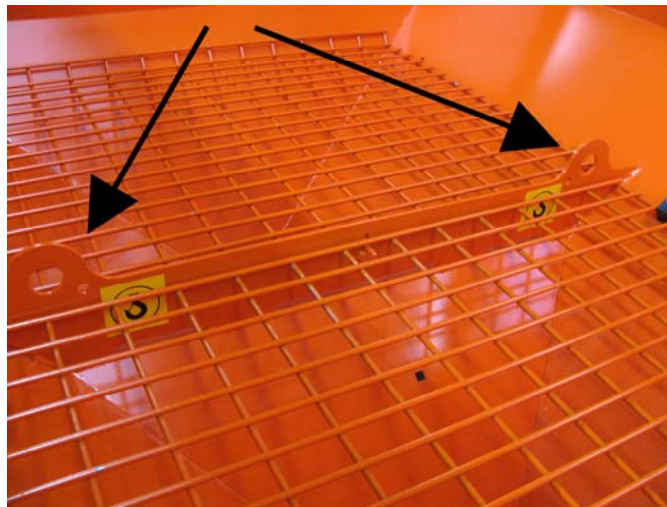

**Picture 5**

Nel caso la macchina non venisse immediatamente montata, ma si rendesse necessario uno stoccaggio temporaneo, dev'essere posta in un ambiente asciutto e al coperto.

Per proteggere le varie parti dagli agenti atmosferici si consiglia di lasciare integri gli imballaggi.

## 4.3 Hitching



The spreader can be hitched to any tractor of suitable power (see technical specifications).

Before hitching the spreader to the tractor, apply the handbrake and make sure the P.T.O. is disengaged. Wear safety gloves.

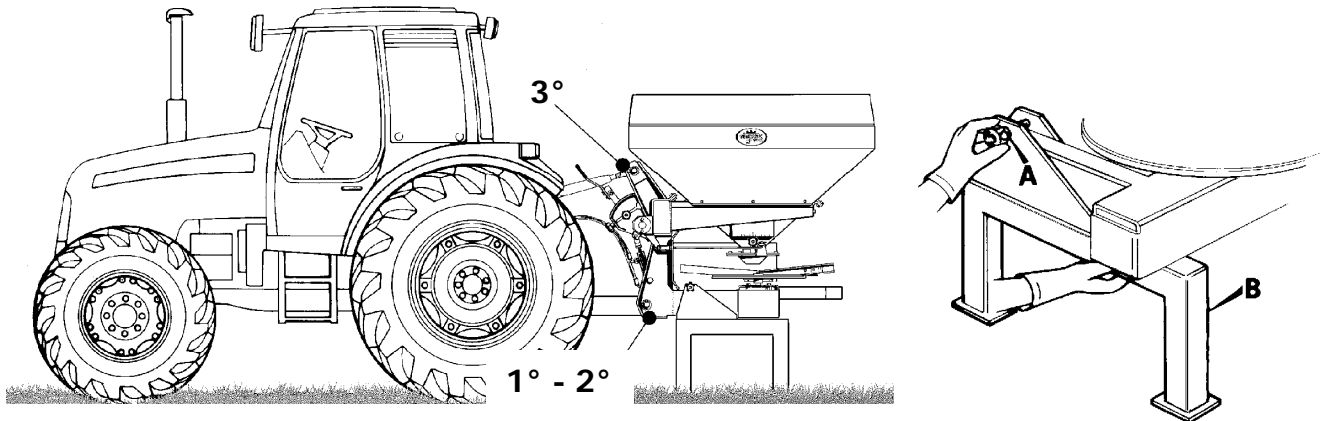

Picture 6

- 1- Apply the minimum front ballast to the tractor (see Appendix A).
- 2- Fix the lower bars of the tractor lifting mechanism to the lower couplings of the spreader (Pic. 6) and then secure with safety pins.
- 3- Connect the upper bar of the 3-point hitch with the suitable pin and safety split pin.
- 4- To increase the machine firmness, fasten the lower bars of the 3-point hitch with the suitable tie-rods.
- 5- Place the drive-shaft, making sure the backstop has been released at the power takeoff and that the screw on the drive-shaft of the fertilizer spreader is locked. Read the handbook of the drive-shaft
- 6- Lift the spreader from the ground using the tractor lifting bars. Release the two support feet B by unscrewing the respective locking handwheels A.

When the P.T.O. shaft is at maximum extension, the two inner tubes have to overlap at least 15-20 cm. When the P.T.O. shaft is completely closed, there must be a gap of at least 4-5 cm to avoid collisions with the outer side (Pic. 7).

The working angle of the P.T.O. has to be the smallest possible; preferably it should not exceed 10° (Pic. 8), so has to make the P.T.O. shaft and the machine last longer.

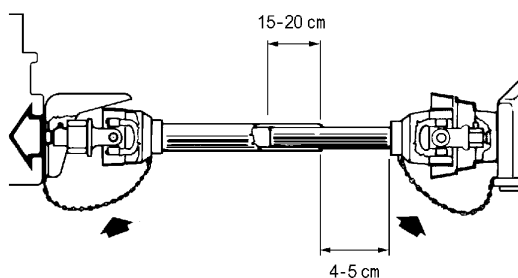

Picture 7

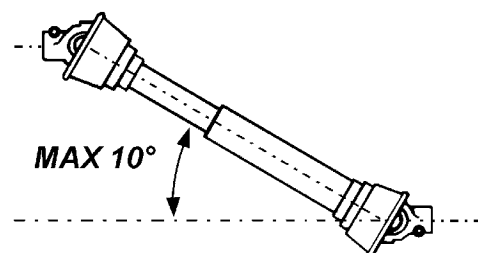

Picture 8

**7** – Adjust the 3-point lifting mechanism of the tractor so that the working position of the spreader is horizontal (70-80 cm above the ground) see (Pic. 9).

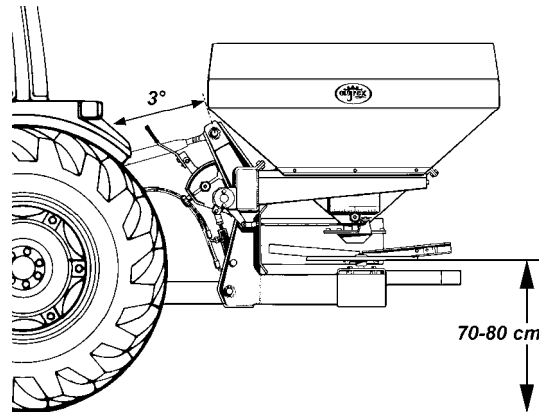

**Picture 9**

**8** – Connect the hoses of the double-acting hydraulic couplings of the tractor (Pic. 9). In this way the shutters can be easily controlled from the driver's seat. Another aspect that the flow regulation on the hydraulic cylinder offers is that one varies the lever opening and closing speed. Before connecting the hydraulic hoses or carry out any maintenance work on the hydraulic system, lower the spreader to the ground, turn the engine off and drop the pressure.

#### 4.4 Preliminary cleaning

Once all connections have been made, the whole machine must be cleaned of dirt that has built up during transit, storage and handling.

Use suitable non-corrosive degreasing products and dry all machine parts - exposed metal and paintwork alike - using soft, dry cloths.

#### 4.5 General inspection



Before starting to use the machine, safety devices must be checked to ensure they are efficient and working perfectly.

To work in complete safety it is necessary to:

- Tighten the bolts and all locking devices.
- Make sure all safety guards are properly installed.
- Do not leave tools or other objects not belonging to the machine inside the hopper or on the mechanical parts.

## 5 SECTION – Use

---

### 5.1 Prior to use

Before operating the machine, the operator must have read and understood all parts of this manual, especially those given in “Section 3” on Safety.

Check the machine's conditions carefully, especially parts most subject to wear and tear.

### 5.2 Starting up

The machine must be operated exclusively by skilled personnel, who have been properly trained in the use of the machine and in the main safety procedures. Before starting the machine, personnel are required to make themselves familiar with its controls.

### 5.3 Adjustments



**Warning**

**In order to avoid accidents and dangerous situations every machine adjustments has to be done exclusively with the machine switched off and the ignition keys have to be disconnected.**

The adjustment should be done accordingly to this use and maintenance manual

The machine control is described in 2.2 Control Devices.

#### 5.3.1 Product spreading adjustment

---

- 1- Release the regulation lever by unscrewing the ball crank handle (A)
- 2- Move the index to the desired position. By moving the index towards the higher values the fertilizer quantity increases, while moving the index towards the lower values the quantity of fertilizer decreases to a complete closing of distribution. The regulation must be done for both left and right sides.
- 3- Block the regulation lever by screwing the ball crank handle (A).

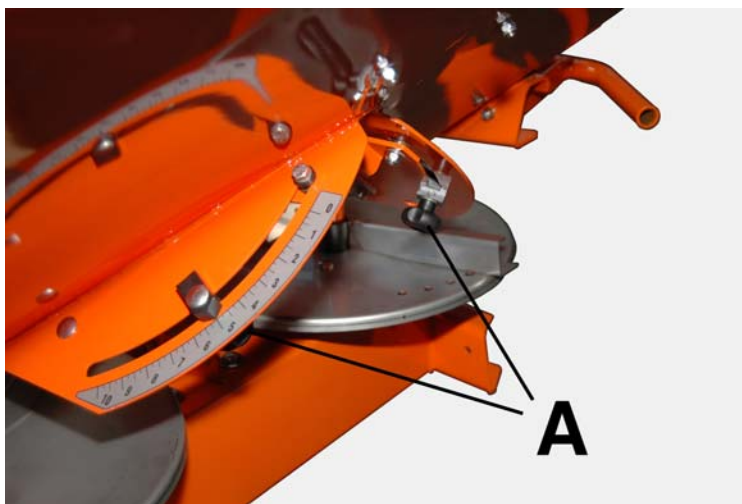

Picture 10

### 5.3.2 Spreading width adjustment

In order to get an even spreading on both left and right sides, according to the different specific weights of the fertilizers, it is possible to change the position of the vanes by fixing them in the stops 1-2-3-4-5.

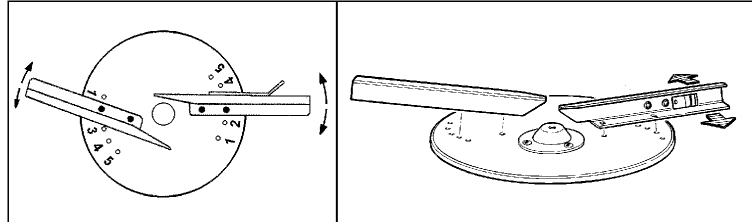

Picture 11

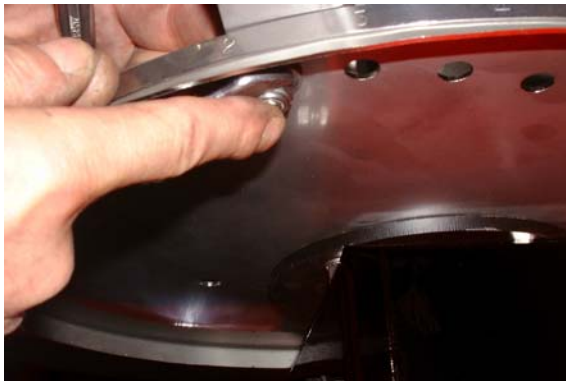

1. Unscrew the paddles screw.

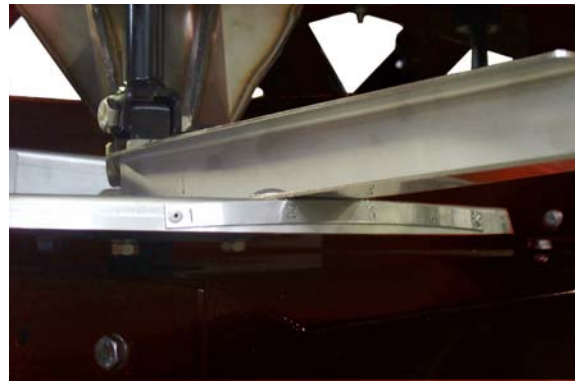

2. Move the paddles to the new position.

To adjust the spreading width and the spreading uniformity refer to the adjustment table and act on (see picture 12):

1. Short spreading vane: **(C)**: by increasing the opening angle the fertilizer quantity increases to the centre of the spreading (first 6-7 meters) and by decreasing the opening angle the concentration of fertilizer decreases
2. Long spreading vane: **(D)**: by increasing the opening angle the fertilizer quantity increases on the medium distance fertilizing area (8-10 meters) while by decreasing the opening angle the concentration of fertilizer increases on the spreading area extremity (more than 10 meters).

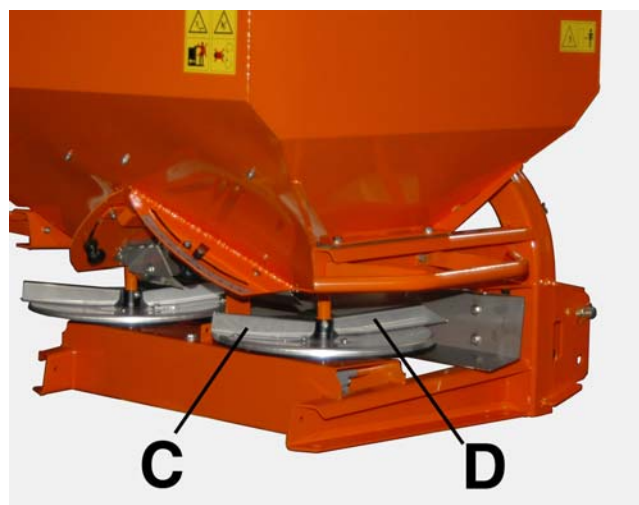

Picture 12



### 5.3.3 Spreading patterns

It is possible to obtain three different spreading patterns by operating on the levers (or on the hydraulic actuator if present) (fig. 13 e fig. 14).

- 180° spreading width : Levers (F) and (E) open.
- 90° right spreading width: lever (E) closed, lever (F) open.
- 90° left spreading width : lever (E) open, lever (F) closed.



Picture 13

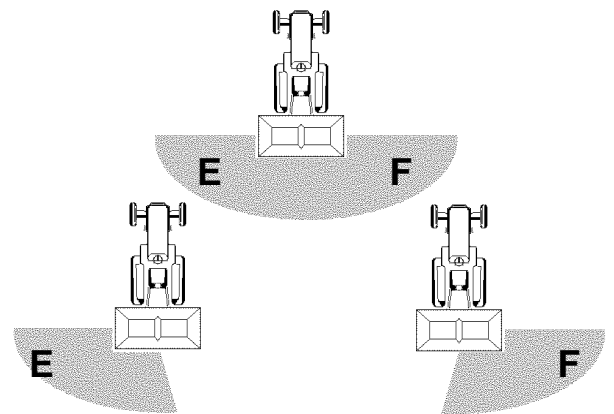

Picture 14

To enable the regulation levers to work independently it is necessary to act on the locking lever which keeps them together:



1. Lever positioned on right side – left side spreading **hooked**.

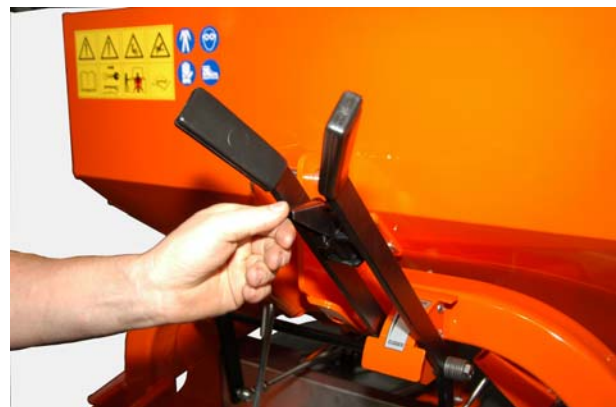

2. Lever positioned on right side – left side spreading **released**.

For the distributors with the OPEN – CLOSE hydraulic system, the patterns of spreading can be obtained by operating on the OPEN – CLOSE control of the hydraulic distributor of the tractor.

### 5.3.4 Loading the machine's hopper

---

It is very important to check the stability of the fertilizer spreader after coupling to the tractor.

- Before loading the fertilizer spreader, follow the instructions provided in Appendix A to this manual in order to calculate the minimum front ballast to be applied to the tractor required to ensure the stability necessary after the tractor and fertilizer spreader have been coupled together.
- Lower the fertilizer spreader into loading position (until it touches the ground), switch off the tractor's engine, and set the parking brake in order to prevent any and all accidental movement.
- Fill the hopper to the required level, making sure to distribute the fertilizer homogeneously inside to a flat level on top.
- **Never load the hopper above its maximum acceptable loading level – See Table 1 Technical Data.**

Remember that the product to be spread must be clean, and that stones and scraps of metal can both create risk and irreparably damage the machine's moving parts.

### 5.3.5 Distribution

---

- Operate the tractor power take off.

- Set the tractor hydraulic system control in order to open (and close) the batching selvage.

Thanks to the stirrer moving, the product goes onto the spreading disc and, because of a centrifugal force, it will be cast outward by the spreading vanes.

### 5.3.6 Driving technique suggestions

---

The quality of spreading depends greatly on the operator's driving technique.

- During fertilizer spreading, maintain the speed indicated in the spreading tables as constantly as possible. Spreading the fertilizer at insufficient speed increases the concentration of the fertilizer spread on the soil, whereas excessive speed decreases such concentration.
- During spreading, adopt evenly-distanced spreading passages in order to maintain constant distance from all previous spreading passages.
- Stop spreading in the vicinity of the ends of the drills and during manoeuvres. In order to avoid spreading fertilizer outside the edges of the field, switch spreading back on again only after approaching the end of the field at a distance equal to the maximum rear spreading length (see the spreading tables).
- Grains of fertilizer are very lightweight and their trajectory of movement varies with the amount of wind. For this reason, stop spreading when wind speed is too high, otherwise the distribution of the fertilizer spread over the soil will be irregular.

### 5.3.7 Late top-spreading

---

For late top-spreading it is necessary to tilt the spreader.

1. To set the spreader tilt, set the length of the 3-point hitch.

### 5.3.8 Side spreading conveyor (optional)

The side spreading conveyor allows for localized spreading on row cultivation of 1.5 – 5 meters.



To adjust the spreading width of the deflector it is necessary to:

1. Unscrew the ball crank handle (G)
2. Position the deflector in the desired position
3. Screw the ball crank handle for blocking (G)

This operation must be done on both sides.

## 6 SECTION – Maintenance

---

### 6.1 Routine maintenance



**BEFORE CARRYING OUT ANY MAINTENANCE WORK ON THE MACHINE, DETACH THE TOWING VEHICLE AND DISENGAGE THE SPREADER DISC TRANSMISSION BY MEANS OF THE LEVER PROVIDED.**

**ALWAYS SWITCH OFF THE TRACTOR'S ENGINE BEFORE PROCEEDING TO MAINTENANCE.**

The various maintenance operations are described below.

**The time intervals given refer to normal operating conditions; consequently, if the machine is subjected to particularly heavy duty, they must be reduced accordingly.**

The purpose of these instructions is to assure efficiency, reduce wear and generally make the machine last longer: the user has everything to gain from keeping the machine in pristine condition.

#### 6.1.1 Daily cleaning

---

After each day's work, the machine must be cleaned thoroughly, removing any waste and/or residues left behind after processing, or other damp or dusty materials.

#### 6.1.2 General checks

---

The vibrations produced during work and movement of the equipment from one place to another may in the long term cause loosening of the bolts. You are advised to check the nuts and bolts roughly every 50 working hours.

Grease the PTO shaft cross every 10 hours and check the tension of the belts that drive the spreading discs. The lubrication of the transmission group must be checked every 200 hours.

#### 6.1.4 Spreading paddle assembly/disassembly

---



**Before proceeding to the assembly/disassembly of the fertilizer spreader paddles, switch off the tractor's engine and set the parking brake.**

1. Loosen the screws that fasten the spreader paddle to the fertilizer spreader disk.
2. Replace the old fertilizer spreader paddles with new ones and re-tighten the fixing screws.

**Warning!** The fertilizer spreader's paddles must be assembled in the correct disk rotation direction.

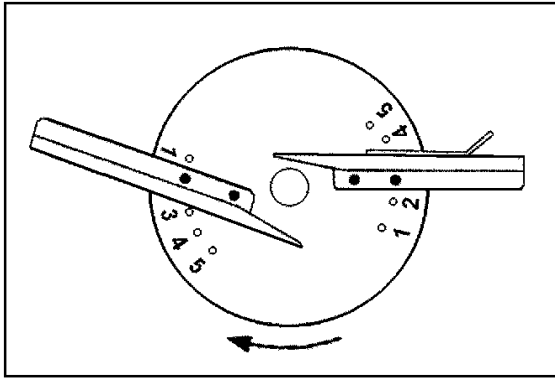

Correctly assembled paddles

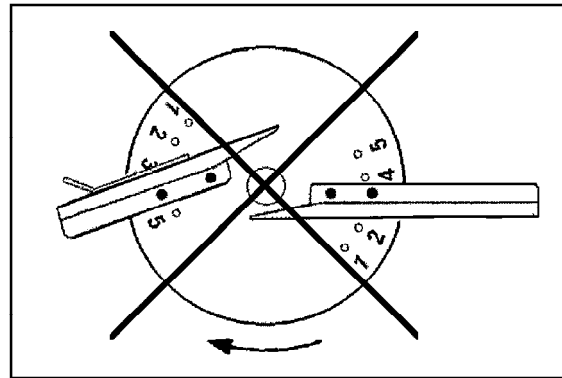

Incorrectly assembled paddles

## 6.2 Extra maintenance

It is essential to conduct a general inspection of the machine's mechanical parts at regular intervals. In particular, it is necessary to check the usury of the vanes.

## 6.3 To keep in mothball

**PARK THE FERTILIZER SPREADER ONLY WITH THE HOPPER EMPTY AND ONLY ON SOLID, LEVEL GROUND.**

If the machine is not employed for a long time it is necessary to check its mechanical and electrical parts, so that to avoid problems when bringing it into use again.

All parts subjected to wear must be carefully controlled. The worn out and damaged parts should be immediately replaced by original spare parts provided by the distributor or the producer.

Besides, check that the bolts of the machine are not shaken loose during the working.

Such instructions are meant to maintain the machine in good conditions, reducing its wear and tear and prolonging its life.

Uncouple the fertilizer spreader from the tractor by undoing the operations indicated in Section 4.2 (Coupling to the tractor).

After the fertilizer spreader has been uncoupled, couple the cardan shaft to the respective support (see the respective figure) in order to avoid damaging the protections provided for the cardan shaft itself.

For the models with the hydraulic system, hook the hydraulic distributor to its support. (see the picture).

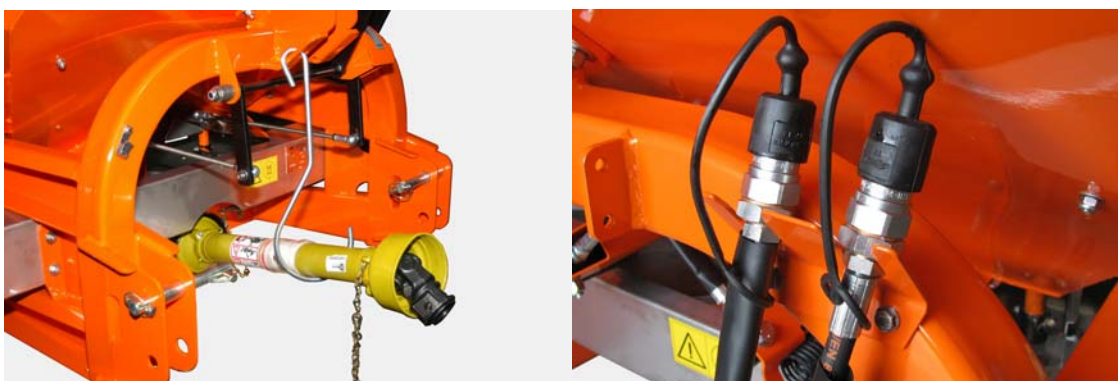

## 6.4 Re-start



Before putting the machine back into service, it is always a good idea to check its general conditions: its current state will depend on the conditions it was mothballed in.

## 6.5 Dismantling the machine

Should the decision be made to dismantle the machine, its components must be sorted into groups of like materials and disposed of individually in accordance with the local laws in force on disposal of special waste.



**WHEN DISPOSING OF THE VARIOUS COMPONENTS, ONLY GO THROUGH A LEGALLY AUTHORIZED FIRM THAT WILL ISSUE A RECEIPT ATTESTING TO DISPOSAL.**

## 7 SECTION – Spare parts

---

### 7.1 Spare parts

All the spare parts can be ordered from the manufacturer, quoting:

- **machine model**
  - **machine's serial number**
  - **year of manufacture**
  - **reference code of the part** (to be found in the spare parts catalogue);
- **means of transport**: if no preference is specified, the manufacturer shall do its best to ensure you receive good service, though it declines all responsibility for any delays in shipment as a result of force majeure.

Lastly, remember you can always contact the manufacturer for your servicing.





# SDA

## 500/600

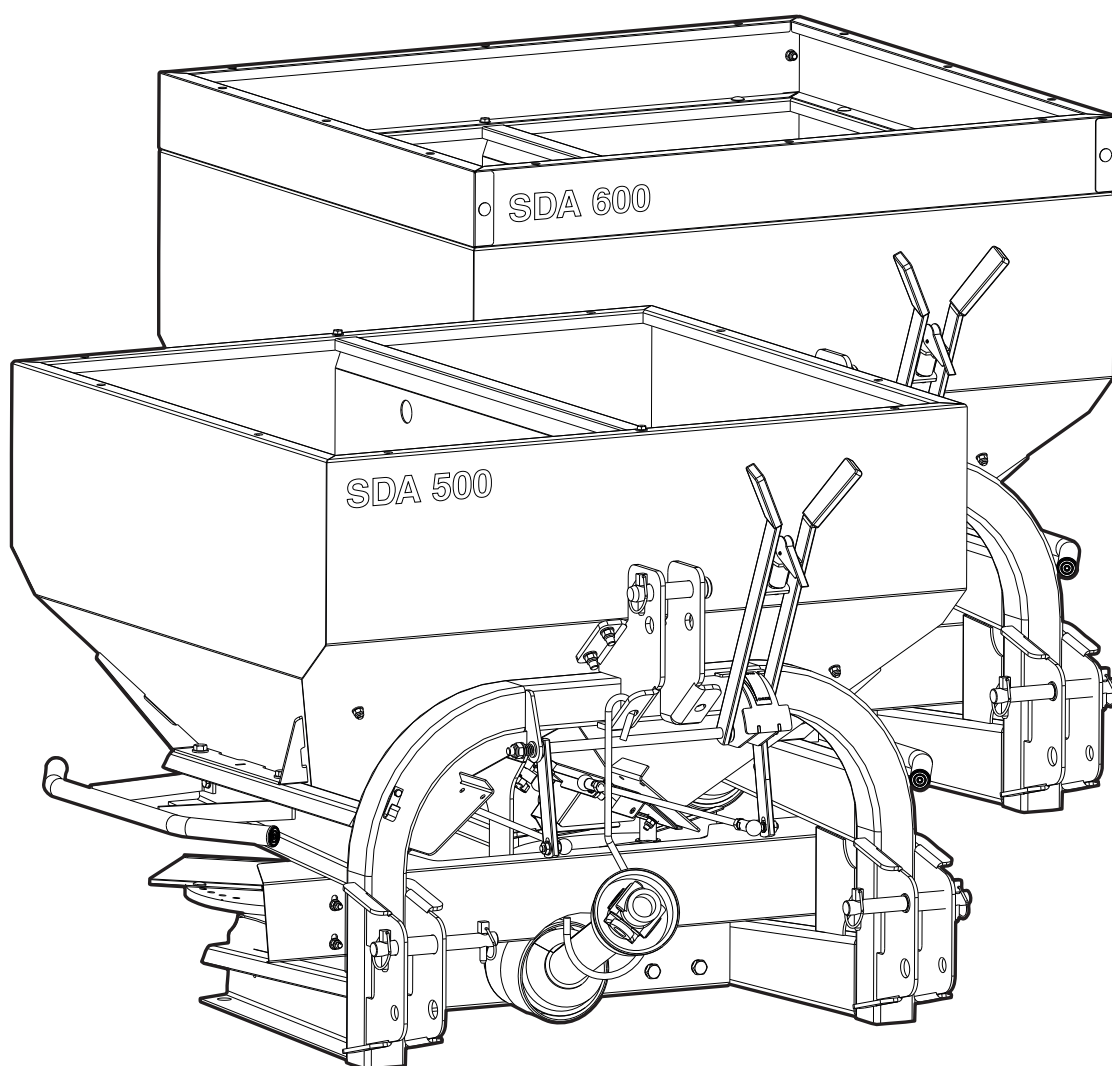

### **CATALOGO RICAMBI**

**ATTENZIONE!** Per un corretto funzionamento delle nostre macchine usare esclusivamente **RICAMBI ORIGINALI**

### **SPARE PARTS**

**WARNING!** Use **ORIGINAL PARTS** to ensure the correct functioning of the machine

# TELAIO

## FRAME

**SDA 500**

**SDA 600**

Disponibile su richiesta  
 Available on request  
 Disponible sur demande  
 Disponible por pedido  
 Auf Anfrage  
 Доступно по запросу

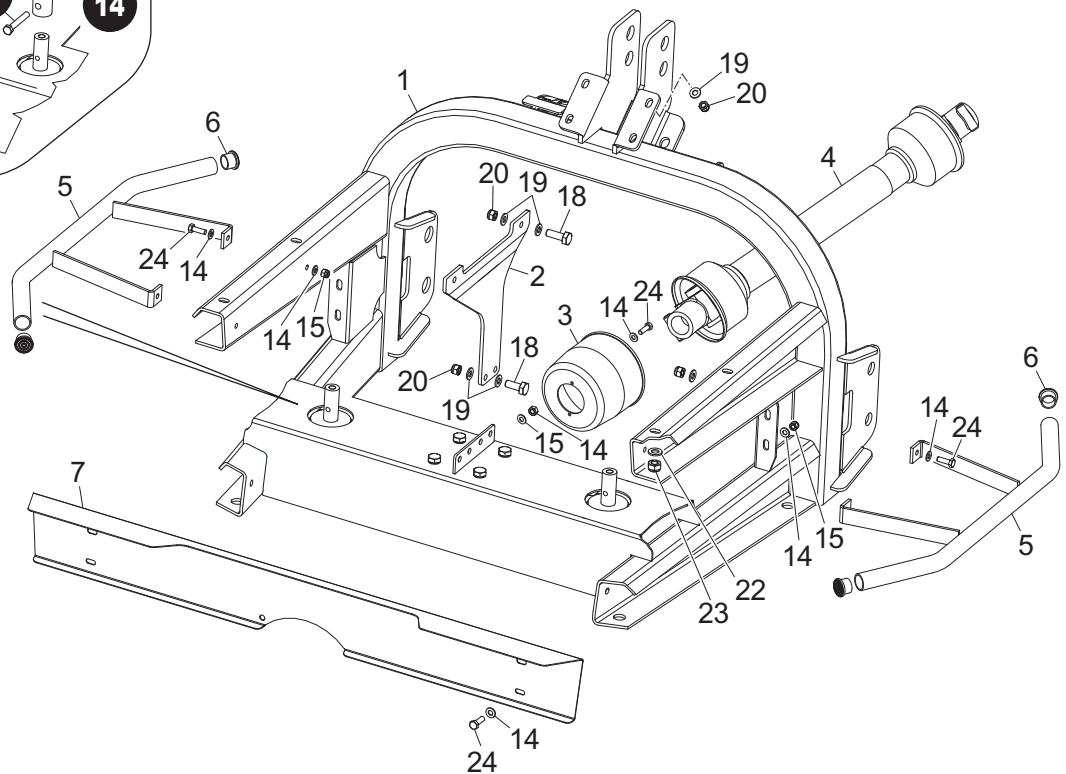
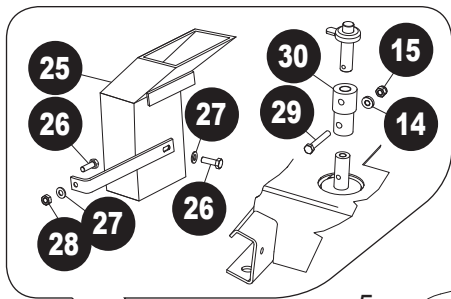
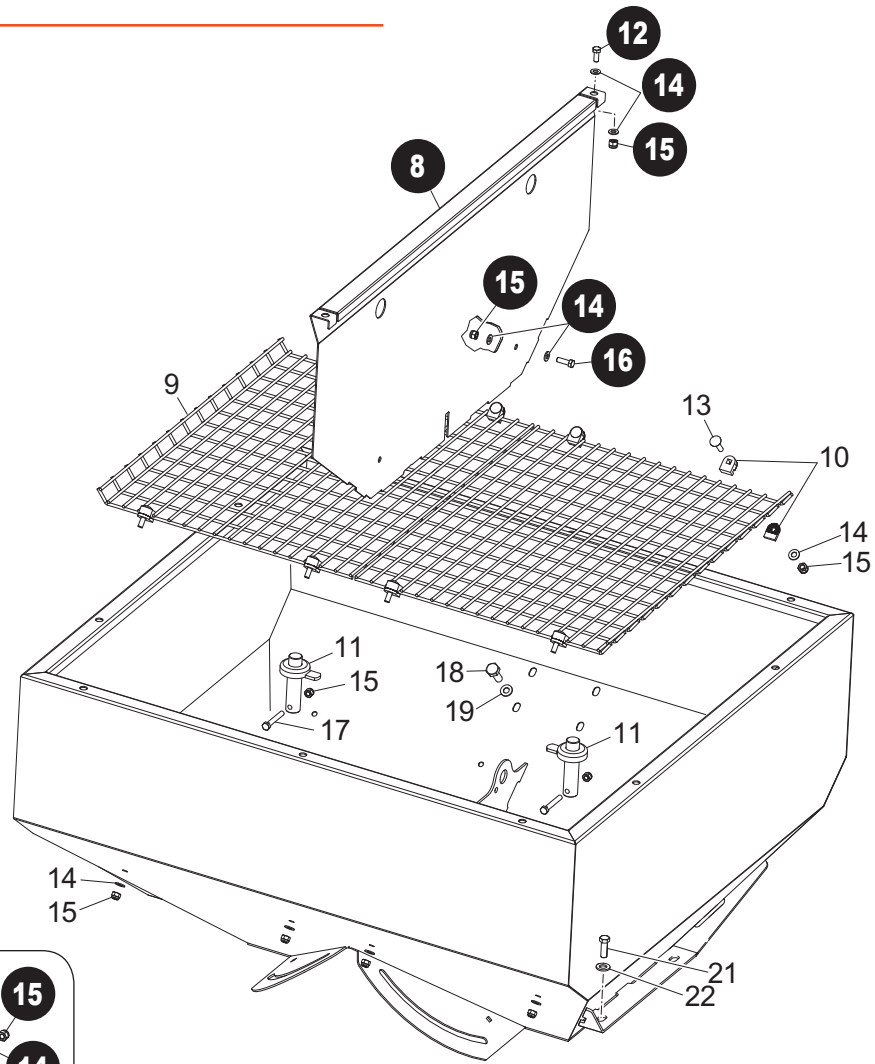



# TRAMOGGIA DI CARICO

## LOADING HOPPER

**SDA 500**

**SDA 600**

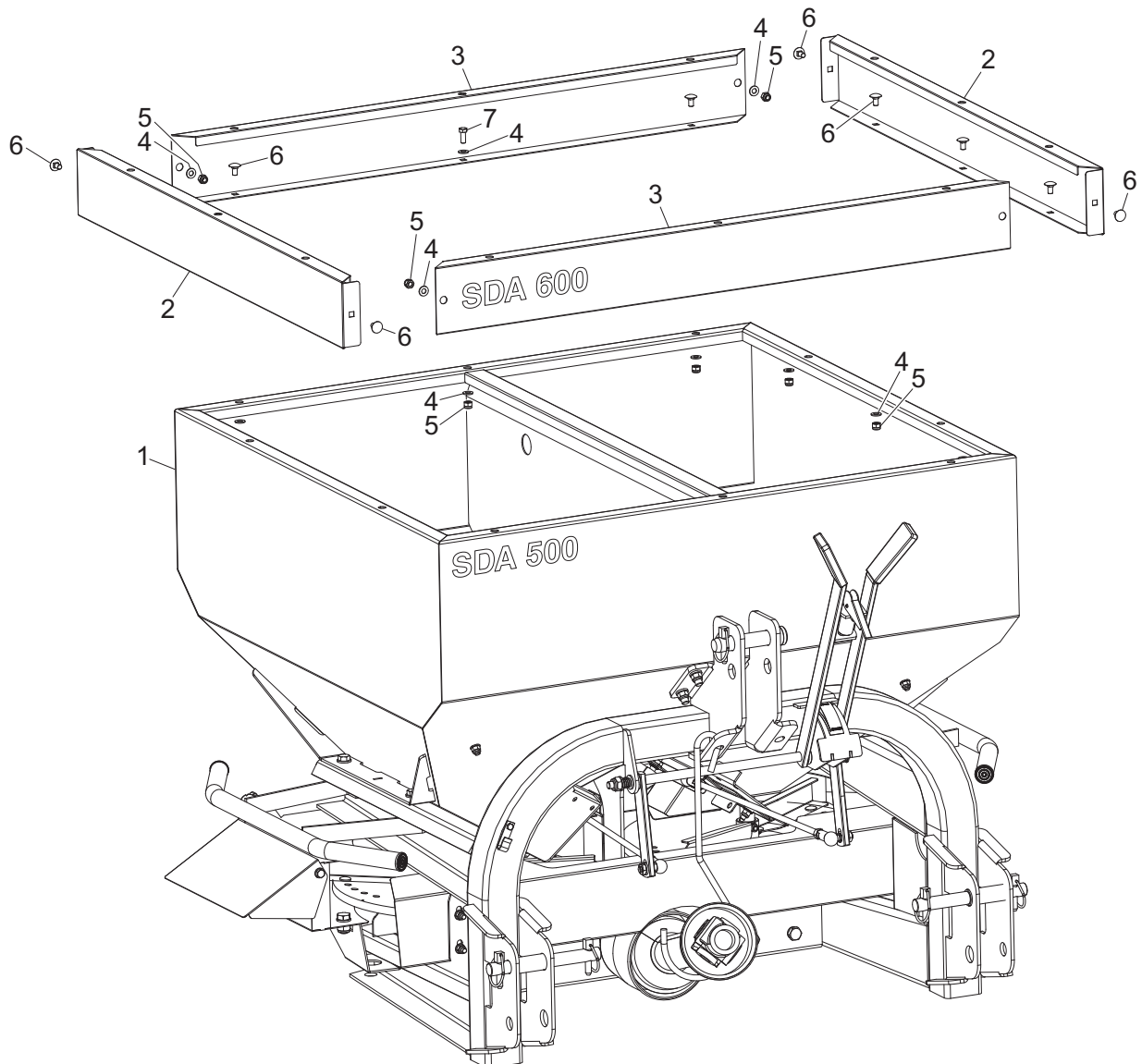



# GRUPPO DISTRIBUZIONE

## DISTRIBUTION GROUP

**SDA 500**

**SDA 600**

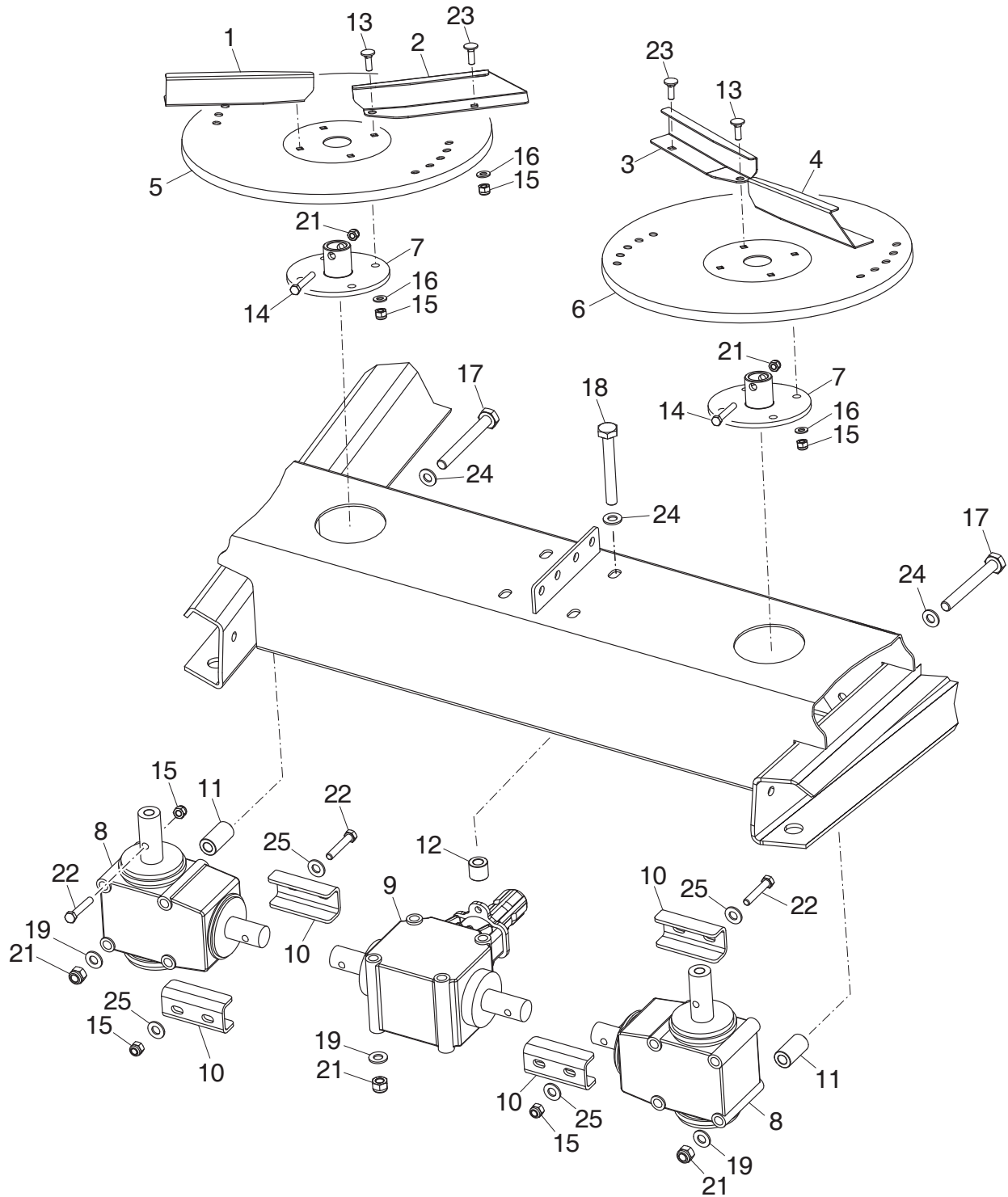

**SDA500/600**

Spandiconcime centrifugo doppio disco  
Catalogo ricambi

Cod. RGenSDA56R02 - 02.2014

© Agrex S.p.A.



# REGOLAZIONI

## ADJUSTMENTS

### SDA 500

### SDA 600

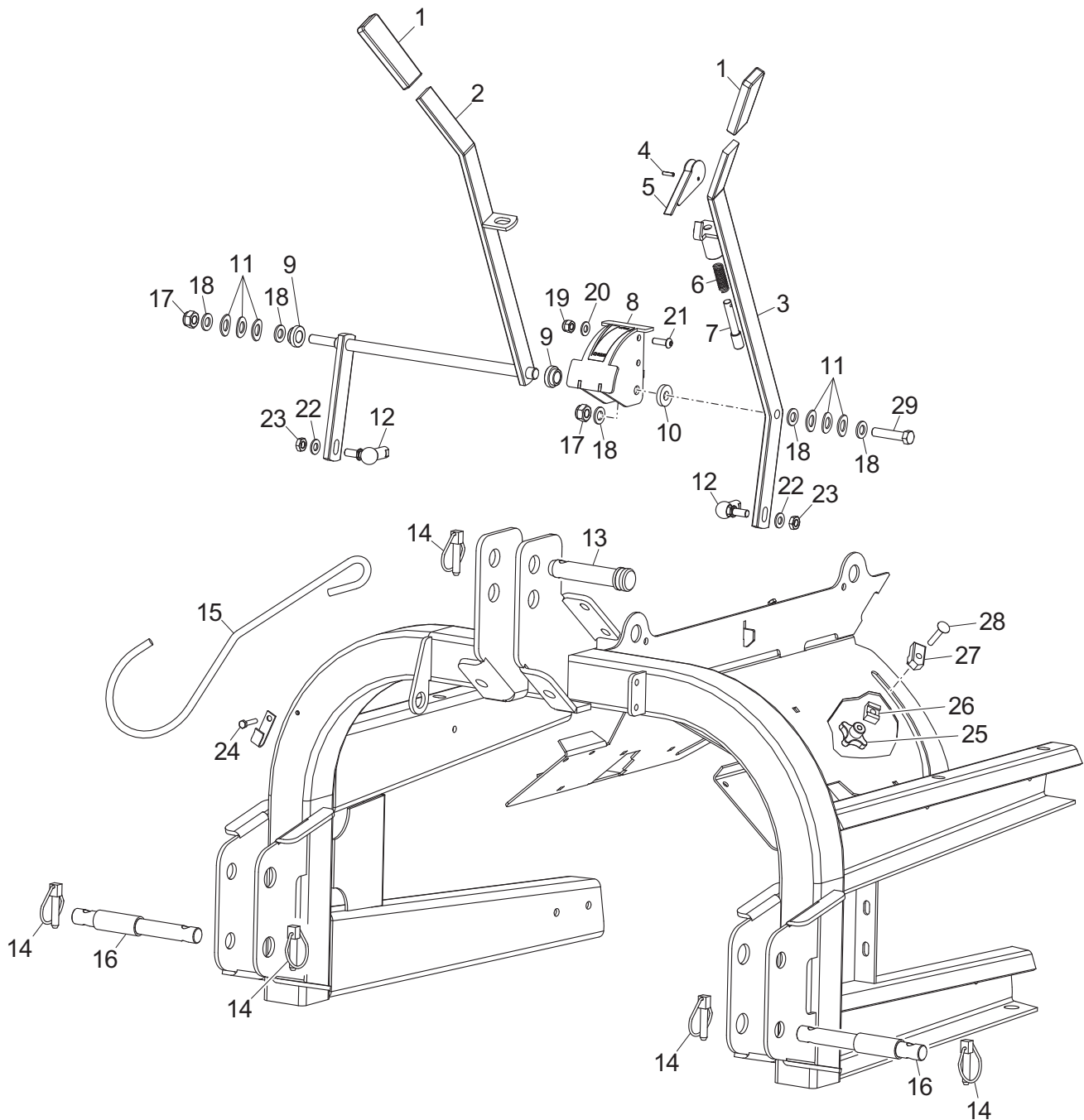
**SDA500/600**Spandiconcime centrifugo doppio disco  
Catalogo ricambiCod. **RCenSDA56R02** - 02.2014

© Agrex S.p.A.





# SERRANDE DI DOSATURA

## DOSING SHUTTERS

**SDA 500**

**SDA 600**

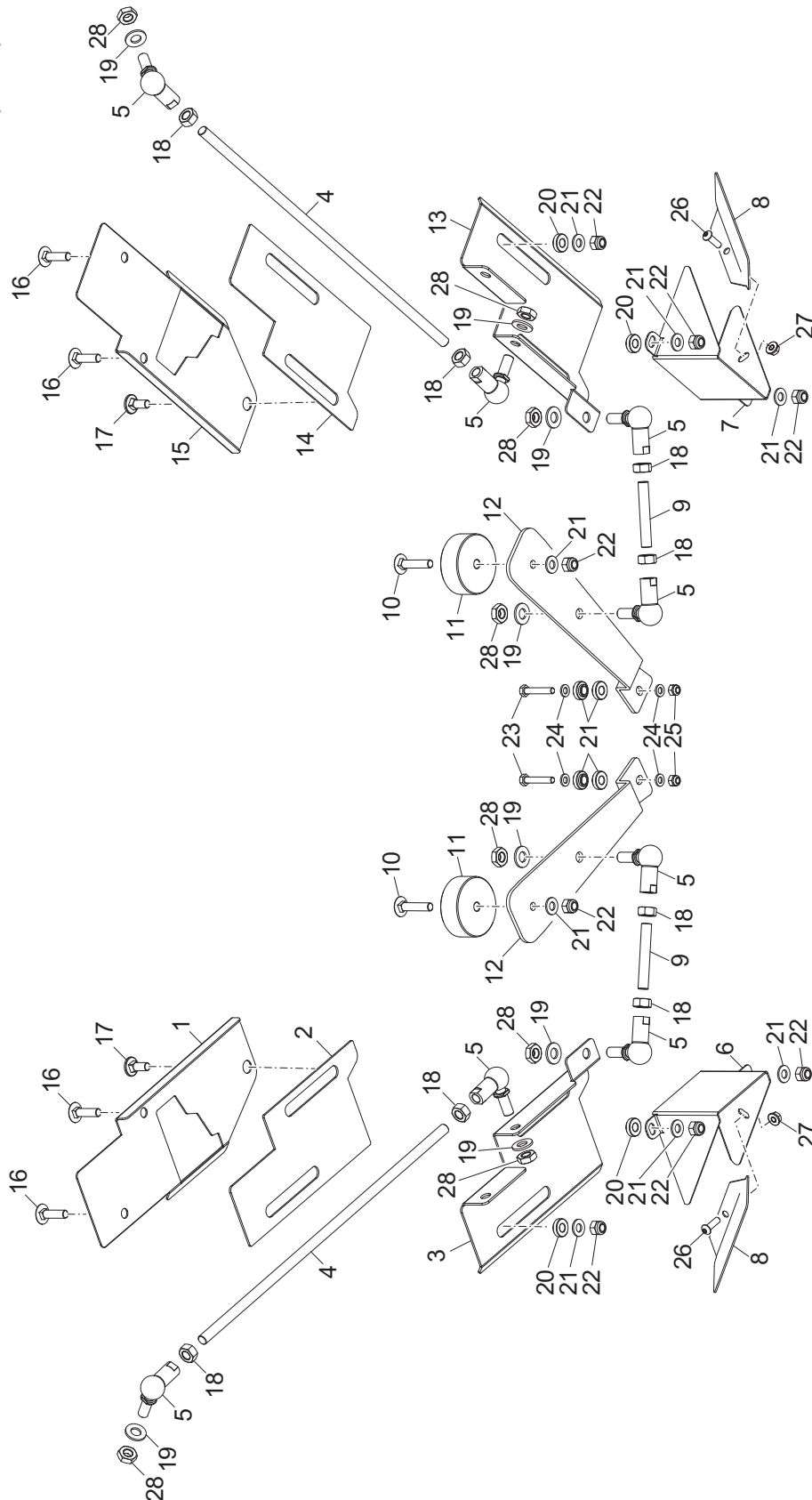

**SDA500/600**

Spandiconcime centrifugo doppio disco  
Catalogo ricambi

**Cod. RGenSDA56R02 - 02.2014**

© Agrex S.p.A.



# COMANDO IDRAULICO (Opzionale)

## HYDRAULIC CONTROL (Optional)

**SDA 500**

**SDA 600**

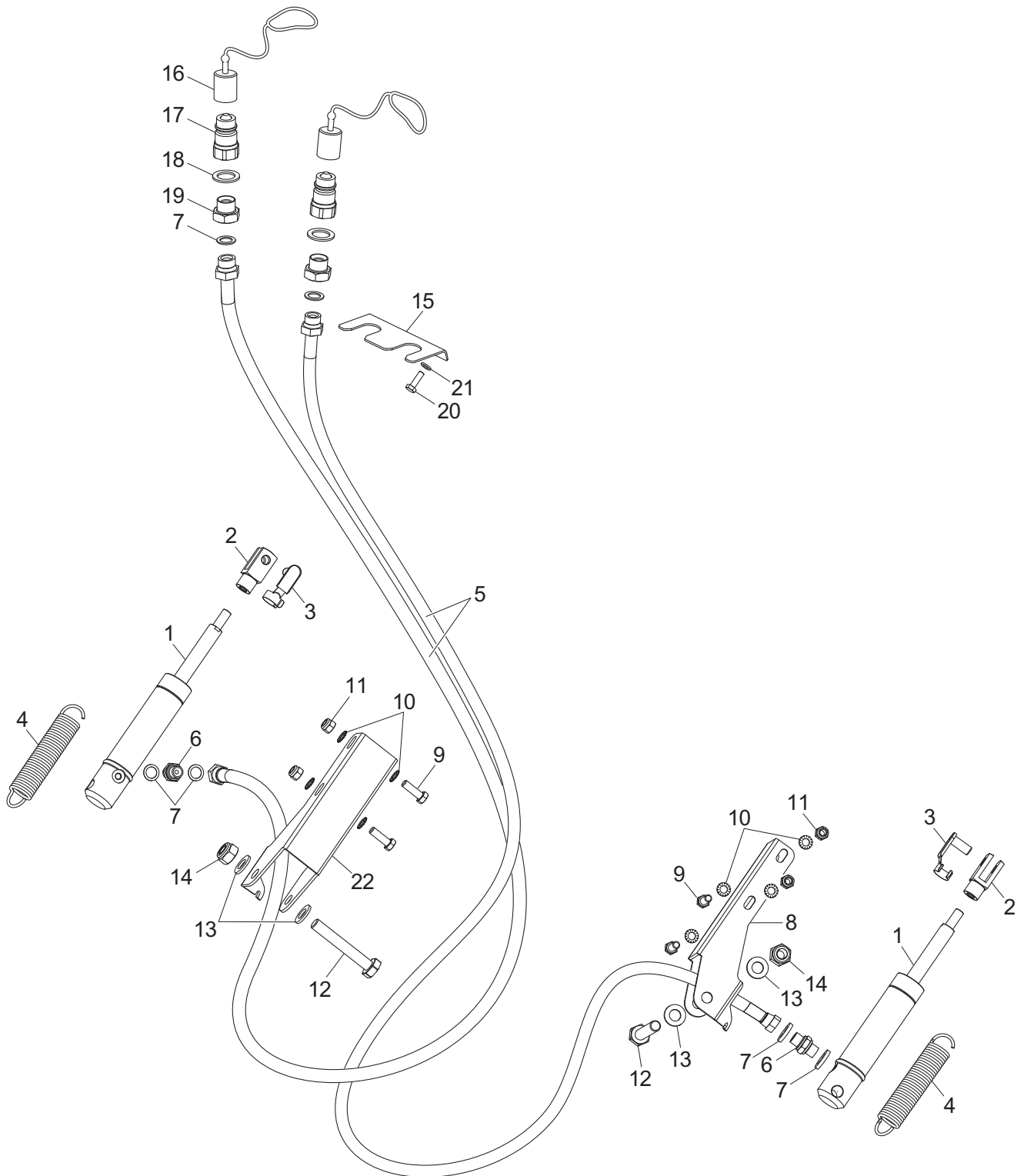

**SDA500/600**

Spandiconcime centrifugo doppio disco  
Catalogo ricambi

Cod. RGenSDA56R02 - 02.2014

© Agrex S.p.A.



# COMANDO IDRAULICO (Opzionale)

## HYDRAULIC CONTROL (Optional)

**SDA 500**

**SDA 600**

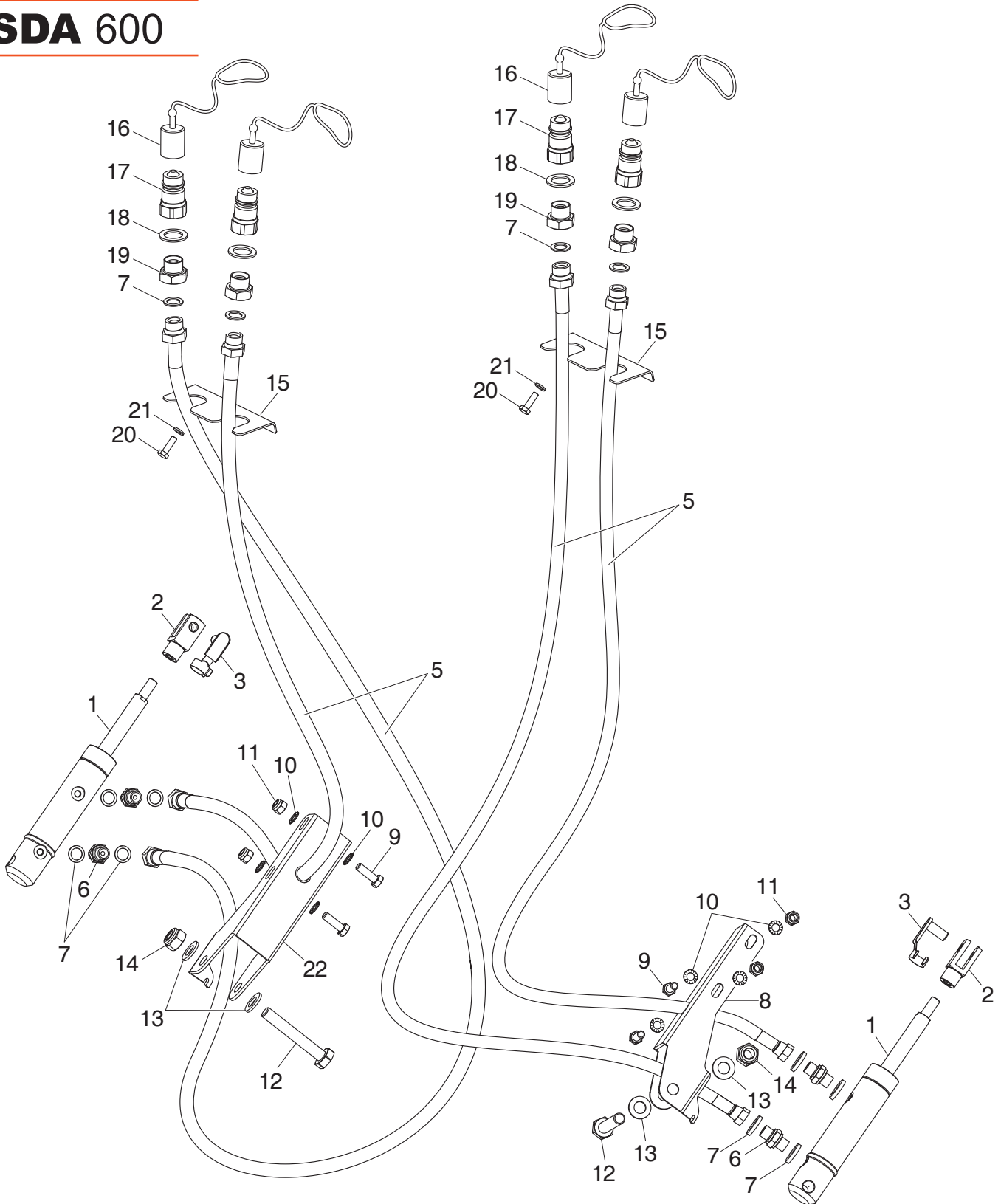

**SDA500/600**

Spandiconcime centrifugo doppio disco  
Catalogo ricambi

Cod. RGenSDA56R02 - 02.2014

© Agrex S.p.A.



# CONVOGLIATORE BILATERALE (Opzionale)

## DOUBLE BANDING (Optional)

**SDA 500**

**SDA 600**

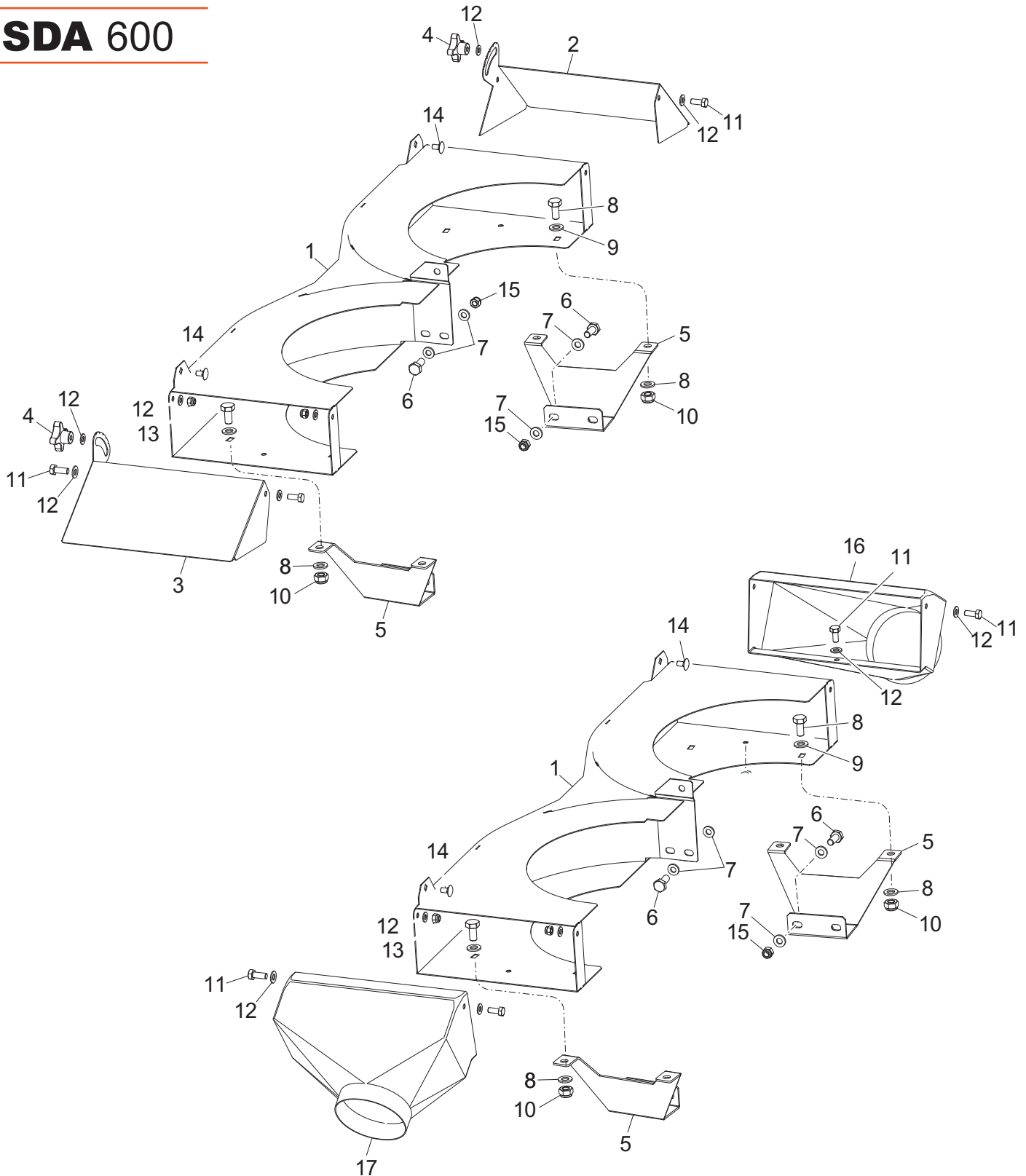





## 8 Annex A - Stability of the tractor distributor combination

As a consequence of mass of the spreader itself and of the materials present in the hopper, the tractor distributor combination may become unstable. For verify the total stabiliti, the following expression can be applied for the calculation of the minimum ballasting at the front of  $I_{F,min}$  which allows to have a weight on the front axel equal to 20% of the unladen weight of the tractor:

$$I_{F,min} = \frac{(I_R \times (c + d)) - (T_F \times b) + (0,2 \times T_E \times b)}{(a + b)}$$

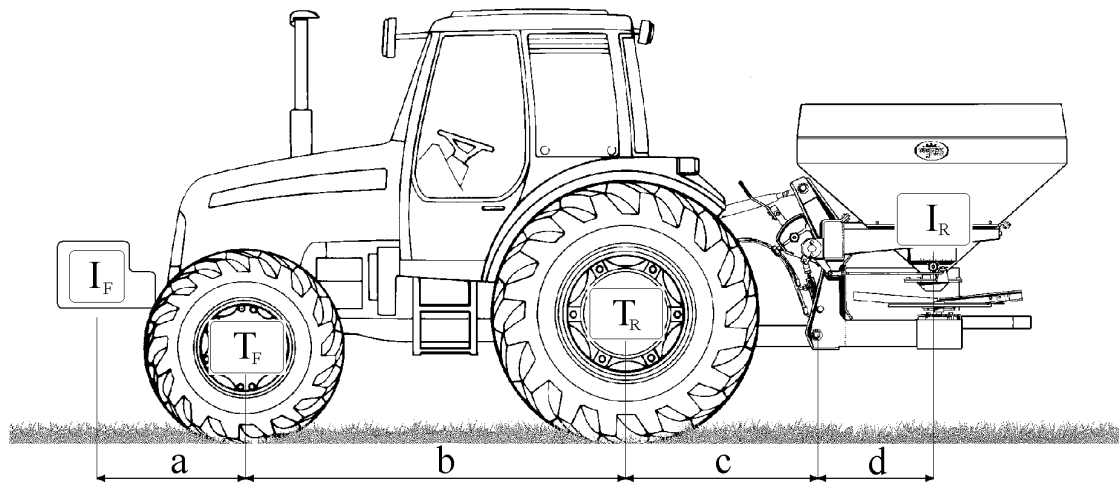

$T_E$ [kg]	Unladen weight of tractor	①
$T_F$ [kg]	Front axle load of unladen tractor	①
$T_R$ [kg]	Rear axle load of unladen tractor	①
$I_R$ [kg]	Combinated weight of rear mounted implement/rear ballast	②
$I_F$ [kg]	Combinated weight of front mounted implement/front ballast	②
$a$ [m]	Distance from centre of gravity for combined front mounted implement/front ballast to front axle centre	② ③
$b$ [m]	Tractor wheelbase	① ③
$c$ [m]	Distance from rear axle centre to centre of lower link balls	① ③
$d$ [m]	Distance from centre of lower link balls to centre of gravity for combined rear mounted implement/rear ballast (0.585 m)	② ③
①	see instruction handbook of the tractor	
②	see price list and/or instruction handbook of the implement	
③	to be measured	

# Spreading Tables

**NORMAL SPREADING**

**6 Metres**

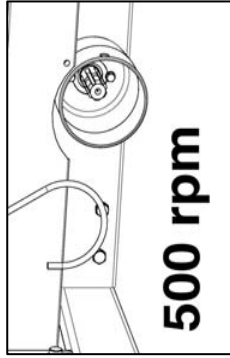
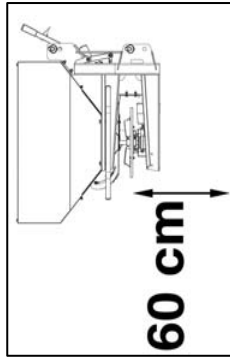
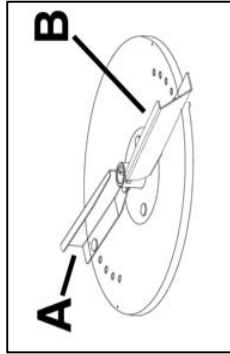

**AMMONIONITRATE 27% GRANULATED**

**1**

Opening lever	kg/min	Blade position		Speed (km/h)		
		A	B	6	8	10
0,5	2,0	4	1	33	24	20
1	3,9	4	1	64	48	39
1,5	8,4	4	1	139	104	84
2	12,8	4	1	214	160	128
2,5	19,3	4	1	322	241	193
3	25,8	4	1	431	323	258
3,5	35,5	4	1	592	444	355
4	45,2	4	1	754	566	452
4,5	58,3	4	1	971	728	583
5	71,3	4	1	1188	891	713
5,5	83,7	4	1	1395	1046	837
6	96,1	4	1	1601	1201	961
6,5	111,2	4	1	1853	1390	1112
7	126,3	4	1	2105	1579	1263
7,5	135,6	4	1	2260	1695	1356
8	144,9	4	1	2416	1812	1449
8,5	159,3	4	1	2655	1991	1593
9	173,7	4	1	2895	2171	1737
9,5	176,5	4	1	2942	2206	1765
10	179,3	4	1	2988	2241	1793

**NPK 6-9-25 GRANULATED**

**2**

Opening lever	kg/min	Blade position		Speed (km/h)		
		A	B	6	8	10
0,5	2,4	5	2	40	30	24
1	4,8	5	2	79	59	48
1,5	9,4	5	2	156	117	94
2	13,9	5	2	231	173	139
2,5	19,6	5	2	327	245	196
3	25,3	5	2	421	316	253
3,5	34,9	5	2	581	436	349
4	43,8	5	2	730	548	438
4,5	55,8	5	2	929	697	558
5	67,7	5	2	1129	847	677
5,5	78,5	5	2	1308	981	785
6	89,3	5	2	1488	1116	893
6,5	101,9	5	2	1698	1273	1019
7	114,4	5	2	1907	1431	1144
7,5	128,7	5	2	2145	1609	1287
8	143,0	5	2	2383	1787	1430
8,5	162,3	5	2	2704	2028	1623
9	181,5	5	2	3024	2268	1815
9,5	184,7	5	2	3078	2309	1847
10	187,9	5	2	3131	2348	1879

**POTASSIUM CHLORIDE 60%**

**3**

Opening lever	kg/min	Blade position		Speed (km/h)		
		A	B	6	8	10
0,5	1,0	5	3	17	13	10
1	4,1	5	3	68	51	41
1,5	6,7	5	3	112	84	67
2	11,7	5	3	195	147	117
2,5	16,9	5	3	281	211	169
3	25,3	5	3	422	316	253
3,5	27,6	5	3	461	346	276
4	42,9	5	3	714	536	429
4,5	51,0	5	3	849	637	510
5	60,3	5	3	1004	753	603
5,5	72,8	5	3	1213	910	728
6	86,1	5	3	1434	1076	861
6,5	100,9	5	3	1681	1261	1009
7	113,2	5	3	1886	1415	1132
7,5	122,9	5	3	2048	1536	1229
8	137,8	5	3	2297	1722	1378
8,5	151,4	5	3	2524	1893	1514
9	162,4	5	3	2707	2031	1624
9,5	182,0	5	3	3034	2275	1820
10	178,6	5	3	2977	2233	1786

# NORMAL SPREADING

# 6 Metres

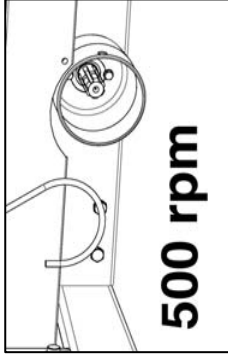
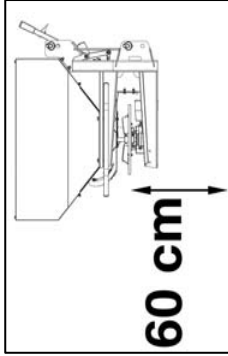
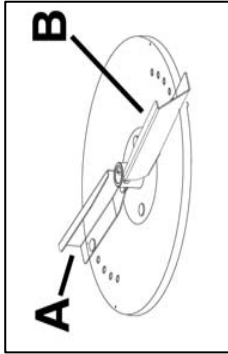

**4**

**NS27-5 BB GRANULATED**

Opening lever	kg/min	Blade position		Speed (km/h)		
		A	B	6	8	10
0,5	1,9	3	1	32	24	19
1	3,8	3	1	63	47	38
1,5	7,0	3	1	117	88	70
2	10,2	3	1	170	128	102
2,5	18,6	3	1	310	233	186
3	27,0	3	1	449	337	270
3,5	37,6	3	1	626	469	376
4	48,1	3	1	802	601	481
4,5	62,1	3	1	1035	776	621
5	76,1	3	1	1269	952	761
5,5	87,0	3	1	1450	1088	870
6	97,9	3	1	1631	1223	979
6,5	116,8	3	1	1947	1460	1168
7	135,7	3	1	2261	1696	1357
7,5	145,1	3	1	2418	1813	1451
8	154,4	3	1	2573	1930	1544
8,5	161,7	3	1	2695	2021	1617
9	169,0	3	1	2817	2113	1690
9,5	170,6	3	1	2843	2132	1706
10	172,1	3	1	2868	2151	1721

**5**

**KALI 49**

Opening lever	kg/min	Blade position		Speed (km/h)		
		A	B	6	8	10
0,5	2,2	4	1	36	27	22
1	4,3	4	1	71	53	43
1,5	8,7	4	1	144	108	87
2	13,0	4	1	216	162	130
2,5	20,6	4	1	343	257	206
3	28,1	4	1	469	352	281
3,5	36,3	4	1	605	454	363
4	44,5	4	1	741	556	445
4,5	57,7	4	1	961	721	577
5	70,8	4	1	1180	885	708
5,5	81,8	4	1	1363	1023	818
6	92,9	4	1	1549	1162	929
6,5	114,6	4	1	1910	1433	1146
7	136,3	4	1	2272	1704	1363
7,5	143,8	4	1	2396	1797	1438
8	151,2	4	1	2521	1891	1512
8,5	168,5	4	1	2808	2106	1685
9	185,7	4	1	3095	2322	1857
9,5	187,9	4	1	3132	2349	1879
10	190,1	4	1	3168	2376	1901

**6**

**BIAMMONIUM PHOSPHATE 18-46**

Opening lever	kg/min	Blade position		Speed (km/h)		
		A	B	6	8	10
0,5	4,1	5	3	69	52	41
1	8,5	5	3	141	106	85
1,5	10,1	5	3	169	127	101
2	12,0	5	3	201	151	120
2,5	15,1	5	3	252	189	151
3	19,2	5	3	320	240	192
3,5	18,9	5	3	316	237	189
4	32,1	5	3	535	401	321
4,5	38,7	5	3	645	484	387
5	45,7	5	3	762	571	457
5,5	57,5	5	3	958	718	575
6	65,2	5	3	1086	815	652
6,5	72,1	5	3	1201	901	721
7	83,9	5	3	1399	1049	839
7,5	94,4	5	3	1574	1181	944
8	109,6	5	3	1827	1370	1096
8,5	128,1	5	3	2135	1601	1281
9	143,0	5	3	2384	1788	1430
9,5	172,6	5	3	2876	2157	1726
10	173,9	5	3	2898	2173	1739

**NORMAL SPREADING**

**6 Metres**

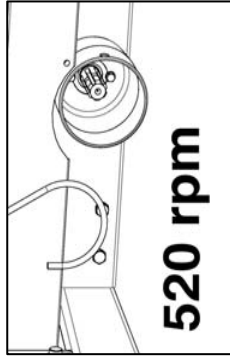
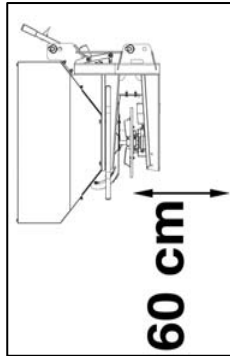
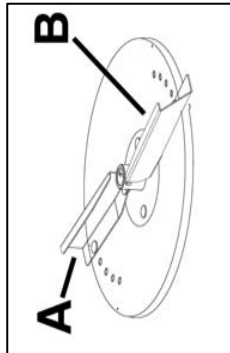

**7**

Opening lever	kg/min		Speed (km/h)			
	A	B	6	8	10	
			kg/ha			
0,5	0,9	3	2	15	12	9
1	1,9	3	2	31	24	19
1,5	3,0	3	2	50	37	30
2	5,2	3	2	87	66	52
2,5	6,9	3	2	116	87	69
3	9,5	3	2	158	118	95
3,5	11,5	3	2	192	144	115
4	24,7	3	2	411	308	247
4,5	31,5	3	2	525	394	315
5	39,7	3	2	661	496	397
5,5	48,7	3	2	812	609	487
6	55,0	3	2	917	688	550
6,5	61,6	3	2	1027	770	616
7	72,4	3	2	1207	905	724
7,5	82,9	3	2	1382	1036	829
8	98,3	3	2	1638	1228	983
8,5	114,0	3	2	1900	1425	1140
9	131,0	3	2	2183	1637	1310
9,5	172,5	3	2	2875	2156	1725
10	180,1	3	2	3002	2252	1801

**UREA PRILLED AGRICOLA**

**8**

Opening lever	kg/min	Blade position		Speed (km/h)		
		A	B	6	8	10
		kg/ha				
0,5	2,2	4	3	37	28	22
1	5,4	4	3	90	67	54
1,5	10,1	4	3	168	126	101
2	14,8	4	3	246	185	148
2,5	21,6	4	3	360	270	216
3	28,4	4	3	473	355	284
3,5	37,0	4	3	616	462	370
4	45,5	4	3	758	568	455
4,5	53,8	4	3	896	672	538
5	62,0	4	3	1034	775	620
5,5	73,6	4	3	1226	919	736
6	85,1	4	3	1419	1064	851
6,5	91,1	4	3	1518	1138	911
7	97,0	4	3	1617	1213	970
7,5	100,0	4	3	1667	1250	1000
8	103,0	4	3	1717	1288	1030
8,5	114,2	4	3	1903	1428	1142
9	125,5	4	3	2092	1569	1255
9,5	125,7	4	3	2095	1571	1257
10	126,0	4	3	2100	1575	1260

**NPK 22-2-12 PRILLED**

**9**

Opening lever	kg/min	Blade position		Speed (km/h)		
		A	B	6	8	10
		kg/ha				
0,5	1,9	3	1	32	24	19
1	3,8	3	1	64	48	38
1,5	10,3	3	1	171	128	103
2	16,7	3	1	279	209	167
2,5	24,8	3	1	413	310	248
3	32,9	3	1	548	411	329
3,5	45,4	3	1	756	567	454
4	57,8	3	1	964	723	578
4,5	72,5	3	1	1208	906	725
5	87,2	3	1	1453	1090	872
5,5	98,8	3	1	1646	1234	988
6	110,3	3	1	1838	1379	1103
6,5	130,4	3	1	2173	1630	1304
7	150,5	3	1	2508	1881	1505
7,5	165,3	3	1	2754	2066	1653
8	180,0	3	1	3000	2250	1800
8,5	173,0	3	1	2883	2162	1730
9	195,8	3	1	3263	2447	1958
9,5	209,9	3	1	3498	2624	2099
10	224,0	3	1	3733	2800	2240

# NORMAL SPREADING

12 Metres

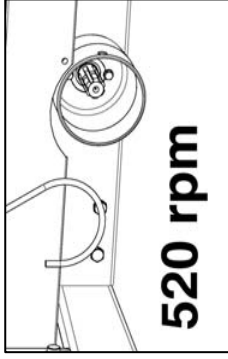
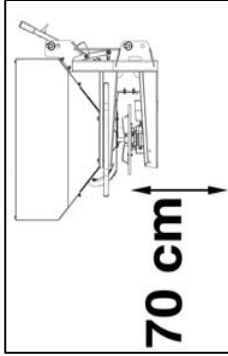
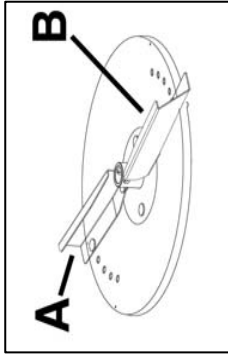

## AMMONIUMNITRATE 27% GRANULATED

1

Opening lever	kg/min	Blade position		Speed (km/h)		
		A	B	6	8	10
0,5	2,0	4	1	16	12	10
1	3,9	4	1	32	24	19
1,5	8,4	4	1	70	52	42
2	12,8	4	1	107	80	64
2,5	19,3	4	1	161	121	97
3	25,8	4	1	215	161	129
3,5	35,5	4	1	296	222	178
4	45,2	4	1	377	283	226
4,5	58,3	4	1	485	364	291
5	71,3	4	1	594	445	356
5,5	83,7	4	1	698	523	419
6	96,1	4	1	800	600	480
6,5	111,2	4	1	927	695	556
7	126,3	4	1	1053	789	632
7,5	135,6	4	1	1130	848	678
8	144,9	4	1	1208	906	725
8,5	159,3	4	1	1328	996	797
9	173,7	4	1	1448	1086	869
9,5	176,5	4	1	1471	1103	883
10	179,3	4	1	1494	1120	896

## NPK 6-9-25 GRANULATED

2

Opening lever	kg/min	Blade position		Speed (km/h)		
		A	B	6	8	10
0,5	2,4	4	1	20	15	12
1	4,8	4	1	40	30	24
1,5	9,4	4	1	78	58	47
2	13,9	4	1	116	87	69
2,5	19,6	4	1	163	123	98
3	25,3	4	1	211	158	126
3,5	34,9	4	1	290	218	174
4	43,8	4	1	365	274	219
4,5	55,8	4	1	465	348	279
5	67,7	4	1	564	423	339
5,5	78,5	4	1	654	491	393
6	89,3	4	1	744	558	446
6,5	101,9	4	1	849	637	509
7	114,4	4	1	954	715	572
7,5	128,7	4	1	1073	804	644
8	143,0	4	1	1191	894	715
8,5	162,3	4	1	1352	1014	811
9	181,5	4	1	1512	1134	907
9,5	184,7	4	1	1539	1154	924
10	187,9	4	1	1566	1174	939

## POTASSIUM CHLORIDE 60%

3

Opening lever	kg/min	Blade position		Speed (km/h)		
		A	B	6	8	10
0,5	1,0	5	2	8	6	5
1	4,1	5	2	34	26	20
1,5	6,7	5	2	56	42	34
2	11,7	5	2	98	73	59
2,5	16,9	5	2	140	105	84
3	25,3	5	2	211	158	127
3,5	27,6	5	2	230	173	138
4	42,9	5	2	357	268	214
4,5	51,0	5	2	425	318	255
5	60,3	5	2	502	377	301
5,5	72,8	5	2	607	455	364
6	86,1	5	2	717	538	430
6,5	100,9	5	2	840	630	504
7	113,2	5	2	943	707	566
7,5	122,9	5	2	1024	768	614
8	137,8	5	2	1148	861	689
8,5	151,4	5	2	1262	947	757
9	162,4	5	2	1354	1015	812
9,5	182,0	5	2	1517	1138	910
10	178,6	5	2	1489	1116	893

**NORMAL SPREADING**

**12 Metres**

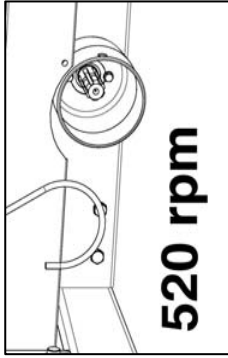
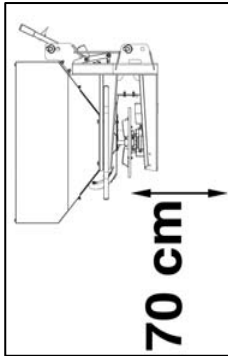
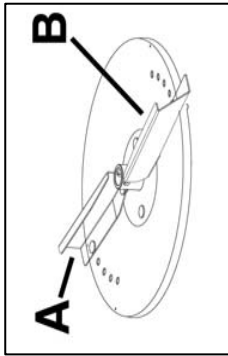

**4**

**NS27-5 BB GRANULATED**

Opening lever	kg/min	Blade position		Speed (km/h)		
		A	B	6	8	10
0,5	1,9	3	1	16	12	10
1	3,8	3	1	32	24	19
1,5	7,0	3	1	58	44	35
2	10,2	3	1	85	64	51
2,5	18,6	3	1	155	116	93
3	27,0	3	1	225	169	135
3,5	37,6	3	1	313	235	188
4	48,1	3	1	401	301	241
4,5	62,1	3	1	518	388	311
5	76,1	3	1	635	476	381
5,5	87,0	3	1	725	544	435
6	97,9	3	1	815	612	489
6,5	116,8	3	1	973	730	584
7	135,7	3	1	1131	848	678
7,5	145,1	3	1	1209	907	725
8	154,4	3	1	1287	965	772
8,5	161,7	3	1	1348	1011	809
9	169,0	3	1	1408	1056	845
9,5	170,6	3	1	1421	1066	853
10	172,1	3	1	1434	1076	861

**5**

**KALI 49**

Opening lever	kg/min	Blade position		Speed (km/h)		
		A	B	6	8	10
0,5	2,2	4	1	18	13	11
1	4,3	4	1	35	27	21
1,5	8,7	4	1	72	54	43
2	13,0	4	1	108	81	65
2,5	20,6	4	1	171	128	103
3	28,1	4	1	235	176	141
3,5	36,3	4	1	303	227	182
4	44,5	4	1	371	278	222
4,5	57,7	4	1	480	360	288
5	70,8	4	1	590	443	354
5,5	81,8	4	1	682	511	409
6	92,9	4	1	774	581	465
6,5	114,6	4	1	955	716	573
7	136,3	4	1	1136	852	681
7,5	143,8	4	1	1198	898	719
8	151,2	4	1	1260	945	756
8,5	168,5	4	1	1404	1053	842
9	185,7	4	1	1548	1161	929
9,5	187,9	4	1	1566	1174	940
10	190,1	4	1	1584	1188	950

**6**

**BIAMMONIUM PHOSPHATE 18-46**

Opening lever	kg/min	Blade position		Speed (km/h)		
		A	B	6	8	10
0,5	4,1	4	2	35	26	21
1	8,5	4	2	71	53	42
1,5	10,1	4	2	84	63	51
2	12,0	4	2	100	75	60
2,5	15,1	4	2	126	95	76
3	19,2	4	2	160	120	96
3,5	18,9	4	2	158	118	95
4	32,1	4	2	268	201	161
4,5	38,7	4	2	322	242	193
5	45,7	4	2	381	286	229
5,5	57,5	4	2	479	359	287
6	65,2	4	2	543	407	326
6,5	72,1	4	2	601	450	360
7	83,9	4	2	699	524	420
7,5	94,4	4	2	787	590	472
8	109,6	4	2	913	685	548
8,5	128,1	4	2	1068	801	641
9	143,0	4	2	1192	894	715
9,5	172,6	4	2	1438	1079	863
10	173,9	4	2	1449	1087	869



# NORMAL SPREADING

12 Metres

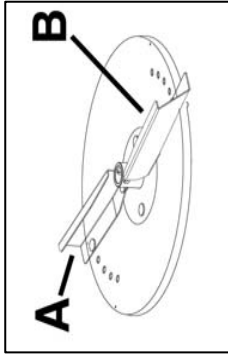

**7**

Opening lever	kg/min		Speed (km/h)		
	A	B	6	kg/ha	
				8	10
0,5	3	1	17	13	10
1	3	1	35	26	21
1,5	3	1	56	42	34
2	3	1	77	58	46
2,5	3	1	118	89	71
3	3	1	160	120	96
3,5	3	1	212	159	127
4	3	1	264	198	159
4,5	3	1	319	239	192
5	3	1	374	281	225
5,5	3	1	441	331	265
6	3	1	509	382	305
6,5	3	1	587	440	352
7	3	1	665	499	399
7,5	3	1	760	570	456
8	3	1	856	642	513
8,5	3	1	959	719	575
9	3	1	1062	796	637
9,5	3	1	1065	798	639
10	3	1	1068	801	641

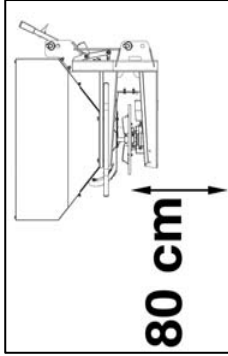

**8**

Opening lever	kg/min	Blade position		Speed (km/h)		
		A	B	6	kg/ha	
					8	10
0,5	2,2	3	2	18	14	11
1	5,4	3	2	45	34	27
1,5	10,1	3	2	84	63	51
2	14,8	3	2	123	92	74
2,5	21,6	3	2	180	135	108
3	28,4	3	2	237	178	142
3,5	37,0	3	2	308	231	185
4	45,5	3	2	379	284	227
4,5	53,8	3	2	448	336	269
5	62,0	3	2	517	388	310
5,5	73,6	3	2	613	460	368
6	85,1	3	2	710	532	426
6,5	91,1	3	2	759	569	455
7	97,0	3	2	808	606	485
7,5	100,0	3	2	833	625	500
8	103,0	3	2	858	644	515
8,5	114,2	3	2	952	714	571
9	125,5	3	2	1046	784	627
9,5	125,7	3	2	1048	786	629
10	126,0	3	2	1050	788	630

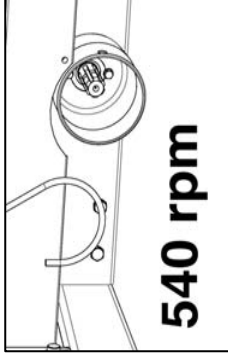

**9**

Opening lever	kg/min	Blade position		Speed (km/h)		
		A	B	6	kg/ha	
					8	10
0,5	1,9	4	1	16	12	10
1	3,8	4	1	32	24	19
1,5	10,3	4	1	85	64	51
2	16,7	4	1	139	104	84
2,5	24,8	4	1	207	155	124
3	32,9	4	1	274	206	164
3,5	45,4	4	1	378	283	227
4	57,8	4	1	482	362	289
4,5	72,5	4	1	604	453	363
5	87,2	4	1	726	545	436
5,5	98,8	4	1	823	617	494
6	110,3	4	1	919	689	551
6,5	130,4	4	1	1087	815	652
7	150,5	4	1	1254	941	752
7,5	165,3	4	1	1377	1033	826
8	180,0	4	1	1500	1125	900
8,5	173,0	4	1	1442	1081	865
9	195,8	4	1	1631	1224	979
9,5	209,9	4	1	1749	1312	1050
10	224,0	4	1	1867	1400	1120

**NORMAL SPREADING**

**15 Metres**

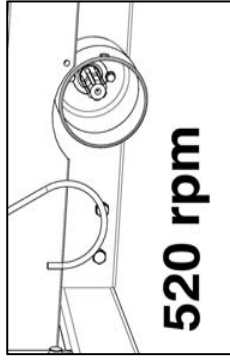
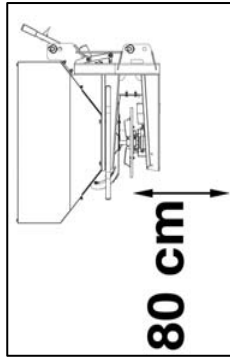
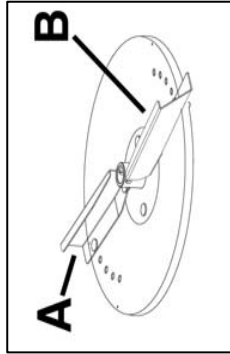

**1**

**AMMONIONITRATE 27% GRANULATED**

Opening lever	kg/min	Blade position		Speed (km/h)		
		A	B	6	8	10
0,5	2,0	4	1	13	10	8
1	3,9	4	1	26	19	15
1,5	8,4	4	1	56	42	33
2	12,8	4	1	85	64	51
2,5	19,3	4	1	129	97	77
3	25,8	4	1	172	129	103
3,5	35,5	4	1	237	178	142
4	45,2	4	1	302	226	181
4,5	58,3	4	1	388	291	233
5	71,3	4	1	475	356	285
5,5	83,7	4	1	558	419	335
6	96,1	4	1	640	480	384
6,5	111,2	4	1	741	556	445
7	126,3	4	1	842	632	505
7,5	135,6	4	1	904	678	542
8	144,9	4	1	966	725	580
8,5	159,3	4	1	1062	797	637
9	173,7	4	1	1158	869	695
9,5	176,5	4	1	1177	883	706
10	179,3	4	1	1195	896	717

**2**

**NPK 6-9-25 GRANULATED**

Opening lever	kg/min	Blade position		Speed (km/h)		
		A	B	6	8	10
0,5	2,4	4	1	16	12	10
1	4,8	4	1	32	24	19
1,5	9,4	4	1	62	47	37
2	13,9	4	1	92	69	55
2,5	19,6	4	1	131	98	78
3	25,3	4	1	169	126	101
3,5	34,9	4	1	232	174	139
4	43,8	4	1	292	219	175
4,5	55,8	4	1	372	279	223
5	67,7	4	1	452	339	271
5,5	78,5	4	1	523	393	314
6	89,3	4	1	595	446	357
6,5	101,9	4	1	679	509	407
7	114,4	4	1	763	572	458
7,5	128,7	4	1	858	644	515
8	143,0	4	1	953	715	572
8,5	162,3	4	1	1082	811	649
9	181,5	4	1	1210	907	726
9,5	184,7	4	1	1231	924	739
10	187,9	4	1	1252	939	751

**3**

**POTASSIUM CHLORIDE 60%**

Opening lever	kg/min	Blade position		Speed (km/h)		
		A	B	6	8	10
0,5	1,0	5	2	7	5	4
1	4,1	5	2	27	20	16
1,5	6,7	5	2	45	34	27
2	11,7	5	2	78	59	47
2,5	16,9	5	2	112	84	67
3	25,3	5	2	169	127	101
3,5	27,6	5	2	184	138	111
4	42,9	5	2	286	214	171
4,5	51,0	5	2	340	255	204
5	60,3	5	2	402	301	241
5,5	72,8	5	2	485	364	291
6	86,1	5	2	574	430	344
6,5	100,9	5	2	672	504	403
7	113,2	5	2	755	566	453
7,5	122,9	5	2	819	614	492
8	137,8	5	2	919	689	551
8,5	151,4	5	2	1010	757	606
9	162,4	5	2	1083	812	650
9,5	182,0	5	2	1213	910	728
10	178,6	5	2	1191	893	715

# NORMAL SPREADING

15 Metres

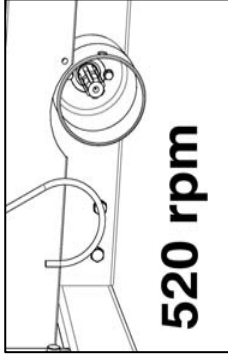
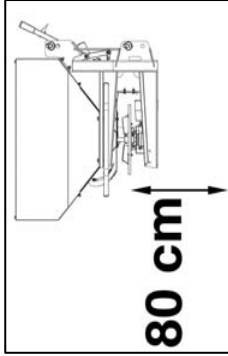
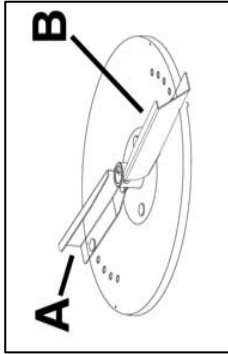

## NS27-5 BB GRANULATED

4

Opening lever	kg/min	Blade position		Speed (km/h)		
		A	B	6	8	10
0,5	1,9	3	1	13	10	8
1	3,8	3	1	25	19	15
1,5	7,0	3	1	47	35	28
2	10,2	3	1	68	51	41
2,5	18,6	3	1	124	93	74
3	27,0	3	1	180	135	108
3,5	37,6	3	1	250	188	150
4	48,1	3	1	321	241	192
4,5	62,1	3	1	414	311	248
5	76,1	3	1	508	381	305
5,5	87,0	3	1	580	435	348
6	97,9	3	1	652	489	391
6,5	116,8	3	1	779	584	467
7	135,7	3	1	904	678	543
7,5	145,1	3	1	967	725	580
8	154,4	3	1	1029	772	618
8,5	161,7	3	1	1078	809	647
9	169,0	3	1	1127	845	676
9,5	170,6	3	1	1137	853	682
10	172,1	3	1	1147	861	688

## KALI 49

5

Opening lever	kg/min	Blade position		Speed (km/h)		
		A	B	6	8	10
0,5	2,2	4	1	14	11	9
1	4,3	4	1	28	21	17
1,5	8,7	4	1	58	43	35
2	13,0	4	1	86	65	52
2,5	20,6	4	1	137	103	82
3	28,1	4	1	188	141	113
3,5	36,3	4	1	242	182	145
4	44,5	4	1	296	222	178
4,5	57,7	4	1	384	288	231
5	70,8	4	1	472	354	283
5,5	81,8	4	1	545	409	327
6	92,9	4	1	620	465	372
6,5	114,6	4	1	764	573	458
7	136,3	4	1	909	681	545
7,5	143,8	4	1	958	719	575
8	151,2	4	1	1008	756	605
8,5	168,5	4	1	1123	842	674
9	185,7	4	1	1238	929	743
9,5	187,9	4	1	1253	940	752
10	190,1	4	1	1267	950	760

## BIAMMONIUM PHOSPHATE 18-46

6

Opening lever	kg/min	Blade position		Speed (km/h)		
		A	B	6	8	10
0,5	4,1	4	2	28	21	17
1	8,5	4	2	56	42	34
1,5	10,1	4	2	68	51	41
2	12,0	4	2	80	60	48
2,5	15,1	4	2	101	76	60
3	19,2	4	2	128	96	77
3,5	18,9	4	2	126	95	76
4	32,1	4	2	214	161	128
4,5	38,7	4	2	258	193	155
5	45,7	4	2	305	229	183
5,5	57,5	4	2	383	287	230
6	65,2	4	2	435	326	261
6,5	72,1	4	2	480	360	288
7	83,9	4	2	559	420	336
7,5	94,4	4	2	630	472	378
8	109,6	4	2	731	548	438
8,5	128,1	4	2	854	641	512
9	143,0	4	2	954	715	572
9,5	172,6	4	2	1151	863	690
10	173,9	4	2	1159	869	695

**NORMAL SPREADING**

**18 Metres**

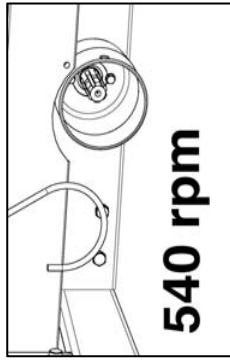
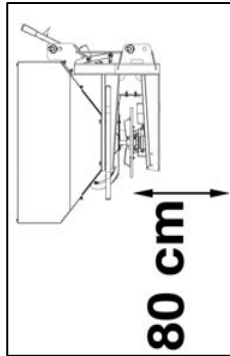
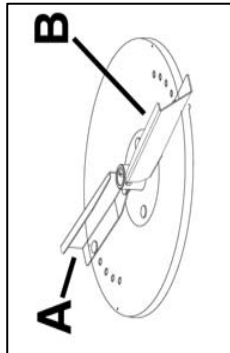

**1**

**AMMONIUNITRATE 27% GRANULATED**

Opening lever	kg/min	Blade position		Speed (km/h)		
		A	B	6	8	10
0,5	2,0	4	1	11	8	7
1	3,9	4	1	21	16	13
1,5	8,4	4	1	46	35	28
2	12,8	4	1	71	53	43
2,5	19,3	4	1	107	80	64
3	25,8	4	1	144	108	86
3,5	35,5	4	1	197	148	118
4	45,2	4	1	251	189	151
4,5	58,3	4	1	324	243	194
5	71,3	4	1	396	297	238
5,5	83,7	4	1	465	349	279
6	96,1	4	1	534	400	320
6,5	111,2	4	1	618	463	371
7	126,3	4	1	702	526	421
7,5	135,6	4	1	753	565	452
8	144,9	4	1	805	604	483
8,5	159,3	4	1	885	664	531
9	173,7	4	1	965	724	579
9,5	176,5	4	1	981	735	588
10	179,3	4	1	996	747	598

**2**

**NPK 6-9-25 GRANULATED**

Opening lever	kg/min	Blade position		Speed (km/h)		
		A	B	6	8	10
0,5	2,4	3	1	13	10	8
1	4,8	3	1	26	20	16
1,5	9,4	3	1	52	39	31
2	13,9	3	1	77	58	46
2,5	19,6	3	1	109	82	65
3	25,3	3	1	140	105	84
3,5	34,9	3	1	194	145	116
4	43,8	3	1	243	183	146
4,5	55,8	3	1	310	232	186
5	67,7	3	1	376	282	226
5,5	78,5	3	1	436	327	262
6	89,3	3	1	496	372	298
6,5	101,9	3	1	566	424	340
7	114,4	3	1	636	477	381
7,5	128,7	3	1	715	536	429
8	143,0	3	1	794	596	477
8,5	162,3	3	1	901	676	541
9	181,5	3	1	1008	756	605
9,5	184,7	3	1	1026	770	616
10	187,9	3	1	1044	783	626

**3**

**POTASSIUM CHLORIDE 60%**

Opening lever	kg/min	Blade position		Speed (km/h)		
		A	B	6	8	10
0,5	1,0	4	1	6	4	3
1	4,1	4	1	23	17	14
1,5	6,7	4	1	37	28	22
2	11,7	4	1	65	49	39
2,5	16,9	4	1	94	70	56
3	25,3	4	1	141	105	84
3,5	27,6	4	1	154	115	92
4	42,9	4	1	238	179	143
4,5	51,0	4	1	283	212	170
5	60,3	4	1	335	251	201
5,5	72,8	4	1	404	303	243
6	86,1	4	1	478	359	287
6,5	100,9	4	1	560	420	336
7	113,2	4	1	629	472	377
7,5	122,9	4	1	683	512	410
8	137,8	4	1	766	574	459
8,5	151,4	4	1	841	631	505
9	162,4	4	1	902	677	541
9,5	182,0	4	1	1011	758	607
10	178,6	4	1	992	744	595

# NORMAL SPREADING

# 18 Metres

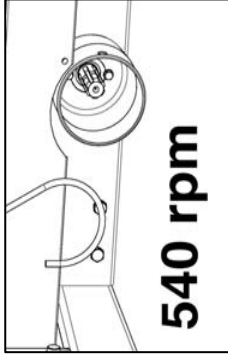
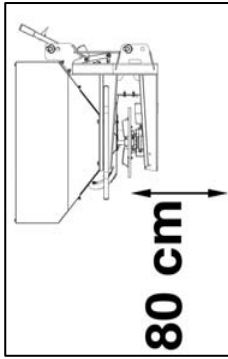
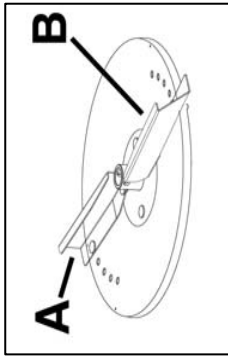

**4**

**NS27-5 BB GRANULATED**

Opening lever	kg/min	Blade position		Speed (km/h)		
		A	B	6	8	10
0,5	1,9	3	1	11	8	6
1	3,8	3	1	21	16	13
1,5	7,0	3	1	39	29	23
2	10,2	3	1	57	43	34
2,5	18,6	3	1	103	78	62
3	27,0	3	1	150	112	90
3,5	37,6	3	1	209	156	125
4	48,1	3	1	267	200	160
4,5	62,1	3	1	345	259	207
5	76,1	3	1	423	317	254
5,5	87,0	3	1	483	363	290
6	97,9	3	1	544	408	326
6,5	116,8	3	1	649	487	389
7	135,7	3	1	754	565	452
7,5	145,1	3	1	806	604	484
8	154,4	3	1	858	643	515
8,5	161,7	3	1	898	674	539
9	169,0	3	1	939	704	563
9,5	170,6	3	1	948	711	569
10	172,1	3	1	956	717	574

**5**

**KALI 49**

Opening lever	kg/min	Blade position		Speed (km/h)		
		A	B	6	8	10
0,5	2,2	4	1	12	9	7
1	4,3	4	1	24	18	14
1,5	8,7	4	1	48	36	29
2	13,0	4	1	72	54	43
2,5	20,6	4	1	114	86	69
3	28,1	4	1	156	117	94
3,5	36,3	4	1	202	151	121
4	44,5	4	1	247	185	148
4,5	57,7	4	1	320	240	192
5	70,8	4	1	393	295	236
5,5	81,8	4	1	454	341	273
6	92,9	4	1	516	387	310
6,5	114,6	4	1	637	478	382
7	136,3	4	1	757	568	454
7,5	143,8	4	1	799	599	479
8	151,2	4	1	840	630	504
8,5	168,5	4	1	936	702	562
9	185,7	4	1	1032	774	619
9,5	187,9	4	1	1044	783	626
10	190,1	4	1	1056	792	634

**6**

**BIAMMONIUM PHOSPHATE 18-46**

Opening lever	kg/min	Blade position		Speed (km/h)		
		A	B	6	8	10
0,5	4,1	4	1	23	17	14
1	8,5	4	1	47	35	28
1,5	10,1	4	1	56	42	34
2	12,0	4	1	67	50	40
2,5	15,1	4	1	84	63	50
3	19,2	4	1	107	80	64
3,5	18,9	4	1	105	79	63
4	32,1	4	1	178	134	107
4,5	38,7	4	1	215	161	129
5	45,7	4	1	254	190	152
5,5	57,5	4	1	319	239	192
6	65,2	4	1	362	272	217
6,5	72,1	4	1	400	300	240
7	83,9	4	1	466	350	280
7,5	94,4	4	1	525	394	315
8	109,6	4	1	609	457	365
8,5	128,1	4	1	712	534	427
9	143,0	4	1	795	596	477
9,5	172,6	4	1	959	719	575
10	173,9	4	1	966	724	580







**AGREX S.p.A.**

**Production & Sales Dept:**

---

Via Balla, 55/57 (Loc. Taggi di Sotto)

---

35010 Villafranca Padovana (PD) - ITALIA

---

Tel. +39 049 50 00 000

---

Fax. +39 049 90 75 524

---

E-mail: [info@agrex.com](mailto:info@agrex.com)

---

Web Site: [www.agrex.com](http://www.agrex.com)

---