

Commercial Frontload Washers

Refer to Page 5 for Model Numbers

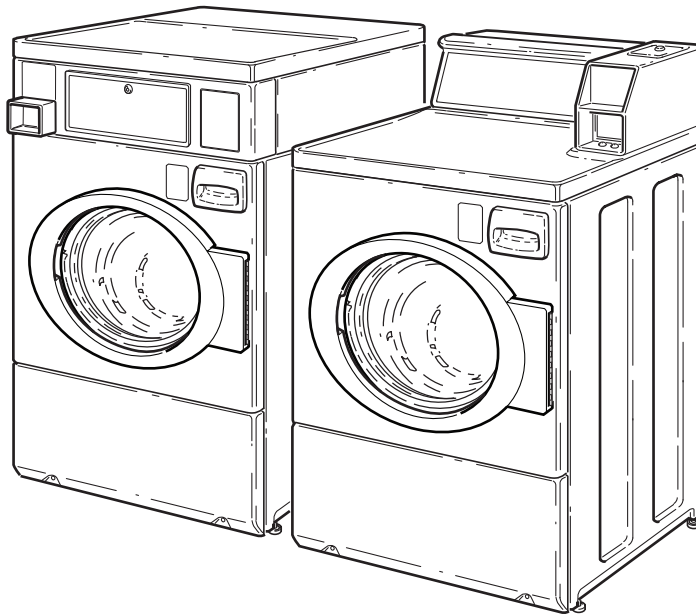

FLW1535C

— Troubleshooting —

Table of Contents

Section 1 – Safety Information	2
Locating an Authorized Servicer.....	3
Section 2 – Introduction	4
Customer Service.....	4
Nameplate Location.....	4
Model Identification	5
Theory of Operation	6
Section 3 – General Troubleshooting	8
1. Motor Circuit.....	8
2. Troubleshooting Knocking Noise	9
3. Troubleshooting Coin Drop	9
4. No Spin Due to Out-of-Balance Switch Wiring Problem Starting Serial Nos. Beginning 0307.....	14
5. Troubleshooting LEDs on Inverter Controls Starting Machine Serial No. 0911014603	15
6. No Spin	15
7. Troubleshooting Shock Absorber	17
Section 4 – Electronic Control Troubleshooting.....	18
8. Error Code Listing	18
9. PDA Does Not Communicate With Control.....	21
10. Coins Ignored When Entered.....	22
11. No Visible Display on Control.....	23
12. Washer Will Not Start – “door” Displayed.....	25
13. Washer Will Not Start – “E dL” on Display	27
14. Washer Will Not Fill (Machine Empty, No “E SP” on Display).....	29
15. Washer Overflows.....	31
16. Pump or Drain Valve Does Not Operate	33
17. Serial Communication Error (“E SP” on Display).....	35
18. Motor Does Not Run (“E dF” on Display)	37
19. Washer Will Not Heat (Models Equipped with Heater) (“E oP” or “E SH” Displayed)	39
20. Washer Will Not Heat (Models Equipped with Heater) (3 Phase Heater Machines Only)	41
Section 5 – Adjustments	43
21. Cabinet Leveling Legs	43
22. Loading Door	44
23. Motor Belt Tension	45
24. Door Catch	46
25. Shipping Braces	48
26. Cleaning Non-Electronic Coin Drop.....	49
27. Cleaning Electronic Coin Drop.....	51

© Copyright 2016, Alliance Laundry Systems LLC

All rights reserved. No part of the contents of this book may be reproduced or transmitted in any form or by any means without the expressed written consent of the publisher.

Section 1

Safety Information

Throughout this manual and on machine decals, you will find precautionary statements (“CAUTION,” “WARNING” and “DANGER”) followed by specific instructions. These precautions are intended for the personal safety of the operator, user, servicer, and those maintaining the machine.

▲ DANGER

Danger indicates an imminently hazardous situation that, if not avoided, will cause severe personal injury or death.

▲ WARNING

Warning indicates a hazardous situation that, if not avoided, could cause severe personal injury or death.

▲ CAUTION

Caution indicates a hazardous situation that, if not avoided, may cause minor or moderate personal injury or property damage.

Additional precautionary statements (“IMPORTANT” and “NOTE”) are followed by specific instructions.

IMPORTANT

The word “IMPORTANT” is used to inform the reader of specific procedures where minor machine damage will occur if the procedure is not followed.

NOTE

The word “NOTE” is used to communicate installation, operation, maintenance or servicing information that is important but not hazard related.

In the interest of safety, some general precautions relating to the operation of this machine follow.

	WARNING
<ul style="list-style-type: none">• Failure to install, maintain and/or operate this product according to the manufacturer’s instructions may result in conditions which can produce serious injury, death and/or property damage.• Do not repair or replace any part of the product or attempt any servicing unless specifically recommended or published in this Service Manual and unless you understand and have the skills to carry out the servicing.• Whenever ground wires are removed during servicing, these ground wires must be reconnected to ensure that the product is properly grounded and to reduce the risk of fire, electric shock, serious injury or death.	
<small>W006R2</small>	



WARNING

To reduce the risk of electric shock, fire, explosion, serious injury or death:

- Disconnect electric power to the washer before servicing.
- Never start the washer with any guards/panels removed.
- Whenever ground wires are removed during servicing, these ground wires must be reconnected to ensure that the washer is properly grounded.
- Motor not grounded! Disconnect electric power before servicing motor.

W485



WARNING

Repairs that are made to your products by unqualified persons can result in hazards due to improper assembly or adjustments subjecting you or the inexperienced person making such repairs to the risk of serious injury, electrical shock or death.

W007



WARNING

If you or an unqualified person perform service on your product, you must assume the responsibility for any personal injury or property damage which may result. The manufacturer will not be responsible for any injury or property damage arising from improper service and/or service procedures.

W008

NOTE: The WARNINGS and IMPORTANT INSTRUCTIONS appearing in this manual are not meant to cover all possible conditions and situations that may occur. Common sense, caution and care must be exercised when installing, maintaining or operating the washer.

Always contact your dealer, distributor, service agent or the manufacturer about any problems or conditions you do not understand.

Locating an Authorized Servicer

Alliance Laundry Systems is not responsible for personal injury or property damage resulting from improper service. Review all service information before beginning repairs.

Warranty service must be performed by an authorized technician, using authorized factory parts. If service is required after the warranty expires, Alliance Laundry Systems also recommends contacting an authorized technician and using authorized factory parts.

Section 2

Introduction

Customer Service

If literature or replacement parts are required, contact the source from whom the machine was purchased or contact Alliance Laundry Systems at (920) 748-3950 for the name and address of the nearest authorized parts distributor.

For technical assistance, call either of the numbers listed below:

(920) 748-3121 Ripon, Wisconsin

+32 56 41 20 54 Wevelgem, Belgium

Nameplate Location

When calling or writing about your product, be sure to mention model and serial numbers. Model and serial numbers are located on nameplate(s) as shown.

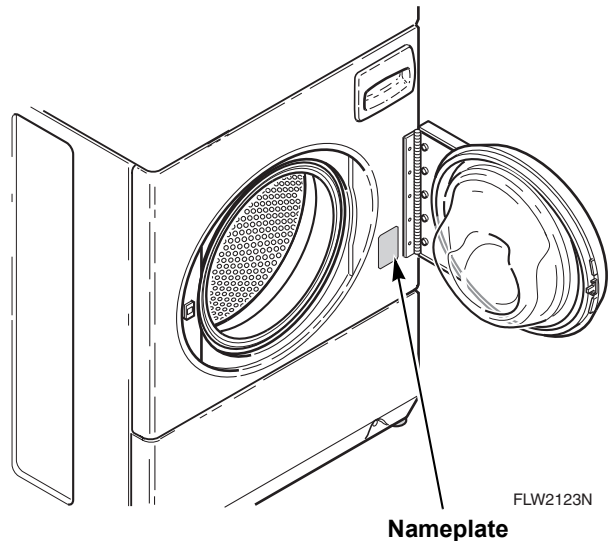

Model Identification

Information in this manual is applicable to these washers.

BF3LLFSG401UN01	NF3LLFSG401UN01	SFNLCFSP111TW01	SFNNXRSP111TW02
BF3LLFSG401UW01	NF3LLFSG401UT01	SFNLCFSP111TWNA	SFNNXRSP112TW02
BF3LLFSG402UN01	NF3LLFSG401UT06	SFNLCRSP111TW01	SFNNXRSP542NW23
BF3LLFSG402UW01	NF3LLFSG402UN01	SFNLCRSP111TW02	SFNNYFJP112TW01
BF3LLFSP401UN01	NF3LLFSG402UT01	SFNLCRSP111TWAF	SFNNYFSG112TN01
BF3LLFSP401UW01	NF3LLFSG402UT06	SFNLCRSP111TWNA	SFNNYFSG112TW01
BF3LLFSP402UN01	NF3LLFSP401NN22	SFNLXFSG082JW01	SFNNYFSP112TN01
BF3LLFSP402UW01	NF3LLFSP401NW22	SFNLXFSG111TW01	SFNNYFSP112TW01
BF3LXFSG401UN01	NF3LLFSP401UN01	SFNLXFSP111TN01	SFNNYRSP111TW01
BF3LXFSG401UW01	NF3LLFSP401UT01	SFNLXFSP111TW01	SFNNYRSP112TW01
BF3LXFSG402UN01	NF3LLFSP401UT06	SFNLXFSP301AN01	SFNWCFSG111TN01
BF3LXFSP401UN01	NF3LLFSP401UW01	SFNLXFSP301AW01	SFNWCFSG112TN01
BF3LXFSP401UW01	NF3LLFSP402NN22	SFNLXFSP302AN01	SFNWCFSG112TN11
BF3LXFSP402UN01	NF3LLFSP402NW22	SFNLXFSP302AW01	SFNWCFSP111TN01
BF3LXFSP402UW01	NF3LLFSP402UN01	SFNLYRSP111TW02	SFNWCFSP112TN01
HFNLEFSP111CW01	NF3LLFSP402UT01	SFNLYFJP111TW01	SFNWCFSP112TN11
HFNLEFSP111CWNA	NF3LLFSP402UT06	SFNLYFSG111TN01	SFNWYFSG111TN01
HFNLERSP111CW01	NF3LLFSP402UW01	SFNLYFSG111TW01	SFNWYFSG112TN01
HFNLERSP111CWNA	NF3LXFSG401UN01	SFNLYFSG111TWNA	SFNWYFSG112TN11
HFNLXFSP111CN01	NF3LXFSG401UW01	SFNLYFSP111TN01	SFNWYFSP111TN01
HFNLXFSP111CW01	NF3LXFSG402UN01	SFNLYFSP111TW01	SFNWYFSP112TN01
HFNLXRSP111CW01	NF3LXFSG402UW01	SFNLYFSP111TWNA	SFNWYFSP112TN11
HFNLYFSP111CW01	NF3LXFSP401UN01	SFNLYRSP111TW01	
HFNLYFSP111CWNA	NF3LXFSP401UW01	SFNLYRSP111TWNA	
HFNLYRSP111CW01	NF3LXFSP402NW22	SFNDCFJP112TW01	
HFNLYRSP111CWNA	NF3LXFSP402UN01	SFNDCFSG111TN01	
HFNNEFSP112CW01	NF3LXFSP402UW01	SFNDCFSG112TN01	
HFNNERSP112CW01	NF3LXFSP402UW06	SFNDCFSG112TQ01	
HFNNXFSP111CW01	NF3LYFSG401UW01	SFNDCFSG112TW01	
HFNNXFSP112CN01	NF3LYFSG402UW01	SFNDCFSP111TN01	
HFNNXFSP112CW01	PF3LGFSP402UG01	SFNDCFSP111TW01	
HFNNXRSP111CW01	PF3LLFSP402UG01	SFNDCFSP112TN01	
HFNNXRSP112CW01	PF3LXFSP402UG01	SFNDCFSP112TQ01	
HFNNYFSP112CW01	PFNLXFSP302UG01	SFNDCFSP112TW01	
HFNNYRSP112CW01	RFNLYFSP111CW01	SFNDCRSP111TW01	
JF3LEFSP411EW01	SFNLCFJP111TW01	SFNDCRSP111TW02	
JF3LGFSP411EW01	SFNLCFSG111TN01	SFNDCRSP112TW01	
JF3LGFSP411EW06	SFNLCFSG111TQ01	SFNDCRSP112TW02	
JF3LMFSG411EN01	SFNLCFSG111TW01	SFNNXFSG082JW01	
JF3LMFSG411EN06	SFNLCFSG111TWNA	SFNNXFSG112TW01	
JFNLEFSG301EW01	SFNLCFSP111TN01	SFNNXFSP112TN01	
JFNLEFSP301EW01	SFNLCFSP111TQ01	SFNNXFSP112TW01	

Theory of Operation

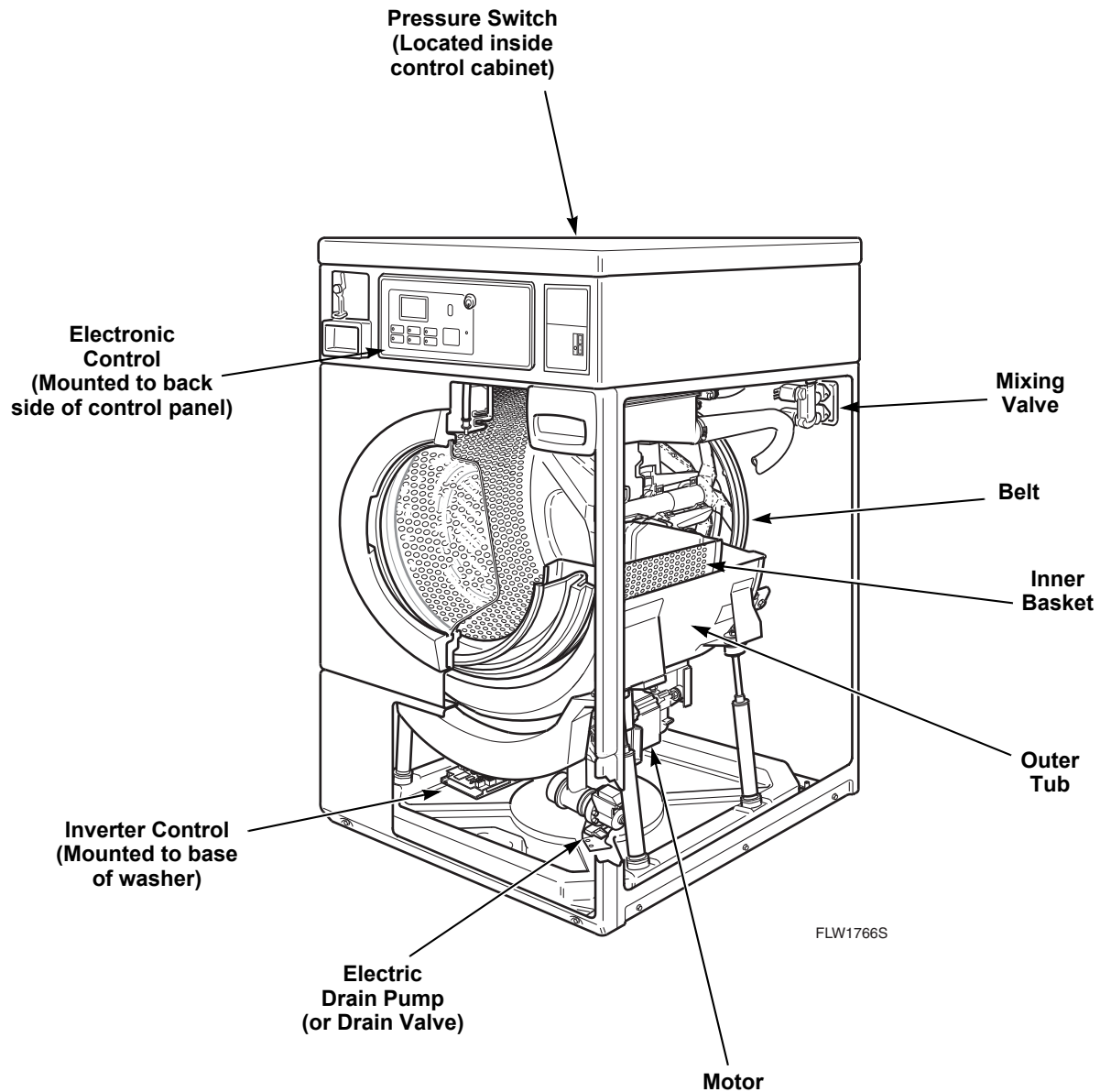

General

This frontload washer provides some of the same principles of operation as the typical topload washers. It senses water level, it dispenses the desired laundry detergent, agitates the clothes for good cleaning action, removes the water out of the washer and spins the clothing in preparation for the dryer.

The difference in operation is primarily the rotational washing agitation created for the horizontal basket and drum. This agitation tumbles the clothes in a clockwise, pause, and counter-clockwise direction. This reversing tumbling action provides an efficient washing process

and requires less laundry detergent and less water.

The cycle begins by locking the loading door after the vend is satisfied. The type of cycle and water temperature are determined by the appropriate pads on the electronic control.

The inner basket starts agitating during the wash water fill. A column of air is trapped in a pressure bulb and hose. The air pressure continues to increase as the inner basket fills with water until it is great enough to activate the pressure switch which then causes the wash fill to stop.

The agitate cycle tumbles the clothing in a clockwise direction for a period of 15 seconds, pauses for nine seconds and then tumbles the clothing in a counterclockwise direction for 15 seconds. This agitation continues until the end of the wash cycle. The machine stops agitating and turns on the pump or drain valve which removes the wash water.

Upon completion of the wash cycle, the machine goes into a rinse cycle. Fresh cold water is brought into the inner basket via the mixing valve until the pressure switch shuts off the water while agitating. The rinse cycle consists of agitation for a predetermined amount of time then a spin mode with the pump running where the machine goes into a series of 4 short 500 RPM spins. Two of these rinse cycles will normally take place with a third extra rinse cycle being optional.

After all the rinse cycles have been completed, the washer goes into a final spin cycle to extract as much water as possible from the clothing to prepare them for the dryer. The spin speeds and duration of this final spin cycle are determined by the type of wash cycle selected (refer to *Table 1* or *Table 2*).

NOTE: Washer may not reach 1000 RPM because of an out-of-balance condition. Control may limit speed depending on severity of out-of-balance condition.

Models Through Serial No. 0911014602

	Regular	Perm Press	Delicate
650 RPM	3 minutes	4 minutes	4 minutes
1000 RPM	3 minutes	2 minutes	0 minutes

Table 1

Models Starting Serial No. 0911014603

	Regular	Perm Press	Delicate
500 RPM	0 minutes	0 minutes	4 minutes
650 RPM	3 minutes	6 minutes	0 minutes
1000 RPM	3 minutes	0 minutes	0 minutes

Table 2

Technical

The basic operational system of this washer consists of the electronic control, the inverter control, pressure switch, water valves, electric pump (or drain valve) and A.C. motor.

The electronic control performs all control and timing functions like the timer in a topload washer. The electronic control sends simple speed and output commands to the inverter control via serial communication. The electronic control powers the door lock, pump (or drain valve) and the inverter control.

The inverter control powers the A.C. motor and performs all motor control functions. The inverter control also powers the water and dispenser valves and passes the pressure switch status to the electronic control. The inverter control is powered through the door switch, door lock switch and electronic control. The inverter control also alerts the electronic control to any errors in the motor.

The inverter control uses a speed sensor on the motor to measure the drum RPM. Before entering any spin step the inverter control measures the RPM of the drum to sense out-of-balance. The inverter control will try to redistribute the clothes if an out-of-balance condition exists the inverter control will limit the spin speed to several speeds depending on the severity of the out-of-balance condition. If the out-of-balance condition is severe enough the inverter control will limit speed to 90 RPM and will not spin.

NOTE: An additional out-of-balance switch is used to detect any out-of-balance condition during spins. If this switch opens during a spin step, the inverter control immediately stops and then restarts the spin.

Section 3

General Troubleshooting



WARNING

To reduce the risk of electric shock, fire, explosion, serious injury or death:

- Disconnect electric power to the washer before servicing.
- Never start the washer with any guards/panels removed.
- Whenever ground wires are removed during servicing, these ground wires must be reconnected to ensure that the washer is properly grounded.
- Motor not grounded! Disconnect electric power before servicing motor.

W485

1. Motor Circuit

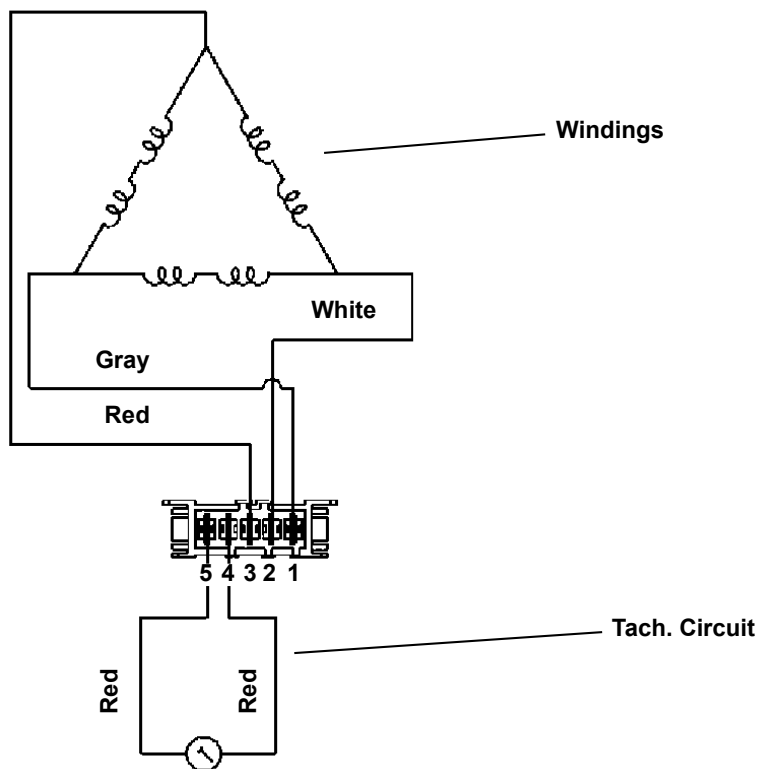

Resistance Values:

Tachometer Circuit:
Terminals 4-5
Approx. 115 ohms

Windings:

Terminals 1-2, 2-3, 1-3
Approx. 4.5 ohms



WARNING

To reduce the risk of electric shock, fire, explosion, serious injury or death:

- Disconnect electric power to the washer before servicing.
- Never start the washer with any guards/panels removed.
- Whenever ground wires are removed during servicing, these ground wires must be reconnected to ensure that the washer is properly grounded.
- Motor not grounded! Disconnect electric power before servicing motor.

W485

2. Troubleshooting Knocking Noise

If a frontload washer produces a noise similar to a knock on a door, it might be due to a flat spot on the belt. The knocking sound is made when the flat spot hits the pulley. The knocking may occur during a pulse spin and fade after reaching a higher RPM.

To correct this condition, replace the belt.

3. Troubleshooting Coin Drop

a. Non-Electronic Coin Drops:

When coin is placed into coin slot, the coin should roll down drop and be heard dropping into coin vault. If coin does not fall into coin vault or if coin drop sensor does not register that coin has been entered, follow troubleshooting instructions on following page. Refer to *Figure 1* for path that coin follows when working properly.

IMPORTANT: Never use oil to correct coin drop problems. Oil residue will prevent coins from rolling properly.

IMPORTANT: Do not bend or damage mechanical parts within coin drop.

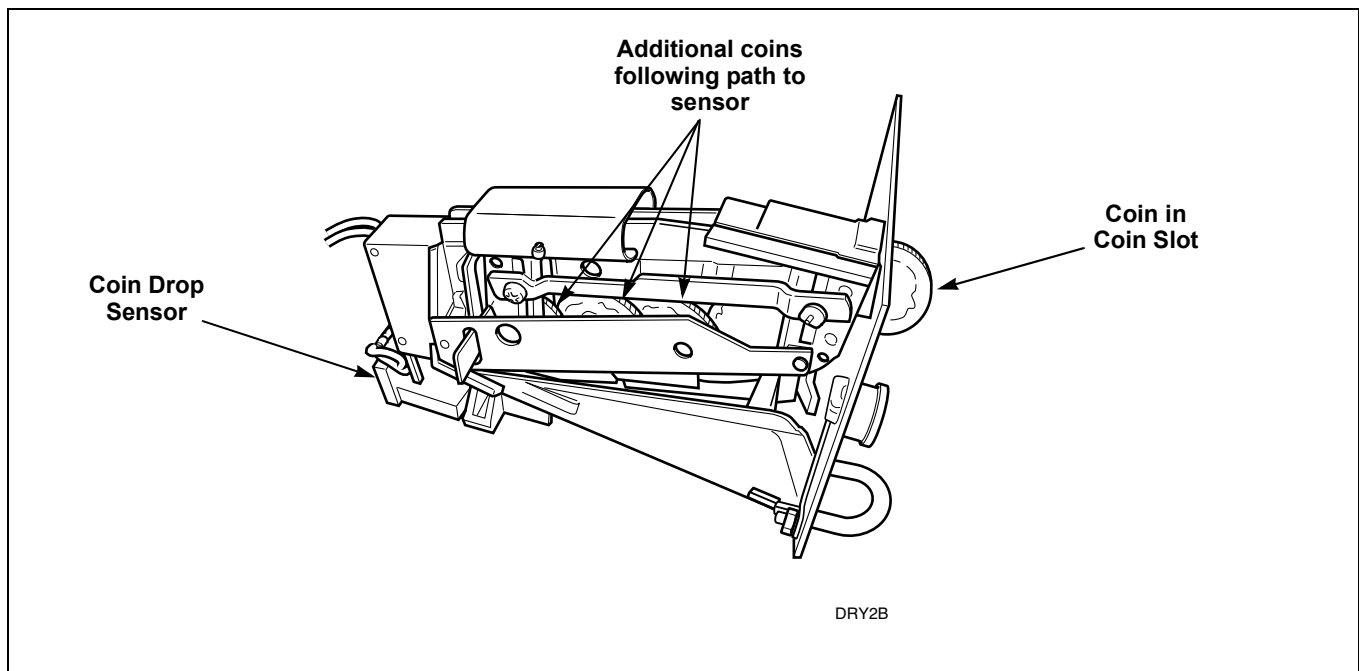

Figure 1



WARNING

To reduce the risk of electric shock, fire, explosion, serious injury or death:

- Disconnect electric power to the washer before servicing.
- Never start the washer with any guards/panels removed.
- Whenever ground wires are removed during servicing, these ground wires must be reconnected to ensure that the washer is properly grounded.
- Motor not grounded! Disconnect electric power before servicing motor.

W485

3. Troubleshooting Coin Drop (continued)

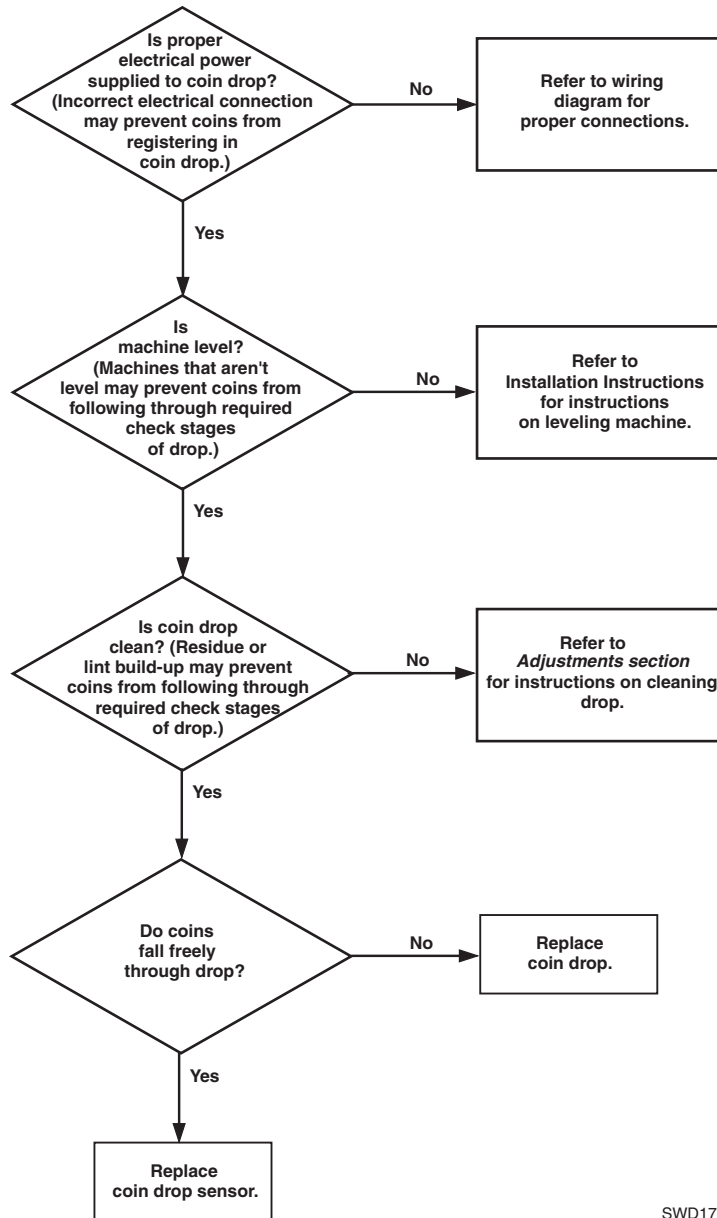

SWD1714S



WARNING

To reduce the risk of electric shock, fire, explosion, serious injury or death:

- Disconnect electric power to the washer before servicing.
- Never start the washer with any guards/panels removed.
- Whenever ground wires are removed during servicing, these ground wires must be reconnected to ensure that the washer is properly grounded.
- Motor not grounded! Disconnect electric power before servicing motor.

W485

b. Electronic Coin Drops:

If coin drop is not accepting coins, perform the following:

- (1) Clean coin drop. Refer to *Paragraph 27*.
- (2) On electronic coin drops with an old-style tension spring (shown in *Figure 2* and *Figure 4*), test and replace tension spring using the following instructions.

Remove Coin Drop From Machine

- (1) Disconnect electrical power to machine and drop.
- (2) Remove coin drop from machine.

Test Tension Spring

- (1) Push coin return button to open and close coin drop cover to clear possible coin jams. Refer to *Figure 2*.

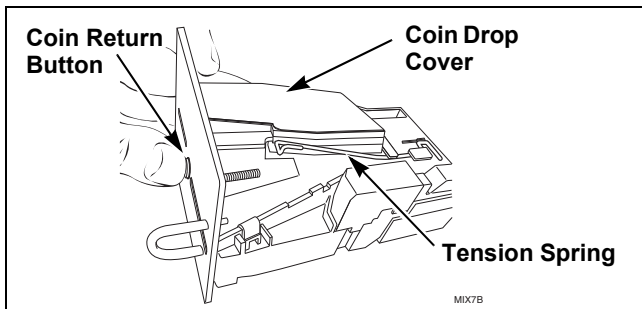

Figure 2

- (2) Manually hold down coin drop cover and insert coin. Refer to *Figure 3*.

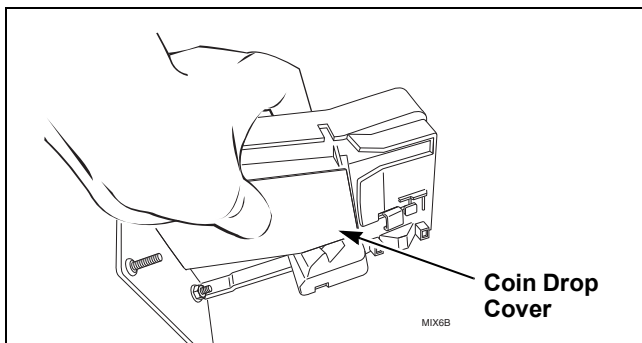

Figure 3

- (3) If coin drop now operates properly, replace tension spring using instructions on following pages.

Replace Tension Spring

- (1) Move tension spring downward until cover catch is free. Refer to *Figure 4*.

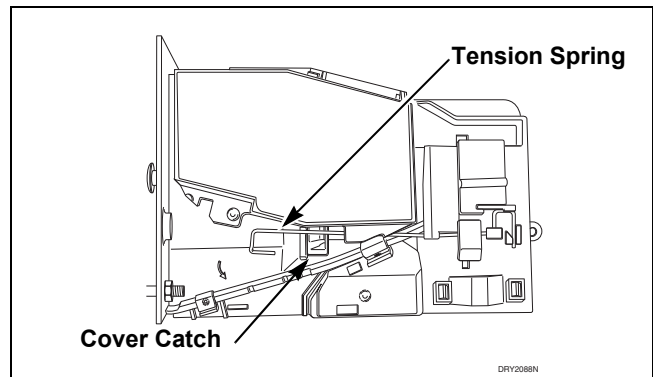

Figure 4

- (2) Open cover for coin drop.



WARNING

To reduce the risk of electric shock, fire, explosion, serious injury or death:

- Disconnect electric power to the washer before servicing.
- Never start the washer with any guards/panels removed.
- Whenever ground wires are removed during servicing, these ground wires must be reconnected to ensure that the washer is properly grounded.
- Motor not grounded! Disconnect electric power before servicing motor.

W485

- (3) Place a small flathead screwdriver under right side of tension spring and lift up. Refer to *Figure 5*.

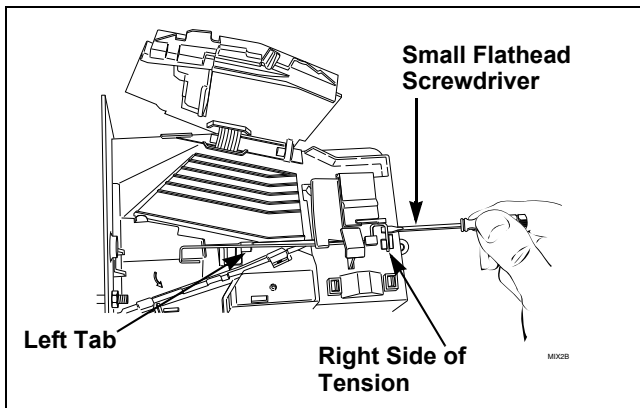

Figure 5

- (4) Use screwdriver to move spring approximately 3 mm to left.
 (5) Lift spring over left tab. Refer to *Figure 5*.
 (6) Rotate spring clockwise, 40 to 60 degrees, until it is free from right tabs. Refer to *Figure 6*.

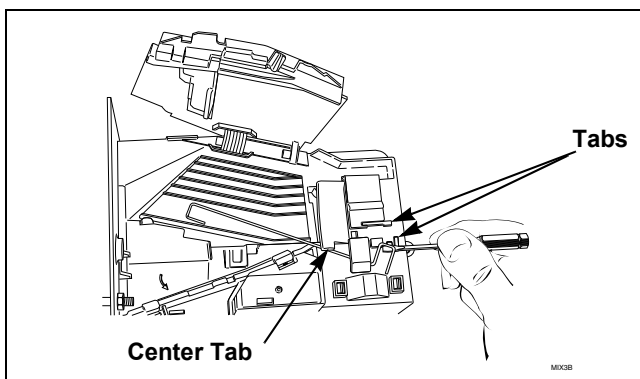

Figure 6

- (7) Use screwdriver to remove spring from center tab. Refer to *Figure 6*.
 (8) Lift spring, with attached clip, off drop.

- (9) Remove clip from spring. Refer to *Figure 7*.

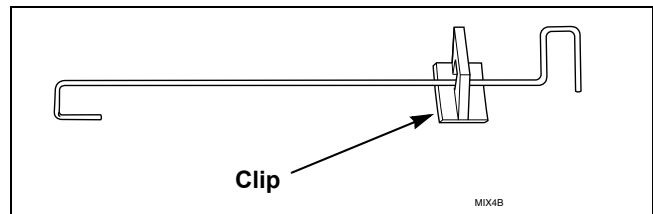

Figure 7

- (10) Attach clip to new tension spring, Part No. 209/00598/02.
 (11) Place clip, installed on spring, in slot on coin drop. Refer to *Figure 8*.

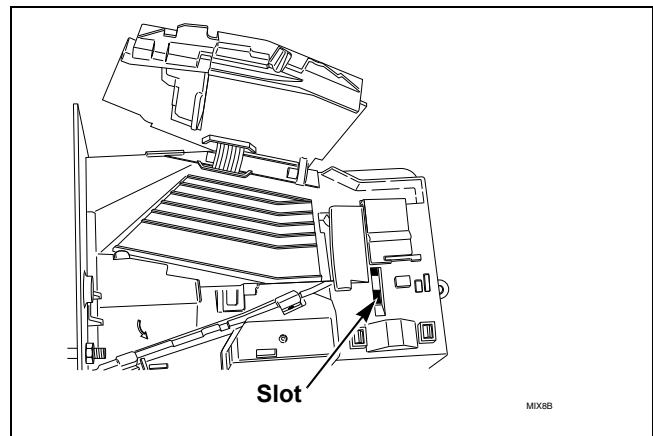

Figure 8



WARNING

To reduce the risk of electric shock, fire, explosion, serious injury or death:

- Disconnect electric power to the washer before servicing.
- Never start the washer with any guards/panels removed.
- Whenever ground wires are removed during servicing, these ground wires must be reconnected to ensure that the washer is properly grounded.
- Motor not grounded! Disconnect electric power before servicing motor.

W485

- (12) Use a small flathead screwdriver to push spring under center tab. Refer to *Figure 9*.

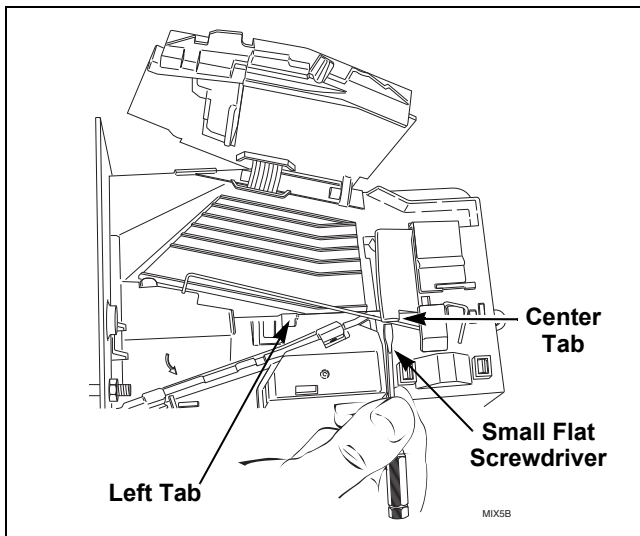

Figure 9

- (13) Lift spring gently to place in position under left tab.
- (14) Push spring to right until it snaps into position. Refer to *Figure 5*.
- (15) Close coin drop cover.
- (16) Move tension spring over cover catch. Refer to *Figure 4*.

Reinstall Coin Drop Into Machine

- (1) Reinstall coin drop into machine.
- (2) Reconnect electrical power to machine and drop.
- (3) Add a coin to drop to verify that coin drop is operating properly and that electrical connection is working properly.



WARNING

To reduce the risk of electric shock, fire, explosion, serious injury or death:

- Disconnect electric power to the washer before servicing.
- Never start the washer with any guards/panels removed.
- Whenever ground wires are removed during servicing, these ground wires must be reconnected to ensure that the washer is properly grounded.
- Motor not grounded! Disconnect electric power before servicing motor.

W485

4. No Spin Due to Out-of-Balance Switch Wiring Problem Starting Serial Nos. Beginning 0307

A “no spin” condition could be the result of an open circuit in the wire harness or out-of-balance switch. First, check that the harness is still connected to the out-of-balance switch. The out-of-balance switch is a **normally closed switch**. (continued)

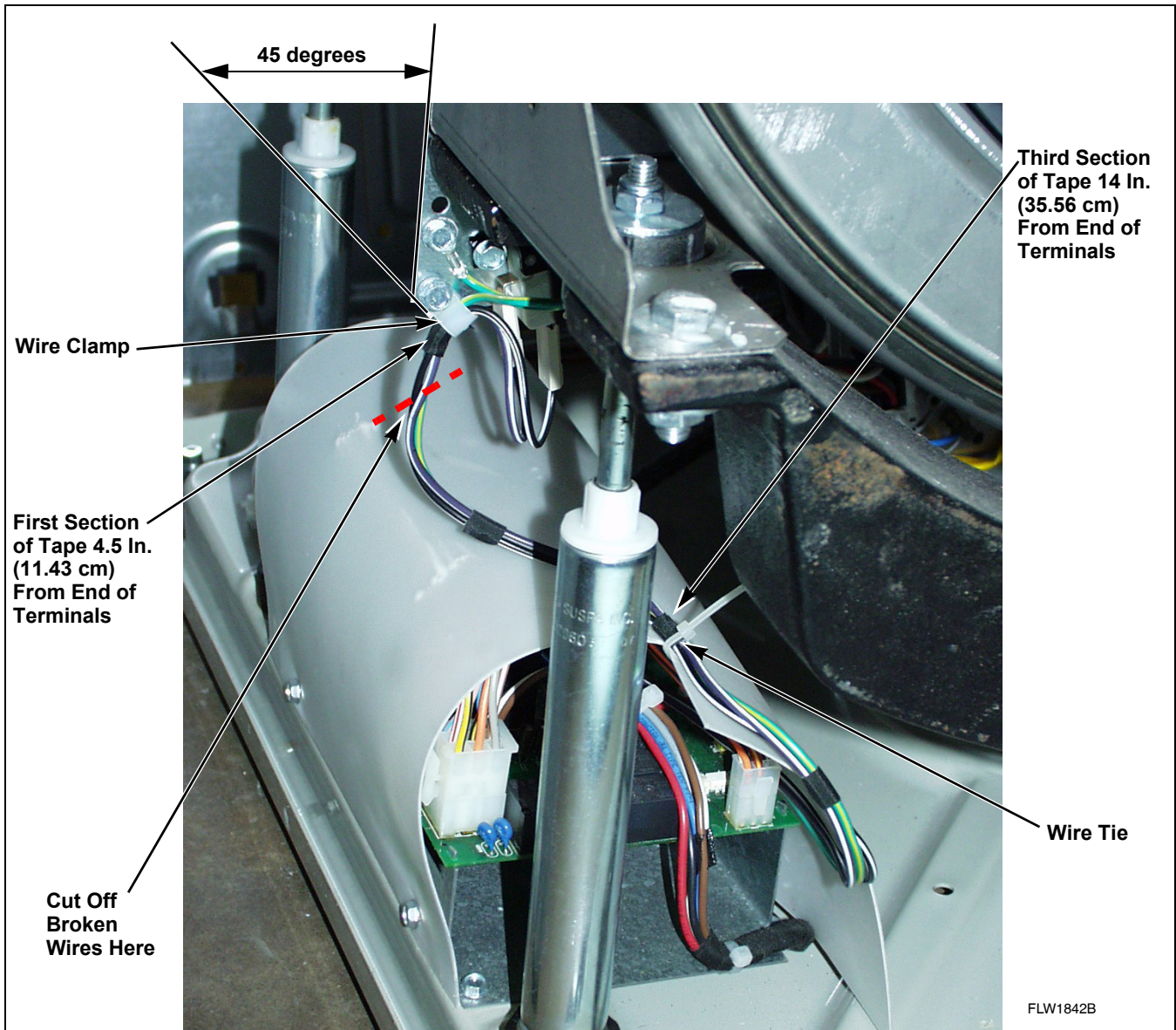

Figure 10



WARNING

To reduce the risk of electric shock, fire, explosion, serious injury or death:

- Disconnect electric power to the washer before servicing.
- Never start the washer with any guards/panels removed.
- Whenever ground wires are removed during servicing, these ground wires must be reconnected to ensure that the washer is properly grounded.
- Motor not grounded! Disconnect electric power before servicing motor.

W485

If broken wires are found at the out-of-balance switch wire support, cut off portion of wires as shown in *Figure 10* and add new UL approved terminals.

- a. To test the electrical circuit, disconnect electrical power to the washer.
- b. Remove the “H1” connector from the inverter control assembly.
- c. Use an Ohm meter to check the black/white to violet/white wires. Circuit should read closed. An open reading indicates a bad switch or wire harness problem.
- d. Flex the harness at the plastic wire clamp and test continuity. If the base wire harness has an open circuit it **MUST** be replaced or the broken wires must be repaired with UL approved terminals.
- e. After replacing or repairing the wire harness, wrap electrical tape around wires in two locations as indicated below and in *Figure 10*. Then secure the harness wires to the original factory locations using clamp and wire tie. Refer to *Figure 10*.
 - (1) The plastic wire clamp should be angled toward the switch at 45 degrees.
 - (2) The clamp should wrap around the first section of tape on the harness, which should be placed approximately 4.5 inches (11.43 cm) from end of terminals.
 - (3) The harness should be secured to the inverter control shield with a wire tie.
 - (4) The tie should wrap around the third section of tape on the harness, which should be placed approximately 14 inches (35.56 cm) from end of terminals. Refer to *Figure 10*.

5. Troubleshooting LEDs on Inverter Controls Starting Machine Serial No. 0911014603

There are three LEDs on the control to assist with troubleshooting (refer to *Figure 11*):

- Green LED on constant = 5VDC power supply present
- Green LED flashing one second on/one second off = inverter control power up
- Red LED flashing four times/second = inverter control is communicating with front end control

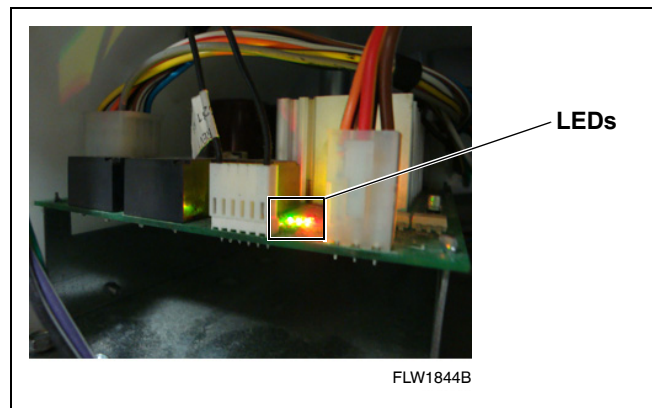

Figure 11

6. No Spin

A no spin condition is not caused by intermittent operation of the motor or motor control (inverter assembly). **DO NOT** replace these components for no spin complaints if the unit passes the following procedure:



WARNING

To reduce the risk of electric shock, fire, explosion, serious injury or death:

- Disconnect electric power to the washer before servicing.
- Never start the washer with any guards/panels removed.
- Whenever ground wires are removed during servicing, these ground wires must be reconnected to ensure that the washer is properly grounded.
- Motor not grounded! Disconnect electric power before servicing motor.

W485

6. No Spin (continued)

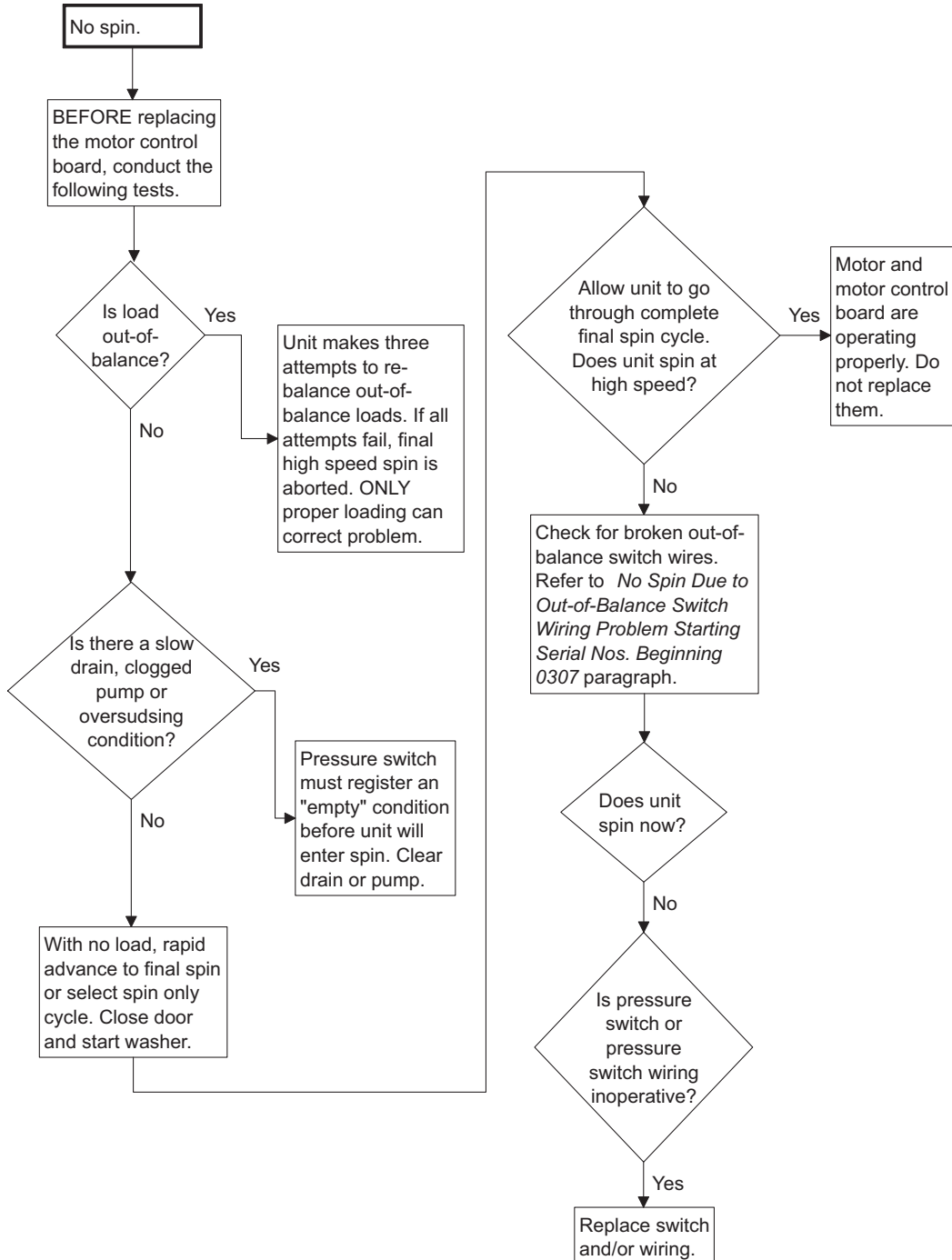

FLW1789S



WARNING

To reduce the risk of electric shock, fire, explosion, serious injury or death:

- Disconnect electric power to the washer before servicing.
- Never start the washer with any guards/panels removed.
- Whenever ground wires are removed during servicing, these ground wires must be reconnected to ensure that the washer is properly grounded.
- Motor not grounded! Disconnect electric power before servicing motor.

W485

7. Troubleshooting Shock Absorber

A squeaking noise, oil seen on the base of the washer, or an out-of-balance condition may mean one or more shock absorbers need to be replaced.

To determine if there is an inoperative shock:

1. Remove front access panel.
2. Check height of rod or rod spacing above shock.
If all four shocks are uniform and have about two inches of rod showing when basket is empty, shocks don't need replacing. Refer to *Figure 12*.

If one or more shocks is showing less than two inches of rod, then an internal spring has broken and all four shocks should be replaced.

3. Check base of washer below shock absorbers for grease or oil. Shocks are not oil filled. Any oil is from grease used internally to lubricate damper of shock. A small amount of grease/oil on base is normal and doesn't indicate failure. A large amount of grease/oil indicates a shock that might fail soon. Do not replace shock until the internal spring has broken as described in step 2.

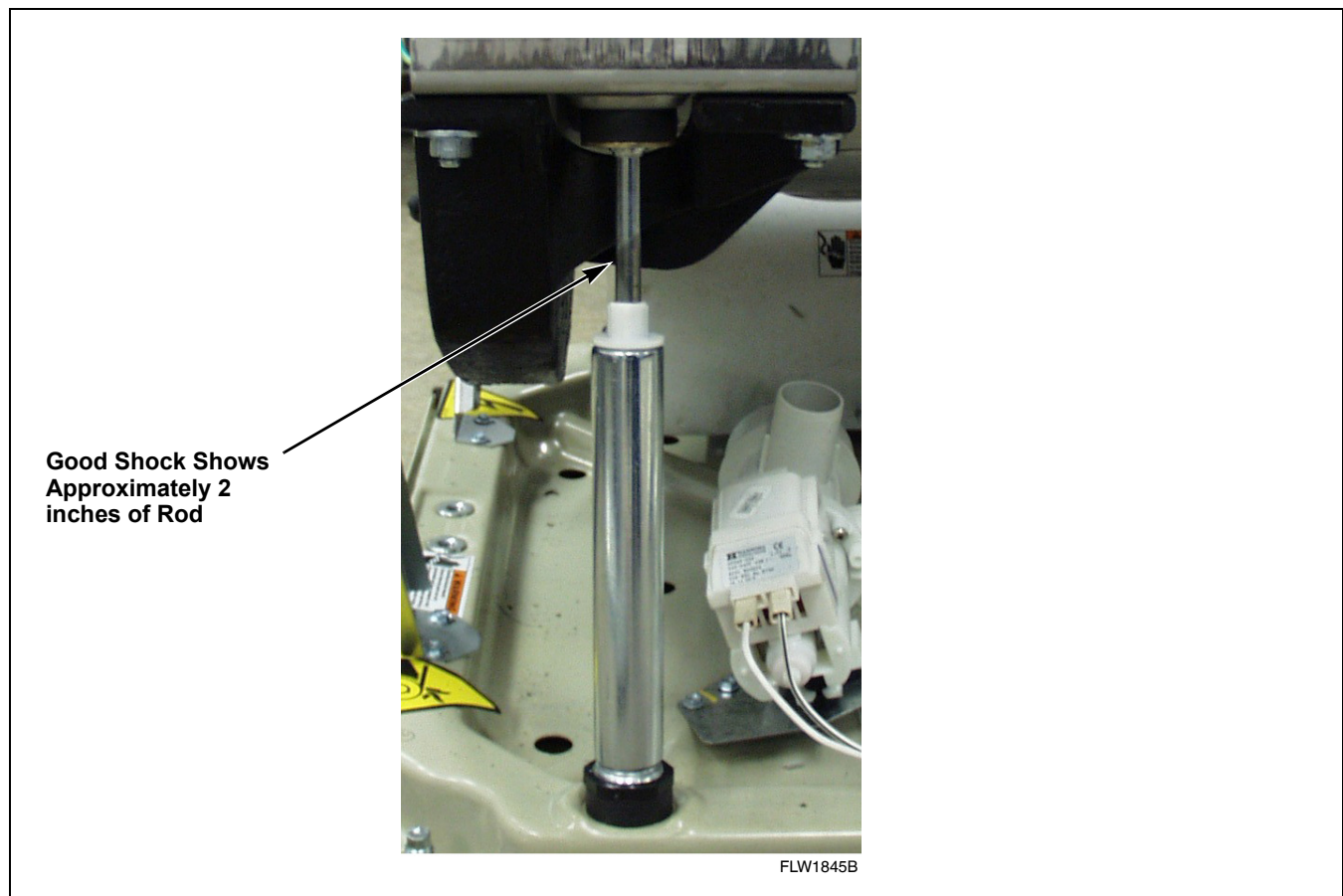



Figure 12

Section 4

Electronic Control Troubleshooting

	WARNING
<p>To reduce the risk of electric shock, fire, explosion, serious injury or death:</p> <ul style="list-style-type: none"> • Disconnect electric power to the washer before servicing. • Never start the washer with any guards/panels removed. • Whenever ground wires are removed during servicing, these ground wires must be reconnected to ensure that the washer is properly grounded. • Motor not grounded! Disconnect electric power before servicing motor. 	
W485	

8. Error Code Listing

Following is a list of possible error codes for an electronic control. Errors beginning with “EI” refer to external device Infra-red communication errors. Errors

beginning with “EC” refer to card reader errors. All other errors refer to machine errors.

Display	Description	Cause/ Corrective Action
EI01	Transmission Failure	Communication failure. Re-aim external device and try again.
EI02	Time-out Error	Communication failure. Re-aim external device and try again.
EI03	Invalid Command Code	Communication successful, but the command was not valid for this machine type, or the control could not perform the command in its current mode of operation. Ensure data is for current machine type and control is in correct mode.
EI04	Expecting Upload Request	Communication failure. Re-aim external device and try again.
EI05	Invalid or Out-of-Range Data	The value in at least one of the programming options is invalid or out of range. Recheck the programming option’s value and try again.
EI09	CRC-16 Error	Communication failure. Re-aim external device and try again.
EI0A	Framing Error	Communication error. Re-aim external device and try again.
EI0C	Time-out Exceeded	Communication error. Re-aim external device and try again.
EI0E	Encryption Error	Communication error. Re-aim external device and try again. If the problem persists, check that the security code is correct.

Table 3

Display	Description	Cause/ Corrective Action
EI0F	Infra-red Disabled	Communication failure or infra-red is disabled. Manually enable infra-red on control or re-aim external device and try again.
EC02	Time-out Error	Communication failure. Try card again.
EC03	Invalid Command Code	Communication successful, but the command was not valid for this machine type, or the control could not perform the command in its current mode of operation. Ensure data is for current machine type and control is in correct mode.
EC05	Invalid or Out-of-Range Data	The value in at least one of the programming options is invalid or out of range. Recheck the programming option's value and try again.
EC11	No Card Reader Initialization	Communication is valid, but there is no card reader initialization. Power down, power up and try again.
EC18	No Communication	Card reader is initialized, communication lost. Power down, power up and try again. If error persists, replace control or card reader.
EC19	No Card Reader Communication	Communication failure. Power down, power up and try again. If error persists, replace control or card reader.
Right most decimal point Lit	Network Communication Error	Communication problem. Wait for 1.5 minutes for error to clear. If error doesn't clear, power-down and power-up the machine. If error persists, replace control or network board.
ALrn	Break-in Alarm Error	Service the door or coin vault switches.
oFF	Break-in Alarm Shutdown Error	Service the door or coin vault switches.
E FL	Fill Error	Pressure switch fails to open in 30 minutes (or other programmed length of time) in any fill agitate cycle.
E SP	SPI Communications Error	Master control cannot communicate with motor control. Caused by transformer unplugged or wiring to motor control incorrect. Power down the machine, power up and try again.
E dL	Door Lock Error	Door does not lock within 15 seconds of closing (open and reclose door) or doesn't unlock 3 minutes after cycle completion.
E do	Door Opened During A Running Cycle	Control detects door open and door locked inputs high. Caused by pulling on door while locked or about to lock. Correct inoperative door locking system.
E Ub	Unbalance Error	Unable to balance load. Redistribute load and run cycle.
E dF	Drive Failure	Motor unplugged, motor failure, tachometer circuit open or drum locked up. Unpower machine to reset.
EdF1	Motor/Control Failure	No tachometer signal within six seconds; Refer to <i>Motor Does Not Run</i> paragraph

Table 3

Electronic Control Troubleshooting

Display	Description	Cause/ Corrective Action
EdF2	Motor/Control Failure	DC Bus Voltage error; Replace inverter control
EdF3	Motor/Control Failure	Control senses five consecutive overcurrent faults from IPM; Replace inverter control
EdF4	Motor/Control Failure	IPM temperature error; Replace inverter control
EdF5	Motor/Control Failure	Motor fails to spin up to 20 RPM in 10 seconds; Refer to <i>Motor Does Not Run</i> paragraph
door	Door Open Indicator	Door is not closed during an active cycle. If door is closed, check for improper wiring or faulty door switch.
E rr	Coin Error	Invalid coin pulse or inoperative coin sensor. Check coin drop area and remove obstructions. If error persists, tampering may have occurred. Evaluate security procedures.
E oP (models equipped with heater)	Open Thermistor Error	Thermistor circuit opens while heating. Heater will turn off and cycle will continue.
E SH (models equipped with heater)	Shorted Thermistor Error	Thermistor circuit is shorted while heating. Heater will turn off and cycle will continue.
E Ht (models equipped with heater)	Heater Error	Programmed temperature hasn't been reached in more than two hours. Cycle will continue with heater off.

Table 3

9. PDA Does Not Communicate With Control

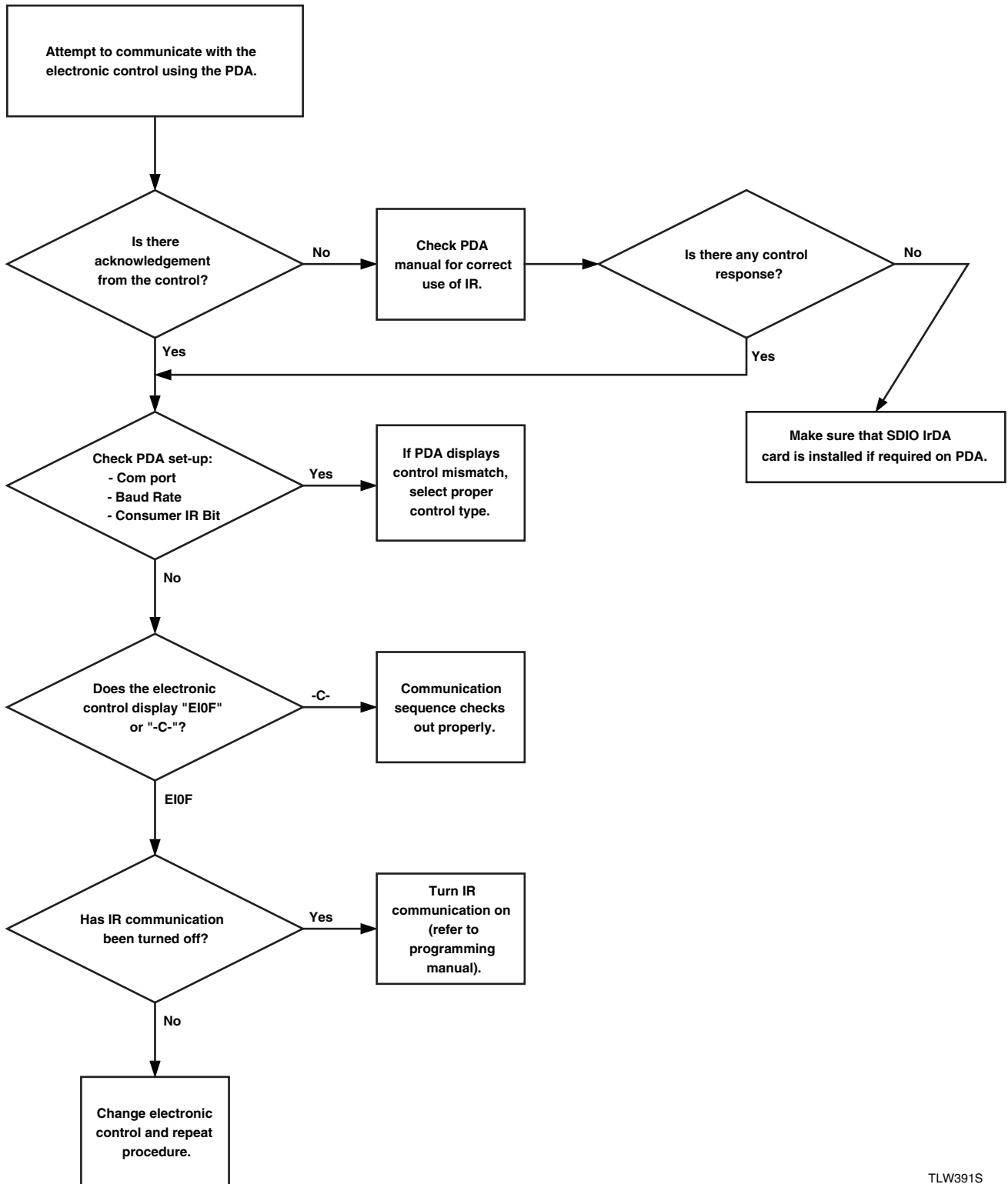

TLW391S

10. Coins Ignored When Entered

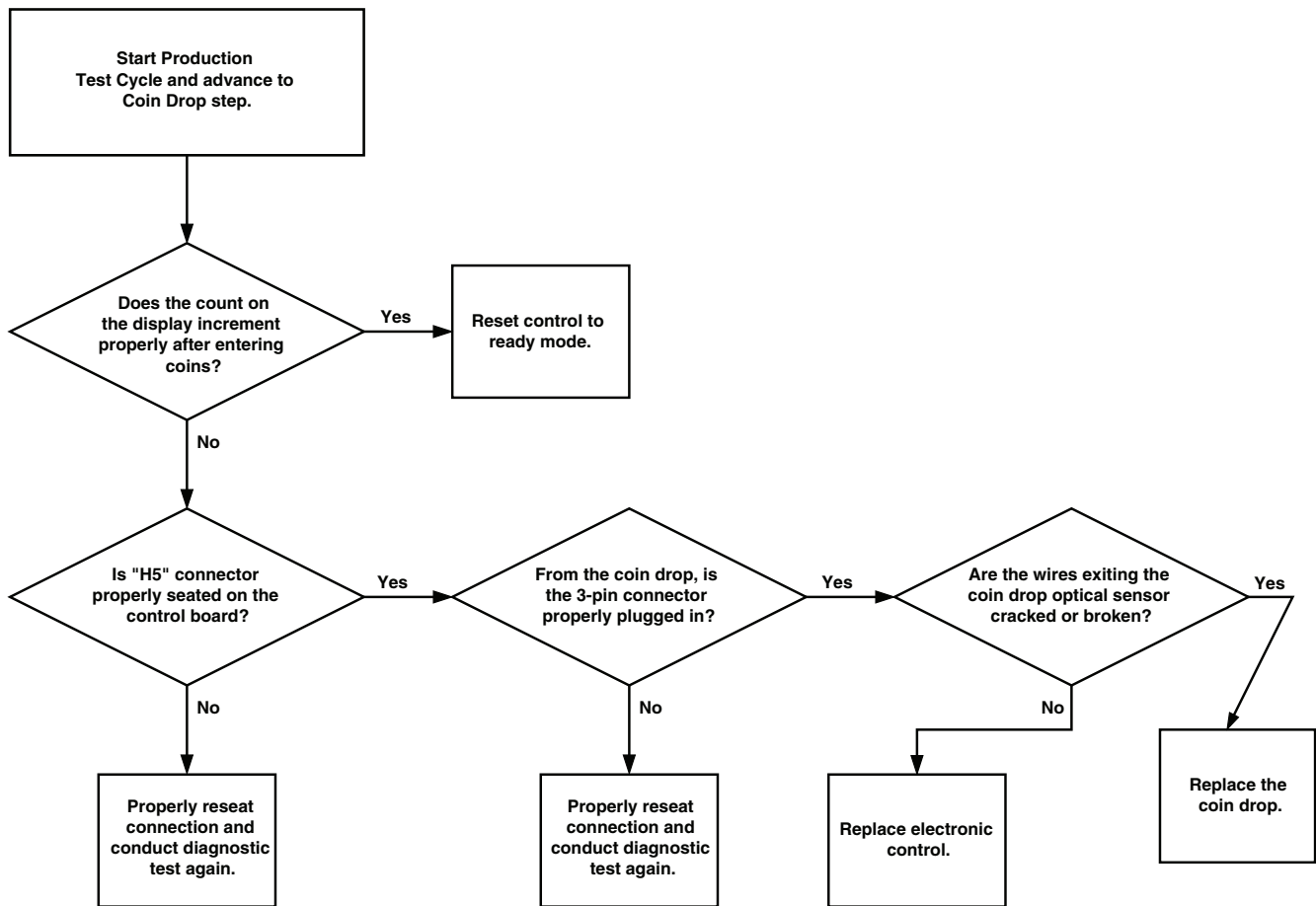

FLW1781S

11. No Visible Display on Control

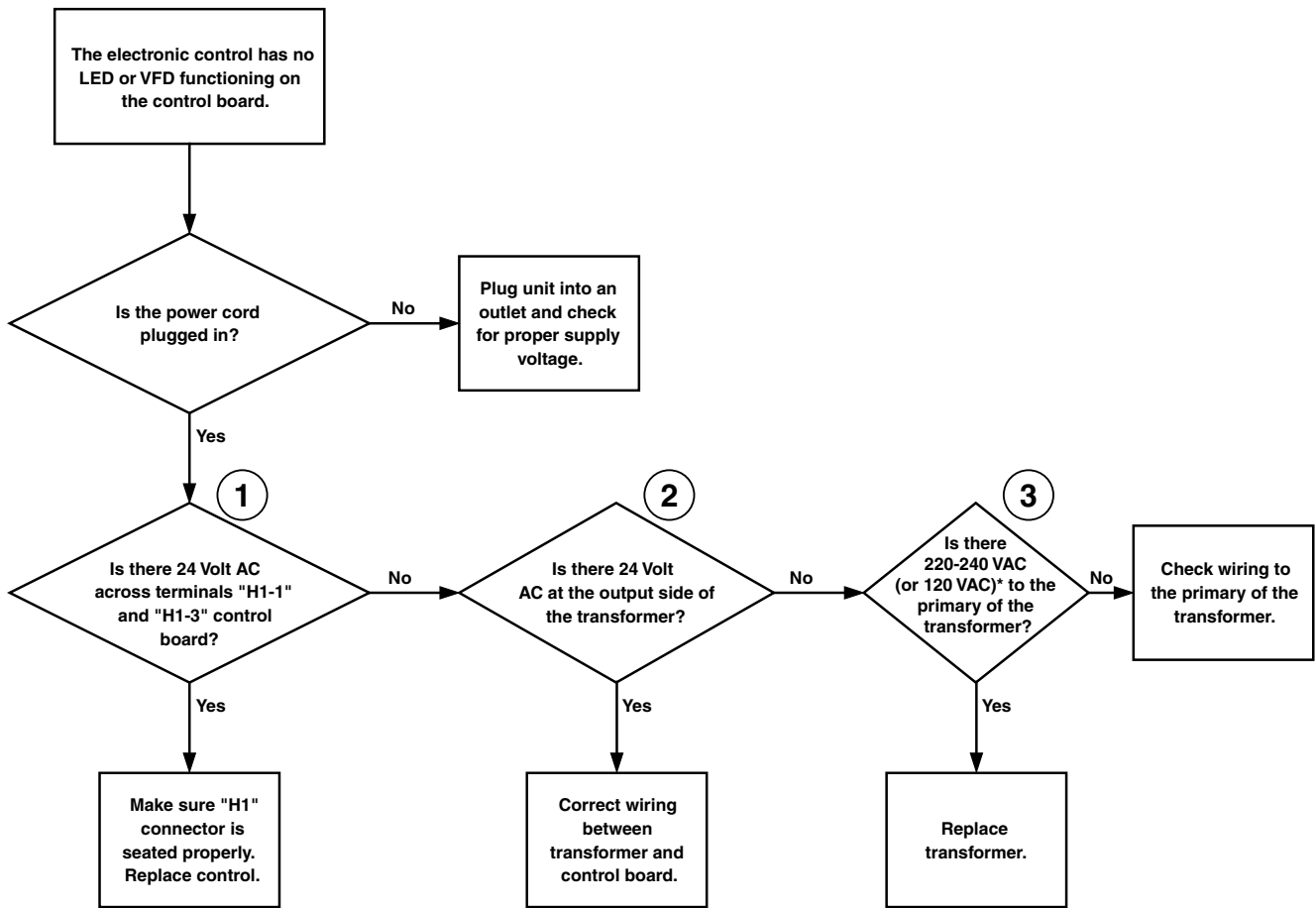

*Refer to machine serial plate for correct voltage.

FLW1695S

No Visible Display on Control

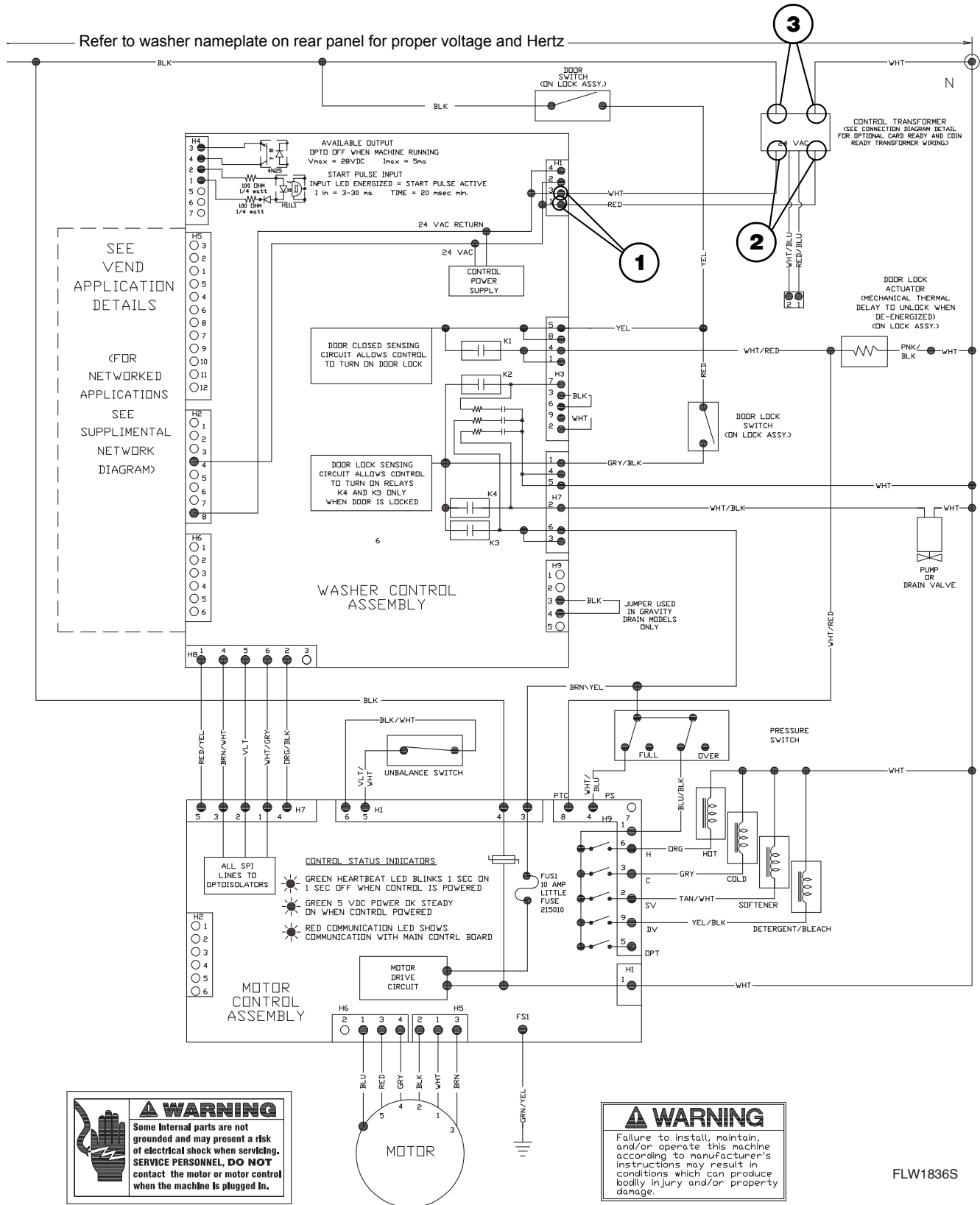

12. Washer Will Not Start – “door” Displayed

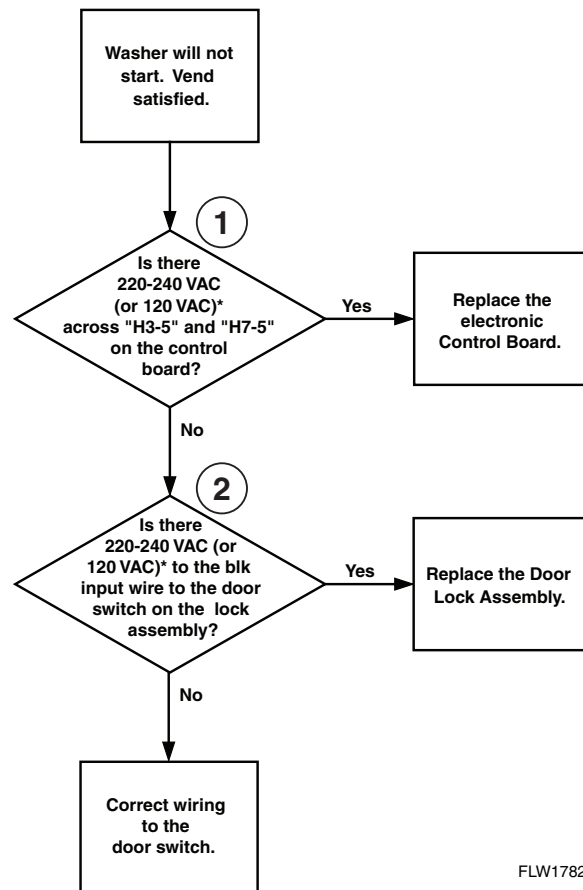

FLW1782S

*Refer to machine serial plate for correct voltage.

Washer Will Not Start – “door” Displayed

Refer to washer nameplate on rear panel for proper voltage and Hertz

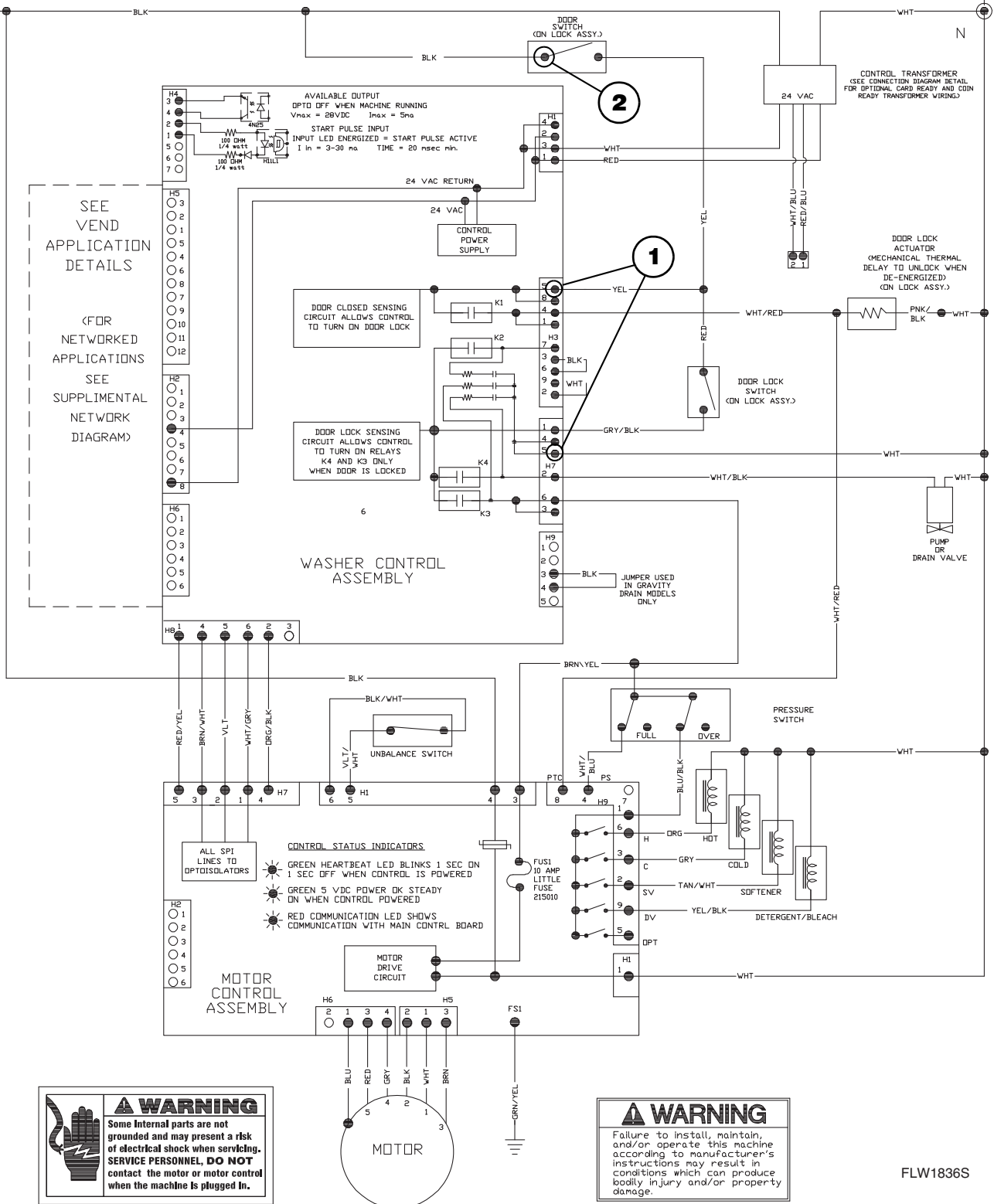

FLW1836S

13. Washer Will Not Start – “E dL” on Display

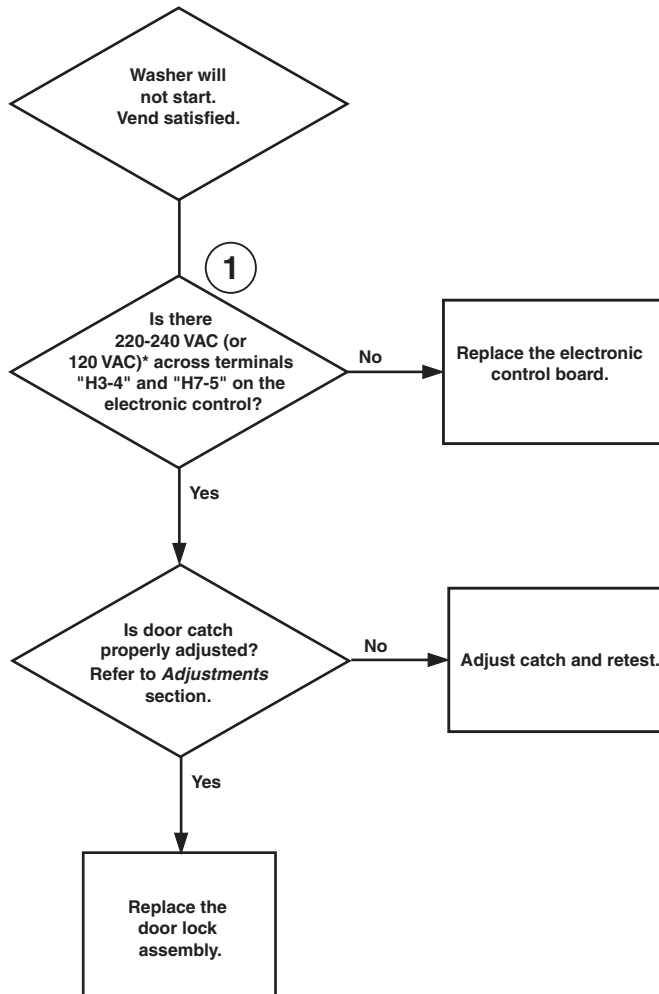

*Refer to machine serial plate for correct voltage.

FLW1783S

Washer Will Not Start – “E dL” on Display

Refer to washer nameplate on rear panel for proper voltage and Hertz

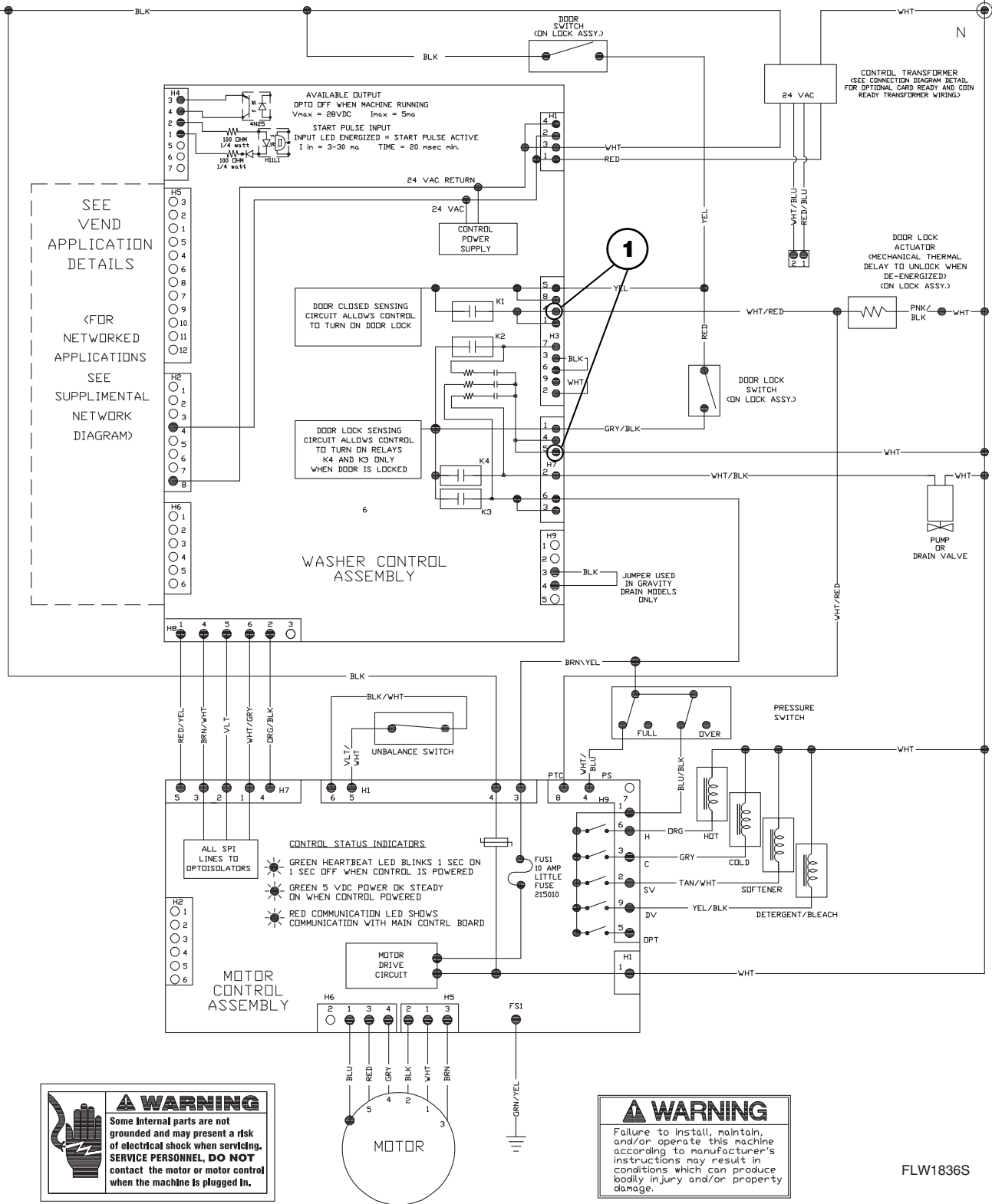

FLW1836S

14. Washer Will Not Fill (Machine Empty, No "E SP" on Display)

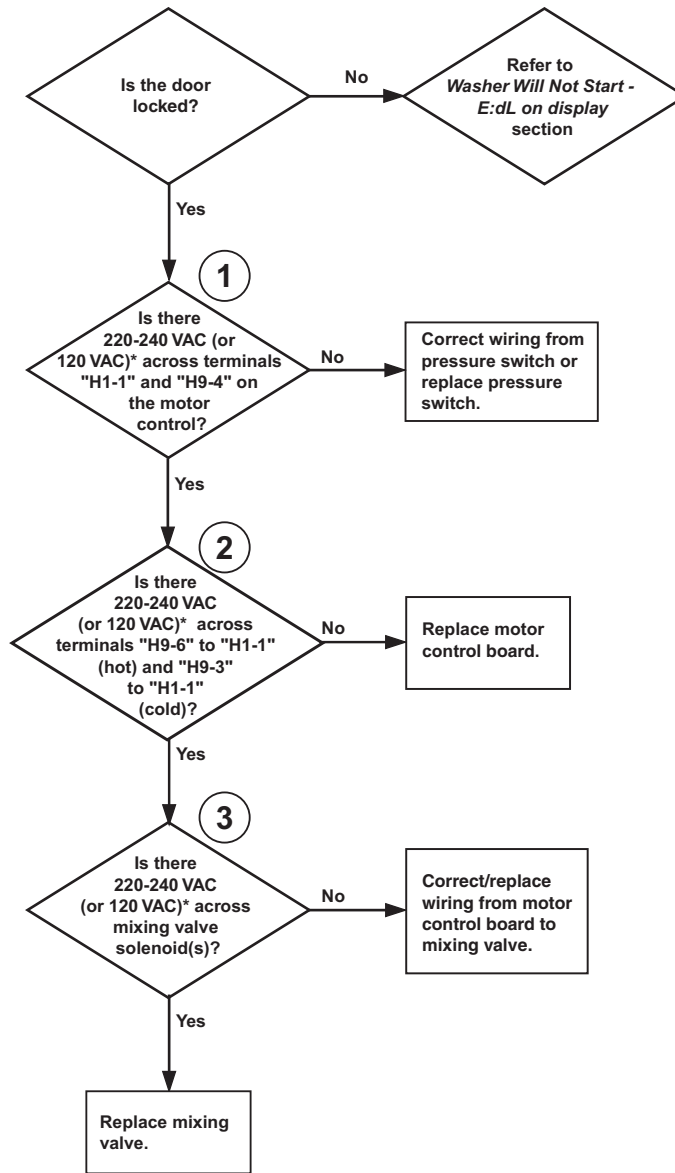

*Refer to machine serial plate for correct voltage.

FLW1787S

Washer Will Not Fill (Machine empty, No "E SP" on Display)

Refer to washer nameplate on rear panel for proper voltage and Hertz

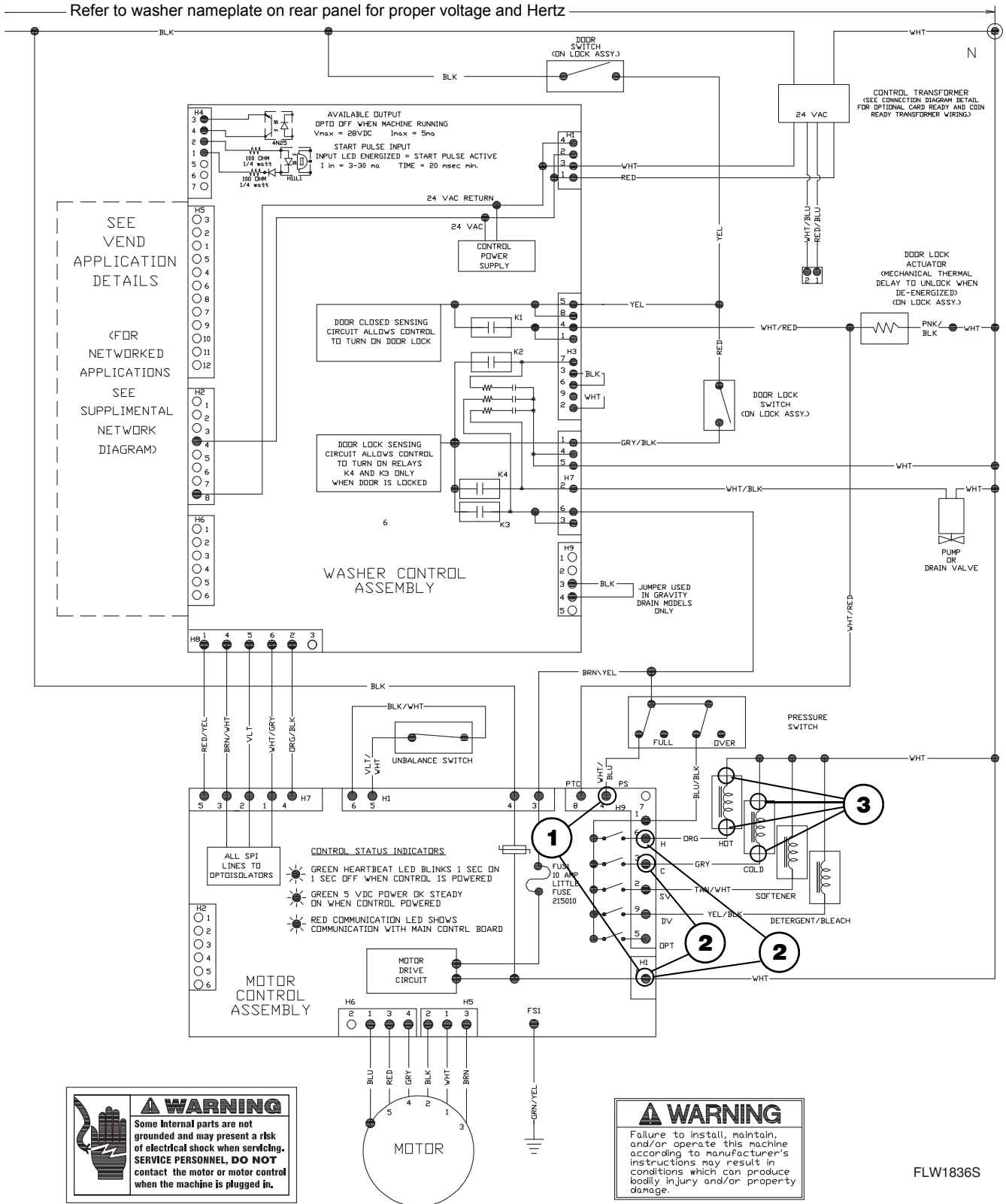

FLW1836S

15. Washer Overflows

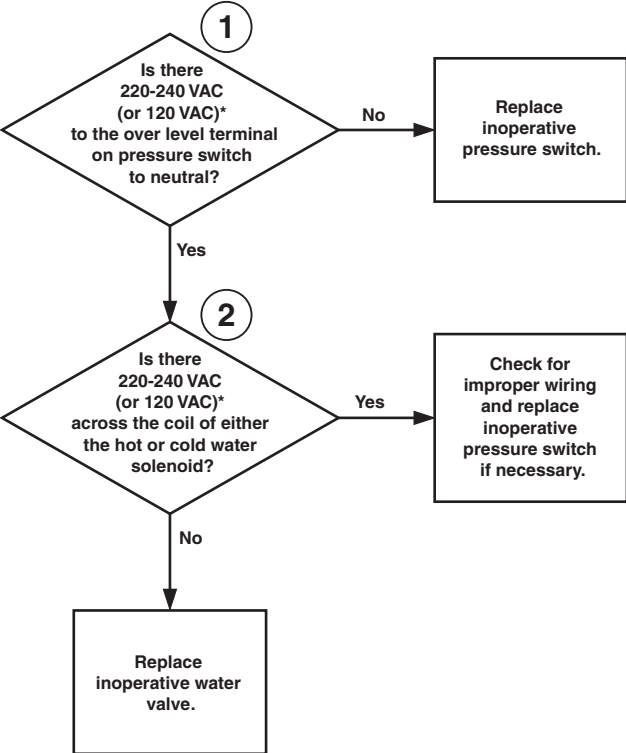

*Refer to machine serial plate for correct voltage.

FLW1699S

Washer Overflows

Refer to washer nameplate on rear panel for proper voltage and Hertz

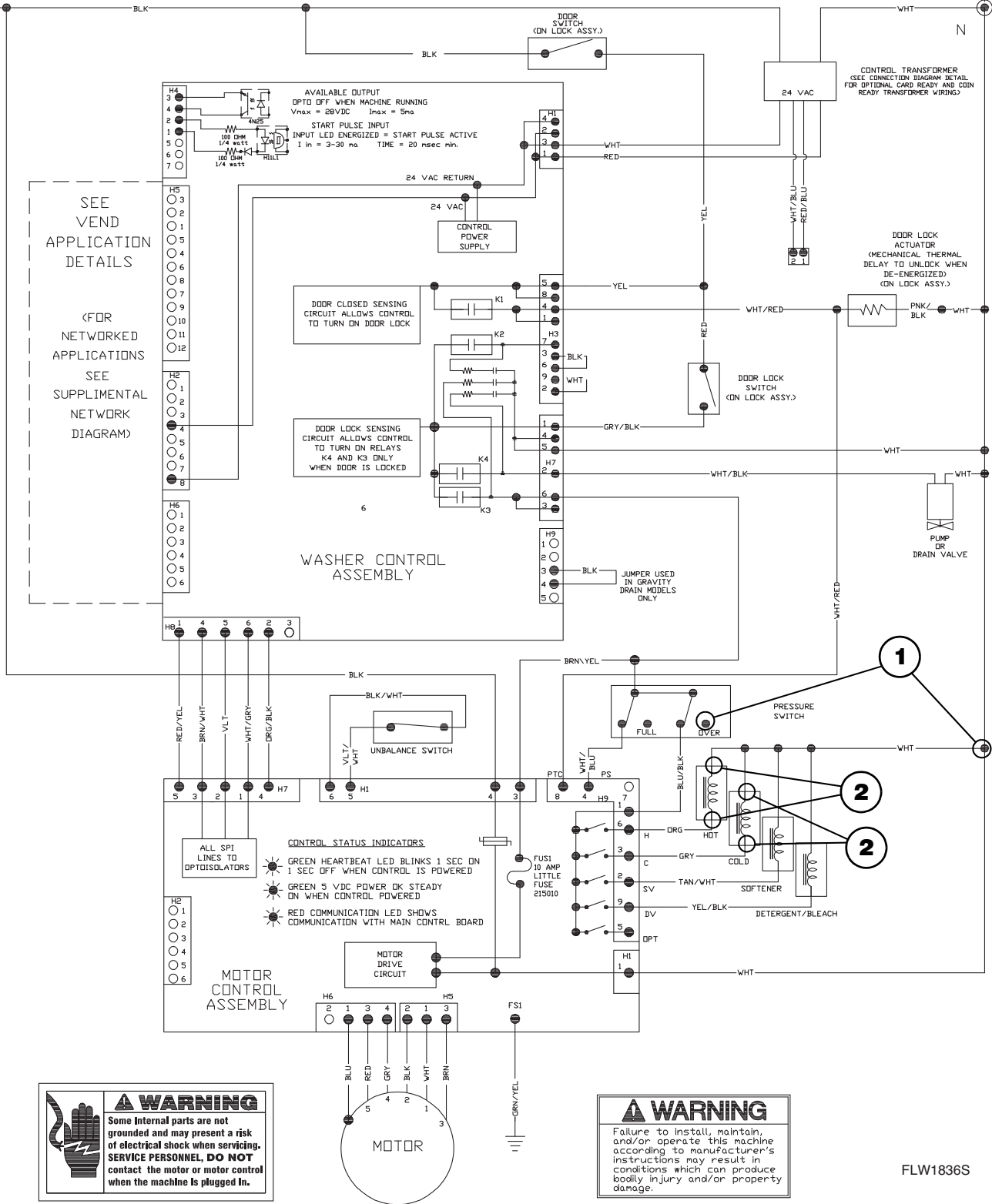

FLW1836S

16. Pump or Drain Valve Does Not Operate

NOTE: Check at beginning of spin/drain portion of cycle.

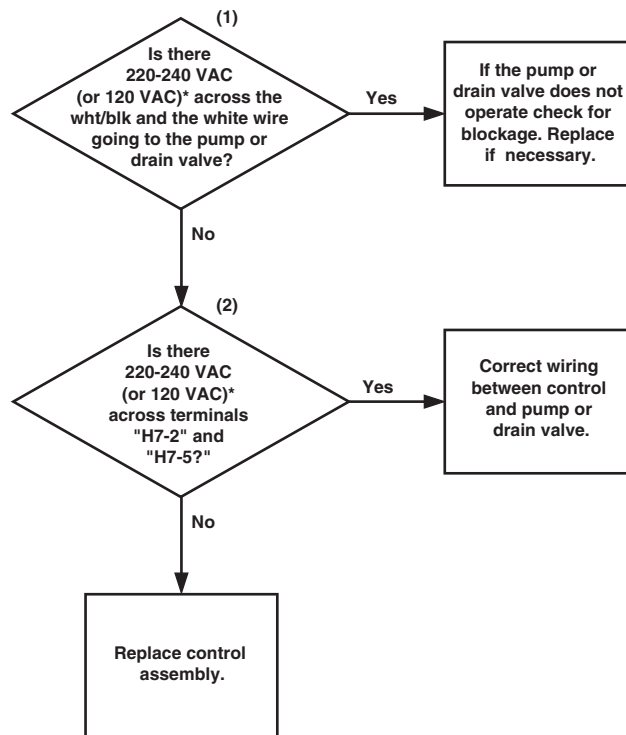

*Refer to machine serial plate for correct voltage.

FLW1784S

Pump or Drain Valve Does Not Operate

Refer to washer nameplate on rear panel for proper voltage and Hertz

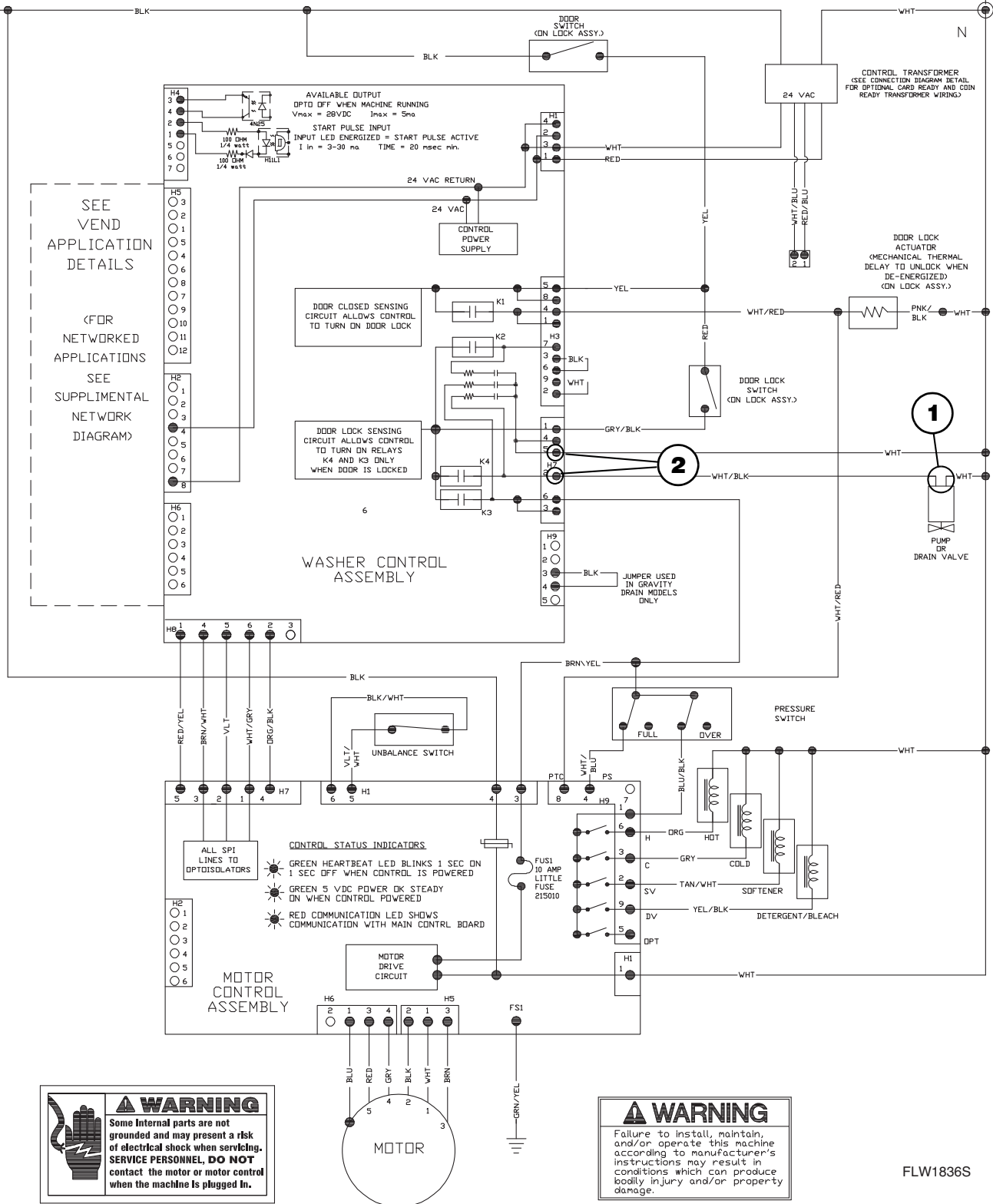

FLW1836S

17. Serial Communication Error (“E SP” on Display)

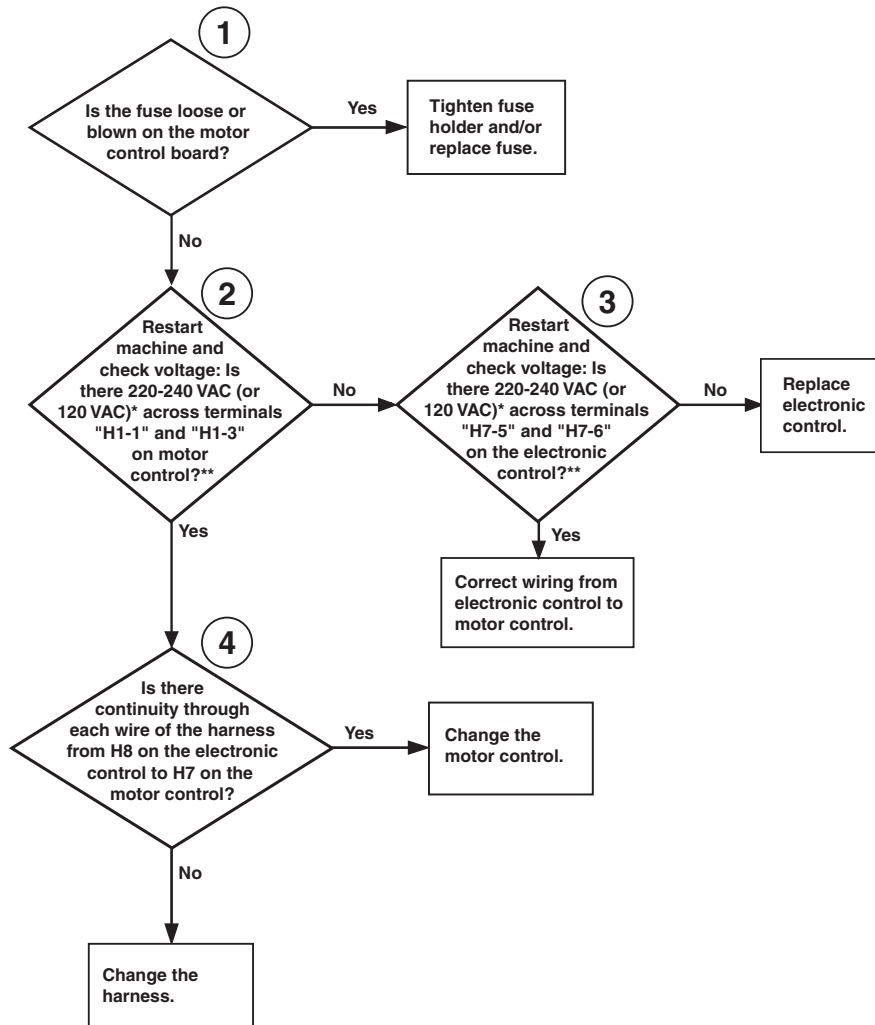

*Refer to machine serial plate for correct voltage.

**NOTE: Machine must be restarted to check voltage.
Voltage will be intermittently present during first 15
seconds until E SP is displayed.

FLW1785S

18. Motor Does Not Run (“E dF” on Display)

Mechanical Check

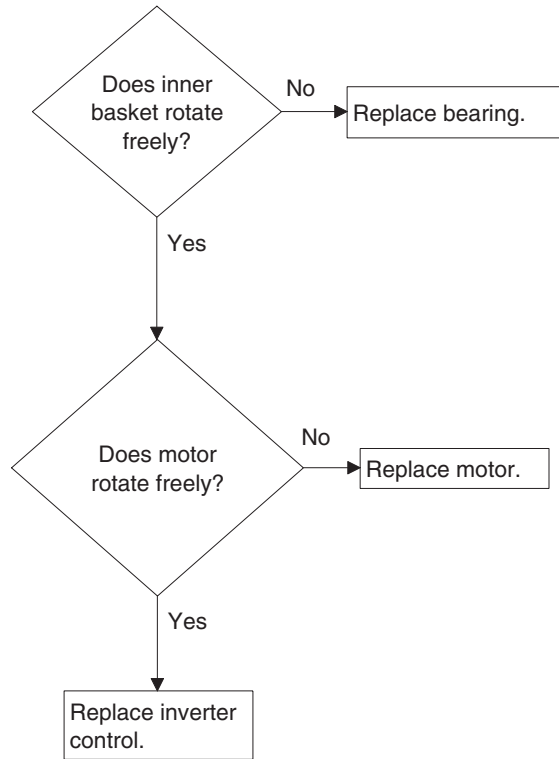

FLW1790S

Electrical Check

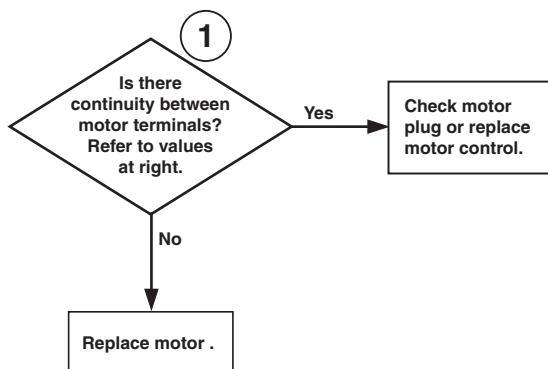

Motor Resistance Values:
Tach. Circuit: Approx. 115 ohms (Terminals 4-5)
Windings: Approx. 4 - 5 ohms (Terminals 1-2, 1-3, 2-3)

FLW1702S

Motor Does Not Run (“E dF” on Display)

Refer to washer nameplate on rear panel for proper voltage and Hertz

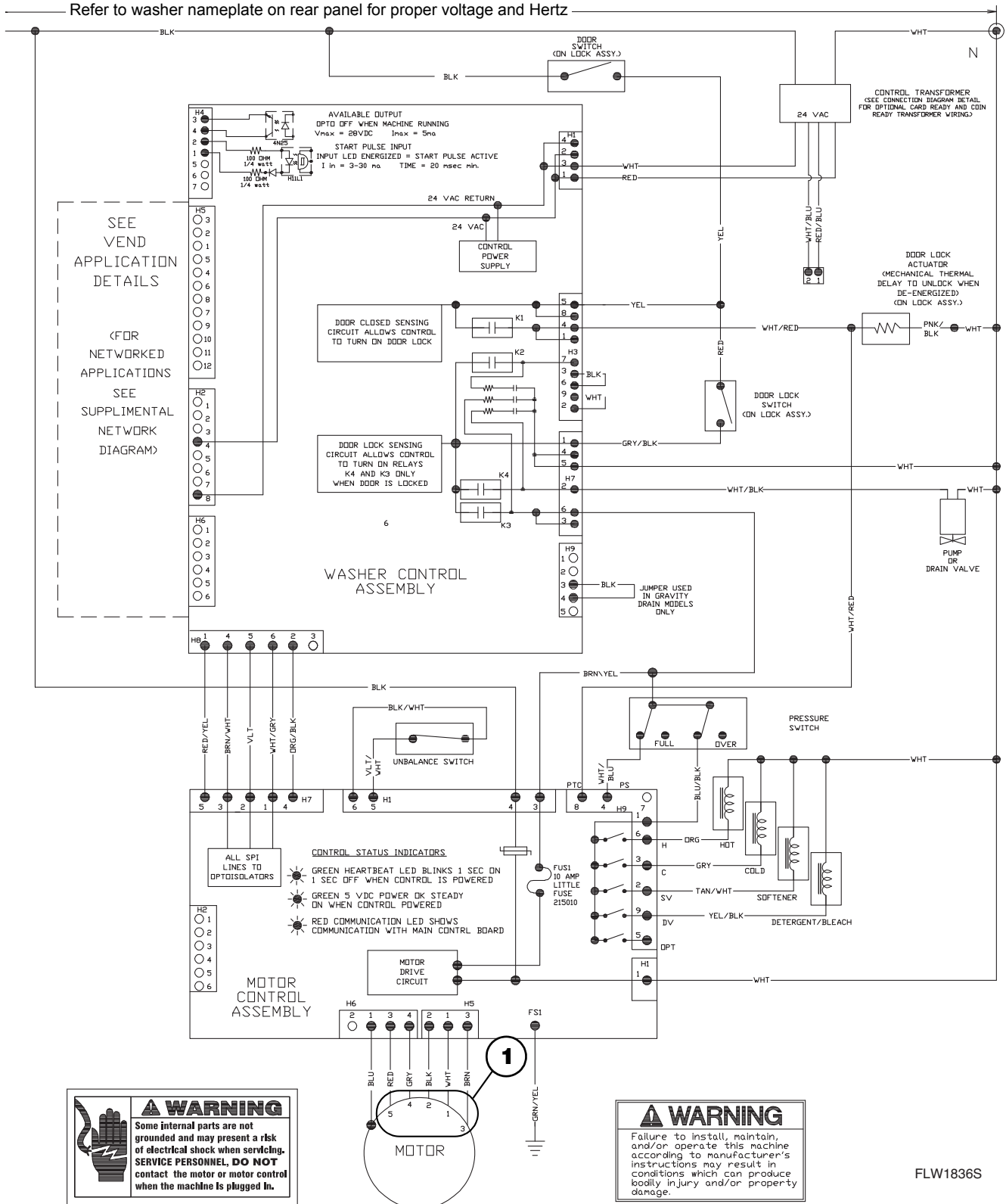

19. Washer Will Not Heat (Models Equipped with Heater) (“E oP” or “E SH” Displayed)

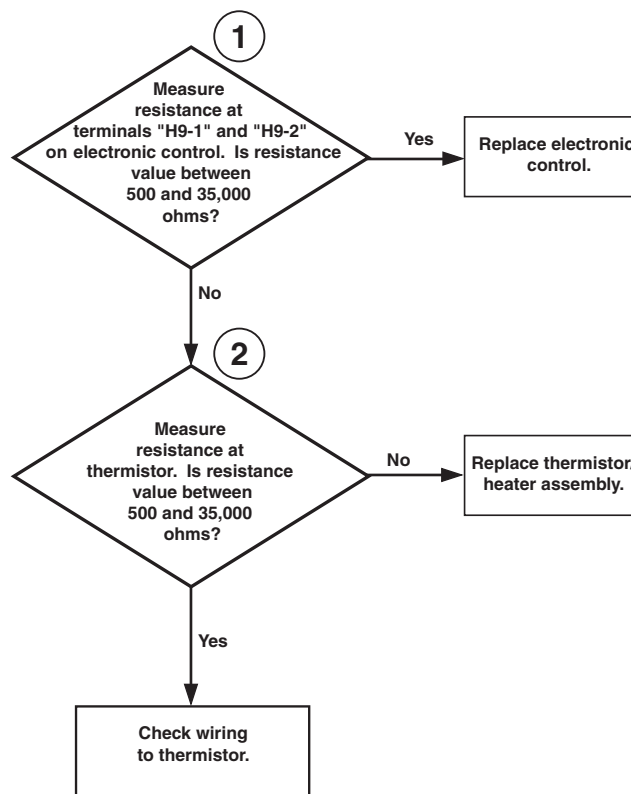

FLW1786S

Washer Will Not Heat (Models Equipped with Heater) (“E oP” or “E SH” Displayed)

FLW1780S

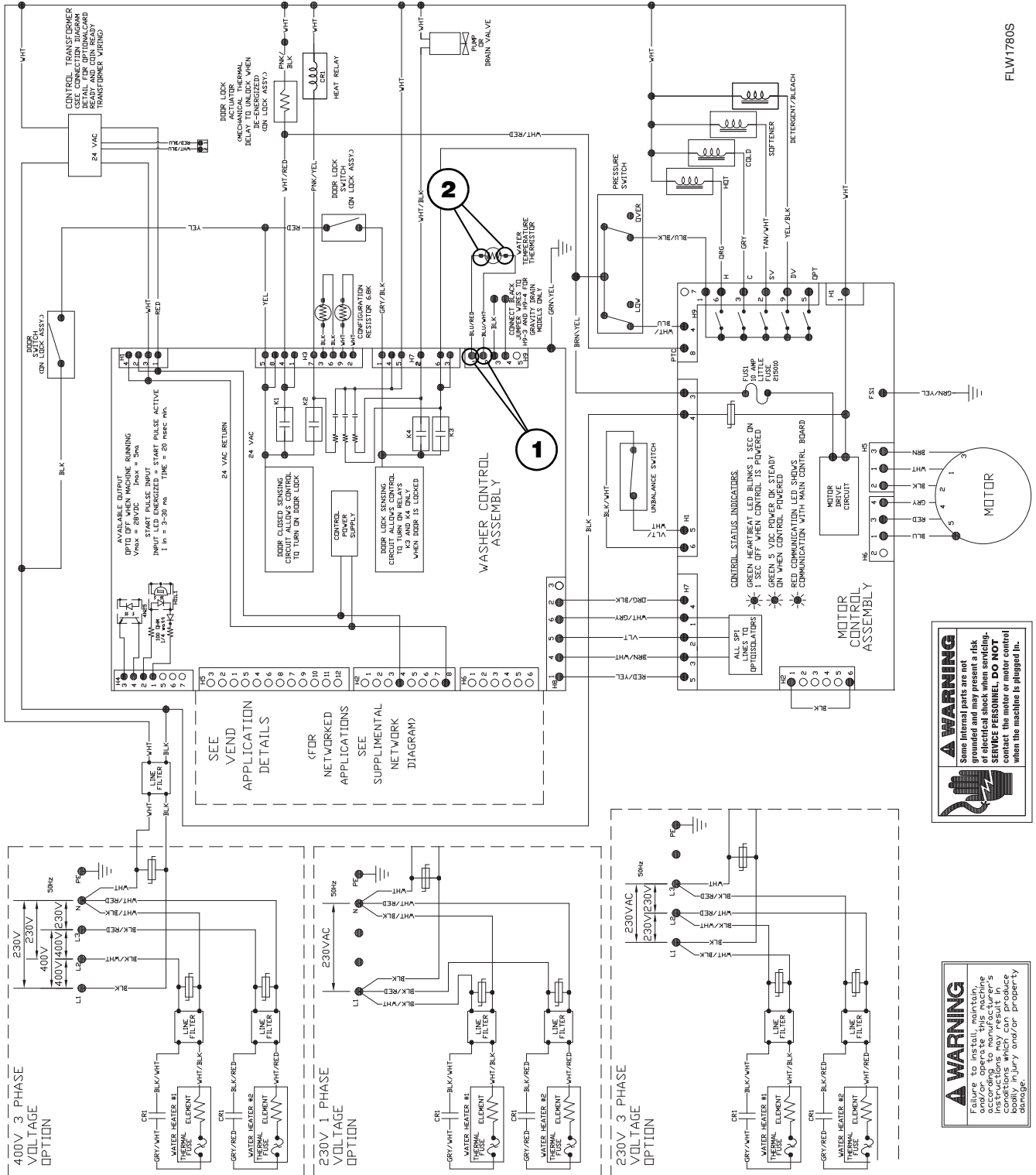

20. Washer Will Not Heat (Models Equipped with Heater) (3 Phase Heater Machines Only)

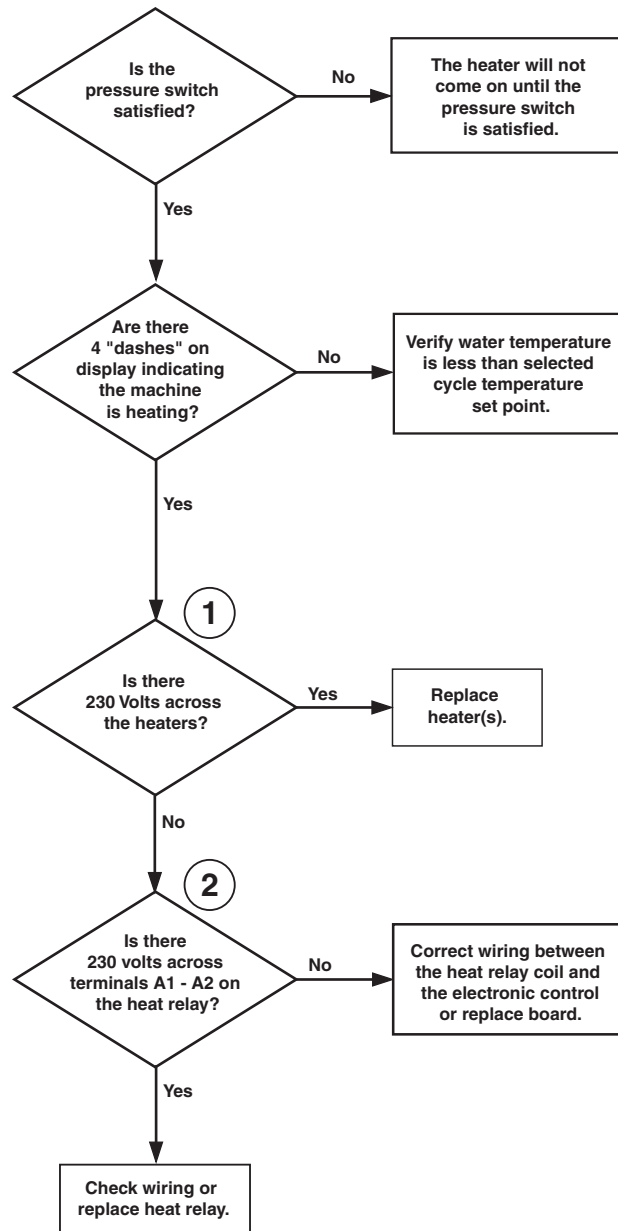

FLW1703S

Washer Will Not Heat (Models Equipped with Heater) (3 Phase Heater Machines Only)

FLW1780S

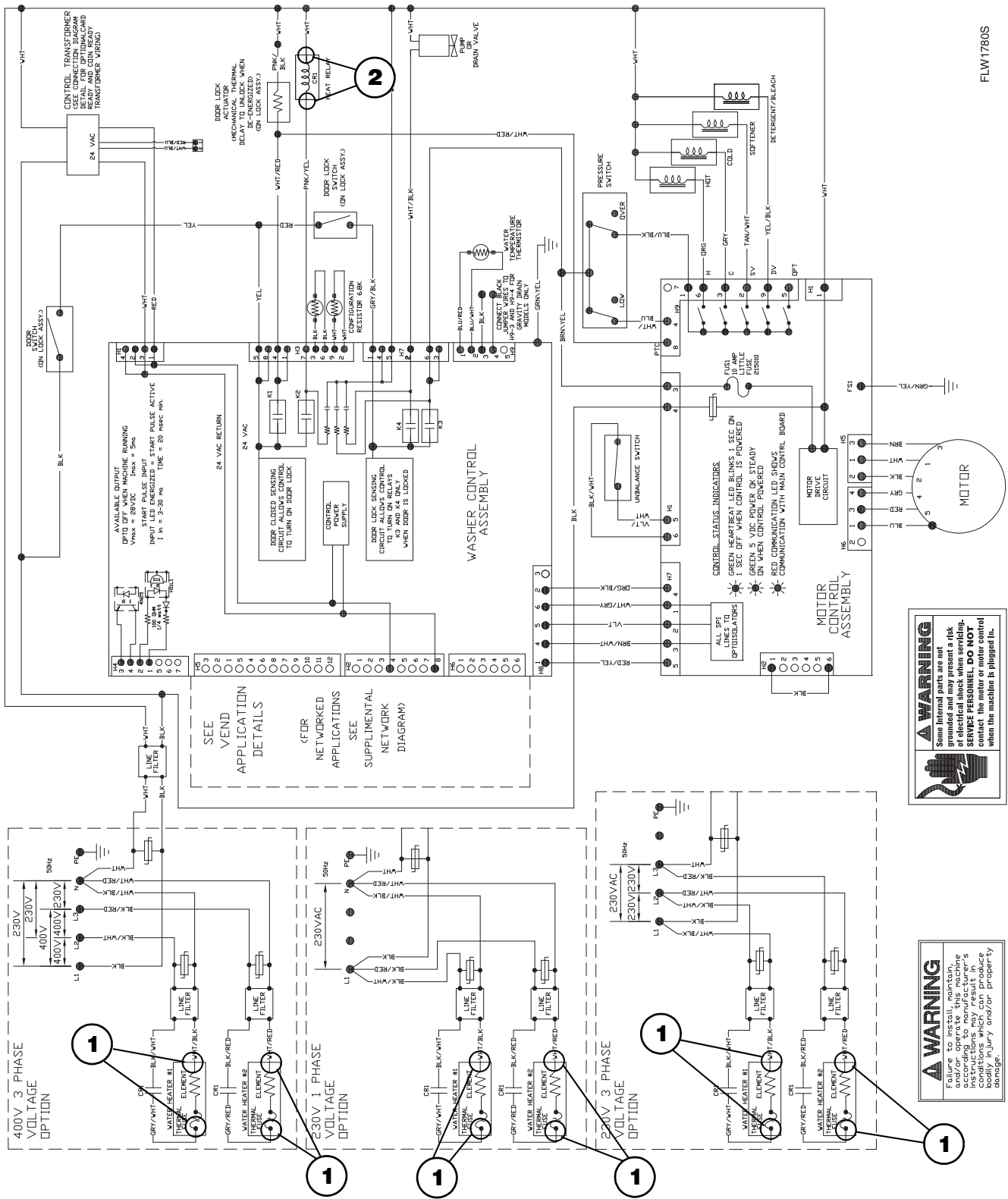

Section 5 Adjustments



WARNING

To reduce the risk of electric shock, fire, explosion, serious injury or death:

- Disconnect electric power to the washer before servicing.
- Never start the washer with any guards/panels removed.
- Whenever ground wires are removed during servicing, these ground wires must be reconnected to ensure that the washer is properly grounded.
- Motor not grounded! Disconnect electric power before servicing motor.

W485

IMPORTANT: When reference is made to directions (right or left) in this manual, it is from operator's position facing front of washer.

21. Cabinet Leveling Legs

- Place washer in position on a solid, sturdy and level floor. Installing the washer on any type of carpeting, soft tile, a platform, or other weak support structures is not recommended.
- Place level on washer, refer to *Figure 13*, and check if washer is level from side to side and front to back.

NOTE: Level must rest on raised portion of top panel. Refer to *Figure 13*.

- If washer is not level, tilt washer to access front and rear leveling legs. For easier access to leveling legs, prop up washer with wooden block. Refer to *Figure 13*.
- Loosen locknuts and adjust the leveling legs until the washer is level from side to side and front to back (using a level). **Make sure washer does not rock.** Refer to *Figure 13*.

- Tighten the locknuts securely against the washer base. If the locknuts are not tight, washer will move out of position during operation.



CAUTION

DO NOT slide washer across floor if the leveling legs have been extended, as legs and base could become damaged.

W248



CAUTION

Use of the dispenser drawer or washer door as a handle in the transportation of the washer may cause damage to the dispenser or door.

W185

- Place rubber feet on all four leveling legs. Refer to *Figure 13*.
- Verify that washer doesn't rock.

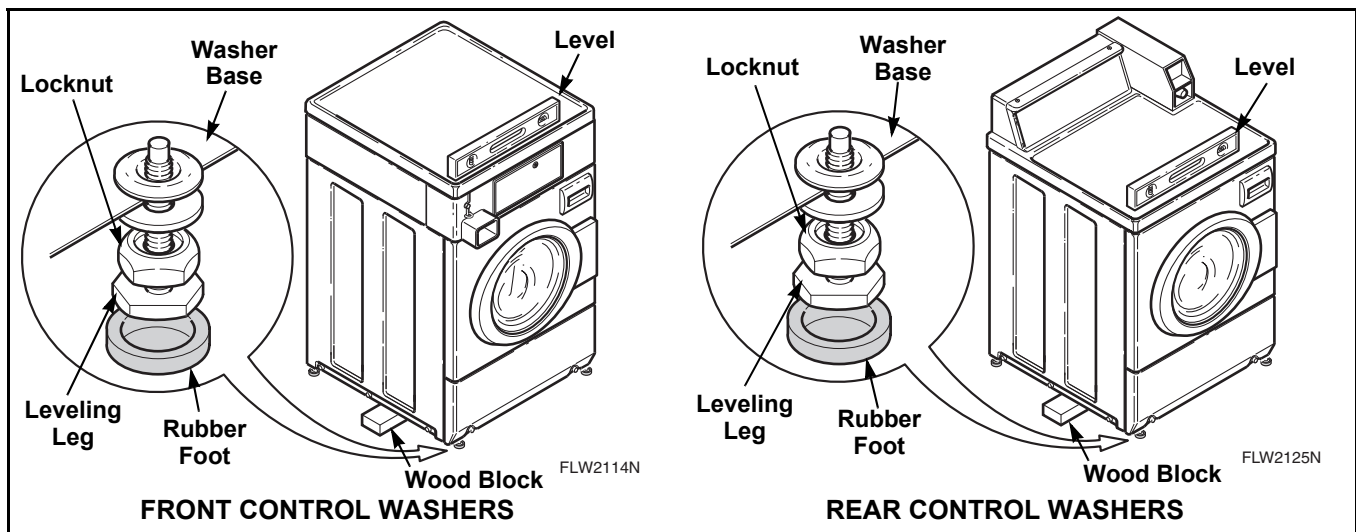

Figure 13



WARNING

To reduce the risk of electric shock, fire, explosion, serious injury or death:

- Disconnect electric power to the washer before servicing.
- Never start the washer with any guards/panels removed.
- Whenever ground wires are removed during servicing, these ground wires must be reconnected to ensure that the washer is properly grounded.
- Motor not grounded! Disconnect electric power before servicing motor.

W485

22. Loading Door

- Open loading door.
- The loading door can be adjusted up or down somewhat by loosening screws holding door hinge to front panel, then raise or lower door before retightening screws. Refer to *Figure 14*.

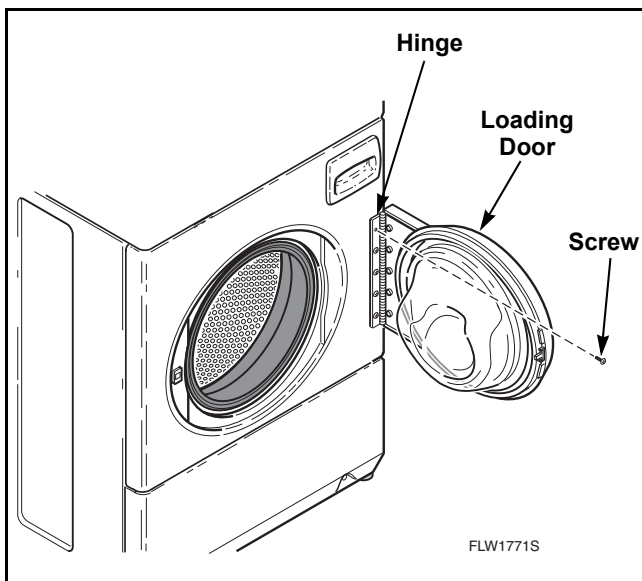

Figure 14



WARNING

To reduce the risk of electric shock, fire, explosion, serious injury or death:

- Disconnect electric power to the washer before servicing.
- Never start the washer with any guards/panels removed.
- Whenever ground wires are removed during servicing, these ground wires must be reconnected to ensure that the washer is properly grounded.
- Motor not grounded! Disconnect electric power before servicing motor.

W485

23. Motor Belt Tension

NOTE: Belt adjustment procedures are done through front of washer, however, as an option, washer can be moved from its location and belt adjustment can be done through lower access panel opening at rear of washer.

- While supporting lower front access panel, remove two screws from bottom edge of access panel and remove panel.
- Working through the lower front access door opening, place a locking pliers on the metal rod and loosen the two adjusting bolts. Refer

to *Figure 15*. Repeat procedure to loosen the two pivot bolts. Refer to *Figure 15*.

- Pull down on motor to increase belt tension. Use a Burroughs belt gauge to obtain proper tension. Proper belt tension is obtained when belt can be deflected approximately 1/4 inch (6.35 mm) from normal position when moderate pressure 50 to 60 pounds (22.68 to 27.22 Kg) is applied to a point midway between pulleys. Refer to *Figure 15*.
- After proper belt tension has been obtained, tighten belt adjusting bolts firmly, then tighten pivot bolts. Refer to *Figure 15*.

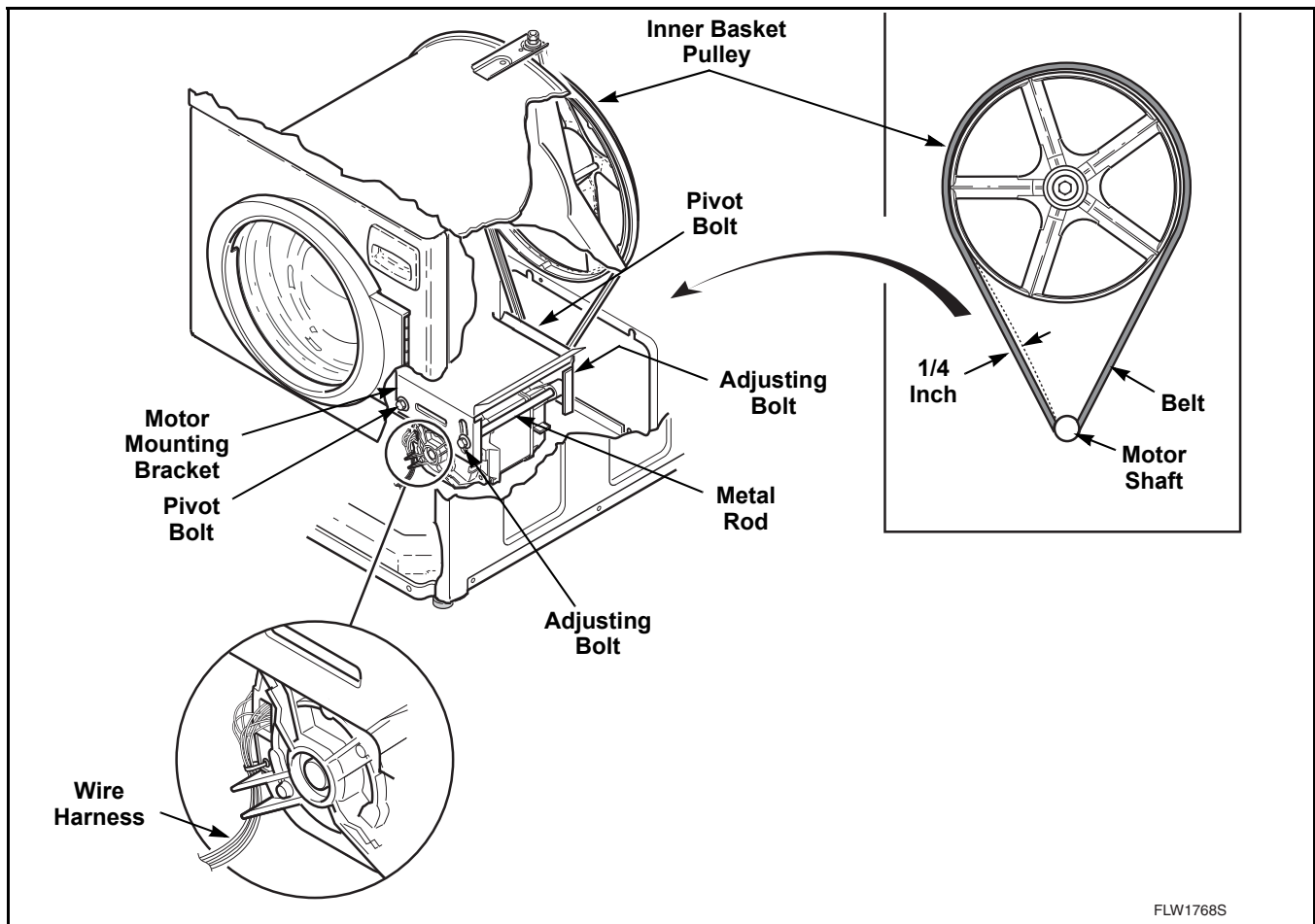

FLW1768S

Figure 15



WARNING

To reduce the risk of electric shock, fire, explosion, serious injury or death:

- Disconnect electric power to the washer before servicing.
- Never start the washer with any guards/panels removed.
- Whenever ground wires are removed during servicing, these ground wires must be reconnected to ensure that the washer is properly grounded.
- Motor not grounded! Disconnect electric power before servicing motor.

W485

24. Door Catch

NOTE: When repairing a broken or inoperative No. 802803 Door Catch, proceed as follows:

- a. Open loading door.
- b. Remove 11 T-20 Torx head screws holding outer door bezel to inner door bezel. Refer to *Figure 16*.
- c. Pull hinge side of outer bezel away from door and slide forward. Refer to *Figure 16*.
- d. Remove two screws and nuts holding door catch to door and remove door catch.
- e. Install new door catch and tighten screws and nuts to the point of being snug.
- f. Adjust door catch so the outside edge is aligned with the edge of the lock. Refer to *Figure 17*.

- g. Visually check that the door catch properly engages the funnel of the door latch/switch assembly. Refer to *Figure 17*.
- h. Recheck the alignment in Step f. Adjust if needed.
- i. Torque the two nuts to approximately 20 inch pounds (2.25 Nm).
- j. Reinstall outer door bezel by aligning outer bezel tabs with cut aways on inner bezel and sliding outer bezel into position. Refer to *Figure 16*.
- k. Replace 11 screws holding outer door bezel to inner door bezel.

IMPORTANT: Do not overtighten screws or bezel holes will strip.

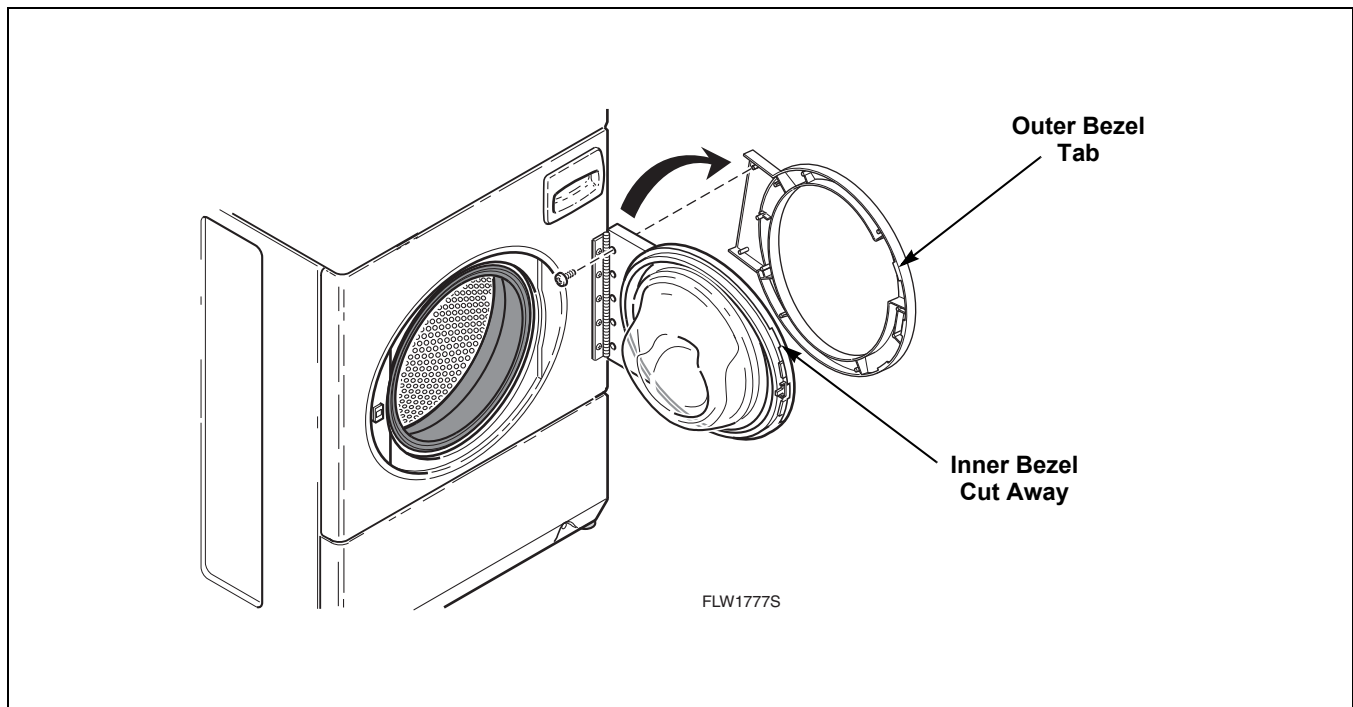

Figure 16



WARNING

To reduce the risk of electric shock, fire, explosion, serious injury or death:

- Disconnect electric power to the washer before servicing.
- Never start the washer with any guards/panels removed.
- Whenever ground wires are removed during servicing, these ground wires must be reconnected to ensure that the washer is properly grounded.
- Motor not grounded! Disconnect electric power before servicing motor.

W485

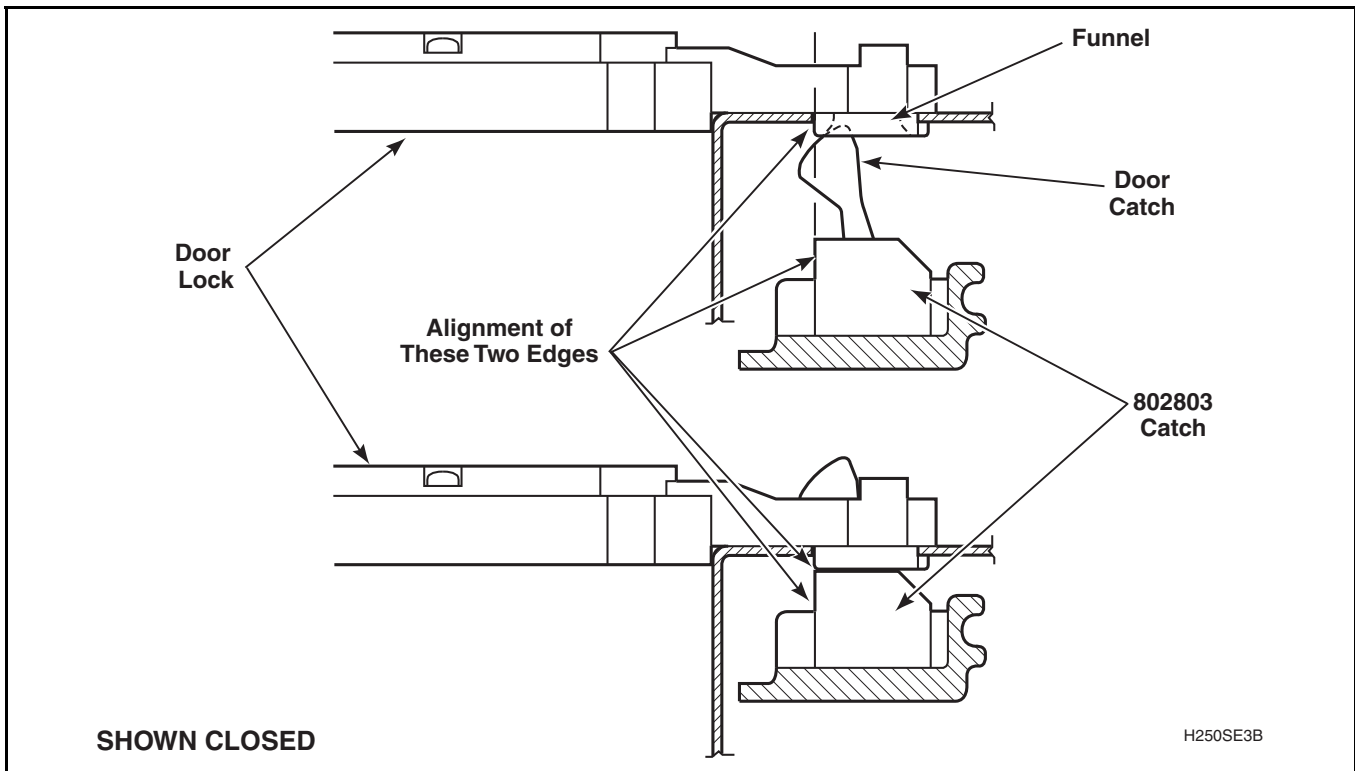

Figure 17



WARNING

To reduce the risk of electric shock, fire, explosion, serious injury or death:

- Disconnect electric power to the washer before servicing.
- Never start the washer with any guards/panels removed.
- Whenever ground wires are removed during servicing, these ground wires must be reconnected to ensure that the washer is properly grounded.
- Motor not grounded! Disconnect electric power before servicing motor.

W485

25. Shipping Braces

All frontload washers, when shipped from the factory are equipped with two factory installed shipping supports. **DO NOT** remove this shipping material until after washer is placed in its final installed position. Refer to *Figure 18*.

damage to the shock absorbers and will **VOID** the product warranty.

NOTE: Shipping supports MUST be kept for future re-positioning or moving of the washer.

IMPORTANT: DO NOT tip or move washer once these supports have been removed. Removal of supports prior to final installation may cause

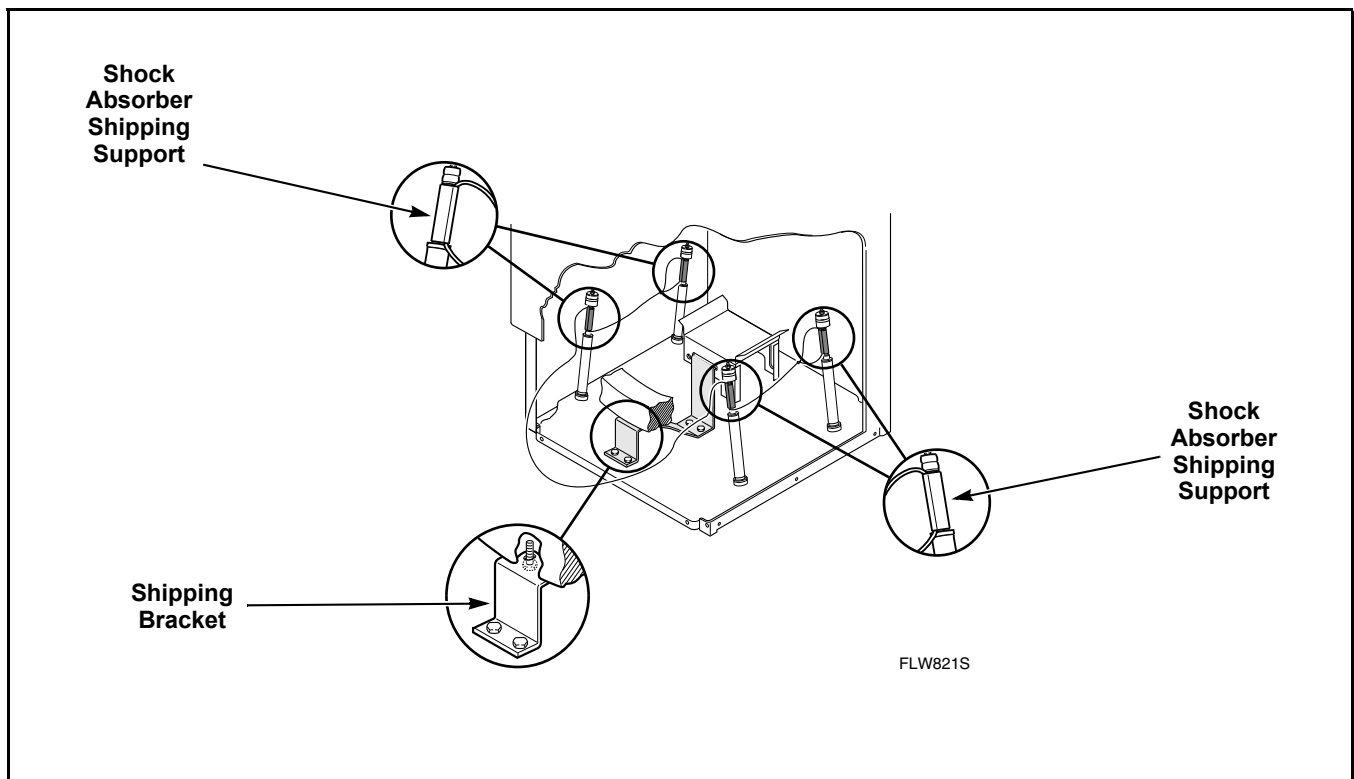

Figure 18



WARNING

To reduce the risk of electric shock, fire, explosion, serious injury or death:

- Disconnect electric power to the washer before servicing.
- Never start the washer with any guards/panels removed.
- Whenever ground wires are removed during servicing, these ground wires must be reconnected to ensure that the washer is properly grounded.
- Motor not grounded! Disconnect electric power before servicing motor.

W485

26. Cleaning Non-Electronic Coin Drop

- Disconnect electrical power to machine and drop.
- Remove coin drop from machine.
- If lint is preventing coins from rolling through coin drop, blow compressed air through coin drop, and along the side of the coin drop. Refer to *Figure 19*.

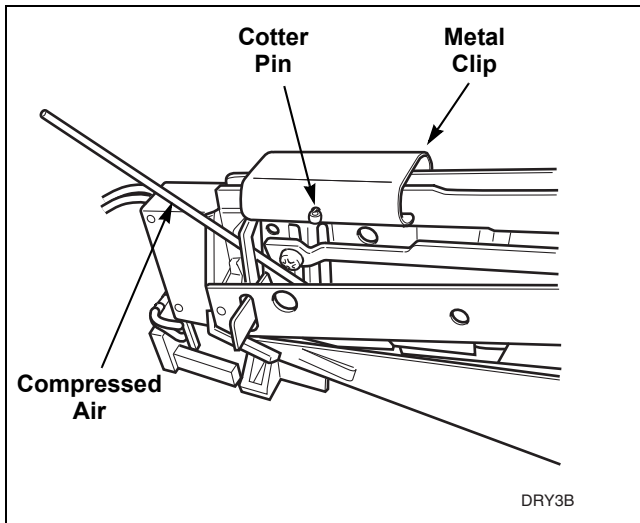

Figure 19

- Insert a coin through the coin drop. If coin does not roll through drop, continue with the following.
- Remove cotter pin from top of drop. Refer to *Figure 19*. Save pin for reinstallation when cleaning is complete.
- Move metal clip closer to sensor so that it comes off frame. Refer to *Figure 19*.

- Remove coin return from coin drop frame. Refer to *Figure 20*.

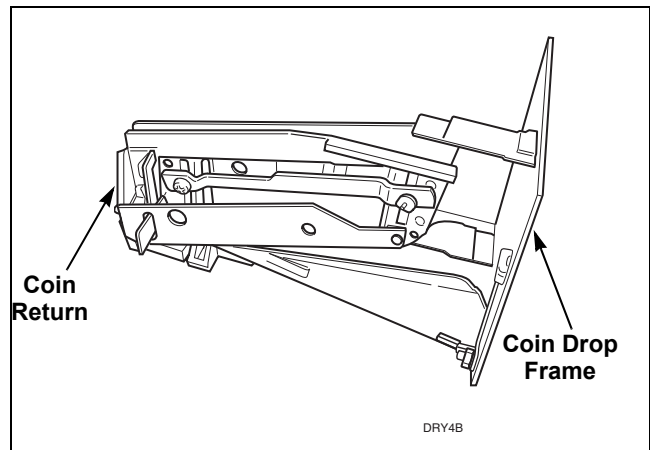

Figure 20

- Check coin path in coin drop for lint and residue. If lint or light residues are present, use a cotton swab to remove. If heavy residue is present, it may be necessary to first scrape off excessive residue and then use a cotton swab dipped in water or isopropyl alcohol (rubbing alcohol) to remove remainder of residue. Refer to *Figure 21*.

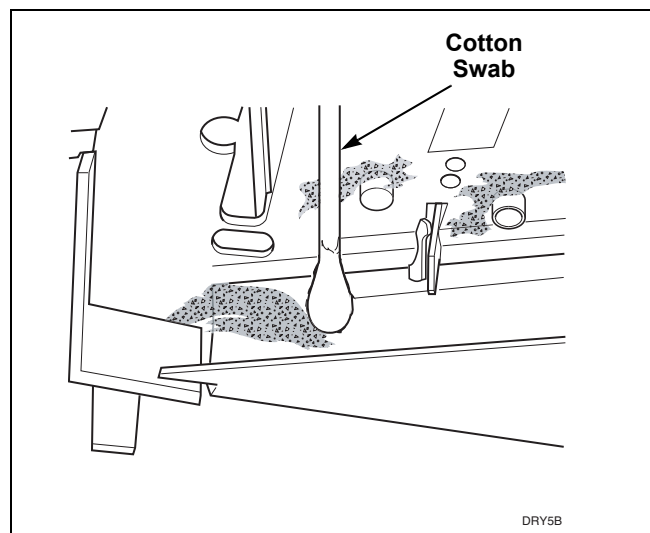

Figure 21



WARNING

To reduce the risk of electric shock, fire, explosion, serious injury or death:

- Disconnect electric power to the washer before servicing.
- Never start the washer with any guards/panels removed.
- Whenever ground wires are removed during servicing, these ground wires must be reconnected to ensure that the washer is properly grounded.
- Motor not grounded! Disconnect electric power before servicing motor.

W485

- i. Check coin return pendulum to verify it swings freely. If pendulum does not swing freely, spray pendulum pivot point with Teflon based lubricant and move pendulum back and forth two to three times. An additional application of Teflon based lubricant may be necessary to ensure that pendulum swings freely. Refer to *Figure 22*.

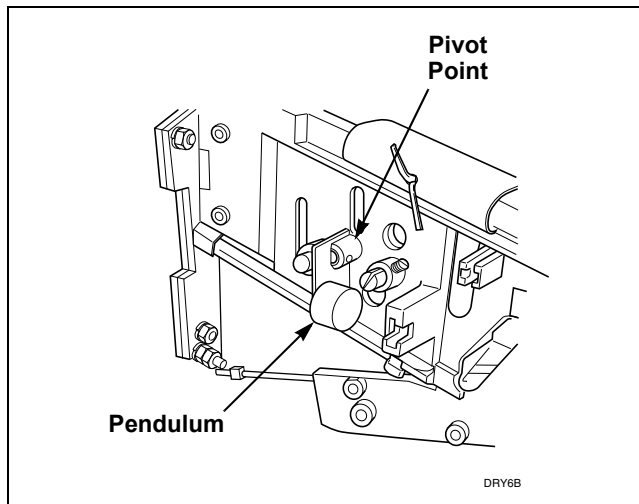

Figure 22

- j. Check coin drop sensor for dust or dirt on eyes. Wipe eyes with dry cotton swab. Refer to *Figure 23*.

IMPORTANT: DO NOT use isopropyl alcohol to clean electronic sensor or eyes.

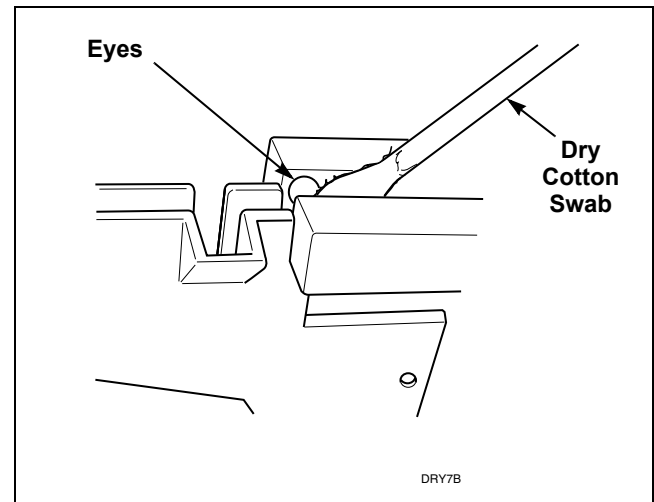

Figure 23

- k. Reinstall coin return on to coin drop frame.
- l. Reinstall metal clip and slide towards coin insert slot. All cotter pin holes must line up.
 - m. Reinstall cotter pin.
 - n. Place drop on level surface to verify that coins follow correct path in drop. It may be necessary to lift drop to allow coin to follow through sensor.
 - o. Reinstall coin drop into machine.
 - p. Reconnect electrical power to machine and drop.
 - q. Add a coin to drop to verify that coin drop is operating properly and that electrical connection is working properly.

NOTE: If coin drop does not operate properly after above steps have been completed, corrosion of metal or vandalized components within coin drop may be preventing the coin drop from functioning correctly. Replace coin drop.



WARNING

To reduce the risk of electric shock, fire, explosion, serious injury or death:

- Disconnect electric power to the washer before servicing.
- Never start the washer with any guards/panels removed.
- Whenever ground wires are removed during servicing, these ground wires must be reconnected to ensure that the washer is properly grounded.
- Motor not grounded! Disconnect electric power before servicing motor.

W485

27. Cleaning Electronic Coin Drop

NOTE: The electronic coin drop should be cleaned once a year. Clean the drop more often if it is exposed to high levels of residue or lint build-up.

- Disconnect electrical power to machine and drop.
- Remove coin drop from machine.
- Check the spring style of coin drop.

Coin Drops with Old-Style Spring (refer to Figure 24):

- (1) Move spring downward until cover catch is free. Refer to *Figure 24*.

NOTE: Do not lift or overbend the spring in any direction.

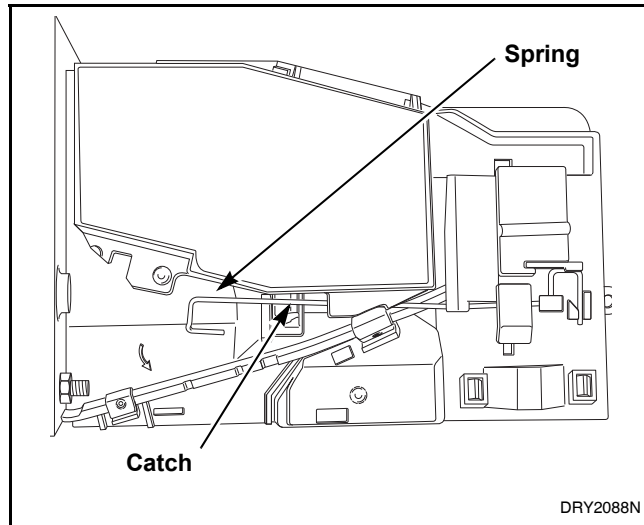

Figure 24

- (2) Open cover for coin drop. Refer to *Figure 25*.

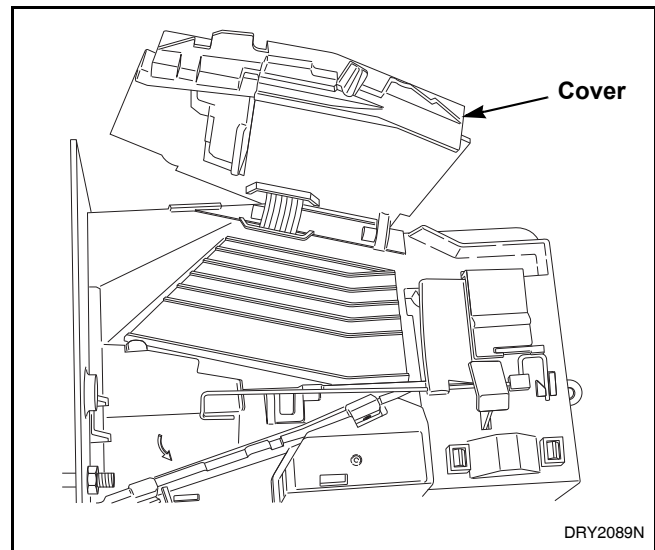

Figure 25

Coin Drops with New-Style Spring (refer to Figure 26):

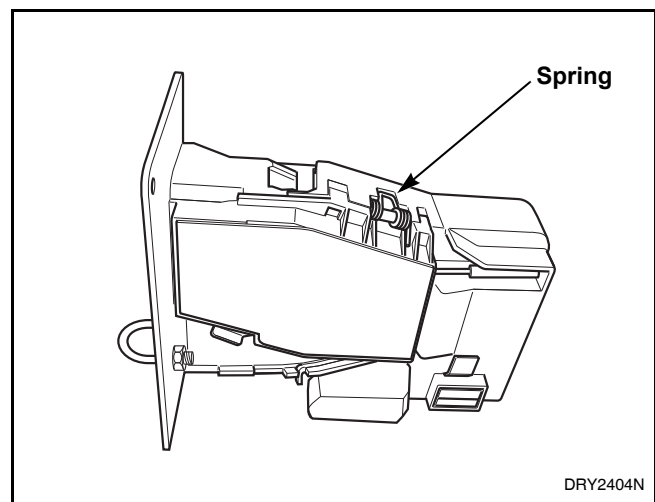

Figure 26

- (3) Open cover of coin drop. Refer to *Figure 27*.



WARNING

To reduce the risk of electric shock, fire, explosion, serious injury or death:

- Disconnect electric power to the washer before servicing.
- Never start the washer with any guards/panels removed.
- Whenever ground wires are removed during servicing, these ground wires must be reconnected to ensure that the washer is properly grounded.
- Motor not grounded! Disconnect electric power before servicing motor.

W485

NOTE: Do not overbend the spring by opening cover too far.

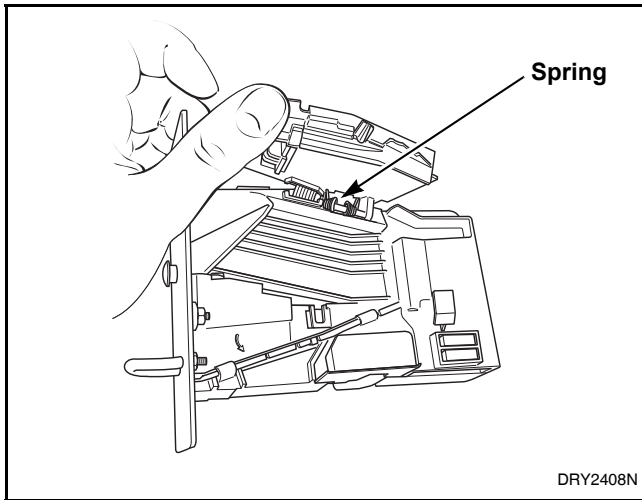

Figure 27



Figure 29

- d. Clean the coin path with a soft brush and wipe exposed surfaces with an alcohol moistened cloth. Refer to *Figure 28* or *Figure 29*.

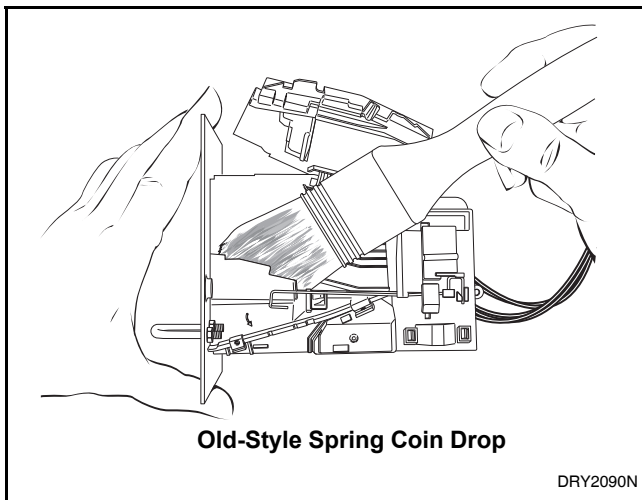

Figure 28

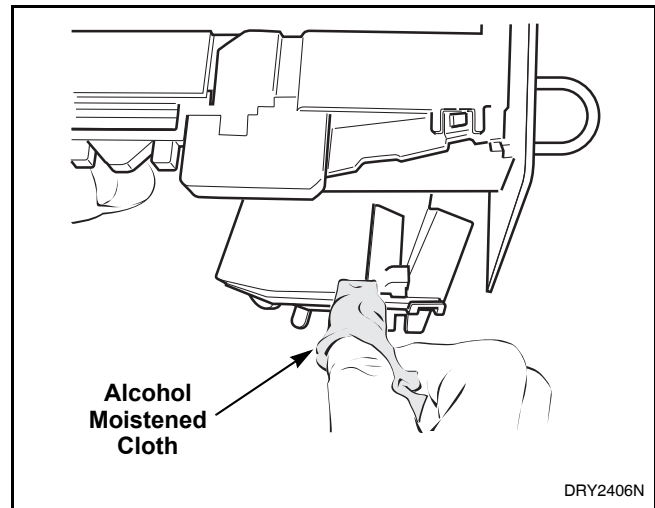

Figure 30



WARNING

To reduce the risk of electric shock, fire, explosion, serious injury or death:

- Disconnect electric power to the washer before servicing.
- Never start the washer with any guards/panels removed.
- Whenever ground wires are removed during servicing, these ground wires must be reconnected to ensure that the washer is properly grounded.
- Motor not grounded! Disconnect electric power before servicing motor.

W485

- f. Clean light sensors with a soft brush or air spray duster. Refer to *Figure 31*.

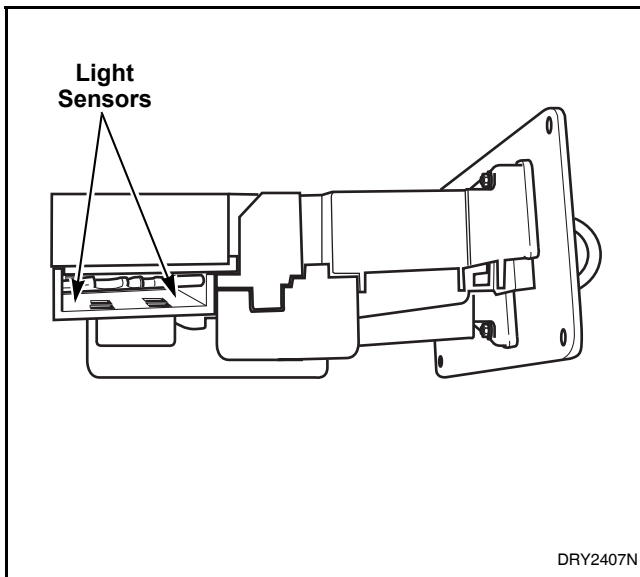

Figure 31

- g. Close cover for coin drop.
- h. **Coin Drops with OLD-Style Spring** - Move spring back over cover catch.
- i. Reinstall coin drop into machine.
- j. Reconnect electrical power to machine and drop.
- k. Add a coin to drop to verify that coin drop is operating properly and that electrical connection is working properly.