

MODELS AM5XT AND AM5eXT VOICE/DATA TRANSMISSION TEST SET

INSTRUCTION MANUAL

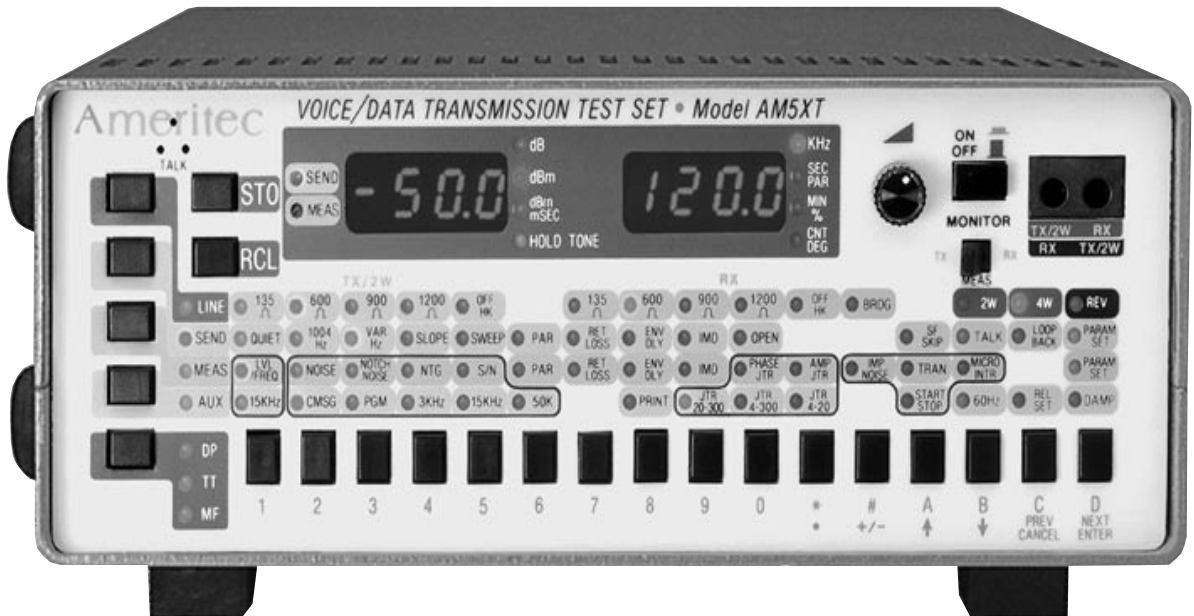

MODELS AM5XT and AM5eXT
Voice/Data Transmission Test Set
Instruction Manual

October 17, 2000

**Technical Data Subject to
Change without Notice**

Ameritec

760 Arrow Grand Circle
Covina, CA 91722 USA
TEL 626.915.5441
FAX 626.915.7181
www.ameritec.com

**For extra copies of this
manual, order Part
No. 18-0022**

© 2000 Ameritec Corporation

Record of Revisions

| | | |
|----|-------------------|--|
| A | January 1991 | Change from Revision Date to Revision Letter & Date. |
| B | September 5, 1995 | Changes to Page 8-3 and 9-3 |
| C | June 1992 | Added Change -200 Option Addenda 18-0128 and 18-0129, Caution on 480062 cables, and Note on 135Ω Noise Measurements. |
| D | July 1992 | Added Record of Revision Page. |
| E | July 1996 | Corrections throughout manual. |
| F | May 1997 | Added Calibration Procedure Appendix |
| F1 | May 21, 1999 | Page 8-7, Section 8.06 third paragraph: changed Psophometric to C-Message. |
| G | October 17, 2000 | Generated Electronic Copy and Reformatted Manual. |

This manual was produced on a Power Macintosh using MS Word 6.0, Canvas 3.5 (pict), Adobe Photoshop 3.0.5 (eps), Adobe Illustrator 6.0 (eps), and Macromedia Freehand 5.0 (eps).

Table of Contents

| | |
|---|------------|
| 1. INTRODUCTION..... | 1-1 |
| 1.1 Overview | 1-1 |
| 1.2 Unpacking..... | 1-1 |
| 1.3 AM5XT/eXT Basic Units..... | 1-2 |
| 1.4 AM5eXT-200 (ce)..... | 1-2 |
| 2. POWER CONSIDERATIONS | 2-1 |
| 2.1 Commercial Power | 2-1 |
| 2.2 Optional Battery Pack..... | 2-1 |
| 3. PHYSICAL AND FUNCTIONAL DESCRIPTION..... | 3-1 |
| 3.1 Introduction | 3-1 |
| 3.2 General | 3-1 |
| 3.3 Front Panel Notes..... | 3-2 |
| 3.4 Front Panel Components | 3-4 |
| 3.5 Rear Panel Components..... | 3-11 |
| 3.6 Optional Equipment | 3-15 |
| 3.7 AM-47XT Hand-Held Printer (Optional) | 3-16 |
| 3.8 Accessories..... | 3-23 |
| 3.9 Mask Feature (Optional) | 3-26 |
| 4. SELF-TEST AND OPERATION TECHNIQUES..... | 4-1 |
| 4.1 Introduction | 4-1 |
| 4.2 Self-Test Setup | 4-1 |
| 4.3 Switch Setup | 4-1 |
| 4.4 Quiet Send Mode | 4-1 |
| 4.5 Send 1004 Hz..... | 4-2 |
| 4.6 Send PAR..... | 4-2 |
| 4.7 Send Envelope Delay (ENV DLY) | 4-3 |
| 4.8 Send IMD | 4-3 |
| 4.9 Auto Calibrate (Up to version 7* only) | 4-3 |
| 4.10 Calibration Check (Up to version 7* only)..... | 4-4 |

| | | |
|--|------------------|--|
| Table of Contents | (18-0022) | AM5XT/eXT Voice/Data Transmission |
| 4.11 Calibration (Version 8* and up)..... | | 4-4 |
| 4.12 Parameter Set..... | | 4-5 |
| 4.13 Data Displays..... | | 4-6 |
| 5. CONNECTION AND CONFIGURATION INSTRUCTIONS..... | | 5-1 |
| 5.1 Introduction | | 5-1 |
| 5.2 General | | 5-1 |
| 5.3 Connectors and Cables | | 5-2 |
| 5.4 Line Termination Impedances | | 5-5 |
| 5.5 Configurations | | 5-5 |
| 6. LINE FUNCTIONS..... | | 6-1 |
| 6.1 Introduction | | 6-1 |
| 6.2 General Line Function Notes..... | | 6-2 |
| 6.3 Generator Source Impedances..... | | 6-6 |
| 6.4 OFF HK (Send Pair Off-Hook/On-Hook)..... | | 6-6 |
| 6.5 Termination Impedances (Receive Pair)..... | | 6-7 |
| 6.6 OFF HK (Receive Pair Off-Hook/On-Hook) | | 6-7 |
| 6.7 BRDG (Receive Pair Bridged/Terminated)..... | | 6-7 |
| 6.8 2W (2-Wire)..... | | 6-8 |
| 6.9 4W (4-Wire)..... | | 6-8 |
| 6.10 REV (Reversed) | | 6-8 |
| 7. SEND FUNCTIONS | | 7-1 |
| 7.1 Introduction | | 7-1 |
| 7.2 Quiet..... | | 7-2 |
| 7.3 1004 Hz..... | | 7-3 |
| 7.4 VAR HZ (Variable Tone) | | 7-4 |
| 7.5 Slope | | 7-4 |
| 7.6 Sweep..... | | 7-5 |
| 7.7 PAR (Peak-to-Average Ratio) | | 7-7 |
| 7.8 RET LOSS (Return Loss)..... | | 7-7 |
| 7.9 ENV DLY (Envelope Delay) (AM5XT ONLY) | | 7-9 |
| 7.10 GROUP DLY (Group Delay) (AM5eXT ONLY) | | 7-12 |

7.11 IMD (Intermodulation Distortion) 7-14

7.12 OPEN..... 7-16

7.13 SF SKIP (Signaling Frequency Skip)..... 7-16

7.14 TALK..... 7-16

7.15 LOOP BACK..... 7-17

8. MEASURE FUNCTIONS 8-1

8.1 Introduction 8-1

8.2 LVL/FREQ (Level/Frequency) 8-2

8.3 General Noise Measurement Notes..... 8-6

8.4 NOISE (Idle Channel Noise) 8-9

8.5 NOTCH NOISE (Noise-with-Tone) 8-9

8.6 NTG (Noise-to-Ground) 8-10

8.7 S/N (Signal-to-Noise Ratio)..... 8-11

8.8 PAR (Peak-to-Average Ratio) 8-12

8.9 RET LOSS (Return Loss)..... 8-15

8.10 ENV DLY (Envelope Delay) (AM5XT ONLY) 8-17

8.11 GROUP DLY (Group Delay) (AM5eXT ONLY) 8-27

8.12 IMD (Intermodulation Distortion) 8-32

8.13 PHASE JTR (Phase Jitter)..... 8-34

8.14 AMP JTR (Amplitude Jitter)..... 8-35

8.15 IMP NOISE (Impulse Noise without Tone)..... 8-35

8.16 TRAN (Transients) 8-37

8.17 MICRO INTR (Micro-interruptions)..... 8-39

9. AUXILIARY FUNCTIONS 9-1

9.1 Introduction 9-1

9.2 Filter for Narrow-Band Level/Frequency 9-2

9.3 Noise Weighting Filters..... 9-3

9.4 QUASI PK (Quasi-Peak Detector Enable) (AM5eXT ONLY) 9-4

9.5 Print Enable 9-4

9.6 Jitter Bandwidth Select 9-6

9.7 START STOP (Timed Study Start/Stop)..... 9-6

9.8 60 Hz Filter 9-7

Table of Contents (18-0022) AM5XT/eXT Voice/Data Transmission

9.9 REL SET (Relative Measure Zero Set)..... 9-7

9.10 DAMP (Display Update Select)..... 9-9

10. DIALING..... 10-1

10.1 Introduction 10-1

10.2 Manual Dialing 10-1

10.3 Storage of Dialed Number 10-3

10.4 Automatic Speed Dialing 10-4

10.5 Dual-Tone Dialing Frequencies..... 10-5

10.6 Dial Pulse (DP) Requirements 10-5

10.7 Dial Pulse (DP) Requirements 10-6

10.8 Remote Control Using TT Commands..... 10-7

10.9 Remote Control Using TT Commands..... 10-8

11. MEMORY CONSIDERATIONS (STORE & RECALL) 11-1

11.1 Introduction 11-1

11.2 Factory Set Defaults..... 11-1

11.3 User Entered Memories 11-8

12. RS232 COMMANDS 12-1

12.1 Introduction 12-1

12.2 Command Protocol 12-2

12.3 Response Protocol..... 12-6

12.4 Password Security 12-10

12.5 Miscellaneous Commands 12-10

12.6 RS232 Port Configuration..... 12-11

12.7 Auxiliary RS232 Port 12-11

12.8 Daisy Chaining..... 12-11

12.9 Conditioning Mask Definition Format..... 12-12

13. PRINTING AND PLOTTING 13-1

13.1 Introduction 13-1

13.2 Types of Printouts (up to Version 7)..... 13-1

13.3 Types of Printouts (Version 8 and up) 13-2

13.4 XY Plotter Operation..... 13-3

14. ORDERING INFORMATION..... 14-1

15. WARRANTY, CALIBRATION, AND SERVICE..... 15-1

15.1 Warranty..... 15-1

15.2 Service Policy..... 15-1

15.3 Calibration Policy..... 15-1

15.4 Return of Unit..... 15-2

16. TECHNICAL SPECIFICATIONS..... 16-1

16.1 Measurements..... 16-1

16.2 Send Functions (Signal Generator)..... 16-1

16.3 Receive Functions..... 16-5

16.4 General.....16-12

A. APPENDIX A: CALIBRATION..... A-1

A.1 Scope.....A-1

A.2 Equipment Required.....A-1

A.3 Calibration Procedure.....A-1

A.4 Validation Procedure.....A-3

List of Figures

| | |
|--|------|
| Figure 3-1. Front Panel Components | 3-2 |
| Figure 3-2. Level and Noise Units of Measurement | 3-8 |
| Figure 3-3. Rear Panel Components | 3-11 |
| Figure 3-4. Hand-Held Printer, Component Location | 3-17 |
| Figure 3-5. Standard Cables Supplied with the AM-47XT Printer | 3-18 |
| Figure 3-6. Ribbon and paper Installation for the AM-47XT | 3-20 |
| Figure 3-7. Printer Hookup | 3-21 |
| Figure 3-8. Bantam Plug Line Cables | 3-23 |
| Figure 3-9. RS232 Cables | 3-25 |
| | |
| Figure 5-1. AM-47XT Hand-Held Printer Connection with AC Power | 5-3 |
| Figure 5-2. AM5XT/eXT Connection Cables | 5-4 |
| Figure 5-3. 4-Wire End-to-End Testing | 5-6 |
| Figure 5-4. 4-Wire Testing with Responder | 5-7 |
| Figure 5-5. 2-Wire Testing with Responder | 5-8 |
| | |
| Figure 6-1. Procedure to Enable Line Functions | 6-1 |
| Figure 6-2. 2-Wire Line Circuit Block Diagram | 6-3 |
| Figure 6-3. 4-Wire Line Circuit Block Diagram | 6-3 |
| | |
| Figure 7-1. Procedure to Enable Send Functions | 7-1 |
| | |
| Figure 8-1. Procedure to Enable Measure Modes | 8-1 |
| Figure 8-2. Setup to Measure 4-Wire Envelope Delay | 8-20 |
| Figure 8-3. Setup to Measure 2-Wire Envelope Delay | 8-25 |
| Figure 8-4. Setup to Measure Group Delay | 8-31 |
| | |
| Figure 9-1. Procedure to Enable Auxiliary Functions | 9-1 |
| Figure 9-2. Function Boxes | 9-2 |
| Figure 9-3. C-Message Weighting Characteristic (AM5XT) | 9-9 |
| Figure 9-4. Program Weighting Characteristic (AM5XT) | 9-9 |
| Figure 9-5. 3 kHz Flat Weighting Characteristic (AM5eXT) | 9-10 |

Table of Contents (18-0022) **AM5XT/eXT Voice/Data Transmission**

Figure 9-6. 15 kHz Flat Weighting Characteristic (AM5XT) 9-10
Figure 9-7. 50 Kilobit Weighting Characteristic (AM5XT) 9-11
Figure 9-8. Psophometric Characteristic (AM5eXT)..... 9-11
Figure 9-9. Sound Weighted Characteristic (AM5eXT)..... 9-12
Figure 9-10. Sound Unweighted Characteristic (AM5eXT)..... 9-12
Figure 9-11. 3 kHz Flat Characteristic (AM5XT)..... 9-13
Figure 9-12. 2 kHz Flat Characteristic (AM5eXT)..... 9-13

List of Tables

Table 3-1. Acceptable Holding Tone Ranges..... 3-9

Table 3-2. RS232 Connector Pin Assignment 3-13

Table 3-3. DIP Switch Settings 3-14

Table 3-4. Auxiliary RS232 Connector Pin Assignment..... 3-14

Table 3-5. AM-47XT Technical Specifications..... 3-16

Table 8-1. Noise Weighting Filters..... 8-7

Table 8-2. P/AR Requirements of Telephone Lines..... 8-13

Table 9-1. Noise Weighting Filters..... 9-3

Table 9-2. AM5XT Noise Weighting Filters 9-3

Table 9-3. AM5eXT Noise Weighting Filters 9-4

Table 9-4. Jitter Bandwidth Weighting Filters 9-6

Table 10-1. MF and TT (DTMF) Tone Pairs..... 10-5

Table 11-1. Stored Memories and Purpose 11-1

Table 12-1. Line Control Commands..... 12-2

Table 12-2. Send Control Commands 12-3

Table 12-3. Measure Control Commands..... 12-4

Table 12-4. Auxiliary Control Commands..... 12-5

Table 12-5. Response Protocols 12-7

Table 12-6. Bandwidth Parameter Limits..... 12-13

Table 14-1. Voice/Data Transmission Test Set Ordering 14-1

Table 16-1. ERL Filter Response (Frequency Weighting)..... 16-13

Table 16-2. SRL Low Filter Response (Frequency Weighting)..... 16-13

Table 16-3. SRL High Filter Response (Frequency Weighting) 16-14

Table 16-4. P/AR Line Spectrum..... 16-14

Table 16-5. Combination of IEEE and O.91 Specification..... 16-15

Table of Contents (18-0022) **AM5XT/eXT Voice/Data Transmission**

Table 16-6. Amplitude Jitter Frequency Weighting 20 – 300 Hz.....16-15
Table 16-7. Amplitude Jitter Frequency Weighting 4 – 300 Hz.....16-16

1. INTRODUCTION

1.1 OVERVIEW

This instruction manual describes the operation of the Ameritec Model AM5XT and AM5eXT Voice/Data Transmission Test Sets.

The AM5XT and AM5eXT are microprocessor based test instruments used to measure transmission impairments on 2- and 4-wire telephone lines. The AM5XT measures transmission impairments in accordance with IEEE Standard 743-1984 (Bell Standard 41009). The AM5eXT complies with CCITT recommendations for export.

The instrument also contains a separate full function signal generator able to generate the test tones normally used with the tests.

The instrument contains 4 impedance selections per line, separate DC hold circuits, pulse, MF, and DTMF signaling, built-in speaker monitor and talk microphone. Optional features include RS232 remote control port, batteries for cordless portable operation, and rack mounting kit for permanent installations.

1.2 UNPACKING

The unit was thoroughly tested and carefully packed before shipment, and was in good condition when turned over to the carrier for shipment.

Upon receipt, thoroughly inspect the outside of the shipping container for damage, and if damage is noted, immediately contact the carrier. The name of the carrier will be noted on the packing slip which is attached to the outside of the shipping container.

Open the container carefully and compare the contents with the packing slip. Note any damage or shortages. Notify the carrier in the event of damage. Notify Ameritec in the event of shortage.

Save the shipping container for future use in the event that the unit may be returned to the factory.

1.3 AM5XT/eXT BASIC UNITS

The Digital Signal Processor (DSP) board is not installed in the AM5XT-BASIC, AM5XT-200 BASIC, AM5eXT-BASIC, and AM5eXT-200 BASIC, as indicated in the last QUIET Mode PARAMETER DISPLAY (see Display 6 in ¶7.2).

Because of the absence of the DSP board, all BASIC units are **NOT** equipped with the measurements listed below, even though these functions are included on the front panel. The absence of these functions is evident because their function LEDs will not light when the respective Function Enable Keys are pressed.

The functions listed below can be added by contacting Ameritec to order a “factory upgrade” of an AM5XT-BASIC, AM5XT-200 BASIC, AM5eXT-BASIC, and AM5eXT-200 BASIC to the standard AM5XT or eXT version (P/N 25-0036).

Functions of the AM5XT or eXT which are not included in the BASIC versions are:

- Envelope Delay
- Intermodulation Distortion
- Phase Jitter
- Micro-Interruptions
- Transient Tests:
 - Gain Hits
 - Phase Hits
 - Dropouts
- X-Y Plotter (Option)

1.4 AM5eXT-200 (ce)



CAUTION: If the equipment is used in a manner not specified by Ameritec Corporation, the protection provided by the equipment may be impaired.

1. All AM5eXT-200(ce) units come equipped with an Ameritec P/N 70009200 Desktop Transformer (230 VAC In, 14 VAC Out), equipped with a U.S. standard power cord. Use only this provided Desktop Transformer. The user may change the AC power cord so long as the selected power cord has <HAR> markings.

2. All AM5eXT-200(ce) units come equipped with the following options:
 - 24-0017 Sealed Lead Acid Batteries and Integral Charger
 - 25-0019 RS232 Remote Control Port with AUX RS232 Output Port
 - 25-0045 X-Y Plotter Option

CE Mark certification is based solely on the above configuration. Use of any other AM5 options, such as LIDs, will negate the certification.

3. The AM5eXT-200(ce) is not equipped with the T/R/T1/R1/Gnd Terminal Block (see ¶3.5).
4. The AM5eXT-200(ce) is not equipped with the AC Power Selector Switch, Step-Down Transformer, Fuse Holder, and Power Plug (items 1, 2, 4, and 6) as shown in ¶3.5. These items are replaced by a Power Connector Mounting Adapter and the Desktop Transformer.
5. The AM5eXT-200(ce) contains both sealed lead acid batteries and lithium batteries. The lithium batteries are built into an Integrated Circuit. All batteries are clearly marked with the  warning symbol. Be sure to dispose of these batteries in accordance with local regulations.

2. POWER CONSIDERATIONS

2.1 COMMERCIAL POWER

The AM5XT and AM5eXT are powered from commercial 115 VAC or 230 VAC 50/60 Hz power. A rear panel selector switch allows user selection of 115 VAC or 230 VAC.

A detachable 3-wire cord is furnished, which mates with a rear panel mounted CCE standard V-type connector. A rear panel mounted fuse, rated at 1/2A, is provided.

The AM5XT and AM5eXT are equipped with a non-volatile memory. Loss of power will cause operation of the unit to cease. However, any front panel configurations previously stored in memory will not be lost.

2.2 OPTIONAL BATTERY PACK

The AM5XT and AM5eXT may be equipped with an optional internal battery pack to allow full cordless (no commercial power) operation.

The power pack consists of two sealed lead acid batteries and associated charging circuitry. The batteries, when fully charged, will power the unit for approximately 5 to 8 hours.

A low battery indicator is provided in the form of blinking decimal points in the front panel display. Blinking decimal points indicate approximately 1/2 hour of remaining battery operation before recharging is required.

The unit may be operated while the batteries are recharging. Recharging will automatically occur whenever the unit is plugged into commercial AC power, regardless of whether the unit is on or off. Charging will be accomplished faster when the unit power switch is "OFF".

3. PHYSICAL AND FUNCTIONAL DESCRIPTION

3.1 INTRODUCTION

This section illustrates and explains the components of the AM5XT/eXT. Also described are optional equipment and accessories, including the Ameritec AM-47XT Hand-Held Printer, designed to be used with the AM5XT/eXT. The paragraphs in this section are listed below:

- 3.2 General
- 3.3 Front Panel Notes
- 3.4 Front Panel Components
- 3.5 Rear Panel Components
- 3.6 Optional Equipment
- 3.7 AM-47XT Hand-Held Printer
- 3.8 Accessories

3.2 GENERAL

Weight. The AM5XT/eXT weighs 5 pounds without the optional battery pack, and 10 pounds with the battery pack.

Dimensions.

Portable: 8.3"W x 3.5"H x 12.1"D (210mm x 89mm x 307mm)

Rack Mount: 19.0"W x 3.5"H x 12.1"D (83mm x 89mm x 307mm)

Construction. Electronic components are mounted on four (4) plug-in printed circuit boards, interconnected with harness connectors and housed in a sturdy metal case. If the optional canvas Padded Carrying Case is not ordered, a removable snap-on cover is supplied to protect the front panel during transport. There are no user serviceable parts inside the case.

Mounting. A portable unit has a carrying handle and can be stood on any of three (3) possible sides, each of which has rubber feet.

When placed on a table, the unit can be set in a tilted position for easier viewing of the front panel. This is done by extending supports located behind the front feet on the front panel side. The 19" Rack Mount Kit (85-(X)76) can be ordered for fixed installations.

3.3 FRONT PANEL NOTES

The Front Panel of the AM5XT is illustrated in Figure 3-1. See ¶3.4 for descriptions of the components called out.

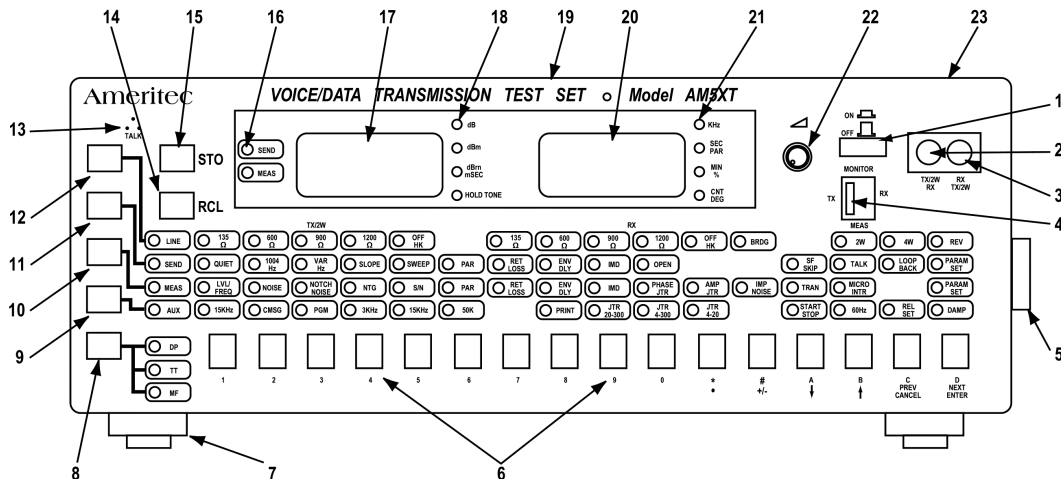

Figure 3-1. Front Panel Components

Front Panel Layout. The AM5XT front panel is a surface approximately 3” (7.5cm) high by 8” (20.5cm) wide. It contains switches, keys, LEDs, and displays for controlling the unit and indicating its operational status.

Color Coding and Marking. The front panel functions are color coded to tie together associated functions:

- GRAY Store and Recall Keys, normal 2-wire or 4-wire interface select, dialing mode select
- BLACK Pair reversal
- GREEN Send (Transmit, TX) functions
- BLUE Measure (Receive, RX) functions
- VIOLET Auxiliary functions, associated with measure functions

Some of the measure (blue) functions that always work together with certain auxiliary (violet) functions are enclosed with a black border; these are referred to as Function Boxes. See ¶9.1 and Figure 9-2.

Unit Status. After setting up a test, Function LEDs remain on to indicate the function is enabled. The status of the unit can thus be determined at a glance. The Send and Measure functions have prompt-driven DATA and PARAMETER DISPLAYS which are scrolled through to make readings and set parameters.

Keys. All push-button keys are discrete switches, non-membrane type, and offer good visual, tactile and audible feedback. All indicators, including the display, are LEDs and should never need replacement. The unit is controlled by pressing keys arranged along the left and bottom edges of an X-Y matrix of function LEDs. Along the **left edge** of the front panel, there are five (5) Keys, which are used to select one (1) of the five (5) horizontal rows of operating functions, LINE, SEND, MEASure, AUXiliary, or Dialing (DP, TT, or MF).

Note: Because of space limitation, most of the keys along the left edge are not located directly next to the function rows they control. Carefully follow the color coding which associates a key with the horizontal function row that it enables.

Along the bottom edge of the front panel, there are 16 Function Enable Keys referred to as [1], [2], [3], [4], [5], [6], [7], [8], [9], [0], [*], [#], [A], [B], [C], [D]. A Function Enable Key is used to enable the function that is located vertically above it, within the function row that is enabled at the time the key is pressed.

- For example, press [SEND] key (item 11 in Figure 3-1); SEND LED lights. Then press [7]. Return Loss send function is enabled (RET LOSS LED lights). Then, repeatedly press [7] to step through the three (3) Return Loss send DATA DISPLAYS.
- When [D] is pressed with either SEND or MEAS row enabled, the PARAM SET LED (green) lights, and the PARAMETER DISPLAY(S) appear, if present. If there is no PARAMETER DISPLAY for the function enabled, the PARAM SET LED does not light. When a PARAM SET LED is on, the 16 keys along the bottom edge are used to set parameter values.
- When Dialing Mode (DP, TT, MF) is enabled (using item 8 in Figure 3-1), pressing a key along the bottom edge causes the respective digit to be dialed (outputted).

See Section 4 for a full explanation of key operation.

3.4 FRONT PANEL COMPONENTS

The numbering of the descriptions below corresponds to the numbering of the components in Figure 3-1.

1. Power On/Off Push Button

Note: When using AC power, observe **CAUTION** in ¶3.5 before turning on power.

Push button IN to turn power ON. Push button again (button will pop OUT) to turn power OFF.

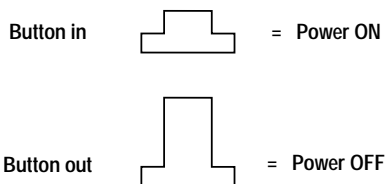

See Section 2 for power considerations.

2. TX/2W Bantam Jack

For 2-wire circuits (2W LED on): Connect the 2-wire pair to this jack.

Signals are both transmitted and received over this same pair of contacts.

For 4-wire circuits (4W LED on): Connect the send (transmit, TX) pair, over which the AM5XT/eXT sends signals.

For reverse (REV LED on): This pair becomes the receive pair, RX, over which the AM5XT/eXT receives signals.

See Figure 3-6 for mating cables.

The connections of this jack are the same as screw terminals T and R on the Rear Panel, item 10 in Figure 3-3.

3. RX Bantam Jack

For 4-wire circuits (4W LED on): Connect the receive pair, RX, over which the AM5XT/eXT receives signals. For 4-wire reversed (REV LED on): this pair becomes the send (transmit, TX) pair, over which the AM5XT/eXT sends signals.

For 2-wire reversed (REV LED on), signals are both transmitted and received over this pair of contacts.

See Figure 3-6 for mating cables.

The connections of this jack are the same as screw terminals T1 and R1 on the Rear Panel, item 9 in Figure 3-3.

4. Monitor Switch

Three-position switch used to select the point to which the internal amplifier/speaker is connected.

TX (Transmit): Connects the internal amplifier/speaker to the output of the signal generator.

MEAS (Measure): Connects the internal amplifier/speaker to the output of the receive circuit auto ranging amplifier and associated filters. This considerably increases the volume of the speaker and is useful to monitor low level signals. The signal is always in an 18 dB range for input signals ranging from -65 to +10 dBm. This setting is particularly useful for audibly monitoring the residual noise in notched noise and S/N ratio measurements.

RX (Receive): Connects the internal amplifier/speaker to the signal being measured. The possibilities are:

- RX (receive) pair of the 4-wire circuit under test.
- 2-wire circuit under test.
- if measuring 2-wire Return Loss, the receive pair of the Internal Hybrid.
- if measuring Noise-to-Ground, the Noise-to-Ground circuit.

5. Carrying Handle

Thick, soft, flexible plastic handle on right panel. Extends for use, retracts against case when not in use. The Carrying handle is not installed when the 19" Rack Mounting Kit is installed.

6. 16 Function Enable Keys

See explanation in ¶3.3 under "Keys".

7. Rubber Feet (portable version only)

Set of four (4) Rubber Feet on the bottom panel. Behind the front pair of feet are hinged plastic supports that can be swung forward (snap into place) to raise the front and tilt the unit for easier viewing of the Front Panel. In addition, there is a set of four (4) rubber feet on the left panel on which the unit can be conveniently set after transporting with the Carrying Handle (item 5).

8. Dialing Mode Enable Key

Repeatedly press as necessary to enable desire Dialing Mode, indicated by lighting of respective LED.

DP = Dial Pulse

TT = Touch Tone

MF = Multi-Frequency

See Section 10 concerning Dialing.

9. Auxiliary Function Row Enable Key

This is referred to as the [AUX] key. Press to enable the Auxiliary Function Row. AUX LED is on when this row is enabled. The Display MEAS LED (item 16) also lights. See Section 9 concerning Auxiliary Functions.

10. Measure Function Row Enable Key

This is referred to as the [MEAS] key. Press to enable the Measure Function Row. MEAS LED is on when this row is enabled. The Display MEAS LED (item 16) also lights. See Section 8 concerning Measure Functions.

11. Send Function Row Enable Key

This is referred to as the [SEND] key. Press to enable the SEND Function Row. SEND LED is on when this row is enabled. The Display SEND LED (item 16) also lights. See Section 7 concerning Send Functions.

12. Line Function Row Enable Key

This is referred to as the [LINE] key. Press to enable the Line Function Row. LINE LED is on when this row is enabled. See Section 7 concerning Send Functions.

13. Microphone

Three holes labeled TALK. The Microphone is located behind the Front Panel. Speak into the Microphone when in one of the TALK modes. See ¶7.14 for details.

14. Recall Key [RCL]

This key is used to recall and execute commands stored in non-volatile memory, either front panel setups or dialed numbers. Up to 40 **front panel setups** can be recalled. See Section 11 for details. Up to 10 **dialed numbers** can be recalled, each with up to 48 digits. Also, the last dialed number can always be recalled and redialed using this key. See ¶10.2 and 10.3 for details.

15. Store Key [STO]

This key is used to store commands in non-volatile memory, either front panel setups or dialed numbers. Up to 40 **front panel setups** can be stored. See Section 11 for details. Up to 10 **dialed numbers** can be stored, each with up to 48 digits. See ¶10.2 for details.

16. Display LEDs, SEND and MEASure

These LEDs indicate what function is being viewed on the Display. One of these LEDs is always on.

SEND on = enabled SEND function being viewed on the Display.

MEAS on = enabled Measure function being viewed on the Display.

The SEND Display LED automatically lights when the [SEND] key (item 11) is pressed. The MEAS Display LED automatically lights when either the [MEAS] key (item 10) or [AUX] key (item 9) is pressed.

17. Left LED Display

This is a red LED display with four (4) 7-segmented characters with floating decimal points. The type of reading (Send Function or Measure Function) is indicated by the LEDs to the left of this display; see item 16. The unit of measurement is indicated by LEDs located to the right of this display. See item 18.

18. Units of Measurement LEDs

Each of these LEDs is labeled with a unit(s) of measurement. One of these LEDs is lit, as appropriate, to indicate the unit of measurement for a numerical value displayed in the left display (item 17).

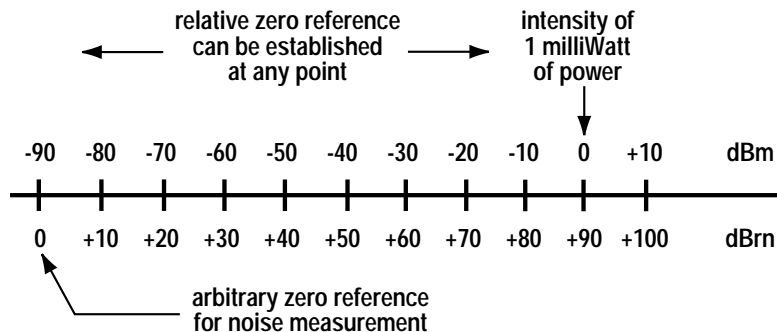

Figure 3-2. Level and Noise Units of Measurement

The possible units of measurement are explained as follows:

dB

The deciBel (dB) is a logarithmic (base 10) electrical unit used to compare or indicate changes in level. The dB unit is only a relative unit however, and does not have a meaning unless a point of reference is established. Thus the systems of dBm and dBm were established as described below.

dBm

To establish a point of reference in making comparisons in **level** (and **noise** for CCITT standard) measurements in transmission testing, the system of dBm was adopted.

00.0 dBm is defined as the level of one (1) milliWatt of power, hence the abbreviation “m” after the dB. Levels of less power than this reference point are negative, -dBm values; and levels of greater power are positive, +dBm values. See Figure 3-2.

It turns out that 00.0 dBm is a strong level for a telephone line, so most of the level measurements in units of dBm are negative, i.e., less power than the 00.0 dBm reference. For example, -10.0 dBm is a typical level at which dialing tones are sent.

dBm (AM5XT only)

The dBm unit is used in noise level measurements, “m” meaning relative noise. Note in Figure 3-2 that the zero reference for noise measurement has been established at -90 dBm, an extremely low level for a telephone line. Thus, noise measurements will always be positive (higher level) with respect to the 00.0 dBm reference.

Absolute and Relative Measurements. An **absolute** level measurement is made in units of dBm, as described above. A **relative** measurement is in units of dB. A zero point of reference is established at any level, and subsequent level measurements are made relative to that level. See ¶9.9 for an explanation of how relative measurements are used.

mSEC

milli-seconds. One mSEC = one thousandth of a second. Unit of measure in Envelope Delay.

HOLD TONE. This LED lights when a valid Holding Tone is present at the receive port. A valid Holding Tone is required for Notched Noise, S/N Ratio, Phase Jitter, Amplitude Jitter, and Transient Tests. This LED must be on for these tests to be valid. A Holding Tone is nominally 1004 Hz. See Table 3-1 for Holding Tone range specifications, which depend on the type of measurement.

Table 3-1. Acceptable Holding Tone Ranges

| Acceptable Range | Type of Measurement |
|-------------------|-----------------------------------|
| 990 Hz to 1030 Hz | Phase Jitter and Amplitude Jitter |
| 995 Hz to 1025 Hz | All other Holding Tone tests |

19. Metal Case

This is a sturdy aluminum case, painted blue, with a steel rear panel. For portable units, if the optional canvas Padded Carrying Case is not ordered, a removable snap-on cover is supplied to protect the front panel during transport. For fixed installations, an optional 19" Rack Mounting Kit (installed at the factory) can be ordered.

20. Right LED Display

This is a red LED display with four (4) 7-segmented characters with floating decimal points. The type of reading (Send Function or Measure Function) is indicated by the LEDs on the far left of the display area; see item 16. The unit of measurement is indicated by LEDs located to the right of this display. See item 21.

21. Units of Measurement LEDs

Each of these LEDs is labeled with a unit(s) of measurement. One of these LEDs will light as appropriate to indicate the unit of measurement for a numerical value displayed in the right display (item 20). The possible units of measurement are explained below.

kHz = Kilo-Hertz = 1000 Hertz = 1000 cycles per second.

Note: All frequencies are expressed in kHz, not Hz. A common mistake is to try to set a frequency value and enter it as if it were expressed in Hz instead of kHz. For example, enter 1004 Hz as 1.004 kHz (be sure to enter the decimal point between the 1 and the 0). If an attempt were made to enter this as 1004 without the decimal point, the display would default to 200 kHz, the maximum possible value for a frequency. Thus, if the display “mysteriously” shows 200 kHz instead of the value entered, the frequency was entered as if it were in units of Hz. Reenter the correct value in units of kHz, with a decimal point in the appropriate place.

SEC = Seconds (time).

PAR = (Peak-to-Average Ratio) units. See ¶8.8.

MIN = Minutes.

% = Percent.

CNT = Counts.

DEG = Degrees.

22. Volume Control Knob

This controls the volume of the speaker, item 23. Turn clockwise to increase speaker volume and turn counter-clockwise to decrease speaker volume.

23. Speaker

This is located on the top of the unit near the front. The speaker is connected to a monitor point determined by the position of the Speaker Monitor Switch, item 4. Speaker volume is controlled by the Volume Control Knob, item 22.

3.5 REAR PANEL COMPONENTS

The numbering of the descriptions below corresponds to the numbering of the components in Figure 3-3.

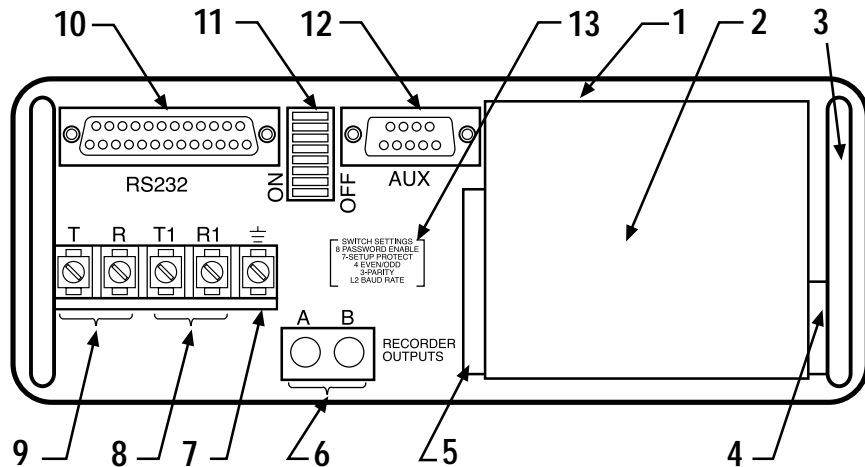

Figure 3-3. Rear Panel Components

1. AC Power Selector Switch

115V/230V. Red slide switch. Before plugging in the power cord, set this switch to match the power source to which the power cord is to be connected, either 115 VAC or 230 VAC.



CAUTION: Observe the **CAUTION** printed on the back of the unit. When connected to a 230 VAC source, be sure to set this switch to the 230V position before turning on the power. Damage to the unit will result if 230 VAC is applied with this switch set to 115V.

2. Step-Down Transformer

Part of the power supply.

3. Foot/Guard

Two places. The unit can be stood on end, resting on these rubber-coated supports. They protrude to allow clearance for rear panel components and rear-mounted cables.

4. Fuse Holder

With slotted cover. Unscrew with common blade screwdriver to inspect/replace the fuse. The fuse is 1/2 amp, 250V.

5. Power Plug

Three pronged male, for 115 or 230 VAC. Mating power cord is supplied. Be sure AC Power Selector Switch (item 1) is in correct position.

6. Recorder Outputs (optional)

These Bantam Jacks, labeled “A” and “B”, are the outputs of the X-Y Plotter, Option 25-0045. See ¶3.6 and Section 13 for details concerning the plotter function. In general, these contacts are used as follows:

“A” Bantam Jack: Sleeve = ground
Tip = not used
Ring = auxiliary logic output

“B” Bantam Jack: Sleeve = ground
Tip = Plot X or auxiliary logic output
Ring = Plot Y or auxiliary logic output

7. Screw Terminal, Ground

This is the same connection as the Sleeve contacts on the front-panel Bantam Jacks (items 2 and 3 in Figure 3-1). Use this ground as the reference ground in the Noise-to-Ground test (¶8.6).

8. Screw Terminals, T1, R1

These are the same connections as the Tip and Ring of the **right** front-panel Bantam Jack (item 3 in Figure 3-1. See ¶3.4,3).

9. Screw Terminals, T, R

These are the same connections as the Tip and Ring of the **left** front-panel Bantam Jack (item 2 in Figure 3-1. See ¶3.4,2).

10. RS232 Connector (optional)

25-pin male DB25, only with units equipped with Option 25-0019. Connector pin assignments are listed in Table 3-2.

Table 3-2. RS232 Connector Pin Assignment

| PIN | FUNCTION | DIRECTION |
|-----|-------------------------|----------------|
| 2 | TD Transmit Data | From AM5XT/eXT |
| 3 | RD Received Data | To AM5XT/eXT |
| 4 | RTS Request to Send | Not Used |
| 5 | CTD Clear to Send | Not Used |
| 7 | GNF Common | ---- |
| 9 | +V +Power (+12 Vdc) | From AM5XT/eXT |
| 10 | -V -Power (-12 Vdc) | From AM5XT/eXT |
| 20 | DTR Data Terminal Ready | Not Used |
| 22 | RI Ring Indicator | Not Used |

A printer or terminal can be connected here. This connector is also used to connect the unit in a chain if this is other than the first unit in the chain. See Section 12 concerning RS232 port operation.

Note: This area is filled with a plastic cover if the unit is not equipped with the RS232 option.

11. 8-Switch DIP Switch

Table 3-3 lists the switch functions and positions. An abbreviated list, item 13, is given on the rear panel.

Table 3-3. DIP Switch Settings

| DIP SWITCH | FUNCTION | CODE |
|------------|-----------------|---|
| 1 & 2 | Set Baud Rate | 1 OFF, 2 OFF = 300 BAUD 1 ON, 2 OFF = 1200 BAUD 1 OFF, 2 ON = 2400 BAUD 1 ON, 2 ON = 9600 BAUD |
| 3 | Parity Enable | ON = PARITY, OFF = NO PARITY |
| 4 | Parity Select | ON = EVEN PARITY, OFF = ODD PARITY |
| 5 | Not Used | ---- |
| 6 | Not Used | ---- |
| 7 | Setup Protect | ON = PROTECT, OFF = UNPROTECTED |
| 8 | Password Enable | ON = Password needed, OFF = No Password needed |

Switches 1 thru 4 control the operating characteristics of the RS232 port. See Section 12 concerning RS232 port operation.

Switches 5 and 6 are not used.

Switch 7 protects/unprotects the front panel setups stored in non-volatile memory. Note that Switch 7 does **not** protect Dialed Numbers stored in non-volatile memory per ¶10.2.

Switch 8 controls the remote control password enable.

12. Auxiliary (AUX) RS232 Connector

9-pin female D-type miniature. This is used to connect to the RS232 port of an auxiliary unit (printer, test access switch, etc.), installed near the AM5XT/eXT. Use cable 48-0083 for this function. See ¶12.1 for details. Available pins are listed in Table 3-4.

Table 3-4. Auxiliary RS232 Connector Pin Assignment

| Pin | Function | Direction |
|-----|------------------|----------------|
| 2 | RD Received Data | To AM5XT/eXT |
| 3 | TD Transmit Data | From AM5XT/eXT |
| 7 | GND Common | ---- |

Baud Rate and Parity are the same as those of the main RS232 port (set with Switches 1 thru 4 of the DIP switch, item 11).

13. List of DIP Switch Settings

See Table 3-3 for detailed information on settings.

3.6 OPTIONAL EQUIPMENT

This paragraph describes features that can be made a part of the AM5XT/eXT when specially ordered. See ¶3.7 and 3.8 for accessories that can be specially ordered to use with the AM5XT/eXT.

Sealed Lead Acid Batteries and Integral Charger, Option 24-0017

When fully charged, these batteries allow 5 to 8 hours of cordless (no commercial power) operation. See ¶2.2 for details.

RS232 Port, Option 25-0019

The RS232 port is required for printouts and external control of the AM5XT/eXT from a terminal or computer. The RS232 port makes possible additional functions and capabilities that cannot be done with the front panel controls alone. A unit equipped with this option has an RS232 connector (item 10 in Figure 3-3) on the rear panel. See Section 12 concerning RS232 port operation.

19" Rack Mounting Kit, Option 85-0076

Order this option if the unit is to be mounted in a 19" relay rack. The Carrying Handle and Rubber Feet are not included when this option is ordered.

X-Y Plotter Outputs, Option 25-0045

Voltages are delivered to rear panel Bantam Jacks, which are connected to an external plotter for hard copy graph of test results. A unit equipped with this option has two (2) Bantam Jacks (item 6 in Figure 3-3) on the rear panel. See ¶13.1 for details. This option is not available for an AM5XT-BASIC.

Delete Front Panel, Option 25-0020

RS232 Port, Option 25-0019, must also be ordered. The Front Panel is deleted for exclusive remote control of the unit through the RS232 Port when front panel manual control will never be needed.

Siemens Adapter, Option 25-0041 (AM5eXT only)

This brings the line connections to two (2) 3-socket connectors, designed to mate with lines that are connected with a 3-pronged Siemens-type Banana connector, a standard in some European countries. These connectors are mounted on the bottom of the AM5eXT, flush with the front panel.

3.7 AM-47XT HAND-HELD PRINTER (Optional)

The AM-47XT Hand-Held Printer is designed to be used with an AM5XT or AM5eXT to provide a hard copy of the measurements and setups.

Operating Instructions

See ¶13.1.

Technical Specifications

Table 3-5. AM-47XT Technical Specifications

| CHARACTERISTICS | SPECIFICATIONS |
|---------------------|---|
| Input Signal | Serial ASCII RS232 (modified for plot function) |
| Input Connector | 4-Wide Modular Jack |
| Input Speed | 300, 1200, Or 9600 Baud with 1500 Character FIFO Buffer |
| Print Type | 6 x 8 Impact Dot Matrix |
| Paper | 2.25" w x 1.8" Dia. Adding Machine Paper (Part No. 26-0014) |
| Ink Supply | Replaceable Inked Ribbon Cartridge (Part No. 26-0015) |
| Characters per Line | 40 |
| Print Speed | 0.4 Lines per Second |
| Power | Internal NiCad Battery Pack with Built-in Charger |
| Battery Life | Approximately 7,000 Lines |
| Charge Time | 8 to 14 hours |
| Size | 7.6"L x 3.4"W x 1.9"D |
| Weight | 1.5 lbs. |
| Cables | Printer Cable (48-0095) and AC Adapter (70-0029), supplied |

Component Locations

See illustration in Figure 3-4.

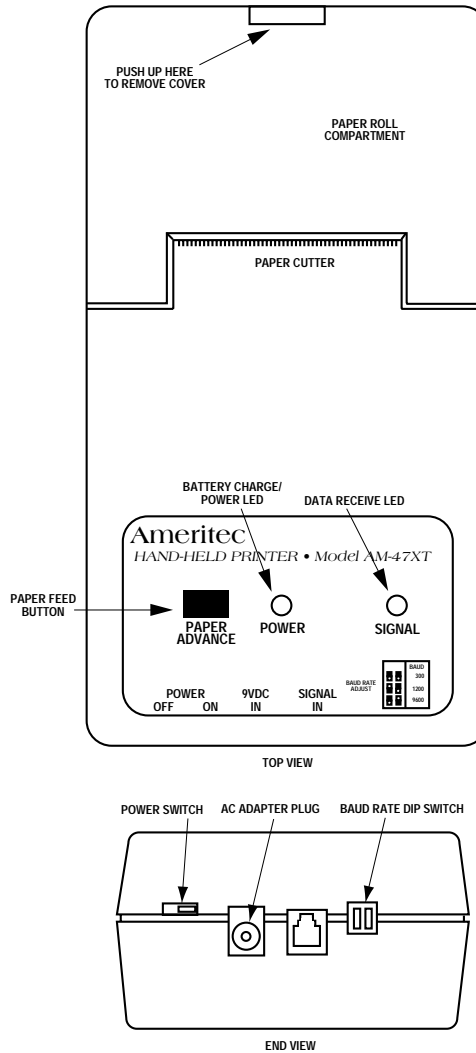

Figure 3-4. Hand-Held Printer, Component Location

Connectors, Cables

The connectors are used with the AC Adapter (70-0029) and the Printer Cable (48-0095), shown in Figure 3-5. Both of these cables are supplied with the AM-47XT.

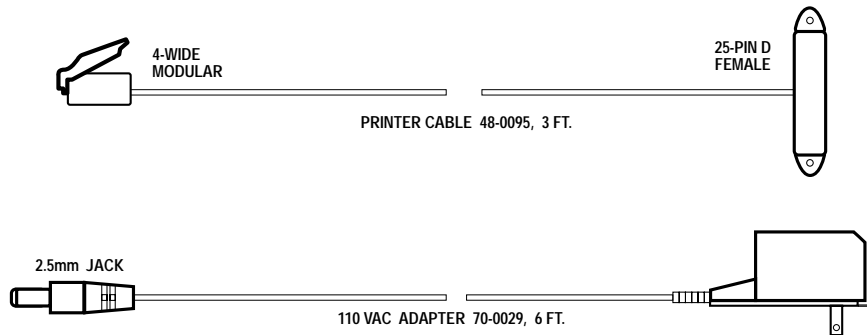

Figure 3-5. Standard Cables Supplied with the AM-47XT Printer

Power

Power is supplied by an internal NiCad battery pack. There is an internal charging circuit in the printer that operates when the AC Adapter is plugged in.

Power Switch

See charging instructions in ¶13.1 concerning the position of this switch during charging and operation.

2-Position DIP Switch

This is used to set the BAUD Rate (300, 1200, or 9600). Settings are indicated in a table on the label above the switches.

Note: Printer Power Switch must be OFF when changing Baud Rate on the AM-47XT. Moving DIP switches with the Printer Power Switch ON does not change the Baud Rate until the Printer is switched OFF and then switched ON again.

LEDs

The LEDs light as described below:

1. The POWER LED lights continuously when the AC Adapter is connected and the battery pack is charging (starts charge cycle each time power is turned ON).

2. The POWER LED blinks when power is ON and the battery pack has been charged.
3. The SIGNAL LED lights when data is being received from the AM5XT/eXT.

Printing Mechanism

Printing mechanism is dot matrix impact type with replaceable ribbon cartridge. Standard-width adding machine paper is used. The ribbon cartridge and paper roll are housed within the case. The printout is in 40-column format, at a speed of 0.4 lines per second.

Ribbon Cartridge Replacement

Refer to Figure 3-6. For replacement ribbon cartridges, order Part No. 26-0015.

1. Push up on end of housing to remove paper roll compartment cover.
2. Observe how ribbon is routed on the old cartridge.
3. Push on end of cartridge as indicated in Figure 3-6 to eject old cartridge.
4. Snap in new cartridge, being careful to insert ribbon correctly.
5. Rotate manual ribbon take-up to apply tension to the ribbon.
6. Re-install compartment cover.

Paper Roll Installation

Refer to Figure 3-6. For additional rolls of paper, order Part No. 26-0014.

1. Push up on end of housing to remove paper roll compartment cover.
2. Install paper roll in cradle and feed paper into slot.
3. Push [PAPER ADVANCE] button to route paper through printer.
4. Re-install compartment cover.

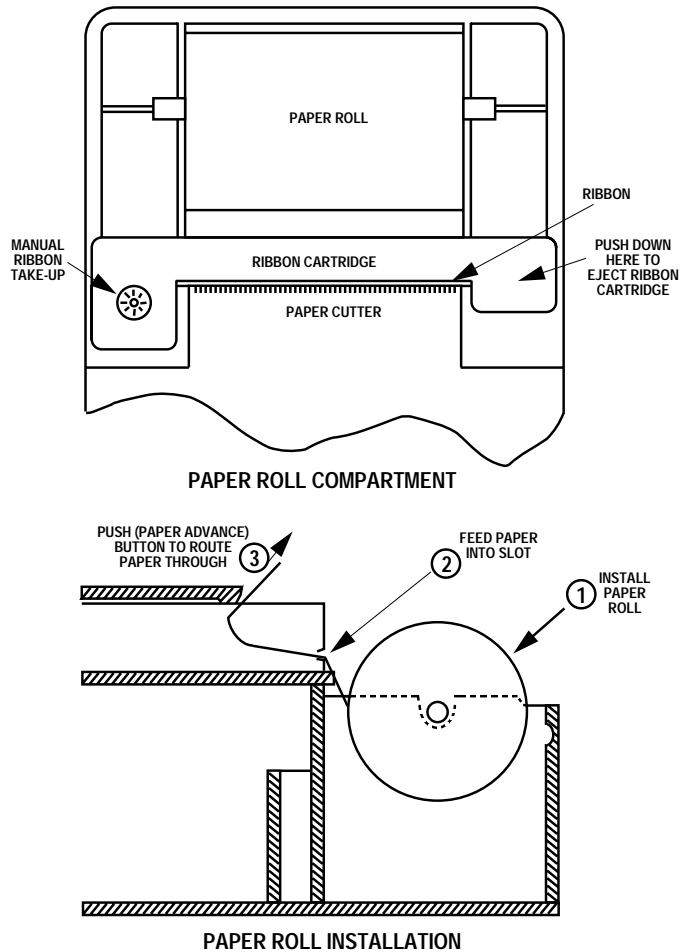

Figure 3-6. Ribbon and Paper Installation for AM-47XT

Self Test

For a printout of all possible characters, hold down the [PAPER ADVANCE] button and set the POWER switch to ON. Self test printouts will continue to output until the [PAPER ADVANCE] button is released.

Charging Considerations

The AM-47XT NiCad battery pack is charged through the AC Adapter (70-0029). See Figure 3-7 for connection.

AM5XT/eXT Voice/Data Transmission (18-0022) Physical and Functional Description

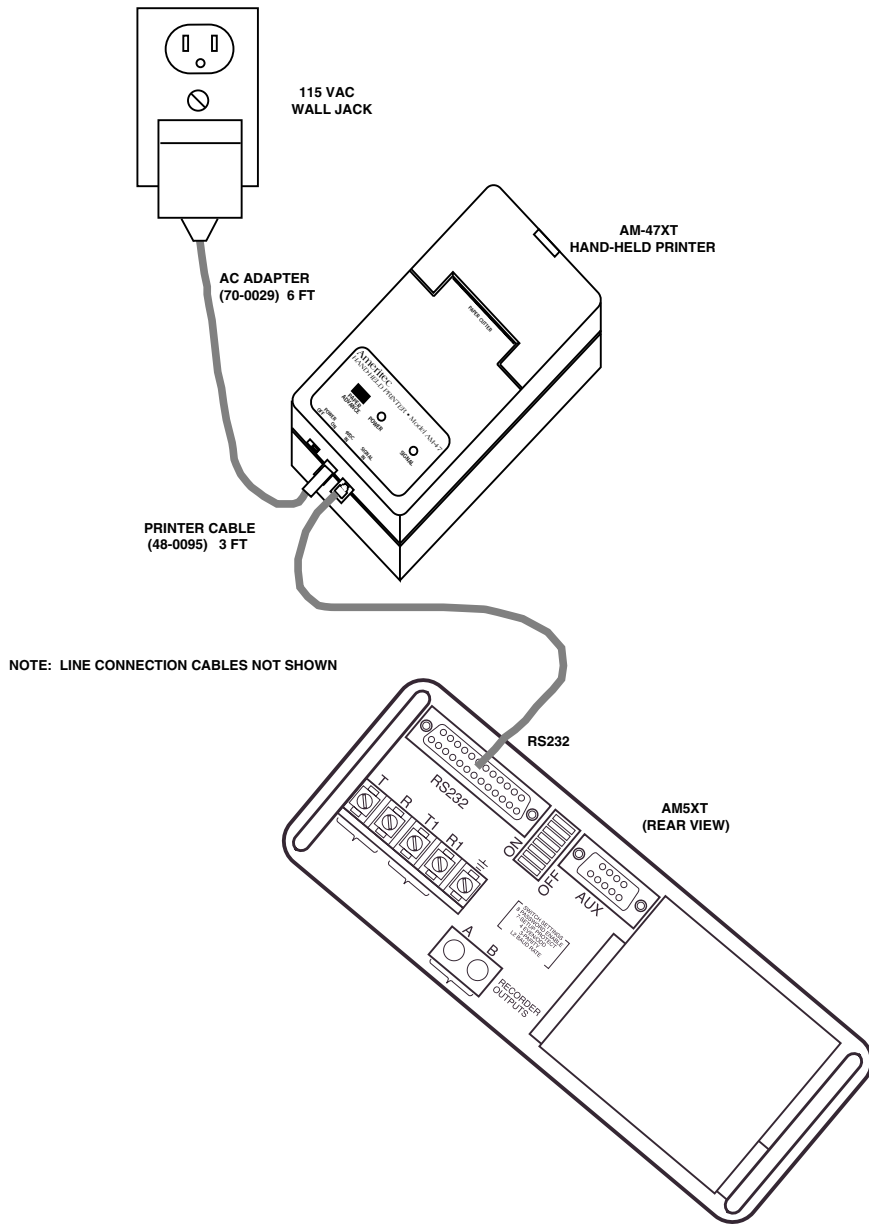

Figure 3-7. Printer Hookup

Charging is controlled by a microprocessor that is programmed to run the charging circuitry without sensing the actual charged or discharged state of the battery pack.

With the AC Adapter connected, each time the power is turned ON, the microprocessor assumes the worst case and goes into a full 14-hour charge cycle.

With the AC Adapter connected and the power OFF, the AM-47XT is charged with a very low trickle current which takes several days to charge the battery pack.

Note: The AM-47XT is normally charged with the power ON even though many other devices are typically charged with the power OFF.

The AC Adapter can be left continuously connected to the AM-47XT. There is no danger of “overcharging” the battery pack.

After the charging cycle, the POWER LED will blink. Also after the charging cycle, a timer is set which will start the charge cycle again after it is decremented to zero. Each time a line is printed, the timer is decremented a certain amount. If the POWER switch is left ON, the AM-47XT can print about 7,000 lines before the timer is decremented to zero and a new charge cycle is initiated.

There are two (2) charging procedures:

1. A normal procedure.
2. A procedure if the battery pack is **completely** discharged.

Normal Charging Procedure

Connect AC Adapter (70-0029) as shown in Figure 5-2. Turn POWER switch ON and note POWER LED. If LED lights, unit is charging. If LED does not light, battery pack is completely discharged; go to next charging procedure.

When charging cycle is complete (after about 14 hours), POWER LED will blink.

Note: Each time power is turned ON with the AC Adapter connected, the AM-47XT will go through a complete charging cycle, regardless of the charge of the battery pack..

Charging Procedure When Battery Pack is Completely Discharged

Connect AC Adapter (70-0029) as shown in Figure 5-2. Turn POWER switch ON to verify POWER LED does not light. Turn POWER switch OFF. This will initiate a trickle charge that will charge the battery pack enough to operate the microprocessor-controlled charging circuitry. Leave the POWER switch OFF for about one (1) hour.

Turn the POWER switch ON. The POWER LED will now light continuously, indicating that the full charge cycle has begun. After about 14 hours, the POWER LED will start to blink, indicating that charging is complete.

3.8 ACCESSORIES

The items described in this paragraph are not automatically supplied with the AM5XT/eXT; they must be added to the order per customer request. See ¶3.7 concerning the AM-47XT Hand-Held Printer.

Line Cables

Bantam Plug Line Cables are illustrated in Figure 3-8, along with their lengths and part numbers.

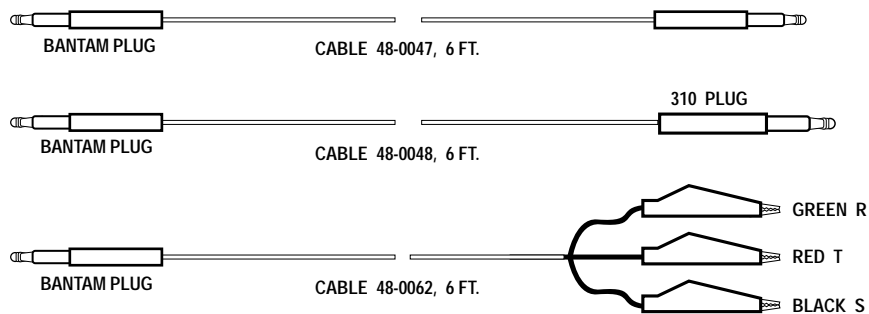

Figure 3-8. Bantam Plug Line Cables

Each of these cables can be used for a front-panel line connection, mating to the Bantam Jacks (items 2 and 3, Figure 3-1) in the upper right-hand corner of the unit.

Padded Carrying Case, Model No. 87-0070B

This case is ideal to protect and carry the AM5XT/eXT and AM-47XT Printer while field testing. The AM5XT/eXT could be operated without removing it from the case. This case is constructed of green/gray heavy canvas, filled with foam padding. Other features are listed below:

- Case dimensions: approximately 11”L x 5”W x 13”H (28cmL x 13cmW x 33cmH).
- Side pocket with individual Velcro fastened cover flap, designed to carry AM-47XT Hand-Held Printer.
- Hand-carrying strap and padded shoulder carrying strap.

RS232 Cables

Cables that can be used with the RS232 Port are illustrated in Figure 3-9, along with their lengths and part numbers.

AM5XT/eXT Voice/Data Transmission (18-0022) Physical and Functional Description

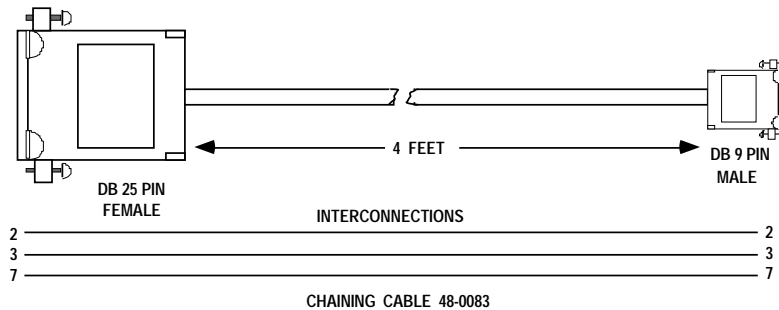
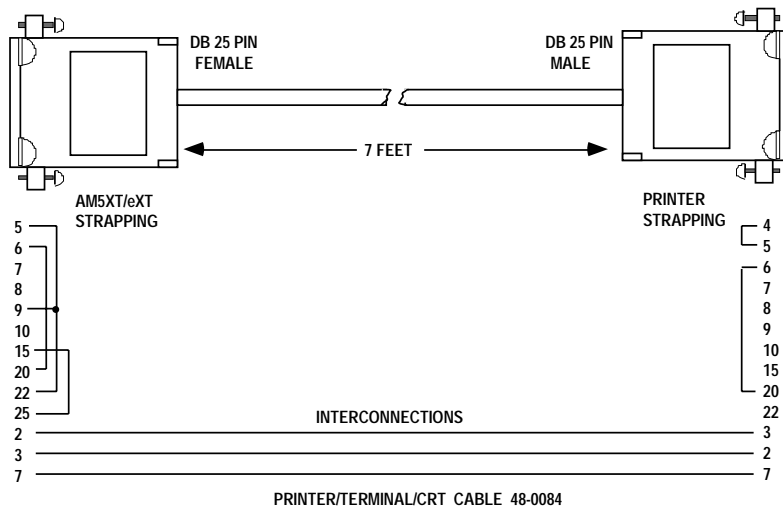
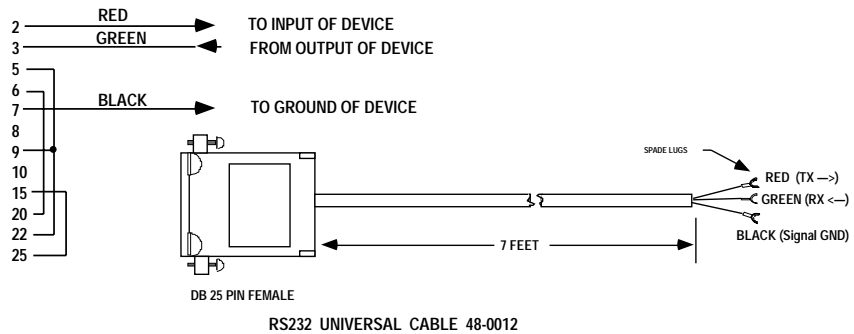

Figure 3-9. RS232 Cables

Each of these cables mates to the RS232 port connector (item 10, Figure 3-3). See Section 12 for applications that use these cables.

3.9 MASK FEATURE (Optional)

This feature provides eight sets of performance limits (masks) that are applied to Level/Freq and Delay sweep results to determine whether a line is measuring according to its specifications. When the measurement results are within limits, the printer/plotter output is normal. When a measurement result is outside the mask, an indication of the error is recorded on the printer plot.

There are eight different performance masks to select from, each with eight different limit specifications. A mask is selected using the “Cond” parameter for Level/Frequency or Group Delay measurements. Stored memory recalls 81 to 88 are also reserved for this purpose. Masks are recalled independently from LINE parameters or MEASUREMENT setups.

A printer plot output of a mask specification allows a graphic display of the mask. This plot uses the same scaling parameter as a normal printer plot, so it can be compared with an actual plot of the line under test.

4. SELF-TEST AND OPERATION TECHNIQUES

4.1 INTRODUCTION

This section describes procedures to verify that the AM5XT/eXT is working properly. Refer to Figure 3-1 for front panel details. Some important operation techniques are discussed in this section.

4.2 SELF-TEST SETUP

These tests are done with the AM5XT/eXT looped back on itself, not connected to any external equipment. The signals sent (generated) through the Transmit (TX) port are routed directly back to the Receive (RX) port through a Bantam cable plugged into the front panel jacks or through a pair of wires attached to the rear panel screw terminals (T to T1 and R to R1).

When the AM5XT/eXT is turned on, all LEDs and displays are lit for approximately three (3) seconds. TEST PASS is then displayed. The unit then assumes its default configuration.

4.3 SWITCH SETUP

Place Monitor Switch in the TX (Transmit) mode.

Press the LINE key. Turn off the BRDG LED by pressing [#]. Verify that the unit is set for 600Ω TX, 600Ω RX, and 4W.

Verify that CMSG (PSHO for AM5eXT) is lit on the AUX line.

4.4 QUIET SEND MODE

Press the SEND key. The SEND LED lights. Press key [1] to activate QT (Quiet) mode.

Press the MEAS key. The MEAS LED lights. Verify that the LVL/FREQ LED is lit. The display should read “undr” with units “dBm”.

Press key [2] for NOISE. The display should read “undr” with units “dBm” (“dBm” for AM5eXT).

4.5 SEND 1004 Hz

Press the SEND key. The SEND LED lights. Press key [2] to send 1004 Hz (at 00.0 dBm).

Note: Turn volume control up or down as desired to increase or decrease volume of the speaker sound. The speaker is monitoring the 1004 Hz tone being sent.

Press the MEAS key. The MEAS LED lights. Press key [1] for LVL/FREQ. The display should read 00.0 ± 1.0 dBm, $1.004 \pm .002$ kHz.

Press key [2] for NOISE. The display should read 90.0 ± 1 dBm (01.0 ± 1.0 dBm for AM5eXT).

Press key [3] for NOTCH NOISE. Note that the HOLD TONE LED is on (signal being received). The reading on the display must be less than 40.0 dBm and at 1.004 kHz (-50 dBm for AM5eXT). If the left display reads undr, the right display is blank.

Press key [5] for S/N (signal-to-noise ratio). Note that the HOLD TONE LED is still on. The display should read greater than 50.0 dB (or should read over) and at $1.004 \pm .002$ kHz.

Verify that the JTR 20-300 LED is on in the AUX line.

Press key [0] for PHASE JTR. The display should read PJTr and 00.0 ± 0.2 with the DEG LED lit.

Press key [*] for AMP JTR. The display should read AJTr and $00.0 \pm .2$ with the % LED lit.

4.6 SEND PAR

Press the SEND key. Press key [6] for PAR. The display should read 0.00 dBm and PAR. Press the MEAS key. Press key [6] for PAR. The display should read 00.0 ± 1.0 dBm and 100 ± 2 PAR.

4.7 SEND ENVELOPE DELAY (ENV DLY)

Press the SEND key. Press key [8] for ENV DLY. Press key [8] again to display 00.0 dBm and rEF.

Press the MEAS key. The display should read $3.965 \pm .010$ mSEC and $1.800 \pm .002$ kHz.

4.8 SEND IMD

Press the SEND key. Press key [9] for IMD. Press the MEAS key. The display should read $00.0 \pm .5$ dBm and 4T. Press key [9]. The display should change to OVER dB and 2 4T. Press key [9] again. The display should change to OVER dB and 3 4T.

Press the SEND key. Press key [9]. The display should read 00.0 dBm and TEST. Press the MEAS key. The display should read $30.0 \pm .5$ dBm and 3 4T. Press key [9]. The display should read $00.0 \pm .5$ dBm and 4T. Press key [9] again. The display should read $20.0 \pm .5$ dB and 2 4T. Press key [9] again. The display should read $30.0 \pm .5$ dB and 3 4T.

4.9 AUTO CALIBRATE (Up to version 7* only)

Note: See ¶7.2, Display 5 to determine the software installed in the AM5XT/eXT being used.

The AM5XT/eXT was calibrated at the factory for proper measurement accuracy by loading certain values into internal RAM. RAM is maintained by a small internal “super cap” (1 farad capacitor) with 30-day life. As long as the AM5XT/eXT is connected to commercial power at least once each 30 days **or** if equipped with the internal battery option, the RAM “super cap” will retain its charge indefinitely.

If the unit is **not** equipped with the internal battery option **and** is not connected to commercial power for 30 days or more, the unit will require recalibration. This is easily accomplished in the field. As part of the power-on self-test, the unit automatically diagnoses itself and informs the operator of the need for recalibration.

If during the power-on self-test, the display indicates AUTO CAL?, proceed as follows:

1. Remove all input leads.
2. Press the [AUX] key to enter AUX mode.
3. Press the [#] key.
4. Press the [D] key.

The unit will go through an auto-calibration process wherein the send/receive pairs are internally looped. The internal signal generator sends 6 different levels at 1004 Hz plus 1 level at PAR while the measurement circuitry calibrates itself. This process takes approximately 30 seconds, following which the unit reverts to normal operation.

4.10 CALIBRATION CHECK (Up to version 7* only)

When desired, the AM5XT/eXT can be forced into auto-calibration any time by entering AUX mode and pressing the [#] key and the [ENTER] or [D] key. Make certain that all input leads are disconnected during auto-calibration or erroneous calibration will result.

4.11 CALIBRATION (Version 8* and up)

AM5XT/eXTs with version 8 and up software allow for complete field calibration using only a high accuracy digital voltmeter. The voltmeter must read out in AC Volts RMS and be accurate at 1000 Hz within .4%. Minimum input impedance should be 200 k Ω .



CAUTION: Do not enable the FULL CAL unless you have a high accuracy digital voltmeter available. Corruption of calibration will result.

1. Disconnect all input leads from the AM5XT/eXT.
2. Connect the leads of the voltmeter to T1 and R1 either on the front right Bantam jack or rear terminal screws.
3. Press the [AUX] key to enter the AUX mode.
4. Press the [#] key. The display reads AUTO CAL?
5. Press the [#] key again. The display reads FULL CAL?

6. Press any key (other than [D]) to abort the FULL CAL?
7. Toggle DIP Switch 5 to enable the FULL CAL?
8. Press the [D, ENTER] key. The display reads V1 on the left and four dashes on the right. The PARAM SET LED is lit.
9. Enter the voltage shown on the voltmeter, with the decimal. The PARAM SET LED blinks. The voltage should be larger than 1.200 and smaller than 2.600. Larger or smaller readings cannot be entered. If the reading is outside this range, the unit must be repaired. Press the [D, ENTER] key to enter the reading. The PARAM SET LED remains lit.
10. Press the [D, ENTER] key. The display reads V2 on the left and four dashes on the right.
11. Enter the voltage shown on the voltmeter, with the decimal. The PARAM SET LED blinks. The voltage should be larger than 0.250 and smaller than 0.450. Larger or smaller readings cannot be entered. If the reading is outside this range, the unit must be repaired. Press the [D, ENTER] key to enter the reading. The PARAM SET LED remains lit.
12. Press the [D, ENTER] key. The display is blank on the left and reads CAL? on the right. The PARAM SET LED goes out.
13. Disconnect the voltmeter from the AM5XT/eXT.
14. Press the [D, ENTER] key. The unit begins to calibrate itself. This process takes approximately 4 minutes. After calibration is completed, the unit goes into operating mode and is ready for use.

4.12 PARAMETER SET

The Parameter Set mode is used with Send and Measure functions to change/adjust the signal level, variable frequency, and sweep parameters. To enter Parameter Set mode:

1. Press the [SEND] or [MEAS] key to enable the Send or Measure function row.
2. Press [D].

3. The PARAM SET LED lights. Press [D] to step to the next parameter.
Press [C] to step to the previous parameter.

It is important to note that the PARAM SET LED indicates the state of the values entered/changed:

- If the PARAM SET LED is ON, the value displayed is entered into the AM5XT/eXT. The value can be changed with the number keys, or in increments with the up and down arrow keys.
- If the PARAM SET LED is BLINKING, the value displayed has been changed but not entered. Press [D] to **enter** or press [C] to **cancel** the value and revert to the previous value.
- If the PARAM SET LED is OFF, all values have been entered and the user is able to begin testing

To exit Parameter Set mode, press the [SEND] or [MEAS] key again.

4.13 DATA DISPLAYS

Data Displays are accessed by pressing the same key that is used to enable the function. For example, RETURN LOSS has three types of white-noise test tones. Refer to ¶7.8, Displays 1, 2, and 3.

1. Press the [SEND] key.
2. Press [7] to select Echo Return Loss (ErL).
3. Press [7] again to select Singing Return Loss-Lo (SrLL).
4. Press [7] again to select Singing Return Loss-Hi (SrLH).
5. Press [7] again to return to Echo Return Loss (ErL).

5. CONNECTION AND CONFIGURATION INSTRUCTIONS

5.1 INTRODUCTION

This section describes the AM5XT/eXT connections and configurations made in preparation for testing. It is divided into the following paragraphs:

- 5.2 General
- 5.3 Connectors and Cables
- 5.4 Line Termination Impedances
- 5.5 Configurations

In ¶5.5, basic operating instructions are given for testing with the Western Electric 829 loopback device, and also with Ameritec Responders.

5.2 GENERAL

Low-Level Measurements

Power the AM5XT/eXT with batteries when making a low-level noise measurement. Do **not** use AC power for this test because interference from the AC source can affect the measurement.

Independent Send and Measure Modes

The Send, Measure, and Filter modes of the AM5XT/eXT operate independently. Almost any combination of Send, Measure, or Filter can be selected. However, depending on the setup, the resulting measurements may or may not be valid.

For example, a 1004 Hz holding tone must be sent for various measure modes, and a PAR waveform must be sent when PAR is measured. If the 1004 Hz tone or PAR waveform were not present in the corresponding measurement, the measurement would not be valid. The AM5XT/eXT configuration (see ¶5.5) determines in what part of the system the signals need to be sent and measured.

The correct Send, Measure, and Filter modes are indicated for each test described in the operating instructions of Sections 7 and 8.

5.3 CONNECTORS AND CABLES

See Figures 3-2 and 3-3 for illustrations of the AM5XT/eXT connectors and cables. Note that some cables are standard and others are optional. Connect the appropriate cable(s) described in this paragraph according to the desired application.

AC Operation

Connect the power cord (supplied) to the three-pronged connector on the rear panel of the unit. Connect the other end into a standard 115 or 230 VAC wall socket. Note that positioning of the red 115/230 switch near the AC connector on the unit for proper setting.



CAUTION: Severe damage will occur to the unit if set for 115 VAC and connected to the 230 VAC power.

Printer Cables

There are two (2) types of cables used with printers. The 48-0095 is used with the AM-47XT Hand-Held Printer. The 48-0078 is used to connect to most other 25-pin female serial EIA printers. There is also a 48-0083 cable used to connect an EIA Serial ASCII type device to the AUX port of the AM5XT/eXT.

Figure 5-1 shows the connections for the AM-47XT Hand-Held Printer.

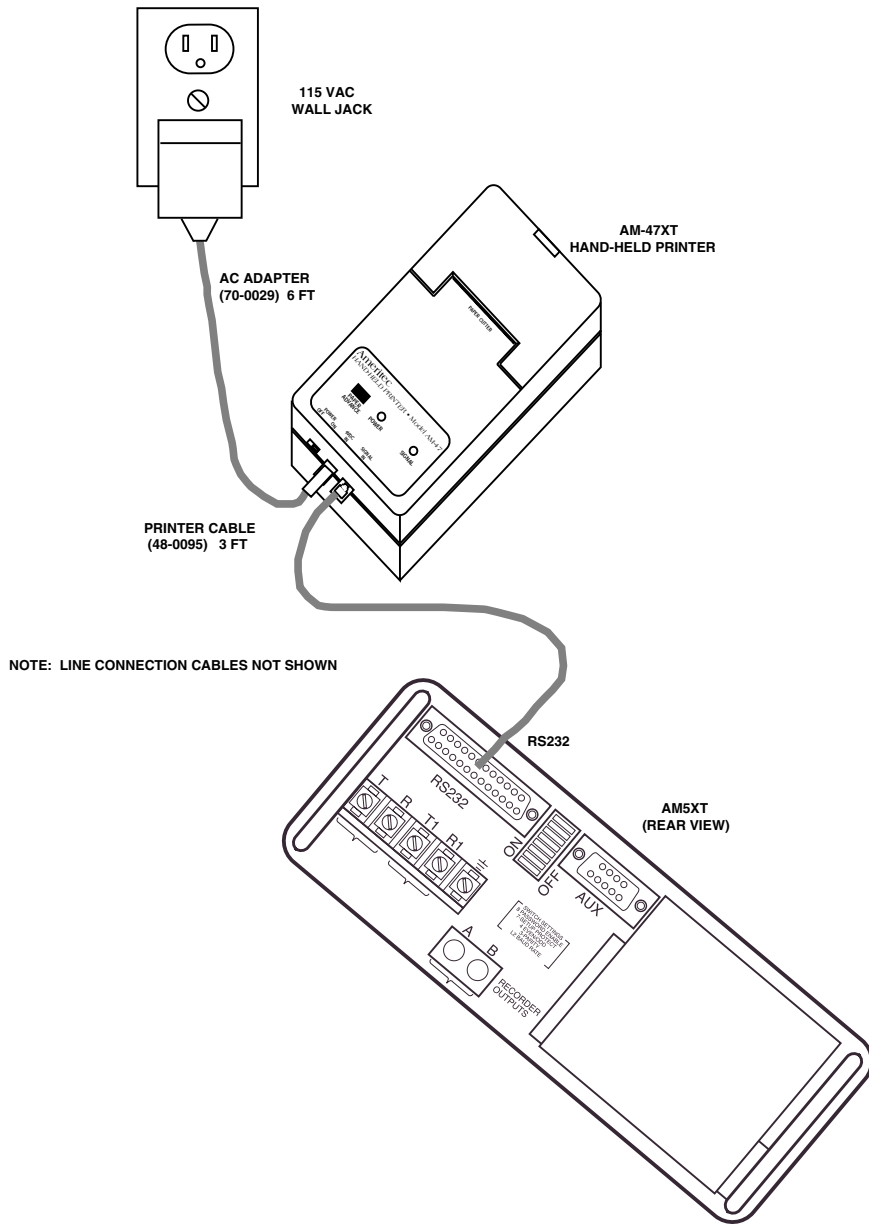

Figure 5-1. AM-47XT Hand-Held Printer Connection with AC Power

See ¶13.1 for operating instructions for printing.

Line Connection Cables

There are three (3) Bantam cables illustrated in Figure 5-2 that are used for line connections. Use these cables as required to connect the AM5XT/eXT to 2-wire or 4-wire lines.

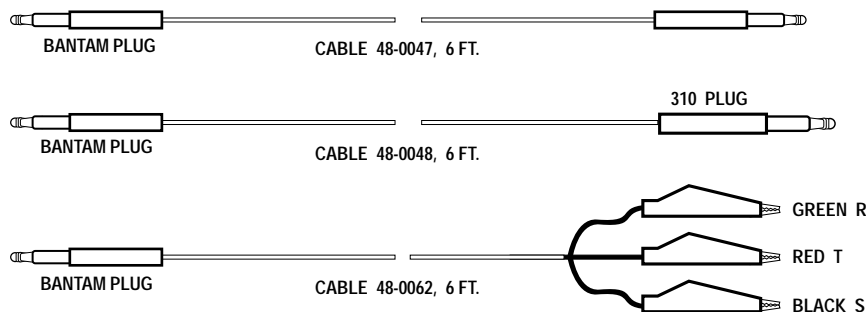

Figure 5-2. AM5XT/eXT Connection Cables

Note: The rear panel screw terminals and Bantam jacks are wired in parallel, resulting in the identical connection by using either type.

AM5XT/eXT Interface with Line Connections

The state of the Line Reverse LED determines the connection of the AM5XT/eXT internal circuitry to the 2-Wire or 4-Wire lines. The connections for the different settings are listed below:

- 2W** Connects together the internal measurement circuitry and signal generator across the 2-Wire line at the TX jack. The signal generator source impedance of 135 Ω , 600 Ω , 900 Ω , or 1200 Ω (determined by the line selections) terminates the line in all signal generator modes except OPEN.
- 4W** Connects the internal measurement circuitry to the RX pair and the internal signal generator to the TX pair.
- REV** Send and receive pairs (as defined above) are reversed.

AM5XT/eXT is Polarity Sensitive

It does not matter which way the Send pair or the Receive pair of contacts are connected. The Send T and R can be interchanged without affecting the measurement. Also, the Receive T1 and R1 could be switched without changing the measurement.

5.4 LINE TERMINATION IMPEDANCES

It is important that the line(s) be properly terminated with a matching impedance. This paragraph gives instructions for terminating lines with 135 Ω , 600 Ω , 900 Ω , or 1200 Ω impedance.

To terminate the line(s) correctly:

1. Choose either terminate or bridge mode:
 - A. Select terminate mode **or**
 - B. Select bridge mode and terminate the line with some other device (such as a modem) of proper impedance.
2. Set the transmit and receive impedances to match those of the circuit under test.

5.5 CONFIGURATIONS

There are three basic AM5XT/eXT configurations to test 2-Wire and 4-Wire telephone and data communication lines:

1. End-to-end – requiring two AM5XT/eXTs
2. Loopback
3. Testing with responders

This paragraph describes the different configurations, explains how they are used, and discusses the advantages and disadvantages.

Note: End-to-End and responder testing applies to either 2-Wire or 4-Wire. Loopback testing only applies to 4-Wire.

End-to-End Testing

Measurements on telephone transmission lines are usually made by applying an appropriate signal at one end of the transmission line and then measuring the results at the other end of the line. This configuration requires a test set at each end of the line and is called “end-to-end” testing. Figure 5-3 shows a 4-Wire end-to-end configuration, making measurements over a telephone network that normally connects two modems.

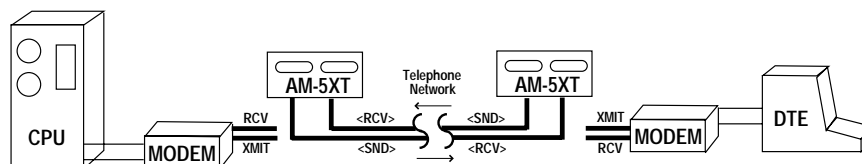

Figure 5-3. 4-Wire End-to-End Testing

Each AM5XT/eXT both sends and receives signals, sending a signal over the TX pair of lines, and measuring the signal received over the RX pair of lines.

End-to-End testing can also be done over 2-Wire lines. The AM5XT/eXT on one end sends a signal and the AM5XT/eXT on the other end measures the received signal. End-to-End testing is necessary to perform Envelope Delay measurements.

End-to-End testing is the most reliable for characterizing the near-to-far impairments, but it has the disadvantage of requiring two test sets and an operator at each test site.

Loopback Testing

The distant end of a 4-wire transmission line can be looped back (1) manually or (2) with a commandable loopback device such as the Western Electric Model 829. The AM5XT/eXT at the near end sends a signal which travels to the distant end where it makes a U-turn and travels back to the AM5XT/eXT which measures the received signal.

The advantage of this configuration is that it requires only one (1) operator and a test set at a central site. Although this method is more convenient and less costly than end-to-end testing, it is also less reliable. The disadvantage is that it does not characterize transmission impairments in each direction. Instead of detecting impairments, a loopback measurement could actually cover them up. An apparently satisfactory loopback measurement may contain impairments in each direction which cancel each other. This method of testing may be useful however, providing its limitations are recognized.

Note: A loopback test can not be done on 2-wire because signals can not be sent and measured simultaneously on the same pair of lines.

To do a loopback test with a Western Electric Model 829:

1. Connect the AM5XT/eXT at the near end of the 4-wire line under test.
2. Momentarily press “Loop Back” (Send/C) to send a 2713 Hz (or whatever is the necessary loopback tone) tone over the TX line. This trips the distant Model 829 into loopback.
3. Send the desired test signal with the AM5XT/eXT and make the desired measurement of the looped-back signal.
4. After testing is finished, momentarily press “Loop Back” to restore the Model 829 to its normal, transparent state.

Testing with Responders

Using multifunction responders has most of the advantages of end-to-end testing with the added advantage of not requiring an AM5XT/eXT at the far end of the system. This configuration is similar to loopback testing except that the responder can generate signals in addition to looping back. Unlike a dedicated loopback device, responders can be used in 2-wire far-to-near testing.

On 4-wire circuits, a DTMF commandable responder, such as the Ameritec Model AM3-4, may be placed permanently at the distant modem, where it remains transparent until commanded by DTMF signals sent from the AM5XT/eXT at the central site. In addition to performing loopback, the responder can send various tones. This allows far-to-near tests as well as loopback tests.

Example: 4-wire far-to-near and loopback tests for level and frequency with an Ameritec AM3-4A or AM3-4B Responder:

1. Connect an AM5XT/eXT to the near end of a 4-wire facility, and an Ameritec AM3-4A or AM3-4B Responder at the far end. A typical configuration is illustrated in Figure 5-4.

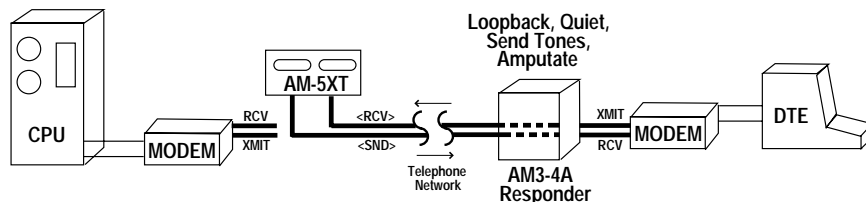

Figure 5-4. 4-Wire Testing with Responder

2. Use AM5XT/eXT “TT” digits to send the appropriate DTMF command sequence to command the responder into milliwatt mode (responder generates 1004 Hz, 0 dBm signal). Measure received signal and note level and frequency.
3. Use AM5XT/eXT “TT” digits to send the appropriate DTMF command sequence to command the responder into loopback.
4. Use AM5XT/eXT to send 1004 Hz tone at 0 dBm. Measure loopback received level and frequency.
5. Use AM5XT/eXT “TT” digits to send DTMF command sequence to restore responder to normal.

On a 2-wire network, dial access responders are very useful in measuring far-to-near characteristics. An Ameritac AM3-2C Responder (automatic milliwatt) or AM3-2A Responder can be dialed up over the network path under test using the AM5XT/eXT keypad. It can then be commanded with touch tone from the AM5XT/eXT to make level measurements or send tones. The AM3-2C can perform far-to-near level and frequency, idle channel noise, and noise with tone. In addition to the AM3-2C functions, the AM3-2A can also perform far-to-near gain slope and near-to-far level. A typical configuration is illustrated in Figure 5-5.

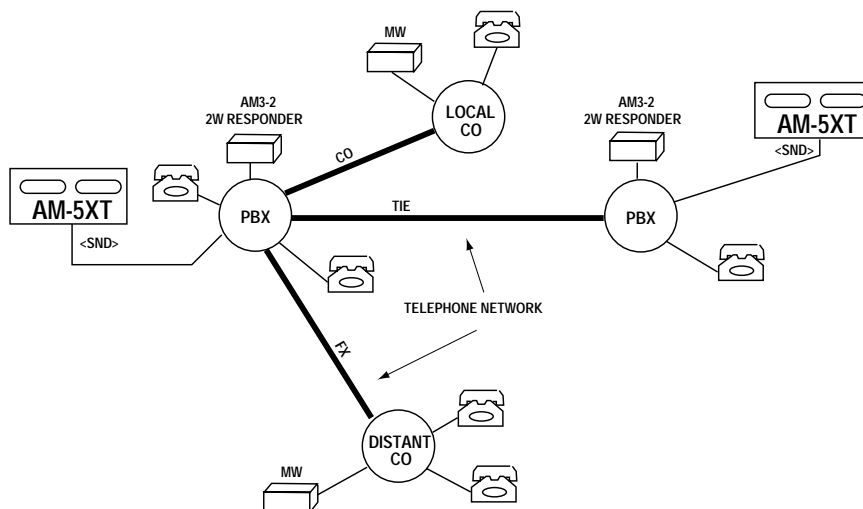

Figure 5-5. 2-Wire Testing with Responder

6. LINE FUNCTIONS

6.1 INTRODUCTION

LINE Functions determine the condition of the interface of the AM5XT/eXT with the 2- or 4-wire telephone line connected for test.

Some Line Functions are color-coded per the line pair to which the function is applied:

GREEN (TX/2W) = 2-wire pair, or 4-wire transmit pair: T, R

BLUE (RX) = 4-wire receive pair: T1, R1

Other Line Functions are color-coded to match the type of connection enabled:

GRAY = 2-wire or 4-wire normal connection

BLACK = 2-wire or 4-wire with connections reversed (T, R becomes T1, R1 and vice versa)

Note: The color coding of the Line Functions matches the color coding of the labels of the Line Bantam Jacks (see items 2 and 3 in Figure 3-1).

See Figure 6-1 for instructions to select the desired Line Function.

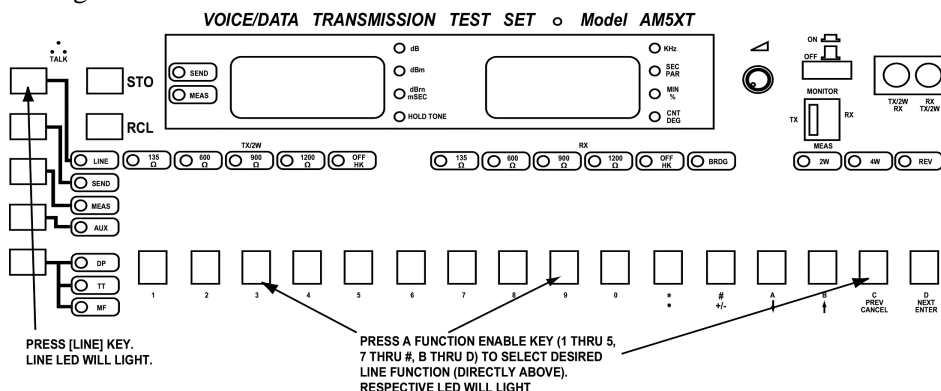

Figure 6-1. Procedure to Enable Line Functions

Unlike the Send and Measure Functions, there are **no displays** associated with Line Functions. The status of the Line Functions is completely determined by the condition of the Line Function LEDs. Also, unlike the Send and Measure Functions, more than one Line Function LED will be on at the same time.

In this section, the Function enable Key for each Line Function is shown enclosed in a square □. For example, **8** 600Ω indicates that key [8] is pressed to connect 600Ω to the receive pair, RX (T1, R1), when the line is terminated (BRDG LED off).

Paragraphs in this section are listed below:

- 6.2 General Line Function Notes
- 6.3 Generator Source Impedances
- 6.4 OFF HK (Send Pair Off-Hook/On Hook)
- 6.5 Termination Impedances
- 6.6 OFF HK (Receive Pair Off-Hook/On Hook)
- 6.7 BRDG (Receive Pair Bridged/Terminated)
- 6.8 2W (2-Wire)
- 6.9 4W (4-Wire)
- 6.10 REV (Reversed)

6.2 GENERAL LINE FUNCTION NOTES

Note: Line functions enabled are stored/recalled separate from other front panel functions. See ¶11.2.

Line Circuits Block Diagrams

See Figures 6-2 and 6-3. For reverse (REV), note that the RX (T1, R1) and TX (T, R) pair are reversed, as indicated in the black-background labeling under the front panel Bantam jacks.

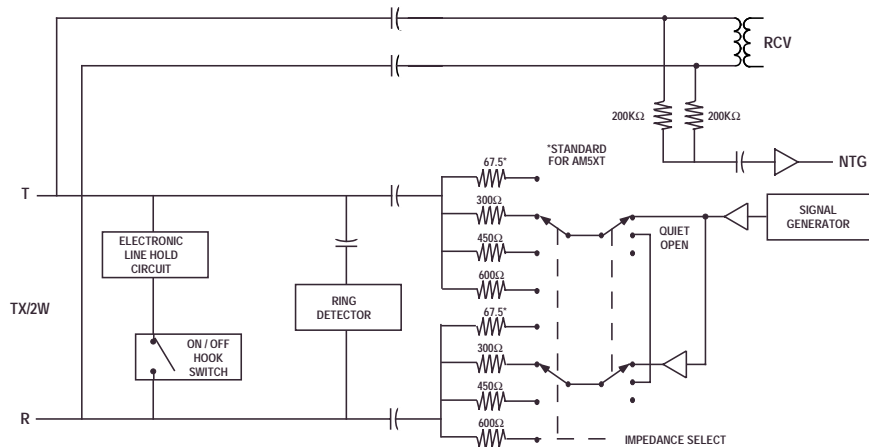

Figure 6-2. 2-Wire Line Circuit Block Diagram

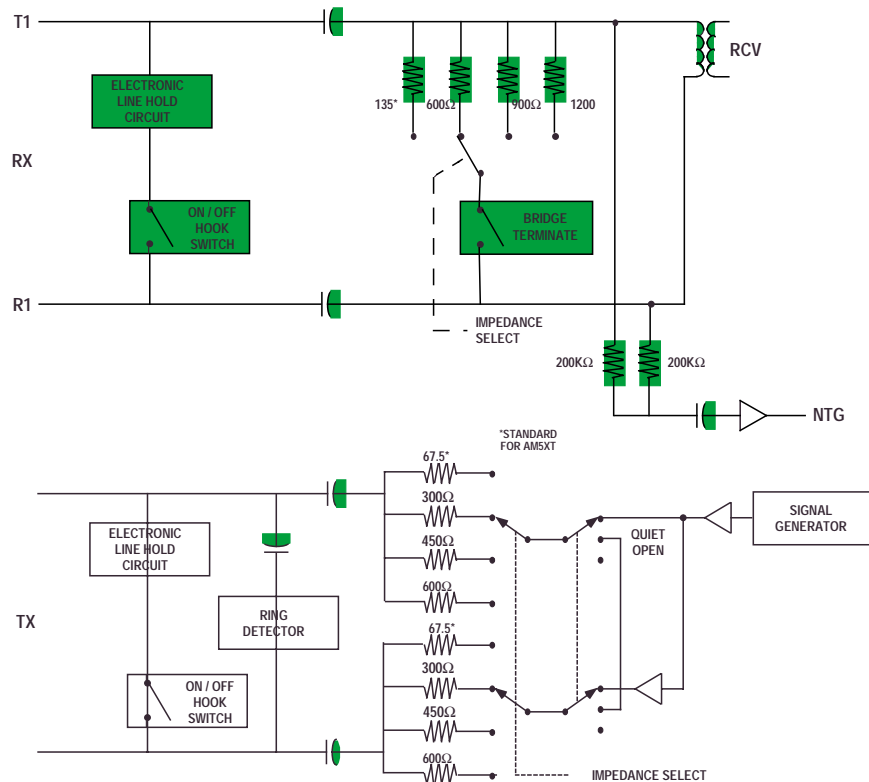

Figure 6-3. 4-Wire Line Circuit Block Diagram

Line Impedances

The Transmit Pair, TX (T, R), and Receive Pair, RX (T1, R1), each have four (4) impedances from which to select:

- 135Ω (150Ω for AM5eXT)
- 600Ω
- 900Ω
- 1200Ω

Line Function Enable Keys [1] thru [4] and [7] thru [0] are used to select the line impedances. The LEDs of the selected line impedances will be on.

Note: The dBm and dBm readings are always calculated based on the AM5XT/eXT RX line impedance selected, even when the RX pair is bridged. The internal microprocessor takes the internal voltage and calculates the reading using the formula:

$$\text{dBm} = 10 \log \frac{E^2 \times 1000}{R}$$

Where: R = selected RX line impedance
E = measured voltage

The receive pair, RX (T1, R1), of a 4-wire circuit under test is terminated with the selected RX impedance only when the line is **terminated** (BRDG LED off) – see below and ¶6.7 concerning the Bridge/Terminate Line Function.

When sending a test tone, the transmit line TX/2W (T, R), is always terminated because the selected source impedance for the signal generator terminates the line. The transmit line is bridged only when the SEND function is OPEN (signal generator is disconnected). Likewise, a 2-wire line is bridged only when the SEND function is OPEN.

DC Line Hold (On-Hook/Off-Hook)

The TX/2W (T, R) and RX (T1, R1) lines have separate DC hold circuits. The hold circuits are electronic equivalents of a line hold coil. Key [5] is used to connect/disconnect the TX/2W (T, R) line hold circuit, while key [*] is used to connect/disconnect the RX (T1, R1) line hold circuit. With DC hold on (OFF HK LED on), the circuit connects a 200Ω DC path across T and R (or T1 and R1) which presents a high impedance path (>50 kΩ) to AC signals.

Bridge/Terminate

The RX (T1, R1) line pair can be either bridged or terminated, using key [#].

For 4-wire circuits, “terminated” means that the RX (T1, R1) line is terminated by the selected AM5XT/eXT RX impedance. “Bridged” (not terminated) means that the AM5XT/eXT presents a high impedance (>50 k Ω) to the RX (T1, R1) line under test. When in bridged mode, the RX (T1, R1) line must be terminated by a device external to the AM5XT/eXT. The TX (T1, R1) line is always terminated unless the SEND function is OPEN.

In 2-wire mode, (2W LED on), the line will only be bridged when the OPEN send mode is enabled, in which case the signal generator is disconnected.

Note: A line under test is terminated by either an external impedance or the AM5XT/eXT. Do **not** terminate the line both externally **and** with the AM5XT/eXT.

2W, 4W, REV (2-Wire, 4-Wire, Reversed)

Keys [B] and [C] are used to select the type of line (2-wire or 4-wire) connected to the AM5XT/eXT. Key [D] is used to conveniently reverse the connections. When Reversed, TX/2W (T, R) becomes RX (T1, R1) and vice versa.

Line Connections (for normal non-reversed operation)

4-Wire Circuits

Front Panel Connection:

- Connect the receive pair (over which the AM5XT/eXT receives signals) to the RX Bantam jack.
- Connect the send (transmit) pair (over which the AM5XT/eXT sends signals) to the TX/2W Bantam jack.

Rear Panel Connection:

- Connect the receive pair (over which the AM5XT/eXT receives signals) to the T1 and R1 screw terminals.
- Connect the send (transmit) pair (over which the AM5XT/eXT sends signals) to the T and R screw terminals.

2-Wire Circuits

Front Panel Connection:

- Connect the pair to the TX/2W Bantam jack.

Rear Panel Connection:

- Connect the pair to the T and R screw terminals.

6.3 GENERATOR SOURCE IMPEDANCES (Transmit Pair)

The front panel labels are color-coded **green** for each of the possible generator source impedances. The choices are listed below, along with their Function Enable Keys:

- 1 135 Ω (150 Ω for AM5eXT)
- 2 600 Ω
- 3 900 Ω
- 4 1200 Ω

One of the associated LEDs will be on to indicate which of these impedances has been selected for AM5XT/eXT signal generator. The selected source impedance is connected to the transmit pair, TX (T, R), as indicated in Figures 6-2 and 6-3. Note that half of the impedance is connected to each side of the line.

When the Send Function is set to QUIET, the signal generator is disconnected and the Transmit pair, TX (T, R), is terminated with the selected source impedance. When the Send Function is set to OPEN, both the signal generator and the selected generator source impedance are disconnected from the TX (T, R) pair.

6.4 5 OFF HK (Send Pair Off-Hook/On-Hook)

OFF HK LED ON

Off-hook condition with DC path (>50 k Ω AC path) across transmit pair, TX (T, R), equivalent to 200 Ω holding coil.

OFF HK LED OFF

On-hook condition with holding coil disconnected.

6.5 TERMINATION IMPEDANCES (Receive Pair)

The front panel labels are color-coded **blue** for each of the possible termination impedances. The choices are listed below, along with their Function Enable

Keys:

7 135Ω (150Ω for AM5eXT)

8 600Ω

9 900Ω

0 1200Ω

One of the associated LEDs will be on to indicate which of these impedances has been selected for the receive pair, RX (T1, R1).

With the BRDG LED off (RX terminated), the selection termination impedance is connected across the receive pair, RX (T1, R1), as indicated in Figures 6-2 and 6-3. With the BRDG LED on, RX becomes high impedance (no termination).

With the BRDG LED on (RX bridged), set the RX impedance to the same value as the external termination impedance on the receive pair, RX (T1, R1). This setting is used to tell the AM5XT/eXT microprocessor the value of the external termination impedance so that it can calculate the proper measure reading. The formula is given in ¶6.2 under “Line Impedances”.

6.6 * OFF HK (Receive Pair Off-Hook/On-Hook)

OFF HK LED ON

Off-hook condition with DC path (>50 kΩ AC path) across receive pair, RX (T1, R1), equivalent to 200Ω holding coil.

OFF HK LED OFF

On-hook condition with holding coil disconnected.

6.7 # BRDG (Receive Pair Bridged/Terminated)

BRDG LED ON

High impedance bridge (>50 kΩ) across receive pair, RX (T1, R1).

BRDG LED OFF

Receive pair, RX (T1, R1), terminated by impedance selected per ¶6.5.

6.8 [B] 2W (2-Wire)

This function is color-coded **gray** on the front panel.

2W LED ON

Transmit pair TX (T, R), is connected to both the signal generator (send) and the measure (receive) circuits, as shown in Figure 6-2.

6.9 [C] 4W (4-Wire)

This function is color-coded **gray** on the front panel.

4W LED ON

Transmit pair TX (T, R), is connected to the signal generator and receive pair, RX (T1, R1), is connected to the measure (receive) circuitry.

Tone Ringer, Incoming Ring

With this feature enabled, a ringback tone will be heard from the AM5XT/eXT speaker when a ringing voltage appears across the transmit pair, TX (T, R).

To enable the tone ringer, press the appropriate keys on the front panel to enable 4W and OPEN:

1. With LINE LED on, press [C]. 4W LED will light.
2. With SEND LED on, press [0]. OPEN LED will light.

6.10 [D] REV (Reversed)

This function is color-coded **black** on the front panel.

REV LED ON

Transmit pair TX (T, R), and receive pair, RX (T1, R1), connections reversed compared to the connections listed in ¶6.8 and ¶6.9. Note labeling with black background under front panel Bantam jacks, which indicates this connection reversal.

7. SEND FUNCTIONS

7.1 INTRODUCTION

The AM5XT/eXT contains a highly flexible signal generator capable of generating a variety of test tones which are applied to the Transmit (TX) pair.

SEND refers to the signal generator condition applied to the TX pair of the line under test. See Figure 7-1 for instructions to select the desired Send Function. Note that **SEND** Functions are color-coded GREEN.

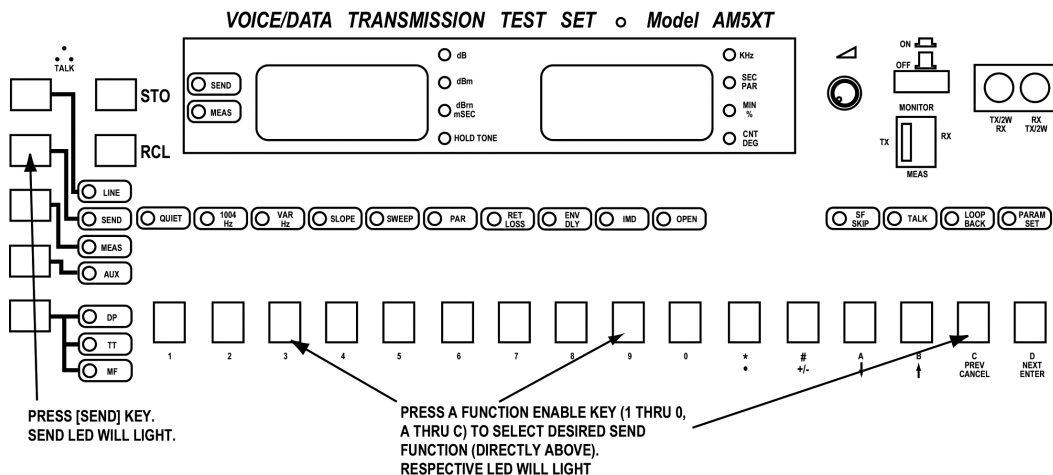

Figure 7-1. Procedure to Enable Send Functions

In this section, the paragraph heading for each Send Function shows its Function Enable Key enclosed in a square . For example, QUIET indicates that key [1] is pressed to select QUIET Send mode. DATA and PARAMETER DISPLAY information is also provided. Section 4 explains how the DATA and PARAMETER DISPLAYS are accessed and used.

To access the level display:

1. Press the [SEND] key.
2. Press any Send Function Enable key.
3. Press [D] to access Set Level Display (first PARAMETER DISPLAY).

Remember that when the level value is changed, it changes the level for all SEND signals, except for dialed tones (see Display 4, ¶7.2, for PARAMETER DISPLAY to set Touch Tone level). When power is turned off, the send level always defaults to 00.0 dBm. The level for dialed tones, however, is stored in non-volatile memory.

7.2 1 QUIET



The signal generator is disconnected from the TX line and the line is quiet terminated with a passive resistance equal to the TX line impedance selected per ¶6.3.

Miscellaneous PARAMETER DISPLAYs

Parameters are set and information is displayed here that is of a general nature or can not be conveniently implemented elsewhere. Note that these displays are not related to the QUIET mode.

Display 2

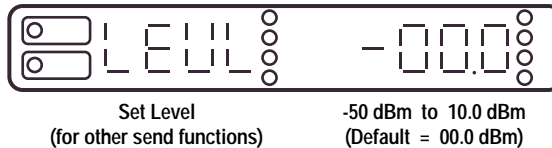

Set Level for send functions. Note that Level does not have meaning for QUIET mode.

Display 3

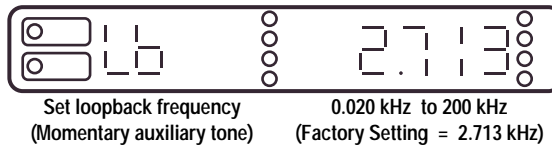

Set frequency for Loop Back Tone, sent by pressing [C]. See ¶7.15.

Display 4

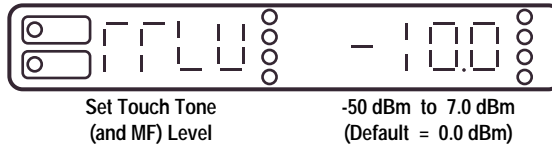

Set level for DTMF (Touch Tone) or MF tones dialed. See ¶10.1 concerning dialing.

Displays 5 & 6

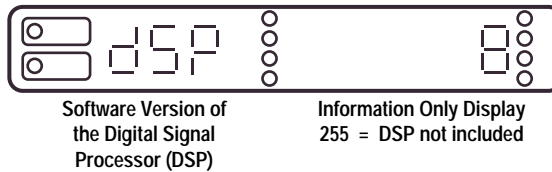
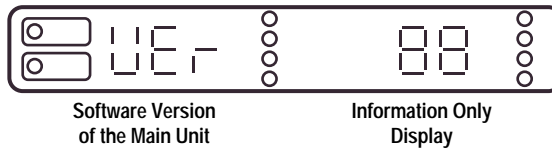

These displays indicate the present software installed.

7.3 2 1004 Hz

The signal generator outputs a continuous 1004 Hz sine wave to the TX pair.

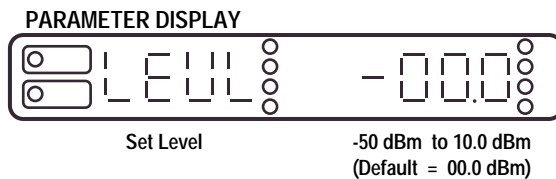
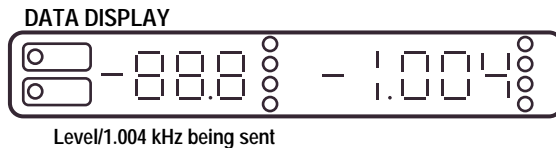

Level is adjustable with the PARAMETER DISPLAY.

7.4 3 VAR HZ (Variable Tone)

The signal generator outputs a sine wave tone to the TX pair.

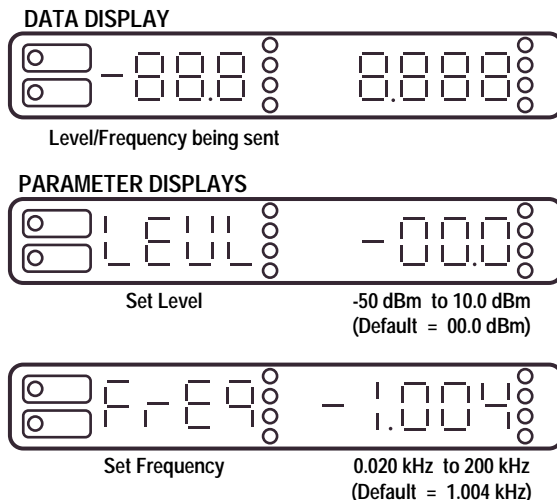

Level and Frequency are adjustable with the PARAMETER DISPLAYS.

7.5 4 SLOPE

The signal generator outputs:

1. **AM5eXT** Four tones: 1004 Hz, 2003 Hz, 3004 Hz, and 304 Hz in a repetitive cycle.

This sequence of tones is used for multiple-point gain/slope measurements, i.e., a plot of transmission loss vs. frequency at four points.

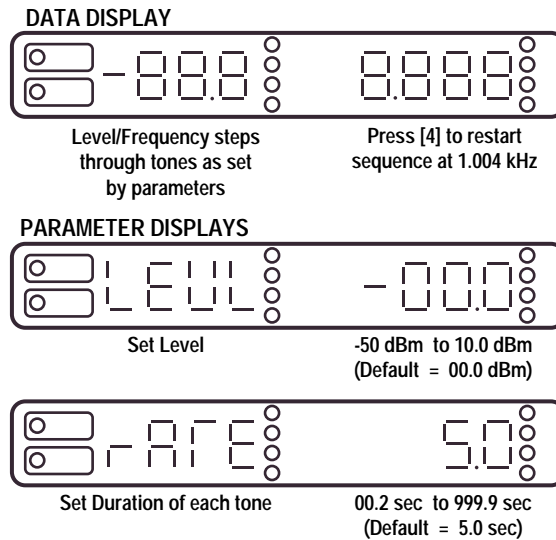

Level and Rate (duration of each tone) are adjustable with the PARAMETER DISPLAYS.

7.6 5 SWEEP

The signal generator sweeps through a series of frequencies. With factory default parameter settings, the sweep starts at 0.204 kHz and increases in 0.100 kHz steps every one second, until 5.004 kHz is reached, at which time the sweep starts again at 0.204 kHz.

DATA DISPLAY

| | |
|--|-------------------------------------|
| | |
| Level/Frequency steps through tones as set by parameters | Press [5] to restart sweep sequence |

PARAMETER DISPLAYS

| | |
|---|---|
| | |
| Set Level | -50 dBm to 10.0 dBm (Default = 00.0 dBm) |
| | |
| Set start frequency (Start of sweep) | 0.20 kHz to 200.0 kHz (Default = 0.204 kHz) |
| | |
| Set stop frequency (End of sweep) | 0.20 kHz to 200.0 kHz (Default = 5.004 kHz) |
| | |
| Set step size | 0.020 kHz to 200 kHz (Default = 0.100 kHz) |
| | |
| Set Duration of each tone | 00.1 sec to 999.9 sec (Default = 1.0 sec) |
| | |
| Set additional dwell inserted before and after sweep sequence | 00.1 sec to 999.9 sec (Default = 1.0 sec) |

All parameters are adjustable with the PARAMETER DISPLAYS, including the Level and Delay Time (inserted before and after the sweep sequence).

7.7 6 PAR (Peak-to-Average Ratio)

The signal generator outputs 16 specific frequencies simultaneously per Bell 41009 specification. This composite test tone is used for a P/AR (peak-to-average) measurement.

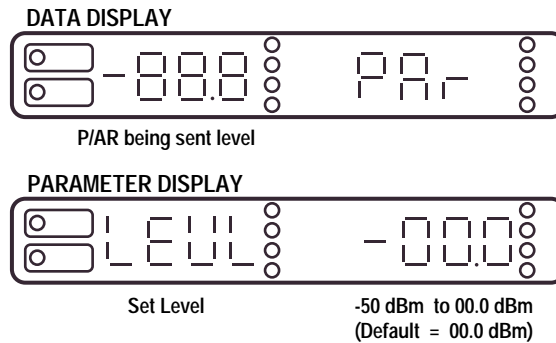

The composite Level is adjustable with the PARAMETER DISPLAY.

7.8 7 RET LOSS (Return Loss)

The signal generator outputs shaped, white-noise test tones, used in the **Return Loss** measurement mode (§8.9). Three (3) measurements are made using these tones, each with its characteristic test tone band.

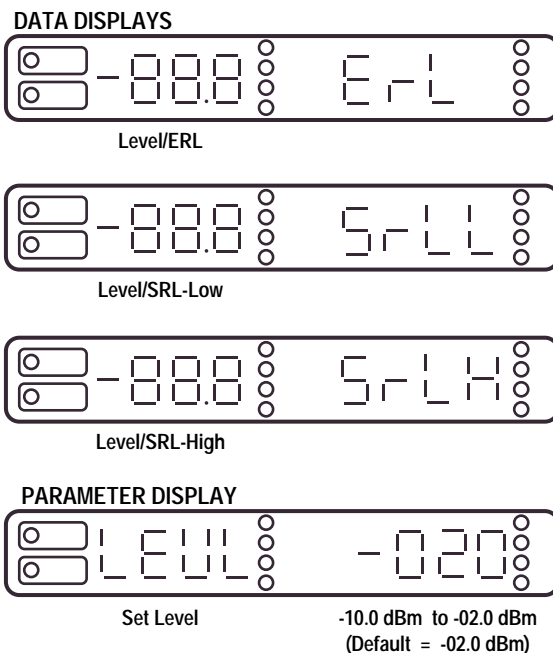

1. **Echo Return Loss (ERL)**, with white noise test tone band-limited (3 dB points at 560 Hz and 1965 Hz).
2. **Singing Return Loss LO (SRLLO)**, white noise test tone band-limited to exclude high frequency components (3 dB points at 260 Hz and 500 Hz).
3. **Singing Return Loss HI (SRLHI)**, white noise test tone band-limited to exclude low frequency components (3 dB points at 2200 Hz and 3400 Hz).

Enable the appropriate DATA DISPLAY to send the respective Return Loss test tone.

Level is adjustable with the PARAMETER DISPLAY.

7.9 8 ENV DLY (Envelope Delay) (AM5XT ONLY)

An Envelope Delay test measures the non-linearities in the phase response of a line. A transmission test set is required at each end of the circuit to be measured.

There are two (2) types of send signals generated with an Envelope Delay test:

1. A Sweep series of carrier frequencies, usually from 200 Hz to 4000 Hz, modulated by 83-1/3 Hz.
2. A constant carrier Reference Frequency, usually 1800 Hz, also modulated by 83-1/3 Hz.

One or the other of these signals is generated from both the near-end and far-end test set.

The displays listed are identified by number for ease of reference.

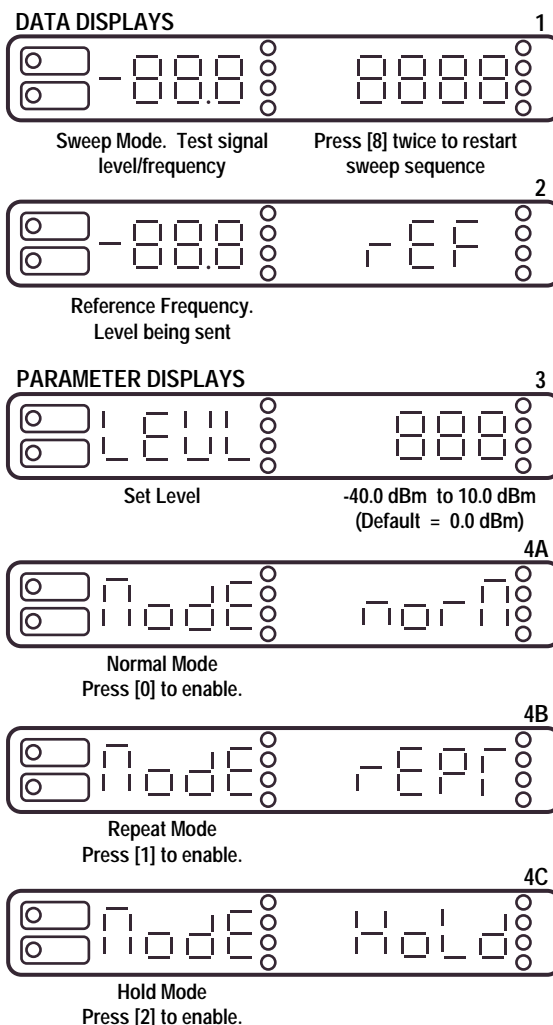

Displays 4A, 4B, and 4C can also be accessed from the Measure Display PARAMETER DISPLAY LIST (see ¶8-10).

Note: Displays 4A, 4B, and 4C show the three possible selections for the mode parameter. These displays are enabled by pressing keys [0], [1], and [2], respectively, or by using the up or down arrow key.

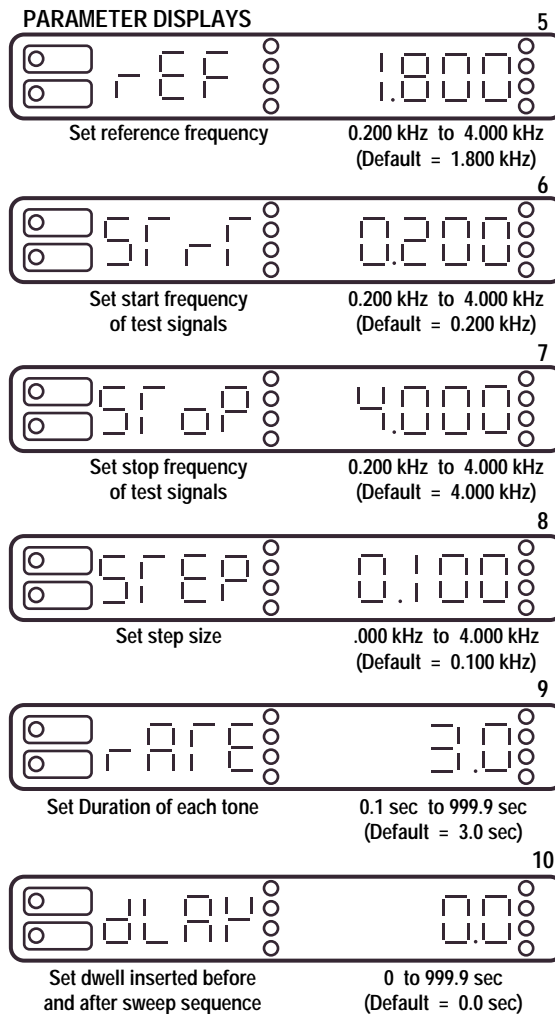

See ¶8.10 for Setup and Test Procedures, including both Send and Measure functions.

7.10 8 GROUP DLY (Group Delay) (AM5eXT ONLY)

A Group Delay test measures the non-linearities in the phase response of a line. A transmission test set is required at each end of the circuit to be measured. Test signals are generated over a 2-wire circuit from the test set on one end, and the Group Delay is measured on the other end. See ¶8.11 for Measure functions and Test Procedure.

With a Group Delay test, there are two (2) types of send signals which are alternately generated for 120ms:

- A constant carrier **Reference** Frequency, usually 1800 Hz, modulated by 41-2/3 Hz.
- A **Sweep** series of carrier frequencies, usually from 200 Hz to 20 kHz, also modulated by 41-2/3 Hz.

The displays listed are identified by number for ease of reference. Display 1 indicates the level and frequency of the **Sweep** carrier frequency being set at the time. With factory default parameter settings, the **Sweep** starts at 0.200 kHz and increases in 0.100 kHz steps every 3 seconds until 20.00 kHz is reached, at which time the **Sweep** starts again at 0.200 kHz.

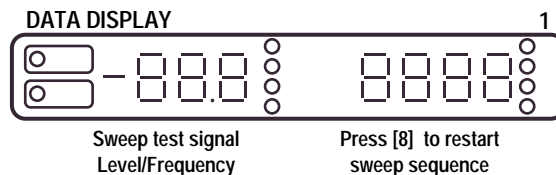

All parameters are adjustable with the PARAMETER DISPLAYS, including the Level, Reference Frequency, and Delay Time (inserted before and after the sweep sequence).

PARAMETER DISPLAYS 2

LEVEL

- 00.0

Set Level -50 dBm to 10.0 dBm
(Default = 00.0 dBm)

3

REF

1.800

Set reference frequency 0.200 kHz to 20.00 kHz
(Default = 1.800 kHz)

4

START

0.200

Set start frequency of test signals 0.200 kHz to 20.00 kHz
(Default = 0.200 kHz)

5

STOP

20.00

Set stop frequency of test signals 0.200 kHz to 20.00 kHz
(Default = 20.00 kHz)

6

STEP

0.100

Set step size 0.000 kHz to 20.00 kHz
(Default = 0.100 kHz)

7

RATE

3.0

Set Duration of each tone 0.1 sec to 999.9 sec
(Default = 3.0 sec)

8

DWELL

0.0

Set dwell, inserted before and after sweep sequence 0.0 to 999.9 sec
(Default = 0.0 sec)

7.11 9 IMD (Intermodulation Distortion*)

* Licensed under U.S. Patent #3,862,380.

Definition. Intermodulation Distortion is also known as “Non-Linear Distortion” or “4-Tone Test”. Intermodulation Distortion is signal component generation that is produced from the transmitted signal and adds to the transmitted signal. These additional signal components are usually undesirable.

Send Signals. Three (3) types of signals are used with the Intermodulation Distortion test. See ¶8.12 for the Test Procedure that explains how these signals are used.

The Intermodulation Distortion send displays are numbered for ease of reference.

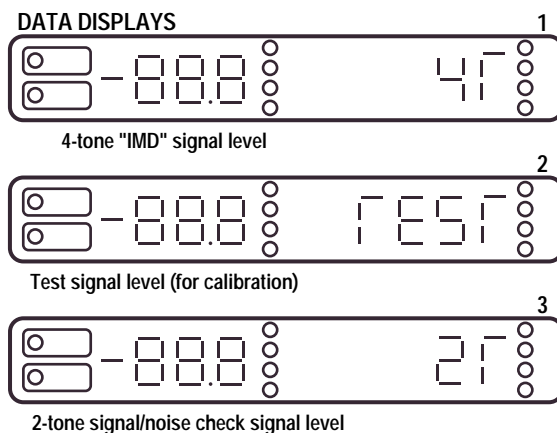

The send signals are described below:

1. **4-Tone Signal.** This test signal is composed of four (4) tones, all at the same level, as described below:
 - Two (2) tones are 6 Hz apart, centered at 860 Hz.
 - Two (2) tones are 16 Hz apart, centered at 1380 Hz.

The 4-Tone Signal is sent when Display 1 is enabled.

2. **Calibration Test Signal.** This is a special signal used to self-test the calibration of the AM5XT/eXT when the unit is looped back on itself (send, TX, connected directly to receive, RX). This signal is composed of the 4 tones listed above, plus additional tones which represent second and third order intermodulation products. The Calibration Test Signal is sent when Display 2 is enabled.
3. **2-Tone Signal.** This signal is composed of two (2) of the tones listed under **4-Tone Signal** (those centered at 860 Hz). The 2-Tone Signal is sent when Display 3 is enabled.

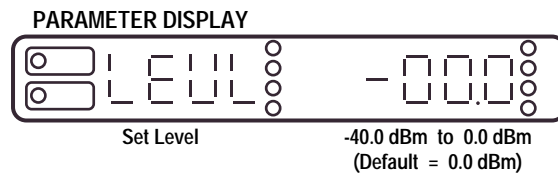

7.12 0 OPEN

Similar to QUIET (§7.2) mode, but completely disconnects the signal generator from the transmit line. For this mode, the transmit line is **not** terminated by the generator impedance.

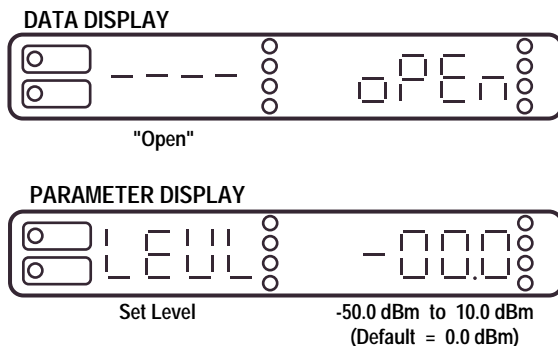

7.13 A SF SKIP (Signaling Frequency Skip)

SF SKIP is used to avoid sending tones in the “signaling frequency” band to avoid knocking down a long distance dialed circuit. **SF SKIP** is an ON/OFF toggle used in connection with the VAR HZ, SWEEP, and ENVELOPE (or GROUP) DELAY modes.

With the **SF SKIP** LED on, the signal generator **cannot** be set to send frequencies in the band 2450 Hz through 2750 Hz (2130 Hz to 2430 Hz for AM5eXT). With the **SF SKIP** LED off, the signal generator is fully variable.

7.14 B TALK

Instead of the internal signal generator, the **TALK** mode connects a front panel microphone to the transmit line. This allows the operator to talk to a testing partner at the distant end of the line under test. The **TALK** function will work on wet or dry (no DC voltage) 2- or 4-wire lines. Two (2) modes are available: Full Duplex and Push-to-Talk. Full Duplex in 2-wire mode employs a hybrid to provide hands-free “speaker phone” operation.

Full-Duplex TALK Mode, LED flashes.

1. Press [B] **momentarily** to disconnect the signal generator and connect the built-in microphone to the TX line. The microphone is located behind the three holes labeled TALK in the upper left corner of the front panel.
2. Set the MONITOR switch to RX to enable the speaker.
3. Full Duplex (speaker phone) operation is now enabled. For 2-wire, a hybrid is used to allow Full Duplex operation.

To exit Full Duplex mode, **momentarily** press [B]. The LED will go out.

In some cases audible regenerative feedback may result, especially in the 2-wire mode, where the line under test is not impedance matched to the hybrid, and at high volume settings. This may be overcome by using the “push-to-talk” mode, described next.

Half-Duplex TALK Mode (“Push-to-Talk”), LED continually ON.

Press and hold [B] to enable the Push-to-Talk mode. [B] is also used to select the direction of the conversation:

- To speak, hold down [B] to operate the microphone and mute the speaker. The microphone (item 13 in Figure 3-1) is located behind the three holes labeled TALK in the upper left corner of the front panel.
- To listen, release [B] to disconnect the microphone and enable the speaker (TALK LED remains steady on).

To exit Push-to-Talk mode, **momentarily** press [B]. The LED will go out.

7.15 LOOP BACK

LOOP BACK is a Programmable Momentary Auxiliary Tone intended to trip and restore a 4-wire loopback device such as a Western Electric Model 829.

The frequency and level of this tone is set with a **QUIET** Send mode PARAMETER DISPLAY (Display 3), see ¶7.2. To activate a Model 829, program the frequency for 2713 Hz, the default setting.

Momentarily press [C] to disconnect the present Send mode and send the Auxiliary Tone over the TX pair. The Auxiliary Tone will be applied as long as the [C] key is held down.

Release [C] to automatically restore the previous Send (signal generator) mode.

8. MEASURE FUNCTIONS

8.1 INTRODUCTION

The AM5XT/eXT contains highly versatile detectors and filters which are connected to the receive line (RX) under test. The term MEASURE refers to the detection mode being used in order to detect and display the characteristics of the received signal(s). See Figure 8-1 for instructions to select the desired Measure Mode. Note that **MEASURE** Functions are color-coded BLUE.

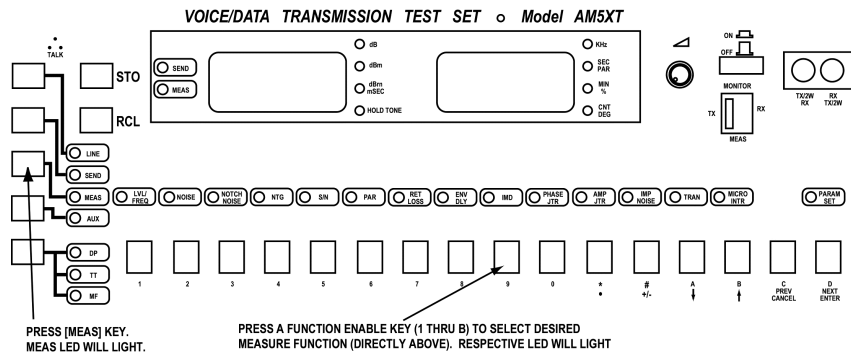

Figure 8-1. Procedure to Enable Measure Modes

In this section, the paragraph heading for each Measure Function shows its Function Enable Key enclosed in a square . For example, 6 PAR indicates that key [6] is pressed to select PAR Measure mode. DATA and PARAMETER DISPLAY information is also provided. Section 5 explains how the DATA and PARAMETER DISPLAYs are accessed and used.

Paragraphs in this section are listed below:

- 8.2 LVL/FREQ (Level/Frequency)
- 8.3 General Notes Concerning Noise Measurements
- 8.4 NOISE (Idle Channel Noise)
- 8.5 NOTCH NOISE (Noise with Tone)
- 8.6 NTG (Noise-to-Ground)
- 8.7 S/N (Signal-to-Noise Ratio)
- 8.8 PAR (Peak-to-Average Ratio)
- 8.9 RET LOSS (Return Loss)

- 8.10 ENV DLY (Envelope Delay) for AM5XT only
- 8.11 GROUP DLY (Group Delay) for AM5eXT only
- 8.12 IMD (Intermodulation Distortion)
- 8.13 PHASE JTR (Phase Jitter)
- 8.14 AMP JTR (Amplitude Jitter)
- 8.15 IMP NOISE Impulse Noise without Tone)
- 8.16 TRAN (Transients)
- 8.17 MICRO INTR (Micro-Interruptions)

8.2 1 LVL/FREQ (Level/Frequency)

Note: There is a dark box around the LVL/FREQ and 15kHz LEDs for the AM5XT (LVL/FREQ and UN WTD LEDs for AM5eXT). This “Level Box” indicates that the 15 kHz (or UN WTD) filter is always associated with the Level/Frequency Measurement. See ¶9.2 and ¶9.3 for descriptions of 15 kHz (AM5XT) and Sound-Unweighted (AM5eXT) low-pass filters, enabled in the Auxiliary Function row, AUX.



Wide-Band Level/Frequency (AUX filter not used)

An autoranging amplifier, average detector, and frequency counter are connected to the RX pair. A 200 kHz low-pass filter is used, allowing full bandwidth operation. The detected average voltage is converted to dBm by the microprocessor, based on the impedance selected for the RX line (¶6.2 thru ¶6.5).

To enable this mode:

1. Set LVL/FREQ LED "ON".
2. Set 15kHz LED "OFF" (AM5XT) or UN WTD LED "OFF" (AM5eXT)

Narrow-Band Level/Frequency (AUX filter used)

This is the same as above, except the AUX Function filter in the "Level Box" is enabled (LED "ON"). The filter is a low-pass filter connected to the front end, effectively eliminating high-frequency components. This mode is useful in making measurements on voice-band circuits where high-frequency components are of no interest.

To enable this mode:

2. With MEAS LED on, set LVL/FREQ LED "ON".
3. With AUX LED on for AM5XT, set 15 kHz LED "ON" (connecting 15 kHz low-pass filter), or for AM5eXT, set UN WTD LED "ON" (connecting Sound-Unweighted low-pass filter).

Setup

For end-to-end testing, the transmitted (Send) test tone is applied to the far-end transmit (TX) circuit. For 4-wire loopback testing, the transmitted (Send) test tone is applied to the near-end transmit (TX) circuit.

Enable the appropriate Send Function (Section 7):

- 1004 HZ for single point loss tests
- SLOPE for 3-point (4-point for AM5eXT) gain/slope tests
- VAR HZ or SWEEP for multi-point Frequency response curve tests.

Operation

The AM5XT/eXT measures the resultant signal on the near-and receive pair (RX). Read the voltage and frequency in the DATA DISPLAY.

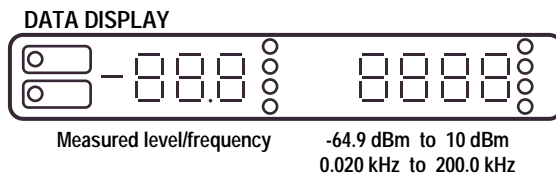

If the received signal has excessive power-line hum or excessive high-frequency components (in excess of 15 kHz), an erratic display may result.

Connect the appropriate filter(s) to eliminate undesired frequencies and stabilize the display:

1. To eliminate power-line hum:
 - Enable the Auxiliary Functions (AUX LED "ON")
 - Press [B] to connect the 60 Hz high pass filter (60 Hz LED will light). With the 60 Hz filter connected, frequency components below 60 Hz will be effectively eliminated from the reading. Press [B] again to disconnect the filter from the measurement (60 Hz LED will go out).
2. To eliminate high frequency, make a Narrow-Band Level/Frequency measurement (described above), using the AUX filter.

Rapidly fluctuating readings may be captured as follows:

1. Enable the Auxiliary Function (AUX LED "ON").
2. Press [D] (DAMP LED will light). With DAMP ON, the display will update at the rate of 2-times per second, half the normal 4-times per second update rate.

A slight peaking effect at 90 kHz to 120 kHz may occur when making attenuation measurements when the AM5XT is making loop-back test (AM5XT signal generator and receiver being used simultaneously) on high loss (>20 dB for this effect to occur). This effect can be avoided in end to end tests by quiet-terminating the transmitter when making measurements on the receiving end of the circuit.

Plotting

For plotting a graph of the results through the RS2432 port, use PARAMETER DISPLAYS to set:

2. Low level limit of the plot
3. High level limit of the plot
4. Rate at which lines are printed
5. Performance limits for line on printer/plotter

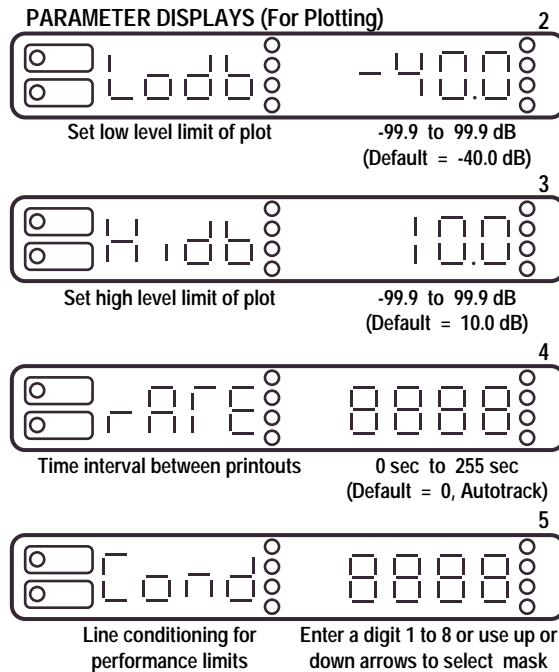

See ¶13.1 for details concerning plotting.

Automatic Tracking Printing Mode

To deliver a printout each time there is a shift in frequency, set the RATE parameter to “0”. With RATE = 0, there must be a discrete, stable shift in the frequency in order for there to be a printout. If the frequency changes at least 8 Hz (approximately), and stabilizes for about 0.5 sec., there will be a printout. This setting is useful when the Send Function is SLOPE (3 or 4 frequency steps) or SWEEP (multiple frequency steps).

Note: Do not set RATE to 0 when the Send source is a continuous (not step) sweep generator. With a continuous sweep, no frequency lasts for 0.5 sec., so there would never be a printout with the RATE set to “0”.

8.3 GENERAL NOISE MEASUREMENT NOTES

The information discussed here applies to all four (4) types of noise measurements:

1. (Idle Channel) NOISE
2. NOTCH NOISE
3. NOISE-TO-GROUND (NTG)
4. SIGNAL-TO-NOISE (S/N) RATIO

Note: There is a dark box around the function LEDs that are associated with noise measurements, enclosing the noise functions in the MEAS row and the noise filters in the AUX row. This box is referred to as the “Noise Box”.

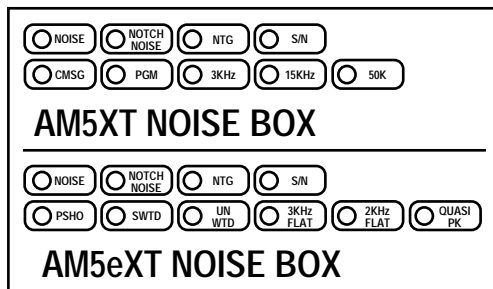

Noise Measurement with Filter

To set up a noise measurement using a filter:

1. In the Measure Functions row (with **MEAS** LED ON), press the appropriate key to enable the desired noise test (NOISE, NOTCH NOISE, NTG, or S/N). The corresponding LED will light.
2. Press the [AUX] key. The **AUX** LED will light.
3. Press the appropriate key, [2] thru [6], to enable the desired noise filter. The respective LED will light, indicating that the filter is enabled. Possible filters are listed in Table 8-1.

Table 8-1. Noise Weighting Filters

| KEY | AM5XT | AM5eXT |
|-----|-------------------|---------------------------|
| 2 | C-Message (CMMSG) | Psophometric (PSHO) |
| 3 | Program (PGM) | Sound-Weighted (SWTD) |
| 4 | 3kHz flat | Sound-Unweighted (UN WTD) |
| 5 | 15kHz flat | 3kHz flat |
| 6 | 50kBit | 2kHz flat |

160kHz-Filter Noise Measurement

To set up a 160kHz-FILTER noise measurement:

1. In the Measure Functions row (with **MEAS** LED ON), press the appropriate key to enable the desired noise test (NOISE, NOTCH NOISE, NTG, or S/N). The corresponding LED will light.
2. In the Auxiliary (**AUX**) Functions row, check if a filter is enabled (LED lit). Possible filters are listed in Table 8-1.
3. If a filter is enabled (LED lit), press the same key that was used to enable the filter (with **AUX** LED ON). The LED will extinguish, indicating that the filter is disabled. Note that if the same filter key is pressed repeatedly, it will toggle (alternate) between enabled and disabled as evidenced by the LED turning ON and OFF.
4. If none of the filters shown in Table 8-1 are selected, a 160 kHz low-pass filter will be in the measurement path.

Quasi-Peak Detector (AM5eXT only)

With the AM5eXT there is a choice of devices to measure the voltage on the receive pair. Select either the RMS Detector or the Quasi-Peak Detector.

With the AM5eXT, follow the steps below to make a noise measurement using the Quasi-Peak Detector:

1. In the Measure Functions row (with **MEAS** LED ON), press the appropriate key to enable the desired noise test (NOISE, NOTCH NOISE, NTG, or S/N). The corresponding LED will light.
2. Press the [AUX] key. The **AUX** LED will light.

3. Press [7]. The **QUASI PK** LED will light, indicating that the Quasi-Peak Detector is enabled.

For the AM5eXT, the Quasi-Peak Detector is enabled when the **QUASI PK** LED is ON. The RMS Detector is enabled when the **QUASI PK** LED is OFF.

For the AM5XT, all noise measurements are made with the RMS Detector (there is no **QUASI PK** LED).

Test Setup

Enable the appropriate Send signal (QUIET or 1004Hz). For end-to-end testing, the Send signal is connected to the far-end transmit (TX) circuit. For 4-Wire Loopback testing, the Send signal is applied to the near-end transmit (TX) circuit. When using a responder, command the responder into the appropriate send mode.

Units of Measurement for Noise

For noise measurements, the voltage on the receive pair is measured using an RMS Detector (RMS Detector or Quasi-Peak Detector for the AM5eXT). This voltage is converted to dBm by the microprocessor, based upon the selected terminate impedance (§6.2). In the AM5XT, the microprocessor further converts the readings to dBrn in accordance with the formula: $dBrn = dBm + 90$. For example, $-50 \text{ dBm} = -50 + 90 = 40 \text{ dBrn}$. With the AM5XT therefore, noise measurements are in units of dBrn and the AM5eXT noise measurements are in units of dBm.

8.4 2 NOISE (Idle Channel Noise)

The Idle Channel NOISE test measures the noise, through a selected filter, on a theoretically “quiet” line, i.e., a QUIET terminated circuit without a test signal. See notes in ¶8.3 concerning noise measurements.

Send Function

Set the Send Function to QUIET (¶7.2).

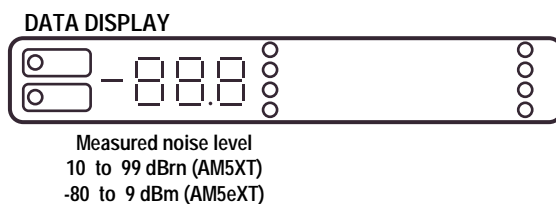

Note: The right-hand display does not operate during idle channel NOISE measurements.

Filter Selection

For the AM5XT, the usual noise-weighting filter used for Idle Channel **NOISE** measurements is the C-Message filter (key [2]). For the AM5eXT, the usual filter used for Notch Noise measurements is the Psophometric filter (key [2]).

In general, any of the filters listed in Table 8-1 can be used.

8.5 3 NOTCH NOISE (Noise-with-Tone)

The Notch Noise Test measures the noise, through a selected filter, on a line that has a 1004 Hz tone. The 1004 Hz tone is removed in the measuring circuit through a 1010 Hz “notch” filter, then the residual noise is measured. This test is sometimes referred to as a “noise-with-tone” measurement.

Send Function

Set the Send Function to 1004 Hz (¶7.3).

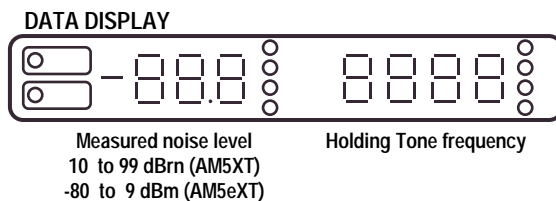

Note: In order for the Notch Noise measurement to be valid, the “HOLD TONE” indicator green LED must be ON, indicating that the 1004 Hz tone is present at the proper frequency and level. Acceptable frequency is from 995 Hz to 1025 Hz at a level of greater than -40 dBm. The right-hand display will also indicate the frequency of the received tone for further verification.

Filter Selection

For the AM5XT, the usual noise-weighting filter used for Notch Noise measurements is the C-Message filter (key [2]). See Figure 9-2 for a graph of the C-Message filter. For the AM5eXT, the usual filter used for Notch Noise measurements is the Psophometric filter (key [2]).

In general, any of the filters listed in Table 8-1 can be used.

Note: If no filter is selected, the AM5eXT Psophometric filter is automatically selected.

8.6 4 NTG (Noise-to-Ground)

Noise-to-Ground is measured by internally summing the signals on the Tip and Ring wires of the receive (RX) line within the AM5XT/eXT, then measuring the noise, through a selected filter, with reference to ground. For the ground reference, use either the ground screw terminal on the rear panel (item 8 in Figure 3-3) or the sleeve contact of the RX front panel Bantam Jack.

Send Function

Set the Send Function to QUIET (¶7.2).

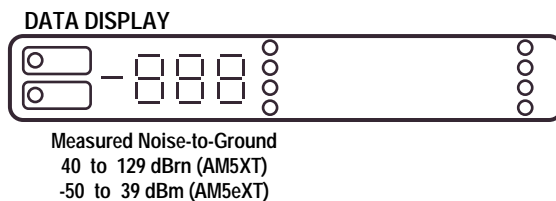

Note: The right-hand display does not operate during NTG measurements.

Filter Selection

For the AM5XT, the usual noise-weighting filter used for Noise-to-Ground measurements is the C-Message filter (key [2]). For the AM5eXT, the usual filter used for Noise-to-Ground measurements is the Psophometric filter (key [2]).

In general, any of the filters listed in Table 8-1 can be used.

8.7 5 S/N (Signal-to-Noise Ratio)

Signal-to-Noise Ratio measurement is similar to the notch noise measurement in that a 1004 Hz test tone is expected at the received end. The receive circuit contains an average detector, a 1004 Hz notch filter, a noise weighting filter, and an RMS Detector (RMS Detector or Quasi-Peak Detector for AM5eXT).

1. The average detector measures the amplitude of the received test tone (primarily 1004 Hz) and the microprocessor keeps this value in memory. This is the “signal” reading.
2. The RMS or Quasi-Peak detector measures the value of the residual noise after the 1004 Hz tone is notched out. This value is also kept in memory by the microprocessor. This is the “noise” reading.
3. The microprocessor computes the difference, in dB, between the value in “1” and the value in “2”. This is the Signal-to-Noise Ratio.

Send Function

Set the Send Function to 1004 Hz (¶7.3).

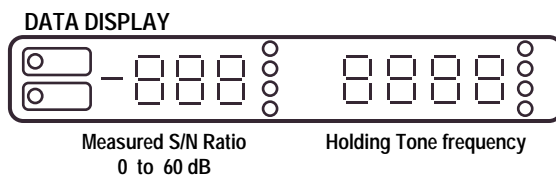

Note: In order for the Signal-to-Noise measurements to be valid, the “HOLD TONE” indicator green LED must be ON, indicating that the 1004 Hz tone is present at the proper frequency and level. Acceptable frequency is from 995 Hz to 1025 Hz at a level of greater than -40 dBm. The right hand display will also indicate the frequency of the received tone for further verification.

Filter Selection

For the AM5XT, the usual noise-weighting filter used for Signal-to-Noise measurements is the C-Message filter (key [2]). For the AM5eXT, the usual filter used for Signal-to-Noise measurements is the Psophometric filter (key [2]).

In general, any of the filters listed in Table 8-1 can be used.

8.8 6 PAR (Peak-to-Average Ratio)

Definition of P/AR

P/AR (Peak-to-Average Ratio) measurements are made by applying a special 16 tone (PAR) signal at the distant end of the line under test. At the near end, the AM5XT simultaneously measures the peak value and average value of the received test signal. **The Ratio of the Peak value to the Average value of the transmitted signal is arbitrarily assigned a value of 100.**

If the transmission channel were non-dispersive, the received Peak-to-Average Ratio would also have a value of 100. A typical telephone channel causes smearing or Intersymbol Interference however, and a value other than 100 is observed.

Table 8-2 shows some typical values that might be used to judge the acceptability of a telephone line to reliably transmit data.

Example: If a modem requires a C2 conditioned line, and a P/AR of 50 is measured, this line is likely to encounter transmission problems. On the other hand, if a P/AR of 78 is measured, Intersymbol Interference will not cause problems.

Table 8-2. P/AR Requirements of Telephone Lines

| CIRCUIT CONDITIONING | TYPICAL P/AR VALUES |
|----------------------|---------------------|
| Basic Channel | 45 |
| C1 | 48 |
| C2 | 78 |
| C4 | 87 |
| C5 | 95 |

The P/AR value of the received (distorted) signal is made according to the following formula:

$$P/AR = 100 * (K P/Afw - 1)$$

Where P = peak voltage of received signal
 Afw = full-wave average of the received signal
 K = a constant

The constant K is derived by giving undistorted signal a nominal value of 100. Therefore:

$$K = 2Afw/Po$$

Where Po = peak voltage of the undistorted (original) signal
 Afwo = full-wave average of the undistorted (original) signal

Therefore:

$$P/AR = 100 * [2(P/Po) / (Afw/Afwo) - 1]$$

or

$$P/AR = 100 * [2(Pn/Afwn) - 1]$$

Where Pn = normalized peak voltage of the received signal
 Afwn = normalized full-wave average of the received signal

Factors Which Affect P/AR

P/AR is most sensitive to envelope delay distortion and return loss problems. To a lesser degree, it is affected by attenuation distortion, noise, and nonlinear (intermodulation) distortion. It is basically unaffected by transient phenomena such as impulse noise and phase and gain hits.

Envelope Delay Distortion

There is a high correlation between measured P/AR values and values calculated from a plot of envelope delay distortion. In fact, for an envelope delay response containing significant ripples, P/AR is a better indication of the ability of the network to pass data reliably. Return loss problems are a common source of envelope delay ripple.

Effect of Noise

Noise can have a significant affect on P/AR measurement. For this reason, it is important to measure signal-to-noise ratio (or noise-with-tone) before making a P/AR measurement. If the signal-to-noise ratio is less than 25 dB, the P/AR reading will be significantly reduced by noise alone.

Effect of Nonlinear Distortion

Nonlinear (Intermodulation) Distortion can similarly affect the P/AR reading. The effect depends on whether the second or third order products dominate as the source of distortion. If the third order products dominate, they increase or decrease the P/AR value, depending upon the sign of the added products.

Send Function

Set the Send Function to PAR (¶7.7), a composite wave form per Bell 41009 specifications, made up of 16 specific phrase-related frequencies.

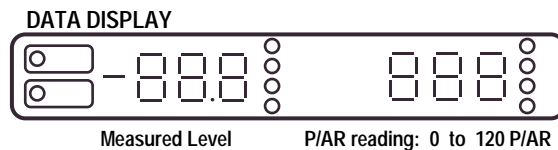

Note in the DATA DISPLAY that the left reading is the RMS level of the received P/AR waveform in dBm, and the right reading is the Peak-to-Average Ratio in P/AR units (100 P/AR = value for transmitted signal).

8.9 7 RET LOSS (Return Loss)

Definition

Return Loss is the ratio, in dB, of the power incident on a transmission system discontinuity to the power reflected from the discontinuity. It indicates how well the input and output impedances are matched throughout a circuit. Return Loss measurements are made on both 2-wire and 4-wire circuits.

Setup

A test signal is transmitted from the near end while the far end is Quiet terminated. At the near end, the level of the transmitted test tone (TX) is compared with the measured level on the receive line (RX). The difference between the transmit and receive signal is the Return Loss in dB.

Test Signals

Four (4) possible test signals can be transmitted:

1. Echo Return Loss (ERL) signal
2. Singing Return Loss (SRL) LO signal
3. Singing Return Loss (SRL) HI signal
4. Sine Wave (VAR HZ) in 200 Hz to 5 kHz band, per ¶7.4

ERL, SRL LO, and SRL HI are band-limited white-noise test signals (see ¶7.8).

Since the Return Loss measurement is the ratio between transmitted energy and received energy, the absolute amplitude of transmit energy is somewhat immaterial. The AM5XT/eXT, however, has the ability to generate the ERL, SRL LO, and SRL HI waveforms anywhere between -10 dBm and -2 dBm (see ¶7.8).

2-Wire Return Loss

In 2-wire Return Loss measurements, the test signal is applied to the transmit pair (TX) of the internal 4-wire to 2-wire hybrid, and at the same time the RMS detector measures the energy on the receive pair (RX) of the hybrid. The hybrid balancing impedance is the selected line impedance (¶6.2) in series with 2.16 μ F. If the 2-wire circuit under test is properly terminated and free of send/receive coupling, very little of the transmitted energy will be returned on the receive pair and the Return Loss reading in dB (which is a measure of the transmitted energy versus received energy) will be a large reading.

The AM5XT/eXT may be used as a passive 2-wire termination (900Ω in series with $2.16\mu\text{F}$) by selecting 2-Wire Line Mode, Ret Loss Meas Mode, and Quiet Send Mode. The 900Ω , $2.16\mu\text{F}$ termination is provided only when the unit is in the 2-Wire Line Mode and Return Loss Measure Mode.

4-Wire Return Loss

In 4-wire Return Loss measurements, the internal hybrid is not used. The test waveform and RMS detector are connected directly to the 4-wire transmit (TX) and receive (RX) pairs, respectively. Because most 4-wire circuits have loss or gain circuits in their transmit or receive leg, a correction factor must be used to compensate for this gain or loss in order to provide a meaningful Return Loss measurement. The correction factor is an offset adjustment called TLP (Transmission Level Point). The AM5XT/eXT subtracts the TLP setting from the original reading and then displays the corrected Return Loss measurement.

Because of the need to determine and set the value of the TLP, 4-wire Return Loss measurements require a special procedure, as listed below:

1. Send the desired test signal (ERL, SRL LO, SRL HI, or sine wave) per ¶7.8 or ¶7.4)
2. Press [D] to enable the **PARAM SET** LED and bring up the TLP parameter prompt.
3. Set the value of TLP to "00.0".
4. Loop back the far end (be sure termination is correct).
5. Press [7] to bring up the Return Loss Data Display.
6. Read and note the loop-around Return Loss on the Data Display. This is the amount of loss (+dB reading) or gain (-dB reading) of the circuit.
7. Repeat Step 2.
8. Set the value of TLP equal to the Return Loss reading in Step 6. Be sure both the sign and the value are the same. Example: If loop-around Return Loss in the 4-wire circuit is -15.0 dB, set TLP for -15.0 dB.
9. Unloop the 4-wire circuit and Quiet Terminate the far end per ¶7.2.
10. Repeat Step 5.

11. Read the actual Return Loss on the DATA DISPLAY. Note that the AM5XT/eXT automatically uses the TLP setting to adjust the measurement and displays the correct reading.

Send Function

Set the Send Function to ERL, SRL LO, SRL HI (¶7.8), or VAR HZ (¶7.4).

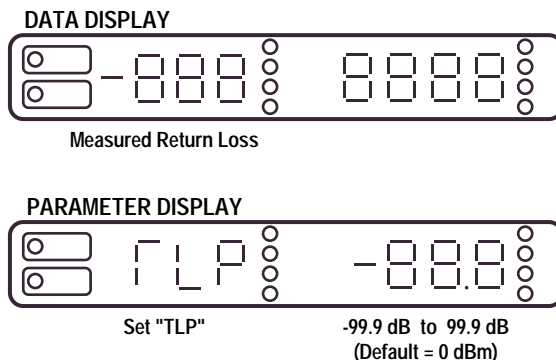

Note: The TLP setting can be kept for future use if it is stored as part of a test setup store (see ¶5.1).

See ¶8.10 for Setup and Test Procedures, including both Send and Measure functions.

8.10 8 ENV DLY (Envelope Delay) (AM5XT only)

An Envelope Delay test measures the nonlinearities in the phase response of a line. See ¶7.9 for Send function parameter settings. This test requires a transmission test set at each end of the circuit to be measured. A special procedure must be followed, which is outlined below.

The displays are numbered for ease of reference.

Displays 1, 2, and 3 are selected by repeatedly depressing the **ENV DLY** button while in **MEAS** mode. These three (3) displays only work in Normal or Hold mode. "REPT" is displayed in Repeat mode.

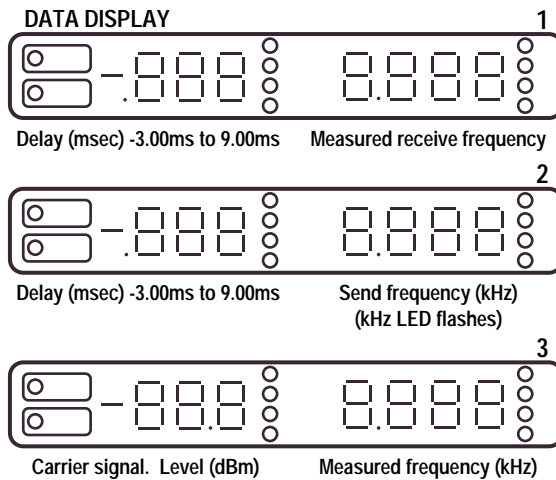

The PARAMETER Average display shows the number of readings averaged for displays 1 and 2. Enter the value per the display's stability. Increase the value if the display is unstable. The sweep rate of the carrier must be reduced as the number of the average is increased.

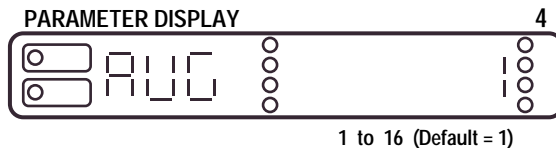

PARAMETER DISPLAYS 5A, 5B, and 5C are identical to the mode select displays 4A, 4B, and 4C included in the Envelope Delay send parameters (¶7.9). They are repeated here for ease of reference.

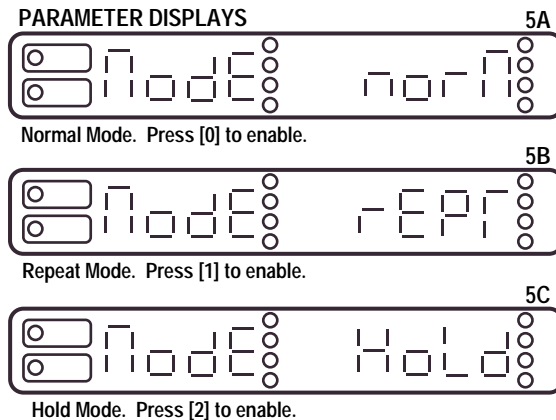

Plotting

There are additional PARAMETER DISPLAYS used for plotting graphs of the measurement through the RS232 port or XY plotter outputs.

PARAMETER DISPLAYS, for Plotting 6

L o E d - 1.00

Set low delay limit of Env. Delay plots -4.00 msec to 10.00 msec
(Default = -1.00 msec)

H i E d 1.000

Set high delay limit of Env. Delay plots -4.00 msec to 10.00 msec
(Default = 1.000 msec)

L o d b - 40.0

Set low level limit of level/freq. plot -99.9 dB to 99.9 dB
(Default = -40.0 dB)

H i d b 10.0

Set high level limit of level/freq. plot -99.9 dB to 99.9 dB
(Default = 10.0 dB)

T i m e I n t e r v a l 0

Time Interval Between Printouts 0 sec to 255 sec
(Default = 0, AutoTrack)

L i n e C o n d i t i o n i n g 8888

Line conditioning for performance limits. Enter a digit 1 to 8 or use up or down arrows to select mask.

1. Low delay limit of the plot of display 1 or display 2.
2. High delay limit of the plot of display 1 or display 2.
3. Low level limit of the plot of display 3.
4. High level limit of the plot of display 3.

5. Rate at which lines are printed.
6. Performance limits for line on printer/plotter.

Automatic Tracking Printing Mode

To deliver a printout each time there is a shift in frequency, set RATE parameter to “0”. With RATE = 0, there must be a discrete, stable shift in the frequency to cause a printout. If the frequency changes at least 8 Hz (approximately) and stabilizes for about 0.5 sec, there will be a printout.

4-Wire Setup

Two (2) types of 4-wire Envelope Delay tests can be made:

1. Near-to-Far Envelope Delay
2. Far-to-Near Envelope Delay

Figure 8-2 shows the setup to measure both types of 4-wire Envelope Delay.

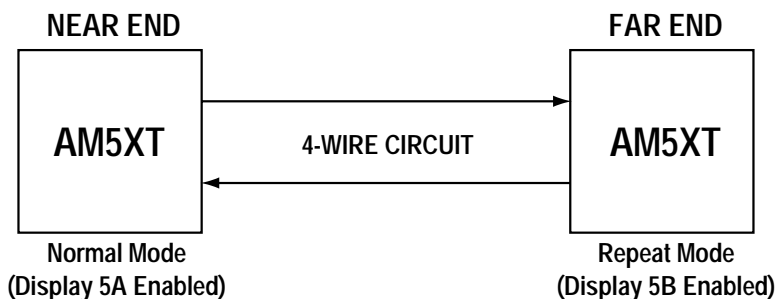

Figure 8-2. Setup to Measure 4-Wire Envelope Delay

Control of Far-End AM5XT

There are three (3) ways to control the far-end AM5XT:

1. Manually, with a person at the far end controlling the AM5XT. An additional telephone line is used for communication between the people at the near and far-end test sets, or they may use TALK mode (§7.14) to communicate through the AM5XT units.
2. Use Touch Tone (TT) commands over the line being tested, sent from the near-end AM5XT to RECALL “canned” test setups with the STORE function.

To RECALL a test setup stored in a memory of the far-end AM5XT:

8. In the near AM5XT, enable TT Dialing Mode as explained in ¶10.2.
9. Dial “A” followed by the 2-digit memory location. For example, dial “A01” to recall setup in memory location 01.
3. Send commands from the near end to the far end over a separate telephone line to the far-end AM5XT RS232 port. See ¶12.1 concerning RS232 operation.

Operation

Follow the appropriate procedure outlined below to measure either Near-to-Far or Far-to-Near Envelope Delay.

TEST PROCEDURE: 4-WIRE, NEAR-TO-FAR

Summary:

NEAR END

1. Send REFERENCE frequency.
2. Set NORMAL Mode.
3. Enable Measure Display 2 (Delay/Send Freq).
4. Zero to Reference Frequency with REL SET.
5. Send ENV DLY Sweep.
6. Read Envelope Delay on Measure Display 2.

FAR END

1. Send REFERENCE frequency.
2. Set REPEAT Mode.
3. Enable Measure Display 3 (Level/Freq.).

Note: Send “Display 1” thru “Display 10” refer to displays shown in Section 7.
Measure “Display 1” thru “Display 11” refer to displays shown in Section 8.

Detailed Instructions:

1. On both near and far AM5XT, press [SEND] key and enable Send Function row. Press [8] to enable ENV DLY.
 - On near AM5XT, if other than default settings are desired, use PARAM SET to set desired values for the Sweep parameters with Send Displays 6 thru 11 (see ¶7.9).
 - On both near and far AM5XT, if other than default Reference Frequency is desired, use PARAM SET to set desired Reference Frequency with Send Display 5.
 - On both near and far AM5XT, send Reference Frequency by enabling Send Display 2 (see ¶7.9).
- On both near and far AM5XT, press [MEAS] key and enable Measure Function row. Press [8] to enable ENV DLY. With PARAM SET, set the near-end AM5XT to NORMAL mode (Measure Display 5A), and set the far-end AM5XT to REPEAT mode (Measure Display 5B). At both ends, press [MEAS] key again to exit PARAM SET.
- On near AM5XT, press [8] as necessary to enable Measure Display 2 (kHz LED will flash). On far AM5XT, press [8] as necessary to enable Measure Display 3.
- On near AM5XT, press AUX key, then press [C] to enable REL SET (note that REL SET LED does not light). The left display of Measure Display 2 will go to “0.000 msec”, indicating that the delay measure has been zeroed at the Reference Frequency.
- On near AM5XT, press [SEND] key to enable Send Function row. Press [8] as necessary to enable Send Display 1 (ENV DLY Sweep Mode) (see ¶7.9). Leave far AM5XT in Send Reference Frequency.
- On near AM5XT, press [MEAS] key to enable Measure Display 2 (kHz LED will flash). Read the Envelope Delay in msec.
- If reading in Step 6 is unstable, increase setting of Measure Display 4 to increase the number of readings AVeraGed before the result is displayed. As the averaging number is increased, the sweep rate must be reduced.

- If the results are to be plotted or printed out, set constraints with Measure Display 6 thru 11.

TEST PROCEDURE: 4-WIRE, FAR-TO-NEAR**Summary:****NEAR END**

1. Send REFERENCE frequency.
2. Set NORMAL Mode.
3. Enable Measure Display 1 (Delay/Rev Freq).
4. Zero to Reference Frequency with REL SET.
6. Read Envelope Delay on Measure Display 1.

FAR END

1. Send REFERENCE frequency.
2. Set REPEAT Mode.
5. Send ENV DLY Sweep.

Note: Send “Display 1” thru “Display 10” refer to displays shown in Section 7.
Measure “Display 1” thru “Display 11” refer to displays shown in Section 8.

Detailed Instructions:

1. On both near and far AM5XT, press [SEND] key and enable Send Function row. Press [8] to enable ENV DLY.
 - On far AM5XT, if other than default settings are desired, use PARAM SET to set desired values for the Sweep parameters with Send Displays 6 thru 10 (see ¶7.9).
 - On both near and far AM5XT, if other than default Reference Frequency is desired, use PARAM SET to set desired Reference Frequency with Send Display 5.
 - On both near and far AM5XT, send Reference Frequency by enabling Send Display 2 (see ¶7.9).

2. On both near and far AM5XT, press [MEAS] key and enable Measure Function row. Press [8] to enable ENV DLY. With PARAM SET, set the near-end AM5XT to NORMAL mode (Measure Display 5A), and set the far-end AM5XT to REPEAT mode (Measure Display 5B). On near end, press [MEAS] key again to exit PARAM SET.
3. On near AM5XT, press [8] as necessary to enable Measure Display 1 (kHz LED will be continuously ON).
4. On near AM5XT, press AUX key, then press [C] to enable REL SET (note that REL SET LED does not light). The left display of Measure Display 1 will go to “000.0 msec”, indicating that the delay measure has been zeroed at the Reference Frequency.
5. On far AM5XT, press [SEND] key to enable Send Function row. Press [8] as necessary to enable Send Display 1 (ENV DLY Sweep Mode) (see ¶7.9). Leave near AM5XT in Send Reference Frequency.
6. Read the Envelope Delay in msec.
7. If reading in Step 6 is unstable, increase setting of Measure Display 4 to increase the number of readings AVeraGed before the result is displayed. As the averaging number is increased, the sweep rate must be reduced.
8. If the results are to be plotted or printed out, set constraints with Measure Display 6 thru 11.

2-Wire Envelope Delay

The ability to make a 2-wire Envelope Delay measurement is an exclusive testing feature, found only in the Ameritec AM5XT. This allows the delay to be measured without using an additional line for a return path.

A phase-locked loop (PLL) generator in the near-end AM5XT is used to “lock on” to the 83-1/3 Hz modulation frequency of the Reference carrier frequency sent from the far end. This establishes a phase reference in the near end AM5XT. The HOLD mode is used in the near AM5XT to “hold” this phase reference so delay can be measured as the far end sweeps the carrier frequency.

The Envelope Delay measurement will drift slightly from the time HOLD Mode is enabled. It will change a maximum of 15 microseconds/minute. This is due to the slight instability of the PLL phase reference. The Envelope Delay measurement should, therefore, be made soon after HOLD Mode is enabled. For example, the Envelope Delay measurement must be made within 2 minutes of enabling HOLD Mode (second part of step 7 in procedure) to guarantee no more than 30 micro-seconds of error in the reading.

Setup

Figure 8-3 shows the setup to measure 2-Wire Envelope Delay.

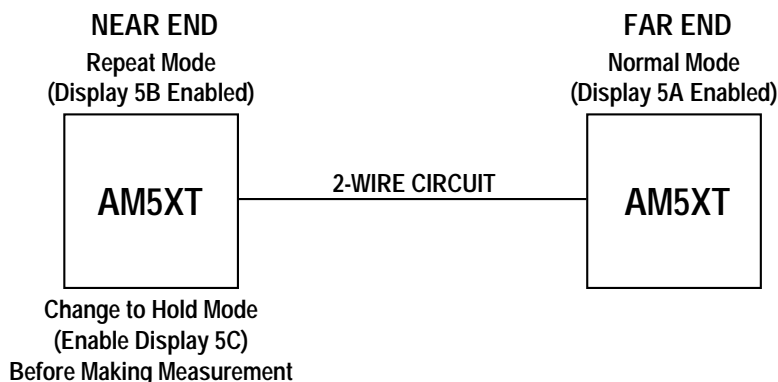

Figure 8-3. Setup to Measure 2-Wire Envelope Delay

TEST PROCEDURE: 2-WIRE, FAR-TO-NEAR

Summary:

NEAR END

1. Set Send to QUIET Mode.
2. Set REPEAT Mode.
5. Wait at least 10 sec.
6. Set Measure HOLD Mode, Enable Measure Display 1 (Delay/Rev Freq.).
7. Zero to Reference Frequency with REL SET.
9. Read Envelope Delay on Measure Display 1.

FAR END

3. Send REFERENCE frequency.
4. Set NORMAL Mode.

8. Send ENV DLY Sweep Mode.

Note: Send “Display 1” thru “Display 10” refer to displays shown in Section 7.
Measure “Display 1” thru “Display 11” refer to displays shown in Section 8.

Detailed Instructions:

1. On near end:
 - Press [SEND] key to enable Send Function row.
 - Press [1] to enable QUIET Send Mode (§7.2).
2. On near end:
 - Press [MEAS] key to enable Measure Function row.
 - Press [8] to enable ENV DLY.
 - Use PARAM SET to set Repeat Mode (Display 5B).
3. On far end:
 - Press [SEND] key and enable Send Function row.
 - Press [8] to enable ENV DLY (see §7.9).
 - Press [8] as necessary to enable Send Display 2 (send Reference Frequency).
 - If other than default Reference Frequency is desired, use PARAM SET to set desired Reference Frequency with Send Display 5.
4. On far end:
 - Use PARAM SET to set NORMAL MODE (Display 5A).
5. Wait at least 10 seconds to allow the Near End Phase Lock Loop (PLL) Generator to “lock on” precisely to the phase of the modulation frequency of the Reference Frequency.
6. On near end:
 - Press [MEAS] key and enable Measure Function row.
 - Use PARAM SET to set Envelope Delay HOLD Mode (Display 5C).
 - On near end, press [MEAS] key again to exit PARAM SET.
 - Press [8] as necessary to enable Measure Display 1 (Delay/Rev Freq).

7. On near end:
 - Press [AUX] key, then press [C] to enable REL SET (note that REL SET LED does not light).
 - The left display of Measure Display 1 will go to “0.000 msec”, indicating that the delay measure has been zeroed at the Reference Frequency.
8. On far end:
 - Press [SEND] key and enable Send Function row.
 - Press [8] as necessary to enable Send Display 1 (ENV DLY Sweep).
 - If other than default Sweep settings are desired, use PARAM SET to set desired parameter values with Send Displays 6 thru 10 (see ¶7.9).
9. On near end, read Envelope Delay on Measure Display 1.

8.11 8 GROUP DLY (Group Delay) (AM5eXT ONLY)

A Group Delay test measures the non-linearities in the phase response of a line. A transmission test set is required at each end of the circuit to be measured. Test signals are generated over a 2-wire circuit from the test set on one end, and the Group Delay is measured on the other end. See ¶8.11 for Measure functions and Test Procedure.

With a Group Delay test, there are two (2) types of send signals which are alternately generated for 120ms:

1. A constant carrier **Reference** Frequency, usually 1800 Hz, modulated by 41-2/3 Hz.
2. A **Sweep** series of carrier frequencies, usually from 200 Hz to 20 kHz, also modulated by 41-2/3 Hz.

The Measure Displays listed are identified by number for ease of reference

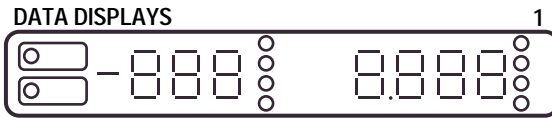

Measured Group Delay at indicated test frequency

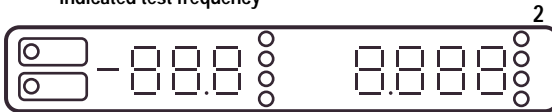

Measured level of test signal, at indicated frequency, relative to reference. In other words, the difference between levels: Test level - Reference level.



Measured frequency of reference signal

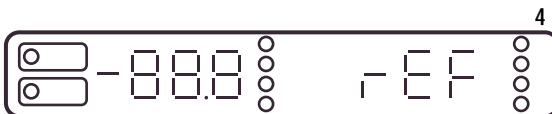

Measured level of reference (ref) signal

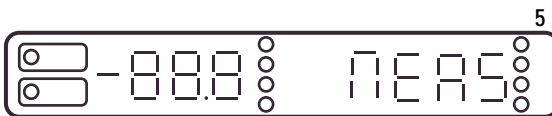

Measured level of test (meas) signal



Filter out (Default): press [0] to disable

Filter in: press [1] to enable.



No. of readings averaged for display 1. Enter value per display stability. Increase value if display is unstable. Range: 1 to 16 (Default = 1)

Plotting

There are additional PARAMETER DISPLAY used for plotting graphs of measurement Display 1 or Display 2 through the RS232 port or XY plotter outputs. These parameters are used respectively to set:

- 8. Low delay limit of the plot of display 1.
- 9. High delay limit of the plot of display 1.
- 10. Low level limit of the plot of display 2.
- 11. High level limit of the plot of display 2.
- 12. Rate at which lines are printed.
- 13. Performance limits for line on printer/plotter.

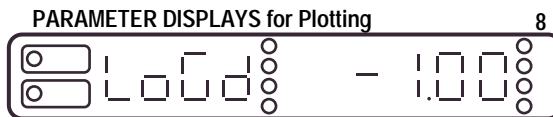

PARAMETER DISPLAYS for Plotting
Set low time limit of Group Delay plot -12.00 msec to 12.00 msec (Default = -1.00 msec)

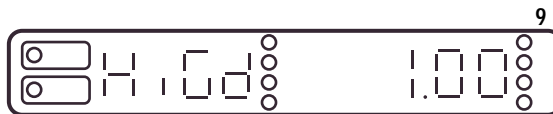

Set high time limit of Group Delay plot -12.00 msec to 12.00 msec (Default = -1.00 msec)

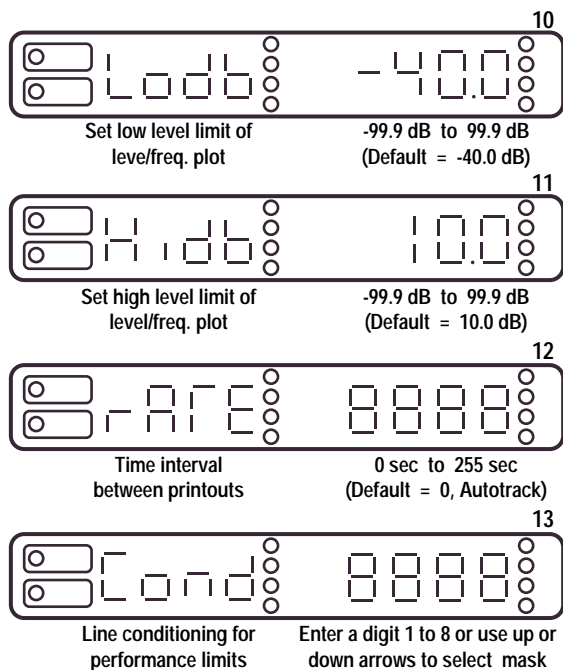

See Section 13 for details and examples concerning plotting.

Automatic Tracking Printing Mode

To deliver a printout-plot each time there is a shift in frequency, set RATE parameter to "0". With RATE = 0, there must be a discrete, stable shift in the frequency to cause a printout/plot. If the frequency changes at least 8 Hz (approximately) and stabilizes for about 0.5 sec, there will be a printout/plot.

Setup

Group Delay is measured over a 2-wire circuit, generating the composite signals at one end and measuring the Group Delay at the other end.

For 4-wire, a Group Delay measurement is made individually over each pair (TX pair and RX pair). Since the Send and Measure functions of the AM5eXT are independent, both Group Delay measurements could be made simultaneously at both ends of the circuit, each test set measuring the Group Delay of the signals being sent from the opposite end.

Figure 8-4 shows the setup to measure Group Delay.

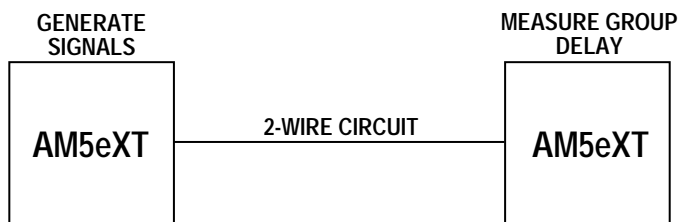

Figure 8-4. Setup to Measure Group Delay

Operation

Follow the procedure outlined below:

1. For other than default Send signals, set desired send signals as indicated in ¶7.10.
 - Set level of send signals with GROUP DLY Send Display 2.
 - Set Reference Frequency with GROUP DLY Send Display 3.
 - Set Test Signal sweep parameters with GROUP DLY Send Display 4 thru Display 8.
 2. If high-frequency noise is causing interference, enable the high-frequency filter:
 - Use Measure PARAM SET.
 - Access GROUP DLY Measure Display 6.
 - Press [1].
 - Measure Display 6 will read “FLTR IN”.
 3. Repeatedly press [8] as needed, to make readings from Measure Display 1 thru Display 5.
- and/or**
4. Print out readings from Measure Display 1 or Display 2 by:
 - Setting the plotting parameters with Display 8 thru Display 13.
 - Pressing [AUX] key and then holding down [8] to initiate the printout.

Note: If the high-frequency filter is used, set the STOP frequency of the sweep no higher than 4 kHz. The filter introduces 30 microseconds of error to the Group Delay at 4 kHz.

8.12 9 IMD (Intermodulation Distortion*)

* Licensed under U.S. Patent #3,862,380.

Definition. Intermodulation Distortion is also known as “Non-Linear Distortion” or “4-Tone Test”. Intermodulation Distortion is signal component generation that is produced from the transmitted signal and adds to the transmitted signal. These additional signal components are usually undesirable.

The Intermodulation Distortion signal is composed four (4) tones, all at the same level, as described below:

- Two (2) tones are 6 Hz apart, centered at 860 Hz.
- Two (2) tones are 16 Hz apart, centered at 1380 Hz.

Third-order non-linear distortion creates six (6) intermodulation products in a narrow band centered at 1.9 kHz. The power produced by these third order intermodulations is measured and expressed in dB below the received signal.

Second-order non-linear distortion creates four (4) intermodulation products in each of 2 narrow bands centered at 520 Hz and 2240 Hz. The power in each of these second-order intermodulation bands is also measured. The average of these two second-order distortion powers is expressed in dB below the received signal.

See ¶7.11 for Send Function parameter settings.

The Noise Correction Factor is used to automatically correct the displayed readings of 2nd and 3rd order distortion when a 4-tone signal is received.

The second digit in the right display indicates if the Noise Correction Factor is enabled:

- C = Noise Correction Factor captured
- “ “ (blank) = Noise Correction Factor not determined

When a 2-tone signal is transmitted for 15 seconds, the receiver will automatically measure background noise level and save. Readings are then displayed with the “C” to tell the operator the display reading has been “corrected”.

Data displayed when receiving a 2-Tone signal after capturing the Noise Correction Factor

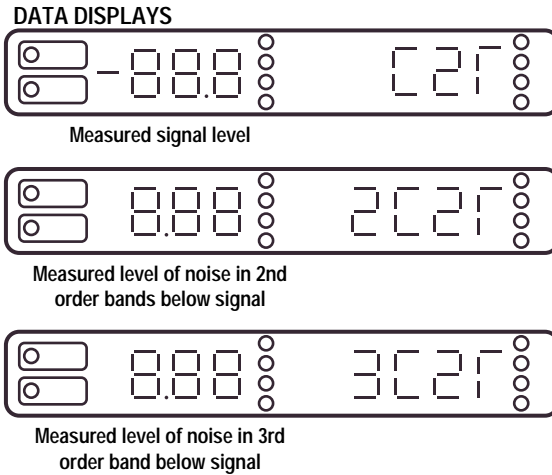

Data displayed when receiving a 4-Tone signal after capturing the Noise Correction Factor

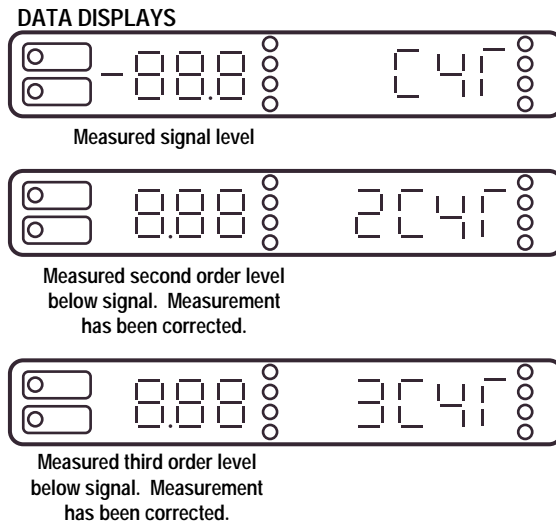

If IMD Measure mode is exited to enable another Measure function, the correction factor is lost. When IMD mode is enabled again, the absence of the correction factor is indicated by the absence of the “[“ in the second digit of the right display.

Data displayed when receiving a 4-Tone signal without Noise Correction Factor

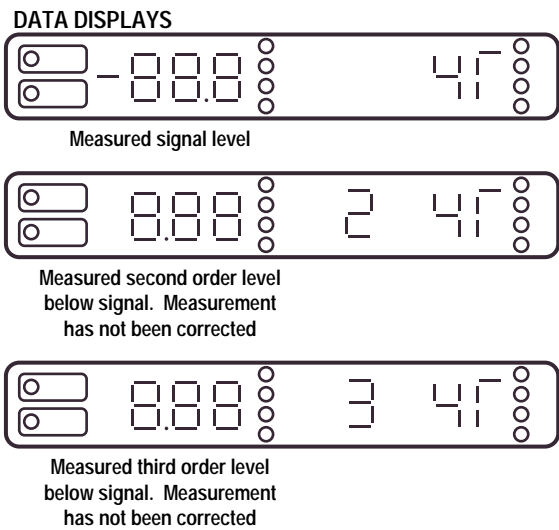

8.13 [0] PHASE JTR (Phase Jitter)

This measurement requires a 1004 Hz nominal Holding Tone. This test measures the peak-to-peak phase variation of the modulation of the holding tone. The bandwidth (range of frequencies) is selected over which the phase jitter is measured. A phase-locked-loop generator locks on the holding tone and an average peak-to-peak phase jitter is measured in degrees.

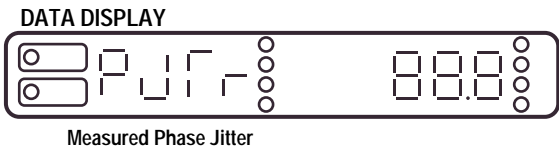

The bandwidth can be set to either:

- 20 Hz to 300 Hz (default)
- 4 Hz to 300 Hz
- 4 Hz to 20 Hz

8.14 * AMP JTR (Amplitude Jitter)

The test for amplitude jitter is the same as the phase jitter measurement, except that instead of measuring the variation of the phase, the variation of the amplitude of the modulation is measured. The unit of measurement for the amplitude jitter is average percent peak-to-peak variation.

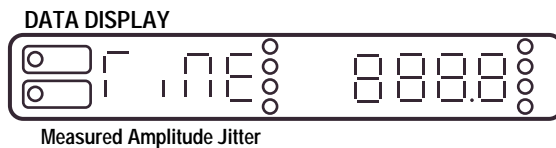

Measured Amplitude Jitter

Because this is an amplitude measurement, the phase-locked-loop frequency is not of interest.

8.15 # IMP NOISE (Impulse Noise without Tone)

This is a timed study which counts the number of noise pulses that exceed each of three levels (thresholds). No Holding Tone is used for this test.

Three (3) noise thresholds are established: low, middle, and high levels, with an equal interval between them called the “delta”. The time over which the run is to be made is the duration.

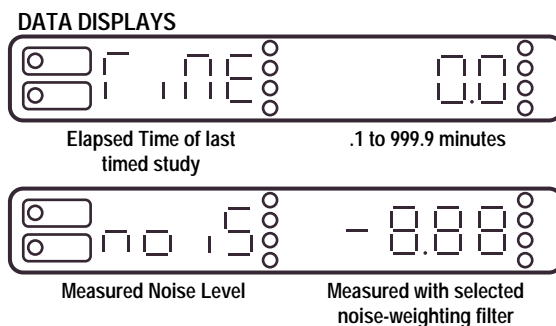

Elapsed Time of last timed study

.1 to 999.9 minutes

Measured Noise Level

Measured with selected noise-weighting filter



Count of Noise Impulses
exceeding low threshold

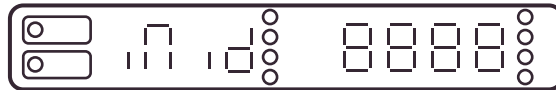

Count of Noise Impulses
exceeding mid threshold



Count of Noise Impulses
exceeding high threshold

The run is started and a running count is kept of the number of noise pulses that exceed each threshold. The run will automatically stop when the duration time is reached. The test can be stopped manually at any time.

The blanking interval is the time after a noise pulse when the counter does not count. The blanking interval for a threshold is started when a pulse exceeds the threshold for the first time. The noise pulse counter does not count during the blanking interval. The purpose of the blanking interval is to minimize the effect of ringing on the count. Without the blanking interval, several counts could be made immediately after the first pulse, due to secondary pulses caused by ringing. The blanking interval allows time for the ringing to die down.

PARAMETER DISPLAYS



Set Duration of Test

.1 to 999.9 minutes
(Default = 15.0 minutes)



Set Impulse Noise
Low Threshold

20.0 dBm to 110.0 dBm
(Default = 70.0 dBm)

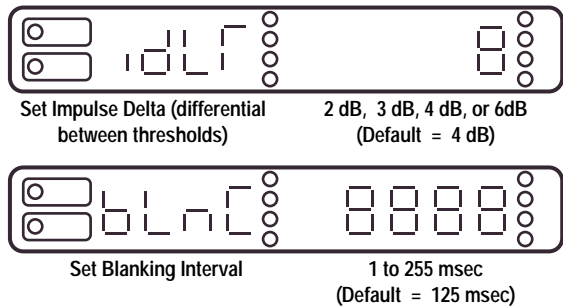

A typical duration time for the study is 15 minutes, although a study of up to 999.9 minutes (16 hours) could be made. Note that only duration, low level threshold, and impulse delta are set.

8.16 A TRAN (Transients)

PHASE HITS

A phase hit is a sudden change in the phase of the modulation of a Holding Tone. A threshold of from 5 to 45 degrees is set and the number of phase hits that exceed that threshold during the timed study is counted.

GAIN HITS

A gain hit is a sudden change in the amplitude of the modulation of a Holding Tone. A threshold of 2, 3, 4, or 6 dB is set and the number of gain hits that exceed that threshold during the timed study is counted.

DROPOUTS

A dropout is the loss of Holding Tone. The number of losses of Holding Tone during a timed study is counted. A “loss” of Holding Tone occurs if the Holding Tone level and/or frequency go out of the acceptable range for valid transient measurements, usually a 12 dB reduction in the Holding Tone level as measured at the start of the test.

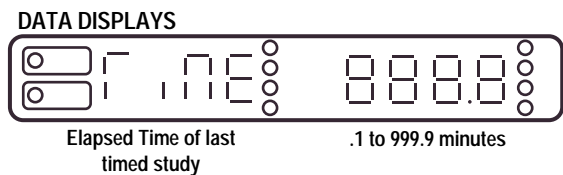

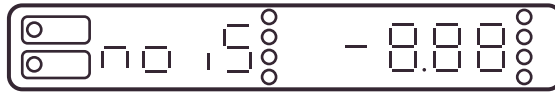

Measured Noise Level



Count of Noise Impulses
exceeding low threshold

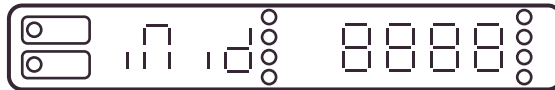

Count of Noise Impulses
exceeding mid threshold



Count of Noise Impulses
exceeding high threshold

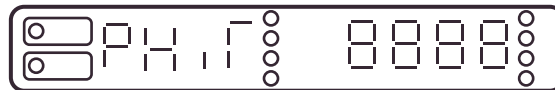

Count of Phase Hits exceeding
Phase Hit threshold



Count of Gain Hits exceeding
Gain Hit threshold

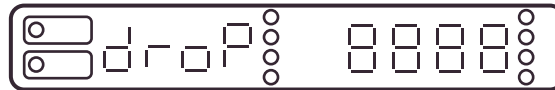

Count of Dropouts

PARAMETER DISPLAYS



Set Duration of Test

.1 to 999.9 minutes
(Default = 15.0 minutes)

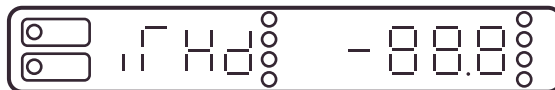

Set Impulse Noise
Low Threshold

20.0 dBm to 110.0 dBm
(Default = 70.0 dBm)

Set Impulse Delta (differential between thresholds) 2 dB, 3 dB, 4 dB, or 6dB (Default = 4 dB)

Set Phase Hit Threshold 5 to 45 degrees (Default = 25 deg.)

Set Gain Hit Threshold 2, 3, 4, 6, 8, or 10 dB (Default = 2 dB)

Set Blanking Interval 1 to 255 msec (Default = 125 msec)

8.17 B MICRO INTR (Micro-interruptions)

Micro-interruptions is a test for dropouts that exceed a specified threshold. Duration of test, threshold of interruption, and blanking interval are set and the test is started. Five (5) different counts are logged depending on the length of the interruption, and can be displayed during or after the test.

DATA DISPLAYS

Elapsed Time of last timed study .1 to 999.9 minutes

Count of Interruptions lasting 0.3 - 3.0 msec

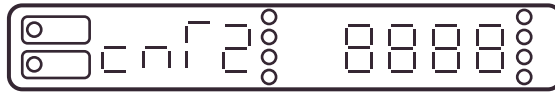

Count of Interruptions
lasting 3.0 - 30 msec

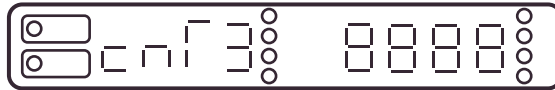

Count of Interruptions
lasting 30 - 300 msec

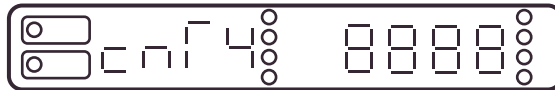

Count of Interruptions
lasting 300 msec - 1 minute

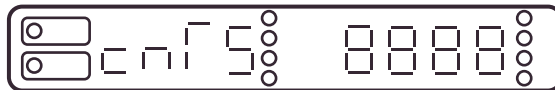

Count of Interruptions
lasting > 1 minute

PARAMETER DISPLAYS



Set Duration of Test

.1 to 999.9 minutes
(Default = 15.0 minutes)



Set Threshold of interruption
(in dB,s below initial input level)

3 dB, 6 dB, 10 dB, or 20 dB
(Default = 3 dB)



Set Blanking Interval

1 to 255 msec
(Default = 125 msec)

9. AUXILIARY FUNCTIONS

9.1 INTRODUCTION

AUXILIARY Functions are associated with the Measure Functions. See Figure 9-1 for instructions to select the desired Auxiliary Function. Note that Auxiliary Functions are color-coded VIOLET.

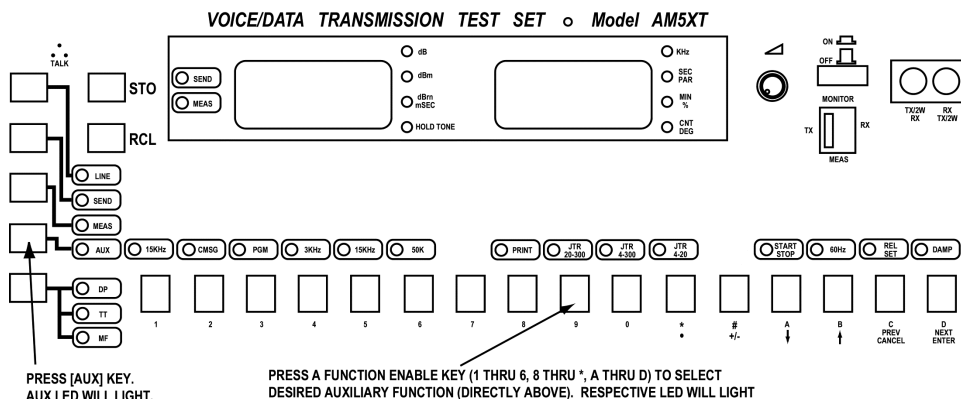

Figure 9-1. Procedure to Enable Auxiliary Functions

In this section, the Function Enable Key for each Auxiliary Function is shown enclosed in a square. For example, 8 PRINT indicates that key [8] is pressed to output information to an external printer.

Function Boxes

Some Auxiliary Functions are only associated with certain Measure Functions; these Auxiliary Functions are enclosed in a black border, together with the Measure Functions with which they are associated. These are referred to as Function Boxes. There are four (4) Function Boxes, which are illustrated in Figure 9-2.

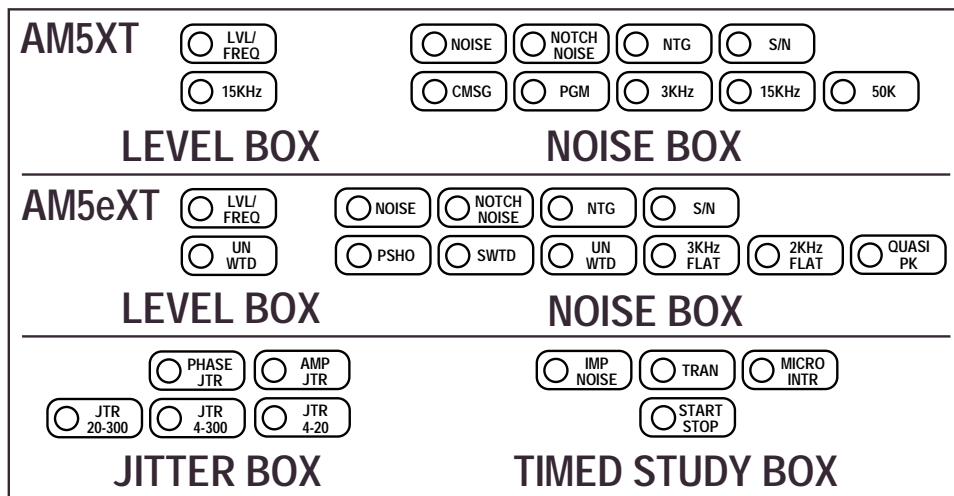

Figure 9-2. Function Boxes

Note that the Level Box and the Noise Box are different for the AM5XT and the AM5eXT; the Jitter Box and Timed Study Box are the same for the AM5XT and the AM5eXT.

Paragraphs in this section are listed below:

- 9.2 Filter for Narrow-Band Level/Frequency Measurement
- 9.3 Noise Weighting Filters
- 9.4 QUASI PK (Quasi-Peak Detector Enable) **AM5eXT only**
- 9.5 PRINT Enable
- 9.6 Jitter Bandwidth Select
- 9.7 START STOP (Timed Study Start/Stop)
- 9.8 60 Hz Filter
- 9.9 REL SET (Relative Measure Zero Set)
- 9.10 DAMP (Display Update Select)

9.2 1 FILTER FOR NARROW-BAND LEVEL/FREQUENCY

This function is part of the Level (Function) Box as shown in Figure 9-2. It is a low-pass filter, connected to the front end of the measurement circuitry, effectively eliminating high-frequency components. For the AM5XT, this is a 15 kHz filter; for the AM5eXT, a sound-unweighted filter (30 Hz to 20 kHz).

Enable this filter (LED on) in a Level/Frequency measurement when making measurements on voice-band circuits where high frequency components are of no interest. With this filter enabled, the test is referred to as a “narrow-band level/frequency measurement”. See ¶8.2 for Level/Frequency measurement information.

9.3 NOISE WEIGHTING FILTERS

Noise weighting filters are part of the Noise (Function) Box as shown in Figure 9-2. If a noise measurement is to be made with a noise weighting filter, there are five (5) noise weighting filters from which to choose. Only one (1) of the filters (or none) can be selected for a given noise measurement. The possible filters are listed in Table 9-1.

Table 9-1. Noise Weighting Filters

| KEY | AM5XT | AM5eXT |
|-----|-------------------|--------------------------|
| [2] | C-Message (CMMSG) | Psophometric (PSHO) |
| [3] | Program (PGM) | Sound-Weighted (SWTD) |
| [4] | 3 kHz flat | Sound-Unweighted (UNWTD) |
| [5] | 15 kHz flat | 3 kHz FLAT |
| [6] | 50 kBit | 2 kHz FLAT |

The AM5XT filters comply with IEEE STD 743-1984 (formerly Bell 41009) specification. The AM5eXT filters comply with CCITT recommendations.

Tables 9-2 and 9-3 describe, respectively, the AM5XT and AM5eXT noise weighting filters and reference the figures that illustrate the filter characteristics.

Note: In addition to a noise weighting filter, the 60 Hz filter may be connected as desired during the measurement. See ¶9.8.

Table 9-2. AM5XT Noise Weighting Filters

| FILTER | DESCRIPTION | ILLUSTRATION |
|-------------------|--|--------------|
| CMMSG (C-Message) | Bandpass filter | Figure 9-3 |
| PGM (Program) | Bandpass filter | Figure 9-4 |
| 3 kHz | Low pass filter (3 dB down @ 3 kHz, 12 dB/octave rolloff) | Figure 9-11 |
| 15 kHz | Low pass filter (3 dB down @ 15 kHz, 12 dB/octave rolloff) | Figure 9-6 |
| 50K (50 KBit) | Combination low pass and high pass filter | Figure 9-7 |

Table 9-3. AM5eXT Noise Weighting Filters

| FILTER | DESCRIPTION | ILLUSTRATION |
|----------------------------|----------------------------|--------------|
| PSHO (Psophometric) | Bandpass filter | Figure 9-8 |
| SWTD (Sound-Weighted) | low pass, high pass filter | Figure 9-9 |
| UN WTD (Sound Un-Weighted) | low pass, high pass filter | Figure 9-10 |
| 3 kHz FLAT | Bandpass filter | Figure 9-5 |
| 2 kHz FLAT | Bandpass filter | Figure 9-12 |

9.4 7 QUASI PK (Quasi-Peak Detector Enable) (AM5eXT Only)

With AM5eXT noise measurements, there is a choice of devices to measure the voltage on the receive pair; select either the RMS Detector or the Quasi-Peak Detector.

With the AM5eXT, perform the following steps to make a noise measurement using the Quasi-Peak Detector:

1. In the Measure Functions row (with MEAS LED ON), press the appropriate key to enable the desired noise test (NOISE, NOTCH NOISE, NTG, or S/N); corresponding LED will light.
2. Press [AUX] key. AUX LED will light.
3. Press [7]. QUASI PK LED will light, indicating that the Quasi-peak detector is enabled.

For the AM5eXT, the Quasi-Peak Detector is enabled when the QUASI PK LED is on. The RMS Detector is enabled when the QUASI PK LED is off.

Note: For the AM5XT, all noise measurements are made with the RMS Detector only (there is no QUASI PK LED).

9.5 8 PRINT ENABLE

The print key is used to initiate a printout through the RS232 port. For this print key to operate, the unit must be equipped with the optional RS232 port (Part No. 25-0019) and have a printer connected.

A printout can be made of:

- A. The front panel setup together with the present reading(s) of the enabled measurement function.
- B. For Level/Frequency or Envelope Delay (Group Delay for the AM5eXT) tests only: a simultaneous plot and printout of the test results being displayed in the measure display, output periodically at a rate set by the user.

These two (2) types of printout are implemented as outlined below:

Up to Version 7

Printout of Front Panel Setup and Present Measurement(s)

This printout is a “snapshot” of the front panel setup and measure reading(s) at the time the print key is pressed. To obtain this printout:

- A. Press [AUX] key.
- B. Momentarily press [8].
- C. The PRINT LED will not light during this print mode.

Periodic Printout/Plot of Reading on Measure Display

This printout mode is for Level/Frequency or Envelope Delay (Group Delay for the AM5eXT) tests only. To initiate this printout/plot:

1. Set the upper and lower limits of the plot and the rate of the printouts/plot. See PARAMETER DISPLAYS “for Plotting” in ¶8.2 (Level/Frequency), ¶8.10 (Envelope Delay), or ¶8.11 (Group Delay).
2. Set LVL/FREQ, ENV DLY, or GROUP DLY Measurement display to the DATA DISPLAY to be printed/plotted.
3. Press [AUX] key.
4. Continuously press [8] for approximately 2 seconds.
5. The PRINT LED will flash on/off during this print mode.
6. To exit this print mode, again continuously press [8] for approximately 2 seconds; PRINT LED will go out.

See Section 13 for information on obtaining hard copies of test results using a printer and/or x-y plotter. See ¶13.3 for printing/plotting with Version 8 and up.

9.6 JITTER BANDWIDTH SELECT

The three (3) Jitter Bandwidth Weighting Filters are part of the Jitter (Function) Box as shown in Figure 9-2. When making Phase Jitter or Amplitude Jitter measurements, one (1) of these Bandwidths must be chosen for the test. Therefore, one (1) of the Jitter Bandwidth LEDs will always be on, indicating the Bandwidth is selected.

The possible Phase Jitter or Amplitude Jitter Bandwidths are listed in Table 9-4.

Table 9-4. Jitter Bandwidth Weighting Filters

| KEY | FILTER | BANDWIDTH |
|-----|------------|------------------------------------|
| [9] | JTR 20-300 | 20 Hz to 300 Hz (power on default) |
| [0] | JTR 4-300 | 4 Hz to 300 Hz |
| [*] | JYTR 4-20 | 4 Hz to 20 Hz |

9.7 A START STOP (Timed Study Start/Stop)

The Start/Stop function is part of the Timed Study (Function) Box as shown in Figure 9-2. It is used to Start/Stop the Timed Study tests enclosed in the Timed Study Box:

| | |
|-------------------|------------------------------|
| IMP NOISE | Impulse Noise (without tone) |
| TRAN | Transient Tests |
| | Impulse Noise (with tone) |
| | Phase Hits |
| | Gain Hits |
| | Dropouts |
| MICRO INTR | Micro Interruptions |

To start a timed test:

1. Press [AUX] key to turn AUX LED on.
2. Press [A], turning on the START STOP LED. The LED will flash during the test.

When the START STOP LED begins to flash, all the DATA DISPLAYS are reset to zero, ready to start recording the counts during the present test run. See ¶8.15 thru ¶8.17 for illustrations of the timed test DATA DISPLAYS.

There are two (2) ways for the START STOP LED to stop flashing, indicating the end of the timed test:

- A. The LED will stop flashing automatically if the DUR (test duration) PARAMETER DISPLAY is set to a value other than 0 (no time out), and the test is left to run the full DUR time.
- B. The LED can be manually turned off by pressing [A] again (with AUX LED on) during the course of the timed test.

9.8 B 60 Hz FILTER

The 60 Hz high-pass filter is meant for temporary insertion to eliminate frequencies 60 Hz or lower. Power line hum due to 50 Hz or 60 Hz components can cause erratic readings on the display. Connect this filter to eliminate power line hum and stabilize the reading on the display.

To connect/disconnect the 60 Hz filter:

1. Press [AUX] key to turn AUX LED on.
2. Press [B] to connect the 60 Hz high-pass filter (60 Hz LED, green, will light).
3. Press [B] again to disconnect the filter from the measurement (60 Hz LED will go out).

9.9 C REL SET (Relative Measure Zero Set)

All level and noise measurements are normally expressed as absolute values in units of dBm or dBm. When the REL SET LED is set on, the absolute value display of dBm or dBm (left hand display) will go to "00.0 dB". Once REL SET is enabled, all subsequent readings will be relative to the zeroed reading, displayed in units of dB.

Note: In the Envelope Delay measurement, when REL SET is used to zero the delay measure to the Reference Frequency, REL SET is a momentary function and its LED does not light.

Absolute and Relative Measurements

Either an Absolute or Relative measurement can be made with any level or noise measurement. The choice is made by setting the REL SET LED to off (absolute) or on (relative). The use of absolute and relative measurements is outlined below:

- A. Normally, the absolute setting (REL SET LED off) is used for noise and level measurements.
- B. The Relative setting (REL SET LED on) is used to establish a new zero reference level. This is useful in tests such as frequency response where levels at various frequencies are to be compared with the level at a reference frequency.

To make a relative reading:

1. Start with REL SET LED off.
2. When the desired reference point is established, press [C] (with AUX LED on) to turn on REL SET LED.
3. When REL SET LED turns on, the display will read “00.0 dB”, meaning that the level or noise reading is now referenced to the reading that was on the display when REL SET was enabled.
4. Subsequent readings are now referenced to this new zero reference.
5. To summarize, a reading with the REL SET LED on means “relative to the last reading before REL SET was enabled”.

EXAMPLE: Changing from absolute to relative with a level measurement:

1. With the MEAS LED on and LVL/FREQ LED on, REL SET LED off, a level of “-17.7 dBm” is displayed..
2. [AUX] key is pressed (AUX LED lights).
3. [C] is pressed (REL SET lights).
4. Reading is now “00.0 dB” (note that units are now in dB not dBm).
5. With REL SET LED still on, the reading changes to “-2.3 dB”; this means the level is -2.3 dB relative to the reading before REL SET was enabled.
6. The absolute reading would be $-17.7 + -2.3 = -20.0$ dBm.

9.10 D DAMP (Display Update Select)

DAMP LED off = Front panel display updated four (4) times each second. This is the normal setting.

DAMP LED on = Front panel display update is slowed down to two (2) updates per second. This setting is useful to capture erratic readings.

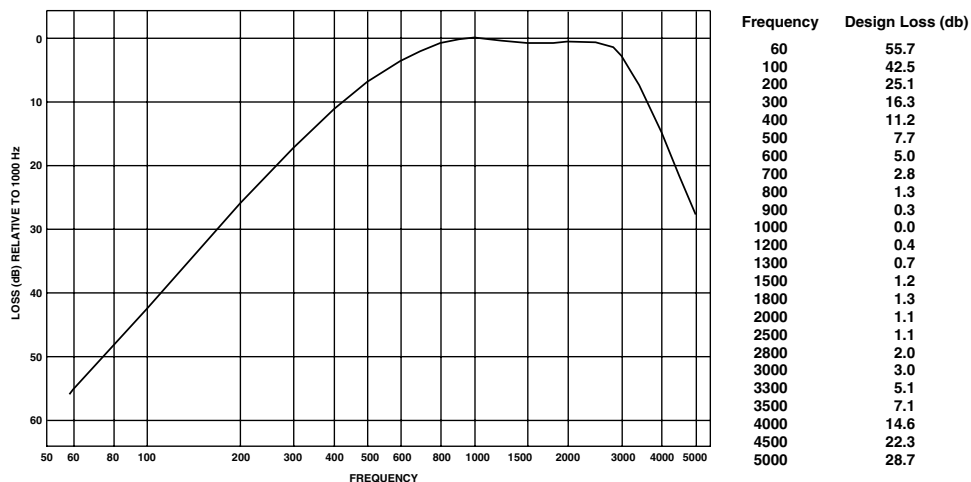

Figure 9-3. C-Message Weighting Characteristic (AM5XT)

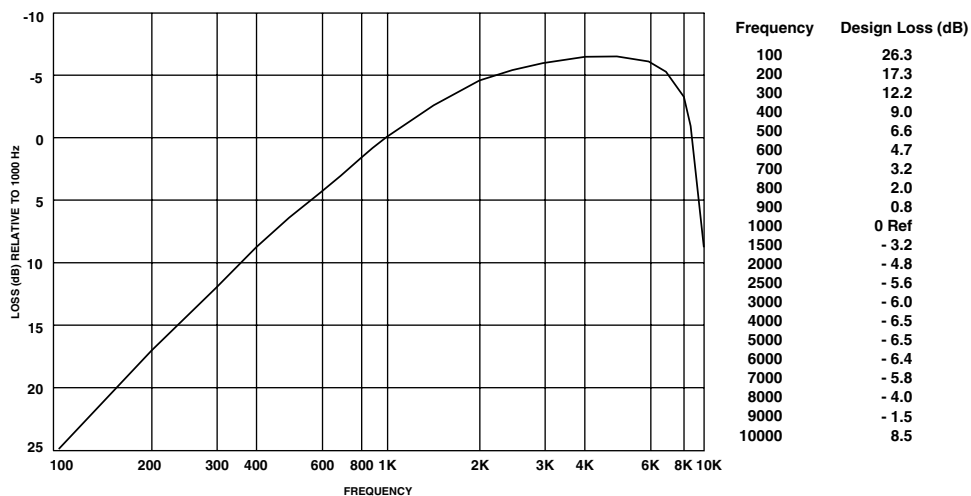

Figure 9-4. Program Weighting Characteristic (AM5XT)

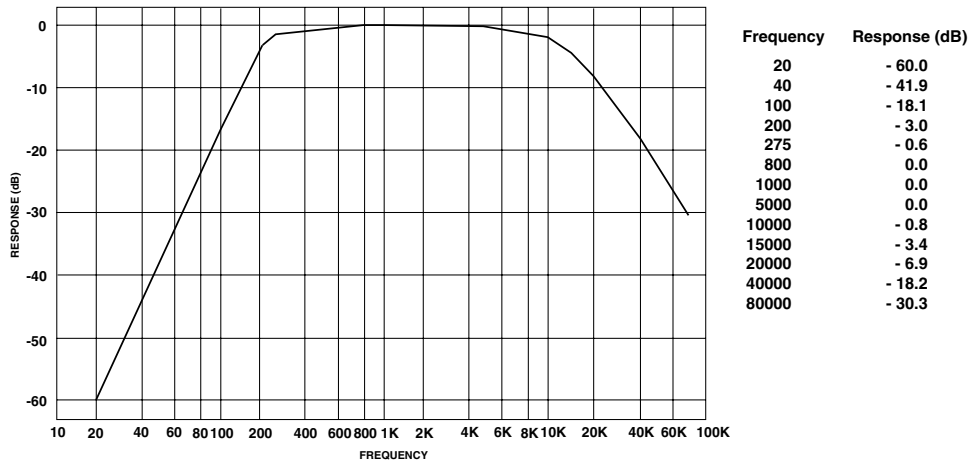

Figure 9-5. 3 kHz Flat Weighting Characteristic (AM5eXT)

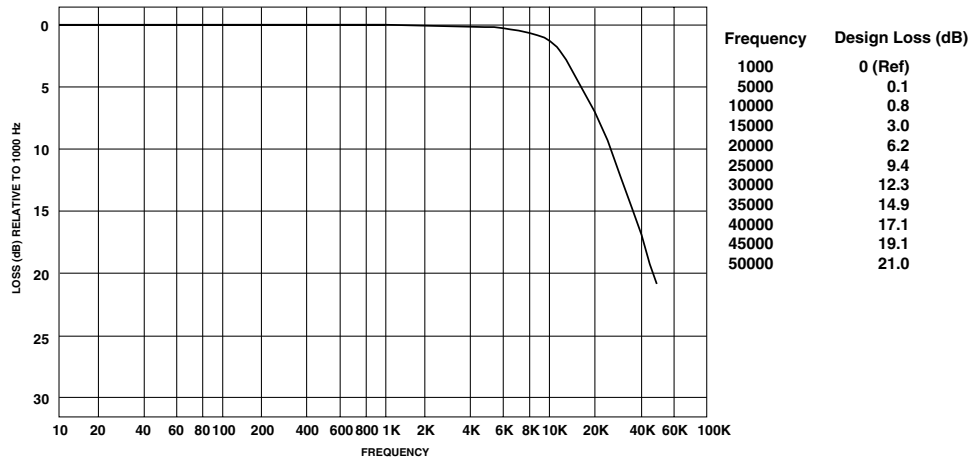

Figure 9-6. 15 kHz Flat Weighting Characteristic (AM5XT)

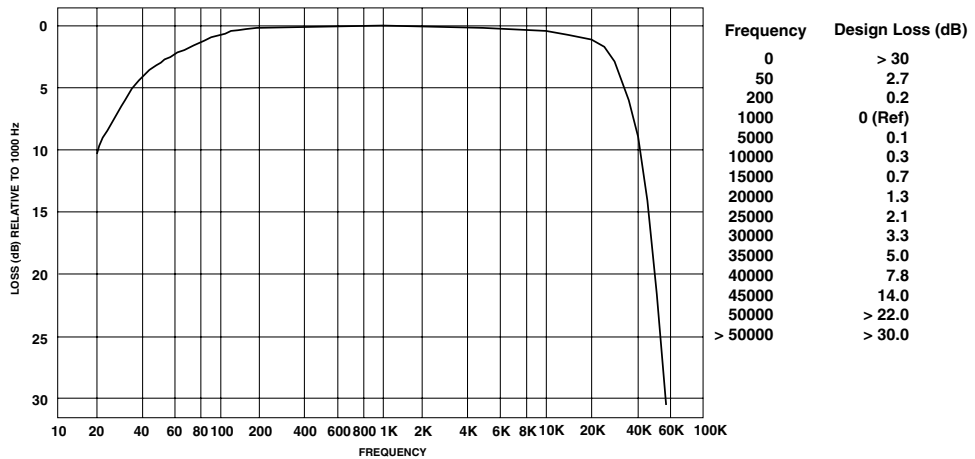

Figure 9-7. 50 Kilobit Weighting Characteristic (AM5XT)

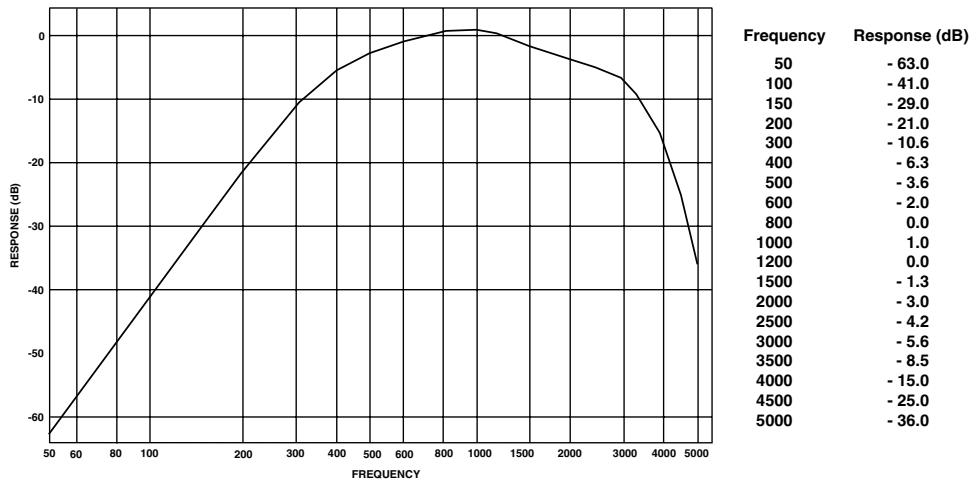

Figure 9-8. Psophometric Characteristic (AM5eXT)

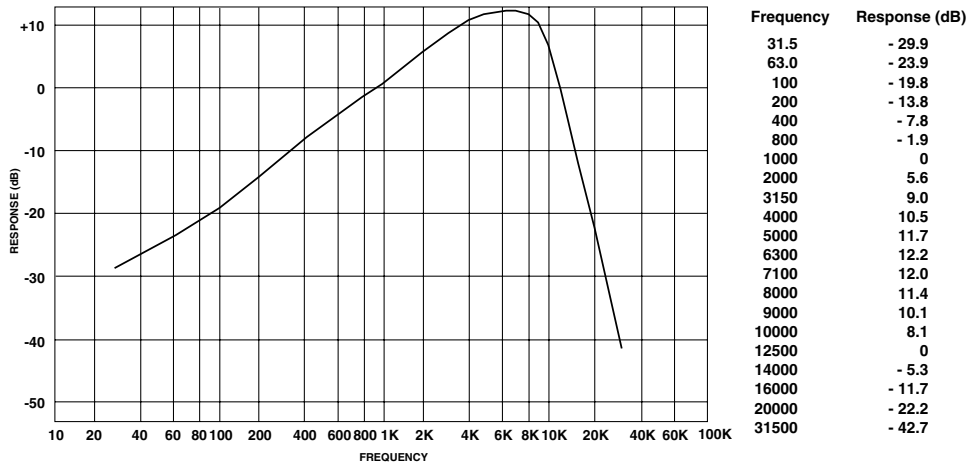

Figure 9-9. Sound Weighted Characteristic (AM5eXT)

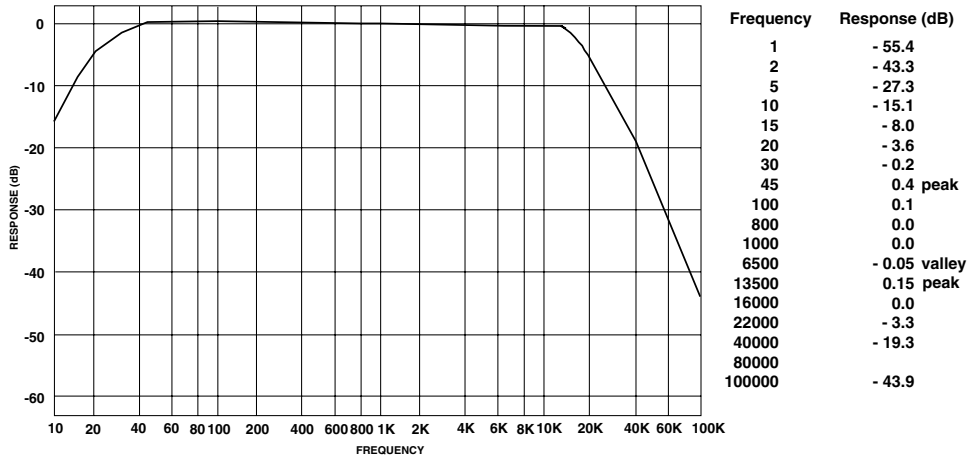

Figure 9-10. Sound Unweighted Characteristic (AM5eXT)

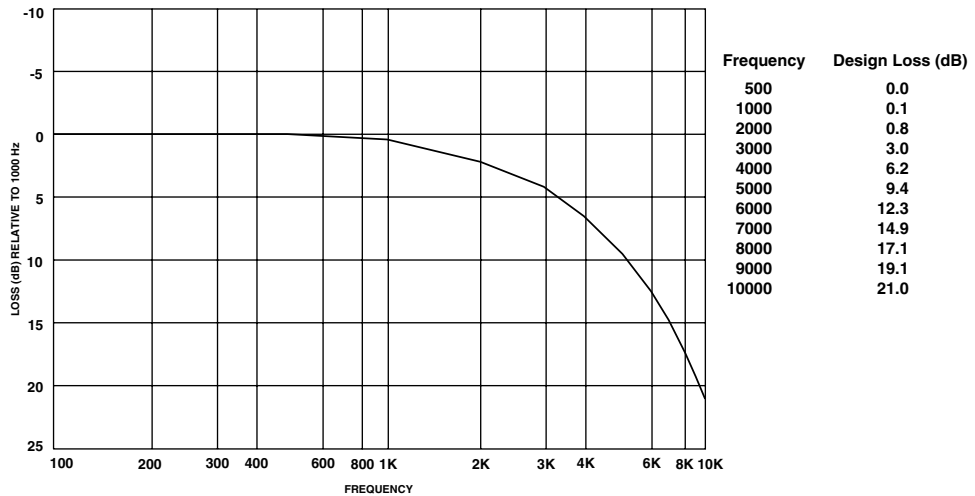

Figure 9-11. 3 kHz Flat Characteristic (AM5XT)

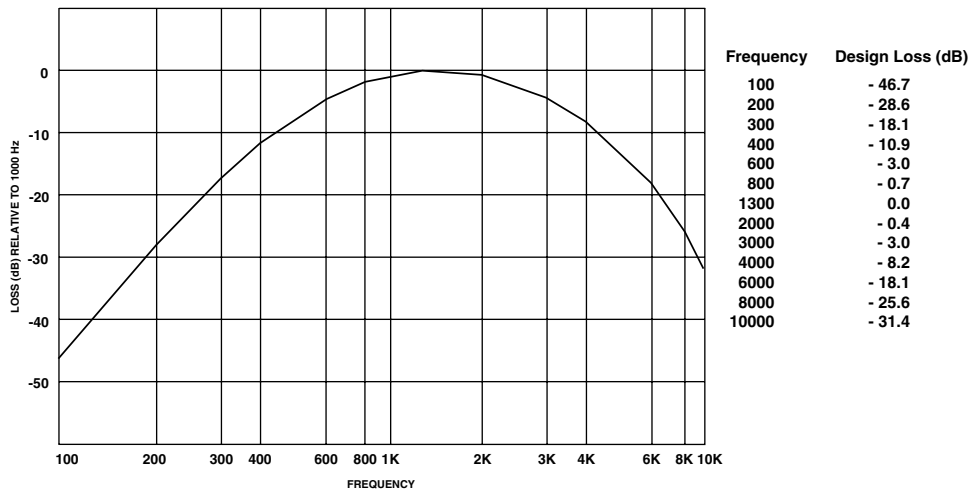

Figure 9-12. 2 kHz Flat Characteristic (AM5eXT)

10. DIALING

10.1 INTRODUCTION

This section covers the dialing (signaling) capability of the AM5XT/eXT. The AM5XT/eXT can output in any of the three (3) dialing modes listed below:

DP (Dial Pulse)

TT (Touch Tone – DTMF)

MF (Multifrequency)

This section is divided into the following paragraphs:

- 10.2 Manual Dialing
- 10.3 Storage of Dialed Number
- 10.4 Automatic Speed Dialing
- 10.5 Dual-Tone Dialing Frequencies
- 10.6 Dial Pulse (DP) Requirements
- 10.7 Dialing Controlled through RS232 port
- 10.8 Remote Control Using TT Commands
- 10.9 TT Responder Control

10.2 MANUAL DIALING

Tone Dialing Level

For tone dialing (TT or MF), follow the procedure below to set the dual-tone composite level.

1. Set Send Function to QUIET mode.
2. Go to QUIET mode Display 4, “TTLV” in PARAMETER DISPLAYS, (illustrated in ¶7.2.4). Set the parameter for the level desired for the TT/MF tones. Range: -50 dBm to +7 dBm.

Note: The maximum level for the TT/MF tones is +7 dBm, even though the generator is capable of levels up to +10 dBm for single tones.

Dial Mode Select

To select a Dial Mode:

1. Locate the [DP/TT/MF] key in the lower left corner of the front panel.
2. Repeatedly press the [DP/TT/MF] key as necessary until the LED lights next to the desired Dialing Mode.

DP = Dial Pulse

TT = Touch Tone (also called DTMF, Dual Tone Multi-frequency)

MF = Multi-frequency

Note: Once a Dial Mode (DP, TT, or MF) has been selected, it will remain selected unless changed, even when Dialing Mode is exited to go to another mode (LINE, SEND, MEAS, or AUX). When Dial Mode is enabled, the last selected Dial Mode will still be enabled (if power has been on continuously).

Dialing

To dial (outpulse) a digit:

1. Select the desired Dial Mode per the Dial Mode Select procedure.
2. Locate the row of 16 keys along the bottom edge of the front panel, labeled (from left to right) 1 thru 0, *, #, A, B, C, D.
3. Press the key associated with the digit to be outpulsed.

Monitoring Dialing

Note the following:

- A. In order to listen to dialing:
 - 1) Set MONITOR Switch (item 4, Figure 3-1) to the TX position.
 - 2) With Volume Knob (item 22, Figure 3-1), adjust speaker sound to comfortable level.
- B. For indication of dialing on the display:
 - 1) Press [SEND] key (display SEND LED will light), before entering dialing mode (TT or MF).

- 2) When a key is pressed to dial a digit, the left-hand display will indicate the level outputted (for tone dialing) and the right-hand display will read “DIAL” as indicated in the sample display below:

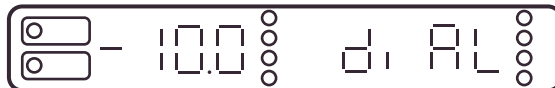

10.3 STORAGE OF DIALED NUMBER

Up to ten (10) telephone numbers consisting of up to 48 digits each may be stored in dialed number memory locations 0 thru 9. Dialed number memory is non-volatile, so the numbers stored are retained even if power is turned off. In addition, the last number dialed is automatically stored. See ¶10.4 for procedures to recall and speed dial telephone numbers stored in memory.

Storing a Telephone Number:

1. Enter dialing mode and select Dialing Mode DP, TT, or MF.
2. Dial the desired number (up to 48 digits).
3. Press [STO].
4. Press any digit 0 thru 9 corresponding to the memory location desired to store the number.
5. Exit dialing mode by selecting any other mode (LINE, SEND, MEAS, or AUX).

Normally the digits are output to the line as step 2 is performed. To avoid actually sending the digits to the line, use the DP dialing mode in step 1 with the transmit line ON HOOK (OFF HOOK LED off).

Note: Only the number is stored. The level and Dialing Mode (DP, TT, or MF) are not stored. For example, a dialed number could be stored while in DP mode and later recalled and speed dialed while in TT mode. See ¶10.4 for Speed Dialing.

Clearing a Stored Number:

Before a new number can be stored, the old number must be cleared or the new number will be stored after the sequence for the old number.

1. Exit dialing mode by selecting any other mode (LINE, SEND, MEAS, or AUX).
2. Enter dialing mode and select Dialing Mode DP, TT, or MF.
3. Press [STO].
4. Press digit of memory location you wish to clear.
5. Follow procedure for Storing a Telephone Number.

10.4 AUTOMATIC SPEED DIALING

Before speed dialing, manually set the Tone Dialing Level and Dial Mode per instructions in ¶10.2.

Last Number Automatic Speed Dial

Any time that:

1. a dialing mode is entered,
2. a number is dialed (either manually or using the recall function), and
3. dialing mode is exited (to LINE, SEND, MEAS, or AUX),

the number just dialed is automatically stored in the last-number-dialed memory.

To dial that number again:

1. Enter dialing mode and select Dialing Mode DP, TT, or MF.
2. Press [RCL] and then [*].
3. The “last number dialed” will be recalled from memory and speed dialed.

Recall and Speed Dial of Stored Dialed Number

Any of the telephone numbers stored per ¶10.3 may be recalled from memory and speed dialed:

1. Enter dialing mode and select Dialing Mode DP, TT, or MF.
2. Press [RCL].
3. Press the key 0 thru 9 corresponding to the memory location containing the desired telephone number.
4. The telephone number will be recalled from memory and speed dialed.

10.5 DUAL-TONE DIALING FREQUENCIES

TT and MF Dialing Modes output dual-tone signals. The frequencies of these tones are listed in Table 10-1. Note that there is no MF signal on key [D].

Table 10-1. MF and TT (DTMF) Tone Pairs

| KEY | MF TONE PAIRS (Hz) | TT TONE PAIRS (Hz) |
|------------|--------------------|--------------------|
| [1] | 700/900 | 1209/697 |
| [2] | 700/1100 | 1336/697 |
| [3] | 900/1100 | 1477/697 |
| [4] | 700/1300 | 1209/770 |
| [5] | 900/1300 | 1336/770 |
| [6] | 1100/1300 | 1477/770 |
| [7] | 700/1500 | 1209/852 |
| [8] | 900/1500 | 1336/852 |
| [9] | 1100/1500 | 1477/852 |
| [*] (KP) | 1100/1700 | 1209/941 |
| [0] | 1300/1500 | 1336/941 |
| [#] (ST) | 1500/1700 | 1477/941 |
| [A] (ST3P) | 700/1700 | 1633/697 |
| [B] (STP) | 900/1700 | 1633/770 |
| [C] (ST2P) | 1300/1700 | 1633/852 |
| [D] | | 1633/941 |

10.6 DIAL PULSE (DP) REQUIREMENTS

Unlike tone dialing (TT or MF) which can be done over circuits with or without line battery voltage, Dial Pulse (DP) requires loop current. Dial pulses are output by disconnecting (breaking) and connecting (making) the loop, at 60% break and 40% make. Therefore, Dial Pulse can only be done on a line over which loop current is flowing, such as a 2-wire POT (Plain Old Telephone) line. Dial Pulse cannot be done over dry (no loop current) 4-wire lines.

Observe the following procedure to dial 2-wire Dial Pulse (DP), TT, or MF:

1. Press [LINE] key to go to LINE mode.
2. Press [5] to light the OFF HK LED and go off-hook.
3. The line connected to the AM5XT/eXT (at TX/2W jack) should now provide Dial Tone.
4. Adjust the speaker volume (item 22 in Figure 3-1 to a comfortable level.
5. Enter dialing mode and select Dialing Mode DP, TT, or MF.
6. Dial the number with the appropriate keys along the bottom edge of the front panel.
7. If time-out occurs before dialing is completed, temporarily go back on-hook.
 - A. Go to LINE mode.
 - B. Press [5] to turn off OFF HK LED and wait for 2 to 3 seconds.
 - C. Press [5] again to turn off the OFF HK LED again, then re-enter the dialed number.
8. If a person has been dialed, the operator can talk to the person at the distant end of the line. See ¶7.14 for TALK mode instructions.

10.7 DIAL PULSE (DP) REQUIREMENTS

If dialing is controlled through the RS232 port, the following commands can be included in the dialed number string:

- A. Go off-hook, then proceed to the next digit.
- B. Pause for Dial Tone, then proceed to the next digit.
- C. Wait 1 second, then proceed to the next digit.
- D. 500ms hook flash, then proceed to the next digit.

See Section 12 for details.

Note, however, that the dialed number store and recall functions cannot be controlled using the RS232 port.

10.8 REMOTE CONTROL USING TT COMMANDS

Note: This feature is not enabled in the AM5XT-BASIC because it requires a Digital Signal Processor (DSP) board, not installed in the AM5XT-BASIC.

A far-end AM5XT/eXT can be controlled from a near-end AM5XT/eXT using TT dialing. Observe the following procedure:

1. Manually enter desired front panel setups into memory locations in the unit to be used at the far (remote) site. Store each setup using the procedure below:
 - A. Set Rear Panel DIP switch 7 to OFF (open).
 - B. Enable desired front panel setup.
 - C. Press [STO].
 - D. Press the two (2) number keys (00 thru 39) of desired store location of front panel setup.
 - E. Press [D] to enter.
2. Install the near and far-end AM5XT/eXTs.
3. To recall a front panel setup previously restored in a memory location of the far-end AM5XT/eXT:
 - A. In the near-end AM5XT/eXT, enable TT Dialing Mode.
 - B. Press [A].
 - C. Press the two (2) number keys (00 thru 39) of desired front panel setup.
 - D. The far-end AM5XT/eXT will automatically configure itself to the desired front panel setup.

10.9 REMOTE CONTROL USING TT COMMANDS

TT (DTMF)-commandable responders can be controlled with an AM5XT/eXT. Use the AM5XT/eXT to output TT digits per the responder command set to tell the responder to go into any of its possible states. Some possible responder states are:

- Quiet termination
- Loopback (see note below)
- Send 1004 Hz (Milliwatt)
- Send slope tones
- Amputate
- Send certain digital bit patterns
- Reset to through (transparent) mode

Note: A dedicated loopback device is controlled with a momentary auxiliary tone. See ¶7.15.

11. MEMORY CONSIDERATIONS (STORE & RECALL)

11.1 INTRODUCTION

The AM5XT/eXT is equipped with 79 store and recall locations for test set-up and recall of frequently performed measurements. In addition to these, there are also ten locations for storing and recalling telephone numbers of up to 48 digits in length. Finally there is a “last number dialed” recall memory.

11.2 FACTORY SET DEFAULTS

The unit is shipped with 30 memories loaded with information which may be recalled by the user. This information may be overwritten, if desired, if the SETUP PROTECT DIP switch on the rear panel (#7) is in the OPEN (= off) position. The stored information is protected if the unit is equipped with the optional battery pack (P/N 24-0017). If the unit is not equipped with this option, and is left unused for approximately two weeks, the super-cap will discharge, resulting in a loss of memory. The battery pack will prevent this from happening.

Stored memory recalls 00-21 are Factory Default Programs for functions **not** including LINE. Recalls 41 to 44 and 51 to 54 are for LINE functions that are Factory set.

To RECALL (RCL):

1. Press [RCL] key.
2. Press the two number keys of the store location of the desired setup.
3. Unit will immediately configure itself to the recalled setup.

Table 11-1 lists the 30 stored memories and their intended purpose.

Table 11-1. Stored Memories and Purpose

| RECALL 00 | |
|-----------|-------------------|
| SEND | OPEN - SF SKIP |
| MEASURE | LVL/FREQ |
| AUX | CMSG - JTR 20-300 |
| DISPLAY | SEND - OPEN |
| Purpose | Power Up Settings |

Memory Considerations (Store & Recall) (18-0022) AM5XT/eXT Voice/Data Transmission

| RECALL 01 | |
|------------------|---|
| SEND | 1.004 kHz @ 0 dBm – SF SKIP |
| MEASURE | LVL/FREQ |
| AUX | MSG - JTR 20-300 |
| DISPLAY | MEAS - dBm |
| Purpose | Line Loss |
| RECALL 02 | |
| SEND | .404 kHz @ 0 dBm – SF SKIP (.304 kHz @ 0 dBm – SF SKIP on AM5eXT) |
| MEASURE | LVL/FREQ |
| AUX | MSG - JTR 20-300 |
| DISPLAY | MEAS - dBm |
| Purpose | Line Loss |
| RECALL 03 | |
| SEND | 2.804 kHz @ 0 dBm – SF SKIP (2.004 kHz @ 0 dBm – SF SKIP on AM5eXT) |
| MEASURE | LVL/FREQ |
| AUX | MSG - JTR 20-300 |
| DISPLAY | MEAS - dBm |
| Purpose | Line Loss |
| RECALL 04 | |
| SEND | SLOPE @ 0 dBm – SF SKIP |
| MEASURE | LVL/FREQ |
| AUX | MSG - JTR 20-300 |
| DISPLAY | MEAS - dBm |
| Purpose | 3-Tone Slope (4-Tone Slope on AM5eXT) |
| RECALL 05 | |
| SEND | SWEEP @ 0 dBm (204 Hz – 3004 Hz) – SF SKIP |
| MEASURE | LVL/FREQ |
| AUX | MSG - JTR 20-300 |
| DISPLAY | MEAS - dBm |
| Purpose | Voiceband Sweep |
| RECALL 06 | |
| SEND | QUIET – SF SKIP |
| MEASURE | NOISE |
| AUX | MSG - JTR 20-300 |
| DISPLAY | MEAS - dBm |
| Purpose | Idle Channel Noise |

AM5XT/eXT Voice/Data Transmission (18-0022) Memory Considerations (Store & Recall)

| RECALL 07 | |
|---|--|
| SEND | 1.004 kHz @ 0 dBm – SF SKIP |
| MEASURE | NOTCH NOISE |
| AUX | CMSG - JTR 20-300 |
| DISPLAY | MEAS – dBm – HOLD TONE - kHz |
| Purpose | Noise with Tone (Notched Noise) |
| RECALL 08 | |
| SEND | 1.004 kHz @ 0 dBm – SF SKIP |
| MEASURE | S/N |
| AUX | CMSG - JTR 20-300 |
| DISPLAY | MEAS – dB – HOLD TONE - kHz |
| Purpose | Signal-to-Noise Ratio |
| RECALL 09 | |
| SEND | QUIET – SF SKIP |
| MEASURE | IMP NOISE |
| AUX | CMSG - JTR 20-300 |
| DISPLAY | MEAS - MIN |
| Purpose | 15 min. Impulse Noise w/o Tone |
| Note: Press "A" (START) to start test. Press MEAS, continually press "#" (IMP NOISE) to view results. | |
| RECALL 10 | |
| SEND | 1.004 kHz @ 0 dBm – SF SKIP |
| MEASURE | TRAN |
| AUX | CMSG - JTR 20-300 |
| DISPLAY | MEAS – HOLD TONE - MIN |
| Purpose | 15 min. Impulse Noise with Tone + Phase & Gain Hits and Dropouts |
| Note: Press "A" (START) to start test. Press MEAS, continually press "A" (TRAN) to view results. | |
| RECALL 11 | |
| SEND | RET LOSS (ERL) – SF SKIP |
| MEASURE | RET LOSS |
| AUX | CMSG - JTR 20-300 |
| DISPLAY | SEND - dBm |
| Purpose | Return Loss |
| Note: Press "7" (RET LOSS) to select ERL, SRL-Lo, or SRL-Hi. Press "MEAS" to measure the return loss. | |

| RECALL 12 | |
|---|--|
| SEND | PAR @ 0 dBm – SF SKIP |
| MEASURE | PAR |
| AUX | MSG - JTR 20-300 |
| DISPLAY | MEAS – dBm – PAR |
| Purpose | PAR |
| RECALL 13 | |
| SEND | 1.004 kHz @ 0 dBm – SF SKIP |
| MEASURE | PHAS JTR |
| AUX | MSG - JTR 20-300 |
| DISPLAY | MEAS – HOLD TONE - DEG |
| Purpose | Phase Jitter (20-300 Hz) |
| RECALL 14 | |
| SEND | 1.004 kHz @ 0 dBm – SF SKIP |
| MEASURE | AMP JTR |
| AUX | MSG - JTR 20-300 |
| DISPLAY | MEAS – HOLD TONE - % |
| Purpose | Amplitude Jitter (20-300 Hz) |
| RECALL 15 | |
| SEND | IMD (2T) – SF SKIP |
| MEASURE | IMD |
| AUX | MSG - JTR 20-300 |
| DISPLAY | MEAS - dBm |
| Purpose | 4 tone intermodulation distortion test |
| Note: This recall should be used in conjunction with, and prior to, recall number 16. First, recall 15 and wait for display to read "C2T" (approx. 5 sec.), then recall 16. | |
| RECALL 16 | |
| SEND | IMD (4T) – SF SKIP |
| MEASURE | IMD |
| AUX | MSG - JTR 20-300 |
| DISPLAY | MEAS - dBm |
| Purpose | 4 tone intermodulation distortion test |
| Note: Press "9" (IMD) to view 2 nd and 3 rd harmonics. | |

AM5XT/eXT Voice/Data Transmission (18-0022) Memory Considerations (Store & Recall)

| RECALL 17 (AM5XT Only) | |
|--|--|
| SEND | ENV DLY (REF) – SF SKIP |
| MEASURE | ENV DLY (Mode = NORM) |
| AUX | CMSG - JTR 20-300 |
| DISPLAY | MEAS – MSEC - kHz |
| Purpose | Envelope Delay |
| Note: This test should be used with recall numbers 18, 19, 20, and 21. See Envelope Delay Notes . | |
| RECALL 18 (AM5XT Only) | |
| SEND | ENV DLY (SWEEP .204 – 3.504 kHz) – SF SKIP |
| MEASURE | ENV DLY (Mode = NORM) |
| AUX | CMSG - JTR 20-300 |
| DISPLAY | MEAS – MSEC – kHz (BLINKING) |
| Purpose | Envelope Delay |
| Note: You are now measuring the near to far envelope delay. (Displaying the delay and send freqs). | |
| RECALL 19 (AM5XT Only) | |
| SEND | ENV DLY (REF) – SF SKIP |
| MEASURE | ENV DLY (Mode = NORM) |
| AUX | CMSG - JTR 20-300 |
| DISPLAY | MEAS – MSEC - kHz |
| Purpose | Envelope Delay |
| RECALL 20 (AM5XT Only) | |
| SEND | ENV DLY (REF) – SF SKIP |
| MEASURE | ENV DLY (Mode = REPT) |
| AUX | CMSG - JTR 20-300 |
| DISPLAY | MEAS - kHz |
| Purpose | Envelope Delay |
| RECALL 21 (AM5XT Only) | |
| SEND | ENV DLY (SWEEP .204 – 3.504 kHz) – SF SKIP |
| MEASURE | ENV DLY (Mode = REPT) |
| AUX | CMSG - JTR 20-300 |
| DISPLAY | MEAS - kHz |
| Purpose | Envelope Delay |
| ENVELOPE DELAY NOTES | |
| <p>For measuring delay in the transmit leg, recall "17", dial (TT) "A20" (this recalls #20 in the far end). Press "C" to zero out the reading. Recall #18. This will display the delay to the near-to-far leg.</p> <p>For measuring delay in the receive leg, recall "17", dial (TT) "A20" (this recalls #20 in the far end). Press "C" to zero out the reading. Recall "19" and dial (TT) "A21" (this recalls #21 in the far end).. This will display the delay to the far-to-near leg.</p> | |

| RECALL 17 (AM5eXT Only) | |
|---|--|
| SEND | GRP DLY (SWEEP .204 – 3.504 kHz) – SF SKIP |
| MEASURE | GRP DLY |
| AUX | PSHO - JTR 20-300 |
| DISPLAY | MEAS – MSEC - kHz |
| Purpose | Group Delay |
| RECALL 18 (AM5eXT Only) | |
| SEND | GRP DLY (SWEEP .204 – 3.504 kHz) – SF SKIP |
| MEASURE | GRP DLY |
| AUX | PSHO - JTR 20-300 |
| DISPLAY | MEAS – MSEC - kHz |
| Purpose | Group Delay – Narrow Band |
| RECALL 19 (AM5eXT Only) | |
| SEND | GRP DLY (SWEEP .204 – 3.504 kHz) – SF SKIP |
| MEASURE | GRP DLY |
| AUX | PSHO - JTR 20-300 |
| DISPLAY | MEAS – dB - kHz |
| Purpose | Group Delay – Relative Loss - Narrow Band |
| RECALL 20 (AM5eXT Only) | |
| SEND | GRP DLY (SWEEP .200 – 20.00 kHz) – SF SKIP |
| MEASURE | GRP DLY |
| AUX | PSHO - JTR 20-300 |
| DISPLAY | MEAS – dB - kHz |
| Purpose | Group Delay – Wide Band |
| RECALL 21 (AM5eXT Only) | |
| SEND | GRP DLY (SWEEP .200 – 20.00 kHz) – SF SKIP |
| MEASURE | GRP DLY |
| AUX | PSHO - JTR 20-300 |
| DISPLAY | MEAS – dB - kHz |
| Purpose | Group Delay – Relative Loss - Wide Band |
| GROUP DELAY NOTES | |
| All group delay measurements are one way, with the path being measured towards the AM5XT/eXT. Both AM5XT/eXT's use the same recalls for each test. | |
| RECALL 41 | |
| LINE | 135Ω (150Ω on AM5eXT) TX 135Ω (150Ω on AM5eXT) RX 4W |

AM5XT/eXT Voice/Data Transmission (18-0022) Memory Considerations (Store & Recall)

| | |
|------------------|--|
| RECALL 42 | |
| LINE | 600Ω TX - 600Ω RX - 4W |
| RECALL 43 | |
| LINE | 900Ω TX - 900Ω RX - 4W |
| RECALL 44 | |
| LINE | 1200Ω TX - 1200Ω RX - 4W |
| RECALL 51 | |
| LINE | 135Ω (150Ω on AM5eXT) TX 135Ω (150Ω on AM5eXT) RX 2W |
| RECALL 52 | |
| LINE | 600Ω TX - 600Ω RX - 2W |
| RECALL 53 | |
| LINE | 900Ω TX - 900Ω RX - 2W |
| RECALL 54 | |
| LINE | 1200Ω TX - 1200Ω RX - 2W |

To enter additional stored LINE setups, set the unit in the configuration desired using the LINE line information. Press [STO], followed by two (2) digits – 40, 45 to 50, or 55 to 79. Press [D] to “ENTER” and complete the store.

Note: Remember that if 00-21, 41-44, or 51-54 is entered, the factory default is overwritten with the new configuration.

RECALL 80 (Version 8 and up)

Recalls all setups that were active when the unit was powered down.

On Version 8 and up units, recalls 81-88 are for setting performance limits (masks) for use when printing/plotting Level/Frequency and Delay sweep results.

Recalls 81-88 are factory set and cannot be changed from the front panel of the AM5XT/eXT. They can be changed through the RS232 port and stored for later use. See ¶12.9 for Conditioning Mask Definition Format.

11.3 USER ENTERED MEMORIES

It is suggested that the first 22 (00-21) recalls be left intact. In the event that there are operational problems, Ameritec Customer Service can more easily lead the customer through tests to determine problems..

To enter additional stored setups, set DIP switch number 7, on the rear panel, to its open position. Set the unit in the configuration desired for recall by using the SEND, MEAS, and AUX line information. Press [STO] followed by two digits, 22 to 39. Press [D] to “ENTER” and complete the store.

Note: The keypad mode (SEND, MEAS, and AUX) and display selection are also stored. When the setup is recalled, these selections are also recalled..

12. RS232 COMMANDS

12.1 INTRODUCTION

In general, the AM5XT/eXT RS232 commands and functions follow the layout of the front panel. All commands that can be executed from the front panel can be executed remotely. All commands start with a “(“ and end with a “)”. The commands are executed as soon as the “)” is received. Other control characters, such as carriage return <CR> and line feed <LF>, are not required and will be ignored if received. Only characters between the “(“ and “)” are processed.

The first letter of the command generally corresponds to the row in the front panel where that function is located. The second character corresponds to the key (0-9, *, #, A-D) for the function being controlled. The commands have exactly the same effect as they would have if entered from the front panel. Front panel controls which act as alternate on/off toggles are remotely controlled using a “+” or “-“ in the command to turn that selection on or off.

A few RS232 commands have no front panel counterparts and are exclusive to remote control operation. Their formats do not follow the previously explained guidelines, but are activated using the same command format.

To display a Help Menu, press “?” and a brief explanation of command functions will be displayed. Control commands can be reviewed, if desired, along with display and set parameter instructions.

To display the parameter for a given command, include Pn after the command within the parentheses. To change the parameter for a given command, include Pn = n.n after the command within the parentheses. For example:

| | |
|--------------|--|
| (S3) | Sends variable Hz |
| (S3P1) | Displays parameter 1 (Freq) |
| (S3P1=n.nnn) | Sends variable Hz and sets parameter 1 (Freq) to n.nnn kHz |

12.2 COMMAND PROTOCOL

Table 12-1 lists the Line control commands.

Table 12-1. Line Control Commands

| COMMAND | DESCRIPTION |
|---------|-------------------------------|
| (L) | LINE MODE |
| (L1) | SENDZ = 135Ω (150Ω ON AM5eXT) |
| (L2) | SENDZ = 600Ω |
| (L3) | SENDZ = 900Ω |
| (L4) | SENDZ = 1200Ω |
| (L5+) | SEND OFF HOOK |
| (L5-) | SEND ON HOOK |
| (L7) | RCVZ = 135Ω (150Ω ON AM5eXT) |
| (L8) | RCVZ = 600Ω |
| (L9) | RCVZ = 900Ω |
| (L0) | RCVZ = 1200Ω |
| (L*+) | RCV OFF HOOK |
| (L*-) | RCV ON HOOK |
| (L#+) | BRIDGE |
| (L#-) | TERMINATE |
| (LB) | 2 WIRE |
| (LC) | 4 WIRE |
| (LD+) | REVERSE |
| (LD-) | NORMAL |

The following line control commands can only be executed from the RS232 port, not from the front panel:

- (WR+) Enter “WAIT FOR RING” mode
- (WR-) Terminate “WAIT FOR RING” mode

“Wait for ring” mode causes the RCV pair (if in 4W), or the SND pair (if in 2W), to go on hook and enter a high impedance state, attached only to the ring detector. If in 4W mode, the signal generator is temporarily put in quiet, but the SND pair line holding circuit remains in the state it was in before receiving the command. When a ringing burst is detected (about 500ms of ringing voltage), the AM5XT/eXT will send the following message:

(RING) <CR> <LF>

Note: <CR> and <LF> are used to represent the ASCII carriage return and line feed characters.

Wait for ring mode is terminated either by the (WR-) command, or by going off hook on that pair.

Table 12-2 lists the Send control commands.

Table 12-2. Send Control Commands

| COMMAND | DESCRIPTION |
|---------------|---|
| (S) | SEND MODE |
| (S1) | QUIET P0=LEVEL, P1=LBFREQ, P2=TTLV |
| (S2) | 1004 P0=LEVEL |
| (S3) | VARIABLE HZ P0=LEVEL, P1=FREQ |
| (S4) | SLOPE P0=LEVEL, P1=RATE |
| (S5) | SWEEP P0=LEVEL, P1=START, P2=STOP, P3=STEP, P4=RATE, P5=DELAY |
| (S6) | PAR P0=LEVEL |
| (S7) | ERL/SRLL/SRLH |
| (S70) | ERL |
| (S71) | SRLL |
| (S72) | SRLH P0=LEVEL |
| (S8) (AM5XT) | ENVELOPE DELAY |
| (S80) (AM5XT) | ENV DLY SWEEP TEST FREQ |
| (S81) (AM5XT) | ENV DLY REF FREQ P0=LEVEL, P1=MODE (0, 1, 2 FOR NORM, REPT, HOLD), P2=REF FREQ, P3=START, P4=STOP, P5=STEP, P6=RATE, P7=DELAY |
| (S8) (AM5eXT) | GROUP DLY P0=LEVEL, P1=REF FREQ, P2=START, P3=STOP, P4=STEP, P5=RATE, P6=DELAY |
| (S9) | IMD |
| (S90) | IMD |
| (S91) | IMD TEST |
| (S92) | IMD S/N CHECK P0=LEVEL |

| COMMAND | DESCRIPTION |
|---------|-----------------------|
| (S0) | OPEN P0=LEVEL |
| (SA+) | SF SKIP ON |
| (SA-) | SF SKIP OFF |
| (SB+) | TALK ON |
| (SB-) | TALK OFF |
| (SC) | 2713 HZ FOR 1 SECOND |
| (SCn) | 2713 HZ FOR n SECONDS |

Table 12-3 lists the Measure control commands.

Table 12-3. Measure Control Commands

| COMMAND | DESCRIPTION |
|--------------|---|
| (M) | MEASURE MODE |
| (M1) | LEVEL/FREQ P0=LODB, P1=HIDB, P2=RATE, P3=COND |
| (M2) | NOISE |
| (M3) | NOTCHED NOISE |
| (M4) | NOISE TO GROUND |
| (M5) | SIGNAL TO NOISE |
| (M6) | PAR |
| (M7) | RETURN LOSS |
| (M9) | IMD |
| (M90) | IMD LEVEL |
| (M91) | IMD 2 ND ORDER |
| (M92) | IMD 3 RD ORDER |
| (MA) | TRANS |
| (MA0) | TRANS TIME |
| (MA1) | TRANS NOISE |
| (MA2) | TRANS LO |
| (MA3) | TRANS MID |
| (MA4) | TRANS HI |
| (MA5) | TRANS PHITS |
| (MA6) | TRANS GHITS |
| (MA7) | TRANS DROPOUTS (TRANS DROP 6 DB on AM5eXT) |
| (MA8) | TRANS DROP 10 DB (AM5eXT ONLY) P0=DUR, P1=ITHLD, P2=DELTA, P3=PTHLD, P4=GTHLD, P5=BLANKING |
| (M8) (AM5XT) | ENVELOPE DELAY |

| COMMAND | DESCRIPTION |
|----------------|---|
| (M80) (AM5XT) | ENV DLY DLY/MEAS FREQ |
| (M81) (AM5XT) | ENV DLY DLY/SEND FREQ |
| (M82) (AM5XT) | ENV DLY LEVEL/FREQ P0=AVG, P1=MODE (0, 1, 2 FOR NORM, REPT, HOLD), P2=LOED, P3=HIED, P4=LODB, P5=HIDB, P6=RATE, P7=COND |
| (M8) (AM5eXT) | GROUP DELAY |
| (M80) (AM5eXT) | GDLY DLY/FREQ |
| (M81) (AM5eXT) | GDLY LEVEL/FREQ |
| (M82) (AM5eXT) | GDLY REF FREQ |
| (M83) (AM5eXT) | GDLY REF LEVEL |
| (M84) (AM5eXT) | GDLY MEAS LEVEL P0=FILTER (0, 1 FOR FILTER OUT, IN), P1=AVG, P2=LOGD, P3=HIGD, P4=LODB, P5=HIDB, P6=RATE, P7=COND |
| (M0) | PHASE JITTER |
| (M*) | AMPLITUDE JITTER |
| (M#) | IMP NOISE |
| (M#0) | IMP NOISE TIME |
| (M#1) | IMP NOISE NOISE |
| (M#2) | IMP NOISE LO |
| (M#3) | IMP NOISE MID |
| (M#4) | IMP NOISE HI P0=DUR, P1=ITHLD, P2=DELTA, P3=BLANKING |
| (MB) | UINTR |
| (MB0) | UINTR TIME |
| (MB1) | UINTR CNT 1 |
| (MB2) | UINTR CNT 2 |
| (MB3) | UINTR CNT 3 |
| (MB4) | UINTR CNT 4 |
| (MB5) | UINTR CNT 5 P0=DUR, P1=THLD, P2=BLANKING |

Table 12-4 lists the Auxiliary control commands.

Table 12-4. Auxiliary Control Commands

| COMMAND | DESCRIPTION |
|--------------|---------------|
| (A) | AUX MODE |
| (A1+) | LF FILTER IN |
| (A1-) | LF FILTER OUT |
| (A2) (AM5XT) | CMSG FILTER |

| COMMAND | DESCRIPTION |
|----------------|-------------------------|
| (A2) (AM5eXT) | PSOPHOMETRIC FILTER |
| (A3) (AM5XT) | PGM FILTER |
| (A3) (AM5eXT) | SOUND WEIGHTED FILTER |
| (A4) (AM5XT) | 3 KHZ FILTER |
| (A4) (AM5eXT) | SOUND UNWEIGHTED FILTER |
| (A5) (AM5XT) | 15 KHZ FILTER |
| (A5) (AM5eXT) | 3250 FLAT FILTER |
| (A6) (AM5XT) | 50 KBIT FILTER |
| (A6) (AM5eXT) | 2300 FLAT FILTER |
| (AF) | NO NOISE FILTER |
| (A7+) (AM5eXT) | QUASI PEAK |
| (A7-) (AM5eXT) | RMS |
| (A8) | PRINT |
| (A8+) | PRINT PLOT ON |
| (A8-) | PRINT PLOT OFF |
| (A9) | JITTER 20-300 |
| (A0) | JITTER 4-300 |
| (A*) | JITTER 4-20 |
| (A#) | AUTOCALIBRATE |
| (AA+) | START STUDY |
| (AA-) | STOP STUDY |
| (AB+) | 60 HZ FILTER IN |
| (AB-) | 60 HZ FILTER OUT |
| (AC+) | RELATIVE ON |
| (AC-) | RELATIVE OFF |
| (AD+) | DAMP ON |
| (AD-) | DAMP OFF |

12.3 RESPONSE PROTOCOL

All responses from commands are enclosed in parentheses and terminated by the ASCII <CR> <LF> (carriage return line feed). For ease of interpretation by machine, all the fields are fixed width so the fields always start and stop at predefined character positions in the line. The character positions are numbered above the sample output lines.

The following commands are used to read the current setup, or take a measurement remotely. They result in a response from the AM5XT/eXT as shown in Table 12-5.

Table 12-5. Response Protocols

| COMMAND RESPONSES | |
|---|---|
| COMMAND | FUNCTION |
| (A1) | Read the displays and annunciators. |
| (ACn) | Read the displays and annunciators every n seconds until "(" command received. |
| (ALE) | Read line setup. |
| (ASE) | Read send setup. |
| (AME) | Read measure setup. |
| (AAE) | Read auxiliary setup. |
| (AE) | Read line, send, measure, and auxiliary setups. |
| DIALING COMMANDS | |
| (TTxxxxxx) | Dial Touch Tone |
| (DPxxxxxx) | Dial Dial Pulse |
| (MFxxxxxx) | Dial Multi Freq |
| xxxxxx may be a maximum of 48 digits, including any dialed digit 1-0, #, *, A, B, C, or D, or: P = pause for dial tone and then proceed to next digit (dial tone is 1 second of continuous energy >24 dBm). - = wait 1 second and then proceed to next digit. F = 500ms on hook flash and then proceed to next digit. H = go off hook and then proceed to next digit. | |
| A1 COMMAND | |
| The (A1) command is used to read the contents of the AM5XT/eXT numerical displays, along with the pertinent annunciators. | |
| Characters | Definition |
| 1 | "(" |
| 2-5 | "SEND" or "MEAS" depending on display. |
| 6 | Space |
| 7-14 | Alpha-numeric contents of left display. It is 8 characters long to allow for up to 4 characters and 4 decimal points, though currently there is never more than 1 decimal point. A "+" sign appears in this field even though it appears as a blank on the front panel display. |
| 15 | Space |
| 16-22 | Left display annunciator. "DBM", "DB", or DBRN/MS". "HOLD TONE" will appear in character position 41-45. |
| 23 | Space |
| 24-31 | Alpha-numeric contents of right display. |

| Characters | Definition |
|--|--|
| 32 | Space |
| 33-39 | Right display annunciator. Blanks if no annunciator is on. |
| 40 | Space |
| 41-45 | Holding tone annunciator. |
| 46 | Low battery annunciator. Space if off, "*" if on. The front panel low battery indicator is flashing decimal points that will not appear on the RS232 displays. |
| 47 |)" |
| 48-49 | <CR> <LF> |
| ALE COMMAND | |
| The (ALE) command is used to read the status of the AM5XT/eXT line control annunciators. | |
| Characters | Definition |
| 1 | (" |
| 2-6 | "SENDZ=" |
| 7-10 | Current send impedance, left justified. |
| 11 | Space |
| 12-18 | Send pair ON/OFF hook status |
| 19 | Space |
| 20-24 | "RCVZ=" |
| 25-28 | Current receive impedance, left justified. |
| 29 | Space |
| 30-36 | Receive pair ON/OFF hook status |
| 37 | Space |
| 38-43 | Receive pair TERM/BRIDGE status |
| 44 | Space |
| 45-46 | 2W-4W mode |
| 47 | Space |
| 48-50 | NOR/REV status |
| 51 |)" |
| 52-53 | <CR> <LF> |
| ASE COMMAND | |
| The (ASE) command is used to read the status of the AM5XT/eXT send control annunciators and related items. | |
| Characters | Definition |
| 1 | (" |
| 2-7 | "SMODEZ=" |
| 8-12 | Current send mode |
| 13 | Space |

| Characters | Definition |
|---|---|
| 14-17 | "LEV=" |
| 18-22 | Current send level (even if in quiet) |
| 23 | Space |
| 24-27 | "FRQ=" |
| 28-34 | Current var Hz frequency (even if not sending var Hz), in kHz to 1 Hz resolution. |
| 35 | Space |
| 36-41 | SF skip status |
| 42 | Space |
| 43-49 | Talk status |
| 50 | ")" |
| 51-52 | <CR> <LF> |
| AME COMMAND | |
| The (AME) command is used to read the status of the AM5XT/eXT measure control annunciators and related items. | |
| Characters | Definition |
| 1 | "(" |
| 2-7 | "MMODE=" |
| 8-13 | Current measure mode |
| 14 | ")" |
| 15-16 | <CR> <LF> |
| AAE COMMAND | |
| The (AAE) command is used to read the status of the AM5XT/eXT auxiliary control annunciators and related items. | |
| Characters | Definition |
| 1 | "(" |
| 2-12 | "L/F FILTER=" |
| 13-15 | Filter IN/OUT status |
| 16 | Space |
| 17-23 | "FILTER=" |
| 24-29 | Noise weighting filter in use |
| 30 | Space |
| 31-34 | "JTR=" |
| 35-40 | Jitter bandwidth selected |
| 41 | Space |
| 42-47 | "STUDY=" |
| 48-52 | Timed study STOP/START status |
| 53 | Space |

| Characters | Definition |
|--|---|
| 54-57 | "60 HZ" or "NO60" for 60 Hz filter status. |
| 58 | Space |
| 59-62 | "REL=" |
| 63-67 | Relative measure zero set "OFF" or with a relative reference level if on. |
| 68 | Space |
| 69-72 | "DAMP" or "NOR" for display update select. |
| 73 |)" |
| 74-75 | <CR> <LF> |
| AE COMMAND | |
| The (AE) command is used to read the entire status of the AM5XT/eXT. It gives the same response as the (ALE), (ASE), (AME), and (AAE) commands, in that order. It gives a complete picture of the AM5XT/eXT setup. | |

12.4 PASSWORD SECURITY

The following have to do with password security:

(Pxxxx) Logon with password, up to 63 characters. May not include “(“, “)”, “!”, or “?”. Logon is not needed if password DIP switch #8 is OFF. After turning password switch ON, unit will remain logged on until 2 minute timeout or (B) command, just as if it had been logged on with a password.

(XYZxxxx) Set new password with up to 63 characters. May not include “(“, “)”, “!”, or “?”.

12.5 MISCELLANEOUS COMMANDS

The following have to do with password security:

(B) BYE, logoff
) Repeat last command entered
 (Znn) Store front panel nn
 (Rnn) Recall front panel nn
 (AY+) Enable front panel display and keypad
 (AY-) Disable front panel display and keypad
 (AYK) Disable front panel keypad
 (E+) Echo ON
 (E-) Echo OFF

12.6 RS232 PORT CONFIGURATION

The operating characteristics of the RS232 port are controlled by DIP switch settings of switches 1-4 on the rear panel. Switches 7 and 8 control front panel setup protect and password.

See Table 3-2 for RS232 connector pin assignments.

See Table 3-3 for DIP switch settings.

12.7 AUXILIARY RS232 PORT

A second RS232 port is provided on the rear panel of the AM5XT/eXT in the form of a 9-pin female “D” miniature connector. It is labeled “AUX” port.

It is used to connect to the RS232 port of an “auxiliary unit”, such as a printer, test access switch, etc., which may be co-located with the AM5XT/eXT and where it is desired to communicate with the auxiliary device via the main RS232 port of the AM5XT/eXT.

See Table 3-4 for auxiliary RS232 connector pin assignments. The baud rate and parity selection will be the same as that set for the main RS232 port.

12.8 DAISY CHAINING

In normal operation, the ASCII characters received by the AM5XT/eXT are decoded and acted upon by the AM5XT/eXT in accordance with the protocol described in ¶12.2. It is possible to command the AM5XT/eXT to become transparent so that all subsequent ASCII characters received by the AM5XT/eXT RS232 port are sent through to the “AUX” port.

The AM5XT/eXT will respond to a two-character transparent mode command at any time. The command is “!x”, where “x” is any character “A”-“Z”. An “A” disables transparent mode and activates normal command processing. Any other character puts the unit in transparent mode. The “!” character is always sent out the “AUX” port when it is received. The character following the “!” is decremented if it is in the range “B”-“Z”, then sent out the “AUX” port. In this way, several AM5XT/eXT’s can be daisy chained together. “!A” will select the first unit in the chain for command processing, “!B” selects the second unit, “!C” the third unit, etc.



CAUTION: DO NOT daisy chain AM5XT/eXT's together with the baud rate set at 9600. Corruption of data will result.

When in transparent mode, any character received on the RS232 port is sent out the AUX port, and vice versa. When not in transparent mode, nothing is sent out the AUX port (except “!x” commands), and anything received on the AUX port is ignored.

12.9 CONDITIONING MASK DEFINITION FORMAT

The eight (8) performance limits, or masks, that can be used with the printer/plotter can be selected from the AM5XT/eXT front panel or selected and changed remotely via the RS232 port.

The unit has a set of eight (8) masks programmed into it when it is shipped from the factory. To recall the masks from the front panel, press [RCL] and the number key 81-88 that corresponds to the appropriate mask. Remotely, the command is (Rnn), where nn = 81 to 88.

To redefine a mask remotely, enter the following:

(CnN = NAME), where
n = 1 to 8 corresponding to masks
NAME is 4 characters or less.

The mask to be redefined has now been named. Now the limit specifications must be set. The command for defining limits for Level/Frequency is:

(CnLs = FFF.FFF, SLL.L, SHH.H), where
n = mask to be redefined, 1-8
s = limit specification 1-8 within the mask for Level/Frequency
FFF.FFF = frequency in kHz, up to 6 digits
SLL.L = low level limit in dBm, up to 3 digits and a sign
SHH.H = high level limit in dBm, up to 3 digits and a sign

The command for redefining limits for Delay is:

(CnDs = FFF.FFF, SLL.LLL, SHH.HHH), where

n = mask to be redefined, 1-8

s = limit specification 1-8 within the mask for Delay

FFF.FFF = frequency in kHz, up to 6 digits

SLL.LLL = low delay limit in ms, up to 5 digits and a sign

SHH.HHH = high delay limit in ms, up to 5 digits and a sign

To end limit specifications for a mask, enter:

(CnLs = *) for Level/Frequency

(CnDs = *) for Delay

Example: Bell Standards require the following bandwidth parameter limits, as shown in Table 12-6.

Table 12-6. Bandwidth Parameter Limits

| Channel Conditioning | ATTENUATION DISTORTION (FREQUENCY RESPONSE) RELATIVE TO 1004 Hz | | ENVELOPE DELAY DISTORTION | |
|----------------------|---|-----------------------|---------------------------|----------------------|
| | Frequency Range (Hz) | Variation (dB) | Frequency Range (Hz) | Variation (μ s) |
| Basic | 500-2500 300-3000 | -2 to +8 -3 to +12 | 800-2600 | 1750 |

Note: A (+) means loss with respect to 1004 Hz, and (-) means gain with respect to 1004 Hz. Therefore, (-) means a lower level, and (+) means a higher level on the AM5XT/eXT.

Mask 1, in this example, will be for Basic channel conditioning. The name of the mask will be BASE. Enter: (C1N = BASE).

Next, enter the lowest frequency, the low level limit, and the high level limit for the first limit specification. For this example, enter: (C1L1 = 0.3, -12.0, 3.0).

Continue entering the next highest frequency and the corresponding low and high level limits:

(C1L2 = 0.5, -8.0, 2.0)

(C1L3 = 2.5, -12.0, 3.0)

(C1L4 = 3.0, -99.9, 99.9)

(C1L5 = *)

The -99.9 and 99.9 in C1L4 indicate no low or high limit for this frequency. The * in C1L5 indicates there are no more limit specifications for this mask (Level/Frequency).

Entering the Delay Distortion is similar to the Level/Frequency process. Enter the lowest frequency, low delay limit, and high delay limit for the first limit specification. Enter the next highest frequency and the corresponding low and high delay limits. Low and high delay limits are entered in milliseconds (ms).

(C1D1 = 0.8, 0.0, 1.75)

(C1D2 = 2.6, -13.0, 13.0)

(C1D3 = *)

The -13.0 and 13.0 in C1D2 indicate no low or high delay limit. The * in C1D3 indicates there are no more limit specifications for this mask (Delay).

Mask 1 has now been redefined and stored in recall 81. To recall masks, the command is (Rnn), where nn is 81 to 88.

13. PRINTING AND PLOTTING

13.1 INTRODUCTION

In order for the AM5XT/eXT to give a printout, the unit must be equipped with the optional RS232 Port (P/N 25-0019).

To use the AM5XT/eXT with an X/Y Plotter, the unit must be equipped with the X/Y Plotter Output option (P/N 25-0045).

13.2 TYPES OF PRINTOUTS (up to Version 7)

There are two (2) types of printouts:

- Printout of the activated front panel test setup.
- Printout of the test results being displayed in the measure display. This type of printout is possible for the following tests:
 1. Level/Frequency
 2. Envelope Delay (AM5XT)/Group Delay (AM5eXT)

How to implement each type of printout is discussed below.

Setup

Connect an AM47XT or other appropriate printer to the RS232 port (25-pin D-type connector) on the rear panel.

Be sure the Baud rate is set the same as the Baud rate of the AM5XT/eXT; see Table 3-3 for Baud rate settings for the AM5XT/eXT.

Printout of Front Panel Setup

1. Press [AUX] key.
2. Momentarily press [8].
3. The PRINT LED will not be ON during this print mode.

Printout of Measurement

1. Set LVL/FREQ, ENV DLY, or GROUP DLY Measurement display to the display to be printed/plotted.
2. Set low and high plotting parameters by referring to ¶8.2, 8.10, and 8.11. Refer to the section in these paragraphs entitled **Plotting**.

3. Press [AUX] key.
4. Continuously press [8] for approximately 2 seconds.
5. The PRINT LED will flash ON/OFF during this print mode.
6. To exit this print mode, again continuously press [8] for approximately 2 seconds; PRINT LED will go out.

13.3 TYPES OF PRINTOUTS (Version 8 and up)

There are three (3) types of printouts:

- Printout of the activated front panel test setup.
- Printout of the plot results and measurements being displayed in the measure display. This type of printout is possible for the following tests:
 1. Level/Frequency
 2. Envelope Delay (AM5XT)/Group Delay (AM5eXT)
 3. Printout of the plot condition mask

Select low and high plotting parameters and plot condition mask by referring to ¶8.2, 8.3, and 8.11. Refer to the section in these paragraphs titled **Plotting**.

How to implement each type of printout is discussed below.

Printout of Front Panel Setup

1. Press [AUX] key.
2. Press [8, PRINT] key. Display cycles through three (3) print options and one (1) blank option. Release [8, PRINT] key when display reads “PrnT”.
3. The PRINT LED will be ON during this print mode.

Printout of Plot Measurement Results

1. Set LVL/FREQ, ENV DLY, or GRP DLY Measurement display to the display to be printed/plotted.
2. Set low and high plotting parameters by referring to ¶8.2, 8.10, and 8.11. Refer to the section in these paragraphs entitled **Plotting**.
3. Press [AUX] key.

4. Press [8, PRINT] key. Display cycles through three (3) print options and one (1) blank option. Release [8, PRINT] key when display reads “PrnT PLoT”.
5. The PRINT LED will be flashing during this mode.

Printout of Plot Condition Mask

1. Press [AUX] key.
2. Press [8, PRINT] key. Display cycles through three (3) print options and one (1) blank option. Release [8, PRINT] key when display reads “PrnT Cond”.
3. The PRINT LED will be flashing during this mode.

Exiting Print Mode Before Printing

1. Press [8, PRINT] key. Wait until PRINT LED stops flashing, then release [8, PRINT] key.

Exiting Print Mode While Printing

1. Press [8, PRINT] key. Wait until PRINT LED stops flashing, then release [8, PRINT] key.

13.4 XY PLOTTER OPERATION

Start and Stop Frequencies for Plotter Limits

1. Go to “START” frequency of frequency Sweep by pressing [SEND] key, [SWEEP] key (or [ENV DLY] on AM5XT or [GROUP DLY] on AM5eXT), then [PARAM SET] as necessary.
2. Enter frequency that corresponds to minimum frequency to be plotted.
3. Go to “STOP” frequency of frequency Sweep by pressing [PARAM SET] once.
4. Enter frequency that corresponds to maximum frequency to be plotted.

Note: When using Automatic Tracking, the send rate on both units must be the same to allow time at the beginning and end of each plot for the pen to catch up with the change in frequencies during the Delay Time.

Set Up Plotter Zero and Scaling

1. Choose a scale on the plotter which will keep the entire plot on the paper and be convenient to read.
2. Go to low limit of plotting parameter (LoDb, LoEd, or LoGd) by pressing [MEAS] key, [LVL/FREQ] key (or [ENV DLY] on AM5XT or [GROUP DLY] on AM5eXT), then [PARAM SET] as necessary. AM5XT/eXT is now outputting minimum frequency and minimum level or delay to plotter.
3. Adjust “ZERO” controls on plotter to obtain desired location of minimum frequency and minimum level or delay.
4. On AM5XT/eXT, enter value of level or delay that corresponds to the current position of the plotter.
5. Go to high limit plotter parameter (HiDb, HiEd, or HiGd) by pressing [PARAM SET] once. AM5XT/eXT is now outputting maximum frequency and maximum level or delay to plotter.
6. Adjust gain controls on plotter to obtain desired location of maximum frequency and maximum level or delay.
7. On AM5XT/eXT, enter value of level or delay that corresponds to the current location of the plotter.
8. Repeat steps 1 through 7 to minimize the effect of interaction between the zero controls and gain controls on the plotter.

Choosing Plotter Algorithm

1. While in Measure Mode, press [PARAM SET] key as necessary to get to “RATE” parameter.
2. For Auto-Track plotting, enter “0”. For Continuous Plotting, enter any number except “0” (up to 255 seconds).

Begin Plot

1. Press [MEAS] key to display readings to be plotted.
2. Set Reference if relative measurement is desired. Set far end to reference level and frequency. If Envelope Delay, also set near end to reference level and frequency.

3. Press [AUX] key, then [REL SET] key to establish reference level or “0” delay.
4. Start frequency sweep at far end (or applicable end if envelope delay).
5. Wait for plotter to move to first plot point, then lower the plotting pen.
6. Wait for plotter to move to last plot point, then raise the plotting pen.

14. ORDERING INFORMATION



760 Arrow Grand Circle
Covina, CA 91722 USA
TEL 626.915.5441
FAX 626.915.7181
www.ameritec.com

Table 14-1. Voice/Data Transmission Test Set Ordering

| PART NO. | DESCRIPTION |
|--------------------------|---|
| MAINFRAME | |
| AM5XT | Voice/Data Wideband Analog Transmission Test Set w/120 kHz bandwidth. |
| AM5XT-200 | Voice/Data Wideband Analog Transmission Test Set w/200 kHz bandwidth. |
| AM5eXT | Voice/Data Wideband Analog Transmission Test Set w/120 kHz bandwidth. |
| AM5eXT-200 | Voice/Data Wideband Analog Transmission Test Set w/200 kHz bandwidth. |
| MAINFRAME OPTIONS | |
| 24-0017 | Sealed Lead Acid Batteries and Integral Charger. |
| 24-0019 | RS232 Remote Control Port with AUX RS232 Output Port. |
| 25-0041 | Siemens type "banana" input adapter. |
| 25-0145 | 310 input adapter |
| 30-0033XT | Signaling Adapter with Ring Generator. |
| 25-0045 | XY Plotter Option |
| 25-0144 | 310 Option for Rack Mount Kit |
| 25-0176 | 220 VAC/50Hz option for 30-0033XT. |
| 30-0070 | DDS Loopback Test Set |
| 30-0070S | DDS Loopback Test Set equipped with "Switched 56" capability. |
| ACCESSORIES | |
| AM-47XT | Hand-Held Printer Plotter. Includes cable and one roll of paper. |
| 26-0014 | One roll of paper for AM-47XT |
| 87-0070 | Padded Carrying case. |
| 85-0076 | 19" Rack Mount Kit for AM5XT and AM5eXT. |
| 85-0076-200 | 19" Rack Mount Kit for AM5XT-200 and AM5eXT-200 |
| CABLES | |
| 48-0047 | Bantam (M) to Bantam (M) Input Cable (6'). |
| 48-0048 | Bantam (M) to 310 (M) Input Cable (6'). |
| 48-0062 | Bantam (M) to Miniclip Input Cable (6'). |

Ordering Information

(18-0022)

AM5XT/eXT Voice/Data Transmission

| PART NO. | DESCRIPTION |
|-----------------|--------------------|
| 48-0083 | Chaining Cable. |
| 48-0084 | RS232 Cable. |

15. WARRANTY, CALIBRATION, AND SERVICE

15.1 Warranty

Ameritec Corporation warrants that its electronic instrument products are manufactured to the highest commercial standards and are free from any defects in material or workmanship. For a period of one (1) year from shipment, Ameritec will repair without charge to the original purchaser any unit which upon inspection by Ameritec proves to be defective.

This warranty is the sole warranty offered by Ameritec and is in lieu of all other obligations or liabilities, including claims of consequential damage; however, an EXTENDED WARRANTY PLAN may be purchased. For information contact an Ameritec Sales Representative.

15.2 Service Policy

Ameritec products are designed with plug-in printed circuit boards and modular assemblies. Once a problem is localized, service is accomplished by PC board (or module) replacement.

15.3 Calibration Policy

All Ameritec products are manufactured to commercial standards and are calibrated with equipment traceable to NIST (National Institute of Standards and Technology). With the exception of component failures or abuse, Ameritec instruments are designed to maintain compliance with their published specifications throughout their service life

While periodic calibration verification is normally not required, in critical applications it is recommended that verification be accomplished annually.

Calibration verification is most efficiently accomplished by return of the equipment to the Ameritec factory where specialized test equipment is used. Field calibration verification is not supported by Ameritec.

15.4 Return of Unit

In the event of a malfunction call or write to the Ameritec factory and obtain a return authorization number. Return the unit to Ameritec freight prepaid with a note (in-warranty repair) or a Purchase Order for the repair (out-of-warranty repair) listing the following information:

- Return authorization number from Ameritec.
- Return shipment address of purchaser.
- Name and telephone number of person at purchaser's location familiar with the problem.
- Brief description of problem (include any printouts that may have a bearing on the problem, if possible).
- Terms of payment for repair costs (out-of-warranty unit).

The unit will be repaired and returned freight-prepaid for units in warranty and freight-collect for units out-of-warranty. As stated above, a Purchase Order to cover the cost of repair must accompany any out-of-warranty return of the unit to Ameritec.

The logo for Ameritec, with 'Ameri' in red and 'tec' in blue.

760 Arrow Grand Circle
Covina, CA 91722 USA
TEL 626.915.5441
FAX 626.915.7181
www.ameritec.com

16. TECHNICAL SPECIFICATIONS

16.1 Measurements

| PARAMETER | RANGE |
|---------------------------------|---|
| Level | -65 to +10 dBm |
| Frequency | 20 Hz to 120 kHz |
| Noise | AM5XT, 10 to 100 dBm AM5eXT, -80 to +10 dBm |
| Noise with Tone | AM5XT, 10 to 100 dBm AM5eXT, -80 to +10 dBm |
| S/N Ratio | 10 to 50 dB |
| Noise to Ground | AM5XT, 40 to 130 dBm AM5eXT, -50 to +40 dBm |
| Impulse Noise | 3 Level |
| Transients | Phase Hits, Gain Hits, Interruptions, Impulse Noise |
| Micro Interruptions Return Loss | 2 Wire, 4 Wire |
| Envelope Delay Distortion | AM5XT |
| Group Delay | AM5eXT |
| Phase Jitter | |
| Amplitude (Gain) Jitter | |
| P/AR | |
| Intermodulation Distortion | U.S. Patent 3,862,380 |

16.2 Send Functions (Signal Generator)

| PARAMETER | RANGE |
|--------------------------------|--|
| VAR | Variable frequency/level settable by user. |
| Frequency Range | 20 Hz to 120 kHz |
| Frequency Resolution | a. 10 Hz single stepping 100 Hz automatic repeat stepping. b. 1 Hz from 20 to 9999 Hz; 10 Hz from 10 kHz to 99.99 kHz; 100 Hz from 100 kHz to 120 kHz using 4-digit manual parameter entry. c. 1 Hz through the whole range using remote control via RS232 port. |
| Frequency Accuracy (Tolerance) | +0.01% |
| Level Range | -50 dBm to +10 dBm for the entire frequency range. |
| Level Resolution | 0.1 dB through the entire range, any mode of entry. |

| PARAMETER | RANGE | | | | | | | | | | | | | | | | | | | | | | | |
|--|--|--------------------|---------|--------------------|--|--|--|--|-------|-------|-------|--|-------|--|--|--|---------|---------|---------|--|---------|---------|---------|--|
| Level Accuracy (Tolerance) | <table border="1"> <thead> <tr> <th colspan="2"></th> <th colspan="3">DISTORTION READING</th> </tr> <tr> <th colspan="2"></th> <th>10 dB</th> <th>55 dB</th> <th>65 dB</th> </tr> </thead> <tbody> <tr> <td rowspan="3">R C V L E V E L</td> <td>0 dBm</td> <td></td> <td></td> <td></td> </tr> <tr> <td>-30 dBm</td> <td>±1.0 dB</td> <td>±1.5 dB</td> <td></td> </tr> <tr> <td>-40 dBm</td> <td>±1.0 dB</td> <td>±2.5 dB</td> <td></td> </tr> </tbody> </table> <p>Accuracy is not specified below 400 Hz when using 135Ω (150Ω, AM5eXT) termination.</p> | | | DISTORTION READING | | | | | 10 dB | 55 dB | 65 dB | R C V L E V E L | 0 dBm | | | | -30 dBm | ±1.0 dB | ±1.5 dB | | -40 dBm | ±1.0 dB | ±2.5 dB | |
| | | DISTORTION READING | | | | | | | | | | | | | | | | | | | | | | |
| | | 10 dB | 55 dB | 65 dB | | | | | | | | | | | | | | | | | | | | |
| R C V L E V E L | 0 dBm | | | | | | | | | | | | | | | | | | | | | | | |
| | -30 dBm | ±1.0 dB | ±1.5 dB | | | | | | | | | | | | | | | | | | | | | |
| | -40 dBm | ±1.0 dB | ±2.5 dB | | | | | | | | | | | | | | | | | | | | | |
| Signaling Frequencies (SF) Skip | Frequency Range skipped in automatic sweep modes or disallowed in manual entry modes, when SF function is selected, is: 2450 Hz to 2750 Hz (2130 Hz to 2430 Hz AM5eXT). | | | | | | | | | | | | | | | | | | | | | | | |
| Holding Tone | Used when performing Level/Frequency (when not in VAR mode), Phase/Amplitude Jitter, Noise with Tone, or Transients Measurements. Alternately, the operator can set the desired frequency (e.g. 1020 Hz) using VAR. | | | | | | | | | | | | | | | | | | | | | | | |
| Frequency | 1004 Hz @ <0.1 deg phase jitter | | | | | | | | | | | | | | | | | | | | | | | |
| Level | -50 to +10 dBm | | | | | | | | | | | | | | | | | | | | | | | |
| 2 kHz Tone | Selected under VAR mode when measuring micro interruptions. | | | | | | | | | | | | | | | | | | | | | | | |
| Frequency | 2 kHz | | | | | | | | | | | | | | | | | | | | | | | |
| Level/Range | -50 to +10 dBm | | | | | | | | | | | | | | | | | | | | | | | |
| Slope Tones | Tones generated when measuring gain slope (frequency response). | | | | | | | | | | | | | | | | | | | | | | | |
| Fixed Tones | | | | | | | | | | | | | | | | | | | | | | | | |
| Frequencies | 404, 1004, 2804 Hz (AM5XT); 304, 1004, 2004, 3004 Hz (AM5eXT) | | | | | | | | | | | | | | | | | | | | | | | |
| Dwell | 5 seconds per tone default. Operator settable (.1 to 999.9). | | | | | | | | | | | | | | | | | | | | | | | |
| Level Range | -50 to +10 dBm | | | | | | | | | | | | | | | | | | | | | | | |
| Sweep Mode | Operator settable level (20 Hz – 120 kHz), start frequency, stop frequency, frequency step size, step rate, and delay to start of next sweep. | | | | | | | | | | | | | | | | | | | | | | | |
| Return Loss | All signals specified below are band limited noise. The frequency characteristics are indicated in Tables 16-1, 16-2, and 16-3. | | | | | | | | | | | | | | | | | | | | | | | |
| Echo Return Loss (ERL) | 560 to 1965 Hz | | | | | | | | | | | | | | | | | | | | | | | |
| Singing Return Loss – Low (SRL-LO) | 260 to 500 Hz | | | | | | | | | | | | | | | | | | | | | | | |
| Singing Return Loss – High (SRL-HI) | 2220 to 3400 Hz | | | | | | | | | | | | | | | | | | | | | | | |
| Level | Settable: -2 to -10 dBm | | | | | | | | | | | | | | | | | | | | | | | |
| Level Accuracy | ±0.5 dB | | | | | | | | | | | | | | | | | | | | | | | |

| | |
|--|--|
| Peak to Average Ratio (PAR) | |
| P/AR Line Spectrum | Per IEEE 4.6.2.1. See Table 16-4. |
| P/AR Distortion | Spurious outputs ≤ 4 kHz >50 dB below component at 1890.625 Hz. Spurious outputs >4 kHz >40 dB below component at 1890.625 Hz. |
| Period | 64.0ms $\pm 0.1\%$ |
| Level Range | 0 to -40 dBm (true RMS) |
| Group Delay Transmitter (CCITT 0.81) (AM5eXT) | |
| Reference Signal (Carrier) Frequency | 1800 Hz default, settable 200 Hz to 20 kHz $\pm 0.5\%$ |
| Measuring Signal (Carrier) Sweep | |
| Start Frequency | 200 – 20 kHz |
| Stop Frequency | 200 – 20 kHz |
| Step Size | 1 – 9999 Hz |
| Rate | 0.1 – 999.9 sec. This is the length of time each measuring carrier will be generated. The finest resolution is 0.24 sec (based on change over frequency). Due to this fact, the AM5eXT will round the entered value to the nearest 0.24 sec. |
| Delay Before Start & After Stop | 0.1 – 999.9 sec |
| Modulation Signal | |
| Frequency | 41.66 Hz $\pm 0.5\%$ |
| Modulation Depth | 0.4 ± 0.05 (40% $\pm 5\%$) |
| Identifying Signal | |
| Frequency | 166.6 Hz $\pm 0.5\%$ (derived from modulation frequency) |
| Modulation Depth | 0.2 ± 0.05 (20% $\pm 5\%$) |
| Send Duration of Signal | 24ms (1 cycle of modulation signal) |
| Change Over Frequency | Minimum period at which measured carrier can be changed to a new value |
| Frequency | 4.166 Hz $\pm 0.5\%$ (derived from modulation frequency) |
| Period | 240ms |
| Composite Output Signal | |
| Level | -40 dBm to $+10$ dBm (600 Ω) |
| Level Accuracy | ± 0.3 dBm |
| Modulation Distortion | $<1\%$ (Ratio of RMS value of unwanted sidebands to that of wanted sidebands) |

| PARAMETER | RANGE |
|---|---|
| Carrier Change Over Time | <100µs (From one carrier to the next) |
| Deviation Between Carrier Change Over Point and Envelope Minimum | ≤±0.2ms (Figure 2-8) |
| Harmonic Distortion | <1.0% |
| Spurious Distortion | <0.1% |
| Maximum Error in Group Delay Measurement Contributed by Generator | 200 – 400 Hz ±5µs 400 – 600 Hz ±3µs 600 – 20K Hz ±1µs |
| Envelope Delay Distortion Transmitter (AM5XT) | |
| Frequency Range | 200 – 4000 Hz ±1 Hz |
| Level Range | 10 to -40 dBm ±.1 dB |
| Delay Distortion of Transmitter | <±5µs 600 to 4000 Hz <±15µs 200 to 599 Hz |
| Modulation | 83.333 Hz ±0.1% 50% ±5% |
| Distortion | 83.33, 3 fc + 83.3 Hz at least 52 dB below carrier. Other spurious signals at least 46 dB below carrier. Total distortion at least 43 dB below carrier. |
| Non-Linear Distortion (4 Tone) | U.S. Patent 3,862,380 |
| Transmitter | |
| Level Range | 0 to -40 dBm RMS |
| Level Accuracy | ±1 dB |
| Spectrum | 857, 863, 1372, 1388 Hz at equal (±0.2 dB) levels |
| Harmonic Distortion | >35 dB below tone |
| Background Noise | Any noise within passband of distortion filters >70 dB below 4 tone signal. |
| Signal/Noise Check | 857, 863 Hz pair |
| Self Check Signal | |
| 2 nd Order | 20 ±0.5 dB |
| 3 rd Order | 30 ±0.5 dB |

16.3 Receive Functions

| PARAMETER | RANGE | | | | | | | | | | | | | | | | | | | | |
|--------------------------|--|--------|--------|---------|--------|---------|---------|--|--|--|--|---------|-----|-----|-----|--|---------|------|------|------|--|
| Level Measure | | | | | | | | | | | | | | | | | | | | | |
| Range | -64.9 to +10 dBm | | | | | | | | | | | | | | | | | | | | |
| Resolution | 0.1 dB | | | | | | | | | | | | | | | | | | | | |
| Accuracy in dB | <table border="1"> <thead> <tr> <th></th> <th>20 Hz</th> <th>200 Hz</th> <th>20 kHz</th> <th>120 kHz</th> </tr> </thead> <tbody> <tr> <td>+10 dBm</td> <td></td> <td></td> <td></td> <td></td> </tr> <tr> <td>-50 dBm</td> <td>±.5</td> <td>±.2</td> <td>±.5</td> <td></td> </tr> <tr> <td>-65 dBm</td> <td>±1.0</td> <td>±1.0</td> <td>±1.0</td> <td></td> </tr> </tbody> </table> <p>At 1004-1020 Hz, accuracy is ±0.1 dBm from 0 to -20 dBm. When using 135Ω (150Ω, AM5eXT) accuracy is not specified below 400 Hz.</p> | | 20 Hz | 200 Hz | 20 kHz | 120 kHz | +10 dBm | | | | | -50 dBm | ±.5 | ±.2 | ±.5 | | -65 dBm | ±1.0 | ±1.0 | ±1.0 | |
| | 20 Hz | 200 Hz | 20 kHz | 120 kHz | | | | | | | | | | | | | | | | | |
| +10 dBm | | | | | | | | | | | | | | | | | | | | | |
| -50 dBm | ±.5 | ±.2 | ±.5 | | | | | | | | | | | | | | | | | | |
| -65 dBm | ±1.0 | ±1.0 | ±1.0 | | | | | | | | | | | | | | | | | | |
| Noise Protection | Low frequency (60 Hz) switchable in or out. High frequency, 120 kHz low pass always inserted. In addition, 15K Flat (AM5XT) or Sound Unweighted (AM5eXT) filter may be inserted. | | | | | | | | | | | | | | | | | | | | |
| Detector | Average | | | | | | | | | | | | | | | | | | | | |
| Frequency Measure | | | | | | | | | | | | | | | | | | | | | |
| Range | 20 Hz to 120 kHz | | | | | | | | | | | | | | | | | | | | |
| Resolution/Accuracy | 20 Hz to 10 kHz – 1 Hz/±1 Hz; 10 kHz to 100 kHz – 10 Hz/±10 Hz; 100 kHz to 120 kHz – 100 Hz/±100 Hz | | | | | | | | | | | | | | | | | | | | |
| Signal Level | -55 to +10 dBm with S/N ratio >20 dB | | | | | | | | | | | | | | | | | | | | |
| Noise Measure | | | | | | | | | | | | | | | | | | | | | |
| Level | 1004 Hz @ <0.1 deg phase jitter | | | | | | | | | | | | | | | | | | | | |
| Noise (AM5XT) | 10 to 99 dBm (20 - 99 dBm @ 135Ω) | | | | | | | | | | | | | | | | | | | | |
| Noise (AM5eXT) | -80 to +9 dBm (-70 - +9 dBm @ 150Ω) | | | | | | | | | | | | | | | | | | | | |
| Noise to Ground (AM5XT) | 40 to 129 dBm | | | | | | | | | | | | | | | | | | | | |
| Noise to Ground (AM5eXT) | -50 to +39 dBm | | | | | | | | | | | | | | | | | | | | |
| Resolution | 1 dB | | | | | | | | | | | | | | | | | | | | |
| Accuracy | | | | | | | | | | | | | | | | | | | | | |
| Noise (AM5XT) | 20 to 99 dBm, ±1 dB; 10 to 20 dBm, ±2 dB (±1 dB CMSG) | | | | | | | | | | | | | | | | | | | | |
| Noise (AM5eXT) | -70 to +9 dBm, ±1 dB; -80 to -70 dBm, ±2 dB (±1 dB PSO) | | | | | | | | | | | | | | | | | | | | |
| Noise to Ground | ±1.5 dB | | | | | | | | | | | | | | | | | | | | |
| Filters | | | | | | | | | | | | | | | | | | | | | |
| (AM5XT) | C-Message, Program 3 kHz flat, 15 kHz flat, 50 k Bit, 60 Hz | | | | | | | | | | | | | | | | | | | | |
| (AM5eXT) | Psophometric (P.53), Sound Wtd. (J.16), Sound Unwtd (J.16), Flat (275-3250 Hz) (O.71), Flat (750-2300 Hz) (O.71), 60 Hz | | | | | | | | | | | | | | | | | | | | |
| Detector | RMS or Quasi-Peak (J.16) (AM5eXT only) as selected. | | | | | | | | | | | | | | | | | | | | |

| PARAMETER | RANGE | | |
|--|--|--|--|
| Noise With Tone Measure | | | |
| Notch | 995 – 1025 Hz, 50 dB minimum (Other specifications same as Noise Measure). | | |
| Signal to Noise Measure | | | |
| Signal Range | -40 to +10 dBm | | |
| Noise Range | | | |
| (AM5XT) | 10 dBm to 70 dBm | | |
| (AM5eXT) | -80 to -20 dBm | | |
| Display Range | 10 to 60 dB | | |
| Accuracy | | | |
| (AM5XT) | Noise above 20 dBm, ±1 dB; Noise below 20 dBm, ±2 dB (±1 dB CMSG) | | |
| (AM5eXT) | Noise above -70 dBm, ±1 dB; Noise below -70 dBm, ±2 dB (±1 dB PSO) | | |
| (Both) | S/N Ratio 0 – 40 dB, ±1 dB; S/N Ratio 40 – 45 dB, ±2 dB; S/N Ratio 45 – 50 dB, ±3 dB; S/N Ratio 50 – 60 dB, ±3 dB (typical performance, not guaranteed). | | |
| Impulse Noise Measure (3 Level) | | | |
| | AM5XT | AM5eXT | |
| Minimum Threshold | 30 dBm | -60 dBm | |
| Maximum Threshold | 135Ω (150Ω) 600Ω 900Ω 1200Ω | 112 dBm 106 dBm 104 dBm 103 dBm | +22 dBm +16 dBm +14 dBm +13 dBm |
| Threshold Difference | 2, 3, 4, 6 dB, Operator settable | | |
| Threshold Accuracy | ±1 dB | | |
| Study Timer | User settable 0.1 – 999.9 min. or continuous. Default = 15.0 min. | | |
| Max Count | 9999 (each threshold) | | |
| Dead Time | Settable 1-255ms (125ms default) | | |
| Impulse Noise with Tone Measure | See Transients | | |
| P/AR Measure | | | |
| Test Signal | P/AR Waveform | | |
| Range | 0 to 120 P/AR units | | |
| Resolution | 1 P/AR unit | | |
| Accuracy | P/AR = 30 to 110 - ±2 P/AR units; P/AR = 0 to 120 - ±4 P/AR units | | |
| Signal Level Range | -50 to 0 dBm (measured with RMS detector) | | |
| Receive Filter | 2 cascaded bandpass filters Q = 2, F = 1300 Hz | | |
| Detectors | Full Wave Average, Peak and RMS | | |

| PARAMETER | RANGE | | | | | | | | | | | | | | | | |
|-------------------------------------|---|-----------------------------------|--------------------------------|--------------------------------|------------|---------------|-----------|---------------|----------|----------------------------|-------------------------|------------|-----------|-------------|----------|-------------|-------|
| Return Loss Measure | | | | | | | | | | | | | | | | | |
| Test Signals | Band limited white noise (ERL, SRL-LO, SRL-HI) or sine wave @ -10 to -2 dBm | | | | | | | | | | | | | | | | |
| Range | 0 to 40 dB (2 wire); 0 to 50 dB (4 wire) | | | | | | | | | | | | | | | | |
| Resolution | 0.1 dB | | | | | | | | | | | | | | | | |
| Accuracy | ±0.5 dB | | | | | | | | | | | | | | | | |
| 4 Wire Level Compensation (TLP) | +99.9 to -99.9 dB IN .1 dB steps | | | | | | | | | | | | | | | | |
| Detector | True RMS | | | | | | | | | | | | | | | | |
| Group Delay Measure (AM5eXT) | | | | | | | | | | | | | | | | | |
| Input Level Range | -50 dBm to +10 dBm (-40 dBm for 135/150Ω) | | | | | | | | | | | | | | | | |
| Delay Measuring Range | -12000 to +12000μs | | | | | | | | | | | | | | | | |
| Delay Measuring Accuracy | ±1% of reading + errors from table below <table border="0"> <thead> <tr> <th><u>Measuring Freq</u></th> <th><u>Additional Error</u></th> </tr> </thead> <tbody> <tr> <td>200 to 400 Hz</td> <td>50 μs</td> </tr> <tr> <td>400 to 600 Hz</td> <td>15 μs</td> </tr> <tr> <td>600 to 20K Hz</td> <td>5 μs</td> </tr> <tr> <th><u>Amplitude Variation</u></th> <th><u>Additional Error</u></th> </tr> <tr> <td>0 to 10 dB</td> <td>50 μs</td> </tr> <tr> <td>10 to 30 dB</td> <td>10 μs</td> </tr> <tr> <td>30 to 50 dB</td> <td>20 μs</td> </tr> </tbody> </table> | <u>Measuring Freq</u> | <u>Additional Error</u> | 200 to 400 Hz | 50 μs | 400 to 600 Hz | 15 μs | 600 to 20K Hz | 5 μs | <u>Amplitude Variation</u> | <u>Additional Error</u> | 0 to 10 dB | 50 μs | 10 to 30 dB | 10 μs | 30 to 50 dB | 20 μs |
| <u>Measuring Freq</u> | <u>Additional Error</u> | | | | | | | | | | | | | | | | |
| 200 to 400 Hz | 50 μs | | | | | | | | | | | | | | | | |
| 400 to 600 Hz | 15 μs | | | | | | | | | | | | | | | | |
| 600 to 20K Hz | 5 μs | | | | | | | | | | | | | | | | |
| <u>Amplitude Variation</u> | <u>Additional Error</u> | | | | | | | | | | | | | | | | |
| 0 to 10 dB | 50 μs | | | | | | | | | | | | | | | | |
| 10 to 30 dB | 10 μs | | | | | | | | | | | | | | | | |
| 30 to 50 dB | 20 μs | | | | | | | | | | | | | | | | |
| Level Measurement Accuracy | <table border="0"> <thead> <tr> <th><u>Relative Level Reading (±)</u></th> <th><u>Relative Level Accuracy</u></th> <th><u>Absolute Level Accuracy</u></th> </tr> </thead> <tbody> <tr> <td>0 to 10 dB</td> <td>+0.15 dB</td> <td>±0.25 dBm</td> </tr> <tr> <td>10 to 30 dB</td> <td>±0.30 dB</td> <td>+0.30 dBm</td> </tr> <tr> <td>30 to 40 dB</td> <td>±0.50 dB</td> <td>+0.50 dBm</td> </tr> <tr> <td>40 to 50 dB</td> <td>±1.00 dB</td> <td>±1.00 dBm</td> </tr> </tbody> </table> | <u>Relative Level Reading (±)</u> | <u>Relative Level Accuracy</u> | <u>Absolute Level Accuracy</u> | 0 to 10 dB | +0.15 dB | ±0.25 dBm | 10 to 30 dB | ±0.30 dB | +0.30 dBm | 30 to 40 dB | ±0.50 dB | +0.50 dBm | 40 to 50 dB | ±1.00 dB | ±1.00 dBm | |
| <u>Relative Level Reading (±)</u> | <u>Relative Level Accuracy</u> | <u>Absolute Level Accuracy</u> | | | | | | | | | | | | | | | |
| 0 to 10 dB | +0.15 dB | ±0.25 dBm | | | | | | | | | | | | | | | |
| 10 to 30 dB | ±0.30 dB | +0.30 dBm | | | | | | | | | | | | | | | |
| 30 to 40 dB | ±0.50 dB | +0.50 dBm | | | | | | | | | | | | | | | |
| 40 to 50 dB | ±1.00 dB | ±1.00 dBm | | | | | | | | | | | | | | | |
| Frequency Readings | ±1% | | | | | | | | | | | | | | | | |
| Noise Immunity | <p>A low pass filter to reduce interfering signals above 4 kHz is selectable. The filter meets the following requirements: Group delay at 2600 Hz relative to 1 kHz <±5μs; Group delay at 2800 Hz relative to 1 kHz <±30μs.</p> <p>Group delay error <±20μs in presence of white noise, band limited to 4 kHz, at a level of 26 dB below carrier level and a sweep rate less than 25 Hz/sec.</p> <p>The error due to presence of tone near the reference or measuring signal, when the level of the tone is 26 dB below the signal, will be as follows:</p> <p>Tone Frequency Deviation from Signal Error - ±150 Hz = ≤20μs; ±200 Hz = ≤2μs.</p> | | | | | | | | | | | | | | | | |

| | |
|---|---|
| Envelope Delay Distortion Receiver | (AM5XT) |
| Measurement Range | -3000 to +9000 μ s |
| Frequency Range | 200 – 4000 Hz |
| Level Range | -40 to +10 dBm |
| Resolution | 1 microsecond |
| Accuracy | 600 – 4000 Hz, $\pm 5\mu$ s; 200 – 599 Hz, $\pm 15\mu$ s |
| Display Response Time | <1 second |
| Repeat Mode Settling Time | <3 seconds |
| Signal/Noise Ratio | Accuracy specifications are met with S/N ratio ≥ 24 dB |
| Turnover | Accuracy is unaffected by interchanging the input leads |
| Analog Output | DC voltages suitable for driving an X-Y recorder are provided |
| Drift | After warm-up, the reference zero will not drift by more than 10 microseconds in any 30 minute period. |
| Repeat Mode | Both forward reference and return reference modes are provided. |
| Hold Mode | Provides a 2-wire "one way" measurement with drift <15 μ s per minute |
| Phase Jitter Measure | (IEEE, CCITT 0.91) |
| Test Signal | 990 – 1030 Hz <0.1 Deg Jitter, -40 to +10 dBm |
| Jitter Range | 0.0 to 30 Degrees P-P |
| Accuracy | $\pm 5\%$ of Value, ± 0.2 Degrees |
| Noise Protection | 400 Hz high pass, 12 dB/octave 1800 Hz low pass, 24 dB/octave Band limited (250-3500 Hz) white noise down 30 dB from 12 kHz sine wave reads <4 degrees jitter peak-peak |
| Single Frequency Interference | Per IEEE 4.5.1.76 (no applicable CCITT specification) |
| Frequency Weighting | 4-300 Hz, see Table 16-5. 4-20 Hz, see Table 16-5. 20-300 Hz, see Table 16-5. |
| Level to Phase Conversion | Per IEEE 4.5.1.8 and CCITT 0.91 2.5 |
| Amplitude to Phase Conversion | Using a test signal of 1 kHz 10% amplitude modulated, the phase jitter reads less than 0.2 degrees |
| Peak Detector Performance | Per IEEE 5.4.1.11 and CCITT 0.91 |
| Demodulated Signals | Carrier – provided; Phase Jitter – provided |
| Time to Display Correct Reading | 4-20, 4-300 Hz – 25 seconds; 20-300 Hz – 4 seconds |

| Amplitude Jitter | |
|--|---|
| Test Signal | 990-1030 Hz <0.1% jitter, -40 to +10 dBm |
| Accuracy | ±5% of reading ±0.2% |
| Measurement Range | 0.0 – 25.0% Peak |
| Noise Rejection | Per IEEE 4.5.2.5 |
| Frequency Weighting Using Two Tone Test Signal of IEEE 4.5.2.6 | See Table 16-6 and 16-7 |
| Signal Frequency Interference | Per IEEE 4.5.2.7 |
| Level to Amplitude Jitter Conversion | Per IEEE 4.5.2.8 |
| Phase to Amplitude Jitter Conversion | Per IEEE 4.5.2.9 |
| Measurement Averaging Time | Per IEEE 4.5.2.10 |
| Detector | Peak-to-Peak per IEEE 4.5.2.11 |
| Time to Display Correct Reading | 4-300 Hz – 25 seconds; 20-300 Hz – 4 seconds |
| Demodulated Signal Output | Provided |
| Transients | |
| Test Signal | 995-1025 Hz, +10 to –40 dBm tone with >20 dB S/N ratio (C-Notch) |
| Blanking Interval | 125ms factory default 1-255ms operator settable |
| Qualification Interval | 3.5 – 4.39ms (AM5XT); 3.6 – 4.4ms (AM5eXT) |
| Polarity of Input Signal | Accuracy specifications are met with interchange of input leads. |
| Study Timer | 0.1 to 999.9 minutes accurate to ±0.1% |
| Count Hierarchy | Dropout blocks all counters for duration plus 1 second |
| Noise Protection for Hit and Dropout Counters | High pass with cutoff frequency of 400 Hz and 12 dB per octave rolloff plus low pass with cutoff frequency of 1800 Hz and 24 dB per octave rolloff. Satisfies IEEE & CCITT requirements for single frequency interference, amplitude to phase conversion, phase to amplitude conversion, and hit amplitude and duration limits. |
| Counters | All counters are 4 digit (9999 max) |
| Impulse Noise (3 Level) | AM5XT AM5eXT |
| Minimum Threshold | 30 dBrn -60 dBm |
| Maximum Threshold | 135Ω (150Ω) 112 dBrn +22 dBm 600Ω 106 dBrn +16 dBm 900Ω 104 dBrn +14 dBm 1200Ω 103 dBrn +13 dBm |
| Threshold Difference | 2, 3, 4, 6 dB |

| PARAMETER | RANGE |
|---|--|
| Threshold Accuracy | ±1 dB |
| Filters | See 3.3, Filters |
| Counter Independence | The counters for low, mid, and high threshold operate independently and simultaneously as required by input conditions. |
| Phase Hits | |
| Threshold Range | 5-45 Degrees in 1 Degree Steps |
| Threshold Accuracy | ±(10% of setting +.5 Degrees) |
| Single Frequency Interference | Per IEEE 4.4.4.4 (No applicable CCITT Spec) |
| Amplitude to Phase Conversion | 10 dB gain hit will not cause phase hit with 10 Degrees threshold setting |
| Loop Recovery Time (Hit Rate of Change) | Tested with linear phase change of 100 Degrees and 20 Degrees threshold. Rise time > 50ms = no count. Rise time < 20ms = count |
| Phase Hit Amplitude and Duration Limits | With threshold of 20 degrees and phase hits of 25 degrees. Count All > 5.0ms Count none < 3.6ms |
| Gain Hits | |
| Threshold Settings | 2, 3, 4, 6, 8, 10 dB (AM5eXT does not have 10 dB setting) |
| Threshold Accuracy | ±0.5 dB (0.2ms rise time) |
| Single Frequency Interference | Per IEEE 4.4.5.4 (No applicable CCITT Spec) |
| Phase to Amplitude Conversion | 180 Degrees phase hit shall not count at any threshold |
| Loop Recovery (Hit Rate of Change) | Test with linear amplitude change of 4 dB in either direction and threshold set to 2 dB. Rise time > 600ms = no count. Rise time < 200ms = count |
| Gain Hit Amplitude and Duration Limits | With threshold of 2 dB and hits of 3 dB. Count All ≥ 5.0ms Count none ≤ 3.6ms |
| Interruptions | (AM5eXT) |
| Level Thresholds | 6 dB and 10 dB (10 dB interruption blocks Hit and Impulse counters) |
| Threshold Accuracy | ±1 dB |
| Qualification | < 2.0ms Ignore >3.5ms Recognize |
| Separation | > 4.0ms to guarantee recognition as separate |
| Dropouts | (AM5XT) |
| Threshold | 12 ±1 dB |
| Single Frequency Interference | Per IEEE 4.4.6.3 (No applicable CCITT Spec) |
| Ancillary Detector – HCMOS 5v Logic Outputs | 0 = signal above threshold 1 = signal below threshold |

| Micro Interruptions | (0.62) | | | | | | | | | | | | | | | | | | | | |
|---|---|--------------------|---------|--|--|--|-------|-------|-------|-------------|-------|--|--|-----------------------|---------|---------|---------|--|---------|---------|---------|
| Test Signal Frequency | 2000 ± 100 Hz | | | | | | | | | | | | | | | | | | | | |
| Input Level Range | -30 dB to +10 dB | | | | | | | | | | | | | | | | | | | | |
| Level Threshold Below Initial Level | Selectable 3, 6, 10, 20 dB | | | | | | | | | | | | | | | | | | | | |
| Threshold Accuracy | ±1 dB @ 3, 6, 10 dB ±2 dB @ 20 dB | | | | | | | | | | | | | | | | | | | | |
| Detector Sensitivity to Interruption Duration | 100% detected if >0.45ms 50% detected at 0.3ms duration | | | | | | | | | | | | | | | | | | | | |
| Dead Time | Selectable 1-225ms or Shortest Possible (as short as 500µs) | | | | | | | | | | | | | | | | | | | | |
| Auxiliary Detector Output | HCMOS 5V logic output. 0 = signal above threshold 1 = signal below threshold | | | | | | | | | | | | | | | | | | | | |
| Study Timer | Same as for impulse noise | | | | | | | | | | | | | | | | | | | | |
| Counters | 5 four-digit Counters based on duration of interruption. CNT1 for 0.3 – 3ms duration CNT2 for 3 – 30ms duration CNT3 for 30 – 300ms duration CNT4 for 300ms – 1 minute duration CNT5 for > 1 minute duration | | | | | | | | | | | | | | | | | | | | |
| Non-Linear Distortion | (4 Tone) U.S Patent 3,862,380 | | | | | | | | | | | | | | | | | | | | |
| Receiver | | | | | | | | | | | | | | | | | | | | | |
| Signal Level | 0 to -40 dBm | | | | | | | | | | | | | | | | | | | | |
| Measurement Range | 10 to 65 dB for 2 nd and 3 rd order products | | | | | | | | | | | | | | | | | | | | |
| Resolution | 0.1 dB | | | | | | | | | | | | | | | | | | | | |
| Measurement Accuracy | <table border="1" style="margin-left: auto; margin-right: auto;"> <thead> <tr> <th colspan="4">DISTORTION READING</th> </tr> <tr> <th></th> <th>10 dB</th> <th>55 dB</th> <th>65 dB</th> </tr> </thead> <tbody> <tr> <td>R C V</td> <td>0 dBm</td> <td></td> <td></td> </tr> <tr> <td>L E V E L</td> <td>-30 dBm</td> <td>±1.0 dB</td> <td>±1.5 dB</td> </tr> <tr> <td></td> <td>-40 dBm</td> <td>±1.0 dB</td> <td>±2.5 dB</td> </tr> </tbody> </table> <p>(Accuracy not specified for 135Ω/150Ω if level < -30 dBm)</p> | DISTORTION READING | | | | | 10 dB | 55 dB | 65 dB | R C V | 0 dBm | | | L E V E L | -30 dBm | ±1.0 dB | ±1.5 dB | | -40 dBm | ±1.0 dB | ±2.5 dB |
| DISTORTION READING | | | | | | | | | | | | | | | | | | | | | |
| | 10 dB | 55 dB | 65 dB | | | | | | | | | | | | | | | | | | |
| R C V | 0 dBm | | | | | | | | | | | | | | | | | | | | |
| L E V E L | -30 dBm | ±1.0 dB | ±1.5 dB | | | | | | | | | | | | | | | | | | |
| | -40 dBm | ±1.0 dB | ±2.5 dB | | | | | | | | | | | | | | | | | | |
| Filter Characteristics | | | | | | | | | | | | | | | | | | | | | |
| 2 nd Order | 503-537, 2223-2257 Hz | | | | | | | | | | | | | | | | | | | | |
| 3 rd Order | 1877-1923 Hz Bandwidth test per O.42, 3.2.4; IEEE 4.6.3.2.4, 4.6.3.2.5 | | | | | | | | | | | | | | | | | | | | |
| Detector | RMS | | | | | | | | | | | | | | | | | | | | |
| Crosstalk | Generator does not impact receiver accuracy | | | | | | | | | | | | | | | | | | | | |
| Signal/Noise Correction | Automatic | | | | | | | | | | | | | | | | | | | | |
| Spurious Tone Detection | Provided | | | | | | | | | | | | | | | | | | | | |
| Measurement Response Time | Within 1 dB of final reading 10 seconds | | | | | | | | | | | | | | | | | | | | |
| Display Update Rate | 3 seconds | | | | | | | | | | | | | | | | | | | | |

16.4 General

| PARAMETER | RANGE | | | | | | | | | | | | |
|---------------------|--|--------------------|-------------|--------------------|-------------|--------|--------|--------------|--------|--------|---------------|--------|--------|
| Input | 2 or 4 wire transmission line. Separate 135Ω(150Ω), 600Ω, 900Ω, or 1200Ω selectable terminate impedance (50 KΩ) bridge. Separate DC hold circuits. | | | | | | | | | | | | |
| DC Blocking | 200 VDC | | | | | | | | | | | | |
| Balance | >90 dB, 50 Hz – 120 Hz: decreasing 6 dB per octave above 120 Hz. | | | | | | | | | | | | |
| Return Loss | <table border="0"> <tr> <td></td> <td><u>150Ω</u></td> <td><u>600 - 1200Ω</u></td> </tr> <tr> <td>20 - 200 Hz</td> <td>>15 dB</td> <td>>25 dB</td> </tr> <tr> <td>200 - 20K Hz</td> <td>>30 dB</td> <td>>40 dB</td> </tr> <tr> <td>20K - 120K Hz</td> <td>>30 dB</td> <td>>30 dB</td> </tr> </table> | | <u>150Ω</u> | <u>600 - 1200Ω</u> | 20 - 200 Hz | >15 dB | >25 dB | 200 - 20K Hz | >30 dB | >40 dB | 20K - 120K Hz | >30 dB | >30 dB |
| | <u>150Ω</u> | <u>600 - 1200Ω</u> | | | | | | | | | | | |
| 20 - 200 Hz | >15 dB | >25 dB | | | | | | | | | | | |
| 200 - 20K Hz | >30 dB | >40 dB | | | | | | | | | | | |
| 20K - 120K Hz | >30 dB | >30 dB | | | | | | | | | | | |
| Signaling | Pulse, DTMF (touch tone), or MF (multi-frequency) from full 16 button keypad. | | | | | | | | | | | | |
| Monitor/Talk | Built-in speaker monitor and microphone with 2/4 wire hybrid for hands free speaker phone or push-to-talk operation. | | | | | | | | | | | | |
| Power | 115 VAC or 230 VAC 50/60 Hz @ 26 VA. Internal rechargeable battery (sealed lead/acid) optional. Battery charge life approximately 5 hours. Low battery warning at .5 hour remaining. | | | | | | | | | | | | |
| Weight | Basic Unit Net: 5 lbs. Shipping: 8 lbs. W/Battery Option Net: 10 lbs. Shipping: 13 lbs. | | | | | | | | | | | | |
| Dimensions | Portable: 8.3"W x 3.5"H x 12.1"D Rack Mt: 19.0"W x 3.5"H x 12.1"D | | | | | | | | | | | | |
| Operating | 0 to 40 deg. Celsius | | | | | | | | | | | | |
| Storage | -40 to +75 deg. Celsius | | | | | | | | | | | | |
| Humidity | 10% to 90% non-condensing | | | | | | | | | | | | |
| Line Connections | Dual miniature phone jack (mates with ADC PJ777 or Switchcraft TT253. Commonly known as "Bantam" plug). 0.173" dia. On .312" centers (front panel) and screw terminal strip (rear panel). | | | | | | | | | | | | |
| Remote Control Port | (Optional) | | | | | | | | | | | | |
| Type | RS232, ASCII | | | | | | | | | | | | |
| Baud Rate | 300, 1200, 2400, 9600 baud switch-selectable | | | | | | | | | | | | |
| Connection | 25 pin male, D-miniature type | | | | | | | | | | | | |
| Parity | Odd, even, or none; switch-selectable | | | | | | | | | | | | |
| Functions | All functions and settings of set may be remotely controlled. All measurements may be remotely accessed. | | | | | | | | | | | | |

| | |
|---|---|
| Auxiliary Port | (Furnished with Remote Control Port) |
| Type | RS232, ASCII |
| Baud Rate | 300, 1200, 2400, 9600 baud switch-selectable |
| Connection | 9 pin female, D-miniature type |
| Parity | Odd, even, or none; switch-selectable |
| Store/Recall Functions | 40 user-defined unit setups 40 user-defined line related setups 10 user-defined telephone numbers (plus last number redialed) |
| Specifications may be changed without notice. | |

Table 16-1. ERL Filter Response (Frequency Weighting)

| Frequency (Hz) | Relative Loss (dB) | Tolerance (dB) |
|----------------|--------------------|----------------|
| <200 | >30.0 | --- |
| 300 | 21.8 | ±2.3 |
| 560 | 3.0 | ±0.4 |
| 750 | 0.2 | ±0.2 |
| 1000 | 0.0 | ±0.1 |
| 1500 | 0.1 | ±0.2 |
| 1965 | 3.0 | ±0.4 |
| 2400 | 10.9 | ±1.2 |
| 3000 | 22.9 | ±3.0 |
| 4000 | 42.6 | ±5.0 |
| >5000 | >45.0 | --- |

Table 16-2. SRL Low Filter Response (Frequency Weighting)

| Frequency (Hz) | Relative Loss (dB) | Tolerance (dB) |
|----------------|--------------------|----------------|
| <100 | >20 | --- |
| 120 | 20 | ±3.0 |
| 200 | 9.5 | ±1.1 |
| 260 | 3 | ±0.5 |
| 360 | 0 | ±0.2 |
| 500 | 3 | ±0.5 |
| 650 | 10 | ±1.2 |
| 1000 | 20 | ±3.0 |
| >1200 | >20 | --- |

Table 16-3. SRL High Filter Response (Frequency Weighting)

| Frequency (Hz) | Relative Loss (dB) | Tolerance (dB) |
|----------------|--------------------|----------------|
| <1000 | >30 | --- |
| 1300 | 30 | ±4.0 |
| 2000 | 11.5 | ±1.3 |
| 2200 | 3 | ±0.5 |
| 2700 | 0 | ±0.2 |
| 3400 | 3 | ±0.5 |
| 3700 | 10.9 | ±1.3 |
| 5700 | 30 | ±4.0 |
| >6000 | >30 | --- |

Table 16-4. P/AR Line Spectrum

| LINE SPECTRUM | | | LINE SPECTRUM TOLERANCE | |
|----------------|----------------|----------------|-------------------------|-----------------|
| Frequency (Hz) | Magnitude (dB) | Phase (Degree) | Level (±dB) | Phase (±Degree) |
| 140.625 | -33.737 | -173.73 | 0.80 | 5.0 |
| 390.625 | -15.881 | -161.24 | 0.30 | 3.0 |
| 640.625 | -14.556 | -143.95 | 0.20 | 2.0 |
| 890.625 | -15.181 | -114.31 | 0.20 | 0.5 |
| 1140.626 | -16.303 | -55.37 | 0.20 | 0.4 |
| 1390.625 | -11.937 | 30.19 | 0.10 | 0.4 |
| 1640.625 | -3.961 | 86.41 | 0.10 | 0.4 |
| 1890.625 | -0.000 | 113.78 | 0.00 | 0.4 |
| 2140.625 | -0.438 | 128.62 | 0.10 | 0.4 |
| 2390.626 | -3.104 | 137.78 | 0.10 | 0.4 |
| 2640.625 | -6.512 | 144.00 | 0.20 | 0.5 |
| 2890.625 | -10.082 | 148.52 | 0.20 | 1.0 |
| 3140.625 | -13.658 | 151.95 | 0.30 | 3.0 |
| 3390.625 | -17.240 | 154.67 | 0.30 | 4.0 |
| 3640.625 | -20.892 | 156.87 | 0.30 | 5.0 |
| 3890.625 | -24.722 | 158.70 | 0.50 | 5.0 |

Table 16-5. Combination of IEEE and O.91 Specification

| Frequency Difference (Hz) | Phase Jitter (Degrees) | | |
|---------------------------|------------------------|------------|------------|
| | Frequency Band (Hz) | | |
| | 4 – 300 | 4 – 20 | 20 – 300 |
| 0.3 | <1 | <1 | XXX |
| 0.4 | <1 | <1 | XXX |
| 0.75 | <3 | <3 | XXX |
| 1.0 | <3 | <3 | XXX |
| 1.5 | <8 | <8 | XXX |
| 2.0 | <8 | <8 | <1 |
| 4.0 | 10.7 ± 1.5 | 10.7 ± 1.5 | XXX |
| 5.0 | XXX | XXX | <3 |
| 6.0 | 11.2 ± 1.0 | 11.2 ± 1.0 | XXX |
| 8.0 | 11.5 ± 0.7 | 11.5 ± 0.7 | XXX |
| 10.0 | 11.5 ± 0.7 | 11.5 ± 0.7 | <8 |
| 12.0 | 11.5 ± 0.7 | 11.5 ± 0.7 | <10 |
| 16.0 | 11.5 ± 0.7 | 11.5 ± 0.7 | XXX |
| 20.0 | 11.5 ± 0.7 | 11.1 ± 1.1 | 11.5 ± 0.7 |
| 33.0 | 11.5 ± 0.7 | <3 | 11.5 ± 0.7 |
| 47.0 | 11.5 ± 0.7 | <1 | 11.5 ± 0.7 |
| 240 | 11.5 ± 0.7 | XXX | 11.5 ± 0.7 |
| 300 | 11.1 ± 1.1 | XXX | 11.1 ± 1.1 |
| 500 | <3 | XXX | <3 |
| 700 | <1 | XXX | <1 |

XXX = Does NOT APPLY

Table 16-6. Amplitude Jitter Frequency Weighting 20 – 300 Hz

| Frequency Difference (Hz) | Amplitude Jitter Reading (%) |
|---------------------------|------------------------------|
| 2 | <0.9 |
| 5 | <2.6 |
| 10 | <7.0 |
| 20 – 240 | 9.4 – 10.6 |
| 300 | 8.7 – 10.6 |
| 500 | <2.6 |

Table 16-7. Amplitude Jitter Frequency Weighting 4 – 300 Hz

| Frequency Difference (Hz) | Amplitude Jitter Reading (%) |
|---------------------------|------------------------------|
| 0.4 | <0.9 |
| 1.0 | <2.6 |
| 2.0 | <7.0 |
| 4.0 | 8.0 – 10.6 |
| 8 – 240 | 9.4 – 10.6 |
| 300 | 8.7 – 10.6 |
| 500 | <2.6 |

A. APPENDIX A: CALIBRATION

A.1 Scope

This procedure is to calibrate and validate the calibration of the AM5-XT, AM5eXT, AM5-XT-200, and AM5eXT-200 with **105A** or later software only. Refer to the AM5-XT Instruction Manual (Section 7.02, *Quiet* mode) to help identify the software version the unit currently has installed.

A.2 Equipment Required

- A highly accurate AC voltmeter (up to 4 decimal places, +/- 0.1% at 1000 Hz)
- Bantam to Minigator and/or Bantam to Bantam cables.
- A 600Ω load resistor, accurate to 1% tolerance (1/4 watt).

A.3 Calibration Procedure

Transmit and Receive Calibration

1. Remove all input leads.
2. Connect T1 and R1 leads of the AM5eXT of either the front right bantam jack or rear terminal screws to the AC Voltmeter.
3. Set the voltmeter to measure AC voltage.
4. Press [**AUX**] key to enter AUX mode.
5. Press [**#**] key. The unit display will read “**AUTO CAL?**”.
6. Press [**#**] key again. The unit display will read “**FULL CAL?**”.
7. **Toggle dip switch 5** on the back panel to enable “**FULL CAL?**”.

Note: To abort “**FULL CAL?**” press any key other than [**D**].

8. Press the [**D**, **ENTER**] key. Display will read V1 on the left and four dashes on the right. PARAM SET LED will turn on. Wait approximately 3 seconds for the AC voltmeter reading to stabilize.
9. Enter V1 from the voltmeter reading (4 digits) in millivolts. The PARAM SET LED will blink. The voltage should be larger than 3431 mV and smaller than 4319 mV. Press the [**D**, **ENTER**] key twice to enter the reading. Any

voltage entered outside the lower and upper ranges will display “**DATA ERROR**” and any key pressed thereafter will abort calibration. The PARAM SET LED will remain on.

Note: If the calibration procedure is aborted before completion, power the unit off, and then on again. The unit display should read “**FULL CAL?**”. Press [**D, ENTER**] key and complete steps 9 through 14.

Repeat Steps 11 and 12 until you have entered voltages for V2 to V9. The minimum and maximum of readings are as follows.

| <u>DISPLAY</u> | | <u>VALID RANGES</u> | |
|----------------|------|---------------------|--------------|
| | | <u>lower</u> | <u>upper</u> |
| V1 | ---- | 3431 mV | 4319 mV |
| V2 | ---- | 859.2 mV | 1081 mV |
| V3 | ---- | 632.8 mV | 796.5 mV |
| V4 | ---- | 158.7 mV | 199.6 mV |

The rest of the voltages should be entered as the AC voltmeter reads in millivolts *(times) 10. Your measurements should be within the below ranges.

| | | | |
|----|------|----------|----------|
| V5 | ---- | 1587 mV | 1996 mV |
| V6 | ---- | 109.6 mV | 137.9 mV |
| V7 | ---- | 282.5 mV | 355.6 mV |
| V8 | ---- | 206.8 mV | 260.2 mV |
| V9 | ---- | 54.13 mV | 68.13 mV |

10. After V9 is entered, display will be blank on the left and read “**CAL?**” on the right. PARAM SET LED will go out.
11. Disconnect the AC voltmeter leads from the AM5eXT being calibrated.
12. Press [**D, ENTER**] key. The unit will begin to calibrate itself. This process takes approximately 4 minutes. After calibration is completed, unit goes to AUX mode, displaying “**UNDR**”. Now Auto Calibration must be conducted.

Auto Calibration (Receive Only)

1. Remove all input leads on the unit to be calibrated.
2. Press [**AUX**] key to enter auxiliary mode.

3. Press [#] key. The left display will prompt with “AUTO CAL?”
4. Press [D] or [ENTER] key.
5. Wait approximately 45 seconds for the auto calibration to complete.

A.4 Validation Procedure

1. Connect the Bantam to Minigator cable from the AM5 “4W SEND” to the 600Ω load resistor.
2. Connect the AC volt meter leads to the 600Ω resistor. See the drawing below.

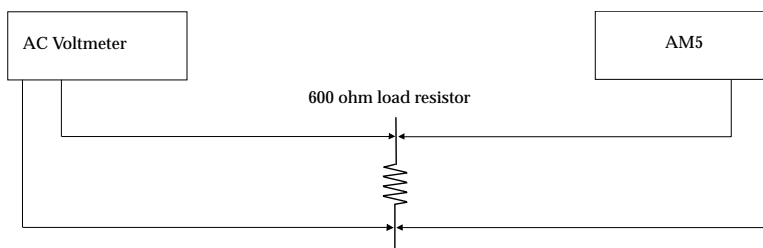

3. Set the voltmeter to measure AC voltage.
4. Program the AM5 to 4W, 600Ω Term and transmit 1004 Hz at different levels. Read AC voltage on the Voltmeter and make sure readings correspond to the values below:

| | <u>Low</u> | <u>High</u> |
|---------------------------|------------|-------------|
| Transmit 1004 Hz @ +5 dBm | 1.363 V | 1.393 V |
| -10 dBm | 242.2 mV | 247.70 mV |
| -25 dBm | 43.70 mV | 44.40 mV |
| -40 dBm | 7.66 mV | 7.83 mV |
| -50 dBm | 2.32 mV | 2.59 mV |

Note: Any reading which does not fall within the above values indicates that the unit is in need of re-calibration. Refer to the Calibration Procedure.

Refer to the Self-Test Instructions in the User Manual to verify proper operation. If the unit fails Calibration, Validation of Calibration, or the Self Test Instructions twice, the unit should be sent to Ameritec for repair.

Warranty, Calibration, And Service

(18-0022)

AM5XT/eXT Voice/Data Transmission

INDEX

#

| | |
|--|------|
| 1004 Hz..... | 7-3 |
| 15 kHz Flat Weighting Characteristic | 9-10 |
| 160kHz-Filter Noise Measurement..... | 8-7 |
| 19" Rack Mounting Kit | 3-15 |
| 2 kHz Flat Characteristic..... | 9-13 |
| 2 kHz Tone | 16-2 |
| 2-Position DIP Switch, AM-47XT | 3-18 |
| 2-Tone Signal | 7-15 |
| 2-Wire Envelope Delay | 8-24 |
| 2-Wire Envelope Delay Setup..... | 8-25 |
| 2-Wire Far to Near Test..... | 8-25 |
| 2-Wire Line Circuit Block Diagram | 6-3 |
| 2-Wire Return Loss | 8-15 |
| 2-Wire Testing with Responder..... | 5-8 |
| 2W (2-Wire)..... | 6-8 |
| 3 kHz Flat Characteristic..... | 9-13 |
| 3 kHz Flat Weighting Characteristic..... | 9-10 |
| 4-Tone Signal..... | 7-14 |
| 4-Wire End-to-End Testing | 5-6 |
| 4-Wire Envelope Delay Setup..... | 8-20 |
| 4-Wire Far to Near Test..... | 8-23 |
| 4-Wire Line Circuit Block Diagram | 6-3 |
| 4-Wire Near to Far Test..... | 8-21 |
| 4-Wire Return Loss | 8-16 |
| 4-Wire Testing with Responder..... | 5-7 |
| 4W (4-Wire)..... | 6-8 |
| 50 Kilobit Weighting Characteristic | 9-11 |
| 60 Hz Filter..... | 9-7 |
| 8-Switch DIP Switch..... | 3-14 |
| A | |
| A1 Command | 12-7 |

| | |
|---|--------------|
| AAE Command | 12-9 |
| Absolute Measurement..... | 3-9, 9-8 |
| AC Operation | 5-2 |
| AC Power Selector Switch | 3-12 |
| Acceptable Holding Tone Ranges..... | 3-9 |
| Accessories | 3-23, 14-1 |
| AE Command..... | 12-10 |
| ALE Command..... | 12-8 |
| AM-47XT Hand-Held Printer | 3-16 |
| AM-47XT Hand-Held Printer Connection with AC Power | 5-3 |
| AM-47XT Technical Specifications | 3-16 |
| AM5eXT Noise Weighting Filters..... | 9-4 |
| AM5eXT-200 (ce)..... | 1-2 |
| AM5XT Noise Weighting Filters..... | 9-3 |
| AM5XT/eXT Basic Units | 1-2 |
| AM5XT/eXT Connection Cables..... | 5-4 |
| AME Command..... | 12-9 |
| AMP JTR | 8-35 |
| Amplitude Jitter | 8-35, 16-9 |
| Amplitude Jitter Frequency Weighting..... | 16-15, 16-16 |
| Appendix A: Calibration..... | A-1 |
| ASE Command | 12-8 |
| Auto Calibrate | 4-3 |
| Auto Calibration (Receive Only) | A-2 |
| Automatic Speed Dialing | 10-4 |
| Auxiliary Control Commands | 12-5 |
| Auxiliary Function Enable | 9-1 |
| Auxiliary Function Row Enable Key..... | 3-6 |
| Auxiliary Functions | 9-1 |
| Auxiliary Port..... | 16-13 |
| Auxiliary RS232 Connector..... | 3-14 |
| Auxiliary RS232 Connector Pin Assignment | 3-14 |
| Auxiliary RS232 Port..... | 12-11 |

B

| | |
|----------------------------------|-------|
| Balance | 16-12 |
| Bandwidth Parameter Limits | 12-13 |
| Bantam Plug Line Cables | 3-23 |
| Battery | 3-15 |
| Battery Pack | 2-1 |
| Begin Plot | 13-4 |
| BRDG | 6-7 |
| Bridge/Terminate | 6-5 |

C

| | |
|---|------------|
| C-Message Weighting Characteristic | 9-9 |
| Cables | 14-1 |
| Calibration | 4-4, A-1 |
| Calibration Check | 4-4 |
| Calibration Policy | 15-1 |
| Calibration Procedure | A-1 |
| Calibration Test Signal | 7-15 |
| Carrying Case | 3-24 |
| Carrying Handle | 3-5 |
| Chaining | 12-11 |
| Charging Considerations, AM-47XT | 3-20 |
| Charging Procedure, AM-47XT | 3-22, 3-23 |
| Choosing Plotter Algorithm | 13-4 |
| Clearing a Stored Number | 10-4 |
| Color Coding and Marking | 3-2 |
| Combination of IEEE and O.91 Specification | 16-15 |
| Command Protocol | 12-2 |
| Command Responses | 12-7 |
| Commercial Power | 2-1 |
| Conditioning Mask Definition Format .. | 12-12 |
| Configuration Instructions | 5-1 |
| Configurations | 5-5 |
| Connection and Configuration Instructions | 5-1 |

| | |
|--------------------------------------|------|
| Connectors and Cables | 5-2 |
| Connectors and Cables, AM-47XT | 3-18 |
| Construction | 3-1 |

D

| | |
|-------------------------------------|------------|
| Daisy Chaining | 12-11 |
| DAMP | 9-9 |
| Data Displays | 4-6 |
| DC Blocking | 16-12 |
| DC Line Hold | 6-4 |
| Dial Mode Select | 10-2 |
| Dial Pulse (DP) Requirements | 10-5, 10-6 |
| Dialing | 10-1, 10-2 |
| Dialing Commands | 12-7 |
| Dialing Mode Enable Key | 3-6 |
| Dimensions | 3-1, 16-12 |
| DIP Switch Settings | 3-14 |
| Display LEDs | 3-7 |
| Display Update Select | 9-9 |
| Dropouts | 8-37 |
| Dual-Tone Dialing Frequencies | 10-5 |

E

| | |
|--|------------------|
| Effect of Noise | 8-14 |
| Effect of Non-linear Distortion | 8-14 |
| End-to-End Testing | 5-5 |
| ENV DLY | 7-9, 8-17 |
| Envelope Delay | 7-9, 8-17 |
| Envelope Delay Distortion ... | 8-14, 16-4, 16-8 |
| ERL Filter Response | 16-13 |
| Exiting Print Mode Before Printing | 13-3 |
| Exiting Print Mode While Printing | 13-3 |

F

| | |
|--|------|
| Factory Set Defaults | 11-1 |
| Filter for Narrow Band Level/Frequency ... | 9-2 |

- Foot/Guard.....3-12
- Frequency Measure..... 16-5
- Front Panel Components..... 3-2, 3-4
- Front Panel Delete Option.....3-15
- Front Panel Layout3-2
- Front Panel Notes3-2
- Full-Duplex Talk..... 7-17
- Function Boxes.....9-2
- Function Enable Keys3-5
- Functional Description3-1
- Fuse Holder.....3-12
- G**
- Gain Hits 8-37
- General 16-12
- General Line Function Notes6-2
- General Noise Measurement Notes8-6
- Generator Source Impedances.....6-6
- Group Delay..... 7-12, 8-27, 16-7
- Group Delay Setup8-31
- Group Delay Transmitter 16-3
- GROUP DLY 7-12, 8-27
- H**
- Half-Duplex Talk 7-17
- Hand-Held Printer,
 Component Location 3-17
- Hold Tone.....3-9, 16-2
- Holding Tone Ranges.....3-9
- Humidity 16-12
- I**
- Idle Channel Noise8-9
- IMD..... 7-14, 8-32
- IMP NOISE 8-35
- Impulse Noise Measure (3 Level) 16-6
- Impulse Noise with Tone Measure 16-6
- Impulse Noise without Tone 8-35
- Independent Send and Measure Modes5-1
- Input..... 16-12
- Intermodulation Distortion 7-14, 8-32
- Introduction..... 1-1
- J**
- Jitter Bandwidth Select.....9-6
- Jitter Bandwidth Weighting Filters.....9-6
- Jitter Frequency Weighting.....16-15, 16-16
- K**
- Keys3-3
- L**
- Last Number Automatic Speed Dial 10-4
- LED Display 3-7, 3-10
- LEDs, AM-47XT 3-18
- Level and Noise Units of Measurement.....3-8
- Level Measure 16-5
- Level/Frequency8-2
- Line Cables.....3-23
- Line Connection Cables.....5-4
- Line Connection Interface.....5-4
- Line Connections 6-5, 16-12
- Line Control Commands..... 12-2
- Line Function Enable6-1
- Line Function Row Enable Key.....3-6
- Line Functions.....6-1
- Line Impedances6-4
- Line Termination Impedances.....5-5
- LOOP BACK 7-17
- Loopback Testing.....5-6
- Low-Level Measurements.....5-1
- LVL/FREQ8-2

M

Mainframe 14-1
 Mainframe Options..... 14-1
 Manual Dialing..... 10-1
 Mask Definition Format..... 12-12
 Mask Feature..... 3-26
 Measure Control Commands 12-4
 Measure Function Row Enable Key 3-6
 Measure Functions..... 8-1
 Measure Mode Enable..... 8-1
 Measurements..... 16-1
 Memory Considerations..... 11-1
 Metal Case..... 3-10
 MF and TT (DTMF) Tone Pairs 10-5
 MICRO INTR 8-39
 Micro-interruptions..... 8-39, 16-11
 Microphone..... 3-7
 Miscellaneous Commands..... 12-10
 Miscellaneous Parameter Displays..... 7-2
 Monitor Switch..... 3-5
 Monitor/Talk 16-12
 Monitoring Dialing..... 10-2
 Mounting..... 3-1

N

Narrow-Band Level/Frequency 8-3
 NOISE 8-9, 16-5
 Noise Measurement with Filter 8-6
 Noise to Ground..... 8-10
 Noise Units of Measurement..... 3-8
 Noise Weighting Filters 8-7, 9-3
 Noise with Tone..... 8-9, 16-6
 Non-Linear Distortion (4 Tone).... 16-4, 16-11
 NOTCH NOISE..... 8-9
 NTG 8-10

O

OFF HK 6-6, 6-7
 OPEN 7-16
 Operating..... 16-12
 Operation Techniques 4-1
 Optional Equipment..... 3-15
 Ordering Information 14-1
 Overview..... 1-1

P

P/AR Definition 8-12
 P/AR Effects 8-13
 P/AR Line Spectrum 16-14
 P/AR Requirements of Telephone Lines . 8-13
 Paper Installation for the AM-47XT..... 3-20
 Paper Roll Installation 3-19
 PAR..... 7-7, 8-12
 Parameter Set 4-5
 Password Security 12-10
 Peak-to-Average Ratio 7-7, 8-12, 16-3
 Phase Hits..... 8-37
 Phase Jitter..... 8-34, 16-8
 PHASE JTR..... 8-34
 Physical and Functional Description..... 3-1
 Plotting 13-1
 Polarity 5-4
 Power 16-12
 Power, AM-47XT 3-18
 Power Considerations..... 2-1
 Power On/Off Push Button..... 3-4
 Power Plug..... 3-12
 Power Switch, AM-47XT 3-18
 Print Enable 9-4
 Printer Cables 5-2
 Printer Hookup 3-21

- Printing and Plotting 13-1
 Printing Mechanism..... 3-19
 Printout of Front Panel Setup..... 13-1, 13-2
 Printout of Measurement..... 13-1
 Printout of Plot Condition Mask..... 13-3
 Printout of Plot Measurement Results..... 13-2
 Printout Types 13-1, 13-2
 Program Weighting Characteristic 9-9
 Psophometric Characteristic 9-11
- Q**
- QUASI PK..... 9-4
 Quasi-Peak Detector 8-7
 Quasi-Peak Detector Enable 9-4
 Quiet..... 7-2
 Quiet Send Mode 4-1
- R**
- Rear Panel Components..... 3-11
 Recall 3-7, 11-1, 16-13
 Recall 80 11-7
 Recall and Speed Dial of
 Stored Dialed Number 10-4
 Receive Functions 16-5
 Receive Pair Bridged/Terminated 6-7
 Receive Pair Off-Hook/On-Hook) 6-7
 Recorder Outputs 3-12
 REL SET 9-7
 Relative Measure Zero Set 9-7
 Relative Measurement..... 3-9, 9-8
 Remote Control Port 16-12
 Remote Control Using
 TT Commands 10-7, 10-8
 Response Protocol..... 12-6, 12-7
 RET LOSS..... 7-7, 8-15
 Return Loss..... 7-7, 8-15, 16-2, 16-7, 16-12
 Return of Unit..... 15-2
 REV 6-8
 Reversed..... 6-8
 Ribbon and Paper Installation
 for the AM-47XT 3-20
 Ribbon Cartridge Replacement..... 3-19
 RS232 Cables 3-25
 RS232 Commands..... 12-1
 RS232 Connector 3-13
 RS232 Connector Pin Assignment 3-13
 RS232 Port Configuration..... 12-11
 RS232 Port Option 3-15
 Rubber Feet..... 3-6
 RX Bantam Jack 3-4
- S**
- S/N..... 8-11
 Screw Terminal..... 3-13
 Self Test, AM-47XT 3-20
 Self-Test and Operation Techniques..... 4-1
 Self-Test Setup 4-1
 Send 1004 Hz 4-2
 Send Control Commands 12-3
 Send Envelope Delay 4-3
 Send Function Enable..... 7-1
 Send Function Row Enable Key..... 3-6
 Send Functions 7-1, 16-1
 Send IMD 4-3
 Send Pair Off-Hook/On-Hook)..... 6-6
 Send PAR 4-2
 Service Policy..... 15-1
 Set Up Plotter Zero and Scaling..... 13-4
 SF SKIP 7-16
 Siemens Adapter Option..... 3-16
 Signal to Noise Ratio 8-11, 16-6
 Signaling 16-12

- Signaling Frequency Skip 7-16, 16-2
 Slope 7-4, 16-2
 Sound Unweighted Characteristic 9-12
 Sound Weighted Characteristic 9-12
 Speaker 3-11
 Specifications 16-1
 Speed Dialing 10-4
 SRL High Filter Response 16-14
 SRL Low Filter Response 16-13
 Standard Cables Supplied with
 AM-47XT Printer 3-18
 Start and Stop Frequencies for
 Plotter Limits 13-3
 START STOP 9-6
 Step-Down Transformer 3-12
 Storage 16-12
 Storage of Dialed Number 10-3
 Store 3-7, 11-1, 16-13
 Stored Memories and Purpose 11-1
 Storing a Telephone Number 10-3
 Sweep 7-5
 Switch Setup 4-1
- T**
- TALK 7-16
 Technical Specifications 16-1
 Termination Impedances (Receive Pair) 6-7
 Testing with Responders 5-7
 Timed Study Start/Stop 9-6
 Tone Dialing Level 10-1
 Tone Ringer, Incoming Ring 6-8
 TRAN 8-37
 Transients 8-37, 16-9
 Transmit and Receive Calibration A-1
 TX/2W Bantam Jack 3-4
- U**
- Unit Status 3-3
 Units of Measurement LEDs 3-8, 3-10
 Unpacking 1-1
 User Entered Memories 11-8
- V**
- Validation Procedure A-3
 VAR 16-1
 VAR HZ 7-4
 Variable Tone 7-4
 Voice/Data Transmission Test Set
 Ordering 14-1
 Volume Control Knob 3-11
- W**
- Warranty 15-1
 Warranty, Calibration, and Service 15-1
 Weight 3-1, 16-12
 Wide-Band Level/Frequency 8-2
- X**
- XY Plotter Operation 13-3
 XY Plotter Outputs 3-15



Ameritec is dedicated to serving the worldwide telecommunications community by providing competitively priced, state-of-the-art test equipment that is supported by the finest in marketing, engineering development and customer service.

Ameritec

760 Arrow Grand Circle
Covina, CA 91722 USA

TEL 626.915.5441

FAX 626.915.7181

www.ameritec.com