



Is Now Part of



ON Semiconductor®

To learn more about ON Semiconductor, please visit our website at

www.onsemi.com

ON Semiconductor and the ON Semiconductor logo are trademarks of Semiconductor Components Industries, LLC dba ON Semiconductor or its subsidiaries in the United States and/or other countries. ON Semiconductor owns the rights to a number of patents, trademarks, copyrights, trade secrets, and other intellectual property. A listing of ON Semiconductor's product/patent coverage may be accessed at www.onsemi.com/site/pdf/Patent-Marking.pdf. ON Semiconductor reserves the right to make changes without further notice to any products herein. ON Semiconductor makes no warranty, representation or guarantee regarding the suitability of its products for any particular purpose, nor does ON Semiconductor assume any liability arising out of the application or use of any product or circuit, and specifically disclaims any and all liability, including without limitation special, consequential or incidental damages. Buyer is responsible for its products and applications using ON Semiconductor products, including compliance with all laws, regulations and safety requirements or standards, regardless of any support or applications information provided by ON Semiconductor. "Typical" parameters which may be provided in ON Semiconductor data sheets and/or specifications can and do vary in different applications and actual performance may vary over time. All operating parameters, including "Typicals" must be validated for each customer application by customer's technical experts. ON Semiconductor does not convey any license under its patent rights nor the rights of others. ON Semiconductor products are not designed, intended, or authorized for use as a critical component in life support systems or any FDA Class 3 medical devices or medical devices with a same or similar classification in a foreign jurisdiction or any devices intended for implantation in the human body. Should Buyer purchase or use ON Semiconductor products for any such unintended or unauthorized application, Buyer shall indemnify and hold ON Semiconductor and its officers, employees, subsidiaries, affiliates, and distributors harmless against all claims, costs, damages, and expenses, and reasonable attorney fees arising out of, directly or indirectly, any claim of personal injury or death associated with such unintended or unauthorized use, even if such claim alleges that ON Semiconductor was negligent regarding the design or manufacture of the part. ON Semiconductor is an Equal Opportunity/Affirmative Action Employer. This literature is subject to all applicable copyright laws and is not for resale in any manner.

Simplified Intelligent Port Design Using the 74ACT1284

Introduction

Until recently a standard for parallel port data transfer has been missing in the industry. IEEE1284, approved by the IEEE in March 1994, addresses the lack of a parallel port specification. The standard, entitled "A Standard Signaling Method for a Bi-Directional Parallel Peripheral Interface for Personal Computers", will eventually displace the antiquated, slow, quasi-bi-directional method of transferring data between host and peripheral. Described within the standard is a high speed, fully interlocked bi-directional peripheral connectivity port which greatly improves performance while maintaining backward compatibility with systems which are IEEE 1284 non-compliant.

There are five operational modes described in the standard. The two truly bi-directional modes, the EPP (enhanced parallel port) and the ECP (extended capabilities port) provide for the greatest increase in port performance. The EPP and ECP modes allow half duplex data communication between the host and its peripheral at speeds greater than 100 times that of the SPP (standard parallel port). This translates to a remarkable speed upgrade of more than 2 Mbytes/sec. However, in order to realize the tremendous increase in speed and the advantages of true bi-directionality made possible by IEEE 1284, system designers must pay particular attention to the port interface circuitry.

There are key areas one needs to be concerned with when designing IEEE 1284 compliant systems. Of primary importance is ensuring data integrity at the high rates made possible by the new standard. Another important consideration is the limitations peripheral ASIC controllers may have when attempting to directly drive the IEEE 1284 specified 10 meter cable lengths. These things serve to underscore the fact that port I/O drive and receive components must possess the capability for maintaining IEEE 1284 specified signal levels and timing.

74ACT1284

The 74ACT1284 provides the necessary low impedance drive for transmission of the control and data signals necessary for reliable intelligent peripheral and host interface communication. The device was developed in response to the IEEE 1284 standard and an anticipated expansion in the intelligent peripheral market. Fairchild Semiconductor design philosophy for the 74ACT1284 was to accommodate the IEEE 1284 standard and to provide system manufacturers a solution to the problems associated with using ASICs to drive the high bandwidth IEEE 1284 port. The 74ACT1284 meets or exceeds all IEEE 1284 specified parameters for driving and receiving signals over an intelligent peripheral interface port and addresses such critical design areas as high speed parallel port handshaking, low impedance cable driving, and increased ESD protection.

The 74ACT1284 device functions as a 7-bit bus transceiver designed for asynchronous two-way communication. As shown in the logic diagram, Figure 1, the IC contains four non-inverting bi-directional buffers and three non-inverting unidirectional buffers. The B Port buffers can be configured either as open drain or high drive outputs. The HD input pin enables the B Ports to switch from open drain to a high drive totem pole configuration, capable of sourcing and sinking 14 mA on all seven buffers. The DIR input determines the direction of data flow on the bi-directional buffers. The DIR control function implementation helps to minimize external timing requirements.

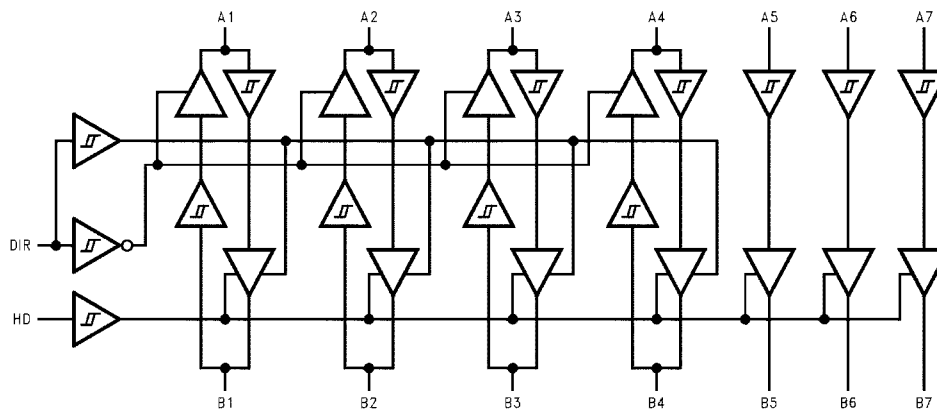

FIGURE 1. 74ACT1284 Logic Diagram

74ACT1284 (Continued)

The FSC 74ACT1284 gives the designer significant advantage when designing the port interface circuitry. System manufacturers who design to the IEEE 1284 standard using an ASIC controller to drive the parallel port directly may encounter problems. ASIC controller power and drive constraints become evident when attempting to drive lengthy, highly capacitive, low impedance cables. Consequently, IEEE 1284 specifications may not be met. When using the 74ACT1284, designers have an integrated solution which ensures that critical port interface signal properties are preserved.

Some advantages for using the 74ACT1284 at an IEEE 1284 compliant port are the following:

- Full IEEE 1284 specification compliance
- Provides a solution for easing controller power and drive design constraints
- Bi-directional Port buffering with input hysteresis
- Optimized printed circuit layout through localization of port drive circuitry
- Advanced CMOS technology for low power consumption
- Guaranteed class 3 ESD performance for protection of sensitive I/O signal controllers
- TTL and CMOS compatible input thresholds

Host-Side Application of the 74ACT1284

Perhaps it is more likely that the 74ACT1284 function will be utilized at the intelligent peripheral port, however, there are benefits for its use at both the host and peripheral port interfaces. There are several important advantages for using the 74ACT1284 at the host as well as the peripheral. They are as follows: 1) adequate cable drive over the required IEEE 1284 data bandwidth 2) increased port ESD protection and most importantly 3) the assurance of full IEEE 1284 compliance.

An application example for using the 74ACT1284 at the host in ECP mode appears in Figure 2. In the figure, a generic host controller is shown with three 74ACT1284s (shown as one block) placed at the I/O port. The diagram denotes compatibility mode signals, with ECP mode signals shown in parenthesis, interconnecting the host and peripheral. 74ACT1284 devices are used here to drive and buffer signals between host and peripheral, insuring signal integrity and protection of the host controller from damage caused by noise spikes should the peripheral be powered down or arbitrarily disconnected.

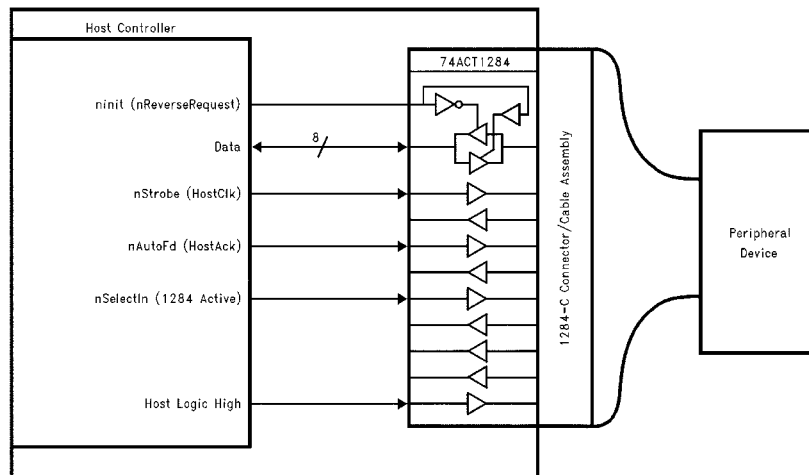

FIGURE 2. Host-Side 74ACT1284 Application

Peripheral-Side Application of the 74ACT1284

Similar to Figure 2, Figure 3 shows a diagram of peripheral-side application of the 74ACT1284. Both Figure 2 and Figure 3 application examples depict the peripheral and host controller direct I/O port interface portion of the system only.

Register names and hooks will vary depending on controller design, therefore, it is likely that not all register connections will be shown in the figures. We would like to re-

emphasize that buffering of all signals at the port is the best way of assuring system functionality and reliability.

The peripheral can take many forms and still support IEEE 1284. Other devices that use the new IEEE 1284 standard are scanners, tape backup, CD ROM and network/LAN adapters.

For clarity, Figure 4 has been included to show the signal connections which comprise the entire system. It is beyond the scope of this paper to assume how all signals might be used to and from the controller registers. The examples show basic IEEE 1284 control signal names. There may be other signals used which are not shown in the examples.

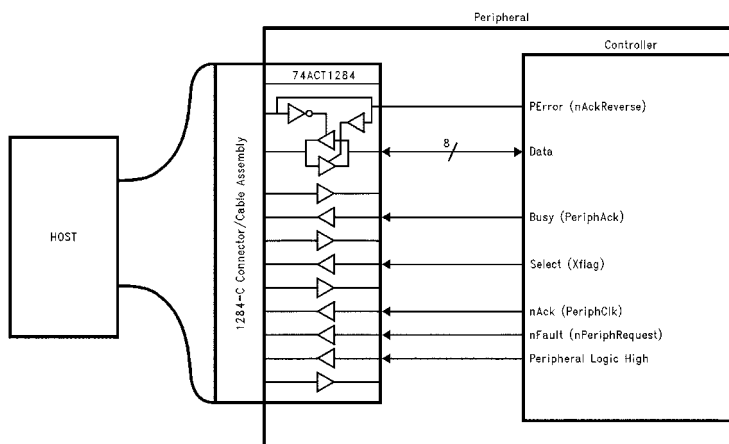

FIGURE 3. Peripheral-Side 74ACT1284 Application

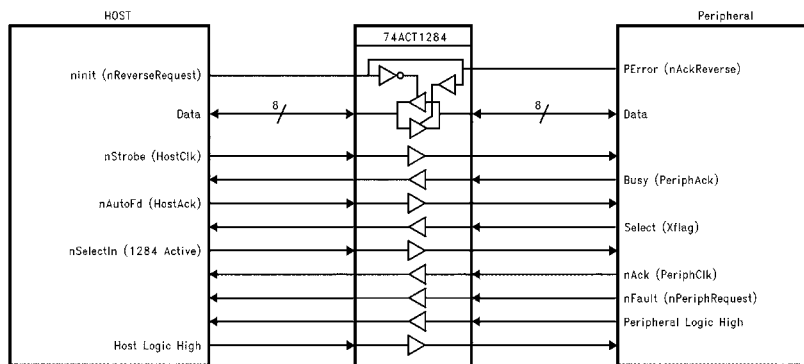

FIGURE 4. Host/Peripheral System Signals

Summary

With the advent of IEEE 1284, system designers are looking at a new horizon with which to implement the information exchange between computer and peripheral. The proliferation of high performance computing systems coupled with IEEE 1284 compliant intelligent peripheral devices will serve to outmode the old methods of transporting data via the parallel port and its external support medium.

For new IEEE 1284 compliant designs to reach their market in a shorter time, solutions which enhance the design cycle through simplification are usually a good alternative. The 74ACT1284 was developed to provide a packaged solution to the design of the bus interface in IEEE 1284 compliant systems. It is a device intended to alleviate the problems associated with IEEE 1284 specification conformance and can be thought of as a drop-in stage for ensurance of IEEE 1284 compliance.

Fairchild does not assume any responsibility for use of any circuitry described, no circuit patent licenses are implied and Fairchild reserves the right at any time without notice to change said circuitry and specifications.

LIFE SUPPORT POLICY

FAIRCHILD'S PRODUCTS ARE NOT AUTHORIZED FOR USE AS CRITICAL COMPONENTS IN LIFE SUPPORT DEVICES OR SYSTEMS WITHOUT THE EXPRESS WRITTEN APPROVAL OF THE PRESIDENT OF FAIRCHILD SEMICONDUCTOR CORPORATION. As used herein:

1. Life support devices or systems are devices or systems which, (a) are intended for surgical implant into the body, or (b) support or sustain life, and (c) whose failure to perform when properly used in accordance with instructions for use provided in the labeling, can be reasonably expected to result in a significant injury to the user.
2. A critical component in any component of a life support device or system whose failure to perform can be reasonably expected to cause the failure of the life support device or system, or to affect its safety or effectiveness.

www.fairchildsemi.com

ON Semiconductor and  are trademarks of Semiconductor Components Industries, LLC dba ON Semiconductor or its subsidiaries in the United States and/or other countries. ON Semiconductor owns the rights to a number of patents, trademarks, copyrights, trade secrets, and other intellectual property. A listing of ON Semiconductor's product/patent coverage may be accessed at www.onsemi.com/site/pdf/Patent-Marking.pdf. ON Semiconductor reserves the right to make changes without further notice to any products herein. ON Semiconductor makes no warranty, representation or guarantee regarding the suitability of its products for any particular purpose, nor does ON Semiconductor assume any liability arising out of the application or use of any product or circuit, and specifically disclaims any and all liability, including without limitation special, consequential or incidental damages. Buyer is responsible for its products and applications using ON Semiconductor products, including compliance with all laws, regulations and safety requirements or standards, regardless of any support or applications information provided by ON Semiconductor. "Typical" parameters which may be provided in ON Semiconductor data sheets and/or specifications can and do vary in different applications and actual performance may vary over time. All operating parameters, including "Typicals" must be validated for each customer application by customer's technical experts. ON Semiconductor does not convey any license under its patent rights nor the rights of others. ON Semiconductor products are not designed, intended, or authorized for use as a critical component in life support systems or any FDA Class 3 medical devices or medical devices with a same or similar classification in a foreign jurisdiction or any devices intended for implantation in the human body. Should Buyer purchase or use ON Semiconductor products for any such unintended or unauthorized application, Buyer shall indemnify and hold ON Semiconductor and its officers, employees, subsidiaries, affiliates, and distributors harmless against all claims, costs, damages, and expenses, and reasonable attorney fees arising out of, directly or indirectly, any claim of personal injury or death associated with such unintended or unauthorized use, even if such claim alleges that ON Semiconductor was negligent regarding the design or manufacture of the part. ON Semiconductor is an Equal Opportunity/Affirmative Action Employer. This literature is subject to all applicable copyright laws and is not for resale in any manner.

PUBLICATION ORDERING INFORMATION

LITERATURE FULFILLMENT:

Literature Distribution Center for ON Semiconductor
19521 E. 32nd Pkwy, Aurora, Colorado 80011 USA
Phone: 303-675-2175 or 800-344-3860 Toll Free USA/Canada
Fax: 303-675-2176 or 800-344-3867 Toll Free USA/Canada
Email: orderlit@onsemi.com

N. American Technical Support: 800-282-9855 Toll Free
USA/Canada
Europe, Middle East and Africa Technical Support:
Phone: 421 33 790 2910
Japan Customer Focus Center
Phone: 81-3-5817-1050

ON Semiconductor Website: www.onsemi.com
Order Literature: <http://www.onsemi.com/orderlit>
For additional information, please contact your local
Sales Representative