

OPERATION MANUAL
SIGNAL GENERATOR
MG3601A/MG3602A

OPERATION MANUAL

SIGNAL GENERATOR

MG3601A/MG3602A

CERTIFICATION

ANRITSU CORPORATION certifies that this instrument has been thoroughly tested and inspected, and found to meet published specifications prior to shipping.

Anritsu further certifies that its calibration measurements are based on the Japanese Electrotechnical Laboratory and Radio Research Laboratory standards.

WARRANTY

All parts of this product are warranted by Anritsu Corporation of Japan against defects in material or workmanship for a period of one year from the date of delivery. In the event of a defect occurring during the warranty period, Anritsu Corporation will repair or replace this product within a reasonable period of time after notification, free-of-charge, provided that: it is returned to Anritsu; has not been misused; has not been damaged by an act of God; and that the user has followed the instructions in the operation manual.

Any unauthorized modification, repair, or attempt to repair, will render this warranty void.

This warranty is effective only for the original purchaser of this product and is not transferable if it is resold.

ALL OTHER EXPRESSED WARRANTIES ARE DISCLAIMED AND ALL IMPLIED WARRANTIES FOR THIS PRODUCT, INCLUDING THE WARRANTIES OF MERCHANTABILITY AND FITNESS FOR A PARTICULAR PURPOSE, ARE LIMITED IN DURATION TO A PERIOD OF ONE YEAR FROM THE DATE OF DELIVERY. IN NO EVENT SHALL ANRITSU CORPORATION BE LIABLE TO THE CUSTOMER FOR ANY DAMAGES, INCLUDING LOST PROFITS, OR OTHER INCIDENTAL OR CONSEQUENTIAL DAMAGES, ARISING OUT OF THE USE OR INABILITY TO USE THIS PRODUCT.

All requests for repair or replacement under this warranty must be made as soon as possible after the defect has been noticed and must be directed to Anritsu Corporation or its representative in your area.

Copyright © 1988 by ANRITSU CORP. Printed in Japan.
All rights reserved. No part of this manual may be reproduced in any form without written permission of ANRITSU CORP.



WARNING

**NO OPERATOR SERVICEABLE PARTS INSIDE.
REFER SERVICING TO QUALIFIED PERSONNEL.**

CAUTION

**FOR CONTINUED FIRE PROTECTION REPLACE
ONLY WITH SPECIFIED TYPE AND RATED FUSE.**

Note:

1. The instrument is operable on a nominal voltage of 100 to 127 Vac or 200 to 250 Vac by changing the connections on the power transformer taps.

The voltage and current ratings are indicated on the rear panel when the instrument is shipped from the factory.

To operate on the other voltage, change the connections on the power supply transformer. The plate on the rear panel indicating the voltage and current ratings should be changed to the appropriate one. Order the plate from ANRITSU CORP. if needed.

2. In this manual, the power supply voltage and current ratings are represented by **Vac and ***A, respectively.
3. The relationship between power supply voltage and current rating is shown below.

Vac	*A
100 to 127 V	3.15 A
200 to 250 V	1.6 A

BNC-TYPE CONNECTOR INSTALLATION

The BNC-type connector installation has been modified as follows:

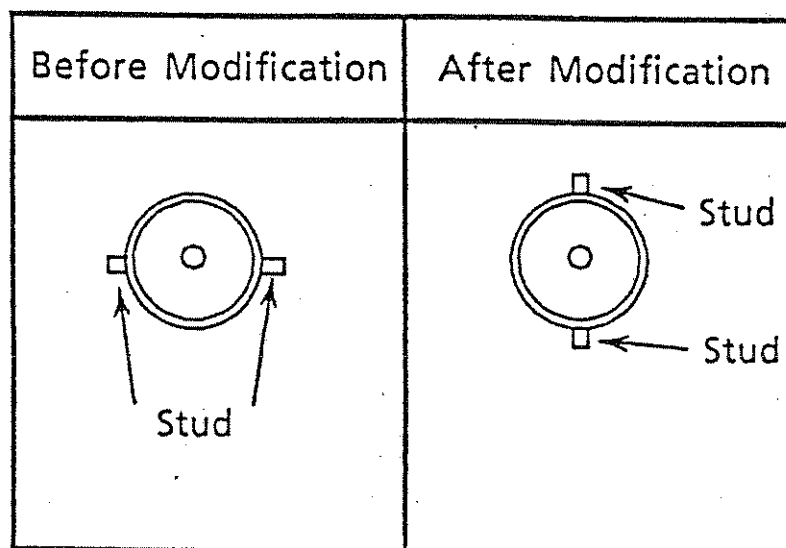

LEGENDS

WARNINGS, CAUTIONS, and Notes, and footnotes are used in this manual. Their meanings are given below:

(1) Hierarchy

The hierarchy priority is WARNING > CAUTION > Note > footnote.

(2) Definition

WARNING: WARNING is used when there is a personal injury hazard.

CAUTION: CAUTION is used when the equipment may be damaged.

Note: Note is used to provide information about exceptions, corrections, and restrictions.

Footnote: Footnotes provide comments at the foot of the same page as the text. Footnotes are referenced by either an asterisk (*) or by combination of asterisk and numeral.

OPERATION KEY REPRESENTATIONS

The operation keys in the descriptions of the operating procedure are represented as shown below.

Representation example	Meaning	
<div style="border: 1px solid black; padding: 2px; display: inline-block;"> RECALL <hr style="width: 80%; margin: 0 auto;"/> STORE </div>	<p>When only a key is shown in the operating procedure, it means press the key.</p> <p>Actions performed one or more times, such as [press several times], [press continuously], etc. are appended.</p>	
[RECALL] [SHIFT] [STORE]	<p>As a rule, key representations in the text are enclosed in [].</p>	
Key lamp	On <div style="display: inline-block; vertical-align: middle; margin-left: 20px;"> <div style="border: 1px solid black; padding: 2px; display: inline-block;"> <input checked="" type="checkbox"/> TUNE <hr style="width: 80%; margin: 0 auto;"/> RESET </div> </div>	<p>Lighting of the lamp in the key is presented by <input checked="" type="checkbox"/>.</p>
Off	<div style="display: inline-block; vertical-align: middle;"> <div style="border: 1px solid black; padding: 2px; display: inline-block;"> <input type="checkbox"/> TUNE <hr style="width: 80%; margin: 0 auto;"/> RESET </div> </div>	<p>Turning off of the lamp in the key is represented by <input type="checkbox"/>.</p>

The MG3601A/MG3602A is assumed to be equipped with Option 04 (internal modulation frequency 20 Hz to 100 kHz) in this manual.

FRONT AND REAR PANELS DESCRIPTION TABLE

MG3601A/MG3602A front and rear panel diagrams and a table describing them is appended to the end of this manual as a foldout. This manual can be read while looking at the panels by opening this foldout.

TABLE OF CONTENTS

		Page
SECTION 1	GENERAL	
1.1	Overview	1-1
1.2	Composition	1-1
1.2.1	Standard composition	1-2
1.2.2	Options	1-3
1.3	Application Parts and Peripheral Devices ...	1-4
1.4	Specifications	1-6
SECTION 2	PREPARATIONS	
2.1	Installation Precautions	2-1
2.1.1	Installation site environmental conditions	2-1
2.1.2	Rack mounting	2-3
2.2	Power Supply Safety Measures	2-3
2.2.1	Power cord polarity	2-3
2.2.2	Grounding	2-4
2.2.3	Fuse replacement	2-5
2.3	Storage Precautions	2-7
2.3.1	Precautions before storage	2-7
2.3.2	Recommended storage conditions	2-7

TABLE OF CONTENTS (Continued)

	Page
2.4 Repacking and Transportation	2-7
2.4.1 Repacking	2-8
2.4.2 Transportation	2-8
 SECTION 3 STARTING AND SIMPLE CHECKS	
3.1 Power On and Initial Setting	3-1
3.1.1 Power on	3-1
3.1.2 Reproduction of set parameters	3-4
3.2 Description of Displays	3-7
3.3 Simple Checks	3-12
3.3.1 Power-on initial setting display check	3-15
3.3.2 Carrier frequency and output level check	3-18
3.3.3 FM/φM check	3-21
3.3.4 AM check	3-26
3.3.5 MOD OUTPUT check	3-29
3.3.6 MOD INPUT check	3-30
 SECTION 4 CALIBRATION AND PERFORMANCE TESTS	
4.1 Daily Servicing and Preventive Maintenance	4-1
4.2 Calibration and Performance Tests Equipment	4-2

TABLE OF CONTENTS (Continued)

	Page
4.3	Calibration 4-3
4.3.1	Standard oscillator frequency accuracy (1) 4-3
4.3.2	Standard oscillator frequency accuracy (2) 4-6
4.4	Performance Tests 4-8
4.4.1	Frequency output 4-8
4.4.2	Output level frequency characteristic ... 4-10
4.4.3	Output level accuracy 4-12
4.4.4	FM deviation and FM distortion 4-16
4.4.5	AM modulation factor and AM distortion .. 4-19
4.5	Service 4-21
 SECTION 5 OPERATION	
5.1	Setting Carrier Frequency 5-1
5.1.1	Setting frequency from keyboard (DATA ENTRY) 5-2
5.1.2	Setting frequency using TUNE knob (TUNE) 5-7
5.1.3	Setting frequency using the step keys .. 5-13
5.1.4	Displaying relative frequency (FRL) 5-16
5.1.5	Reading carrier frequency when modulation frequency set 5-24

TABLE OF CONTENTS (Continued)

	Page
5.2	Setting Output Level 5-25
5.2.1	Open-circuit voltage display and terminated voltage display (SP03, 04) ... 5-27
5.2.2	Setting output level at keyboard (DATA ENTRY) 5-31
5.2.3	Setting output level using output setting knob 5-34
5.2.4	Setting output level using step keys ... 5-40
5.2.5	Reading output level from relative level (LRL) 5-42
5.2.6	Output level on/off 5-45
5.3	Basic Operations for Modulation 5-47
5.3.1	Outline of the MODULATION section/ DATA ENTRY section panel operations 5-48
5.3.2	Confirming modulation settings at initial setting 5-51
5.3.3	Switching internal modulation frequency 5-53
5.4	Modulation ON/OFF Operations 5-57
5.4.1	MODULATION ON/OFF using [MOD OFF] key .. 5-57
5.4.2	MODULATION ON/OFF using the modulation mode selection keys 5-58
5.4.3	Turning modulation on and selecting modes using [AM], [FM], and [øM] keys ... 5-64
5.4.4	MODULATION display at simultaneous modulation 5-71

TABLE OF CONTENTS (Continued)

	Page	
5.5	Setting AF OSC Frequency (20 Hz to 100 kHz)	5-73
5.5.1	Reading modulation frequency when carrier frequency set	5-74
5.5.2	Setting internal modulation frequency from keyboard (DATA ENTRY)	5-75
5.5.3	Setting AF OSC modulation frequency using TUNE knob (TUNE)	5-78
5.5.4	Setting AF OSC modulation frequency using step keys	5-84
5.6	Setting FM Modulation	5-87
5.6.1	Setting frequency deviation at keyboard (DATA ENTRY)	5-89
5.6.2	Setting frequency deviation using step keys	5-91
5.6.3	External FM modulation	5-93
5.6.4	Frequency calibration at dc FM modulation	5-95
5.7	Setting AM Modulation	5-96
5.7.1	Setting AM modulation factor at keyboard (DATA ENTRY)	5-98
5.7.2	Setting AM modulation factor using step keys	5-100
5.7.3	External AM modulation	5-102
5.8	Setting ϕ M Modulation	5-104
5.8.1	Setting phase deviation at keyboard (DATA ENTRY)	5-106
5.8.2	Setting phase deviation using step keys	5-108

TABLE OF CONTENTS (Continued)

	Page
5.8.3 External ϕ M modulation	5-111
5.9 Video Modulation	5-113
5.9.1 Selecting video modulation mode	5-114
5.9.2 Inputting video signals	5-115
5.10 Memory	5-118
5.10.1 FREQ memory	5-118
5.10.2 Function memory	5-121
5.11 Special Functions	5-122
5.11.1 Special function status	5-124
5.11.2 Initial settings (SP00)	5-124
5.11.3 Buzzer ON/OFF (SP02/01)	5-125
5.11.4 Switching terminated voltage display and open-circuit voltage display (SP04/03)	5-125
5.11.5 Video modulation ON/OFF (SP06/05)	5-127
5.11.6 Memory sequential read mode (SF08/07)	5-127
5.11.7 Memory protect ON/OFF (SP10/09)	5-129
5.11.8 RF frequency range cancel ON/OFF (SP14/13)	5-130
5.11.9 Switching external reference input to 10M/1M (SP15/16)	5-130
5.11.10 RF frequency offset mode ON/OFF (SP18/17)	5-131
5.11.11 Setting RF frequency offset value (SP31)	5-132

TABLE OF CONTENTS (Continued)

	Page
5.11.12 Output level offset mode ON/OFF (SP20/19)	5-134
5.11.13 Setting output level offset value (SP32)	5-136
5.11.14 Frequency calibration ON during dc FM modulation (SP30)	5-137
5.11.15 Simultaneous modulation with external and separate FM ON/OFF (SP34/33)	5-138
5.11.16 LCD backlight ON/OFF (SP36/35)	5-140
5.11.17 FREQ memory clear (SP61)	5-140
5.11.18 Initialize FUNCTION memory (SP62)	5-140
5.11.19 Setting frequency 0 Hz (SP63)	5-141
5.11.20 LCD and LED check (SP64)	5-141
5.11.21 RAM check (SP65)	5-141
5.11.22 ROM check (SP66)	5-141
5.11.23 Option display (SP67)	5-142
5.11.24 Dc FM high-stability mode ON/OFF (SP38/SP37)	5-142
5.12 External FM Polarity Switching (Option 06)	5-144
5.12.1 Outline	5-144
5.12.2 FM modulation polarity	5-144
5.12.3 Operation	5-145
5.13 External FM Modulation Factor Display (Option 07)	5-146
5.13.1 Outline	5-146

TABLE OF CONTENTS (Continued)

	Page
5.13.2 Specifications	5-146
5.13.3 Basic operation	5-147
5.13.4 Variableness of frequency deviation	5-149
5.13.5 Superimposition with internal modulation	5-151
5.13.6 Option 07 mode cancel	5-152
5.13.7 Precautions on use	5-153
5.13.8 Others	5-153
5.14 STATUS	5-154

SECTION 6 MEASUREMENT

6.1 Measuring Sensitivity	6-1
6.1.1 Measuring 20 dB NQ sensitivity	6-2
6.1.2 Measuring 12 dB SINAD sensitivity	6-5
6.2 Measuring One-Signal Selectivity	6-8
6.2.1 Using 20 dB NQ method to measure FM receiver selectivity	6-8
6.2.2 Measuring spurious response	6-14
6.3 Measuring Two-Signal Selectivity	6-19
6.3.1 Measuring blocking effect of FM receiver	6-20
6.3.2 Measuring cross-modulation characteristics	6-26

TABLE OF CONTENTS (Continued)

	Page	
SECTION 7	PRINCIPLES OF OPERATION	
7.1	Outline	7-1
7.2	Block Explanation	7-1
SECTION 8	OVERVIEW OF GP-IB	
8.1	Outline	8-1
8.2	Specifications	8-2
8.2.1	GP-IB interface function	8-2
8.2.2	Device message	8-3
SECTION 9	GP-IB ADDRESS	
9.1	Precautions before Using GP-IB	9-1
9.1.1	GP-IB cable connection and disconnection	9-1
9.1.2	Setting and confirming GP-IB address	9-1
SECTION 10	GENERAL FORMAT OF GP-IB DEVICE MESSAGE	
10.1	Device Message	10-1
10.2	Device Message Formatting	10-1
10.2.1	Device message syntax diagram notation	10-5
10.2.2	Explanation of each device message factor	10-6

TABLE OF CONTENTS (Continued)

	Page
10.2.3 Device message types	10-17
10.3 General Format of MG3601A/MG3602A Device Message	10-19
10.3.1 General format of control message	10-19
10.3.2 General format of data request message	10-21
10.3.3 General format of talker output message	10-22

SECTION 11 DETAILS OF GP-IB DEVICE MESSAGES

11.1 Frequency Setting	11-1
11.1.1 Setting center frequency	11-1
11.1.2 Frequency and resolution setting by TUNE knob	11-2
11.1.3 Frequency setting by ΔF step key	11-2
11.1.4 Setting relative frequency mode	11-3
11.2 Data Request Message for Frequency	11-3
11.2.1 Reading set frequency	11-4
11.2.2 Reading ΔF frequency	11-5
11.2.3 Reading relative frequency	11-5
11.3 Setting Output Level	11-6
11.3.1 Setting output level	11-6
11.3.2 Setting by step key	11-7
11.3.3 Setting output level and resolution by output setting knob	11-7

TABLE OF CONTENTS (Continued)

	Page
11.3.4	Setting relative output level mode 11-8
11.3.5	ON/OFF control of output level 11-8
11.4	Data Request Message for Output Level 11-9
11.4.1	Reading set output level 11-9
11.4.2	Reading relative output level 11-10
11.4.3	Unit changeover 11-11
11.5	Setting AM Modulation 11-11
11.5.1	Setting internal modulation 11-12
11.5.2	Setting external modulation 11-12
11.6	Setting FM Modulation 11-13
11.6.1	Setting internal modulation 11-13
11.6.2	Setting external modulation 11-14
11.7	Setting ϕ M Modulation 11-14
11.7.1	Setting internal modulation 11-14
11.7.2	Setting external modulation 11-15
11.8	Setting Modulation Factor by Step Key 11-15
11.8.1	Setting set resolution 11-15
11.8.2	Resolution 11-16
11.9	Setting Modulation Frequency 11-17
11.9.1	Setting 400 Hz/1 kHz 11-18
11.9.2	Selection of AF oscillator and frequency setting 11-18



1.1 Overview

The MG3601A/MG3602A Signal Generator is a synthesized signal generator which provides amplitude, frequency, phase, and video modulation over the 0.1 to 1040/0.1 to 2080 MHz range.

In addition to its many modulation functions, its frequency stability, output level accuracy, SSB phase noise, residual FM, and other performance are excellent and it can be widely used to evaluate receivers (mobile radio, pocket pager, AM/FM radio, TV, etc.), and as a general purpose signal source. Since memory and GP-IB remote control functions are standard, it can also be used for automatic measurement and labor saving.

1.2 Composition

This paragraph describes the MG3601A/MG3602A Signal Generator standard composition and the options for expanding its functions.

..2.1 Standard composition

The MG3601A/MG3602A standard composition is listed in Table 1-1.

Table 1-1 Standard Composition

Item	Name	Qty.	Remarks
Instrument	MG3601A (or MG3602A) Signal Generator	1	
	50 Ω coaxial cable	1	S-5DWP S-5DWP [] 5D-2W Approx. 1 m [] Application: Output use
	50 Ω coaxial cable	1	BNC-P BNC-P [] RG-58A/U Approx. 1 m [] Application: Modulation use
Accessories	Power cord	1	
	Ac fuse	2	***A
	Operation manual	1	
	Service manual	1	

1.2.2 Options

The MG3601A/MG3602A options are listed in Table 1-2.

Table 1-2 Options

Option 01 Reference oscillator (10 MHz)	Aging rate: 2×10^{-8} /day (after 24-hour warm-up) Starting characteristics: 1×10^{-7} /day (after 30-min operation) 5×10^{-8} /day (after 60-min operation) Temperature characteristics: $\pm 5 \times 10^{-8}$ (0° to 50°C)
Option 02 Reference oscillator (10 MHz)	Aging rate: 5×10^{-9} /day (after 24-hour warm-up) Starting characteristics: 7×10^{-8} /day (after 30-min operation) 3×10^{-8} /day (after 60-min operation) Temperature characteristics: $\pm 5 \times 10^{-8}$ (0° to 50°C)
Option 03 Reference oscillator (10 MHz)	Aging rate: 2×10^{-9} /day (after 24-hour warm-up) Starting characteristics: 2×10^{-8} /day (after 60-min operation) Temperature characteristics: $\pm 5 \times 10^{-8}$ (0° to 50°C)
Option 04 AF oscillator	Frequency: 20 Hz to 100 kHz Resolution: 0.1 Hz Frequency accuracy: ≈ 100 ppm
Option 05 Video modulation	See Table 1-5.
Option 06 External modulation polarity switching	The relationship between the voltage polarity of the external modulation signal and the deviation increment and decrement can be selected as reversed or non-reversed.
Option 07 External FM modulation factor display	<ul style="list-style-type: none"> • Display range: 0% to 102% of modulation factor set value • Accuracy: $\pm 4\%$ (excluding modulation accuracy)

1.3 Application Parts and Peripheral Devices

The MG3601A/MG3602A application parts are listed in Table 1-3 and the peripheral devices are listed in Table 1-4.

Table 1-3 Application Parts

Name	Application/composition	Remarks
Accessory	Protection cover, front panel handle kit, rack mounting kit	For details, see APPENDIX A(1).
MP51A, MP52A 50 Ω \longleftrightarrow 75 Ω Pad	50 Ω \longleftrightarrow 75 Ω impedance transformer	For details, see APPENDIX A(2).
MP614A 50 Ω \longleftrightarrow 75 Ω Impedance Transformer	Used when circuit under test is 75 Ω	For details, see APPENDIX A(3).
Z-164A/B T-pad 50 Ω , 75 Ω	Used in two-signal characteristics measurement	For details, see APPENDIX A(4).
MP659A Four-port Junction Pad	Used in three-signal characteristics measurement	For details, see APPENDIX A(5).
MP721[] Attenuator dc to 12.4 GHz	3, 6, 10 to 60 dB (10 dB steps) attenuators available	For details, see APPENDIX A(6).

Table 1-4 Peripheral Devices

Name	Application/composition	Remarks
MG442A Synthesized Level Generator	Used as external modulation signal	For details, see APPENDIX B.
MS612A Spectrum Analyzer	Transmitter and receiver automated by combining MS612A with MG3601A/MG3602A	For details, see APPENDIX C.
Packet V Personal Technical Computer	Used as controller to remotely control MG3601A/MG3602A by GP-IB	For details, see APPENDIX D.
MH055B GP-IB Extender	Used to convert GP-IB interface to serial interface	For details, see APPENDIX E.
MS010A Multi-function Selector	Can be controlled by PTA or personal computer via GP-IB (Application) Used as various scanners	For details, see APPENDIX F.
ML422A Selective Level Meter	Accurate transmission characteristics tests performed by combining ML422A with MG3601A/MG3602A	For details, see APPENDIX G.

1.4 Specifications

Table 1-5 shows the specifications (≤ 1040 MHz) common to the MG3601A and MG3602A; Table 1-6 shows the specification (> 1040 MHz) that are different from Table 1-5.

Table 1-5 Specifications (≤ 1040 MHz)

Specifications (Common to MG3601A and MG3602A, ≤ 1040 MHz)				
Carrier frequency	Frequency range	0.1 to 1040 MHz		
	Resolution	10 Hz		
	Accuracy	Same as those of the reference oscillator		
	Reference oscillator	Frequency	100 MHz	
		Stability	Aging rate: 2×10^{-6} /year Temperature characteristics: 5×10^{-6} (for 0°C to 50°C change of temperature at reference oscillator). Note: Better aging rate of up to 2×10^{-9} /day are available as options.	
	External reference input	10 MHz, > 2 Vp-p into 50 Ω load		
	External reference output	10 MHz, TTL level		
	Setting	Keyboard, rotary encoder or GP-IB		
Output	Level range	-133 to +13 dBm (-20 to +126 dB μ V e.m.f.)		
	Resolution	0.1 dB		
	Accuracy	± 1 dB (≥ -10 dBm)		
		± 1.5 dB (≥ -123 dBm)		
		± 2 dB (< -123 dBm)		
	Frequency characteristics	≤ 1 dB (at 0 dBm)		
	Impedance	50 Ω , VSWR ≤ 1.5 (at $\leq +3$ dBm), N-type connector		
	Radiation interference	≤ 1 μ V (Value is voltage-terminated with 50 Ω load measured at 25 mm from the front panel with a two-turn 25 mm diameter loop antenna)		
Setting	Keyboard, rotary encoder or GP-IB			

Signal purity	Harmonics	≤ -25 dBc (2nd or 3rd harmonics)																	
	Non harmonic spurious	≤ -60 dBc (greater than 5 kHz from carrier)																	
	SSB phase noise	In CW mode, at 20 kHz offset ≤ -117 dBc/Hz ($0.1 \text{ MHz} \leq f_c < 130 \text{ MHz}$, $520 \text{ MHz} \leq f_c \leq 1040 \text{ MHz}$) ≤ -123 dBc/Hz ($260 \text{ MHz} \leq f_c < 520 \text{ MHz}$) ≤ -129 dBc/Hz ($130 \text{ MHz} \leq f_c < 260 \text{ MHz}$) where f_c is carrier frequency																	
	Residual AM	$\leq 0.03\%$ (-76 dBc) [>150 kHz carrier frequency, demodulation band 50 Hz to 15 kHz]																	
	Residual FM	<table border="1"> <thead> <tr> <th rowspan="2">Frequency range</th> <th colspan="2">Demodulation band</th> </tr> <tr> <th>0.3 to 3 kHz</th> <th>50 Hz to 15 kHz</th> </tr> </thead> <tbody> <tr> <td>$520 \text{ MHz} \leq f_c \leq 1040 \text{ MHz}$</td> <td>7 Hz (50 dB)</td> <td>16 Hz</td> </tr> <tr> <td>$0.1 \text{ MHz} \leq f_c < 130 \text{ MHz}$</td> <td>7 Hz (50 dB)</td> <td>16 Hz</td> </tr> <tr> <td>$260 \text{ MHz} \leq f_c < 520 \text{ MHz}$</td> <td>4 Hz (55 dB)</td> <td>8 Hz</td> </tr> <tr> <td>$130 \text{ MHz} \leq f_c < 260 \text{ MHz}$</td> <td>2 Hz (61 dB)</td> <td>4 Hz</td> </tr> </tbody> </table> Measured by r.m.s. detector Values in parentheses are relative values compared with 3.5 kHz deviation.	Frequency range	Demodulation band		0.3 to 3 kHz	50 Hz to 15 kHz	$520 \text{ MHz} \leq f_c \leq 1040 \text{ MHz}$	7 Hz (50 dB)	16 Hz	$0.1 \text{ MHz} \leq f_c < 130 \text{ MHz}$	7 Hz (50 dB)	16 Hz	$260 \text{ MHz} \leq f_c < 520 \text{ MHz}$	4 Hz (55 dB)	8 Hz	$130 \text{ MHz} \leq f_c < 260 \text{ MHz}$	2 Hz (61 dB)	4 Hz
Frequency range	Demodulation band																		
	0.3 to 3 kHz	50 Hz to 15 kHz																	
$520 \text{ MHz} \leq f_c \leq 1040 \text{ MHz}$	7 Hz (50 dB)	16 Hz																	
$0.1 \text{ MHz} \leq f_c < 130 \text{ MHz}$	7 Hz (50 dB)	16 Hz																	
$260 \text{ MHz} \leq f_c < 520 \text{ MHz}$	4 Hz (55 dB)	8 Hz																	
$130 \text{ MHz} \leq f_c < 260 \text{ MHz}$	2 Hz (61 dB)	4 Hz																	
Amplitude modulation	Modulation factor	0% to 100% at output levels $\leq +7$ dBm																	
	Resolution	1%																	
	Accuracy	\pm (indicated value $\times 0.04 + 2$)% at 1 kHz internal modulation frequency, $\leq 90\%$ modulation factor																	
	Internal modulation frequency	400 Hz, 1 kHz (20 Hz to 50 kHz modulation is possible using optional built-in AF oscillator.) Accuracy: ≤ 100 ppm																	
	External modulation	20 Hz to 50 kHz at AC couple (± 1 dB bandwidth) DC to 50 kHz at DC couple (± 1 dB bandwidth) Input level: Approx. 1 V _{rms} /600 Ω																	
	Distortion	$\leq 1\%$ at 30% modulation factor } (for 1 kHz internal modulation frequency) $\leq 3\%$ at 60% modulation factor }																	
	Incidental FM	≤ 200 Hz peak at 1 kHz modulation frequency, 30% AM, 0.3 to 3 kHz demodulation bandwidth																	
Frequency modulation	Frequency modulation range	0 to 199 kHz 0 to 99.9 kHz (130 to 260 MHz) FM not specified for $f_c - (\Delta f_{pk}) < 100$ kHz																	
	Resolution	10 Hz at 0 to 9.99 kHz 100 Hz at 10 to 99.9 kHz 1 kHz at 100 to 199 kHz																	
	Accuracy	$\pm 5\%$ of indicated value at 1 kHz modulation frequency except residual FM																	
	Internal modulation frequency	400 Hz, 1 kHz (20 Hz to 100 kHz modulation is possible using optional built-in oscillator.) Accuracy: ≤ 100 ppm																	
	External modulation frequency range	AC mode	20 Hz to 100 kHz (± 1 dB bandwidth)																
		DC mode	DC to 100 kHz (± 1 dB bandwidth)																
	Distortion	$\leq 1\%$ at 1 kHz modulation frequency, 22.5 kHz deviation																	
	Incidental AM	$\leq 0.1\%$ (at ≥ 500 kHz carrier, 1 kHz modulation frequency, 20 kHz deviation)																	
	Center frequency accuracy at DC FM mode	$\leq \pm 500$ Hz (f_c : 500 MHz) for 3-minute period after calibration and after 2-hour warm-up compared with frequency of AC FM mode																	
Calibration function	Automatic self calibration possible																		
Phase modulation	Phase modulation range	0 to 9.99 rad (Indicates MAX. 999 rad at internal modulation mode)																	
	Resolution	0.01 rad (0 to 9.99 rad) 0.1 rad (10 to 99.9 rad) 1 rad (100 to 999 rad)																	
	Accuracy	$\pm 5\%$ of indicated value (at 1 kHz internal modulation frequency except residual FM)																	
	Internal modulation frequency	400 Hz, 1 kHz (20 Hz to 100 kHz*1 modulation is possible using optional built-in oscillator.) *1 The MG 3601A displays phase deviation (radian) derived from frequency deviation and modulation frequency of FM. Therefore, max. phase deviation is given as (max. deviation)/(modulation frequency).																	
	External modulation frequency	200 Hz to 8 kHz (± 1 dB bandwidth) Input level: Approx. 1 V _{rms} /600 Ω																	

Video modulation (option)	Input signal	Video composite signal		
	Input level	1 V _{p-p} /75Ω (Pedestal level: 0 V, White level: positive voltage)		
	Modulation factor	When the specified voltage video signal is applied, modulated wave includes the signal as follows. White level: Approx. 12.5% of carrier peak Pedestal level: Approx. 75% of carrier peak		
	Carrier level accuracy.	CW output level accuracy: ± 3 dB at peak level		
Functions	Modulation signal output	Output level: Approx. 1 V _{rms} /600Ω		
	Simultaneous modulation	INT/EXT: AM/FM (φM), FM (φM)/AM, FM (φM)/FM (φM) INT/INT, EXT/EXT: AM/FM (φM)		
	Reverse power protection	≤50 W and ≤±50 VDC		
	Other functions	Relative value indication	Relative value display of carrier frequency and level is possible	
		Continuously variable output mode	0.1 dB step adjustment of output level is possible with no output interruption in a ±5 dB range around an arbitrary level.	
		Frequency memory	Stores and recalls up to 100 frequencies	
		Function memory	Stores and recalls up to 30 sets of panel settings	
External control	GP-IB	SH1, AH1, T6, L4, TE0, LE0, SR1, RL1, PP0, DC1, DT0, C0		
General	Ambient temperature, rated range of use	0° to 50°C		
	Power	AC **V ±10% (max. 250 V), 50/60 Hz, ≤100 VA		
	Dimensions and weight	132.5H x 426W x 451D mm, <16 kg		
Options	Option 01 Reference oscillator (10 MHz)	Aging rate: 2×10 ⁻⁹ /day (after 24-hour warm-up) Starting characteristics: 1×10 ⁻⁷ /day (after 30-min operation) 5×10 ⁻⁸ /day (after 60-min operation) Temperature characteristics: ±5×10 ⁻⁸ (0° to 50 °C)		
	Option 02 Reference oscillator (10 MHz)	Aging rate: 5×10 ⁻⁹ /day (after 24-hour warm-up) Starting characteristics: 7×10 ⁻⁸ /day (after 30-min operation) 3×10 ⁻⁸ /day (after 60-min operation) Temperature characteristics: ±5×10 ⁻⁸ (0° to 50 °C)		
	Option 03 Reference oscillator (10 MHz)	Aging rate: 2×10 ⁻⁹ /day (after 24-hour warm-up) Starting characteristics: 2×10 ⁻⁸ /day (after 60-min operation) Temperature characteristics: ±1.5×10 ⁻⁸ (0° to 50 °C)		
	Option 04 AF oscillator	Frequency: 20 Hz to 100 kHz Resolution: 0.1 Hz Frequency accuracy: ≤100 ppm		
	Option 05 Video modulation	See Video modulation in this table.		
	Option 06 External modulation polarity switching	The relationship between the voltage polarity of the external modulation signal and the deviation increment and decrement can be selected as reversed or non-reversed.		
	Option 07 External FM modulation factor display	<ul style="list-style-type: none"> • Display range: 0% to 102% of modulation factor set value • Accuracy: ±4% (excluding modulation accuracy) 		

** Specify one nominal line voltage between 100 V and 250 V when ordering.

Table 1-6 Specifications (>1040 MHz)

Specifications (MG3602A, >1040 MHz)		
Carrier frequency	Frequency range	Up to 2080 MHz
	Resolution	20 Hz
Output	Level range	Up to +7 dBm (-20 to +120 dB μ V e.m.f.)
	Accuracy	± 1.5 dB (≥ -10 dBm) ± 2 dB (≥ -123 dBm) ± 3 dB (< -123 dBm)
	Frequency characteristics	≤ 1.5 dB
	Impedance	50 Ω , VSWR ≤ 1.8 (at ≤ -3 dBm)
Signal purity	Subharmonics (1/2fc, 3/2fc)	≤ -30 dBc
	Non harmonic spurious	≤ -54 dBc (greater than 5 kHz apart from carrier)
	SSB phase noise	≤ -110 dBc/Hz at 20 kHz offset
	Residual FM	15 Hz (0.3 to 3 kHz demodulation) 32 Hz (50 Hz to 15 kHz demodulation)
Amplitude modulation	Modulation factor	0 to 100% (at $\leq +1$ dBm)
	Accuracy	\pm (indicated value $\times 0.04 + 2$)% at 1 kHz internal modulation frequency, <60% modulation factor
	External modulation	20 Hz to 30 kHz at AC couple (± 1 dB bandwidth) DC to 30 kHz at DC couple (± 1 dB bandwidth)
	Distortion	$\leq 2.5\%$ at 30% modulation factor (at 1 kHz internal modulation frequency)
	Incidental FM	≤ 400 Hz peak (at 1 kHz internal modulation frequency, 30% modulation, 0.3 to 3 kHz demodulation bandwidth)
Function	Reverse power protection	≤ 25 W and $\leq \pm 50$ VDC

Notes:

1. Other specifications not shown in Table 1-6 are the same as in Table 1-5.
2. At >1040 MHz, the video modulation does not function.



SECTION 2

PREPARATIONS

This section describes the work to be performed before using the MG3601A/MG3602A and the related precautions: (1) installation precautions, (2) power safety measures, (3) storage, (4) repacking and transportation.

For a description of GP-IB cable connection, address setting, etc., see SECTION 9.

TABLE OF CONTENTS

	Page
SECTION 2 PREPARATIONS	
2.1 Installation Precautions	2-1
2.1.1 Installation site environmental conditions	2-1
2.1.2 Rack mounting	2-3
2.2 Power Supply Safety Measures	2-3
2.2.1 Power cord polarity	2-3
2.2.2 Grounding	2-4
2.2.3 Fuse replacement	2-5
2.3 Storage Precautions	2-7
2.3.1 Precautions before storage	2-7
2.3.2 Recommended storage conditions	2-7

TABLE OF CONTENTS (Continued)

	Page
2.4 Repacking and Transportation	2-7
2.4.1 Repacking	2-8
2.4.2 Transportation	2-8

2.1 Installation Precautions

This paragraph describes the MG3601A/MG3602A Signal Generator General installation precautions and mechanical assembly when mounting it in a rack.

2.1.1 Installation site environmental conditions

The MG3601A/MG3602A operates normally at ambient temperatures of 0° to 50°C. However, for best performance, do not use or store it where:

- . It may be subjected to strong vibrations
- . It may be exposed to damp or dust
- . It may be exposed to direct sunlight
- . It may be exposed to active gases

To maintain stable operation for a long time, in addition to meeting the conditions listed above, the MG3601A/MG3602A should be used at stable room temperatures and where ac line voltage fluctuations are small.

CAUTION

If the MG3601A/MG3602A is used at room temperature after being used or stored at a low temperature for a long time, condensation may occur inside the instrument and may cause short circuits. Always ensure that the MG3601A/MG3602A is thoroughly dry before turning on the power.

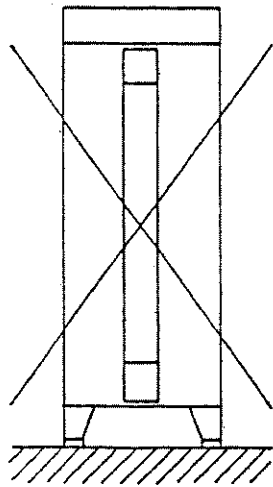
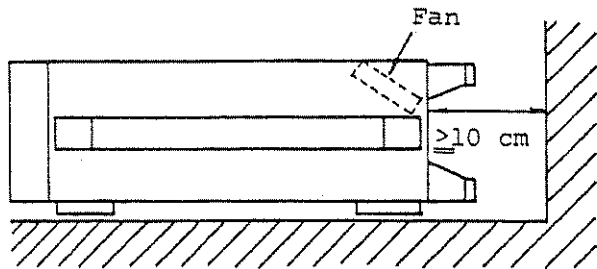

Do not use instrument
on its side.

Fig. 2-1 Fan Clearance

(1) Fan clearance

To suppress any temperature increase inside the MG3601A/MG3602A, a cooling fan is mounted on the rear panel as shown in Fig. 2-1. Leave a space of at least 10 cm between the rear panel and walls, peripheral devices, obstructions, etc. so that the air flow is not obstructed.

2.1.2 Rack mounting

When mounting the MG3601A/MG3602A in a rack, the optional rack mounting kit is necessary. Order the rack mounting kit by using the order number given in APPENDIX A(1).

The mounting instructions are supplied with the kit.

2.2 Power Supply Safety Measures

The MG3601A/MG3602A Signal Generator operates normally on a ** Vac $\pm 10\%$ (max. 250 V), 48 to 63 Hz power supply.

However, observe the following safety measures before supplying ac power.

2.2.1 Power cord polarity

Since the 3-pole (ground-type 2-pole) power cord is connected to the live line(L), neutral line(N), and ground line, the MG3601A/MG3602A is designed so that the power supply polarity is always matched when the plug is inserted into a 3-pole (ground-type 2-pole) supply outlet.

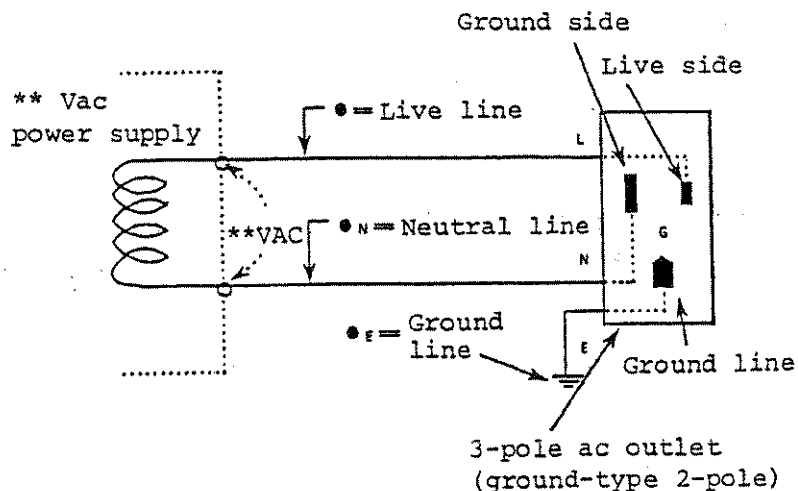

Fig. 2-2 Three-Pole Power Cord Plug and Outlet

2.2.2 Grounding

(1) Grounding frame ground (FG) terminal

When a 3-pole ac outlet (Fig. 2-2) is not available, ground the FG terminal (Fig. 2-3) directly to earth potential.

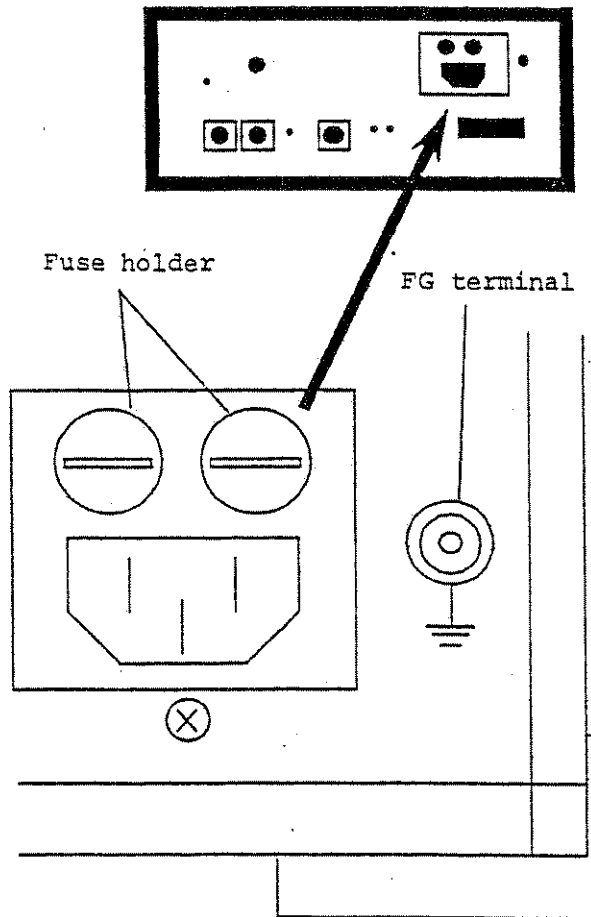

Fig. 2-3 Grounding (FG) Terminal

(2) Grounding by 3-pole ac outlet

If a 3-pole (ground type 2-pole) ac outlet is available, the MG3601A/MG3602A frame is connected to earth potential when the power cord is plugged into ac outlet and the FG terminal does not have to be grounded.

2.2.3 Fuse replacement

The standard system is supplied with the fuses shown in Table 1-1. The two fuses shown in Fig. 2-3 are rated at ***A.

When a fuse blows, locate and correct the cause of the trouble before changing the fuse.

WARNING

1. Before replacing a fuse, turn off the power switch and unplug the power cord from the ac outlet.

There is an electric shock hazard if a fuse is replaced while the power is on.

2. Before turning on the power after replacing a fuse, check the protective grounding described in paragraph 2.2.2 and check that the ac supply voltage is suitable. There is an electric shock hazard if the power is turned on without the protective grounding.

If the ac supply voltage is unsuitable, the equipment may be damaged.

The fuse replacement procedure (Fig. 2-3) based on the above safety measures, is described below.

Step	Procedure
1	Set the POWER switch on the front panel to OFF and unplug the power cord from the ac outlet.
2	Turn the fuse holder counterclockwise and remove the cap, together with the fuse.
3	Remove the blown fuse from the cap and replace it with the spare fuse.
4	Refit the cap and turn it clockwise until it will turn no further.

If the fuse blows again after replacing it, check that the replacement is of the same type, rated voltage and current, as the original.

If the fuse is not the same type, it may not fit the holder, contact may be poor, or the fusing time may be too long.

If the rated voltage and current of the replacement fuse are too high and trouble reoccurs, the new fuse may not blow and the instrument may catch fire.

Set the power to ON after step 4 above.

For the power supply connection procedure, see SECTION 3.

2.3 Storage Precautions

This paragraph describes the precautions to take when storing the MG3601A/MG3602A Signal Generator for a long time.

2.3.1 Precautions before storage

1. Wipe any dust and fingermarks off the cabinet.
2. Check the performance as described in SECTION 4 and check that the MG3601A/MG3602A operates normally.
3. The maximum and minimum storage temperature range is 60° to -20°C. The maximum humidity is 90%.

2.3.2 Recommended storage conditions

In addition to meeting the conditions listed in paragraph 2.3.1, the MG3601A/MG3602A should preferably be stored where:

1. Temperature is 0° to 30°C
2. Humidity is 40% to 80%
3. Temperature and humidity are stable

Before using the MG3601A/MG3602A after storage, check the performance as described in SECTION 4.

2.4 Repacking and Transportation

When transporting the MG3601A/MG3602A over long distances, observe the precautions described below.

2.4.1 Repacking

Use the original packing materials. If the original packing materials were thrown away or destroyed, repack the MG3601A/MG3602A as follows:

1. Install the protective covers (34Y7326C) over the front and rear panels.
2. Wrap the MG3601A/MG3602A in plastic or similar material.
3. Obtain a cardboard, wood, or aluminum box 10 to 15 cm larger than the MG3601A/MG3602A on all sides.
4. Put the MG3601A/MG3602A in the center of the box and fill the surrounding space with shock absorbent material.
5. Secure the box with twine, tape, or bands.

Note:

It is easy to repack the MG3601A/MG3602A if the original packing materials are saved.

2.4.2 Transportation

Transport the MG3601A/MG3602A under the storage conditions recommended in paragraph 2.3.2.

SECTION 3

STARTING AND SIMPLE CHECKS

This section describes handling and simple checks at the start of MG3601A/MG3602A Signal Generator operation.

Starting is centered about a description of the display and turning the power on and off.

The purpose of the simple checks is to quickly and easily check the basic operation and performance of the MG3601A/MG3602A. When detailed tests are necessary, test the performance as described in SECTION 4.

TABLE OF CONTENTS

	Page
SECTION 3 STARTING AND SIMPLE CHECKS	
3.1 Power On and Initial Setting	3-1
3.1.1 Power on	3-1
3.1.2 Reproduction of set parameters	3-4
3.2 Description of Displays	3-7
3.3 Simple Checks	3-12
3.3.1 Power-on initial setting display check	3-15
3.3.2 Carrier frequency and output level check	3-18
3.3.3 FM/ ϕ M check	3-21

TABLE OF CONTENTS (Continued)

	Page
3.3.4 AM check	3-26
3.3.5 MOD OUTPUT check	3-29
3.3.6 MOD INPUT check	3-30

3.1 Power On and Initial Setting

This paragraph describes the following:

- . Power on Power switch and its related functions and power on procedure
- . Reproduction of set parameters .. Description of panel function settings and display at power-on

3.1.1 Power on

Before turning on the power to the MG3601A/MG3602A Signal Generator, ground the instrument based on the safety measures described in paragraph 2.2, then plug the power cord into an ac inlet.

WARNING

If the power is turned on without the frame grounded, there is a danger of electric shock to personnel.

When a 3-pole (ground type 2-pole) ac outlet is not available, before supplying power to the MG3601A/MG3602A, always connect the rear panel frame ground (FG) terminal to earth potential.

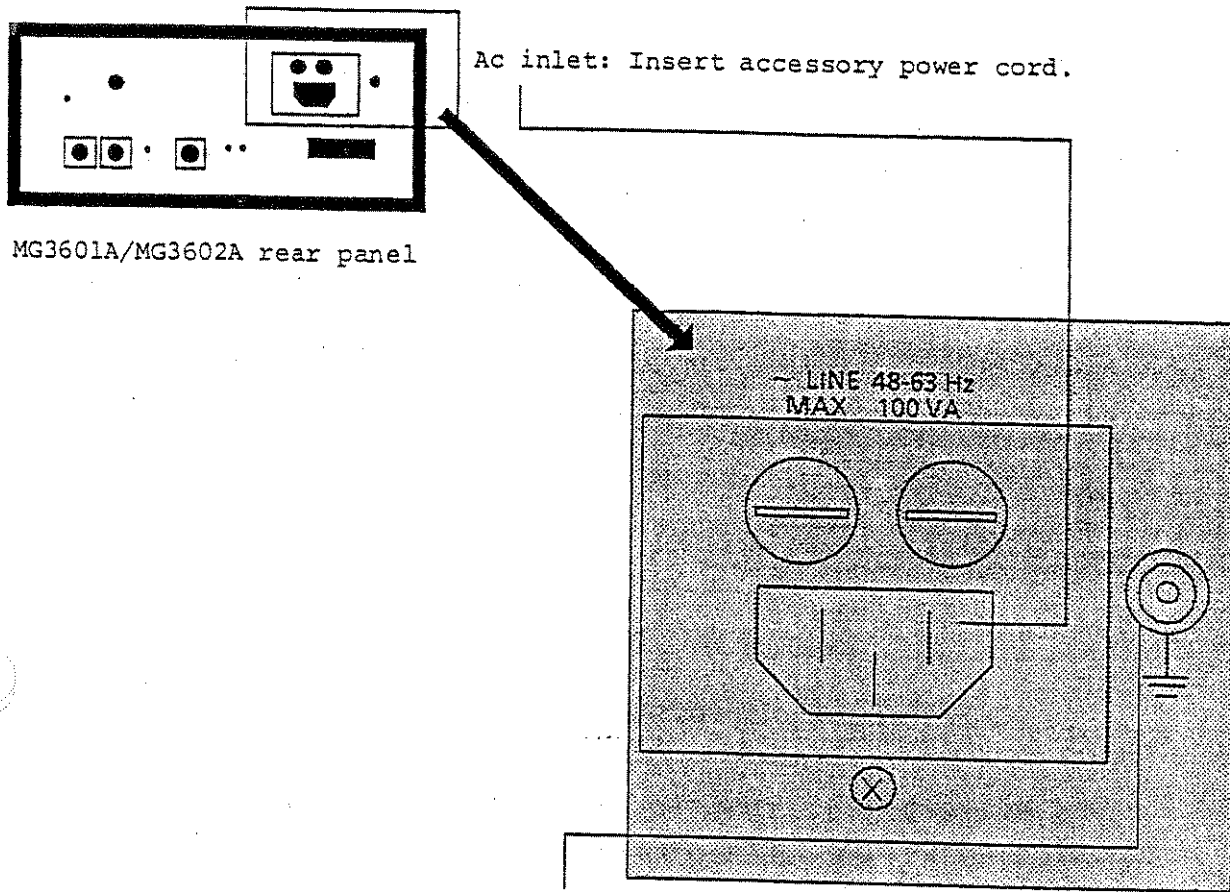

Ac inlet: Insert accessory power cord.

MG3601A/MG3602A rear panel

Frame ground terminal: Connect this terminal to earth potential to prevent electric shock.

Fig. 3-1 Rear Panel

CAUTION

If the ac line voltage is unsuitable, the instrument may be damaged by an abnormal voltage. Before turning on the power to the MG3601A/MG3602A, check that the ac line voltage is the specified value (** V $\pm 10\%$, max. 250 V).

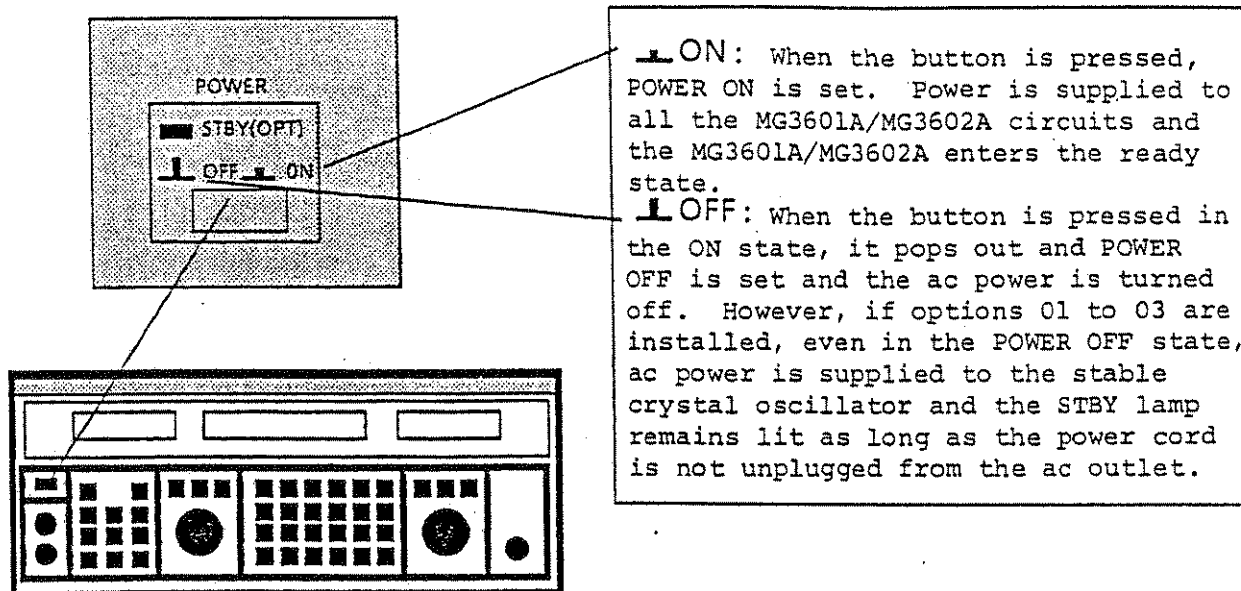

Fig. 3-2 Front Panel POWER Switch

The general procedure for connecting power to the MG3601A/MG3602A in accordance with the description up to this point is shown below.

Power connection procedure

Step	Procedure
1	Connect the rear panel FG terminal to earth potential.
2	Before plugging the power cord into the ac outlet, check that the ac line voltage is the specified value.

(continued)

Step	Procedure
3	After checking that the front panel POWER switch is set to the OFF position, plug the power cord into an ac outlet.
4	Set the front panel POWER switch to the ON position.

3.1.2 Reproduction of set parameters

Since the set conditions (function parameters) are automatically stored when the power is turned off, the set conditions when the power was turned off can be reproduced immediately when the power is turned on again.

(1) POWER OFF

When the MG3601A/MG3602A power is turned off when the parameters shown below are set, the parameters are simultaneously stored to the internal backed-up memory.

MOD INT MOD
MOD FREQ 1 kHz
AM 55%
CENTER FREQ 999 MHz
OUTPUT -33.3 dBm

The MG3601A/MG3602A Signal Generator is shipped with the set parameters in the initial state set by a special function stored in the internal memory. For a description of how to check these set parameters, see paragraph 3.3.

(2) POWER ON

When the power is turned on, all the LCDs and LEDs on the front panel, except STBY, light for one second while the internal processor initial routine is executed. (Shaded area characters and LEDs indicated by ■ on the key top in Fig. 3-3)

Note:

Since all the LCDs and LEDs, except STBY, light at POWER ON, check the front panel LCD and LED display characters by checking that all the LCDs and LEDs are lit at POWER ON. Lighting of the LCDs and LEDs can also be checked by pressing the [SPCL][6][4] keys.

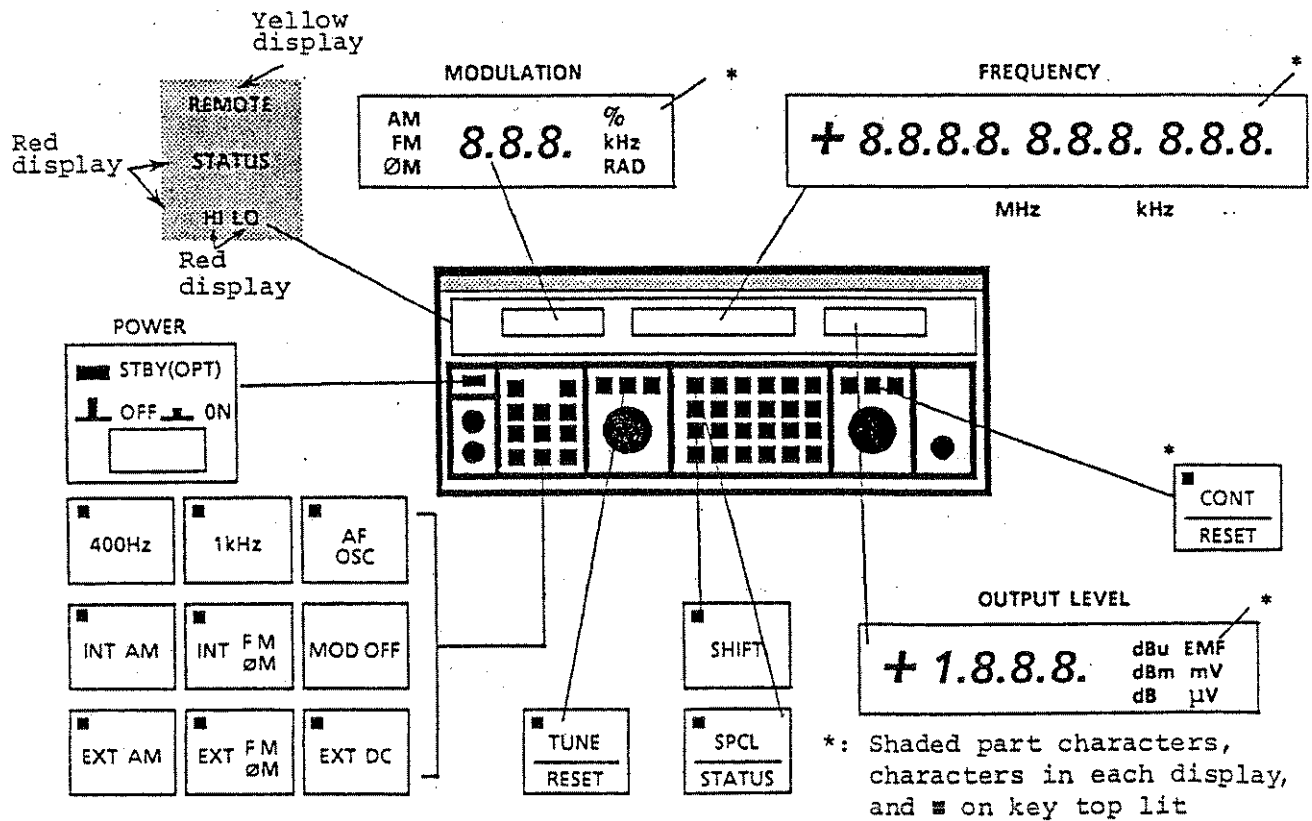

Fig. 3-3 Lighting of All LCDs and LEDs at POWER ON

About one second after POWER ON, Fig. 3-3 changes to Fig. 3-4.

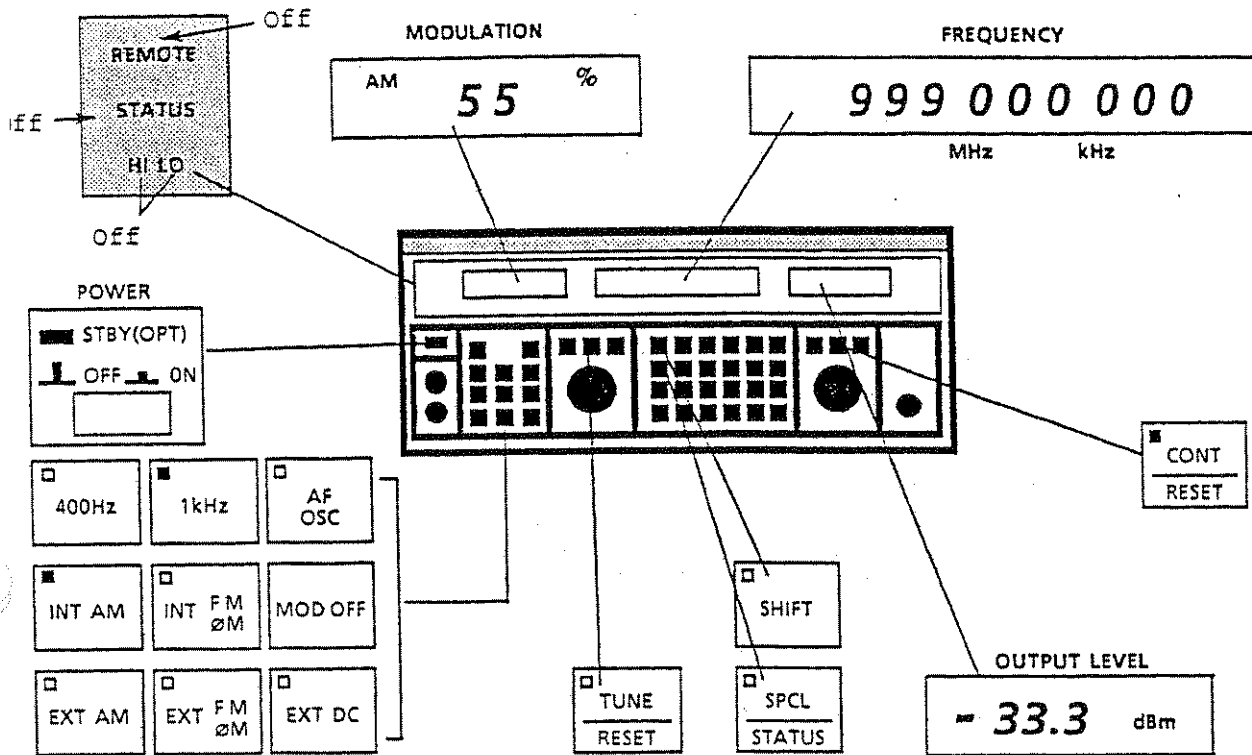

Fig. 3-4 Set Parameters Immediately before POWER OFF

3.2 Description of Displays

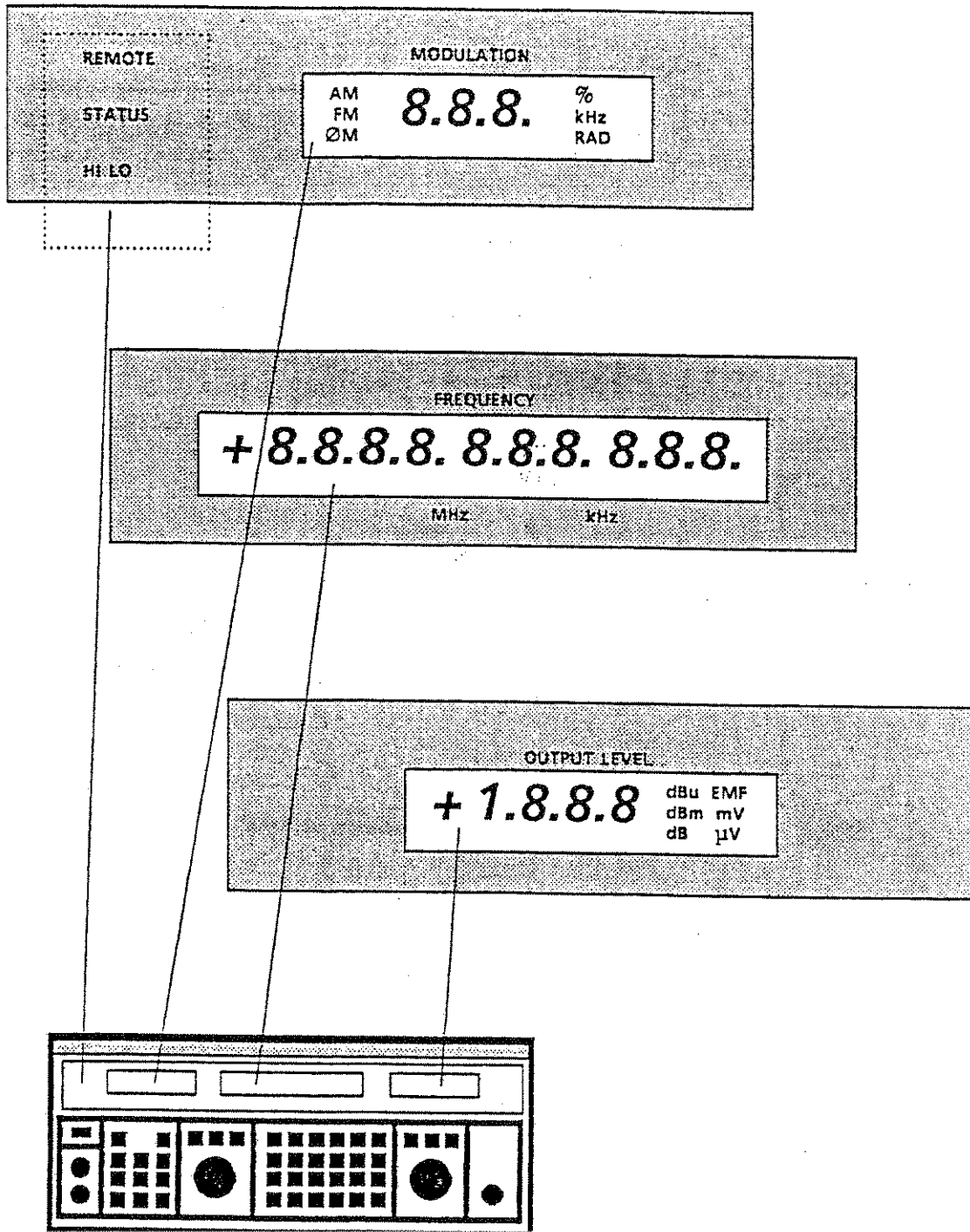

Fig. 3-5 Displays

The MG3601A/MG3602A display functions shown in Fig. 3-5 are described in Table 3-1.

Table 3-1 Display Functions

Display	Function
REMOTE	When the MG3601A/MG3602A is in the GP-IB remote control mode, the REMOTE lamp lights yellow. The REMOTE lamp remains off in the local mode.
STATUS	The STATUS lamp lights red for erroneous operation and input data overrange (for example, frequency setting outside the frequency range, output level setting outside the output level range).
HI LO	When the external modulation input (MOD INPUT) signal is too large, the HI lamp lights. When the external modulation input is too small, the LO lamp lights red.
MODULATION	Modulation factor display (AM, FM, ϕ M)

Lit in AM, FM, and ϕ M modes, respectively
 During simultaneous modulation, a combination of two of the lamps from among AM, FM, and ϕ M is lit, but the set value is the data of the last selected mode.
 For example, in the AM-FM mode, if AM 30% is set first and FM 3.5 kHz is set next, the following is displayed:

AM	3.50 kHz
FM	

- AM . Simultaneous lighting of AM and FM at left signifies the AM-FM mode.
- FM . FM frequency deviation 3.5 kHz is shown.
- ϕ M . To display the AM modulation factor, the header and unit keys of the mode whose set value is not displayed (AM and % in this case) are pressed in the DATA ENTRY section.

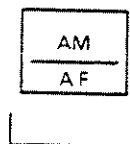

HEADER

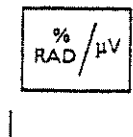

UNIT

Table 3-1 Display Functions (Cont'd)

Display	Function
---------	----------

This operation changes the display as follows:



	Numeric display range	Numeric display range
	AM mode 0 to 100%	Since the resolution is 1%, the decimal point is not displayed.
8.8.8.	FM mode 0 to 199 kHz	Since the resolution can be varied from 10 Hz to 1 kHz, the decimal point is displayed at the second or third digit.
	φM mode 0 to 999 RAD	Since the resolution can be varied from 0.01 to 1 RAD, the decimal point is displayed at the second or third digit.
% kHz RAD	Suffix showing amplitude modulation, frequency deviation, and phase shift amount, in order from top	

Table 3-1 Display Functions (Cont'd)

Display	Function
FREQUENCY	Display showing carrier frequency or internal modulation frequency
+	Displays + or - in relative mode

Numeric display range

. Carrier frequency: Max 10 digits. Units MHz and kHz display position fixed

0 is displayed at the first digit. The display range

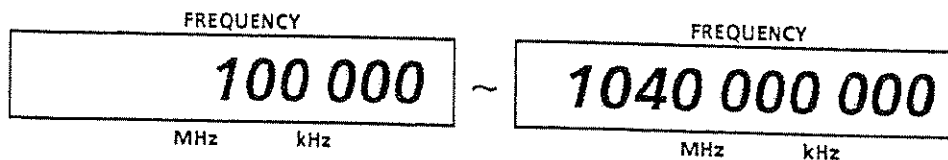

8. ~ 8.

10 digits

MHz kHz

. Internal AM oscillator frequency*:

Max 7 digits. MHz is read as kHz and kHz is read as Hz.

Display range is:

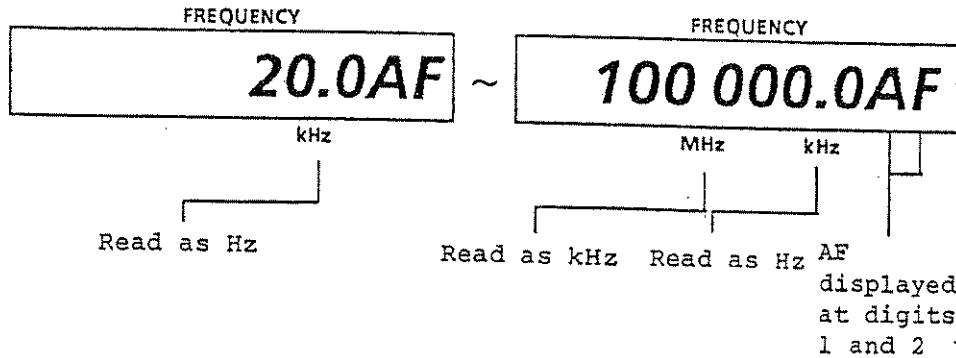

Decimal point display ... Fixed display over kHz for internal modulation frequency only

* Option

Table 3-1 Display Functions (Cont'd)

Display	Function		
OUTPUT LEVEL	Display showing absolute output level or relative output level of carrier		
	Used as sign display		
+	<ul style="list-style-type: none"> . When unit is dB ... "+" or "-" displayed . When unit is dBm or dBu ... Only "-" displayed nothing is displayed for "+" . When unit is mV or μV ... blank 		
	Numeric display range		
+ 1.8.8.8	<ul style="list-style-type: none"> . -133 to 13.0 dBm . -12.0 to 126 dBu (EMF) . 0.100 to 1999 mV (EMF) . 0.320 to 999 μV (EMF) 		
	Decimal point display ... displayed at digit 2 to 4 according to set value		
	Output level power unit display ... dBm		
	Output level voltage unit display ... If not specified dBu, mV, or μ V is displayed with open circuit voltage display (EMF)		
<div style="border: 1px solid black; padding: 5px; width: fit-content;"> dBu EMF dBm mV dB μV </div>	<div style="border: 1px solid black; padding: 5px; width: fit-content;"> dBu EMF </div>	<div style="border: 1px solid black; padding: 5px; width: fit-content;"> EMF mV </div>	<div style="border: 1px solid black; padding: 5px; width: fit-content;"> EMF μV </div>
	If the [SPCL][0][4] keys are pressed, terminated voltage display is selected and above EMF is not displayed.		
	Relative output level display ... dB		

3.3 Simple Checks

This paragraph describes simple checks of the delivered MG3601A/MG3602A Signal Generator. Before the MG3601A/MG3602A is shipped, it is checked to see that the catalog specifications are satisfied over a temperature range of 0° to 50°C.

If the simple checks are normal, the MG3601A/MG3602A can be immediately used as a 1 or 2 GHz band signal source. The simple checks described in this manual can be performed without a detailed knowledge of panel operation.

Note:

Since the standard signal generator specifications and peripheral device specifications are summed in the check result, take the measurement accuracy into account when making the checks. If the results of the simple checks are abnormal, test the performances as described in SECTION 4.

(1) Simple checks test equipment

- . Spectrum analyzer ... Frequency range
 - 0.1 to 1040 MHz (MG3601A)
 - 0.1 to 2080 MHz (MG3602A)
- . Oscilloscope
- . AF oscillator (AF OSC) ... MG442A

(2) Set-up

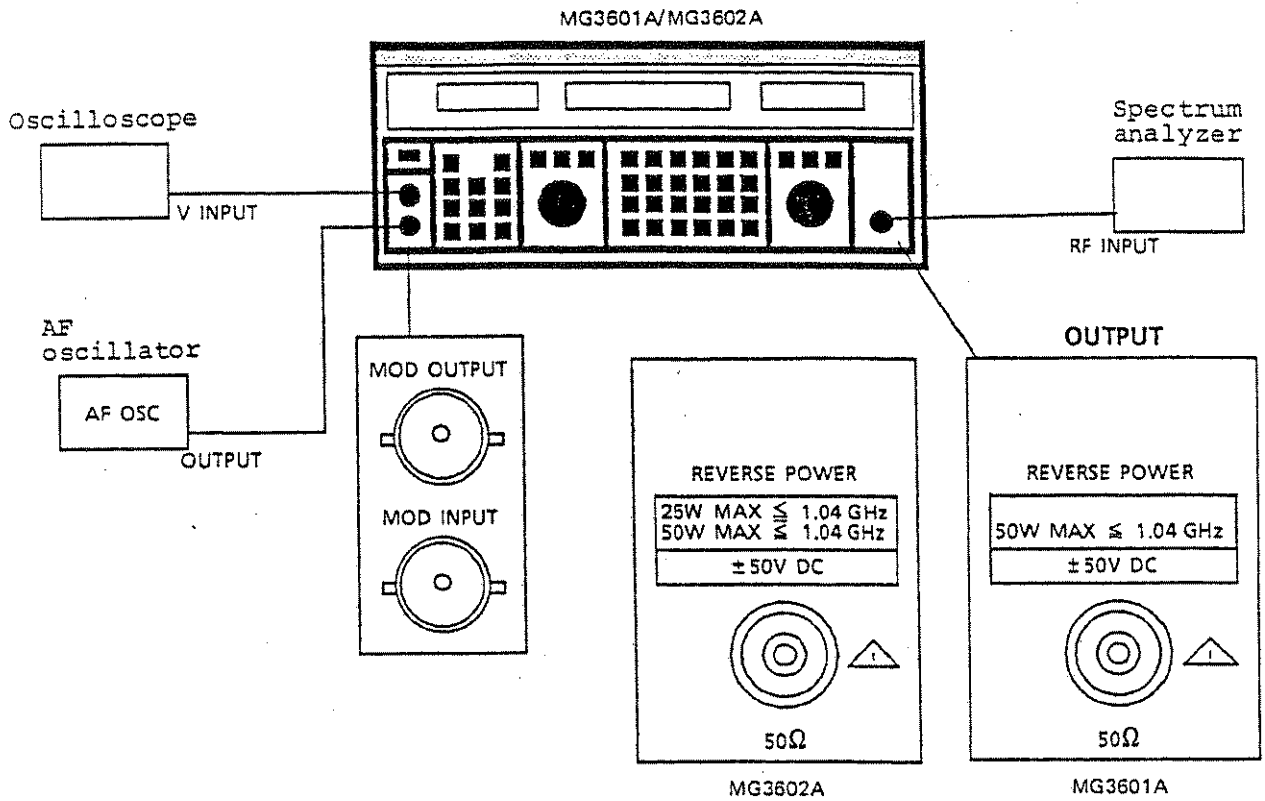
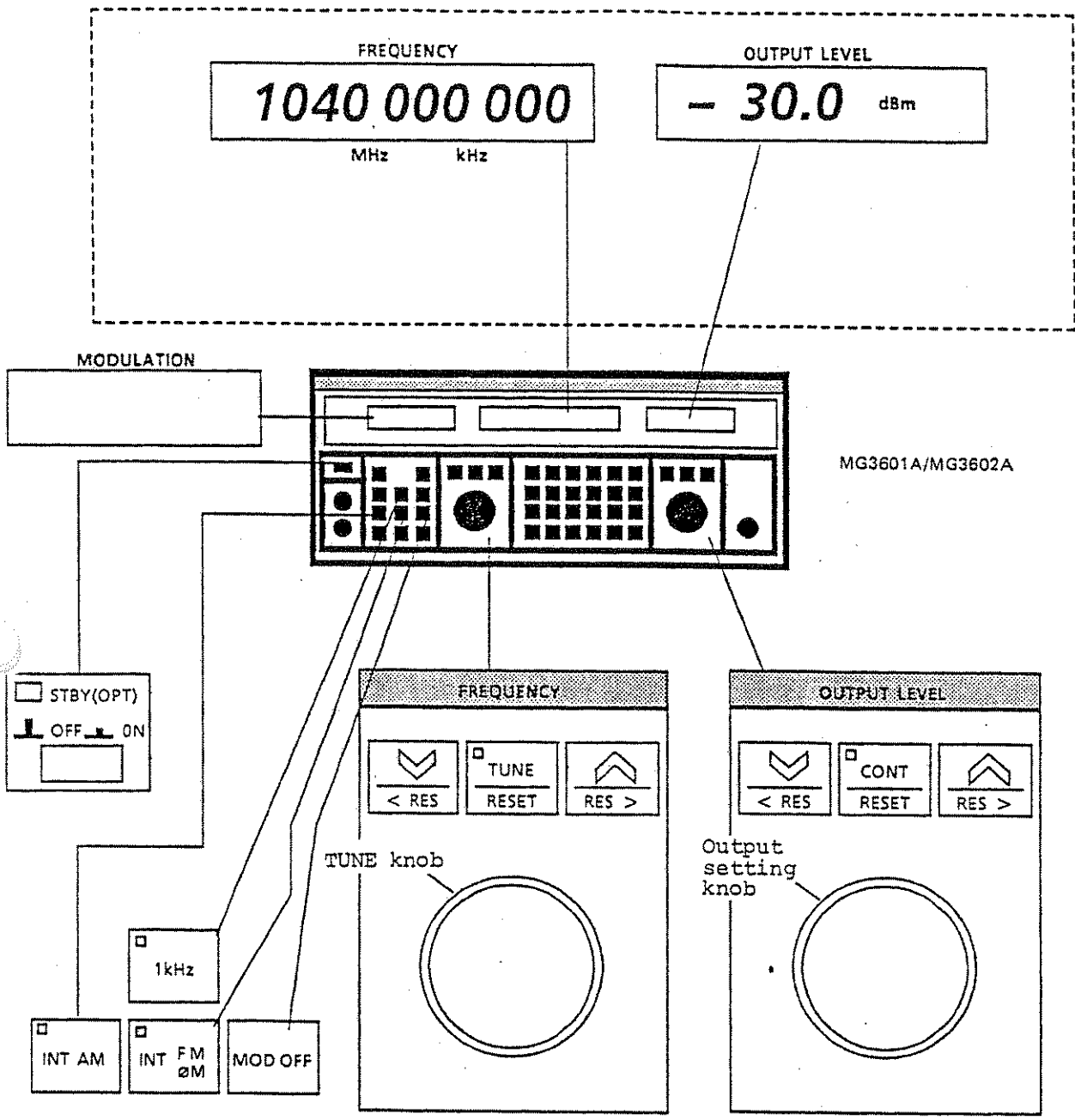

Fig. 3-6 Simple Checks



Initial setting at power-on (factory set parameters)

3.3.1 Power-on initial setting display check

Without setting up the equipment as shown in Fig. 3-6, turn on the power in accordance with the power connection procedure described in paragraph 3.1.1.

Then check the MG3601A/MG3602A as follows:

Step	Procedure
1	Check that all the LCDs and LEDs on the front panel light for approximately one second as described in paragraph 3.1.2 (2) and Fig. 3-3 immediately after power-on.
2	Check that FREQUENCY and OUTPUT LEVEL are digitally displayed as shown in the dotted frame in the figure above.
3	Press the [TUNE] key. After the key LED lights, turn the TUNE knob counterclockwise and clockwise and check that the frequency display value decreases and increases, respectively at a 10 Hz resolution.
4	Press the FREQUENCY section [\wedge] or [\vee] key and check that the frequency display value is incremented or decremented in 1 MHz steps.
5	Turn the OUTPUT section output knob clockwise and counter clockwise and check that the output level display value is incremented and decremented, respectively, at a 0.1 dB resolution.
6	Press the OUTPUT section [\wedge] or [\vee] key and check if the output level display value is incremented or decremented respectively in 10 dB steps.

(continued)

Step	Procedure
7	Press the MODULATION section [INT AM] key and check that the key LEDs of the [INT AM] and [1 kHz] keys light and AM 30% is digitally displayed on the MODULATION display.
8	Press the MODULATION section [INT FM] key and check that the key LED lights and AM FM simultaneous modulation is indicated, and 3.50 kHz frequency deviation is digitally displayed at the MODULATION display.
9	Press the [MOD OFF] key in the MODULATION section and check that the lit key LED goes off, and the MODULATION display also goes off, and the MG3601A/MG360A modulation function is turned off.
10	Press the [MOD OFF] key again and check that Step 8 is reproduced. ([MOD OFF] key is turned on and off alternately.)
11	Press the [INT AM] key and check that the AM function is turned off and that only the FM function remains on. Also, press the [INT FM] key and check that the FM function is turned off and that only the AM function remains on.

STEP	ACTION	VERIFICATION
7.	<input type="checkbox"/> INT AM	<input checked="" type="checkbox"/> INT AM <input checked="" type="checkbox"/> 1kHz <div style="border: 1px solid black; padding: 5px; display: inline-block;">AM 30 %</div>
8.	<input type="checkbox"/> INT FM øM	<input checked="" type="checkbox"/> INT FM øM <div style="border: 1px solid black; padding: 5px; display: inline-block;">AM FM 3.50 kHz</div>
9.	MOD OFF	<input type="checkbox"/> INT AM <input type="checkbox"/> INT FM øM <input type="checkbox"/> 1kHz <div style="border: 1px solid black; height: 20px; width: 100%;"></div>
10.	MOD OFF	<input checked="" type="checkbox"/> INT AM <input checked="" type="checkbox"/> INT FM øM <input checked="" type="checkbox"/> 1kHz <div style="border: 1px solid black; padding: 5px; display: inline-block;">AM FM 3.50 kHz</div>
11.	<input checked="" type="checkbox"/> INT AM	<input type="checkbox"/> INT AM <input checked="" type="checkbox"/> INT FM øM <input checked="" type="checkbox"/> 1kHz <div style="border: 1px solid black; padding: 5px; display: inline-block;">FM 3.50 kHz</div>

Note:

The MG3601A/MG3602A Signal Generator is shipped with the settings described above stored in the internal memory. The main settings associated with the front panel display are summarized below.

For the detailed settings, see paragraph 5.10.

Note: (Cont'd)

CENTER FREQ 1.04 MHz
ΔF 1 MHz
FREQ RESOLUTION 10 Hz
RELATIVE FREQ OFF
FREQ TUNING OFF
OUTPUT LEVEL -30 dBm
LEVEL RESOLUTION 0.1 dB
CONTINUE MODE OFF
MODULATION OFF
FM 3.5 kHz
AM 30%
ϕM 1 RAD
INT MOD OUTPUT 1 kHz

In the following checks, the signals that should be generated by the settings described above and output at the OUTPUT connector are checked with the test equipment shown in Fig. 3-6.

3.3.2 Carrier frequency and output level check

The frequency and output level are checked from the spectrum analyzer CRT.

Step	Procedure
1	Connect the RF INPUT connector of the spectrum analyzer (Fig. 3-6) to the OUTPUT connector of the MG3601A/MG3602A with the 50 Ω coaxial cable (5D-2W) supplied.

(continued)

Step	Procedure
2	Turn off the MG3601A/MG3602A modulation by pressing the the [MOD OFF] key.
3	Press the FREQUENCY section [^] and [v] keys and turn the TUNE knob to set the FREQUENCY display to 1040 000 000.
4	Press the OUTPUT LEVEL section [^] and [v] keys and turn the output setting knob to set the OUTPUT LEVEL display to -30 dBm.
5	Set the spectrum analyzer as follows: REFERENCE LEVEL (REF) -30.0 dBm RESOLUTION BANDWIDTH (RBW) 3 kHz CENTER FREQ (CENTER) 1040 MHz FREQ SPAN (SPAN) 500 kHz
6	Check that the spectrum shown below appears on the spectrum analyzer CRT. The trace waveform peak point should be near the center of the screen and the level should be near -30 dBm.

(continued)

Step

Procedure

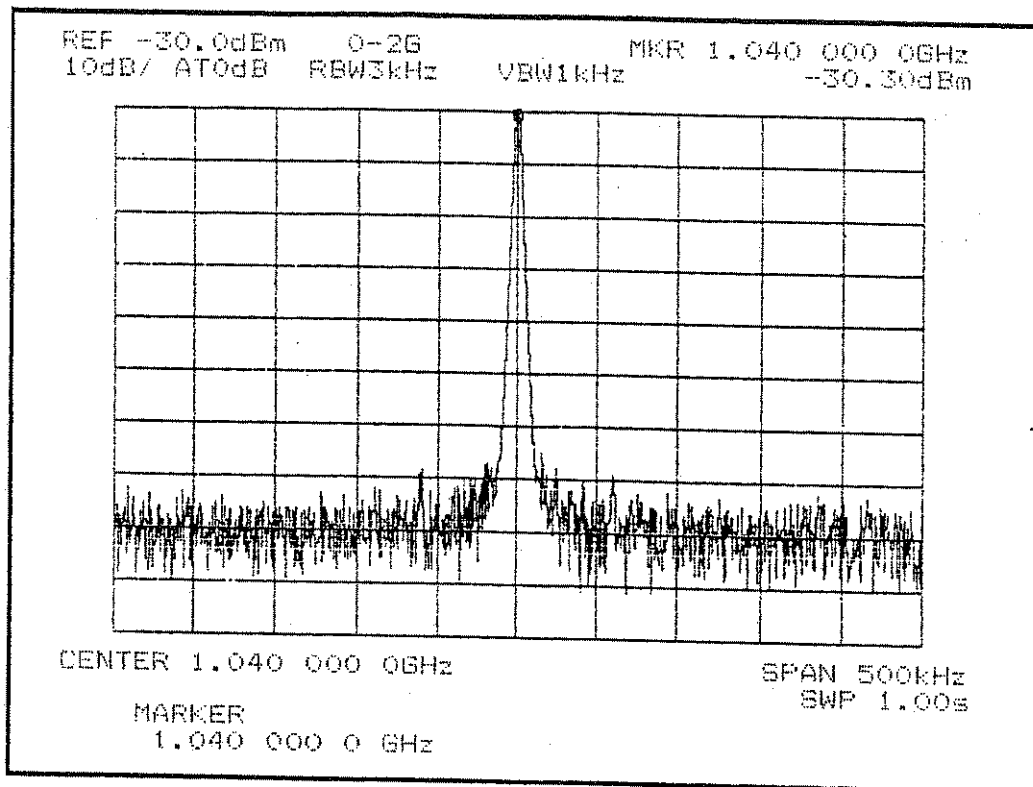

Note:

Since the MG3601A/MG3602A measurement error and the spectrum analyzer measurement error are added, the frequency may not be exactly 1040 MHz and the level may not be exactly -30 dBm. For higher measured result accuracy, see the performance tests in SECTION 4.

3.3.3 FM/ϕM check

A 3.5 kHz frequency deviation FM wave and 1 RAD phase shift ϕM wave are checked with the spectrum analyzer. The state of Step 11 in paragraph 3.3.1 is assumed as the last stage of the MODULATION SECTION. The modulation function was turned off by Step 2 in paragraph 3.3.2.

Step	Procedure
1	Press the MODULATION section [MOD OFF] key and reproduce the 3.5 kHz deviation FM modulation function and check the following two points: <ol style="list-style-type: none">1. LEDs in [INT FM] and [1 kHz] keys lit2. MODULATION display LCD lit: FM 3.50 kHz
2	Set the spectrum analyzer as follows: REFERENCE LEVEL (REF): -30.0 dBm RESOLUTION BANDWIDTH (RBW): 300 Hz CENTER FREQ (CENTER): 1040 MHz FREQ SPAN (SPAN): 20 kHz or 50 kHz
3	At the spectrum analyzer CRT, check that a 1 kHz modulation frequency, 3.5 kHz deviation FM wave is output. (Count the spectrum in 2 or 5 kHz/div.)

(continued)

Step

Procedure

REF -30.0dBm 0-26 MKR 1.040 000 006Hz
10dB/ AT0dB RBW300Hz VBW1kHz -39.20dBm

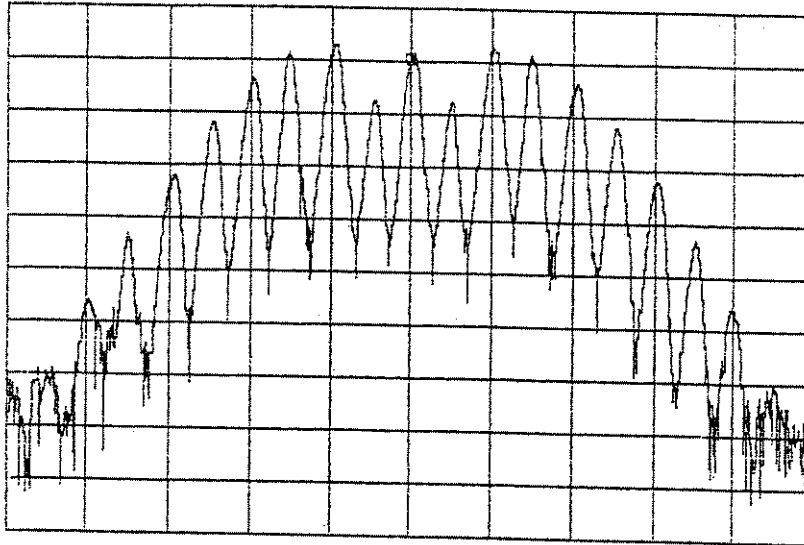

CENTER 1.040 000 006Hz

SPAN 20.0kHz
SWP 1.00s

SPAN
20.0 kHz

REF -30.0dBm 0-26 MKR 1.040 000 006Hz
10dB/ AT0dB RBW300Hz VBW30Hz -39.00dBm

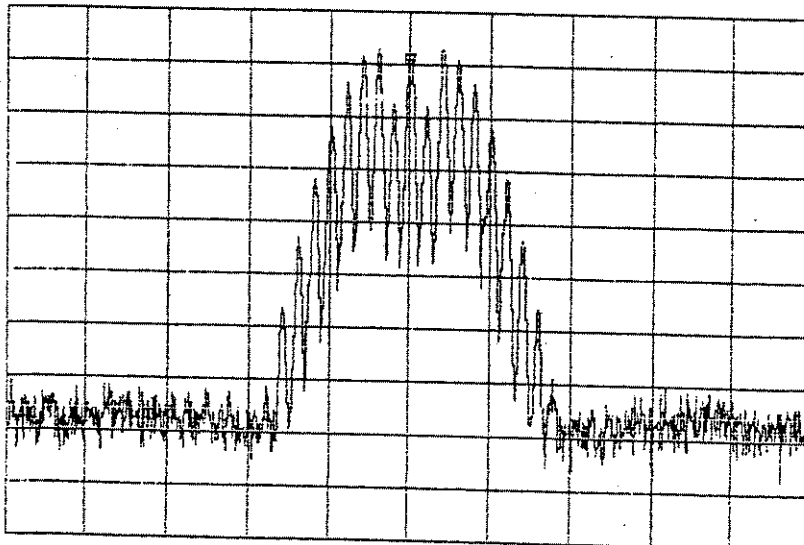

CENTER 1.040 000 006Hz

SPAN 50.0kHz
SWP 25.0s

VIDEO BW
30 Hz

(continued)

Step

Procedure

- 4 If the spectrum analyzer does not have a resolution bandwidth (RBW) of up to 300 Hz, set RBW to 1 kHz and check the spectrum waveform shown below.

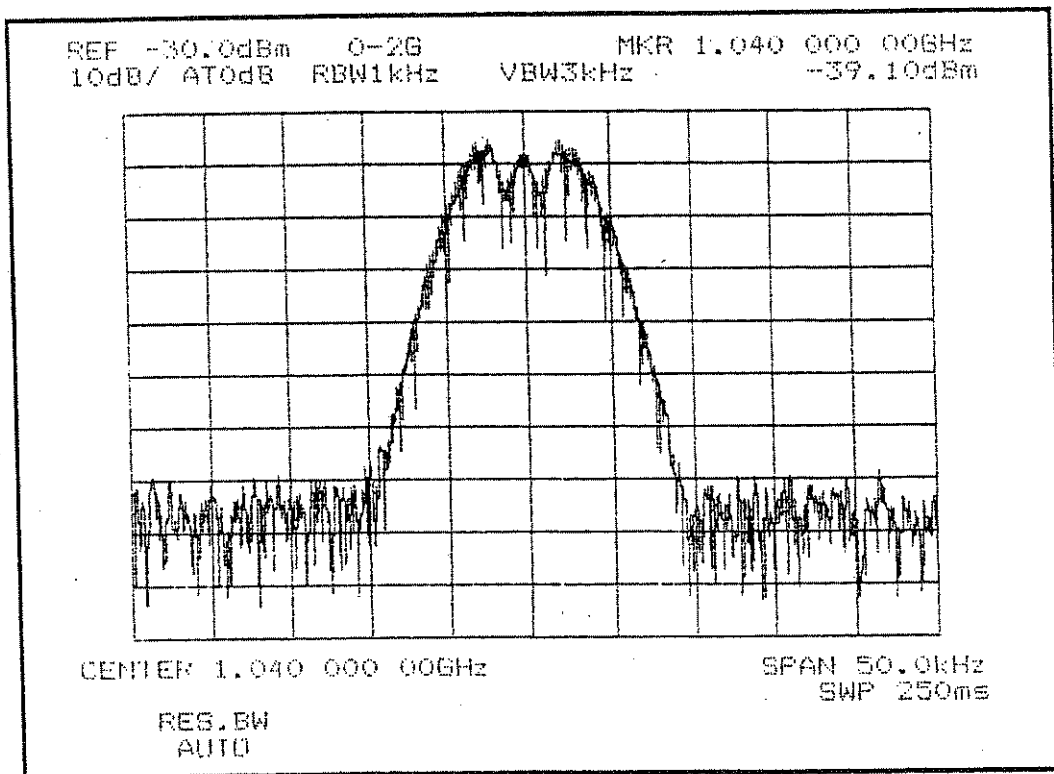

(continued)

- | Step | Procedure |
|------|--|
| 5 | Press the DATA ENTRY section [SHIFT], [ϕ M], and [RAD] keys, in that order, and check that " ϕ M 1.00 RAD" is digitally displayed. |
| 6 | Since the modulation frequency is 1 kHz, a 1 RAD phase deviation ϕ M wave is equivalent to a 1 kHz frequency deviation FM wave. Therefore, check that it is about 1/3 narrower than the 3.5 kHz deviation FM wave shown in step 4. The spectrum waveform of a 1 RAD phase deviation ϕ M wave is shown below. |

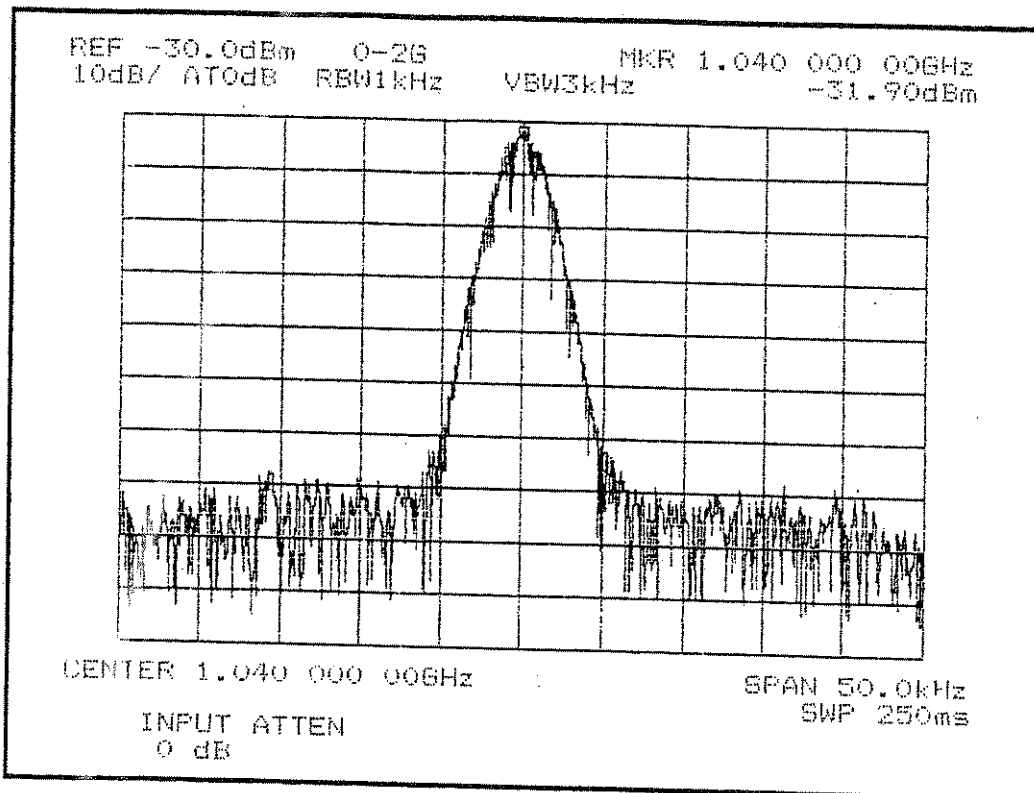

STEP	ACTION	VERIFICATION
1.	<input type="checkbox"/> MOD OFF	<div style="display: flex; justify-content: space-around;"> <div style="border: 1px solid black; padding: 2px;"><input type="checkbox"/> INT AM</div> <div style="border: 1px solid black; padding: 2px;"><input checked="" type="checkbox"/> INT FM ØM</div> <div style="border: 1px solid black; padding: 2px;"><input checked="" type="checkbox"/> 1kHz</div> </div> <div style="border: 1px solid black; padding: 5px; margin-top: 10px; text-align: center;"> FM 3.50 kHz </div>
5.	<div style="border: 1px solid black; padding: 2px; margin-bottom: 5px;"><input type="checkbox"/> SHIFT</div> <div style="border: 1px solid black; padding: 2px; margin-bottom: 5px; text-align: center;"> FM <hr style="width: 50%; margin: 0 auto;"/> ØM </div> <div style="border: 1px solid black; padding: 2px; text-align: center;"> % RAD / μV </div>	<div style="border: 1px solid black; padding: 5px; text-align: center;"> ØM 1.00 RAD </div>

3.3.4 AM check

Following paragraph 3.3.3, a 1 kHz modulation frequency, 30% AM wave is checked with the spectrum analyzer.

The state of Step 5 in paragraph 3.3.3 is assumed as the last stage of the MODULATION section (1 RAD phase deviation ϕ M mode state).

Step	Procedure
1	To cancel the current 1 RAD phase modulation ϕ M mode, press the [INT FM] key. Check that the LEDs in the [INT FM] and [1 kHz] keys, and the LCD of the MODULATION display go off.
2	To output a 1 kHz modulation frequency, 30% AM wave, press the [INT AM] key. Check that the LED in the [INT AM] key lights, and that AM 30% is digitally displayed on the MODULATION display.
3	Set the spectrum analyzer as follows: RESOLUTION BANDWIDTH (RBW): 300 Hz FREQ SPAN (SPAN): 10 kHz or 20 kHz
4	At the spectrum analyzer CRT, check as shown below that a 1 kHz modulation frequency, 30% AM wave is output.

(continued)

Step	Procedure
------	-----------

REF -30.0dBm 0-2B MKR 1.040 000 00GHz
10dB/ AT5dB RBW300Hz VBW1kHz -32.20dBm

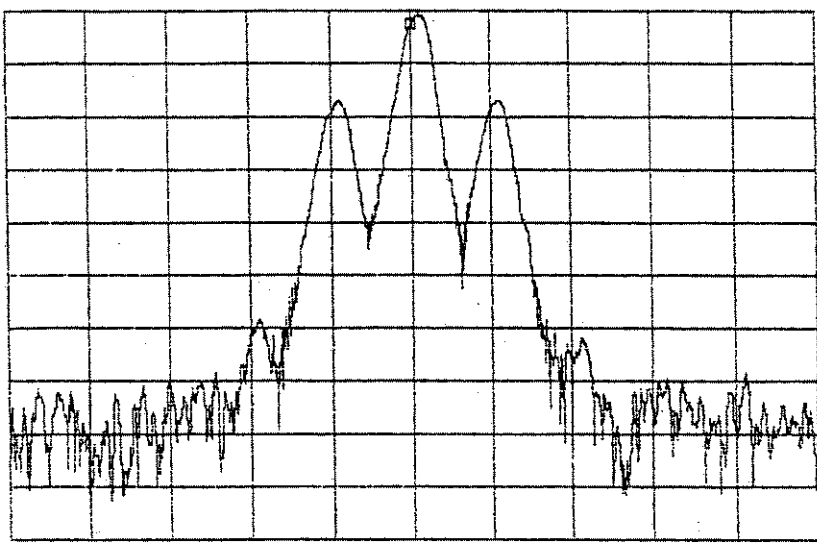

CENTER 1.040 000 00GHz SPAN 10.0kHz
SWP 500ms
SPAN 10.0 kHz

REF -30.0dBm 0-2B MKR 1.040 000 00GHz
10dB/ AT5dB RBW300Hz VBW1kHz -31.30dBm

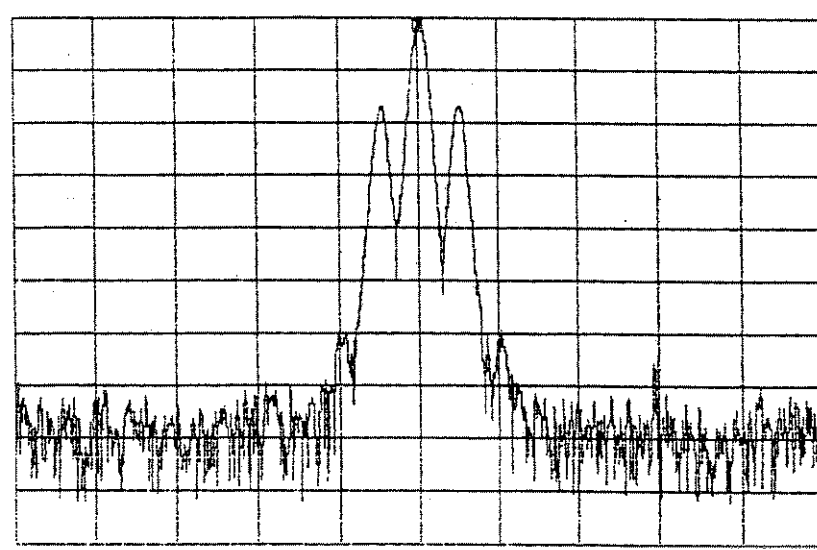

CENTER 1.040 000 00GHz SPAN 20.0kHz
SWP 1.00s
SPAN 20.0 kHz

STEP	ACTION	VERIFICATION
1.	<input checked="" type="checkbox"/> INT FM <input type="checkbox"/> M	<input type="checkbox"/> INT FM <input type="checkbox"/> M <input type="checkbox"/> 1kHz
2.	<input type="checkbox"/> INT AM	<input checked="" type="checkbox"/> INT AM <input checked="" type="checkbox"/> 1kHz <input type="checkbox"/> AM 30 %

3.3.5 MOD OUTPUT check

Following paragraph 3.3.4, check with the oscilloscope whether or not the initially set internal 1 kHz signal is output from the MOD OUTPUT connector.

The state set in Step 2 of paragraph 3.3.4 is assumed as the last stage of the MODULATION section (internal 1 kHz oscillation mode).

Step	Procedure
1	Connect the VERTICAL INPUT connector of the oscilloscope to the MOD OUTPUT connector of the MG3601A/MG3602A with a BNC-BNC cable Fig. 3-6.
2	Set the oscilloscope as shown below and check the 1 kHz modulation frequency. TIME/DIV: 1 ms or .1 ms VOLTS/DIV: 1 V The waveform when TIME/DIV = .1 ms was set is shown below.

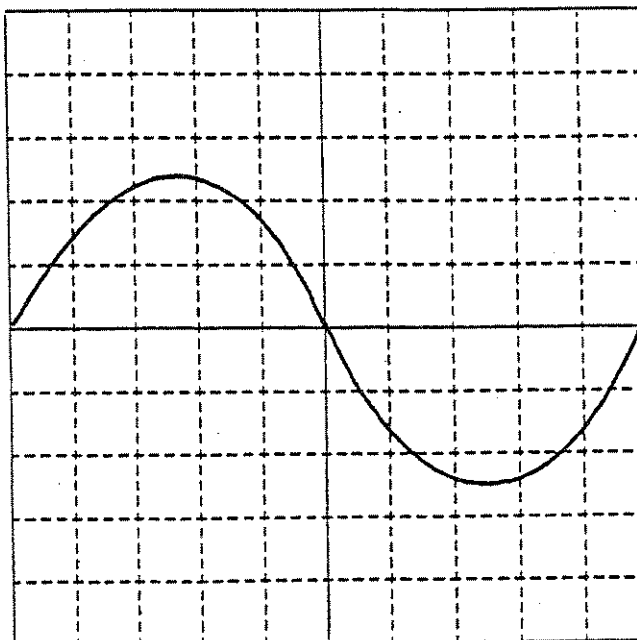

3.3.6 MOD INPUT check

Following paragraph 3.3.5, a 1 kHz signal is input to the MOD INPUT connector from the external AF signal source. The spectrum analyzer is used to check whether or not the results are the same as the FM, ϕ M, and AM checks in the internal modulation mode.

Since the waveform on the spectrum analyzer CRT is the same trace as previously described, it is omitted in this paragraph and only the procedure steps are described.

The state of Step 2 of paragraph 3.3.4 is assumed as the last stage of the MODULATION section (INT AM mode).

Step	Procedure
1	To cancel the INT AM mode, press either the [INT AM] key or [MOD OFF] key. Check that the MG3601A/MG3602A modulation function goes off (LEDs in [INT AM] and [1 kHz] keys and LCD on MODULATION display go off).
	<u>EXT AM check</u>
2	Press the [EXT AM] key. Check that the LED in the [EXT AM] key and the LO display at the left side of the MODULATION display frame come on. Since a modulation signal is not applied to the MOD INPUT connector even though AM 30% is displayed on the MODULATION display, also check that only a carrier is output from the MG3601A/MG3602A OUTPUT connector.
3	Connect the OUTPUT connector of the AF oscillator (Fig. 3-6) to the MOD INPUT connector of the MG3601A/MG3602A with a coaxial cable (RG-58A/U).
4	Adjust the AF oscillator output level so that both the HI and LO displays go off. Check that Step 3 in paragraph 3.3.4 can be reproduced.

(continued)

Step	Procedure
<u>EXT FM check</u>	
5	Turn off the modulation function by pressing the [EXT AM] key.
6	Set the EXT FM mode by pressing the [EXT FM] key. FM 3.5 kHz is displayed on the MODULATION display. Check that Step 3 in paragraph 3.3.3 can be reproduced.
<u>EXT ϕM check</u>	
7	When the [SHIFT], [ϕ M], and [RAD] keys of the DATA ENTRY section are pressed, in that order, " ϕ M 1.00 RAD" is displayed on the MODULATION display. Check that Step 6 in paragraph 3.3.3 can be reproduced.
<u>MOD OUTPUT check</u>	
8	Check that the 1 kHz AF signal applied to the MOD INPUT connector is output from the MOD OUTPUT connector by repeating the paragraph 3.3.5 check.

STEP	ACTION	VERIFICATION
1.	<input checked="" type="checkbox"/> INT AM	<input type="checkbox"/> INT AM <input type="checkbox"/> 1kHz
	or	
	<input type="checkbox"/> MOD OFF	
2.	<input type="checkbox"/> EXT AM	<input checked="" type="checkbox"/> EXT AM
		AM 30 %
5.	<input checked="" type="checkbox"/> EXT AM	<input type="checkbox"/> EXT AM
6.	<input type="checkbox"/> EXT FM	<input checked="" type="checkbox"/> EXT FM
		FM 3.50 kHz
7.	<input type="checkbox"/> SHIFT	ØM 1.00 RAD
	<input type="checkbox"/> FM <input type="checkbox"/> ØM	
	<input type="checkbox"/> % <input type="checkbox"/> RAD/ μ V	

SECTION 4

CALIBRATION AND PERFORMANCE TESTS

This section describes the MG3601A/MG3602A Signal Generator routine calibration and performance tests.

TABLE OF CONTENTS

	Page
SECTION 4 CALIBRATION AND PERFORMANCE TESTS	
4.1 Daily Servicing and Preventive Maintenance	4-1
4.2 Calibration and Performance Tests Equipment	4-2
4.3 Calibration	4-3
4.3.1 Standard oscillator frequency accuracy (1)	4-3
4.3.2 Standard oscillator frequency accuracy (2)	4-6
4.4 Performance Tests	4-8
4.4.1 Frequency output	4-8
4.4.2 Output level frequency characteristic ...	4-10
4.4.3 Output level accuracy	4-12
4.4.4 FM deviation and FM distortion	4-16
4.4.5 AM modulation factor and AM distortion ..	4-19
4.5 Service	4-21



4.1 Daily Servicing and Preventive Maintenance

To prevent degradation of the performance of the MG3601A/MG3602A, the MG3601A/MG3602A should be operated correctly under the specified conditions (paragraph 2.1) Calibration and performance tests should also be performed routinely.

The regular servicing method and interval are shown in Table 4-1.

Table 4-1 Regular Servicing

	Period	Method
Soiling	. Before long-term storage	Wipe with damp cloth and soapy water or cleaning solvent* (DAIFLON)
	. When used in dusty locations	
Dust	. When noticeable dust and dirt have accumulated inside cabinet	Open cabinet and blow out dust with compressed air
Lubrication	None	
Loose screws	When detected	Retighten with recommended tool

* Do not use acetone or benzene; the paint finish may be damaged.

For the detailed cabinet-removal instructions, refer to the separate service manual. When the MG3601A/MG3602A is temporarily not in use, or when it is to be stored for a long time, follow the instructions in paragraph 2.3.

4.2 Calibration and Performance Tests Equipment

Table 4-2 lists the calibration and performance test equipment.

Table 4-2 Equipment Required for Calibration and Performance Test

Test item	Test equipment	Required performance*	Recommended model	Reference
Standard oscillator frequency accuracy	Oscilloscope	50 MHz, external trigger possible		4.3.1
Frequency output	Microwave frequency counter	100 kHz to 2.08 GHz	MF76A	4.4.1
Output level frequency characteristic	Power meter	100 kHz to 3 GHz -30 dBm to +20 dBm	ML4803A MA4601A (Sensor)	4.4.2
Output level accuracy	Level and attenuation calibrator	100 kHz to 1.3 GHz -20 dBu to +130 dBu	ME642A	4.4.3
	Pre-amplifier	100 kHz to 1200 MHz 1200 MHz to 2080 MHz	MH648A	
FM frequency deviation	Modulation analyzer	150 kHz to 2080 MHz	MS616A	4.4.4
AM modulation factor	Modulation analyzer	150 kHz to 2080 MHz AM, FM, ϕ M	MS616A	4.4.5
Modulation distortion	Distortion meter	20 Hz to 100 kHz		4.4.5

* Only part of the performance that covers the test item measurement range is listed.

4.3 Calibration

The MG3601A/MG3602A internal standard oscillator frequency must be calibrated about once every six months.

When an item does not satisfy the specifications at calibration or performance tests, adjustment or repairs must be made in accordance with the service manual. If adjustment or repair is difficult, contact the ANRITSU service department.

4.3.1 Standard oscillator frequency accuracy (1)

This paragraph describes calibration when options 01 to 03 are installed.

Since the MG3601A/MG3602A 10 MHz standard oscillator stability is $\pm 2 \times 10^{-8}$ /day, a standard signal generator, which either receives a standard signal or receives a color television subcarrier (signal locked to a rubidium atomic standard) and generates a signal locked to this signal, is used as the frequency standard.

(1) Calibration specifications

Standard oscillator (Option 01)

- . Aging rate 2×10^{-8} /day
- . Temperature characteristic $\pm 5 \times 10^{-8}$
(0° to 50°C)
- . Frequency 10 MHz

Standard oscillator (Option 02)

- . Aging rate 5×10^{-9} /day
- . Temperature characteristic $\pm 5 \times 10^{-8}$
(0° to 50°C)
- . Frequency 10 MHz

Standard oscillator (Option 03)

- . Aging rate 2×10^{-9} /day
- . Temperature characteristic $\pm 1.5 \times 10^{-8}$
(0° to 50°C)
- . Frequency 10 MHz

(2) Calibration test equipment

- . Oscilloscope 10 MHz measurement, external trigger
- . Frequency counter ... Accuracy $\geq 2 \times 10^{-8}$, 1 GHz measurement
- . Frequency standard .. Standard with standard signal receiver, or equivalent function (accuracy $\geq 1 \times 10^{-9}$ order)

(3) Set up

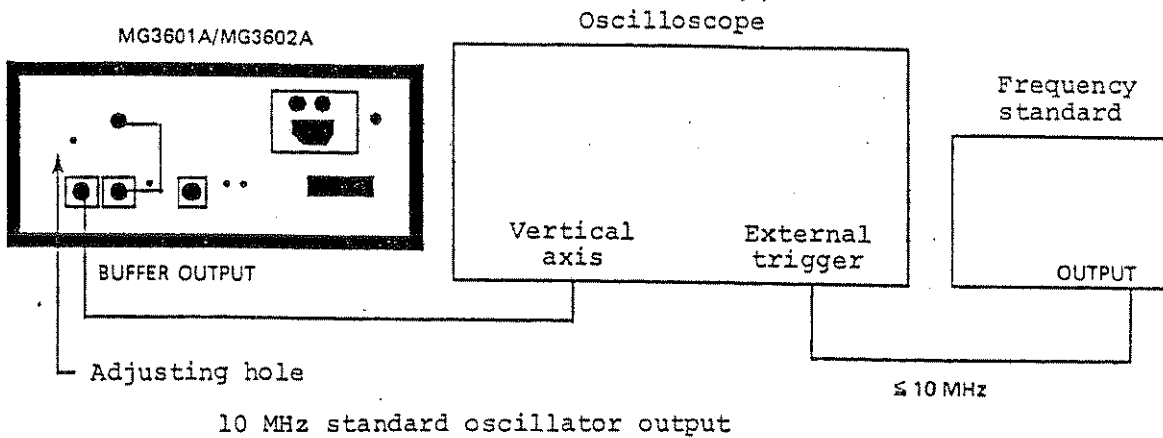

Fig. 4-1 Standard Oscillator Calibration

(4) Calibration procedure

Step	Procedure
1	Set up the equipment as shown in Fig. 4-1 in a room at $23^{\circ} \pm 5^{\circ}\text{C}$.
2	To warm-up the MG3601A/MG3602A standard oscillator, set the POWER switch to STBY and leave the instrument in that state for 24 hours.
3	After 24 hours, set the MG3601A/MG3602A front panel POWER switch to ON.
4	Apply the standard frequency signal to the oscilloscope external trigger input. Also, apply the output signal from the BUFFER OUTPUT connector on the MG3601A/MG3602A rear panel to the oscilloscope vertical axis X.
5	Adjust the oscilloscope so that the input waveform can be observed. If the input waveform on the oscilloscope moves to the right or left and is not synchronized, the standard oscillator frequency does not match the standard frequency.
6	Adjust the potentiometer inside the standard oscillator calibration hole in the MG3601A/MG3602A rear panel shown in Fig. 4-1 so that the input waveform on the oscilloscope does not move to the left or right.

(5) Calibration precautions

The standard signal is 10 MHz and when this signal is applied to the Y-axis of the oscilloscope, a Lissajous waveform will be displayed. At this time, adjust the standard oscillator frequency at Step 6 so that this waveform becomes a static circle.

4.3.2 Standard oscillator frequency accuracy (2)

This paragraph describes calibration when Options 01 to 03 are not installed: that is, for the standard instrument.

Standard oscillator (standard instrument)

- . Aging rage 2×10^{-6} /year
- . Temperature characteristic $\pm 5 \times 10^{-6}$ (0° to 50°C, however, at standard oscillator ambient temperature)
- . Frequency 10 MHz

(1) Setup

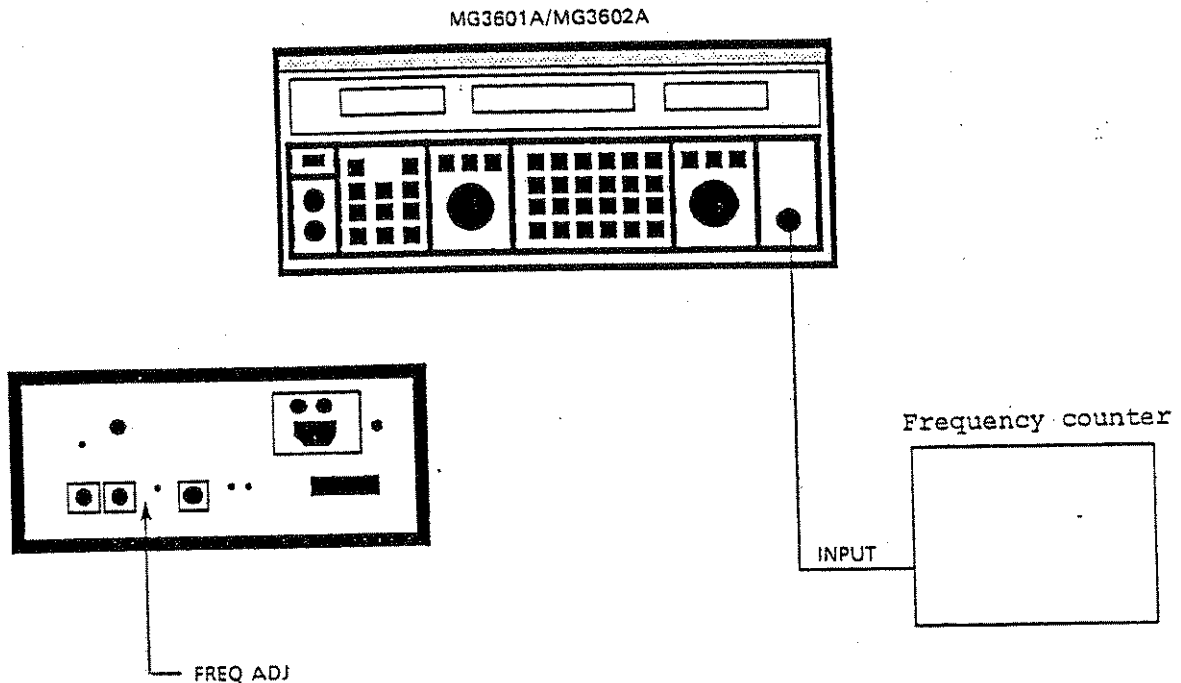

Fig. 4-2 Standard Oscillator Frequency Accuracy

(2) Test procedure (standard instrument)

Step	Procedure
1	Setup the equipment as shown in Fig. 4-2.
2	Set the MG3601A/MG3602A frequency to 1000 MHz.
3	Set the frequency counter resolution to 10 Hz or less.
4	While reading the frequency with the frequency counter, turn the FREQ ADJ variable resistor on the MG3601A/MG3602A rear panel with a screwdriver so that the frequency counter reads 1000 MHz.

4.4 Performance Tests

When performance tests are necessary at MG3601A/MG3602A acceptance inspection, routine inspection, performance checks after repair, etc., proceed as described in paragraphs 4.4.1 to 4.4.5. Since performance tests are performed in the normal usage state, there are no internal adjustments, such as calibration. Test important items regularly for preventive maintenance.

Note:

The MG3601A/MG3602A warmup time can be as long as 24 hours, depending on the test item. For some test items, warm-up the instrument for at least 30 minutes and test the performance after the MG3601A/MG3602A has stabilized.

The warmup time of the test equipment must also be considered before making any measurements. For the highest measurement accuracy, in addition to the above, tests must be made at room temperature. The ac line voltage must be stable, and noise, vibration, dust and humidity must not be a problem.

4.4.1 Frequency output

This test checks if the set frequency is output normally.

(1) Tested specifications

- . Frequency range 0.1 to 1040 MHz (MG3601A)
 0.1 to 2080 MHz (MG3602A)
- . Setting resolution 10 Hz (MG3601A and MG3602A,
 ≤ 1040 MHz)
 20 Hz (MG3602A, >1040 MHz)

(2) Test equipment

- . Frequency counter

(3) Setup

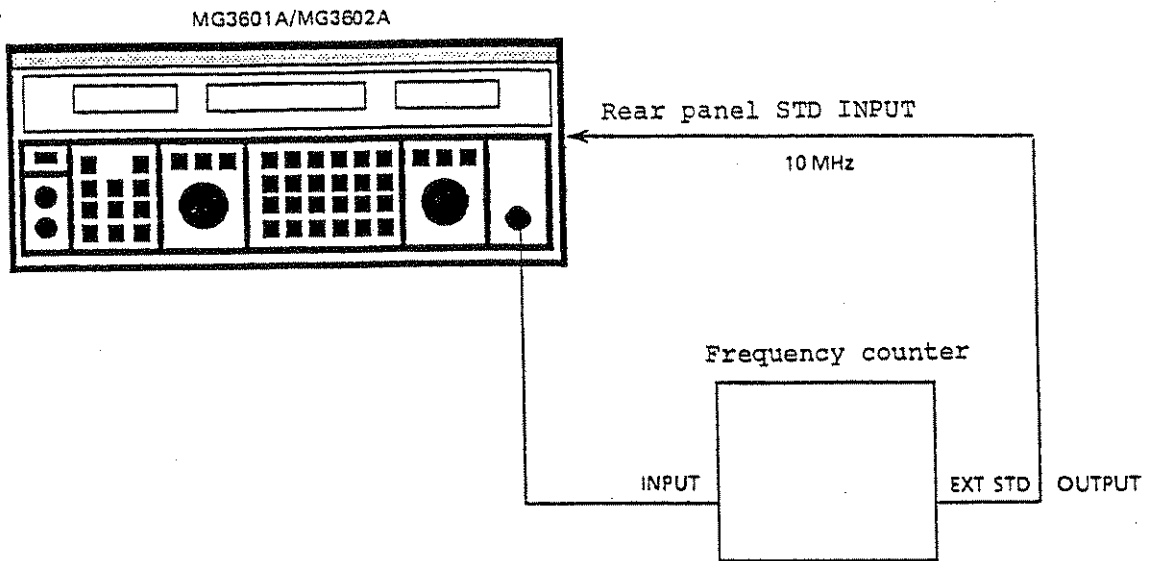

Fig. 4-3 Frequency Output

(4) Test procedure

Step	Procedure
1	Connect the standard frequency output (10 MHz) of the frequency counter to the external standard input of the MG3601A/MG3602A.
2	Connect the MG3601A/MG3602A output to the frequency counter input as shown in Fig. 4-3.
3	Set the MG3601A/MG3602A output level to +7 dBm.

OUTPUT
LEVEL
OFF

7

MHz/dBm

(continued)

Step	Procedure							
4	Set the MG3601A/MG3602A to any frequency. For example, if 465.5 MHz,							
	<table border="1"><tr><td>CENTER FREQ ΔF</td><td>4</td><td>6</td><td>5</td><td>* • FRL</td><td>5</td><td>MHz/dBm</td></tr></table>	CENTER FREQ ΔF	4	6	5	* • FRL	5	MHz/dBm
CENTER FREQ ΔF	4	6	5	* • FRL	5	MHz/dBm		
5	Check that the frequency counter reading is the same as the set value.							
6	Change the frequency and repeat the measurement.							

(5) Test precautions

The counter reading may include a ± 1 count error.

4.4.2 Output level frequency characteristic

(1) Tested specifications

- . ≤ 1 dB (at 0 dBm) (MG3601A and MG3602A, ≤ 1040 MHz)
- . ≤ 1.5 dB (at 0 dBm) (MG3602A, > 1040 MHz)

(2) Test equipment

- . Power meter: 100 kHz to 1040 MHz (MG3601A)
- 100 kHz to 2080 MHz (MG3602A)

(3) Setup

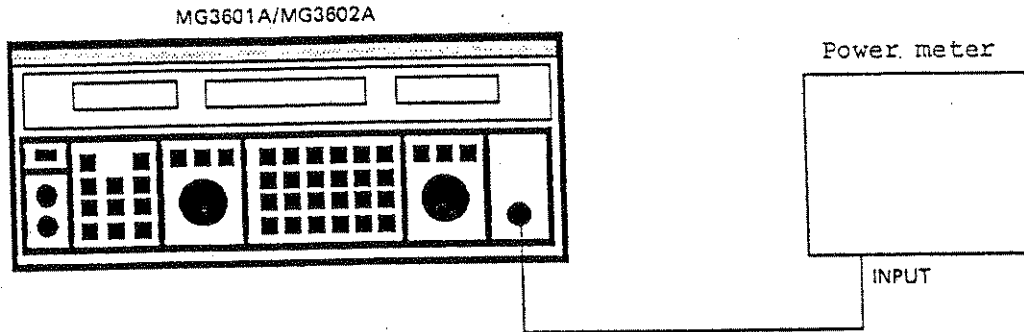



Fig. 4-4 Output Level Frequency Characteristic

(4) Test procedure

Step	Procedure
1	Turn off the MG3601A/MG3602A output level and zero-adjust the power meter.
	
2	Set the MG3601A/MG3602A output level to 0 dBm.
	

(continued)

Step	Procedure
3	Set the MG3601A/MG3602A to the frequency to be measured (for example, the table below).

Frequency	100 kHz	1 MHz	10 MHz	100 MHz	200 MHz	500 MHz	1040 MHz	1500 MHz	2080 MHz
Level deviation									

- 4 Set the calibration factor of the power meter sensor and read the output level.

(5) Test precautions

The MG3601A/MG3602A output level frequency characteristic at the OUTPUT connector is specified. Therefore, when making measurements, connect the power meter sensor directly to the MG3601A/MG3602A output connector.

4.4.3 Output level accuracy

(1) Test specifications

. MG3601A and MG3602A, ≤ 1040 MHz

- ± 1 dB (at ≥ -10 dBm)
- ± 1.5 dB (at ≥ -123 dBm)
- ± 2 dB (at < -123 dBm)

. MG3602A, > 1040 MHz

- ± 1.5 dB (at ≥ -10 dBm)
- ± 2 dB (at ≥ -123 dBm)
- ± 3 dB (at < -123 dBm)

(2) Test equipment

- . Level and attenuation calibrator
 - 100 kHz to 1040 MHz (MG3601A used)
 - 100 kHz to 2080 MHz (MG3602A used)
- . Preamplifier
 - 100 kHz to 1040 MHz, gain 30 dB (MG3601A used)
 - 100 kHz to 2080 MHz, gain 30 dB (MG3602A used)

(3) Setup

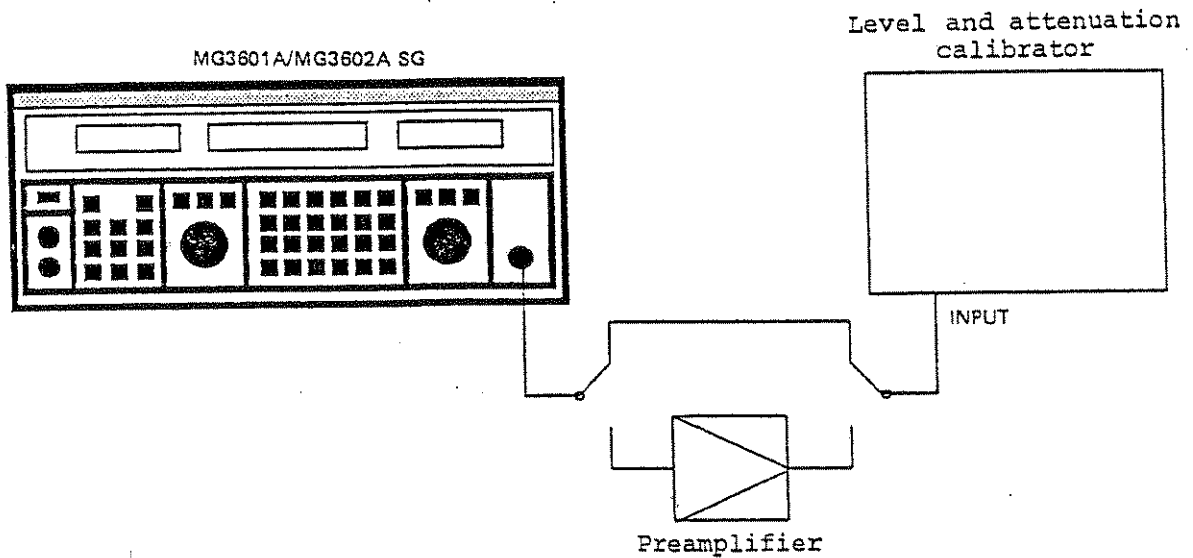

Fig. 4-5 Output Level Accuracy

(4) Test procedure

Step	Procedure
1	Set the SG to the measurement frequency and set the output level to +13 dBm (using MG3601A and MG3602A, ≤ 1040 MHz) or +7 dBm (using MG3602A, > 1040).
2	Set the level and attenuation calibrator to the same frequency as the MG3601A/MG3602A and set the meter indication to 0 with the ATT and fine-adjustment control.
3	Attenuate the SG output level in accordance with the table below. At the same time, change ATT of the calibrator by the same amount and read the deviation of the meter indication at that time.
4	Repeat Step 3 until the SG output level reaches -113 dBm.
5	Next, insert the preamplifier between the SG and calibrator.
6	Set the meter indication to the same value as before the preamplifier was inserted, with the calibrator ATT and fine-adjustment control.
7	Attenuate the SG output level again. At the same time, change the calibrator ATT by the same amount and read the deviation of the meter indication at that time.

MG3601A/ MG3602A set frequency SG Output level (dB)	100 kHz	130/1040 MHz	1040/2080 MHz
+13			
+7			
+6			
+5			
+4			
+3			
+2			
+1			
0			
-1			
-2			
-3			
-13			
-23			
-33			
-43			
-53			
-63			
-73			
-83			
-93			
-103			
-113			
-123			
-133			

4.4.4 FM deviation and FM distortion

(1) Tested specifications

- . 0 to 199 kHz (0 to 99.9 kHz at 130 to 260 MHz)
- . FM deviation accuracy $\pm 5\%$ (internal 1 kHz)
- . Distortion $\leq 1\%$ (internal 1 kHz, 22.5 kHz deviation)

(2) Test equipment

- . Modulation analyzer
- . Distortion meter

(3) Setup

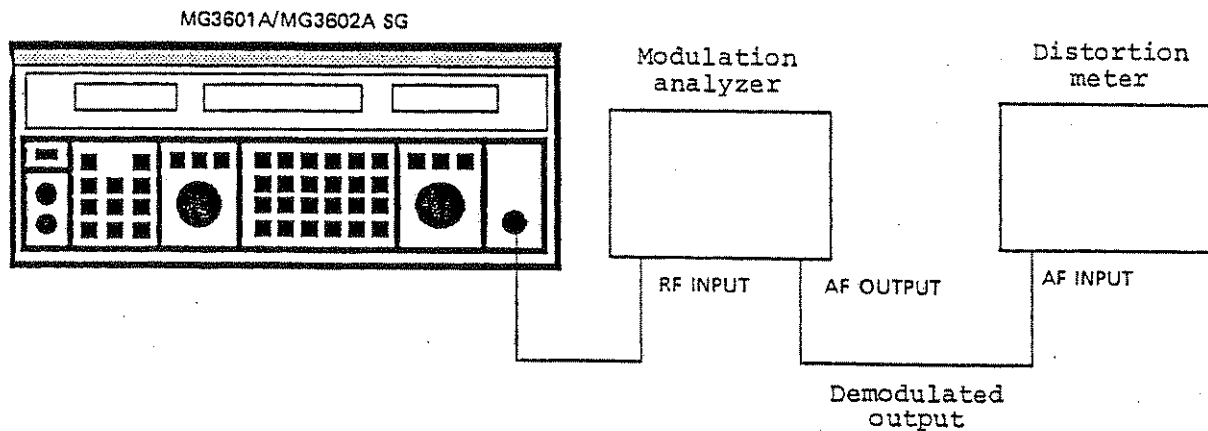

Fig. 4-6 FM Deviation and FM Distortion

(4) Test procedure

Step	Procedure
------	-----------

FM deviation

- 1 Set the SG output level to +7 dBm.

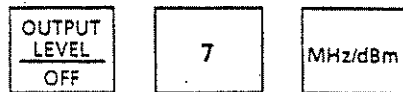

- 2 Set the SG frequency to the measurement frequency.
For example, if 465.5 MHz,

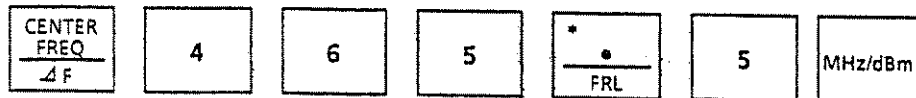

- 3 Turn on the SG FM. (If other modulations are on,
turn them off.)

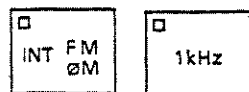

- 4 Set the SG FM frequency deviation.

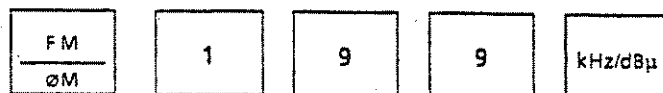

(continued)

Step	Procedure
5	Read the modulation analyzer indication.
6	Change the SG FM frequency deviation and repeat the measurement.

FM distortion

- 7 Set the SG FM frequency



- 8 Measure the modulation analyzer demodulated output with the distortion meter.

(5) Test precautions

- . At FM deviation measurement, set the modulation analyzer demodulation bandwidth to 0.3 to 3 kHz.
- . Measure distortion at a 0.3 to 15 kHz demodulation bandwidth.
- . If a modulation analyzer with a large residual FM is used, when the FM deviation is small, distortion measurement will be adversely affected. Therefore, use a modulation analyzer with a small residual FM.

4.4.5 AM modulation factor and AM distortion

(1) Tested specifications

. Range: 0% to 100%

. Accuracy

MG3601A and MG3602A, ≤ 1040 MHz:

$\pm(4\%$ of set value $+2\%)$

($\leq 90\%$ modulation)

MG3602A, >1040 MHz:

$\pm(4\%$ of set value $+2\%)$

($\leq 60\%$ modulation)

. Distortion

MG3601A and MG3602A, ≤ 1040 MHz:

$\leq 1\%$ (internal 1 kHz 30% modulation)

$\leq 3\%$ (internal 1 kHz 60% modulation)

MG3602A, >1040 MHz:

$\leq 2.5\%$ (internal 1 kHz 30% modulation)

(2) Test equipment

. Modulation analyzer

. Distortion meter

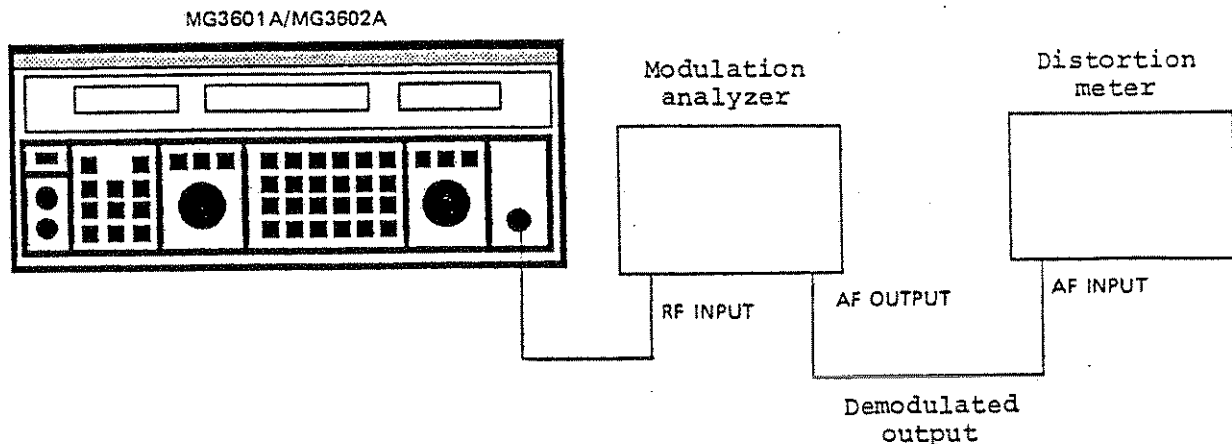

Fig. 4-7 AM Modulation Factor and AM Distortion

(4) Test procedure

Step	Procedure					
<u>Modulation factor</u>						
1	Set the SG output level to +7 dBm (MG3601A and MG3602A, ≤ 1040 MHz) or +1 dBm (MG3602A, > 1040 MHz).					
	<table border="1"><tr><td>OUTPUT LEVEL OFF</td><td>7</td><td>MHz/dBm</td></tr></table>	OUTPUT LEVEL OFF	7	MHz/dBm		
OUTPUT LEVEL OFF	7	MHz/dBm				
2	Set the frequency to the measurement frequency.					
	<table border="1"><tr><td>CENTER FREQ ΔF</td><td>4</td><td>6</td><td>5</td><td>MHz/dBm</td></tr></table>	CENTER FREQ ΔF	4	6	5	MHz/dBm
CENTER FREQ ΔF	4	6	5	MHz/dBm		
3	Turn on the SG AM mode. (If other modulations are on, turn them off.)					
	<table border="1"><tr><td><input type="checkbox"/> INT AM ◊M</td><td><input type="checkbox"/> 1kHz</td></tr></table>	<input type="checkbox"/> INT AM ◊M	<input type="checkbox"/> 1kHz			
<input type="checkbox"/> INT AM ◊M	<input type="checkbox"/> 1kHz					
4	Set the SG AM modulation factor.					
	<table border="1"><tr><td>AM AF</td><td>9</td><td>0</td><td>%</td></tr></table>	AM AF	9	0	%	
AM AF	9	0	%			
5	Read the modulation analyzer indication.					
6	Change the MG3601A/MG3602A AM modulation factor and repeat the measurement.					

(continued)

Step	Procedure
<u>Modulation distortion</u>	
7	Set the MG3601A/MG3602A AM modulation factor to 30% and 60%.
8	Measure the modulation analyzer demodulated output with the distortion meter.

(5) Test precautions

At modulation factor measurement, set the modulation analyzer demodulation bandwidth to 0.3 to 3 kHz and at distortion measurement, set the demodulation bandwidth to 0.3 to 15 kHz or 0.3 to 20 kHz.

4.5 Service

When the instrument is damaged or does not operate normally, contact the purchase agent or ANRITSU for repair.

When requesting repair, please specify the following:

- (a) Instrument name and the serial No. on the rear panel
- (b) Trouble symptoms
- (c) Name and office of person to be contacted when checking trouble or after repair



SECTION 5

OPERATION

The MG3601A/MG3602A Signal Generator can be operated either locally or remotely. For local operation the controls on the front and rear panels are operated manually.

For remote operations, all local operations except for turning the power supply switch on/off can be programmed using the GP-IB functions. Refer to SECTIONS 8 to 12 and the GP-IB Basic Guide for details of the GP-IB remote control operations.

This section explains local operations. See Appendix O for a brief explanation of the front and rear panels, and accompanying front and rear panel layouts of the MG3601A/MG3602A.

TABLE OF CONTENTS

	Page
SECTION 5 OPERATION	
5.1 Setting Carrier Frequency	5-1
5.1.1 Setting frequency from keyboard	5-2
(DATA ENTRY)	
5.1.2 Setting frequency using TUNE knob	
(TUNE)	5-7
5.1.3 Setting frequency using the step keys ..	5-13
5.1.4 Displaying relative frequency (FRL)	5-16
5.1.5 Reading carrier frequency when modulation	
frequency set	5-24

TABLE OF CONTENTS (Continued)

	Page
5.2	Setting Output Level 5-25
5.2.1	Open-circuit voltage display and terminated voltage display (SP03, 04) ... 5-27
5.2.2	Setting output level at keyboard (DATA ENTRY) 5-31
5.2.3	Setting output level using output setting knob 5-34
5.2.4	Setting output level using step keys ... 5-40
5.2.5	Reading output level from relative level (LRL) 5-42
5.2.6	Output level on/off 5-45
5.3	Basic Operations for Modulation 5-47
5.3.1	Outline of the MODULATION section/ DATA ENTRY section panel operations 5-48
5.3.2	Confirming modulation settings at initial setting 5-51
5.3.3	Switching internal modulation frequency 5-53
5.4	Modulation ON/OFF Operations 5-57
5.4.1	MODULATION ON/OFF using [MOD OFF] key .. 5-57
5.4.2	MODULATION ON/OFF using the modulation mode selection keys 5-58
5.4.3	Turning modulation on and selecting modes using [AM], [FM], and [ØM] keys ... 5-64
5.4.4	MODULATION display at simultaneous modulation 5-71

TABLE OF CONTENTS (Continued)

	Page
5.5	Setting AF OSC Frequency (20 Hz to 100 kHz) 5-73
5.5.1	Reading modulation frequency when carrier frequency set 5-74
5.5.2	Setting internal modulation frequency from keyboard (DATA ENTRY) 5-75
5.5.3	Setting AF OSC modulation frequency using TUNE knob (TUNE) 5-78
5.5.4	Setting AF OSC modulation frequency using step keys 5-84
5.6	Setting FM Modulation 5-87
5.6.1	Setting frequency deviation at keyboard (DATA ENTRY) 5-89
5.6.2	Setting frequency deviation using step keys 5-91
5.6.3	External FM modulation 5-93
5.6.4	Frequency calibration at dc FM modulation 5-95
5.7	Setting AM Modulation 5-96
5.7.1	Setting AM modulation factor at keyboard (DATA ENTRY) 5-98
5.7.2	Setting the AM modulation factor using step keys 5-100
5.7.3	External AM modulation 5-102
5.8	Setting ϕ M Modulation 5-104
5.8.1	Setting phase deviation at keyboard (DATA ENTRY) 5-106
5.8.2	Setting phase deviation using step keys 5-109

TABLE OF CONTENTS (Continued)

	Page
5.8.3 External ϕ M modulation	5-111
5.9 Video Modulation	5-113
5.9.1 Selecting video modulation mode	5-114
5.9.2 Inputting video signals	5-115
5.10 Memory	5-118
5.10.1 FREQ memory	5-118
5.10.2 Function memory	5-121
5.11 Special Functions	5-122
5.11.1 Special function status	5-124
5.11.2 Initial settings (SP00)	5-124
5.11.3 Buzzer ON/OFF (SP02/01)	5-125
5.11.4 Switching terminated voltage display and open-circuit voltage display (SP04/03)	5-125
5.11.5 Video modulation ON/OFF (SP06/05)	5-127
5.11.6 Memory sequential read mode (SP08/07)	5-127
5.11.7 Memory protect ON/OFF (SP10/09)	5-129
5.11.8 RF frequency range cancel ON/OFF (SP14/13)	5-130
5.11.9 Switching external reference input to 10M/1M (SP15/16)	5-130
5.11.10 RF frequency offset mode ON/OFF (SP18/17)	5-131
5.11.11 Setting RF frequency offset value (SP31)	5-132

TABLE OF CONTENTS (Continued)

	Page
5.11.12	Output level offset mode ON/OFF (SP20/19) 5-134
5.11.13	Setting output level offset value (SP32) 5-136
5.11.14	Frequency calibration ON during dc FM modulation (SP30) 5-137
5.11.15	Simultaneous modulation with external and separate FM ON/OFF (SP34/33) 5-138
5.11.16	LCD backlight ON/OFF (SP36/35) 5-140
5.11.17	FREQ memory clear (SP61) 5-140
5.11.18	Initialize FUNCTION memory (SP62) 5-140
5.11.19	Setting frequency 0 Hz (SP63) 5-141
5.11.20	LCD and LED check (SP64) 5-141
5.11.21	RAM check (SP65) 5-141
5.11.22	ROM check (SP66) 5-141
5.11.23	Option display (SP67) 5-142
5.11.24	Dc FM high-stability mode ON/OFF (SP38/SP37) 5-142
5.12	External FM Polarity Switching (Option 06) 5-144
5.12.1	Outline 5-144
5.12.2	FM modulation polarity 5-144
5.12.3	Operation 5-145
5.13	External FM Modulation Factor Display (Option 07) 5-146
5.13.1	Outline 5-146



5.1 Setting Carrier Frequency

This paragraph explains how to set the carrier frequency of the MG3601A/MG3602A Signal Generator.

The carrier frequency (hereafter frequency) can be set and read as follows:

1. Setting frequency at keyboard
2. Setting frequency using TUNE knob
3. Setting frequency using step keys
4. Reading relative frequency using [FRL] key
5. Reading carrier frequency when modulation frequency set

The following table outlines MG3601A/MG3602A specifications related to frequency settings.

Item	MG3601A	MG3602
■ Frequency range	100 kHz to 1.04 GHz	100 kHz to 2.08 GHz
■ Resolution	10 Hz	10 Hz ($f_c \leq 1040$ MHz), 20 Hz ($f_c > 1040$ MHz)

Note:

If an attempt is made to set a frequency outside the frequency range, the STATUS LED (Fig. 5-1) goes on. Input a new HEADER to turn the STATUS LED off.

While the STATUS LED is on, the error code can be displayed by pressing the [SHIFT] key and holding the [STATUS] key down.

The FREQUENCY display on the front panel displays the error code.

See paragraph 5.14 or APPENDIX H for an explanation of the error codes.

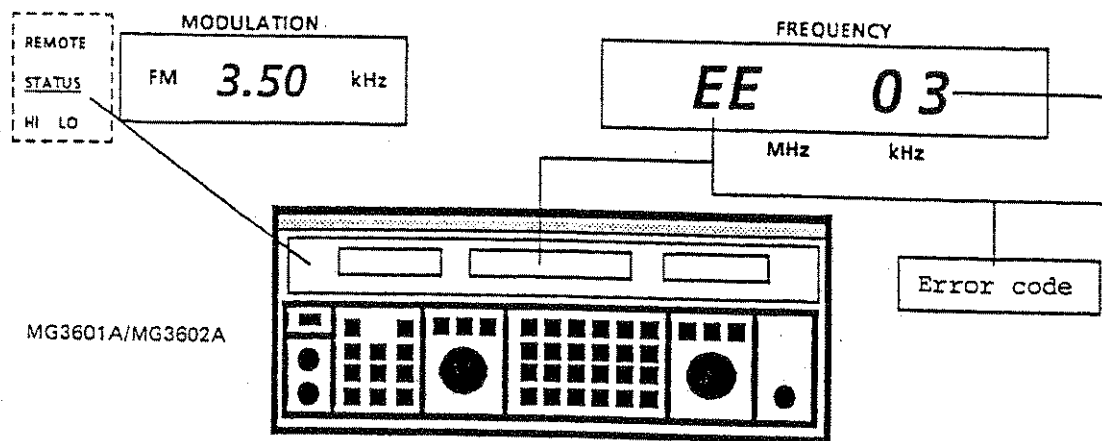

Fig. 5-1 STATUS LED and Error Code Display

5.1.1 Setting frequency from keyboard (DATA ENTRY)

The frequency is set by operating the header (HEADER) keys, numeric (DATA) keys, and unit (UNIT) keys in this order. As shown in Fig. 5-2, these keys are located in the DATA ENTRY section on the front panel. This paragraph explains the keys used to set the frequency.

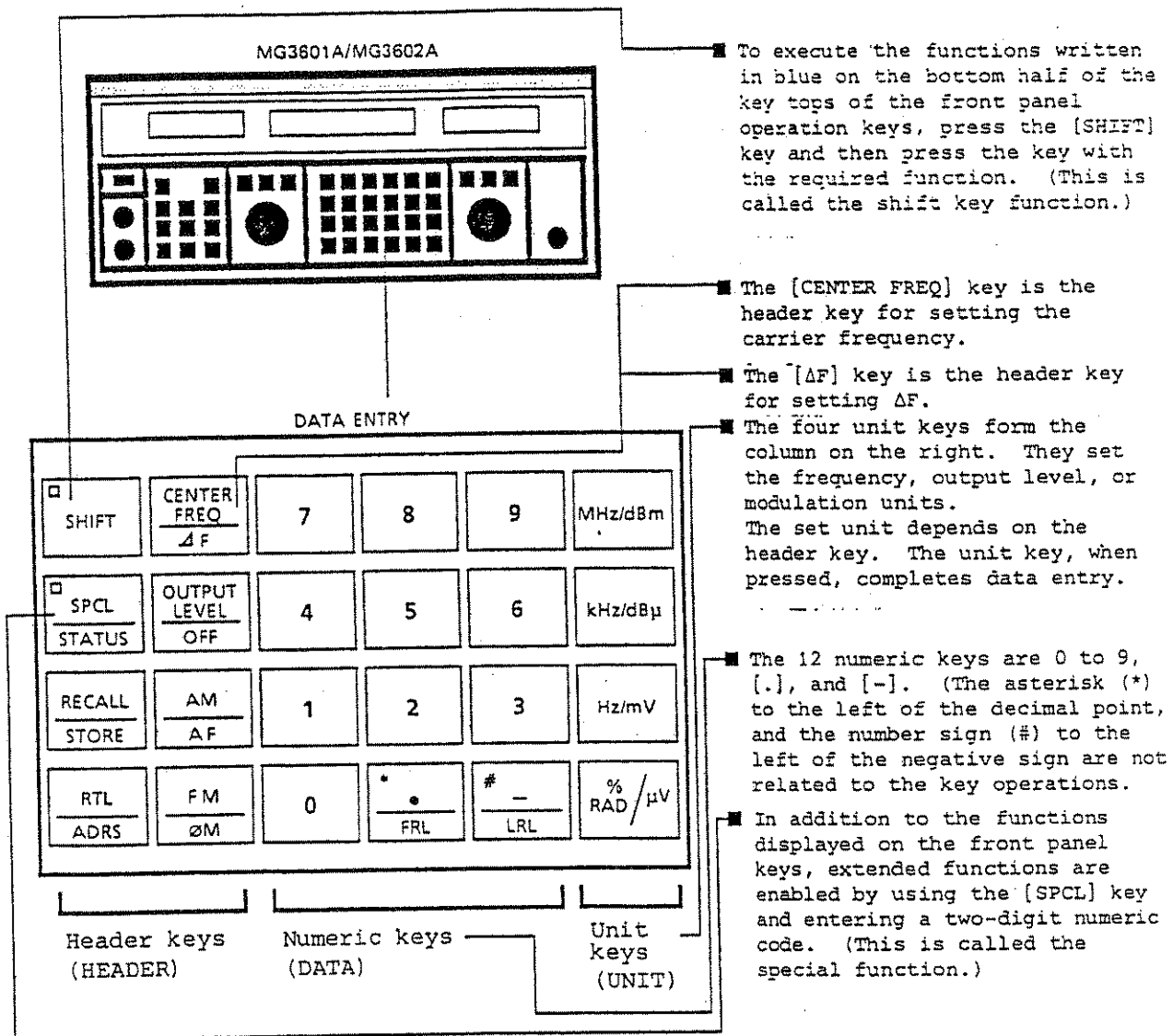

Fig. 5-2 Setting Using Keyboard (Numeric and Unit Keys)

See paragraph 5.11 for details of the special function.







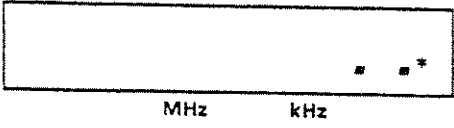

Example:

Setting 465.050 MHz

Step	Procedure								
a.	CENTER FREQ ΔF	4	6	5	$\frac{\bullet}{\text{FRL}}$	0	5	MHz/dBm	
b.	CENTER FREQ ΔF	4	6	5	0	5	0	kHz/dBμ	
c.	CENTER FREQ ΔF	4	6	5	0	5	0		
		0	0	0				Hz/mV	
	[]	[]					[]		
	Header keys (HEADER)	Numeric keys (DATA)					Unit keys (UNIT)		

To indicate whether data is being entered, the FREQUENCY display is cleared when the header is input. During data entry, the fixed decimal point* (100 Hz and 10 Hz positions) and input decimal point are displayed. When data entry is completed, (when the unit key is pressed) the output frequency is displayed.

The data displayed by the FREQUENCY display changes as shown in the column on the right below according to the key operation steps.

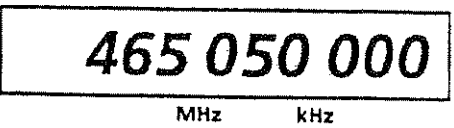
STEP	ACTION	VERIFICATION
1.		
2.	    	
3.		

* A decimal point is displayed at the 10 Hz and 100 Hz positions during data entry (before the unit key is pressed) to indicate that data is being entered.

Notes:

1. If any of the three settings of the header, numeric, or unit keys is omitted, or if a key not used to set the frequency is pressed, the previously-set frequency is displayed.
2. When operating the header and unit keys, the FREQUENCY display is cleared when the header key is pressed. When the unit key is pressed, the FREQUENCY display returns to the previous frequency display (465.05 MHz in this example).

Notes: (cont.)

3. When the header and numeric keys are pressed, data entry status is set so that a new frequency can be set. By keying-in [CENTER FREQ][1][2][3], for example, the previous frequency display is cleared (465.05 MHz in this example) and 123 is displayed.
 4. Data entry is completed when the unit key is pressed after the header and numeric keys. If a key other than a unit key is pressed, however, the previous frequency (465.05 MHz in this example) is displayed.
 5. If the [SHIFT] key is pressed after pressing the header and numeric keys, the value input by the numeric keys is displayed. When the key for the required shift function is pressed, the previous frequency (465.05 MHz in this example) is displayed.
- (a) 1 Hz digit setting and display

The 1 Hz digit display changes to zero when the unit key is pressed, even if one of the effective numeric keys 1 to 9 is pressed. For example, when 123.456789 MHz is entered and 9 is entered as the 1 Hz digit, zero is displayed at the 1 Hz digit when the unit key is pressed, as shown in Fig. 5-3.

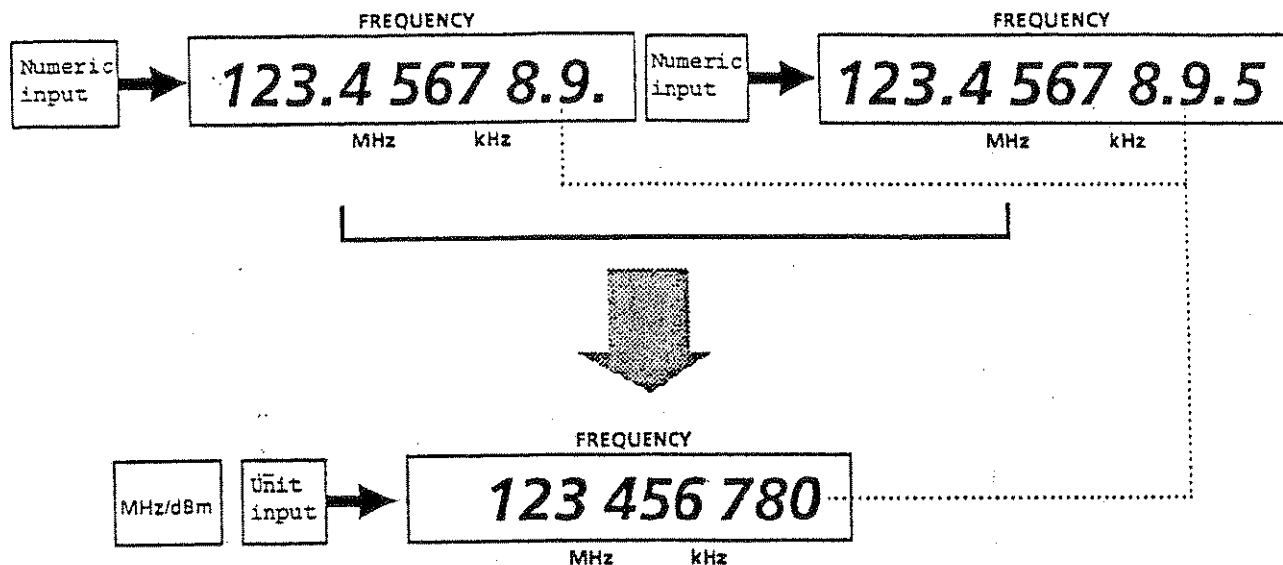

Fig. 5-3 1 Hz Digit Setting and Display

5.1.2 Setting frequency using TUNE knob (TUNE)

The TUNE knob (Fig. 5-4) continuously varies and sets frequencies.

By using the [SHIFT] and [RES>], or [SHIFT] and [<RES] keys, and setting the resolution for any of the digits from 10 Hz to 100 MHz beforehand, the TUNE knob can be used to continuously vary the output of the frequency at the resolution of the set digit.

The [TUNE], [SHIFT], [<RES], and [RES>] keys, and TUNE knob can be used when the starting point of the frequency for continuous variation is set at the keyboard.

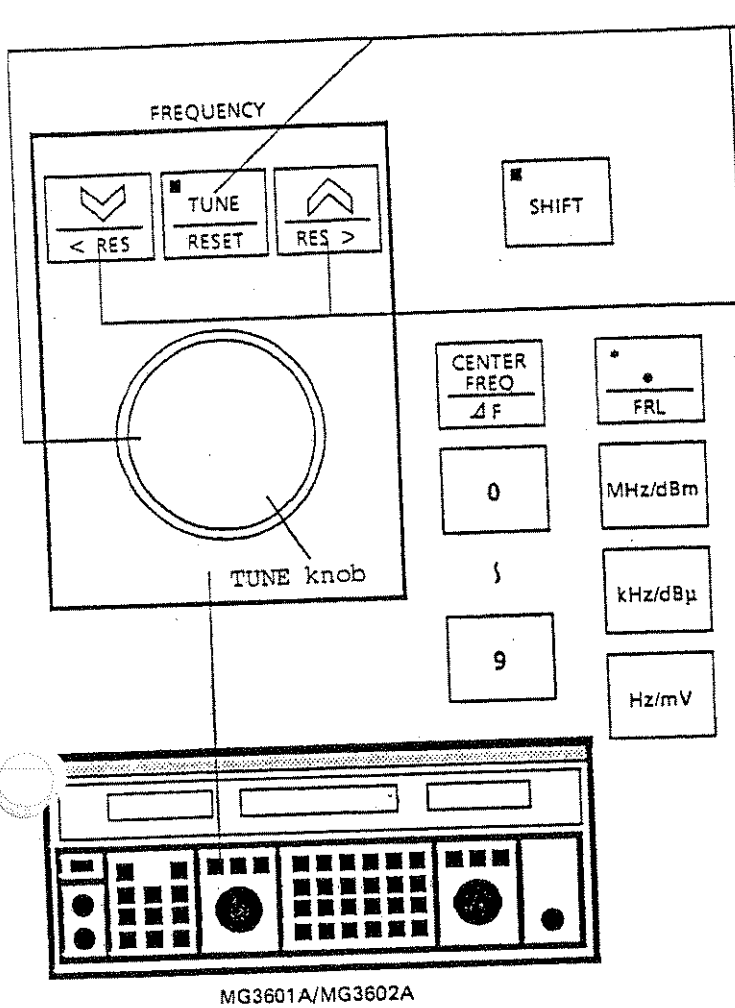







MG3601A/MG3602A

- Press the [TUNE] key to set the TUNE mode. When the resolution has been set using the [SHIFT] [RES>], or [SHIFT] [<RES] keys, the TUNE knob can be used to vary the frequency continuously at the set resolution intervals.
- Pressing the [SHIFT] and [RESET] keys,
 - Returns to the value set immediately after TUNE mode is set.
 - Sets the relative value to 0 for relative frequency displays.
- Press the [Λ] key to increment the carrier frequency or AF OSC frequency at equal intervals.
- Press the [SHIFT] [RES>] keys to set the resolution of the carrier frequency or internal modulation frequency from the high-order digit to low-order digit.
- Press the [V] key to decrement the carrier frequency or AF OSC frequency at equal intervals.
- Press the [SHIFT] [<RES] keys to set the resolution of the carrier frequency or internal modulation frequency from the low-order digit to high-order digit.

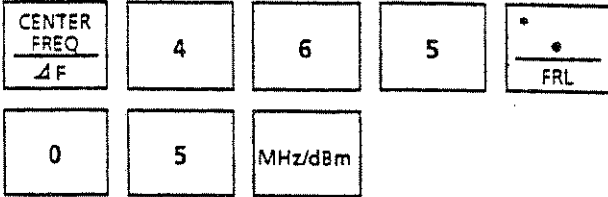
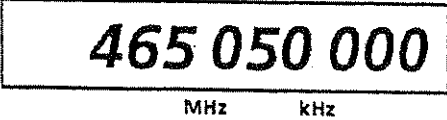
Fig. 5-4 Setting Modulation Frequency Using TUNE Knob

Example:

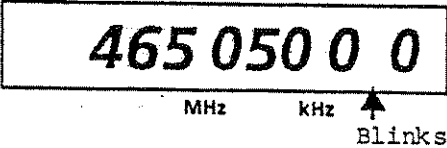
Setting frequency to 465.050 MHz then changing frequency at 10 Hz minimum resolution

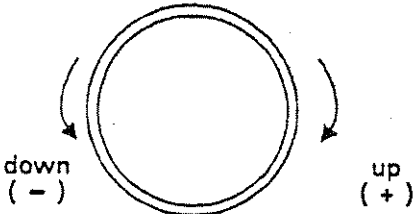
STEP	ACTION	VERIFICATION
1.		<p>The output frequency is set to 465.05 MHz.</p> 
2.		 <p>TUNING is set to ON. The [TUNE] key lamp lights.</p>
3.	 <p>← Press the [RES>] key until the value at the 10 Hz digit blinks once.*</p>	 <p>The [SHIFT] key lamp lights while the [RES>] key is pressed.</p> 
4.	<p>Release the [RES>] key when the value at the 10 Hz digit blinks once.</p>	 <p>The [SHIFT] key lamp goes off and 10 Hz minimum solution is set.</p> 
5.		<p>Turn the knob clockwise to increase the frequency and turn it counterclockwise to decrease the frequency at 10 Hz resolution.</p>

* Hold the [<RES] or [RES>] key down to move the resolution digit left or right.

Modifying resolution, releasing TUNE mode, and setting the frequency again when TUNE mode is started are explained next.

(1) Modifying resolution

To continuously vary the frequency using the TUNE knob:

- . First set the MG3601A/MG3602A to TUNE mode. (The [TUNE] key lamp is on; if it is not on, press the [TUNE] key.)
- . Use the [<RES] or [RES>] key to set or change the resolution interval.
- . Press the [SHIFT] key and then press the [<RES] or [RES>] key until the desired resolution is obtained.
- . The resolution must be able to be set to 100 MHz, 10 MHz, 1 MHz, 100 kHz, 10 kHz, 1 kHz, 100 Hz, or 10 Hz.

The above procedures are illustrated below.

TUNE mode is set in step 1 and the resolution is set in step 2 a or b.

STEP	ACTION	VERIFICATION
------	--------	--------------



1.  ← Press the [TUNE] key to set TUNE mode.

 The [TUNE] key lamp remains on until TUNE mode is released.

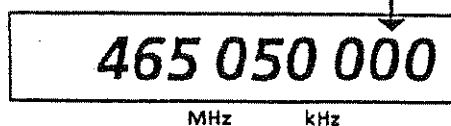
The previously-set resolution digit, for example 10 Hz, blinks once.



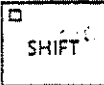

2. a. Setting the low-order digit → high-order digit

  ← Press the [<RES] key until the value at the digit of the desired resolution blinks once.

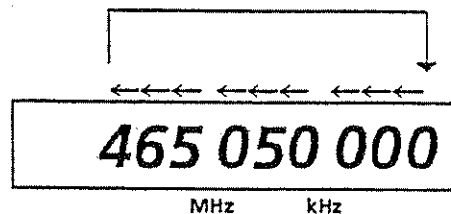
 ← Confirm that the [SHIFT] key lamp is on. The digits go off and then come on as indicated by the arrows below.



b. Setting the high-order digit → low-order digit

  ← Press the [RES>] key until the value at the digit of the desired resolution blinks once.

 ← Confirm that the [SHIFT] key lamp is on. The digits go off and then come on as indicated by the arrows below.

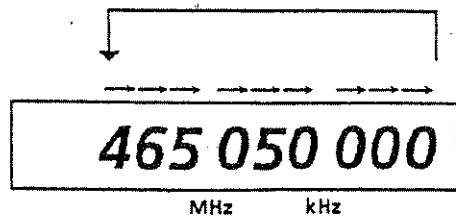

(2) Turning TUNE mode off

Press the [TUNE] key to turn the TUNE mode off. The [TUNE] key lamp goes off to indicate that the TUNE mode has been turned off.

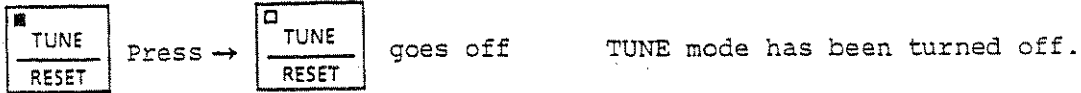

Note:

When the TUNE mode is turned off, the resolution at that time is stored. The resolution is reset when the TUNE mode is turned on again.

(3) Resetting TUNE mode start frequency

When the [TUNE] key is pressed with the lamp currently off and the lamp comes on, the start frequency (465.05 MHz for example) can be continuously varied using the TUNE knob to another frequency (465.055 MHz for example).

The start frequency can be reset using either of the following two methods.

- (1) Setting frequency at keyboard
- (2) Pressing [SHIFT] [RESET] keys

The second method is simpler.

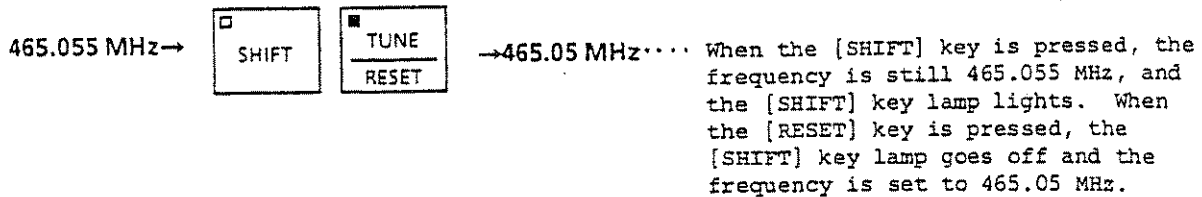

In the TUNE mode, therefore, the frequency can be set according to the intended use, as follows:

1. Continuously variable setting of the frequency ..
 Setting using the TUNE knob
2. Setting the frequency immediately after the TUNE mode Using the [SHIFT] [RESET] keys
3. Setting an arbitrary frequency after continuous variation ... Setting the frequency from the keyboard

5.1.3 Setting frequency using the step keys

As shown in Fig. 5-5, the [\vee] and [\wedge] keys are used to step-down or step-up the frequency by ΔF steps.

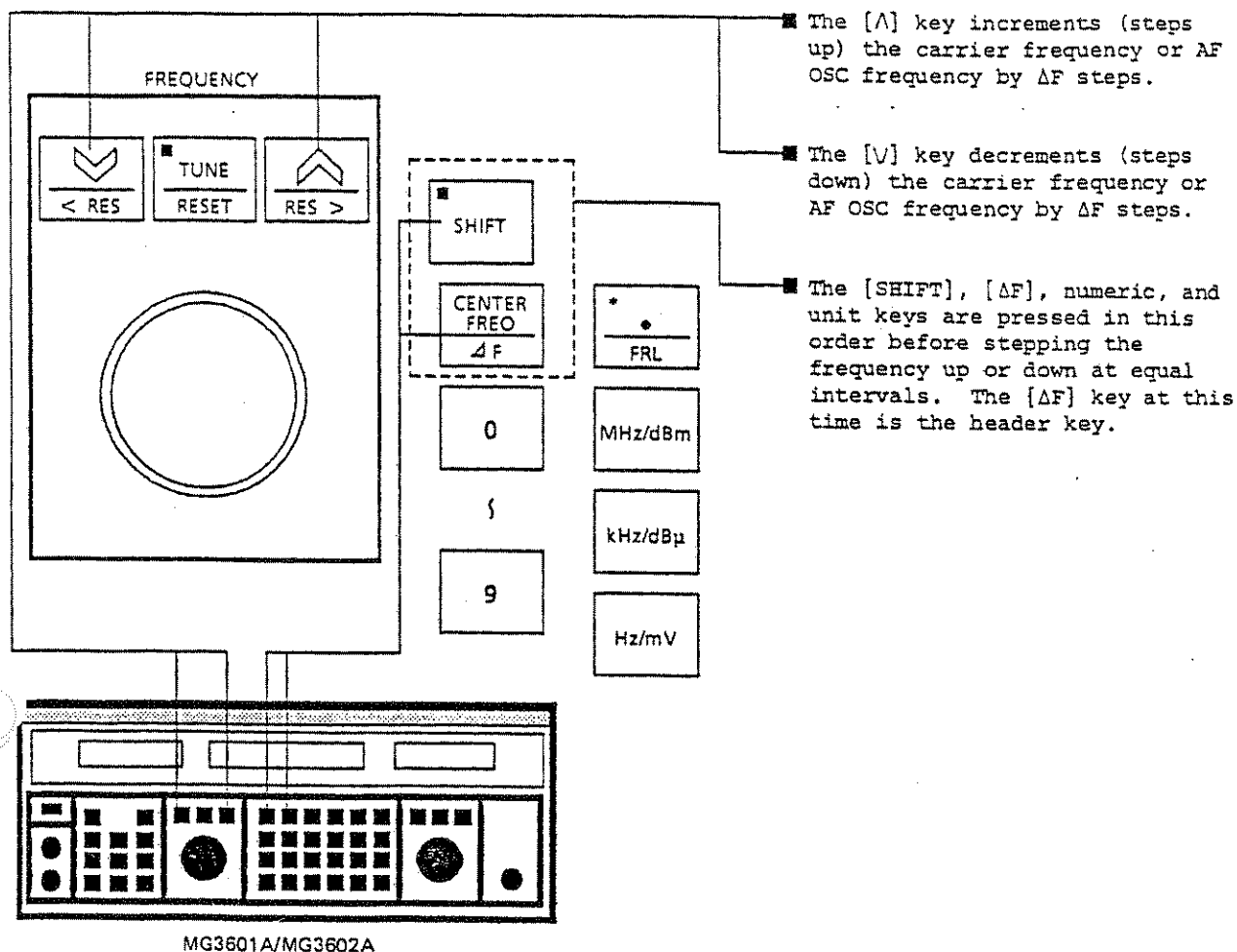

Fig. 5-5 Setting Frequency Using Step Keys

The step value ΔF is set using the [SHIFT], [ΔF], numeric, and unit keys in this order.

- . The ΔF upper limit is 999.999999 MHz.
- . The ΔF lower limit is 10 Hz.
- . The interval between the upper and lower limits of ΔF is set in multiples of 10 Hz resolution (1 Hz digit is fixed to 0).

Therefore, for setting 51 Hz to 59 Hz, for example, the 1 Hz digit is set to 0, then 50 Hz is actually set.

Example:

Setting frequency to 465.050 MHz as center frequency and then increasing and decreasing frequency by 100 Hz steps

STEP	ACTION	VERIFICATION
1.	<div style="display: flex; justify-content: space-around; align-items: center;"> <div style="border: 1px solid black; padding: 2px; text-align: center;"> <small>CENTER FREQ</small> ΔF </div> <div style="border: 1px solid black; padding: 2px; text-align: center; width: 30px;">4</div> <div style="border: 1px solid black; padding: 2px; text-align: center; width: 30px;">6</div> <div style="border: 1px solid black; padding: 2px; text-align: center; width: 30px;">5</div> <div style="border: 1px solid black; padding: 2px; text-align: center;"> <small>* .</small> FRL </div> </div> <div style="display: flex; justify-content: space-around; align-items: center;"> <div style="border: 1px solid black; padding: 2px; text-align: center; width: 30px;">0</div> <div style="border: 1px solid black; padding: 2px; text-align: center; width: 30px;">5</div> <div style="border: 1px solid black; padding: 2px; text-align: center;">MHz/dBm</div> </div>	<p>The output frequency is set to 465.05 MHz.</p> <div style="border: 1px solid black; padding: 5px; text-align: center; margin: 5px 0;"> 465 050 000 </div> <div style="display: flex; justify-content: space-around; font-size: 0.8em;"> MHz kHz </div>
2.	<div style="display: flex; justify-content: space-around; align-items: center;"> <div style="border: 1px solid black; padding: 2px; text-align: center;"> <input type="checkbox"/> SHIFT </div> <div style="border: 1px solid black; padding: 2px; text-align: center;"> <small>CENTER FREQ</small> ΔF </div> <div style="border: 1px solid black; padding: 2px; text-align: center; width: 30px;">1</div> <div style="border: 1px solid black; padding: 2px; text-align: center; width: 30px;">0</div> <div style="border: 1px solid black; padding: 2px; text-align: center; width: 30px;">0</div> </div>	<div style="border: 1px solid black; padding: 2px; display: flex; align-items: center;"> <div style="border: 1px solid black; padding: 2px; text-align: center; width: 30px; margin-right: 5px;"> <input checked="" type="checkbox"/> SHIFT </div> <div> Confirm that 100 Hz is set before pressing the unit key. </div> </div> <div style="border: 1px solid black; padding: 5px; text-align: center; margin: 5px 0;"> 100 </div> <div style="display: flex; justify-content: space-around; font-size: 0.8em;"> MHz kHz </div>
3.	<div style="display: flex; align-items: center;"> <div style="border: 1px solid black; padding: 2px; text-align: center; margin-right: 10px;"> Hz/mV </div> <div style="font-size: 2em;">←</div> <div> Press the unit key. Setting ΔF = 100 Hz is completed. </div> </div>	<div style="border: 1px solid black; padding: 5px; text-align: center; margin: 5px 0;"> 465 050 000 </div> <div style="display: flex; justify-content: space-around; font-size: 0.8em;"> MHz kHz </div> <p>This completes preparation for stepping the frequency up/down in 100 Hz steps with 465.05 MHz as the reference frequency.</p>
4.	<div style="display: flex; align-items: center;"> <div style="border: 1px solid black; padding: 2px; text-align: center; margin-right: 10px;"> RES > </div> <div style="font-size: 2em;">←</div> <div> Press the [Δ] key once. </div> </div>	<div style="border: 1px solid black; padding: 5px; text-align: center; margin: 5px 0;"> 465 050 100 </div> <div style="display: flex; justify-content: space-around; font-size: 0.8em;"> MHz kHz </div> <p>465.05 MHz is increased by 100 Hz.</p>
5.	<div style="display: flex; align-items: center;"> <div style="border: 1px solid black; padding: 2px; text-align: center; margin-right: 10px;"> < RES </div> <div style="font-size: 2em;">←</div> <div> Press the [V] key once. </div> </div>	<div style="border: 1px solid black; padding: 5px; text-align: center; margin: 5px 0;"> 465 050 000 </div> <div style="display: flex; justify-content: space-around; font-size: 0.8em;"> MHz kHz </div> <p>465.0501 MHz is decreased by 100 Hz.</p>

5.1.4 Displaying relative frequency (FRL)

When the [SHIFT] [FRL] keys are operated when an output frequency is displayed by the FREQUENCY display, the output frequency display value is set to 0, which becomes the reference value 0 of the relative frequency display.

The frequency can be set using method (1) or method (2) below. The relative frequency from the reference value 0 is displayed.

(1) Setting using ΔF step key

Specify the ΔF value using the [SHIFT] [ΔF] keys and vary the value from reference value 0 using the [^] and [v] keys.

(2) Setting in TUNE mode

Use the TUNE knob to vary the resolution set using the [<RES] and [RES>] keys from reference value 0.

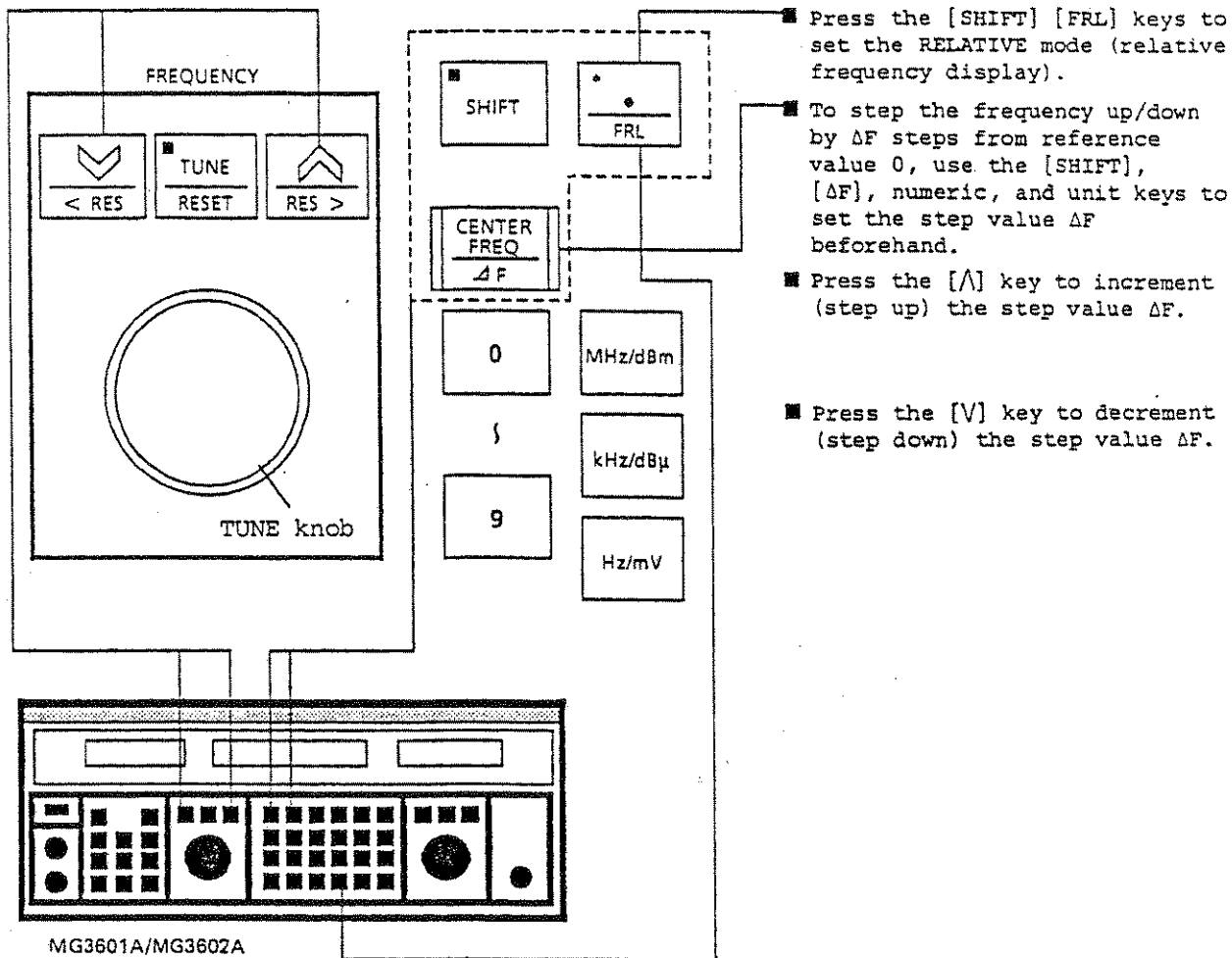

Fig. 5-6 Setting Relative Frequency Display



(1) Setting using ΔF step key and displaying relative frequency

Example:

Setting 10.7 MHz as center frequency and setting ± 1 kHz

STEP	ACTION			VERIFICATION
1.				<p>The center frequency is set to 10.7 MHz.</p>
2.				<p>Reference value "0" is displayed.</p>
3.				The [SHIFT] key lamp lights while 1 kHz is being set.
4.		← Press the unit key. Setting $\Delta F = 1$ kHz is completed.		<p>This completes preparations for stepping the frequency up/down in 1 Hz steps with 10.7 MHz as the reference frequency.</p>
5.		← Press the [Λ] key once.		<p>10.7 MHz is increased by 1 kHz.</p>

(cont'd)

STEP	ACTION	VERIFICATION
6.	  ← Press the [SHIFT] key and then press and hold the [FRL] key.	<div style="border: 1px solid black; padding: 5px; text-align: center;">10 701 000 MHz kHz</div> <p>10.7 MHz + 1 kHz = 10.701 MHz is monitored while the key is pressed.</p>
7.	 ← Press the [V] key twice.	<div style="border: 1px solid black; padding: 5px; text-align: center;">— 1 000 MHz kHz</div> <p>10.7 MHz is decreased by 1 kHz.</p>

The output frequency has the following relationship:

Output frequency = Frequency when the [FRL] key is pressed + Current relative value display

To confirm the above output frequency, press the [SHIFT] key and then press and hold the [FRL] key.

By the above operations,

In step 6 ... 10.7 MHz + 1 kHz = 10.701 MHz is monitored.

In step 7 ... 10.7 MHz - 1 kHz = 10.699 MHz is monitored.

Pressing the [RES>] or [<RES] key increments or decrements the output frequency by the frequency set at ΔF .

(2) Setting and displaying relative frequency in TUNE mode

Example:

Setting 465.050 MHz as center frequency and setting center frequency ± 25 kHz at 1 kHz resolution

STEP	ACTION	VERIFICATION
1.		<p>The center frequency is set.</p>
2.		← The lamp is on while TUNE mode is set.
3.	<p>← Press the [RES>] key until 1 kHz resolution is obtained.</p>	← The lamp goes off after 1 kHz resolution is obtained.
4.		<p>The RELATIVE mode is set.</p>
5.	<p>+25 kHz ... Turn the TUNE knob clockwise until +25 kHz is obtained.</p> <p>-25 kHz ... Turn the TUNE knob counter-clockwise until -25 kHz is obtained.</p>	<p>465.05 MHz + 25 MHz is set.</p> <p>465.05 MHz -25 kHz is set.</p>

Example:

Setting 500 MHz as center frequency and setting
center frequency ± 10 MHz

STEP	ACTION	VERIFICATION
1.	<div style="display: flex; align-items: center; gap: 5px;"> <div style="border: 1px solid black; padding: 2px; text-align: center;"> <small>CENTER FREQ</small> ΔF </div> <div style="border: 1px solid black; width: 30px; height: 30px; text-align: center; line-height: 30px;">5</div> <div style="border: 1px solid black; width: 30px; height: 30px; text-align: center; line-height: 30px;">0</div> <div style="border: 1px solid black; width: 30px; height: 30px; text-align: center; line-height: 30px;">0</div> <div style="border: 1px solid black; padding: 2px;">MHz/dBm</div> </div>	<p>The center frequency is set.</p> <div style="border: 1px solid black; padding: 5px; text-align: center;"> 500 000 000 <small>MHz kHz</small> </div>
2.	<div style="display: flex; align-items: center; gap: 10px;"> <div style="border: 1px solid black; padding: 2px; text-align: center;"> <small>SHIFT</small> </div> <div style="border: 1px solid black; padding: 2px; text-align: center;"> <small>* FRL</small> </div> </div>	<div style="border: 1px solid black; padding: 5px; text-align: center;"> + 0 <small>MHz kHz</small> </div> <p>The RELATIVE mode is set.</p>
3.	<div style="display: flex; align-items: center; gap: 5px;"> <div style="border: 1px solid black; padding: 2px; text-align: center;"> <small>CENTER FREQ</small> ΔF </div> <div style="border: 1px solid black; width: 30px; height: 30px; text-align: center; line-height: 30px;">5</div> <div style="border: 1px solid black; width: 30px; height: 30px; text-align: center; line-height: 30px;">1</div> <div style="border: 1px solid black; width: 30px; height: 30px; text-align: center; line-height: 30px;">0</div> <div style="border: 1px solid black; padding: 2px;">MHz/dBm</div> </div>	<div style="border: 1px solid black; padding: 5px; text-align: center;"> + 10 000 000 <small>MHz kHz</small> </div> <p>500 MHz + 10 MHz is set.</p>
4.	<div style="display: flex; align-items: center; gap: 10px;"> <div style="border: 1px solid black; padding: 2px; text-align: center;"> <small>SHIFT</small> </div> <div style="border: 1px solid black; padding: 2px; text-align: center;"> <small>* FRL</small> </div> <div style="font-size: 2em; margin-left: 10px;">←</div> <div> <p>Press the [SHIFT] key then press and hold the [FRL] key.</p> </div> </div>	<div style="border: 1px solid black; padding: 5px; text-align: center;"> 510 000 000 <small>MHz kHz</small> </div> <p>500 MHz + 10 MHz = 510 MHz is monitored while the key is pressed.</p>
5.	<div style="display: flex; align-items: center; gap: 5px;"> <div style="border: 1px solid black; padding: 2px; text-align: center;"> <small>CENTER FREQ</small> ΔF </div> <div style="border: 1px solid black; width: 30px; height: 30px; text-align: center; line-height: 30px;">4</div> <div style="border: 1px solid black; width: 30px; height: 30px; text-align: center; line-height: 30px;">9</div> <div style="border: 1px solid black; width: 30px; height: 30px; text-align: center; line-height: 30px;">0</div> <div style="border: 1px solid black; padding: 2px;">MHz/dBm</div> </div>	<div style="border: 1px solid black; padding: 5px; text-align: center;"> - 10 000 000 <small>MHz kHz</small> </div> <p>500 MHz - 10 MHz is set.</p>

(cont'd)

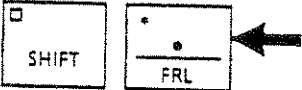
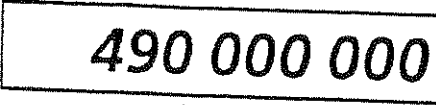
STEP	ACTION	VERIFICATION
6.	 Press the [SHIFT] key then press and hold the [FRL] key.	 <p>490 000 000 MHz kHz</p> <p>500 MHz - 10 MHz = 490 MHz is monitored while the key is pressed.</p>

(3) Releasing relative frequency display mode

Press the [SHIFT] key then press and quickly release the [FRL] key to release the relative frequency display mode. When the relative frequency display mode is released, the current output CURRENT FREQ is displayed by the FREQUENCY display.

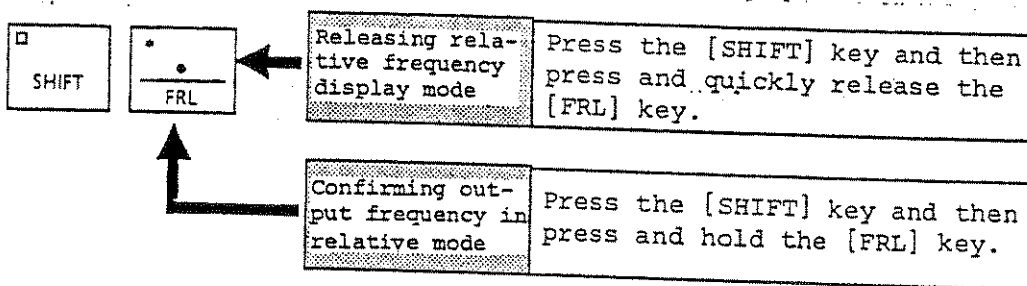

Note:

When the [SHIFT] and [FRL] keys are pressed in this order in the relative frequency display mode, the relative frequency displayed mode is released. At this time, if the [FRL] key is pressed and held, the CURRENT FREQ is displayed and the relative frequency display mode is set again.

- (4) Restoring to reference value 0 at relative frequency display mode setting

When a relative value is set in the relative frequency display mode, press the [SHIFT] and [RESET] key to restore to the reference value 0 set in the relative frequency display mode.

For the relative frequency display and TUNE modes, restoring to the reference value 0 in the relative frequency display mode has priority.

Example:

At output frequency F_0 , relative mode set and then restored at relative value + 5 kHz

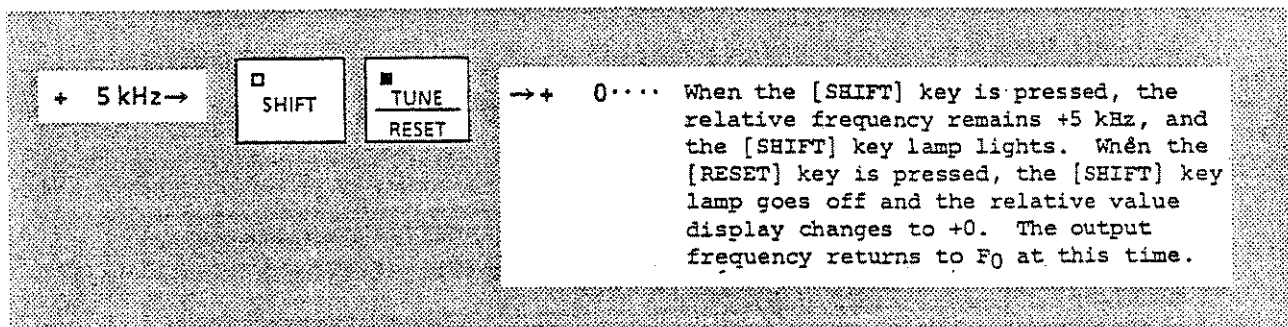

In the above example,

For +5 kHz, when the relative mode is released, the TUNE mode is set and the output frequency is set to $(F_0 + (5 \text{ kHz} + N))$ using the TUNE knob or step keys. The output frequency can be restored to $(F_0 + (5 \text{ kHz}))$ by operating the [SHIFT] and [RESET] keys.

For +5 kHz, when the relative mode is not released, the TUNE mode is set and the output frequency is set to $(F_0 + (5 \text{ kHz} + N))$ using the TUNE knob or step keys.

The relative frequency display changes to +0 by operating the [SHIFT] and [RESET] keys. The output frequency returns to F_0 at this time.

5.1.5 Reading carrier frequency when modulation frequency set

To return to the original carrier frequency display while the FREQUENCY display is being used as the internal modulation frequency display, press the [CENTER FREQ] key then one of the unit keys [MHz], [kHz], or [Hz].

Example:

Setting modulation frequency 23 kHz then returning to previously set carrier frequency 510 MHz

STEP	ACTION	VERIFICATION
1.	<input type="checkbox"/> SHIFT AM / AF 2 3 kHz/dBμ	The internal modulation frequency is set.* <div style="border: 1px solid black; padding: 5px; text-align: center;"> 23 000.0AF MHz kHz </div>
2.	CENTER FREQ / ΔF	<div style="border: 1px solid black; padding: 5px; text-align: center;"> " " </div> MHz kHz
3.	MHz/dBm kHz/dBμ Hz/mV ← Press one of the unit keys.	<div style="border: 1px solid black; padding: 5px; text-align: center;"> 510 000 000 MHz kHz </div>

* To read the internal modulation frequency unit on the FREQUENCY display, replace MHz with kHz and kHz with Hz.

5.2 Setting Output Level

This paragraph explains how to set the output level of the MG3601A/MG3602A.

The output level of the frequency can be set and read as follows:

1. Setting output level at keyboard
2. Setting the output level using output level setting knob
3. Setting output level using step keys
4. Reading relative output level using LRL key

The following table outlines MG3601A/MG3602A specifications related to output level settings.

Item	MG3601A	MG3602
Output level range	-133 to +13 dBm	-133 to +13 dBm ($f_c \leq 1040$ MHz) -133 to +7 dBm ($f_c > 1040$ MHz)
Resolution	0.1 dB	0.1 dB

As shown above, the minimum resolution of the output level setting is 0.1 dB. Therefore, for output level settings in voltage units, the minimum resolution of the voltage output level differs depending on the output level range. The following table lists the setting range according to the output level unit and the minimum resolution according to the range.

Unit	Level value	Minimum resolution of display		Minimum resolution of output level
dBm	13.0 to -133.0	0.1	dBm	0.1 dB
dBμ (EMF)	126.0 to -20.0	0.1	dBμ	0.1 dB
mV (EMF)	1999 to 100	1	mV	0.1 dB
	99.9 to 10.0	0.1	mV	0.1 dB
	9.99 to 1.00	0.01	mV	0.1 dB
	0.999 to 0.100	0.001	mV	0.1 dB
μV (EMF)	999 to 100	1	μV	0.1 dB
	99.9 to 10.0	0.1	μV	0.1 dB
	9.99 to 1.00	0.01	μV	0.1 dB
	0.999 to 0.320	0.001	μV	0.1 dB

Note:

If an attempt is made to set an output level outside the output level range, the STATUS LED (Fig. 5-1) comes on. Input a new HEADER to turn the STATUS LED indicator off. While the STATUS LED is on, the error code can be displayed by pressing the [SHIFT] key and holding the [STATUS] key down. The FREQUENCY display on the front panel displays the error code.

5.2.1 Open-circuit voltage display and terminated voltage display (SP03, 04)

The MG3601A/MG3602A can display the output level for the setting range in the following units:

1. Output level power unit display dBm
2. Output level voltage unit display ... dB μ , mV, μ V
3. Relative output level display dB

For the voltage unit display, terminated voltage display or open-circuit voltage (EMF) display can be selected.

The terminated voltage display and open-circuit voltage display are switched as follows.

- (1) Open-circuit voltage display



After the above key operations, (EMF) is displayed when the voltage is displayed.

Example:



Note:

Open-circuit voltage display is set at the factory.

(2) Terminated voltage display



After the above key operations, (EMF) is not displayed when the voltage is displayed.

Example:



The relationship of each display unit of the output level is shown below.

If the 1 mW power is applied to an external terminated load (standard impedance 50Ω) equal to the signal source impedance 50Ω of the signal generator, the relationship of the three items shown above changes as shown in Fig. 5-7.

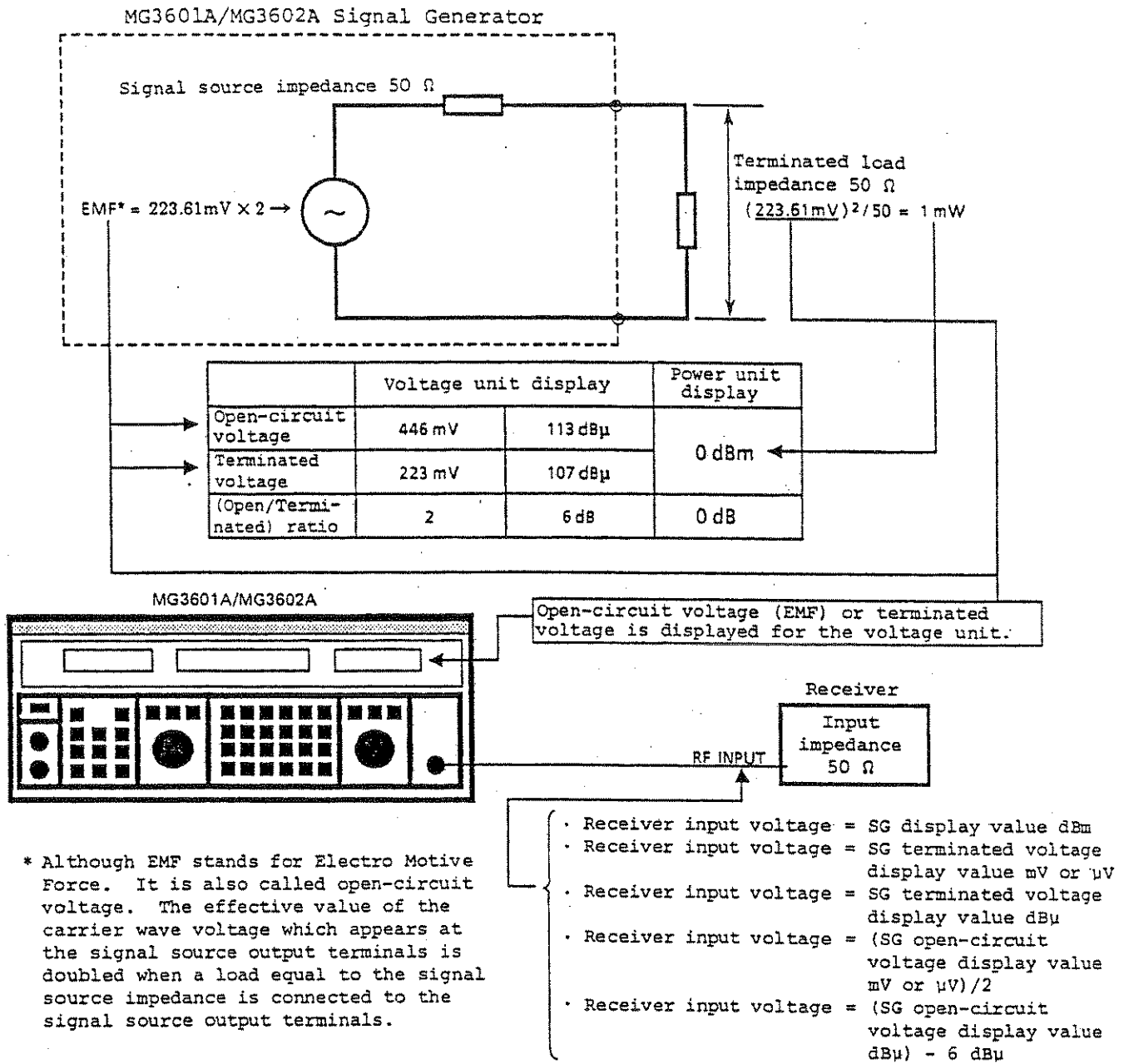

Fig. 5-7 Open-Circuit Voltage and Terminated Voltage

CAUTION

The MG3601A/MG3602A output section has a reverse-voltage protection circuit to protect the internal circuits from excess reverse power. Since the protection circuit uses a mechanical switch, the contact may be damaged if excess reverse power is applied. Therefore, do not apply reverse power. The STATUS LED lights and the output level is off while the reverse power protection circuit is operating. All keys other than [SHIFT] + [STATUS] are disabled.

This status can be released as follows:

1. [SHIFT] [SPCL/STATUS] Confirms error status
 2. [SHIFT] [OUTPUT LEVEL/OFF] Enables all keys and returns to normal mode
-

5.2.2 Setting output level at keyboard (DATA ENTRY)

The output level is set by operating the header (HEADER), numeric (DATA), and unit (UNIT) key in this order. As shown in Fig. 5-8, these keys are located in the DATA ENTRY section on the front panel. This paragraph explains the keys used to set the output level.

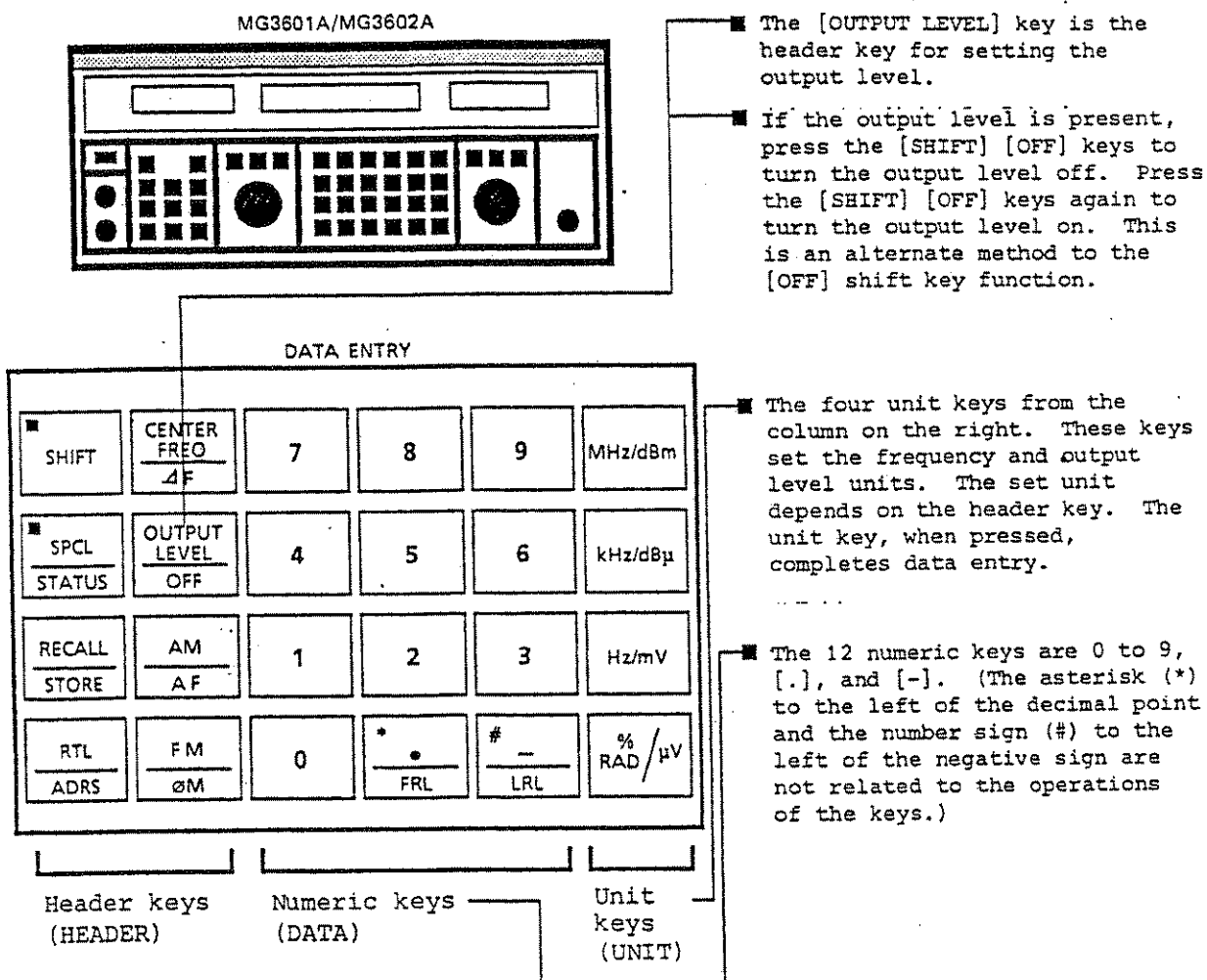

Fig. 5-8 Setting Using Keyboard (Numeric and Unit Keys)

Note:

OUTPUT LEVEL display unit and sign display

. dBm and dBμ ... "-" only (Blank for "+")

. mV and μV Blank

. dB "+", "-"

The output level unit can be changed by pressing the [OUTPUT LEVEL] and unit keys in this order.

Example:

Setting output level to -15.2 dBm

STEP	ACTION	VERIFICATION
1.	<div data-bbox="240 947 342 1037" style="border: 1px solid black; padding: 2px; display: inline-block;"> OUTPUT LEVEL OFF </div> Blank The unit is also cleared.	<div data-bbox="915 947 1243 1037" style="border: 1px solid black; width: 100%; height: 100%;"></div> Blank The unit is also cleared.
2.	<div data-bbox="240 1136 342 1226" style="border: 1px solid black; padding: 2px; display: inline-block;"> # - LRL </div> <div data-bbox="363 1136 466 1226" style="border: 1px solid black; padding: 2px; display: inline-block; margin: 0 5px;">1</div> <div data-bbox="487 1136 589 1226" style="border: 1px solid black; padding: 2px; display: inline-block; margin: 0 5px;">5</div> <div data-bbox="610 1136 712 1226" style="border: 1px solid black; padding: 2px; display: inline-block;"> * . FRL </div> <div data-bbox="734 1136 836 1226" style="border: 1px solid black; padding: 2px; display: inline-block; margin: 0 5px;">2</div>	<div data-bbox="915 1136 1243 1226" style="border: 1px solid black; padding: 5px; display: inline-block;"> -15.2 </div> Data is set from the left. If the first input is other than -(minus), input starts from the second digit from the left.
3.	<div data-bbox="240 1388 342 1478" style="border: 1px solid black; padding: 2px; display: inline-block;"> MHz/dBm </div>	<div data-bbox="915 1388 1243 1478" style="border: 1px solid black; padding: 5px; display: inline-block;"> - 15.2 dBm </div> Data entry is completed when the unit dBm is input.

Example:

Setting minimum output level of MG6301A/MG3602A and changing unit

STEP	ACTION			VERIFICATION
1.	<div style="border: 1px solid black; padding: 2px; display: inline-block;"> OUTPUT LEVEL OFF </div>	<div style="border: 1px solid black; padding: 2px; display: inline-block;"> # - LRL </div>	<div style="border: 1px solid black; padding: 2px; display: inline-block; width: 30px; text-align: center;">1</div> <div style="border: 1px solid black; padding: 2px; display: inline-block; width: 30px; text-align: center;">3</div> <div style="border: 1px solid black; padding: 2px; display: inline-block; width: 30px; text-align: center;">3</div>	<div style="border: 1px solid black; padding: 5px; display: inline-block;"> MHz/dBm - 133.0 dBm </div>
<u>Changing unit</u>				
2.	<div style="border: 1px solid black; padding: 2px; display: inline-block;"> OUTPUT LEVEL OFF </div>	<div style="border: 1px solid black; padding: 2px; display: inline-block;"> kHz/dBμ </div>		<div style="border: 1px solid black; padding: 5px; display: inline-block;"> - 20.0 dBμ EMF </div>
3.	<div style="border: 1px solid black; padding: 2px; display: inline-block;"> OUTPUT LEVEL OFF </div>	<div style="border: 1px solid black; padding: 2px; display: inline-block;"> % RAD / μV </div>		<div style="border: 1px solid black; padding: 5px; display: inline-block;"> .100 EMF μV </div>

Note:

When the level of the MG3601A/MG3602A is set using the voltage unit and the unit is changed to dBm or dBμ, an error of 0.1 dB may occur.

When changing units, the values for which units have not been changed are set as initial values and are used for reference when changing the units. Changing the units from mV < > μV, however, is prohibited.

5.2.3 Setting output level using output setting knob

There are two methods for setting the output level using the output setting knob as shown in Fig. 5-9.

- (1) Use the [SHIFT] [RES>] keys or the [SHIFT] [<RES] keys to set the resolution at one of the positions 0.1, 1, or 10 dB beforehand. Then use the output setting knob to continuously vary the output level at the set resolution.
- (2) Press the [CONT] key, then turn the output setting knob to automatically set the resolution to 0.1 dB. The output level can be varied continuously using the output setting knob within ± 5 dB from the point where the [CONT] key is pressed. The advantage of this method is that continuously variable settings can be made without using output setting attenuator switching. In addition, OFF TIME is not set during the output interval.

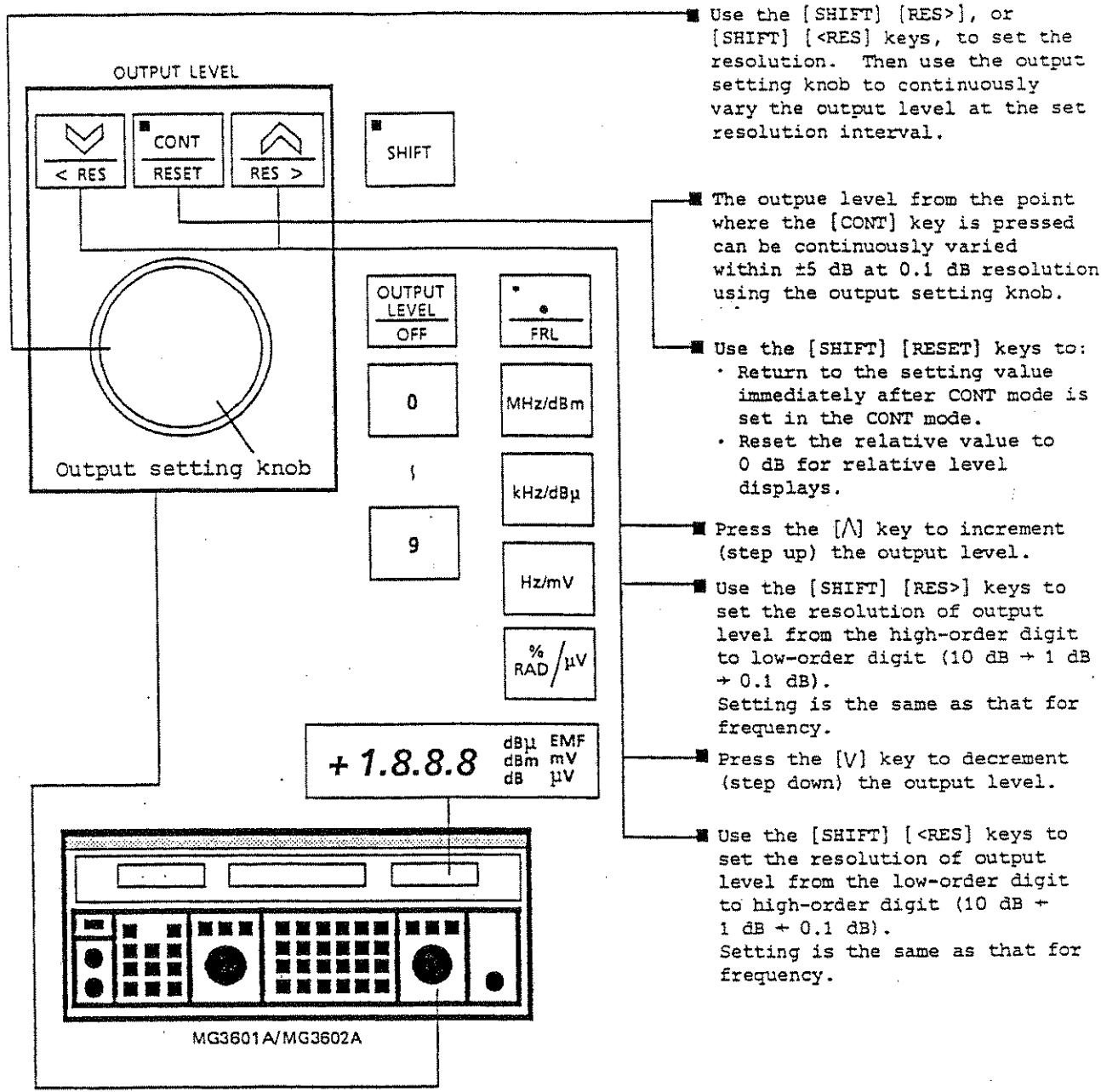

■ Use the [SHIFT] [RES>], or [SHIFT] [<RES] keys, to set the resolution. Then use the output setting knob to continuously vary the output level at the set resolution interval.

■ The output level from the point where the [CONT] key is pressed can be continuously varied within ± 5 dB at 0.1 dB resolution using the output setting knob.

■ Use the [SHIFT] [RESET] keys to:

- Return to the setting value immediately after CONT mode is set in the CONT mode.
- Reset the relative value to 0 dB for relative level displays.

■ Press the [^] key to increment (step up) the output level.

■ Use the [SHIFT] [RES>] keys to set the resolution of output level from the high-order digit to low-order digit (10 dB \rightarrow 1 dB \rightarrow 0.1 dB). Setting is the same as that for frequency.

■ Press the [v] key to decrement (step down) the output level.





■ Use the [SHIFT] [<RES] keys to set the resolution of output level from the low-order digit to high-order digit (10 dB \rightarrow 1 dB \rightarrow 0.1 dB). Setting is the same as that for frequency.

Fig. 5-9 Setting Output Level Using Output Setting Knob

(1) Setting output level without using [CONT] key

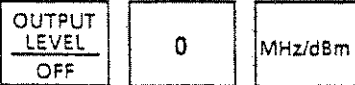



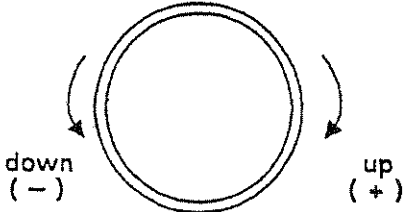
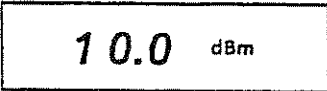
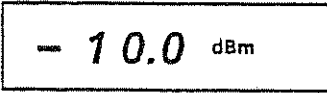

Example 1:

Changing output level from 0 dBm to ± 10 dBm in 1 dB steps

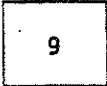
STEP	ACTION	VERIFICATION
1.		 <p>The output level is set to 0 dBm.</p>
2.	 <p>← Press the [RES>] key until 1 dB resolution is obtained.</p>	 <p>← Lamp goes off when 1 dB resolution is selected.</p>
3.		 <p>0 dB \rightarrow +10 dBm is set.</p>
	<p>+10 dBm ... Turn the output setting knob clockwise until +10 dBm is obtained.</p>	
	<p>-10 dBm ... Turn the output setting knob counterclockwise until -10 dBm is obtained.</p>	<p>+10 dBm \rightarrow -10 dBm is set.</p>

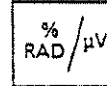
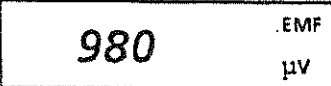
Example 2:

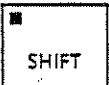
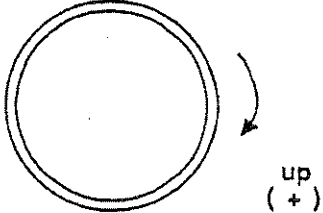
Setting output level to 980 μV then setting it to 1.10 mV at minimum resolution

STEP	ACTION				VERIFICATION	
1.						
	The output level is set to 980 μV .					
2.			← Press the [RES>] key until 1 μV resolution is obtained.			
	← Goes off when 1 μV resolution is selected.					
3.						
	1.10 mV is set at minimum resolution 0.01 mV.					
Turn the output setting knob clockwise until 1.10 mV is obtained.						

Notes:

- As shown in examples 1 and 2, if the final setting value of the output level is above or below the current level, the [\wedge] and [\vee] keys can be used with the output setting knob to change to the upper or lower output level in 10 dB steps. By holding the keys, the output level can be varied continuously. For the output setting knob and the [\wedge] and [\vee] keys, the output level cannot be incremented past +13 dBm or decremented past -133 dBm.

Notes (Cont'd)

2. In example 2, the unit changes automatically from μV to mV when changing from 999 μV to 1000 μV . The minimum resolution also changes from the 1 μV order to the 0.01 mV order. The minimum resolution of the output level thus changes in the output level or voltage unit range.

(2) Setting output level using the [CONT] key

The [CONT] key sets the ± 5 dB continuous variable mode. When the [CONT] key is pressed, the output level at that time can be varied continuously within ± 5 dB. The resolution is fixed to 0.1 dB.

(a) Releasing ± 5 dB continuously variable mode (CONT mode)

The CONT mode is set when the [CONT] key lamp is on. Pressing the [CONT] key at this time releases CONT mode and turns the lamp off.



Although the current output level is reset when the CONT mode is released, the resolution unit is returned to that immediately before the CONT mode was set.

(b) Returning to output level at setting of ± 5 dB continuously variable mode (CONT mode)

Press the [SHIFT] [RESET] keys in CONT mode to return to the value immediately after CONT mode was set.

Example:

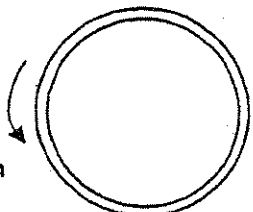
Setting CONT mode and varying -5 dB at -10 dBm (resolution 1 dB), then returning to original -10 dBm

STEP	ACTION	VERIFICATION
1.		<div style="border: 1px solid black; padding: 5px; text-align: center;"> - 10.0 dBm </div>
2.	 <p data-bbox="682 777 933 934">Turn the output setting knob counterclockwise until -15 dBm is obtained.</p>	<div style="border: 1px solid black; padding: 5px; text-align: center;"> - 15.0 dBm </div>
3.		<div style="border: 1px solid black; padding: 5px; text-align: center;"> - 10.0 dBm </div> <div style="border: 1px solid black; padding: 2px; text-align: center; font-size: small;"> CONT mode set </div>
4.		<div style="border: 1px solid black; padding: 5px; text-align: center;"> - 10.0 dBm </div> <div style="border: 1px solid black; padding: 2px; text-align: center; font-size: small;"> CONT mode released </div>

5.2.4 Setting output level using step keys

The OUTPUT LEVEL section [∇] and [\blacktriangle] keys on the front panel are used to step-down or step-up the output level in units of 10 dB.

The step keys can be used with the output setting knob. They can be pressed one-at-a-time or held down. The output level, however, cannot be incremented past +13 dBm or decremented past -133 dBm. In addition, these keys cannot be used in the CONT mode.

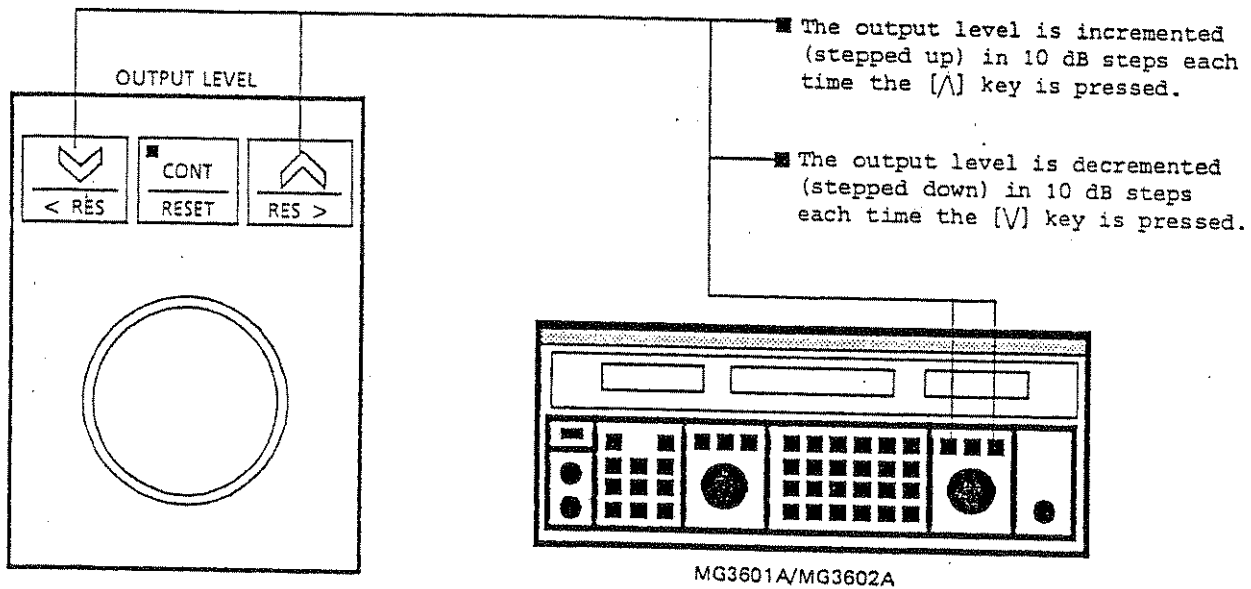

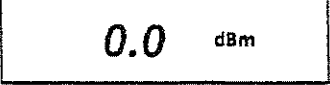



Fig. 5-10 Setting Output Level Using Step Keys

Example:

Setting output level in 10 dB intervals from 0 dBm to -50 dBm

STEP	ACTION	VERIFICATION
1.		 <p data-bbox="1013 705 1421 764">The output level is set to 0 dBm.</p>
2.	 <p data-bbox="342 905 945 940">Press the [V] key five times or hold it down until 15 dBm is obtained.</p>	

5.2.5 Reading output level from relative level (LRL)

When an output level is displayed by the OUTPUT LEVEL display, press the [SHIFT] [LRL] keys to set the output level display value to 0 dB. This value is the relative level display reference value 0 dB.

The keyboard, [^] and [v] keys, or the output setting knob, are used to set and display the relative level from the reference value 0 dB. Settings can also be made in the CONT mode.

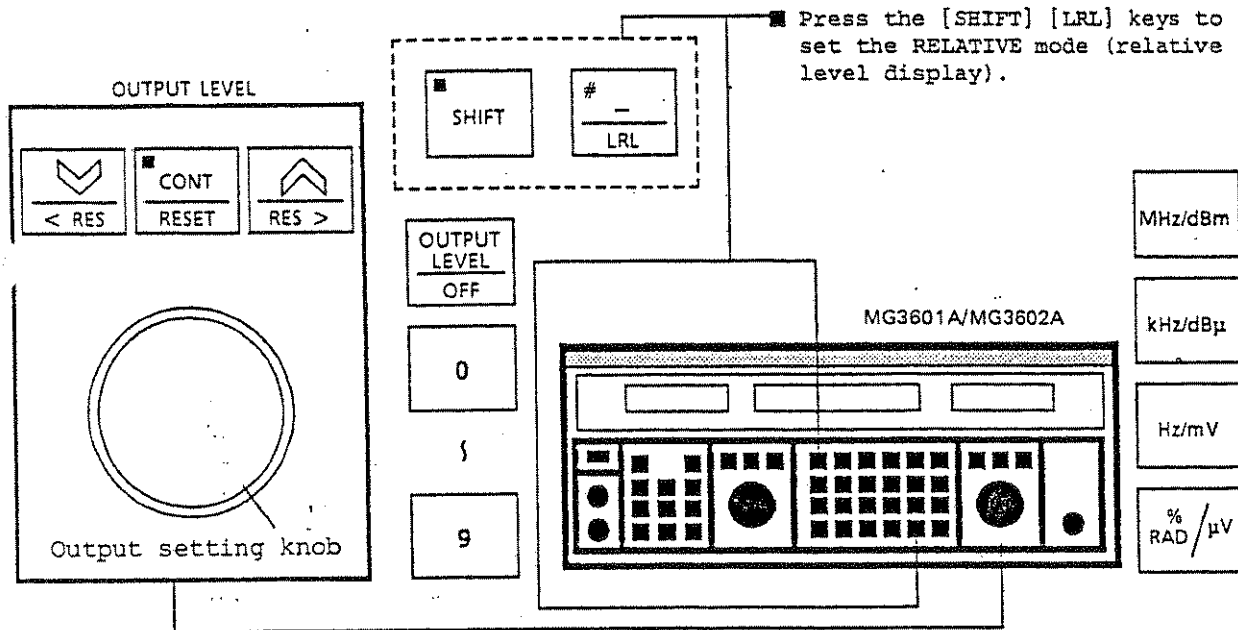



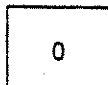
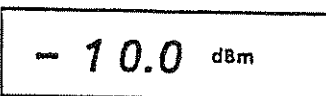

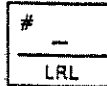
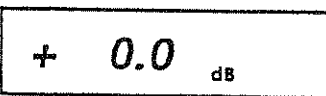

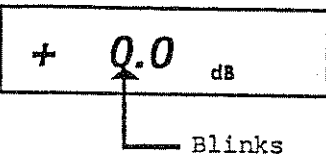
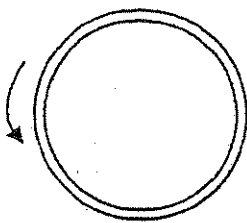



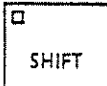

Fig. 5-11 Setting Relative Level Display

Example:

Setting -10 dBm to reference value 0 dB then setting relative level -5 dB at 1 dB resolution

STEP	ACTION				VERIFICATION
1.					 The output level is set to -10 dBm.
			← The relative level mode is set.		
2.			← Press the [RES>] key until 1 dB resolution is obtained.		
3.			Turn the output setting knob counterclockwise until -5 dB is obtained.		

(1) Confirming current output level in relative level mode

  ← Hold the [LRL] key down to display the current output level.

- (2) Returning to relative vlaue 0 dB when relative level mode set



Press the [SHIFT] [RESET] keys to return the current relative value to 0 dB. If the relative level mode is released, the output level when the relative level mode is set is displayed.

Note:

In the CONT mode, the same operations can be performed to return to the output level held when the CONT mode is set.

When both the relative level and CONT modes are set, resetting the level in the relative level mode has priority.

- (3) Releasing relative level mode

Press the [SHIFT] key then press and quickly release the [LRL] key to release the relative level display mode. When the relative level display mode is released, the current output CURRENT LEVEL is displayed by the OUTPUT LEVEL display.

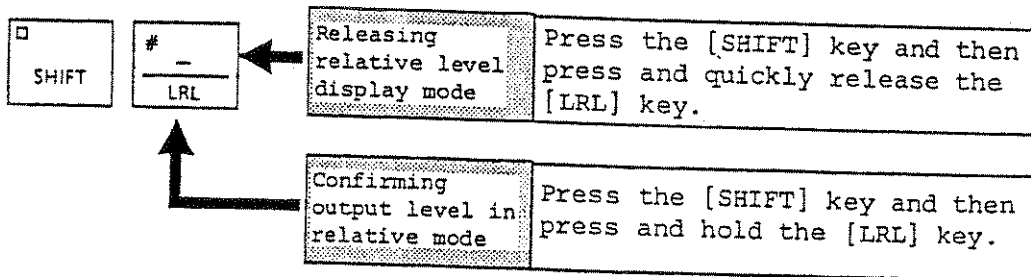

Note:

When the [SHIFT] and [LRL] keys are pressed in this order in the relative level display mode, the relative level display mode is released. At this time, when the [LRL] key is pressed and held, the CURRENT LEVEL is displayed and relative level display mode is set again.

5.2.6 Output level on/off

When the output level is present, press the [SHIFT] [OFF] keys to turn the output level off. Press the [SHIFT] [OFF] keys again to turn the output level on. The [OFF] shift key function alternately turns the output level on and off.

Example:

Setting output level -30 dBm then turning output off then on

STEP	ACTION					VERIFICATION
1.	<input type="checkbox"/> OUTPUT LEVEL OFF	# - LRL	3	0	MHz/dBm	- 30.0 dBm The output level is set to -30 dBm.
2.	<input type="checkbox"/> SHIFT	OUTPUT LEVEL OFF				OFF
3.	<input type="checkbox"/> SHIFT	OUTPUT LEVEL OFF				- 30.0 dBm

Although the output level can be alternately turned on and off by repeating steps 2 and 3 above, the same setting (releasing output OFF) as step 3 can be made by the three types of settings shown below.

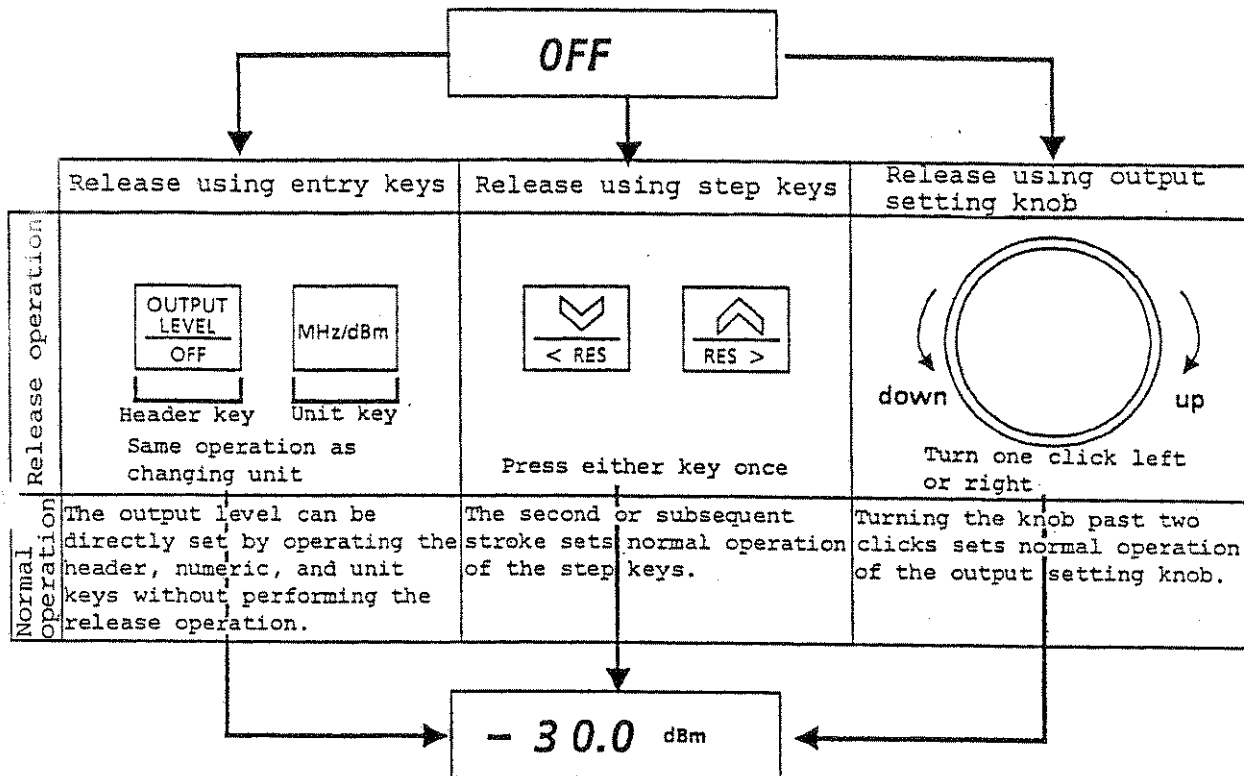

5.3 Basic Operations for Modulation

This paragraph explains the general operations for AM, FM, and ϕ M modulation, or simultaneous modulation by combining AM, FM and ϕ M modulation.

The main specifications of the MG3601A/MG3602A for setting the modulation frequency at frequency modulation are as follows.

Item	MG3601A/MG3602A
Internal fixed frequency	400 Hz, 1 kHz
Internal variable AF oscillator	Option 04
Frequency range	20 Hz to 100 kHz
Minimum resolution	0.1 Hz
Internal modulation frequency accuracy	100 ppm
External modulation frequency	
Frequency range (ac couple)	20 Hz to 100 kHz (± 1 dB bandwidth)
Frequency range (dc couple)	Dc to 100 kHz (± 1 dB bandwidth)

. FM modulation has the widest range of modulation frequencies. See paragraphs 1.4, 5.7, and 5.8 for details on AM and ϕ M modulation. This manual assumes that option 04 is installed.

. Unless otherwise indicated, AF OSC refers to the internal variable AF oscillator.

Note:

If an attempt is made to set a modulation frequency outside the frequency range specified beforehand for the AM, FM, or ϕ M, the STATUS LED (Fig. 5-1) comes on.

Note: (cont'd)

Input a new HEADER to turn the STATUS LED off. While the STATUS LED is on, the error code can be displayed by pressing the [SHIFT] key and holding the STATUS key down. The FREQUENCY display on the front panel displays the error code.

5.3.1 Outline of the MODULATION section/DATA ENTRY section panel operations

This paragraph outlines the key functions of the front panel MODULATION and DATA ENTRY sections used to set the AM, FM, or ϕ M modulation factor (see paragraphs 5.3.2 and after for details). Figure 5-12 shows only the part of the DATA ENTRY section used to set modulation.

- . Basic DATA ENTRY section operations for setting modulation

AM, FM, and ϕ M modulation is set using the corresponding header (HEADER), numeric (DATA), and unit (UNIT) keys in this order.

The following is an example of setting HEADER → DATA → UNIT of the DATA ENTRY section shown in Fig. 5-12.

- . AM 30% Setting amplitude modulation 30%
- . FM 3.5 kHz Setting frequency deviation 3.5 kHz
- . AF OSC 100 Hz ... Setting internal variable oscillation frequency 100 Hz
- . ϕ M 199 RAD Setting phase deviation 199 radians

MODULATION section function list and corresponding keys

The relationship between the key functions of the MODULATION section and the corresponding key operations is shown below.

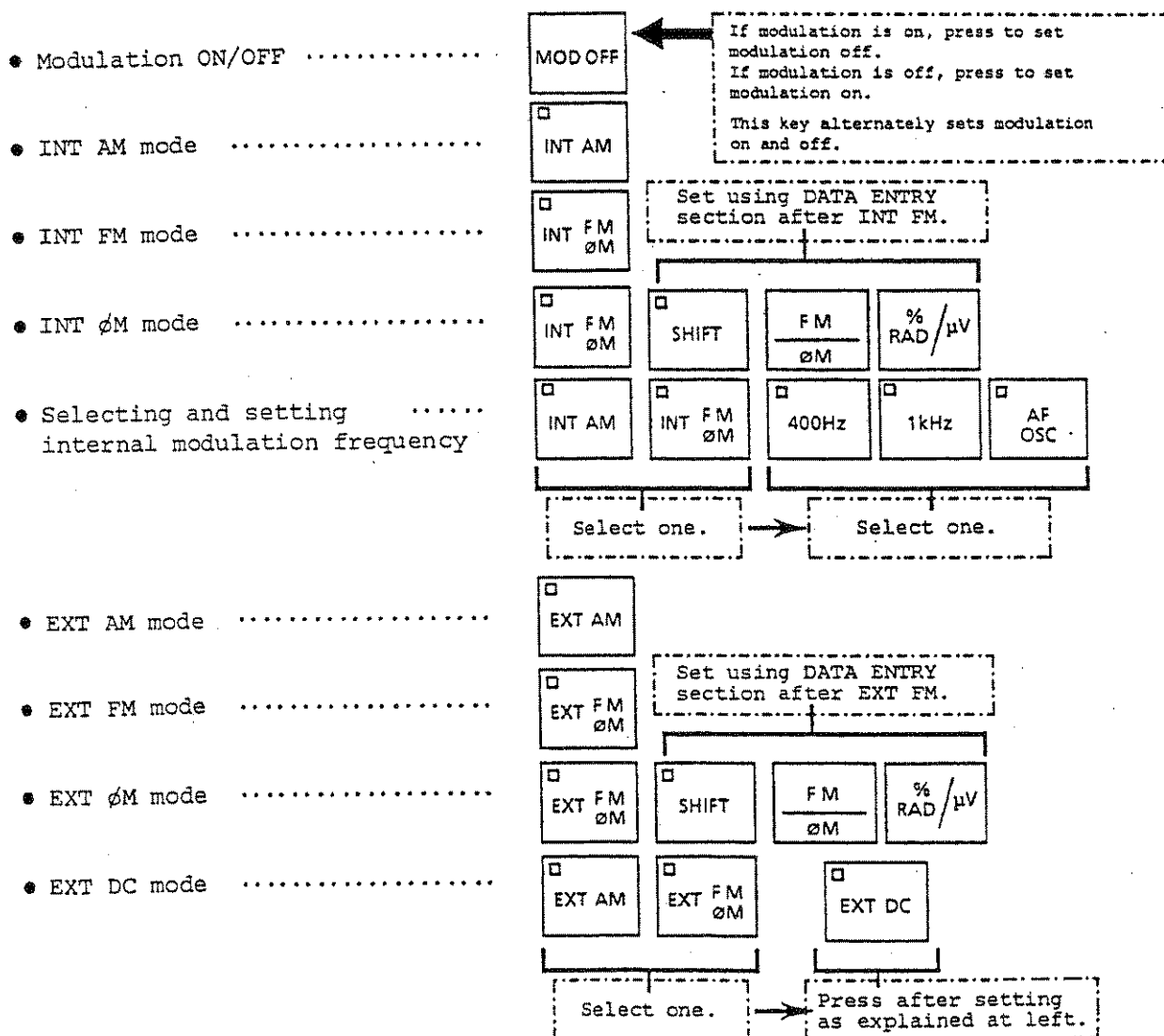

• Increasing or decreasing step....
value of modulation factor

• Setting resolution of
modulation factor

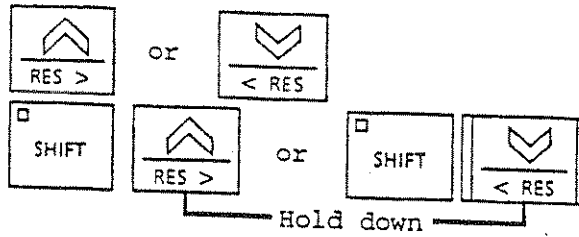

MODULATION

AM 199 RAD

ØM

- AM(%) ... Setting 1 to 2 digits, minimum resolution 1%
- FM(kHz) ... Setting 3 digits, minimum resolution 0.01 kHz
- ØM(RAD) ... Setting 3 digits, minimum resolution 0.01 RAD

FREQUENCY

100.0AF

MHz kHz

The modulation frequency is set using the DATA ENTRY section as follows:

- Frequency range 20 Hz to 100 kHz
- Maximum 7 digits, minimum resolution 0.1 Hz
- For AF OSC, read kHz instead of MHz and Hz instead of kHz.

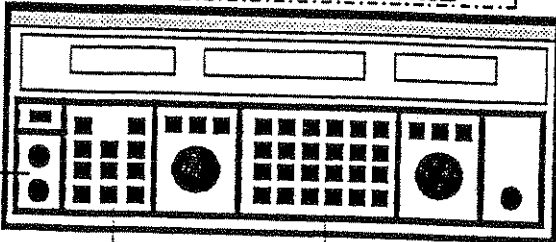
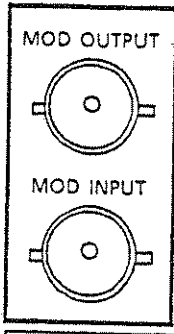

■ MOD OUTPUT: In the internal modulation mode, an optional wave of 400 Hz, 1 kHz, or AF OSC (20 Hz to 100 kHz) is output. In the external modulation mode, a signal with MOD INPUT added is output. Output impedance: 600 Ω

■ MOD INPUT: In the external modulation mode, a signal from dc to 100 kHz where neither the HI nor LO lamps light, is applied. Input impedance: 600 Ω

Example of using DATA ENTRY section to set modulation

HEADER	DATA	UNIT
AM / AF	3 0	% / µV
FM / ØM	3 . 5	kHz/dBµ
SHIFT AM / AF	1 0 0	Hz/mV
SHIFT FM / ØM	1 9 9	% / µV

MODULATION

< RES RES >

INT MOD OUTPUT: 400Hz 1kHz AF OSC

MOD ON/OFF: INT AM INT FM ØM MOD OFF

EXT AM EXT FM ØM EXT DC

Outlined on previous page

The modulation factor previously set on the MODULATION display, or the AF OSC previously set on the FREQUENCY display, can be confirmed by keying-in HEADER + UNIT, even if the settings are not displayed. In this case, the [kHz] key must be pressed for the FM UNIT key.

In addition, simultaneous modulation of external/internal and different modulation modes is possible.

Fig. 5-12 MODULATION and DATA ENTRY Sections (for Modulation)

5.3.2 Confirming modulation settings at initial setting

Since the MG3601A/MG3602A can redisplay immediately after power-on the setting conditions held at power-off, the modulation settings held at power-off can also be redisplayed.

The initial settings can be redisplayed by keying-in [SPCL] [0][0].

The items related to modulation are as follows.

CENTER FREQ	1.04 MHz
MODULATION	OFF
INT MOD OUTPUT	1 kHz
AM	30%
FM	3.5 kHz
ϕ M	1 RAD

For CENTER FREQ and MODULATION among the above settings, since the MODULATION section is off:

- . An unmodulated carrier is output.
- . Because all parameters of the MODULATION section are OFF for internal and external modes, pressing the [MOD OFF] key of the MODULATION section has no effect.

INT MOD OUTPUT... 1 kHz to ϕ M... 1 RAD are as follows.

■ MODULATION section is OFF

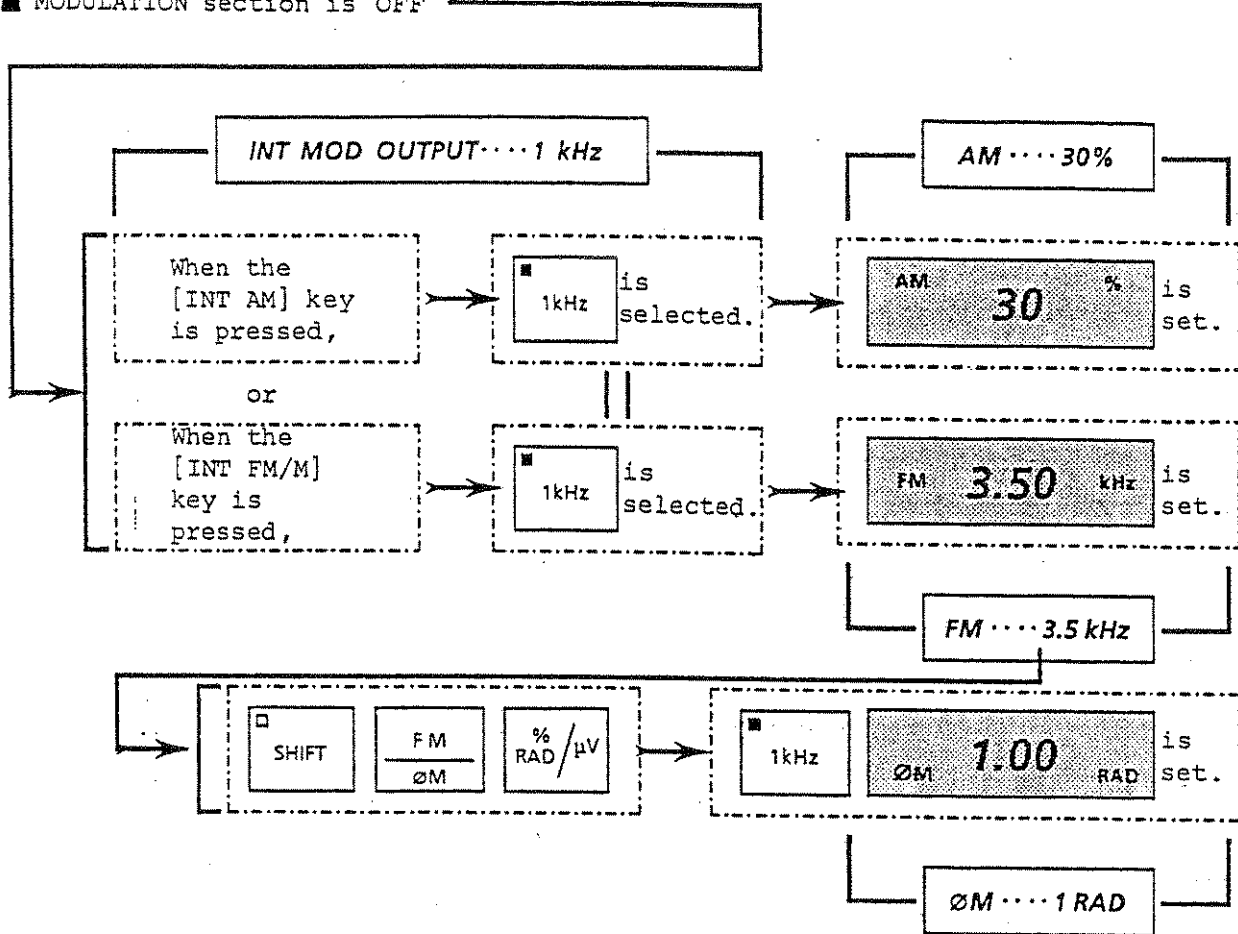

5.3.3 Switching internal modulation frequency

Any one of 400 Hz fixed, 1 kHz fixed, or AF OSC (20 Hz to 100 kHz) can be selected and set as the internal modulation frequency.

By assigning A as the MOD ON/OFF and internal modulation mode switching block shown in the figure below, the internal modulation frequency is set after performing the operations in block A.

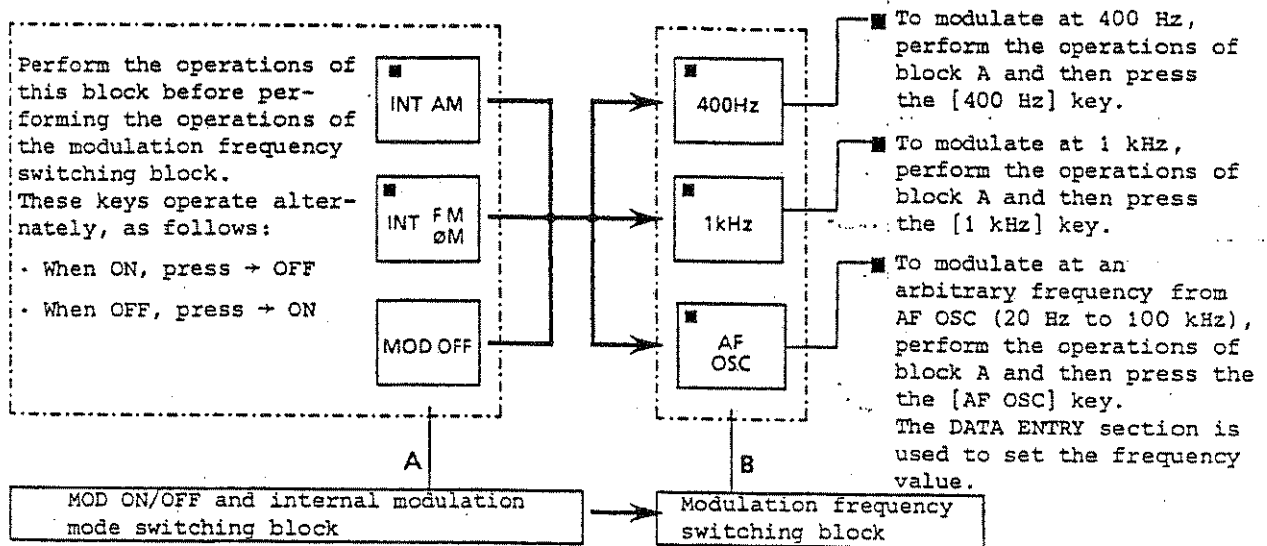

Since the required modulation frequency is selected in the modulation frequency switching block, MOD ON can be set and the previously selected modulation frequency automatically set again by pressing any key in block A if modulation frequency 400 Hz, 1 kHz, or AF OSC is selected before MOD OFF is set.

Therefore, to use the previously selected modulation frequency again, the modulation frequency switching block operations are not required. If MOD OFF status is currently set and MOD ON is to be set next, the modulation parameter settings are as follows.

The parameters to be set are the same as those set before MOD OFF is set : Press the [MOD OFF] key. The previously set parameters are set again.

The parameters to be set are not the same as those set before MOD OFF is set : Press the [INT AM] key for AM. Press the [INT FM/φM] key for FM, or press the [INT FM/φM] key for φM. If the modulation frequency is to be changed, press the [400 Hz] key for 400 Hz, or press the [1 kHz] key for 1 kHz. Press the [AF OSC] key for AF OSC, and use the DATA ENTRY section to set the frequency value. If the frequency value has already been set using the DATA ENTRY section, press the [AF OSC] key.

If the settings are INT FM 1 kHz and FM 3.5 kHz (frequency deviation 3.5 kHz) before MOD OFF is set, the settings are changed to INT FM 400 Hz from the MOD OFF status. The processing flow is shown below.

There are two methods for setting the status shown above, as shown in the processing flow below.

1. Pressing [MOD OFF] key to start (MOD OFF start)
2. Pressing [INT FM/φM] key to start (INT MOD start)

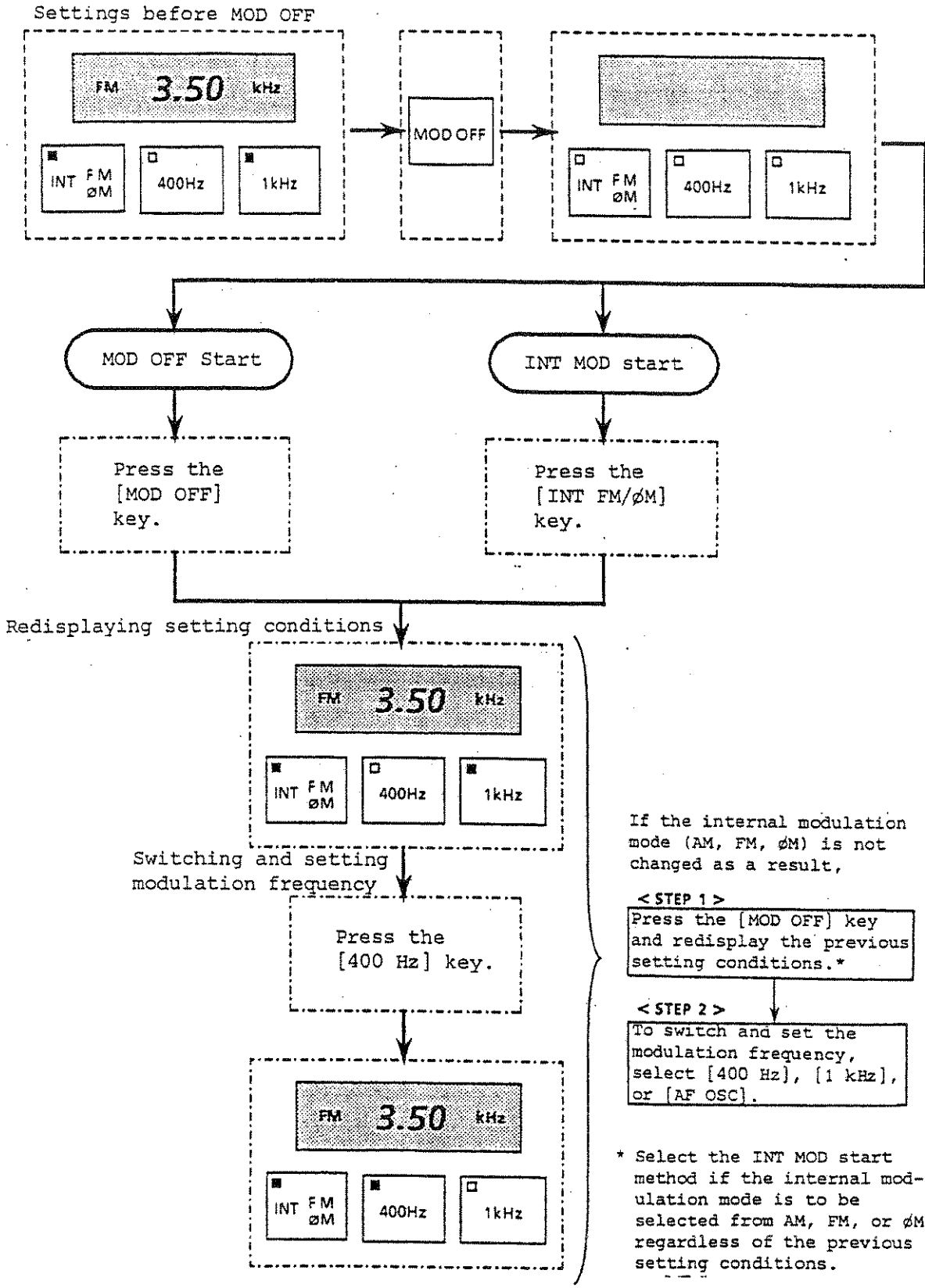

Fig. 5-13 Changing the Modulation Frequency from 1 kHz to 400 Hz

The key operations of the modulation frequency switching block for step 2 shown in Figure 5-13 are shown below. (The solid square (■) indicates that the key lamp of the selected frequency is on. The open square (□) indicates that the key lamp of the unselected frequency is off.) The key lamps before the keys are operated are [400Hz] OFF, [1kHz] ON, and [AF OSC] OFF.



STEP	ACTION		VERIFICATION			
1.	Press the [400Hz] key.	→	<table border="1"> <tr> <td style="text-align: center;">■ 400Hz</td> <td style="text-align: center;">□ 1kHz</td> <td style="text-align: center;">□ AF OSC</td> </tr> </table> [400Hz] ON [1kHz] OFF	■ 400Hz	□ 1kHz	□ AF OSC
■ 400Hz	□ 1kHz	□ AF OSC				
2.	Press the [1kHz] key.	→	<table border="1"> <tr> <td style="text-align: center;">□ 400Hz</td> <td style="text-align: center;">■ 1kHz</td> <td style="text-align: center;">□ AF OSC</td> </tr> </table> [400Hz] OFF [1kHz] ON	□ 400Hz	■ 1kHz	□ AF OSC
□ 400Hz	■ 1kHz	□ AF OSC				
3.	Press the [AF OSC] key.	→	<table border="1"> <tr> <td style="text-align: center;">□ 400Hz</td> <td style="text-align: center;">□ 1kHz</td> <td style="text-align: center;">■ AF OSC</td> </tr> </table> [AF OSC] ON [1kHz] OFF	□ 400Hz	□ 1kHz	■ AF OSC
□ 400Hz	□ 1kHz	■ AF OSC				
4.	Press the [1kHz] key.	→	<table border="1"> <tr> <td style="text-align: center;">□ 400Hz</td> <td style="text-align: center;">■ 1kHz</td> <td style="text-align: center;">□ AF OSC</td> </tr> </table> [AF OSC] OFF [1kHz] ON	□ 400Hz	■ 1kHz	□ AF OSC
□ 400Hz	■ 1kHz	□ AF OSC				
5.	Press the [400Hz] key.	→	<table border="1"> <tr> <td style="text-align: center;">■ 400Hz</td> <td style="text-align: center;">□ 1kHz</td> <td style="text-align: center;">□ AF OSC</td> </tr> </table> [400Hz] ON [1kHz] OFF	■ 400Hz	□ 1kHz	□ AF OSC
■ 400Hz	□ 1kHz	□ AF OSC				

Notes:

1. Keys that are currently ON are not turned OFF when pressed.

Although the six keys of the MOD ON/OFF section operate like this, the three keys of the INT MOD OUTPUT section operate differently.

Notes: (cont'd)

That is, if either of the INT MOD OUTPUT section keys that are OFF is pressed, the key will be turned ON and the keys that are currently ON will be turned OFF. Therefore, except for initial status explained in paragraph 5.3.2, one of the three keys will always be ON.

2. [AF OSC] of the MG3601A/MG3602A is option 04. If option 04 is not installed, [AF OSC] cannot be selected.

5.4 Modulation ON/OFF Operations

This paragraph explains how to select modulation mode and switch the MODULATION displays based on MODULATION ON/OFF.

5.4.1 MODULATION ON/OFF using [MOD OFF] key

(1) MODULATION ON

Press the [MOD OFF] key to turn modulation on.

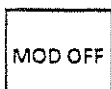

The mode selected immediately before modulation was turned off is set.
The internal modulation frequency is set in the same way.

(2) MODULATION OFF

Press the [MOD OFF] key to turn modulation off.

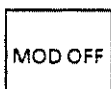

The MODULATION display and the [400 Hz], [1 kHz], [AF OSC], [INT AM], [EXT AM], [INT FM/φM], [EXT FM/φM], and [EXT DC] LEDs are cleared.

Note:

The [^], [v], [<RES], and [RES>] keys of [MODULATION] are disabled when modulation is off.

5.4.2 MODULATION ON/OFF using the modulation mode selection keys

(1) MODULATION ON

Press one of the modulation mode selection keys [INT AM], [EXT AM], or [INT FM/φM] to turn modulation on.



The internal modulation frequency selected immediately before modulation was turned off is set.

(2) MODULATION OFF

Turn [INT AM], [EXT AM], [INT FM/φM] and [EXT FM/φM] off to turn modulation off.

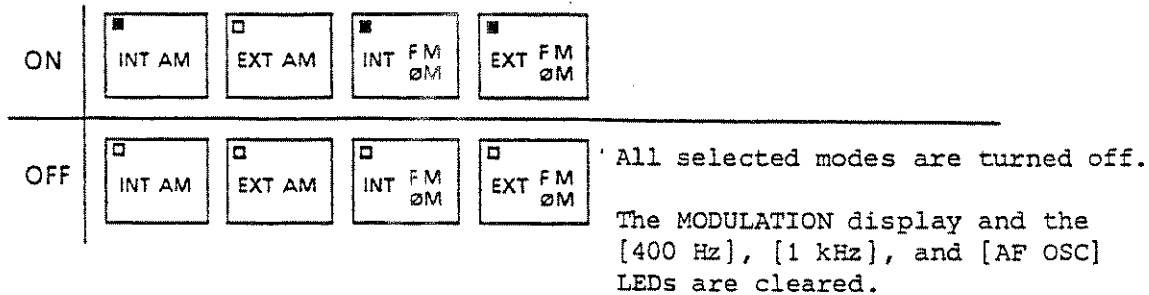

Note:

The [^], [v], [<RES], and [RES>] keys of [MODULATION] are disabled when modulation is off.

(3) Prohibited combinations of modulation modes

When external and internal modulation are combined, AM and AM combinations and φM and FM combinations are prohibited. That is, the following five combinations are prohibited. All other combinations, however, are allowed.

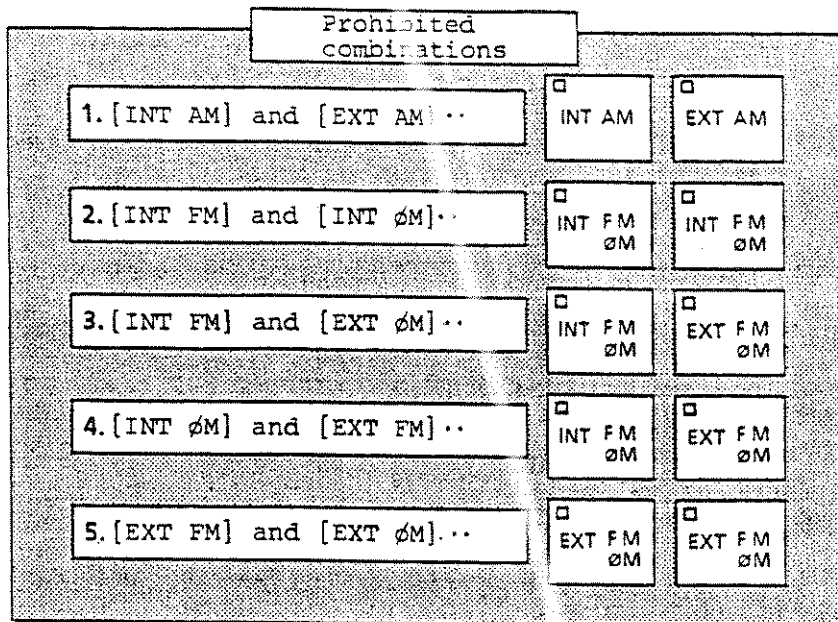

Note:

When [INT FM/ ϕ M] or [EXT FM/ ϕ M] is on, the data set after is effective.

(4) Selecting the modulation modes

Table 5-1 lists all possible modes that can be selected using the [INT AM], [EXT AM], [INT FM/ ϕ M], and [EXT FM/ ϕ M] keys.

Lines 1, 2, and 6 are used to illustrate how to read the table.

(a) Selecting MOD OFF of line 1

Since MOD OFF of the MODULATION section is selected, the MG3601A/MG3602A is set to the MOD OFF mode.

At this time:

- . When the [INT AM] key of column 1 is pressed, the MG3601A/MG3602A is set to the INT AM mode. Set the MOD OFF mode again.
- . When the [EXT AM] key of column 2 is pressed, the MG3601A/MG3602A is set to the EXT AM mode. Set the MOD OFF mode again.
- . When the [INT FM/φM] key of column 3 is pressed, the MG3601A/MG3602A is set to the INT FM mode. Set the MOD OFF mode again.
- . When the [EXT FM/φM] key of column 4 is pressed, the MG3601A/MG3602A is set to the EXT FM mode.

Note:

When selecting the column, set the line as indicated in the table. Set the other lines and columns in the same way. In the above examples, set the MOD OFF mode before selecting columns 2 and 3.

(b) Selecting INT AM of line 2

Since INT AM of the MODULATION section is selected, the MG3601A/MG3602A is set to INT AM mode.

At this time:

- . When the [INT AM] key of column 1 is pressed, the MG3601A/MG3602A is set to the MOD OFF mode. Set the INT AM mode again.
- . When the [EXT AM] key of column 2 is pressed, the MG3601A/MG3602A is set to the EXT AM mode. Set the INT AM mode again.
- . When the [INT FM/φM] key of column 3 is pressed, the MG3601A/MG3602A is set to the INT AM and INT FM modes. Set the INT AM mode again.
- . When the [EXT FM/φM] key of column 4 is pressed, the MG3601A/MG3602A is set to the INT AM and EXT FM modes.

(c) Selecting INT φM of line 6

Key-in [SHIFT] [φM] [RAD] in the INT FM mode and set the MG3601A/MG3602A to the INT φM mode.

At this time:

- . When the [INT AM] key of column 1 is pressed, the MG3601A/MG3602A is set to the INT AM and INT φM modes. Set the INT φM mode again.

- . When the [EXT AM] key of column 2 is pressed, the MG3601A/MG3602A is set to the EXT AM and INT ϕ M modes.
Set the INT ϕ M mode again.
- . When the [INT FM/ ϕ M] key of column 3 is pressed, the MG3601A/MG3602A is set to the MOD OFF mode.
Set the INT ϕ M mode again.
- . When the [EXT FM/ ϕ M] key of column 4 is pressed, the MG3601A/MG3602A is set the to INT ϕ M and EXT ϕ M modes.

(5) [EXT DC] key

One or both of the [EXT AM] or [EXT FM/ ϕ M] keys must be ON to select the [EXT DC] key. It cannot be individually selected. The [EXT DC] key is automatically turned OFF when both the [EXT AM] and [EXT FM/ ϕ M] keys are OFF.

Table 5-1 Selecting Mode Using [INT AM], [EXT AM], [INT FM/ØM], and [EXT FM/ØM] Keys

Key operation Selection status	INT AM	EXT AM	INT FM ØM	EXT FM ØM
MOD OFF	INT AM	EXT AM	INT FM	EXT FM
INT AM	MOD OFF	EXT AM	INT AM, INT FM	INT AM, EXT FM
EXT AM	INT AM	MOD OFF	EXT AM, INT FM	EXT AM, EXT FM
INT FM	INT AM, INT FM	EXT AM, INT FM	MOD OFF	INT FM, EXT FM
EXT FM	INT AM, EXT FM	EXT AM, EXT FM	INT FM, EXT FM	MOD OFF
INT ØM	INT AM, INT ØM	EXT AM INT ØM	MOD OFF	INT ØM, EXT ØM
EXT ØM	INT AM, EXT ØM	EXT AM, EXT ØM	INT ØM, EXT ØM	MOD OFF
INT AM, INT FM	INT FM	EXT AM, INT FM	INT AM	INT AM, INT FM, EXT FM
INT AM, EXT FM	EXT FM	EXT AM, EXT FM	INT AM, EXT FM, INT FM	INT AM
INT AM, INT ØM	INT ØM	EXT AM, INT ØM	INT AM	INT AM, INT ØM, EXT ØM
INT AM, EXT ØM	EXT ØM	EXT AM, EXT ØM	INT AM, EXT ØM INT ØM	INT AM
EXT AM, INT FM	INT AM, INT FM	INT FM	EXT AM	EXT AM, INT FM, EXT FM
EXT AM, EXT FM	INT AM, EXT FM	EXT FM	EXT AM, EXT FM, INT FM	EXT AM
EXT AM, INT ØM	INT AM, INT ØM	INT ØM	EXT AM	EXT AM, INT ØM, EXT ØM
EXT AM, EXT ØM	INT AM, EXT ØM	EXT ØM	EXT AM, EXT ØM, INT ØM	EXT AM
INT FM, EXT FM	INT AM, INT FM, EXT FM	EXT AM, INT FM EXT FM	EXT FM	INT FM
INT ØM, EXT ØM	INT AM, INT ØM, EXT ØM	EXT AM, INT ØM EXT ØM	EXT ØM	INT ØM
INT AM, INT FM, EXT FM	INT FM, EXT FM	EXT AM, INT FM, EXT FM	INT AM, EXT FM	INT AM, INT FM
INT AM, INT ØM, EXT ØM	INT ØM, EXT ØM	EXT AM, INT ØM EXT ØM	INT AM, EXT ØM	INT AM, INT ØM
EXT AM, INT FM, EXT FM	INT AM, INT FM, EXT FM	INT FM, EXT FM	EXT AM, EXT FM	EXT FM, INT FM
EXT AM, INT ØM, EXT ØM	INT AM, INT ØM, EXT ØM	INT ØM, EXT ØM	EXT AM, EXT ØM	EXT AM, INT ØM

* The LED is on before the key is pressed in the selected status. The LED goes off when the key is pressed. (This also applies to Tables 5-2 and 5-3.)

5.4.3 Turning modulation on and selecting modes using [AM], [FM], and [øM] keys

- (1) Modulation is turned on when data is set using the [AM], [FM], and [øM] keys



The AM mode is turned on, and the internal modulation frequency immediately before the modulation was turned off is reset.

OR



The AM mode is turned on, and the internal modulation frequency immediately before the modulation was turned off is reset

(2) Selecting modes

- (a) Using ENTRY keys to select mode (at MOD ON)

Table 5-2 lists the changes in the modulation modes when one of the modes is on and the ENTRY keys are used to select a mode.

Lines 1 and 3 are used to illustrate how to read the table.

- (i) Selecting INT AM of line 1

Since INT AM of the MODULATION section is selected, the MG3601A/MG3602A is set to the INT AM mode.

At this time:

- . When the [AM] [%] keys of column 1 are pressed, the MG3601A/MG3602A remains in the INT AM mode.
Set the INT AM mode again.
- . When the [FM] [kHz] keys of column 2 are pressed, the MG3601A/MG3602A is set to the INT AM and INT FM modes.
Set the INT AM mode again.
- . When the [SHIFT] [øM] [RAD] keys of column 3 are pressed, the MG3601A/MG3602A is set to the INT AM and INT øM modes.

Note:

When selecting the column, set the line as indicated in the table. The relationship of the subsequent lines and columns is the same. In the above examples, set the INT AM mode before selecting columns 2 and 3.

(ii) Selecting INT FM of line 3

Since INT FM of the MODULATION section is selected, the MG3601A/MG3602A is set to the INT FM mode.

At this time:

- . When the [AM] [%] keys of column 1 are pressed, the MG3601A/MG3602A is set to the INT AM and INT FM modes.
Set the INT FM mode again.

- . When the [FM] [kHz] keys of column 2 are pressed, the modulation mode of the MG3601A/MG3602A remains unchanged.
- . When the [SHIFT] [øM] [RAD] keys of column 3 are pressed, the MG3601A/MG3602A is set to the INT øM mode.

Table 5-2 Selecting Mode Using ENTRY Keys
(MOD ON)

Key operation Selection status	AM set		FM set		ØM set		
	AM AF	% RAD/ μ V	FM ØM	kHz/dB μ	SHIFT	FM ØM	% RAD/ μ V
INT AM	No change		INT AM, INT FM		INT AM, INT ØM		
EXT AM	No change		EXT AM, INT FM		EXT AM, INT ØM		
INT FM	INT AM, INT FM		No change		INT ØM		
EXT FM	INT AM, EXT FM		No change		EXT ØM		
INT ØM	INT AM, INT ØM		INT FM		No change		
EXT ØM	INT AM, EXT ØM		EXT FM		No change		
INT AM, INT FM	No change		No change		INT AM, INT ØM		
INT AM, EXT FM	No change		No change		INT AM, EXT ØM		
INT AM, INT ØM	No change		INT AM, INT FM		No change		
INT AM, EXT ØM	No change		INT AM, EXT FM		No change		
EXT AM, INT FM	No change		No change		EXT AM, INT ØM		
EXT AM, EXT FM	No change		No change		EXT AM, EXT ØM		
EXT AM, INT ØM	No change		EXT AM, INT FM		No change		
EXT AM, EXT ØM	No change		EXT AM, EXT FM		No change		
INT FM, EXT FM	INT AM, INT FM, EXT FM		No change		INT ØM, EXT ØM		
INT ØM, EXT ØM	INT AM, INT ØM, EXT ØM		INT FM, EXT FM		No change		
INT AM, INT FM, EXT FM	No change		No change		INT AM, INT ØM EXT ØM		
INT AM, INT ØM, EXT ØM	No change		INT AM, INT FM EXT FM		No change		
EXT AM, INT FM, EXT FM	No change		No change		EXT AM, INT ØM EXT ØM		
EXT AM, INT ØM, EXT ØM	No change		EXT AM, INT FM EXT FM		No change		

(b) Using ENTRY keys to select mode (at MOD OFF)

Table 5-3 lists the modes selection using the ENTRY keys (at MOD OFF).

Lines 1, 2, and 4 are used to illustrate how to read the table.

(i) Selecting all OFF of line 1

MOD OFF of the MODULATION section is set, and the status immediately before MOD OFF is MOD OFF.

At this time:

. When the [AM] [%] keys of column 1 are pressed, the MG3601A/MG3602A is set to the INT AM mode.

Set the MOD OFF mode again.

. When the [FM] [kHz] keys of column 2 are pressed, the MG3601A/MG3602A is set to the INT FM mode.

Set the MOD OFF mode again.

. When the [SHIFT] [øM] [RAD] keys of column 3 are pressed, the MG3601A/MG3602A is set to the INT øM mode.

(ii) Selecting MOD OFF (INT AM preceded immediately) of line 2

MOD OFF of the MODULATION section is set, and the status immediately before MOD OFF is INT AM.

At this time:

. When the [AM] [%] keys of column 1 are pressed, the MG3601A/MG3602A is set to the INT AM mode.

Set the MOD OFF mode from INT AM again.

. When the [MF] [kHz] keys of column 2 are pressed, the MG3601A/MG3602A is set to the INT FM mode.

Set the MOD OFF mode from INT FM again.

. When the [SHIFT] [øM] [RAD] keys of column 3 are pressed, the MG3601A/MG3602A is set to INT øM mode.

(iii) Selecting MOD OFF (INT FM preceded immediately) of line 4

MOD OFF of the MODULATION section is set, and the status immediately before MOD OFF is INT FM.

At this time:

. When the [AM] [%] keys of column 1 are pressed, the MG3601A/MG3602A is set to the INT AM mode.

Set the MOD OFF mode from INT AM again.

. When the [FM] [kHz] keys of column 2 are pressed, the MG3601A/MG3602A is set to the INT FM mode.

Set the MOD OFF mode from INT FM again.

. When the [SHIFT] [øM] [RAD] keys of column 3 are pressed, the MG3601A/MG3602A is set to INT øM mode.

Table 5-3 Selecting Modes Using ENTRY Keys
(MOD OFF)

Key operation Selection status at MOD OFF	AM set		FM set		øM set		
	AM AF	% RAD/ μ V	FM øM	kHz/dB μ	SHIFT	FM øM	% RAD/ μ V
ALL OFF	INT AM		INT FM				INT øM
INT AM	INT AM		INT FM				INT øM
EXT AM	EXT AM		INT FM				INT øM
INT FM	INT AM		INT FM				INT øM
EXT FM	INT AM		EXT FM				INT øM
INT øM	INT AM		INT FM				INT øM
EXT øM	INT AM		INT FM				EXT øM
INT AM, INT FM	INT AM		INT FM				INT øM
INT AM, EXT FM	INT AM		EXT FM				INT øM
INT AM, INT øM	INT AM		INT FM				INT øM
INT AM, EXT øM	INT AM		INT FM				EXT øM
EXT AM, INT FM	EXT AM		INT FM				INT øM
EXT AM, EXT FM	EXT AM		EXT FM				INT øM
EXT AM, INT øM	EXT AM		INT FM				INT øM
EXT AM, EXT øM	EXT AM		INT FM				EXT øM
INT FM, EXT FM	INT AM		INT FM, EXT FM				INT øM
INT øM, EXT øM	INT AM		INT FM				INT øM, EXT øM
INT AM, INT FM, EXT FM	INT AM		INT FM, EXT FM				INT øM
INT AM, INT øM, EXT øM	INT AM		INT FM				INT øM, EXT øM
EXT AM, INT FM, EXT FM	EXT AM		INT FM, EXT FM				INT øM
EXT AM, INT øM, EXT øM	EXT AM		INT FM				INT øM, EXT øM

5.4.4 MODULATION display at simultaneous modulation

At simultaneous modulation such as AM-FM and AM- ϕ M, the MODULATION display displays the data of the mode selected later. In the following examples, the modulation frequency is internal modulation frequency 1 kHz.

Examples:

STEP	ACTION	VERIFICATION
<u>Confirming the AM \rightarrow AM-FM \rightarrow AM set values</u>		
1.	<div style="display: flex; gap: 10px;"> <div style="border: 1px solid black; padding: 5px; text-align: center;">AM — AF</div> <div style="border: 1px solid black; padding: 5px; text-align: center;">5</div> <div style="border: 1px solid black; padding: 5px; text-align: center;">% RAD/μV</div> </div>	<div style="border: 1px solid black; padding: 5px; text-align: center;">AM 5 %</div> <div style="display: flex; justify-content: space-around; margin-top: 10px;"> <div style="border: 1px solid black; padding: 5px; text-align: center;">1kHz</div> <div style="border: 1px solid black; padding: 5px; text-align: center;">INT AM</div> </div> <div style="text-align: right; margin-top: -10px;">← INT AM ON</div>
2.	<div style="display: flex; gap: 10px;"> <div style="border: 1px solid black; padding: 5px; text-align: center;">FM — ϕM</div> <div style="border: 1px solid black; padding: 5px; text-align: center;">3</div> <div style="border: 1px solid black; padding: 5px; text-align: center;">kHz/dBμ</div> </div>	<div style="border: 1px solid black; padding: 5px; text-align: center;">AM FM 3.00 kHz</div> <div style="margin-top: 10px;"> <div style="border: 1px solid black; padding: 5px; text-align: center;">INT FM</div> <div style="text-align: right; margin-top: -10px;">← INT FM ON</div> </div>
3.	<div style="display: flex; gap: 10px;"> <div style="border: 1px solid black; padding: 5px; text-align: center;">AM — AF</div> <div style="border: 1px solid black; padding: 5px; text-align: center;">% RAD/μV</div> </div>	<div style="border: 1px solid black; padding: 5px; text-align: center;">AM FM 5 %</div>
<u>AM OFF after confirming the AM-ϕM \rightarrow AM set values</u>		
4.	<div style="display: flex; gap: 10px;"> <div style="border: 1px solid black; padding: 5px; text-align: center;"><input type="checkbox"/> SHIFT</div> <div style="border: 1px solid black; padding: 5px; text-align: center;">FM — ϕM</div> <div style="border: 1px solid black; padding: 5px; text-align: center;">4</div> <div style="border: 1px solid black; padding: 5px; text-align: center;">% RAD/μV</div> </div>	<div style="border: 1px solid black; padding: 5px; text-align: center;">AM ϕM 4.00 RAD</div>
5.	<div style="display: flex; gap: 10px;"> <div style="border: 1px solid black; padding: 5px; text-align: center;">AM — AF</div> <div style="border: 1px solid black; padding: 5px; text-align: center;">% RAD/μV</div> </div>	<div style="border: 1px solid black; padding: 5px; text-align: center;">AM ϕM 5 %</div>
6.	<div style="border: 1px solid black; padding: 5px; text-align: center;"><input checked="" type="checkbox"/> INT AM</div>	<div style="border: 1px solid black; padding: 5px; text-align: center;">ϕM 4.00 RAD</div> <div style="margin-top: 10px;"> <div style="border: 1px solid black; padding: 5px; text-align: center;"><input type="checkbox"/> INT AM</div> <div style="text-align: right; margin-top: -10px;">← INT AM OFF</div> </div>

(cont'd)

STEP	ACTION	VERIFICATION
<u>Restoring FM 3 kHz + restoring AM-FM + restoring AM-ØM</u>		
7.	<input type="checkbox"/> FM ØM kHz/dBµ	FM 3.00 kHz
8.	<input type="checkbox"/> INT AM	AM FM 5 % <input type="checkbox"/> INT FM ← INT FM ON
9.	<input type="checkbox"/> SHIFT FM ØM 4 % RAD/µV	AM ØM 4.00 RAD

5.5 Setting AF OSC Frequency (20 Hz to 100 kHz)

Since 400 Hz and 1 kHz are fixed among the internal modulation frequencies, 400 Hz or 1 kHz modulation can be applied simply by pressing the corresponding [400 Hz] or [1 kHz] key.

Since the AF OSC frequency can be set beforehand to a value from 20 Hz to 100 kHz by using the DATA ENTRY section, modulation at the set frequency can be applied simply by pressing the [AF OSC] key.

The frequency of the internal modulation variable oscillator can be set, or the modulation frequency read, for the MG3601A/MG3602A, as follows:

1. Setting internal modulation frequency at keyboard
2. Setting internal modulation frequency using TUNE knob
3. Setting internal modulation frequency using step keys
4. Reading internal modulation frequency when carrier frequency set

Note:

The main difference between the internal modulation frequency and the carrier frequency operations is that, for the modulation frequency, the [FRL] key cannot be used to display the relative frequency. When the modulation frequency is displayed by the FREQUENCY display, the operation required to display the relative frequency using the [FRL] key sets the relative frequency display for the carrier frequency currently not displayed and automatically releases the AF OSC frequency display mode. This is known from the fact that the carrier frequency is displayed by the FREQUENCY display when the [SHIFT] [FRL] keys are finally operated and the relative frequency display mode is released.

5.5.1 Reading modulation frequency when carrier frequency set*

Since the FREQUENCY display is used to display the carrier frequency and the internal modulation variable oscillator frequency, the modulation frequency can be read by the following method when the carrier frequency is set.

To return to the set internal modulation frequency display while the FREQUENCY display is being used as the carrier frequency display, press the [SHIFT] [AF] keys and then press one of the unit keys [MHz], [kHz], or [Hz].

Example:

Setting carrier frequency 510 MHz then returning to previously set modulation frequency 23 kHz display

STEP	ACTION	VERIFICATION
1.	<div style="display: flex; gap: 10px; align-items: center;"> <div style="border: 1px solid black; padding: 2px; text-align: center;">CENTER FREQ ΔF</div> <div style="border: 1px solid black; padding: 2px; text-align: center;">5</div> <div style="border: 1px solid black; padding: 2px; text-align: center;">1</div> <div style="border: 1px solid black; padding: 2px; text-align: center;">0</div> <div style="border: 1px solid black; padding: 2px; text-align: center;">MHz/dBm</div> </div>	<div style="border: 1px solid black; padding: 5px; text-align: center;"> 510 000 000 <small>MHz kHz</small> </div>
2.	<div style="display: flex; gap: 10px; align-items: center;"> <div style="border: 1px solid black; padding: 2px; text-align: center;">□ SHIFT</div> <div style="border: 1px solid black; padding: 2px; text-align: center;">AM AF</div> </div>	<div style="border: 1px solid black; padding: 5px; text-align: center;"> .A.F <small>MHz kHz</small> </div>
3.	<div style="display: flex; align-items: center; gap: 10px;"> <div style="border: 1px solid black; padding: 2px; text-align: center;">MHz/dBm</div> <div style="border: 1px solid black; padding: 2px; text-align: center;">kHz/dBμ</div> <div style="border: 1px solid black; padding: 2px; text-align: center;">Hz/mV</div> <div style="margin-left: 10px;"> ← Press one of the unit keys. </div> </div>	<div style="border: 1px solid black; padding: 5px; text-align: center;"> 23 000.0AF <small>MHz kHz</small> </div>

* To read the internal modulation frequency unit on the FREQUENCY display, replace MHz with kHz, and kHz with Hz.

5.5.2 Setting internal modulation frequency from keyboard (DATA ENTRY)

The internal modulation frequency is set by operating the header (HEADER) keys, numeric (DATA) keys, and unit (UNIT) keys in this order. As shown in Fig. 5-14, these keys are located in the DATA ENTRY section on the front panel. This paragraph explains the keys that are used for internal modulation frequency variable setting.

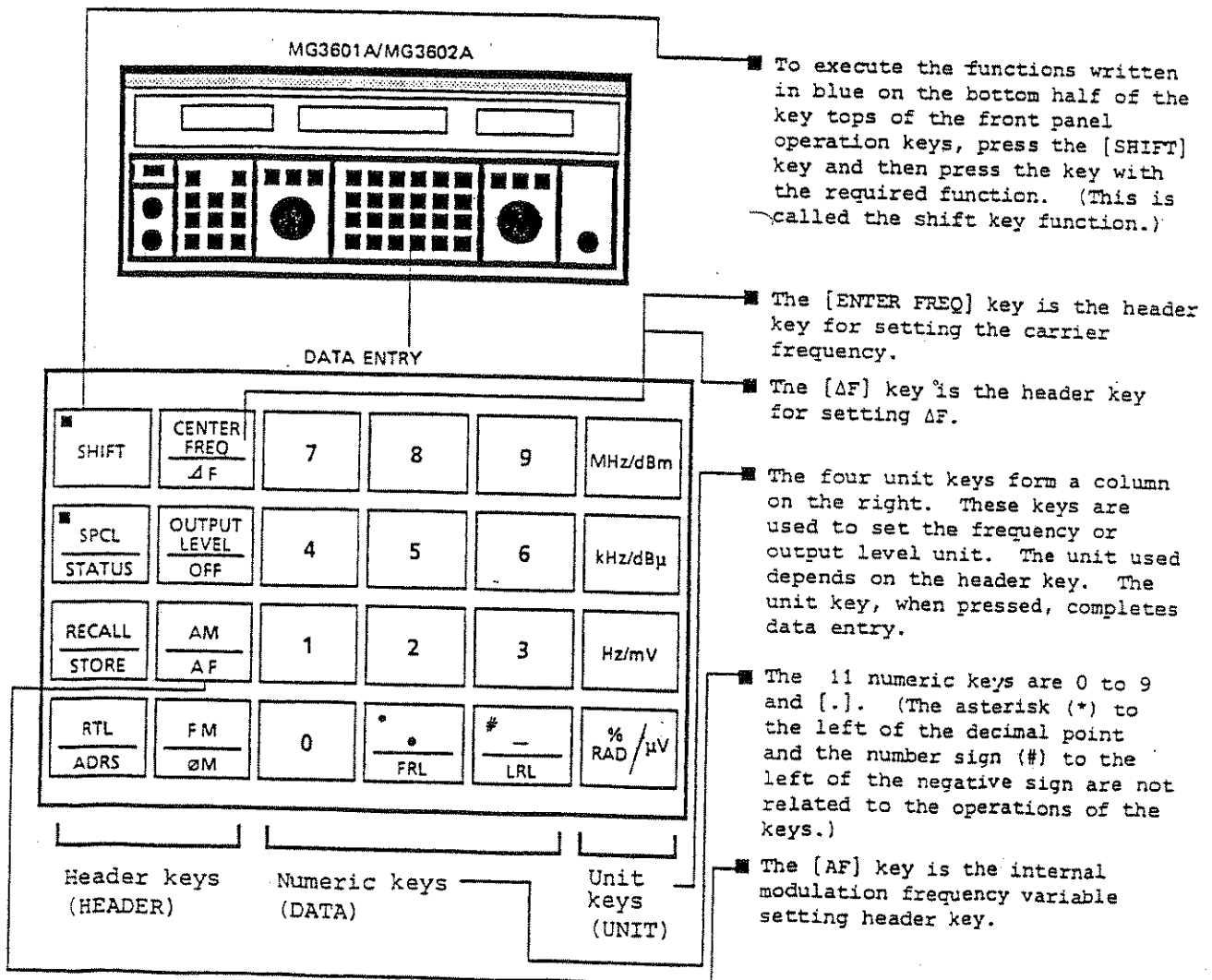

Fig. 5-14 Setting Using Keyboard (Numeric and Unit Keys)

Example:

Setting 12.3 kHz

PROCEDURE								
a.	<input type="checkbox"/> SHIFT	AM AF	$\overset{\bullet}{\text{FRL}}$	0	1	2	3	MHz/dBm
b.	<input type="checkbox"/> SHIFT	AM AF	1	2	$\overset{\bullet}{\text{FRL}}$	3	0	kHz/dBμ
c.	<input type="checkbox"/> SHIFT	AM AF	1	2	3	0	0	Hz/mV
	Header keys (HEADER)		Numeric keys (DATA)				Unit keys (UNIT)	

To indicate whether AF data is being entered, AF is displayed on the right of the FREQUENCY display. During data entry, the fixed decimal point (100 Hz and 10 Hz digits) and input decimal point are displayed. When data entry is complete, (when the unit key is pressed) the decimal point is positioned at the 1 Hz digit and the keyed-in modulation frequency is displayed.

The modulation frequency is preset as the display value until changed to another value. Pressing the MODULATION section [AF OSC] key, modulates the carrier frequency.

The data displayed by the FREQUENCY display changes according to the key operation steps as shown in the column on the right below.

STEP	ACTION	VERIFICATION			
1.	<div style="display: inline-block; border: 1px solid black; padding: 2px; margin-right: 10px;"> <input type="checkbox"/> SHIFT </div> <div style="display: inline-block; border: 1px solid black; padding: 2px;"> <table style="border-collapse: collapse; width: 100%;"> <tr> <td style="border: none; padding: 2px;">AM</td> </tr> <tr> <td style="border: none; padding: 2px;">AF</td> </tr> </table> </div>	AM	AF	<div style="border: 1px solid black; padding: 5px; display: inline-block;"> .A.F </div> <div style="display: flex; justify-content: space-around; font-size: 0.8em; margin-top: 5px;"> MHz kHz </div>	
AM					
AF					
2.	<div style="display: inline-block; border: 1px solid black; padding: 2px; margin-right: 10px;">1</div> <div style="display: inline-block; border: 1px solid black; padding: 2px; margin-right: 10px;">2</div> <div style="display: inline-block; border: 1px solid black; padding: 2px; margin-right: 10px;"> <table style="border-collapse: collapse; width: 100%;"> <tr> <td style="border: none; padding: 2px;">*</td> </tr> <tr> <td style="border: none; padding: 2px;">•</td> </tr> <tr> <td style="border: none; padding: 2px;">FRL</td> </tr> </table> </div> <div style="display: inline-block; border: 1px solid black; padding: 2px; margin-right: 10px;">3</div> <div style="display: inline-block; border: 1px solid black; padding: 2px;">4</div>	*	•	FRL	<div style="border: 1px solid black; padding: 5px; display: inline-block;"> 12.34 .A.F </div> <div style="display: flex; justify-content: space-around; font-size: 0.8em; margin-top: 5px;"> MHz kHz </div>
*					
•					
FRL					
3.	<div style="border: 1px solid black; padding: 2px; display: inline-block;">kHz/dBμ</div>	<div style="border: 1px solid black; padding: 5px; display: inline-block;"> 12 340.0AF </div> <div style="display: flex; justify-content: space-around; font-size: 0.8em; margin-top: 5px;"> MHz kHz </div>			

Notes:

If any of the three settings of the header, numeric, or unit keys is omitted, or if a key not used to set the frequency is pressed, the previously-set frequency is displayed.

1. When operating the header and unit keys, the FREQUENCY display displays AF when the header key is pressed. When the unit key is pressed, the FREQUENCY display returns to the previous frequency display (12.34 kHz in this example).
2. When the header and numeric keys are pressed, data entry status is set so that a new frequency can be set. By keying-in [AF] [5] [6] [7], for example, the previous frequency display is cleared (12.34 kHz in this example) and 567 is displayed.

Notes: (cont'd)

3. Data entry is completed when the unit key is pressed after the header and numeric keys. If a key other than a unit key is pressed, however, the previous frequency (12.34 MHz in this example) is displayed.
4. If the [SHIFT] key is pressed after pressing the header and numeric keys, the value input by the numeric keys is displayed. When the key for the required shift function is pressed, the previous frequency (12.34 kHz in this example) is displayed.

5.5.3 Setting AF OSC modulation frequency using TUNE knob (TUNE)

The TUNE knob (Fig. 5-15) continuously varies and sets AF OSC modulation frequencies.

By using the [SHIFT] and [RES>], or [SHIFT] and [<RES] keys and setting the resolution for any of the digits from 0.1 Hz to 10 kHz beforehand, the TUNE knob can be used to continuously vary the output of the frequency at the set resolution.

The [TUNE] key, [SHIFT] key, [<RES] key, [RES>] key, and TUNE knob can be used when the starting point of the frequency for continuous variation is set at the keyboard.

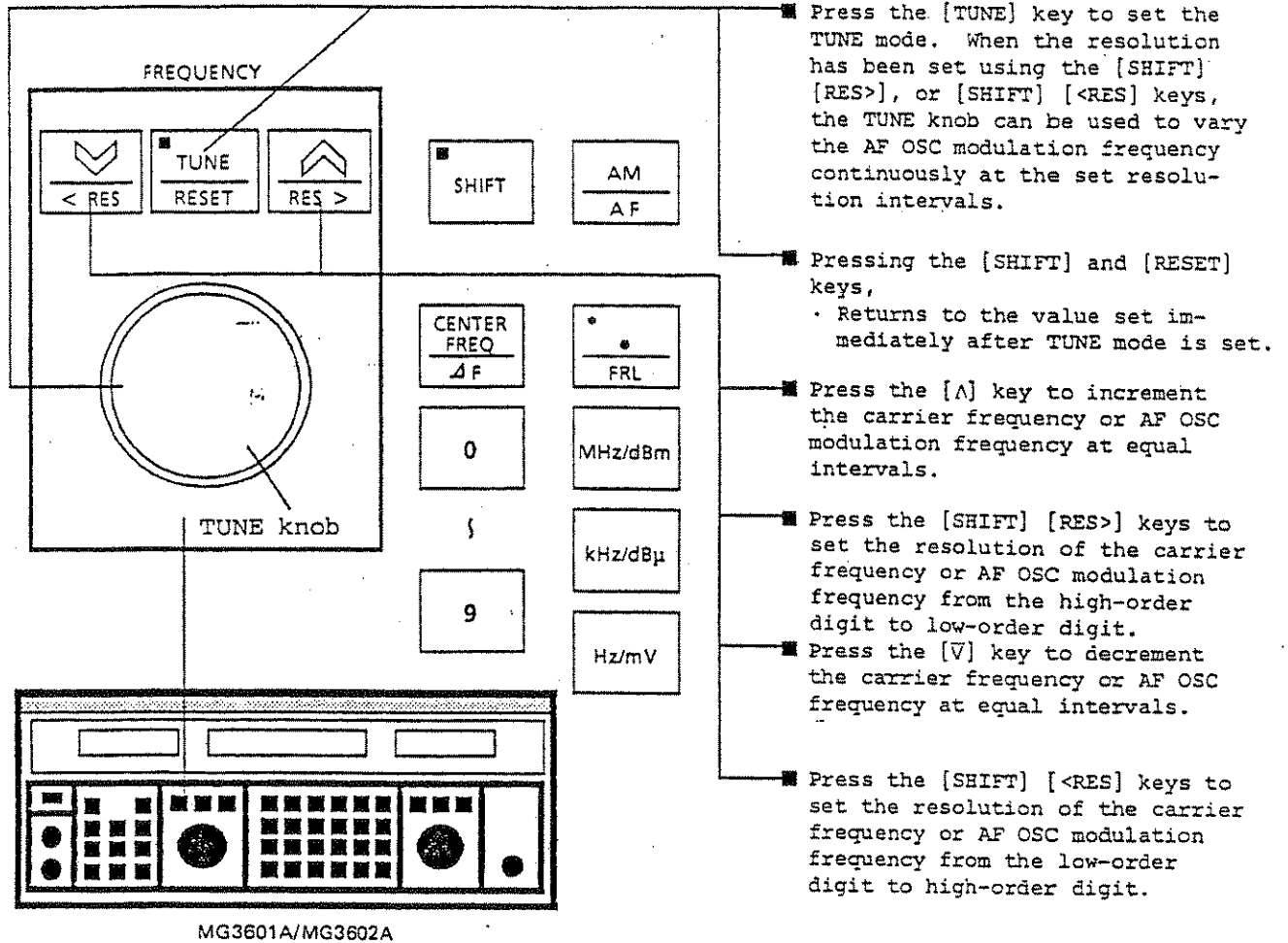
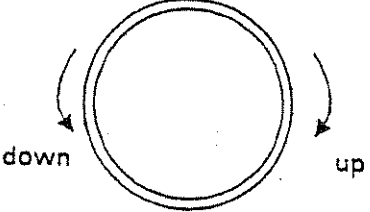

Fig. 5-15 Setting AF OSC Modulation Frequency Using TUNE Knob

Example:

Setting frequency to 465.5 Hz then changing frequency at 0.1 Hz minimum resolution

STEP	ACTION	VERIFICATION
1.	<div style="display: flex; gap: 10px;"> <div style="border: 1px solid black; padding: 2px; width: 60px; text-align: center;"> <input type="checkbox"/> SHIFT </div> <div style="border: 1px solid black; padding: 2px; width: 60px; text-align: center;"> AM AF </div> <div style="border: 1px solid black; padding: 2px; width: 60px; text-align: center;">4</div> <div style="border: 1px solid black; padding: 2px; width: 60px; text-align: center;">6</div> <div style="border: 1px solid black; padding: 2px; width: 60px; text-align: center;">5</div> </div> <div style="display: flex; gap: 10px;"> <div style="border: 1px solid black; padding: 2px; width: 60px; text-align: center;"> <input type="checkbox"/> FRL </div> <div style="border: 1px solid black; padding: 2px; width: 60px; text-align: center;">5</div> <div style="border: 1px solid black; padding: 2px; width: 60px; text-align: center;">Hz/mV</div> </div>	<p>The output frequency is set to 465.5 Hz.</p> <div style="border: 1px solid black; padding: 5px; text-align: center; font-size: 1.2em;"> 465.5AF </div> <p style="text-align: center; margin-top: 5px;">MHz kHz</p>
2.	<div style="border: 1px solid black; padding: 2px; width: 60px; text-align: center;"> <input type="checkbox"/> TUNE RESET </div>	<div style="border: 1px solid black; padding: 2px; width: 60px; text-align: center;"> <input checked="" type="checkbox"/> TUNE RESET </div> <p>TUNING is set to ON. The [TUNE] key lamp lights.</p>
3.	<div style="display: flex; align-items: center; gap: 10px;"> <div style="border: 1px solid black; padding: 2px; width: 60px; text-align: center;"> <input type="checkbox"/> SHIFT </div> <div style="border: 1px solid black; padding: 2px; width: 60px; text-align: center;"> <input checked="" type="checkbox"/> RES > </div> <div style="font-size: 2em; margin: 0 10px;">←</div> <div> <p>Press the [RES>] key until the value at the 0.1 Hz digit is cleared.</p> </div> </div>	<div style="border: 1px solid black; padding: 2px; width: 60px; text-align: center;"> <input checked="" type="checkbox"/> SHIFT </div> <p>The [SHIFT] key lamp lights while the [RES>] key is pressed.</p> <div style="border: 1px solid black; padding: 5px; text-align: center; font-size: 1.2em;"> 465. AF </div> <p style="text-align: center; margin-top: 5px;">MHz kHz</p>
4.	<p>Release the [RES>] key when the value at the 0.1 Hz digit blinks once.</p>	<div style="border: 1px solid black; padding: 2px; width: 60px; text-align: center;"> <input type="checkbox"/> SHIFT </div> <p>The [SHIFT] key lamp goes off and 0.1 Hz minimum resolution is set.</p>
5.		<div style="border: 1px solid black; padding: 5px; text-align: center; font-size: 1.2em;"> 465.5AF </div> <p style="text-align: center; margin-top: 5px;">MHz kHz</p> <p>Turn the knob clockwise to increase the frequency at 0.1 Hz resolution. Turn it counterclockwise to decrease the frequency at 0.1 Hz resolution.</p>

Modifying resolution, releasing TUNE mode, and setting the frequency again when the TUNE mode is started are explained next.





(1) Modifying resolution

To continuously vary the frequency using the TUNE knob, first set the MG3601A/MG3602A to the TUNE mode. (The [TUNE] key lamp is on. If it is not on, press the [TUNE] key.)

- . Use the [<RES] or [RES>] key to set or change the resolution interval.
- . Press the [SHIFT] key and then press the [<RES] or [RES>] key until the desired resolution is obtained.
- . The resolution must be able to be set to 10 kHz, 1 kHz, 100 Hz, 10 Hz, 1 Hz, or 0.1 Hz.

The above procedures are illustrated below.

TUNE mode is set in step 1 and the resolution is set in step 2 a or b.

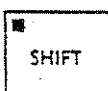
STEP	ACTION	VERIFICATION
1.	 ← Press the [TUNE] key to set the TUNE mode.	 The [TUNE] key lamp remains on until the TUNE mode is released. The previously-set resolution digit, for example 10 Hz, blinks once. <div style="border: 1px solid black; padding: 5px; text-align: center; margin-top: 10px;"> 12 345.6AF <small>MHz kHz</small> </div>
2.	<p style="text-align: center;"><u>a. Setting the low-order digit + high-order digit</u></p>   ← Press the [<RES] key until the value at the digit of the desired resolution is cleared.	 Confirm that the [SHIFT] key lamp is on. The digits go off and then come on as indicated by the arrows below. <div style="border: 1px solid black; padding: 5px; text-align: center; margin-top: 10px;"> 12 345.6AF <small>MHz kHz</small> </div>

(cont'd)

STEP	ACTION	VERIFICATION
------	--------	--------------

3. b. Setting the high-order digit → low-order digit

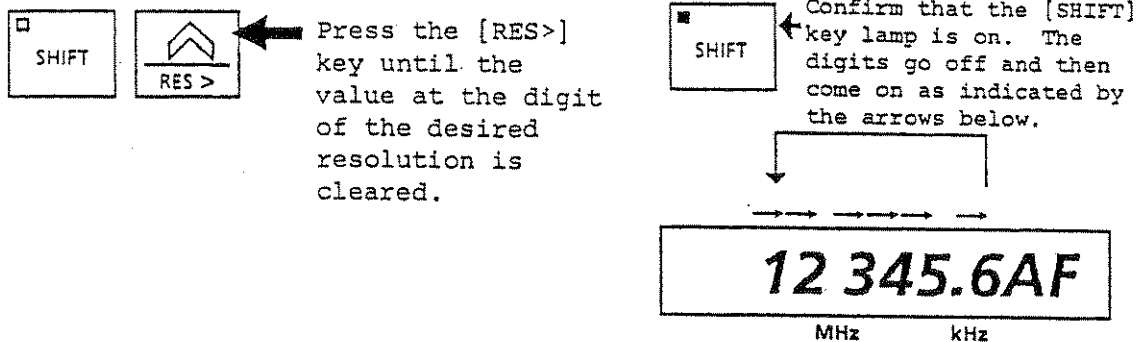

(2) Turning TUNE mode off

Press the [TUNE] key to turn the TUNE mode off. The [TUNE] key lamp goes off to indicate that the TUNE mode has been turned off.



Note:

When the TUNE mode is turned off, the resolution at that time is stored. Resolution is reset when the TUNE mode is turned on again.

(3) Resetting TUNE mode start frequency

When the [TUNE] key is pressed with the lamp currently off and the lamp comes on, the start frequency (12.3456 kHz for example) can be continuously varied using the TUNE knob to another frequency (12.3666 kHz for example).

The start frequency can be reset using either of the following two methods.

- (1) Setting frequency at keyboard
- (2) Pressing [SHIFT] [RESET] keys

The second method is simpler.

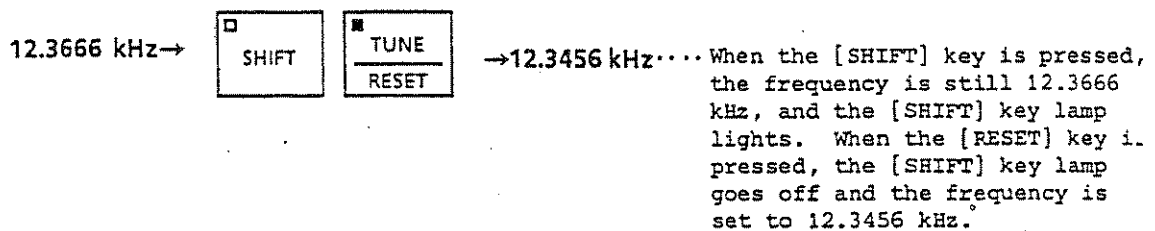

In the TUNE Mode, therefore, the modulation frequency can be set according to the intended use, as follows:

1. Continuously variable setting of the frequency
... Setting using the TUNE knob.
2. Setting the frequency immediately after the TUNE mode ... Using the [SHIFT] [RESET] keys
3. Setting an arbitrary frequency after continuous variation.. Setting the frequency from the keyboard

5.5.4 Setting AF OSC modulation frequency using step keys

As shown in Fig. 5-16, the [∇] and [∧] keys are used to step-down or step-up the frequency by ΔF steps.

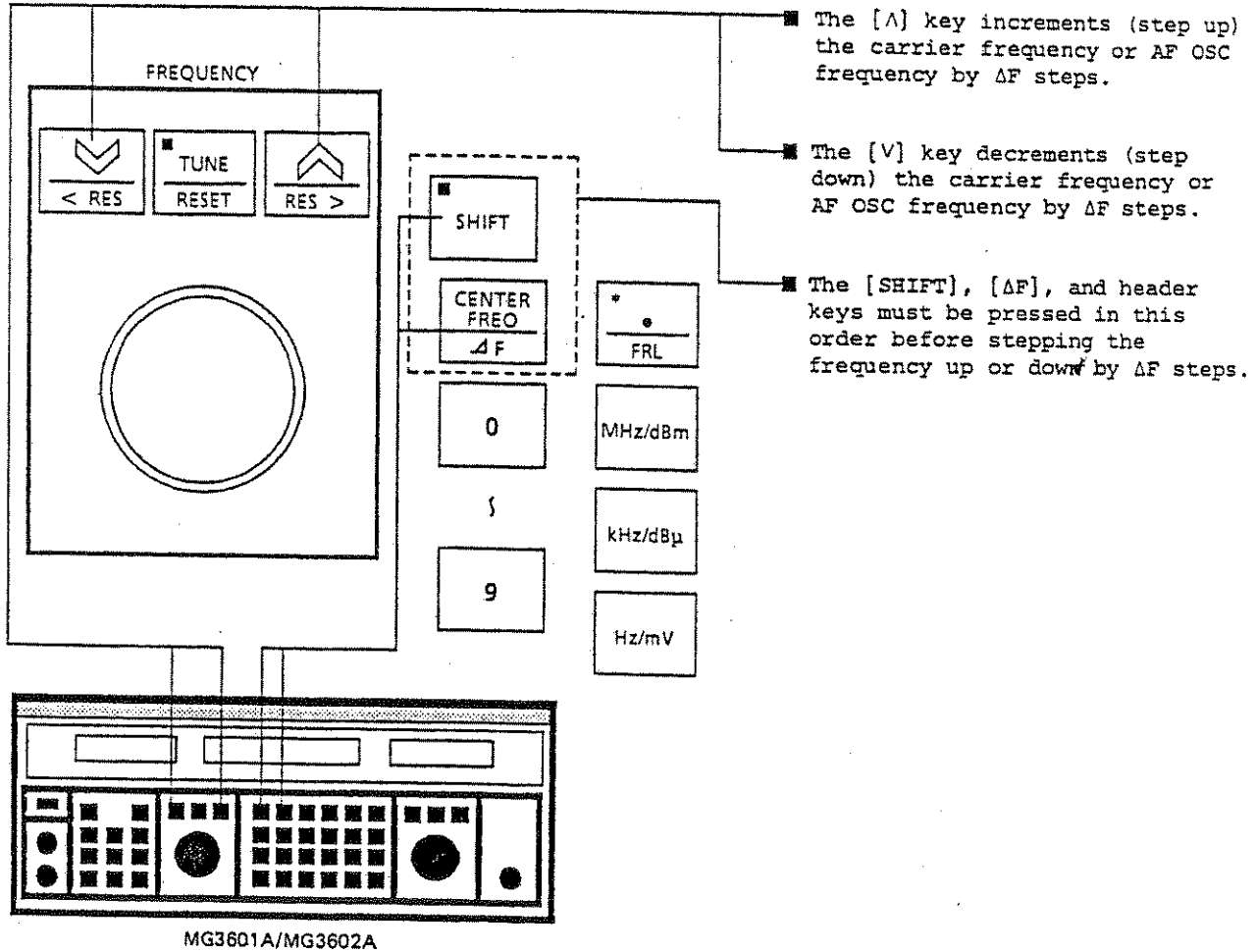

Fig. 5-16 Setting AF OSC Modulation Frequency Using Step Keys

The step value ΔF is set using the [SHIFT], [ΔF], numeric and unit keys in this order.

- . The ΔF upper limit is 99.999 kHz.
- . The ΔF lower limit is 0.1 Hz.
- . The interval between the upper and lower limits of ΔF is set in multiples of 0.1 Hz resolution.



Therefore, for setting $\Delta F = 12.56$ Hz, for example, 12.5 Hz is actually set.

Example:

Setting frequency to 465.5 Hz as center frequency, then increasing and decreasing frequency by 100 Hz steps

STEP	ACTION	VERIFICATION
1.	<div style="display: flex; align-items: center; gap: 10px;"> <div style="border: 1px solid black; padding: 2px; text-align: center;"> <input type="checkbox"/> SHIFT </div> <div style="border: 1px solid black; padding: 2px; text-align: center;"> AM — AF </div> <div style="border: 1px solid black; padding: 2px; text-align: center;">4</div> <div style="border: 1px solid black; padding: 2px; text-align: center;">6</div> <div style="border: 1px solid black; padding: 2px; text-align: center;">5</div> </div> <div style="display: flex; align-items: center; gap: 10px;"> <div style="border: 1px solid black; padding: 2px; text-align: center;"> <input type="checkbox"/> FRL </div> <div style="border: 1px solid black; padding: 2px; text-align: center;">5</div> <div style="border: 1px solid black; padding: 2px; text-align: center;">Hz/mV</div> </div>	<p>The output frequency is set to 465.5 Hz.</p> <div style="border: 1px solid black; padding: 5px; text-align: center; font-size: 1.2em;">465.5AF</div> <div style="display: flex; justify-content: space-around; font-size: 0.8em;"> MHz kHz </div>
2.	<div style="display: flex; align-items: center; gap: 10px;"> <div style="border: 1px solid black; padding: 2px; text-align: center;"> <input type="checkbox"/> SHIFT </div> <div style="border: 1px solid black; padding: 2px; text-align: center;"> CENTER FREQ — ΔF </div> <div style="border: 1px solid black; padding: 2px; text-align: center;">1</div> <div style="border: 1px solid black; padding: 2px; text-align: center;">0</div> <div style="border: 1px solid black; padding: 2px; text-align: center;">0</div> </div>	<div style="border: 1px solid black; padding: 2px; text-align: center;"> <input checked="" type="checkbox"/> SHIFT </div> <p>← The [SHIFT] key lamp is on while 1 kHz is being set.</p> <div style="border: 1px solid black; padding: 5px; text-align: center; font-size: 1.5em;">100</div> <div style="display: flex; justify-content: space-around; font-size: 0.8em;"> MHz kHz </div>
3.	<div style="display: flex; align-items: center; gap: 10px;"> <div style="border: 1px solid black; padding: 2px; text-align: center;">Hz/mV</div> <div style="font-size: 2em;">←</div> <div> <p>Press the unit key. Setting $\Delta F = 100$ Hz is completed.</p> </div> </div>	<div style="border: 1px solid black; padding: 5px; text-align: center; font-size: 1.2em;">465.5AF</div> <div style="display: flex; justify-content: space-around; font-size: 0.8em;"> MHz kHz </div> <p>This completes preparation for stepping the frequency up/down in 100 Hz steps with 465.5 Hz as the reference frequency.</p>

(cont'd)

STEP	ACTION	VERIFICATION
4.	 Press the [\wedge] key once.	<div data-bbox="902 436 1347 527" style="border: 1px solid black; padding: 5px; text-align: center;">565.5AF</div> <p data-bbox="1057 531 1235 552">MHz kHz</p> <p data-bbox="902 569 1284 632">465.5 Hz is increased by 100 Hz.</p>
5.	 Press the [\vee] key once.	<div data-bbox="902 674 1347 764" style="border: 1px solid black; padding: 5px; text-align: center;">465.5AF</div> <p data-bbox="1057 772 1235 793">MHz kHz</p> <p data-bbox="902 810 1284 873">565.5 Hz is decreased by 100 Hz.</p>

5.6 Setting FM Modulation

This paragraph explains how to set frequency deviation of FM modulation for the MG3601A/MG3602A. The frequency deviation can be set as follows:

1. Setting frequency deviation at keyboard
2. Setting frequency deviation using step keys

In the FM INT mode, the internal modulation frequency is selected from 400 Hz, 1 kHz, or AF OSC. The main specifications of the MG3601A/MG3602A for setting the frequency deviation are as follows.

Item	MG3601A/MG3602A
Deviation range	0 to 199 kHz (<130 MHz) (Carrier frequency - frequency deviation) must be >100 kHz 0 to 99.9 kHz (130 to 260 MHz) 0 to 199 kHz (<u>></u> 260 MHz)
Resolution	10 Hz (<9.99 kHz Deviation) 100 Hz (10 to 99.9 kHz Deviation) 1 kHz (100 to 199 kHz Deviation)
Internal fixed frequency	400 Hz, 1 kHz
Internal variable frequency oscillator	Option 04
Frequency range	20 Hz to 100 kHz
Minimum resolution	0.1 Hz
Internal modulation frequency accuracy	100 ppm
External modulation frequency	
Frequency range (ac couple)	20 Hz to 100 kHz (± 1 dB bandwidth)
Frequency range (dc couple)	Dc to 100 kHz (± 1 dB bandwidth)
Input level	1 Vrms approx.
Input impedance	Nominal 600 Ω

Notes:

The STATUS LED (Fig. 5-1) comes on when:

- . An attempt is made to set a frequency deviation range outside the frequency deviation range.
- . The carrier frequency is set and (carrier frequency - frequency deviation) ≤ 100 kHz.
- . An attempt is made to set the frequency deviation minimum resolution to 10 Hz or less.

Input a new HEADER to turn the STATUS LED off.

While the STATUS LED is on, the error code can be displayed by pressing the [SHIFT] key and holding the [STATUS] key down. The FREQUENCY display on the front panel displays the error code.

5.6.1 Setting frequency deviation at keyboard (DATA ENTRY)

The frequency deviation is set by operating the header (HEADER) keys, numeric (DATA) keys, and unit (UNIT) keys in this order.

As shown in Fig. 5-17, these keys are located in the DATA ENTRY section on the front panel.

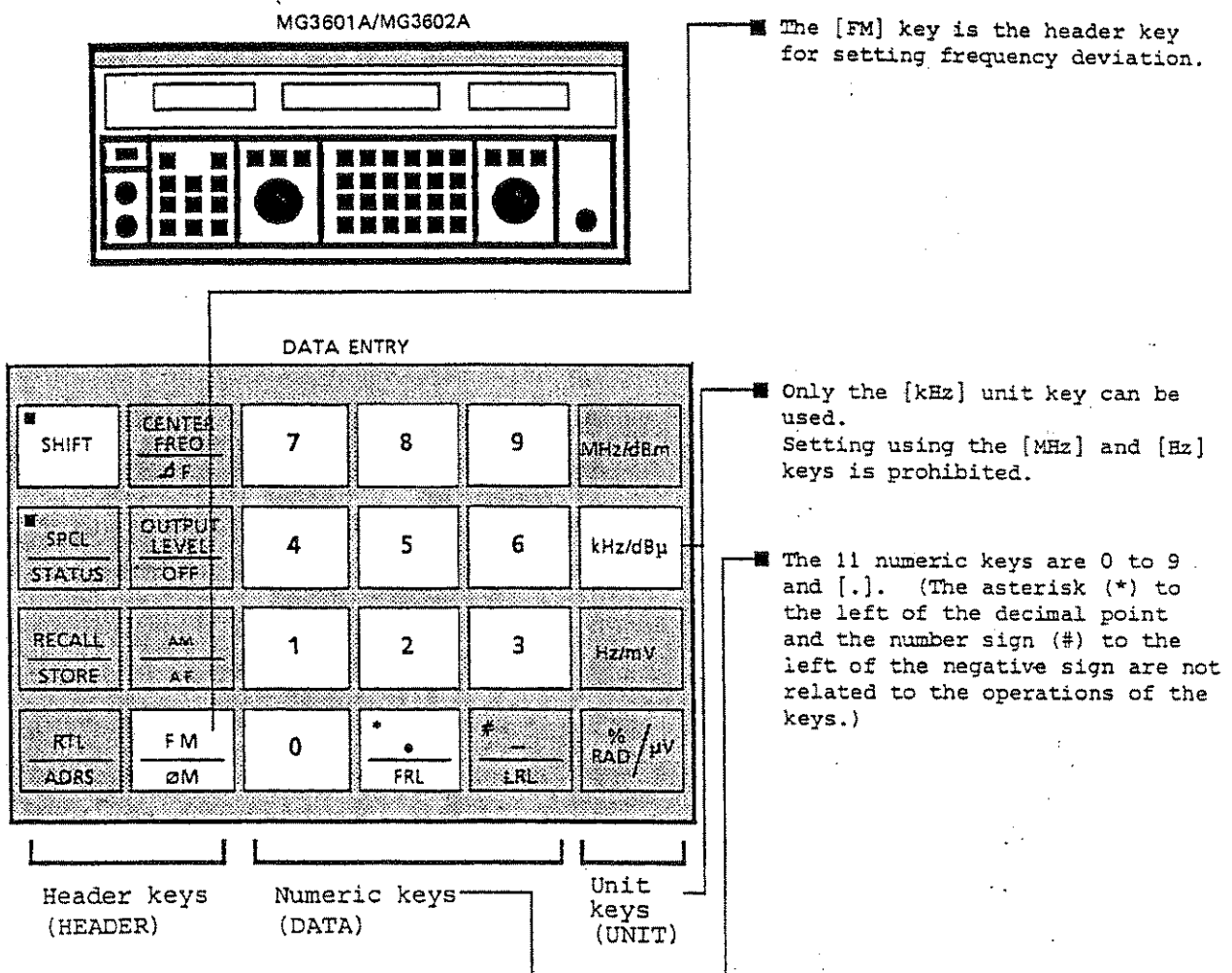

Fig. 5-17 Setting Using Keyboard (Numeric and Unit Keys)

Example:

Setting internal modulation frequency 800 Hz and deviation 800 Hz then setting internal modulation frequency 400 Hz and deviation 3.5 kHz

STEP	ACTION	VERIFICATION
<u>AF OSC 800 Hz preset</u>		
1.	<input type="checkbox"/> SHIFT $\frac{AM}{AF}$ 8 0 0	<div style="border: 1px solid black; padding: 5px; display: inline-block;"> 800 .A.F </div> MHz kHz
2.	<input type="checkbox"/> Hz/mV	<div style="border: 1px solid black; padding: 5px; display: inline-block;"> 800.0AF </div> MHz kHz
<u>Setting deviation 800 Hz</u>		
3.	$\frac{FM}{\emptyset M}$ 0 $\frac{\cdot}{FRL}$ 8 kHz/dB μ	<div style="border: 1px solid black; padding: 5px; display: inline-block;"> FM 0.80 kHz </div> <input checked="" type="checkbox"/> INT FM \emptyset M <input checked="" type="checkbox"/> 1kHz
4.	<input type="checkbox"/> AF OSC	<input checked="" type="checkbox"/> AF OSC ← AF OSC 800 Hz is set.
<u>Setting deviation 3.5 kHz</u>		
5.	$\frac{FM}{\emptyset M}$ 3 $\frac{\cdot}{FRL}$ 5 kHz/dB μ	<div style="border: 1px solid black; padding: 5px; display: inline-block;"> FM 3.50 kHz </div>
6.	<input type="checkbox"/> 400Hz	<input type="checkbox"/> AF OSC <input checked="" type="checkbox"/> 400Hz ← Internal fixed modulation frequency 400 Hz is set.

5.6.2 Setting frequency deviation using step keys

The MODULATION section [∇] and [\blacktriangle] keys on the front panel are used to step-down or step-up the frequency deviation in 0.01 kHz, 0.1 kHz, or 1 kHz steps.

By using the [SHIFT] [RES>], or [SHIFT] [<RES] keys and setting the resolution to be used when stepping-down/up the frequency deviation for any of the digits 0.01 kHz, 0.2 kHz, or 1 kHz beforehand, the [∇] or [\blacktriangle] keys can be used to continuously vary the frequency deviation at the set resolution.

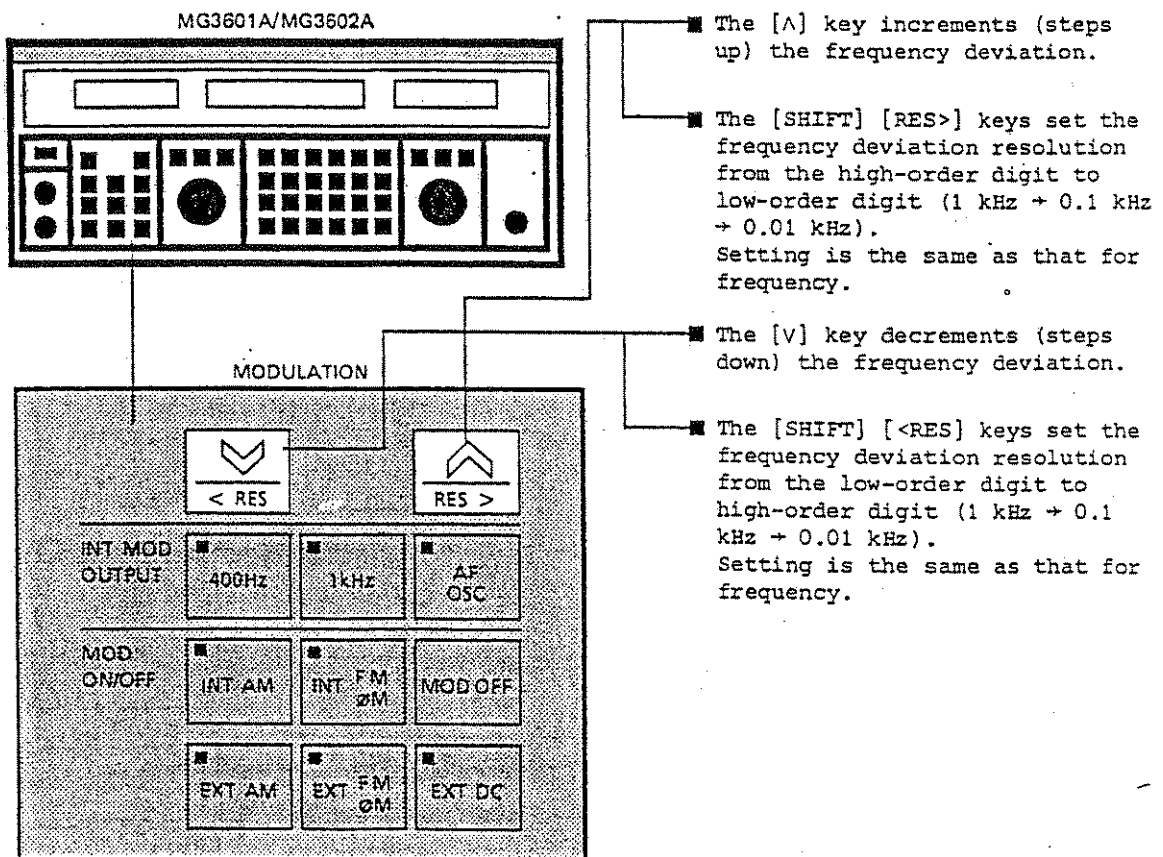

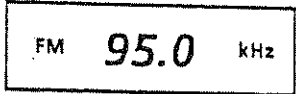
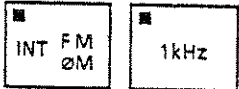

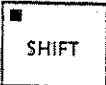
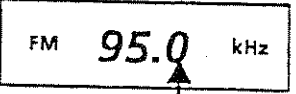

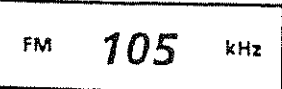

Fig. 5-18 Setting Frequency Deviation Using Step Keys

Example:

Setting frequency deviation 95 kHz and internal modulation frequency 1 kHz then varying up to 105 kHz at minimum resolution

STEP	ACTION	VERIFICATION
1.		  <p>The INT FM mode is automatically set in step 1. If the previous modulation frequency setting is 1 kHz, this value is automatically set again.</p>
2.	 <p>← Press the [RES>] key until the value at the 0.1 kHz digit blinks once.</p>	 <p>The [SHIFT] key lamp lights while the [RES>] key is pressed.</p>  <p>← Blinks</p>
3.	<p>Release the [RES>] key when the value at the 0.1 kHz digit blinks once.</p>	 <p>The [SHIFT] key lamp goes off and the minimum resolution is set to 0.1 kHz.</p>
4.	 <p>← Press until the frequency deviation reaches 105 kHz.</p>	

5.6.3 External FM modulation

To apply external FM modulation, press the [EXT FM] key (Fig. 5-19); the key lamp lights. A modulation signal of approximately 1 Vrms/600 Ω will then be applied to the MOD INPUT connector.

The modulation signal range is as follows:

1. Ac couple 20 Hz to 100 kHz (± 1 dB bandwidth)
2. Dc couple dc to 100 kHz (± 1 dB bandwidth)

The HI LED will come on if the modulation input signal is too high. The LO LED will come on if the modulation input signal is too low. Adjust the modulation signal level so that both LEDs are off.

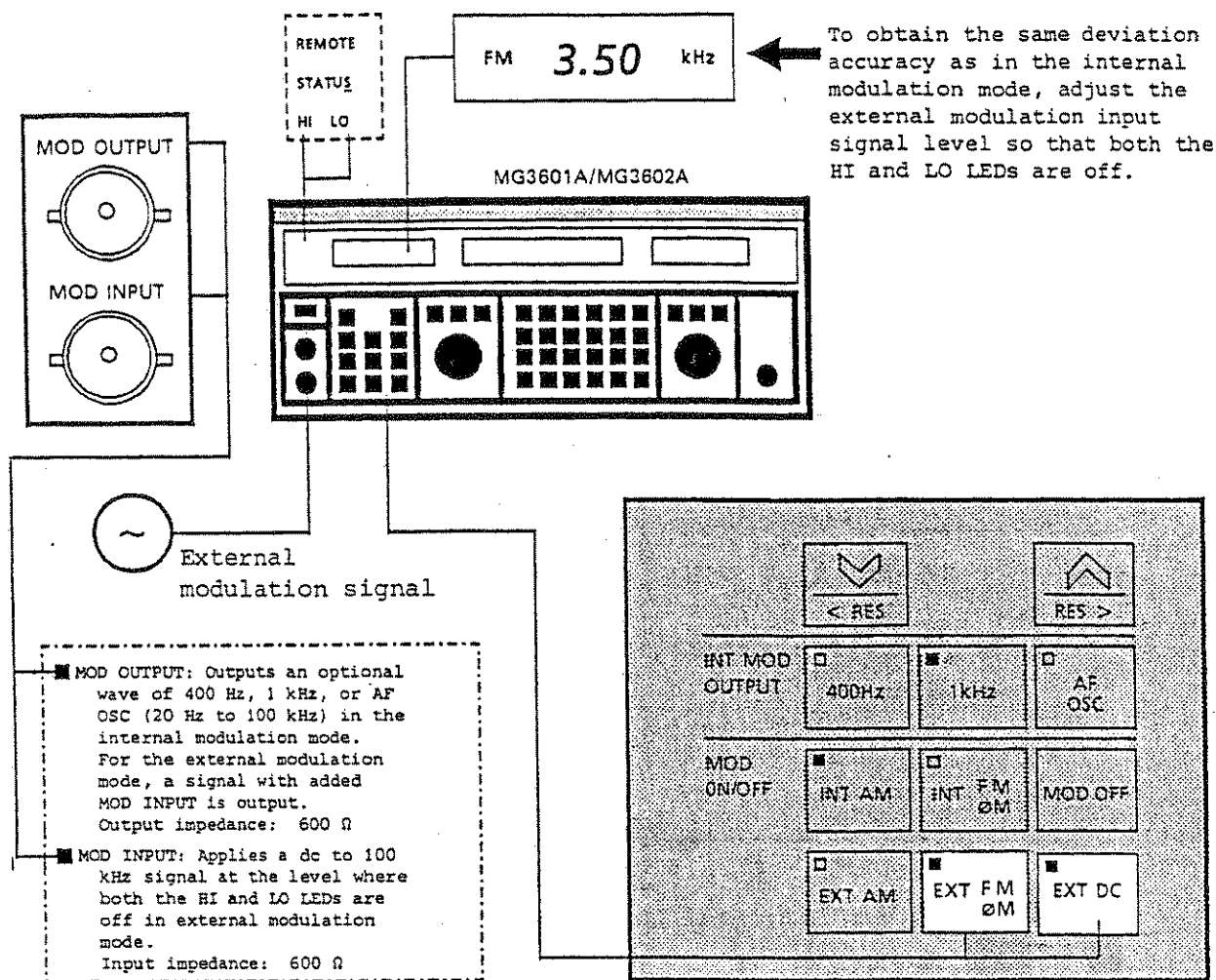

Fig. 5-19 External FM Modulation

Note:

One or both of the [EXT AM] or [EXT FM/φM] keys must be set to ON to select the [EXT DC] key. It cannot be individually selected. The [EXT DC] key is automatically turned off when both the [EXT AM] and [EXT FM/φM] keys are set to OFF.

5.6.4 Frequency calibration at dc FM modulation

Dc FM modulation is used when a low-rate FSK signal such as that for a pager is required. Although the frequency accuracy and stability generally deteriorate at dc FM modulation, the MG3601A/MG3602A has a frequency calibration function so that accurate frequencies can be obtained at dc FM. By using this function, the drifting output frequency can be restored to the original frequency.

Frequency calibration procedures

Step	Procedure
1	Select dc FM then press the [0] key.
2	The following characters are displayed by the frequency display for two seconds to indicate that calibration is being performed.

FREQUENCY
F . CA I
MHz kHz

The output signal frequency is set to the original frequency again.

- | | |
|---|--|
| 3 | When calibration is completed, the above characters are cleared and the original frequency is displayed. After frequency calibration, measurement can be performed at an accuracy of ± 500 Hz* (260 to 520 MHz) for three minutes. |
|---|--|

* ± 1 kHz for 100 kHz to 130 MHz, and 520 to 1040 MHz.
 ± 250 Hz for 130 to 260 MHz.

Notes:

1. Since the dc FM modulation factor responds to dc, part of the loop of the PLL circuit that adds the modulation signal is disconnected. As a result, the oscillator is in a free-run status and the accuracy and stability of the frequency is poorer than CW and ac FM.
2. In step 3 in the above procedures, the frequency stability largely depends on the length of the warm-up time.

Immediately after power-on, therefore, the frequency may drift above ± 500 Hz within the first three minutes after calibration.

Therefore, allow the MG3601A/MG3602A to warm up for at least two hours before using the frequency calibration function.

5.7 Setting AM Modulation

This paragraph explains how to set the AM modulation factor.

The AM modulation factor for the MG3601A/MG3602A can be set as follows:

1. Setting AM modulation factor at keyboard
2. Setting AM modulation factor using step keys

In the AM INT mode, the internal modulation frequency is selected from 400 Hz, 1 kHz, or AF OSC. The main specifications of the MG3601A/MG3602A for setting the AM modulation factor are as follows.

Item	MG3601A/MG3602A
Setting range	0 to 100% ($\leq +7$ dBm)
Setting resolution	1%
Accuracy	When MG3601A or MG3602A ($f_c \leq 1040$ MHz) used $\pm(\text{setting value} \times 4\% + 2\%)$ However, internal modulation frequency 1 kHz at $<90\%$ AM When MG3602A ($f_c > 1040$ MHz) used $\pm(\text{setting value} \times 4\% + 2\%)$ However, internal modulation frequency 1 kHz at $<60\%$ AM
Internal fixed frequency	400 Hz, 1 kHz
Internal variable frequency oscillator	Option 04
Frequency range	20 Hz to 50 kHz
Minimum resolution	0.1 Hz
Internal modulation frequency accuracy	100 ppm
External modulation frequency	
Frequency range (ac couple)	When MG3601A or MG3602A ($f_c \leq 1040$ MHz) used 20 Hz to 50 kHz (± 1 dB Bandwidth) When MG3602A ($f_c > 1040$ MHz) used 20 Hz to 30 kHz (± 1 dB Bandwidth)
Frequency range (dc couple)	When MG3601A or MG3602A ($f_c \leq 1040$ MHz) used Dc to 50 kHz (± 1 dB Bandwidth) When MG3602A ($f_c > 1040$ MHz) used Dc to 30 kHz (± 1 dB Bandwidth)

Note:

If an attempt is made to set the modulation factor outside the range of the AM modulation factor, or if an attempt is made to set a modulation frequency outside the range set for the AM modulation factor, the STATUS LED (Fig. 5-1) will come on.

Input a new HEADER to turn the STATUS LED off.

While the STATUS LED is on, the error code can be displayed by pressing the [SHIFT] key and holding the [STATUS] key down. The FREQUENCY display on the front panel displays the error code.

5.7.1 Setting AM modulation factor at keyboard (DATA ENTRY)

The AM modulation factor is set by operating the header (HEADER) keys, numeric (DATA) keys, and unit (UNIT) keys in this order. As shown in Fig. 5-20, these keys are located in the DATA ENTRY section on the front panel. The white keys shown in Fig. 5-20 set the AM modulation factor.

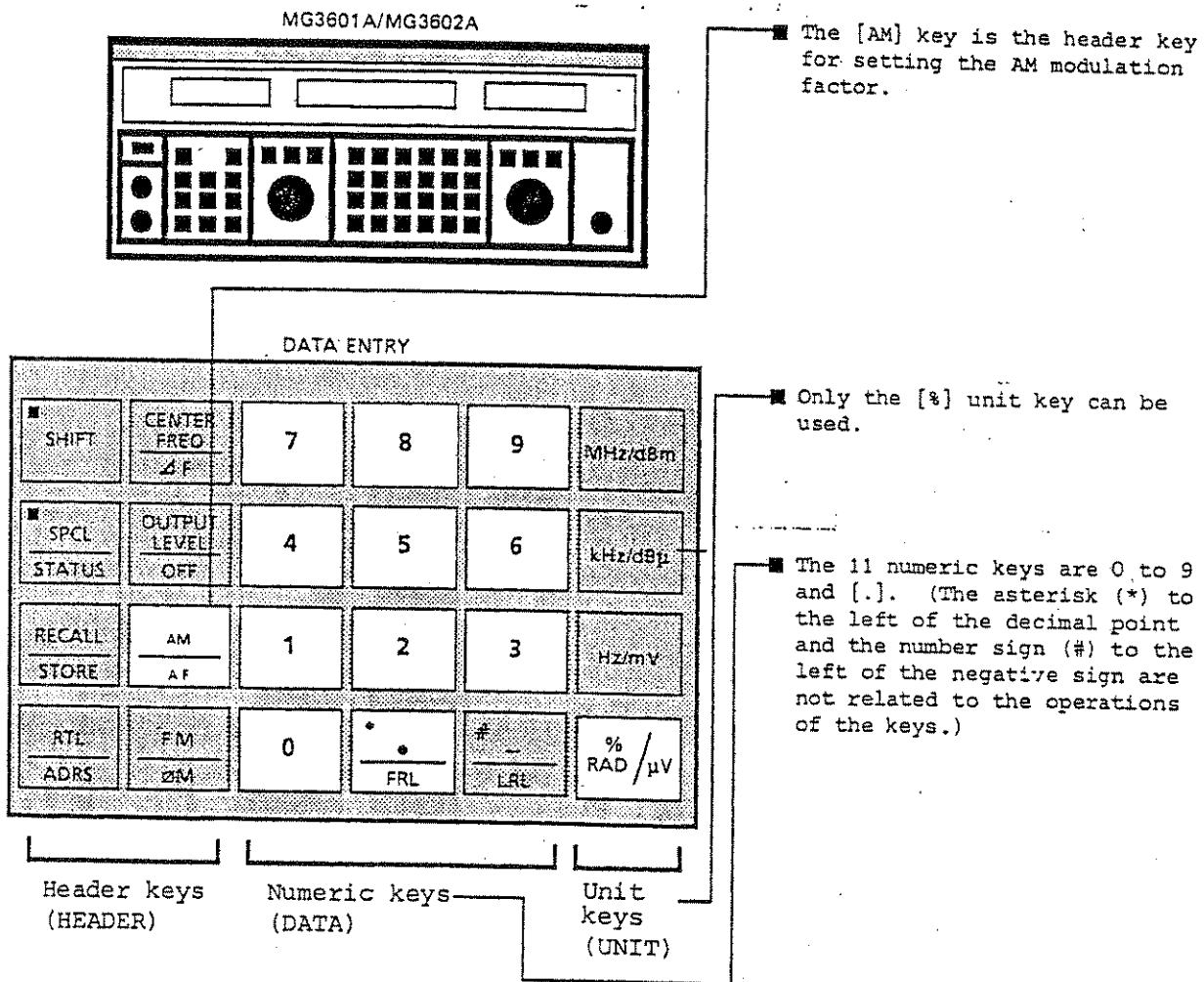

Fig. 5-20 Setting Using Keyboard (Numeric and Unit Keys)

Note:

Since the setting resolution of the AM modulation factor is 1%, any values less than this will be truncated. For example, 59% will be set for 59.1% and 59.9%.

Example:

Setting internal modulation frequency 800 Hz and modulation factor 30% then setting internal modulation frequency 1 kHz and modulation factor 60%

STEP	ACTION	VERIFICATION
<u>AF OSC 800 Hz preset</u>		
1.	<input type="checkbox"/> SHIFT $\frac{AM}{AF}$ 8 0 0	<div style="border: 1px solid black; padding: 5px; display: inline-block;"> 800 .A.F <small>MHz kHz</small> </div>
2.	<input type="checkbox"/> Hz/mV	<div style="border: 1px solid black; padding: 5px; display: inline-block;"> 800.0AF <small>MHz kHz</small> </div>
<u>Setting 30% modulation factor</u>		
3.	$\frac{AM}{AF}$ 3 0 $\frac{\%}{RAD/HV}$	<div style="border: 1px solid black; padding: 5px; display: inline-block;"> <small>AM</small> 30 <small>%</small> </div>
		<input checked="" type="checkbox"/> INT FM \emptyset M <input checked="" type="checkbox"/> 1kHz
4.	<input type="checkbox"/> AF OSC	<input checked="" type="checkbox"/> AF OSC ← AF OSC 800 Hz is set.
<u>Setting 60% modulation factor</u>		
5.	$\frac{AM}{AF}$ 6 0 $\frac{\%}{RAD/HV}$	<div style="border: 1px solid black; padding: 5px; display: inline-block;"> <small>AM</small> 60 <small>%</small> </div>
6.	<input type="checkbox"/> 1 kHz	<input checked="" type="checkbox"/> AF OSC <input checked="" type="checkbox"/> 1 kHz ← Internal fixed modulation frequency 1 kHz is set.

5.7.2 Setting AM modulation factor using step keys

The MODULATION section [∇] and [\wedge] keys on the front panel step-down or step-up the AM modulation factor in 10% or 1% steps.

By using the [SHIFT] [RES>], or [SHIFT] [<RES] keys and setting the resolution to be used when stepping-down/up the AM modulation factor to the 10% or 1% digit beforehand, the [∇] or [\wedge] keys can be used to continuously vary the AM modulation factor at the set resolution.

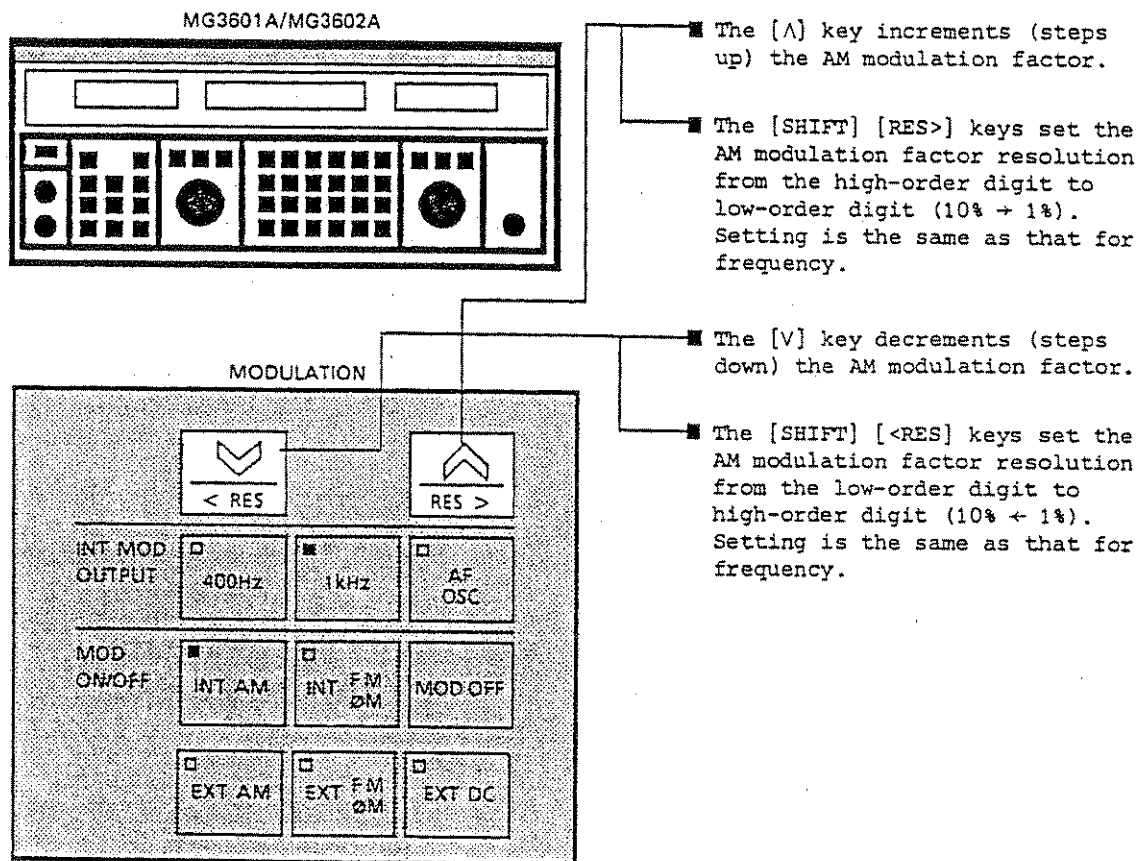



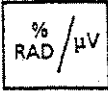













Fig. 5-21 Setting AM Modulation Factor Using Step Keys

Example:

Setting AM 50%, then varying up to 55% in 1% steps

STEP	ACTION	VERIFICATION
1.	   	
		 
		<p>The INT AM mode is automatically set in step 1. If the previous modulation frequency setting is 1 kHz, this value is automatically set again.</p>
2.	 	<p>← Press the [RES>] key until the value at this 1% digit blinks once.</p>
		 <p>The [SHIFT] key lamp lights while the [RES>] key is pressed.</p>
		 <p>↑ Blinks</p>
3.	<p>Release the [RES>] key when the value at the 1% digit blinks once.</p>	 <p>The [SHIFT] key lamp goes off and the minimum resolution is set to 1%.</p>
		
4.	 <p>← Press until the AM modulation factor reaches 55%.</p>	

5.7.3 External AM modulation

To apply external AM modulation, press the [EXT AM] key (Fig. 5-22); the key lamp lights. A modulation signal of approximately 1 Vrms/600 Ω will then be applied to the MOD INPUT connector.

The modulation signal range is as follows:

1. Ac couple ... 20 Hz to 50 kHz (± 1 dB bandwidth)
2. Dc couple ... dc to 50 kHz (± 1 dB bandwidth)

The HI LED will come on if the modulation input signal is too high.

The LO LED will come on if the modulation input signal is too low.

Adjust the modulation signal level so that both LEDs are off.

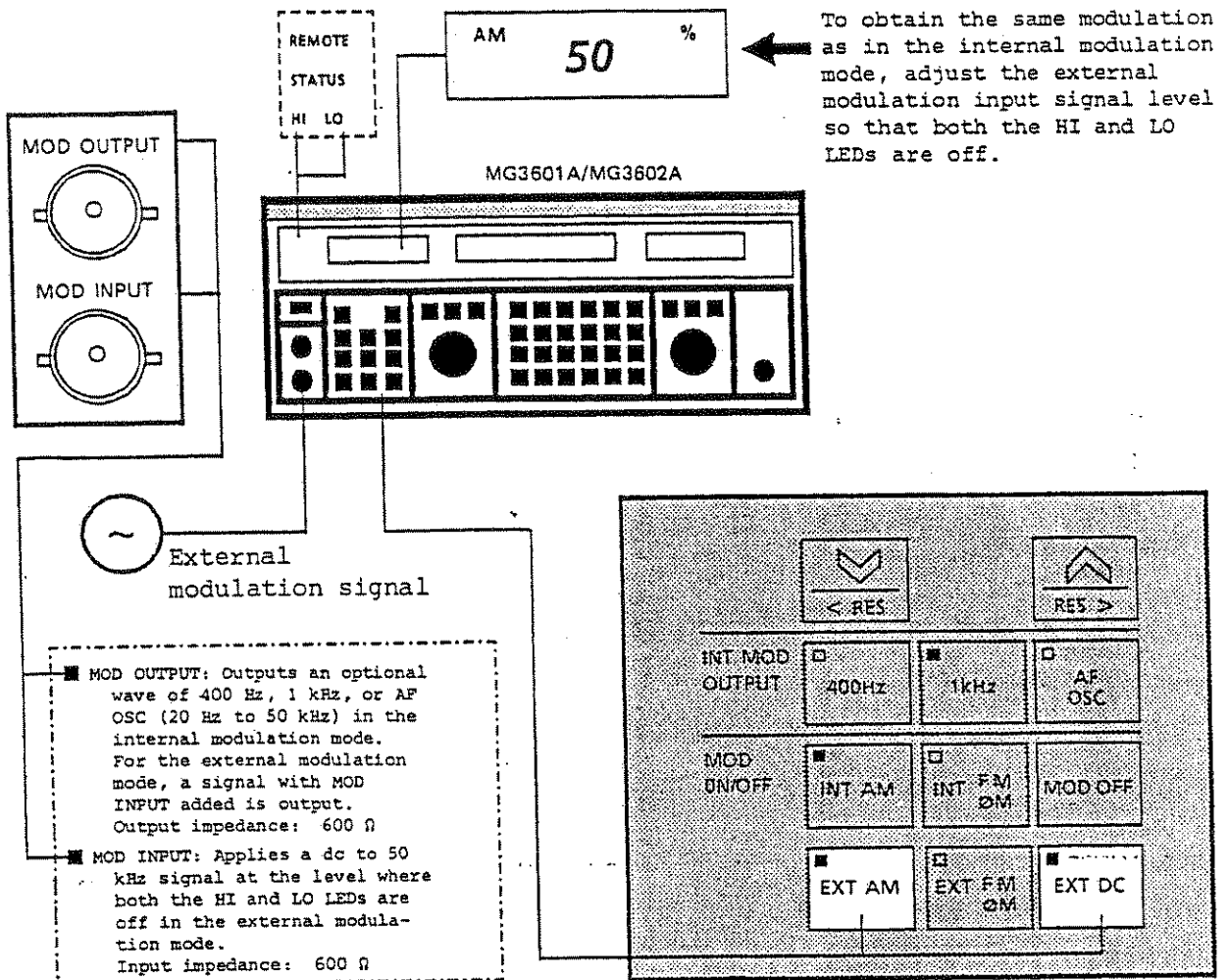

Fig. 5-22 External AM Modulation

Note:

One or both of the [EXT AM] or [EXT FM/φM] keys must be set to ON to select the [EXT DC] key. It cannot be individually selected. The [EXT-DC] key is automatically turned off when both the [EXT AM] and [EXT FM/φM] keys are set to off.

5.8 Setting ϕ M Modulation

This paragraph explains how to set phase modulation. The phase deviation for the MG3601A/MG3602A can be set as follows:

1. Setting phase deviation at keyboard
2. Setting phase deviation using step keys

In the ϕ M INT mode, the internal modulation frequency is selected from 400 Hz, 1 kHz, or AF OSC. The main specifications of the MG3601A/MG3602A for setting the phase deviation are as follows.

Item	MG3601A/MG3602A
Phase deviation range	0 to 9.99 rad (The maximum radian display for internal modulation is 999 rad.)
Accuracy	$\pm 5\%$ of setting value
Resolution	0.01 rad (0 to 9.99 rad) 0.1 rad (10 to 99.9 rad) 1 rad (200 to 999 rad)
Internal fixed frequency	400 Hz, 1 kHz
Internal variable frequency oscillator	Option 04
Frequency range	20 Hz to 100 kHz
Minimum resolution	0.1 Hz
Internal modulation frequency accuracy	100 ppm
External modulation frequency	
Frequency range (ac couple)	200 Hz to 8 kHz (± 1 dBm Bandwidth)
Input level	Approx. 1 Vrms
Input impedance	Nominal 600 Ω

Notes:

The STATUS LED (Fig. 5-1) comes on when:

1. An attempt is made to set phase deviation outside the phase deviation range.
2. The product of the amount of phase deviation attempted to be set and the modulation frequency exceeded the maximum frequency deviation of the MG3601A/MG3602A. The maximum frequency deviation of the MG3601A/MG3602A is 199 kHz.
3. An attempt is made to set the phase deviation minimum resolution to 0.01 RAD or less.

Input a new HEADER to turn the STATUS LED off.

While the STATUS LED is on, the error code can be displayed by pressing the [SHIFT] key and holding the [STATUS] key down.

The FREQUENCY display on the front panel displays the error code.

Since the maximum frequency deviation ΔF described in the previous notes can be set up to 199.999 kHz, in the following example where $\Delta\theta$ RAD is the phase deviation and f_m kHz is the modulation frequency the O indicates that setting is allowed and the x indicates that setting is not allowed.

$\Delta F = \Delta\theta \times f_m$ The product on the left must be less than 200 kHz.

- O 199.87 = 8.69 RAD x 23 kHz
- O 199,9992 = 8.00 RAD x 24.9999 kHz
- X 200 = 25 RAD x 8 kHz
- X 200.1 = 8.7 RAD x 23 kHz

5.8.1 Setting phase deviation at keyboard (DATA ENTRY)

The phase deviation is set by operating the header (HEADER) keys, numeric (DATA) keys, and unit (UNIT) keys in this order. As shown in Fig. 5-23, these keys are located in the DATA ENTRY section on the front panel. The white keys shown (Fig. 5-23) are used to set the phase deviation.

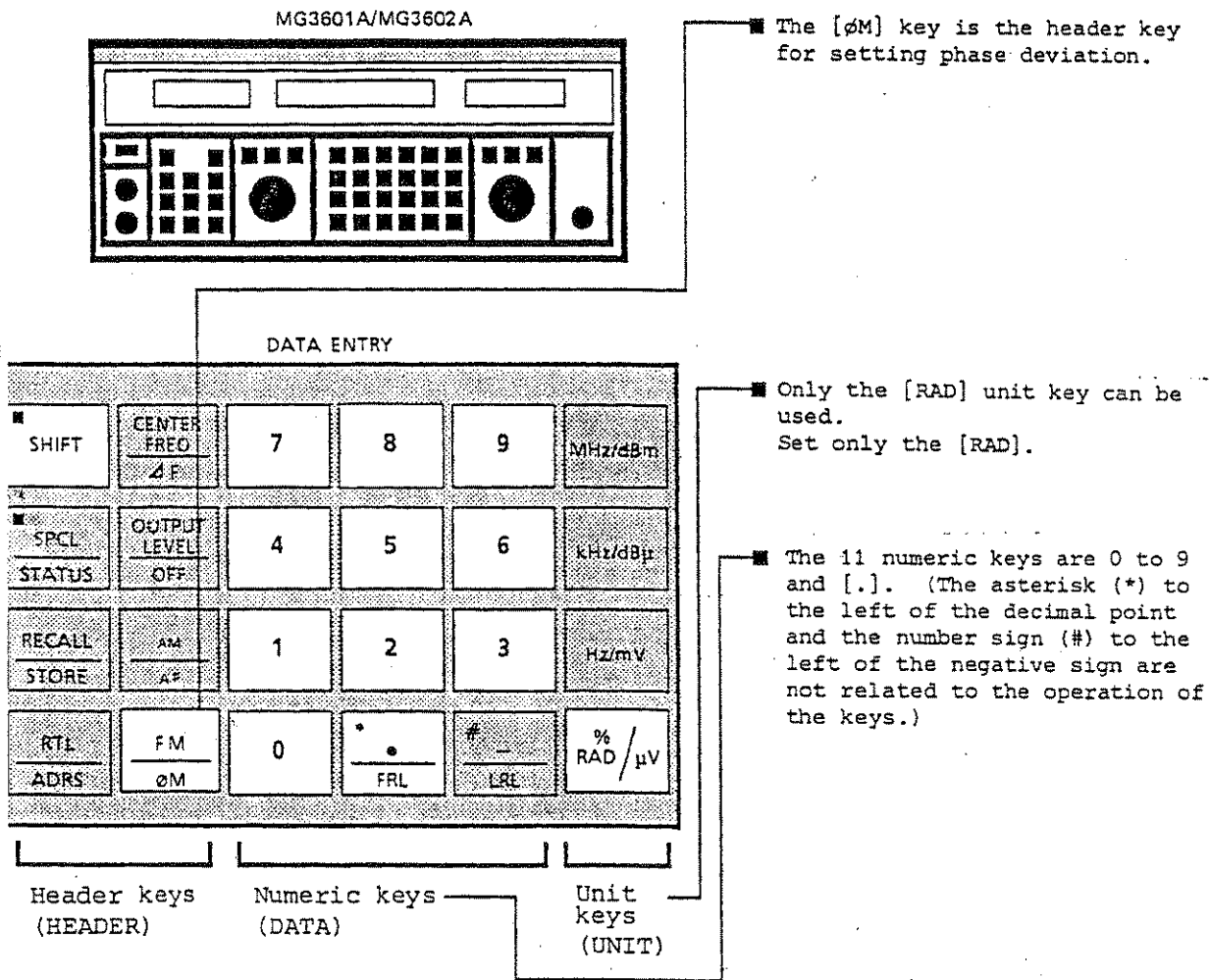

Fig. 5-23 Setting Using Keyboard (Numeric and Unit Keys)

Example:

Setting internal modulation frequency 800 Hz and phase deviation 199 RAD then setting internal modulation frequency 400 Hz and phase deviation 3.5 RAD

STEP	ACTION	VERIFICATION
<u>AF OSC 800 Hz preset</u>		
1.	<input type="checkbox"/> SHIFT $\frac{AM}{AF}$ 8 0 0	<div style="border: 1px solid black; padding: 5px; display: inline-block;"> 800 .A.F </div> MHz kHz
2.	<input type="checkbox"/> Hz/mV	<div style="border: 1px solid black; padding: 5px; display: inline-block;"> 800.0AF </div> MHz kHz
<u>Setting phase deviation 199 RAD</u>		
3.	<input type="checkbox"/> SHIFT $\frac{FM}{\emptyset M}$ 1 9 9 <input type="checkbox"/> % RAD / μV	<div style="border: 1px solid black; padding: 5px; display: inline-block;"> $\emptyset M$ 199 RAD </div> <input checked="" type="checkbox"/> INT FM <input checked="" type="checkbox"/> 1kHz $\emptyset M$
4.	<input type="checkbox"/> AF OSC	<input checked="" type="checkbox"/> AF OSC ← AF OSC 800 Hz is set.

(cont'd)

STEP	ACTION	VERIFICATION
------	--------	--------------

Setting phase deviation 3.5 RAD

5. SHIFT $\frac{FM}{\emptyset M}$ 3 $\frac{*}{FRL}$ 5

%
RAD/ μ V

$\emptyset M$ 3.50 RAD

6. 400Hz

AF
OSC

400Hz

← Internal fixed modulation frequency 400 Hz is set.

5.8.2 Setting phase deviation using step keys

The MODULATION section [∇] and [\wedge] keys on the front panel are used to step-down or step-up the phase deviation in 0.01 RAD, 0.1 RAD, 1 RAD, 10 RAD, or 100 RAD steps.

By using the [SHIFT] [RES>], or [SHIFT] [<RES] keys, and setting the resolution to be used when stepping-up/down the phase deviation for any of the digits 100 RAD, 10 RAD, 1 RAD, 0.1 RAD, or 0.01 RAD beforehand, the [∇] or [\wedge] keys can be used to continuously vary the phase deviation at the set resolution.

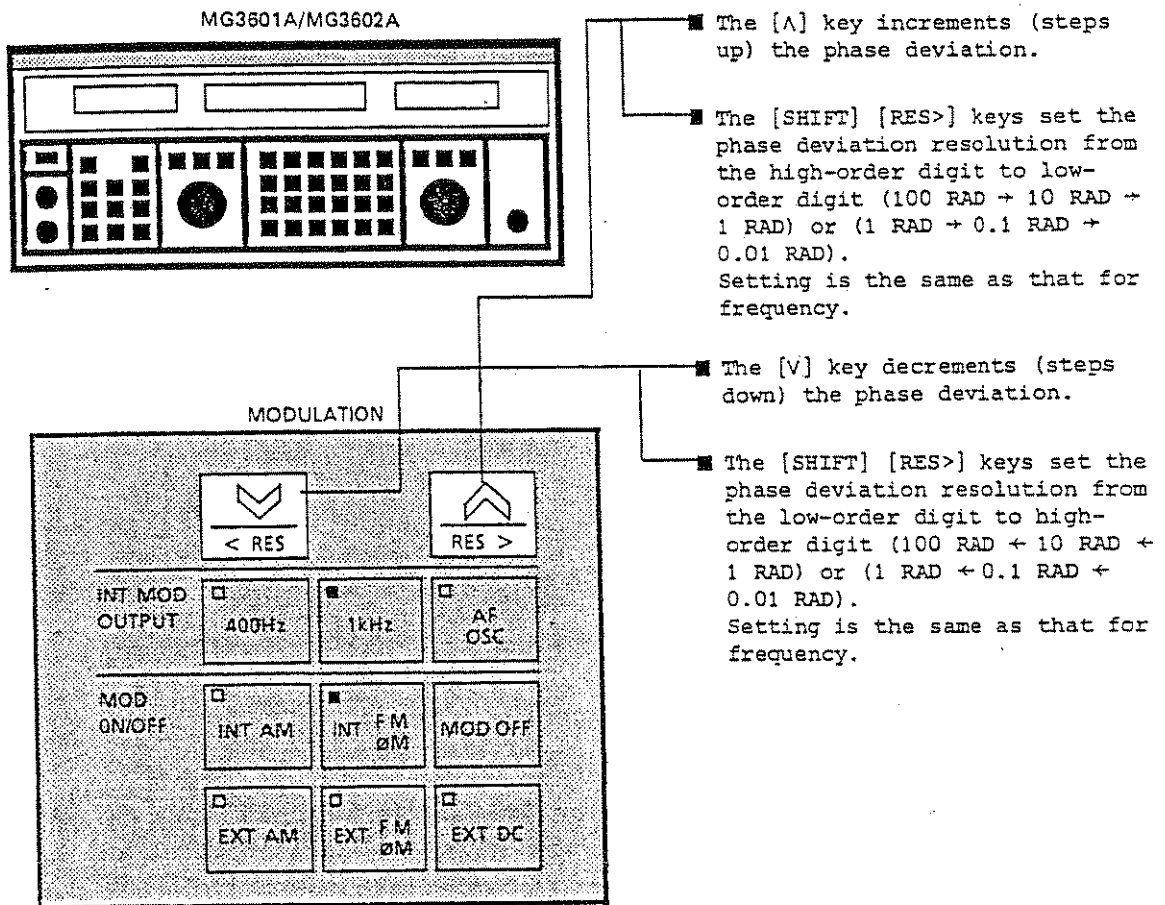



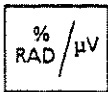

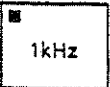



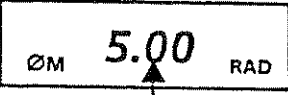



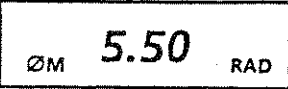

Fig. 5-24 Setting Phase Deviation Using Step Keys

Example:

Setting from $\emptyset M$ 5 RAD to 5.5 RAD in 0.1 steps

STEP	ACTION	VERIFICATION
1.	   	   <p>The INT $\emptyset M$ 5.00 mode is automatically set in step 1. If the previous modulation frequency setting is 1 kHz, this value is automatically reset.</p>
2.	  <p>← Press the [RES>] key until the value at the 0.1 RAD digit blinks once.</p>	 <p>The [SHIFT] key lamp lights while the [RES>] key is pressed.</p>  <p>← Blinks</p>
3.	<p>Release the [RES>] key when the value at the 0.1 RAD digit blinks once.</p>	 <p>The [SHIFT] key lamp goes off and the minimum resolution is set to 0.1 RAD.</p> 
4.	 <p>← Press until the phase deviation reaches 5.5 RAD.</p>	

5.8.3 External ϕ M modulation

To apply external ϕ M modulation, press the [EXT ϕ M] key (Fig. 5-25) in the ϕ M mode (the key lamp lights). A modulation signal of approximately 1 V_{rms}/600 Ω will then be applied to the MOD INPUT connector.

The modulation signal range is as follows:

. Ac couple 200 Hz to 8 kHz (± 1 dB bandwidth)

The HI LED will come on if the modulation input signal level is too high.

The LO LED will come on if the modulation input signal level is too low.

Adjust the modulation signal level so that both LEDs are off.

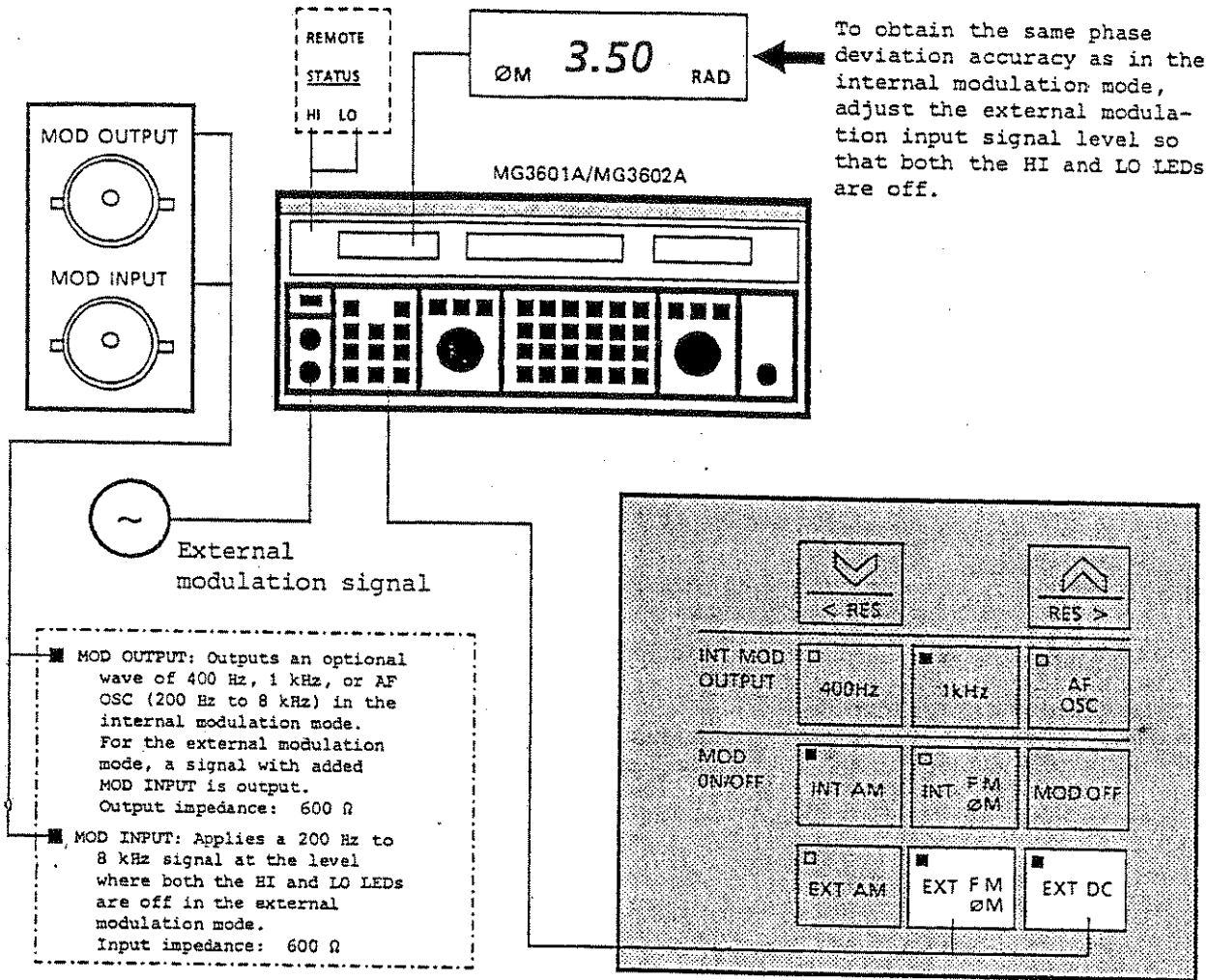

To obtain the same phase deviation accuracy as in the internal modulation mode, adjust the external modulation input signal level so that both the HI and LO LEDs are off.

Fig. 5-25 External ØM Modulation

Note:

One or both of the [EXT AM] and [EXT FM/ØM] keys must be set to ON to select the [EXT DC] key. It cannot be individually selected. The [EXT DC] key is automatically turned off when both the [EXT AM] and [EXT FM/ØM] keys are set to OFF.

5.9 Video Modulation

This paragraph explains how to use the video modulation (OPT 05) and set the modulation factor.

The main specifications of the MG3601A/MG3602A for setting video modulation are as follows.





Item	MG3601A/MG3602A
Modulation method	AM (double side-band)
Modulation signal	Video composite signal
Modulation factor	At the above input level, the white level is approximately 12.5% of maximum amplitude and the pedestal level is approximately 75%.
Input level	1 Vp-p (pedestal level 0 V) (white at positive voltage)
Input impedance	Nominal 75 Ω
Carrier output level accuracy	Output level accuracy at CW 13 dB (at peak value level)

Note:

Video modulation is an option (OPT 05). If this option is not installed, paragraphs 5.9.1 and 5.9.2 can be skipped.

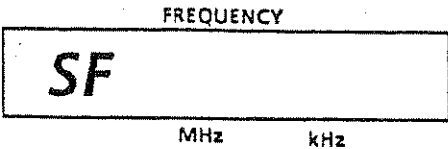
5.9.1 Selecting video modulation mode

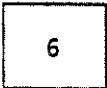
Before inputting the video signal, use the special function to select the video modulation mode as follows.

STEP	ACTION	VERIFICATION
1.		 <p>Indicates that the instrument is waiting for the special function code to be entered.</p>
2.	 	<p>Enter code 06 to set the video modulation to ON.</p>  <p>The modulation display is as shown above to indicate that the video modulation mode has been selected.</p>

Note:

- . To release the video modulation mode, use the special function and enter code 05.
- . The modulation display is then restored to its original status.
- . Video modulation is prohibited when AM modulation is selected.

5.9.2 Inputting video signals

When the video modulation mode is selected, connect the video signal generator to the MG3601A/MG3602A as shown in Fig. 5-26. Use a 75 Ω coaxial cable to connect the output terminal of the video signal generator to the VIDEO INPUT terminal on the rear panel of the MG3601A/MG3602A. When a video signal is applied to the video input, a signal modulated by the video signal is obtained at the MG3601A/MG3602A output as shown in Fig. 5-27.

The video modulator gain of the MG3601A/MG3602A has been adjusted at the factory so that a modulation depth shown in Fig. 5-27 is obtained when a video signal with an amplitude of approximately 1 Vp-p (Fig. 5-26) is applied.

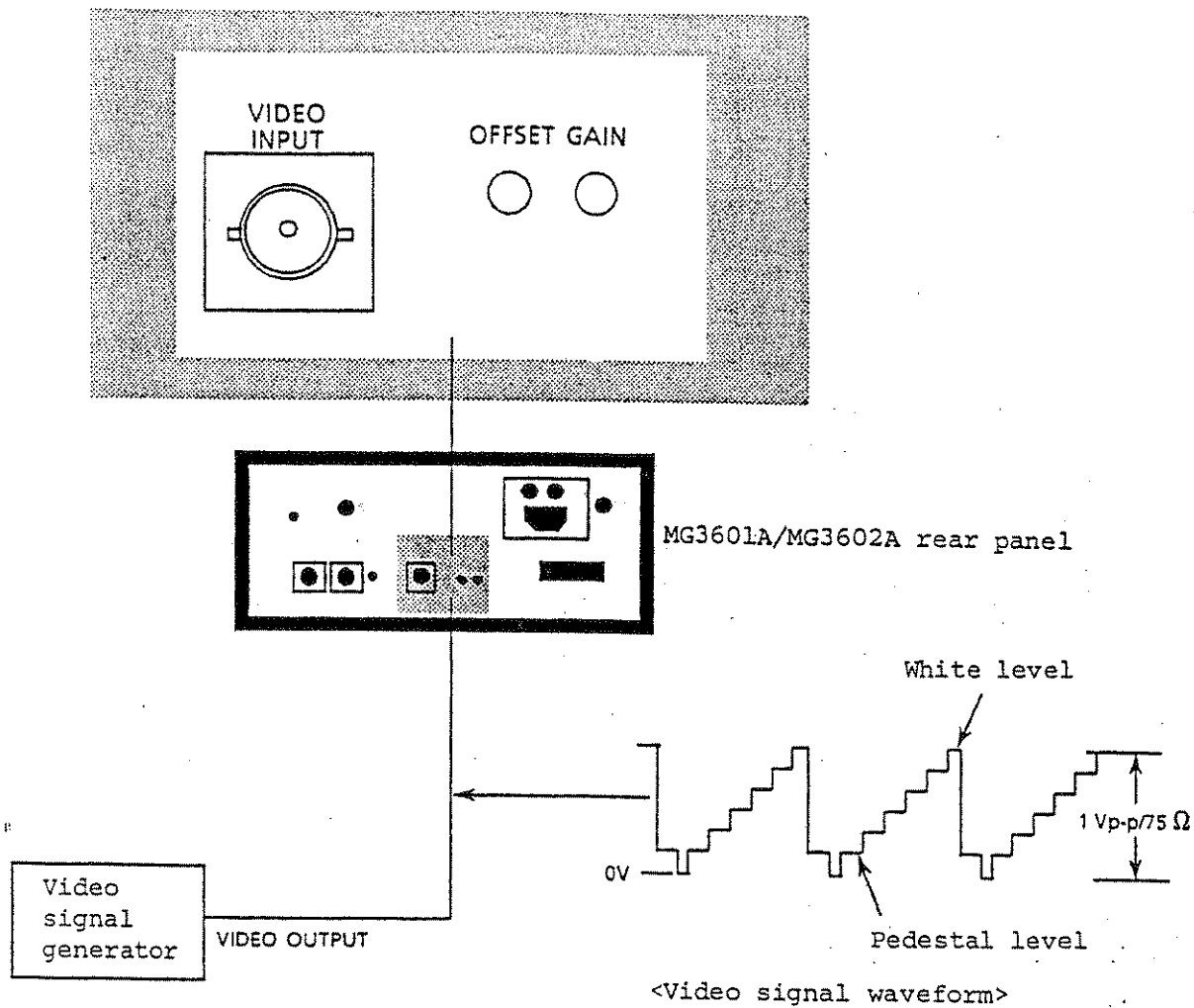
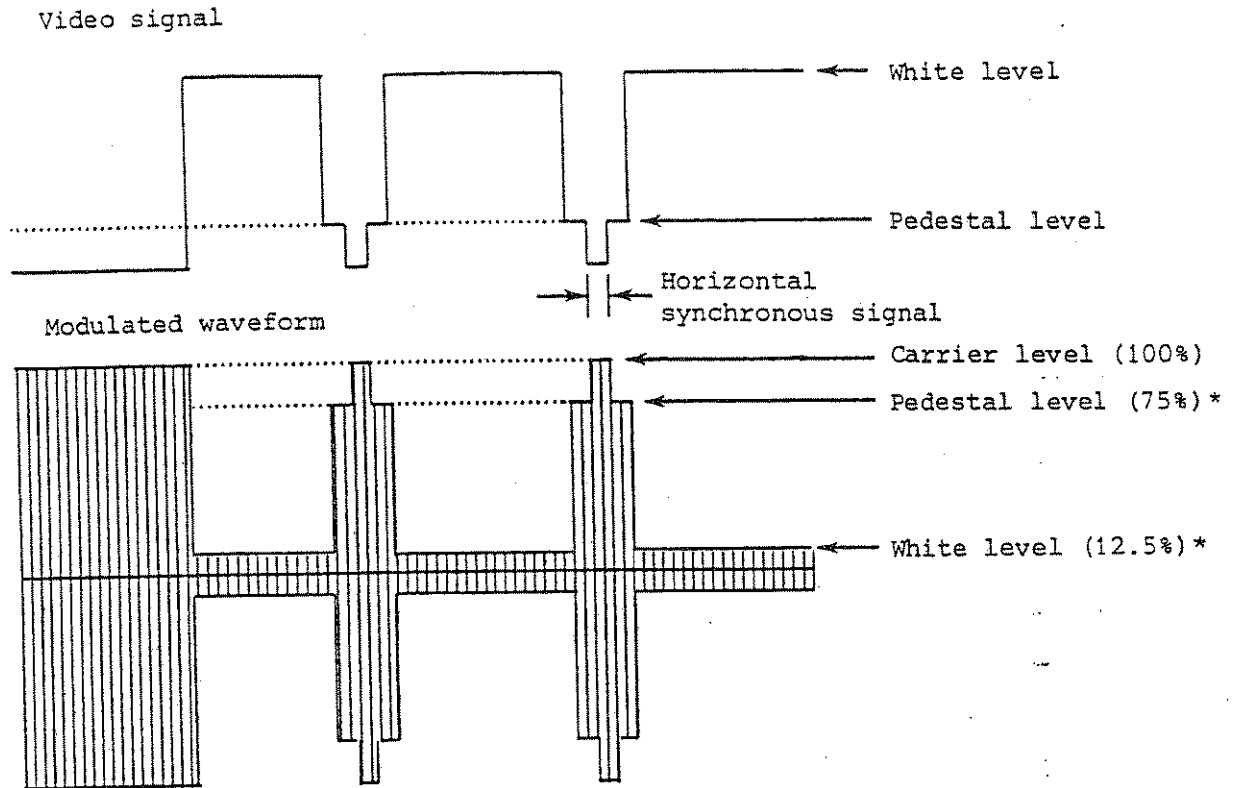

Fig. 5-26 Video Signal Input

Note:

Even when the video modulation mode is set to OFF (special function 05), the output will be slightly modulated by the modulation signal if the video signal is input at the VIDEO INPUT.

Therefore, if video modulation is not required, do not input the video signal to the video modulation input terminal.



* Ratio of each level when the carrier level is 100%.

Fig. 5-27 Video Signal and Modulated Waveform

Notes:

1. To readjust the modulation depth (Fig. 5-27), use a screwdriver to turn the internal variable resistors through the OFFSET and GAIN adjustment holes (Fig. 5-26). Use the OFFSET variable resistor for rough adjustment of the modulation factor. Use the GAIN variable resistor for fine adjustment.

Notes: (cont'd)

2. The output level switching time in the video modulation mode is approximately two seconds longer.
3. The level indicator at video modulation shows the peak value.
4. Set the output level to +7 dBm or less.

5.10 Memory

There are two types of memory: FREQ memory and FUNCTION memory.

5.10.1 FREQ memory

The FREQ memory can store up to 100 frequencies. The memory addresses are two-digit addresses from 00 to 99 (two digits must be entered).

(1) Storing

Press the [SHIFT] [STORE] memory address [CENTER FREQ] keys in this order to store the output frequency in the specified FREQ memory address.

(2) Recalling

Press the [RECALL] memory address [CENTER FREQ] keys in this order to recall the contents (frequency) from the specified FREQ memory address.

Example:

Setting output frequency to 15 MHz, storing this frequency in memory address 5, then recalling frequency from memory address 5

STEP	ACTION	VERIFICATION
<u>Setting frequency</u>		
1.	<div style="display: flex; gap: 10px;"> <div style="border: 1px solid black; padding: 2px; text-align: center;"> CENTER FREQ ΔF </div> <div style="border: 1px solid black; padding: 2px; text-align: center;">1</div> <div style="border: 1px solid black; padding: 2px; text-align: center;">5</div> <div style="border: 1px solid black; padding: 2px;">MHz/dBm</div> </div>	<div style="border: 1px solid black; padding: 5px; font-size: 1.2em;">15 000 000</div> <div style="display: flex; justify-content: space-around; font-size: 0.8em;"> MHz kHz </div>
<u>Storing</u>		
2.	<div style="display: flex; gap: 10px;"> <div style="border: 1px solid black; padding: 2px; text-align: center;"> <input type="checkbox"/> SHIFT </div> <div style="border: 1px solid black; padding: 2px; text-align: center;"> RECALL STORE </div> </div>	<div style="border: 1px solid black; padding: 5px; font-size: 1.5em;">Ad</div> <div style="display: flex; justify-content: space-around; font-size: 0.8em;"> MHz kHz </div>
3.	<div style="display: flex; gap: 10px;"> <div style="border: 1px solid black; padding: 2px; text-align: center;">0</div> <div style="border: 1px solid black; padding: 2px; text-align: center;">5</div> </div>	<div style="border: 1px solid black; padding: 5px; font-size: 1.5em;">Ad 05</div> <div style="display: flex; justify-content: space-around; font-size: 0.8em;"> MHz kHz </div>
4.	<div style="border: 1px solid black; padding: 2px; text-align: center;"> CENTER FREQ ΔF </div>	<div style="border: 1px solid black; padding: 5px; font-size: 1.2em;">15 000 000</div> <div style="display: flex; justify-content: space-around; font-size: 0.8em;"> MHz kHz </div>

The previous display is restored and 15 MHz is stored.

(cont'd)

STEP	ACTION	VERIFICATION				
	<u>Recalling</u>					
5.	<table border="1"><tr><td>RECALL</td></tr><tr><td>STORE</td></tr></table>	RECALL	STORE	<table border="1"><tr><td style="text-align: center;">Ad</td></tr><tr><td style="text-align: center;">MHz kHz</td></tr></table>	Ad	MHz kHz
RECALL						
STORE						
Ad						
MHz kHz						
6.	<table border="1"><tr><td>0</td><td>5</td></tr></table>	0	5	<table border="1"><tr><td style="text-align: center;">Ad 05</td></tr><tr><td style="text-align: center;">MHz kHz</td></tr></table>	Ad 05	MHz kHz
0	5					
Ad 05						
MHz kHz						
7.	<table border="1"><tr><td>CENTER FREQ ΔF</td></tr></table>	CENTER FREQ ΔF	<table border="1"><tr><td style="text-align: center;">150 000 000</td></tr><tr><td style="text-align: center;">MHz kHz</td></tr></table>	150 000 000	MHz kHz	
CENTER FREQ ΔF						
150 000 000						
MHz kHz						

15 MHz stored at address 5
is referenced and displayed.

Note:

In addition to the recall method explained above, special function 08 can also be used for continuous reading.

See paragraph 5.11.6

5.10.2 Function memory

The FUNCTION memory is used to store/recall panel settings. Up to 30 panel settings can be stored/recalled in/from memory addresses 0 to 29.

(1) Storing

Press the [SHIFT] [STORE] memory address [FRL] keys in this order to store the panel setting to the specified FUNCTION memory address.

(2) Recalling

Press the [RECALL] memory address [FRL] keys to recall the contents (panel setting) from the specified FUNCTION memory address.

Example:

Storing current panel setting in memory address 2 then recalling panel setting from memory address 2

STEP	ACTION	VERIFICATION
<u>Storing</u>		
1.	<div style="display: flex; align-items: center; gap: 10px;"> <div style="border: 1px solid black; padding: 5px; text-align: center;"> □ SHIFT </div> <div style="border: 1px solid black; padding: 5px; text-align: center;"> RECALL <hr style="width: 50%; margin: 0 auto;"/> STORE </div> <div style="border: 1px solid black; padding: 5px; text-align: center; width: 30px;">0</div> <div style="border: 1px solid black; padding: 5px; text-align: center; width: 30px;">2</div> <div style="border: 1px solid black; padding: 5px; text-align: center;"> * <hr style="width: 50%; margin: 0 auto;"/> • FRL </div> </div>	The current panel setting is stored in FUNCTION memory address 2.
<u>Recalling</u>		
2.	<div style="display: flex; align-items: center; gap: 10px;"> <div style="border: 1px solid black; padding: 5px; text-align: center;"> RECALL <hr style="width: 50%; margin: 0 auto;"/> STORE </div> <div style="border: 1px solid black; padding: 5px; text-align: center; width: 30px;">0</div> <div style="border: 1px solid black; padding: 5px; text-align: center; width: 30px;">2</div> <div style="border: 1px solid black; padding: 5px; text-align: center;"> * <hr style="width: 50%; margin: 0 auto;"/> • FRL </div> </div>	The contents of FUNCTION memory address 2 are recalled.

Note:

In addition to the recall method explained above, special function 08 can also be used for continuous reading.

See paragraph 5.11.6

5.11 Special Functions

The MG3601A/MG3602A has special functions in addition to the basic front panel functions explained in the previous sections.

These special functions enable the MG3601A/MG3602A to be used for more varied applications.

Table 5-4 lists the special function codes and contents. The codes listed in Table 5-4 can be used as GP-IB program codes by using SP instead of the [SPCL] key and two-digit codes instead of the numeric keys.

GP-IB code	Key operation		
SP00	<input type="checkbox"/> SPCL STATUS	0	0
}	}	}	}
SP67	<input type="checkbox"/> SPCL STATUS	6	7

Note:

1. Program codes of the RF frequency offset value header and the output level offset value header are exceptional and become F0 and L0, respectively.
2. Special function codes 0 to 9 cannot be input as one-digit codes.

All special functions must be input as two-digit codes as shown above. For special function 5, for example, key-in [SPCL] [0] [5].

Table 5-4 Special Functions

Parameter (special function contents)		Program code	Key operation
Initial setting		SP00	[SPCL] [0] [0]
FREQUENCY display code list group	Buzzer OFF	SP01	[SPCL] [0] [1]
	Buzzer ON*	SP02	[SPCL] [0] [2]
	Open-circuit voltage display ON*	SP03	[SPCL] [0] [3]
	Terminated voltage display ON	SP04	[SPCL] [0] [4]
	VIDEO modulation OFF*	SP05	[SPCL] [0] [5]
	VIDEO modulation (OPT 05) ON	SP06	[SPCL] [0] [6]
	Memory sequential read mode OFF*	SP07	[SPCL] [0] [7]
	Memory sequential read mode ON	SP08	[SPCL] [0] [8]
	Memory protect OFF*	SP09	[SPCL] [0] [9]
	Memory protect ON	SP10	[SPCL] [1] [0]
	EXT FM polarity switching OFF*	SP11	[SPCL] [1] [1]
	EXT FM polarity switching ON (OPT 06)	SP12	[SPCL] [1] [2]
	RF frequency range cancel OFF*	SP13	[SPCL] [1] [3]
	RF frequency range cancel ON	SP14	[SPCL] [1] [4]
	External reference input 10 MHz mode ON*	SP15	[SPCL] [1] [5]
	External reference input 1 MHz mode ON	SP16	[SPCL] [1] [6]
	RF frequency offset mode OFF*	SP17	[SPCL] [1] [7]
	RF frequency offset mode ON	SP18	[SPCL] [1] [8]
	Output level offset mode OFF*	SP19	[SPCL] [1] [9]
	Output level offset mode ON	SP20	[SPCL] [2] [0]
Dc FM	Frequency calibration ON during dc FM modulation	SP30	[SPCL] [3] [0]
	Dc FM high stabilized mode OFF*	SP37	[SPCL] [3] [7]
	Dc FM high stabilized mode ON	SP38	[SPCL] [3] [8]
Offset	Header of RF frequency offset value	F0.	[SPCL] [3] [1]
	Header of output level offset value	L0	[SPCL] [3] [2]
Simultaneous modulation	Simultaneous modulation with external and separate FM OFF*	SP33	[SPCL] [3] [3]
	Simultaneous modulation with external and separate FM ON	SP34	[SPCL] [3] [4]
Back-light	LCD backlight OFF*	SP35	[SPCL] [3] [5]
	LCD backlight ON	SP36	[SPCL] [3] [6]
EXT FM	EXT FM modulation factor display OFF*	SP39	[SPCL] [3] [9]
	EXT FM modulation factor display (OPT 07) ON	SP40	[SPCL] [4] [0]
SRQ	SRQ ERROR MASK OFF	SP41	[SPCL] [4] [1]
	SRQ BUSY/READY MASK OFF	SP42	[SPCL] [4] [2]
	SRQ Excess reverse power MASK OFF	SP43	[SPCL] [4] [3]
	SRQ PARAMETER OUT MASK OFF	SP44	[SPCL] [4] [4]
		SP45	[SPCL] [4] [5]
		SP46	[SPCL] [4] [6]
	SRQ ALL MASK*	SP47	[SPCL] [4] [7]
		SP48	[SPCL] [4] [8]
		SP49	[SPCL] [4] [9]
		SP50	[SPCL] [5] [0]
Memory function	Initialize FREQ memory (1040 MHz).	SP61	[SPCL] [6] [1]
	Initialize FUNCTION memory (SP00 status).	SP62	[SPCL] [6] [2]
	Set frequency 0 Hz.	SP63	[SPCL] [6] [3]
	Check LCD and LED.	SP64	[SPCL] [6] [4]
	Check RAM.	SP65	[SPCL] [6] [5]
	Check ROM.	SP66	[SPCL] [6] [6]
	Display option.	SP67	[SPCL] [6] [7]

* Indicates initial status

5.11.1 Special function status

To confirm the special function settings, press the [SPCL] and [SHIFT] keys then hold the [STATUS] key down. The FREQUENCY display displays the settings while the [STATUS] key is pressed.

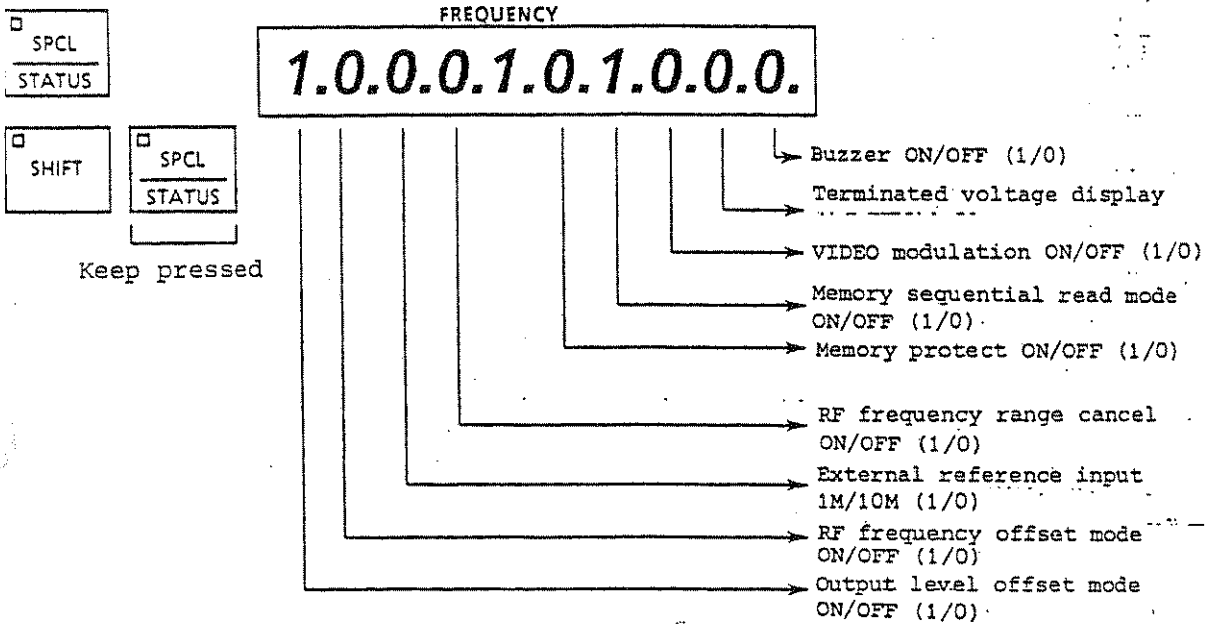

5.11.2 Initial settings (SP00)

Key-in [SPCL][0][0] to set the panel status and setting values of the MG3601A/MG3602A to initial status.

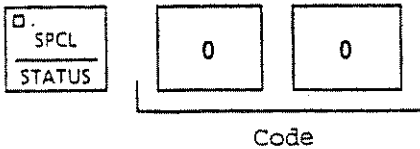

CENTER FREQ	1.04 GHz
ΔF	1 MHz
FREQ RESOLUTION	10 Hz
RELATIVE FREQ	OFF
FREQ TUNING	OFF
OUTPUT LEVEL	-30 dBm
LEVEL RESOLUTION	0.1 dB
CONTINUE MODE	OFF
MODULATION	OFF
FM	3.5 kHz
AM	30 %
∅M	1 RAD
INT MOD OUTPUT	1 kHz
SRQ	MASK
Special functions	Indicated by an asterisk (*) in Table 5-4
AF OSC	1 kHz
Data request message	CFRD

5.11.3 Buzzer ON/OFF (SP02/01)

These special functions set the buzzer ON/OFF to indicate that key input is accepted.

- (1) [SPCL][0][1]: Sets buzzer OFF
- (2) [SPCL][0][2]: Sets buzzer ON

5.11.4 Switching terminated voltage display and open-circuit voltage display (SP04/03)

Key-in [SPCL] [0] [4] to set the output level display to the terminated voltage display mode. Key-in [SPCL] [0] [3] to return to the open-circuit voltage display mode.

Only the display is changed when the terminated and open-circuit voltage display modes are switched. The output is not changed.

If SP03 or SP04 is input while the dBm unit is used, no change will occur. The open-circuit or terminated voltage is displayed when either the dBu, mV, or μ V unit is set.

The open-circuit voltage is displayed by appending EMF to the unit.

Display in dBu or mV at output level 0 dBm

STEP	ACTION			VERIFICATION
<u>Switching from dBm to dBu</u>				
1.	OUTPUT LEVEL OFF	0	MHz/dBm	0.0 dBm
2.	OUTPUT LEVEL OFF		kHz/dB μ	113.0 dB μ EMF
<u>Terminated voltage display</u>				
3.	<input type="checkbox"/> SPCL STATUS	0	4	107.0 dB μ
<u>Returning to open-circuit voltage display</u>				
4.	<input type="checkbox"/> SPCL STATUS	0	3	113.0 dB μ EMF
5.	OUTPUT LEVEL OFF		Hz/mV	446 EMF mV
<u>Terminated voltage display</u>				
6.	<input type="checkbox"/> SPCL STATUS	0	4	223 mV

5.11.5 Video modulation ON/OFF (SP06/05)

These special functions control ON/OFF of video modulation.

- (1) [SPCL] [0] [6]: Sets video modulation ON
- (2) [SPCL] [0] [5]: Sets video modulation OFF

See paragraph 5.9 for details of video modulation.



5.11.6 Memory sequential read mode (SP08/07)

By keying-in [SPCL] [0][8], data stored in the FUNCTION or FREQ memory can be read sequentially using the following keys in the FREQUENCY section.

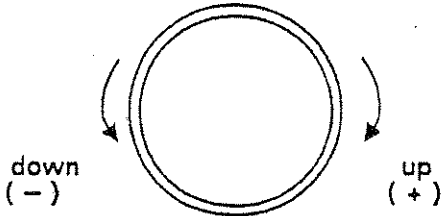

- . FUNCTION memory contents: [^] or [v] key
- . FREQ memory contents: TUNE knob

Key-in [SPCL] [0][7] to set the sequential read mode OFF. The example below reads the contents at the following addresses.

Address	FUNCTION memory	FREQ memory
0	MOD FREQ, 1 kHz, INT AM30%, FREQ 1.05 MHz, OUTPUT -30 dBm	5.05 MHz
1	MOD FREQ, 1 kHz, INT FM 3.5 kHz, FREQ 565.05 MHz, OUTPUT 7 dBm	465.05 MHz

STEP	ACTION	VERIFICATION
1.	<div style="display: flex; align-items: center; gap: 10px;"> <div style="border: 1px solid black; padding: 2px; display: inline-block; text-align: center;"> <input type="checkbox"/> SPCL STATUS </div> <div style="border: 1px solid black; padding: 5px; display: inline-block; text-align: center; width: 30px;">0</div> <div style="border: 1px solid black; padding: 5px; display: inline-block; text-align: center; width: 30px;">8</div> </div>	<p>The current address and contents are read when sequential read mode is turned OFF.</p>
<u>Reading FUNCTION memory</u>		
2.		<div style="border: 1px solid black; padding: 5px; margin-bottom: 5px; display: flex; justify-content: space-between;"> <i>Ad</i> 00 </div> <div style="display: flex; justify-content: space-around; font-size: 10pt;"> MHz kHz </div> <div style="border: 1px solid black; padding: 5px; margin-bottom: 5px; text-align: center; font-size: 24pt;">5050000</div> <div style="display: flex; justify-content: space-around; font-size: 10pt;"> MHz kHz </div> <div style="border: 1px solid black; padding: 5px; margin-bottom: 5px; display: flex; justify-content: space-between;"> <i>Ad</i> 01 </div> <div style="display: flex; justify-content: space-around; font-size: 10pt;"> MHz kHz </div> <div style="border: 1px solid black; padding: 5px; margin-bottom: 5px; text-align: center; font-size: 24pt;">465050000</div> <div style="display: flex; justify-content: space-around; font-size: 10pt;"> MHz kHz </div>
<p>Turn the knob clockwise or counterclockwise according to the result of step 1 to read addresses 0 and 1.</p>		
<u>Reading FUNCTION memory</u>		
3.	<div style="display: flex; align-items: center; gap: 10px;"> <div style="border: 1px solid black; padding: 5px; display: inline-block; text-align: center;">  RES > </div> <div style="font-size: 24pt;">←</div> <div> <p>Press the key so that address 00 is read.</p> </div> </div>	<div style="display: flex; justify-content: space-between; margin-bottom: 5px;"> <div style="border: 1px solid black; padding: 2px; display: flex; align-items: center; gap: 5px;"> AM 30 % </div> <div style="border: 1px solid black; padding: 2px; display: flex; align-items: center; gap: 5px;"> <input type="checkbox"/> INT AM </div> <div style="border: 1px solid black; padding: 2px; display: flex; align-items: center; gap: 5px;"> <input type="checkbox"/> 1kHz </div> </div> <div style="border: 1px solid black; padding: 5px; margin-bottom: 5px; text-align: center; font-size: 24pt;">1050000</div> <div style="display: flex; justify-content: space-around; font-size: 10pt;"> MHz kHz </div> <div style="border: 1px solid black; padding: 5px; margin-bottom: 5px; display: flex; justify-content: space-between;"> -30.0 dBm </div>

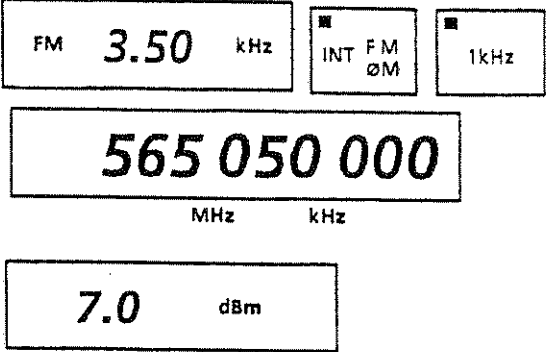
(cont'd)

STEP	ACTION	VERIFICATION
4.	 ← Press and release immediately.	
5.		Sequential read mode cancelled.

Notes:

1. The [TUNE] is inhibited in the memory sequential read mode.
2. The memory sequential read start address is initially 0. Otherwise, sequential reading is started at the address where the memory sequential read mode was last set to OFF.

5.11.7 Memory protect ON/OFF (SP10/09)

These special functions inhibit data writing in the **FREQ** and **FUNCTION** memories or cancel this protection.

- (1) [SPCL] [1] [0]: Sets memory protect ON
- (2) [SPCL] [0] [9]: Sets memory protect OFF

5.11.8 RF frequency range cancel ON/OFF (SP14/13)

These special functions expand the lower and upper limits of the RF frequency setting range to 10 kHz, and 1050 MHz (MG3601A) and 2100 MHz (MG3602A), respectively. The STATUS lamp lights.



Sets lower and upper limits of RF frequency setting range to 10 kHz, and 1050 MHz (MG3601A) and 2100 MHz (MG3602A).



Cancels SP14 mode and sets lower and upper limits of RF frequency setting range to 100 kHz, and 1040 MHz (MG3601A) and 2080 MHz (MG3602A).

Note:

If the RF frequency is set to less than 100 kHz when the RF frequency range cancel mode is set to OFF, it is set to 100 kHz. If it is set to more than 1040 MHz, or more than 2080 MHz, it is set to 1040 MHz (MG3601A) or 2080 MHz, respectively. However, at <100 kHz, >1040 MHz, and >2080 MHz frequencies, the setting (RF frequency) is out-of-standard.

5.11.9 Switching external reference input to 10M/1M (SP15/16)

These special functions set the external input reference frequency.

(1) [SPCL] [1] [5]: Sets external reference input to 10 MHz

(2) [SPCL] [1] [6]: Sets external reference input to 1 MHz

5.11.10 RF frequency offset mode ON/OFF (SP18/17)

The RF frequency offset mode function displays carrier frequency values not as actually set frequency values but as values obtained by adding (or subtracting) a specific offset value to (or from) the frequency values.

Example 1:

For a carrier frequency of 100 MHz and an offset value of 1 MHz, the displayed frequency value is 101 MHz.

Example 2:

For a carrier frequency of 100 MHz and an offset value of -1 MHz, the displayed frequency value is 99 MHz.

See paragraph 5.11.11 for the offset value setting.

RF frequency offset mode ON/OFF control is performed as follows.

- (1) [SPCL] [1] [8]: Sets RF frequency offset mode ON
- (2) [SPCL] [1] [7]: Sets RF frequency offset mode OFF
- (3) Application

Using MG3601A/MG3602A as local oscillator of heterodyne receiver

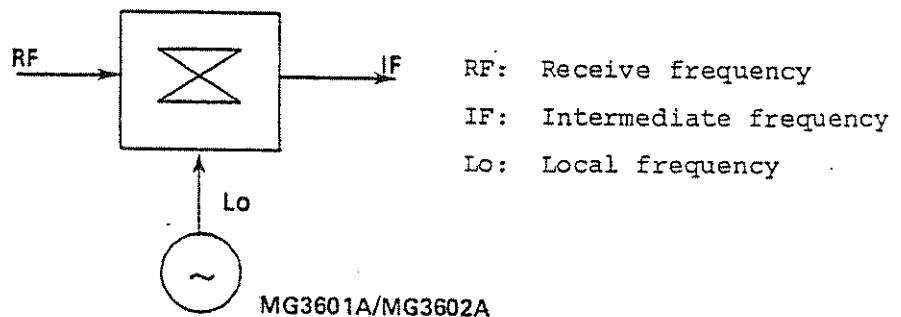

$$RF = Lo \pm IF$$







Therefore, by setting +IF or -IF as the offset value in the offset mode assuming the MG3601A/MG3602A output frequency as Lo, the receive frequency RF can be displayed directly.

5.11.11 Setting RF frequency offset value (SP31)

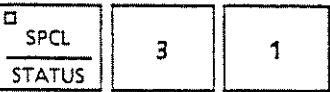
This special function sets the RF frequency offset value.

Example:

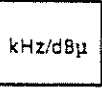
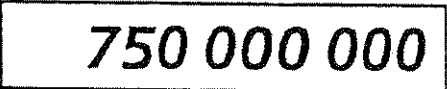
Setting offset value to +1.5 kHz for 750 MHz and displaying resulting value

STEP	ACTION	VERIFICATION
1.	Set the offset value input mode. 	The offset value entry status is set.  MHz kHz
2.	Input offset value. 	The offset value is displayed.  MHz kHz
3.	 ← Press the unit key to complete input.	When input is completed, the original display is restored.  MHz kHz
4.	Set the offset mode to ON. 	When the offset mode is turned on, 750 MHz +1.50 kHz is displayed and two decimal points are indicated. The output frequency is 750 MHz.  MHz kHz

(cont'd)

STEP	ACTION	VERIFICATION					
5.	Set the offset mode to OFF.	The following shows the display when the offset mode is set to OFF. The two decimal points are deleted and the original display is restored.					
	<table border="1"><tr><td data-bbox="350 541 456 632"><input type="checkbox"/> SPCL STATUS</td><td data-bbox="477 541 583 632">1</td><td data-bbox="604 541 711 632">7</td></tr></table>	<input type="checkbox"/> SPCL STATUS	1	7	<table border="1"><tr><td data-bbox="1044 642 1386 695">750 000 000</td></tr><tr><td data-bbox="1133 716 1292 741">MHz kHz</td></tr></table>	750 000 000	MHz kHz
<input type="checkbox"/> SPCL STATUS	1	7					
750 000 000							
MHz kHz							

Notes:

1. Although the frequency display is changed in steps 3 and 4, the output frequency is not changed.
2. Under the minimum resolution 10 Hz, the offset value setting range X is
$$-500 \text{ MHz} \leq X \leq 500 \text{ MHz}.$$
3. The offset value can be set when the offset mode is off.

5.11.12 Output level offset mode ON/OFF (SP20/19)

The output level offset mode is as follows.

The output level offset mode function displays output level values not as actual values but as values obtained by adding (or subtracting) a specific offset value to (or from) the actual values.

Example 1:

For output level +10 dBm and offset value +10 dB, the displayed output level is +20 dBm.

Example 2:

For output level +10 dBm and offset value -10 dBm, the displayed output level is +0 dBm.

See paragraph 5.11.13 for the offset value setting.

Output level offset mode ON/OFF control is performed as follows.

- (1) [SPCL] [2] [0]: Sets output level offset mode ON
- (2) [SPCL] [1] [9]: Sets output level offset mode OFF

(3) Application 1

Inserting amplifier after MG3601A/MG3602A output to extend output level range, and displaying amplifier output level at output level display of MG3601A/MG3602A.

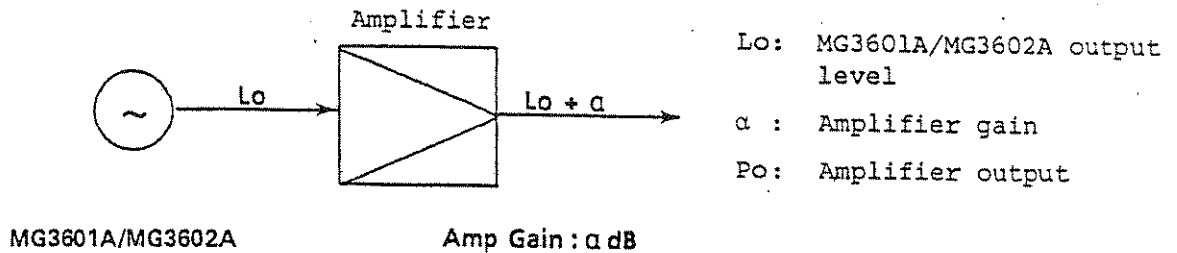

$$P_o = L_o + \alpha$$

Therefore, by setting $+\alpha$ as the offset value in offset mode assuming the MG3601A/MG3602A output as L_o , amplifier output P_o can be displayed.

(4) Application 2

Inputting cable and transmission line insertion loss and transmission loss as offset value, and displaying last output level at output level display of MG3601A/MG3602A.

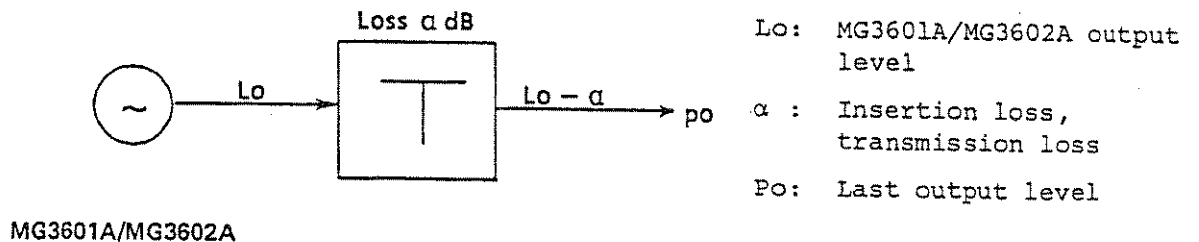

$$P_o = L_o - \alpha$$

Therefore, by setting $-\alpha$ as the offset value assuming the MG3601A/MG3602A output as L_o , the last output level P_o can be displayed at the output level display.

5.11.3 Setting output level offset value (SP32)

This special function sets the output level offset value.

Example:

Setting offset value to +10 dB for output level -100 dBm and displaying resulting value

STEP	ACTION	VERIFICATION
1.	Set offset value input mode. <div style="display: flex; align-items: center; gap: 10px;"> <div style="border: 1px solid black; padding: 2px;"> <div style="display: flex; justify-content: space-between; width: 100%;"> ■ SPCL </div> <hr style="border: 0; border-top: 1px solid black; margin: 2px 0;"/> <div style="display: flex; justify-content: space-between; width: 100%;"> STATUS </div> </div> <div style="border: 1px solid black; padding: 2px; text-align: center;">3</div> <div style="border: 1px solid black; padding: 2px; text-align: center;">2</div> </div>	The offset value input mode is set and the display is cleared. <div style="border: 1px solid black; width: 150px; height: 30px; margin-top: 10px;"></div>
2.	Input offset value. <div style="display: flex; align-items: center; gap: 10px;"> <div style="border: 1px solid black; padding: 2px; text-align: center;">1</div> <div style="border: 1px solid black; padding: 2px; text-align: center;">0</div> </div>	The input offset value is displayed. <div style="border: 1px solid black; padding: 10px; text-align: center; font-size: 1.2em;">10</div>
3.	<div style="display: flex; align-items: center; gap: 10px;"> <div style="border: 1px solid black; padding: 2px;">MHz/dBm</div> <div style="font-size: 2em;">←</div> <div>Press the unit key to complete input.</div> </div>	When input is completed, the original display is restored. <div style="border: 1px solid black; padding: 10px; text-align: center; font-size: 1.2em;">- 100.0 dBm</div>
4.	Set the offset mode to ON. <div style="display: flex; align-items: center; gap: 10px;"> <div style="border: 1px solid black; padding: 2px;"> <div style="display: flex; justify-content: space-between; width: 100%;"> ■ SPCL </div> <hr style="border: 0; border-top: 1px solid black; margin: 2px 0;"/> <div style="display: flex; justify-content: space-between; width: 100%;"> STATUS </div> </div> <div style="border: 1px solid black; padding: 2px; text-align: center;">2</div> <div style="border: 1px solid black; padding: 2px; text-align: center;">0</div> </div>	When the offset mode is set to ON, -100 dBm +10 dBm is displayed. The output level is -100 dBm. <div style="border: 1px solid black; padding: 10px; text-align: center; font-size: 1.2em;">- 90.0 dBm</div>
5.	Set the offset mode to OFF. <div style="display: flex; align-items: center; gap: 10px;"> <div style="border: 1px solid black; padding: 2px;"> <div style="display: flex; justify-content: space-between; width: 100%;"> ■ SPCL </div> <hr style="border: 0; border-top: 1px solid black; margin: 2px 0;"/> <div style="display: flex; justify-content: space-between; width: 100%;"> STATUS </div> </div> <div style="border: 1px solid black; padding: 2px; text-align: center;">1</div> <div style="border: 1px solid black; padding: 2px; text-align: center;">9</div> </div>	The following shows the display when offset mode is set to OFF. <div style="border: 1px solid black; padding: 10px; text-align: center; font-size: 1.2em;">- 100.0 dBm</div>

Notes:

1. The offset value setting range X is
 $-100 \text{ dB} \leq X \leq 100 \text{ dB}$.
2. The offset value can be set when the offset mode is off.
3. For the unit key, read [dBm] or [dBu] as [dB].
4. The offset mode cannot be used for [mV] or [μ V].

5.11.14 Frequency calibration ON during dc FM modulation (SP30)

This special function activates frequency calibration during dc FM modulation. This is the same as the function explained in paragraph 5.6.4.

Frequency calibration procedures

Step	Procedure
1	Key-in [SPCL] [3] [0] when dc FM is selected.
2	The following characters are displayed by the frequency display for two seconds to indicate that calibration is being performed.

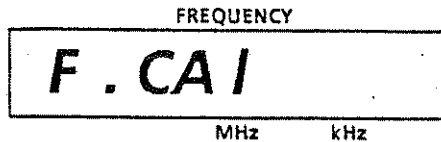

- 3 When calibration is completed, the above characters are cleared and the display returns to the original frequency display mode. After frequency calibration, measurement can be performed at an accuracy of $\pm 500 \text{ Hz}^*$ (260 to 520 MHz) for three minutes.

* $\pm 1 \text{ kHz}$ for 100 kHz to 130 MHz, or 520 to 1040 MHz; $\pm 250 \text{ Hz}$ for 130 to 260 MHz

5.11.15 Simultaneous modulation with external and separate FM ON/OFF (SP34/33)

These special functions control ON/OFF of simultaneous modulation with external and separate FM.

- (1) [SPCL] [3] [4]: Sets simultaneous modulation with external and separate FM to ON
 For internal modulation, the deviation value displayed by the display is set.
 For external modulation, however, another FM deviation value can be set separately from the value. The deviation result is the sum of both values.

- (2) [SPCL] [3] [3]: Sets simultaneous modulation with external and separate FM to OFF
 Internal and external modulation can be performed simultaneously.
 However, the deviation value set for internal modulation affects external modulation.
 SP34 and SP33 are equivalent to switches S1 and S2.

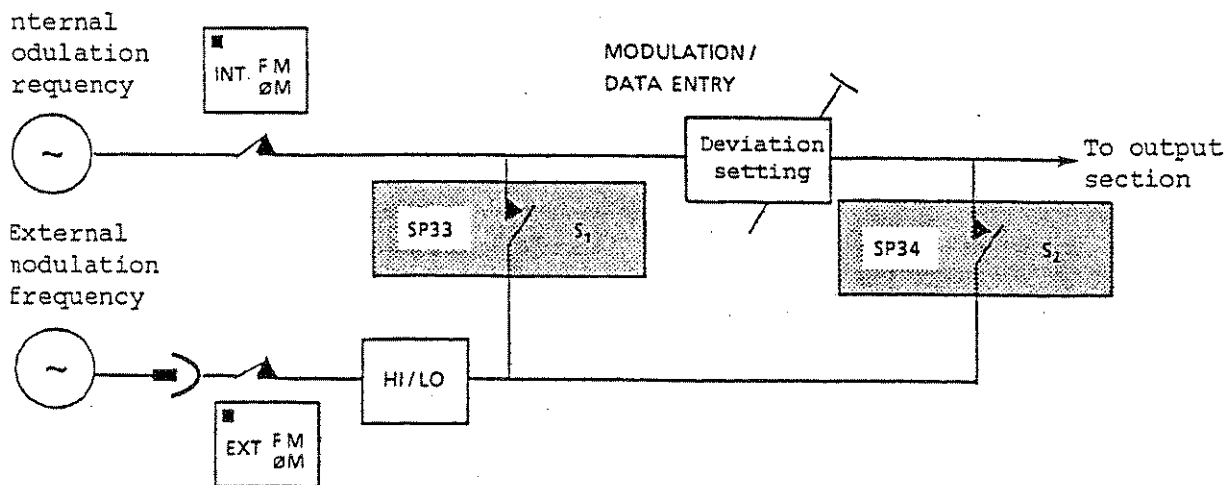
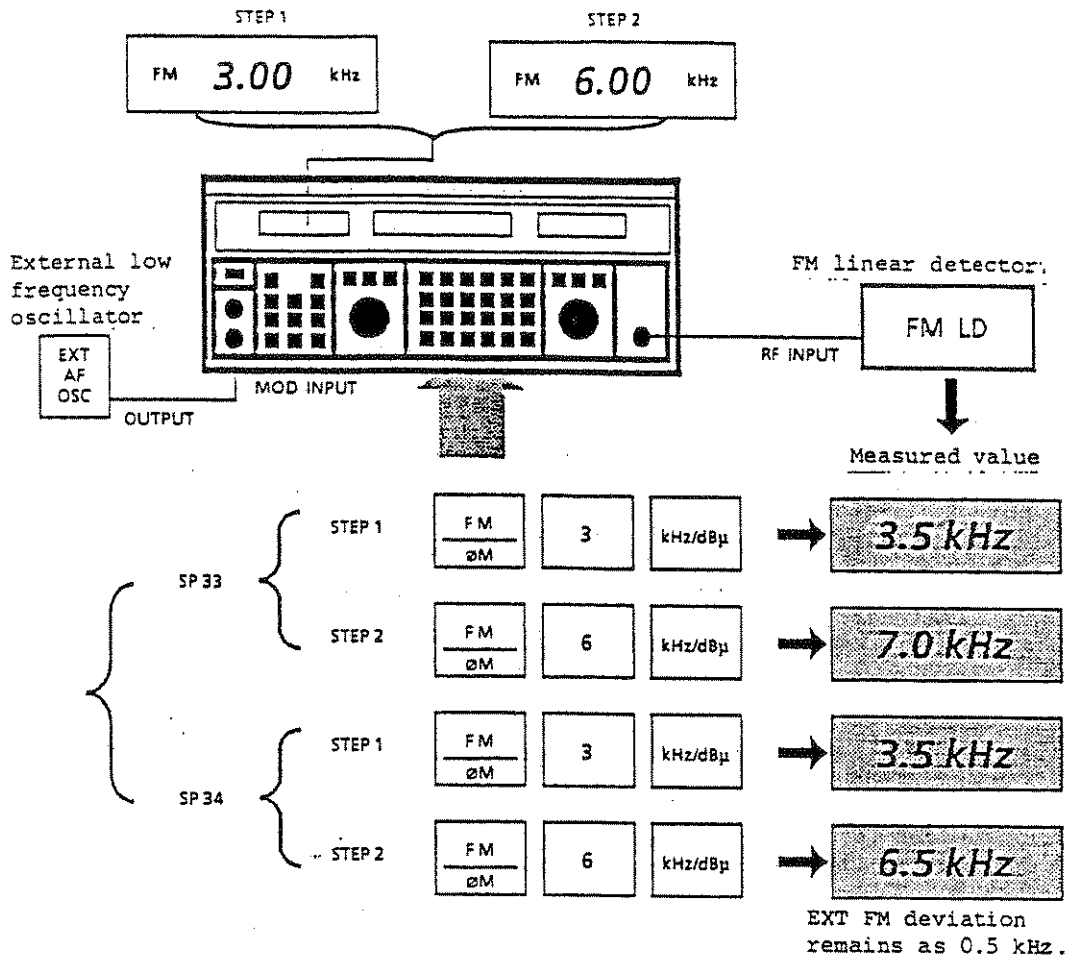

Fig. 5-28 Difference between SP33 and SP34 Modulation Routes



- | SP33 | SP34 |
|---|--|
| 1) Set S1 ON and S2 OFF (Fig. 5-28) | 1) Set S1 OFF and S2 ON (Fig. 5-28) |
| 2) Set 3 kHz deviation for INT FM (step 1). | |
| 3) Select EXT FM while retaining INT FM and adjust the level of the external low-frequency oscillator so that the measured value of the FM linear detector is 3.5 kHz. As a result, 0.5 kHz deviation is set for EXT FM (confirm the measured value of the FM linear detector at step 1 in the figure above). | |
| 4) Set 6 kHz deviation for INT FM (step 2) | |
| 5) Since INT FM and EXT FM share the deviation setting route, if the INT FM deviation setting is doubled, the EXT FM deviation result is also doubled. See measured result 7 kHz in step 2 of SP33 in the above figure. | 6) Since the INT FM route does not share the EXT FM route, the INT FM deviation setting does not affect EXT FM. As shown in the figure above, the measured result in step 2 of SP34 is the sum of both, for example (INT FM 3 kHz x 2) + EXT FM 0.5 kHz. |

Fig. 5-29 Difference between SP33 and SP34

Note:

For modulation using the EXT FM route, the external modulation input level must be adjusted after pressing the [EXT FM] key so that both the HI and LO LEDs are off. However, to set EXT FM deviation while INT FM and EXT FM are both on as explained in this paragraph, set the EXT FM deviation while measuring deviation using the FM linear detector connected to the OUTPUT of the signal generator. In this case, therefore, ignore the HI and LO LEDs.

5.11.16 LCD backlight ON/OFF (SP36/35)

These special functions control the LCD backlight ON/OFF.

- (1) [SPCL] [3] [6]: Sets LCD backlight ON
- (2) [SPCL] [3] [5]: Sets LCD backlight OFF

5.11.17 FREQ memory clear (SP61)

This special function sets 1040 MHz in all FREQ memory addresses.

[SPCL] [6] [1]: Initializes FREQ memory

5.11.18 Initialize FUNCTION memory (SP62)

This special function sets all FUNCTION memory addresses to SP00 status.

[SPCL] [6] [2]: Initializes FUNCTION memory

5.11.19 Setting frequency 0 Hz (SP63)

This special function sets the frequency to 0 Hz.

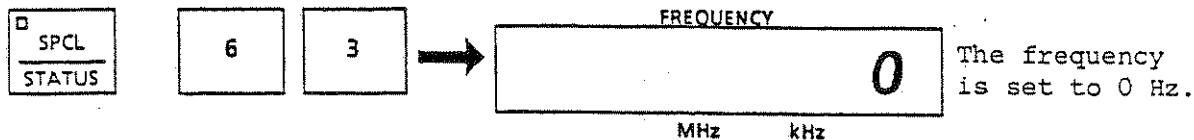

To cancel the setting, set a new carrier frequency value (see paragraph 5.1).

5.11.20 LCD and LED check (SP64)

This special function lights all LCDs and LEDs for three seconds.

When three seconds elapse, the LCDs and LEDs return to the status held before [SP64] was executed.

[SPCL] [6] [4]: Executes LCD and LED check .

5.11.21 RAM check (SP65)

This special function executes the RAM READ and WRITE check.

[SPCL] [6] [5]: Executes RAM check

By writing four patterns such as 00, FF, AA, and 55 to all RAM addresses, verification is made for read values.

The initial status (SP00 status) is set when the RAM check is completed.

5.11.22 ROM check (SP66)

This special function executes the ROM check using the sum check method (in the entire program area.)

[SPCL] [6] [6]: Executes ROM check

5.11.23 Option display (SP67)

This special function displays the currently installed options.

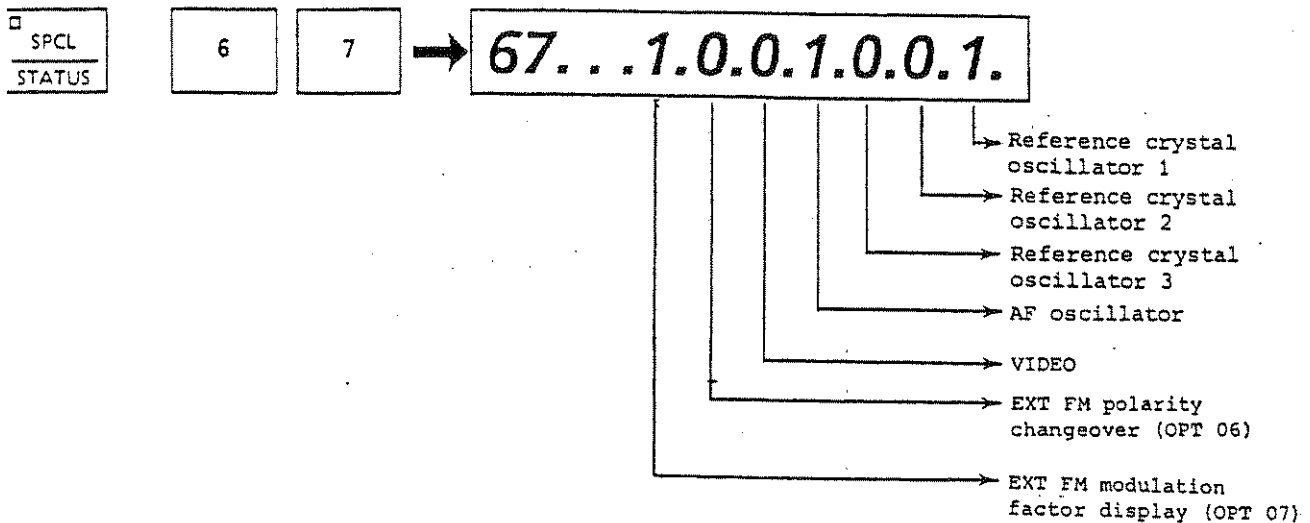

1 indicates that the option is set; 0 indicates that the option is not installed.

Press the [CENTER FREQ] and [MHz/dBm] keys to return to the original frequency display.

5.11.24 Dc FM high-stability mode ON/OFF (SP38/SP37)

This special function selects the dc FM high-stability mode. Since this mode has excellent long-term carrier frequency stability compared to the ordinary dc FM mode, it is convenient for testing digital FM radios which require special stability. The above-mentioned special function SP38 is keyed-in to select this mode. SP37 is keyed in to return to the ordinary dc FM mode.

(1)

<input type="checkbox"/> SPCL
STATUS

3

8

Sets dc FM high-stability mode to ON

When the EXT dc FM mode is selected, a decimal point is displayed at the position shown in the following figure of the frequency indicator to indicate the dc FM high-stability mode.

750 000 000
MHz kHz

(2)

<input type="checkbox"/> SPCL
STATUS

3

7

Sets dc FM high-stability mode to OFF to enter ordinary Dc FM mode.

Note:

The difference between the ordinary dc FM mode and the dc FM high-stability mode is described below:

Since the dc FM high-stability mode stabilizes the frequency, using an AFC circuit, it is different from the dc FM. That is, even if the frequency is changed by dc control, it returns to the center frequency after some time. However, it is not the same as the fast-repeating dc control of the dc FM because of its remarkably long response time.

Therefore, it is recommended that the SP37 mode be used for complete dc control and the SP38 mode be used for testing dc FM such as in pagers.

5.12 External FM Polarity Switching (Option 06)



5.12.1 Outline

Option 06 of the MG3601A/MG3602A has a function to switch the FM modulation polarity by external modulation input at external FM modulation.

This function is convenient for switching polarity at dc FM modulation.

5.12.2 FM modulation polarity

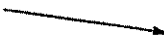

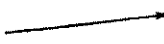
The polarity of the external modulation input and frequency deviation is shown below:

FM polarity	External modulation input	Frequency deviation
Non-reversed (SP11)	+	
	-	
Reversed (SP12)	+	
	-	

For example, if FM polarity reversal is selected, the carrier frequency falls when the external modulation input is positive voltage and it rises when it is negative voltage.

5.12.3 Operation

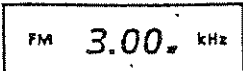
A special code is used to set the option 06 mode to ON/OFF. FM polarity switching procedures are described below:

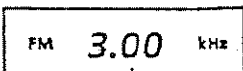
STEP	ACTION	VERIFICATION
1.	Set the carrier frequency to 500 MHz and FM modulation factor to 3.0 kHz and set the external FM modulation to ON.	
2.	Key-in special code 12 to set the reversed mode.	
		
3.	Check that the modulation display section is as shown on the right and that the FM polarity is set to the reversed mode.	
4.	Key-in special code 11 to set the non-reversed mode.	
		
5.	Check that the modulation display section is as shown on the right and that the FM polarity is set to the non-reversed mode.	

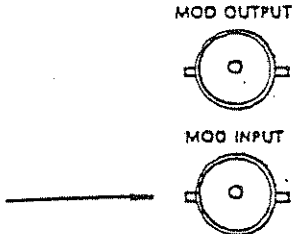
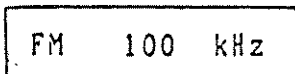
STEP	ACTION	VERIFICATION
4.	<u>External modulation signal input</u> Input an AM signal (20 Hz to 100 kHz) to the MOD INPUT terminal from an external signal source with an amplitude of 1 V _{rms} .	
5.	<u>Deviation display</u> When the external input is approx. 1 V _{rms} (HI and LO lamp off), the frequency deviation displays approx. 100 kHz as shown on the right.	

Notes:

1. The display accuracy is the percentage of the difference between the full-scale display (display at maximum input of approx. 1 V_{rms}) and the deviation set value, at that time, to the set value.

$$\text{Display accuracy} = \frac{\text{Deviation set value} - \text{Maximum input display}}{\text{Deviation set value}} \times 100 (\%)$$

2. The modulation accuracy is determined by the display accuracy ($\pm 4\%$) and the set accuracy of the mainframe ($\pm 5\%$), and is $\pm 9\%$ of the display at the maximum full scale point.
3. The display can not be 0 when an external signal is not applied. Part 3 of paragraph 5.13.3 explains that 0 is displayed, but actually a value is displayed due to the influence of the internal detection circuit offset voltage. The value appears to indicate modulation, but actually there is no modulation. This residual value display depends on the set value and is expressed by the following equation:

$$\text{Residual display} = \text{Deviation set value} \times 0.01$$

Therefore, a maximum residual value of 1% is displayed when no signal is input.

5.12.3 Operation

A special code is used to set the option 06 mode to ON/OFF. FM polarity switching procedures are described below:

STEP	ACTION	VERIFICATION
1.	Set the carrier frequency to 500 MHz and FM modulation factor to 3.0 kHz and set the external FM modulation to ON.	
2.	Key-in special code 12 to set the reversed mode.	
	<div style="display: flex; align-items: center; gap: 10px;"> <div style="border: 1px solid black; padding: 2px;"> <small>SPCL</small> STATUS </div> <div style="border: 1px solid black; padding: 2px;">1</div> <div style="border: 1px solid black; padding: 2px;">2</div> </div>	
3.	Check that the modulation display section is as shown on the right and that the FM polarity is set to the reversed mode.	<div style="border: 1px solid black; padding: 5px; display: inline-block;"> FM 3.00 kHz </div>
4.	Key-in special code 11 to set the non-reversed mode.	
	<div style="display: flex; align-items: center; gap: 10px;"> <div style="border: 1px solid black; padding: 2px;"> <small>SPCL</small> STATUS </div> <div style="border: 1px solid black; padding: 2px;">1</div> <div style="border: 1px solid black; padding: 2px;">1</div> </div>	
5.	Check that the modulation display section is as shown on the right and that the FM polarity is set to the non-reversed mode.	<div style="border: 1px solid black; padding: 5px; display: inline-block;"> FM 3.00 kHz </div>

STEP	ACTION	VERIFICATION
------	--------	--------------

4. External modulation signal input
 Input an AM signal (20 Hz to 100 kHz) to the MOD INPUT terminal from an external signal source with an amplitude of 1 V_{rms}.

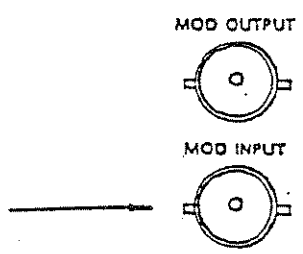

5. Deviation display
 When the external input is approx. 1 V_{rms} (HI and LO lamp off), the frequency deviation displays approx. 100 kHz as shown on the right.

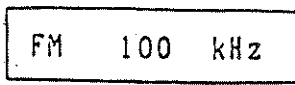

Notes:

1. The display accuracy is the percentage of the difference between the full-scale display (display at maximum input of approx. 1 V_{rms}) and the deviation set value, at that time, to the set value.

$$\text{Display accuracy} = \frac{\text{Deviation set value} - \text{Maximum input display}}{\text{Deviation set value}} \times 100 (\%)$$

2. The modulation accuracy is determined by the display accuracy ($\pm 4\%$) and the set accuracy of the mainframe ($\pm 5\%$), and is $\pm 9\%$ of the display at the maximum full scale point.
3. The display can not be 0 when an external signal is not applied. Part 3 of paragraph 5.13.3 explains that 0 is displayed, but actually a value is displayed due to the influence of the internal detection circuit offset voltage. The value appears to indicate modulation, but actually there is no modulation. This residual value display depends on the set value and is expressed by the following equation:

$$\text{Residual display} = \text{Deviation set value} \times 0.01$$

Therefore, a maximum residual value of 1% is displayed when no signal is input.

Example:

If the external modulation input is set to 0, the following residual value is displayed:

Maximum 0.1 kHz when deviation set value 10 k

Maximum 1 kHz when deviation set value 100 k

Maximum 2 kHz when deviation set value 199 k

5.13.4 Variableness of frequency deviation

The frequency deviation can be changed using the following procedures after following the basic operation procedures described in paragraph 5.13.3.

STEP	ACTION	VERIFICATION
1.	<u>Lower deviation</u> Lower the external modulation signal level. For example, when 1 V _{rms} is reduced to 0.1 V _{rms} , the deviation will be approx. 10.0 kHz.	<div style="border: 1px solid black; padding: 5px; display: inline-block;">FM 100 kHz</div> ↓ <div style="border: 1px solid black; padding: 5px; display: inline-block;">FM 10.0 kHz</div> ↓
2.	<u>Raise deviation</u> Raise the external modulation signal level. For example, when the level is changed from 0.1 V _{rms} to 0.1 V _{rms} . The deviation will be approx. 50 kHz.	<div style="border: 1px solid black; padding: 5px; display: inline-block;">FM 50.0 kHz</div> ↓

(continued)

STEP	ACTION	VERIFICATION
3.	<u>Further the external modulation signal level</u> When the external modulation signal is raised further, the display will change from 100 to 101 and 102 at a modulation point that is slightly higher than $1 V_{rms}$. At a modulation point higher than 102, decimal points and blanks are displayed, which represents the over-range display. Reduce the level so that the HI lamp goes off.	<div style="border: 1px solid black; padding: 5px; display: inline-block;">FM 100 kHz</div> ↓ <div style="border: 1px solid black; padding: 5px; display: inline-block;">FM 101 kHz</div> ↓ <div style="border: 1px solid black; padding: 5px; display: inline-block;">FM 102 kHz</div> ↓ <div style="border: 1px solid black; padding: 5px; display: inline-block;">FM ... kHz</div>

5.13.5 Superimposition with internal modulation

The display for external modulation superimposition with internal modulation is explained below. This follows the operation described in paragraph 5.13.4.

STEP	ACTION	VERIFICATION
1.	Set the external modulation signal level to 0.5 V _{rms} . The deviation display will be approx. 50.0 kHz.	<div style="border: 1px solid black; padding: 5px; display: inline-block;">FM 50.0 kHz</div>
2.	<u>Setting internal modulation to ON</u> Key-in INT FM.	↓ <div style="border: 1px solid black; padding: 5px; display: inline-block;">FM 150 kHz</div>
	<div style="border: 1px solid black; padding: 2px; display: inline-block; margin-left: 20px;"> INT FM ON </div>	
3.	The FM deviation display changes from 50.0 kHz to 150 kHz.	
4.	<u>FM deviation re-setting</u> Set the FM deviation to 50 kHz by key-entry.	↓
	<div style="display: flex; align-items: center; gap: 10px; margin-left: 20px;"> <div style="border: 1px solid black; padding: 2px; display: inline-block;"> FM 0M </div> <div style="border: 1px solid black; padding: 2px; display: inline-block;">5</div> <div style="border: 1px solid black; padding: 2px; display: inline-block;">0</div> <div style="border: 1px solid black; padding: 2px; display: inline-block;">kHz/dBμ</div> </div>	<div style="border: 1px solid black; padding: 5px; display: inline-block;">FM 75.0 kHz</div>
	The deviation display will be approx. 75 kHz as shown on the right.	

5.13.6 Option 07 mode cancel

The option 07 mode is cancelled using the following procedures:

STEP	ACTION	VERIFICATION
1.	Option 07 mode cancellation Key-in special code 39.	<div style="border: 1px solid black; padding: 5px; display: inline-block;"> FM 75.0 kHz </div>
2.	<u>Deviation display restoration</u> The deviation display returns to the ordinary modulation state.	<div style="text-align: center;">↓</div> <div style="border: 1px solid black; padding: 5px; display: inline-block;"> FM 50.0 kHz </div>

Note:

Even if the option 07 mode is cancelled, the internal and external simultaneous modulation state is maintained in the above condition.

5.13.7 Precautions on use

Attention must be paid to the following points when using option 07.

- (1) Option 07 cannot be used for ϕ M (phase modulation).
- (2) Option 07 does not respond to direct current at dc FM. The response frequency range is 20 Hz to 100 kHz.
- (3) When the external, independent FM modulation is selected in SP34 and option 07 is also selected, the deviation display will change but the modulation accuracy is not guaranteed. Therefore, in this state, the modulation factor must be confirmed using an FM linear detector.

5.13.8 Others

1. Since option 07 is backed-up, the setting is stored and retained even when the power is cut off. Therefore, when the power is turned on again, option 07 need not be reset.

5.14 STATUS

The STATUS LED lights if a function item exceeding the prescribed range is set. Press the [SHIFT] key then hold the [STATUS] key down to display the status code.



In addition, the special function setting status can be confirmed by pressing the [SPCL] [SHIFT] [STATUS] keys (see paragraph 5.11.1).

Note:

The [STATUS] LED lights if the error code is other than EE00 (normal).

Error code priority

Highest priority

[EE 51] → [EE 01, 02, 03, 11, 21, 22, 31, 32, 33, 39, 41, 42, 43, 61] → [EE 81]

[EE 82] → [EE 95] → EE 91] → [EE 92] → [EE 94] → [EE 93] → [EE 00]

Table 5-5 Error Codes

Function	Error code	Explanation	
ALL FUNCTION	EE01	Too much input data	
	02	Error input	
	03	Data outside data setting range	
MODULATION	EE11	Modulation frequency selected at MOD OFF	
MEMORY	EE21	Data not stored because memory protected	
	EE22	No data at recalled memory	
SPECIAL FUNCTION	EE31	Special function not registered	
	EE32	RAM check error	
	EE33	ROM check error	
Others	EE51	Reverse power protection circuit operation	
UNCAL	EE91	LEVEL UNCAL	} The status is always set at UNCAL. If another error occurs, the error is handled according to the priority rules. (Among UNCALS, the priority (from high to low) is FREQ, LEVEL, FM, ϕ M, and AM.)
	EE92	FM UNCAL	
	EE93	AM UNCAL	
	EE94	ϕ M UNCAL	
	EE95	FREQ UNCAL	
Normal	EE00		
Option	EE41	AF oscillator not set	
	EE42	VIDEO not set	
GP-IB	EE61	Read error	
Offset	EE82	Output level offset	



SECTION 6
MEASUREMENT

This section mainly explains how to measure the sensitivity and selectivity of receivers as typical measurement examples using the MG3601A/MG3602A Signal Generator. The reception frequency values of the receivers, that is, the frequency values set in the signal generator, are given only as examples.

In addition, the signal generator is assumed to be in the initial state before measurements are started.

TABLE OF CONTENTS

	Page
SECTION 6 MEASUREMENT	
6.1 Measuring Sensitivity	6-1
6.1.1 Measuring 20 dB NQ sensitivity	6-2
6.1.2 Measuring 12 dB SINAD sensitivity	6-5
6.2 Measuring One-Signal Selectivity	6-8
6.2.1 Using 20 dB NQ method to measure FM receiver selectivity	6-8
6.2.2 Measuring spurious response	6-14
6.3 Measuring Two-Signal Selectivity	6-19
6.3.1 Measuring blocking effect of FM receiver	6-20
6.3.2 Measuring cross-modulation characteristics	6-26



6.1 Measuring Sensitivity

The sensitivity of a receiver is the minimum signal input level required to obtain the rated signal output of the receiver. At this time, the signal level, noise level, and signal distortion of the output are handled as follows:

1. AM receiver

The sensitivity is indicated by the minimum value of the standard modulated carrier voltage required to obtain the rated signal output at the specified S/N ratio.

For example, the minimum value of the 60%-modulated carrier input voltage required to obtain the 50 mW signal output when $S/N = 20$ dB, is 10 μ V.

2. FM receiver

The sensitivity is indicated by the minimum value of the standard deviated carrier voltage required to obtain the rated output at the specified value of signal to noise and distortion (SINAD) (for example, -12 dB for the 400 MHz band). In addition, the minimum value of the carrier voltage required to suppress by 20 dB the noise output of the receiver when no signal is being received can also be used. This is called the 20 dB noise quieting (NQ) sensitivity.

This paragraph explains how to measure the 20 dB NQ sensitivity and 12 dB SINAD sensitivity.

6.1.1 Measuring 20 dB NQ sensitivity

The 20 dB noise quieting (NQ) sensitivity is the minimum carrier input voltage (output voltage read on the signal generator) required to suppress the noise output by 20 dB when no signal is being input. Obtain the noise output before suppression by using the volume controller of the low-frequency amplification stage so that the rated signal output can be obtained.

(1) Setup

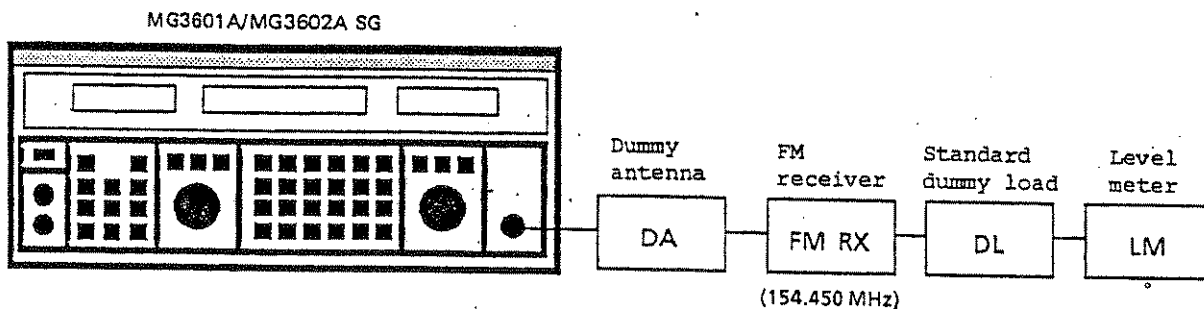

Fig. 6-1 20 dB NQ Sensitivity Measurement

(2) Measurement procedures

Step	Procedure
------	-----------

- 1 Set the MG3601A/MG3602A to 154.45 MHz as shown below.



- 2 Set the frequency deviation of the signal generator (SG) to 70% of the specified maximum frequency deviation. If the specified maximum frequency deviation is 5 kHz, for example, set the frequency deviation of the SG to 3.5 kHz. Also, set the internal modulation frequency to 1 kHz.



- 3 Set the output level of the SG high enough (usually, to 30 dBμ or more), then supply it to the receiver.



- 4 Tune the receiver to receive frequency 154.45 MHz (so that the deflection of the level meter (LM) is maximum). Adjust the volume controller of the low-frequency amplification stage of the receiver so that the rated output can be obtained from the receiver according to the LM indication.

Step	Procedure
------	-----------

- 5 Turn the SG output OFF. Also, turn the squelch of the receiver OFF.

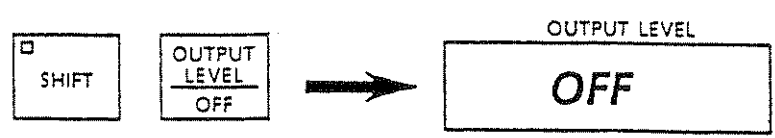

- 6 Use the level meter to measure the noise output of the receiver, and set the meter indication to 0 dB.
- 7 Set the SG modulation to OFF. Set the SG output to ON and set the output level resolution to 0.1 dB.

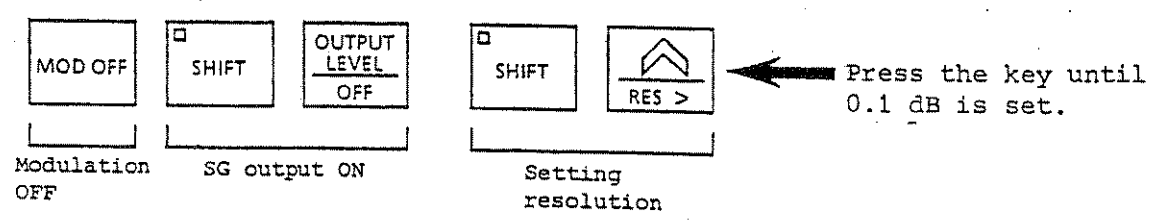

- 8 Operate the step key and output setting knob in the OUTPUT section of the SG so that the LM indicates -20 dB.

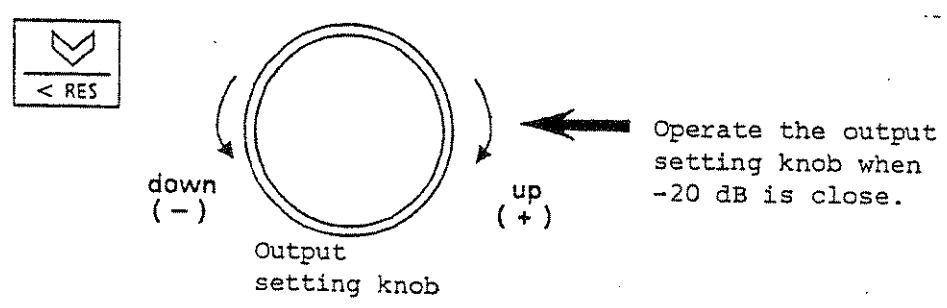

The value read on the OUTPUT LEVEL display of the SG is the 20 dB NQ sensitivity.

6.1.2 Measuring 12 dB SINAD sensitivity

The SINAD sensitivity is indicated by the output level of the signal generator when the distortion factor reaches the prescribed value (-12 dB for the 400 MHz band in Japan) by lowering the output level of the SG while measuring the distortion of the receive demodulation output (to be exact, output and noise) of the standard modulated signal.

(1) Setup

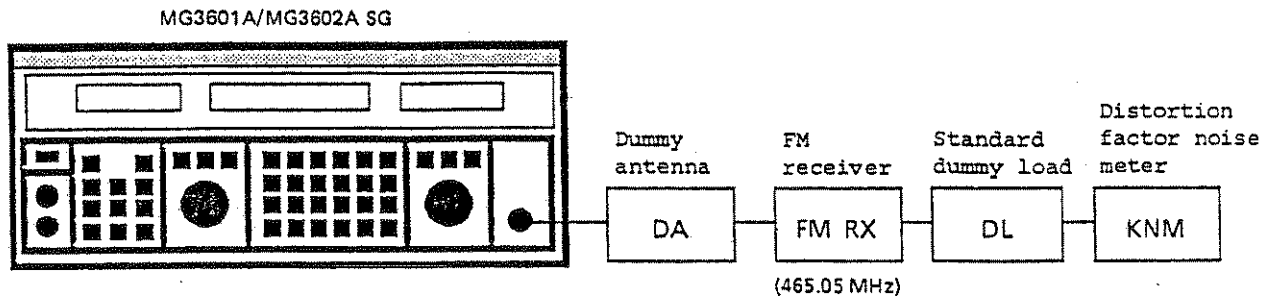

Fig. 6-2 12 dB SINAD Sensitivity Measurement

(2) Measurement procedures

Step	Procedure
------	-----------

- 1 Set the MG3601A/MG3602A to 465.05 MHz as shown below.

CENTER FREQ ΔF	4	6	5	* • FRL	0	5	MHz/dBm
----------------------	---	---	---	---------------	---	---	---------

- 2 Set the frequency deviation of the SG to 70% of the specified maximum frequency deviation. If the specified maximum frequency deviation is 5 kHz, for example, set the frequency deviation of the SG to 3.5 kHz. Also, set the internal modulation frequency to 1 kHz.

FM ØM	3	* • FRL	5	kHz/dBμ
----------	---	---------------	---	---------

- 3 Set the output level of the SG high enough (usually, to 30 dBμ or more), then supply it to the receiver.

OUTPUT LEVEL OFF	3	0	kHz/dBμ
------------------------	---	---	---------

- 4 Turn the squelch of the receiver OFF, then tune the receiver to receive frequency 465.05 MHz (so that the deflection of the KNM-is maximum). Adjust the volume controller of the low frequency amplification stage of the receiver so that the rated output can be obtained from the receiver according to the KNM indication.

(cont'd)

Step	Procedure
------	-----------

- 5 Set the SG output level resolution to 0.1 dB.

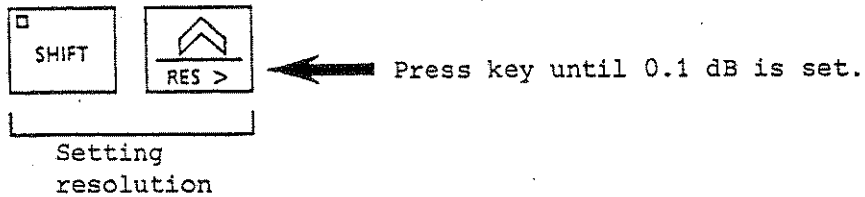

- 6 Operate the step key and output setting knob in the OUTPUT section of the SG so that the SINAD indication value of the KNM is -12 dB.

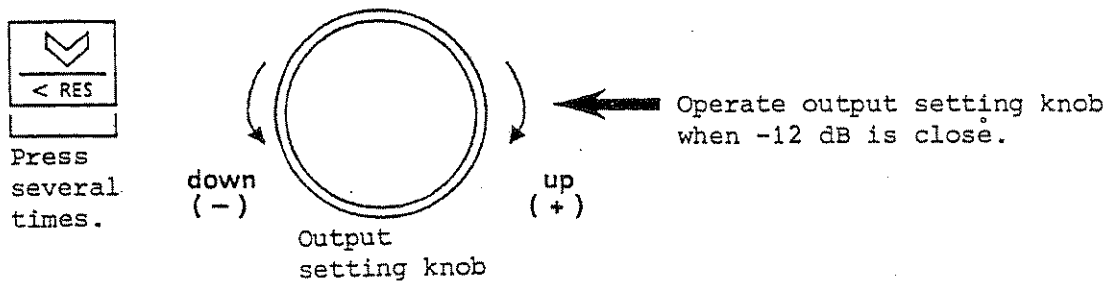

The value read on the OUTPUT LEVEL display of the SG is the 12 dB SINAD sensitivity.

6.2 Measuring One-Signal Selectivity

The one-signal selectivity measurement is performed when the desired wave and interference wave are weak and the receiver will operate in the linear area. When connecting the signal generator to the input terminal of the receiver in the state where the desired wave is received, the selectivity is the relative receiver input voltage ratio required to obtain the same receiver output when the frequency is changed to the desired or interference frequency. In this measurement, the pass bandwidth, attenuation slope, and spurious response are measured.

6.2.1 Using 20 dB NQ method to measure FM receiver selectivity

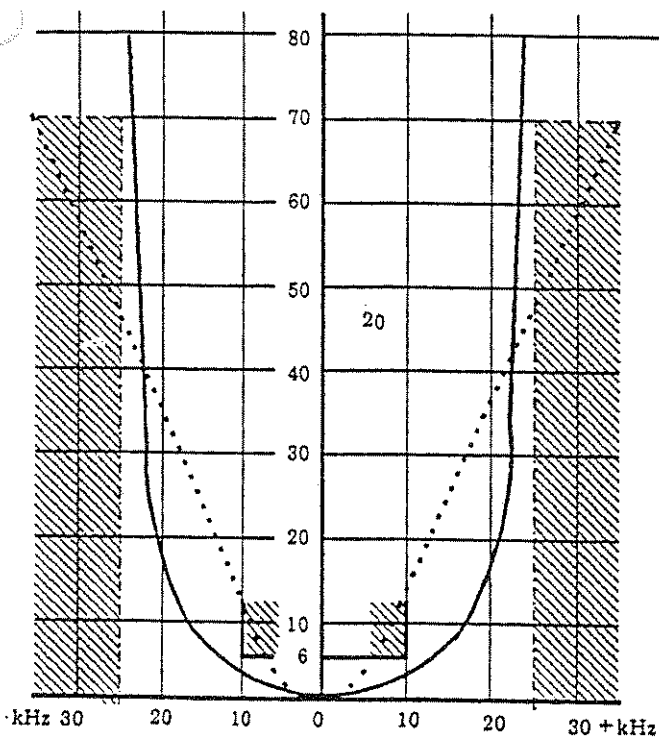

The figure on the left shows the selectivity characteristics of the 146 to 162 MHz single-channel receiver. The acceptable ranges are as follows:

- Pass bandwidth:
The width lowered by 6 dBu is 20 kHz or more.
- Attenuation:
The bandwidth lowered by 70 dBu is 50 kHz or more.

Therefore, when using the 20 dB NQ method to measure the selectivity,

- Pass bandwidth:
Obtained from the frequency width obtained by increasing the SG output to 6 dBu higher than the NQ sensitivity, and adjusting the frequency so that the output will be the same as the NQ sensitivity again.
- Attenuation:
Obtained in the same way as above except for increasing the output by 70 dBu instead of 6 dBu.

The characteristic curve must not overlap the shaded parts.

The solid-line curve is acceptable; the dashed-line curve is unacceptable.

(1) Setup

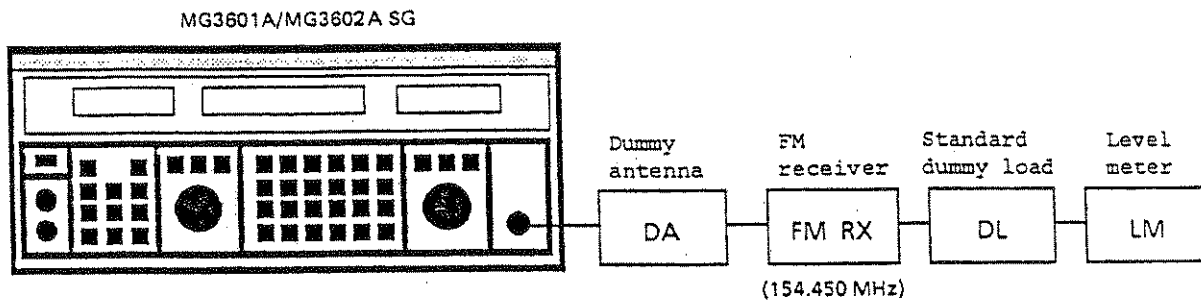
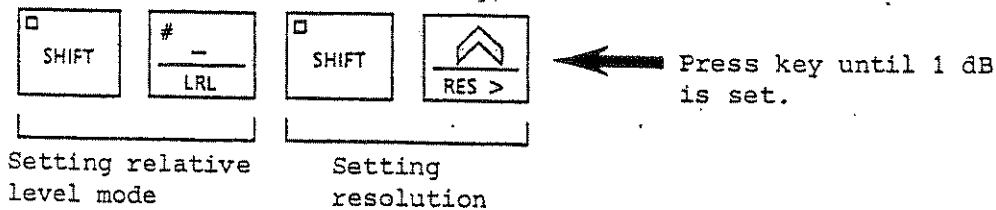

Fig. 6-3 Using 20 dB NQ Method of Measure Selectivity

(2) Measurement procedures 1 -- Pass bandwidth

Step	Procedure
------	-----------

- 1 Set the frequency and output level of the SG, and FM RX in the same way as in 20 dB NQ sensitivity measurement (see paragraph 6.1.1).
- 2 Set the SG to the relative level mode; set the output level resolution to 1 dB.



- 3 Turn the output setting knob clockwise to increase the output level of the SG to 6 dB higher than the 20 dB NQ sensitivity.

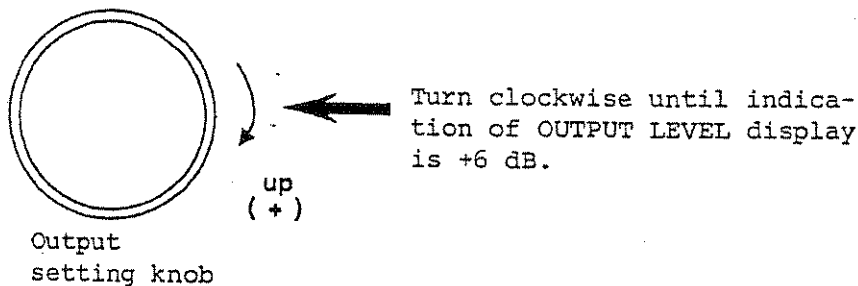

- 4 Set the SG to TUNE mode; set the output frequency resolution to 1 kHz.

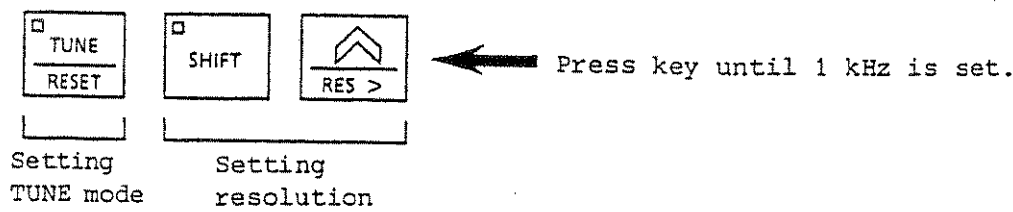

Step

Procedure

- 5 Turn the TUNE knob counterclockwise to lower the frequency and obtain the frequency where the 20 dB NQ sensitivity is indicated again.

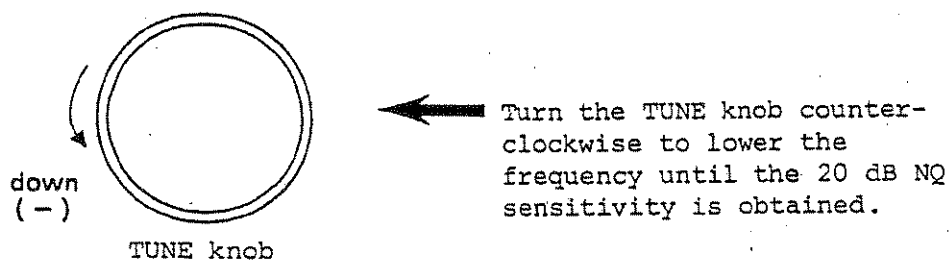

- 6 Set the SG to the relative frequency mode.

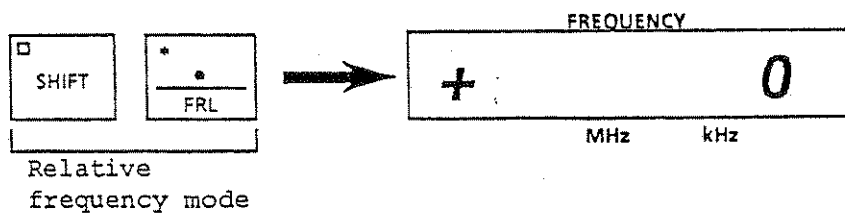

- 7 Turn the TUNE knob clockwise to increase the frequency and obtain the frequency where the 20 dB NQ sensitivity is indicated again.

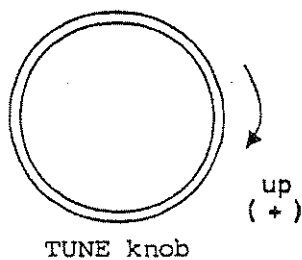

The value on the SG FREQUENCY display is the pass bandwidth.

(3) Measurement procedures 2 -- Attenuation

Step	Procedure
------	-----------

- 1 Set the frequency and output level of the SG, and FM RX in the same way as in 20 dB NQ sensitivity measurement (see paragraph 6.1.1).
- 2 Set the SG to the relative level mode; set the output level resolution to 10 dB.

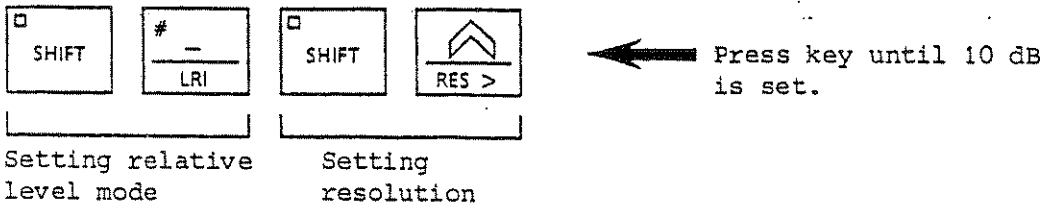

- 3 Turn the output setting knob clockwise to increase the output level of the SG to 70 dB higher than the 20 dB NQ sensitivity.

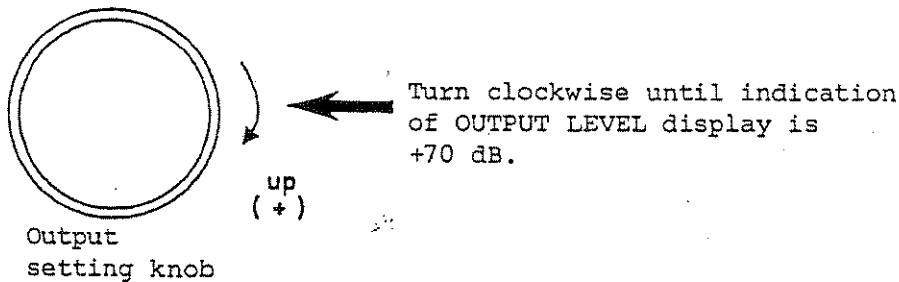

- 4 Set the SG to the TUNE mode; set the output frequency resolution to 1 kHz.

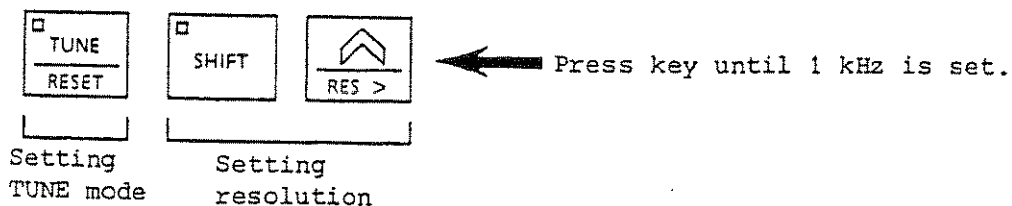

(cont'd)

Step

Procedure

- 5 Turn the TUNE knob counterclockwise to lower the frequency and obtain the frequency where the 20 dB NQ sensitivity is indicated again.

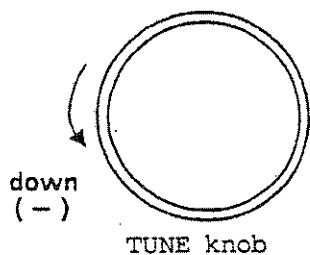

← Turn TUNE knob counterclockwise to lower frequency until 20 dB NQ sensitivity is obtained.

- 6 Set the SG to the relative frequency mode.

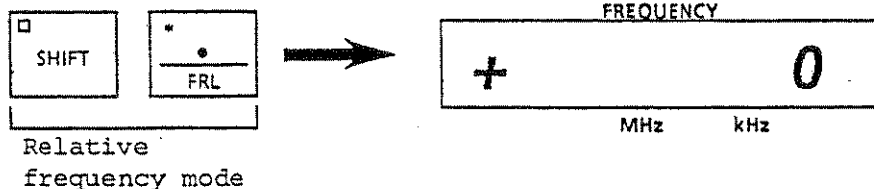

- 7 Turn the TUNE knob clockwise to increase the frequency and obtain the frequency where the 20 dB NQ sensitivity is indicated again.

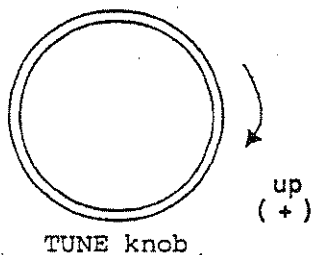

The value on the SG FREQUENCY display is the attenuation of the bandwidth lowered by 70 dB μ .

6.2.2 Measuring spurious response

The spurious sensitivity is low when the difference between the receiver output obtained by receiving the desired modulated frequency and the receiver output obtained by receiving the modulated spurious frequency is large. To measure the spurious response, adjust the SG output level of the spurious frequency so that both receiver outputs are equal. Then, obtain the difference between the level and the SG output level of the desired frequency.

Assuming the desired frequency to be f_d , receiver IF to be f_i , and receiver local to be f_L , the spurious frequency f_s is:

. Image frequency interference:

$$[f_s = f_L \pm f_i = f_d \pm 2f_i]$$

. Harmonic interference:

$$[f_s = f_L \pm f_i/2, f_s = n = f_d \pm f_i/2]$$

When a frequency is received that causes the difference from the local oscillation frequency to be $f_i/2$, the second harmonic of $f_i/2$ becomes the intermediate frequency and interference occurs.

. Local oscillation frequency harmonic interference:

$$[f_s = nf_L \pm f_i]$$

An example for $f_d = 154.450$ MHz, $f_s = f_d + 2f_i$, and $f_i = 10.7$ MHz is given here.

(1) Setup

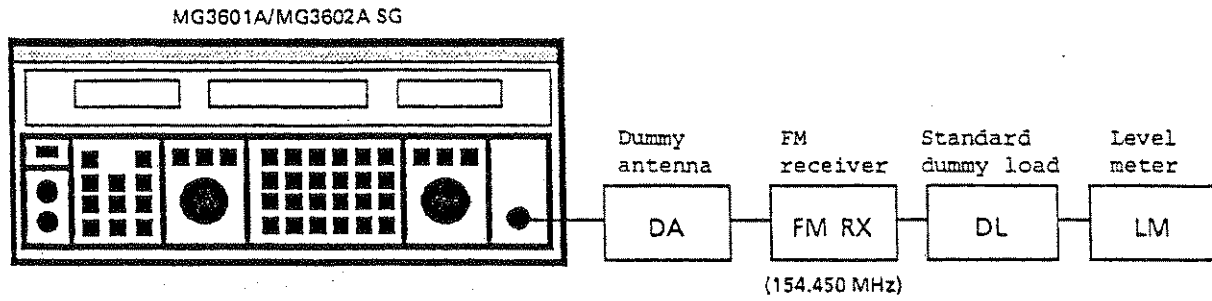

Fig. 6-4 Spurious Sensitivity Measurement

(2) Measurement procedures

Step	Procedure
------	-----------

- 1 Set the MG3601A/MG3602A to the required frequency
 $f_d = 154.45$ MHz.



- 2 Set the frequency deviation of the SG to 70% of the specified maximum frequency deviation.
 If the specified maximum frequency deviation is 5 kHz, for example, set the frequency deviation of the SG to 3.5 kHz. Also, set the internal modulation frequency to 1 kHz.



- 3 Set the output level of the SG high enough (usually, to -83 dBm or more), then supply it to the receiver.



- 4 Tune the receiver to receive the 154.45 MHz frequency (so that the deflection of the LM is maximum).
 Adjust the volume controller at the low frequency amplification stage (at the initial stage, if possible) of the receiver so that the rated output can be obtained from the receiver according to the LM indication.

Step	Procedure
------	-----------

5 Set the SG to the relative frequency mode.

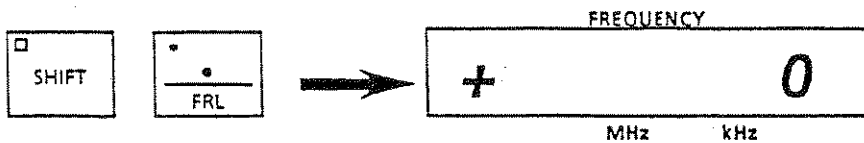

6 Supply spurious frequency $f_s = f_d + 2f_i$ to the receiver while keeping the receiver status and the modulation frequency and frequency deviation of the SG as is.

For the spurious frequency, add $2 \times \Delta F = 2 \times 10.7$ MHz in the relative frequency mode.

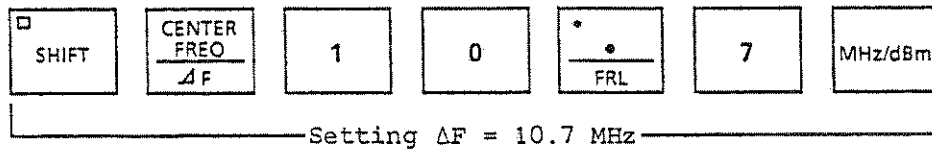

Press the FREQUENCY section [Λ] key.

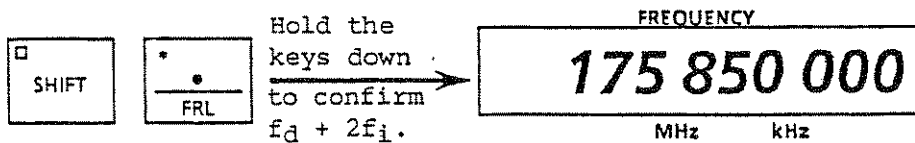

7 Set the SG to the relative level mode.

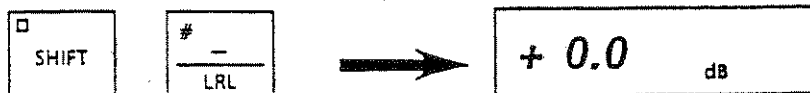

Step	Procedure
------	-----------

- 8 Set the SG Output level resolution to 1 dB.

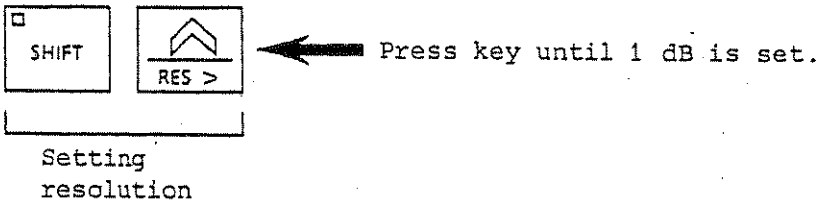

- 9 Operate the step key and output setting knob in the OUTPUT section of the SG so that the LM indicates the same value as the rated output in step 4.

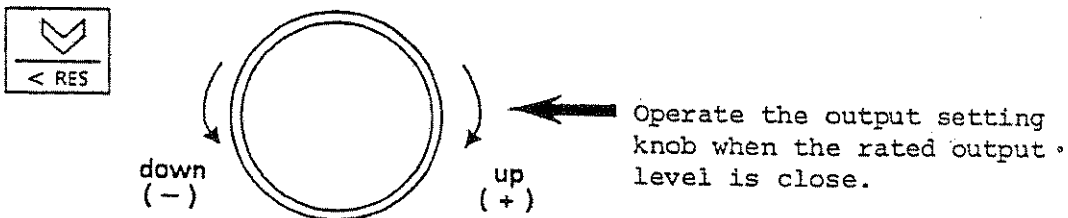

The value on the SG OUTPUT LEVEL display is the spurious sensitivity.

6.3 Measuring Two-Signal Selectivity

In conventional one-signal selectivity measurements, the input signal level must be changed from around 0 dB μ up to around 100 dB μ to measure the selectivity using the fixed-output method.

Because of such a large change in the level, it is generally difficult for amplifiers to always operate linearly and accurately. Usually, amplifiers operate linearly when the level is changed by up to 20 or 30 dB. For a larger change, however, the sensitivity is lowered at high signal input due to the saturation of the amplification degree etc., which causes errors in the measurement values.

The two-signal selectivity (or effective selectivity) measurement is more suited to the actual receiver status. This selectivity can directly indicate the interference separation capability of the receiver. That is, it indicates the maximum allowable input level of the interference wave for suppressing the interference wave in the receiver output down to a fixed value while receiving the desired wave. The following items are included.

1. Blocking effect
2. Cross-modulation characteristics
3. Inter-modulation characteristics

6.3.1 Measuring blocking effect of FM receiver

When both the desired wave and interference wave are not modulated, by supplying the interference wave separated by Δf kHz from the desired wave when the desired input voltage 6 dB higher than the input voltage required for suppressing the noise by 20 dB has been supplied, the blocking effect is indicated by the input level of the interference wave where the noise is suppressed by 20 dB. By measuring the input level of the interference wave by changing its frequency, the characteristics shown in the figure are obtained.

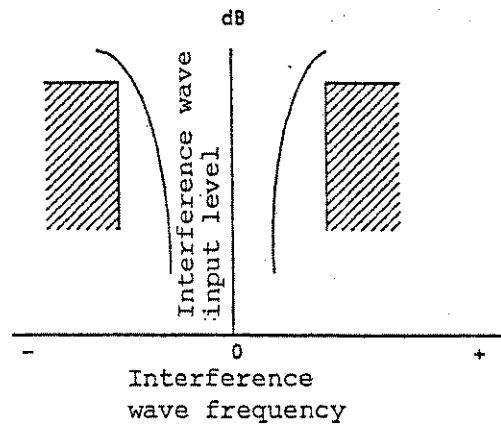

This paragraph explains the measurement procedures where the desired wave is 154.450 MHz and the interference wave is ± 40 kHz \times n the desired wave.

(1) Setup

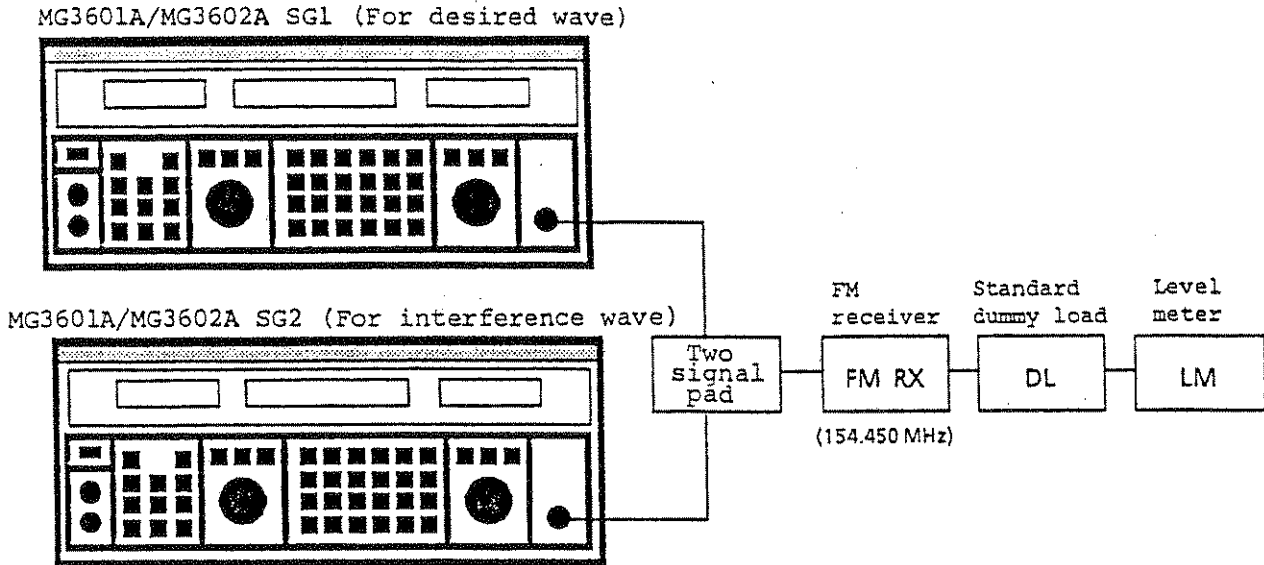

Fig. 6-5 Two-signal Selectivity Measurement

(2) Measurement procedures

Step	Procedure
1	Set the SG2 output to OFF.
2	<p>Set the frequency and output level of the SG1, and FM RX in the same way as in 20 dB NQ sensitivity measurement (see paragraph 6.1.1).</p> <p>Assume the noise level to be V_N dB at this time.</p>

(cont'd)

Step	Procedure
3	Set the SG1 output to OFF. Set the frequency and output level of the SG2, and FM RX in the same way as in 20 dB NQ sensitivity measurement (see paragraph 6.1.1). Assume the noise level to be V_N dB at this time.
4	Set the SG2 output to OFF and the SG1 output to on again.
5	Set the SG1 to the relative level mode. Set the output level resolution to 1 dB.

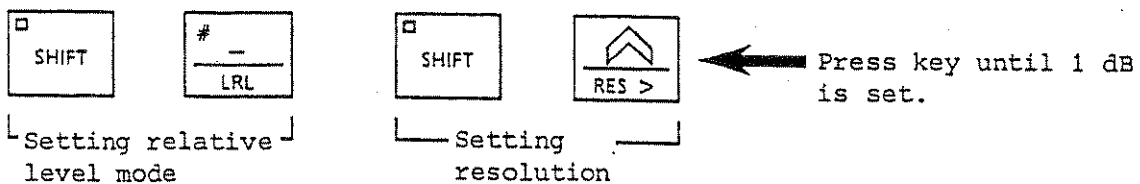

- 6 Turn the output setting knob of the SG1 clockwise to increase the output level to 6 dB higher than the 20 dB NQ sensitivity.

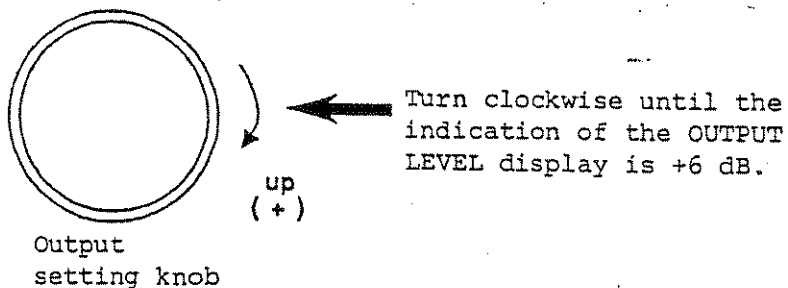

- | Step | Procedure |
|------|---|
| 7 | Hold the SG1 in the status of step 5. Set the SG2 output to ON and set it to the relative frequency mode. |

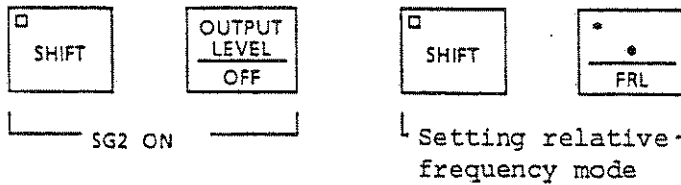

- | | |
|---|---|
| 8 | Set the SG2 to the relative level mode and set the output level resolution to 1 dB. |
|---|---|

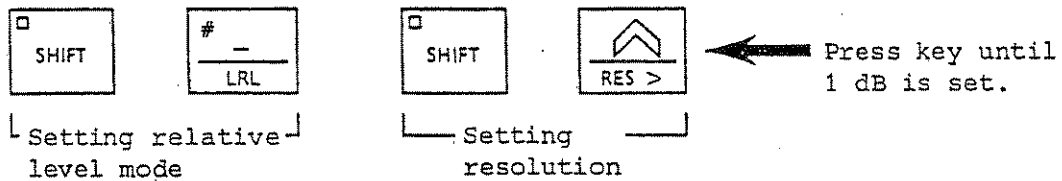

- | | |
|---|---|
| 9 | Set ΔF of the SG2 to 40 kHz and set the SG2 to the TUNE mode. |
|---|---|

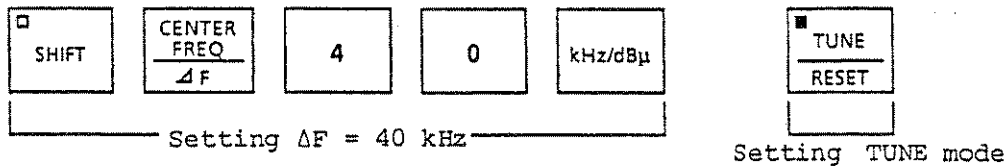

- | | |
|----|---|
| 10 | Adjust the output setting knob of the OUTPUT LEVEL section of the SG2 so that the noise output of the receiver is V_N dB in step 2 each time the [\wedge] key of the FREQUENCY section is pressed. At this time, the value indicated by the OUTPUT LEVEL display is the interference wave input level (dB) at $\Delta F \times n$ more than the desired wave. |
|----|---|

Step

Procedure

10
(cont.)

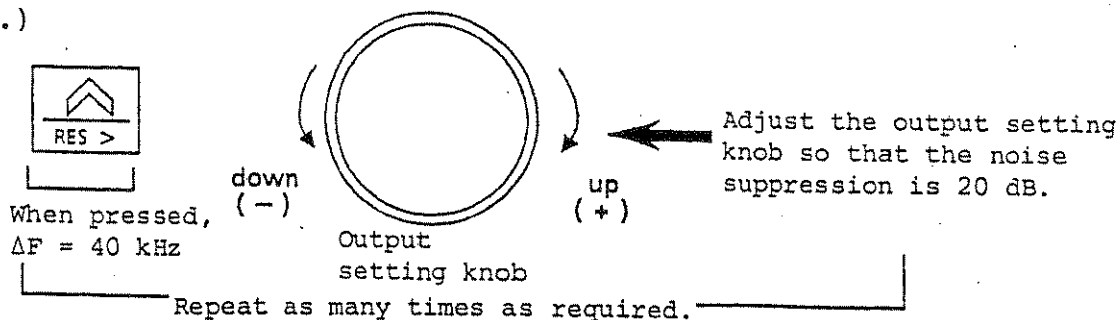

11 Reset the SG2 frequency to the frequency when the TUNE mode was set (this is the desired frequency value set in steps 2 and 3).

Also, reset the SG2 output level to the level when the relative level mode was set in step 7.

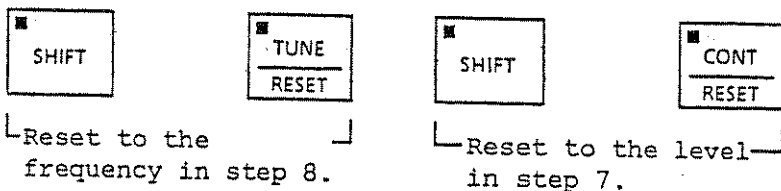

12 Adjust the output setting knob of the OUTPUT LEVEL section of the SG2 so that the noise output of the receiver is V_N dB in step 2 each time the [∇] key of the FREQUENCY section is pressed.

At this time, the value indicated by the OUTPUT LEVEL display is the interference wave input level (dB) at $\Delta F \times n$ less than the desired wave.

(cont'd)

Step

Procedure

12
(cont.)

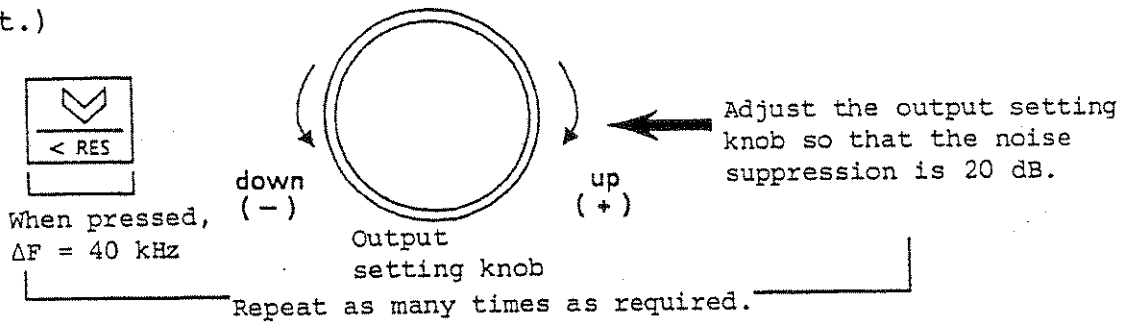

From steps 10 and 12, the following blocking characteristics are obtained.

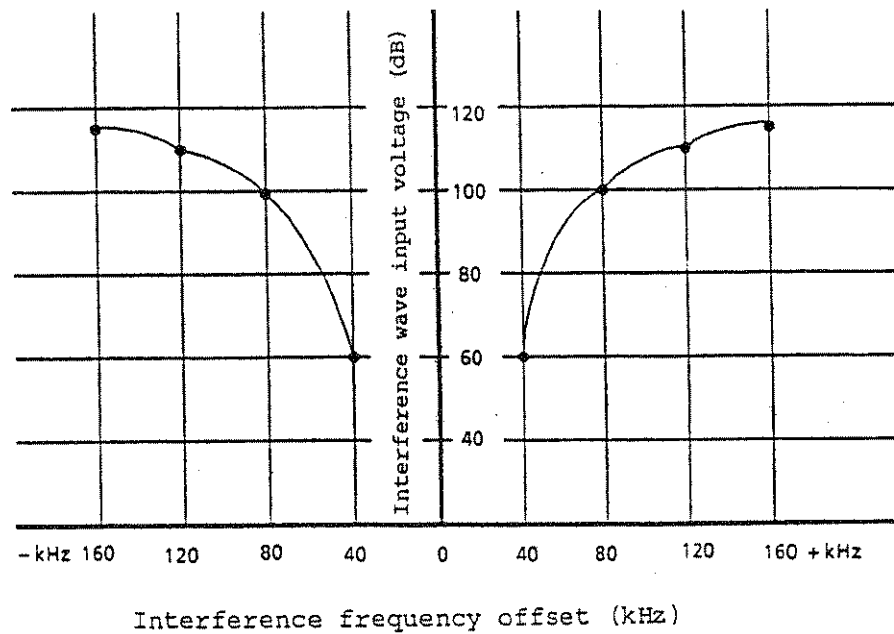

6.3.2 Measuring cross-modulation characteristics

The cross-modulation characteristics are indicated by the input level of the interference wave when the receiver output obtained when the desired signal is a non-modulated wave and there is a near-by interference modulated wave is lower than the one obtained when the desired signal is modulated wave and there is no interference wave.

Note:



When the desired receive frequency and the modulated interference wave with another frequency at a higher level are supplied to the receiver, cross-modulation indicates a symptom where the desired signal appears in the receiver output as a signal modulated by the modulation signal of the interference wave due to the non-linear operation of the receiver.

(1) Setup

Figure 6-5 shows the required setup. Measuring AM waves is explained.

In the measurement procedures, it is assumed that the desired wave is 1500 kHz and that the interference wave is ± 5 kHz $\times n$ that of the desired wave.

(2) Measurement procedures

Step	Procedure
1	Set the SG2 output (for the interference wave) to OFF. 
2	Set the SG1 frequency (for the desired wave) to 1500 kHz. 
3	Set the AM modulation factor of the SG1 to 30% and the internal modulation frequency to 400 Hz. 
4	Tune the receiver to receive frequency 1500 kHz (so that the deflection of the LM is maximum). Set the AGC of the receiver to OFF and adjust the receiver to the optimum status.

Step	Procedure
------	-----------

- 5 Set the output level resolution of the SG1 to 0.1 dB.

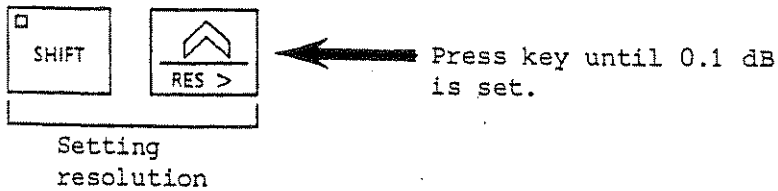

- 6 Operate the step key and output setting knob in the OUTPUT section of the SG1 so that the LM indicates the rated signal output.

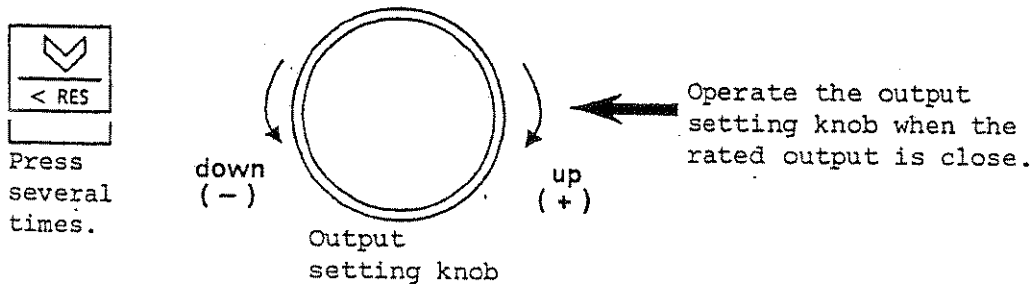

- 7 Assume the value of the SG1 OUTPUT LEVEL display in step 6 to be E_1 dB μ .

- 8 Set the SG1 modulation (for the desired wave) to OFF.
Set the SG2 output (for the interference wave) to ON.

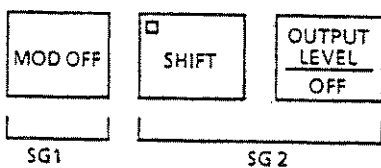

(cont'd)

Step

Procedure

- 9 Set the SG2 (for the interference wave) to 1500 kHz.

CENTER FREQ ΔF	1	5	0	0	kHz/dBμ
----------------------	---	---	---	---	---------

- 10 Set the SG2 output level so that it is the same as the SG1 output level (E_1 dBμ) in step 7. For example, if the SG1 output level is -2.5 dBμ, set as follows:

OUTPUT LEVEL OFF	# - LRI	2	* • FRL	5	% RAD/μV
------------------------	---------------	---	---------------	---	-------------

- 11 Set the modulation factor and modulation frequency of the SG2 in the same way as for the SG1 in step 3.

AM AF	3	0	% RAD/μV	□ 400Hz
----------	---	---	-------------	------------

- 12 Operate the output setting knob of the SG2. Assume the output level of the SG2 to be E_2 dBμ when the receiver output is 20 dB less than the rated signal output in step 6 (this is the cross-modulation characteristic when the interference wave is the same as the desired frequency). Assume the level 20 dB (1/10) less than the rated output to be V_S dB.

(cont'd)

Step	Procedure
------	-----------

- 13 Set the SG2 to the relative frequency and relative level modes and set the output level resolution to 1 dB.

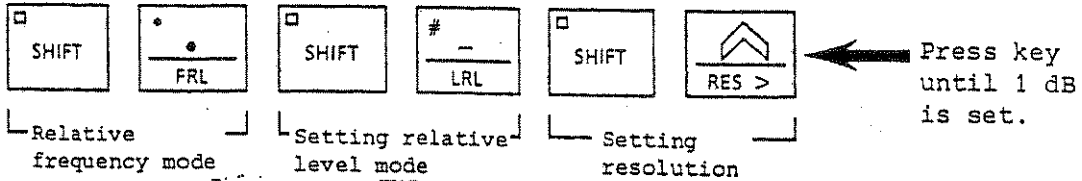

- 14 Set ΔF of the SG2 to 5 kHz and set the SG2 to the TUNE mode.

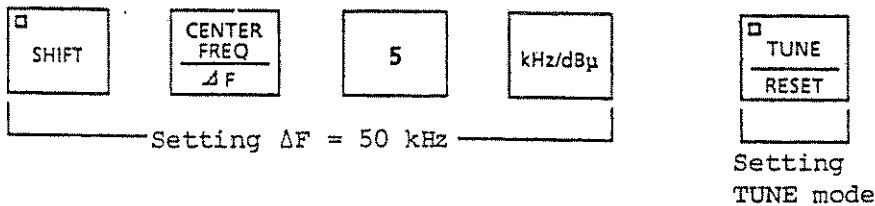

- 15 Adjust the output setting knob of the OUTPUT LEVEL section of the SG2 so that the noise output of the receiver is V_S dB in step 12 each time the [\wedge] key of the FREQUENCY section is pressed. At this time, the value indicated by the OUTPUT LEVEL display is the interference wave input level (dB) at $\Delta F \times n$ more than the desired wave.
-

Step	Procedure
------	-----------

15
(cont.)

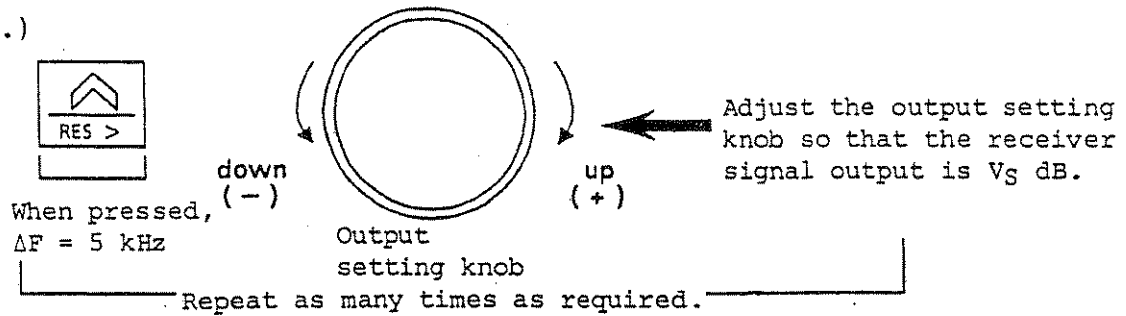

16 Reset the SG2 frequency to the frequency when the TUNE mode was set (this is the required frequency value set in step 9).

Also, reset the SG2 output level to the level when the relative level mode was set in step 13.

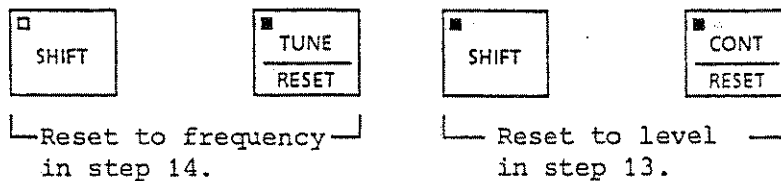

17 Adjust the output setting knob of the OUTPUT LEVEL section of the SG2 so that the noise output of the receiver is V_S dB in step 12 each time [∇] key of the FREQUENCY section is pressed.

At this time, the value indicated by the OUTPUT LEVEL display is the interference wave input level (dB) at $\Delta F \times n$ less than the desired wave.

(cont'd)

Step	Procedure
------	-----------

17
(cont.)

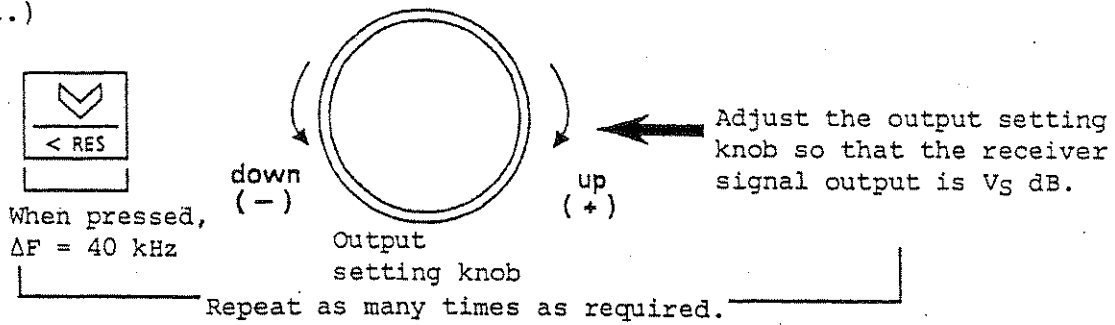

From steps 15 and 17, the following selectivity characteristic with cross-modulation considered are obtained.

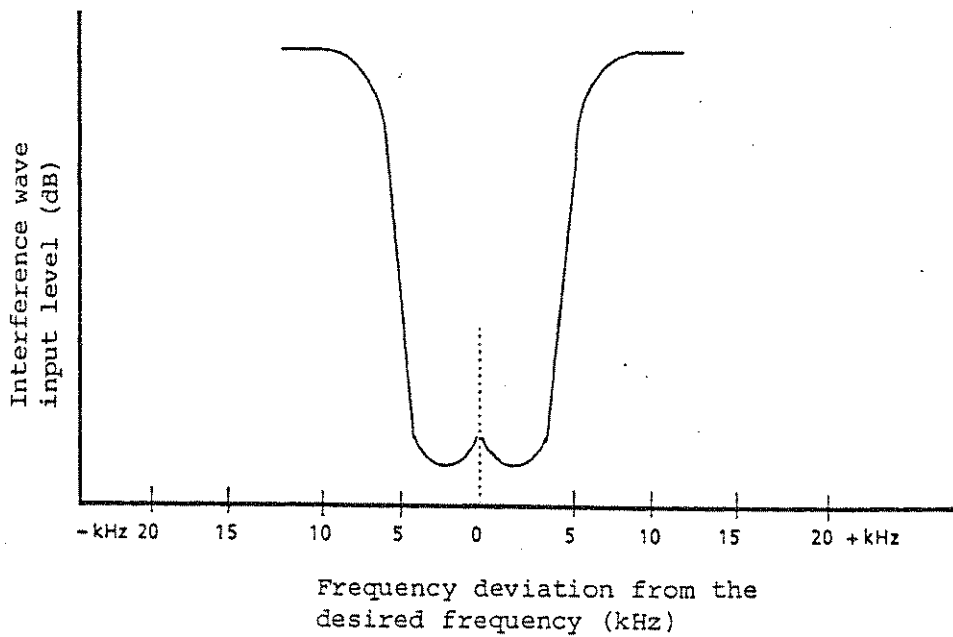

SECTION 7
PRINCIPLES OF OPERATION

This section briefly explains the operation of the MG3601A/MG3602A Signal Generator.

TABLE OF CONTENTS

	Page
SECTION 7 PRINCIPLES OF OPERATION	
7.1 Outline	7-1
7.2 Block Explanation	7-1



7.1 Outline

The MG3601A/MG3602A mainly consists of the following sections. Figure 7-1 shows the MG3601A/MG3602A block diagram.

- <1> Reference oscillator
- <2> Main oscillator
- <3> Main PLL section
- <4> Subsynthesizer
- <5> Frequency divider
- <6> Output amplifier (1 GHz band)
- <7> Heterodyne section
- <8> Attenuator
- <9> Controller
- <10> Frequency doubler section
- <11> Output amplifier (2 GHz band)

7.2 Block Explanation

The following explains the blocks shown in Fig. 7-1.

- <1> Reference oscillator

The reference frequencies (1 MHz, 50 MHz, 100 MHz, 150 MHz, 200 MHz, and 600 MHz) required by the other sections are synthesized by dividing, adding, or multiplying the output signal of the reference crystal oscillator. When one of the options 01 to 03 is installed as the reference crystal oscillator, synchronization with more accurate frequencies can be performed.

<2> Main oscillator

The main oscillator oscillates at frequencies of 520 to 1040 MHz.

The output is sent to the main PLL section <3> and frequency divider <5>.

<3> Main PLL section

The main PLL section consists of a phase-locked loop for synchronizing the frequency output by the main oscillator to the reference signal. This section adds or subtracts the signal (770 to 820 MHz) from the subsynthesizer <4> and the signal (50, 100, 150, 200, 250 MHz) from the reference oscillator <1>.

<4> Subsynthesizer

The subsynthesizer outputs frequencies of 770 to 820 MHz in 10 Hz steps. This section consists of three PLL circuits. FM modulation is applied in the subsynthesizer.

<5> Frequency divider

The frequency divider obtains signals of 260 to 520 MHz or 130 to 260 MHz by halving or quartering the 520 to 1040 MHz frequencies output by the main oscillator. This section consists of the frequency divider, filter switching circuit, etc.

<6> Output amplifier (1 GHz band)

The output amplifier generates the final output level by amplifying or attenuating the output from the frequency divider <5>. This section consists of the amplification and attenuation circuits.

Part of the amplifier output is detected and compared with the reference voltage, and automatic level control (ALC) is performed to keep the output at a fixed level.

Since AM modulation is performed by modifying the reference voltage using the modulation signal, modulation with good linearity is obtained.

<7> Heterodyne section

The heterodyne section obtains signals of 100 kHz to 130 MHz by using the heterodyne method. This section consists of the mixer, low-pass filter, and amplifier. This section receives and amplifies the frequency obtained by subtracting the 600 MHz signal output by the reference oscillator <1> from the 600 to 730 MHz signal output by the output amplifier <6>.

<8> Attenuator

The attenuator consists of π -type resistance attenuators. 5, 10, 20, and 25 dB components are switched using relays. The maximum amount of attenuation obtained is 135 dB. The reverse power detection circuit is provided before the output connector to protect the attenuator from excess reverse input power.

<9> Controller

The controller has an 8-bit microprocessor. By decoding data input from the front panel and the GP-IB, the controller gives the required setting information to each hardware component and generates the audio signal required for modulation.

<10> Frequency doubler section

The frequency doubler section doubles the 520 to 1040 MHz signal output from the main oscillator to a signal of 1040 to 2080 MHz. It consists of the multiplier and high-pass and low-pass filters.

<11> Output amplifier (2 GHz band)

The output amplifier generates the final output level by amplifying or attenuating the 1040 to 2080 MHz output from the frequency doubler section. Automatic level control (ALC) is performed in the same way as at the output amplifier (1 GHz band) <6> to keep the output at a fixed level.

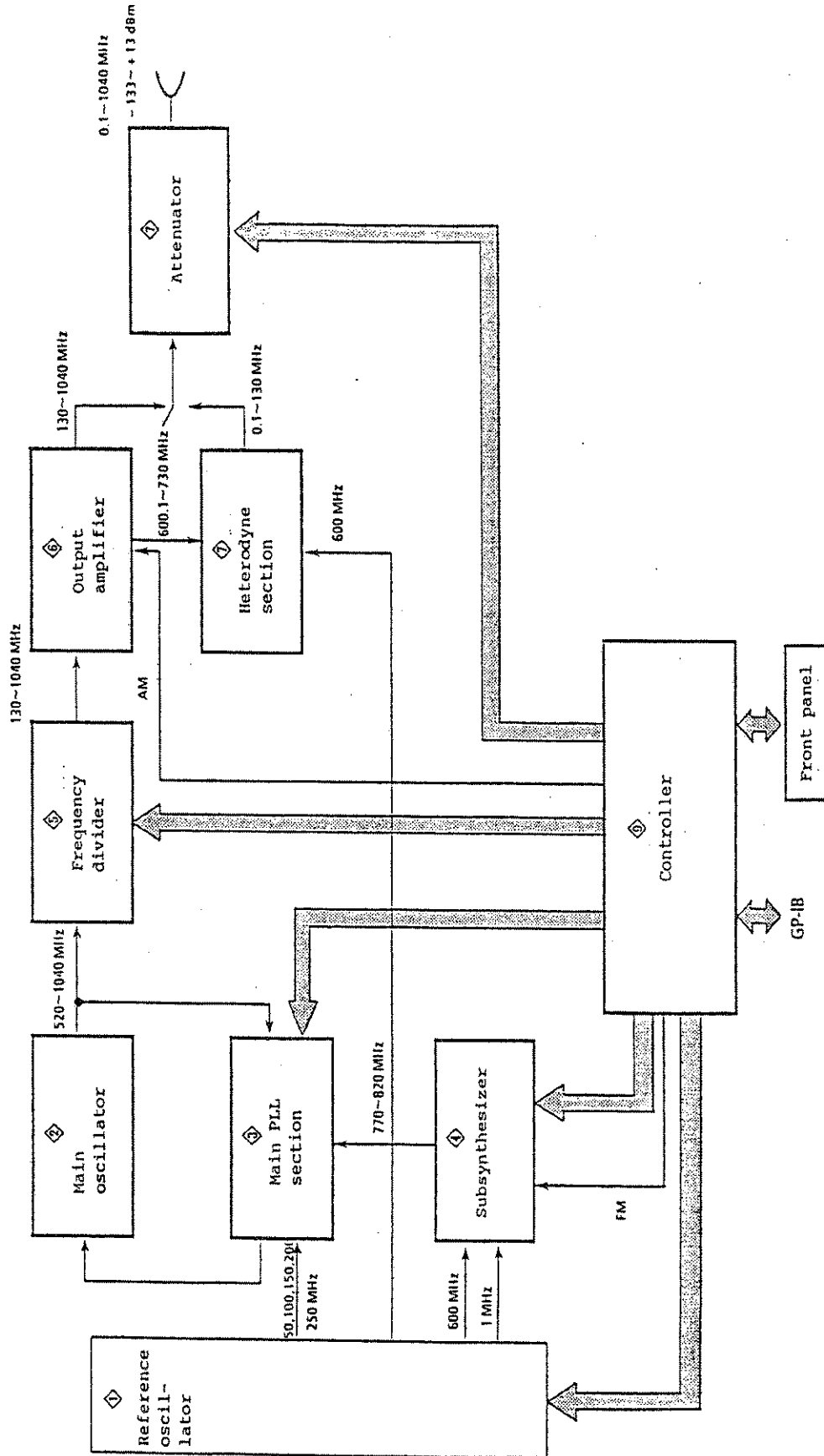

Fig. 7-1 MG3601A Block Diagram

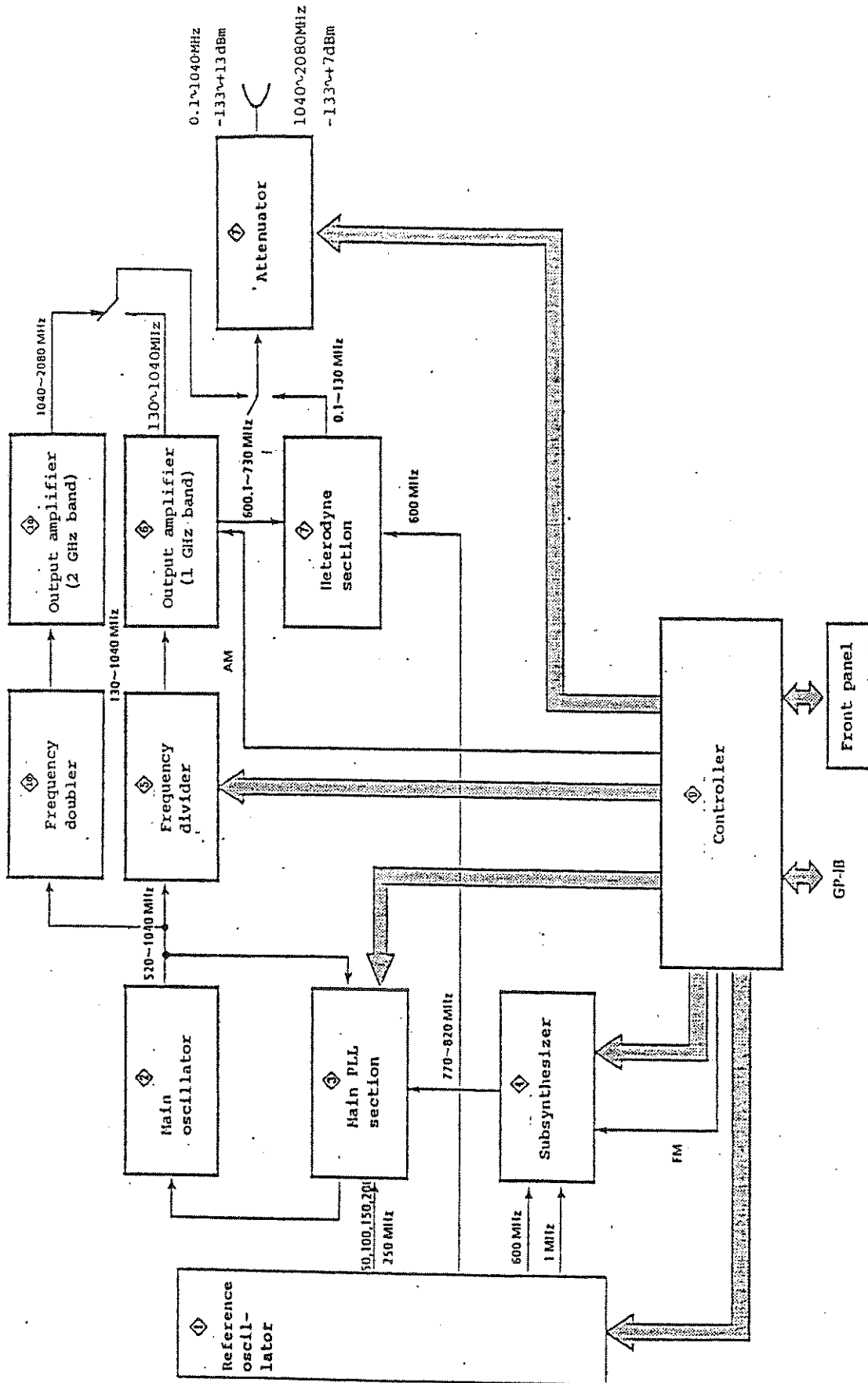

Fig. 7-2 MG3602A Block Diagram

SECTION 8
OVERVIEW OF GP-IB

This section outlines the GP-IB function and specifications (interface and device message) of the MG3601A/MG3602A.

TABLE OF CONTENTS

	Page
SECTION 8 OVERVIEW OF GP-IB	
8.1 Outline	8-1
8.2 Specifications	8-2
8.2.1 GP-IB interface function	8-2
8.2.2 Device message	8-3

8.1 Outline

The GP-IB interface is MG3601A/MG3602A standard equipment. The GP-IB is a standard measuring instrument interface bus as specified in IEEE-488 (Institute of Electrical and Electronic Engineers) and IEC-625 (International Electrotechnical Committee.)

The MG3601A/MG3602A GP-IB has the following functions.

1. Controls all functions except power switch and LOCAL key
2. Reads all measurement conditions and measurement data
3. Displays GP-IB address at LCD
4. Uses interrupt function and serial polling operation
5. Makes an automatic measurement system easy to configure in combination with personal computers and other measuring instruments

This operation manual uses program examples based on the ANRITSU Packet V series Personal Technical Computer.

8.2 Specifications

8.2.1 GP-IB interface function

Table 8-1 lists the GP-IB interface functions of the MG3601A/MG3602A Signal Generator.

Table 8-1 MG3601A/MG3602A GP-IB Interface Functions

Symbol	Interface function	Remarks
SH1	All source handshake functions provided	Data sendable
AH1	All accept handshake functions provided	Data receivable
T6	Basic talker function provided Serial polling function provided Talk only function not provided Talker release function by MLA provided	Talker function provided
L4	Basic listener function provided Listen only function not provided Listener release function by MTA provided	Listener function provided
TE0	Address extension talker function not provided	Neither talker nor listener provided with function to extend up to second address
LE0	Address extension listener function not provided	
SR1	All service request functions provided	Interrupt function provided
RL1	All remote/local functions provided	Local lockout function provided
PP0	Parallel polling function not provided	
DC1	All device clear functions provided	All MG3601A/MG3602A functions made SP00 condition
DT0	Device trigger function not provided	
CO	Control function not provided	Control function not provided

Paragraph 1.4.2 of the GP-IB Basic Guide (available from ANRITSU), describes how to view the subset. In example 2, Table 8-1 is explained in more detail.

8.2.2 Device messages

Tables 8-2 to 8-5 list the MG3601A/MG3602A device messages by type.

- . Table 8-2 GP-IB Data Request Messages
- . Table 8-3 Status Message Line Allocations
- . Table 8-4 GP-IB Program Codes
- . Table 8-5 Special Function Messages

To use these messages refer to SECTION 11 and SECTION 12. APPENDIX A lists the device messages in alphabetical order. APPENDIX B lists the special function codes in numerical order.

Also, the GP-IB Basic Guide (available from ANRITSU) has two sections: SECTION 1 and SECTION 2. It is for beginners, refer to it when necessary.

Table 8-2 GP-IB Data Request Messages

Program code	Data contents	Unit
CFRD, FRRD	Set frequency	Hz
DFRD	Δ F frequency	Hz
RFRD	Relative frequency	Hz
OLRD, APRD	Output level	dBm/dB μ /V in voltage unit
RLRD	Relative level	
AMRD	AM modulation factor	dB
FMRD	FM frequency deviation	%
HMRD	ϕ M phase modulation	Hz
AFRD	AF oscillator set frequency	RAD
SPRD	SP function status	Hz
SURD	Error status	none
		none
FORD	Frequency offset value	Hz
LORD	Level offset value	dB

Note:

"CFRD" is set at initialization. The data set by the data request message is valid until it is reset.

The output level unit is the unit specified at that time.

If the specified data is not set, 0 is output.

For example, when any of "AMRD", "FMRD" or "HMRD" is sent and the data is read without modulation specification, the value becomes 0.

Table 8-3 Status Message Line Allocations

Bit Line Value	Bit 7 DIO8	Bit 6 DIO7	Bit 5 DIO6	Bit 4 DIO5	Bit 3 DIO4	Bit 2 DIO3	Bit 1 DIO2	Bit 0 DIO1
1	X	With service request	ERROR (Abnormal condition)	BUSY (Under processing)	With excessive reverse power	PARAMETER OUT (Internal data setting completed)	X	X
0	X	Without service request	NO ERROR (Normal condition)	READY (Ready condition)	Without excessive reverse power	Internal data setting not completed	X	X
Weight	128	64	32	16	8	4	2	1
Sending	0	1 0	1 0	1 0	1 0	1 0	0	0

X: Unused and 0

Table 8-4 GP-IB Program Codes

	Parameter	Program code
D A T A	NUMERALS 0 to 9 MINUS DECIMAL POINT	0 to 9 - .
U N I T	dB dBm dBu V mV µV GHz MHz kHz Hz % RADIAN	DB DBM DBU V MV UV GHZ MHZ KHZ HZ PC RAD
F R E Q U E N C Y	CENTER FREQ or FREQUENCY ΔF FREQ INCREMENTAL (ΔF) STEP UP FREQ INCREMENTAL (ΔF) STEP DOWN TUNABLE FREQ RESET TO CENTER FREQ TUNE OFF FREQ TUNE ON FREQ TUNE UP FREQ TUNE DOWN FREQ RESOLUTION 10 Hz FREQ RESOLUTION 100 Hz FREQ RESOLUTION 1 kHz FREQ RESOLUTION 10 kHz FREQ RESOLUTION 100 kHz FREQ RESOLUTION 1 MHz FREQ RESOLUTION 10 MHz FREQ RESOLUTION 100 MHz FREQ RELATIVE OFF FREQ RELATIVE ON	CF or FR DF IU ID TR T0 T1 FU FD R1 R2 R3 R4 R5 R6 R7 R8 F0 F1
O U T P U T L E V E L	OUTPUT LEVEL OUTPUT LEVEL 10 dB STEP UP OUTPUT LEVEL 10 dB STEP DOWN OUTPUT LEVEL RELATIVE, CONTINUE RESET OUTPUT LEVEL CONTINUOUS MODE OFF OUTPUT LEVEL CONTINUOUS MODE ON OUTPUT LEVEL FINE KNOB UP OUTPUT LEVEL FINE KNOB DOWN OUTPUT LEVEL RESOLUTION 1st digit OUTPUT LEVEL RESOLUTION 2nd digit OUTPUT LEVEL RESOLUTION 3rd digit OUTPUT LEVEL RELATIVE OFF OUTPUT LEVEL RELATIVE ON OUTPUT LEVEL OFF OUTPUT LEVEL ON	OL or AP L5 L6 RS C0 C1 LU LD L2 L3 L4 L0 L1 RF RO

Table 8-4 GP-IB Program Codes (Cont'd)

	Parameter	Program code
M O D U L A T I O N	AM (Amplitude Modulation)	AM
	FM (Frequency Modulation)	FM
	ØM (Phase Modulation)	HM
	MODULATION STEP UP	MU
	MODULATION STEP DOWN	MD
	RESOLUTION 1st digit	S1
	RESOLUTION 2nd digit	S2
	RESOLUTUION 3rd digit	S3
	INT AM mode OFF	A0
	INT AM mode ON	A1
	EXT AM mode OFF	A2
	EXT AM mode ON	A3
	INT FM mode OFF	D0
	INT FM mode ON	D1
	EXT FM mode OFF	D2
	EXT FM mode ON	D3
	INT ØM mode OFF	H0
	INT ØM mode ON	H1
	EXT ØM mode OFF	H2
	EXT ØM mode ON	H3
EXT DC OFF	E0	
EXT DC ON	E1	
MOD OFF	MF	
MOD ON	MO	
A F O S C	AF(Audio Frequency) INT MOD FREQ OUTPUT 1 kHz INT MOD FREQ OUTPUT 400 Hz INT MOD FREQ OUTPUT AF OSC	AF (Option 04) M1 M3 M5 (Option 04)
M E M O R Y	STORE RECALL FREQ FUNCTION	ST RL FQ FN
S P E C I A L	SPECIAL FUNCTION	SP
O F F S E T	FREQ OFFSET LEVEL OFFSET	FO LO
R E V E R S E	R-PP OFF	RP

Table 8-5 Special Function Messages

Parameter (special function contents)	Program code	Key operation
Initial setting	SP00	[SPCL][0][0]
Bell OFF	SP01	[SPCL][0][1]
Bell ON*	SP02	[SPCL][0][2]
Terminated voltage indication OFF*	SP03	[SPCL][0][3]

ERROR: ioerror
OFFENDING COMMAND: image

STACK:

-dictionary-
-filestream-
-filestream-
-mark-
-savelevel-
-savelevel-

(continued)

No.	Panel marking	Function
-----	---------------	----------

6	MODULATION	
---	------------	--

MODULATION: This generates the internal modulation frequency, switches the external and internal modulation modes, turns modulation on and off, sets the modulation factor, and sets the modulation factor resolution.

When the [MOD OFF] key is pressed, MODULATION OFF is set and all the MODULATION functions shown above are turned off.

When the [MOD OFF] key is pressed again, MODULATION ON is reset and the setting of each MODULATION key before MODULATION was turned off is reproduced.

MODULATION

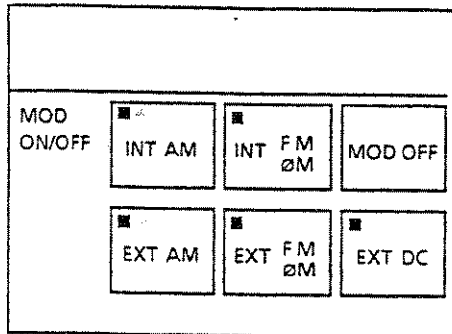

The [INT AM] and [EXT AM] keys set INT AM and EXT AM, respectively.







The internal or external FM or øM mode can be selected by pressing the [INT FM/øM] key or [EXT FM/øM] key. The mode is switched from FM to øM or from øM to FM with the DATA ENTRY [FM] and [øM] keys.

The [EXT DC] key is used when applying external modulation at a low region between dc and 20 Hz in the EXT AM and EXT FM/øM modes.

(continued)

No.	Panel marking	Function
-----	---------------	----------

7	INT MOD OUTPUT	<input checked="" type="checkbox"/> 400Hz	<input checked="" type="checkbox"/> 1kHz	<input checked="" type="checkbox"/> AF OSC	Selects internal modulation frequency 400 Hz fixed, 1 kHz fixed, or AF OSC (20 Hz to 100 kHz)	When the [400 Hz] key is pressed, 400 Hz is turned on.	
		<input type="checkbox"/> 400Hz	<input checked="" type="checkbox"/> 1kHz	<input type="checkbox"/> AF OSC			When the [1 kHz] key is pressed, 400 Hz is turned off and 1 kHz is turned on.
		<input type="checkbox"/> 400Hz	<input type="checkbox"/> 1kHz	<input checked="" type="checkbox"/> AF OSC			When the [AF OSC] key is pressed, 1 kHz is turned off and AF OSC is turned on.

8	 < RES	 RES >	 < RES	When the [↓] key is pressed, the modulation factor is decremented.	
			 RES >	When the [↑] key is pressed, the modulation factor is incremented.	
			<input checked="" type="checkbox"/> SHIFT	 < RES	Sets modulation factor resolution from low-order digit to high-order digit
			<input checked="" type="checkbox"/> SHIFT	 RES >	Sets modulation factor resolution from high-order digit to low-order digit

9	MODULATION		Display modulation factor set values of MODULATION settings described in Nos. 6, 7, and 8, with % as unit for AM, kHz as unit for FM, and RAD as unit for ØM, at maximum of three digits. For simultaneous modulation, displays combination of any two of AM, FM, and ØM. However, data of last selected mode displayed as set value.
	AM	%	
	FM	kHz	
	ØM	RAD	

(continued)

No. Panel marking Function

FREQUENCY: This increments and decrements carrier frequency or internal modulation frequency, sets resolution, sets frequency by TUNE knob and resets frequency by TUNE Mode.

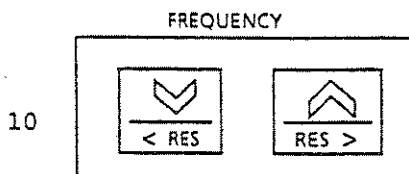

Decrements carrier frequency or AF OSC frequency



Increments carrier frequency or AF OSC frequency



Sets carrier frequency or internal modulation frequency resolution from low-order digit to high-order digit



Sets carrier frequency or internal modulation frequency resolution from high-order digit to low-order digit

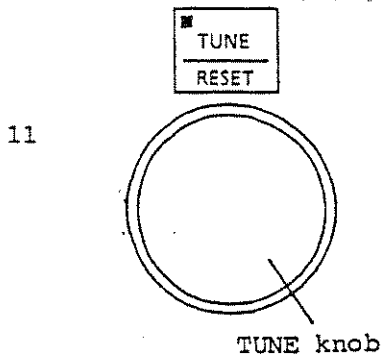

When the [TUNE] key is pressed, the TUNE mode is set.

After the resolution is set by pressing the [SHIFT][RES>] or [SHIFT][<RES] keys, the frequency can be continuously varied at the set resolution step by turning the TUNE knob.

When the [SHIFT][RESET] keys are pressed:

TUNE mode: This returns to the value set immediately after the TUNE mode was set.
Relative frequency displays: This returns the relative value to 0 dB.

(continued)

No.	Panel marking	Function
-----	---------------	----------

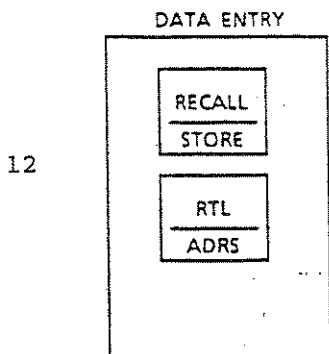

DATA ENTRY: This inputs the output frequency or output level setting data in header keys, numeric keys, unit key order. (The header keys are the eight keys of the two columns at the left side of the numeric keys, the numeric keys are the nine keys of the three columns at the center, and the unit keys are the four keys of the single column at the right side of the numeric keys.)

The [RECALL] key recalls a frequency or panel function from the internal memory.

Example:

Recall the frequency stored in address 5.



The [STORE] key stores the frequency or panel function to the internal memory.

Example:

Store the currently set output frequency to address 5.

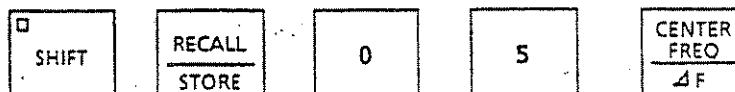

When the [RTL] key is pressed, the instrument is returned from remote control to local control.
(Return to Local)

The GP-IB address can be checked or set by pressing the [SHIFT] [ADRS] keys.

(continued)

No.	Panel marking	Function
13		<p>To perform the function labeled in blue characters on the front panel keys, press the [SHIFT] key, then press the blue-character key with the desired function. (This is called the shift key function)</p> <p>To add other functions besides the functions shown on each key on the front panel, press the [SPCL] key, then key in a 2-digit numeric code. (This is called the special function).</p> <p>When the STATUS lamp described at No. 3 is lit, the status code is displayed on the frequency display while the [STATUS] key is being pressed after the [SHIFT] [STATUS] keys were pressed.</p>

[CENTER FREQ] is the carrier frequency setting header key.

Example:

Set the carrier frequency to 456.89 MHz.

14

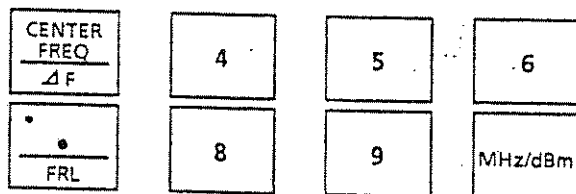
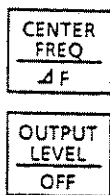

[ΔF] is the ΔF setting header key.

Example:

Set ΔF to 123 Hz.

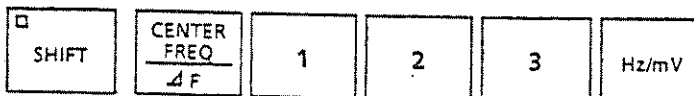

(continued)

No.	Panel marking	Function
-----	---------------	----------

[OUTPUT LEVEL] is the output level setting header key.

Example:

Set the output level to -12.3 dBm.

14
(cont.)

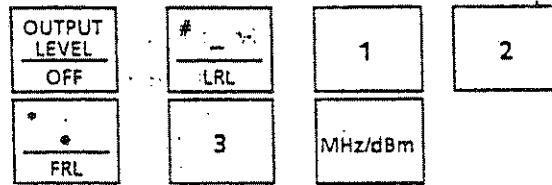

When the [SHIFT] [OFF] keys are pressed when there is an output level, the output level is turned off.

When the [SHIFT] [OFF] keys are pressed again, the output level is turned on.

The [AM] key is the AM modulation factor setting header key.

Example:

Set the AM modulation factor to 45%.

15

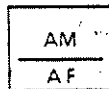

The [AF] key is the internal modulation frequency setting header key. (option)

Example:

Set the internal modulation frequency to 23 kHz.



(continued)

No.	Panel marking	Function
-----	---------------	----------

The [FM] key is the FM frequency deviation setting header key.

Example:

Set the frequency deviation to 75 kHz.



15
(cont.)

The [øM] key is the øM phase deviation setting header key.

Example:

Set the phase deviation to 123RAD.

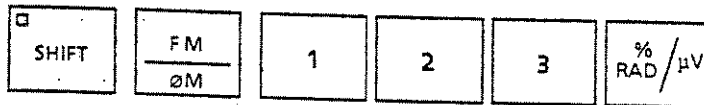

The [0] to [9] and [.] [-] keys are used in numeric data setting. (The * above and to the left of the decimal point and the # above and to the left of the minus sign are meaningless for key operation.)

The column of four keys at the right sets the frequency or output level unit. The unit used is determined by the header. Data entry is ended by pressing a unit key.

When the [SHIFT] [FRL] keys are pressed, the RELATIVE mode (relative frequency display) is set.

When the [SHIFT] [LRL] keys are pressed, the RELATIVE mode (relative level display) is set.

Ten keypad

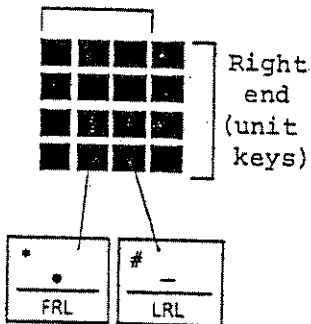

FRL: Frequency Relative
LRL: Level Relative

16

(continued)

No.	Panel marking	Function
-----	---------------	----------

17	<p>FREQUENCY</p> <div style="border: 1px solid black; width: 150px; height: 30px; margin: 5px auto;"></div> <p style="text-align: center;">MHz kHz</p>	<p>Displays carrier frequency (MHz or kHz units, maximum 10 digits) or internal modulation frequency (kHz or Hz units, maximum 7 digits) (Internal modulation frequency is optional)</p> <p>Display example for displaying the first example of No. 14 and example for AF in No. 15:</p>
----	---	--

In the relative model, + or - is displayed at the left end.

→

4	5	6	8	9	0	0	0	0
---	---	---	---	---	---	---	---	---

MHz kHz

2	3	0	0	0	0	A	F
---	---	---	---	---	---	---	---

MHz kHz

For AF, MHz is read as kHz and kHz is read as Hz.

18	<p>OUTPUT LEVEL</p> <div style="border: 1px solid black; padding: 5px;"><table><tbody><tr><td>dBμ</td><td>EMF</td></tr><tr><td>dBm</td><td>mV</td></tr><tr><td>dB</td><td>μV</td></tr></tbody></table></div>	dBμ	EMF	dBm	mV	dB	μV	
dBμ	EMF							
dBm	mV							
dB	μV							

Sign display

Displays absolute output level and relative output level at maximum 4 digits, minimum resolution 0.1 dB.

The units at the right end are displayed according to which DATA ENTRY unit key is pressed.

The left end is the sign display.

(continued)

No. Panel marking Function

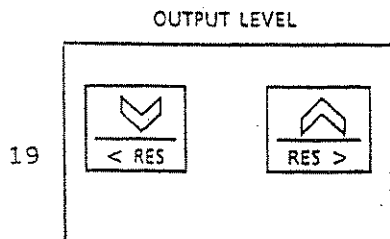

OUTPUT LEVEL: This increments and decrements, the absolute output level or relative output level, sets the resolution, and sets the level by CONT knob and resets the level in the TURN mode.



Increments output level



Decrements output level



Sets output level resolution from low-order digit to high-order digit

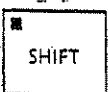

Sets output level resolution from high-order digit to low-order digit

20

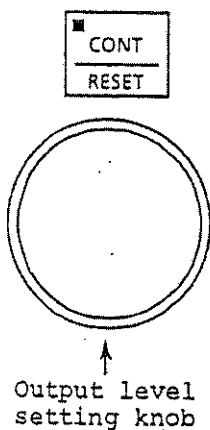



When the [CONT] key is pressed, the CONT mode is set. The output level can be continuously varied by ± 5 dB at a 0.1 dB resolution by turning the output level setting knob.

When the [SHIFT] [RESET] keys are pressed:

CONT mode: This returns to the value set immediately after the CONT mode was set.

Relative level: This returns the relative value to 0 dB.

(continued)

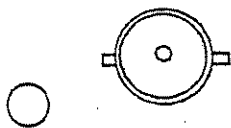
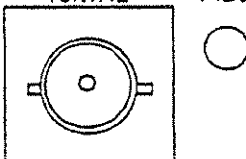
No.	Panel marking	Function
21	MG3601A panel REVERSE POWER 50W MAX \leq 1GHz \pm 50V DC  50 Ω	The MG3601A outputs a 0.1 to 1040 MHz, -133 to +13 dBm signal at an output impedance of 50 Ω . The MG3602A output a 0.1 to 1040 MHz or 1040 to 2080 MHz, -133 to +7 dBm signal at an output impedance of 50 Ω .
	MG3602A panel REVERSE POWER 25W MAX > 1GHz 50W MAX \leq 1GHz \pm 50V DC  50 Ω	Since an RPP (Reverse Power Protection) relay operates if too much power is applied to the OUTPUT connector accidentally, the instrument is protected. However, never apply 50 W (MG3601A and MG3602A, $f < 1040$ MHz), 25 W (MG3602A, $f > 1040$ MHz) or greater, or ± 50 Vdc or greater because they exceed the RPP operation limit and the instrument will be damaged.
22	STD OUTPUT 10MHz 	STD OUTPUT 10 MHz (Option): When an external standard oscillator (10 MHz) is installed in the MG3601A/MG3602A, this connector is used to connect it to the STD INPUT 10 MHz connector with the accessory U-link. The small hole at the left is used to fine-adjust the frequency of the oscillator.
23	STD INPUT 10MHz FREQ ADJ 	The STD INPUT 10 MHz connector is used to input the standard signal from an external standard oscillator or the No. 22 STD OUTPUT 10 MHz connector. When the signal is input at the prescribed input level (> 2 Vp-p), the external standard oscillator mode is set automatically. The small FREQ ADJ hole at the right is used to fine-adjust the frequency.

(continued)

No.	Panel marking	Function
-----	---------------	----------

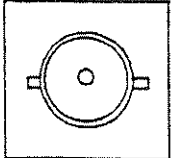
24	<p>BUFFER OUTPUT 10MHz</p> 	Outputs external standard signal input to No. 23 STD INPUT 10 MHz connector or internal standard signal at TTL level
----	--	--

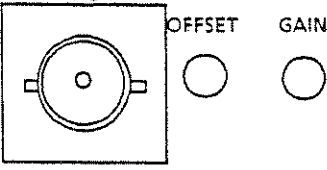
25	<p>VIDEO INPUT</p> 	<p>The VIDEO INPUT connector is used to video-modulate (AM) an RF signal with a composite video signal. Input level: 1 Vp-p, impedance: Nominal 75 Ω</p> <p>OFFSET GAIN: The video modulation is adjusted to 87.5% AM modulation factor inside the instrument. This control is used to fine-adjust it.</p>
----	---	--

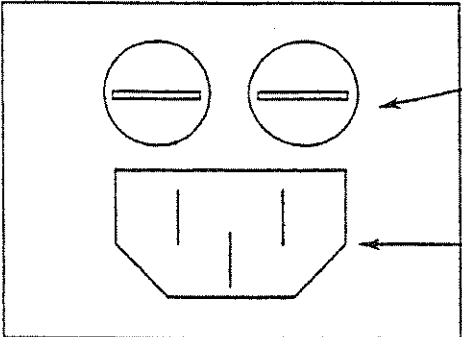
26		<p>Fuse holder. Holds *** A fuses</p> <p>Ac inlet for accessory power cord</p>
----	---	--

27	<p>GP-IB</p> 	In GP-IB remote control, the GP-IB interface is connected to this connector. In the remote mode, the front panel REMOTE LED indicator lights.
----	--	---

(continued)

No.	Panel marking	Function
28		Ground this terminal to prevent an electric shock hazard. It is called the frame ground (FG) terminal.

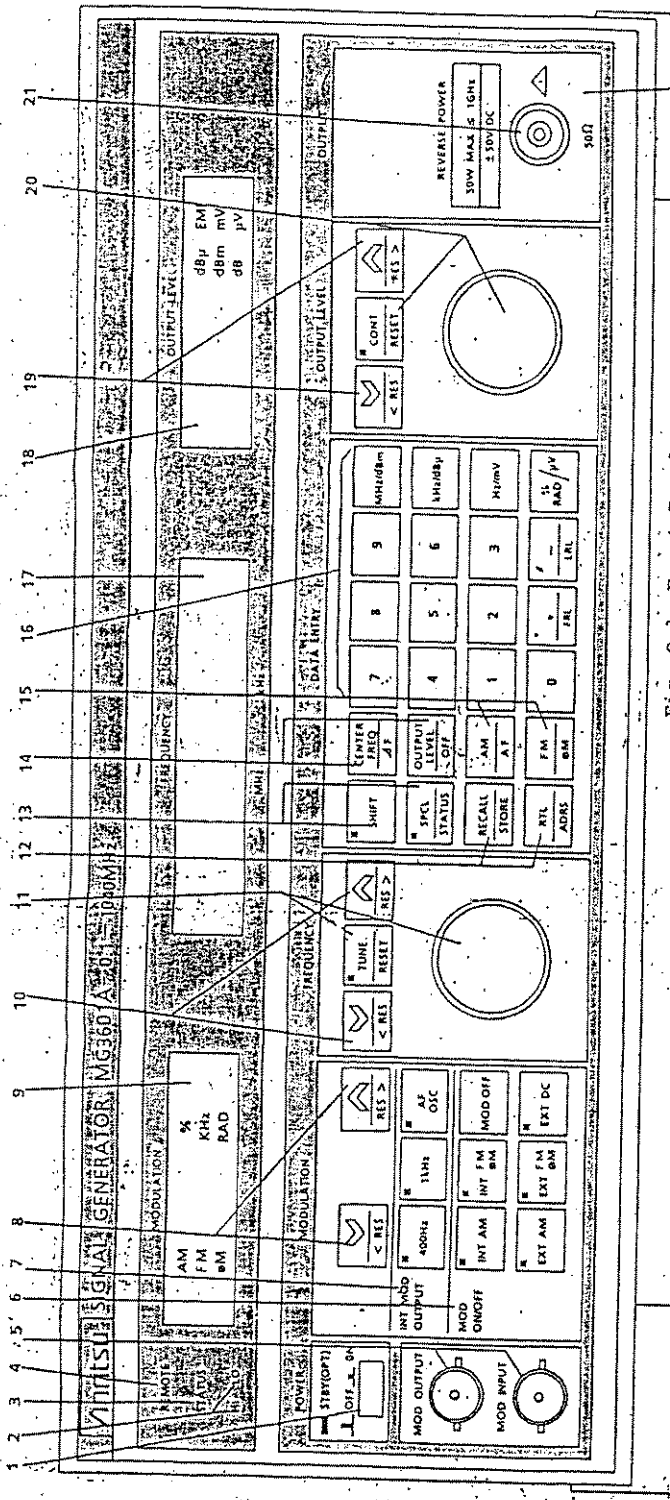

Fig. O-1 Front Panel

Table O-1
Panel Abbreviations
(Alphabetical order)

Abbreviation	Meaning
ADJ	Adjustment
ADRS	Address
AM	Amplitude Modulation
CONT	Continuous
EMF	Electro Motive Force
EXT	External
FM	Frequency Modulation
FRL	Frequency Relative
HI	High
INT	Internal
LO	Low
LRL	Level Relative
MOD	Modulation
OPT	Option
OSC	Oscillator
RAD	Radian
RES	Resolution
RTL	Return to Local
SPCL	Special
STBY	Stand by
STD	Standard
ØM	Phase Modulation
∨	Down
∧	Up
<	Resolution increment
>	Resolution decrement

When the MG3602A is used,
this panel is shown below.

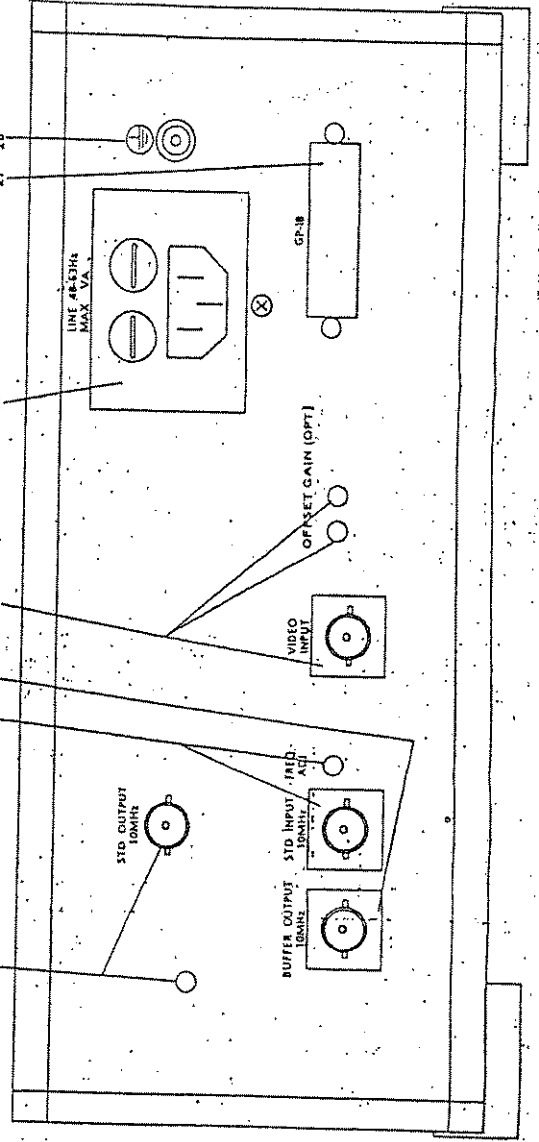
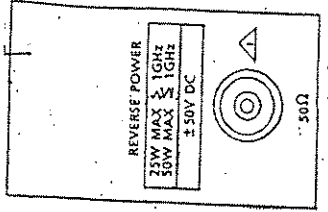

Fig. O-2 Rear Panel

O-15/(O-16 blank)

APPENDIXES
TABLE OF CONTENTS

	Page
APPENDIX A APPLICATION PARTS	
(1) Accessories	A-1
(2) 50 Ω — 75 Ω pad (MP51A, MP52A)	A-1
(3) 50 Ω - 75 Ω impedance transformer (MP614A)	A-2
(4) T-pad (Z-164A/B)	A-2
(5) Four-port junction pad (MP659A)	A-3
(6) Attenuator (MP721)	A-4
APPENDIX B SYNTHESIZED LEVEL GENERATOR (MG442A)	B-1
APPENDIX C SPECTRUM ANALYZER (MS612A)	C-1
APPENDIX D PACKET V PERSONAL TECHNICAL COMPUTER	D-1
APPENDIX E GP-IB EXTENDER (MH055B)	E-1
APPENDIX F MULTIFUNCTION SELECTOR (MS010A)	F-1
APPENDIX G SELECTIVE LEVEL METER (ML422A)	G-1
APPENDIX H ERROR CODES	H-1
APPENDIX I SPECIAL FUNCTIONS	I-1

APPENDIXES

TABLE OF CONTENTS (Continued)

	Page
APPENDIX J DEVICE MESSAGES IN ALPHABETICAL ORDER	J-1
APPENDIX K SPECIAL FUNCTIONS IN CODE ORDER	K-1
APPENDIX L UNIVERSAL ASCII CODE LIST	L-1
APPENDIX M BIT ALLOCATION INDICATING GP-IB INTERFACE INTERRUPTION CAUSES	M-1
A>>EMDOX N IEEE STANDARD PROPER ABBREVIATION INDEX	N-1
APPENDIX O FRONT AND REAR PANELS DESCRIPTION TABLE	O-1

APPENDIXES
TABLE OF CONTENTS

	Page
APPENDIX A APPLICATION PARTS	
(1) Accessories	A-1
(2) 50 Ω \rightarrow 75 Ω pad (MP51A, MP52A)	A-1
(3) 50 Ω - 75 Ω impedance transformer (MP614A)	A-2
(4) T pad (Z-164A/B)	A-2
(5) Four-port junction pad (MP659A)	A-3
(6) Attenuator (MP721)	A-4
APPENDIX B SYNTHESIZED LEVEL GENERATOR (MG442A)	B-1
APPENDIX C SPECTRUM ANALYZER (MS612A)	C-1
APPENDIX D PACKET V PERSONAL TECHNICAL COMPUTER	D-1
APPENDIX E GP-1B EXTENDER (MH055B)	E-1
APPENDIX F MULTIFUNCTION SELECTOR (MS010A)	F-1
APPENDIX G SELECTIVE LEVEL METER (ML422A)	G-1
APPENDIX H ERROR CODES	H-1
APPENDIX I SPECIAL FUNCTIONS	I-1

TABLE OF CONTENTS (Cont'd)

	Page
APPENDIX J DEVICE MESSAGES IN ALPHABETICAL ORDER... ..	J-1
APPENDIX K SPECIAL FUNCTIONS IN CODE ORDER	K-1
APPENDIX L UNIVERSAL ASCII CODE LIST	L-1
APPENDIX M BIT ALLOCATION INDICATING GP-IB INTERFACE INTERRUPTION CAUSES	M-1
APPENDIX N IEEE STANDARD PROPER ABBREVIATION INDEX	N-1
APPENDIX O FRONT AND REAR PANELS DESCRIPTION TABLE	O-1

APPENDIX A
APPLICATION PARTS

(1) Accessories

Order No.	Name	Remarks
34Y73726C	Protection covers	Protect front and rear panels, One-touch installation
34Y73731C	Front handle kit	Two handles
34Y73732C	Rack mounting kit	Handle + frame angle : 2

(2) 50 Ω \longrightarrow 75 Ω pad (MP51A, MP52A)

The MP51A and MP52A pads are n-type resistance attenuation circuit impedance transformers used when matching the measuring system impedance.

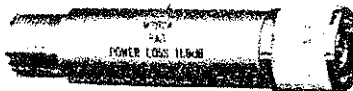

They are especially suitable when converting the output impedance of a measurement signal source. Maximum allowable power is 0.5 W.

. MP51A

Frequency range: 0 to 200 MHz

Insertion loss: 10 dB (voltage ratio at 75 Ω \longrightarrow 50 Ω)

VSWR: ≤ 1.2

Connector: BNC-P (75 Ω side)
 BNC-J (50 Ω side)
 . MP52A

Frequency range: 0 to 200 MHz

Insertion loss: 10 dB (voltage ratio at 50 Ω \rightarrow 75 Ω)

VSWR: ≤ 1.2

Connector: M-J (75 Ω side)
 N-P (50 Ω side)

(3) 50 Ω - 75 Ω impedance transformer (MP614A)

The MP614A is used to match impedance when the impedance of the circuit under test is 75 Ω .



Frequency range: 10 to 1200 MHz

Connector: 50 Ω side N-P
 75 Ω side NC-J

Insertion loss: ≤ 1 dB (≤ 600 MHz)
 ≤ 1.5 dB (> 600 MHz)

(4) T pad (Z-164A/B)

The Z-164A/B are used as matching pads for mixing and applying the outputs of two standard signal generators to the input terminals of the receiver when measuring the two signal characteristics (sensitivity suppression effect, intermodulation characteristic, etc.) of a receiver.

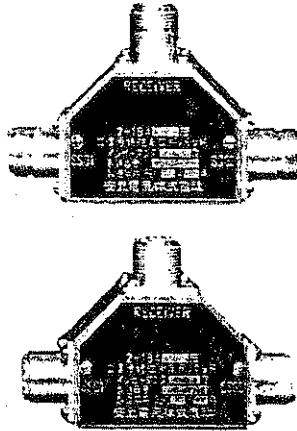

. Z-164A (50 Ω)

Frequency range: 0 to 1000 MHz

Insertion loss: 6 \pm 0.5 dB (voltage ratio)

VSWR: \leq 1.3 (\leq 500 MHz)

\leq 1.5 (>500 MHz)

Connector: N-J

. Z-164B (75 Ω)

Frequency range: 0 to 200 MHz

Insertion loss: 6 \pm 0.5 dB (voltage ratio)

VSWR: \leq 1.2

Connector: M-J

(5) Four-port junction pad (MP659A)

The MP659A four-port junction pad is used as a matching pad when mixing and applying the outputs of three signal generators to the input terminals of the receiver when measuring the three signal characteristics (intermodulation characteristic, etc.) of a receiver.

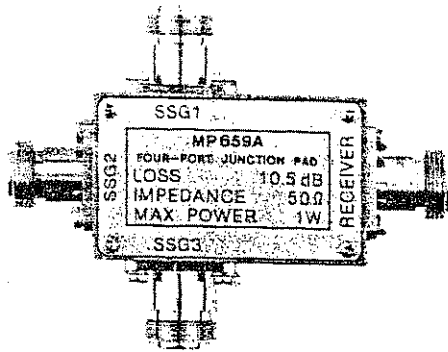

Frequency range: 40 to 1000 MHz

Impedance: 50 Ω

VSWR: ≤ 1.3

Insertion loss: 10.5 ± 1 dB

Isolation: SSG1 - SSG2 } ≥ 30 dB
 SSG2 - SSG3 }

SSG2 - SSG3 ≥ 25 dB

Rated power: 1 W

Input/output connectors: N(J)

(6) Attenuator (MP721)

The MP721 series attenuator is used in level adjustment, impedance improvement, etc. Models with nominal attenuations of 3 dB, 6 dB, and 10 to 60 dB (10 dB steps) are available. Their attenuation frequency characteristic, attenuation accuracy, and VSWR are excellent over the dc to 12.4 GHz frequency range.

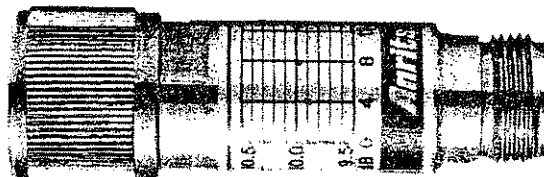

Model	Attenuation (dB)	DC-8 GHz		8-12.4 GHz		Allowable input power	Impedance	Connector	Ambient temperature, rated range of use	Dimensions and weight
		Attenuation accuracy (dB)	VSWR	Attenuation accuracy (dB)	VSWR					
MP721A	3	±0.3	1.25	±0.3	1.35	2 W*	50 Ω	N type	0° to 50°C	21 φ x 66 mm ≦100 g
MP721B	6	±0.3	1.2	±0.3	1.3					
MP721C	10	±0.3	1.2	±0.3	1.3					
MP721D	20	±0.5	1.2	±0.5	1.3					
MP721E	30	±0.5	1.2	±0.5	1.3					
MP721F	40	±1.0	1.2	±1.5	1.3					
MP721G	50	±1.0	1.2	±1.5	1.3					
MP721H	60	±1.0	1.2	±1.5	1.3					

* Test frequency: 1 GHz

APPENDIX B
SYNTHESIZED LEVEL GENERATOR (MG442A)

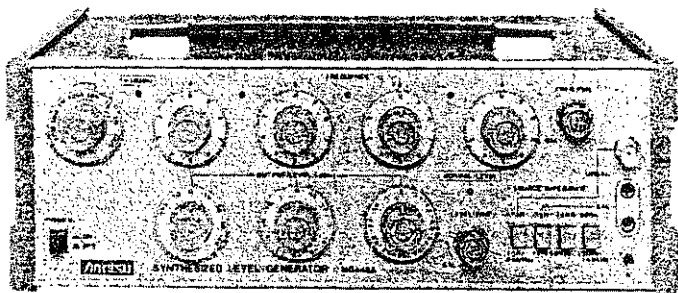

Specifications

Frequency	Range	10 Hz to 20 MHz (75 Ω unbalanced output) 4 to 650 kHz (75 Ω , 150 Ω balanced output) 30 Hz to 150 kHz (600 Ω balanced output)				
	Setting	By 4 step dials and FREQ FINE, 6 bands				
Resolution	Resolution	Band	Minimum digit of step dial	Fine adjust		
		10 Hz to 1 kHz	0.1 Hz	The FREQ FINE dial can vary below one step at the lowest digit of the step dial		
		1 to 10 kHz	1 Hz			
		10 to 100 kHz	10 Hz			
		100 kHz to 1 MHz	100 Hz			
		1 to 10 MHz	1 kHz			
10 to 20 MHz						
Accuracy	$\pm 50 \times 10^{-6}$ (100 Hz to 20 MHz) at CAL position of FREQ FINE In < 100 Hz, $\pm 500 \times 10^{-6}$ at CAL position of FREQ FINE					
Level range	- 51 to + 15 dBm					
Attenuator	3 dials of 5 dB \times 1 + 10 dB \times 5, 1 dB \times 10, 0.1 dB \times 10, and LEVEL FINE					
Frequency characteristics	Within ± 0.1 dB (< 13 MHz), and within ± 0.15 dB (\geq 13 MHz) at 0 dBm (75 Ω unbalanced) referred to 10 kHz					
Output	Level accuracy	At CAL position of LEVEL FINE 75 Ω unbalanced output:				
		Level \ Frequency		10 Hz to 13 MHz	13 to 20 MHz	
		+ 15 to - 30 dBm		± 0.2 dB	± 0.3 dB	
		- 30 to - 51 dBm		± 0.3 dB	± 0.4 dB	
		75 Ω , 150 Ω balanced output:				
		Level \ Frequency		4 to 650 kHz		
		+ 15 to - 30 dBm		± 0.3 dB		
		- 30 to - 51 dBm		± 0.4 dB		
		600 Ω balanced output:				
		Level \ Frequency		30 to 300 Hz	0.3 to 150 kHz	
		+ 15 to + 5 dBm		—	± 0.3 dB ± 0.4 dB	
		+ 5 to - 30 dBm		± 0.7 dB		
- 30 to - 51 dBm		± 0.8 dB				
Impedance	Impedance	Source impedance	Return loss	Connector		
		75 Ω unbalanced			≥ 30 dB	BNC
		75 Ω balanced				I-214
		150 Ω balanced				
		600 Ω balanced				
Relative harmonic content	$\leq - 30$ dB, 2nd and 3rd harmonics (10 Hz to 20 MHz) $\leq - 40$ dB, 2nd and 3rd harmonics (100 Hz to 6 MHz) ≥ 300 Hz (600 Ω balanced)					

APPENDIX C

SPECTRUM ANALYZER (MS612A)

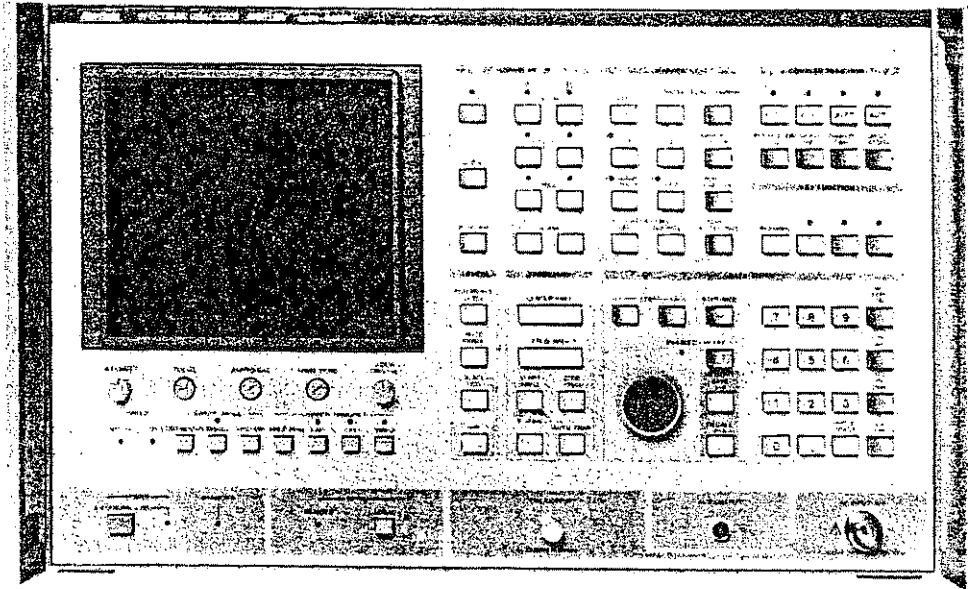

Item		Specification		
Frequency	Measurement range	50 Hz to 2 GHz and 1.7 to 5.5 GHz		
	CRT display	Center-span, start-stop, start-span, or full span		
	Center frequency	Setting range	0 to 2.099 999 999 GHz or 1.7 to 5.509 999 999 GHz (maximum resolution 1 Hz)	
		Display resolution	0.1% of frequency span (>1 Hz)	
		Display accuracy	± (Tuning frequency x standard frequency accuracy + 1.5% of frequency span + 1/2 of resolution bandwidth)	
		Setting	Number/units keys, step keys, data knob, and marker → center key, signal tracking key, zoom key	
	Start frequency/stop frequency	Setting range	Same as center frequency. However (stop frequency - start frequency) >100 Hz	
		Display resolution	Approx 0.1% (>1 Hz) of frequency span	
		Display accuracy	±(Set frequency x standard frequency accuracy +0.5% of frequency span (2.5% for stop frequency) +1/2 of resolution bandwidth)	
		Setting	Number/units keys, step keys, data knob, and Δ maker → span key	

(Cont'd)

Item		Specification		
Frequency	Frequency span	Setting range	100 Hz to 3.80 GHz at horizontal axis 10 divs. varied at 3 digits (100 to 999) and 0 Hz (fixed tuning)	
		Display accuracy	±(2% of frequency difference between two points +0.5% of set frequency span)	
		Setting	Number/units keys, step keys, data knob, and Δ marker → span key	
	Resolution	Resolution bandwidth (6 dB bandwidth)	10 Hz to 3 MHz, variable in 1-3-10 sequence, Manual setting or automatic setting according to frequency span	
		Selectivity (60 dB/6 dB)	<5:1 (3 MHz) <8:1 (100 kHz to 1 MHz) <4:1 (30 kHz) <7:1 (10 Hz to 10 kHz)	
		Residual FM	≤2 Hzp-p/0.1 s (frequency span ≤10 kHz)	
		Drift	≤15 Hz/3 mins (frequency span ≤10 kHz, constant ambient temperature after 1 hour warmup)	
		Sideband noise	<-80 dBc (20 kHz from signal at resolution bandwidth 1 kHz, video bandwidth 30 Hz, receiving frequency ≤4 GHz)	
		Measurement range	+25 dBm to -135 dBm (average noise level)	
	Dynamic range	Average noise level	≤-135 dBm (frequency 800 kHz to 5.5 GHz)	
2nd harmonic distortion		<80 dB (frequency 5 to 900 MHz) When difference of input attenuation subtracted from input level is -30 dBm		
Two signal 3rd inter-modulation distortion		<-80 dB (frequency difference ≥2.5 MHz at frequency >20 MHz) When difference of input attenuation subtracted from input level is -25 dBm		
Residual response		<-110 dBm (input attenuator 0 dB, 50 Ω termination, frequency 500 Hz to 100 kHz)		
Video bandwidth		1 Hz to 3 MHz, variable in 1-3-10 sequence, manual setting or automatic setting according to frequency span		
Input attenuator		Up to 55 dB, 5 dB steps, manual setting or automatic setting according to reference level and resolution bandwidth		
Remote control		GP-1B (IEEE488, IEC625-1.24), all front panel operating functions, except power switch, CRT intensity, focus, video trigger level, frequency ZERO, and amplitude CAL adjustment knob, can be controlled and memory contents can be read. Interface: SH1,AH1,T6,L4,SR1,RL1,PP0,DC1,DT1,C0		

APPENDIX D

PACKET V PERSONAL TECHNICAL COMPUTER

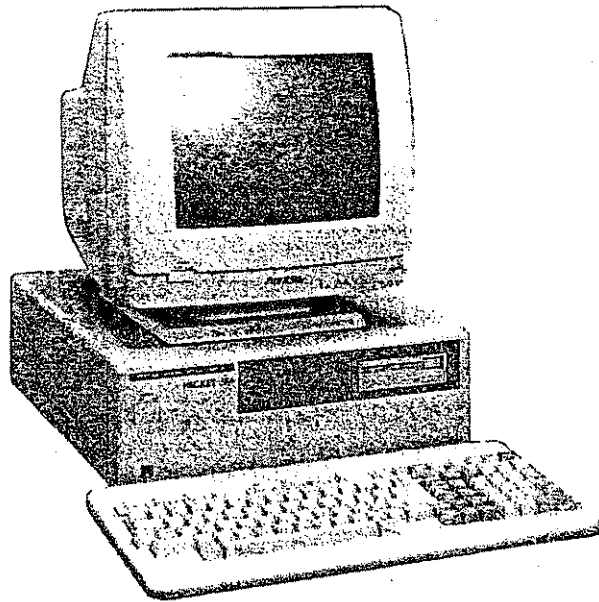

Specifications

Main unit

Product name		Packet V _r (MC1201A)	Packet V _H (MC1202A)	Packet V _s (MC1203A)
CPU		68000 (clock frequency 8 MHz)		
Memory	ROM	32 KB		
	RAM	512 KB (no-wait) 14 MB maximum (with expansion box, 1 clock wait added)		
	VRAM	<ul style="list-style-type: none"> • 128 KB for graphics • 16 KB for characters 		
	CMOS RAM	1 K x 4 bits (battery backup)		
Display functions	Interface	Separate video outputs (one connector for both color and monochrome displays)		
	Resolution	640 x 400 dots		
	Character fonts	Alphanumeric 6 x 10 dots		
	Character screen	80 characters x 25 lines		
	Graphics screen	<ul style="list-style-type: none"> • Page mode 4 screens (can be superimposed) • RGBI mode 1 screen Both character and graphics screens can be superimposed.		
	Monochrome display	16 gradations		
Colors	<ul style="list-style-type: none"> • RGBI mode: 15 colors • Page mode: 2 colors (for each graphics screen) 			
Clock		Year / month / day / hour / minute / second / day-of-week (backed up by a lithium battery for longer than 7 years)		
Timer		10 ms resolution		
Counter		1 ms resolution		
Tone generator		Frequency: 200 Hz to 15 kHz Duration: 2 ms to 32.767 s Volume control: 0 to 30 dB (relative value) with triad and noise generators		
Auxiliary storage		<ul style="list-style-type: none"> • One 3.5" floppy disk drive (640 KB) (Additional drive is available as option.)	<ul style="list-style-type: none"> • One 3.5" hard disk drive (20 MB) • One 3.5" floppy disk drive (640 KB) 	<ul style="list-style-type: none"> • One bubble cassette drive (128 KB) • One bubble memory board (512 KB)
Expansion slots		3 slots (VME bus type)		
Operating conditions	Temperature	5° to 45°C		0° to 50°C
	Humidity	20% to 80% (no condensation)		
Power		85 to 132 V or 170 to 250 V, 47 to 63 Hz		
		130 VA	170 VA	150 VA
Dimensions		132.5H x 390W x 400D mm		
Weight		8.5 kg	10.0 kg	9.0 kg
Option 01		Additional 3.5" floppy disk drive (640 KB)		—
Option 03		1 MB RAM		

CRT display

Product name		Monochrome display monitor (MC3601A)	Color display monitor (MC3602A)
Screen size		12 inches	12 inches
Color		Amber	15 colors (RGBI)
Resolution		640 dots (horizontal) x 400 dots (vertical)	
Tilt		0° to 20° (vertical)	
Swivel		± 45° (horizontal)	
Horizontal sync. frequency		24.83 kHz	
Vertical sync. frequency		56.4 Hz	
Operating conditions	Temperature	0° to 50°C	
	Humidity	20% to 80% (no condensation)	
Power consumption		85 to 264 V, < 50 VA	90 to 130 V or 180 to 250 V, < 100 VA
Dimensions		341H x 326W x 363D mm	
Weight		9 kg	11.2 kg

APPENDIX E

GP-IB EXTENDER (MH055B)

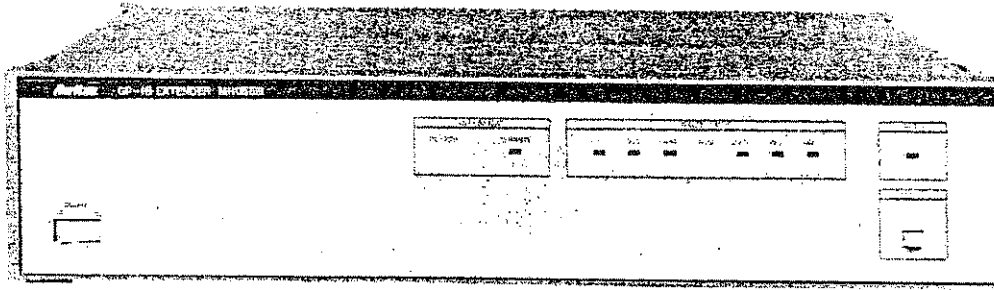

Item	Specifications
GP-IB interface transfer	GP-IB interface status can be sent to the opposite extender.
Serial interface	<ul style="list-style-type: none"> . Modem interface (JISC6361, RS232C) . Current loop interface (20 mA) . Internal modem (Option)
Communication system	<ul style="list-style-type: none"> . Full duplex . Asynchronous
Communication speed	110,300,600,1200,2400,4800,9600 bit/s
Character format	<ul style="list-style-type: none"> . Start bit 1 . Data bits 8 . Parity bit Even/odd/none . Stop bit 1/2
Serial interface connector	DB-25P



APPENDIX F

MULTIFUNCTION SELECTOR (MS010A)

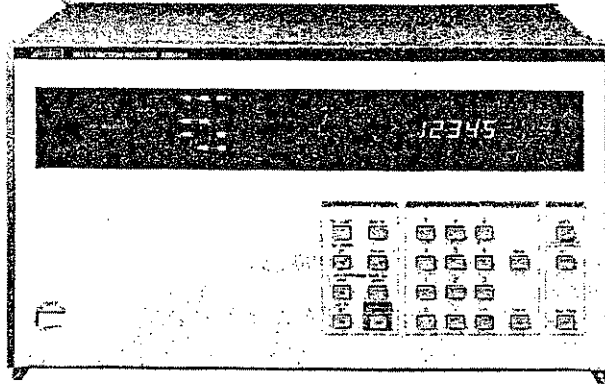

Item		Specifications						
Slots for units		23 slots, multiple slots used according to the kind of unit						
Interface		GP-IB SH1, AH1, T6, L4, SR1, RL1, PP0, CD1, DT0, C0						
Channel combination setting		60						
Collection data setting		60						
Self-check function		SELF TEST key, executed when power turned on						
Units								
Model	Number of channels (connector)	Common channel (connector)	Frequency range	Impedance	Insertion loss	Return loss	Crosstalk attenuation	Passband noise
MH356A	6 (57-40500)	1 (HR10-10R-12S)	DC to 650kHz 650kHz to 2MHz	75Ω balanced	≦0.2dB	≧35dB	≧100dB ≧90dB	≦-120dBm
MH357A	6 (57-40500)	1 (HR10-10R-12S)	DC to 650kHz 650kHz to 2MHz	110Ω balanced	≦0.2dB	≧35dB	≧100dB ≧90dB	≦-120dBm
MH358A	6 (57-40500)	1 (HR10-10R-12S)	DC to 650kHz 650kHz to 2MHz	135Ω balanced	≦0.2dB	≧35dB	≧100dB ≧90dB	≦-120dBm
MH359A	6 (57-40500)	1 (HR10-10R-12S)	DC to 650kHz 650kHz to 2MHz	150Ω balanced	≦0.2dB	≧35dB	≧100dB ≧100dB	≦-120dBm
MH220A	6 (57-40500)	1 (HR10-10R-12S)	DC to 150kHz	600Ω balanced	≦0.2dB	≧35dB	≧115dB	≦-120dBm
MH483A	6 (BNC)	1 (BNC)	DC to 10MHz	75Ω unbalanced	≦0.2dB	≧30dB	≧80dB	≦-120dBm
MH494AB	6 (BNC) (SP2.5CPS)	1 (BNC) (SP2.5CPS)	DC to 13MHz 13 to 30MHz 30 to 100MHz	75Ω unbalanced	≦0.2dB ≦0.3dB ≦0.5dB	≧35dB ≧33dB ≧22dB	≧115dB ≧105dB ≧95dB	≦-120dBm
MH655A	4 (BNC)	4 (BNC)	DC to 100kHz 100 to 500MHz	50Ω unbalanced	≦0.2dB ≦0.5dB	≧25dB ≧22dB	≧90dB ≧80dB	≦-100dBm

APPENDIX G

SELECTIVE LEVEL METER (ML422A)

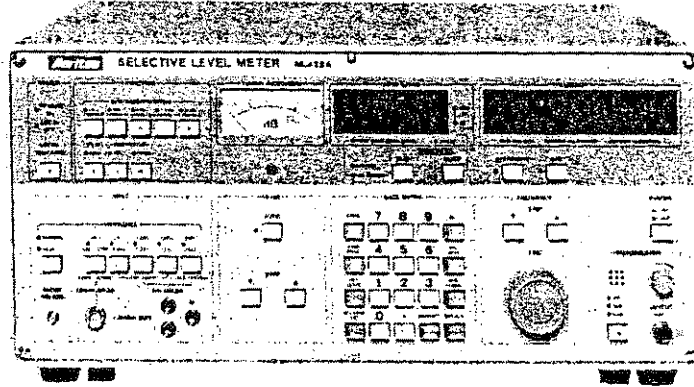

Item	Specification																															
Frequency range	200 Hz to 30 MHz (BW: 40 Hz), 10 kHz to 30 MHz (BW: 1.74 kHz)																															
Level measuring range	-120 to +30 dBm (BW: 40 Hz), -100 to +30 dBm (BW: 1.74 kHz)																															
	LOW NOISE, DEMODULATOR (OFF), UNCAL (OFF), AFC (ON), meter indication (0 ±1 dB), BW (40 Hz):																															
	1) 75 Ω unbalanced																															
Level measuring accuracy	<table border="1"> <thead> <tr> <th rowspan="2">Level range</th> <th colspan="3">Temperature range</th> </tr> <tr> <th>23° ±5°C</th> <th colspan="2">0 to 45°C</th> </tr> <tr> <th></th> <th colspan="3">Frequency range</th> </tr> <tr> <th></th> <th>10 kHz to 13 MHz</th> <th>200 Hz to 13 MHz</th> <th>13 to 30 MHz</th> </tr> </thead> <tbody> <tr> <td>0 to +20 dBm</td> <td>±0.15 dB</td> <td>±0.15 dB</td> <td>±0.2 dB</td> </tr> <tr> <td>-80 to 0 dBm</td> <td>±0.1 dB</td> <td></td> <td></td> </tr> <tr> <td>-100 to -80 dBm</td> <td>±0.3 dB</td> <td>±0.5 dB</td> <td>±0.5 dB</td> </tr> <tr> <td>-110 to -100 dBm</td> <td>±1 dB</td> <td>±1.5 dB</td> <td>±1.5 dB</td> </tr> </tbody> </table>	Level range	Temperature range			23° ±5°C	0 to 45°C			Frequency range				10 kHz to 13 MHz	200 Hz to 13 MHz	13 to 30 MHz	0 to +20 dBm	±0.15 dB	±0.15 dB	±0.2 dB	-80 to 0 dBm	±0.1 dB			-100 to -80 dBm	±0.3 dB	±0.5 dB	±0.5 dB	-110 to -100 dBm	±1 dB	±1.5 dB	±1.5 dB
	Level range		Temperature range																													
		23° ±5°C	0 to 45°C																													
		Frequency range																														
		10 kHz to 13 MHz	200 Hz to 13 MHz	13 to 30 MHz																												
	0 to +20 dBm	±0.15 dB	±0.15 dB	±0.2 dB																												
-80 to 0 dBm	±0.1 dB																															
-100 to -80 dBm	±0.3 dB	±0.5 dB	±0.5 dB																													
-110 to -100 dBm	±1 dB	±1.5 dB	±1.5 dB																													
	2) Balanced: ±0.1 dB added to above accuracy																															
Input impedance	75 Ω unbalanced (200 Hz to 30 MHz), 75 Ω, 135 Ω, 150 Ω balanced (1 kHz to 2 MHz) 600 Ω balanced (200 Hz to 150 kHz)																															
Bandwidth	40 Hz, 1.74 kHz																															
	GP-IB (Option 03)																															
Remote control	ML422A and MG655A frequency tracking precautions: Since frequency setting data is sent from the MG655A to the ML422A only when the setting data changed, to make accurate measurements with the ML422A, the MG655A frequency setting must be changed in small increments by using an encoder, INCR key, etc.																															

APPENDIX H
ERROR CODES

Error code	Explanation	Function
EE 00		Normal
EE 01	Too much input data	ALL FUNCTION
EE 02	Error input	
EE 03	Data outside data setting range	
EE 11	Modulation frequency selected at MOD OFF	MODULATION
EE 21	Data not stored because memory protected	MEMORY
EE 22	No data at recalled memory	
EE 31	Special function not registered	SPECIAL FUNCTION
EE 32	RAM check error	
EE 33	ROM check error	
EE 41	AF oscillator not set	Option
EE 42	VIDEO not set	
EE 51	Reverse power protection circuit operation	Others
EE 61	Read error	GP-IB
EE 82	Output level offset	Offset
EE 91	LEVEL UNCAL	The status is always set at UNCAL. If another error occurs, the error is handled according to the priority rules. (Among UNCALS, the priority (from high to low) is FREQ, LEVEL, FM, \emptyset M, and AM.)
EE 92	FM UNCAL	
EE 93	AM UNCAL	
EE 94	\emptyset M UNCAL	
EE 95	FREQ UNCAL	
		UNCAL

APPENDIX I
SPECIAL FUNCTIONS

Program code	Parameter (special function contents)	key function	
SP00	Initial setting	[SPCL] [0] [0]	
SP01	Bell OFF	[SPAL] [0] [1]	
SP02	Bell ON*	[SPCL] [0] [2]	
SP03	Terminated voltage display OFF*	[SPCL] [0] [3]	
SP04	Terminated voltage display ON	[SPCL] [0] [4]	FREQUENCY display code list group
SP05	VIDEO modulation OFF*	[SPCL] [0] [5]	
SP06	VIDEO modulation ON	[SPCL] [0] [6]	
SP07	Memory sequential read mode OFF*	[SPCL] [0] [7]	
SP08	Memory sequential read mode ON	[SPCL] [0] [8]	
SP09	Memory protect OFF*	[SPCL] [0] [9]	
SP10	Memory protect ON	[SPCL] [1] [0]	
SP11	EXT FM polarity switching OFF*	[SPCL] [1] [1]	
SP12	EXT FM polarity switching (OPT 06) ON	[SPCL] [1] [2]	
SP13	RF frequency range cancel OFF*	[SPCL] [1] [3]	
SP14	RF frequency range cancel ON	[SPCL] [1] [4]	
SP15	External reference input 10 MHz mode ON*	[SPCL] [1] [5]	
SP16	External reference input 1 MHz mode ON	[SPCL] [1] [6]	
SP17	RF frequency offset mode OFF*	[SPCL] [1] [7]	
SP18	RF frequency offset mode ON	[SPCL] [1] [8]	
SP19	Output level offset mode OFF*	[SPCL] [1] [9]	
SP20	Output level offset mode ON	[SPCL] [2] [0]	
SP30	Frequency calibration ON during dc FM modulation	[SPCL] [3] [0]	DC/FM
SP37	Dc FM high stability mode OFF*	[SPCL] [3] [7]	
SP38	Dc FM high stability mode (OPT 07) ON	[SPCL] [3] [8]	
SP31	Header of RF frequency offset value	[SPCL] [3] [1]	Offset
SP32	Header of output level offset value	[SPCL] [3] [2]	
SP33	Simultaneous modulation with external and separate FM OFF*	[SPCL] [3] [3]	Simultaneous modulation
SP34	Simultaneous modulation with external and separate FM ON	[SPCL] [3] [4]	
SP35	LCD backlight OFF*	[SPCL] [3] [5]	Backlight
SP36	LCD backlight ON	[SPCL] [3] [6]	
SP39	EXT FM modulation factor display OFF*	[SPCL] [3] [9]	
SP40	EXT FM modulation factor display ON	[SPCL] [4] [0]	
SP41	SRQ ERROR MASK OFF	[SPCL] [4] [1]	SRQ
SP42	SRQ BUSY/READY MASK OFF	[SPCL] [4] [2]	
SP43	SRQ Excess reverse power MASK OFF	[SPCL] [4] [3]	
SP44	SRQ PARAMETER OUT MASK OFF	[SPCL] [4] [4]	
SP45		[SPCL] [4] [5]	
SP46		[SPCL] [4] [6]	
SP47	SRQ ALL MASK*	[SPCL] [4] [7]	
SP48		[SPCL] [4] [8]	
SP49		[SPCL] [4] [9]	
SP50		[SPCL] [5] [0]	
SP61	Clear FREQ memory (1040 MHz)	[SPCL] [6] [1]	Memory
SP62	Initialize FUNCTION memory (SP00 status)	[SPCL] [6] [2]	
SP63	Set frequency 0 Hz	[SPCL] [6] [3]	
SP64	Check LCD and LED	[SPCL] [6] [4]	
SP65	Check RAM	[SPCL] [6] [5]	
SP66	Check ROM	[SPCL] [6] [6]	
SP67	Display option	[SPCL] [6] [7]	

* Indicates the initial status



APPENDIX J

DEVICE MESSAGES IN ALPHABETICAL ORDER*

Program code	Parameter	Program code	Parameter
A0	INT AM mode OFF	GHZ	GHz
A1	INT AM mode ON	H0	INT ØM mode OFF
A2	EXT AM mode OFF	H1	INT ØM mode ON
A3	EXT AM mode ON	H2	EXT ØM mode OFF
AF	AF(OPT-4-Audio Freq)	H3	EXT ØM mode ON
AFRD	AF oscillator set frequency (unit: Hz)	HM	ØM(Phase Modulation)
AM	AM (Amplitude Modulation)	HMRD	ØM phase modulation (unit: RAD)
AMRD	AM modulation factor (unit: %)	HZ	Hz
AP	OUTPUT LEVEL	ID	FREQ INCREMENTAL (ΔF) STEP DOWN
APRD	Output level (unit: dBm/ dBu, V for voltage units)	IU	FREQ INCREMENTAL (ΔF) STEP UP
C0	OUTPUT LEVEL CONTINUOUS MODE OFF	KHZ	kHz
C1	OUTPUT LEVEL CONTINUOUS MODE ON	L0	OUTPUT LEVEL RELATIVE OFF
CF	CENTER FREQ or FREQUENCY	L1	OUTPUT LEVEL RELATIVE ON
CFRD	Set frequency (unit: Hz)	L2	OUTPUT LEVEL RESOLUTION 1
D0	INT FM mode OFF	L3	OUTPUT LEVEL RESOLUTION 2
D1	INT FM mode ON	L4	OUTPUT LEVEL RESOLUTION 3
D2	EXT FM mode OFF	L5	OUTPUT LEVEL 10 dB STEP UP
D3	EXT FM mode ON	L6	OUTPUT LEVEL 10 dB STEP DOWN
DB	dB	LD	OUTPUT LEVEL FINE KNOB DOWN
DBM	dBm	LO	LEVEL OFFSET
DBU	dBu	LORD	Level offset value (unit: dB)
CF	ΔF	LU	OUTPUT LEVEL FINE KNOB UP
DFRD	ΔF frequency (unit: Hz)	M1	INT MOD FREQ OUTPUT 1 kHz
E0	EXT DC OFF	M3	INT MOD FREQ OUTPUT 400 Hz
E1	EXT DC ON	M5	INT MOD FREQ OUTPUT AF OSC(OPT-4)
F0	FREQ RELATIVE OFF	MD	MODULATION STEP DOWN
F1	FREQ RELATIVE ON		
FD	FREQ TUNE DOWN		
FM	FM (Frequency Modulation)		
FMRD	FM frequency deviation (unit: Hz)		
FO	FREQ OFFSET		
FORD	Frequency offset value (unit: Hz)		
FR	CENTER FREQ		
FRRD	Set frequency (unit: Hz)		
FU	FREQ TUNE UP		

* For special functions refer to Appendix K.

APPENDIX J

DEVICE MESSAGES IN ALPHABETICAL ORDER* (Continued)

Program code	Parameter	Program code	Parameter
MF	MOD OFF	SPRD	SP function status
MHZ	MHz	ST	STORE
MU	MODULATION STEP UP	SURD	Error status
MO	MOD ON	T0	FREQ TUNE OFF
MV	mV	T1	FREQ TUNE ON
OL	OUTPUT LEVEL	TR	TUNABLE FREQ RESET
OLRD	Output level (unit: dB)		TO CENTER
PC	%	UV	UV
R1	FREQ RESOLUTION 10 Hz	V	V
R2	FREQ RESOLUTION 100 Hz		
R3	FREQ RESOLUTION 1 kHz		
R4	FREQ RESOLUTION 10 kHz		
R5	FREQ RESOLUTION 100 kHz		
R6	FREQ RESOLUTION 1 MHz		
R7	FREQ RESOLUTION 10 MHz		
R8	FREQ RESOLUTION 100 MHz		
RAD	RADIAN		
RF	OUTPUT LEVEL OFF		
RL	RECALL		
RLRD	Relative level (unit: dB)		
RO	OUTPUT LEVEL ON		
RP	R-PP OFF		
RS	OUTPUT LEVEL RELATIVE, CONTINUE RESET		
S1	MOD RESOLUTION 1st digit		
S2	MOD RESOLUTION 2nd digit		
S3	MOD RESOLUTION 3rd digit		
SP	SPECIAL FUNCTION		

APPENDIX K
SPECIAL FUNCTIONS IN CODE ORDER

Program code	Parameter	Classification
SP00	Initial setting	
SP01	Bell OFF	
SP02	Bell ON*	
SP03	Terminated voltage display OFF*	
SP04	Terminated voltage display ON	
SP05	VIDEO modulation OFF*	FREQUENCY
SP06	VIDEO modulation (OPT 05) ON	display code
SP07	Memory continuous-read mode OFF*	list group
SP08	Memory continuous-read mode ON	
SP09	Memory protect OFF*	
SP10	Memory protect ON	
SP11	EXT FM polarity switching OFF*	
SP12	EXT FM polarity switching (OPT 06) ON	
SP13	RF frequency range release OFF*	
SP14	RF frequency range release ON	
SP15	External reference input 10 MHz-mode ON*	
SP16	External reference input 1 MHz-mode ON	
SP17	RF frequency-offset mode OFF*	
SP18	RF frequency-offset mode ON	
SP19	Output-level offset mode OFF*	
SP20	Output-level offset mode ON	
SP30	Frequency calibration ON during dc FM modulation	DC/FM
SP37	Dc FM high stabilized mode OFF*	
SP38	Dc FM high stabilized mode (OPT 07) ON	

* Indicates initial state

APPENDIX K

SPECIAL FUNCTIONS IN CODE ORDER (Continued)

Program code	Parameter	Classification
F0	Header of RF frequency- offset value	Offset
L0	Header of output-level offset value	
SP33	External independent-FM simultaneous modulation OFF	Simultaneous modulation
SP34	External independent-FM simultaneous modulation ON	
SP35	LCD display backlight OFF	Backlight
SP36	LCD display backlight ON	
SP39	EXT FM modulation factor display OFF*	EXT/FM
SP40	EXT FM modulation factor display ON	
SP41	SRQ ERROR MASK OFF	SRQ
SP42	SRQ BUSY/READY MASK OFF	
SP43	SRQ Excessive reverse electromotive force MASK OFF	
SP44	SRQ PARAMETER OUT MASK OFF	
SP47	SRQ ALL MASK*	
SP61	FREQ memory initialize (1040 MHz)	Related to memory
SP62	FUNCTION memory initialize (SP00 state)	
SP63	Frequency 0 Hz setting	
SP64	LCD/LED check	
SP65	RAM check	
SP66	ROM check	
SP67	Option display	

* Indicates initial state

APPENDIX L

UNIVERSAL ASCII* CODE LIST

BITS B7 B6 B5 B4 B3 B2 B1	0 0	0 0 1	0 1 0	0 1 1	1 0 0	1 0 1	1 1 0	1 1 1
	CONTROL		NUMBERS SYMBOLS		UPPER CASE		LOWER CASE	
0 0 0 0	0 NUL	20 DLE	40 SP	60 0	100 @	120 P	140 ,	160 p
0 0 0 1	1 SOH	21 LLO DC1	41 !	61 1	101 A	121 Q	141 a	161 q
0 0 1 0	2 STX	22 DC2	42 "	62 2	102 B	122 R	142 b	162 r
0 0 1 1	3 ETX	23 DC3	43 #	63 3	103 C	123 S	143 c	163 s
0 1 0 0	4 EOT	24 DCL DC4	44 \$	64 4	104 D	124 T	144 d	164 t
0 1 0 1	5 ENQ	25 PPU NAK	45 %	65 5	105 E	125 U	145 e	165 u
0 1 1 0	6 ACK	26 SYN	46 &	66 6	106 F	126 V	146 f	166 v
0 1 1 1	7 BEL	27 ETB	47 '	67 7	107 G	127 W	147 g	167 w
1 0 0 0	8 BS	30 SPE CAN	50 (70 8	110 H	130 X	150 h	170 x
1 0 0 1	9 HT	31 SPD EM	51)	71 9	111 I	131 Y	151 i	171 y
1 0 1 0	10 LF	32 SUB	52 *	72 :	112 J	132 Z	152 j	172 z
1 0 1 1	11 VT	33 ESC	53 ÷	73 ;	113 K	133 [153 k	173 {
1 1 0 0	12 FF	34 FS	54 .	74 <	114 L	134 \	154 l	174
1 1 0 1	13 CR	35 GS	55 -	75 =	115 M	135]	155 m	175 }
1 1 1 0	14 SO	36 RS	56 .	76 >	116 N	136 ^	156 n	176 ~
1 1 1 1	15 SI	37 US	57 /	77 ?	117 UNL O	137 UNT _	157 o	177 RUBOUT (DEL)
	Address Universal command		Listen address		Talk address		Secondary address or command	

KEY

octal	25	ppu	GP-IB code
hex	15	21	decimal

NAK

ASCII character

L-1

* USA Standard Code for Information Interchange



APPENDIX M

BIT ALLOCATION INDICATING GP-IB
INTERFACE INTERRUPTION CAUSES

Bit No.	Cause
0	Set to controller
1	EOI detected Interruption occurred when Packet is controller and not talker or listener
2	SRQ received
3	Change in remote/local state
4	MTA received
5	MLA received
6	GET received
7	Device clear received
8	IFC received
9	
10	
11	Parity error occurred during reading data
12	MLA/MTA released
13	
14	
15	

1
2
3
4
5
6
7
8
9
10
11
12
13
14
15
16
17
18
19
20
21
22
23
24
25
26
27
28
29
30
31
32
33
34
35
36
37
38
39
40
41
42
43
44
45
46
47
48
49
50
51
52
53
54
55
56
57
58
59
60
61
62
63
64
65
66
67
68
69
70
71
72
73
74
75
76
77
78
79
80
81
82
83
84
85
86
87
88
89
90
91
92
93
94
95
96
97
98
99
100

APPENDIX N

IEEE STANDARD PROPER ABBREVIATION INDEX

A

AC Address Command
 ACDS Accept Date State
 ACG Addressed Command Group
 ACRS Acceptor Ready State
 AD Address
 AH Acceptor Handshake
 AIDS Acceptor Idle State
 ANRS Acceptor Not Ready State
 APRS Affirmative Poll Response State
 ATN Attention
 AWNS Acceptor Wait for New cycle State

C

C Controller
 CACS Controller Active State
 CADS Controller Addressed State
 CAWS Controller Active Wait State
 CIDS Controller Idle State
 CPWS Controller Parallel Poll Wait State
 CSBS Controller Standby State
 CSNS Controller Service not Requested State
 CPPS Controller Parallel Poll State
 CSRS Controller Service Requested State
 CSWS Controller Synchronous Wait State
 CTRS Controller Transfer State

D

DAB Data Byte
 DAC Data Accepted
 DAV Data Valid
 DC Device Clear
 DCAS Device Clear Active State
 DCIS Device Clear Idle State
 DCL Device Clear
 DD Device Data
 DIO Data input/output
 DT Device Trigger
 DTAS Device Trigger Active State
 DTIS Device Trigger Idle State

E

END End
 EOI End Or Identify
 EOS End of String

G

GET Group execute Trigger
 GTL Go to Local
 gts go to stanby

I

IDY Identify
 IFC Interface Clear
 ist individual Status

L

L Listener
 LACS Listener Active State
 LAD Listener Address
 LADS Listener Addressed State
 LAG Listen Address Group
 LE Extended Listener
 LIDS Listener Idle State
 LLO Local Lock Out
 LOCS Local State
 lon Listen only
 LPAS Listener Primary Addressed State
 lpe Local Poll enabled
 LPIS Listener Primary Idle State
 ltn Listen
 LWLS Local with Lockout State
 lun Local unlisten

M

MLA My Listen Address
 MSA My Secondary Address
 MTA My Talk Address

N

nba new byte available
 NDAC Not Data Accepted