

# Service Manual

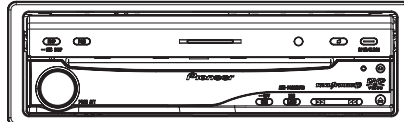

AVH-P5950DVD/XN/RC

ORDER NO.  
**CRT3916**

DVD AV RECEIVER

# AVH-P5950DVD<sub>/XN/RC</sub>

# AVH-P5950DVD<sub>/XN/RD</sub>

# AVH-P5950DVD<sub>/XN/RI</sub>

This service manual should be used together with the following manual(s):

Model No.	Order No.	Mech.Module	Remarks
CX-3212	CRT3896	MS5	DVD Mech. Module : Circuit Descriptions, Mech. Descriptions, Disassembly

"DTS" and "DTS Digital Surround" are registered trademarks of Digital Theater Systems, Inc.

Dolby noise reduction manufactured under license from Dolby Laboratories Licensing Corporation.

"Dolby" and the double-D symbol are trademarks of Dolby Laboratories Licensing Corporation.



For details, refer to "Important Check Points for Good Servicing".

# SAFETY INFORMATION

## CAUTION

This service manual is intended for qualified service technicians; it is not meant for the casual do-it-yourselfer. Qualified technicians have the necessary test equipment and tools, and have been trained to properly and safely repair complex products such as those covered by this manual.

Improperly performed repairs can adversely affect the safety and reliability of the product and may void the warranty. If you are not qualified to perform the repair of this product properly and safely, you should not risk trying to do so and refer the repair to a qualified service technician.

### 1. Safety Precautions for those who Service this Unit.

- Follow the adjustment steps in the service manual when servicing this unit. When checking or adjusting the emitting power of the laser diode exercise caution in order to get safe, reliable results.

#### Caution:

- During repair or tests, minimum distance of 13 cm from the focus lens must be kept.
- During repair or tests, do not view laser beam for 10 seconds or longer.

### 2. The triangular label is attached to the mechanism unit frame.

#### CAUTION

This product contains a laser diode of higher class than 1. To ensure continued safety, do not remove any covers or attempt to gain access to the inside of the product.

Refer all servicing to qualified personnel.

The following caution label appears on your unit.

#### 小心:

本产品包含有1级以上的辐射二极管。为了保证安全，切勿打开任何机盖或者试图接触本机内部，必要时应请求专业技术人员提供服务。

下面的提醒标签贴于本机上。

位置：本机后面板上。

On the top of the player.

在机器的机壳上。

<b>CAUTION</b>	: VISIBLE AND INVISIBLE LASER RADIATION WHEN OPEN. : AVOID EXPOSURE TO BEAM.
<b>VORSICHT</b>	: SICHTBARE UND UNSICHTBARE LASERSTRAHLUNG, WENN ABDECKUNG GE...FFNET NICHT DEM STRAHL AUSSETZEN!
<b>ADVARSEL</b>	: SYNLIG OG OSYNLIG LASERSTRÅLING VED ÅBNING : UNDGÅ UDSÆTTELSE FOR STRÅLING.
<b>VARNING</b>	: SYNLIG OCH OSYNLIG LASERSTRÅLNING NÅR DENNA DEL ÅR...ÖPPNAD BETRÄKTA EJ STRÅLNING.
<b>VARO!</b>	: AVATTAESSA ALTISTUTIN KYVÄJÄN KÄYNNÄ...MÄLLÄ LASERSATEILYLLÄ. LÄ KÄTSÖ SÄ TEESÄN.

VRW1860

<b>CAUTION</b>	: VISIBLE AND INVISIBLE LASER RADIATION WHEN OPEN. AVOID EXPOSURE TO BEAM.
----------------	--

<b>注意</b>	: 若打开会发生可见和不可见的辐射辐射，请勿受辐射。
-----------	----------------------------

VRW1904

**WARNING!**

The AEL (accessible emission level) of the laser power output is less than CLASS 1 but the laser component is capable of emitting radiation exceeding the limit for CLASS 1.  
A specially instructed person should do servicing operation of the apparatus.

**Laser diode characteristics**

Wave length:

DVD:640 nm to 660 nm

CD:770 nm to 810 nm

DVD : 2.48 mW(Emitting period :9 sec.)

CD : 705  $\mu$ W(Emitting period : unlimited)

**Additional Laser Caution**

Transistors Q1101 and Q1102 in PCB drive the laser diodes for DVD and CD respectively. When Q1101 or Q1102 is shorted between their terminals, the laser diodes for DVD or CD will radiate beam. If the top cover is removed with no disc loaded while such short-circuit is continued, the naked eyes may be exposed to the laser beam.

**CAUTION**

Danger of explosion if battery is incorrectly replaced.  
Replaced only with the same or equivalent type recommended by the manufacture.  
Discard used batteries according to the manufacture's instructions.

## [Important Check Points for Good Servicing]

In this manual, procedures that must be performed during repairs are marked with the below symbol. Please be sure to confirm and follow these procedures.

### 1. Product safety



Please conform to product regulations (such as safety and radiation regulations), and maintain a safe servicing environment by following the safety instructions described in this manual.

- ① Use specified parts for repair.

Use genuine parts. Be sure to use important parts for safety.

- ② Do not perform modifications without proper instructions.

Please follow the specified safety methods when modification (addition/change of parts) is required due to interferences such as radio/TV interference and foreign noise.

- ③ Make sure the soldering of repaired locations is properly performed.

When you solder while repairing, please be sure that there are no cold solder and other debris. Soldering should be finished with the proper quantity. (Refer to the example)

- ④ Make sure the screws are tightly fastened.

Please be sure that all screws are fastened, and that there are no loose screws.

- ⑤ Make sure each connectors are correctly inserted.

Please be sure that all connectors are inserted, and that there are no imperfect insertion.

- ⑥ Make sure the wiring cables are set to their original state.

Please replace the wiring and cables to the original state after repairs. In addition, be sure that there are no pinched wires, etc.

- ⑦ Make sure screws and soldering scraps do not remain inside the product.

Please check that neither solder debris nor screws remain inside the product.

- ⑧ There should be no semi-broken wires, scratches, melting, etc. on the coating of the power cord.

Damaged power cords may lead to fire accidents, so please be sure that there are no damages. If you find a damaged power cord, please exchange it with a suitable one.

- ⑨ There should be no spark traces or similar marks on the power plug.

When spark traces or similar marks are found on the power supply plug, please check the connection and advise on secure connections and suitable usage. Please exchange the power cord if necessary.

- ⑩ Safe environment should be secured during servicing.

When you perform repairs, please pay attention to static electricity, furniture, household articles, etc. in order to prevent injuries. Please pay attention to your surroundings and repair safely.

### 2. Adjustments



To keep the original performance of the products, optimum adjustments and confirmation of characteristics within specification. Adjustments should be performed in accordance with the procedures/instructions described in this manual.

### 3. Lubricants, Glues, and Replacement parts



Use grease and adhesives that are equal to the specified substance. Make sure the proper amount is applied.

### 4. Cleaning



For parts that require cleaning, such as optical pickups, tape deck heads, lenses and mirrors used in projection monitors, proper cleaning should be performed to restore their performances.

### 5. Shipping mode and Shipping screws



To protect products from damages or failures during transit, the shipping mode should be set or the shipping screws should be installed before shipment. Please be sure to follow this method especially if it is specified in this manual.



# CONTENTS

SAFETY INFORMATION .....	2	
1. SERVICE PRECAUTIONS.....	6	
2. SPECIFICATIONS.....	8	A
2.1 SPECIFICATIONS .....	8	
2.2 DISC/CONTENT FORMAT .....	9	
2.3 PANEL FACILITIES .....	10	
2.4 CONNECTION DIAGRAM.....	15	
3. BASIC ITEMS FOR SERVICE .....	16	
3.1 CHECK POINTS AFTER SERVICING .....	16	
3.2 PCB LOCATIONS.....	17	
3.3 JIG CONNECTION DIAGRAM .....	18	
4. BLOCK DIAGRAM .....	20	
5. DIAGNOSIS .....	32	
5.1 OPERATIONAL FLOW CHART.....	32	
5.2 CONNECTOR FUNCTION DESCRIPTION .....	33	B
5.3 BACK END SECTION FLOW .....	34	
6. SERVICE MODE.....	56	
6.1 DVD TEST MODE .....	56	
7. DISASSEMBLY.....	60	
8. EACH SETTING AND ADJUSTMENT .....	67	
8.1 DVD ADJUSTMENT .....	67	
8.2 VIDEO LEVEL ADJUSTMENT .....	72	
8.3 MOTHER UNIT ADJUSTMENT.....	74	
8.4 INVERTER ADJUSTMENT .....	76	
8.5 MONITOR ADJUSTMENT.....	78	
8.6 MONITOR TEST MODE.....	84	
8.7 CALIBRATION TEST .....	90	C
9. EXPLODED VIEWS AND PARTS LIST .....	98	
9.1 PACKING.....	98	
9.2 EXTERIOR(1) .....	100	
9.3 EXTERIOR(2) .....	102	
9.4 EXTERIOR(3) .....	106	
9.5 EXTERIOR(4) .....	108	
9.6 DVD MECHANISM MODULE.....	110	
10. SCHEMATIC DIAGRAM.....	112	
10.1 MOTHER UNIT(SYSTEM PART)(GUIDE PAGE).....	112	
10.2 MOTHER UNIT(POWER SUPPLY PART)(GUIDE PAGE) .....	118	
10.3 KEYBOARD UNIT .....	124	D
10.4 MONITOR PCB(MONITOR PART)(GUIDE PAGE) .....	126	
10.5 MONITOR PCB(OSD & $\mu$ CON PART)(GUIDE PAGE) .....	132	
10.6 DVD CORE UNIT(1/2)(GUIDE PAGE) .....	138	
10.7 DVD CORE UNIT(2/2) .....	144	
10.8 COMPOUND UNIT(A) AND COMPOUND UNIT(B) .....	146	
10.9 RCA PCB.....	147	
10.10 UPPER PCB.....	148	
10.11 OPT PCB .....	149	
10.12 MAIN PCB UNIT(SERVICE), SWITCH PCB UNIT AND VOLUME PCB UNIT .....	150	
10.13 WAVEFORMS.....	152	
11. PCB CONNECTION DIAGRAM .....	154	
11.1 MOTHER UNIT .....	154	E
11.2 KEYBOARD UNIT.....	158	
11.3 MONITOR PCB.....	160	
11.4 DVD CORE UNIT.....	164	
11.5 COMPOUND UNIT(A) AND COMPOUND UNIT(B) .....	168	
11.6 RCA PCB .....	169	
11.7 UPPER PCB .....	170	
11.8 OPT PCB .....	171	
11.9 MAIN PCB UNIT(SERVICE), SWITCH PCB UNIT AND VOLUME PCB UNIT .....	172	
12. ELECTRICAL PARTS LIST .....	173	F

# 1. SERVICE PRECAUTIONS

## ● Service Precautions

- A 1) You should conform to the regulations governing the product (safety, radio and noise, and other regulations), and should keep the safety during servicing by following the safety instructions described in this manual.
- 2) Be careful in handling ICs. Some ICs such as MOS type are so fragile that they can be damaged by electrostatic induction.
- 3) Before disassembling the unit, be sure to turn off the power. Unplugging and plugging the connectors during power-on mode may damage the ICs inside the unit.
- 4) To protect the pickup unit from electrostatic discharge during servicing, take an appropriate treatment (shorting-solder) by referring to "the DISASSEMBLY" .
- 5) After replacing the pickup unit, be sure to skew adjustment.
- 6) During disassembly, be sure to turn the power off since an internal IC might be destroyed when a connector is plugged or unplugged.
- 7) In case the internal fuse has blown, check the voltage of the rear stage.
- 8) Handling instructions for touch panel  
Please handle the touch panel with care as it contains glass.  
Dropping or giving a strong shock may break the panel.  
Wear gloves, etc. to protect your hands from the glass edges that are not deburred.
- B 9) Remove a small board (2 screws) provided for pulling out an RCA line, before removing the mother board.
- 10) Hot areas

Red area: Hot area. Be careful not to burn yourself

Moter Unit(Side A)

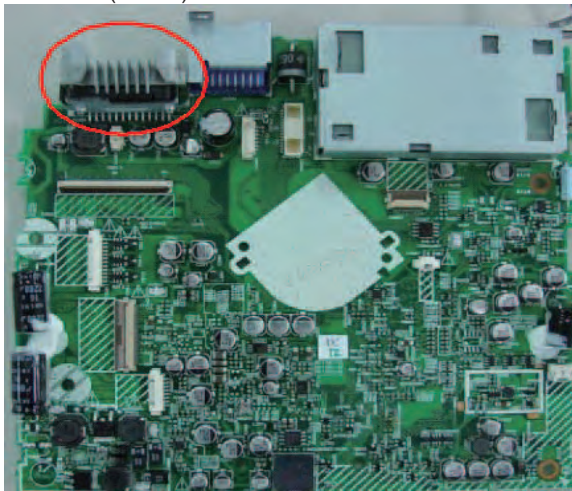

Moter Unit(Side B)

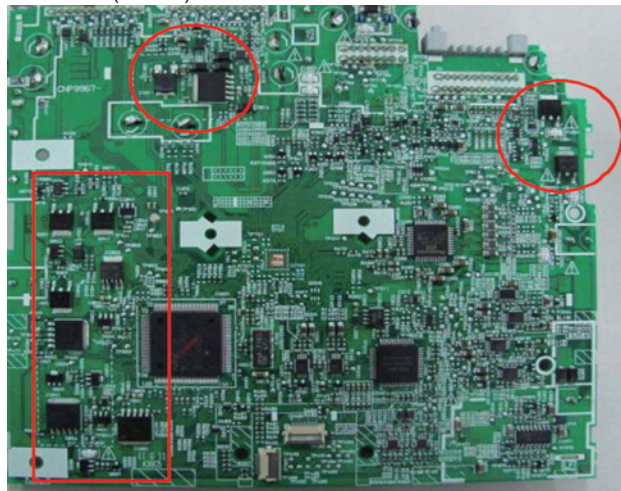

Red-circled area: The heat from hot parts on the B-side of the board is removed from the product bottom through a heat transfer sheet.

Be careful not to burn yourself with the hot area.

Bottom

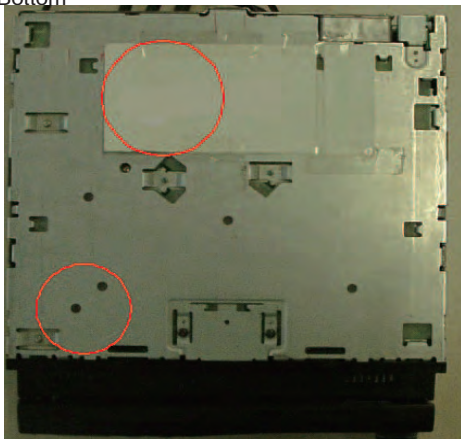

DVD is a trademark of DVD Format/Logo Licensing Corporation.

## NOTES ON SOLDERING

- For environmental protection, lead-free solder is used on the printed circuit boards mounted in this unit.  
Be sure to use lead-free solder and a soldering iron that can meet specifications for use with lead-free solders for repairs accompanied by reworking of soldering.
- Compared with conventional eutectic solders, lead-free solders have higher melting points, by approximately 40°C.  
Therefore, for lead-free soldering, the tip temperature of a soldering iron must be set to around 373 °C in general, although the temperature depends on the heat capacity of the PC board on which reworking is required and the weight of the tip of the soldering iron.

Compared with eutectic solders, lead-free solders have higher bond strengths but slower wetting times and higher melting temperatures (hard to melt/easy to harden).

The following lead-free solders are available as service parts:

- Parts numbers of lead-free solder:  
GYP1006 1.0 in dia.  
GYP1007 0.6 in dia.  
GYP1008 0.3 in dia.

# 2. SPECIFICATIONS

## 2.1 SPECIFICATIONS

**A**

**General**

Rated power source ..... 14.4 V DC  
(allowable voltage range:  
12.0 V to +4.4 V DC)

Grounding system ..... Negative type

Max. current consumption  
..... 10.0 A

**Backup current ..... 5 mA or less**

Dimensions (W × H × D):  
DIN  
Chassis ..... 178 × 50 × 160 mm  
Nose ..... 188 × 58 × 33 mm  
D  
Chassis ..... 178 × 50 × 165 mm  
Nose ..... 170 × 46 × 28 mm

Weight ..... 2.4 kg

**B**

**Display**

Screen size/aspect ratio ..... 7.0 inch wide/16:9  
(effective display area: 154  
× 87 mm)

Pixels ..... 336 960 (1 440 × 234)

Type ..... TFT active matrix, transmis-  
sive type

Color system ..... NTSC/PAL/PAL-M/SECAM  
compatible

Storage temperature range  
..... -20 °C to +80 °C

Angle adjustment ..... 50° to 110°  
(initial settings: 90°)

**C**

**Audio**

Maximum power output ..... 50 W × 4  
50 W × 2/4 Ω + 70 W × 1/2  
Ω (for subwoofer)

Continuous power output ..... 22 W × 4 (50 Hz to 15 000  
Hz, 5% THD, 4 Ω load, both  
channels driven)

Load impedance ..... 4 Ω to 8 Ω × 4  
4 Ω to 8 Ω × 2 + 2 Ω × 1

Preout max output level/output impedance  
..... 4.0 V/100 Ω

Equalizer (7-Band Graphic Equalizer):  
Frequency ..... 50/125/315/800/2k/5k/12.5k  
Hz

Gain ..... ±12 dB

Loudness contour:  
Low ..... +3.5 dB (100 Hz), +3 dB (10  
kHz)

**D**

**E**

**F**

Mid ..... +10 dB (100 Hz), +6.5 dB  
(10 kHz)

High ..... +11 dB (100 Hz), +1 dB  
(10 kHz)  
(volume: -30 dB)

HPF:  
Frequency ..... 50/63/80/100/125 Hz  
Slope ..... -12 dB/oct

Subwoofer (mono):  
Frequency ..... 50/63/80/100/125 Hz  
Slope ..... -18 dB/oct  
Gain ..... +6 dB to -24 dB  
Phase ..... Normal/Reverse

Bass boost:  
Gain ..... +12 dB to 0 dB

**DVD Player**

System ..... DVD video, DVD-VR, Video  
CD, CD, WMA, MP3, AAC,  
DivX system

Usable discs ..... DVD video, Video CD, CD,  
CD-R/RW, DVD-R/RW

Region number:  
for Middle East Asian and South African models  
..... 2  
for Southeast Asian models  
..... 3  
for South American and Oceanian models  
..... 4

Signal format:  
Sampling frequency ..... 44.1/48/96 kHz  
Number of quantization bits  
..... 16/20/24; linear

Frequency response ..... 5 Hz to 44 000 Hz (with DVD,  
at sampling frequency 96  
kHz)

Signal-to-noise ratio ..... 97 dB (1 kHz) (IEC-A net-  
work)  
(CD: 96 dB (1 kHz) (IEC-A  
network))

Dynamic range ..... 95 dB (1 kHz)  
(CD: 94 dB (1 kHz))

Distortion ..... 0.008 % (1 kHz)

Output level:  
Video ..... 1.0 Vp-p/75 Ω (±0.2 V)

Number of channels ..... 2 (stereo)

MP3 decoding format ..... MPEG-1 & 2 Audio Layer 3

WMA decoding format ..... Ver. 7, 7.1, 8, 9, 10 (2ch  
audio)  
(Windows Media Player)

AAC decoding format ..... MPEG-4 AAC (iTunes® en-  
coded only)

DivX decoding format ..... Home Theater Ver. 3, 4, 5.2  
(.avi, .divx)

**FM tuner**

Frequency range ..... 87.5 MHz to 108.0 MHz

Usable sensitivity ..... 8 dBf (0.7 μV/75 Ω mono,  
S/N: 30 dB)

Signal-to-noise ratio ..... 75 dB (IEC-A network)

Distortion ..... 0.3 % (at 65 dBf, 1 kHz,  
stereo)  
0.1 % (at 65 dBf, 1 kHz,  
mono)

Frequency response ..... 30 Hz to 15 000 Hz (±3 dB)

Stereo separation ..... 45 dB (at 65 dBf, 1 kHz)

**AM tuner**

Frequency range ..... 531 kHz to 1 602 kHz (9 kHz)  
530 kHz to 1 640 kHz (10  
kHz)

Usable sensitivity ..... 18 μV (S/N: 20 dB)

Signal-to-noise ratio ..... 65 dB (IEC-A network)

**Infrared remote control**

Wavelength ..... 945 nm

Output ..... typ. 10 mw/sr per Infrared  
LED

## 2.2 DISC/CONTENT FORMAT

### Playable discs

DVD, Video CD and CD discs that display the logos shown below can be played back on this player.

#### DVD video



#### Video CD



#### CD



#### Notes

- **DVD** is a trademark of DVD Format/Logo Licensing Corporation.
- This player can only play back discs bearing the marks shown above.

## 2.3 PANEL FACILITIES

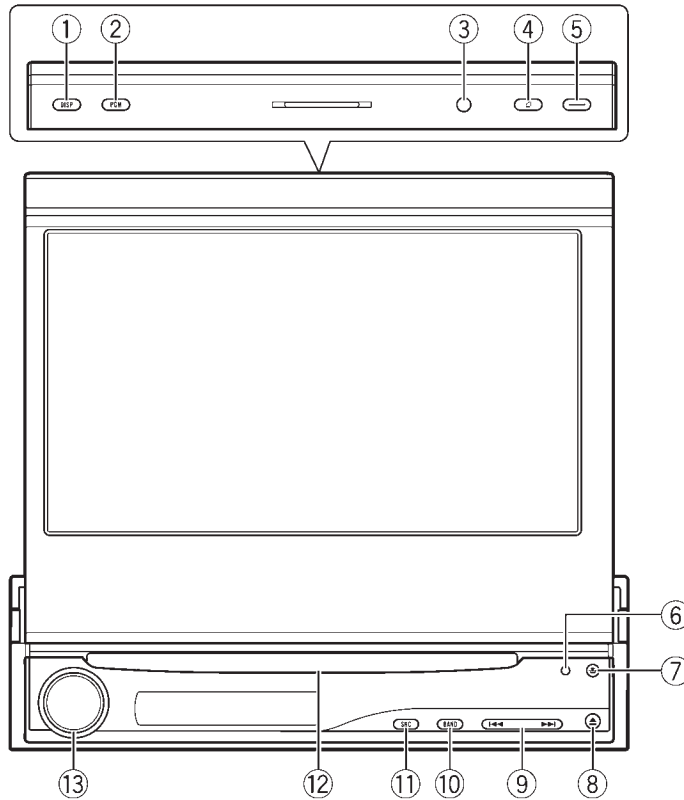

### What's What Head unit

#### ① **DISPLAY button**

Press to turn the information display on or off when the video is displayed.

Press and hold to switch between the displays on the sub-display.

- When a rear view camera video is displayed, press and hold **DISPLAY** return to the source display.

#### ② **PGM button**

Press to operate the preprogrammed functions for each source.

#### ③ **Ambient light sensor**

Senses ambient light. This system automatically adjusts the brightness of the display to compensate for ambient light.

#### ④ **FLIP DOWN button**

Press to turn the LCD panel horizontal temporarily from upright position.

#### ⑤ **OPEN/CLOSE button**

Press to open or close the LCD panel.

#### ⑥ **RESET button**

Press to return to the factory settings (initial settings).

#### ⑦ **DETACH button**

Press to remove the front panel from the head unit.

**⑧ EJECT button**

Press to eject a disc from this unit.

**⑨ |◀◀/▶▶| button**

Press to do manual seek tuning, fast forward, reverse and track search controls.

**⑩ BAND/ESC button**

Press to select among three FM bands and one AM band and to cancel the control mode of functions.

**⑪ SOURCE button**

This unit is turned on by selecting a source. Press to cycle through all the available sources.

**⑫ Disc loading slot**

Insert a disc to play.

**⑬ VOLUME/ATT button**

Rotate it to increase or decrease the volume.

Press to quickly lower the volume level, by about 90%. Press once more to return to the original volume level.

A

B

C

D

E

F

A

B

C

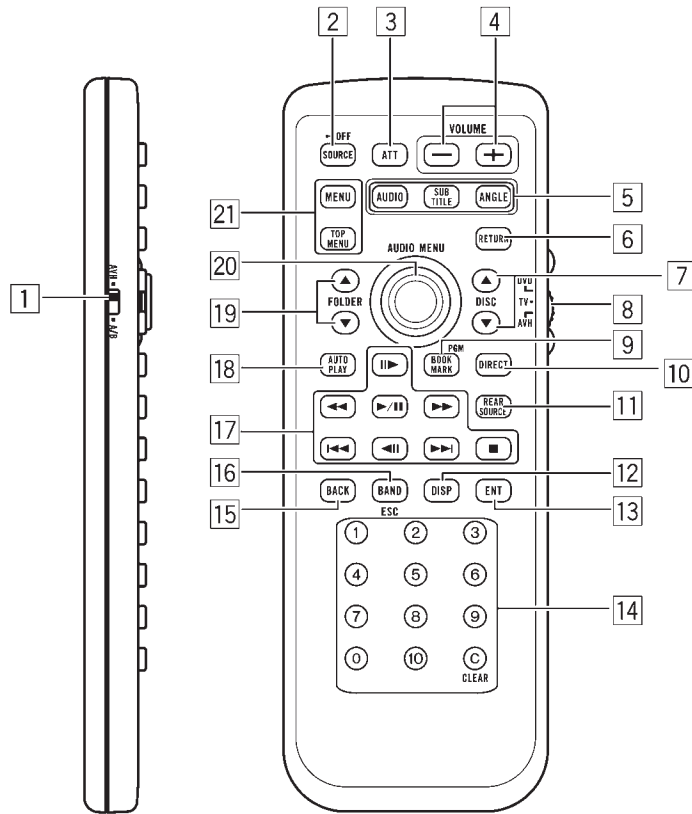

### Remote control

	Button names	AVH mode	DVD mode
1	Remote control selection switch	Switch to change the setting of the remote control.	
2	<b>SOURCE</b> button	Press to cycle through all the available sources. Press and hold to turn the source off.	
3	<b>ATT</b> button	Press to quickly lower the volume level, by about 90%. Press once more to return to the original volume level.	
4	<b>VOLUME</b> buttons	Press to increase or decrease the volume.	
5	<b>AUDIO</b> button	Press to change the audio language during DVD playback.	
	<b>SUBTITLE</b> button	Press to change the subtitle language during DVD playback.	
	<b>ANGLE</b> button	Press to change the viewing angle during DVD playback.	
6	<b>RETURN</b> button	Press to display the PBC (playback control) menu during PBC playback.	

D

E

F



	Button names	AVH mode	DVD mode
7	▲/▼ buttons (DISC)	Not used.	<b>Remote control code: AVH or B</b> Not used. <b>Remote control code: A</b> Press to select the next/previous disc.
8	Remote control operation mode switch	Switch the operation mode between <b>AVH</b> , <b>DVD</b> and <b>TV</b> modes. Normally, set to <b>AVH</b> . For details, refer to <i>Using the remote control operation mode switch</i> on the next page.	
9	<b>BOOKMARK</b> button/ <b>PGM</b> button	Press to operate the preprogrammed functions for each source. (Refer to <i>Using the PGM button</i> on page 56.)	Press to turn the bookmark function on or off when your DVD player features bookmark function. For details, refer to DVD player's operation manual.
10	<b>DIRECT</b> button	Not used.	
11	<b>REAR SOURCE</b> button	Not used.	<b>Remote control code: AVH</b> Not used. <b>Remote control code: A or B</b> Press to turn the DVD player on or off.
12	<b>DISPLAY</b> button	Press to select different displays.	<b>Remote control code: AVH</b> Not used. <b>Remote control code: A or B</b> Press to select different displays.
13	<b>ENTERTAINMENT</b> button	Not used.	
14	<b>0 to 10</b> buttons, <b>CLEAR</b> button	Press <b>0</b> to <b>10</b> to input numbers. Buttons <b>1</b> to <b>6</b> can operate the preset tuning for the tuner or disc changing for DVD player or multi-CD player. Press <b>CLEAR</b> to clear the input numbers.	Press to select a menu item on the Video CDs featuring PBC (playback control).
15	<b>BACK</b> button	Press to return to the previous display.	Not used.
16	<b>BAND/ESC</b> button	Press to select the tuner band when tuner is selected as a source. Also used to cancel the control mode of functions. Press to switch mode between compressed audio and audio data (CD-DA) when playing discs with compressed audio and audio data (CD-DA) such as CD-EXTRA and MIXED-MODE CDs.	Press to switch mode between compressed audio and audio data (CD-DA) when playing discs with compressed audio and audio data (CD-DA) such as CD-EXTRA and MIXED-MODE CDs.

	Button names	AVH mode	DVD mode
A  B	<b>PLAY/PAUSE</b> (▶/⏸) button	Press to switch sequentially between playback and pause.	
	<b>REVERSE</b> (◀◀) button	Press to perform fast reverse.	
	<b>FORWARD</b> (▶▶) button	Press to perform fast forward.	
	<b>17 PREVIOUS</b> (I◀◀) button	Press to return to the previous track (chapter).	
	<b>NEXT</b> (▶▶I) button	Press to go to the next track (chapter).	
	<b>STEP</b> (II▶/◀II) buttons	Press to move ahead one frame at a time during DVD/VideoCD playback. Press and hold for one second to activate slow playback.	
	<b>STOP</b> (■) button	Press to stop playback.	
<b>18</b>	<b>AUTO PLAY</b> button	Press to turn the DVD auto-playback function on or off.	
<b>19</b>	<b>▲/▼</b> buttons ( <b>FOLDER</b> )	Press to select the next/previous folder.	
<b>20</b>	Joystick	Move to do fast forward, reverse and track search controls. Click to recall <b>MENU</b> .	Move to select a menu on the DVD menu.
C  D	<b>21 MENU</b> button	Press to display the DVD menu during DVD playback.	
	<b>TOP MENU</b> button	Press to return to the top menu during DVD playback.	

## Using the remote control operation mode switch

There are three remote control operation modes on the remote control.

### AVH mode operation

When operating this unit by remote control, the mode is normally switched to **AVH**.

### DVD mode operation

If you switch the mode to **DVD**, the joystick and **0** to **10** operations are changed for DVD player.

#### ● When you want to operate the following functions, switch the mode to **DVD**:

- When operating the DVD menu by using the joystick.

- When operating the PBC menu by using **0** to **10**.

### TV mode operation

TV operations available with a Pioneer TV tuner (e.g. GEX-P5750TV(P)) can be controlled with **AVH** mode. **TV** mode is not used with this unit.

- For details concerning operation, refer to the TV tuner's operation manuals. □

### Fastening the front panel

If you do not plan to detach the front panel, the front panel can be fastened with supplied screws.

- **Fix the front panel to the unit using screws after removing the trim ring.**

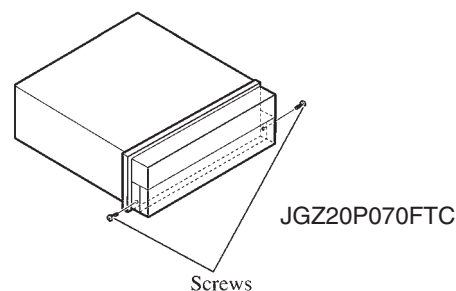

# 2.4 CONNECTION DIAGRAM

## ● Connection Diagram

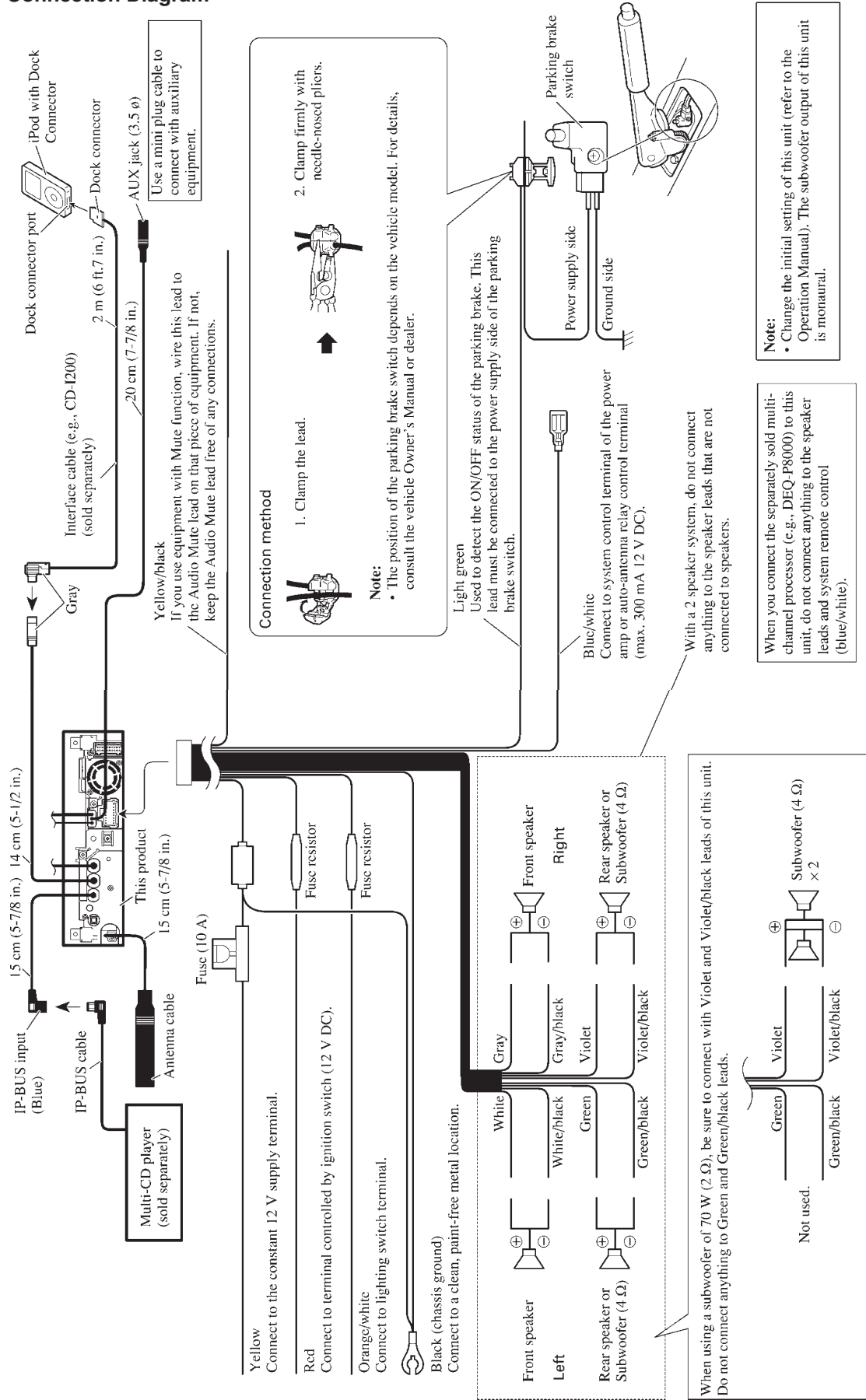

# 3. BASIC ITEMS FOR SERVICE

## 3.1 CHECK POINTS AFTER SERVICING

A

### CHECK POINTS AFTER SERVICING (AVH)

To keep the product quality after servicing, please confirm following check points.

No.		Procedures	Check points	Remark
1		Confirm whether the customer complain has been solved. If the customer complain occurs with the specific media, use it for the operation check.	The customer complain must not be reappeared. Display, video, audio and operations must be normal.	
2	Flap-mecha	Check the operation of the flap mechanism.	The flap mechanism operation must be smooth without making the noise and scratches.	When flap-mecha exists
3	DVD	Measure playback error rates at the innermost and outermost tracks by using the test mode with the following disc. DVD test disc (GGV1025)	Deterioration of mecha-drive can be checked. The error rates must be less than 2.5e-4.	
4	DVD	Play back a DVD. (Menu operation; Title/chapter search)	Display, video, audio and operations must be normal.	
5	CD	Play back a CD. (Track search)	Display, audio and operations must be normal.	
6	FM/AM tuner	Check FM/AM tuner action. (Seek, Preset) Switch band to check both FM and AM.	Display, audio and operations must be normal.	
7	TV tuner	Check TV tuner action. (Seek; Preset)	Display, video, audio and operations must be normal.	
8		Check whether no disc is inside the product.	The media used for the operating check must be ejected.	
9		Appearance check	No scratches or dirt on its appearance after receiving it for service.	

B

C

See the table below for the items to be checked regarding video and audio:

Item to be checked regarding video	Item to be checked regarding audio
Block-noise	Distortion
Horizontal noise	Noise
Dot noise	Volume too low
Disturbed image (video jumpiness)	Volume too high
Too dark	Volume fluctuating
Too bright	Sound interrupted
Mottled color	

D

E

F

## 3.2 PCB LOCATIONS

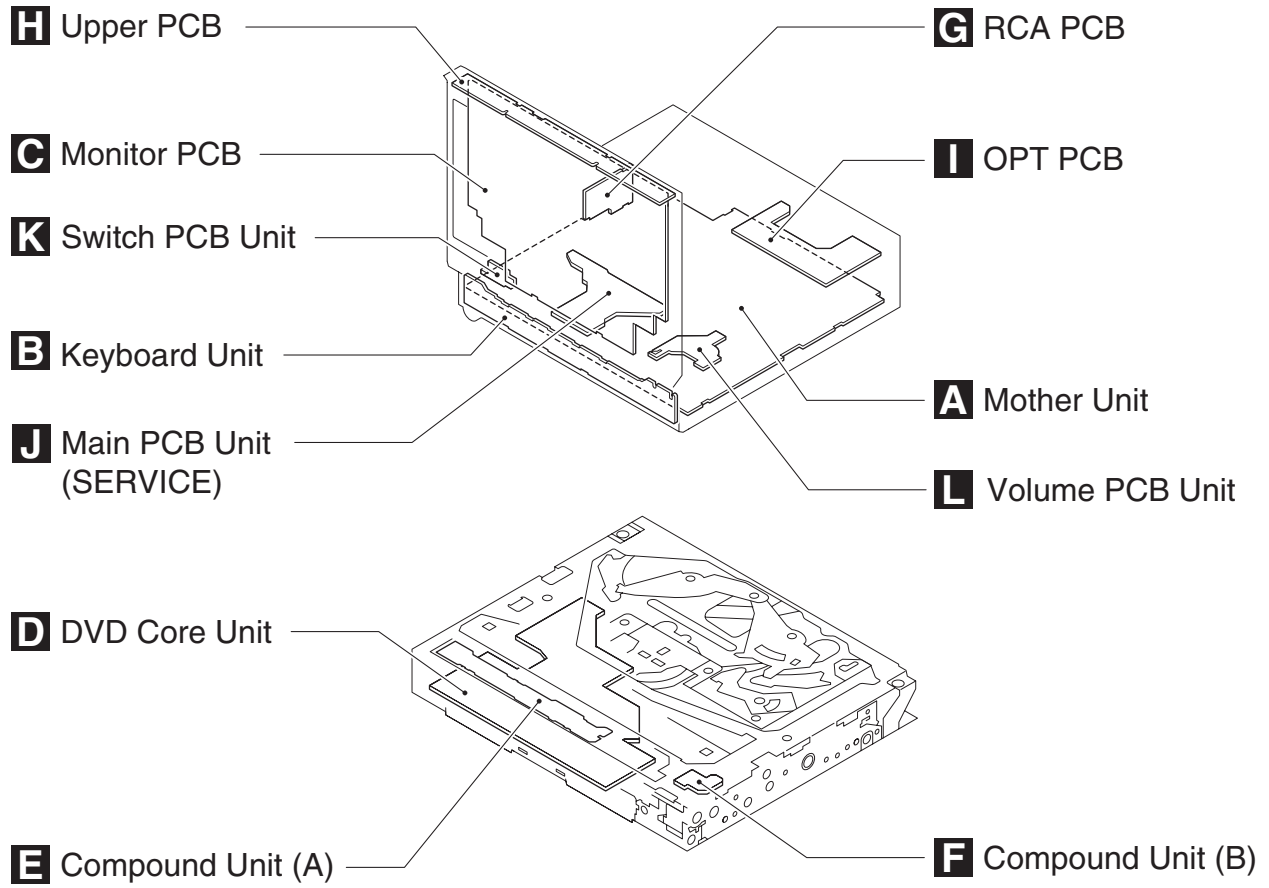

Unit Number : (RC,RD,RI)  
 Unit Name : Mother Unit  
 Unit Number :  
 Unit Name : Keyboard Unit  
 Unit Number : CWN2330  
 Unit Name : Monitor Unit  
**Monitor Unit**  
**Consists of**  
**Monitor PCB**  
**Upper PCB**  
 Unit Number : YWX5005  
 Unit Name : DVD Core Unit  
 Unit Number : CWX3154  
 Unit Name : Compound Unit(A)  
 Unit Number : CWX3394  
 Unit Name : Compound Unit(B)

**DVD Amp Assy**  
**Consists of**  
**Mother Unit**  
**OPT PCB**  
**RCA PCB**

Unit Number : CXX2316  
 Unit Name : Main PCB Unit(SERVICE)  
 Unit Number : CZW5029  
 Unit Name : Switch PCB Unit  
 Unit Number : CZW5028  
 Unit Name : Volume PCB Unit

### 3.3 JIG CONNECTION DIAGRAM

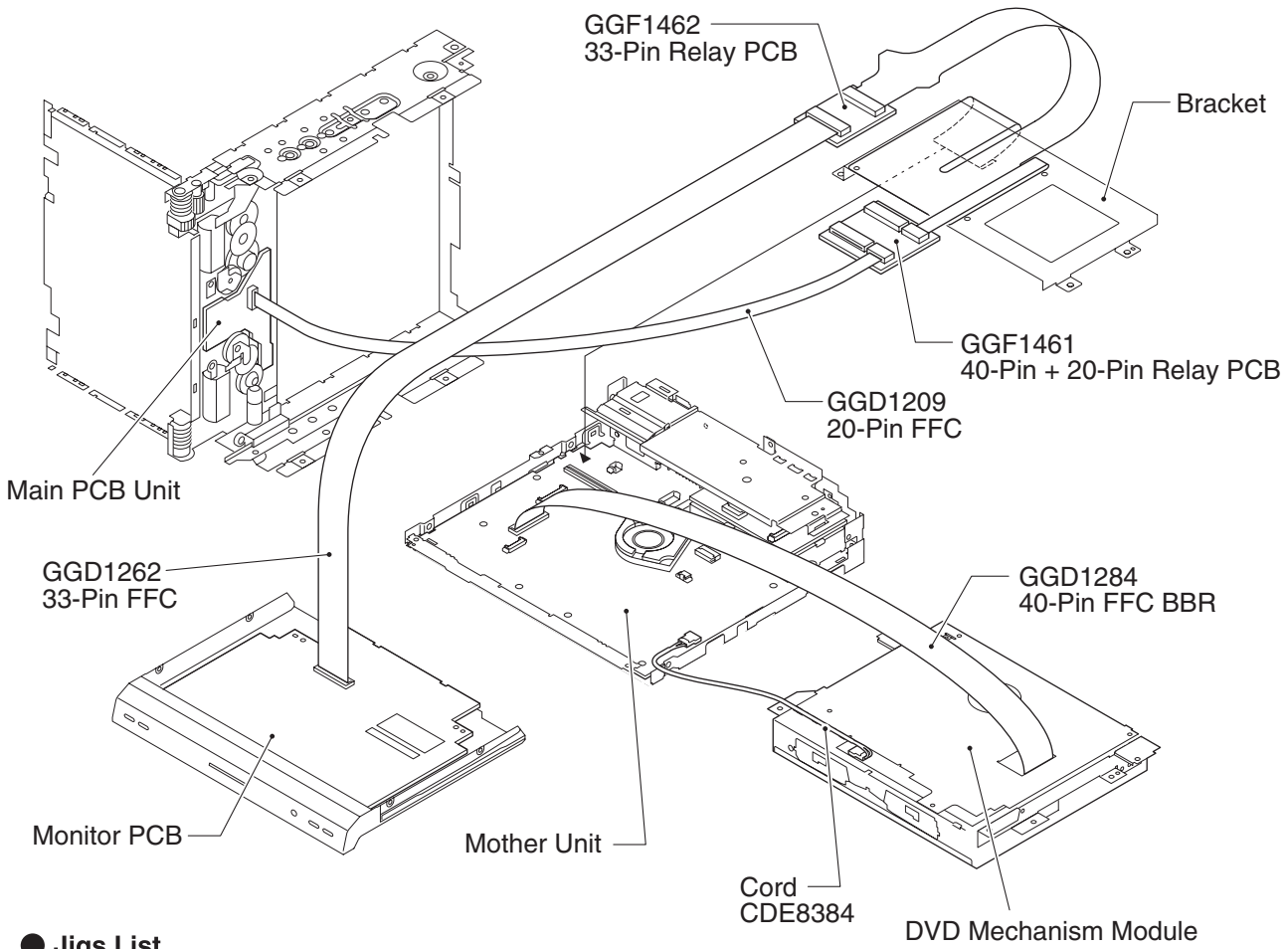

● Jigs List

Name	Jig No.	Remarks
40-Pin FFC BBR	GGD1284	DVD Mechanism Module <--> DVD Amp Assy
33-Pin Relay PCB	GGF1462	DVD Amp Assy <--> Monitor Unit
33-Pin FFC	GGD1262	DVD Amp Assy <--> Monitor Unit
40-Pin + 20-Pin Relay PCB	GGF1461	DVD Amp Assy <--> Main PCB Unit
20-Pin FFC	GGD1209	DVD Amp Assy <--> Main PCB Unit
Disc	GGV1018	Skew adjustment
TORX driver(T2)	GGK1095	Skew adjustment
Bond	GEM1033	Skew adjustment

## ● Grease List

Name	Jig No.	Remarks
Grease	GEM1024	DVD Mechanism Module and Chassis
Grease	GEM1043	DVD Mechanism Module and Chassis
Grease	GEM1045	DVD Mechanism Module
Grease	GEM1050	DVD Mechanism Module
Locking agents	1401M	DVD Mechanism Module (1401M:produced by THREE BOND)
Grease	GEM1011	Chassis
Grease	GEM1047	Chassis
Grease	GEM1071	Chassis
Grease	GEM1072	Chassis



## CLEANING

Before shipping out the product, be sure to clean the following portions by using the prescribed cleaning tools:

Portions to be cleaned	Cleaning tools
DVD pickup lenses	Cleaning liquid : GEM1004 Cleaning paper : GED-008

Portions to be cleaned	Cleaning tools
Fans	Cleaning paper : GED-008

# 4. BLOCK DIAGRAM

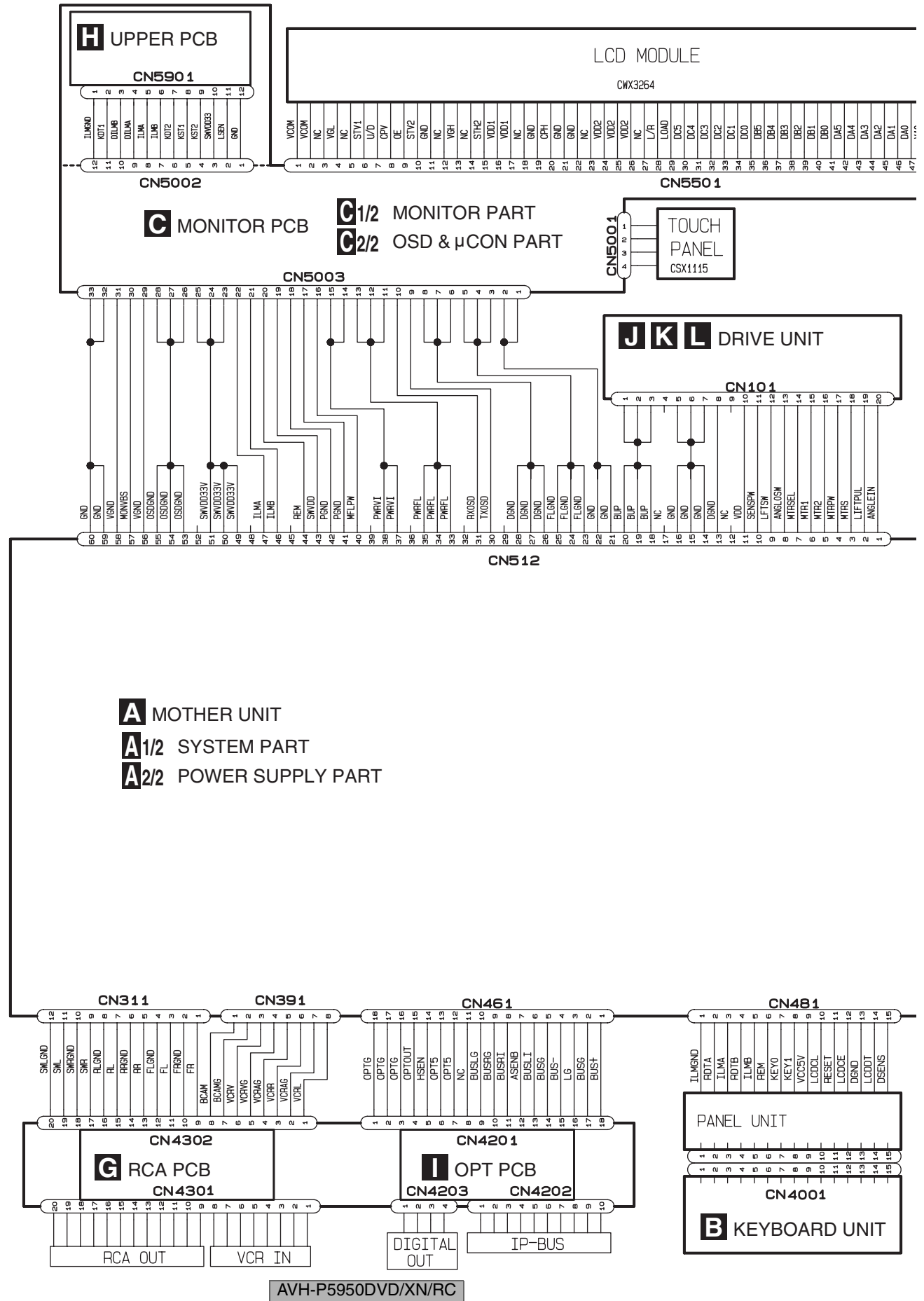



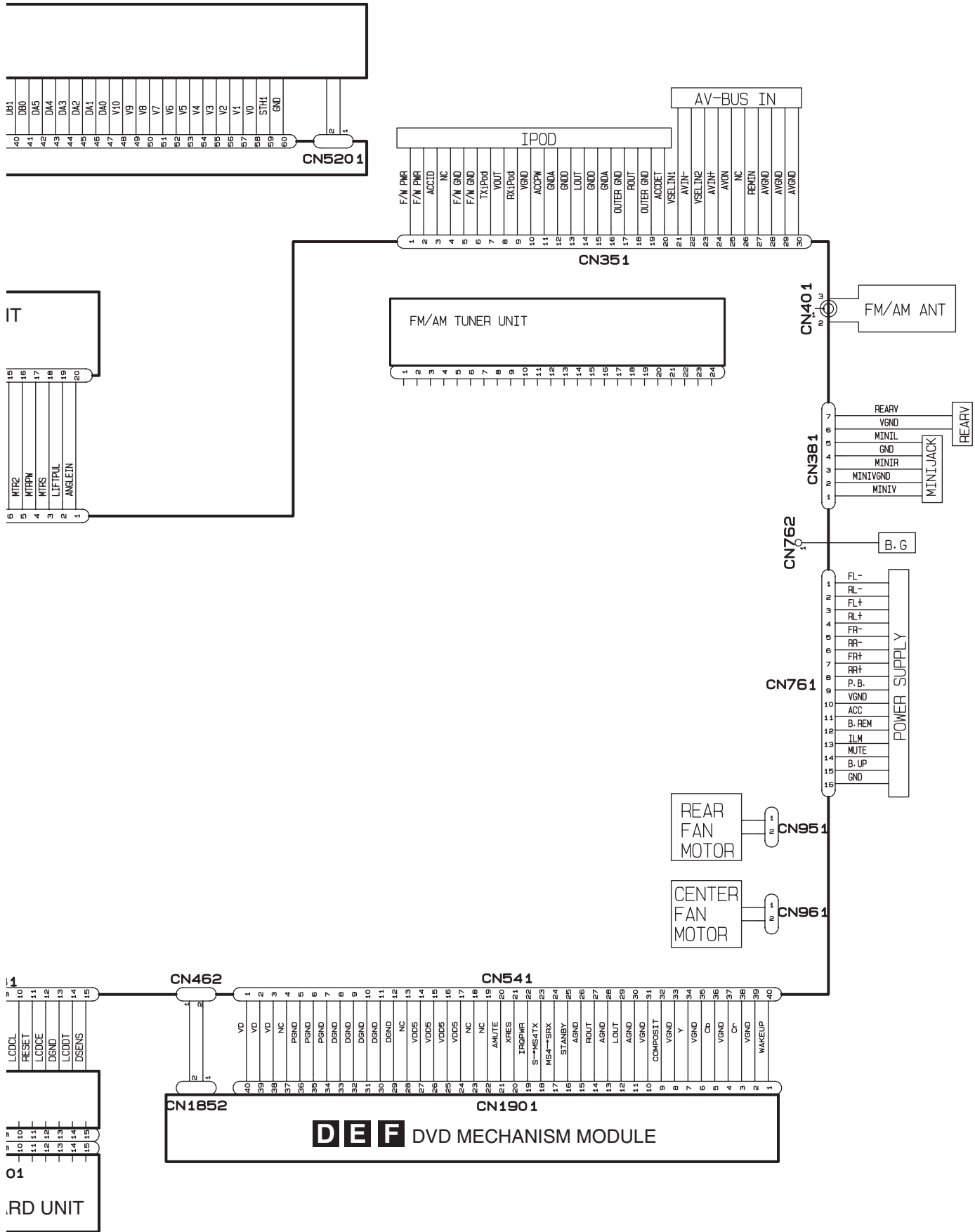

# A MOTHER UNIT (1/2)

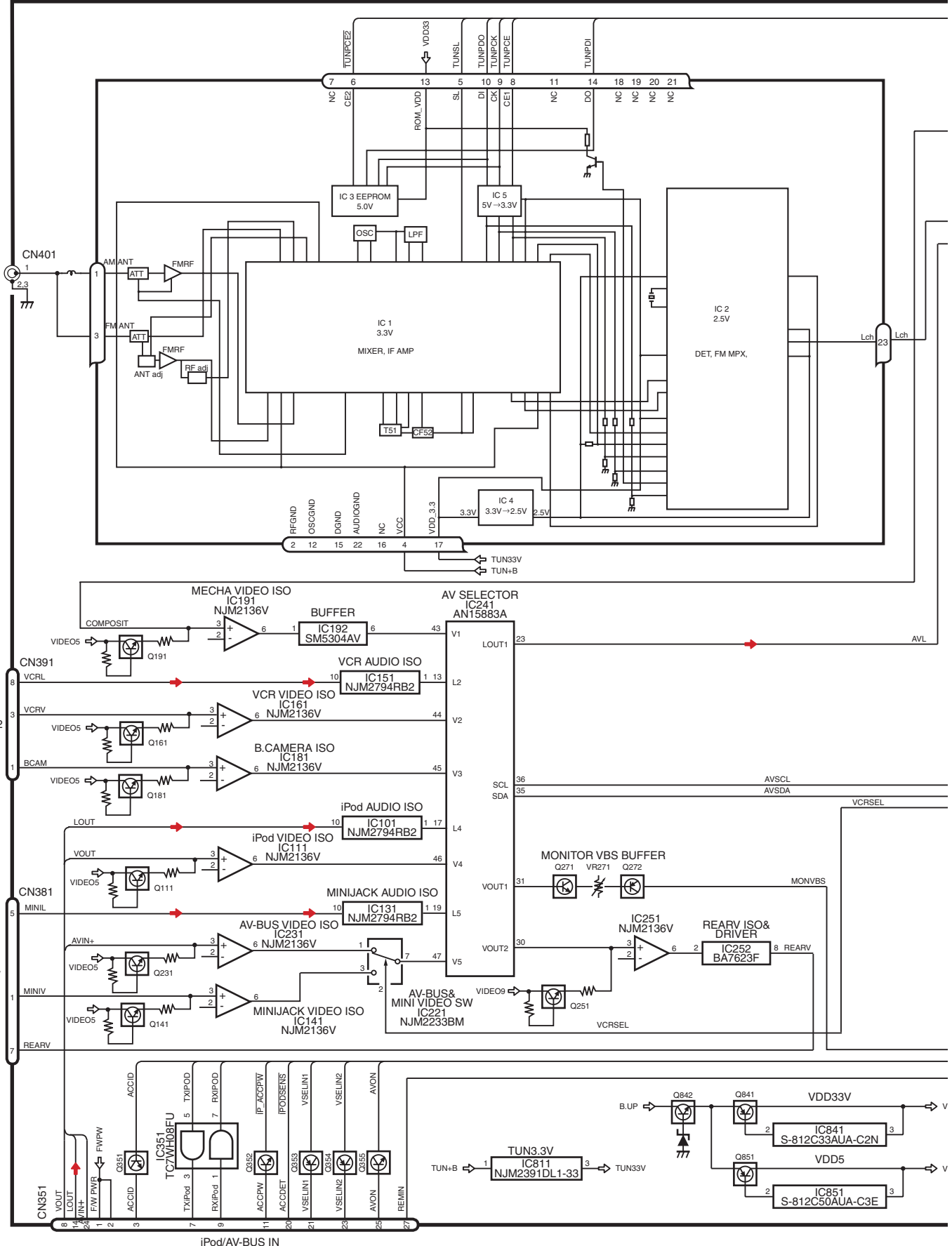

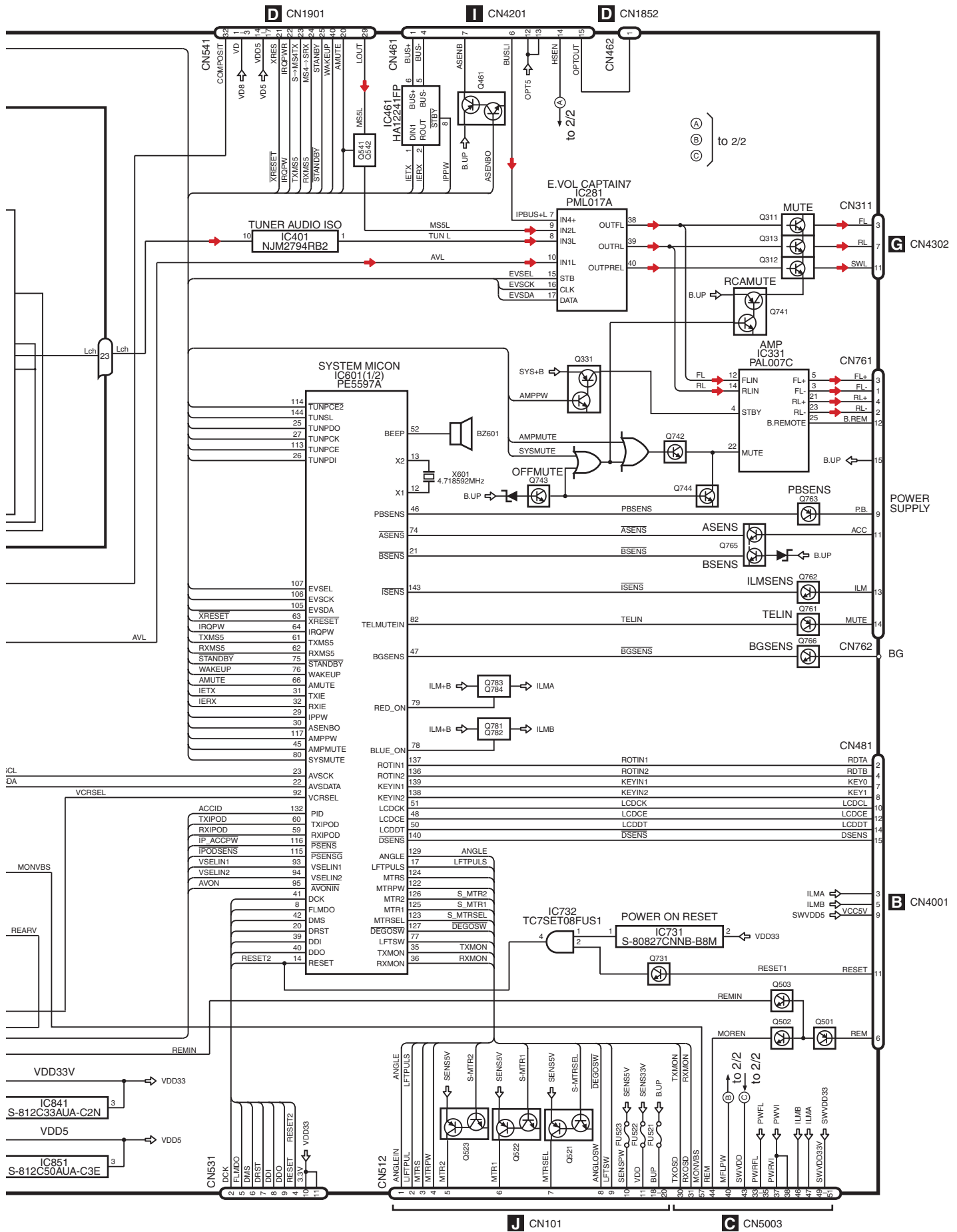

# A MOTHER UNIT (2/2)

SYSTEM MICON  
IC601 (2/2)  
PE5597A

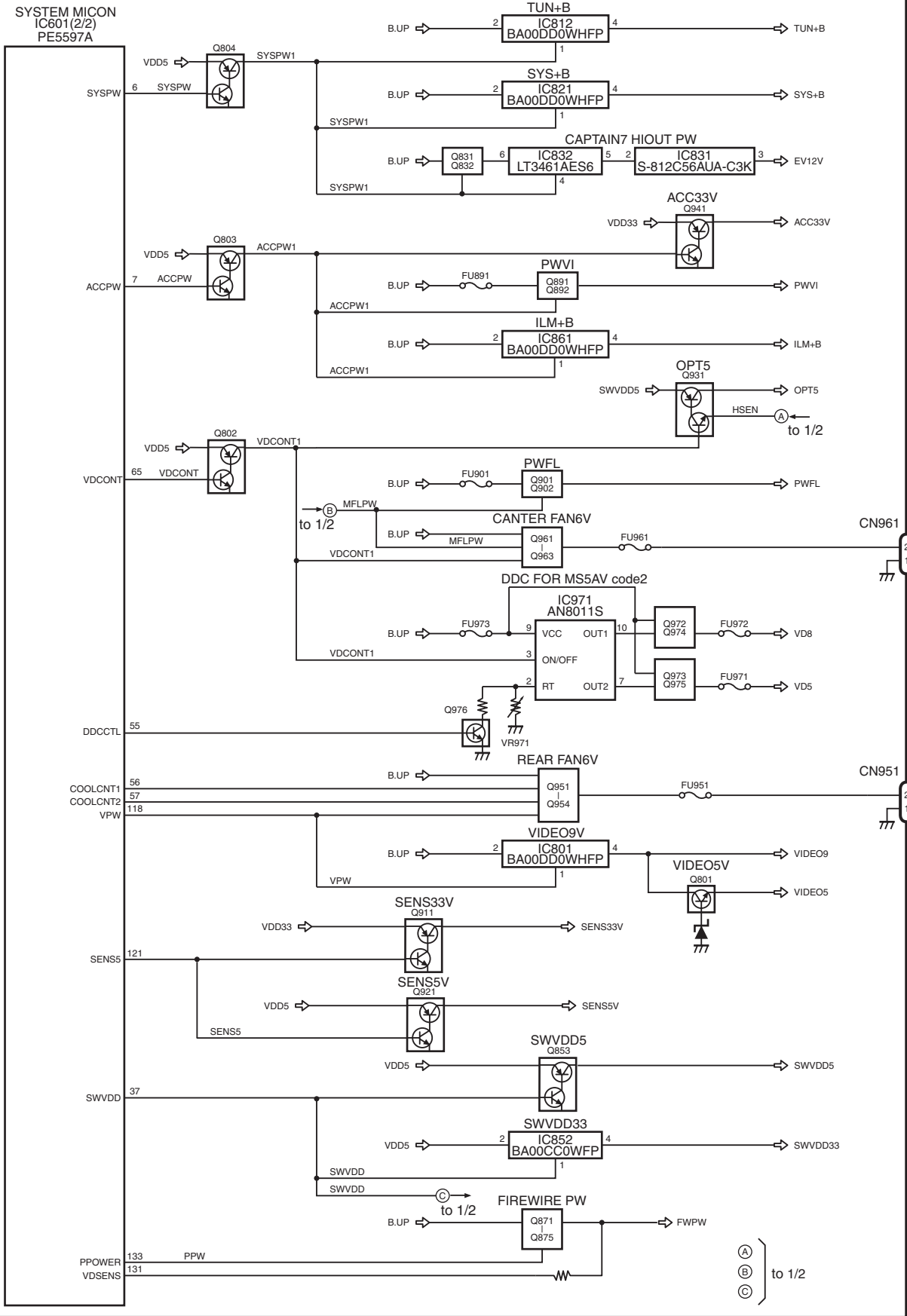

(A)  
(B)  
(C) to 1/2

### G RCA PCB

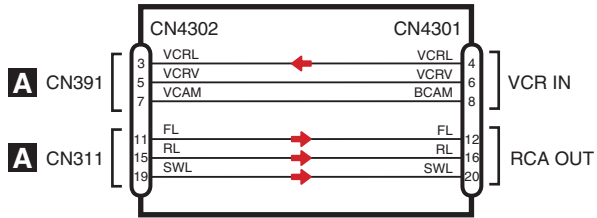

### I OPT PCB

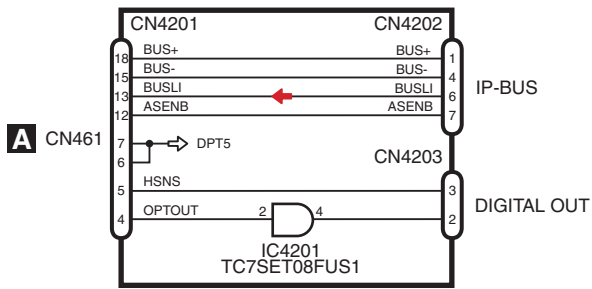

### B KEYBOARD UNIT

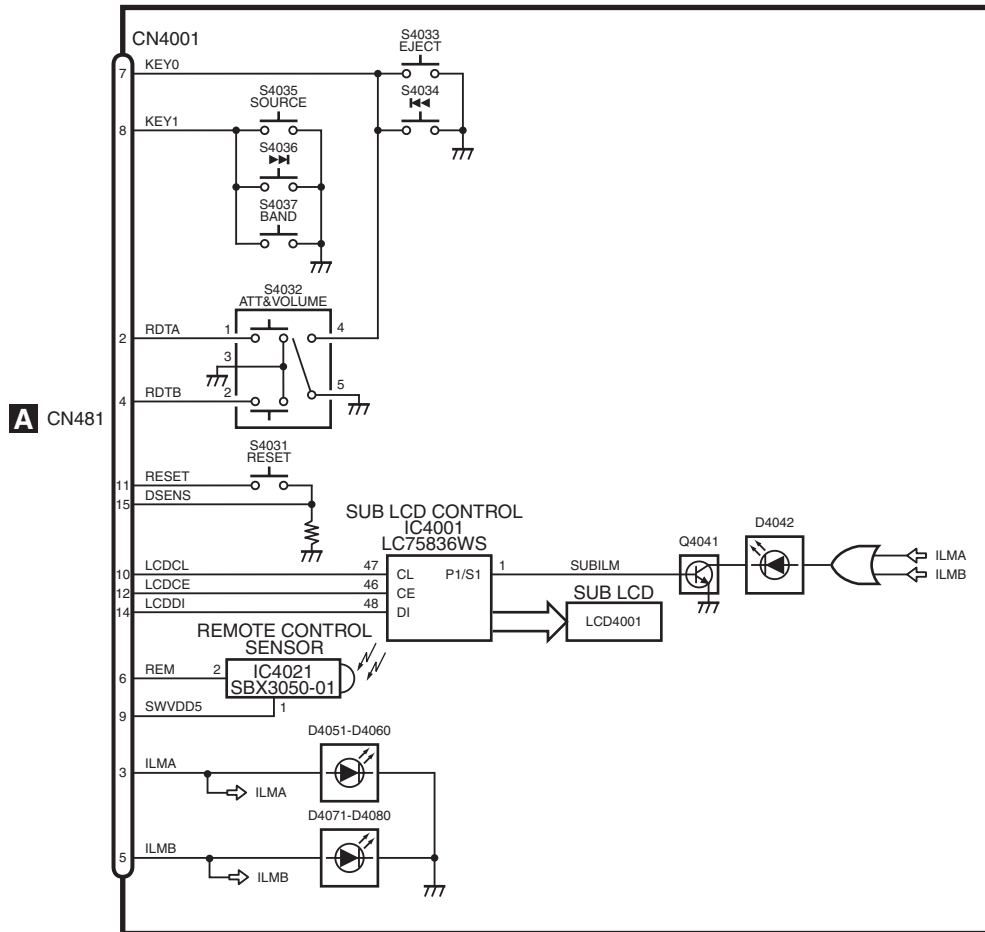

# C MONITOR PCB

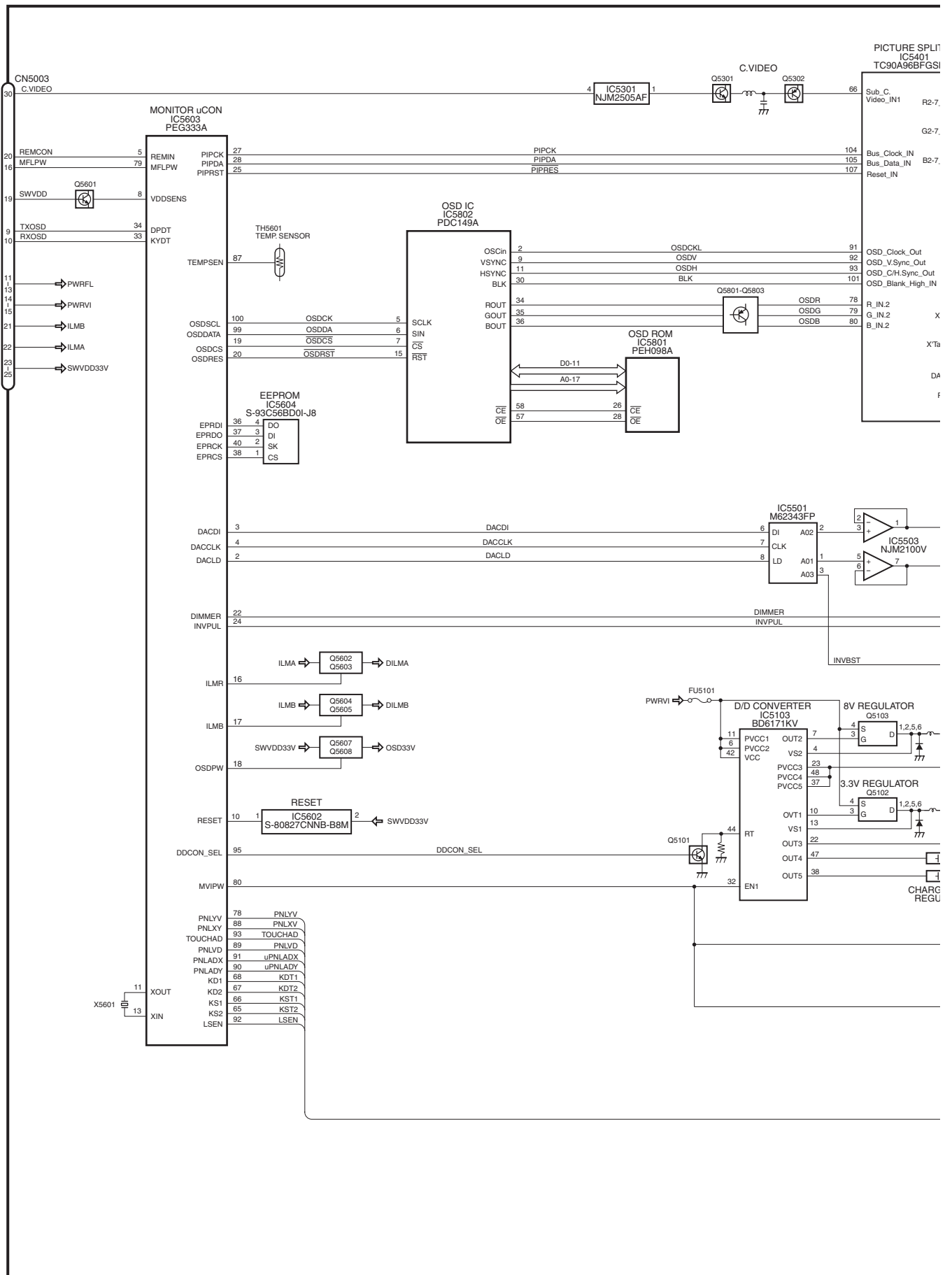

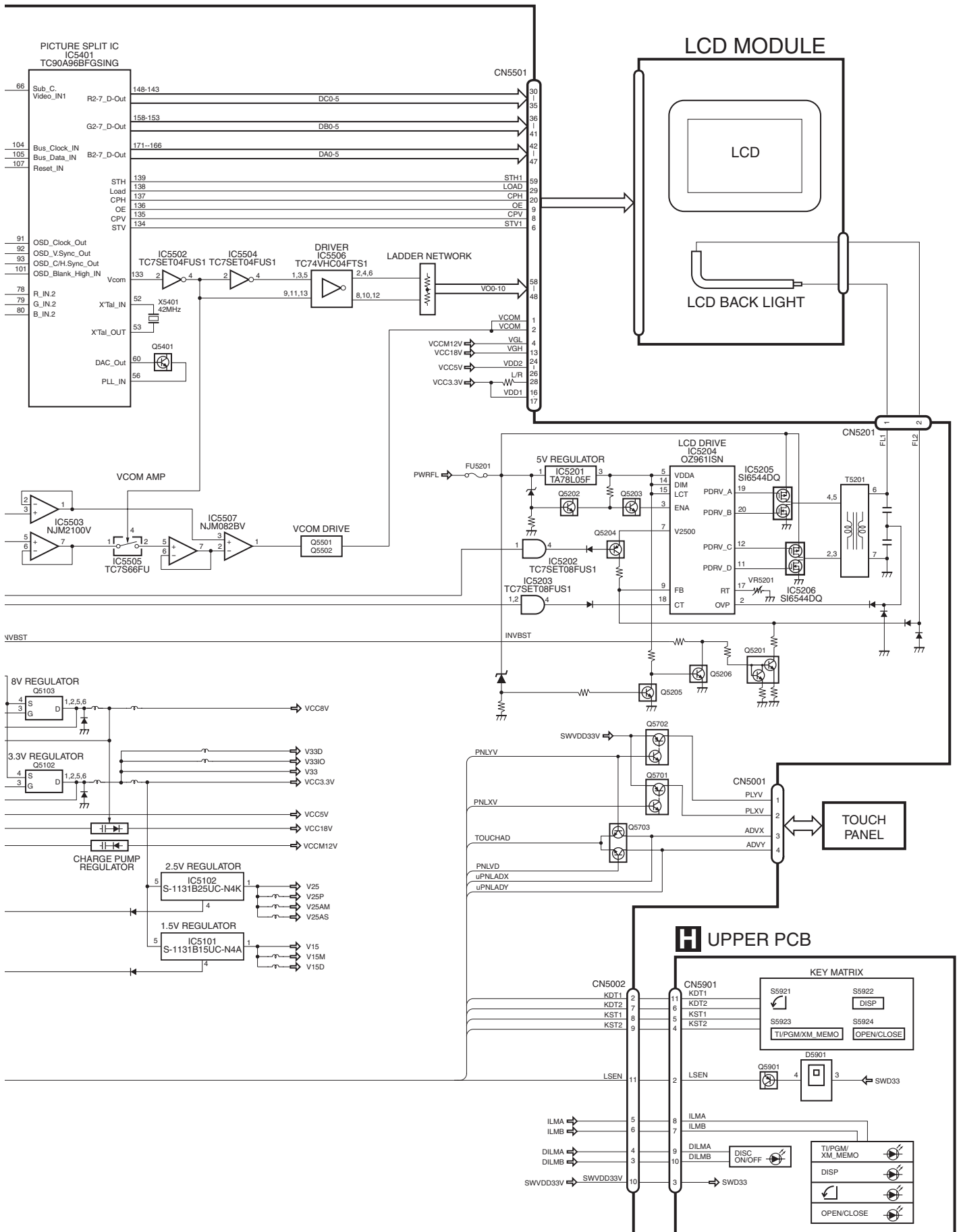

DVD CORE UNIT

A

B

C

D

E

F

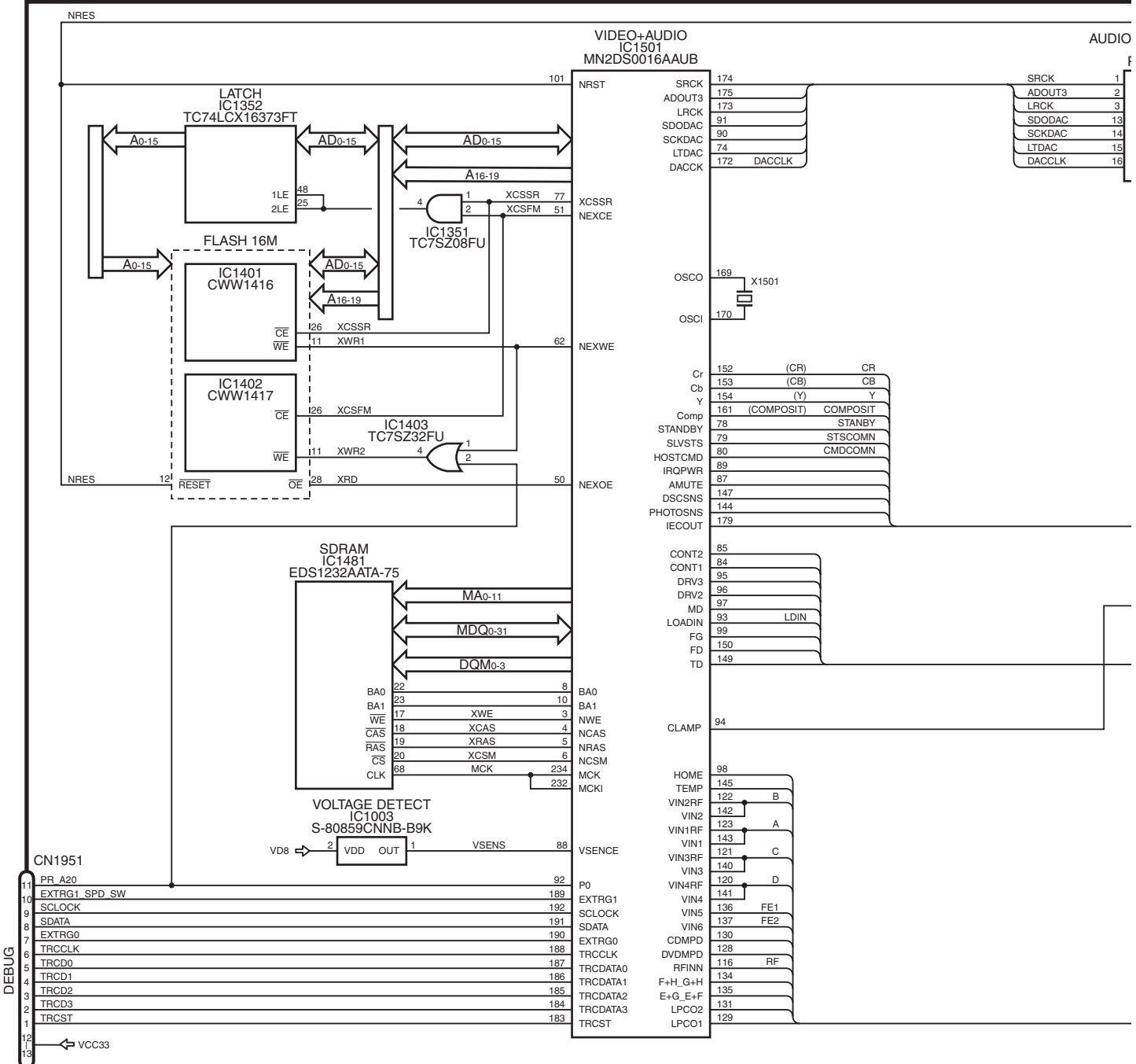



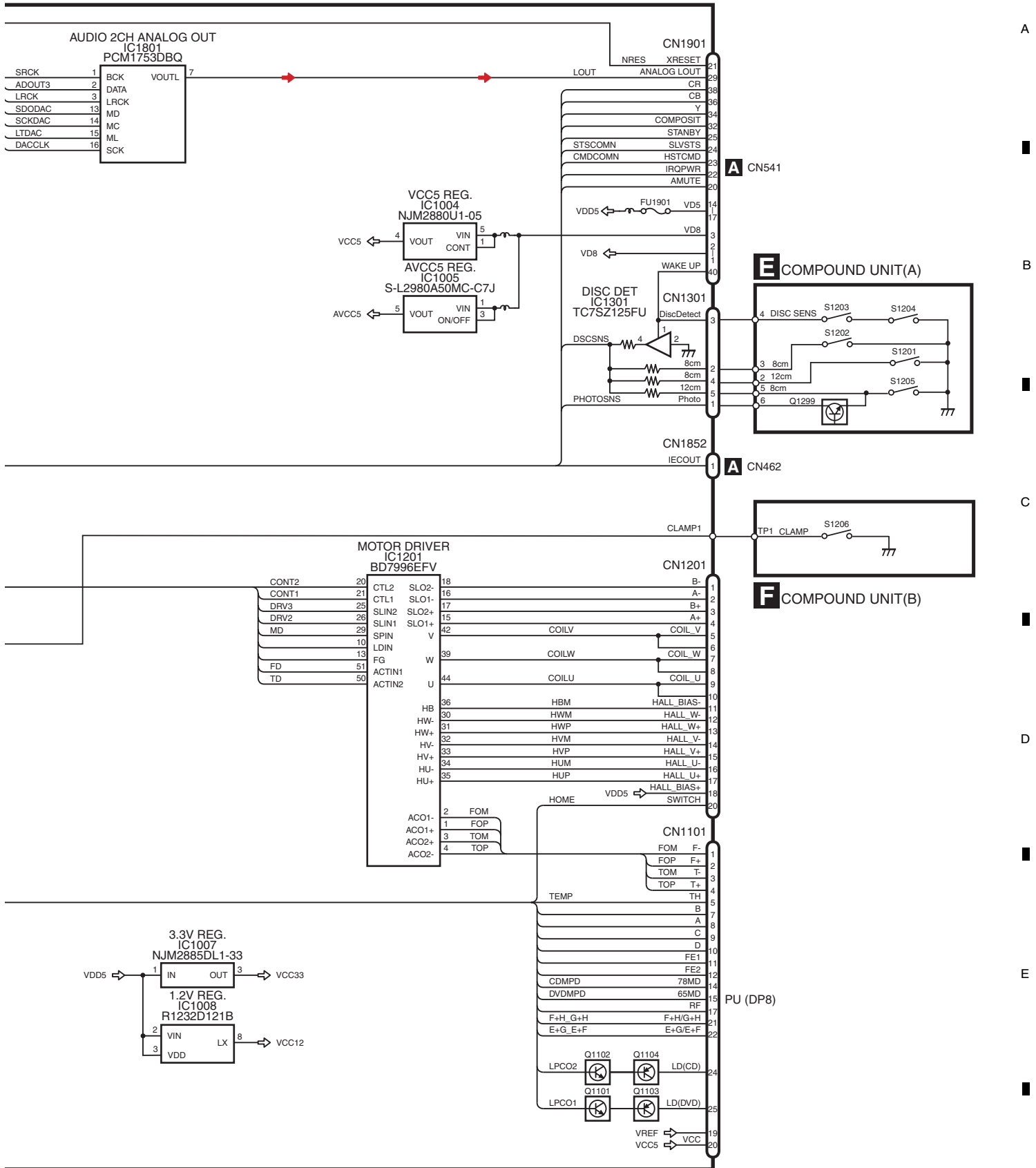

# J MAIN PCB UNIT(SERVICE)

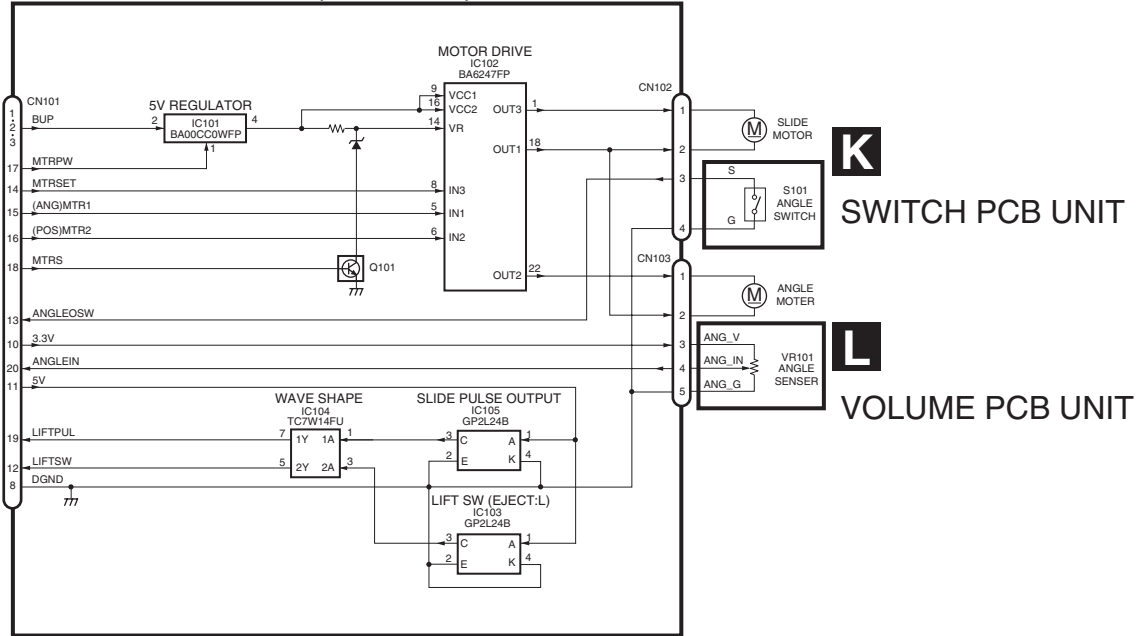

A

B

C

D

E

F

A CN512

SEGMENT

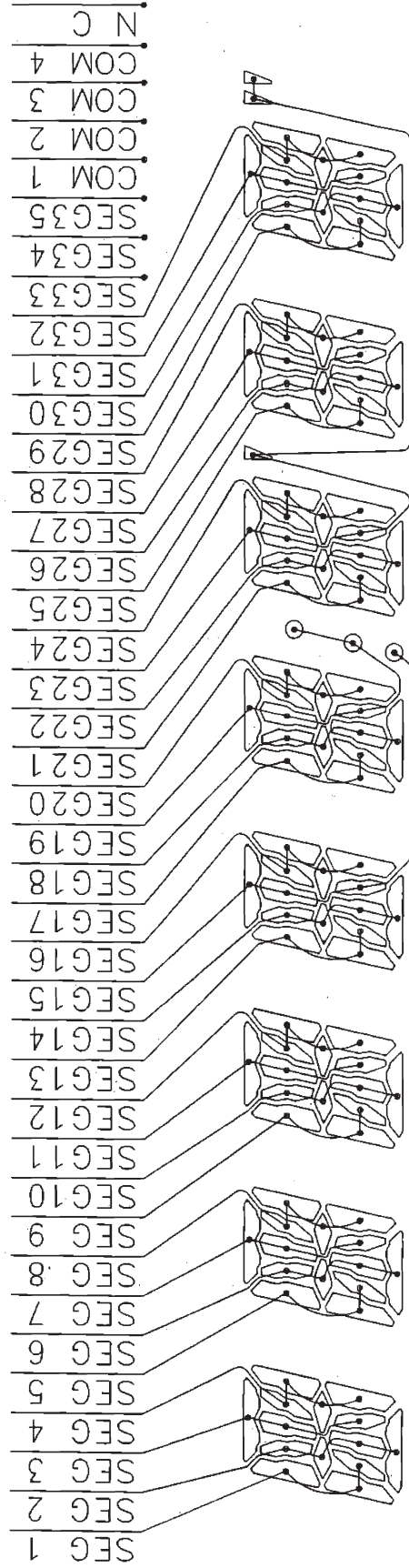

COMMON

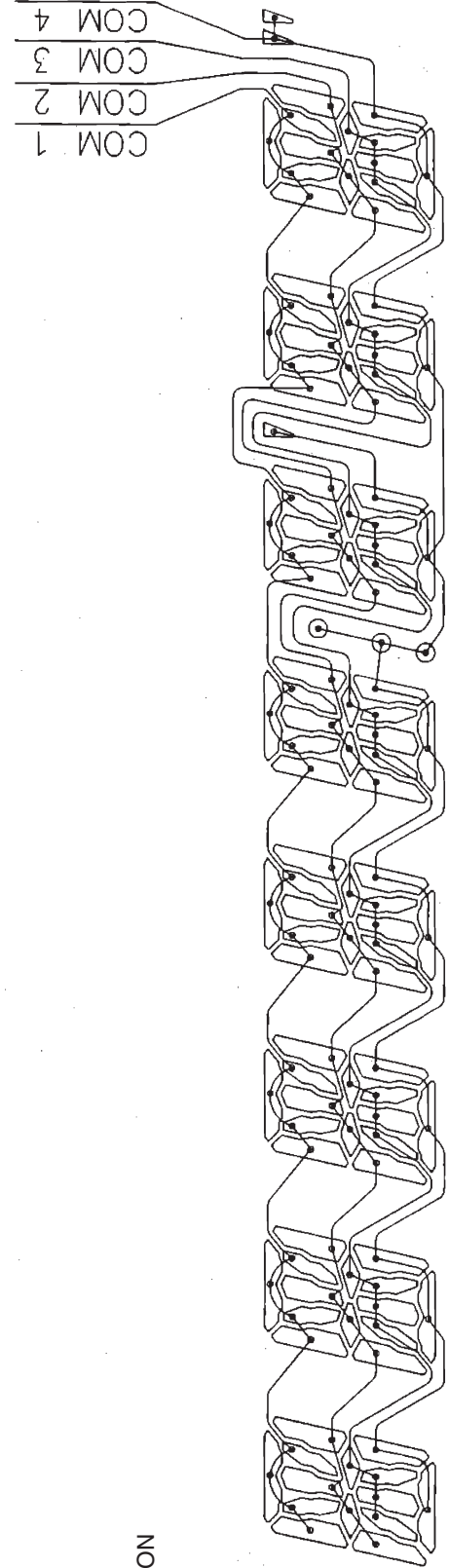

# 5. DIAGNOSIS

## 5.1 OPERATIONAL FLOW CHART

A

B

C

D

E

F

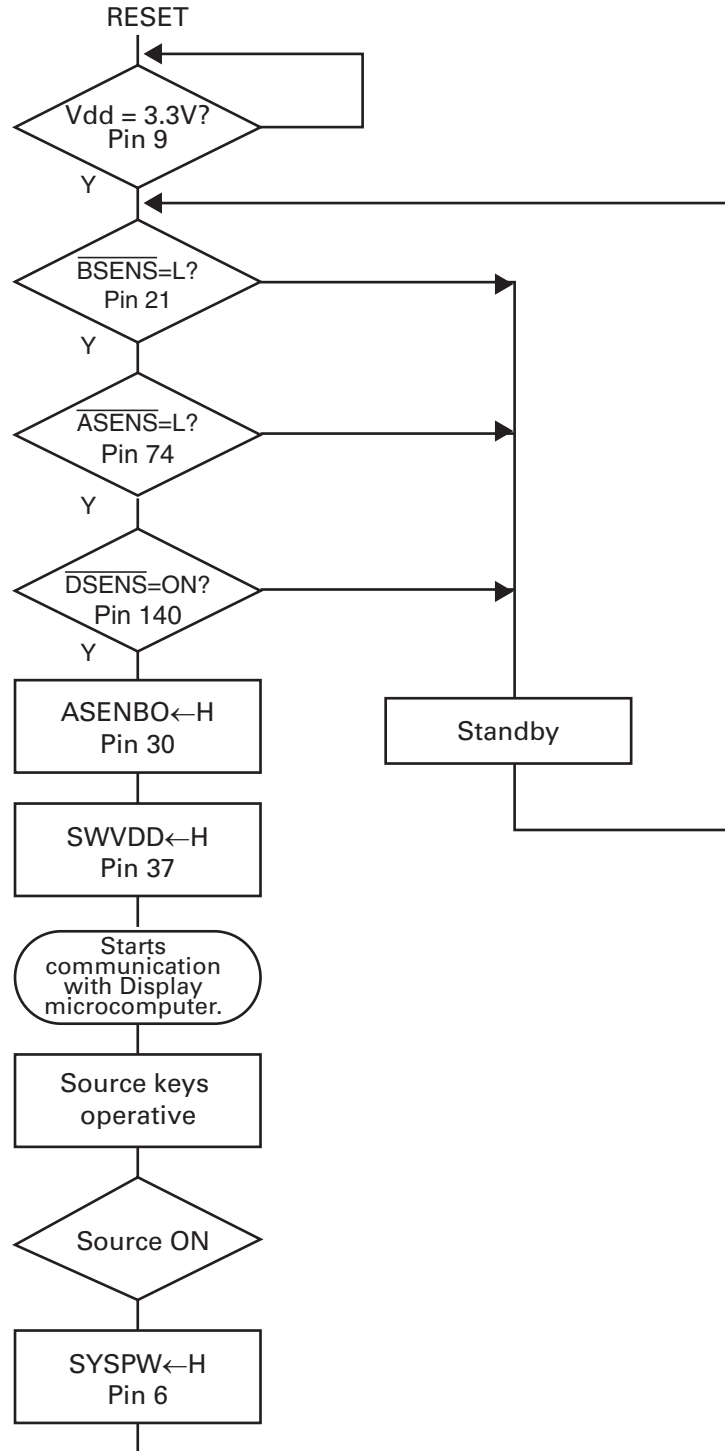

DSENS:  
 0 [v] to 0.85 [v] = OFF  
 0.85 [v] to 2.45 [v] = ON  
 2.45 [v] to 3.3 [v] = OFF

Completes power-on operation.  
 (After that, proceed to each source operation)

# 5.2 CONNECTOR FUNCTION DESCRIPTION

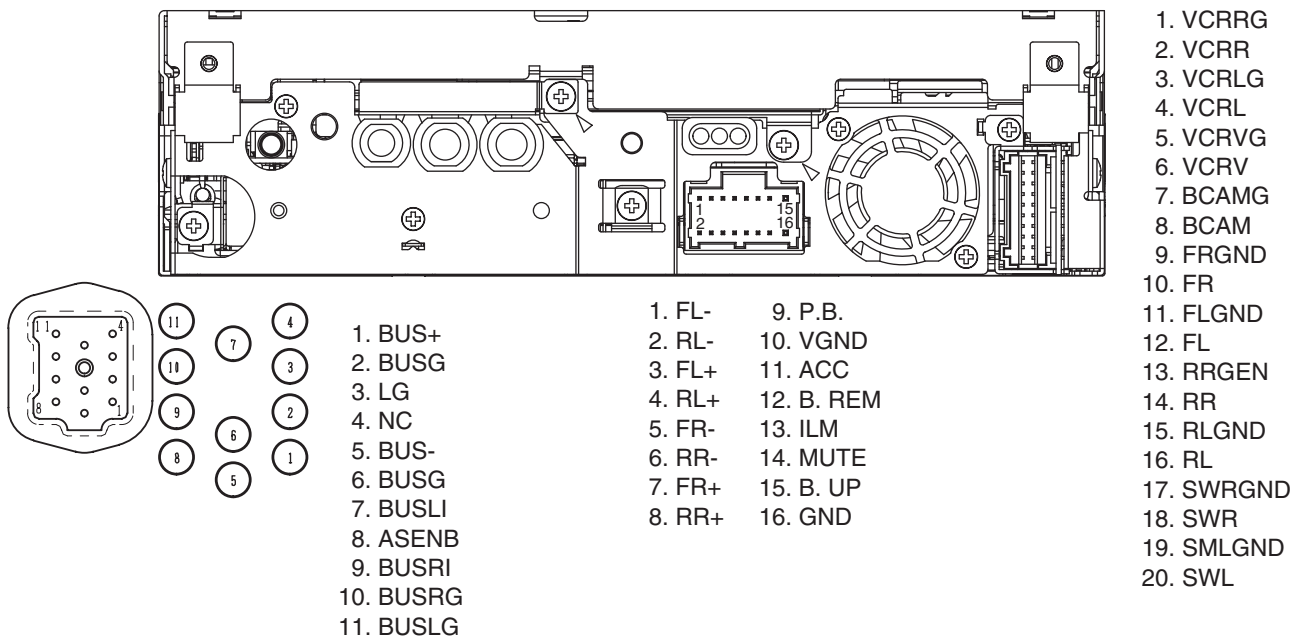
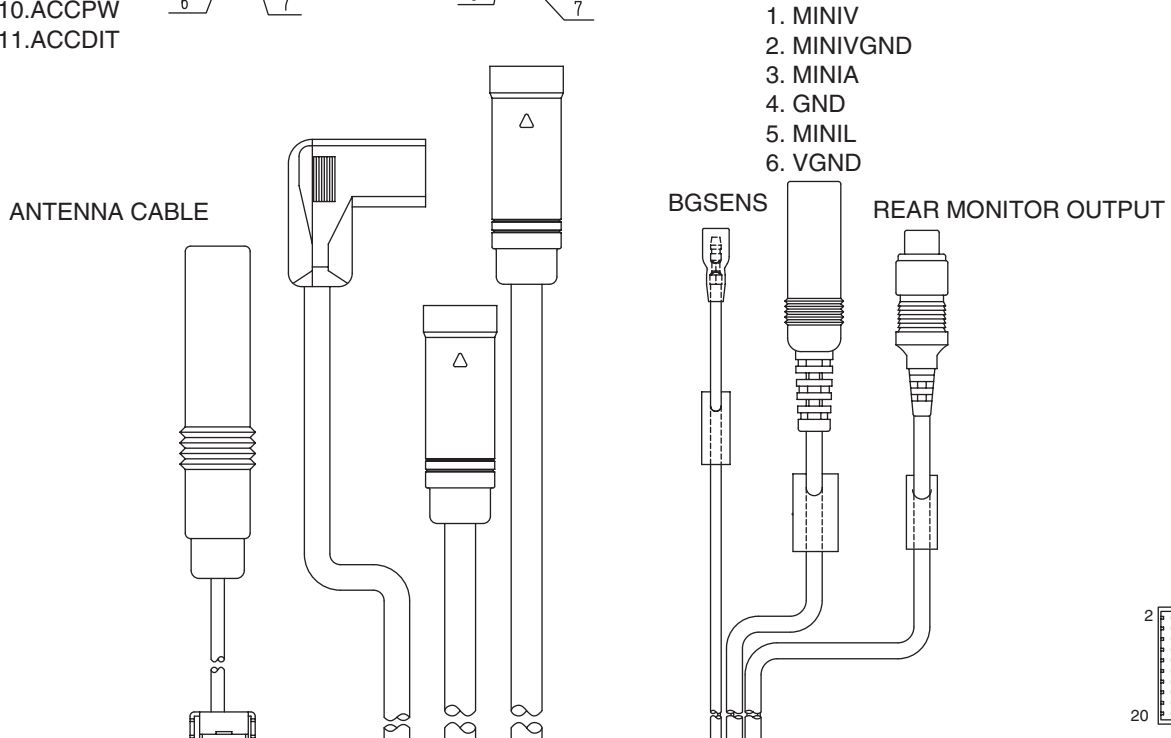
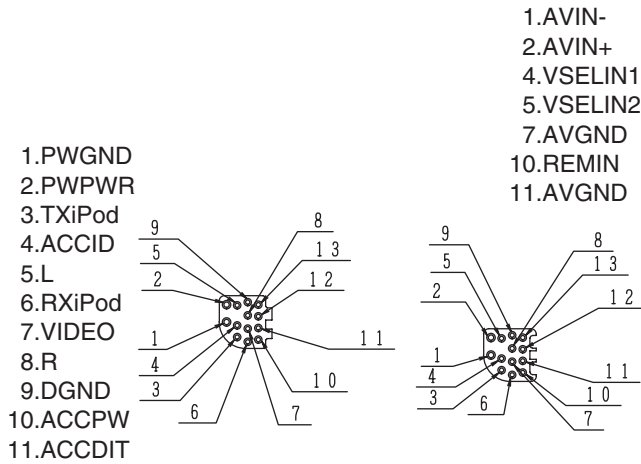

# 5.3 BACK END SECTION FLOW

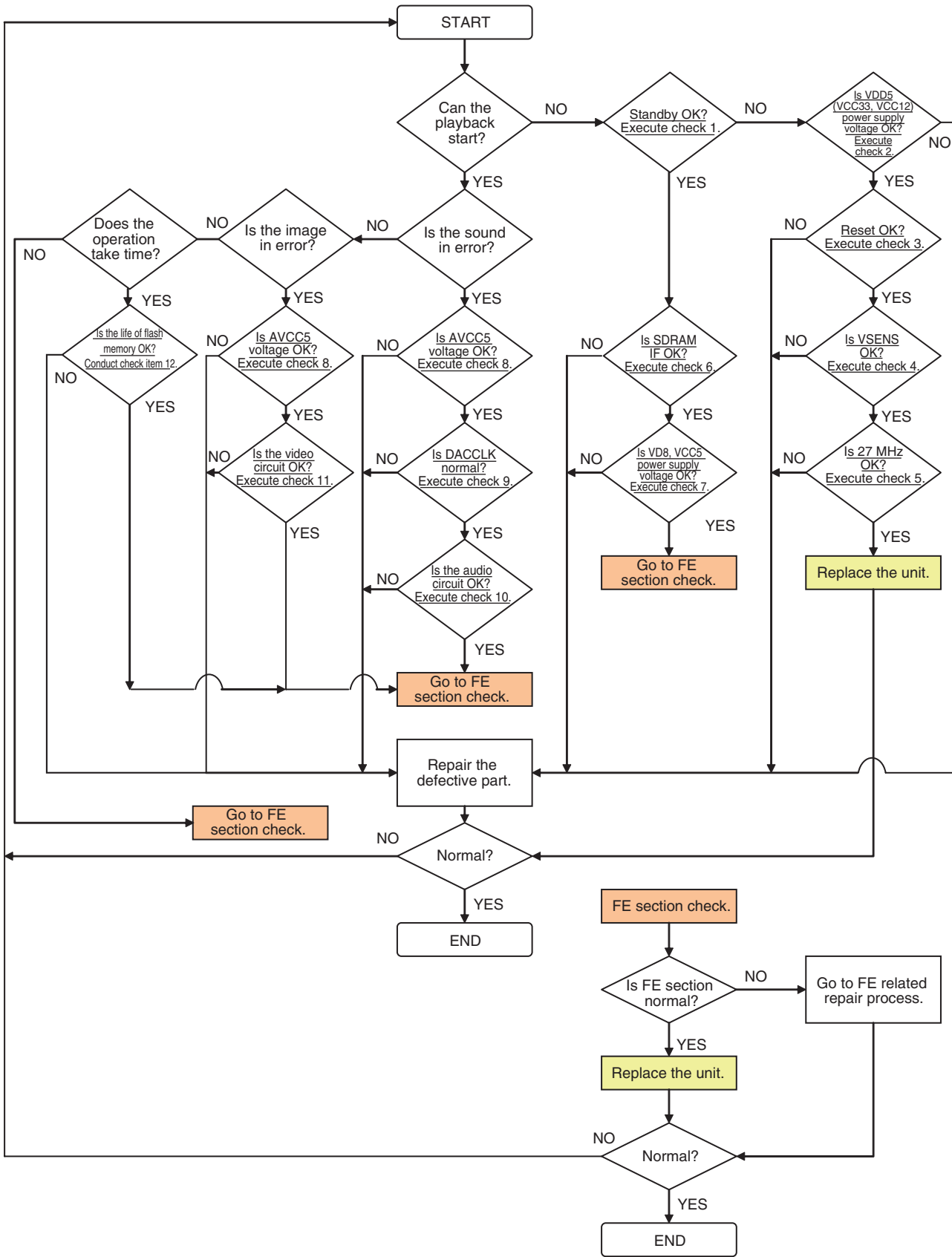

## Check 1: Standby OK?

<Check> Check the voltage at the “STANBY” test point while the power is on.  
Use the “DGND1” test point at the reference.

NO.	Check point	Module No.	Specification value	Unit
1	STANBY-DGND1	ALL	VCC33 V- 0.6 V or more	V

Side A

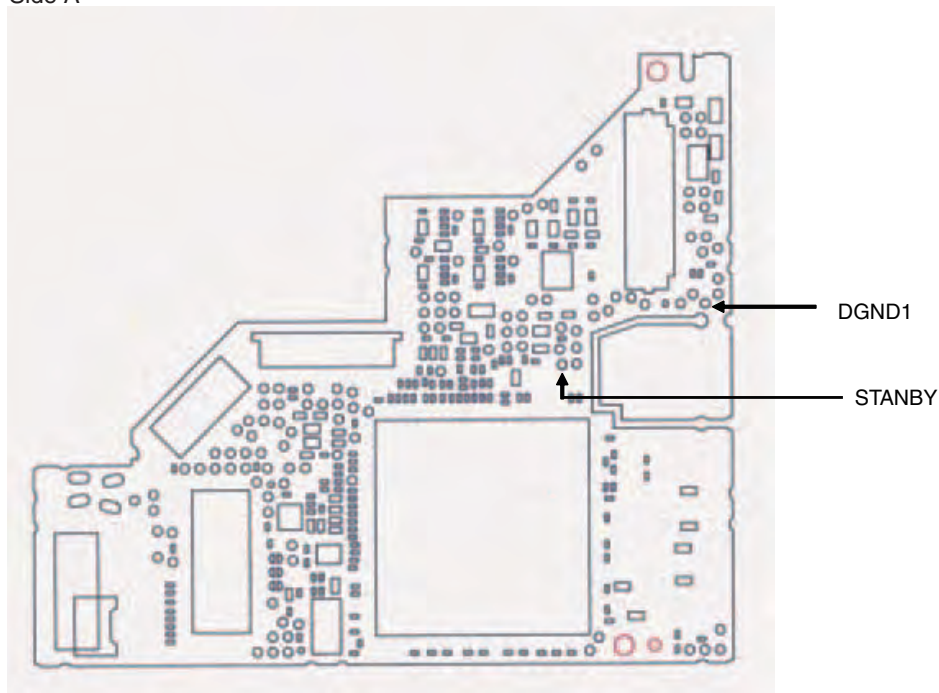

Fig 1.1: STANBY check point

### Check 2: Is VDD5 (VCC33, VCC12) power supply voltage OK?

A

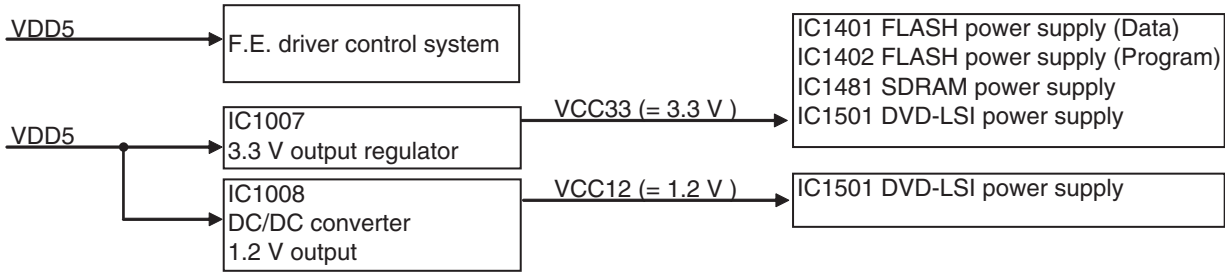

Fig 2.1: Power supply configuration

B

<Check> Check the voltage at the “VDD5\_3, VCC33\_3 and VCC12\_1” test point while the power is on.  
Use the “DGND1” test point at the reference.

NO.	Check point	Module No.	Specification value	Unit
1	VDD5_3 - DGND1	ALL	5.0 ± 0.4	V
2	VCC33_3 - DGND1	ALL	3.3 ± 0.15	V
3	VCC12_1 - DGND1	ALL	1.2 ± 0.12	V

Side A

C

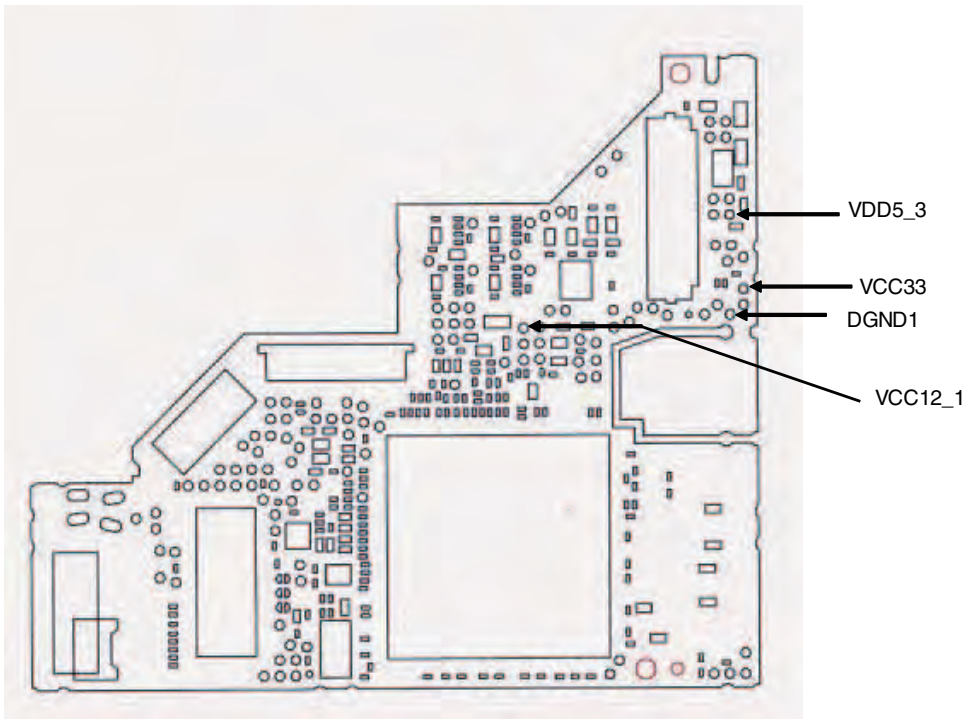

Fig 2.2: VDD5, VCC33, VCC12 voltage check points

D

E

F



## Check 3: Reset OK?

<Check> Check the voltage at the “XRES” test point while the power is on.  
Use the “DGND1” test point at the reference.

NO.	Check point	Module No.	Specification value	Unit
1	XRES-DGND1	ALL	VCC33 × 0.7 or more	V

Side A

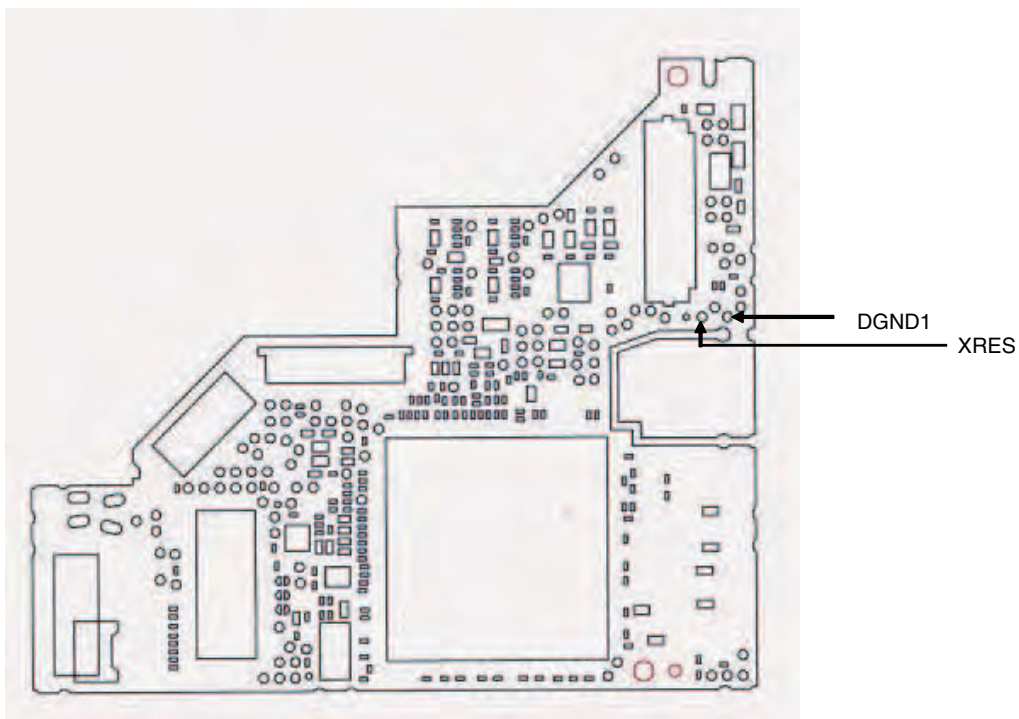

Fig 3.1: RESET check point

### Check 4: Is VSENS OK?

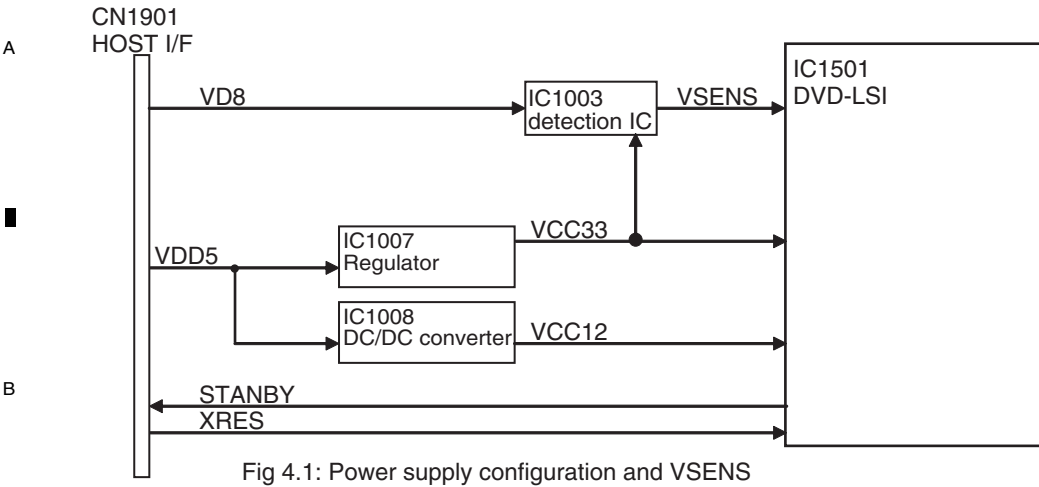

Fig 4.1: Power supply configuration and VSENS

<Check> Check the voltage at the “VSENS” test point while the power is on. Use the “DGND1” test point at the reference.

NO.	Check point	Module No.	Specification value	Unit
1	VSENS - DGND1	ALL	VCC33 × 0.7 or more	V

Side A

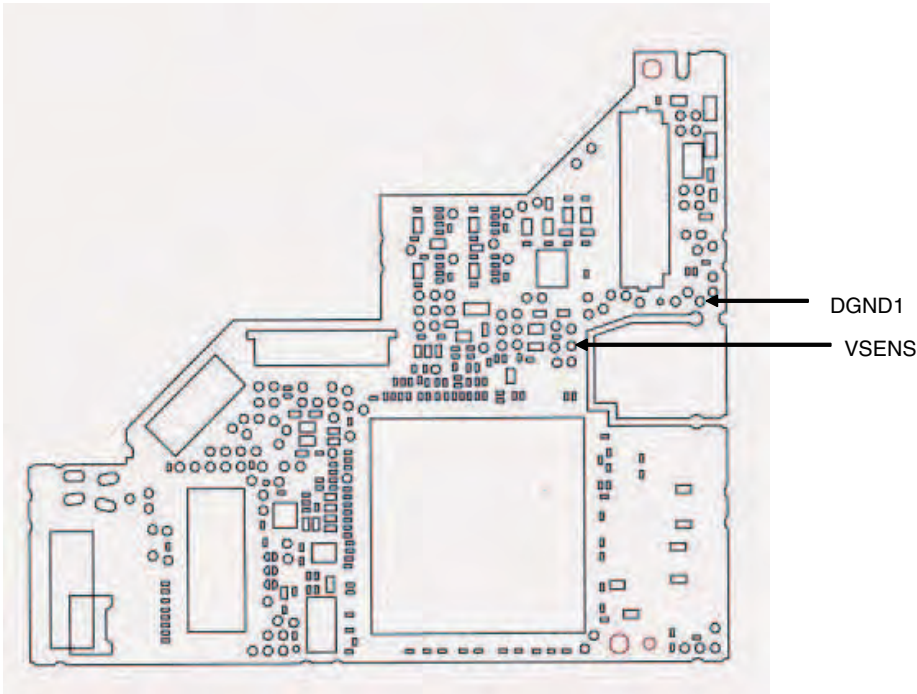

Fig 4.2: VSENS check point

### Check 5: 27 MHz Normal?

<Outline> Each clock is created inside the IC1501 using the 27 MHz master crystal oscillator (X1501).

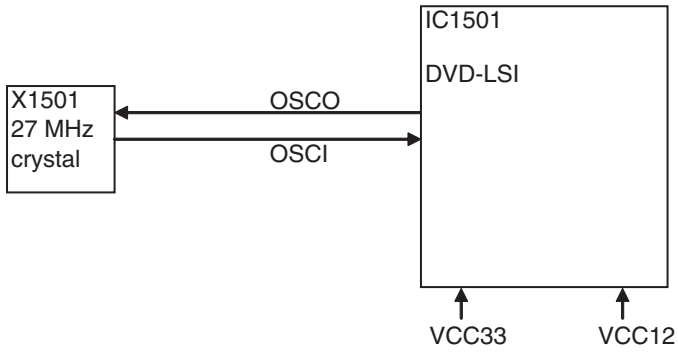
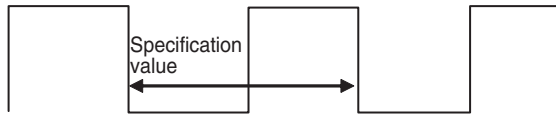

Fig 5.1: Clock configuration

<Check method> Turn the power on, and check with DGND being the reference.  
 In case of NG, check the applicable line, periphery of IC1501, soldering of the peripheral components and defective components.

NO.	Check point	Module No.	Specification value	Unit
2	IC1501 169pin	ALL	27 MHz ± 50 ppm	ppm



GND

Fig 5.2: Clock specification value

Side A

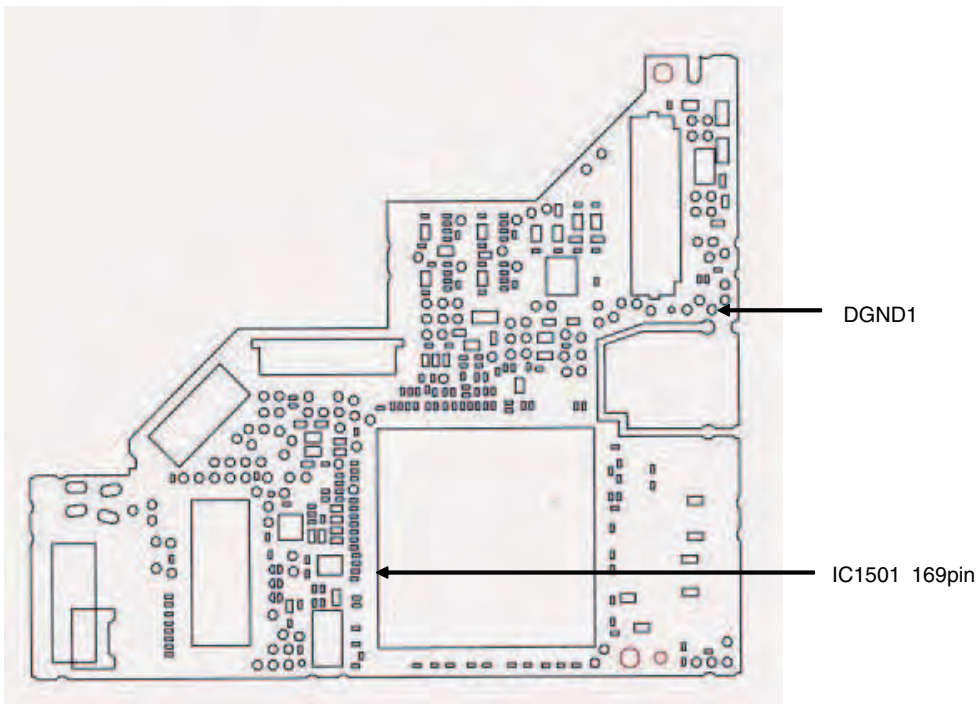

Fig 5.3: 27 MHz check point

### Check 6: Is SDRAM I/F OK?

A <Outline> In order to secure the MPEG stream data as the buffer,  
 the capacity of communication I/F SDRAM between the LSI and the memory is 128Mbit.  
 Be careful as XCSM, XWE, XCAS, XRAS and XSCM of IC1481 are called differently in IC1501,  
 namely NCSM, NWE, NCAS, NRAS, NCSM.

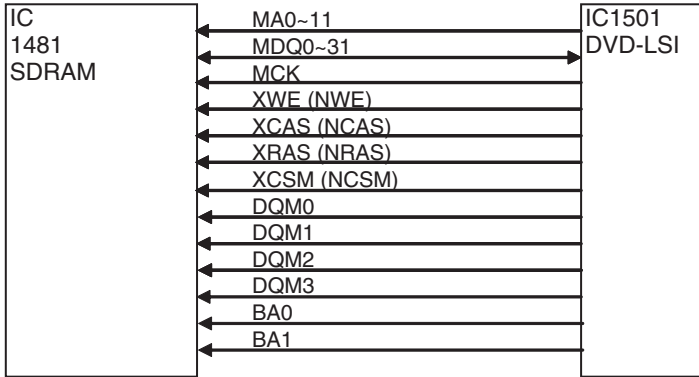

Fig 6.1: SDRAM I/F

C

D

E

F

<Check> Check the conductivity at “check point 1” and “check point 2” without power.  
In case of NG, check the soldering and defective components throughout the  
“output → input” of the applicable section.

NO.	Signal name	Check point 1	Check point 2	Specification value
1	MA0	IC1481 25pin	IC1501 16pin	56 Ω ± 5 %
2	MA1	IC1481 26pin	IC1501 18pin	56 Ω ± 5 %
3	MA2	IC1481 27pin	IC1501 20pin	56 Ω ± 5 %
4	MA3	IC1481 60pin	IC1501 22pin	56 Ω ± 5 %
5	MA4	IC1481 61pin	IC1501 21pin	56 Ω ± 5 %
6	MA5	IC1481 62pin	IC1501 19pin	56 Ω ± 5 %
7	MA6	IC1481 63pin	IC1501 17pin	56 Ω ± 5 %
8	MA7	IC1481 64pin	IC1501 15pin	56 Ω ± 5 %
9	MA8	IC1481 65pin	IC1501 11pin	56 Ω ± 5 %
10	MA9	IC1481 66pin	IC1501 9pin	56 Ω ± 5 %
11	MA10	IC1481 24pin	IC1501 14pin	56 Ω ± 5 %
12	MA11	IC1481 21pin	IC1501 7pin	56 Ω ± 5 %
13	MDQ0	IC1481 2pin	IC1501 237pin	56 Ω ± 5 %
14	MDQ1	IC1481 4pin	IC1501 239pin	56 Ω ± 5 %
15	MDQ2	IC1481 5pin	IC1501 241pin	56 Ω ± 5 %
16	MDQ3	IC1481 7pin	IC1501 243pin	56 Ω ± 5 %
17	MDQ4	IC1481 8pin	IC1501 248pin	56 Ω ± 5 %
18	MDQ5	IC1481 10pin	IC1501 250pin	56 Ω ± 5 %
19	MDQ6	IC1481 11pin	IC1501 252pin	56 Ω ± 5 %
20	MDQ7	IC1481 13pin	IC1501 254pin	56 Ω ± 5 %
21	MDQ8	IC1481 74pin	IC1501 253pin	56 Ω ± 5 %
22	MDQ9	IC1481 76pin	IC1501 251pin	56 Ω ± 5 %
23	MDQ10	IC1481 77pin	IC1501 249pin	56 Ω ± 5 %
24	MDQ11	IC1481 79pin	IC1501 244pin	56 Ω ± 5 %
25	MDQ12	IC1481 80pin	IC1501 242pin	56 Ω ± 5 %
26	MDQ13	IC1481 82pin	IC1501 240pin	56 Ω ± 5 %
27	MDQ14	IC1481 83pin	IC1501 238pin	56 Ω ± 5 %
28	MDQ15	IC1481 85pin	IC1501 236pin	56 Ω ± 5 %
29	MDQ16	IC1481 31pin	IC1501 29pin	56 Ω ± 5 %
30	MDQ17	IC1481 33pin	IC1501 31pin	56 Ω ± 5 %
31	MDQ18	IC1481 34pin	IC1501 33pin	56 Ω ± 5 %
32	MDQ19	IC1481 36pin	IC1501 37pin	56 Ω ± 5 %
33	MDQ20	IC1481 37pin	IC1501 39pin	56 Ω ± 5 %
34	MDQ21	IC1481 39pin	IC1501 41pin	56 Ω ± 5 %
35	MDQ22	IC1481 40pin	IC1501 43pin	56 Ω ± 5 %
36	MDQ23	IC1481 42pin	IC1501 45pin	56 Ω ± 5 %
37	MDQ24	IC1481 45pin	IC1501 44pin	56 Ω ± 5 %
38	MDQ25	IC1481 47pin	IC1501 42pin	56 Ω ± 5 %
39	MDQ26	IC1481 48pin	IC1501 40pin	56 Ω ± 5 %
40	MDQ27	IC1481 50pin	IC1501 38pin	56 Ω ± 5 %
41	MDQ28	IC1481 51pin	IC1501 34pin	56 Ω ± 5 %
42	MDQ29	IC1481 53pin	IC1501 32pin	56 Ω ± 5 %
43	MDQ30	IC1481 54pin	IC1501 30pin	56 Ω ± 5 %
44	MDQ31	IC1481 56pin	IC1501 28pin	56 Ω ± 5 %
45	MCK	IC1481 68pin	IC1501 234pin	0.17 Ω ± or lower
46	XWE	IC1481 17pin	IC1501 3pin	56 Ω ± 5 %
47	XCAS	IC1481 18pin	IC1501 4pin	56 Ω ± 5 %
48	XRAS	IC1481 19pin	IC1501 5pin	56 Ω ± 5 %
49	XCSM	IC1481 20pin	IC1501 6pin	56 Ω ± 5 %
50	DQM0	IC1481 16pin	IC1501 255pin	56 Ω ± 5 %
51	DQM1	IC1481 71pin	IC1501 256pin	56 Ω ± 5 %
52	DQM2	IC1481 28pin	IC1501 26pin	56 Ω ± 5 %
53	DQM3	IC1481 59pin	IC1501 27pin	56 Ω ± 5 %
54	BA0	IC1481 22pin	IC1501 8pin	56 Ω ± 5 %
55	BA1	IC1481 23pin	IC1501 10pin	56 Ω ± 5 %

Side B

A

B



Check point 1 (IC1481)

Side A

C

D

E

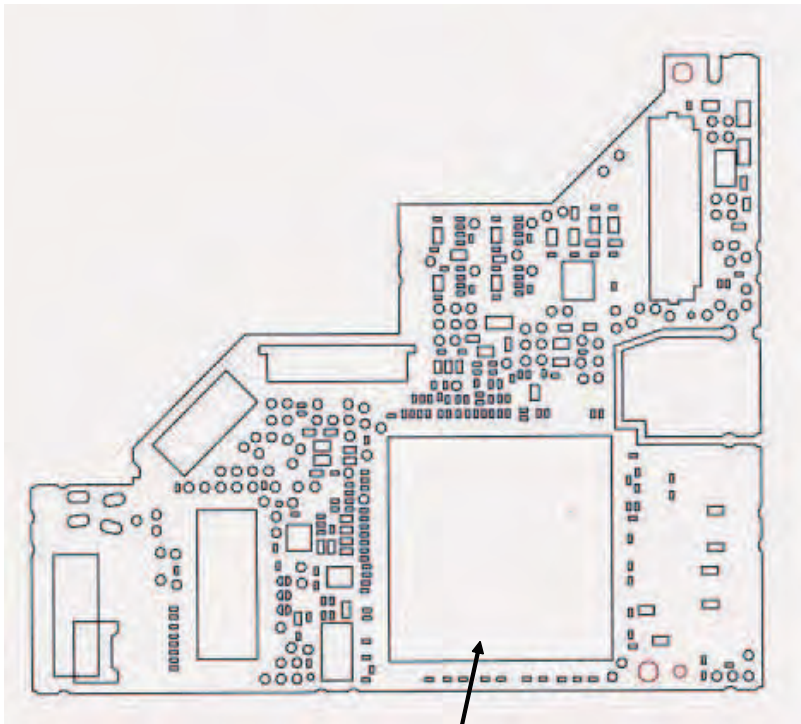

Check point 2 (IC1501)

Fig 6.2: SDRAM I/F check point

F



## Check 7: Is VD8, VCC5 power supply voltage OK?

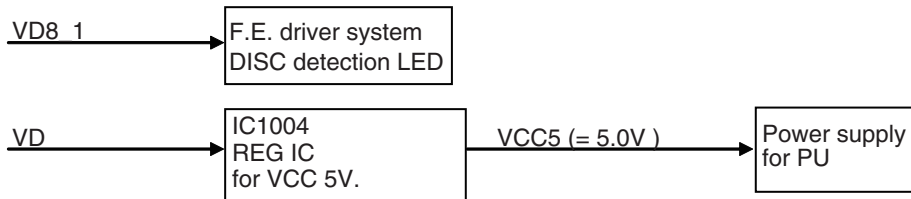

Fig 7.1: Power supply configuration

<Check> Check the voltage at the “VD8\_1, VD and VCC5\_1” test point while the power is on.  
Use the “PGND3 and AGND1” test point at the reference.

NO.	Check point	Module No.	Specification value	Unit
1	VD8_1 - PGND3	ALL	$8.0 \pm 0.4$	V
2	VD - PGND3	ALL	$8.0 \pm 0.4$	V
3	VCC5_1- AGND1	ALL	$5.0 \pm 0.1$	V

Side A

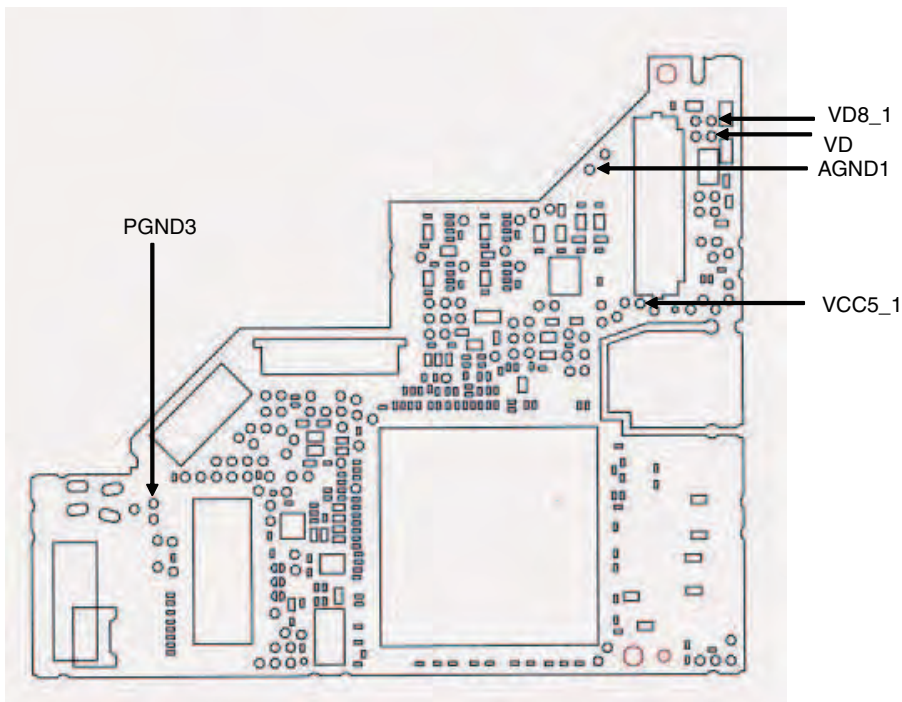

Fig 7.2: VD8, VCC5 voltage check points

### Check 8: Is AVCC5 voltage OK?

A

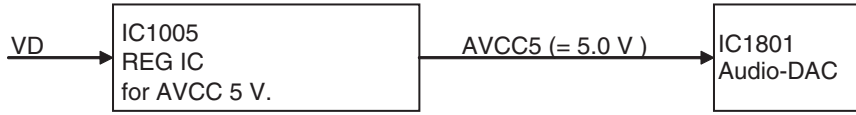

Fig 8.1: Power supply configuration

<Check> Playback DVD-REF-A1 TITLE 1 and check the voltage at the stylus.  
Check with PGND and GND AU being the reference.

B

NO.	Check point	Module No.	Specification value	Unit
1	VD - PGND_3	ALL	8.0 ± 0.4	V
2	AVCC5 - GND AU1	ALL	5.0 ± 0.1	V

Side A

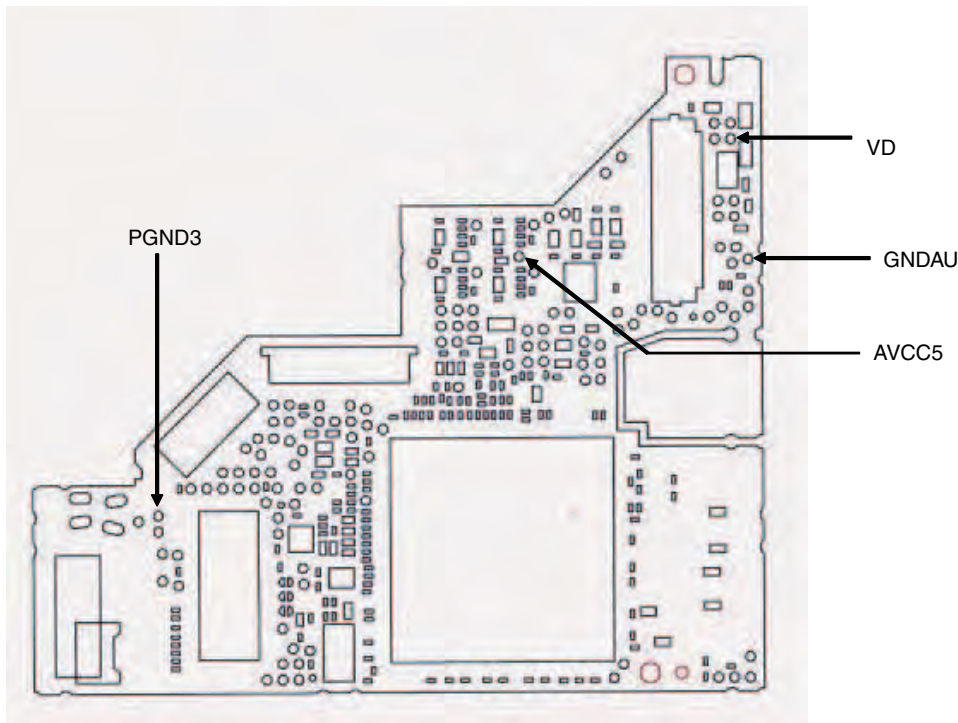

Fig 8.2: VD8, AVCC5 voltage check points

E

F



### Check 9: Is DACCLK normal?

<Outline> DACCLK for Audio-DAC is created by IC1501 using the 27 MHz master crystal oscillator (X1501).

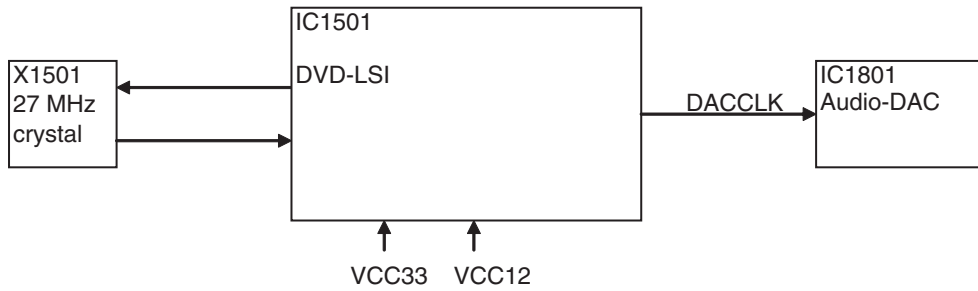

Fig 9.1: Clock configuration

<Check method>

DVD: DVD-REF-A1 TITLE 1

CD: Playback a normal CDDA.

Common to all DVD-V compatible modules.

Check with DGND being the reference.

In case of NG, check the applicable line, the periphery of IC1501, soldering of the peripheral components and defective components.

NO.	Check point 1 (stylus)	Media	Specification value 1	Specification value 2	Specification value 3
1	DACCK	DVD	2.0 V~VCC33 V	DGND~-0.8 V	36.8640 MHz±300 ppm
2	DACCK	CD	2.0 V~VCC33 V	DGND~-0.8 V	33.8688 MHz±300 ppm

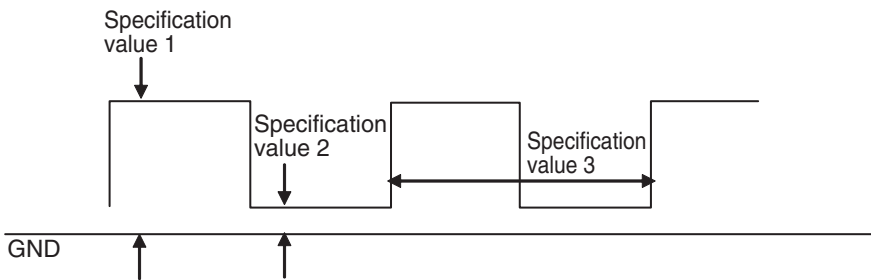
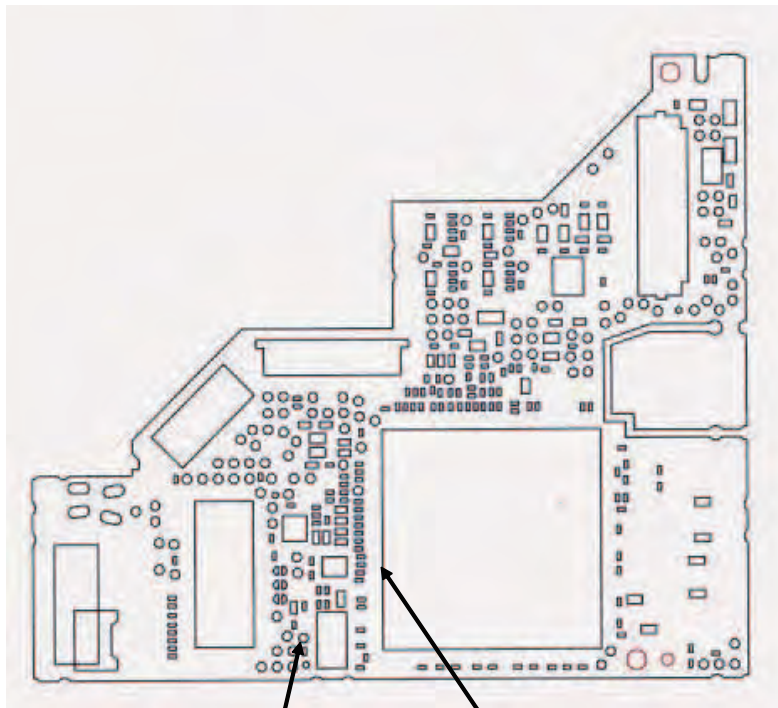

Fig 9.2: Clock specification value

Side A



Check point 2 (IC1501 172 pin)  
Check point 1 (stylus)

Fig 9.3: 27 MHz, DACCLK check point

### Check 10: Is the audio circuit OK?

<Outline> The serial 3 lines digital output + DACCLK, output from DVD-LSI (IC1501), are converted to analog audio signal at Audio-DAC (IC1801) and are output from the HOST I/F (CN1901). Simultaneously, the analog MUTE signal is also output from DVD-LSI (IC1501) via the HOST I/F. The digital audio signal (IECOUT), output from DVD-LSI (IC1501), is output via CN1852.

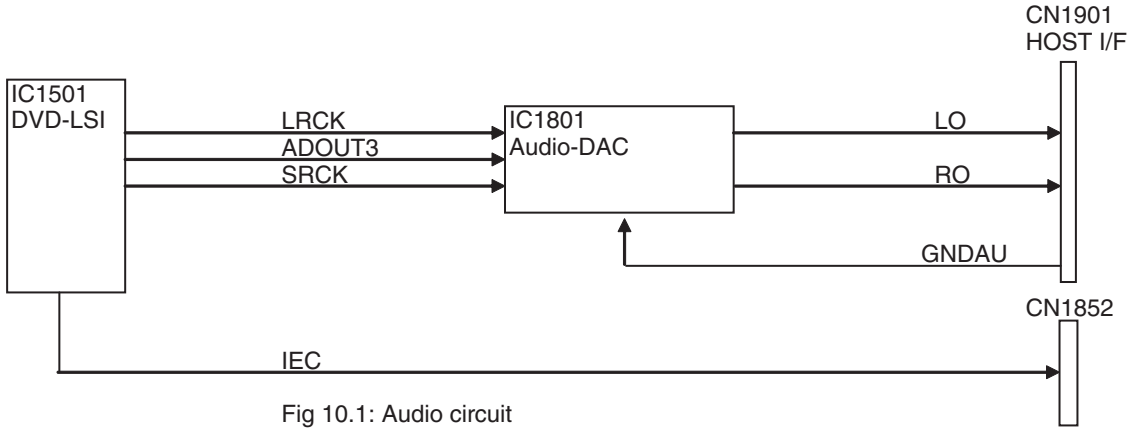

Fig 10.1: Audio circuit

<Check method> Playback DVD-REF-A1 TITLE 2 CHAPTER 1 (48 k/16 bit 1 kHz 0 dB), and check with DGND being the reference. In case of NG, check the applicable line, periphery of major components as described in the above drawing, soldering of the peripheral components and defective components.

NO.	Check point 1 (stylus)	Specification value 1	Specification value 2	Reference waveform
1	ADOUT3	VCC33 V-0.6 V or higher	0.4 V or lower	Waveform 1
2	SRCK	VCC33 V-0.6 V or higher	0.4 V or lower	Waveform 2
3	LRCK	VCC33 V-0.6 V or higher	0.4 V or lower	Waveform 3

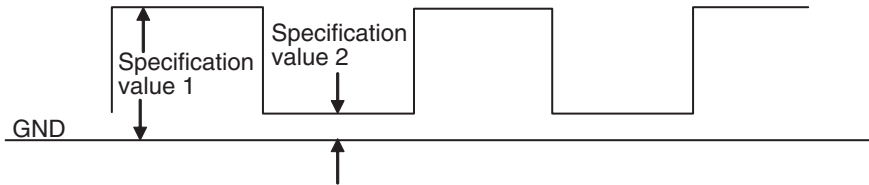

Fig 10.2: Serial 3 lines specification value

Side A

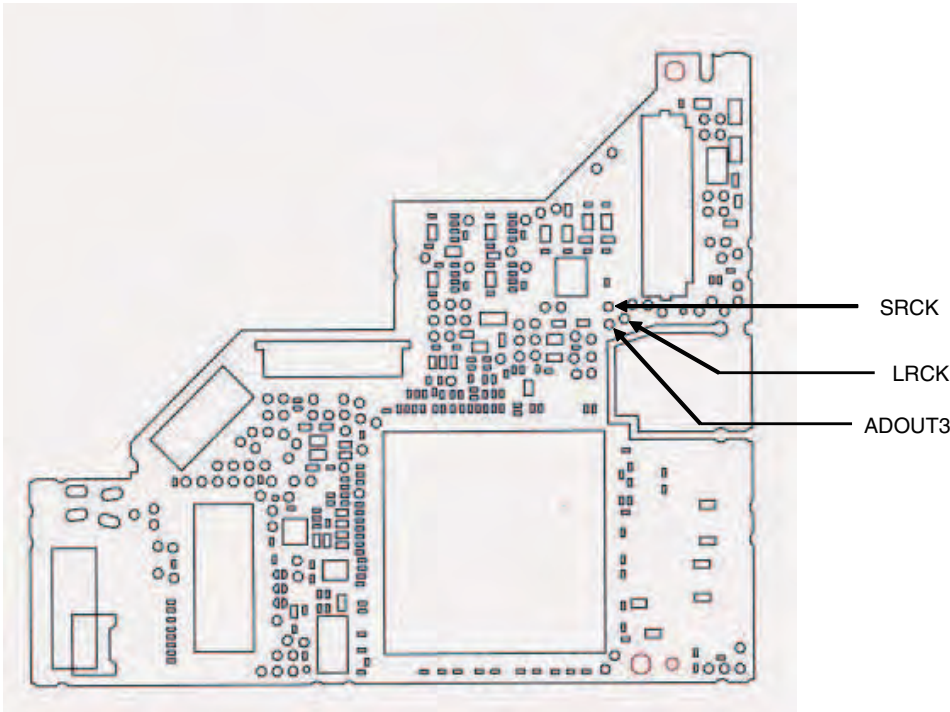
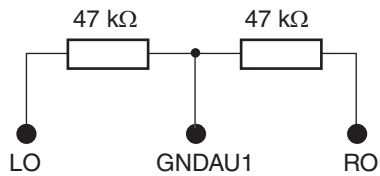

Fig 10.3: Serial 3 lines check points

The following checks shall be conducted using the following measurement circuits with GNDAU1 being the reference.



NO.	Check point 1 (stylus)	Specification value (rms)	Reference waveform
4	LO	1 400 ± 150 mV	Waveform 4
5	RO	1 400 ± 150 mV	Waveform 4

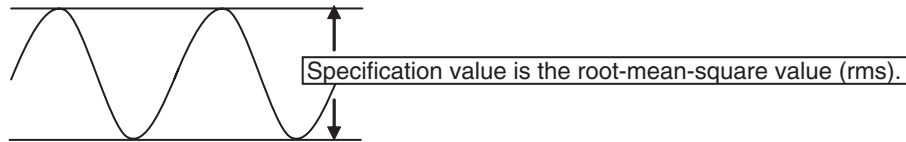

Fig 10.4: Analog audio out (LO, RO) specification value.

Side A

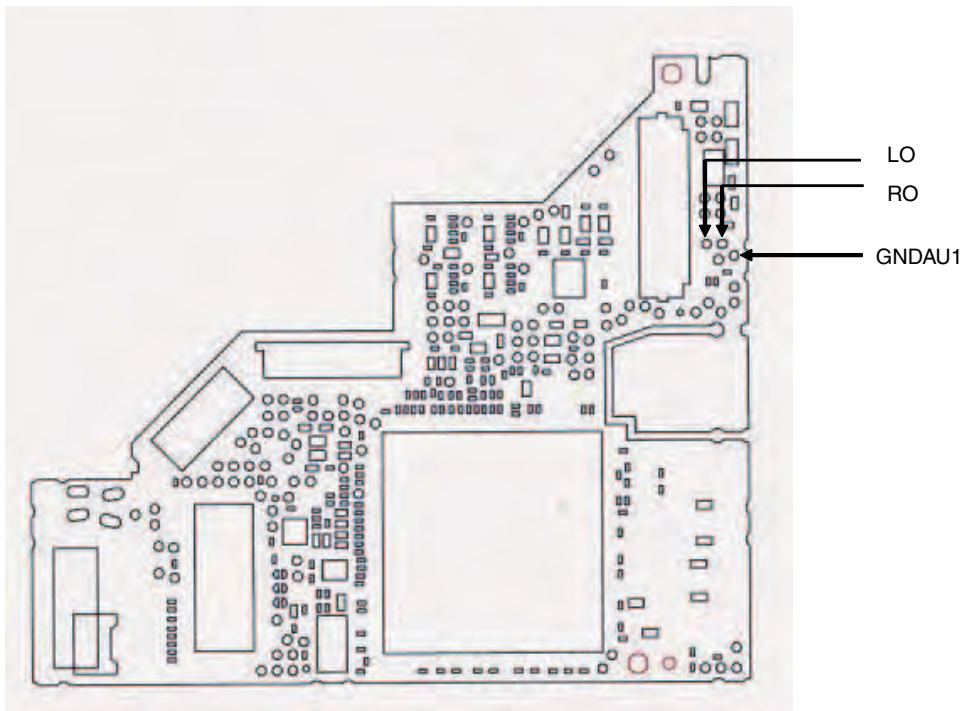

Fig 10.5: Analog audio out check point

Check with DGND being the reference.  
 Check 2pin cord after connecting it to a jig, etc.

NO.	Check point 1 (stylus)	Specification value 1	Specification value 2	Reference waveform
6	IEC	VCC33 V-0.6 V or higher	0.4 V or lower	Waveform 5

Side A

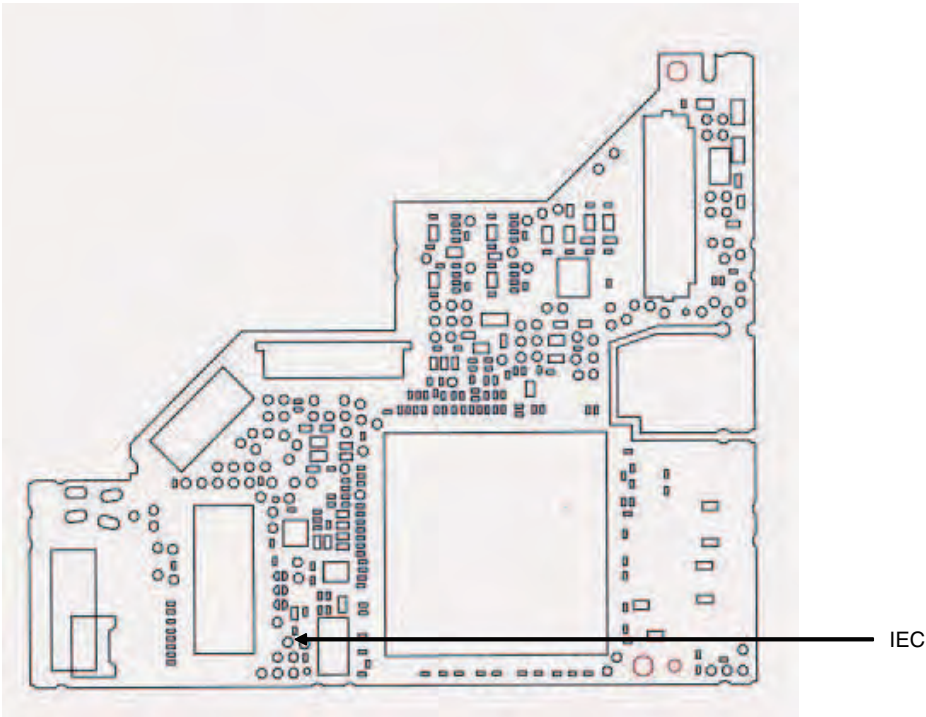
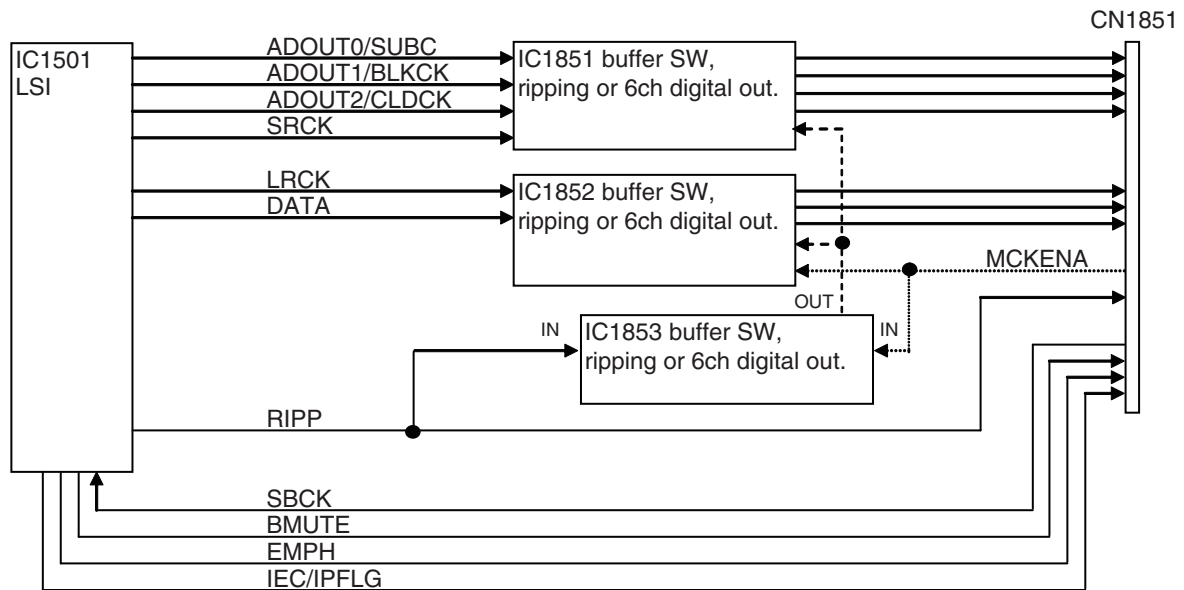

Fig 10.6: Digital audio signal (IECOUT) check point

<Outline> At the time of 6ch digital out, the serial 6 lines output from DVD-LSI (IC1501) is output via CN1581.  
Furthermore, at the time of ripping, the serial 3 lines digital output + SUBC, output from DVD-LSI (IC1501), is output in 4 times speed via CN1851.



The signal at CN1851 for 6ch digital out/Ripping.

Pin No.	Pin name	6ch digital out	Ripping
23	SRCK	SRCK	SRCK
21	LRCK	LRCK	LRCK
19	AD0/SUBC	ADOUT0	SUBC
17	AD1/BLK	ADOUT1	BLKCK
15	AD2/CLD	ADOUT2	CLDCK
13	AD3/DATA	ADOUT3	DATA
11	IEC/IPFLG	IEC	IPFLG
9	-	-	-
7	SBCK	-	SBCK
5	BMUTE	BMUTE	-
4	MCKENA	Low	High
3	RIPP	High	Low
2	EMPH	EMPH	EMPH

Pins 1, 6, 8, 10, 12, 14, 16, 18, 20, 22 and 24 are GNDD.

Fig 10.7: 6ch digital out/Ripping circuit

Playback DVD-REF-A1 TITLE22 CHAPTER 1, and check with GNDD being the reference.  
In case of NG, check the applicable line, the periphery of the major components in the drawing above, soldering of the peripheral components and defective components.

A Check 24pin FFC after connecting it to a jig, etc.

NO.	Check point 1 (stylus)	Specification value 1	Specification value 2
7	SRCK	VCC33 V-0.6 V or higher	0.4 V or lower
8	LRCK	VCC33 V-0.6 V or higher	0.4 V or lower
9	ADOUT0	VCC33 V-0.6 V or higher	0.4 V or lower
10	ADOUT1	VCC33 V-0.6 V or higher	0.4 V or lower
11	ADOUT2	VCC33 V-0.6 V or higher	0.4 V or lower
12	IEC	VCC33 V-0.6 V or higher	0.4 V or lower
13	MCKENA	-	VCC33 V x 0.3 V or lower

B Rip common CDDA, and check with GNDD being the reference.  
In case of NG, check the applicable line, the periphery of the major components in the drawing above, soldering of the peripheral components and defective components.

Check 24pin FFC after connecting it to a jig, etc.

NO.	Check point 1 (stylus)	Specification value 1	Specification value 2
14	SRCK	VCC33 V-0.6 V or higher	0.4 V or lower
15	LRCK	VCC33 V-0.6 V or higher	0.4 V or lower
16	SUBC	VCC33 V-0.6 V or higher	0.4 V or lower
17	BLKCK	VCC33 V-0.6 V or higher	0.4 V or lower
18	CLDCK	VCC33 V-0.6 V or higher	0.4 V or lower
19	DATA	VCC33 V-0.6 V or higher	0.4 V or lower
20	SBCK	VCC33 V-0.6 V or higher	0.4 V or lower
21	RIPP	-	VCC33 V x 0.3 V or lower

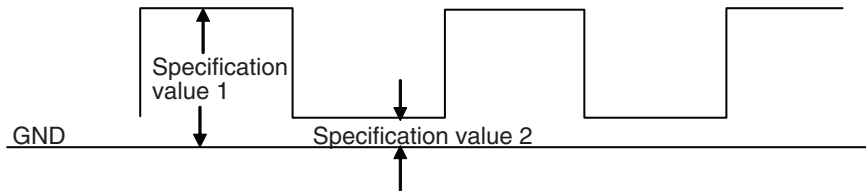
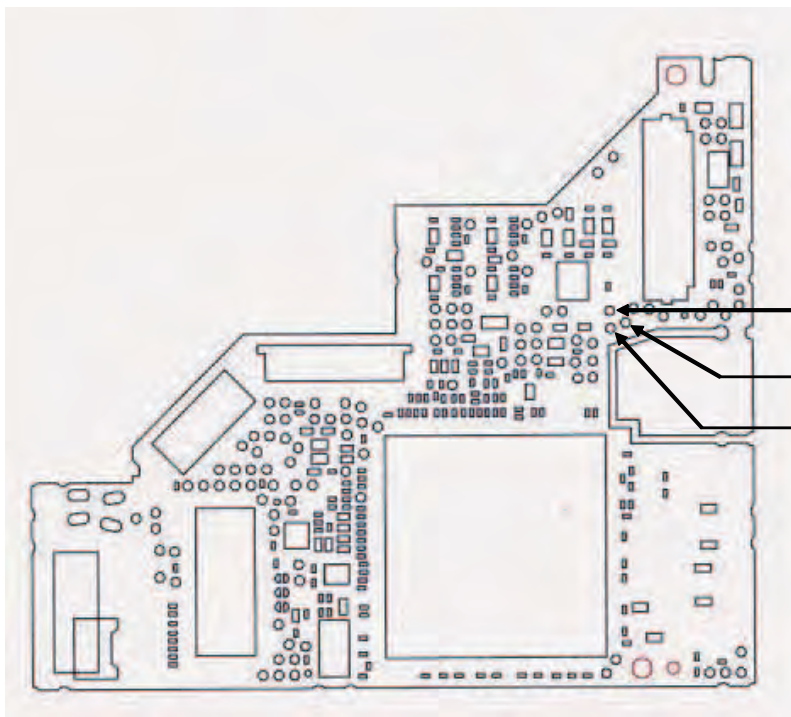

Fig 10.8: 6ch digital out/Ripping specification value



Side A



Side B

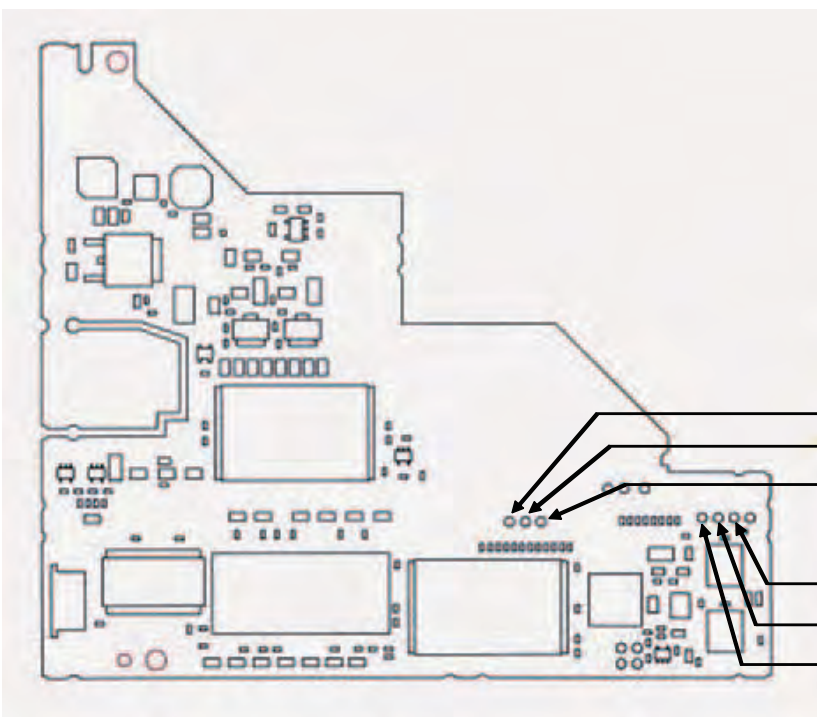

Fig 10.9: 6ch digital out/Ripping check point

# Check 11: Is the video circuit OK?

<Outline> Composite signal and component signal are output from DVD-LSI (IC1501), and are output from the HOST I/F (CN1901) via a buffer circuit.

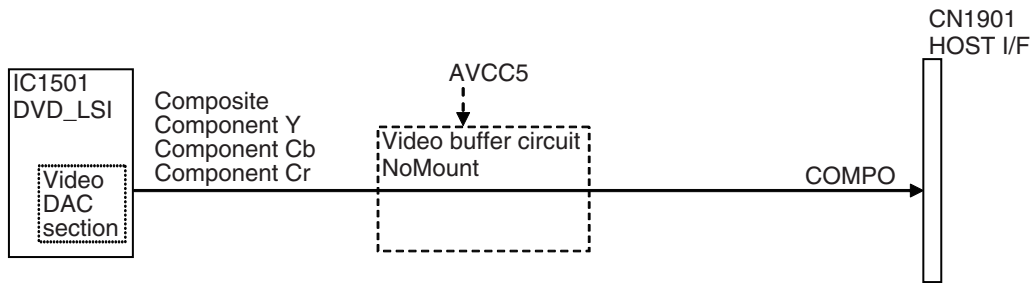

Fig 11.1: Video circuit

<Checking method> Playback DVD-REF-A1 TITLE2 CHAPTER5 (WHITE 100%), and monitor COMPO signal with an oscilloscope with GNDV1 (stylus) being the reference. Set the trigger mode to "TV trigger" and the trigger line to "150 line".

Check point 1 (stylus)

NO.		Specification value	Reference waveform
1	COMPO	1 000 mVpp ± 5 %	Waveform 6

In case of NG, check the applicable line, the periphery of the major components in the drawing above, soldering of the peripheral components and defective components.

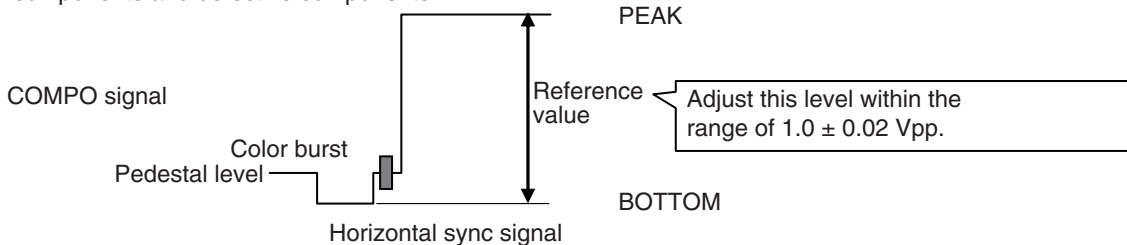

Fig 11.2: Waveform for the case of composite white 100% output

<Video level readjustment method>

In case the video composite output is outside of the specification value, readjust the level according to the method described below. (Note : Units are exchanged, the video output is not adjusted. )

Turn the volume (VR1671) to adjust the video level within the range of 1.0 ± 0.02 Vpp.

The adjustment specification is 1.0 ± 0.02 Vpp.

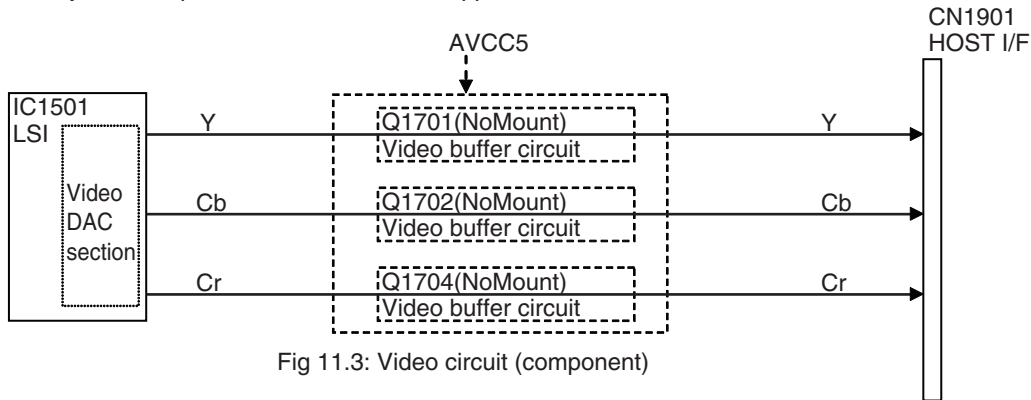

Fig 11.3: Video circuit (component)



<Checking method> Playback DVD-REF-A1 TITLE2 CHAPTER19 (100% Color Bars), and monitor Y, Cb, and Cr signal with an oscilloscope with GNDV1 (stylus) being the reference. Set the trigger mode to "TV trigger" and the trigger line to "150 line".

NO.	Check point 1 (stylus)	Specification value	Reference waveform
2	Y	1 000 mVpp $\pm$ 5%	Waveform 7
3	Cb	700 mVpp $\pm$ 5%	Waveform 7
4	Cr	700 mVpp $\pm$ 5%	Waveform 7

In case of NG, check the applicable line, the periphery of the major components in the drawing above, soldering of the peripheral components and defective components.

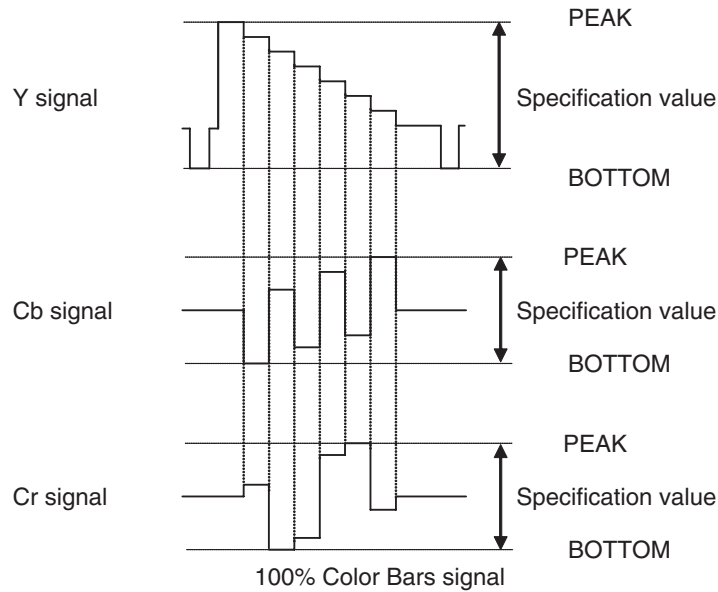

Fig 11.4 Waveform for the case of component 100% Color Bars output

Side A

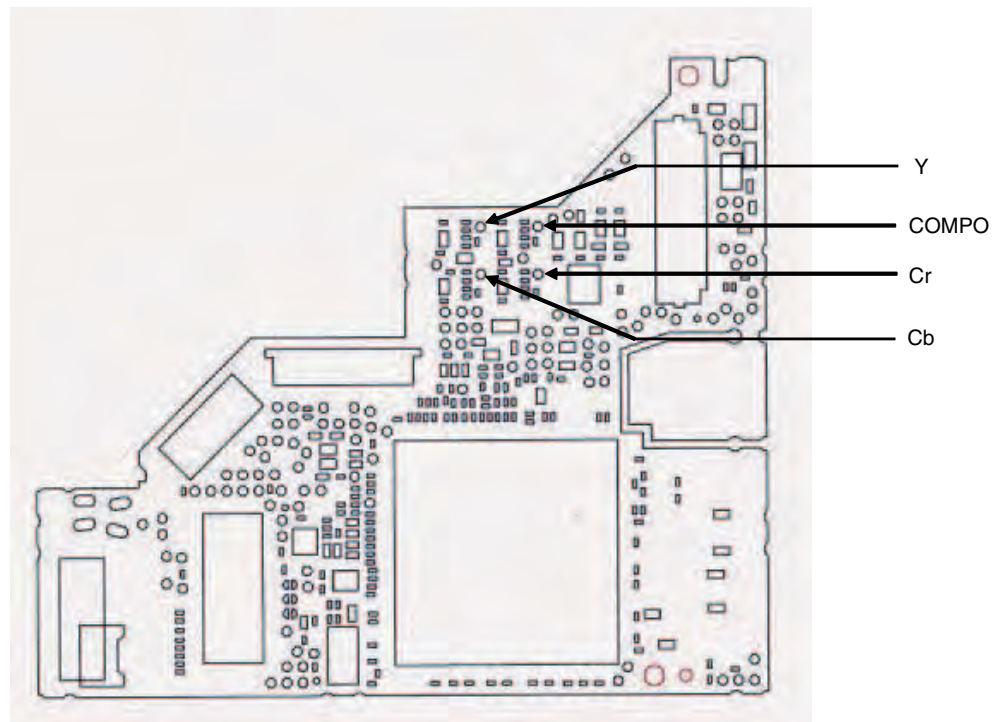

Fig 11.5: VIDEO signal check point

### Check 12:How to judge whether the flash memory has reached its life or not.

If the reaction to user operation is slow or operation is slow in general, there is a possibility that the flash memory has reached its life.

Make judgment regarding the flash memory life by looking at the display of the LD energizing time.

1.Let the LD energizing time displayed.

(Refer to the FE test mode for the method of displaying the LD energizing time.)

2.If the second digit from the left of the energizing time display is showing E, such as “\*E\*\* \*\*\*\*”, it means that the flash memory has reached its life.

Example:

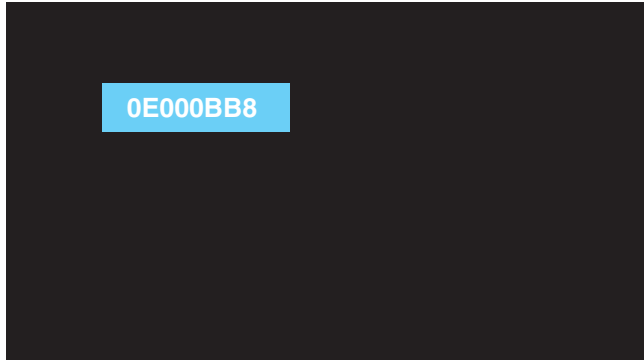

A

B

C

D

E

F

# AUDIO VIDEO

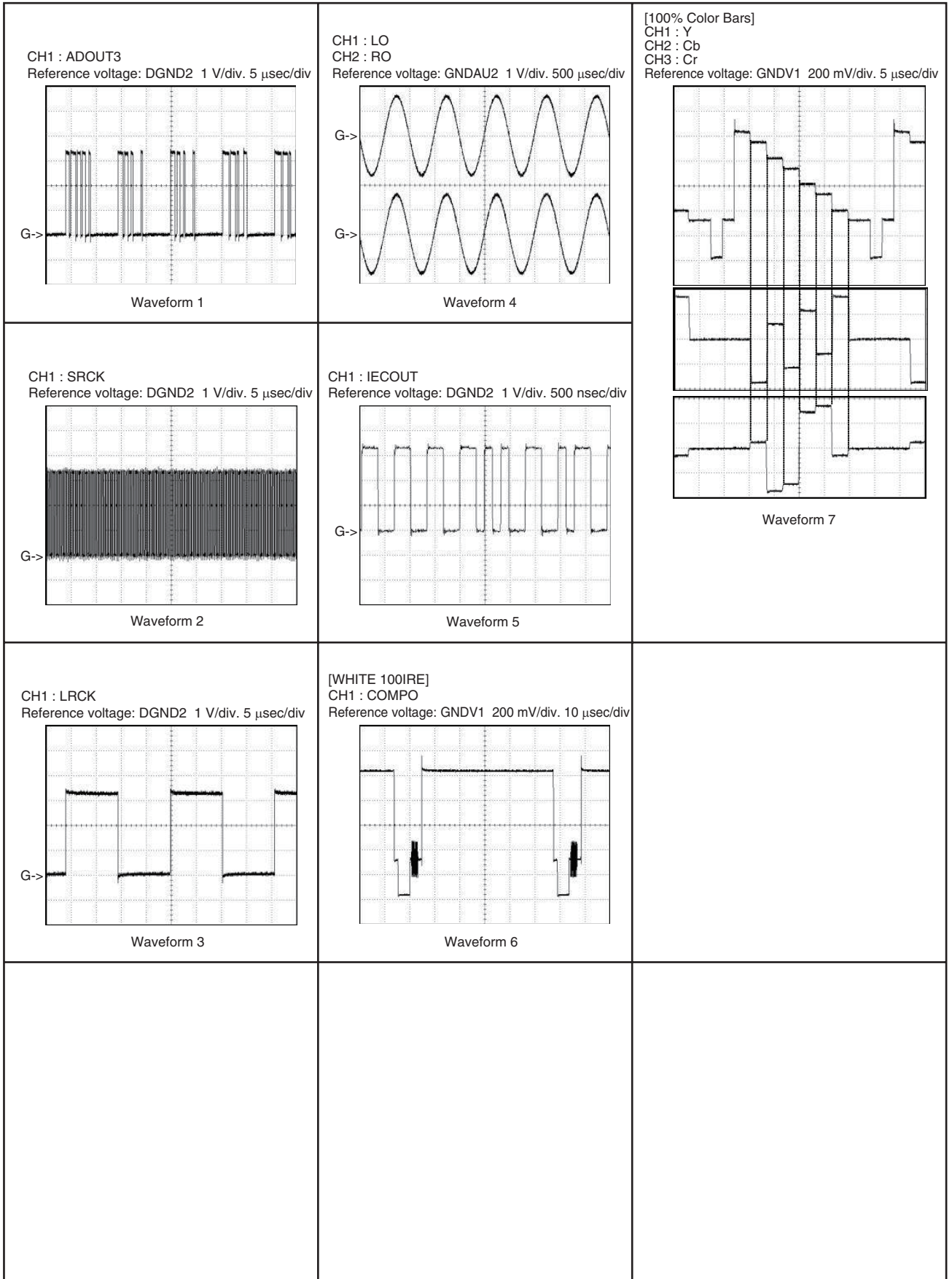

A

B

C

D

E

F

# 6. SERVICE MODE

## 6.1 DVD TEST MODE

### Image of the test mode.

The following operations are done by remote control.

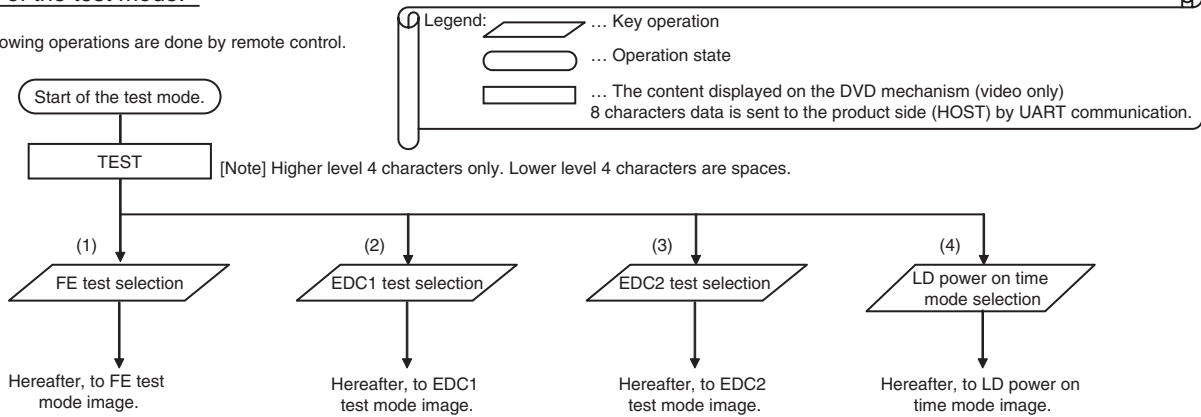

[Note] In order to move on to another test after selecting a test (FE/EDC1/EDC2), it is necessary to restart the DVD mechanism in the test mode.

### Image of the front end test mode.

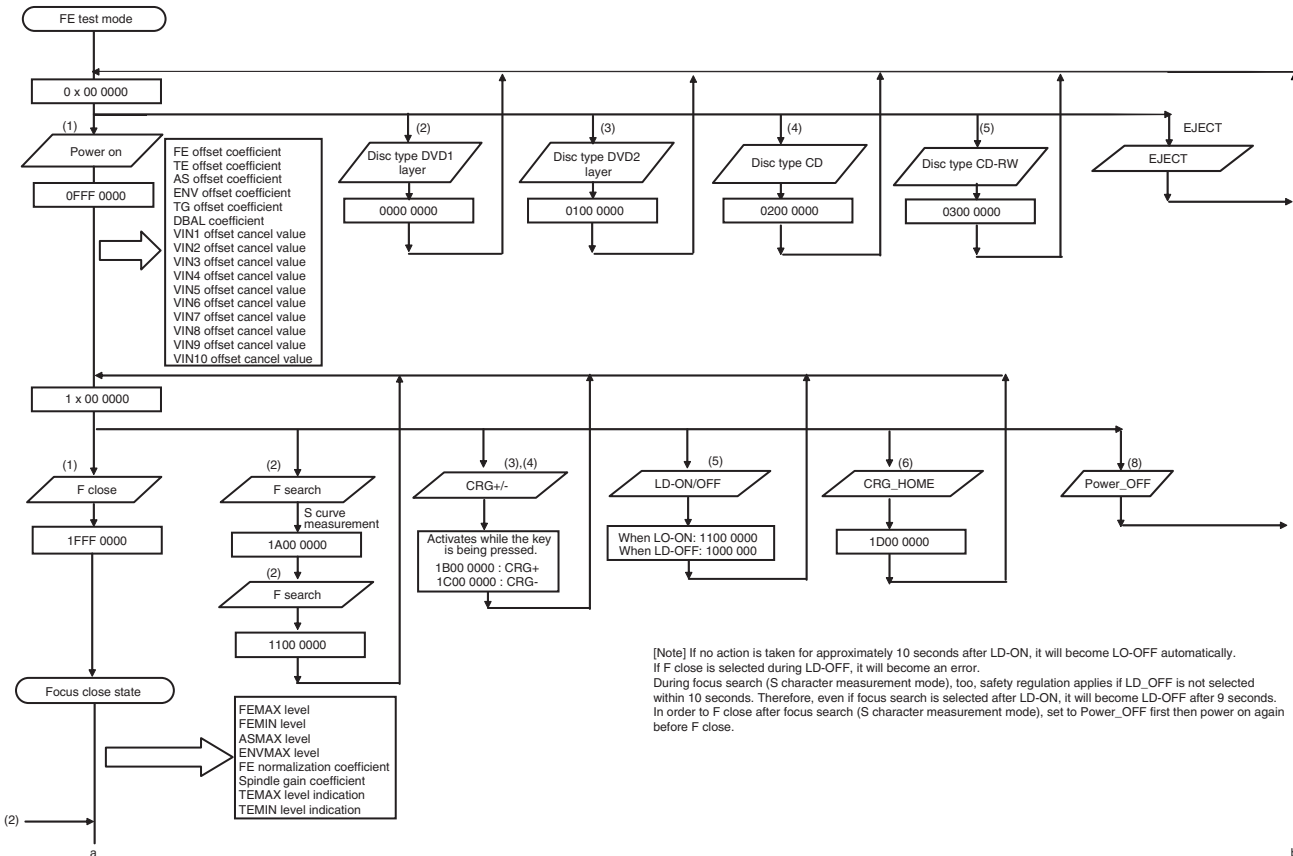
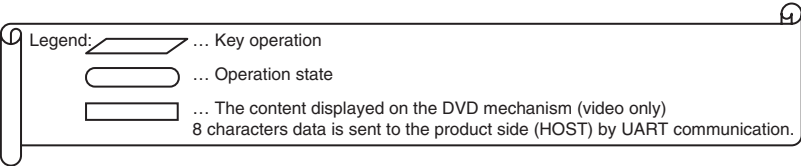

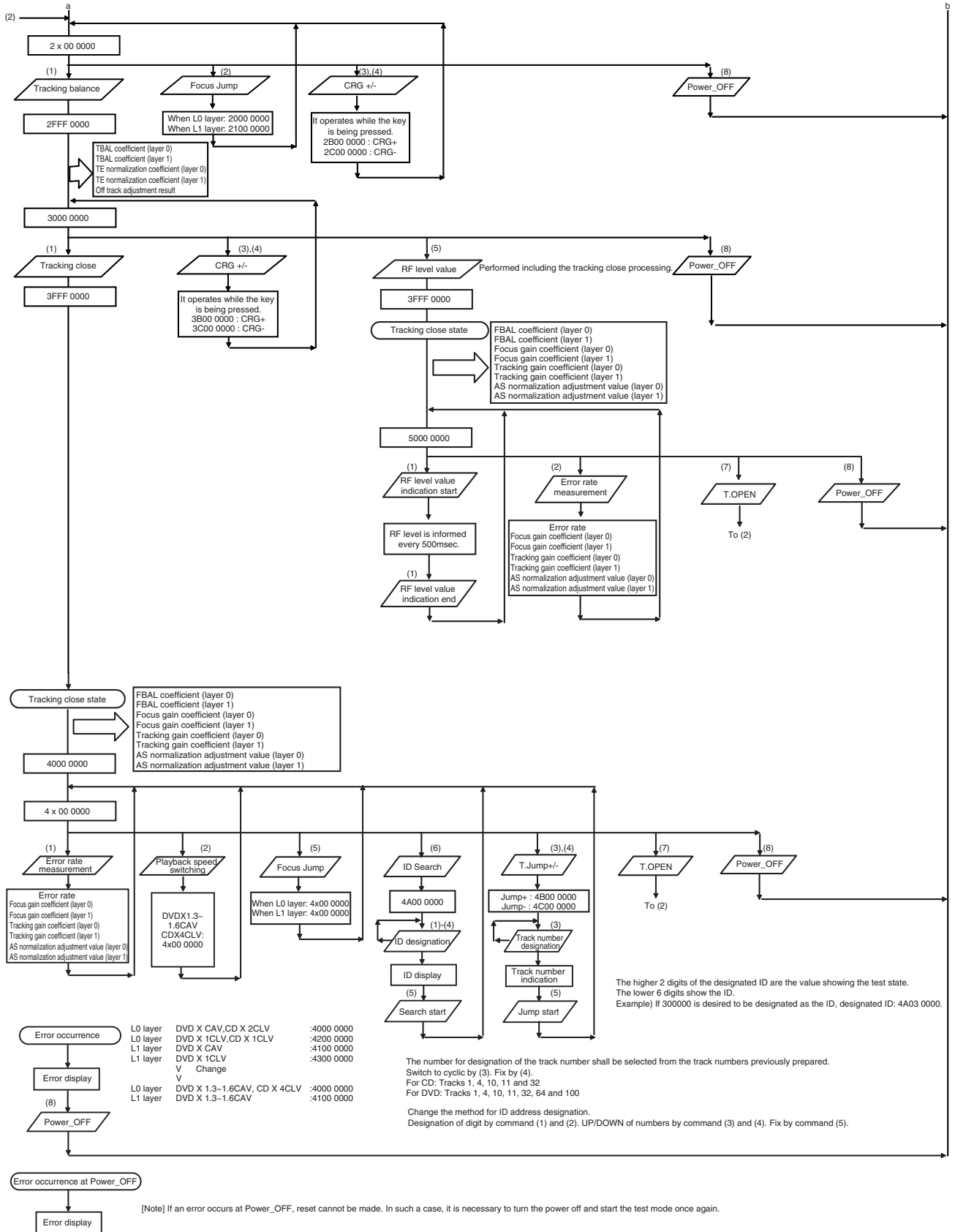

### EDC. Image of the test mode

Legend:

- ... Key operation
- ... Operational state
- ... The content displayed on the DVD mechanism (video only)  
8 characters data is sent to the product side (HOST) by UART communication.

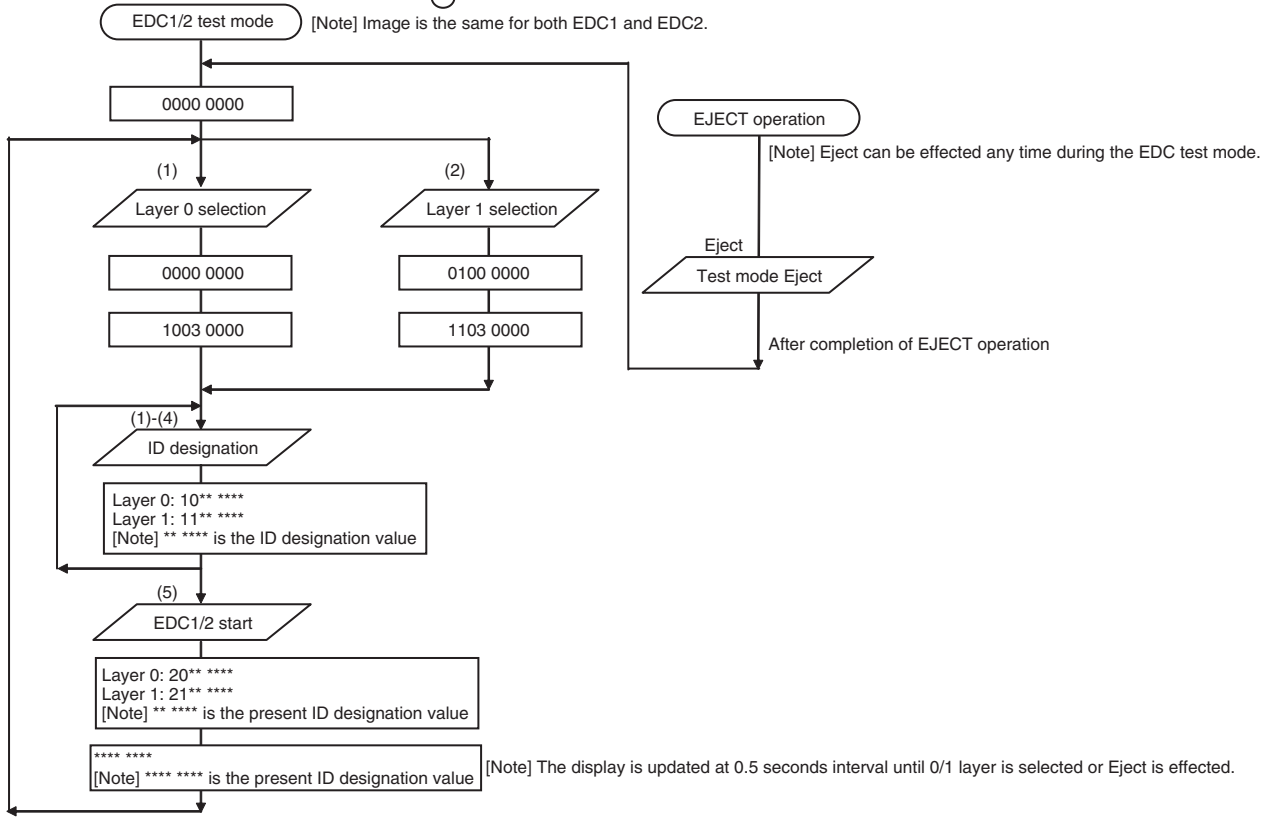

### Image of the LD power on time mode.

Legend:

- ... Key operation
- ... Operational state
- ... The content displayed on the DVD mechanism (video only)  
8 characters data is sent to the product side (HOST) by UART communication.

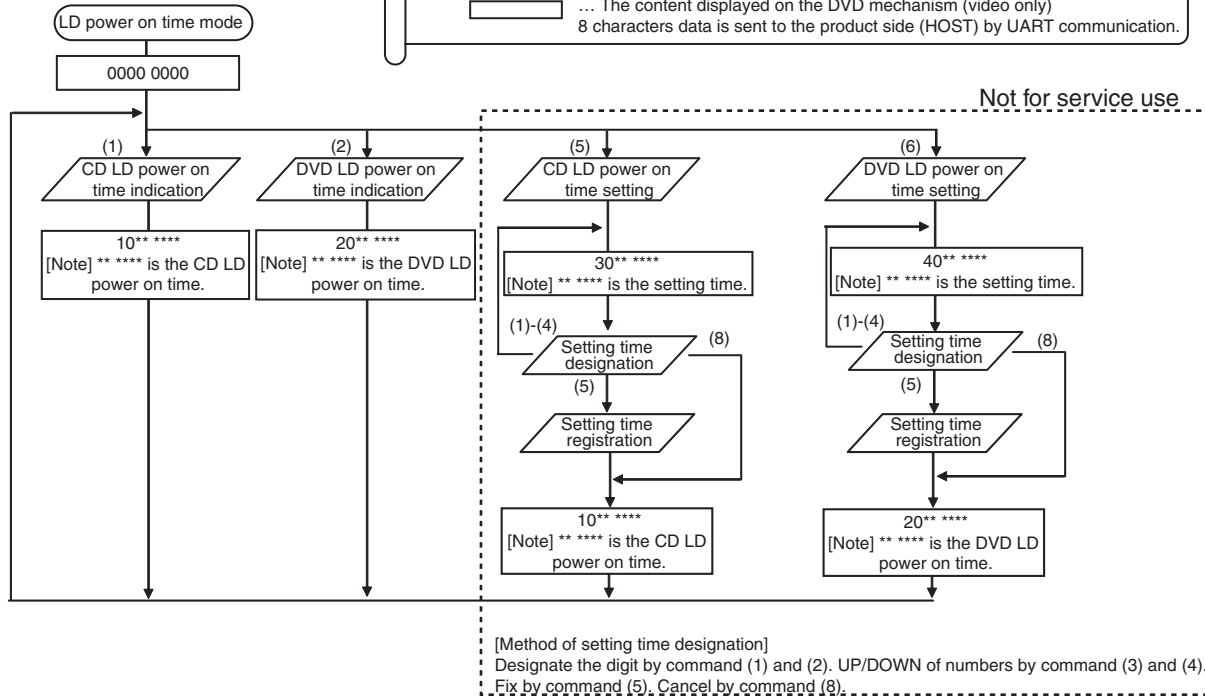

[Note] If the power on time is 999999 hours or more, it is always reported as 999999 hours.  
[Note] If the power on time is "E\*\*\*\*\*", the value may not be correct due to the life of the flash memory.

Error status	OSD *1	UART *2	Meaning	Method of reset			
				ACC Off/On	Source Off/On	Eject	Play Key
Media Error	It is a disc unable to be played back. NON-PLAYABLE DISC	00h	A disc containing the unplayable Format only.	X	X	X	-
Open	(No display)	10h	Door open error	*	*	*	*
Read Error	ERROR-02-99	20h	Transfer start error	X	X	X	X
Focus Error(Focus Error in mechanism set up)	ERROR-02-90	21h	Focus error	X	X	X	X
Surface Error	ERROR-02-9E	22h	Focus error during set up (A focus has never been achieved with that disc.)	X	X	X	X
Address not found (Invalid Track)	ERROR-02-80	23h	Address not found.	X	X	X	X
Spindle Lock	ERROR-02-91	24h	Spindle lock NG (the disc cannot rotate)	X	X	X	X
Carriage HOME	ERROR-02-92	25h	Carriage home NG (The pick up tries to return to carriage home, but it cannot go back and stopped.)	X	X	X	X
ID/SUBCODE Read Error	ERROR-02-94	26h	ID/SUBCODE Read Error (ID/SUBCODE cannot be read due to scratch or stain.)	X	X	X	X
AV CHIP decode Error	ERROR-02-9A	2Ah	AV CHIP decode NG (AV chip cannot be decoded.)	X	X	X	X
AV CHIP Recovery NG	ERROR-02-9B	2Bh	AV CHIP recovery NG	X	X	X	X
Error of PLAY BACK Mode Status	ERROR-02-9C	2Ch	Playback state error (An error due to software bug.)	X	X	X	X
Disc Data Error	ERROR-02-9D	2Dh	Disc Data NG	X	X	X	X
Temp Error (In Case of High Temperature)	Temperature protection circuit is being activated. THERMAL PROTECTION IN MOTION	30h	High temperature (Playback is stopped because the pick up temperature is 89 °C or higher.)	X	-	-	-
No Disc (including Disc loading and ejecting)	(No display)	40h	Disc has not been inserted. (Including Load in process or Eject in process.)	*	*	*	*
Loading_Mecha Error	(No display)	50h	Loading mechanism error (The disc cannot be clamped.)	X	-	X	-
DRM Error	It is a protected disc. PROTECTED DISC	70h	DRM error (All music cannot be played back due to DRM.)	-	-	X	-
Region code Error NG	Region code is incorrect. DIFFERENT REGION DISC	90h	Region code NG (Unable to be played back due to incorrect mechanism region.)	-	-	X	-
CPPM*3 Key Error *4	It is a disc unable to be played back. NON-PLAYABLE DISC	91h	Key Error for playback	-	-	X	-
CPRM Key Error *7	NON-PLAYABLE DISC	93h	Key Error for playback	-	-	X	-
AWM*5 Error *4	(No display)	*6	Playback the illegally copied disc by DVD-A (Mute the sound on the mechanism side.)	X	X	X	-
REQUEST error	ERROR-02-A0	A0h	REQUEST error	X	X	X	X
Failure in issuing read command (chip dependent)	ERROR-02-A1	A1h	Failure in issuing the read command	X	X	X	X
Adjustment of L0 is NG.	ERROR-02-A2	A2h	L0 adjustment is NG.	X	X	X	X
Adjustment of L1 is NG.	ERROR-02-A3	A3h	L1 adjustment is NG	X	X	X	X
LD system NG	ERROR-02-A4	A4h	LD system NG	X	X	X	X
Gain adjustment system NG.	ERROR-02-A5	A5h	Gain adjustment system NG.	X	X	X	X
Gain determining system NG.	ERROR-02-A6	A6h	Gain determining system NG.	X	X	X	X
Servo initial setting related items NG.	ERROR-02-A7	A7h	Servo initial setting related items NG.	X	X	X	X
Disc is not clamped yet.	ERROR-02-A8	A8h	Disc is not clamped yet.	X	X	X	X
Tracking system NG.	ERROR-02-A9	A9h	Tracking system NG	X	X	X	X
Media setting system NG.	ERROR-02-AA	AAh	Media setting system NG	X	X	X	X
Focus Error	ERROR-02-AB	ABh	JUMP over layers NG	X	X	X	X
Error of PLAY BACK Mode Status	ERROR-02-B0	B0h	Navigation command error	X	X	X	X
Error of PLAY BACK Mode Status	ERROR-02-B1	B1h	Retry over	X	X	X	X
Undefined Error	ERROR-FF-FF	FFh	Undefined error	X	X	X	X

X: Cancel the error by operation. -: Error is not cancelled by operation. \*: No setting

\*1 A content displayed on OSD. As for the items having multiple display patterns, the upper row is for the Japanese version Full GUI, and the lower row is for the Touch Panel model and Full GUI (English version).

\*2 A parameter of UART command, such as "receipt error notice", that the DVD mechanism transmits.

\*3 CPPM(Content Protection for Prerecorded Media) : A copyright protection technique used in DVD-A. The protection is realized by using the keys recorded on the media and the device key held by the player.

\*4 DVD-A compatible model only.

When an error has occurred, only the audio output will be muted but playback operation will continue. Furthermore, acceptance of the user operation will be the same as usual.

\*5 AWM (Audio WaterMark): Electronic watermark. Information on the copyright owner or CCI (copy control information) are recorded so that illegally copied discs can be identified.

\*6 Notice as an error status will not be given

\*7 CPRM(Content Protection for Recordable Media) : A copyright protection technique for digital contents used for re-writable DVD or memory card. (DVD-VR model only)



# 7. DISASSEMBLY

## ● Removing the Grille Assy and the Panel Unit (Fig.1)

- 1** Push the [Detach] Button and then remove the Grille Assy.
- 2** Remove the two screws and then remove the Holder.
- 3** Disconnect the connector.
- 4** Remove the two screws and then remove the Panel Unit.

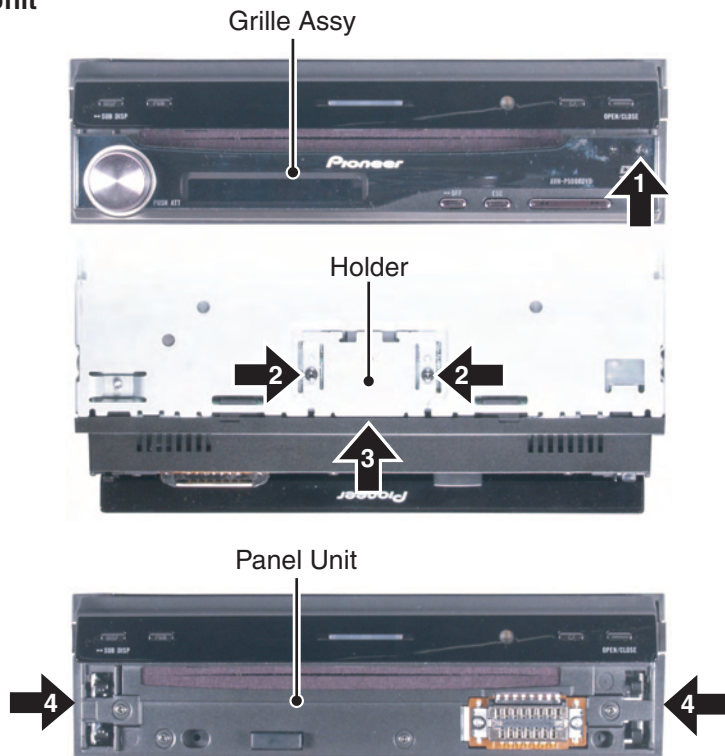

Fig.1

## ● How to Separate the Upper Case and the Lower Case (Fig. 2)

- 1** Remove the seven screws.
- 2** Open the Upper Case and the Lower Case in the direction indicated by arrows.

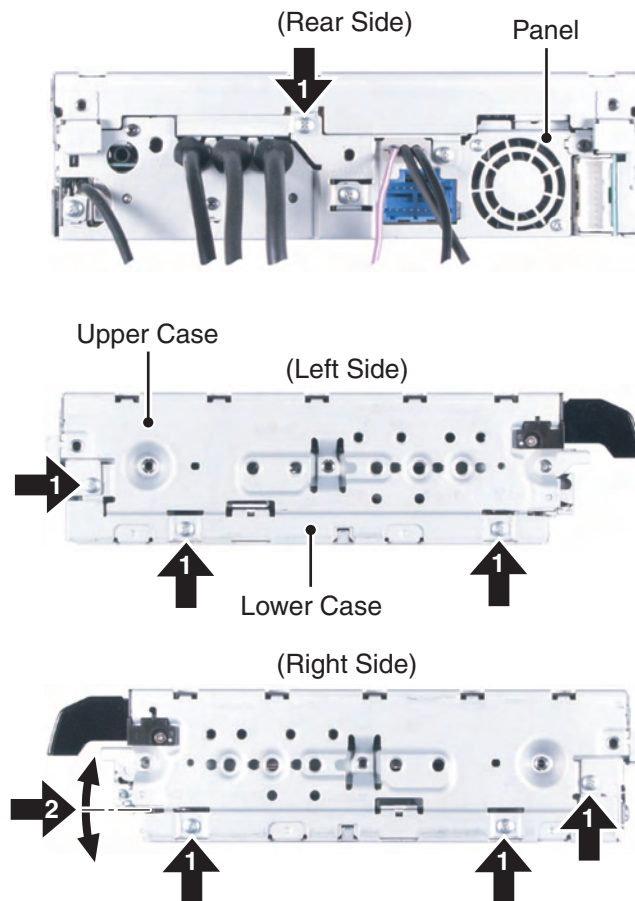

Fig.2



● Removing the DVD Mechanism Module (Fig.3)

➡ 1 Remove the four screws and then bring down the Bracket toward the Upper Case. See Fig.3 (2/2).

➡ 2 Remove the four screws and then bring down the DVD Mechanism Module toward the Upper Case. See Fig.3 (2/2).

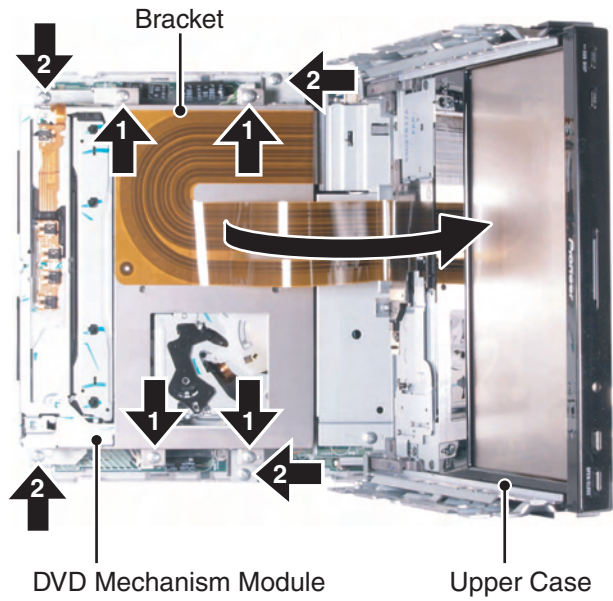

Fig.3 (1/2)

➡ 3 Disconnect the three connectors.

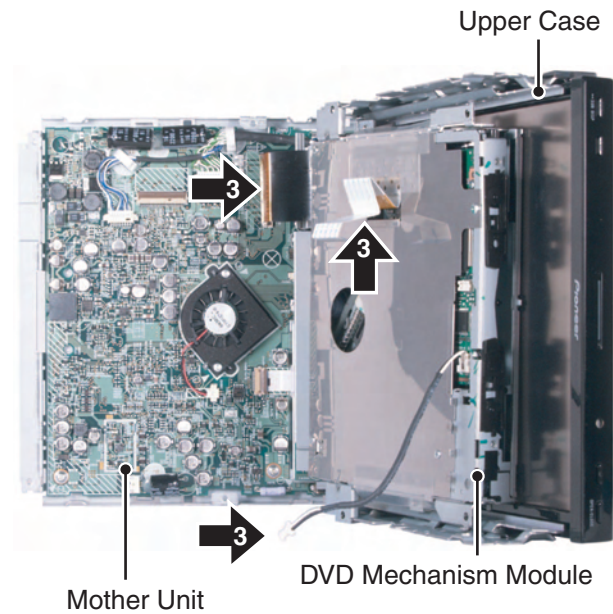
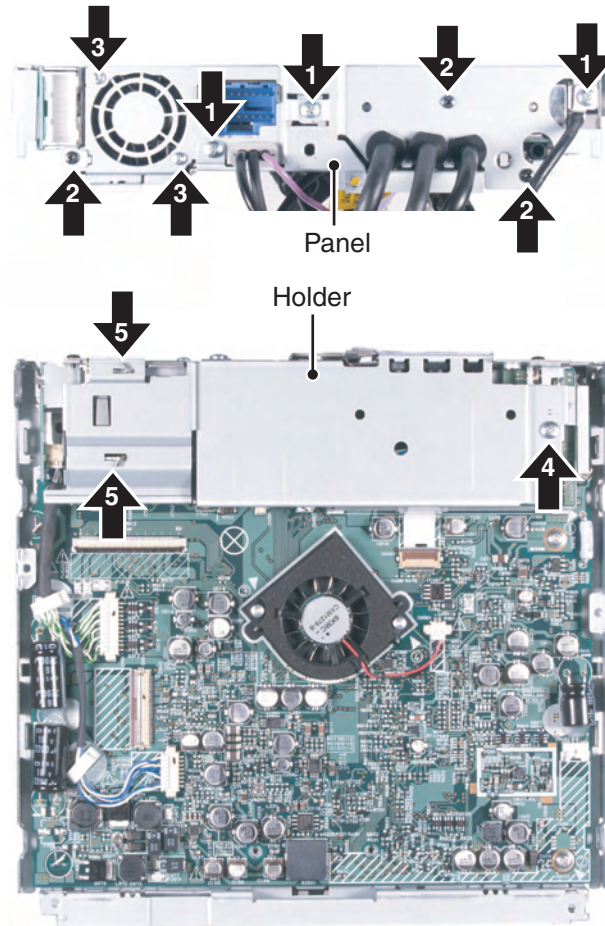

Fig.3 (2/2)

● Removing the Holder and the Panel (Fig.4)

- 1** Remove the three screws.
- 2** Remove the three screws.
- 3** Remove the two screws and then remove the Panel.
- 4** Remove the screw.
- 5** Straighten the tabs at two locations indicated and then remove the Holder.



[Caution]  
 The Panel cannot be removed in **3** unless the Holder is removed in advance in **4** and **5**.

Fig.4

● Removing the Mother Unit (Fig.5)

- 1** Disconnect the connector.
- 2** Remove the two screws.
- 3** Remove the two screws.
- 4** Straighten the tabs at three locations indicated and then remove the Mother Unit.

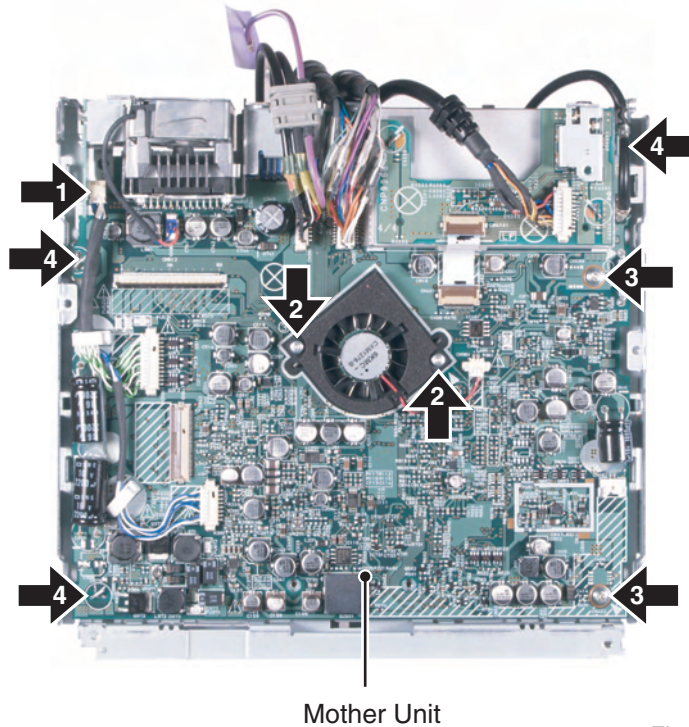
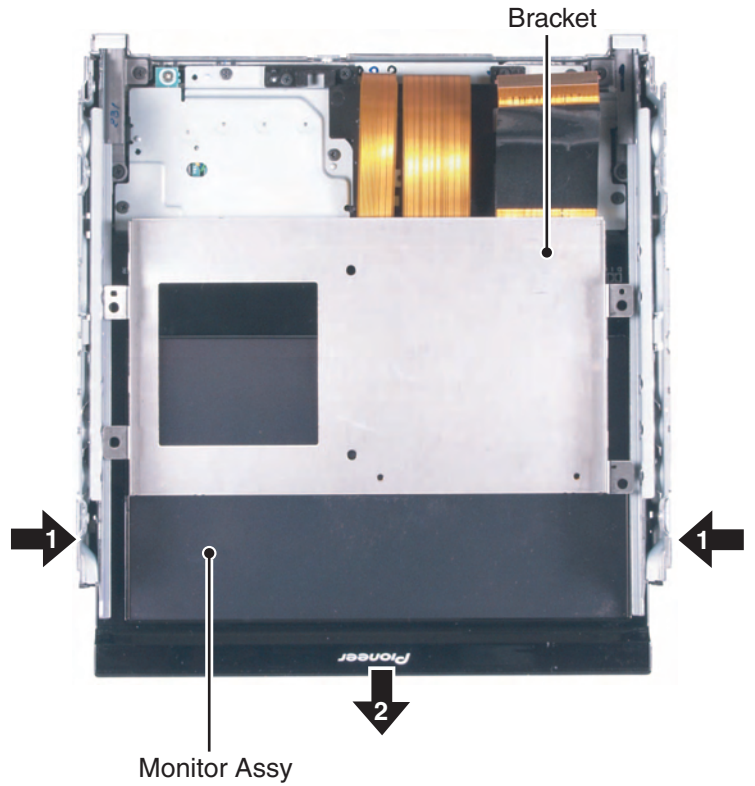

Fig.5

● Removing the Monitor PCB 1/2 (Fig.6)

**1** Remove the two screws and then remove the two Guides(Right side and Left side).

**2** Pull out the Monitor Assy in the direction indicated by an arrow.



**3** Remove the three screws and then remove the Cover.

**4** Disconnect the connector.

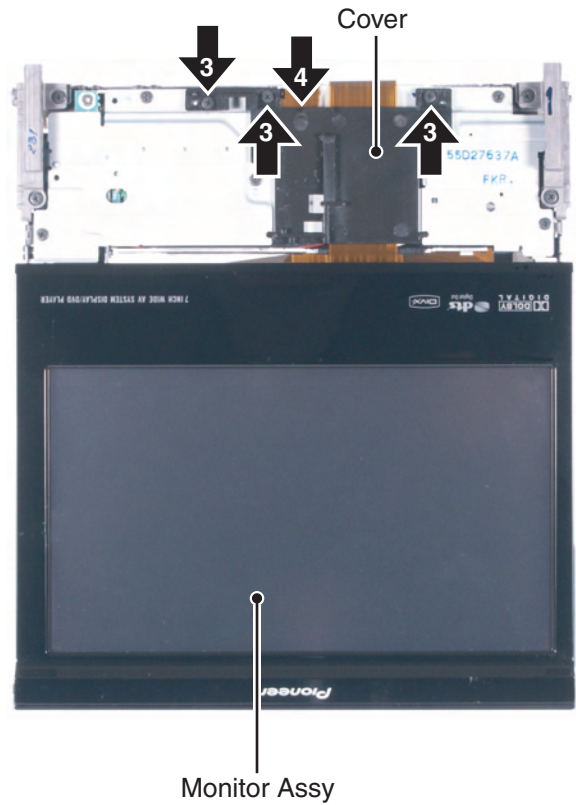

Fig.6



● Removing the Monitor PCB 2/2 (Fig.7)

A

➔ 1 Remove the two screws and then remove the Holder.

➔ 2 Remove the eight screws and then remove the Monitor Assy.

➔ 3 Remove the Cover Unit.

B

➔ 4 Disconnect the connector.

[Caution]

The Monitor Assy cannot be removed unless the Cover Unit is removed in advance after removing the screws.

C

➔ 5 Disconnect the three connectors and then remove the Monitor PCB.

D

E

F

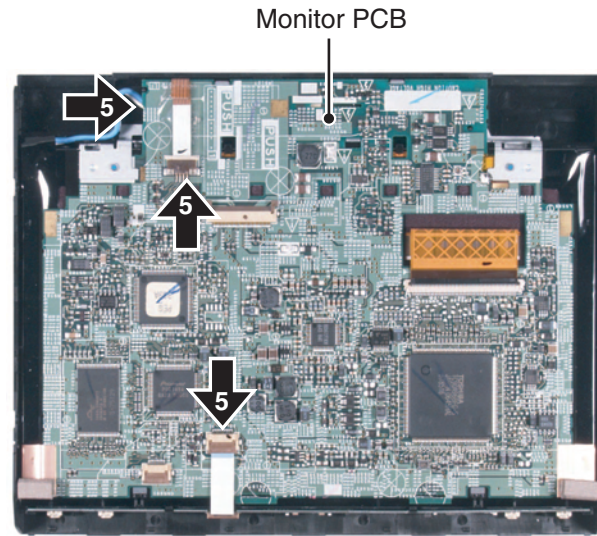
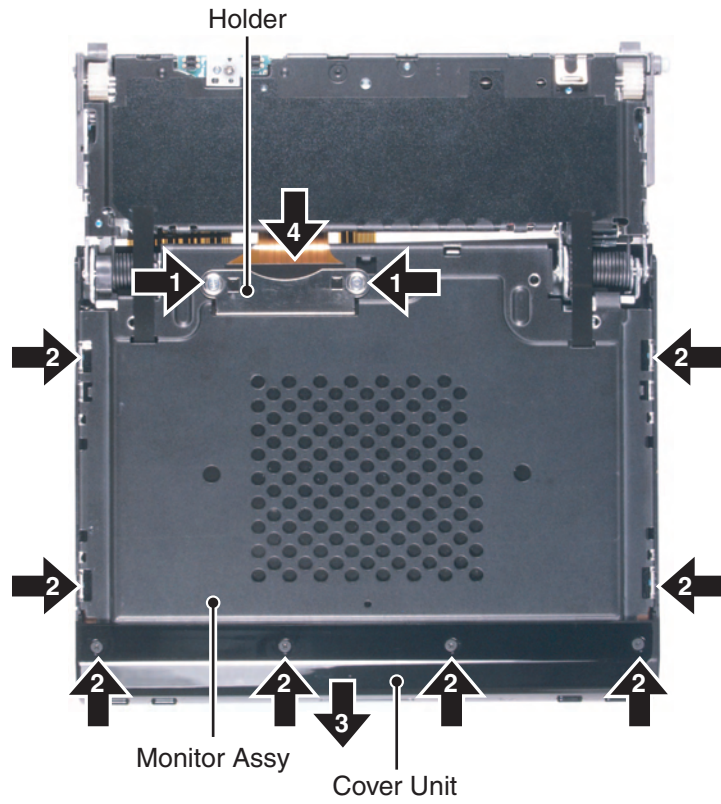

Fig.7

### ● How to hold the mechanism section (Fig 1)

1. Hold the main frame and the top frame.
2. As the mechanical strength of the front part of the top frame is not strong, do not hold this part.
3. Do not touch the switches provided on the top face of the mechanism section.
4. Be careful not to pull the flexible PCB on the side face.

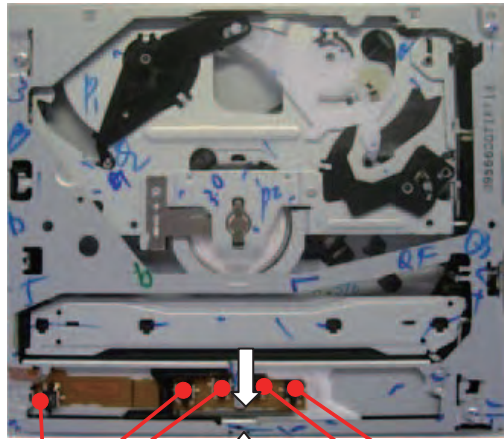

Fig 1

Do not touch this part. Do not touch this part. Do not touch this part.

### ● How to remove the module PCB (Fig 2, Fig 3)

1. Put the mechanism section in locked state (disc load standby position).
2. Hold the mechanism module with its top face down.
3. Make the lands at 2 locations on the pick up flexible PCB short.
4. Disconnect the connectors of the pick up flexible PCB and the SPDL flexible PCB.  
(Be sure to disconnect the connectors as the flexible PCB will be damaged if the PCB is removed without removing the flexible PCB.)
5. Remove the solder joint of the lead wire of the load motor and the clamp SW.
6. Remove the two screws, and then remove the module PCB.  
(Lift up point A slightly and remove it toward B direction. Be careful as the point C is connected with a flexible PCB.)
7. Disconnect the connector of the 8-12 detection flexible PCB from the PCB.

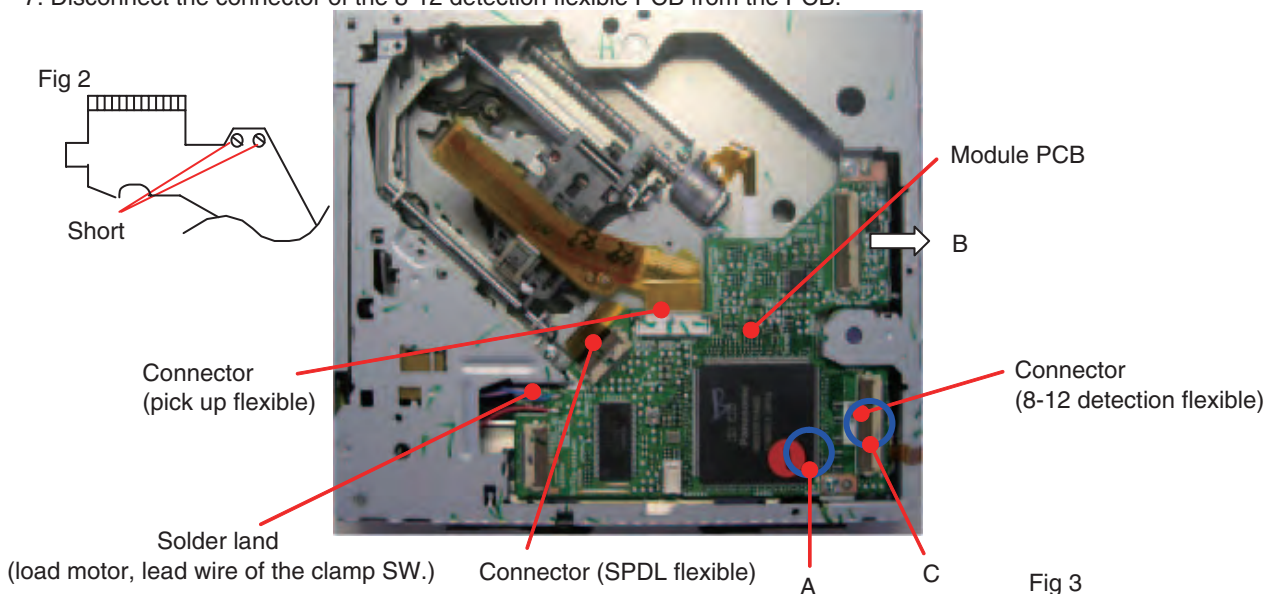

Fig 3

● How to remove the CRG motor assy (Fig 4)

1. Remove the module PCB according to the instructions in "How to remove the module PCB".
2. Remove the Mylar tape.
3. Remove the flexible PCB of the CRG motor from the connector of the spindle motor.
4. Remove the two screws, and then remove the CRG motor assy.

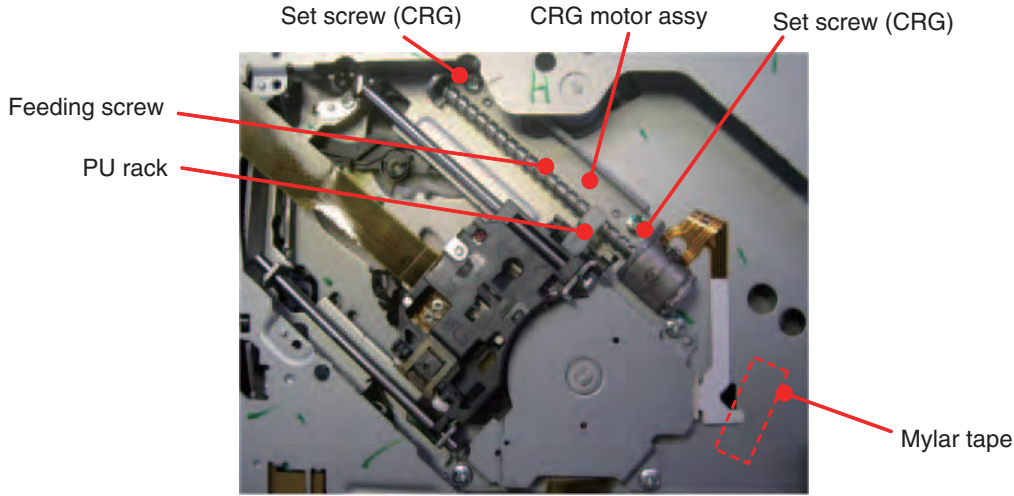

Fig 4

● How to remove the PU unit (Fig 5)

1. Remove the module PCB according to the instructions in "How to remove the module PCB".
2. Hang the main shaft holding spring to the CRG chassis temporary hanger.
3. Remove the CRG motor assy according to the instructions in "How to remove the CRG motor assy".
4. Remove the holding plate spring of the main shaft.
5. While lifting up the tip of the pick up rack, slide the main shaft, and remove the PU unit.

(Note) When mounting the PU unit again, make sure to do the adjustments of the devices mounted thereon according to the descriptions of the service manual. Furthermore, make sure to hang the main shaft holding spring permanently.

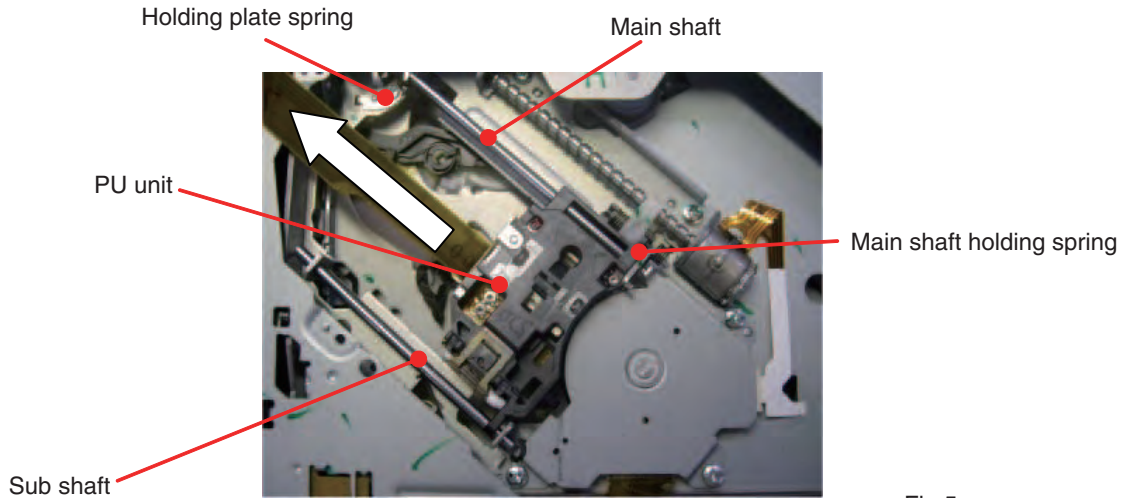
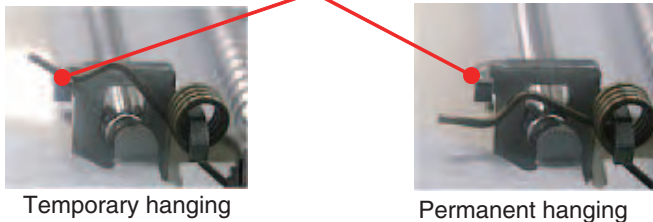

Fig 5

CRG chassis temporary hanging section



# 8. EACH SETTING AND ADJUSTMENT

## 8.1 DVD ADJUSTMENT



### 1) Precautions

This product uses 5 V and 3.3 V as standard voltages. The electrical potential that is the reference for signals, is not GND, but VREF (approximately 2.2 V) and VHALF (approximately 1.65 V).

During product adjustments, if the reference voltage is mistakenly taken as GND, and a grounding contact is made, not only would it be impossible to measure the accurate electrical potential, but also the servo motor would malfunction, resulting in the application of a strong impact on the pick up. The following precautionary measures should be strictly adhered to, in order to avoid such problems.

The reference voltage and GND should not be confused when using the minus probe of a measurement device. When an oscilloscope is being used special care should be taken to make sure that the reference voltage is not connected to the probe of ch1 (on the minus side), while the probe of ch2 (on the minus side), is connected to GND. Further, since the body frame of most measurement devices have the same electrical potential as the minus side of the probe, the body frame of the measurement device should be set to floating ground.

If the reference voltage is connected to GND by mistake, turn the regulator OFF immediately, or turn the power OFF

- Remove the filters and wires used for measurements only after the regulator has been turned OFF.
- After the power supply is turned on, regulator ON the following adjustment and measurement are promptly done.
- Whenever the product is in the test mode, the software will not take any protective action. For this reason, special care should be taken to make sure that no mechanical or electrical shock could be applied to the product when taking measurements in the test mode.
- Whenever the EJECT key is pressed to eject the disk, no other keys, other than the EJECT key, should be pressed until the disk eject action has been completed.
- Press the EJECT key only after the disk has stopped completely.
- If the product hangs up turn the power OFF immediately.
- Laser diodes may be damaged, if the volume switch for the laser power adjustment of the pick up unit, is turned.

Attention)

- Test mode starting procedure  
Reset start while pressing the ATT and RIGHT keys together.
- Test mode stopping procedure  
Reset or ACC OFF-ON.



● SKEW adjustment

When one of the following replacements has taken place, SKEW adjustment for the pick up will be required.

A

- (1) Replacement of the pick up unit
- (2) Replacement of the spindle motor
- (3) Replacement of the carriage chassis
- (4) Replacement of the main shaft of the pick up unit
- (5) Replacement of the sub shaft of the pick up unit

- Measurement equipment and tools/jigs: Oscilloscope  
 Driver for SKEW adjustment — TORX driver (T2) (GGK1095)  
 Bond for fixing the SKEW (GEM1033)  
 Bond for locking the screw (Locking agents(1401M : produced by THREE BOND))

• Disc used: GGV1018

B

- Measurement reference: AGND2
- Measurement point: RF

• Connection drawing  
DVD core unit

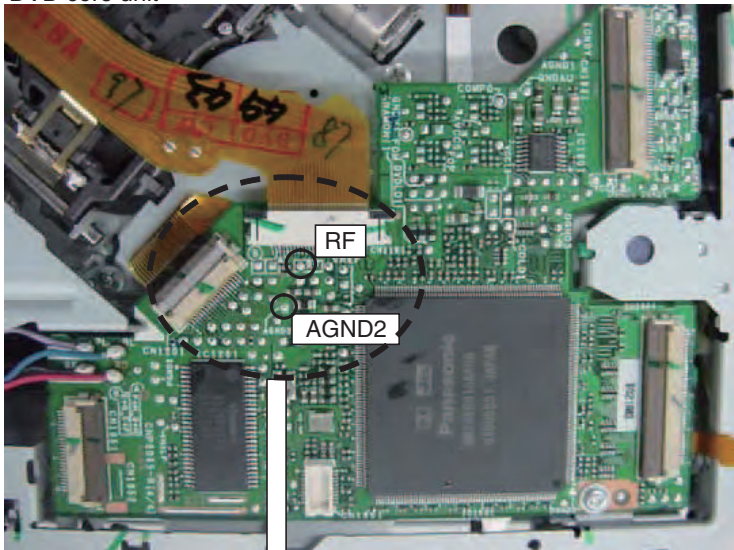

C

Enlargement

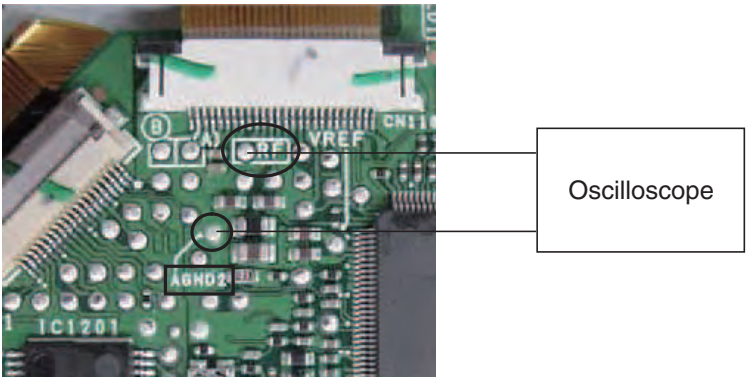

D

E

Symptom in case the adjustment is not adequate: Worsening of the error rate  $10^{-3}$   
 (Normally  $10^{-4}$  or less.)  
 Large RF jitter  
 RF waveform distortion  
 Tracking drawing/Unstable servo

\* Caution: Do not look into the laser light during adjustment.

F



There are two methods for adjustment, a method whereby the adjustment is made while monitoring the RF waveform using the oscilloscope (method ①) and a method whereby the adjustment is made while checking the RF level in value by OSD (method ②).

The adjustment procedure is shown below. Refer to the paragraph for the service test mode regarding entering of the test mode and the operation procedure.

Adjustment procedure:

1. Turn the DVD mechanism module upside down so that the pick up can be adjusted.  
When the module is turned upside down, there is a possibility that the disc is rubbed.  
So, first place a coin with the thickness of approximately 1.5mm on a desk, and set the module upside down in a way that section ① in the illustration below comes right above the coin.
2. Install the pick up. (Refer to the section regarding removal of the pick up from the mechanism unit.)  
As for the precautions in handling the pick up, refer to the precautions in handling the PU as described below.
3. Method ①:  
Connect the oscilloscope by referring to the connection drawing so that the RF signal can be monitored with AGND2 as the reference.  
Method ②:  
There is no need for setting of any equipment. Proceed to step 4.
4. Turn the power ON, and load the disc for adjustment.(GGV1018)
5. After setting the disc type to DVD layer 1 in the front end test mode, turn the power ON, and move the pick up to the inner periphery. (CRG – Home)
6. Turn the LD ON.
7. Set to focus close, and make auto adjustment for all items under that state, then set to tracking close.  
And make auto adjustment for all items under that state as well.
8. Make an intermediate periphery (ID: 100 000) search, and move the PU to intermediate periphery.
9. Method ①:  
Proceed to step 10.  
Method ②:  
After setting to Tracking Open, make all auto adjustments, and set to Tracking Close this time with a command that can be RF displayed. Make auto adjustment for all items under that state as well.
10. Use TORX driver (T2) (GGK1095) for the following.  
Method ①:  
While monitoring the RF waveform on the oscilloscope, turn SKEW adjustment screw A just a little bit in a way that the level will reach the maximum.  
While the pick up is at the intermediate periphery, turn SKEW adjustment screw B just a little bit in a way that the level will reach the maximum.  
While the pick up is at the intermediate periphery, turn SKEW adjustment screw A just a little bit in a way that the level will reach the maximum.  
(Make adjustment in the order of A -> B -> A, Please end the each adjustment by turning screw clockwise. )  
Method ②:  
While monitoring the RF level value on the OSD display, turn the SKEW adjustment screw A just a little bit in a way that the level will reach the maximum.  
While the pick up is at the intermediate periphery, turn SKEW adjustment screw B just a little bit in a way that the level will reach the maximum.  
While the pick up is at the intermediate periphery, turn SKEW adjustment screw A just a little bit in a way that the level will reach the maximum.  
(Make adjustment in the order of A -> B -> A, Please end the each adjustment by turning screw clockwise. )  
If the error is not good, please perform Method ① again.
11. Turn the power OFF in the test mode, and after confirming that the disc has stopped, eject the disc.
12. Apply adhesive for fixing the SKEW and lock the screw.  
Refer to the illustration below for the adhesion points.

A

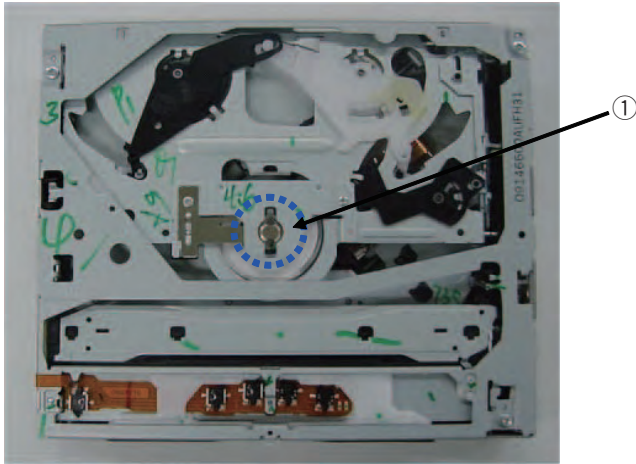

B

SKEW adjustment locations.

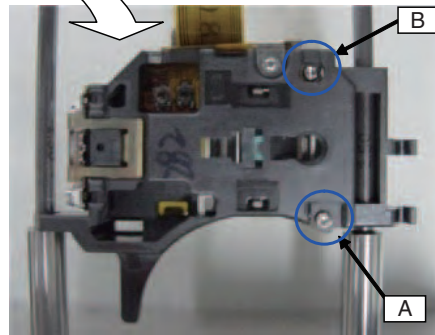
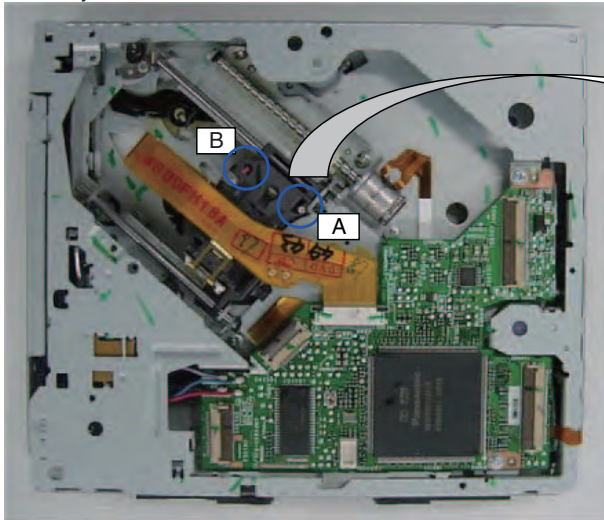

C

SKEW adhesive locations(GEM1033)

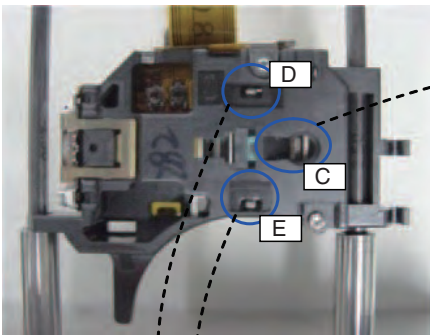

RAD-SKEW adhesive locations

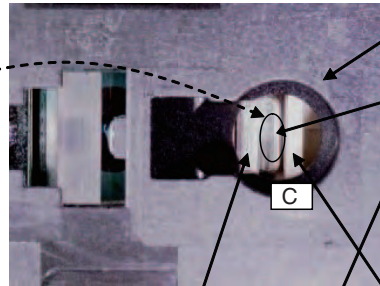

PU case

Adhesive application locations

Sheet metal (yoke base) section

Resin (suspension support) section

TAN-SKEW adhesive locations

PU case



Sheet metal (yoke base) section

Cross section of R-SKEW adhesive locations.

\* Caution: Make a cross link to both the resin section and the sheet metal section.

Adhesive application locations

\* Caution: Make a cross link to both the case section and the sheet metal section.

D

E

F

Screw locking adhesive location(1401M : produced by THREE BOND)

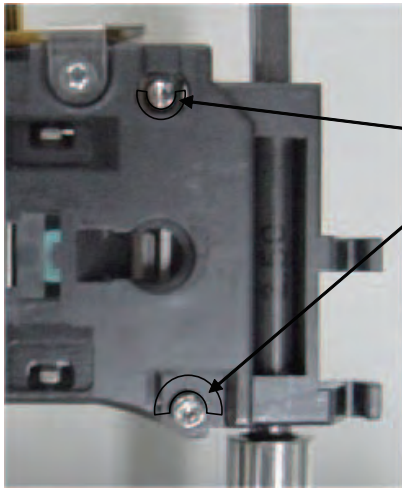

Screw locking adhesive location  
 Apply the locking agent for more than half of the screw head circumference.  
 \* Caution: The locking agent shall not overflow to outside of the PU case.

Precautions in handling the PU.

\* Caution: Do not touch the shaded section in the drawing below.

RF level adjustment section

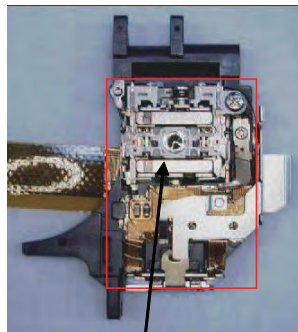
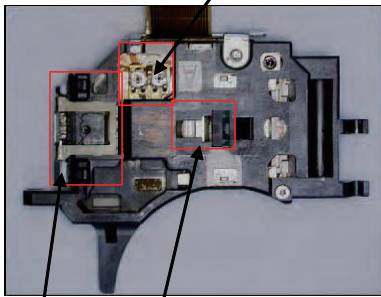

Do not touch the optical parts.

Do not touch the springs.

Hologram (be careful for the static electricity)  
 GRT adjustment section

## 8.2 VIDEO LEVEL ADJUSTMENT



Adjustment point

A

Mother Unit(Side B)

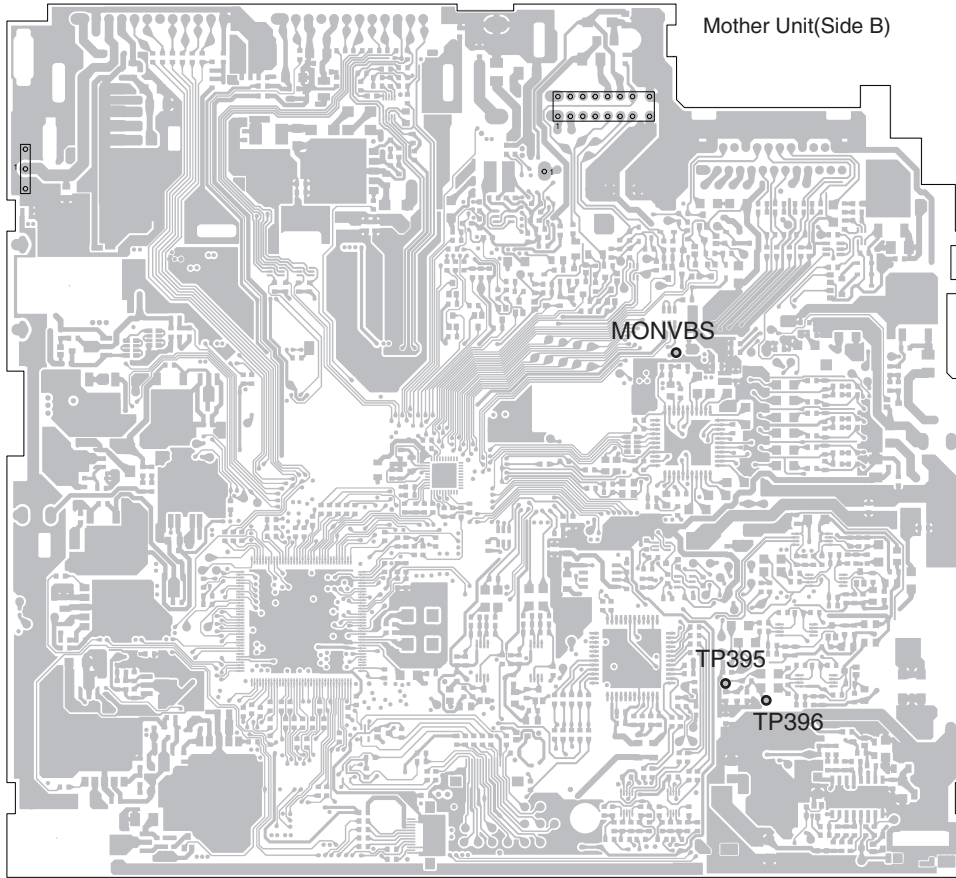

B

C

D

E

F

Mother Unit(Side A)

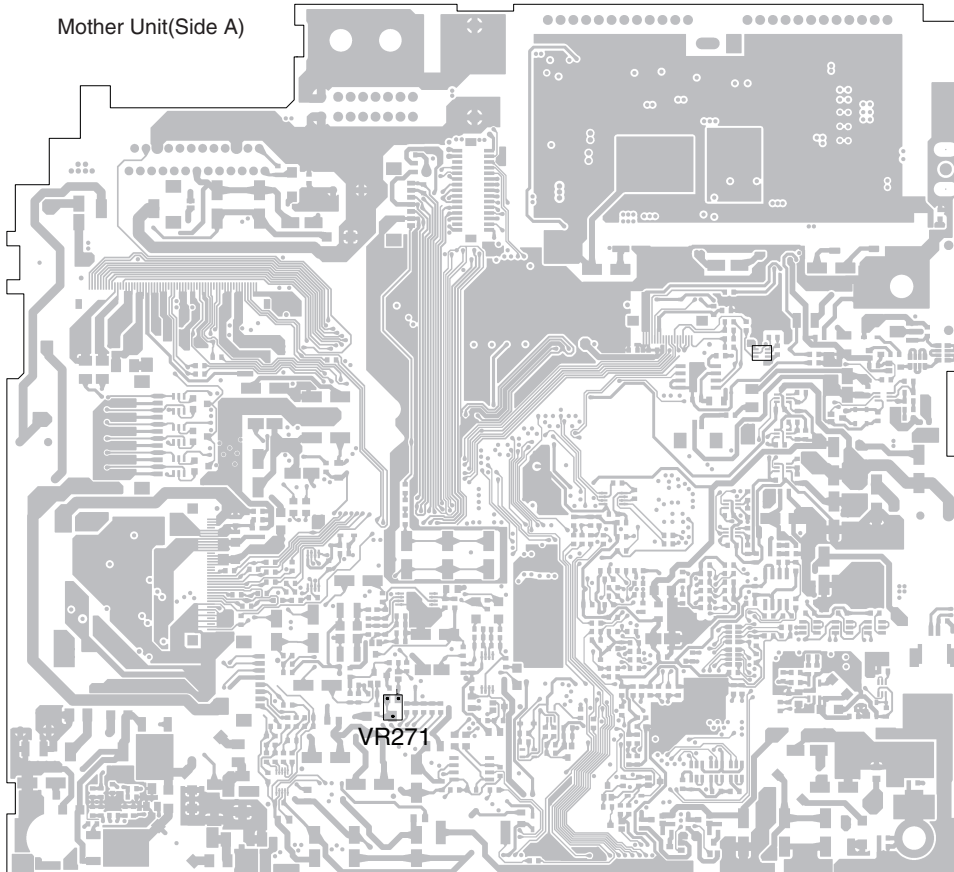

Tuning of image output: Measure level at the measuring point as shown below while DVD is being replayed.

Step	Mother PCB adjustment	Mode	Input signal (input test pin,specs, other conditions)	Output signal (measuring point, waveform)	Measuring instruments	Specs	Adjusting point
1	Main video level	AV	Input test pin: TP396....100 IRE (white 100%), 1.0 Vp-p, (input via 75 ohms) TP395....GND (VIDEO GND)	Measuring point : MONVBS 	Oscilloscope	1.35 V ± 0.05 Vp-p Measure between the sync tip and 100 IRE (top wave). Symptoms with poor adjustment: Over level : Luminance is too high. Under level : Luminance is too low.	VR271



# 8.3 MOTHER UNIT ADJUSTMENT

Adjustment point

A

Mother Unit(Side B)

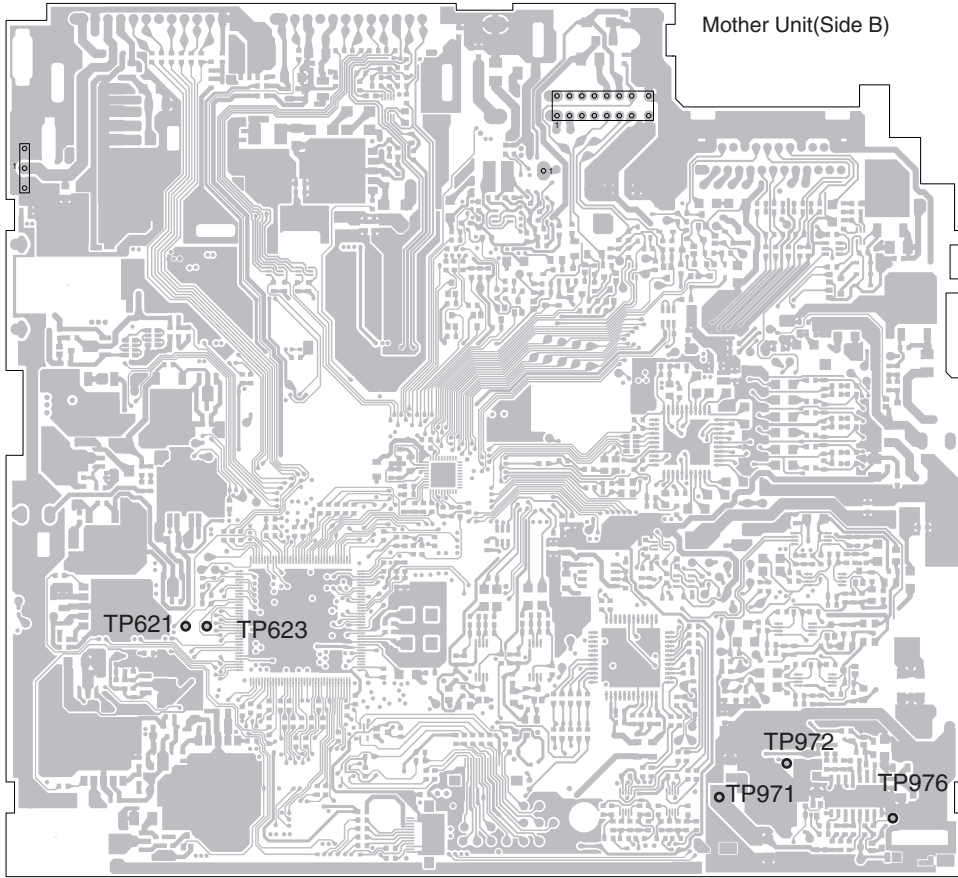

B

C

D

E

F

Mother Unit(Side A)

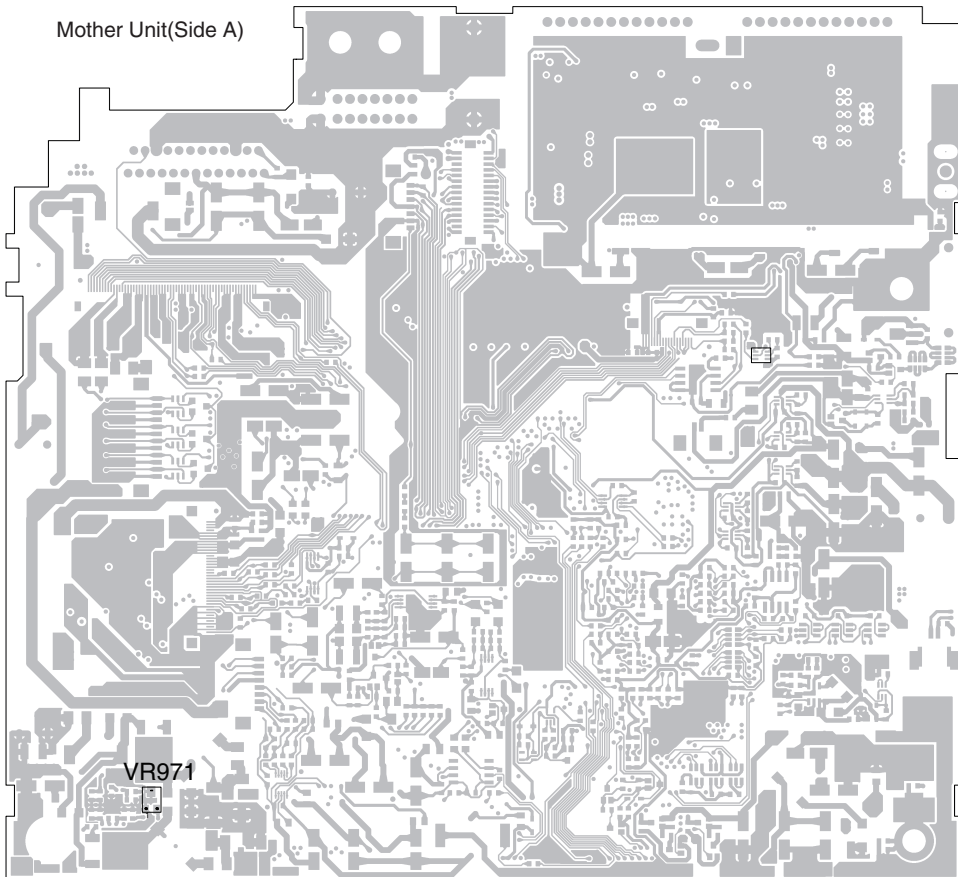

Measure with the frequency counter at the measuring point as shown below while TUNER is turned ON.

Step	Mother PCB adjustment	Mode	Input signal (input test pin, specs, other conditions)	Output signal (measuring point, waveform)	Measuring instruments	Specs	Adjusting point
1	Clock frequency Check		After the power supply is turned on, IC601 pin83(TP621) to 3.3 V	IC601 pin86(TP623)	Frequency Counter	18.874 368 MHz $\pm$ 754 Hz	
2	DC-DC converter frequency Adjustment		Connect 33 $\Omega$ (1.8 W or more) between TP 972 and GND. Connect 20 $\Omega$ (1.2 W or more) between TP 971 and GND.	TP976	Frequency Counter	370 kHz $\pm$ 5 kHz	VR841

# 8.4 INVERTER ADJUSTMENT



Adjustment point

Monitor PCB(Side B)

A

B

C

D

E

F

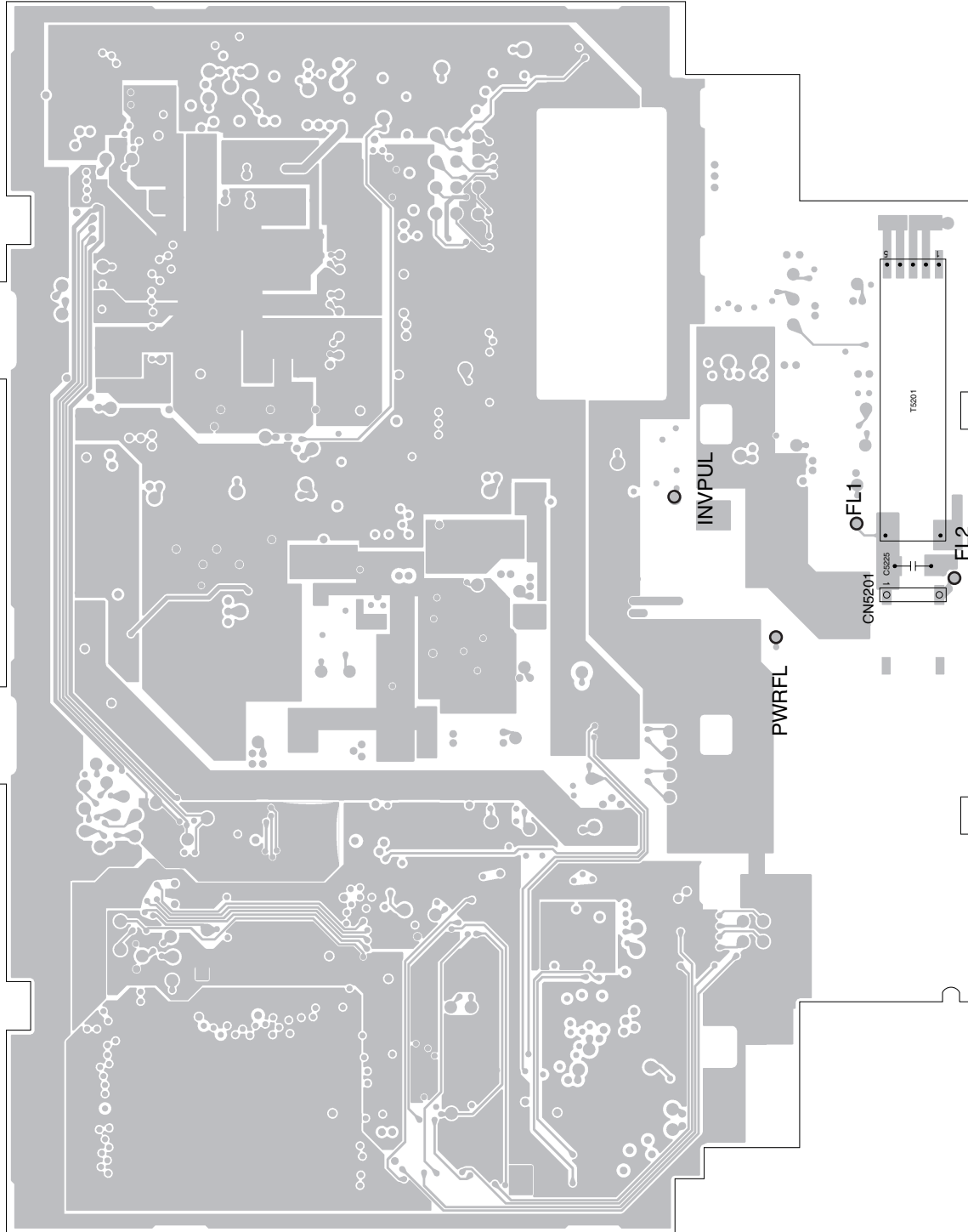

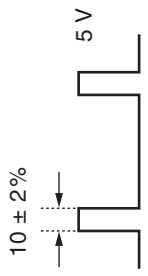
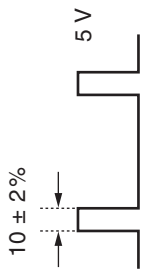
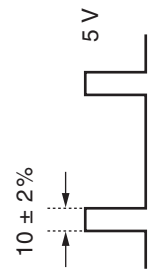

Instead of inserting LCD connector into CN5201, connect 100kΩ between TP FL1 and FL2.  
Measure with the frequency counter at the measuring point as shown below.

No.	Adjustment item	Input signal	Measurement point	Adjustment point	Adjustment	Note
1	Basic drive Frequency adjustment	14.4 ± 0.2 V to TP PWRFL TP DIMDY : GND TP FLGND : GND TP INVPUL : GND	TP FL1 TP FL2	VR5201	48.0 ± 0.1 kHz	Connect 100 kΩ between TP FL1 and FL2. Monitor the waveform after voltage division or TP FL2. Do not monitor TP FL1 directly (measurement meter may be damaged because of high voltage).
2	Check frequency switching	Input 98.0 ± 1 kHz waveform below to TP INVPUL. 	TP FL1 TP FL2	-	49.0 ± 0.5 kHz	Verify that the frequency of waveform measured in No.1 is 49 kHz.
3	Check frequency switching	Input 102.0 ± 1 kHz waveform below to TP INVPUL. 	TP FL1 TP FL2	-	51.0 ± 0.5 kHz	Verify that the frequency of waveform measured in No.1 is 51 kHz.
4	Check frequency switching	Input 104.0 ± 1 kHz waveform below to TP INVPUL. 	TP FL1 TP FL2	-	52.0 ± 0.5 kHz	Verify that the frequency of waveform measured in No.1 is 52 kHz.

# 8.5 MONITOR ADJUSTMENT

1

2

3

4



Adjustment point

Monitor PCB(Side A)

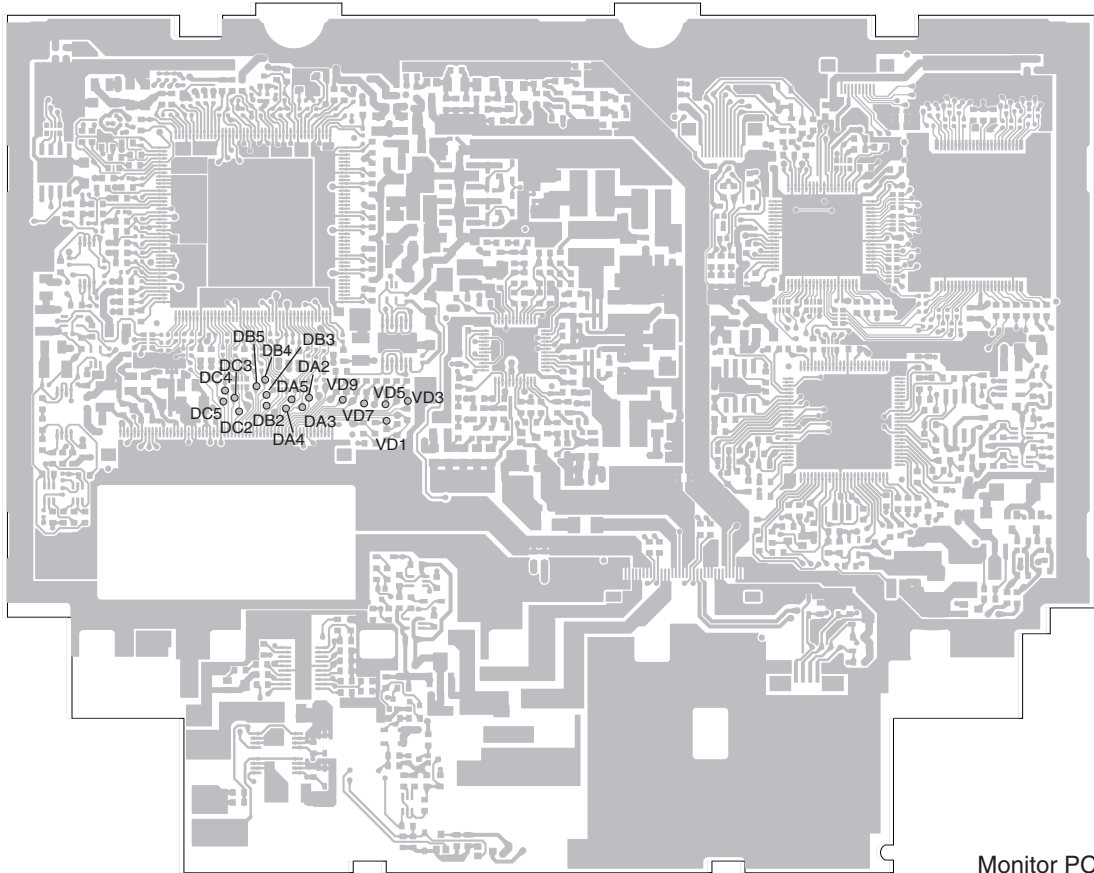

Monitor PCB(Side B)

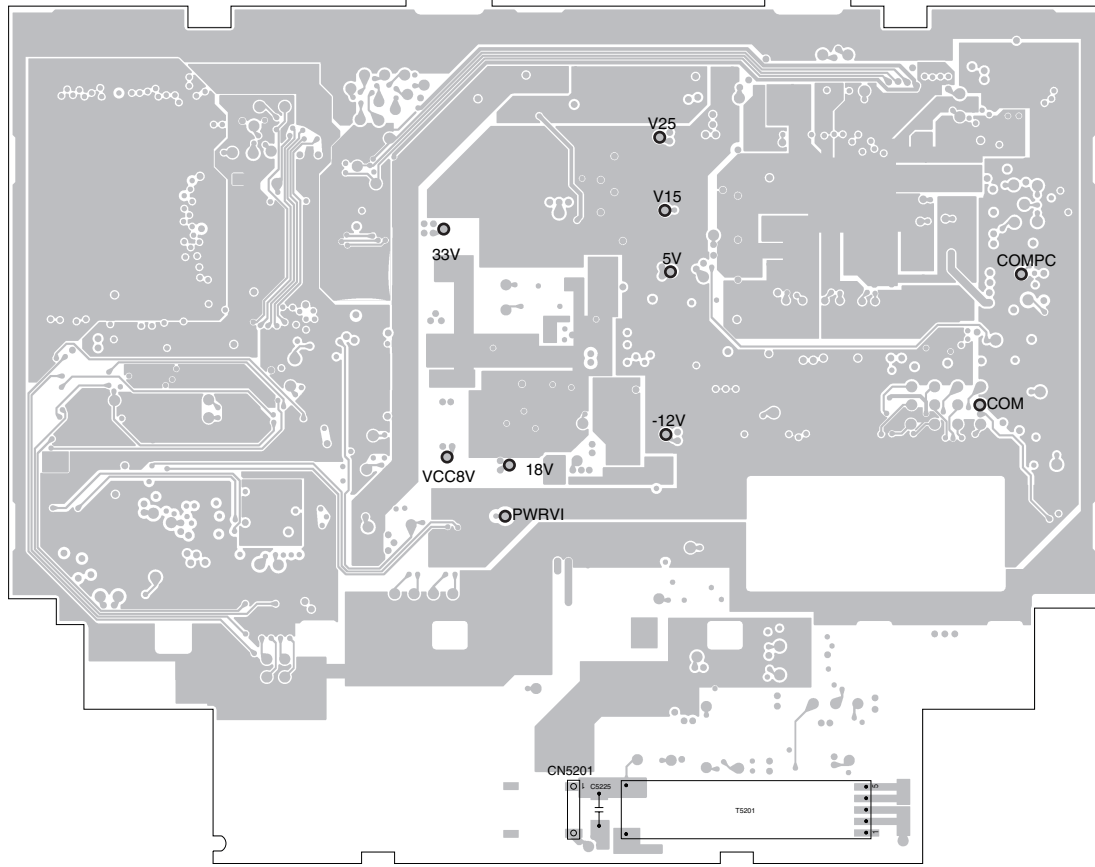

1



2

3

4

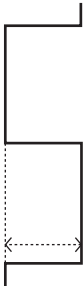
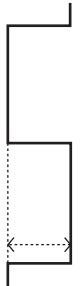
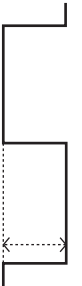
NOTE : When shutting off the power supply of TC90A96BFG-P, be careful not to energize each IC terminal. However, IIC lines (SDA and SCL) is not included in this case and it is possible to energize them with up to 5 V.

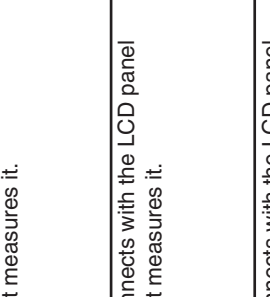
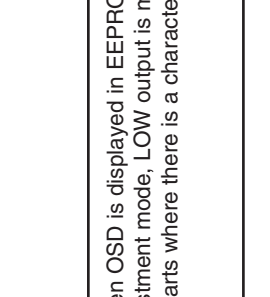
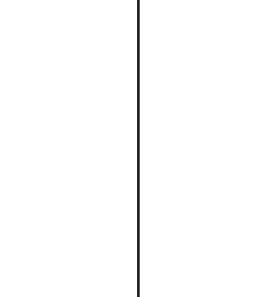
No.	Adjustment item	Input signal	Measurement point	Adjustment point	Adjustment	Note
1	Check 3.3 V power supply voltage	TP:PWRV1 to 14.4 V	TP:33V	-	33V = 3.3 ± 0.25 V	
2	Check 2.5 V power supply voltage	TP:PWRV1 to 14.4 V	TP:V25	-	V25 = 2.5 ± 0.15 V	
3	Check 1.5 V power supply voltage	TP:PWRV1 to 14.4 V	TP:V15	-	V15 = 1.5 ± 0.08 V	
4	Check 5 V power supply voltage	TP:PWRV1 to 14.4 V	TP:5V	-	5V = 4.9 ± 0.3 V	
5	Check 8 V power supply voltage	TP:PWRV1 to 14.4 V	TP:VCC8V	-	VCC8V = 8.0 ± 0.5 V	
6	Check 18.5 V power supply voltage	TP:PWRV1 to 14.4 V	TP:18V	-	18V = 18.5 ± 0.5 V	
7	Check -12 V power supply voltage	TP:PWRV1 to 14.4 V	TP:-12V	-	-12V = -12.0 ± 0.6 V	
8	Vcom amplifier output amplitude check	No definition.	TP:COM	-	4.70 ± 0.10 V 	Connect LCD panel for measurement.
9	Tone voltage amplitude check V1	No definition.	TP:VD1	-	4.20 ± 0.30 V 	Connect LCD panel for measurement.
10	Tone voltage amplitude check V3	No definition.	CN5501 55pin (TP:VD3)	-	1.75 ± 0.10 V 	Connect LCD panel for measurement.

No.	Adjustment item	Input signal	Measurement point	Adjustment point	Adjustment	Note
11	Tone voltage amplitude adjustment V5	INo definition.	TP:VD5	-	$0.35 \pm 0.10$ V 	It connects with the LCD panel and it measures it.
12	Tone voltage amplitude adjustment V7	No definition.	TP:VD7	-	$0.60 \pm 0.10$ V 	It connects with the LCD panel and it measures it.
13	Tone voltage amplitude adjustment V9	No definition.	TP:VD9	-	$3.30 \pm 0.20$ V 	It connects with the LCD panel and it measures it.
14	Check RGB digital output	Input white 100% signal from IC5802	TP CCR, CCG, CCB	-	$0.70 \pm 0.05$ V 	(When OSD is displayed in EEPROM adjustment mode, LOW output is mixed to the parts where there is a character.)
15	Image check of RGB signal	Input Color-bar signal from IC5802	Screen	-	-	
16	Composite level adjustment	Input composite image 10-step signal to TP MONVBS (1.35 Vpp ± 1%)	DAC output	Resistor setting of SA13h D5 - 0	 <p>The amplitude of the 9-step and the 0-step is <math>1.77 \pm 0.05</math> V.</p>	

No.	Adjustment item	Input signal	Measurement point	Adjustment point	Adjustment	Note
17	Image check	Input composite image lamp signal (monochrome) to TP MONVBS	Screen	-	Make sure that tone changes smoothly, and there is no colored area in the entire display.	Execute to verify that IC5401 digital-out is not bridged or "OPEN" ed.
18	Aging	No definition.	-	-	Leave for more than 30 minutes in operation mode.	Input white 100% signal
19	Flicker adjustment	Input black-white reverse signal per 1 line from IC5802	Screen	TP COMDC DC output	Adjust the flicker level to minimum from all directions.	Black-white reverse signal can be the input to TP MONVBS (however, adjustment in RGB comes first). Brightness level of reverse signal should be 50%. Adjustment point can be COM DC of flicker adjustment mode.

SA:\*\*h in this chart means the sub-address of TC90A96BFG-P.

### Memory item list and EEPROM

ADDRESS	Bit15	Bit14	Bit13	Bit12	Bit11	Bit10	Bit9	Bit8	Bit7	Bit6	Bit5	Bit4	Bit3	Bit2	Bit1	Bit0		
RELATED DIMMER	00h	Outside light of dimmer adjustment coordinates (high)							Backlight of dimmer adjustment coordinates (high)									
	01h	Outside light of dimmer adjustment coordinates (middle)							Backlight of dimmer adjustment coordinates (middle)									
	02h	Outside light of dimmer adjustment coordinates (low)							Backlight of dimmer adjustment coordinates (low)									
	03h	Outside light threshold for dimmer (high)							Outside light threshold for dimmer (low)									
	04h	Maximum value of backlight output							Minimum value of backlight output									
	05h	Checksum																
RELATED PIP (Dot adjustment system)	06h-09h	Don't care							Don't care									
RELATED PIP (Last memory value)	0Ah	Common reverse output DC center value							Common reverse output amplitude adjustment value									
	0Bh	Don't care	Brightness R															
	0Ch	Don't care	Brightness G															
	0Dh	Don't care	Brightness B															
	0Eh	Don't care							Main Y contrast									
	0Fh	Don't care	Main horizontal enhancer						Main vertical enhancer						Don't care			
			Gain	Limiter			fo	Gain	Replicate	Coring								
	10h	Don't care							Sub Y contrast									
	11h	Don't care	Sub horizontal enhancer						Sub vertical enhancer						Don't care			
			Gain	Limiter			fo	Gain	Replicate	Coring								
	12h	$\gamma$ setting ON/OFF	RGB simultaneous $\gamma$ slope A			R output DC offset			Don't care			RGB simultaneous $\gamma$ 1 inflection point						
	13h	RGB simultaneous $\gamma$ slope B		RGB simultaneous $\gamma$ 2 inflection point				RGB simultaneous $\gamma$ slope C			RGB simultaneous $\gamma$ 3 inflection point							
	14h	Don't care				G output DC offset			Don't care									
	15h	Don't care				B output DC offset			Don't care									
	16h	SA24h UPPER							SA24h LOWER									
	17h	SA25h UPPER							SA25h LOWER									
	18h	SA26h UPPER TV							SA26h LOWER TV									
	19h	SA26h UPPER							SA26h LOWER									
	1Ah	SA27h UPPER TV							SA27h LOWER TV									
	1Bh	SA27h UPPER							SA27h LOWER									
	1Ch	SA46h UPPER							SA46h LOWER									
	1Dh	SA47h UPPER							SA47h LOWER									
	1Eh	SA48h UPPER							SA48h LOWER									
	1Fh	SA49h UPPER							SA49h LOWER									
	20h	SA4Ah UPPER							SA4Ah LOWER									
	21h	SA4Bh UPPER							SA4Bh LOWER									
	22h	SA4Ch UPPER							SA4Ch LOWER									
	23h	SA4Dh UPPER							SA4Dh LOWER									
	24h	SA4Eh UPPER							SA4Eh LOWER									
	25h	SA4Fh UPPER							SA4Fh LOWER									
26h-2Bh	Don't care				Main SYNC IN sampling		Main PLL3 gain down		Main H-PLL3									
2Ch,2Dh	Don't care							Don't care										
2Eh	Flicker adjustment result							Don't care										
2Fh	Checksum																	
RELATED PIP (Dot adjustment system --- Factory shipment value)	30h-33h	Don't care							Don't care									

	ADDRESS	Bit15	Bit14	Bit13	Bit12	Bit11	Bit10	Bit9	Bit8	Bit7	Bit6	Bit5	Bit4	Bit3	Bit2	Bit1	Bit0
Touch correction value (Factory shipment value)	34h	Touch panel X coordinate 1								Touch panel Y coordinate 1							
	35h	Touch panel X coordinate 2								Touch panel Y coordinate 2							
	36h	Touch panel X coordinate 3								Touch panel Y coordinate 3							
	37h	Touch panel X coordinate 4								Touch panel Y coordinate 4							
	38h	Touch panel X coordinate 5								Touch panel Y coordinate 5							
	39h	Touch panel X coordinate 6								Touch panel Y coordinate 6							
	3Ah	Touch panel X coordinate 7								Touch panel Y coordinate 7							
	3Bh	Touch panel X coordinate 8								Touch panel Y coordinate 8							
	3Ch	Touch panel X coordinate 9								Touch panel Y coordinate 9							
	3Dh	Touch panel X coordinate 10								Touch panel Y coordinate 10							
	3Eh	Touch panel X coordinate 11								Touch panel Y coordinate 11							
	3Fh	Touch panel X coordinate 12								Touch panel Y coordinate 12							
	40h	Touch panel X coordinate 13								Touch panel Y coordinate 13							
	41h	Touch panel X coordinate 14								Touch panel Y coordinate 14							
	42h	Touch panel X coordinate 15								Touch panel Y coordinate 15							
	43h	Touch panel X coordinate 16								Touch panel Y coordinate 16							
44h	Don't care								Touch panel calibration adjustment result								
45h	Checksum																
Touch outermost circumference correction value (Factory shipment value)	46h	Outermost circumference X min								Outermost circumference Y min							
	47h	Outermost circumference X max								Outermost circumference Y max							
	48h	Don't care								Touch panel outermost circumference adjustment result							
	49h	Checksum															
Touch outermost circumference correction value	4Ah	Outermost circumference X min coordinate value for correction								Outermost circumference Y min coordinate value for correction							
	4Bh	Outermost circumference X max coordinate value for correction															
	4Ch	Outermost circumference Y max coordinate value for correction															
	4Dh	Checksum															
Touch correction coordinates (User calibration value)	4Eh	(USER)Touch panel X coordinate 1								(USER)Touch panel Y coordinate 1							
	4Fh	(USER)Touch panel X coordinate 2								(USER)Touch panel Y coordinate 2							
	50h	(USER)Touch panel X coordinate 3								(USER)Touch panel Y coordinate 3							
	51h	(USER)Touch panel X coordinate 4								(USER)Touch panel Y coordinate 4							
	52h	(USER)Touch panel X coordinate 5								(USER)Touch panel Y coordinate 5							
	53h	(USER)Touch panel X coordinate 6								(USER)Touch panel Y coordinate 6							
	54h	(USER)Touch panel X coordinate 7								(USER)Touch panel Y coordinate 7							
	55h	(USER)Touch panel X coordinate 8								(USER)Touch panel Y coordinate 8							
	56h	(USER)Touch panel X coordinate 9								(USER)Touch panel Y coordinate 9							
	57h	(USER)Touch panel X coordinate 10								(USER)Touch panel Y coordinate 10							
	58h	(USER)Touch panel X coordinate 11								(USER)Touch panel Y coordinate 11							
	59h	(USER)Touch panel X coordinate 12								(USER)Touch panel Y coordinate 12							
	5Ah	(USER)Touch panel X coordinate 13								(USER)Touch panel Y coordinate 13							
	5Bh	(USER)Touch panel X coordinate 14								(USER)Touch panel Y coordinate 14							
	5Ch	(USER)Touch panel X coordinate 15								(USER)Touch panel Y coordinate 15							
	5Dh	(USER)Touch panel X coordinate 16								(USER)Touch panel Y coordinate 16							
5Eh	Don't care								(USER)Touch panel outermost circumference adjustment result								
Touch outermost circumference value (User calibration value)	5Fh	(USER)Outermost circumference X min								(USER)Outermost circumference Y min							
	60h	(USER)Outermost circumference X max								(USER)Outermost circumference Y max							
	61h	Don't care								(USER)Touch panel outermost circumference adjustment result							
AD correction touch	62h	Touch AD correction value X coordinates								Touch AD correction value Y coordinates							
	63h	(USER)Touch AD correction value X coordinates								(USER)Touch AD correction value Y coordinates							
Others	64h	EEPROM completion								EJECT lock status value							



## 8.6 MONITOR TEST MODE

### [Outline]

It is a mode used to adjust each preset value stored in the EEPROM for storing the preset values.  
The adjusted values are stored in the EEPROM for storing the preset values.

### [Method for Mode IN]

The method for Mode IN varies depending on the operational environment.

- When operated as a unit  
Reset the monitor micro computer while the [STEST1] terminal is set to Low and the [EPRTTEST] terminal is set to Low.
- When operated as a product  
Reset the monitor micro computer while the [STEST1] terminal is set to High and the [EPRTTEST] terminal is set to Low.  
Or, turn the power ON while pressing DISP key and FLIP DOWN key.

### [Basic explanation on each menu]

- In the "setting content", adjustment range, initial value, and displayed character string of the items preset in each menu are described.

### [Example) Setting content]

Setting item		Adjustment range	Initial value
Content	Displayed character string		
Dot search threshold	TH DOT	0-255	112
YS search threshold	TH YS	0-4	3
Phase search threshold	TH PHASE	0-255	112
X disp	X DISP	0-63	32
YS disp	YS DISP	0-4	2

Character string displayed on the screen.

- In the "display specifications", the screen actually displayed under each menu is explained.  
Display example is shown below for explanation.

### [Example) Display specifications]

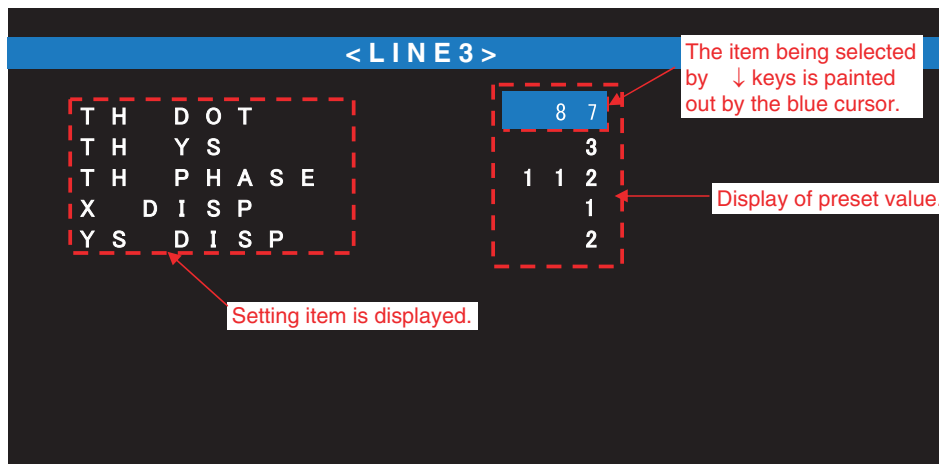

- Cursor color  
When accessing normally to EEPROM:  
The cursor color will change blue → red → blue.  
(The blue color continues for the convenience of the display cycle. But it is not an error.)  
When accessing abnormally to EEPROM(error):  
The cursor color will stay red (blue → red → red) even if the key is released.  
Note) When a value is changed continuously, the cursor color may change blue → red → red → ... → blue.  
But it is not an error.  
(The red color continues for the convenience of the display cycle.)

## [Flicker adjustment menu]

## [Setting content]

Setting item		Adjustment range	Initial value
Content	Displayed character string		
Common inverted output center value	COM DC	0-255	92

## [Line adjustment 1 menu]

## [Setting content]

Setting item		Adjustment range	Initial value
Content	Displayed character string		
Bright	BRIGHT	0-255	150
RGB simultaneous contrast(SA0C[D7-0])	CONTRAST	0-255	168
Common inverted output amplitude adjusted value	COM AMP AJ	0-255	150
R output DC offset(SA1A[D11-8])	ROUT BIAS	0-15	8
G output DC offset(SA1C[D11-8])	GOUT BIAS	0-15	8
B output DC offset(SA1E[D11-8])	BOUT BIAS	0-15	8
Main Y contrast(SA0F[D5-0])	RGB CNTRST	0-63	34
Sub Y contrast(SA13[D5-0])	CMP CNTRST	0-63	26
Dither bit(SA0D[D15])	DITHER BIT	0-1	0(OFF)

- The bright value is determined by the image quality setting table based on the user setting step and the common inverted output amplitude adjusted value (COM AMPAJ). This bright value controls the output of [DACDI] of the monitor micro computer terminal.
  - Supplement 1) When the bright value is changed in the test mode, however, it will not be reflected in the user setting step value.
  - Supplement 2) In the test mode during monitor unit operation, the user setting step will not be reflected in the bright value calculation.

**Note 1...** The "black density (=bright)" adjustment by the user is accomplished only by controlling the common inverted output amplitude, and the brightness of the double window IC is not used.

**Note 2...** The content of bright and of RGB simultaneous contrast are reference values (adjustable though) only when adjusting other items, and are not stored in the EEPROM.

**Note 3...** Be careful as the content of R(G/B) output DC offset, main Y contrast and sub Y contrast are different between the displayed values (EEPROM written values) and the register setting values in the double window IC.

(Because the relationship between the double window IC register value and the screen output value is not linear, there is a need for conversion by software.)

The cases where the displayed value (EEPROM written values) and the register setting values in the double window IC are different are summarized below.

## [R(G/B) output DC offset]

Displayed value (=adjusted value) (DEC)	EEPROM written value (DEC)	Double window IC register value (BIN)	
15	15	0111	(MAX)
14	14	0110	
:	:	:	
9	9	0001	
8	8	0000	(TYP)
7	7	1111	
:	:	:	
1	1	1001	
0	0	1000	(MIN)

## [Main Y contrast, sub Y contrast]

Displayed value (=adjusted value) (DEC)	EEPROM written value (DEC)	Double window IC register value (BIN)	
63	63	01111	(MAX)
62	62	01110	
:	:	:	
33	33	00001	
32	32	00000	(TYP)
31	31	11111	
:	:	:	
1	1	10001	
0	0	10000	(MIN)

## [Line adjustment 2 menu]

## [Setting content]

Setting item		Adjustment range	Initial value
Content	Displayed character string		
RGB & YS horizontal positioning(SA2B[D15-8])	DOT H POSIT	0-255	63
YS sampling phase 1(SA2D[D15-12])	YS SAMPL	0-15	12
AD sampling phase B(SA2D[D11-8])	B SAMPL	0-15	12
AD sampling phase G(SA2D[D7-4])	G SAMPL	0-15	12
AD sampling phase R(SA2D[D3-0])	R SAMPL	0-15	12
YS internal delay adjustment(SA2F[D3-0])	YS DELAY	0-15	12

Note 1... Be careful as the displayed value (EEPROM written value) and the register setting values in the double window IC are different for the following items.  
(Because the relationship between the double window IC register value and the screen output value is not linear, there is a need for conversion by software.)

- YS sampling phase 1
- AD sampling phase B
- AD sampling phase G
- AD sampling phase R
- YS internal delay adjustment

The cases where the displayed value (EEPROM written values) and the register setting values in the double window IC are different are summarized below.

## [YS sampling phase 1, AD sampling phase B/G/R, YS internal delay adjustment]

Displayed value (=adjusted value) (DEC)	E2PROM written value (DEC)	Double window IC register value (BIN)	
15	15	0111	(MAX)
14	14	0110	
:	:	:	
9	9	0001	
8	8	0000	(TYP)
7	7	1111	
:	:	:	
1	1	1001	
0	0	1000	(MIN)

## [Line adjustment 3 menu]

## [Setting content]

Setting item		Adjustment range	Initial value
Content	Displayed character string		
Dot search threshold	TH DOT	0-255	87
YS search threshold	TH YS	0-4	3
Phase search threshold	TH PHASE	0-255	112
X disp	X DISP	0-63	1
YS disp	YS DISP	0-4	2

## [Line adjustment 4 menu]

## [Setting content]

Setting item		Adjustment range	Initial value
Content	Displayed character string		
Main horizontal enhancer gain(SA10[D13-12])	M H GAIN	0-3	0
Main horizontal enhancer limiter(SA10[D11-10])	M H LIMIT	0-3	0
Main horizontal enhancer f0(SA10[D8])	M H F0	0-1	0
Main vertical enhancer gain(SA10[D7-6])	M V GAIN	0-3	0
Main vertical enhancer return(SA10[D5-4])	M V ORI	0-3	0
Main vertical enhancer corering(SA10[D3-2])	M V CORE	0-3	0

## [Line adjustment 5 menu]

## [Setting content]

Setting item		Adjustment range	Initial value
Content	Displayed character string		
Sub horizontal enhancer gain(SA10[D13-12])	S H GAIN	0-3	0
Sub horizontal enhancer limiter(SA10[D11-10])	S H LIMIT	0-3	1
Sub horizontal enhancer f0(SA10[D8])	S H F0	0-1	1
Sub vertical enhancer gain(SA10[D7-6])	S V GAIN	0-3	0
Sub vertical enhancer return(SA10[D5-4])	S V ORI	0-3	1
Sub vertical enhancer coring(SA10[D3-2])	S V CORE	0-3	2

## [Line adjustment 6 menu]

## [Setting content]

Setting item		Adjustment range	Initial value
Content	Displayed character string		
Brightness R(SA0C[D13-8])	BRIGHT R	0-63	16
Brightness G(SA0D[D13-8])	BRIGHT G	0-63	16
Brightness B(SA0E[D13-8])	BRIGHT B	0-63	16
$\gamma$ correction ON/OFF(SA1A[D15])	GAMMA		OFF
RGB simultaneous ? 1 inflection point(SA1A[D5-0])	GAMMA 1	0-63	0
RGB simultaneous ? 2 inflection point(SA1B[D12-8])	GAMMA 2	0-31	4
RGB simultaneous ? 3 inflection point(SA1B[D4-0])	GAMMA 3	0-31	1
RGB simultaneous ? inclination A(SA1A[D14-12])	GAMMASLP A	0-7	4
RGB simultaneous ? inclination B(SA1B[D15-13])	GAMMASLP B	0-7	1
RGB simultaneous ? inclination C(SA1B[D7-5])	GAMMASLP C	0-7	1

**Note 1...** Be careful as the displayed value (EEPROM written value) and the register setting values in the double window IC are different for the following items.  
(Because the relationship between the double window IC register value and the screen output value is not linear, there is a need for conversion by software.)

- Brightness R
- Brightness G
- Brightness B

The cases where the displayed value (EEPROM written values) and the register setting values in the double window IC are different are summarized below.

## [Brightness R/G/B]

Displayed value (=adjusted value) (DEC)	EEPROM written value (DEC)	Double window IC register value (BIN)	
63	63	011111	(MAX)
62	62	011110	
:	:	:	
33	33	000001	
32	32	000000	(TYP)
31	31	111111	
:	:	:	
1	1	100001	
0	0	100000	(MIN)

## [Line adjustment 7 menu]

## [Setting content]

Setting item		Adjustment range	Initial value
Content	Displayed character string		
Main PLL0(SA24[D15-8])	MAIN PLL0	0-255	158
Main PLL1(SA24[D7-0])	MAIN PLL1	0-255	13
Main PLL2(SA25[D15-8])	MAIN PLL2	0-255	204
Main PLL3(SA25[D7-0])	MAIN PLL3	0-255	4

## [Line adjustment 8 menu]

## [Setting content]

Content	Setting item		Adjustment range	Initial value
	Content	Displayed character string		
During TV, sub PLL0(SA26[D15-8])		SUB PLL0 TV	0-255	140
During TV, sub PLL1(SA26[D7-0])		SUB PLL1 TV	0-255	136
Other, sub PLL0(SA27[D15-8])		SUB PLL0	0-255	140
Other, sub PLL1(SA27[D7-0])		SUB PLL1	0-255	141
During TV, sub PLL2(SA28[D15-8])		SUB PLL2 TV	0-255	100
During TV, sub PLL3(SA28[D7-0])		SUB PLL3 TV	0-255	68
Other, sub PLL2(SA29[D15-8])		SUB PLL2	0-255	152
Other, sub PLL3(SA29[D7-0])		SUB PLL3	0-255	107

## [Line adjustment 9 menu]

## [Setting content]

Content	Setting item		Adjustment range	Initial value
	Content	Displayed character string		
SA46[D15-8]		SA46H UPPER	0-255	2
SA46[D7-0]		SA46H LOWER	0-255	0
SA47[D15-8]		SA47H UPPER	0-255	0
SA47[D7-0]		SA47H LOWER	0-255	0
SA48[D15-8]		SA48H UPPER	0-255	0
SA48[D7-0]		SA48H LOWER	0-255	0
SA49[D15-8]		SA49H UPPER	0-255	0
SA49[D7-0]		SA49H LOWER	0-255	0
SA4A[D15-8]		SA4AH UPPER	0-255	0
SA4A[D7-0]		SA4AH LOWER	0-255	0

## [Line adjustment 10 menu]

## [Setting content]

Content	Setting item		Adjustment range	Initial value
	Content	Displayed character string		
SA4B[D15-8]		SA4BH UPPER	0-255	0
SA4B[D7-0]		SA4BH LOWER	0-255	0
SA4C[D15-8]		SA4CH UPPER	0-255	0
SA4C[D7-0]		SA4CH LOWER	0-255	0
SA4D[D15-8]		SA4DH UPPER	0-255	0
SA4D[D7-0]		SA4DH LOWER	0-255	0
SA4E[D15-8]		SA4EH UPPER	0-255	0
SA4E[D7-0]		SA4EH LOWER	0-255	0
SA4F[D15-8]		SA4FH UPPER	0-255	0
SA4F[D7-0]		SA4FH LOWER	0-255	0

## [Dimmer parameter setting menu]

### [Setting content]

Setting item		Adjustment range	Initial value
Content	Displayed character string		
Backlight output max value	BL MAX	0x00-0xFF	C4
Backlight output min value	BL MIN	0x00-0xFE	59
Dimmer threshold value (high)	REF H	0x01-0xFE	C0
Dimmer threshold value (low)	REF L	0x00-0xFD	60
External light point (high)	LUM H	0x02-0xFF	E2
External light point (medium)	LUM M	0x01-0xFE	87
External light point (low)	LUM L	0x00-0xFD	52
Backlight point (high)	BL H	0x00-0xFF	C4
Backlight point (medium)	BL M	0x00-0xFF	C4
Backlight point (low)	BL L	0x00-0xFF	68

- The data of the points (coordinates) for the dimmer is stored in the EEPROM but not used for CS calculation as it is changed by the user operation.

**Note 1...** The adjustment range of each item listed above is the range applicable when the following relationships are satisfied.

The value which destroys the relationship below cannot be set even if it is within the adjustment range.

- Regarding the backlight output minimum value, there is a relationship where;  
"backlight output minimum value < backlight output maximum value"  
and "backlight output minimum value  $\leq$  backlight point (low)"
- "External light point (low)  $\leq$  dimmer threshold value (low) < external light point (medium)  $\leq$  dimmer threshold value (high) < external light point (high)"
- "Backlight point (low)  $\leq$  backlight point (medium)  $\leq$  backlight point (high)  $\leq$  backlight output maximum value"

### [Operational specifications]

Operational description	Main unit key	Remote controller key
Main page select -	PGM(TA)	BAND/ESC
Main page select +	DISP	BACK
Selection cursor upward movement	-	↑
Selection cursor downward movement	-	↓
Item content adjustment	-	←
Item content adjustment	-	→

# 8.7 CALIBRATION TEST

**[Mode IN method]**

After pressing [PGM+OPEN/CLOSE], press RESET and START. Then the screen will change to [touch panel adjustment mode].

**[Menu types for mode]**

Calibration test mode consists of the following menu.  
(By clicking each menu, you can read the explanation for each menu.)

TOP menu

- Outermost circumference Inspection
- 16 points adjustment
- Coordinate inspection
- Calibration verification
- Data initialization

**0. Explanation of the TOP menu**

**[Operational specifications]**

Operational description	Remote controller key
Menu determination	MENU_ENTER
Selection cursor up movement	↑
Selection cursor down movement	↓

Select the menu desired to be adjusted using the up/down key (↑ ↓), then press ENTER key to enter into the selected menu.

Note 1) Calibration menu can be selected only when adjustment of the outermost circumference has been completed normally.

**[Display specifications]**

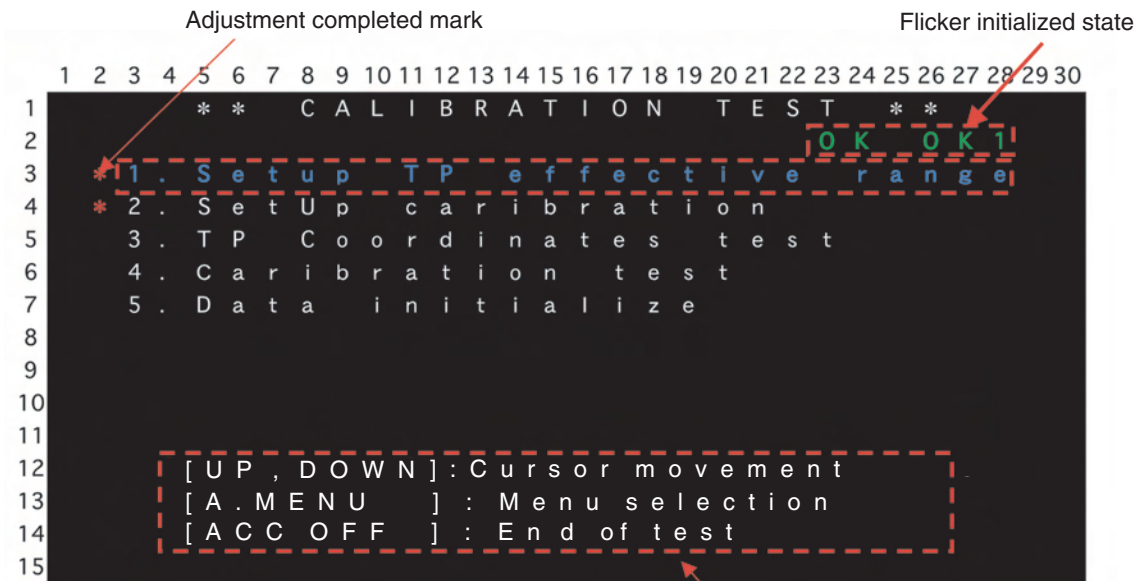

Operational specifications are displayed



Conditions for lighting of the adjustment complete mark “\* ”.

Outermost circumference inspection :

In case the outermost circumference inspection has been completed normally.

16 points adjustment :

In case the calibration has been completed normally.

Conditions for the adjustment complete mark “\* ” to go out

Outermost circumference inspection :

In case the outermost circumference inspection has never been performed.

In case the EEPROM initialization has been performed.

In case the adjustment value has been initialized.

16 points adjustment :

In case the 16 points adjustment has never been performed.

In case the EEPROM initialization has been performed.

In case the adjustment value has been initialized.

## 1. Set up TP effective range

### [Outline]

Outermost circumference value of X and Y is obtained by tracing the outermost circumference of the touch panel screen.

When exiting the menu screen by pressing ENTER key, the captured value is stored in the EEPROM.

Furthermore, when storing the value, checking is made as to whether the value is within the range or not.

If the value is within the range, OK is displayed, and X/Y upper and lower limit value and normal ending information, total of 5 byte data, are written in the EEPROM. (In or out of the range check is conducted according to the [Table of allowable range of setting value] shown below.)

In the following cases, however, NG will be displayed without storing the EEPROM captured value.

When the set value is outside of the range. (When the value exceeded the [Table of allowable range of setting value] below.)

However, "adjustment NG information" (1 byte) is written into the EEPROM.

When writing into the EEPROM failed.

The transition of the state for the above described outermost circumference inspection is outlined below.

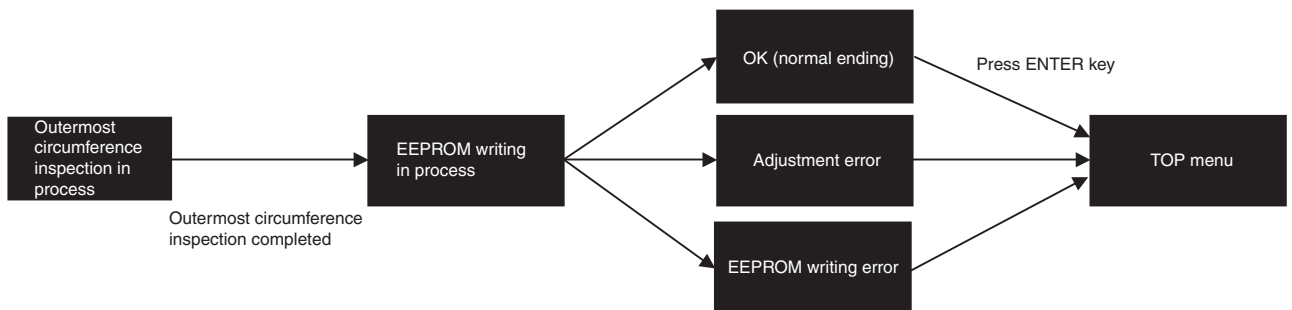

Refer to the "Memory item list and EEPROM" for the stored area of the setting value in the EEPROM. Initial value and setting value allowable range are as shown below.

A [Table of BEFORE initial value]

Coordinate	Minimum value	Maximum value
X	43	247
Y	50	238

[Table of AFTER initial value]

Coordinate	Minimum value	Maximum value
X	90	180
Y	90	180

[Table of setting value allowable range]

Coordinate	Minimum value	Maximum value
X	0~72	205~255
Y	0~80	205~255

B [Display specifications]

Outermost circumference inspection in process

```

1 2 3 4 5 6 7 8 9 10 11 12 13 14 15 16 17 18 19 20 21 22 23 24 25 26 27 28 29 30
1  * * S e t u p   T P   e f f e c t i v e   r a n g e * *
2
3
4           ( B E F O R E . A F T E R )
5           X m i n       : ( 9 9 9 .   9 9 9 )
6           Y m i n       : ( 9 9 9 .   9 9 9 )
7           X m a x       : ( 9 9 9 .   9 9 9 )
8           Y m a x       : ( 9 9 9 .   9 9 9 )
9           X c o r r e c t : ( 9 9 9 .   9 9 9 )
10          Y c o r r e c t : ( 9 9 9 .   9 9 9 )
11          < C a u t i o n >
12          P l e a s e   t o u c h   a r o u n d   p a n e l
13          [ A . M E N U ] : C h e c k   t h e   v a l u e
14
15

```

D X/Y information of [MIN] and [MAX] of the outermost circumference are displayed.  
 [BEFOR] indicates the value stored in the EEPROM.  
 [AFTER] indicates MIN/MAX of the A/D value currently captured.

When ended normally.

```

1 2 3 4 5 6 7 8 9 10 11 12 13 14 15 16 17 18 19 20 21 22 23 24 25 26 27 28 29 30
1
2
3
4
5
6
7           O . K
8
9
10
11
12
13          [ A . M E N U ] : R e t u r n   t o   M e n u
14
15

```

The data written are as follows.  
 Upper limit value and lower limit value of X.  
 Upper limit value and lower limit value of Y.  
 Adjustment OK information.

When the captured value is outside of the allowable range.

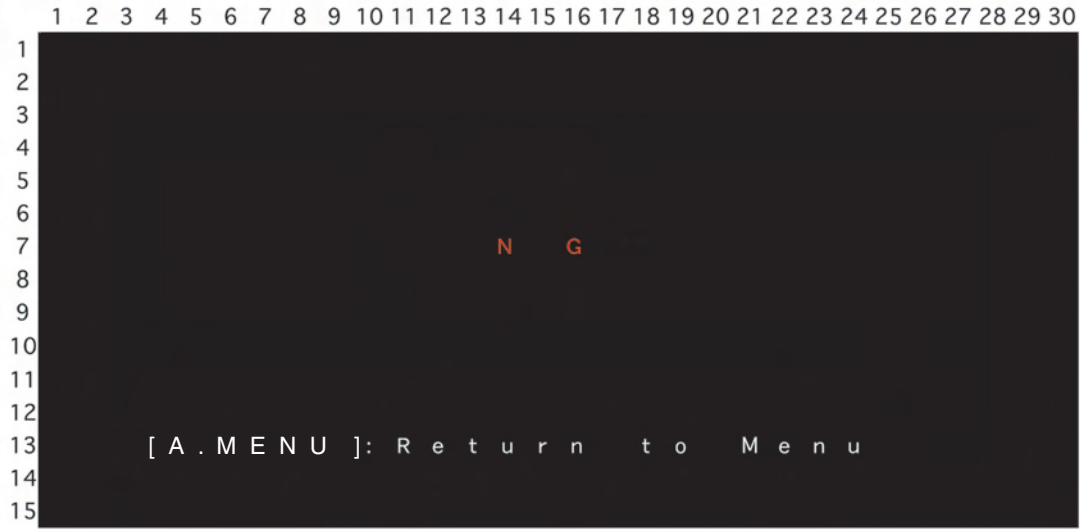

The data written is as follows.  
 Adjustment NG information.

**[Key operation specifications]**

Operational description	Remote controller key
To TOP menu	MENU_ENTER

**2. Set up calibration**

**[Outline]**

Touch the cursor [+] displayed on the screen. When correctly touched, the cursor will disappear, and the next cursor will appear. Calibration is conducted by repeating this process 16 times. When the 17th point has been finally touched, setting information for the 16 points and the normal ending information, total of 17 byte data, are written into the EEPROM, and the screen returns to the TOP menu.

In the following cases, however, NG will be displayed without storing the EEPROM captured value.

When the menu is exited before touching the 17th point.

However, 'adjustment NG information' (1 byte) is written into the EEPROM.  
 When writing into the EEPROM failed.

The transition of the state for the above described 16 points adjustment is outlined below.

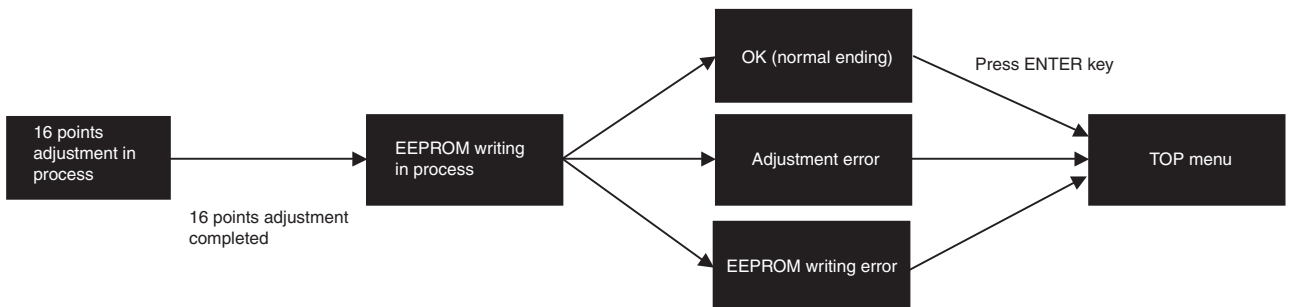

1

2

3

4

Refer to the material titled [Memory item list and EEPROM] for the stored area of the setting value in the EEPROM.

**[Display specifications]**

A

16 points adjustment in process

	1	2	3	4	5	6	7	8	9	10	11	12	13	14	15	16	17	18	19	20	21	22	23	24	25	26	27	28	29	30	
1																															
2																															
3																															
4																															
5																															
6																															
7																															
8																															
9																															
10																															
11																															
12																															+
13																															
14																															
15																															

B

C

When ended normally.

	1	2	3	4	5	6	7	8	9	10	11	12	13	14	15	16	17	18	19	20	21	22	23	24	25	26	27	28	29	30	
1																															
2																															
3																															
4																															
5																															
6																															
7																															F I N I S H E D
8																															
9																															
10																															
11																															
12																															
13																															[ A . M E N U ] : R e t u r n t o M e n u
14																															
15																															

D

The data written are as follows.

X coordinate (16 points)

Y coordinate (16 points)

E

**[Key operation specifications]**

Operational description	Remote controller key
To TOP menu	MENU_ENTER

F

AVH-P5950DVD/XN/RC

94

1

2

3

4

### 3. TP coordinates test

#### [Outline]

Coordinate before and after the correction when the touch panel is touched is displayed, and the operation is verified. Furthermore, the cursor can be moved by using the up/down/left/right keys, and the coordinate of the cursor center is displayed.

The cursor is displayed in red at the positions where the cursor was displayed during 16 points adjustment.

#### [Display specifications]

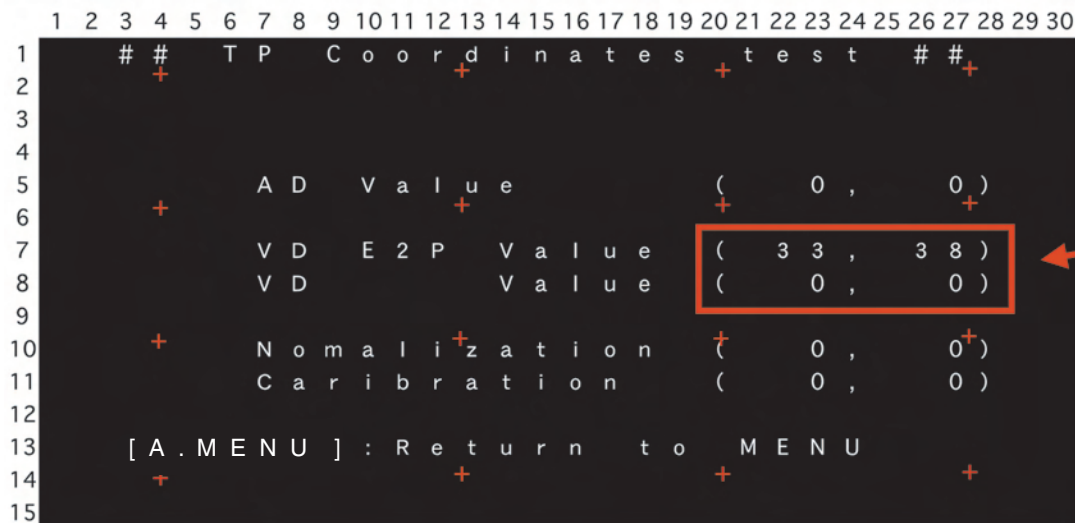

AD : AD data value (X direction, Y direction), representing the coordinate of the point pressed, is displayed.

VD E2P : VD value (the value registered at the time of circumference setting) preset in the EEPROM.

VD : VD value currently being pressed.

NORMAL : The coordinate (X direction, Y direction), which is the result of normalizing the AD data value currently being pressed within the effective range, is displayed.

CALIBRATION : The coordinate (X direction, Y direction), which is the result of applying the correction by calibration to the normalized coordinate, is displayed.

#### [Key operation specifications]

Operational description	Remote controller key
To TOP menu	MENU_ENTER
Cursor upward movement	↑
Cursor downward movement	↓
Cursor leftward movement	←
Cursor rightward movement	→

**[Calibration verification]**

**[Outline]**

- A ■ Touch the center of the "+" cursor displayed on the screen. When touched correctly, the cursor will disappear, and the next cursor will be displayed.  
By repeating this 16 times, corrected value for each "+" point is obtained.  
The information are written into the EEPROM as a data of 16 times. The screen will return to the top menu.

**[Display specifications]**



"+" changes into red when coordinates to touch are outside the range.

- When terminated normally. (After pressing the 16th point.)



**[Key operation specifications]**

Operational description	Remote controller key
To top menu	MENU_ENTER

## [Data initialization]

### [Outline]

- Result of outermost circumference inspection and of calibration inspection (corrected value) are returned to their initial values.  
As for the initialized items, the initial values are written into the EEPROM and the adjustment information is cleared.

### [Display specifications]

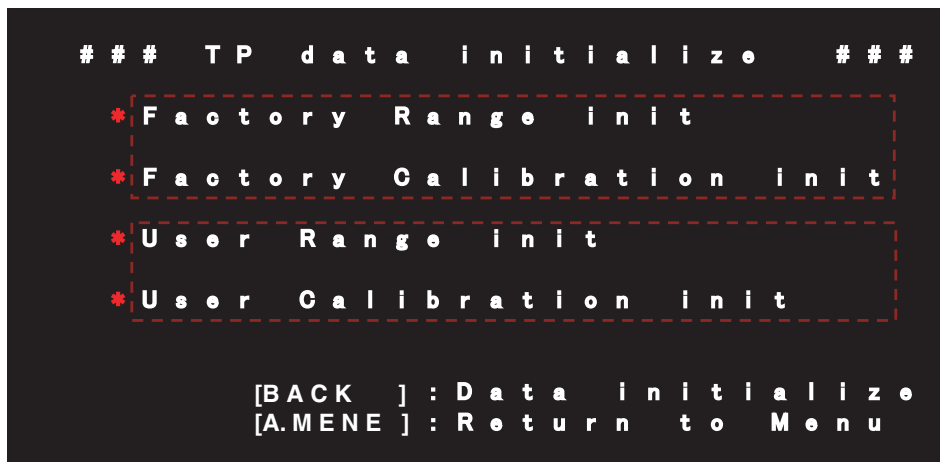

- Conditions for the adjustment completion mark (\*) to be lighted up.  
(The mark will be lighted up if one of the multiple conditions is met.)
  - Outermost circumference inspection  
When the outermost circumference inspection of the calibration for line has been completed normally.
  - 16 point adjustment  
When the calibration inspection for line has been completed normally.
  - User outermost circumference inspection  
When the outermost circumference inspection of calibration for line has been completed normally.  
(Because the writing is made to both the Factory region and the User region, **the user side will also be treated as adjusted.**)  
When the outermost circumference inspection of the user calibration has been completed normally.
  - User 16 point adjustment  
When the calibration inspection for line has been completed normally.  
(Because the writing is made to both the Factory region and the User region, **the user side will also be treated as adjusted.**)  
When the calibration inspection of the user calibration has been completed normally.
- Conditions for the adjustment completion mark (\*) to go out.  
(The mark will go out if one of the multiple conditions is met.)
  - Outermost circumference inspection  
When the above mentioned lighting conditions are not applicable.  
When the adjusted value has been initialized (Data initialize).  
When the EEPROM has been initialized.
  - 16 point adjustment  
When the above mentioned lighting conditions are not applicable.  
When the adjusted value has been initialized (Data initialize).  
When the EEPROM has been initialized.
  - User outermost circumference inspection  
When the above mentioned lighting conditions are not applicable.  
When the adjusted value has been initialized (Data initialize).  
When the EEPROM has been initialized.
  - User 16 point adjustment  
When the above mentioned lighting conditions are not applicable.  
When the adjusted value has been initialized (Data initialize).  
When the EEPROM has been initialized.

### [Key operation specifications]

Operational description	Remote controller key
Determination of initializing item	BACK
Selected cursor up movement	↑
Selected cursor down movement	↓
To top menu	MENU ENTER

# 9. EXPLODED VIEWS AND PARTS LIST

NOTES : • Parts marked by " \* " are generally unavailable because they are not in our Master Spare Parts List.  
• The ⚠ mark found on some component parts indicates the importance of the safety factor of the part. Therefore, when replacing, be sure to use parts of identical designation.  
• Screw adjacent to ▽ mark on the product are used for disassembly.  
• For the applying amount of lubricants or glue, follow the instructions in this manual.  
(In the case of no amount instructions, apply as you think it appropriate.)

## 9.1 PACKING

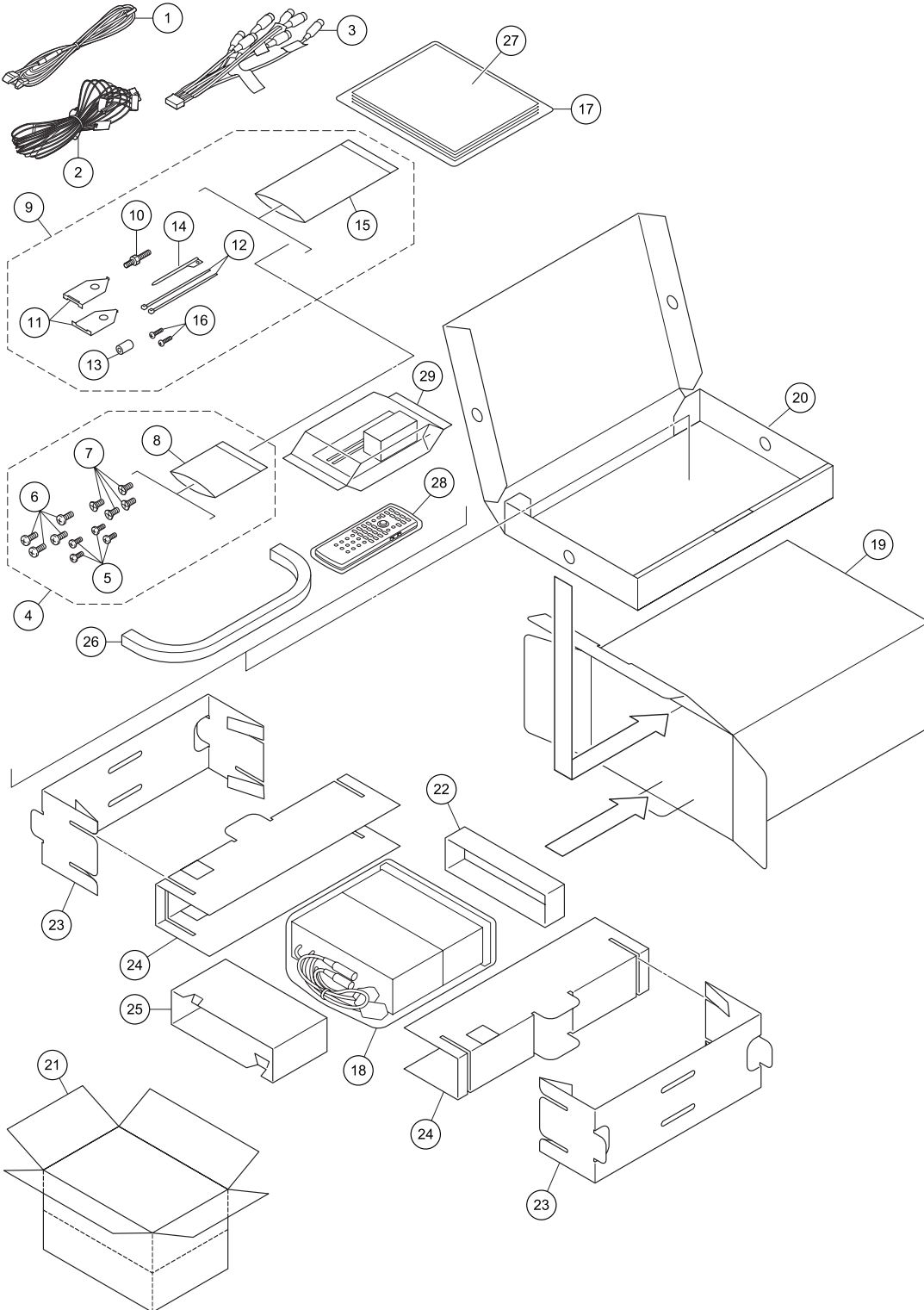



**(1)PACKING SECTION PARTS LIST**

<u>Mark No.</u>	<u>Description</u>	<u>Part No.</u>	<u>Mark No.</u>	<u>Description</u>	<u>Part No.</u>
1	Cord Assy	CDE7321	18	Polyethylene Bag	CEG1042
2	Cord Assy	CDP1013	19	Unit Box	See Contrast table(2)
3	Cord Assy	CDP1014	20	Sub Unit Box	CHG6195
4	Screw Assy	CEA5144			
5	Screw	BMZ50P060FTC	21	Contain Box	See Contrast table(2)
			22	Protector	CHP2540
6	Screw(M4 x 3)	CBA1870	23	Protector	CHP3351
7	Screw	CMZ50P060FTC	24	Protector	CHP3352
*	8 Polyethylene Sheet	CNM4338	25	Protector	CHP3353
*	9 Accessory Assy	CEA7477			
10	Screw	CBA1650	26	Sheet	CNN1741
			27-1	Owner's Manual	CRB2366
11	Bracket	CND4079	27-2	Owner's Manual	See Contrast table(2)
*	12 Lock Tie	CNV-754	27-3	Owner's Manual	See Contrast table(2)
13	Bush	CNV3930	27-4	Installation Manual	See Contrast table(2)
14	Pen	CNV8969			
*	15 Polyethylene Bag	E36-615	27-5	Caution Card	CRP1310
			28	Remote Control Unit	CXC6317
16	Screw	JGZ20P070FTC	29	Optical Terminal Conversion Assy	See Contrast table(2)
17	Polyethylene Bag	CEG1116			

**(2) CONTRAST TABLE**

AVH-P5950DVD/XN/RC, AVH-P5950DVD/XN/RD and AVH-P5950DVD/XN/RI are constructed the same except for the following:

Mark	No.	Description	AVH-P5950DVD/XN/RC	AVH-P5950DVD/XN/RD	AVH-P5950DVD/XN/RI
	19	Unit Box	CHG6191	CHG6192	CHG6194
	21	Contain Box	CHL6191	CHL6192	CHL6194
	27-2	Owner's Manual	CRB2367	CRB2369	CRB2371
	27-3	Owner's Manual	CRB2368	CRB2370	Not used
	27-4	Installation Manual	CRD4215	CRD4216	CRD4217
	29	Optical Terminal Conversion Assy	CXC3584	CXC3584	Not used

**Owner's Manual,Installation Manual**

Part No.	Language
CRB2366	English
CRB2367	Traditional Chinese
CRB2368	Korean
CRB2369	Spanish
CRB2370	Portuguese(B)
CRB2371	Arabic
CRD4215	English, Traditional Chinese, Korean
CRD4216	English, Spanish, Portuguese(B)
CRD4217	English, Arabic

# 9.2 EXTERIOR(1)

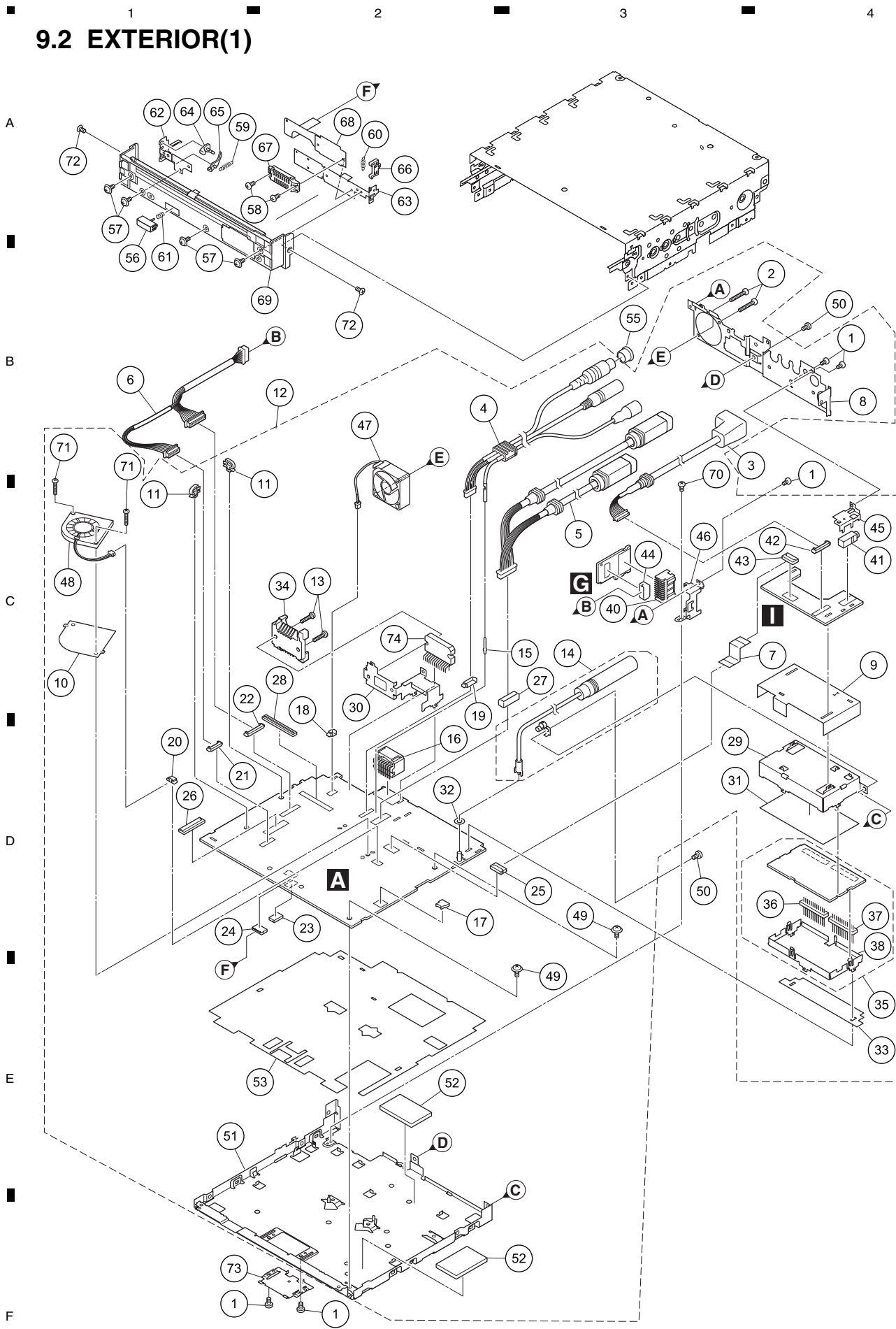

**(1) EXTERIOR(1) SECTION PARTS LIST**

<u>Mark No.</u>	<u>Description</u>	<u>Part No.</u>	<u>Mark No.</u>	<u>Description</u>	<u>Part No.</u>
1	Screw	BMZ20P030FTB	38	Holder	CND1432
2	Screw	BMZ20P160FTC	39	•••••	
3	Cord Assy	CDE8381	40	Connector(CN4301)	CKM1506
4	Cord Assy	CDE8382			
5	Cord Assy	CDE8383	41	Jack(CN4203)	CKN1022
			42	Connector(CN4202)	CKS4985
6	Cord Assy	CDE8385	43	Connector(CN4201)	CKS5041
7	Flat Cable	CDE8386	44	Connector(CN4302)	CKS5270
8	Panel	CNB3383	45	Holder	CND3849
9	Insulator	CNN1578			
10	Insulator	CNN1737	46	Holder	CND3996
			47	Fan Motor	CXM1262
11	Clamper	CNV9670	48	Fan Motor	CXM1276
12	DVD Amp Assy	See Contrast table(2)	49	Screw	AMZ26P040FTC
13	Screw	BMZ26P120FTC	50	Screw	BMZ26P030FTC
14	Antenna Cable	CDH1362			
15	Terminal(CN762)	CKF-047	51	Case	CNB3384
			52	Sheet	CNM8228
16	Plug(CN761)	CKM1516	53	Insulator	CNN1575
17	Connector(CN462)	CKS4817	54	•••••	
18	Connector(CN951)	CKS4822	55	Cap	CNV6727
19	Connector(CN381)	CKS4827			
20	Connector(CN961)	CKS4977	56	Button	CAI1460
			57	Screw(M2 x 3)	CBA2078
21	Connector(CN391)	CKS4983	58	Screw(M2 x 3)	CBA2079
22	Connector(CN311)	CKS4987	59	Spring	CBH2681
23	Connector(CN531)	CKS5036	60	Spring	CBH2682
24	Connector(CN481)	CKS5038			
25	Connector(CN461)	CKS5041	61	Spring	CBH2683
			62	Holder	CND3852
26	Connector(CN541)	CKS5100	63	Holder	CND3853
27	Connector(CN351)	CKS5529	64	Arm	CNV8571
28	Connector(CN512)	CKS5722	65	Arm	CNV8572
29	Holder	CND3847			
30	Holder	CND3848	66	Arm	CNV8573
			67	Connector	CKS4658
31	Insulator	CNM9521	68	Flexible PCB	CNP9973
32	Spacer	CNN1909	69	Panel Unit	CXC7633
33	Spacer	CNM9523	70	Screw	JGZ20P020FTB
34	Heat Sink	CNR1906			
35	FM/AM Tuner Unit	CWE2046	71	Screw(M2 x 8)	CBA1752
			72	Screw(M2 x 3)	CBA1877
36	Connector(CN101)	CKS4653	73	Holder	CND4167
37	Connector(CN102)	CKS4653	74	IC(IC331)	PAL007C

**(2) CONTRAST TABLE**

AVH-P5950DVD/XN/RC, AVH-P5950DVD/XN/RD and AVH-P5950DVD/XN/RI are constructed the same except for the following:

Mark	No.	Description	AVH-P5950DVD/XN/RC	AVH-P5950DVD/XN/RD	AVH-P5950DVD/XN/RI
	12	DVD Amp Assy	CXC7509	CXC7510	CXC7511

# 9.3 EXTERIOR(2)

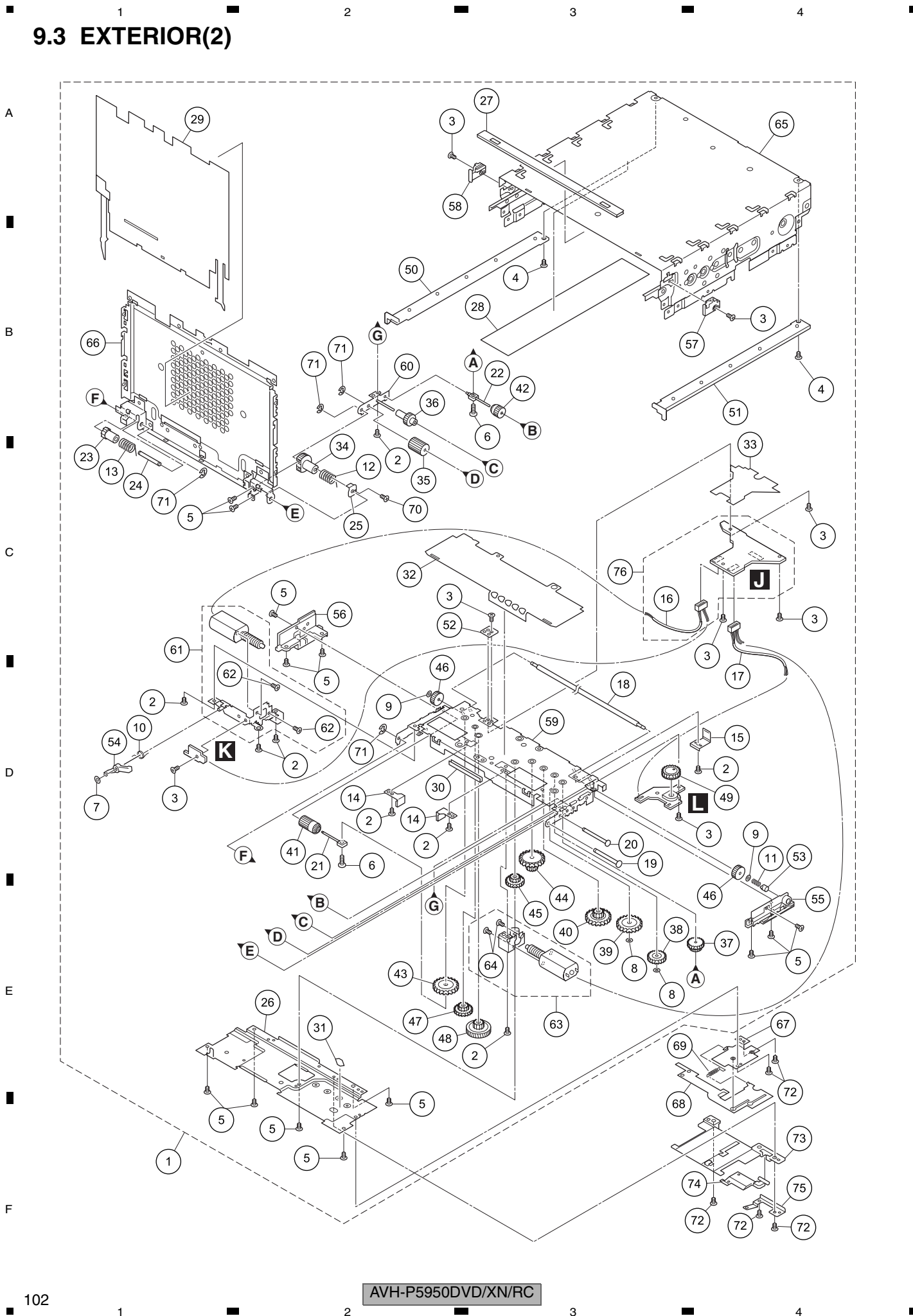

AVH-P5950DVD/XN/RC

## EXTERIOR(2) SECTION PARTS LIST

<u>Mark No.</u>	<u>Description</u>	<u>Part No.</u>	<u>Mark No.</u>	<u>Description</u>	<u>Part No.</u>	
1	Drive Unit	CXC7637	50	Rack	CNV8995	
2	Screw(M2 x 2)	CBA1608				
3	Screw(M2 x 1.5)	CBA1615	51	Rack	CNV8996	
4	Screw(M2 x 2)	CBA1872	52	Guide	CNV8999	
5	Screw(M2 x 3)	CBA1877	53	Lever	CNV9000	
			54	Arm	CNV9001	
6	Screw(M2.3 x 6)	CBA2027	*	55	Guide	CNV9534
7	Washer	CBF1037				
8	Washer	CBF1039	*	56	Guide	CNV9535
9	Washer	CBF1064	57	Guide	CNV9003	
10	Spring	CBH2906	58	Guide	CNV9004	
			59	Frame Unit	CXC6143	
11	Spring	CBH2907	60	Holder Unit	CXC6145	
12	Spring	CBH2908				
13	Spring	CBH2909	61	Motor Unit	CXC6638	
14	Spring	CBL1723	62	Screw	JGZ20P025FTC	
15	Spring	CBL1734	63	Motor Unit	CXC6639	
			64	Screw	JGZ20P025FTC	
16	Cord	CDE8127	*	65	Chassis Unit	CXC7638
17	Cord	CDE8128				
18	Shaft	CLA4651	*	66	Case Unit	CXC7640
19	Shaft	CLA4661	67	Bracket Unit	CXC7978	
20	Shaft	CLA4662	68	Lever	CND4077	
			69	Spring	CBH2750	
21	Shaft	CLA4663	70	Screw	JFZ17P025FTC	
22	Shaft	CLA4664				
23	Shaft	CLA4665	71	Washer	YE15FTC	
24	Shaft	CLA4666	72	Screw(M2 x 3)	CBA1877	
25	Holder	CND3245	73	Cover	CNV9643	
			74	Arm	CNV9644	
26	Cover	CND3252	75	Spring	CBL1766	
27	Sheet	CNN1055	76	Main PCB Unit(SERVICE)	CXX2316	
28	Sheet	CNN1056				
*	29 Insulator	CNN1583				
	30 Sheet	CNN1065				
31	Insulator	CNN1068				
*	32 Sheet	CNN1349				
	33 Insulator	CNN1058				
	34 Gear	CNR1855				
	35 Gear	CNR1856				
36	Gear	CNR1857				
37	Gear	CNR1859				
38	Gear	CNR1860				
39	Gear	CNR1861				
40	Gear	CNR1862				
41	Gear	CNR1864				
42	Gear	CNR1925				
43	Gear	CNR1926				
44	Gear	CNV8980				
45	Gear	CNV8981				
46	Gear	CNV8983				
47	Gear	CNV8984				
48	Gear	CNV8985				
49	Gear	CNV8987				

### The gear assembly figure of the Drive Unit

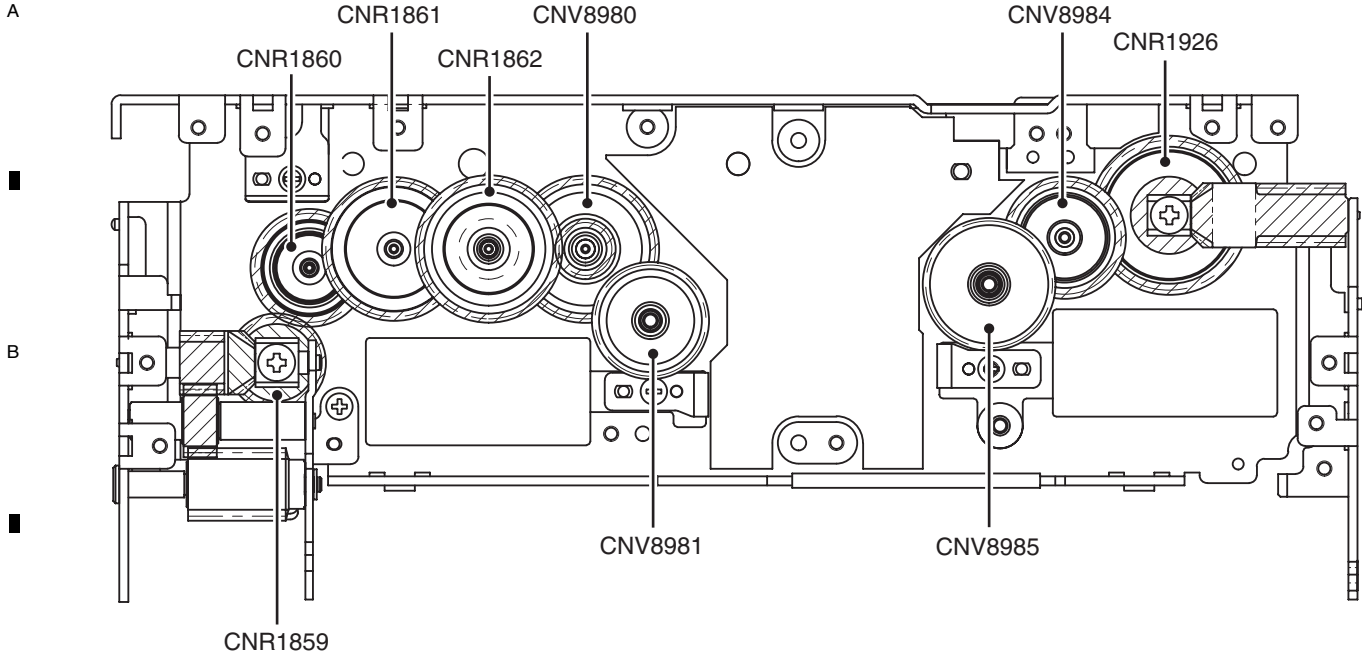

### Grease

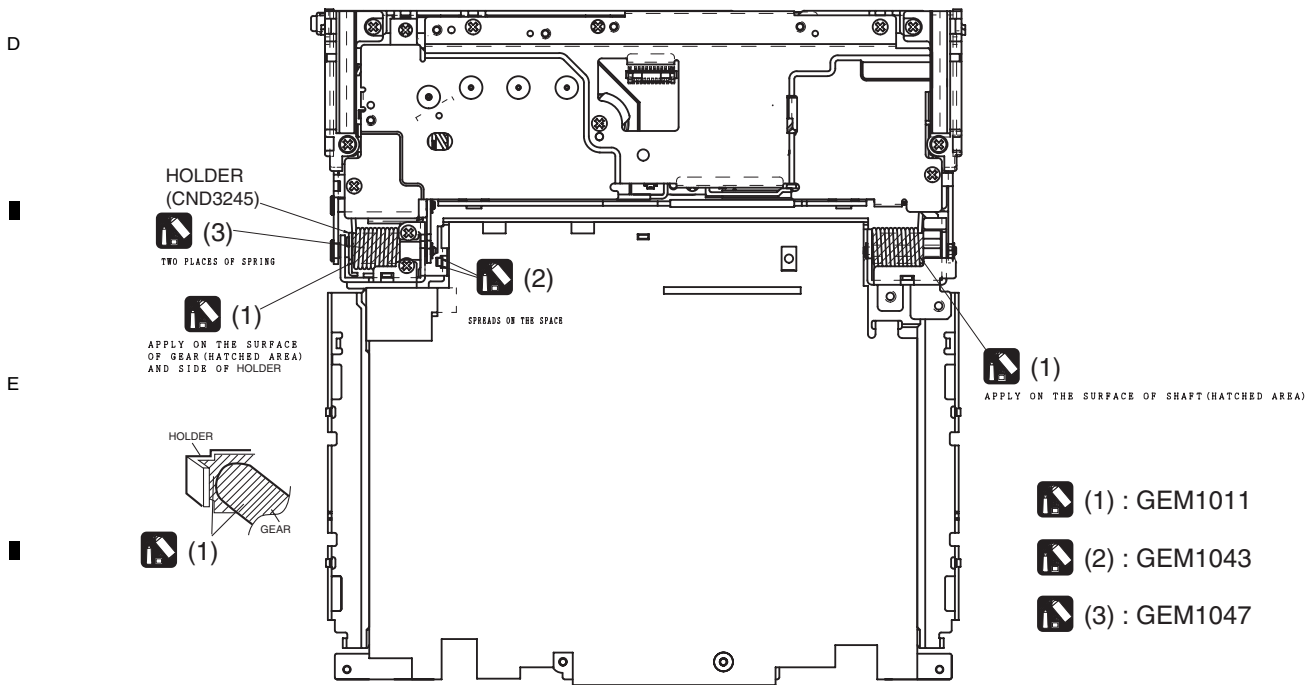

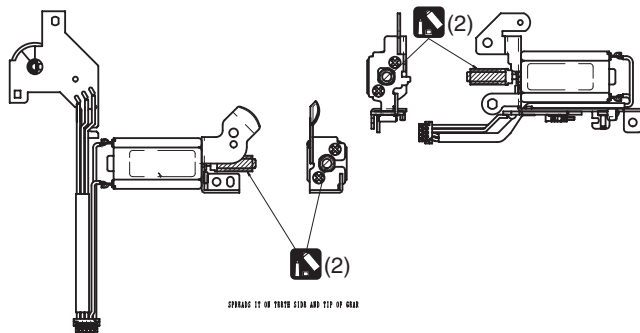
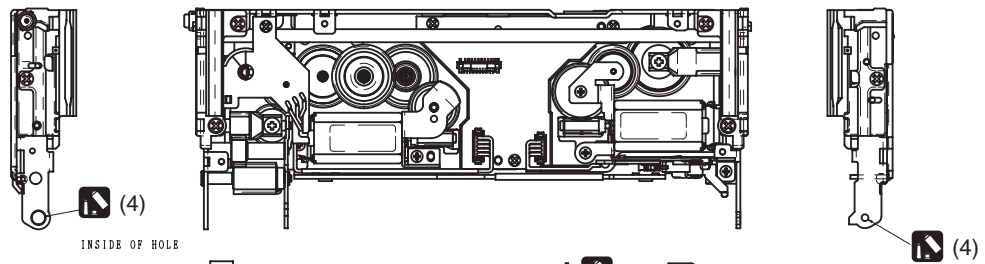
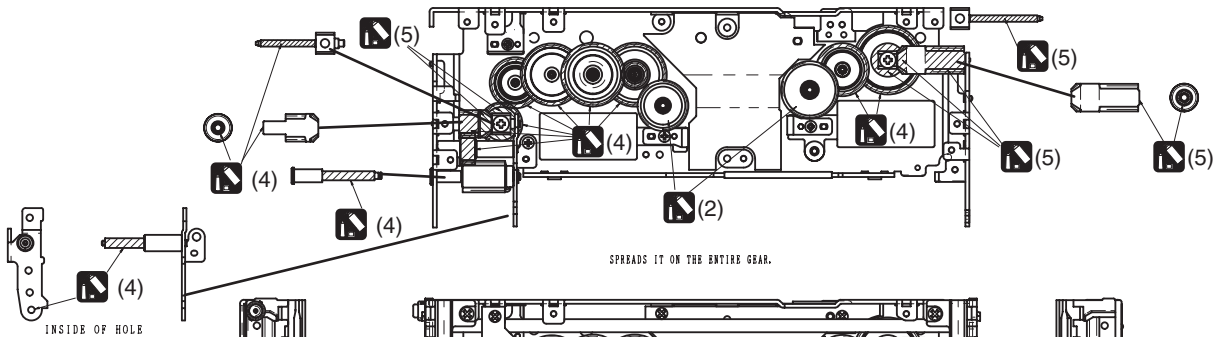
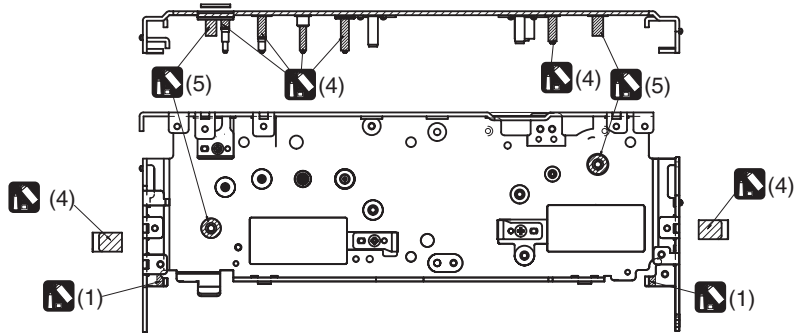
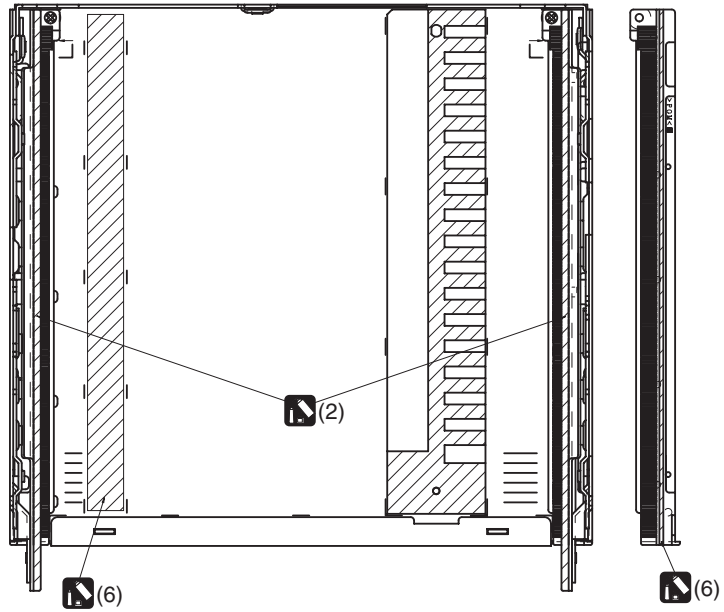

- (1) : GEM1011
- (2) : GEM1043
- (3) : GEM1047
- (4) : GEM1024
- (5) : GEM1072
- (6) : GEM1071



# 9.4 EXTERIOR(3)

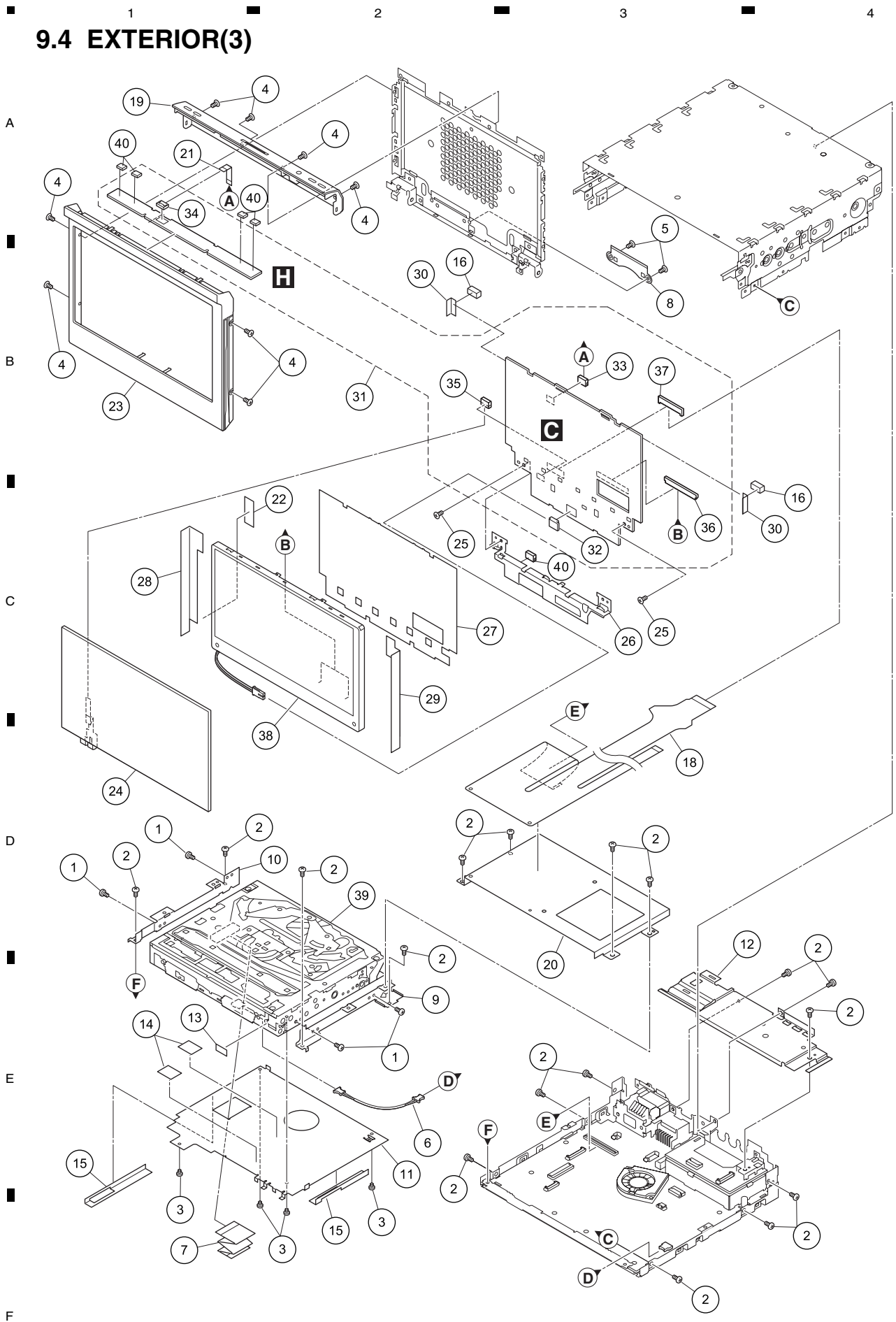

### EXTERIOR(3) SECTION PARTS LIST

<u>Mark No.</u>	<u>Description</u>	<u>Part No.</u>	
1	Screw	BMZ20P025FTC	
2	Screw	BMZ26P030FTC	
3	Screw(M2 x 1.4)	CBA1593	A
4	Screw(M2 x 2)	CBA1872	
5	Screw(M2 x 1.4)	CBA2042	
6	Cord	CDE8384	
7	Flat Cable	CDE8469	
8	Holder	CND3271	
9	Bracket	CND3842	
10	Bracket	CND3843	
11	Bracket	CND3844	B
12	Holder	CND3846	
13	Spacer	CNN1582	
14	Sheet	CNN1698	
15	Insulator	CNN1739	
16	Cushion	CNN1753	
17	.....		
18	Flexible PCB	CNQ1085	
19	Cover Unit	CXC7711	
20	Bracket	CND3845	C
21	FFC	CDE8387	
22	Sheet	CNN1694	
23	Grille	CNS8975	
24	Touch Panel	CSX1115	
25	Screw(M2 x 2)	CBA1872	
26	Holder	CND3850	
27	Insulator	CNN1584	
28	Sheet	CNN1748	
29	Sheet	CNN1749	
30	Sheet	CNN1750	D
31	Monitor Unit	CWN2330	
32	Connector(CN5201)	CKS4428	
33	Connector(CN5002)	CKS5035	
34	Connector(CN5901)	CKS5035	
35	Connector(CN5001)	CKS5105	
36	Connector(CN5501)	CKS5111	
37	Connector(CN5003)	CKS5637	
38	LCD Module	CWX3264	E
39	DVD Mechanism Module(MS5AVCODE2)	CXK6631	
40	Sheet	CNN2026	

# 9.5 EXTERIOR(4)

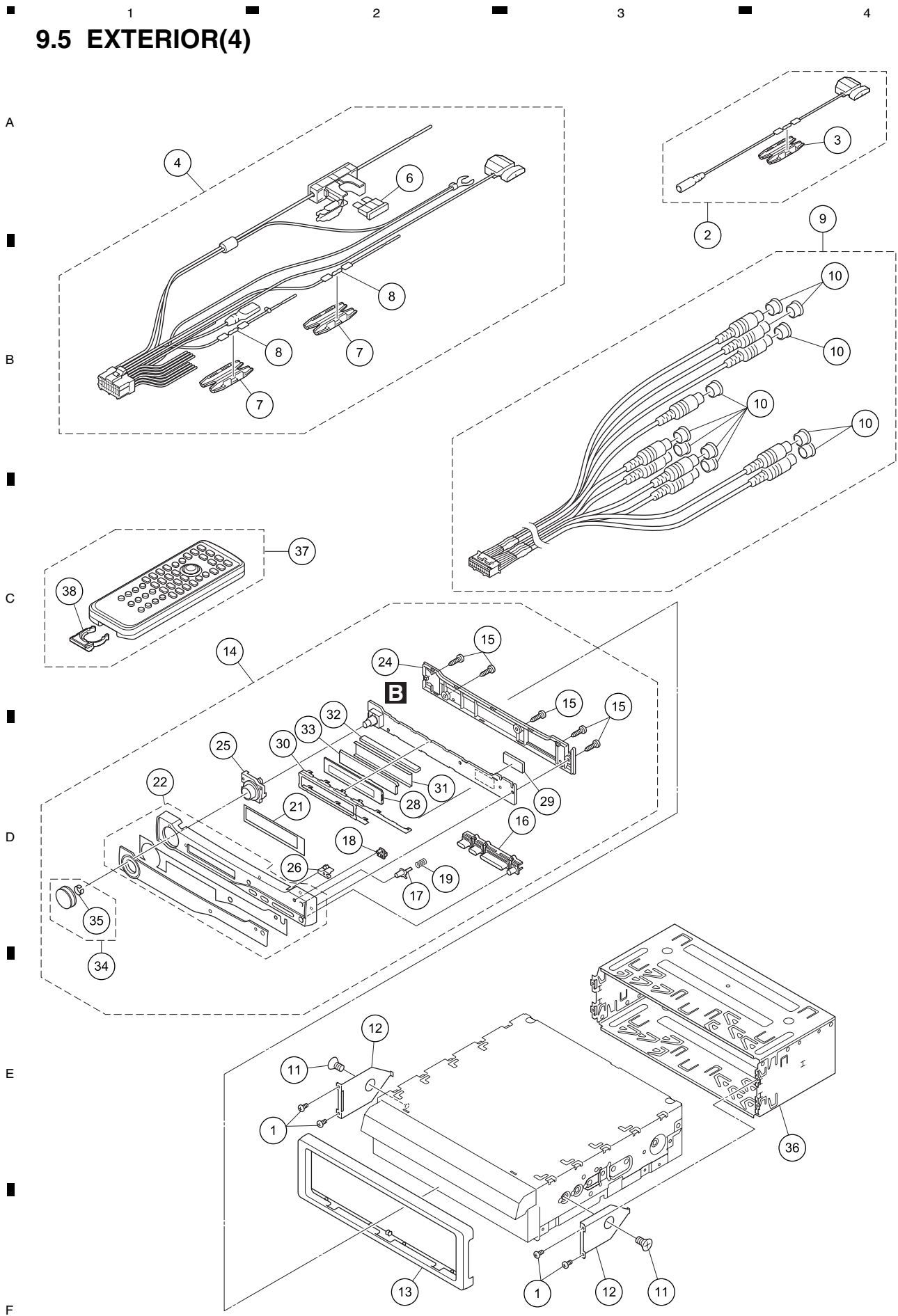

## EXTERIOR(4) SECTION PARTS LIST

<u>Mark No.</u>	<u>Description</u>	<u>Part No.</u>	
1	Screw	BMZ20P030FTB	
2	Cord Assy	CDE7321	A
3	Cap	CNS1472	
4	Cord Assy	CDP1013	
5	.....		
 6	Fuse(10 A)	CEK1136	
7	Cap	CNS1472	
8	Resistor	RS1/2PMF102J	
9	Cord Assy	CDP1014	
10	Cap	CNV6727	
11	Screw	CMZ50P060FTC	B
12	Bracket	CND3855	
13	Panel	CNS8978	
14	Grille Assy	CXC7521	
15	Screw	BPZ20P080FTB	
16	Button(BAND, SEEK)	CAI1175	
17	Button(DETACH)	CAI1176	
18	Button(RESET)	CAI1177	
19	Spring	CBH2680	
20	.....		C
21	Sheet	CNN1587	
22	Grille Assy	CXC8814	
23	.....		
24	Cover	CNS8964	
25	Lighting Conductor	CNV9504	
26	Lighting Conductor	CNV9506	
27	.....		
28	LCD	CAW1946	
29	Connector(CN4001)	CKS4657	D
30	Holder	CND3851	
31	Sheet	CNN1580	
32	Connector	CNV9502	
33	Lighting Conductor	CNV9503	
34	Knob Unit	CXC7631	
35	Spring	CBL1761	
36	Holder	CND3854	
37	Remote Control Unit	CXC6317	
38	Cover	CZN7062	E
40	Cushion	CNN1887	

# 9.6 DVD MECHANISM MODULE

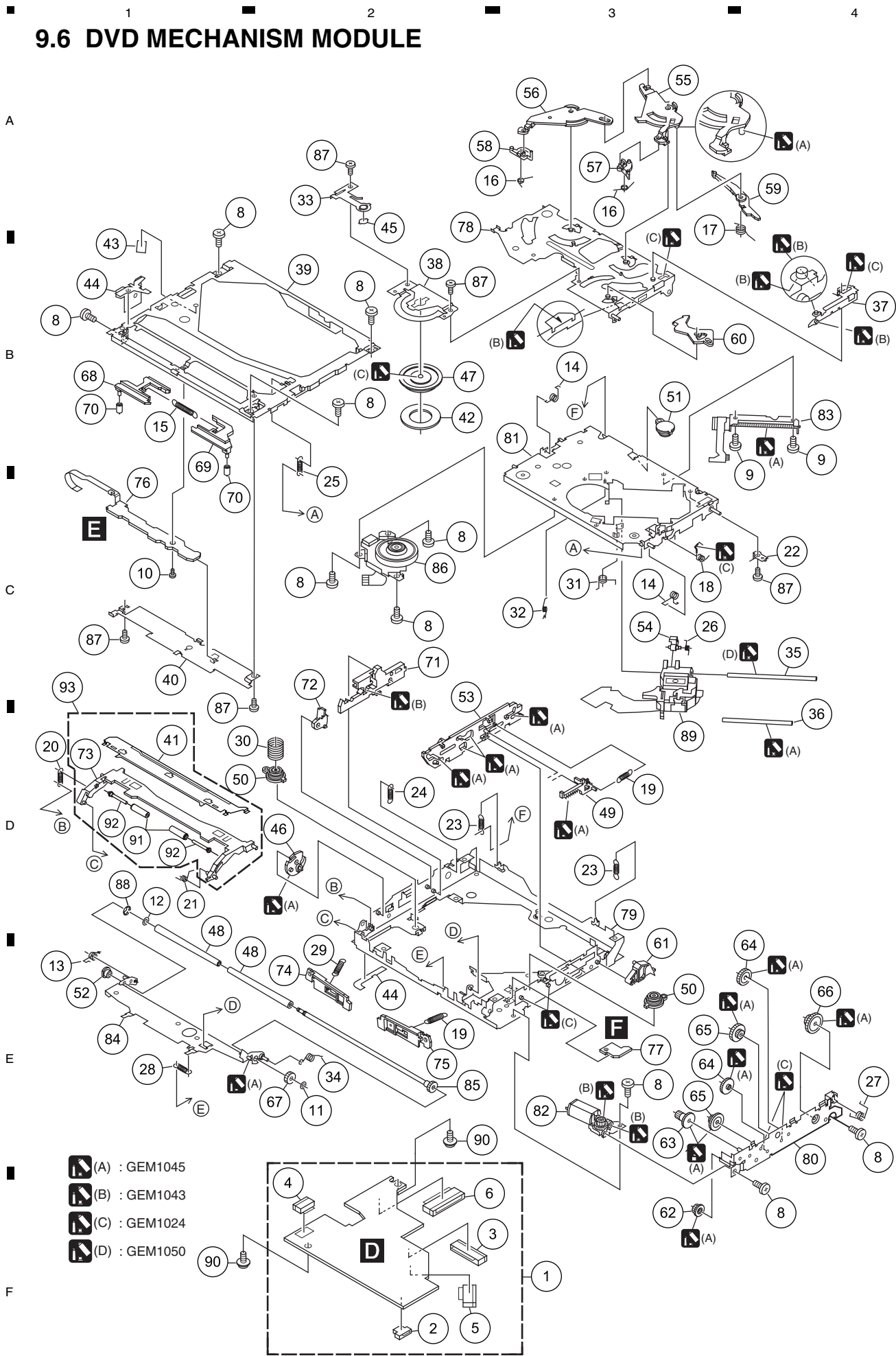

- (A) : GEM1045
- (B) : GEM1043
- (C) : GEM1024
- (D) : GEM1050

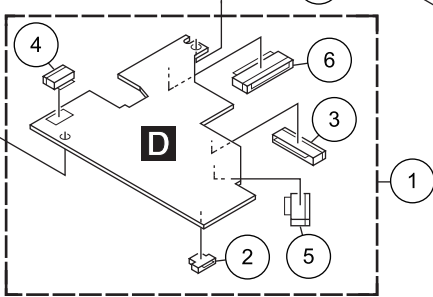

AVH-P5950DVD/XN/RC

## DVD MECHANISM MODULE SECTION PARTS LIST

<u>Mark No.</u>	<u>Description</u>	<u>Part No.</u>	<u>Mark No.</u>	<u>Description</u>	<u>Part No.</u>
1	DVD Core Unit	YWX5005	50	Damper	CNV9061
2	Connector(CN1852)	CKS4817			
3	Connector(CN1101)	CKS4841	51	Damper	CNV9062
4	Connector(CN1301)	CKS5017	52	Collar	CNV8845
5	Connector(CN1201)	CKS5043	53	Lever	CNV8865
			54	Rack	CNV9063
6	Connector(CN1901)	CKS5054	55	Arm	CNV8867
7	.....				
8	Screw	BMZ20P020FTC	56	Arm	CNV8868
9	Screw	BMZ20P025FNI	57	Arm	CNV9577
10	Screw	CBA1787	58	Arm	CNV8870
			59	Arm	CNV8871
11	Washer	CBF1038	60	Arm	CNV8872
12	Washer	CBF1064			
13	Spring	CBH2586	61	Arm	CNV8873
14	Spring	CBH2588	62	Gear	CNV8874
15	Spring	CBH2589	63	Gear	CNV8875
			64	Gear	CNV8876
16	Spring	CBH2590	65	Gear	CNV8877
17	Spring	CBH2591			
18	Spring	CBH2592	66	Gear	CNV8878
19	Spring	CBH2593	67	Gear	CNV8879
20	Spring	CBH2596	68	Lever	CNV8903
			69	Lever	CNV8904
21	Spring	CBH2597	70	Roller	CNV8905
22	Spring	CBL1726			
23	Spring	CBH2599	71	Lever	CNV8908
24	Spring	CBH2600	72	Arm	CNV8909
25	Spring	CBH2601	73	Guide	CNV9569
			74	Arm	CNV9116
26	Spring	CBH2926	75	Arm	CNV9117
27	Spring	CBH2604			
28	Spring	CBH2605	76	Compound Unit(A)	CWX3154
29	Spring	CBH2710	77	Compound Unit(B)	CWX3394
30	Spring	CBH2711	78	Arm Unit	CXC7872
			79	Frame Unit	CXC6442
31	Spring	CBH2935	80	Bracket Unit	CXB8685
32	Spring	CBH2890			
33	Spring	CBL1689	81	Chassis Unit	CXC6443
34	Spring	CBH2898	82	Motor Unit(LOAD)(M1)	CXC4912
35	Shaft	CLA4206	83	Motor(STEPPING)(M2)	CXM1364
			84	Arm Unit	CXC5486
36	Shaft	CLA4701	85	Roller Unit	CXC5708
37	Lever	CNC9933			
38	Holder	CND2643	86	Motor(SPDL)(M3)	CXM1362
39	Frame	CND2250	87	Screw	JFZ20P018FTC
40	Holder	CND2251	88	Washer	YE20FTC
			89	Pickup Unit(Service)	CXX2118
41	Holder	CND3936	90	Screw	IMS20P030FTC
42	Sheet	CNM6883			
43	Sheet	CNM8697	91	Collar	CNV9570
44	Sheet	CNM9658	92	Shaft	CLA4771
45	Sheet	CNM9407	93	Guide Unit	CXC8572
46	Cam	CNV7156			
47	Clamper	CNV7158			
48	Roller	CNV7165			
49	Rack	CNV7175			

# 10. SCHEMATIC DIAGRAM

## 10.1 MOTHER UNIT(SYSTEM PART)(GUIDE PAGE)

Note: When ordering service parts, be sure to refer to "EXPLODED VIEWS AND PARTS LIST" or "ELECTRICAL PARTS LIST".

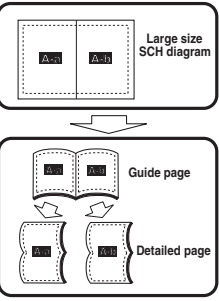

A-a 1/2

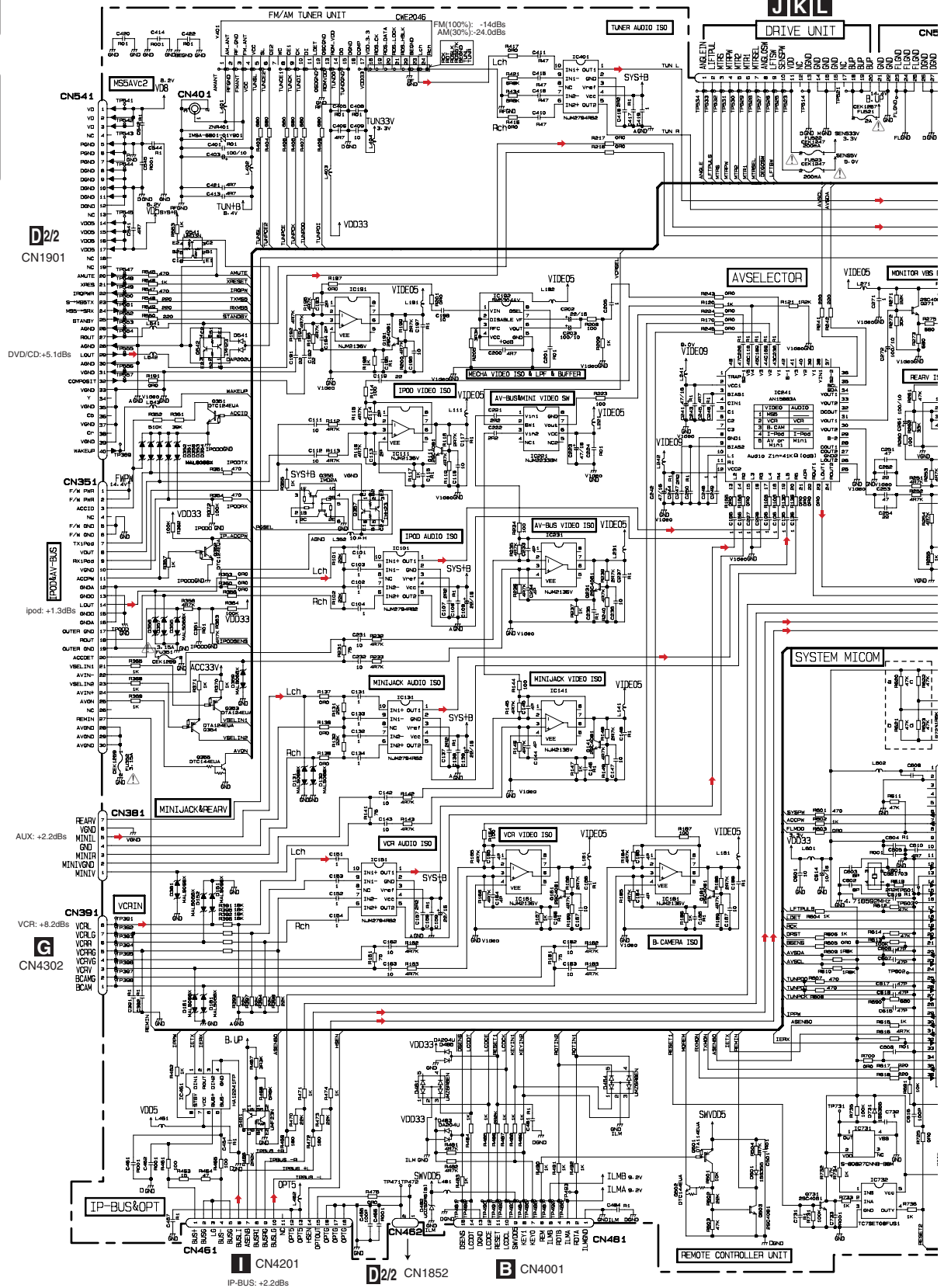

A 1/2

AVH-P5950DVD/XN/RC



# A-b 1/2

A

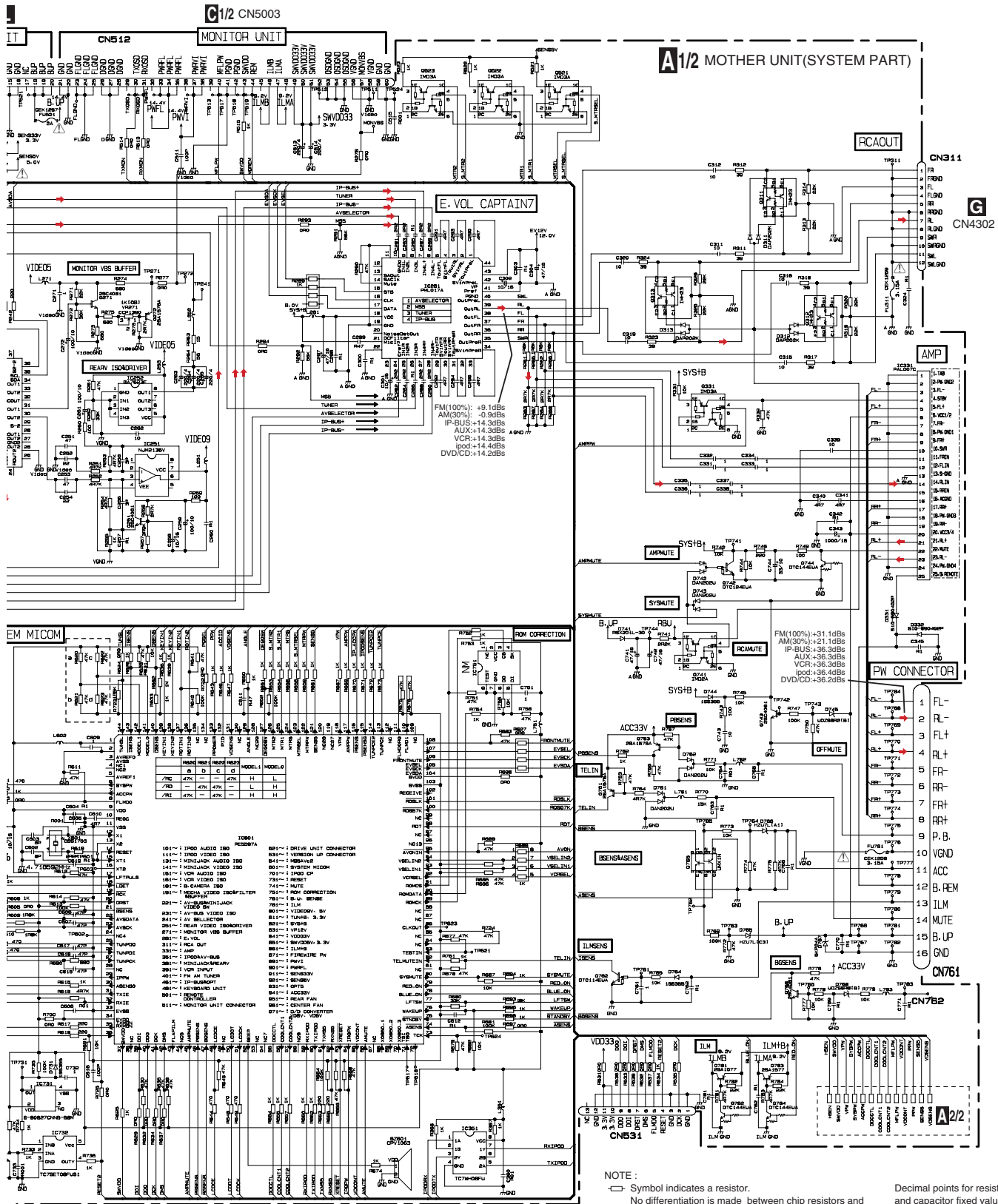

B

C

D

E

F

The  $\Delta$  mark found on some component parts indicates the importance of the safety factor of the part. Therefore, when replacing, be sure to use parts of identical designation.



A-b 1/2

CH/2 CN5003

MONITOR UNIT

Circuit diagram for the Monitor Unit section, showing connections for CN512 and various signal lines like IP-BUS+, AVSEL, and MONVBS.

A1/2 MOTHER UNIT(SYSTEM PART)

Main circuit diagram for the AVH-P5950DVD/XN/RC, featuring sections for E. VOL CAPTAINZ, RCAOUT, AMP, SYSB, AMPMUTE, and SYSMUTE. It includes detailed component values and connection points.

AVH-P5950DVD/XN/RC

CONNECTION POINTS: A list of pins and their corresponding signal names, including AVSEL, VBI, Y, and FM CORRECTION.

Vertical labels: A, B, C, D, E, F

Horizontal labels: 1, 2, 3, 4

A-a A-b

114

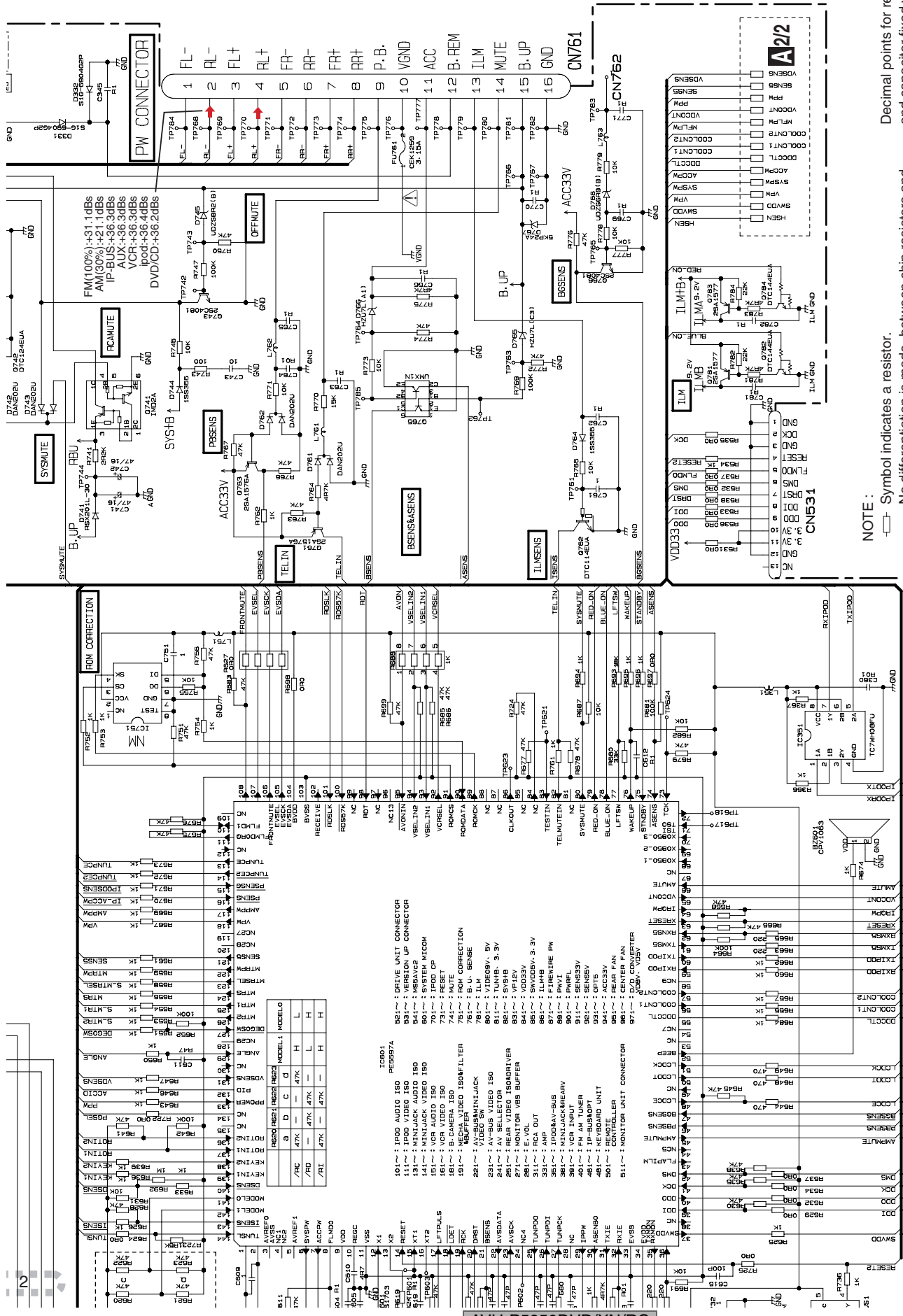

Decimal points for resistor and capacitor fixed values are expressed as :  
 2.2 — 2R2  
 0.022 — R022

NOTE :  
 - Symbol indicates a resistor.  
 - No differentiation is made between chip resistors and discrete resistors.  
 - Symbol indicates a capacitor.  
 - No differentiation is made between chip capacitors and discrete capacitors.

The  $\Delta$  mark found on some component parts indicates the importance of the safety factor of the part. Therefore, when replacing, be sure to use parts of identical designation.

A-b 1/2

A-b 1/2

J K L

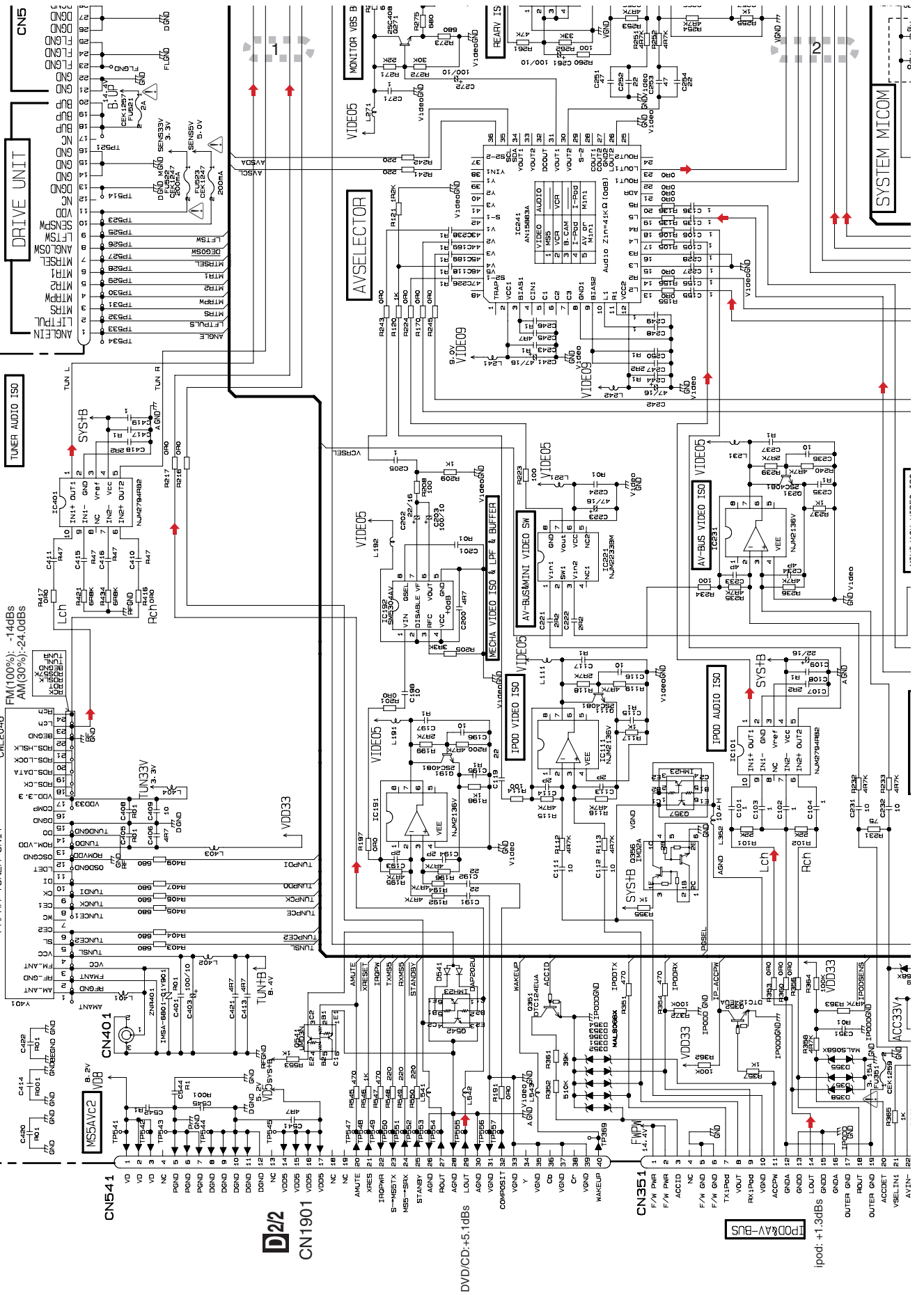

A-a A-b

A-a 1/2

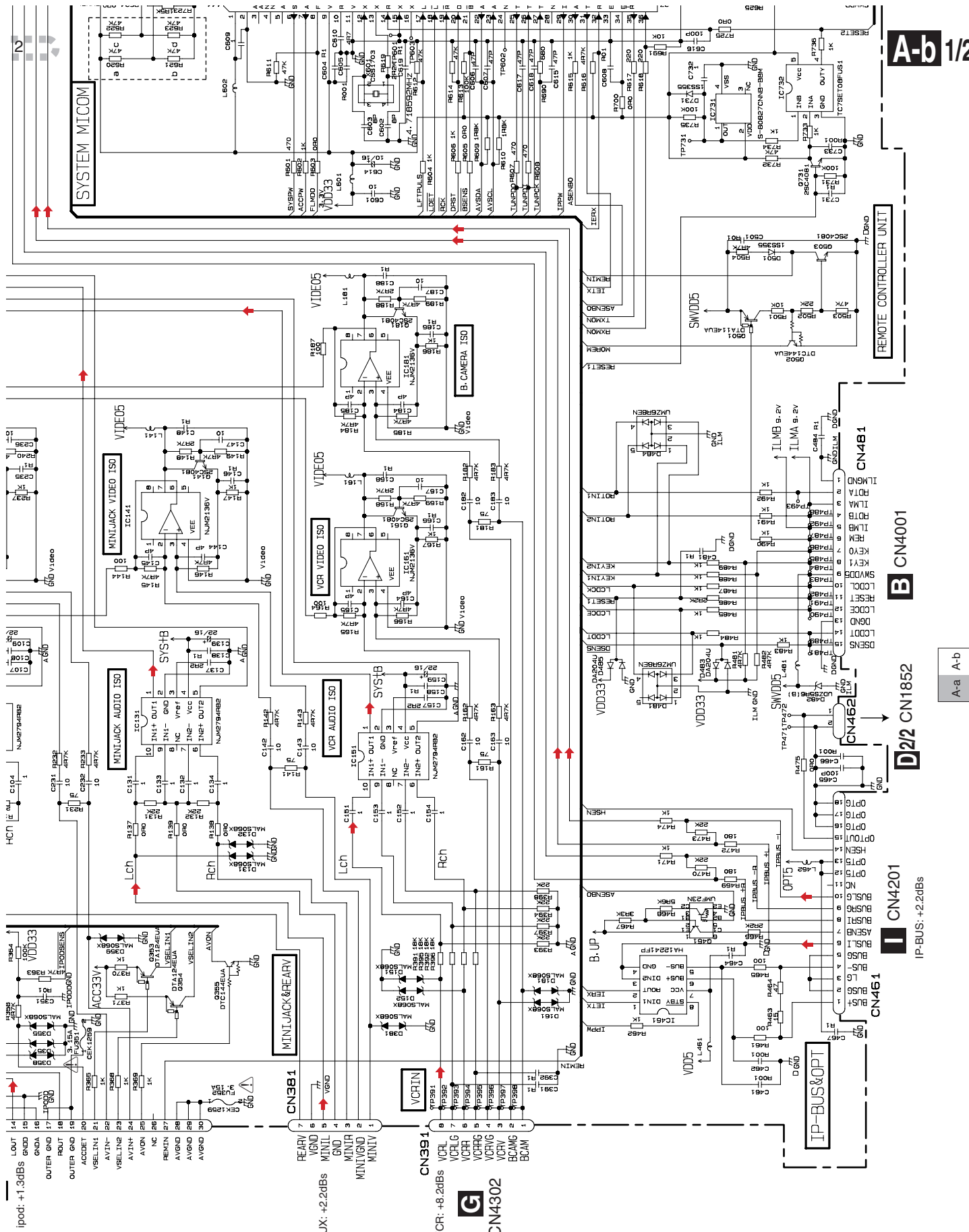

A-b 1/2

B CN4001

D/2/2 CN1852

I CN4201

CN451

CN462

CN461

A-a 1/2

# 10.2 MOTHER UNIT(POWER SUPPLY PART)(GUIDE PAGE)

A-a 2/2

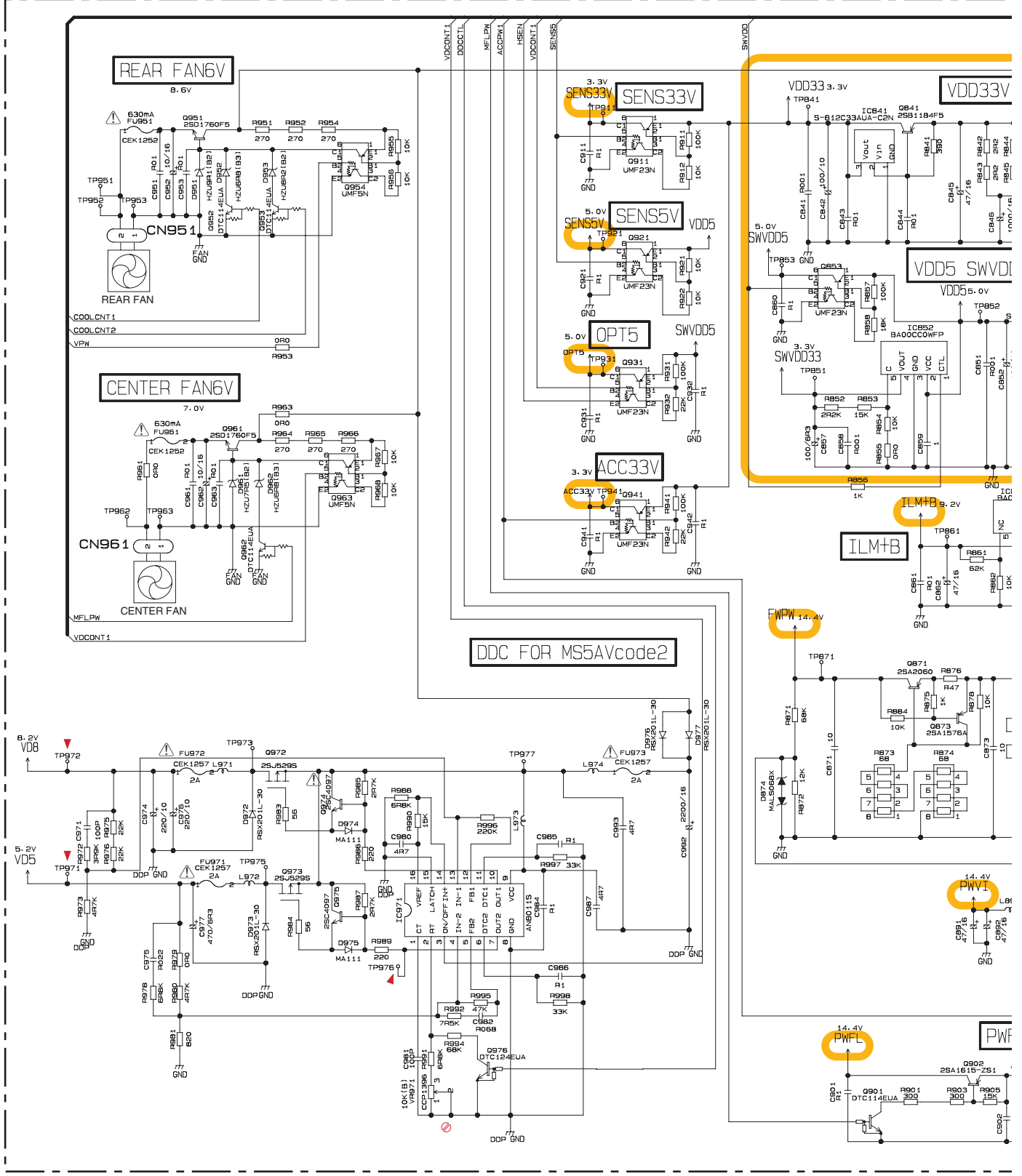

A2/2



# A-b 2/2

## A2/2 MOTHER UNIT(POWER SUPPLY PART)

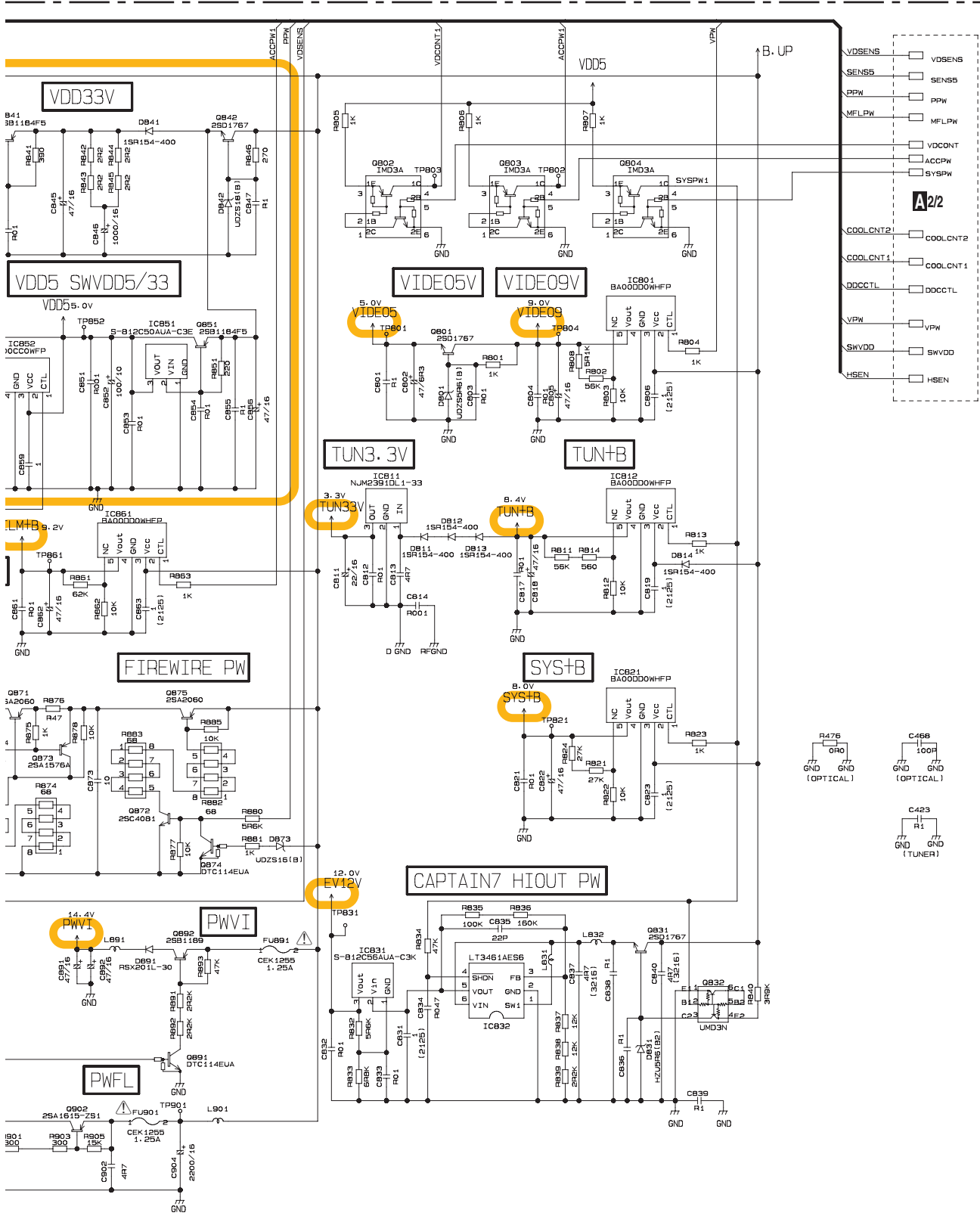

: The power supply is shown with the marked box.

# A2/2 MOTHER UNIT(POWER SUPPLY PART)

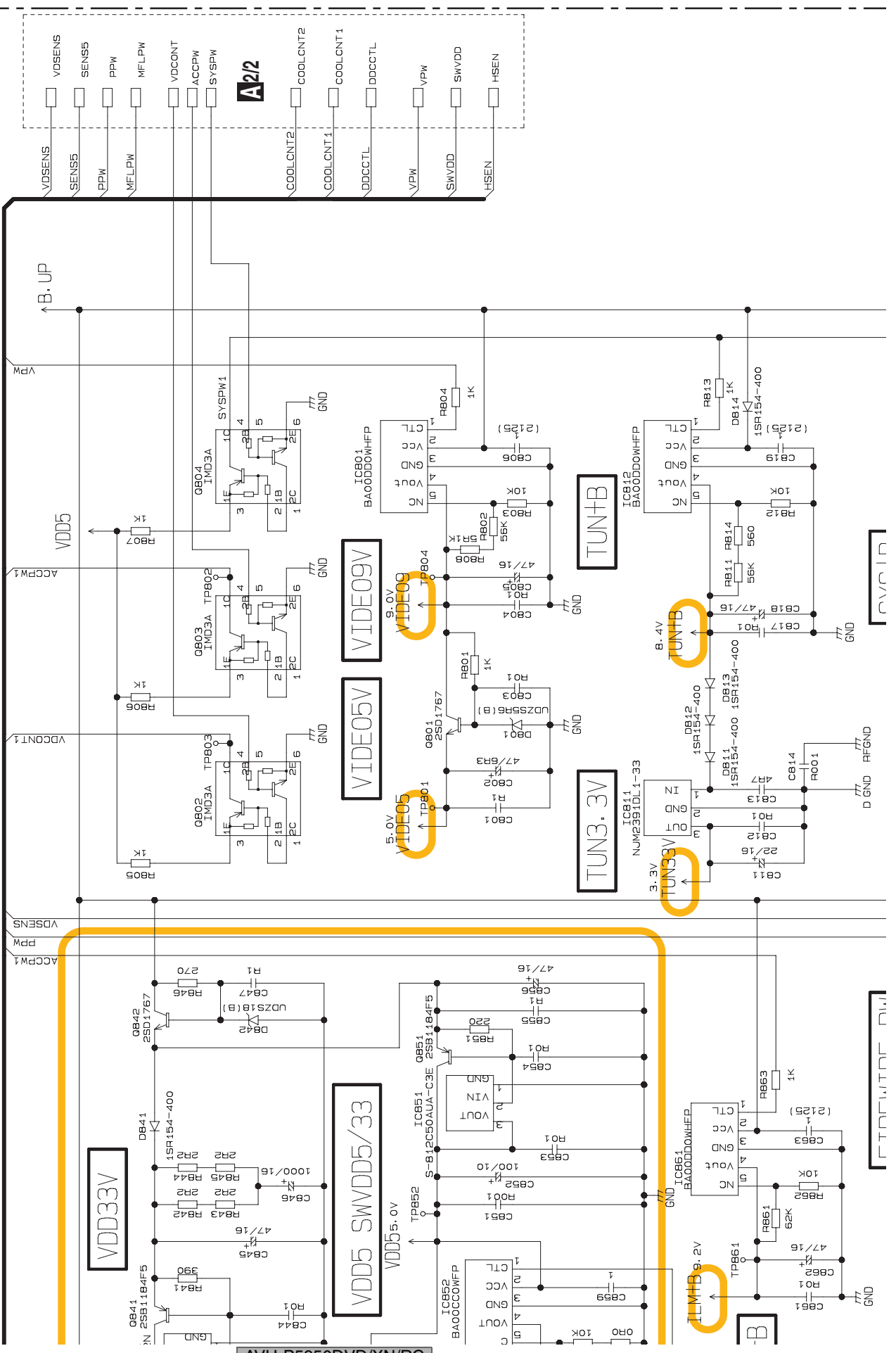

A-a A-b

A-b 2/2



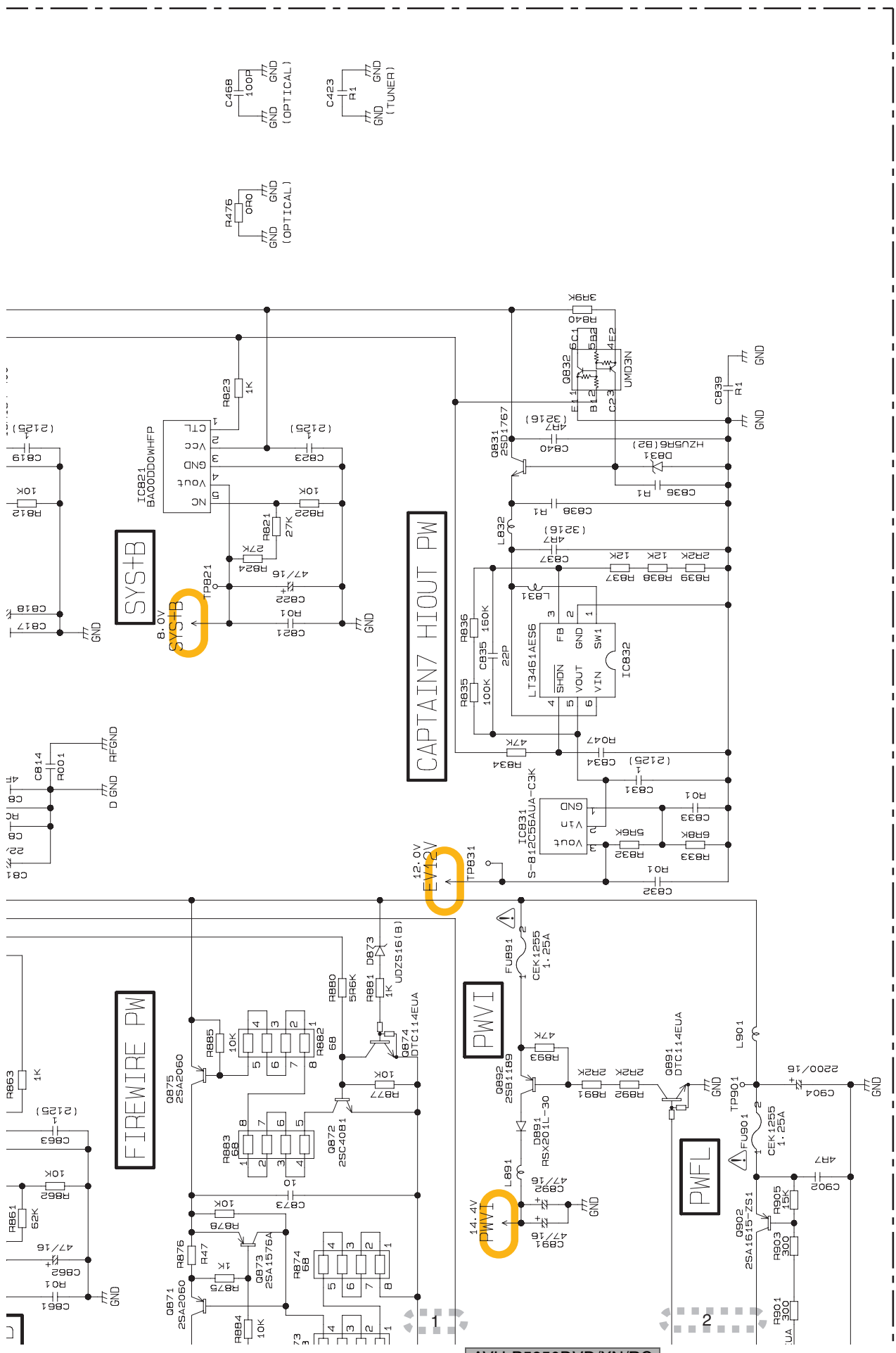

: The power supply is shown with the marked box.

A-a A-b

A B C D E F

A

A-b 2/2

B

C

D

E

F

A-a A-b

A-a 2/2

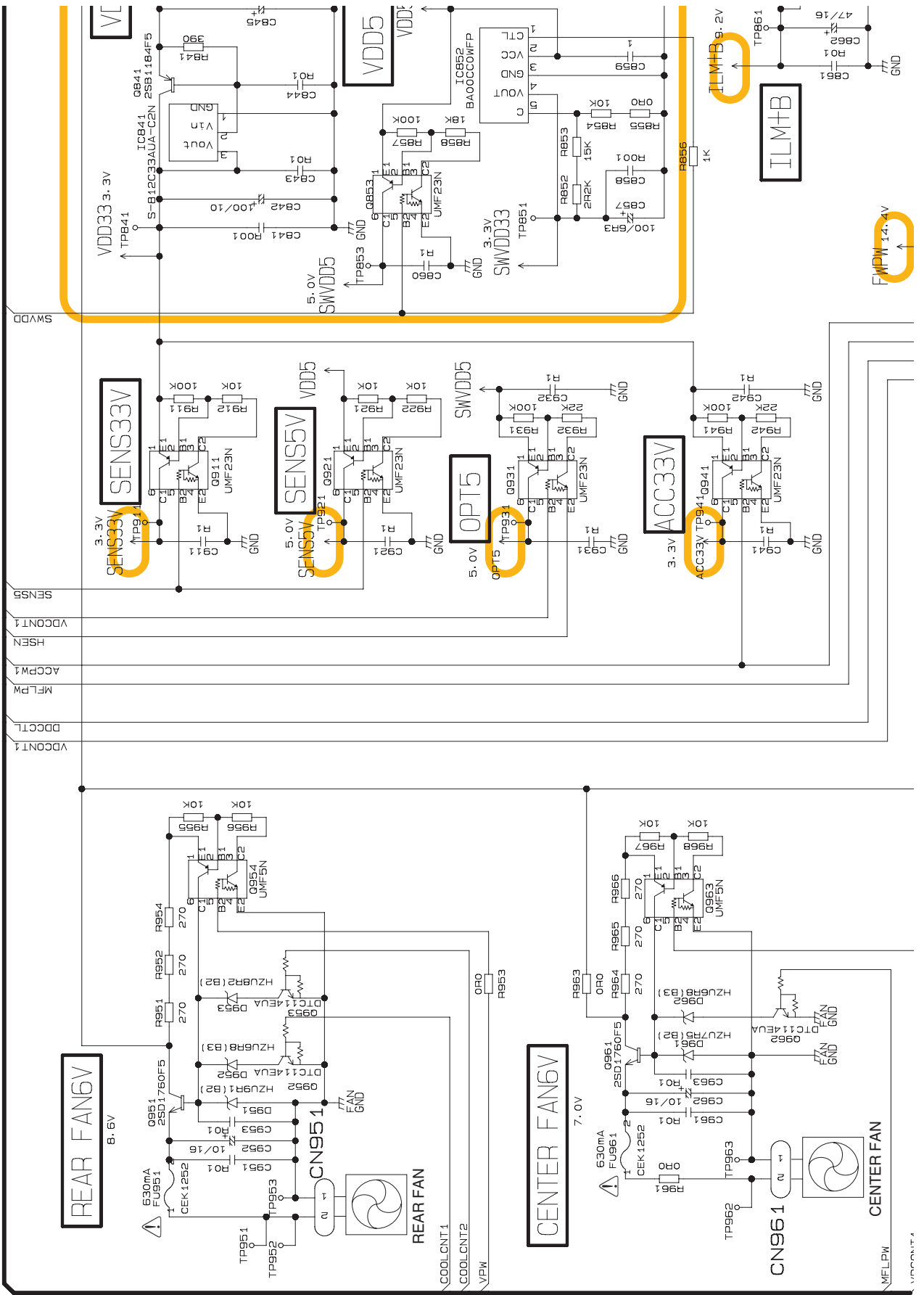

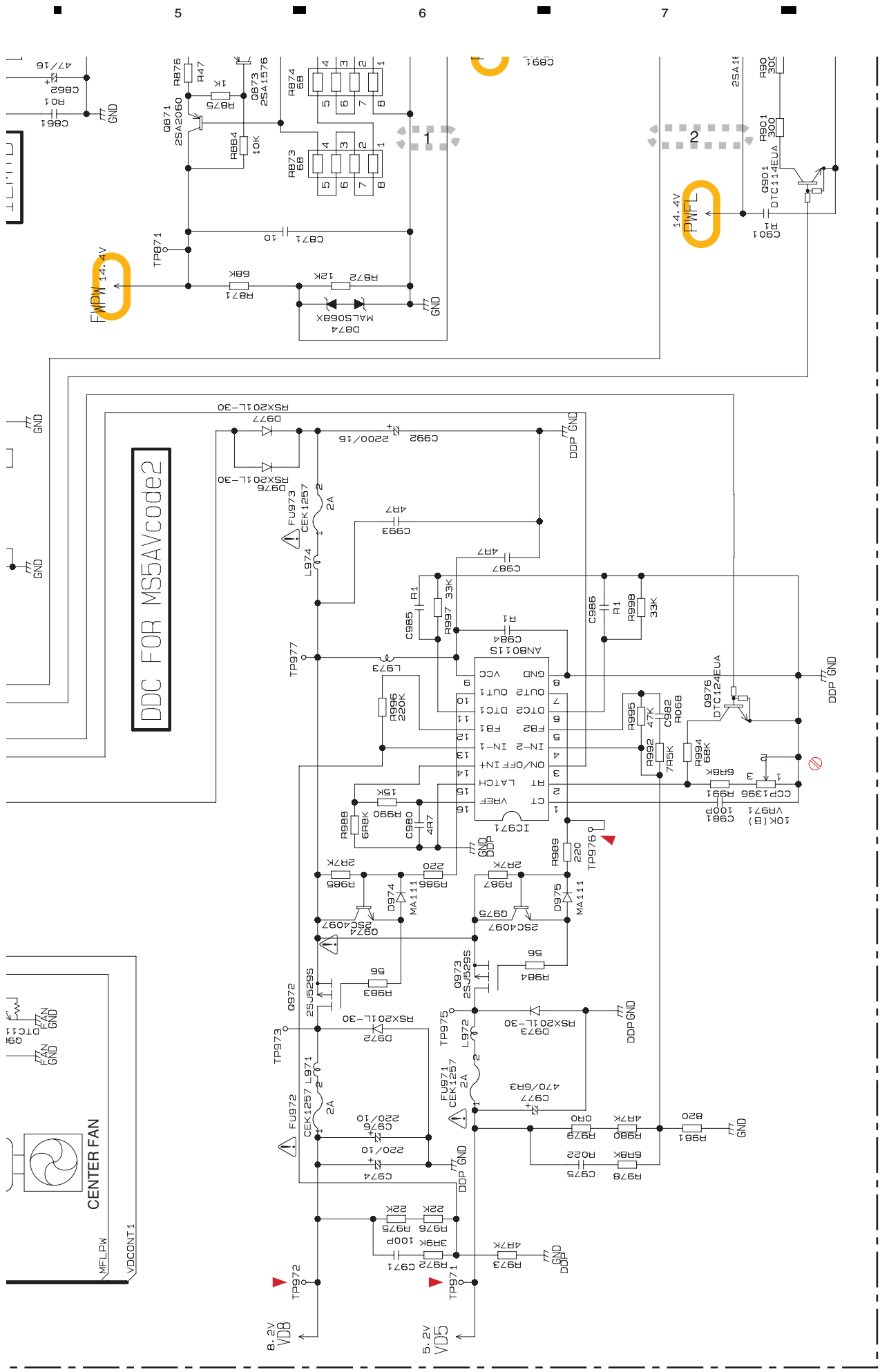

A-b 2/2

A-a A-b

A-a 2/2

# 10.3 KEYBOARD UNIT

A  
B  
C  
D  
E  
F

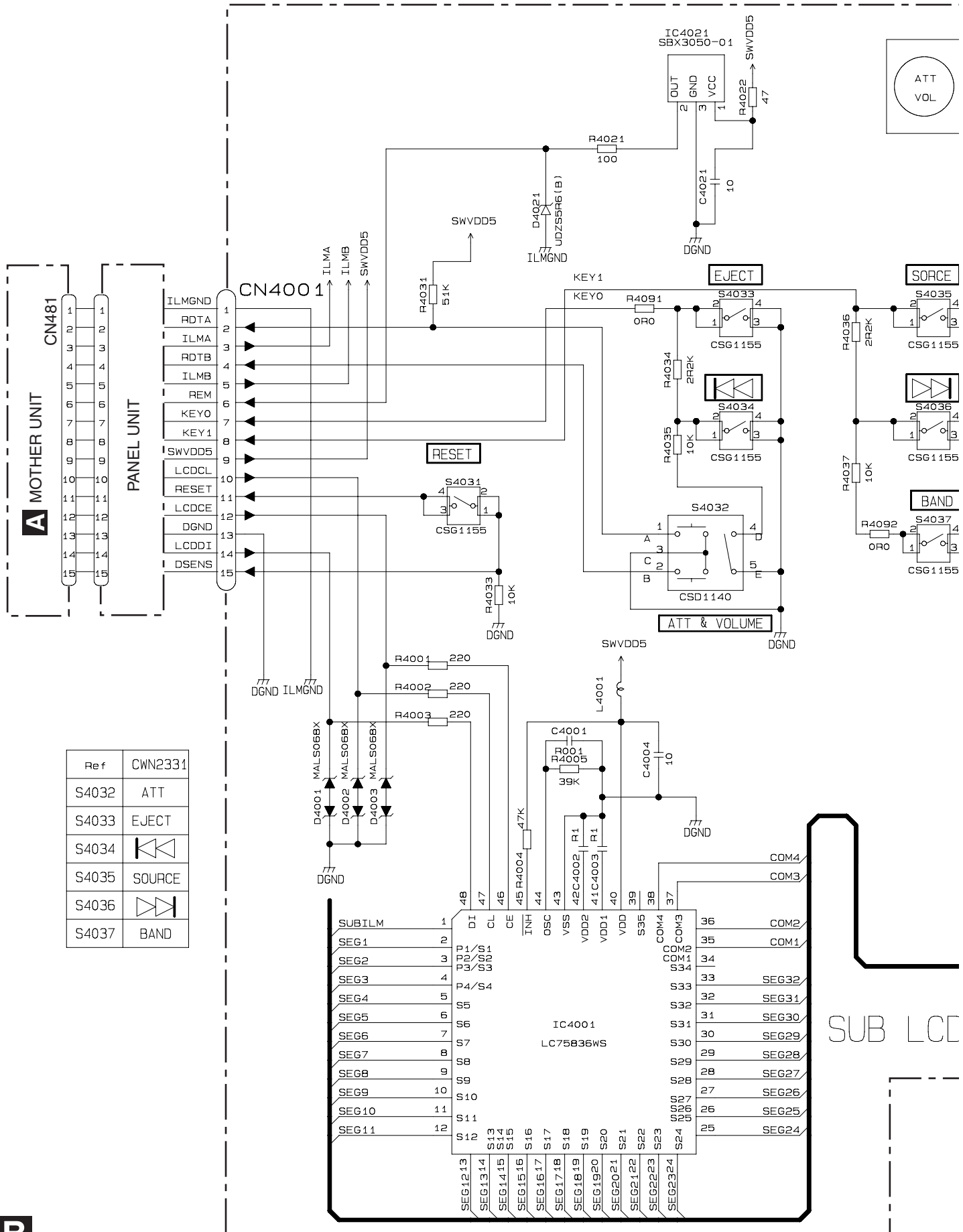

Ref	CWN2331
S4032	ATT
S4033	EJECT
S4034	
S4035	SOURCE
S4036	
S4037	BAND

# B KEYBOARD UNIT

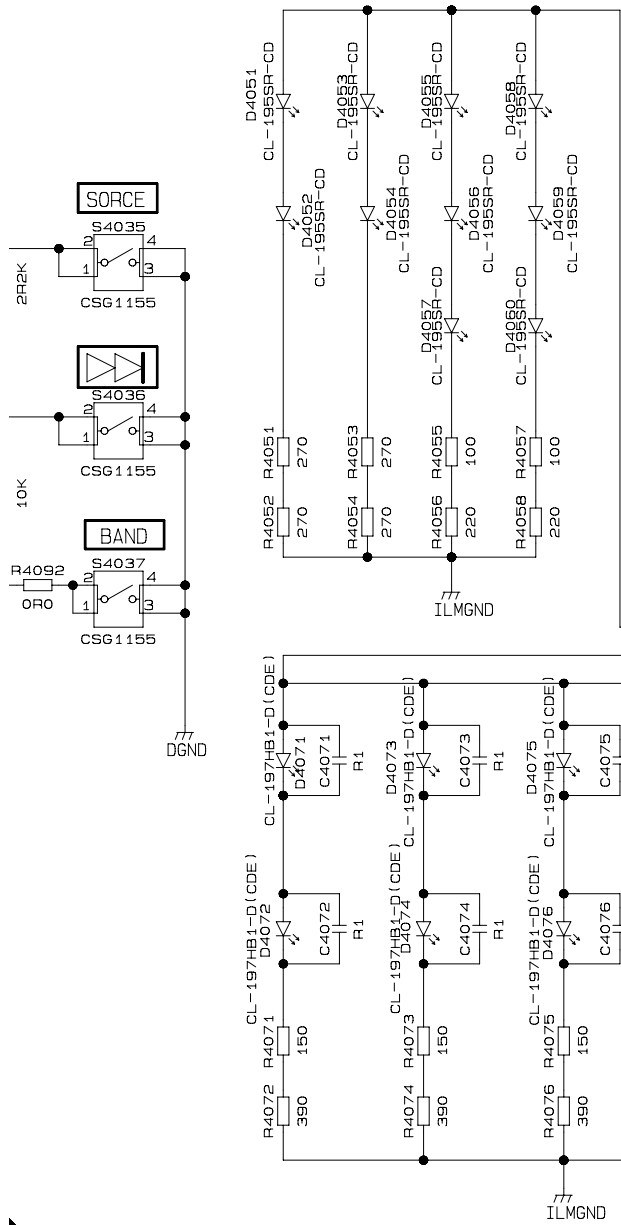
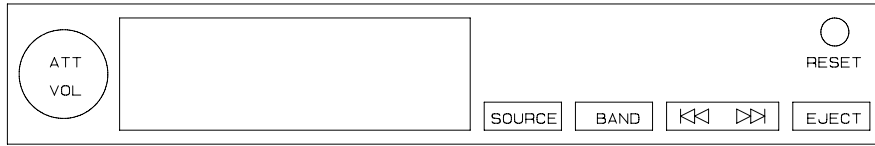

BLE : CL-197HB1-D(CDE):2.9typ~3.1Vmax (20mA)  
 RED : CL-195SR-CD:2.0typ~2.6Vmax (20mA)  
 WHT : NESW505c-5273:3.6typ~4.0Vmax (15mA)

Circuit Block	Reference
4-COM Block & interface Block	4001~4020
Remote control sensor	4021~4030
SW Block	4031~4040
Product Change	4091~
Backlight ILM	4041~4050
RED LED	4051~4060
Blue LED	4071~

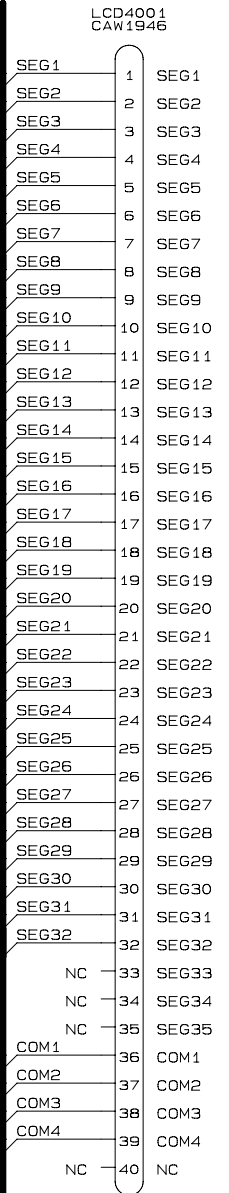

## JB LCD CONTROL

## SUB LCD



# 10.4 MONITOR PCB(MONITOR PART)(GUIDE PAGE)

C-a 1/2

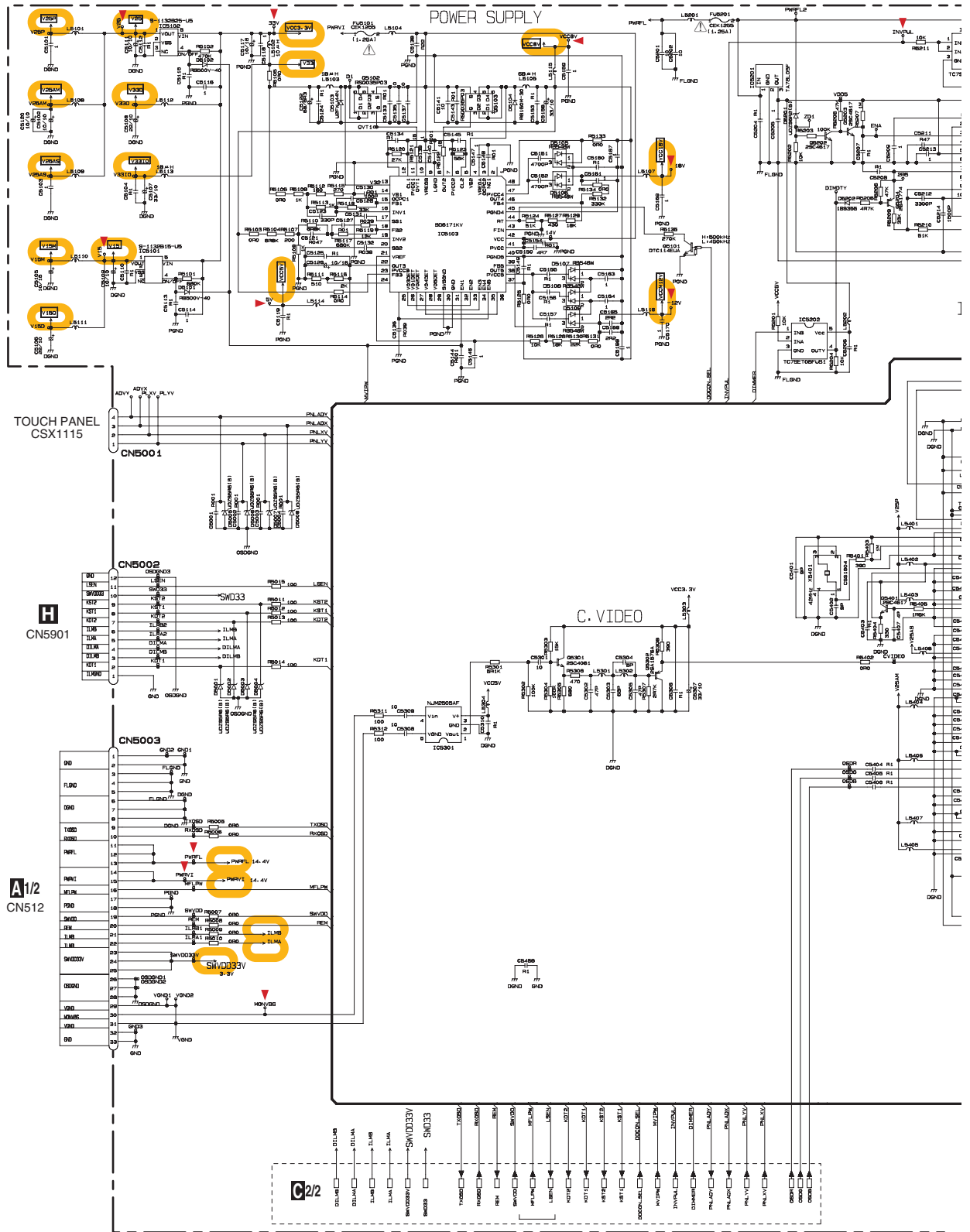

C 1/2

C-b 1/2

A

B

C

D

E

F

LCD MODULE

CN520 1

LCD PANEL  
CX3264

G1/2 MONITOR PCB(MONITOR PART)

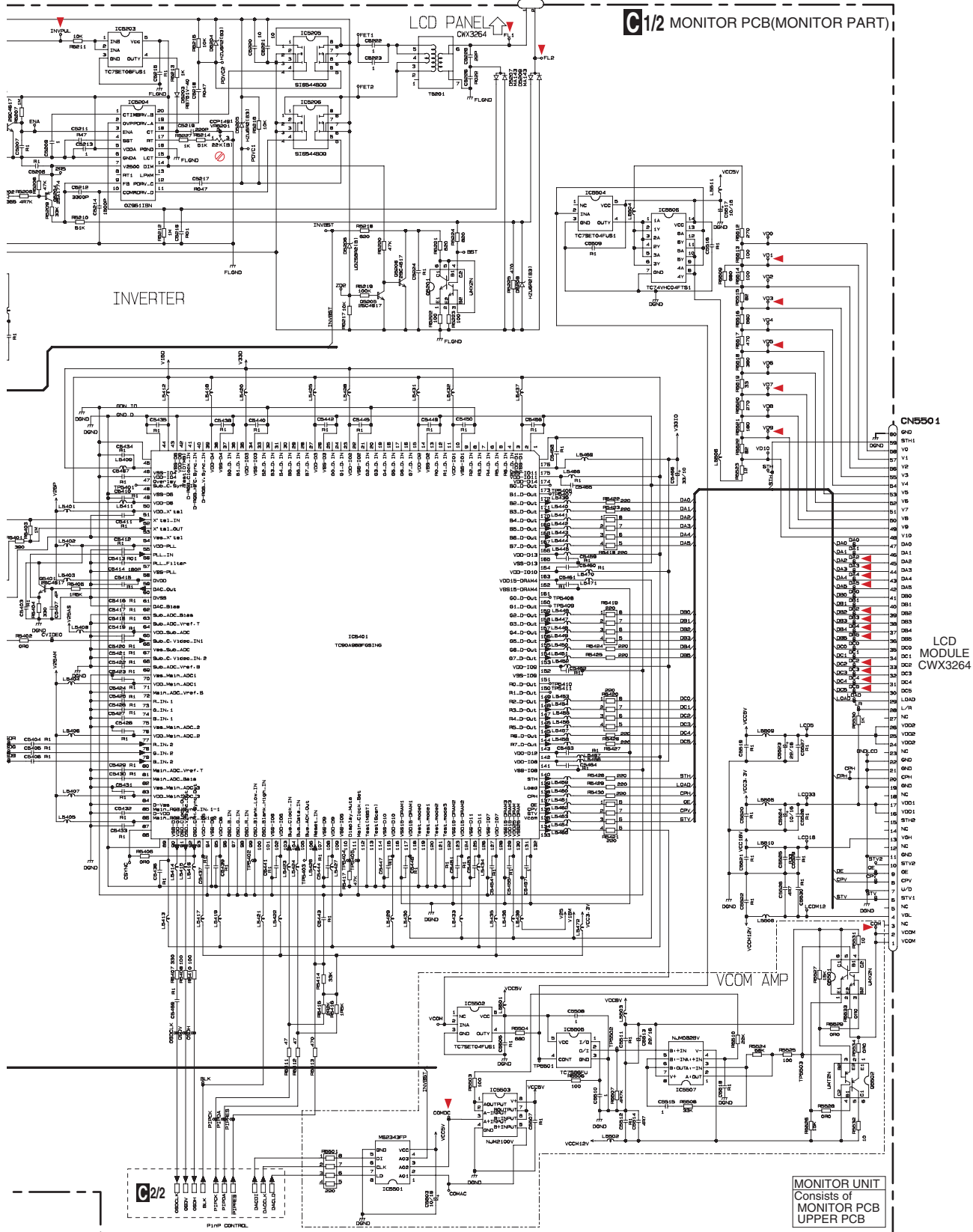

MONITOR UNIT  
Consists of  
MONITOR PCB  
UPPER PCB

G1/2







A B C D E F

C-b 1/2

C-a C-b

C-a 1/2

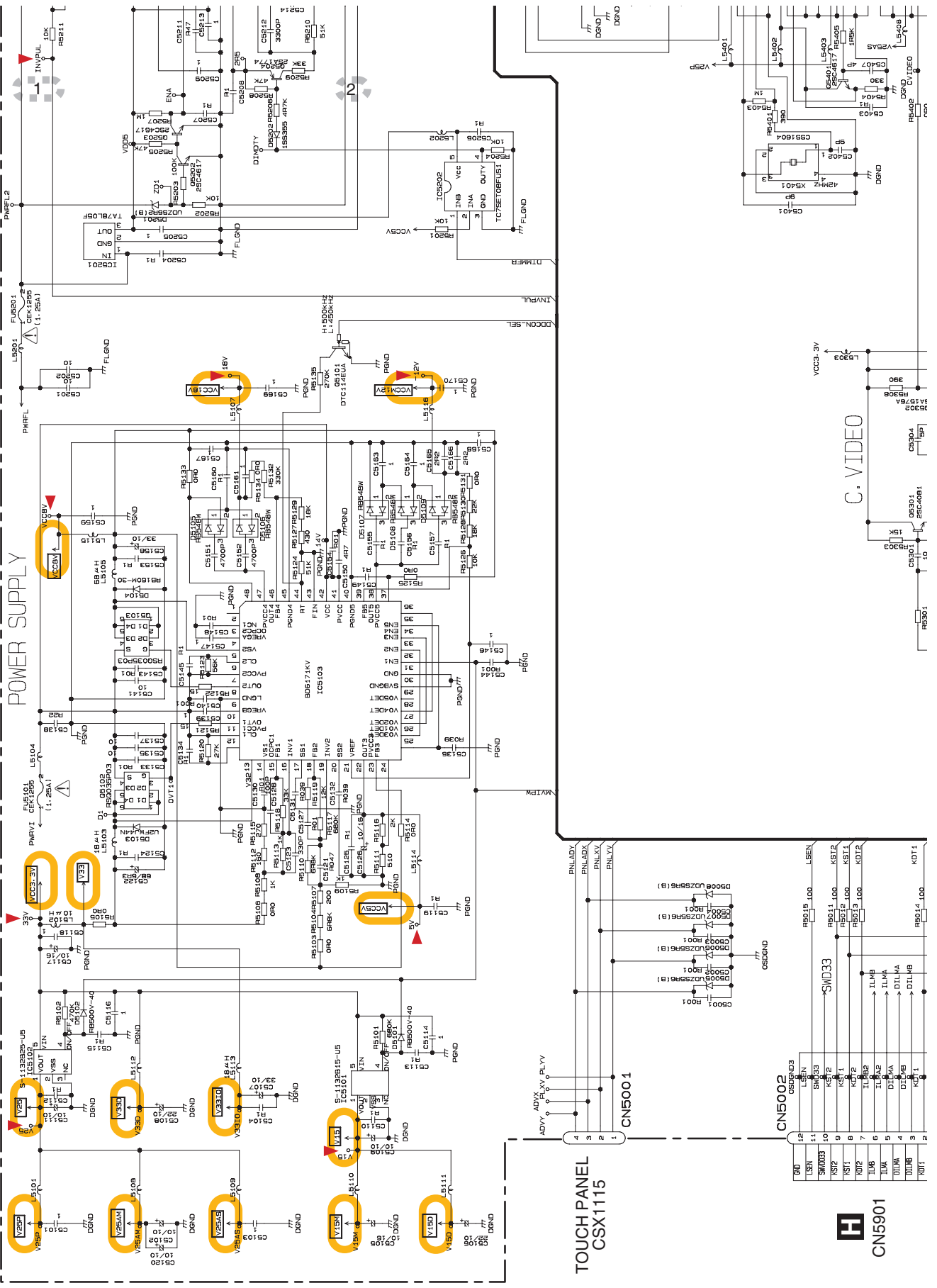

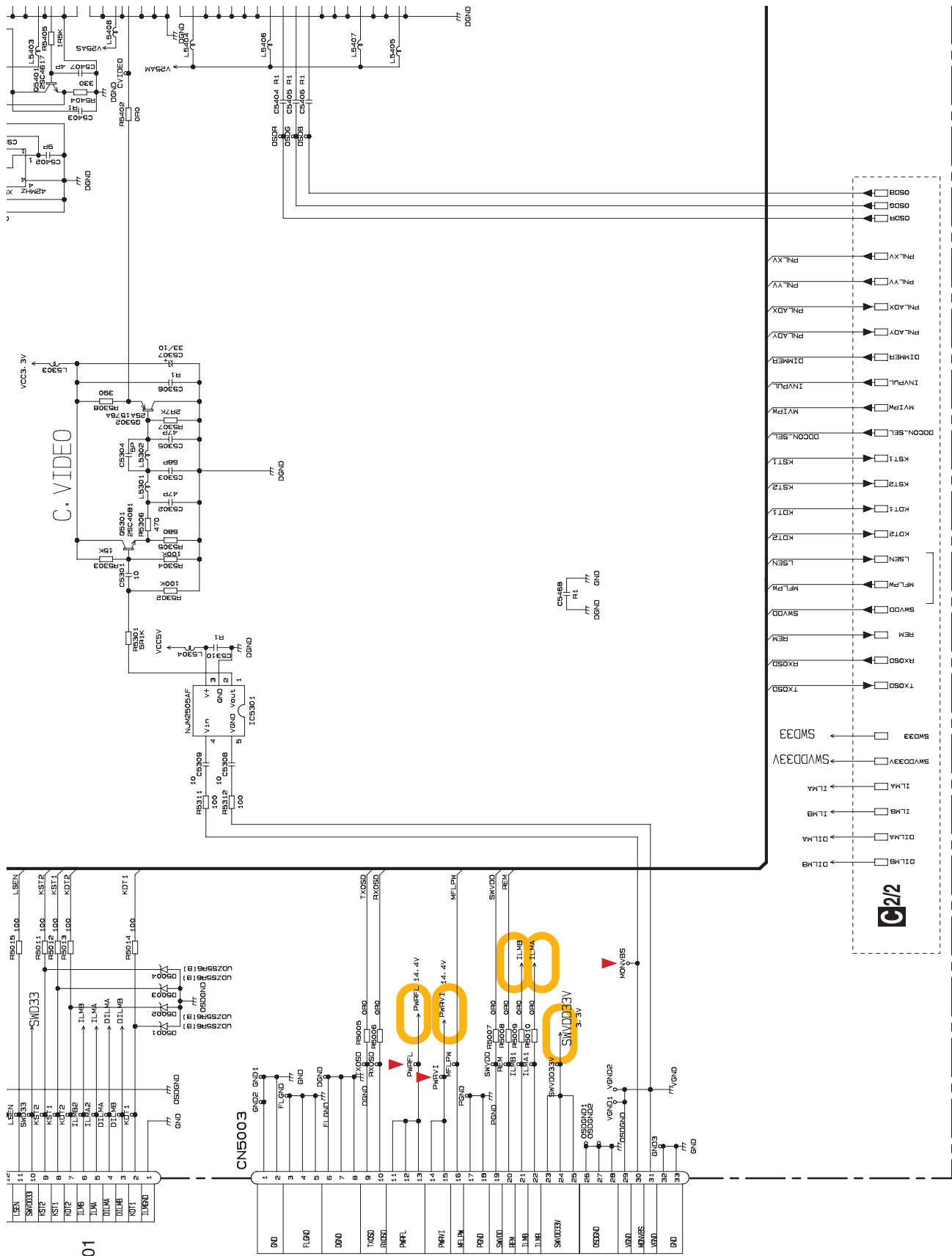





**C2/2** MONITOR PCB(OSD & μCON PART)

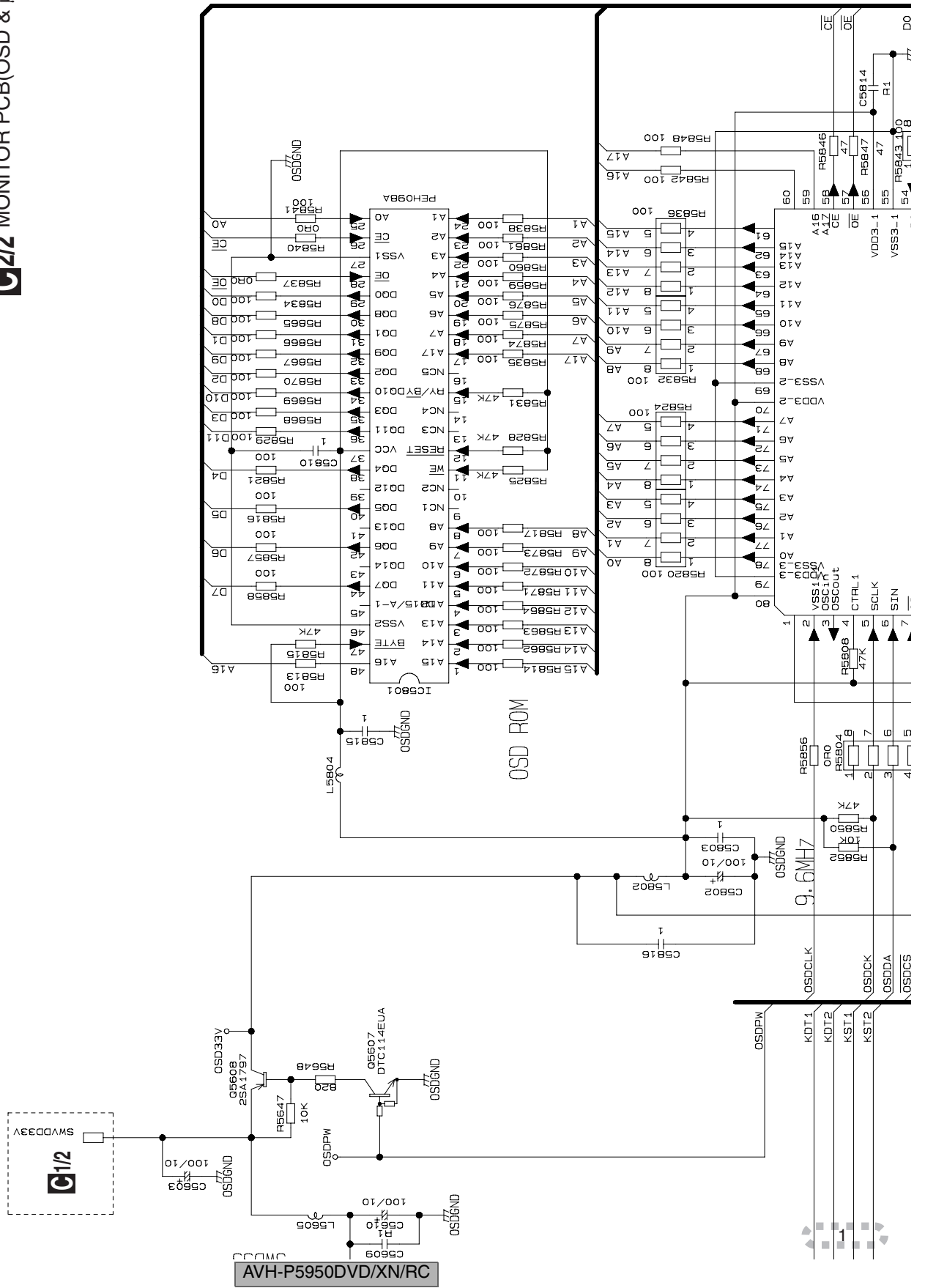

C-a C-b

**C-b 2/2**

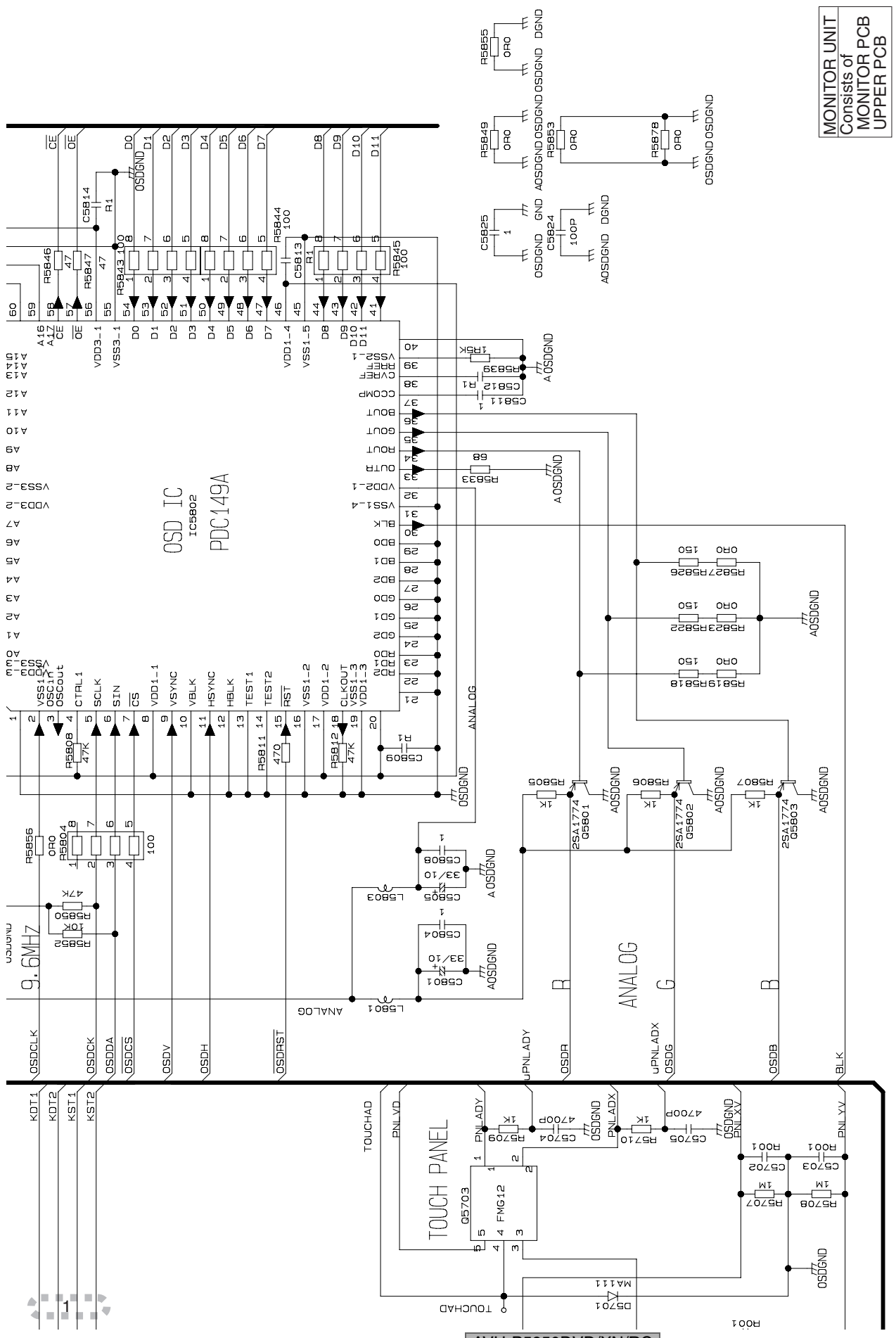

MONITOR UNIT  
Consists of  
MONITOR PCB  
UPPER PCB

C-a C-b

A B C D E F

AVH-P5950DVD/XN/RC

C-b 2/2

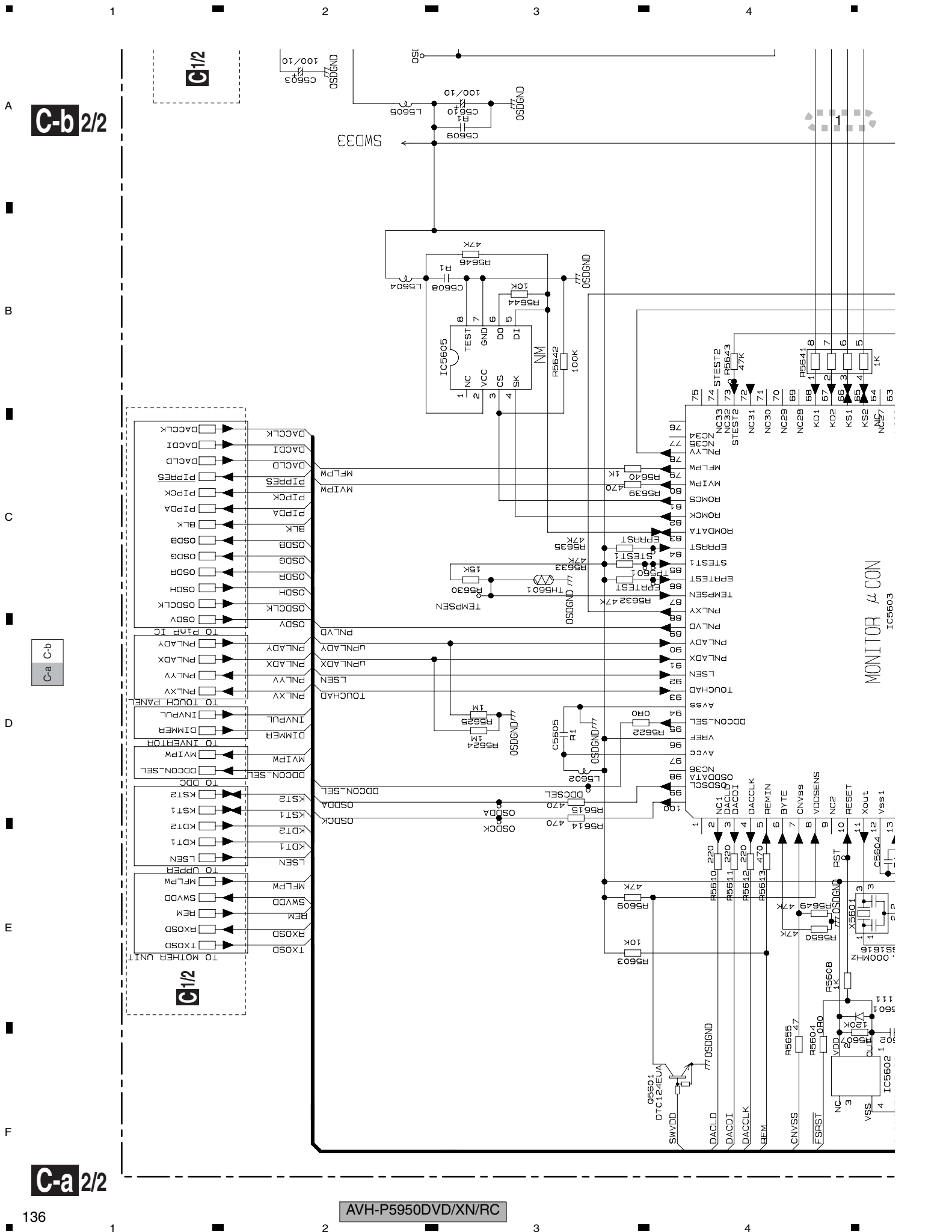

C-b 2/2

C-a C-b

C-a 2/2



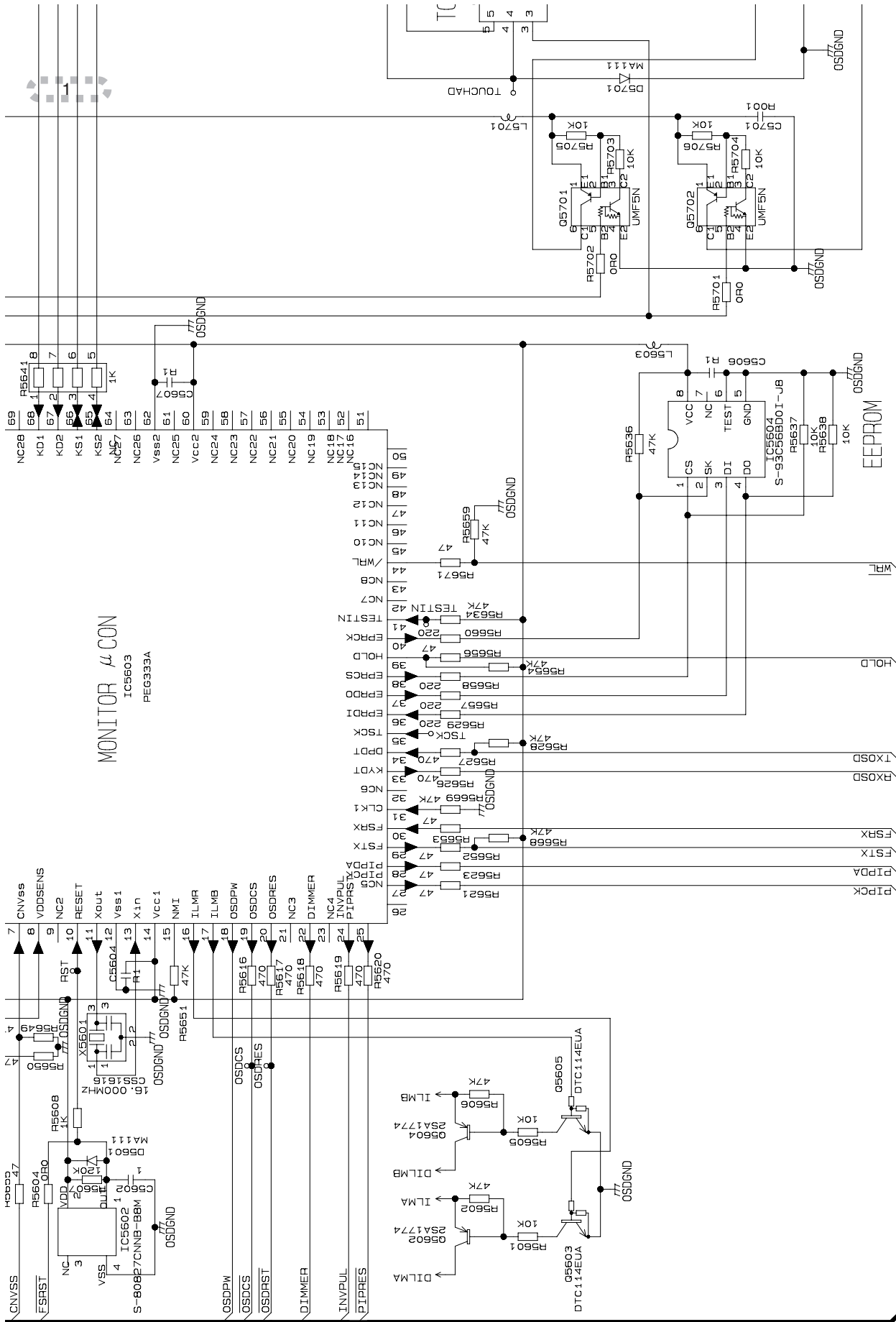

**MONITOR  $\mu$  CON**  
 IC5603  
 PEG333A

C-b 2/2

C-a C-b

C-a 2/2

# 10.6 DVD CORE UNIT(1/2)(GUIDE PAGE)

D-a 1/2

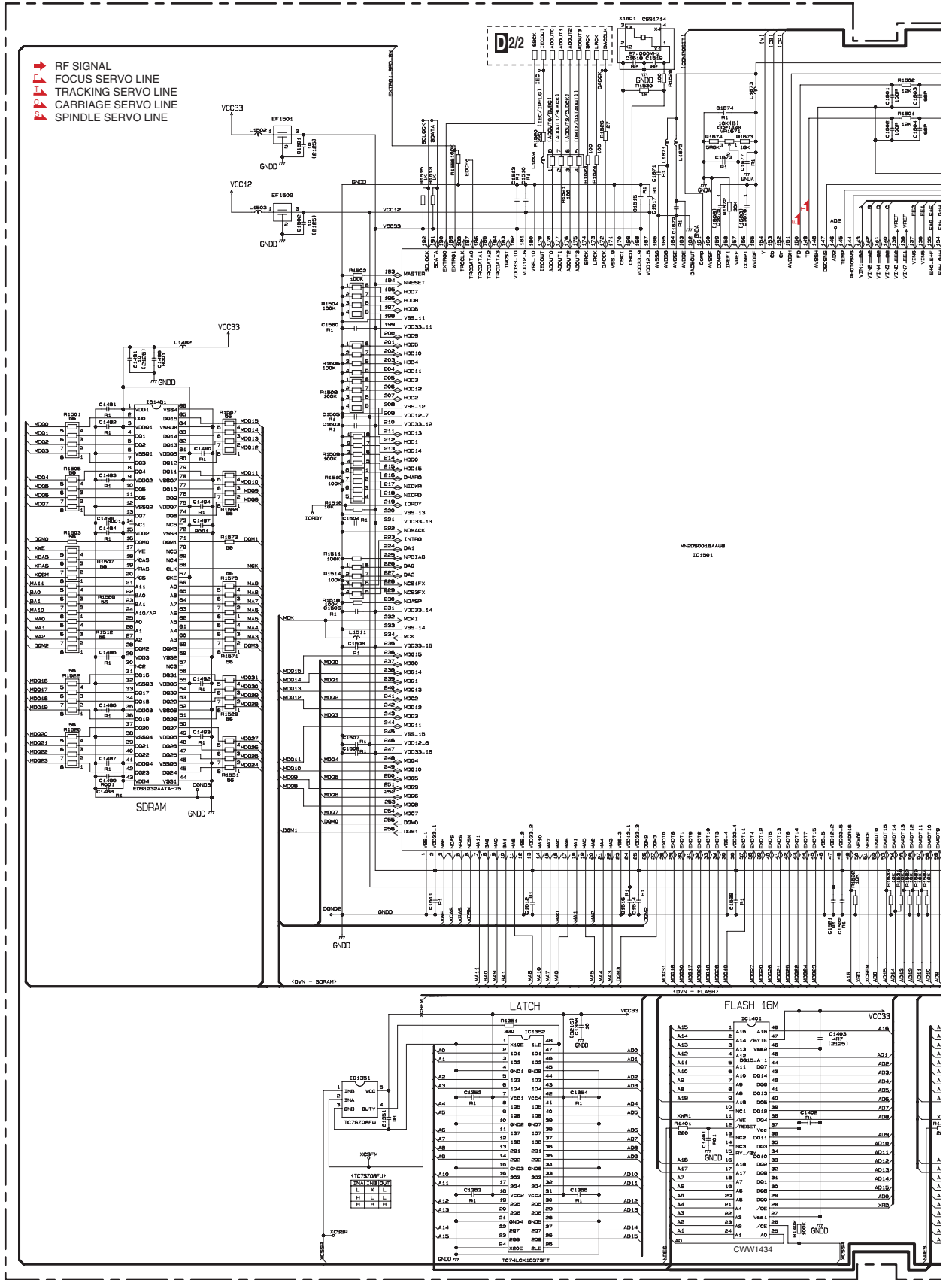

D1/2

# D-b 1/2

## D 1/2 DVD CORE UNIT (1/2)

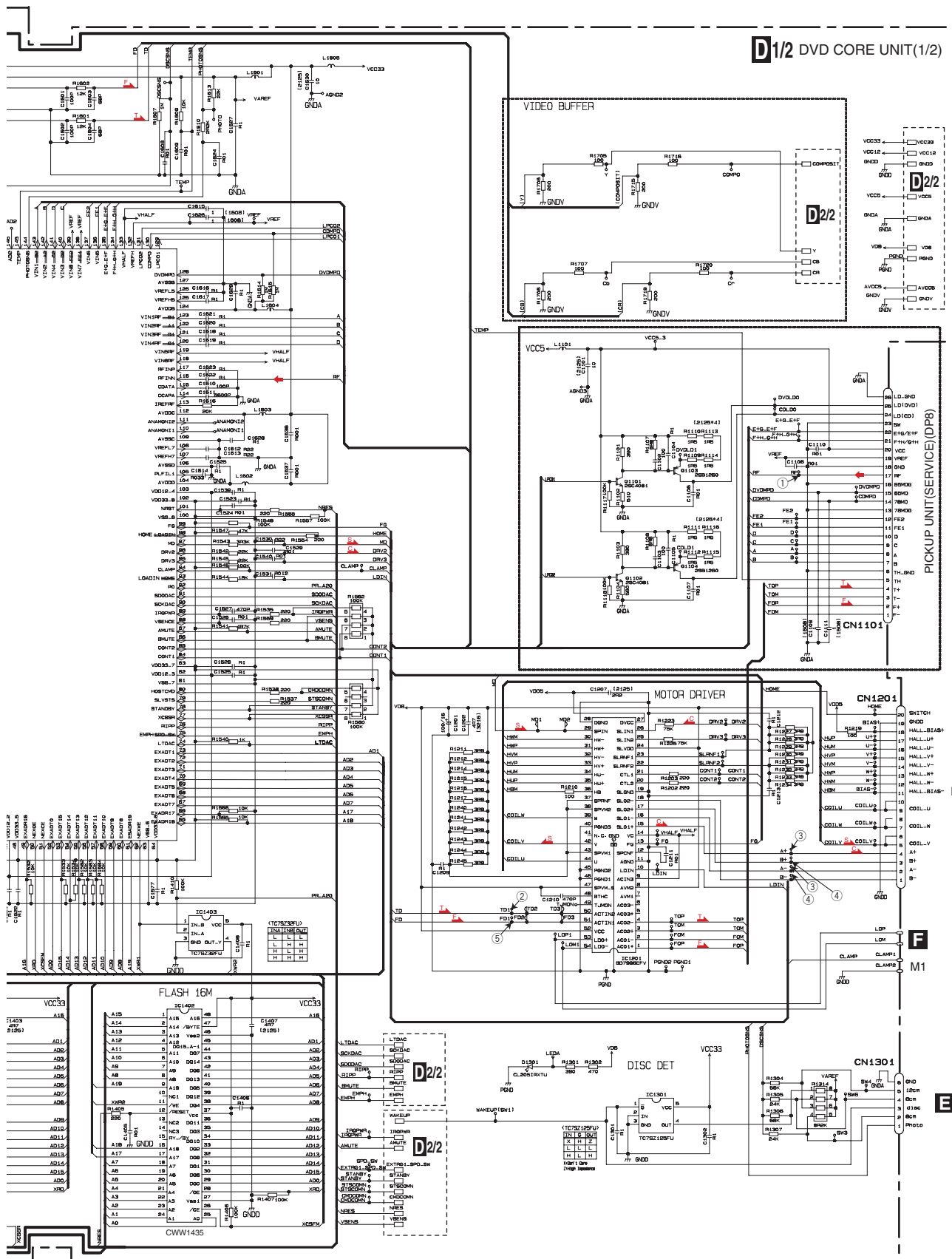

A

B

C

D

E

F

# D 1/2

A

B

C

D

E

F

D-a D-b

D-a 1/2

# D1/2 DVD CORE UNIT(1/2)

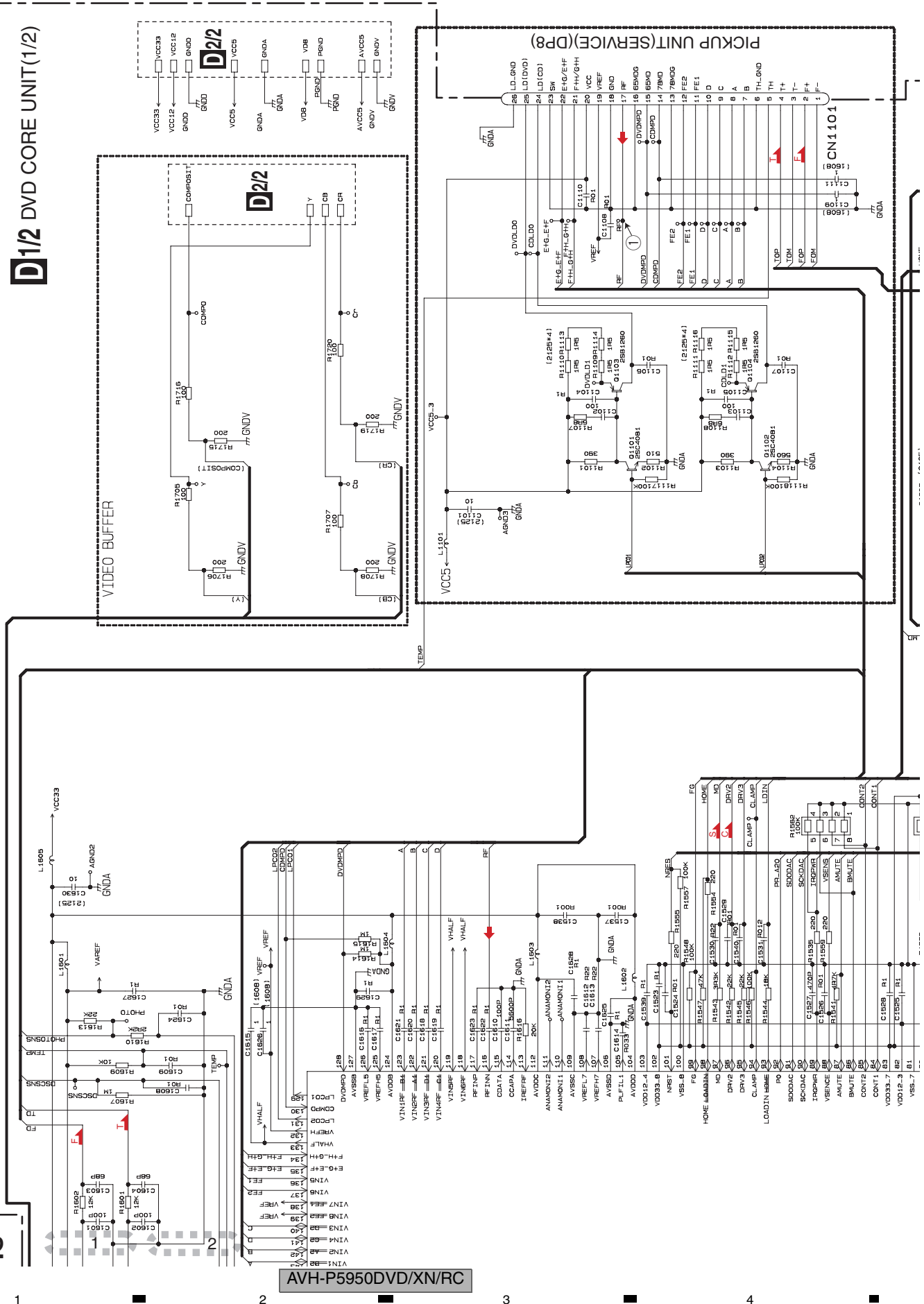

M2, M3

E

F

M1

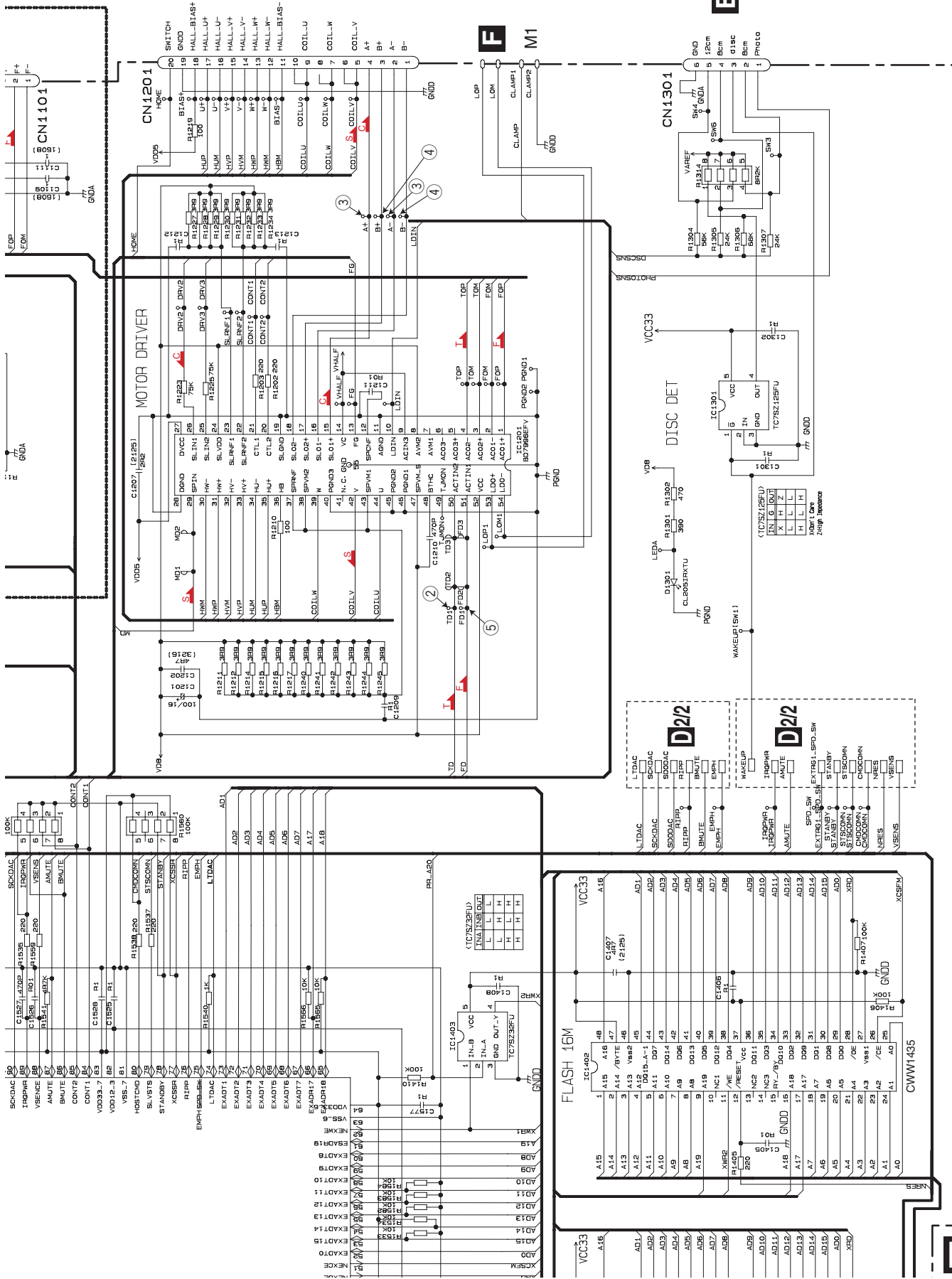

D-a D-b

A B C D E F

AVH-P5950DVD/XN/RC

D-b 1/2

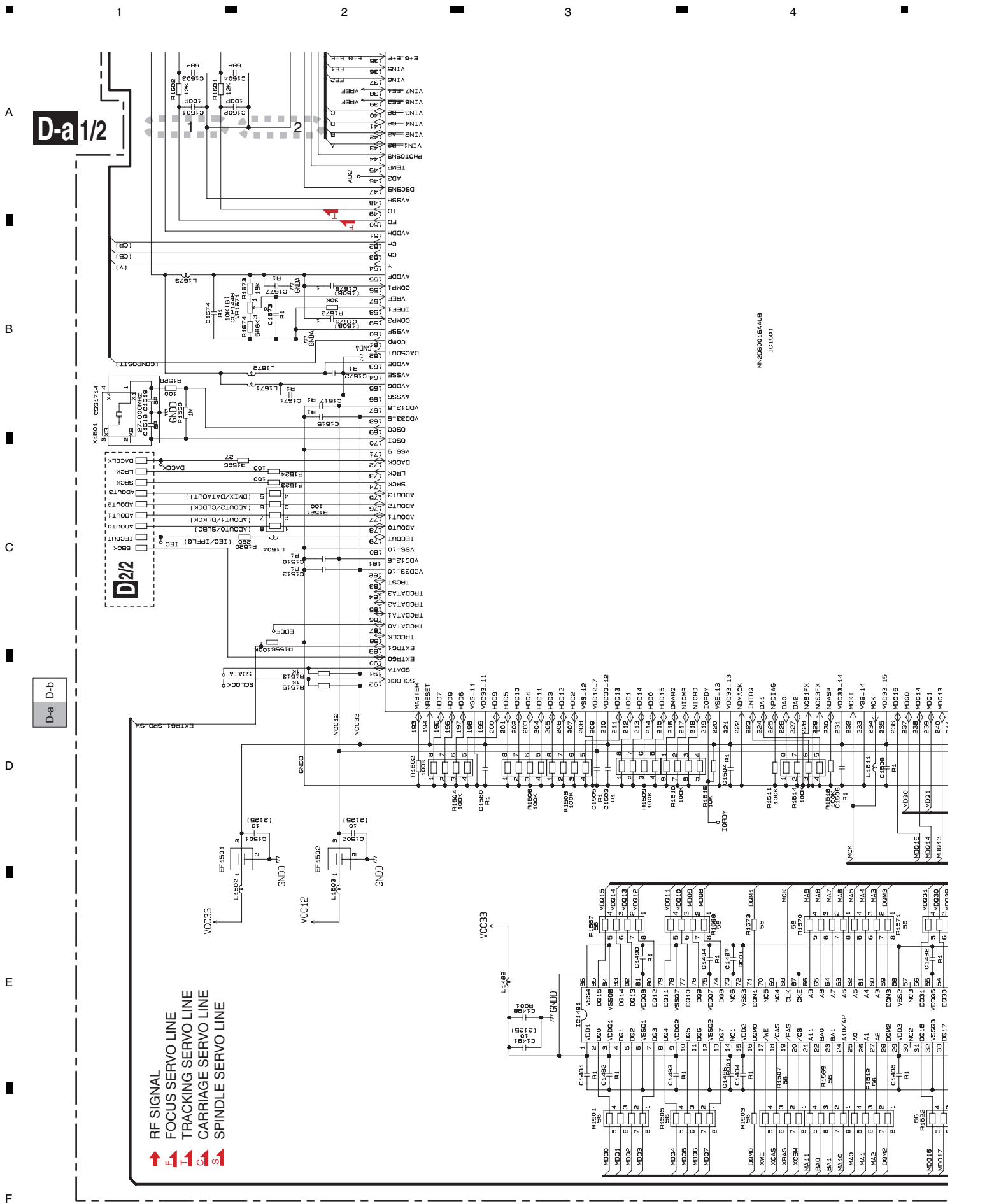

D-a 1/2

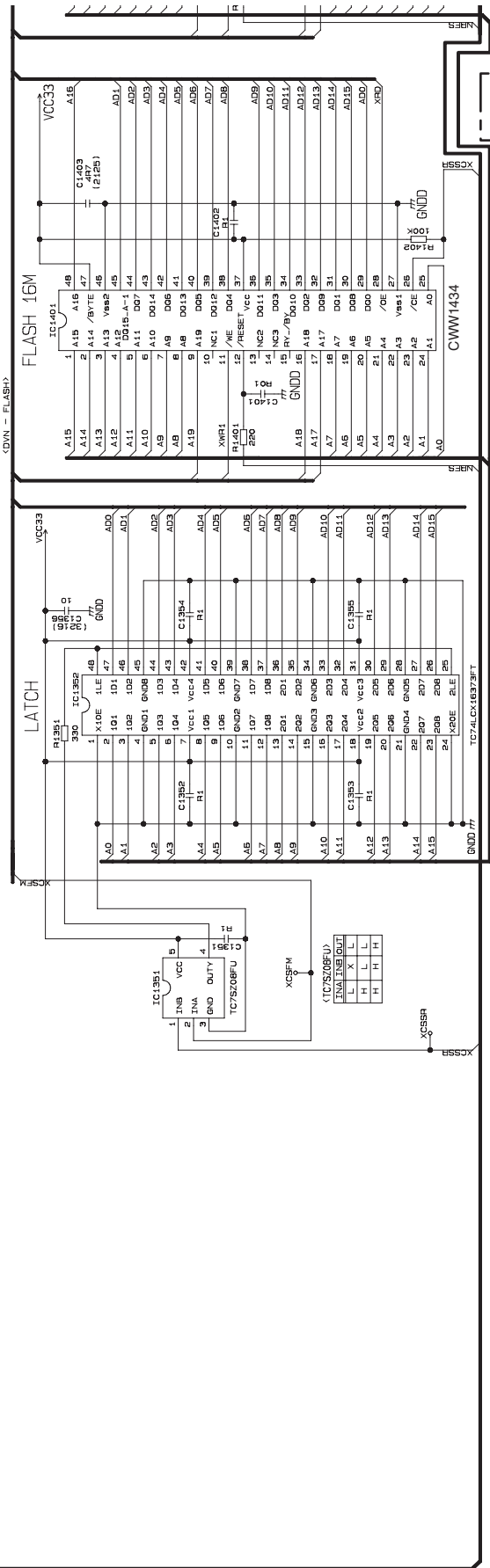
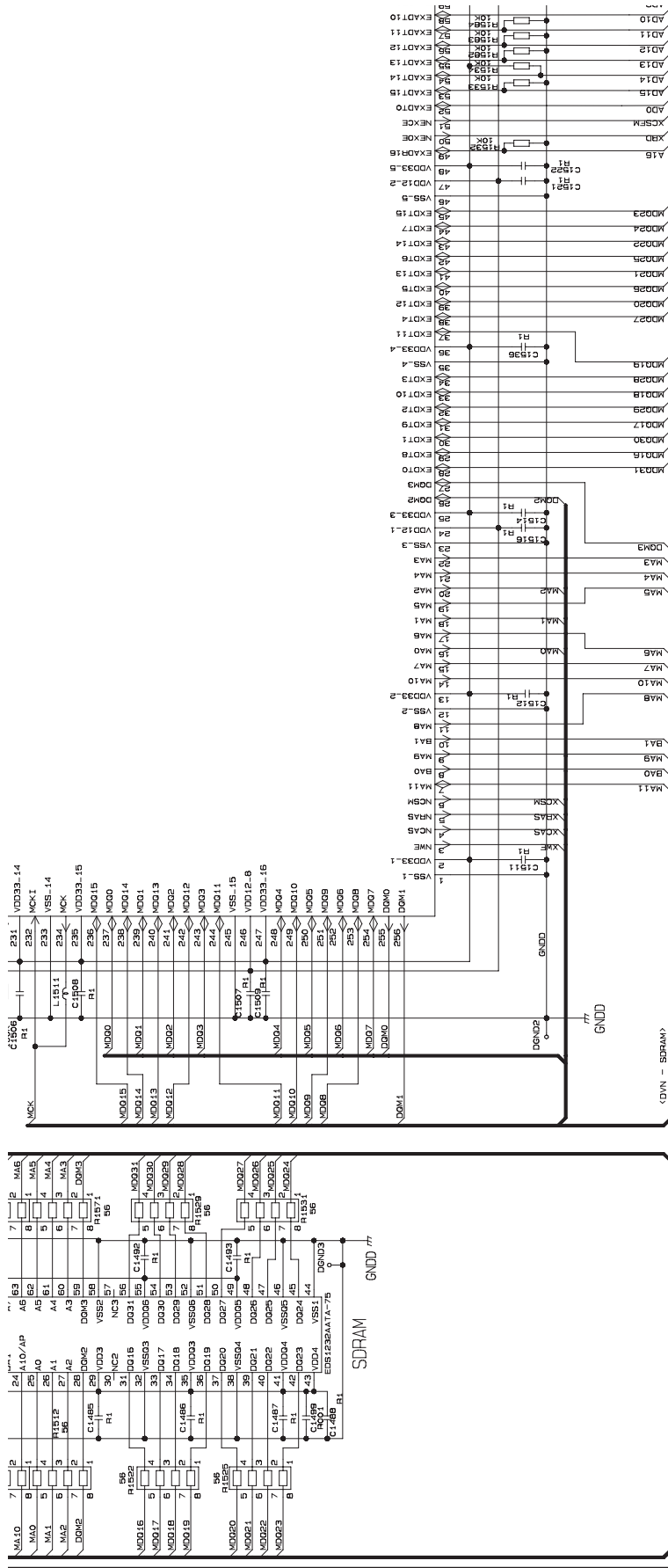

D-b 1/2

A

B

C

D

E

F

D-a D-b

D-a 1/2

# 10.7 DVD CORE UNIT(2/2)

A

B

C

D

E

F

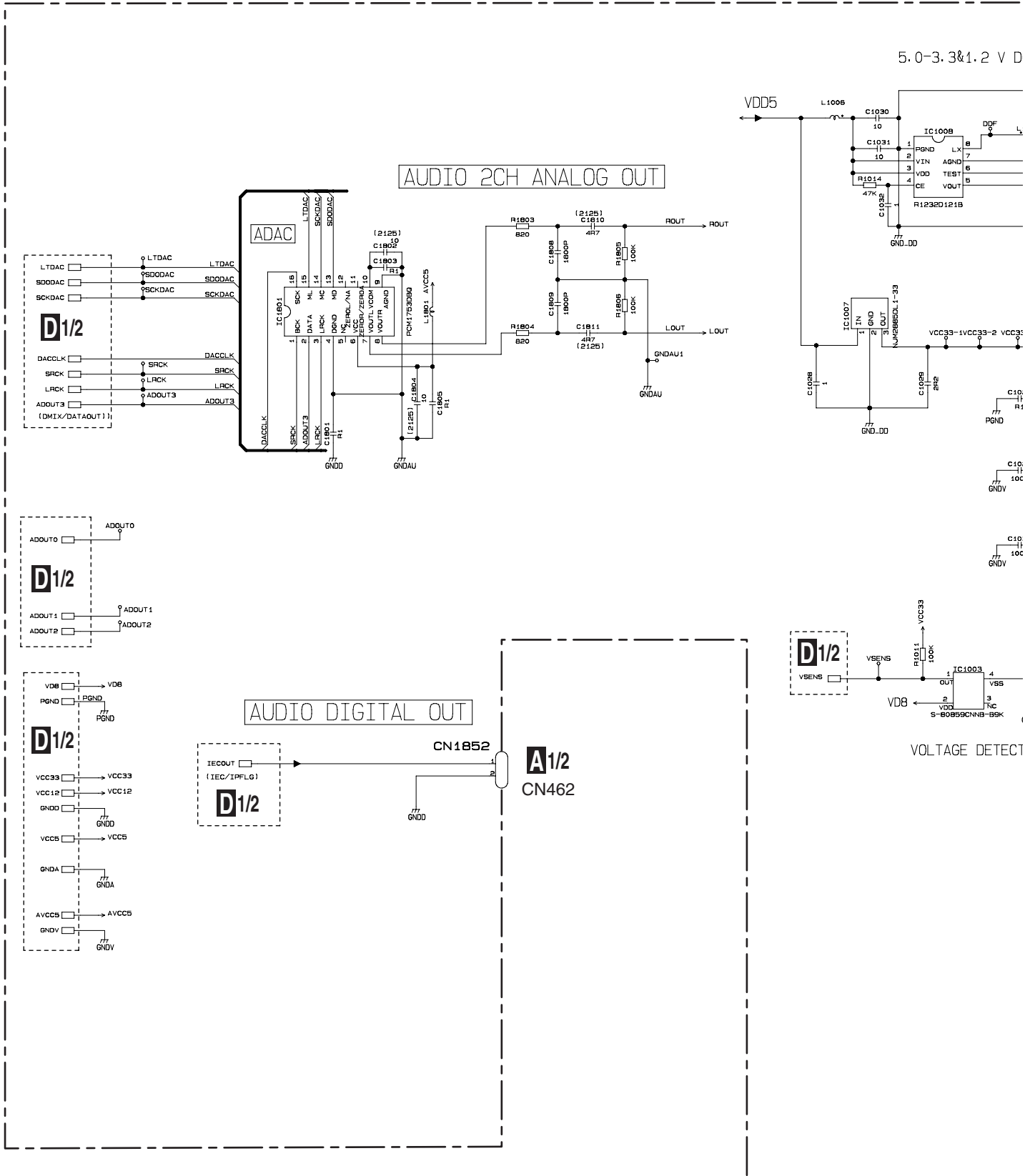



# D2/2 DVD CORE UNIT(2/2)

0-3.3&1.2 V DC/DC

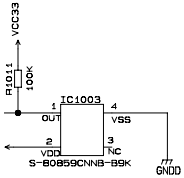
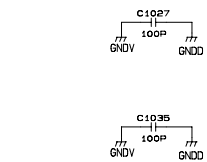
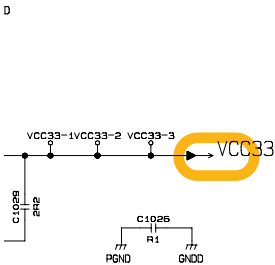
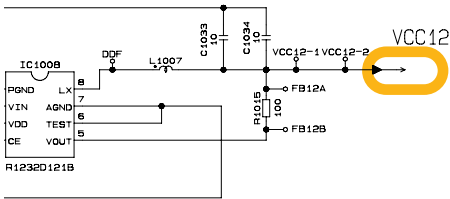

VOLTAGE DETECT

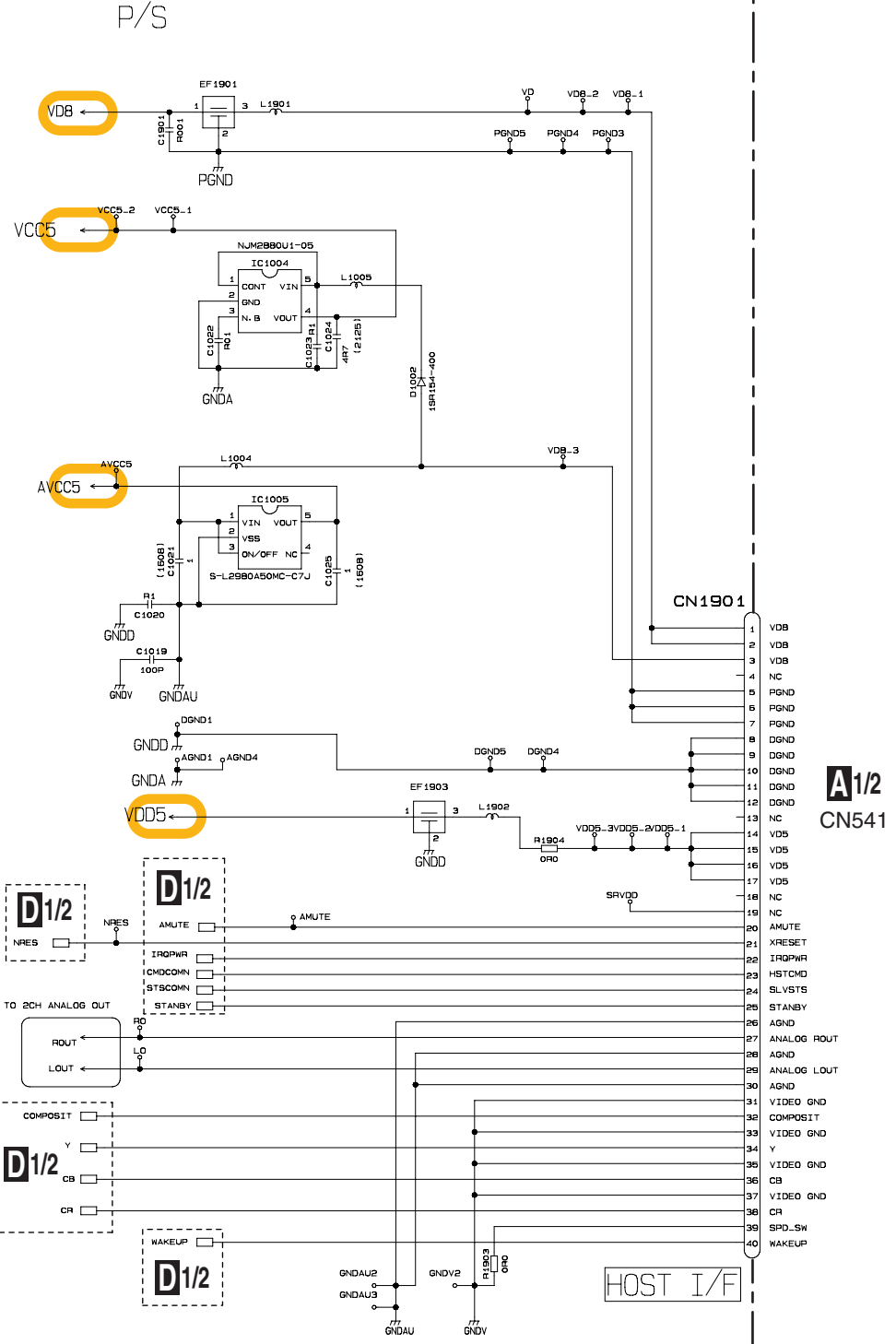

A1/2  
CN541

# 10.8 COMPOUND UNIT(A) AND COMPOUND UNIT(B)

## E COMPOUND UNIT(A)

D1/2  
CN1301

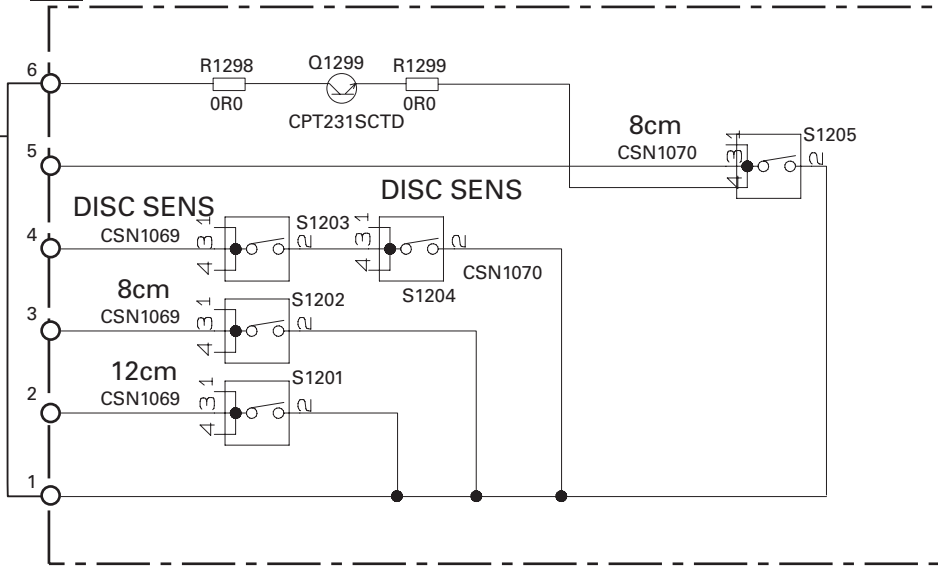

## F COMPOUND UNIT(B)

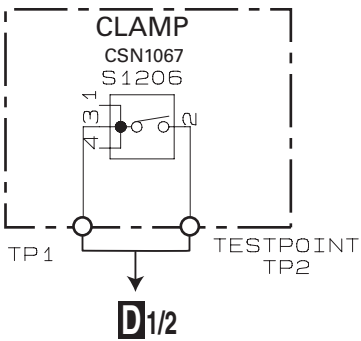

E F

# 10.9 RCA PCB

5 6 7 8

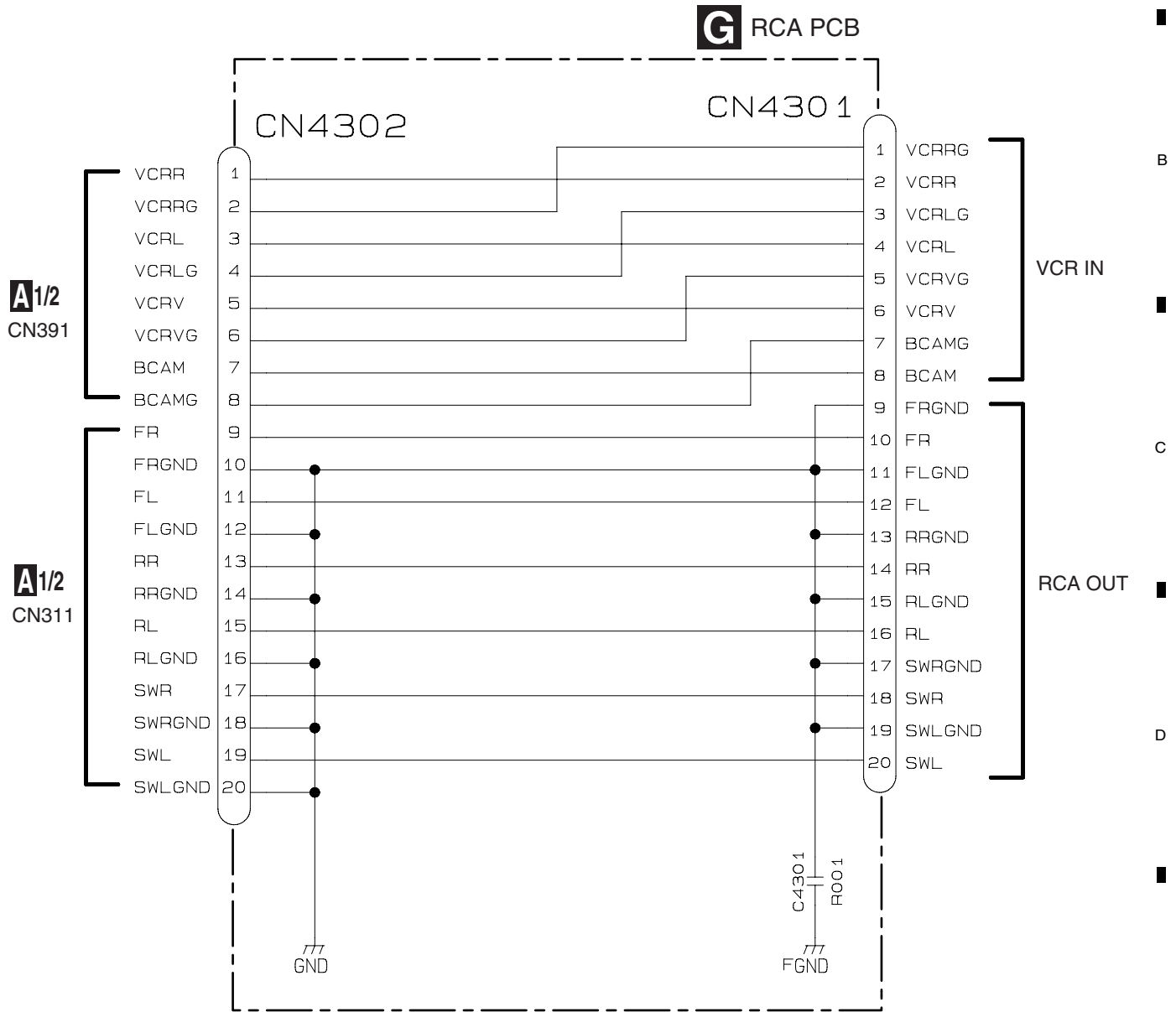

**OPT/RCA UNIT**  
 Consists of  
 RCA PCB  
 OPT PCB



# 10.10 UPPER PCB

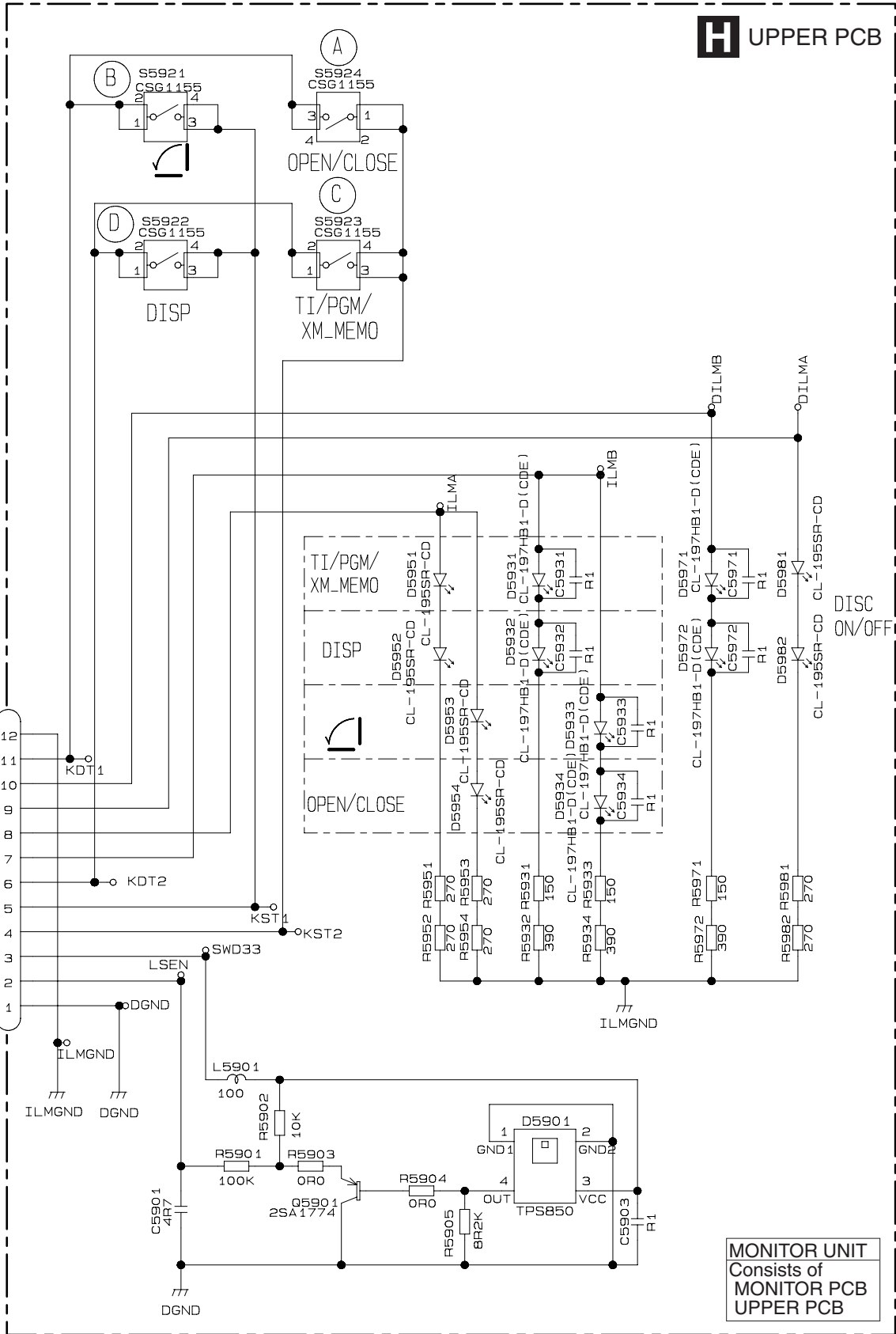

**MONITOR UNIT**  
 Consists of  
 MONITOR PCB  
 UPPER PCB

# 10.11 OPT PCB

**A1/2**  
CN461

**I** OPT PCB

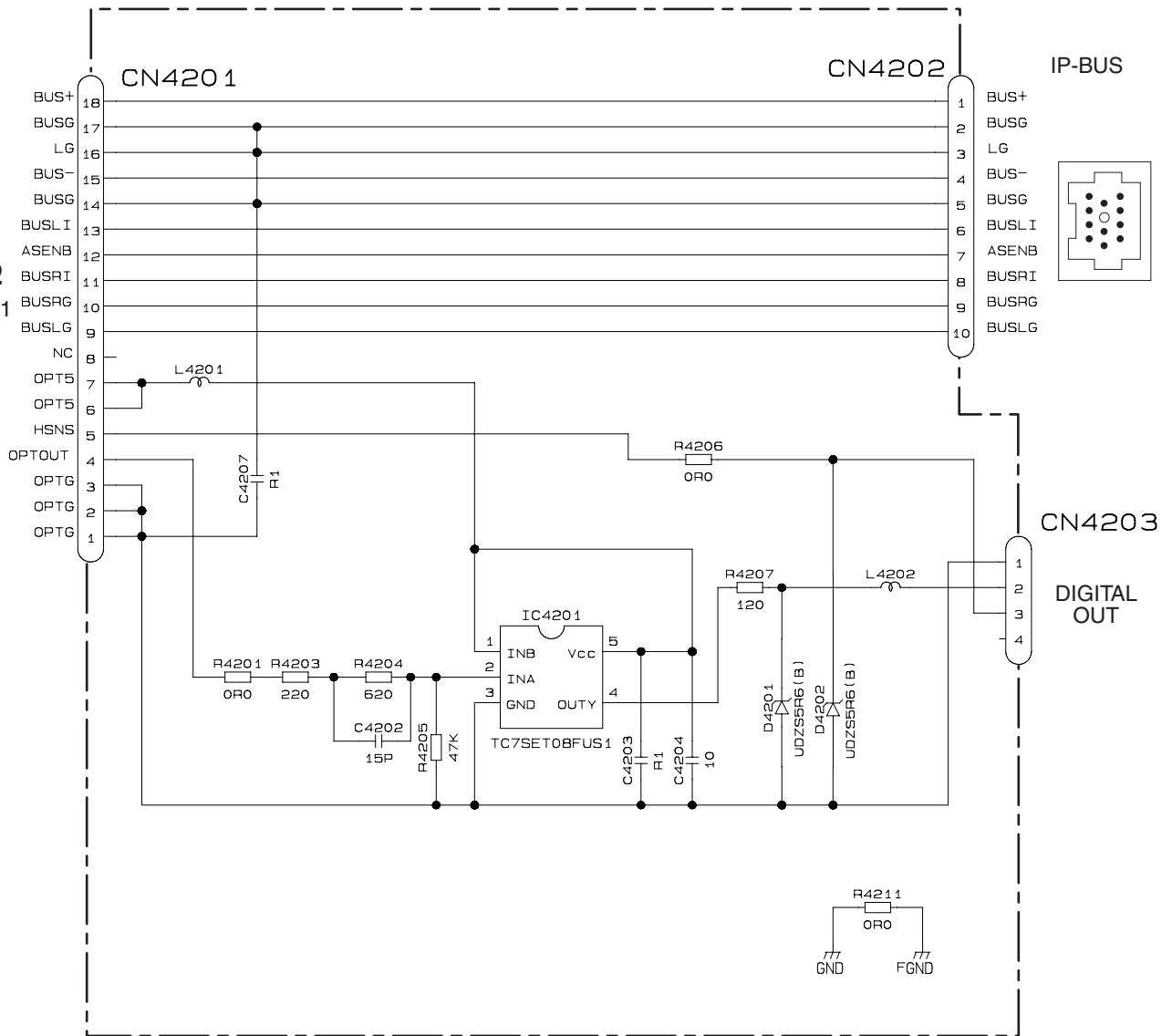

**OPT/RCA UNIT**  
Consists of  
RCA PCB  
OPT PCB



# 10.12 MAIN PCB UNIT(SERVICE), SWITCH PCB UNIT AND VOLUME PCB UNIT

$$V_{out} = V_c * (R_1 + R_2) / R_1$$

$$V_c = 1.225V (typ)$$

$$R_1 = 5.09, R_2 = 33k$$

$$V_{out} = 9.15V$$

## J MAIN PCB UNIT(SERVICE)

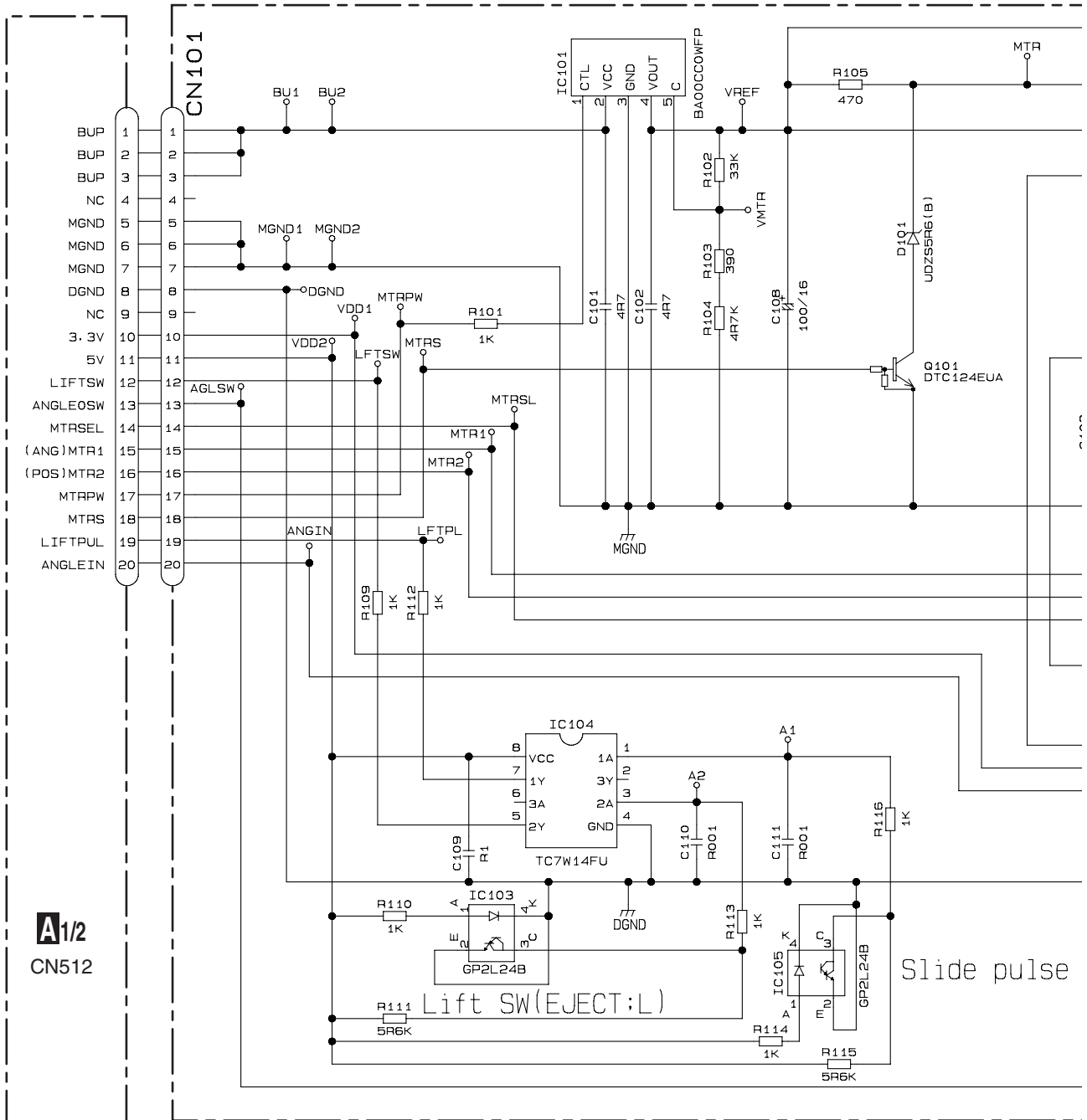

A1/2  
CN512

Lift SW(EJECT:L)

Slide pulse

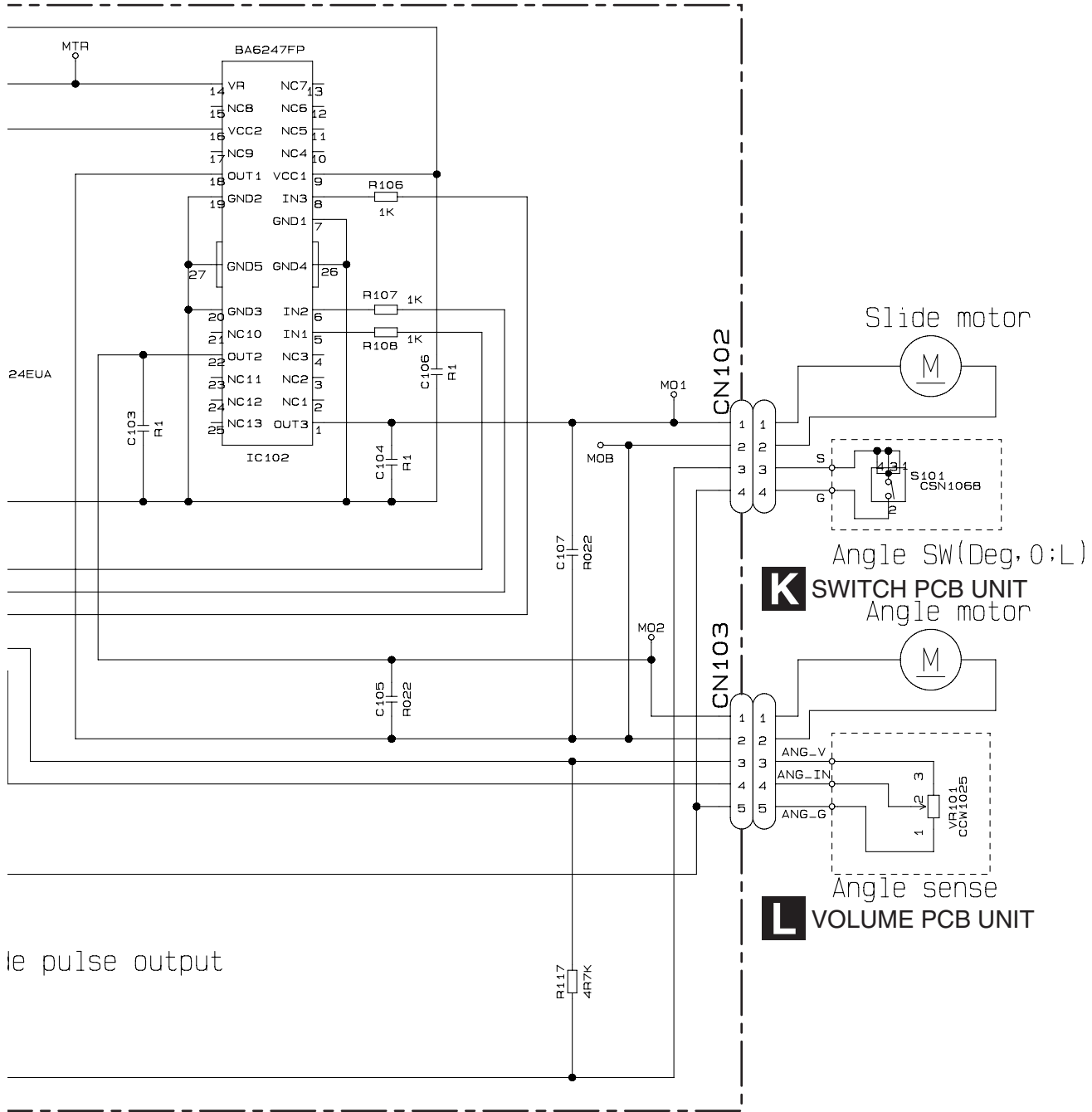

le pulse output

# 10.13 WAVEFORMS

## ● DVD Core Unit

Note: 1. The encircled number denote measuring points in the circuit diagram.  
 2. Reference voltage: 1.65 V(TD1,FD1)(=VHALF)  
 2.2 V(RF)(=VREF)  
 In the waveform, it is seeing on the GND standard.  
 Offset of 1.65 V or 2.2 V is put in.

- 1 RF
- 2 TD1
- 3 A+, A-
- 4 B+, B-
- 5 FD1

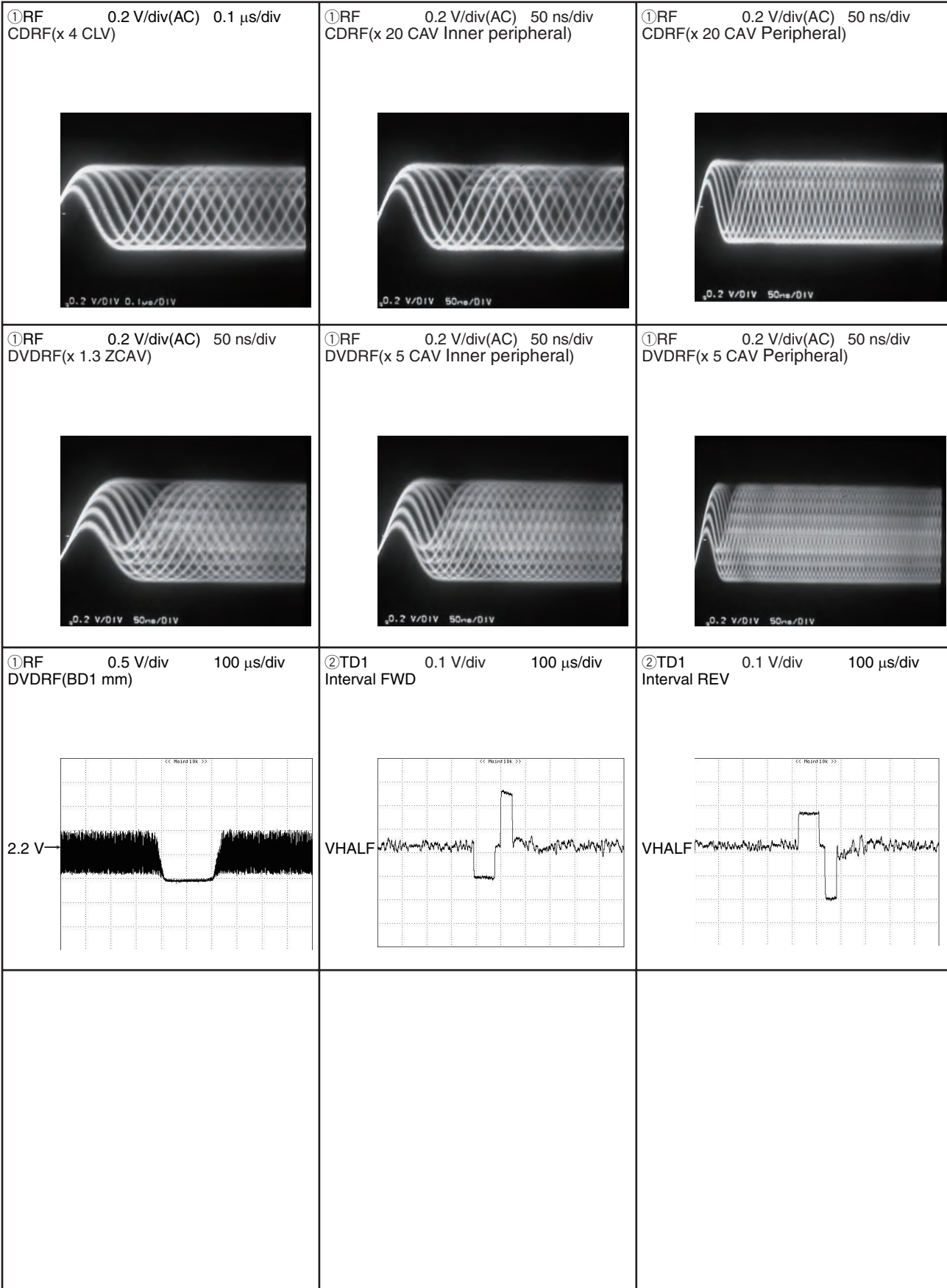



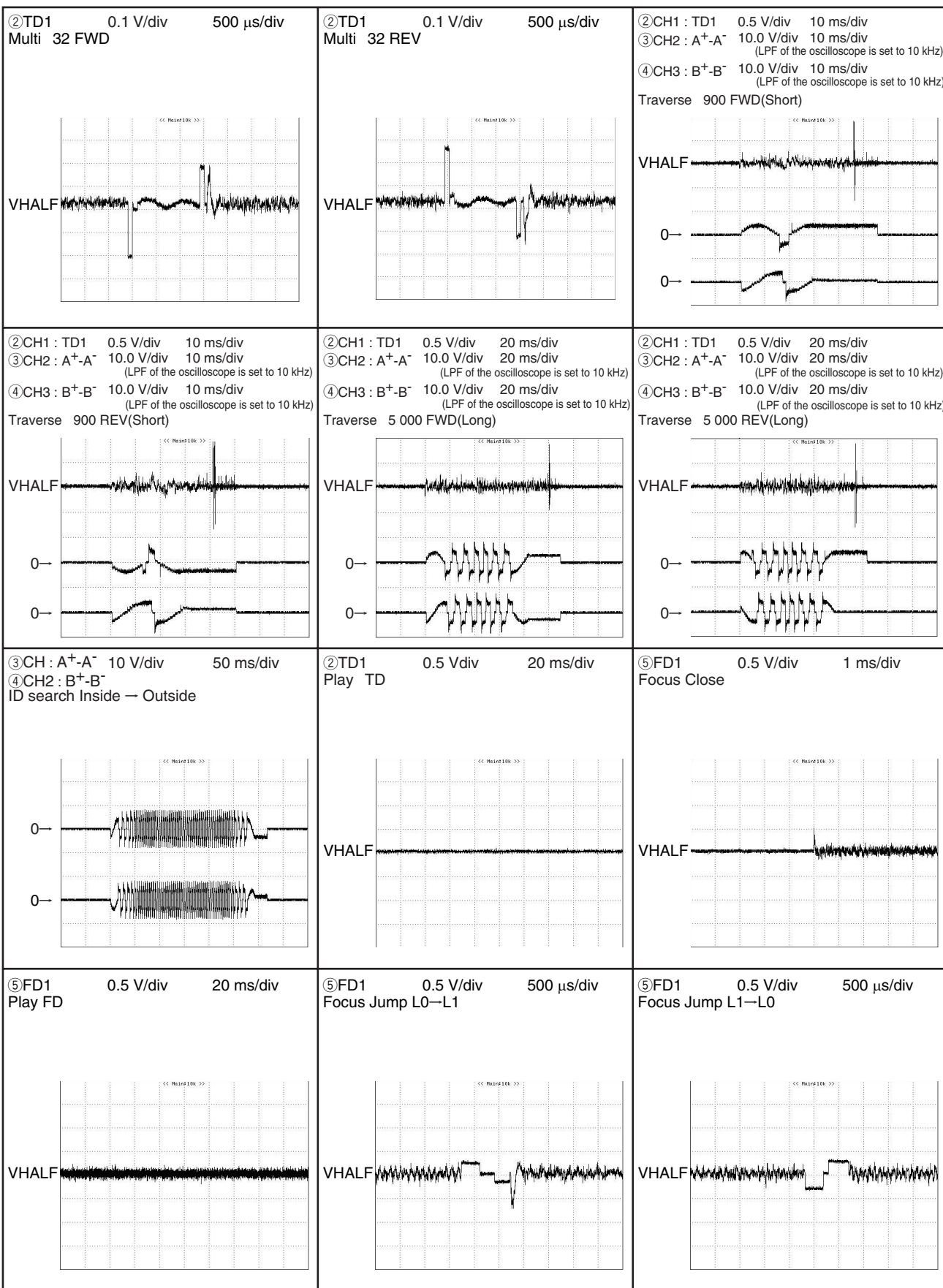

# 11. PCB CONNECTION DIAGRAM

## 11.1 MOTHER UNIT

### NOTE FOR PCB DIAGRAMS

1. The parts mounted on this PCB include all necessary parts for several destination.

For further information for respective destinations, be sure to check with the schematic diagram.

2. Viewpoint of PCB diagrams

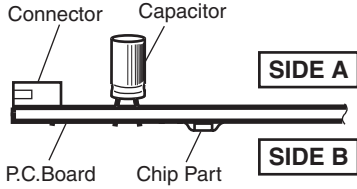

### A MOTHER UNIT

△	FU 521	(A,23,92)	Fuse 2 A	CEK1257
△	FU 522	(A,19,91)	Fuse 200 mA	CEK1247
△	FU 523	(A,16,91)	Fuse 200 mA	CEK1247
△	FU 961	(A,134,86)	Fuse 630 mA	CEK1252
△	FU 971	(A,39,5)	Fuse 2 A	CEK1257
△	FU 972	(A,43,24)	Fuse 2 A	CEK1257
△	FU 973	(A,15,30)	Fuse 2 A	CEK1257

A

B

C

D

E

F

**A**

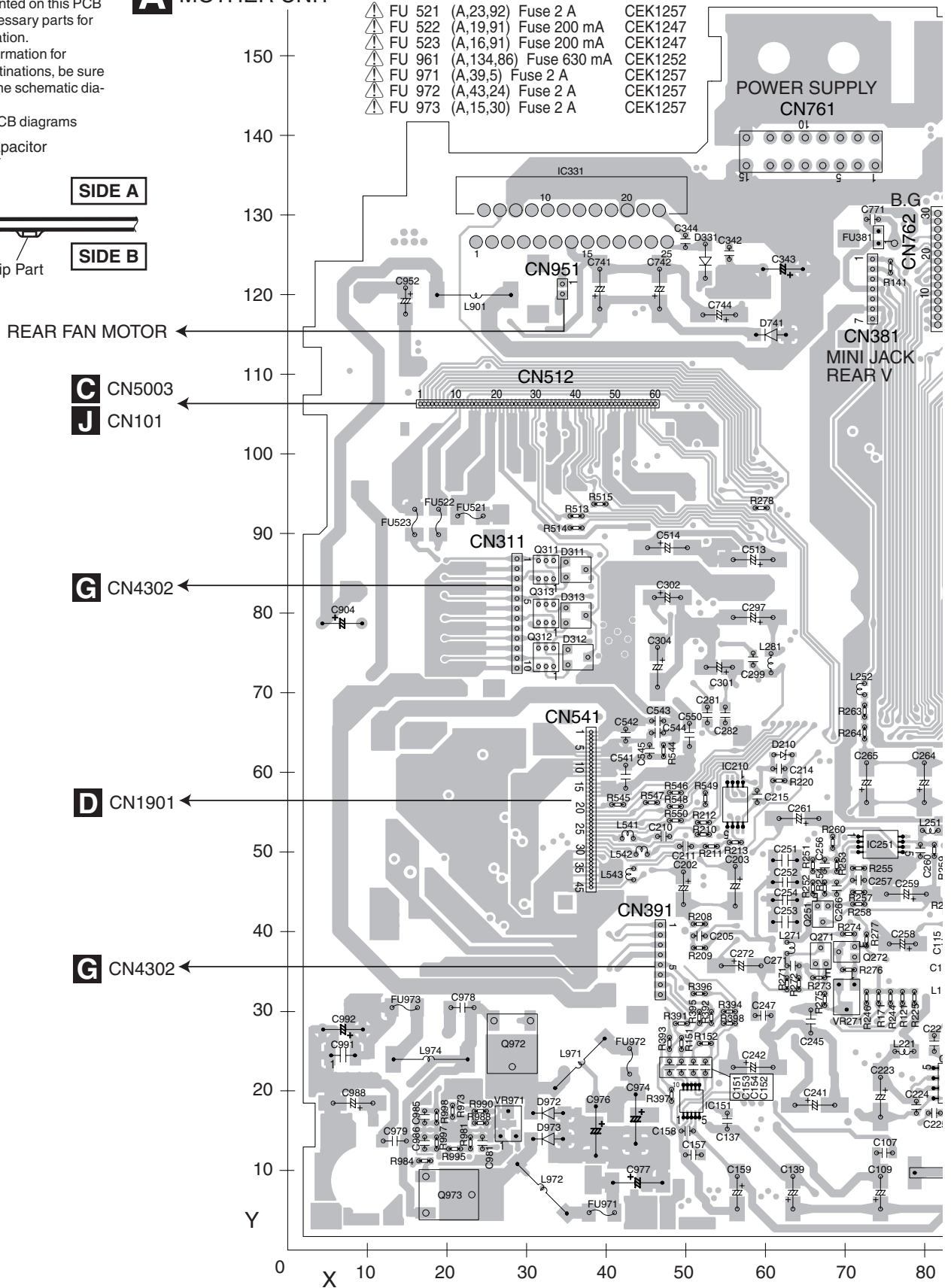

SIDE A

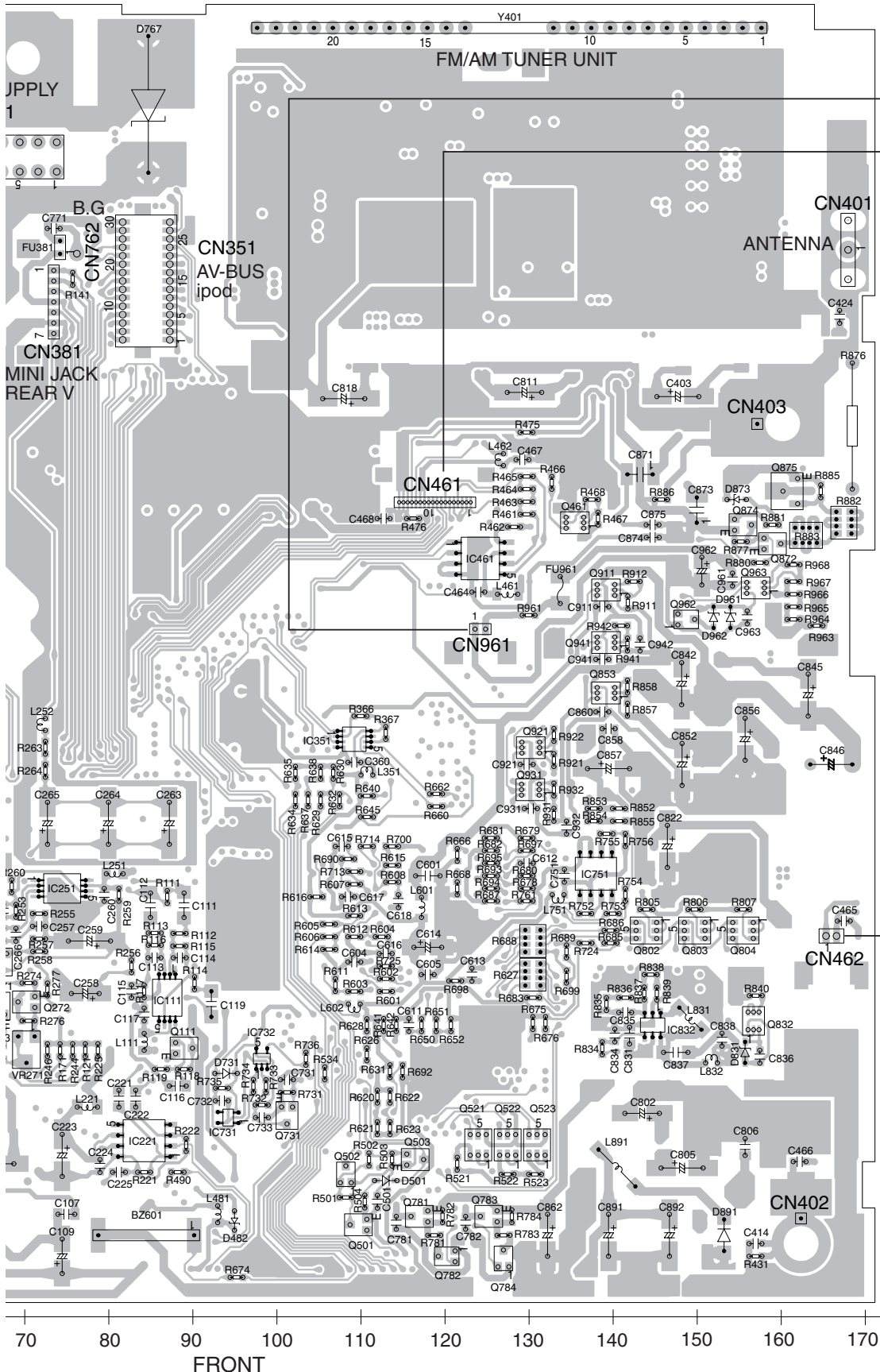

CENTER FAN MOTOR

**I** CN4201

CN401 ANTENNA

JPPPLY 1

CN381 MINI JACK REAR V

CN351 AV-BUS ipod

CN403

CN461

CN961

**D** CN1852

CN462

CN402

FRONT

AVH-P5950DVD/XN/RC

**A**

# A MOTHER UNIT

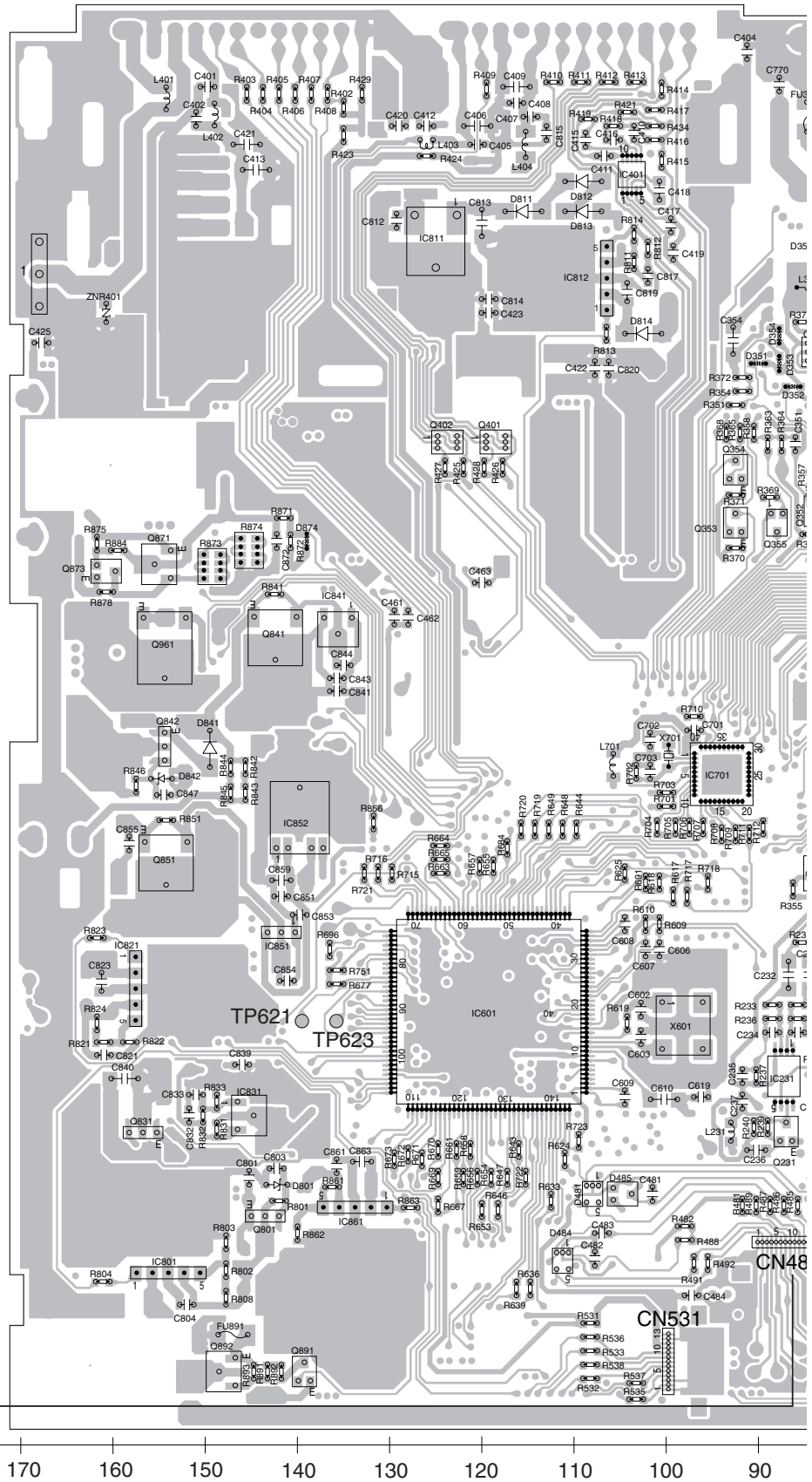

**B** CN4001 ←

**A**

AVH-P5950DVD/XN/RC



SIDE B

- ⚠ FU 311 (B,18,74) Fuse 3.15 A CEK1259
- ⚠ FU 351 (B,85,144) Fuse 3.15 A CEK1259
- ⚠ FU 352 (B,79,144) Fuse 3.15 A CEK1259
- ⚠ FU 761 (B,68,146) Fuse 3.15 A CEK1259
- ⚠ FU 891 (B,147,12) Fuse 1.25 A CEK1255
- ⚠ FU 901 (B,8,92) Fuse 1.25 A CEK1255
- ⚠ FU 951 (B,13,113) Fuse 630 mA CEK1252

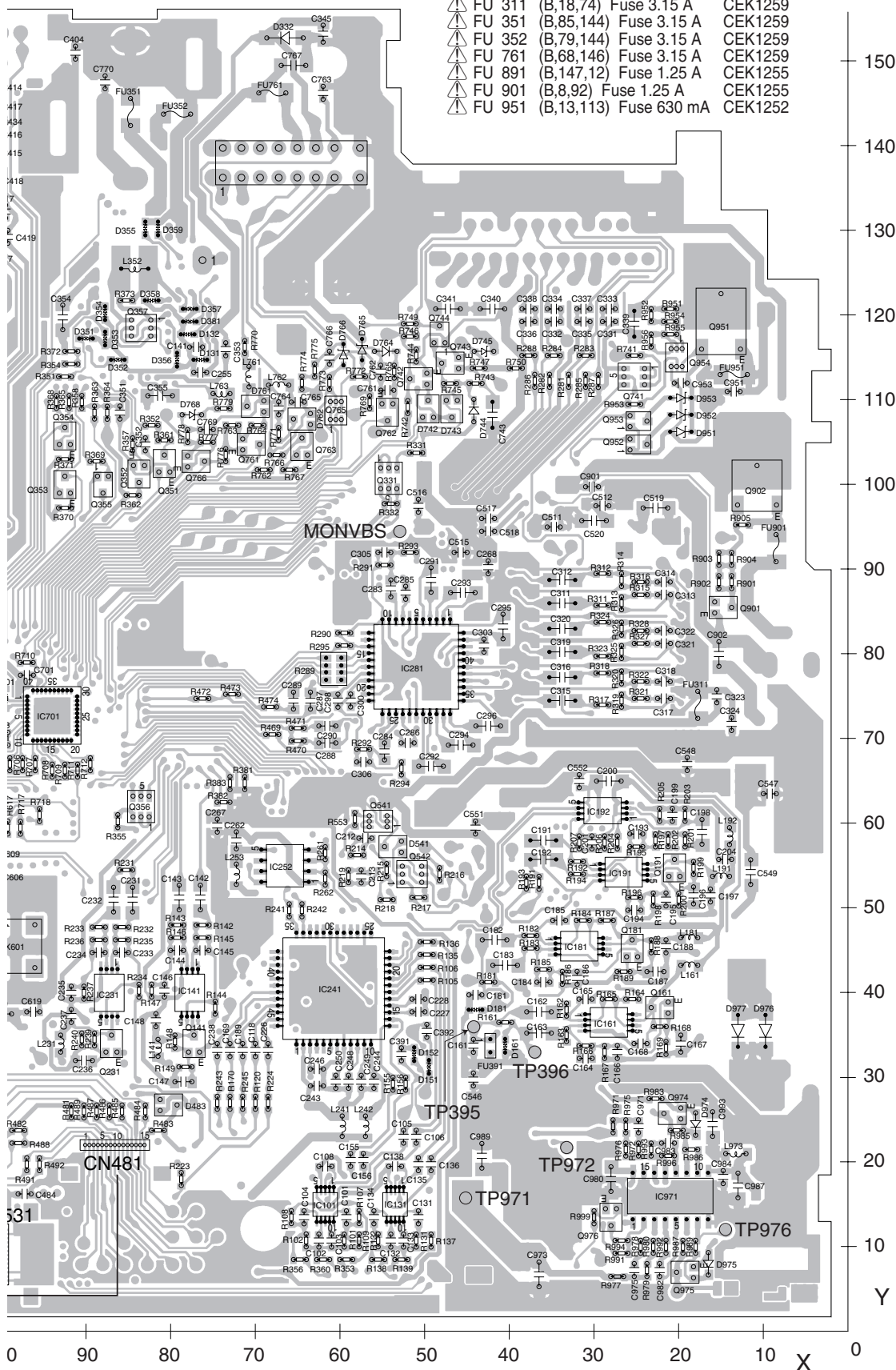

# 11.2 KEYBOARD UNIT

## B KEYBOARD UNIT

SIDE A

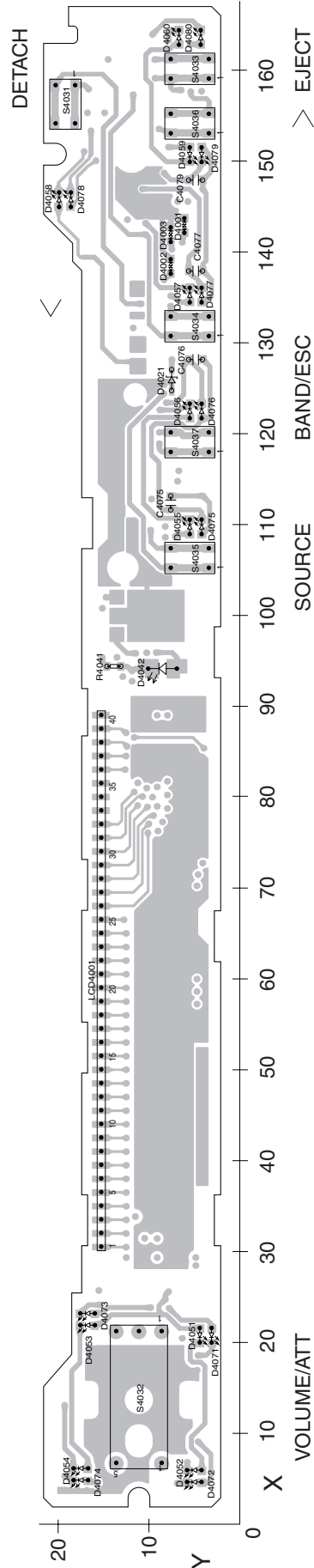

AVH-P5950DVD/XN/RC

B



# 11.3 MONITOR PCB

## C MONITOR PCB

A

B

C

D

E

F

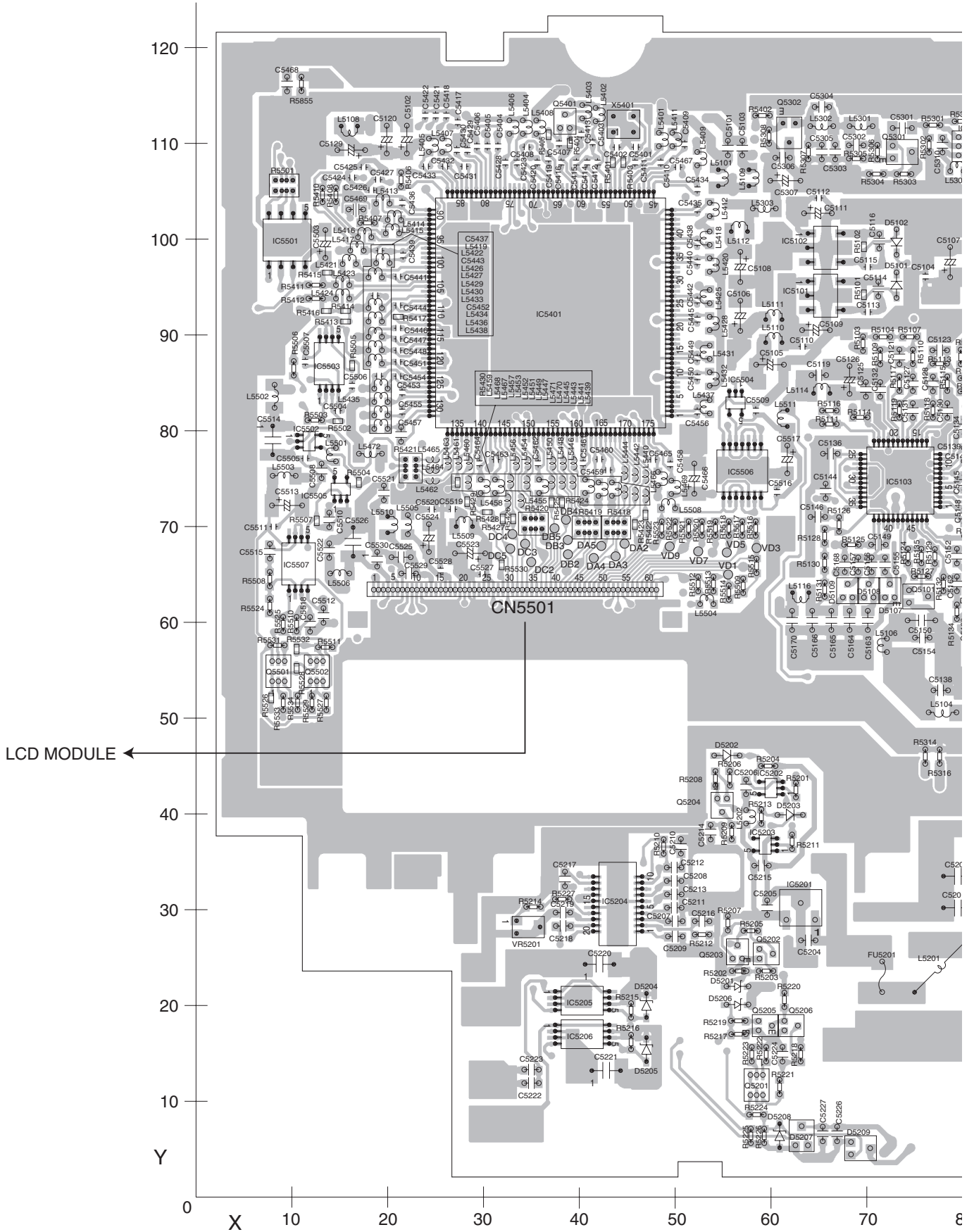



AVH-P5950DVD/XN/RC



SIDE A

**H** CN5901

 FU 5101 (A,83,51) Fuse 1.25 A CEK1255  
 FU 5201 (A,72,23) Fuse 1.25 A CEK1255

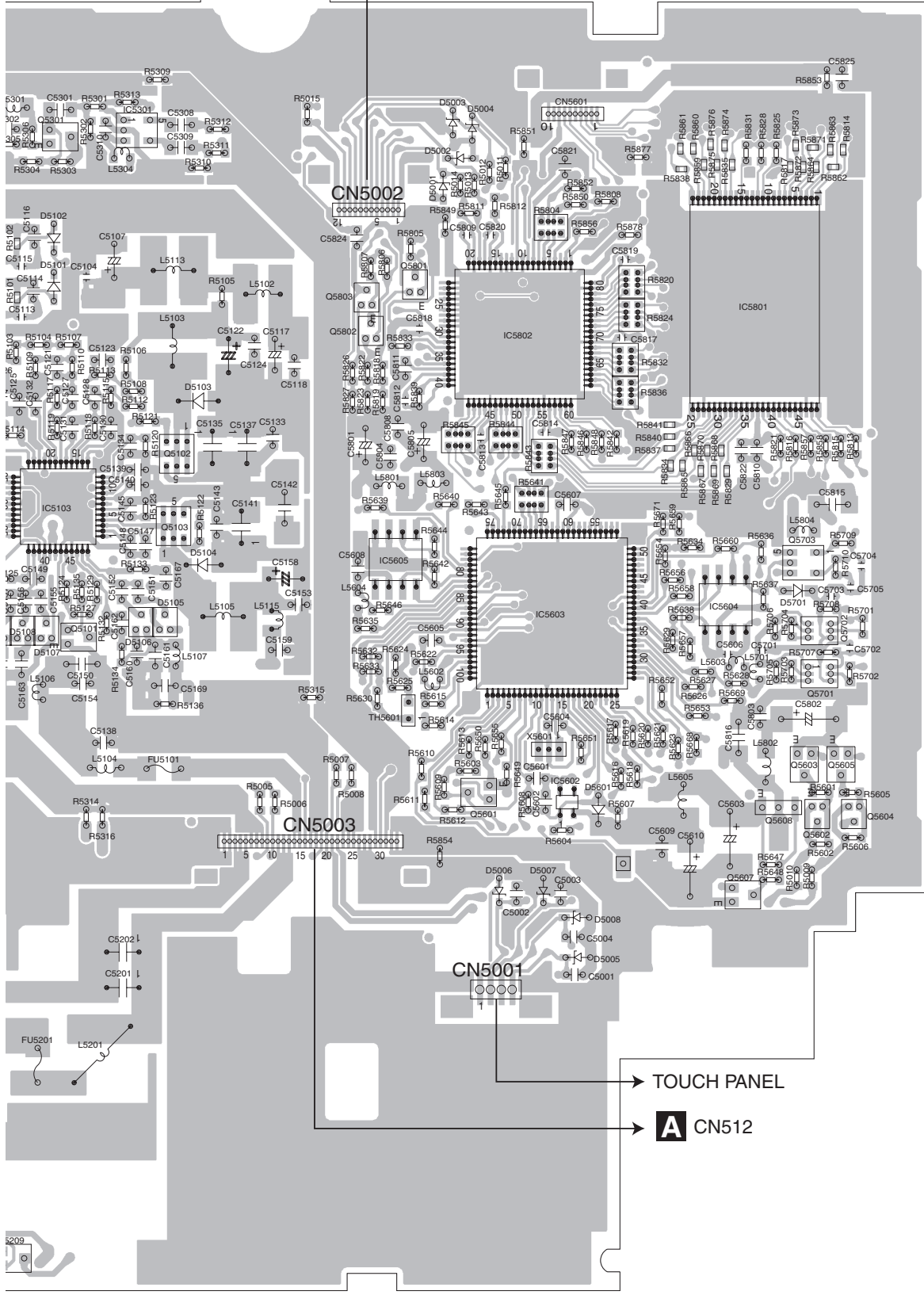

A

B

C

D

E

F

**C**

# C MONITOR PCB

A

B

C

D

E

F

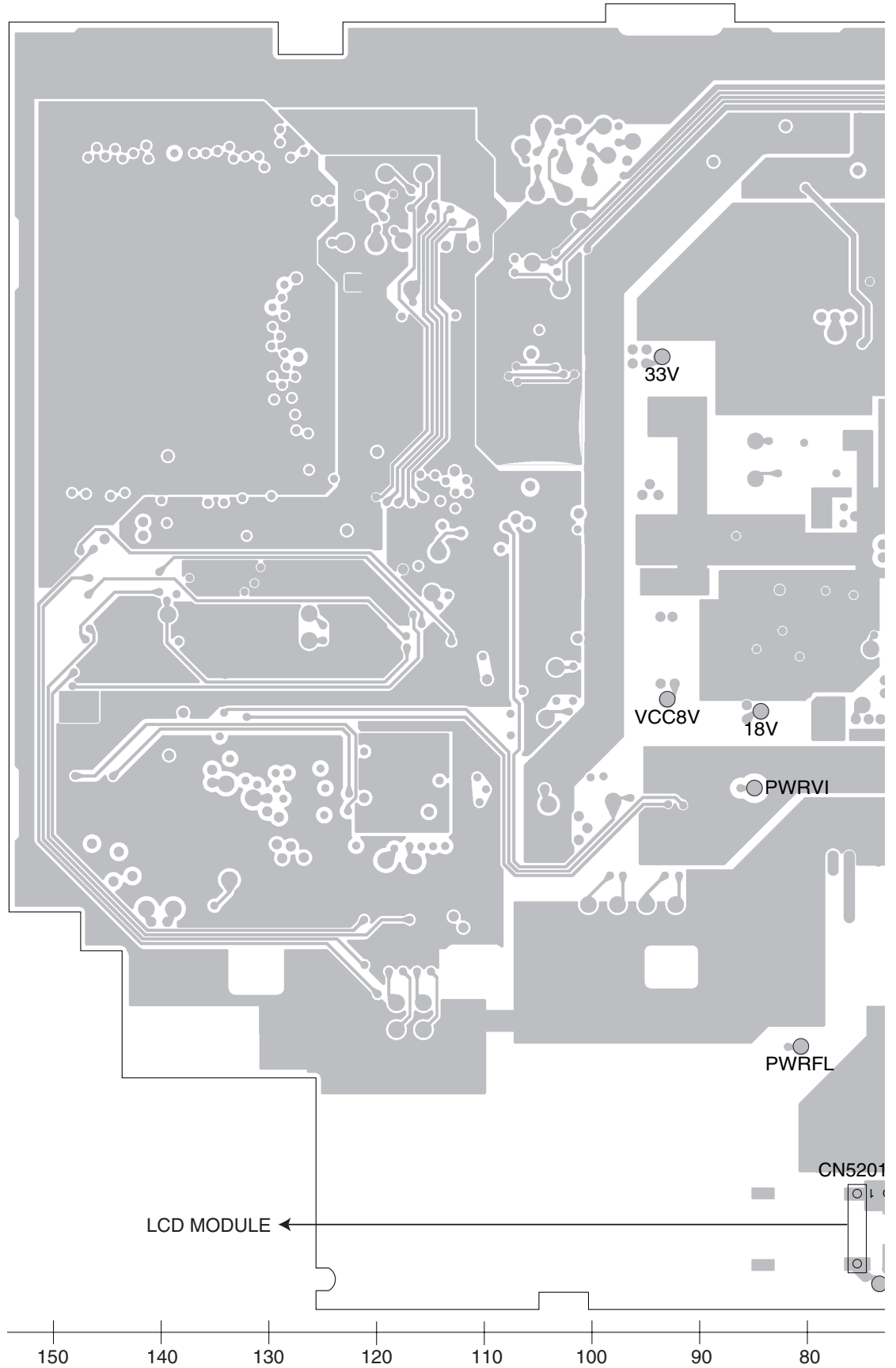

# C

SIDE B

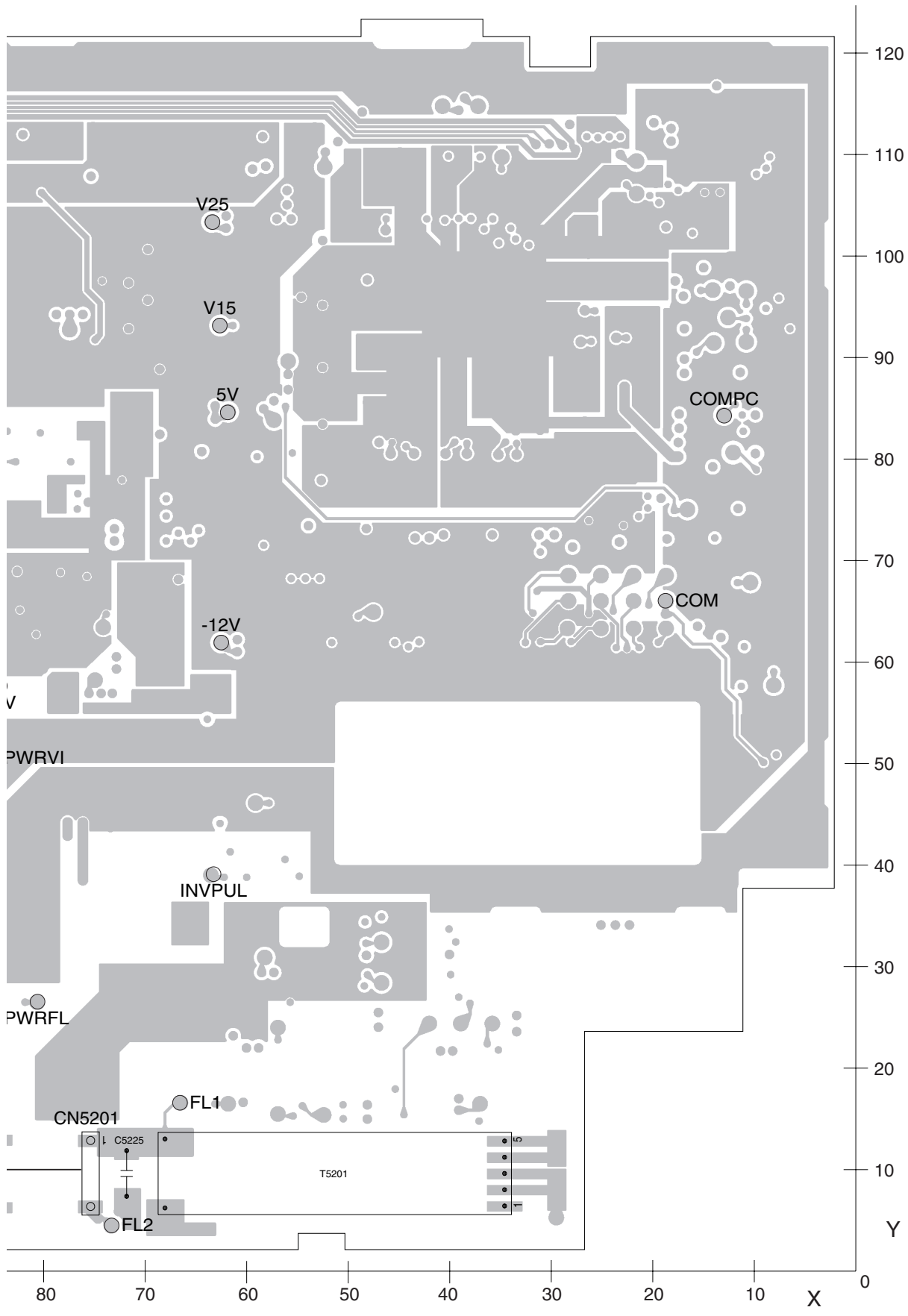

A

B

C

D

E

F

C

# 11.4 DVD CORE UNIT

## D DVD CORE UNIT

A

B

C

D

E

F

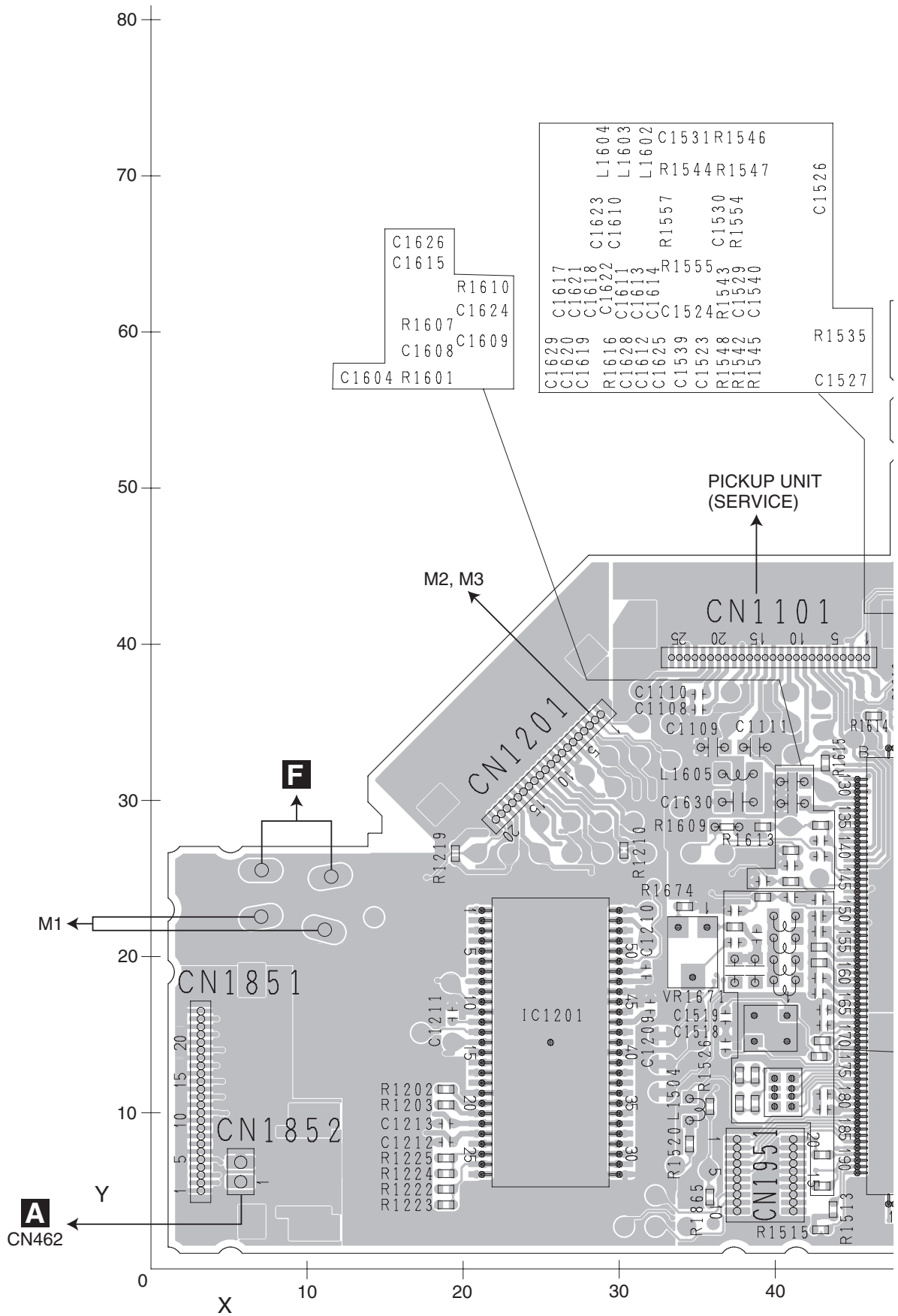

SIDE A

A

B

C

D

E

F

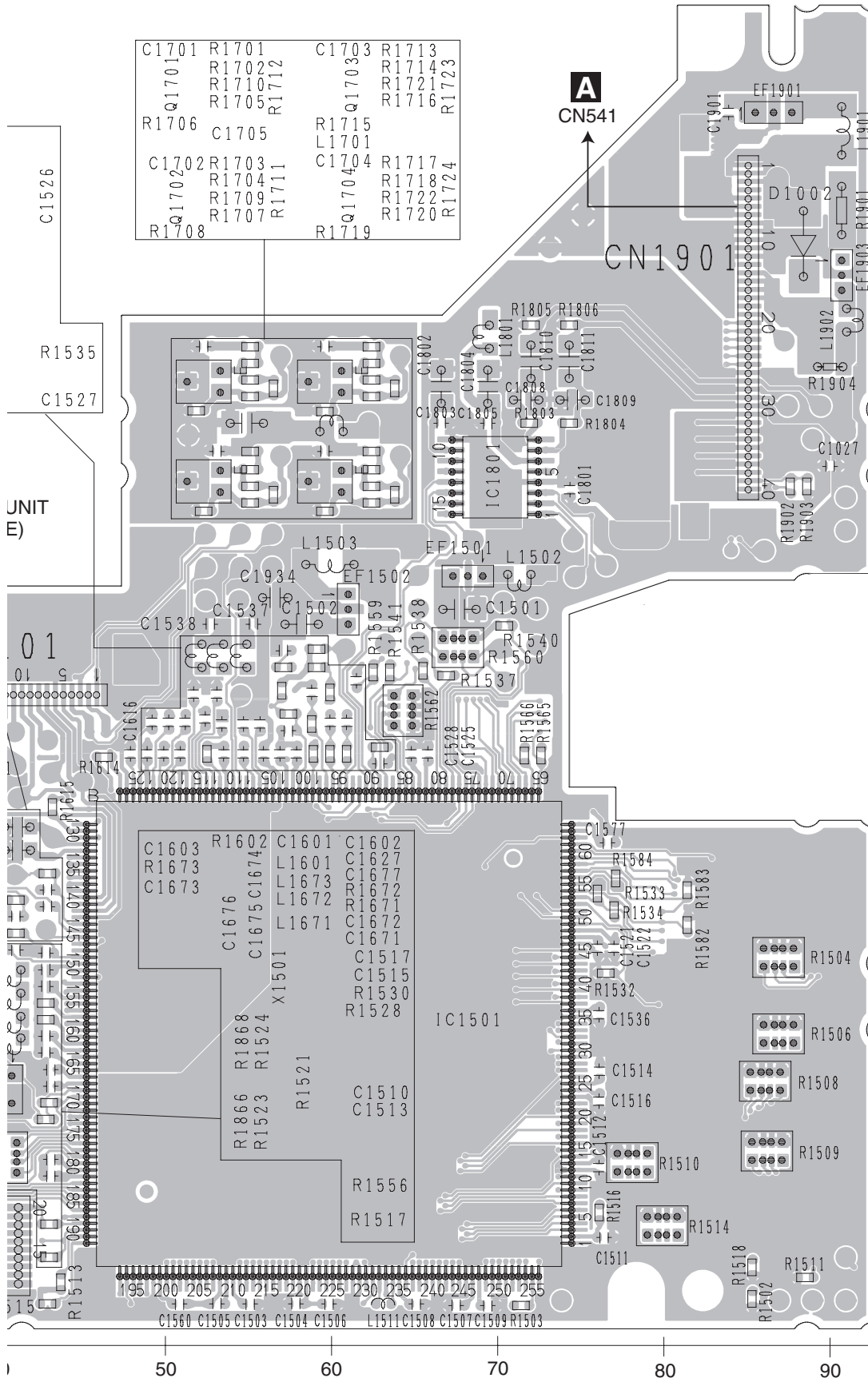

# D DVD CORE UNIT

A

B

C

D

E

F

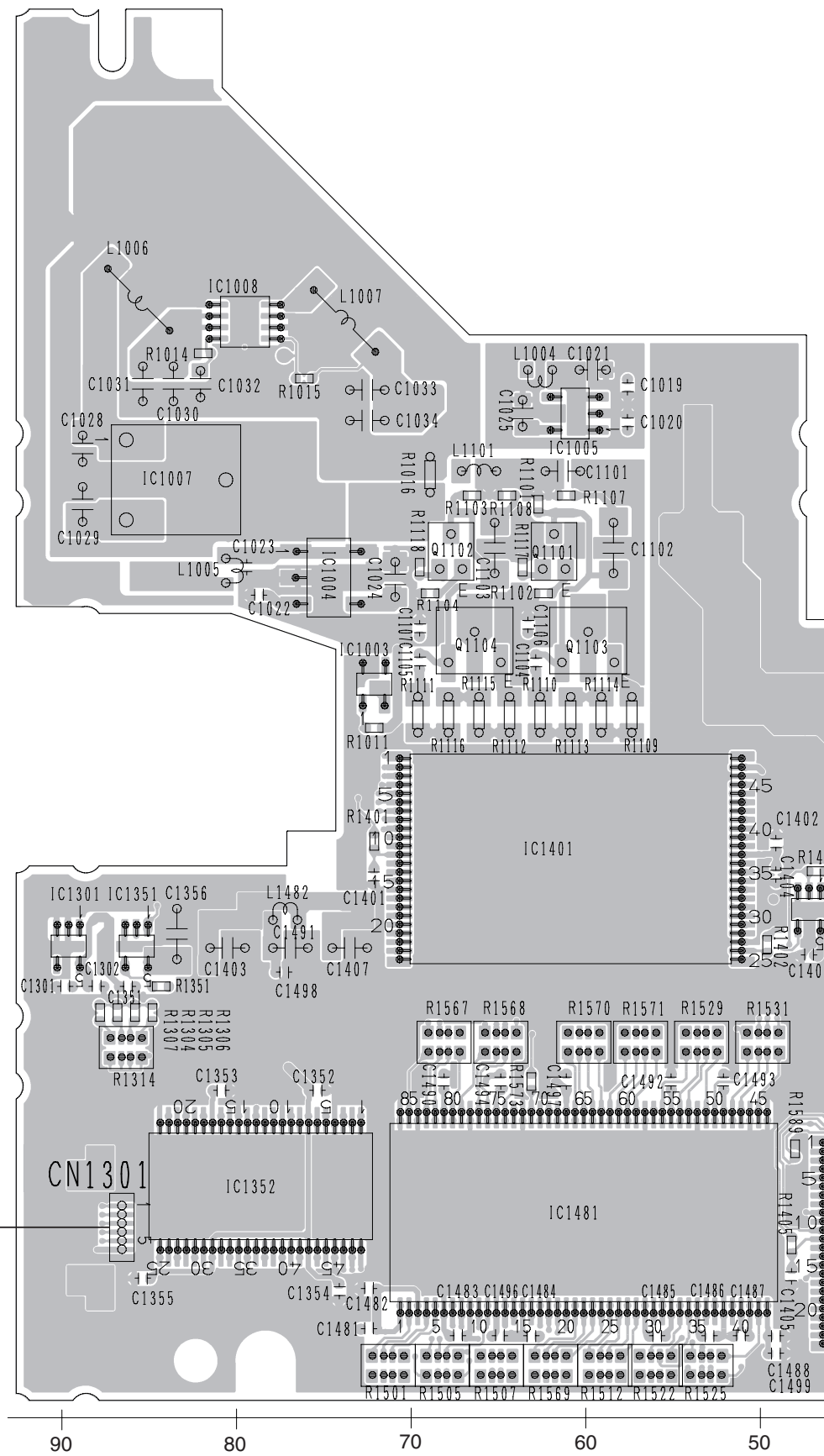

**D**

SIDE B

A

B

C

D

E

F

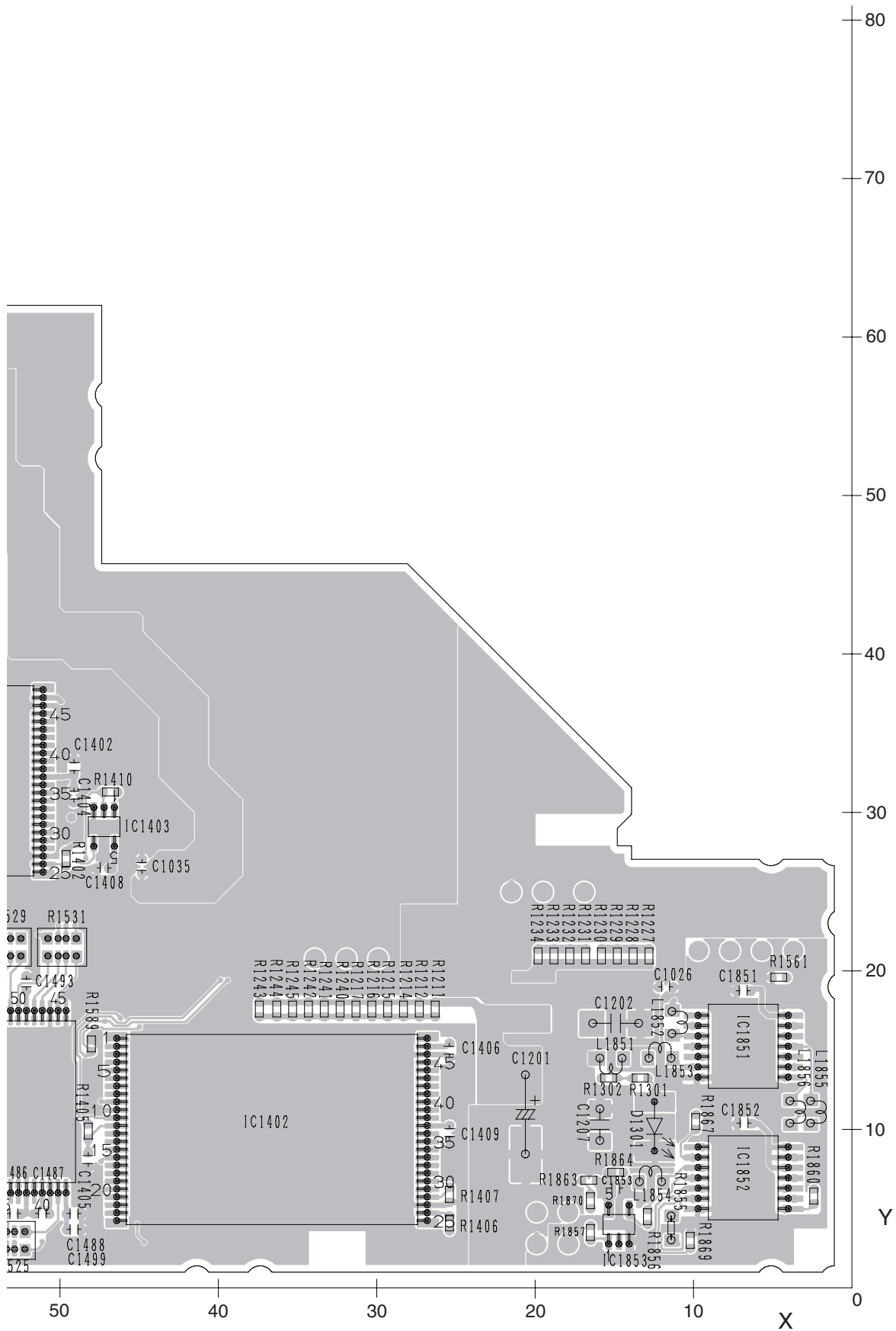

D

# 11.5 COMPOUND UNIT(A) AND COMPOUND UNIT(B)

**E** COMPOUND UNIT(A)

**F** COMPOUND UNIT(B)

A

B

C

D

E

F

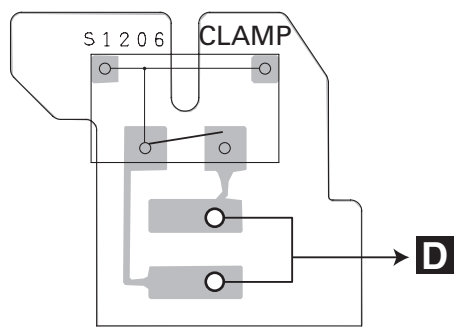
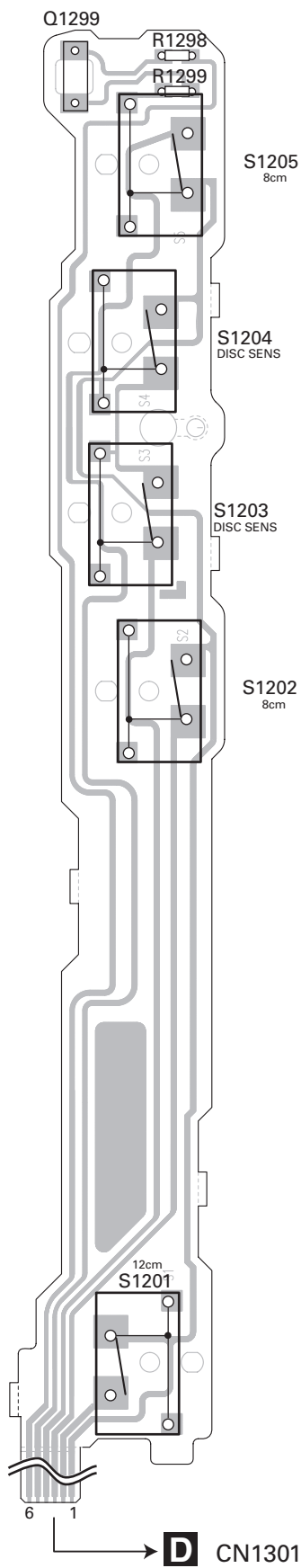

**E F**



5  
**11.6 RCA PCB**

**G** RCA PCB

**SIDE A**

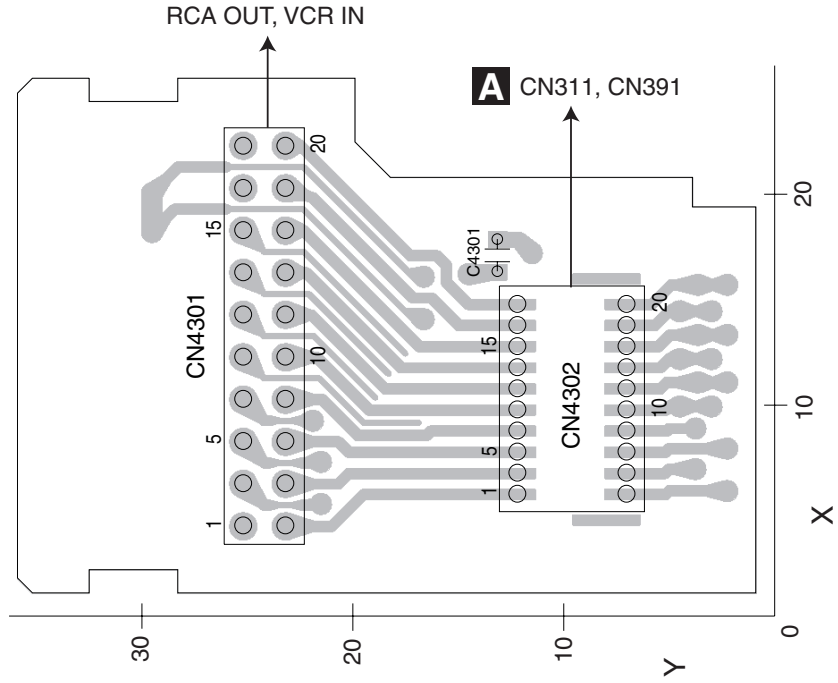

**G** RCA PCB

**SIDE B**

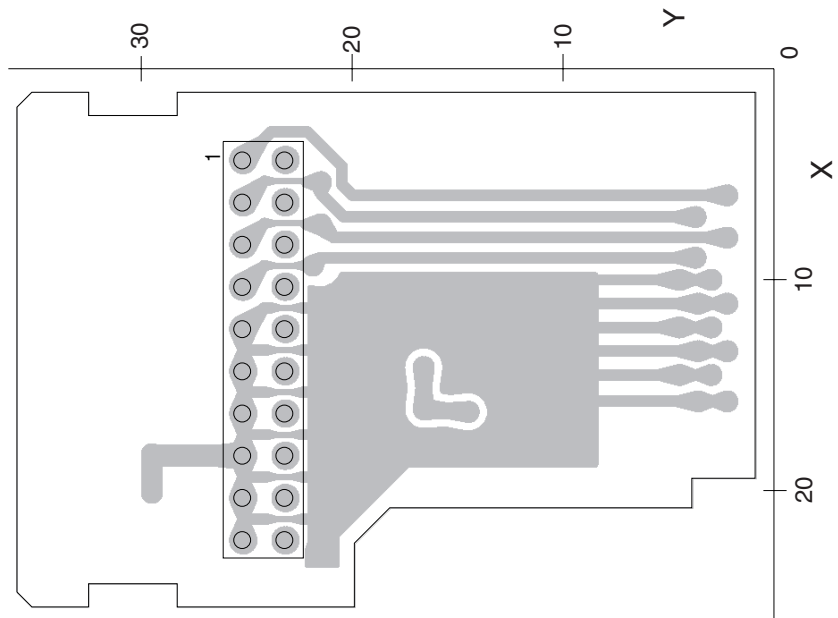

# 11.7 UPPER PCB

## UPPER PCB

SIDE A

## UPPER PCB

SIDE B

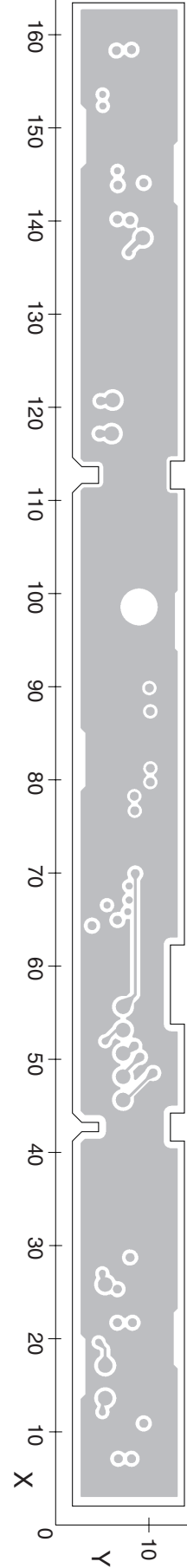
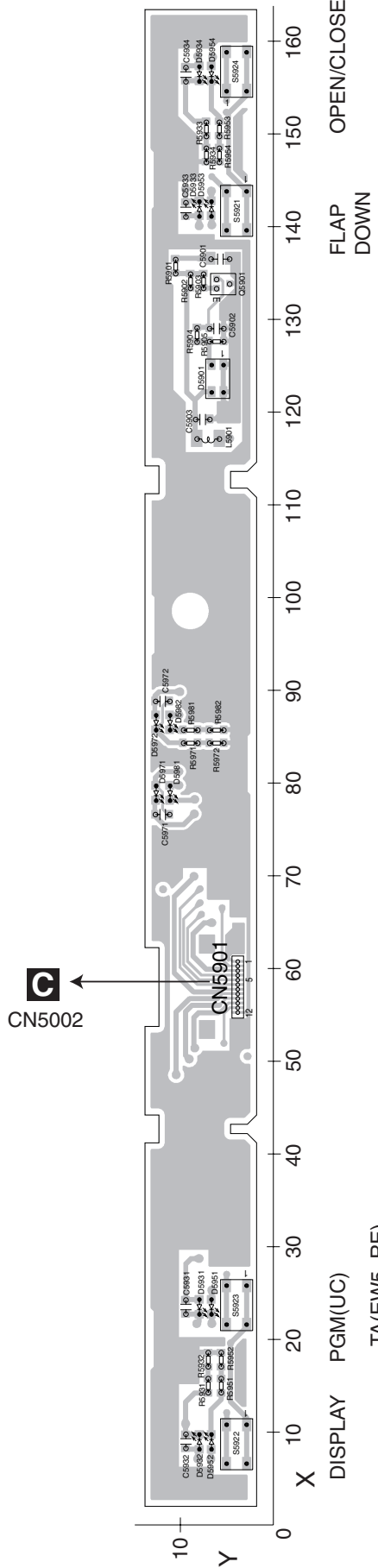

5 6 7 8

# 11.8 OPT PCB

**I** OPT PCB

**SIDE A**

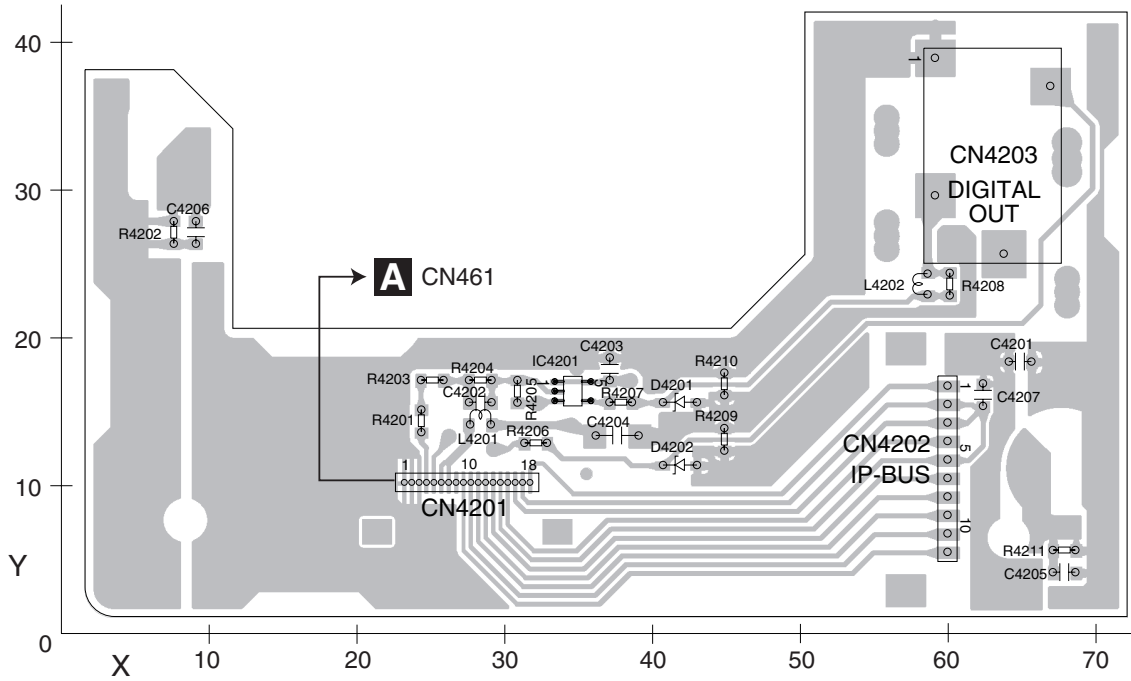

**I** OPT PCB

**SIDE B**

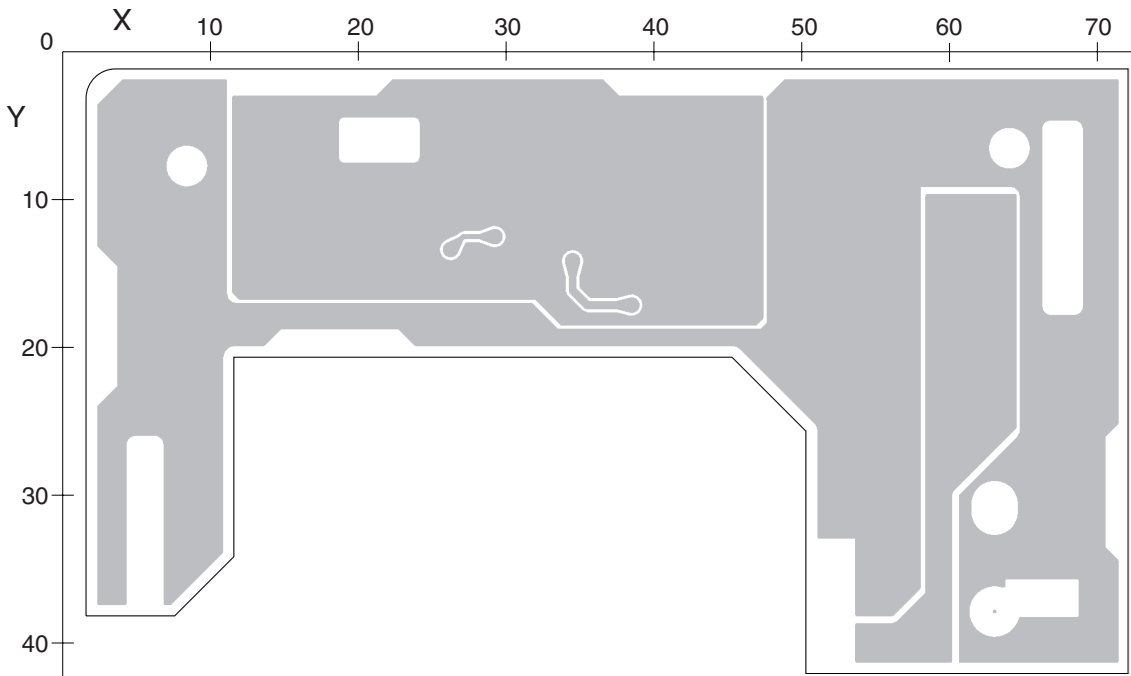

11.9 MAIN PCB UNIT(SERVICE), SWITCH PCB UNIT AND VOLUME PCB UNIT

**J** MAIN PCB UNIT(SERVICE)

**SIDE A**

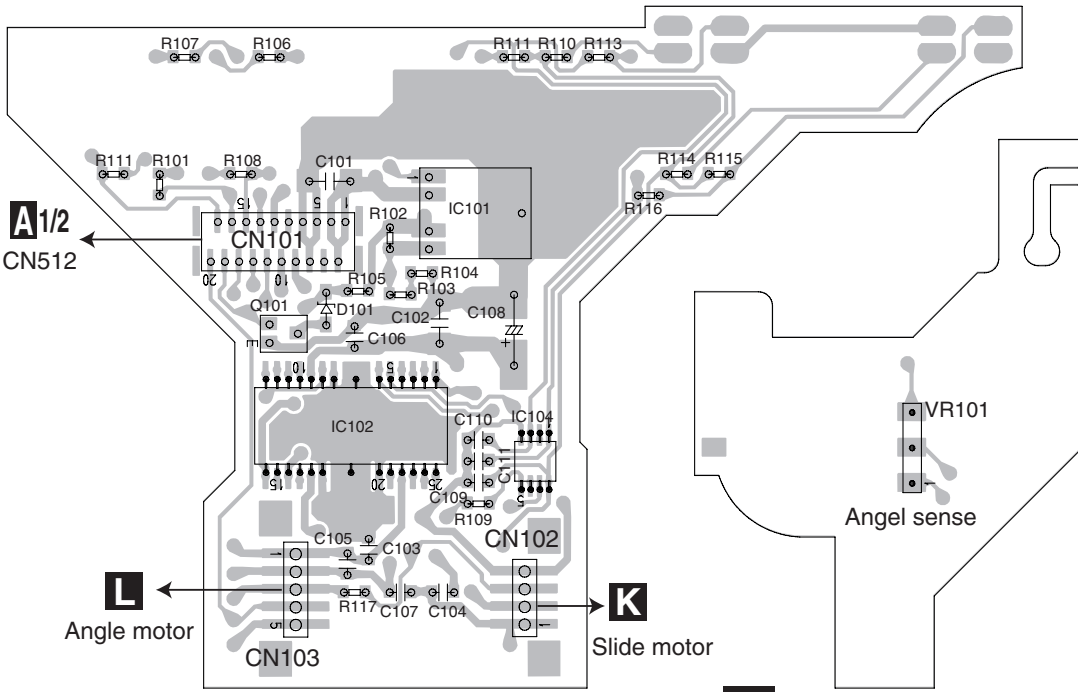

**A1/2**  
CN512

**K**  
SWITCH PCB UNIT

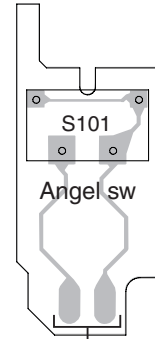

**K** CN102

**L**  
Angle motor

**K**  
Slide motor

**L** VOLUME PCB UNIT

**J** MAIN PCB UNIT(SERVICE)

**L** VOLUME PCB UNIT

**SIDE B**

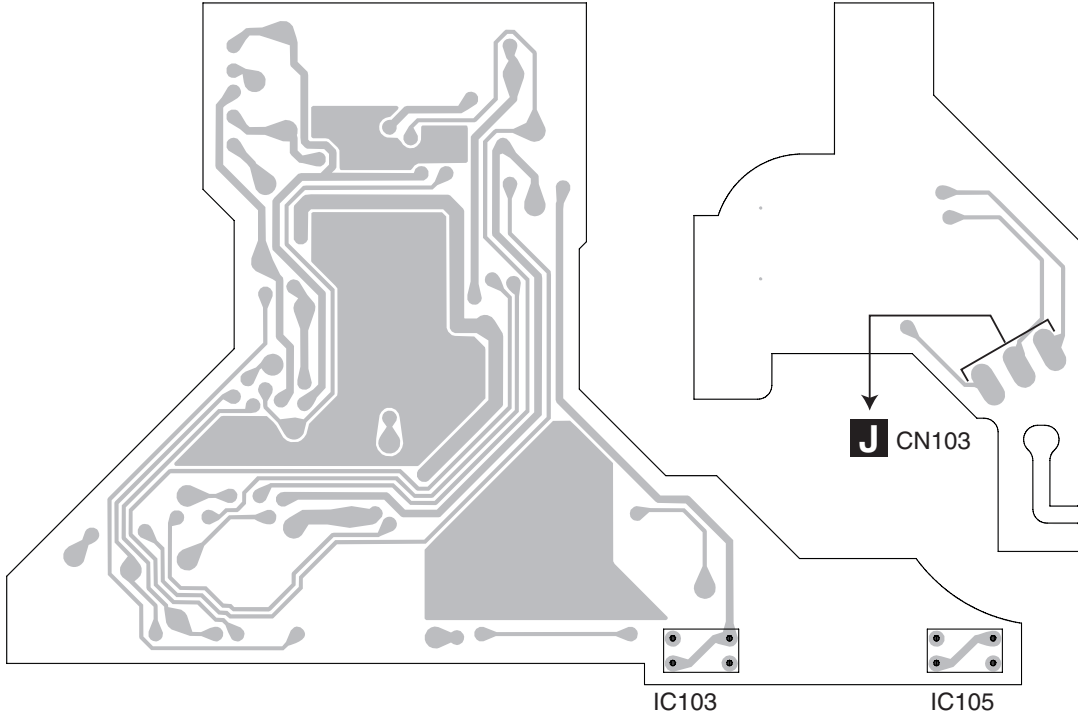

**J** CN103

IC103

IC105

**J K L**

# 12. ELECTRICAL PARTS LIST

## NOTE:

- Parts whose parts numbers are omitted are subject to being not supplied.
- The part numbers shown below indicate chip components.

### Chip Resistor

RS1/○S○○○○J,RS1/○○S○○○○J

### Chip Capacitor (except for CQS.....)

CKS....., CCS....., CSZS.....

- The  $\triangle$  mark found on some component parts indicates the importance of the safety factor of the part. Therefore, when replacing, be sure to use parts of identical designation.
- Meaning of the figures and others in the parentheses in the parts list.

Example) IC 301 is on the point (face A, 91 of x-axis, and 111 of y-axis) of the corresponding PC board.

IC 301 (A, 91, 111) IC NJM2068V

<u>Circuit Symbol and No.</u>	<u>Part No.</u>	<u>Circuit Symbol and No.</u>	<u>Part No.</u>
<b>Unit Number : (RC, RD, RI)</b>		IC 101 (B,62,15) IC	NJM2794RB2
<b>Unit Name : Mother Unit</b>		IC 111 (A,87,38) IC	NJM2136V
<b>Unit Number :</b>		IC 131 (B,53,15) IC	NJM2794RB2
<b>Unit Name : Keyboard Unit</b>		IC 141 (B,78,40) IC	NJM2136V
<b>Unit Number : CWN2330</b>		IC 151 (A,51,19) IC	NJM2794RB2
<b>Unit Name : Monitor Unit</b>		IC 161 (B,28,36) IC	NJM2136V
<b>Unit Number : YWX5005</b>		IC 181 (B,32,45) IC	NJM2136V
<b>Unit Name : DVD Core Unit</b>		IC 191 (B,26,54) IC	NJM2136V
<b>Unit Number : CWX3154</b>		IC 192 (B,29,61) IC	SM5304AV
<b>Unit Name : Compound Unit(A)</b>		IC 221 (A,84,21) IC	NJM2233BM
<b>Unit Number : CWX3394</b>		IC 231 (B,87,40) IC	NJM2136V
<b>Unit Name : Compound Unit(B)</b>		IC 241 (B,61,40) IC	AN15883A
<b>Unit Number : CXX2316</b>		IC 251 (A,74,51) IC	NJM2136V
<b>Unit Name : Main PCB Unit(SERVICE)</b>		IC 252 (B,66,55) IC	BA7623F
<b>Unit Number : CZW5029</b>		IC 281 (B,51,78) IC	PML017A
<b>Unit Name : Switch PCB Unit</b>		IC 331 (A,36,132) IC	PAL007C
<b>Unit Number : CZW5028</b>		IC 351 (A,109,69) IC	TC7WH08FU
<b>Unit Name : Volume PCB Unit</b>		IC 401 (B,104,138) IC	NJM2794RB2
		IC 461 (A,124,90) IC	HA12241FP
		IC 601 (B,119,47) IC	PE5597A
		IC 731 (A,94,24) IC	S-80827CNNB-B8M
		IC 732 (A,98,31) L-MOS And Gate	TC7SET08FUS1
		IC 801 (B,154,24) IC	BA00DD0WHFP
		IC 811 (B,125,129) IC	NJM2391DL1-33
		IC 812 (B,112,126) IC	BA00DD0WHFP
		IC 821 (B,152,49) IC	BA00DD0WHFP
		IC 831 (B,145,36) IC	S-812C56AUA-C3K
		IC 832 (A,145,35) IC	LT3461AES6
		IC 841 (B,136,88) IC	S-812C33AUA-C2N
		IC 851 (B,142,54) IC	S-812C50AUA-C3E
		IC 852 (B,140,69) Regulator	BA00CC0WFP
		IC 861 (B,134,20) IC	BA00DD0WHFP
		IC 971 (B,21,16) IC	AN8011S
		Q 111 (A,89,32) Transistor	2SC4081
		Q 141 (B,77,34) Transistor	2SC4081
		Q 161 (B,22,38) Transistor	2SC4081
		Q 181 (B,25,45) Transistor	2SC4081
		Q 191 (B,20,55) Transistor	2SC4081
		Q 231 (B,87,34) Transistor	2SC4081
		Q 251 (A,67,42) Transistor	2SC4081
		Q 271 (A,67,37) Transistor	2SC4081

**A**

**Unit Number : (RC, RD, RI)**  
**Unit Name : Mother Unit**

## MISCELLANEOUS

	1	2	3	4
	<u>Circuit Symbol and No.</u>	<u>Part No.</u>	<u>Circuit Symbol and No.</u>	<u>Part No.</u>
	Q 272 (A,70,37) Chip Transistor	2SA1576A	Q 953 (B,25,107) Digital Transistor	DTC114EUA
	Q 311 (A,32,85) Transistor	IMH23	Q 954 (B,20,115) Transistor	UMF5N
	Q 312 (A,32,74) Transistor	IMH23	Q 961 (B,154,85) Transistor	2SD1760F5
A	Q 313 (A,32,80) Transistor	IMH23	Q 962 (A,149,83) Digital Transistor	DTC114EUA
	Q 331 (B,54,101) Transistor	IMD3A	Q 963 (A,157,87) Transistor	UMF5N
	Q 351 (B,81,102) Chip Transistor	DTC124EUA	Q 972 (A,28,24) Transistor	2SJ529S
	Q 352 (B,84,101) Chip Transistor	DTC124EUA	Q 973 (A,22,7) Transistor	2SJ529S
	Q 353 (B,92,100) Chip Digital Transistor	DTA124EUA	Q 974 (B,21,26) Transistor	2SC4097
	Q 354 (B,92,106) Chip Digital Transistor	DTA124EUA	Q 975 (B,19,7) Transistor	2SC4097
	Q 355 (B,88,100) Digital Transistor	DTC144EUA	Q 976 (B,28,13) Chip Transistor	DTC124EUA
	Q 356 (B,83,62) Transistor	IMD2A	D 131 (B,76,115) Diode	MALS068X
	Q 357 (B,83,118) Transistor	IMH23	D 132 (B,78,118) Diode	MALS068X
	Q 461 (A,135,94) Transistor	UMF23N	D 151 (B,49,31) Diode	MALS068X
	Q 501 (A,110,11) Chip Transistor	DTA114EUA	D 152 (B,51,33) Diode	MALS068X
B	Q 502 (A,108,17) Digital Transistor	DTC144EUA	D 161 (B,40,34) Diode	MALS068X
	Q 503 (A,116,19) Transistor	2SC4081	D 181 (B,44,38) Diode	MALS068X
	Q 521 (A,124,20) Transistor	IMD3A	D 311 (A,36,85) Diode	DAP202K
	Q 522 (A,127,20) Transistor	IMD3A	D 312 (A,36,74) Diode	DAP202K
	Q 523 (A,131,20) Transistor	IMD3A	D 313 (A,36,80) Diode	DAP202K
	Q 541 (B,55,60) Transistor	UMD3N	D 331 (A,52,124) Diode	S1G-6904G2P
	Q 542 (B,51,54) Transistor	IMH23	D 332 (B,66,153) Diode	S1G-6904G2P
	Q 731 (A,101,24) Transistor	2SC4081	D 351 (B,90,117) Diode	MALS068X
	Q 741 (B,25,113) Transistor	IMD2A	D 352 (B,86,115) Diode	MALS068X
	Q 742 (B,51,112) Chip Transistor	DTC124EUA	D 353 (B,88,117) Diode	MALS068X
C	Q 743 (B,47,114) Transistor	2SC4081	D 354 (B,88,120) Diode	MALS068X
	Q 744 (B,48,118) Digital Transistor	DTC144EUA	D 355 (B,83,130) Diode	MALS068X
	Q 761 (B,70,105) Chip Transistor	2SA1576A	D 356 (B,79,115) Diode	MALS068X
	Q 762 (B,54,109) Chip Transistor	DTC114EUA	D 357 (B,78,121) Diode	MALS068X
	Q 763 (B,64,104) Chip Transistor	2SA1576A	D 358 (B,82,122) Diode	MALS068X
	Q 765 (B,60,109) Transistor	UMX1N	D 359 (B,81,130) Diode	MALS068X
	Q 766 (B,77,103) Transistor	2SC4081	D 381 (B,78,119) Diode	MALS068X
	Q 781 (A,117,12) Transistor	2SA1577	D 481 (B,108,27) Diode	UMZ6R8EN
	Q 782 (A,120,7) Digital Transistor	DTC144EUA	D 482 (A,95,11) Diode	UDZS5R6(B)
	Q 783 (A,125,12) Transistor	2SA1577	D 483 (B,80,27) Diode Network	DA204U
	Q 784 (A,127,7) Digital Transistor	DTC144EUA	D 484 (B,111,20) Diode	UMZ6R8EN
D	Q 801 (B,143,23) Transistor	2SD1767	D 485 (B,105,27) Diode Network	DA204U
	Q 802 (A,144,46) Transistor	IMD3A	D 501 (A,113,16) Diode	1SS355
	Q 803 (A,150,46) Transistor	IMD3A	D 541 (B,54,57) Diode	DAP202U
	Q 804 (A,155,46) Transistor	IMD3A	D 731 (A,94,29) Diode	1SS355
	Q 831 (B,157,36) Transistor	2SD1767	D 741 (A,61,115) Diode	RSX201L-30
	Q 832 (A,157,35) Transistor	UMD3N	D 742 (B,50,109) Diode	DAN202U
	Q 841 (B,142,85) Transistor	2SB1184F5	D 743 (B,47,109) Diode	DAN202U
	Q 842 (B,156,76) Transistor	2SD1767	D 744 (B,44,109) Diode	1SS355
	Q 851 (B,154,61) Transistor	2SB1184F5	D 745 (B,43,116) Diode	UDZS8R2(B)
	Q 853 (A,139,74) Transistor	UMF23N	D 761 (B,70,109) Diode	DAN202U
E	Q 871 (B,155,95) Transistor	2SA2060	D 762 (B,64,108) Diode	DAN202U
	Q 872 (A,159,92) Transistor	2SC4081	D 764 (B,55,116) Diode	1SS355
	Q 873 (B,161,95) Chip Transistor	2SA1576A	D 765 (B,57,116) Diode	HZU7L(C3)
	Q 874 (A,155,94) Chip Transistor	DTC114EUA	D 766 (B,60,115) Diode	HZU7L(A1)
	Q 875 (A,160,98) Transistor	2SA2060	D 767 (A,85,144) Diode	5KP24A
	Q 891 (B,139,8) Chip Transistor	DTC114EUA	D 768 (B,77,108) Diode	UDZS6R8(B)
	Q 892 (B,148,8) Transistor	2SB1189	D 801 (B,142,28) Diode	UDZS5R6(B)
	Q 901 (B,15,85) Chip Transistor	DTC114EUA	D 811 (B,115,134) Diode	1SR154-400
	Q 902 (B,11,102) Transistor	2SA1615-ZS1	D 812 (B,109,137) Diode	1SR154-400
	Q 911 (A,139,86) Transistor	UMF23N	D 813 (B,109,134) Diode	1SR154-400
	Q 921 (A,130,68) Transistor	UMF23N	D 814 (B,102,120) Diode	1SR154-400
F	Q 931 (A,130,63) Transistor	UMF23N	D 831 (A,156,31) Diode	HZU5R6(B2)
	Q 941 (A,139,80) Transistor	UMF23N	D 841 (B,149,75) Diode	1SR154-400
	Q 951 (B,15,121) Transistor	2SD1760F5	D 842 (B,155,72) Diode	UDZS18(B)
	Q 952 (B,25,105) Digital Transistor	DTC114EUA	D 873 (A,155,97) Diode	UDZS16(B)

5		6		7		8	
<u>Circuit Symbol and No.</u>		<u>Part No.</u>		<u>Circuit Symbol and No.</u>		<u>Part No.</u>	
D 874	(B,139,98) Diode	MALS068X		△FU352	(B,79,144) Fuse 3.15 A	CEK1259	
D 891	(A,153,10) Diode	RSX201L-30		△FU521	(A,23,92) Fuse 2 A	CEK1257	
D 951	(B,20,106) Diode	HZU9R1(B2)		△FU522	(A,19,91) Fuse 200 mA	CEK1247	
D 952	(B,20,108) Diode	HZU6R8(B3)		△FU523	(A,16,91) Fuse 200 mA	CEK1247	A
D 953	(B,20,110) Diode	HZU8R2(B2)		△FU761	(B,68,146) Fuse 3.15 A	CEK1259	
D 961	(A,154,83) Diode	HZU7R5(B2)		△FU891	(B,147,12) Fuse 1.25 A	CEK1255	
D 962	(A,152,83) Diode	HZU6R8(B3)		△FU901	(B,8,92) Fuse 1.25 A	CEK1255	
D 972	(A,33,17) Diode	RSX201L-30		△FU951	(B,13,113) Fuse 630 mA	CEK1252	
D 973	(A,33,14) Diode	RSX201L-30		△FU961	(A,134,86) Fuse 630 mA	CEK1252	
D 974	(B,18,24) Diode	MA111		△FU971	(A,39,5) Fuse 2 A	CEK1257	
D 975	(B,16,8) Diode	MA111		△FU972	(A,43,24) Fuse 2 A	CEK1257	
D 976	(B,10,35) Diode	RSX201L-30		△FU973	(A,15,30) Fuse 2 A	CEK1257	
D 977	(B,13,35) Diode	RSX201L-30		BZ601	(A,84,10) Buzzer	CPV1063	
ZNR401	(B,161,123) Surge Protector	IMSA-6801-01Y901					
<b>RESISTORS</b>							
L 111	(A,84,33) Chip Ferrite Bead	CTF1399		R 101	(B,59,11)	RS1/16S223J	B
L 141	(B,81,33) Chip Ferrite Bead	CTF1399		R 102	(B,64,11)	RS1/16S223J	
L 161	(B,19,43) Chip Ferrite Bead	CTF1399		R 105	(B,50,41)	RS1/16S0R0J	
L 181	(B,19,46) Chip Ferrite Bead	CTF1399		R 106	(B,50,43)	RS1/16S0R0J	
L 191	(B,15,54) Chip Ferrite Bead	CTF1399		R 112	(A,88,46)	RS1/16S472J	
L 192	(B,14,58) Chip Ferrite Bead	CTF1399					
L 221	(A,77,25) Inductor	LCKBW100K2520		R 113	(A,85,46)	RS1/16S472J	
L 231	(B,93,34) Chip Ferrite Bead	CTF1399		R 114	(A,90,40)	RS1/16S101J	
L 241	(B,60,24) Chip Coil	LCTAW100J2520		R 115	(A,88,44)	RS1/16S472J	
L 242	(B,57,24) Chip Coil	LCTAW100J2520		R 116	(A,85,44)	RS1/16S472J	
L 251	(A,81,53) Chip Ferrite Bead	CTF1399		R 117	(A,84,39)	RS1/16S102J	
L 252	(A,72,70) Inductor	CTF1383		R 118	(A,89,29)	RS1/16S272J	C
L 253	(B,72,54) Inductor	LCTAW150J2520		R 119	(A,86,29)	RS1/16S472J	
L 271	(A,63,38) Inductor	CTF1473		R 120	(B,70,27)	RS1/16S102J	
L 281	(A,61,74) Inductor	LCTAW2R2J2520		R 121	(A,77,32)	RS1/16S122J	
L 351	(A,111,64) Inductor	CTF1306		R 131	(B,51,11)	RS1/16S223J	
L 352	(B,84,125) Choke Coil 10 μH	CTH1259		R 132	(B,55,11)	RS1/16S223J	
L 401	(B,154,146) Inductor	LCTAW220J2520		R 135	(B,50,44)	RS1/16S0R0J	
L 402	(B,149,144) Chip Coil	LCTAW1R0J2520		R 136	(B,50,46)	RS1/16S0R0J	
L 403	(B,126,141) Inductor	CTF1379		R 137	(B,49,11)	RS1/16S0R0J	
L 404	(B,115,141) Inductor	LCTAW1R0J3225		R 138	(B,55,8)	RS1/16S0R0J	
L 461	(A,127,86) Inductor	LCTAW2R2J2520		R 139	(B,53,8)	RS1/16S0R0J	D
L 462	(A,127,102) Inductor	CTF1473		R 141	(A,76,123)	RS1/16S750J	
L 481	(A,93,12) Chip Ferrite Bead	CTF1399		R 142	(B,76,48)	RS1/16S472J	
L 541	(A,43,52) Inductor	CTF1473		R 143	(B,79,48)	RS1/16S472J	
L 542	(A,44,50) Inductor	CTF1473		R 144	(B,75,38)	RS1/16S101J	
L 543	(A,43,47) Inductor	CTF1473		R 145	(B,76,46)	RS1/16S472J	
L 601	(A,117,49) Inductor	LCTAW2R2J2520		R 146	(B,79,46)	RS1/16S472J	
L 602	(A,109,37) Inductor	CTF1473		R 147	(B,82,40)	RS1/16S102J	
L 751	(A,133,50) Inductor	CTF1306		R 148	(B,79,34)	RS1/16S272J	
L 761	(B,71,113) Inductor	LCTAW2R2J2520		R 149	(B,78,31)	RS1/16S472J	
L 762	(B,67,112) Inductor	LCTAW2R2J2520		R 155	(B,54,29)	RS1/16S0R0J	
L 763	(B,74,111) Inductor	CTF1295		R 156	(B,52,29)	RS1/16S0R0J	E
L 831	(A,149,35) Power Inductor(10U)	DTL1124		R 161	(B,40,36)	RS1/16S750J	
L 832	(A,152,30) Inductor	CTF1473		R 162	(B,33,38)	RS1/16S472J	
L 891	(A,140,18) Coil	CTH1267		R 163	(B,33,35)	RS1/16S472J	
L 901	(A,23,120) Inductor	CTH1262		R 164	(B,25,39)	RS1/16S101J	
L 971	(A,37,23) Coil	CTH1303		R 165	(B,28,39)	RS1/16S472J	
L 972	(A,32,8) Coil	CTH1303		R 166	(B,31,34)	RS1/16S472J	
L 973	(B,13,21) Chip Coil	LCTAW100J2520		R 167	(B,29,33)	RS1/16S102J	
L 974	(A,18,24) Inductor	CTH1254		R 168	(B,22,36)	RS1/16S272J	
X 601	(B,98,45) Oscillator 4.718592 MHz	CSS1703		R 169	(B,21,33)	RS1/16S472J	
VR271	(A,70,32) Semi-fixed 1 KΩ(OB)	CCP1390		R 170	(B,73,27)	RS1/16S0R0J	F
VR971	(A,28,16) Semi-fixed 10 kΩ(B)	CCP1396		R 181	(B,42,41)	RS1/16S750J	
△FU311	(B,18,74) Fuse 3.15 A	CEK1259		R 182	(B,37,47)	RS1/16S472J	
△FU351	(B,85,144) Fuse 3.15 A	CEK1259		R 183	(B,37,45)	RS1/16S472J	

	1		2		3		4	
	<u>Circuit Symbol and No.</u>		<u>Part No.</u>		<u>Circuit Symbol and No.</u>		<u>Part No.</u>	
A	R 184	(B,31,49)	RS1/16S472J	R 284	(B,35,115)	RS1/16S272J		
	R 185	(B,36,43)	RS1/16S472J	R 285	(B,31,112)	RS1/16S182J		
	R 186	(B,34,42)	RS1/16S102J	R 286	(B,37,112)	RS1/16S182J		
	R 187	(B,28,49)	RS1/16S101J	R 287	(B,29,112)	RS1/16S272J		
	R 188	(B,23,45)	RS1/16S272J	R 288	(B,38,115)	RS1/16S272J		
B	R 189	(B,26,42)	RS1/16S472J	R 289	(B,61,78)	RAB4C102J		
	R 191	(B,36,53)	RS1/16S0R0J	R 290	(B,59,82)	RS1/16S473J		
	R 192	(B,32,55)	RS1/16S472J	R 291	(B,55,90)	RS1/16S563J		
	R 194	(B,32,54)	RS1/16S472J	R 292	(B,57,69)	RS1/16S563J		
	R 195	(B,25,57)	RS1/16S472J	R 293	(B,52,92)	RS1/16S0R0J		
C	R 196	(B,25,51)	RS1/16S472J	R 294	(B,53,66)	RS1/16S0R0J		
	R 197	(B,23,58)	RS1/16S0R0J	R 311	(B,29,86)	RS1/16S390J		
	R 198	(B,23,51)	RS1/16S102J	R 312	(B,29,89)	RS1/16S390J		
	R 199	(B,18,55)	RS1/16S272J	R 313	(B,27,86)	RS1/16S223J		
	R 200	(B,20,51)	RS1/16S472J	R 314	(B,27,89)	RS1/16S223J		
D	R 201	(B,19,58)	RS1/16S0R0J	R 317	(B,29,74)	RS1/16S390J		
	R 205	(B,22,61)	RS1/16S332J	R 318	(B,29,78)	RS1/16S390J		
	R 208	(A,52,41)	RS1/16S101J	R 319	(B,27,74)	RS1/16S223J		
	R 209	(A,52,38)	RS1/16S102J	R 320	(B,27,77)	RS1/16S223J		
	R 216	(B,48,54)	RS1/16S0R0J	R 323	(B,29,80)	RS1/16S390J		
E	R 217	(B,51,51)	RS1/16S0R0J	R 324	(B,29,84)	RS1/16S390J		
	R 223	(B,79,18)	RS1/16S101J	R 325	(B,27,80)	RS1/16S223J		
	R 224	(B,68,27)	RS1/16S0R0J	R 326	(B,27,83)	RS1/16S223J		
	R 231	(B,85,54)	RS1/16S750J	R 331	(B,51,104)	RS1/16S103J		
	R 232	(B,86,48)	RS1/16S472J	R 332	(B,54,98)	RS1/16S473J		
F	R 233	(B,88,48)	RS1/16S472J	R 351	(B,92,113)	RS1/16S471J		
	R 234	(B,84,40)	RS1/16S101J	R 352	(B,82,107)	RS1/16S514J		
	R 235	(B,86,46)	RS1/16S472J	R 353	(B,59,8)	RS1/16S0R0J		
	R 236	(B,88,46)	RS1/16S472J	R 354	(B,92,114)	RS1/16S471J		
	R 237	(B,90,40)	RS1/16S102J	R 355	(B,86,60)	RS1/16S102J		
G	R 239	(B,89,34)	RS1/16S272J	R 356	(B,65,8)	RS1/16S0R0J		
	R 240	(B,90,34)	RS1/16S472J	R 357	(B,84,105)	RS1/16S102J		
	R 241	(B,66,50)	RS1/16S221J	R 358	(B,90,110)	RS1/16S472J		
	R 242	(B,64,50)	RS1/16S221J	R 360	(B,62,8)	RS1/16S0R0J		
	R 243	(B,74,27)	RS1/16S0R0J	R 361	(B,81,105)	RS1/16S393J		
H	R 245	(B,71,27)	RS1/16S0R0J	R 362	(B,84,99)	RS1/16S104J		
	R 251	(A,66,48)	RS1/16S472J	R 363	(B,89,108)	RS1/16S472J		
	R 252	(A,66,45)	RS1/16S472J	R 364	(B,87,108)	RS1/16S104J		
	R 253	(A,69,48)	RS1/16S472J	R 365	(B,92,110)	RS1/16S102J		
	R 254	(A,67,45)	RS1/16S472J	R 366	(A,110,71)	RS1/16S102J		
I	R 255	(A,72,48)	RS1/16S102J	R 367	(A,113,69)	RS1/16S102J		
	R 256	(A,83,42)	RS1/16S272J	R 368	(B,93,110)	RS1/16S102J		
	R 257	(A,72,45)	RS1/16S392J	R 369	(B,89,103)	RS1/16S102J		
	R 259	(A,81,50)	RS1/16S101J	R 370	(B,92,97)	RS1/16S102J		
	R 260	(A,68,51)	RS1/16S101J	R 371	(B,92,103)	RS1/16S102J		
J	R 261	(B,62,56)	RS1/16S4702D	R 372	(B,92,116)	RS1/16S104J		
	R 262	(B,62,53)	RS1/16S3302D	R 391	(A,49,28)	RS1/16S183J		
	R 263	(A,72,68)	RS1/16S150J	R 392	(A,53,29)	RS1/16S183J		
	R 264	(A,72,65)	RS1/16S560J	R 393	(A,48,26)	RS1/16S223J		
	R 271	(A,63,33)	RS1/16S223J	R 394	(A,55,30)	RS1/16S223J		
K	R 272	(A,64,33)	RS1/16S303J	R 395	(A,52,29)	RS1/16S183J		
	R 273	(A,67,34)	RS1/16S681J	R 396	(A,52,32)	RS1/16S183J		
	R 274	(A,70,40)	RS1/16S681J	R 397	(A,48,19)	RS1/16S223J		
	R 275	(A,67,31)	RS1/16S681J	R 398	(A,55,28)	RS1/16S223J		
	R 276	(A,70,35)	RS1/16S272J	R 403	(B,145,146)	RS1/16S681J		
L	R 277	(A,73,39)	RS1/16S0R0J	R 404	(B,144,146)	RS1/16S681J		
	R 278	(A,59,93)	RS1/16S0R0J	R 405	(B,142,146)	RS1/16S681J		
	R 281	(B,33,112)	RS1/16S182J	R 406	(B,140,146)	RS1/16S681J		
	R 282	(B,35,112)	RS1/16S182J	R 407	(B,138,146)	RS1/16S681J		
	R 283	(B,31,115)	RS1/16S272J	R 409	(B,119,147)	RS1/16S681J		



5		6	7		8
<u>Circuit Symbol and No.</u>		<u>Part No.</u>	<u>Circuit Symbol and No.</u>		<u>Part No.</u>
R 416	(B,101,141)	RS1/16S0R0J	R 604	(A,112,45)	RS1/16S102J
R 417	(B,101,145)	RS1/16S0R0J	R 605	(A,106,47)	RS1/16S0R0J
R 421	(B,104,144)	RS1/16S682J	R 606	(A,106,45)	RS1/16S102J
R 434	(B,101,143)	RS1/16S682J	R 607	(A,109,51)	RS1/16S471J
R 461	(A,130,95)	RS1/16S101J	R 608	(A,114,52)	RS1/16S471J
R 462	(A,128,94)	RS1/16S102J	R 609	(B,101,56)	RS1/16S182J
R 463	(A,130,97)	RS1/16S150J	R 610	(B,102,56)	RS1/16S182J
R 464	(A,130,98)	RS1/16S470J	R 611	(A,107,39)	RS1/16S473J
R 465	(A,130,100)	RS1/16S101J	R 612	(A,109,45)	RS1/16S473J
R 466	(A,133,99)	RS1/16S222J	R 613	(A,109,48)	RS1/16S104J
R 467	(A,138,95)	RS1/16S332J	R 614	(A,106,44)	RS1/16S473J
R 468	(A,137,97)	RS1/16S562J	R 615	(A,114,54)	RS1/16S102J
R 469	(B,68,70)	RS1/16S181J	R 616	(A,105,50)	RS1/16S472J
R 470	(B,65,70)	RS1/16S223J	R 617	(B,99,59)	RS1/16S221J
R 471	(B,65,71)	RS1/16S102J	R 618	(B,101,61)	RS1/16S221J
R 472	(B,76,75)	RS1/16S181J	R 619	(B,104,46)	RS1/16S222J
R 473	(B,73,75)	RS1/16S223J	R 620	(A,112,26) (RC,RI)	RS1/16S473J
R 474	(B,68,74)	RS1/16S102J	R 621	(A,112,22) (RD)	RS1/16S473J
R 475	(A,130,105)	RS1/16S0R0J	R 622	(A,113,26) (RD,RI)	RS1/16S473J
R 476	(A,116,95)	RS1/16S0R0J	R 623	(A,113,22) (RC)	RS1/16S473J
R 481	(B,92,26)	RS1/16S472J	R 624	(B,111,31)	RS1/16S0R0J
R 482	(B,98,24)	RS1/16S472J	R 625	(B,104,62)	RS1/16S102J
R 483	(B,81,24)	RS1/16S102J	R 626	(A,111,31)	RS1/16S102J
R 484	(B,83,26)	RS1/16S102J	R 627	(A,130,41)	RAB4C0R0J
R 485	(B,86,26)	RS1/16S102J	R 628	(A,111,35)	RS1/16S473J
R 486	(B,87,26)	RS1/16S222J	R 629	(A,105,61)	RS1/16S0R0J
R 487	(B,89,26)	RS1/16S102J	R 630	(A,107,65)	RS1/16S473J
R 488	(B,98,22)	RS1/16S102J	R 631	(A,113,29)	RS1/16S103J
R 489	(B,90,26)	RS1/16S102J	R 632	(A,107,61)	RS1/16S0R0J
R 490	(A,88,17)	RS1/16S102J	R 633	(B,112,26)	RS1/16S102J
R 491	(B,97,20)	RS1/16S102J	R 634	(A,102,61)	RS1/16S0R0J
R 492	(B,95,20)	RS1/16S102J	R 635	(A,102,65)	RS1/16S473J
R 501	(A,108,14)	RS1/16S103J	R 636	(B,115,17)	RS1/16S102J
R 502	(A,111,19)	RS1/16S223J	R 637	(A,104,61)	RS1/16S0R0J
R 503	(A,114,19)	RS1/16S473J	R 638	(A,105,65)	RS1/16S473J
R 504	(A,110,14)	RS1/16S472J	R 639	(B,116,17)	RS1/16S102J
R 513	(A,36,92)	RS1/16S0R0J	R 641	(A,113,35)	RS1/16S473J
R 514	(A,36,91)	RS1/16S0R0J	R 642	(A,114,35)	RS1/16S104J
R 515	(A,39,94)	RS1/16S102J	R 643	(B,116,32)	RS1/16S102J
R 521	(A,121,18)	RS1/16S102J	R 644	(B,110,67)	RS1/16S471J
R 522	(A,127,17)	RS1/16S102J	R 645	(A,111,59)	RS1/16S473J
R 523	(A,131,17)	RS1/16S102J	R 646	(B,118,25)	RS1/16S102J
R 531	(B,108,13)	RS1/16S0R0J	R 647	(B,117,29)	RS1/16S102J
R 532	(B,108,7)	RS1/16S0R0J	R 648	(B,111,67)	RS1/16S471J
R 533	(B,108,10)	RS1/16S0R0J	R 649	(B,113,67)	RS1/16S471J
R 534	(A,106,29)	RS1/16S102J	R 650	(A,117,35)	RS1/16S102J
R 535	(B,103,5)	RS1/16S0R0J	R 651	(A,119,35)	RS1/16S102J
R 536	(B,108,12)	RS1/16S0R0J	R 652	(A,121,35)	RS1/16S104J
R 537	(B,103,7)	RS1/16S0R0J	R 653	(B,120,25)	RS1/16S102J
R 538	(B,108,9)	RS1/16S0R0J	R 654	(B,119,29)	RS1/16S102J
R 545	(A,41,56)	RS1/16S471J	R 655	(B,119,63)	RS1/16S102J
R 546	(A,49,57)	RS1/16S102J	R 656	(B,120,29)	RS1/16S102J
R 547	(A,46,56)	RS1/16S471J	R 657	(B,120,63)	RS1/16S102J
R 548	(A,49,56)	RS1/16S221J	R 658	(B,121,32)	RS1/16S102J
R 549	(A,52,57)	RS1/16S221J	R 659	(B,122,29)	RS1/16S102J
R 550	(A,49,54)	RS1/16S221J	R 660	(A,119,61)	RS1/16S102J
R 553	(B,58,60)	RS1/16S102J	R 661	(B,123,32)	RS1/16S102J
R 601	(A,113,39)	RS1/16S471J	R 662	(A,119,62)	RS1/16S102J
R 602	(A,113,40)	RS1/16S102J	R 663	(B,124,62)	RS1/16S221J
R 603	(A,109,39)	RS1/16S0R0J	R 664	(B,124,65)	RS1/16S104J

	1		2		3		4	
	<u>Circuit Symbol and No.</u>		<u>Part No.</u>		<u>Circuit Symbol and No.</u>		<u>Part No.</u>	
	R 665	(B,124,63)	RS1/16S221J		R 761	(A,130,49)	RS1/16S102J	
	R 666	(A,121,55)	RS1/16S473J		R 762	(B,69,102)	RS1/16S102J	
A	R 667	(B,125,26)	RS1/16S102J		R 763	(B,73,107)	RS1/16S473J	
	R 668	(A,121,51)	RS1/16S473J		R 764	(B,70,107)	RS1/16S472J	
	R 669	(B,125,29)	RS1/16S102J		R 765	(B,54,113)	RS1/16S103J	
	R 670	(B,125,32)	RS1/16S102J		R 766	(B,67,103)	RS1/16S473J	
	R 671	(B,126,31)	RS1/16S102J		R 767	(B,66,102)	RS1/16S473J	
	R 672	(B,128,31)	RS1/16S102J		R 769	(B,56,110)	RS1/16S104J	
	R 673	(B,129,31)	RS1/16S102J		R 770	(B,71,116)	RS1/16S153J	
	R 674	(A,95,5)	RS1/16S102J		R 771	(B,67,106)	RS1/16S103J	
	R 675	(A,130,35)	RS1/16S473J		R 772	(B,58,113)	RS1/16S473J	
	R 676	(A,132,35)	RS1/16S473J		R 773	(B,61,112)	RS1/16S103J	
	R 677	(B,136,50)	RS1/16S473J		R 774	(B,64,112)	RS1/16S473J	
B	R 678	(A,130,51)	RS1/16S473J		R 775	(B,63,113)	RS1/16S472J	
	R 679	(A,130,57)	RS1/16S473J		R 776	(B,73,103)	RS1/16S473J	
	R 680	(A,130,52)	RS1/16S333J		R 777	(B,76,105)	RS1/16S103J	
	R 681	(A,125,57)	RS1/16S104J		R 778	(B,78,106)	RS1/16S103J	
	R 682	(A,125,55)	RS1/16S103J		R 779	(B,74,109)	RS1/16S103J	
	R 683	(A,130,38)	RS1/16S473J		R 781	(A,119,10)	RS1/16S472J	
	R 684	(B,117,65)	RS1/16S102J		R 782	(A,120,12)	RS1/16S223J	
	R 685	(A,140,44)	RS1/16S473J		R 783	(A,127,10)	RS1/16S472J	
	R 686	(A,140,46)	RS1/16S473J		R 784	(A,128,12)	RS1/16S223J	
	R 687	(A,125,49)	RS1/16S103J		R 801	(B,142,26)	RS1/16S102J	
	R 688	(A,130,45)	RAB4C102J		R 802	(B,148,19)	RS1/16S5602D	
C	R 690	(A,108,54)	RS1/16S681J		R 803	(B,148,22)	RS1/16S1002D	
	R 691	(B,102,61)	RS1/16S103J		R 804	(B,161,18)	RS1/16S102J	
	R 692	(A,115,29)	RS1/16S105J		R 805	(A,144,48)	RS1/16S102J	
	R 693	(A,125,52)	RS1/16S183J		R 806	(A,150,48)	RS1/16S102J	
	R 694	(A,125,51)	RS1/16S102J		R 807	(A,155,48)	RS1/16S102J	
	R 695	(A,125,54)	RS1/16S102J		R 808	(B,148,16)	RS1/16S5101D	
	R 696	(B,136,54)	RS1/16S102J		R 811	(B,103,128)	RS1/16S5602D	
	R 697	(A,130,55)	RS1/16S0R0J		R 812	(B,102,130)	RS1/16S1002D	
	R 698	(A,121,40)	RS1/16S0R0J		R 813	(B,106,120)	RS1/16S102J	
	R 699	(A,134,40)	RS1/16S473J		R 814	(B,103,131)	RS1/16S5600D	
	R 700	(A,114,56)	RS1/16S0R0J		R 821	(B,161,44)	RS1/16S2702D	
D	R 722	(B,115,29)	RS1/16S0R0J		R 822	(B,158,44)	RS1/16S1002D	
	R 723	(B,109,33)	RS1/16S1501D		R 823	(B,162,55)	RS1/16S102J	
	R 724	(A,137,44)	RS1/16S473J		R 824	(B,162,46)	RS1/16S2702D	
	R 725	(A,113,42)	RS1/16S0R0J		R 832	(B,150,36)	RS1/16S5601D	
	R 731	(A,101,27)	RS1/16S104J		R 833	(B,149,37)	RS1/16S6801D	
	R 732	(A,98,25)	RS1/16S473J		R 834	(A,139,32)	RS1/16S473J	
	R 733	(A,99,27)	RS1/16S102J		R 835	(A,139,37)	RS1/16S104J	
	R 734	(A,97,27)	RS1/16S102J		R 836	(A,141,38)	RS1/16S164J	
	R 735	(A,93,27)	RS1/16S104J		R 837	(A,144,38)	RS1/16S123J	
	R 736	(A,103,31)	RS1/16S102J		R 838	(A,144,41)	RS1/16S123J	
	R 741	(B,25,115)	RS1/16S222J		R 839	(A,145,38)	RS1/16S222J	
E	R 742	(B,52,109)	RS1/16S103J		R 840	(A,157,38)	RS1/16S392J	
	R 743	(B,44,112)	RS1/16S101J		R 841	(B,142,92)	RS1/16S391J	
	R 744	(B,51,115)	RS1/16S103J		R 842	(B,146,73)	RS1/16S2R2J	
	R 745	(B,47,112)	RS1/16S103J		R 843	(B,146,71)	RS1/16S2R2J	
	R 746	(B,52,117)	RS1/16S221J		R 844	(B,147,73)	RS1/16S2R2J	
	R 747	(B,44,114)	RS1/16S104J		R 845	(B,147,71)	RS1/16S2R2J	
	R 749	(B,52,119)	RS1/16S101J		R 846	(B,157,71)	RS1/16S271J	
	R 750	(B,39,114)	RS1/16S473J		R 851	(B,154,68)	RS1/16S221J	
	R 751	(B,136,51)	RS1/16S473J		R 852	(A,141,60)	RS1/16S2201D	
	R 752	(A,137,48)	RS1/16S102J		R 853	(A,138,60)	RS1/16S1502D	
F	R 753	(A,140,48)	RS1/16S102J		R 854	(A,138,59)	RS1/16S1002D	
	R 754	(A,141,50)	RS1/16S102J		R 855	(A,141,59)	RS1/16S0R0J	
	R 755	(A,139,57)	RS1/16S103J		R 856	(B,132,67)	RS1/16S102J	
	R 756	(A,141,57)	RS1/16S473J		R 857	(A,142,72)	RS1/16S104J	

5		6		7		8	
<u>Circuit Symbol and No.</u>		<u>Part No.</u>		<u>Circuit Symbol and No.</u>		<u>Part No.</u>	
R 858	(A,142,75)	RS1/16S183J		R 990	(A,24,17)	RS1/16S1502D	
R 861	(B,136,28)	RS1/16S6202D		R 991	(B,27,9)	RS1/16S6801D	
R 862	(B,140,23)	RS1/16S1002D		R 992	(B,21,10)	RS1/16S7501D	A
R 863	(B,128,26)	RS1/16S102J		R 994	(B,27,11)	RS1/16S6802D	
R 871	(B,141,100)	RS1/16S683J		R 995	(A,21,13)	RS1/16S4702D	
R 872	(B,141,98)	RS1/16S123J		R 996	(B,21,21)	RS1/16S2203D	
R 873	(B,149,95)	RAB4C680J		R 997	(A,19,17)	RS1/16S3302D	
R 874	(B,145,97)	RAB4C680J		R 998	(A,19,13)	RS1/16S3302D	
R 875	(B,162,98)	RS1/16S102J		<b><u>CAPACITORS</u></b>			
R 876	(A,168,106)	RS2PMFR47J		C 101	(B,59,13)	CKSRYB105K10	
R 877	(A,155,92)	RS1/16S103J		C 102	(B,62,11)	CKSRYB105K10	
R 878	(B,161,92)	RS1/16S103J		C 103	(B,61,11)	CKSRYB105K10	
R 880	(A,157,90)	RS1/16S562J		C 104	(B,64,13)	CKSRYB105K10	B
R 881	(A,159,94)	RS1/16S102J		C 105	(B,52,23)	CKSRYB105K10	
R 882	(A,167,94)	RAB4C680J		C 106	(B,51,23)	CKSRYB105K10	
R 883	(A,163,93)	RAB4C680J		C 107	(A,75,12)	CKSQYB225K10	
R 884	(B,159,97)	RS1/16S103J		C 108	(B,62,19)	CKSRYB104K50	
R 885	(A,165,98)	RS1/16S103J		C 109	(A,74,7)	CEVLW220M16	
R 891	(B,143,8)	RS1/16S222J		C 110	(A,89,49)	CKSYB106K6R3	
R 892	(B,142,8)	RS1/16S222J		C 111	(A,89,49)	CKSYB106K6R3	
R 893	(B,145,8)	RS1/16S473J		C 112	(A,85,49)	CKSYB106K6R3	
R 901	(B,14,88)	RS1/16S301J		C 113	(A,85,43)	CCSRCK2R0C50	
R 903	(B,15,91)	RS1/16S301J		C 114	(A,88,43)	CCSRCK2R0C50	
R 905	(B,12,95)	RS1/16S153J		C 115	(A,83,39)	CKSRYB104K50	
R 911	(A,142,85)	RS1/16S104J		C 116	(A,88,27) 10 $\mu$ F	CCG1171	C
R 912	(A,142,87)	RS1/16S103J		C 117	(A,84,36)	CKSRYB104K50	
R 921	(A,133,66)	RS1/16S103J		C 118	(B,70,33)	CKSRYB104K50	
R 922	(A,133,69)	RS1/16S103J		C 119	(A,92,37) 22 $\mu$ F	CCG1178	
R 931	(A,133,60)	RS1/16S104J		C 131	(B,51,13)	CKSRYB105K10	
R 932	(A,133,63)	RS1/16S223J		C 132	(B,54,11)	CKSRYB105K10	
R 941	(A,142,80)	RS1/16S104J		C 133	(B,52,11)	CKSRYB105K10	
R 942	(A,141,82)	RS1/16S223J		C 134	(B,56,13)	CKSRYB105K10	
R 951	(B,21,121)	RS1/16S271J		C 135	(B,51,20)	CKSRYB105K10	
R 952	(B,23,120)	RS1/16S271J		C 136	(B,49,20)	CKSRYB105K10	
R 953	(B,25,109)	RS1/16S0R0J		C 137	(A,55,16)	CKSQYB225K10	
R 954	(B,21,119)	RS1/16S271J		C 138	(B,53,19)	CKSRYB104K50	D
R 955	(B,21,118)	RS1/16S103J		C 139	(A,63,7)	CEVLW220M16	
R 956	(B,23,117)	RS1/16S103J		C 142	(B,76,51)	CKSYB106K6R3	
R 961	(A,130,83)	RS1/16S0R0J		C 143	(B,79,51)	CKSYB106K6R3	
R 963	(A,164,82)	RS1/16S0R0J		C 144	(B,79,45)	CCSRCH4R0D50	
R 964	(A,161,83)	RS1/16S271J		C 145	(B,76,45)	CCSRCH4R0D50	
R 965	(A,161,84)	RS1/16S271J		C 146	(B,81,40)	CKSRYB104K50	
R 966	(A,161,86)	RS1/16S271J		C 147	(B,78,29) 10 $\mu$ F	CCG1171	
R 967	(A,161,87)	RS1/16S103J		C 148	(B,82,37)	CKSRYB104K50	
R 968	(A,161,89)	RS1/16S103J		C 151	(A,48,23)	CKSRYB105K10	
R 972	(B,25,21)	RS1/16S3901D		C 152	(A,52,23)	CKSRYB105K10	E
R 973	(A,21,17)	RS1/16S4701D		C 153	(A,49,23)	CKSRYB105K10	
R 975	(B,26,24)	RS1/16S2202D		C 154	(A,51,23)	CKSRYB105K10	
R 976	(B,26,21)	RS1/16S2202D		C 155	(B,59,20)	CKSRYB105K10	
R 978	(B,24,10)	RS1/16S6801D		C 156	(B,57,20)	CKSRYB105K10	
R 979	(B,24,7)	RS1/16S0R0J		C 157	(A,51,12)	CKSQYB225K10	
R 980	(B,23,10)	RS1/16S4701D		C 158	(A,50,15)	CKSRYB104K50	
R 981	(A,23,13)	RS1/16S8200D		C 159	(A,56,7)	CEVLW220M16	
R 983	(B,23,27)	RS1/16S560J		C 162	(B,36,38)	CKSYB106K6R3	
R 984	(A,17,11)	RS1/16S560J		C 163	(B,36,35)	CKSYB106K6R3	
R 985	(B,20,24)	RS1/16S272J		C 164	(B,31,32)	CCSRCH4R0D50	F
R 986	(B,18,21)	RS1/16S221J		C 165	(B,31,39)	CCSRCH4R0D50	
R 987	(B,19,10)	RS1/16S272J		C 166	(B,27,33)	CKSRYB104K50	
R 988	(A,24,16)	RS1/16S6801D		C 167	(B,20,34) 10 $\mu$ F	CCG1171	
R 989	(B,18,10)	RS1/16S221J					

	1	2	3	4
	<u>Circuit Symbol and No.</u>	<u>Part No.</u>	<u>Circuit Symbol and No.</u>	<u>Part No.</u>
	C 168 (B,24,34)	CKSRYP104K50	C 264 (A,80,59)	CEVLW221M4
A	C 169 (B,73,33)	CKSRYP104K50	C 265 (A,73,59)	CEVLW221M4
	C 182 (B,42,46)	CKSYB106K6R3	C 266 (A,69,45)	CCSRCJ3R0C50
	C 183 (B,40,43)	CKSYB106K6R3	C 271 (A,63,36)	CKSRYP105K10
	C 184 (B,36,41)	CCSRCH4R0D50	C 272 (A,57,36)	CEVLW101M10
	C 185 (B,34,49)	CCSRCH4R0D50	C 281 (A,53,67)	CKSQYB225K10
	C 186 (B,32,42)	CKSRYP104K50	C 282 (A,55,67)	CKSQYB225K10
	C 187 (B,23,42) 10 µF	CCG1171	C 283 (B,54,88)	CKSQYB225K10
	C 188 (B,21,45)	CKSRYP104K50	C 284 (B,55,68)	CKSQYB225K10
	C 189 (B,71,33)	CKSRYP104K50	C 285 (B,52,87)	CKSRYP104K50
	C 191 (B,36,58) 22 µF	CCG1178	C 286 (B,52,69)	CKSRYP104K50
	C 192 (B,36,56) 22 µF	CCG1178	C 287 (B,63,74)	CKSQYB225K10
	C 193 (B,25,59)	CCSRCK2R0C50	C 288 (B,61,69)	CKSQYB225K10
B	C 194 (B,25,50)	CCSRCK2R0C50	C 289 (B,65,74)	CKSQYB225K10
	C 195 (B,21,51)	CKSRYP104K50	C 290 (B,61,71)	CKSQYB225K10
	C 196 (B,18,51) 10 µF	CCG1171	C 291 (B,49,89)	CKSYB475K16
	C 197 (B,16,51)	CKSRYP104K50	C 292 (B,49,67)	CKSYB475K16
	C 198 (B,17,59)	CKSYB106K6R3	C 293 (B,45,87)	CKSYB475K16
	C 200 (B,28,65)	CKSYB475K16	C 294 (B,46,69)	CKSYB475K16
	C 201 (B,30,58)	CKSRYP103K50	C 295 (B,41,83)	CKSYB475K16
	C 202 (A,50,45)	CEVLW220M16	C 296 (B,42,71)	CKSYB475K16
	C 203 (A,56,46)	CEVLW101M10	C 297 (A,58,79)	CEVLW470M16
	C 205 (A,52,39)	CKSRYP105K10	C 298 (B,60,74)	CKSRYP104K50
	C 221 (A,81,26)	CKSQYB225K10	C 299 (A,58,74)	CKSRYP474K16
C	C 222 (A,83,26)	CKSQYB225K10	C 300 (B,59,74)	CKSRYP104K50
	C 223 (A,74,19)	CEVLW470M16	C 301 (A,54,73)	CEVLW100M16
	C 224 (A,79,18)	CKSRYP103K50	C 302 (A,48,82)	CEVLW100M16
	C 226 (B,68,33)	CKSRYP104K50	C 303 (B,43,81)	CKSRYP104K50
	C 227 (B,51,38)	CKSRYP105K10	C 304 (A,46,73)	CEVLW470M16
	C 228 (B,51,39)	CKSRYP105K10	C 311 (B,34,86) 10 µF	CCG1182
	C 231 (B,84,51)	CKSYB106K6R3	C 312 (B,34,89) 10 µF	CCG1182
	C 232 (B,87,51)	CKSYB106K6R3	C 315 (B,34,74) 10 µF	CCG1182
	C 233 (B,86,45)	CCSRCH4R0D50	C 316 (B,34,77) 10 µF	CCG1182
	C 234 (B,88,45)	CCSRCH4R0D50	C 319 (B,34,80) 10 µF	CCG1182
	C 235 (B,92,40)	CKSRYP104K50	C 320 (B,34,83) 10 µF	CCG1182
D	C 236 (B,90,32) 10 µF	CCG1171	C 324 (B,14,72)	CKSRYP104K50
	C 237 (B,92,37)	CKSRYP104K50	C 331 (B,28,119)	CKSRYP105K10
	C 238 (B,74,33)	CKSRYP104K50	C 332 (B,35,119)	CKSRYP105K10
	C 241 (A,66,18)	CEVLW470M16	C 333 (B,28,121)	CKSRYP105K10
	C 242 (A,58,23)	CEVLW470M16	C 334 (B,35,121)	CKSRYP105K10
	C 243 (B,63,29)	CKSRYP104K50	C 335 (B,31,119)	CKSRYP105K10
	C 244 (B,56,29)	CKSRYP104K50	C 336 (B,38,119)	CKSRYP105K10
	C 245 (A,66,29)	CKSYB475K16	C 337 (B,31,121)	CKSRYP105K10
	C 246 (B,63,31)	CKSRYP104K50	C 338 (B,38,121)	CKSRYP105K10
	C 247 (A,60,29)	CKSQYB225K10	C 339 (B,25,119) 10 µF	CCG1182
	C 248 (B,59,29)	CKSRYP105K10	C 340 (B,42,121)	CKSYB475K16
E	C 249 (B,57,29)	CKSRYP105K10	C 341 (B,47,121)	CKSYB475K16
	C 250 (B,60,29)	CKSRYP104K50	C 342 (A,55,125)	CKSRYP104K50
	C 251 (A,62,49) 47 µF	CCG1181	C 343 (A,62,123) 1 000 µF/16 V	CCH1428
	C 252 (A,62,46) 22 µF	CCG1178	C 345 (B,62,153)	CKSQYB104K50
	C 253 (A,62,41) 47 µF	CCG1181	C 351 (B,86,108)	CKSRYP103K50
	C 254 (A,62,44) 22 µF	CCG1178	C 360 (A,109,66)	CKSRYP103K50
	C 256 (A,67,48)	CCSRCJ3R0C50	C 391 (B,53,33)	CKSRYP104K50
	C 257 (A,72,46)	CKSRYP104K50	C 392 (B,50,35)	CKSRYP104K50
	C 258 (A,77,38)	CEVLW100M16	C 401 (B,150,147)	CKSRYP103K50
	C 259 (A,78,45)	CEVLW101M10	C 403 (A,148,109)	CEVLW101M10
F	C 260 (A,79,50)	CKSRYP104K50	C 405 (B,120,141)	CKSRYP103K50
	C 261 (A,64,54)	CEVLW101M10	C 406 (B,120,143)	CKSYB475K16
	C 262 (B,72,58) 10 µF	CCG1171	C 408 (B,116,145)	CKSRYP103K50
	C 263 (A,87,59)	CEVLW221M4	C 409 (B,116,147)	CKSYB106K6R3

5		6		7		8	
<u>Circuit Symbol and No.</u>		<u>Part No.</u>		<u>Circuit Symbol and No.</u>		<u>Part No.</u>	
C 410	(B,103,142)	CKSRYP474K16		C 764	(B,67,109)	CKSRYP103K50	
C 411	(B,107,140)	CKSRYP474K16		C 765	(B,65,110)	CKSRYP104K50	
C 413	(B,144,138)	CKSRYP475K16		C 766	(B,61,115)	CKSRYP104K50	A
C 414	(A,157,9)	CKSRYP102K50		C 769	(B,76,106)	CKSRYP104K50	
C 415	(B,109,141)	CKSRYP474K16		C 770	(B,88,147)	CKSRYP104K50	
C 416	(B,106,141)	CKSRYP474K16		C 771	(A,73,129)	CKSRYP104K50	
C 417	(B,99,132)	CKSRYP104K50		C 781	(A,114,11)	CKSRYP104K50	
C 418	(B,101,136)	CKSQYB225K10		C 782	(A,122,11)	CKSRYP104K50	
C 419	(B,99,129)	CKSRYP105K10		C 801	(B,145,29)	CKSRYP104K50	
C 420	(B,129,143)	CKSRYP103K50		C 802	(A,143,24)	CEVLW470M6R3	
C 421	(B,145,141)	CKSRYP475K16		C 803	(B,142,30)	CKSRYP103K50	
C 422	(B,108,117)	CKSRYP103K50		C 804	(B,152,15)	CKSRYP103K50	
C 423	(B,119,123)	CKSRYP104K50		C 805	(A,148,18)	CEVLW470M16	
C 461	(B,129,90)	CKSRYP102K50		C 806	(A,156,20)	CKSQYB105K16	B
C 462	(B,128,90)	CKSRYP102K50		C 811	(A,129,110)	CEVLW220M16	
C 464	(A,124,86)	CKSRYP104K50		C 812	(B,129,133)	CKSRYP103K50	
C 465	(A,167,47)	CCSRCH101J50		C 813	(B,120,132)	CKSRYP475K16	
C 466	(A,162,18)	CKSRYP102K50		C 814	(B,119,124)	CKSRYP102K50	
C 467	(A,129,102)	CKSRYP104K50		C 817	(B,102,127)	CKSRYP103K50	
C 468	(A,113,95)	CCSRCH101J50		C 818	(A,108,109)	CEVLW470M16	
C 481	(B,101,27)	CKSRYP104K50		C 819	(B,104,125)	CKSQYB105K16	
C 484	(B,97,16)	CKSRYP104K50		C 821	(B,161,42)	CKSRYP103K50	
C 501	(A,112,14)	CKSRYP103K50		C 822	(A,146,56)	CEVLW470M16	
C 511	(B,35,95)	CCSRCH101J50		C 823	(B,161,50)	CKSQYB105K16	
C 513	(A,58,87)	CEVLW221M4		C 831	(A,142,33)	CKSQYB105K16	C
C 514	(A,48,88)	CEVLW221M4		C 832	(B,152,36)	CKSRYP103K50	
C 515	(B,46,92)	CKSRYP102K50		C 833	(B,151,38)	CKSRYP103K50	
C 541	(A,42,59)	CKSRYP475K16		C 834	(A,140,33)	CKSRYP473K50	
C 542	(A,42,65)	CKSRYP104K50		C 835	(A,141,36)	CCSRCH220J50	
C 544	(A,46,65)	CKSRYP104K50		C 836	(A,157,31)	CKSRYP104K50	
C 545	(A,45,63)	CKSRYP102K50		C 837	(A,147,31)	CKSRYP475K16	
C 601	(A,118,52)	CKSRYP106K6R3		C 838	(A,153,33)	CKSRYP104K50	
C 602	(B,103,47)	CCSRCH8R0D50		C 839	(B,146,41)	CKSRYP104K50	
C 603	(B,103,44)	CCSRCH8R0D50		C 840	(B,159,40)	CKSRYP475K16	
C 604	(A,109,42)	CKSRYP104K50		C 841	(B,136,82)	CKSRYP102K50	
C 605	(A,118,41)	CKSRYP102K50		C 842	(A,148,75)	CEVLW101M10	D
C 606	(B,101,54)	CCSRCH470J50		C 843	(B,136,83)	CKSRYP103K50	
C 607	(B,102,54)	CCSRCH470J50		C 844	(B,135,85)	CKSRYP103K50	
C 608	(B,104,56)	CKSRYP103K50		C 845	(A,163,74)	CEVLW470M16	
C 609	(B,104,38)	CKSRYP105K10		C 846	(A,166,66)	1 000 µF/16 V CCH1428	
C 610	(B,100,37)	CKSRYP475K16		C 847	(B,154,70)	CKSRYP104K50	
C 611	(A,116,35)	CKSRYP474K16		C 851	(B,142,59)	CKSRYP102K50	
C 612	(A,130,54)	CKSRYP104K50		C 852	(A,148,66)	CEVLW101M10	
C 614	(A,118,44)	CEVLW100M16		C 853	(B,140,57)	CKSRYP103K50	
C 615	(A,108,56)	CCSRCH470J50		C 854	(B,141,50)	CKSRYP103K50	
C 616	(A,113,43)	CCSRCH101J50		C 855	(B,158,65)	CKSRYP104K50	
C 617	(A,108,50)	CCSRCH470J50		C 856	(A,156,69)	CEVLW470M16	
C 618	(A,114,49)	CCSRCH470J50		C 857	(A,139,65)	CEVLW101M6R3	
C 619	(B,96,38)	CKSRYP104K50		C 858	(A,139,70)	CKSRYP102K50	
C 731	(A,101,28)	CKSRYP104K50		C 859	(B,142,61)	CKSQYB105K16	
C 732	(A,93,26)	CKSRYP105K10		C 860	(A,139,72)	CKSRYP104K50	
C 733	(A,98,24)	CKSRYP102K50		C 861	(B,136,30)	CKSRYP103K50	
C 741	(A,39,121)	CEVLW470M16		C 862	(A,132,10)	CEVLW470M16	
C 742	(A,47,121)	CEVLW470M16		C 863	(B,133,31)	CKSQYB105K16	
C 743	(B,42,108)	CCG1182		C 871	(A,143,100)	10 µF CCG1223	
C 744	(A,54,117)	CEVLW330M10		C 873	(A,150,96)	10 µF CCG1223	
C 751	(A,134,52)	CKSRYP105K10		C 891	(A,139,10)	CEVLW470M16	F
C 761	(B,54,111)	CKSRYP105K10		C 892	(A,147,10)	CEVLW470M16	
C 762	(B,55,113)	CKSRYP104K50		C 901	(B,30,100)	CKSRYP104K50	
C 763	(B,62,146)	CKSRYP104K50		C 902	(B,15,80)	CKSRYP475K16	

	1	2	3	4
	<u>Circuit Symbol and No.</u>	<u>Part No.</u>	<u>Circuit Symbol and No.</u>	<u>Part No.</u>
	C 904 (A,7,79) 2 200 µF/16V	CCH1659	D 4076 (A,123,4) LED	CL-197HB1-D(CDE)
A	C 911 (A,139,84)	CKSRYB104K50	D 4077 (A,135,4) LED	CL-197HB1-D(CDE)
	C 921 (A,130,66)	CKSRYB104K50	D 4078 (A,146,19) LED	CL-197HB1-D(CDE)
	C 931 (A,130,60)	CKSRYB104K50	D 4079 (A,151,4) LED	CL-197HB1-D(CDE)
	C 932 (A,134,58)	CKSRYB104K50	D 4080 (A,164,4) LED	CL-197HB1-D(CDE)
	C 941 (A,139,78)	CKSRYB104K50	L 4001 (B,94,14) Inductor	CTF1473
	C 942 (A,143,80)	CKSRYB104K50	S 4031 (A,156,19) Push Switch	CSG1155
	C 951 (B,13,111)	CKSRYB103K50	S 4032 (A,14,11) Encoder	CSD1140
	C 952 (A,15,119)	CEVLW100M16	S 4033 (A,160,6) Push Switch	CSG1155
	C 953 (B,20,112)	CKSRYB103K50	S 4034 (A,132,6) Push Switch	CSG1155
	C 961 (A,154,88)	CKSRYB103K50	S 4035 (A,106,6) Push Switch	CSG1155
	C 962 (A,151,89)	CEVLW100M16	S 4036 (A,154,6) Push Switch	CSG1155
	C 963 (A,156,83)	CKSRYB103K50	S 4037 (A,119,6) Push Switch	CSG1155
B	C 971 (B,25,24)	CCSRCH101J50	LCD	CAW1946
	C 974 (A,44,16) 220 µF/10 V	CCH1409		
	C 975 (B,25,7)	CKSRYB223K50		

### RESISTORS

	C 976 (A,39,15) 220 µF/10 V	CCH1409	R 4001 (B,103,6)	RS1/16S221J
	C 977 (A,44,8) 470 µF/6.3 V	CCH1437	R 4002 (B,103,5)	RS1/16S221J
	C 980 (B,28,18)	CKSYB475K16	R 4003 (B,89,4)	RS1/16S221J
	C 981 (A,24,13)	CCSRCH101J50	R 4004 (B,89,6)	RS1/16S473J
	C 982 (B,22,7)	CKSRYB683K16	R 4005 (B,86,8)	RS1/16S393J
	C 984 (B,15,18)	CKSRYB104K50	R 4021 (B,98,10)	RS1/16S101J
	C 985 (A,17,17)	CKSRYB104K50	R 4022 (B,97,13)	RS1/16S470J
	C 986 (A,17,13)	CKSRYB104K50	R 4031 (B,34,8)	RS1/16S513J
C	C 987 (B,13,17)	CKSYB475K16	R 4033 (B,159,15)	RS1/16S103J
	C 992 (A,7,28) 2 200 µF/16V	CCH1659	R 4034 (B,158,10)	RS1/16S222J
	C 993 (B,16,24)	CKSYB475K16	R 4035 (B,29,11)	RS1/16S103J
			R 4036 (B,152,7)	RS1/16S222J
			R 4037 (B,155,6)	RS1/16S103J
			R 4041 (A,94,14)	RS1/16S391J
			R 4042 (B,97,14)	RS1/16S391J
			R 4051 (B,17,7)	RS1/16S271J
			R 4052 (B,17,10)	RS1/16S271J
			R 4053 (B,15,19)	RS1/16S271J
			R 4054 (B,18,16)	RS1/16S271J
			R 4055 (B,152,9)	RS1/16S101J

**B**

**Unit Number :**

**Unit Name : Keyboard Unit**

### MISCELLANEOUS

D	IC 4001 (B,79,9) IC	LC75836WS		
	IC 4021 (A,100,10) IC	SBX3050-01	R 4056 (B,154,11)	RS1/16S221J
	Q 4041 (B,100,13) Digital Transistor	DTC143EUA	R 4057 (B,159,8)	RS1/16S101J
	D 4001 (A,143,6) Diode	MALS068X	R 4058 (B,156,9)	RS1/16S221J
	D 4002 (A,138,8) Diode	MALS068X	R 4071 (B,10,7)	RS1/16S151J
	D 4003 (A,142,8) Diode	MALS068X	R 4072 (B,13,8)	RS1/16S391J
	D 4021 (A,126,8) Diode	UDZS5R6(B)	R 4073 (B,12,19)	RS1/16S151J
	D 4041 (B,107,6) Diode	DAN202U	R 4074 (B,17,16)	RS1/16S391J
	D 4042 (A,94,9) White LED	NESW505C-5273	R 4075 (B,111,7)	RS1/16S151J
	D 4051 (A,21,4) LED	CL-195SR-CD	R 4076 (B,111,10)	RS1/16S391J
			R 4077 (B,157,19)	RS1/16S151J
E	D 4052 (A,6,5) LED	CL-195SR-CD		
	D 4053 (A,22,17) LED	CL-195SR-CD	R 4078 (B,157,18)	RS1/16S391J
	D 4054 (A,6,18) LED	CL-195SR-CD	R 4079 (B,159,14)	RS1/16S151J
	D 4055 (A,110,6) LED	CL-195SR-CD	R 4080 (B,156,14)	RS1/16S391J
	D 4056 (A,123,6) LED	CL-195SR-CD	R 4091 (B,159,5)	RS1/16S0R0J
				R 4092 (B,152,5)
	D 4057 (A,135,6) LED	CL-195SR-CD		
	D 4058 (A,146,20) LED	CL-195SR-CD		
	D 4059 (A,151,6) LED	CL-195SR-CD		
	D 4060 (A,164,7) LED	CL-195SR-CD	C 4001 (B,88,8)	CCSRCH102J25
	D 4071 (A,21,3) LED	CL-197HB1-D(CDE)	C 4002 (B,91,7)	CKSRYB104K50
			C 4003 (B,91,9)	CKSRYB104K50
F	D 4072 (A,5,5) LED	CL-197HB1-D(CDE)	C 4004 (B,88,10) 10 µF	CCG1171
	D 4073 (A,23,17) LED	CL-197HB1-D(CDE)	C 4021 (B,100,9) 10 µF	CCG1171
	D 4074 (A,5,18) LED	CL-197HB1-D(CDE)		
	D 4075 (A,110,4) LED	CL-197HB1-D(CDE)	C 4041 (B,94,9)	CKSRYB104K50

### CAPACITORS

5		6	
<u>Circuit Symbol and No.</u>		<u>Part No.</u>	
C 4071	(B,20,5)	CKSRYB104K50	
C 4072	(B,10,4)	CKSRYB104K50	
C 4073	(B,26,14)	CKSRYB104K50	
C 4074	(B,10,19)	CKSRYB104K50	
C 4075	(A,112,8)	CKSRYB104K50	
C 4076	(A,128,5)	CKSRYB104K50	
C 4077	(A,138,5)	CKSRYB104K50	
C 4078	(B,152,15)	CKSRYB104K50	
C 4079	(A,148,5)	CKSRYB104K50	
C 4080	(B,159,12)	CKSRYB104K50	

**Monitor Unit**

**Consists of**

**Monitor PCB**

**Upper PCB**



**Unit Number : CWN2330**

**Unit Name : Monitor Unit**

**MISCELLANEOUS**

IC 5101	(A,66,94) Regulator IC	S-1132B15-U5
IC 5102	(A,66,99) IC	S-1132B25-U5
IC 5103	(A,74,75) IC	BD6171KV
IC 5201	(A,63,31) IC	TA78L05F
IC 5202	(A,60,43) L-MOS And Gate	TC7SET08FUS1
IC 5203	(A,59,37) L-MOS And Gate	TC7SET08FUS1
IC 5204	(A,44,31) IC	OZ961ISN
IC 5205	(A,40,21) FET	SI6544BDQ
IC 5206	(A,40,17) FET	SI6544BDQ
IC 5301	(A,81,110) IC	NJM2505AF
IC 5401	(A,37,92) IC	TC90A96BFGSING
IC 5501	(A,10,100) IC	M62343FP
IC 5502	(A,12,79) IC	TC7SET04FUS1
IC 5503	(A,14,87) IC	NJM2100V
IC 5504	(A,56,83) IC	TC7SET04FUS1
IC 5505	(A,15,74) IC	TC7S66FU
IC 5506	(A,57,76) IC	TC74VHC04FTS1
IC 5507	(A,11,66) IC	NJM082BV
IC 5602	(A,121,47) IC	S-80827CENN-B8M
IC 5603	(A,119,65) IC	PEG333A
IC 5604	(A,135,66) IC	S-93C56BD0I-J8
IC 5801	(A,138,94) IC	PEH098A
IC 5802	(A,116,91) IC	PDC149A
Q 5101	(A,75,63) Chip Transistor	DTC114EUA
Q 5102	(A,85,80) FET	RSQ035P03
Q 5103	(A,84,73) FET	RSQ035P03
Q 5201	(A,59,12) Transistor	UMX2N
Q 5202	(A,60,25) Transistor	2SC4617
Q 5203	(A,57,26) Transistor	2SC4617
Q 5204	(A,55,41) Transistor	2SA1774
Q 5205	(A,59,18) Transistor	2SC4617
Q 5206	(A,62,18) Transistor	2SC4617
Q 5301	(A,74,109) Transistor	2SC4081
Q 5302	(A,62,111) Transistor	2SA1576A
Q 5401	(A,39,112) Transistor	2SC4617
Q 5501	(A,9,55) Transistor	UMX2N
Q 5502	(A,13,55) Transistor	UMT2N

7		8	
<u>Circuit Symbol and No.</u>		<u>Part No.</u>	
Q 5601	(A,113,48) Chip Transistor	DTC124EUA	
Q 5602	(A,144,46) Transistor	2SA1774	
Q 5603	(A,143,51) Chip Transistor	DTC114EUA	
Q 5604	(A,147,46) Transistor	2SA1774	
Q 5605	(A,146,51) Chip Transistor	DTC114EUA	
Q 5607	(A,137,39) Chip Transistor	DTC114EUA	
Q 5608	(A,140,45) Transistor	2SA1797	
Q 5701	(A,144,59) Transistor	UMF5N	
Q 5702	(A,144,63) Transistor	UMF5N	
Q 5703	(A,143,70) Transistor	FMG12	
Q 5801	(A,107,95) Transistor	2SA1774	
Q 5802	(A,103,91) Transistor	2SA1774	
Q 5803	(A,102,94) Transistor	2SA1774	
Q 5901	(A,134,5) Transistor	2SA1774	
D 5001	(A,109,105) Diode	UDZS5R6(B)	
D 5002	(A,111,107) Diode	UDZS5R6(B)	
D 5003	(A,110,110) Diode	UDZS5R6(B)	
D 5004	(A,112,110) Diode	UDZS5R6(B)	
D 5005	(A,122,33) Diode	UDZS5R6(B)	
D 5006	(A,114,39) Diode	UDZS5R6(B)	
D 5007	(A,119,39) Diode	UDZS5R6(B)	
D 5008	(A,122,37) Diode	UDZS5R6(B)	
D 5101	(A,73,95) Diode	RB500V-40	
D 5102	(A,73,100) Diode	RB500V-40	
D 5103	(A,87,85) Diode	U2FWJ44N	
D 5104	(A,87,69) Diode	RB160M-30	
D 5105	(A,83,64) Diode	RB548W	
D 5106	(A,81,64) Diode	RB548W	
D 5107	(A,72,63) Diode	RB548W	
D 5108	(A,70,63) Diode	RB548W	
D 5109	(A,68,63) Diode	RB548W	
D 5201	(A,57,22) Diode	UDZS6R2(B)	
D 5202	(A,55,46) Diode	1SS355	
D 5203	(A,62,40)	RB751V-40	
D 5204	(A,47,20) Diode	HZU6R2(B3)	
D 5205	(A,47,15) Diode	HZU6R2(B3)	
D 5206	(A,57,20) Diode	UDZS8R2(B)	
D 5207	(A,63,6) Diode	MA143	
D 5208	(A,61,6) Diode	HZU6R2(B3)	
D 5209	(A,69,5) Diode	MA143	
D 5601	(A,124,47) Diode	MA111	
D 5701	(A,142,67) Diode	MA111	
D 5901	(A,124,6) IC	TPS850	
D 5931	(A,24,8) LED	CL-197HB1-D(CDE)	
D 5932	(A,9,8) LED	CL-197HB1-D(CDE)	
D 5933	(A,142,8) LED	CL-197HB1-D(CDE)	
D 5934	(A,156,8) LED	CL-197HB1-D(CDE)	
D 5951	(A,24,7) LED	CL-195SR-CD	
D 5952	(A,9,7) LED	CL-195SR-CD	
D 5953	(A,142,7) LED	CL-195SR-CD	
D 5954	(A,156,7) LED	CL-195SR-CD	
D 5971	(A,79,13) LED	CL-197HB1-D(CDE)	
D 5972	(A,87,13) LED	CL-197HB1-D(CDE)	
D 5981	(A,79,11) LED	CL-195SR-CD	
D 5982	(A,87,11) LED	CL-195SR-CD	
L 5101	(A,55,106) Inductor	CTF1635	
L 5102	(A,93,95) Choke Coil 10 µH	CTH1249	
L 5103	(A,84,90) Choke Coil 18 µH	CTH1250	
L 5104	(A,78,51) Inductor	CTF1488	
L 5105	(A,89,65) Choke Coil 68 µH	CTH1318	

	1		2		3		4	
	<u>Circuit Symbol and No.</u>		<u>Part No.</u>		<u>Circuit Symbol and No.</u>		<u>Part No.</u>	
	L 5107	(A,84,61) Inductor	DTL1096		L 5446	(A,39,77) Ferrite Bead	CTF1528	
	L 5108	(A,16,112) Inductor	CTF1635		L 5447	(A,39,75) Ferrite Bead	CTF1528	
	L 5109	(A,58,106) Inductor	CTF1635		L 5448	(A,38,77) Ferrite Bead	CTF1528	
A	L 5110	(A,60,89) Inductor	CTF1635		L 5449	(A,38,75) Ferrite Bead	CTF1528	
	L 5111	(A,60,92) Inductor	CTF1635		L 5450	(A,37,77) Ferrite Bead	CTF1528	
	L 5112	(A,57,101) Inductor	CTF1635		L 5451	(A,37,75) Ferrite Bead	CTF1528	
	L 5113	(A,84,97) Choke Coil 18 μH	CTH1250		L 5452	(A,36,74) Inductor	CTF1306	
	L 5114	(A,65,84) Inductor	CTF1635		L 5453	(A,35,75) Ferrite Bead	CTF1528	
	L 5115	(A,93,64) Inductor	CTF1635		L 5454	(A,35,77) Ferrite Bead	CTF1528	
	L 5116	(A,63,63) Inductor	CTF1635		L 5455	(A,34,73) Ferrite Bead	CTF1528	
	L 5201	(A,78,24) Coil	CTH1338		L 5456	(A,33,77) Ferrite Bead	CTF1528	
	L 5202	(A,57,40) Inductor	CTF1306		L 5457	(A,33,75) Ferrite Bead	CTF1528	
	L 5301	(A,69,112) Inductor	LCKAW220J2520		L 5458	(A,33,73) Ferrite Bead	CTF1528	
B	L 5302	(A,65,112) Inductor	LCKAW270J2520		L 5459	(A,28,75) Ferrite Bead	CTF1528	
	L 5303	(A,59,103) Inductor	LCKAW101J2520		L 5460	(A,29,77) Ferrite Bead	CTF1528	
	L 5304	(A,79,107) Inductor	CTF1379		L 5461	(A,27,77) Ferrite Bead	CTF1528	
	L 5401	(A,48,110) Inductor	CTF1306		L 5462	(A,25,75) Ferrite Bead	CTF1528	
	L 5402	(A,42,113) Inductor	CTF1306		L 5463	(A,26,77) Ferrite Bead	CTF1528	
	L 5403	(A,40,113) Inductor	CTF1306		L 5464	(A,25,76) Ferrite Bead	CTF1528	
	L 5404	(A,34,112) Inductor	CTF1306		L 5465	(A,25,77) Ferrite Bead	CTF1528	
	L 5405	(A,24,110) Inductor	CTF1306		L 5466	(A,48,75) Inductor	CTF1306	
	L 5406	(A,33,112) Inductor	CTF1306		L 5467	(A,31,74) Inductor	CTF1306	
	L 5407	(A,26,110) Inductor	CTF1306		L 5468	(A,30,74) Inductor	CTF1306	
	L 5408	(A,36,112) Inductor	CTF1306		L 5469	(A,50,74) Inductor	CTF1306	
C	L 5409	(A,52,108) Inductor	CTF1306		L 5470	(A,42,74) Inductor	CTF1306	
	L 5411	(A,50,110) Inductor	CTF1306		L 5471	(A,41,74) Inductor	CTF1306	
	L 5412	(A,54,103) Inductor	CTF1306		L 5472	(A,18,78) Inductor	LCKAW101J2520	
	L 5413	(A,20,104) Inductor	CTF1306		L 5501	(A,15,78) Inductor	CTF1306	
	L 5414	(A,21,102) Inductor	CTF1306		L 5502	(A,8,84) Inductor	LCKAW101J2520	
	L 5415	(A,21,101) Inductor	CTF1306		L 5503	(A,9,75) Inductor	LCKAW101J2520	
	L 5416	(A,18,100) Inductor	CTF1306		L 5504	(A,53,62) Inductor	CTF1306	
	L 5417	(A,17,99) Inductor	CTF1306		L 5505	(A,22,70) Inductor	DTL1096	
	L 5418	(A,54,100) Inductor	CTF1306		L 5506	(A,15,65) Inductor	DTL1096	
	L 5419	(A,20,98) Inductor	CTF1306		L 5508	(A,49,72) Inductor	CTF1306	
	L 5420	(A,54,97) Inductor	CTF1306		L 5509	(A,28,70) Inductor	CTF1635	
D	L 5421	(A,16,97) Inductor	CTF1306		L 5510	(A,20,70) Inductor	CTF1635	
	L 5422	(A,19,96) Inductor	CTF1306		L 5511	(A,62,81) Inductor	CTF1635	
	L 5423	(A,15,95) Inductor	CTF1306		L 5602	(A,108,59) Inductor	CTF1306	
	L 5424	(A,15,94) Inductor	CTF1306		L 5603	(A,136,60) Inductor	CTF1306	
	L 5425	(A,54,94) Inductor	CTF1306		L 5604	(A,101,66) Inductor	CTF1306	
	L 5426	(A,19,93) Inductor	CTF1306		L 5605	(A,132,48) Inductor	CTF1488	
	L 5427	(A,19,91) Inductor	CTF1306		L 5701	(A,139,60) Inductor	CTF1379	
	L 5428	(A,54,91) Inductor	CTF1306		L 5801	(A,104,77) Inductor	LCKAW2R2J2520	
	L 5429	(A,19,90) Inductor	CTF1306		L 5802	(A,139,51) Inductor	CTF1488	
	L 5430	(A,19,88) Inductor	CTF1306		L 5803	(A,108,77) Inductor	LCKAW2R2J2520	
	L 5431	(A,54,88) Inductor	CTF1306		L 5804	(A,143,73) Inductor	CTF1395	
E	L 5432	(A,54,85) Inductor	CTF1306		L 5901	(A,117,7) Inductor	LCKBW100K2520	
	L 5433	(A,19,87) Inductor	CTF1306		T 5201	(B,51,10) Transformer	CTT1119	
	L 5434	(A,19,84) Inductor	CTF1306		TH5601	(A,106,56) Thermistor	CCX1051	
	L 5435	(A,19,83) Inductor	CTF1306		X 5401	(A,45,112) Crystal Resonator 42 MHz	CSS1604	
	L 5436	(A,19,82) Inductor	CTF1306		X 5601	(A,119,52) Ceramic Resonator 16.000 MHz	CSS1616	
	L 5437	(A,54,83) Inductor	CTF1306		S 5921	(A,142,4) Push Switch	CSG1155	
	L 5438	(A,19,80) Inductor	CTF1306		S 5922	(A,9,4) Push Switch	CSG1155	
	L 5439	(A,47,73) Ferrite Bead	CTF1528		S 5923	(A,24,4) Push Switch	CSG1155	
	L 5440	(A,47,75) Ferrite Bead	CTF1528		S 5924	(A,157,4) Push Switch	CSG1155	
	L 5441	(A,46,73) Ferrite Bead	CTF1528		VR5201	(A,35,28) Semi-fixed 22 kΩ(B)CCP1491		
F	L 5442	(A,46,75) Ferrite Bead	CTF1528		△FU5101	(A,83,51) Fuse 1.25 A	CEK1255	
	L 5443	(A,45,74) Ferrite Bead	CTF1528		△FU5201	(A,72,23) Fuse 1.25 A	CEK1255	
	L 5444	(A,45,76) Ferrite Bead	CTF1528					
	L 5445	(A,43,74) Inductor	CTF1306					

**RESISTORS**



5  
**Circuit Symbol and No.**

6  
**Part No.**

7  
**Circuit Symbol and No.**

8  
**Part No.**

R 5005 (A,92,47)  
R 5006 (A,94,47)  
R 5007 (A,99,50)  
R 5008 (A,101,50)  
R 5009 (A,143,40)

RS1/16S0R0J  
RS1/16S0R0J  
RS1/16S0R0J  
RS1/16S0R0J  
RS1/16S0R0J

R 5215 (A,45,20)  
R 5216 (A,45,16)  
R 5217 (A,57,17)  
R 5218 (A,63,15)  
R 5219 (A,57,18)

RS1/16S103J  
RS1/16S103J  
RS1/16S103J  
RS1/16S621J  
RS1/16S104J

A

R 5010 (A,142,40)  
R 5011 (A,115,106)  
R 5012 (A,114,106)  
R 5013 (A,112,105)  
R 5014 (A,111,105)

RS1/16S0R0J  
RS1/16S101J  
RS1/16S101J  
RS1/16S101J  
RS1/16S101J

R 5220 (A,61,21)  
R 5221 (A,61,12)  
R 5222 (A,60,15)  
R 5223 (A,58,15)  
R 5224 (A,59,9)

RS1/16S473J  
RS1/16S621J  
RS1/16S101J  
RS1/16S101J  
RS1/16S821J

R 5015 (A,97,111)  
R 5101 (A,70,94)  
R 5102 (A,70,99)  
R 5103 (A,70,89)  
R 5104 (A,72,90)

RS1/16S101J  
RS1/16SS684J  
RS1/16SS474J  
RS1/16S0R0J  
RS1/16S6801D

R 5225 (A,58,6)  
R 5227 (A,38,31)  
R 5301 (A,77,112)  
R 5302 (A,77,110)  
R 5303 (A,74,107)

RS1/16S471J  
RS1/16S1001D  
RS1/16S512J  
RS1/16S104J  
RS1/16S153J

B

R 5105 (A,89,94)  
R 5106 (A,80,88)  
R 5107 (A,75,90)  
R 5108 (A,81,86)  
R 5109 (A,71,88)

RS1/16S0R0J  
RS1/16S0R0J  
RS1/16S201J  
RS1/16S1001D  
RS1/16S1001D

R 5304 (A,71,107)  
R 5305 (A,69,108)  
R 5306 (A,71,109)  
R 5307 (A,64,109)  
R 5308 (A,60,111)

RS1/16S104J  
RS1/16S681J  
RS1/16S471J  
RS1/16S272J  
RS1/16S391J

R 5110 (A,75,88)  
R 5111 (A,66,81)  
R 5112 (A,81,84)  
R 5113 (A,78,87)  
R 5114 (A,69,81)

RS1/16S682J  
RS1/16S5100F  
RS1/16S1600D  
RS1/16S102J  
RS1/16S0R0J

R 5311 (A,88,108)  
R 5312 (A,88,110)  
R 5401 (A,44,108)  
R 5402 (A,59,113)  
R 5403 (A,45,108)

RS1/16S101J  
RS1/16S101J  
RS1/16SS391J  
RS1/16S0R0J  
RS1/16SS105J

C

R 5115 (A,78,85)  
R 5116 (A,66,82)  
R 5117 (A,73,85)  
R 5118 (A,77,82)  
R 5119 (A,73,82)

RS1/16S2700D  
RS1/16S2001F  
RS1/16S684J  
RS1/16S333J  
RS1/16S123J

R 5404 (A,39,110)  
R 5405 (A,37,111)  
R 5406 (A,21,106)  
R 5407 (A,18,102)  
R 5408 (A,15,105)

RS1/16SS331J  
RS1/16SS152J  
RS1/16S0R0J  
RS1/16S331J  
RS1/16S101J

R 5120 (A,82,80)  
R 5121 (A,82,83)  
R 5122 (A,87,72)  
R 5123 (A,82,75)  
R 5124 (A,74,67)

RS1/16S273J  
RS1/16S150J  
RS1/16S150J  
RS1/16S563J  
RS1/16S5102D

R 5410 (A,13,105)  
R 5411 (A,13,95)  
R 5412 (A,13,94)  
R 5413 (A,16,91)  
R 5414 (A,16,93)

RS1/16S101J  
RS1/16S470J  
RS1/16S470J  
RS1/16SS471J  
RS1/16SS333J

R 5125 (A,68,68)  
R 5126 (A,67,70)  
R 5127 (A,76,65)  
R 5128 (A,66,69)  
R 5129 (A,77,67)

RS1/16S0R0J  
RS1/16S1002D  
RS1/16S4300D  
RS1/16S1802D  
RS1/16S1802D

R 5415 (A,14,97)  
R 5416 (A,14,93)  
R 5417 (A,21,92)  
R 5418 (A,44,70)  
R 5419 (A,41,70)

RS1/16SS222J  
RS1/16SS152J  
RS1/16SS473J  
RAB4CQ221J  
RAB4CQ221J

D

R 5130 (A,66,66)  
R 5131 (A,66,63)  
R 5132 (A,78,64)  
R 5133 (A,81,69)  
R 5134 (A,79,61)

RS1/16S2202D  
RS1/16S0R0J  
RS1/16S3303D  
RS1/16S0R0J  
RS1/16S0R0J

R 5420 (A,35,70)  
R 5421 (A,22,76)  
R 5422 (A,47,71)  
R 5423 (A,46,70)  
R 5424 (A,38,73)

RAB4CQ221J  
RAB4CQ221J  
RS1/16SS221J  
RS1/16SS221J  
RS1/16SS221J

R 5135 (A,76,67)  
R 5201 (A,63,43)  
R 5202 (A,57,24)  
R 5203 (A,60,24)  
R 5204 (A,60,45)

RS1/16S2703D  
RS1/16S103J  
RS1/16S103J  
RS1/16S104J  
RS1/16S103J

R 5425 (A,37,73)  
R 5426 (A,33,71)  
R 5427 (A,32,71)  
R 5428 (A,30,72)  
R 5429 (A,28,73)

RS1/16SS221J  
RS1/16SS221J  
RS1/16SS221J  
RS1/16SS221J  
RS1/16SS221J

E

R 5205 (A,56,29)  
R 5206 (A,56,44)  
R 5207 (A,58,28)  
R 5208 (A,54,44)  
R 5209 (A,56,38)

RS1/16S473J  
RS1/16S472J  
RS1/16S105J  
RS1/16S473J  
RS1/16S333J

R 5430 (A,27,75)  
R 5501 (A,9,106)  
R 5503 (A,12,81)  
R 5504 (A,17,75)  
R 5506 (A,10,87)

RS1/16SS221J  
RAB4CQ221J  
RS1/16S101J  
RS1/16SS681J  
RS1/16S101J

R 5210 (A,49,37)  
R 5211 (A,62,37)  
R 5212 (A,53,27)  
R 5213 (A,59,40)  
R 5214 (A,35,30)

RS1/16S513J  
RS1/16S103J  
RS1/16S105J  
RS1/16S102J  
RS1/16S5102D

R 5507 (A,13,71)  
R 5508 (A,8,65)  
R 5509 (A,57,64)  
R 5510 (A,11,60)  
R 5512 (A,52,64)

RS1/16SS472J  
RS1/16S3302D  
RS1/16S6800D  
RS1/16SS223J  
RS1/16S27R0D

F

	1	2	3	4
	<u>Circuit Symbol and No.</u>	<u>Part No.</u>	<u>Circuit Symbol and No.</u>	<u>Part No.</u>
A	R 5513 (A,54,64)	RS1/16S10R0D	R 5640 (A,110,75)	RS1/16S102J
	R 5514 (A,56,63)	RS1/16S1000D	R 5641 (A,117,76)	RAB4CQ102J
	R 5515 (A,59,66)	RS1/16S82R0F	R 5642 (A,108,68)	RS1/16S104J
	R 5516 (A,58,70)	RS1/16S56R0D	R 5643 (A,112,75)	RS1/16S473J
	R 5517 (A,57,70)	RS1/16S47R0D	R 5644 (A,108,71)	RS1/16S103J
■	R 5518 (A,56,70)	RS1/16S36R0D	R 5646 (A,103,65)	RS1/16S473J
	R 5519 (A,54,70)	RS1/16S33R0F	R 5647 (A,140,42)	RS1/16S103J
	R 5520 (A,53,70)	RS1/16S27R0D	R 5648 (A,140,40)	RS1/16S821J
	R 5521 (A,51,70)	RS1/16S1800D	R 5649 (A,115,50)	RS1/16S473J
	R 5522 (A,50,70)	RS1/16S82R0F	R 5650 (A,113,53)	RS1/16S473J
B	R 5523 (A,49,70)	RS1/16S12R0F	R 5651 (A,122,52)	RS1/16S473J
	R 5524 (A,8,62)	RS1/16S5602D	R 5652 (A,130,57)	RS1/16S470J
	R 5525 (A,9,60)	RS1/16S101J	R 5653 (A,133,55)	RS1/16S470J
	R 5526 (A,8,52)	RS1/16SS153J	R 5654 (A,130,70)	RS1/16S473J
	R 5527 (A,14,52)	RS1/16S153J	R 5655 (A,115,53)	RS1/16S470J
■	R 5528 (A,11,55)	RS1/16SS0R0J	R 5656 (A,131,68)	RS1/16S470J
	R 5529 (A,12,52)	RS1/16S0R0J	R 5657 (A,132,62)	RS1/16S221J
	R 5530 (A,32,66)	RS1/16SS102J	R 5658 (A,131,67)	RS1/16S221J
	R 5531 (A,9,58)	RS1/16S100J	R 5659 (A,131,73)	RS1/16S473J
	R 5532 (A,11,57)	RS1/16SS100J	R 5660 (A,135,71)	RS1/16S221J
C	R 5533 (A,9,52)	RS1/16S0R0J	R 5668 (A,133,53)	RS1/16S473J
	R 5534 (A,11,52)	RS1/16S0R0J	R 5669 (A,136,57)	RS1/16S473J
	R 5601 (A,144,48)	RS1/16S103J	R 5671 (A,130,73)	RS1/16S470J
	R 5602 (A,144,44)	RS1/16S473J	R 5701 (A,148,64)	RS1/16S0R0J
	R 5603 (A,112,50)	RS1/16S103J	R 5702 (A,147,59)	RS1/16S0R0J
■	R 5604 (A,120,45)	RS1/16S0R0J	R 5703 (A,142,60)	RS1/16S103J
	R 5605 (A,147,48)	RS1/16S103J	R 5704 (A,142,64)	RS1/16S103J
	R 5606 (A,147,44)	RS1/16S473J	R 5705 (A,140,60)	RS1/16S103J
	R 5607 (A,125,46)	RS1/16S124J	R 5706 (A,140,64)	RS1/16S103J
	R 5608 (A,117,47)	RS1/16S102J	R 5707 (A,145,61)	RS1/16S105J
D	R 5609 (A,109,49)	RS1/16S473J	R 5708 (A,145,65)	RS1/16S105J
	R 5610 (A,107,51)	RS1/16S221J	R 5709 (A,146,71)	RS1/16S102J
	R 5611 (A,108,48)	RS1/16S221J	R 5710 (A,146,69)	RS1/16S102J
	R 5612 (A,110,47)	RS1/16S221J	R 5804 (A,119,101)	RAB4CQ101J
	R 5613 (A,112,53)	RS1/16S471J	R 5805 (A,106,99)	RS1/16S102J
■	R 5614 (A,108,55)	RS1/16S471J	R 5806 (A,104,97)	RS1/16S102J
	R 5615 (A,108,57)	RS1/16S471J	R 5807 (A,103,97)	RS1/16S102J
	R 5616 (A,126,50)	RS1/16S471J	R 5808 (A,124,103)	RS1/16S473J
	R 5617 (A,125,54)	RS1/16S471J	R 5811 (A,114,103)	RS1/16S471J
	R 5618 (A,127,50)	RS1/16S471J	R 5812 (A,112,102)	RS1/16S473J
■	R 5619 (A,127,54)	RS1/16S471J	R 5813 (A,148,80)	RS1/16S101J
	R 5620 (A,128,54)	RS1/16S471J	R 5814 (A,146,108)	RS1/16SS101J
	R 5621 (A,130,54)	RS1/16S470J	R 5815 (A,146,80)	RS1/16S473J
	R 5622 (A,107,60)	RS1/16S0R0J	R 5816 (A,142,80)	RS1/16S101J
	R 5623 (A,131,52)	RS1/16S470J	R 5817 (A,141,106)	RS1/16SS101J
E	R 5624 (A,105,60)	RS1/16S105J	R 5818 (A,104,87)	RS1/16S1500D
	R 5625 (A,105,58)	RS1/16S105J	R 5819 (A,104,85)	RS1/16S0R0J
	R 5626 (A,132,58)	RS1/16S471J	R 5820 (A,127,96)	RAB4CQ101J
	R 5627 (A,133,60)	RS1/16S471J	R 5821 (A,141,80)	RS1/16S101J
	R 5628 (A,136,58)	RS1/16S473J	R 5822 (A,102,87)	RS1/16S1500D
■	R 5629 (A,131,62)	RS1/16S221J	R 5823 (A,102,85)	RS1/16S0R0J
	R 5630 (A,103,57)	RS1/16S153J	R 5824 (A,127,93)	RAB4CQ101J
	R 5632 (A,103,61)	RS1/16S473J	R 5825 (A,140,108)	RS1/16S473J
	R 5633 (A,103,60)	RS1/16S473J	R 5826 (A,101,87)	RS1/16S1500D
	R 5634 (A,132,71)	RS1/16S473J	R 5827 (A,101,85)	RS1/16S0R0J
F	R 5635 (A,102,64)	RS1/16S473J	R 5828 (A,139,108)	RS1/16S473J
	R 5636 (A,139,71)	RS1/16S473J	R 5829 (A,136,78)	RS1/16SS101J
	R 5637 (A,139,66)	RS1/16S103J	R 5831 (A,137,108)	RS1/16S473J
	R 5638 (A,131,65)	RS1/16S103J	R 5832 (A,126,88)	RAB4CQ101J
	R 5639 (A,103,75)	RS1/16S471J	R 5833 (A,105,90)	RS1/16S680J

5  
**Circuit Symbol and No.**

6  
**Part No.**

7  
**Circuit Symbol and No.**  
**CAPACITORS**

8  
**Part No.**

R 5834	(A,130,79)	RS1/16SS101J			
R 5835	(A,136,107)	RS1/16SS101J	C 5001	(A,121,31)	CKSRYP102K50
R 5836	(A,126,85)	RAB4CQ101J	C 5002	(A,116,39)	CKSRYP102K50
R 5837	(A,130,80)	RS1/16SS0R0J	C 5003	(A,120,39)	CKSRYP102K50
R 5838	(A,131,106)	RS1/16SS101J	C 5004	(A,121,35)	CKSRYP102K50
			C 5101	(A,56,110)	CKSRYP105K16
R 5839	(A,107,85)	RS1/16S1501D			
R 5840	(A,130,81)	RS1/16SS0R0J	C 5102	(A,22,110)	CSZS100M10
R 5841	(A,130,82)	RS1/16SS101J	C 5103	(A,57,110)	CKSRYP105K16
R 5842	(A,125,81)	RS1/16S101J	C 5104	(A,76,96)	CKSSYP104K10
R 5843	(A,119,80)	RAB4CQ101J	C 5105	(A,60,87)	CSZS100M16
			C 5106	(A,57,92)	CSZSR220M10
R 5844	(A,115,81)	RAB4CQ101J			
R 5845	(A,111,81)	RAB4CQ101J	C 5107	(A,79,98)	CSZSR330M10
R 5846	(A,123,81)	RS1/16S470J	C 5108	(A,57,97)	CSZSR220M10
R 5847	(A,121,81)	RS1/16S470J	C 5109	(A,65,91)	CSZS100M10
R 5848	(A,124,81)	RS1/16S101J	C 5110	(A,63,89)	CKSSYP104K10
			C 5111	(A,65,103)	CSZS100M10
R 5849	(A,109,101)	RS1/16S0R0J			
R 5850	(A,122,103)	RS1/16S473J	C 5112	(A,65,104)	CKSSYP104K10
R 5852	(A,122,104)	RS1/16S103J	C 5113	(A,70,92)	CKSSYP104K10
R 5853	(A,145,115)	RS1/16S0R0J	C 5114	(A,71,95)	CKSRYP105K16
R 5855	(A,11,116)	RS1/16S0R0J	C 5115	(A,70,97)	CKSSYP104K10
			C 5116	(A,71,100)	CKSRYP105K16
R 5856	(A,122,100)	RS1/16S0R0J			
R 5857	(A,143,80)	RS1/16S101J	C 5117	(A,94,89)	CSZS100M16
R 5858	(A,145,80)	RS1/16S101J	C 5118	(A,95,88)	CKSRYP105K16
R 5859	(A,133,107)	RS1/16SS101J	C 5119	(A,65,86)	CKSRYP104K50
R 5860	(A,132,108)	RS1/16SS101J	C 5120	(A,20,110)	CSZS100M10
			C 5121	(A,73,88)	CKSRYP473K50
R 5861	(A,131,108)	RS1/16SS101J			
R 5862	(A,145,106)	RS1/16SS101J	C 5122	(A,89,89) 68 μF/6.3 V	CCH1440
R 5863	(A,145,108)	RS1/16SS101J	C 5123	(A,78,88)	CCSRCH331J50
R 5864	(A,144,106)	RS1/16SS101J	C 5124	(A,92,90)	CKSRYP104K50
R 5865	(A,131,79)	RS1/16SS101J	C 5125	(A,70,84)	CKSRYP104K50
			C 5126	(A,68,85)	CSZS100M16
R 5866	(A,133,80)	RS1/16SS101J			
R 5867	(A,133,78)	RS1/16SS101J	C 5127	(A,75,85)	CKSRYP103K50
R 5868	(A,135,80)	RS1/16SS101J	C 5128	(A,77,85)	CCSRCH101J50
R 5869	(A,134,78)	RS1/16SS101J	C 5130	(A,78,82)	CKSRYP103K50
R 5870	(A,134,80)	RS1/16SS101J	C 5131	(A,75,82)	CKSRYP393K50
			C 5132	(A,71,84)	CKSRYP393K50
R 5871	(A,144,108)	RS1/16SS101J			
R 5872	(A,143,106)	RS1/16SS101J	C 5133	(A,93,81)	CKSRYP103K50
R 5873	(A,142,108)	RS1/16SS101J	C 5134	(A,80,80)	CKSRYP104K50
R 5874	(A,135,108)	RS1/16SS101J	C 5135	(A,88,80) 10 μF	CCG1223
R 5875	(A,135,107)	RS1/16SS101J	C 5136	(A,66,78)	CKSRYP393K50
			C 5137	(A,91,80) 10 μF	CCG1223
R 5876	(A,134,108)	RS1/16SS101J			
R 5878	(A,127,100)	RS1/16S0R0J	C 5138	(A,78,53)	CKSRYP224K16
R 5901	(A,136,11)	RS1/16S104J	C 5139	(A,81,78)	CKSRYP105K16
R 5902	(A,134,9)	RS1/16S103J	C 5140	(A,81,77)	CKSRYP102K50
R 5903	(A,134,8)	RS1/16S0R0J	C 5141	(A,91,73) 10 μF	CCG1223
			C 5143	(A,88,73)	CKSRYP103K50
R 5904	(A,128,8)	RS1/16S0R0J			
R 5905	(A,128,6)	RS1/16S822J	C 5144	(A,66,74)	CKSRYP102K50
R 5931	(A,15,7)	RS1/16S151J	C 5145	(A,80,75)	CKSRYP104K50
R 5932	(A,18,7)	RS1/16S391J	C 5146	(A,65,71)	CKSRYP105K16
R 5933	(A,151,7)	RS1/16S151J	C 5147	(A,82,71)	CKSRYP105K16
			C 5148	(A,80,71)	CKSRYP103K50
R 5934	(A,148,7)	RS1/16S391J			
R 5951	(A,15,6)	RS1/16S271J	C 5149	(A,71,68)	CKSRYP104K50
R 5952	(A,18,6)	RS1/16S271J	C 5150	(A,76,60)	CKSYB475K16
R 5953	(A,151,6)	RS1/16S271J	C 5151	(A,81,67)	CKSRYP472K50
R 5954	(A,148,6)	RS1/16S271J	C 5152	(A,79,67)	CKSRYP472K50
			C 5153	(A,96,66)	CKSRYP104K50
R 5971	(A,84,9)	RS1/16S151J			
R 5972	(A,84,6)	RS1/16S391J	C 5154	(A,76,58)	CKSRYP103K50
R 5981	(A,86,9)	RS1/16S271J	C 5155	(A,72,66)	CKSRYP104K50
R 5982	(A,86,6)	RS1/16S271J	C 5156	(A,71,66)	CKSRYP104K50

	1	2	3	4
	<u>Circuit Symbol and No.</u>	<u>Part No.</u>	<u>Circuit Symbol and No.</u>	<u>Part No.</u>
	C 5157 (A,69,66)	CKSRYB104K50	C 5416 (A,38,108)	CKSSYB104K10
	C 5158 (A,95,68) 33 $\mu$ F/10 V	CCH1586	C 5417 (A,27,112)	CKSSYB104K10
A	C 5159 (A,94,62)	CKSRYB105K16	C 5418 (A,26,113)	CKSSYB104K10
	C 5160 (A,81,61)	CKSRYB104K50	C 5419 (A,37,108)	CKSSYB104K10
	C 5161 (A,83,61)	CKSQYF105Z25	C 5420 (A,36,108)	CKSSYB104K10
	C 5163 (A,70,60)	CKSQYF105Z25	C 5421 (A,25,113)	CKSSYB104K10
	C 5164 (A,68,60)	CKSQYF105Z25	C 5422 (A,24,113)	CKSSYB104K10
	C 5165 (A,66,60)	CKSQYF225Z16	C 5423 (A,34,108)	CKSSYB104K10
	C 5166 (A,64,60)	CKSQYF225Z16	C 5424 (A,16,106)	CKSSYB104K10
	C 5167 (A,84,68)	CKSRYB105K16	C 5425 (A,18,108)	CKSSYB104K10
	C 5168 (A,68,66)	CKSRYB105K16	C 5426 (A,18,105)	CKSSYB104K10
	C 5169 (A,83,58)	CKSQYF105Z25	C 5427 (A,19,106)	CKSSYB104K10
	C 5170 (A,62,60)	CKSQYF105Z25	C 5428 (A,32,108)	CKSSYB104K10
B	C 5201 (A,80,30) 10 $\mu$ F	CCG1223	C 5429 (A,28,109)	CKSSYB104K10
	C 5202 (A,80,34) 10 $\mu$ F	CCG1223	C 5430 (A,27,109)	CKSSYB104K10
	C 5204 (A,64,27)	CKSRYB104K50	C 5431 (A,28,108)	CKSSYB104K10
	C 5205 (A,60,30)	CKSRYB105K16	C 5432 (A,26,108)	CKSSYB104K10
	C 5206 (A,57,43)	CKSRYB104K50	C 5433 (A,24,108)	CKSSYB104K10
	C 5207 (A,50,29)	CKSRYB104K50	C 5434 (A,52,105)	CKSSYB104K10
	C 5208 (A,50,33)	CKSRYB104K50	C 5435 (A,52,103)	CKSSYB104K10
	C 5209 (A,50,27)	CKSRYB105K16	C 5436 (A,22,104)	CKSSYB104K10
	C 5211 (A,50,30)	CKSRYB474K16	C 5437 (A,19,99)	CKSSYB104K10
	C 5212 (A,50,34)	CKSRYB332K50	C 5438 (A,52,100)	CKSSYB104K10
	C 5213 (A,50,32)	CKSRYB105K16	C 5439 (A,22,98)	CKSSYB104K10
C	C 5214 (A,51,37)	CKSRYB152K50	C 5440 (A,52,98)	CKSSYB104K10
	C 5215 (A,59,35)	CKSRYB104K50	C 5441 (A,21,96)	CKSSYB104K10
	C 5216 (A,53,29)	CKSRYB103K50	C 5442 (A,52,94)	CKSSYB104K10
	C 5217 (A,39,33)	CKSRYB473K50	C 5443 (A,19,94)	CKSSYB104K10
	C 5218 (A,38,28)	CKSRYB473K50	C 5444 (A,21,93)	CKSSYB104K10
	C 5219 (A,38,30)	CCSRCH221J50	C 5445 (A,52,92)	CKSSYB104K10
	C 5220 (A,42,24) 10 $\mu$ F	CCG1223	C 5447 (A,21,90)	CKSSYB104K10
	C 5221 (A,43,13) 10 $\mu$ F	CCG1223	C 5448 (A,21,88)	CKSSYB104K10
	C 5222 (A,35,12)	CKSRYB105K16	C 5449 (A,52,88)	CKSSYB104K10
	C 5223 (A,35,13)	CKSRYB105K16	C 5450 (A,52,86)	CKSSYB104K10
	C 5224 (A,61,15)	CKSRYB104K50	C 5451 (A,21,87)	CKSSYB104K10
D	C 5225 (B,72,10) 22 pF	CCG1140	C 5453 (A,21,86)	CKSSYB104K10
	C 5226 (A,67,7)	CKSRYB223K50	C 5454 (A,22,84)	CKSSYB104K10
	C 5301 (A,74,112) 10 $\mu$ F	CCG1171	C 5455 (A,22,82)	CKSSYB104K10
	C 5302 (A,69,110)	CCSRCH470J50	C 5456 (A,52,82)	CKSSYB104K10
	C 5303 (A,67,109)	CCSRCH680J50	C 5457 (A,21,80)	CKSRYB105K16
	C 5304 (A,65,114)	CCSRCH5R0C50	C 5458 (A,50,77)	CKSSYB104K10
	C 5305 (A,65,109)	CCSRCH470J50	C 5459 (A,43,76)	CKSSYB104K10
	C 5306 (A,61,109)	CKSRYB104K50	C 5460 (A,42,77)	CKSSYB104K10
	C 5307 (A,62,106)	CSZSR330M10	C 5461 (A,40,77)	CKSSYB104K10
	C 5308 (A,85,110) 10 $\mu$ F	CCG1171	C 5462 (A,36,77)	CKSSYB104K10
	C 5309 (A,85,108) 10 $\mu$ F	CCG1171	C 5463 (A,31,77)	CKSSYB104K10
E	C 5310 (A,78,110)	CKSRYB104K50	C 5464 (A,30,77)	CKSSYB104K10
	C 5401 (A,46,110)	CCSSCH9R0D50	C 5465 (A,48,77)	CKSSYB104K10
	C 5402 (A,44,110)	CCSSCH9R0D50	C 5466 (A,52,75)	CSZSR330M10
	C 5403 (A,41,110)	CKSSYB104K10	C 5467 (A,50,108)	CKSSYB104K10
	C 5404 (A,32,110)	CKSSYB104K10	C 5468 (A,10,116)	CKSRYB104K50
	C 5405 (A,30,110)	CKSSYB104K10	C 5469 (A,17,103)	CKSRYB104K50
	C 5406 (A,29,110)	CKSSYB104K10	C 5503 (A,14,100)	CSZS100M16
	C 5407 (A,38,110)	CCSSCH4R0C50	C 5505 (A,11,77)	CKSSYB104K10
	C 5410 (A,49,108)	CKSSYB104K10	C 5507 (A,11,87)	CKSSYB104K10
	C 5411 (A,46,108)	CKSSYB104K10	C 5508 (A,13,76)	CKSRYB105K16
F	C 5412 (A,42,108)	CKSSYB104K10	C 5509 (A,58,82)	CKSSYB104K10
	C 5413 (A,40,111)	CKSSYB103K16	C 5510 (A,14,71)	CKSRYB105K16
	C 5414 (A,41,108)	CCSSCH181J25	C 5511 (A,8,70)	CKSSYB104K10
	C 5415 (A,40,108)	CKSSYB104K10	C 5512 (A,13,61)	CKSRYB104K50

5		6	
<u>Circuit Symbol and No.</u>		<u>Part No.</u>	
C 5513	(A,10,72)	CSZSR220M16	
C 5514	(A,8,79) 4.7 μF	CCG1111	
C 5515	(A,8,67)	CKSRYB105K16	
C 5516	(A,61,74)	CKSSYB104K10	
C 5517	(A,62,77)	CSZS100M16	
C 5518	(A,12,60)	CKSRYB104K50	
C 5519	(A,27,72)	CKSSYB104K10	
C 5520	(A,25,72)	CKSSYB104K10	
C 5521	(A,20,74)	CKSRYB104K50	
C 5522	(A,14,68)	CKSRYB104K50	
C 5523	(A,29,67)	CSZSR220M16	
C 5524	(A,24,69)	CSZS100M16	
C 5525	(A,21,67)	CKSQYF334Z25	
C 5526	(A,16,68) 4.7 μF	CCG1111	
C 5527	(A,30,65)	CKSSYB104K10	
C 5528	(A,26,65)	CKSSYB104K10	
C 5529	(A,22,65)	CKSRYB104K50	
C 5530	(A,19,67)	CKSRYB104K50	
C 5602	(A,119,47)	CKSRYB105K16	
C 5603	(A,136,44)	CSZSC101M10	
C 5604	(A,120,55)	CKSRYB104K50	
C 5605	(A,108,62)	CKSRYB104K50	
C 5606	(A,136,61)	CKSSYB104K10	
C 5607	(A,121,75)	CKSRYB104K50	
C 5608	(A,101,69)	CKSRYB104K50	
C 5609	(A,130,43)	CKSRYB104K50	
C 5610	(A,132,41)	CSZSC101M10	
C 5701	(A,139,62)	CKSSYB102K50	
C 5702	(A,147,62)	CKSSYB102K50	
C 5703	(A,145,67)	CKSSYB102K50	
C 5704	(A,148,69)	CKSSYB472K25	
C 5705	(A,147,67)	CKSSYB472K25	
C 5801	(A,102,81)	CSZSR330M10	
C 5802	(A,143,55)	CSZSC101M10	
C 5803	(A,139,55)	CKSRYB105K16	
C 5804	(A,104,79)	CKSRYB105K16	
C 5805	(A,107,81)	CSZSR330M10	
C 5808	(A,105,82)	CKSRYB105K16	
C 5809	(A,111,100)	CKSSYB104K10	
C 5810	(A,138,80)	CKSRYB105K16	
C 5811	(A,106,88)	CKSRYB105K16	
C 5812	(A,106,85)	CKSSYB104K10	
C 5813	(A,113,81)	CKSSYB104K10	
C 5814	(A,119,82)	CKSSYB104K10	
C 5815	(A,145,75)	CKSYB105K16	
C 5816	(A,137,53)	CKSYB105K16	
C 5824	(A,101,100)	CCSRCH101J50	
C 5825	(A,146,115)	CKSRYB105K10	
C 5901	(A,137,6) 4.7 μF	CCG1201	
C 5903	(A,119,8)	CKSRYB104K50	
C 5931	(A,24,9)	CKSRYB104K50	
C 5932	(A,9,9)	CKSRYB104K50	
C 5933	(A,142,9)	CKSRYB104K50	
C 5934	(A,156,9)	CKSRYB104K50	
C 5971	(A,77,12)	CKSRYB104K50	
C 5972	(A,89,12)	CKSRYB104K50	

7 8  
**Circuit Symbol and No. Part No.**  
**Unit Name : DVD Core Unit**

**MISCELLANEOUS**

IC 1003	(B,72,42) IC	S-80859CNNB-B9K
IC 1004	(B,75,48) Regulator IC	NJM2880U1-05
IC 1005	(B,61,58) IC	S-L2980A50MC-C7J
IC 1007	(B,82,54) IC	NJM2885DL1-33
IC 1008	(B,80,63) IC	R1232D121B
IC 1201	(A,26,15) IC	BD7996EFV
IC 1301	(B,90,27) IC	TC7SZ125FU
IC 1351	(B,86,27) IC	TC7SZ08FU
IC 1352	(B,79,13) IC	TC74LCX16373FT
IC 1401	(B,61,32) Flash ROM Unit	CWW1434
IC 1402	(B,37,10) Flash ROM Unit	CWW1435
IC 1403	(B,47,29) IC	TC7SZ32FU
IC 1481	(B,60,12) IC	EDS1232AATA-75
IC 1501	(A,60,19) IC	MN2DS0016AAUB
IC 1801	(A,70,52) D/A Converter	PCM1753DBQ
Q 1101	(B,62,50) Transistor	2SC4081
Q 1102	(B,68,50) Transistor	2SC4081
Q 1103	(B,60,45) Transistor	2SB1260
Q 1104	(B,66,45) Transistor	2SB1260
D 1002	(A,88,66) Diode	1SR154-400
D 1301	(B,12,10) Chip LED	CL205IRXTU
L 1004	(B,63,60) Inductor	CTF1472
L 1005	(B,81,49) Inductor	CTF1465
L 1006	(B,86,64) Inductor	CTF1678
L 1007	(B,74,63) Inductor	CTF1623
L 1101	(B,66,54) Inductor	CTF1305
L 1482	(B,77,29) Inductor	CTF1473
L 1502	(A,71,46) Inductor	CTF1378
L 1503	(A,60,47) Inductor	CTF1487
L 1504	(A,35,10) Inductor	CTF1387
L 1511	(A,63,3) Inductor	CTF1680
L 1601	(A,41,23) Inductor	CTF1473
L 1602	(A,55,42) Inductor	CTF1473
L 1603	(A,54,42) Inductor	CTF1473
L 1604	(A,52,42) Inductor	CTF1473
L 1605	(A,38,32) Inductor	CTF1395
L 1671	(A,41,19) Inductor	CTF1473
L 1672	(A,41,20) Inductor	CTF1473
L 1673	(A,41,21) Inductor	CTF1473
L 1801	(A,70,61) Inductor	CTF1473
L 1901	(A,91,73) Inductor	CTF1487
L 1902	(A,91,62) Inductor	CTF1558
X 1501	(A,40,15) Crystal 27.000 MHz	CSS1714
VR1671	(A,35,20) Semi-fixed 10 kΩ(B)	CCP1448
EF1501	(A,68,46) EMI Filter	DTL1106
EF1502	(A,61,44) EMI Filter	DTL1106
EF1901	(A,87,74) EMI Filter	DTF1106
EF1903	(A,91,64) EMI Filter	DTL1106

**RESISTORS**

R 1011	(B,72,40)	RS1/16SS104J
R 1014	(B,82,61)	RS1/16SS473J
R 1015	(B,76,60)	RS1/16SS101J
R 1101	(B,63,52)	RS1/16SS391J
R 1102	(B,62,47)	RS1/16SS511J
R 1103	(B,67,53)	RS1/16SS391J

**D**  
**Unit Number : YWX5005**

	1	2	3	4
	<u>Circuit Symbol and No.</u>	<u>Part No.</u>	<u>Circuit Symbol and No.</u>	<u>Part No.</u>
	R 1104 (B,69,47)	RS1/16SS561J	R 1508 (A,86,16)	RAB4CQ104J
	R 1107 (B,61,53)	RS1/16SS6R8J	R 1509 (A,86,12)	RAB4CQ104J
	R 1108 (B,65,53)	RS1/16SS6R8J	R 1510 (A,78,11)	RAB4CQ104J
A	R 1109 (B,57,40)	RS1/10S1R5J	R 1511 (A,88,4)	RS1/16SS104J
	R 1110 (B,63,40)	RS1/10S1R5J	R 1512 (B,59,3)	RAB4CQ560J
	R 1111 (B,70,40)	RS1/10S1R5J	R 1513 (A,44,4)	RS1/16SS102J
	R 1112 (B,64,40)	RS1/10S1R5J	R 1514 (A,80,7)	RAB4CQ104J
	R 1113 (B,61,40)	RS1/10S1R5J	R 1515 (A,43,3)	RS1/16SS102J
	R 1114 (B,59,40)	RS1/10S1R5J	R 1516 (A,76,8)	RS1/16SS103J
	R 1115 (B,66,40)	RS1/10S1R5J	R 1518 (A,85,5)	RS1/16SS104J
	R 1116 (B,68,40)	RS1/10S1R5J	R 1520 (A,35,8)	RS1/16SS221J
	R 1117 (B,64,49)	RS1/16SS104J	R 1521 (A,41,11)	RAB4CQ101J
	R 1118 (B,70,49)	RS1/16SS104J	R 1522 (B,56,3)	RAB4CQ560J
	R 1202 (A,19,12)	RS1/16SS221J	R 1523 (A,39,11)	RS1/16SS101J
B	R 1203 (A,19,11)	RS1/16SS221J	R 1524 (A,39,12)	RS1/16SS101J
	R 1210 (A,30,27)	RS1/16SS101J	R 1525 (B,53,3)	RAB4CQ560J
	R 1211 (B,26,18)	RS1/16SS3R9J	R 1526 (A,36,10)	RS1/16SS270J
	R 1212 (B,27,18)	RS1/16SS3R9J	R 1528 (A,43,14)	RS1/16SS101J
	R 1214 (B,28,18)	RS1/16SS3R9J	R 1529 (B,53,22)	RAB4CQ560J
	R 1215 (B,29,18)	RS1/16SS3R9J	R 1530 (A,43,15)	RS1/16SS105J
	R 1216 (B,30,18)	RS1/16SS3R9J	R 1531 (B,50,22)	RAB4CQ560J
	R 1217 (B,31,18)	RS1/16SS3R9J	R 1532 (A,77,22)	RS1/16SS103J
	R 1219 (A,20,27)	RS1/16SS101J	R 1533 (A,76,27)	RS1/16SS103J
	R 1223 (A,19,4)	RS1/16SS753J	R 1534 (A,77,26)	RS1/16SS103J
C	R 1225 (A,19,7)	RS1/16SS753J	R 1535 (A,63,36)	RS1/16SS221J
	R 1227 (B,13,21)	RS1/16SS3R9J	R 1537 (A,67,40)	RS1/16SS221J
	R 1228 (B,14,21)	RS1/16SS3R9J	R 1538 (A,66,41)	RS1/16SS221J
	R 1229 (B,15,21)	RS1/16SS3R9J	R 1540 (A,70,43)	RS1/16SS102J
	R 1230 (B,16,21)	RS1/16SS3R9J	R 1541 (A,64,41)	RS1/16SS472J
	R 1231 (B,17,21)	RS1/16SS3R9J	R 1542 (A,60,36)	RS1/16SS223J
	R 1232 (B,18,21)	RS1/16SS3R9J	R 1543 (A,59,37)	RS1/16SS332J
	R 1233 (B,19,21)	RS1/16SS3R9J	R 1544 (A,57,41)	RS1/16SS183J
	R 1234 (B,20,21)	RS1/16SS3R9J	R 1545 (A,61,36)	RS1/16SS223J
	R 1240 (B,32,18)	RS1/16SS3R9J	R 1546 (A,59,42)	RS1/16SS104J
D	R 1241 (B,33,18)	RS1/16SS3R9J	R 1547 (A,59,41)	RS1/16SS473J
	R 1242 (B,34,18)	RS1/16SS3R9J	R 1548 (A,59,36)	RS1/16SS104J
	R 1243 (B,37,18)	RS1/16SS3R9J	R 1554 (A,60,39)	RS1/16SS221J
	R 1244 (B,36,18)	RS1/16SS3R9J	R 1555 (A,57,38)	RS1/16SS221J
	R 1245 (B,35,18)	RS1/16SS3R9J	R 1556 (A,43,7)	RS1/16SS104J
	R 1301 (B,13,13)	RS1/16SS391J	R 1557 (A,57,39)	RS1/16SS104J
	R 1302 (B,15,13)	RS1/16SS471J	R 1559 (A,63,41)	RS1/16SS221J
	R 1304 (B,87,23)	RS1/16SS563J	R 1560 (A,68,42)	RAB4CQ104J
	R 1305 (B,86,23)	RS1/16SS243J	R 1562 (A,64,38)	RAB4CQ104J
	R 1306 (B,85,23)	RS1/16SS683J	R 1565 (A,73,36)	RS1/16SS103J
	R 1307 (B,88,23)	RS1/16SS243J	R 1566 (A,72,36)	RS1/16SS103J
	R 1314 (B,86,21)	RAB4CQ822J	R 1567 (B,68,22)	RAB4CQ560J
E	R 1351 (B,84,25)	RS1/16SS331J	R 1568 (B,65,22)	RAB4CQ560J
	R 1401 (B,72,33)	RS1/16SS221J	R 1569 (B,62,3)	RAB4CQ560J
	R 1402 (B,50,27)	RS1/16SS104J	R 1570 (B,60,22)	RAB4CQ560J
	R 1405 (B,48,10)	RS1/16SS221J	R 1571 (B,57,22)	RAB4CQ560J
	R 1406 (B,25,4)	RS1/16SS104J	R 1573 (B,63,19)	RS1/16SS560J
	R 1407 (B,25,6)	RS1/16SS104J	R 1582 (A,81,25)	RS1/16SS103J
	R 1410 (B,47,31)	RS1/16SS104J	R 1583 (A,81,27)	RS1/16SS103J
	R 1501 (B,71,3)	RAB4CQ560J	R 1584 (A,77,28)	RS1/16SS103J
	R 1502 (A,85,3)	RS1/16SS104J	R 1601 (A,41,25)	RS1/16SS123J
	R 1503 (A,71,2)	RS1/16SS560J	R 1602 (A,39,24)	RS1/16SS123J
F	R 1504 (A,87,23)	RAB4CQ104J	R 1607 (A,41,27)	RS1/16SS105J
	R 1505 (B,68,3)	RAB4CQ560J	R 1609 (A,37,28)	RN1/16SE1002D
	R 1506 (A,87,19)	RAB4CQ104J	R 1610 (A,43,28)	RS1/16SS222J
	R 1507 (B,65,3)	RAB4CQ560J	R 1613 (A,39,28)	RS1/16SS223J

5		6		7		8	
<u>Circuit Symbol and No.</u>		<u>Part No.</u>		<u>Circuit Symbol and No.</u>		<u>Part No.</u>	
R 1614	(A,46,35)	RS1/16SS105J		C 1302	(B,88,25)	CKSSYB104K10	
R 1615	(A,43,32)	RS1/16SS105J		C 1351	(B,86,25)	CKSSYB104K10	
R 1616	(A,53,36)	RS1/16SS2002D		C 1352	(B,75,19)	CKSSYB104K10	
R 1672	(A,43,21)	RS1/16SS303J					
R 1673	(A,37,22)	RS1/16SS183J		C 1353	(B,81,19)	CKSSYB104K10	A
R 1674	(A,34,23)	RS1/16SS562J		C 1354	(B,74,7)	CKSSYB104K10	
R 1705	(A,55,57)	RS1/16SS101J		C 1355	(B,85,8)	CKSSYB104K10	
R 1706	(A,52,56)	RS1/16SS201J		C 1356	(B,83,28)	CKSSYB106K6R3	
R 1707	(A,55,51)	RS1/16SS101J		C 1401	(B,72,31)	CKSSYB103K16	
R 1708	(A,52,50)	RS1/16SS201J		C 1402	(B,49,33)	CKSSYB104K10	
R 1715	(A,60,56)	RS1/16SS201J		C 1403	(B,81,27)	CKSQYB475K6R3	
R 1716	(A,62,57)	RS1/16SS101J		C 1405	(B,48,8)	CKSSYB103K16	
R 1719	(A,60,50)	RS1/16SS201J		C 1406	(B,25,15)	CKSSYB104K10	
R 1720	(A,62,51)	RS1/16SS101J		C 1407	(B,74,27)	CKSQYB475K6R3	
R 1803	(A,72,56)	RS1/16SS821J		C 1408	(B,47,27)	CKSSYB104K10	
R 1804	(A,74,56)	RS1/16SS821J		C 1481	(B,72,5)	CKSSYB104K10	B
R 1805	(A,72,61)	RS1/16SS104J		C 1482	(B,72,7)	CKSSYB104K10	
R 1806	(A,74,61)	RS1/16SS104J		C 1483	(B,67,5)	CKSSYB104K10	
R 1903	(A,89,52)	RS1/16SS0R0J		C 1484	(B,63,5)	CKSSYB104K10	
R 1904	(A,90,59)	RS1/16S0R0J		C 1485	(B,56,5)	CKSSYB104K10	

**CAPACITORS**

C 1019	(B,58,59)	CCSSCH101J50		C 1491	(B,77,27)	CKSQYB106K6R3	
C 1020	(B,58,57)	CKSSYB104K10		C 1492	(B,55,19)	CKSSYB104K10	C
C 1021	(B,60,60)	CKSRYB105K10		C 1493	(B,52,19)	CKSSYB104K10	
C 1022	(B,79,47)	CKSSYB103K16		C 1494	(B,65,19)	CKSSYB104K10	
C 1023	(B,79,49)	CKSSYB104K10		C 1496	(B,65,5)	CKSSYB102K50	
C 1024	(B,71,48)	CKSQYB475K10		C 1497	(B,61,19)	CKSSYB102K50	
C 1025	(B,64,58)	CKSRYB105K10		C 1498	(B,77,26)	CKSSYB102K50	
C 1026	(B,12,19)	CKSSYB104K10		C 1499	(B,49,4)	CKSSYB102K50	
C 1027	(A,90,53)	CCSSCH101J50		C 1501	(A,68,44)	CKSQYB106K6R3	
C 1028	(B,89,56)	CKSRYB105K10		C 1502	(A,58,43)	CKSQYB106K6R3	
C 1029	(B,89,52)	CKSQYB225K10		C 1503	(A,55,3)	CKSSYB104K10	
C 1030	(B,84,59)	CKSQYB106K6R3		C 1504	(A,58,3)	CKSSYB104K10	
C 1031	(B,85,59)	CKSQYB106K6R3		C 1505	(A,53,3)	CKSSYB104K10	D
C 1032	(B,82,59)	CKSRYB105K10		C 1506	(A,60,3)	CKSSYB104K10	
C 1033	(B,73,59)	CKSQYB106K6R3		C 1507	(A,68,2)	CKSSYB104K10	
C 1034	(B,73,57)	CKSQYB106K6R3		C 1508	(A,65,3)	CKSSYB104K10	
C 1035	(B,45,27)	CCSSCH101J50		C 1509	(A,69,2)	CKSSYB104K10	
C 1101	(B,61,54) 10 μF	CCG1192		C 1510	(A,43,11)	CKSSYB104K10	
C 1102	(B,58,50) 100 μF	CCG1232		C 1511	(A,76,7)	CKSSYB104K10	
C 1103	(B,65,50) 100 μF	CCG1232		C 1512	(A,76,11)	CKSSYB104K10	
C 1104	(B,63,43)	CKSSYB104K10		C 1513	(A,43,10)	CKSSYB104K10	
C 1105	(B,70,43)	CKSSYB104K10		C 1514	(A,76,17)	CKSSYB104K10	
C 1106	(B,63,45)	CKSSYB103K16		C 1515	(A,43,16)	CKSSYB104K10	
C 1107	(B,70,45)	CKSSYB103K16		C 1516	(A,76,15)	CKSSYB104K10	E
C 1108	(A,35,36)	CKSSYB103K16		C 1517	(A,43,17)	CKSSYB104K10	
C 1109	(A,36,33)	CKSRYB105K10		C 1518	(A,37,14)	CCSSCH8R0D50	
C 1110	(A,35,37)	CKSSYB103K16		C 1519	(A,37,16)	CCSSCH8R0D50	
C 1111	(A,39,33)	CKSRYB105K10		C 1521	(A,76,24)	CKSSYB104K10	
C 1201	(B,21,11)	CEVW101M16		C 1522	(A,77,24)	CKSSYB104K10	
C 1202	(B,15,17)	CKSYB475K16		C 1523	(A,58,36)	CKSSYB104K10	
C 1207	(B,16,10)	CKSQYB225K10		C 1524	(A,57,37)	CKSSYB103K16	
C 1209	(A,32,17)	CKSSYB104K10		C 1525	(A,66,36)	CKSSYB104K10	
C 1210	(A,32,19)	CKSSYB471K50		C 1526	(A,62,40)	CKSSYB103K16	
C 1211	(A,19,16)	CKSSYB103K16		C 1527	(A,63,35)	CKSSYB471K50	
C 1212	(A,19,8)	CKSSYB104K10		C 1528	(A,65,36)	CKSSYB104K10	F
C 1213	(A,19,9)	CKSSYB104K10		C 1529	(A,60,38)	CKSSYB103K16	
C 1301	(B,90,25)	CKSSYB104K10		C 1530	(A,59,39)	CKSSYB224K6R3	

1

**Circuit Symbol and No.**

C 1531 (A,57,42)  
 C 1536 (A,76,20)  
 C 1537 (A,55,43)

A

C 1538 (A,53,43)  
 C 1539 (A,57,36)  
 C 1540 (A,61,38)  
 C 1560 (A,51,3)  
 C 1577 (A,77,30)

■

C 1601 (A,41,24)  
 C 1602 (A,43,24)  
 C 1603 (A,37,23)  
 C 1604 (A,39,25)  
 C 1608 (A,41,26)

B

C 1609 (A,43,26)  
 C 1610 (A,53,39)  
 C 1611 (A,53,37)  
 C 1612 (A,55,36)  
 C 1613 (A,55,37)

■

C 1614 (A,56,37)  
 C 1615 (A,41,30)  
 C 1616 (A,48,36)  
 C 1617 (A,49,38)  
 C 1618 (A,51,38)

C

C 1619 (A,51,36)  
 C 1620 (A,50,36)  
 C 1621 (A,50,38)  
 C 1622 (A,52,38)  
 C 1623 (A,52,39)

■

C 1624 (A,43,27)  
 C 1625 (A,56,36)  
 C 1626 (A,41,31)  
 C 1627 (A,43,23)  
 C 1628 (A,54,36)

D

C 1629 (A,49,36)  
 C 1630 (A,38,30)  
 C 1671 (A,43,18)  
 C 1672 (A,43,19)  
 C 1673 (A,37,21)

■

C 1674 (A,39,21)  
 C 1675 (A,39,19)  
 C 1676 (A,37,19)  
 C 1677 (A,43,22)  
 C 1801 (A,74,52)

E

C 1802 (A,67,58) 10 μF  
 C 1803 (A,67,56)  
 C 1804 (A,69,58) 10 μF  
 C 1805 (A,69,56)  
 C 1808 (A,72,57)

■

C 1809 (A,75,57)  
 C 1810 (A,72,59)  
 C 1811 (A,74,59)  
 C 1901 (A,84,74)

**E****Unit Number : CWX3154****Unit Name : Compound Unit(A)**

F

Q 1299 Photo-taransistor CPT231SCTD  
 S 1201 Spring Switch(12cm) CSN1069  
 S 1202 Spring Switch(8cm) CSN1069

2

**Part No.**

CKSSYB123K16  
 CKSSYB104K10  
 CKSSYB102K50

CKSSYB102K50  
 CKSSYB104K10  
 CKSSYB103K16  
 CKSSYB104K10  
 CKSSYB104K10

CCSSCH101J50  
 CCSSCH101J50  
 CCSSCH680J50  
 CCSSCH680J50  
 CKSSYB103K16

CKSSYB103K16  
 CCSSCH101J50  
 CKSSYB562K25  
 CKSSYB224K6R3  
 CKSSYB224K6R3

CKSSYB333K16  
 CKSRYB105K10  
 CKSSYB104K10  
 CKSSYB104K10  
 CKSSYB104K10

CKSSYB104K10  
 CKSSYB104K10  
 CKSSYB104K10  
 CKSSYB104K10  
 CKSSYB104K10

CKSSYB103K16  
 CKSSYB104K10  
 CKSRYB105K10  
 CKSSYB104K10  
 CKSSYB104K10

CKSSYB104K10  
 CKSQYB106K6R3  
 CKSSYB104K10  
 CKSSYB104K10  
 CKSSYB104K10

CKSSYB104K10  
 CKSRYB105K10  
 CKSRYB105K10  
 CKSSYB104K10  
 CKSSYB104K10

CCG1192  
 CKSSYB104K10  
 CCG1192  
 CKSSYB104K10  
 CCSRCH182J50

CCSRCH182J50  
 CKSQYB475K6R3  
 CKSQYB475K6R3  
 CKSSYB102K50

3

**Circuit Symbol and No.**

S 1203 Spring Switch(DISC SENS) CSN1069  
 S 1204 Spring Switch(DISC SENS) CSN1070

S 1205 Spring Switch(8cm) CSN1070  
 R 1298 RS1/16S0R0J  
 R 1299 RS1/16S0R0J

**F****Unit Number : CWX3394****Unit Name : Compound Unit(B)**

S 1206 Switch(CLAMP) CSN1067

**OPT/RCA Unit****Consists of****OPT PCB****RCA PCB****G I****Unit Number :****Unit Name : OPT/RCA Unit****MISCELLANEOUS**

IC 4201 (A,35,16) L-MOS And Gate TC7SET08FUS1  
 D 4201 (A,42,16) Diode UDZS5R6(B)  
 D 4202 (A,42,11) Diode UDZS5R6(B)  
 L 4201 (A,28,14) Inductor CTF1379  
 L 4202 (A,59,24) Inductor CTF1389

**RESISTORS**

R 4201 (A,24,14) RS1/16S0R0J  
 R 4203 (A,25,17) RS1/16S221J  
 R 4204 (A,28,17) RS1/16S621J  
 R 4205 (A,31,16) RS1/16S473J  
 R 4206 (A,32,13) RS1/16S0R0J

R 4207 (A,38,16) RS1/16S121J  
 R 4211 (A,68,6) RS1/16S0R0J

**CAPACITORS**

C 4202 (A,28,16) CCSRCH150J50  
 C 4203 (A,37,18) CKSRYB104K50  
 C 4204 (A,38,13) CKSYB106K10  
 C 4207 (A,62,16) CKSRYB104K50  
 C 4301 (A,17,13) CKSRYB102K50

**K****Unit Number : CXX2316****Unit Name : Main PCB Unit(SERVICE)****MISCELLANEOUS**

IC 101 IC BA00CC0WFP  
 IC 102 IC BA6247FP  
 IC 103 Photo-interrupter GP2L24B  
 IC 104 IC TC7W14FU  
 IC 105 Photo-interrupter GP2L24B



5  
**Circuit Symbol and No.**

6  
**Part No.**

Q 101	Transistor	DTC124EUA
D 101	Diode	UDZS5R6(B)

**RESISTORS**

R 101	RS1/16S102J
R 102	RS1/16S3302D
R 103	RS1/16S3900D
R 104	RS1/16S4701D
R 105	RS1/16S471J
R 106	RS1/16S102J
R 107	RS1/16S102J
R 108	RS1/16S102J
R 109	RS1/16S102J
R 110	RS1/16S102J
R 111	RS1/16S562J
R 112	RS1/16S102J
R 113	RS1/16S102J
R 114	RS1/16S102J
R 115	RS1/16S562J
R 116	RS1/16S102J
R 117	RS1/16S472J

**CAPACITORS**

C 101	CKSYB475K16
C 102	CKSYB475K16
C 103	CKSRYB104K16
C 104	CKSRYB104K16
C 105	CKSRYB223K16
C 106	CKSRYB104K16
C 107	CKSRYB223K16
C 108	CEVW101M16
C 109	CKSRYB104K16
C 110	CCSRCH102J50
C 111	CCSRCH102J50

**L**

**Unit Number : CZW5029**  
**Unit Name : Switch PCB Unit**

S 101	Switch(Angel sw)	CSN1068
-------	------------------	---------

**M**

**Unit Number : CZW5028**  
**Unit Name : Volume PCB Unit**

VR101	Volume(Angel sense)	CCW1025
-------	---------------------	---------

**Miscellaneous Parts List**

M 1	Pickup Unit(Service)	CXX2118
M 2	Motor Unit(LOADING)	CXC4912
M 3	Motor(STEPPING)	CXM1364
M 3	Motor(SPINDLE)	CXM1362