

Service Manual

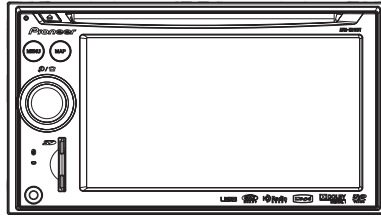

AVIC-X910BT/XS/UC

ORDER NO.
CRT4321

FLASH MEMORY MULTIMEDIA AV NAVIGATION RECEIVER

AVIC-X910BT /XS/UC

NAVIGATION AV SYSTEM

AVIC-F910BT /XS/EU5

AVIC-F910BT /XS/AU

This service manual should be used together with the following manual(s):

Model No.	Order No.	Mech.Module	Remarks
CX-3250	CRT4300	LS1	DVD Mech. Module : Circuit Descriptions, Mech. Descriptions, Disassembly



For details, refer to "Important Check Points for Good Servicing".

SAFETY INFORMATION

CAUTION

This service manual is intended for qualified service technicians; it is not meant for the casual do-it-yourselfer. Qualified technicians have the necessary test equipment and tools, and have been trained to properly and safely repair complex products such as those covered by this manual. Improperly performed repairs can adversely affect the safety and reliability of the product and may void the warranty. If you are not qualified to perform the repair of this product properly and safely, you should not risk trying to do so and refer the repair to a qualified service technician.

WARNING

This product may contain a chemical known to the State of California to cause cancer, or birth defects or other reproductive harm.
Health & Safety Code Section 25249.6 - Proposition 65

Where in a manufacturer's service documentation, for example in circuit diagrams or lists of components, a symbol is used to indicate that a specific component shall be replaced only by the component specified in that documentation for safety reasons, the following symbol shall be used:



● Safety Precautions for those who Service this Unit.

When checking or adjusting the emitting power of the laser diode exercise caution in order to get safe, reliable results.

Caution:

1. During repair or tests, minimum distance of 13 cm from the focus lens must be kept.
2. During repair or tests, do not view laser beam for 10 seconds or longer.

**CAUTION:
USE OF CONTROLS OR ADJUSTMENTS OR PERFORMANCE OF PROCEDURES OTHER THAN THOSE SPECIFIED HEREIN MAY RESULT IN HAZARDOUS RADIATION EXPOSURE.**

CAUTION

CLASS 1M INVISIBLE LASER RADIATION WHEN OPEN. DO NOT VIEW DIRECTLY WITH OPTICAL INSTRUMENTS

WARNING!

The AEL (accessible emission level) of the laser power output is less than CLASS 1 but the laser component is capable of emitting radiation exceeding the limit for CLASS 1.

A specially instructed person should do servicing operation of the apparatus.

Laser diode characteristics

Wave length:

DVD:660 nm to 670 nm

CD:780 nm to 800 nm

Focus lens on Maximum output:

CD:6.26 mW(Emitting period :9 sec.)

DVD:1.27 mW (Emitting period : unlimited)

Additional Laser Caution

Transistors Q1103 and Q1104 in PCB drive the laser diodes for DVD and CD respectively. When Q1103 or Q1104 is shorted between their terminals, the laser diodes for DVD or CD will radiate beam. If the top cover is removed with no disc loaded while such short-circuit is continued, the naked eyes may be exposed to the laser beam.

[Important Check Points for Good Servicing]

In this manual, procedures that must be performed during repairs are marked with the below symbol. Please be sure to confirm and follow these procedures.

1. Product safety



Please conform to product regulations (such as safety and radiation regulations), and maintain a safe servicing environment by following the safety instructions described in this manual.

- ① Use specified parts for repair.

Use genuine parts. Be sure to use important parts for safety.

- ② Do not perform modifications without proper instructions.

Please follow the specified safety methods when modification (addition/change of parts) is required due to interferences such as radio/TV interference and foreign noise.

- ③ Make sure the soldering of repaired locations is properly performed.

When you solder while repairing, please be sure that there are no cold solder and other debris. Soldering should be finished with the proper quantity. (Refer to the example)

- ④ Make sure the screws are tightly fastened.

Please be sure that all screws are fastened, and that there are no loose screws.

- ⑤ Make sure each connectors are correctly inserted.

Please be sure that all connectors are inserted, and that there are no imperfect insertion.

- ⑥ Make sure the wiring cables are set to their original state.

Please replace the wiring and cables to the original state after repairs. In addition, be sure that there are no pinched wires, etc.

- ⑦ Make sure screws and soldering scraps do not remain inside the product.

Please check that neither solder debris nor screws remain inside the product.

- ⑧ There should be no semi-broken wires, scratches, melting, etc. on the coating of the power cord.

Damaged power cords may lead to fire accidents, so please be sure that there are no damages. If you find a damaged power cord, please exchange it with a suitable one.

- ⑨ There should be no spark traces or similar marks on the power plug.

When spark traces or similar marks are found on the power supply plug, please check the connection and advise on secure connections and suitable usage. Please exchange the power cord if necessary.

- ⑩ Safe environment should be secured during servicing.

When you perform repairs, please pay attention to static electricity, furniture, household articles, etc. in order to prevent injuries. Please pay attention to your surroundings and repair safely.

2. Adjustments



To keep the original performance of the products, optimum adjustments and confirmation of characteristics within specification. Adjustments should be performed in accordance with the procedures/instructions described in this manual.

3. Lubricants, Glues, and Replacement parts



Use grease and adhesives that are equal to the specified substance. Make sure the proper amount is applied.

4. Cleaning



For parts that require cleaning, such as optical pickups, tape deck heads, lenses and mirrors used in projection monitors, proper cleaning should be performed to restore their performances.

5. Shipping mode and Shipping screws



To protect products from damages or failures during transit, the shipping mode should be set or the shipping screws should be installed before shipment. Please be sure to follow this method especially if it is specified in this manual.

CONTENTS

SAFETY INFORMATION	2	
1. SERVICE PRECAUTIONS.....	6	
1.1 SERVICE PRECAUTIONS	6	A
1.2 NOTES ON SOLDERING	6	
2. SPECIFICATIONS.....	7	
2.1 SPECIFICATIONS	7	
2.2 DISC/CONTENT FORMAT	13	
2.3 PANEL FACILITIES.....	14	
2.4 CONNECTION DIAGRAM.....	17	
3. BASIC ITEMS FOR SERVICE	19	
3.1 CHECK POINTS AFTER SERVICING	19	
3.2 PCB LOCATIONS	20	
3.3 JIGS LIST	21	
3.4 CLEANING	22	
4. BLOCK DIAGRAM	24	B
4.1 OVERALL CONNECTION DIAGRAM	24	
4.2 BLOCK DIAGRAM.....	28	
4.3 POWER SUPPLY SYSTEM FIGURE	36	
5. DIAGNOSIS	40	
5.1 OPERATIONAL FLOWCHART	40	
5.2 INSPECTION METHOD OF PICKUP UNIT	42	
5.3 DIAGNOSIS FLOWCHART	45	
5.4 ERROR CODE LIST	72	
5.5 CONNECTOR FUNCTION DESCRIPTION	74	
5.6 TROUBLESHOOTING	75	
6. SERVICE MODE.....	79	C
6.1 TEST MODE.....	79	
6.2 DVD TEST MODE	91	
6.3 uBOOT MENU	97	
6.4 USING THE TEST DISC	98	
7. DISASSEMBLY	104	
8. EACH SETTING AND ADJUSTMENT	118	
8.1 DVD ADJUSTMENT	118	
8.2 AV UNIT ADJUSTMENT.....	126	
8.3 FLICKER ADJUSTMENT	128	
9. EXPLODED VIEWS AND PARTS LIST	130	
9.1 PACKING	130	
9.2 EXTERIOR(1).....	134	D
9.3 EXTERIOR(2).....	136	
9.4 EXTERIOR(3).....	138	
9.5 DVD MECHANISM MODULE	140	
10. SCHEMATIC DIAGRAM.....	144	
10.1 AV UNIT(PS/IF SECTION)(GUIDE PAGE)	144	
10.2 AV UNIT(A/V SECTION)(GUIDE PAGE)	150	
10.3 AV UNIT(TUNER SECTION).....	156	
10.4 AV UNIT(SYSTEM uCOM SECTION)(GUIDE PAGE)	158	
10.5 AV UNIT(RGB LED DRIVER SECTION).....	164	
10.6 AV UNIT(IF SECTION)(GUIDE PAGE).....	166	
10.7 CK UNIT	172	
10.8 DVD CORE UNIT(GUIDE PAGE)	174	E
10.9 CONNECT PCB.....	180	
10.10 KEYBOARD UNIT	182	
10.11 WAVEFORMS.....	184	
11. PCB CONNECTION DIAGRAM	186	
11.1 AV UNIT.....	186	
11.2 CK UNIT	190	
11.3 DVD CORE UNIT.....	192	
11.4 CONNECT PCB.....	194	
11.5 KEYBOARD UNIT	196	
12. ELECTRICAL PARTS LIST	197	F

1. SERVICE PRECAUTIONS

1.1 SERVICE PRECAUTIONS



1. You should conform to the regulations governing the product (safety, radio and noise, and other regulations), and should keep the safety during servicing by following the safety instructions described in this manual.
2. Be careful in handling ICs. Some ICs such as MOS type are so fragile that they can be damaged by electrostatic induction.
3. Before disassembling the unit, be sure to turn off the power. Unplugging and plugging the connectors during power-on mode may damage the ICs inside the unit.
4. To protect the pickup unit from electrostatic discharge during servicing, take an appropriate treatment (shorting-solder) by referring to "the DISASSEMBLY" .
5. After replacing the pickup unit, be sure to skew adjustment.
6. During disassembly, be sure to turn the power off since an internal IC might be destroyed when a connector is plugged or unplugged.
7. Gasket(CNN2533) must not come in contact with the terminal(Panel Unit).

EJECT LOCK MODE for DVD mechanism

In order to change the EJECT LOCK/UNLOCK status of the mechanism, please perform following procedure.

< Procedure >

Top Menu -> AV Source -> Source OFF



Short push area "A" -> Short push area "B" -> Long push area "C" on above screen.
(In order to change the status, follow the same operation.)

The current status can be confirmed by "OFF" character color.

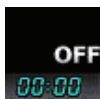

Eject Lock: OFF
(White)

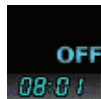

Eject Lock: ON
(Blue)

1.2 NOTES ON SOLDERING

- For environmental protection, lead-free solder is used on the printed circuit boards mounted in this unit. Be sure to use lead-free solder and a soldering iron that can meet specifications for use with lead-free solders for repairs accompanied by reworking of soldering.
- Compared with conventional eutectic solders, lead-free solders have higher melting points, by approximately 40 °C. Therefore, for lead-free soldering, the tip temperature of a soldering iron must be set to around 373 °C in general, although the temperature depends on the heat capacity of the PC board on which reworking is required and the weight of the tip of the soldering iron.
- Compared with eutectic solders, lead-free solders have higher bond strengths but slower wetting times and higher melting temperatures (hard to melt/easy to harden).

The following lead-free solders are available as service parts:

- Parts numbers of lead-free solder:
 - GYP1006 1.0 in dia.
 - GYP1007 0.6 in dia.
 - GYP1008 0.3 in dia.

2. SPECIFICATIONS

2.1 SPECIFICATIONS

UC model

General

Rated power source	14.4 V DC (allowable voltage range: 10.8 V to 15.1 V DC)
Grounding system	Negative type
Maximum current consumption	10.0 A
Backup current	6.5 mA or less
Dimensions (W × H × D):	
Chassis	178 mm × 100 mm × 157 mm (7 in. × 3-7/8 in. × 6-1/8 in.)
Nose	171 mm × 97 mm × 8 mm (6-3/4 in. × 3-7/8 in. × 3/8 in.)
Weight:	2.1 kg
NAND flash memory	2 GB

Navigation

GPS Receiver:	
System	L1, C/Acode GPS SPS (Standard Positioning Service)
Reception system	30-channel multi-channel reception system
Reception frequency	1 575.42 MHz
Sensitivity	-140 dBm (typ)
Position update frequency	Approx. once per second
GPS antenna:	
Antenna	Micro strip flat antenna/ right-handed helical polariza- tion
Antenna cable	5.0 m (16 ft. 5 in.)
Dimensions (W × H × D)	33 mm × 15 mm × 36 mm (1-1/4 in. × 5/8 in. × 1-3/8 in.)
Weight	96 g (0.2 lbs)

Display

Screen size/aspect ratio	5.8 inch wide/16:9 (effective display area: 128 mm × 72 mm)
Pixels	384 000 (800 × 480)
Display method	TFT Active matrix driving
Backlight	LED
Color system	NTSC compatible
Tolerable temperature range:	
Power on	+14 °F to +140 °F
Power off	-4 °F to +176 °F

Audio

Maximum power output	50 W × 4 50 W × 2 ch/4Ω + 70 W × 1 ch/2Ω (for subwoofer)
Continuous power output	22 W × 4 (50 Hz to 15 kHz, 5%THD, 4Ω LOAD, Both Channels Driven)
Load impedance	4Ω (4Ω to 8Ω [2Ω for 1 ch] allowable)
Preout output level (max)	2.2 V
Preout impedance	1 kohm
Equalizer (3-Band Parametric Equalizer):	
Low	
Frequency	40 Hz/80 Hz/100 Hz/160 Hz
Q Factor	0.35/0.59/0.95/1.15 (+6 dB when boosted)
Gain	±12 dB
Mid	
Frequency	200 Hz/500 Hz/1 kHz/2 kHz
Q Factor	0.35/0.59/0.95/1.15 (+6 dB when boosted)
Gain	±12 dB
High	
Frequency	3.15 kHz/8 kHz/10 kHz/ 12.5 kHz
Q Factor	0.35/0.59/0.95/1.15 (+6 dB when boosted)
Gain	±12 dB
Loudness contour:	
Low	+3.5 dB (100 Hz), +3 dB (10 kHz)
Mid	+10 dB (100 Hz), +6.5 dB (10 kHz)
High	+11 dB (100 Hz), +11 dB (10 kHz) (volume: -30 dB)
HPF:	
Frequency	50 Hz/63 Hz/80 Hz/100 Hz/ 125 Hz
Slope	-12 dB/oct
Subwoofer:	
Frequency	50 Hz/63 Hz/80 Hz/100 Hz/ 125 Hz
Slope	-18 dB/oct
Gain	-24/+6 dB
Phase	Normal/Reverse
Bass boost:	
Gain	0 dB to +12 dB
DVD drive	
System	DVD-Video, CD, MP3, WMA, AAC, DivX system
Usable discs	DVD-Video, CD, MP3, WMA, AAC, DivX

Region number	1
Signal format:	
Sampling frequency	44.1 kHz/48 kHz/96 kHz
Number of quantization bits	16 bit/20 bit/24 bit; linear
Frequency response	5 Hz to 44 000 Hz (with DVD, at sampling frequency 96 kHz)
Signal-to-noise ratio	97 dB (1 kHz) (IHF-A network) (CD: 96 dB (1 kHz) (IHF-A network))
Dynamic range	95 dB (1 kHz) (CD: 94 dB (1 kHz))
Distortion	0.008 % (1 kHz)
Output level:	
Video	1.0 V _{p-p} /75 Ω (±0.2 V)
Audio	1.0 V (1 kHz, 0 dB)
Number of channels	2 (stereo)
MP3 decoding format	MPEG-1 & 2 Audio Layer 3
WMA decoding format	Ver.9.0 L3
AAC decoding format	MPEG-4 AAC (only encoded by iTunes): .m4a
DivX decoding format	Home Theater Ver.3.11, Ver.4.X, Ver.5.X, Ver.6.X: .avi, .divx

USB

USB standard spec.	USB 2.0 High Speed
Max current supply	500 mA
Max memory capacity	8 GB
File system	FAT16, FAT32
USB class	Mass storage class
Decoding format	MP3/WMA/AAC/WAVE/ MPEG4

SD

Compatible physical format	Version 2.00
----------------------------------	--------------

Max memory capacity	8 GB
File system	FAT16, FAT32
Decoding format	MP3/WMA/AAC/WAVE/ MPEG4

Bluetooth

Version	Bluetooth 1.2 certified
Output power	+4 dBm Max. (Power class 2)

FM tuner

Frequency range	87.9 MHz to 107.9 MHz
Usable sensitivity	8 dBf (0.7 μV/75 Ω, mono, S/N: 30 dB)
Signal-to-noise ratio	75 dB (IHF-A network)
Distortion	0.3 % (at 65 dBf, 1 kHz, stereo) 0.1 % (at 65 dBf, 1 kHz, mono)
Frequency response	30 Hz to 15 000 Hz (±3 dB)
Stereo separation	45 dB (at 65 dBf, 1 kHz)

AM tuner

Frequency range	530 kHz to 1 710 kHz (10 kHz)
Usable sensitivity	18 μV (S/N: 20 dB)
Signal-to-noise ratio	65 dB (IHF-A network)

CEA2006 Specifications



Power output	14 W RMS × 4 Channels (4 Ω and ≤ 1 % THD+N)
S/N ratio	91 dBA (reference: 1 W into 4 Ω)



Note

Specifications and design are subject to possible modifications without notice due to improvements. ■

EU5 model

General

Rated power source 14.4 V DC
(allowable voltage range:
12.0 V to 14.4 V DC)

Earthing system Negative type
Maximum current consumption
..... 10.0 A

Backup current 6.5 mA or less

Dimensions (W × H × D):

DIN
Chassis 178 mm × 100 mm ×
149 mm
Nose 188 mm × 118 mm ×
16 mm

D
Chassis 178 mm × 100 mm ×
157 mm
Nose 171 mm × 97 mm × 8 mm

Weight:
..... 2.6 kg

NAND flash memory 2 GB

Navigation

GPS Receiver:

System L1, C/Acode GPS
SPS (Standard Positioning
Service)

Reception system 30-channel multi-channel
reception system

Reception frequency 1 575.42 MHz

Sensitivity -140 dBm (typ)

Position update frequency
..... Approx. once per second

GPS aerial:

Aerial Micro strip flat aerial/right-
handed helical polarisation

Aerial cable 5.0 m

Dimensions (W × H × D)
..... 33 mm × 15 mm × 36 mm

Weight 96 g

Display

Screen size/aspect ratio 5.8 inch wide/16:9
(effective display area:
128 mm × 72 mm)

Pixels 384 000 (800 × 480)

Display method TFT Active matrix driving

Backlight LED

Colour system:

..... NTSC/PAL compatible

Tolerable temperature range:

Power on -10 °C to +60 °C

Power off -20 °C to +80 °C

Audio

Maximum power output 50 W × 4
50 W × 2 ch/4Ω + 70 W ×
1 ch/2Ω (for subwoofer)

Continuous power output ... 22 W × 4 (50 Hz to 15 kHz,
5%THD, 4Ω LOAD, Both
Channels Driven)

Load impedance 4Ω (4Ω to 8Ω [2Ω for 1 ch]
allowable)

Preout output level (max) 2.2 V

Preout impedance 1 kohm

Equaliser (3-Band Parametric Equaliser):

Low

Frequency 40 Hz/80 Hz/100 Hz/160 Hz

Q Factor 0.35/0.59/0.95/1.15 (+6 dB
when boosted)

Gain ±12 dB

Mid

Frequency 200 Hz/500 Hz/1 kHz/2 kHz

Q Factor 0.35/0.59/0.95/1.15 (+6 dB
when boosted)

Gain ±12 dB

High

Frequency 3.15 kHz/8 kHz/10 kHz/
12.5 kHz

Q Factor 0.35/0.59/0.95/1.15 (+6 dB
when boosted)

Gain ±12 dB

Loudness contour:

Low +3.5 dB (100 Hz), +3 dB
(10 kHz)

Mid +10 dB (100 Hz), +6.5 dB
(10 kHz)

High +11 dB (100 Hz), +11 dB
(10 kHz)
(volume: -30 dB)

HPF:

Frequency 50 Hz/63 Hz/80 Hz/100 Hz/
125 Hz

Slope	-12 dB/oct
Subwoofer:	
Frequency	50 Hz/63 Hz/80 Hz/100 Hz/ 125 Hz
Slope	-18 dB/oct
Gain	-24/+6 dB
Phase	Normal/Reverse
Bass boost:	
Gain	0 dB to +12 dB

DVD drive

System	DVD-Video, CD, MP3, WMA, AAC, DivX system
Usable discs	DVD-Video, CD, MP3, WMA, AAC, DivX
Region number	2
Signal format:	
Sampling frequency	44.1 kHz/48 kHz/96 kHz
Number of quantisation bits	16 bit/20 bit/24 bit; linear
Frequency response	5 Hz to 44 000 Hz (with DVD, at sampling frequency 96 kHz)
Signal-to-noise ratio	97 dB (1 kHz) (IEC-A net- work) (CD: 96 dB (1 kHz) (IEC-A network))
Dynamic range	95 dB (1 kHz) (CD: 94 dB (1 kHz))
Distortion	0.008 % (1 kHz)
Output level:	
Video	1.0 V _{p-p} /75 Ω (±0.2 V)
Audio	1.0 V (1 kHz, 0 dB)
Number of channels	2 (stereo)
MP3 decoding format	MPEG-1 & 2 Audio Layer 3
WMA decoding format	Ver.9.0 L3
AAC decoding format	MPEG-4 AAC (only encoded by iTunes): .m4a
DivX decoding format	Home Theater Ver.3.11, Ver.4.X, Ver.5.X, Ver.6.X : .avi, .divx

USB

USB standard spec.	USB 2.0 High Speed
Max current supply	500 mA
Max memory capacity	8 GB
File system	FAT16, FAT32
USB class	Mass storage class
Decoding format	MP3/WMA/AAC/WAVE/ MPEG4

SD

Compatible physical format	Version 2.00
Max memory capacity	8 GB
File system	FAT16, FAT32
Decoding format	MP3/WMA/AAC/WAVE/ MPEG4

Bluetooth

Version	Bluetooth 1.2 certified
Output power	+4 dBm Max. (Power class 2)

FM tuner

Frequency range	87.5 MHz to 108.0 MHz
Usable sensitivity	8 dBf (0.7 μV/75 Ω, mono, S/N: 30 dB)
Signal-to-noise ratio	75 dB (IEC-A network)
Distortion	0.3 % (at 65 dBf, 1 kHz, stereo) 0.1 % (at 65 dBf, 1 kHz, mono)
Frequency response	30 Hz to 15 000 Hz (±3 dB)
Stereo separation	45 dB (at 65 dBf, 1 kHz)

MW tuner

Frequency range	531 kHz to 1 602 kHz (9 kHz)
Usable sensitivity	18 μV (S/N: 20 dB)
Signal-to-noise ratio	65 dB (IEC-A network)

LW tuner

Frequency range	153 kHz to 281 kHz
Usable sensitivity	30 μV (S/N: 20 dB)
Signal-to-noise ratio	65 dB (IEC-A network)



Note

Specifications and design are subject to possible modifications without notice due to improvements. 

AU model

General

Rated power source 14.4 V DC
(allowable voltage range:
10.8 V to 15.1 V DC)

Earthing system Negative type
Maximum current consumption
..... 10.0 A

Backup current **6.5 mA or less**

Dimensions (W × H × D):

D
Chassis 178 mm × 100 mm ×
157 mm

Nose 171 mm × 97 mm × 8 mm

Weight 2.1 kg

NAND flash memory 1 GB

Navigation

GPS Receiver:

System L1, C/Acode GPS
SPS (Standard Positioning
Service)

Reception system 30-channel multi-channel
reception system

Reception frequency 1575.42 MHz

Sensitivity -140 dBm (typ)

Position update frequency
..... Approx. once per second

GPS aerial:

Aerial Micro strip flat aerial/right-
handed helical polarisation

Aerial cable 5.0 m

Dimensions (W × H × D)
..... 33 mm × 14.7 mm × 36 mm

Weight 96 g

Display

Screen size/aspect ratio 5.8 inch wide/16:9
(effective display area:
128 mm × 72 mm)

Pixels 384 000 (800 × 480)

Display method TFT Active matrix driving

Backlight LED

Colour system PAL/NTSC compatible

Tolerable temperature range:

Power on -10 °C to +60 °C

Power off -20 °C to +80 °C

Audio

Maximum power output 50 W × 4
50 W × 2 ch/4Ω + 70 W ×
1 ch/2Ω (for subwoofer)

Continuous power output ... 22 W × 4 (50 Hz to 15 kHz,
5 %THD, 4Ω LOAD, Both
Channels Driven)

Load impedance 4Ω (4Ω to 8Ω [2Ω for 1 ch]
allowable)

Preout output level (max) 2.2 V

Preout impedance 1 kohm

Equaliser (3-Band Parametric Equaliser):

Low

Frequency 40 Hz/80 Hz/100 Hz/160 Hz

Q Factor 0.35/0.59/0.95/1.15 (+6 dB
when boosted)

Gain ±12 dB

Mid

Frequency 200 Hz/500 Hz/1 kHz/2 kHz

Q Factor 0.35/0.59/0.95/1.15 (+6 dB
when boosted)

Gain ±12 dB

High

Frequency 3.15 kHz/8 kHz/10 kHz/
12.5 kHz

Q Factor 0.35/0.59/0.95/1.15 (+6 dB
when boosted)

Gain ±12 dB

Loudness contour:

Low +3.5 dB (100 Hz), +3 dB
(10 kHz)

Mid +10 dB (100 Hz), +6.5 dB
(10 kHz)

High +11 dB (100 Hz), +11 dB
(10 kHz)
(volume: -30 dB)

HPF:

Frequency 50 Hz/63 Hz/80 Hz/100 Hz/
125 Hz

Slope -12 dB/oct

Subwoofer:

Frequency 50 Hz/63 Hz/80 Hz/100 Hz/
125 Hz

Slope -18 dB/oct

Gain -24/+6 dB

Phase Normal/Reverse

Bass boost:

Gain 0 dB to +12 dB

DVD Drive

System DVD-Video, CD, MP3, WMA,
AAC, DivX system

Usable discs DVD-Video, CD, MP3, WMA,
AAC, DivX

Region number 4

Signal format:

Sampling frequency 44.1 kHz/48 kHz/96 kHz

A	Number of quantisation bits	16 bit/20 bit/24 bit; linear
	Frequency response	5 Hz to 44 000 Hz (with DVD, at sampling frequency 96 kHz)
B	Signal-to-noise ratio	97 dB (1 kHz) (IEC-A network) (CD: 96 dB (1 kHz) (IEC-A network))
	Dynamic range	95 dB (1 kHz) (CD: 94 dB (1 kHz))
	Distortion	0.008 % (1 kHz)
C	Output level:	
	Video	1.0 Vp-p/75 Ω (±0.2 V)
D	Audio	1.0 V (1 kHz, 0 dB)
	Number of channels	2 (stereo)
	MP3 decoding format	MPEG-1 & 2 Audio Layer 3
	WMA decoding format	Ver.9.0 L3
	AAC decoding format	MPEG-4 AAC (only encoded by iTunes): .m4a
	DivX decoding format	Home Theater Ver.3.11, Ver.4.X, Ver.5.X, Ver.6.X: .avi, .divx

USB

USB standard spec.	USB 2.0 High Speed
Max current supply	500 mA
Max memory capacity	8 GB
File system	FAT16, FAT32
USB class	Mass storage class
Decoding format	MP3/WMA/AAC/WAVE/ MPEG4

SD

Compatible physical format	Version 2.00
Max memory capacity	8 GB
File system	FAT16, FAT32
Decoding format	MP3/WMA/AAC/WAVE/ MPEG4

Bluetooth

Version	Bluetooth 1.2 certified
Output power	+4 dBm Max. (Power class 2)

FM tuner

Frequency range	87.9 MHz to 107.9 MHz
Usable sensitivity	8 dBf (0.7 μV/75 Ω, mono, S/N: 30 dB)
Signal-to-noise ratio	75 dB (IEC-A network)

Distortion	0.3 % (at 65 dBf, 1 kHz, stereo)
	0.1 % (at 65 dBf, 1 kHz, mono)
Frequency response	30 Hz to 15 000 Hz (±3 dB)
Stereo separation	45 dB (at 65 dBf, 1 kHz)

AM tuner

Frequency range	531 kHz to 1 602 kHz (9 kHz) 530 kHz to 1 640 kHz (10 kHz)
Usable sensitivity	18 μV (S/N: 20 dB)
Signal-to-noise ratio	65 dB (IEC-A network)



Note

Specifications and design are subject to possible modifications without notice due to improvements. □

DVD-Video and CD

DVD and CD discs that display the logos shown below generally can be played on this built-in DVD drive.

DVD-Video



CD



- DVD** is a trademark of DVD Format/Logo Licensing Corporation.
- It is not possible to play DVD-Audio discs. This DVD drive may not be able to play all discs bearing the marks shown above.

2.3 PANEL FACILITIES

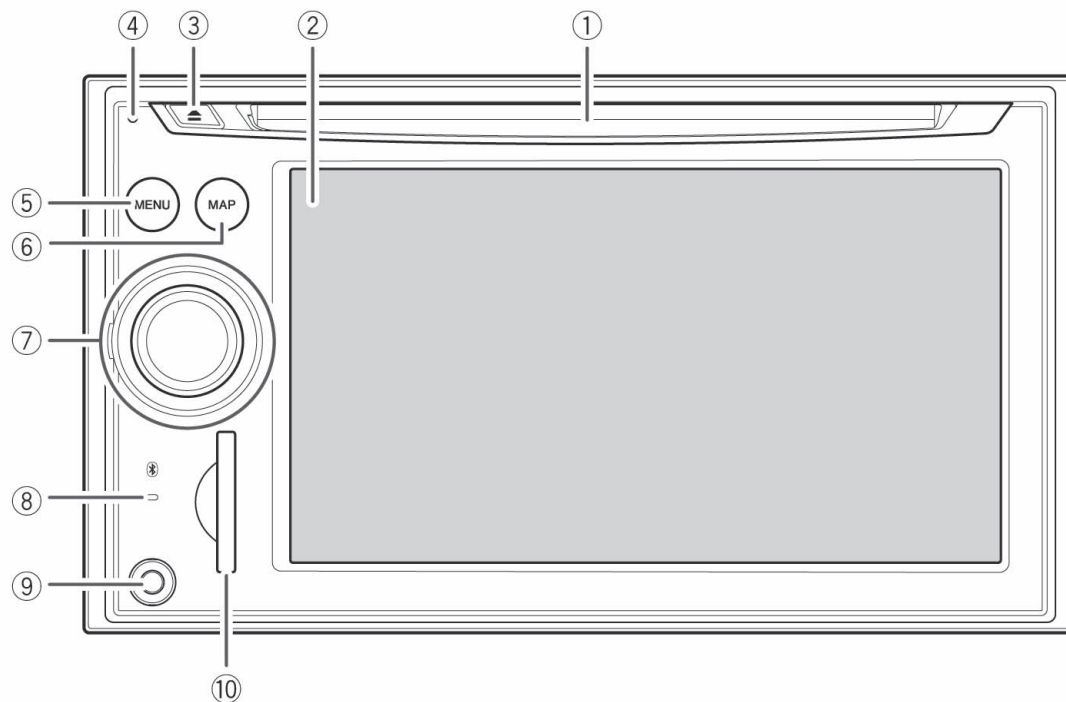

Checking part names and functions

This chapter gives information about the names of the parts and the main features using the buttons.

① **Disc loading slot**
Insert a disc to play.

② **LCD screen**

③ **EJECT button**

④ **RESET button**

⑤ **MENU button**
Press the **MENU** button to display the “**Top Menu**”.

Press and hold the button on the “**Top Menu**” to display the “**Screen Calibration**” screen.

⑥ **MAP button**

Press to view the map screen.
Press and hold to display the “**Picture Adjustment**” screen.

⑦ **MULTI-CONTROL**
Rotating;

Adjusts the AV (Audio and Video) source volume.

Moving upward or downward once;
Changes the map scale one step at a time.

Keep moving upward or downward;

Changes the map scale continuously.

- This operation is available only while the map screen is displayed.

Moving MULTI-CONTROL to the left or right;

Allows you to change the frequency one step at a time; operates track search controls.

Keep moving MULTI-CONTROL to the left or right;

Allows you to perform manual seek tuning, fast forward or reverse.

Pressing the center of MULTI-CONTROL;

Enables you to start the voice operation when "English" is selected in "Program language:". (When a language other than "English" is selected, pressing the center allows you to hear the previous route guidance.)

- When your phone is paired to the navigation system, press the center of the multicontrol to answer an incoming call or end the phone call.

Keep pressing the center of MULTI-CONTROL;

Mutes the AV (Audio and Video) source. To cancel the muting, press and hold it again.

- ⑧ **Bluetooth connection status indicator**
Lights up when your phone is paired to the navigation system by Bluetooth wireless technology.

⑨ **"AV2" input jack**

This is the "AV2" input terminal. Use the CD-RM10 (sold separately) to connect the external video component.

- To connect your iPod by using USB interface cable for iPod (CD-IU230V), use "AV1" input (RCA) on the back of the unit.

⑩ **SD card slot****Inserting and ejecting a disc****Inserting a disc**

- **Insert a disc into the disc loading slot.**

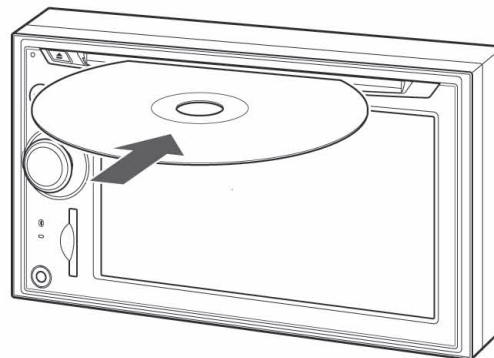

- Do not insert anything other than a disc into the disc loading slot.

Ejecting a disc

- **Press the EJECT button.**

The disc is ejected.

Inserting and ejecting an SD memory card**CAUTION**

- Keep the dummy SD card out of the reach of small children to prevent them from accidentally swallowing it.
- To prevent data loss and damage to the storage device, never remove it from this navigation system while data is being transferred.
- If data loss or corruption occurs on the storage device for any reason, it is usually not possible to recover the data. Pioneer accepts no liability for damages, costs or expenses arising from data loss or corruption.

Inserting an SD memory card

- Insert an SD memory card into the SD card slot.

Insert it with the contact surface facing to the left and press the card until it clicks and completely locks.

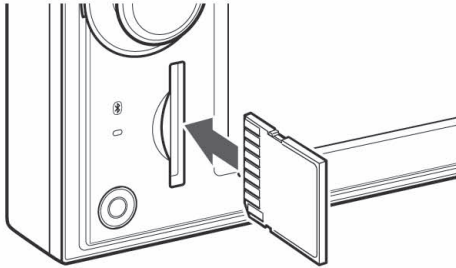

- ❑ This system is not compatible with Multi Media Card (MMC).
- ❑ Compatibility with all SD memory cards is not guaranteed.
- ❑ This unit may not achieve optimum performance with some SD memory cards.
- ❑ Do not insert anything other than SD memory cards or dummy SD cards into the SD card slot.

Ejecting an SD memory card

- 1 Press the SD memory card until it clicks. The SD memory card is ejected.

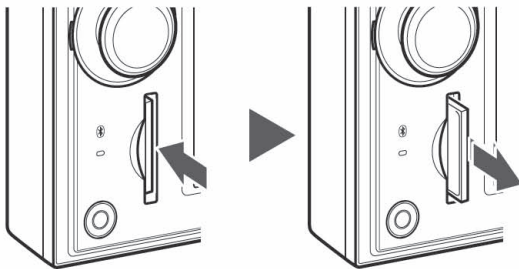

- 2 Pull out the SD memory card.

- ❑ Insert the dummy SD card to keep the SD card slot free of dust when the SD memory card is not inserted. ❑

Plugging and unplugging a USB storage device

⚠ CAUTION

- To prevent data loss and damage to the storage device, never remove it from this navigation system while data is being transferred.
- If data loss or corruption occurs on the storage device for any reason, it is usually not possible to recover the data. Pioneer accepts no liability for damages, costs or expenses arising from data loss or corruption.
- Never remove the USB storage device immediately after plugging it. It may cause that the navigation system cannot recognize the external storage device (USB, SD).

Plugging in a USB storage device

- Plug a USB storage device into the USB connector.

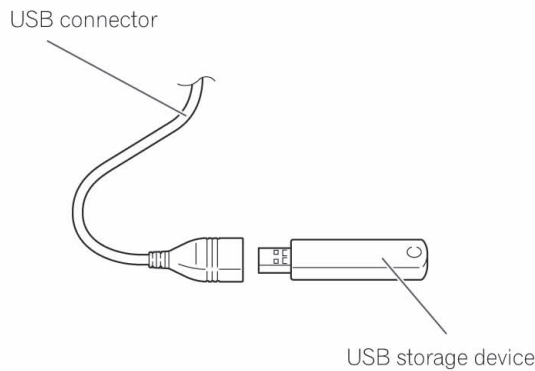

- ❑ Compatibility with all USB storage device is not guaranteed. This navigation system may not achieve optimum performance with some USB storage devices.
- ❑ Connection via USB hub is not possible.

Unplugging a USB storage device

- Pull out the USB storage device after checking that no data is being accessed. ❑

2.4 CONNECTION DIAGRAM

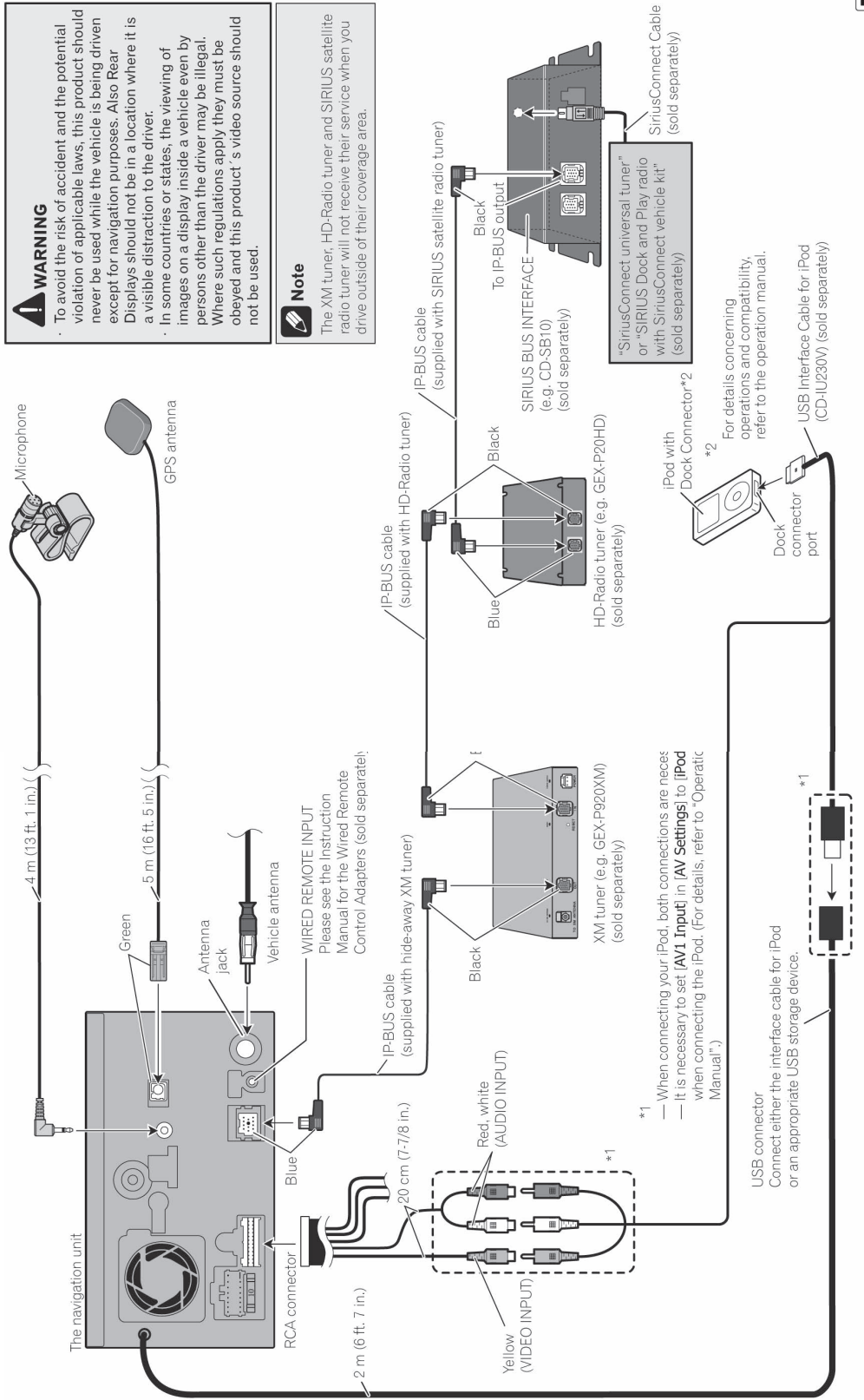

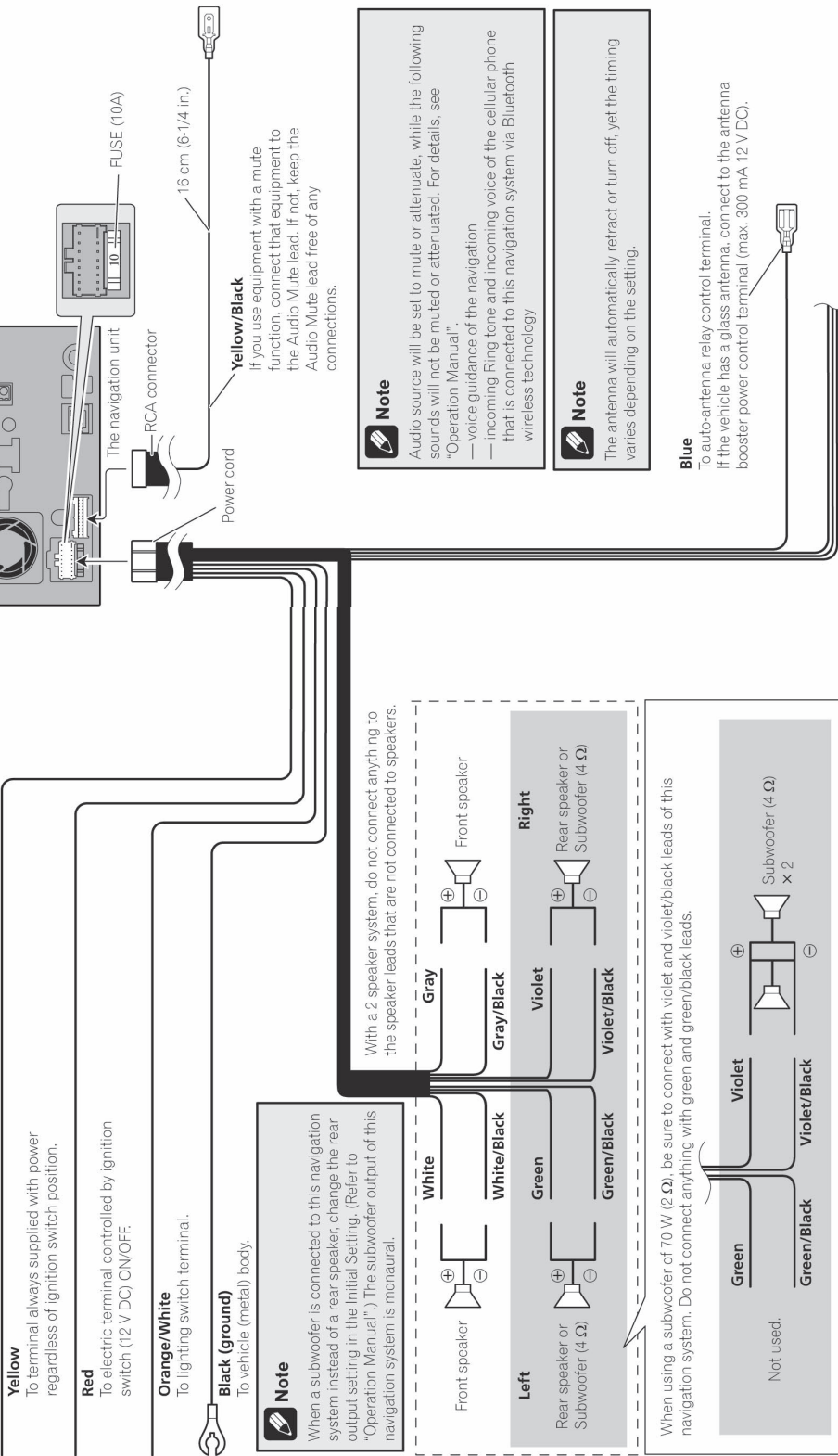

3. BASIC ITEMS FOR SERVICE

3.1 CHECK POINTS AFTER SERVICING

To keep the product quality after servicing, please confirm following check points.

No.		Procedures	Item to be confirmed
1		Confirm whether the customer complain has been solved. If the customer complain occurs with the specific media, use it for the operation check.	The customer complain must not be reappeared. Display, video, audio and operations must be normal.
2	DVD	Measure playback error rates at the innermost and outermost tracks by using the test mode with the following disc. DVD test disc (GGV1025)	Deterioration of mecha-drive can be checked. The error rate must be less than the threshold value. (Refer to the chapter of DIAGNOSIS for the threshold value.)
3	DVD	Play back a DVD. (Menu operation; Title/chapter search)	Display, video, audio and operations must be normal.
4	CD	Play back a CD. (Track search)	Display, audio and operations must be normal.
5	FM/AM tuner	Check FM/AM tuner action. (Seek, Preset) Switch band to check both FM and AM.	Display, audio and operations must be normal.
6	GPS positioning	Connect GPS antenna to the product, and check whether the current location is correct.	Current location must be correct. Display and operations must be normal.
7	Map display Touch-panel operation Remote-control operation	Check functions of map scale change and map scroll.	Display and operations must be normal.
8		Delete data added during the operating check. Check whether no media (CD etc.) is inside the product.	Make sure to delete data added during the operating check. The media used for the operating check must be ejected.
9		Appearance check	No scratches or dirt on its appearance after receiving it for service.

See the table below for the items to be checked regarding video and audio:

Item to be checked regarding video	Item to be checked regarding audio
Block-noise	Distortion
Horizontal noise	Noise
Dot noise	Volume too low
Disturbed image (video jumpiness)	Volume too high
Too dark	Volume fluctuating
Too bright	Sound interrupted
Mottled color	

3.2 PCB LOCATIONS

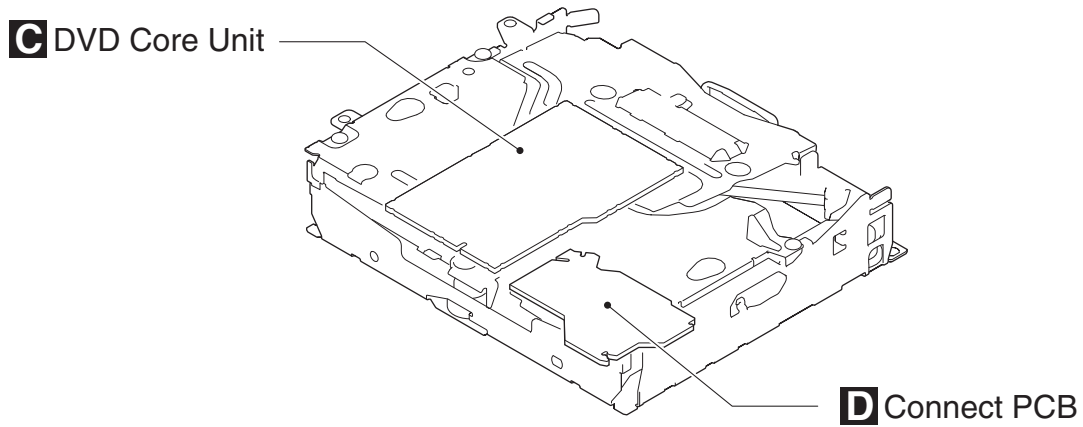
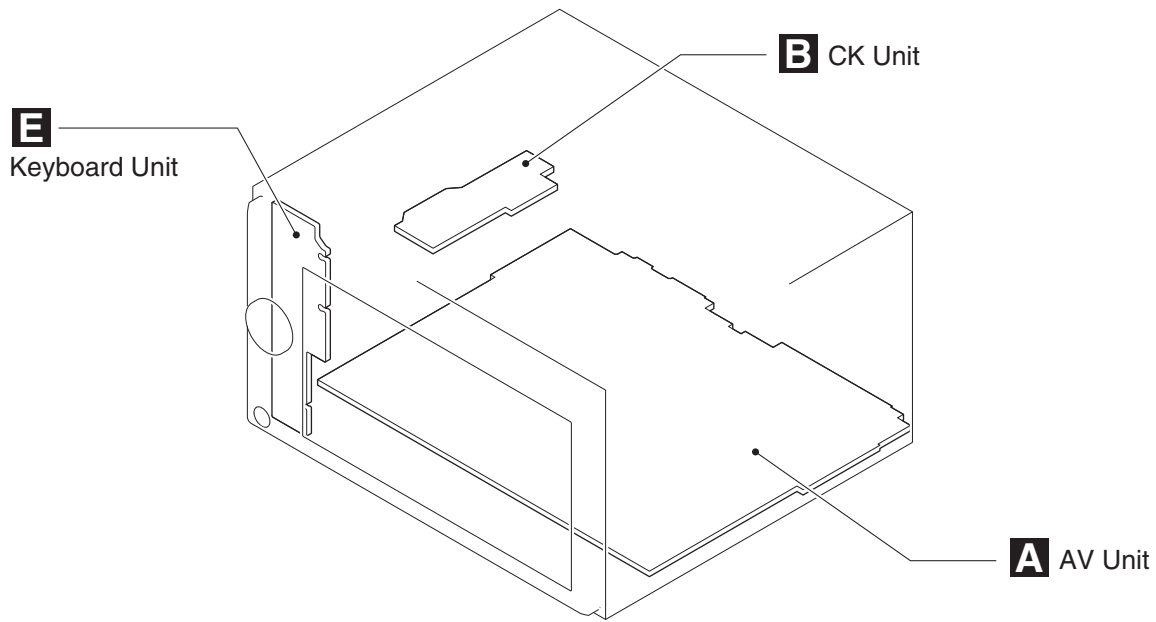

Unit Number	:	CWN4237(UC)
Unit Number	:	CWN4238(EU5)
Unit Number	:	CWN4239(AU)
Unit Name	:	AV Unit
Unit Number	:	CWN4251
Unit Name	:	CK Unit
Unit Number	:	YWX5009
Unit Name	:	DVD Core Unit
Unit Number	:	
Unit Name	:	Connect PCB
Unit Number	:	
Unit Name	:	Keyboard Unit

3.3 JIGS LIST

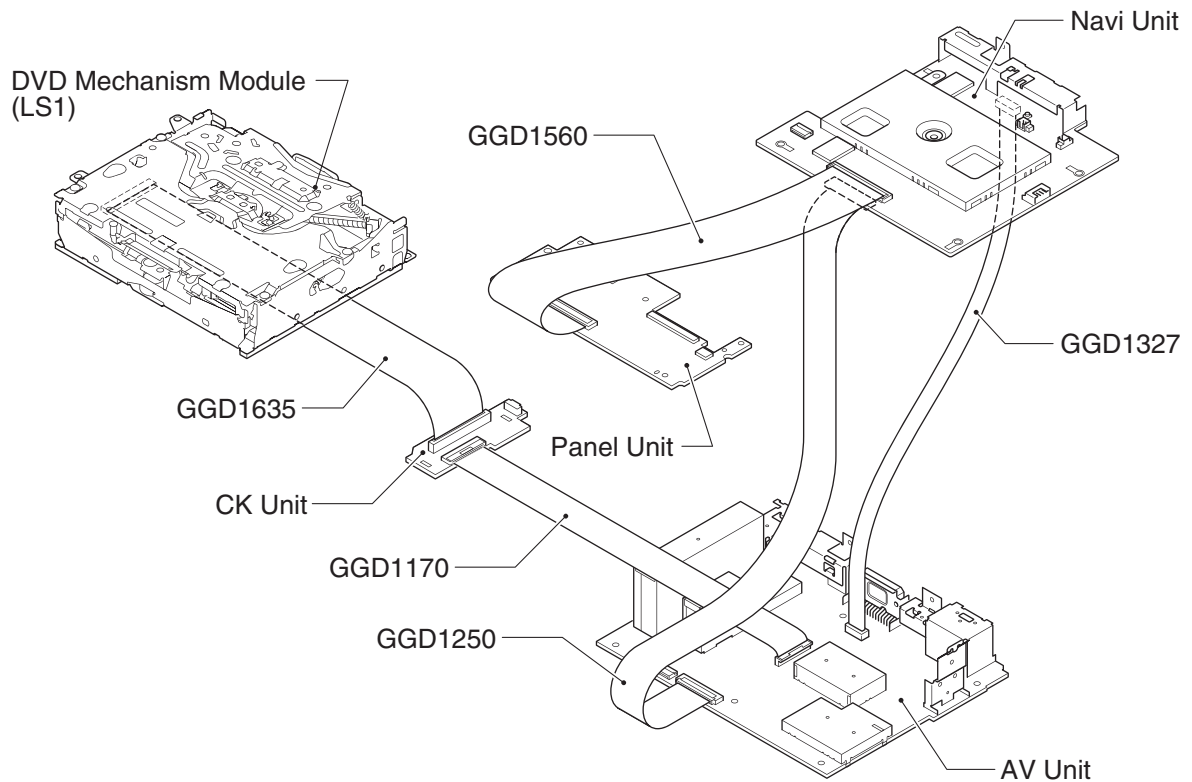

● Jigs List

Name	Jig No.	Remarks
15P FFC	GGD1123	Navi Unit <---> SD Unit
74P FFC	GGD1560	Navi Unit <---> Panel Unit
50P FFC	GGD1250	Navi Unit <---> AV Unit
20P Extension Cable	GGD1327	Navi Unit <---> AV Unit
TORX screwdriver	GGK1068	T8 (For top cover)
40P FFC	GGD1170	AV Unit <---> CK Unit
30P FFC BBR	GGD1635	CK Unit <---> DVD Mechanism Module
Disc	TDV-582	Skew adjustment, Check points after servicing, Inspection method of Pickup Unit
Disc	TCD-782	Inspection method of Pickup Unit

● Grease List

Name	Jig No.	Remarks
Grease	GEM1024	DVD Mechanism Module
Grease	GEM1038	DVD Mechanism Module
Grease	GEM1045	DVD Mechanism Module
Locking agents	1401M	Skew adjustment (1401M:produced by THREE BOND)
Bond	GEM1033	Skew adjustment
Bond	1530	Skew adjustment (1530:produced by THREE BOND)

3.4 CLEANING



A

Before shipping out the product, be sure to clean the following portions by using the prescribed cleaning tools:

Portions to be cleaned	Cleaning tools
DVD pickup lenses	Cleaning liquid : GEM1004 Cleaning paper : GED-008

Portions to be cleaned	Cleaning tools
Fans	Cleaning paper : GED-008

B

C

D

E

F

A

B

C

D

E

F

4. BLOCK DIAGRAM

4.1 OVERALL CONNECTION DIAGRAM

AVIC-X910BT/XS/UC
 AVIC-F910BT/XS/EU5
 AVIC-F910BT/XS/AU

A

B

C

D

E

F

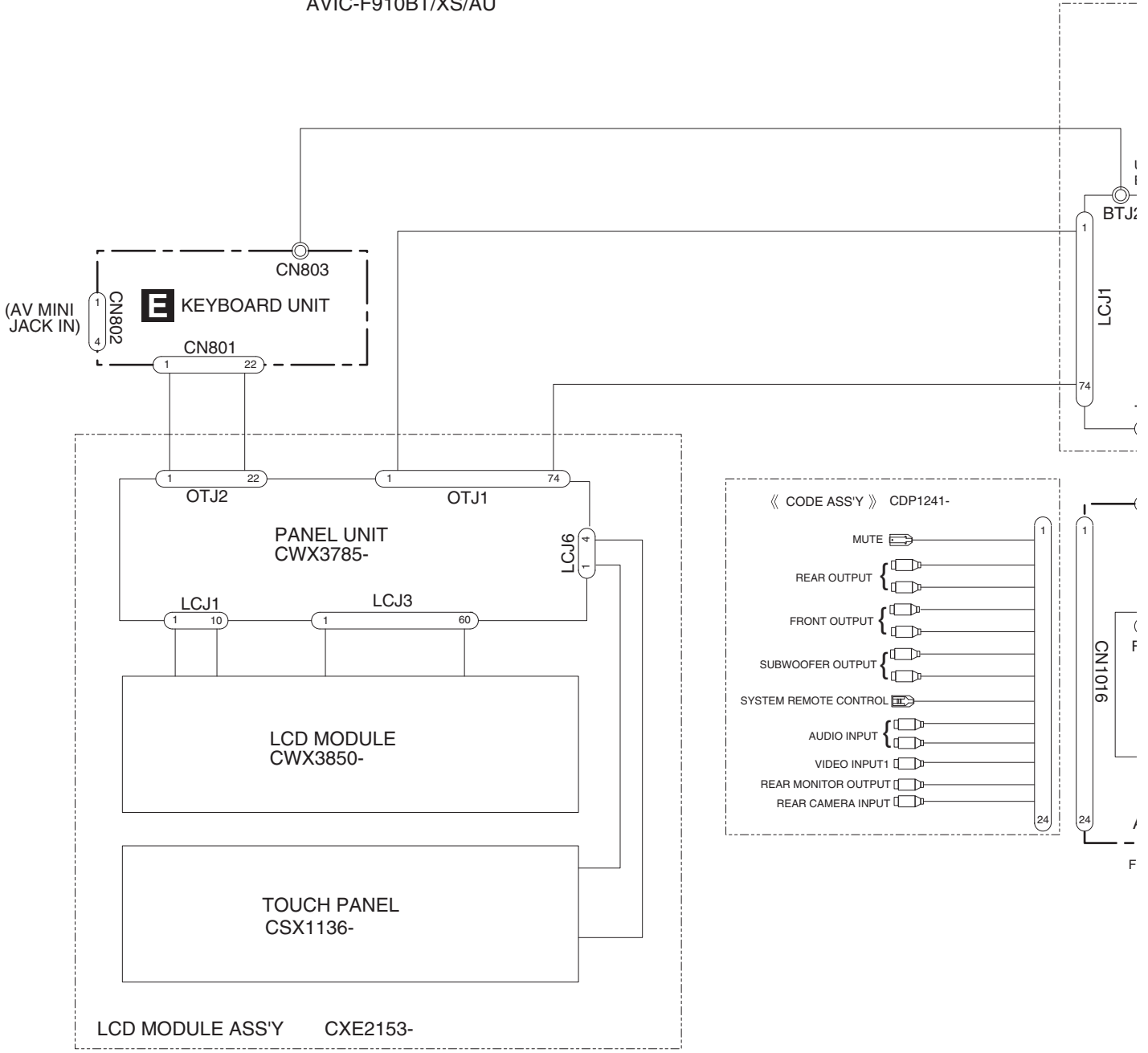

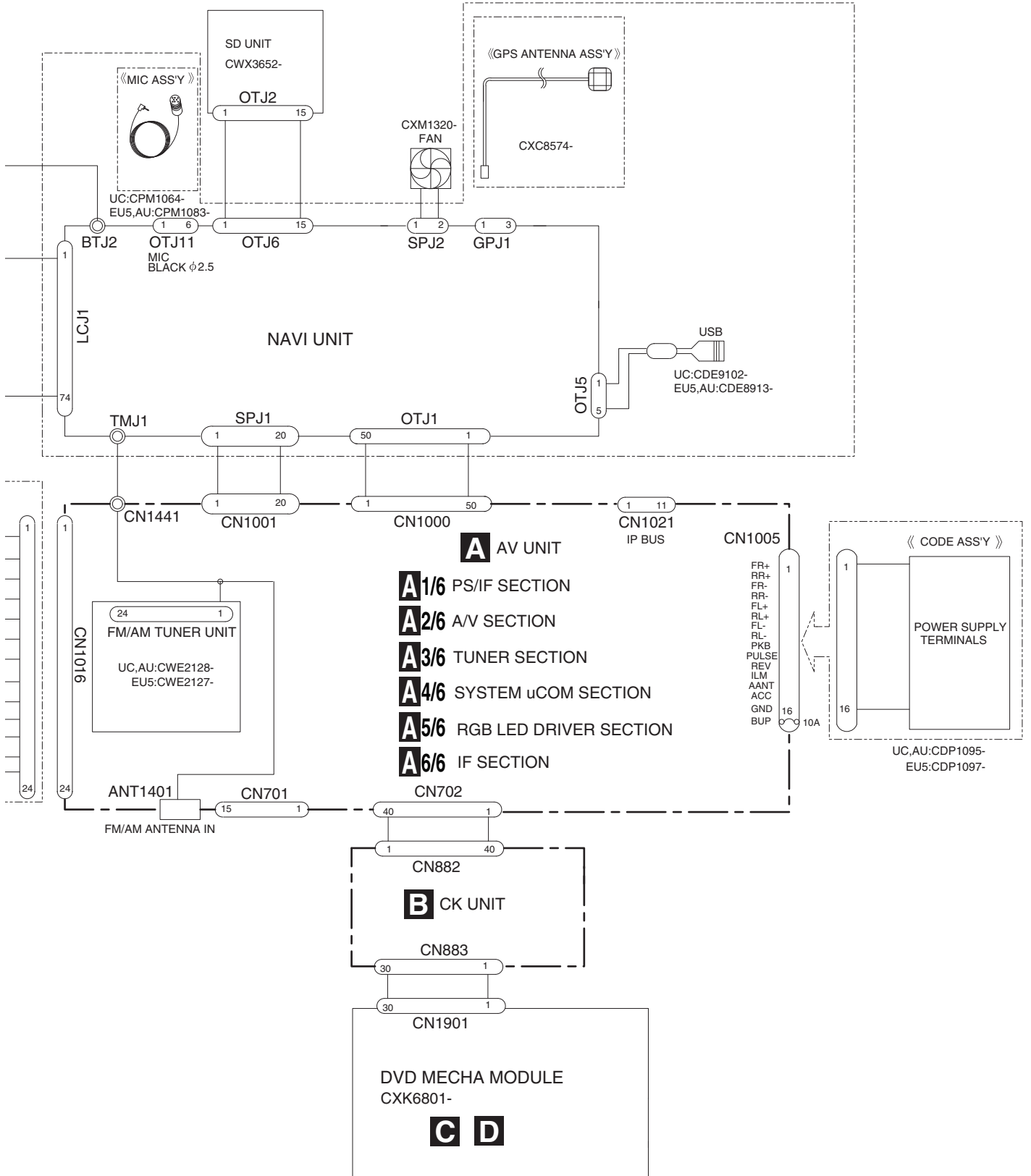

A

B

C

D

E

F

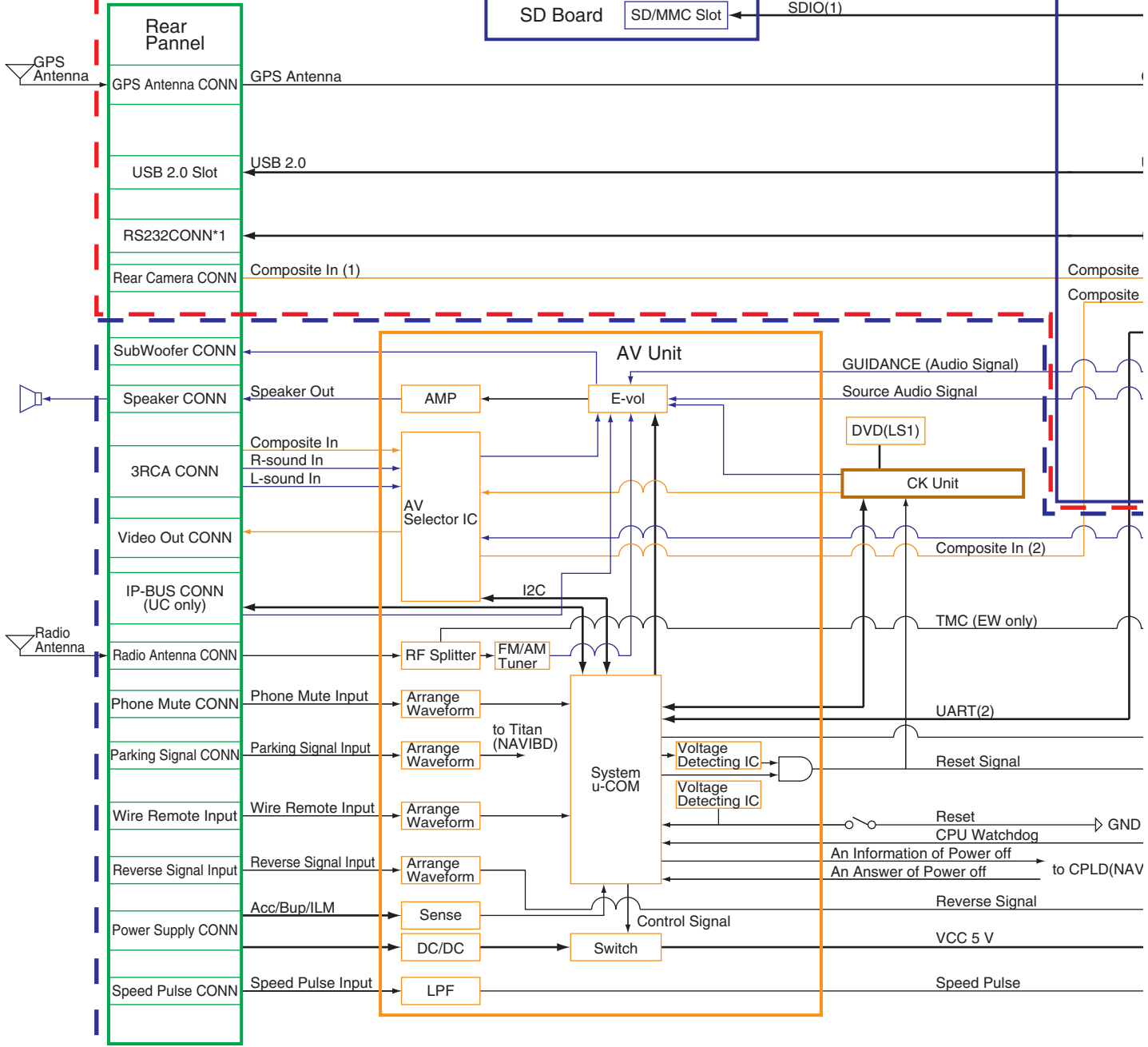

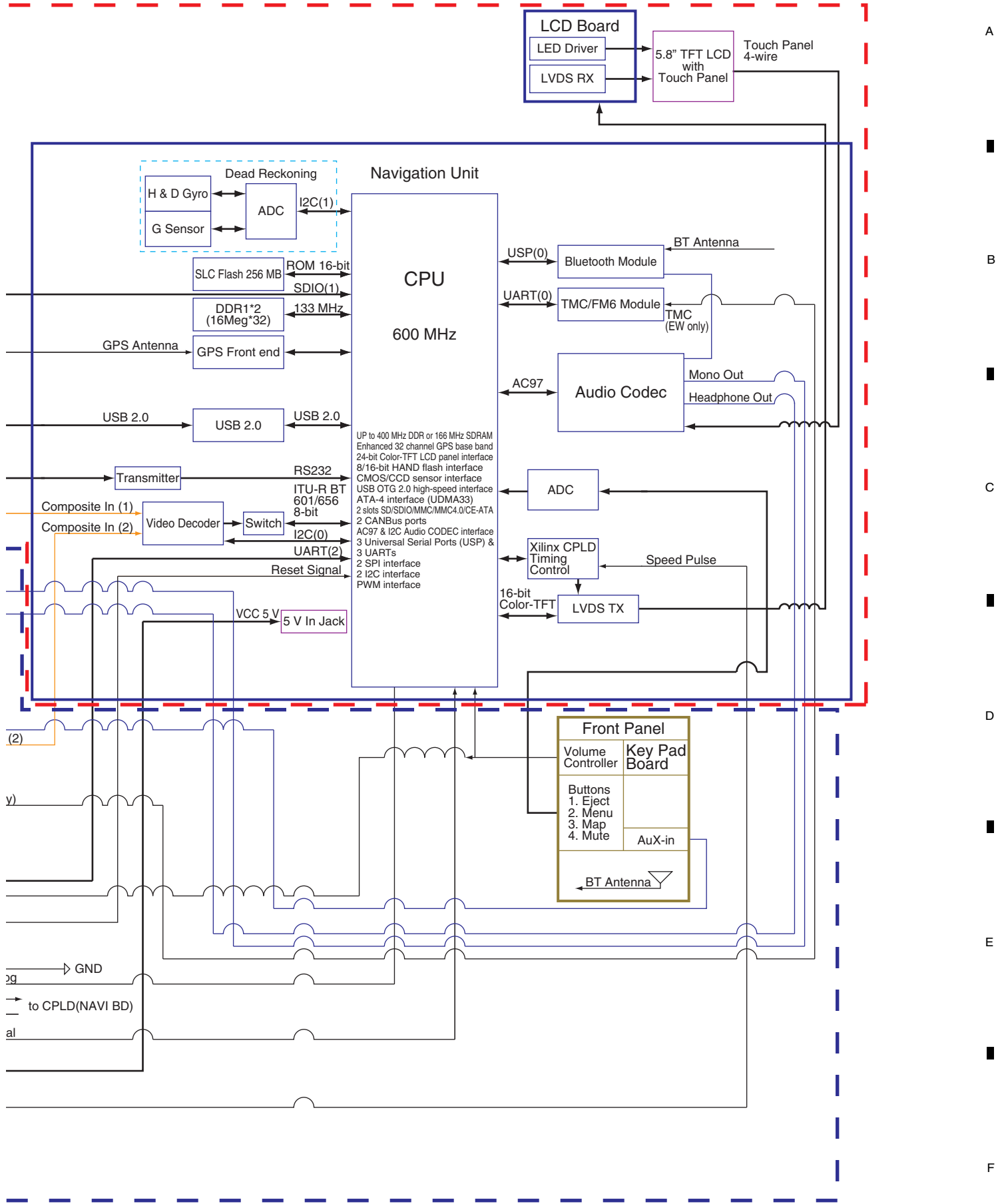

4.2 BLOCK DIAGRAM

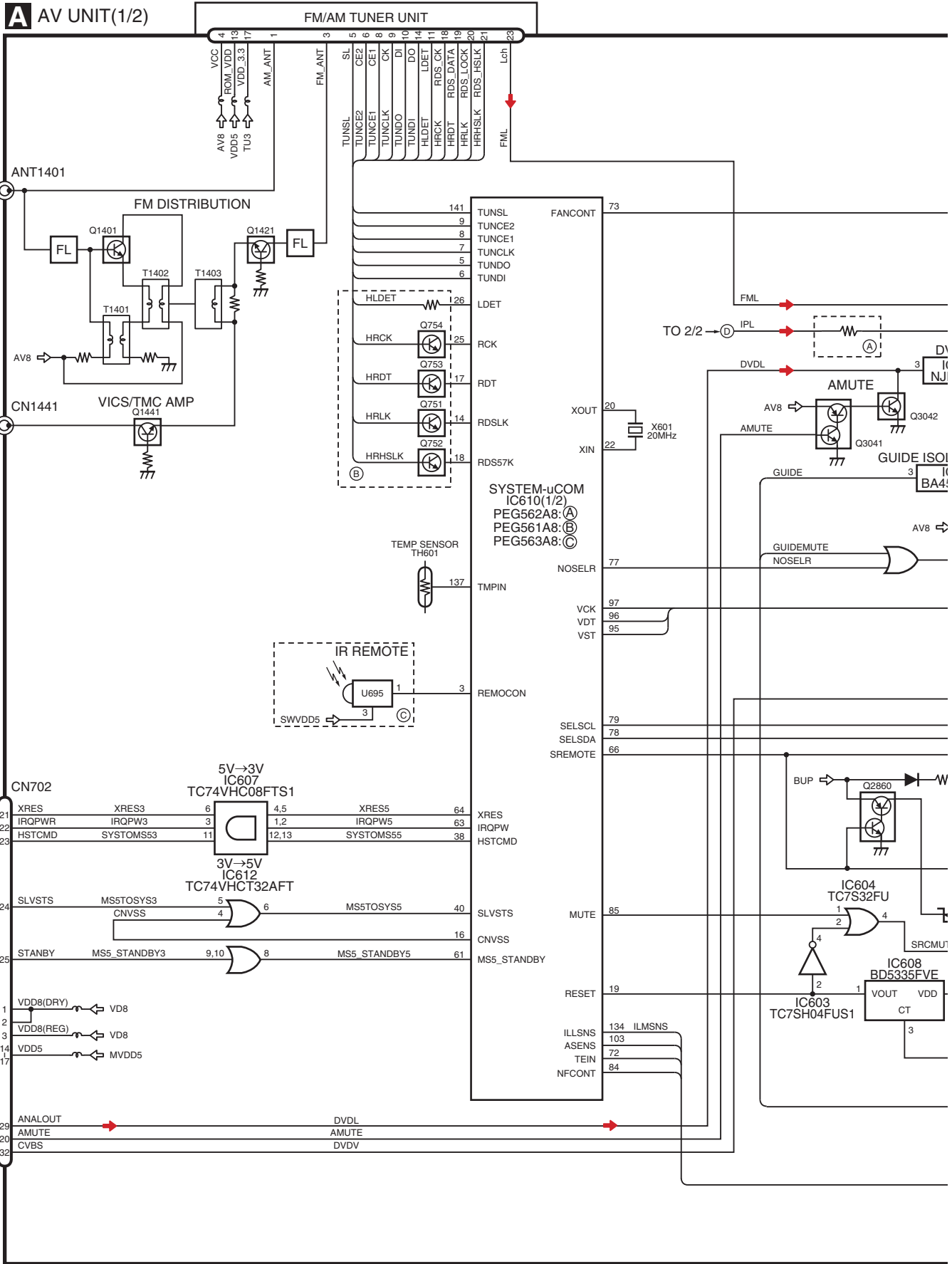

- (A) AVIC-X910BT/XS/UC
- (B) AVIC-F910BT/XS/EU5
- (C) AVIC-F910BT/XS/AU
- (D) TO 2/2

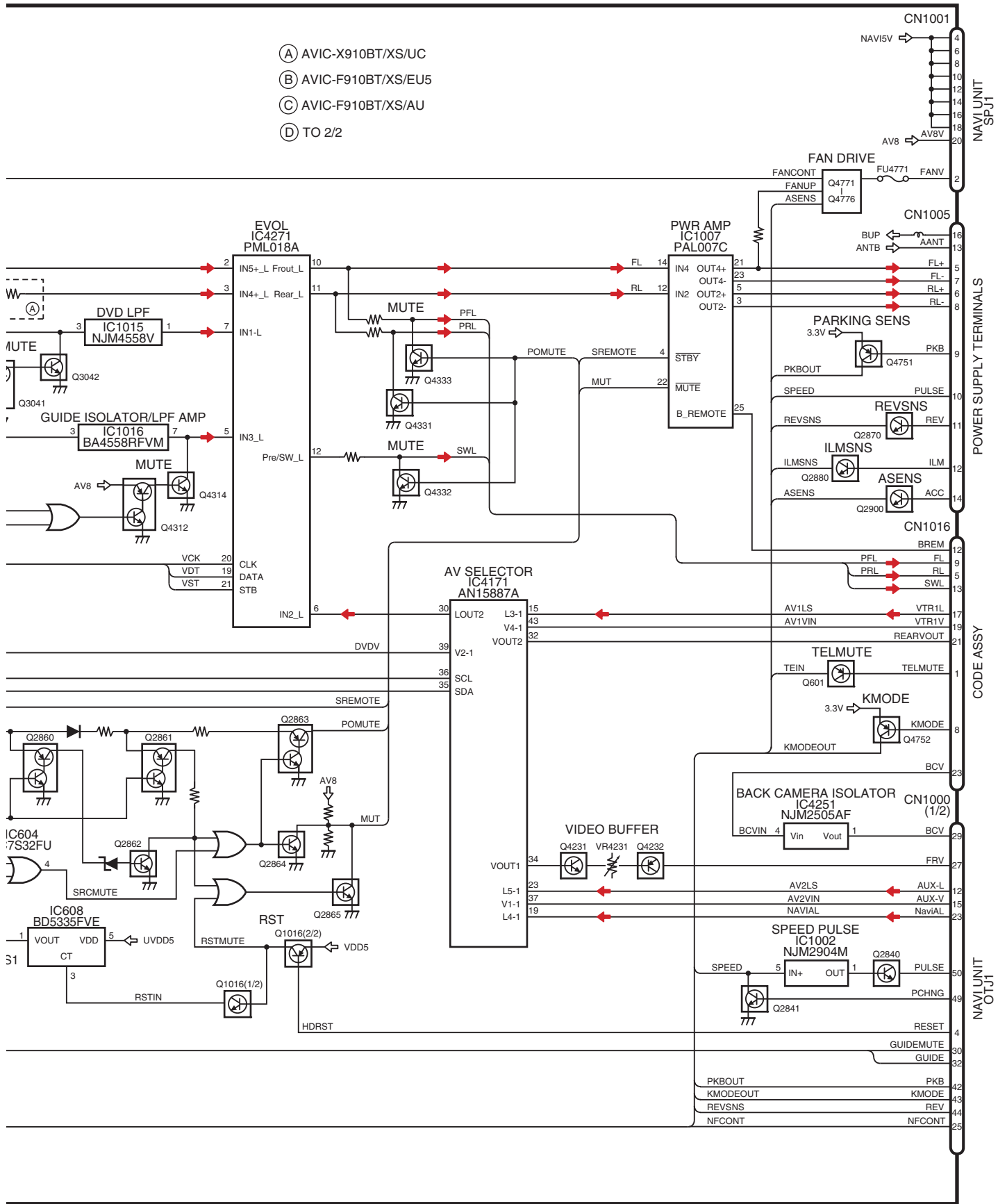

A AV UNIT(2/2)

A

B

C

D

E

F

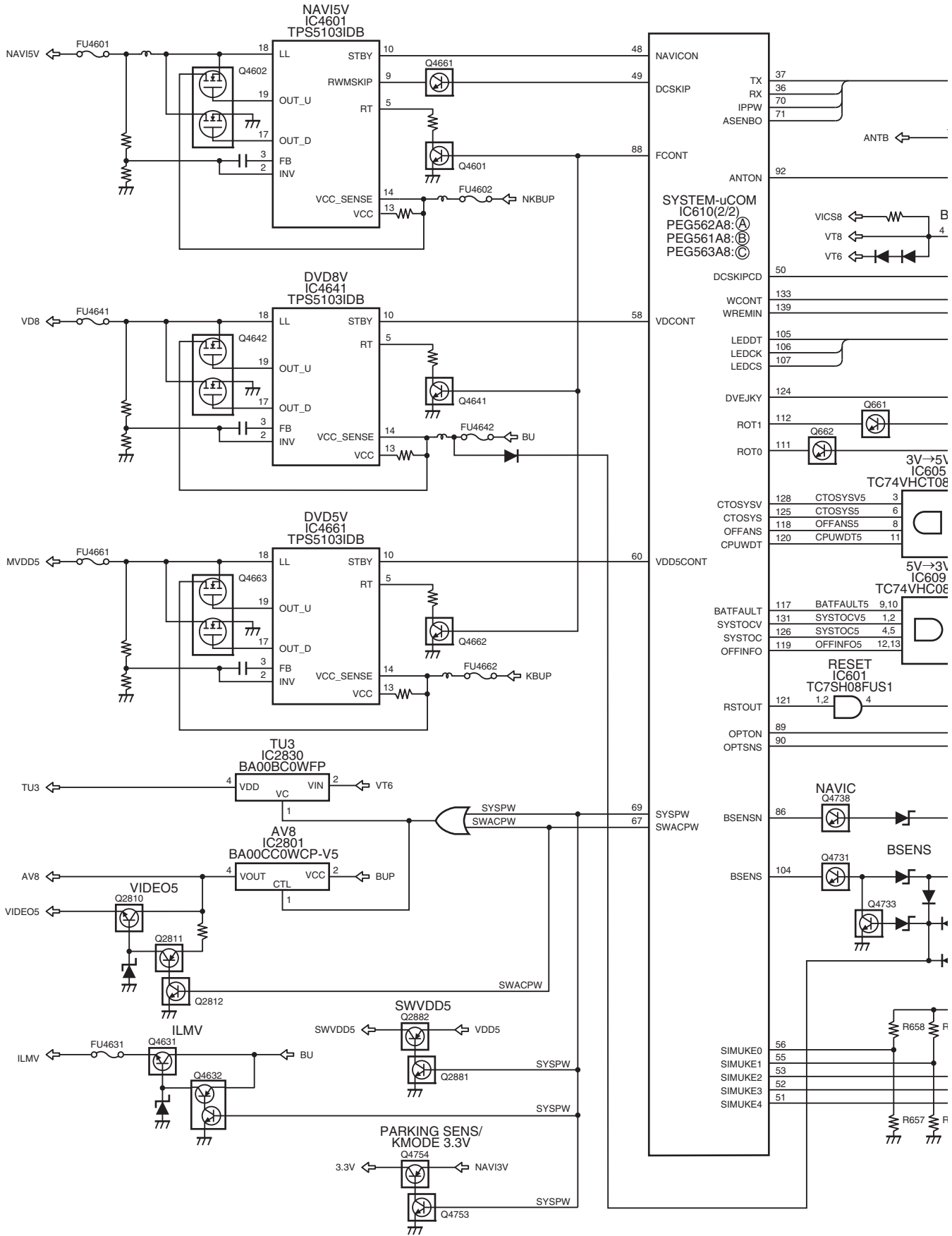

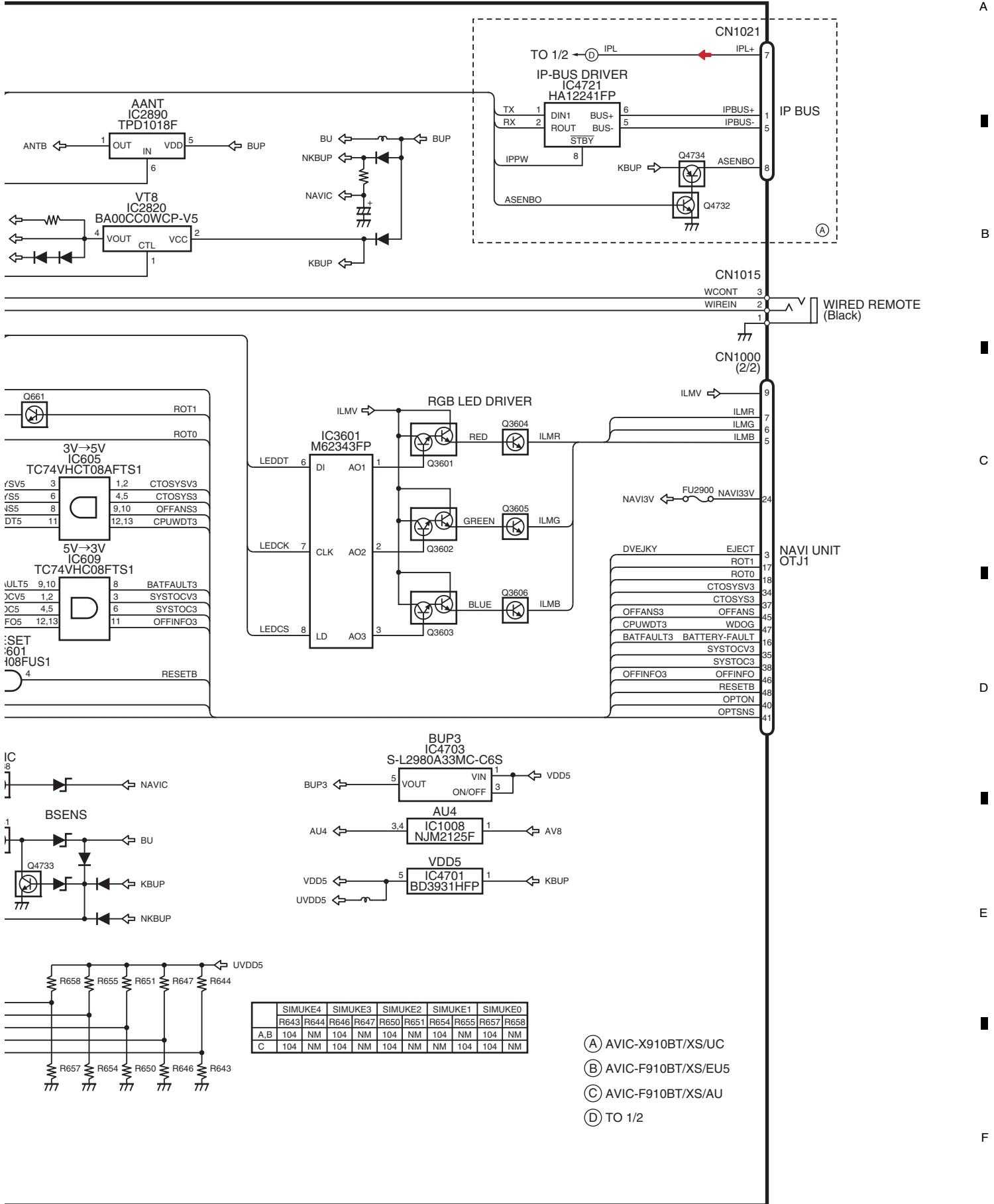

C DVD CORE UNIT

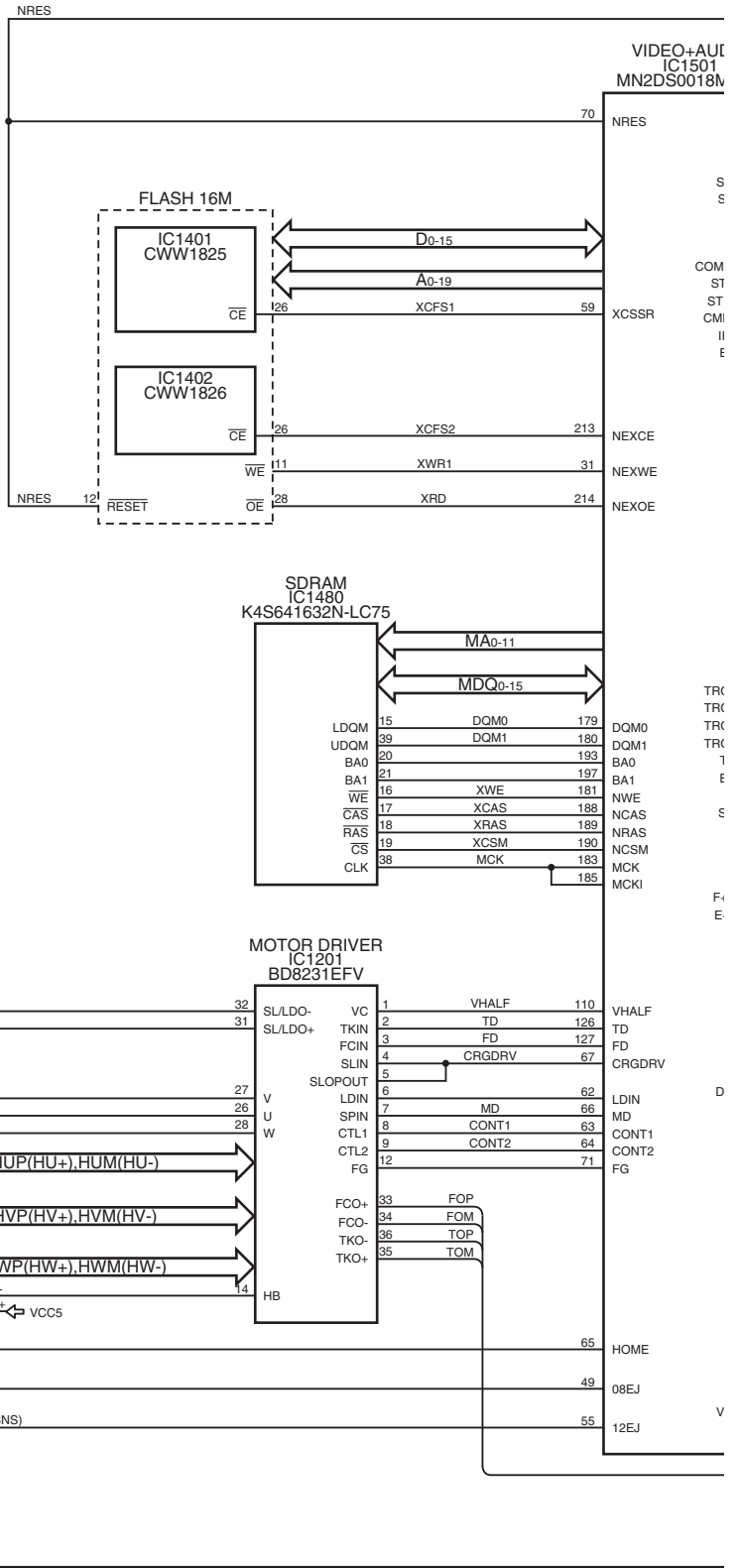

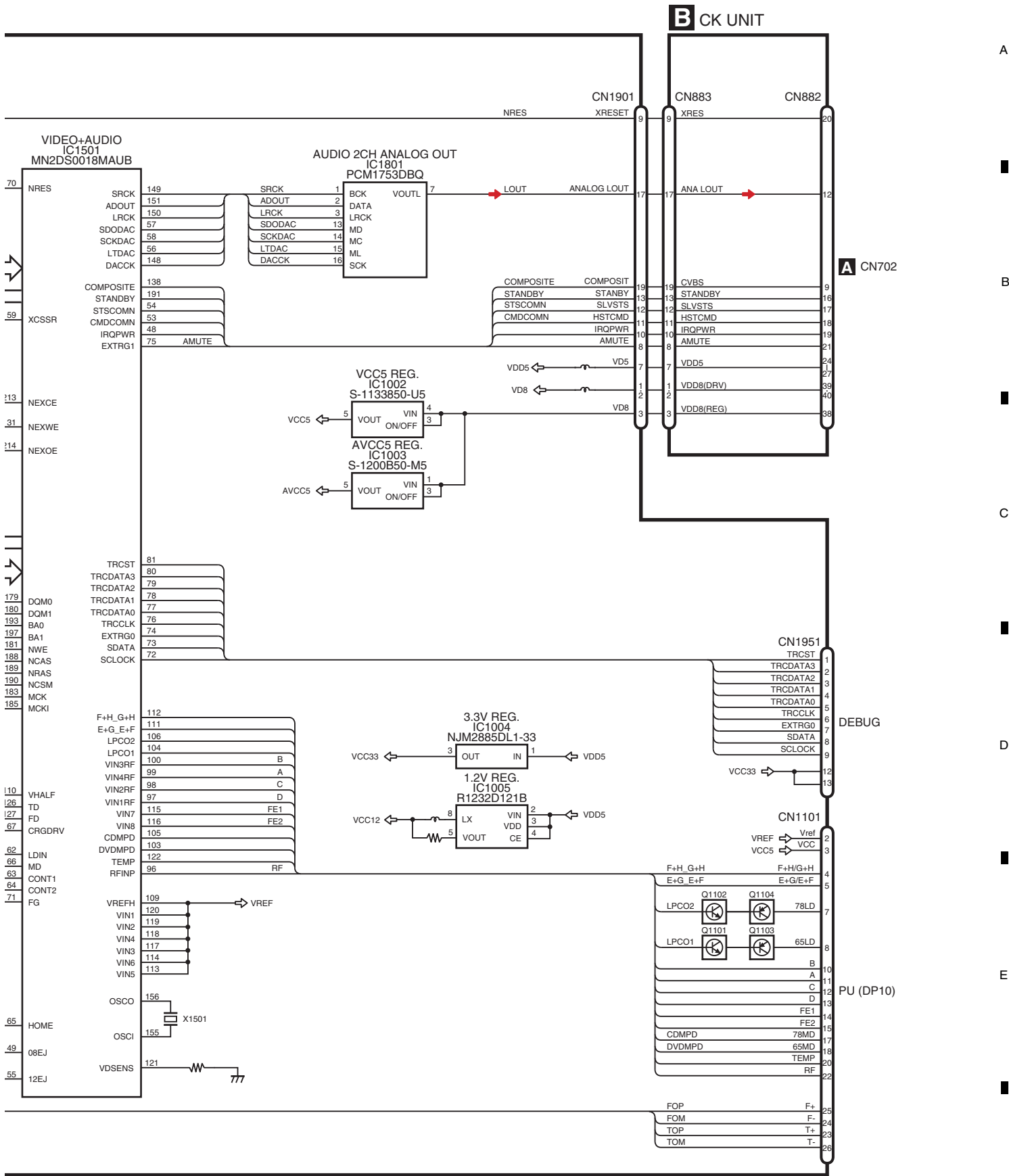

A

B

C

D

E

F

KEYBOARD UNIT

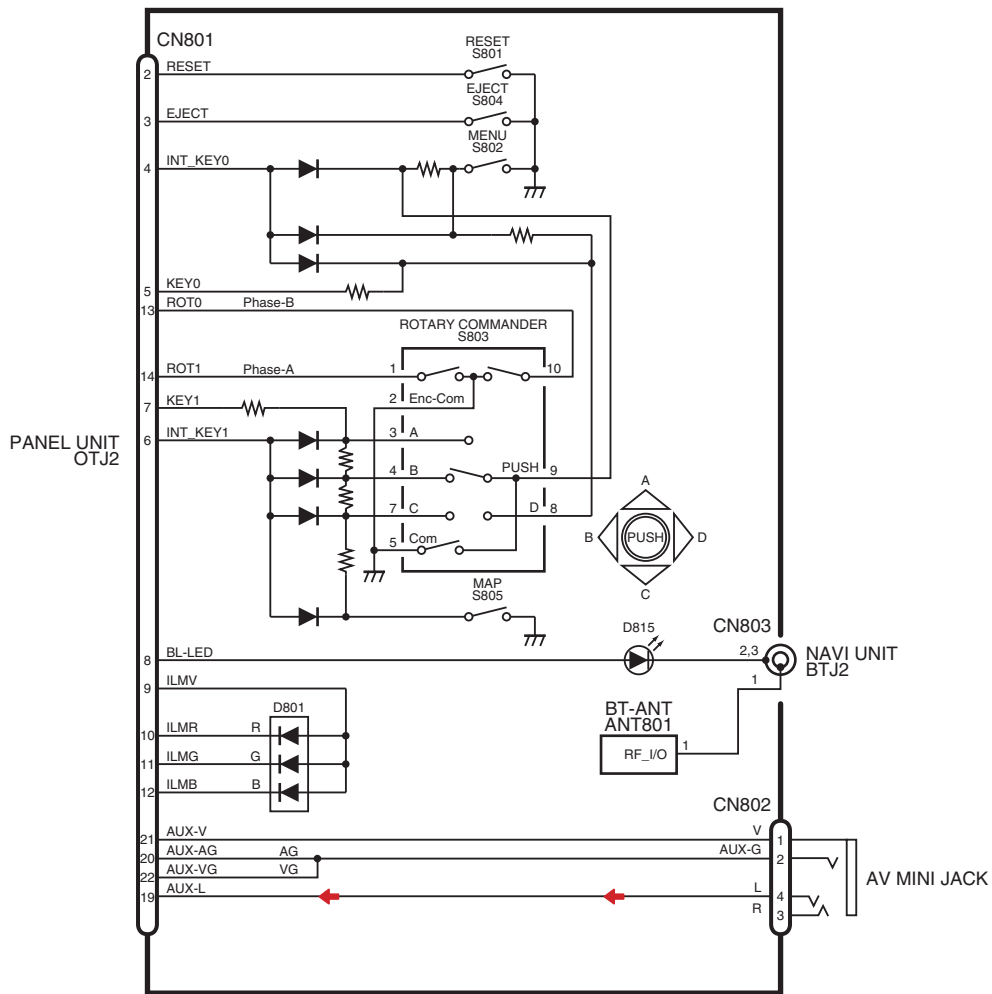

A

B

C

D

E

F

4.3 POWER SUPPLY SYSTEM FIGURE

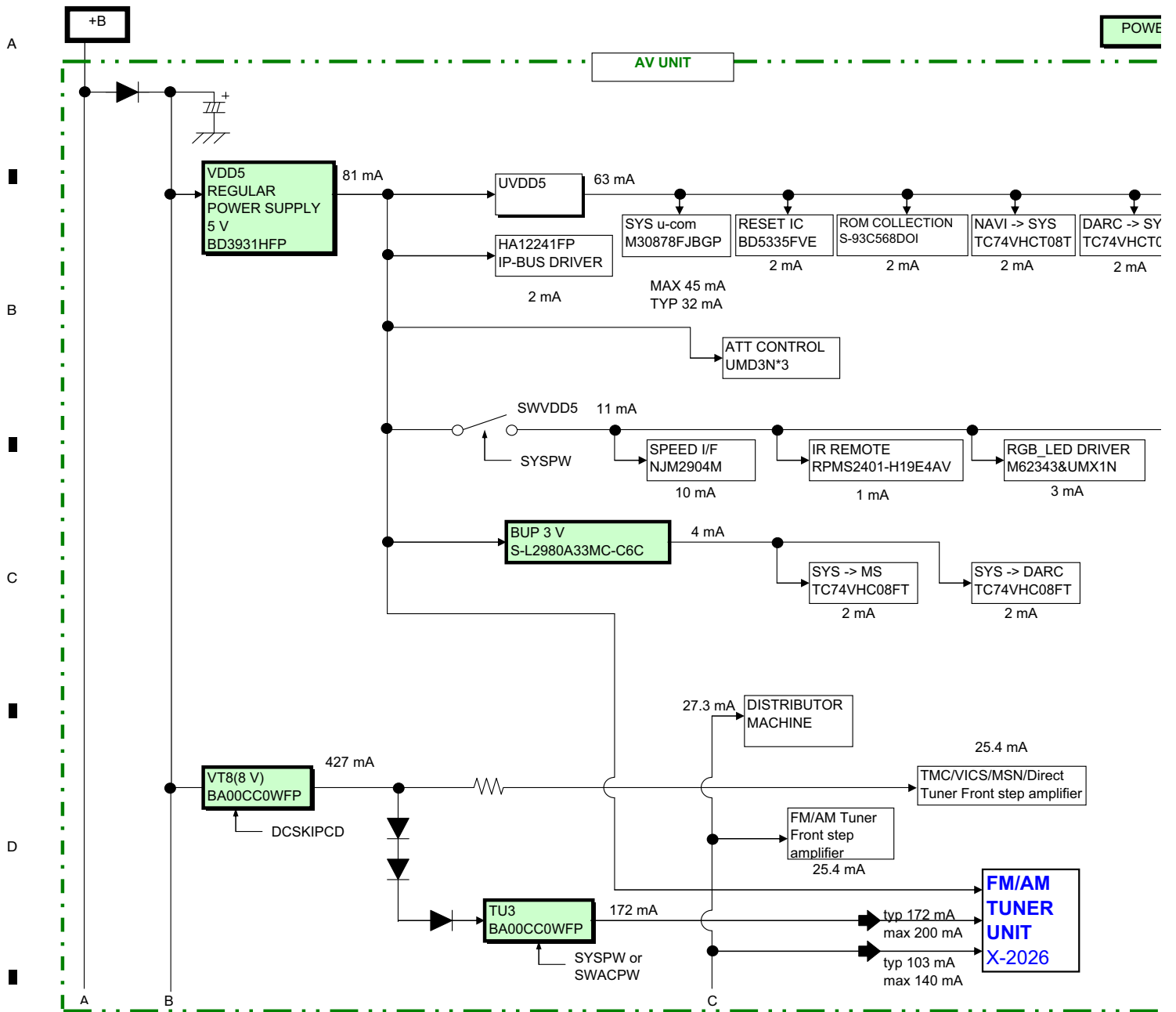

POWER SUPPLY

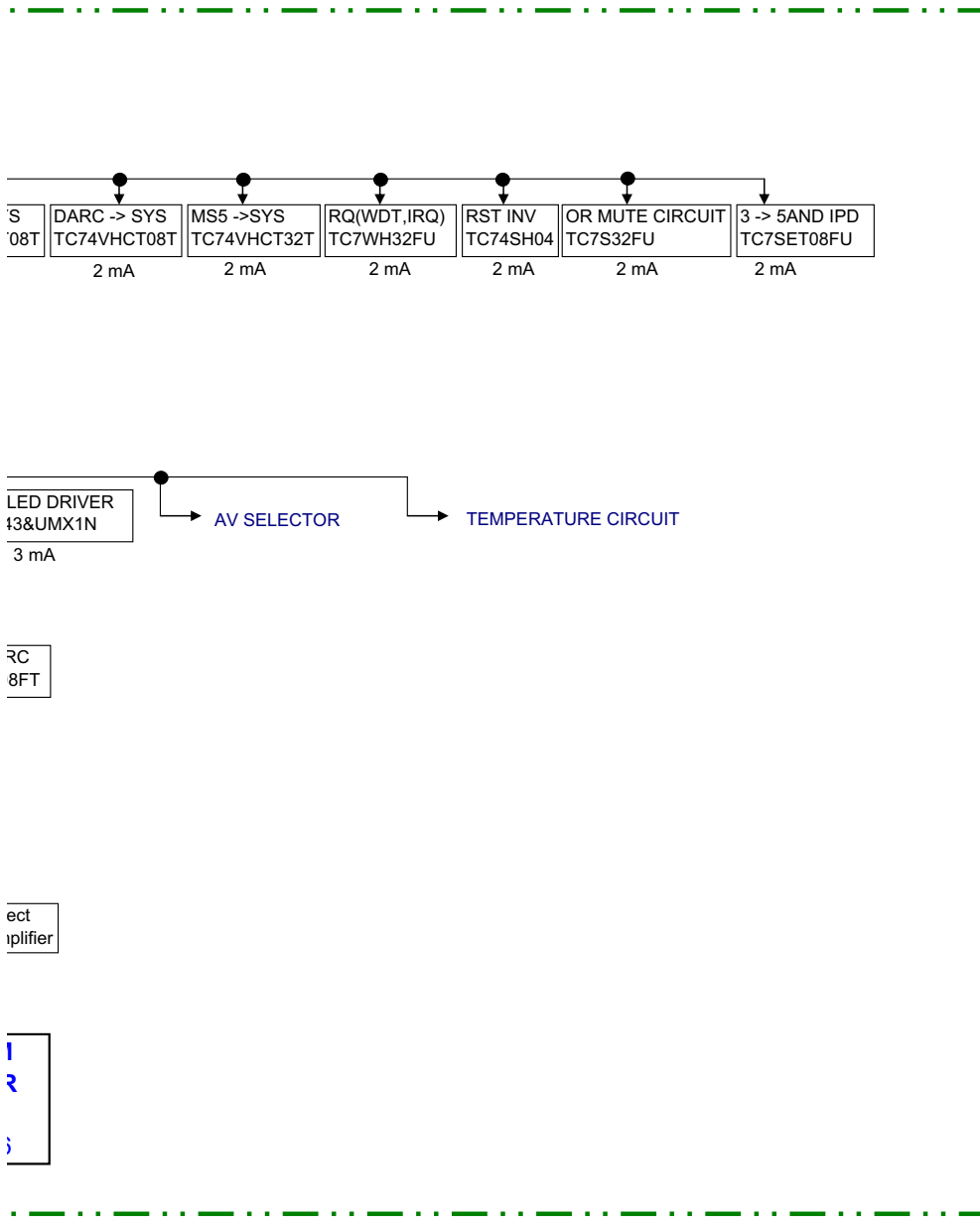

A

B

C

D

E

F

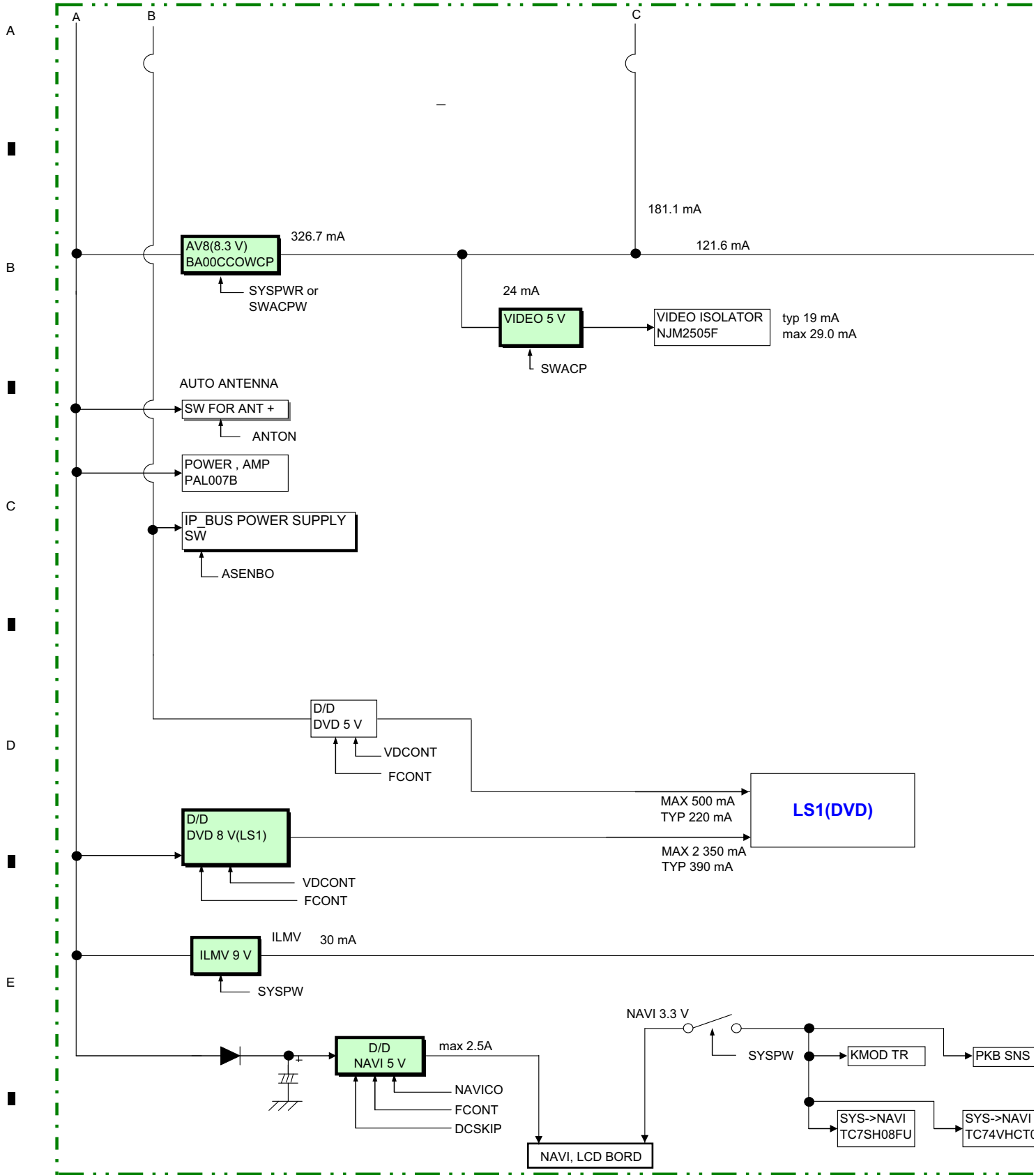

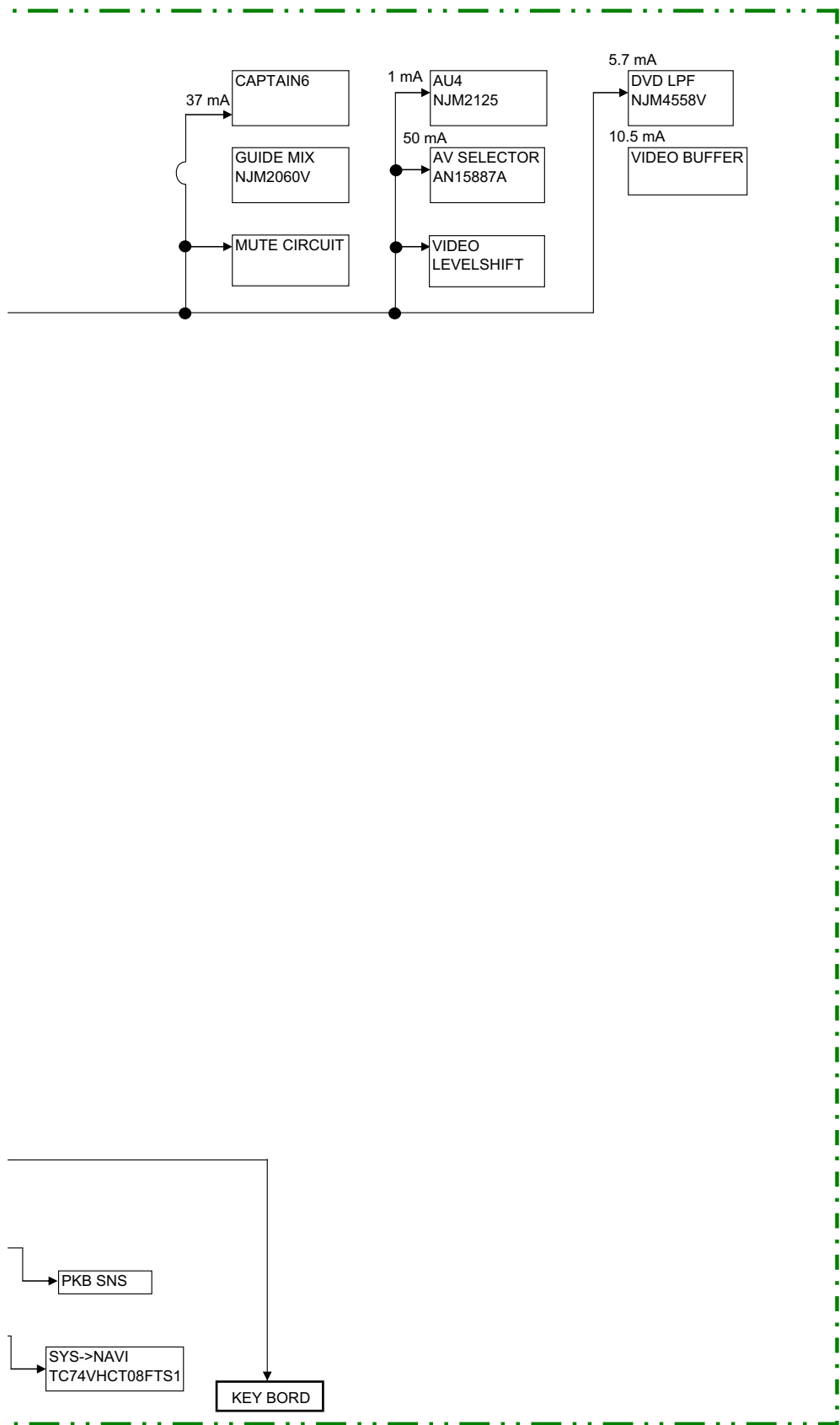

A

B

C

D

E

F

5. DIAGNOSIS

5.1 OPERATIONAL FLOWCHART

1

2

3

4

A

Acc on (USUALLY Acc ON)

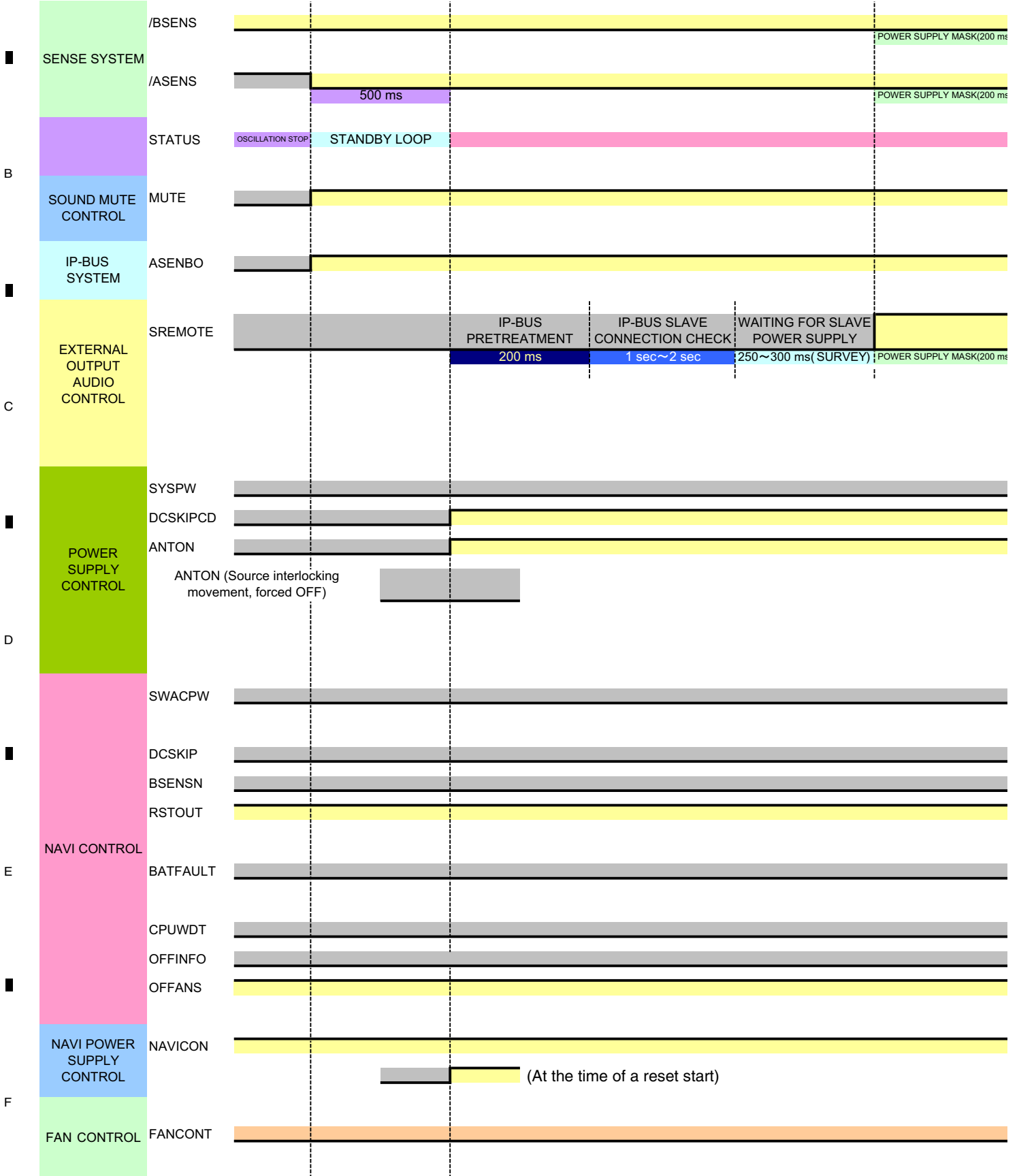

1

2

3

4

A

B

C

D

E

F

A

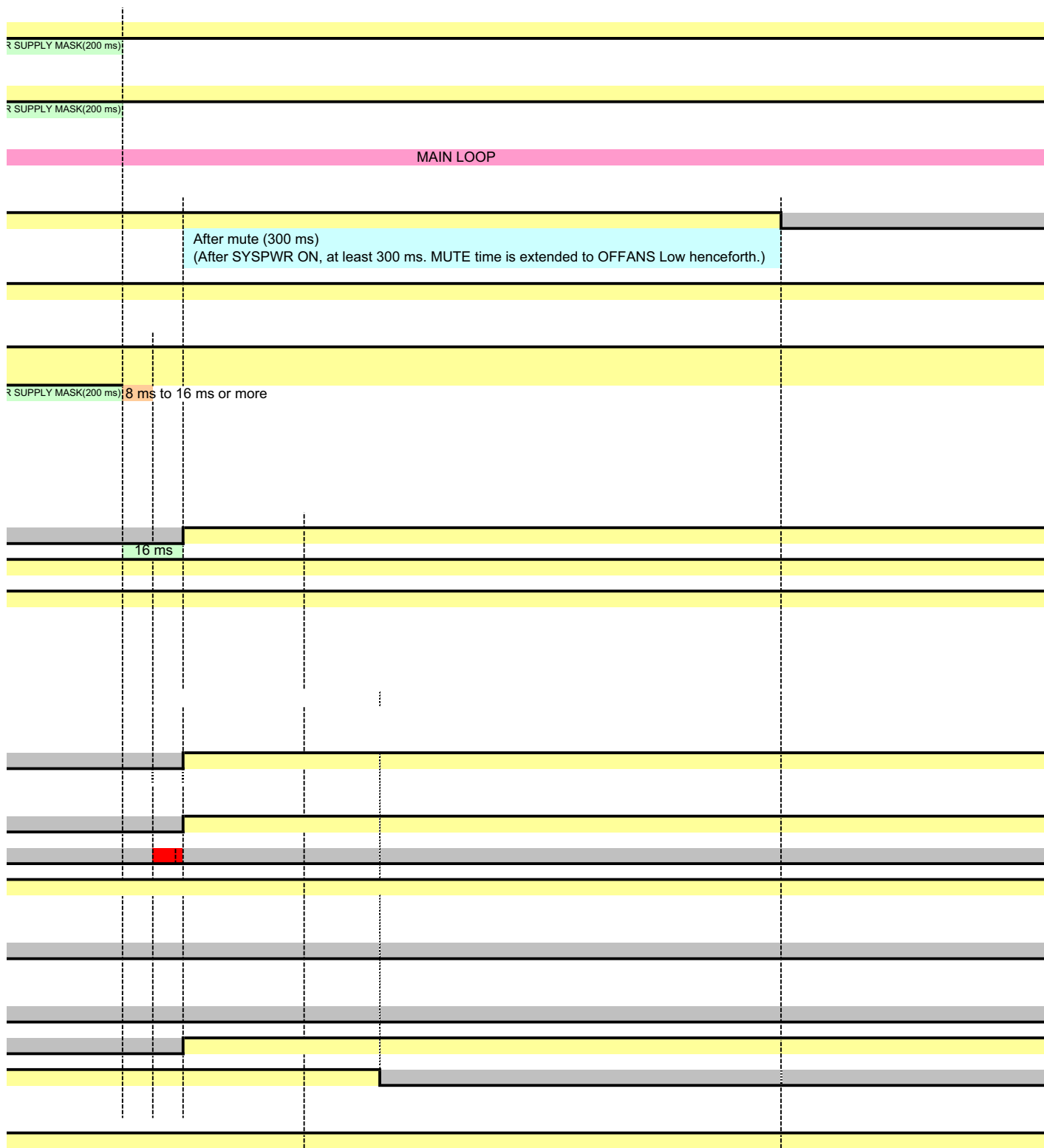

B

C

D

E

F

FANCONT(At the time of high temperature)

5.2 INSPECTION METHOD OF PICKUP UNIT

Disc to be used

CD-DA: TCD-782

DVD-Video: GGV1025

Execution method

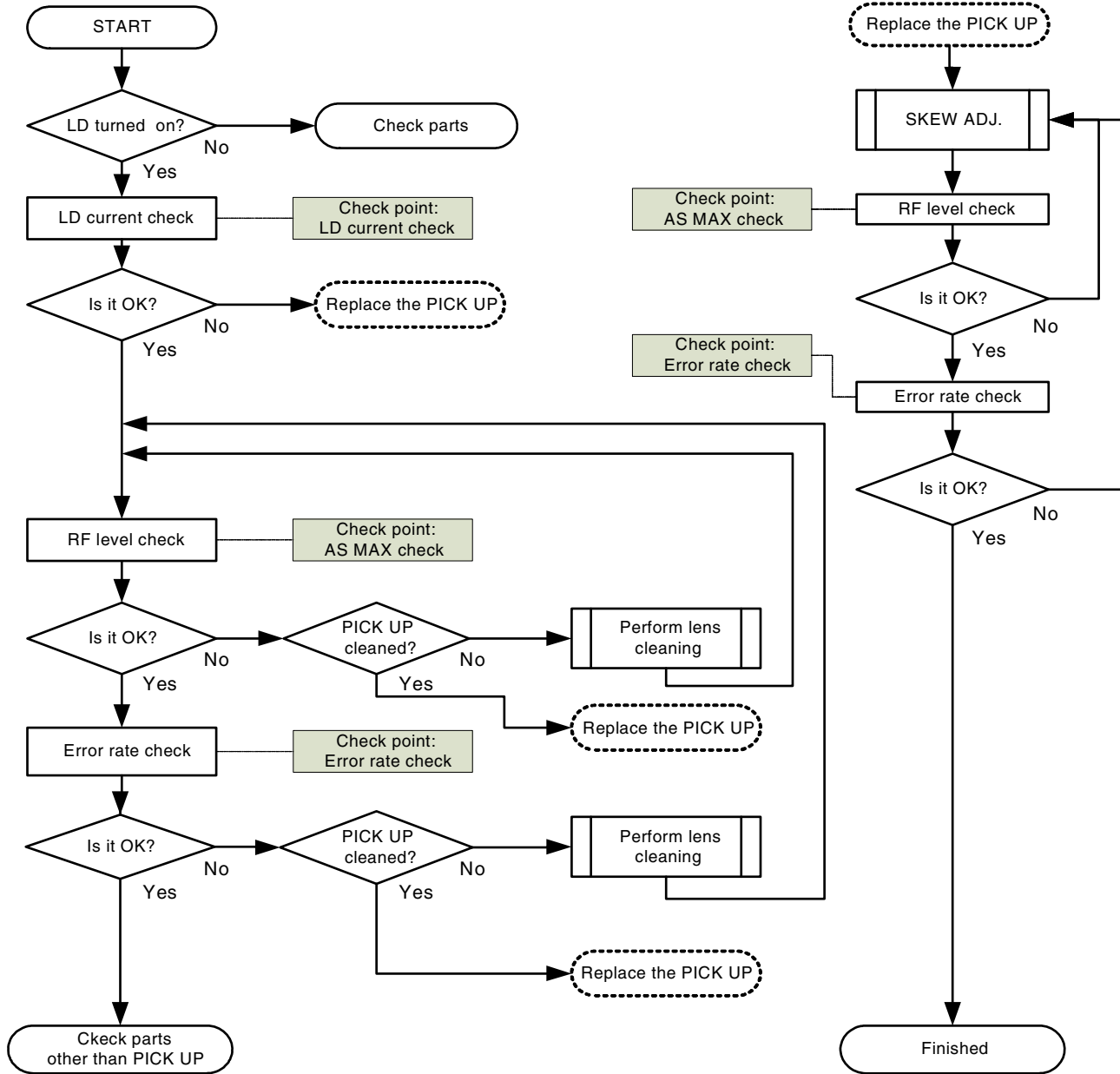

LD current check

Check

Status: [Focus closed] of TEST MODE

NO.	Disc	Check Point	Threshold	Remarks: LD current
1	GGV1025	DVDLD1-VCC5_3	60 - 390 (mV)	10 - 65 (mA)

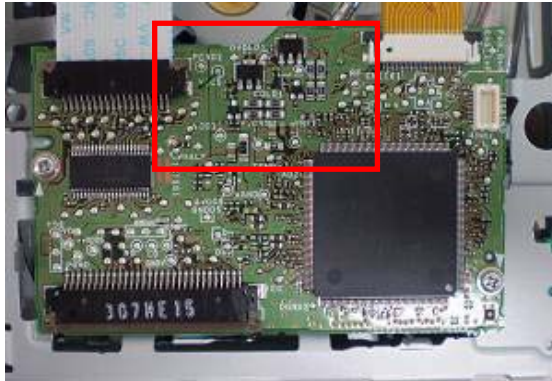

Expansion

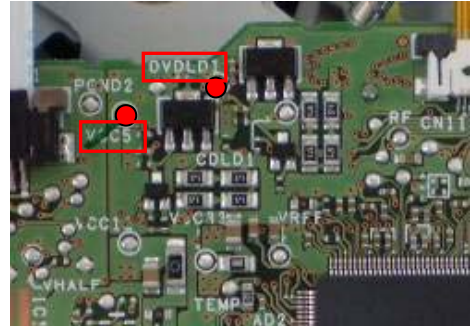

NO.	Disc	Check Point	Threshold	Remarks: LD current
2	TCD-782	CDLD1-VCC5_3	60 - 360 (mV)	10 - 60 (mA)

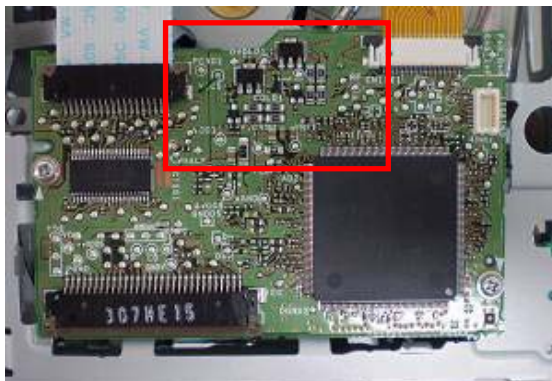

Expansion

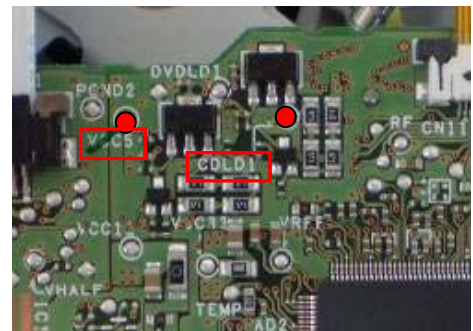

Notes: Please pay attention to the laser diode damage by static electricity.

A

ASMAX check

ASMAX value shows the value of RF level.

Status: [Focus closed] of TEST MODE

No.	Disc	Check Point	Threshold	Remarks:
1	GGV1025	8 digits value of ASMAX on display	more than 0000 0B00	Only four last digits are displayed according to the product.
2	TCD-782	8 digits value of ASMAX on display	more than 0000 0C00	Only four last digits is displayed according to the product.

B

Test mode display will not appear on the display of this product. Connect the rear monitor output to a monitor.

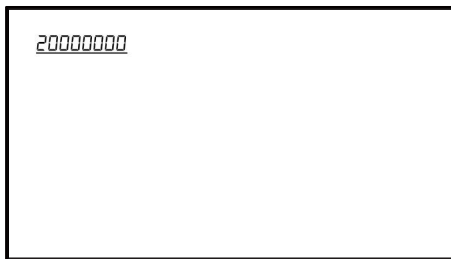

In this case, the value is displayed for a split second. When you tried to perform [FOCS CLOSE], the display will change automatically in the following order. [1FFF0000]->[FEMAX]->[FE MIN]->[AS MAX]->[ENV MAX]->[FE normal]->[Spindle gain]->[TEMAX]->[TEMIN] ->[20000000] Watch carefully the value of ASMAX.

C

Error rate check

Status: [Tracking Closed] of TEST MODE

No.	Disc	Check Point	Threshold	Remarks:
1	GGV1025	ID: 40000	less than 1.000E-03	
2	GGV1025	ID: 200000	less than 1.000E-03	
3	TCD-782	ID: HOME Position	less than 2.500E-03	

D

Test mode display will not appear on the display of this product. Connect the rear monitor output to a monitor.

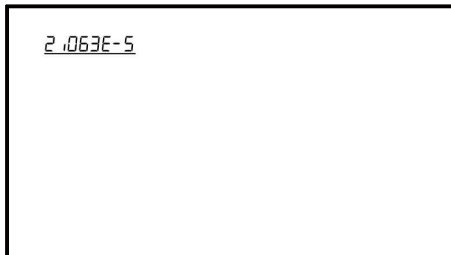

E

F

5.3 DIAGNOSIS FLOWCHART

BACK END section flow

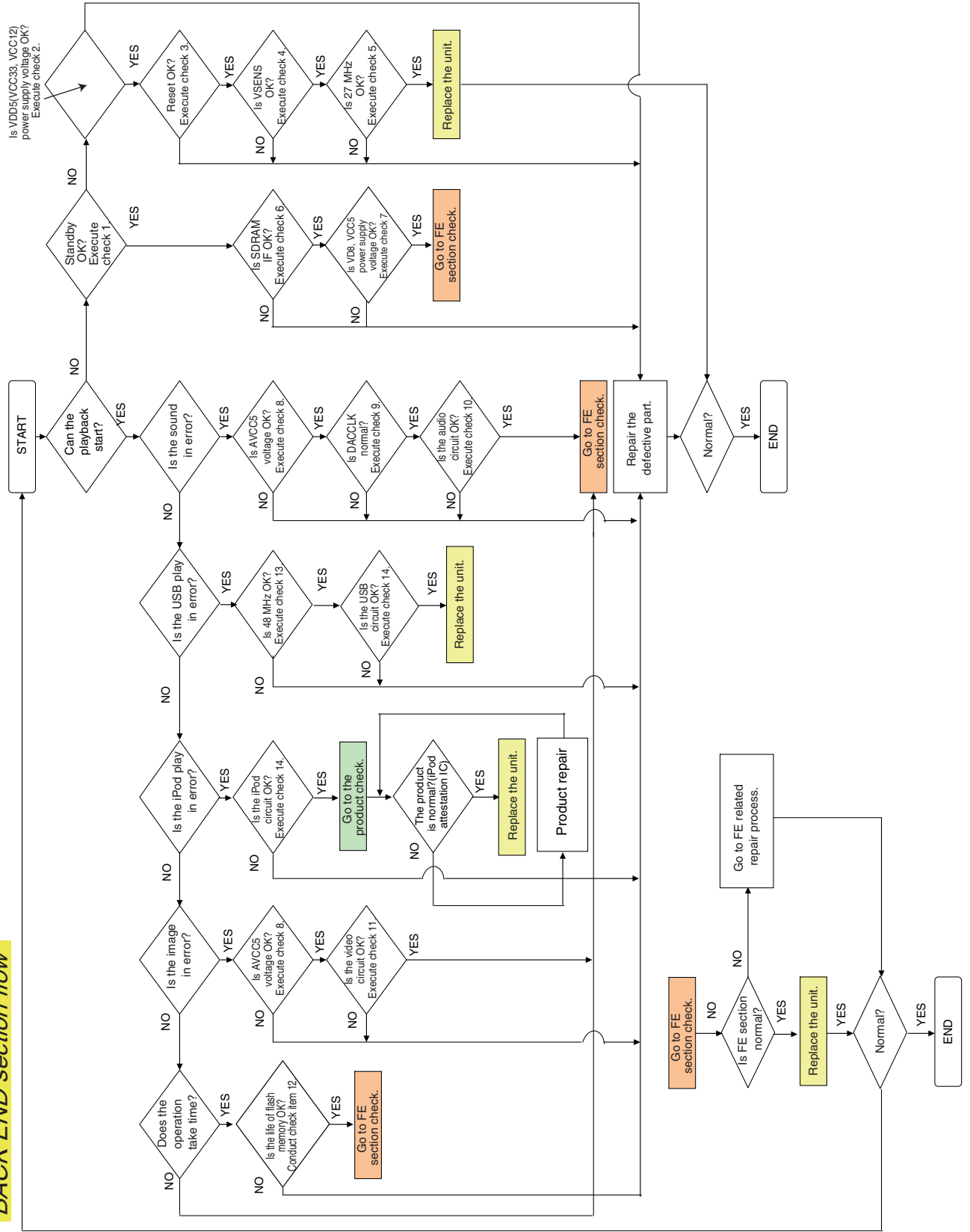

Check 1: Standby OK?

A <Check> Check the voltage at the “STANBY” test point while the power is on.
Use the “DGND1” test point at the reference.

NO.	Check point	Module No.	Specification value	Unit
1	STANBY-DGND1	ALL	VCC33 V- 0.6 V or more	V

Side A

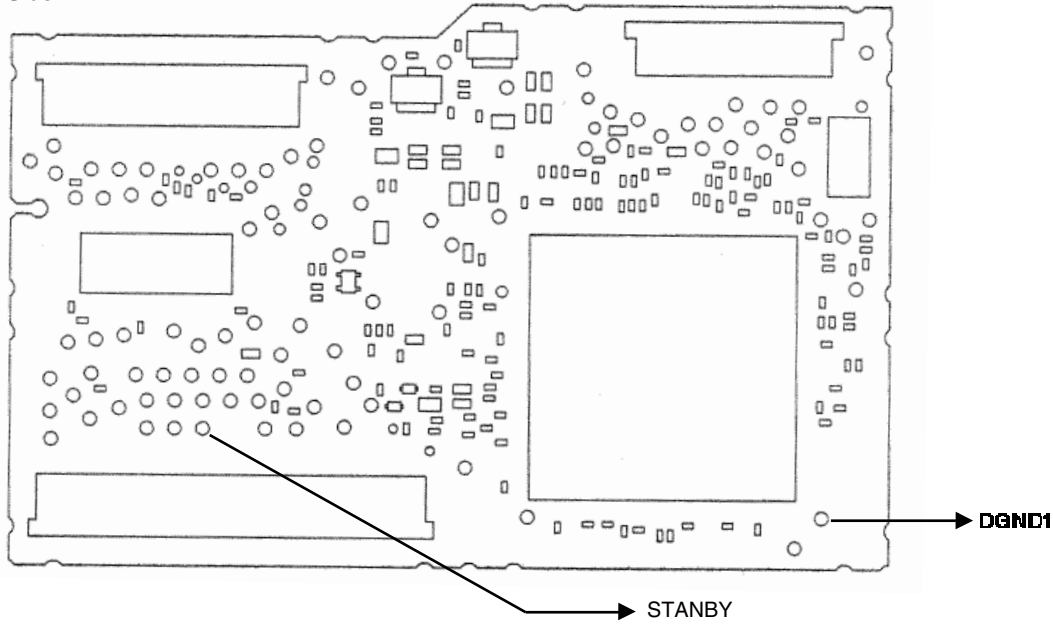

Fig 1.1: STANBY check point

D

E

F

Check 2: Is VDD5 (VCC33, VCC12) power supply voltage OK?

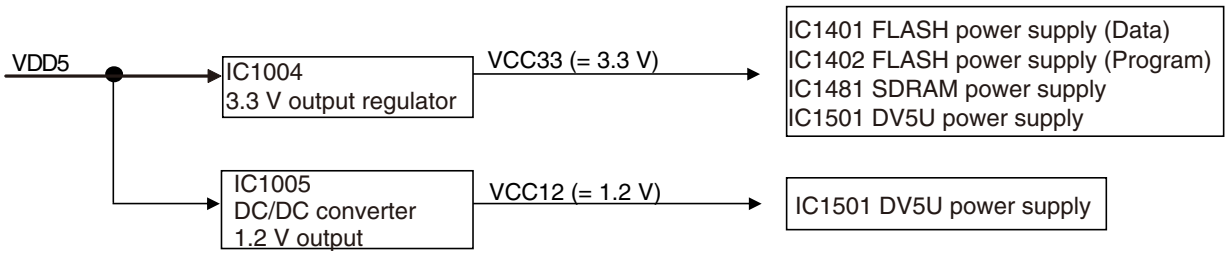

Fig 2.1: Power supply configuration

<Check> Check the voltage at the “VDD5_1, VCC33_1 and VCC12_1” test point while the power is on. Use the “DGND1” test point at the reference.

NO.	Check point	Module No.	Specification value	Unit
1	VDD5_1 - DGND1	ALL	5.0 ± 0.4	V
2	VCC33_1 - DGND1	ALL	3.3 ± 0.15	V
3	VCC12_1 - DGND1	ALL	1.2 ± 0.12	V

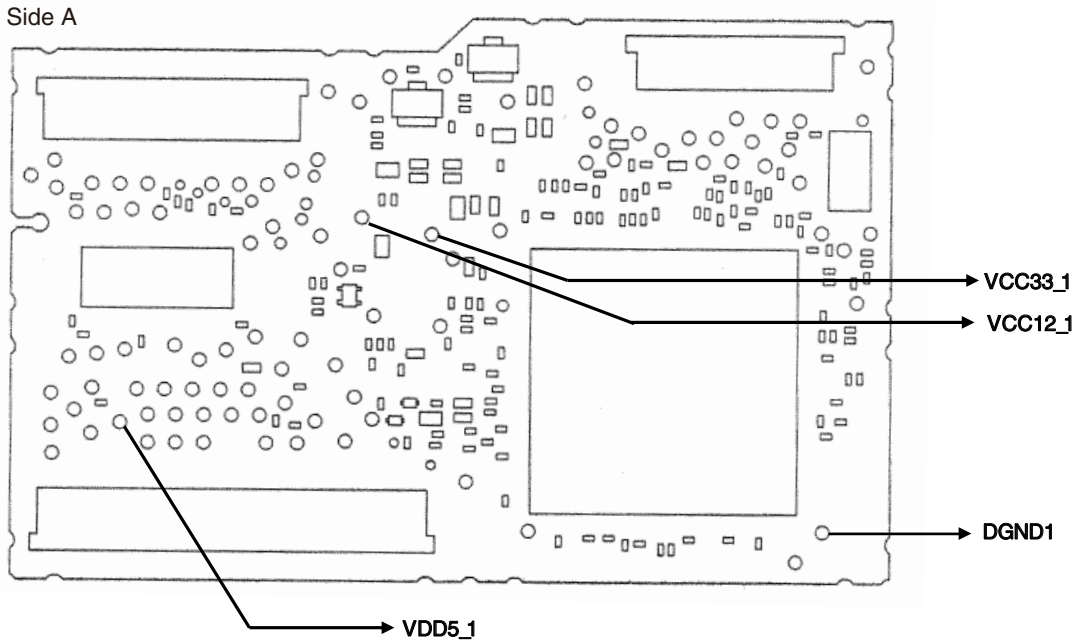

Fig 2.2: VDD5, VCC33, VCC12 voltage check points

Check 3: Reset OK?

A

<Check> Check the voltage at the "XRES" test point while the power is on.
Use the "DGND1" test point at the reference.

NO.	Check point	Module No.	Specification value	Unit
1	XRES-DGND1	ALL	VCC33 × 0.7 or more	V

Side A

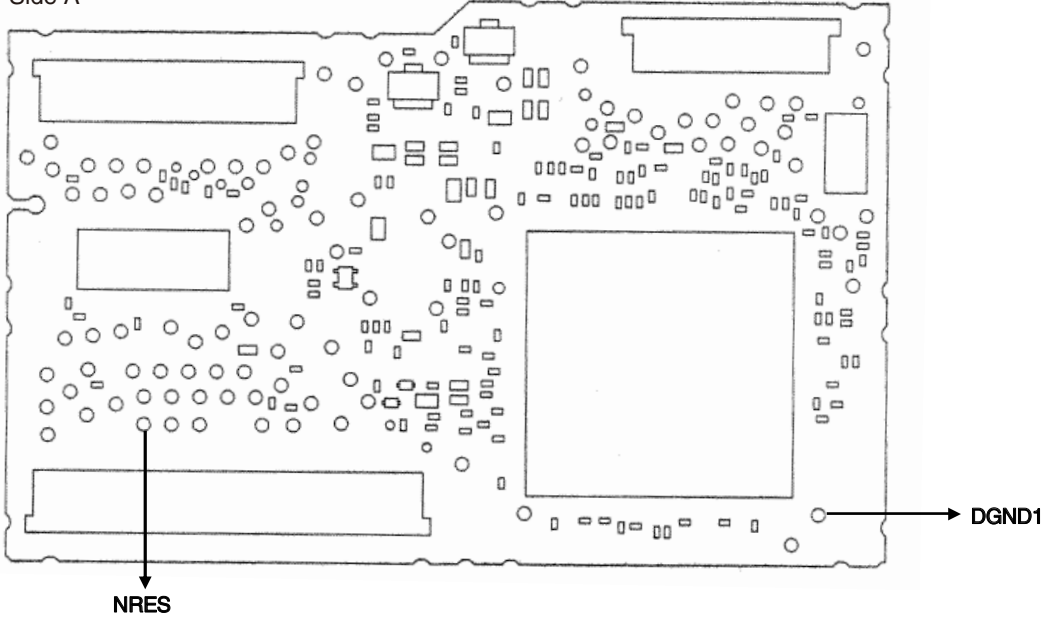

Fig 3.1: RESET check point

D

E

F

Check 4: Is VSENS OK?

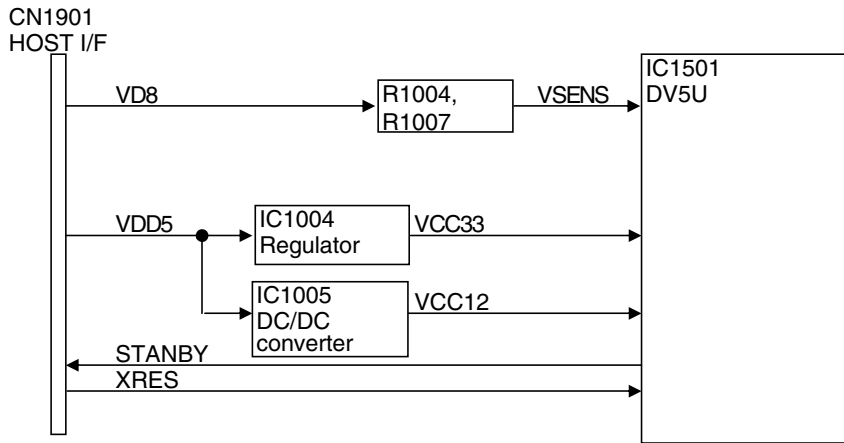

Fig 4.1: Power supply configuration and VSENS

<Check> Check the voltage at the “VSENS” test point while the power is on.
Use the “DGND1” test point at the reference.

NO.	Check point	Module No.	Specification value	Unit
1	VSENS - DGND1	ALL	0.95 - 1.07	V

VD8 = 8.0 ± 0.4 V

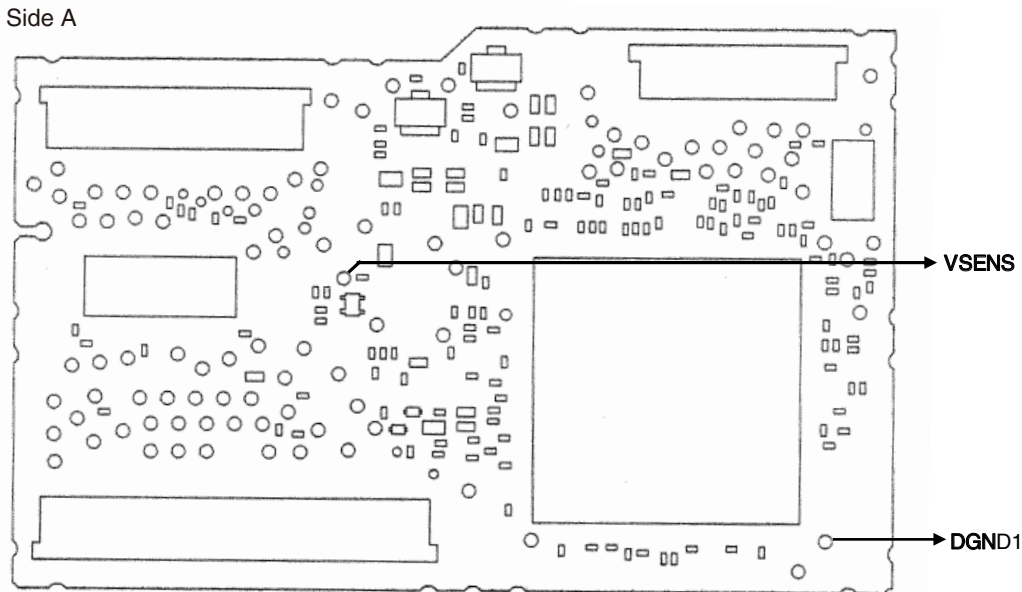
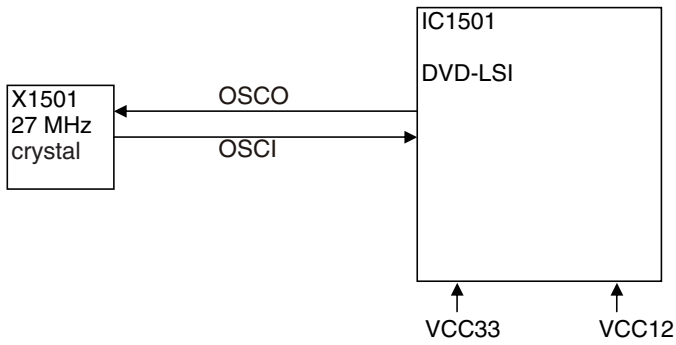

Fig 4.2: VSENS check point

Check 5: 27 MHz Normal?

<Outline> Each clock is created inside the IC1501 using the 27 MHz master crystal oscillator (X1501).

A



B

Fig 5.1: Clock configuration

<Check method> Turn the power on, and check with DGND being the reference.
In case of NG, check the applicable line, periphery of IC1501, soldering of the peripheral components and defective components.

C

NO.	Check point	Module No.	Specification value	Unit
2	IC1501 169pin	ALL	27 MHz ± 50 ppm	ppm

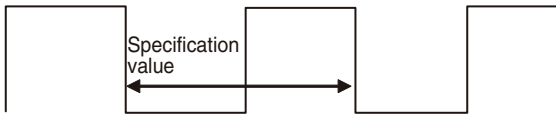

GND

Fig 5.2: Clock specification value

D

Side A

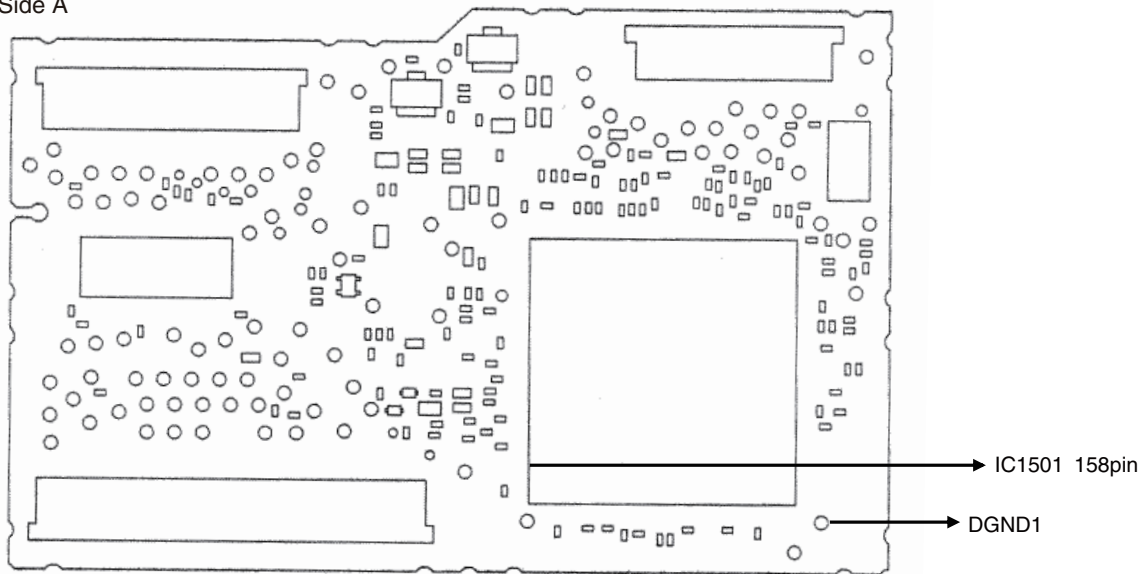

Fig 5.3: 27 MHz check point

F

Check 6: Is SDRAM I/F OK?

<Outline> In order to secure the MPEG stream data as the buffer, the capacity of communication I/F SDRAM between the LSI and the memory is 64Mbit. Be careful as XCSM, XWE, XCAS and XRAS of IC1480 are called differently in IC1501, namely NCSM, NWE, NCAS, NRAS.

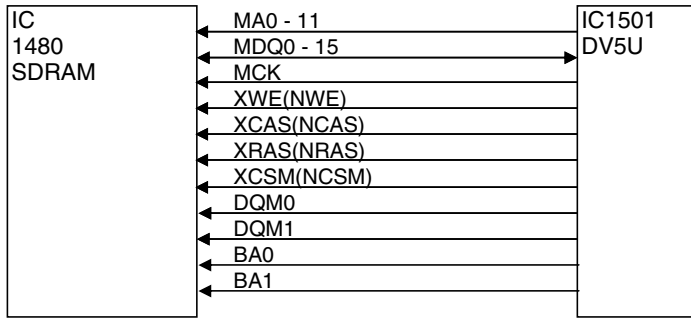

Fig 6.1: SDRAM I/F

<Check> Check the conductivity at “check point 1” and “check point 2” without power.
In case of NG, check the soldering and defective components throughout the
“output → input” of the applicable section.

A

NO.	Signal name	Check point 1	Check point 2	Specification value
1	MA0	IC1480 23pin	IC1501 201pin	56 ohm ± 5 %
2	MA1	IC1480 24pin	IC1501 203pin	56 ohm ± 5 %
3	MA2	IC1480 25pin	IC1501 207pin	56 ohm ± 5 %
4	MA3	IC1480 29pin	IC1501 209pin	56 ohm ± 5 %
5	MA4	IC1480 30pin	IC1501 208pin	56 ohm ± 5 %
6	MA5	IC1480 31pin	IC1501 206pin	56 ohm ± 5 %
7	MA6	IC1480 32pin	IC1501 202pin	56 ohm ± 5 %
8	MA7	IC1480 33pin	IC1501 200pin	56 ohm ± 5 %
9	MA8	IC1480 34pin	IC1501 198pin	56 ohm ± 5 %
10	MA9	IC1480 33pin	IC1501 194pin	56 ohm ± 5 %
11	MA10	IC1480 22pin	IC1501 199pin	56 ohm ± 5 %
12	MA11	IC1480 35pin	IC1501 192pin	56 ohm ± 5 %
13	MDQ0	IC1480 2pin	IC1501 160pin	56 ohm ± 5 %
14	MDQ1	IC1480 4pin	IC1501 162pin	56 ohm ± 5 %
15	MDQ2	IC1480 5pin	IC1501 164pin	56 ohm ± 5 %
16	MDQ3	IC1480 7pin	IC1501 168pin	56 ohm ± 5 %
17	MDQ4	IC1480 8pin	IC1501 170pin	56 ohm ± 5 %
18	MDQ5	IC1480 10pin	IC1501 172pin	56 ohm ± 5 %
19	MDQ6	IC1480 11pin	IC1501 176pin	56 ohm ± 5 %
20	MDQ7	IC1480 13pin	IC1501 178pin	56 ohm ± 5 %
21	MDQ8	IC1480 42pin	IC1501 177pin	56 ohm ± 5 %
22	MDQ9	IC1480 44pin	IC1501 175pin	56 ohm ± 5 %
23	MDQ10	IC1480 45pin	IC1501 171pin	56 ohm ± 5 %
24	MDQ11	IC1480 47pin	IC1501 169pin	56 ohm ± 5 %
25	MDQ12	IC1480 48pin	IC1501 167pin	56 ohm ± 5 %
26	MDQ13	IC1480 50pin	IC1501 163pin	56 ohm ± 5 %
27	MDQ14	IC1480 51pin	IC1501 161pin	56 ohm ± 5 %
28	MDQ15	IC1480 53pin	IC1501 159pin	56 ohm ± 5 %
29	MCK	IC1480 38pin	IC1501 183pin	0.17 ohm or lower
30	XWE	IC1480 16pin	IC1501 181pin	56 ohm ± 5 %
31	XCAS	IC1480 17pin	IC1501 188pin	56 ohm ± 5 %
32	XRAS	IC1480 18pin	IC1501 189pin	56 ohm ± 5 %
33	XCSM	IC1480 19pin	IC1501 190pin	56 ohm ± 5 %
34	DQM0	IC1480 15pin	IC1501 179pin	56 ohm ± 5 %
35	DQM1	IC1480 39pin	IC1501 180pin	56 ohm ± 5 %
36	BA0	IC1480 20pin	IC1501 193pin	56 ohm ± 5 %
37	BA1	IC1480 21pin	IC1501 197pin	56 ohm ± 5 %

B

C

D

E

F

Side B

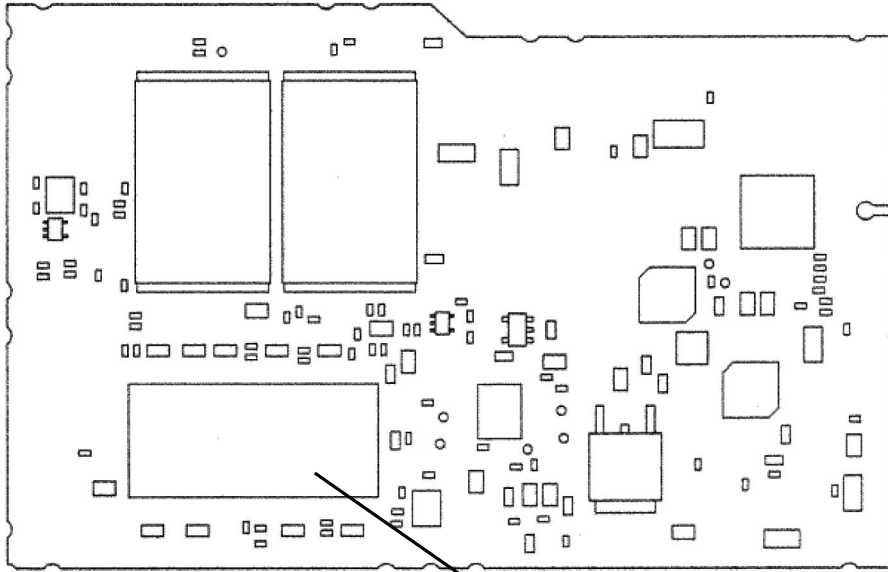

Check point 1 (IC1480)

Side A

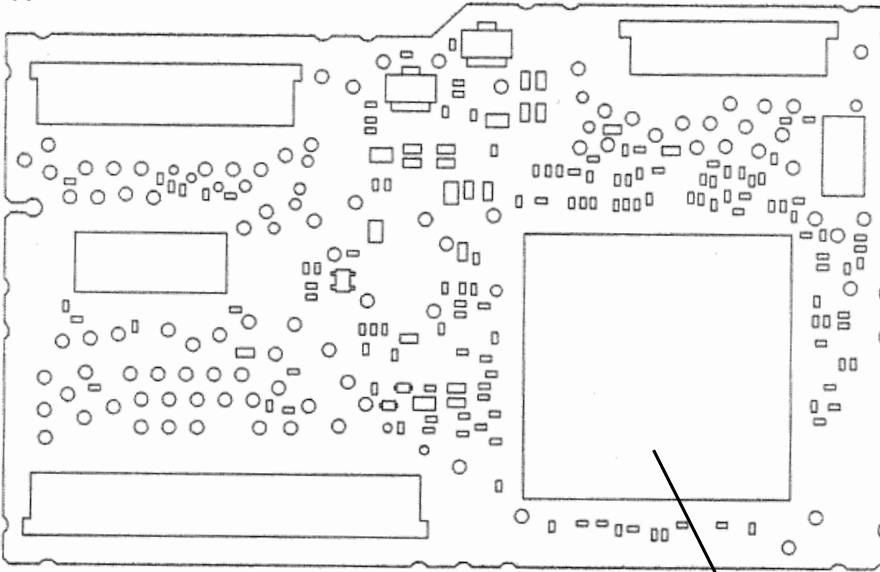

Check point 2 (IC1501)

Fig 6.2: SDRAM I/F check point

Check 7: Is VD8, VCC5 power supply voltage OK?

A

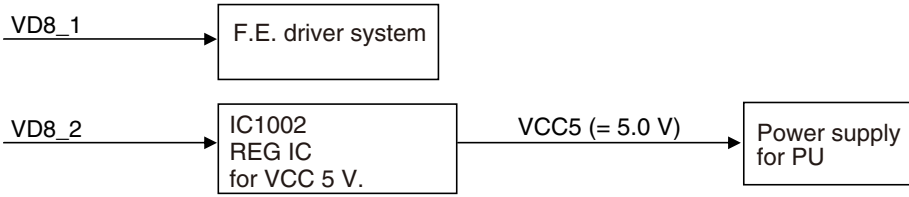

Fig 7.1: Power supply configuration

<Check> Check the voltage at the “VD8_1, VD and VCC5_1” test point while the power is on.
 Use the “PGND3 and AGND1” test point at the reference.

B

NO.	Check point	Module No.	Specification value	Unit
1	VD8_1 - PGND3	ALL	8.0 ± 0.4	V
2	VD - PGND3	ALL	8.0 ± 0.4	V
3	VCC5_1- AGND1	ALL	5.0 ± 0.1	V

C

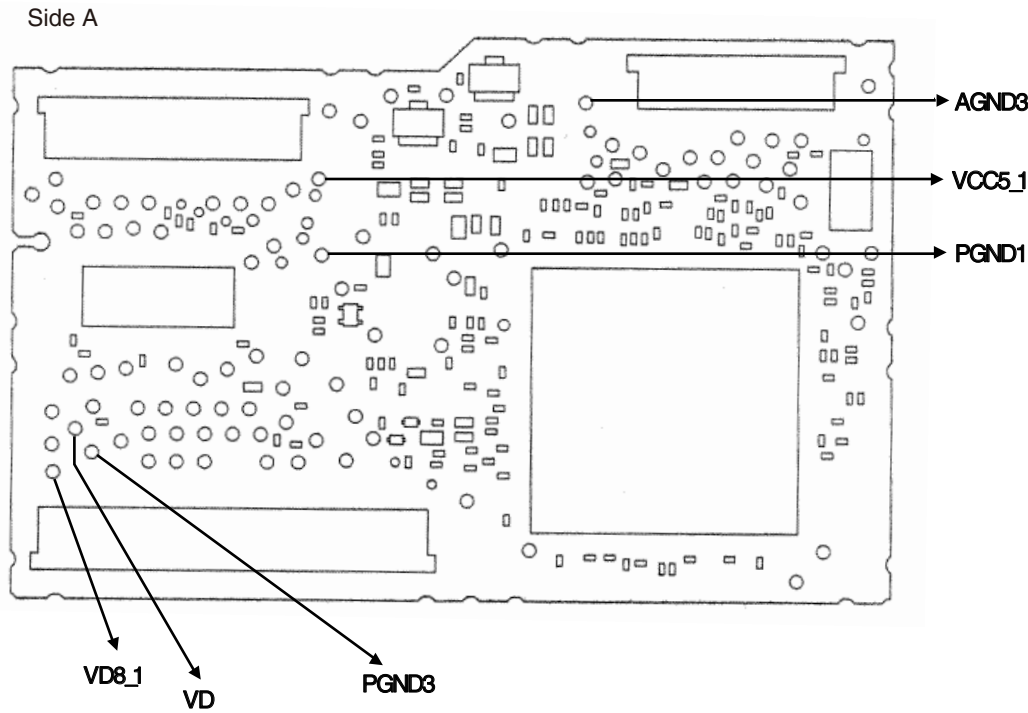

D

Fig 7.2: VD8, VCC5 voltage check points

E

F

Check 8: Is AVCC5 voltage OK?

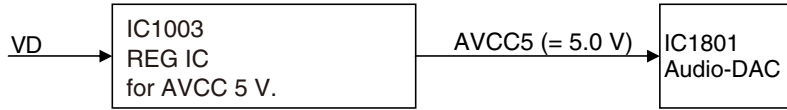

Fig 8.1: Power supply configuration

<Check> Playback DVD-REF-A1 TITLE 1 and check the voltage at the stylus.
Check with PGND and GND AU being the reference.

NO.	Check point	Module No.	Specification value	Unit
1	VD - PGND_3	ALL	8.0 ± 0.4	V
2	AVCC5 - GND AU1	ALL	5.0 ± 0.1	V

Side A

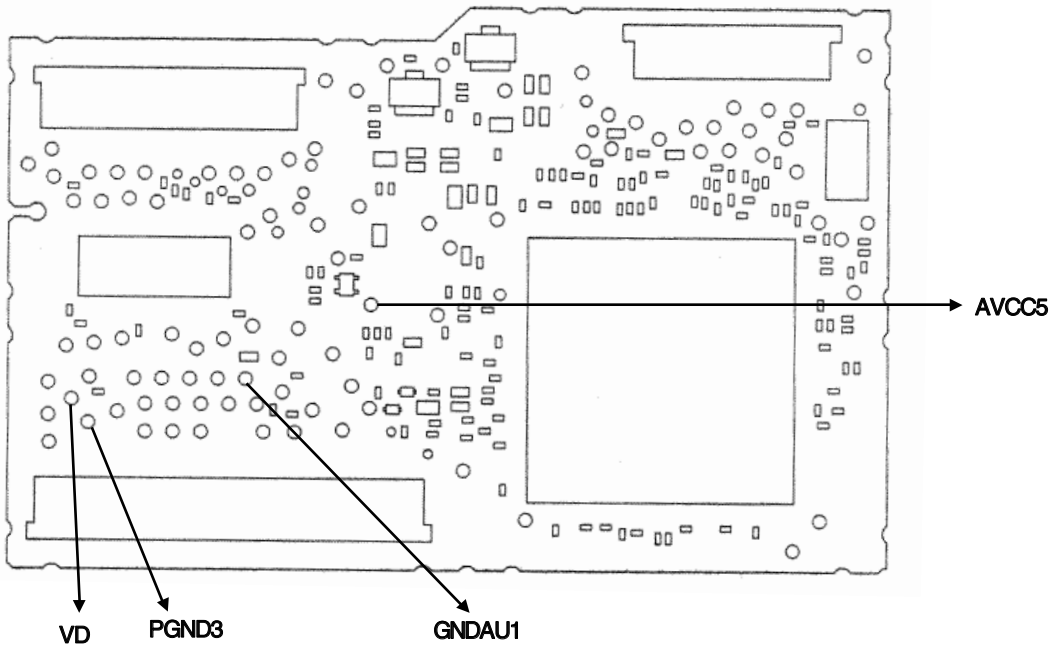

Fig 8.2: VD8, AVCC5 voltage check points

Check 9: Is DACCLK normal?

<Outline> DACCLK for Audio-DAC is created by IC1501 using the 27 MHz master crystal (X1501).

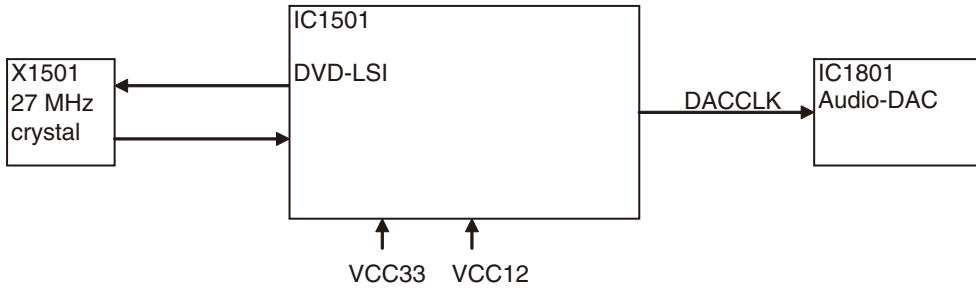

Fig 9.1: Clock configuration

<Check method>

DVD: DVD-REF-A1 TITLE 1

CD: Playback a normal CDDA.

Common to all DVD-V compatible modules.

Check with DGND being the reference.

In case of NG, check the applicable line, the periphery of IC1501, soldering of the peripheral components and defective components.

NO.	Check point 1 (stylus)	Media	Specification value 1	Specification value 2	Specification value 3
1	DACCK	DVD	2.0 V~VCC33 V	DGND~0.8 V	36.864 0 MHz ± 300 ppm
2	DACCK	CD	2.0 V~VCC33 V	DGND~0.8 V	33.868 8 MHz ± 300 ppm

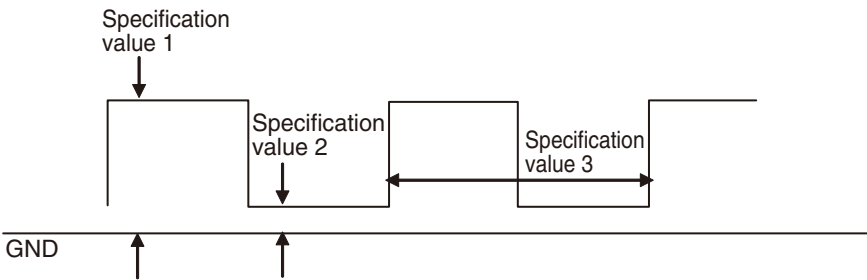
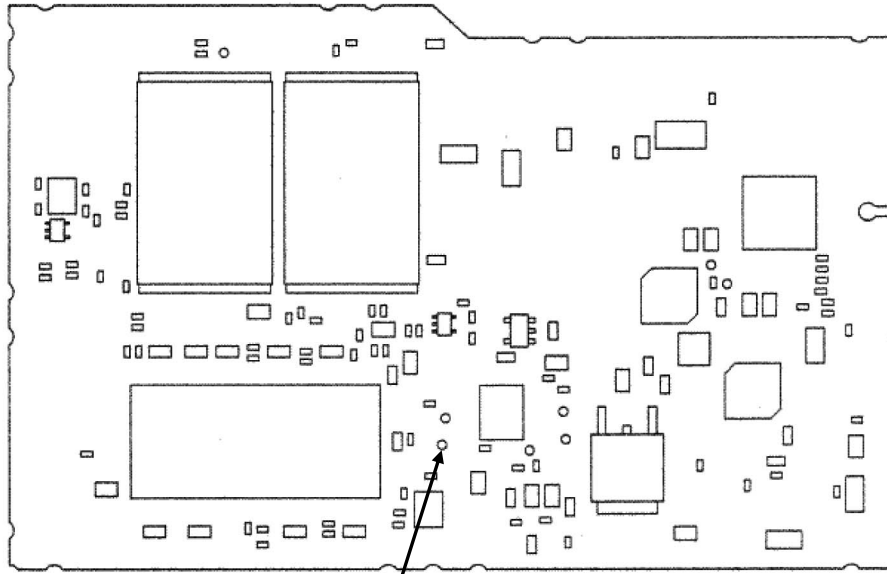

Fig 9.2: Clock specification value

Side B



Check point 1 (DACCK stylus)

Side A

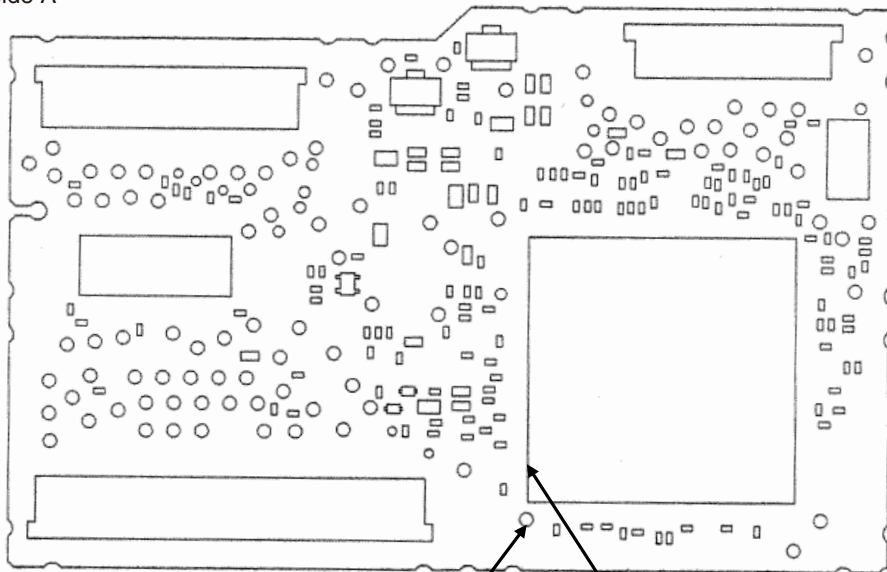

DGND2

Check point 2 (IC1501 148 pin)

Fig 9.3: 27 MHz, DACCLK check point

Check 10: Is the audio circuit OK?

<Outline> The serial 3 lines digital output + DACCLK, output from DVD-LSI (IC1501), are converted to analog audio signal at Audio-DAC (IC1801) and are output from the HOST I/F (CN1901). Simultaneously, the analog MUTE signal is also output from DVD-LSI (IC1501) via the HOST I/F. The digital audio signal (IECOUT), output from DVD-LSI (IC1501).

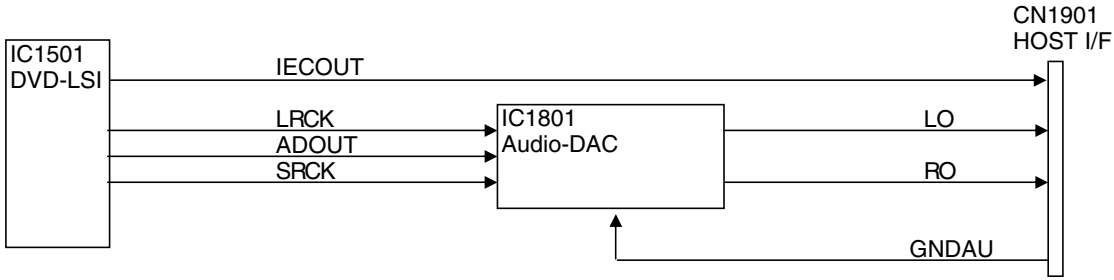

Fig 10.1: Audio circuit

<Check method> Playback DVD-REF-A1 TITLE 2 CHAPTER 1 (48 k/16 bit 1 kHz 0 dB), and check with DGND being the reference. In case of NG, check the applicable line, periphery of major components as described in the above drawing, soldering of the peripheral components and defective components.

NO.	Check point 1 (stylus)	Specification value 1	Specification value 2	Reference waveform
1	ADOUT3	VCC33 V-0.6 V or higher	0.4 V or lower	Waveform 1
2	SRCK	VCC33 V-0.6 V or higher	0.4 V or lower	Waveform 2
3	LRCK	VCC33 V-0.6 V or higher	0.4 V or lower	Waveform 3

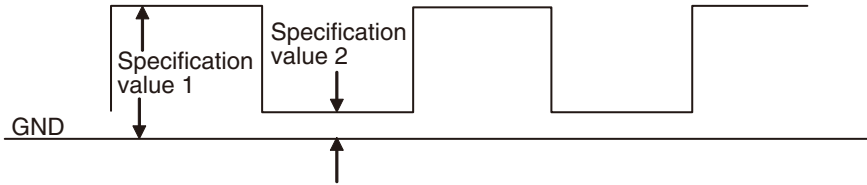
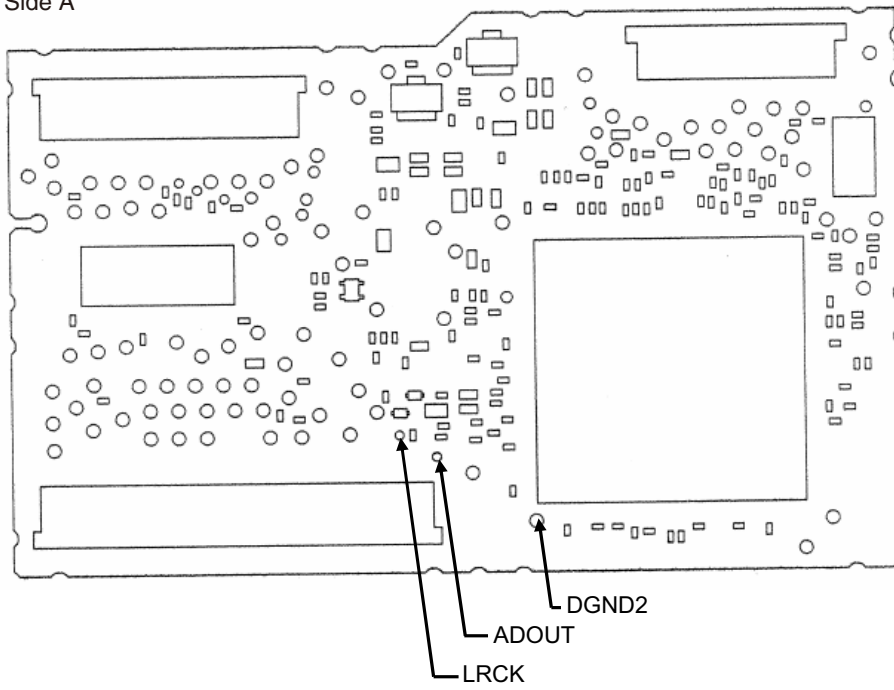

Fig 10.2: Serial 3 lines specification value

Side A



Side B

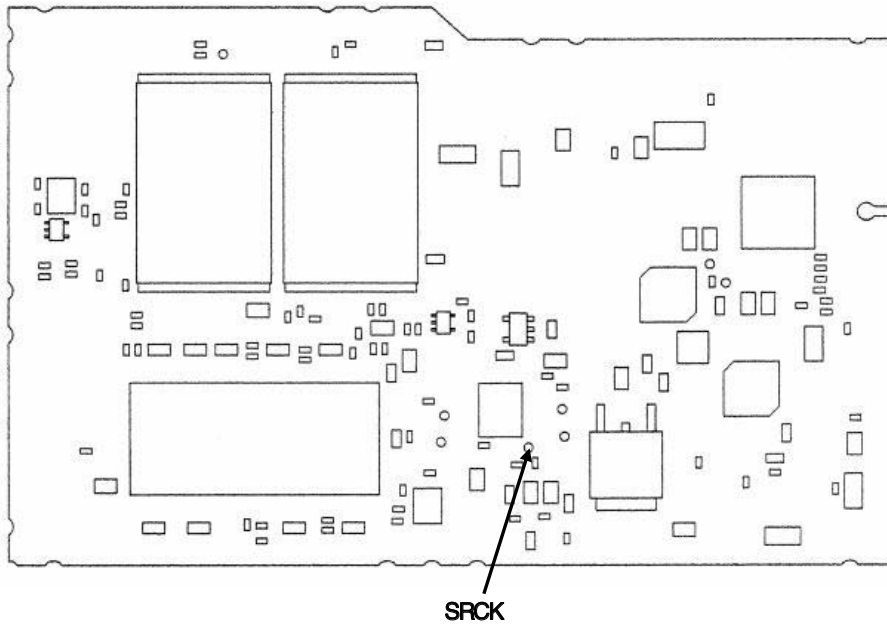
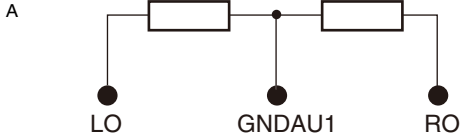

Fig 10.3: Serial 3 lines check points

The following checks shall be conducted using the following measurement circuits with GNDAU1 being the reference.



NO.	Check point 1 (stylus)	Specification value (rms)	Reference waveform
4	LO	1 400 ± 150 mV	Waveform 4
5	RO	1 400 ± 150 mV	Waveform 4

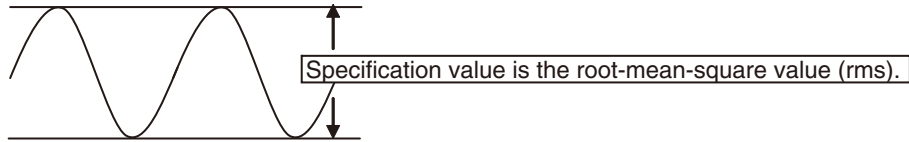

Fig 10.4: Analog audio out (LO, RO) specification value.

Side A

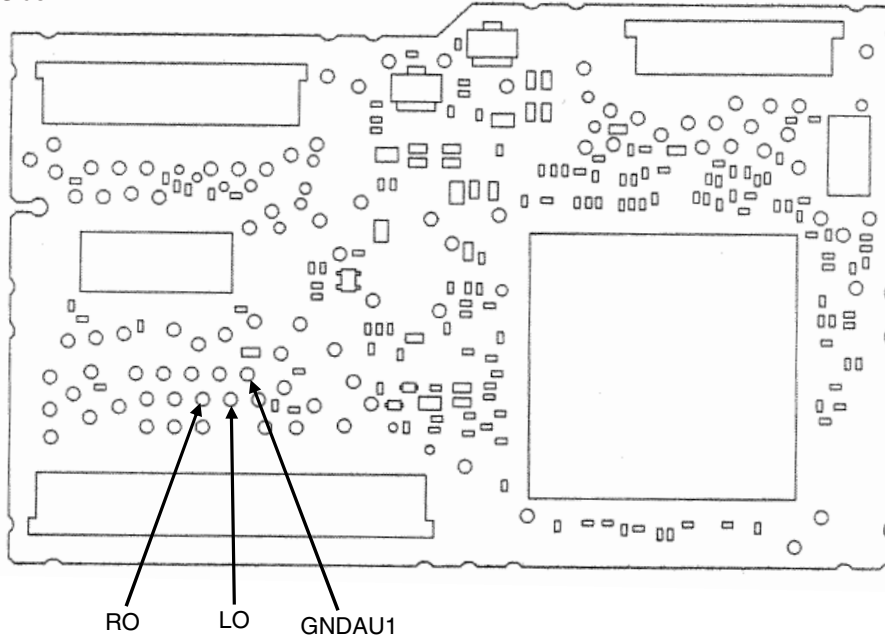

Fig 10.5: Analog audio out check point

Check with DGND being the reference.

NO.	Check point 1 (stylus)	Specification value 1	Specification value 2	Reference waveform
6	IEC	VCC33 V-0.6 V or higher	0.4 V or lower	Waveform 5

Side A

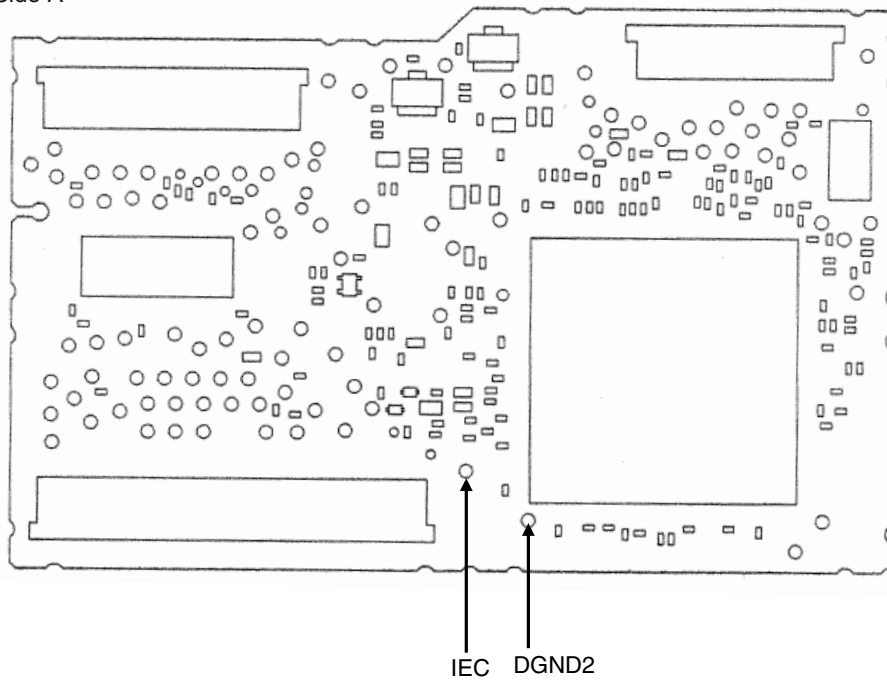
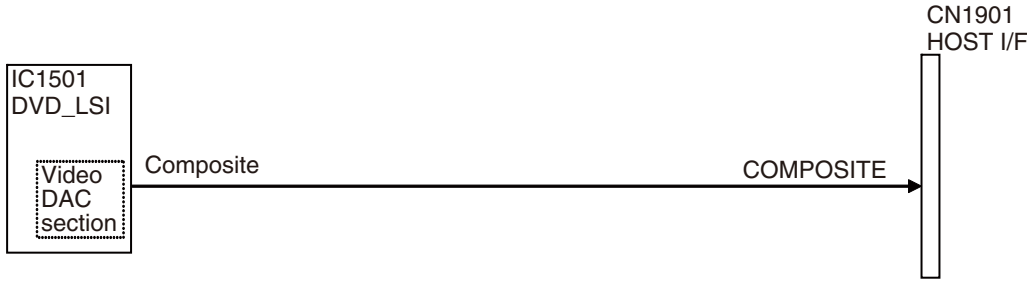

Fig 10.6: Digital audio signal (IECOUT) check point

Check 11: Is the video circuit OK?

<Outline> Composite signal and component signal are output from DVD-LSI (IC1501), and are output from the HOST I/F (CN1901) via a buffer circuit.

A



B

Fig 11.1: Video circuit

<Checking method> Playback DVD-REF-A1 TITLE2 CHAPTER5 (WHITE 100%), and monitor COMPOSITE signal with an oscilloscope with GNDV1 (stylus) being the reference. Set the trigger mode to "TV trigger" and the trigger line to "150 line".

Check point 1 (stylus)

NO.		Specification value	Reference waveform
1	COMPOSITE	1 000 mVpp ± 5 %	Waveform 6

C

In case of NG, check the applicable line, the periphery of the major components in the drawing above, soldering of the peripheral components and defective components.

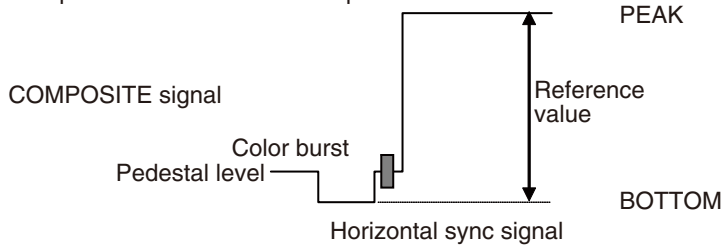

D

Fig 11.2: Waveform for the case of composite white 100% output

E

F

Side A

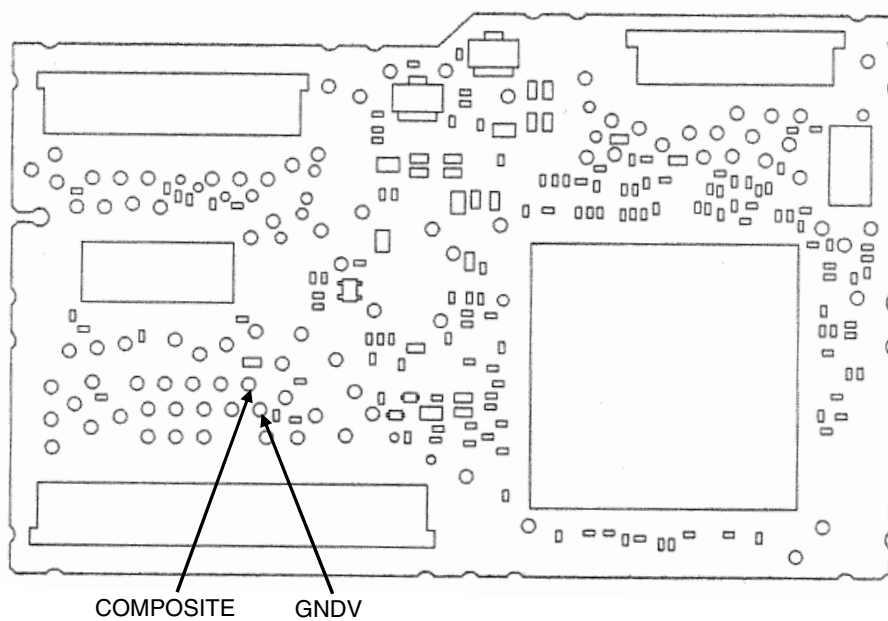

Fig 11.3: VIDEO signal check point

Check 12:How to judge whether the flash memory has reached its life or not.

A

If the reaction to user operation is slow or operation is slow in general, there is a possibility that the flash memory has reached its life.

Make judgment regarding the flash memory life by looking at the display of the LD energizing time.

1.Let the LD energizing time displayed.

(Refer to the FE test mode for the method of displaying the LD energizing time.)

2.If the second digit from the left of the energizing time display is showing E, such as “*E * * * * *”, it means that the flash memory has reached its life.

Example:

B

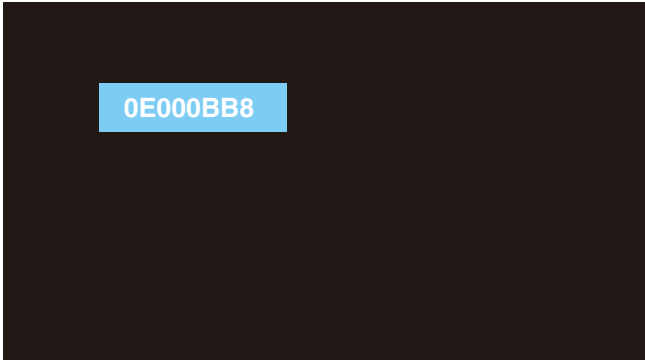

C

D

E

F

Check 13: 48 MHz Normal?

<Outline> Each clock is created inside the IC1501 using the 48 MHz master crystal oscillator (X1501).

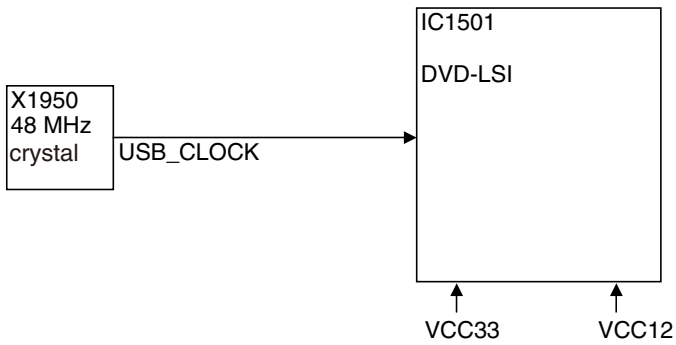

Fig 13.1: Clock configuration

<Check method> Turn the power on, and check with DGND1 being the reference.
In case of NG, check the applicable line, periphery of IC1501, soldering of the peripheral components and defective components.

NO.	Check point	Module No.	Specification value	Unit
2	IC1501 50pin-DGND1	ALL	48 MHz ± 50 ppm	ppm

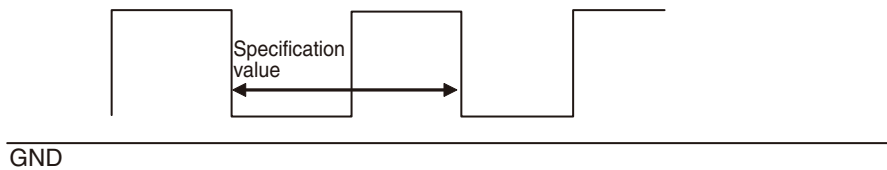

Fig 13.2: Clock specification value

Side A

A

B

C

D

E

F

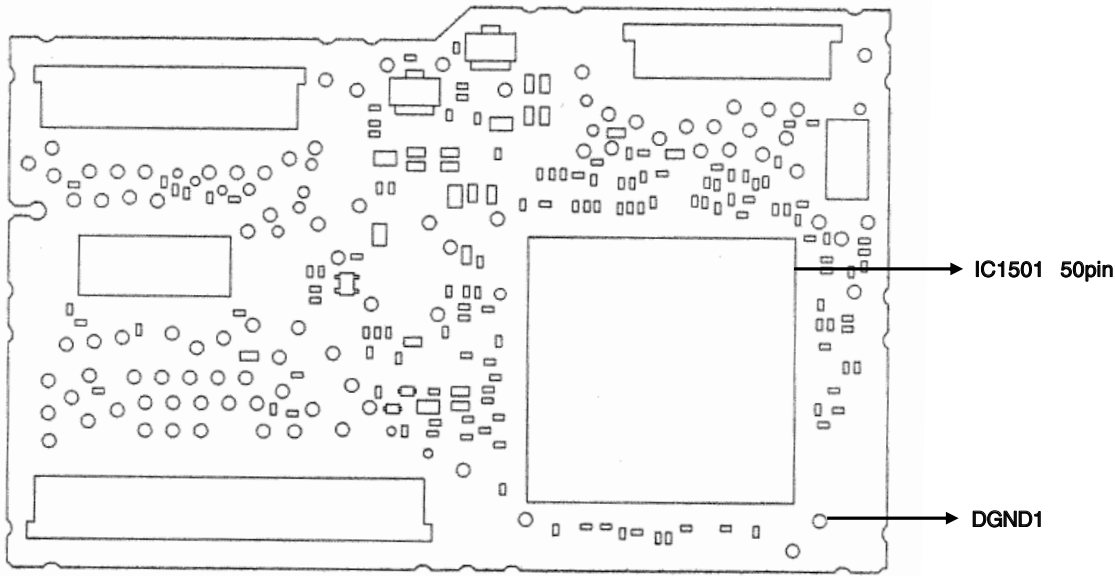

Fig 13.3: 48 MHz check point

Check 14: Is USB Circuit OK?

<Outline>

The data is transmitted through D+, D- and SDA of HOST I/F while playing USB/IPOD.

USB memory uses only D+ and D-, but IPOD uses SDA (DATA) and SCL (CLOCK) in addition to D+ and D-.

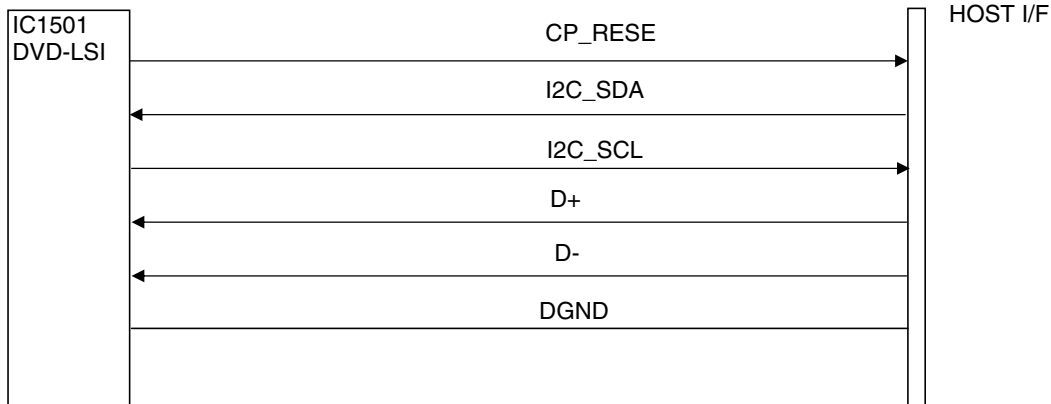

Fig. 14-1: USB Circuit

<Check Method>

1. USB Memory: Play a song from USB memory and check D+ and D- with the DGND standards.

2. iPod: Connect iPod and check CP_RESET, SDA and SCL with the DGND standards until the pioneer log appears.

Play a song from iPod and check D+/D- with the DGND standards.

When it does not conform to the standards, check appropriate line, main parts shown in the above figure, soldering of peripheral parts and malfunctions in parts.

No.	Checking spot (stylus)	Standard value 1	Standard value 2
1	CP_RESET	VCC33*0.7 or more	
2	SDATA	VCC33*0.7 or more	VCC33*0.2 or less
3	SCLOCK	VCC33*0.7 or more	VCC33*0.2 or less
4	D+	VCC33*0.7 or more	VCC33*0.3 or less
5	D-	VCC33*0.7 or more	VCC33*0.3 or less

*Until the pioneer log appears after connecting the iPod

*Until the pioneer log appears after connecting the iPod

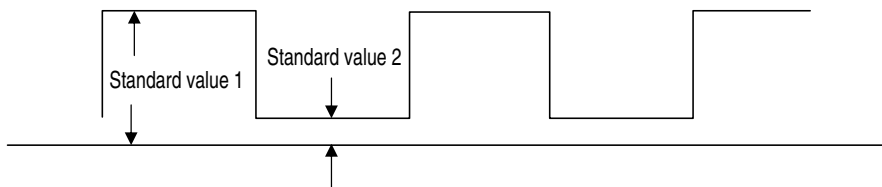

Fig. 14.2: USB Circuit Communication Wave

Side A

A

B

C

D

E

F

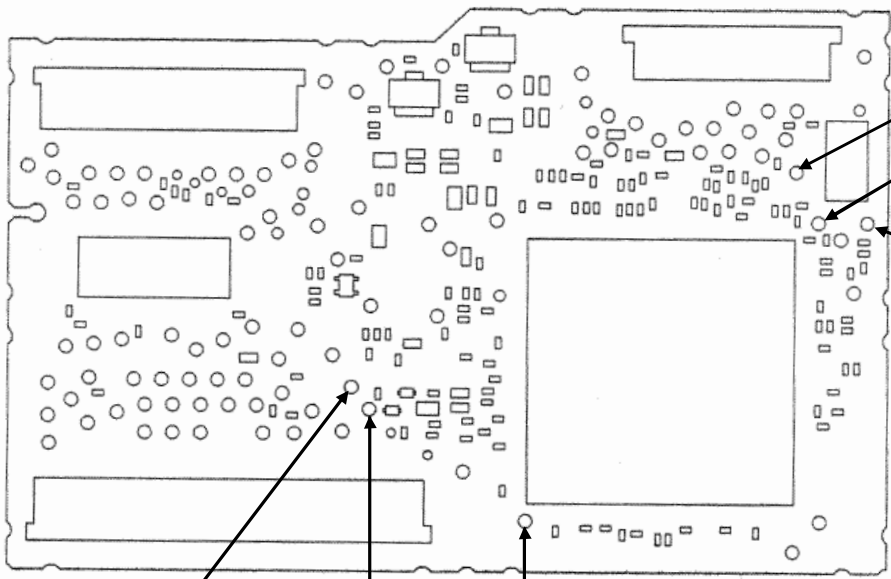

SDATA

CP_RESET

SCLOCK

D-

D+

DGND2

AUDIO

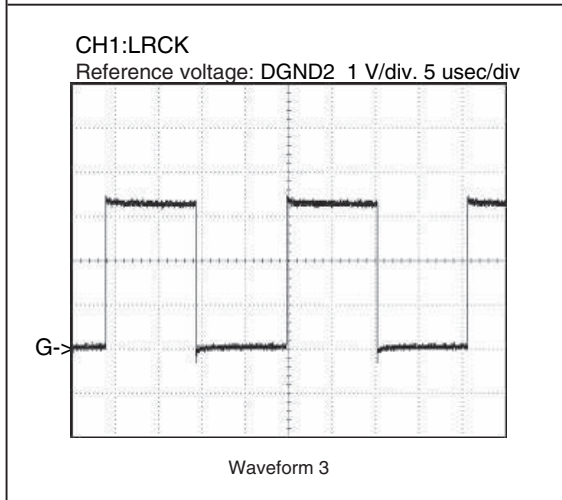
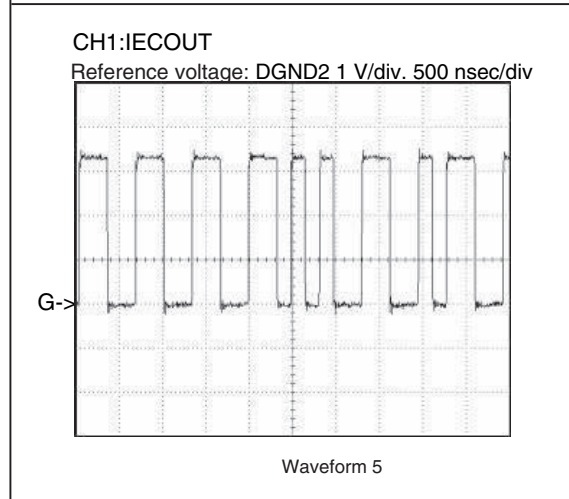
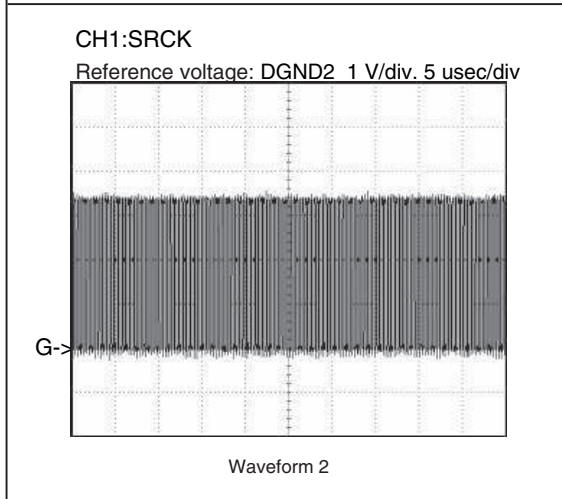
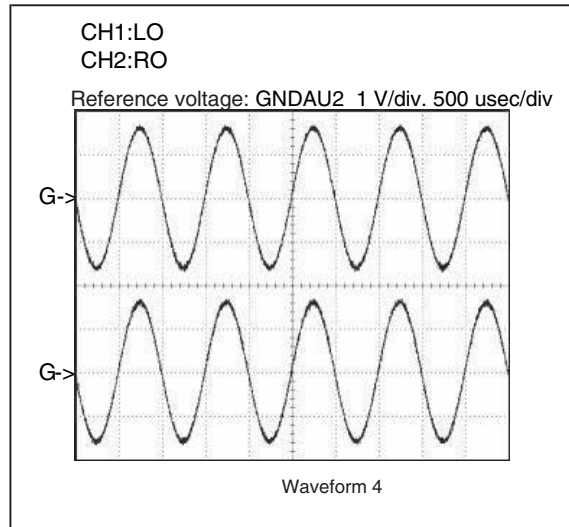
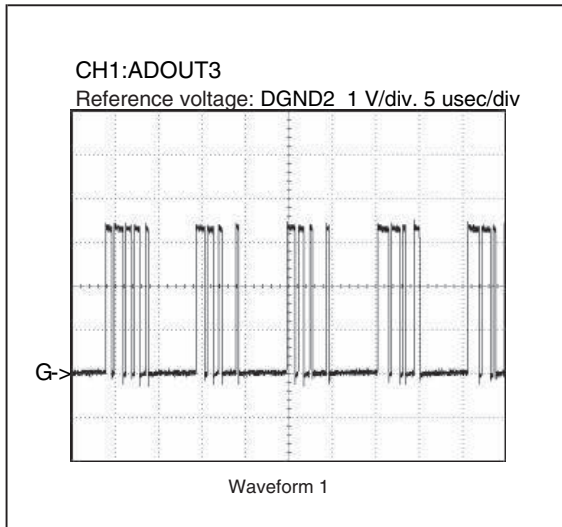

A

B

C

D

E

F

VIDEO

A

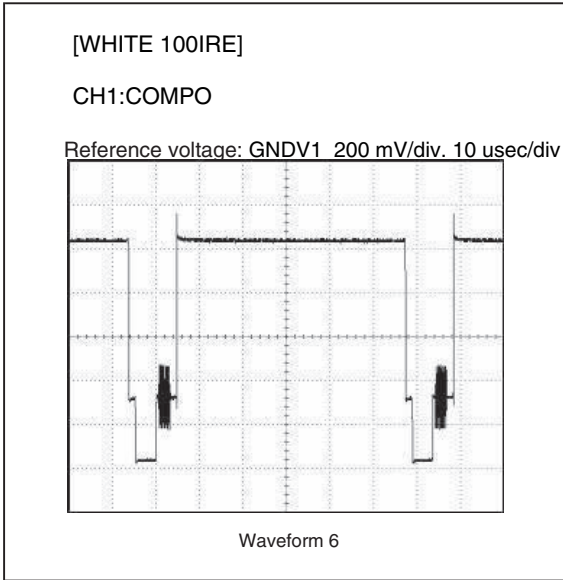

B

USB memory

C

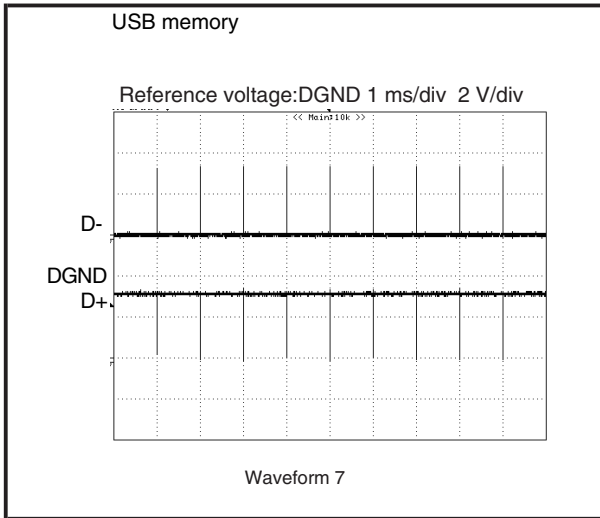

D

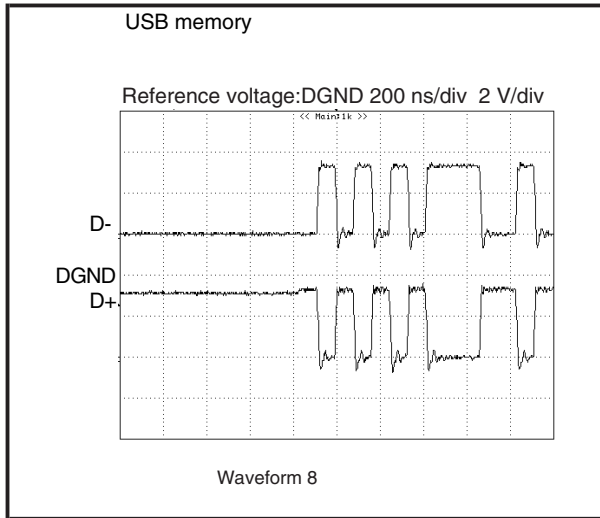

E

F

iPod

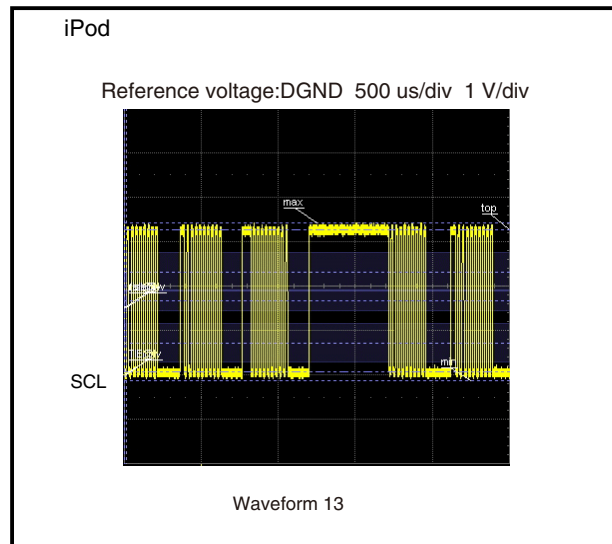
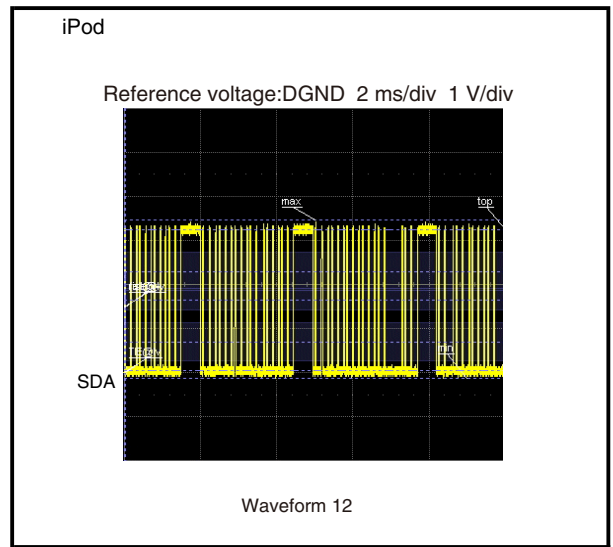
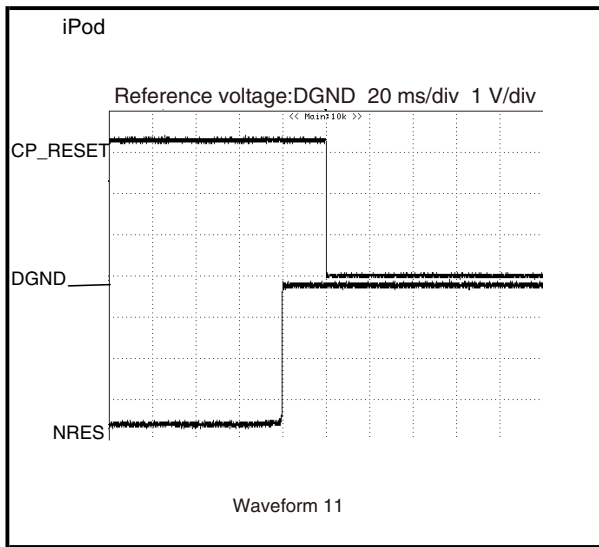
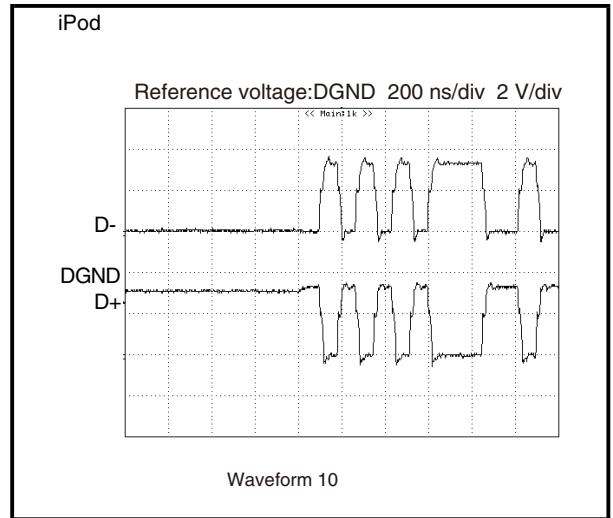
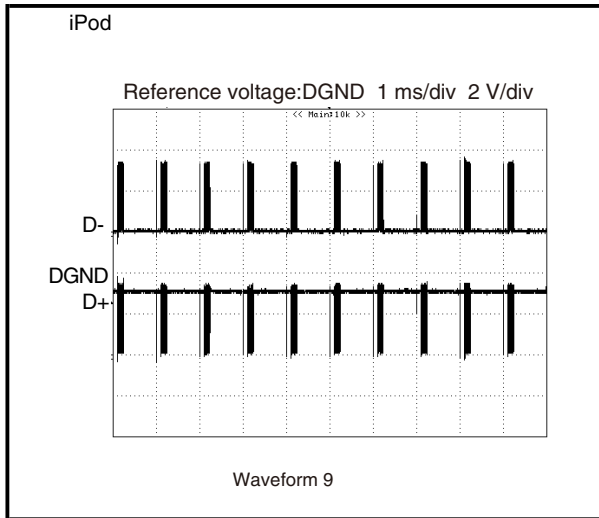

A

B

C

D

E

F

5.4 ERROR CODE LIST

Error status	OSD *1	UART *2	Meaning	Generation source			Method of reset			
				Disc	USB (MSC)	USB (iPod)	ACC Off/On	Source Off/On	Eject	Play Key
Media Error	NON-PLAYABLE DISC	00h	A disc containing the unplayable Format only	X	-	-	X	X	X	-
	INCOMPATIBLE DEVICE	00h	USB device that doesn't correspond	-	X	X	X	X	-	-
	UNPLAYABLE FILE	00h	USB device of format alone that cannot be reproduced	-	X	-	X	X	-	-
Open	(No display)	10h	Door open error	X	-	-	*	*	*	*
Read Error	ERROR-02-99	20h	Transfer start error	X	-	-	X	X	X	X
Focus Error(Focus Error in mechanism set up)	ERROR-02-90	21h	Focus error	X	-	-	X	X	X	X
Surface Error	ERROR-02-9E	22h	Focus error during set up (A focus has never been achieved with that disc.)	X	-	-	X	X	X	X
Address not found(Invalid Track)	ERROR-02-80	23h	Address not found.	X	-	-	X	X	X	X
Spindle Lock	ERROR-02-91	24h	Spindle lock NG (the disc cannot rotate)	X	-	-	X	X	X	X
Carriage HOME	ERROR-02-92	25h	Carriage home NG (The pick up tries to return to carriage home, but it cannot go back and stopped.)	X	-	-	X	X	X	X
ID/SUBCODE Read Error	ERROR-02-94	26h	ID/SUBCODE Read Error (ID/SUBCODE cannot be read due to scratch or stain.)	X	-	-	X	X	X	X
AV CHIP decode Error	ERROR-02-9A	2Ah	AV CHIP decode NG (AV chip cannot be decoded.)	X	X	-	X	X	X	X
AV CHIP Recovery NG	ERROR-02-9B	2Bh	AV CHIP recovery NG	X	X	X	X	X	X	X
Error of PLAY BACK Mode Status	ERROR-02-9C	2Ch	Playback state error (An error due to software bug.)	X	X	-	X	X	X	X
Disc Data Error	ERROR-02-9D	2Dh	Disc Data NG	X	-	-	X	X	X	X
Temp Error (In Case of High Temperature)	THERMAL PROTECTION IN MOTION	30h	High temperature (Playback is stopped because the pick up temperature is 89. C or higher.)	X	-	-	X	-	-	-
No Disc (including Disc loading and ejecting)	(No display)	40h	Disc has not been inserted. (Including Load in process or Eject in process.)	X	-	-	*	*	*	*
Loading_Mecha Error	(No display)	50h	Loading mechanism error (The disc cannot be clamped.)	X	X	X	X	-	X	-
Communication fault attesting iPod	ERROR-02-60	60h	Communication fault attesting iPod	X	-	X	-	-	X	-
iPod authentication data is abnormal	ERROR-02-61	61h	iPod authentication data is abnormal	X	-	X	-	-	X	-
iPod attestation retrying failure	ERROR-02-62	62h	iPod attestation retrying failure	X	-	X	-	-	X	-
iPod attestation time out	ERROR-02-63	63h	iPod attestation time out	X	-	X	-	-	X	-
Error when iPod is connected/ It is generated STALL by the USB communication.	ERROR-02-64	64h	Error when iPod is connected/ It is generated STALL by the USB communication.	-	-	X	-	-	X	-
Error setting iPod	ERROR-02-65	65h	Error setting iPod	-	-	X	-	-	X	-
Demand timeout when initial is communicated	ERROR-02-66	66h	Demand timeout when initial is communicated	-	-	X	-	-	X	-
Protocol version non-correspondence	ERROR-02-67	67h	Protocol version non-correspondence	-	-	X	-	-	X	-
Timeout when protocol version is judged	ERROR-02-68	68h	Timeout when protocol version is judged	-	-	X	-	-	X	-
No songs error	(No display)	69h	No songs error	-	-	X	-	-	X	-
iPod control forwarding/ Intarapta forwarding error	ERROR-02-6A	6Ah	iPod control forwarding/ Intarapta forwarding error	-	-	X	-	-	X	-
Demand timeout iPod's reproducing	ERROR-02-6B	6Bh	Demand timeout iPod's reproducing	-	-	X	-	-	X	-
Remote switch error	ERROR-02-6C	6Ch	Remote switch error	-	-	X	-	-	X	-
Remote switch demand timeout	ERROR-02-6D	6Dh	Remote switch demand timeout	-	-	X	-	-	X	-
DRM Error	PROTECTED DISC	70h	DRM error (All music cannot be played back due to DRM.)	X	-	-	-	-	X	-
	NO ACCESSIBLE DATA AVAILABL	70h	DRM error (All music cannot be played back due to DRM.)	-	X	-	-	-	-	-
Region code Error NG	DIFFERENT REGION DISC	90h	Region code NG (Unable to be played back due to incorrect mechanism region.)	X	-	-	-	-	X	-
CPRM*7 Key Error *8	NON-PLAYABLE DISC	93h	Key Error for playback	X	-	-	-	-	X	-
REQUEST error	ERROR-02-A0	A0h	REQUEST error	X	-	-	X	X	X	X
Failure in issuing read command (chip dependent)	ERROR-02-A1	A1h	Failure in issuing the read command	X	-	-	X	X	X	X
Adjustment of L0 is NG.	ERROR-02-A2	A2h	L0 adjustment is NG.	X	-	-	X	X	X	X
Adjustment of L1 is NG.	ERROR-02-A3	A3h	L1 adjustment is NG	X	-	-	X	X	X	X
LD system NG	ERROR-02-A4	A4h	LD system NG	X	-	-	X	X	X	X
Gain adjustment system NG.	ERROR-02-A5	A5h	Gain adjustment system NG.	X	-	-	X	X	X	X
Gain determining system NG.	ERROR-02-A6	A6h	Gain determining system NG.	X	-	-	X	X	X	X
Servo initial setting related items NG.	ERROR-02-A7	A7h	Servo initial setting related items NG.	X	-	-	X	X	X	X
Disc is not clamped yet.	ERROR-02-A8	A8h	Disc is not clamped yet.	X	-	-	X	X	X	X
Tracking system NG.	ERROR-02-A9	A9h	Tracking system NG	X	-	-	X	X	X	X
Media setting system NG.	ERROR-02-AA	AAh	Media setting system NG	X	-	-	X	X	X	X
Focus Error	ERROR-02-AB	ABh	JUMP over layers NG	X	-	-	X	X	X	X
Error of PLAY BAC K Mode Status	ERROR-02-B0	B0h	Navigation command error	X	-	-	X	X	X	X
Error of PLAY BAC K Mode Status	ERROR-02-B1	B1h	Retry over	X	-	-	X	X	X	X
Audio Property Timeout Error *9	ERROR-02-C0	C0h	Audio property timeout error	X	-	-	X	X	X	-
Error when MCS is connected/ It is generated STALL by the USB communication.	ERROR-02-D0	D0h	Error when MCS is connected/ It is generated STALL by the USB communication.	-	X	-	-	-	X	-
CBW and CSW forwarding error	ERROR-02-D1	D1h	CBW and CSW forwarding error	-	X	-	-	-	X	-
Audio class band securing failure	ERROR-02-D8	D8h	Audio class band securing failure	-	-	X	-	-	X	-
Audio class FS setting failure	ERROR-02-D9	D9h	Audio class FS setting failure	-	-	X	-	-	X	-
Undefined Error	ERROR-FF-FF	FFh	Undefined error	X	-	-	X	X	X	X

X: Cancel the error by operation. -: Error is not cancelled by operation. *: No setting

*1 A content displayed on OSD. As for the items having multiple display patterns, the upper row is for the Japanese version Full GUI, and the lower row is for the Touch Panel model and Full GUI (English version).

*2 A parameter of UART command, such as "receipt error notice", that the DVD mechanism transmits.

*3 CPPM(Content Protection for Prerecorded Media) : A copyright protection technique used in DVD-A. The protection is realized by using the keys recorded on the media and the device key held by the player.

*4 DVD-A compatible model only.

When an error has occurred, only the audio output will be muted but playback operation will continue. Furthermore, acceptance of the user operation will be the same as usual.

*5 AWM (Audio WaterMark): Electronic watermark. Information on the copyright owner or CCI (copy control information) are recorded so that illegally copied discs can be identified.

*6 Notice as an error status will not be given

*7 CPRM(Content Protection for Recordable Media) : A copyright protection technique for digital contents used for re-writable DVD or memory card. (DVD-VR model only)

A

B

C

D

E

F

5.5 CONNECTOR FUNCTION DESCRIPTION

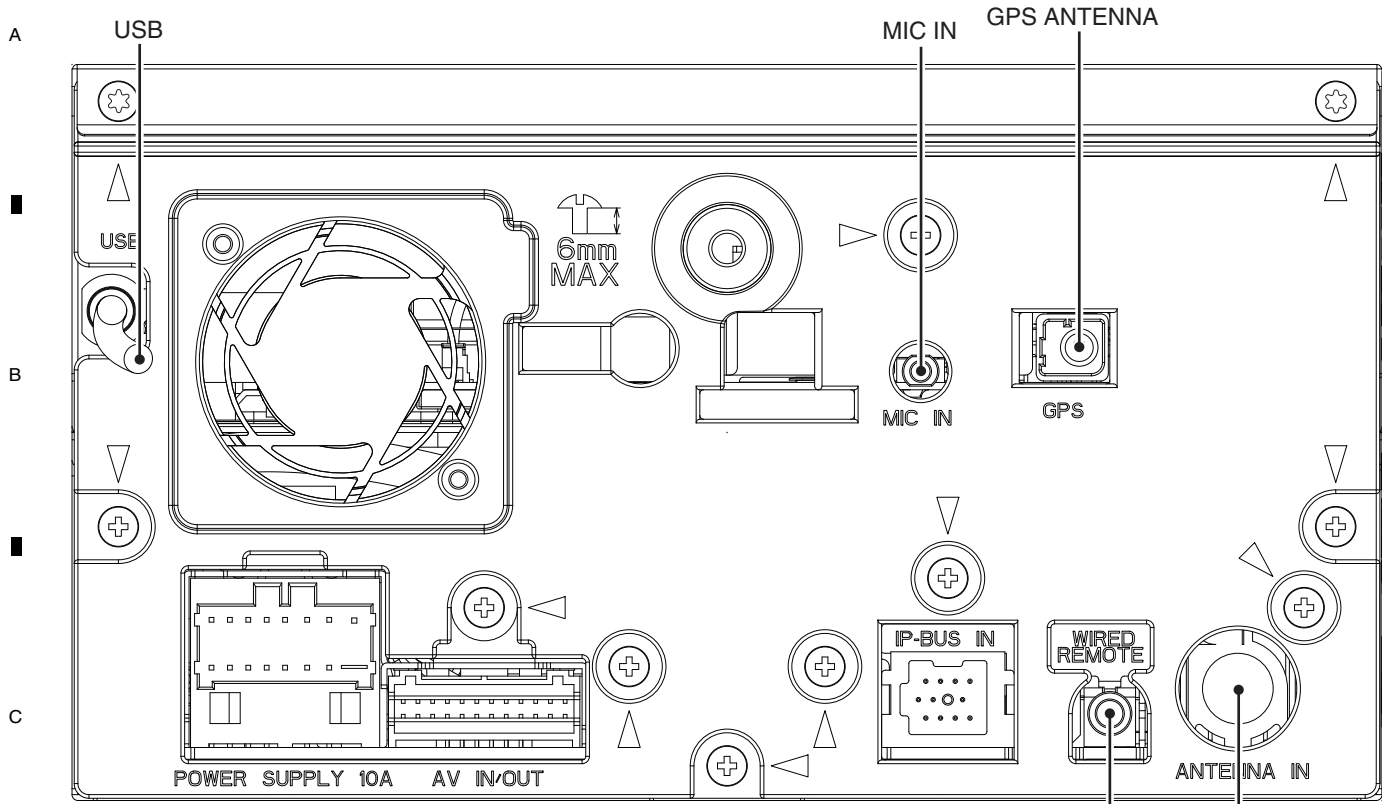

POWER SUPPLY

1	3	5	7	9	11	13	15
2	4	6	8	10	12	14	16

AV IN/OUT

1	3	5	7	9	11	13	15	17	19	21	23
2	4	6	8	10	12	14	16	18	20	22	24

IP-BUS IN (UC)

8	9	10	11
5	6	7	
1	2	3	4

WIRED REMOTE

FM/AM ANTENNA

- 1. FR+
- 2. RR+
- 3. FR-
- 4. RR-
- 5. FL+
- 6. RL+
- 7. FL-
- 8. RL-
- 9. PKB
- 10. PULSE
- 11. REV
- 12. ILM
- 13. AANT
- 14. ACC
- 15. GND
- 16. BUP

- 1. TELMUTE
- 2. DTVVGND
- 3. RR
- 4. DTVV
- 5. RL
- 6. REARGND
- 7. FR
- 8. KMODE
- 9. FL
- 10. FRONTGND
- 11. SWR
- 12. BREM
- 13. SWL
- 14. SWGND
- 15. VTR1R
- 16. VTR1RGND
- 17. VTR1L
- 18. VTR1LGND
- 19. VTR1V
- 20. VTR1VGND
- 21. REARVOUT
- 22. GNDV
- 23. BCV
- 24. BCVGND

- 1. IPBUS+
- 2. IPBUSG
- 3. IPLG
- 4. NC
- 5. IPBUS-
- 6. IPRG
- 7. IPL+
- 8. ASENBO
- 9. IPR+
- 10. IPR-
- 11. IPL-

5.6 TROUBLESHOOTING

● FLOWCHART

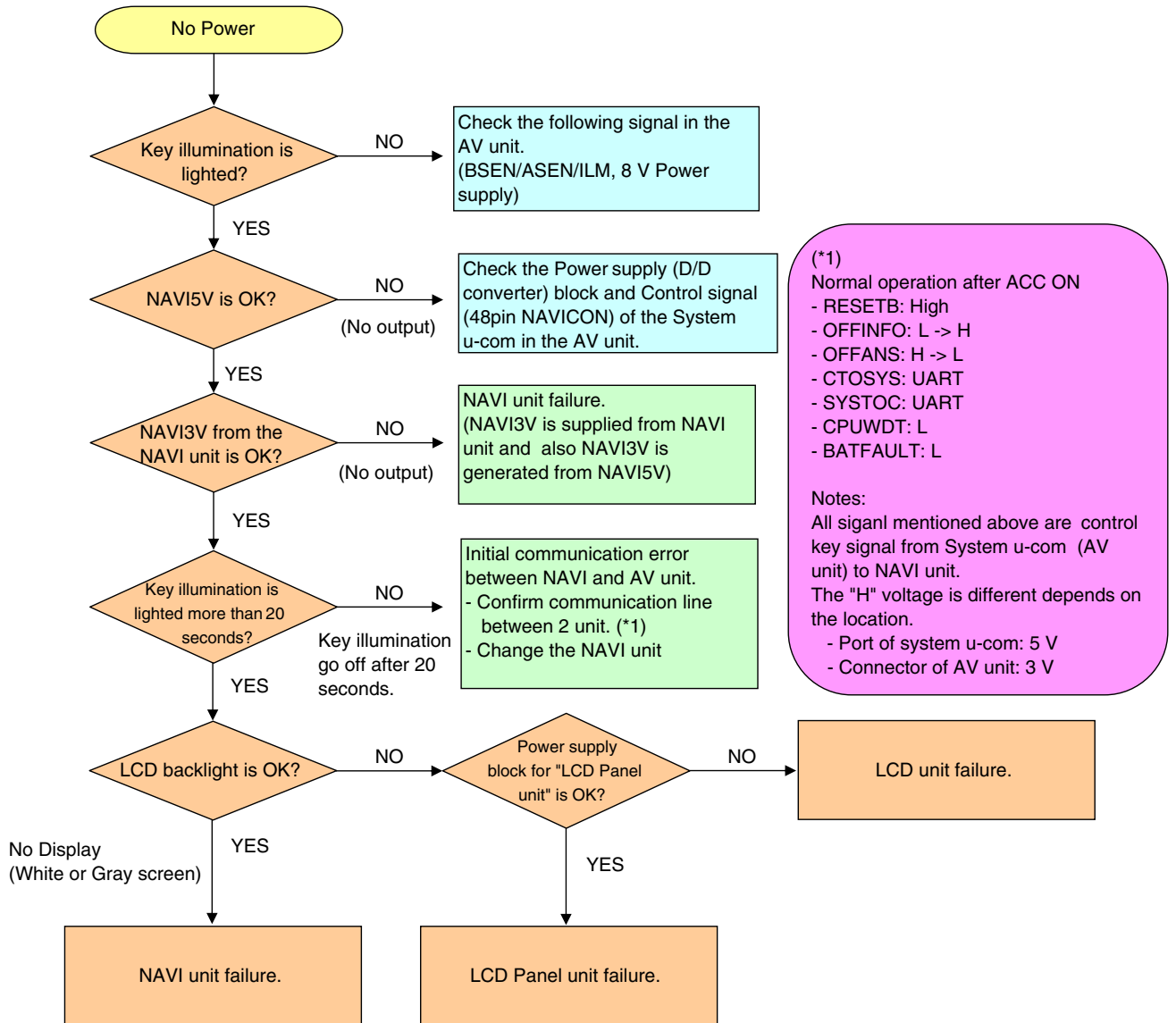

● DIAGNOSIS POINT

NAVI BD Side A

NAVI BD Side B

LCD BD Side A

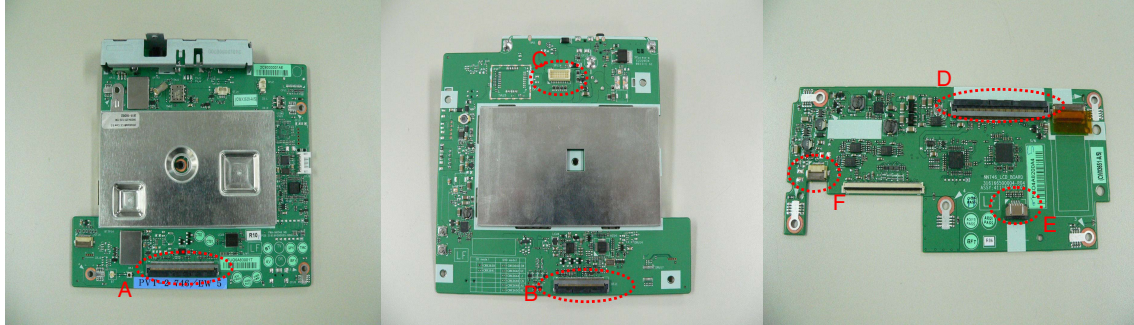

Case 1 System can not wake-up.

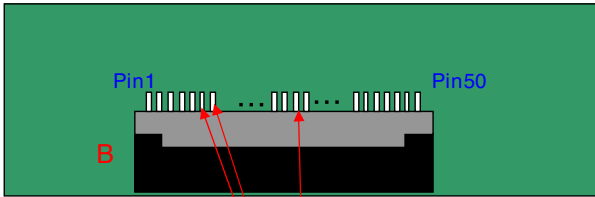

Pin27: NAVI33V	ACC ON	ACC OFF	This power supply is from NAVI BD to AV BD.
Pin5: OFFINFO	High	High	This signal is from AV BD(system-ucom) to NAVI BD.
Pin6: OFFANS	High	Low	This signal is from NAVI BD to AV BD(system-ucom).
	Low	High	(High = 3.3 V)
Pin13: SYSTOC	Communication line (Sys u-com to NAVI unit)		
Pin14: CTOSYS	Communication line (NABI unit to Sys u-com)		

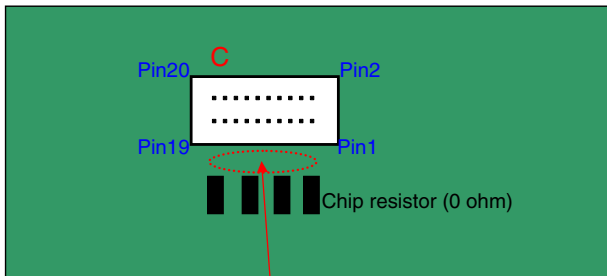

Pin3,5,7,9,11,13,15,17,19	ACC ON	ACC OFF	
NAVI 5V	5V	5V	power supply is from AV BD to NAVI BD.

Case 2 Navi image can not be displayed on LCD.

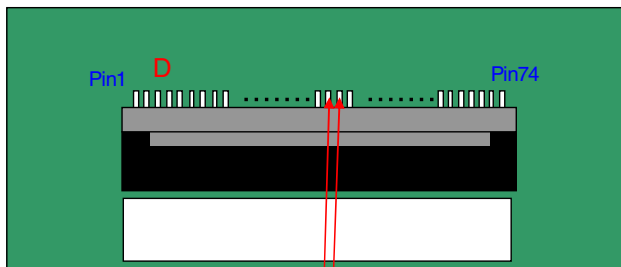

Pin36: LVDSN	Video signal (LVDS) from NAVI to LCD BD.
Pin37: LVDSP	Video signal (LVDS) from NAVI to LCD BD.

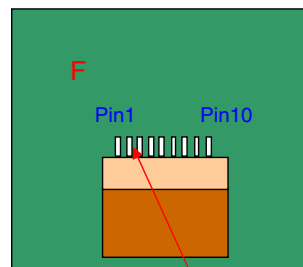

Pin1: TFT_ANODE	Power supply from LCD BD to LCD unit
Pin2: TFT_ANODE2	
Pin6: TFT_CATHODE	
Pin7: TFT_CATHODE	

Case 3 Touch panel operation doesn't work

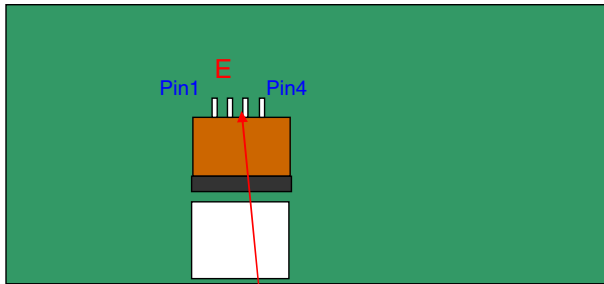

Pin1: nYPON
Pin2: nXPON
Pin3: YMON
Pin4: XMON

The signal from touch-panel to LCD BD
(Waveform pulse can be mintored while operating touch-panel.)

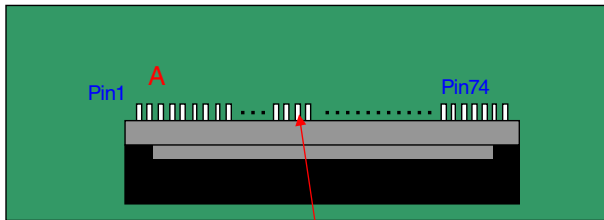

Pin29: nYPON
Pin30: nXPON
Pin31: YMON
Pin32: XMON

The signal from LCD BD to NAVI BD
(Waveform pulse can be mintored while operating touch-panel.)

Case 4 Hard Key doesn't work

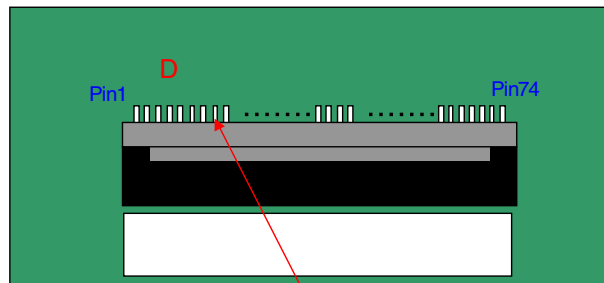

Pin8: KEY0
Pin9: KEY1
Pin11: ROT0
Pin12: ROT1

KEY (Push, Menu, Right) signal from KEY BD to LCD BD (DC Voltage)
KEY (MAP, Left, Down ,Up) signal from KEY BD to LCD BD (DC Voltage)
KEY (Rotary) signal from KEY BD to LCD BD (Pulse waveform)
KEY (Rotary) signal from KEY BD to LCD BD (Pulse waveform)

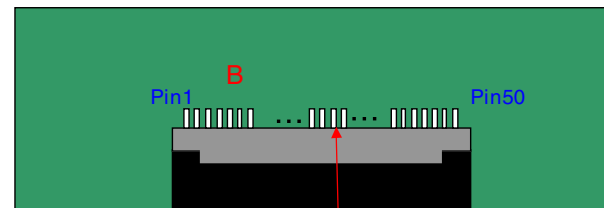

Pin33: ROT0
Pin34: ROT1

KEY (Rotary) signal from KEY BD to LCD BD (Pulse waveform)
KEY (Rotary) signal from KEY BD to LCD BD (Pulse waveform)

Case 5 Audio (NAVI SOURCE) or Guide voice (BEEP sound) is NG.

A

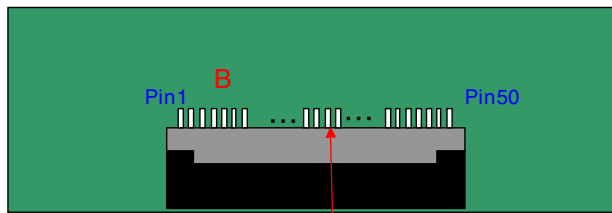

- Pin19: GUI_P Guidance or BEEP sound
- Pin28: NAVI L Audio Lch
- Pin30: NAVI R Audio Rch
- Pin29,31: GND

B

C

D

E

F

6. SERVICE MODE

6.1 TEST MODE

Jig No : GGV1322

1. Test mode menu selection method

The main keyboard cannot be used for this operation.
Double-click the touch panel directly.

2. Test mode activation method

1. Copy a "TestMode" folder under "TestMode" folder on GGV1322 to a SD card.
Note: "TestMode" folder must be on the SD card root.
2. Download a ID file from the Service Site and copy the file to the "TestMode" folder on the SD card.
3. Insert the SD card into the main unit.
4. Turn ACC ON.
5. The test mode menu is displayed.

<< Enter the test mode in the set procedure. >>

Start screen

When the set procedure is followed (Procedure OK)

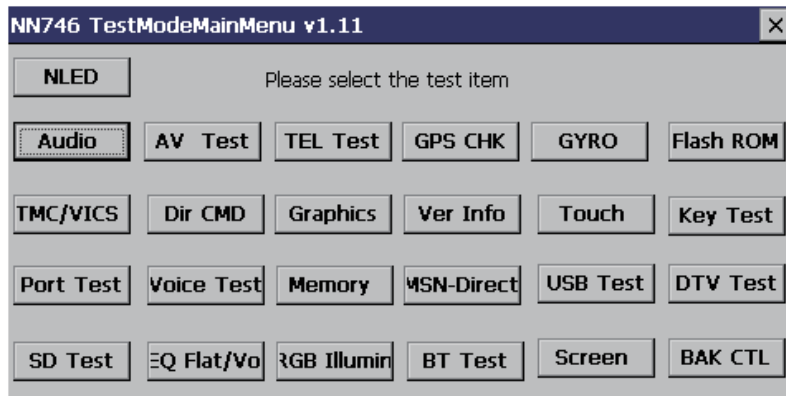

3. Test mode menu

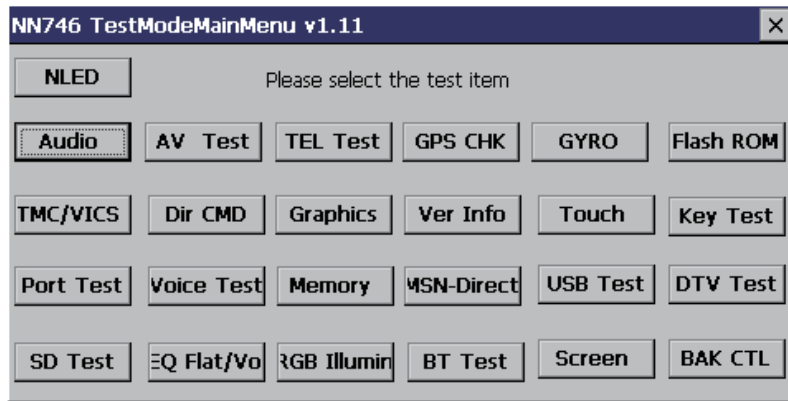

No.	Test Item	Test Content
1	Audio	Playback of audio
2	AV Test	Not for service
3	TEL Test	Not for service
4	GPS CHK	GPS receiver test
5	GYRO	Gyro test
6	Flash ROM	Flash ROM read/write test
7	TMC/VICS	FM multiplex error test
8	Dir CMD	Not for service
9	Graphics	Graphics test
10	Ver Info	Display version information of software, mecha, and microcomputers.
11	Touch	Correction and test of Touch Panel
12	Key Test	Not for service
13	Port Test	Display states such as parking and reverse.
14	Voice Test	Not for service
15	Memory	Not for service
16	MSN-Direct	Not for service
17	USB Test	Not for service
18	DTV Test	Not for service
19	SD Test	SD card test
20	EQ Flat/Vo	Not for service
21	RGB Illumin	Not for service
22	BT Test	Not for service
23	Screen	Not for service
24	BAK CTL	Not for service

Audio Test Screen

Audio Test Mode

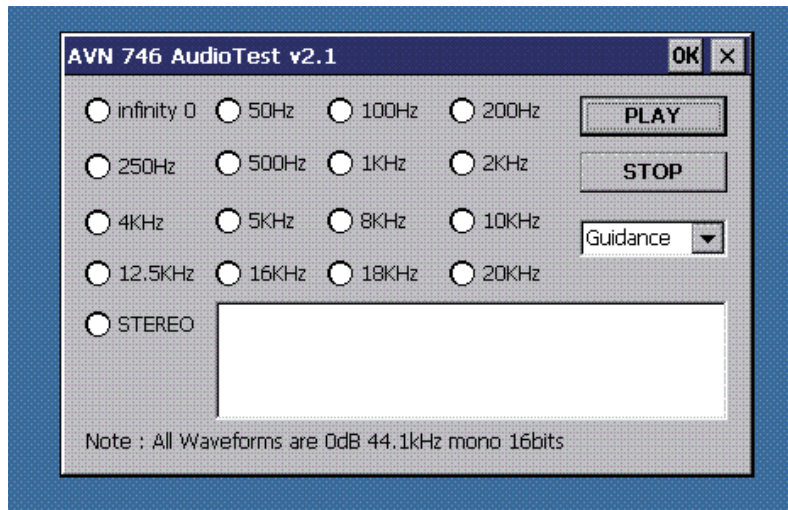

<< Key Operation >>

[Play] ... Play

[Stop] ... Stop

[Guidance] ... Output of guidance

[Stereo] ... Output of stereo

[OK] ... Terminate Audio Test.

Note : Big sound (0 dB signal) is output

Gps Viewer Execution Screen

Starttest

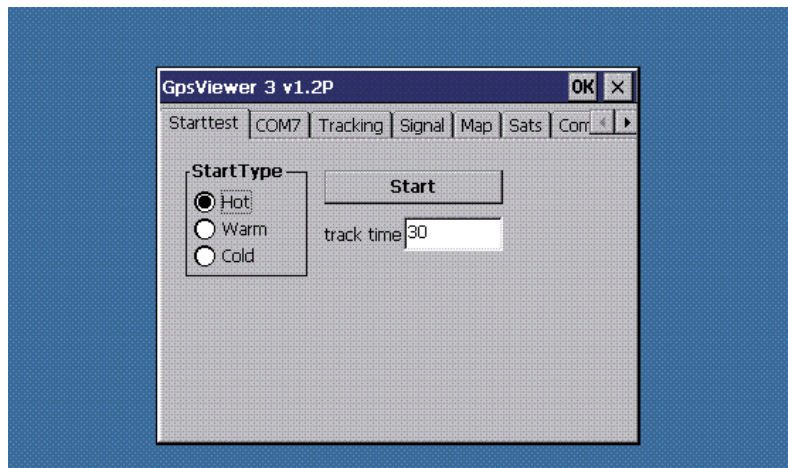

<< Operation method >>

1. Select 'Start Type'. Normally, 'Hot'.

2. Press 'Start' to start the test.

Tracking

A

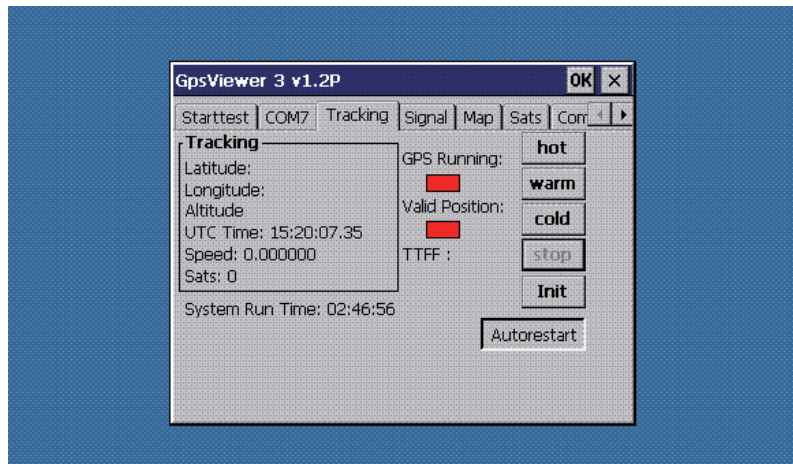

B

<< Operation method >>

1. When GPS Running is red, press 'hot'.

C



D

<< Operation method >>

1. When GPS Running is green, the test is started.
2. When Valid Position is green, the measurement is successfully conducted.

Signal

E

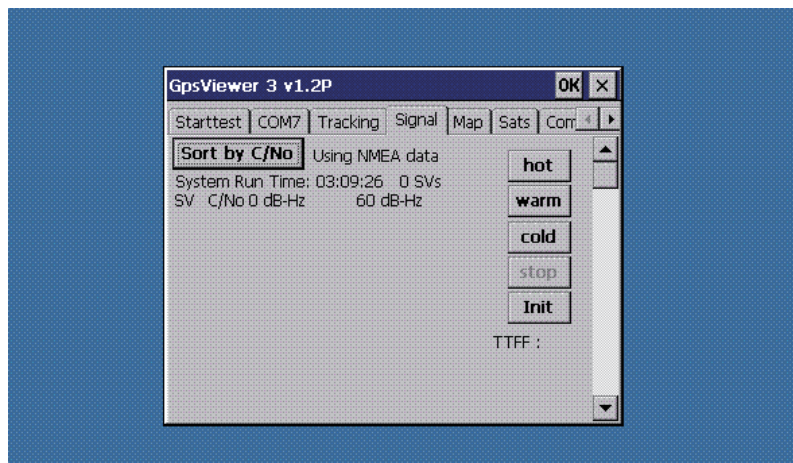

F

<< Operation method >>

1. The screen will be in this state if the test is not started.
2. To start the test, press 'hot'.

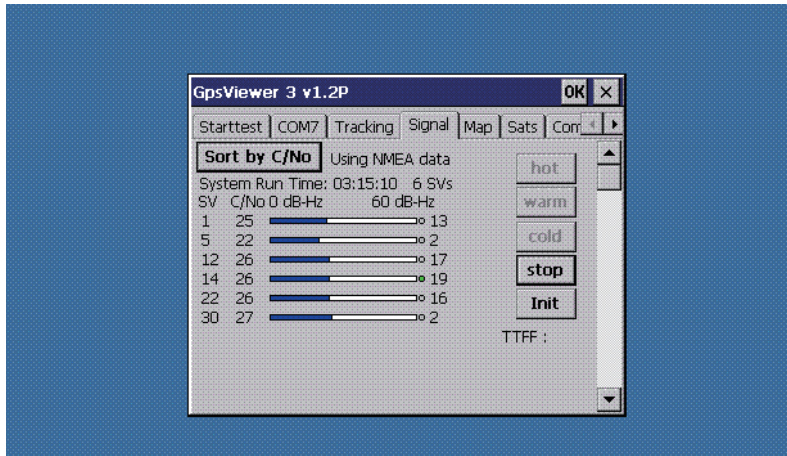

<< Operation method >>

1. The screen will be in this state if the test starts.
2. When the blue color bar appears, GPS signal is locked.

Sats

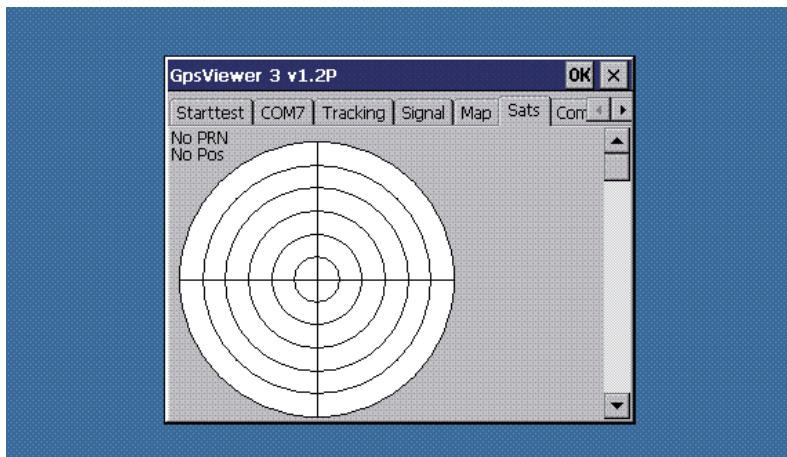

<< Operation method >>

1. The screen will be in this state if the test is not started.
2. To start the test, refer to 'Start test' tab.

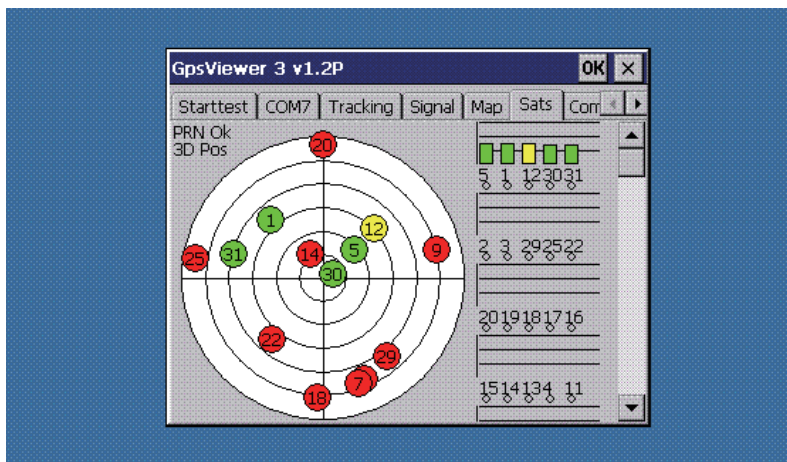

<< Operation method >>

1. When the test starts and a satellite is started to be acquired, the screen will be in this state. Red ... Not acquired. Yellow ... Already acquired. Green ... Acquired and data obtained.

TestGyro Screen

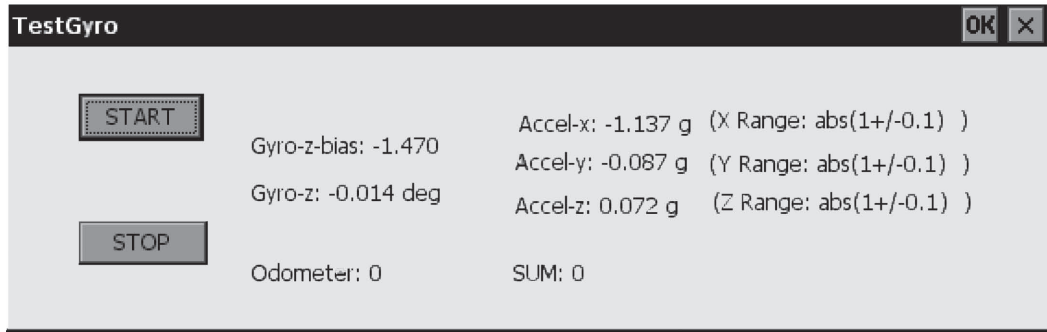

• Gyro-z-bias test

1. Press "Start" and wait 2 seconds, then the "Gyro-z-bias" result will be displayed. The result should be within the range between - 2 and 2 degrees.

• Gyro-z test

1. Rotate the unit 360 degrees. (or 180 degrees)
The "Gyro-z" result should be within the range of 360 +/- 14.4 degrees. (or 180 +/- 7.2 degrees)
2. Press "Stop" and then press "Start" again.
3. Rotate the unit -360 degrees. (or 180 degrees)
The "Gyro-z" result should be within the range of -360 +/- 14.4 degrees. (or 180 +/- 7.2 degrees)

• Accelerometer Testing

1. Set the unit "Face Down" position to +1 g (pointing up). You will then get an "Accel-x" result
2. Set the unit "Face Up" position to -1 g (pointing up). You will then get an "Accel-x" result
3. Calculate the difference of the two results. The difference should be within the range of 2 +/- 0.1 g.
For example, the result of step 1 is "1.045 g" and step 2 is "-0.902 g", the difference is 1.045+0.902=1.947 g.
4. Set the unit "Right side up" position to +1 g (pointing up). You will get an "Accel-y" result.
5. Set the unit "Right side down" position to -1 g (pointing up). You will get an "Accel-y" result.
6. Calculate the difference of the two results. The difference should be within the range of 2 +/- 0.2 g.
7. Set the unit "Up side down" position to +1 g (pointing up). You will get an "Accel-z" result.
8. Set the unit "Normal" position to -1 g (pointing up). You will get an "Accel-z" result.
9. Calculate the difference of the two results. The difference should be within the range of 2 +/- 0.2 g.

NAND Flash test mode start screen

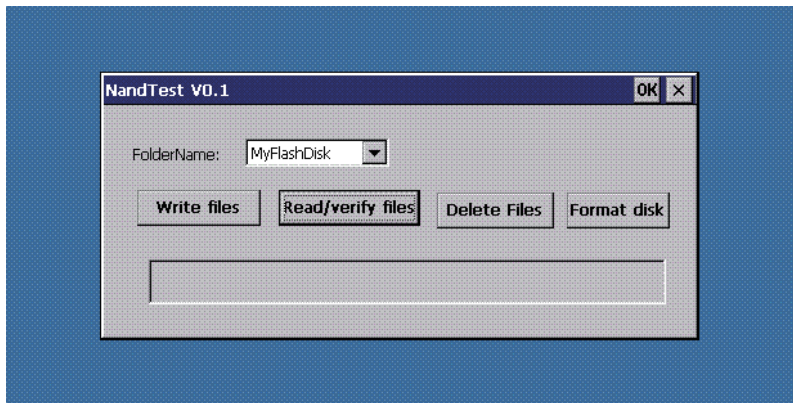

Write files	Conduct a write test to NAND Flash disc.
Read/verify files	Conduct a read test to NAND Flash disc. Notes) It will take time by test completion.
Delete Files	Conduct a deletion test to NAND Flash disc.
Format disc	Conduct a formatting test to NAND Flash disc. Notes) After performing "Format disc", all data is deleted include APL and MAP data.

TMC measurement selection screen

GpsTmcDemo

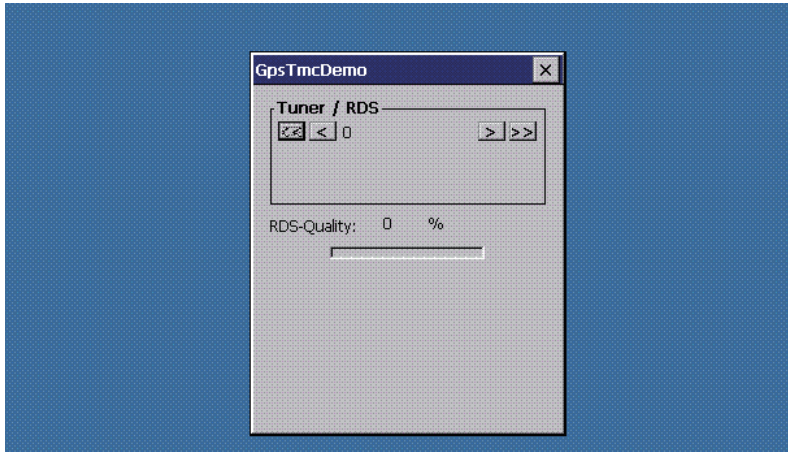

<< Test Content >>

The TMC error rate can be measured.

The frequency can be changed by tapping '<' or '>'.

The test can be terminated by tapping the left 'x' mark.

Graphics Test start screen

Start screen

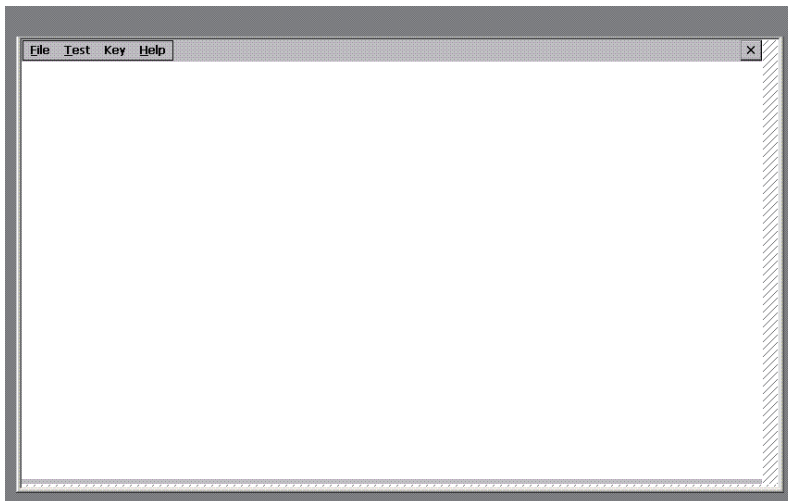

<< Operation method >>

1. The screen will be in this state after started.

2. Press 'Test' to start the test.

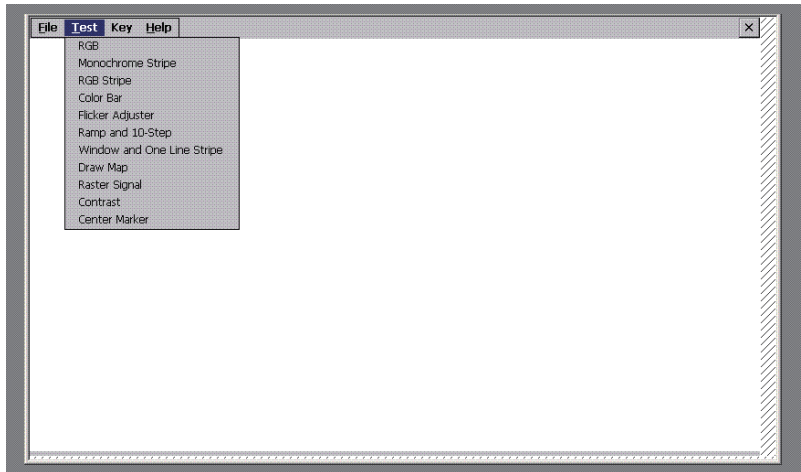

<< Operation method >>

- 1. The menu appears when 'Test' is pressed. Select the item to test.

<< Operation method >>

- 1. To terminate the test, press 'File' and then 'Exit'.

Version Information screen

Start screen

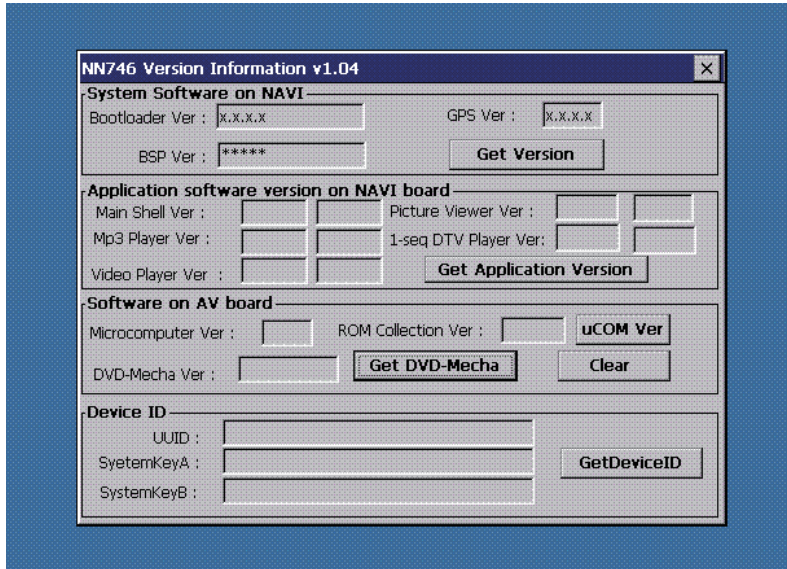

<< Key operation >>

[Get Version] ... Display the version of Bootloader, GPS, and BSP.

[Get Application Version] ... Display the version of each application.

[uCOM Ver] ... Display the microcomputer version and ROM Collection version.

[Get DVD-Mecha] ... Display the DVD and CD mecha version.

[Clear] ... Clear the display of the version of microcomputer, ROM, and mecha.

[GetDeviceID] ... Display the device ID.

Touch Panel Test screen

Start screen



<< Key operation >>

[Calibration] ... Conduct calibration.

[Touch panel test] ... Conduct touch panel test.

Calibration

A

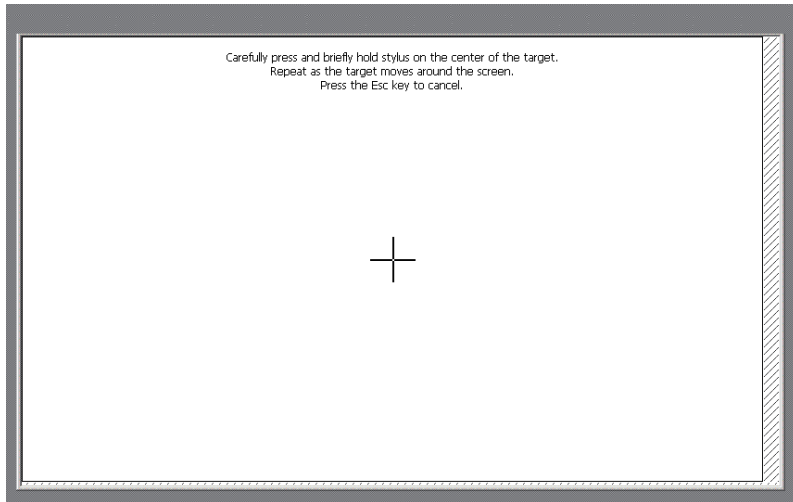

B

<< Key operation >>

Touch panel calibration can be conducted by tapping five '+' marks.

Touch Panel Test

C

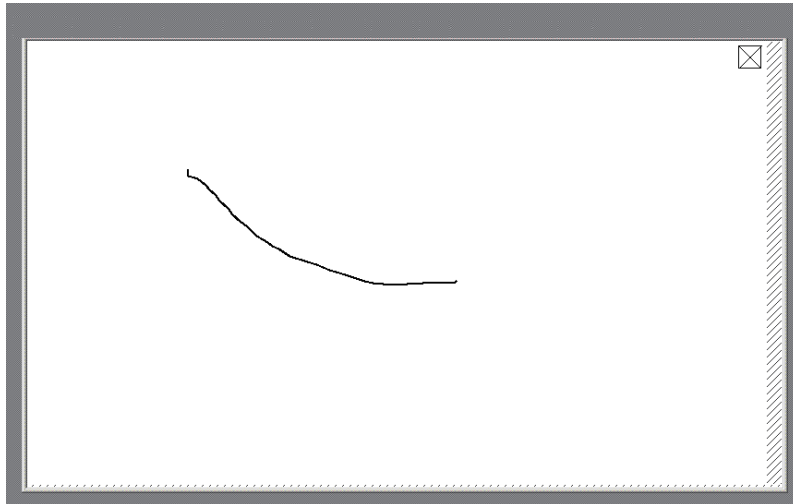

D

<< Key operation >>

A line appears when a line is drawn by a finger on the touch panel. The test can be terminated by pressing the top right 'x' mark.

E

F

Port Test screen

Start screen

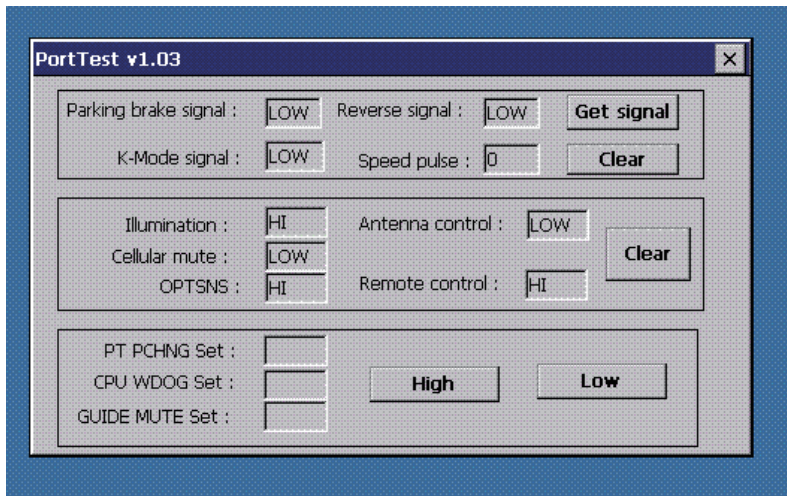

<< Key operation >>

[Get signal] ... Display the states of Parking brake, Reverse, K-Mode, and Speed Pulse. The states of Illumination, Cellular mute, OPTSNS, Antenna control, and Remote control are displayed automatically.

[Clear] ... Clear the display.

[High] ... Not for service

[Low] ... Not for service

SD Card Test screen

Start screen

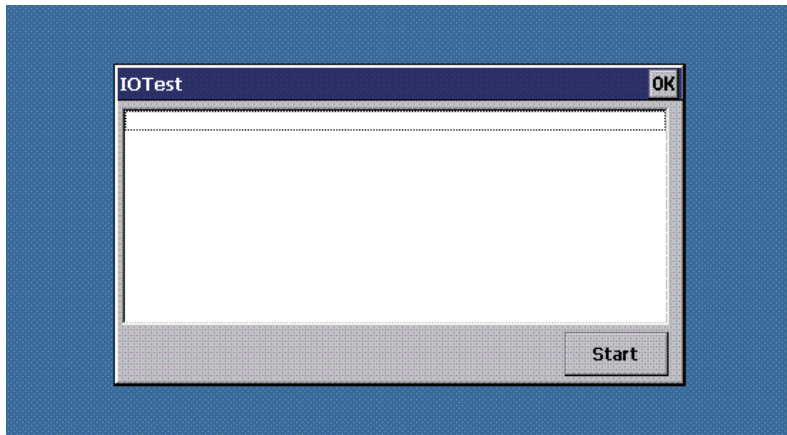

<< Key operation >>

[Start] ... Start the test.

Error screen

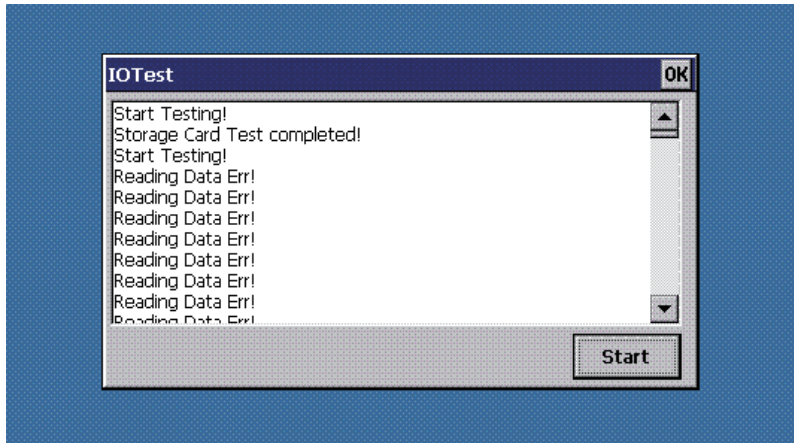

This is the state when an error occurred in the test.

6.2 DVD TEST MODE

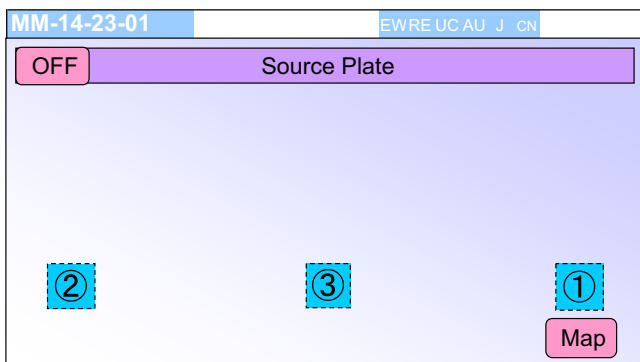

(1), (2) and (3) are invisible buttons

In this screen, press long the areas (1), (2) and (3) that display the test mode selection screen by implementing the operations below in order.

Detailed procedure

Step1 change the screen to source OFF screen

Step2 press the area of (1) long

Step3 press the area of (2) long

Step4 press the area of (3) long

* When the operation above is normally implemented, BEEP sound 1 is output.

③ If the operation is completed successfully, the screen shifts to test mode screen after (3) is pressed long

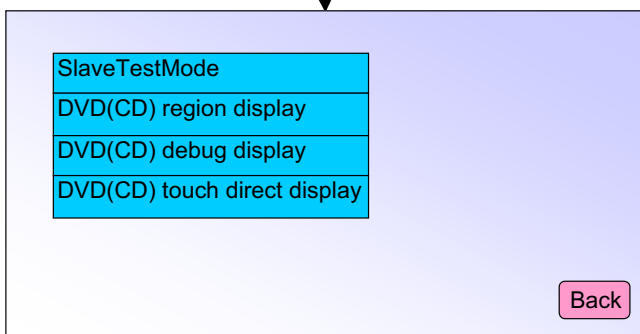

The test mode is released by ACC-OFF operation

Shift to selected test mode.

Image of the test mode.

A

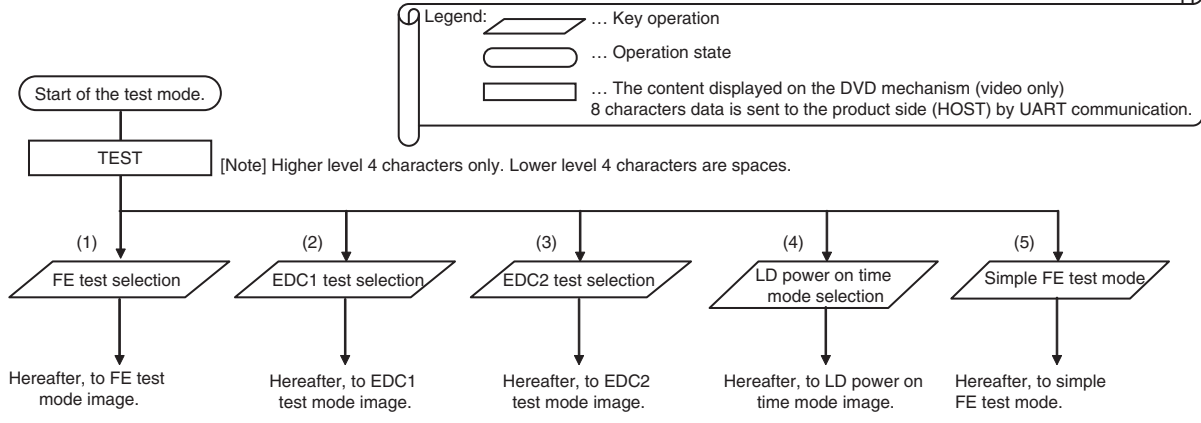

[Note] In order to move on to another test after selecting a test (FE/EDC1/EDC2), it is necessary to restart the DVD mechanism in the test mode.

Image of the front end test mode.

C

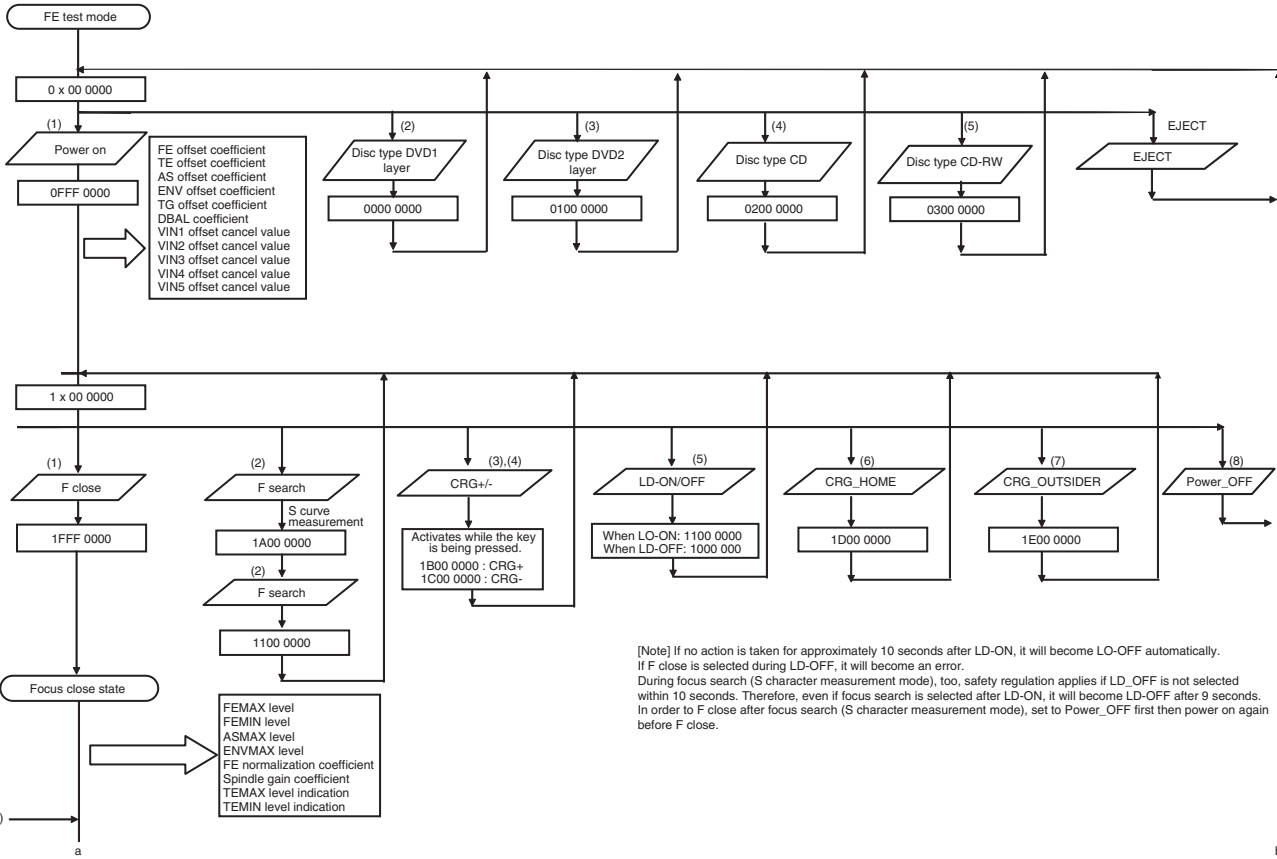
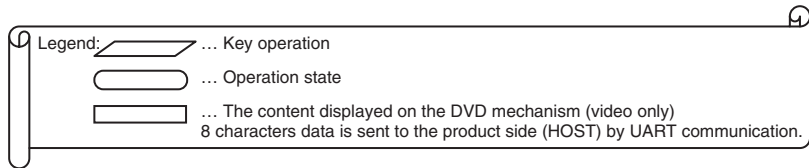

F

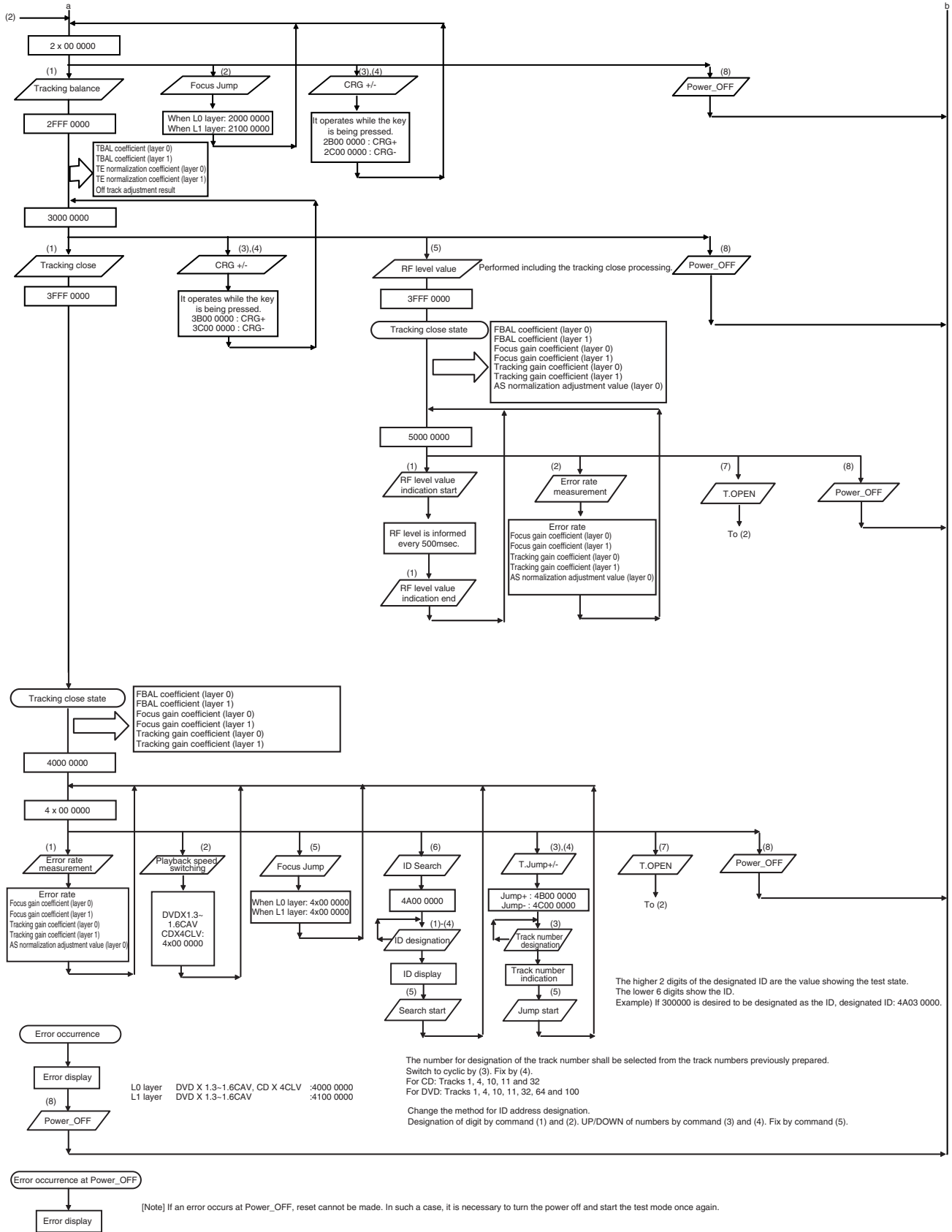

EDC. Image of the test mode

Legend:

- ▭ ... Key operation
- ▭ ... Operational state
- ▭ ... The content displayed on the DVD mechanism (video only)
8 characters data is sent to the product side (HOST) by UART communication.

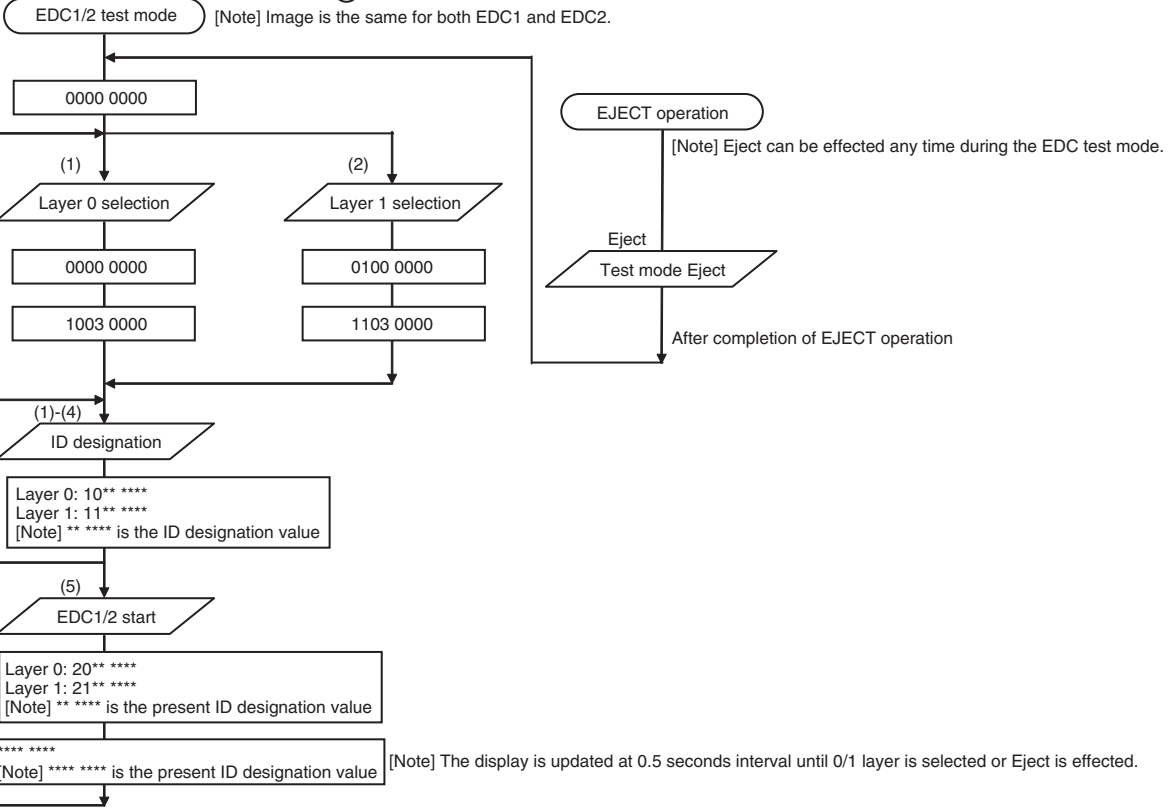
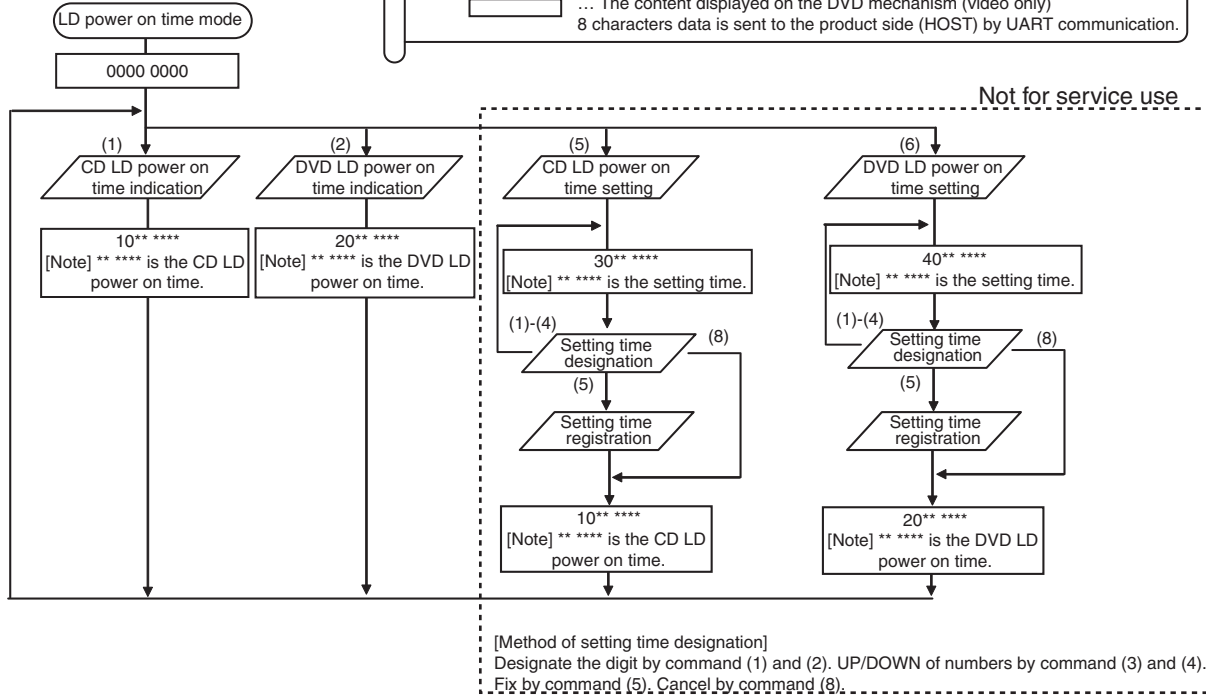

Image of the LD power on time mode.

Legend:

- ▭ ... Key operation
- ▭ ... Operational state
- ▭ ... The content displayed on the DVD mechanism (video only)
8 characters data is sent to the product side (HOST) by UART communication.



[Note] If the power on time is 999999 hours or more, it is always reported as 999999 hours.
 [Note] If the power on time is "E*****", the value may not be correct due to the life of the flash memory.

Simple test mode

The selection of the figure of each screen can be selected by "Key command for the test".
To display following screen, connect the "COMPOSITE" and "GND" line of the LS1 mecha module to a monitor.

Side A

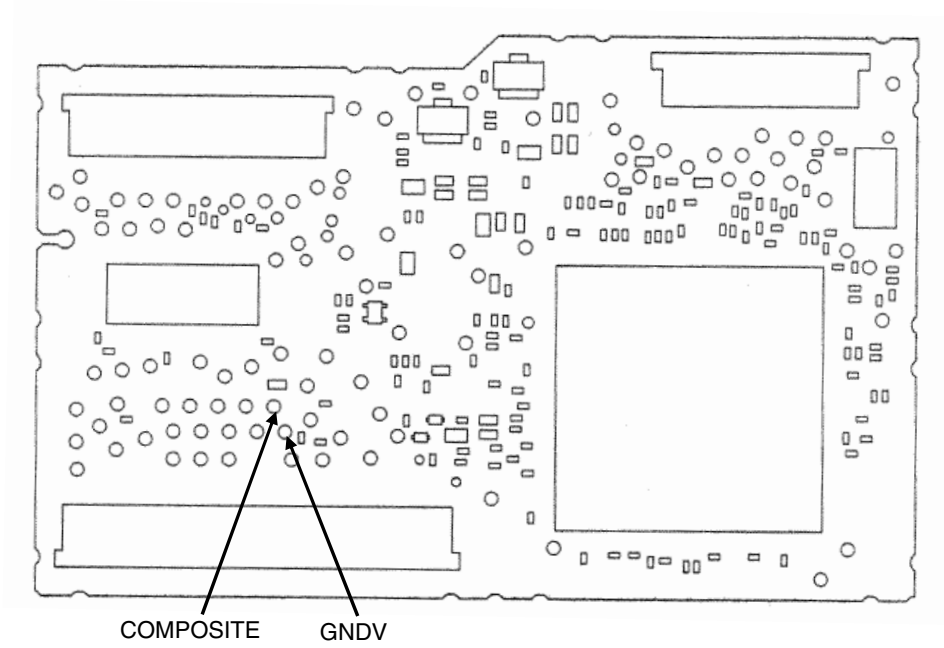

<Flow chart>

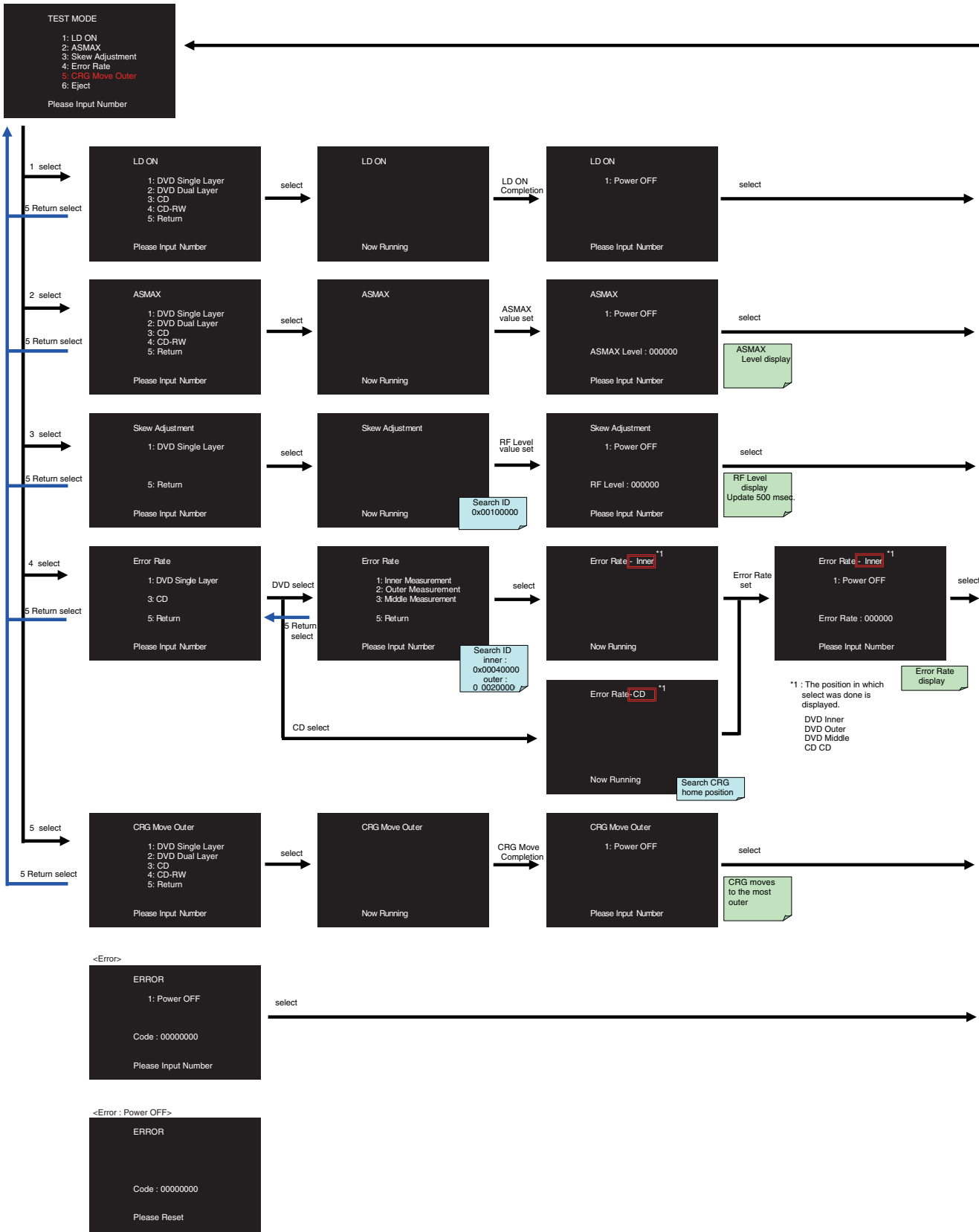

6.3 uBOOT MENU

UBOOT Upgrade

1. Copy the Uboot files named as "uboot.bin" and "uboot.cks" to the SD/MMC card
2. Inset SD/MMC card to the Main Unit at first, then enter the Uboot interface.
3. Select ""3=UBOOT Upgrade" item in Uboot menu, then select ""1=UBOOT by SD/MMC" item in "UBOOT Upgrade" menu and execute.

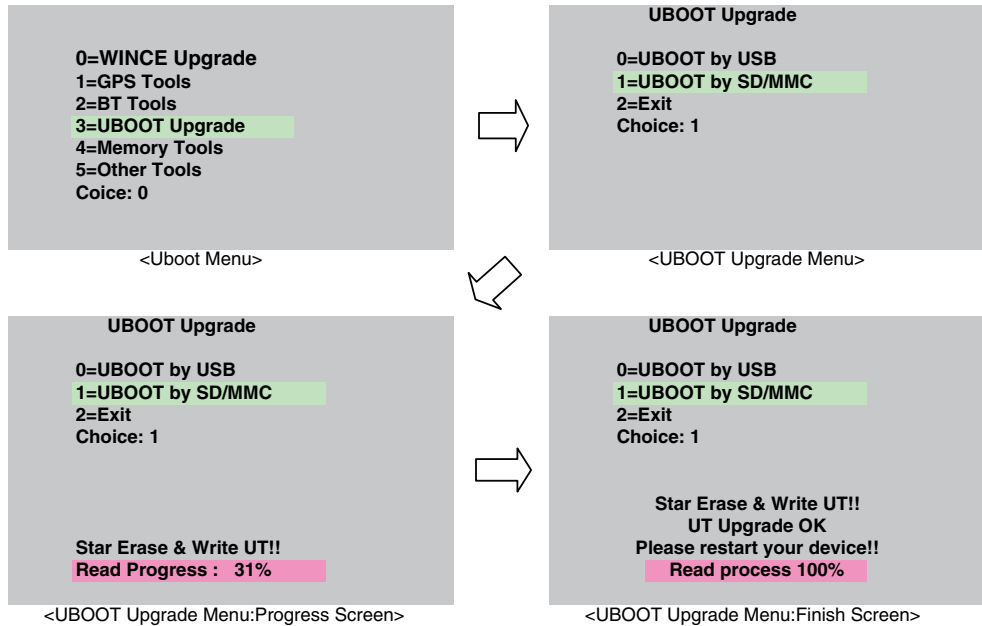

4. After the menu of "UBOOT Upgrade" show "UT Upgrade OK", restart the device.

WINCE Image Upgrade

1. Copy the image files named as "winceimg.bin" and "winceimg.cks" to the SD/MMC card.
2. Inset SD/MMC card to the Main Unit at first, then enter the Uboot interface.
3. Select "0=WINCE Upgrade" item in Uboot menu, then select "1=WINCE bySD/MMC" item in "WINCE Upgrade" menu and execute.

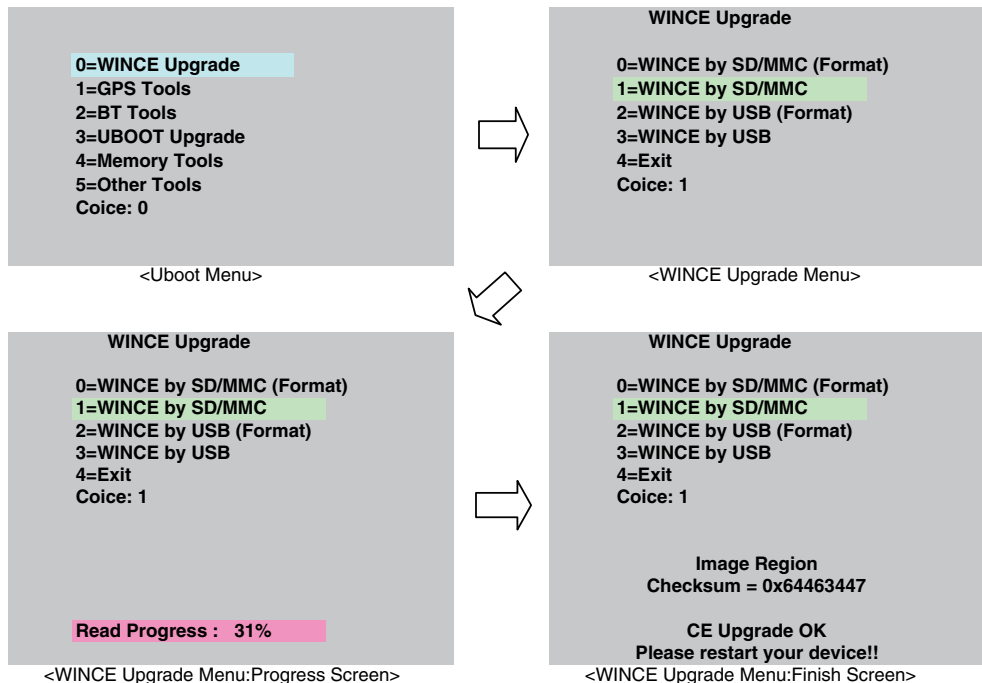

4. After the menu of "WINCE Upgrade" show "CE Upgrade OK", restart the device.

6.4 USING THE TEST DISC

Jig No : GGV1322

Test Disc 1 Start Screen Specification

Test Disc 1 Start

1. Copy all files under "Test Disc1" folder on GGV1322 to a SD card.
2. Download a ID file from the Service Site and copy the file to the SD card.
3. Insert the SD card into the Main Unit and turn ACC OFF ON. Then, the test disc starts.

The test can be terminated by turning ACC OFF. After turning ACC OFF, remove the SD card.

Test Disc 1 Start Screen

Version Check



<< Operation method >>

1. This screen appears when the Test Disc is activated.
 2. When 'Version' is tapped, the test starts.
- If the "Reality" corresponds to "Plan", the result becomes "OK".

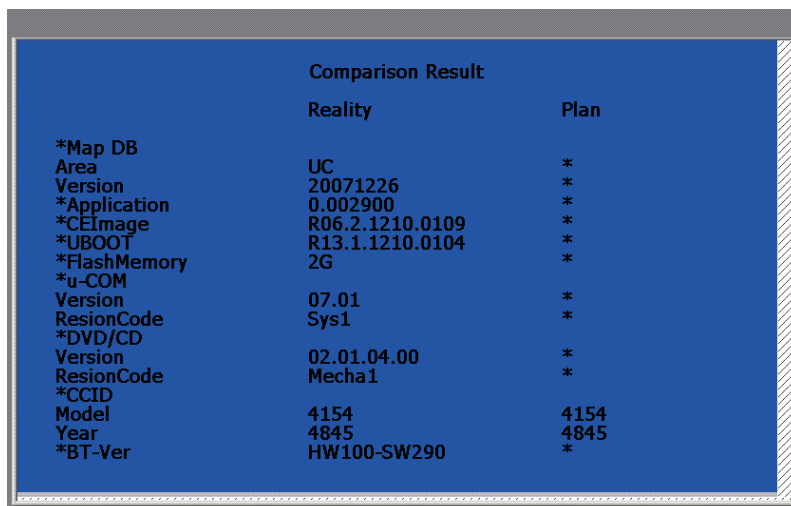

	Reality	Plan
*Map DB		
Area	UC	*
Version	20071226	*
*Application	0.002900	*
*CEImage	R06.2.1210.0109	*
*UBOOT	R13.1.1210.0104	*
*FlashMemory	2G	*
*u-COM		
Version	07.01	*
ResionCode	Sys1	*
*DVD/CD		
Version	02.01.04.00	*
ResionCode	Mecha1	*
*CCID		
Model	4154	4154
Year	4845	4845
*BT-Ver	HW100-SW290	*

<< Operation method >>

If the test result is "OK", the blue screen is displayed.
"Reality" is each version on actual machine and the "Plan" is the version information described in "Information.txt" of SD card.

Comparison Result		
	Reality	Plan
*Map DB		
Area	UC	EW
Version	20071226	*
*Application	0.002900	*
*CEImage	R06.2.1210.0109	*
*UBOOT	R13.1.1210.0104	*
*FlashMemory	2G	*
*u-COM		
Version	07.01	*
ResionCode	Sys1	*
*DVD/CD		
Version	02.01.04.00	*
ResionCode	Mecha1	*
*CCID		
Model	4154	4154
Year	4845	4845
*BT-Ver	HW100-SW290	*

<< Operation method >>

If the test result is "NG", the red screen is displayed.

MIC Test

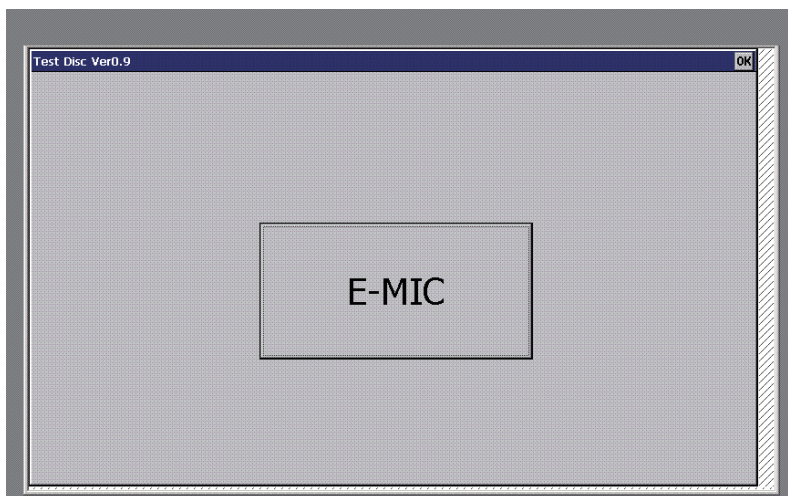

<< Operation method >>

1. This screen appears when the Test Disc is activated.
2. Tap 'E-MIC' to start the test.

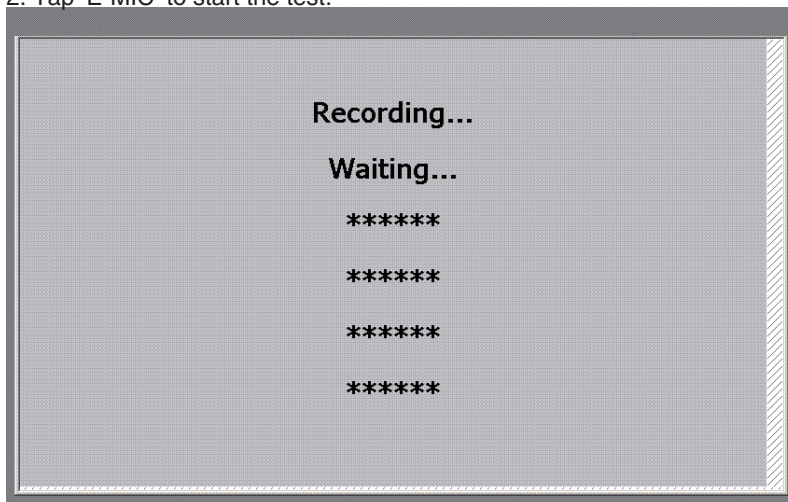

<< Operation method >>

1. This screen appears when the test is started.
2. Put a sound into the microphone while this screen is shown. The sound is recorded.

A

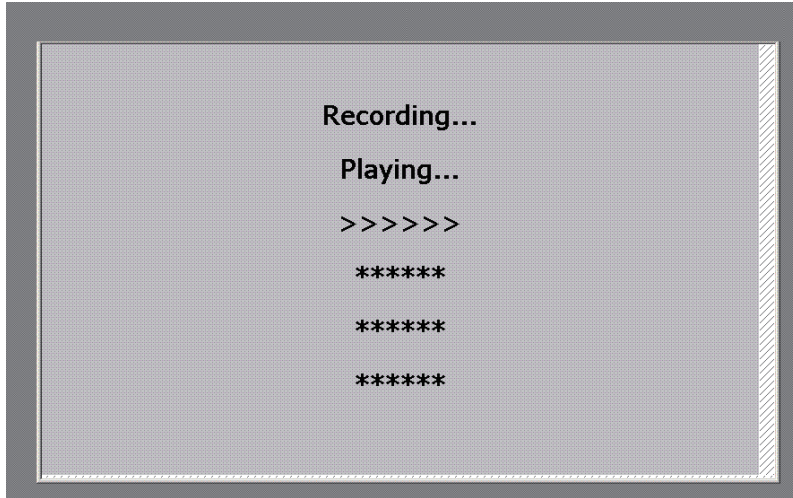

B

<< Operation method >>

- 1. When this screen appears, the recorded sound is played 'loudly'.
- Notes) The sound volume cannot be adjusted.

C



D

<< Operation method >>

- 1. When this screen appears, the recorded sound is played 'quietly'.
- Notes) The sound volume cannot be adjusted.

E



F

<< Operation method >>

- 1. When this screen appears, the recorded sound is muted.
- Notes) The sound volume cannot be adjusted.

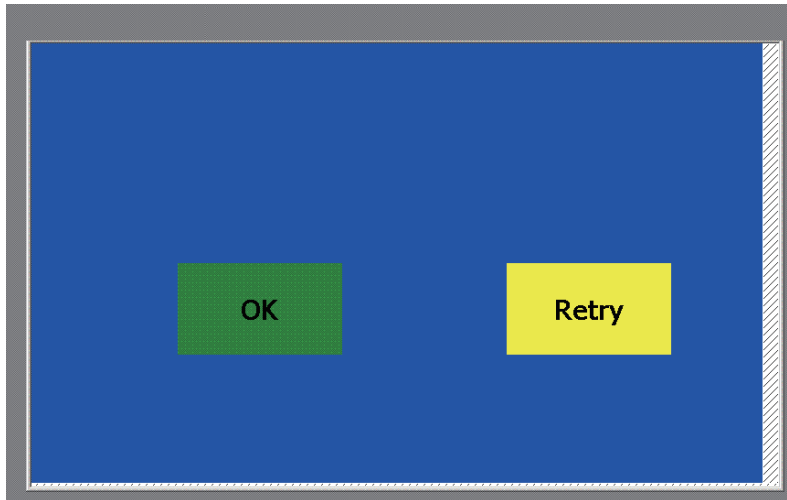

<< Operation method >>

1. When the test finishes, this screen appears.
2. To proceed to the next test, tap 'OK'. To conduct MIC Test again, tap 'Retry'.

GPS Test



<< Operation method>>

1. This screen appears when the Test Disc is activated. If you tap "GPS_TTFF", the test is started.

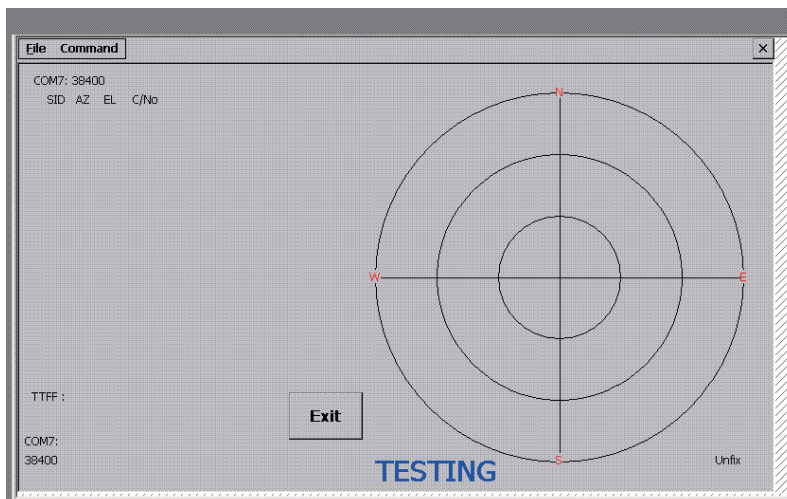

<< Operation method >>

1. When the test is started, this screen is displayed. When you terminate the test in the way, tap the "Exit".

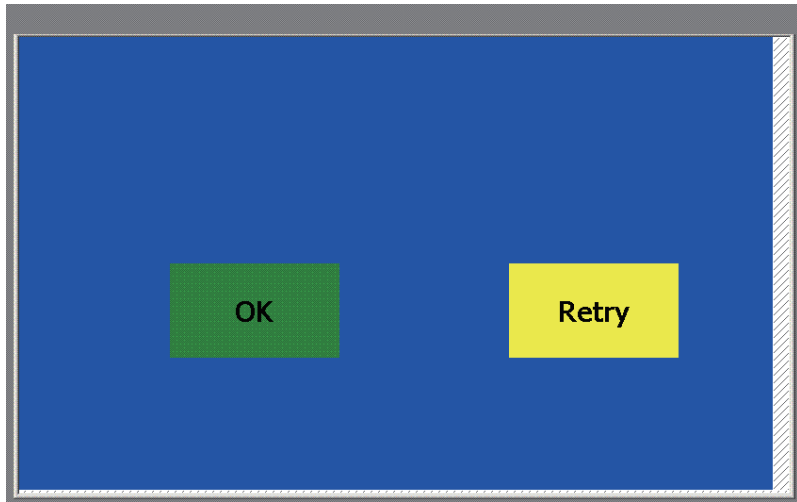

<< Operation method >>

When the positioning is terminated within one minute, the test is completed successfully, and this screen is displayed.

If you implement the test again, tap the "Retry".

If you go to next step, tap "OK".

A

B

C

D

E

F

Jig No : GGV1322

Test Disc 2 Start Screen Specification

Test Disc 2 Start

1. Copy all files under "Test Disc 2" folder on GGV1322 to a SD card.
2. Download a ID file from the Service Site and copy the file to the SD card.
3. Insert the SD card into the Main Unit and turn ACC OFF ON. Then, the test disc starts.

The test can be terminated by turning ACC OFF. After turning ACC OFF, remove the SD card.

Test Disc 2 Start Screen

The user data is deleted

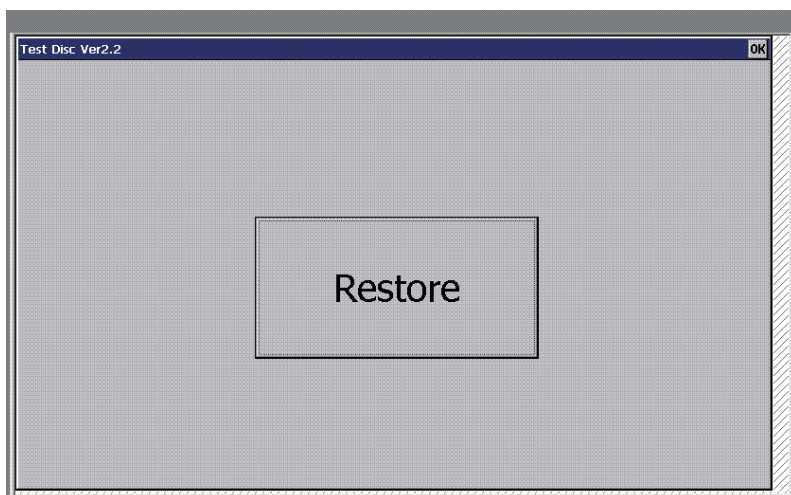

<< Operation method >>

1. This screen appears when the Test Disc is activated.
2. If you tap the "Restore", the user data is deleted.

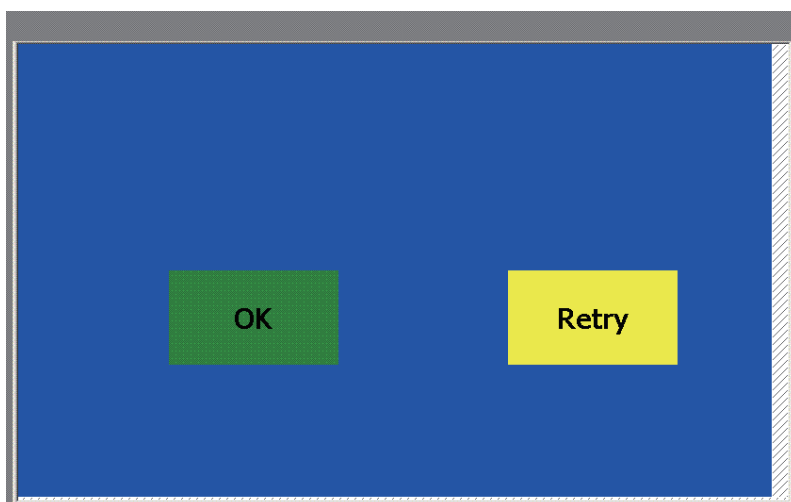

<< Operation method >>

If the deletion is terminated, this screen is displayed.

Notes:) "Splash screen setting" is not back to default after performing this function.
Please set the "Splash screen setting", before performing this function.

7. DISASSEMBLY

NOTE) While the photograph shown is slightly different from this model in shape, the disassembly procedure is the same.

● Removing the Case (Fig.1)

- 1 Remove the two screws and then remove the Case.

Note)
To remove the screws, use jig No. GGK1068.

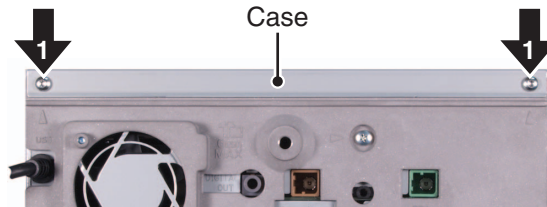
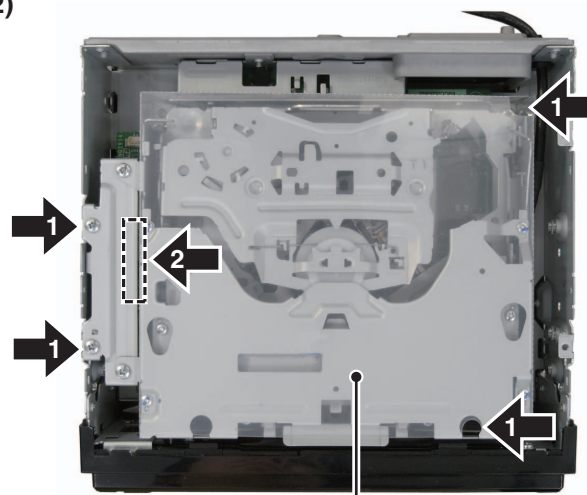

Fig.1

● Removing the DVD Mechanism Module (Fig.2)

- 1 Remove the four screws.
- 2 Disconnect the connector and then remove the DVD Mechanism Module.



DVD Mechanism Module

Fig.2

When unplugging the cord assy, make sure to use jig GGF1539.
If the antenna cable is directly unplugged without using jig GGF1539, you might damage your fingertip or fingernail.

● How to Remove the Cord Assy

When unplugging cord assy, hook the point of jig GGF1539 on the lid of cord assy and vertically draw out along with the engagement axis of connector.

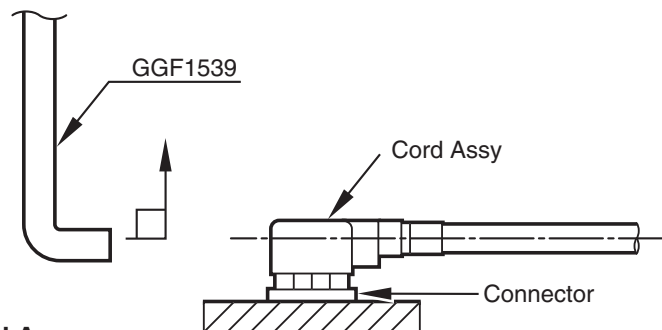

● How to Attach the Cord Assy

For inserting cord assy, adjust cord assy with the engagement axis of connector and insert it as vertically as possible.

Do not insert the cord assy in extreme slant, as the connector might suffer damage.

● Removing the Monitor Assy (Fig.3)

➔ 1 Peel off the Mylar tape.

➔ 2 Disconnect the FFC.

Attention when assembling:
Please fix the FFC (CDE9039) with the Mylar tape (GYH1031) as shown in figure.

➔ 3 Disconnect the Cord Assy using GGF1539.

➔ 4 Disconnect the FFC.

➔ 5 Remove the six screws.

➔ 6 Release the two latches and then remove the Monitor Assy.

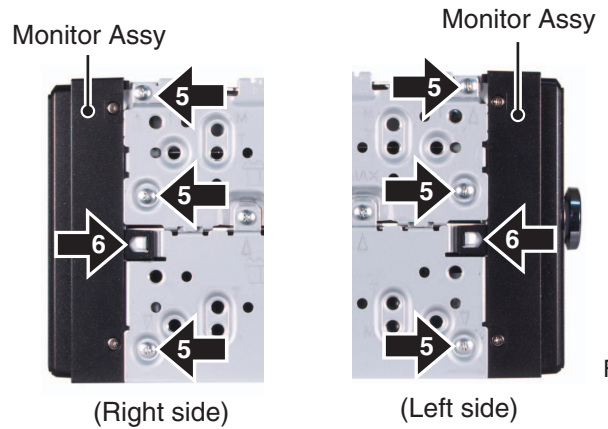
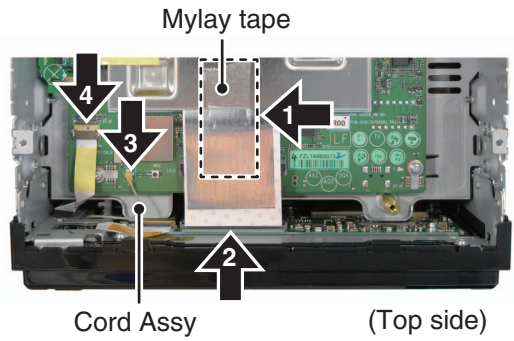

Fig.3

● Removing the Heat sink (Fig.4)

➔ 1 Disconnect the FAN Cord.

➔ 2 Remove the two screws.

➔ 3 Remove the seven screws and then remove the Heat sink.

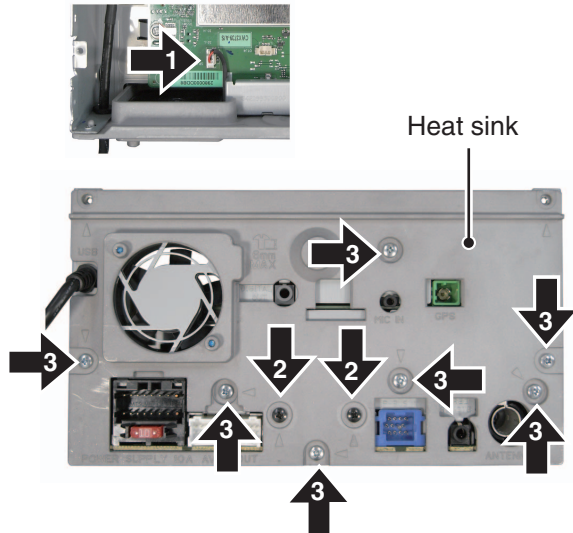

Fig.4

● Separating the upper and lower chassis. (Fig.5)

A **1** Peel off the Mylar tape.

2 Disconnect the FFC.

Attention when assembling:
Please fix the FFC (CDE8912) with the Mylar tape (GYH1031) as shown in figure.

3 Disconnect the Cord.

Attention when assembling:
The connector is inserted in the direction of figure.
The cable is not loosened and pushed below.

4 Remove the FFC.

5 Remove the three screws and then left the Chassis(Upper) from right side.

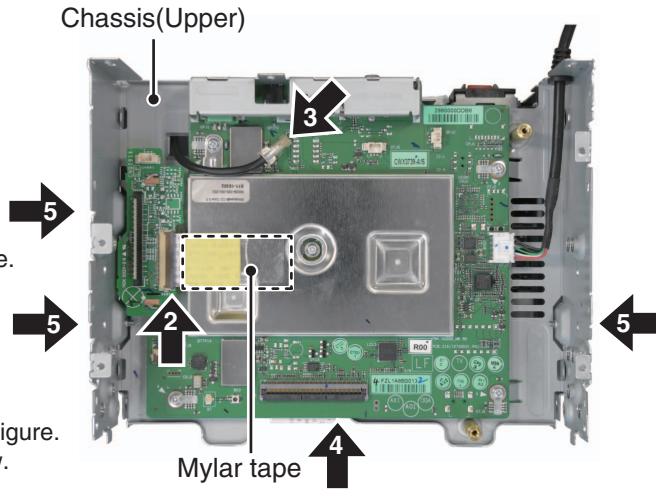

C **6** Disconnect the Cord Assy and then remove the Chassis(Upper).

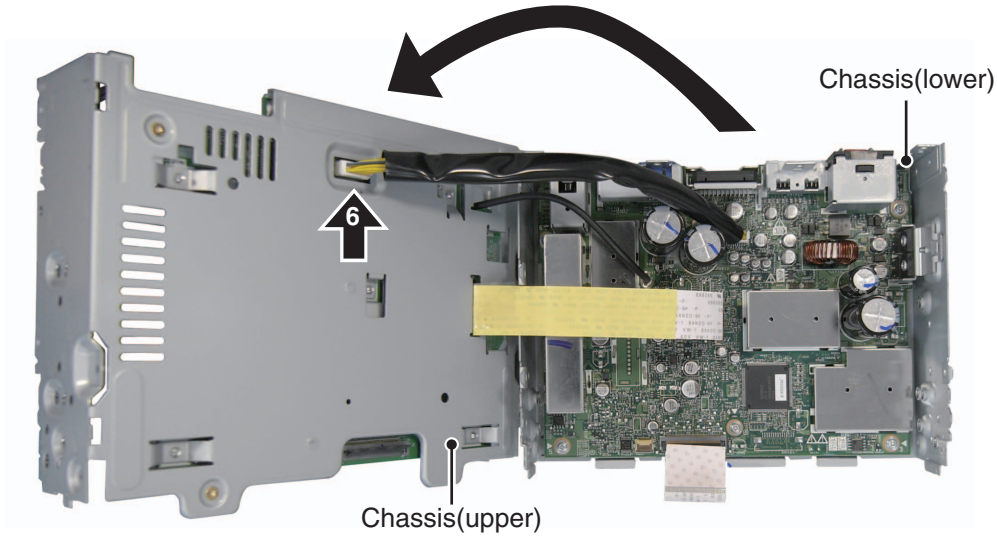

Fig.5

6 Disconnect the Cord Assy and then remove the Chassis(Upper).

● Removing the CK Unit and the Navi Unit (Fig.6)

- 1** Straighten the tabs at two locations indicated and then remove the CK Unit.
- 2** Disconnect the Cable.
- 3** Remove the five screws and then remove the Navi Unit.

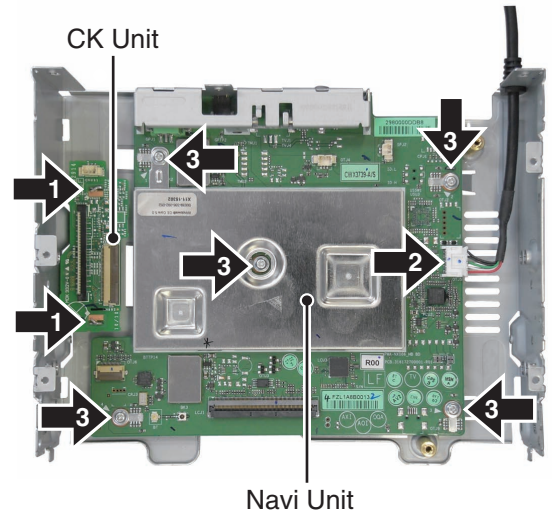

Fig.6

● Removing the AV Unit (Fig.7)

- 1** Remove the six screws.
- 2** Remove the screw and then remove the AV Unit.

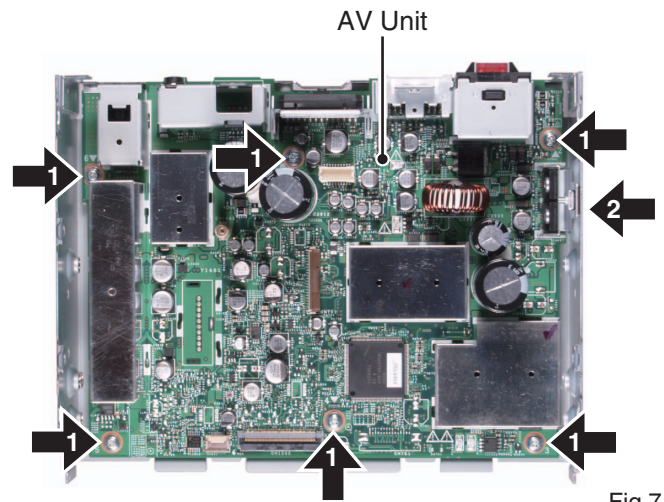

Fig.7

● Removing the SD Unit and LCD Module Assy (Fig.8)

- 1** Peel off the Insulator.
- 2** Disconnect the FFC.
- 3** Remove the screw and then remove the SD Unit.
- 4** Disconnect the two cables.
- 5** Remove the two screws and the Holder and Cover.
- 6** Remove the four screws.
- 7** Release the two latches using Tweezers.
- 8** Release the three latches and then remove the LCD Module Assy.

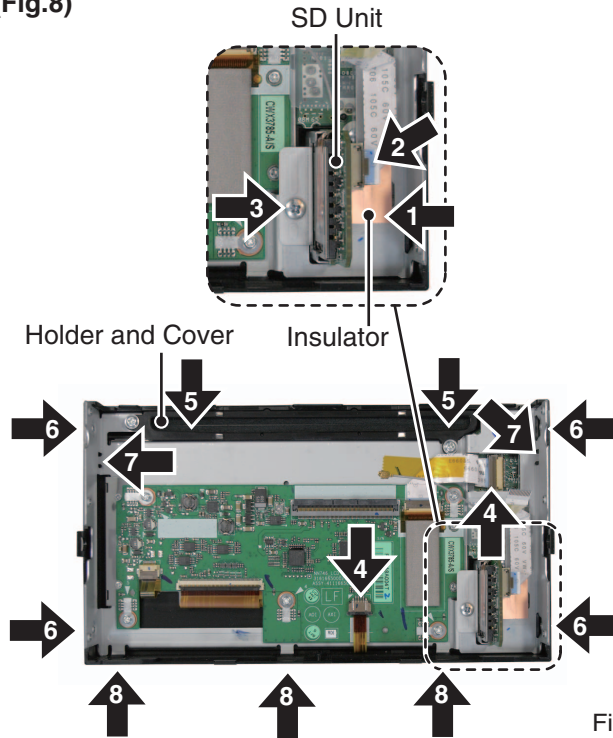

Fig.8

● Removing the Panel Unit (Fig.9)

- 1** Disconnect the three cables.
- 2** Remove the five screws and then remove the Panel Unit.

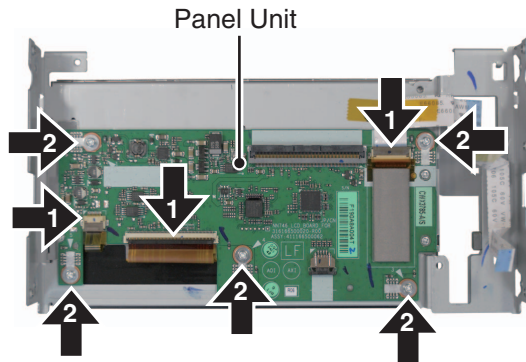

Fig.9

● Removing the Keyboard Unit (Fig.10)

- 1** Remove the four screws and then remove the Keyboard Unit.

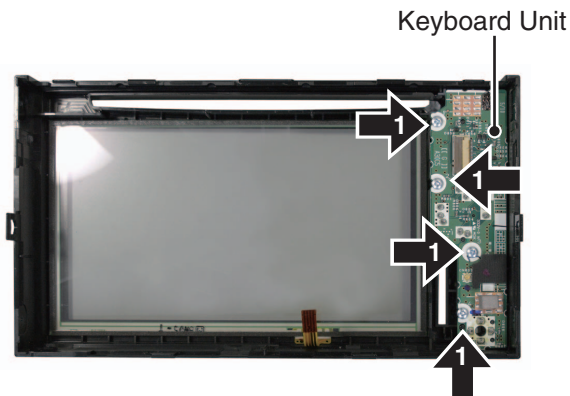
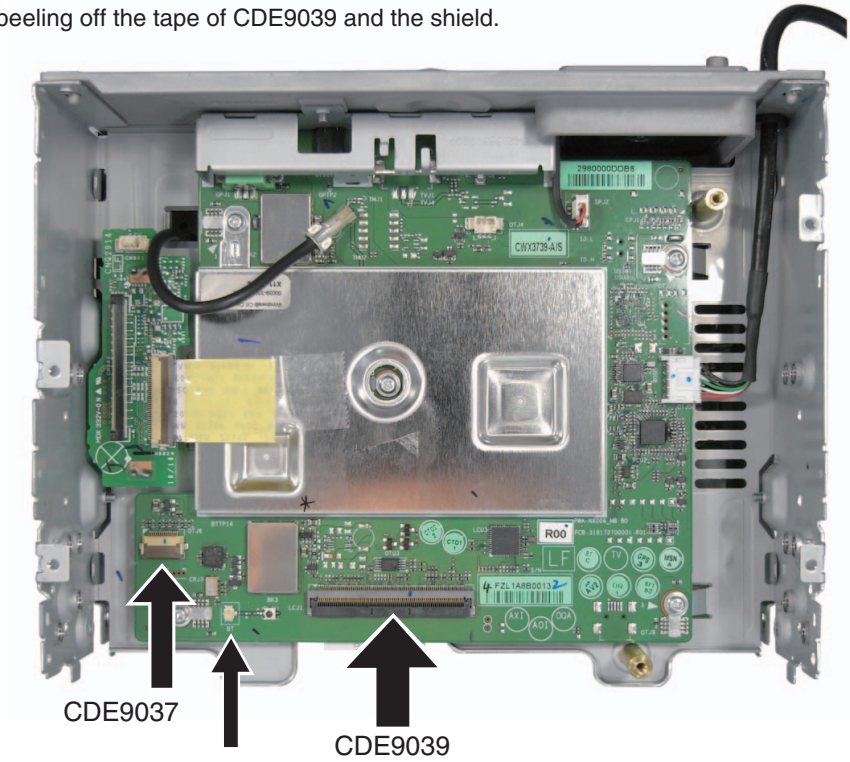

Fig.10

• Notes on disassembly

- When separating the MONITOR ASSY from the MAIN UNIT ASSY, do so slowly. Two FFCs (CDE9037, CDE9039) and one CODE ASSY (CDE8559) are connected. The strength of the joint part of the code and terminals of CDE8559 (CODE ASSY for Bluetooth to connect the keyboard unit and navi unit) is weak, it may break or the code may extend. Remove after peeling off the tape of CDE9039 and the shield.



★ Actually does the CODE ASSY (CDE8559) to a left connector of a round inclosing.

- When demounting LCD PANEL ASSY from the grille, be careful not to bend LCD plate (CND4319) as there are snap fits on the right and left. Demount LCD PANEL ASSY by extending snap fits on the grille side.

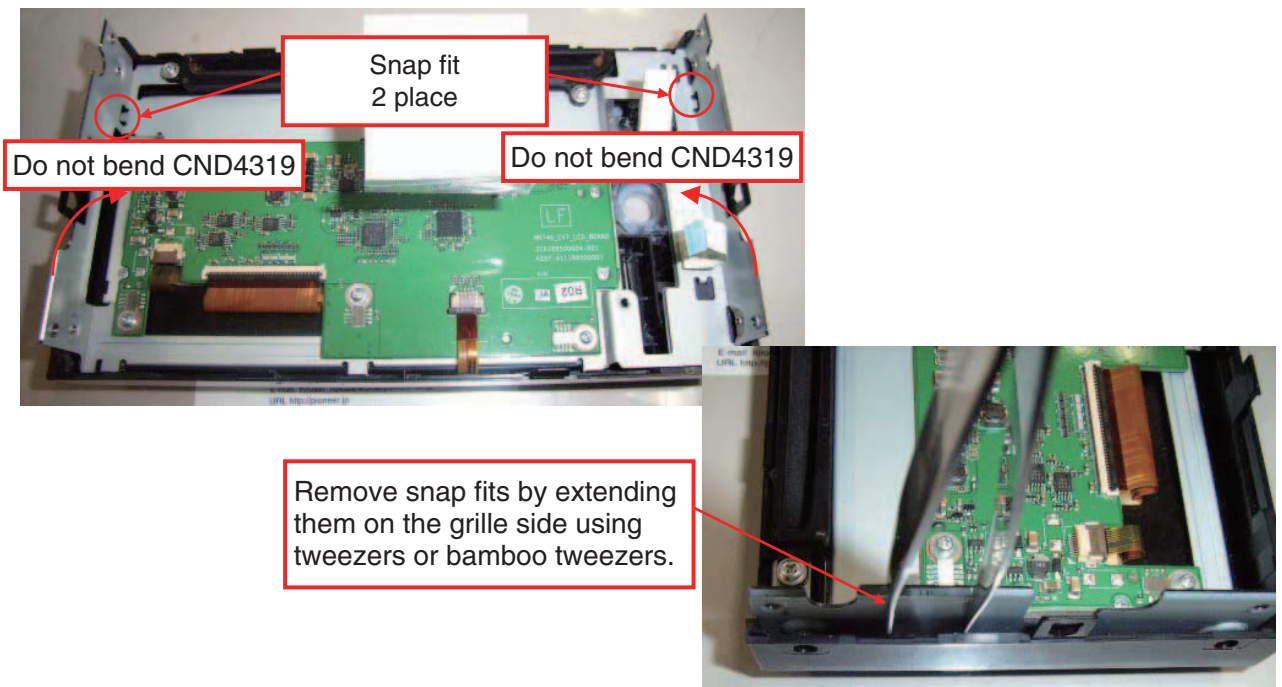

- Be sure to remove the MONITOR ASSY after removing the DVD mecha. If the procedure is done oppositely, the FFC (CDE9039) connecting the MONITOR ASSY and the MAIN UNIT ASSY will be damaged. At assembly, be sure to fix the MONITOR ASSY first and then fix the DVD mecha. If it is done oppositely, the FFC (CDE9039) cannot be folded as intended under the DVD mecha.



- When connecting the code assy connecting 1F AV UNIT and 2F NAVI UNIT (CDH1381) on NAVI UNIT side, do so as shown below.

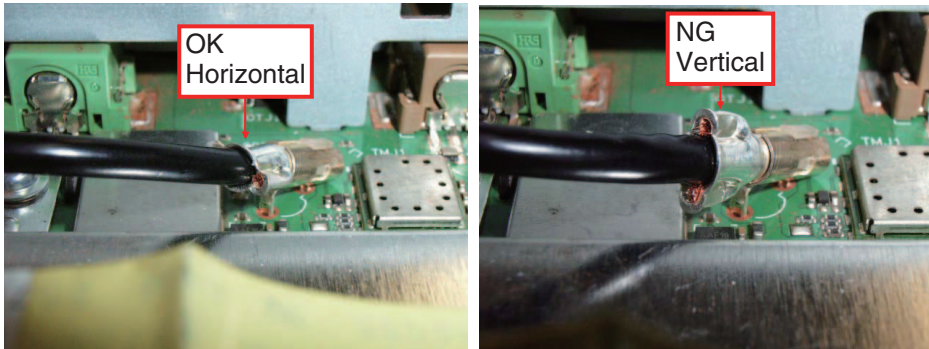

- The code assy connecting 1F AV UNIT and 2F NAVI UNIT (CDE8393) shall be fitted on the back side of the choke coil (CTH1347) after 1F Chassis Unit and 2F Chassis Unit are fixed, as shown below.

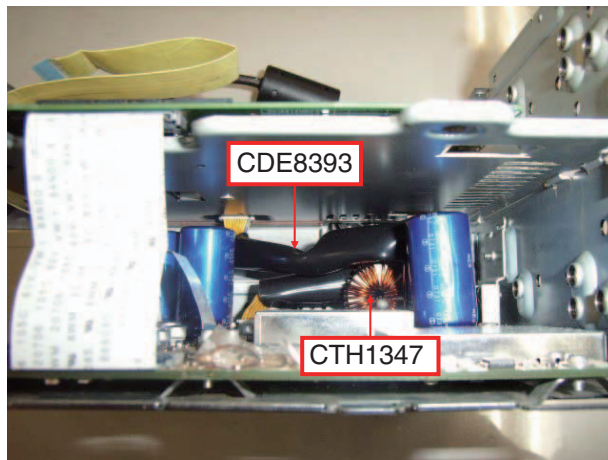

- When mounting KNOB ASSY (CXE1633) in the MONITOR ASSY, be careful to don't destroy encoder part.



- Since two case (CNB3472) fixing screws are 'TORX tamper' (tamper-proof screws with a projection in TORX), a special tool is required.
TORX screwdriver(T8) : GGK1068

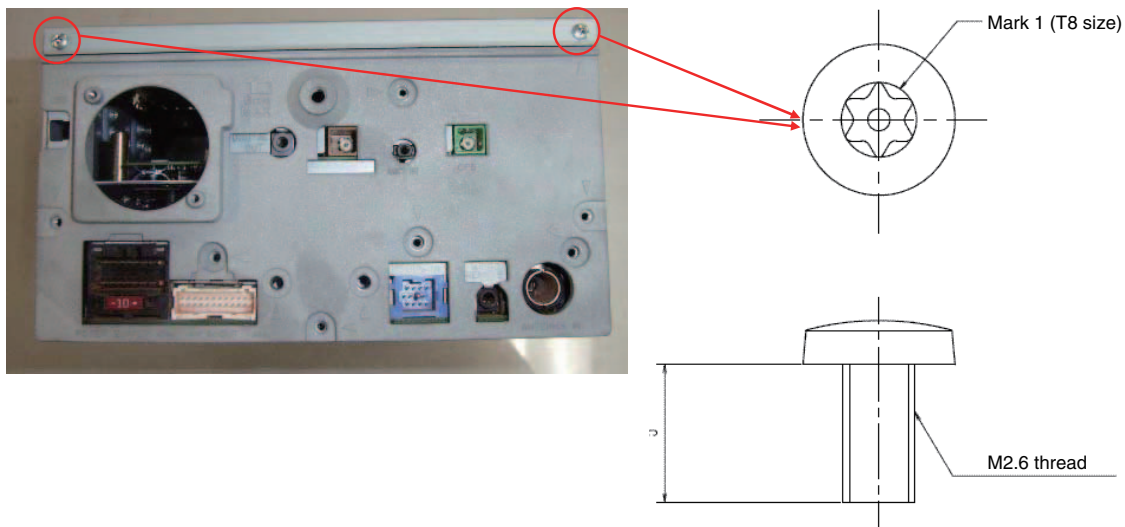

● How to install the Insulator to LS1 Mechanism Module.

A Peel off release liners at  areas.

Sticking procedure of the insulator

1: Fit the 2 hooks on the LS1 mech temporarily to the insulator.

2: Peel off 9 release liners.

■ 3: Stick A to F in this order.

(Stick both sides at once except for B and D.)

B: Sick one by one.

D: Stick the left side first and then stick the right side as pulling the insulator to the right.

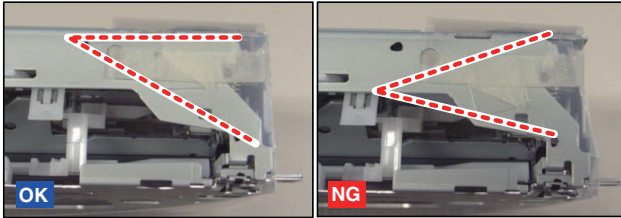
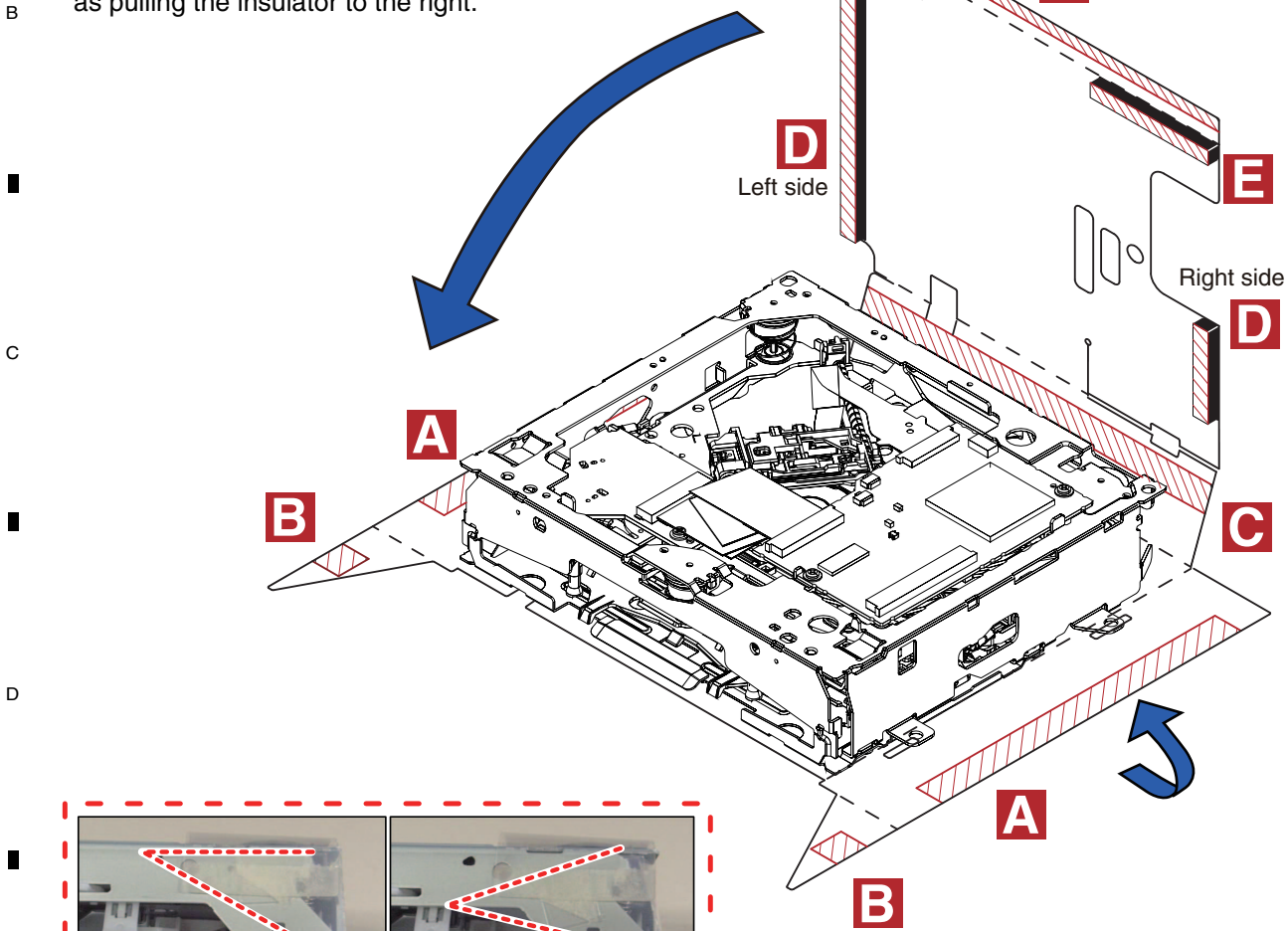

Keep the insulator off the slot at point B.

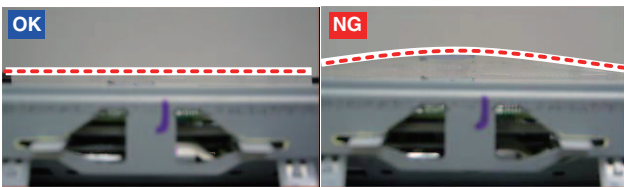

Stick the insulator fast at point D.

How to have it

1. Have a specified part.

Handling OK

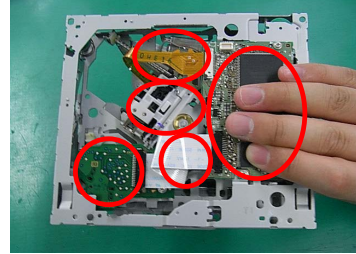
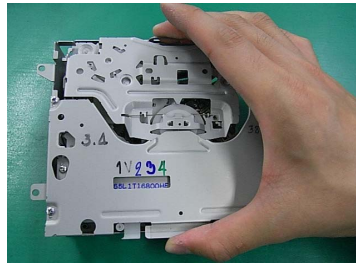
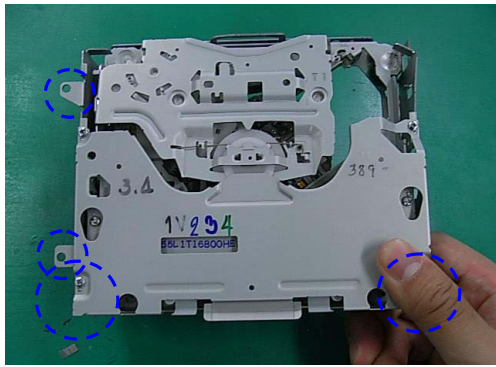

Handling NG

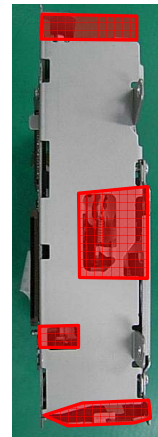
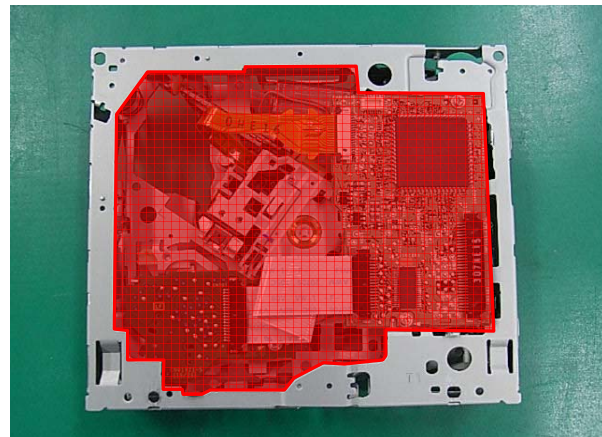
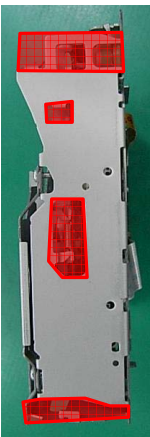
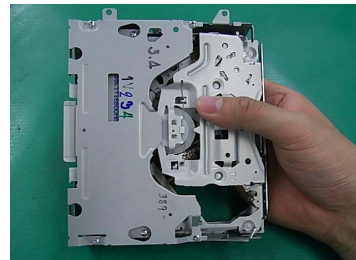
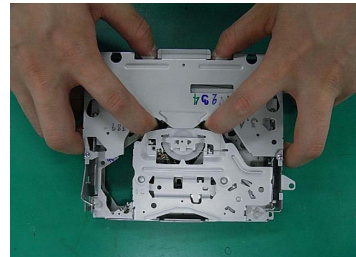
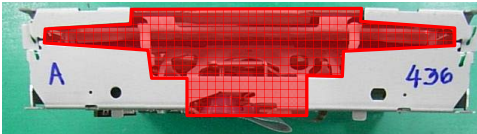
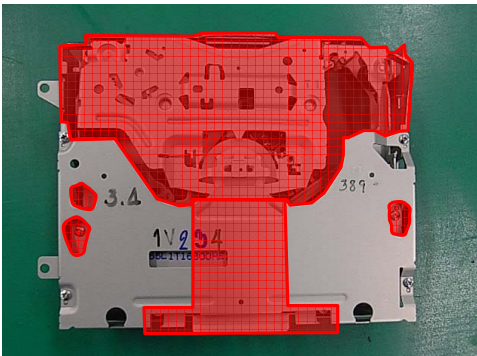
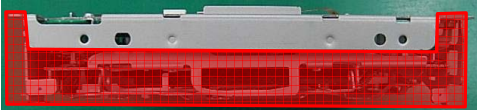

Mecha Module Bringing into the Clamp State with No Disc Loaded

1. Remove the relay FFC from the connector on the module PCB side (Fig. 1).
 (Precaution) When it is difficult to apply 4V to the motor in procedure 2 below, remove the connector on the relay PCB side, then remove the FFC, and remove the solder of the CRG motor lead and apply voltage to the lead.
2. Push the Disc detection arm while applying 4V to the CRG motor (Fig. 2)
 By this action, the mecha moves to the clamp state and the PU moves to the outer periphery.
3. Stop the motor when the PU comes to the vicinity of the intermediate periphery.
 (Precaution) If the PU goes to the outer most periphery, it idles.
 It is not a problem, but please try not to let it idle as much as possible.

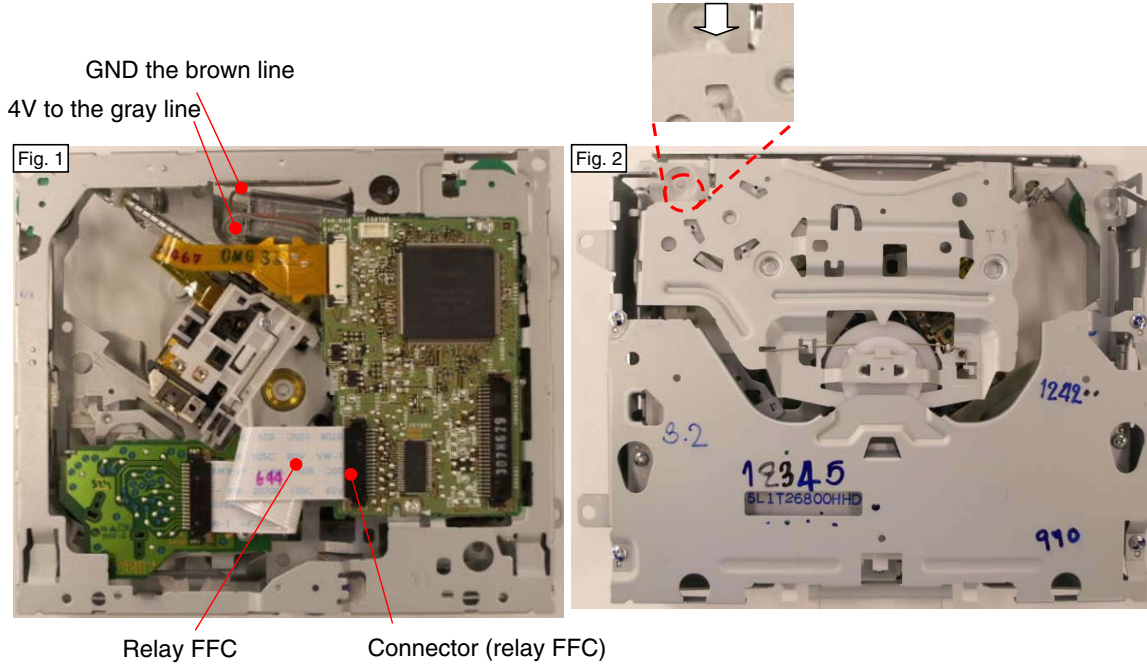

CRG Mecha_Bringing into the Clamp State with No Disc Loaded

- 1.Remove the T-case washer and then remove the drive gear. (Fig. 1)
- 2.Lift the clamp arm assy until it is in the state shown in Fig. 2_b (open-lock state).
- 3.Put your finger on the area A of Fig. 2_c and then slide it to the direction of the arrow (the direction of the playing state).
- 4.Push down the clamp arm.

(Precaution) When bringing the CRG mecha into the ejecting state again, install the drive gear after sliding the drive lever and bringing it to the ejecting state, in order to prevent the cog of the pinion in the drive gear from chipping at the time of its installation.

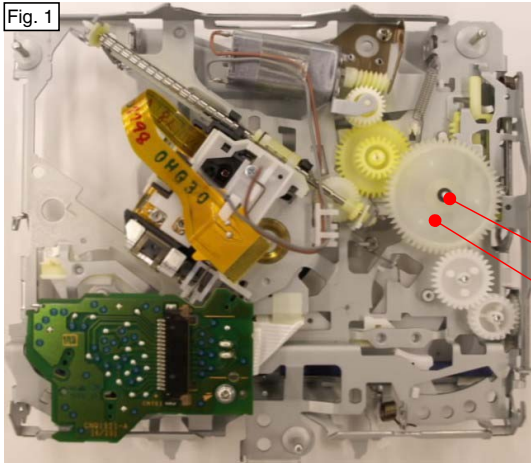
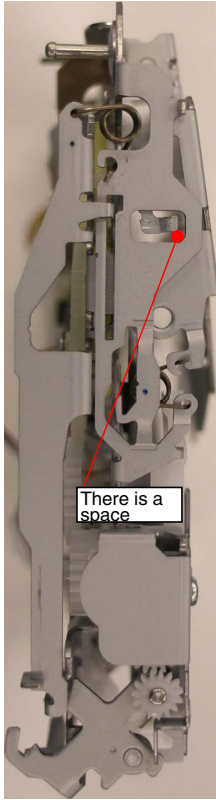
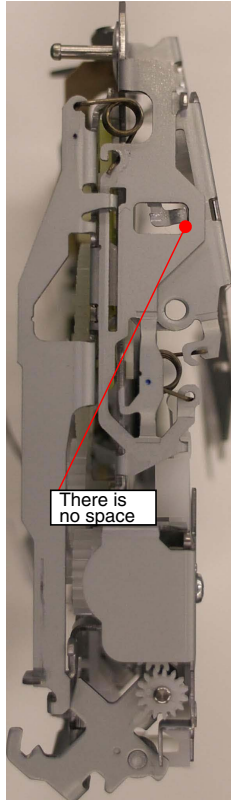

Fig. 2

a. Ejecting state



b. Open-lock state



c. Clamp state with no disc loaded

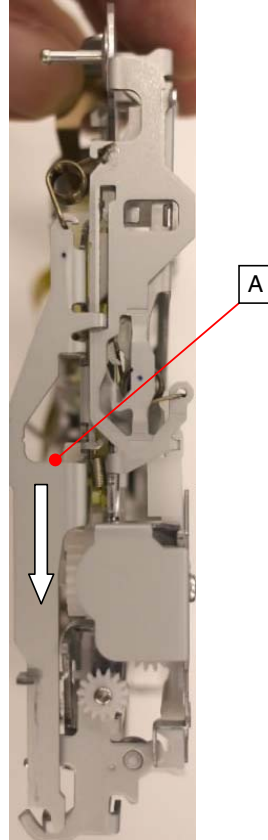

Removing the Module PCB

- 1.Short-circuit two spots on the land of the pick up FPC. (Fig. 1)
- 2.Remove the pick up FPC and the relay FFC from the connector. (Fig. 2)
- 3.Temporarily attach the pick up FPC to the pick up rack. (Fig. 3)
(in order to prevent the damage to the pick up FPC)
- 4.Remove the two PCB clinch screws and then remove the module PCB. (Fig. 2)

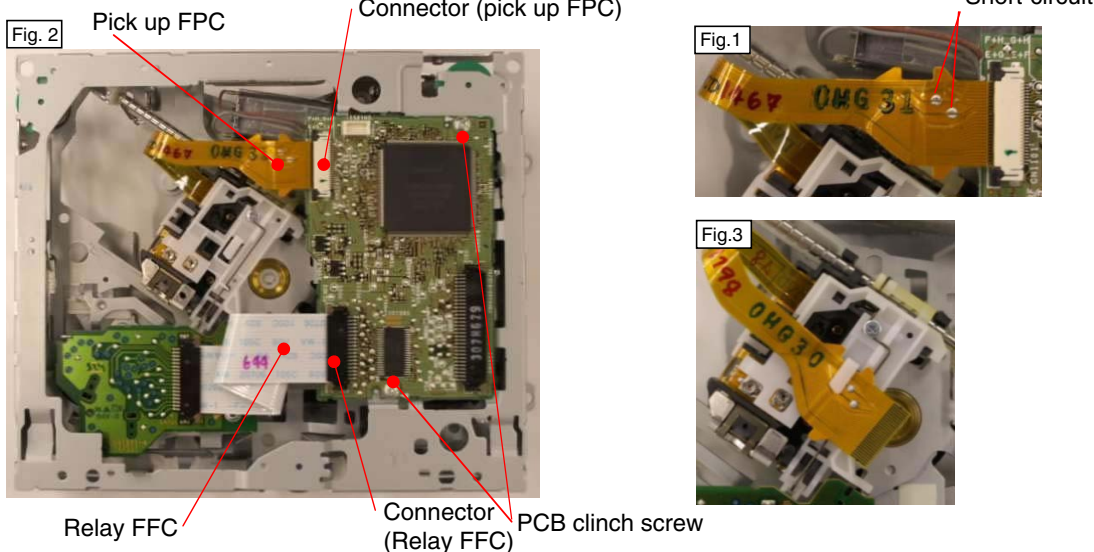

Removing/Installing the Relay PCB

Removing)

- 1.Remove the relay FFC from the connector
(remove both sides so that the entire FFC will be removed). (Fig. 2)
- 2.Remove the solder on the lead for the CRG motor. (Fig. 4)
- 3.Remove the one relay PCB clinch screw. (Fig. 4)
- 4.Slide the relay PCB to the direction of the arrow and then remove the relay PCB from the hook A and the hook B. (Fig. 4)
- 5.Turn the relay PCB over and then remove the SPDL motor FFC from the connector.

Installing)

- 1.Check the mecha is in the ejecting state (disc-load suspended state).
When it is not in the ejecting state, apply 4V to the lead (motor) and then bring it to the ejecting state (4V to the brown line and GND the gray line).
- 2.Fit the SPDL motor FFC to the connector (back of the relay PCB).
- 3.Hold the relay PCB so that it does not touch the SW knob as in Fig. 5.
- 4.Insert it into the hook B as it is a little off to the clockwise direction.
(Precaution) This is to prevent the SW knob from getting into the NG position as in Fig. 6.
- 5.Push down the relay PCB lightly and then rotate it to the counterclockwise direction.
It sets the relay PCB in the hook A and the positioning dowel.
(Precaution) Pay attention so the SW knob will not get onto the PU rack. (Fig. 6)
- 6.As in the Figures, while supporting the location A with your fingers, screw the relay PCB. (Fig. 7 / Fig. 8)
- 7.Solder the lead for the CRG motor.
- 8.Fit the relay FFC to the connector.

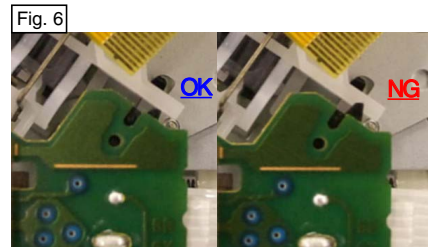
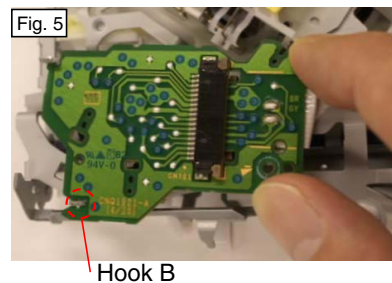
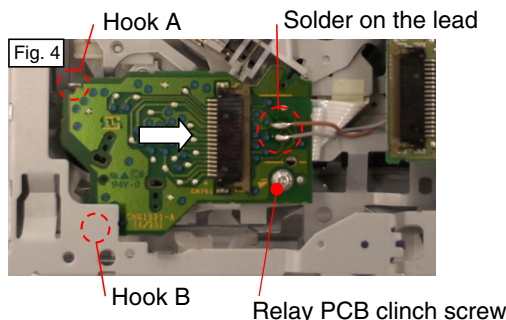
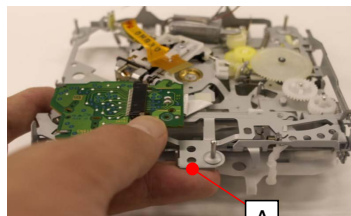

Fig. 7



A

Fig. 8

Removing the PU Unit

1. Hook the feed screw biasing spring on the temporary hook (Fig. 2b). Be careful not to get injured by the tip of the spring.
2. Hold the PU at the location A in Fig. 1 and slide and scoot it to the direction of the inner periphery.
3. As in Fig. 3, shift the back end of the feed screw to the side and then to above and remove it from the outside holder.
4. Remove the tucking joint for the chassis at the location B and the PU unit by lifting them up without changing their position and then remove the PU unit.

(Precaution) When installing the PU again, make sure to tuck the chassis in B and the PU unit (Fig. 4) first. Moreover, do not forget to permanently hook the feed screw biasing spring (Fig. 2a). Adjustments to the PU after its installation should be made according to the service manual.

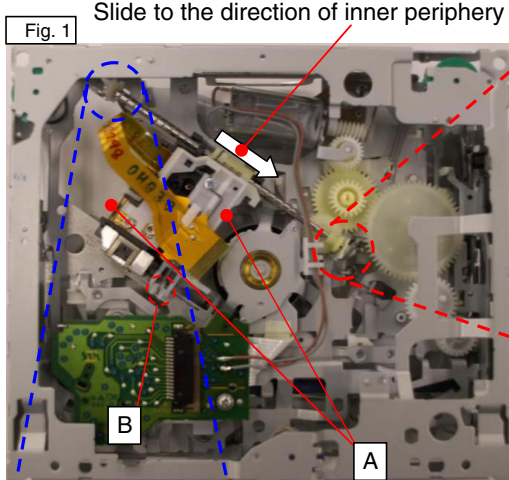

Permanently hooked position Temporary hooked position

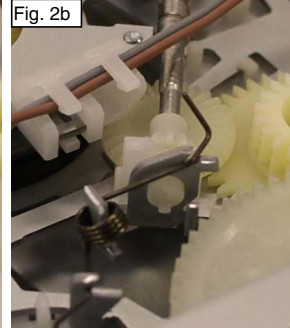
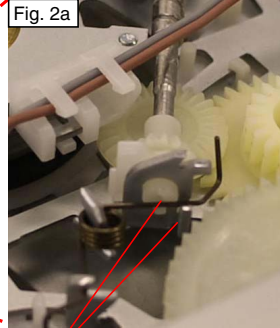

The spring is installed under the resin flange and inside the bended metal plate.

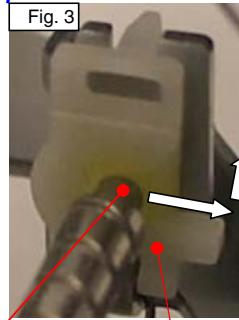

Back end of the feed screw Outside holder

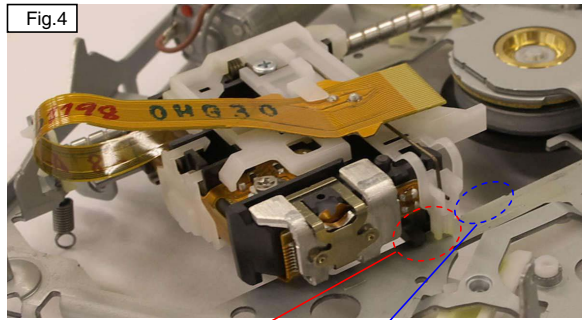

Regularly installed position

Install avoiding the area with blue broken line (the connected metal plate part)

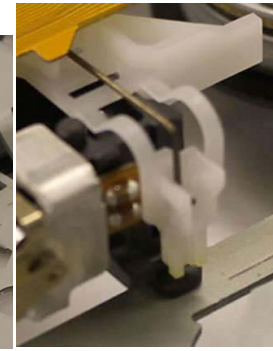

[Installation NG] The chassis is not tucked between the PU case and the PU rack.

Sending the PU to the outer periphery

1. Bring to the clamp state with no disc loaded according to the "Mecha Module_Bringing into the Clamp State with No Disc Loaded" manual.

(Precaution) The relay FFC must be removed for certainty in order to prevent the IC damage.
2. Apply 1.5V to the CRG motor and then transfer the PU to the outer periphery.

(Precaution) Do not forget to reinstall the relay FFC after sending the PU to the outer periphery and take the necessary measures.

8. EACH SETTING AND ADJUSTMENT

8.1 DVD ADJUSTMENT



1) Precautions

This product uses 5 V and 3.3 V as standard voltages. The electrical potential that is the reference for signals, is not GND, but VREF (approximately 2.2 V) and VHALF (approximately 1.65 V) .

During product adjustments, if the reference voltage is mistakenly taken as GND, and a grounding contact is made, not only would it be impossible to measure the accurate electrical potential, but also the servo motor would malfunction, resulting in the application of a strong impact on the pick up. The following precautionary measures should be strictly adhered to, in order to avoid such problems.

The reference voltage and GND should not be confused when using the minus probe of a measurement device. When an oscilloscope is being used special care should be taken to make sure that the reference voltage is not connected to the probe of ch1 (on the minus side), while the probe of ch2 (on the minus side), is connected to GND. Further, since the body frame of most measurement devices have the same electrical potential as the minus side of the probe, the body frame of the measurement device should be set to floating ground.

If the reference voltage is connected to GND by mistake, turn the regulator OFF immediately, or turn the power OFF.

- Remove the filters and wires used for measurements only after the regulator has been turned OFF.
- After the power supply is turned on, regulator ON the following adjustment and measurement are promptly done.
- Whenever the product is in the test mode, the software will not take any protective action. For this reason, special care should be taken to make sure that no mechanical or electrical shock could be applied to the product when taking measurements in the test mode.
- Whenever the EJECT key is pressed to eject the disk, no other keys, other than the EJECT key, should be pressed until the disk eject action has been completed.
- Press the EJECT key only after the disk has stopped completely.
- If the product hangs up turn the power OFF immediately.
- Laser diodes may be damaged, if the volume switch for the laser power adjustment of the pick up unit, is turned.

● SKEW adjustment

When one of the following replacements has taken place, SKEW adjustment for the pick up will be required.

- (1) Replacement of the pick up unit
- (2) Replacement of the spindle motor
- (3) Replacement of the carriage chassis
- (4) Replacement of the main shaft of the pick up unit

Measurement equipment and tools/jigs: Oscilloscope

Driver for SKEW adjustment -> Driver

Bond for fixing the SKEW -> GEM1033

Bond for resonance -> 1530 (1530 : produced by THREE BOND)

Bond for locking the screw -> 1401M (1401M : produced by THREE BOND)

Disc used:GGV1025

Measurement reference: AGND3

Measurement point: RF

Connection drawing

DVD core unit

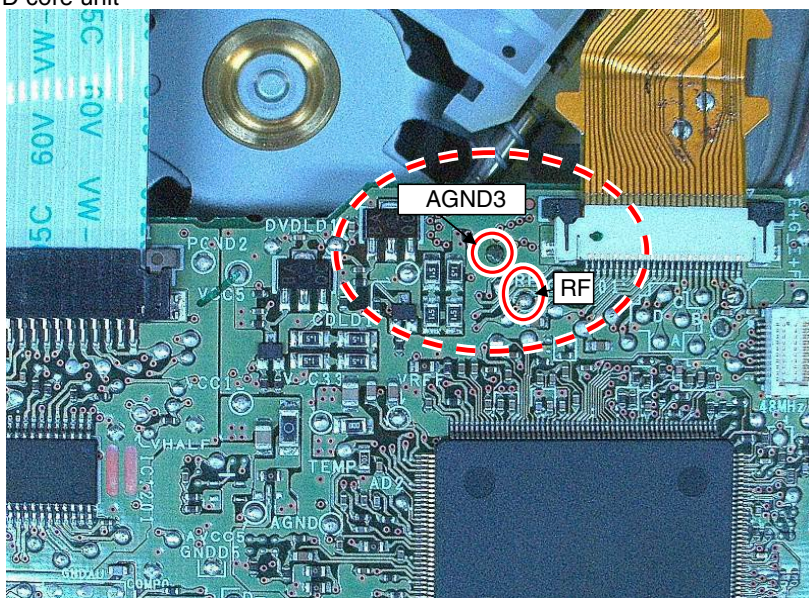

Expansion

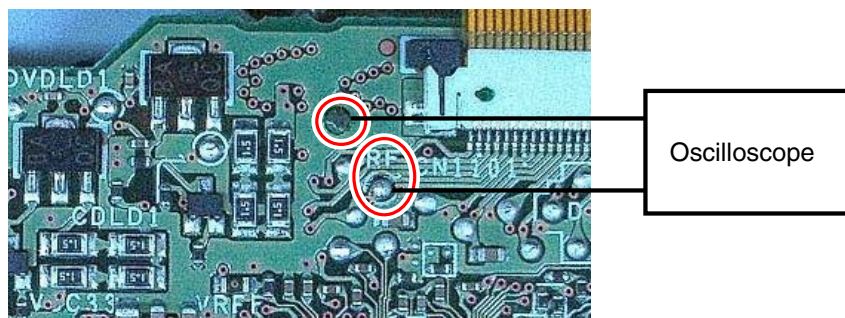

Symptom in case the adjustment is not adequate: Worsening of the error rate 10^{-3}
 (Normally 10^{-4} or less.)
 Large RF jitter
 RF waveform distortion
 Tracking drawing/Unstable servo

* Caution: Do not look into the laser light during adjustment.

There are two methods of making adjustment: a method of making adjustment through monitoring RF waves by the oscilloscope (method 1) and a method of making adjustment through checking the numerical value of the RF level by OSD (method 2).

Adjusting procedure is shown below, but regarding how to start the test mode and the operating procedure, please refer to the clause on the service test mode.

Adjusting Procedure:

1. Install the pickup

(Refer to the removal of the pickup from the mecha unit.)

When handling the pickup, refer to the precautions on how to handle the PU listed below.

2. Method 1:

Connect the oscilloscope according to the AGND3 standards with reference to the connection diagram so that the RF signals can be monitored.

Method 2:

The device does not need to be set. Proceed to the procedure 3.

3. Turn ON the power of the product.

4. Start the simplified FE test mode.

(Regarding how to start the test mode and the operating procedure, refer to the clause on the service test mode.)

5. Load the disc for adjustment (GGV1025).

6. TEST MODE

Select "3: Skew Adjustment."

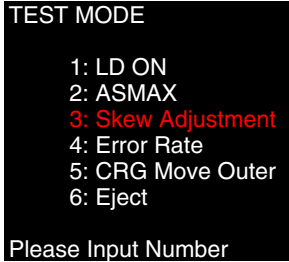

7. Skew Adjustment

Select "1: DVD Single Layer."

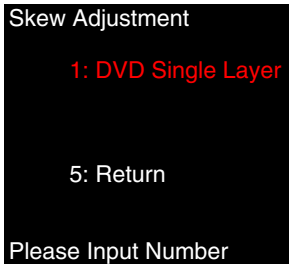

8. Adjust the Skew using a driver while checking the RF value.

Refer to the following pages concerning the locations to make SKEW adjustment.

Method 1:

Slightly turn the skew adjusting screw A while checking the RF wave level by the oscilloscope and make adjustment so the wave level would reach its maximum.

Next, slightly turn the skew adjusting screw B so the wave level would reach its maximum.

Slightly turn the skew adjusting screw A again so the wave level would reach its maximum.

(Make adjustment in the order of A->B->A and in the end complete adjustment by turning each screw in the clockwise direction.)

Method 2:

Slightly turn the skew adjusting screw A while checking the value of the RF level through the OSD display so the wave level would reach its maximum.

Next, slightly turn the skew adjusting screw B so the level would reach its maximum.

Slightly turn the skew adjusting screw A again so the level would reach its maximum.

(Make adjustment in the order of A->B->A and in the end complete adjustment by turning each screw in the clockwise direction.)

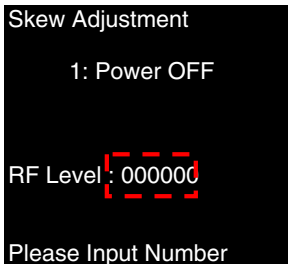

9. Skew Adjustment
Select "1: Power OFF."

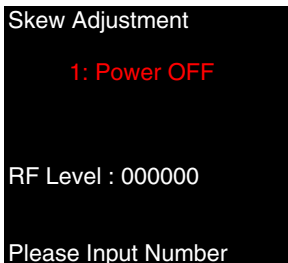

10. TEST MODE
Select "6: Eject."

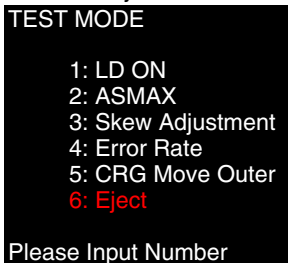

11. TEST MODE
Select "5: CRG Move Outer."

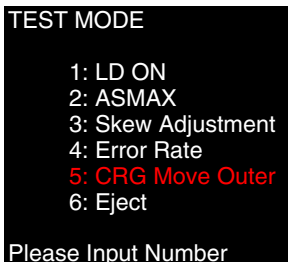

12. In order to produce the clamping state with no disc loaded, slightly move the disc detection arm in the counterclockwise direction while moving the switch arms outward.



Switch arms

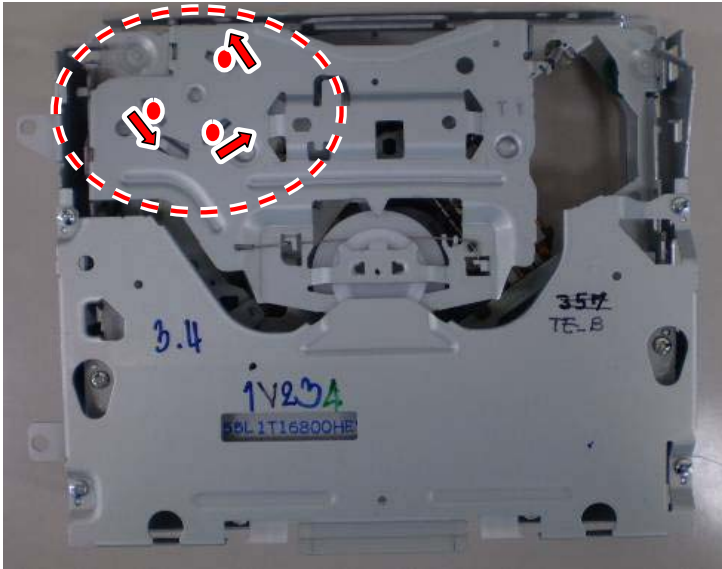

Disc Detection Arm

13. CRG Move Outer
 Select "1: DVD Single Layer."

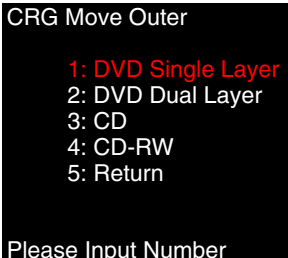

Please Input Number

The pickup moves to the outer periphery.
 Apply the adhesive to fix the skew, the resonance adhesive and the screw lock.
 Refer to the next page regarding the locations of adhesive joining.

14. CRG Move Outer
 1: Power OFF

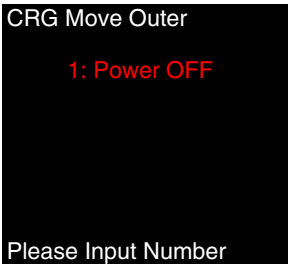

Please Input Number

15. TEST MODE
 Select "6: Eject."

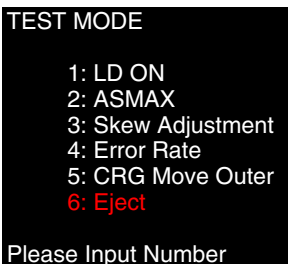

Please Input Number

Locations to make SKEW adjustment

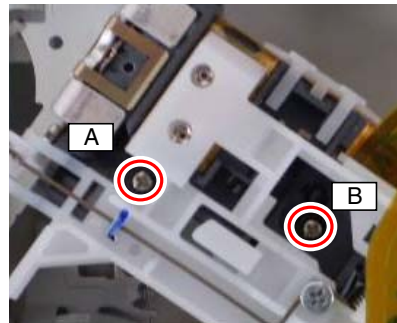

Locations to adhere the SKEW 1,2,3: GEM1033

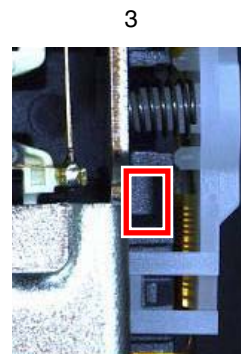
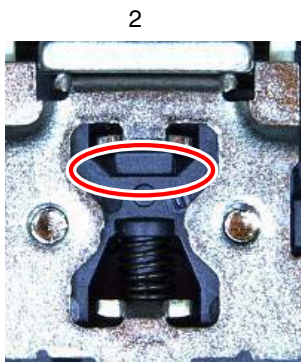
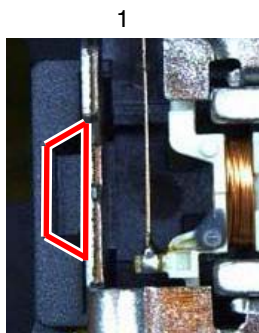
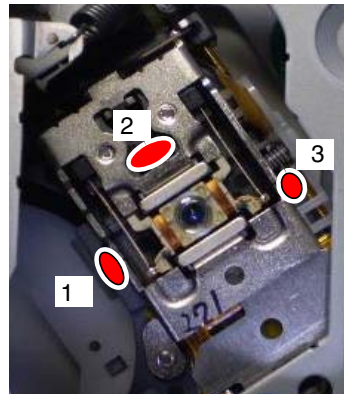

Bond for resonance 4:Three Bond 1530

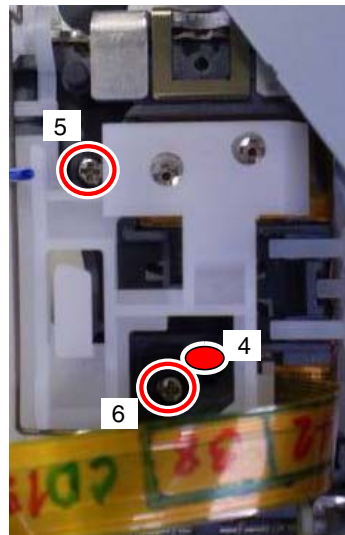

Bond for locking the screw 5,6 : Three Bond 1401M

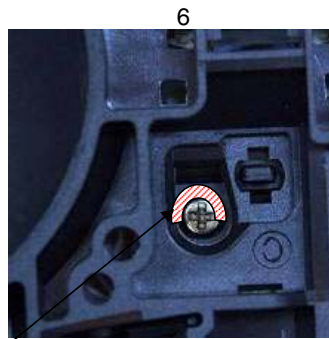
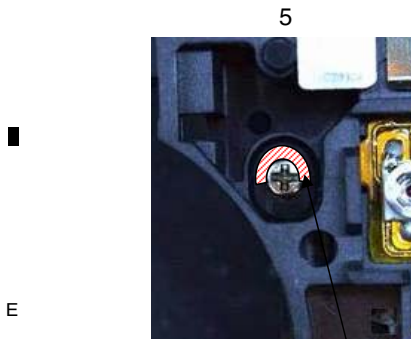

Bond for locking the screw

Precautions on handling the PU

*Precaution: Do not touch those shaded areas in the following figures.

Do not touch the optical part

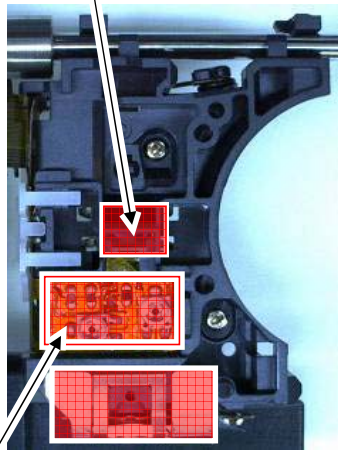

RF level adjusting part

Hologram (Beware of the static)

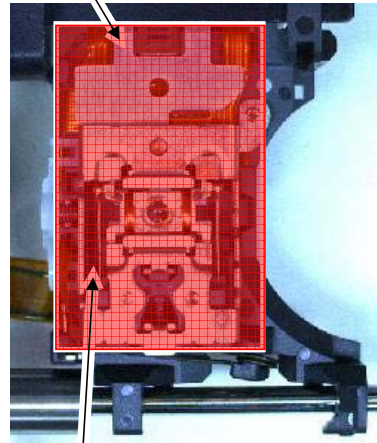

Do not touch the spring

A

B

C

D

E

F

8.2 AV UNIT ADJUSTMENT



● Adjustment point

AV UNIT(SIDE A)

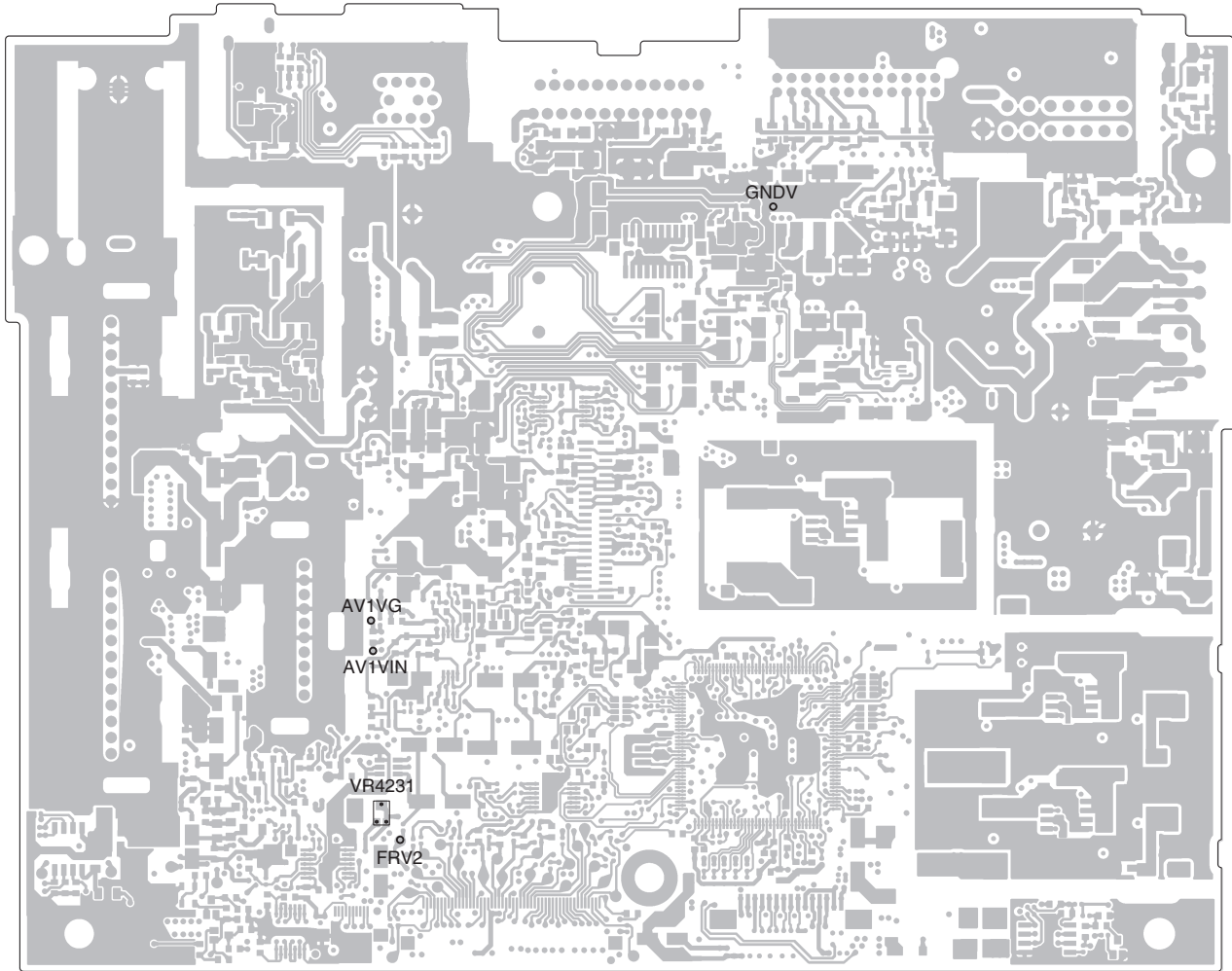

● AV UNIT ADJUSTMENT

Step	Adjustment item	Mode	Input signal (Input test pin, specs, other conditions)	Output signal (Measurement point, wave pattern)	Measuring instruments	Specs	Adjusting point
1	Video level adjustment	AV selector VTR1	GGV1025 Title3 chap3 play (white 100%) 1.0 Vp-p To perform AV unit only TP AV1VIN (input) TP AV1VG (GND) 100IRE (white 100%) 1.0 Vp-p (input via 75 ohm)	Measurement point: FRV2 GNDV (GND) (To measure the AV Unit only, connect 1.4 kohm between TP FRV2 and GNDV.) 	Oscilloscope	• 1.00 V ± 0.02 Vp-p Measure between the sync tip and 100 IRE (wave top). Symptoms with poor adjustment. Over level: Luminance is too high. Under level: Luminance is too low.	VR4231

8.3 FLICKER ADJUSTMENT



● FLICKER ADJUSTMENT

	Adjustment item	Measurement point	Adjustment point	The contents of adjustment	Remarks
1	Aging			Input white 100% signal. Leave for more than 30 minutes in operation mode.	
2	Flicker adjustment	Screen	LCVR1	Adjust the flicker level to minimum from all directions.	Signal for Flicker adjustment... Select "Graphics" → "Flicker Adjustment" in the Test Mode. (Input a signal for alternate white and black line. The luminance level of the input signal : 50%)

A

B

C



D

E

F

9. EXPLODED VIEWS AND PARTS LIST

NOTES : • Parts marked by " * " are generally unavailable because they are not in our Master Spare Parts List.

- The  mark found on some component parts indicates the importance of the safety factor of the part. Therefore, when replacing, be sure to use parts of identical designation.
- Screw adjacent to  mark on the product are used for disassembly.
- For the applying amount of lubricants or glue, follow the instructions in this manual. (In the case of no amount instructions, apply as you think it appropriate.)

9.1 PACKING

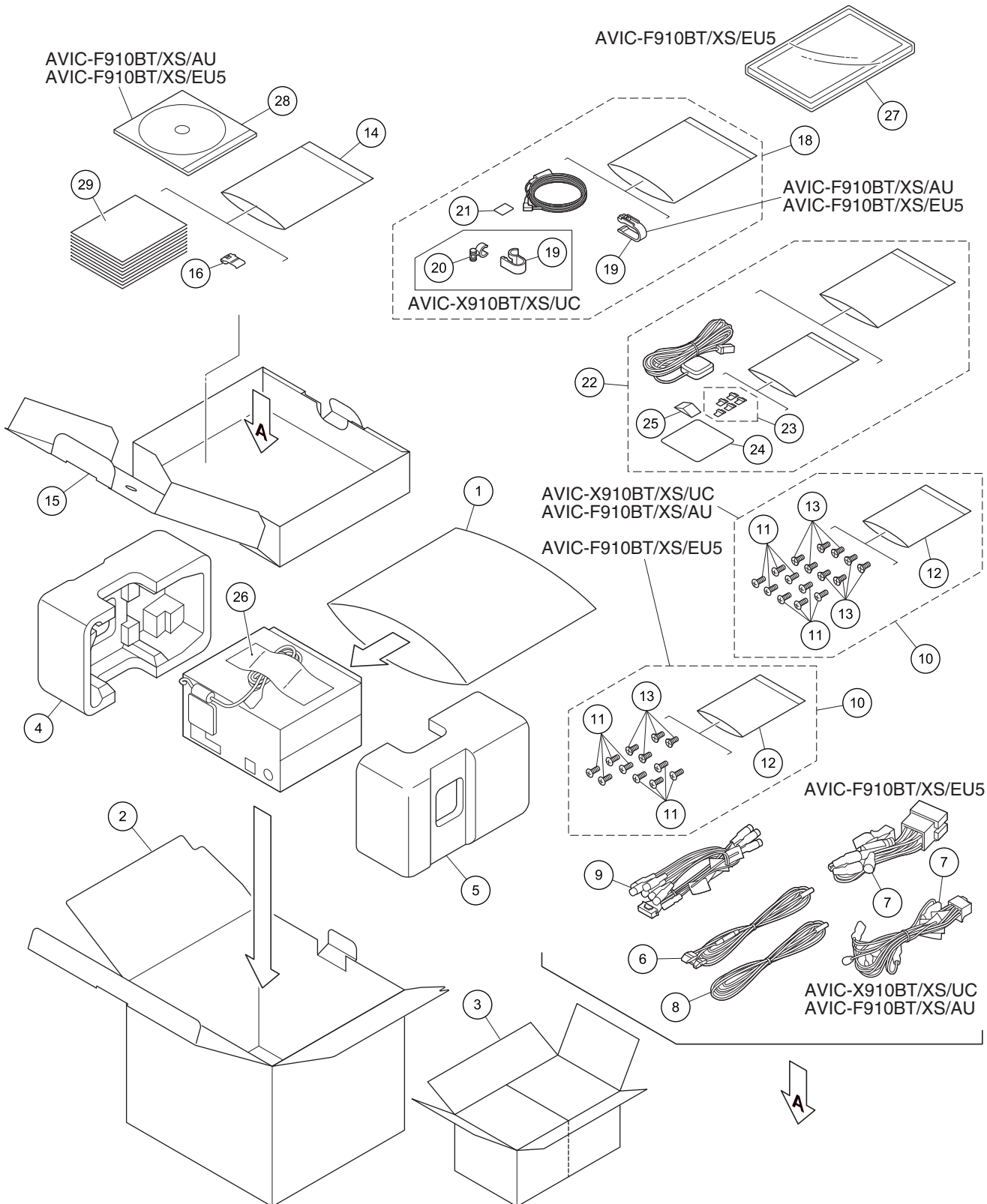

PACKING SECTION PARTS LIST

Mark	No.	Description	AVIC-X910BT/XS/UC	AVIC-F910BT/XS/EU5	AVIC-F910BT/XS/AU
	1	Polyethylene Bag	CEG1402	CEG1401	CEG1401
	2	Unit Box	CHG6774	CHG6772	CHG6775
	3	Contain Box	CHL6774	CHL6772	CHL6775
	4	Protector	CHP3552	CHP3550	CHP3552
	5	Protector	CHP3553	CHP3551	CHP3553
	6	Cord	CDE6825	CDE6825	CDE6825
	7	Cord Assy	CDP1095	CDP1097	CDP1095
	8	Cord	CDP1157	CDP1157	CDP1157
	9	Cord Assy	CDP1241	CDP1241	CDP1241
	10	Screw Assy	CEA3797	CEA7395	CEA3797
	11	Screw	BMZ50P060FTC	BMZ50P060FTC	BMZ50P060FTC
*	12	Polyethylene Bag	CEG-127	CEG-127/CNM4388	CEG-127
	13	Screw	CMZ50P060FTC	CMZ50P060FTC	CMZ50P060FTC
	14	Polyethylene Bag	CEG1116	CEG1116	CEG1116
	15	Sub Unit Box	CHG6491	CHG6491	CHG6491
	16	Connector	CKX1049	CKX1049	CKX1049
	17			
	18	Microphone Assy	CPM1064	CPM1083	CPM1083
	19	Clip Holder	CZN5471	*CZN7912	*CZN7912
	20	Microphone Holder	CZN5472	Not used	Not used
	21	Cushion	CZN5473	*CZN7913	*CZN7913
	22	GPS Antenna Assy	CXC8574	CXC8574	CXC8574
*	23	Clamper Assy	CZE3090	CZE3090	CZE3090
	24	Water Proof Pad	CZN5442	CZN5442	CZN5442
	25	Sheet	CZN7151	CZN7151	CZN7151
	26	Seal	CNN2515	CNN2515	CNN2515
	27	Panel	Not used	CNS8665	Not used
*	28	IM CD-ROM/PEE	Not used	CPJ1273	CPJ1273
	29-1	Owner's Manual	CRB2985	Not used	Not used
	29-2	Owner's Manual	CRB2986	Not used	Not used
	29-3	Installation Manual	CRD4409	CRD4411	CRB3008
	29-4	Quick Start Guide	CRB2987	CRB2995	CRB3006
	29-5	Quick Start Guide	CRB2988	CRB2996	Not used
	29-6	Quick Start Guide	Not used	CRB2997	Not used
	29-7	Quick Start Guide	Not used	CRB2998	Not used
	29-8	Quick Start Guide	Not used	CRB2999	Not used
	29-9	Quick Start Guide	Not used	CRB3000	Not used
	29-10	Important Information	Not used	CRD4410	CRB3007
*	29-11	Caution Card	CRP1310	Not used	CRP1310
*	29-12	Warranty Card	CRY1246	CRY1265	Not used
*	29-13	Registration Card	CRY1271	Not used	Not used
*	29-14	Passport	Not used	CRY1268	Not used

Owner's Manual, Installation Manual

Part No.	Language
CRB2985	English
CRB2986	French
CRB2987	English
CRB2988	French
CRD4409	English, French
CRB2995	English
CRB2996	Spanish(Espanol)
CRB2997	German
CRB2998	French
CRB2999	Italian
CRB3000	Dutch
CRD4410	English, Spanish(Espanol), German, French, Italian, Dutch
CRD4411	English, Spanish(Espanol), German, French, Italian, Dutch
CRB3006	English
CRB3007	English
CRB3008	English

CONTENTS OF CD-ROM (Operation Manual), CPJ1274

Part No.	Language
* CRB2989	English
* CRB2990	Spanish(Espanol)
* CRB2991	German
* CRB2992	French
* CRB2993	Italian
* CRB2994	Dutch
* CRB3005	English

**All operation manuals are supplied in PDF files by the CD-ROM.
Regarding the availability of paper manual, contact Pioneer Service representative in your region.**

A

B

C

D

E

F

9.2 EXTERIOR(1)

1

2

3

4

A

B

C

D

E

F

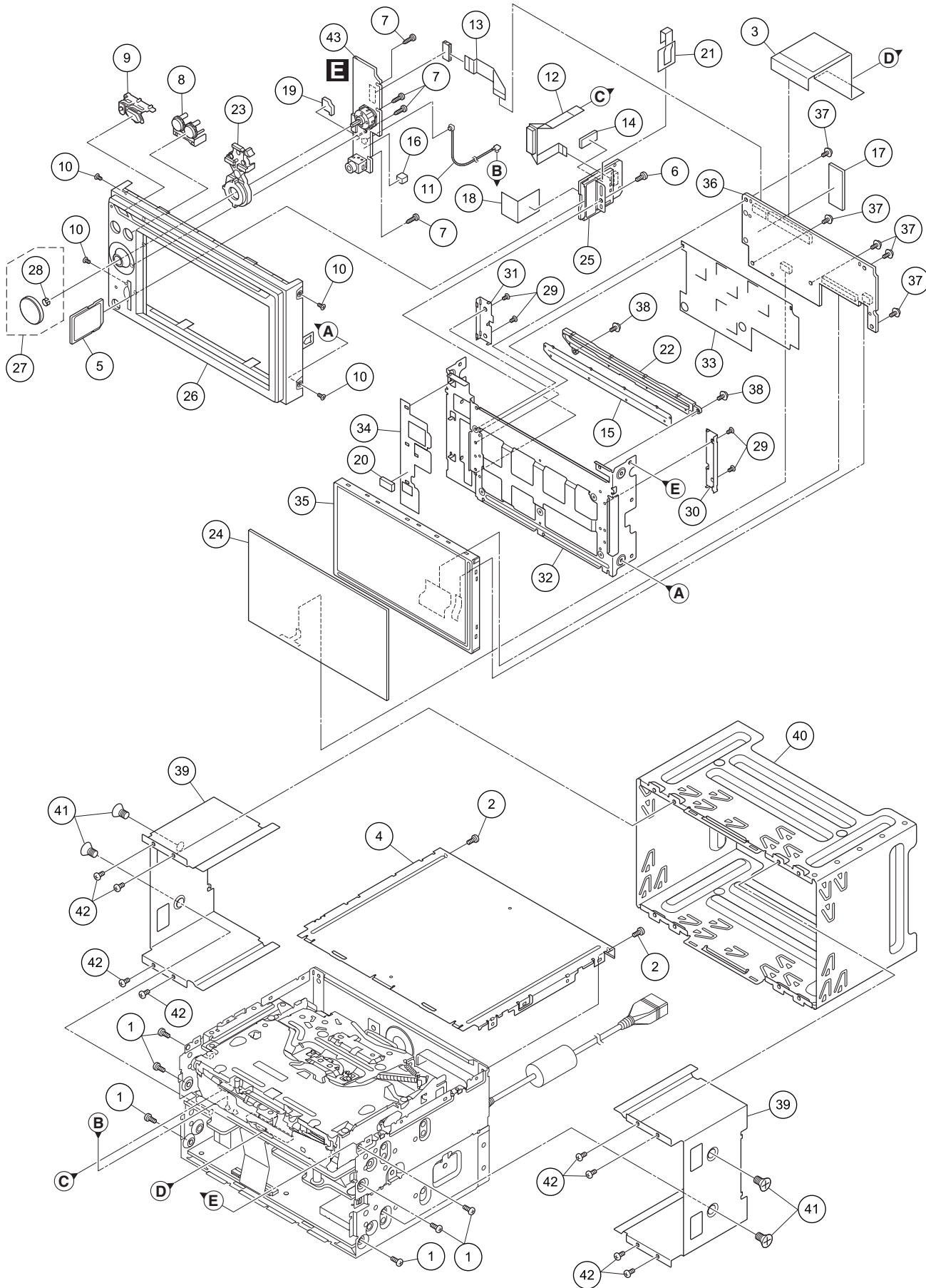

1

2

3

4

(1) EXTERIOR(1) SECTION PARTS LIST

<u>Mark No.</u>	<u>Description</u>	<u>Part No.</u>	<u>Mark No.</u>	<u>Description</u>	<u>Part No.</u>
1	Screw	BMZ26P050FTC	23	Lighting Conductor	CNW1561
2	Screw(M2.6 x 5)	CBA2145	24	Touch Panel	CSX1136
3	FFC	CDE9039	25	SD Unit	CWX3652
4	Case	CNB3472			
5	Card	CNW1231	26	Grille Unit	See Contrast table (2)
			27	Knob Unit	CXE1633
6	Screw	BMZ26P050FTC	*	28	Spring
7	Screw	BPZ20P080FTC		29	Screw(M2 x 2)
8	Button(MENU, MAP)	CAI1705		30	Holder
9	Button(RESET, EJECT)	CAI2435			
10	Screw(M2 x 3)	CBA1797		31	Holder
				32	Holder
11	Cord Assy	CDE8559		33	Insulator
12	FFC	CDE9037		34	Insulator
13	FFC	CDE9038		35	LCD Module
14	Spacer	See Contrast table (2)			
15	Cover	CNN2046		36	Panel Unit
				37	Screw
16	Gasket	CNN2501		38	Screw
17	Gasket	CNN2533		39	Holder
18	Insulator	CNN2534		40	Holder
19	Cushion	See Contrast table (2)			
20	Gasket	See Contrast table (2)		41	Screw
				42	Screw
21	Insulator	See Contrast table (2)		43	Keyboard Unit
22	Holder	CNV9903			

(2) CONTRAST TABLE

AVIC-X910BT/XS/UC, AVIC-F910BT/XS/EU5 and AVIC-F910BT/XS/AU are constructed the same except for the following:

<u>Mark</u>	<u>No.</u>	<u>Description</u>	<u>AVIC-X910BT/XS/UC</u>	<u>AVIC-F910BT/XS/EU5</u>	<u>AVIC-F910BT/XS/AU</u>
	14	Spacer	CNM9246	Not used	CNM9246
	19	Cushion	CNN2723	Not used	CNN2723
	20	Gasket	CNN2724	Not used	CNN2724
	21	Insulator	CNN2725	Not used	CNN2725
	26	Grille Unit	CXE1623	CXE1624	CXE1625
	39	Holder	Not used	CND3431	Not used
	40	Holder	Not used	CND3430	Not used
	41	Screw	Not used	CMZ50P060FTC	Not used
	42	Screw	Not used	BMZ30P060FTC	Not used

9.3 EXTERIOR(2)

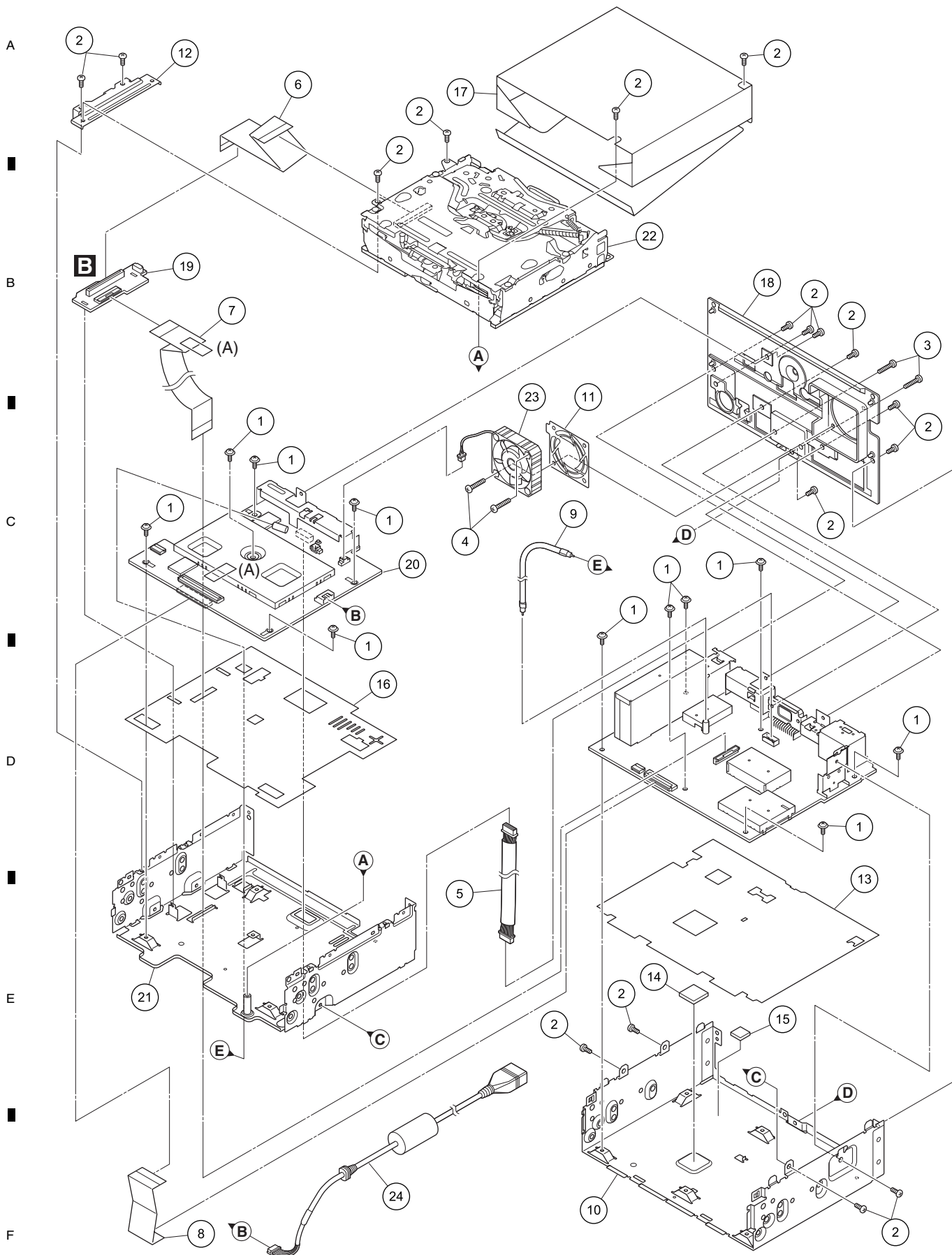

(A) GYH1031(Mylar tape)

* Hold the flexible cable to the shield on the Navi Unit.

EXTERIOR(2) SECTION PARTS LIST

<u>Mark No.</u>	<u>Description</u>	<u>Part No.</u>	
1	Screw	ASZ26P050FTC	
2	Screw	BMZ26P050FTC	A
3	Screw	BMZ26P160FTB	
4	Screw(M2.6 x 12)	CBA2102	
5	Cord Assy	CDE8393	
6	FFC	CDE8911	
7	FFC	CDE8912	
8	FFC	CDE9036	
9	Cord Assy	CDH1381	
10	Chassis	CNA3114	
11	Cover	CND3917	B
12	Bracket	CND4564	
13	Insulator	CNN2042	
14	Sheet	CNN2294	
15	Gasket	CNN2529	
16	Insulator	CNN2807	
17	Sheet	CNN2808	
18	Heat Sink	CNR1944	
19	CK Unit	CWN4251	
20	Navi Unit(UC)	CWX3739	C
	Navi Unit(EU5)	CWX3740	
	Navi Unit(AU)	CWX3741	
21	Chassis Unit	CXE1631	
22	DVD Mechanism Module(LS1)	CXK6801	
23	Fan Motor	CXM1320	
24	Cord Assy(UC)	CDE9102	
	Cord Assy(EU5)	CDE8913	
	Cord Assy(AU)	CDE8913	D

9.4 EXTERIOR(3)

1

2

3

4

A

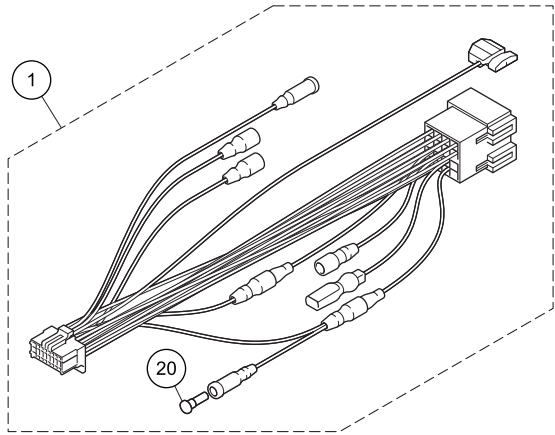
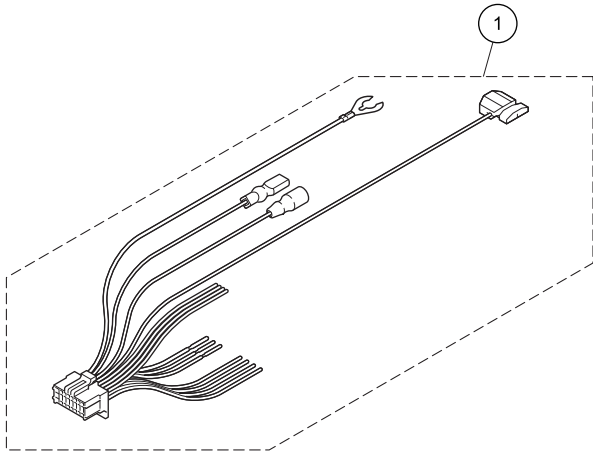

AVIC-F910BT/XS/EU5

AVIC-X910BT/XS/UC
AVIC-F910BT/XS/AU

B

C

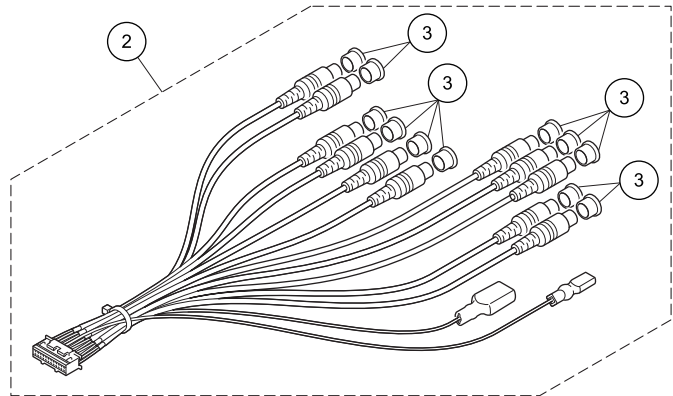
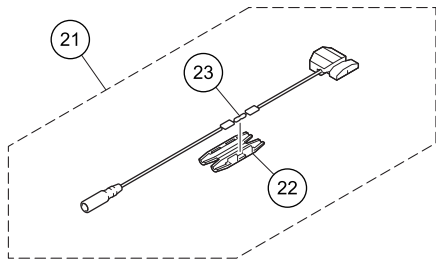

D

E

F

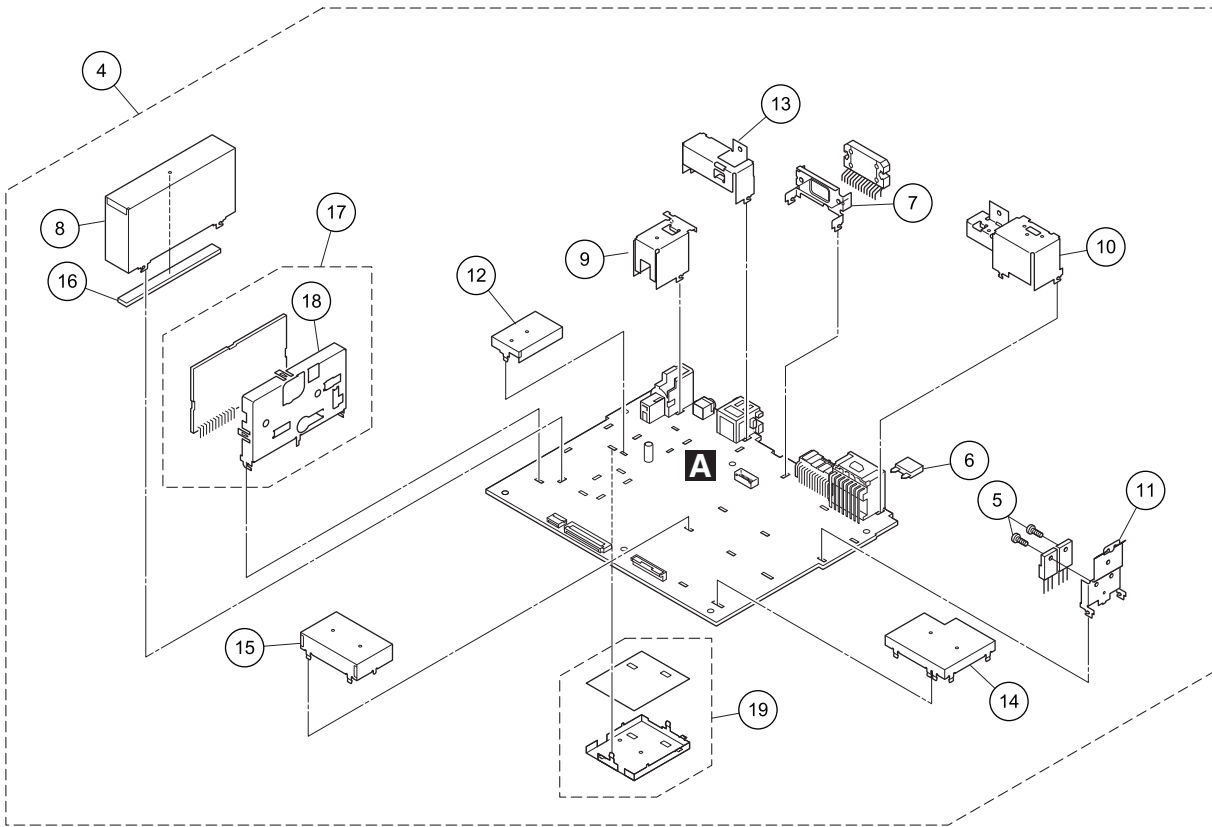

1

2

3

4

(1) EXTERIOR(3) SECTION PARTS LIST

<u>Mark No.</u>	<u>Description</u>	<u>Part No.</u>	<u>Mark No.</u>	<u>Description</u>	<u>Part No.</u>
1	Cord Assy	See Contrast table (2)	13	Holder	See Contrast table (2)
2	Cord Assy	CDP1241	14	Shield	CND4320
3	Cap	CNW1490	15	Shield	CND4563
4	AV Unit	See Contrast table (2)	16	Sheet	CNM9805
5	Screw	BMZ26P060FTC	17	FM/AM Tuner Unit(Y1461)	See Contrast table (2)
⚠ 6	Fuse(10 A)	CEK1208	18	Holder	CND4324
7	Holder	CNC9921	19	Shield Unit	CXC8983
8	Shield	CND3004	20	Terminal Cover	See Contrast table (2)
9	Holder	CND3181	21	Cord	CDE6825
10	Holder	CND3693	22	Cap	CNS1472
11	Holder	CND3695	23	Resistor	RS1/2PMF102J
12	Shield	CND3769			

(2) CONTRAST TABLE

AVIC-X910BT/XS/UC, AVIC-F910BT/XS/EU5 and AVIC-F910BT/XS/AU are constructed the same except for the following:

Mark	No.	Description	AVIC-X910BT/XS/UC	AVIC-F910BT/XS/EU5	AVIC-F910BT/XS/AU
	1	Cord Assy	CDP1095	CDP1097	CDP1095
	4	AV Unit	CWN4237	CWN4238	CWN4239
	13	Holder	CND4314	CND4315	CND4315
	17	FM/AM Tuner Unit(Y1461)	CWE2128	CWE2127	CWE2128
	20	Terminal Cover	Not used	CKX-003	Not used

9.5 DVD MECHANISM MODULE

A

B

C

D

E

F

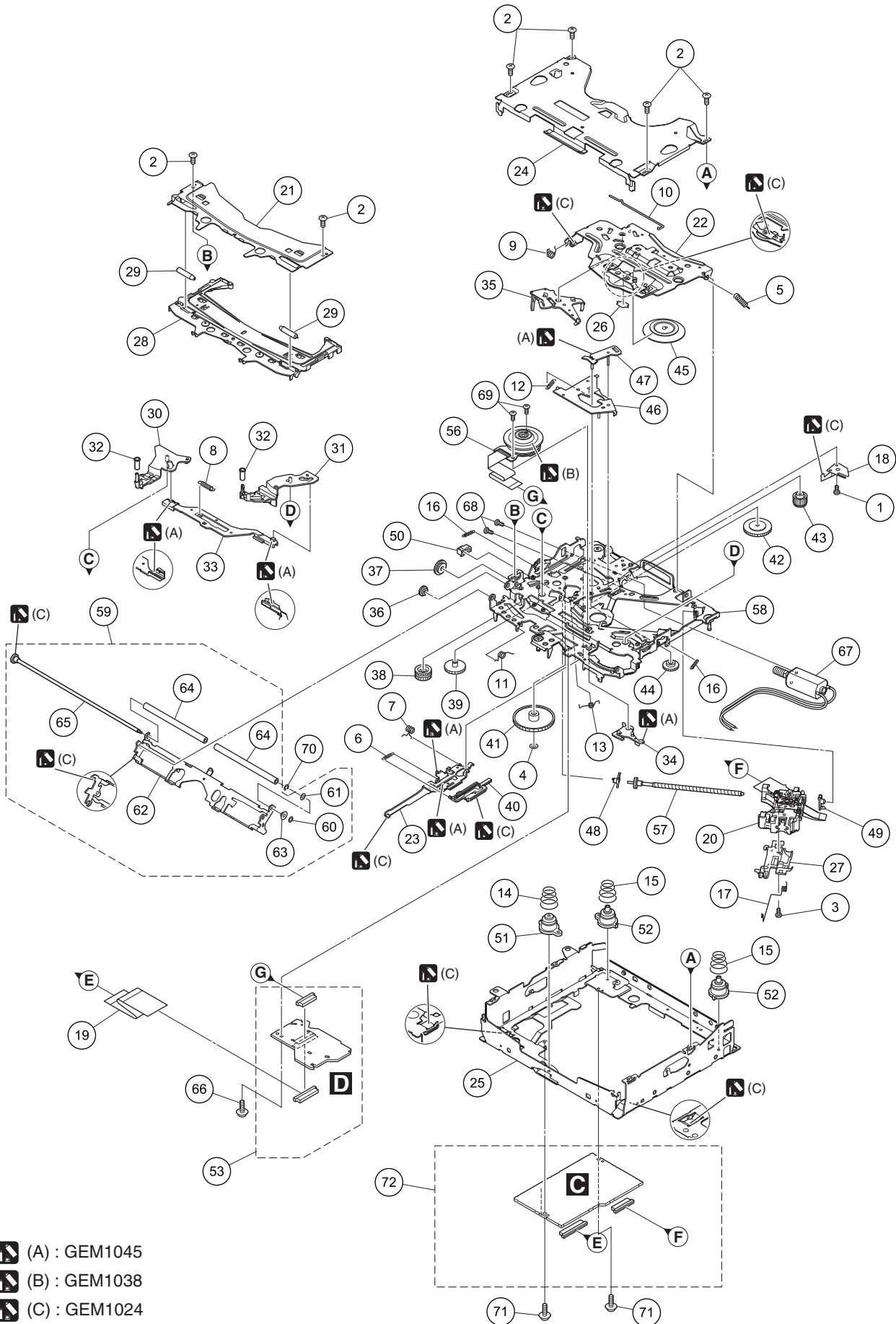

- (A) : GEM1045
- (B) : GEM1038
- (C) : GEM1024

DVD MECHANISM MODULE SECTION PARTS LIST

<u>Mark No.</u>	<u>Description</u>	<u>Part No.</u>	<u>Mark No.</u>	<u>Description</u>	<u>Part No.</u>
1	Screw	BMZ20P020FTC	50	Holder	CNW1195
2	Screw	BSZ20P040FTC			
3	Screw(M2 x 4)	CBA1835	51	Damper	CNW1197
4	Washer	CBF1038	52	Damper	CNW1198
5	Spring	CBH2860	*	53 Connect PCB Unit	CWX3618
			54	
6	Spring	CBH3010	55	
7	Spring	CBH3011			
8	Spring	CBH3012	56	Motor Unit	CXC4026
9	Spring	CBH3013	57	Screw Unit	CXC8894
10	Spring	CBH3014	58	Chassis Unit	CXC8895
			59	Arm Assy	CXC8896
11	Spring	CBH3015	60	Washer	CBF1037
12	Spring	CBH3016			
13	Spring	CBH3017	61	Washer	CBF1038
14	Spring	CBH3018	62	Arm	CND4554
15	Spring	CBH3019	63	Collar	CNV6906
			64	Roller	CNW1196
16	Spring	CBH3020	65	Gear Unit	CXC8893
17	Spring	CBH3030			
18	Plate Spring	CBL1797	66	Screw(M2 x 5)	EBA1028
19	Cable	CDE8631	67	Motor	EXM1050
20	Service PU Unit	CXX2398	68	Screw	JFZ20P025FTC
			69	Screw	JGZ17P022FTC
21	Bracket	CND4553	70	Washer	YE15FTC
22	Arm	CND4555			
23	Lever	CND4556	71	Screw	IMS20P030FTC
24	Frame	CND4557	72	DVD Core Unit	YWX5009
25	Frame	CND4558			
26	Sheet	CNN2280			
27	Rack	CNW1170			
28	Guide	CNW1171			
29	Roller	CNW1172			
30	Arm	CNW1173			
31	Arm	CNW1174			
32	Roller	CNW1175			
33	Lever	CNW1176			
34	Arm	CNW1177			
35	Arm	CNW1178			
36	Gear	CNW1180			
37	Gear	CNW1181			
38	Gear	CNW1182			
39	Gear	CNW1183			
40	Rack	CNW1184			
41	Gear	CNW1185			
42	Gear	CNW1186			
43	Gear	CNW1187			
44	Gear	CNW1188			
45	Clamper	CNW1190			
46	Arm	CNW1191			
47	Arm	CNW1192			
48	Holder	CNW1193			
49	Holder	CNW1194			

A

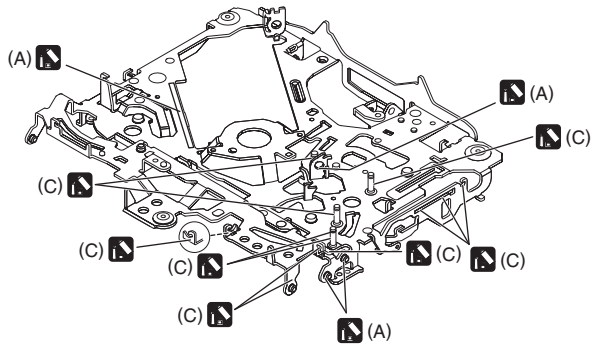

B

C

D

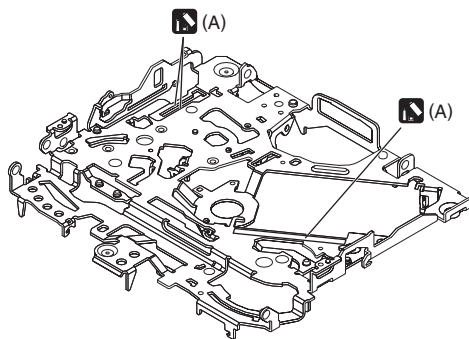

E

F

- (A) : GEM1045
- (B) : GEM1038
- (C) : GEM1024

A

B

C

D

E

F

A-b 1/6

MODEL
 AVIC-X910BT/XS/UC
 AVIC-F910BT/XS/EU5
 AVIC-F910BT/XS/AU

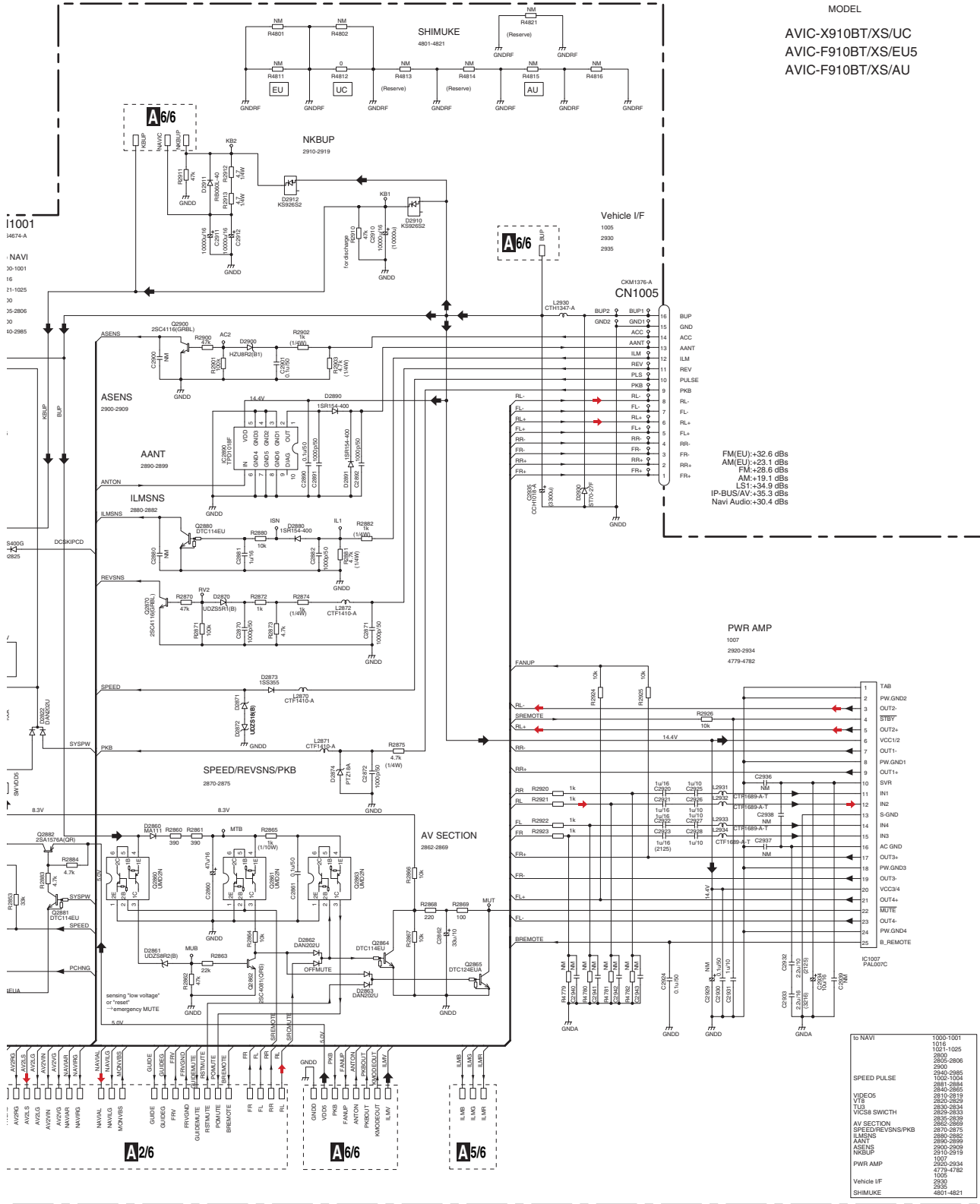

1000-1001
1016
1055-11025
2890
2900
2910-2919
2920-2934
2935
2940-2949
2950-2959
2960-2969
2970-2975
2980-2982
2983-2989
2990-2999
3000
3010
3020
3030
3040
3050
3060
3070
3080
3090
3100
3110
3120
3130
3140
3150
3160
3170
3180
3190
3200
3210
3220
3230
3240
3250
3260
3270
3280
3290
3300
3310
3320
3330
3340
3350
3360
3370
3380
3390
3400
3410
3420
3430
3440
3450
3460
3470
3480
3490
3500
3510
3520
3530
3540
3550
3560
3570
3580
3590
3600
3610
3620
3630
3640
3650
3660
3670
3680
3690
3700
3710
3720
3730
3740
3750
3760
3770
3780
3790
3800
3810
3820
3830
3840
3850
3860
3870
3880
3890
3900
3910
3920
3930
3940
3950
3960
3970
3980
3990
4000
4010
4020
4030
4040
4050
4060
4070
4080
4090
4100
4110
4120
4130
4140
4150
4160
4170
4180
4190
4200
4210
4220
4230
4240
4250
4260
4270
4280
4290
4300
4310
4320
4330
4340
4350
4360
4370
4380
4390
4400
4410
4420
4430
4440
4450
4460
4470
4480
4490
4500
4510
4520
4530
4540
4550
4560
4570
4580
4590
4600
4610
4620
4630
4640
4650
4660
4670
4680
4690
4700
4710
4720
4730
4740
4750
4760
4770
4780
4790
4800
4810
4820
4830
4840
4850
4860
4870
4880
4890
4900
4910
4920
4930
4940
4950
4960
4970
4980
4990
5000

A1/6

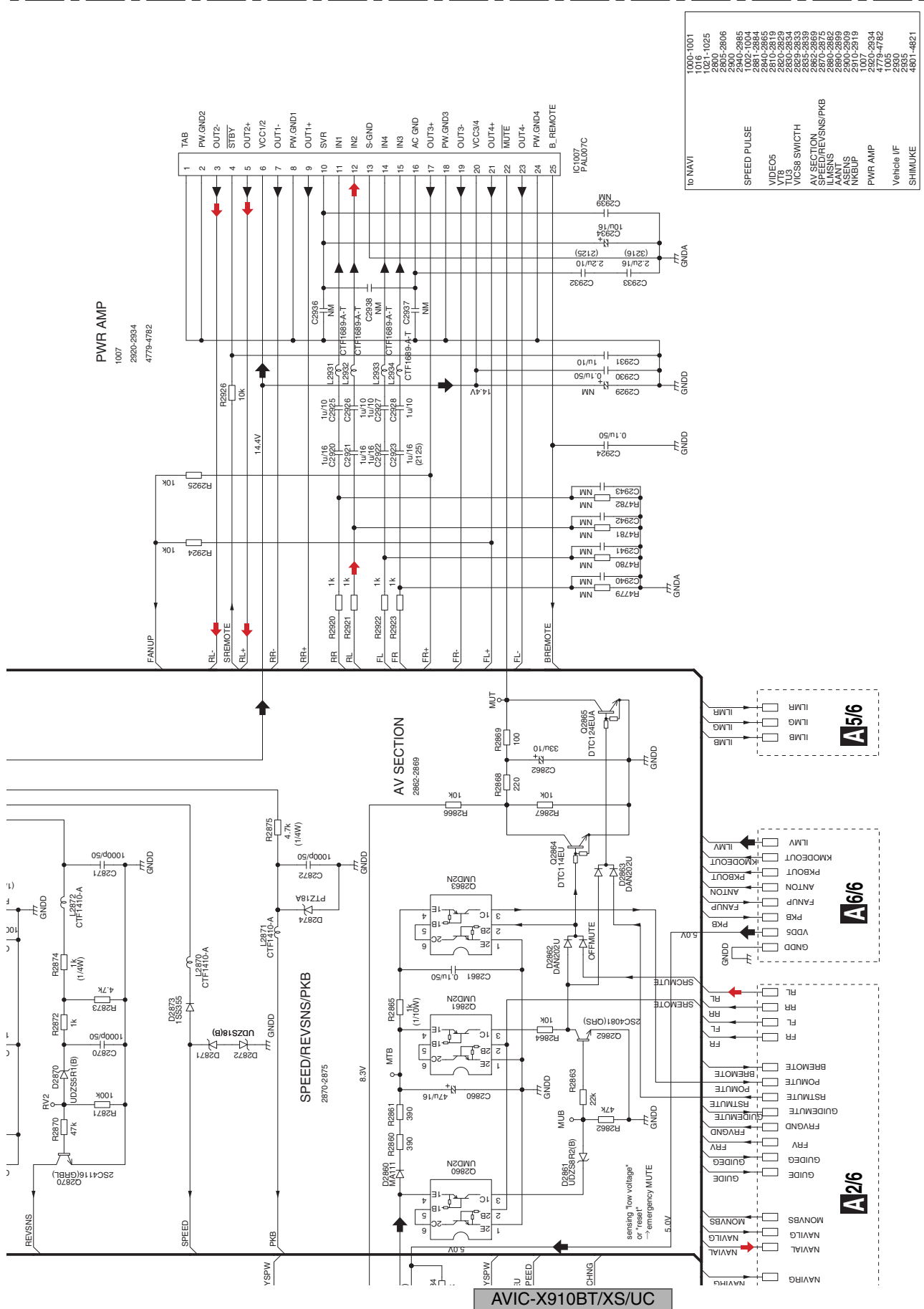

A-a

A-b 1/6

NOTE :

- Symbol indicates a resistor.
- No differentiation is made between chip resistors and discrete resistors.
- ⊃ Symbol indicates a capacitor.
- No differentiation is made between chip capacitors and discrete capacitors.

NM : No Mount

The Δ mark found on some component parts indicates the importance of the safety factor of the part. Therefore, when replacing, be sure to use parts of identical designation.

A1/6 AV UNIT (PS/IF SECTION)

NAVI UNIT SPJ1

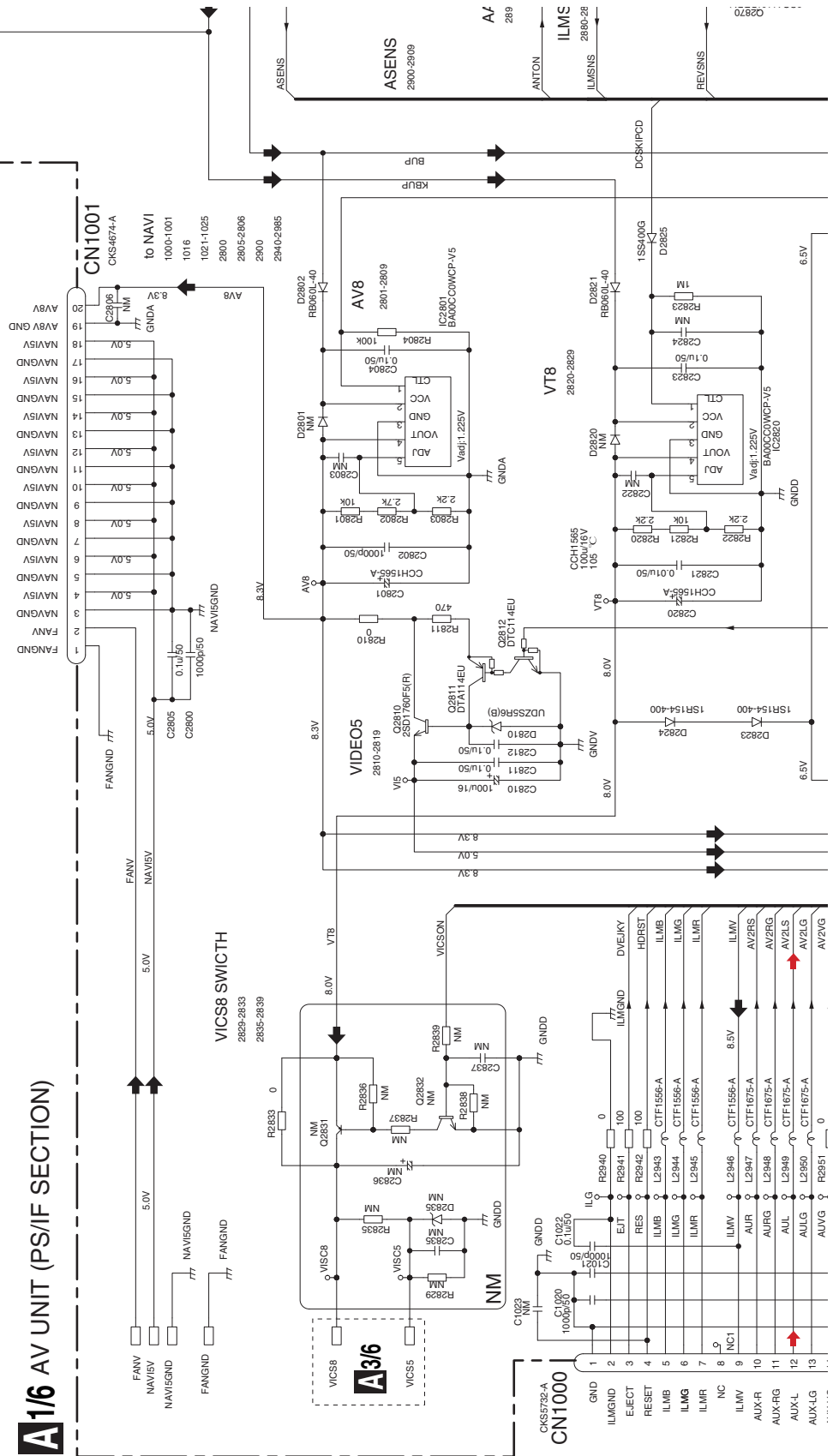

to NAVI	1000-1001
	1016
	1021-1025
	2800
	2805-2806
	2800
	2840-2885

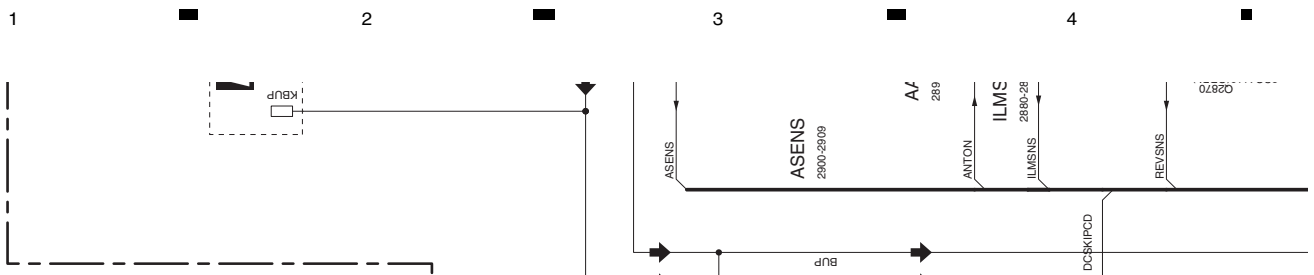

NAVI UNIT OTJ1

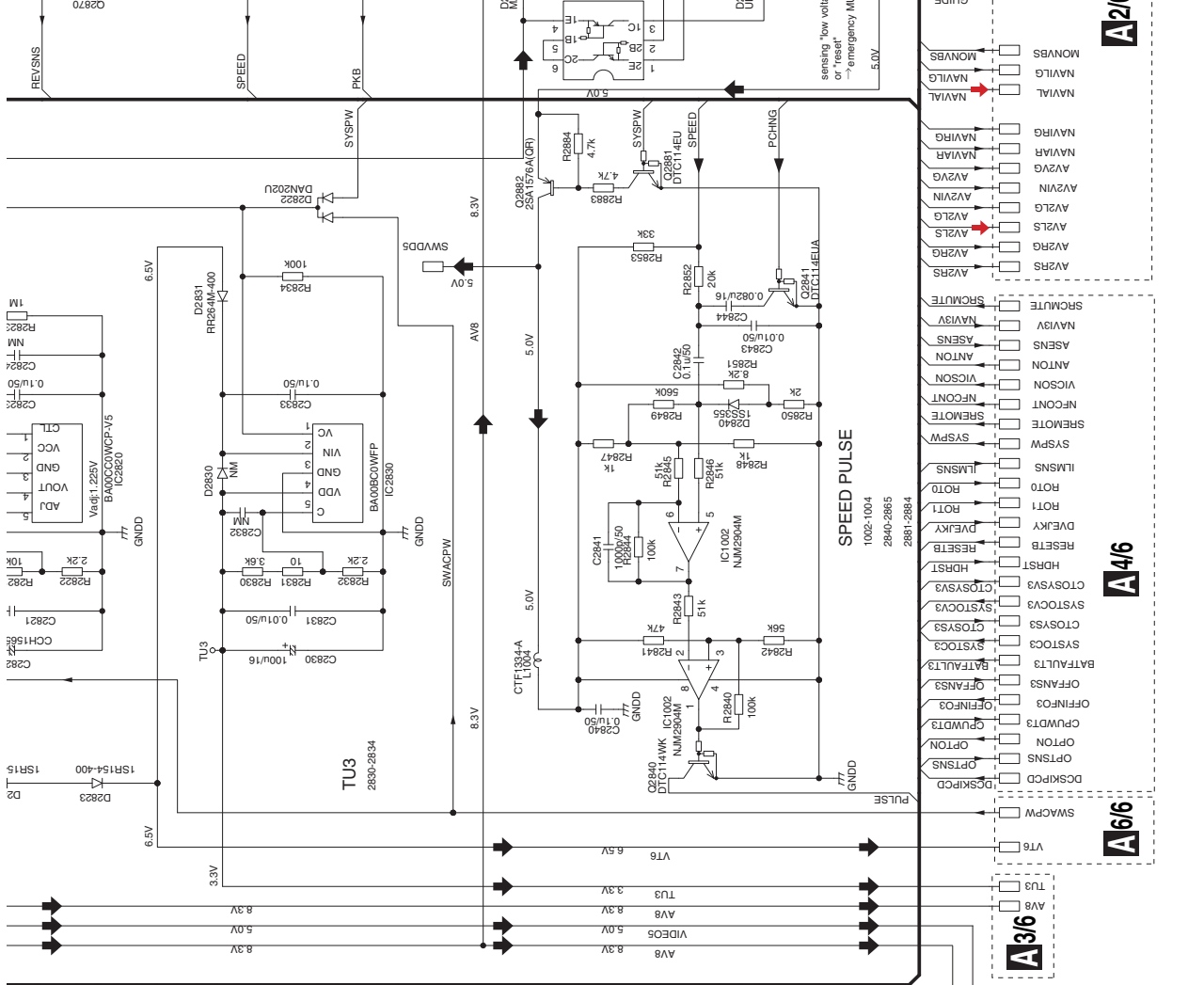
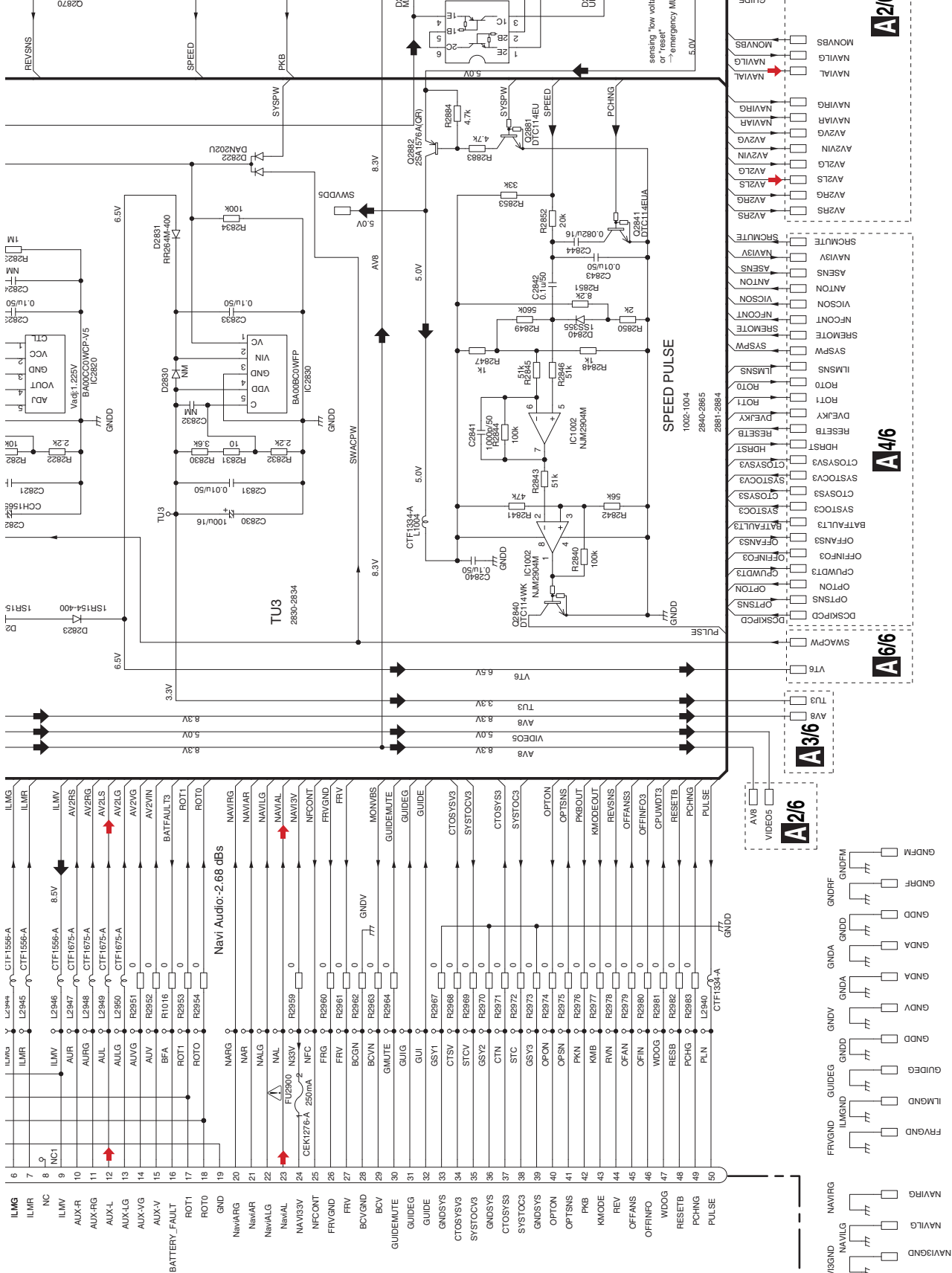

A-a 1/6

A-b 1/6

A-a A-b

A B C D E F

A-b 2/6

A/2/6 AV UNIT (A/V SECTION)

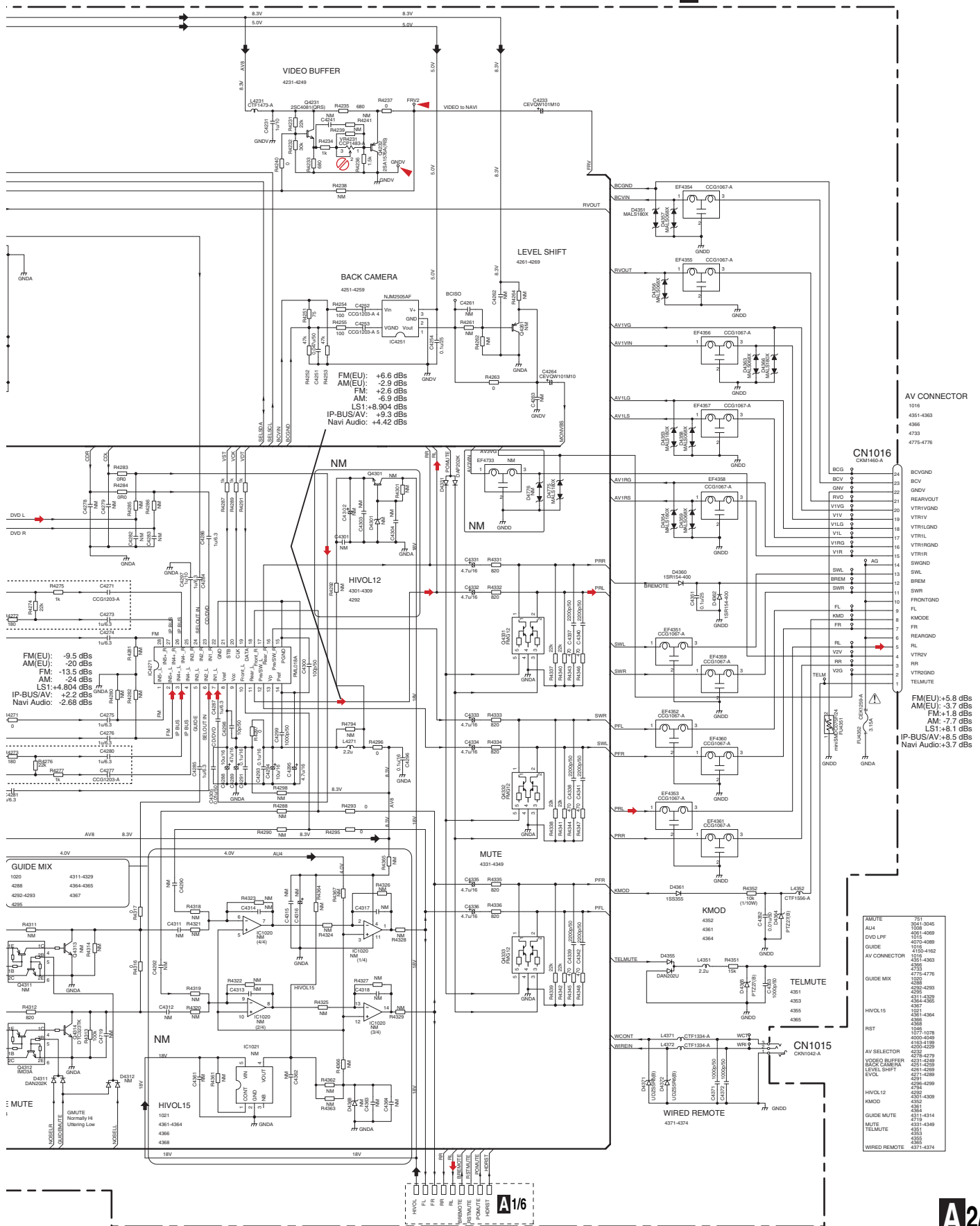

A2/6 AV UNIT (AV SECTION)

A-a A-b

A-b 2/6

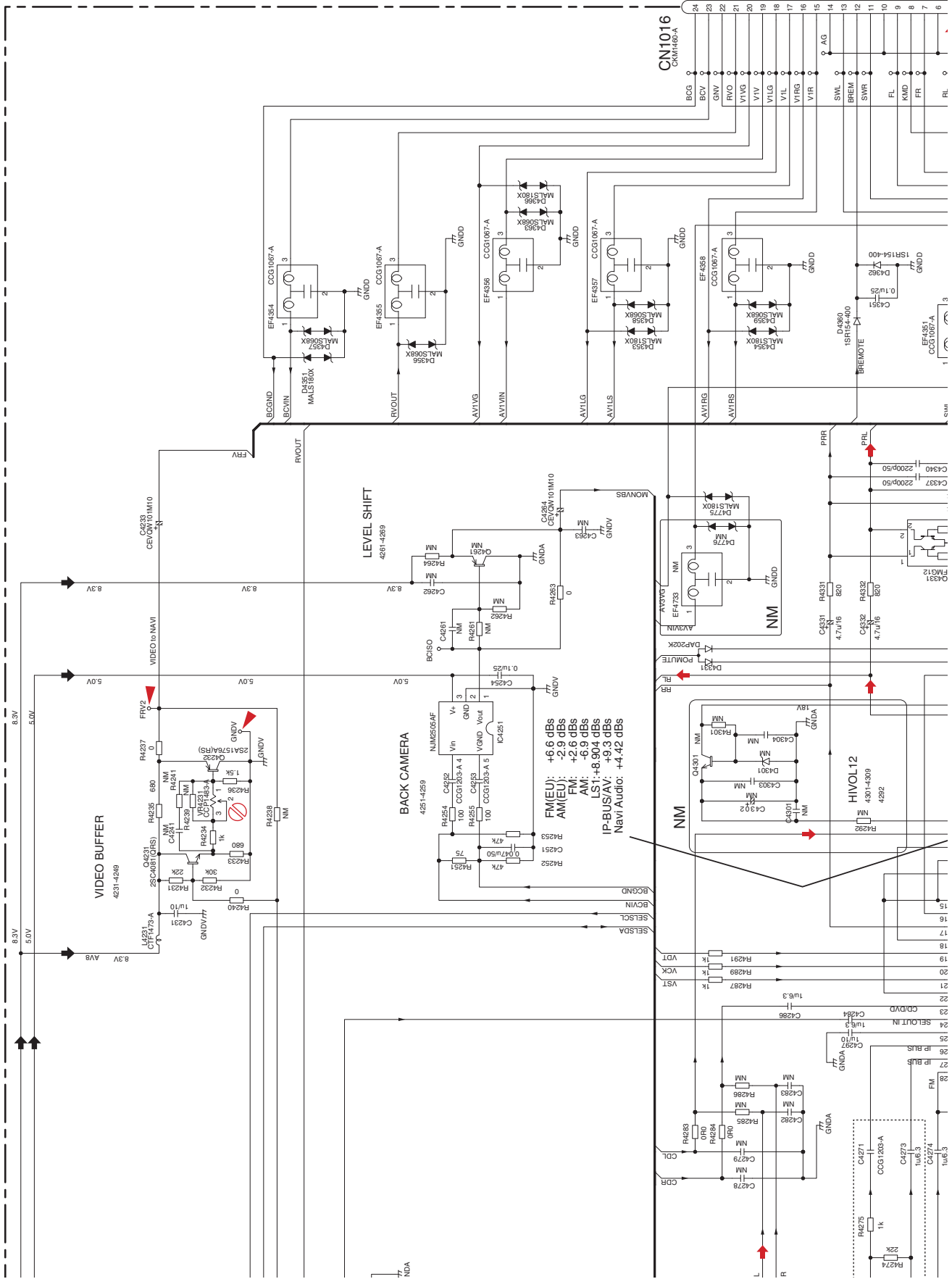

AVIC-X910BT/XS/UC

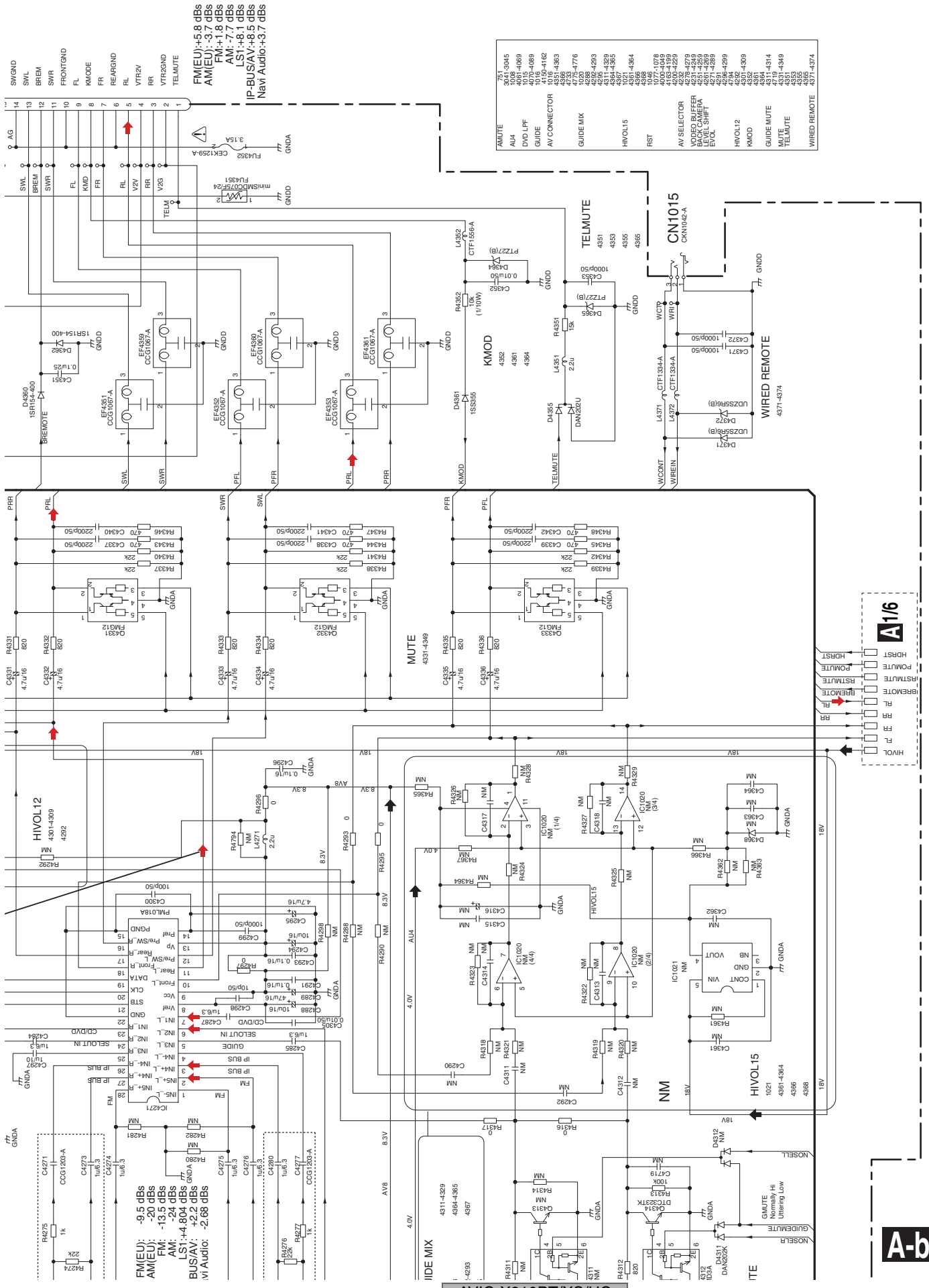

AVIC-X910BT/XS/UC

A-b 2/6

A-a A-b

A-b 2/6

A-a 2/6

AVIC-X910BT/XS/UC

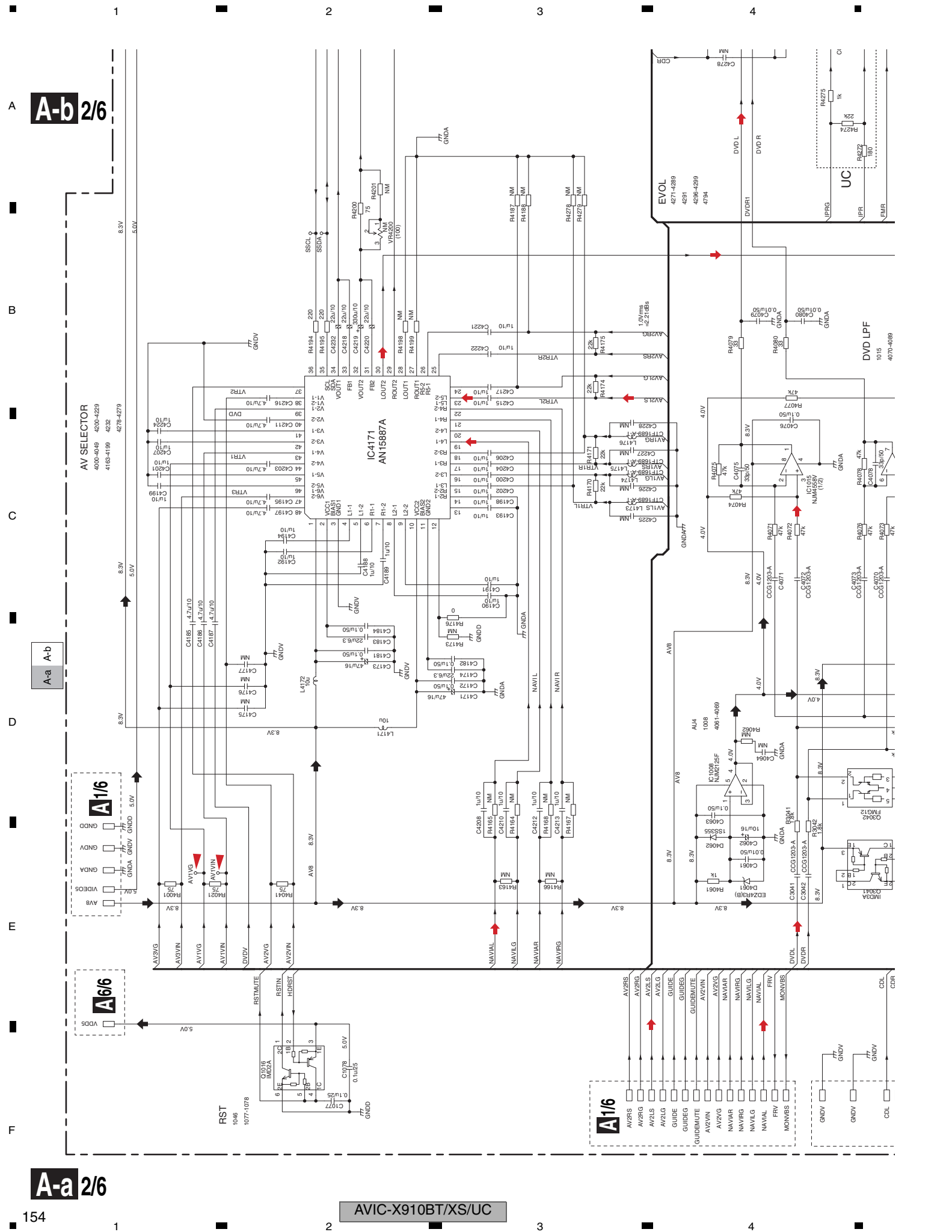

10.3 AV UNIT(TUNER SECTION)

A

B

C

D

E

F

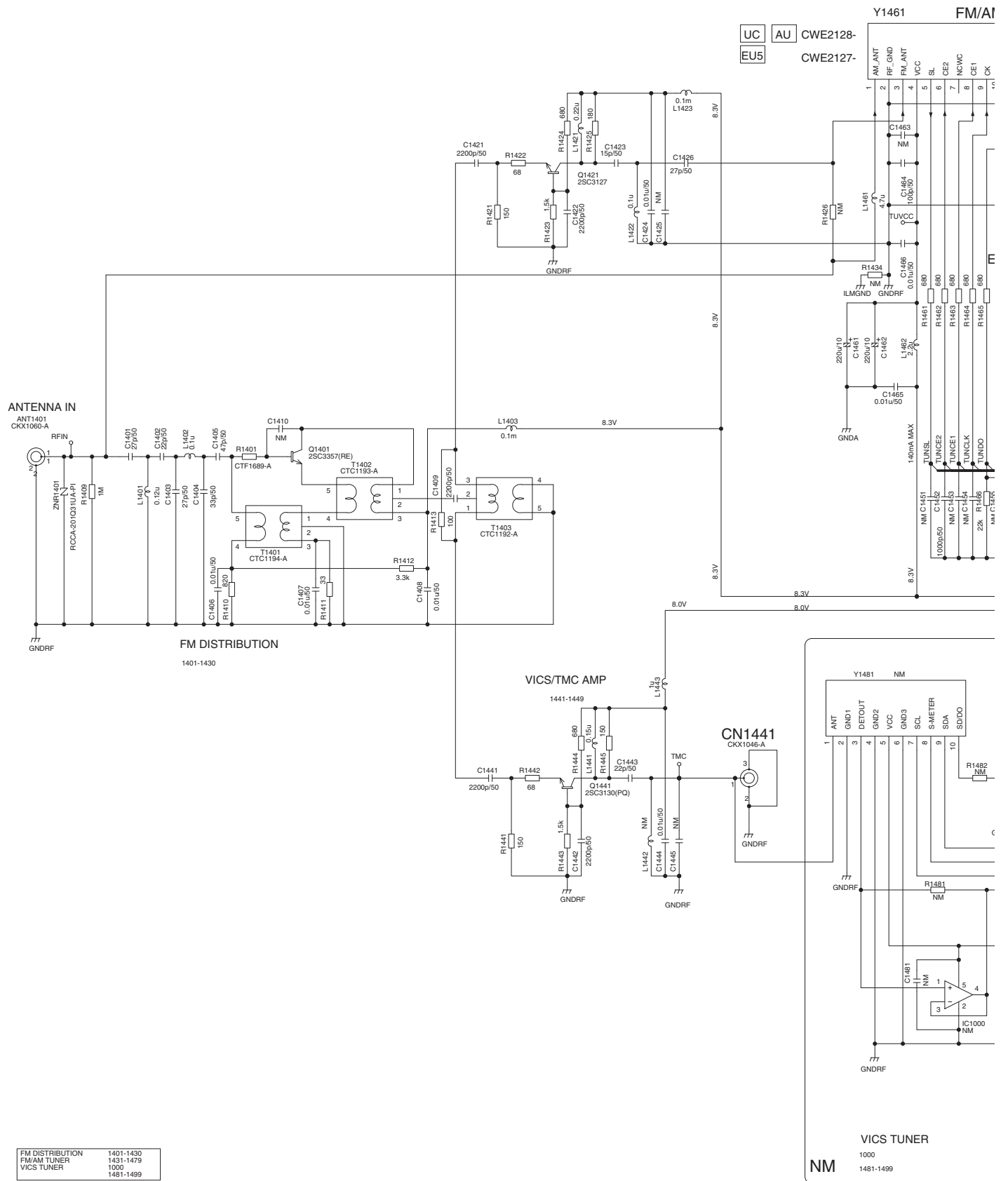

FM DISTRIBUTION	1401-1430
FM/AM TUNER	1431-1479
VICS TUNER	1000
VICS TUNER	1481-1499

A3/6 AV UNIT (TUNER SECTION)

161 FM/AM TUNER UNIT

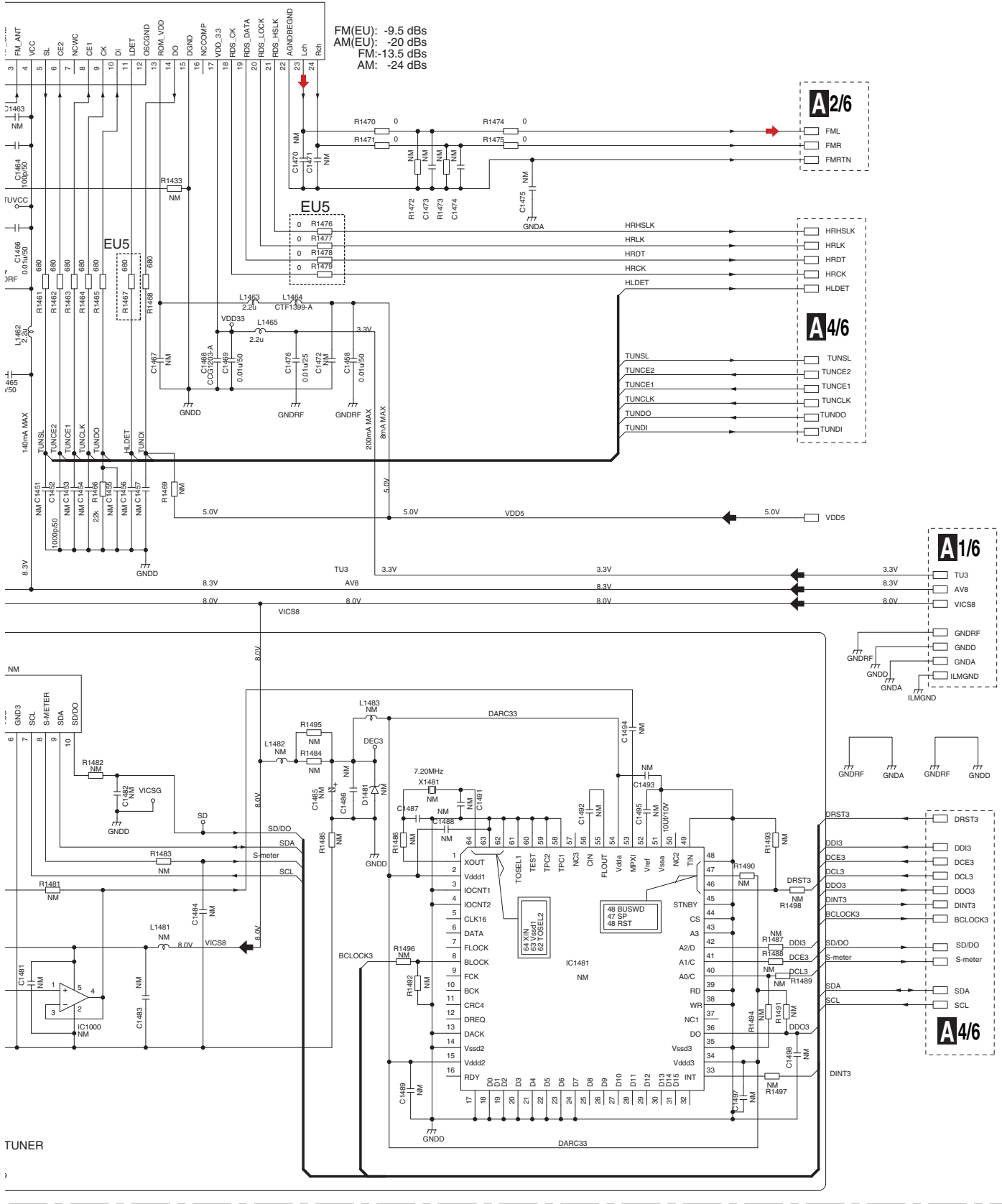

TUNER

10.4 AV UNIT(SYSTEM uCOM SECTION)(GUIDE PAGE)

A-a 4/6

B CN882

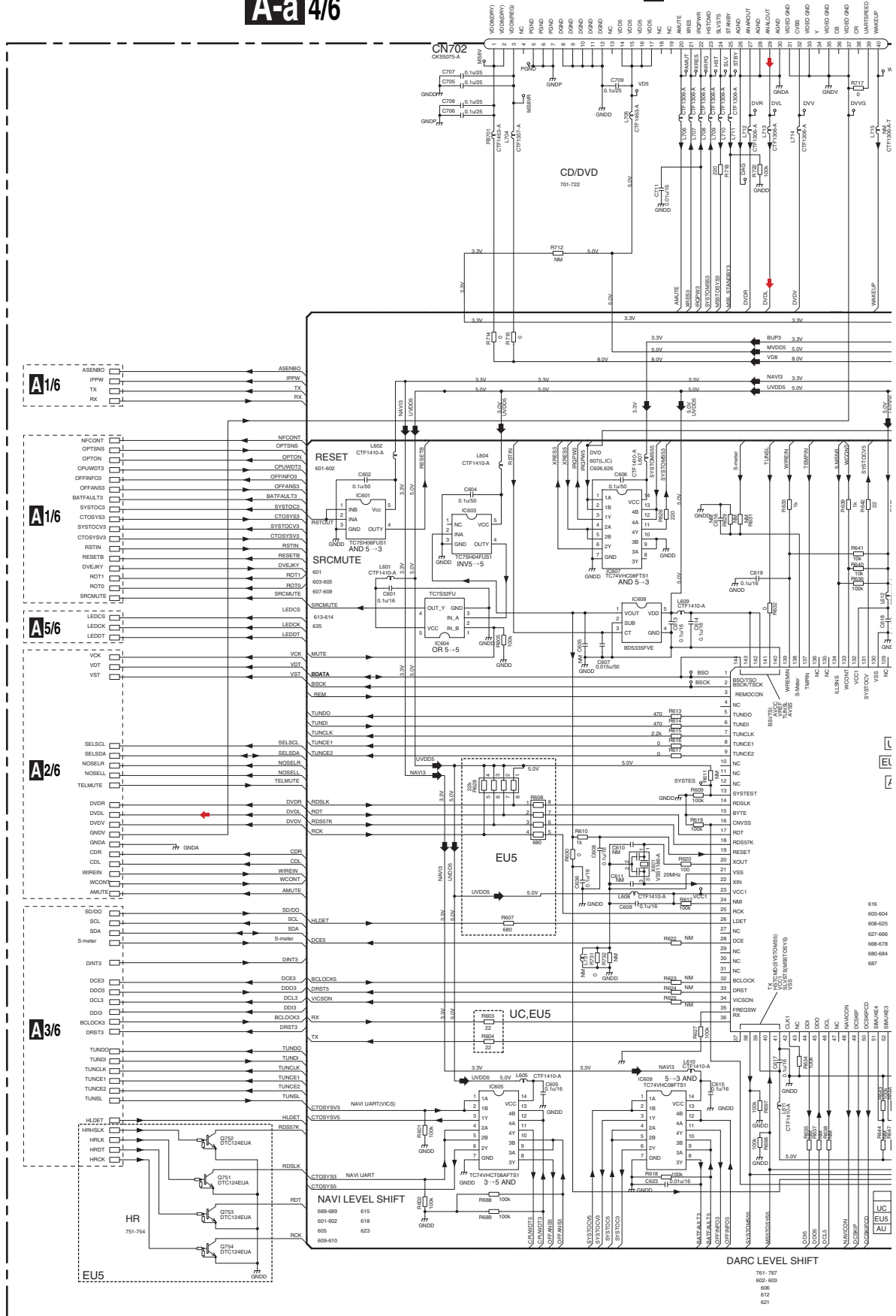

A 4/6

AVIC-X910BT/XS/UC

A-b 4/6

A/4/6 AV UNIT (SYSTEM uCOM SECTION)

VDD8(DRY):1800MA MAX
 VDD8(REG):220MA MAX
 VDD5 :650MA MAX

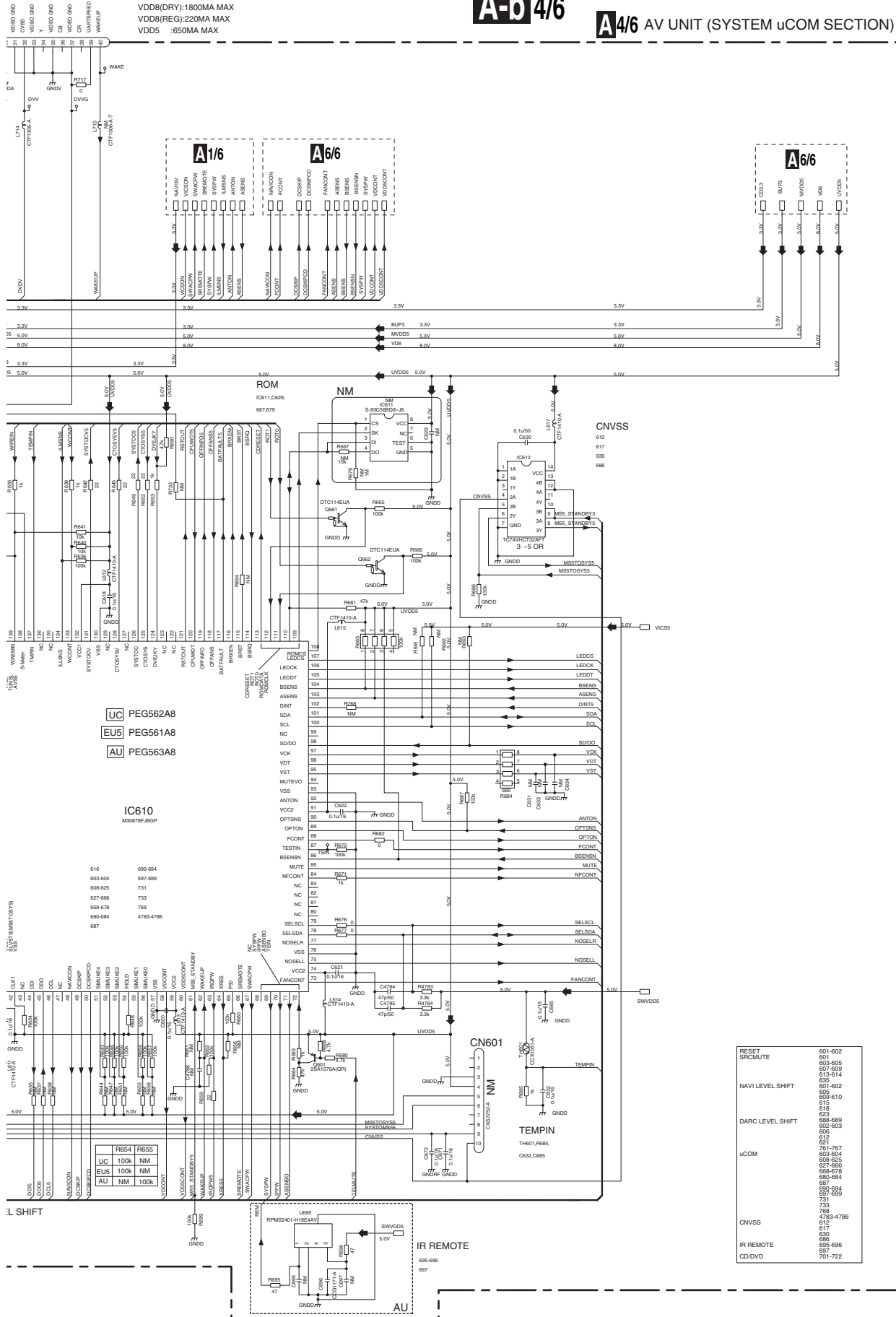

- UC PEG562A8
- EUS PEG561A8
- AU PEG563A8

IC610
M30879J85P

616	690-694
603-604	697-699
608-625	731
627-666	733
668-678	768
689-684	4783-4786
687	

- R654 100k NM
- R655 100k NM
- EUS 100k NM
- AU 100k NM

RESET	601-602
SRMUTE	603
	603-605
	607-609
	613-614
	631
NAVI LEVEL SHIFT	601-602
	603
	609-610
	615
	618
	620
DARC LEVEL SHIFT	688-689
	602-603
	685
	612
	617-707
	693-694
	695-696
	697-698
	699-694
	695-699
	731
	733
	768
	4783-4786
CNVSS	612
	617
	630
	688
IR REMOTE	695-696
	697
CD/DVD	701-722



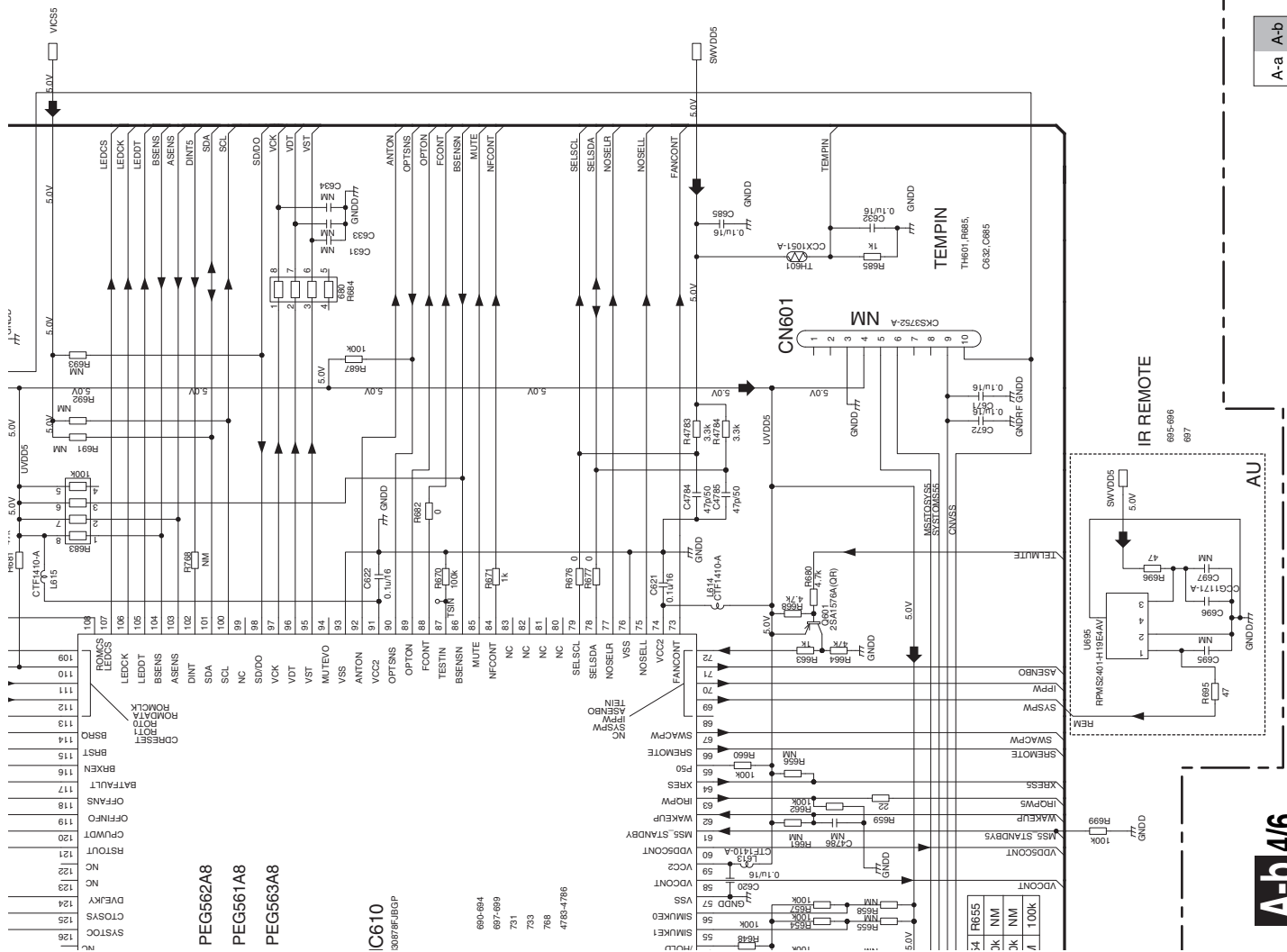

AVIC-X910BT/XS/UC

A-b 4/6

A-a A-b

601-602	RESET
603-605	SI/MUTE
607-609	
610-614	
615	
616-618	NAVI LEVELSHIFT
619-620	
621-623	
624-626	DARC LEVELSHIFT
627-629	
630-632	
633-635	
636-638	
639-641	
642-644	
645-647	
648-650	
651-653	
654-656	
657-659	
660-662	
663-665	
666-668	
669-671	
672-674	
675-677	
678-680	
681-683	
684-686	
687-689	
690-692	
693-695	
696-698	
699-701	
702-704	
705-707	
708-710	
711-713	
714-716	
717-719	
720-722	
723-725	
726-728	
729-731	
732-734	
735-737	
738-740	
741-743	
744-746	
747-749	
750-752	
753-755	
756-758	
759-761	
762-764	
765-767	
768-770	
771-773	
774-776	
777-779	
780-782	
783-785	
786-788	
789-791	
792-794	
795-797	
798-800	
801-803	
804-806	
807-809	
810-812	
813-815	
816-818	
819-821	
822-824	
825-827	
828-830	
831-833	
834-836	
837-839	
840-842	
843-845	
846-848	
849-851	
852-854	
855-857	
858-860	
861-863	
864-866	
867-869	
870-872	
873-875	
876-878	
879-881	
882-884	
885-887	
888-890	
891-893	
894-896	
897-899	
900-902	
903-905	
906-908	
909-911	
912-914	
915-917	
918-920	
921-923	
924-926	
927-929	
930-932	
933-935	
936-938	
939-941	
942-944	
945-947	
948-950	
951-953	
954-956	
957-959	
960-962	
963-965	
966-968	
969-971	
972-974	
975-977	
978-980	
981-983	
984-986	
987-989	
990-992	
993-995	
996-998	
999-1001	

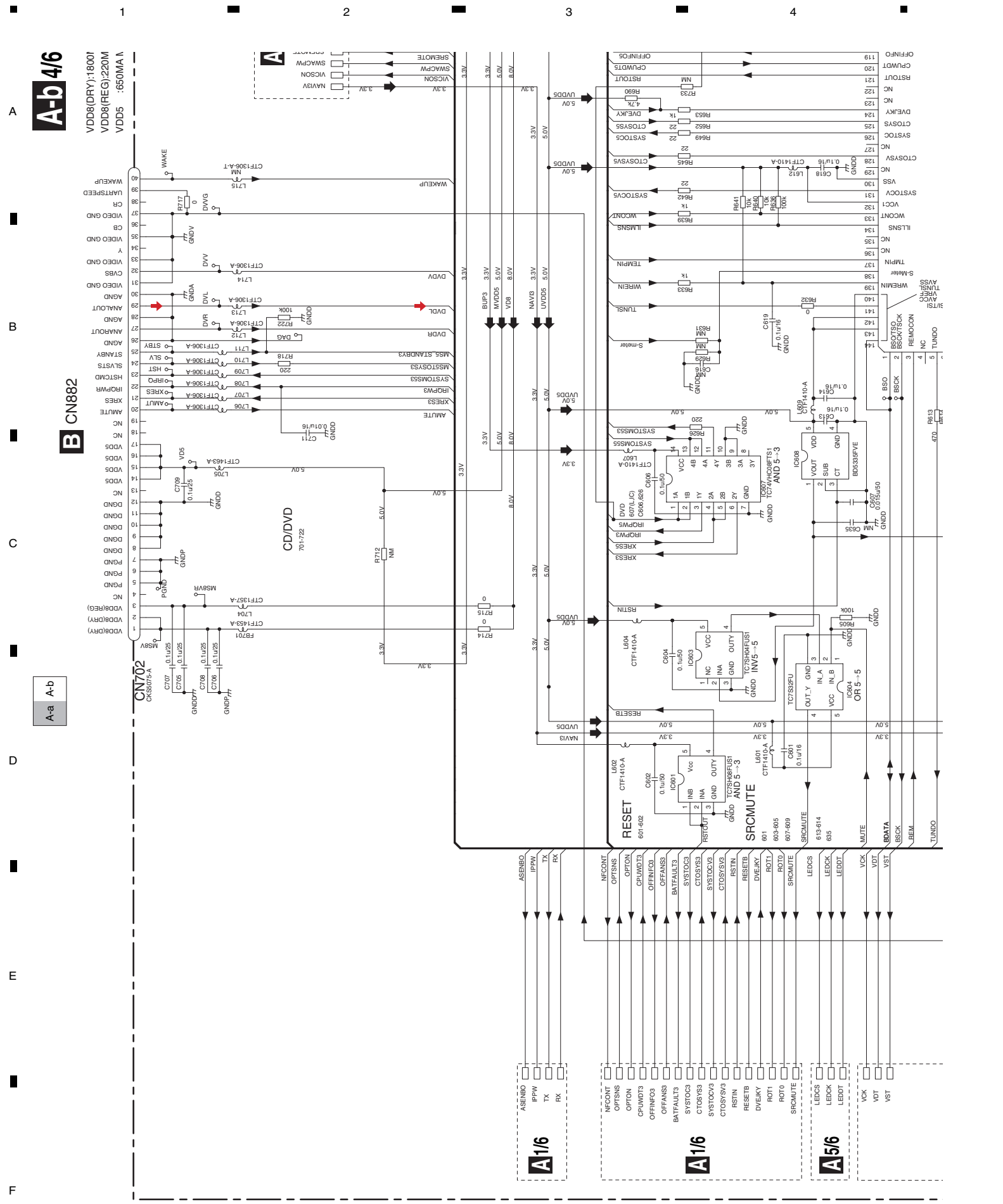

A-b 4/6

B CN882

A-a A-b

A-a 4/6

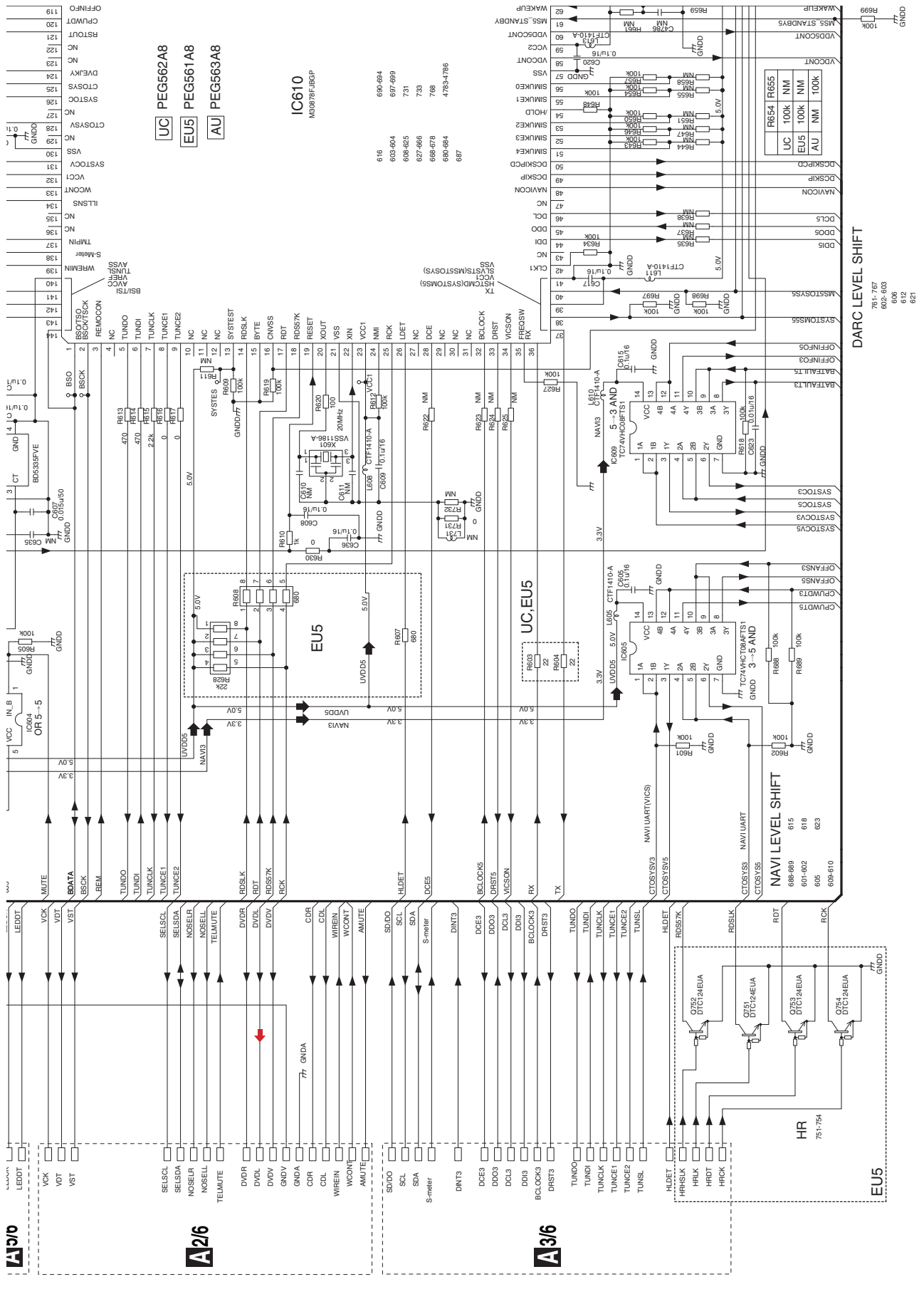

HR
751-754

EU5

A-a A-b

A-b 4/6

A-a 4/6

10.5 AV UNIT(RGB LED DRIVER SECTION)

A

B

C

D

E

F

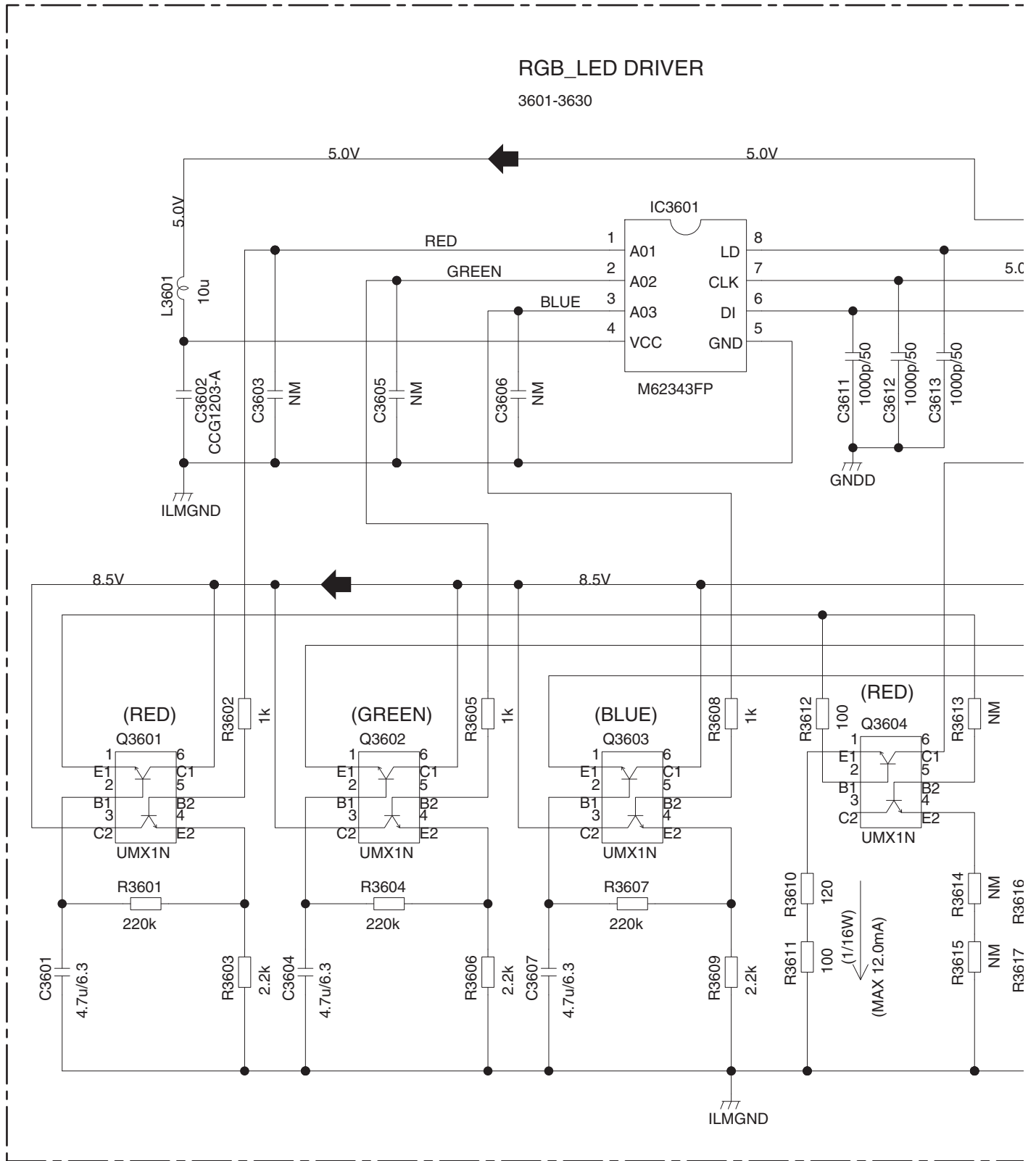

A5/6 AV UNIT (RGB LED DRIVER SECTION)

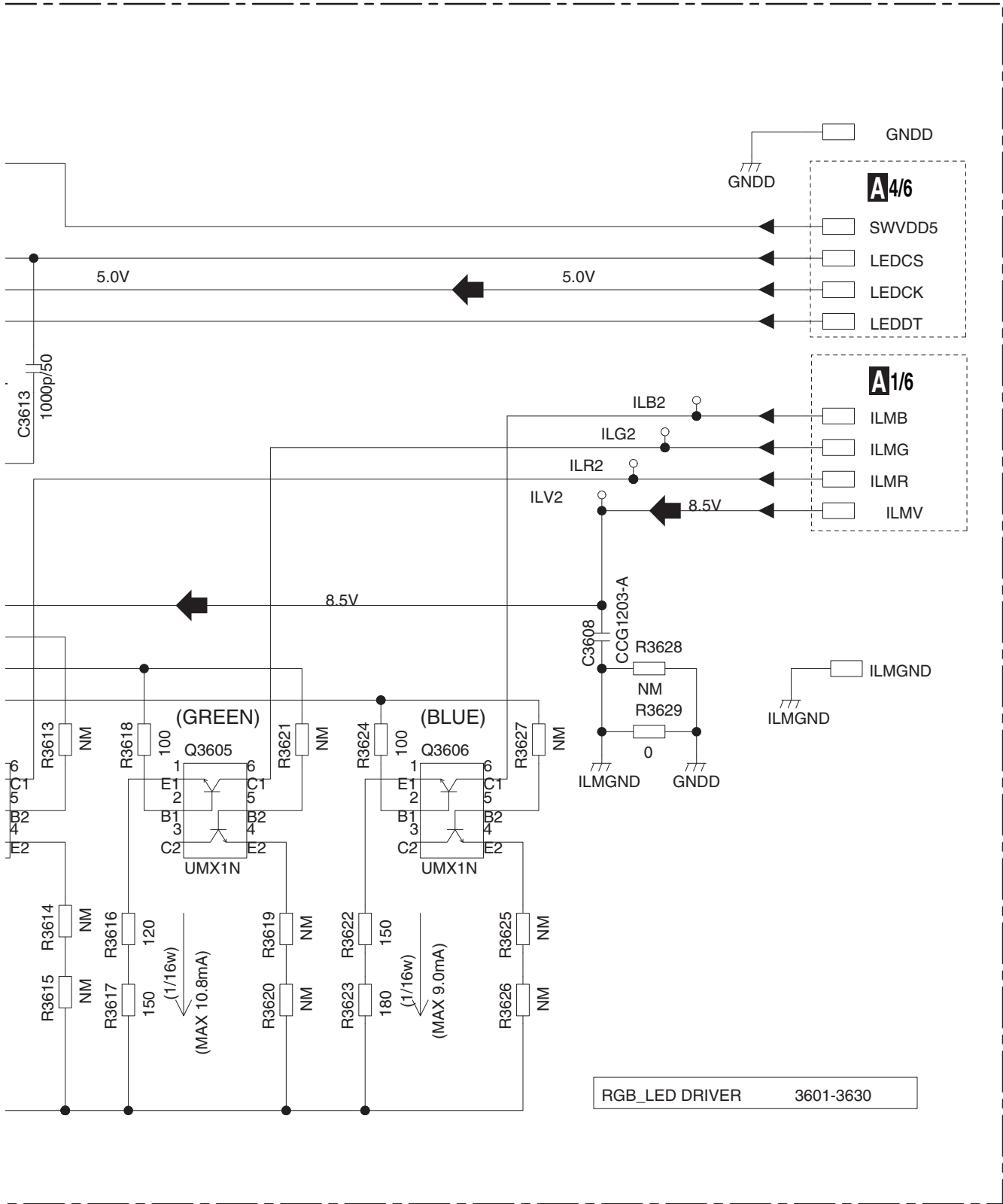

A
B
C
D
E
F

10.6 AV UNIT(IF SECTION)(GUIDE PAGE)

A-a 6/6

A

B

C

D

E

F

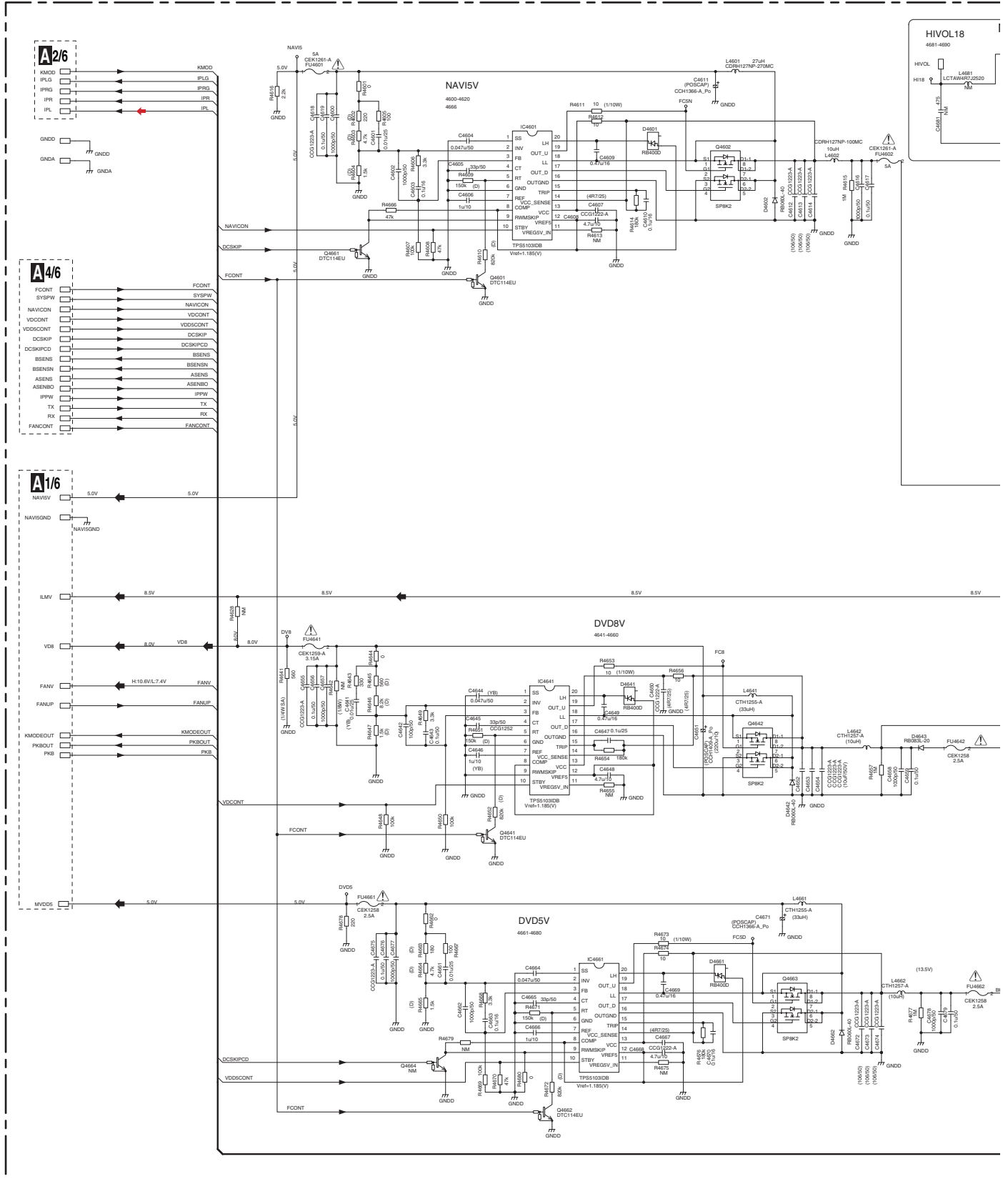

A-b 6/6

A6/6 AV UNIT (IF SECTION)

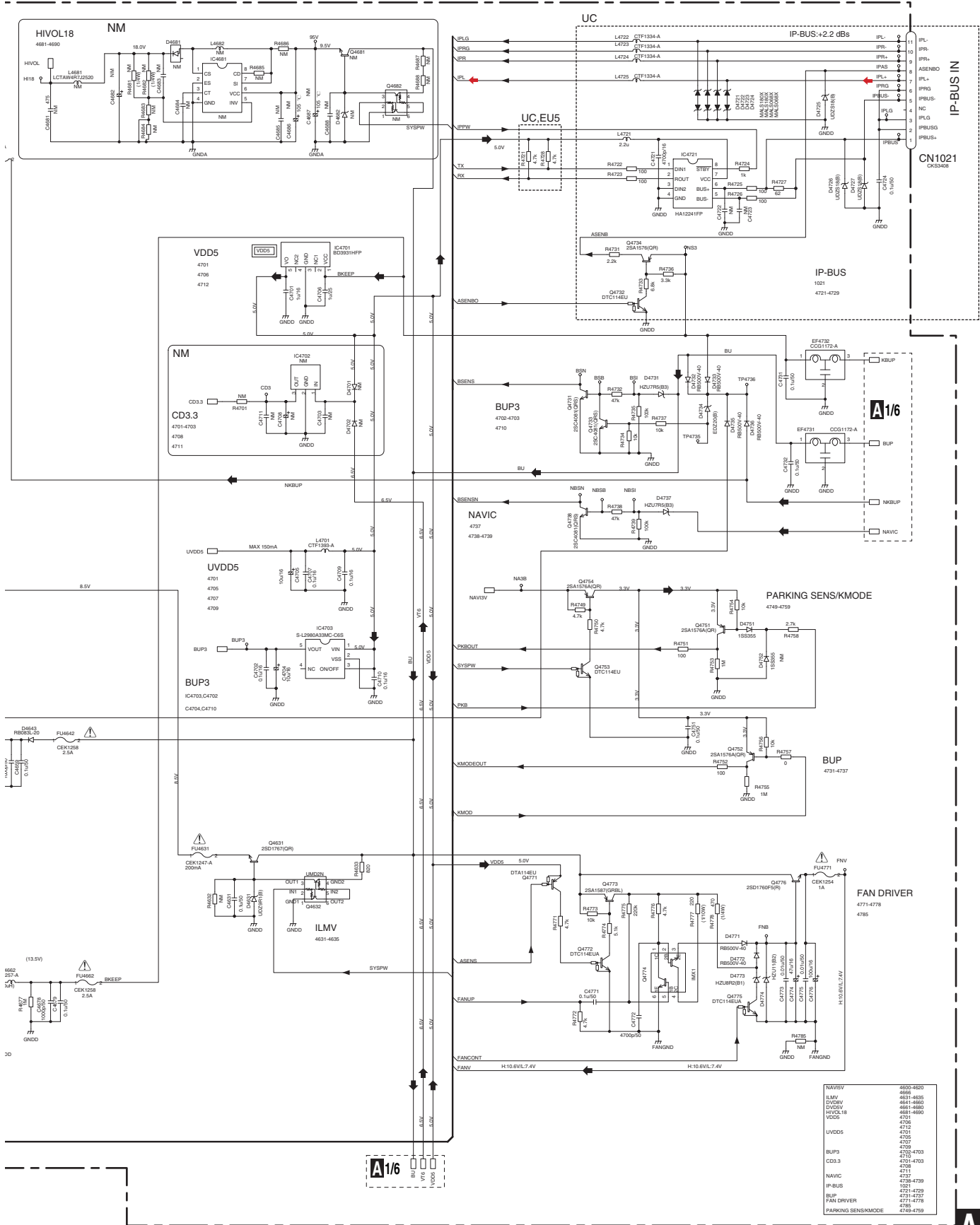

NAV1SV	4690-4690
ILMV	4631-4635
DVDDV	4641-4660
HIVOL18	4681-4690
VDD5	4701-4703
UVDD5	4707-4709
BUP3	4702-4703
CD3.3	4701-4703
NAVIC	4737
PARKING SENS/KMODE	4749-4759
IP-BUS	4721-4729
BUP	4731-4737
FAN DRIVER	4771-4778
PARKING SENS/KMODE	4749-4759

A-b 6/6

A-a A-b

A-a 6/6

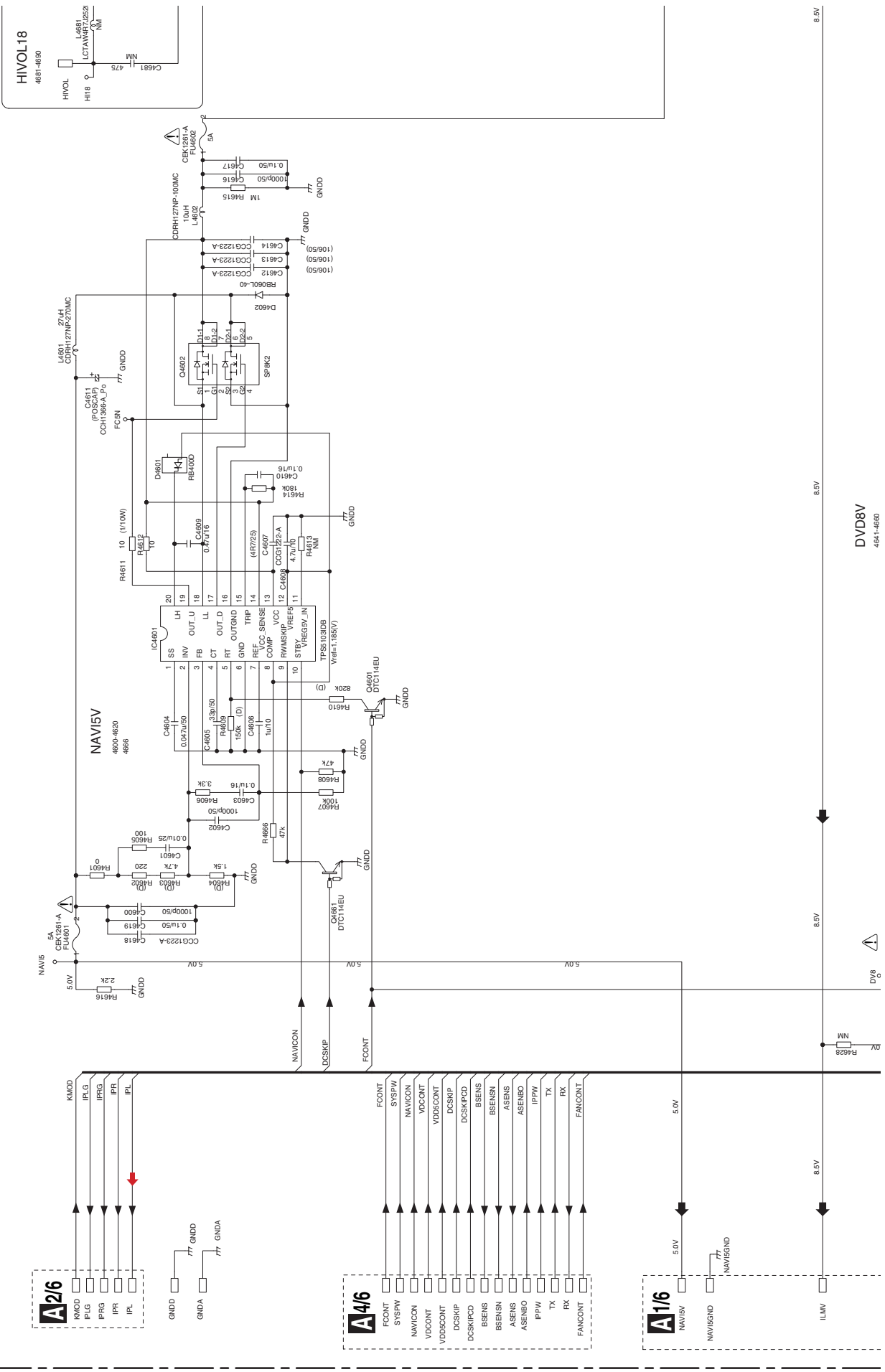

A

B

C

D

E

F

8.5V

8.5V

8.5V

8.5V

8.5V

DVD8V
4611-4610

DV/8

0V

5.0V

5.0V

10.7 CK UNIT

A

B

C

D

E

F

C
CN1901

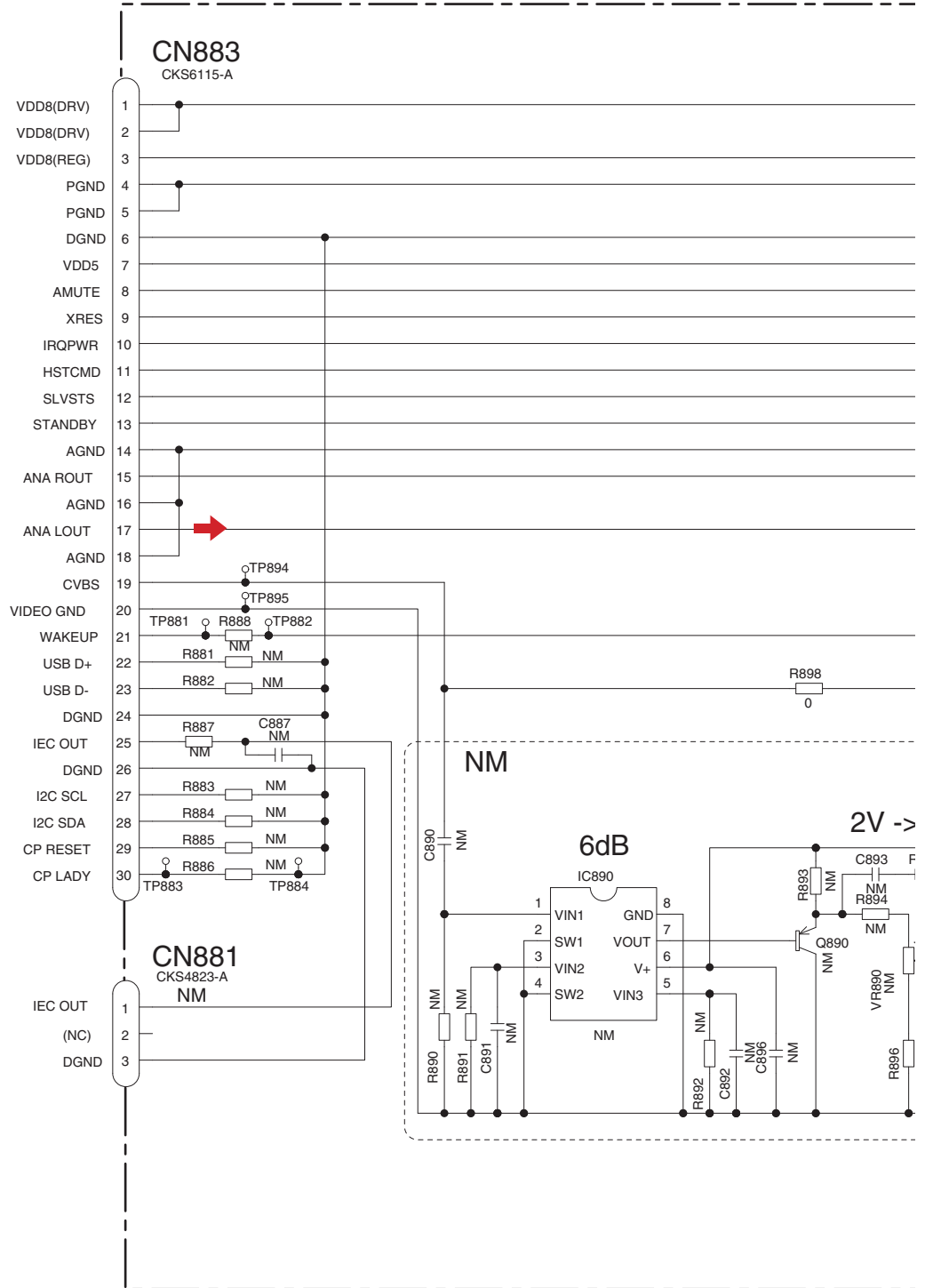

B

B CK UNIT

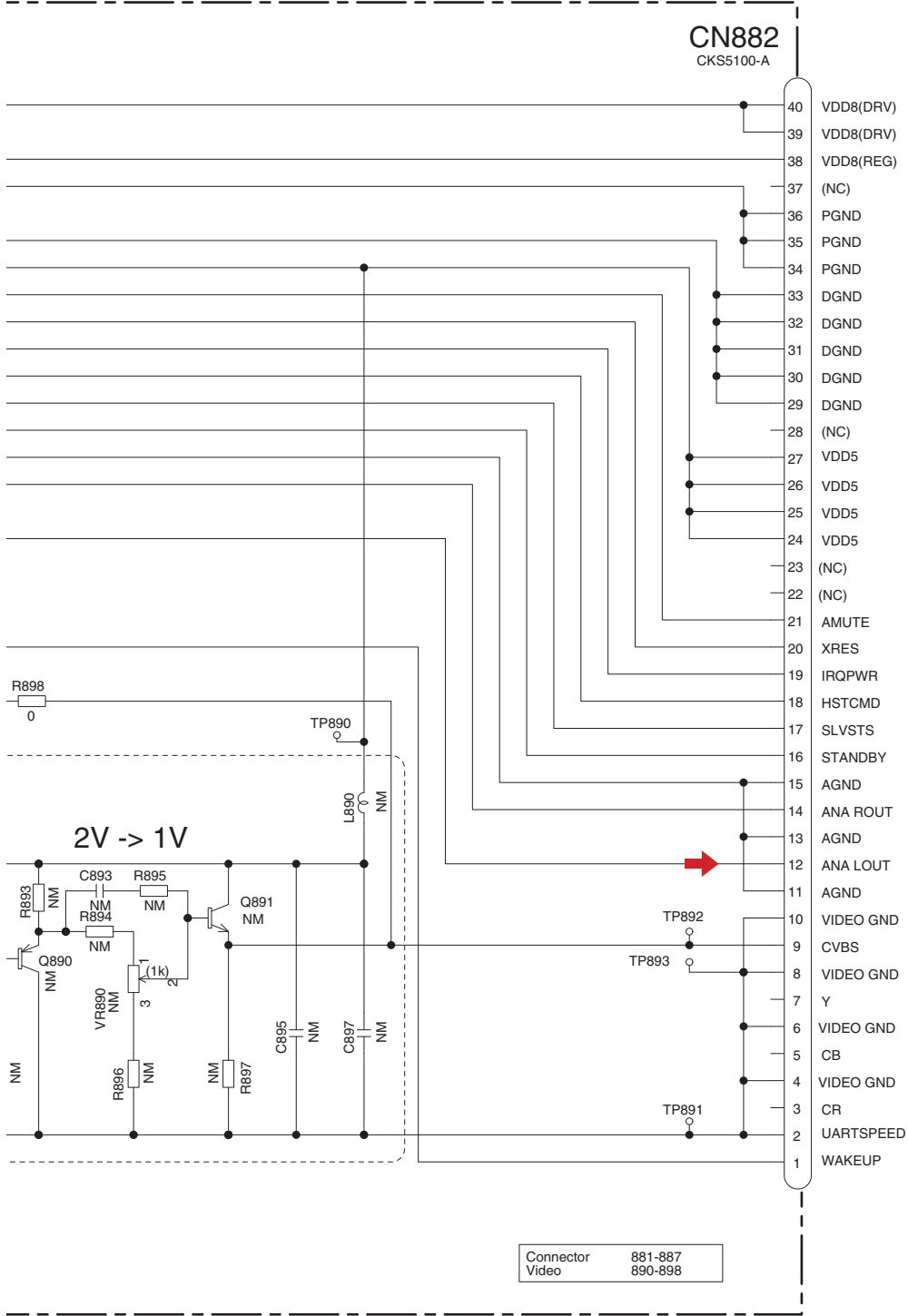

A

B

C

D

E

F

10.8 DVD CORE UNIT(GUIDE PAGE)

C-a

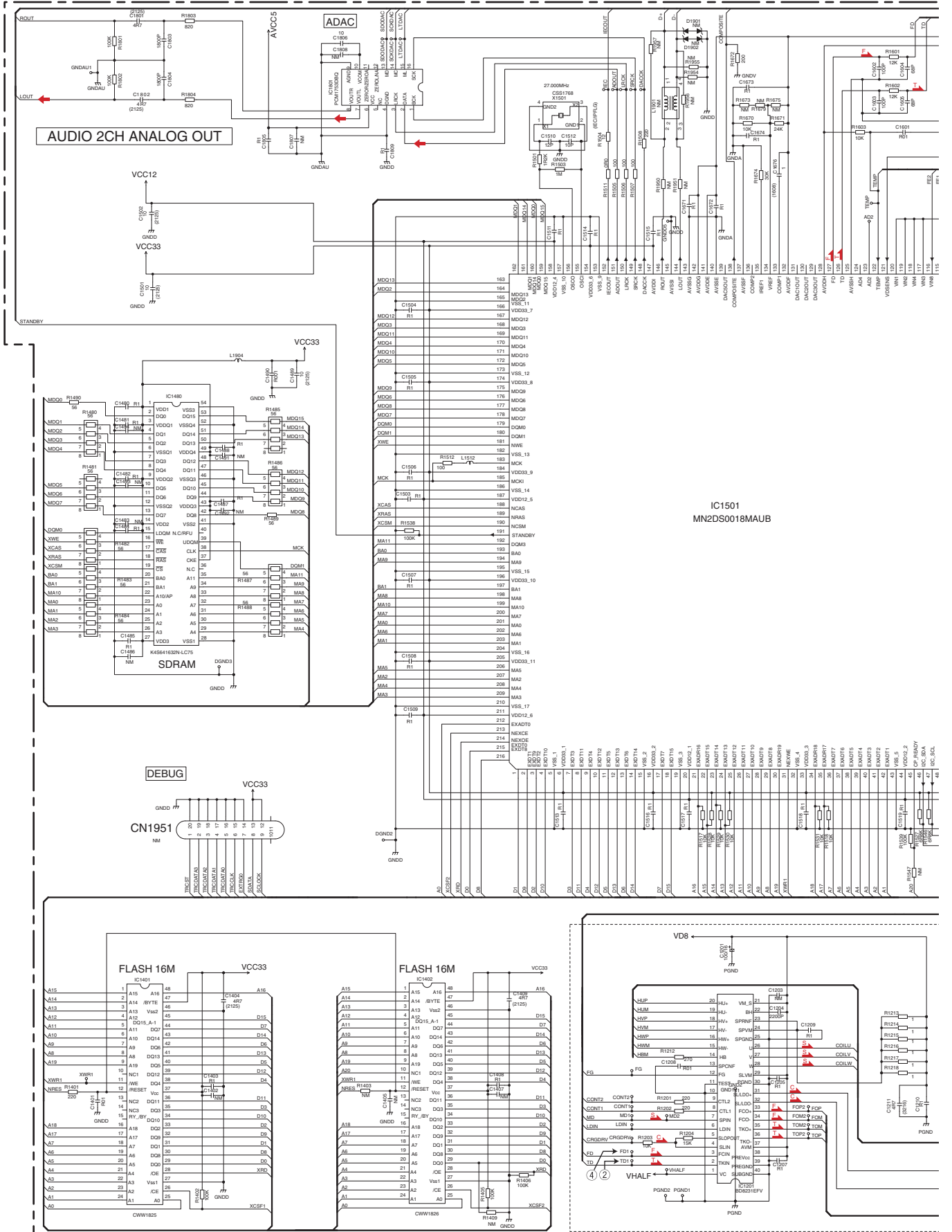

AVIC-X910BT/XS/UC

C DVD CORE UNIT

- FOCUS SERVO LINE
- TRACKING SERVO LINE
- CARRIAGE SERVO LINE
- SPINDLE SERVO LINE
- RF SIGNAL

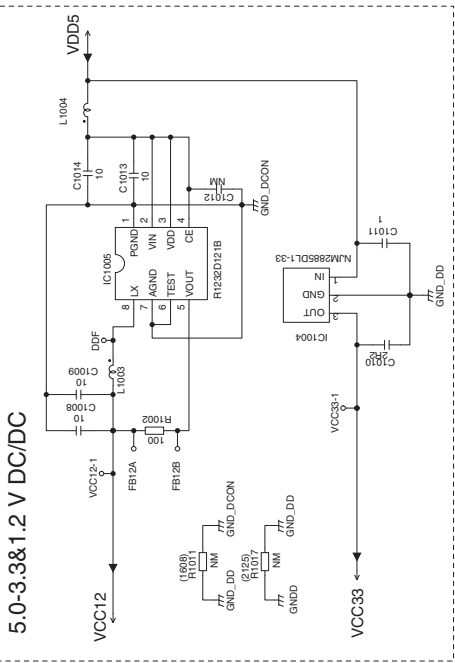

5.0-3.3&1.2 V DC/DC

POWER SUPPLY

1000->1049	ACT-SPDL
1050->1099	FLASH
1100->1149	SDRAM
1150->1199	EEPROM(S)
1200->1249	DYN(IBE)
1250->1299	DYN(BE)
1300->1349	VVIDEO (ANALOG)
1350->1399	AUDIO (ANALOG)
1400->1449	AUDIO (DIGITAL)
1450->1499	OUTSIDE I/F
1500->1549	USB

VOLTAGE DETECT VCC33

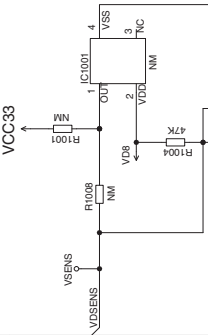

C-a C-b

C-b

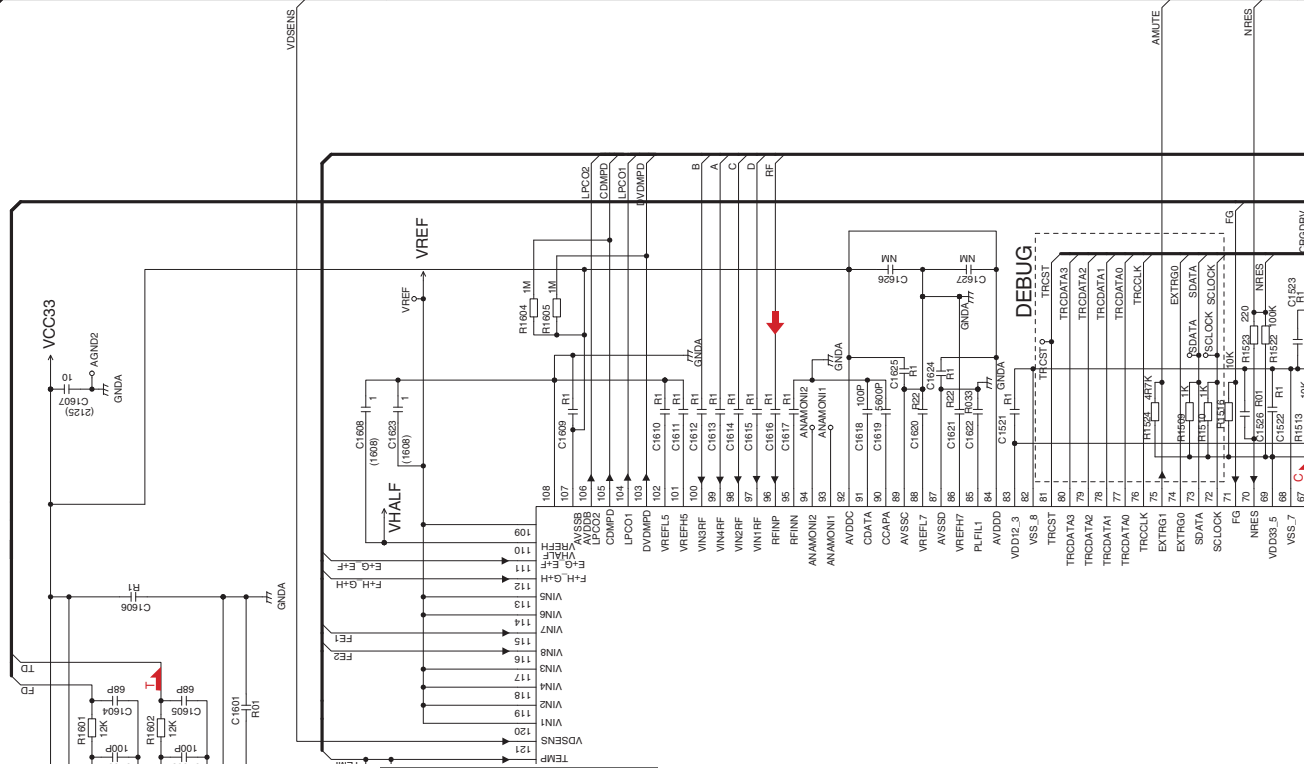

AVIC-X910BT/XS/UC

B
CN883

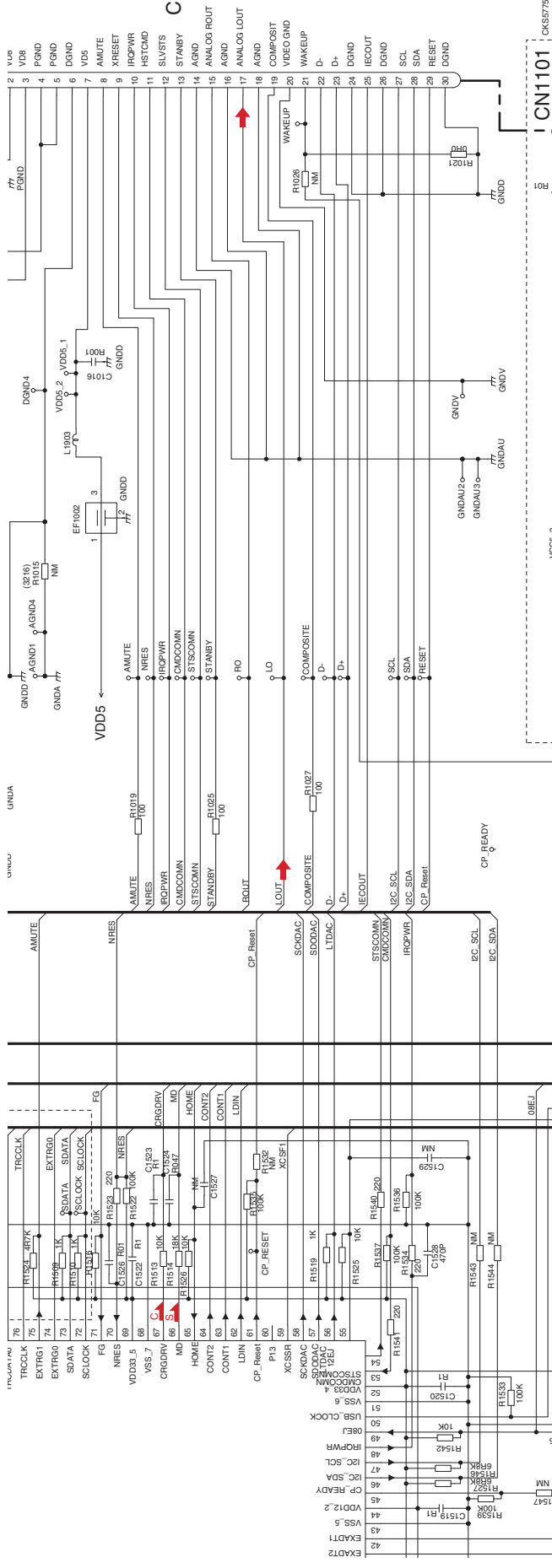

PICKUP UNIT (SERVICE)

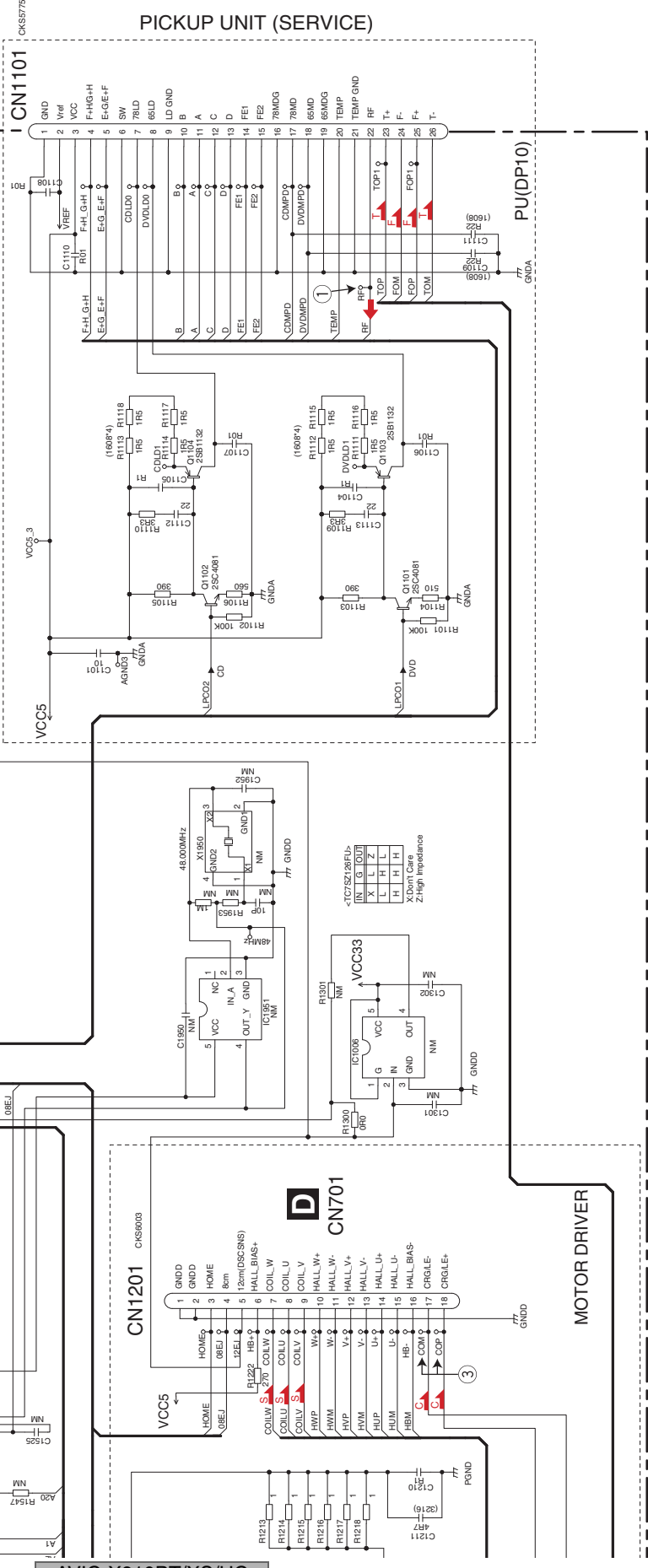

C-a C-b

C-b

C-b

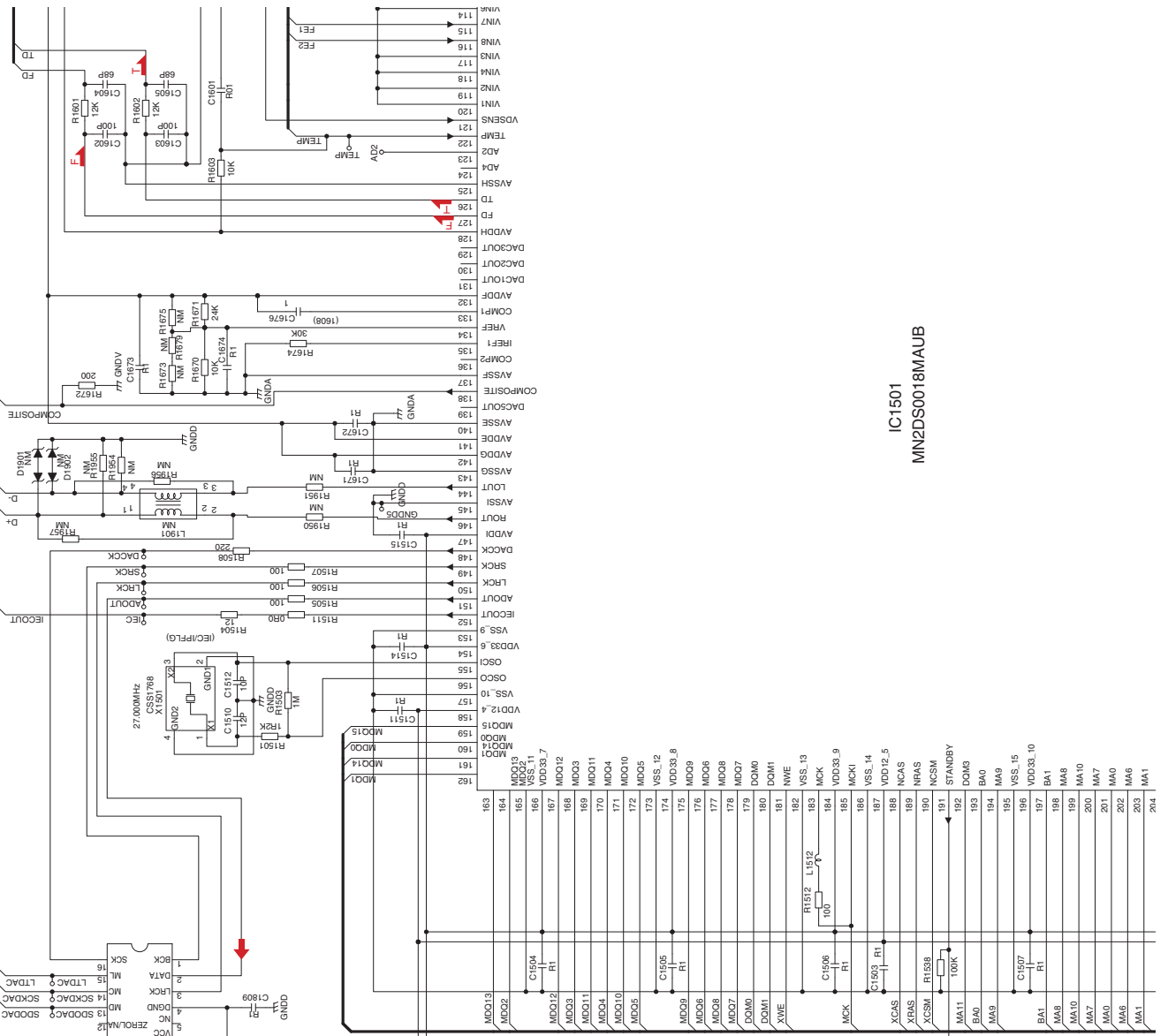

IC1501
MN2DS0018MAUB

C-a C-b

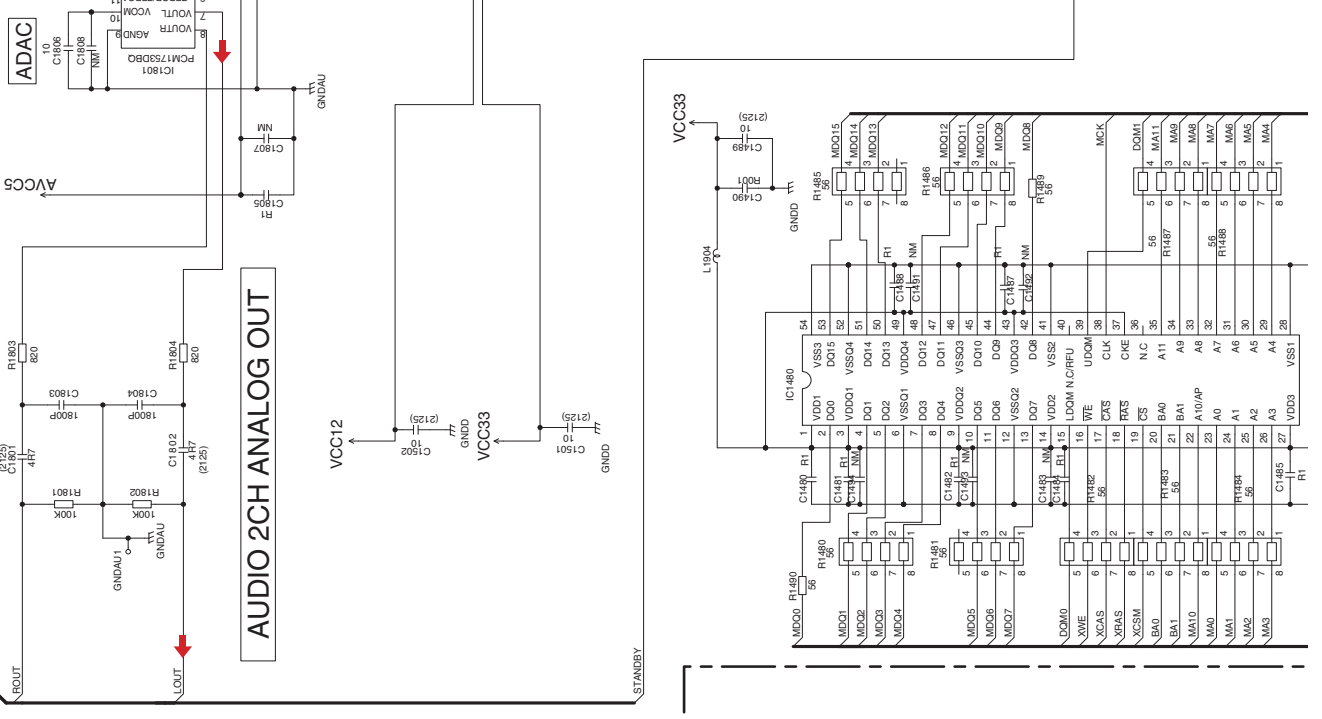

C-a

AVIC-X910BT/XS/UC

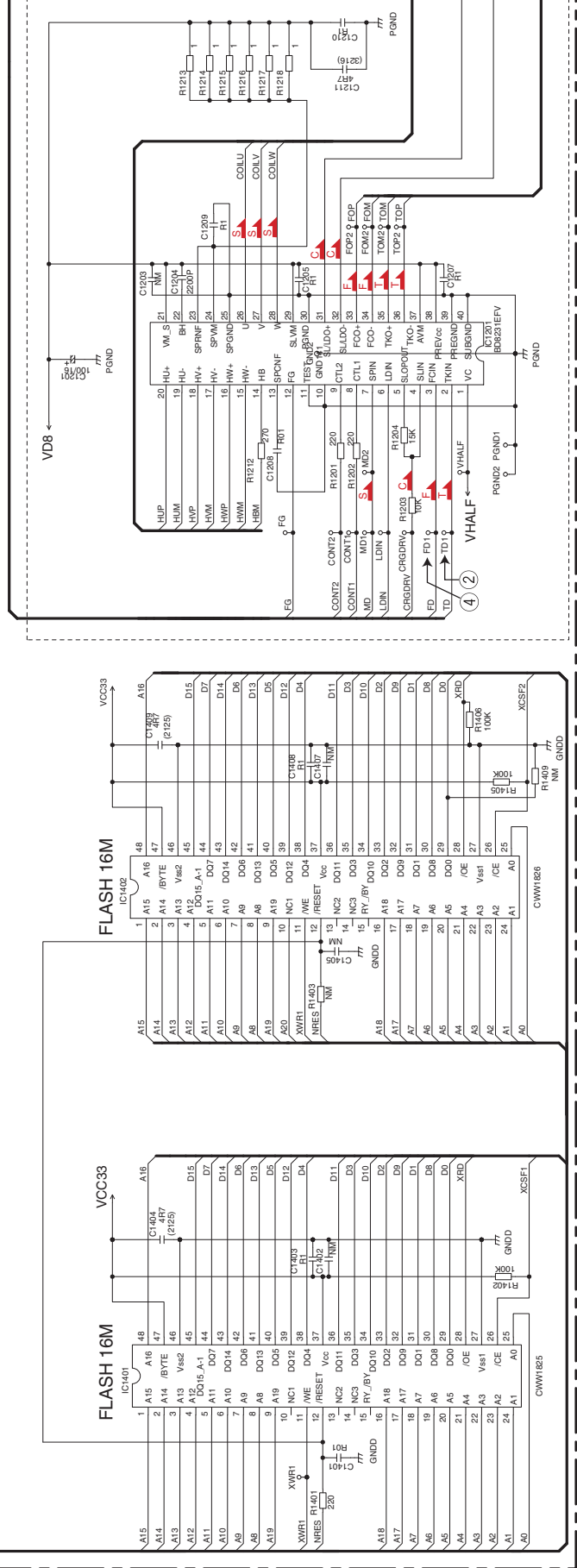
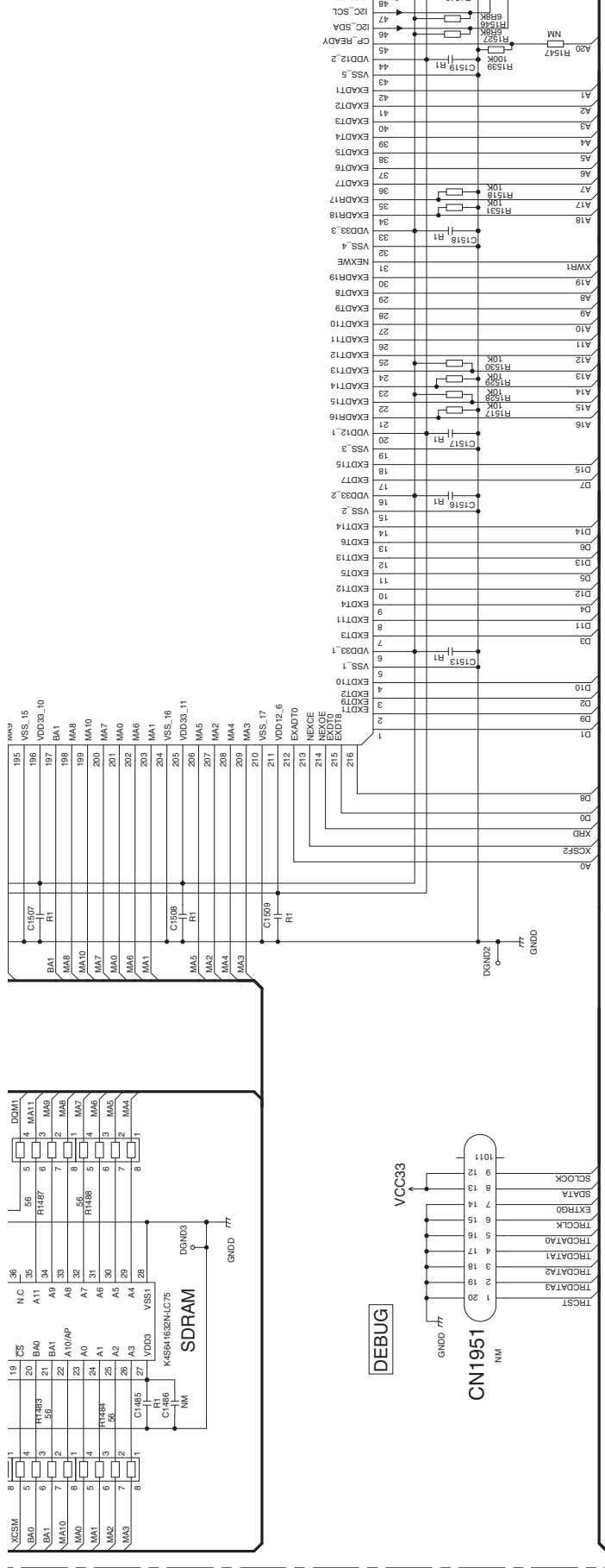

C-b

C-a C-b

C-a

10.9 CONNECT PCB

D CONNECT PCB

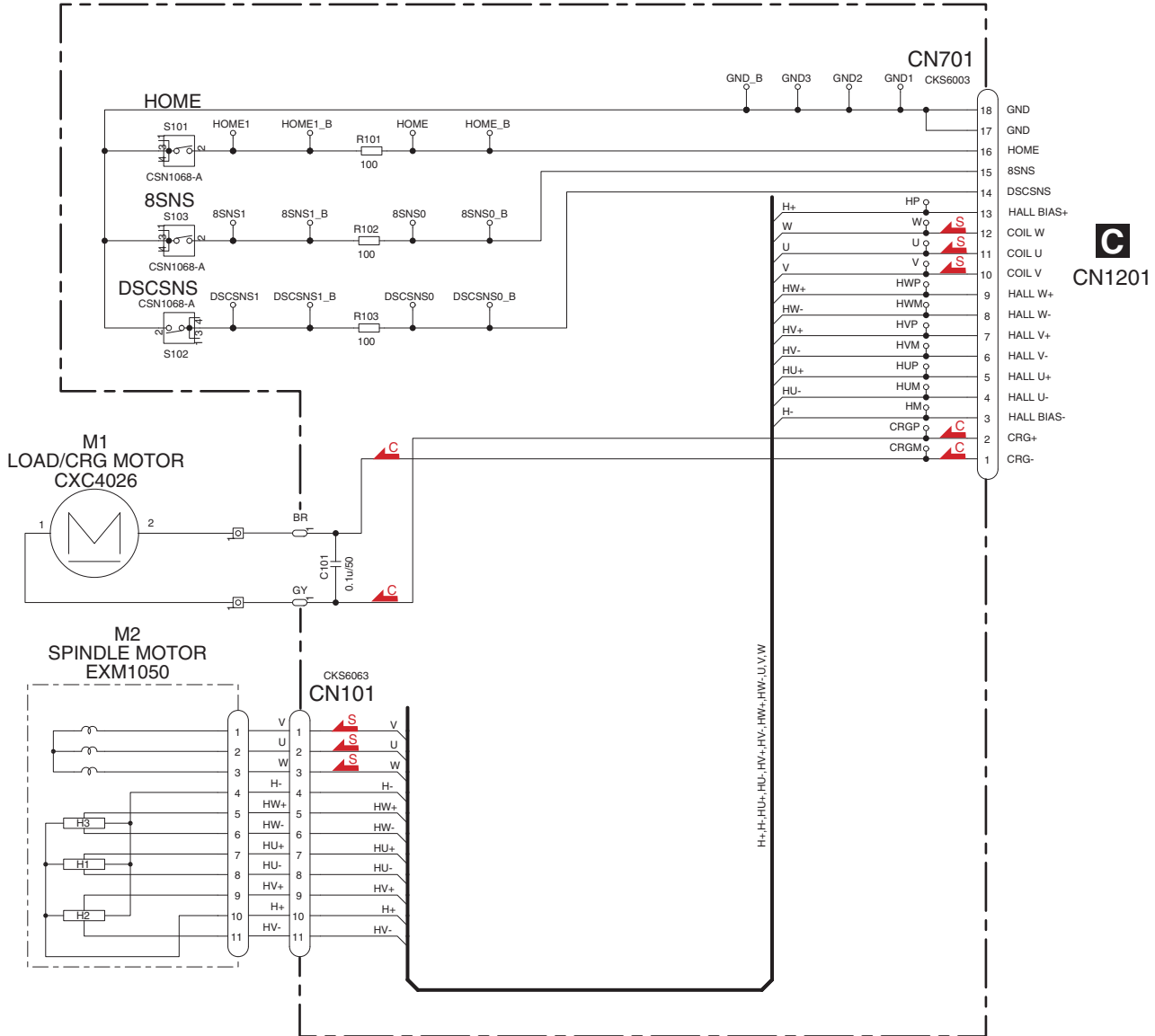

A

B

C

D

E

F

10.10 KEYBOARD UNIT

A

B

C

D

E

F

to PANEL UNIT OTJ2

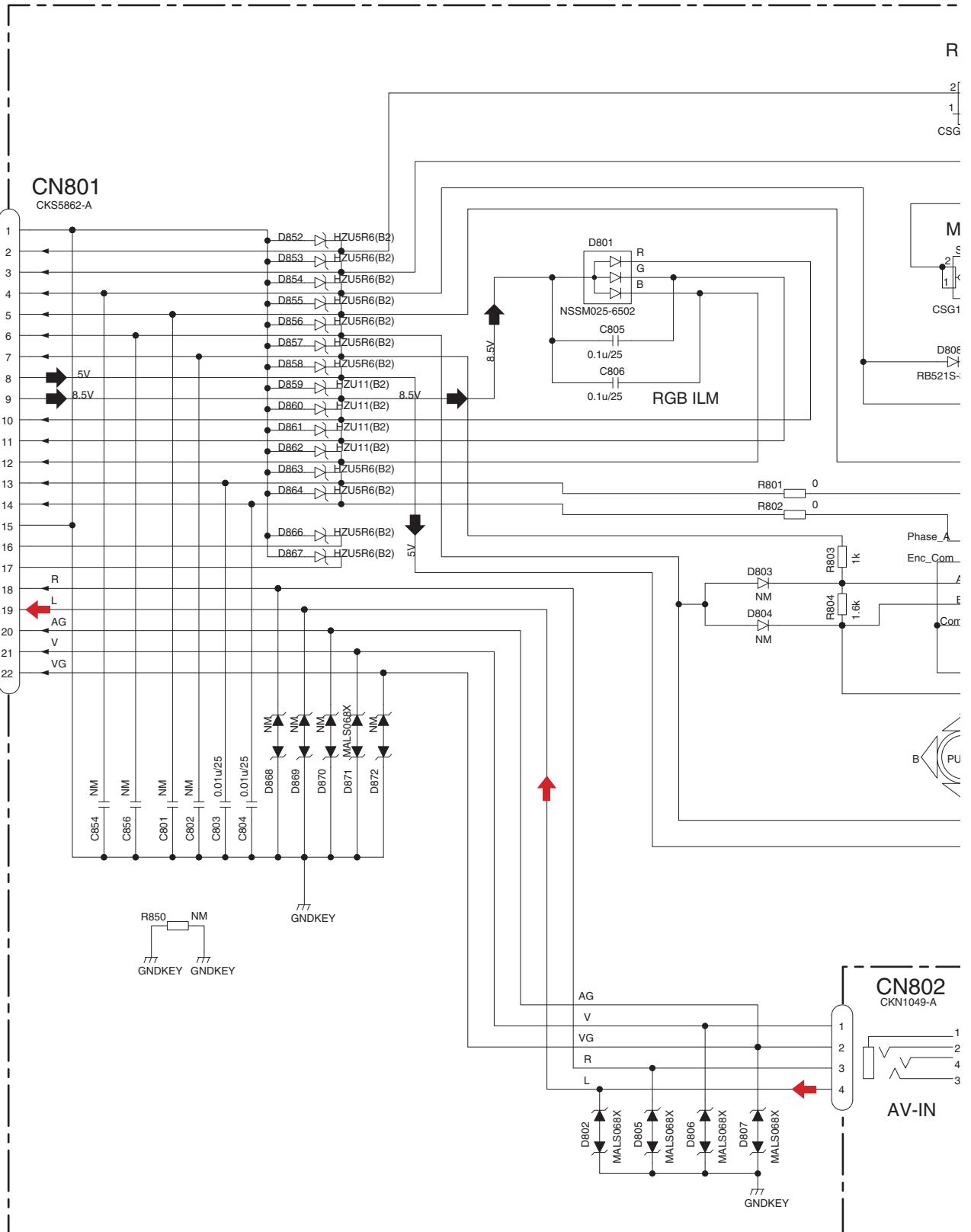

E KEYBOARD UNIT

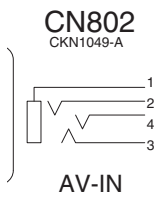
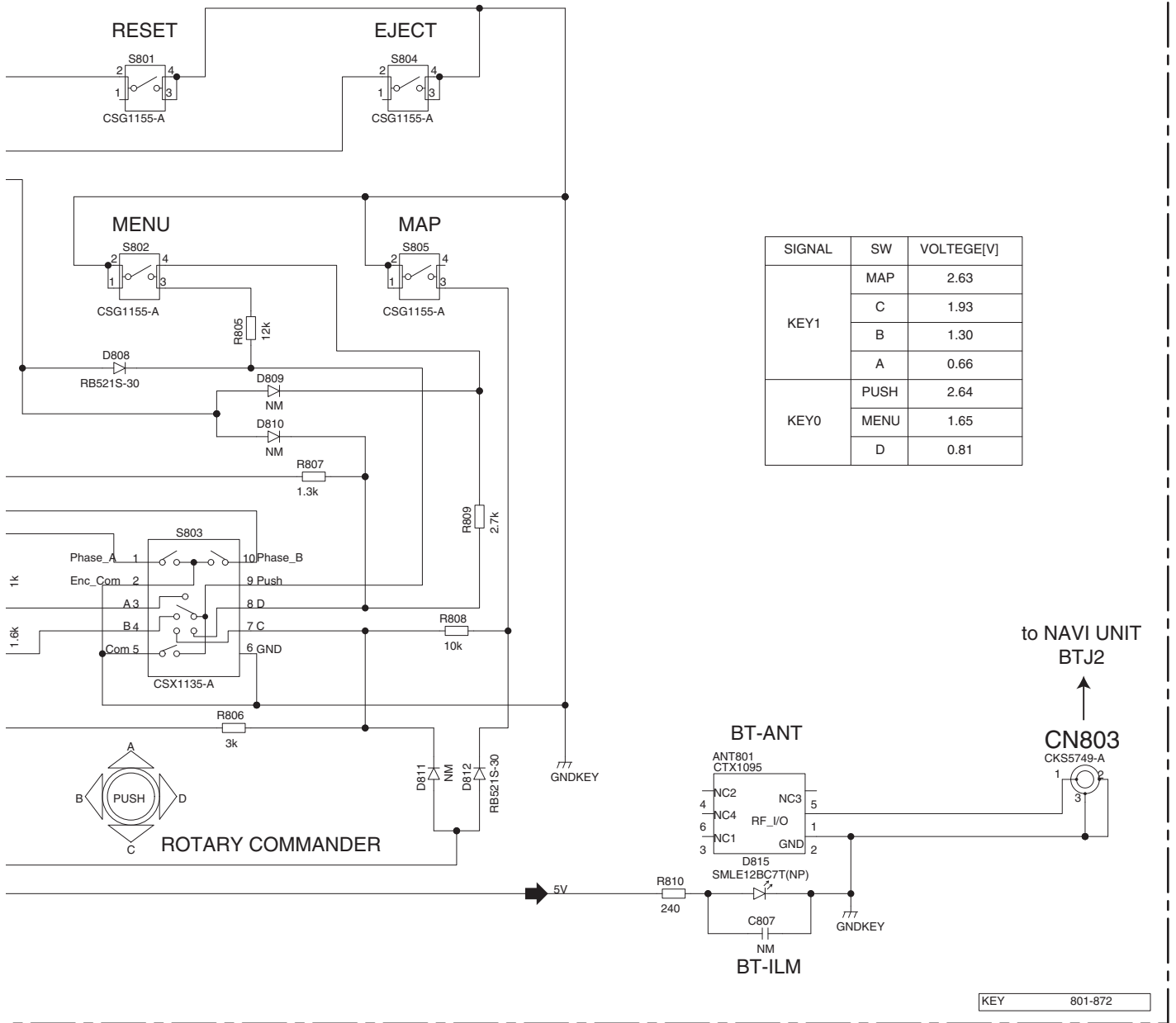

10.11 WAVEFORMS

DVD CORE UNIT

Note: 1. The encircled number denote measuring points in the circuit diagram.
 2. Reference voltage: 1.65 V(TD1,FD1)(=VHALF)
 2.2 V(RF)(=VREF)

In the waveform, it is seeing on the GND standard.
 Offset of 1.65 V or 2.2 V is put in.

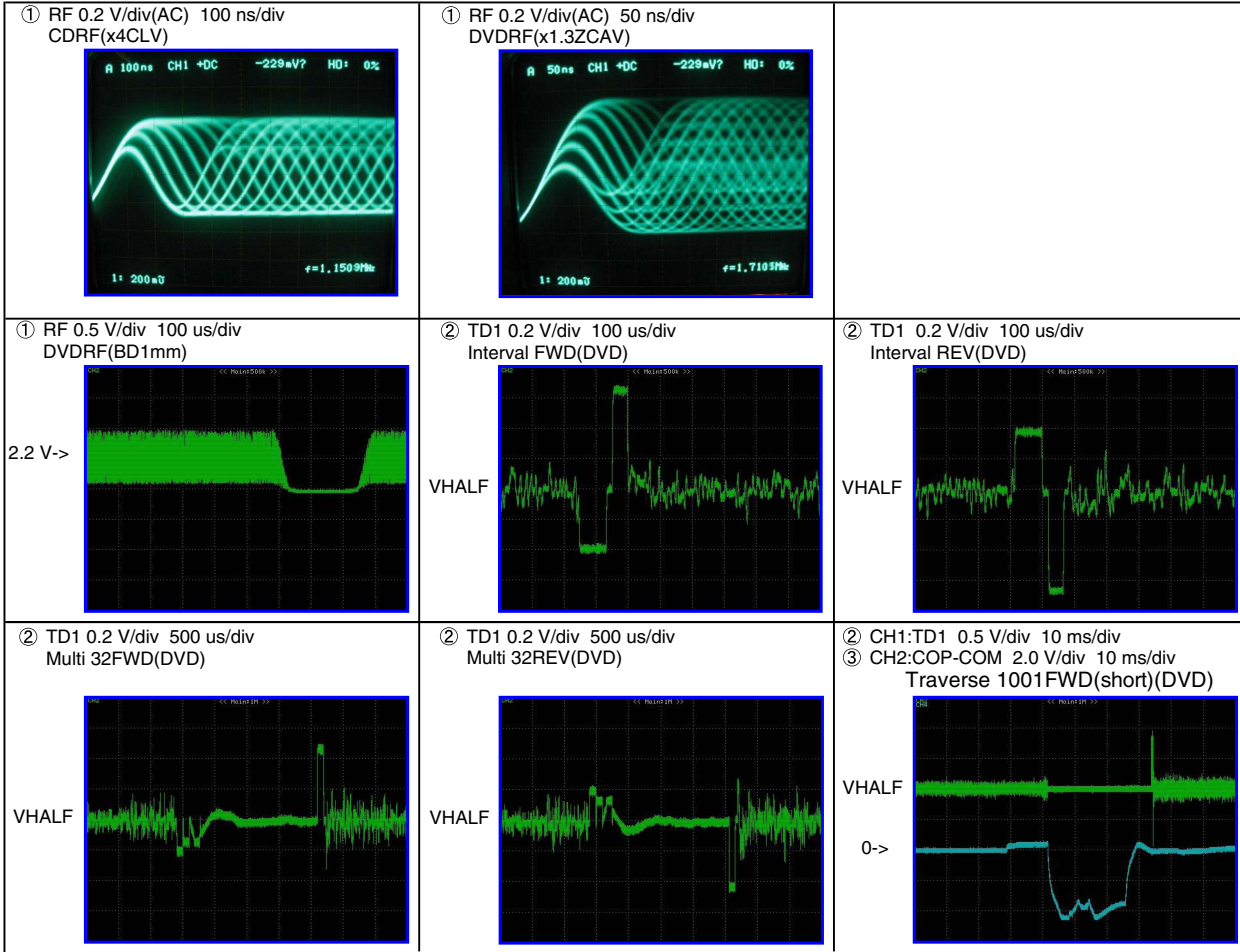

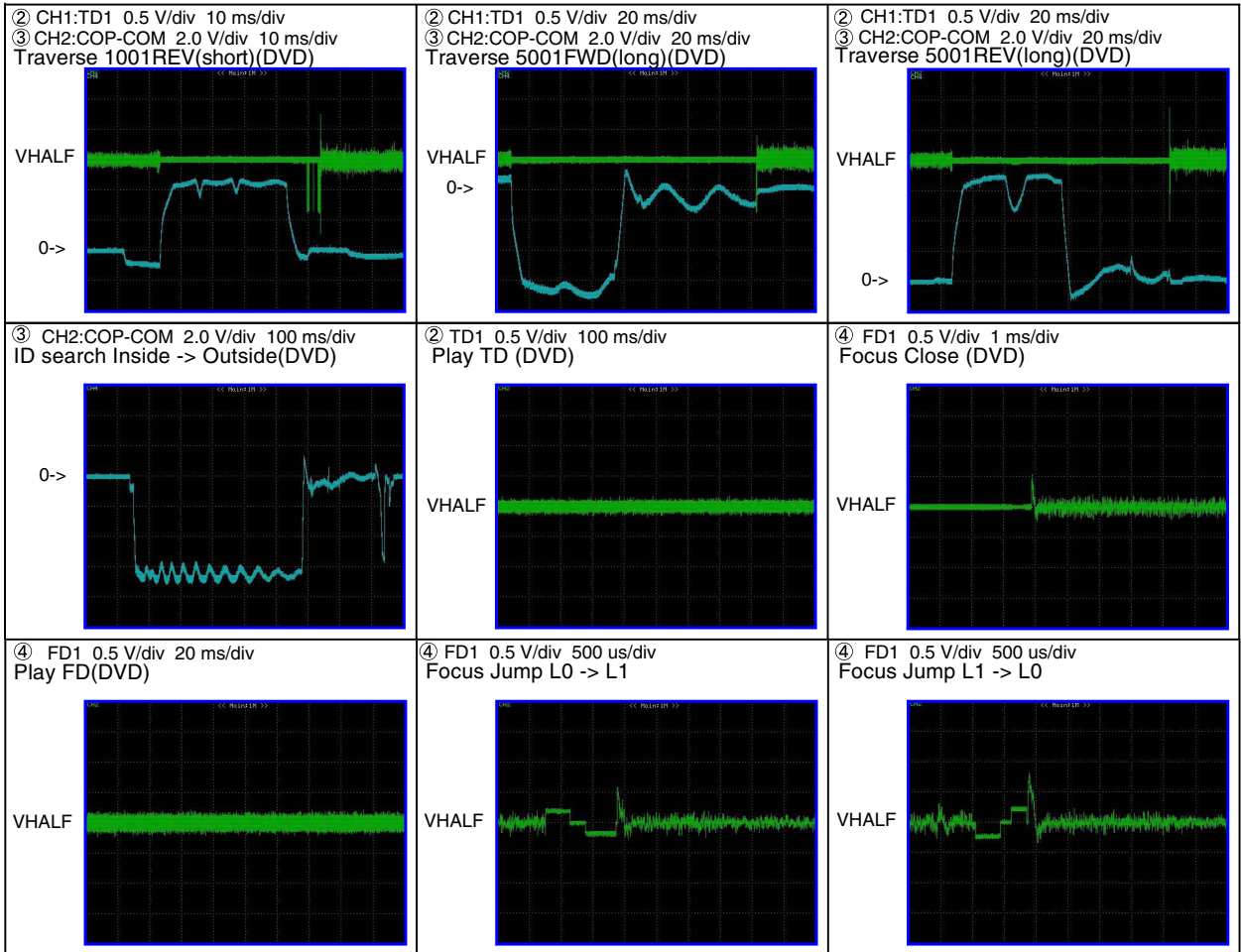

A

B

C

D

E

F

11. PCB CONNECTION DIAGRAM

11.1 AV UNIT

A NOTE FOR PCB DIAGRAMS

1. The parts mounted on this PCB include all necessary parts for several destination.
For further information for respective destinations, be sure to check with the schematic diagram.

2. Viewpoint of PCB diagrams

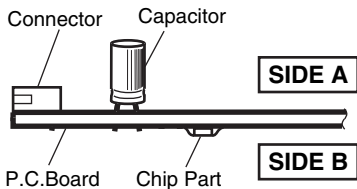

A AV UNIT

NAVI UNIT
TMJ1

B CN882

- △ FU 4631 (A,115,86) Fuse 200 mA CEK1247
- △ FU 4641 (A,141,8) Fuse 3.15 A CEK1259
- △ FU 4661 (A,137,8) Fuse 2.5 A CEK1258
- △ FU 4771 (A,115,106) Fuse 1 A CEK1254

D

E

F

NAVI UNIT
OTJ1

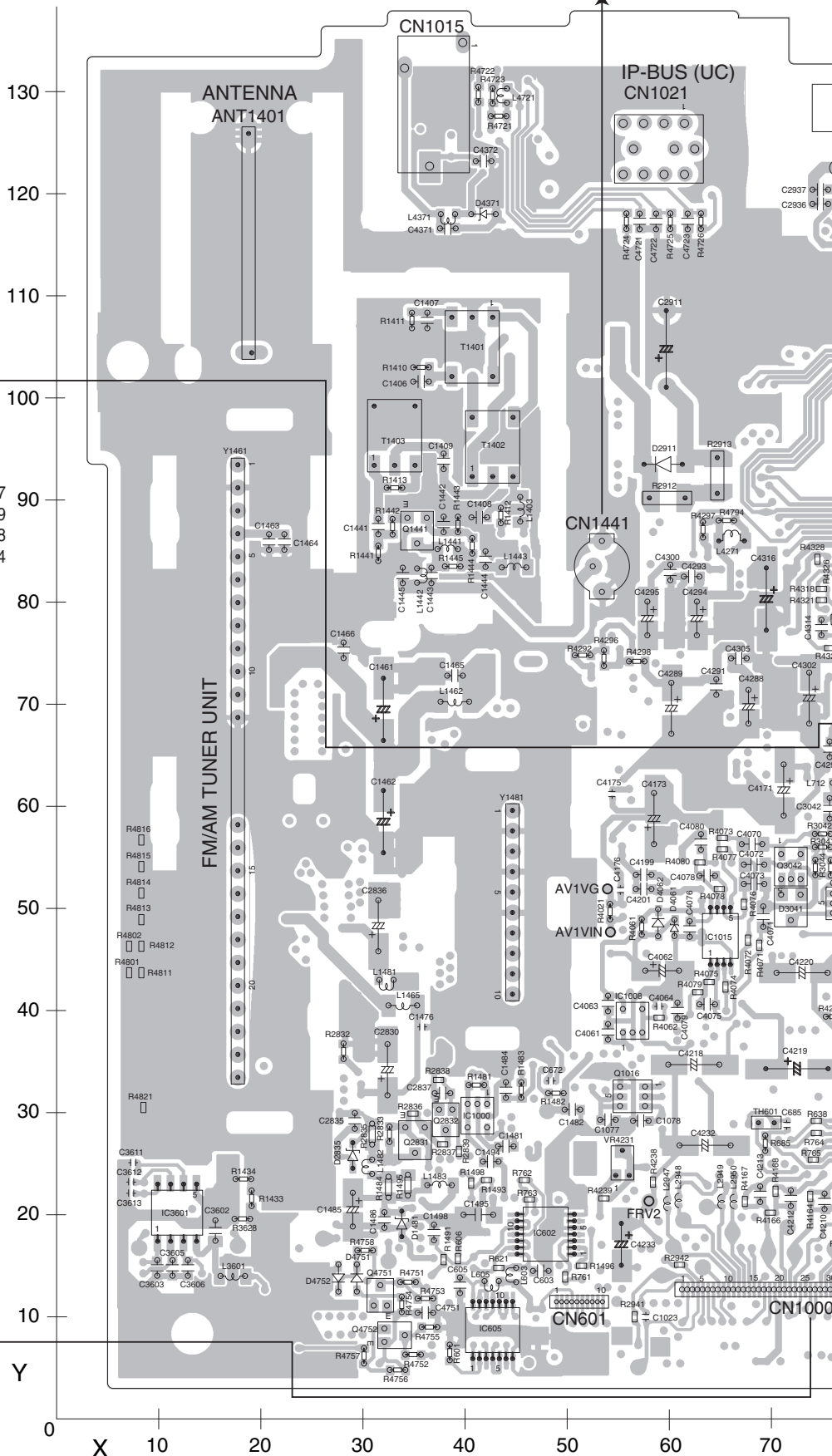

AVIC-X910BT/XS/UC

SIDE A

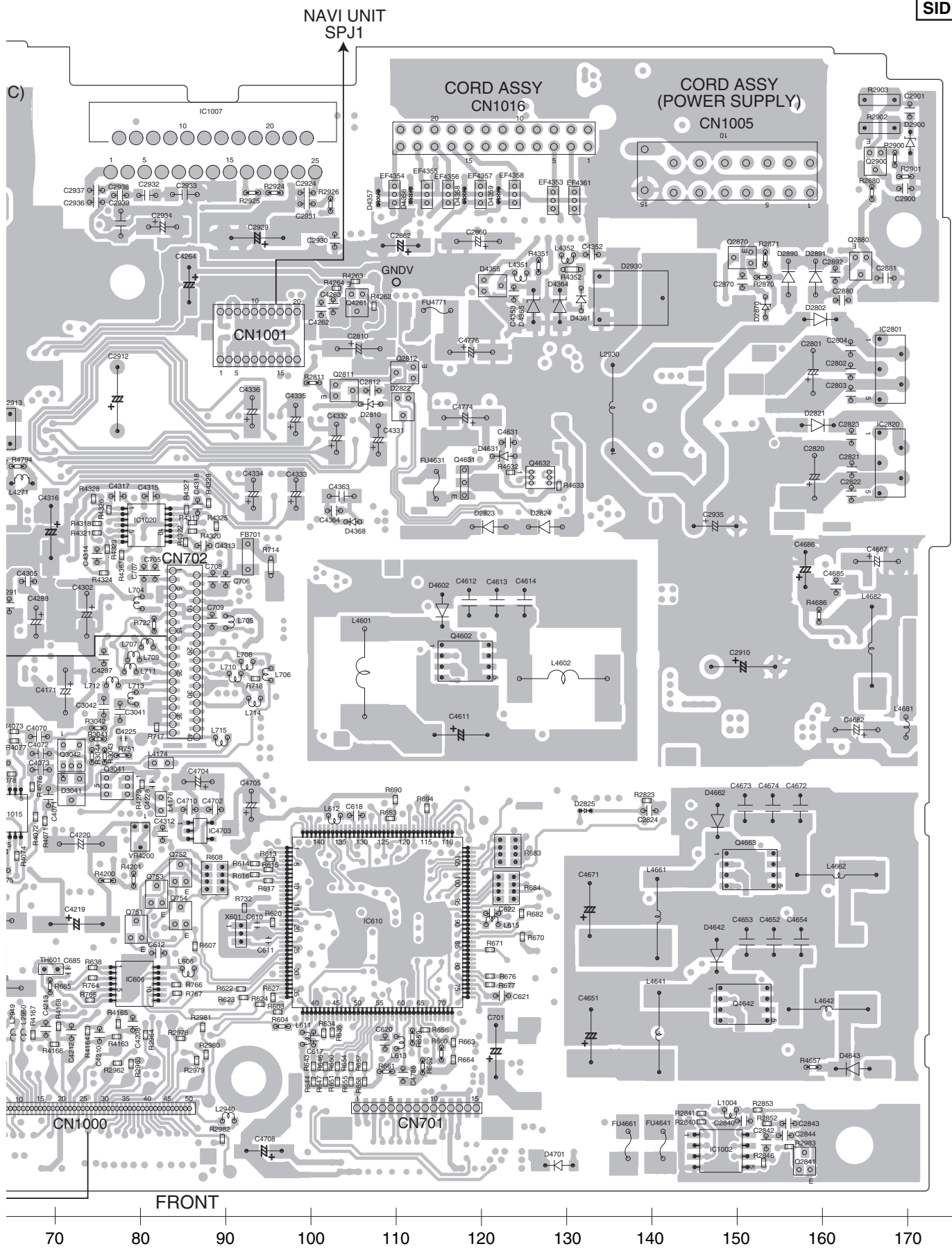

AVIC-X910BT/XS/UC

A

A

A AV UNIT

- ⚠ FU 2900 (B,72,8) Fuse 250 mA CEK1276
- ⚠ FU 4352 (B,129,133) Fuse 3.15 A CEK1259
- ⚠ FU 4601 (B,104,61) Fuse 5 A CEK1261
- ⚠ FU 4602 (B,144,58) Fuse 5 A CEK1261
- ⚠ FU 4642 (B,158,72) Fuse 2.5 A CEK1258
- ⚠ FU 4662 (B,148,55) Fuse 2.5 A CEK1258

B

C

D

E

F

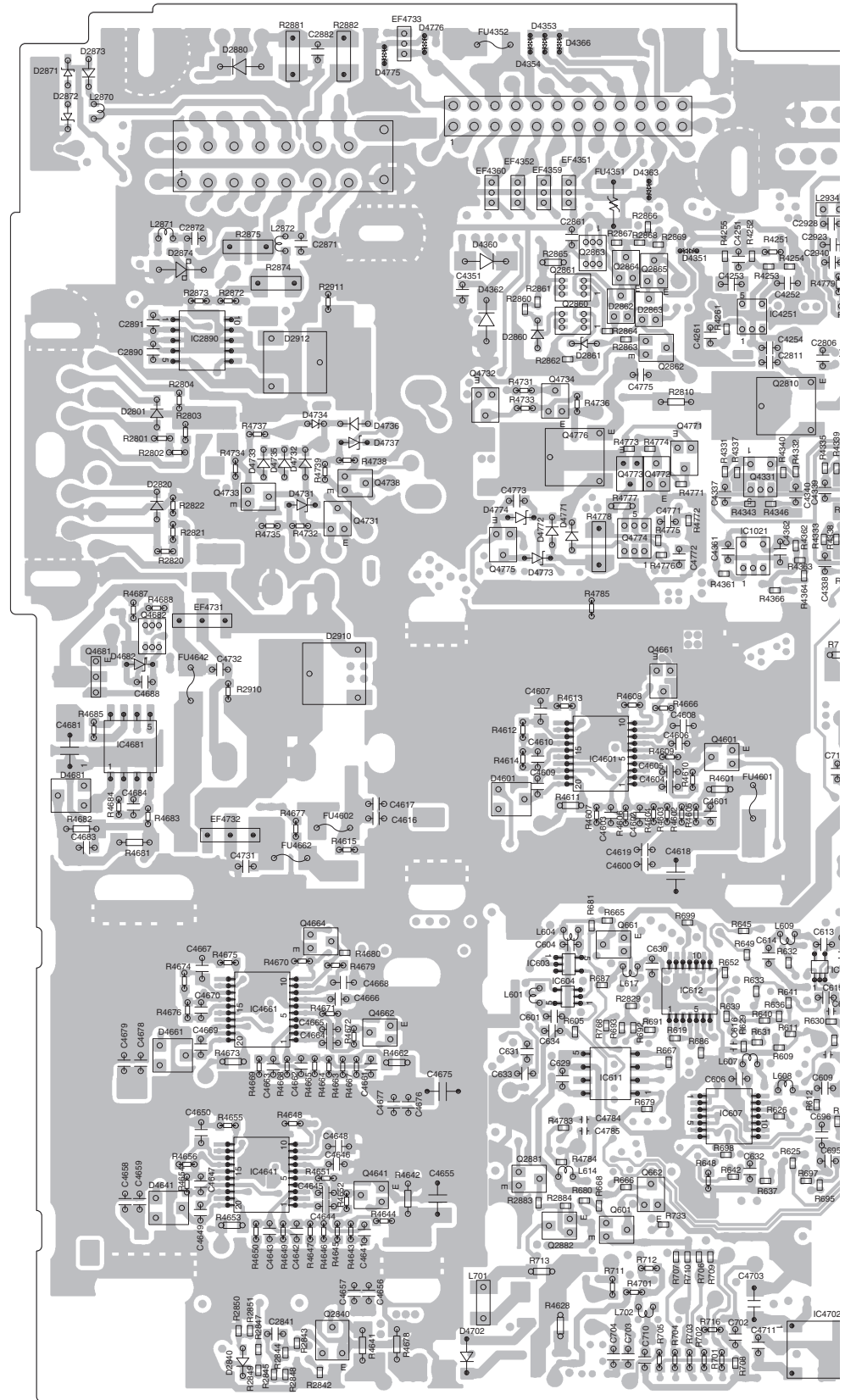

170 160 150 140 130 120 110 100

AVIC-X910BT/XS/UC

11.2 CK UNIT

B CK UNIT

SIDE A

B CK UNIT

SIDE B

A

B

C

D

E

F

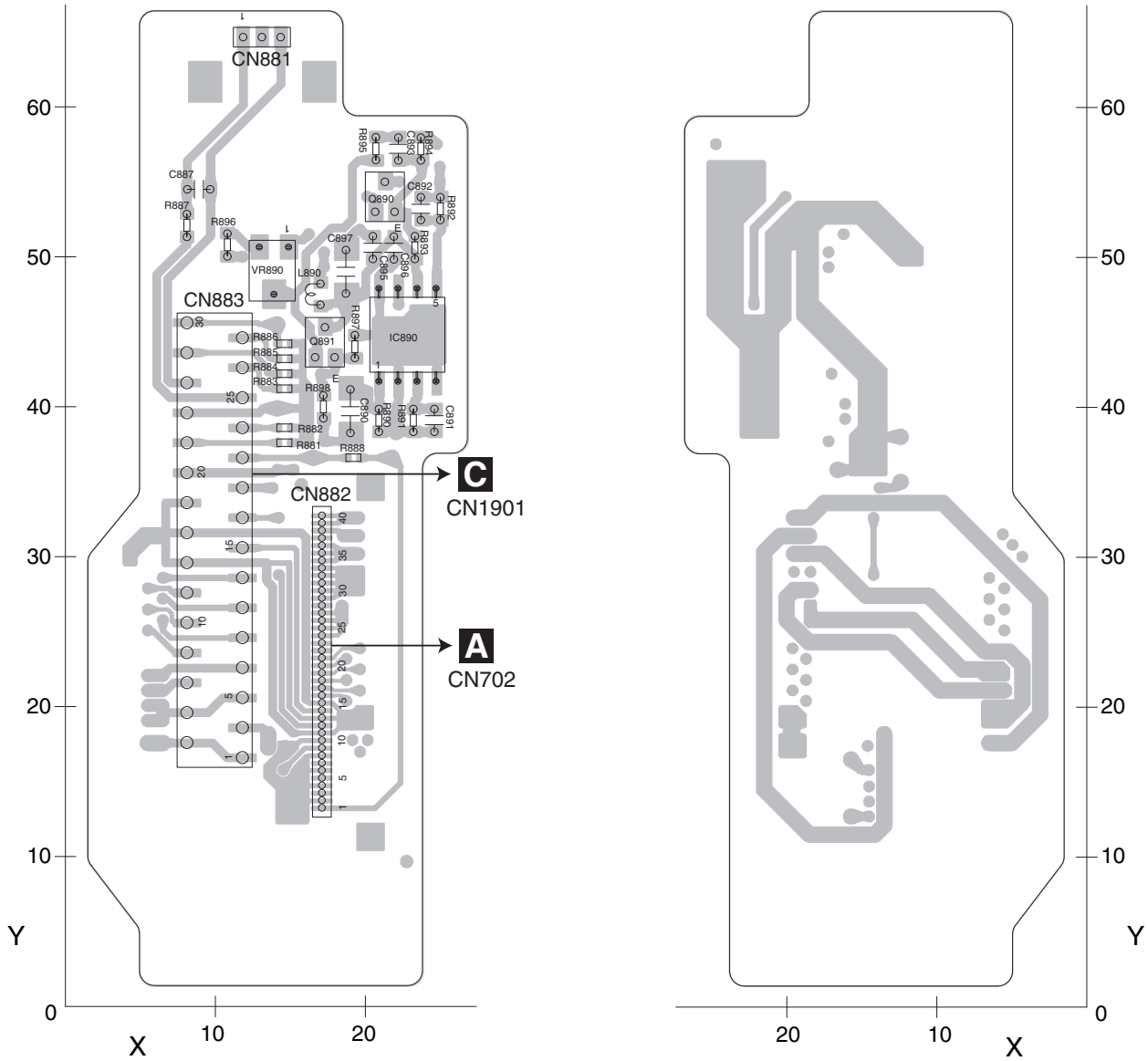

B

A

B

C

D

E

F

11.3 DVD CORE UNIT

C DVD CORE UNIT

SIDE A

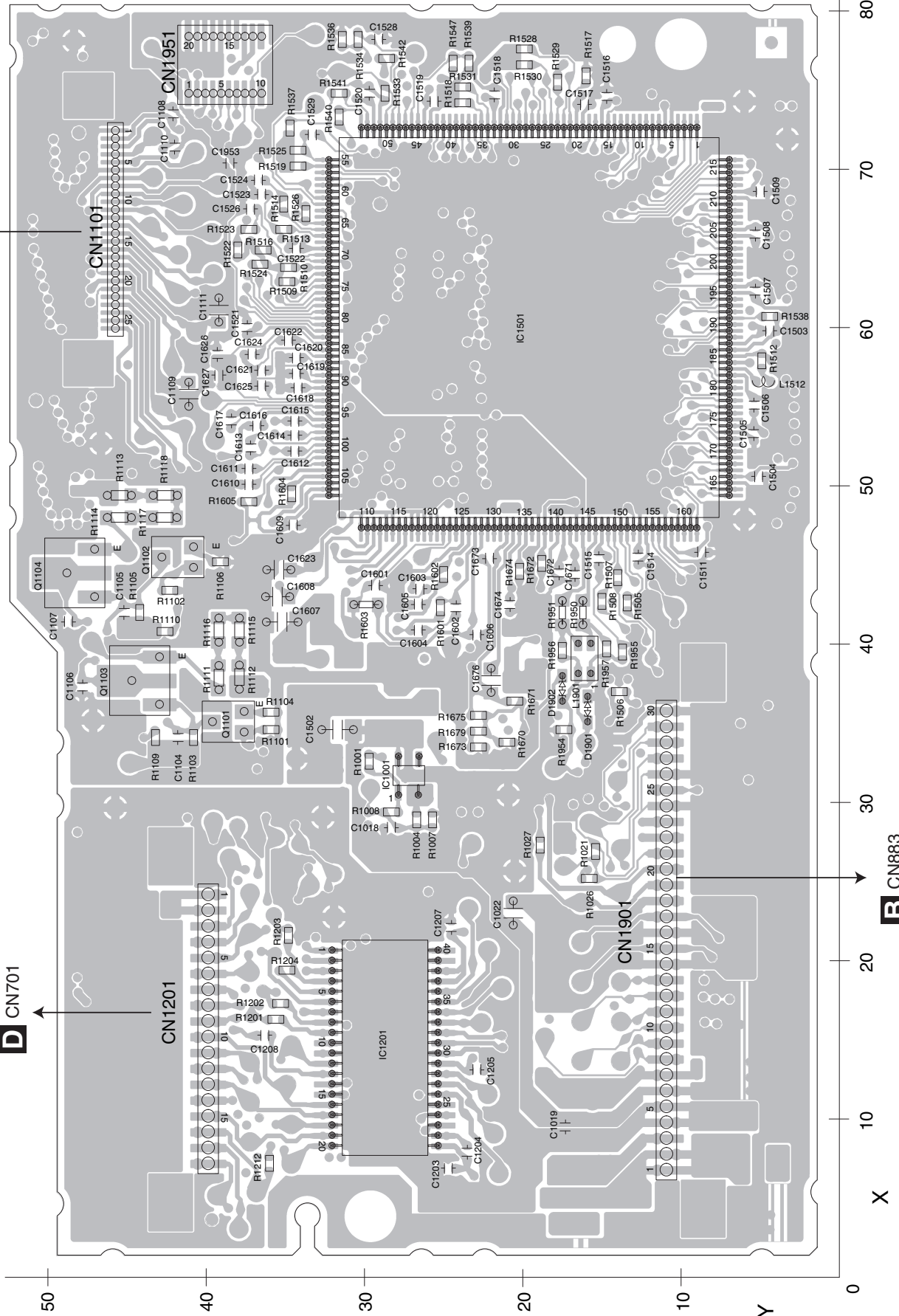

11.4 CONNECT PCB

D CONNECT PCB

SIDE A

A

B

C

D

E

F

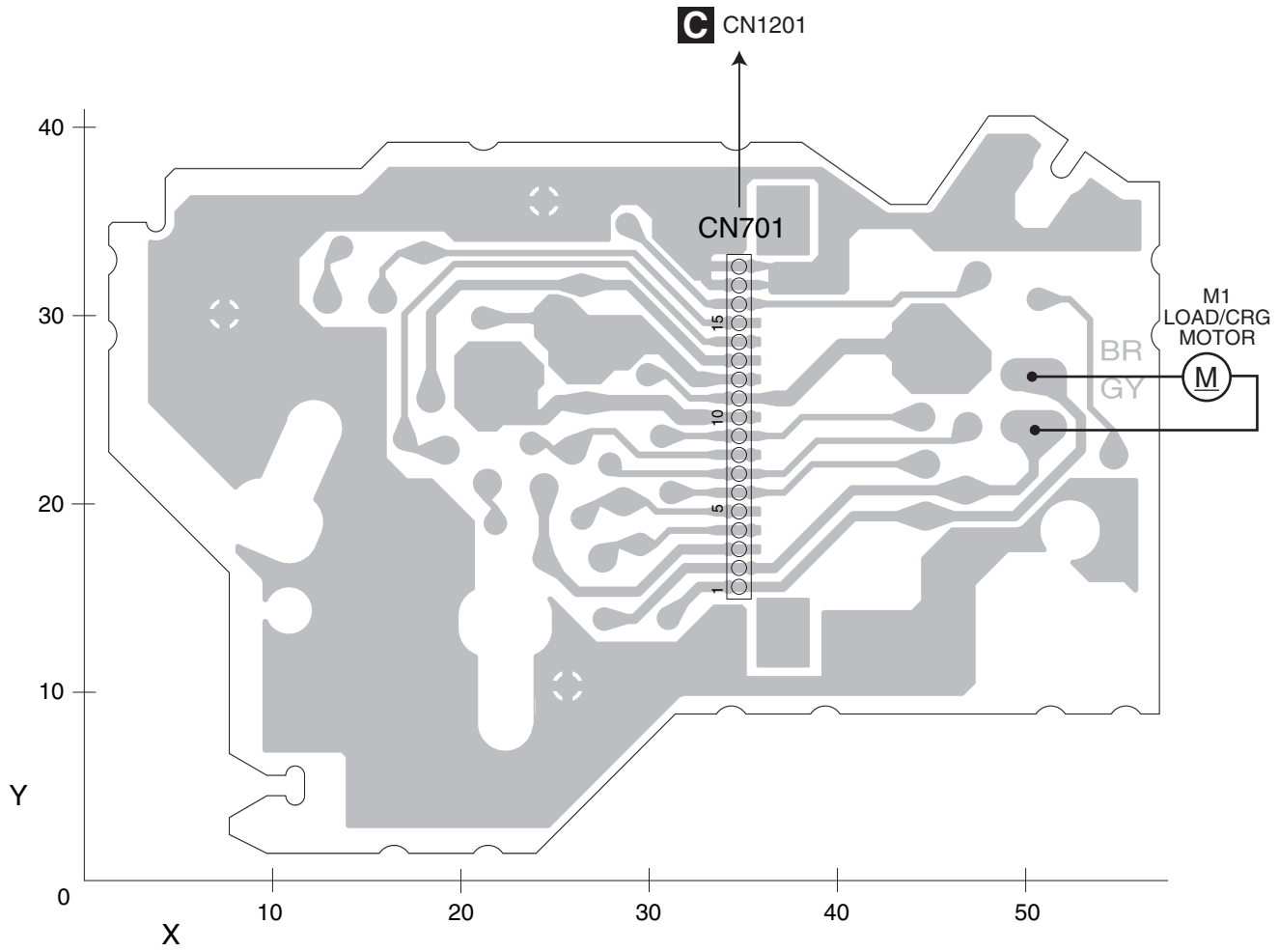

D

A

B

C

D

E

F

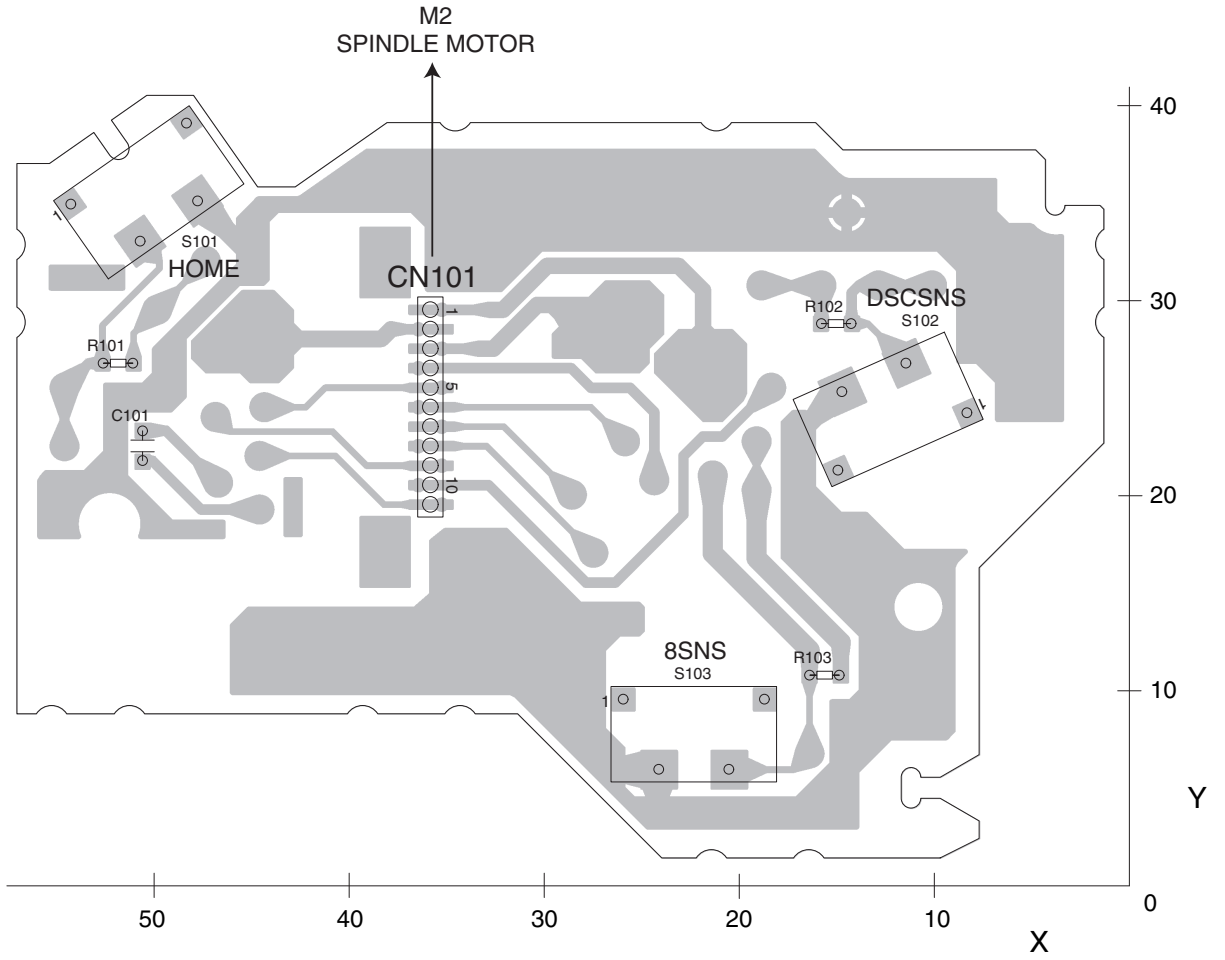

11.5 KEYBOARD UNIT

E KEYBOARD UNIT

SIDE A

E KEYBOARD UNIT

SIDE B

A

B

C

D

E

F

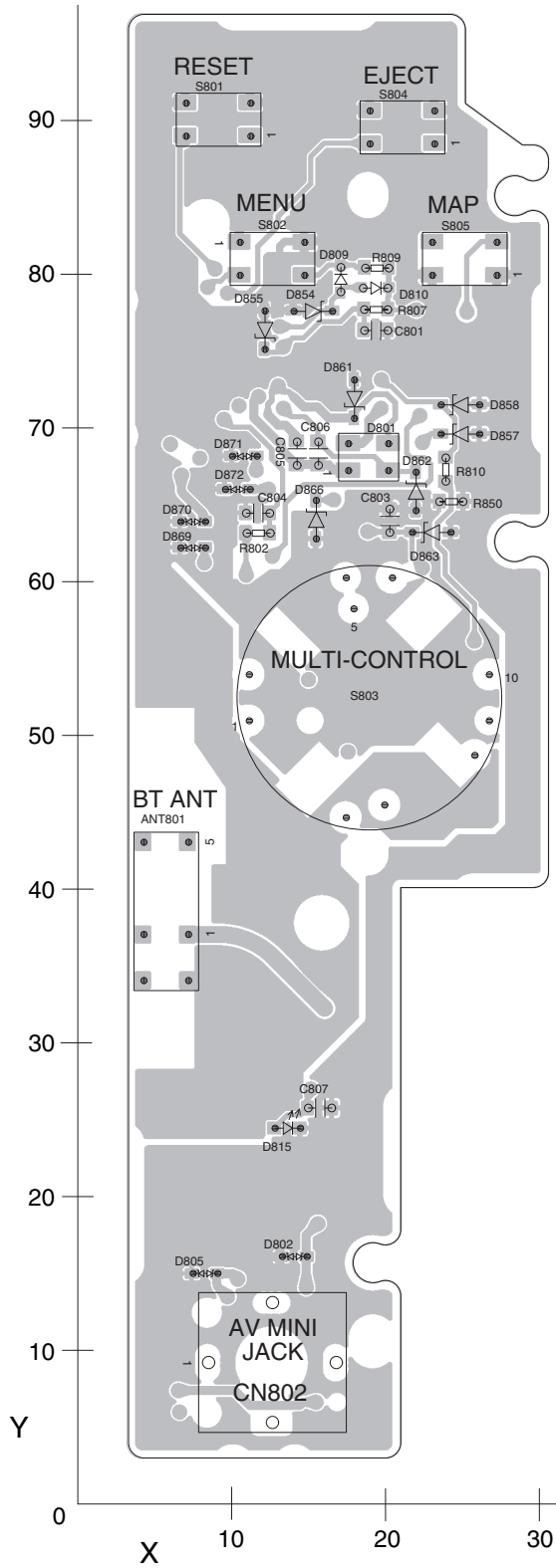

PANEL UNIT
OTJ2

NAVI UNIT
PTJ2

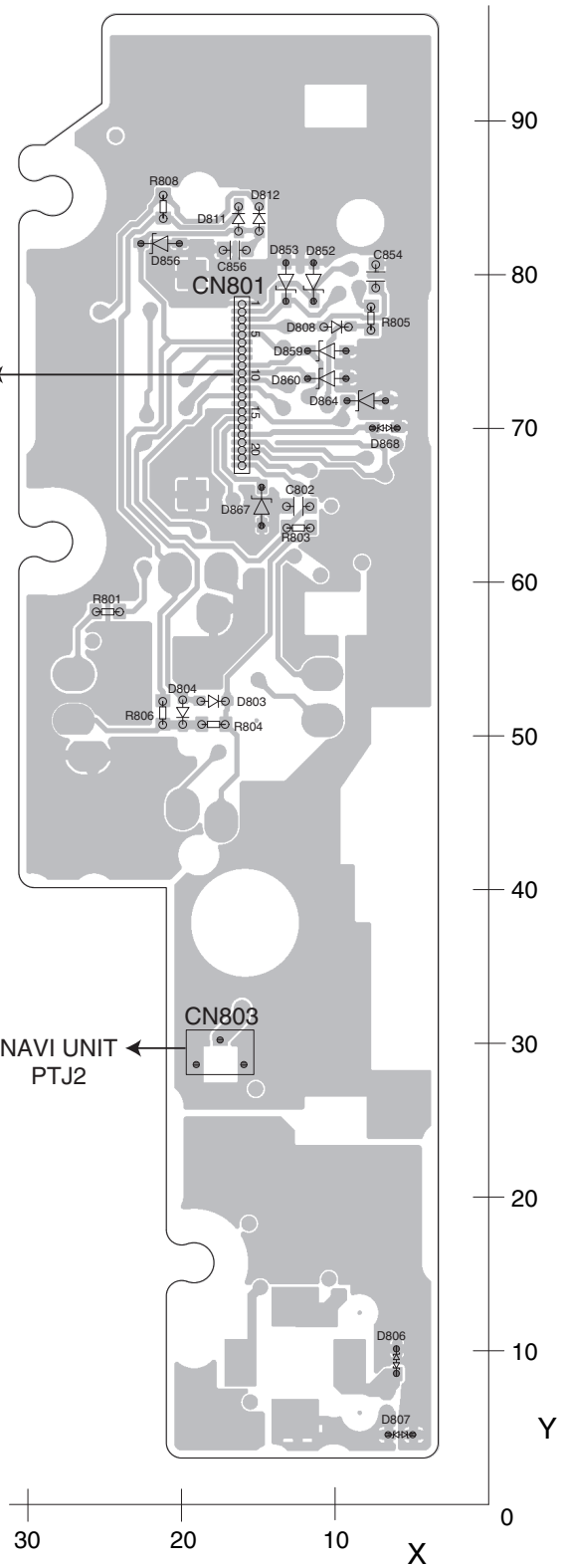

12. ELECTRICAL PARTS LIST

NOTE:

- Parts whose parts numbers are omitted are subject to being not supplied.
- The part numbers shown below indicate chip components.

Chip Resistor

RS1/OS○○○○J,RS1/○○S○○○○J

Chip Capacitor (except for CQS.....)

CKS....., CCS....., CSZS.....

- The \triangle mark found on some component parts indicates the importance of the safety factor of the part. Therefore, when replacing, be sure to use parts of identical designation.
- Meaning of the figures and others in the parentheses in the parts list.

Example) IC 301 is on the point (face A, 91 of x-axis, and 111 of y-axis) of the corresponding PC board.

IC 301 (A, 91, 111) IC NJM2068V

<u>Circuit Symbol and No.</u>	<u>Part No.</u>	<u>Circuit Symbol and No.</u>	<u>Part No.</u>
Unit Number : CWN4237(UC)	IC 1008 (A,56,39) IC	NJM2125F	
	IC 1015 (A,65,47) IC	NJM4558V	
Unit Number : CWN4238(EU5)	IC 1016 (B,70,33) IC	BA4558RFVM	
Unit Number : CWN4239(AU)	IC 2801 (A,169,99) IC	BA00CC0WCP-V5	
Unit Name : AV Unit	IC 2820 (A,169,88) IC	BA00CC0WCP-V5	
Unit Number : CWN4251	IC 2830 (B,34,37) IC	BA00BC0WFP	
Unit Name : CK Unit	IC 2890 (B,157,105) IC	TPD1018F	
Unit Number : YWX5009	IC 3601 (A,12,20) IC	M62343FP	
Unit Name : DVD Core Unit	IC 4171 (B,68,49) IC	AN15887A	
Unit Number :	IC 4251 (B,104,107) IC	NJM2505AF	
Unit Name : Connect PCB	IC 4271 (B,69,74) IC	PML018A	
Unit Number :	IC 4601 (B,118,65) IC	TPS5103IDB	
Unit Name : Keyboard Unit	IC 4641 (B,151,25) IC	TPS5103IDB	
	IC 4661 (B,151,41) IC	TPS5103IDB	
	IC 4701 (B,89,55) IC	BD3931HFP	
	IC 4703 (A,87,45) IC	S-L2980A33MC-C6S	
	IC 4721 (B,45,129) IC(UC)	HA12241FP	
	Q 601 (B,117,20) Chip Transistor	2SA1576A	
	Q 661 (B,117,47) Chip Transistor	DTC114EUA	
	Q 662 (B,114,23) Chip Transistor	DTC114EUA	
	Q 751 (A,80,34) Chip Transistor(EU5)	DTC124EUA	
	Q 752 (A,85,40) Chip Transistor(EU5)	DTC124EUA	
	Q 753 (A,82,38) Chip Transistor(EU5)	DTC124EUA	
	Q 754 (A,85,35) Chip Transistor(EU5)	DTC124EUA	
	Q 1016 (A,56,32) Transistor	IMD2A	
	Q 1401 (B,39,105) Transistor	2SC3357	
	Q 1421 (B,39,96) Transistor	2SC3127	
	Q 1441 (A,35,87) Transistor	2SC3130	
	Q 2810 (B,103,99) Transistor	2SD1760F5	
	Q 2811 (A,104,97) Chip Transistor	DTA114EUA	
	Q 2812 (A,111,99) Chip Transistor	DTC114EUA	
	Q 2840 (B,144,9) Transistor	DTC114WK	
	Q 2841 (A,158,7) Chip Transistor	DTC114EUA	
	Q 2860 (B,121,107) Transistor	UMD2N	
	Q 2861 (B,121,110) Transistor	UMD2N	
	Q 2862 (B,113,104) Transistor	2SC4081	
	Q 2863 (B,119,113) Transistor	UMD2N	
	Q 2864 (B,116,112) Chip Transistor	DTC114EUA	
	Q 2865 (B,113,112) Chip Transistor	DTC124EUA	
	Q 2870 (A,151,113) Transistor	2SC4116	
	Q 2880 (A,165,112) Chip Transistor	DTC114EUA	
MISCELLANEOUS			
IC 601 (B,47,7) IC	TC7SH08FUS1		
IC 603 (B,121,45) IC	TC7SH04FUS1		
IC 604 (B,122,42) IC	TC7S32FU		
IC 605 (A,43,9) IC	TC74VHCT08AFTS1		
IC 607 (B,106,30) IC	TC74VHC08FTS1		
IC 608 (B,97,45) IC	BD5335FVE		
IC 609 (B,28,9) IC	TC74VHC08FTS1		
IC 610 (A,108,35) IC(UC)	PEG562A8		
(A,108,35) IC(EU5)	PEG561A8		
(A,108,35) IC(AU)	PEG563A8		
IC 612 (B,110,42) Logic IC	TC74VHCT32AFT		
IC 1002 (A,148,8) IC	NJM2904M		
IC 1007 (A,89,128) IC	PAL007C		

1

2

3

4

Circuit Symbol and No.**Part No.****Circuit Symbol and No.****Part No.**

Q 2881	(B,125,24) Chip Transistor	DTC114EUA	D 2880	(B,153,131) Diode	1SR154-400
Q 2882	(B,122,20) Chip Transistor	2SA1576A	D 2890	(A,156,110) Diode	1SR154-400
Q 2900	(A,166,124) Transistor	2SC4116	D 2891	(A,159,110) Diode	1SR154-400
Q 3041	(A,77,51) Transistor	IMD3A	D 2900	(A,170,126) Diode	HZU8R2(B1)
Q 3042	(A,72,54) Transistor	FMG12	D 2910	(B,146,73) Diode	KS926S2
Q 3601	(B,31,21) Transistor	UMX1N	D 2911	(A,59,94) Diode	RB060L-40
Q 3602	(B,23,19) Transistor	UMX1N	D 2912	(B,145,103) Diode	KS926S2
Q 3603	(B,15,19) Transistor	UMX1N	D 2930	(A,141,108) Diode	ST70-27F
Q 3604	(B,29,16) Transistor	UMX1N	D 3041	(A,72,50) Diode	DAP202K
Q 3605	(B,20,18) Transistor	UMX1N	D 4061	(A,61,48) Diode	EDZ4R3(B)
Q 3606	(B,11,17) Transistor	UMX1N	D 4062	(A,59,49) Diode	1SS355
Q 4231	(B,60,24) Transistor	2SC4081	D 4311	(B,83,31) Diode	DAN202K
Q 4232	(B,56,18) Chip Transistor	2SA1576A	D 4312	(B,87,33) Diode	DAN202K
Q 4312	(B,78,39) Transistor	IMD3A	D 4331	(B,92,96) Diode	DAP202K
Q 4314	(B,78,35) Transistor	DTC323TK	D 4351	(B,110,114) Diode	MALS180X
Q 4331	(B,103,92) Transistor	FMG12	D 4353	(B,124,133) Diode	MALS180X
Q 4332	(B,93,85) Transistor	FMG12	D 4354	(B,125,133) Diode	MALS180X
Q 4333	(B,93,92) Transistor	FMG12	D 4355	(A,121,109) Diode	DAN202U
Q 4601	(B,107,65) Chip Transistor	DTC114EUA	D 4356	(A,112,120) Diode	MALS068X
Q 4602	(A,118,65) FET	SP8K2	D 4357	(A,108,120) Diode	MALS068X
Q 4631	(A,120,86) Transistor	2SD1767	D 4358	(A,118,120) Diode	MALS068X
Q 4632	(A,127,87) Transistor	UMD2N	D 4359	(A,122,120) Diode	MALS068X
Q 4641	(B,140,23) Chip Transistor	DTC114EUA	D 4360	(B,129,113) Diode	1SR154-400
Q 4642	(A,151,25) FET	SP8K2	D 4361	(A,132,108) Diode	1SS355
Q 4661	(B,112,72) Chip Transistor	DTC114EUA	D 4362	(B,129,107) Diode	1SR154-400
Q 4662	(B,140,38) Chip Transistor	DTC114EUA	D 4363	(B,114,119) Diode	MALS068X
Q 4663	(A,152,41) FET	SP8K2	D 4364	(A,129,107) Diode	PTZ27(B)
Q 4731	(B,144,88) Transistor	2SC4081	D 4365	(A,126,107) Diode	PTZ27(B)
Q 4732	(B,129,99) Chip Transistor(UC)	DTC114EUA	D 4366	(B,122,133) Diode	MALS180X
Q 4733	(B,151,90) Transistor	2SC4081	D 4371	(A,42,118) Diode	UDZS5R6(B)
Q 4734	(B,123,99) Chip Transistor(UC)	2SA1576A	D 4372	(B,44,124) Diode	UDZS5R6(B)
Q 4738	(B,142,91) Transistor	2SC4081	D 4601	(B,127,61) Diode	RB400D
Q 4751	(A,32,12) Chip Transistor	2SA1576A	D 4602	(A,115,71) Diode	RB060L-40
Q 4752	(A,33,8) Chip Transistor	2SA1576A	D 4631	(A,123,89) Diode	UDZS9R1(B)
Q 4753	(B,36,11) Chip Transistor	DTC114EUA	D 4641	(B,160,22) Diode	RB400D
Q 4754	(B,33,7) Chip Transistor	2SA1576A	D 4642	(A,148,31) Diode	RB060L-40
Q 4771	(B,110,94) Chip Transistor	DTA114EUA	D 4643	(A,164,17) Diode	RB083L-20
Q 4772	(B,113,92) Chip Transistor	DTC114EUA	D 4661	(B,159,36) Diode	RB400D
Q 4773	(B,116,92) Transistor	2SA1587	D 4662	(A,148,46) Diode	RB060L-40
Q 4774	(B,115,86) Transistor	IMX1	D 4721	(B,49,122) Diode(UC)	MALS180X
Q 4775	(B,128,85) Chip Transistor	DTC114EUA	D 4722	(B,51,119) Diode(UC)	MALS180X
Q 4776	(B,123,94) Transistor	2SD1760F5	D 4723	(B,55,116) Diode(UC)	MALS068X
D 2802	(A,160,105) Diode	RB060L-40	D 4724	(B,50,127) Diode(UC)	MALS068X
D 2810	(A,107,95) Diode	UDZS5R6(B)	D 4725	(B,56,116) Diode(UC)	UDZS18(B)
D 2821	(A,159,93) Diode	RB060L-40	D 4726	(B,63,116) Diode(UC)	UDZS18(B)
D 2822	(A,111,95) Diode	DAN202U	D 4727	(B,59,116) Diode(UC)	UDZS18(B)
D 2823	(A,121,81) Diode	1SR154-400	D 4731	(B,147,89) Diode	HZU7R5(B3)
D 2824	(A,128,81) Diode	1SR154-400	D 4732	(B,147,93) Diode	RB500V-40
D 2825	(A,132,48) Diode	1SS400G	D 4733	(B,151,93) Diode	RB500V-40
D 2831	(B,38,27) Diode	RR264M-400	D 4734	(B,146,97) Diode	EDZ20(B)
D 2840	(B,153,7) Diode	1SS355	D 4735	(B,149,93) Diode	RB500V-40
D 2860	(B,124,106) Diode	MA111	D 4736	(B,142,97) Diode	RB500V-40
D 2861	(B,120,105) Diode	UDZS8R2(B)	D 4737	(B,142,95) Diode	HZU7R5(B3)
D 2862	(B,116,108) Diode	DAN202U	D 4751	(A,29,14) Diode	1SS355
D 2863	(B,114,108) Diode	DAN202U	D 4752	(A,28,14) Diode	1SS355
D 2870	(A,153,107) Diode	UDZS5R1(B)	D 4771	(B,121,86) Diode	RB500V-40
D 2871	(B,170,131) Diode	UDZS18(B)	D 4772	(B,123,87) Diode	RB500V-40
D 2872	(B,170,126) Diode	UDZS18(B)	D 4773	(B,124,84) Diode	HZU8R2(B1)
D 2873	(B,168,131) Diode	1SS355	D 4774	(B,126,88) Diode	HZU11(B2)
D 2874	(B,159,112) Diode	PTZ18A	D 4775	(B,139,132) Diode	MALS180X

1

2

3

4

5		6		7		8	
<u>Circuit Symbol and No.</u>		<u>Part No.</u>		<u>Circuit Symbol and No.</u>		<u>Part No.</u>	
ZNR1401	(B,17,112) Surge Protector	CSA30-201N		L 4173	(B,80,57) Inductor	CTF1689	
L 601	(B,124,42) Inductor	CTF1410		L 4174	(A,82,53) Inductor	CTF1689	
L 602	(B,42,6) Inductor	CTF1410		L 4175	(B,82,50) Inductor	CTF1689	
L 604	(B,121,48) Inductor	CTF1410		L 4176	(A,82,48) Inductor	CTF1689	A
L 605	(A,43,14) Inductor	CTF1410		L 4231	(B,64,25) Inductor	CTF1473	
L 607	(B,104,35) Inductor	CTF1410		L 4271	(A,66,86) Inductor	LCYA2R2J2520	
L 608	(B,101,33) Inductor	CTF1410		L 4351	(A,125,111) Inductor	LCTC2R2K1608	
L 609	(B,100,48) Inductor	CTF1410		L 4352	(A,130,113) Inductor	CTF1556	
L 610	(B,33,12) Inductor	CTF1410		L 4371	(A,38,118) Inductor	CTF1334	
L 611	(A,99,21) Inductor	CTF1410		L 4372	(B,40,124) Inductor	CTF1334	
L 612	(A,103,47) Inductor	CTF1410		L 4601	(A,106,64) Choke Coil 27 uH	CTH1402	
L 613	(A,110,20) Inductor	CTF1410		L 4602	(A,130,63) Choke Coil 10 uH	CTH1403	
L 614	(B,122,25) Inductor	CTF1410		L 4641	(A,141,22) Inductor	CTH1255	
L 615	(A,121,34) Inductor	CTF1410		L 4642	(A,161,24) Inductor	CTH1257	
L 617	(B,116,45) Inductor	CTF1410		L 4661	(A,141,35) Inductor	CTH1255	B
L 704	(A,80,72) Inductor	CTF1357		L 4662	(A,162,40) Inductor	CTH1257	
L 705	(A,90,70) Inductor	CTF1463		L 4701	(B,87,44) Inductor	CTF1393	
L 706	(A,95,64) Inductor	CTF1306		L 4721	(A,44,130) Inductor(UC)	LCYC2R2K1608	
L 707	(A,81,67) Inductor	CTF1306		L 4722	(B,50,124) Inductor(UC)	CTF1334	
L 708	(A,93,65) Inductor	CTF1306		L 4723	(B,50,120) Inductor(UC)	CTF1334	
L 709	(A,79,65) Inductor	CTF1306		L 4724	(B,53,115) Inductor(UC)	CTF1334	
L 710	(A,91,64) Inductor	CTF1306		L 4725	(B,49,125) Inductor(UC)	CTF1334	
L 711	(A,79,64) Inductor	CTF1306		T 1401	(A,41,105) Coil	CTC1194	
L 712	(A,77,62) Inductor	CTF1306		T 1402	(A,43,95) Coil	CTC1193	
L 713	(A,80,61) Inductor	CTF1306		T 1403	(A,33,96) Coil	CTC1192	C
L 714	(A,93,61) Inductor	CTF1306		TH601	(A,70,29) Thermistor	CCX1051	
L 1004	(A,149,13) Inductor	CTF1334		X 601	(A,92,33) Ceramic Resonator 20.000 MHz	VSS1186	
L 1401	(B,23,112) Inductor	LCTAWR12J2520		VR4231	(A,55,25) Semi-fixed 1 kohm(OB)	CCP1483	
L 1402	(B,29,111) Inductor	LCYCR10K2125		△FU2900	(B,72,8) Fuse 250 mA	CEK1276	
L 1403	(A,45,89) Inductor	LCTAW101J2520		FU4351	(B,117,118) Poly Switch	MINISMDC075F/24	
L 1421	(B,42,96) Inductor	LCTCR22K2125		△FU4352	(B,129,133) Fuse 3.15 A	CEK1259	
L 1422	(B,30,105) Inductor	LCTCR10K2125		△FU4601	(B,104,61) Fuse 5 A	CEK1261	
L 1423	(B,44,89) Inductor	LCTAW101J2520		△FU4602	(B,144,58) Fuse 5 A	CEK1261	
L 1441	(A,38,85) Inductor	LCTCR15K2125		△FU4631	(A,115,86) Fuse 200 mA	CEK1247	
L 1443	(A,45,83) Chip Coil	LCTAW1R0J2520		△FU4641	(A,141,8) Fuse 3.15 A	CEK1259	
L 1461	(B,17,110) Chip Coil	LCTAW4R7J2520		△FU4642	(B,158,72) Fuse 2.5 A	CEK1258	D
L 1462	(A,39,70) Inductor	LCTAW2R2J3225		△FU4661	(A,137,8) Fuse 2.5 A	CEK1258	
L 1463	(B,25,57) Inductor	LCTAW2R2J2520		△FU4662	(B,148,55) Fuse 2.5 A	CEK1258	
L 1464	(B,27,54) Chip Ferrite Bead	CTF1399		△FU4771	(A,115,106) Fuse 1 A	CEK1254	
L 1465	(A,34,41) Inductor	LCTAW2R2J3225		FB701	(A,93,77) Inductor	CTF1453	
L 2870	(B,167,127) Inductor	CTF1410		EF4351	(B,121,119) EMI Filter	CCG1067	
L 2871	(B,160,115) Inductor	CTF1410		EF4352	(B,126,119) EMI Filter	CCG1067	
L 2872	(B,149,114) Inductor	CTF1410		EF4353	(A,128,119) EMI Filter	CCG1067	
L 2930	(A,135,95) Choke Coil 600 uH	CTH1347		EF4354	(A,110,120) EMI Filter	CCG1067	
L 2931	(B,92,117) Inductor	CTF1689		EF4355	(A,114,120) EMI Filter	CCG1067	
L 2932	(B,79,115) Inductor	CTF1689		EF4356	(A,116,120) EMI Filter	CCG1067	
L 2933	(B,79,117) Inductor	CTF1689		EF4357	(A,120,120) EMI Filter	CCG1067	E
L 2934	(B,96,118) Inductor	CTF1689		EF4358	(A,124,120) EMI Filter	CCG1067	
L 2940	(A,90,11) Inductor	CTF1334		EF4359	(B,124,119) EMI Filter	CCG1067	
L 2943	(B,61,12) Inductor	CTF1556		EF4360	(B,129,119) EMI Filter	CCG1067	
L 2944	(B,61,14) Inductor	CTF1556		EF4361	(A,131,119) EMI Filter	CCG1067	
L 2945	(B,58,13) Inductor	CTF1556		EF4731	(B,157,78) EMI Filter	CCG1172	
L 2946	(B,66,8) Inductor	CTF1556		EF4732	(B,154,57) EMI Filter	CCG1172	
L 2947	(A,60,21) Inductor	CTF1675		ANT1401	(A,19,119) Antenna Jack	CKX1060	
L 2948	(A,61,21) Inductor	CTF1675		Y 1461	(A,18,93) FM/AM Tuner Unit(UC,AU)	CWE2128	
L 2949	(A,65,21) Inductor	CTF1675			(A,18,93) FM/AM Tuner Unit(EU5)	CWE2127	
L 2950	(A,66,21) Inductor	CTF1675		U 695	(B,92,27) IR Remote(AU)	RPMS2401-H19	F
L 3601	(A,17,14) Chip Coil	LCTAW100J2520		CN702	(A,85,66) Connector	CKS5627	
L 4171	(B,72,62) Chip Coil	LCTAW100J2520		CN1000	(A,74,9) Connector	CKS5732	
L 4172	(B,60,61) Chip Coil	LCTAW100J2520		CN1001	(A,94,103) Connector	CKS4674	

1

2

3

4

Circuit Symbol and No.**Part No.****Circuit Symbol and No.****Part No.**

CN1005 (A,149,129) Plug

CKM1550

R 681 (B,119,49)

RS1/16SS473J

R 682 (A,125,36)

RS1/16SS0R0J

R 683 (A,123,43)

RAB4C104J

CN1015 (A,37,129) Jack

CKN1042

CN1016 (A,122,132) Connector

CKM1460

CN1021 (A,58,129) Connector(UC)

CKS3408

R 684 (A,123,39)

RAB4C681J

CN1441 (A,53,84) Mini Pin Jack

CKX1046

R 685 (A,69,27)

RS1/16S102J

R 686 (B,109,37)

RS1/16SS104J

R 687 (B,118,43)

RS1/16SS104J

R 688 (B,44,9)

RS1/16SS104J

RESISTORS

R 601 (A,39,7)

RS1/16S104J

R 602 (B,39,6)

RS1/16S104J

R 603 (A,96,24) (UC,EU5)

RS1/16SS220J

R 604 (A,97,22) (UC,EU5)

RS1/16S220J

R 605 (B,121,39)

RS1/16SS104J

R 607 (A,86,32) (EU5)

RS1/16SS681J

R 608 (A,89,40) (EU5)

RAB4C681J

R 609 (B,101,37)

RS1/16SS104J

R 610 (B,96,38)

RS1/16SS102J

R 612 (B,98,32)

RS1/16SS104J

R 613 (A,95,42)

RS1/16SS471J

R 614 (A,93,41)

RS1/16SS471J

R 615 (A,95,41)

RS1/16SS222J

R 616 (A,93,40)

RS1/16SS0R0J

R 617 (A,95,39)

RS1/16SS0R0J

R 618 (B,25,10)

RS1/16SS104J

R 619 (B,111,38)

RS1/16SS104J

R 620 (A,96,35)

RS1/16SS101J

R 626 (B,101,30)

RS1/16SS221J

R 627 (A,96,26)

RS1/16SS104J

R 628 (B,89,40) (EU5)

RAB4C223J

R 632 (B,100,45)

RS1/16SS0R0J

R 633 (B,103,42)

RS1/16SS102J

R 634 (A,102,22)

RS1/16SS104J

R 636 (B,101,40)

RS1/16SS104J

R 639 (B,106,40)

RS1/16SS102J

R 640 (B,103,40)

RS1/16SS103J

R 641 (B,100,41)

RS1/16SS103J

R 642 (B,106,25)

RS1/16SS220J

R 643 (A,100,18)

RS1/16SS104J

R 646 (A,102,18)

RS1/16SS104J

R 648 (B,108,24)

RS1/16S104J

R 649 (B,104,46)

RS1/16SS220J

R 650 (A,103,18)

RS1/16SS104J

R 652 (B,106,44)

RS1/16SS220J

R 653 (A,109,47)

RS1/16SS102J

R 654 (A,105,18)

RS1/16SS104J

R 657 (A,106,18)

RS1/16SS104J

R 659 (A,112,21)

RS1/16S220J

R 660 (A,115,19)

RS1/16S104J

R 661 (A,109,17)

RS1/16S104J

R 662 (A,113,18)

RS1/16S104J

R 663 (A,117,20)

RS1/16SS102J

R 664 (A,117,18)

RS1/16SS473J

R 665 (B,118,49)

RS1/16SS104J

R 666 (B,116,24)

RS1/16SS104J

R 668 (B,119,22)

RS1/16SS472J

R 670 (A,125,33)

RS1/16SS104J

R 671 (A,121,31)

RS1/16SS102J

R 676 (A,121,28)

RS1/16SS0R0J

R 677 (A,121,27)

RS1/16SS0R0J

R 680 (B,120,22)

RS1/16SS472J

R 689 (B,40,10)

RS1/16SS104J

R 690 (A,110,49)

RS1/16SS472J

R 695 (B,97,24) (AU)

RS1/16SS470J

R 696 (B,96,30) (AU)

RS1/16SS470J

R 697 (B,99,24)

RS1/16SS104J

R 698 (B,106,27)

RS1/16SS104J

R 699 (B,110,49)

RS1/16SS104J

R 714 (A,95,76)

RS1/10S0R0J

R 715 (B,95,75)

RS1/10S0R0J

R 717 (A,82,57)

RS1/16SS0R0J

R 718 (A,94,63)

RS1/16SS221J

R 722 (A,82,69)

RS1/16S104J

R 731 (B,95,35)

RS1/16SS0R0J

R 751 (A,78,54)

RS1/16S0R0J

R 1016 (B,70,16)

RS1/16SS0R0J

R 1401 (B,41,109) Inductor

CTF1742

R 1409 (B,20,112)

RS1/16S105J

R 1410 (A,36,103)

RS1/16S821J

R 1411 (A,35,108)

RS1/16S330J

R 1412 (A,44,89)

RS1/16S332J

R 1413 (A,33,91)

RS1/16S101J

R 1421 (B,38,92)

RS1/16S151J

R 1422 (B,36,94)

RS1/16S680J

R 1423 (B,41,93)

RS1/16S152J

R 1424 (B,43,93)

RS1/16S681J

R 1425 (B,44,96)

RS1/16S181J

R 1441 (A,32,85)

RS1/16S151J

R 1442 (A,33,87)

RS1/16S680J

R 1443 (A,39,88)

RS1/16S152J

R 1444 (A,41,86)

RS1/16S681J

R 1445 (A,39,84)

RS1/16S151J

R 1461 (B,25,71)

RS1/16SS681J

R 1462 (B,25,70)

RS1/16SS681J

R 1463 (B,25,69)

RS1/16SS681J

R 1464 (B,25,68)

RS1/16SS681J

R 1465 (B,25,67)

RS1/16SS681J

R 1466 (B,27,66)

RS1/16SS223J

R 1467 (B,25,65) (EU5)

RS1/16SS681J

R 1468 (B,25,59)

RS1/16SS681J

R 1470 (B,26,47)

RS1/16SS0R0J

R 1471 (B,26,45)

RS1/16SS0R0J

R 1474 (B,30,47)

RS1/16SS0R0J

R 1475 (B,33,45)

RS1/16SS0R0J

R 1476 (B,28,49) (EU5)

RS1/16SS0R0J

R 1477 (B,27,51) (EU5)

RS1/16SS0R0J

R 1478 (B,28,50) (EU5)

RS1/16SS0R0J

R 1479 (B,27,52) (EU5)

RS1/16SS0R0J

R 2801 (B,160,96)

RN1/16SE1002D

R 2802 (B,159,94)

RN1/16SE2701D

R 2803 (B,158,96)

RN1/16SE2201D

R 2804 (B,159,99)

RS1/16S104J

R 2810 (B,111,99)

RS1/8S0R0J

5		6		7		8	
<u>Circuit Symbol and No.</u>		<u>Part No.</u>		<u>Circuit Symbol and No.</u>		<u>Part No.</u>	
R 2811	(A,100,98)	RS1/16S471J		R 2940	(B,61,7)	RS1/16S0R0J	
R 2820	(B,160,85)	RS1/16S2201D		R 2941	(A,57,10)	RS1/16SS101J	
R 2821	(B,159,87)	RS1/16S1002D		R 2942	(A,61,15)	RS1/16SS101J	
R 2822	(B,159,89)	RS1/16S2201D		R 2951	(B,67,18)	RS1/16SS0R0J	A
R 2823	(A,139,49)	RS1/16SS105J		R 2952	(B,68,18)	RS1/16SS0R0J	
R 2830	(B,33,28)	RS1/16S3601D		R 2953	(B,66,13)	RS1/16SS0R0J	
R 2831	(B,31,24)	RS1/16S10R0D		R 2954	(B,70,11)	RS1/16SS0R0J	
R 2832	(A,28,36)	RS1/16S2201D		R 2959	(B,77,5)	RS1/16S0R0J	
R 2833	(A,33,28)	RS1/16S0R0J		R 2960	(B,74,8)	RS1/16SS0R0J	
R 2834	(B,38,30)	RS1/16S104J		R 2961	(B,75,8)	RS1/16SS0R0J	
R 2840	(A,146,11)	RS1/16SS104J		R 2962	(A,77,18)	RS1/16SS0R0J	
R 2841	(A,146,12)	RS1/16SS473J		R 2963	(A,79,18)	RS1/16SS0R0J	
R 2842	(B,145,6)	RS1/16SS563J		R 2964	(A,81,21)	RS1/16SS0R0J	
R 2843	(B,148,9)	RS1/16SS513J		R 2967	(B,77,18)	RS1/16SS0R0J	
R 2844	(B,149,8)	RS1/16SS104J		R 2968	(B,76,8)	RS1/16SS0R0J	B
R 2845	(B,150,6)	RS1/16SS513J		R 2969	(B,78,8)	RS1/16SS0R0J	
R 2846	(A,153,6)	RS1/16SS513J		R 2970	(B,80,15)	RS1/16SS0R0J	
R 2847	(B,151,8)	RS1/16SS102J		R 2971	(B,79,8)	RS1/16SS0R0J	
R 2848	(B,149,6)	RS1/16SS102J		R 2972	(B,81,8)	RS1/16SS0R0J	
R 2849	(B,151,6)	RS1/16SS564J		R 2973	(B,82,15)	RS1/16SS0R0J	
R 2850	(B,153,10)	RS1/16SS202J		R 2974	(B,82,8)	RS1/16SS0R0J	
R 2851	(B,152,10)	RS1/16SS822J		R 2975	(B,83,8)	RS1/16SS0R0J	
R 2852	(A,154,11)	RS1/16SS203J		R 2976	(B,84,8)	RS1/16SS0R0J	
R 2853	(A,152,13)	RS1/16SS333J		R 2977	(B,85,8)	RS1/16SS0R0J	
R 2860	(B,126,108)	RS1/16SS391J		R 2978	(A,85,21)	RS1/16SS0R0J	C
R 2861	(B,124,109)	RS1/16SS391J		R 2979	(A,87,18)	RS1/16SS0R0J	
R 2862	(B,122,103)	RS1/16SS473J		R 2980	(A,88,19)	RS1/16SS0R0J	
R 2863	(B,116,105)	RS1/16SS223J		R 2981	(A,87,22)	RS1/16SS0R0J	
R 2864	(B,118,106)	RS1/16SS103J		R 2982	(A,90,9)	RS1/16SS0R0J	
R 2865	(B,123,112)	RS1/10S102J		R 2983	(A,156,8)	RS1/16SS0R0J	
R 2866	(B,114,116)	RS1/16SS103J		R 3041	(A,75,56)	RS1/16S182J	
R 2867	(B,117,114)	RS1/16SS103J		R 3042	(A,75,57)	RS1/16S182J	
R 2868	(B,115,114)	RS1/16SS221J		R 3043	(A,76,54)	RS1/16S473J	
R 2869	(B,113,114)	RS1/16SS101J		R 3044	(A,74,54)	RS1/16S473J	
R 2870	(A,153,110)	RS1/16S473J		R 3601	(B,29,22)	RS1/16S224J	
R 2871	(A,153,112)	RS1/16S104J		R 3602	(B,34,21)	RS1/16S102J	D
R 2872	(B,154,109)	RS1/16S102J		R 3603	(B,27,24)	RS1/16S222J	
R 2873	(B,157,109)	RS1/16S472J		R 3604	(B,23,21)	RS1/16S224J	
R 2874	(B,150,110)	RS1/4S102J		R 3605	(B,18,14)	RS1/16S102J	
R 2875	(B,152,114)	RS1/4S472J		R 3606	(B,24,23)	RS1/16S222J	
R 2880	(A,166,120)	RS1/16S103J		R 3607	(B,16,21)	RS1/16S224J	
R 2881	(B,148,132)	RS1/4S472J		R 3608	(B,16,15)	RS1/16S102J	
R 2882	(B,143,132)	RS1/4S102J		R 3609	(B,15,24)	RS1/16S222J	
R 2883	(B,124,22)	RS1/16SS472J		R 3610	(B,29,19)	RS1/16S121J	
R 2884	(B,122,22)	RS1/16SS472J		R 3611	(B,27,21)	RS1/16S101J	
R 2900	(A,169,124)	RS1/16S473J		R 3612	(B,31,15)	RS1/16S101J	
R 2901	(A,170,122)	RS1/16S104J		R 3616	(B,20,20)	RS1/16S121J	E
R 2902	(A,167,128)	RS1/4S102J		R 3617	(B,20,23)	RS1/16S151J	
R 2903	(A,167,131)	RS1/4S472J		R 3618	(B,21,16)	RS1/16S101J	
R 2910	(B,154,71)	RS1/16S473J		R 3622	(B,11,20)	RS1/16S151J	
R 2911	(B,145,109)	RS1/16S473J		R 3623	(B,12,23)	RS1/16S181J	
R 2912	(A,60,90)	RS1/4S4R7J		R 3624	(B,14,16)	RS1/16S101J	
R 2913	(A,65,92)	RS1/4S4R7J		R 3629	(B,71,8)	RS1/16S0R0J	
R 2920	(B,90,109)	RS1/16S102J		R 4001	(B,57,61)	RS1/16S750J	
R 2921	(B,89,113)	RS1/16S102J		R 4021	(A,54,50)	RS1/16S750J	
R 2922	(B,91,113)	RS1/16S102J		R 4041	(B,57,37)	RS1/16S750J	
R 2923	(B,95,108)	RS1/16S102J		R 4061	(A,57,48)	RS1/16S102J	F
R 2924	(A,96,120)	RS1/16S103J		R 4071	(A,69,46)	RS1/16SS473J	
R 2925	(A,93,120)	RS1/16S103J		R 4072	(A,68,47)	RS1/16SS473J	
R 2926	(A,102,119)	RS1/16S103J		R 4073	(A,65,57)	RS1/16SS473J	

1

2

3

4

Circuit Symbol and No.**Part No.****Circuit Symbol and No.****Part No.**

R 4074	(A,66,42)	RS1/16SS473J	R 4333	(B,97,86)	RS1/16SS821J
R 4075	(A,64,43)	RS1/16SS473J	R 4334	(B,90,86)	RS1/16SS821J
R 4076	(A,67,50)	RS1/16SS473J	R 4335	(B,97,93)	RS1/16SS821J
A					
R 4077	(A,65,56)	RS1/16SS473J	R 4336	(B,90,93)	RS1/16SS821J
R 4078	(A,65,52)	RS1/16SS473J	R 4337	(B,105,92)	RS1/16SS223J
R 4079	(A,63,42)	RS1/16SS330J	R 4338	(B,96,86)	RS1/16SS223J
R 4080	(A,63,55)	RS1/16SS330J	R 4339	(B,96,93)	RS1/16SS223J
R 4151	(B,65,32)	RS1/16SS103J	R 4340	(B,101,92)	RS1/16SS223J
R 4152	(B,64,34)	RS1/16SS103J	R 4341	(B,91,86)	RS1/16SS223J
R 4153	(B,67,34)	RS1/16SS103J	R 4342	(B,91,93)	RS1/16SS223J
R 4154	(B,66,32)	RS1/16SS103J	R 4343	(B,104,89)	RS1/16SS471J
R 4155	(B,69,36)	RS1/16SS102J	R 4344	(B,94,83)	RS1/16SS471J
R 4156	(B,70,36)	RS1/16SS104J	R 4345	(B,94,90)	RS1/16SS471J
B					
R 4157	(B,73,35)	RS1/16SS104J	R 4346	(B,102,89)	RS1/16SS471J
R 4158	(B,75,33)	RS1/16SS683J	R 4347	(B,93,83)	RS1/16SS471J
R 4159	(B,73,33)	RS1/16SS473J	R 4348	(B,93,90)	RS1/16SS471J
R 4170	(B,80,54)	RS1/16SS223J	R 4351	(A,127,112)	RS1/16S153J
R 4171	(B,80,50)	RS1/16SS223J	R 4352	(A,131,111)	RS1/10S103J
R 4174	(B,66,22)	RS1/16SS223J	R 4601	(B,107,62)	RS1/10S0R0J
R 4175	(B,64,22)	RS1/16SS223J	R 4602	(B,111,59)	RS1/16S2200D
R 4176	(B,75,57)	RS1/16SS0R0J	R 4603	(B,112,59)	RS1/16S4701D
R 4194	(B,63,42)	RS1/16SS221J	R 4604	(B,113,59)	RS1/16S1501D
R 4195	(B,64,41)	RS1/16SS221J	R 4605	(B,109,59)	RS1/16S101J
R 4200	(A,76,39)	RS1/16S750J	R 4606	(B,116,59)	RS1/16S332J
R 4231	(B,60,26)	RS1/16SS223J	R 4607	(B,119,59)	RS1/16S104J
R 4232	(B,60,22)	RS1/16SS303J	R 4608	(B,115,70)	RS1/16S473J
R 4233	(B,58,22)	RS1/16SS681J	R 4609	(B,112,65)	RS1/16S1503D
R 4234	(B,57,24)	RS1/16SS102J	R 4610	(B,110,63)	RS1/16S8203D
R 4235	(B,62,22)	RS1/16SS681J	R 4611	(B,121,60)	RS1/10S100J
R 4236	(B,54,19)	RS1/16SS152J	R 4612	(B,126,68)	RS1/16S100J
R 4237	(B,58,18)	RS1/16SS0R0J	R 4614	(B,126,65)	RS1/16S184J
R 4240	(B,60,27)	RS1/16SS0R0J	R 4615	(B,143,56)	RS1/16S105J
R 4251	(B,102,113)	RS1/16S750J	R 4616	(B,93,99)	RS1/16S222J
R 4252	(B,104,113)	RS1/16SS473J	R 4633	(A,129,86)	RS1/16SS821J
R 4253	(B,102,112)	RS1/16SS473J	R 4641	(B,141,8)	RS1/4SA561J
D					
R 4254	(B,100,112)	RS1/16SS101J	R 4643	(B,142,19)	RS1/16S331J
R 4255	(B,106,113)	RS1/16SS101J	R 4644	(B,139,20)	RS1/16S0R0J
R 4263	(A,105,110)	RS1/16SS0R0J	R 4645	(B,144,19)	RS1/16S5600D
R 4271	(B,58,66)	RS1/16S0R0J	R 4646	(B,145,19)	RS1/16S8201D
R 4272	(B,86,65) (UC)	RS1/16S181J	R 4647	(B,146,19)	RS1/16S1501D
R 4273	(B,56,68) (UC)	RS1/16S181J	R 4648	(B,148,30)	RS1/16S473J
R 4274	(B,87,67) (UC)	RS1/16S223J	R 4649	(B,149,19)	RS1/16S332J
R 4275	(B,85,67) (UC)	RS1/16S102J	R 4650	(B,151,19)	RS1/16S104J
R 4276	(B,53,69) (UC)	RS1/16S223J	R 4651	(B,145,24)	RS1/16S1503D
R 4277	(B,51,70) (UC)	RS1/16S102J	R 4652	(B,143,22)	RS1/16S8203D
R 4285	(B,59,73)	RS1/16SS0R0J	R 4653	(B,154,20)	RS1/10S100J
E					
R 4286	(B,85,71)	RS1/16SS0R0J	R 4654	(B,158,24)	RS1/16S184J
R 4287	(B,76,75)	RS1/16SS102J	R 4656	(B,158,26)	RS1/16S100J
R 4289	(B,76,76)	RS1/16SS102J	R 4657	(A,159,18)	RS1/16S105J
R 4291	(B,76,77)	RS1/16SS102J	R 4662	(B,138,36)	RS1/10S0R0J
R 4293	(B,77,80)	RS1/16SS0R0J	R 4663	(B,143,35)	RS1/16S1800D
R 4295	(B,59,77)	RS1/16SS0R0J	R 4664	(B,144,35)	RS1/16S4701D
R 4296	(A,54,75)	RS1/16S0R0J	R 4665	(B,146,35)	RS1/16S1501D
R 4297	(A,63,87)	RS1/16S0R0J	R 4666	(B,112,70)	RS1/16S473J
R 4312	(B,78,32)	RS1/16SS821J	R 4667	(B,142,35)	RS1/16S101J
R 4313	(B,79,37)	RS1/16SS104J	R 4668	(B,148,35)	RS1/16S332J
F					
R 4316	(B,84,44)	RS1/16SS0R0J	R 4669	(B,151,35)	RS1/16S104J
R 4317	(B,80,45)	RS1/16SS0R0J	R 4670	(B,147,45)	RS1/16S473J
R 4331	(B,106,92)	RS1/16SS821J	R 4671	(B,144,40)	RS1/16S1503D
R 4332	(B,100,92)	RS1/16SS821J	R 4672	(B,142,38)	RS1/16S8203D

1

2

3

4

5		6		7		8	
<u>Circuit Symbol and No.</u>		<u>Part No.</u>		<u>Circuit Symbol and No.</u>		<u>Part No.</u>	
R 4673	(B,154,36)	RS1/10S100J		C 617	(A,100,21)	CKSRYB104K16	
R 4674	(B,158,43)	RS1/16S100J		C 618	(A,105,47)	CKSRYB104K16	
R 4676	(B,158,41)	RS1/16S184J		C 619	(B,97,42)	CKSRYB104K16	
				C 620	(A,109,20)	CKSRYB104K16	A
R 4677	(B,148,58)	RS1/16S105J		C 621	(A,122,26)	CKSRYB104K16	
R 4678	(B,138,9)	RS1/4SA221J		C 622	(A,121,36)	CKSRYB104K16	
R 4680	(B,143,46)	RS1/16SS0R0J		C 623	(B,71,16)	CKSRYB103K16	
R 4721	(A,43,128) (UC,EU5)	RS1/16S472J		C 630	(B,113,45)	CKSRYB104K50	
R 4722	(A,41,130) (UC)	RS1/16S101J		C 632	(B,104,25)	CKSRYB104K16	
R 4723	(A,43,130) (UC)	RS1/16S101J					
R 4724	(A,56,117) (UC)	RS1/16S102J		C 636	(B,95,40)	CKSSYB104K16	
R 4725	(A,60,117) (UC)	RS1/16S101J		C 671	(B,52,10)	CKSSYB104K16	
R 4726	(A,63,117) (UC)	RS1/16S101J		C 672	(A,48,33)	CKSSYB104K16	
R 4727	(B,61,117) (UC)	RS1/16S620J		C 685	(A,72,29)	CKSSYB104K16	
				C 696	(B,97,29) (AU)	CKSQYB106K6R3	
R 4728	(B,43,134) (UC,EU5)	RS1/16S472J					
R 4731	(B,126,100) (UC)	RS1/16S222J		C 705	(A,82,76)	CKSRYB104K25	B
R 4732	(B,147,87)	RS1/16S473J		C 706	(A,90,75)	CKSRYB104K25	
R 4733	(B,126,98) (UC)	RS1/16S682J		C 707	(A,80,76)	CKSRYF104Z25	
R 4734	(B,153,93)	RS1/16S103J		C 708	(A,89,75)	CKSRYF104Z25	
				C 709	(A,88,70)	CKSRYF104Z25	
R 4735	(B,150,87)	RS1/16S104J					
R 4736	(B,121,99) (UC)	RS1/16S332J		C 711	(B,96,64)	CKSRYB103K16	
R 4737	(B,151,96)	RS1/16S103J		C 1020	(B,70,8)	CKSRYB102K50	
R 4738	(B,143,93)	RS1/16S473J		C 1021	(B,68,8)	CKSRYB102K50	
R 4739	(B,145,92)	RS1/16S104J		C 1022	(B,63,9)	CKSRYB104K50	
				C 1077	(A,54,29)	CKSRYB104K25	
R 4749	(B,35,7)	RS1/16S472J					
R 4750	(B,33,10)	RS1/16S472J		C 1078	(A,57,29)	CKSRYB104K25	C
R 4751	(A,34,13)	RS1/16S101J		C 1401	(B,21,110)	CCSRCH270J50	
R 4752	(A,35,6)	RS1/16S101J		C 1402	(B,25,111)	CCSRCH220J50	
R 4753	(A,36,12)	RS1/16S105J		C 1403	(B,26,113)	CCSRCH270J50	
				C 1404	(B,32,111)	CCSRCH330J50	
R 4754	(A,34,11)	RS1/16S103J					
R 4755	(A,37,9)	RS1/16S105J		C 1405	(B,31,109)	CCSRCH470J50	
R 4756	(A,33,5)	RS1/16S103J		C 1406	(A,36,102)	CKSRYB103K50	
R 4757	(A,30,6)	RS1/16S0R0J		C 1407	(A,36,108)	CKSRYB103K50	
R 4758	(A,30,17)	RS1/16S272J		C 1408	(A,41,88)	CKSRYB103K50	
				C 1409	(A,38,94)	CKSRYB222K50	
R 4771	(B,111,91)	RS1/16SS472J					
R 4772	(B,110,88)	RS1/16SS472J		C 1421	(B,35,93)	CKSRYB222K50	
R 4773	(B,116,95)	RS1/16SS103J		C 1422	(B,40,93)	CKSRYB222K50	D
R 4774	(B,114,95)	RS1/16SS512J		C 1423	(B,31,100)	CCSRCH150J50	
R 4775	(B,113,86)	RS1/16SS224J		C 1424	(B,43,92)	CKSRYB103K50	
				C 1426	(B,30,102)	CCSRCH270J50	
R 4776	(B,113,84)	RS1/16SS472J					
R 4777	(B,116,89)	RS1/10S221J		C 1441	(A,32,87)	CKSRYB222K50	
R 4778	(B,119,85)	RS1/4S471J		C 1442	(A,38,88)	CKSRYB222K50	
R 4783	(B,122,29)	RS1/16SS332J		C 1443	(A,37,83)	CCSRCH220J50	
R 4784	(B,122,26)	RS1/16SS332J		C 1444	(A,42,84)	CKSRYB103K50	
				C 1452	(B,27,70)	CKSSYB102K50	
R 4811	(A,8,44) (EU5)	RS1/16SS0R0J					
R 4812	(A,8,46) (UC)	RS1/16SS0R0J		C 1458	(B,29,59)	CKSRYB103K50	
R 4815	(A,8,54) (AU)	RS1/16SS0R0J		C 1461	(A,32,70)	CEVW221M10	
				C 1462	(A,32,59)	CEVW221M10	E
				C 1464	(A,22,86)	CCSRCH101J50	
				C 1465	(A,39,73)	CKSRYB103K50	
<u>CAPACITORS</u>							
C 601	(B,123,40)	CKSRYB104K16					
C 602	(B,44,6)	CKSRYB104K50		C 1466	(A,28,75)	CKSRYB103K50	
C 604	(B,121,47)	CKSRYB104K50		C 1468	(B,25,51) 10 uF	CCG1203	
C 605	(A,40,13)	CKSRYB104K16		C 1469	(B,23,51)	CKSRYB103K50	
C 606	(B,105,34)	CKSRYB104K50		C 1476	(A,36,38)	CKSSYB103K25	
				C 2800	(B,95,104)	CKSRYB102K50	
C 607	(B,95,46)	CKSRYB153K50					
C 608	(B,97,36)	CKSSYB104K16		C 2801	(A,159,99) 100 uF/16 V	CCH1565	
C 609	(B,97,33)	CKSRYB104K16		C 2802	(A,163,99)	CCSRCH102J50	
C 613	(B,97,47)	CKSRYB104K16		C 2804	(A,163,102)	CKSRYB104K50	F
C 614	(B,102,46)	CKSRYB104K16		C 2805	(B,94,101)	CKSRYB104K50	
				C 2810	(A,106,102)	CEVW101M16	
C 615	(B,32,10)	CKSRYB104K16					
				C 2811	(B,102,103)	CKSRYB104K50	

1

2

3

4

Circuit Symbol and No.**Part No.****Circuit Symbol and No.****Part No.**

C 2812	(A,107,97)	CKSRYB104K50	C 4076	(A,62,48)	CKSRYB104K50
C 2820	(A,159,87) 100 uF/16 V	CCH1565	C 4078	(A,64,53)	CCSRCH330J50
C 2821	(A,163,88)	CKSRYB103K50	C 4079	(A,61,40)	CKSRYB103K50
C 2823	(A,163,91)	CKSRYB104K50	C 4080	(A,63,57)	CKSRYB103K50
C 2830	(A,32,34)	CEVW101M16	C 4151	(B,63,31) 10 uF	CCG1203
C 2831	(B,33,30)	CKSRYB103K50	C 4152	(B,61,32) 10 uF	CCG1203
C 2833	(B,36,29)	CKSRYB104K50	C 4153	(B,67,32)	CCSSCH221J50
C 2840	(A,151,11)	CKSRYB104K50	C 4154	(B,70,31)	CKSSYB104K16
C 2841	(B,150,10)	CKSRYB102K50	C 4155	(B,67,36)	CKSSYB103K25
C 2842	(A,153,9)	CKSRYB104K50	C 4156	(B,75,35)	CKSSYB104K16
C 2843	(A,156,11)	CKSRYB103K50	C 4157	(B,74,35)	CCSSCH151J50
C 2844	(A,156,10)	CKSRYB823K16	C 4158	(B,72,35)	CCSSCH151J50
C 2860	(A,120,114)	CEVW470M16	C 4159	(B,78,30)	CKSQYB225K10
C 2861	(B,121,115)	CKSRYB104K50	C 4160	(B,66,34)	CCSSCH221J50
C 2862	(A,111,114)	CEVW330M10	C 4171	(A,71,62)	CEVLW470M16
C 2870	(A,151,110)	CKSRYB102K50	C 4172	(B,73,61)	CKSRYB104K50
C 2871	(B,147,114)	CKSRYB102K50	C 4173	(A,59,59)	CEVLW470M16
C 2872	(B,157,115)	CKSRYB102K50	C 4174	(B,75,61)	CKSYB226K6R3
C 2881	(A,167,110)	CKSQYB105K16	C 4181	(B,62,58)	CKSRYB104K50
C 2882	(B,146,133)	CKSRYB102K50	C 4182	(B,77,59)	CKSRYB104K50
C 2890	(B,161,104)	CKSRYB104K50	C 4183	(B,63,60)	CKSYB226K6R3
C 2891	(B,161,107)	CKSRYB102K50	C 4184	(B,65,61)	CKSRYB104K50
C 2892	(A,162,111)	CKSRYB102K50	C 4185	(B,58,40)	CKSQYB475K10
C 2901	(A,170,130)	CKSRYB104K50	C 4186	(B,58,50)	CKSQYB475K10
C 2910	(A,151,65)	CEAT103M16(P30)	C 4187	(B,59,43)	CKSQYB475K10
C 2911	(A,60,105)	CEAT103M16(P30)	C 4188	(B,67,61)	CKSRYB105K10
C 2912	(A,77,96)	CEAT103M16(P30)	C 4189	(B,69,61)	CKSRYB105K10
C 2920	(B,93,114)	CKSQYB105K16	C 4190	(B,70,59)	CKSRYB105K10
C 2921	(B,85,115)	CKSQYB105K16	C 4191	(B,71,59)	CKSRYB105K10
C 2922	(B,85,117)	CKSQYB105K16	C 4192	(B,68,59)	CKSRYB105K10
C 2923	(B,96,114)	CKSQYB105K16	C 4193	(B,79,60)	CKSRYB105K10
C 2924	(A,100,120)	CKSRYB104K50	C 4194	(B,66,59)	CKSRYB105K10
C 2925	(B,94,117)	CKSRYB105K10	C 4195	(B,58,55)	CKSQYB475K10
C 2926	(B,81,115)	CKSRYB105K10	C 4197	(B,58,58)	CKSQYB475K10
C 2927	(B,81,117)	CKSRYB105K10	C 4198	(B,80,60)	CKSRYB105K10
C 2928	(B,96,116)	CKSRYB105K10	C 4199	(A,58,53)	CKSRYB105K10
C 2929	(A,94,115)	CEVW101M25	C 4200	(B,79,53)	CKSRYB105K10
C 2930	(A,103,115)	CKSRYB104K50	C 4201	(A,58,52)	CKSRYB105K10
C 2931	(A,100,119)	CKSRYB105K10	C 4202	(B,78,54)	CKSRYB105K10
C 2932	(A,81,120)	CKSQYB225K10	C 4203	(B,58,53)	CKSQYB475K10
C 2933	(A,85,120)	CKSYB225K16	C 4204	(B,78,51)	CKSRYB105K10
C 2934	(A,83,116)	CEVW100M16	C 4206	(B,78,50)	CKSRYB105K10
C 2935	(A,147,81) 3 300 uF/16 V	CCH1018(P30)	C 4207	(B,58,48)	CKSRYB105K10
C 3041	(A,78,59) 10 uF	CCG1203	C 4208	(A,79,23)	CKSRYB105K10
C 3042	(A,76,60) 10 uF	CCG1203	C 4210	(A,75,21)	CKSRYB105K10
C 3601	(B,27,23)	CKSQYB475K6R3	C 4211	(B,57,43)	CKSQYB475K10
C 3602	(A,16,18) 10 uF	CCG1203	C 4212	(A,72,22)	CKSRYB105K10
C 3604	(B,22,23)	CKSQYB475K6R3	C 4213	(A,69,22)	CKSRYB105K10
C 3607	(B,14,23)	CKSQYB475K6R3	C 4215	(B,77,44)	CKSRYB105K10
C 3611	(A,8,25)	CKSSYB102K50	C 4216	(B,59,37)	CKSQYB475K10
C 3612	(A,7,23)	CKSSYB102K50	C 4217	(B,76,43)	CKSRYB105K10
C 3613	(A,7,22)	CKSSYB102K50	C 4219	(A,73,34)	CEVW331M16
C 4061	(A,54,38)	CKSRYB103K50	C 4220	(A,73,44)	CEVWNP220M10
C 4062	(A,59,44)	CEVW100M16	C 4221	(B,73,40)	CKSRYB105K10
C 4063	(A,54,41)	CKSRYB104K50	C 4222	(B,74,40)	CKSRYB105K10
C 4070	(A,68,56) 10 uF	CCG1203	C 4224	(B,58,47)	CKSRYB105K10
C 4071	(A,69,49) 10 uF	CCG1203	C 4231	(B,62,24)	CKSRYB105K10
C 4072	(A,68,54) 10 uF	CCG1203	C 4232	(A,64,27)	CEVWNP220M10
C 4073	(A,68,52) 10 uF	CCG1203	C 4233	(A,55,17)	CEVQW101M10
C 4075	(A,64,41)	CCSRCH330J50	C 4251	(B,105,113)	CKSRYB473K50

1

2

3

4

5		6		7		8	
<u>Circuit Symbol and No.</u>		<u>Part No.</u>		<u>Circuit Symbol and No.</u>		<u>Part No.</u>	
C 4252	(B,100,110) 10 uF	CCG1203	CCG1203	C 4616	(B,140,59)	CKSRYB102K50	
C 4253	(B,106,110) 10 uF	CCG1203	CCG1203	C 4617	(B,140,60)	CKSRYB104K50	
C 4254	(B,102,104)	CKSRYB104K25	CKSRYB104K25	C 4618	(B,111,54) 10 uF	CCG1223	
C 4264	(A,86,109)	CEVQW101M10	CEVQW101M10	C 4619	(B,114,56)	CKSRYB104K50	A
C 4271	(B,82,67) 10 uF(UC)	CCG1203	CCG1203	C 4631	(A,123,91)	CKSRYB104K50	
C 4273	(B,85,66) (UC)	CKSRYB105K6R3	CKSRYB105K6R3	C 4641	(B,141,19)	CKSRYB103K25	
C 4274	(B,79,64)	CKSRYB105K6R3	CKSRYB105K6R3	C 4642	(B,148,19)	CCSRCH101J50	
C 4275	(B,60,64)	CKSRYB105K6R3	CKSRYB105K6R3	C 4643	(B,150,19)	CKSRYB104K50	
C 4276	(B,59,67)	CKSRYB105K6R3	CKSRYB105K6R3	C 4644	(B,145,22)	CKSRYB473K50	
C 4277	(B,54,71) 10 uF(UC)	CCG1203	CCG1203	C 4645	(B,145,23) 33 pF	CCG1252	
C 4280	(B,61,68) (UC)	CKSRYB105K6R3	CKSRYB105K6R3	C 4646	(B,144,26)	CKSRYB105K10	
C 4281	(B,60,72)	CKSRYB105K6R3	CKSRYB105K6R3	C 4647	(B,157,24)	CKSRYF104Z25	
C 4284	(B,83,69)	CKSRYB105K6R3	CKSRYB105K6R3	C 4648	(B,144,28)	CKSQYB475K10	
C 4285	(B,61,70)	CKSRYB105K6R3	CKSRYB105K6R3	C 4649	(B,157,21)	CKSRYF474Z16	
C 4286	(B,79,71)	CKSRYB105K6R3	CKSRYB105K6R3	C 4650	(B,157,29) 4.7 uF	CCG1222	B
C 4287	(B,61,73)	CKSRYB105K6R3	CKSRYB105K6R3	C 4651	(A,133,21) 220 uF/10 V	CCH1409	
C 4288	(A,68,70)	CEVW100M16	CEVW100M16	C 4652	(A,154,32) 10 uF	CCG1223	
C 4289	(A,60,70)	CEVW470M16	CEVW470M16	C 4653	(A,151,32) 10 uF	CCG1223	
C 4291	(A,65,72)	CKSRYB104K16	CKSRYB104K16	C 4654	(A,158,32) 10 uF	CCG1223	
C 4293	(A,62,83)	CKSRYB104K16	CKSRYB104K16	C 4655	(B,134,23) 10 uF	CCG1223	
C 4294	(A,63,78)	CEVW100M16	CEVW100M16	C 4656	(B,141,13)	CKSRYB104K50	
C 4295	(A,58,78)	CEVW4R7M16	CEVW4R7M16	C 4657	(B,142,13)	CKSRYB102K50	
C 4296	(B,58,64)	CKSRYB104K16	CKSRYB104K16	C 4658	(B,164,22)	CKSRYB102K50	
C 4297	(A,76,66)	CKSRYB105K10	CKSRYB105K10	C 4659	(B,163,22)	CKSRYB104K50	
C 4298	(B,62,75)	CCSRCH100D50	CCSRCH100D50	C 4661	(B,140,35)	CKSRYB103K25	C
C 4299	(B,62,82)	CKSRYB102K50	CKSRYB102K50	C 4662	(B,147,35)	CCSRCH102J50	
C 4300	(A,60,83)	CCSRCH101J50	CCSRCH101J50	C 4663	(B,150,35)	CKSRYB104K16	
C 4305	(A,67,75)	CKSRYB103K50	CKSRYB103K50	C 4664	(B,144,37)	CKSRYB473K50	
C 4331	(A,108,91)	CEVW4R7M16	CEVW4R7M16	C 4665	(B,144,39) 33 pF	CCG1252	
C 4332	(A,103,91)	CEVW4R7M16	CEVW4R7M16	C 4666	(B,144,42)	CKSRYB105K10	
C 4333	(A,98,85)	CEVW4R7M16	CEVW4R7M16	C 4667	(B,157,45) 4.7 uF	CCG1222	
C 4334	(A,93,85)	CEVW4R7M16	CEVW4R7M16	C 4668	(B,143,43)	CKSQYB475K10	
C 4335	(A,98,94)	CEVW4R7M16	CEVW4R7M16	C 4669	(B,157,37)	CKSRYF474Z16	
C 4336	(A,93,94)	CEVW4R7M16	CEVW4R7M16	C 4670	(B,157,41)	CKSRYB104K16	
C 4337	(B,106,90)	CKSRYB222K50	CKSRYB222K50	C 4671	(A,133,36) 330 uF/6.3 V	CCH1366	
C 4338	(B,97,84)	CKSRYB222K50	CKSRYB222K50	C 4672	(A,157,48) 10 uF	CCG1223	D
C 4339	(B,97,91)	CKSRYB222K50	CKSRYB222K50	C 4673	(A,151,48) 10 uF	CCG1223	
C 4340	(B,100,90)	CKSRYB222K50	CKSRYB222K50	C 4674	(A,154,48) 10 uF	CCG1223	
C 4341	(B,90,84)	CKSRYB222K50	CKSRYB222K50	C 4675	(B,134,33) 10 uF	CCG1223	
C 4342	(B,90,91)	CKSRYB222K50	CKSRYB222K50	C 4676	(B,137,32)	CKSRYB104K50	
C 4351	(B,132,110)	CKSRYB104K25	CKSRYB104K25	C 4677	(B,138,32)	CKSRYB102K50	
C 4352	(A,133,113)	CKSRYF103Z50	CKSRYF103Z50	C 4678	(B,163,36)	CKSRYB102K50	
C 4353	(A,124,108)	CKSRYB102K50	CKSRYB102K50	C 4679	(B,164,36)	CKSRYB104K50	
C 4371	(A,38,117)	CKSRYB102K50	CKSRYB102K50	C 4701	(B,87,48)	CKSYB105K16	
C 4372	(A,42,123)	CKSRYB102K50	CKSRYB102K50	C 4702	(A,89,48)	CKSRYB104K16	
C 4600	(B,114,55)	CKSRYB102K50	CKSRYB102K50	C 4704	(A,87,51)	CEVW100M16	
C 4601	(B,108,59)	CKSRYB103K25	CKSRYB103K25	C 4705	(A,93,48)	CEVW100M16	E
C 4602	(B,115,59)	CCSRCH102J50	CCSRCH102J50	C 4706	(B,92,48)	CKSYB105K25	
C 4603	(B,117,59)	CKSRYB104K16	CKSRYB104K16	C 4707	(B,89,45)	CKSRYB104K16	
C 4604	(B,112,62)	CKSRYB473K50	CKSRYB473K50	C 4709	(B,87,46)	CKSRYB104K16	
C 4605	(B,112,63) 33 pF	CCG1252	CCG1252	C 4710	(A,86,48)	CKSRYB104K16	
C 4606	(B,111,66)	CKSRYB105K10	CKSRYB105K10	C 4721	(A,57,117) (UC)	CKSRYB472K50	
C 4607	(B,124,69) 4.7 uF	CCG1222	CCG1222	C 4724	(B,59,133) (UC)	CKSRYB104K50	
C 4608	(B,110,68)	CKSQYB475K10	CKSQYB475K10	C 4731	(B,152,54)	CKSRYB104K50	
C 4609	(B,124,62)	CKSRYF474Z16	CKSRYF474Z16	C 4732	(B,155,73)	CKSRYB104K50	
C 4610	(B,124,65)	CKSRYB104K16	CKSRYB104K16	C 4751	(A,36,10)	CKSRYB104K50	
C 4611	(A,118,57) 330 uF/6.3 V	CCH1366	CCH1366	C 4771	(B,112,88)	CKSRYB104K50	F
C 4612	(A,119,72) 10 uF	CCG1223	CCG1223	C 4772	(B,111,84)	CKSRYB472K50	
C 4613	(A,122,72) 10 uF	CCG1223	CCG1223	C 4773	(B,126,90)	CKSRYB103K50	
C 4614	(A,125,72) 10 uF	CCG1223	CCG1223	C 4774	(A,118,94)	CEVW470M16	

1

2

3

4

Circuit Symbol and No.**Part No.****Circuit Symbol and No.****Part No.**

C 4775 (B,115,102) CKSRYB103K50
 C 4776 (A,119,101) CEVW101M16
 C 4784 (B,120,30) CCSSCH470J50
 C 4785 (B,120,29) CCSSCH470J50
 C 4786 (A,111,17) CKSRYB104K16

R 1025 (B,19,11)
 R 1027 (A,27,19)
 R 1101 (A,35,36)
 R 1102 (A,43,42)
 R 1103 (A,34,41)
 R 1104 (A,36,36)
 R 1105 (A,42,44)
 R 1106 (A,45,39)
 R 1109 (A,34,43)
 R 1110 (A,41,43)

RS1/16SS101J
 RS1/16SS101J
 RS1/16SS104J
 RS1/16SS104J
 RS1/16SS391J
 RS1/16SS511J
 RS1/16SS391J
 RS1/16SS561J
 RS1/16SS3R3J
 RS1/16SS3R3J

B**Unit Number : CWN4251****Unit Name : CK Unit****MISCELLANEOUS**

CN882 (A,21,23) Connector CKS5660
 CN883 (A,10,31) Connector CKS6115

R 1111 (A,38,39)
 R 1112 (A,38,38)
 R 1113 (A,49,46)
 R 1114 (A,48,46)
 R 1115 (A,41,38)

RS1/10SR1R5J
 RS1/10SR1R5J
 RS1/10SR1R5J
 RS1/10SR1R5J
 RS1/10SR1R5J

RESISTORS

R 898 (A,17,40) RS1/16S0R0J

R 1116 (A,41,39)
 R 1117 (A,48,43)
 R 1118 (A,49,43)
 R 1201 (A,16,36)
 R 1202 (A,17,35)

RS1/10SR1R5J
 RS1/10SR1R5J
 RS1/10SR1R5J
 RS1/16SS221J
 RS1/16SS221J

C**Unit Number : YWX5009****Unit Name : DVD Core Unit****MISCELLANEOUS**

IC 1002 (B,21,41) Regulator IC S-1133B50-U5
 IC 1003 (B,35,23) IC S-1200B50-M5
 IC 1004 (B,25,11) IC NJM2885DL1-33
 IC 1005 (B,19,21) IC R1232D121B
 IC 1201 (A,15,29) IC BD8231EFV

R 1203 (A,22,35)
 R 1204 (A,19,35)
 R 1212 (A,7,36)
 R 1213 (B,8,29)
 R 1214 (B,8,27)

RS1/16SS103J
 RS1/16SS153J
 RS1/16SS271J
 RS1/16SS1R0J
 RS1/16SS1R0J

*IC1401 (B,63,36) Flash ROM Unit CWW1825
 *IC1402 (B,50,36) Flash ROM Unit CWW1826
 IC 1480 (B,59,13) SDRAM(64M) K4S641632N-LC75
 IC 1501 (A,60,20) IC MN2DS0018MAUB
 IC 1801 (B,37,16) D/A Converter PCM1753DBQ

R 1215 (B,8,28)
 R 1216 (B,8,24)
 R 1217 (B,8,25)
 R 1218 (B,8,26)
 R 1222 (B,26,39)

RS1/16SS1R0J
 RS1/16SS1R0J
 RS1/16SS1R0J
 RS1/16SS1R0J
 RS1/16SS271J

Q 1101 (A,35,39) Transistor 2SC4081
 Q 1102 (A,46,42) Transistor 2SC4081
 Q 1103 (A,38,45) Transistor 2SB1132
 Q 1104 (A,45,49) Transistor 2SB1132

R 1300 (B,39,24)
 R 1401 (B,63,49)
 R 1402 (B,70,27)
 R 1405 (B,56,24)
 R 1406 (B,54,25)

RS1/16SS0R0J
 RS1/16SS221J
 RS1/16SS104J
 RS1/16SS104J
 RS1/16SS104J

L 1003 (B,22,26) Inductor CTF1677
 L 1004 (B,14,17) Inductor CTF1678
 L 1512 (A,57,5) Inductor CTF1743
 L 1902 (B,5,8) Inductor CTF1487
 L 1903 (B,12,11) Inductor CTF1558

R 1480 (B,52,21)
 R 1481 (B,56,21)
 R 1482 (B,61,21)
 R 1483 (B,64,21)
 R 1484 (B,67,21)

RAB4CQ560J
 RAB4CQ560J
 RAB4CQ560J
 RAB4CQ560J
 RAB4CQ560J

L 1904 (B,46,19) Inductor CTF1473
 X 1501 (B,43,7) Oscillator 27.000 MHz CSS1768
 EF1001 (B,5,12) Chip EMI Filter DTF1106
 EF1002 (B,11,13) Chip EMI Filter DTL1106
 CN1101 (A,66,49) Connector CKS5775

R 1485 (B,50,5)
 R 1486 (B,55,5)
 R 1487 (B,64,5)
 R 1488 (B,68,5)
 R 1489 (B,59,5)

RAB4CQ560J
 RAB4CQ560J
 RAB4CQ560J
 RAB4CQ560J
 RS1/16SS560J

CN1201 (A,16,44) Connector CKS6003
 CN1901 (A,21,7) Connector CKS6025

R 1490 (B,50,21)
 R 1501 (B,46,7)
 R 1503 (B,45,8)
 R 1504 (B,45,13)
 R 1505 (A,43,13)

RS1/16SS560J
 RS1/16SS122J
 RS1/16SS105J
 RS1/16SS120J
 RS1/16SS101J

RESISTORS

R 1002 (B,18,27) RS1/16SS101J
 R 1004 (A,29,27) RS1/16SS4702D
 R 1007 (A,29,26) RS1/16SS6801D
 R 1019 (B,15,9) RS1/16SS101J
 R 1021 (A,27,15) RS1/16SS0R0J

R 1506 (A,37,14)
 R 1507 (A,44,14)
 R 1508 (A,43,15)
 R 1509 (A,63,35)
 R 1510 (A,64,35)

RS1/16SS101J
 RS1/16SS101J
 RS1/16SS221J
 RS1/16SS102J
 RS1/16SS102J

R 1511 (B,46,13) RS1/16S0R0J
 R 1512 (A,58,5) RS1/16SS101J
 R 1513 (A,66,35) RS1/16SS103J
 R 1514 (A,68,35) RS1/16SS183J
 R 1516 (A,65,36) RS1/16SS103J

1

2

3

4

1

2

3

4

Circuit Symbol and No.**Part No.****Circuit Symbol and No.****Part No.**

C 1606 (A,41,23) CKSSYB104K10
 C 1607 (A,41,35) CKSQYB106K6R3
 C 1608 (A,43,36) CKSRYB105K10
 C 1609 (A,48,35) CKSSYB104K10
 C 1610 (A,50,37) CKSSYB104K10

D 812 (B,15,84) Diode RB521S-30
 D 815 (A,14,24) LED SMLE12BC7T(NP)
 D 852 (B,11,80) Diode HZU5R6(B2)
 D 853 (B,13,80) Diode HZU5R6(B2)
 D 854 (A,15,78) Diode HZU5R6(B2)
 D 855 (A,12,76) Diode HZU5R6(B2)
 D 856 (B,21,82) Diode HZU5R6(B2)
 D 857 (A,25,70) Diode HZU5R6(B2)
 D 858 (A,25,72) Diode HZU5R6(B2)

C 1611 (A,51,37) CKSSYB104K10
 C 1612 (A,52,34) CKSSYB104K10
 C 1613 (A,52,37) CKSSYB104K10
 C 1614 (A,53,34) CKSSYB104K10
 C 1615 (A,54,34) CKSSYB104K10

D 859 (B,11,75) Diode HZU11(B2)
 D 860 (B,11,73) Diode HZU11(B2)
 D 861 (A,18,72) Diode HZU11(B2)
 D 862 (A,22,66) Diode HZU11(B2)
 D 863 (A,23,63) Diode HZU5R6(B2)

C 1616 (A,54,37) CKSSYB104K10
 C 1617 (A,54,38) CKSSYB104K10
 C 1618 (A,56,34) CCSSCH101J50
 C 1619 (A,57,34) CKSSYB562K25
 C 1620 (A,58,34) CKSSYB224K6R3

D 864 (B,8,72) Diode HZU5R6(B2)
 D 866 (A,16,64) Diode HZU5R6(B2)
 D 867 (B,15,65) Diode HZU5R6(B2)
 D 871 (A,11,68) Diode MALS068X
 S 801 (A,9,90) Push Switch CSG1155

C 1621 (A,57,37) CKSSYB224K6R3
 C 1622 (A,59,35) CKSSYB333K16
 C 1623 (A,45,35) CKSRYB105K10
 C 1624 (A,58,37) CKSSYB104K10
 C 1625 (A,56,37) CKSSYB104K10

S 802 (A,13,81) Push Switch CSG1155
 S 803 (A,19,52) Switch(MULTI-CONTROL) CSX1135
 S 804 (A,21,90) Push Switch CSG1155
 S 805 (A,25,81) Push Switch CSG1155
 ANT801 (A,6,40) Antenna CTX1095

C 1671 (A,44,17) CKSSYB104K10
 C 1672 (A,45,18) CKSSYB104K10
 C 1673 (A,45,22) CKSSYB104K10
 C 1674 (A,43,21) CKSSYB104K10
 C 1676 (A,38,22) CKSRYB105K10

CN801 (B,19,73) Connector CKS5862
 CN802 (A,13,9) Jack CKN1049
 CN803 (B,18,29) Connector CKS5749

C 1801 (B,34,8) CKSQYB475K6R3
 C 1802 (B,32,8) CKSQYB475K6R3
 C 1803 (B,36,8) CCSRCH182J50
 C 1804 (B,31,7) CCSRCH182J50
 C 1805 (B,32,19) CKSSYB104K10

RESISTORS

C 1806 (B,39,9) 10 uF DCH1201
 C 1809 (B,43,16) CKSSYB104K10
 C 1934 (B,42,29) CCSRCH680J50

R 801 (B,25,58) RS1/16S0R0J
 R 802 (A,12,63) RS1/16S0R0J
 R 803 (B,12,64) RS1/16S102J
 R 804 (B,18,51) RS1/16S162J
 R 805 (B,8,77) RS1/16S123J

D**Unit Number :****Unit Name : Connect PCB****MISCELLANEOUS**

S 101 (B,51,37) Switch(HOME) CSN1068
 S 102 (B,12,23) Switch(DSCSNS) CSN1068
 S 103 (B,22,10) Switch(8SNS) CSN1068
 R 101 (B,52,27) RS1/16S101J
 R 102 (B,15,29) RS1/16S101J

R 806 (B,21,51) RS1/16S302J
 R 807 (A,19,78) RS1/16S132J
 R 808 (B,21,84) RS1/16S103J
 R 809 (A,19,80) RS1/16S272J
 R 810 (A,24,67) RS1/16S241J

R 103 (B,16,11) RS1/16S101J
 C 101 (B,51,23) CKSRYB104K50

CAPACITORS

C 803 (A,20,64) CKSRYB103K25
 C 804 (A,12,64) CKSRYB103K25
 C 805 (A,14,68) CKSRYB104K25
 C 806 (A,16,68) CKSRYB104K25

E**Unit Number :****Unit Name : Keyboard Unit****MISCELLANEOUS**

D 801 (A,19,68) LED NSSM025-6502
 D 802 (A,14,16) Diode MALS068X
 D 805 (A,8,15) Diode MALS068X
 D 806 (B,6,9) Diode MALS068X
 D 807 (B,6,5) Diode MALS068X

Miscellaneous Parts List

M 1 Pickup Unit(Service) CXX2398
 M 1 Motor Unit(LOAD/CRG) CXC4026
 M 2 Motor(SPINDLE) EXM1050

D 808 (B,10,77) Diode RB521S-30

1

2

3

4

Service Manual

ORDER NO.
CRT4300

DVD MECHANISM MODULE(LS1)

CX-3250

- This service manual describes the operation of the DVD mechanism module incorporated in models listed in the table below.
- When performing repairs use this manual together with the specific manual for model under repair.

Model	Service manual	DVD Mechanism Module
DVH-P4100UB/XN/EW5 DVH-P4100UB/XN/UW5	CRT4256	CXK6800
DVH-P4150UB/XN/RC DVH-P4150UB/XN/RD DVH-P4150UB/XN/RI DVH-P4190UB/XN/ID	CRT4282	CXK6800

CONTENTS

1. CIRCUIT DESCRIPTIONS	2
2. MECHANISM DESCRIPTIONS	17
3. DISASSEMBLY	22

1. CIRCUIT DESCRIPTIONS

1. Front end section (MN2DS0018MAUB : IC1501)

MN2DS0018MAUB is a 1 chip LSI for DVD-Player. A DVD-Player system can be constructed by connecting this LSI, driver IC, SDRAM, Flash-ROM, Audio-DAC, etc.

This LSI includes a front end (SODC/FE) which executes RF signal processing, servo processing and decode processing, a AV decoder(back end/BE) which executes video decode processing such as MPEG1/MPEG2/JPEG and audio decode processing such as DVD-Audio/Dolby Digital² /DTS/MP3, and a system controller which controls the system.

The front end section realizes optical head signal computation processing and RF signal processing, digital signal processing (16-8 demodulation, error correction) for DVD-ROM playback according to the DVD specifications, digital signal processing of CD-DA/CD-ROM (error correction), AV decoder transfer, servo control, spindle motor control and seek control.

In the case of MN2DS0018MAUB, the front end servo system waveforms, such as FE, TE and AS, are not observed as in the case of DVD mechanism module (MS5) CX-3212. Please pay attention.

1.1 Analog block (MN2DS0018MAUB : IC1501)

The functions of the analog block are as described below.

1. Reference power circuit
2. SERVO system/DPD system signal processing circuit
Gain switching amplifier and Low Pass Filter (LPF)
3. RF signal processing circuit
RF adding circuit, circuit to make inline, Variable Gain Amplifier (VGA) circuit
4. Laser power control (LPC) circuit
5. A/D converter for SERVO (10 bit, DPD system-4ch),DPD converter, PWM

1.1.1 APC circuit

The optical output of the laser diode (LD) has a large negative temperature characteristic.

Therefore, if the LD is driven by a constant current, a constant optical output cannot be obtained.

APC circuit is a circuit to control the current so that the output at the monitor diode (MD) will be constant.

MN2DS0016AAUB includes 2 types of APC circuit, one for DVD and the other for CD.

The LD current can be obtained by dividing the measured voltage between DVDLD1 (CDLD1) and 5 V by 6 (1.5 x 4=6), in the case of DVD (CD). It will be approximately 50 mA (45 mA) in the case of DVD (CD).

The potential difference between DVDLD1(CDLD1) and 5 V is set to approx. 300 mV(270 mV).

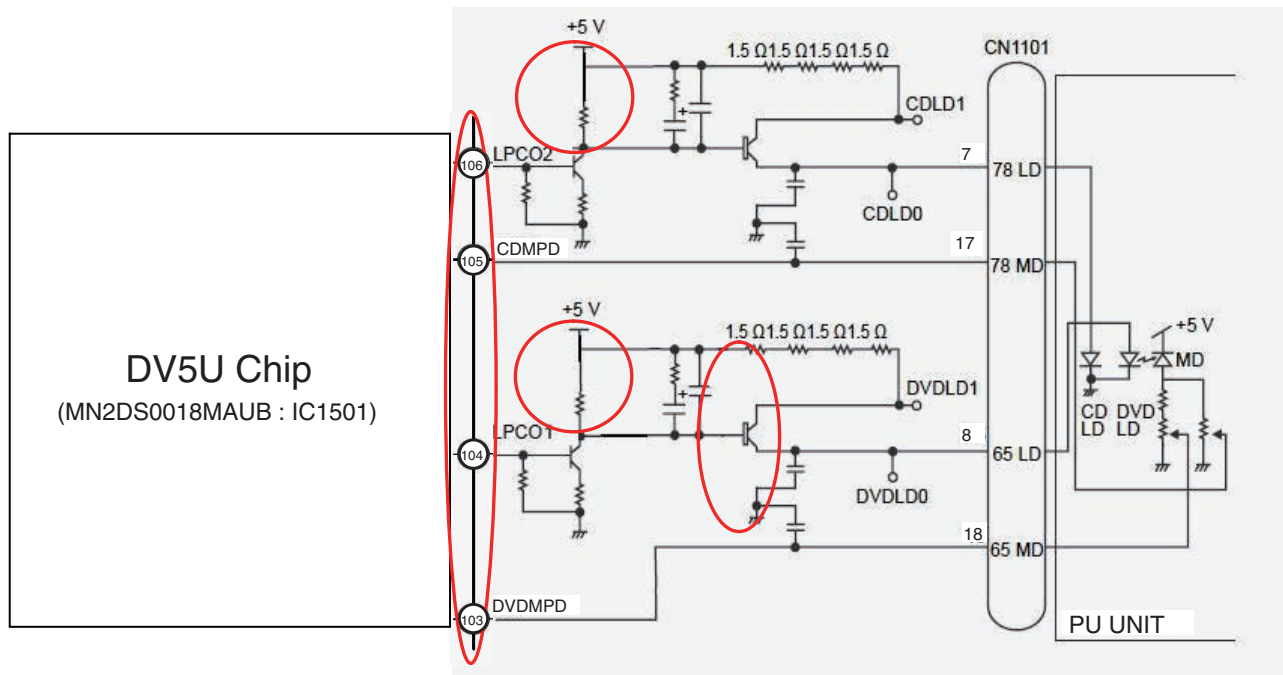

1.1.2 FE forming circuit

Focus error (FE) forming circuit

The signal from PU, FE1 and FE2, are AD converted inside IC1501 and captured. After that, a differential is obtained by taking the offset cancellation into consideration, and FE is obtained.

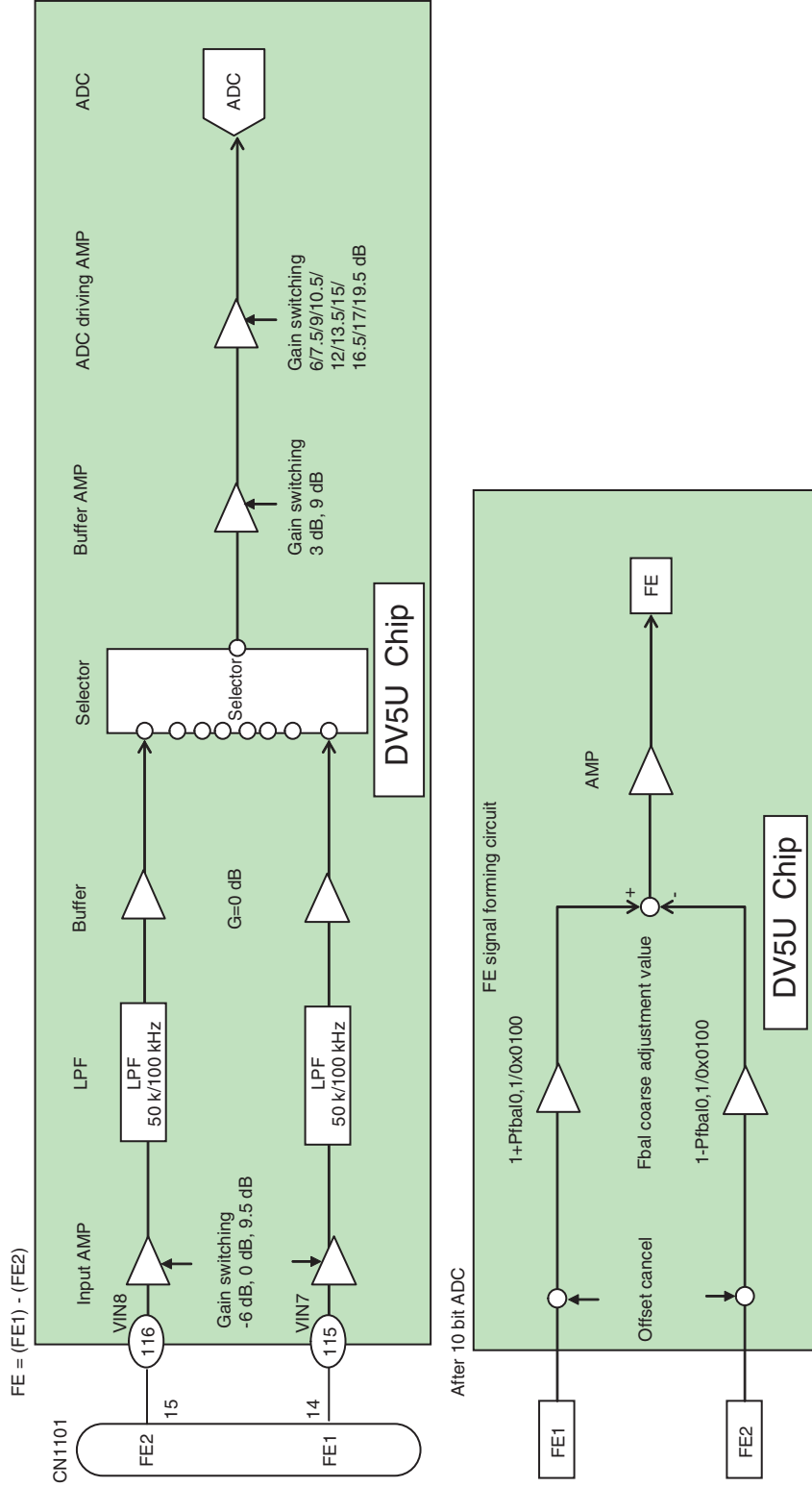

1

2

3

4

1.1.3 TE forming circuit

Tracking error (TE) forming circuit

In the case of a DVD, the phase difference method is used for TE forming, and the TE is formed from the phase difference among (A+C) and (B+D). In the case of a CD, 3 beam method is used, and after entering the signal into a variable amplifier, it is AD converted, and a TE is formed by the equation of $TE = (F+H_G+H) - (E+G_E+F)$.

- DVD (phase difference TE)

The diagram illustrates the DV5 Chip TE forming circuit, which is organized into several functional blocks:

- Input AMP:** Four parallel channels (VIN1RF to VIN4RF) with gain switching (-7.5 dB, 0 dB, 3.5 dB).
- LPF:** Low-pass filters (11.3 M / 5.7 MHz) for each channel.
- Buffer:** Gain switching (G=0, 3, 6, 9, 12, 15 dB) for each channel.
- HPF:** High-pass filters (1 MHz/25 MHz / Through) for each channel.
- AMP:** Amplifiers with a gain of G=-1 dB for each channel.
- ADC:** DACs and DAC control filters for each channel.
- Phase comparator:** Receives signals from the DAC control filters and compares them.
- LPF (integrator):** Integrates the output of the phase comparator.
- TE signal forming circuit:** The final output stage, including an AMP and a TE block.

External connections include CN1101 (pins 11, 10, 12, 13) and 0.1 μF capacitors connected to pins 99, 100, 98, and 97.

CX-3250

4

1

2

3

4

• CD (3 beam TE)

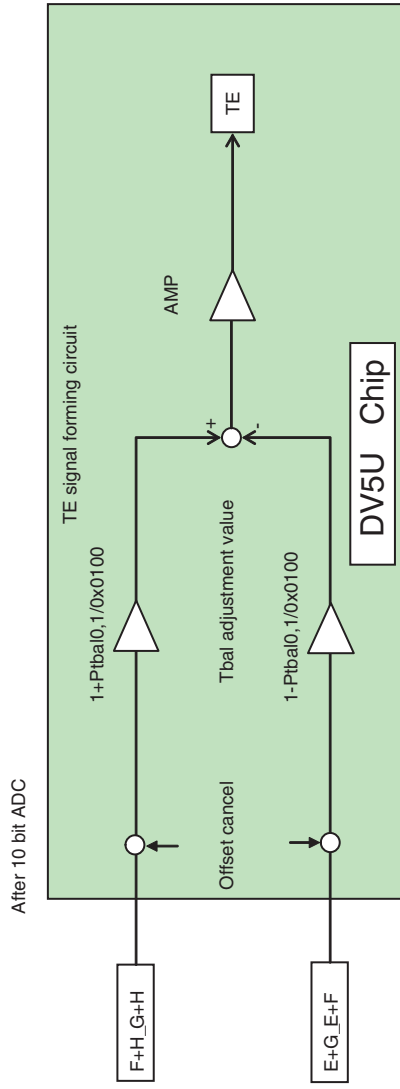
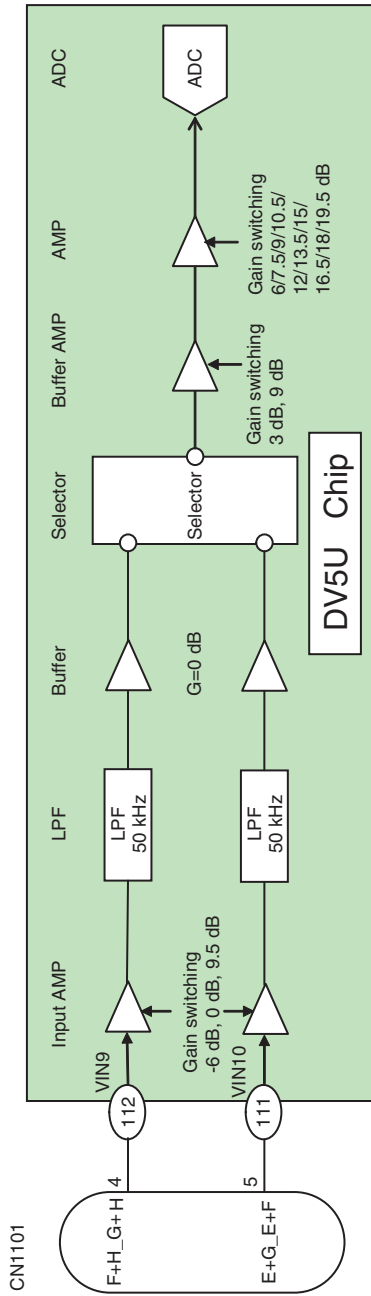

After 10 bit ADC

CNT1101

F+H_G+H

E+G_E+F

F+H_G+H

E+G_E+F

DV5U Chip

DV5U Chip

1.2 Servo block (MN2DS0018MAUB : IC1501)

At the servo block, focusing, tracking, servo control of traverse, spindle motor control and seek control are performed.

1.2.1 Focus close

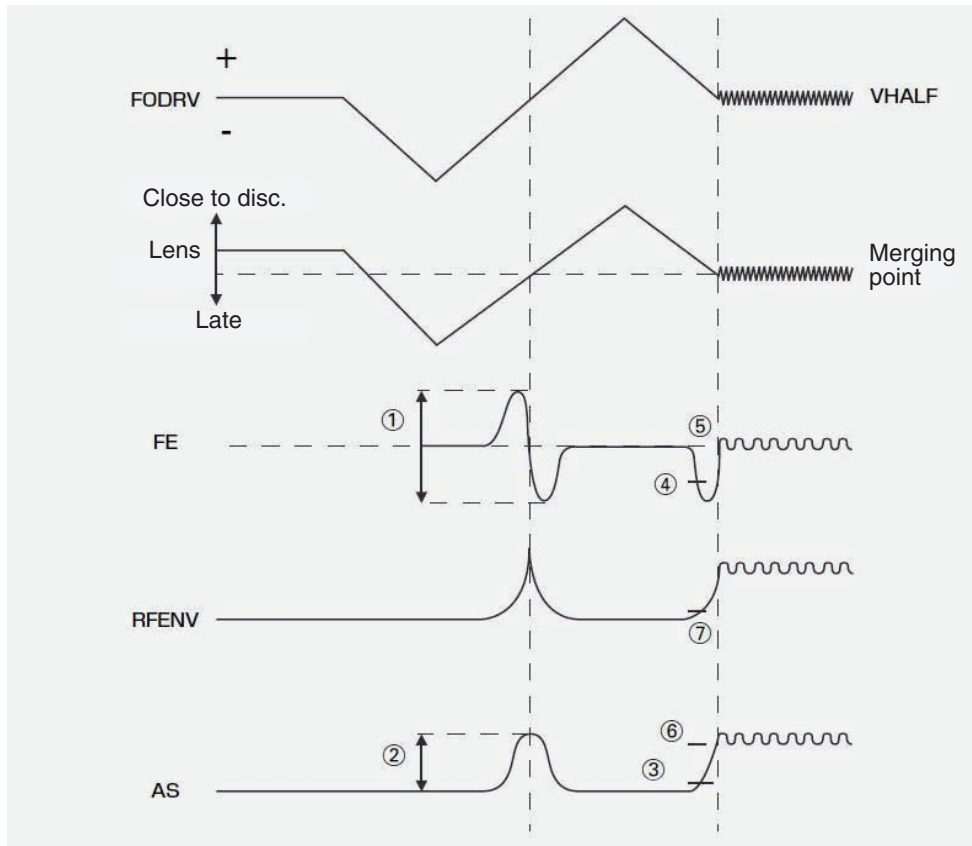

After issuing the focus close command, both the DVD and the CD will perform the following processing.

1. Measurement and optimization of the signal level.

First the PU lens is driven in the direction getting away from the disc, then it is driven in the direction getting close to the disc. At this time, each signal level of FE, AS and RFENV are measured at the focused focal point that the lens passes, and the levels of FE and AS are optimized. (1 and 2 in the figure)

2. Focus adjustment

Next, after detecting the drawing level of FE and AS by driving the lens away from the disc, the focus loop filter is activated and the focus is drawn. (3~6)

3. Confirmation of adjustment

Confirm the drawing at the signal level of AS and RFENV. (6, 7)

The signal levels of FE, AS and RFENV and the focus drive voltage can be checked by the focus search in the test mode.

1.2.2 Tracking close

After issuing the tracking close command, both the DVD and the CD will perform the following processing.

1. Tracking brake

1/2 cycle of the track cross is measured and if the cycle is within the specified range, the brake pulse is output.

The output direction of the brake pulse is determined by the phase relationship of the OFTR and the TKC (binary signal of TE) signals. When it is confirmed that the swinging of the lens against the disc has been controlled, braking will be stopped and enters into drawing. If the drawing conditions are not met within 10 msec, after the brake output, the brake will be ended and entered into drawing.

2. Tracking adjustment

Tracking drive hold processing by the OFTR signal will be performed.

3. Confirmation of adjustment

Checking is made that the number of track jumps within the specified period of time are at the designated numbers or less. The time out for confirmation of adjustment is 8.4 msec. and retry is performed by the command from the microcomputer.

1.2.3 Track jump

In this system, one of the three methods, interval jump, multi jump or traverse seek, is selected depending on the number of target moving tracks.

1. Interval jump

Detailed seek can be performed to execute repeated track jump of 1 track, and it is used when the target track gets close or at the time of seek operation to the adjacent track.

2. Multi jump

Both edges of the track cross signal TKC are counted, and track count move of the designated number is executed. Furthermore, the CRG motor is driven according to the number of jumps.

3. Traverse seek

Track count by TKC is performed, and I control movement speed and seek it.

I minimize vibration of PU occurring for movement.

It indicates the setting for jump switching common to DVD and CD.

Types of target move number of jumps.

DVD

1~10 Interval jump

11~500 Multi jump

501~1000 Combination of multi jump and interval jump

1001~ Traverse seek (short)

CD

1~10 Interval jump

11~100 Multi jump

101~500 Combination of multi jump and interval jump

501~ Traverse seek (short)

The waveform of track jump is shown on the next page.

Tracking-on process

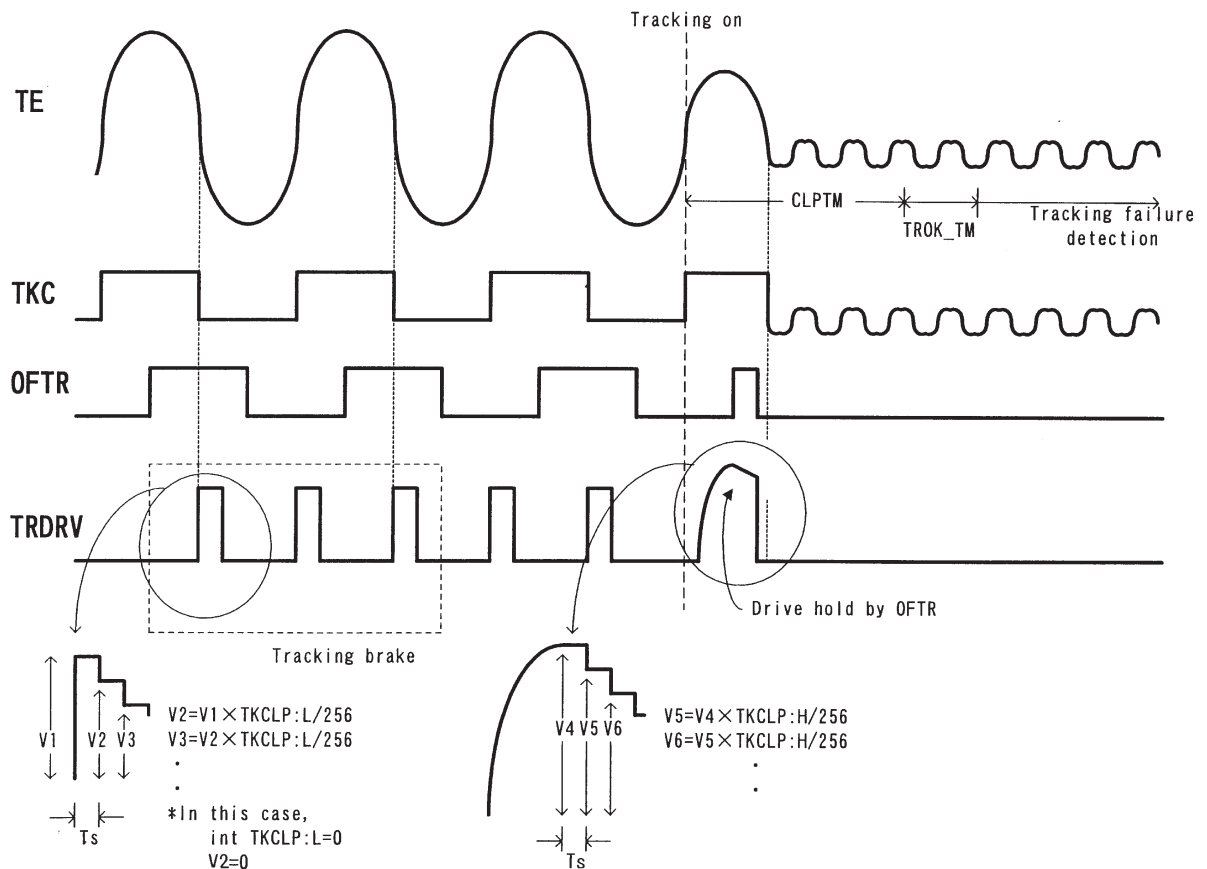

A

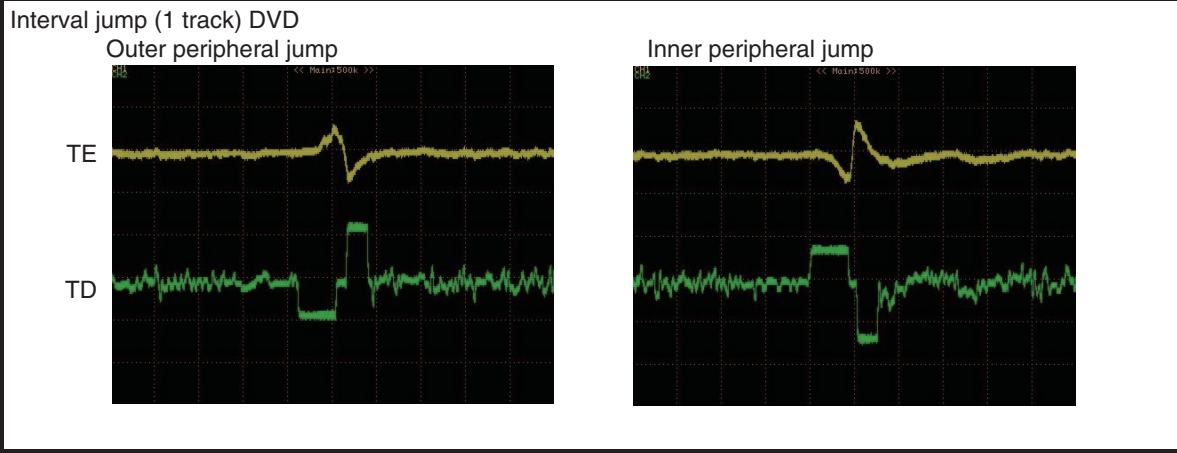

B

C

C

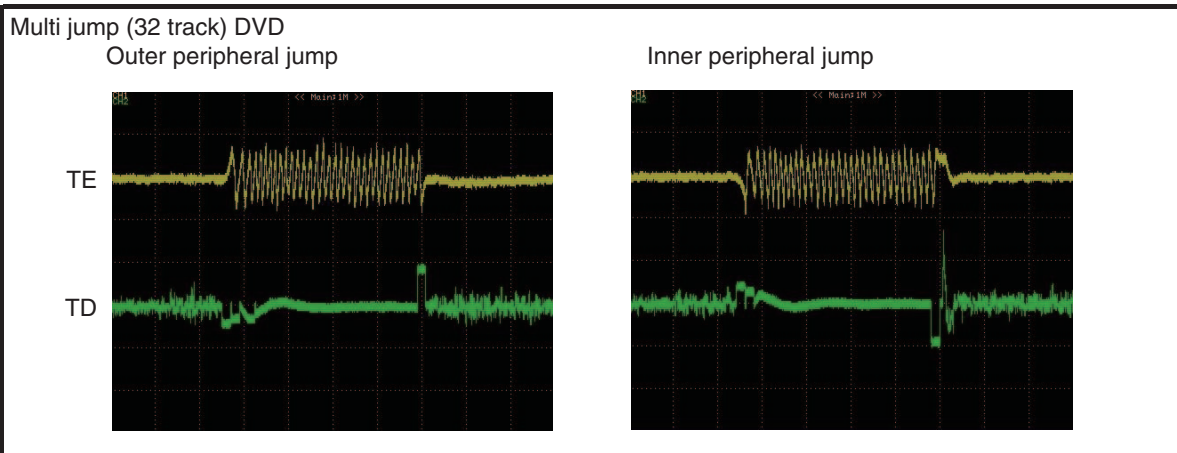

D

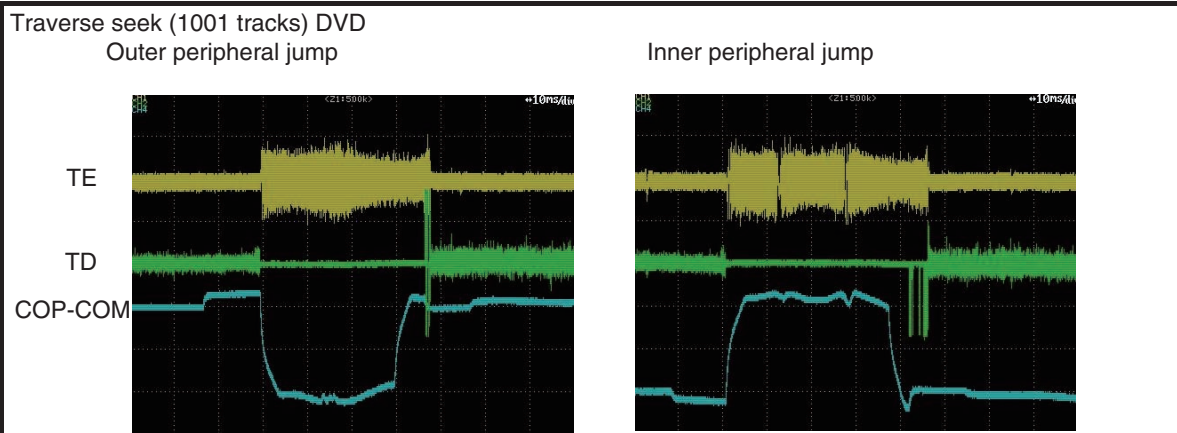

E

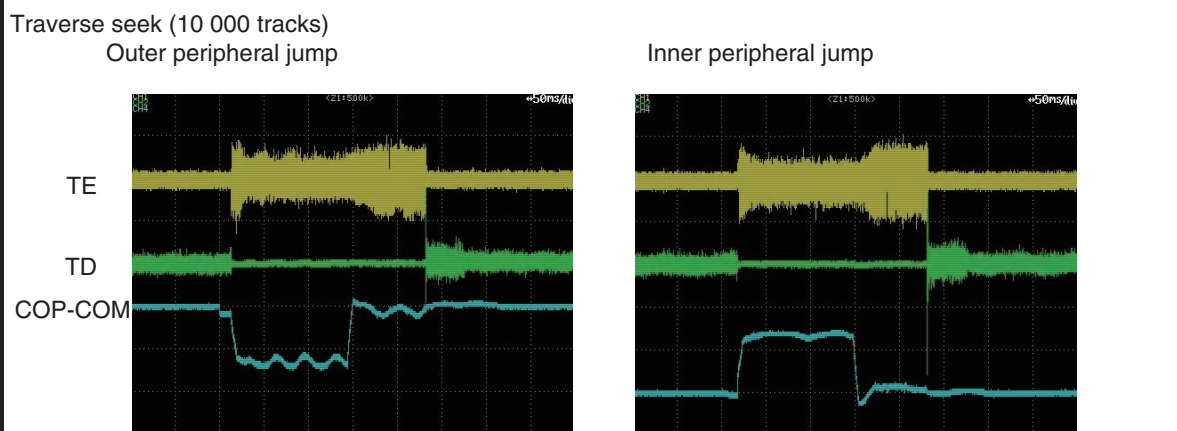

F

1.2.4 Focus jump

Focus jump is a function compatible to 2 layers on one side or 2 layers on both sides. Looking from the object lens, the layer close to the lens is called "layer 0" (L0) and the layer away from the lens is called "layer 1" (L1).

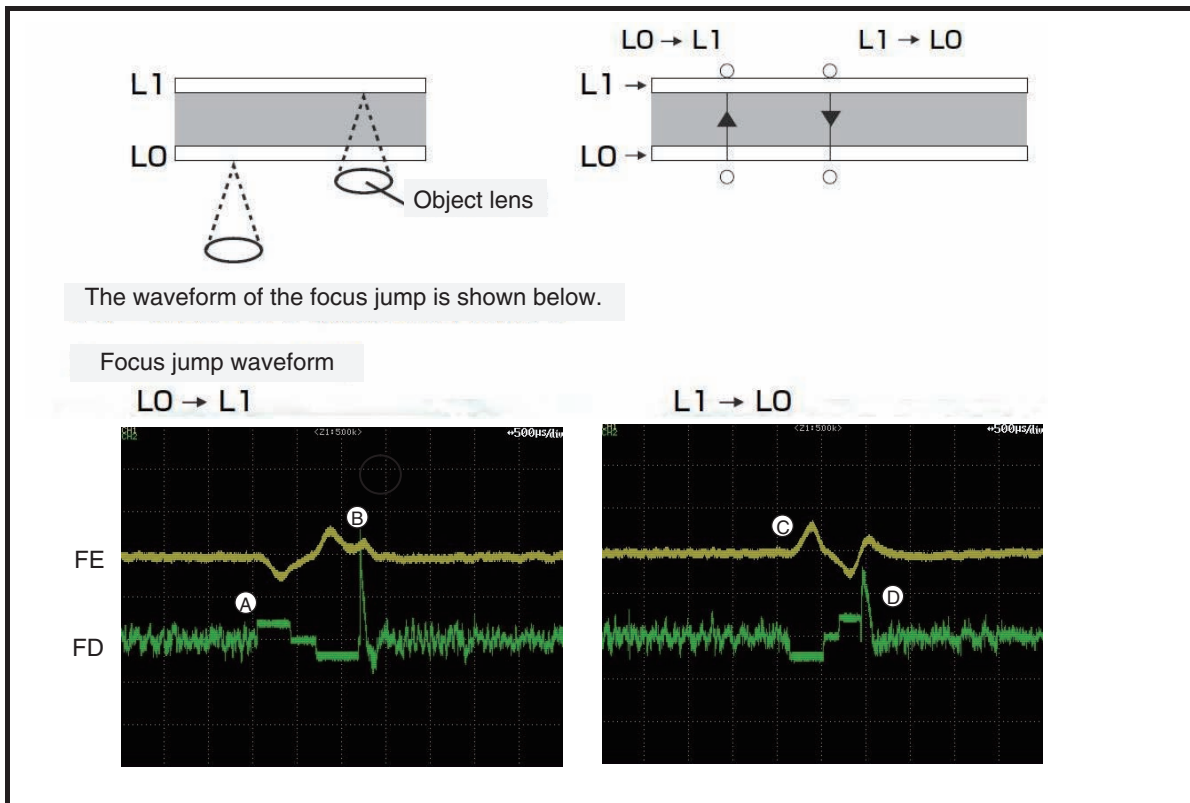

The flow of the focus jump is shown below.

1. The tracking is opened by the layer being played back.
2. A command is issued to execute jump to the target layer.
3. The tracking is closed at the layer after the jump and the playback is resumed.

Incidentally, the process when the jump command is issued is as described below.

1. The lens is accelerated to the target layer until the FE signal detects the focus jump acceleration end level. Acceleration will be ended by force, however, if the time for acceleration timeout has elapsed before detecting the acceleration end level.
2. The drive voltage is not output until the FE signal detects the speed reduction start level, and the lens is moved by inertia.
3. The lens speed is reduced from detection of the speed reduction start level until detection of the speed reduction end level. Speed reduction will be ended by force, however, if the time for speed reduction timeout has elapsed before detecting the speed reduction end level.

1.3 Auto adjustment function

All circuit adjustments are automated in this system.
Details of each auto adjustment are explained below.

1.3.1 VIN7, VIN8, VIN9, VIN10 offset cancel

Each signal from VIN7,8, 9 and 10 output by PU is converted to a digital signal by the AD converter in the servo block. Offset cancel is a function to cancel input offset of the AD converter at the time of power ON.

1.3.2 VCO gain adjustment (VARI adjustment)

It has a function to absorb variation of VCO gain among individual LSI by learning so that auto adjustment is made to maintain the VCO gain at a certain level. VCO is locked against the reference frequency for learning. And, a frequency control value (FCNT) is read, and VARI register is adjusted so that the read value becomes the same as the target FCNT value.

1.3.3 FE normalization adjustment

FE signal level measured at the time of focus close is adjusted so that it will become 190LSB at the digital equalizer input stage.

1.3.4 Focus balance (FBAL) adjustment

The focus position is adjusted so that the RFENV will be the maximum at the time of focus close tracking open and tracking close.

1.3.5 DPD amplitude adjustment

I perform the gain adjustment of the analog step so that the input signal of the DPD comparator of the TE generation circuit of the DVD becomes constant.

1.3.6 Learning of tracking error amplitude

At the time of focus close and tracking open, the lens is oscillated in the track direction and adjusted so that the TE amplitude level becomes 190 LSB at the digital equalizer input stage.

1.3.7 Tracking balance (TBAL) adjustment

At the time of focus close and tracking open, the lens is oscillated in the track direction and the balanced point where the DC offset becomes zero is searched and adjusted by using the Newton-Raphson method.

1.3.8 OFTR adjustment

The binary threshold level is adjusted to make the OFTR signal into a binary digit.

1.3.9 AS normalization adjustment

The AS signal level is measured for the designated number of samples at the time of track closing, and after A/D conversion at the ADSC, it is fine adjusted to become 64 LSB at the digital equalizer input stage.

1.3.10 Focus gain adjustment, tracking gain adjustment

At the time of tracking close, a disturbance is entered into the servo loop to adjust to the target gain intersection.

All auto adjustments can be confirmed by displaying the adjustment result in the test mode.
The list of auto adjustment coefficient

State	Coefficient	DVD	CD
Power ON	VIN7 offset	05FB~0A17	←
	VIN8 offset	05FB~0A17	←
	VIN9 offset	-	0533~0B0C
	VIN10 offset	-	0533~0B0C
F close	FEPP(FEMAX-FEMIN)	1D84~6C08	2E18~A8CF
	AS MAX	No standard	←
	FE normalization	No standard	←
F close (after TBAL)	TEPP(TEMAX-TEMIN)	2328~59D8	1E91~98D1
	TE normalization	No standard	←
T close	F gain	0100~0400	←
	T gain	0100~0400	←
	AS normalization	No standard	←

Note) Coefficient values are indicated in hexadecimals. In all cases, specifications at the production line are described. For discs, TDV-582 is used for DVD and TCD-792 is used for CD.

1.4 CIRC block (MN2DS0018MAUB : IC1501)

The CIRC block includes the digital signal processing function (EFM modulation and error correction) of CD-DA and CD-ROM and the digital servo processing function of the spindle motor.

1.5 DRC block (MN2DS0018MAUB : IC1501)

The digital read channel (DRC) is equipped with A/D converter, digital equalizer (DEQ), Adaptive filter, Viterbi detector, digital PLL circuit, RISC interface and periphery circuits for reading of signal on optical disc.

1.6 LS1 Power Supply Map

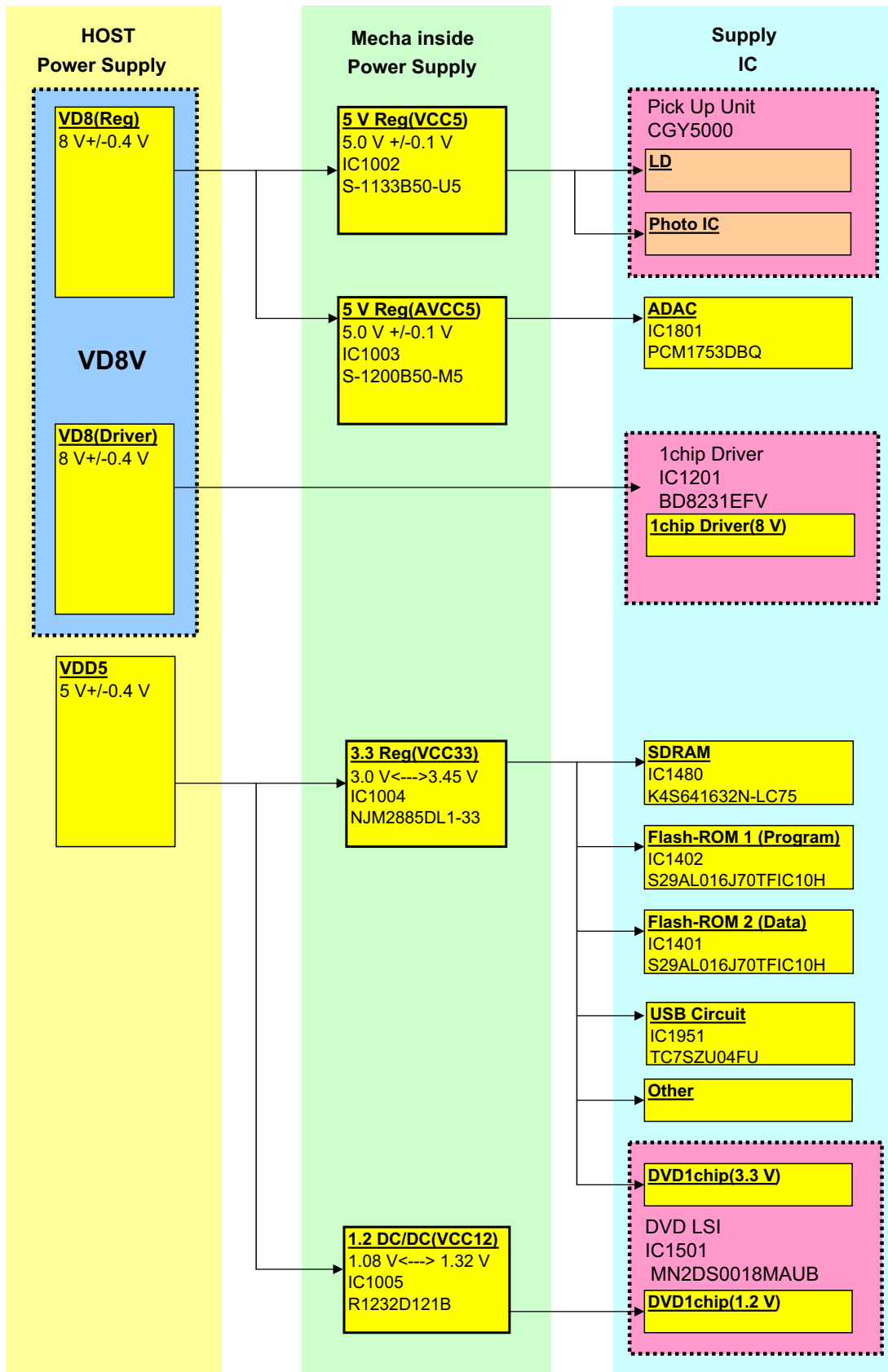

A
B
C
D
E
F

1.7 LS1 Clock circuit

[Outline]

By connecting a 27 MHz crystal oscillator to DVD-LSI (IC1501), DACCLK for externally connected Audio-DAC is formed and supplied by the clock generator inside the DVD-LSI in addition to the clock used inside the LSI.

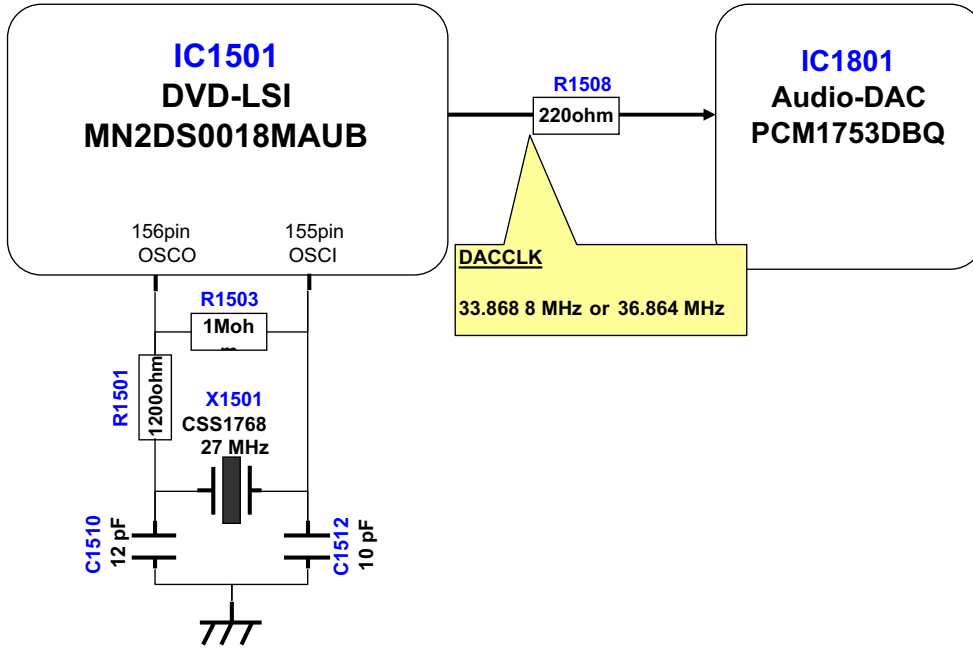

[USB_Clock outline]

By connecting a 48 MHz crystal oscillator to DVD-LSI (IC1501), clock is formed and supplied by the clock generator inside the DVD-LSI in addition to the clock used inside the USB circuit.

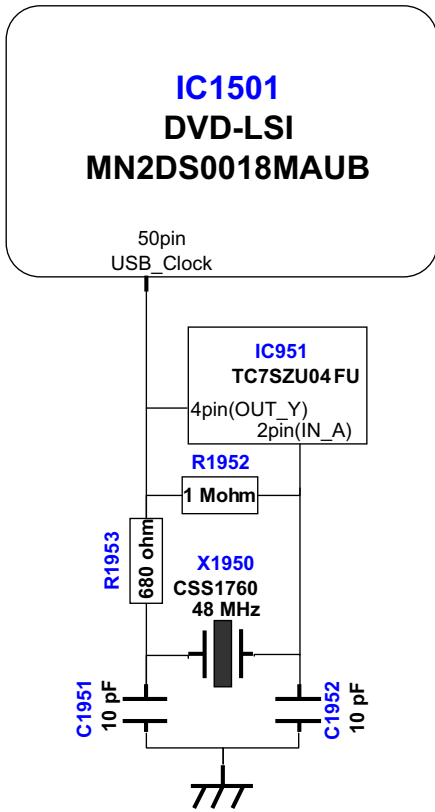

1.8 LS1 Audio circuit

[Outline]

1 Analog audio signal

Serial 3 line digital output + DACCLK (audio clock) output from DVD-LSI (IC1501) are converted to analog audio signal by Audio-DAC (IC1801), and are output from HOST IF connector (CN1901). Furthermore, analog MUTE signal is also output from DVD-LSI (IC1501) via HOST IF connector (CN1901) simultaneously.

2 Digital audio signal (IEC60958/IEC61937)

Digital audio signal (IEC60958/IEC61937), output from DVD-LSI (IC1501), is output via Multi-ch/Ripping IF connector (CN1901).

[Analog audio signal]

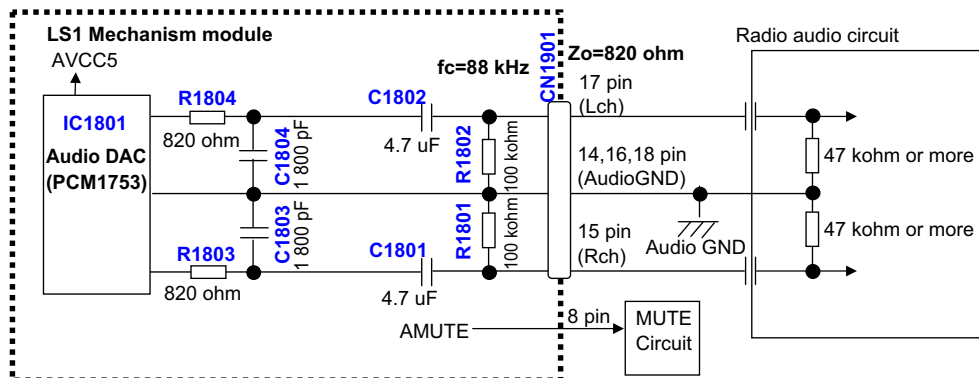

[Digital audio signal]

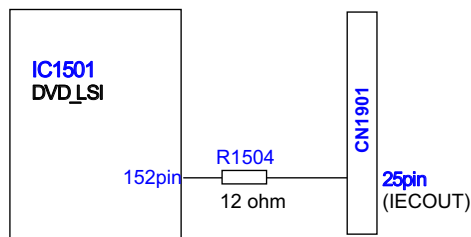

1.9 LS1 Video circuit

[Outline]

Composite signal is output from DVD-LSI (IC1501), and output from HOST IF (CN1901).

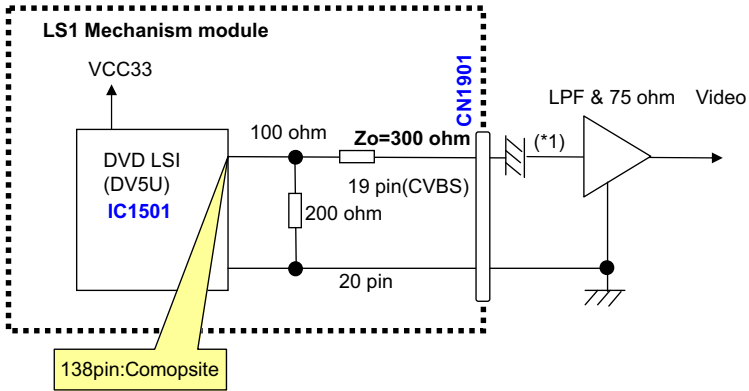

A

B

C

D

E

F

1.10 LS1 SDRAM I/F

[Outline]

It is a memory for realizing the AV decoding function of DVD-LSI (IC1501). It is used for various purposes such as buffering of stream data before decoding, working area for decoding, and storing of AV data or output data after decoding.

SDRAM interface

*When viewed from DVD-LSI

Signal Name	Bits	I/O	Description
MDQ[15:0]	16	I/O	Data bus of external SDRAM
MA[11:0]	12	O	SDRAM address
BA[1:0]	2	O	SDRAM bank address
NRAS	1	O	RAS signal of SDRAM
NCAS	1	O	CAS signal of SDRAM
NEW	1	O	Write enable signal of SDRAM
NCS	1	O	Chip select signal of SDRAM
DQM[0]	1	O	SDRAM data mask 0
DQM[1]	1	O	SDRAM data mask 1
MCK	1	O	Clock input to SDRAM
MCKI	1	I	Clock input for data input from SDRAM

SDRAM specifications

Data bus width: 32 bit

Operating frequency: 121.5 MHz

CAS latency=3

8 word burst transfer

Manual precharge

CAS before RAS refresh (Auto refresh)

SDRAM connection configuration

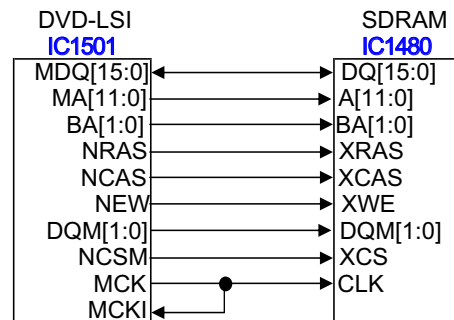

1.11 LS1 USB(iPod) circuit

[Outline]
 It inputs a D-/D+ signal into DVD - LSI (IC1501) than HOST IF (CN1901).
 It uses CP_RESET, SDA, SCL by the iPod certification.

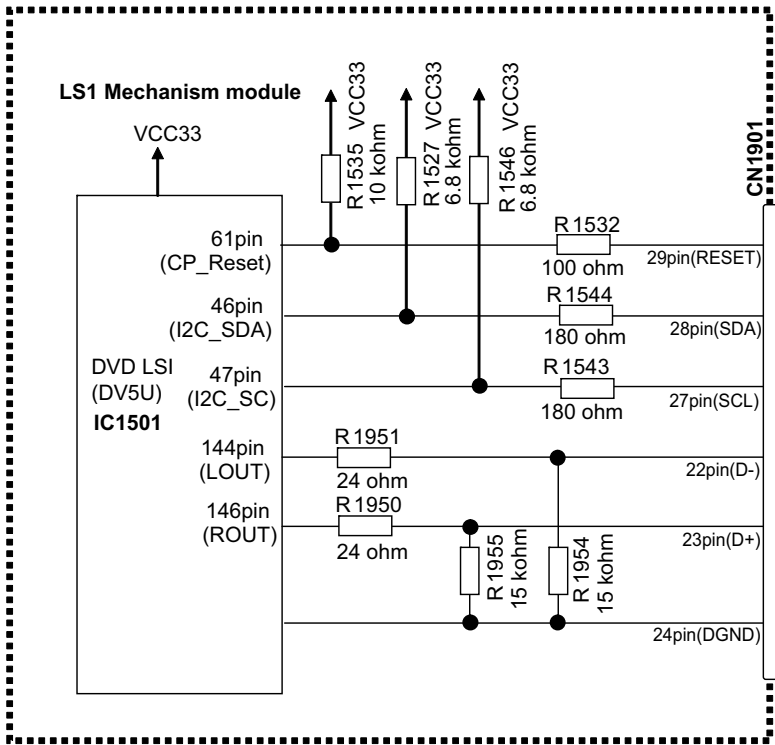

2. MECHANISM DESCRIPTIONS

Construction

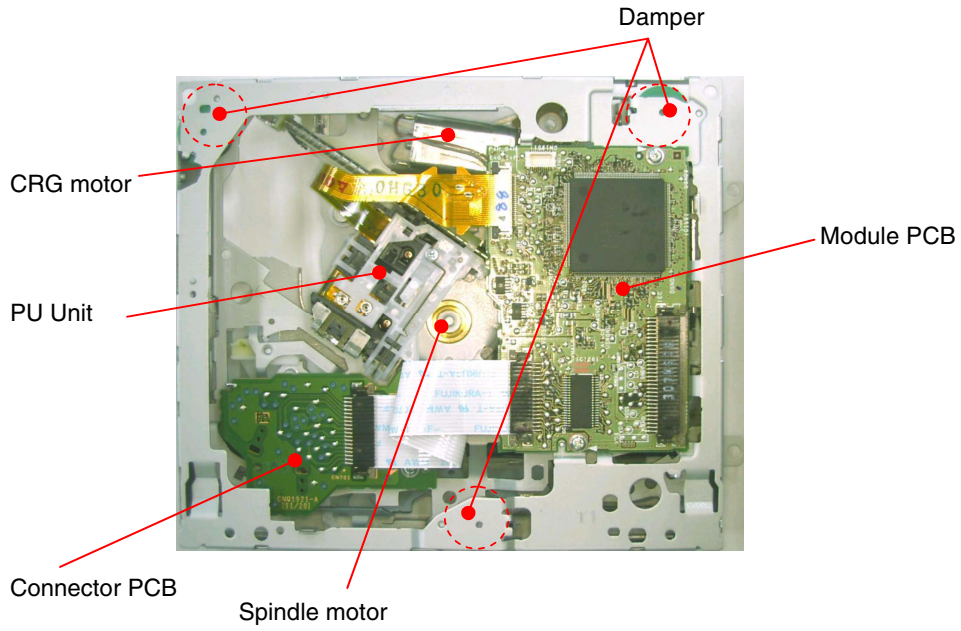
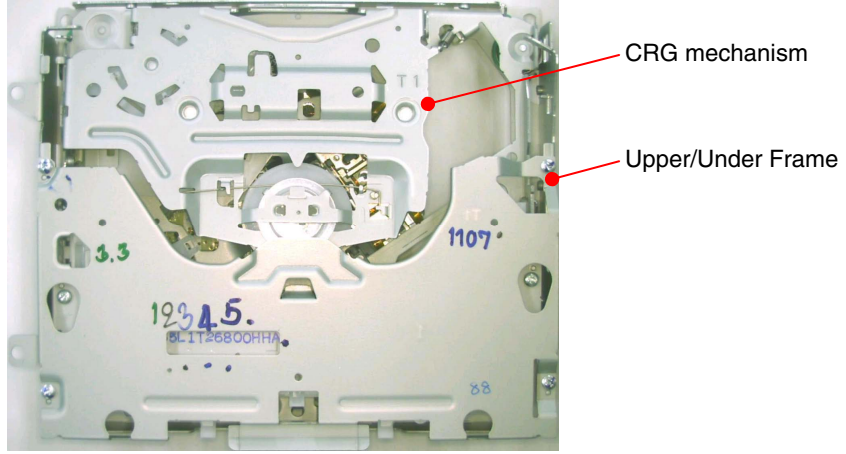

State of CRG mechanism

Clamper arm assy

A

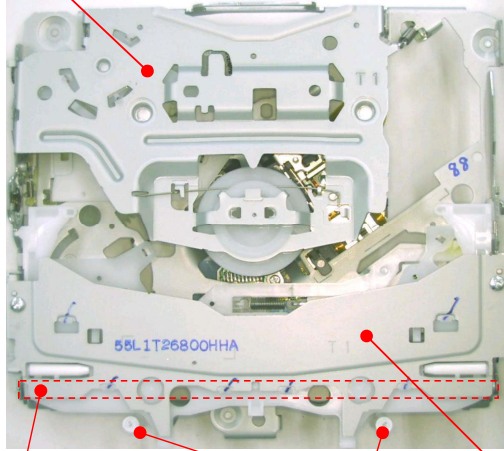

B

Roller arm assy

SW arm

Disc guide assy

C

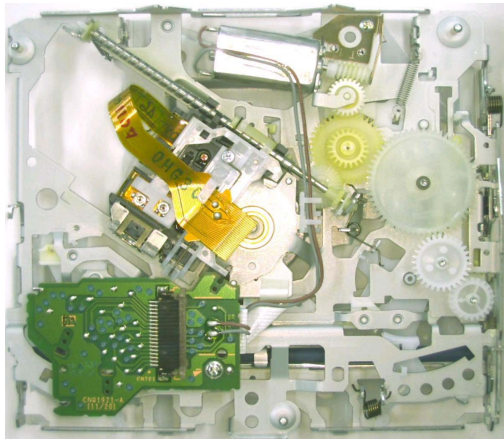

D

E

F

Disc loading operation

1. When the disc is inserted, the SW arm L and R rotate and then SW1 turns ON from OFF.

By the SW1 turning ON from OFF, the load carriage motor starts and then the rubber roller rotates.

2. In the case for a 12cm disc, SW1 is turned OFF from ON by the SW arm being opened widely and then the microcomputer determines that the disc is 12cm.

3. In the case for a 8cm disc, SW arm does not open widely, so SW1 is not turned OFF from ON but goes into the clamp movement and then the microcomputer determines the disc to be 8cm.

(SW arms are jointed on both sides, and even if one side is pushed, the joint part is locked and the arms do not open more than a fixed width. (SW1 is not turned OFF from ON.))

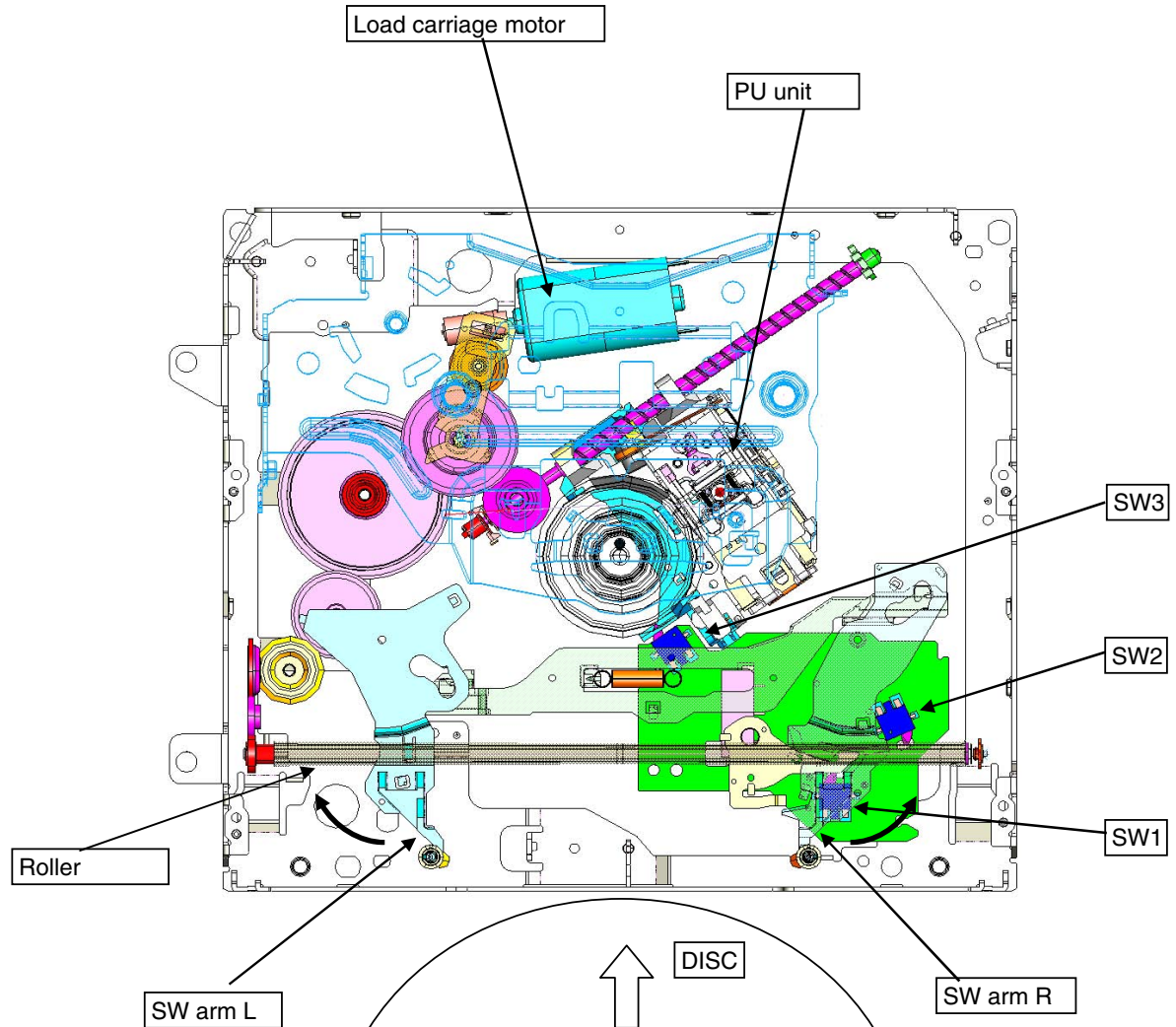

Disc centering mechanism

A

1. 8cm disk is centered with the guide pin and the centering pin.
2. 12cm disk passes under the guide pin and the centering pin, and is centered at the mechanism interior position.

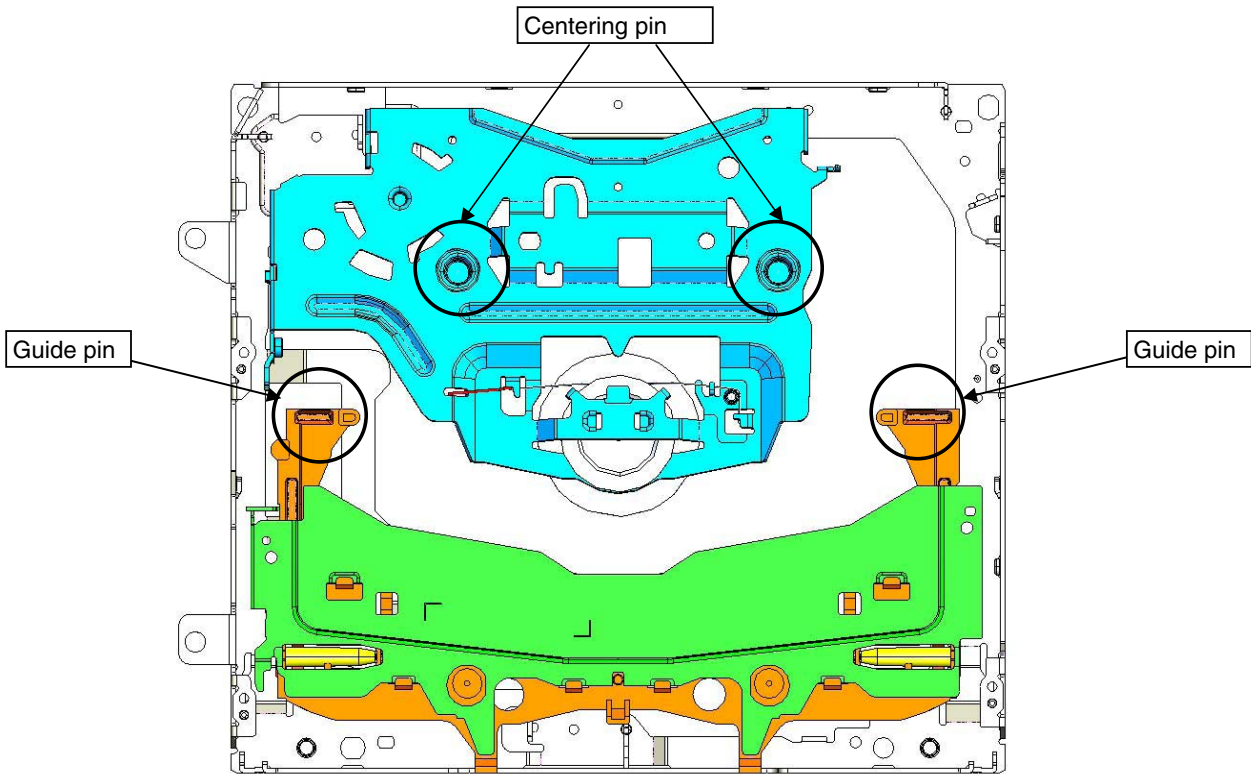

B

C

D

E

F

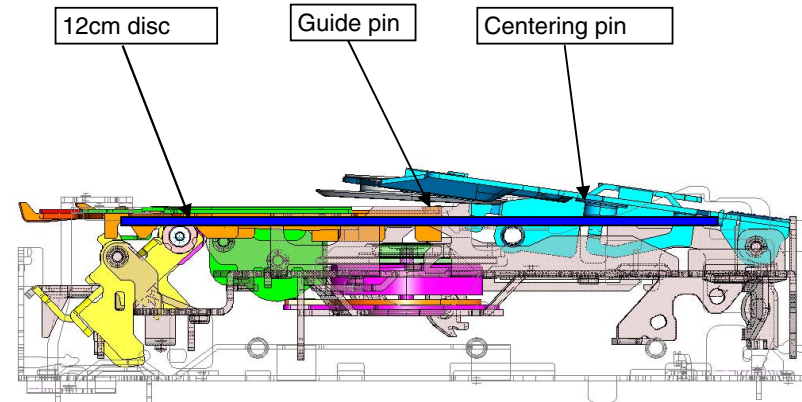
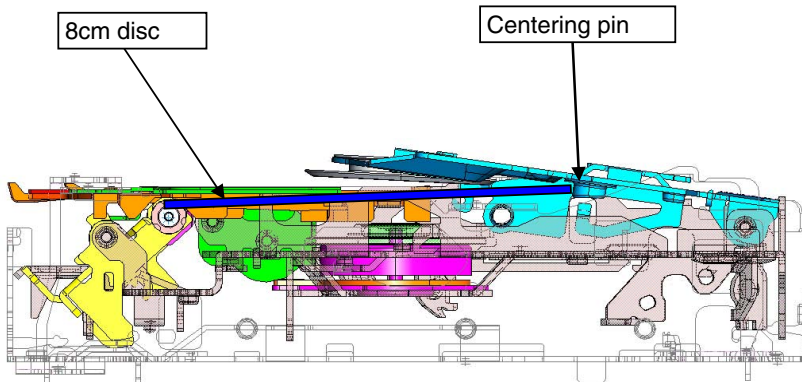

Clamp Operation Structure

1. Drive the detection arm at the position where 8 or 12 cm disc is centered on the spindle.

2. Detection arm matches the jumping rack with the rack drive gear.

3. The drive lever that was jointed with the jumping rack slides and then lowers the clamp arm (it clamps the disc.).
At the same time, it rotates the roller arm and separates the rubber roller from the disc.

Moreover, rotation of the roller arm releases the upper and lower mecha locks and completes the clamp operation.
4. After the completion of the clamp operation, the control by the cam above the drive lever is released and then the switching lock arm rotates.

When the same arm rotates, the switching idler gear is separated from the rack drive gear and meets with the feed screw drive gear and then the carriage operation is executed.

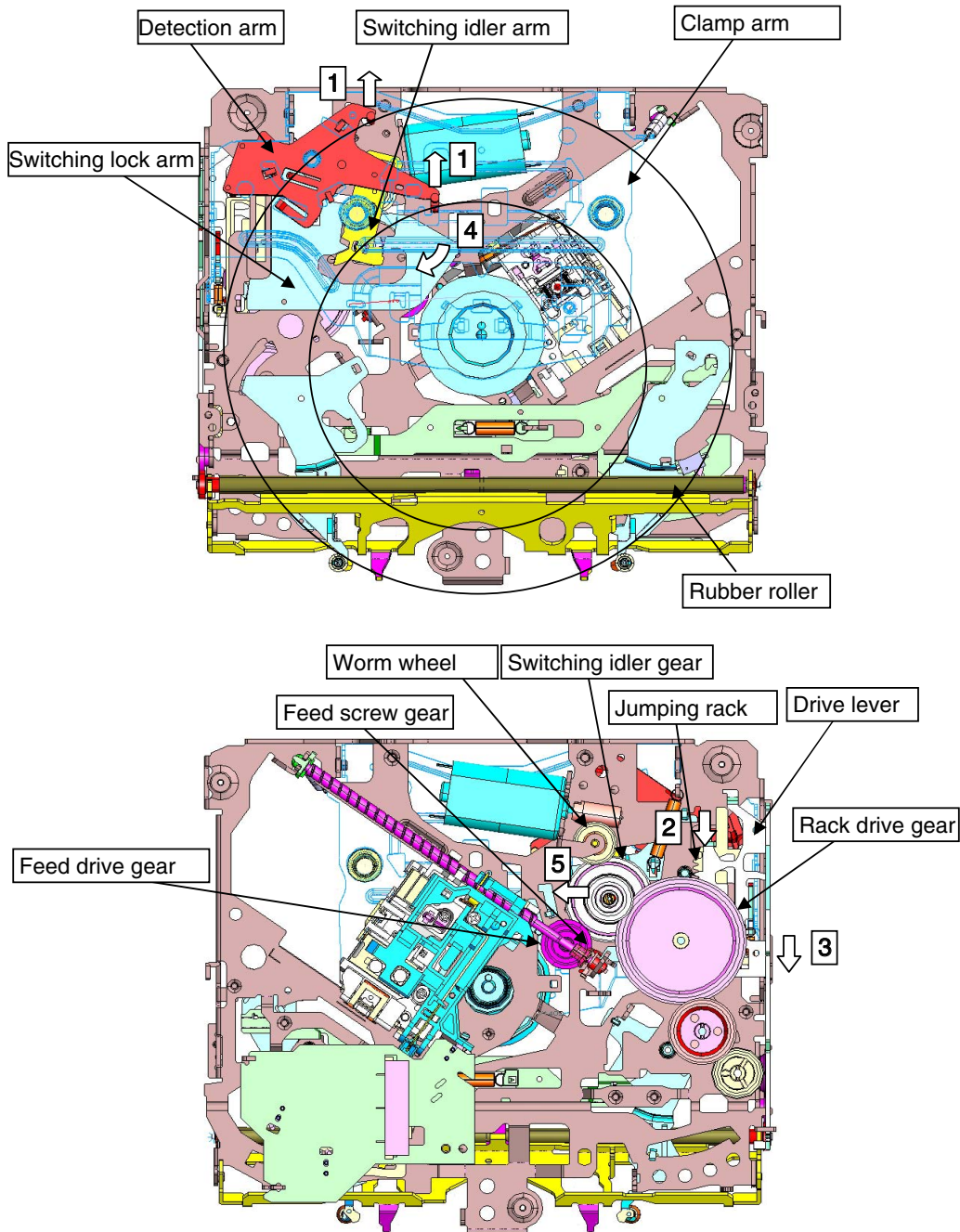

Ejecting Operation

1. It starts the ejecting operation in the reverse order of above procedures when the load carriage motor rotates in the reverse direction and the pick up is sent to the inner periphery with the home SW ON or more.

2. Ejection is completed when SW1 goes OFF->ON->OFF for 12cm disc.

3. Ejection is completed when SW1 goes ON->ON->OFF for 8cm disc.

3. DISASSEMBLY

How to have it

1. Have a specified part.

Please note that holding the front part of the upper frame or the CRG mechanical part, or inserting a foreign substance could cause deformation.

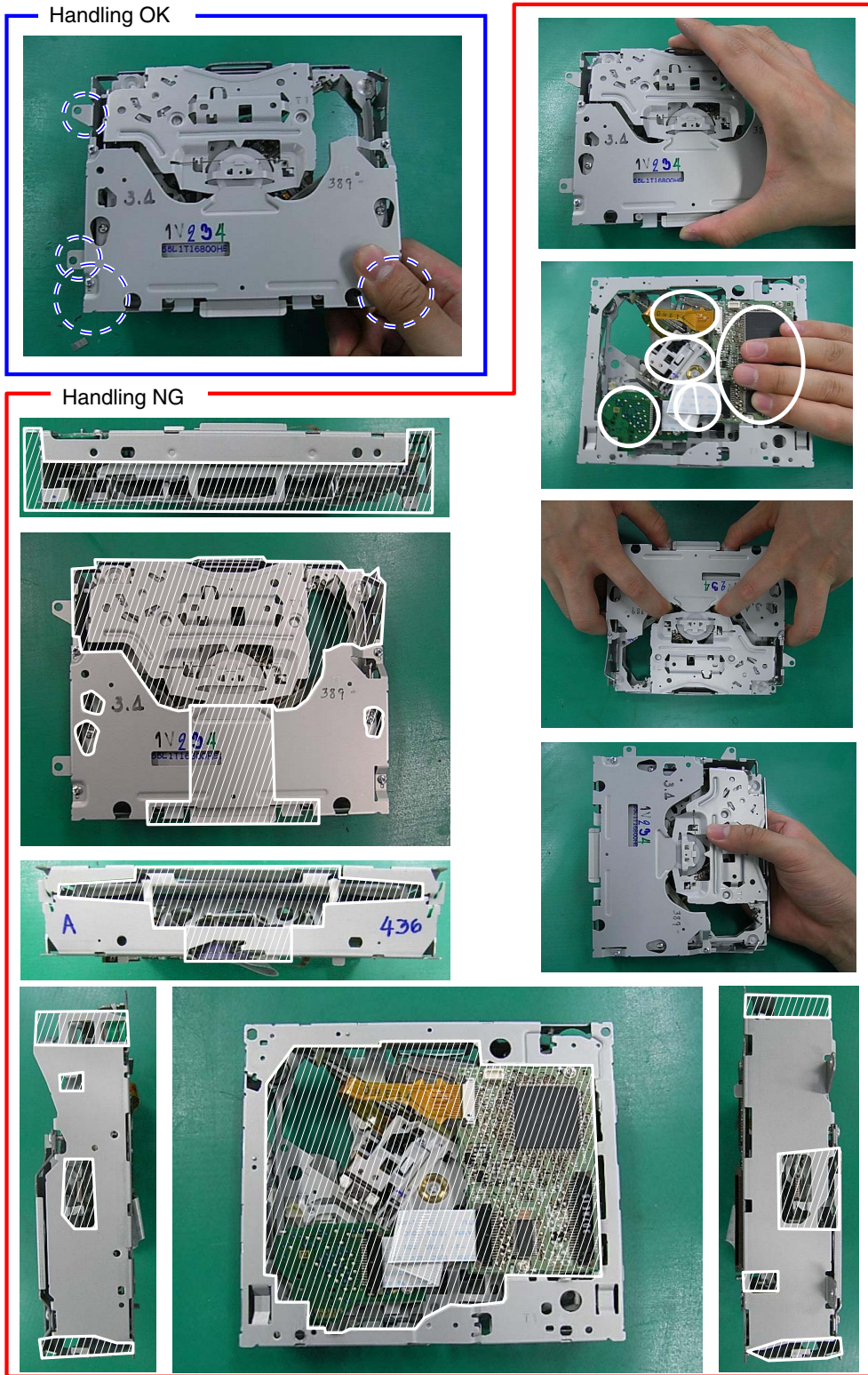

Mecha Module_Bringing into the Clamp State with No Disc Loaded

1. Remove the relay FFC from the connector on the module PCB side (Fig. 1).

(Precaution) When it is difficult to apply 4V to the motor in procedure 2 below, remove the connector on the relay PCB side, then remove the FFC, and remove the solder of the CRG motor lead and apply voltage to the lead.

2. Push the Disc detection arm while applying 4V to the CRG motor (Fig. 2)

By this action, the mecha moves to the clamp state and the PU moves to the outer periphery.

3. Stop the motor when the PU comes to the vicinity of the intermediate periphery.

(Precaution) If the PU goes to the outer most periphery, it idles.

It is not a problem, but please try not to let it idle as much as possible.

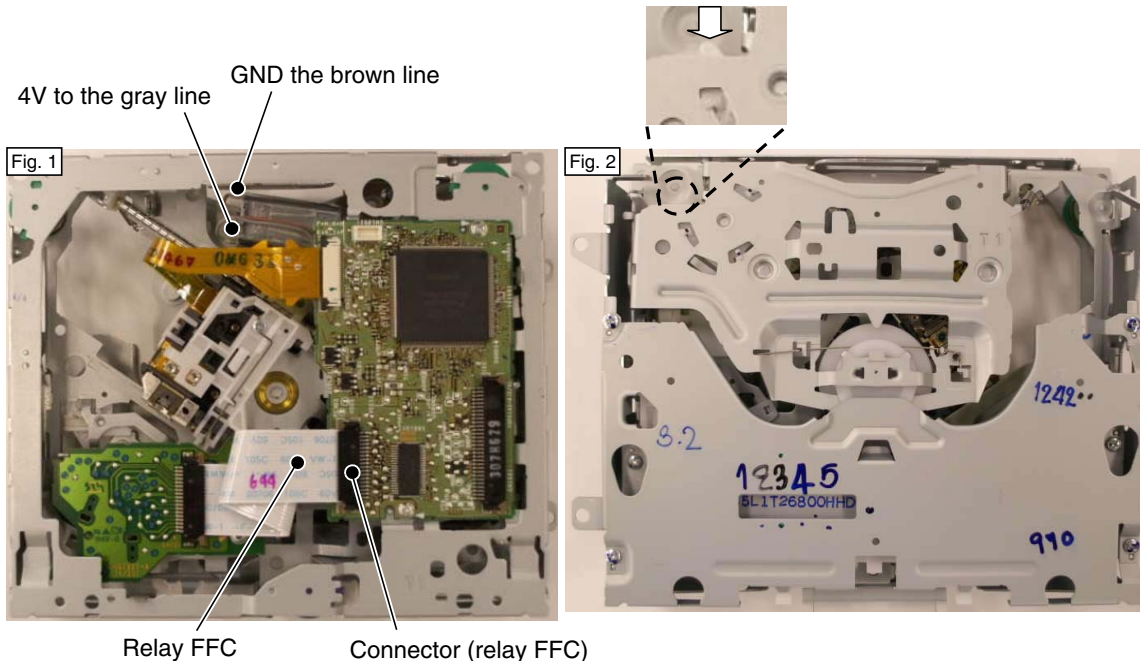

CRG Mecha_Bringing into the Clamp State with No Disc Loaded

1.Remove the CRG mecha assy according to the "Removing the CRG Mecha assy" manual (mecha is in the ejecting state).

A 2.Remove the T-case washer and then remove the drive gear. (Fig. 1)

3.Lift the clamp arm assy until it is in the state shown in Fig. 2_b (open-lock state).

4.Put your finger on the area A of Fig. 2_c and then slide it to the direction of the arrow (the direction of the playing state).

5.Push down the clamp arm.

(Precaution) When bringing the CRG mecha into the ejecting state again, install the drive gear after sliding the drive lever and bringing it to the ejecting state, in order to prevent the cog of the pinion in the drive gear from chipping at the time of its installation.

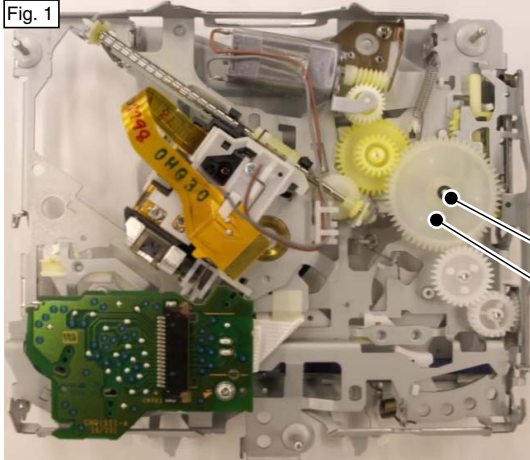
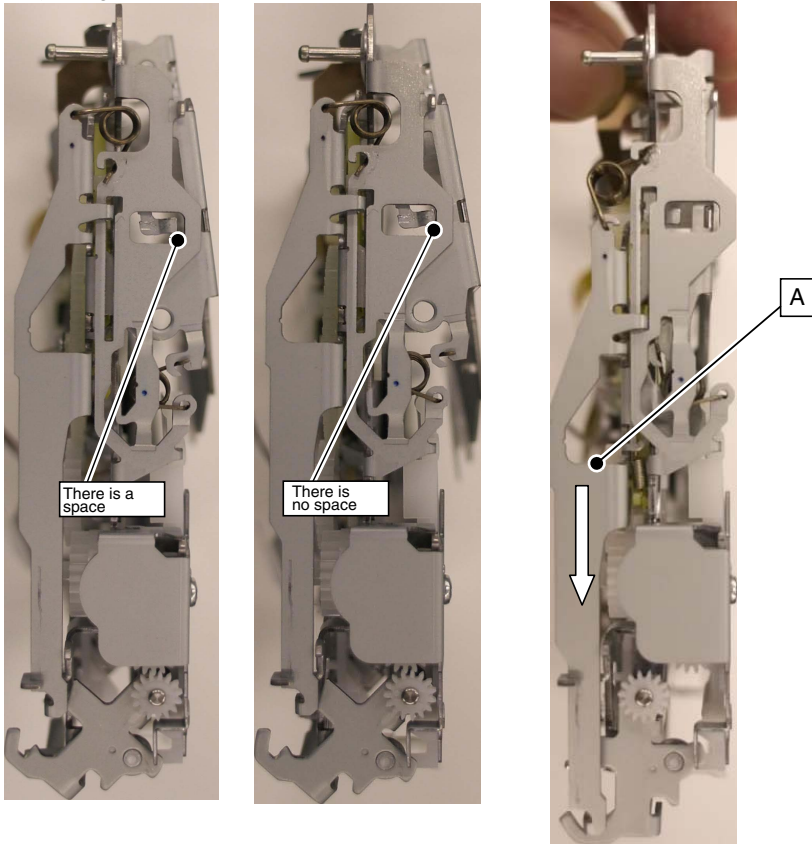
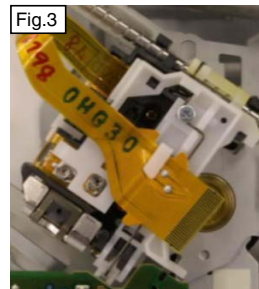
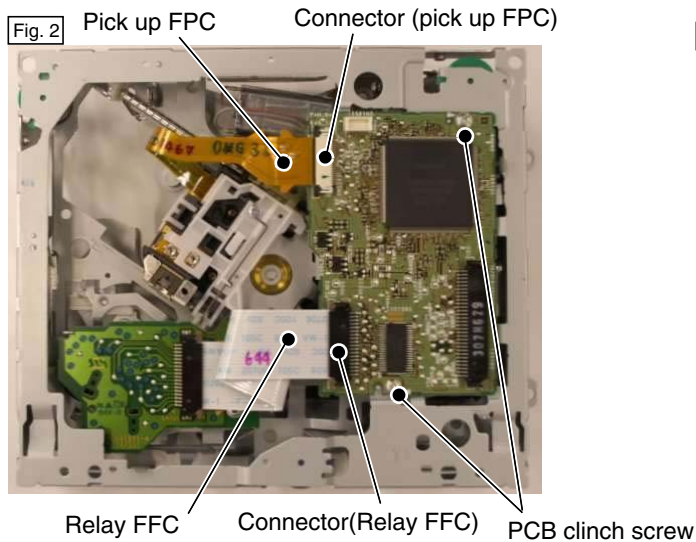

Fig. 2
 a.Ejecting state b.Open-lock state c.Clamp state with no disc loaded



Removing the Module PCB

1. Short-circuit two spots on the land of the pick up FPC. (Fig. 1)
2. Remove the pick up FPC and the relay FFC from the connector. (Fig. 2)
3. Temporarily attach the pick up FPC to the pick up rack. (Fig. 3)
(in order to prevent the damage to the pick up FPC)
4. Remove the two PCB clinch screws and then remove the module PCB. (Fig. 2)



Removing/Installing the Relay PCB

Removing)

1. Remove the relay FFC from the connector (remove both sides so that the entire FFC will be removed). (Fig. 2)
2. Remove the solder on the lead for the CRG motor. (Fig. 4)
3. Remove the one relay PCB clinch screw. (Fig. 4)
4. Slide the relay PCB to the direction of the arrow and then remove the relay PCB from the hook A and the hook B. (Fig. 4)
5. Turn the relay PCB over and then remove the SPDL motor FFC from the connector.

Installing)

1. Check the mecha is in the ejecting state (disc-load suspended state). When it is not in the ejecting state, apply 4V to the lead (motor) and then bring it to the ejecting state (4V to the brown line and GND the gray line).
2. Fit the SPDL motor FFC to the connector (back of the relay PCB).
3. Hold the relay PCB so that it does not touch the SW knob as in Fig. 5.
4. Insert it into the hook B as it is a little off to the clockwise direction. (Precaution) This is to prevent the SW knob from getting into the NG position as in Fig. 6.
5. Push down the relay PCB lightly and then rotate it to the counterclockwise direction. It sets the relay PCB in the hook A and the positioning dowel. (Precaution) Pay attention so the SW knob will not get onto the PU rack. (Fig. 6)
6. As in the Figures, while supporting the location A with your fingers, screw the relay PCB. (Fig. 7 / Fig. 8)
7. Solder the lead for the CRG motor.
8. Fit the relay FFC to the connector.

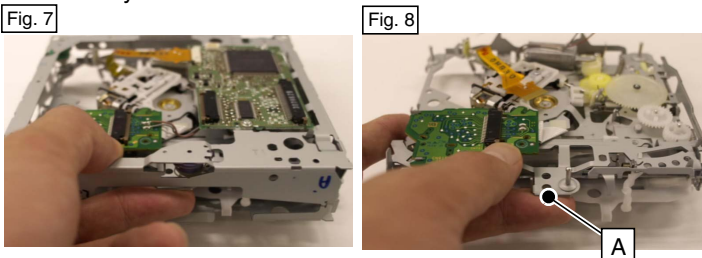
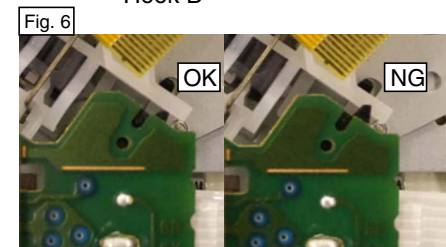
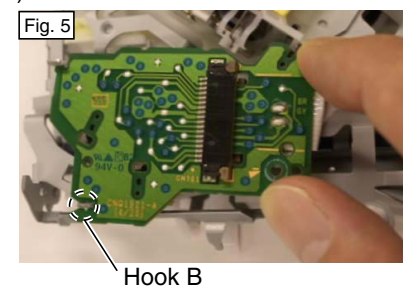
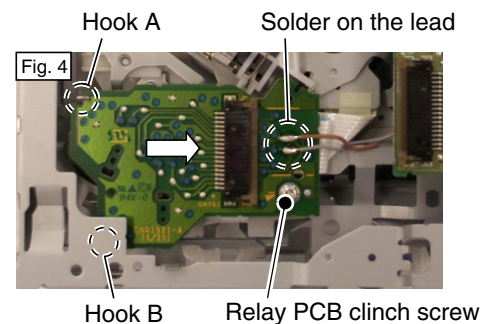

Removing the PU Unit

1. Bring to the clamp state with no disc loaded according to the “Bringing into the Clamp State with No Disc Loaded (Motor Drive)” manual.
 2. Remove the module PCB according to the “Removing the Module PCB” manual.
 3. Hook the feed screw biasing spring on the temporary hook (Fig. 2b). Be careful not to get injured by the tip of the spring.
 4. Hold the PU at the location A in Fig. 1 and slide and scoot it to the direction of the inner periphery.
 5. As in Fig. 3, shift the back end of the feed screw to the side and then to above and remove it from the outside holder.
 6. Remove the tucking joint for the chassis at the location B and the PU unit by lifting them up without changing their position and then remove the PU unit.
- (Precaution) When installing the PU again, make sure to tuck the chassis in B and the PU unit (Fig. 4) first. Moreover, do not forget to permanently hook the feed screw biasing spring (Fig. 2a). Adjustments to the PU after its installation should be made according to the service manual.

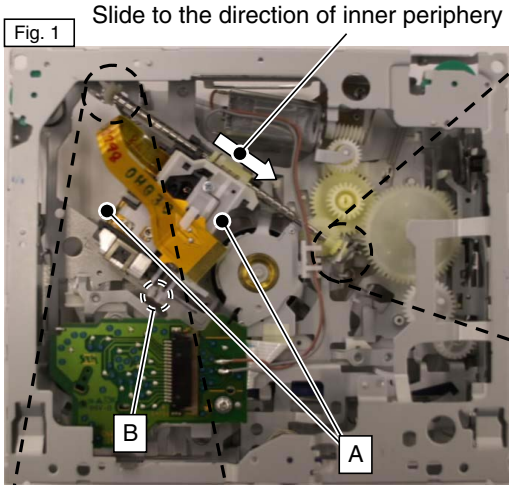

Permanently hooked position Temporary hooked position

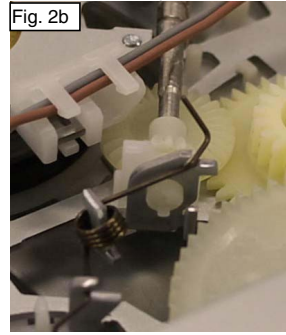
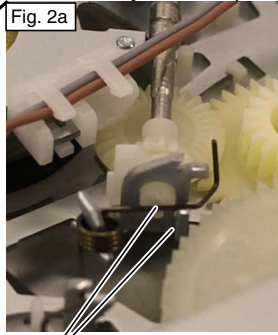

The spring is installed under the resin flange and inside the bended metal plate.

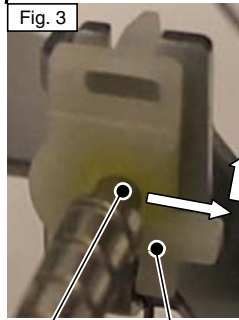

Back end of the feed screw Outside holder

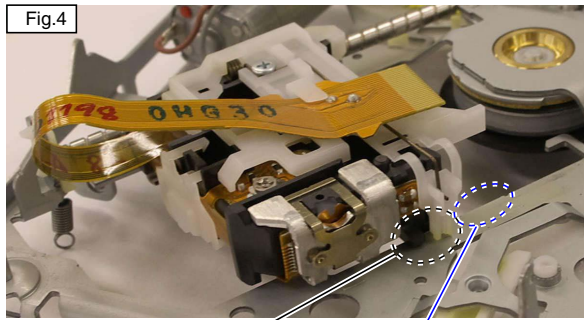

Regularly installed position Install avoiding the area with blue broken line (the connected metal plate part)

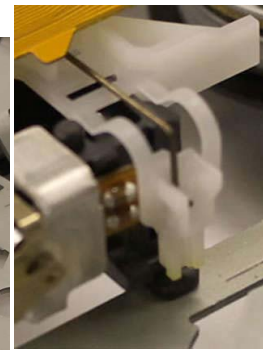

[Installation NG] The chassis is not tucked between the PU case and the PU rack.

Sending the PU to the outer periphery

1. Bring to the clamp state with no disc loaded according to the “Mecha Module_Bringing into the Clamp State with No Disc Loaded” manual.
- (Precaution) The relay FFC must be removed for certainty in order to prevent the IC damage.
2. Apply 1.5V to the CRG motor and then transfer the PU to the outer periphery.
- (Precaution) Do not forget to reinstall the relay FFC after sending the PU to the outer periphery and take the necessary measures.

Removing the Spindle Motor

- 1.Remove the CRG mecha assy according to the “Removing the CRG Mecha assy” manual (mecha is in the ejecting state).
- 2.Bring to the clamp state with no disc loaded according to the “Bringing into the Clamp State with No Disc Loaded (Manual)” manual.
- 3.Remove the clamp arm according to the procedure 3 and after of the “Removing the Clamp Arm” manual.
- 4.Remove the relay PCB according to the “Removing the Relay PCB” manual.
- 5.Remove the two spindle motor clinch screws and then remove the spindle motor assy.

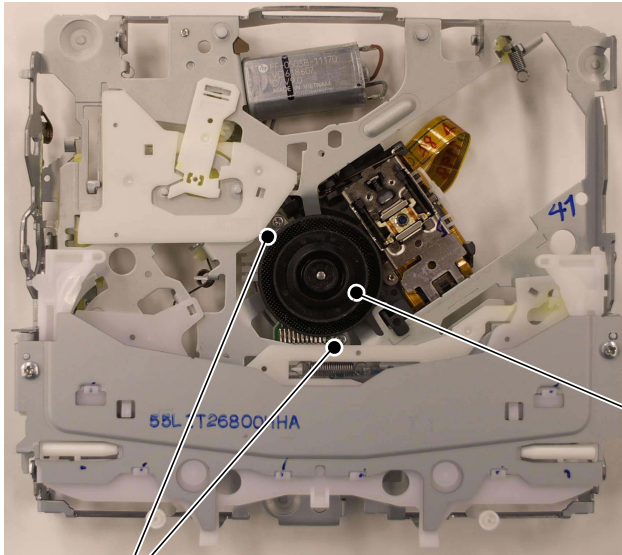

Spindle motor clinch screws

Spindle motor

Removing the Clinch of the Bottom Frame

1. Use the needle-nose pliers when removing the clinch on the right side. Nip the clinch at the location in Fig. 1a and then open it until it is in the position circled by the red broken line in Fig. 2a.

2. Also to remove the clinch on the left side, use the needle-nose pliers, nip the clinch at the location in Fig. 1b and then open it until it is in the position circled by the red broken line in Fig. 2b.

(Precaution) When clinching again, use Fig. 2a and Fig. 2b as a guide.

It is okay as long as the tip of the clinch does not come off from the side a and the side b by the vibration stroke (from front to back and from side to side).

Check Fig. 3a and Fig. 3b for the height of the clinch.

Correct the height with the needle-nose pliers when the height does not meet the standard listed in those Figures.

In case of metal fatigue on the clinch part, exchange the lower frame.

Clinch on the left side

Clinch on the right side



Caution: After repairing, make sure to clinch to the lower frame again.

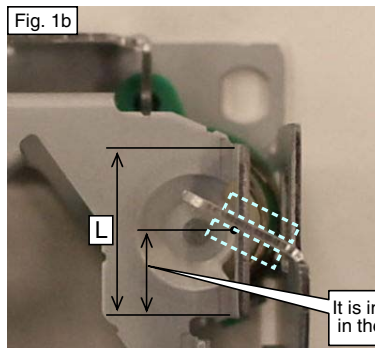
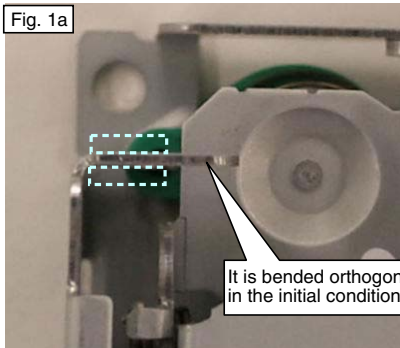

It is bended orthogonally in the initial condition

It is in the L/2 position in the initial condition

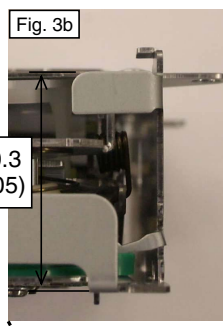
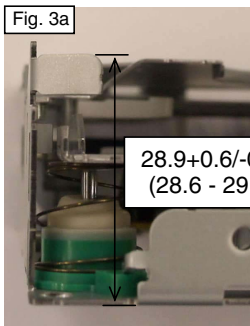
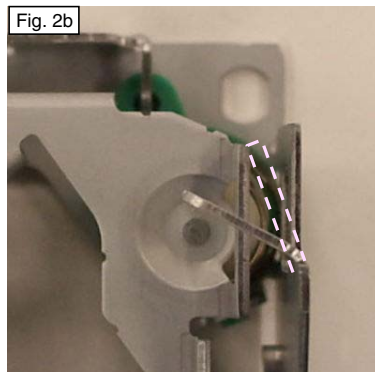
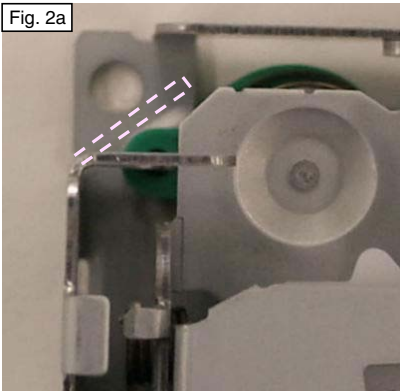

$28.9+0.6/-0.3$
(28.6 - 29.5)

$25.45+0.6/-0.3$
(25.15 - 26.05)



Removing the CRG Mecha assy

1. Follow up to the procedure 3 of the "Removing the Module PCB" manual and then remove the PU FPC from the connector.

2. Remove the relay FFC from the connector (both ends) and then remove the FFC. (Fig. 1)

3. Open the clinch of the bottom frame according to the "Removing the Clinch of the Bottom Frame" manual.

4. Remove the front-pulling springs on both sides. (Fig. 2a & Fig. 2b)

5. Remove four clinch screws of the top frame and then remove the top frame. (Fig. 3)

6. As lifting the carriage mecha, remove it from the dampers at three locations. (Fig. 3)

(Precaution) When assembling the CRG mecha assy again, apply alcohol on the dampers.

Make sure that the damper shafts are inside the three neutral springs (Fig. 4) and that the springs on both sides are hooked according to the "Mecha Module_Bringing into the Clamp State with No Disc Loaded" manual, push the upper part of the damper of the CRG mecha by the finger and then make sure that the damper and the CRG mecha are jointed with certainty. (Fig. 5)

Fig. 1



Fig. 4

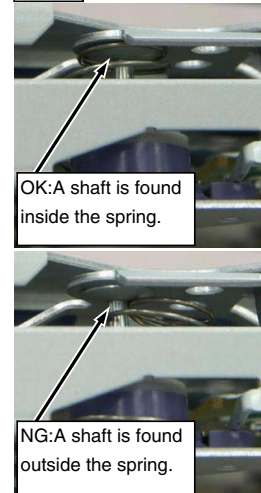

Caution : After repairing, make sure to clinch to the lower frame again.

Caution : After repairing, make sure to clinch to the lower frame again.

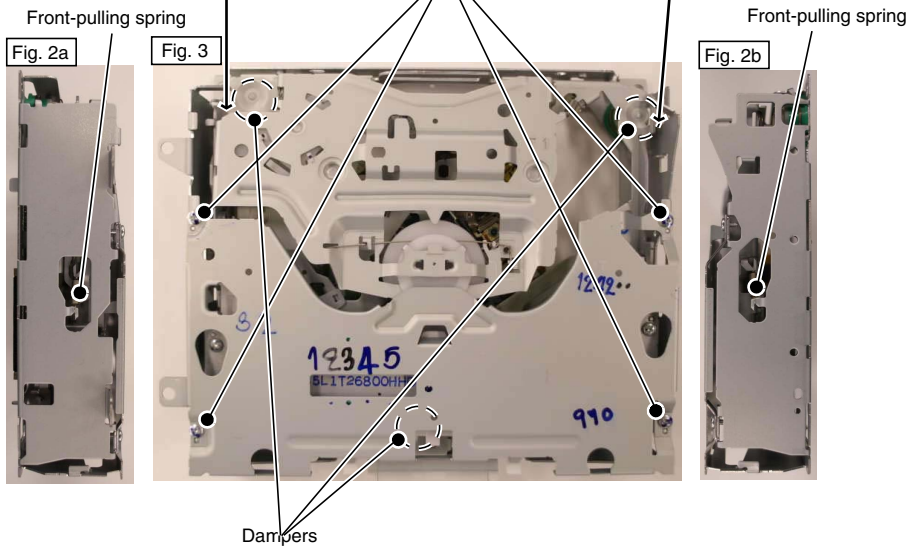
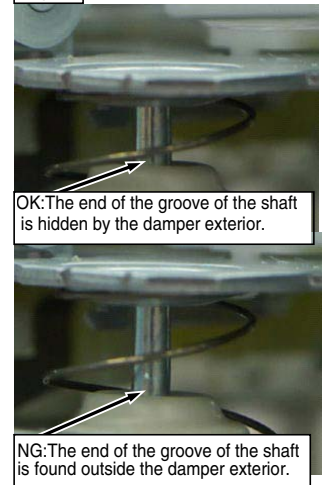

Fig. 5



Removing the Disc Guide assy

(Removing the Roller Transmission Side Gear)

- 1.Remove the CRG mecha assy according to the “Removing the CRG Mecha assy” manual (mecha is in the ejecting state).
 - 2.Remove the two guide bracket clinch screws and then remove the Disc guide assy. (Fig. 1)
 - 3.Remove the two roller transmission side gears. (Fig. 2)
- (Precaution) When assembling the Disc guide assy again, do not forget to install two gears on the side panel.

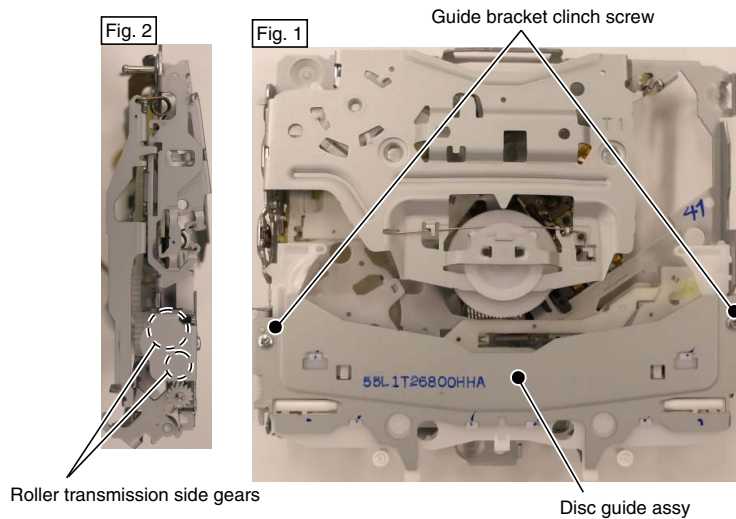

Removing the Roller assy

- 1.Remove the CRG mecha assy according to the “Removing the CRG Mecha assy” manual (mecha is in the ejecting state).
 - 3.Remove the Roller assy biasing spring. (Fig. 3)
 - 4.Remove the Disc guide assy according to the procedure 2 and after of the “Removing the Disc Guide assy” manual.
 - 5.Hold the Roller assy at the locations A, slide it to the left and then remove it. (Fig.4)
- (Precaution) When assembling the Disc guide assy again, do not forget to install two gears on the side panel.

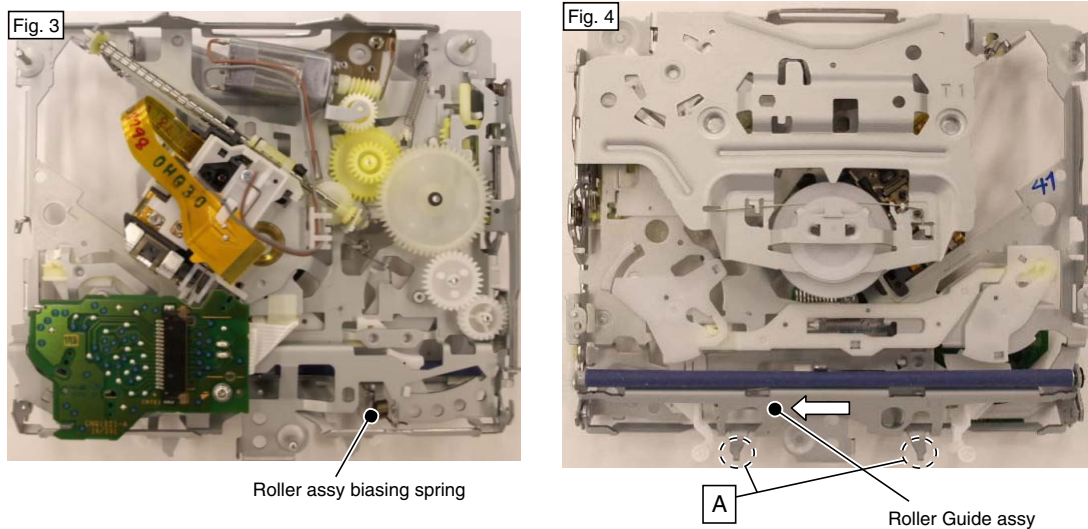

Removing/Reassembling the Clamp Arm assy

1. Remove the CRG mecha assy according to the "Removing the CRG Mecha assy" manual (mecha is in the ejecting state).
2. Bring to the clamp state with no disc loaded according to the "Bringing into the Clamp State with No Disc Loaded (Manual)" manual.
3. Remove the right clamp arm biasing spring. (Just on the clamp-arm side. Do not remove on the chassis side.)
4. Lift the clamp arm assy until it is in the state shown in Fig. 2 (open-lock state).
5. Lightly push the part A and lift the clamp arm assy further to the position in Fig. 3.
6. Remove the left clamp arm biasing spring.
7. Lift the clamp arm assy further to 45-60 degrees, slide it to the left and then remove it. (Fig. 1)

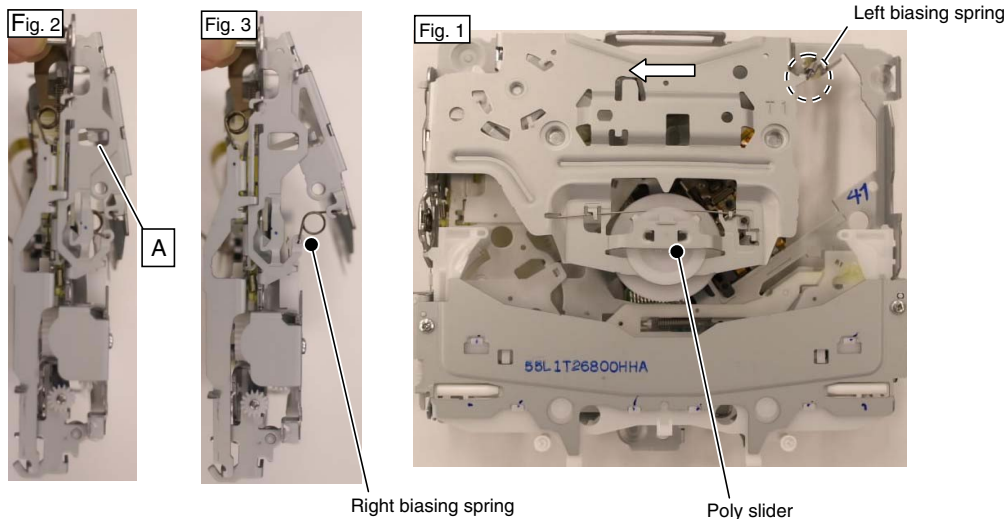

Installing)

1. With the clamp arm assy tilted at 45-60 degrees, install it to the rotation fulcrum by sliding it from the left.
 2. Bring down the clamp arm assy to the position in Fig. 3 (position where it meets the chassis and then stops).
 3. Install the left clamp arm biasing spring.
 4. Completely turn the detection arm to the position OK in Fig. 4 and then push the clamp arm assy to the bottom.
 5. Install the right clamp arm biasing spring.
- (Precaution) –When replacing the clamp arm assy, replace the poly slider with a new part as well.
Do not forget to apply the E paste on the poly slider (Fig. 4).

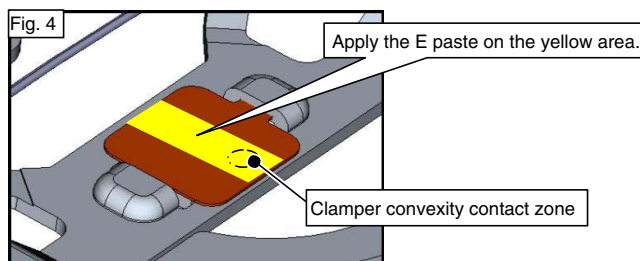
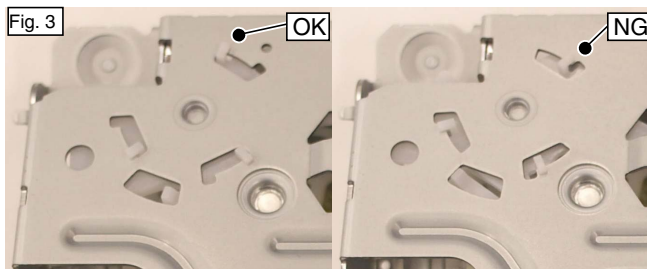

Removing the CRG Motor assy

(Removing the Drive Transmission Gear)

1. Remove the CRG mecha assy according to the "Removing the CRG Mecha assy" manual (mecha is in the ejecting state).
2. Remove the clamp arm assy according to the "Removing the Clamp Arm assy" manual.
3. Remove the solder of the CRG motor lead and then remove the lead from the line clamber. (Fig. 1)
4. Remove the clinch screw of the CRG motor biasing spring and then slide the biasing spring to the direction of the arrow to remove it. (Fig. 1)
5. Nip the gear hook of the switching idler arm by the tips of your fingers and then push it below from the top of the gear. (Fig. 2a -> Fig. 2b)
6. Bend the hook on the chassis side of the switching idler arm to the direction of the arrow by tweezers and then remove the joint with the chassis. (Fig. 3)
7. Pull off the switching idler arm from the top of the mecha (Fig. 4) and then remove the worm wheel and the idler gear. (Fig. 3)
8. Remove the switching idler lock arm biasing spring. (Fig. 3)
9. Remove two CRG motor clinch screws and then remove the CRG motor. (Fig. 3)

(Precaution) When installing the switching idler arm again, temporarily set the idler gear and the worm wheel as in Fig. 5, press the idler gear from its top by your finger and then install the switching idler arm according to the steps in Fig. 6 from the opposite side of the chassis.

Do not forget to install the switching idler arm biasing spring.

Since the idler arm is in the snap fit structure, do not use them again.

When installing the CRG motor, scoot it to the center of the mecha in order to ensure that the gear engages.

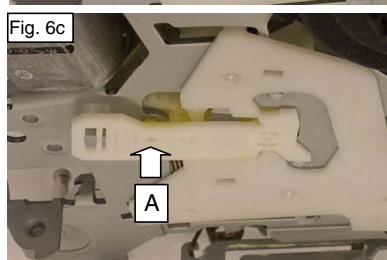
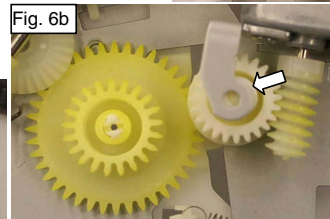
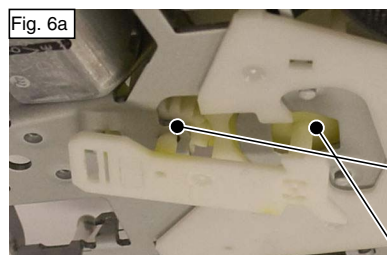
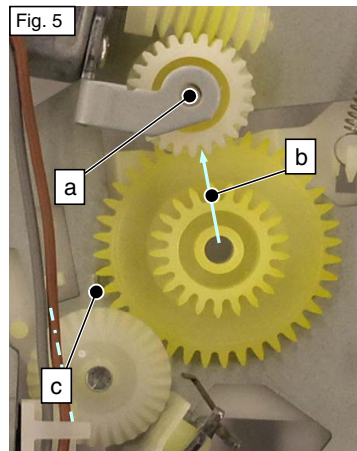
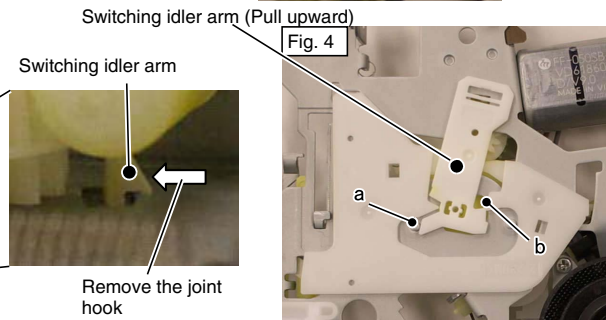
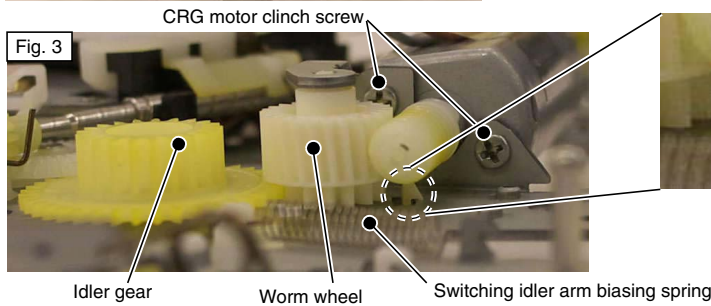
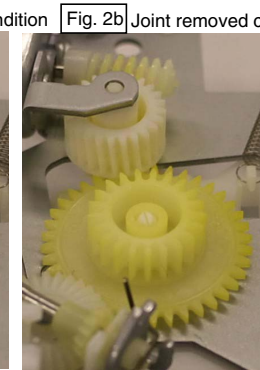
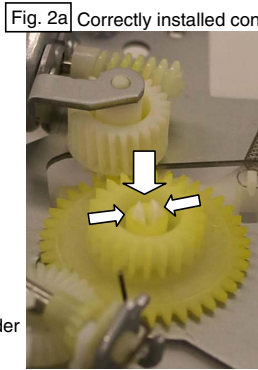
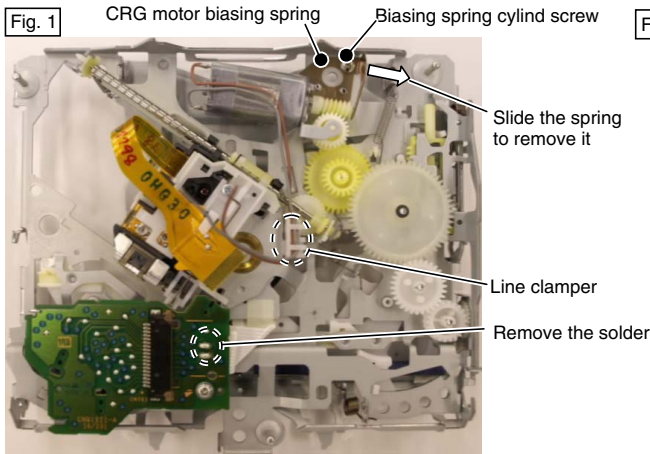

Step 1: Insert the arm rotation fulcrum boss in the worm wheel through the chassis hole. Insert only the tip of the boss as in the figure.

Step 2: As pressing the idler gear from the opposite, insert the gear fulcrum boss into the gear and joint them until they are in the correctly installed condition in Fig. 2a. When the idler arm is not installed correctly, there could be an interference either in the location a or in the location b of Fig. 4. Make a fine adjustment by moving it left and right.
 Step 3: As matching the tip of the rotation fulcrum boss with the metal plate hole by your finger (Fig. 6b), push the area A in Fig. 6c to install the idler arm.

a: Match the fulcrum hole of the worm wheel with the metal plate hole.
 b: Engage the idler gear with the worm wheel.

c: Align the gear with the outer shape of the metal plate concavity as a guide.

Removing the Drive Lever assy

- 1.Remove the CRG mecha assy according to the “Removing the CRG Mecha assy” manual (mecha is in the ejecting state).
- 2.Remove the clamp arm assy according to the “Removing the Clamp Arm assy” manual.
- 3.Remove the drive lever biasing spring. (Fig. 1)
- 4.Slide the drive lever to the direction of the arrow (the direction of ejecting), lift it to the direction of upper right and then remove it. (Fig. 2)

(Precaution) When installing the drive lever assy again, install the part B (Fig. 2) first with the part A in Fig. 3 scooted to the direction of the arrow(*1). Next, install the part C (Fig. 4) of the drive lever in the channel bending the side of the chassis, and in the end, install the part D (Fig. 4) into the L-shaped channel of the chassis and then slide the drive lever to the position in Fig. 1.

*1: If approach of Part A (Fig 3) is inadequate, the drive lever will not be able to be well incorporated.

In this case, the idler gear might be located at the red dashed line (Fig 5). Therefore, approach Part A (Fig 3) to the direction of the arrow as approaching the idler gear to the direction of the arrow (Fig 5). Determine, with the position of Part C in Fig 5, if the approach of Part A is adequate.

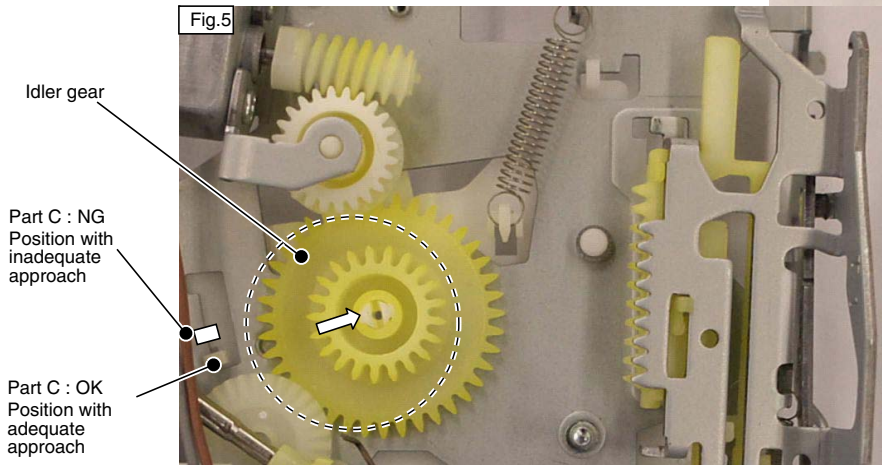
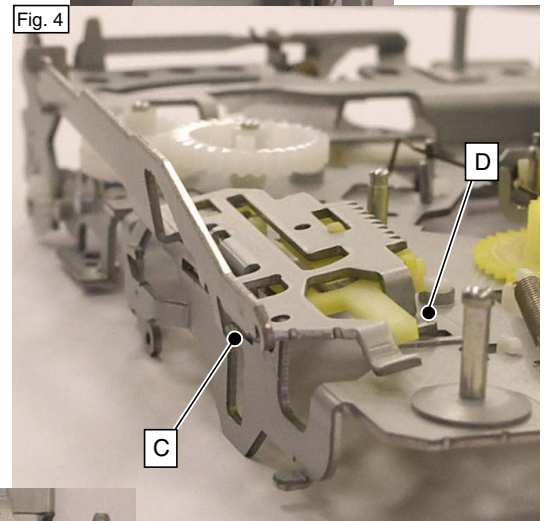
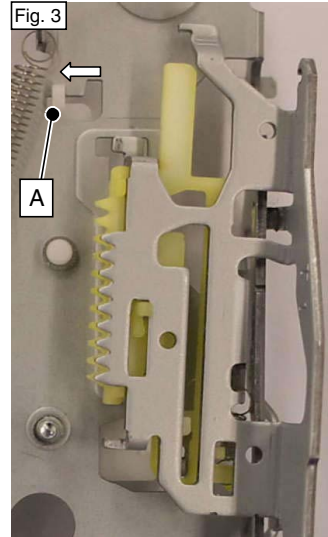
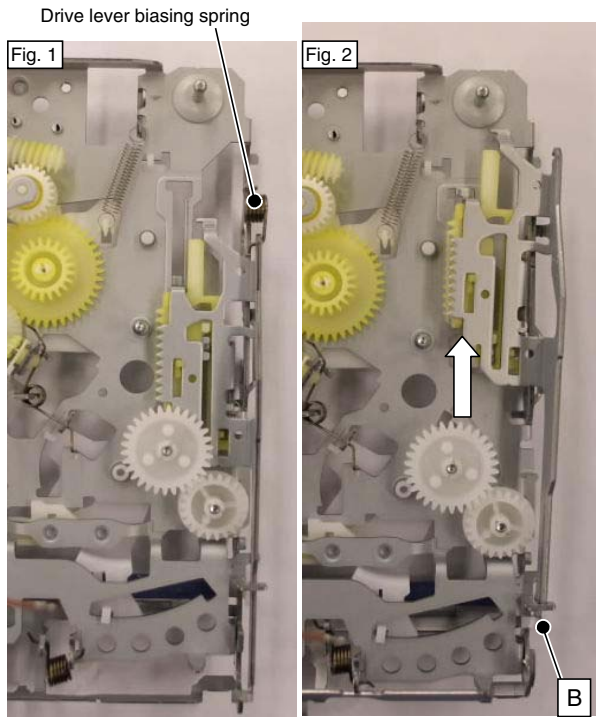

Removing the SW Arm

1. Remove the roller arm assy according to the "Removing the Roller Arm assy" manual.
2. Remove the SW arm connecting lever biasing spring. (Fig. 1)
3. Open the SW arms on both left and right sides until their tips touch the chassis. (Fig. 2)
4. Keep the SW arms open, lift them upward and then remove them.

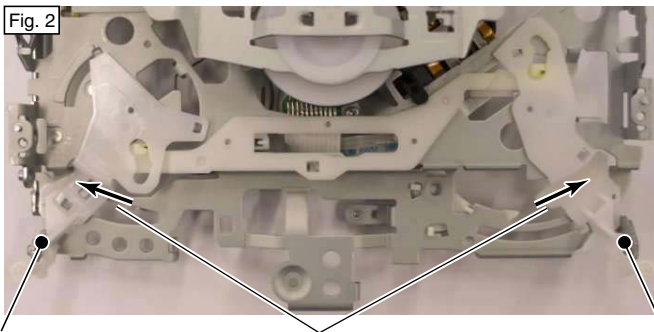
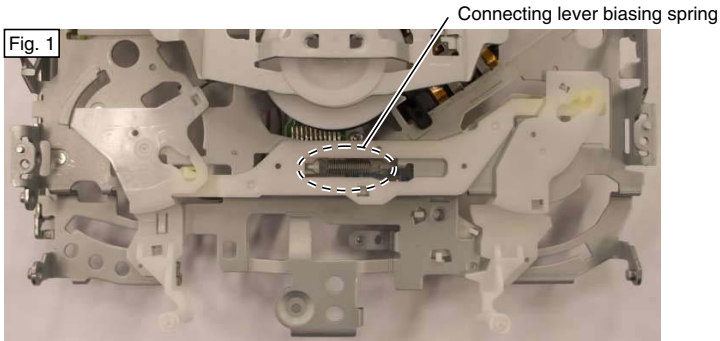

Open the SW arm
on left sides until their tips

Open the SW arms on both left and right side

Open the SW arm
on right sides until their tips

Removing the Damper

1. Remove the CRG mecha according to the "Removing the CRG Mecha assy" manual
 2. Insert the screwdriver under the part A of the metal plate configuration which joints the damper, lift the metal plate to release the damper from being clinched by the part C.
 3. Insert the screwdriver under the part D as well. Lift the metal plate, release the damper from being clinched to remove it.
- Caution: When mounting a damper, hold it tight with a clinch in order to avoid backlash.
In case of metal fatigue on the clinch part, exchange the frame.

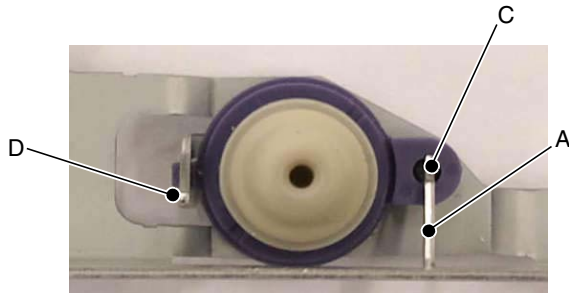

Caution: After repairing, make sure to clinch to the lower frame again.

Removing the PU Rack

1. Remove the PU unit according to the "Removing the PU Unit" manual.

2. Remove the PU rack clinch screw. (Fig. 1)

3. Pick up the root of the hook on the PU rack (Fig. 2) with tweezers as in Fig. 3. While bending it so the tip of the hook would open to the direction of the arrow (unhooked direction), pull out the PU rack upward.

(Precaution) When handling the PU unit, do not "touch the actuator in Fig. 9 or hit the desk with it during the operation." Handle the PU and the PU unit according to "Holding the PU" manual.

When installing the PU rack into the PU again, fold back the PU FPC as in Fig. 5 according to the folding line in Fig. 4 before installing the rack and settle it in the channel on the PU case. To install the PU rack, first install the part a and the part b in Fig. 6 into the PU case, install the FPC folding back part in Fig. 5 so that it is held by the part A in Fig. 7, and push the part B (top of the snap fit) to fit the PU rack.

When it is hard to fit the PU rack, try again as scooting it to the direction of the arrow C in Fig. 7.

After installing the PU rack, insert the feed screw from the side c in Fig. 8. Insert approximately 18mm on the part shown in the figure.

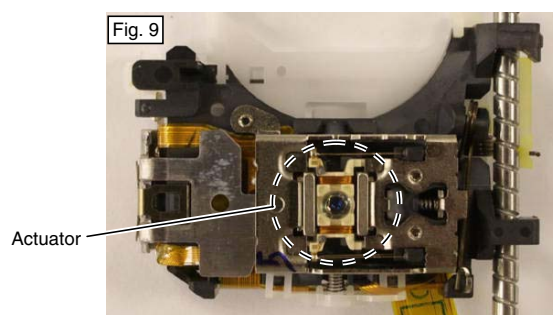
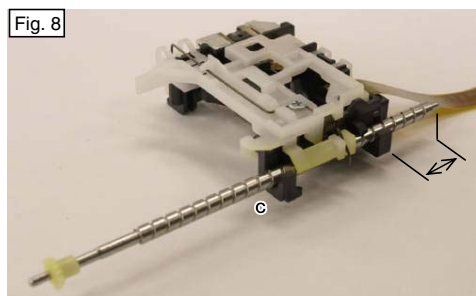
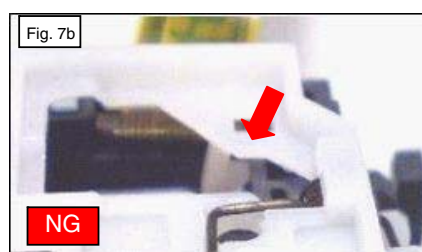
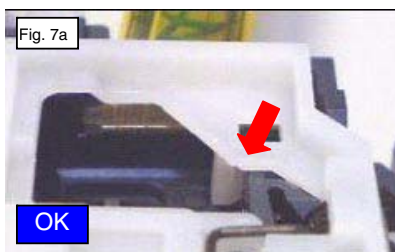
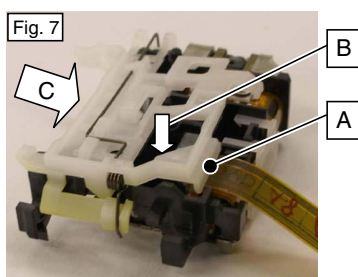
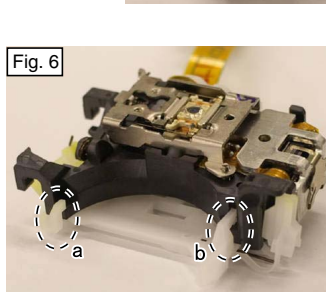
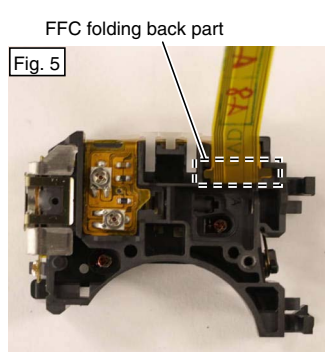
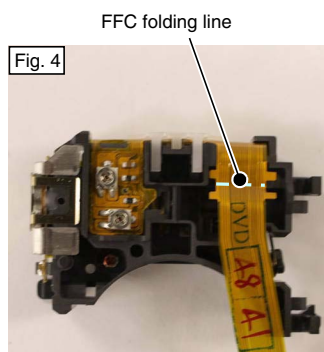
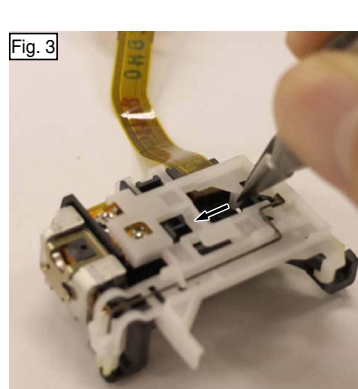
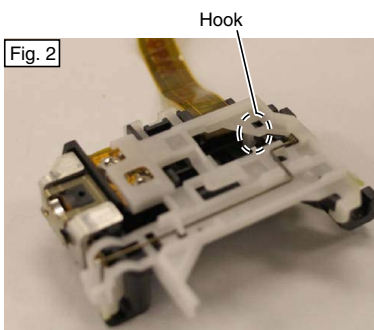
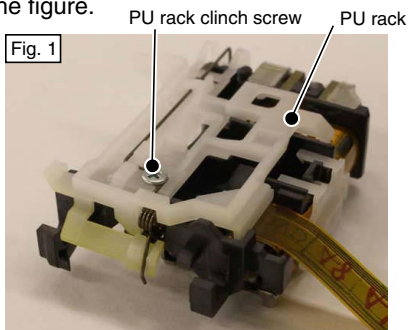

A
B
C
D
E
F

Holding the PU

1. Hold the "Handling OK" area of the PU indicated by the figure. Do not hold the "Handling NG" area.

Handling OK

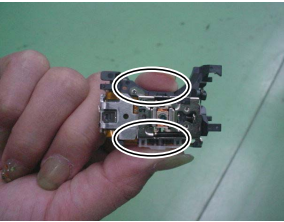
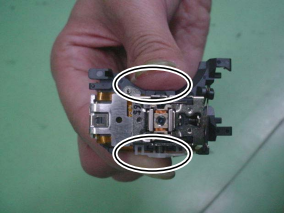
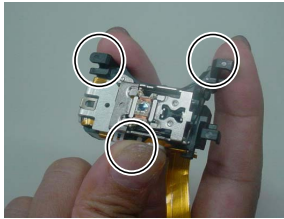

Handling NG

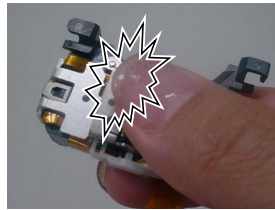

Do not touch the object lens.

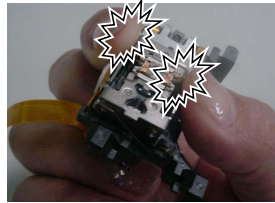

Do not touch the ACT.

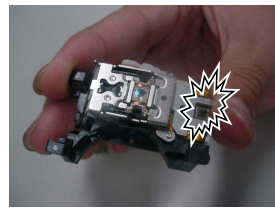

Do not touch the Hologram.



Do not pull the FPC.