

DENON

For U.S.A. , Canada, Europe,
& Taiwan R.O.C. model

SERVICE MANUAL

Ver. 1

MODEL AVR-1707 AVR-1507 AVR-687 AVR-587 AVR-487

AV SURROUND RECEIVER

注意

サービスをおこなう前に、このサービスマニュアルを必ずお読みください。本機は、火災、感電、けがなどに対する安全性を確保するために、さまざまな配慮をおこなっており、また法的には「電気用品安全法」にもとづき、所定の許可を得て製造されております。従ってサービスをおこなう際は、これらの安全性が維持されるよう、このサービスマニュアルに記載されている注意事項を必ずお守りください。

● For purposes of improvement, specifications and design are subject to change without notice.

● 本機の仕様は性能改良のため、予告なく変更することがあります。
● 補修用性能部品の保有期間は、製造打切後8年です。

● Please use this service manual with referring to the operating instructions without fail.

● 修理の際は、必ず取扱説明書を参照の上、作業を行ってください。

● Some illustrations using in this service manual are slightly different from the actual set.

● 本文中に使用しているイラストは、説明の都合上現物と多少異なる場合があります。

DENON

TOKYO, JAPAN
Denon Brand Company, D&M Holdings Inc.

SAFETY PRECAUTIONS

The following check should be performed for the continued protection of the customer and service technician.

LEAKAGE CURRENT CHECK

Before returning the unit to the customer, make sure you make either (1) a leakage current check or (2) a line to chassis resistance check. If the leakage current exceeds 0.5 milliamps, or if the resistance from chassis to either side of the power cord is less than 460 kohms, the unit is defective.

CAUTION Please heed the points listed below during servicing and inspection.

◎ Heed the cautions!

Spots requiring particular attention when servicing, such as the cabinet, parts, chassis, etc., have cautions indicated on labels or seals. Be sure to heed these cautions and the cautions indicated in the handling instructions.

◎ Caution concerning electric shock!

(1) An AC voltage is impressed on this set, so touching internal metal parts when the set is energized could cause electric shock. Take care to avoid electric shock, by for example using an isolating transformer and gloves when servicing while the set is energized, unplugging the power cord when replacing parts, etc.

(2) There are high voltage parts inside. Handle with extra care when the set is energized.

◎ Caution concerning disassembly and assembly!

Though great care is taken when manufacturing parts from sheet metal, there may in some rare cases be burrs on the edges of parts which could cause injury if fingers are moved across them. Use gloves to protect your hands.

◎ Only use designated parts!

The set's parts have specific safety properties (fire resistance, voltage resistance, etc.). For replacement parts, be sure to use parts which have the same properties. In particular, for the important safety parts that are marked \triangle on wiring diagrams and parts lists, be sure to use the designated parts.

◎ Be sure to mount parts and arrange the wires as they were originally!

For safety reasons, some parts use tape, tubes or other insulating materials, and some parts are mounted away from the surface of printed circuit boards. Care is also taken with the positions of the wires inside and clamps are used to keep wires away from heating and high voltage parts, so be sure to set everything back as it was originally.

◎ Inspect for safety after servicing!

Check that all screws, parts and wires removed or disconnected for servicing have been put back in their original positions, inspect that no parts around the area that has been serviced have been negatively affected, conduct an insulation check on the external metal connectors and between the blades of the power plug, and otherwise check that safety is ensured.

(Insulation check procedure)

Unplug the power cord from the power outlet, disconnect the antenna, plugs, etc., and turn the power switch on. Using a 500V insulation resistance tester, check that the insulation resistance between the terminals of the power plug and the externally exposed metal parts (antenna terminal, headphones terminal, microphone terminal, input terminal, etc.) is 1M Ω or greater. If it is less, the set must be inspected and repaired.

CAUTION Concerning important safety parts

Many of the electric and structural parts used in the set have special safety properties. In most cases these properties are difficult to distinguish by sight, and using replacement parts with higher ratings (rated power and withstand voltage) does not necessarily guarantee that safety performance will be preserved. Parts with safety properties are indicated as shown below on the wiring diagrams and parts lists in this service manual. Be sure to replace them with parts with the designated part number.

(1) Schematic diagrams ... Indicated by the \triangle mark.

(2) Parts lists ... Indicated by the \triangle mark.

Using parts other than the designated parts could result in electric shock, fires or other dangerous situations.

注意 サービス、点検時にはつぎのことにご注意願います。

◎ 注意事項をお守りください！

サービスのとき特に注意を必要とする個所についてはキャビネット、部品、シャーシなどにラベルや捺印で注意事項を表示しています。これらの注意書きおよび取扱説明書などの注意事項を必ずお守りください。

◎ 感電に注意！

(1) このセットは、交流電圧が印加されていますので通電時に内部金属部に触れると感電することがあります。従って通電サービス時には、絶縁トランスの使用や手袋の着用、部品交換には、電源プラグを抜くなどして感電にご注意ください。

(2) 内部には高電圧の部分がありますので、通電時の取扱には十分ご注意ください。

◎ 分解、組み立て作業時のご注意！

板金部品の端面の『バリ』は、部品製造時に充分管理をしておりますが、板金端面は鋭利となっている箇所がありますので、部品端面に触れたまま指を動かすとまれに怪我をする場合がありますので十分注意して作業して下さい。手の保護のために手袋を着用して下さい。

◎ 指定部品の使用！

セットの部品は難燃性や耐電圧など安全上の特性を持ったものとなっています。従って交換部品は、使用されていたものと同じ特性の部品を使用して下さい。特に配線図、部品表に \triangle 印で指定されている安全上重要な部品は必ず指定のものをご使用ください。

◎ 部品の取付けや配線の引きまわしは、元どおりに！

安全上、テープやチューブなどの絶縁材料を使用したり、プリント基板から浮かして取付けた部品があります。また内部配線は引きまわしやクランプによって発熱部品や高圧部品に接近しないように配慮されていますので、これらは必ず元どおりにして下さい。

◎ サービス後は安全点検を！

サービスのために取り外したねじ、部品、配線などが元どおりになっているか、またサービスした個所の周辺を劣化させてしまったところがないかなどを点検し、外部金属端子部と、電源プラグの刃の間の絶縁チェックをおこなうなど、安全性が確保されていることを確認してください。

(絶縁チェックの方法)

電源コンセントから電源プラグを抜き、アンテナやプラグなどを外し、電源スイッチを入れます。500V 絶縁抵抗計を用いて、電源プラグのそれぞれの端子と外部露出金属部 [アンテナ端子、ヘッドホン端子マイク端子、入力端子など] との間で、絶縁抵抗値が 1 M Ω 以上であること、この値以下のときはセットの点検修理が必要です。

注意 安全上重要な部品について

本機に使用している多くの電気部品、および機構部品は安全上、特別な特性を持っています。この特性はほとんどの場合、外観では判別つきにくく、またもとの部品より高い定格（定格電力、耐圧）を持ったものを使用しても安全性が維持されることは、限りません。安全上の特性を持った部品は、このサービスマニュアルの配線図、部品表に同じように表示していますので必ず指定されている部品番号のものを使用願います。

(1) 配線図... \triangle マークで表示しています。

(2) 部品表... \triangle マークで表示しています。

指定された部品と異なるものを使用した場合には、感電、火災などの危険を生じる恐れがあります。

DIMENSION

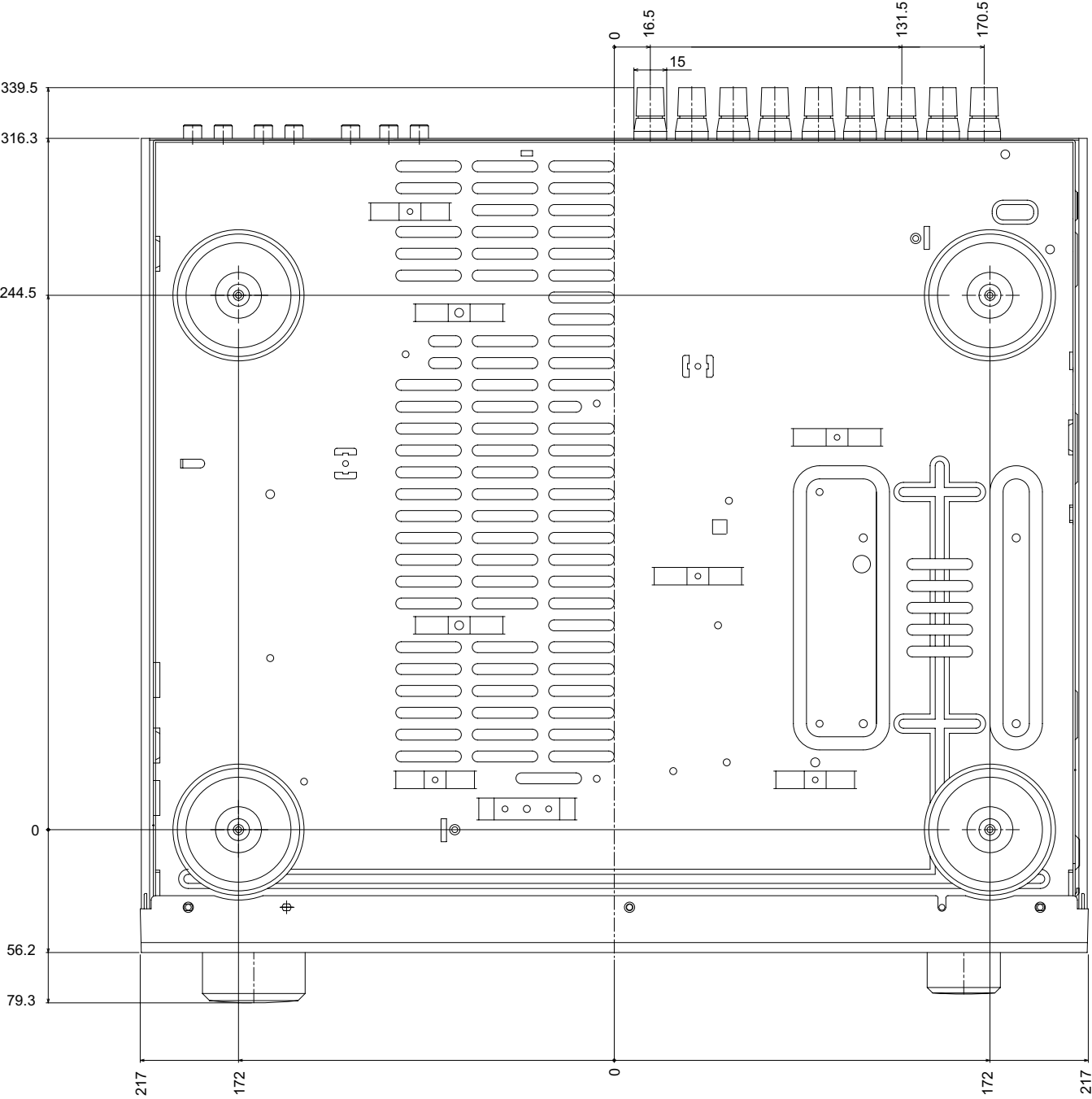

CAUTION IN SERVICING

Initializing AV SURROUND RECEIVER

AV SURROUND RECEIVER initialization should be performed when the μ com, peripheral parts of μ com, and Digital P.W.B. are replaced.

1. Switch off the unit.
2. Hold the following SPEAKERS-A button and SPEAKERS-B button, and switch on the unit.
3. Check that the entire display is flashing with an interval of about 1 second, and release your fingers from the 2 buttons and the microprocessor will be initialized.

Note: • If step 3 does not work, start over from step 1.
• All user settings will be lost and this factory setting will be recovered when this initialization mode.
So make sure to memorize your setting for restoring after the initialization.

サービス時の注意事項

AV サラウンドアンプの初期化について

マイコンやマイコン周辺部品、Digital 基板等を交換した場合は、AV サラウンドアンプの初期化を行って下さい。

1. オン/オフボタンを OFF にします。
2. SPEAKERS-A ボタンと SPEAKERS-B ボタンを同時に押しながら、オン/オフボタンを押して ON にします。
3. ディスプレイ表示が約 1 秒間隔で点滅するのを確認後、2 つのボタンから指を離します。
*マイコンが初期化されます。

注意: • 上記 3 の状態にならない場合は、もう一度操作 1 からやり直してください。
• 初期化を行うとお客様が設定した内容が工場出荷状態に戻りますので、あらかじめ設定内容を控えておき初期化後再設定してください。

ADJUSTMENT

Audio Section

Idling Current

Required measurement equipment: DC Voltmeter

1. Preparation

- (1) Avoid direct blow from an air conditioner or an electric fan, and adjust the unit at normal room temperature 15 °C ~ 30 °C (59 °F ~ 86 °F).
- (2) Presetting
 - POWER (Power source switch) OFF
 - SPEAKER (Speaker terminal) No load
(Do not connect speaker, dummy resistor, etc.)

2. Adjustment

- (1) Remove top cover and set VR101, VR102, VR103, VR104, VR105, on Amp. Unit, VR107SBL, 107SBR on SURR.-BACK ch Amp. Unit at fully counterclockwise (◯) position.
- (2) Connect DC Voltmeter to test points (FRONT-Lch: TP104, FRONT-Rch: TP105, CENTER ch: TP103, SURROUND-Lch: TP101, SURROUND-Rch: TP102, SURROUND-BACK Lch: TP106, SURROUND-BACK Rch: TP107).
- (3) Connect power cord to AC Line, and turn power switch "ON".
- (4) Presetting.
 MASTER VOLUME : "----" counterclockwise (◯ min.)
 MODE : 7CH STEREO
 FUNCTION : CD
- (5) Within 2 minutes after the power on, turn VR101 clockwise (◯) to adjust the TEST POINT voltage to 1.5 mV ± 0.5 mV DC.
- (6) After 10 minutes from the preset above, turn VR101 to set the voltage to 2.0 mV ± 0.5 mV DC.
- (7) Adjust the Variable Resistors of other channels in the same way.

調整

オーディオセクション

アイドリング電流の調整

調整に必要な測定器： DC Voltmeter

1. 準備

- (1) セットをクーラ、扇風機のそばなど風通しの良い場所を避け、通常の使用状態に置きます。セットの周囲温度は 15 ~ 30 °C、湿度は常湿とします。
- (2) プリセット
 - 電源スイッチ OFF
 - スピーカ端子 無負荷
(スピーカ・ダミー抵抗器などを接続しない。)

2. 調整

- (1) 上カバーをはずし、パワーアンプ基板の VR101, VR102, VR103, VR104, VR105 及び SURR.-BACK アンプ基板の VR107SBL, 107SBR を反時計方向 (◯) に回し切った状態にセットします。
- (2) テストポイント (FRONT-Lch: TP104, FRONT-Rch: TP105, CENTER ch: TP103, SURROUND-Lch: TP101, SURROUND-Rch: TP102, SURROUND-BACK Lch: TP106, SURROUND-BACK Rch: TP107) に DC Voltmeter を接続します。
- (3) 電源コードを AC100V (95 ~ 105V の範囲でも可) に接続し、電源スイッチを "ON" にします。
- (4) ON 後、次のようにセットします。
 - MASTER VOLUME (音量調節つまみ) → 反時計方向 (◯) に回す、最小の状態にする。
 - SPEAKER (スピーカ端子) → 無負荷 (スピーカ、ダミー抵抗器などを接続しない。)
 MODE : 7CH STEREO
 FUNCTION : CD
- (5) 2分以内に VR101 を時計方向 (◯) に回しテストポイントの電圧を次のように調整します。
1.5mV ± 0.5mV DC
- (6) 予備調整から 10分後 VR101 を回し、次のように電圧を設定します。
2.0mV ± 0.5mV DC
- (7) 同じ方法で各チャンネルの可変抵抗を調整します。

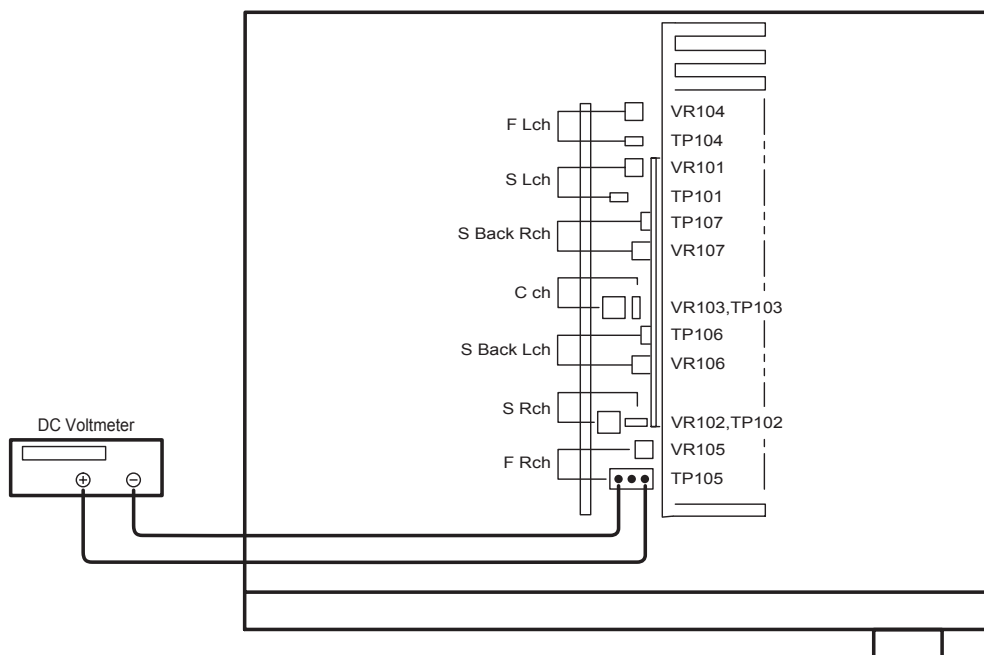

VIDEO Section (AVR-1707/687 ONLY)

1. SETTING

- (1) Connect the oscilloscope to the Y-signal and C-signal of S MONITOR OUT terminal and each terminate at 75 Ohms.
- (2) Connect the oscilloscope to the Y-signal, PB-signal and CB-signal, PR-signal and CR-signal of COMPONENT MONITOR OUT terminal and each terminate at 75 Ohms.
※ Use the 75 Ohms resistance must be 1%
- (3) DVD test disc : DVDT-S01
- (4) COMPOSITE VIDEO OUT of DVD player is connected to COMPOSITE : DVD.

2. BEFORE ADJUSTMENT

2.1. Setting the Oscilloscope as below.

- (1) PB/CB, PR/CR, C
 - (a) TIME/DIV : 10 μ s
 - (b) VOLT/DIV : 100mV
(Use the probe : x10)
- (2) Y (Py)
 - (a) TIME/DIV : 10 μ s
 - (b) VOLT/DIV : 200mV
(Use the probe : x10)

Power on. Power Supply

U.S.A. , Canada & Taiwan R.O.C. :	120V
Europe :	230V
Japan :	100V
China & Korea :	220V

2.2. Setup the DVD player and confirmation of the stators

- (1) Set to "INTERLACED" mode at the COMPONENT OUT.
- (2) Confirm the DVD player's out put level is equal as the item 2.4. in following.

2.3. Preparation

- (1) Turn the FUNCTION knob to select "DVD" input.
- (2) Push [OPEN/CLOSE] button of DVD player, then open the Disc Tray.
Set DVD test disc (DVDT-S01) on the Disc Tray, and then push [CLOSE] button.
- (3) DVD player FL display appear "STOP", push [PLAY] button to playback DVD.
- (4) Push the [DISPLAY] button of remote control of DVD player unit and then appear the ON-Screen Display (GUI) on the monitor TV.
- (5) Push the [+10] and [2] button, select Title 12 of DVD.
- (6) Push the [ENTER] button, playback Title 12.
(color bar 75%)

ビデオセクション (AVR-1707/687 のみ)

1. セッティング手順

- (1) セットの S MONITOR OUT 端子から Y 信号と C 信号をそれぞれオシロスコープ (終端抵抗 : 75 Ω) に接続します。
- (2) セットの COMPONENT MONITOR OUT の端子 (Y,PB/CB, PR/CR) をそれぞれオシロスコープ (終端抵抗 : 75 Ω) に接続します。
※ 75 Ω 抵抗は 1%品を使用する事。
- (3) DVD テストディスク : DVDT-S01 を用意します。
- (4) DVD プレーヤーの COMPOSITE VIDEO OUT を COMPOSITE : DVD に接続します。
- (5)

2. 調整のまえに

2.1. オシロスコープを下記に設定

- (1) PB/CB, PR/CR, C
 - (a) TIME/DIV : 10 μ s
 - (b) VOLT/DIV : 100mV
(プローブ x10 使用)
- (2) Y (Py)
 - (a) TIME/DIV : 10 μ s
 - (b) VOLT/DIV : 200mV
(プローブ x10 使用)

電源電圧

U.S.A. , Canada & Taiwan R.O.C. :	120V
Europe :	230V
Japan :	100V
China & Korea :	220V

2.2. DVD プレーヤーの設定と確認

- (1) COMPONENT OUT の設定を " インターレース " にします。
- (2) DVD プレーヤーの出力が以下 2.4. に合っていることを確認します。

2.3. 準備手順

- (1) FUNCTION ノブを回し、入力を "DVD" に切り替えます。
- (2) DVD プレーヤーの「OPEN/CLOSE」ボタンを押してトレイを開き、トレイ上に DVD テストディスク (DVDT-S01) をセット後、「CLOSE」ボタンを押します。
- (3) DVD プレーヤーの表示管上に "STOP" が表示されてから、「PLAY」ボタンを押し、ディスクを再生します。
- (4) DVD プレーヤーのリモコンの「DISPLAY」ボタンを押してグラフィカル・ユーザー・インターフェイス (GUI) 画面を出します。
- (5) 番号ボタンの「+10」,「2」ボタンを押し、Title 12 を選択します。
- (6) 「ENTER」ボタンを押し、Title 12 を再生します。
(75%カラーバー信号)

2.4. Procedure

(1) Adjust the signal of S MONITOR OUT by the wave of oscilloscope.

(a) Target, Y-signal

Point : C-S VIDEO 1 VR604
 Adjustment Value : 714 ± 14mV
 Waveform

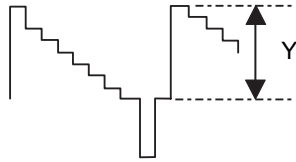

Y-signal of S MONITOR OUT

(b) Target, C-signal

Point : C-S VIDEO 1 VR605
 Adjustment Value : 286 ± 5mV
 Waveform

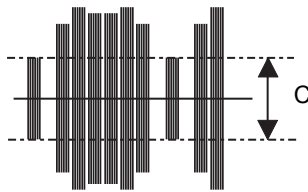

C-signal of S-MONITOR OUT

2.4. 手順

(1) セットの S MONITOR OUT の信号レベルをオシロスコープ上の波高値で調整します。

(a) Y 信号レベル

調整箇所 : C-S VIDEO 1 VR604
 調整値 : 714 ± 14mV
 波形

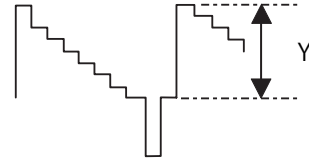

S MONITOR OUT の Y 信号レベル

(b) C 信号レベル

調整箇所 : C-S VIDEO 1 VR605
 調整値 : 286 ± 5mV
 波形

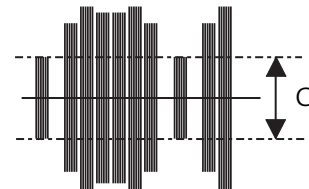

S-MONITOR OUT の C 信号レベル

(2) Adjust the signal of COMPONENT OUT by the wave of oscilloscope.

(a) Target, Y-signal

Point : C-S VIDEO 1 VR601
 Adjustment Value : 714 ± 14mV
 Waveform

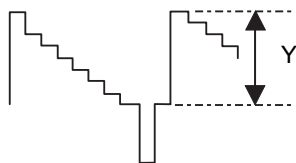

Y-signal COMPONENT OUT

(2) COMPONENT OUT の信号レベルをオシロスコープ上の波高値で調整します。

(a) Y 信号レベル

調整箇所 : C-S VIDEO 1 VR601
 調整値 : 714 ± 14mV
 波形

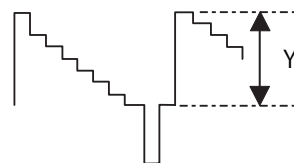

COMPONENT OUT の Y 信号レベル

(b) Target, Pb/Cb-signal

Point : C-S VIDEO 1 VR602
 Adjustment Value : *525 ± 10mV
 Waveform



Pb/Cb-signal COMPONENT OUT

(b) Pb/Cb 信号レベル

調整箇所 : C-S VIDEO 1 VR602
 調整値 : 525 ± 10mV
 波形

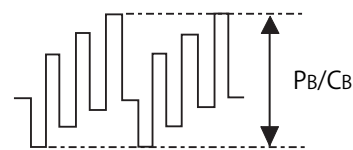

COMPONENT OUT の Pb/Cb 信号レベル

* : 486 ± 10mV for U.S.A. & Canada model

(c) Target, PR/CR-signal

Point : C-S VIDEO 1 VR603
 Adjustment Value : *525 ± 10mV
 Waveform

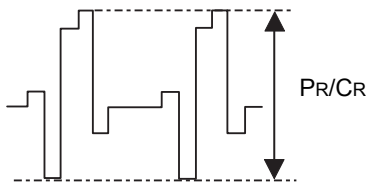

PR/CR-signal COMPONENT OUT

(c) PR/CR 信号レベル

調整個所 : C-S VIDEO 1 VR603
 調整値 : 525 ± 10mV
 波形

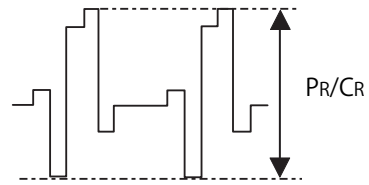

COMPONENT OUT の PR/CR 信号レベル

* : 486 ± 10mV for U.S.A. & Canada model

C-S VIDEO 1 UNIT

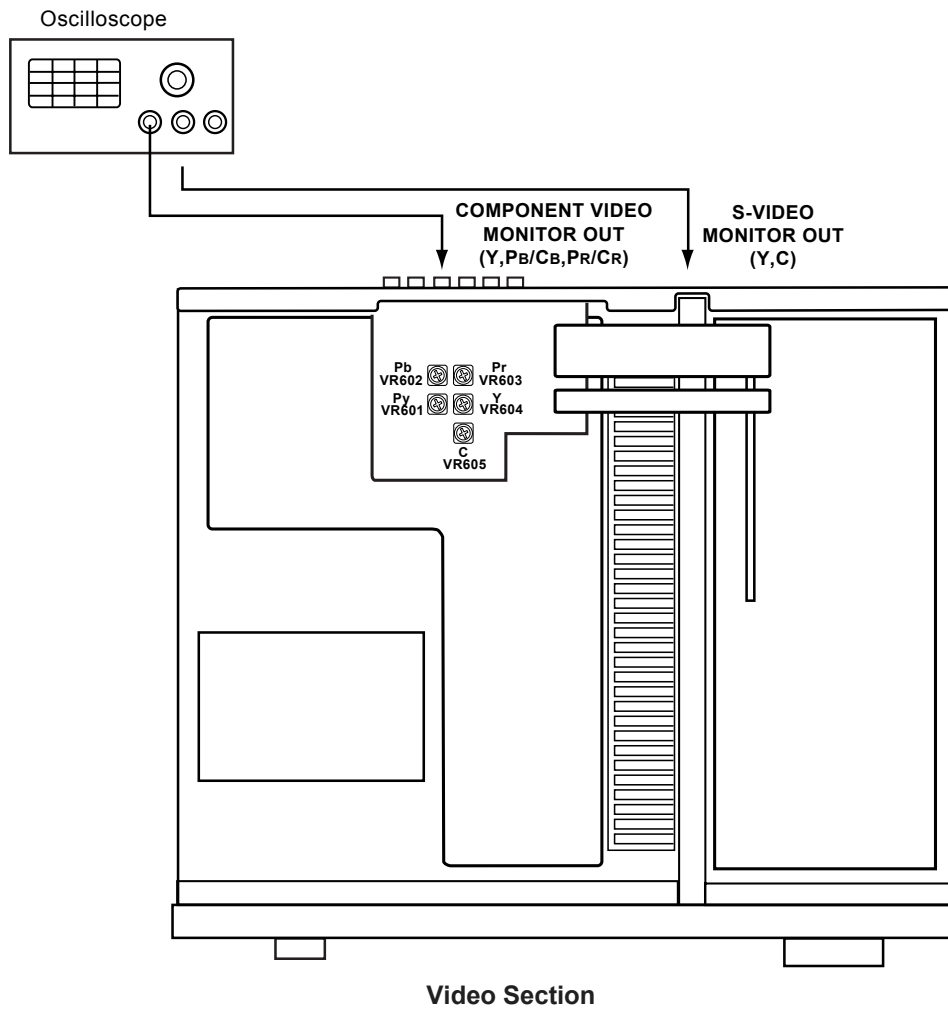

BLOCK DIAGRAM

AVR1507/1707 BLOCK DIAGRAM

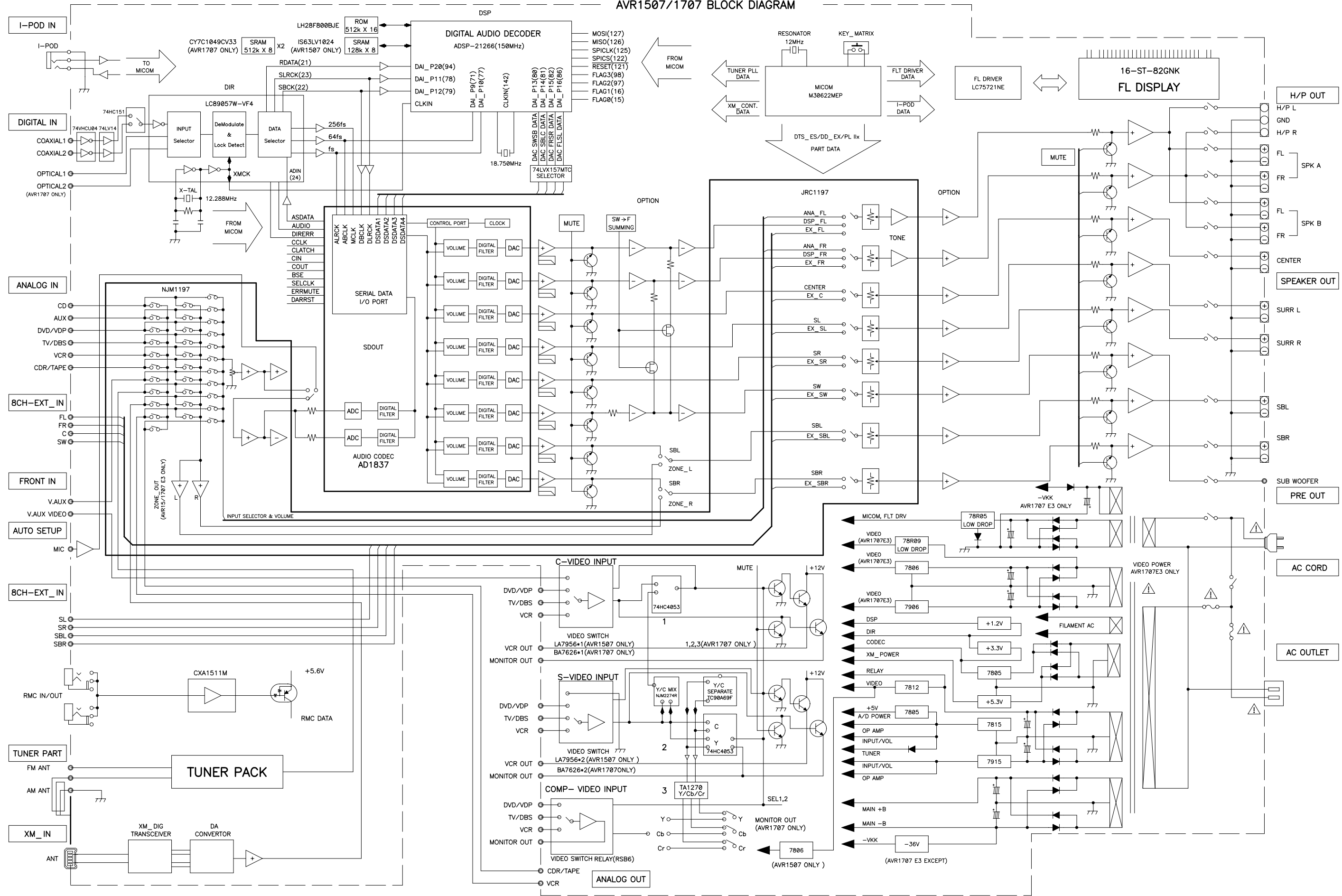

LEVEL DIAGRAMS (1/2)

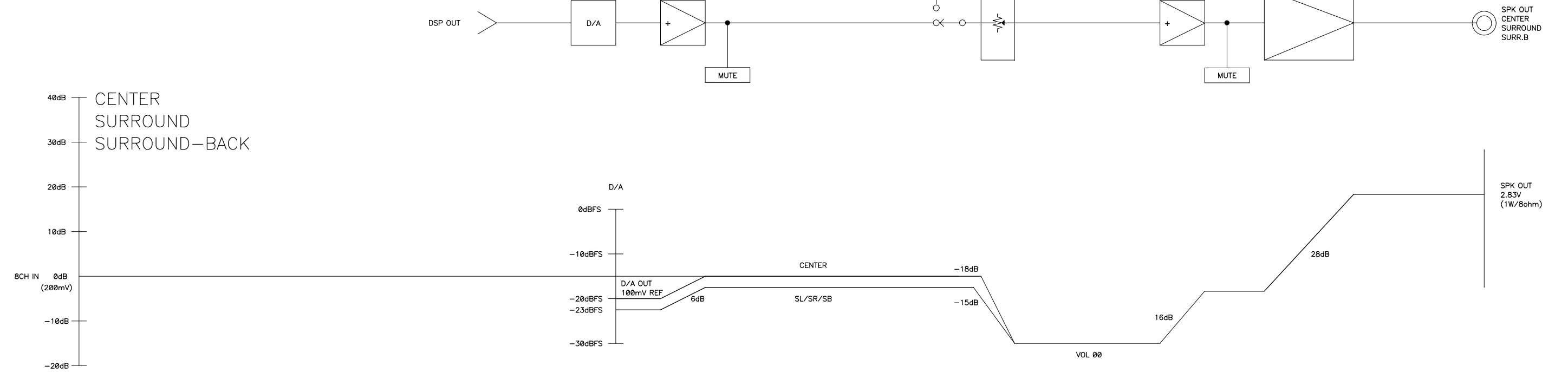
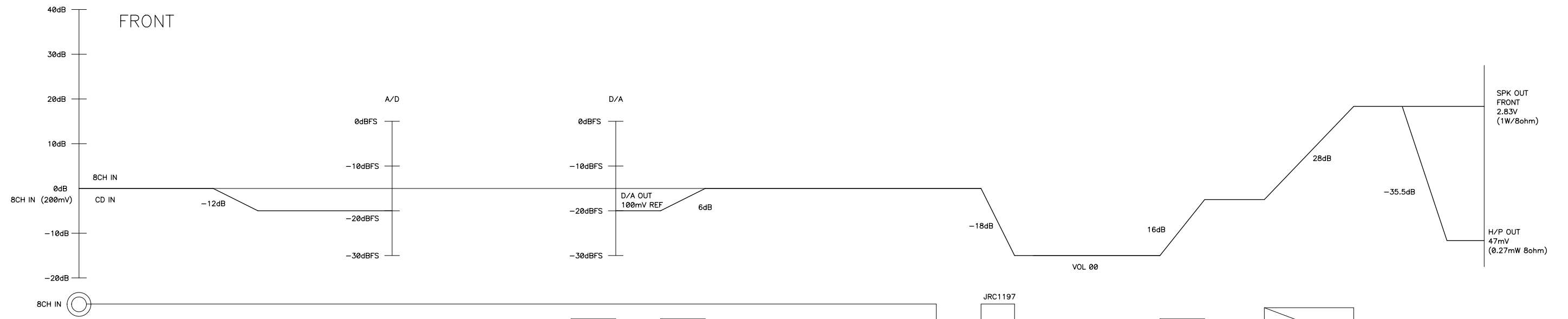
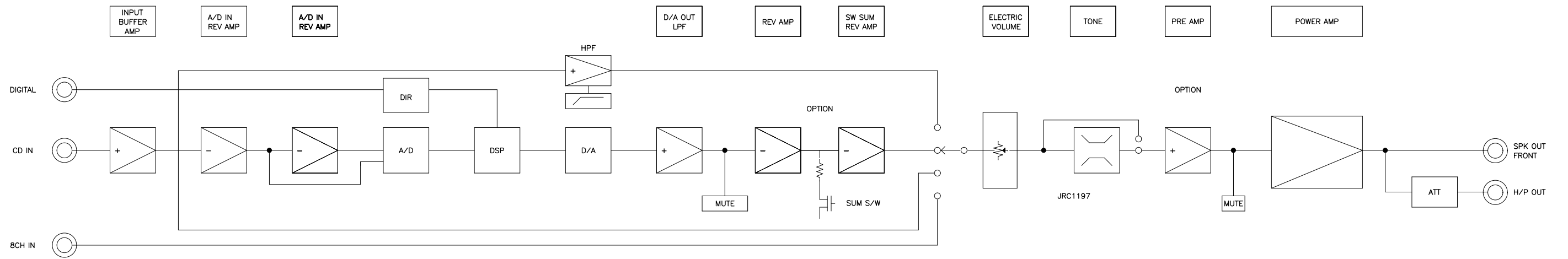

LEVEL DIAGRAMS (2/2)

SUB_WOOFER

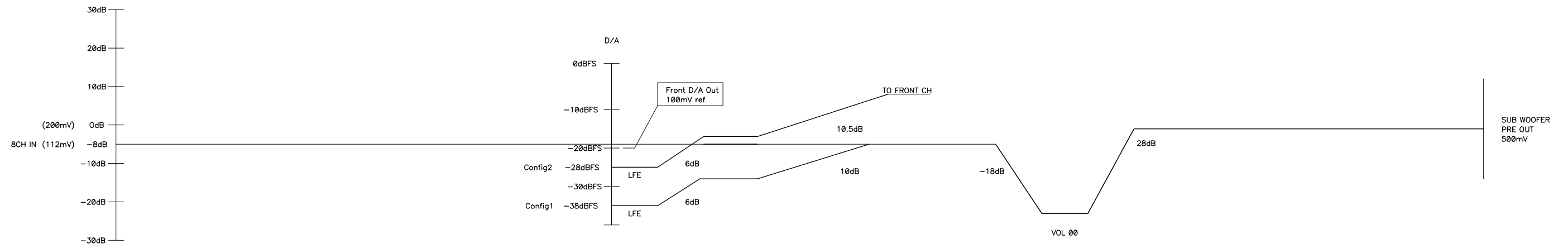
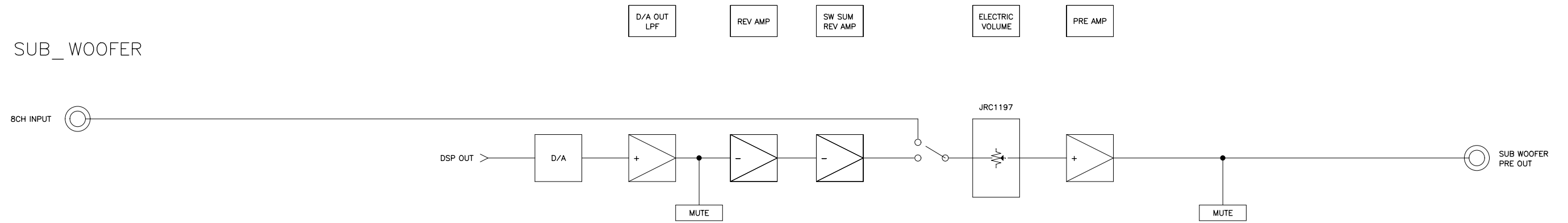

SEMICONDUCTORS

Only major semiconductors are shown, general semiconductors etc. are omitted to list.
 主な半導体を記載しています。汎用の半導体は記載を省略しています。

1. IC's

M30622MEP (IC201)

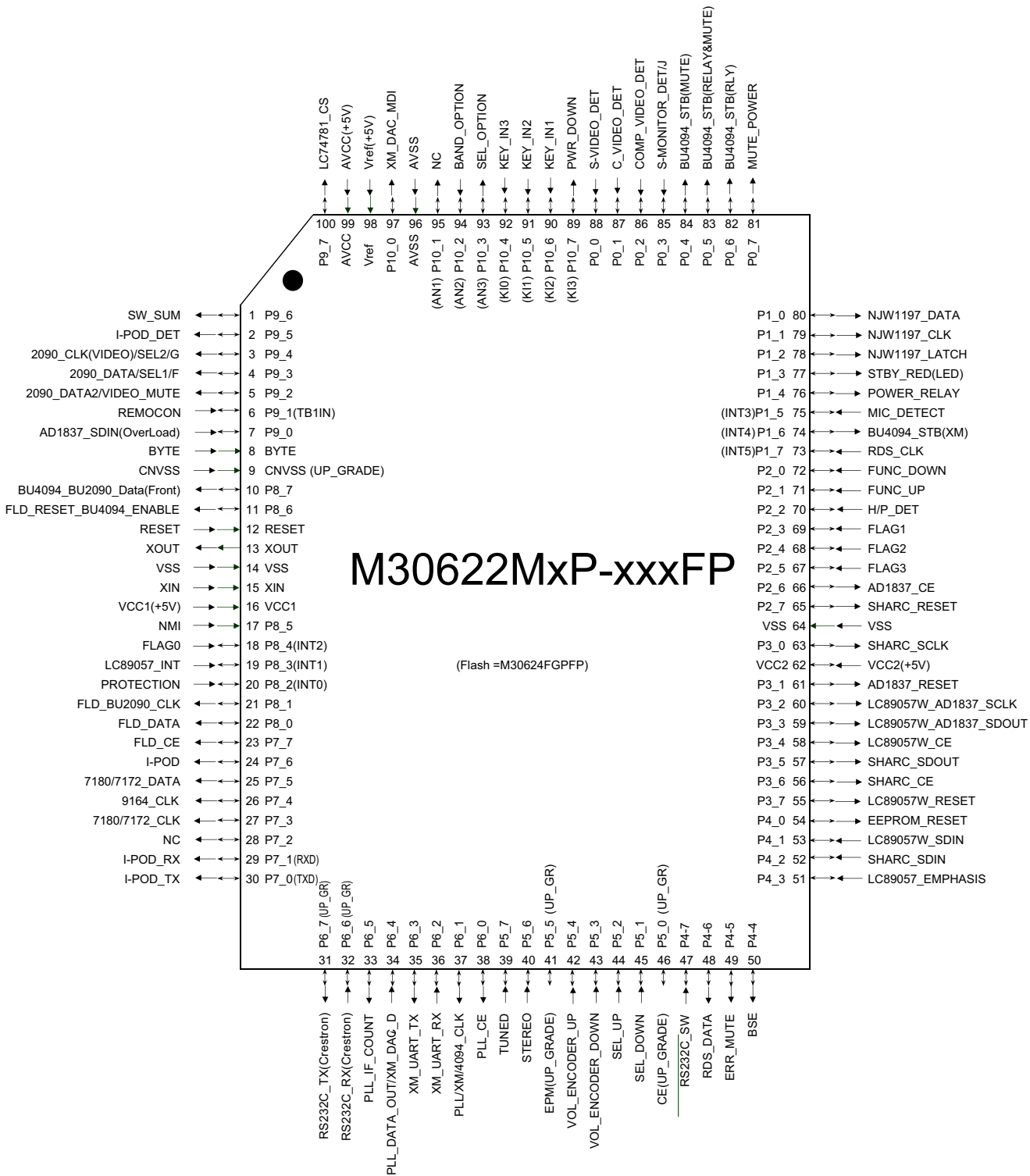

M30622MEP Terminal Function

Pin No.	Pin Name	I/O/T	Pin Function
1	P9_6	O	SW_SUM
2	P9_5	O	I-POD DET
3	P9_4	O	BU209CLK(VIDEO)/SEL2/G
4	P9_3	O	BU2090Data/SEL1/F
5	P9_2	O	BU2090DATA2/VIDEO_MUTE
6	P9_1(TB1IN)	I	REMOCON
7	P9_0	I	AD1837_SDIN(OverLoad)
8	BYTE	I	BYTE
9	CNVSS(UP_GRADE)	I	CNVSS
10	P8_7	O	BU4094_BU2090_Data(Front)
11	P8_6	O	FLD_RESET_BU4094_ENABLE
12	RESET	I	RESET
13	XOUT	O	XOUT
14	VSS	I	VSS
15	XIN	I	XIN
16	VCC1	I	VCC1(+5V)
17	P8_5	I	NMI
18	P8_4(INT2)	I	FLAG0
19	P8_3(INT1)	I	LC89057_INT
20	P8_2(INT0)	I	PROTECTION
21	P8_1	O	FLD_BU2090_CLK
22	P8_0	O	FLD_DATA
23	P7_7	O	FLD_CE
24	P7_6	O	I-POD ??PIN
25	P7_5	O	7180/7172_DATA
26	P7_4	O	TC9273/9164_CLK
27	P7_3	O	7180/7172_CLK
28	P7_2	O	NC
29	P7_1(RXD)	I	I-POD RX
30	P7_0(TXD)	O	I-POD TX
31	P6_7(UP_GRADE)	O	RS232C_TX(Crestron)
32	P6_6(UP_GRADE)	I	RS232C_RX(Crestron)
33	P6_5	I	PLL_IF_COUNT
34	P6_4	O	PLL_DATA OUT/XM_DAC_DATA
35	P6_3	O	XM_UART_TX
36	P6_2	I	XM_UART_RX
37	P6_1	O	PLL_CLK/XM_DAC_CLK/BU4094_CLK
38	P6_0	O	PLL_CE
39	P5_7	I	TUNED
40	P5_6	I	STEREO
41	P5_5(UP_GRADE)		
42	P5_4	I	VOL_ENCODER_UP
43	P5_3	I	VOL_ENCODER_DOWN
44	P5_2	I	SEL_UP
45	P5_1	I	SEL_DOWN
46	P5_0(UP_GRADE)		
47	P4-7	O	RS232C_SW
48	P4-6	I	RDS_DATA
49	P4-5	O	ERR_MUTE
50	P4-4	O	BSE
51	P4_3	I	LC89057_EMPHASIS
52	P4_2	I	SHARC_SDIN
53	P4_1	I	LC89057W_SDIN
54	P4_0	O	EEPROM_RESET
55	P3_7	O	LC89057W_RESET

Pin No.	Pin Name	I/O/T	Pin Function
56	P3_6	O	SHARC_CE
57	P3_5	O	SHARC_SDOOUT
58	P3_4	O	LC89057W_CE
59	P3_3	O	LC89057W_AD1837_SDOOUT
60	P3_2	O	LC89057W_AD1837_SCLK
61	P3_1	O	AD1837_RESET
62	VCC2	I	VCC2(+5V)
63	P3_0	O	SHARC_SCLK
64	VSS	I	VSS
65	P2_7	O	SHARC_RESET
66	P2_6	O	AD1837_CE
67	P2_5	I	FLAG3
68	P2_4	I	FLAG2
69	P2_3	I	FLAG1
70	P2_2	I	H/P_DET
71	P2_1	I	FUNC_ENCODER_UP
72	P2_0	I	FUNC_ENCODER_DOWN
73	(INT5)P1_7	I	RDS_CLOCK
74	(INT4)P1_6	O	4094_STB(XM)
75	(INT3)P1_5	I	MIC_DETECT
76	P1_4	O	POWER_RELAY
77	P1_3	O	STBY_RED_LED
78	P1_2	O	1197_LATCH
79	P1_1	O	1197_CLK
80	P1_0	O	1197_DATA
81	P0_7	O	MUTE_POWER
82	P0_6	O	4094_STB(RLY)
83	P0_5	O	4094_STB(RLY/MUTE)
84	P0_4	O	4094_STB(MUTE)
85	P0_3	I	S-MONITOR_DET
86	P0_2	I	COMPONENT_DET
87	P0_1	I	COMPOSITE_DET
88	P0_0	I	S-VIDEO_DET
89	(KI3)P10_7	I	POWER_DOWN
90	(KI2)P10_6	I	KEY_IN1
91	(KI1)P10_5	I	KEY_IN2
92	(KI0)P10_4	I	KEY_IN3
93	(AN3)P10_3	I	SET_OPTION
94	(AN2)P10_2	I	BAND_OPTION
95	(AN1)P10_1	O	NC
96	AVSS	I	AVSS
97	P10_0	O	XM_DAC_MDI
98	Vref	I	Vref(+5V)
99	AVCC	I	AVCC(+5V)
100	P9_7	O	74781_CS

NJW1197 (IC701)

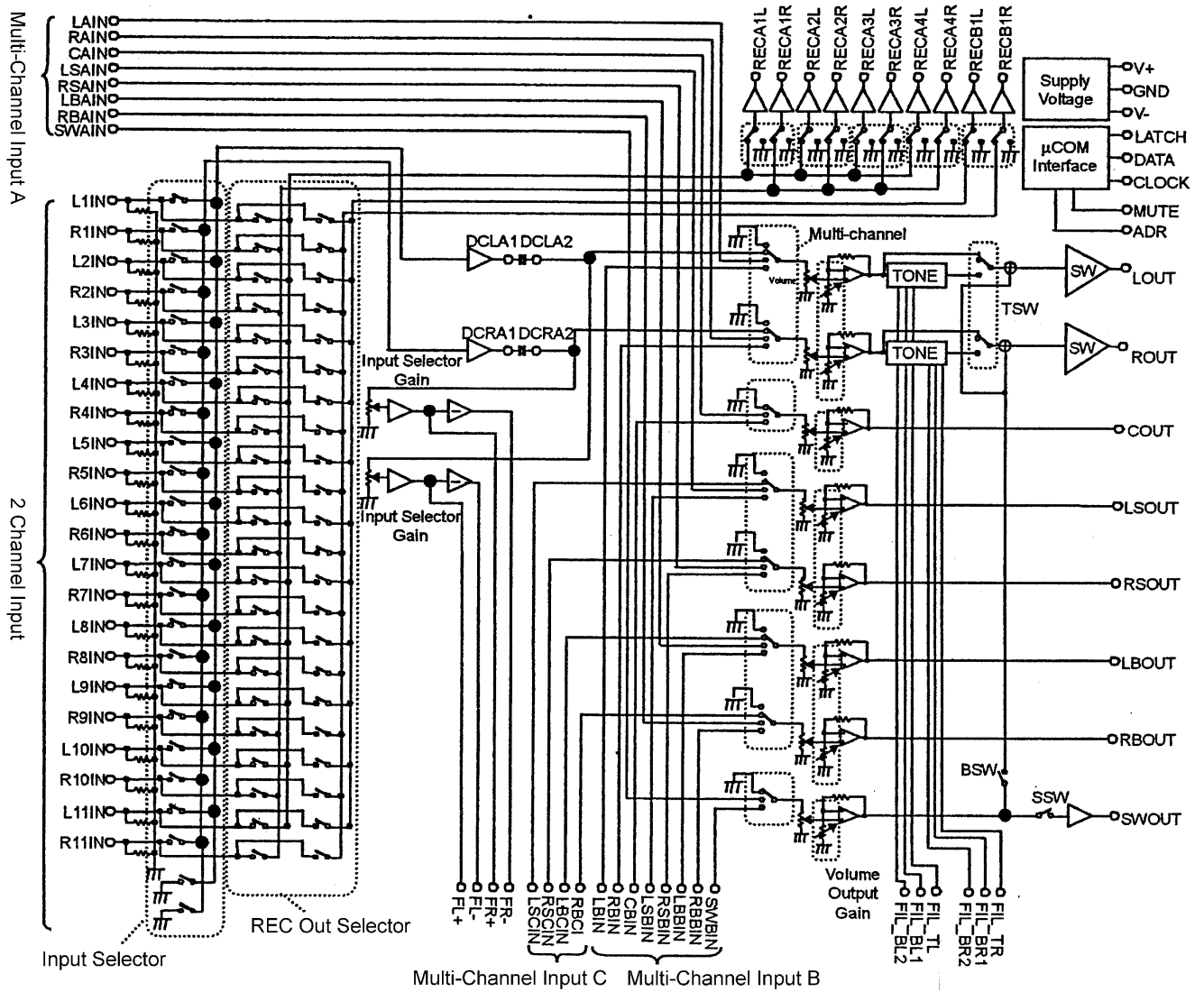
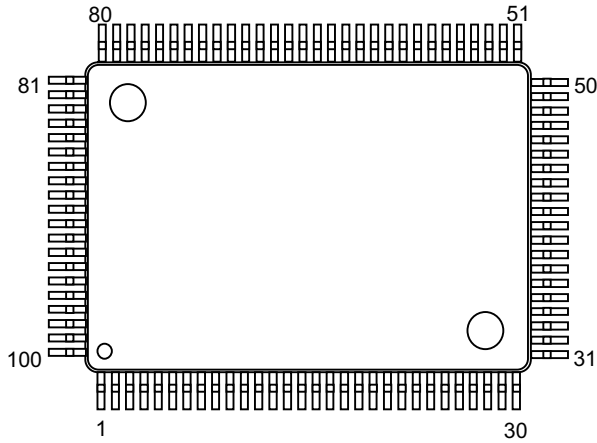

NJW1197 Terminal Function

No.	SYMBOL	FUNCTION	No.	SYMBOL	FUNCTION
1	ROUT	Rch output	51	DCR_IN	Multi-channel selector Rch input
2	COUT	Cch output	52	DCR_OUT	Input selector Rch output
3	LSOUT	LSch output	53	GND	Ground
4	RSOUT	RSch output	54	DCL_IN	Multi-channel selector Lch input
5	LBOUT	LBch output	55	DCL_OUT	Input selector Lch output
6	RBOUT	RBch output	56	GND	Ground
7	SWOUT	SWch output	57	REC_B1R	Input selector Rch REC output B1
8	GND	Ground	58	REC_B1L	Input selector Lch REC output B1
9	FIL_BL2	Lch Bass filter terminal 2	59	REC_A4R	Input selector Rch REC output A4
10	FIL_BL1	Lch Bass filter terminal 1	60	REC_A4L	Input selector Lch REC output A4
11	FIL_TL	Lch Treble filter terminal	61	REC_A3R	Input selector Rch REC output A3
12	TCAP	Switching noise rejection capacitor	62	REC_A3L	Input selector Lch REC output A3
13	FIL_BR2	Rch Bass filter terminal 2	63	REC_A2R	Input selector Rch REC output A2
14	FIL_BR1	Rch Bass filter terminal 1	64	REC_A2L	Input selector Lch REC output A2
15	FIL_TR	Rch Treble filter terminal	65	REC_A1R	Input selector Rch REC output A1
16	V+	+ Power supply voltage input	66	REC_A1L	Input selector Lch REC output A1
17	ADR	Chip address select input	67	VDDOUT	Internal Digital +Power Supply Output
18	V-	- Power supply voltage input	68	DATA	Control data signal input
19	L1IN	Input selector Lch input 1	69	CLOCK	Clock signal input
20	DCCAP_SW	Switching noise rejection capacitor	70	LATCH	Latch signal input
21	R1IN	Input selector Rch input 1	71	MUTE	External Mute control
22	DCCAP_RB	Switching noise rejection capacitor	72	FL+	Input selector gain control Lch no-inverted output
23	L2IN	Input selector Lch input 2	73	FL-	Input selector gain control Lch inverted output
24	DCCAP_LB	Switching noise rejection capacitor	74	FR+	Input selector gain control Rch no-inverted output
25	R2IN	Input selector Rch input 2	75	FR-	Input selector gain control Rch inverted output
26	DCCAP_RS	Switching noise rejection capacitor	76	GND	Ground
27	L3IN	Input selector Lch input 3	77	LSCIN	Multi-channel LSch input C
28	DCCAP_LS	Switching noise rejection capacitor	78	RSCIN	Multi-channel RSch input C
29	R3IN	Input selector Rch input 3	79	LBCIN	Multi-channel LBch input C
30	DCCAP_C	Switching noise rejection capacitor	80	RBCIN	Multi-channel RBch input C
31	L4IN	Input selector Lch input 4	81	GND	Ground
32	DCCAP_R	Switching noise rejection capacitor	82	LAIN	Multi-channel Lch input A
33	R4IN	Input selector Rch input 4	83	RAIN	Multi-channel Rch input A
34	DCCAP_L	Switching noise rejection capacitor	84	CAIN	Multi-channel Cch input A
35	L5IN	Input selector Lch input 5	85	LSAIN	Multi-channel LSch input A
36	GND	Ground	86	RSAIN	Multi-channel RSch input A
37	R5IN	Input selector Rch input 5	87	LBAIN	Multi-channel LBch input A
38	GND	Ground	88	RBAIN	Multi-channel RBch input A
39	L6IN	Input selector Lch input 6	89	SWAIN	Multi-channel SWch input A
40	L9IN	Input selector Lch input 9	90	GND	Ground
41	R6IN	Input selector Rch input 6	91	LBIN	Multi-channel Lch input B
42	R9IN	Input selector Rch input 9	92	RBIN	Multi-channel Rch input B
43	L7IN	Input selector Lch input 7	93	CBIN	Multi-channel Cch input B
44	L10IN	Input selector Lch input 10	94	LSBIN	Multi-channel LSch input B
45	R7IN	Input selector Rch input 7	95	RSBIN	Multi-channel RSch input B
46	R10IN	Input selector Rch input 10	96	LBBIN	Multi-channel LBch input B
47	L8IN	Input selector Lch input 8	97	RBBIN	Multi-channel RBch input B
48	L11IN	Input selector Lch input 11	98	SWBIN	Multi-channel SWch input B
49	R8IN	Input selector Rch input 8	99	GND	Ground
50	R11IN	Input selector Rch input 11	100	LOUT	Lch output

ADSP21266SKSTZ-1B (IC804)

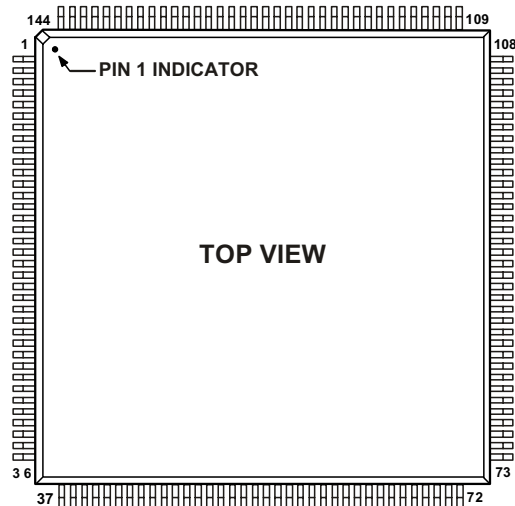

ADSP21266SKSTZ-1B Terminal Function

Pin Name	LQFP Pin #	Pin Name	LQFP Pin #	Pin Name	LQFP Pin #	Pin Name	LQFP Pin #
V _{DDINT}	1	V _{DDINT}	37	V _{DDEXT}	73	GND	109
CLKCFG0	2	GND	38	GND	74	V _{DDINT}	110
CLKCFG1	3	\overline{RD}	39	V _{DDINT}	75	GND	111
BOOTCFG0	4	ALE	40	GND	76	V _{DDINT}	112
BOOTCFG1	5	AD15	41	DAI_P10 (SD2B)	77	GND	113
GND	6	AD14	42	DAI_P11 (SD3A)	78	V _{DDINT}	114
V _{DDEXT}	7	AD13	43	DAI_P12 (SD3B)	79	GND	115
GND	8	GND	44	DAI_P13 (SCLK23)	80	V _{DDEXT}	116
V _{DDINT}	9	V _{DDEXT}	45	DAI_P14 (SFS23)	81	GND	117
GND	10	AD12	46	DAI_P15 (SD4A)	82	V _{DDINT}	118
V _{DDINT}	11	V _{DDINT}	47	V _{DDINT}	83	GND	119
GND	12	GND	48	GND	84	V _{DDINT}	120
V _{DDINT}	13	AD11	49	GND	85	<u>RESET</u>	121
GND	14	AD10	50	DAI_P16 (SD4B)	86	<u>SPIDS</u>	122
FLAG0	15	AD9	51	DAI_P17 (SD5A)	87	GND	123
FLAG1	16	AD8	52	DAI_P18 (SD5B)	88	V _{DDINT}	124
AD7	17	DAI_P1 (SD0A)	53	DAI_P19 (SCLK45)	89	SPICLK	125
GND	18	V _{DDINT}	54	V _{DDINT}	90	MISO	126
V _{DDINT}	19	GND	55	GND	91	MOSI	127
GND	20	DAI_P2 (SD0B)	56	GND	92	GND	128
V _{DDEXT}	21	DAI_P3 (SCLK0)	57	V _{DDEXT}	93	V _{DDINT}	129
GND	22	GND	58	DAI_P20 (SFS45)	94	V _{DDEXT}	130
V _{DDINT}	23	V _{DDEXT}	59	GND	95	A _{VDD}	131
AD6	24	V _{DDINT}	60	V _{DDINT}	96	A _{VSS}	132
AD5	25	GND	61	FLAG2	97	GND	133
AD4	26	DAI_P4 (SFS0)	62	FLAG3	98	CLKOUT	134
V _{DDINT}	27	DAI_P5 (SD1A)	63	V _{DDINT}	99	EMU	135
GND	28	DAI_P6 (SD1B)	64	GND	100	TDO	136
AD3	29	DAI_P7 (SCLK1)	65	V _{DDINT}	101	TDI	137
AD2	30	V _{DDINT}	66	GND	102	TRST	138
V _{DDEXT}	31	GND	67	V _{DDINT}	103	TCK	139
GND	32	V _{DDINT}	68	GND	104	TMS	140
AD1	33	GND	69	V _{DDINT}	105	GND	141
AD0	34	DAI_P8 (SFS1)	70	GND	106	CLKIN	142
\overline{WR}	35	DAI_P9 (SD2A)	71	V _{DDINT}	107	XTAL	143
V _{DDINT}	36	V _{DDINT}	72	V _{DDINT}	108	V _{DDEXT}	144

LC89057W (IC807)

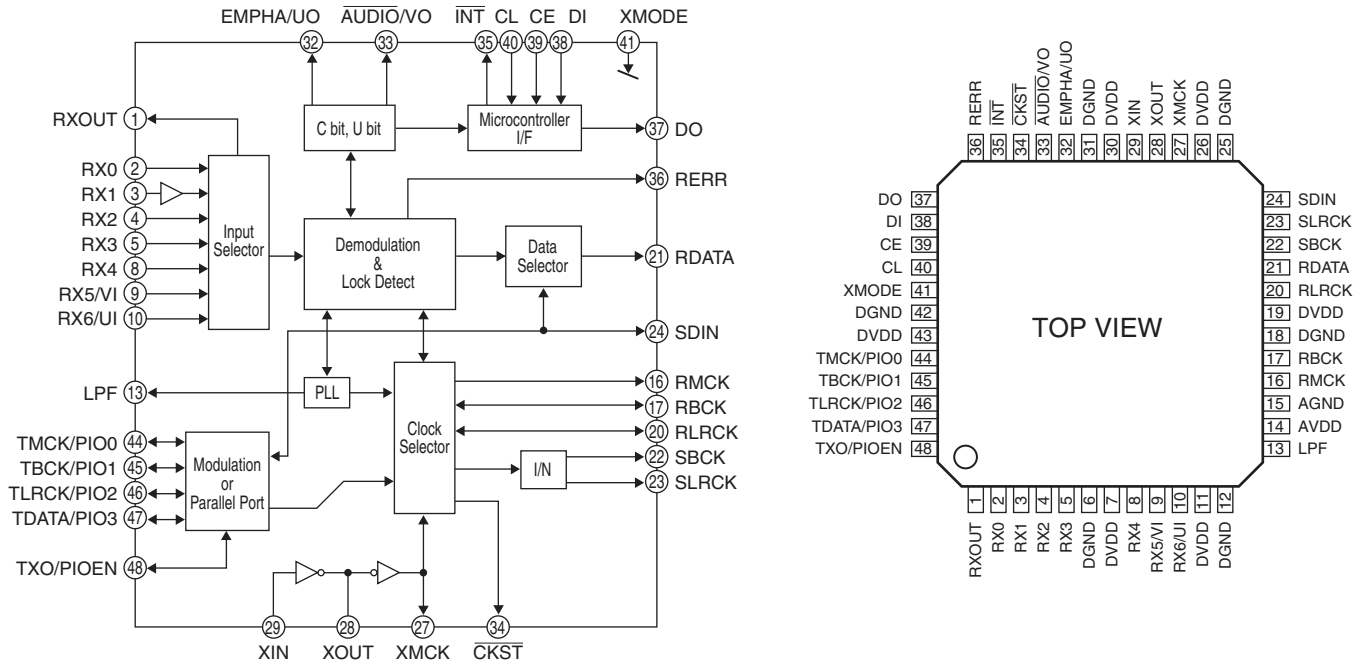

LC89057W Terminal Function

Pin No.	Pin Name	I/O	Function
1	RXOUT	O	Input bi-phase select data output terminal
2	RX0	I	TTL compatible digital data input terminal
3	RX1	I	Coaxial compatible amp built-in digital data input terminal
4	RX2	I	TTL compatible digital data input terminal
5	RX3	I	TTL compatible digital data input terminal
6	DGND	—	Digital GND
7	DVDD	—	Digital power
8	RX4	I	TTL compatible digital data input terminal
9	RX5/VI	I	TTL compatible digital data/Validity flag input terminal for modulation
10	RX6/UI	I	TTL compatible digital data/User data input terminal for modulation
11	DVDD	—	Digital power for PLL
12	DGND	—	Digital GND for PLL
13	LRF	O	PLL loop filter connecting terminal
14	AVDD	—	Analog power for PLL
15	AGND	—	Analog GND for PLL
16	RMCK	O	RMCK clock output terminal (256fs, 512fs, XIN, VCO)
17	RBCK	O/I	RBCK clock in/output terminal (64fs)
18	DGND	—	Digital GND
19	DVDD	—	Digital power
20	RLRCK	O/I	RLRCK clock in/output terminal (fs)
21	RDATA	O	Serial audio data output terminal
22	SBCK	O	SBCK clock output terminal (32fs, 64fs, 128fs)
23	SLRCK	O	SLRCK clock output terminal (fs/2, fs, 2fs)
24	SDIN	I	Serial audio data input terminal
25	DGND	—	Digital GND
26	DVDD	—	Digital power
27	XMCK	O	Osc. amp output terminal

Pin No.	Pin Name	I/O	Function
28	XOUT	O	X'tal osc. connecting output terminal
29	XIN	I	X'tal osc. connection, external clock input terminal (24.576MHz or 12.288MHz)
30	DVDD	—	Digital power
31	DGND	—	Digital GND
32	EMPHA/UO	I/O	Emphasis information/U-data output/Chip address setting terminal
33	AUDIO/VO	I/O	Non-PCM detect/V-flag output/ Chip address setting terminal
34	CKST	I/O	Clock switch transition period output/Demodulation master or slave function switching terminal
35	INT	I/O	Interrupt output for μ com (Interrupt factor selectable)/Modulation or general I/O switching terminal
36	RERR	O	PLL lock error, data error flag output
37	DO	O	μ com I/F, read out data output terminal (3-state)
38	DI	I	μ com I/F, write data input terminal
39	CE	I	μ com I/F, chip enable input terminal
40	CL	I	μ com I/F, clock input terminal
41	XMODE	I	System reset input terminal
42	DGND	—	Digital GND
43	DVDD	—	Digital power
44	TMCK/PIO0	I/O	256fs system clock input for modulation/General I/O in/output terminal
45	TBCK/PIO1	I/O	64fs bit clock input for modulation/General I/O in/output terminal
46	TLRCK/PIO2	I/O	fs clock input for modulation/General I/O in/output terminal
47	TDATA/PIO3	I/O	Serial audio data input for modulation/General I/O in/output terminal
48	TXO/PIOEN	O/I	Modulation data output/ General I/O enable input terminal

* For latch-up countermeasure, perform each power supply ON/OFF in the same timing.

LC75721E (IC301)

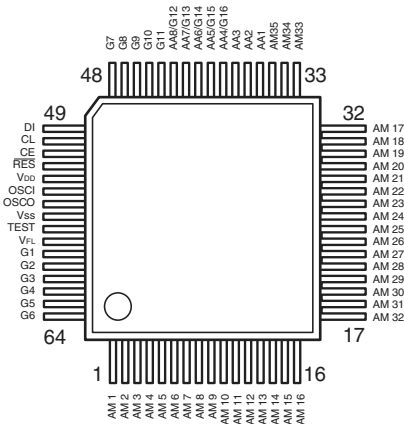

LC75721E Terminal Function

Symbol	Function
V _{DD}	Power terminal +5V
V _{SS}	Power terminal GND
V _{FL}	Power terminal FL drive
DI	Serial data transfer terminal
CL	DI: Data
CE	CL: Clock
	CE: Chip enable
OSC1	External CR connecting terminal
OSC0	External CR connecting terminal
RES	System reset terminal
AM1~AM35	Anode output terminal
AA1~AA3	Anode/Grid output terminal
AA4/G16	Anode/Grid output terminal
AA5/G15	Anode/Grid output terminal
AA6/G14	Anode/Grid output terminal
AA7/G13	Anode/Grid output terminal
AA8/G12	Anode/Grid output terminal
G1~G11	Grid output terminal
TEST	LSI test terminal

BU2090F (IC302,1005,1008)

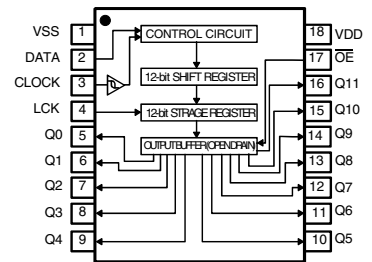

MM74LCX244 (IC809-811)

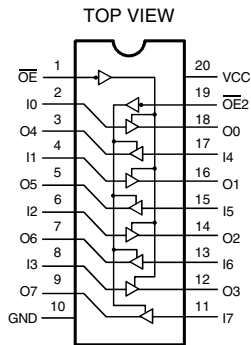

AD1837AAS (IC808)

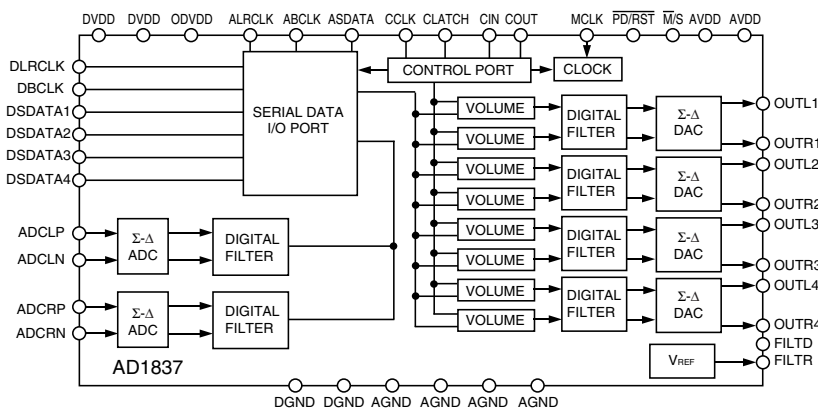
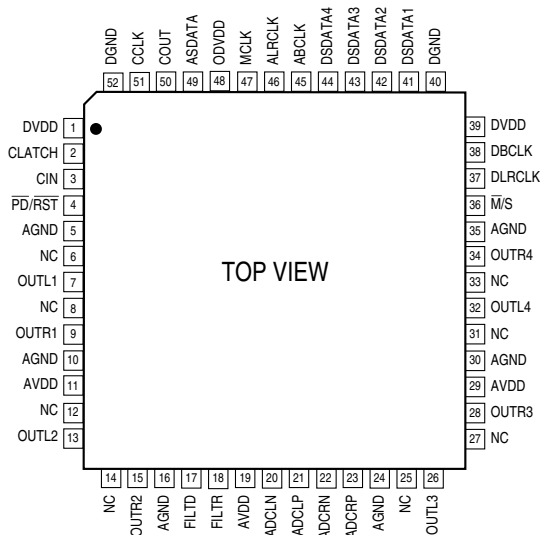

AD1837 Terminal Function

Pin No.	Pin Name	Input/Output	Description
1,39	DVDD		Digital Power Supply. Connect to digital 5V supply.
2	CLATCH	I	Latch Input for Control Data
33	CIN	I	Serial Control Input
4	PD/RST	I	Power-Down/Reset
5,10,16,24,30,35	AGND		Analog Ground
6,12,25,31	NC		Not connected
7,13,26,32	OUTLx	O	DACx Left Channel Output
8,14,27,33	NC		Not connected
9,15,28,34	OUTRx	O	DACx Right Channel Output
11,19,29	AVDD		Analog Power Supply. Connect to analog 5V supply.
17	FILTD		Filter Capacitor Connection. Recommend 10μF/100nF.
18	FILTR		Reference Filter Capacitor Connection. Recommended 10μF/100nF.
20	ADCLN	I	ADC Left Channel Negative Input
21	ADCLP	I	ADC Left Channel Positive Input
22	ADCRN	I	ADC Right Channel Negative Input
23	ADCRP	I	ADC Right Channel Positive Input
36	M/S	I	ADC Master/Slave Select
37	DLRCLK	I/O	DAC LR Clock
38	DBCLK	I/O	DAC Bit Clock
40,52	DGND		Digital Ground
41-44	DSDATAx	I	DACx Input Data (Left and Right Supply)
45	ABCLK	I/O	ADC Bit Clock
46	ALRCLK	I/O	ADC LR Clock
47	MCLK	I	Master Clock Input
48	ADVDD		Digital Output Driver Power Supply
49	ASDATA	O	ADC Serial Data Output
50	COUT	O	Output for Control Data
51	CCLK	I	Control Clock Input for Control Data

BA7626 (IC1004,1016,1019 : for AVR1707/687 model)
(IC652,653 : for AVR1507/487 model)
BA7625 (IC651 : for AVR1507/487 model)

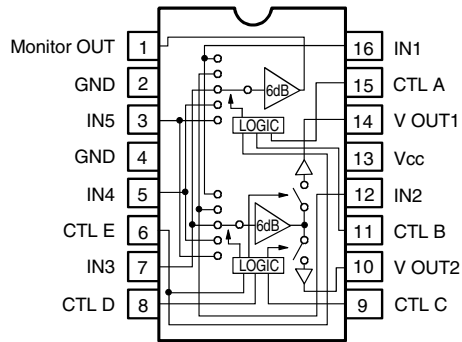

A	B	E	MONITOR OUT
L	L	*	IN 1
H	L	*	IN 2
L	H	*	IN 3
H	H	L	IN 4
H	H	H	IN 5

C	D	E	V OUT 1
L	L	*	—
H	L	*	IN 2
L	H	*	IN 3
H	H	L	IN 4
H	H	H	IN 5

C	D	E	V OUT 2
L	L	*	IN 1
H	L	*	—
L	H	*	IN 3
H	H	L	IN 4
H	H	H	IN 5

Note 1: * mark means that feasible for either H or L.
 Note 2: Each input terminal is provided with sink chip clamp (BA7625).
 Each input terminal takes 20kohm at the end (BA7626).

74LVX157MTC (IC816)

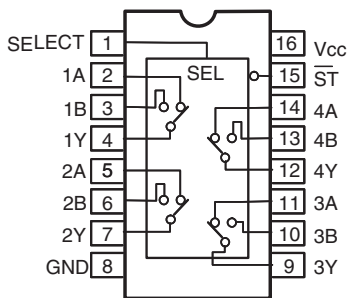

BA4510F (IC815A,816A)

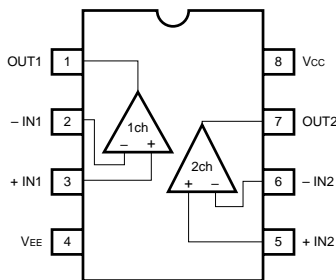

BU4094BCF (IC551,552)

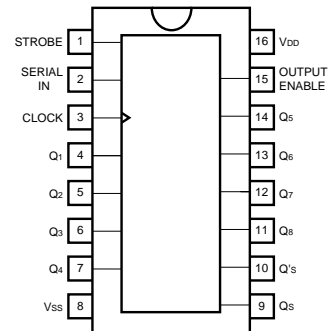

MM74HCT244 (IC812)

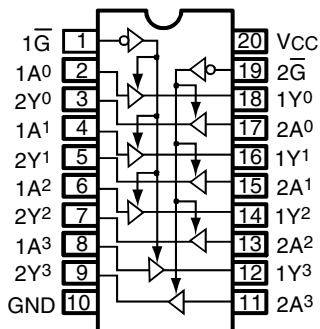

FAN1117-1.2 (IC824)
RC1117-33 (IC823)

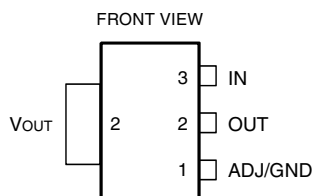

LH28F800BJE (IC805)

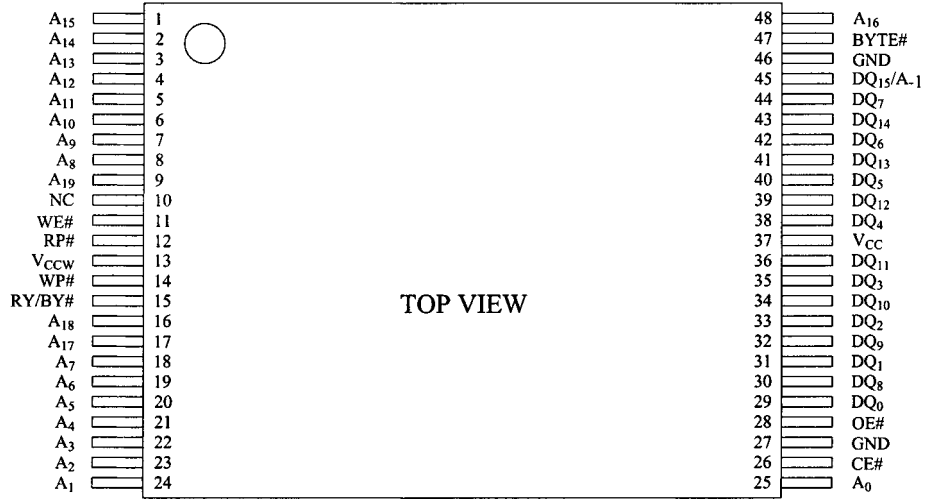

SN74LV573APWR (IC818,819)

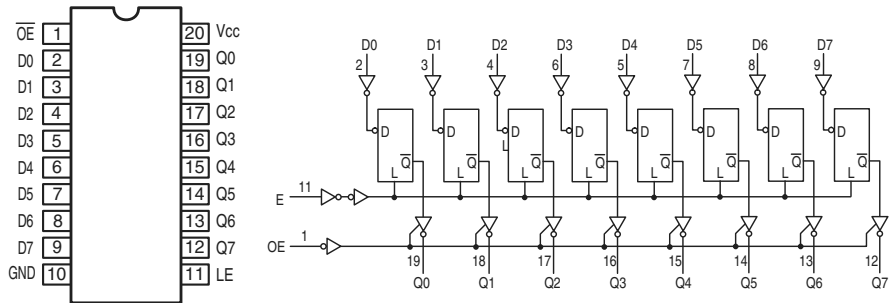

SN74LVC139APWR (IC820)

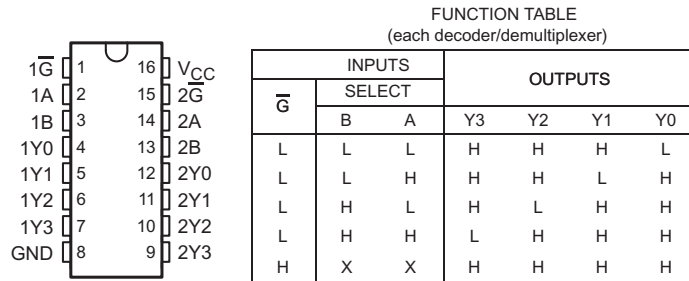

SN74LV14APWR (IC829)

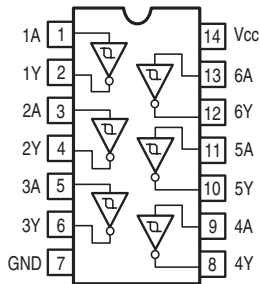

MM74HCT00MTCX (IC814,815)

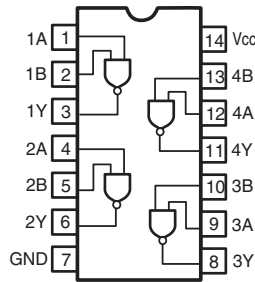

**AS7C34096A-10TCN (IC806,817 : for AVR-1707/687 model)
(IC817 : for AVR-1507 E2 model)**

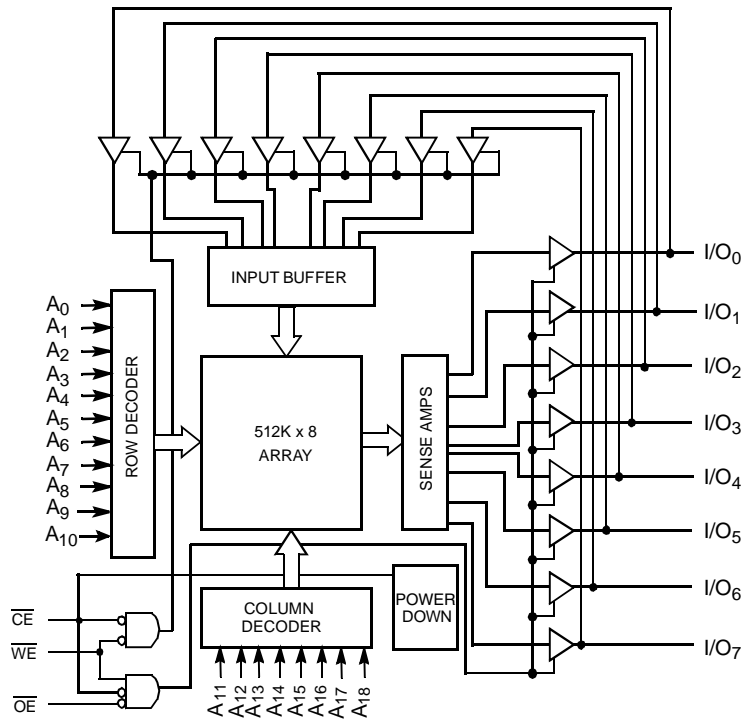
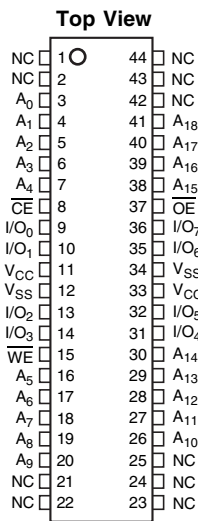

IC63LV1024-10T (IC817 : for AVR1507/587/487 E3 model)

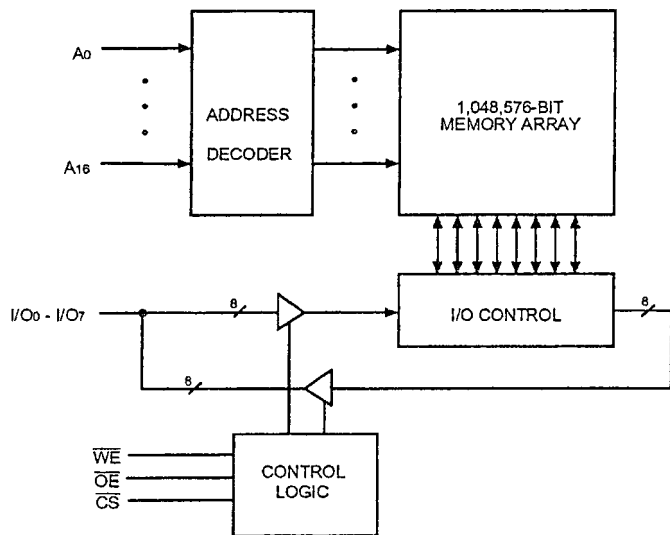
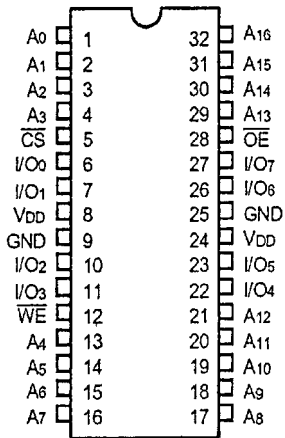

ADV7180BSTZ (IC601 : for AVR1707/687 model)

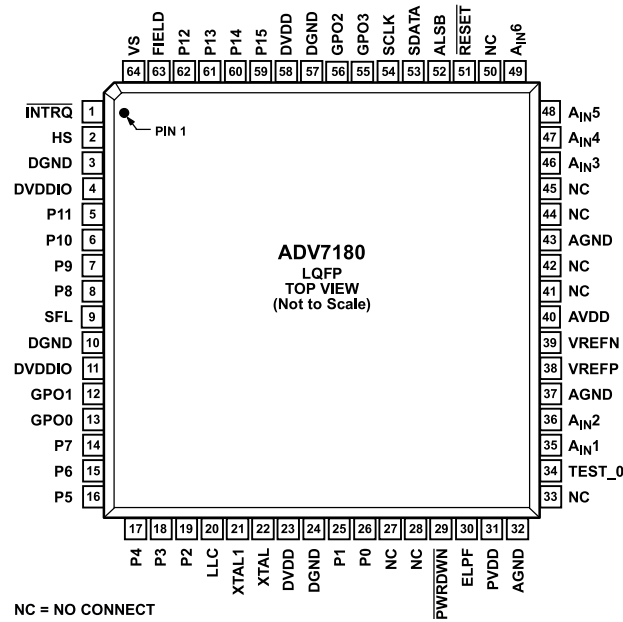

Pin No.	Mnemonic	Type	Function
3, 10, 24, 57	DGND	G	Digital Ground.
32, 37, 43	AGND	G	Analog Ground.
4, 11	DVDDIO	P	Digital I/O Supply Voltage (3.3 V).
23, 58	DVDD	P	Digital Supply Voltage (1.8 V).
40	AVDD	P	Analog Supply Voltage (1.8 V).
31	PVDD	P	PLL Supply Voltage (1.8 V).
38	VREFP	O	Internal Voltage Reference Output.
39	VREFN	O	Internal Voltage Reference Output.
35, 36, 46 to 49	AIN1 to AIN6	I	Analog Video Input Channels.
27, 28, 33, 41, 42, 44, 45, 50,	NC		No Connect Pins. These pins are not connected internally.
5 to 8, 14 to 19, 25, 26, 59 to 62	P11 to P8, P7 to P2, P1, P0, P15 to P12	O	Video Pixel Output Port.
2	HS	O	Horizontal Synchronization Output Signal.
64	VS	O	Vertical Synchronization Output Signal.
63	FIELD	O	Field Synchronization Output Signal.
1	INTRQ	O	Interrupt Request Output. Interrupt occurs when certain signals are detected on the input video.
53	SDATA	I/O	I ² C Port Serial Data Input/Output Pin.
54	SCLK	I	I ² C Port Serial Clock Input. Maximum clock rate of 400 kHz.
52	ALSB	I	This pin selects the I ² C address for the ADV7180. For ALSB set to Logic 0, the address selected for a write is 0x40; for ALSB set to logic high, the address selected is 0x42.
29	PWRDWN	I	A logic low on this pin places the ADV7180 in power-down mode.
30	ELPF	I	The recommended external loop filter must be connected to the ELPF pin.
51	RESET	I	System Reset Input. Active low. A minimum low reset pulse width of 5 ms is required to reset the ADV7180 circuitry.

Pin No.	Mnemonic	Type	Function
9	SFL	O	Subcarrier Frequency Lock. This pin contains a serial output stream that can be used to lock the subcarrier frequency when this decoder is connected to any Analog Devices, Inc., digital video encoder.
20	LLC	O	This is a line-locked output clock for the pixel data output by the ADV7180. It is nominally 27 MHz, but varies up or down according to video line length.
21	XTAL1	O	This pin should be connected to the 28.6363 MHz crystal or left as a no connect if an external 1.8 V, 28.6363 MHz clock oscillator source is used to clock the ADV7180. In crystal mode, the crystal must be a fundamental crystal.
22	XTAL	I	This is the input pin for the 28.6363 MHz crystal, or this pin can be overdriven by an external 1.8 V, 28.6363 MHz clock oscillator source. In crystal mode, the crystal must be a fundamental crystal.
12, 13, 55, 56	GPO0 to GPO3	O	General-Purpose Outputs. These pins can be configured via I ² C to allow control of external devices.
34	TEST_0	I	This pin must be tied to DGND.

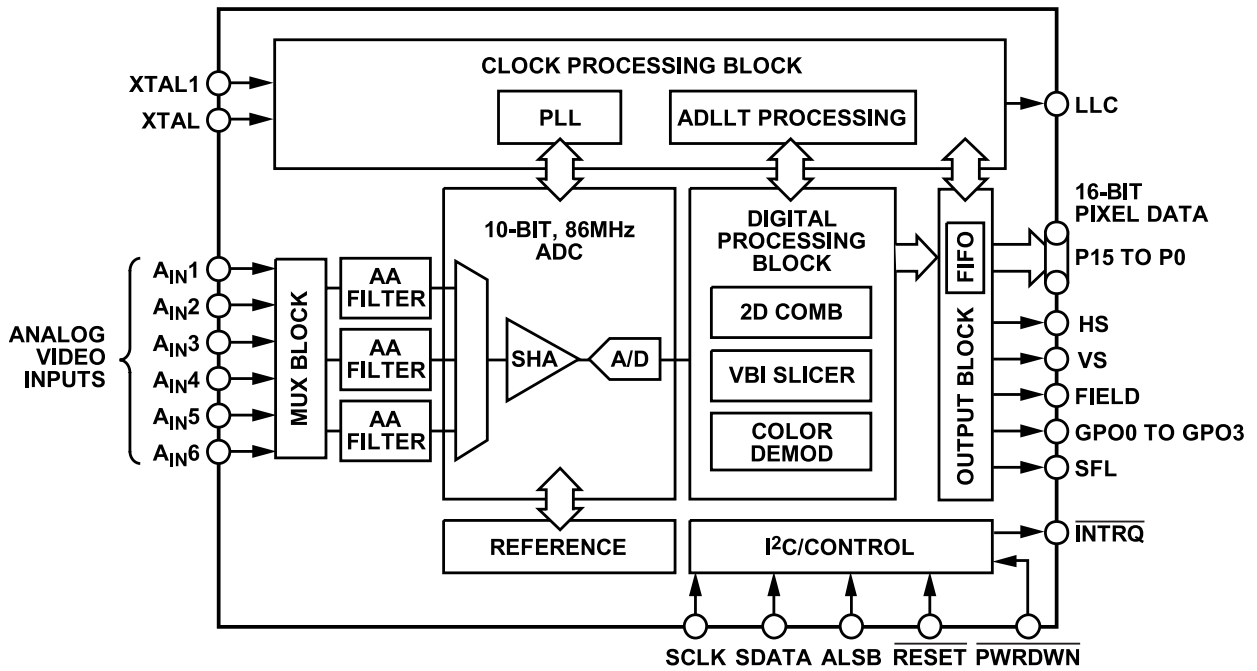

ADV7172KSTZ (IC602 : for AVR1707/687 model)

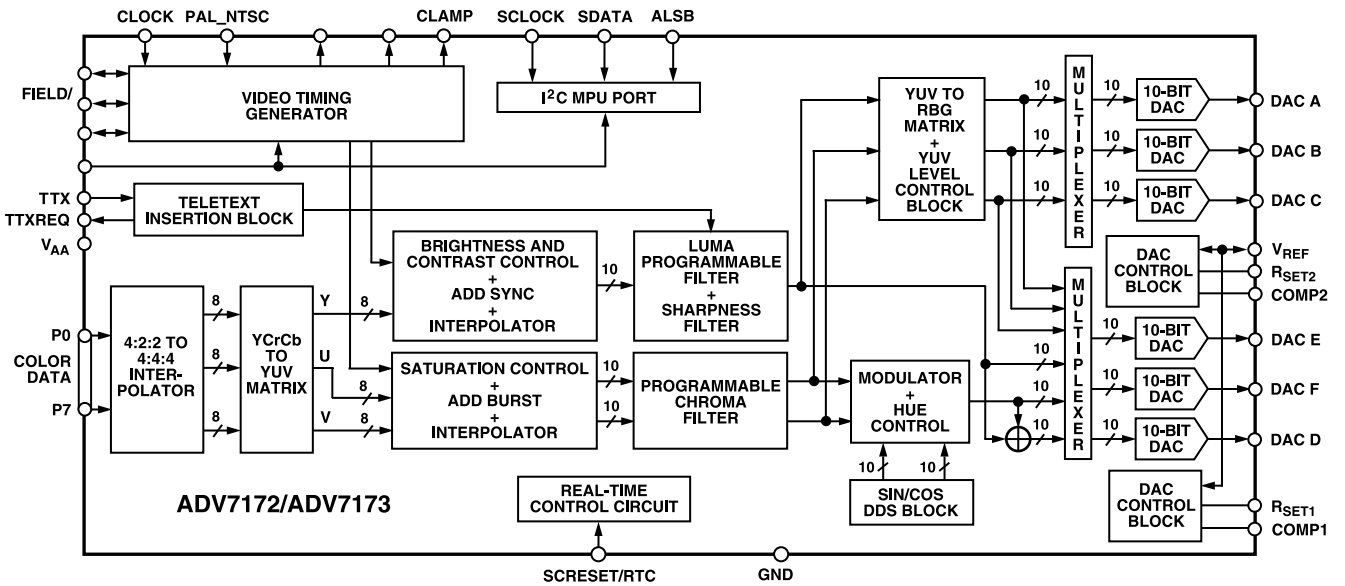
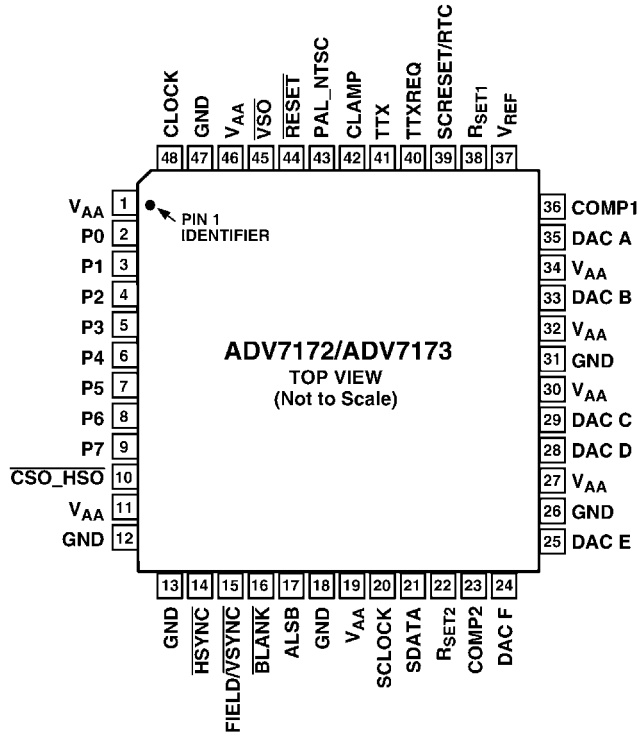

PIN FUNCTION DESCRIPTION

Mnemonic	Input/Output	Function
P7–P0	I	8-Bit 4:2:2 Multiplexed YCrCb Pixel Port (P7–P0) P0 represents the LSB.
CLOCK	I	TTL Clock Input. Requires a stable 27 MHz reference clock for standard operation. Alternatively, a 24.5454 MHz (NTSC) or 29.5 MHz (PAL) can be used for square pixel operation.
$\overline{\text{HSYNC}}$	I/O	$\overline{\text{HSYNC}}$ (Modes 1 and 2) Control Signal. This pin may be configured to output (Master Mode) or as an input and accept (Slave Mode) Sync signals.
FIELD/ $\overline{\text{VSYNC}}$	I/O	Dual Function FIELD (Mode 1) and $\overline{\text{VSYNC}}$ (Mode 2) Control Signal. This pin may be configured to output (Master Mode) or as an input (Slave Mode) and accept these control signals.
$\overline{\text{BLANK}}$	I/O	Video Blanking Control Signal. The pixel inputs are ignored when this is Logic Level “0.” This signal is optional.
SCRESET/RTC	I	This pin can be configured as an input by setting MR42 and MR41 of Mode Register 4. It can be configured as a subcarrier reset pin, in which case a low-to-high transition on this pin will reset the subcarrier phase to Field 0. Alternatively it may be configured as a Real-Time Control (RTC) Input.
V_{REF}	I/O	Voltage Reference Input for DACs or Voltage Reference Output (1.235 V).
RSET1	I	A 150 Ω resistor connected from this pin to GND is used to control full-scale amplitudes of the Video Signals from DACs A, B, and C (the “large” DACs).
RSET2	I	A 600 Ω resistor connected from this pin to GND is used to control full-scale amplitudes of the Video Signals from DACs D, E, and F (the “small” DACs).
COMP1	O	Compensation Pin for DACs A, B, and C. Connect a 0.1 μF Capacitor from COMP to V_{AA} . For Optimum Dynamic Performance in Low Power Mode, the value of the COMP1 capacitor can be lowered to as low as 2.2 nF.
COMP2	O	Compensation Pin for DACs D, E, and F. Connect a 0.1 μF Capacitor from COMP to V_{AA} .
DAC A	O	GREEN/Composite/Y Analog Output. This DAC is capable of providing 34.66 mA output.
DAC B	O	BLUE/S-Video Y/U Analog Output. This DAC is capable of providing 34.66 mA output.
DAC C	O	RED/S-Video C/V Analog Output. This DAC is capable of providing 34.66 mA output.
DAC D	O	GREEN/Composite/Y Analog Output. This DAC is capable of providing 8.66 mA output.
DAC E	O	BLUE/S-Video Y/U Analog Output. This DAC is capable of providing 8.66 mA output.
DAC F	O	RED/S-Video C/V Analog Output. This DAC is capable of providing 8.66 mA output.
SCLOCK	I	MPU Port Serial Interface Clock Input.
SDATA	I/O	MPU Port Serial Data Input/Output.
CLAMP	O	TTL Output Signal to external circuitry to enable clamping of all video signals.
PAL_NTSC	I	Input signal to select PAL or NTSC mode of operation, pin set to Logic “1” selects PAL.
$\overline{\text{VSO}}$	O	$\overline{\text{VSO}}$ TTL Output Sync Signal.
$\overline{\text{CSO_HSO}}$	O	Dual Function $\overline{\text{CSO}}$ or $\overline{\text{HSO}}$ TTL Output Sync Signal.
ALSB	I	TTL Address Input. This signal sets up the LSB of the MPU address.
$\overline{\text{RESET}}$	I	The input resets the on-chip timing generator and sets the ADV7172/ADV7173 into default mode. This is NTSC operation, Timing Slave Mode 0, DACs A, B, and C powered OFF, DACs D, E, and F powered ON, Composite and S-Video out.
TTX	I	Teletext Data Input Pin.
TTXREQ	O	Teletext Data Request output signal used to control teletext data transfer.
V_{AA}	P	Power Supply (3 V to 5 V).
GND	G	Ground Pin.

2. FL DISPLAY HNA-16SM13T (FL301)

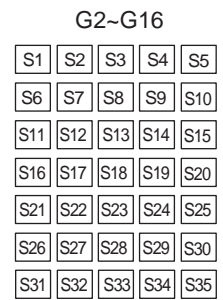
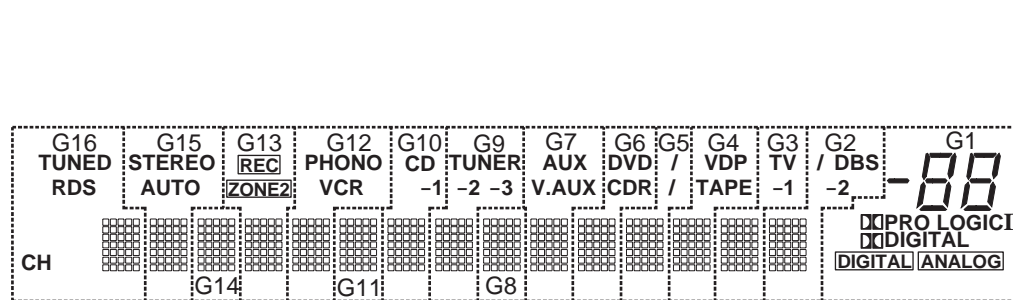
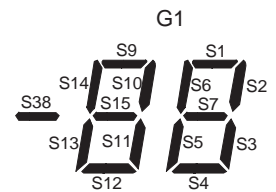
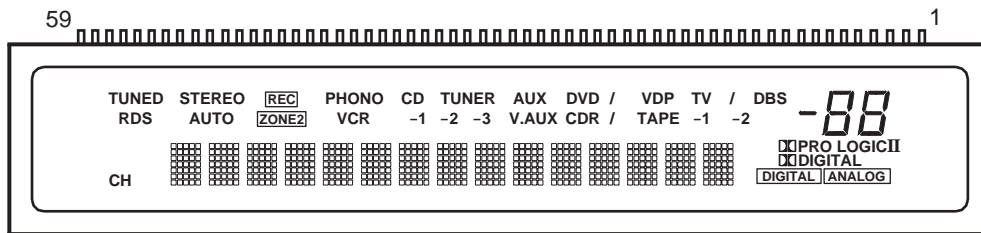

Pin Assignment

PIN NO.	1	2	3	4	5	6	7	8	9	10	11	12	13	14	15	16	17	18	19	20
CONNECTION	F1	F1	NP	S1	S2	S3	S4	S5	S6	S7	S8	S9	S10	S11	S12	S13	S14	S15	S16	S17
PIN NO.	21	22	23	24	25	26	27	28	29	30	31	32	33	34	35	36	37	38	39	40
CONNECTION	S18	S19	S20	S21	S22	S23	S24	S25	S26	S27	S28	S29	S30	S31	S32	S33	S34	S35	S36	S37
PIN NO.	41	42	43	44	45	46	47	48	49	50	51	52	53	54	55	56	57	58	59	
CONNECTION	S38	G16	G15	G14	G13	G12	G11	G10	G9	G8	G7	G6	G5	G4	G3	G2	G1	F2	F2	

F1, F2 : Filament
G1~G16: Grid
S1~S38 : Anode

Anode & Grid Assignment

	G1	G2~G16		G1	G2~G16		G1	G2~G16		G1	G2~G16
S1	S1	S1	S10	S10	S10	S19	---	S19	S28	---	S28
S2	S2	S2	S11	S11	S11	S20	---	S20	S29	---	S29
S3	S3	S3	S12	S12	S12	S21	---	S21	S30	---	S30
S4	S4	S4	S13	S13	S13	S22	---	S22	S31	---	S31
S5	S5	S5	S14	S14	S14	S23	---	S23	S32	---	S32
S6	S6	S6	S15	S15	S15	S24	---	S24	S33	---	S33
S7	S7	S7	S16	---	S16	S25	---	S25	S34	---	S34
S8	---	S8	S17	DIGITAL	S17	S26	---	S26	S35	---	S35
S9	S9	S9	S18	PRO LOGIC II	S18	S27	---	S27			

	G1	G2	G3	G4	G5	G6	G7	G8	G9	G10	G11	G12	G13	G14	G15	G16
S36	DIGITAL	/	TV	VDP	((DVD)	DVD	AUX	---	TUNER	CD	---	PHONO	REC	---	STEREO	TUNED
S37	ANALOG	-2	-1	TAPE	((CDR)	CDR	V.AUX	---	-2	-1	---	VCR	ZONE2	---	AUTO	RDS
S38	S38	DBS	---	---	---	---	---	---	-3	---	---	---	---	---	---	CH

PRINTED WIRING BOARDS
MAIN P.W.B. UNIT (1/2)

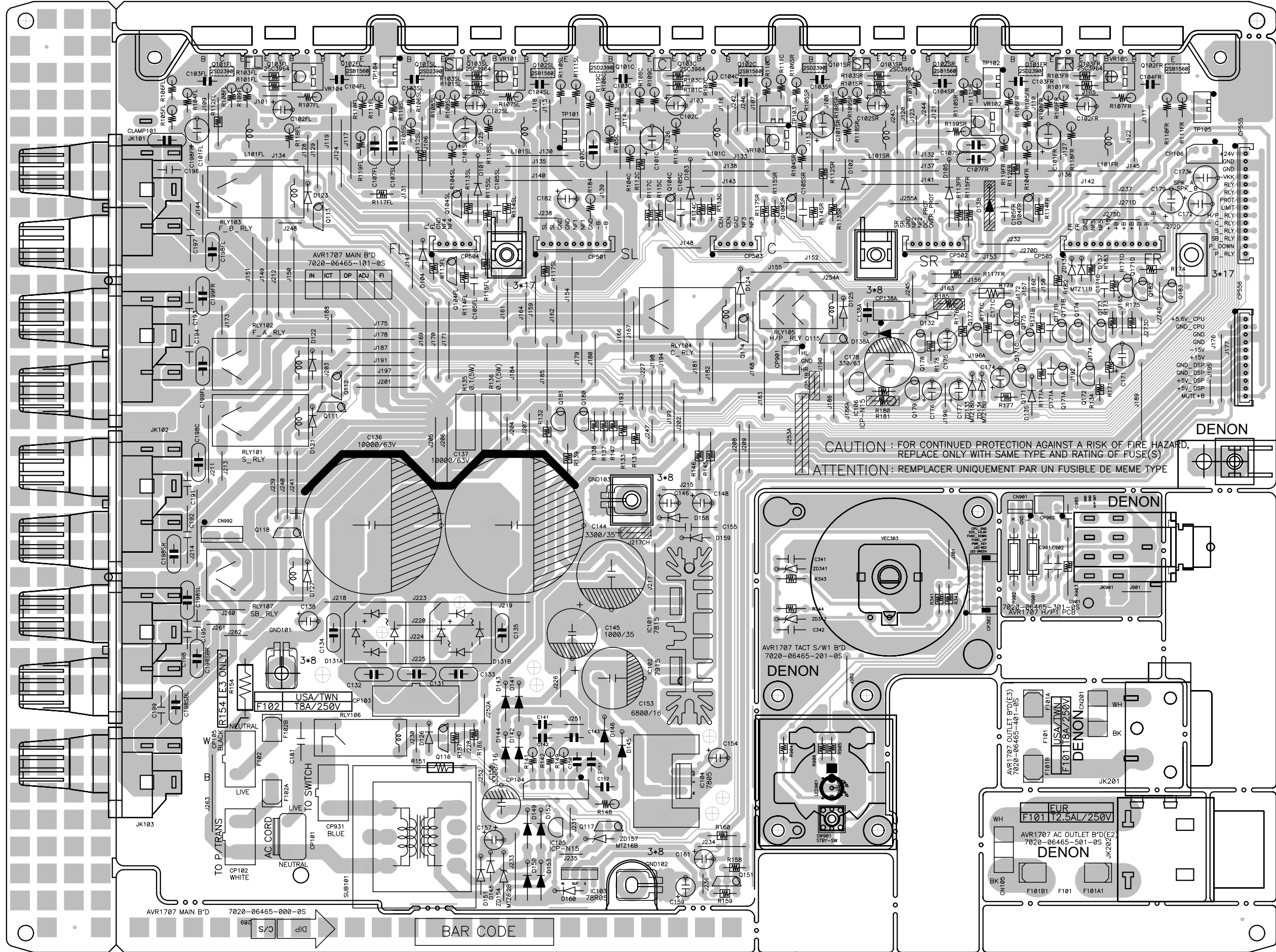

COMPONENT SIDE

PRINTED WIRING BOARDS

MAIN P.W.B. UNIT (2/2)

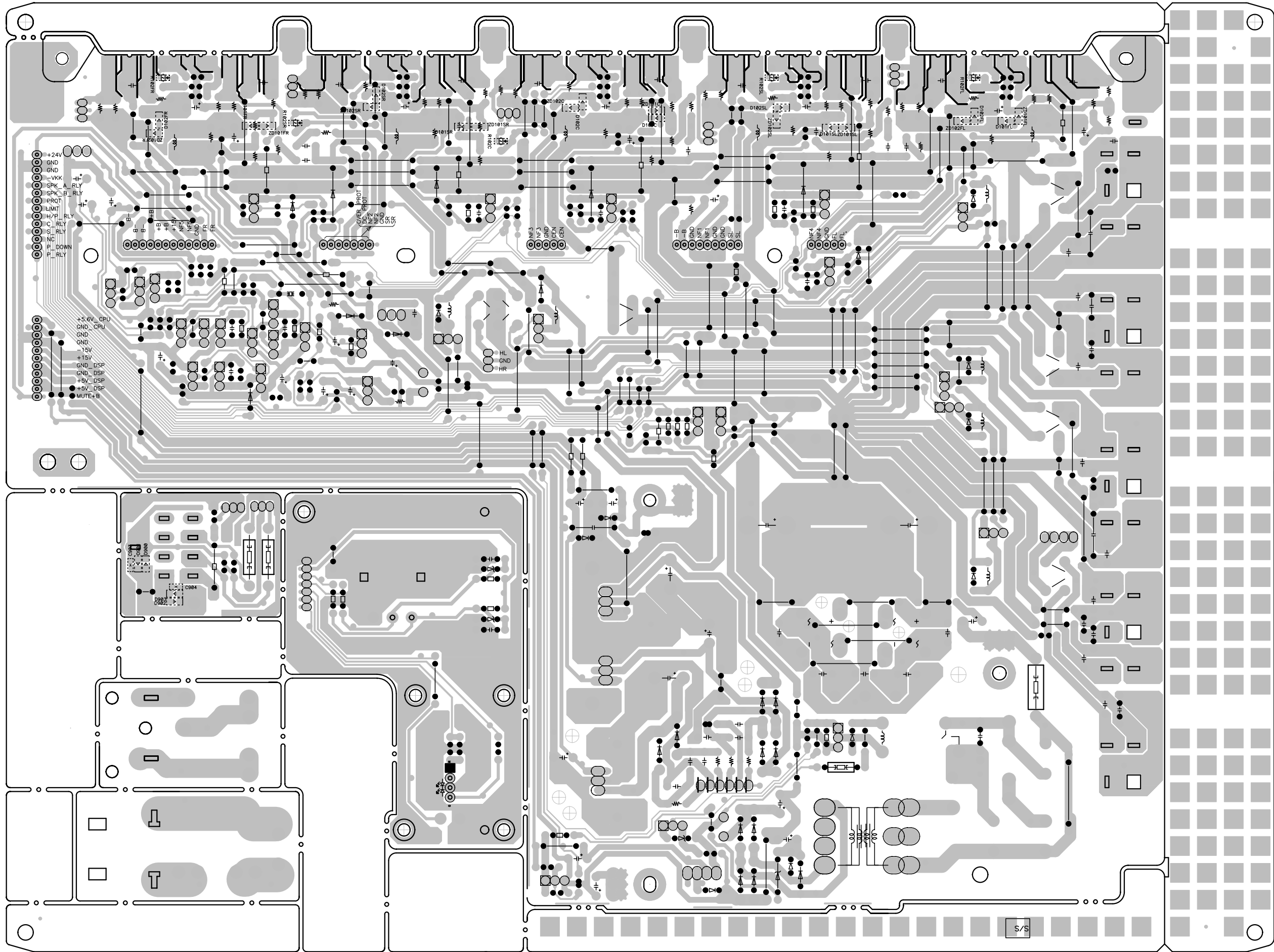

FOIL SIDE

CPU P.W.B. UNIT (1/2)

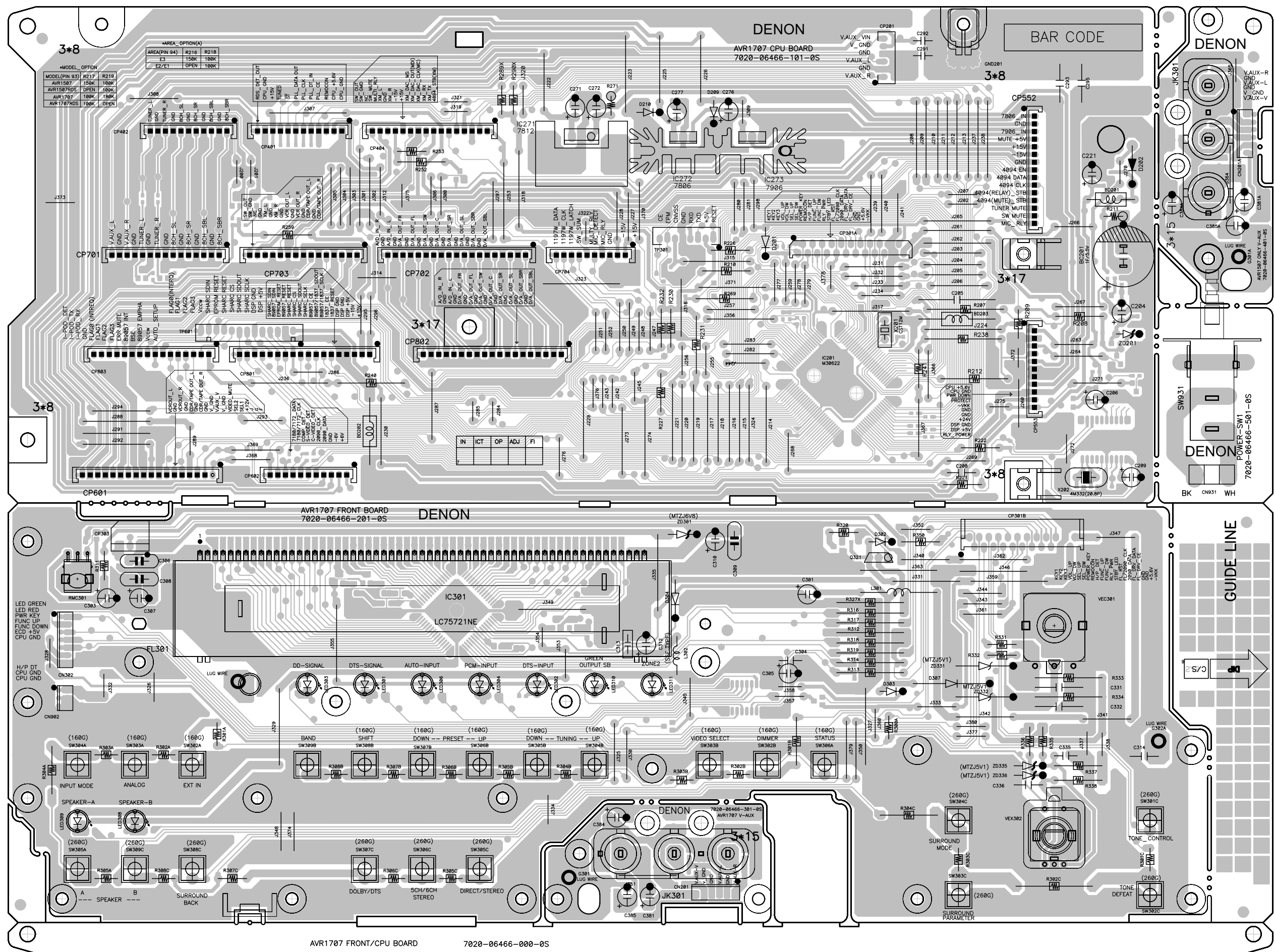

COMPONENT SIDE

CPU P.W.B. UNIT (2/2)

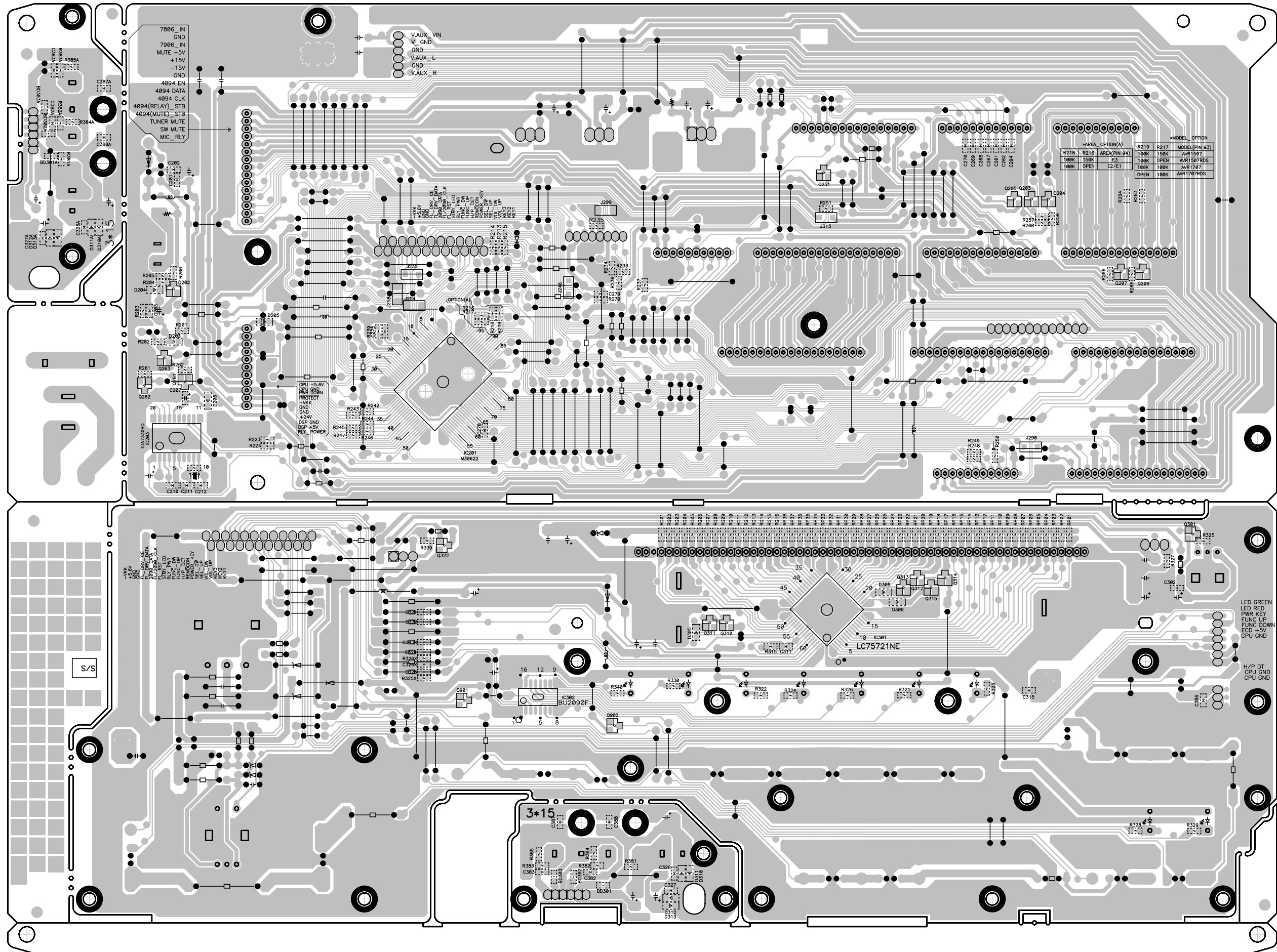

FOIL SIDE

PRE-AMP P.W.B. UNIT (1/2)

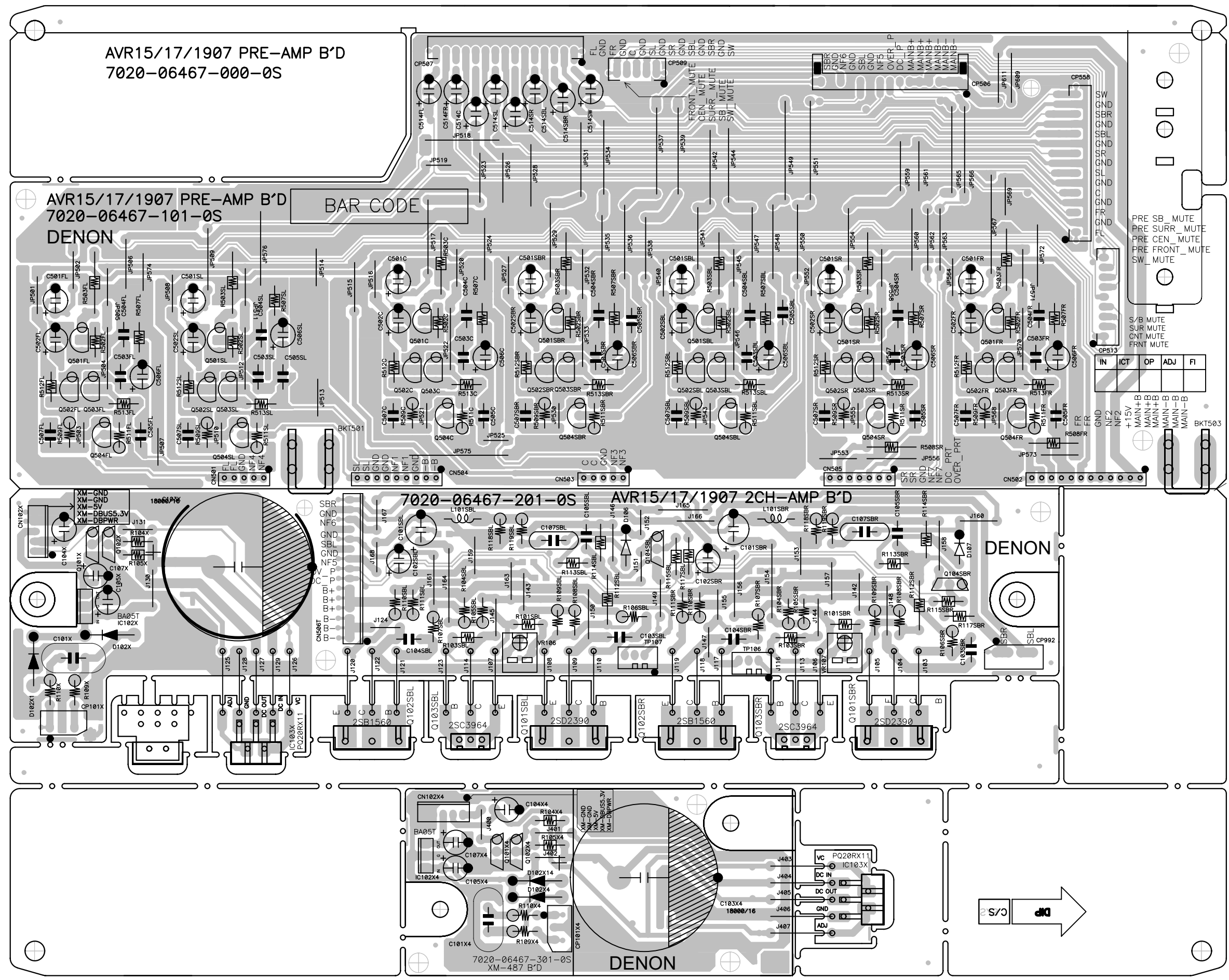

PRE-AMP P.W.B. UNIT (2/2)

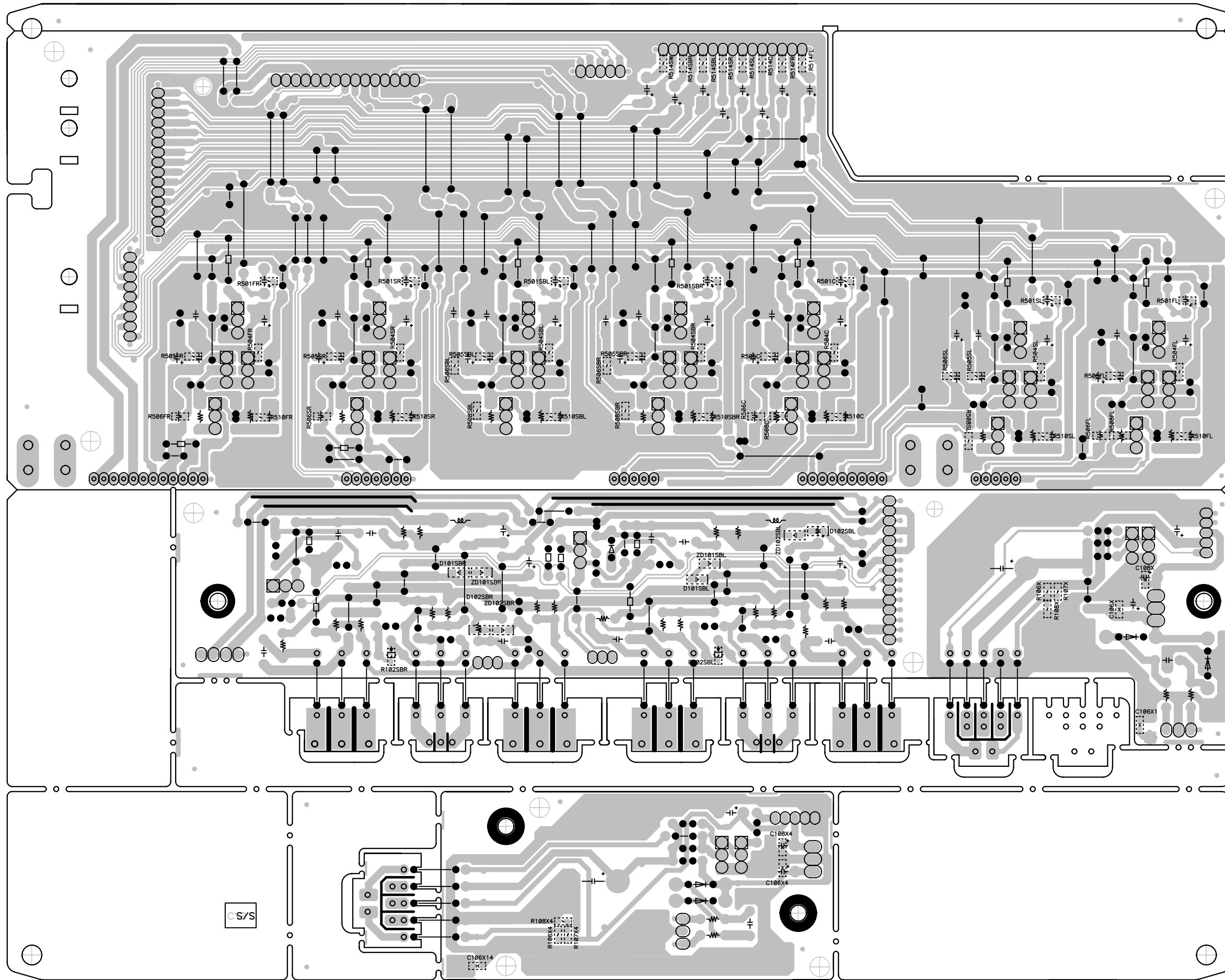

FOIL SIDE

CNT P.W.B. UNIT

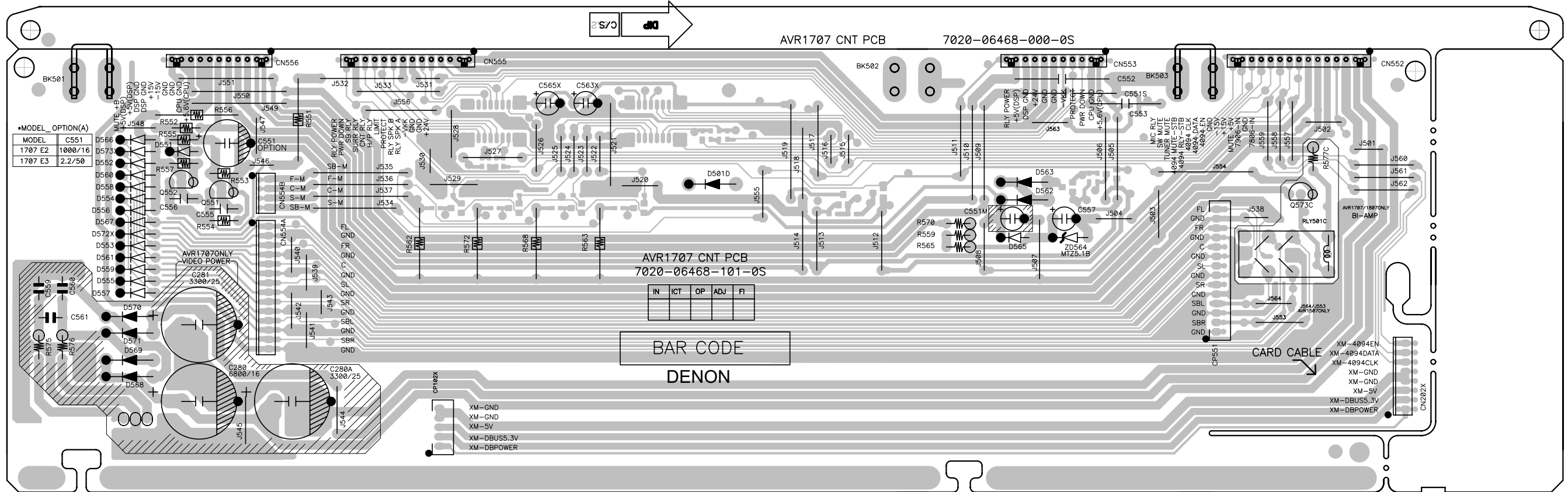

COMPONENT SIDE

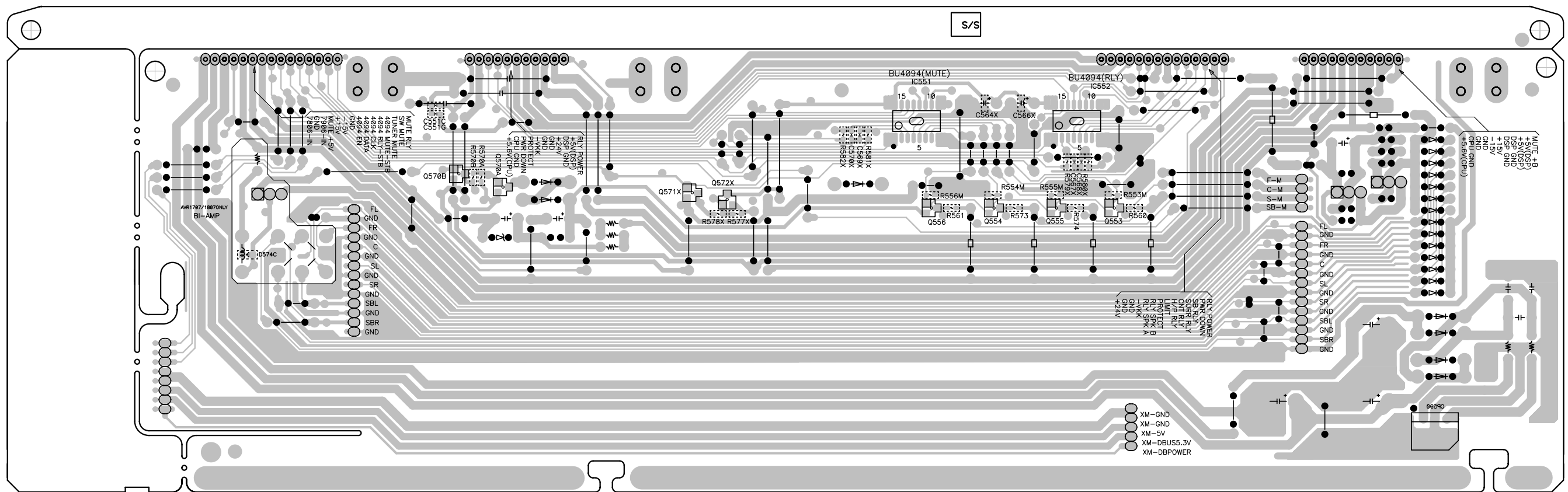

INPUT P.W.B. UNIT

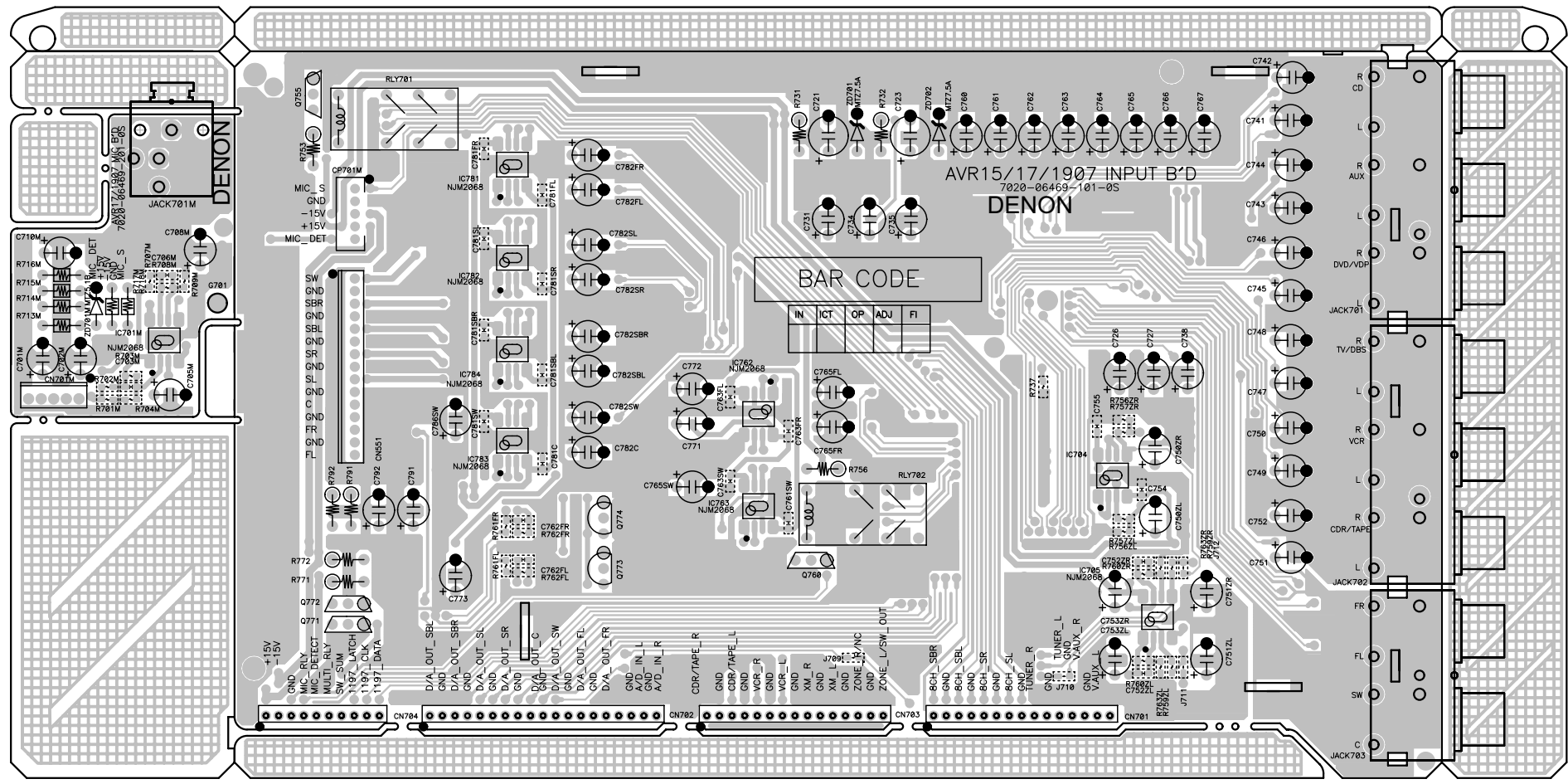

COMPONENT SIDE

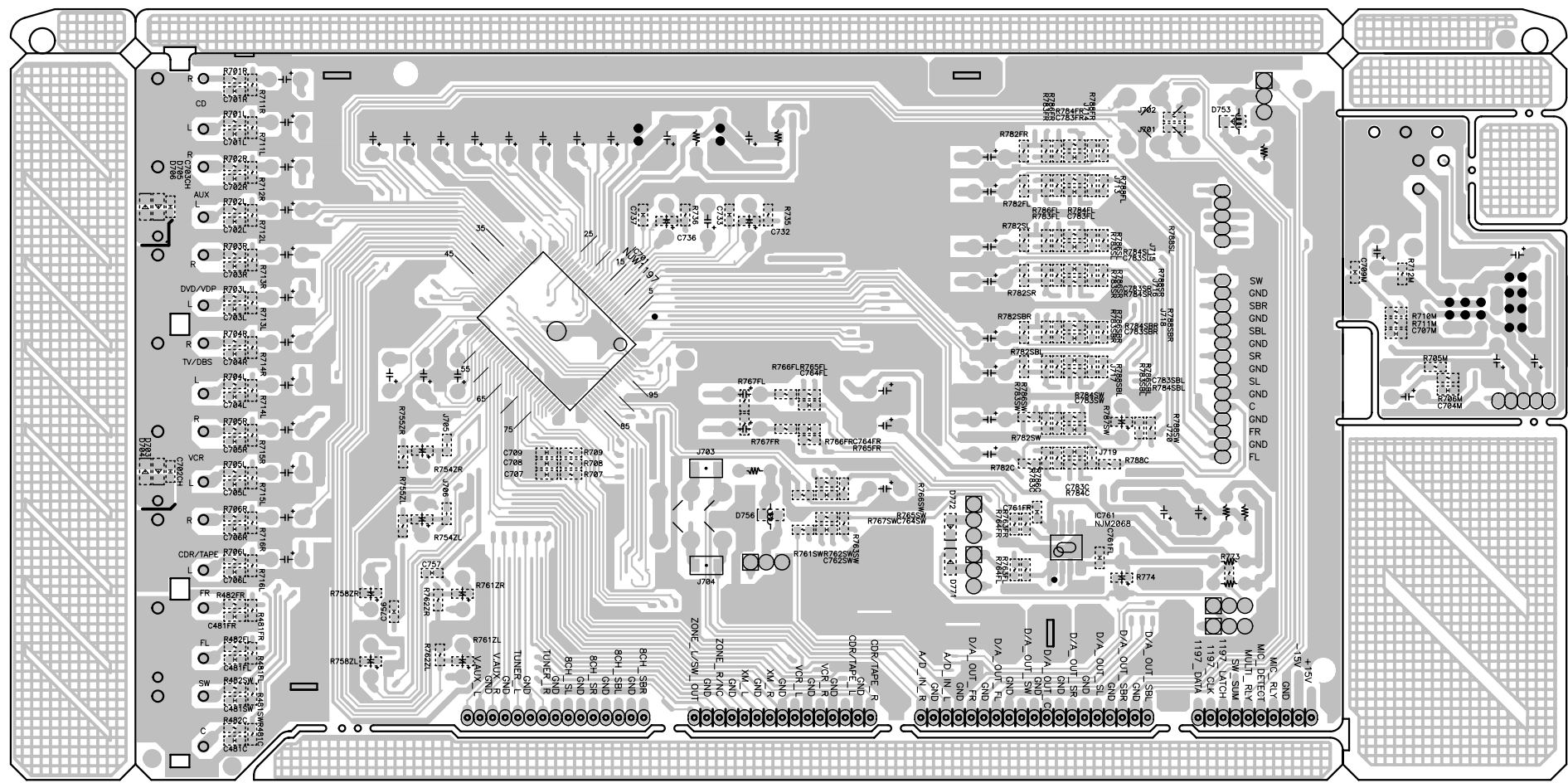

8CH-EXT (XM) P.W.B. UNIT (for AVR-1707/1507/687/587/487 E3 model)

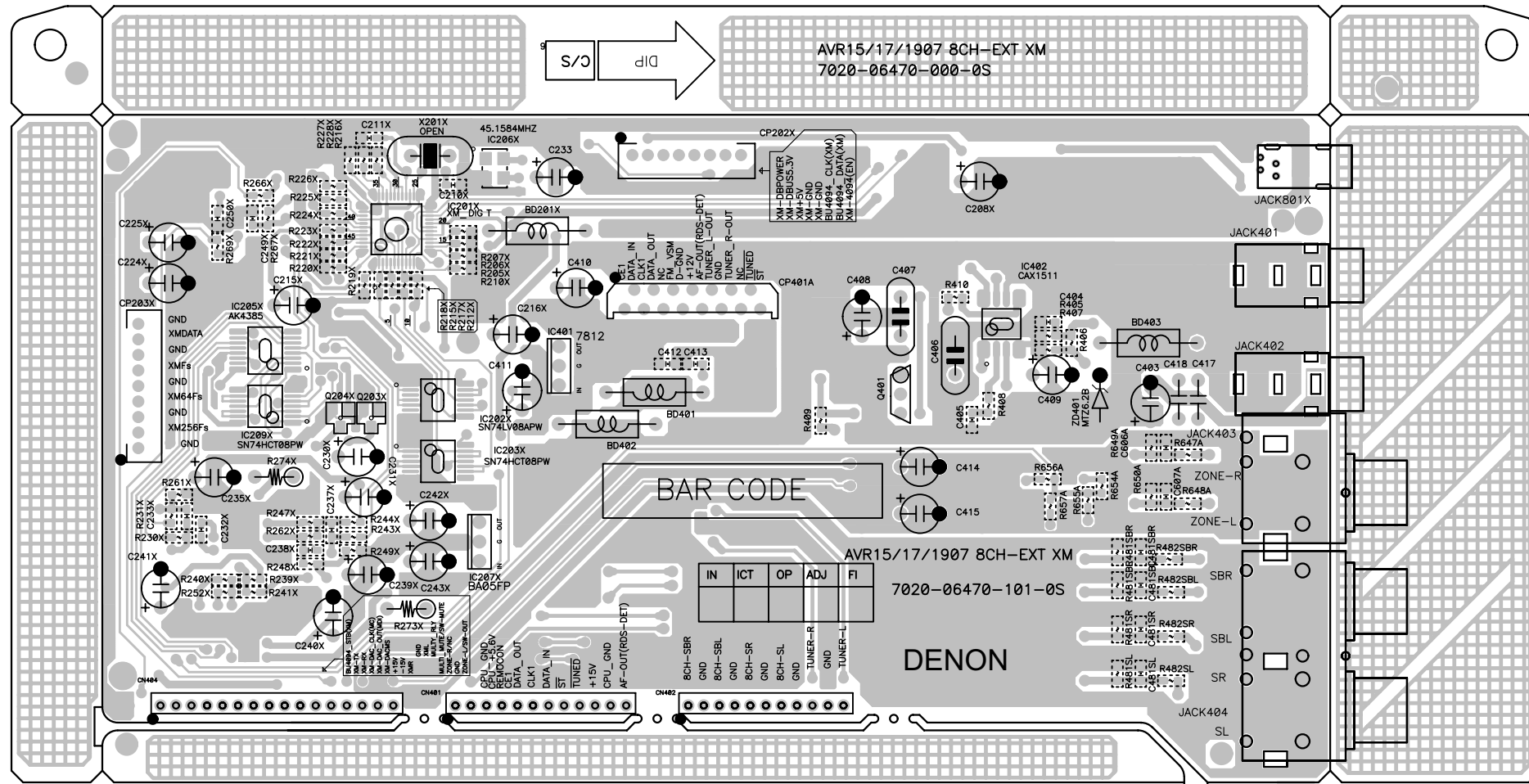

COMPONENT SIDE

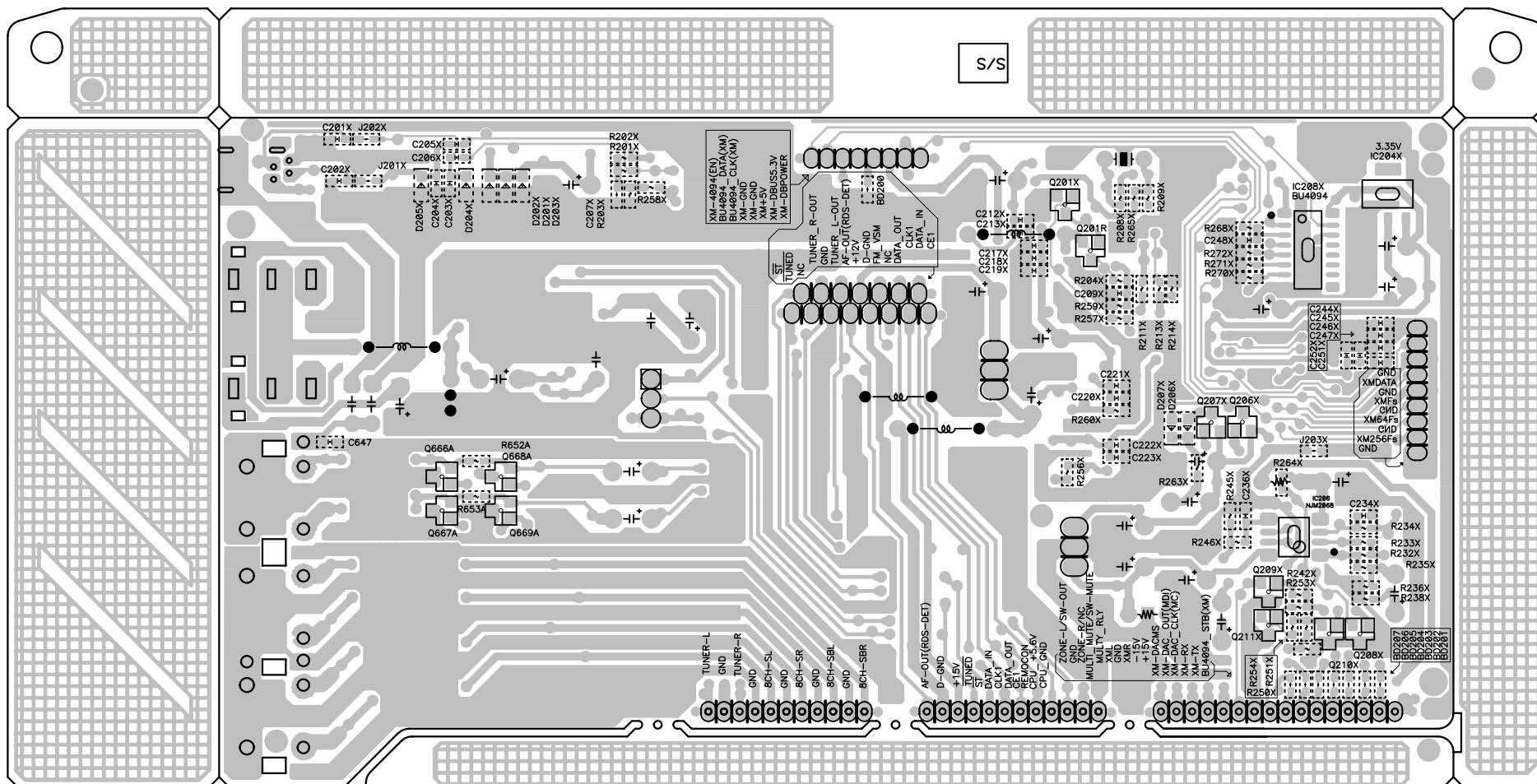

FOIL SIDE

8CH-EXT (E2) P.W.B. UNIT (for AVR-1707E2,EUT, AVR-1507E2 model)

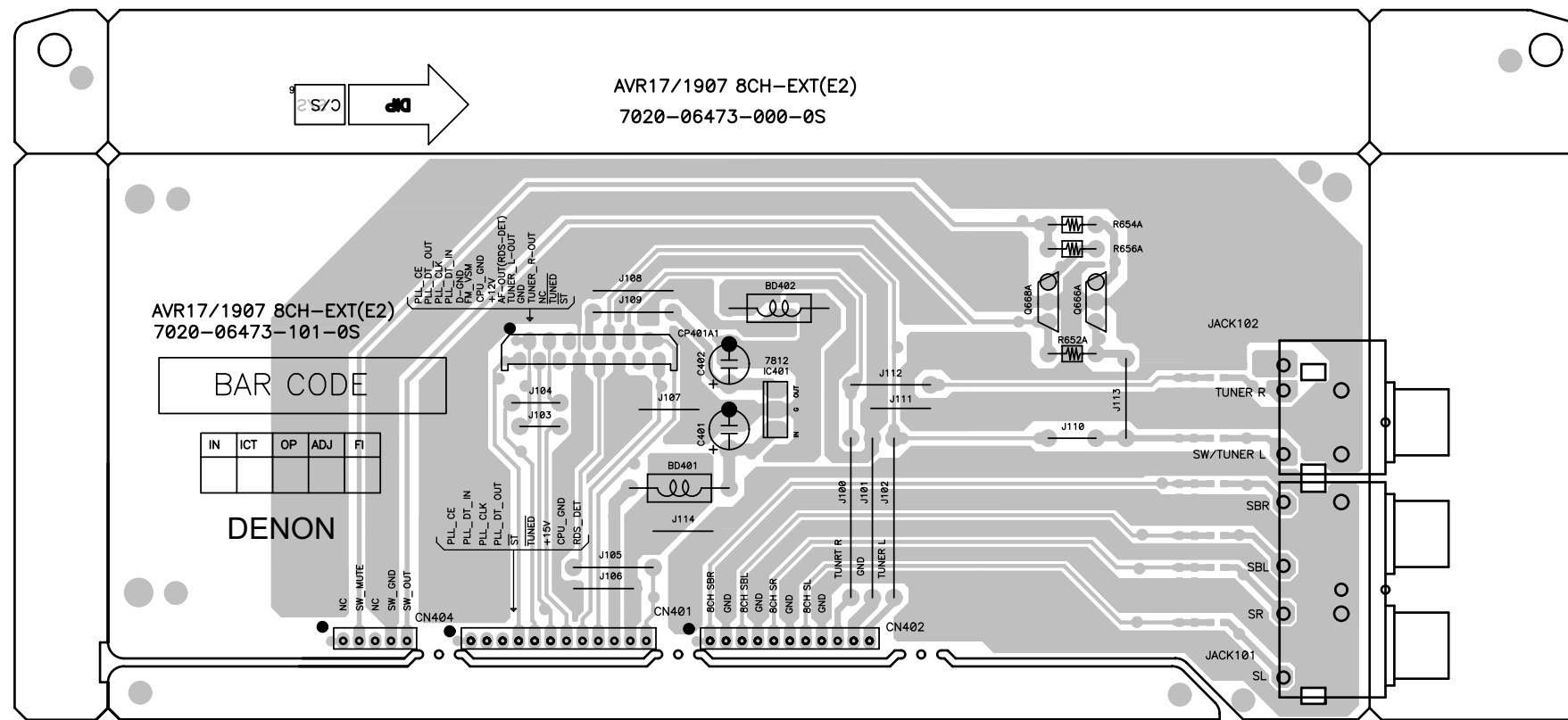

COMPONENT SIDE

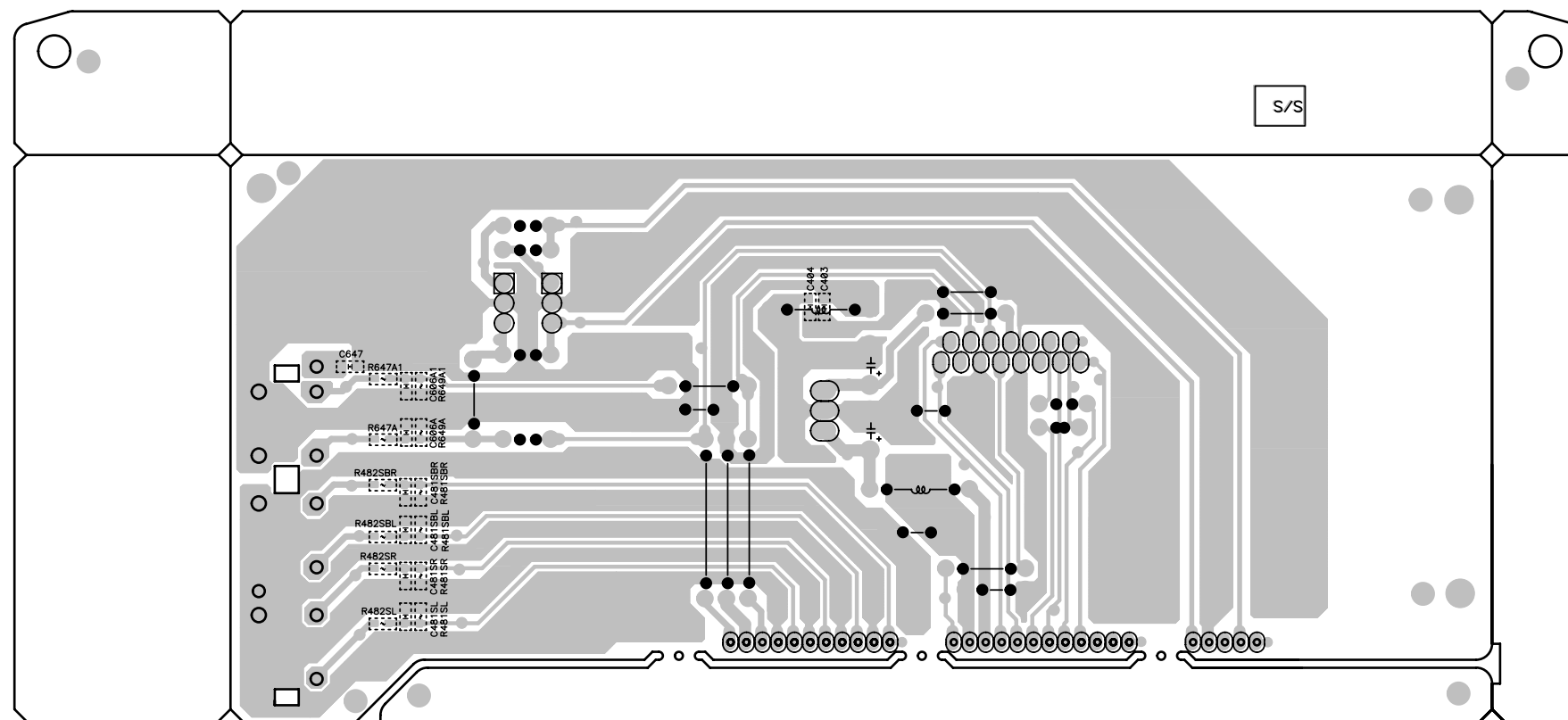

FOIL SIDE

DSP1 P.W.B. UNIT (for AVR-1707/687,AVR-1507 E2 model)

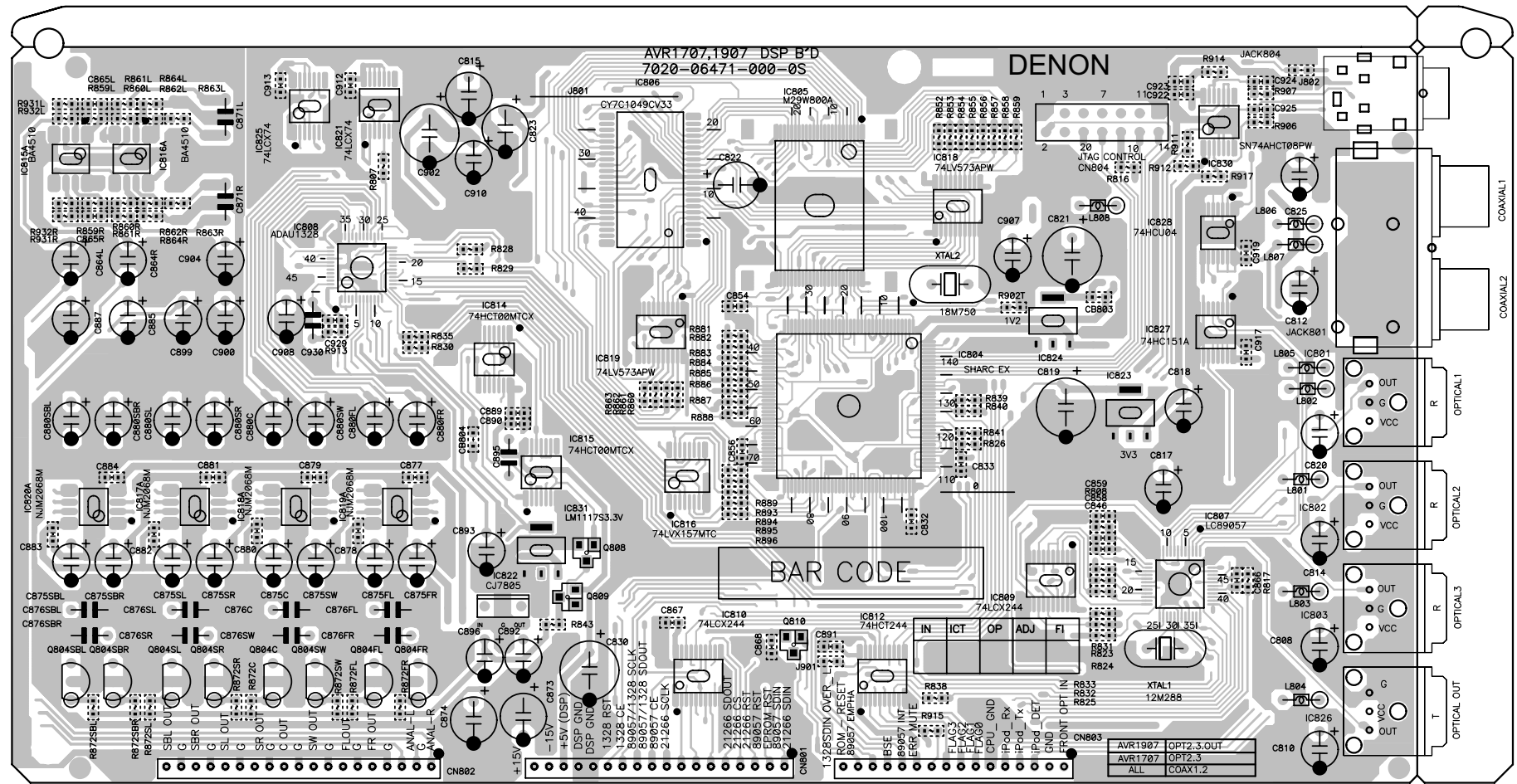

COMPONENT SIDE

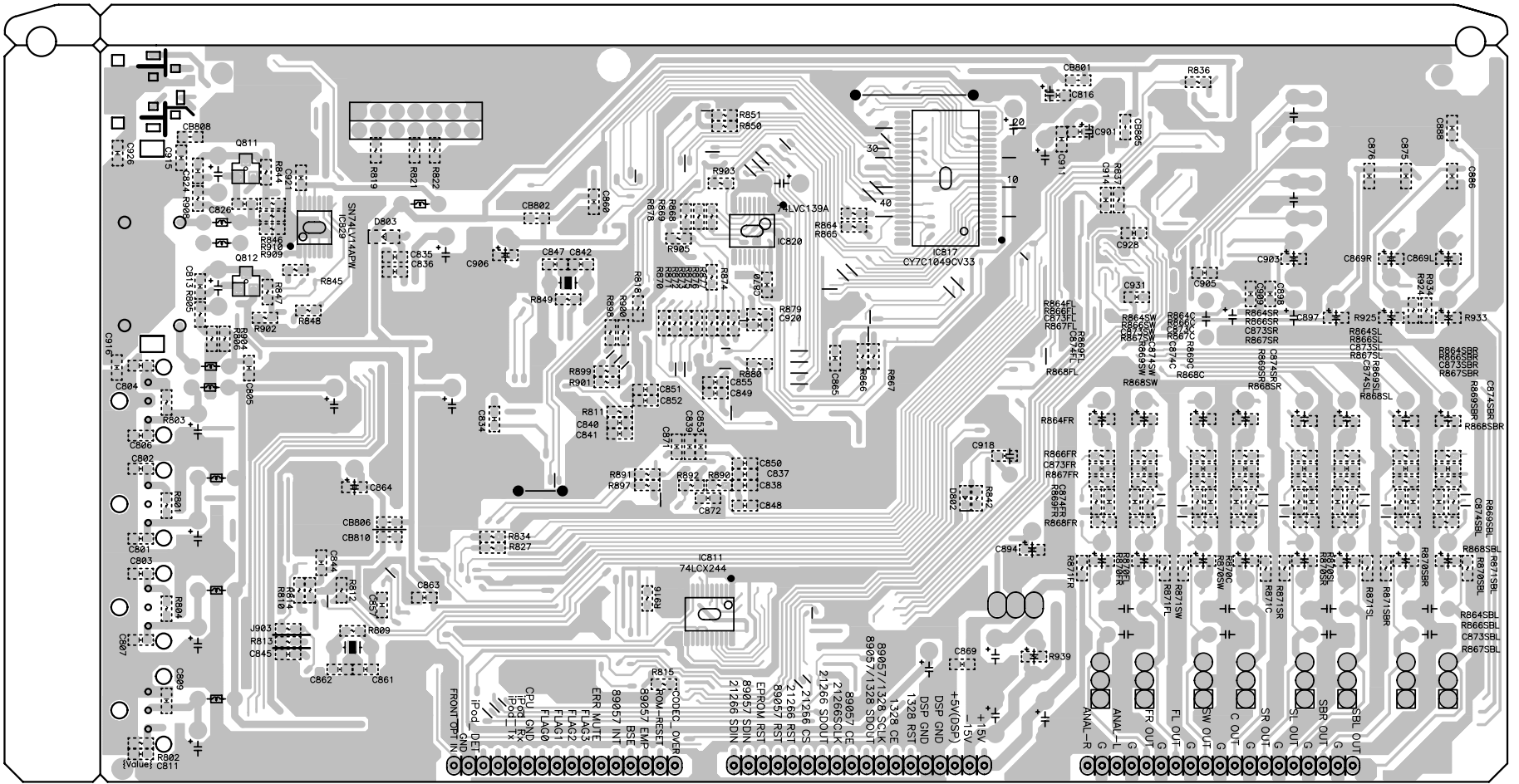

FOIL SIDE

C-S VIDEO2 P.W.B. UNIT (1/2) (for AVR-1507/587/487 model)

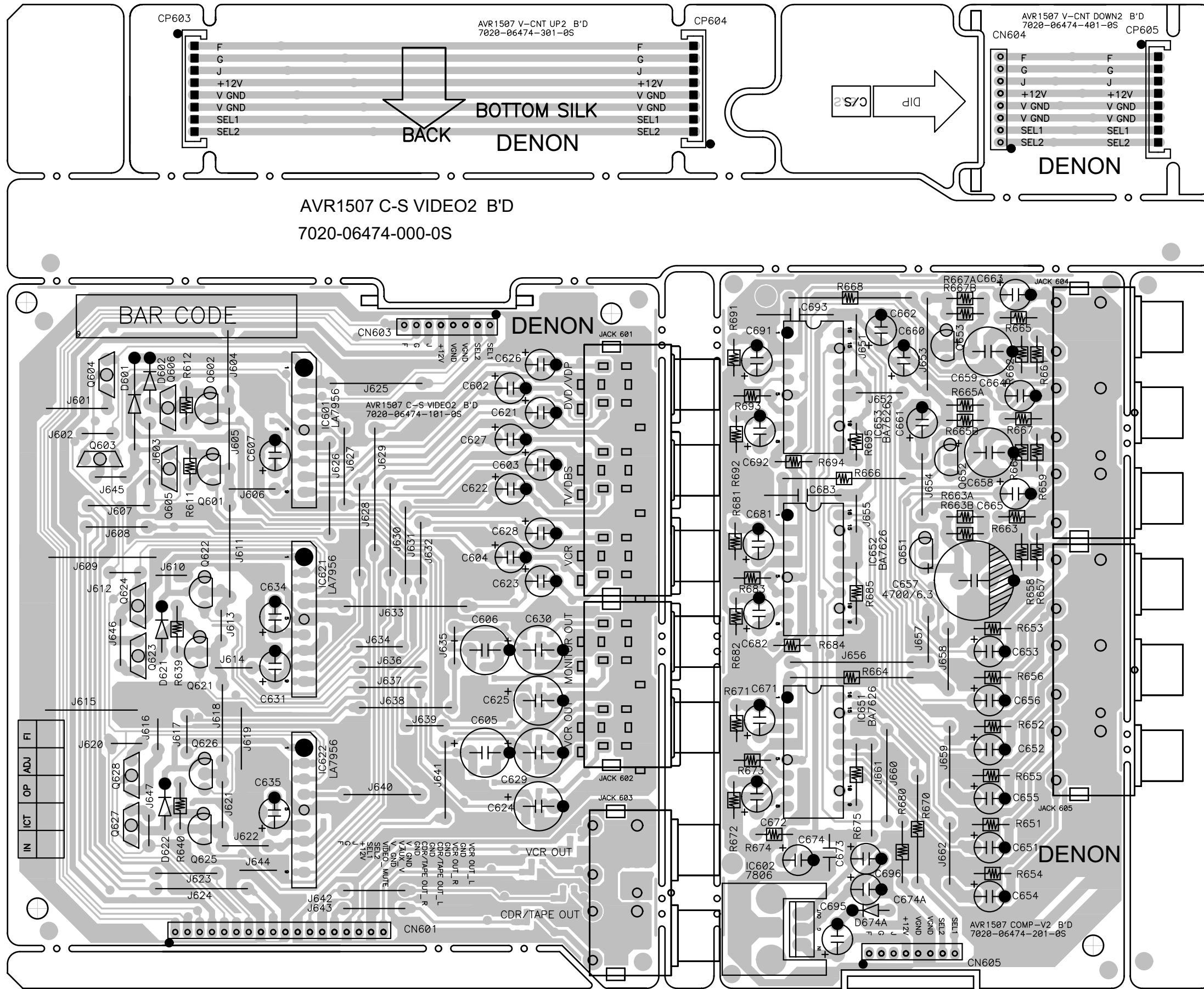

COMPONENT SIDE

NOTE FOR PARTS LIST

- Part indicated with the mark "nsp" are not always in stock and possibly to take a long period of time for supplying, or in some case supplying of part may be refused.
- When ordering of part, clearly indicate "1" and "I" (i) to avoid mis-supplying.
- Ordering part without stating its part number can not be supplied.
- Part indicated with the mark "★" is not illustrated in the exploded view.
- Not including General-purpose Carbon Film Resistor in the P.W.Board parts list. (Refer to the Schematic Diagram for those parts.)
- Not including General-purpose Carbon Chip Resistor in the P.W.Board parts list. (Refer to the Schematic Diagram for those parts.)

WARNING:

Parts marked with this symbol \triangle have critical characteristics. Use ONLY replacement parts recommended by the manufacturer.

● **Resistors**

Ex.: RN 14K 2E 182 G FR

Type	Shape and performance	Power	Resistance	Allowable error	Others
RD : Carbon	2B : 1/8W	F : ±1%	P : Pulse-resistant type		
RC : Composition	2E : 1/4W	G : ±2%	NL : Low noise type		
RS : Metal oxide film	2H : 1/2W	J : ±5%	NB : Non-burning type		
RW : Winding	3A : 1W	K : ±10%	FR : Fuse-resistor		
RN : Metal film	3D : 2W	M : ±20%	F : Lead wire forming		
RK : Metal mixture	3F : 3W				
	3H : 5W				

* **Resistance**

1 8 2 ⇒ 1800 ohm = 1.8 kohm
 Indicates number of zeros after effective number.
 2-digit effective number.
 Units: ohm

1 R 2 ⇒ 1.2 ohm
 1-digit effective number.
 2-digit effective number, decimal point indicated by R.
 Units: ohm

● **Capacitors**

Ex.: CE 04W 1H 2R2 M BP

Type	Shape and performance	Dielectric strength	Capacity	Allowable error	Others
CE : Aluminum foil electrolytic	0J : 6.3V	F : ±1%	HS : High stability type		
CA : Aluminum solid electrolytic	1A : 10V	G : ±2%	BP : Non-polar type		
CS : Tantalum electrolytic	1C : 16V	J : ±5%	HR : Ripple-resistant type		
CQ : Film	1E : 25V	K : ±10%	DL : For change and discharge		
CK : Ceramic	1V : 35V	M : ±20%	HF : For assuring high frequency		
CC : Ceramic	1H : 50V	Z : +80%	U : UL part		
CP : Oil	2A : 100V	-20%	C : CSA part		
CM : Mica	2B : 125V	P : +100%	W : UL-CSA type		
CF : Metallized	2C : 160V	-0%	F : Lead wire forming		
CH : Metallized	2D : 200V	C : ±0.25pF			
	2E : 250V	D : ±0.5pF			
	2H : 500V	= : Others			
	2J : 630V				

* **Capacity (electrolyte only)**

2 2 2 ⇒ 2200μF
 Indicates number of zeros after effective number.
 2-digit effective number.
 Units: μF

2 R 2 ⇒ 2.2μF
 1-digit effective number.
 2-digit effective number, decimal point indicated by R.
 Units: μF

* **Capacity (except electrolyte)**

2 2 2 ⇒ 2200pF=0.0022μF
 (More than 2) — Indicates number of zeros after effective number.
 2-digit effective number.
 Units: pF

2 2 1 ⇒ 220pF
 (0 or 1) — Indicates number of zeros after effective number.
 2-digit effective number.
 Units: pF

When the dielectric strength is indicated in AC, "AC" is included after the dielectric strength value.

部品表について

- nsp 印の部品は常時在庫していませんので供給に長時間を要することがあります。場合によっては、供給をお断りすることがあります。
- 部品を発注する際は特に数字の " 1 " と英字の " I " との区別をはっきり記入してください。
- 部品番号を表示していない部品は供給できません。
- \triangle 印の部品は安全上重要な部品です。交換するときは、安全および性能維持のため必ず指定の部品をご使用ください。
- ★印のついている部品は分解図中には記載していません。
- 汎用カーボン抵抗器は記載していません。定数は回路図を参照願います。
- 汎用カーボンチップ抵抗器は記載していません。定数は回路図を参照願います。
- 部品表の抵抗器、コンデンサの品名記号の読み方は表を参照してください。

● **抵抗器**

例) RN 14K 2E 182 G FR

RN	14K	2E	182	G	FR
種類	形状特性	電力	抵抗値	許容差	その他
RD : カーボン	2B : 1/8 W	F : ±1%	P : 耐パルス形		
RC : 固定体	2E : 1/4 W	G : ±2%	NL : 低雑音形		
RS : 金属系皮膜	2H : 1/2 W	J : ±5%	NB : 不燃形		
RW : 巻線	3A : 1 W	K : ±10%	FR : ヒューズ抵抗		
RN : 金属皮膜	3D : 2 W	M : ±20%	F : リード線成形		
RK : 金属混合体	3F : 3 W				
	3H : 5 W				

* **抵抗値**

18 2 ⇒ 1800Ω=1.8kΩ
 有効数字につづく0の数を表わす。
 2桁の有効数字を表わす。

1R 2 ⇒ 1.2Ω
 1桁の有効数字を表わす。
 2桁の有効数字で小数点はRで表わす。
 単位はΩ

● **コンデンサ**

例) CE 04W 1H 2R2 M BP

CE	04W	1H	2R2	M	BP
種類	形状特性	耐圧	容量	許容差	その他
CE : アルミ箔電解	0J : 6.3 V	F : ±1%	HS : 高安定形		
CA : アルミ固体電解	1A : 10 V	G : ±2%	BP : 無極性形		
CS : タンタル電解	1C : 16 V	J : ±5%	HR : 耐リップル形		
CQ : フィルム	1E : 25 V	K : ±10%	DL : 充放電対策用		
CK : セラミック	1V : 35 V	M : ±20%	HF : 高周波保証用		
CC : セラミック	1H : 50 V	Z : +80%	U : UL 部品		
CP : オイル	2A : 100V	-20%	C : CSA 部品		
CM : マイカ	2B : 125V	P : +100%	W : UL-CSA 部品		
CF : メタライズド	2C : 160 V	- 0%	F : リード線成形		
CH : メタライズド	2D : 200 V	C : ±0.25pF			
	2E : 250 V	D : ±0.5pF			
	2H : 500 V	= : その他			
	2J : 630 V				

* **容量値**

● **電解コンデンサの場合**

22 2 ⇒ 2200μF
 有効数字につづく0の数を表わす。
 2桁の有効数字を表わす。
 単位はμF

2R 2 ⇒ 2.2μF
 1桁の有効数字を表わす。
 2桁の有効数字で小数点はRで表わす。
 単位はμF

● **電解コンデンサ以外の場合**

22 2 ⇒ 2200pF=0.0022μF
 有効数字につづく0の数を表わす。
 (0の数が2以上の場合)
 2桁の有効数字を表わす。
 単位はpF

22 1 ⇒ 220pF
 有効数字につづく0の数を表わす。
 (0の数が0または1の場合)
 2桁の有効数字を表わす。
 単位はpF

● 耐圧を交流で表示する場合は、耐圧表示の次に「AC」を表示します。

PARTS LIST OF P.W.B. UNIT(for AVR-1707/687 model)

*本表に記載されている部品は、補修用部品のため製品に使用している部品とは一部、形状、寸法などが異なる場合があります。

* The parts listed below are for maintenance only, might differ from the parts used in the unit in appearances or dimensions.

* "nsp" 印の部品は常時在庫していませんので供給に長時間を要することがあります。場合によっては、供給をお断りする場合があります。

* Part indicated with the mark "nsp" are not always in stock and possibly to take a long period of time for supplying, or in some case supplying of part may be refused.

Note: The symbols in the column "Remarks" indicate the following destinations.

1707E3 : U.S.A. & Canada model 1707E2 : Europe model 1707EUT : Taiwan R.O.C. model

687E3 : U.S.A. & Canada model (AVR-687)

MAIN P.W.B. UNIT ASSY

	Ref. No.	nsp	Part No.	Part Name	Remarks		Q'ty	New
SEMICONDUCTORS GROUP								
	IC101		00D 963 0219 408	IC CJ7815		J126781500090S		
	IC102		00D 963 0219 505	IC CJ7915F		J126791500070S		
	IC103		00D 963 0057 806	IC KIA78R05PI		J126780500370S		
	IC104		00D 963 0219 204	IC CJ7805		J126780500430S		
△	IC105,106		00D 960 0195 808	IC ICP-N15		J120001500030S		
	Q104C		00D 960 0196 506	TR KSC1845F		J5021845F0000P		
	Q104FL		00D 960 0196 506	TR KSC1845F		J5021845F0000P		
	Q104FR		00D 960 0196 506	TR KSC1845F		J5021845F0000P		
	Q104SL		00D 960 0196 506	TR KSC1845F		J5021845F0000P		
	Q104SR		00D 960 0196 506	TR KSC1845F		J5021845F0000P		
	Q111-115		00D 963 0121 208	TR KRC107M		J6020107M0010S		
	Q116		00D 960 0196 409	TR 2SC1740SR		J5021740S0010S		
	Q117,118		00D 963 0121 208	TR KRC107M		J6020107M0010S		
	Q151		00D 960 0196 409	TR 2SC1740SR		J5021740S0010S		
	Q171		00D 960 0196 700	TR KTC3200BL		J5023200B0050S		
	Q171A		00D 960 0196 302	TR KTA1268BL		J5001268B0050S		
	Q171B		00D 960 0196 302	TR KTA1268BL		J5001268B0050S		
	Q171C		00D 960 0196 302	TR KTA1268BL		J5001268B0050S		
	Q171D		00D 960 0196 302	TR KTA1268BL		J5001268B0050S		
	Q172-177		00D 960 0196 700	TR KTC3200BL		J5023200B0050S		
	Q178		00D 960 0196 302	TR KTA1268BL		J5001268B0050S		
	Q179		00D 960 0133 103	TR KSA916Y		J5000916Y0050P		
	Q180,181		00D 960 0196 302	TR KTA1268BL		J5001268B0050S		
	Q182,183		00D 960 0196 700	TR KTC3200BL		J5023200B0050S		
	D101		00D 963 0020 309	D,SWITCHING 1SS133T		K000013300520S		
	D101C		00D 963 0219 709	D,SWITCHING 1N4148W		K005041480020S		
	D101FL		00D 963 0219 709	D,SWITCHING 1N4148W		K005041480020S		
	D101FR		00D 963 0219 709	D,SWITCHING 1N4148W		K005041480020S		
	D101SL		00D 963 0219 709	D,SWITCHING 1N4148W		K005041480020S		
	D101SR		00D 963 0219 709	D,SWITCHING 1N4148W		K005041480020S		
	D102		00D 963 0020 309	D,SWITCHING 1SS133T		K000013300520S		
	D102C		00D 963 0219 709	D,SWITCHING 1N4148W		K005041480020S		
	D102FL		00D 963 0219 709	D,SWITCHING 1N4148W		K005041480020S		
	D102FR		00D 963 0219 709	D,SWITCHING 1N4148W		K005041480020S		
	D102SL		00D 963 0219 709	D,SWITCHING 1N4148W		K005041480020S		
	D102SR		00D 963 0219 709	D,SWITCHING 1N4148W		K005041480020S		
	D103-105		00D 963 0020 309	D,SWITCHING 1SS133T		K000013300520S		
	D121-127		00D 963 0020 309	D,SWITCHING 1SS133T		K000013300520S		
	D131A		00D 960 0197 107	D,RECTIFIER BRIDGE KBPC604		K047604000020P		
	D131B		00D 960 0197 107	D,RECTIFIER BRIDGE KBPC604		K047604000020P		
	D132		00D 963 0020 309	D,SWITCHING 1SS133T		K000013300520S		
	D135		00D 963 0020 309	D,SWITCHING 1SS133T		K000013300520S		
	D137		00D 963 0020 309	D,SWITCHING 1SS133T		K000013300520S		
	D138A		00D 963 0058 407	D,SWITCHING IN4007		K000400700520S		
	D141-146		00D 963 0058 407	D,SWITCHING IN4007		K000400700520S		
	D148		00D 963 0020 309	D,SWITCHING 1SS133T		K000013300520S		
	D149,150		00D 963 0058 407	D,SWITCHING IN4007		K000400700520S		
	D151		00D 963 0020 309	D,SWITCHING 1SS133T		K000013300520S		

	Ref. No.	nsp	Part No.	Part Name	Remarks		Q'ty	New
	D152,153 D158-160		00D 963 0058 407 00D 963 0020 309	D,SWITCHING IN4007 D,SWITCHING 1SS133T		K000400700520S K000013300520S		
	ZD101C		00D 963 0279 804	D,ZENER 0.2W 4.3V UDZ S		K06604R34P410S		
	ZD101FL ZD101FR ZD101SL ZD101SR ZD102C		00D 963 0279 804 00D 963 0279 804 00D 963 0279 804 00D 963 0279 804 00D 963 0295 503	D,ZENER 0.2W 4.3V UDZ S D,ZENER 0.2W 4.3V UDZ S D,ZENER 0.2W 4.3V UDZ S D,ZENER 0.2W 4.3V UDZ S D,ZENER 0.2W 3.6V UDZ S		K06604R34P410S K06604R34P410S K06604R34P410S K06604R34P410S K06603R64P400S		
	ZD102FL ZD102FR ZD102SL ZD102SR ZD133,134		00D 963 0295 503 00D 963 0295 503 00D 963 0295 503 00D 963 0295 503 00D 963 0046 202	D,ZENER 0.2W 3.6V UDZ S D,ZENER 0.2W 3.6V UDZ S D,ZENER 0.2W 3.6V UDZ S D,ZENER 0.2W 3.6V UDZ S D,ZENER MTZJ18B		K06603R64P400S K06603R64P400S K06603R64P400S K06603R64P400S K06018R044520S		
	ZD136 ZD154 ZD157 ZD341,342		00D 963 0058 601 00D 960 0095 704 00D 963 0219 903 00D 960 0095 500	D,ZENER MTZJ12B D,ZENER MTZJ6.2B D,ZENER MTZJ16B D,ZENER MTZJ5.1B		K06012R044520S K06006R244520S K06016R044520S K06005R144520S		
	LED901		00D 963 0148 605	LED SML1216W RED/GREEN		K500052600030		
RESISTORS GROUP								
	R104C		00D 963 9006 285	R,FIXED 1WJ-5.6K		N113135656220F		
	R104FL R104FR R104SL R104SR R105C		00D 963 9006 285 00D 963 9006 285 00D 963 9006 285 00D 963 9006 285 00D 963 9006 285	R,FIXED 1WJ-5.6K R,FIXED 1WJ-5.6K R,FIXED 1WJ-5.6K R,FIXED 1WJ-5.6K R,FIXED 1WJ-5.6K		N113135656220F N113135656220F N113135656220F N113135656220F N113135656220F		
	R105FL R105FR R105SL R105SR R106C		00D 963 9006 285 00D 963 9006 285 00D 963 9006 285 00D 963 9006 285 00D 963 0215 907	R,FIXED 1WJ-5.6K R,FIXED 1WJ-5.6K R,FIXED 1WJ-5.6K R,FIXED 1WJ-5.6K R,METAL FILM 4.7-J,1W		N113135656220F N113135656220F N113135656220F N113135656220F C0604R7065050S		
	R106FL R106FR R106SL R106SR R107C		00D 963 0215 907 00D 963 0215 907 00D 963 0215 907 00D 963 0215 907 00D 963 0215 907	R,METAL FILM 4.7-J,1W R,METAL FILM 4.7-J,1W R,METAL FILM 4.7-J,1W R,METAL FILM 4.7-J,1W R,METAL FILM 4.7-J,1W		C0604R7065050S C0604R7065050S C0604R7065050S C0604R7065050S C0604R7065050S		
	R107FL R107FR R107SL R107SR R108C		00D 963 0215 907 00D 963 0215 907 00D 963 0215 907 00D 963 0215 907 00D 963 9006 269	R,METAL FILM 4.7-J,1W R,METAL FILM 4.7-J,1W R,METAL FILM 4.7-J,1W R,METAL FILM 4.7-J,1W R,FIXED 1WJ-0.22		C0604R7065050S C0604R7065050S C0604R7065050S C0604R7065050S N113135622820F		
	R108FL R108FR R108SL R108SR R109C		00D 963 9006 269 00D 963 9006 269 00D 963 9006 269 00D 963 9006 269 00D 963 9006 269	R,FIXED 1WJ-0.22 R,FIXED 1WJ-0.22 R,FIXED 1WJ-0.22 R,FIXED 1WJ-0.22 R,FIXED 1WJ-0.22		N113135622820F N113135622820F N113135622820F N113135622820F N113135622820F		
	R109FL R109FR R109SL R109SR R110C		00D 963 9006 269 00D 963 9006 269 00D 963 9006 269 00D 963 9006 269 00D 963 9006 269	R,FIXED 1WJ-0.22 R,FIXED 1WJ-0.22 R,FIXED 1WJ-0.22 R,FIXED 1WJ-0.22 R,FIXED 1WJ-0.22		N113135622820F N113135622820F N113135622820F N113135622820F N113135622820F		
	R110FL R110FR R110SL R110SR R111C		00D 963 9006 269 00D 963 9006 269 00D 963 9006 269 00D 963 9006 269 00D 963 9006 269	R,FIXED 1WJ-0.22 R,FIXED 1WJ-0.22 R,FIXED 1WJ-0.22 R,FIXED 1WJ-0.22 R,FIXED 1WJ-0.22		N113135622820F N113135622820F N113135622820F N113135622820F N113135622820F		
	R111FL R111FR R111SL R111SR R118C		00D 963 9006 269 00D 963 9006 269 00D 963 9006 269 00D 963 9006 269 00D 963 9006 256	R,FIXED 1WJ-0.22 R,FIXED 1WJ-0.22 R,FIXED 1WJ-0.22 R,FIXED 1WJ-0.22 R,FIXED 1WJ-10		N113135622820F N113135622820F N113135622820F N113135622820F N113135610020F		

Ref. No.	nsp	Part No.	Part Name	Remarks		Q'ty	New
R118FL		00D 963 9006 256	R, FIXED 1WJ-10		N113135610020F		
R118FR		00D 963 9006 256	R, FIXED 1WJ-10		N113135610020F		
R118SL		00D 963 9006 256	R, FIXED 1WJ-10		N113135610020F		
R118SR		00D 963 9006 256	R, FIXED 1WJ-10		N113135610020F		
R119C		00D 963 9006 256	R, FIXED 1WJ-10		N113135610020F		
R119FL		00D 963 9006 256	R, FIXED 1WJ-10		N113135610020F		
R119FR		00D 963 9006 256	R, FIXED 1WJ-10		N113135610020F		
R119SL		00D 963 9006 256	R, FIXED 1WJ-10		N113135610020F		
R119SR		00D 963 9006 256	R, FIXED 1WJ-10		N113135610020F		
R135,136		00D 963 0144 502	R, CEMENT 0.1-J 5W		C141R10069000S		
R141,142		00D 963 0216 003	R, METAL FILM 0.22-J, 1W		C060R22065050S		
R148,149		00D 963 0216 003	R, METAL FILM 0.22-J, 1W		C060R22065050S		
R151		00D 963 0232 809	R, METAL FILM 10-J, 1/4W	1707E3,687E3,1707EUT	C060010063520S		
R154		00D 963 0244 305	R, METAL FILM 2.2M 0.5W		C060022564520S		
R179		00D 963 0232 906	R, METAL FILM 47K-F, 1/4W		C060047343530S		
R184		00D 963 9006 256	R, FIXED 1WJ-10		N113135610020F		
R901,902		00D 960 9009 270	R, METAL FILM 470-J, 2W		C060047166520S		
VR101-105		00D 960 0091 601	VR, SEMI CERMET 1KB		C544102015130P		
CAPACITORS GROUP							
C101C		00D 963 0234 506	C, ELECT 47UF-M/50V(Pb Free)		D040470087070F		
C101FL		00D 963 0234 506	C, ELECT 47UF-M/50V(Pb Free)		D040470087070F		
C101FR		00D 963 0234 506	C, ELECT 47UF-M/50V(Pb Free)		D040470087070F		
C101SL		00D 963 0234 506	C, ELECT 47UF-M/50V(Pb Free)		D040470087070F		
C101SR		00D 963 0234 506	C, ELECT 47UF-M/50V(Pb Free)		D040470087070F		
C102C		00D 963 0234 205	C, ELECT 10UF-M/50V		D040100087070F		
C102FL		00D 963 0234 205	C, ELECT 10UF-M/50V		D040100087070F		
C102FR		00D 963 0234 205	C, ELECT 10UF-M/50V		D040100087070F		
C102SL		00D 963 0234 205	C, ELECT 10UF-M/50V		D040100087070F		
C102SR		00D 963 0234 205	C, ELECT 10UF-M/50V		D040100087070F		
C103C		00D 963 9003 084	C, CERAMIC100PF-K/500V		D00410106D050S		
C103FL		00D 963 9003 084	C, CERAMIC100PF-K/500V		D00410106D050S		
C103FR		00D 963 9003 084	C, CERAMIC100PF-K/500V		D00410106D050S		
C103SL		00D 963 9003 084	C, CERAMIC100PF-K/500V		D00410106D050S		
C103SR		00D 963 9003 084	C, CERAMIC100PF-K/500V		D00410106D050S		
C104C		00D 963 9003 084	C, CERAMIC100PF-K/500V		D00410106D050S		
C104FL		00D 963 9003 084	C, CERAMIC100PF-K/500V		D00410106D050S		
C104FR		00D 963 9003 084	C, CERAMIC100PF-K/500V		D00410106D050S		
C104SL		00D 963 9003 084	C, CERAMIC100PF-K/500V		D00410106D050S		
C104SR		00D 963 9003 084	C, CERAMIC100PF-K/500V		D00410106D050S		
C105C		00D 960 9003 108	C, CERAMIC 0.022UF-Z/25V		D005223594520S		
C105FL		00D 960 9003 108	C, CERAMIC 0.022UF-Z/25V		D005223594520S		
C105FR		00D 960 9003 108	C, CERAMIC 0.022UF-Z/25V		D005223594520S		
C105SL		00D 960 9003 108	C, CERAMIC 0.022UF-Z/25V		D005223594520S		
C105SR		00D 960 9003 108	C, CERAMIC 0.022UF-Z/25V		D005223594520S		
C107C		00D 963 9003 097	C, FILM 0.1UF-K/250V		D02010407H080S		
C107FL		00D 963 9003 097	C, FILM 0.1UF-K/250V		D02010407H080S		
C107FR		00D 963 9003 097	C, FILM 0.1UF-K/250V		D02010407H080S		
C107SL		00D 963 9003 097	C, FILM 0.1UF-K/250V		D02010407H080S		
C107SR		00D 963 9003 097	C, FILM 0.1UF-K/250V		D02010407H080S		
C131-135		00D 963 9003 097	C, FILM 0.1UF-K/250V		D02010407H080S		
C136,137		00D 963 0149 400	CAP.E.GENERIC 10000UF/63V		N211210388110F		
C138		00D 963 0293 602	C, ELECT 1UF-M/50V (Pb Free)		D040010087150F		
C138A		00D 963 9003 097	C, FILM 0.1UF-K/250V		D02010407H080S		
C141-143		00D 963 0021 900	C, FILM 0.047UF-J/100V		D02047306C060P		
C144		00D 963 0217 109	C, ELECT 3300UF-M/35V		D040332085010F		
C145		00D 963 9003 123	C, ELECT 1000UF-M/35V		D040102085040F		
C146		00D 963 0293 602	C, ELECT 1UF-M/50V (Pb Free)		D040010087150F		
C148		00D 963 0293 602	C, ELECT 1UF-M/50V (Pb Free)		D040010087150F		
C150-152		00D 963 0021 900	C, FILM 0.047UF-J/100V		D02047306C060P		
C153		00D 963 0021 104	C, ELECT 6800UF-M/16V		D040682083000F		
C154		00D 963 0234 205	C, ELECT 10UF-M/50V		D040100087070F		

	Ref. No.	nsp	Part No.	Part Name	Remarks		Q'ty	New
	C155		00D 963 0020 202	C,CERAMIC 0.1UF-Z/50V		D005104597530S		
	C157		00D 963 0293 602	C,ELECT 1UF-M/50V (Pb Free)		D040010087150F		
	C158		00D 963 0217 002	C,ELECT 3300UF-M/16V		D040332083010F		
	C159		00D 963 0293 602	C,ELECT 1UF-M/50V (Pb Free)		D040010087150F		
	C161		00D 963 0234 205	C,ELECT 10UF-M/50V		D040100087070F		
	C171		00D 963 0293 709	C,ELECT 100UF-M/10V		D040101082070F		
	C171A		00D 963 0020 202	C,CERAMIC 0.1UF-Z/50V		D005104597530S		
	C171B		00D 963 0020 202	C,CERAMIC 0.1UF-Z/50V		D005104597530S		
	C171C		00D 963 0020 202	C,CERAMIC 0.1UF-Z/50V		D005104597530S		
	C171D		00D 963 0020 202	C,CERAMIC 0.1UF-Z/50V		D005104597530S		
	C172,173		00D 963 9005 833	C,ELECT 220UF-M/6.3V		D040221081230F		
	C174		00D 963 0234 205	C,ELECT 10UF-M/50V		D040100087070F		
	C175		00D 963 9006 544	C,ELECT 22UF-M/25V		D040220084050F		
	C176,177		00D 963 0293 602	C,ELECT 1UF-M/50V (Pb Free)		D040010087150F		
	C178		00D 963 9003 149	C,ELECT 330UF-M/63V		D040331088230F		
	C179		00D 963 9005 833	C,ELECT 220UF-M/6.3V		D040221081230F		
⚠	C181		00D 963 9006 191	C,CERAMIC AC(SAFETY) AC13F472MDOA		D00847208K070S		
	C182		00D 963 0234 302	C,ELECT 10UF-M/100V		D04010008C050F		
	C191-198		00D 963 0233 400	C,CERAMIC 2200PF-K/16V	1707E2	D005222773530S		
	C198C		00D 963 0024 703	C,FILM 0.01UF-J/100V	1707E2	D02010306C060P		
	C198FL		00D 963 0024 703	C,FILM 0.01UF-J/100V	1707E2	D02010306C060P		
	C198FR		00D 963 0024 703	C,FILM 0.01UF-J/100V	1707E2	D02010306C060P		
	C198SBL		00D 963 0024 703	C,FILM 0.01UF-J/100V	1707E2	D02010306C060P		
	C198SBR		00D 963 0024 703	C,FILM 0.01UF-J/100V	1707E2	D02010306C060P		
	C198SL		00D 963 0024 703	C,FILM 0.01UF-J/100V	1707E2	D02010306C060P		
	C198SR		00D 963 0024 703	C,FILM 0.01UF-J/100V	1707E2	D02010306C060P		
	C199		00D 963 0233 400	C,CERAMIC 2200PF-K/16V	1707E2	D005222773530S		
	C199FL		00D 963 0024 703	C,FILM 0.01UF-J/100V	1707E2	D02010306C060P		
	C199FR		00D 963 0024 703	C,FILM 0.01UF-J/100V	1707E2	D02010306C060P		
	C341,342		00D 963 0233 303	C,CERAMIC 0.01UF-M/16V		D005103773530S		
	C901,902		00D 963 0233 206	C,CERAMIC 0.001UF-K/50V		D005102177530S		
	C903		00D 963 0233 109	C,CERAMIC 0.01UF-Z/50V		D004103097060S		
	C904		00D 960 9003 108	C,CERAMIC 0.022UF-Z/25V		D005223594520S		
	C905		00D 963 0020 202	C,CERAMIC 0.1UF-Z/50V		D005104597530S		
OTHERS PARTS GROUP								
	CLAMP101	nsp	00D 960 0260 005	CLAMP WIRE		4330000120000S		
	CN201	nsp	00D 963 0148 702	CN,WIRE 120MM/2P		L000121020120P		
	CN901	nsp	00D 963 0184 601	CN,WIRE 260MM/3P		L000261030070P		
	CN992	nsp	00D 963 0235 602	CN,WIRE 270MM/4P		L000271040030P		
	CP101		00D 963 0267 803	CN.WAFER 2P		L108202000220F		
	CP102	nsp	00D 960 0123 304	CN.WAFER 2P		L104353280200S		
	CP103	nsp	00D 963 0066 208	CN.WAFER 3P		L104353280300S		
	CP104	nsp	00D 960 0128 804	CN.WAFER 6P		L102526700600S		
	CP105	nsp	00D 963 0149 109	CN.WAFER (BLACK) 2P		L104353280201S		
	CP106	nsp	00D 960 0123 207	CN.WAFER 3P		L102526700300S		
	CP138A	nsp	00D 960 0123 207	CN.WAFER 3P		L102526700300S		
	CP302		00D 963 0257 800	CN.WAFER 07P		L101220070010S		
	CP501	nsp	00D 963 0206 301	CN.WAFER 5P		L101100040510S		
	CP502	nsp	00D 963 0206 408	CN.WAFER 7P		L101100040710S		
	CP503	nsp	00D 963 0206 301	CN.WAFER 5P		L101100040510S		
	CP504	nsp	00D 963 0206 505	CN.WAFER 9P		L101100040910S		
	CP505	nsp	00D 963 0235 709	CN.WAFER 12P		L101100041210S		
	CP555	nsp	00D 963 0111 108	CN.WAFER 14P		L101100041410S		
	CP556	nsp	00D 963 0087 805	CN.WAFER 11P		L101100041110S		
	CP901,902	nsp	00D 963 0235 806	CN.WAFER 3P		L101220030000S		
	CP931	nsp	00D 963 0149 206	CN.WAFER 2P		L104353280203S		
⚠	F101		00D 963 0236 106	FUSE T8A/250V	1707E3,687E3,1707EUT	N751228001110S		
⚠	F101		00D 963 0104 704	FUSE T2.5A/250V	1707E2	N751222501110S		

	Ref. No.	nsp	Part No.	Part Name	Remarks		Q'ty	New
⚠	F102		00D 963 0236 106	FUSE T8A/250V	1707E3,687E3,1707EUT	N751228001110S		
⚠	F102		00D 963 0104 704	FUSE T3.15A/250V	1707E2	N751223151110S		
	F101A	nsp	00D 960 0005 804	HOLDER,FUSE CLIP		G645000050010		
	F101B	nsp	00D 960 0005 804	HOLDER,FUSE CLIP		G645000050010		
	F102A	nsp	00D 960 0005 804	HOLDER,FUSE CLIP		G645000050010		
	F102B	nsp	00D 960 0005 804	HOLDER,FUSE CLIP		G645000050010		
	G901		00D 963 0257 907	CN,WIRE 160MM/1P		N602141610310F		
	GND101-103		-	TERMINAL EARTH		3790040886000S		
	L101C	nsp	00D 963 0049 005	COIL INDUCTOR 0.5UH		D330R50000000F		
	L101FL	nsp	00D 963 0049 005	COIL INDUCTOR 0.5UH		D330R50000000F		
	L101FR	nsp	00D 963 0049 005	COIL INDUCTOR 0.5UH		D330R50000000F		
	L101SL	nsp	00D 963 0049 005	COIL INDUCTOR 0.5UH		D330R50000000F		
	L101SR	nsp	00D 963 0049 005	COIL INDUCTOR 0.5UH		D330R50000000F		
	RLY101-104		00D 960 0181 702	RELAY G5PA-28 24V 5A		G680240502020S		
	RLY105		00D 963 0218 506	RELAY BC3-24 24V 2A		G680240202040F		
	RLY106		00D 963 0218 205	RELAY G5PA-1 DC9V 250V/5A		G680090102010F		
	RLY107		00D 960 0181 702	RELAY G5PA-28 24V 5A		G680240502020S		
	SW901		00D 963 0200 103	SW,TACT SKHV10920A		G180000270010S		
	TP101-105	nsp	00D 960 0161 405	CN.WAFER 3P		L101530140310S		
	VEC303		00D 963 0095 208	SW,ENCODER EC16B24SA		G121162400040S		
			-	HEAT SINK		2120043538050S		
			-	HEAT SINK		2120044308010S		
⚠			00D 963 0232 100	STAND BY TRANS 120V/60HZ	1707E3,687E3,1707EUT	8200350150200S		
⚠			00D 963 0215 606	STAND BY TRANS 230V/50HZ	1707E2	8200350150210S		
		nsp	00D 963 0018 007	SCREW, 3*8 B-TYPE ZNY/BH		B020030081B10S		
			00D 963 0158 608	2P TER, SP		G611201A0200YS		
			00D 963 0119 906	8P TER, SP		G614801A0200YS		
			00D 963 0294 708	JACK,D6.5 PHONE		G402PJ612AG0YS		
⚠			00D 960 0181 508	AC OUTLET(E3)	1707E3,687E3,1707EUT	G435204004010S		
⚠			00D 960 0143 203	AC OUTLET(E2)	1707E2	G435040110000S		
			00D 963 0247 001	LABEL, FUSE (F102)	1707E2	5527200040030S		
			-	COVER CAPACITOR	1707E2	4310002640010S		

CPU P.W.B. UNIT ASSY

	Ref. No.	nsp	Part No.	Part Name	Remarks		Q'ty	New
SEMICONDUCTORS GROUP								
	IC201		00D 262 3651 009	M3062LFGPFP				
	IC202		00D 963 0057 602	IC TDA7330BD	1707E2	J080733000010F		
	IC272		00D 963 0219 301	IC CJ7806		J126780600190S		
	IC273		00D 963 0235 107	IC CJ7906F		J126790600040S		
	IC301		00D 262 2549 002	LC75721E +C				
	IC302		00D 963 0074 504	IC BU2090F		J044209000010P		
	Q202		00D 963 0121 509	TR KTC3875S		J522038750210S		
	Q203,204		00D 963 0044 301	TR KTC2875B		J5222875B0010S		
	Q205		00D 963 0120 704	TR KRA102S		J520010200210S		
	Q206,207		00D 963 0044 301	TR KTC2875B		J5222875B0010S		
	Q251		00D 963 0120 704	TR KRA102S		J520010200210S		
	Q261		00D 963 0148 508	TR KTA1504S	1707E2	J520015040150S		
	Q262		00D 960 0111 808	TR KRC107S	1707E2	J5020107S0050S		
	Q263		00D 960 0285 006	TR KRC104S		J522104S00210S		
	Q301		00D 963 0120 704	TR KRA102S		J520010200210S		
	Q310		00D 963 0120 704	TR KRA102S		J520010200210S		
	Q311		00D 963 0120 801	TR KRC102S		J522010200210S		
	Q312		00D 963 0120 704	TR KRA102S		J520010200210S		
	Q313		00D 963 0120 801	TR KRC102S		J522010200210S		
	Q314		00D 963 0120 704	TR KRA102S		J520010200210S		
	Q315		00D 963 0120 801	TR KRC102S		J522010200210S		
	Q321		00D 963 0102 803	TR 2SA933S		J5000933S0050S		
	Q322		00D 960 0111 808	TR KRC107S		J5020107S0050S		
	Q901,902		00D 963 0120 704	TR KRA102S		J520010200210S		
	D201		00D 963 0020 309	D,SWITCHING 1SS133T		K000013300520S		
	D202		00D 963 0058 407	D,SWITCHING IN4007		K000400700520S		
	D203-205		00D 963 0219 709	D,SWITCHING 1N4148W	1707E3,687E3,1707EUT	K005041480020S		
	D203-206		00D 963 0219 709	D,SWITCHING 1N4148W	1707E2	K005041480020S		
	D209,210		00D 963 0020 309	D,SWITCHING 1SS133T		K000013300520S		
	D302-304		00D 963 0020 309	D,SWITCHING 1SS133T		K000013300520S		
	D305		00D 963 0219 709	D,SWITCHING 1N4148W		K005041480020S		
	D307		00D 963 0020 309	D,SWITCHING 1SS133T		K000013300520S		
	D308,309		00D 963 0219 709	D,SWITCHING 1N4148W		K005041480020S		
	ZD201		00D 963 0047 502	D,ZENER MTZJ3.3B		K06003R344520S		
	ZD301		00D 960 0095 801	D,ZENER MTZJ6.8B		K06006R844520S		
	ZD331,332		00D 960 0095 500	D,ZENER MTZJ5.1B		K06005R144520S		
	ZD335,336		00D 960 0095 500	D,ZENER MTZJ5.1B		K06005R144520S		
	LED301-304		00D 960 0197 204	LED PI5-RD/HL50RDRF4T		K500052015010S		
	LED306		00D 960 0197 204	LED PI5-RD/HL50RDRF4T		K500052015010S		
	LED308-311		00D 960 0197 204	LED PI5-RD/HL50RDRF4T		K500052015010S		
	FL301		00D 963 0257 305	DISPLAY,FLT HNA-16SM13T		K530161300020S		
RESISTORS GROUP								
	R211		00D 960 9003 807	R,METAL FILM 100-J,1/4W		C060010163050S		
CAPACITORS GROUP								
	C201	nsp	00D 963 9004 698	C,CERAMIC 0.01UF-K/50V		D011103777160S		
	C202	nsp	00D 963 9004 711	C,CERAMIC 0.1UF-Z/50V		D011104597160S		
	C203	nsp	00D 963 9004 698	C,CERAMIC 0.01UF-K/50V		D011103777160S		
	C204		00D 960 9010 010	C,ELECT 4.7UF-M/50V		D0404R7087250F		
	C205		00D 963 0020 202	C,CERAMIC 0.1UF-Z/50V		D005104597530S		
	C206		00D 963 9005 862	C,ELECT 47UF-M/16V	1707E2	D040470083080F		
	C207	nsp	00D 963 9004 698	C,CERAMIC 0.01UF-K/50V	1707E2	D011103777160S		

Ref. No.	nsp	Part No.	Part Name	Remarks		Q'ty	New
C208		00D 963 0223 708	C,CERAMIC 270PF-J/50V	1707E2	D010271167160S		
C209		00D 963 0234 205	C,ELECT 10UF-M/50V	1707E2	D040100087070F		
C210	nsp	00D 963 9004 698	C,CERAMIC 0.01UF-K/50V	1707E2	D011103777160S		
C211,212		00D 963 9004 614	C,CERAMIC 27PF-J/50V	1707E2	D010270167160S		
C221		00D 963 0293 709	C,ELECT 100UF-M/10V		D040101082070F		
C261,262	nsp	00D 963 0223 601	C,CERAMIC 100PF-J/50V		D010101167160S		
C267-270	nsp	00D 963 0223 601	C,CERAMIC 100PF-J/50V		D010101167160S		
C275	nsp	00D 963 9004 711	C,CERAMIC 0.1UF-Z/50V		D011104597160S		
C276,277		00D 963 0234 205	C,ELECT 10UF-M/50V		D040100087070F		
C278	nsp	00D 963 9004 711	C,CERAMIC 0.1UF-Z/50V		D011104597160S		
C279	nsp	00D 963 0223 601	C,CERAMIC 100PF-J/50V		D010101167160S		
C291,292		00D 963 9004 517	C,CERAMIC 0.022UF-Z/50V		D004223597050S		
C293		00D 963 0233 303	C,CERAMIC 0.01UF-M/16V		D005103773530S		
C294	nsp	00D 963 9004 698	C,CERAMIC 0.01UF-K/50V		D011103777160S		
C295		00D 963 0233 303	C,CERAMIC 0.01UF-M/16V		D005103773530S		
C301		00D 963 0234 205	C,ELECT 10UF-M/50V		D040100087070F		
C302	nsp	00D 963 0234 001	C,CERAMIC 0.047UF-Z/50V		D011473597160S		
C303		00D 963 9005 862	C,ELECT 47UF-M/16V		D040470083080F		
C304		00D 960 9003 108	C,CERAMIC 0.022UF-Z/25V		D005223594520S		
C305		00D 963 9005 862	C,ELECT 47UF-M/16V		D040470083080F		
C306		00D 963 0216 401	C,FILM 0.1UF-J/100V		D02010406C060P		
C307		00D 963 0293 602	C,ELECT 1UF-M/50V (Pb Free)		D040010087150F		
C308,309		00D 963 0021 900	C,FILM 0.047UF-J/100V		D02047306C060P		
C310		00D 963 0293 602	C,ELECT 1UF-M/50V (Pb Free)		D040010087150F		
C311	nsp	00D 963 0233 701	C,CERAMIC 30PF-J/50V		D010300167160S		
C312		00D 963 9005 859	C,ELECT 47UF-M/16V		D040470083060F		
C313		-	C,FILM 0.047UF-J/100V		D02047306C070S		
C321	nsp	00D 963 0224 105	C,CERAMIC 1000PF-K/50V		D011102777160S		
C322	nsp	00D 963 0223 601	C,CERAMIC 100PF-J/50V		D010101167160S		
C324,325	nsp	00D 963 0223 601	C,CERAMIC 100PF-J/50V		D010101167160S		
C326X	nsp	00D 963 0223 601	C,CERAMIC 100PF-J/50V		D010101167160S		
C331,332		00D 963 0233 303	C,CERAMIC 0.01UF-M/16V		D005103773530S		
C335,336		00D 963 0233 303	C,CERAMIC 0.01UF-M/16V		D005103773530S		
C343X	nsp	00D 963 0223 601	C,CERAMIC 100PF-J/50V		D010101167160S		
C381		00D 963 9005 862	C,ELECT 47UF-M/16V		D040470083080F		
C382,383	nsp	00D 963 0223 601	C,CERAMIC 100PF-J/50V		D010101167160S		
C384,385		00D 963 0293 602	C,ELECT 1UF-M/50V (Pb Free)		D040010087150F		
C386	nsp	00D 963 0234 001	C,CERAMIC 0.047UF-Z/50V		D011473597160S		
C387,388	nsp	00D 963 9004 711	C,CERAMIC 0.1UF-Z/50V		D011104597160S		
BC201		00D 254 4666 005	CE04W0H105ZC(FG)				
OTHERS PARTS GROUP							
BD201-203	nsp	00D 963 0154 602	BEAD,COIL 3580-AX		7610010030000S		
BD301-303	nsp	00D 963 0234 603	BEAD,COIL MB-160808		D340160800060S		
CN201		00D 963 0245 906	CN,WIRE 240MM/6P		L000241060020F		
CN302		00D 963 0159 209	CN,WIRE 100MM/7P		L000101070080P		
CN902		00D 963 0246 002	CN,WIRE 80MM/3P		L000800030110P		
CN931	nsp	00D 963 0148 809	CN,WIRE 350MM/2P		L000351020100P		
CP201	nsp	00D 963 0097 604	CN.WAFER 6P		L101220060000S		
CP301A	nsp	00D 963 0161 103	CN.FPC 23P		L131112300010F		
CP301B	nsp	00D 963 0161 006	CN.FPC 23P		L131102300010F		
CP303	nsp	00D 963 0236 009	CN.WAFER 3P		L102526803010S		
CP401	nsp	00D 963 0235 709	CN.WAFER 12P		L101100041210S		
CP402	nsp	00D 963 0087 805	CN.WAFER 11P		L101100041110S		
CP404	nsp	00D 963 0087 407	CN.WAFER 16P		L101100041610S		
CP552	nsp	00D 963 0097 507	CN.WAFER 15P		L101100041510S		
CP553	nsp	00D 963 0087 805	CN.WAFER 11P		L101100041110S		
CP601	nsp	00D 963 0087 601	CN.WAFER 18P		L101100041810S		
CP602	nsp	00D 963 0087 805	CN.WAFER 11P		L101100041110S		
CP701	nsp	00D 963 0097 507	CN.WAFER 15P		L101100041510S		

Ref. No.	nsp	Part No.	Part Name	Remarks		Q'ty	New
CP702	nsp	00D 963 0087 504	CN.WAFER 19P		L101100041910S		
CP703	nsp	00D 963 0097 507	CN.WAFER 15P		L101100041510S		
CP704		00D 963 0256 908	CN.WAFER 10P		L101100041010S		
CP801	nsp	00D 963 0087 601	CN.WAFER 18P		L101100041810S		
CP802	nsp	00D 963 0087 504	CN.WAFER 19P		L101100041910S		
CP803	nsp	00D 963 0087 407	CN.WAFER 16P		L101100041610S		
G301		00D 963 0257 509	RING,TER WIRE 80MM/1P		8410800010100F		
GND201		-	TERMINAL EARTH		3790040886000S		
L301	nsp	00D 960 0128 008	COIL,INDUCTOR 100UH		D330101001020S		
L302	nsp	00D 960 0010 307	COIL,INDUCTOR 10UH		D330100700520S		
RMC301		00D 963 0217 808	MODULE,REMOCON NJL34H380A		E940343800010P		
SW301C		00D 963 0200 103	SW,TACT SKHV10920A		G180000270010S		
SW302A		00D 963 0095 305	SW,TACT SKHV10910D01		G180040500010S		
SW302B		00D 963 0095 305	SW,TACT SKHV10910D01		G180040500010S		
SW302C		00D 963 0200 103	SW,TACT SKHV10920A		G180000270010S		
SW303A		00D 963 0095 305	SW,TACT SKHV10910D01		G180040500010S		
SW303B		00D 963 0095 305	SW,TACT SKHV10910D01		G180040500010S		
SW303C		00D 963 0200 103	SW,TACT SKHV10920A		G180000270010S		
SW304A		00D 963 0095 305	SW,TACT SKHV10910D01		G180040500010S		
SW304B		00D 963 0095 305	SW,TACT SKHV10910D01		G180040500010S		
SW304C		00D 963 0200 103	SW,TACT SKHV10920A		G180000270010S		
SW305A		00D 963 0200 103	SW,TACT SKHV10920A		G180000270010S		
SW305B		00D 963 0095 305	SW,TACT SKHV10910D01		G180040500010S		
SW305C		00D 963 0200 103	SW,TACT SKHV10920A		G180000270010S		
SW306A		00D 963 0095 305	SW,TACT SKHV10910D01		G180040500010S		
SW306B		00D 963 0095 305	SW,TACT SKHV10910D01		G180040500010S		
SW306C		00D 963 0200 103	SW,TACT SKHV10920A		G180000270010S		
SW307B		00D 963 0095 305	SW,TACT SKHV10910D01		G180040500010S		
SW307C		00D 963 0200 103	SW,TACT SKHV10920A		G180000270010S		
SW308B		00D 963 0095 305	SW,TACT SKHV10910D01		G180040500010S		
SW308C		00D 963 0200 103	SW,TACT SKHV10920A		G180000270010S		
SW309B		00D 963 0095 305	SW,TACT SKHV10910D01		G180040500010S		
SW309C		00D 963 0200 103	SW,TACT SKHV10920A		G180000270010S		
SW931		00D 963 0145 802	SW,PUSH SDDL-005-S(C-UL)		G000122006060F		
TP301	nsp	00D 963 0060 709	CN.WAFER 8P		L101220080000S		
TP601		00D 960 0123 605	CN.WAFER 13P		L101530141310S		
VEC301,302		00D 963 0095 208	SW,ENCODER EC16B24SA		G121162400040S		
X201		00D 963 0217 701	RESONATOR,CERAMIC ZTT12.00MT		E830120000060P		
X202		00D 963 0217 604	CRYSTAL 4.332MHZ,	1707E2	E800433200100		
	nsp	-	HEAT SINK		2120043538050S		
	nsp	00D 963 0018 007	SCREW, 3*8 B-TYPE ZNY/BH		B020030081B10S		
	nsp	00D 960 0184 408	HOLDER FLT		4320200026000S		
		00D 963 0146 403	TER,RCA 3PIN		G606308HG110YS		

PRE-AMP P.W.B. UNIT ASSY

	Ref. No.	nsp	Part No.	Part Name	Remarks		Q'ty	New
SEMICONDUCTORS GROUP								
	IC102X IC103X		00D 263 1092 003 00D 263 1223 005	BA05T PQ20RX11J00H	1707E3,687E3 1707E3,687E3			
	Q101SBL		00D 963 0044 204	TR 2SD2390-Y		J5032390Y0000P		
	Q101SBR Q101X Q102SBL Q102SBR Q102X		00D 963 0044 204 00D 960 0097 304 00D 963 0044 107 00D 963 0044 107 00D 960 0097 304	TR 2SD2390-Y TR KRC102M TR2SB1560-Y TR2SB1560-Y TR KRC102M	1707E3,687E3 1707E3,687E3	J5032390Y0000P J6020102M0010S J5011560Y0000P J5011560Y0000P J6020102M0010S		
	Q103SBL Q103SBR Q104SBL Q104SBR Q501C		00D 963 0280 107 00D 963 0280 107 00D 960 0196 506 00D 960 0196 506 00D 960 0196 603	TR 2SC3964 TR 2SC3964 TR KSC1845F TR KSC1845F TR KTC2874B		J502396400000S J502396400000S J5021845F0000P J5021845F0000P J502287400010S		
	Q501FL Q501FR Q501SL Q501SR Q502C		00D 960 0196 603 00D 960 0196 603 00D 960 0196 603 00D 960 0196 603 00D 960 0196 205	TR KTC2874B TR KTC2874B TR KTC2874B TR KTC2874B TR KSA992F		J502287400010S J502287400010S J502287400010S J502287400010S J5000992F0050P		
	Q502FL Q502FR Q502SBL Q502SBR Q502SL		00D 960 0196 205 00D 960 0196 205 00D 960 0196 205 00D 960 0196 205 00D 960 0196 205	TR KSA992F TR KSA992F TR KSA992F TR KSA992F TR KSA992F		J5000992F0050P J5000992F0050P J5000992F0050P J5000992F0050P J5000992F0050P		
	Q502SR Q503C Q503FL Q503FR Q503SBL		00D 960 0196 205 00D 960 0196 205 00D 960 0196 205 00D 960 0196 205 00D 960 0196 205	TR KSA992F TR KSA992F TR KSA992F TR KSA992F TR KSA992F		J5000992F0050P J5000992F0050P J5000992F0050P J5000992F0050P J5000992F0050P		
	Q503SBR Q503SL Q503SR Q504C Q504FL		00D 960 0196 205 00D 960 0196 205 00D 960 0196 205 00D 960 0196 506 00D 960 0196 506	TR KSA992F TR KSA992F TR KSA992F TR KSC1845F TR KSC1845F		J5000992F0050P J5000992F0050P J5000992F0050P J5021845F0000P J5021845F0000P		
	Q504FR Q504SBL Q504SBR Q504SL Q504SR		00D 960 0196 506 00D 960 0196 506 00D 960 0196 506 00D 960 0196 506 00D 960 0196 506	TR KSC1845F TR KSC1845F TR KSC1845F TR KSC1845F TR KSC1845F		J5021845F0000P J5021845F0000P J5021845F0000P J5021845F0000P J5021845F0000P		
	Q506SBL Q506SBR		00D 960 0196 603 00D 960 0196 603	TR KTC2874B TR KTC2874B		J502287400010S J502287400010S		
	D101SBL D101SBR		00D 963 0219 709 00D 963 0219 709	D,SWITCHING 1N4148W D,SWITCHING 1N4148W		K005041480020S K005041480020S		
	D102SBL D102SBR D102X D102X1 D106,107		00D 963 0219 709 00D 963 0219 709 00D 963 0058 407 00D 963 0058 407 00D 963 0020 309	D,SWITCHING 1N4148W D,SWITCHING 1N4148W D,SWITCHING IN4007 D,SWITCHING IN4007 D,SWITCHING 1SS133T	1707E3,687E3 1707E3,687E3	K005041480020S K005041480020S K000400700520S K000400700520S K000013300520S		
	ZD101SBL ZD101SBR ZD102SBL ZD102SBR		00D 963 0279 804 00D 963 0279 804 00D 963 0295 503 00D 963 0295 503	D,ZENER 0.2W 4.3V UDZ S D,ZENER 0.2W 4.3V UDZ S D,ZENER 0.2W 3.6V UDZ S D,ZENER 0.2W 3.6V UDZ S		K06604R34P410S K06604R34P410S K06603R64P400S K06603R64P400S		
RESISTORS GROUP								
	R104SBL R104SBR R105SBL R105SBR		00D 963 9006 285 00D 963 9006 285 00D 963 9006 285 00D 963 9006 285	R,FIXED 1WJ-5.6K R,FIXED 1WJ-5.6K R,FIXED 1WJ-5.6K R,FIXED 1WJ-5.6K		N113135656220F N113135656220F N113135656220F N113135656220F		

	Ref. No.	nsp	Part No.	Part Name	Remarks		Q'ty	New
	R106SBL R106SBR R107SBL R107SBR		00D 963 0215 907 00D 963 0215 907 00D 963 0215 907 00D 963 0215 907	R,METAL FILM 4.7-J,1W R,METAL FILM 4.7-J,1W R,METAL FILM 4.7-J,1W R,METAL FILM 4.7-J,1W		C0604R7065050S C0604R7065050S C0604R7065050S C0604R7065050S		
	R108SBL R108SBR R109SBL R109SBR R109X		00D 963 9006 269 00D 963 9006 269 00D 963 9006 269 00D 963 9006 269 00D 963 0216 003	R,FIXED 1WJ-0.22 R,FIXED 1WJ-0.22 R,FIXED 1WJ-0.22 R,FIXED 1WJ-0.22 R,METAL FILM 0.22-J,1W	1707E3,687E3	N113135622820F N113135622820F N113135622820F N113135622820F C060R22065050S		
	R110SBL R110SBR R110X R111SBL R111SBR		00D 963 9006 269 00D 963 9006 269 00D 963 0216 003 00D 963 9006 269 00D 963 9006 269	R,FIXED 1WJ-0.22 R,FIXED 1WJ-0.22 R,METAL FILM 0.22-J,1W R,FIXED 1WJ-0.22 R,FIXED 1WJ-0.22	1707E3,687E3	N113135622820F N113135622820F C060R22065050S N113135622820F N113135622820F		
	R118SBL R118SBR R119SBL R119SBR R509C		00D 963 9006 256 00D 963 9006 256 00D 963 9006 256 00D 963 9006 256 00D 960 9005 902	R,FIXED 1WJ-10 R,FIXED 1WJ-10 R,FIXED 1WJ-10 R,FIXED 1WJ-10 R,METAL FILM 1.2K-J,1/4W		N113135610020F N113135610020F N113135610020F N113135610020F C060012263050S		
	R509FL R509FR R509SBL R509SBR R509SL		00D 960 9005 902 00D 960 9005 902 00D 960 9005 902 00D 960 9005 902 00D 960 9005 902	R,METAL FILM 1.2K-J,1/4W R,METAL FILM 1.2K-J,1/4W R,METAL FILM 1.2K-J,1/4W R,METAL FILM 1.2K-J,1/4W R,METAL FILM 1.2K-J,1/4W		C060012263050S C060012263050S C060012263050S C060012263050S C060012263050S		
	R509SR R511C R511FL R511FR R511SBL		00D 960 9005 902 00D 960 9004 301 00D 960 9004 301 00D 960 9004 301 00D 960 9004 301	R,METAL FILM 1.2K-J,1/4W R,METAL FILM 47-J,1/4W R,METAL FILM 47-J,1/4W R,METAL FILM 47-J,1/4W R,METAL FILM 47-J,1/4W		C060012263050S C060047063050S C060047063050S C060047063050S C060047063050S		
	R511SBR R511SL R511SR VR106,107		00D 960 9004 301 00D 960 9004 301 00D 960 9004 301 00D 963 0105 208	R,METAL FILM 47-J,1/4W R,METAL FILM 47-J,1/4W R,METAL FILM 47-J,1/4W VR,SEMI CERMET 1KB		C060047063050S C060047063050S C060047063050S C544102015140P		
CAPACITORS GROUP								
	C101SBL C101SBR C101X C102SBL		00D 963 0234 506 00D 963 0234 506 00D 963 9003 097 00D 963 0234 205	C,ELECT 47UF-M/50V(Pb Free) C,ELECT 47UF-M/50V(Pb Free) C,FILM 0.1UF-K/250V C,ELECT 10UF-M/50V	1707E3,687E3	D040470087070F D040470087070F D02010407H080S D040100087070F		
	C102SBR C103SBL C103SBR C103X C104SBL		00D 963 0234 205 00D 963 9003 084 00D 963 9003 084 00D 963 0255 501 00D 963 9003 084	C,ELECT 10UF-M/50V C,CERAMIC 100PF-K/500V C,CERAMIC 100PF-K/500V C,ELECT 18000UF-M/16V C,CERAMIC 100PF-K/500V	1707E3,687E3	D040100087070F D00410106D050S D00410106D050S D040183083000S D00410106D050S		
	C104SBR C104X C105SBL C105SBR C105X		00D 963 9003 084 00D 963 0293 709 00D 960 9008 640 00D 960 9008 640 00D 963 0293 709	C,CERAMIC 100PF-K/500V C,ELECT 100UF-M/10V C,FILM 0.022UF-J/100V C,FILM 0.022UF-J/100V C,ELECT 100UF-M/10V	1707E3,687E3 1707E3,687E3	D00410106D050S D040101082070F D02022306C060P D02022306C060P D040101082070F		
	C106X C106X1 C107SBL C107SBR C107X	nsp nsp	00D 963 0224 105 00D 963 9004 708 00D 963 9003 097 00D 963 9003 097 00D 963 0293 709	C,CERAMIC 1000PF-K/50V C,CERAMIC 0.1UF-K/50V C,FILM 0.1UF-K/250V C,FILM 0.1UF-K/250V C,ELECT 100UF-M/10V	1707E3,687E3 1707E3,687E3 1707E3,687E3	D011102777160S D011104577160S D02010407H080S D02010407H080S D040101082070F		
	C108X C501C C501FL C501FR C501SBL	nsp	00D 963 0224 105 00D 963 9006 544 00D 963 9006 544 00D 963 9006 544 00D 963 9006 544	C,CERAMIC 1000PF-K/50V C,ELECT 22UF-M/25V C,ELECT 22UF-M/25V C,ELECT 22UF-M/25V C,ELECT 22UF-M/25V	1707E3,687E3	D011102777160S D040220084050F D040220084050F D040220084050F D040220084050F		
	C501SBR C501SL C501SR C502C C502FL		00D 963 9006 544 00D 963 9006 544 00D 963 9006 544 00D 963 0234 205 00D 963 0234 205	C,ELECT 22UF-M/25V C,ELECT 22UF-M/25V C,ELECT 22UF-M/25V C,ELECT 10UF-M/50V C,ELECT 10UF-M/50V		D040220084050F D040220084050F D040220084050F D040100087070F D040100087070F		

Ref. No.	nsp	Part No.	Part Name	Remarks		Q'ty	New
C502FR		00D 963 0234 205	C,ELECT 10UF-M/50V		D040100087070F		
C502SBL		00D 963 0234 205	C,ELECT 10UF-M/50V		D040100087070F		
C502SBR		00D 963 0234 205	C,ELECT 10UF-M/50V		D040100087070F		
C502SL		00D 963 0234 205	C,ELECT 10UF-M/50V		D040100087070F		
C502SR		00D 963 0234 205	C,ELECT 10UF-M/50V		D040100087070F		
C503C		00D 963 0216 207	C,CERAMIC 220PF 500V		D009092212500S		
C503FL		00D 963 0216 207	C,CERAMIC 220PF 500V		D009092212500S		
C503FR		00D 963 0216 207	C,CERAMIC 220PF 500V		D009092212500S		
C503SBL		00D 963 0216 207	C,CERAMIC 220PF 500V		D009092212500S		
C503SBR		00D 963 0216 207	C,CERAMIC 220PF 500V		D009092212500S		
C503SL		00D 963 0216 207	C,CERAMIC 220PF 500V		D009092212500S		
C503SR		00D 963 0216 207	C,CERAMIC 220PF 500V		D009092212500S		
C504C		00D 963 0216 207	C,CERAMIC 220PF 500V		D009092212500S		
C504FL		00D 963 0216 207	C,CERAMIC 220PF 500V		D009092212500S		
C504FR		00D 963 0216 207	C,CERAMIC 220PF 500V		D009092212500S		
C504SBL		00D 963 0216 207	C,CERAMIC 220PF 500V		D009092212500S		
C504SBR		00D 963 0216 207	C,CERAMIC 220PF 500V		D009092212500S		
C504SL		00D 963 0216 207	C,CERAMIC 220PF 500V		D009092212500S		
C504SR		00D 963 0216 207	C,CERAMIC 220PF 500V		D009092212500S		
C505C		00D 963 0216 100	C,CERAMIC 33PF-J/500V		D00033006D050S		
C505FL		00D 963 0216 100	C,CERAMIC 33PF-J/500V		D00033006D050S		
C505FR		00D 963 0216 100	C,CERAMIC 33PF-J/500V		D00033006D050S		
C505SBL		00D 963 0216 100	C,CERAMIC 33PF-J/500V		D00033006D050S		
C505SBR		00D 963 0216 100	C,CERAMIC 33PF-J/500V		D00033006D050S		
C505SL		00D 963 0216 100	C,CERAMIC 33PF-J/500V		D00033006D050S		
C505SR		00D 963 0216 100	C,CERAMIC 33PF-J/500V		D00033006D050S		
C506C		00D 963 0293 709	C,ELECT 100UF-M/10V		D040101082070F		
C506FL		00D 963 0293 709	C,ELECT 100UF-M/10V		D040101082070F		
C506FR		00D 963 0293 709	C,ELECT 100UF-M/10V		D040101082070F		
C506SBL		00D 963 0293 709	C,ELECT 100UF-M/10V		D040101082070F		
C506SBR		00D 963 0293 709	C,ELECT 100UF-M/10V		D040101082070F		
C506SL		00D 963 0293 709	C,ELECT 100UF-M/10V		D040101082070F		
C506SR		00D 963 0293 709	C,ELECT 100UF-M/10V		D040101082070F		
C507C		00D 963 9003 194	C,FILM 0.0022UF-J/100V		D02022206C060P		
C507FL		00D 963 9003 194	C,FILM 0.0022UF-J/100V		D02022206C060P		
C507FR		00D 963 9003 194	C,FILM 0.0022UF-J/100V		D02022206C060P		
C507SBL		00D 963 9003 194	C,FILM 0.0022UF-J/100V		D02022206C060P		
C507SBR		00D 963 9003 194	C,FILM 0.0022UF-J/100V		D02022206C060P		
C507SL		00D 963 9003 194	C,FILM 0.0022UF-J/100V		D02022206C060P		
C507SR		00D 963 9003 194	C,FILM 0.0022UF-J/100V		D02022206C060P		
OTHERS PARTS GROUP							
BKT501	nsp	00D 960 0184 000	BRACKET SCREW		4010210196000S		
BKT503	nsp	00D 960 0184 000	BRACKET SCREW		4010210196000S		
CN102X	nsp	00D 963 0256 306	CN,WIRE 90MM/5P	1707E3,687E3	L000900050030F		
CN501	nsp	00D 963 0205 700	CN.WAFER 5P		L101100030510S		
CN502	nsp	00D 963 0086 505	CN.WAFER 7P		L101100030710S		
CN503	nsp	00D 963 0205 700	CN.WAFER 5P		L101100030510S		
CN504	nsp	00D 963 0085 506	CN.WAFER 9P		L101100030910S		
CN505	nsp	00D 963 0236 902	CN.WAFER 12P		L101100031210S		
CN506T	nsp	00D 963 0245 401	CN,WIRE 140MM/15P	1707E3,687E3	L000141150030F		
CN506T	nsp	00D 963 0159 704	CN,WIRE 140MM/15P	1707EUT	L000141150020P		
CP101X	nsp	00D 960 0123 207	CN.WAFER 3P	1707E3,687E3	L102526700300S		
CP506	nsp	00D 963 0060 703	CN.WAFER 15P		L101220150000S		
CP513	nsp	00D 963 0066 101	CN.WAFER 5P		L101220050000S		
CP558	nsp	00D 963 0253 406	CN.WAFER 14P		L101220140000S		
CP992	nsp	00D 960 0217 553	CN.WAFER 4P		L102526700400S		
L101SBL	nsp	00D 963 0049 005	COIL INDUCTOR 0.5UH		D330R50000000F		
L101SBR	nsp	00D 963 0049 005	COIL INDUCTOR 0.5UH		D330R50000000F		
TP106,107	nsp	00D 963 0207 203	CN.WAFER 3P		L101530150310S		

CNT P.W.B. UNIT ASSY

	Ref. No.	nsp	Part No.	Part Name	Remarks		Q'ty	New
SEMICONDUCTORS GROUP								
	IC551,552		00D 963 0218 807	IC BU4094BCF		J040140940030P		
	Q551		00D 960 0196 700	TR KTC3200BL		J5023200B0050S		
	Q552		00D 960 0196 302	TR KTA1268BL		J5001268B0050S		
	Q553-556		00D 963 0120 704	TR KRA102S		J520010200210S		
	Q570A		00D 963 0148 508	TR KTA1504S		J520015040150S		
	Q570B		00D 963 0121 606	TR KRC107S		J522107S00210S		
	Q571X		00D 963 0121 606	TR KRC107S		J522107S00210S		
	Q572X		00D 963 0148 508	TR KTA1504S		J520015040150S		
	Q573C		00D 963 0121 004	TR KRC104M		J502104000010S		
	D501D		00D 963 0058 407	D,SWITCHING IN4007		K000400700520S		
	D551-561		00D 963 0020 309	D,SWITCHING 1SS133T		K000013300520S		
	D562,563		00D 963 0058 407	D,SWITCHING IN4007		K000400700520S		
	D565-567		00D 963 0020 309	D,SWITCHING 1SS133T		K000013300520S		
	D568-571		00D 963 0058 407	D,SWITCHING IN4007		K000400700520S		
	D572X		00D 963 0020 309	D,SWITCHING 1SS133T		K000013300520S		
	D573X		00D 963 0020 309	D,SWITCHING 1SS133T		K000013300520S		
	D574C		00D 963 0219 709	D,SWITCHING 1N4148W		K005041480020S		
	ZD564		00D 960 0095 500	D,ZENER MTZJ5.1B		K06005R144520S		
RESISTORS GROUP								
	R559		00D 960 9005 642	R,METAL FILM 1.2K-J,1W		C060012265050S		
	R565		00D 960 9005 642	R,METAL FILM 1.2K-J,1W		C060012265050S		
	R570		00D 960 9005 642	R,METAL FILM 1.2K-J,1W		C060012265050S		
	R575,576		00D 963 0216 003	R,METAL FILM 0.22-J,1W		C060R22065050S		
	R577C		00D 963 0236 203	R,METAL FILM 180-J,1/4W		C060018163050S		
CAPACITORS GROUP								
	C280		00D 963 0021 104	C,ELECT 6800UF-M/16V		D040682083000F		
	C280A		00D 963 0224 804	C,ELECT 3300UF-M/25V		D040332084010F		
	C281		00D 963 0224 804	C,ELECT 3300UF-M/25V		D040332084010F		
	C551		00D 963 0294 106	C,ELECT 2.2UF-M/50V (Pb Free)	1707E3,687E3,1707EUT	D0402R2087160F		
	C551		00D 960 9009 940	C,ELECT 1000UF-M/16V	1707E2	D040102083030F		
	C551C	nsp	00D 963 0234 001	C,CERAMIC 0.047UF-Z/50V		D011473597160S		
	C551G	nsp	00D 963 0234 001	C,CERAMIC 0.047UF-Z/50V		D011473597160S		
	C551S		00D 963 0225 609	C,CERAMIC 0.047UF-Z/50V		D005473597520S		
	C555,556		00D 963 0233 303	C,CERAMIC 0.01UF-M/16V		D005103773530S		
	C557		00D 963 0234 205	C,ELECT 10UF-M/50V		D040100087070F		
	C559-561		00D 963 0145 006	C,FILM 0.047UF-J/50V		D020473167050P		
	C563X		00D 963 0234 205	C,ELECT 10UF-M/50V		D040100087070F		
	C564X	nsp	00D 960 9010 094	C,CERAMIC 0.01UF-Z/50V		D011103597160S		
	C565X		00D 963 0234 205	C,ELECT 10UF-M/50V		D040100087070F		
	C566X	nsp	00D 960 9010 094	C,CERAMIC 0.01UF-Z/50V		D011103597160S		
	C567X	nsp	00D 963 0223 601	C,CERAMIC 100PF-J/50V		D010101167160S		
	C568X	nsp	00D 963 0223 601	C,CERAMIC 100PF-J/50V		D010101167160S		
	C569X	nsp	00D 963 0223 601	C,CERAMIC 100PF-J/50V		D010101167160S		
	C570X	nsp	00D 963 0223 601	C,CERAMIC 100PF-J/50V		D010101167160S		
OTHERS PARTS GROUP								
	CN202X	nsp	00D 963 0256 005	CN,WIRE 350MM/8P	1707E3,687E3	L000351080010F		
	CN552	nsp	00D 963 0097 303	CN.WAFER 15P		L101100031510S		
	CN553	nsp	00D 963 0086 709	CN.WAFER 11P		L101100031110S		
	CN554A		00D 963 0184 805	CN,WIRE 80MM/14P		L000800140060P		
	CN554B		00D 963 0184 708	CN,WIRE 80MM/4P		L000800040110P		
	CN555	nsp	00D 963 0110 701	CN.WAFER 14P		L101100031410S		

	Ref. No.	nsp	Part No.	Part Name	Remarks		Q'ty	New
	CN556	nsp	00D 963 0086 709	CN.WAFER 11P		L101100031110S		
	CP102X	nsp	00D 963 0066 101	CN.WAFER 5P	1707E3,687E3	L101220050000S		
	CP551		00D 963 0253 406	CN.WAFER 14P		L101220140000S		
	CP590	nsp	00D 963 0236 009	CN.WAFER 3P		L102526803010S		
	RLY501C		00D 963 0218 409	RELAY BC3-12 24V 2A		G680240202030F		
		nsp	00D 960 0184 000	BRACKET SCREW		4010210196000S		

INPUT P.W.B. UNIT ASSY

	Ref. No.	nsp	Part No.	Part Name	Remarks		Q'ty	New
SEMICONDUCTORS GROUP								
	IC701 IC701M IC705 IC761-763		00D 963 0295 202 00D 963 0202 305 00D 963 0202 305 00D 963 0202 305	IC NJW1197 IC NJM2068M IC NJM2068M IC NJM2068M	1707E3,687E3	J084119700010 J121206800020S J121206800020S J121206800020S		
	Q755 Q760 Q771 Q772		00D 963 0121 004 00D 963 0121 004 00D 963 0121 004 00D 960 0097 207	TR KRC104M TR KRC104M TR KRC104M TR KRA102M	1707E3,687E3	J502104000010S J502104000010S J502104000010S J6002202M0010S		
	Q773,774 D703-706 D753 D756		00D 960 0196 807 00D 963 0219 709 00D 963 0219 709 00D 963 0219 709	TR 2SK117Y D,SWITCHING 1N4148W D,SWITCHING 1N4148W D,SWITCHING 1N4148W	1707E3,687E3 1707E3,687E3	J5441170Y0050 K005041480020S K005041480020S K005041480020S		
	D771,772 ZD701 ZD701M ZD702		00D 963 0219 709 00D 960 0222 603 00D 960 0095 500 00D 960 0222 603	D,SWITCHING 1N4148W D,ZENER MTZJ7.5A D,ZENER MTZJ5.1B D,ZENER MTZJ7.5A		K005041480020S K06007R544530S K06005R144520S K06007R544530S		
RESISTORS GROUP								
	R709M R731,732 R753		- 00D 963 9005 668 00D 960 9004 301	R,CHIP 1.6K-J,1/10W R,METAL FILM 220-J,1W R,METAL FILM 47-J,1/4W	1707E3,687E3	C200016260200F C060022165050S C060047063050S		
	R756 R771,772 R791,792		00D 960 9004 301 00D 963 9005 639 00D 963 9005 639	R,METAL FILM 47-J,1/4W R,METAL FILM 100-J,1W R,METAL FILM 100-J,1W		C060047063050S C060010165060S C060010165060S		
CAPACITORS GROUP								
	C481C C481FL C481FR C481SW C701L	nsp nsp nsp nsp nsp	00D 963 0223 601 00D 963 0223 601 00D 963 0223 601 00D 963 0223 601 00D 963 0223 601	C,CERAMIC 100PF-J/50V C,CERAMIC 100PF-J/50V C,CERAMIC 100PF-J/50V C,CERAMIC 100PF-J/50V C,CERAMIC 100PF-J/50V		D010101167160S D010101167160S D010101167160S D010101167160S D010101167160S		
	C701M C701R C702CH C702L C702M	nsp nsp nsp nsp	00D 963 0293 602 00D 963 0223 601 00D 963 9004 698 00D 963 0223 601 00D 963 0293 602	C,ELECT 1UF-M/50V(Pb Free) C,CERAMIC 100PF-J/50V C,CERAMIC 0.01UF-K/50V C,CERAMIC 100PF-J/50V C,ELECT 1UF-M/50V(Pb Free)	1707E3,687E3	D040010087150F D010101167160S D011103777160S D010101167160S D040010087150F		
	C702R C703CH C703L C703M C703R	nsp nsp nsp nsp nsp	00D 963 0223 601 00D 963 9004 698 00D 963 0223 601 00D 963 0157 609 00D 963 0223 601	C,CERAMIC 100PF-J/50V C,CERAMIC 0.01UF-K/50V C,CERAMIC 100PF-J/50V C,CERAMIC 150PF-J/50V C,CERAMIC 100PF-J/50V	1707E3,687E3	D010101167160S D011103777160S D010101167160S D010151167160S D010101167160S		
	C704L C704M C704R C705L C705M	nsp nsp nsp nsp	00D 963 0223 601 00D 963 0223 601 00D 963 0223 601 00D 963 0223 601 00D 963 0293 602	C,CERAMIC 100PF-J/50V C,CERAMIC 100PF-J/50V C,CERAMIC 100PF-J/50V C,CERAMIC 100PF-J/50V C,ELECT 1UF-M/50V(Pb Free)		D010101167160S D010101167160S D010101167160S D010101167160S D040010087150F		
	C705R C706L C706M C706R C707	nsp nsp nsp nsp nsp	00D 963 0223 601 00D 963 0223 601 00D 963 0157 609 00D 963 0223 601 00D 963 0223 601	C,CERAMIC 100PF-J/50V C,CERAMIC 100PF-J/50V C,CERAMIC 150PF-J/50V C,CERAMIC 100PF-J/50V C,CERAMIC 100PF-J/50V		D010101167160S D010101167160S D010151167160S D010101167160S D010101167160S		
	C707M C708 C708M C709 C709M C710M	nsp nsp nsp nsp nsp	00D 963 0223 601 00D 963 0223 601 00D 963 0293 602 00D 963 0223 601 00D 963 9004 711 00D 963 0234 205	C,CERAMIC 100PF-J/50V C,CERAMIC 100PF-J/50V C,ELECT 1UF-M/50V(Pb Free) C,CERAMIC 100PF-J/50V C,CERAMIC 0.1UF-Z/50V C,ELECT 10UF-M/50V		D010101167160S D010101167160S D040010087150F D010101167160S D011104597160S D04010087070F		

Ref. No.	nsp	Part No.	Part Name	Remarks		Q'ty	New
C721		00D 963 0293 709	C,ELECT 100UF-M/10V		D040101082070F		
C723		00D 963 0293 709	C,ELECT 100UF-M/10V		D040101082070F		
C726,727		00D 963 0234 205	C,ELECT 10UF-M/50V		D040100087070F		
C731		00D 960 9010 010	C,ELECT 4.7UF-M/50V		D0404R7087250F		
C732	nsp	00D 963 9004 711	C,CERAMIC 0.1UF-Z/50V		D011104597160S		
C733		00D 963 0276 108	C,CERAMIC 3300PF-K/50V		D011332777160S		
C734		00D 963 0293 602	C,ELECT 1UF-M/50V(Pb Free)		D040010087150F		
C735		00D 960 9010 010	C,ELECT 4.7UF-M/50V		D0404R7087250F		
C736	nsp	00D 963 9004 711	C,CERAMIC 0.1UF-Z/50V		D011104597160S		
C737		00D 963 0276 108	C,CERAMIC 3300PF-K/50V		D011332777160S		
C738		00D 963 0293 602	C,ELECT 1UF-M/50V(Pb Free)		D040010087150F		
C741-750		00D 963 0234 205	C,ELECT 10UF-M/50V		D040100087070F		
C750ZL		00D 960 9010 010	C,ELECT 4.7UF-M/50V	1707E3,687E3	D0404R7087250F		
C750ZR		00D 960 9010 010	C,ELECT 4.7UF-M/50V	1707E3,687E3	D0404R7087250F		
C751,752		00D 963 0234 205	C,ELECT 10UF-M/50V	1707E3,687E3	D040100087070F		
C752ZL	nsp	00D 963 0223 601	C,CERAMIC 100PF-J/50V	1707E3,687E3	D010101167160S		
C752ZR	nsp	00D 963 0223 601	C,CERAMIC 100PF-J/50V	1707E3,687E3	D010101167160S		
C753ZL		00D 963 0234 205	C,ELECT 10UF-M/50V	1707E3,687E3	D040100087070F		
C753ZR		00D 963 0234 205	C,ELECT 10UF-M/50V	1707E3,687E3	D040100087070F		
C756,757	nsp	00D 963 9004 698	C,CERAMIC 0.01UF-K/50V	1707E3,687E3	D011103777160S		
C760,761		00D 963 9005 862	C,ELECT 47UF-M/16V		D040470083080F		
C761FL	nsp	00D 963 0234 001	C,CERAMIC 0.047UF-Z/50V		D011473597160S		
C761FR	nsp	00D 963 0234 001	C,CERAMIC 0.047UF-Z/50V		D011473597160S		
C761SW	nsp	00D 963 0234 001	C,CERAMIC 0.047UF-Z/50V		D011473597160S		
C762		00D 963 9005 862	C,ELECT 47UF-M/16V		D040470083080F		
C762FL	nsp	00D 963 0223 601	C,CERAMIC 100PF-J/50V		D010101167160S		
C762FR	nsp	00D 963 0223 601	C,CERAMIC 100PF-J/50V		D010101167160S		
C762SW	nsp	00D 963 0223 601	C,CERAMIC 100PF-J/50V		D010101167160S		
C763		00D 963 9005 862	C,ELECT 47UF-M/16V		D040470083080F		
C763FL	nsp	00D 963 0234 001	C,CERAMIC 0.047UF-Z/50V		D011473597160S		
C763FR	nsp	00D 963 0234 001	C,CERAMIC 0.047UF-Z/50V		D011473597160S		
C763SW	nsp	00D 963 0234 001	C,CERAMIC 0.047UF-Z/50V		D011473597160S		
C764		00D 963 9005 862	C,ELECT 47UF-M/16V		D040470083080F		
C764FL	nsp	00D 963 0223 805	C,CERAMIC 33PF-J/50V		D010330167160S		
C764FR	nsp	00D 963 0223 805	C,CERAMIC 33PF-J/50V		D010330167160S		
C764SW	nsp	00D 963 0233 808	C,CERAMIC 47PF-J/50V		D010470167160S		
C765		00D 963 9005 862	C,ELECT 47UF-M/16V		D040470083080F		
C765FL		00D 963 0234 205	C,ELECT 10UF-M/50V		D040100087070F		
C765FR		00D 963 0234 205	C,ELECT 10UF-M/50V		D040100087070F		
C765SW		00D 963 0234 205	C,ELECT 10UF-M/50V		D040100087070F		
C766,767		00D 963 9005 862	C,ELECT 47UF-M/16V		D040470083080F		
C771,772		00D 963 9005 875	C,ELECT 47UF-M/25V		D040470084070F		
C773		00D 963 0293 602	C,ELECT 1UF-M/50V(Pb Free)		D040010087150F		
C791,792		00D 963 9005 875	C,ELECT 47UF-M/25V		D040470084070F		
OTHERS PARTS GROUP							
CN551		00D 963 0184 407	CN,WIRE 160/14P		L000161140050P		
CN701	nsp	00D 963 0097 303	CN.WAFER 15P		L101100031510S		
CN701M		00D 963 0253 309	CN,WIRE 230MM/5P		L000231050030F		
CN702	nsp	00D 963 0086 204	CN.WAFER 19P		L101100031910S		
CN703	nsp	00D 963 0097 303	CN.WAFER 15P		L101100031510S		
CN704		00D 963 0256 801	CN.WAFER 10P		L101100031010S		
CP701M	nsp	00D 963 0066 101	CN.WAFER 5P		L101220050000S		
RLY701,702		00D 963 0218 409	RELAY BC3-12 24V 2A	1707E3,687E3	G680240202030F		
RLY702		00D 963 0218 409	RELAY BC3-12 24V 2A	1707E2,1707EUT	G680240202030F		
		00D 963 0094 005	CUSHION INPUT		4050210715000S		
		00D 963 0293 505	PLATE INPUT		4470210926000S		
		00D 963 0146 209	TER,RCA 4PIN		G602405B01000S		
		00D 960 0268 803	TER,RCA 6PIN		G603603B09000S		
		00D 963 0158 200	JACK,D3.5 (MIC)		G40132340000YS		

8CH-EXT XM P.W.B. UNIT ASSY (for AVR-1707/687 E3 model)

	Ref. No.	nsp	Part No.	Part Name	Remarks		Q'ty	New
SEMICONDUCTORS GROUP								
	IC201X		00D 262 3517 907	F2602-01-TR				
	IC202X		00D 262 2517 908	SN74LV08APW-EL2 +REF				
	IC203X		00D 262 2813 903	SN74AHCT08PW-EL2 +C				
	IC204X		00D 963 0295 309	IC LM1117S		J126111733030S		
	IC205X		00D 963 0294 902	IC AK4385		J042438500010S		
	IC206		00D 963 0202 305	IC NJM2068M		J121206800020S		
	IC206X		00D 399 1055 909	FCX-02(45.1584MHz)				
	IC207X		00D 263 1092 003	BA05T				
	IC208X		00D 963 0218 807	IC BU4094BCF		J040140940030P		
	IC209X		00D 262 2813 903	SN74AHCT08PW-EL2 +C				
	IC401		00D 960 0296 105	IC CJ7812F	1707E3	J126781200220S		
	IC402		00D 960 0174 104	IC CXA1511M		J030151100010S		
	Q201R		00D 963 0121 402	TR KRA104S		J520010400210S		
	Q201X		00D 963 0120 801	TR KRC102S		J522010200210S		
	Q203X		00D 963 0120 801	TR KRC102S		J522010200210S		
	Q204X		00D 963 0120 801	TR KRC102S		J522010200210S		
	Q206X		00D 963 0120 704	TR KRA102S		J520010200210S		
	Q207X		00D 963 0120 704	TR KRA102S		J520010200210S		
	Q208X		00D 963 0044 301	TR KTC2875B		J5222875B0010S		
	Q209X		00D 963 0044 301	TR KTC2875B		J5222875B0010S		
	Q210X		00D 963 0044 301	TR KTC2875B		J5222875B0010S		
	Q211X		00D 963 0044 301	TR KTC2875B		J5222875B0010S		
	Q401		00D 960 0097 003	TR KRA104M	1707E3	J6000104M0010S		
	Q666A		00D 963 0044 301	TR KTC2875B	1707E3	J5222875B0010S		
	Q667A		00D 963 0044 301	TR KTC2875B		J5222875B0010S		
	Q668A		00D 963 0044 301	TR KTC2875B	1707E3	J5222875B0010S		
	Q669A		00D 963 0044 301	TR KTC2875B		J5222875B0010S		
	D201X		00D 963 0219 709	D,SWITCHING 1N4148W		K005041480020S		
	D202X		00D 963 0219 709	D,SWITCHING 1N4148W		K005041480020S		
	D203X		00D 963 0219 709	D,SWITCHING 1N4148W		K005041480020S		
	D204X		00D 963 0219 709	D,SWITCHING 1N4148W		K005041480020S		
	D205X		00D 963 0219 709	D,SWITCHING 1N4148W		K005041480020S		
	D206X		00D 963 0219 709	D,SWITCHING 1N4148W		K005041480020S		
	D207X		00D 963 0219 709	D,SWITCHING 1N4148W		K005041480020S		
	ZD401		00D 960 0095 704	D,ZENER MTZJ6.2B	1707E3	K06006R244520S		
RESISTORS GROUP								
	R273X		00D 963 9005 639	R,METAL FILM 100-J,1W		C060010165060S		
	R274X		00D 963 9005 639	R,METAL FILM 100-J,1W		C060010165060S		
CAPACITORS GROUP								
	C201X	nsp	00D 963 9006 528	C,CERAMIC 20PF-J/50V		D010200167160S		
	C202X	nsp	00D 963 9006 528	C,CERAMIC 20PF-J/50V		D010200167160S		
	C203X	nsp	00D 963 9006 528	C,CERAMIC 20PF-J/50V		D010200167160S		
	C204X	nsp	00D 963 9006 528	C,CERAMIC 20PF-J/50V		D010200167160S		
	C205X	nsp	00D 963 9004 708	C,CERAMIC 0.1UF-K/50V		D011104577160S		
	C206X	nsp	00D 963 9004 708	C,CERAMIC 0.1UF-K/50V		D011104577160S		
	C207X	nsp	00D 963 9004 708	C,CERAMIC 0.1UF-K/50V		D011104577160S		
	C208X		00D 963 0234 205	C,ELECT 10UF-M/50V		D040100087070F		
	C209X	nsp	00D 963 9004 708	C,CERAMIC 0.1UF-K/50V		D011104577160S		
	C212X	nsp	00D 963 9004 708	C,CERAMIC 0.1UF-K/50V		D011104577160S		
	C213X	nsp	00D 963 0224 105	C,CERAMIC 1000PF-K/50V		D011102777160S		
	C215X		00D 963 0234 205	C,ELECT 10UF-M/50V		D040100087070F		
	C216X		00D 963 0234 205	C,ELECT 10UF-M/50V		D040100087070F		
	C217X	nsp	00D 963 9004 708	C,CERAMIC 0.1UF-K/50V		D011104577160S		
	C218X	nsp	00D 963 9004 708	C,CERAMIC 0.1UF-K/50V		D011104577160S		
	C219X	nsp	00D 963 0224 105	C,CERAMIC 1000PF-K/50V		D011102777160S		

	Ref. No.	nsp	Part No.	Part Name	Remarks		Q'ty	New
	C220X	nsp	00D 963 0224 105	C,CERAMIC 1000PF-K/50V		D011102777160S		
	C221X	nsp	00D 963 9004 708	C,CERAMIC 0.1UF-K/50V		D011104577160S		
	C222X	nsp	00D 963 0224 105	C,CERAMIC 1000PF-K/50V		D011102777160S		
	C223X	nsp	00D 963 9004 708	C,CERAMIC 0.1UF-K/50V		D011104577160S		
	C224X		00D 963 0293 709	C,ELECT 100UF-M/10V		D040101082070F		
	C225X		00D 963 0234 205	C,ELECT 10UF-M/50V		D040100087070F		
	C230X		00D 963 0234 205	C,ELECT 10UF-M/50V		D040100087070F		
	C231X		00D 963 0244 606	C,ELECT 0.1UF-M/50V (Pb Free)		D040R10087080F		
	C232X	nsp	00D 963 9006 146	C,CERAMIC 560PF-J/50V		D010561167160S		
	C233		00D 963 0234 205	C,ELECT 10UF-M/50V		D040100087070F		
	C233X	nsp	00D 960 9009 843	C,CERAMIC 1800PF-K/50V		D011182777160S		
	C234X	nsp	00D 963 9006 146	C,CERAMIC 560PF-J/50V		D010561167160S		
	C235X		00D 963 0234 205	C,ELECT 10UF-M/50V		D040100087070F		
	C236X	nsp	00D 963 9006 146	C,CERAMIC 560PF-J/50V		D010561167160S		
	C237X	nsp	00D 960 9009 843	C,CERAMIC 1800PF-K/50V		D011182777160S		
	C238X	nsp	00D 963 9006 146	C,CERAMIC 560PF-J/50V		D010561167160S		
	C239X		00D 963 0234 205	C,ELECT 10UF-M/50V		D040100087070F		
	C240X		00D 963 0224 503	C,ELECT 22UF-M/50V		D040220087060F		
	C241X		00D 963 0224 503	C,ELECT 22UF-M/50V		D040220087060F		
	C242X		00D 963 0234 205	C,ELECT 10UF-M/50V		D040100087070F		
	C243X		00D 963 0234 205	C,ELECT 10UF-M/50V		D040100087070F		
	C244X	nsp	00D 963 9004 708	C,CERAMIC 0.1UF-K/50V		D011104577160S		
	C245X	nsp	00D 963 9004 708	C,CERAMIC 0.1UF-K/50V		D011104577160S		
	C246X	nsp	00D 963 9004 708	C,CERAMIC 0.1UF-K/50V		D011104577160S		
	C247X	nsp	00D 963 9004 708	C,CERAMIC 0.1UF-K/50V		D011104577160S		
	C248X	nsp	00D 963 0223 601	C,CERAMIC 100PF-J/50V		D010101167160S		
	C249X	nsp	00D 963 0223 601	C,CERAMIC 100PF-J/50V		D010101167160S		
	C250X	nsp	00D 963 9004 698	C,CERAMIC 0.01UF-K/50V		D011103777160S		
	C251X	nsp	00D 963 9004 708	C,CERAMIC 0.1UF-K/50V		D011104577160S		
	C252X	nsp	00D 963 0224 105	C,CERAMIC 1000PF-K/50V		D011102777160S		
	C403		00D 963 0293 602	C,ELECT 1UF-M/50V (Pb Free)	1707E3	D040010087150F		
	C404	nsp	00D 963 9004 698	C,CERAMIC 0.01UF-K/50V	1707E3	D011103777160S		
	C405	nsp	00D 963 0223 601	C,CERAMIC 100PF-J/50V	1707E3	D010101167160S		
	C406,407		00D 960 9008 653	C,FILM 0.012UF-J/100V-5RE	1707E3	D02012306C060P		
	C408		00D 963 9005 862	C,ELECT 47UF-M/16V	1707E3	D040470083080F		
	C409		00D 960 9010 010	C,ELECT 4.7UF-M/50V	1707E3	D0404R7087250F		
	C410,411		00D 963 0234 205	C,ELECT 10UF-M/50V		D040100087070F		
	C412,413	nsp	00D 963 9004 698	C,CERAMIC 0.01UF-K/50V		D011103777160S		
	C481SBL	nsp	00D 963 0223 601	C,CERAMIC 100PF-J/50V		D010101167160S		
	C481SBR	nsp	00D 963 0223 601	C,CERAMIC 100PF-J/50V		D010101167160S		
	C481SL	nsp	00D 963 0223 601	C,CERAMIC 100PF-J/50V		D010101167160S		
	C481SR	nsp	00D 963 0223 601	C,CERAMIC 100PF-J/50V		D010101167160S		
	C606A	nsp	00D 963 0223 601	C,CERAMIC 100PF-J/50V	1707E3	D010101167160S		
	C607A	nsp	00D 963 0223 601	C,CERAMIC 100PF-J/50V		D010101167160S		
	C647	nsp	00D 963 9004 708	C,CERAMIC 0.1UF-K/50V		D011104577160S		
OTHERS PARTS GROUP								
	BD201X	nsp	00D 963 0154 602	COIL,BEAD		7610010030000S		
	BD401,402	nsp	00D 963 0154 602	COIL,BEAD	687E3	7610010030000S		
	BD401-403	nsp	00D 963 0154 602	COIL,BEAD	1707E3	7610010030000S		
	CN401	nsp	00D 963 0236 902	CN.WAFER 12P		L101100031210S		
	CN402	nsp	00D 963 0086 709	CN.WAFER 11P		L101100031110S		
	CN404	nsp	00D 963 0086 107	CN.WAFER 16P		L101100031610S		
	CP202X	nsp	00D 963 0060 709	CN.WAFER 8P		L101220080000S		
	CP203X	nsp	00D 963 0068 303	CN.WAFER 9P		L101220090000S		
	CP401A		00D 963 0149 303	CN.FPC 15P		L131111500010F		
	JACK801X		00D 205 1362 009	XM/DT BUS CONNECTOR				
			00D 963 0244 703	JACK,D3.5 EARPHONE	1707E3	G40130802000YS		
			00D 963 0146 005	TER,RCA 1PIN		G600107A0000YS		
			00D 963 0146 209	TER,RCA 4PIN		G602405B01000S		

8CH-EXT (E2) P.W.B. UNIT ASSY (for AVR-1707 E2/EUT model)

	Ref. No.	nsp	Part No.	Part Name	Remarks		Q'ty	New
SEMICONDUCTORS GROUP								
	IC401		00D 960 0296 105	IC CJ7812F		J126781200220S		
	Q666A		00D 960 0196 603	TR KTC2874B		J502287400010S		
	Q668A		00D 960 0196 603	TR KTC2874B		J502287400010S		
CAPACITORS GROUP								
	C401		00D 963 9005 804	C,ELECT 100UF-M/25V		D040101084060F		
	C402		00D 963 0234 205	C,ELECT 10UF-M/50V		D040100087070F		
	C403,404	nsp	00D 963 9004 698	C,CERAMIC 0.01UF-K/50V		D011103777160S		
	C481SBL	nsp	00D 963 0223 601	C,CERAMIC 100PF-J/50V		D010101167160S		
	C481SBR	nsp	00D 963 0223 601	C,CERAMIC 100PF-J/50V		D010101167160S		
	C481SL	nsp	00D 963 0223 601	C,CERAMIC 100PF-J/50V		D010101167160S		
	C481SR	nsp	00D 963 0223 601	C,CERAMIC 100PF-J/50V		D010101167160S		
	C606A	nsp	00D 963 0223 601	C,CERAMIC 100PF-J/50V		D010101167160S		
	C647	nsp	00D 963 9004 698	C,CERAMIC 0.01UF-K/50V		D011103777160S		
OTHERS PARTS GROUP								
	BD401,402	nsp	00D 963 0154 602	COIL,BEAD		7610010030000S		
	CN401	nsp	00D 963 0236 902	CN.WAFER 12P		L101100031210S		
	CN402	nsp	00D 963 0086 709	CN.WAFER 11P		L101100031110S		
	CN404	nsp	00D 963 0205 700	CN.WAFER 5P		L101100030510S		
	CP401A		00D 963 0149 303	CN.FPC 15P		L131111500010F		
			00D 963 0146 005	TER,RCA 1PIN		G600107A0000YS		
			00D 963 0146 209	TER,RCA 4PIN		G602405B01000S		

DSP 1 P.W.B. UNIT ASSY

	Ref. No.	nsp	Part No.	Part Name	Remarks		Q'ty	New
SEMICONDUCTORS GROUP								
	IC802,803 IC804 IC805 IC806		00D 963 0237 503 00D 262 3662 001 00D 262 3652 008 00D 262 3536 001	JSR1165-C /OPTICAL ADSP21266SKSTZ-1B-AC LH28F800BJE(1707) AS7C34096A-10TCN		E100116500040S		
	IC807 IC808 IC809-811 IC812 IC814,815		00D 262 3066 102 00D 262 3645 002 00D 960 0266 805 00D 960 0266 902 00D 963 0218 904	LC89057W-VF4-E(AC) +REF IC ADAU1328BSTZ IC MM74LCX244 IC MM74HCT244 IC MM74HCT00MTCX		J040742440180P J040742440190P J040740000200P		
	IC815A IC816 IC816A IC817 IC817A		00D 963 0043 807 00D 262 2870 904 00D 963 0043 807 00D 262 3536 001 00D 963 0202 305	IC BA4510F 74LVX157MTC +C IC BA4510F AS7C34096A-10TCN IC NJM2068M		J121451000010P J121451000010P J121206800020S		
	IC818 IC818A IC819 IC819A IC820		00D 262 2642 909 00D 963 0202 305 00D 262 2642 909 00D 963 0202 305 00D 262 3339 907	SN74LV573APWR +REF IC NJM2068M SN74LV573APWR +REF IC NJM2068M SN74LVC139APWR +REF		J121206800020S J121206800020S		
	IC820A IC821 IC822 IC823 IC824		00D 963 0202 305 00D 262 2870 904 00D 960 0296 008 00D 963 0295 309 00D 963 0147 509	IC NJM2068M IC 74LCX74MTC IC CJ7805F IC RC1117-33 IC FAN1112-1.2		J121206800020S J126780500400S J126111733020F J126111712010F		
	IC825 IC827 IC828 IC829 IC830		00D 262 2870 904 00D 963 0219 107 00D 963 0219 000 00D 963 0244 907 00D 262 2813 903	IC 74LCX74MTC IC MM74HC151MTCX IC 74VHCU04 IC SN74LV14APWR IC SN74AHCTO8		J040741510050P J040740400270P J040741400180P		
	Q804C Q804FL Q804FR Q804SBL		00D 960 0196 603 00D 960 0196 603 00D 960 0196 603 00D 960 0196 603	TR KTC2874B TR KTC2874B TR KTC2874B TR KTC2874B		J502287400010S J502287400010S J502287400010S J502287400010S		
	Q804SBR Q804SL Q804SR Q804SW Q808		00D 960 0196 603 00D 960 0196 603 00D 960 0196 603 00D 960 0196 603 00D 963 0120 801	TR KTC2874B TR KTC2874B TR KTC2874B TR KTC2874B TR KRC102S		J502287400010S J502287400010S J502287400010S J502287400010S J522010200210S		
	Q809 Q811,812 D803		00D 963 0120 704 00D 963 0245 100 00D 963 0219 709	TR KRA102S D,SWITCHING KDS226ST1 D,SWITCHING 1N4148W		J520010200210S K005022600020S K005041480020S		
RESISTORS GROUP								
	R831-833	nsp	00D 963 0234 603	COIL,BEAD		D340160800060S		
CAPACITORS GROUP								
	C801	nsp	00D 963 9004 708	C,CERAMIC 0.1UF-K/50V		D011104577160S		
	C802,803 C807 C808 C812 C813	nsp nsp nsp	00D 963 9004 591 00D 963 9004 708 00D 963 9005 862 00D 960 9010 010 00D 963 9004 698	C,CERAMIC 22PF-J/50V C,CERAMIC 0.1UF-K/50V C,ELECT 47UF-M/16V C,ELECT 4.7UF-M/50V C,CERAMIC 0.01UF-K/50V		D010220167160S D011104577160S D040470083080F D0404R7087250F D011103777160S		
	C814 C815 C816 C817 C818 C819	nsp nsp	00D 963 9005 862 00D 960 0298 802 00D 963 9004 708 00D 963 0234 205 00D 963 0293 602 00D 963 9005 901	C,ELECT 47UF-M/16V C,ELECT 470UF-M/6.3V C,CERAMIC 0.1UF-K/50V C,ELECT 10UF-M/50V C,ELECT 1UF-M/50V (Pb Free) C,ELECT 470UF-M/10V,		D040470083080F D040471081070F D011104577160S D040100087070F D040010087150F D040471082060F		

	Ref. No.	nsp	Part No.	Part Name	Remarks		Q'ty	New
	C821		00D 963 0216 906	C,ELECT 1000UF-M/6.3V		D040102081060F		
	C823		00D 960 0298 802	C,ELECT 470UF-M/6.3V		D040471081070F		
	C824	nsp	00D 963 9004 698	C,CERAMIC 0.01UF-K/50V		D011103777160S		
	C825		00D 960 9010 010	C,ELECT 4.7UF-M/50V		D0404R7087250F		
	C830		00D 963 9005 901	C,ELECT 470UF-M/10V,		D040471082060F		
	C832	nsp	00D 963 9004 708	C,CERAMIC 0.1UF-K/50V		D011104577160S		
	C833,834	nsp	00D 963 0233 905	C,CERAMIC 0.015UF-K/50V		D011153777160S		
	C835	nsp	00D 963 9004 708	C,CERAMIC 0.1UF-K/50V		D011104577160S		
	C836,837	nsp	00D 963 0224 105	C,CERAMIC 1000PF-K/50V		D011102777160S		
	C838-841	nsp	00D 963 9004 708	C,CERAMIC 0.1UF-K/50V		D011104577160S		
	C842		00D 963 0129 608	C,CERAMIC 15PF-J/50V		D010150167160S		
	C844-846	nsp	00D 963 9004 708	C,CERAMIC 0.1UF-K/50V		D011104577160S		
	C847		00D 963 0129 608	C,CERAMIC 15PF-J/50V		D010150167160S		
	C848-857	nsp	00D 963 9004 708	C,CERAMIC 0.1UF-K/50V		D011104577160S		
	C858	nsp	00D 963 0224 202	C,CERAMIC 0.022UF-K/25V		D011223777160S		
	C859	nsp	00D 963 0246 507	C,CERAMIC 0.068UF-K/50V		D010683777160S		
	C860	nsp	00D 963 9004 708	C,CERAMIC 0.1UF-K/50V		D011104577160S		
	C861,862	nsp	00D 963 9005 998	C,CERAMIC 24PF-J/50V		D010240167160S		
	C863	nsp	00D 963 9004 698	C,CERAMIC 0.01UF-K/50V		D011103777160S		
	C864	nsp	00D 963 9004 708	C,CERAMIC 0.1UF-K/50V		D011104577160S		
	C864L		00D 963 9005 862	C,ELECT 47UF-M/16V		D040470083080F		
	C864R		00D 963 9005 862	C,ELECT 47UF-M/16V		D040470083080F		
	C865	nsp	00D 963 9004 708	C,CERAMIC 0.1UF-K/50V		D011104577160S		
	C865L	nsp	00D 963 9005 723	C,CERAMIC 120PF-J/50V		D010121167160S		
	C865R	nsp	00D 963 9005 723	C,CERAMIC 120PF-J/50V		D010121167160S		
	C866-869	nsp	00D 963 9004 698	C,CERAMIC 0.01UF-K/50V		D011103777160S		
	C869L	nsp	00D 963 0223 601	C,CERAMIC 100PF-J/50V		D010101167160S		
	C869R	nsp	00D 963 0223 601	C,CERAMIC 100PF-J/50V		D010101167160S		
	C870,871	nsp	00D 963 9004 708	C,CERAMIC 0.1UF-K/50V		D011104577160S		
	C871L		00D 963 0216 304	C,FILM 0.001UF-J/100V		D02010206C060P		
	C871R		00D 963 0216 304	C,FILM 0.001UF-J/100V		D02010206C060P		
	C872	nsp	00D 963 9004 708	C,CERAMIC 0.1UF-K/50V		D011104577160S		
	C873		00D 963 9005 804	C,ELECT 100UF-M/25V		D040101084060F		
	C873C	nsp	00D 963 9004 672	C,CERAMIC 680pF-J 50V		D010681167160S		
	C873FL	nsp	00D 963 9004 672	C,CERAMIC 680pF-J 50V		D010681167160S		
	C873FR	nsp	00D 963 9004 672	C,CERAMIC 680pF-J 50V		D010681167160S		
	C873SBL	nsp	00D 963 9004 672	C,CERAMIC 680pF-J 50V		D010681167160S		
	C873SBR	nsp	00D 963 9004 672	C,CERAMIC 680pF-J 50V		D010681167160S		
	C873SL	nsp	00D 963 9004 672	C,CERAMIC 680pF-J 50V		D010681167160S		
	C873SR	nsp	00D 963 9004 672	C,CERAMIC 680pF-J 50V		D010681167160S		
	C873SW	nsp	00D 963 9004 672	C,CERAMIC 680pF-J 50V		D010681167160S		
	C874		00D 963 9005 804	C,ELECT 100UF-M/25V		D040101084060F		
	C874C	nsp	00D 963 9006 146	C,CERAMIC 560PF-J/50V		D010561167160S		
	C874FL	nsp	00D 963 9006 146	C,CERAMIC 560PF-J/50V		D010561167160S		
	C874FR	nsp	00D 963 9006 146	C,CERAMIC 560PF-J/50V		D010561167160S		
	C874SBL	nsp	00D 963 9006 146	C,CERAMIC 560PF-J/50V		D010561167160S		
	C874SBR	nsp	00D 963 9006 146	C,CERAMIC 560PF-J/50V		D010561167160S		
	C874SL	nsp	00D 963 9006 146	C,CERAMIC 560PF-J/50V		D010561167160S		
	C874SR	nsp	00D 963 9006 146	C,CERAMIC 560PF-J/50V		D010561167160S		
	C874SW	nsp	00D 963 9006 146	C,CERAMIC 560PF-J/50V		D010561167160S		
	C875	nsp	00D 963 9004 708	C,CERAMIC 0.1UF-K/50V		D011104577160S		
	C875C		00D 963 0234 205	C,ELECT 10UF-M/50V		D040100087070F		
	C875FL		00D 963 0234 205	C,ELECT 10UF-M/50V		D040100087070F		
	C875FR		00D 963 0234 205	C,ELECT 10UF-M/50V		D040100087070F		
	C875SBL		00D 963 0234 205	C,ELECT 10UF-M/50V		D040100087070F		
	C875SBR		00D 963 0234 205	C,ELECT 10UF-M/50V		D040100087070F		
	C875SL		00D 963 0234 205	C,ELECT 10UF-M/50V		D040100087070F		
	C875SR		00D 963 0234 205	C,ELECT 10UF-M/50V		D040100087070F		
	C875SW		00D 963 0234 205	C,ELECT 10UF-M/50V		D040100087070F		
	C876	nsp	00D 963 9004 708	C,CERAMIC 0.1UF-K/50V		D011104577160S		
	C876C		00D 960 9008 611	C,FILM 0.0033UF-J/100V		D02033206C060P		
	C876FL		00D 960 9008 611	C,FILM 0.0033UF-J/100V		D02033206C060P		
	C876FR		00D 960 9008 611	C,FILM 0.0033UF-J/100V		D02033206C060P		
	C876SBL		00D 960 9008 611	C,FILM 0.0033UF-J/100V		D02033206C060P		

Ref. No.	nsp	Part No.	Part Name	Remarks		Q'ty	New
C876SBR		00D 960 9008 611	C,FILM 0.0033UF-J/100V		D02033206C060P		
C876SL		00D 960 9008 611	C,FILM 0.0033UF-J/100V		D02033206C060P		
C876SR		00D 960 9008 611	C,FILM 0.0033UF-J/100V		D02033206C060P		
C876SW		00D 960 9008 611	C,FILM 0.0033UF-J/100V		D02033206C060P		
C877-880	nsp	00D 963 9004 708	C,CERAMIC 0.1UF-K/50V		D011104577160S		
C880C		00D 963 0234 205	C,ELECT 10UF-M/50V		D040100087070F		
C880FL		00D 963 0234 205	C,ELECT 10UF-M/50V		D040100087070F		
C880FR		00D 963 0234 205	C,ELECT 10UF-M/50V		D040100087070F		
C880SBL		00D 963 0234 205	C,ELECT 10UF-M/50V		D040100087070F		
C880SBR		00D 963 0234 205	C,ELECT 10UF-M/50V		D040100087070F		
C880SL		00D 963 0234 205	C,ELECT 10UF-M/50V		D040100087070F		
C880SR		00D 963 0234 205	C,ELECT 10UF-M/50V		D040100087070F		
C880SW		00D 963 0234 205	C,ELECT 10UF-M/50V		D040100087070F		
C881-884	nsp	00D 963 9004 708	C,CERAMIC 0.1UF-K/50V		D011104577160S		
C885		00D 963 0234 205	C,ELECT 10UF-M/50V		D040100087070F		
C886	nsp	00D 963 9004 708	C,CERAMIC 0.1UF-K/50V		D011104577160S		
C887		00D 963 0234 205	C,ELECT 10UF-M/50V		D040100087070F		
C888	nsp	00D 963 9004 708	C,CERAMIC 0.1UF-K/50V		D011104577160S		
C889-891	nsp	00D 963 9004 698	C,CERAMIC 0.01UF-K/50V		D011103777160S		
C892		00D 963 0234 205	C,ELECT 10UF-M/50V		D040100087070F		
C893		00D 963 0293 602	C,ELECT 1UF-M/50V (Pb Free)		D040010087150F		
C894	nsp	00D 963 9004 698	C,CERAMIC 0.01UF-K/50V		D011103777160S		
C895		00D 963 0216 508	C,FILM 0.12UF-J/63V		D020124078060S		
C896		00D 963 0244 606	C,ELECT 0.1UF-M/50V (Pb Free)		D040R10087080F		
C897,898	nsp	00D 963 9004 708	C,CERAMIC 0.1UF-K/50V		D011104577160S		
C899,900		00D 963 0234 205	C,ELECT 10UF-M/50V		D040100087070F		
C901	nsp	00D 963 9004 708	C,CERAMIC 0.1UF-K/50V		D011104577160S		
C902		00D 963 9005 901	C,ELECT 470UF-M/10V,		D040471082060F		
C903	nsp	00D 963 9004 708	C,CERAMIC 0.1UF-K/50V		D011104577160S		
C904		00D 963 0234 205	C,ELECT 10UF-M/50V		D040100087070F		
C905,906	nsp	00D 963 9004 708	C,CERAMIC 0.1UF-K/50V		D011104577160S		
C907		00D 963 0293 709	C,ELECT 100UF-M/10V		D040101082070F		
C908		00D 963 0234 205	C,ELECT 10UF-M/50V		D040100087070F		
C909	nsp	00D 963 9004 708	C,CERAMIC 0.1UF-K/50V		D011104577160S		
C910		00D 963 0234 205	C,ELECT 10UF-M/50V		D040100087070F		
C911	nsp	00D 963 9004 708	C,CERAMIC 0.1UF-K/50V		D011104577160S		
C912,913	nsp	00D 963 9004 698	C,CERAMIC 0.01UF-K/50V		D011103777160S		
C914,915	nsp	00D 963 9004 708	C,CERAMIC 0.1UF-K/50V		D011104577160S		
C917	nsp	00D 963 9004 698	C,CERAMIC 0.01UF-K/50V		D011103777160S		
C919	nsp	00D 963 9004 698	C,CERAMIC 0.01UF-K/50V		D011103777160S		
C921	nsp	00D 963 9004 698	C,CERAMIC 0.01UF-K/50V		D011103777160S		
C922	nsp	00D 963 9004 708	C,CERAMIC 0.1UF-K/50V		D011104577160S		
C923	nsp	00D 963 0224 105	C,CERAMIC 1000PF-K/50V		D011102777160S		
C924,925	nsp	00D 963 0223 601	C,CERAMIC 100PF-J/50V		D010101167160S		
OTHERS PARTS GROUP							
CB801-806	nsp	00D 963 0220 002	BEAD,COIL 121JT		7611010000020S		
CB808	nsp	00D 963 0223 009	R,CHIP 0-J,1/16W		C20000006M160F		
CB810	nsp	00D 963 0220 002	BEAD,COIL 121JT		7611010000020S		
CN801	nsp	00D 963 0086 301	CN.WAFER 18P		L101100031810S		
CN802	nsp	00D 963 0086 204	CN.WAFER 19P		L101100031910S		
CN803	nsp	00D 963 0086 107	CN.WAFER 16P		L101100031610S		
L801	nsp	00D 963 0050 803	COIL,INDUCTOR 4.7UH		D3304R7000150S		
L803	nsp	00D 963 0050 803	COIL,INDUCTOR 4.7UH		D3304R7000150S		
XTAL1		00D 963 0217 303	CRYSTAL 12.288MHZ		E80012R288090S		
XTAL2		00D 963 0217 507	CRYSTAL 18.750MHZ		E80018R750010S		
		00D 963 0294 601	JACK,D3.5 EARPHONE		G40100350000YS		
		00D 963 0217 905	TER,RCA 2PIN		G601206A0200YS		

C/S VIDEO 1 P.W.B. UNIT ASSY

Ref. No.	nsp	Part Name	Remarks	Q'ty	New
SEMICONDUCTORS GROUP					
IC601		00D 262 3643 004	ADV7180BSTZ		
IC602		00D 262 3644 003	ADV7172KSTZ		
IC603		00D 963 0295 309	IC LM1117S	J126111733030S	
IC605		00D 963 0295 309	IC LM1117S	J126111718020S	
IC606,607		00D 263 1082 903	TK15420MTL +C		
IC608		00D 963 0295 406	IC BH7868FS	J127786800000S	
IC609		00D 963 0294 805	IC LTC4300	J040430000000S	
IC1002,1003		00D 263 1082 903	TK15420MTL +C		
IC1004		00D 963 0083 304	IC BA7626F	J171762600010S	
IC1005		00D 963 0074 504	IC BU2090F	J044209000010P	
IC1008		00D 963 0074 504	IC BU2090F	J044209000010P	
IC1010		00D 263 1082 903	TK15420MTL +C		
IC1011		00D 963 0068 002	IC BU4052BCF	J040405200060P	
IC1015		00D 963 0147 907	IC TK15420MT	J127154200010	
IC1016		00D 963 0083 304	IC BA7626F	J171762600010S	
IC1019		00D 963 0083 304	IC BA7626F	J171762600010S	
IC1021		00D 263 1082 903	TK15420MTL +C		
IC1022		00D 963 0068 002	IC BU4052BCF	J040405200060P	
Q601-603		00D 960 0068 207	TR KTA1504Y	J5201504Y0210S	
Q604,605		00D 963 0219 602	TR KRC106M	J6020106M0010S	
Q606		00D 960 0068 207	TR KTA1504Y	J5201504Y0210S	
Q607-609		00D 963 0219 602	TR KRC106M	J6020106M0010S	
Q610		00D 960 0285 006	TR KRC104S	J522104S00210S	
Q611-613		00D 963 0219 602	TR KRC106M	J6020106M0010S	
Q614		00D 963 0102 803	TR 2SA933S	J5000933S0050S	
Q615		00D 960 0111 808	TR KRC107S	J5020107S0050S	
Q616		00D 963 0120 801	TR KRC102S	J522010200210S	
Q617		00D 960 0285 006	TR KRC104S	J522104S00210S	
Q618		00D 960 0068 207	TR KTA1504Y	J5201504Y0210S	
Q1003		00D 963 0121 402	TR KRA104S	J520010400210S	
Q1004		00D 960 0097 207	TR KRA102M	J6002202M0010S	
Q1005		00D 963 0121 402	TR KRA104S	J520010400210S	
Q1006		00D 960 0097 508	TR KRC111M	J6020111M0010S	
Q1007		00D 960 0097 207	TR KRA102M	J6002202M0010S	
Q1008		00D 960 0068 207	TR KTA1504Y	J5201504Y0210S	
Q1010,1011		00D 963 0121 402	TR KRA104S	J520010400210S	
Q1012		00D 963 0102 803	TR 2SA933S	J5000933S0050S	
Q1013		00D 963 0253 008	TR KRA107M	J601107M00050S	
Q1017		00D 963 0102 803	TR 2SA933S	J5000933S0050S	
Q1018		00D 963 0253 008	TR KRA107M	J601107M00050S	
Q1021		00D 960 0097 508	TR KRC111M	J6020111M0010S	
Q1022		00D 960 0068 207	TR KTA1504Y	J5201504Y0210S	
Q1025		00D 960 0097 508	TR KRC111M	J6020111M0010S	
Q1026		00D 960 0068 207	TR KTA1504Y	J5201504Y0210S	
D601-607		00D 963 0219 709	D,SWITCHING 1N4148W	K005041480020S	
D609-612		00D 963 0219 709	D,SWITCHING 1N4148W	K005041480020S	
D616		00D 963 0219 709	D,SWITCHING 1N4148W	K005041480020S	
D701,702		00D 963 0219 709	D,SWITCHING 1N4148W	K005041480020S	
D1000,1001		00D 963 0219 709	D,SWITCHING 1N4148W	K005041480020S	
D1010-1014		00D 963 0219 709	D,SWITCHING 1N4148W	K005041480020S	
D1017		00D 963 0219 709	D,SWITCHING 1N4148W	K005041480020S	
RESISTORS GROUP					
R1048		00D 963 9005 639	R,METAL FILM 100-J,1W	C060010165060S	
R1123		00D 963 9005 639	R,METAL FILM 100-J,1W	C060010165060S	
R1140		00D 963 9005 639	R,METAL FILM 100-J,1W	C060010165060S	

Ref. No.	nsp		Part Name	Remarks		Q'ty	New
CAPACITORS GROUP							
C601	nsp	00D 963 9004 708	C,CERAMIC 0.1UF-K/50V		D011104577160S		
C602		00D 963 0234 108	C,FILM 0.1UF-J/50V		D020104167050P		
C603	nsp	00D 963 9004 708	C,CERAMIC 0.1UF-K/50V		D011104577160S		
C604,605	nsp	00D 963 0233 808	C,CERAMIC 47PF-J/50V		D010470167160S		
C606		00D 963 0293 903	C,ELECT 100UF-M/6.3V		D040102081070F		
C607,608		00D 963 9006 557	C,ELECT 220UF-M/6.3V		D040221081060F		
C609	nsp	00D 963 0234 001	C,CERAMIC 0.047UF-Z/50V		D011473597160S		
C610	nsp	00D 963 9004 708	C,CERAMIC 0.1UF-K/50V		D011104577160S		
C611	nsp	00D 963 9004 698	C,CERAMIC 0.01UF-K/50V		D011103777160S		
C612		00D 960 0298 802	C,ELECT 470UF-M/6.3V		D040471081070F		
C613	nsp	00D 963 9004 708	C,CERAMIC 0.1UF-K/50V		D011104577160S		
C614		-	C,CERAMIC 0.082UF-K/50V		D010823777160		
C615	nsp	00D 963 9004 698	C,CERAMIC 0.01UF-K/50V		D011103777160S		
C616	nsp	00D 963 9004 708	C,CERAMIC 0.1UF-K/50V		D011104577160S		
C617		00D 963 0293 709	C,ELECT 100UF-M/10V		D040101082070F		
C618,619		00D 963 0234 108	C,FILM 0.1UF-J/50V		D020104167050P		
C620,621		00D 963 0293 709	C,ELECT 100UF-M/10V		D040101082070F		
C622-625	nsp	00D 963 9004 698	C,CERAMIC 0.01UF-K/50V		D011103777160S		
C626-628		00D 963 0294 203	C,ELECT 33UF-M/16V		D040330083050F		
C629-631		00D 963 0234 108	C,FILM 0.1UF-J/50V		D020104167050P		
C632-634		00D 963 0234 205	C,ELECT 10UF-M/50V		D040100087070F		
C635		00D 963 0293 709	C,ELECT 100UF-M/10V		D040101082070F		
C636		00D 963 0294 009	C,ELECT 22UF-M/16V		D040220083070F		
C637		00D 963 0293 709	C,ELECT 100UF-M/10V		D040101082070F		
C638		00D 963 0294 009	C,ELECT 22UF-M/16V		D040220083070F		
C639		00D 963 0293 709	C,ELECT 100UF-M/10V		D040101082070F		
C640		00D 963 0294 009	C,ELECT 22UF-M/16V		D040220083070F		
C641		00D 963 0144 706	C,FILM 0.01UF-J/50V		D020103167050P		
C642		00D 963 0294 009	C,ELECT 22UF-M/16V		D040220083070F		
C643		00D 963 0144 706	C,FILM 0.01UF-J/50V		D020103167050P		
C644		00D 960 0298 802	C,ELECT 470UF-M/6.3V		D040471081070F		
C645,646		00D 960 9010 188	C,CERAMIC 0.22UF-Z/16V		D011224593160S		
C647		00D 963 0199 308	C,FILM 1UF-J/63V		D020100068050S		
C648	nsp	00D 963 9004 698	C,CERAMIC 0.01UF-K/50V		D011103777160S		
C649	nsp	00D 963 0234 001	C,CERAMIC 0.047UF-Z/50V		D011473597160S		
C650,651	nsp	00D 963 0223 009	R,CHIP THICK 0-J,1/16W		C20000006M160F		
C652	nsp	00D 963 9004 708	C,CERAMIC 0.1UF-K/50V		D011104577160S		
C653	nsp	00D 963 0224 105	C,CERAMIC 1000PF-K/50V		D011102777160S		
C654	nsp	00D 963 9004 708	C,CERAMIC 0.1UF-K/50V		D011104577160S		
C655	nsp	00D 963 9004 698	C,CERAMIC 0.01UF-K/50V		D011103777160S		
C656	nsp	00D 963 9004 708	C,CERAMIC 0.1UF-K/50V		D011104577160S		
C657	nsp	00D 963 9004 698	C,CERAMIC 0.01UF-K/50V		D011103777160S		
C659,660		00D 963 0234 108	C,FILM 0.1UF-J/50V		D020104167050P		
C661,662	nsp	00D 963 9004 708	C,CERAMIC 0.1UF-K/50V		D011104577160S		
C663		00D 963 0234 205	C,ELECT 10UF-M/50V		D040100087070F		
C664		00D 963 0144 706	C,FILM 0.01UF-J/50V		D020103167050P		
C665		00D 963 0293 709	C,ELECT 100UF-M/10V		D040101082070F		
C666		00D 963 0294 009	C,ELECT 22UF-M/16V		D040220083070F		
C667		00D 963 0293 709	C,ELECT 100UF-M/10V		D040101082070F		
C668		00D 963 0294 009	C,ELECT 22UF-M/16V		D040220083070F		
C669		00D 963 0144 706	C,FILM 0.01UF-J/50V		D020103167050P		
C670	nsp	00D 963 9004 698	C,CERAMIC 0.01UF-K/50V		D011103777160S		
C671		00D 963 0293 602	C,ELECT 1UF-M/50V (Pb Free)		D040010087150F		
C672	nsp	00D 963 0224 105	C,CERAMIC 1000PF-K/50V		D011102777160S		
C673	nsp	00D 963 9004 708	C,CERAMIC 0.1UF-K/50V		D011104577160S		
C674	nsp	00D 963 0224 105	C,CERAMIC 1000PF-K/50V		D011102777160S		
C675	nsp	00D 963 9004 708	C,CERAMIC 0.1UF-K/50V		D011104577160S		
C676,677		00D 960 0298 802	C,ELECT 470UF-M/6.3V		D040471081070F		
C678	nsp	00D 963 0224 105	C,CERAMIC 1000PF-K/50V		D011102777160S		
C679,680	nsp	00D 963 9004 708	C,CERAMIC 0.1UF-K/50V		D011104577160S		
C681,682	nsp	00D 963 0224 105	C,CERAMIC 1000PF-K/50V		D011102777160S		
C683	nsp	00D 963 9004 708	C,CERAMIC 0.1UF-K/50V		D011104577160S		

Ref. No.	nsp		Part Name	Remarks		Q'ty	New
C684	nsp	00D 963 0224 105	C,CERAMIC 1000PF-K/50V		D011102777160S		
C685	nsp	00D 963 9004 708	C,CERAMIC 0.1UF-K/50V		D011104577160S		
C686	nsp	00D 963 0224 105	C,CERAMIC 1000PF-K/50V		D011102777160S		
C687	nsp	00D 963 9004 708	C,CERAMIC 0.1UF-K/50V		D011104577160S		
C688	nsp	00D 963 0224 105	C,CERAMIC 1000PF-K/50V		D011102777160S		
C689,690	nsp	00D 963 9004 708	C,CERAMIC 0.1UF-K/50V		D011104577160S		
C691	nsp	00D 963 0224 105	C,CERAMIC 1000PF-K/50V		D011102777160S		
C692	nsp	00D 963 9004 708	C,CERAMIC 0.1UF-K/50V		D011104577160S		
C693,694	nsp	00D 963 0224 105	C,CERAMIC 1000PF-K/50V		D011102777160S		
C695	nsp	00D 963 9004 708	C,CERAMIC 0.1UF-K/50V		D011104577160S		
C701CH	nsp	00D 963 9004 698	C,CERAMIC 0.01UF-K/50V		D011103777160S		
C707L	nsp	00D 963 0223 601	C,CERAMIC 100PF-J/50V		D010101167160S		
C707R	nsp	00D 963 0223 601	C,CERAMIC 100PF-J/50V		D010101167160S		
C708L	nsp	00D 963 0223 601	C,CERAMIC 100PF-J/50V		D010101167160S		
C708R	nsp	00D 963 0223 601	C,CERAMIC 100PF-J/50V		D010101167160S		
C1000		00D 963 9006 544	C,ELECT 22UF-M/25V		D040220084050F		
C1001		00D 963 0293 709	C,ELECT 100UF-M/10V		D040101082070F		
C1004	nsp	00D 963 9004 698	C,CERAMIC 0.01UF-K/50V		D011103777160S		
C1005		00D 963 0293 709	C,ELECT 100UF-M/10V		D040101082070F		
C1006	nsp	00D 963 0234 001	C,CERAMIC 0.047UF-Z/50V		D011473597160S		
C1008	nsp	00D 963 9004 698	C,CERAMIC 0.01UF-K/50V		D011103777160S		
C1009		00D 963 9006 544	C,ELECT 22UF-M/25V		D040220084050F		
C1010		00D 963 0293 709	C,ELECT 100UF-M/10V		D040101082070F		
C1011		00D 963 9006 544	C,ELECT 22UF-M/25V		D040220084050F		
C1012	nsp	00D 963 9004 698	C,CERAMIC 0.01UF-K/50V		D011103777160S		
C1013		00D 963 9006 544	C,ELECT 22UF-M/25V		D040220084050F		
C1014,1015	nsp	00D 963 0223 601	C,CERAMIC 100PF-J/50V		D010101167160S		
C1016		00D 963 0293 709	C,ELECT 100UF-M/10V		D040101082070F		
C1018		00D 963 9006 544	C,ELECT 22UF-M/25V		D040220084050F		
C1019	nsp	00D 963 9004 698	C,CERAMIC 0.01UF-K/50V		D011103777160S		
C1021		00D 963 0234 205	C,ELECT 10UF-M/50V		D040100087070F		
C1022		00D 960 0298 802	C,ELECT 470UF-M/6.3V		D040471081070F		
C1024	nsp	00D 963 0223 601	C,CERAMIC 100PF-J/50V		D010101167160S		
C1025,1026	nsp	00D 963 9004 698	C,CERAMIC 0.01UF-K/50V		D011103777160S		
C1029	nsp	00D 963 9004 698	C,CERAMIC 0.01UF-K/50V		D011103777160S		
C1031	nsp	00D 963 9004 698	C,CERAMIC 0.01UF-K/50V		D011103777160S		
C1032,1033		00D 963 0234 205	C,ELECT 10UF-M/50V		D040100087070F		
C1038		00D 963 0294 106	C,ELECT 2.2UF-M/50V (Pb Free)		D0402R2087160F		
C1039		00D 963 0293 709	C,ELECT 100UF-M/10V		D040101082070F		
C1042	nsp	00D 963 9004 698	C,CERAMIC 0.01UF-K/50V		D011103777160S		
C1043		00D 963 9006 544	C,ELECT 22UF-M/25V		D040220084050F		
C1049,1050		00D 963 0234 205	C,ELECT 10UF-M/50V		D040100087070F		
C1052		00D 963 0293 709	C,ELECT 100UF-M/10V		D040101082070F		
C1053		00D 963 0294 106	C,ELECT 2.2UF-M/50V (Pb Free)		D0402R2087160F		
C1056		00D 963 9006 544	C,ELECT 22UF-M/25V		D040220084050F		
C1057	nsp	00D 963 9004 698	C,CERAMIC 0.01UF-K/50V		D011103777160S		
C1058		00D 963 9006 544	C,ELECT 22UF-M/25V		D040220084050F		
C1060		00D 963 9006 544	C,ELECT 22UF-M/25V		D040220084050F		
C1061	nsp	00D 963 0234 001	C,CERAMIC 0.047UF-Z/50V		D011473597160S		
C1062		00D 963 9006 544	C,ELECT 22UF-M/25V		D040220084050F		
C1063,1064		00D 963 0293 602	C,ELECT 1UF-M/50V (Pb Free)		D040010087150F		
C1065		00D 963 0234 205	C,ELECT 10UF-M/50V		D040100087070F		
C1066		00D 960 0298 802	C,ELECT 470UF-M/6.3V		D040471081070F		
C1067		00D 963 9006 544	C,ELECT 22UF-M/25V		D040220084050F		
C1068		00D 963 0293 602	C,ELECT 1UF-M/50V (Pb Free)		D040010087150F		
C1069,1070		00D 963 9006 544	C,ELECT 22UF-M/25V		D040220084050F		
C1071	nsp	00D 963 0234 001	C,CERAMIC 0.047UF-Z/50V		D011473597160S		
C1074		00D 963 0234 205	C,ELECT 10UF-M/50V		D040100087070F		
C1075		00D 960 9010 023	C,ELECT 0.47UF-M/50V		D040R47087050F		
C1076-1079	nsp	00D 963 9004 698	C,CERAMIC 0.01UF-K/50V		D011103777160S		

Ref. No.	nsp		Part Name	Remarks		Q'ty	New
OTHERS PARTS GROUP							
BD601-603	nsp	00D 963 0234 603	COIL,BEAD		D340160800060S		
CN601	nsp	00D 963 0086 301	CN.WAFER 18P		L101100031810S		
CN602	nsp	00D 963 0086 709	CN.WAFER 11P		L101100031110S		
CN603	nsp	00D 963 0097 303	CN.WAFER 15P		L101100031510S		
CN603	nsp	00D 963 0097 303	CN.WAFER 15P		L101100031510S		
CN604	nsp	00D 963 0086 505	CN.WAFER 7P		L101100030710S		
CN604	nsp	00D 963 0086 505	CN.WAFER 7P		L101100030710S		
CN610	nsp	00D 963 0086 505	CN.WAFER 7P		L101100030710S		
CN612	nsp	00D 963 0097 303	CN.WAFER 15P		L101100031510S		
CP605,606	nsp	00D 963 0097 507	CN.WAFER 15P		L101100041510S		
CP607-609	nsp	00D 963 0206 408	CN.WAFER 7P		L101100040710S		
CP611	nsp	00D 963 0097 507	CN.WAFER 15P		L101100041510S		
L601-604		00D 963 0294 300	COIL,INDUCTOR 22UH		D330220001020		
RLY601-608		00D 963 0218 302	RELAY BC3-6 24V 2A		G680240202020F		
X601		00D 963 0294 407	CRYSTAL 28.63636MHZ		E80028R636010S		
		00D 963 0218 001	TER,RCA 2PIN		G60122001000YS		
		00D 963 0146 209	TER,RCA 4PIN		G602405B01000S		
		00D 963 0218 108	TER,RCA 3PIN		G60630401000YS		
		00D 963 0146 306	TER,RCA 6PIN		G603603B2600YS		

PARTS LIST OF P.W.B. UNIT(for AVR-1507/587/487 model)

* 本表に記載されている部品は、補修用部品のため製品に使用している部品とは一部、形状、寸法などが異なる場合があります。

* The parts listed below are for maintenance only, might differ from the parts used in the unit in appearances or dimensions.

* "nsp" 印の部品は常時在庫していませんので供給に長時間を要することがあります。場合によっては、供給をお断りする場合があります。

* Part indicated with the mark "nsp" are not always in stock and possibly to take a long period of time for supplying, or in some case supplying of part may be refused.

Note: The symbols in the column "Remarks" indicate the following destinations.

1507E3 : U.S.A. & Canada model 587E3 : U.S.A. & Canada model (AVR-587) 487E3 : U.S.A. & Canada model (AVR-487)

1507E2 : Europe model

MAIN P.W.B. UNIT ASSY

	Ref. No.	nsp	Part No.	Part Name	Remarks	ETRO	Q'ty	New
SEMICONDUCTORS GROUP								
	IC101		00D 963 0219 408	IC CJ7815		J126781500090S		
	IC102		00D 963 0219 505	IC CJ7915F		J126791500070S		
	IC103		00D 963 0057 806	IC KIA78R05PI		J126780500370S		
	IC104		00D 963 0219 204	IC CJ7805		J126780500430S		
△	IC105		00D 960 0195 808	IC ICP-N15	1507E2	J120001500030S		
△	IC105,106		00D 960 0195 808	IC ICP-N15	1507E3,587E3	J120001500030S		
	Q104C		00D 960 0196 506	TR KSC1845F		J5021845F0000P		
	Q104FL		00D 960 0196 506	TR KSC1845F		J5021845F0000P		
	Q104FR		00D 960 0196 506	TR KSC1845F		J5021845F0000P		
	Q104SL		00D 960 0196 506	TR KSC1845F		J5021845F0000P		
	Q104SR		00D 960 0196 506	TR KSC1845F		J5021845F0000P		
	Q111-115		00D 963 0121 208	TR KRC107M		J6020107M0010S		
	Q116		00D 960 0196 409	TR 2SC1740SR		J5021740S0010S		
	Q117,118		00D 963 0121 208	TR KRC107M		J6020107M0010S		
	Q151		00D 960 0196 409	TR 2SC1740SR		J5021740S0010S		
	Q171		00D 960 0196 700	TR KTC3200BL		J5023200B0050S		
	Q171A		00D 960 0196 302	TR KTA1268BL		J5001268B0050S		
	Q171B		00D 960 0196 302	TR KTA1268BL		J5001268B0050S		
	Q171C		00D 960 0196 302	TR KTA1268BL		J5001268B0050S		
	Q171D		00D 960 0196 302	TR KTA1268BL		J5001268B0050S		
	Q172-177		00D 960 0196 700	TR KTC3200BL		J5023200B0050S		
	Q178		00D 960 0196 302	TR KTA1268BL		J5001268B0050S		
	Q179		00D 960 0133 103	TR KSA916Y		J5000916Y0050P		
	Q180,181		00D 960 0196 302	TR KTA1268BL		J5001268B0050S		
	Q182,183		00D 960 0196 700	TR KTC3200BL		J5023200B0050S		
	D101		00D 963 0020 309	D,SWITCHING 1SS133T		K000013300520S		
	D101C		00D 963 0219 709	D,SWITCHING 1N4148W		K005041480020S		
	D101FL		00D 963 0219 709	D,SWITCHING 1N4148W		K005041480020S		
	D101FR		00D 963 0219 709	D,SWITCHING 1N4148W		K005041480020S		
	D101SL		00D 963 0219 709	D,SWITCHING 1N4148W		K005041480020S		
	D101SR		00D 963 0219 709	D,SWITCHING 1N4148W		K005041480020S		
	D102		00D 963 0020 309	D,SWITCHING 1SS133T		K000013300520S		
	D102C		00D 963 0219 709	D,SWITCHING 1N4148W		K005041480020S		
	D102FL		00D 963 0219 709	D,SWITCHING 1N4148W		K005041480020S		
	D102FR		00D 963 0219 709	D,SWITCHING 1N4148W		K005041480020S		
	D102SL		00D 963 0219 709	D,SWITCHING 1N4148W		K005041480020S		
	D102SR		00D 963 0219 709	D,SWITCHING 1N4148W		K005041480020S		
	D103-105		00D 963 0020 309	D,SWITCHING 1SS133T		K000013300520S		
	D121-127		00D 963 0020 309	D,SWITCHING 1SS133T		K000013300520S		
	D131A		00D 960 0197 107	D,RECTIFIER BRIDGE KBPC604 6A		K047604000020P		
	D131B		00D 960 0197 107	D,RECTIFIER BRIDGE KBPC604 6A		K047604000020P		
	D132		00D 963 0020 309	D,SWITCHING 1SS133T		K000013300520S		
	D135		00D 963 0020 309	D,SWITCHING 1SS133T		K000013300520S		
	D137		00D 963 0020 309	D,SWITCHING 1SS133T		K000013300520S		
	D138		00D 963 0058 407	D,SWITCHING IN4007		K000400700520S		
	D141-146		00D 963 0058 407	D,SWITCHING IN4007		K000400700520S		
	D148		00D 963 0020 309	D,SWITCHING 1SS133T		K000013300520S		

Ref. No.	nsp	Part No.	Part Name	Remarks	ETRO	Q'ty	New
D149,150 D151 D152,153 D158-160		00D 963 0058 407 00D 963 0020 309 00D 963 0058 407 00D 963 0020 309	D,SWITCHING IN4007 D,SWITCHING 1SS133T D,SWITCHING IN4007 D,SWITCHING 1SS133T		K000400700520S K000013300520S K000400700520S K000013300520S		
ZD101C ZD101FL ZD101FR ZD101SL ZD101SR		00D 963 0279 804 00D 963 0279 804 00D 963 0279 804 00D 963 0279 804 00D 963 0279 804	D,ZENER UDZS4.3B D,ZENER UDZS4.3B D,ZENER UDZS4.3B D,ZENER UDZS4.3B D,ZENER UDZS4.3B		K06604R34P410S K06604R34P410S K06604R34P410S K06604R34P410S K06604R34P410S		
ZD102C ZD102FL ZD102FR ZD102SL ZD102SR		00D 963 0295 503 00D 963 0295 503 00D 963 0295 503 00D 963 0295 503 00D 963 0295 503	D,ZENER UDZS3.6B D,ZENER UDZS3.6B D,ZENER UDZS3.6B D,ZENER UDZS3.6B D,ZENER UDZS3.6B		K06603R64P400S K06603R64P400S K06603R64P400S K06603R64P400S K06603R64P400S		
ZD133,134 ZD136 ZD154 ZD157 ZD341,342		00D 963 0046 202 00D 963 0058 601 00D 960 0095 704 00D 963 0219 903 00D 960 0095 500	D,ZENER MTZJ18B D,ZENER MTZJ12B D,ZENER MTZJ6.2B D,ZENER MTZJ16B D,ZENER MTZJ5.1B		K06018R044520S K06012R044520S K06006R244520S K06016R044520S K06005R144520S		
LED901		00D 963 0148 605	LED SML1216W (RED/GREEN)		K500052600030		
RESISTORS GROUP							
R104C R104FL R104FR R104SL R104SR		00D 963 9006 285 00D 963 9006 285 00D 963 9006 285 00D 963 9006 285 00D 963 9006 285	R,FIXED 1WJ-5.6K R,FIXED 1WJ-5.6K R,FIXED 1WJ-5.6K R,FIXED 1WJ-5.6K R,FIXED 1WJ-5.6K		N113135656220F N113135656220F N113135656220F N113135656220F N113135656220F		
R105C R105FL R105FR R105SL R105SR		00D 963 9006 285 00D 963 9006 285 00D 963 9006 285 00D 963 9006 285 00D 963 9006 285	R,FIXED 1WJ-5.6K R,FIXED 1WJ-5.6K R,FIXED 1WJ-5.6K R,FIXED 1WJ-5.6K R,FIXED 1WJ-5.6K		N113135656220F N113135656220F N113135656220F N113135656220F N113135656220F		
R106C R106FL R106FR R106SL R106SR		00D 963 0215 907 00D 963 0215 907 00D 963 0215 907 00D 963 0215 907 00D 963 0215 907	R,METAL FILM 4.7-J,1W R,METAL FILM 4.7-J,1W R,METAL FILM 4.7-J,1W R,METAL FILM 4.7-J,1W R,METAL FILM 4.7-J,1W		C0604R7065050S C0604R7065050S C0604R7065050S C0604R7065050S C0604R7065050S		
R107C R107FL R107FR R107SL R107SR		00D 963 0215 907 00D 963 0215 907 00D 963 0215 907 00D 963 0215 907 00D 963 0215 907	R,METAL FILM 4.7-J,1W R,METAL FILM 4.7-J,1W R,METAL FILM 4.7-J,1W R,METAL FILM 4.7-J,1W R,METAL FILM 4.7-J,1W		C0604R7065050S C0604R7065050S C0604R7065050S C0604R7065050S C0604R7065050S		
R108C R108FL R108FR R108SL R108SR		00D 963 9006 269 00D 963 9006 269 00D 963 9006 269 00D 963 9006 269 00D 963 9006 269	R,FIXED 1WJ-0.22 R,FIXED 1WJ-0.22 R,FIXED 1WJ-0.22 R,FIXED 1WJ-0.22 R,FIXED 1WJ-0.22		N113135622820F N113135622820F N113135622820F N113135622820F N113135622820F		
R109C R109FL R109FR R109SL R109SR		00D 963 9006 269 00D 963 9006 269 00D 963 9006 269 00D 963 9006 269 00D 963 9006 269	R,FIXED 1WJ-0.22 R,FIXED 1WJ-0.22 R,FIXED 1WJ-0.22 R,FIXED 1WJ-0.22 R,FIXED 1WJ-0.22		N113135622820F N113135622820F N113135622820F N113135622820F N113135622820F		
R110C R110FL R110FR R110SL R110SR		00D 963 9006 269 00D 963 9006 269 00D 963 9006 269 00D 963 9006 269 00D 963 9006 269	R,FIXED 1WJ-0.22 R,FIXED 1WJ-0.22 R,FIXED 1WJ-0.22 R,FIXED 1WJ-0.22 R,FIXED 1WJ-0.22		N113135622820F N113135622820F N113135622820F N113135622820F N113135622820F		
R111C R111FL R111FR R111SL		00D 963 9006 269 00D 963 9006 269 00D 963 9006 269 00D 963 9006 269	R,FIXED 1WJ-0.22 R,FIXED 1WJ-0.22 R,FIXED 1WJ-0.22 R,FIXED 1WJ-0.22		N113135622820F N113135622820F N113135622820F N113135622820F		

Ref. No.	nsp	Part No.	Part Name	Remarks	ETRO	Q'ty	New
R111SR		00D 963 9006 269	R, FIXED 1WJ-0.22		N113135622820F		
R118C		00D 963 9006 256	R, FIXED 1WJ-10		N113135610020F		
R118FL		00D 963 9006 256	R, FIXED 1WJ-10		N113135610020F		
R118FR		00D 963 9006 256	R, FIXED 1WJ-10		N113135610020F		
R118SL		00D 963 9006 256	R, FIXED 1WJ-10		N113135610020F		
R118SR		00D 963 9006 256	R, FIXED 1WJ-10		N113135610020F		
R119C		00D 963 9006 256	R, FIXED 1WJ-10		N113135610020F		
R119FL		00D 963 9006 256	R, FIXED 1WJ-10		N113135610020F		
R119FR		00D 963 9006 256	R, FIXED 1WJ-10		N113135610020F		
R119SL		00D 963 9006 256	R, FIXED 1WJ-10		N113135610020F		
R119SR		00D 963 9006 256	R, FIXED 1WJ-10		N113135610020F		
R135,136		00D 963 0144 502	R, CEMENT 0.1-J 5W		C141R10069000S		
R141,142		00D 963 0216 003	R, METAL FILM 0.22-J, 1W		C060R22065050S		
R148,149		00D 963 0216 003	R, METAL FILM 0.22-J, 1W		C060R22065050S		
R151		00D 963 0232 809	R, METAL FILM 10-J, 1/4W		C060010063520S		
R154		00D 963 0244 305	R, METAL FILM 2.2M 0.5W	1507E3,587E3,487E3	C060022564520S		
R179		00D 963 0232 906	R, METAL FILM 47K-F, 1/4W		C060047343530S		
R181		00D 963 0215 907	R, METAL FILM 4.7-J, 1W	1507E2	C0604R7065050S		
R184		00D 963 9006 256	R, FIXED 1WJ-10		N113135610020F		
R185		00D 963 9005 655	R, METAL FILM 22-J, 1/4W		C060022063050S		
R901,902		00D 960 9009 270	R, METAL FILM 470-J, 2W		C060047166520S		
VR101-105		00D 960 0091 601	VR, SEMI CERMET 1KB		C544102015130P		
CAPACITORS GROUP							
C101C		00D 963 0234 506	C, ELECT 47UF-M/50V(Pb Free)		D040470087070F		
C101FL		00D 963 0234 506	C, ELECT 47UF-M/50V(Pb Free)		D040470087070F		
C101FR		00D 963 0234 506	C, ELECT 47UF-M/50V(Pb Free)		D040470087070F		
C101SL		00D 963 0234 506	C, ELECT 47UF-M/50V(Pb Free)		D040470087070F		
C101SR		00D 963 0234 506	C, ELECT 47UF-M/50V(Pb Free)		D040470087070F		
C102C		00D 963 0234 205	C, ELECT 10UF-M/50V		D040100087070F		
C102FL		00D 963 0234 205	C, ELECT 10UF-M/50V		D040100087070F		
C102FR		00D 963 0234 205	C, ELECT 10UF-M/50V		D040100087070F		
C102SL		00D 963 0234 205	C, ELECT 10UF-M/50V		D040100087070F		
C102SR		00D 963 0234 205	C, ELECT 10UF-M/50V		D040100087070F		
C103C		00D 963 9003 084	C, CERAMIC 100PF-K/500V		D00410106D050S		
C103FL		00D 963 9003 084	C, CERAMIC 100PF-K/500V		D00410106D050S		
C103FR		00D 963 9003 084	C, CERAMIC 100PF-K/500V		D00410106D050S		
C103SL		00D 963 9003 084	C, CERAMIC 100PF-K/500V		D00410106D050S		
C103SR		00D 963 9003 084	C, CERAMIC 100PF-K/500V		D00410106D050S		
C104C		00D 963 9003 084	C, CERAMIC 100PF-K/500V		D00410106D050S		
C104FL		00D 963 9003 084	C, CERAMIC 100PF-K/500V		D00410106D050S		
C104FR		00D 963 9003 084	C, CERAMIC 100PF-K/500V		D00410106D050S		
C104SL		00D 963 9003 084	C, CERAMIC 100PF-K/500V		D00410106D050S		
C104SR		00D 963 9003 084	C, CERAMIC 100PF-K/500V		D00410106D050S		
C105C		00D 960 9003 108	C, CERAMIC 0.022UF-Z/25V		D005223594520S		
C105FL		00D 960 9003 108	C, CERAMIC 0.022UF-Z/25V		D005223594520S		
C105FR		00D 960 9003 108	C, CERAMIC 0.022UF-Z/25V		D005223594520S		
C105SL		00D 960 9003 108	C, CERAMIC 0.022UF-Z/25V		D005223594520S		
C105SR		00D 960 9003 108	C, CERAMIC 0.022UF-Z/25V		D005223594520S		
C107C		00D 963 9003 097	C, FILM -.0.1UF-K/250V		D02010407H080S		
C107FL		00D 963 9003 097	C, FILM -.0.1UF-K/250V		D02010407H080S		
C107FR		00D 963 9003 097	C, FILM -.0.1UF-K/250V		D02010407H080S		
C107SL		00D 963 9003 097	C, FILM -.0.1UF-K/250V		D02010407H080S		
C107SR		00D 963 9003 097	C, FILM -.0.1UF-K/250V		D02010407H080S		
C131-135		00D 963 9003 097	C, FILM -.0.1UF-K/250V		D02010407H080S		
C136,137		00D 963 0149 400	CAPE. GENERIC 1000UF/63V(M)		N211210388110F		
C138		00D 963 0293 602	C, ELECT 1UF-M/50V (Pb Free)		D040010087150F		
C141-143		00D 963 0021 900	C, FILM 0.047UF-J/100V		D02047306C060P		
C144		00D 963 0217 109	C, ELECT 3300UF-M/35V		D040332085010F		
C145		00D 963 9003 123	C, ELECT 1000UF-M/35V		D040102085040F		
C146		00D 963 0293 602	C, ELECT 1UF-M/50V (Pb Free)		D040010087150F		
C148		00D 963 0293 602	C, ELECT 1UF-M/50V (Pb Free)		D040010087150F		

	Ref. No.	nsp	Part No.	Part Name	Remarks	ETRO	Q'ty	New
	C150-152		00D 963 0021 900	C,FILM 0.047UF-J/100V		D02047306C060P		
	C153		00D 963 0021 104	C,ELECT 6800UF-M/16V		D040682083000F		
	C154		00D 963 0234 205	C,ELECT 10UF-M/50V		D040100087070F		
	C155		00D 963 0020 202	C,CERAMIC 0.1UF-Z/50V		D005104597530S		
	C157		00D 963 0293 602	C,ELECT 1UF-M/50V (Pb Free)		D040010087150F		
	C158		00D 963 0217 002	C,ELECT 3300UF-M/16V		D040332083010F		
	C159		00D 963 0293 602	C,ELECT 1UF-M/50V (Pb Free)		D040010087150F		
	C161		00D 963 0234 205	C,ELECT 10UF-M/50V		D040100087070F		
	C171		00D 963 0293 709	C,ELECT 100UF-M/10V		D040101082070F		
	C171A		00D 963 0020 202	C,CERAMIC 0.1UF-Z/50V		D005104597530S		
	C171B		00D 963 0020 202	C,CERAMIC 0.1UF-Z/50V		D005104597530S		
	C171C		00D 963 0020 202	C,CERAMIC 0.1UF-Z/50V		D005104597530S		
	C171D		00D 963 0020 202	C,CERAMIC 0.1UF-Z/50V		D005104597530S		
	C172,173		00D 963 9005 833	C,ELECT 220UF-M/6.3V		D040221081230F		
	C174		00D 963 0234 205	C,ELECT 10UF-M/50V		D040100087070F		
	C175		00D 963 9006 544	C,ELECT 22UF-M/25V		D040220084050F		
	C176,177		00D 963 0293 602	C,ELECT 1UF-M/50V (Pb Free)		D040010087150F		
	C178		00D 963 9003 149	C,ELECT 330UF-M/63V		D040331088230F		
	C179		00D 963 9005 833	C,ELECT 220UF-M/6.3V		D040221081230F		
⚠	C181		00D 963 9006 191	C,CERAMIC AC13F472MDOA		D00847208K070S		
	C182		00D 963 0234 302	C,ELECT 10UF-M/100V		D04010008C050F		
	C191-198		00D 963 0233 400	C,CERAMIC 2200PF-K/16V	1507E2	D005222773530S		
	C198C		00D 963 0024 703	C,FILM 0.01UF-J/100V	1507E2	D02010306C060P		
	C198FL		00D 963 0024 703	C,FILM 0.01UF-J/100V	1507E2	D02010306C060P		
	C198FR		00D 963 0024 703	C,FILM 0.01UF-J/100V	1507E2	D02010306C060P		
	C198SBL		00D 963 0024 703	C,FILM 0.01UF-J/100V	1507E2	D02010306C060P		
	C198SBR		00D 963 0024 703	C,FILM 0.01UF-J/100V	1507E2	D02010306C060P		
	C198SL		00D 963 0024 703	C,FILM 0.01UF-J/100V	1507E2	D02010306C060P		
	C198SR		00D 963 0024 703	C,FILM 0.01UF-J/100V	1507E2	D02010306C060P		
	C199		00D 963 0233 400	C,CERAMIC 2200PF-K/16V	1507E2	D005222773530S		
	C199FL		00D 963 0024 703	C,FILM 0.01UF-J/100V	1507E2	D02010306C060P		
	C199FR		00D 963 0024 703	C,FILM 0.01UF-J/100V	1507E2	D02010306C060P		
	C341,342		00D 963 0233 303	C,CERAMIC 0.01UF-M/16V		D005103773530S		
	C901,902		00D 963 0233 206	C,CERAMIC 0.001UF-K/50V		D005102177530S		
	C903		00D 963 0233 109	C,CERAMIC 0.01UF-Z/50V		D004103097060S		
	C904		00D 960 9003 108	C,CERAMIC 0.022UF-Z/25V		D005223594520S		
	C905		00D 963 0020 202	C,CERAMIC 0.1UF-Z/50V		D005104597530S		
OTHERS PARTS GROUP								
	CLAMP101	nsp	00D 960 0260 005	CLAMP /WIRE		4330000120000S		
	CN201	nsp	00D 963 0148 702	CN,WIRE 120MM/2P		L000121020120P		
	CN901		00D 963 0184 601	CN,WIRE 260MM/3P		L000261030070P		
	CN992	nsp	00D 963 0235 602	CN,WIRE 270MM/4P		L000271040030P		
	CP101		00D 963 0267 803	CN.WAFER 2P		L108202000220F		
	CP102	nsp	00D 960 0123 304	CN.WAFER 2P		L104353280200S		
	CP103	nsp	00D 963 0066 208	CN.WAFER 3P		L104353280300S		
	CP104	nsp	00D 960 0128 804	CN.WAFER 6P		L102526700600S		
	CP105	nsp	00D 963 0149 109	CN.WAFER 2P(BLACK)		L104353280201S		
	CP106	nsp	00D 960 0123 207	CN.WAFER 3P		L102526700300S		
	CP302		00D 963 0257 800	CN.WAFER 7P		L101220070010S		
	CP501	nsp	00D 963 0206 301	CN.WAFER 5P		L101100040510S		
	CP502	nsp	00D 963 0206 408	CN.WAFER 7P		L101100040710S		
	CP503	nsp	00D 963 0206 301	CN.WAFER 5P		L101100040510S		
	CP504	nsp	00D 963 0206 505	CN.WAFER 9P		L101100040910S		
	CP505	nsp	00D 963 0235 709	CN.WAFER 12P		L101100041210S		
	CP555	nsp	00D 963 0111 108	CN.WAFER 14P		L101100041410S		
	CP556	nsp	00D 963 0087 805	CN.WAFER 11P		L101100041110S		
	CP901,902	nsp	00D 963 0235 806	CN.WAFER 3P		L101220030000S		
	CP931	nsp	00D 963 0149 206	CN.WAFER 2P		L104353280203S		
⚠	F101		00D 963 0236 106	FUSE T8A/250V-	1507E3,587E3,487E3	N751228001110S		

	Ref. No.	nsp	Part No.	Part Name	Remarks	ETRO	Q'ty	New
⚠	F101		00D 963 0104 704	FUSE T2.5A/250V	1507E2	N751222501110S		
⚠	F102		00D 963 0236 106	FUSE T8A/250V	1507E3,587E3,487E3	N751228001110S		
⚠	F102		00D 963 0104 704	FUSE T3.15A/250V	1507E2	N751223151110S		
	F101A	nsp	00D 960 0005 804	HOLDER,FUSE CLIP		G645000050010		
	F101B	nsp	00D 960 0005 804	HOLDER,FUSE CLIP		G645000050010		
	F102A	nsp	00D 960 0005 804	HOLDER,FUSE CLIP		G645000050010		
	F102B	nsp	00D 960 0005 804	HOLDER,FUSE CLIP		G645000050010		
	G901		00D 963 0257 907	CN,WIRE 160MM/1P		N602141610310F		
	GND101-103		-	TERMINAL EARTH		3790040886000S		
	L101C	nsp	00D 963 0049 005	COIL,INDUCTOR 0.5UH		D330R50000000F		
	L101FL	nsp	00D 963 0049 005	COIL,INDUCTOR 0.5UH		D330R50000000F		
	L101FR	nsp	00D 963 0049 005	COIL,INDUCTOR 0.5UH		D330R50000000F		
	L101SL	nsp	00D 963 0049 005	COIL,INDUCTOR 0.5UH		D330R50000000F		
	L101SR	nsp	00D 963 0049 005	COIL,INDUCTOR 0.5UH		D330R50000000F		
	RLY101-104		00D 960 0181 702	RELAY G5PA-28 24V 5A		G680240502020S		
	RLY105		00D 963 0218 506	RELAY BC3-24 24V 2A		G680240202040F		
	RLY106		00D 963 0218 205	RELAY G5PA-1 DC9V 250V/5A		G680090102010F		
	RLY107		00D 960 0181 702	RELAY G5PA-28 24V 5A		G680240502020S		
	SW901		00D 963 0200 103	SW,TACT SKHV10920A		G180000270010S		
	TP101-105	nsp	00D 960 0161 405	CN.WAFER 3P		L101530140310S		
	VEC303		00D 963 0095 208	SW,ENCODER EC16B24SA		G121162400040S		
			-	HEAT SINK		2120043538050S		
			-	HEAT SINK		2120044308010S		
⚠			00D 963 0232 100	STAND BY TRANS 120V/60HZ	1507E3,587E3,487E3	8200350150200S		
⚠		nsp	00D 963 0215 606	STAND BY TRANS 230V/50HZ	1507E2	8200350150210S		
			00D 963 0018 007	SCREW, 3*8 B-TYPE ZNY/BH		B020030081B10S		
			00D 963 0158 608	2P TER, SP		G611201A0200YS		
			00D 963 0119 906	8P TER, SP		G614801A0200YS		
			00D 963 0294 708	JACK,D6.5 PHONE		G402PJ612AG0YS		
⚠			00D 960 0181 508	AC OUTLET(E3)	1507E3,587E3,487E3	G435204004010S		
⚠			00D 960 0143 203	AC OUTLET(E2)	1507E2	G435040110000S		
			-	COVER, CAPACITOR	1507E2	4310002640010S		
			00D 963 0247 001	LABEL, FUSE (F102)	1507E2	5527200040030S		
			00D 963 0257 208	4P TER, SP	487E3	G612405E0200YS		

CPU P.W.B. UNIT ASSY

	Ref. No.	nsp	Part No.	Part Name	Remarks		Q'ty	New
SEMICONDUCTORS GROUP								
	IC201		00D 262 3651 009	M3062LFGPFP				
	IC202		00D 963 0057 602	IC TDA7330BD	1507E2	J080733000010F		
	IC271		00D 963 0252 902	IC CJ7812		J126781200230S		
	IC301		00D 262 2549 002	LC75721E +C				
	IC302		00D 963 0074 504	IC BU2090F		J044209000010P		
	Q202		00D 963 0121 509	TR KTC3875S		J522038750210S		
	Q203,204		00D 963 0044 301	TR KTC2875B		J5222875B0010S		
	Q205		00D 963 0120 704	TR KRA102S		J520010200210S		
	Q206,207		00D 963 0044 301	TR KTC2875B		J5222875B0010S		
	Q251		00D 963 0120 704	TR KRA102S		J520010200210S		
	Q261		00D 963 0148 508	TR KTA1504S	1507E2	J520015040150S		
	Q262		00D 960 0111 808	TR KRC107S	1507E2	J5020107S0050S		
	Q263		00D 960 0285 006	TR KRC104S		J522104S00210S		
	Q301		00D 963 0120 704	TR KRA102S		J520010200210S		
	Q310		00D 963 0120 704	TR KRA102S		J520010200210S		
	Q311		00D 963 0120 801	TR KRC102S		J522010200210S		
	Q312		00D 963 0120 704	TR KRA102S		J520010200210S		
	Q313		00D 963 0120 801	TR KRC102S		J522010200210S		
	Q314		00D 963 0120 704	TR KRA102S		J520010200210S		
	Q315		00D 963 0120 801	TR KRC102S		J522010200210S		
	Q321		00D 963 0102 803	TR 2SA933S		J5000933S0050S		
	Q322		00D 960 0111 808	TR KRC107S		J5020107S0050S		
	Q901,902		00D 963 0120 704	TR KRA102S		J520010200210S		
	D201		00D 963 0020 309	D,SWITCHING 1SS133T		K000013300520S		
	D202		00D 963 0058 407	D,SWITCHING IN4007		K000400700520S		
	D203-205		00D 963 0219 709	D,SWITCHING 1N4148W		K005041480020S		
	D302-304		00D 963 0020 309	D,SWITCHING 1SS133T		K000013300520S		
	D305		00D 963 0219 709	D,SWITCHING 1N4148W		K005041480020S		
	D307		00D 963 0020 309	D,SWITCHING 1SS133T		K000013300520S		
	D308,309		00D 963 0219 709	D,SWITCHING 1N4148W		K005041480020S		
	ZD201		00D 963 0047 502	D,ZENER MTZJ3.3B		K06003R344520S		
	ZD301		00D 960 0095 801	D,ZENER MTZJ6.8B		K06006R844520S		
	ZD331,332		00D 960 0095 500	D,ZENER MTZJ5.1B		K06005R144520S		
	ZD335,336		00D 960 0095 500	D,ZENER MTZJ5.1B		K06005R144520S		
	LED301-304		00D 960 0197 204	LED PI5-RD/HL50RDRF4T		K500052015010S		
	LED306		00D 960 0197 204	LED PI5-RD/HL50RDRF4T		K500052015010S		
	LED308-311		00D 960 0197 204	LED PI5-RD/HL50RDRF4T		K500052015010S		
	FL301		00D 963 0257 305	DISPLAY,FLT HNA-16SM13T		K530161300020S		
RESISTORS GROUP								
	R211		00D 960 9003 807	R,METAL FILM 100-J,1/4W		C060010163050S		
	R271		00D 963 0215 907	R,METAL FILM 4.7-J,1W		C0604R7065050S		
CAPACITORS GROUP								
	C201	nsp	00D 963 9004 698	C,CERAMIC 0.01UF-K/50V		D011103777160S		
	C202	nsp	00D 963 9004 711	C,CERAMIC 0.1UF-Z/50V		D011104597160S		
	C203	nsp	00D 963 9004 698	C,CERAMIC 0.01UF-K/50V		D011103777160S		
	C204		00D 960 9010 010	C,ELECT 4.7UF-M/50V		D0404R7087250F		
	C205		00D 963 0020 202	C,CERAMIC 0.1UF-Z/50V		D005104597530S		
	C206		00D 963 9005 862	C,ELECT 47UF-M/16V	1507E2	D040470083080F		
	C207	nsp	00D 963 9004 698	C,CERAMIC 0.01UF-K/50V	1507E2	D011103777160S		
	C208		00D 963 0223 708	C,CERAMIC 270PF-J/50V	1507E2	D010271167160S		
	C209		00D 963 0234 205	C,ELECT 10UF-M/50V	1507E2	D040100087070F		

Ref. No.	nsp	Part No.	Part Name	Remarks		Q'ty	New
C210	nsp	00D 963 9004 698	C,CERAMIC 0.01UF-K/50V	1507E2	D011103777160S		
C211,212		00D 963 9004 614	C,CERAMIC 27PF-J/50V	1507E2	D010270167160S		
C221		00D 963 0293 709	C,ELECT 100UF-M/10V		D040101082070F		
C261,262	nsp	00D 963 0223 601	C,CERAMIC 100PF-J/50V		D010101167160S		
C267-270	nsp	00D 963 0223 601	C,CERAMIC 100PF-J/50V		D010101167160S		
C271,272		00D 963 0234 205	C,ELECT 10UF-M/50V		D040100087070F		
C275	nsp	00D 963 9004 711	C,CERAMIC 0.1UF-Z/50V		D011104597160S		
C278	nsp	00D 963 9004 711	C,CERAMIC 0.1UF-Z/50V		D011104597160S		
C279	nsp	00D 963 0223 601	C,CERAMIC 100PF-J/50V		D010101167160S		
C291,292		00D 963 9004 517	C,CERAMIC 0.022UF-Z/50V		D004223597050S		
C293		00D 963 0233 303	C,CERAMIC 0.01UF-M/16V		D005103773530S		
C294	nsp	00D 963 9004 698	C,CERAMIC 0.01UF-K/50V		D011103777160S		
C295		00D 963 0233 303	C,CERAMIC 0.01UF-M/16V		D005103773530S		
C301		00D 963 0234 205	C,ELECT 10UF-M/50V		D040100087070F		
C302	nsp	00D 963 0234 001	C,CERAMIC 0.047UF-Z/50V		D011473597160S		
C303		00D 963 9005 862	C,ELECT 47UF-M/16V		D040470083080F		
C304		00D 960 9003 108	C,CERAMIC 0.022UF-Z/25V		D005223594520S		
C305		00D 963 9005 862	C,ELECT 47UF-M/16V		D040470083080F		
C306		00D 963 0216 401	C,FILM 0.1UF-J/100V		D02010406C060P		
C307		00D 963 0293 602	C,ELECT 1UF-M/50V (Pb Free)		D040010087150F		
C308,309		00D 963 0021 900	C,FILM 0.047UF-J/100V		D02047306C060P		
C310		00D 963 0293 602	C,ELECT 1UF-M/50V (Pb Free)		D040010087150F		
C311	nsp	00D 963 0233 701	C,CERAMIC 30PF-J/50V		D010300167160S		
C312		00D 963 9005 859	C,ELECT 47UF-M/16V		D040470083060F		
C313		-	C,FILM 0.047UF-J/100V		D02047306C070S		
C321	nsp	00D 963 0224 105	C,CERAMIC 1000PF-K/50V		D011102777160S		
C322	nsp	00D 963 0223 601	C,CERAMIC 100PF-J/50V		D010101167160S		
C324,325	nsp	00D 963 0223 601	C,CERAMIC 100PF-J/50V		D010101167160S		
C326X	nsp	00D 963 0223 601	C,CERAMIC 100PF-J/50V		D010101167160S		
C331,332		00D 963 0233 303	C,CERAMIC 0.01UF-M/16V		D005103773530S		
C335,336		00D 963 0233 303	C,CERAMIC 0.01UF-M/16V		D005103773530S		
C343X	nsp	00D 963 0223 601	C,CERAMIC 100PF-J/50V		D010101167160S		
C381		00D 963 9005 862	C,ELECT 47UF-M/16V	1507E2	D040470083080F		
C381A		00D 963 9005 862	C,ELECT 47UF-M/16V	1507E3,587E3,487E3	D040470083080F		
C382,383	nsp	00D 963 0223 601	C,CERAMIC 100PF-J/50V	1507E2	D010101167160S		
C382A	nsp	00D 963 0223 601	C,CERAMIC 100PF-J/50V	1507E3,587E3,487E3	D010101167160S		
C383A	nsp	00D 963 0223 601	C,CERAMIC 100PF-J/50V	1507E3,587E3,487E3	D010101167160S		
C384,385		00D 963 0293 602	C,ELECT 1UF-M/50V (Pb Free)	1507E2	D040010087150F		
C384A		00D 963 0293 602	C,ELECT 1UF-M/50V (Pb Free)	1507E3,587E3,487E3	D040010087150F		
C385A		00D 963 0293 602	C,ELECT 1UF-M/50V (Pb Free)	1507E3,587E3,487E3	D040010087150F		
C386	nsp	00D 963 0234 001	C,CERAMIC 0.047UF-Z/50V		D011473597160S		
C387,388	nsp	00D 963 9004 711	C,CERAMIC 0.1UF-Z/50V	1507E2	D011104597160S		
C387A	nsp	00D 963 9004 711	C,CERAMIC 0.1UF-Z/50V	1507E3,587E3,487E3	D011104597160S		
C388A	nsp	00D 963 9004 711	C,CERAMIC 0.1UF-Z/50V	1507E3,587E3,487E3	D011104597160S		
BC201		00D 254 4666 005	CE04W0H105ZC(FG)				
OTHERS PARTS GROUP							
BD201-203	nsp	00D 963 0154 602	BEAD,COIL		7610010030000S		
BD301-303	nsp	00D 963 0234 603	COIL,BEAD MB-160808	1507E2	D340160800060S		
BD301A	nsp	00D 963 0234 603	COIL,BEAD MB-160808	1507E3,587E3,487E3	D340160800060S		
BD302A	nsp	00D 963 0234 603	COIL,BEAD MB-160808	1507E3,587E3,487E3	D340160800060S		
BD303A	nsp	00D 963 0234 603	COIL,BEAD MB-160808	1507E3,587E3,487E3	D340160800060S		
CN201		00D 963 0245 906	CN,WIRE 240MM/6P	1507E2	L000241060020F		
CN201A		00D 963 0245 906	CN,WIRE 240MM/6P	1507E3,587E3,487E3	L000241060020F		
CN302		00D 963 0159 209	CN,WIRE 100MM/7P		L000101070080P		
CN902		00D 963 0246 002	CN,WIRE 80MM/3P		L000800030110P		
CN931	nsp	00D 963 0148 809	CN,WIRE 350MM/2P		L000351020100P		
CP201	nsp	00D 963 0097 604	CN.WAFER 6P		L101220060000S		
CP301A	nsp	00D 963 0161 103	CN.FPC 23P		L131112300010F		
CP301B	nsp	00D 963 0161 006	CN.FPC 23P		L131102300010F		

Ref. No.	nsp	Part No.	Part Name	Remarks		Q'ty	New
CP303	nsp	00D 963 0236 009	CN.WAFER 3P		L102526803010S		
CP401	nsp	00D 963 0235 709	CN.WAFER 12P		L101100041210S		
CP402	nsp	00D 963 0087 805	CN.WAFER 11P		L101100041110S		
CP404	nsp	00D 963 0087 407	CN.WAFER 16P		L101100041610S		
CP552	nsp	00D 963 0097 507	CN.WAFER 15P		L101100041510S		
CP553	nsp	00D 963 0087 805	CN.WAFER 11P		L101100041110S		
CP601	nsp	00D 963 0087 601	CN.WAFER 18P		L101100041810S		
CP701	nsp	00D 963 0097 507	CN.WAFER 15P		L101100041510S		
CP702	nsp	00D 963 0087 504	CN.WAFER 19P		L101100041910S		
CP703	nsp	00D 963 0097 507	CN.WAFER 15P		L101100041510S		
CP704		00D 963 0256 908	CN.WAFER 10P		L101100041010S		
CP801	nsp	00D 963 0087 601	CN.WAFER 18P		L101100041810S		
CP802	nsp	00D 963 0087 504	CN.WAFER 19P		L101100041910S		
CP803	nsp	00D 963 0111 108	CN.WAFER 14P		L101100041410S		
G301		00D 963 0257 509	RING,TER WIRE 80MM/1P	1507E2	8410800010100F		
G301A		00D 963 0257 509	RING,TER WIRE 80MM/1P	1507E3,587E3,487E3	8410800010100F		
GND201		-	TERMINAL EARTH		3790040886000S		
L301	nsp	00D 960 0128 008	COIL,INDUCTOR 100UH		D330101001020S		
L302	nsp	00D 960 0010 307	COIL,INDUCTOR 10UH		D330100700520S		
RMC301		00D 963 0217 808	MODULE,REMOCON NJL34H380A		E940343800010P		
SW301C		00D 963 0200 103	SW,TACT SKHV10920A		G180000270010S		
SW302A		00D 963 0095 305	SW,TACT SKHV10910D01		G180040500010S		
SW302B		00D 963 0095 305	SW,TACT SKHV10910D01		G180040500010S		
SW302C		00D 963 0200 103	SW,TACT SKHV10920A		G180000270010S		
SW303A		00D 963 0095 305	SW,TACT SKHV10910D01		G180040500010S		
SW303B		00D 963 0095 305	SW,TACT SKHV10910D01		G180040500010S		
SW303C		00D 963 0200 103	SW,TACT SKHV10920A		G180000270010S		
SW304A		00D 963 0095 305	SW,TACT SKHV10910D01		G180040500010S		
SW304B		00D 963 0095 305	SW,TACT SKHV10910D01		G180040500010S		
SW304C		00D 963 0200 103	SW,TACT SKHV10920A		G180000270010S		
SW305A		00D 963 0200 103	SW,TACT SKHV10920A		G180000270010S		
SW305B		00D 963 0095 305	SW,TACT SKHV10910D01		G180040500010S		
SW305C		00D 963 0200 103	SW,TACT SKHV10920A		G180000270010S		
SW306A		00D 963 0095 305	SW,TACT SKHV10910D01		G180040500010S		
SW306B		00D 963 0095 305	SW,TACT SKHV10910D01		G180040500010S		
SW306C		00D 963 0200 103	SW,TACT SKHV10920A		G180000270010S		
SW307B		00D 963 0095 305	SW,TACT SKHV10910D01		G180040500010S		
SW307C		00D 963 0200 103	SW,TACT SKHV10920A		G180000270010S		
SW308B		00D 963 0095 305	SW,TACT SKHV10910D01		G180040500010S		
SW308C		00D 963 0200 103	SW,TACT SKHV10920A		G180000270010S		
SW309B		00D 963 0095 305	SW,TACT SKHV10910D01		G180040500010S		
SW309C		00D 963 0200 103	SW,TACT SKHV10920A		G180000270010S		
SW931		00D 963 0145 802	SW,PUSH SDDL-005-S(C-UL)		G000122006060F		
TP301	nsp	00D 963 0060 709	CN.WAFER 8P		L101220080000S		
TP601		00D 960 0123 605	CN.WAFER 13P		L101530141310S		
VEC301,302		00D 963 0095 208	SW,ENCODER EC16B24SA		G121162400040S		
X201		00D 963 0217 701	RESONATOR,CERAMIC ZTT12.00MT		E830120000060P		
X202		00D 963 0217 604	CRYSTAL 4.332MHZ	1507E2	E800433200100		
		-	HEAT SINK	1507E2	2120043538050S		
		-	HEAT SINK	1507E3,587E3,487E3	2120044308010S		
	nsp	00D 963 0018 007	SCREW, 3*8 B-TYPE ZNY/BH		B020030081B10S		
	nsp	00D 960 0184 408	HOLDER, FLT		4320200026000S		
		00D 963 0146 403	TER,RCA 3PIN		G606308HG110YS		

PRE-AMP P.W.B. UNIT ASSY

	Ref. No.	nsp	Part No.	Part Name	Remarks		Q'ty	New
SEMICONDUCTORS GROUP								
	IC102X IC102X4 IC103X IC103X4		00D 263 1092 003 00D 263 1092 003 00D 263 1223 005 00D 263 1223 005	IC BA05T IC BA05T IC PQ20RX11 IC PQ20RX11	1507E3,587E3 487E3 1507E3,587E3 487E3			
	Q101SBL Q101SBR Q101X Q101X4		00D 963 0044 204 00D 963 0044 204 00D 960 0097 304 00D 960 0097 304	TR 2SD2390-Y TR 2SD2390-Y TR KRC102M TR KRC102M	1507E3,587E3,1507E2 1507E3,587E3,1507E2 1507E3,587E3 487E3	J5032390Y0000P J5032390Y0000P J6020102M0010S J6020102M0010S		
	Q102SBL Q102SBR Q102X Q102X4 Q103SBL		00D 963 0044 107 00D 963 0044 107 00D 960 0097 304 00D 960 0097 304 00D 963 0280 107	TR 2SB1560-Y TR 2SB1560-Y TR KRC102M TR KRC102M TR 2SC3964	1507E3,587E3,1507E2 1507E3,587E3,1507E2 1507E3,587E3 487E3 1507E3,587E3,1507E2	J5011560Y0000P J5011560Y0000P J6020102M0010S J6020102M0010S J502396400000S		
	Q103SBR Q104SBL Q104SBR Q501C Q501FL		00D 963 0280 107 00D 960 0196 506 00D 960 0196 506 00D 960 0196 603 00D 960 0196 603	TR 2SC3964 TR KSC1845F TR KSC1845F TR KTC2874B TR KTC2874B	1507E3,587E3,1507E2 1507E3,587E3,1507E2 1507E3,587E3,1507E2	J502396400000S J5021845F0000P J5021845F0000P J502287400010S J502287400010S		
	Q501FR Q501SL Q501SR Q502C Q502FL		00D 960 0196 603 00D 960 0196 603 00D 960 0196 603 00D 960 0196 205 00D 960 0196 205	TR KTC2874B TR KTC2874B TR KTC2874B TR KSA992F TR KSA992F		J502287400010S J502287400010S J502287400010S J5000992F0050P J5000992F0050P		
	Q502FR Q502SBL Q502SBR Q502SL Q502SR		00D 960 0196 205 00D 960 0196 205 00D 960 0196 205 00D 960 0196 205 00D 960 0196 205	TR KSA992F TR KSA992F TR KSA992F TR KSA992F TR KSA992F		J5000992F0050P J5000992F0050P J5000992F0050P J5000992F0050P J5000992F0050P		
	Q503C Q503FL Q503FR Q503SBL Q503SBR		00D 960 0196 205 00D 960 0196 205 00D 960 0196 205 00D 960 0196 205 00D 960 0196 205	TR KSA992F TR KSA992F TR KSA992F TR KSA992F TR KSA992F		J5000992F0050P J5000992F0050P J5000992F0050P J5000992F0050P J5000992F0050P		
	Q503SL Q503SR Q504C Q504FL Q504FR		00D 960 0196 205 00D 960 0196 205 00D 960 0196 506 00D 960 0196 506 00D 960 0196 506	TR KSA992F TR KSA992F KSC1845F KSC1845F KSC1845F		J5000992F0050P J5000992F0050P J5021845F0000P J5021845F0000P J5021845F0000P		
	Q504SBL Q504SBR Q504SL Q504SR Q506SBL		00D 960 0196 506 00D 960 0196 506 00D 960 0196 506 00D 960 0196 506 00D 960 0196 603	KSC1845F KSC1845F KSC1845F KSC1845F KTC2874B		J5021845F0000P J5021845F0000P J5021845F0000P J5021845F0000P J502287400010S		
	Q506SBR		00D 960 0196 603	KTC2874B		J502287400010S		
	D101SBL D101SBR D102SBL		00D 963 0219 709 00D 963 0219 709 00D 963 0219 709	D,SWITCHING 1N4148W D,SWITCHING 1N4148W D,SWITCHING 1N4148W	1507E3,587E3,1507E2 1507E3,587E3,1507E2 1507E3,587E3,1507E2	K005041480020S K005041480020S K005041480020S		
	D102SBR D102X D102X1 D102X14 D102X4		00D 963 0219 709 00D 963 0058 407 00D 963 0058 407 00D 963 0058 407 00D 963 0058 407	D,SWITCHING 1N4148W D,SWITCHING IN4007 D,SWITCHING IN4007 D,SWITCHING IN4007 D,SWITCHING IN4007	1507E3,587E3,1507E2 1507E3,587E3 1507E3,587E3 487E3 487E3	K005041480020S K000400700520S K000400700520S K000400700520S K000400700520S		
	D106,107		00D 963 0020 309	D,SWITCHING 1SS133T	1507E3,587E3,1507E2	K000013300520S		
	ZD101SBL ZD101SBR ZD102SBL		00D 963 0279 804 00D 963 0279 804 00D 963 0295 503	D,ZENER UDZS4.3B D,ZENER UDZS4.3B D,ZENER UDZS3.6B	1507E3,587E3,1507E2 1507E3,587E3,1507E2 1507E3,587E3,1507E2	K06604R34P410S K06604R34P410S K06603R64P400S		
	ZD102SBR		00D 963 0295 503	D,ZENER UDZS3.6B	1507E3,587E3,1507E2	K06603R64P400S		

Ref. No.	nsp	Part No.	Part Name	Remarks		Q'ty	New
RESISTORS GROUP							
R104SBL		00D 963 9006 285	R, FIXED 1WJ-5.6K	1507E3,587E3,1507E2	N113135656220F		
R104SBR		00D 963 9006 285	R, FIXED 1WJ-5.6K	1507E3,587E3,1507E2	N113135656220F		
R105SBL		00D 963 9006 285	R, FIXED 1WJ-5.6K	1507E3,587E3,1507E2	N113135656220F		
R105SBR		00D 963 9006 285	R, FIXED 1WJ-5.6K	1507E3,587E3,1507E2	N113135656220F		
R106SBL		00D 963 0215 907	R, METAL FILM 4.7-J,1W	1507E3,587E3,1507E2	C0604R7065050S		
R106SBR		00D 963 0215 907	R, METAL FILM 4.7-J,1W	1507E3,587E3,1507E2	C0604R7065050S		
R107SBL		00D 963 0215 907	R, METAL FILM 4.7-J,1W	1507E3,587E3,1507E2	C0604R7065050S		
R107SBR		00D 963 0215 907	R, METAL FILM 4.7-J,1W	1507E3,587E3,1507E2	C0604R7065050S		
R108SBL		00D 963 9006 269	R, FIXED 1WJ-0.22	1507E3,587E3,1507E2	N113135622820F		
R108SBR		00D 963 9006 269	R, FIXED 1WJ-0.22	1507E3,587E3,1507E2	N113135622820F		
R109SBL		00D 963 9006 269	R, FIXED 1WJ-0.22	1507E3,587E3,1507E2	N113135622820F		
R109SBR		00D 963 9006 269	R, FIXED 1WJ-0.22	1507E3,587E3,1507E2	N113135622820F		
R109X		00D 963 0216 003	R, METAL FILM 0.22-J,1W	1507E3,587E3	C060R22065050S		
R109X4		00D 963 0216 003	R, METAL FILM 0.22-J,1W	487E3	C060R22065050S		
R110SBL		00D 963 9006 269	R, FIXED 1WJ-0.22	1507E3,587E3,1507E2	N113135622820F		
R110SBR		00D 963 9006 269	R, FIXED 1WJ-0.22	1507E3,587E3,1507E2	N113135622820F		
R110X		00D 963 0216 003	R, METAL FILM 0.22-J,1W	1507E3,587E3	C060R22065050S		
R110X4		00D 963 0216 003	R, METAL FILM 0.22-J,1W	487E3	C060R22065050S		
R111SBL		00D 963 9006 269	R, FIXED 1WJ-0.22	1507E3,587E3,1507E2	N113135622820F		
R111SBR		00D 963 9006 269	R, FIXED 1WJ-0.22	1507E3,587E3,1507E2	N113135622820F		
R118SBL		00D 963 9006 256	R, FIXED 1WJ-10	1507E3,587E3,1507E2	N113135610020F		
R118SBR		00D 963 9006 256	R, FIXED 1WJ-10	1507E3,587E3,1507E2	N113135610020F		
R119SBL		00D 963 9006 256	R, FIXED 1WJ-10	1507E3,587E3,1507E2	N113135610020F		
R119SBR		00D 963 9006 256	R, FIXED 1WJ-10	1507E3,587E3,1507E2	N113135610020F		
R509C		00D 960 9005 902	R, METAL FILM 1.2K-J,1/4W		C060012263050S		
R509FL		00D 960 9005 902	R, METAL FILM 1.2K-J,1/4W		C060012263050S		
R509FR		00D 960 9005 902	R, METAL FILM 1.2K-J,1/4W		C060012263050S		
R509SBL		00D 960 9005 902	R, METAL FILM 1.2K-J,1/4W		C060012263050S		
R509SBR		00D 960 9005 902	R, METAL FILM 1.2K-J,1/4W		C060012263050S		
R509SL		00D 960 9005 902	R, METAL FILM 1.2K-J,1/4W		C060012263050S		
R509SR		00D 960 9005 902	R, METAL FILM 1.2K-J,1/4W		C060012263050S		
R511C		00D 960 9004 301	R, METAL FILM 47-J,1/4W		C060047063050S		
R511FL		00D 960 9004 301	R, METAL FILM 47-J,1/4W		C060047063050S		
R511FR		00D 960 9004 301	R, METAL FILM 47-J,1/4W		C060047063050S		
R511SBL		00D 960 9004 301	R, METAL FILM 47-J,1/4W		C060047063050S		
R511SBR		00D 960 9004 301	R, METAL FILM 47-J,1/4W		C060047063050S		
R511SL		00D 960 9004 301	R, METAL FILM 47-J,1/4W		C060047063050S		
R511SR		00D 960 9004 301	R, METAL FILM 47-J,1/4W		C060047063050S		
VR106,107		00D 963 0105 208	VR, SEMI CERMET 1KB	1507E3,587E3,1507E2	C544102015140P		
CAPACITORS GROUP							
C101SBL		00D 963 0234 506	C, ELECT 47UF-M/50V (Pb Free)	1507E3,587E3,1507E2	D040470087070F		
C101SBR		00D 963 0234 506	C, ELECT 47UF-M/50V (Pb Free)	1507E3,587E3,1507E2	D040470087070F		
C101X		00D 963 9003 097	C, FILM 0.1UF-K/250V	1507E3,587E3	D02010407H080S		
C101X4		00D 963 9003 097	C, FILM 0.1UF-K/250V	487E3	D02010407H080S		
C102SBL		00D 963 0234 205	C, ELECT 10UF-M/50V	1507E3,587E3,1507E2	D040100087070F		
C102SBR		00D 963 0234 205	C, ELECT 10UF-M/50V	1507E3,587E3,1507E2	D040100087070F		
C103SBL		00D 963 9003 084	C, CERAMIC 100PF-K/500V	1507E3,587E3,1507E2	D00410106D050S		
C103SBR		00D 963 9003 084	C, CERAMIC 100PF-K/500V	1507E3,587E3,1507E2	D00410106D050S		
C103X		00D 963 0255 501	C, ELECT 18000UF-M/16V	1507E3,587E3	D040183083000S		
C103X4		00D 963 0255 501	C, ELECT 18000UF-M/16V	487E3	D040183083000S		
C104SBL		00D 963 9003 084	C, CERAMIC 100PF-K/500V	1507E3,587E3,1507E2	D00410106D050S		
C104SBR		00D 963 9003 084	C, CERAMIC 100PF-K/500V	1507E3,587E3,1507E2	D00410106D050S		
C104X		00D 963 0293 709	C, ELECT 100UF-M/10V	1507E3,587E3	D040101082070F		
C104X4		00D 963 0293 709	C, ELECT 100UF-M/10V	487E3	D040101082070F		
C105SBL		00D 960 9008 640	C, FILM 0.022UF-J/100V	1507E3,587E3,1507E2	D02022306C060P		
C105SBR		00D 960 9008 640	C, FILM 0.022UF-J/100V	1507E3,587E3,1507E2	D02022306C060P		
C105X		00D 963 0293 709	C, ELECT 100UF-M/10V	1507E3,587E3	D040101082070F		
C105X4		00D 963 0293 709	C, ELECT 100UF-M/10V	487E3	D040101082070F		

	Ref. No.	nsp	Part No.	Part Name	Remarks		Q'ty	New
	C106X	nsp	00D 963 0224 105	C,CERAMIC 1000PF-K/50V	1507E3,587E3	D011102777160S		
	C106X1	nsp	00D 963 9004 708	C,CERAMIC 0.1UF-K/50V	1507E3,587E3	D011104577160S		
	C106X14	nsp	00D 963 9004 708	C,CERAMIC 0.1UF-K/50V	487E3	D011104577160S		
	C106X4	nsp	00D 963 0224 105	C,CERAMIC 1000PF-K/50V	487E3	D011102777160S		
	C107SBL		00D 963 9003 097	C,FILM 0.1UF-K/250V	1507E3,587E3,1507E2	D02010407H080S		
	C107SBR		00D 963 9003 097	C,FILM 0.1UF-K/250V	1507E3,587E3,1507E2	D02010407H080S		
	C107X		00D 963 0293 709	C,ELECT 100UF-M/10V	1507E3,587E3	D040101082070F		
	C107X4		00D 963 0293 709	C,ELECT 100UF-M/10V	487E3	D040101082070F		
	C108X	nsp	00D 963 0224 105	C,CERAMIC 1000PF-K/50V	1507E3,587E3	D011102777160S		
	C108X4	nsp	00D 963 0224 105	C,CERAMIC 1000PF-K/50V	487E3	D011102777160S		
	C501C		00D 963 9006 544	C,ELECT 22UF-M/25V		D040220084050F		
	C501FL		00D 963 9006 544	C,ELECT 22UF-M/25V		D040220084050F		
	C501FR		00D 963 9006 544	C,ELECT 22UF-M/25V		D040220084050F		
	C501SBL		00D 963 9006 544	C,ELECT 22UF-M/25V		D040220084050F		
	C501SBR		00D 963 9006 544	C,ELECT 22UF-M/25V		D040220084050F		
	C501SL		00D 963 9006 544	C,ELECT 22UF-M/25V		D040220084050F		
	C501SR		00D 963 9006 544	C,ELECT 22UF-M/25V		D040220084050F		
	C502C		00D 963 0234 205	C,ELECT 10UF-M/50V		D040100087070F		
	C502FL		00D 963 0234 205	C,ELECT 10UF-M/50V		D040100087070F		
	C502FR		00D 963 0234 205	C,ELECT 10UF-M/50V		D040100087070F		
	C502SBL		00D 963 0234 205	C,ELECT 10UF-M/50V		D040100087070F		
	C502SBR		00D 963 0234 205	C,ELECT 10UF-M/50V		D040100087070F		
	C502SL		00D 963 0234 205	C,ELECT 10UF-M/50V		D040100087070F		
	C502SR		00D 963 0234 205	C,ELECT 10UF-M/50V		D040100087070F		
	C503C		00D 963 0216 207	C,CERAMIC 220PF 500V		D009092212500S		
	C503FL		00D 963 0216 207	C,CERAMIC 220PF 500V		D009092212500S		
	C503FR		00D 963 0216 207	C,CERAMIC 220PF 500V		D009092212500S		
	C503SBL		00D 963 0216 207	C,CERAMIC 220PF 500V		D009092212500S		
	C503SBR		00D 963 0216 207	C,CERAMIC 220PF 500V		D009092212500S		
	C503SL		00D 963 0216 207	C,CERAMIC 220PF 500V		D009092212500S		
	C503SR		00D 963 0216 207	C,CERAMIC 220PF 500V		D009092212500S		
	C504C		00D 963 0216 207	C,CERAMIC 220PF 500V		D009092212500S		
	C504FL		00D 963 0216 207	C,CERAMIC 220PF 500V		D009092212500S		
	C504FR		00D 963 0216 207	C,CERAMIC 220PF 500V		D009092212500S		
	C504SBL		00D 963 0216 207	C,CERAMIC 220PF 500V		D009092212500S		
	C504SBR		00D 963 0216 207	C,CERAMIC 220PF 500V		D009092212500S		
	C504SL		00D 963 0216 207	C,CERAMIC 220PF 500V		D009092212500S		
	C504SR		00D 963 0216 207	C,CERAMIC 220PF 500V		D009092212500S		
	C505C		00D 963 0216 100	C,CERAMIC 33PF-J/500V		D00033006D050S		
	C505FL		00D 963 0216 100	C,CERAMIC 33PF-J/500V		D00033006D050S		
	C505FR		00D 963 0216 100	C,CERAMIC 33PF-J/500V		D00033006D050S		
	C505SBL		00D 963 0216 100	C,CERAMIC 33PF-J/500V		D00033006D050S		
	C505SBR		00D 963 0216 100	C,CERAMIC 33PF-J/500V		D00033006D050S		
	C505SL		00D 963 0216 100	C,CERAMIC 33PF-J/500V		D00033006D050S		
	C505SR		00D 963 0216 100	C,CERAMIC 33PF-J/500V		D00033006D050S		
	C506C		00D 963 0293 709	C,ELECT 100UF-M/10V		D040101082070F		
	C506FL		00D 963 0293 709	C,ELECT 100UF-M/10V		D040101082070F		
	C506FR		00D 963 0293 709	C,ELECT 100UF-M/10V		D040101082070F		
	C506SBL		00D 963 0293 709	C,ELECT 100UF-M/10V		D040101082070F		
	C506SBR		00D 963 0293 709	C,ELECT 100UF-M/10V		D040101082070F		
	C506SL		00D 963 0293 709	C,ELECT 100UF-M/10V		D040101082070F		
	C506SR		00D 963 0293 709	C,ELECT 100UF-M/10V		D040101082070F		
	C507C		00D 963 9003 194	C,FILM 0.0022UF-J/100V		D02022206C060P		
	C507FL		00D 963 9003 194	C,FILM 0.0022UF-J/100V		D02022206C060P		
	C507FR		00D 963 9003 194	C,FILM 0.0022UF-J/100V		D02022206C060P		
	C507SBL		00D 963 9003 194	C,FILM 0.0022UF-J/100V		D02022206C060P		
	C507SBR		00D 963 9003 194	C,FILM 0.0022UF-J/100V		D02022206C060P		
	C507SL		00D 963 9003 194	C,FILM 0.0022UF-J/100V		D02022206C060P		
	C507SR		00D 963 9003 194	C,FILM 0.0022UF-J/100V		D02022206C060P		
OTHERS PARTS GROUP								
	BKT501	nsp	00D 960 0184 000	BRACKET SCREW		4010210196000S		
	BKT503	nsp	00D 960 0184 000	BRACKET SCREW		4010210196000S		

Ref. No.	nsp	Part No.	Part Name	Remarks		Q'ty	New
CN102X	nsp	00D 963 0256 306	CN,WIRE 90MM/5P	1507E3,587E3	L000900050030F		
CN102X4	nsp	00D 963 0256 306	CN,WIRE 90MM/5P	487E3	L000900050030F		
CN501	nsp	00D 963 0205 700	CN.WAFER 5P		L101100030510S		
CN502	nsp	00D 963 0086 505	CN.WAFER 7P		L101100030710S		
CN503	nsp	00D 963 0205 700	CN.WAFER 5P		L101100030510S		
CN504	nsp	00D 963 0085 506	CN.WAFER 9P		L101100030910S		
CN505	nsp	00D 963 0236 902	CN.WAFER 12P		L101100031210S		
CN506T	nsp	00D 963 0245 401	CN,WIRE 140MM/15P	1507E3,587E3	L000141150030F		
CN506T		00D 963 0159 704	CN,WIRE 140MM/15P	1507E2	L000141150020P		
CP101X	nsp	00D 960 0123 207	CN.WAFER 3P	1507E3,587E3	L102526700300S		
CP101X4	nsp	00D 960 0123 207	CN.WAFER 3P	487E3	L102526700300S		
CP506	nsp	00D 963 0060 703	CN.WAFER 15P		L101220150000S		
CP513	nsp	00D 963 0066 101	CN.WAFER 5P		L101220050000S		
CP558		00D 963 0253 406	CN.WAFER 14P		L101220140000S		
CP992	nsp	00D 960 0217 553	CN.WAFER 4P	1507E3,587E3,1507E2	L102526700400S		
L101SBL	nsp	00D 963 0049 005	COIL,INDUCTOR 0.5UH	1507E3,587E3,1507E2	D330R50000000F		
L101SBR	nsp	00D 963 0049 005	COIL,INDUCTOR 0.5UH	1507E3,587E3,1507E2	D330R50000000F		
TP106,107	nsp	00D 963 0207 203	CN.WAFER 3P	1507E3,587E3,1507E2	L101530150310S		

CNT P.W.B. UNIT ASSY

	Ref. No.	nsp	Part No.	Part Name	Remarks		Q'ty	New
SEMICONDUCTORS GROUP								
	IC551,552		00D 963 0218 807	IC BU4094BCF		J040140940030P		
	Q551		00D 960 0196 700	TR KTC3200BL		J5023200B0050S		
	Q552		00D 960 0196 302	TR KTA1268BL		J5001268B0050S		
	Q553-556		00D 963 0120 704	TR KRA102S		J520010200210S		
	Q570A		00D 963 0148 508	TR KTA1504S		J520015040150S		
	Q570B		00D 963 0121 606	TR KRC107S		J522107S00210S		
	Q571X		00D 963 0121 606	TR KRC107S		J522107S00210S		
	Q572X		00D 963 0148 508	TR KTA1504S		J520015040150S		
	D501D		00D 963 0058 407	D,SWITCHING IN4007		K000400700520S		
	D551-561		00D 963 0020 309	D,SWITCHING 1SS133T		K000013300520S		
	D562,563		00D 963 0058 407	D,SWITCHING IN4007		K000400700520S		
	D565-567		00D 963 0020 309	D,SWITCHING 1SS133T		K000013300520S		
	D572X		00D 963 0020 309	D,SWITCHING 1SS133T		K000013300520S		
	D573X		00D 963 0020 309	D,SWITCHING 1SS133T		K000013300520S		
	D574C		00D 963 0219 709	D,SWITCHING 1N4148W	1507E3,587E3	K005041480020S		
	ZD564		00D 960 0095 500	D,ZENER MTZJ5.1B		K06005R144520S		
RESISTORS GROUP								
	R559		00D 960 9005 642	R,METAL FILM 1.2K-J,1W		C060012265050S		
	R565		00D 960 9005 642	R,METAL FILM 1.2K-J,1W		C060012265050S		
	R570		00D 960 9005 642	R,METAL FILM 1.2K-J,1W		C060012265050S		
CAPACITORS GROUP								
	C551		00D 963 0294 106	C,ELECT 2.2UF-M/50V (Pb Free)	1507E3,587E3,487E3	D0402R2087160F		
	C551	nsp	00D 960 9009 940	C,ELECT 1000UF-M/16V	1507E2	D040102083030F		
	C551C	nsp	00D 963 0234 001	C,CERAMIC 0.047UF-Z/50V		D011473597160S		
	C551G	nsp	00D 963 0234 001	C,CERAMIC 0.047UF-Z/50V		D011473597160S		
	C551S		00D 963 0225 609	C,CERAMIC 0.047UF-Z/50V		D005473597520S		
	C555,556		00D 963 0233 303	C,CERAMIC 0.01UF-M/16V		D005103773530S		
	C557		00D 963 0234 205	C,ELECT 10UF-M/50V		D040100087070F		
	C563X		00D 963 0234 205	C,ELECT 10UF-M/50V		D040100087070F		
	C564X	nsp	00D 960 9010 094	C,CERAMIC 0.01UF-Z/50V		D011103597160S		
	C565X		00D 963 0234 205	C,ELECT 10UF-M/50V		D040100087070F		
	C566X	nsp	00D 960 9010 094	C,CERAMIC 0.01UF-Z/50V		D011103597160S		
	C567X	nsp	00D 963 0223 601	C,CERAMIC 100PF-J/50V		D010101167160S		
	C568X	nsp	00D 963 0223 601	C,CERAMIC 100PF-J/50V		D010101167160S		
	C569X	nsp	00D 963 0223 601	C,CERAMIC 100PF-J/50V		D010101167160S		
	C570X	nsp	00D 963 0223 601	C,CERAMIC 100PF-J/50V		D010101167160S		
OTHERS PARTS GROUP								
	CN202X	nsp	00D 963 0256 005	CN,WIRE 350MM/8P	1507E3,587E3,487E3	L000351080010F		
	CN552	nsp	00D 963 0097 303	CN.WAFER 15P		L101100031510S		
	CN553	nsp	00D 963 0086 709	CN.WAFER 11P		L101100031110S		
	CN554A		00D 963 0184 805	CN,WIRE 80MM/14P		L000800140060P		
	CN554B		00D 963 0184 708	CN,WIRE 80MM/4P		L000800040110P		
	CN555	nsp	00D 963 0110 701	CN.WAFER 14P		L101100031410S		
	CN556	nsp	00D 963 0086 709	CN.WAFER 11P		L101100031110S		
	CP102X	nsp	00D 963 0066 101	CN.WAFER 5P	1507E3,587E3,487E3	L101220050000S		
	CP551		00D 963 0253 406	CN.WAFER 14P		L101220140000S		
		nsp	00D 960 0184 000	BRACKET SCREW		4010210196000S		

INPUT P.W.B. UNIT ASSY

	Ref. No.	nsp	Part No.	Part Name	Remarks		Q'ty	New
SEMICONDUCTORS GROUP								
	IC701		00D 963 0295 202	IC NJW1197		J084119700010		
	IC701M		00D 963 0202 305	IC NJM2068M	1507E2	J121206800020S		
	IC705		00D 963 0202 305	IC NJM2068M	1507E3,587E3	J121206800020S		
	IC761-763		00D 963 0202 305	IC NJM2068M		J121206800020S		
	Q755		00D 963 0121 004	TR KRC104M	1507E3,587E3	J502104000010S		
	Q760		00D 963 0121 004	TR KRC104M	1507E2	J502104000010S		
	Q771		00D 963 0121 004	TR KRC104M		J502104000010S		
	Q772		00D 960 0097 207	TR KRA102M		J6002202M0010S		
	Q773,774		00D 960 0196 807	TR 2SK117Y		J5441170Y0050		
	D753		00D 963 0219 709	D,SWITCHING 1N4148W	1507E3,587E3	K005041480020S		
	D756		00D 963 0219 709	D,SWITCHING 1N4148W	1507E2	K005041480020S		
	D771,772		00D 963 0219 709	D,SWITCHING 1N4148W		K005041480020S		
	ZD701		00D 960 0222 603	D,ZENER MTZJ7.5A	1507E2	K06007R544530S		
	ZD701M		00D 960 0095 500	D,ZENER MTZJ5.1B	1507E2	K06005R144520S		
	ZD702		00D 960 0222 603	D,ZENER MTZJ7.5A	1507E2	K06007R544530S		
	ZD701,702		00D 960 0222 603	D,ZENER MTZJ7.5A	1507E3,587E3,487E3	K06007R544530S		
RESISTORS GROUP								
	R731,732		00D 963 9005 668	R,METAL FILM 220-J,1W		C060022165050S		
	R753		00D 960 9004 301	R,METAL FILM 47-J,1/4W	1507E3,587E3	C060047063050S		
	R756		00D 960 9004 301	R,METAL FILM 47-J,1/4W	1507E2	C060047063050S		
	R771,772		00D 963 9005 639	R,METAL FILM 100-J,1W		C060010165060S		
	R791,792		00D 963 9005 639	R,METAL FILM 100-J,1W		C060010165060S		
CAPACITORS GROUP								
	C481C	nsp	00D 963 0223 601	C,CERAMIC 100PF-J/50V		D010101167160S		
	C481FL	nsp	00D 963 0223 601	C,CERAMIC 100PF-J/50V		D010101167160S		
	C481FR	nsp	00D 963 0223 601	C,CERAMIC 100PF-J/50V		D010101167160S		
	C481SW	nsp	00D 963 0223 601	C,CERAMIC 100PF-J/50V		D010101167160S		
	C701L	nsp	00D 963 0223 601	C,CERAMIC 100PF-J/50V		D010101167160S		
	C701M	nsp	00D 963 0293 602	C,ELECT 1UF-M/50V(Pb Free)	1507E2	D040010087150F		
	C701R	nsp	00D 963 0223 601	C,CERAMIC 100PF-J/50V		D010101167160S		
	C702CH	nsp	00D 963 0223 009	R,THICK 0-J,1/16W	1507E3,587E3	C20000006M160F		
	C702L	nsp	00D 963 0223 601	C,CERAMIC 100PF-J/50V		D010101167160S		
	C702M	nsp	00D 963 0293 602	C,ELECT 1UF-M/50V(Pb Free)	1507E2	D040010087150F		
	C702R	nsp	00D 963 0223 601	C,CERAMIC 100PF-J/50V		D010101167160S		
	C703CH	nsp	00D 963 0223 009	R,THICK 0-J,1/16W	1507E3,587E3	C20000006M160F		
	C703L	nsp	00D 963 0223 601	C,CERAMIC 100PF-J/50V		D010101167160S		
	C703M	nsp	00D 963 0157 609	C,CERAMIC 150PF-J/50V	1507E2	D010151167160S		
	C703R	nsp	00D 963 0223 601	C,CERAMIC 100PF-J/50V		D010101167160S		
	C704L	nsp	00D 963 0223 601	C,CERAMIC 100PF-J/50V		D010101167160S		
	C704M	nsp	00D 963 0223 601	C,CERAMIC 100PF-J/50V	1507E2	D010101167160S		
	C704R	nsp	00D 963 0223 601	C,CERAMIC 100PF-J/50V		D010101167160S		
	C705L	nsp	00D 963 0223 601	C,CERAMIC 100PF-J/50V		D010101167160S		
	C705M	nsp	00D 963 0293 602	C,ELECT 1UF-M/50V(Pb Free)	1507E2	D040010087150F		
	C705R	nsp	00D 963 0223 601	C,CERAMIC 100PF-J/50V		D010101167160S		
	C706L	nsp	00D 963 0223 601	C,CERAMIC 100PF-J/50V		D010101167160S		
	C706M	nsp	00D 963 0157 609	C,CERAMIC 150PF-J/50V	1507E2	D010151167160S		
	C706R	nsp	00D 963 0223 601	C,CERAMIC 100PF-J/50V		D010101167160S		
	C707	nsp	00D 963 0223 601	C,CERAMIC 100PF-J/50V	1507E2	D010101167160S		
	C707-709	nsp	00D 963 0223 601	C,CERAMIC 100PF-J/50V	1507E3,587E3,487E3	D010101167160S		
	C707M	nsp	00D 963 0223 601	C,CERAMIC 100PF-J/50V	1507E2	D010101167160S		
	C708	nsp	00D 963 0223 601	C,CERAMIC 100PF-J/50V	1507E2	D010101167160S		
	C708M	nsp	00D 963 0293 602	C,ELECT 1UF-M/50V(Pb Free)	1507E2	D040010087150F		
	C709	nsp	00D 963 0223 601	C,CERAMIC 100PF-J/50V	1507E2	D010101167160S		
	C709M	nsp	00D 963 9004 711	C,CERAMIC 0.1UF-Z/50V	1507E2	D011104597160S		
	C710M		00D 963 0234 205	C,ELECT 10UF-M/50V	1507E2	D040100087070F		

Ref. No.	nsp	Part No.	Part Name	Remarks		Q'ty	New
C721		00D 963 0293 709	C,ELECT 100UF-M/10V		D040101082070F		
C723		00D 963 0293 709	C,ELECT 100UF-M/10V		D040101082070F		
C726,727		00D 963 0234 205	C,ELECT 10UF-M/50V		D040100087070F		
C731		00D 960 9010 010	C,ELECT 4.7UF-M/50V		D0404R7087250F		
C732	nsp	00D 963 9004 711	C,CERAMIC 0.1UF-Z/50V		D011104597160S		
C733		00D 963 0276 108	C,CERAMIC 3300PF-K/50V		D011332777160S		
C734		00D 963 0293 602	C,ELECT 1UF-M/50V(Pb Free)		D040010087150F		
C735		00D 960 9010 010	C,ELECT 4.7UF-M/50V		D0404R7087250F		
C736	nsp	00D 963 9004 711	C,CERAMIC 0.1UF-Z/50V		D011104597160S		
C737		00D 963 0276 108	C,CERAMIC 3300PF-K/50V		D011332777160S		
C738		00D 963 0293 602	C,ELECT 1UF-M/50V(Pb Free)		D040010087150F		
C741-750		00D 963 0234 205	C,ELECT 10UF-M/50V		D040100087070F		
C750ZL		00D 960 9010 010	C,ELECT 4.7UF-M/50V	1507E3,587E3	D0404R7087250F		
C750ZR		00D 960 9010 010	C,ELECT 4.7UF-M/50V	1507E3,587E3	D0404R7087250F		
C751,752		00D 963 0234 205	C,ELECT 10UF-M/50V	1507E3,587E3	D040100087070F		
C752ZL	nsp	00D 963 0223 601	C,CERAMIC 100PF-J/50V	1507E3,587E3	D010101167160S		
C752ZR	nsp	00D 963 0223 601	C,CERAMIC 100PF-J/50V	1507E3,587E3	D010101167160S		
C753ZL		00D 963 0234 205	C,ELECT 10UF-M/50V	1507E3,587E3	D040100087070F		
C753ZR		00D 963 0234 205	C,ELECT 10UF-M/50V	1507E3,587E3	D040100087070F		
C756,757	nsp	00D 963 9004 698	C,CERAMIC 0.01UF-K/50V	1507E3,587E3	D011103777160S		
C760,761		00D 963 9005 862	C,ELECT 47UF-M/16V		D040470083080F		
C761FL	nsp	00D 963 0234 001	C,CERAMIC 0.047UF-Z/50V		D011473597160S		
C761FR	nsp	00D 963 0234 001	C,CERAMIC 0.047UF-Z/50V		D011473597160S		
C761SW	nsp	00D 963 0234 001	C,CERAMIC 0.047UF-Z/50V		D011473597160S		
C762		00D 963 9005 862	C,ELECT 47UF-M/16V		D040470083080F		
C762FL	nsp	00D 963 0223 601	C,CERAMIC 100PF-J/50V		D010101167160S		
C762FR	nsp	00D 963 0223 601	C,CERAMIC 100PF-J/50V		D010101167160S		
C762SW	nsp	00D 963 0223 601	C,CERAMIC 100PF-J/50V		D010101167160S		
C763		00D 963 9005 862	C,ELECT 47UF-M/16V		D040470083080F		
C763FL	nsp	00D 963 0234 001	C,CERAMIC 0.047UF-Z/50V		D011473597160S		
C763FR	nsp	00D 963 0234 001	C,CERAMIC 0.047UF-Z/50V		D011473597160S		
C763SW	nsp	00D 963 0234 001	C,CERAMIC 0.047UF-Z/50V		D011473597160S		
C764		00D 963 9005 862	C,ELECT 47UF-M/16V		D040470083080F		
C764FL	nsp	00D 963 0223 805	C,CERAMIC 33PF-J/50V		D010330167160S		
C764FR	nsp	00D 963 0223 805	C,CERAMIC 33PF-J/50V		D010330167160S		
C764SW	nsp	00D 963 0233 808	C,CERAMIC 47PF-J/50V		D010470167160S		
C765		00D 963 9005 862	C,ELECT 47UF-M/16V		D040470083080F		
C765FL		00D 963 0234 205	C,ELECT 10UF-M/50V		D040100087070F		
C765FR		00D 963 0234 205	C,ELECT 10UF-M/50V		D040100087070F		
C765SW		00D 963 0234 205	C,ELECT 10UF-M/50V		D040100087070F		
C766,767		00D 963 9005 862	C,ELECT 47UF-M/16V		D040470083080F		
C771,772		00D 963 9005 875	C,ELECT 47UF-M/25V		D040470084070F		
C773		00D 963 0293 602	C,ELECT 1UF-M/50V(Pb Free)		D040010087150F		
C791,792		00D 963 9005 875	C,ELECT 47UF-M/25V		D040470084070F		
OTHERS PARTS GROUP							
CN551		00D 963 0184 407	CN,WIRE 160MM/14P		L000161140050P		
CN701	nsp	00D 963 0097 303	CN.WAFER 15P		L101100031510S		
CN701M		00D 963 0253 309	CN,WIRE 230MM/5P	1507E2	L000231050030F		
CN702	nsp	00D 963 0086 204	CN.WAFER 19P		L101100031910S		
CN703	nsp	00D 963 0097 303	CN.WAFER 15P		L101100031510S		
CN704		00D 963 0256 801	CN.WAFER 10P		L101100031010S		
CP701M	nsp	00D 963 0066 101	CN.WAFER 5P	1507E2	L101220050000S		
RLY701		00D 963 0218 409	RELAY BC3-12 24V 2A	1507E3,587E3	G680240202030F		
RLY702		00D 963 0218 409	RELAY BC3-12 24V 2A	1507E2	G680240202030F		
		00D 963 0094 005	CUSHION INPUT		4050210715000S		
		00D 963 0293 505	PLATE INPUT		4470210926000S		
		00D 963 0146 209	TER,RCA 4PIN		G602405B01000S		
		00D 960 0268 803	TER,RCA 6PIN		G603603B09000S		
		00D 963 0158 200	JACK,D3.5 EARPHONE	1507E2	G40132340000YS		

8CH-EXT XM P.W.B. UNIT ASSY (for AVR-1507E3/587E3/487E3 model)

	Ref. No.	nsp	Part No.	Part Name	Remarks		Q'ty	New
SEMICONDUCTORS GROUP								
	IC201X		00D 262 3517 907	F2602-01-TR				
	IC202X		00D 262 2517 908	SN74LV08APW-EL2 +REF				
	IC203X		00D 262 2813 903	SN74AHCT08PW-EL2 +C				
	IC204X		00D 963 0295 309	IC LM1117S		J126111733030S		
	IC205X		00D 963 0294 902	IC AK4385		J042438500010S		
	IC206		00D 963 0202 305	IC NJM2068M		J121206800020S		
	IC206X		00D 399 1055 909	FCX-02(45.1584MHz)				
	IC207X		00D 263 1092 003	BA05T				
	IC208X		00D 963 0218 807	IC BU4094BCF		J040140940030P		
	IC209X		00D 262 2813 903	IC SN74AHCT08				
	IC401		00D 960 0296 105	IC CJ7812F	1507E3	J126781200220S		
	IC402		00D 960 0174 104	IC CXA1511M		J030151100010S		
	Q201R		00D 963 0121 402	TR KRA104S		J520010400210S		
	Q201X		00D 963 0120 801	TR KRC102S		J522010200210S		
	Q203X		00D 963 0120 801	TR KRC102S		J522010200210S		
	Q204X		00D 963 0120 801	TR KRC102S		J522010200210S		
	Q206X		00D 963 0120 704	TR KRA102S		J520010200210S		
	Q207X		00D 963 0120 704	TR KRA102S		J520010200210S		
	Q208X		00D 963 0044 301	TR KTC2875B		J5222875B0010S		
	Q209X		00D 963 0044 301	TR KTC2875B		J5222875B0010S		
	Q210X		00D 963 0044 301	TR KTC2875B		J5222875B0010S		
	Q211X		00D 963 0044 301	TR KTC2875B		J5222875B0010S		
	Q401		00D 960 0097 003	TR KRA104M	1507E3	J6000104M0010S		
	Q666A		00D 963 0044 301	TR KTC2875B	1507E3	J5222875B0010S		
	Q667A		00D 963 0044 301	TR KTC2875B		J5222875B0010S		
	Q668A		00D 963 0044 301	TR KTC2875B	1507E3	J5222875B0010S		
	Q669A		00D 963 0044 301	TR KTC2875B		J5222875B0010S		
	D201X		00D 963 0219 709	D,SWITCHING 1N4148W		K005041480020S		
	D202X		00D 963 0219 709	D,SWITCHING 1N4148W		K005041480020S		
	D203X		00D 963 0219 709	D,SWITCHING 1N4148W		K005041480020S		
	D204X		00D 963 0219 709	D,SWITCHING 1N4148W		K005041480020S		
	D205X		00D 963 0219 709	D,SWITCHING 1N4148W		K005041480020S		
	D206X		00D 963 0219 709	D,SWITCHING 1N4148W		K005041480020S		
	D207X		00D 963 0219 709	D,SWITCHING 1N4148W		K005041480020S		
	ZD401		00D 960 0095 704	D,ZENER MTZJ6.2B	1507E3	K06006R244520S		
RESISTORS GROUP								
	R273X		00D 963 9005 639	R,METAL FILM 100-J,1W		C060010165060S		
	R274X		00D 963 9005 639	R,METAL FILM 100-J,1W		C060010165060S		
CAPACITORS GROUP								
	C201X	nsp	00D 963 9006 528	C,CERAMIC 20PF-J/50V		D010200167160S		
	C202X	nsp	00D 963 9006 528	C,CERAMIC 20PF-J/50V		D010200167160S		
	C203X	nsp	00D 963 9006 528	C,CERAMIC 20PF-J/50V		D010200167160S		
	C204X	nsp	00D 963 9006 528	C,CERAMIC 20PF-J/50V		D010200167160S		
	C205X	nsp	00D 963 9004 708	C,CERAMIC 0.1UF-K/50V		D011104577160S		
	C206X	nsp	00D 963 9004 708	C,CERAMIC 0.1UF-K/50V		D011104577160S		
	C207X	nsp	00D 963 9004 708	C,CERAMIC 0.1UF-K/50V		D011104577160S		
	C208X	nsp	00D 963 0234 205	C,ELECT 10UF-M/50V		D040100087070F		
	C209X	nsp	00D 963 9004 708	C,CERAMIC 0.1UF-K/50V		D011104577160S		
	C212X	nsp	00D 963 9004 708	C,CERAMIC 0.1UF-K/50V		D011104577160S		
	C213X	nsp	00D 963 0224 105	C,CERAMIC 1000PF-K/50V		D011102777160S		
	C215X	nsp	00D 963 0234 205	C,ELECT 10UF-M/50V		D040100087070F		
	C216X	nsp	00D 963 0234 205	C,ELECT 10UF-M/50V		D040100087070F		
	C217X	nsp	00D 963 9004 708	C,CERAMIC 0.1UF-K/50V		D011104577160S		

Ref. No.	nsp	Part No.	Part Name	Remarks	Q'ty	New
C218X	nsp	00D 963 9004 708	C,CERAMIC 0.1UF-K/50V			D011104577160S
C219X	nsp	00D 963 0224 105	C,CERAMIC 1000PF-K/50V			D011102777160S
C220X	nsp	00D 963 0224 105	C,CERAMIC 1000PF-K/50V			D011102777160S
C221X	nsp	00D 963 9004 708	C,CERAMIC 0.1UF-K/50V			D011104577160S
C222X	nsp	00D 963 0224 105	C,CERAMIC 1000PF-K/50V			D011102777160S
C223X	nsp	00D 963 9004 708	C,CERAMIC 0.1UF-K/50V			D011104577160S
C224X		00D 963 0293 709	C,ELECT 100UF-M/10V			D040101082070F
C225X		00D 963 0234 205	C,ELECT 10UF-M/50V			D040100087070F
C230X		00D 963 0234 205	C,ELECT 10UF-M/50V			D040100087070F
C231X		00D 963 0244 606	C,ELECT 0.1UF-M/50V (Pb Free)			D040R10087080F
C232X	nsp	00D 963 9006 146	C,CERAMIC 560PF-J/50V			D010561167160S
C233		00D 963 0234 205	C,ELECT 10UF-M/50V			D040100087070F
C233X	nsp	00D 960 9009 843	C,CERAMIC 1800PF-K/50V			D011182777160S
C234X	nsp	00D 963 9006 146	C,CERAMIC 560PF-J/50V			D010561167160S
C235X		00D 963 0234 205	C,ELECT 10UF-M/50V			D040100087070F
C236X	nsp	00D 963 9006 146	C,CERAMIC 560PF-J/50V			D010561167160S
C237X	nsp	00D 960 9009 843	C,CERAMIC 1800PF-K/50V			D011182777160S
C238X	nsp	00D 963 9006 146	C,CERAMIC 560PF-J/50V			D010561167160S
C239X		00D 963 0234 205	C,ELECT 10UF-M/50V			D040100087070F
C240X		00D 963 0224 503	C,ELECT 22UF-M/50V			D040220087060F
C241X		00D 963 0224 503	C,ELECT 22UF-M/50V			D040220087060F
C242X		00D 963 0234 205	C,ELECT 10UF-M/50V			D040100087070F
C243X		00D 963 0234 205	C,ELECT 10UF-M/50V			D040100087070F
C244X	nsp	00D 963 9004 708	C,CERAMIC 0.1UF-K/50V			D011104577160S
C245X	nsp	00D 963 9004 708	C,CERAMIC 0.1UF-K/50V			D011104577160S
C246X	nsp	00D 963 9004 708	C,CERAMIC 0.1UF-K/50V			D011104577160S
C247X	nsp	00D 963 9004 708	C,CERAMIC 0.1UF-K/50V			D011104577160S
C248X	nsp	00D 963 0223 601	C,CERAMIC 100PF-J/50V			D010101167160S
C249X	nsp	00D 963 0223 601	C,CERAMIC 100PF-J/50V			D010101167160S
C250X	nsp	00D 963 9004 698	C,CERAMIC 0.01UF-K/50V			D011103777160S
C251X	nsp	00D 963 9004 708	C,CERAMIC 0.1UF-K/50V			D011104577160S
C252X	nsp	00D 963 0224 105	C,CERAMIC 1000PF-K/50V			D011102777160S
C403		00D 963 0293 602	C,ELECT 1UF-M/50V (Pb Free)	1507E3		D040010087150F
C404	nsp	00D 963 9004 698	C,CERAMIC 0.01UF-K/50V	1507E3		D011103777160S
C405	nsp	00D 963 0223 601	C,CERAMIC 100PF-J/50V	1507E3		D010101167160S
C406,407		00D 960 9008 653	C,FILM 0.012UF-J/100V-5RE	1507E3		D02012306C060P
C408		00D 963 9005 862	C,ELECT 47UF-M/16V	1507E3		D040470083080F
C409		00D 960 9010 010	C,ELECT 4.7UF-M/50V	1507E3		D0404R7087250F
C410,411		00D 963 0234 205	C,ELECT 10UF-M/50V			D040100087070F
C412,413	nsp	00D 963 9004 698	C,CERAMIC 0.01UF-K/50V			D011103777160S
C481SBL	nsp	00D 963 0223 601	C,CERAMIC 100PF-J/50V	1507E3,587E3		D010101167160S
C481SBR	nsp	00D 963 0223 601	C,CERAMIC 100PF-J/50V	1507E3,587E3		D010101167160S
C481SL	nsp	00D 963 0223 601	C,CERAMIC 100PF-J/50V			D010101167160S
C481SR	nsp	00D 963 0223 601	C,CERAMIC 100PF-J/50V			D010101167160S
C606A	nsp	00D 963 0223 601	C,CERAMIC 100PF-J/50V	1507E3		D010101167160S
C607A	nsp	00D 963 0223 601	C,CERAMIC 100PF-J/50V			D010101167160S
C647	nsp	00D 963 9004 708	C,CERAMIC 0.1UF-K/50V			D011104577160S
OTHERS PARTS GROUP						
BD201X	nsp	00D 963 0154 602	COIL,BEAD			7610010030000S
BD401-403	nsp	00D 963 0154 602	COIL,BEAD	1507E3		7610010030000S
BD401,402	nsp	00D 963 0154 602	COIL,BEAD	587E3,487E3		7610010030000S
CN401	nsp	00D 963 0236 902	CN.WAFER 12P			L101100031210S
CN402	nsp	00D 963 0086 709	CN.WAFER 11P			L101100031110S
CN404	nsp	00D 963 0086 107	CN.WAFER 16P			L101100031610S
CP202X	nsp	00D 963 0060 709	CN.WAFER 8P			L101220080000S
CP203X	nsp	00D 963 0068 303	CN.WAFER 9P			L101220090000S
CP401A		00D 963 0149 303	CN.FPC 15P			L131111500010F
JACK801X		00D 205 1362 009	XM/DT BUS CONNECTOR			

Ref. No.	nsp	Part No.	Part Name	Remarks		Q'ty	New
		00D 963 0244 703	JACK,D3.5 EARPHONE	1507E3	G40130802000YS		
		00D 963 0146 005	TER,RCA 1PIN		G600107A0000YS		
		00D 963 0146 209	TER,RCA 4PIN	1507E3,587E3	G602405B01000S		
		00D 963 0158 501	TER,RCA 2PIN	487E3	G601207AE010YS		

8CH-EXT(E2) P.W.B. UNIT ASSY (for AVR-1507E2 model)

	Ref. No.	nsp	Part No.	Part Name	Remarks		Q'ty	New
SEMICONDUCTORS GROUP								
	IC401		00D 960 0296 105	IC CJ7812F		J126781200220S		
	Q666A		00D 960 0196 603	TR KTC2874B		J502287400010S		
	Q668A		00D 960 0196 603	TR KTC2874B		J502287400010S		
CAPACITORS GROUP								
	C401		00D 963 9005 804	C,ELECT 100UF-M/25V		D040101084060F		
	C402		00D 963 0234 205	C,ELECT 10UF-M/50V		D040100087070F		
	C403,404	nsp	00D 963 9004 698	C,CERAMIC 0.01UF-K/50V		D011103777160S		
	C481SBL	nsp	00D 963 0223 601	C,CERAMIC 100PF-J/50V		D010101167160S		
	C481SBR	nsp	00D 963 0223 601	C,CERAMIC 100PF-J/50V		D010101167160S		
	C481SL	nsp	00D 963 0223 601	C,CERAMIC 100PF-J/50V		D010101167160S		
	C481SR	nsp	00D 963 0223 601	C,CERAMIC 100PF-J/50V		D010101167160S		
	C606A	nsp	00D 963 0223 601	C,CERAMIC 100PF-J/50V		D010101167160S		
	C647	nsp	00D 963 9004 698	C,CERAMIC 0.01UF-K/50V		D011103777160S		
OTHERS PARTS GROUP								
	BD401,402	nsp	00D 963 0154 602	COIL,BEAD		7610010030000S		
	CN401	nsp	00D 963 0236 902	CN.WAFER 12P		L101100031210S		
	CN402	nsp	00D 963 0086 709	CN.WAFER 11P		L101100031110S		
	CN404	nsp	00D 963 0205 700	CN.WAFER 5P		L101100030510S		
	CP401A		00D 963 0149 303	CN.FPC 15P		L131111500010F		
			00D 963 0146 005	TER,RCA 1PIN		G600107A0000YS		
			00D 963 0146 209	TER,RCA 4PIN		G602405B01000S		

DSP1 P.W.B. UNIT ASSY (for AVR-1507E2 model)

	Ref. No.	nsp	Part No.	Part Name	Remarks		Q'ty	New
SEMICONDUCTORS GROUP								
	IC802,803 IC804 IC805 IC806		00D 963 0237 503 00D 262 3662 001 00D 262 3652 008 00D 262 3536 001	JSR1165-C /OPTICAL ADSP21266SKSTZ-1B-AC LH28F800BJE(1707) AS7C34096A-10TCN		E100116500040S		
	IC807 IC808 IC809-811 IC812 IC814,815		00D 262 3066 102 00D 262 3645 002 00D 960 0266 805 00D 960 0266 902 00D 963 0218 904	LC89057W-VF4-E(AC) +REF IC ADAU1328BSTZ IC MM74LCX244 IC MM74HCT244 IC MM74HCT00MTCX		J040742440180P J040742440190P J040740000200P		
	IC815A IC816 IC816A IC817 IC817A		00D 963 0043 807 00D 262 2870 904 00D 963 0043 807 00D 262 3536 001 00D 963 0202 305	IC BA4510F 74LVX157MTC +C IC BA4510F AS7C34096A-10TCN IC NJM2068M		J121451000010P J121451000010P J121206800020S		
	IC818 IC818A IC819 IC819A IC820		00D 262 2642 909 00D 963 0202 305 00D 262 2642 909 00D 963 0202 305 00D 262 3339 907	SN74LV573APWR +REF IC NJM2068M SN74LV573APWR +REF IC NJM2068M SN74LVC139APWR +REF		J121206800020S J121206800020S		
	IC820A IC821 IC822 IC823 IC824		00D 963 0202 305 00D 262 2870 904 00D 960 0296 008 00D 963 0295 309 00D 963 0147 509	IC NJM2068M IC 74LCX74MTC IC CJ7805F IC RC1117-33 IC FAN1112-1.2		J121206800020S J126780500400S J126111733020F J126111712010F		
	IC825 IC827 IC828 IC829 IC830		00D 262 2870 904 00D 963 0219 107 00D 963 0219 000 00D 963 0244 907 00D 262 2813 903	IC 74LCX74MTC IC MM74HC151MTCX IC 74VHCU04 IC SN74LV14APWR IC SN74AHCTO8		J040741510050P J040740400270P J040741400180P		
	Q804C Q804FL Q804FR Q804SBL		00D 960 0196 603 00D 960 0196 603 00D 960 0196 603 00D 960 0196 603	TR KTC2874B TR KTC2874B TR KTC2874B TR KTC2874B		J502287400010S J502287400010S J502287400010S J502287400010S		
	Q804SBR Q804SL Q804SR Q804SW Q808		00D 960 0196 603 00D 960 0196 603 00D 960 0196 603 00D 960 0196 603 00D 963 0120 801	TR KTC2874B TR KTC2874B TR KTC2874B TR KTC2874B TR KRC102S		J502287400010S J502287400010S J502287400010S J502287400010S J522010200210S		
	Q809 Q811,812 D803		00D 963 0120 704 00D 963 0245 100 00D 963 0219 709	TR KRA102S D,SWITCHING KDS226ST1 D,SWITCHING 1N4148W		J520010200210S K005022600020S K005041480020S		
RESISTORS GROUP								
	R831-833	nsp	00D 963 0234 603	COIL,BEAD		D340160800060S		
CAPACITORS GROUP								
	C801	nsp	00D 963 9004 708	C,CERAMIC 0.1UF-K/50V		D011104577160S		
	C802,803 C807 C808 C812 C813	nsp nsp nsp nsp	00D 963 9004 591 00D 963 9004 708 00D 963 9005 862 00D 960 9010 010 00D 963 9004 698	C,CERAMIC 22PF-J/50V C,CERAMIC 0.1UF-K/50V C,ELECT 47UF-M/16V C,ELECT 4.7UF-M/50V C,CERAMIC 0.01UF-K/50V		D010220167160S D011104577160S D040470083080F D0404R7087250F D011103777160S		
	C814 C815 C816 C817 C818 C819	nsp nsp nsp	00D 963 9005 862 00D 960 0298 802 00D 963 9004 708 00D 963 0234 205 00D 963 0293 602 00D 963 9005 901	C,ELECT 47UF-M/16V C,ELECT 470UF-M/6.3V C,CERAMIC 0.1UF-K/50V C,ELECT 10UF-M/50V C,ELECT 1UF-M/50V (Pb Free) C,ELECT 470UF-M/10V,		D040470083080F D040471081070F D011104577160S D040100087070F D040010087150F D040471082060F		

	Ref. No.	nsp	Part No.	Part Name	Remarks		Q'ty	New
	C821		00D 963 0216 906	C,ELECT 1000UF-M/6.3V		D040102081060F		
	C823		00D 960 0298 802	C,ELECT 470UF-M/6.3V		D040471081070F		
	C824	nsp	00D 963 9004 698	C,CERAMIC 0.01UF-K/50V		D011103777160S		
	C825		00D 960 9010 010	C,ELECT 4.7UF-M/50V		D0404R7087250F		
	C830		00D 963 9005 901	C,ELECT 470UF-M/10V,		D040471082060F		
	C832	nsp	00D 963 9004 708	C,CERAMIC 0.1UF-K/50V		D011104577160S		
	C833,834	nsp	00D 963 0233 905	C,CERAMIC 0.015UF-K/50V		D011153777160S		
	C835	nsp	00D 963 9004 708	C,CERAMIC 0.1UF-K/50V		D011104577160S		
	C836,837	nsp	00D 963 0224 105	C,CERAMIC 1000PF-K/50V		D011102777160S		
	C838-841	nsp	00D 963 9004 708	C,CERAMIC 0.1UF-K/50V		D011104577160S		
	C842		00D 963 0129 608	C,CERAMIC 15PF-J/50V		D010150167160S		
	C844-846	nsp	00D 963 9004 708	C,CERAMIC 0.1UF-K/50V		D011104577160S		
	C847		00D 963 0129 608	C,CERAMIC 15PF-J/50V		D010150167160S		
	C848-857	nsp	00D 963 9004 708	C,CERAMIC 0.1UF-K/50V		D011104577160S		
	C858	nsp	00D 963 0224 202	C,CERAMIC 0.022UF-K/25V		D011223777160S		
	C859	nsp	00D 963 0246 507	C,CERAMIC 0.068UF-K/50V		D010683777160S		
	C860	nsp	00D 963 9004 708	C,CERAMIC 0.1UF-K/50V		D011104577160S		
	C861,862	nsp	00D 963 9005 998	C,CERAMIC 24PF-J/50V		D010240167160S		
	C863	nsp	00D 963 9004 698	C,CERAMIC 0.01UF-K/50V		D011103777160S		
	C864	nsp	00D 963 9004 708	C,CERAMIC 0.1UF-K/50V		D011104577160S		
	C864L		00D 963 9005 862	C,ELECT 47UF-M/16V		D040470083080F		
	C864R		00D 963 9005 862	C,ELECT 47UF-M/16V		D040470083080F		
	C865	nsp	00D 963 9004 708	C,CERAMIC 0.1UF-K/50V		D011104577160S		
	C865L	nsp	00D 963 9005 723	C,CERAMIC 120PF-J/50V		D010121167160S		
	C865R	nsp	00D 963 9005 723	C,CERAMIC 120PF-J/50V		D010121167160S		
	C866-869	nsp	00D 963 9004 698	C,CERAMIC 0.01UF-K/50V		D011103777160S		
	C869L	nsp	00D 963 0223 601	C,CERAMIC 100PF-J/50V		D010101167160S		
	C869R	nsp	00D 963 0223 601	C,CERAMIC 100PF-J/50V		D010101167160S		
	C870,871	nsp	00D 963 9004 708	C,CERAMIC 0.1UF-K/50V		D011104577160S		
	C871L		00D 963 0216 304	C,FILM 0.001UF-J/100V		D02010206C060P		
	C871R		00D 963 0216 304	C,FILM 0.001UF-J/100V		D02010206C060P		
	C872	nsp	00D 963 9004 708	C,CERAMIC 0.1UF-K/50V		D011104577160S		
	C873		00D 963 9005 804	C,ELECT 100UF-M/25V		D040101084060F		
	C873C	nsp	00D 963 9004 672	C,CERAMIC 680pF-J 50V		D010681167160S		
	C873FL	nsp	00D 963 9004 672	C,CERAMIC 680pF-J 50V		D010681167160S		
	C873FR	nsp	00D 963 9004 672	C,CERAMIC 680pF-J 50V		D010681167160S		
	C873SBL	nsp	00D 963 9004 672	C,CERAMIC 680pF-J 50V		D010681167160S		
	C873SBR	nsp	00D 963 9004 672	C,CERAMIC 680pF-J 50V		D010681167160S		
	C873SL	nsp	00D 963 9004 672	C,CERAMIC 680pF-J 50V		D010681167160S		
	C873SR	nsp	00D 963 9004 672	C,CERAMIC 680pF-J 50V		D010681167160S		
	C873SW	nsp	00D 963 9004 672	C,CERAMIC 680pF-J 50V		D010681167160S		
	C874		00D 963 9005 804	C,ELECT 100UF-M/25V		D040101084060F		
	C874C	nsp	00D 963 9006 146	C,CERAMIC 560PF-J/50V		D010561167160S		
	C874FL	nsp	00D 963 9006 146	C,CERAMIC 560PF-J/50V		D010561167160S		
	C874FR	nsp	00D 963 9006 146	C,CERAMIC 560PF-J/50V		D010561167160S		
	C874SBL	nsp	00D 963 9006 146	C,CERAMIC 560PF-J/50V		D010561167160S		
	C874SBR	nsp	00D 963 9006 146	C,CERAMIC 560PF-J/50V		D010561167160S		
	C874SL	nsp	00D 963 9006 146	C,CERAMIC 560PF-J/50V		D010561167160S		
	C874SR	nsp	00D 963 9006 146	C,CERAMIC 560PF-J/50V		D010561167160S		
	C874SW	nsp	00D 963 9006 146	C,CERAMIC 560PF-J/50V		D010561167160S		
	C875	nsp	00D 963 9004 708	C,CERAMIC 0.1UF-K/50V		D011104577160S		
	C875C		00D 963 0234 205	C,ELECT 10UF-M/50V		D040100087070F		
	C875FL		00D 963 0234 205	C,ELECT 10UF-M/50V		D040100087070F		
	C875FR		00D 963 0234 205	C,ELECT 10UF-M/50V		D040100087070F		
	C875SBL		00D 963 0234 205	C,ELECT 10UF-M/50V		D040100087070F		
	C875SBR		00D 963 0234 205	C,ELECT 10UF-M/50V		D040100087070F		
	C875SL		00D 963 0234 205	C,ELECT 10UF-M/50V		D040100087070F		
	C875SR		00D 963 0234 205	C,ELECT 10UF-M/50V		D040100087070F		
	C875SW		00D 963 0234 205	C,ELECT 10UF-M/50V		D040100087070F		
	C876	nsp	00D 963 9004 708	C,CERAMIC 0.1UF-K/50V		D011104577160S		
	C876C		00D 960 9008 611	C,FILM 0.0033UF-J/100V		D02033206C060P		
	C876FL		00D 960 9008 611	C,FILM 0.0033UF-J/100V		D02033206C060P		
	C876FR		00D 960 9008 611	C,FILM 0.0033UF-J/100V		D02033206C060P		
	C876SBL		00D 960 9008 611	C,FILM 0.0033UF-J/100V		D02033206C060P		

Ref. No.	nsp	Part No.	Part Name	Remarks		Q'ty	New
C876SBR		00D 960 9008 611	C,FILM 0.0033UF-J/100V		D02033206C060P		
C876SL		00D 960 9008 611	C,FILM 0.0033UF-J/100V		D02033206C060P		
C876SR		00D 960 9008 611	C,FILM 0.0033UF-J/100V		D02033206C060P		
C876SW		00D 960 9008 611	C,FILM 0.0033UF-J/100V		D02033206C060P		
C877-880	nsp	00D 963 9004 708	C,CERAMIC 0.1UF-K/50V		D011104577160S		
C880C		00D 963 0234 205	C,ELECT 10UF-M/50V		D040100087070F		
C880FL		00D 963 0234 205	C,ELECT 10UF-M/50V		D040100087070F		
C880FR		00D 963 0234 205	C,ELECT 10UF-M/50V		D040100087070F		
C880SBL		00D 963 0234 205	C,ELECT 10UF-M/50V		D040100087070F		
C880SBR		00D 963 0234 205	C,ELECT 10UF-M/50V		D040100087070F		
C880SL		00D 963 0234 205	C,ELECT 10UF-M/50V		D040100087070F		
C880SR		00D 963 0234 205	C,ELECT 10UF-M/50V		D040100087070F		
C880SW		00D 963 0234 205	C,ELECT 10UF-M/50V		D040100087070F		
C881-884	nsp	00D 963 9004 708	C,CERAMIC 0.1UF-K/50V		D011104577160S		
C885		00D 963 0234 205	C,ELECT 10UF-M/50V		D040100087070F		
C886	nsp	00D 963 9004 708	C,CERAMIC 0.1UF-K/50V		D011104577160S		
C887		00D 963 0234 205	C,ELECT 10UF-M/50V		D040100087070F		
C888	nsp	00D 963 9004 708	C,CERAMIC 0.1UF-K/50V		D011104577160S		
C889-891	nsp	00D 963 9004 698	C,CERAMIC 0.01UF-K/50V		D011103777160S		
C892		00D 963 0234 205	C,ELECT 10UF-M/50V		D040100087070F		
C893		00D 963 0293 602	C,ELECT 1UF-M/50V (Pb Free)		D040010087150F		
C894	nsp	00D 963 9004 698	C,CERAMIC 0.01UF-K/50V		D011103777160S		
C895		00D 963 0216 508	C,FILM 0.12UF-J/63V		D020124078060S		
C896		00D 963 0244 606	C,ELECT 0.1UF-M/50V (Pb Free)		D040R10087080F		
C897,898	nsp	00D 963 9004 708	C,CERAMIC 0.1UF-K/50V		D011104577160S		
C899,900		00D 963 0234 205	C,ELECT 10UF-M/50V		D040100087070F		
C901	nsp	00D 963 9004 708	C,CERAMIC 0.1UF-K/50V		D011104577160S		
C902		00D 963 9005 901	C,ELECT 470UF-M/10V,		D040471082060F		
C903	nsp	00D 963 9004 708	C,CERAMIC 0.1UF-K/50V		D011104577160S		
C904		00D 963 0234 205	C,ELECT 10UF-M/50V		D040100087070F		
C905,906	nsp	00D 963 9004 708	C,CERAMIC 0.1UF-K/50V		D011104577160S		
C907		00D 963 0293 709	C,ELECT 100UF-M/10V		D040101082070F		
C908		00D 963 0234 205	C,ELECT 10UF-M/50V		D040100087070F		
C909	nsp	00D 963 9004 708	C,CERAMIC 0.1UF-K/50V		D011104577160S		
C910		00D 963 0234 205	C,ELECT 10UF-M/50V		D040100087070F		
C911	nsp	00D 963 9004 708	C,CERAMIC 0.1UF-K/50V		D011104577160S		
C912,913	nsp	00D 963 9004 698	C,CERAMIC 0.01UF-K/50V		D011103777160S		
C914,915	nsp	00D 963 9004 708	C,CERAMIC 0.1UF-K/50V		D011104577160S		
C917	nsp	00D 963 9004 698	C,CERAMIC 0.01UF-K/50V		D011103777160S		
C919	nsp	00D 963 9004 698	C,CERAMIC 0.01UF-K/50V		D011103777160S		
C921	nsp	00D 963 9004 698	C,CERAMIC 0.01UF-K/50V		D011103777160S		
C922	nsp	00D 963 9004 708	C,CERAMIC 0.1UF-K/50V		D011104577160S		
C923	nsp	00D 963 0224 105	C,CERAMIC 100PF-K/50V		D011102777160S		
C924,925	nsp	00D 963 0223 601	C,CERAMIC 100PF-J/50V		D010101167160S		
OTHERS PARTS GROUP							
CB801-806	nsp	00D 963 0220 002	BEAD,COIL 121JT		7611010000020S		
CB808	nsp	00D 963 0223 009	R,CHIP 0-J,1/16W		C20000006M160F		
CB810	nsp	00D 963 0220 002	BEAD,COIL 121JT		7611010000020S		
CN801	nsp	00D 963 0086 301	CN.WAFER 18P		L101100031810S		
CN802	nsp	00D 963 0086 204	CN.WAFER 19P		L101100031910S		
CN803	nsp	00D 963 0086 107	CN.WAFER 16P		L101100031610S		
L801	nsp	00D 963 0050 803	COIL,INDUCTOR 4.7UH		D3304R7000150S		
L803	nsp	00D 963 0050 803	COIL,INDUCTOR 4.7UH		D3304R7000150S		
XTAL1		00D 963 0217 303	CRYSTAL 12.288MHZ		E80012R288090S		
XTAL2		00D 963 0217 507	CRYSTAL 18.750MHZ		E80018R750010S		
		00D 963 0294 601	JACK,D3.5 EARPHONE		G40100350000YS		
		00D 963 0217 905	TER,RCA 2PIN		G601206A0200YS		

DSP2 P.W.B. UNIT ASSY (for AVR-1507E3/587E3/487E3 model)

	Ref. No.	nsp	Part No.	Part Name	Remarks		Q'ty	New
SEMICONDUCTORS GROUP								
	IC802,803 IC804 IC805 IC807		00D 963 0237 503 00D 262 3663 000 00D 262 3652 008 00D 262 3066 102	JSR1165-C /OPTICAL ADSP21266SKSTZ-1B-C LH28F800BJE(1707) LC89057W-VF4-E(AC) +REF		E100116500040S		
	IC808 IC809-811 IC812 IC814,815 IC815A		00D 262 3645 002 00D 960 0266 805 00D 960 0266 902 00D 963 0218 904 00D 963 0043 807	IC ADAU1325BSTZ IC MM74LCX244 IC MM74HCT244 IC MM74HCT00MTCX IC BA4510F		J040742440180P J040742440190P J040740000200P J121451000010P		
	IC816 IC816A IC817 IC817A IC818		00D 262 2870 904 00D 963 0043 807 00D 262 3648 009 00D 963 0202 305 00D 262 2642 909	74LVX157MTC +C IC BA4510F IS63LV1024L-10TL IC NJM2068M SN74LV573APWR +REF		J121451000010P J121206800020S		
	IC818A IC819 IC819A IC820 IC820A		00D 963 0202 305 00D 262 2642 909 00D 963 0202 305 00D 262 3339 907 00D 963 0202 305	IC NJM2068M SN74LV573APWR +REF IC NJM2068M SN74LVC139APWR +REF IC NJM2068M		J121206800020S J121206800020S J121206800020S		
	IC821 IC822 IC823 IC824 IC825		00D 262 2870 904 00D 960 0296 008 00D 963 0295 309 00D 963 0147 509 00D 262 2870 904	IC 74LCX74MTC IC CJ7805F IC RC1117-33 IC FAN1112-1.2 IC 74LCX74MTC		J126780500400S J126111733020F J126111712010F		
	IC827 IC828 IC829 IC830		00D 963 0219 107 00D 963 0219 000 00D 963 0244 907 00D 262 2813 903	IC MM74HC151MTCX IC 74VHCU04 IC SN74LV14APWR IC SN74AHCT08		J040741510050P J040740400270P J040741400180P		
	Q804C Q804FL Q804FR Q804SBL Q804SBR		00D 960 0196 603 00D 960 0196 603 00D 960 0196 603 00D 960 0196 603 00D 960 0196 603	TR KTC2874B TR KTC2874B TR KTC2874B TR KTC2874B TR KTC2874B		J502287400010S J502287400010S J502287400010S J502287400010S J502287400010S		
	Q804SL Q804SR Q804SW Q808 Q809		00D 960 0196 603 00D 960 0196 603 00D 960 0196 603 00D 963 0120 801 00D 963 0120 704	TR KTC2874B TR KTC2874B TR KTC2874B TR KRC102S TR KRA102S		J502287400010S J502287400010S J502287400010S J522010200210S J520010200210S		
	Q811,812 D803		00D 963 0245 100 00D 963 0219 709	D,SWITCHING KDS226ST1 D,SWITCHING 1N4148W		K005022600020S K005041480020S		
RESISTORS GROUP								
	R831-833	nsp	00D 963 0234 603	COIL,BEAD		D340160800060S		
CAPACITORS GROUP								
	C801 C802,803	nsp nsp	00D 963 9004 708 00D 963 9004 591	C,CERAMIC 0.1UF-K/50V C,CERAMIC 22PF-J/50V		D011104577160S D010220167160S		
	C807 C808 C812 C813 C814	nsp nsp	00D 963 9004 708 00D 963 9005 862 00D 960 9010 010 00D 963 9004 698 00D 963 9005 862	C,CERAMIC 0.1UF-K/50V C,ELECT 47UF-M/16V C,ELECT 4.7UF-M/50V C,CERAMIC 0.01UF-K/50V C,ELECT 47UF-M/16V		D011104577160S D040470083080F D0404R7087250F D011103777160S D040470083080F		
	C815 C816 C817 C818 C819	nsp	00D 963 0293 709 00D 963 9004 708 00D 963 0234 205 00D 963 0293 602 00D 963 9005 901	C,ELECT 100UF-M/10V C,CERAMIC 0.1UF-K/50V C,ELECT 10UF-M/50V C,ELECT 1UF-M/50V (Pb Free) C,ELECT 470UF-M/10V		D040101082070F D011104577160S D040100087070F D040010087150F D040471082060F		
	C821		00D 963 9005 901	C,ELECT 470UF-M/10V		D040471082060F		

	Ref. No.	nsp	Part No.	Part Name	Remarks		Q'ty	New
	C824	nsp	00D 963 9004 698	C,CERAMIC 0.01UF-K/50V		D011103777160S		
	C825		00D 960 9010 010	C,ELECT 4.7UF-M/50V		D0404R7087250F		
	C830		00D 963 9005 901	C,ELECT 470UF-M/10V		D040471082060F		
	C832	nsp	00D 963 9004 708	C,CERAMIC 0.1UF-K/50V		D011104577160S		
	C833,834	nsp	00D 963 0233 905	C,CERAMIC 0.015UF-K/50V		D011153777160S		
	C835	nsp	00D 963 9004 708	C,CERAMIC 0.1UF-K/50V		D011104577160S		
	C836,837	nsp	00D 963 0224 105	C,CERAMIC 1000PF-K/50V		D011102777160S		
	C838-841	nsp	00D 963 9004 708	C,CERAMIC 0.1UF-K/50V		D011104577160S		
	C842		00D 963 0129 608	C,CERAMIC 15PF-J/50V		D010150167160S		
	C843-846	nsp	00D 963 9004 708	C,CERAMIC 0.1UF-K/50V		D011104577160S		
	C847		00D 963 0129 608	C,CERAMIC 15PF-J/50V		D010150167160S		
	C848-857	nsp	00D 963 9004 708	C,CERAMIC 0.1UF-K/50V		D011104577160S		
	C858		00D 960 9009 856	C,CERAMIC 0.022UF-Z/50V		D011223597160S		
	C859	nsp	00D 963 0246 507	C,CERAMIC 0.068UF-K/50V		D010683777160S		
	C860	nsp	00D 963 9004 708	C,CERAMIC 0.1UF-K/50V		D011104577160S		
	C861,862	nsp	00D 963 9005 998	C,CERAMIC 24PF-J/50V		D010240167160S		
	C863	nsp	00D 963 9004 698	C,CERAMIC 0.01UF-K/50V		D011103777160S		
	C864	nsp	00D 963 9004 708	C,CERAMIC 0.1UF-K/50V		D011104577160S		
	C864L		00D 963 9005 862	C,ELECT 47UF-M/16V		D040470083080F		
	C864R		00D 963 9005 862	C,ELECT 47UF-M/16V		D040470083080F		
	C865	nsp	00D 963 9004 708	C,CERAMIC 0.1UF-K/50V		D011104577160S		
	C865L	nsp	00D 963 9005 723	C,CERAMIC 120PF-J/50V		D010121167160S		
	C865R	nsp	00D 963 9005 723	C,CERAMIC 120PF-J/50V		D010121167160S		
	C866-868	nsp	00D 963 9004 698	C,CERAMIC 0.01UF-K/50V		D011103777160S		
	C869L	nsp	00D 963 0223 601	C,CERAMIC 100PF-J/50V		D010101167160S		
	C869R	nsp	00D 963 0223 601	C,CERAMIC 100PF-J/50V		D010101167160S		
	C870,871	nsp	00D 963 9004 708	C,CERAMIC 0.1UF-K/50V		D011104577160S		
	C871L		00D 963 0216 304	C,FILM 0.001UF-J/100V		D02010206C060P		
	C871R		00D 963 0216 304	C,FILM 0.001UF-J/100V		D02010206C060P		
	C872	nsp	00D 963 9004 708	C,CERAMIC 0.1UF-K/50V		D011104577160S		
	C873		00D 963 9005 804	C,ELECT 100UF-M/25V		D040101084060F		
	C873C	nsp	00D 963 9004 672	C,CERAMIC 680pF-J 50V		D010681167160S		
	C873FL	nsp	00D 963 9004 672	C,CERAMIC 680pF-J 50V		D010681167160S		
	C873FR	nsp	00D 963 9004 672	C,CERAMIC 680pF-J 50V		D010681167160S		
	C873SBL	nsp	00D 963 9004 672	C,CERAMIC 680pF-J 50V		D010681167160S		
	C873SBR	nsp	00D 963 9004 672	C,CERAMIC 680pF-J 50V		D010681167160S		
	C873SL	nsp	00D 963 9004 672	C,CERAMIC 680pF-J 50V		D010681167160S		
	C873SR	nsp	00D 963 9004 672	C,CERAMIC 680pF-J 50V		D010681167160S		
	C873SW	nsp	00D 963 9004 672	C,CERAMIC 680pF-J 50V		D010681167160S		
	C874		00D 963 9005 804	C,ELECT 100UF-M/25V		D040101084060F		
	C874C	nsp	00D 963 9006 146	C,CERAMIC 560PF-J/50V		D010561167160S		
	C874FL	nsp	00D 963 9006 146	C,CERAMIC 560PF-J/50V		D010561167160S		
	C874FR	nsp	00D 963 9006 146	C,CERAMIC 560PF-J/50V		D010561167160S		
	C874SBL	nsp	00D 963 9006 146	C,CERAMIC 560PF-J/50V		D010561167160S		
	C874SBR	nsp	00D 963 9006 146	C,CERAMIC 560PF-J/50V		D010561167160S		
	C874SL	nsp	00D 963 9006 146	C,CERAMIC 560PF-J/50V		D010561167160S		
	C874SR	nsp	00D 963 9006 146	C,CERAMIC 560PF-J/50V		D010561167160S		
	C874SW	nsp	00D 963 9006 146	C,CERAMIC 560PF-J/50V		D010561167160S		
	C875	nsp	00D 963 9004 708	C,CERAMIC 0.1UF-K/50V		D011104577160S		
	C875C		00D 963 0234 205	C,ELECT 10UF-M/50V		D040100087070F		
	C875FL		00D 963 0234 205	C,ELECT 10UF-M/50V		D040100087070F		
	C875FR		00D 963 0234 205	C,ELECT 10UF-M/50V		D040100087070F		
	C875SBL		00D 963 0234 205	C,ELECT 10UF-M/50V		D040100087070F		
	C875SBR		00D 963 0234 205	C,ELECT 10UF-M/50V		D040100087070F		
	C875SL		00D 963 0234 205	C,ELECT 10UF-M/50V		D040100087070F		
	C875SR		00D 963 0234 205	C,ELECT 10UF-M/50V		D040100087070F		
	C875SW		00D 963 0234 205	C,ELECT 10UF-M/50V		D040100087070F		
	C876	nsp	00D 963 9004 708	C,CERAMIC 0.1UF-K/50V		D011104577160S		
	C876C		00D 960 9008 611	C,FILM 0.0033UF-J/100V		D02033206C060P		
	C876FL		00D 960 9008 611	C,FILM 0.0033UF-J/100V		D02033206C060P		
	C876FR		00D 960 9008 611	C,FILM 0.0033UF-J/100V		D02033206C060P		
	C876SBL		00D 960 9008 611	C,FILM 0.0033UF-J/100V		D02033206C060P		
	C876SBR		00D 960 9008 611	C,FILM 0.0033UF-J/100V		D02033206C060P		
	C876SL		00D 960 9008 611	C,FILM 0.0033UF-J/100V		D02033206C060P		

Ref. No.	nsp	Part No.	Part Name	Remarks		Q'ty	New
C876SR		00D 960 9008 611	C,FILM 0.0033UF-J/100V		D02033206C060P		
C876SW		00D 960 9008 611	C,FILM 0.0033UF-J/100V		D02033206C060P		
C877-880	nsp	00D 963 9004 708	C,CERAMIC 0.1UF-K/50V		D011104577160S		
C880C		00D 963 0234 205	C,ELECT 10UF-M/50V		D040100087070F		
C880FL		00D 963 0234 205	C,ELECT 10UF-M/50V		D040100087070F		
C880FR		00D 963 0234 205	C,ELECT 10UF-M/50V		D040100087070F		
C880SBL		00D 963 0234 205	C,ELECT 10UF-M/50V		D040100087070F		
C880SBR		00D 963 0234 205	C,ELECT 10UF-M/50V		D040100087070F		
C880SL		00D 963 0234 205	C,ELECT 10UF-M/50V		D040100087070F		
C880SR		00D 963 0234 205	C,ELECT 10UF-M/50V		D040100087070F		
C880SW		00D 963 0234 205	C,ELECT 10UF-M/50V		D040100087070F		
C881-884	nsp	00D 963 9004 708	C,CERAMIC 0.1UF-K/50V		D011104577160S		
C885		00D 963 0234 205	C,ELECT 10UF-M/50V		D040100087070F		
C886	nsp	00D 963 9004 708	C,CERAMIC 0.1UF-K/50V		D011104577160S		
C887		00D 963 0234 205	C,ELECT 10UF-M/50V		D040100087070F		
C888	nsp	00D 963 9004 708	C,CERAMIC 0.1UF-K/50V		D011104577160S		
C889-891	nsp	00D 963 9004 698	C,CERAMIC 0.01UF-K/50V		D011103777160S		
C892		00D 963 0234 205	C,ELECT 10UF-M/50V		D040100087070F		
C893		00D 963 0293 602	C,ELECT 1UF-M/50V (Pb Free)		D040010087150F		
C894	nsp	00D 963 9004 698	C,CERAMIC 0.01UF-K/50V		D011103777160S		
C896		00D 963 0244 606	C,ELECT 0.1UF-M/50V (Pb Free)		D040R10087080F		
C897,898	nsp	00D 963 9004 708	C,CERAMIC 0.1UF-K/50V		D011104577160S		
C899,900		00D 963 0234 205	C,ELECT 10UF-M/50V		D040100087070F		
C901	nsp	00D 963 9004 708	C,CERAMIC 0.1UF-K/50V		D011104577160S		
C902		00D 963 9005 901	C,ELECT 470UF-M/10V		D040471082060F		
C903	nsp	00D 963 9004 708	C,CERAMIC 0.1UF-K/50V		D011104577160S		
C904		00D 963 0234 205	C,ELECT 10UF-M/50V		D040100087070F		
C905,906	nsp	00D 963 9004 708	C,CERAMIC 0.1UF-K/50V		D011104577160S		
C907		00D 963 0293 709	C,ELECT 100UF-M/10V		D040101082070F		
C908		00D 963 0234 205	C,ELECT 10UF-M/50V		D040100087070F		
C909	nsp	00D 963 9004 708	C,CERAMIC 0.1UF-K/50V		D011104577160S		
C910		00D 963 0234 205	C,ELECT 10UF-M/50V		D040100087070F		
C911	nsp	00D 963 9004 708	C,CERAMIC 0.1UF-K/50V		D011104577160S		
C912,913	nsp	00D 963 9004 698	C,CERAMIC 0.01UF-K/50V		D011103777160S		
C914,915	nsp	00D 963 9004 708	C,CERAMIC 0.1UF-K/50V		D011104577160S		
C917	nsp	00D 963 9004 698	C,CERAMIC 0.01UF-K/50V		D011103777160S		
C919	nsp	00D 963 9004 698	C,CERAMIC 0.01UF-K/50V		D011103777160S		
C921	nsp	00D 963 9004 698	C,CERAMIC 0.01UF-K/50V		D011103777160S		
C923	nsp	00D 963 0224 105	C,CERAMIC 1000PF-K/50V		D011102777160S		
C924,925	nsp	00D 963 0223 601	C,CERAMIC 100PF-J/50V		D010101167160S		
C927	nsp	00D 963 9004 698	C,CERAMIC 0.01UF-K/50V		D011103777160S		
OTHERS PARTS GROUP							
CB801-806	nsp	00D 963 0220 002	BEAD,COIL 121JT		7611010000020S		
CB808		00D 963 9003 372	R,CHIP 0-J,1/16W		C20000006M160S		
CB810	nsp	00D 963 0220 002	BEAD,COIL 121JT		7611010000020S		
CN801	nsp	00D 963 0086 301	CN.WAFER 18P		L101100031810S		
CN802	nsp	00D 963 0086 204	CN.WAFER 19P		L101100031910S		
CN803	nsp	00D 963 0110 701	CN.WAFER 16P		L101100031410S		
L801	nsp	00D 963 0050 803	COIL,INDUCTOR 4.7UH		D3304R7000150S		
L803	nsp	00D 963 0050 803	COIL,INDUCTOR 4.7UH		D3304R7000150S		
XTAL1		00D 963 0217 303	CRYSTAL 12.288MHZ		E80012R288090S		
XTAL2		00D 963 0217 507	CRYSTAL 18.750MHZ		E80018R750010S		
		00D 963 0294 601	JACK,D3.5 EARPHONE		G40100350000YS		
		00D 963 0217 905	TER,RCA 2PIN		G601206A0200YS		

C/S VIDEO 2 P.W.B. UNIT ASSY

	Ref. No.	nsp	Part No.	Part Name	Remarks		Q'ty	New
SEMICONDUCTORS GROUP								
	IC601		00D 963 0148 401	IC LA7956		J171795600010S		
	IC602		00D 963 0219 301	IC CJ7806		J126780600190S		
	IC621,622		00D 963 0148 401	IC LA7956		J171795600010S		
	IC651		00D 960 0175 200	IC BA7625		J171762500000P		
	IC652,653		00D 963 0083 304	IC BA7626		J171762600000P		
	Q601,602		00D 960 0005 202	TR KTC3198Y		J5023198Y0000S		
	Q603-606		00D 963 0121 208	TR KRC107M		J6020107M0010S		
	Q621,622		00D 960 0005 202	TR KTC3198Y		J5023198Y0000S		
	Q623,624		00D 963 0121 208	TR KRC107M		J6020107M0010S		
	Q625,626		00D 960 0005 202	TR KTC3198Y		J5023198Y0000S		
	Q627,628		00D 963 0121 208	TR KRC107M		J6020107M0010S		
	Q651-653		00D 960 0005 105	TR KTA1266Y		J5001266Y0050S		
	D601,602		00D 963 0020 309	D,SWITCHING 1SS133T		K000013300520S		
	D621,622		00D 963 0020 309	D,SWITCHING 1SS133T		K000013300520S		
	D674A		00D 963 0020 309	D,SWITCHING 1SS133T		K000013300520S		
CAPACITORS GROUP								
	C602-604		00D 963 9005 862	C,ELECT 47UF-M/16V		D040470083080F		
	C605,606		00D 963 9005 901	C,ELECT 470UF-M/10V		D040471082060F		
	C607		00D 960 9009 924	C,ELECT 100UF-M/16V		D040101083070F		
	C612,613	nsp	00D 963 0234 001	C,CERAMIC 0.047UF-Z/50V		D011473597160S		
	C621-623		00D 963 9005 862	C,ELECT 47UF-M/16V		D040470083080F		
	C624,625		00D 963 9005 901	C,ELECT 470UF-M/10V		D040471082060F		
	C626-628		00D 963 9005 862	C,ELECT 47UF-M/16V		D040470083080F		
	C629,630		00D 963 9005 901	C,ELECT 470UF-M/10V		D040471082060F		
	C632,633	nsp	00D 963 0234 001	C,CERAMIC 0.047UF-Z/50V		D011473597160S		
	C634,635		00D 963 0293 602	C,ELECT 1UF-M/50V (Pb Free)		D040010087150F		
	C651-656		00D 960 9010 010	C,ELECT 4.7UF-M/50V		D0404R7087250F		
	C657		00D 963 9005 969	C,ELECT 4700UF-M/6.3V		D040472081000F		
	C658,659		00D 960 0298 802	C,ELECT 470UF-M/6.3V		D040471081070F		
	C660-662		00D 963 0293 806	C,ELECT 100UF-M/10V(Pb Free)		D040101082090F		
	C663-665		00D 960 9010 010	C,ELECT 4.7UF-M/50V		D0404R7087250F		
	C671,672		00D 963 0293 602	C,ELECT 1UF-M/50V (Pb Free)		D040010087150F		
	C673		00D 960 9003 108	C,CERAMIC 0.022UF-Z/25V		D005223594520S		
	C674		00D 963 0293 806	C,ELECT 100UF-M/10V(Pb Free)		D040101082090F		
	C674A		00D 963 0234 506	C,ELECT 47UF-M/50V(Pb Free)		D040470087070F		
	C681,682		00D 963 0293 602	C,ELECT 1UF-M/50V (Pb Free)		D040010087150F		
	C683		00D 960 9003 108	C,CERAMIC 0.022UF-Z/25V		D005223594520S		
	C691,692		00D 963 0293 602	C,ELECT 1UF-M/50V (Pb Free)		D040010087150F		
	C693		00D 960 9003 108	C,CERAMIC 0.022UF-Z/25V		D005223594520S		
	C695,696		00D 963 0234 205	C,ELECT 10UF-M/50V		D040100087070F		
	C707L	nsp	00D 963 0223 601	C,CERAMIC 100PF-J/50V		D010101167160S		
	C707R	nsp	00D 963 0223 601	C,CERAMIC 100PF-J/50V		D010101167160S		
	C708L	nsp	00D 963 0223 601	C,CERAMIC 100PF-J/50V		D010101167160S		
	C708R	nsp	00D 963 0223 601	C,CERAMIC 100PF-J/50V		D010101167160S		
OTHERS PARTS GROUP								
	CN601	nsp	00D 963 0086 301	CN.WAFER 18P		L101100031810S		
	CN603-605	nsp	00D 963 0097 206	CN.WAFER 8P		L101100030810S		
	CP603-605	nsp	00D 963 0097 400	CN.WAFER 8P		L101100040810S		
			00D 963 0218 001	TER,RCA 2PIN		G60122001000YS		
			00D 963 0146 209	TER,RCA 4PIN		G602405B01000S		
			00D 963 0218 108	TER,RCA 3PIN		G60630401000YS		
			-	HEAT SINK		2120044338010S		
			00D 963 0146 306	TER,RCA 6PIN		G603603B2600YS		

EXPLODED VIEW (for AVR-1707 U.S.A. & Canada model)

WARNING:
Parts marked with this symbol  have critical characteristics.
Use **ONLY** replacement parts recommended by the manufacturer.

印の部分は安全を維持するために重要な部品です。従って交換時は必ず指定の部品を使用してください。

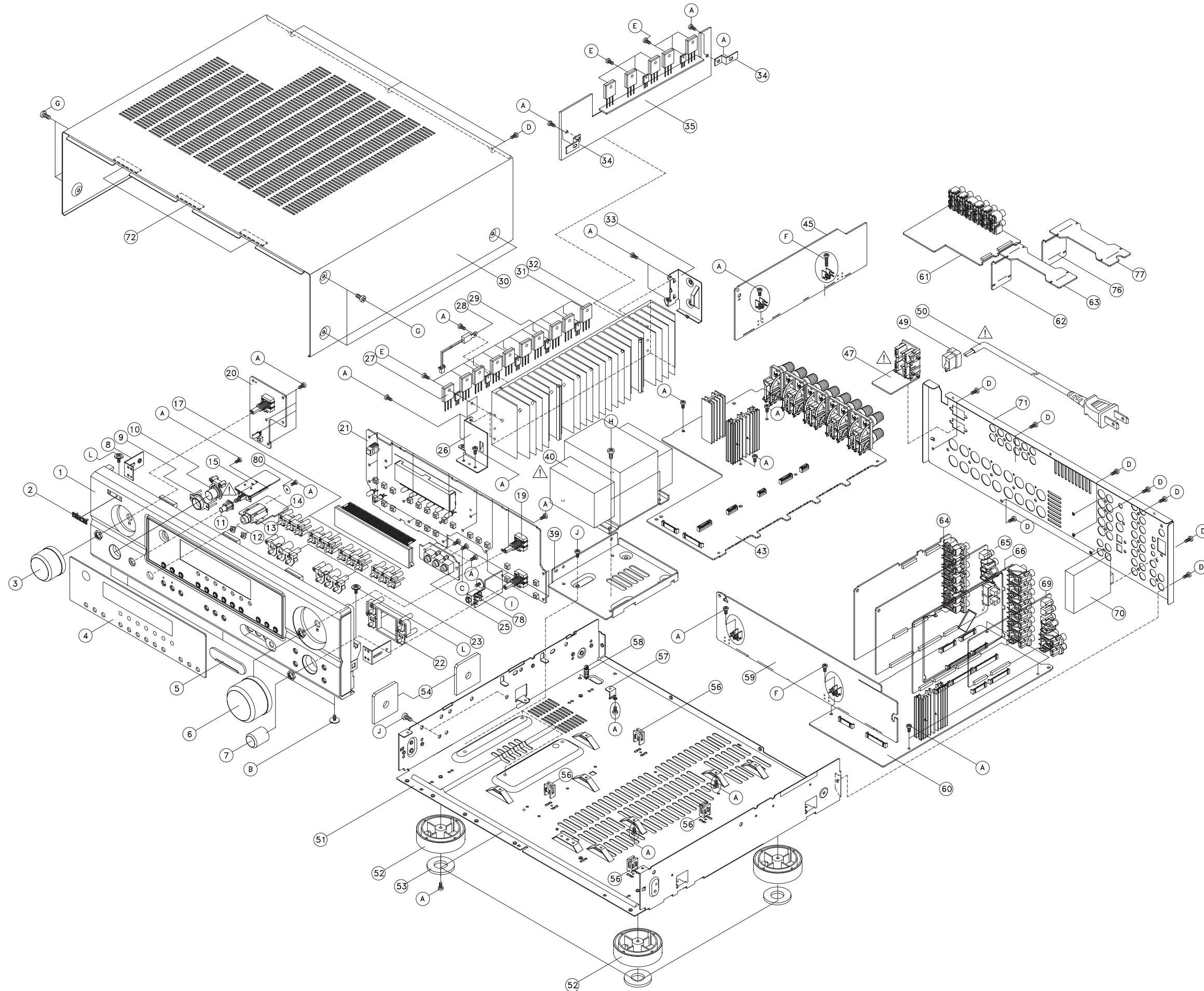

EXPLODED VIEW (for AVR-1707,AVR-1507 Europe model)

WARNING:
Parts marked with this symbol  have critical characteristics.
Use ONLY replacement parts recommended by the manufacturer.

印の部分は安全を維持するために重要な部品です。従って交換時は必ず指定の部品を使用してください。

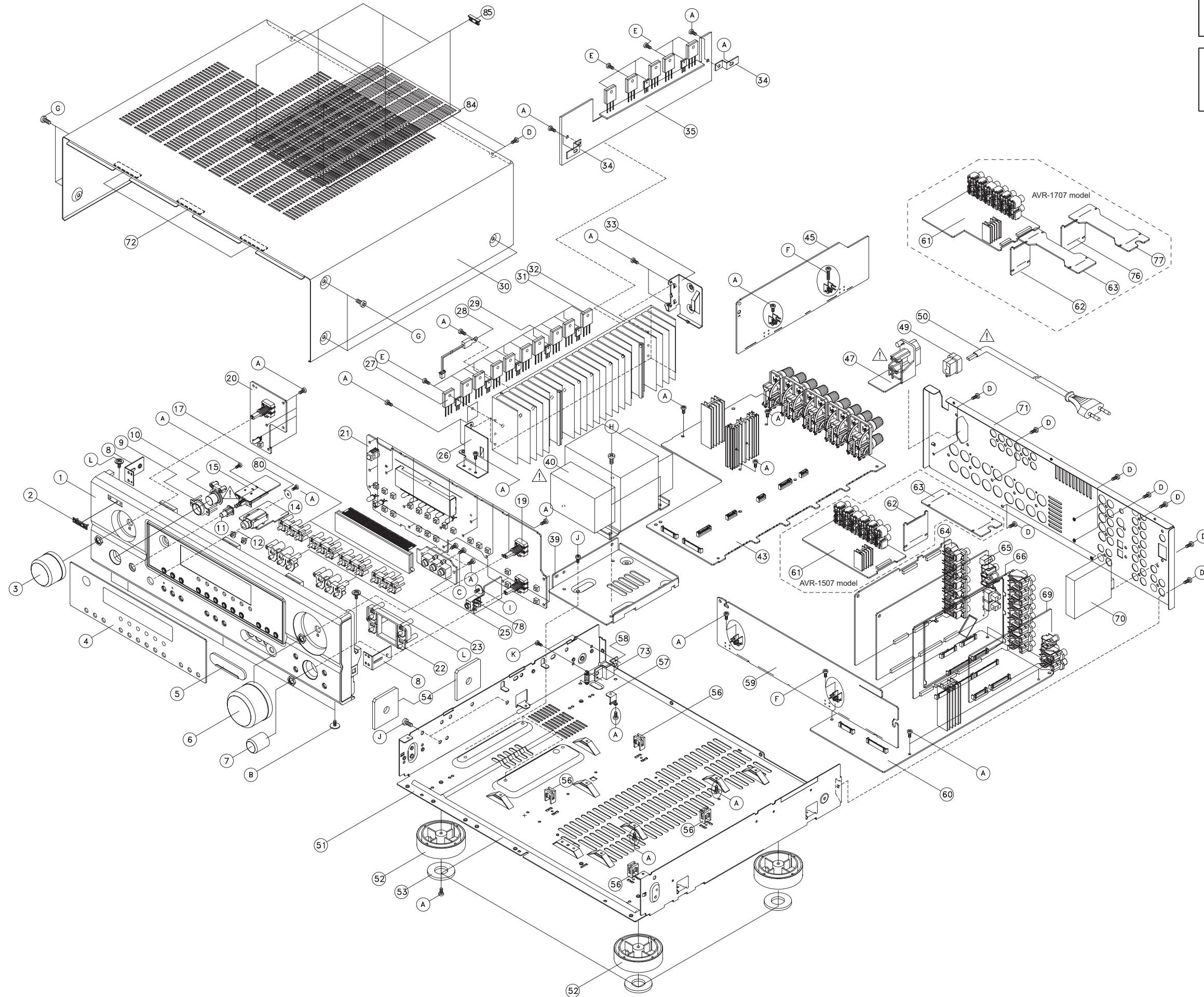

EXPLODED VIEW (for AVR-1707 Taiwan R.O.C. model)

WARNING:
Parts marked with this symbol  have critical characteristics.
Use ONLY replacement parts recommended by the manufacturer.

印の部分は安全を維持するために重要な部品です。従って交換時は必ず指定の部品を使用してください。

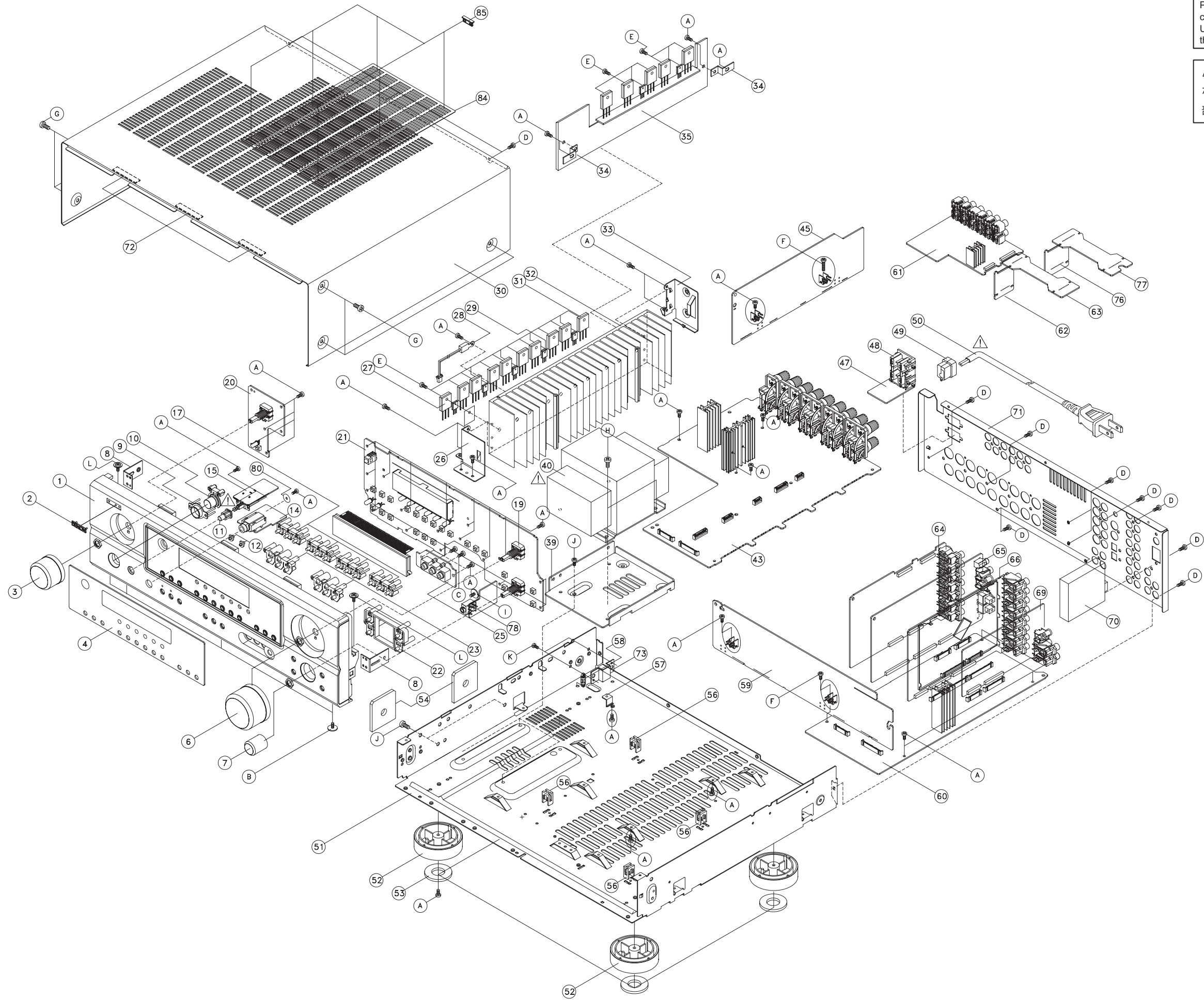

EXPLODED VIEW (for AVR-1507 U.S.A. & Canada model)

WARNING:
Parts marked with this symbol  have critical characteristics.
Use **ONLY** replacement parts recommended by the manufacturer.

印の部分は安全を維持するために重要な部品です。従って交換時は必ず指定の部品を使用してください。

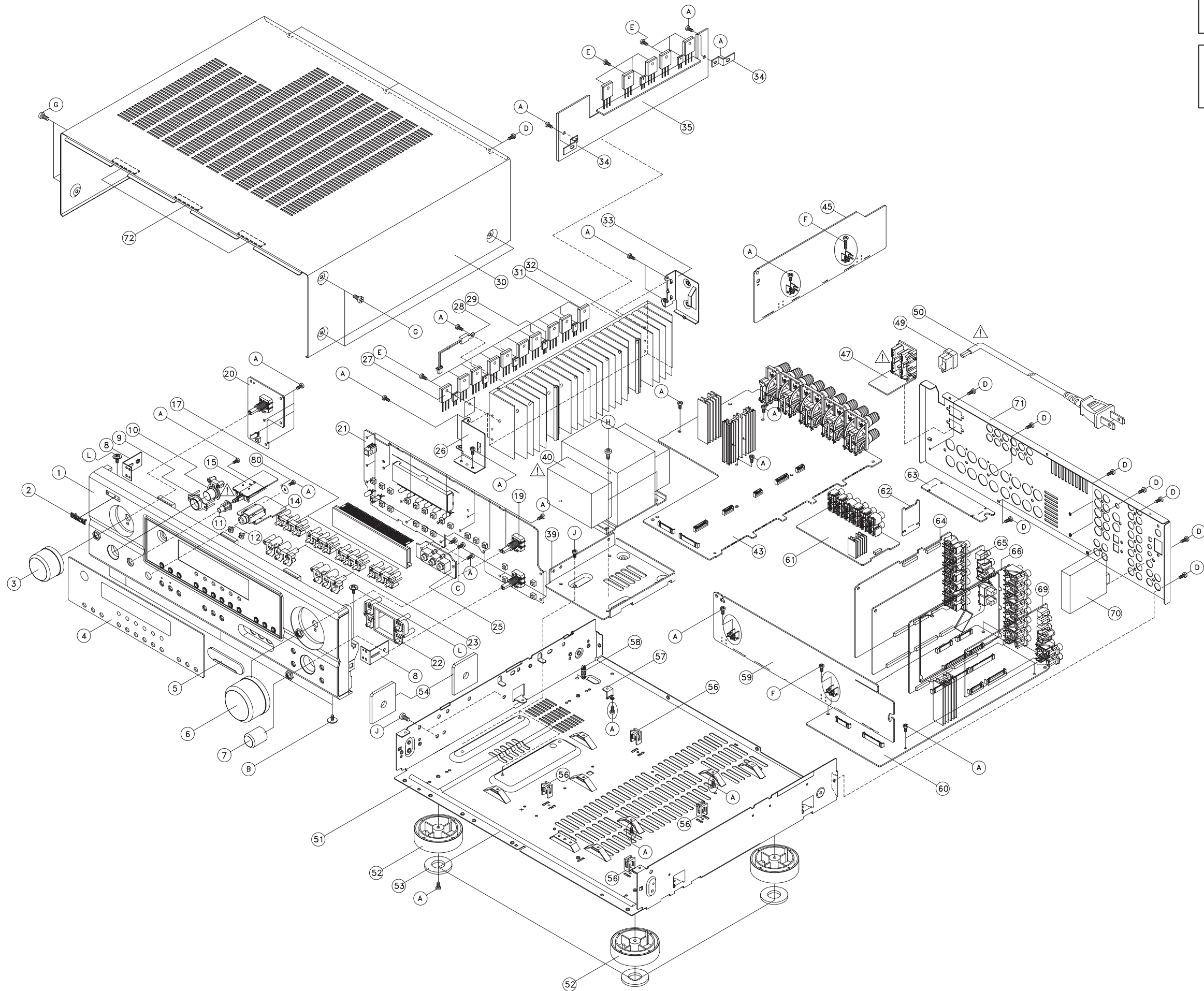

EXPLODED VIEW (for AVR-687,AVR-587 U.S.A. & Canada model)

WARNING:
Parts marked with this symbol  have critical characteristics.
Use ONLY replacement parts recommended by the manufacturer.

印の部分は安全を維持するために重要な部品です。従って交換時は必ず指定の部品を使用してください。

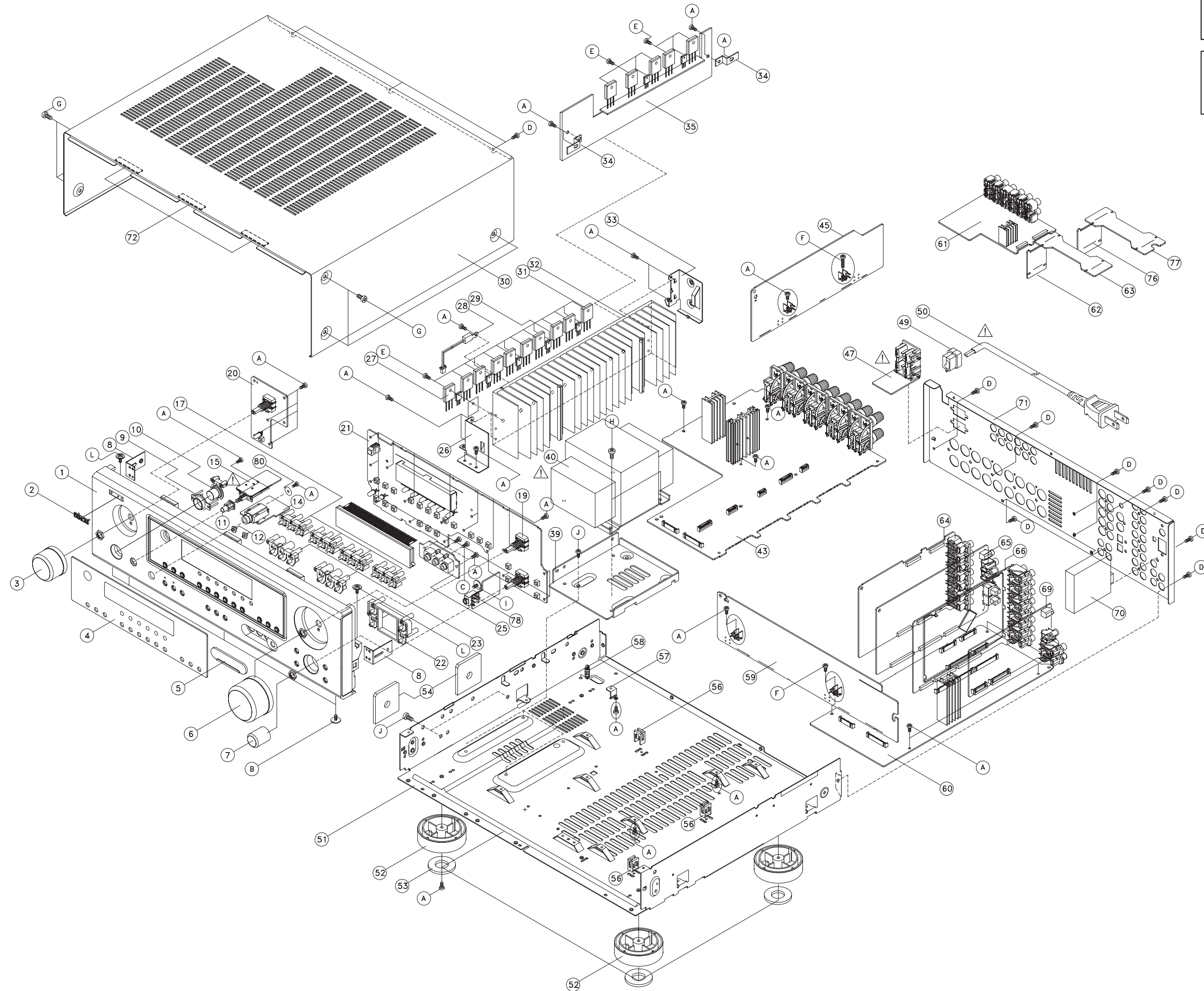

EXPLODED VIEW (for AVR-487 U.S.A. & Canada model)

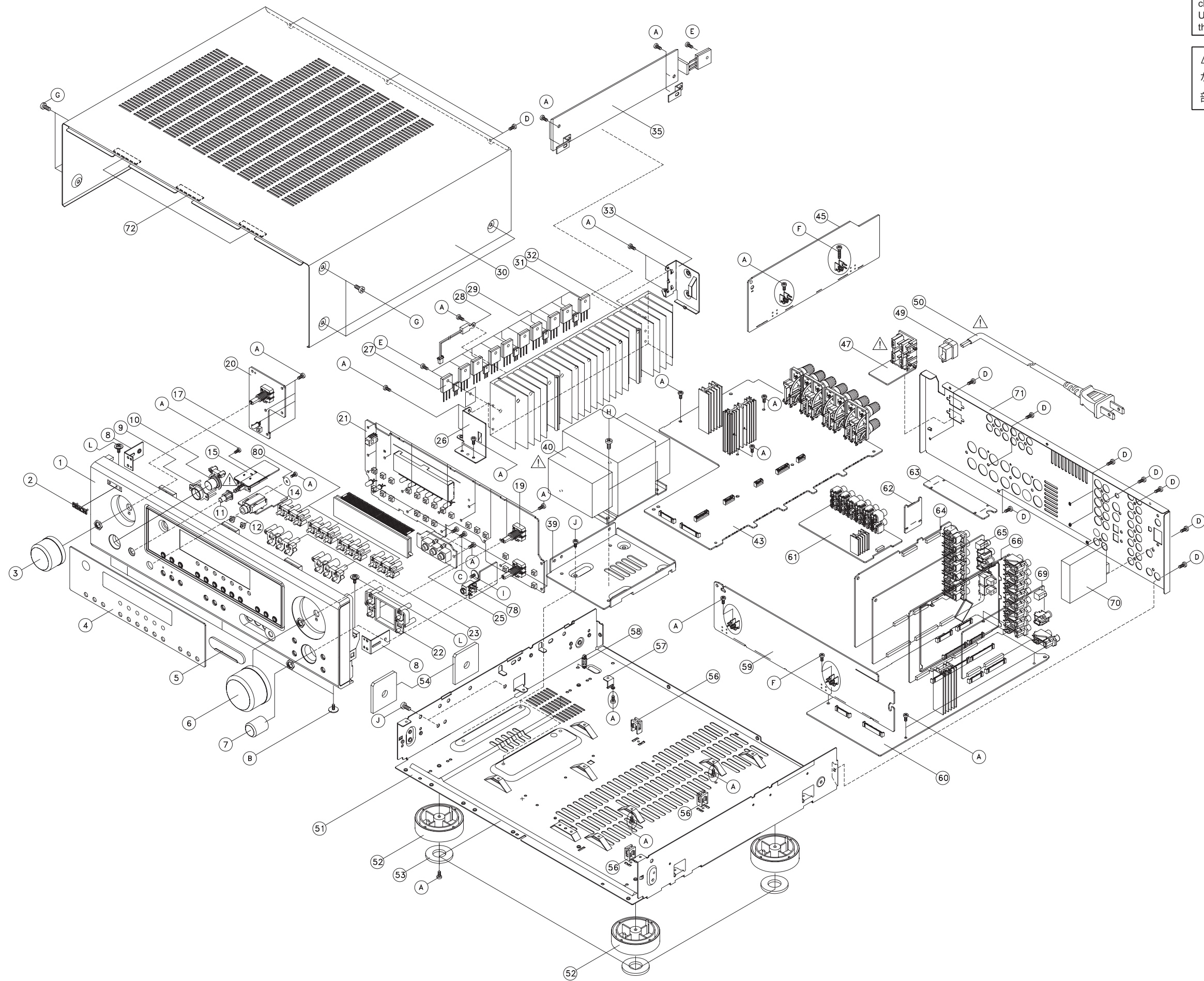

WARNING:
Parts marked with this symbol ⚠ have critical characteristics.
Use ONLY replacement parts recommended by the manufacturer.

⚠印の部分は安全を維持するために重要な部品です。従って交換時は必ず指定の部品を使用してください。

PARTS LIST OF EXPLODED VIEW

* 本表に記載されている部品は、補修用部品のため製品に使用している部品とは一部、形状、寸法などが異なる場合があります。

* The parts listed below are for maintenance only, might differ from the parts used in the unit in appearances or dimensions.

* "nsp" 印の部品は常時在庫していませんので供給に長時間を要することがあります。場合によっては、供給をお断りする場合があります。

* Part indicated with the mark "nsp" are not always in stock and possibly to take a long period of time for supplying, or in some case supplying of part may be refused.

Note: The symbols in the column "Remarks" indicate the following destinations.

1707E3 : U.S.A. & Canada model 1707E2 : Europe model 1707EUT : Taiwan R.O.C. model

687E3 : U.S.A. & Canada model (AVR686)

1507E3 : U.S.A. & Canada model 1507E2 : Europe model

587E3 : U.S.A. & Canada model (AVR586) 487E3 : U.S.A. & Canada model (AVR486)

Black : Black model

Premium Silver : Premium Silver model

Silver : Silver model

	Ref. No.	nsp	Part No.	Part Name	Remarks	ETRO	Q'ty	New
	43A	nsp	00D 963 0286 509	MAIN P.W.B. Assy	1707E3,687E3	7025HK0511010	1	*
	43A	nsp	00D 963 0286 606	MAIN P.W.B. Assy	1707E2	7025HK0511020	1	*
	43A	nsp	00D 963 0286 703	MAIN P.W.B. Assy	1707EUT	7025HK0511030	1	*
	43A	nsp	00D 963 0286 800	MAIN P.W.B. Assy	1507E3,587E3	7025HK0510010	1	*
	43A	nsp	00D 963 0286 907	MAIN P.W.B. Assy	1507E2	7025HK0510020	1	*
	43A	nsp	00D 963 0287 003	MAIN P.W.B. Assy	487E3	7025HK0510060	1	*
	14			HEADPHONE P.W.B.				
	20			TACT SW P.W.B.				
	43			MAIN P.W.B.				
⚠	47			AC OUTLET P.W.B.				
	60A	nsp	00D 963 0287 100	CPU P.W.B. Assy	1707E3,687E3	7025HK0511011	1	*
	60A	nsp	00D 963 0287 207	CPU P.W.B. Assy	1707E2	7025HK0511021	1	*
	60A	nsp	00D 963 0287 304	CPU P.W.B. Assy	1707EUT	7025HK0511031	1	*
	60A	nsp	00D 963 0287 401	CPU P.W.B. Assy	1507E3,587E3	7025HK0510011	1	*
	60A	nsp	00D 963 0287 508	CPU P.W.B. Assy	1507E2	7025HK0510021	1	*
	60A	nsp	00D 963 0287 605	CPU P.W.B. Assy	487E3	7025HK0510061	1	*
⚠	15			POWER SW P.W.B.				
	21			FRONT P.W.B.				
	25			V-AUX P.W.B.				
	60			CPU P.W.B.				
	59A	nsp	00D 963 0287 702	CNT P.W.B. Assy	1707E3,687E3	7025HK0511013	1	*
	59A	nsp	00D 963 0287 809	CNT P.W.B. Assy	1707E2	7025HK0511023	1	*
	59A	nsp	00D 963 0287 906	CNT P.W.B. Assy	1707EUT	7025HK0511033	1	*
	59A	nsp	00D 963 0288 002	CNT P.W.B. Assy	1507E3,587E3	7025HK0510013	1	*
	59A	nsp	00D 963 0288 109	CNT P.W.B. Assy	1507E2	7025HK0510023	1	*
	59A	nsp	00D 963 0288 206	CNT P.W.B. Assy	487E3	7025HK0510063	1	*
	59			CNT P.W.B.				
	69A	nsp	00D 963 0288 303	8CH-EXT XM P.W.B. Assy	1707E3	7025HK0511015	1	*
	69A	nsp	00D 963 0288 400	8CH-EXT XM P.W.B. Assy	687E3	7025HK0511065	1	*
	69A	nsp	00D 963 0288 507	8CH-EXT XM P.W.B. Assy	1507E3	7025HK0510015	1	*
	69A	nsp	00D 963 0288 604	8CH-EXT XM P.W.B. Assy	587E3	7025HK0510055	1	*
	69A	nsp	00D 963 0289 001	8CH-EXT XM P.W.B. Assy	487E3	7025HK0510065	1	*
	69			8CH-EXT XM P.W.B.				
	69A	nsp	00D 963 0288 701	8CH-EXT P.W.B. Assy	1707E2	7025HK0511028	1	*
	69A	nsp	00D 963 0288 808	8CH-EXT P.W.B. Assy	1707EUT	7025HK0511038	1	*
	69A	nsp	00D 963 0288 905	8CH-EXT P.W.B. Assy	1507E2	7025HK0510028	1	*
	69			8CH-EXT P.W.B.				

Ref. No.	nsp	Part No.	Part Name	Remarks	ETRO	Q'ty	New
45A	nsp	00D 963 0289 108	PRE AMP P.W.B. Assy	1707E3,687E3	7025HK0511012	1	*
45A	nsp	00D 963 0289 205	PRE AMP P.W.B. Assy	1707E2	7025HK0511022	1	*
45A	nsp	00D 963 0289 302	PRE AMP P.W.B. Assy	1707EUT	7025HK0511032	1	*
45A	nsp	00D 963 0289 409	PRE AMP P.W.B. Assy	1507E3,587E3	7025HK0510012	1	*
45A	nsp	00D 963 0289 506	PRE AMP P.W.B. Assy	1507E2	7025HK0510022	1	*
45A	nsp	00D 963 0289 603	PRE AMP P.W.B. Assy	487E3	7025HK0510062	1	*
35			2CH-AMP P.W.B.				
45			PRE AMP P.W.B.				
66A	nsp	00D 963 0289 700	INPUT P.W.B. Assy	1707E3,687E3	7025HK0511064	1	*
66A	nsp	00D 963 0289 807	INPUT P.W.B. Assy	1707E2	7025HK0511024	1	*
66A	nsp	00D 963 0289 904	INPUT P.W.B. Assy	1707EUT	7025HK0511034	1	*
66A	nsp	00D 963 0290 003	INPUT P.W.B. Assy	1507E3,587E3	7025HK0510014	1	*
66A	nsp	00D 963 0290 100	INPUT P.W.B. Assy	1507E2	7025HK0510024	1	*
66A	nsp	00D 963 0290 207	INPUT P.W.B. Assy	487E3	7025HK0510064	1	*
66			INPUT P.W.B.				
78			MIC P.W.B.				
64A	nsp	00D 963 0290 304	C-S VIDEO 1 P.W.B. Assy	1707E3,687E3	7025HK0511017	1	*
64A	nsp	00D 963 0290 401	C-S VIDEO 1 P.W.B. Assy	1707E2	7025HK0511027	1	*
64A	nsp	00D 963 0290 508	C-S VIDEO 1 P.W.B. Assy	1707EUT	7025HK0511037	1	*
64A	nsp	00D 963 0290 605	C-S VIDEO 2 P.W.B. Assy	1507E3,587E3	7025HK0510019	1	*
64A	nsp	00D 963 0290 702	C-S VIDEO 2 P.W.B. Assy	1507E2	7025HK0510029	1	*
64A	nsp	00D 963 0290 809	C-S VIDEO 2 P.W.B. Assy	487E3	7025HK0510069	1	*
61			COMP-V1 P.W.B.				
62			V-CNT DOWN 1/2 P.W.B.				
63			V-CNT UP 1/2 P.W.B.				
64			C-S VIDEO1 P.W.B.				
76			V-CNT DOWN 2/2 P.W.B.	Except for 1507E3,487E3			
77			V-CNT UP 2/2 P.W.B.	Except for 1507E3,487E3			
65A		00D 963 0290 906	DSP1 P.W.B. Assy	1707E3,687E3,1707E2, 1707EUT,1507E2	7025HK0511066	1	*
65A		00D 963 0290 906	DSP2 P.W.B. Assy	1507E3,587E3	7025HK0511066	1	*
65A		00D 963 0291 002	DSP2 P.W.B. Assy	487E3	7025HK051006A	1	*
65			DSP1 P.W.B.				*
65			DSP2 P.W.B.				*
1		00D 963 0291 109	PANEL FRONT	1707E3	3067212191200S	1	*
1		00D 963 0291 206	PANEL FRONT	687E3	3067212201200S	1	*
1		00D 963 0291 303	PANEL FRONT	587E3	3067212201310S	1	*
1		00D 963 0291 400	PANEL FRONT	1707EUT	3067212191310S	1	*
1		00D 963 0291 507	PANEL FRONT	1707E2	3067212191300S	1	*
1		00D 963 0291 604	PANEL FRONT	1507E2	3067212191320S	1	*
1		00D 963 0291 701	PANEL FRONT	1507E3	3067211751400S	1	*
1		00D 963 0291 808	PANEL FRONT	487E3	3067212201300S	1	*
2		00D 963 0051 501	BADGE	Black	5630210028000S	1	
2		00D 963 0051 514	BADGE	Premium Silver	5630210028100S	1	
2		00D 963 0051 527	BADGE	Silver	5630210028200S	1	
3		00D 963 0138 301	KNOB INPUT	Black	5087210961000S	1	
3		00D 963 0240 202	KNOB INPUT	Premium Silver	5087210961110S	1	
3		00D 963 0141 505	KNOB INPUT	Silver	5087210961100S	1	
4		00D 963 0291 905	WINDOW DISPLAY	1707E3,687E3	50772119220E0S	1	*
4		00D 963 0237 309	WINDOW DISPLAY	1707EUT	50772119220A0S	1	

	Ref. No.	nsp	Part No.	Part Name	Remarks	ETRO	Q'ty	New
	4		00D 963 0214 704	WINDOW DISPLAY	1707E2,1507E2	5077211922090S	1	
	4		00D 963 0292 001	WINDOW DISPLAY	1507E3,587E3	50772119220B0S	1	*
	4		00D 963 0292 108	WINDOW DISPLAY	487E3	50772119220C0S	1	*
	5		00D 963 0190 200	COVER RCA	1707E3,687E3	4317211701000S	1	
	5		00D 963 0190 307	COVER RCA	1707E2,1507E2	4317211701100S	1	
	5		00D 963 0138 107	COVER RCA	1507E3,587E3,487E3	4317211691000S	1	
	6		00D 963 0138 806	KNOB VOLUME	Black	5087210981000S	1	
	6		00D 963 0240 406	KNOB VOLUME	Premium Silver	5087210981110S	1	
	6		00D 963 0138 903	KNOB VOLUME	Silver	5087210981100S	1	
	7		00D 963 0138 505	KNOB SELECT	Black	5087210971000S	1	
	7		00D 963 0240 309	KNOB SELECT	Premium Silver	5087210971110S	1	
	7		00D 963 0138 602	KNOB SELECT	Silver	5087210971100S	1	
	8	nsp	00D 963 0138 000	BRACKET SIDE L/R		4010211986000S	2	
	9		00D 963 0137 807	LENS STANDBY		3710210503000S	1	
	10		00D 963 0184 106	BUTTON STANDBY	Black	5097212368000SZ	1	
	10		00D 963 0221 904	BUTTON STANDBY	Premium Silver	5097212368030SZ	1	
	10		00D 963 0190 501	BUTTON STANDBY	Silver	5097212368010SZ	1	
	11		00D 963 0184 009	BUTTON POWER	Black	5097212358000SZ	1	
	11		00D 963 0230 005	BUTTON POWER	Premium Silver	5097212358300SZ	1	
	11		00D 963 0194 002	BUTTON POWER	Silver	5097212358100SZ	1	
	12		00D 960 0191 417	LENS LED		3710210043001S	2	
	17		00D 963 0094 801	BUTTON 3KEY(A)		5090211741000S	4	
	22		00D 963 0139 407	BUTTON 4KEY	Black	5097212341000S	1	
	22		00D 963 0249 009	BUTTON 4KEY	Premium Silver	5097212341110S	1	
	22		00D 963 0139 504	BUTTON 4KEY	Silver	5097212341100S	1	
	23		00D 963 0139 106	BUTTON 3KEY	Black	5097212331000S	2	
	23		00D 963 0248 903	BUTTON 3KEY	Premium Silver	5097212331110S	2	
	23		00D 963 0139 203	BUTTON 3KEY	Silver	5097212331100S	2	
	26	nsp	00D 960 0184 301	BRACKET HEAT SINK-F		4010210396000S	1	
	27		00D 963 0044 107	TR PNP 2SB1560-Y	Q102C Q102FL Q102FR Q102SL Q102SR	J5011560Y0000P	5	
	28		00D 960 0187 900	POSISTOR P43T7D330BW16		F320161001020S	1	
	29		00D 963 0280 107	TR NPN 2SC3964	Q103C Q103FL Q103FR Q103SL Q103SR	J502396400000S	5	
	30		00D 963 0247 108	CABINET TOP	Black	3000210096400S	1	
	30		00D 963 0247 205	CABINET TOP	Silver,Premium Silver	3000210096500S	1	
	31		00D 963 0044 204	TR NPN 2SD2390-Y	Q101C Q101FL Q101FR Q101SL Q101SR	J5032390Y0000P	5	
	32	nsp	-	HEAT SINK MAIN		2120210928000S	1	
	33	nsp	00D 960 0184 204	BRACKET HEAT SINK-B		4010210386000S	1	
	34	nsp	00D 963 0101 600	BRACKET PCB		4010210186000S	2	
	39	nsp	00D 963 0092 609	BRACKET TRANS		4010210466002S	1	
⚠	40		00D 963 0301 206	POWER TRANS	1707E3,687E3	8200960660140S	1	*
⚠	40		00D 963 0301 303	POWER TRANS	1707E2	8200960660020S	1	*
⚠	40		00D 963 0301 400	POWER TRANS	1707EUT	8200960660050S	1	*
⚠	40		00D 963 0301 507	POWER TRANS	1507E3,587E3,487E3	8200960660160S	1	*
⚠	40		00D 963 0301 604	POWER TRANS	1507E2	8200960660060S	1	*
	49	nsp	00D 960 0192 403	STOPPER CORD AC		4380210002000S	1	
⚠	50		00D 963 0292 205	AC CORD	1507E3,587E3,487E3	L068125100020S	1	*
⚠	50		00D 963 0292 302	AC CORD	1707EUT	L068125110000S	1	*
⚠	50		00D 963 0292 409	AC CORD	1707E2,1507E2	L068250250040S	1	*
	51	nsp	00D 963 0292 506	CHASSIS MAIN		3200210146305S	1	*
	52	nsp	00D 963 0137 904	FOOT		4007210261000S	4	
	53	nsp	00D 963 0214 607	CUSHION FOOT		4050211295000S	4	
	54	nsp	00D 963 0191 403	CUSHION SIDE		4050211095000S	2	
	56	nsp	00D 960 0003 301	SUPPORTER PCB		4070001601010S	4	
	57	nsp	00D 960 0184 107	BRACKET SUPPORTER		4010210206000S	1	
	58	nsp	-	SUPPORTER P.C.		4070210192000S	1	

Ref. No.	nsp	Part No.	Part Name	Remarks	ETRO	Q'ty	New
70		00D 963 0145 608	TUNER PACK	1507E3,587E3,487E3	E903014000020F	1	
70		00D 216 0125 001	TUNER PACK	1707EUT		1	
70		00D 216 0125 001	TUNER PACK	1707E2,1507E2		1	
71	nsp	00D 963 0292 506	CHASSIS BACK	1707E3	3207211826000S	1	*
71	nsp	00D 963 0292 603	CHASSIS BACK	687E3	3207211826300S	1	*
71	nsp	00D 963 0292 700	CHASSIS BACK	587E3	3207211826310S	1	*
71	nsp	00D 963 0292 807	CHASSIS BACK	1707EUT	3207211826200S	1	*
71	nsp	00D 963 0292 904	CHASSIS BACK	1707E2	3207211826100S	1	*
71	nsp	00D 963 0293 000	CHASSIS BACK	1507E2	3207211826110S	1	*
71	nsp	00D 963 0293 107	CHASSIS BACK	1507E3	3207211826010S	1	*
71	nsp	00D 963 0293 204	CHASSIS BACK	487E3	3207211826A00S	1	*
72	nsp	00D 963 0293 301	SHEET CABINET		1210210235000S	1	
73	nsp	00D 963 0120 306	BRACKET SIDE	1707E2,1507E2,1707EUT	4010210686000S	1	
80	nsp	-	WASHER		B300035161P10S	1	*
82	nsp	-	CUSHION PWB TOP	1507E3	4050211085000S	1	*
84	nsp	00D 963 0192 703	COVER SAFETY	1707E2,1507E2,1707EUT	4310212122000S	1	
85	nsp	00D 449 0139 105	COVER HOLDER	1707E2,1507E2,1707EUT		6	
★	nsp	-	LICENSE LABEL(DOLBY/DTS)	1507E3,587E3,487E3,1707EUT	5507030000311S	1	
★	nsp	-	LABEL ORIGIN (BACK CHASSIS)	1707EUT	5507003020021S	1	
★	nsp	-	LABEL RATING	1707EUT	5507030000480S	1	*
★	nsp	00D 513 3333 005	LABEL (TRANS)			1	*
★	nsp	00D 963 0193 003	CABLE,FLAT CARD 1.25MM		N712151544811S	1	
★	nsp	00D 963 0161 501	CABLE,FLAT CARD 1.25MM		N712232034810S	1	
SCREWS							
A	nsp	00D 963 0018 007	SCREW(3X8 B-TYPE ZNY/BH)		B020030081B10S	63	
B	nsp	00D 960 9008 420	SCREW(3X8 ZnY WASHER PI12)		1500001456010S	4	
C	nsp	00D 963 9004 054	SCREW(3X15 B-TYPE ZNY/BH)		B020030151B10S	2	
D	nsp	00D 960 0108 701	SCREW(3X10 B-TYPE(DOT) BK/BH)		B020030103B11S	36	
E	nsp	00D 963 9006 175	SCREW(3X14 P+S-WASHER ZNY/HH)		B018230141H11S	22	
F	nsp	00D 963 0018 104	SCREW(3X17 B-TYPE ZNY/BH)		B020030171B10S	3	
G		00D 963 0048 307	SCREW(4X8 B-TYPE(DOT) BK/BH)	Black	1500040083B10S	6	
G		00D 963 9004 012	SCREW(4X8 B-TYPE(DOT) NI/BH)	Silver,Premium Silver	1500040084B10S	6	
H	nsp	00D 960 9009 610	SCREW(4X10 P+S-WASHER ZNY/BH)		B028940101B10S	1	
I	nsp	00D 963 0136 701	SCREW(3X8 BK WASHER PI12)		1500001456020S	1	
J	nsp	00D 963 0232 702	SCREW(4X6 S-TYPE ZNY/BH)		B020740061B10S	6	
K	nsp	00D 963 0232 605	SCREW(3X5 B-TYPE ZNY/BH)		B020030051B10S	2	
L	nsp	00D 963 0136 507	SCREW(3X8 PI9.5 B-TYPE ZNY)		1500001206010S	2	

PACKING VIEW

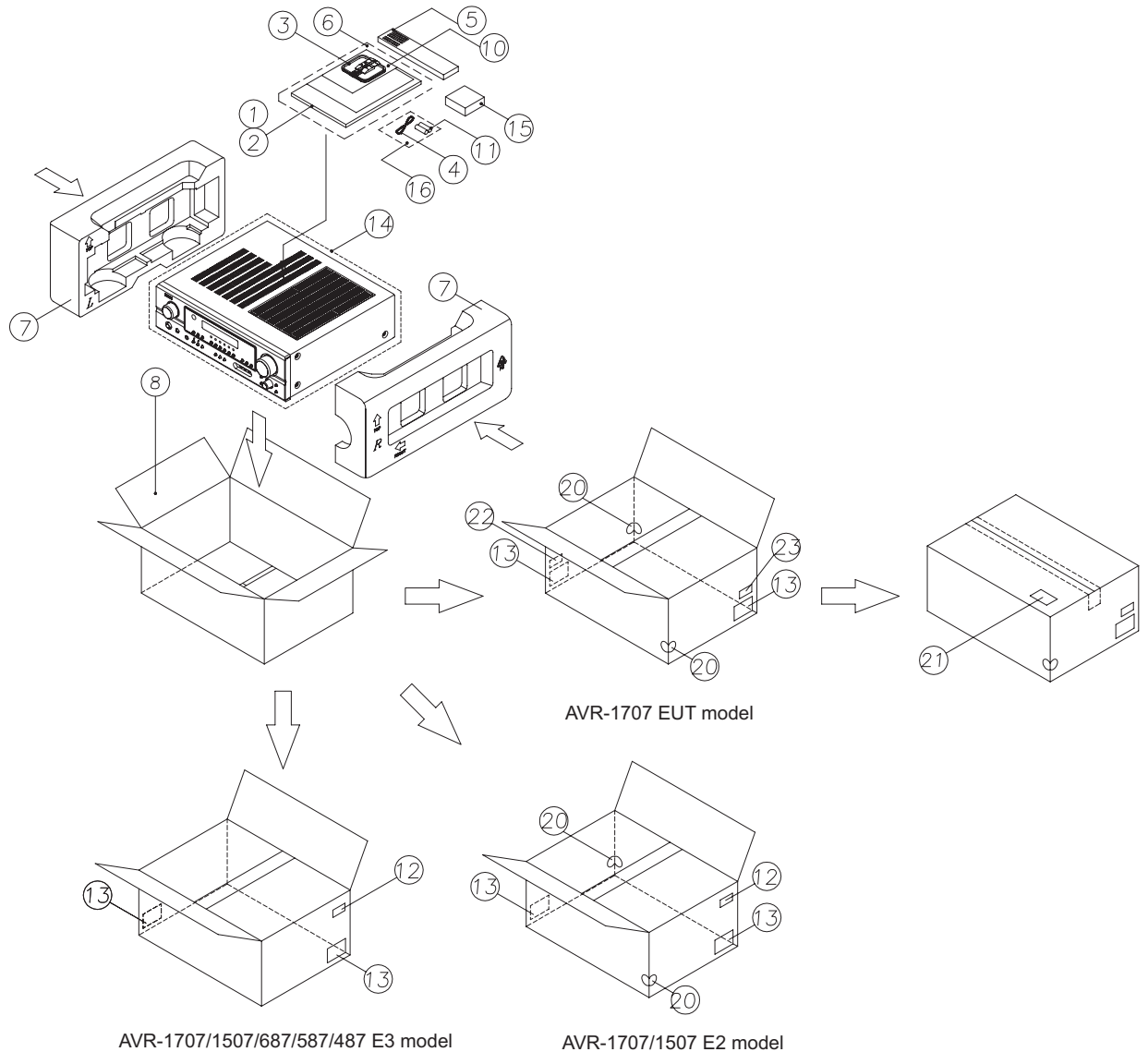

PARTS LIST OF PACKING & ACCESSORIES (for AVR-1707/687 model)

* 本表に記載されている部品は、補修用部品のため製品に使用している部品とは一部、形状、寸法などが異なる場合があります。
 * The parts listed below are for maintenance only, might differ from the parts used in the unit in appearances or dimensions.

* "nsp" 印の部品は常時在庫していませんので供給に長時間を要することがあります。場合によっては、供給をお断りする場合があります。
 * Part indicated with the mark "nsp" are not always in stock and possibly to take a long period of time for supplying, or in some case supplying of part may be refused.

Note: The symbols in the column "Remarks" indicate the following destinations.

1707E3 : U.S.A. & Canada model (AVR-1707)

E2 : Europe model (AVR-1707)

EUT : Taiwan R.O.C. model (AVR-1707)

687E3 : U.S.A. & Canada model (AVR-687)

Ref. No.	nsp	Part No.	Part Name	Remarks	ETRO	Q'ty	New
1		00D 513 4107 007	XM SHEET	E3,687E3		1	
2		00D 963 0285 306	INSTRUCTION MANUAL	E3	5707210130050S	1	*
2		00D 963 0285 306	INSTRUCTION MANUAL	687E3	5707210130050S	1	*
2		00D 963 0285 403	INSTRUCTION MANUAL	E2	5707210130060S	1	*
2		00D 963 0285 500	INSTRUCTION MANUAL	EUT	5707210130070S	1	*
3		00D 231 0089 007	AM LOOP ANTENNA			1	
4		00D 963 0158 006	FM ANTENNA WIRE		E605010070001S	1	
5		00D 963 0286 208	REMOTE CONTROL RC-1048	E3,687E3	8300010480010S	1	*
5		00D 963 0286 305	REMOTE CONTROL RC-1049	E2,EUT	8300010490010S	1	*
6	nsp	00D 963 0045 106	POLY BAG		6330000240000S	1	
7		00D 963 0193 101	CUSHION,SNOW		6230210154001S	1	
8		00D 963 0285 908	BOX,GIFT	E3	6007210310620S	1	*
8		00D 963 0301 701	BOX,GIFT	E2	6007210310700S	1	*
8		00D 963 0286 004	BOX,GIFT	687E3	6007210310630S	1	*
8		00D 963 0286 101	BOX,GIFT	EUT	6007210310640S	1	*
9		-	WARRANTY CARD	E3,687E3	5777001610035S	1	

Ref. No.	nsp	Part No.	Part Name	Remarks	ETRO	Q'ty	New
10		-	S.S LIST		5777001620018S	1	
11		-	BATTERY DRY		G670001R50190	2	
12		-	UPC LABEL	E3	5507002360050S	1	*
12		-	UPC LABEL	E2	5507002360060S	1	*
12		-	UPC LABEL	687E3	5507002360070S	1	*
13		-	CONTROL CARD		5500014920010S	1	
14	nsp	00D 963 0241 405	PE,SHEET		6327040059000S	1	
15		00D 321 0038 005	MIC CONDENSER DM-S205			1	
16		00D 963 0268 006	POLY BAG		6330210222000S	1	
20		00D 963 0110 303	COLOR LABEL(SILVER)	E2	5507020170340S	2	
20		00D 963 0230 209	COLOR LABEL(PREMIUM SILVER)	EUT	5507020170680S	2	
21		-	LABEL KORIN (BOX)	EUT	5507030000470S	1	
22		-	LABEL ORIGIN (BOX)	EUT	5507003010040S	1	
23		-	LABEL ORIGIN (BOX)	EUT	5507003010031S	1	

PARTS LIST OF PACKING & ACCESSORIES (for AVR-1507/587/487 model)

* 本表に記載されている部品は、補修用部品のため製品に使用している部品とは一部、形状、寸法などが異なる場合があります。

* The parts listed below are for maintenance only, might differ from the parts used in the unit in appearances or dimensions.

* "nsp" 印の部品は常時在庫していませんので供給に長時間を要することがあります。場合によっては、供給をお断りする場合があります。

* Part indicated with the mark "nsp" are not always in stock and possibly to take a long period of time for supplying, or in some case supplying of part may be refused.

Note: The symbols in the column "Remarks" indicate the following destinations.

1507E3 : U.S.A. & Canada model (AVR-1507)

587E3 : U.S.A. & Canada model (AVR-587)

487E3 : U.S.A. & Canada model (AVR-487)

E2 : Europe model (AVR-1507)

Ref. No.	nsp	Part No.	Part Name	Remarks	ETRO	Q'ty	New
1		00D 513 4107 007	XM SHEET	1507E3,587E3,487E3		1	
2		00D 963 0285 005	INSTRUCTION MANUAL	1507E3	5707210130010S	1	*
2		00D 963 0285 005	INSTRUCTION MANUAL	487E3	5707210130010S	1	*
2		00D 963 0285 102	INSTRUCTION MANUAL	1507E2	5707210130020S	1	*
2		00D 963 0285 209	INSTRUCTION MANUAL	587E3	5707210130040S	1	*
3		00D 231 0089 007	AM LOOP ANTENNA			1	
4		00D 963 0158 006	FM ANTENNA WIRE		E605010070001S	1	
4		-	BATTERY DRY		G670001R50190	2	
5		00D 963 0286 208	REMOTE CONTROL RC-1048	1507E3,587E3	8300010480010S	1	*
5		00D 963 0286 305	REMOTE CONTROL RC-1049	1507E2	8300010490010S	1	*
5		00D 963 0286 402	REMOTE CONTROL RC-1050	487E3	8300010500010S	1	*
6	nsp	00D 963 0045 106	POLY BAG		6330000240000S	1	
7		00D 963 0193 101	CUSHION,SNOW		6230210154001S	1	
8		00D 963 0285 607	BOX GIFT	1507E3	6007210310570S	1	*
8		00D 963 0301 808	BOX GIFT	1507E2	6007210310690S	1	*
8		00D 963 0285 704	BOX GIFT	587E3	6007210310600S	1	*
8		00D 963 0285 801	BOX GIFT	487E3	6007210310610S	1	*
9		-	WARRANTY CARD	1507E3,587E3,487E3	5777001610035S	1	
10		-	S.S LIST		5777001620018S	1	
12		-	UPC LABEL	1507E3	5507002360010S	1	*
12		-	UPC LABEL	1507E2	5507002360020S	1	*
12		-	UPC LABEL	587E3	5507002360030S	1	*
12		-	UPC LABEL	587E2	5507002360040S	1	*
13		-	CONTROL CARD		5500014920010S	1	
14	nsp	00D 963 0241 405	PE,SHEET		6327040059000S	1	
15		00D 321 0038 005	MIC CONDENSER DM-S205	1507E2		1	
16		00D 963 0268 006	POLY BAG		6330210222000S	1	
20		00D 963 0110 303	COLOR LABEL(SILVER)	1507E2	5507020170340S	1	

WIRING DIAGRAM

CP101	AC CORD
CP102	2P/3.96mm(WH)
CP105	2P/3.96mm(BLK)
CP931	2P/3.96mm(BLUE)

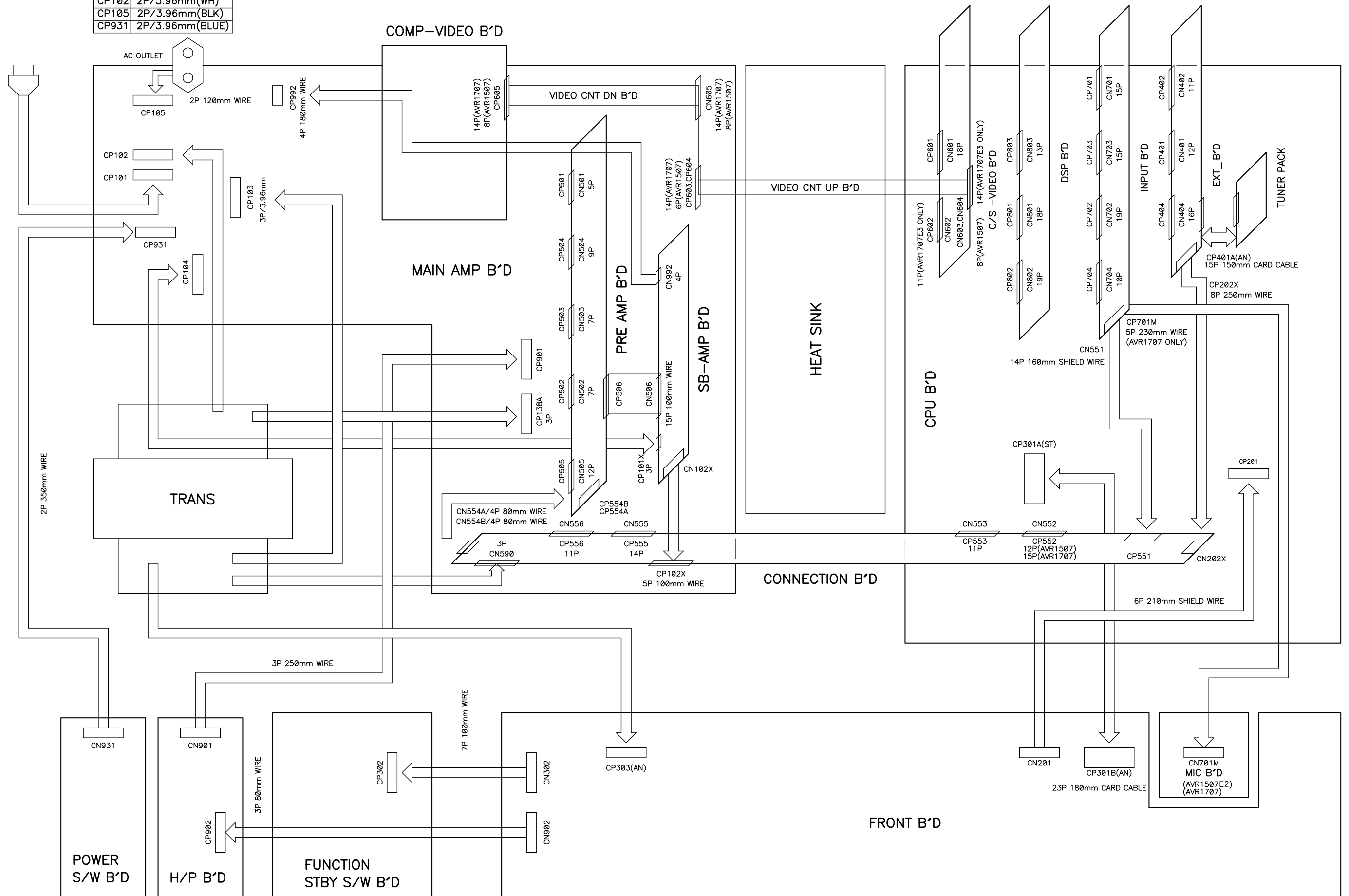

NOTE FOR SCHEMATIC DIAGRAM

WARNING:

Parts marked with this symbol \triangle have critical characteristics. Use ONLY replacement parts recommended by the manufacturer.

CAUTION:

Before returning the unit to the customer, make sure you make either (1) a leakage current check or (2) a line to chassis resistance check. If the leakage current exceeds 0.5 milliamps, or if the resistance from chassis to either side of the power cord is less than 460 kohms, the unit is defective.

WARNING:

DO NOT return the unit to the customer until the problem is located and corrected.

NOTICE:

ALL RESISTANCE VALUES IN OHM. k=1,000 OHM
M=1,000,000 OHM
ALL CAPACITANCE VALUES IN MICRO FARAD.
P=MICRO-MICRO FARAD
EACH VOLTAGE AND CURRENT ARE MEASURED AT
NO SIGNAL INPUT CONDITION.
CIRCUIT AND PARTS ARE SUBJECT TO CHANGE
WITHOUT PRIOR NOTICE.

配線図について

\triangle 印の部品は安全を維持するために重要な部品です。従って交換時は必ず指定の部品を使用してください。

注)

- (1) 指定なき抵抗値は Ω 、k は $k\Omega$ 、M は $M\Omega$ を示す。
- (2) 指定なきコンデンサーの値は μF 、p は pF を示す。
- (3) 各部の電圧は無信号の値を示す。
- (4) この配線図は基本配線図です。改良等のため変更することがありますのでご了承ください。

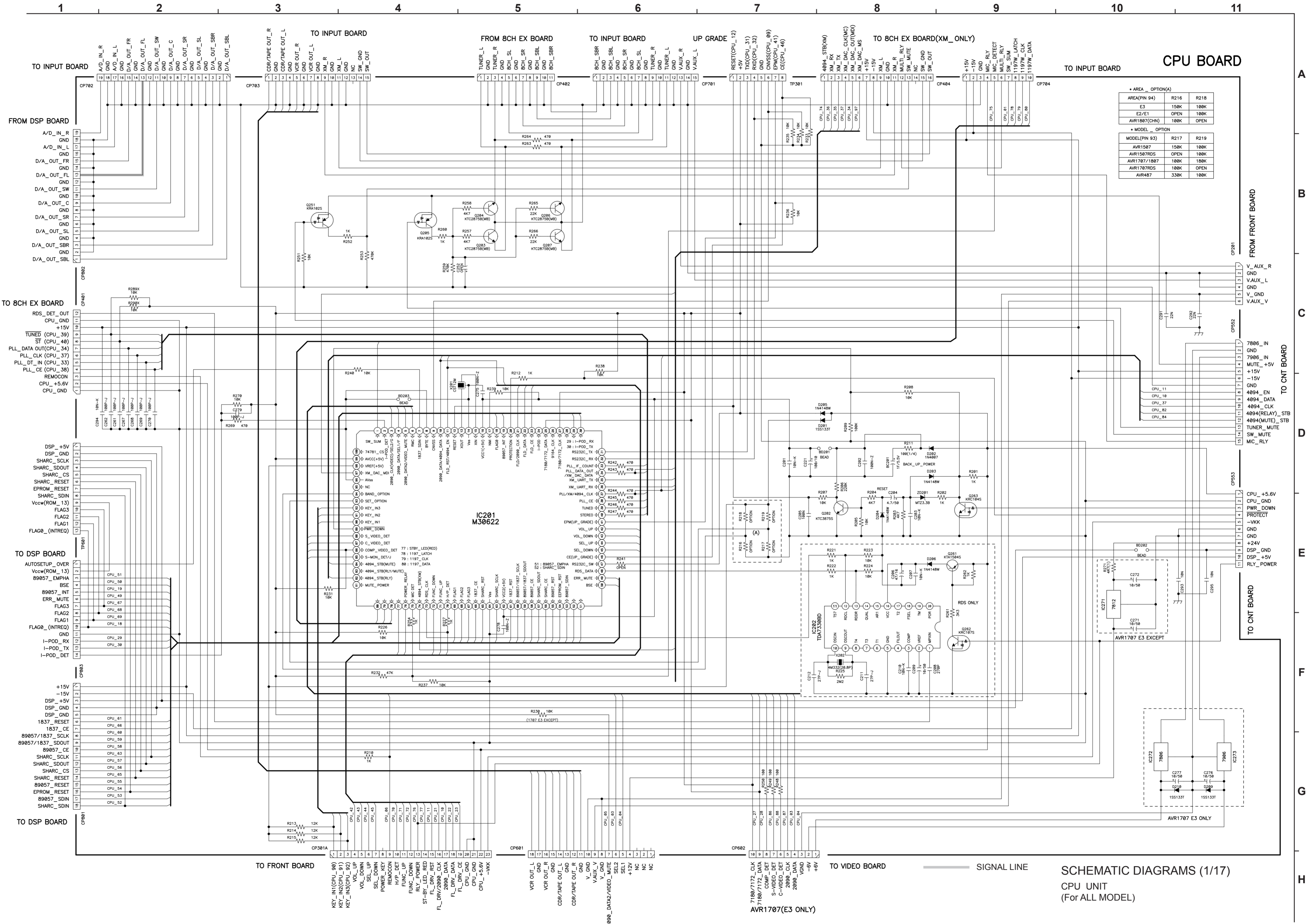

+ AREA_OPTION(A)		
AREA(PIN 94)	R216	R218
E3	159K	189K
E2/E1	OPEN	189K
AVR1887(CHN)	189K	OPEN

+ MODEL_OPTION		
MODEL(PIN 93)	R217	R219
AVR1587	159K	189K
AVR1587RDS	OPEN	189K
AVR1787/1587	189K	189K
AVR1787RDS	189K	OPEN
AVR487	339K	189K

SCHEMATIC DIAGRAMS (1/17)
CPU UNIT
(For ALL MODEL)

AVR1707(E3 ONLY)

AVR1707 E3 EXCEPT

AVR1707 E3 ONLY

SIGNAL LINE

TO VIDEO BOARD

TO FRONT BOARD

FROM FRONT BOARD

TO CNT BOARD

TO CNT BOARD

TO CNT BOARD

TO CNT BOARD

A
B
C
D
E
F
G
H

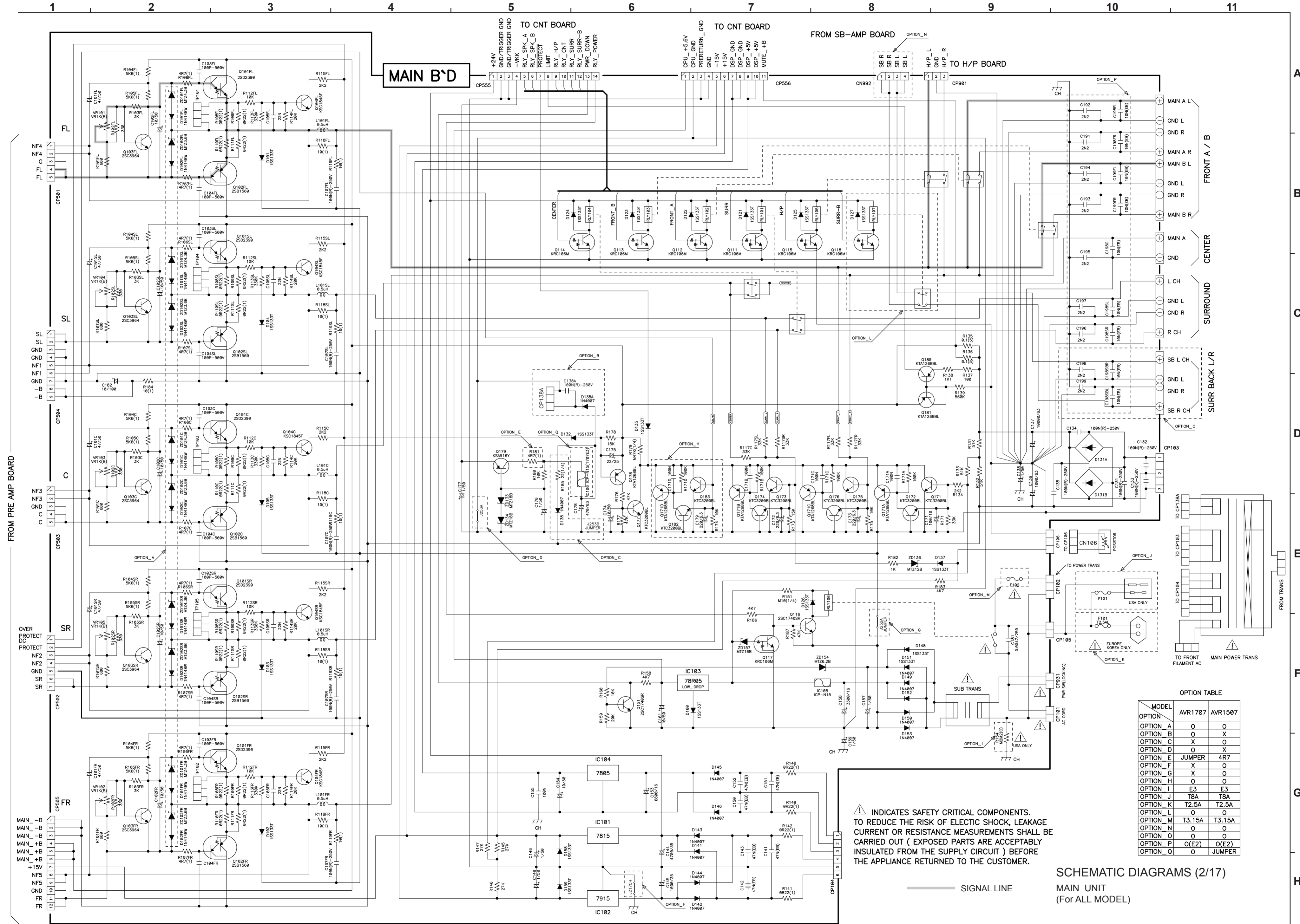

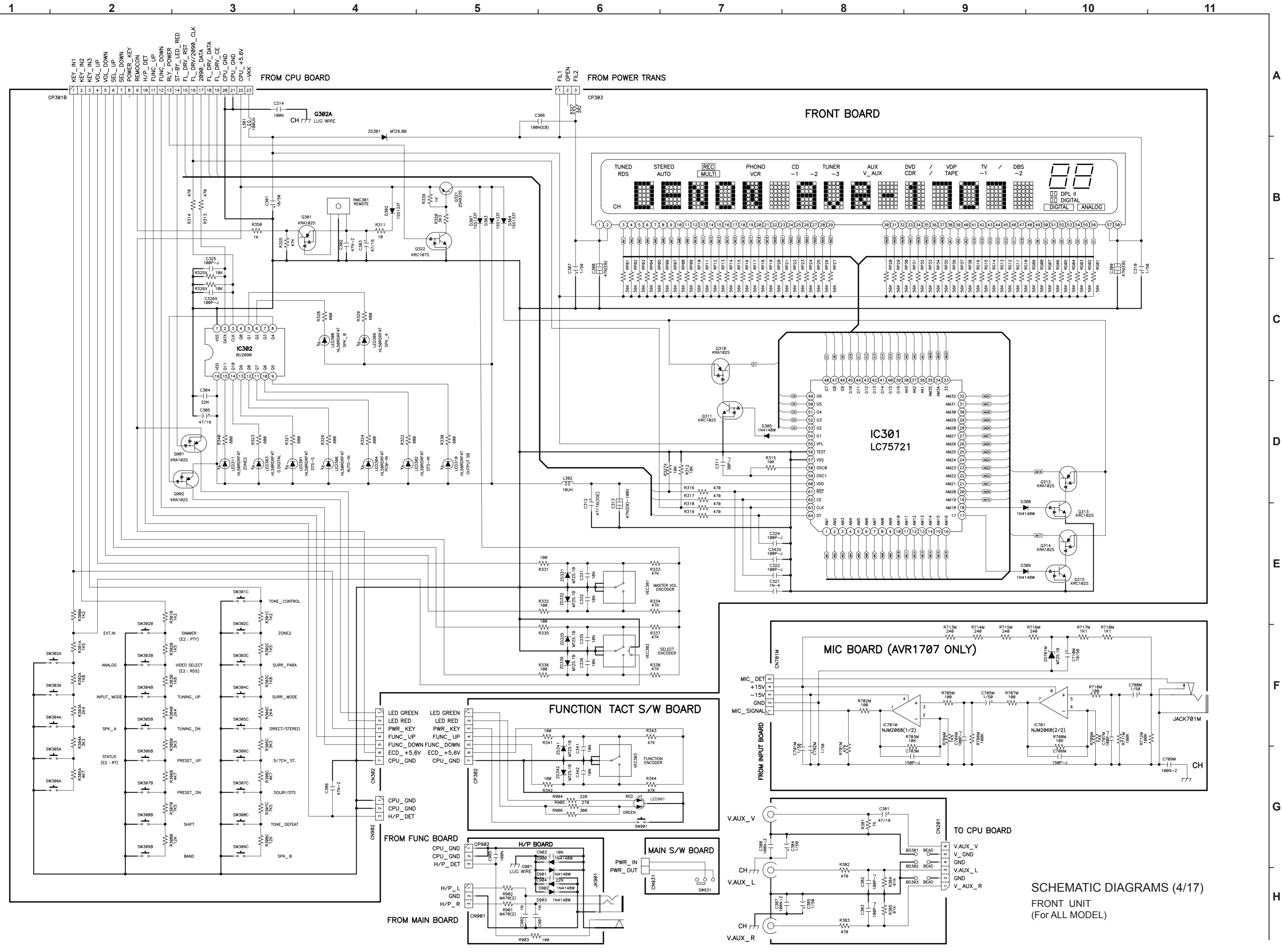

SCHEMATIC DIAGRAMS (4/17)
FRONT UNIT
(For ALL MODEL)

SCHEMATIC DIAGRAMS (5/17)

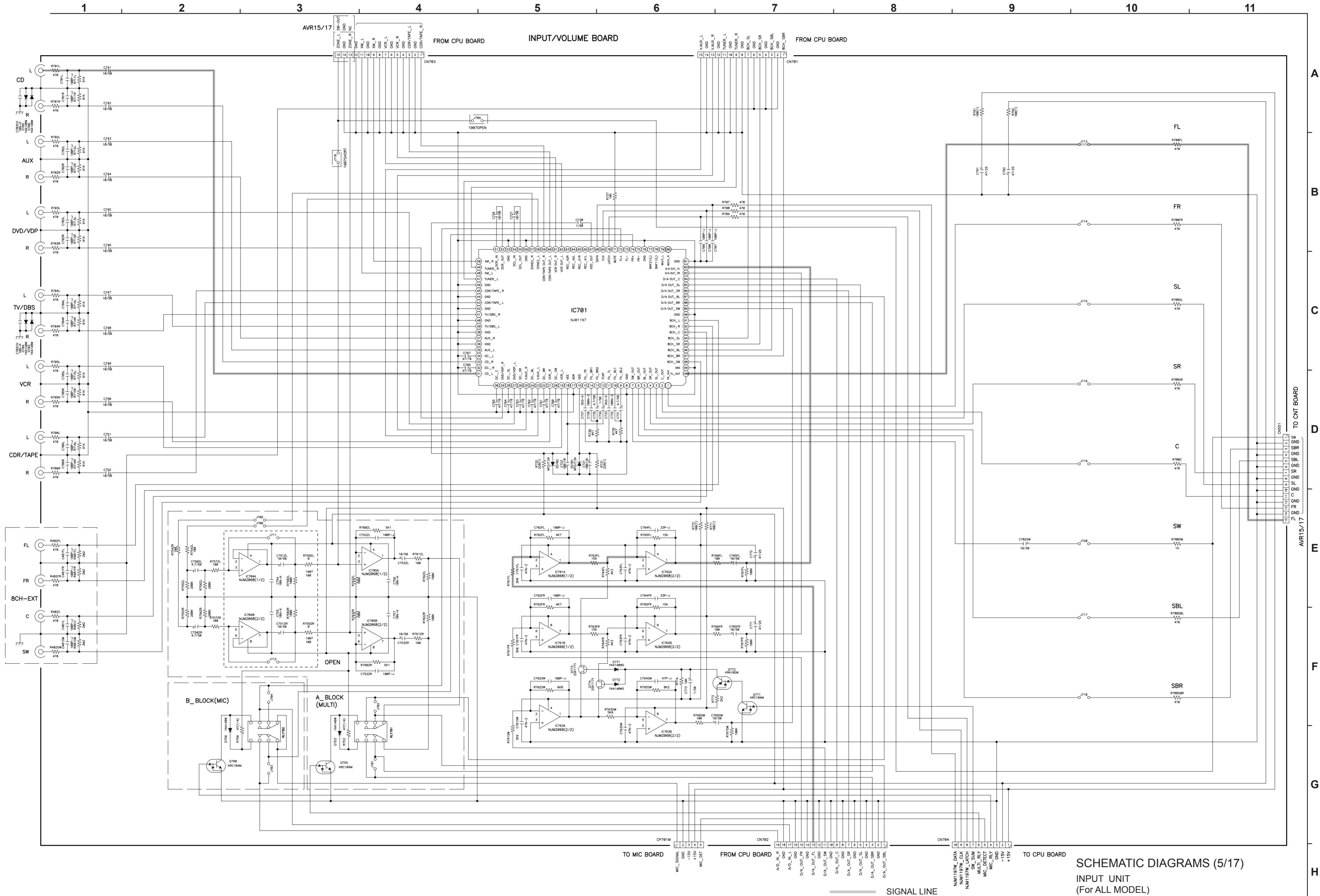

SCHEMATIC DIAGRAMS (5/17)
INPUT UNIT
(For ALL MODEL)

SIGNAL LINE

A
B
C
D
E
F
G
H

1

2

3

4

5

6

7

8

9

10

11

AVR15/17

FROM CPU BOARD

INPUT/VOLUME BOARD

FROM CPU BOARD

IC701
NM1197

TO MIC BOARD

FROM CPU BOARD

TO CPU BOARD

TO CNT BOARD

AVR15/17

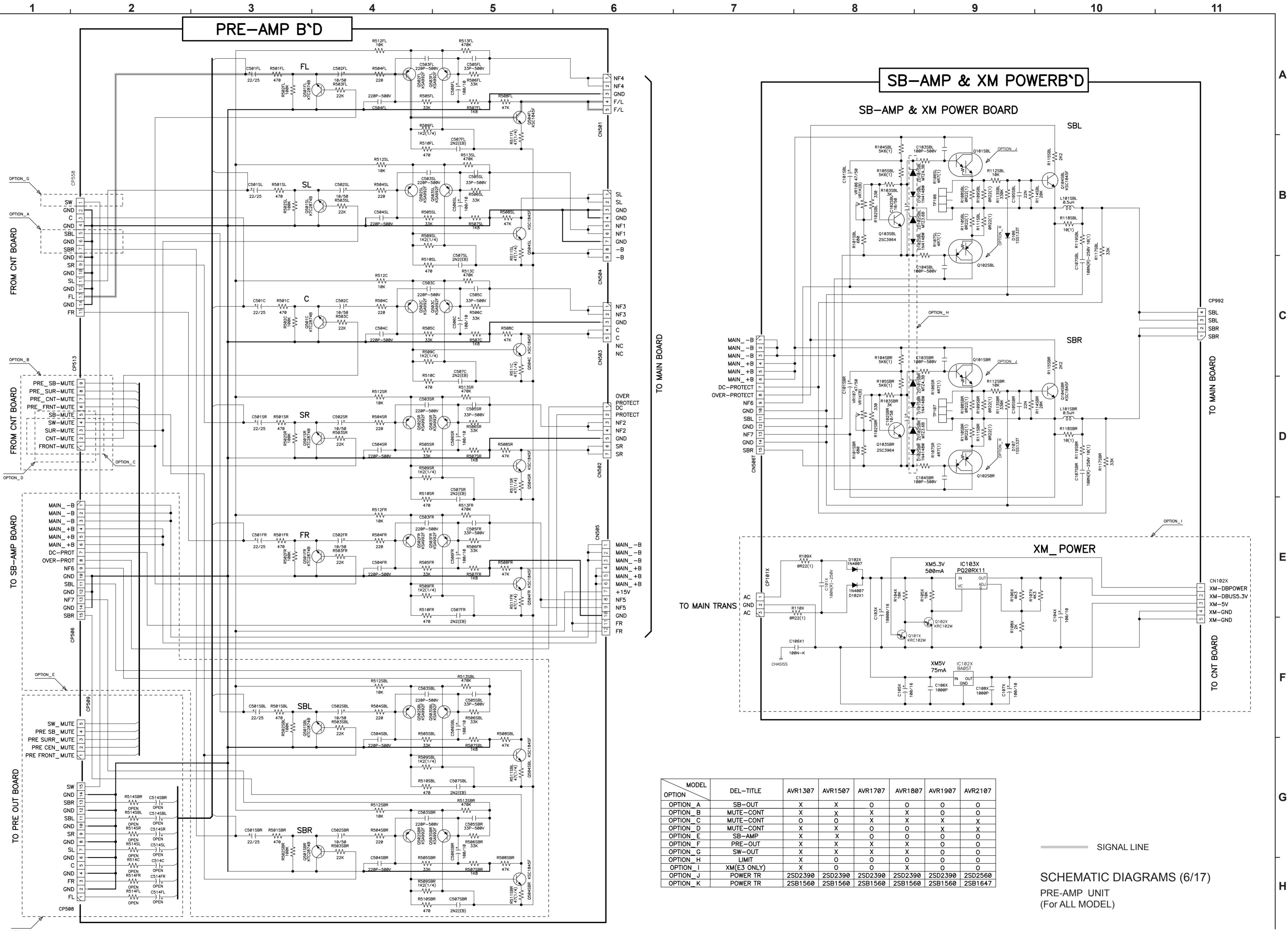

MODEL	DEL-TITLE	AVR1307	AVR1507	AVR1707	AVR1807	AVR1907	AVR2107
OPTION A	SB-OUT	X	X	O	O	O	O
OPTION B	MUTE-CONT	X	X	X	X	O	O
OPTION C	MUTE-CONT	O	O	X	X	X	X
OPTION D	MUTE-CONT	X	X	O	O	O	O
OPTION E	SB-AMP	X	X	O	O	X	X
OPTION F	PRE-OUT	X	X	X	X	O	O
OPTION G	SW-OUT	X	X	X	X	O	O
OPTION H	LIMIT	X	X	X	X	O	O
OPTION I	XM(E3 ONLY)	X	O	O	X	O	O
OPTION J	POWER TR	2SD2390	2SD2390	2SD2390	2SD2390	2SD2390	2SD2560
OPTION K	POWER TR	2SB1560	2SB1560	2SB1560	2SB1560	2SB1560	2SB1647

— SIGNAL LINE

SCHEMATIC DIAGRAMS (6/17)
PRE-AMP UNIT
(For ALL MODEL)

VIDEO B'D PART 2 : SVIDEO

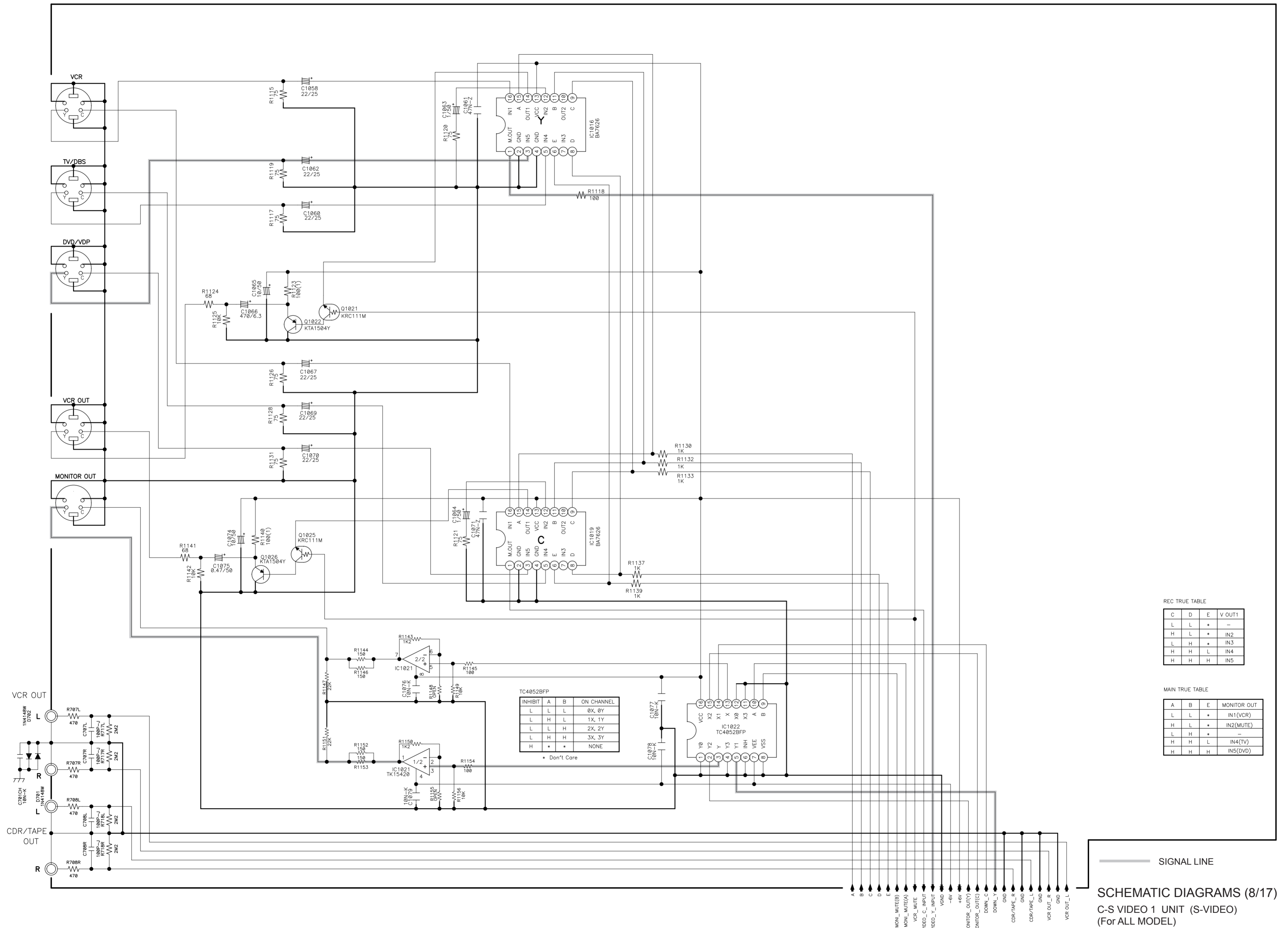

SCHEMATIC DIAGRAMS (8/17)
C-S VIDEO 1 UNIT (S-VIDEO)
(For ALL MODEL)

1 2 3 4 5 6 7 8 9 10 11

VCR
DVD/VDP
TV/DBS
MONITOR OUT

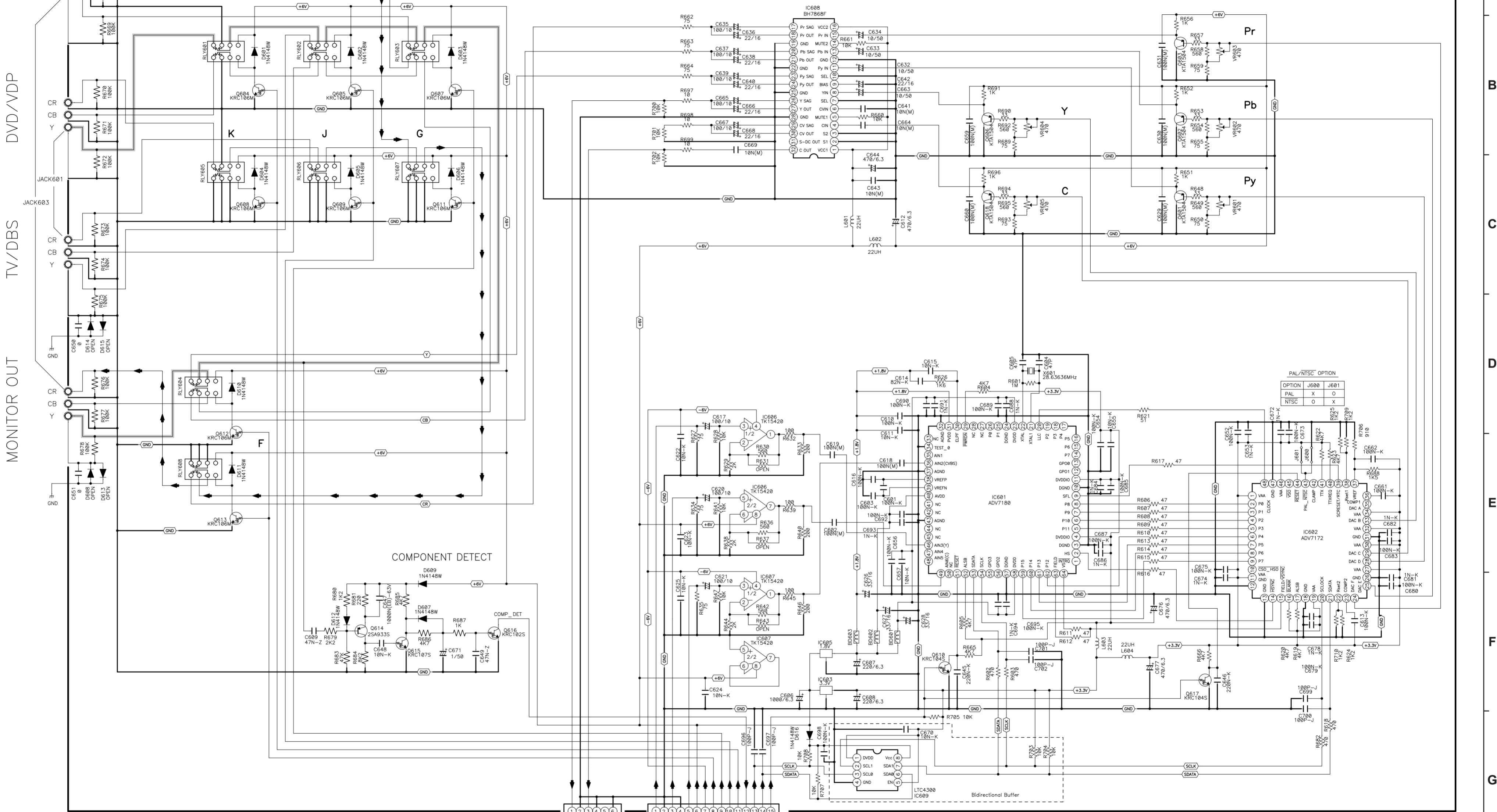

— SIGNAL LINE

SCHEMATIC DIAGRAMS (9/17)
COMP VIDEO 1 UNIT
(For ALL MODEL)

A
B
C
D
E
F
G
H

1 2 3 4 5 6 7 8 9 10 11

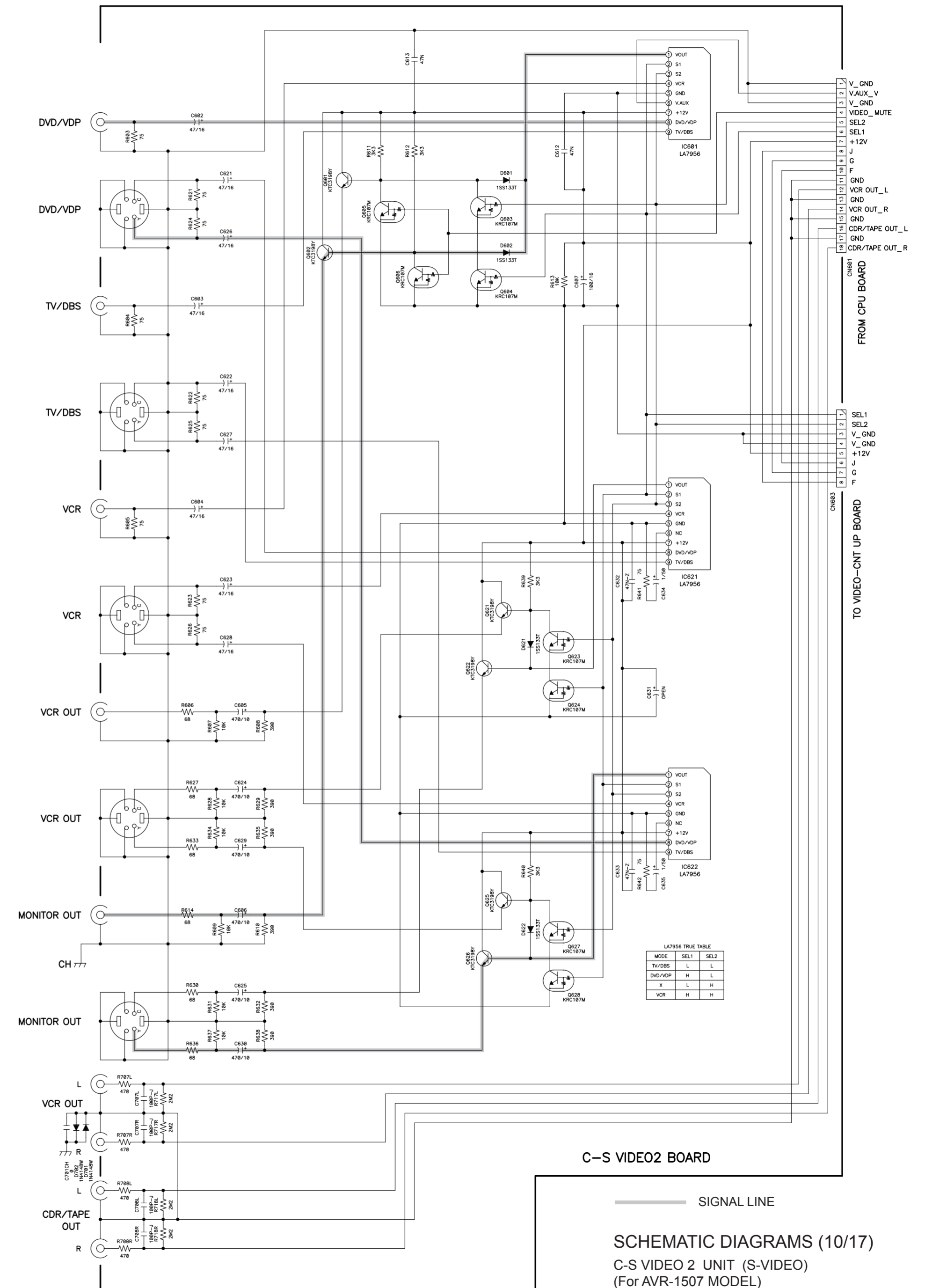
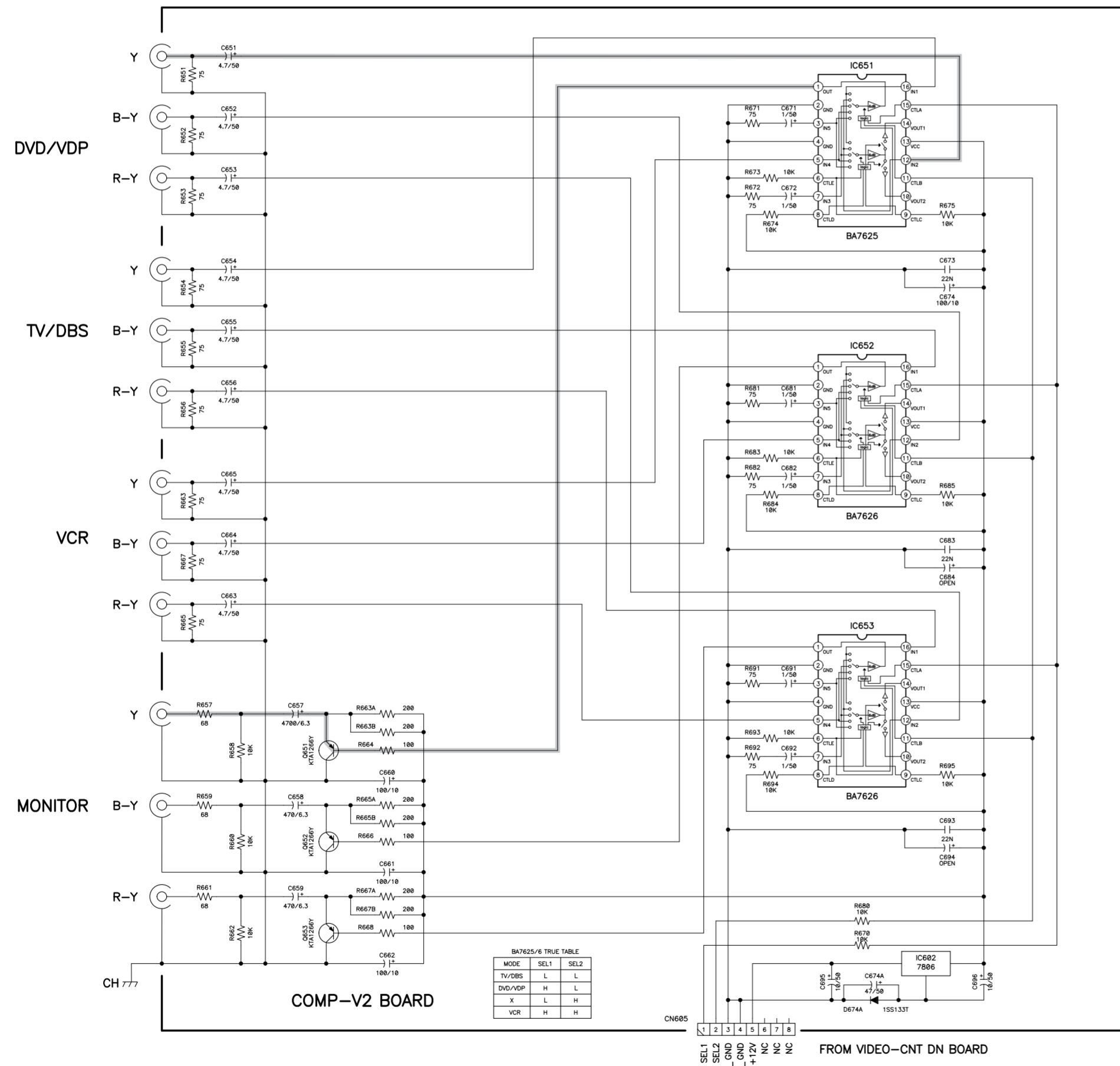
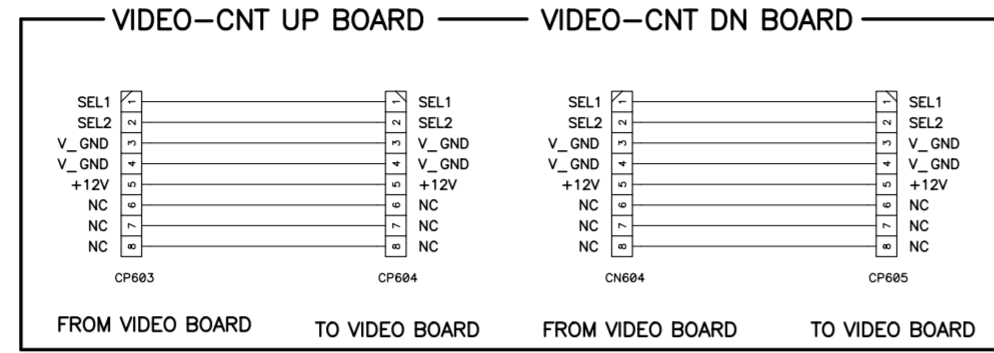

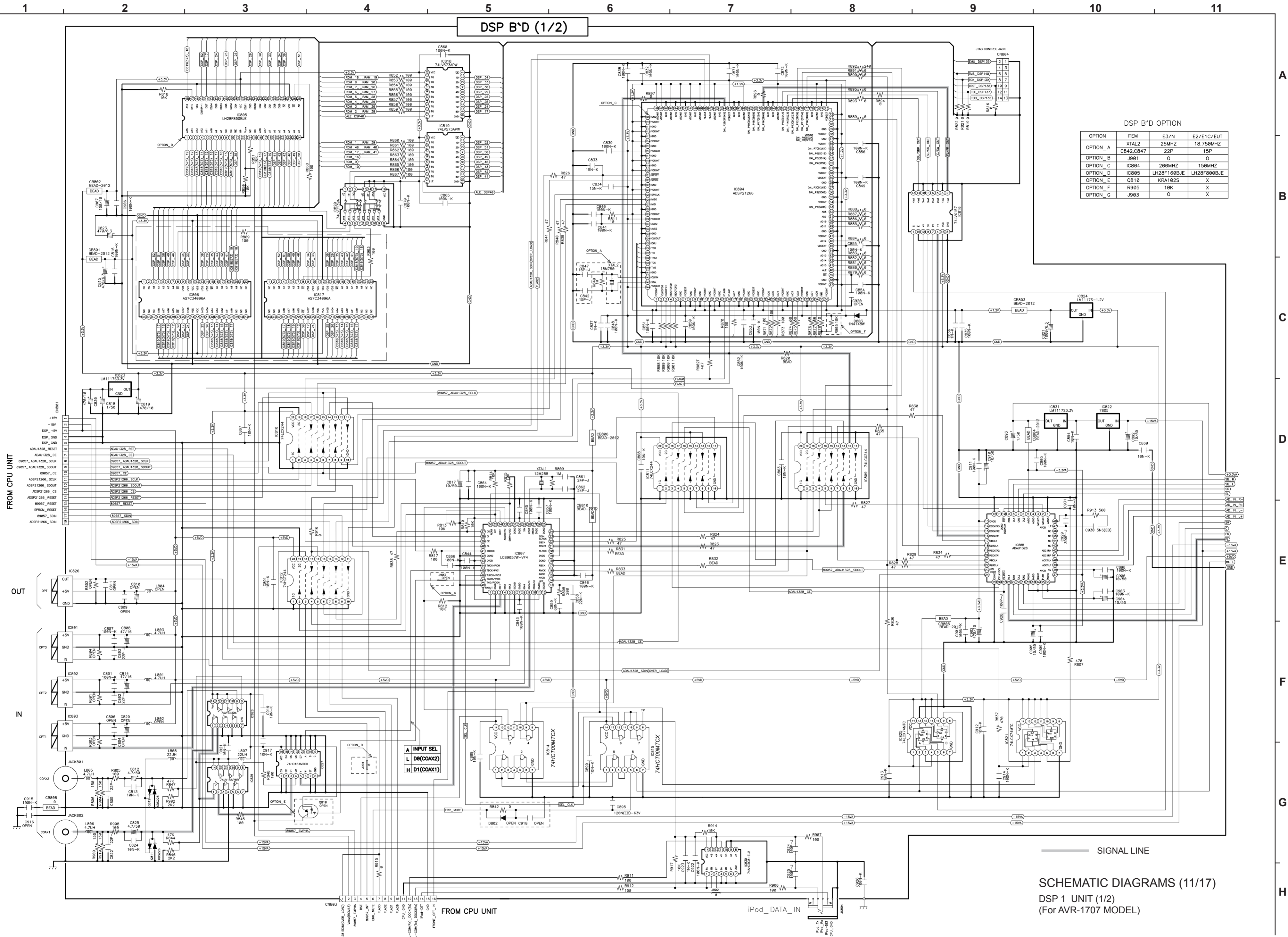

DSP B'D OPTION

OPTION	ITEM	E3/N	E2/E1C/EUT
OPTION_A	XTAL2	25MHZ	18.750MHZ
OPTION_B	C842,C847	22P	15P
OPTION_C	IC804	200MHZ	150MHZ
OPTION_D	IC805	LH28F160BJE	LH28F800BJE
OPTION_E	Q810	KRA102S	X
OPTION_F	R905	10K	X
OPTION_G	J903	O	X

— SIGNAL LINE

SCHEMATIC DIAGRAMS (11/17)
 DSP 1 UNIT (1/2)
 (For AVR-1707 MODEL)

1 2 3 4 5 6 7 8 9 10 11

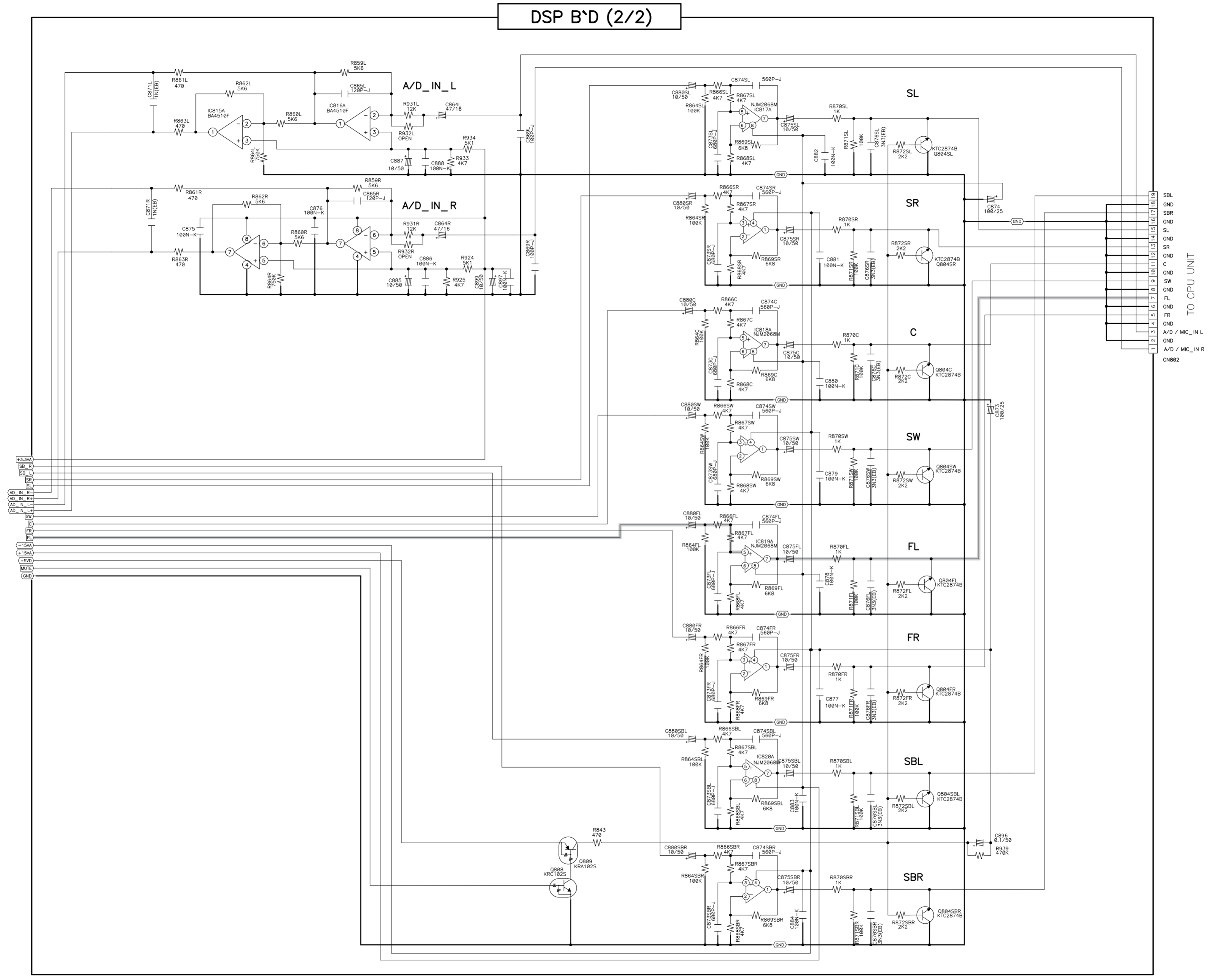

— SIGNAL LINE

1 2 3 4 5 6 7 8 9 10 11

DSP B'D (1/2)

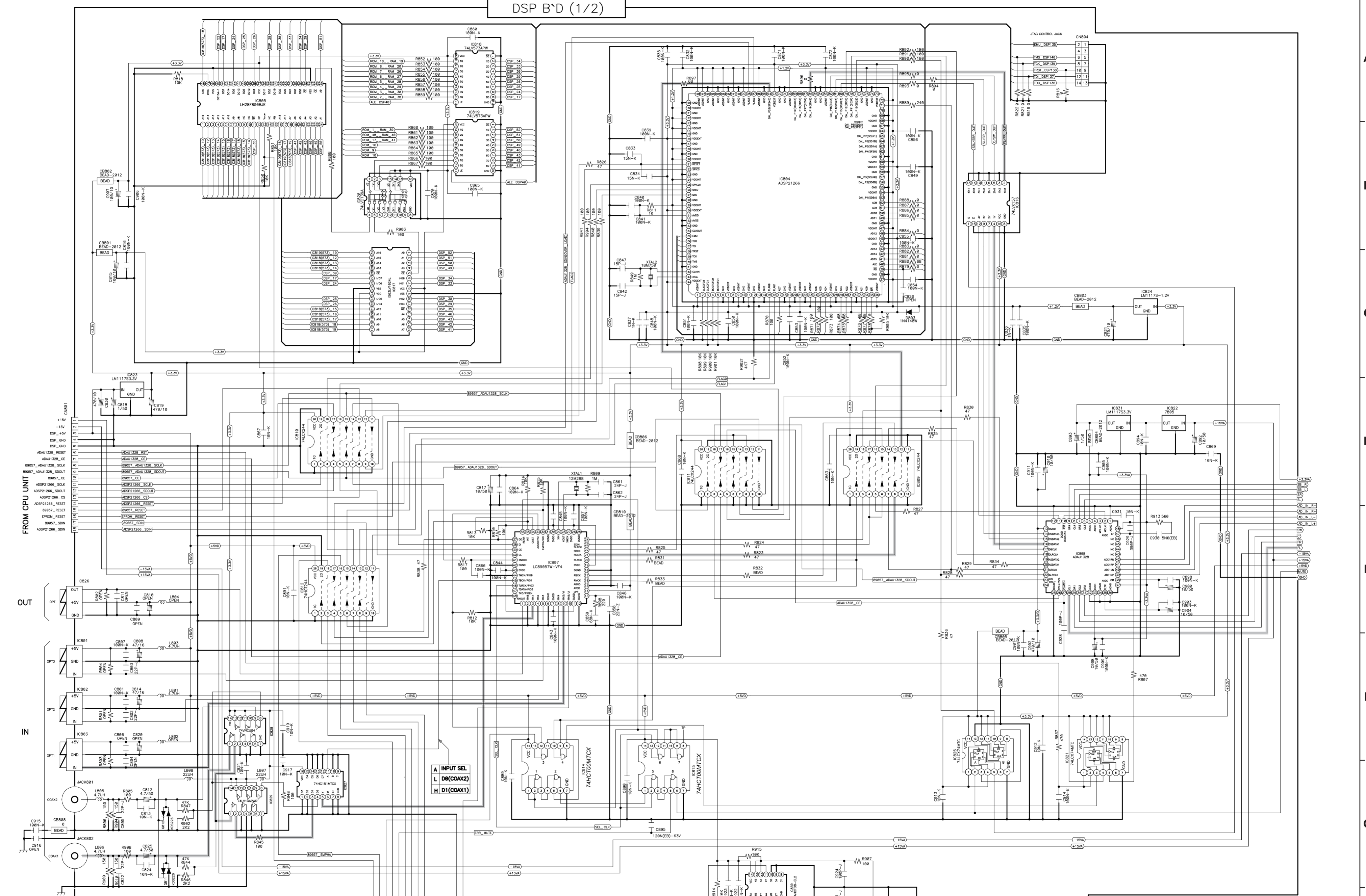

SCHEMATIC DIAGRAMS (13/17)
DSP 2 UNIT (1/2)
(For AVR-1507 MODEL)

FROM CPU UNIT

OUT

IN

A INPUT SEL
L D(COAX2)
H D(COAX1)

FROM CPU UNIT

iPod_DATA_IN

SIGNAL LINE

A
B
C
D
E
F
G
H

1 2 3 4 5 6 7 8 9 10 11

DSP B'D (2/2)

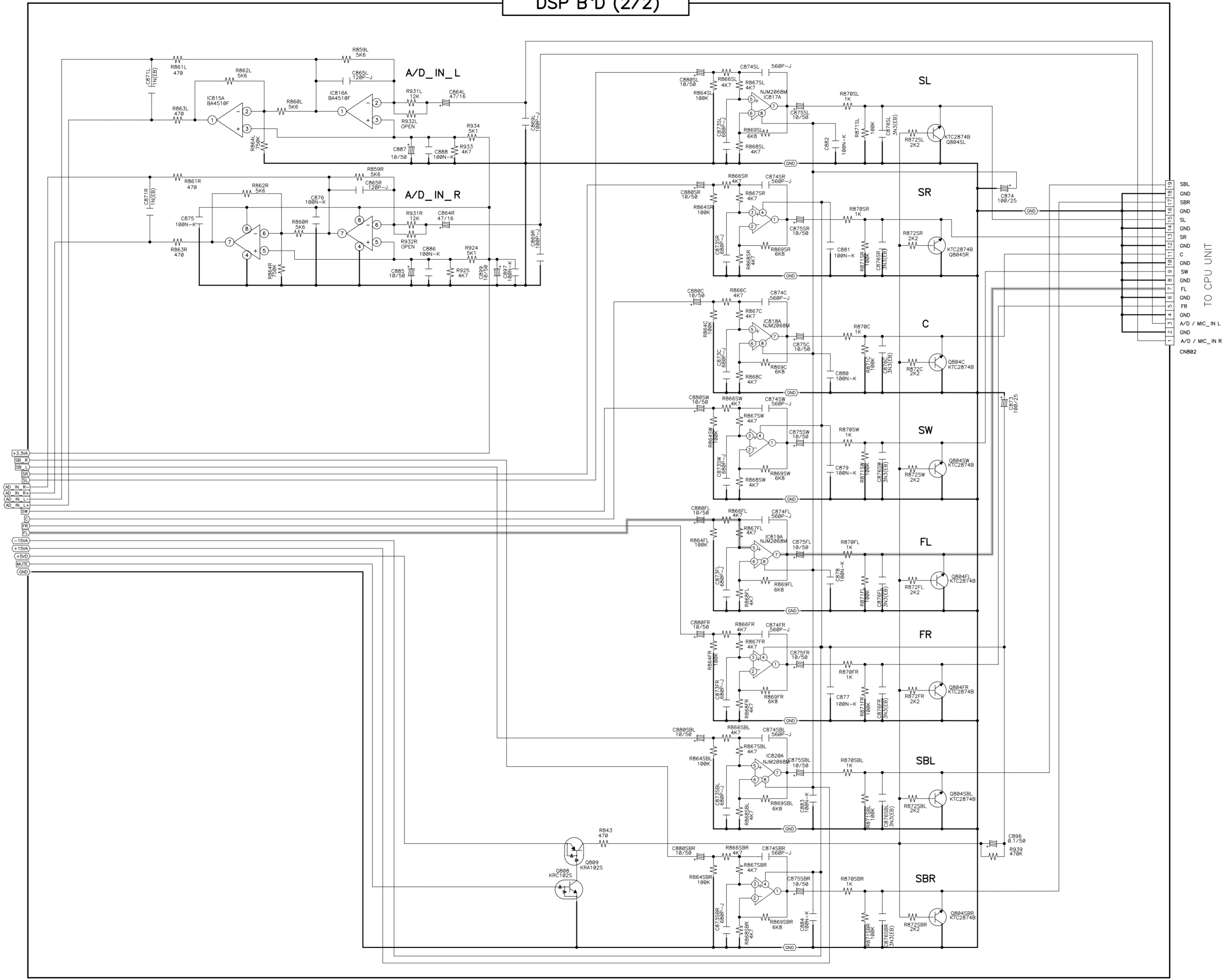

SIGNAL LINE

A
B
C
D
E
F
G
H

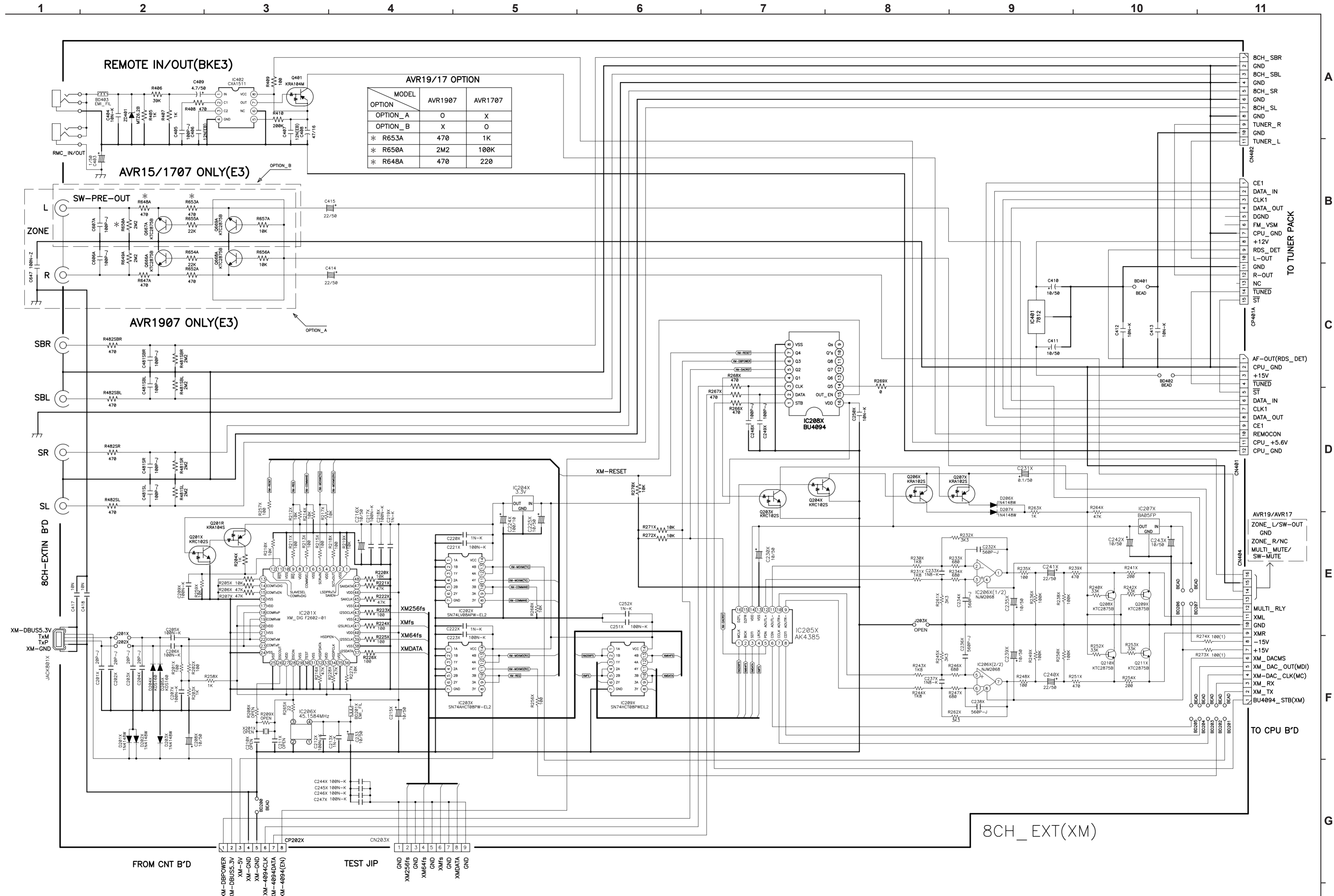

8CH_EXT(XM)

SCHEMATIC DIAGRAMS (15/17)
8CH-EXT(XM) UNIT
(For AVR-1707/1507 E3 MODEL)

1 2 3 4 5 6 7 8 9 10 11

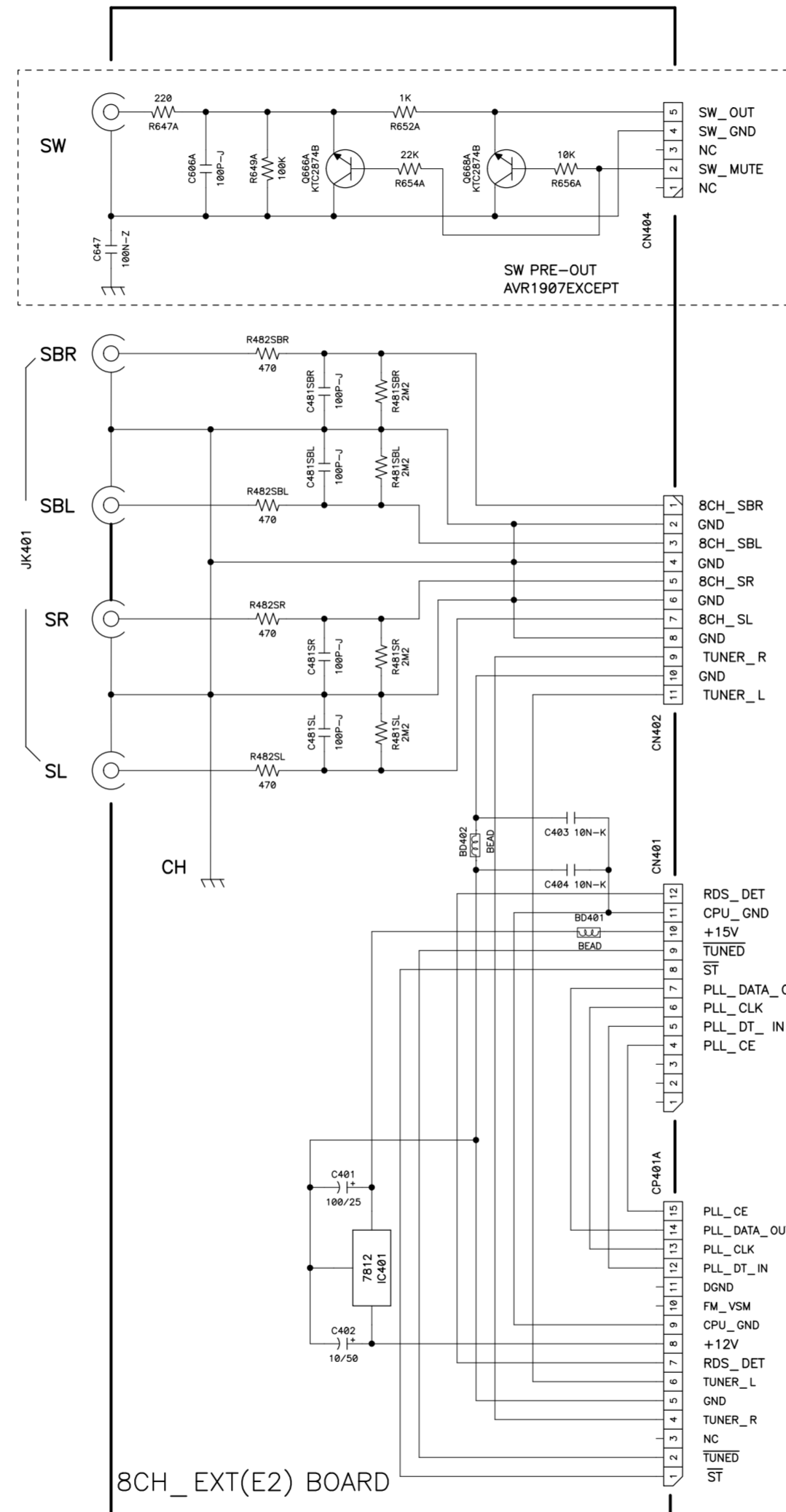

A
B
C
D
E
F
G
H

TUNER BOARD

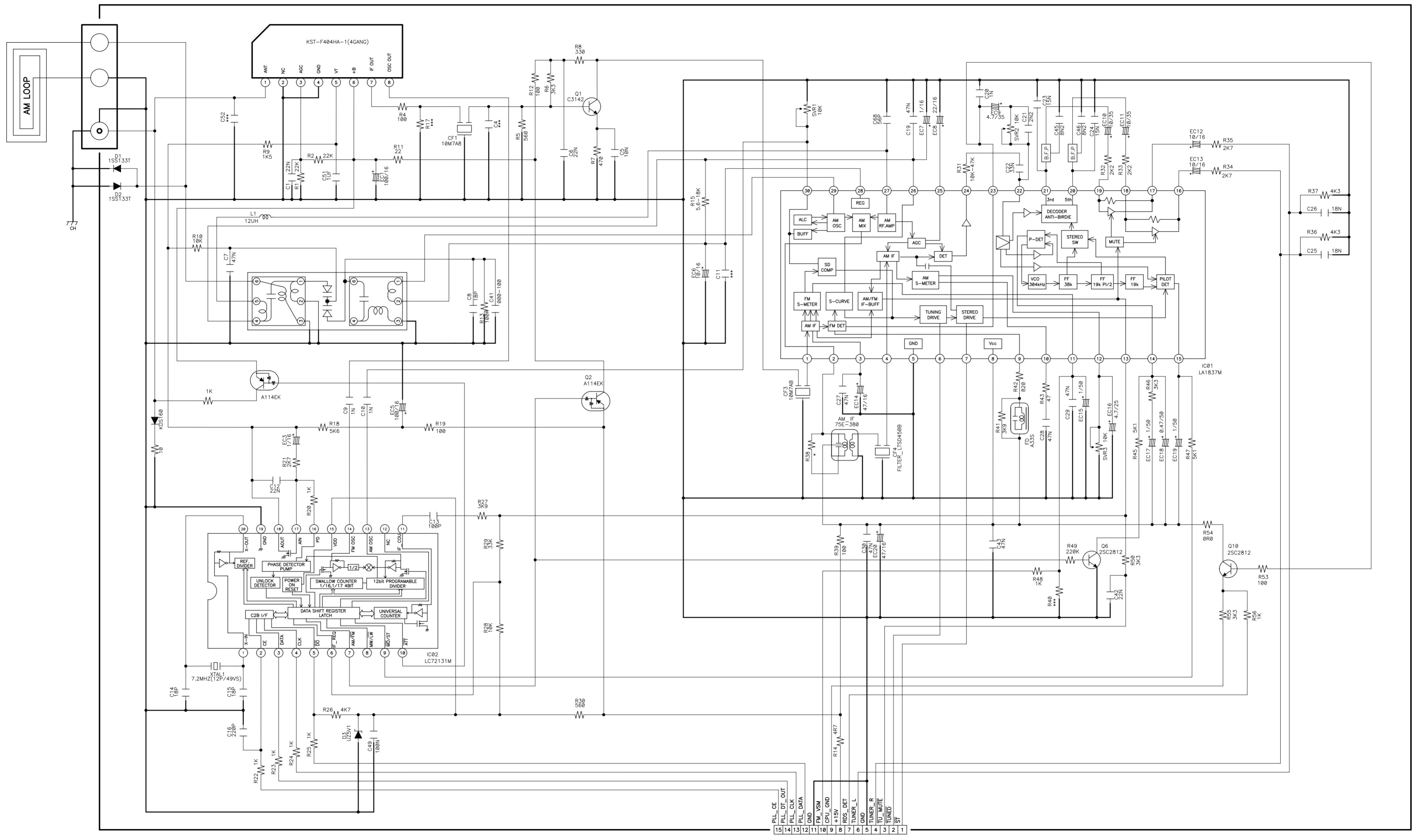

FROM 8CH UNIT

DOCUMENTS FOR WEEE

Details of Recycle parts

* You have to remove the parts that marked "WEEE Mark ◆" when the recycling processing. (Europe model only)

Ref. No.	WEEE Mark	Part Name	Material	Q'ty
1		PANEL FRONT	ABS	1
2		BADGE	Aluminum	1
3		KNOB INPUT	ABS	1
4		WINDOW DISPLAY	PVC	1
5		COVER RCA	ABS	1
6		KNOB VOLUME	ABS	1
7		KNOB SELECT	ABS	1
8		BRACKET SIDE L/R	Steel	2
9		LENS STANDBY	PMMA	1
10	◆	BUTTON STANDBY	Aluminum+ABS	1
11	◆	BUTTON POWER	Aluminum+ABS	1
12		LENS LED	PMMA	1
14	◆	HEADPHONE P.W.B.	Complex	1
15	◆	POWER SW P.W.B.	Complex	1
17		BUTTON 3KEY(A)	ABS	1
20	◆	TACT SW P.W.B.	Complex	1
21	◆	FRONT P.W.B.	Complex	1
22		BUTTON 4KEY	ABS	1
23		BUTTON 3KEY	ABS	1
25	◆	V-AUX P.W.B.	Complex	1
26		BRACKET HEAT SINK-F	Steel	1
27		TR PNP 2SB1560-Y	Complex	5
28		POSISTOR P43T7D330BW16	Complex	1
29		TR NPN 2SC3964	Complex	5
30		CABINET TOP	PVC+Steel	1
31		TR NPN 2SD2390-Y	Complex	5
32		HEAT SINK MAIN	Aluminum	1
33		BRACKET HEAT SINK-B	Steel	1
34		BRACKET PCB	Steel	2
35	◆	2CH-AMP P.W.B.	Complex	1
39		BRACKET TRANS	Steel	1
40		POWER TRANS	Complex	1
43	◆	MAIN P.W.B.	Complex	1
45	◆	PRE AMP P.W.B.	Complex	1
47	◆	AC OUTLET P.W.B.	Complex	1
49		STOPPER CORD AC	PA	1
50	◆	AC CORD	Complex	1
51		CHASSIS MAIN	Steel	1
52		FOOT	ABS	4
53		CUSHION FOOT	Rubber	4
54		CUSHION SIDE	Rubber	2
56		SUPPORTER PCB	PA	3
57		BRACKET SUPPORTER	Steel	1
58		SUPPORTER P.C.	PA	1
59	◆	CNT P.W.B.	Complex	1
60	◆	CPU P.W.B.	Complex	1
61	◆	COMP-V1 P.W.B.	Complex	1
62	◆	V-CNT DOWN 1/2 P.W.B.	Complex	1
63	◆	V-CNT UP 1/2 P.W.B.	Complex	1
64	◆	C-S VIDEO1 P.W.B.	Complex	1

Ref. No.	WEEE Mark	Part Name	Material	Q'ty
65	◆	DSP1 P.W.B.	Complex	1
66	◆	INPUT P.W.B.	Complex	1
69	◆	8CH-EXT P.W.B.	Complex	1
70	◆	TUNER PACK	Complex	1
71		CHASSIS BACK	Steel	1
72		SHEET CABINET	Rubber	1
73		BRACKET SIDE	Steel	1
76	◆	V-CNT DOWN 2/2 P.W.B.	Complex	1
77	◆	V-CNT UP 2/2 P.W.B.	Complex	1
78	◆	MIC P.W.B.	Complex	1
80		WASHER	Steel	1
84		COVER SAFETY	PC	1
85		COVER HOLDER	POM	6
87	◆	CE68W1J103M(DL)	Complex	2
88		POWER TRANS(Sub)	Complex	1
A		SCREW(3X8 B-TYPE ZNY/BH)	Steel	63
B		SCREW(3X8 ZnY WASHER PI12)	Steel	4
C		SCREW(3X15 B-TYPE ZNY/BH)	Steel	2
D		SCREW(3X10 B-TYPE(DOT) BK/BH)	Steel	36
E		SCREW(3X14 P+S-WASHER ZNY/HH)	Steel	22
F		SCREW(3X17 B-TYPE ZNY/BH)	Steel	3
G		SCREW(4X8 B-TYPE(DOT) BK/BH)	Steel	6
H		SCREW(4X10 P+S-WASHER ZNY/BH)	Steel	1
I		SCREW(3X8 BK WASHER PI12)	Steel	1
J		SCREW(4X6 S-TYPE ZNY/BH)	Steel	6
K		SCREW(3X5 B-TYPE ZNY/BH)	Steel	2
L		SCREW(3X8 PI9.5 B-TYPE ZNY)	Steel	2

Exploded view for AVR-1707,AVR-1507 unit

You have to remove the parts that marked "WEEE Mark ◆" when the recycling processing. (Europe model only)

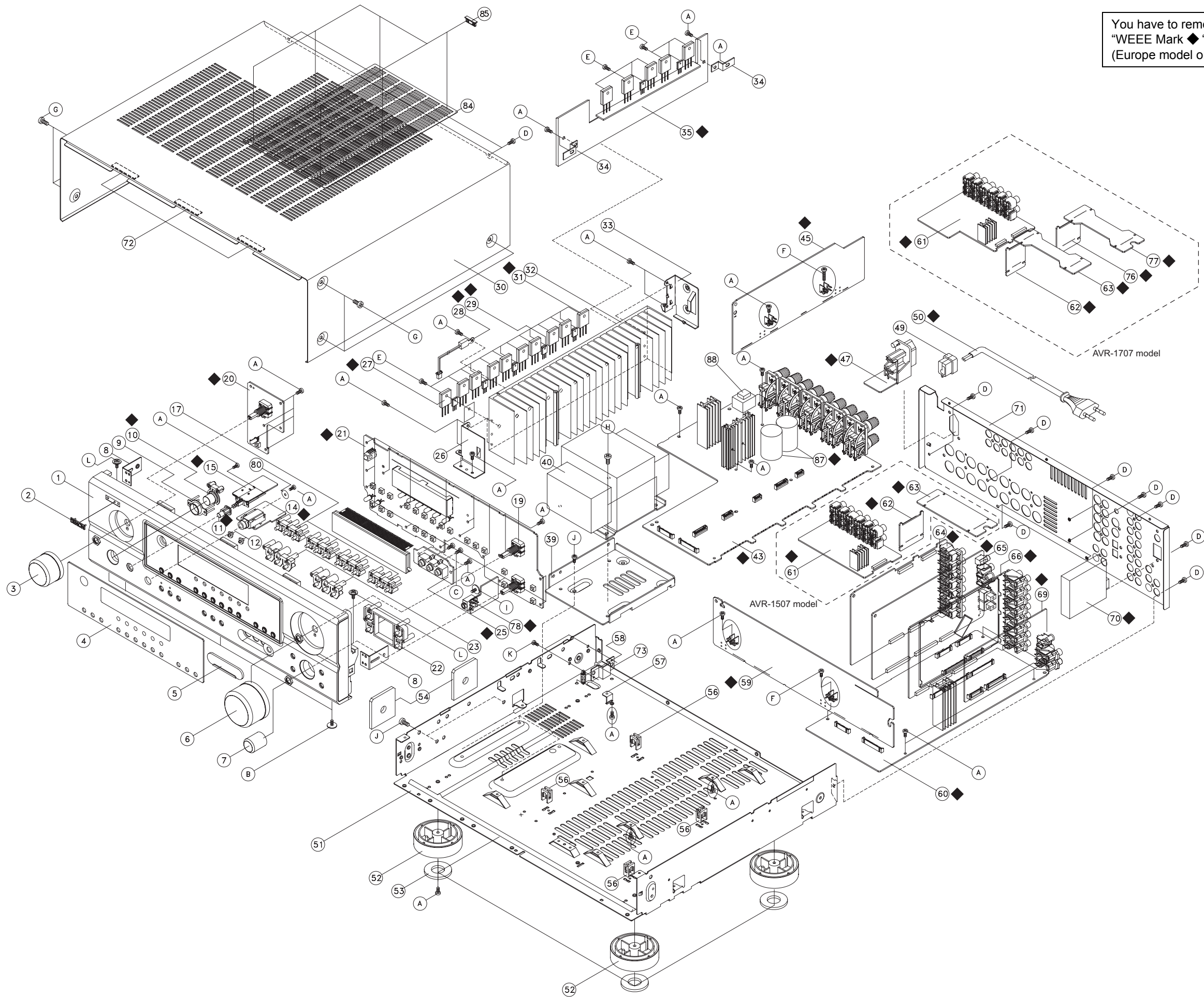

Details of Recycle parts for main transformer

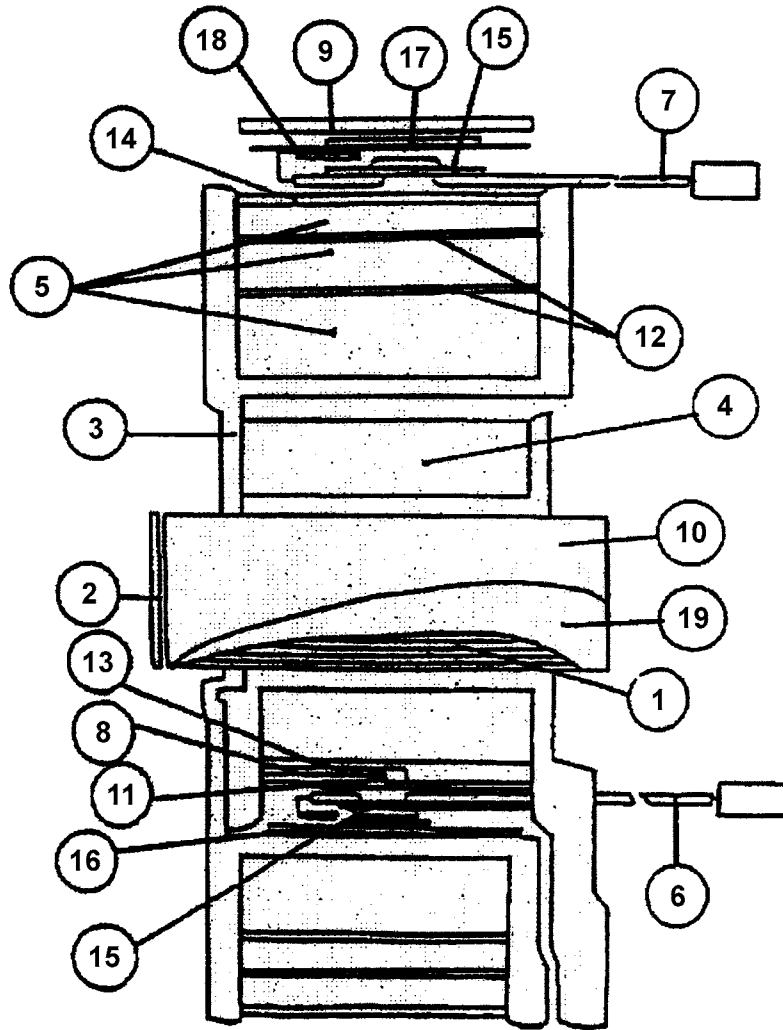

NO.	MATERIAL
1	Silicon Steel Sheet
2	Steel
3	Polyethylene Terephthalate / Polybutylene Terephthalate
4	Polyurethane Enameled Copper Wire
5	Polyurethane Enameled Copper Wire
6	PVC Insulated Copper Wire
7	PVC Insulated Copper Wire
8	Thermal Fuse
9	Copper
10	Silicon Steel
11	Silicon Rubber Tube
12	Polyester Tape
13	Polyester Tape / Press Board or Polyester Film
14	Press Board / polyester film or Polyester Tape
15	Press Board
16	Polyester Tape
17	Polyester Tape / Press Board or Polyester Film
18	Polyester Tape
19	Polyester Non-woven Insulating Tape

Details of Recycle parts for sub transformer

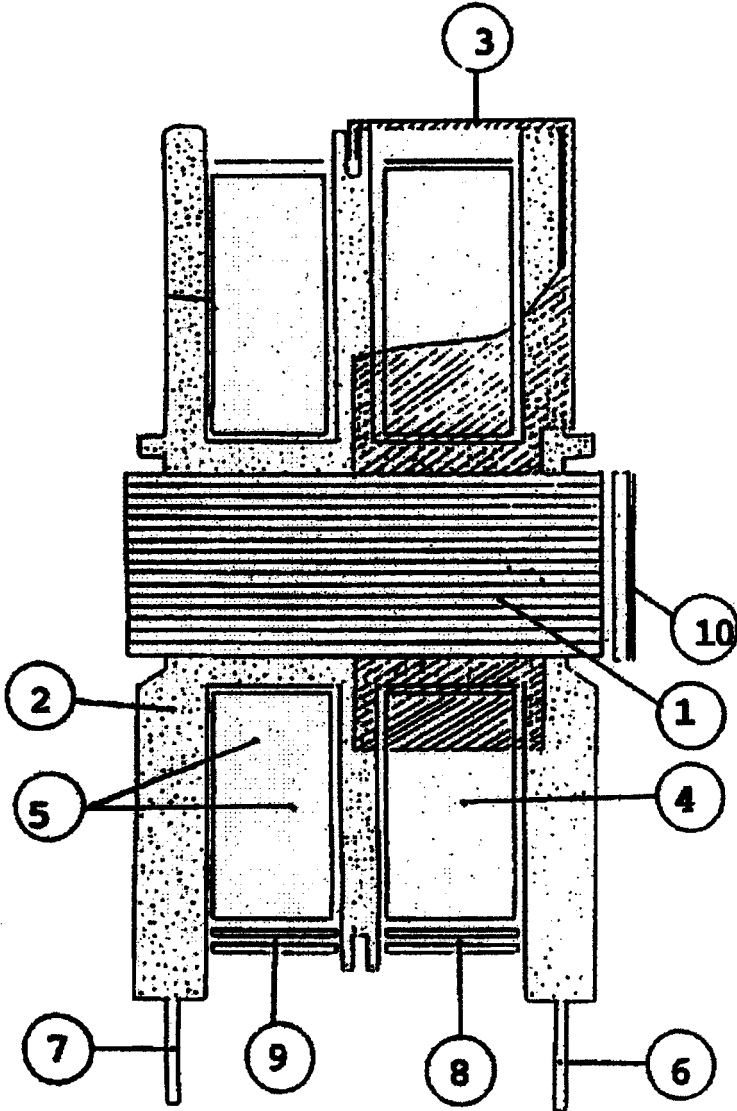

NO.	MATERIAL
1	Silicon Steel Sheet
2	Polyethylene Terephthalate
3	PA66
4	Polyurethane Enameled Copper Wire
5	Polyurethane Enameled Copper Wire
6	Copper Alloy
7	Copper Alloy
8	Polyester Tape
9	Press Board or Polyester Film
10	Polyester Tape