

aiwa

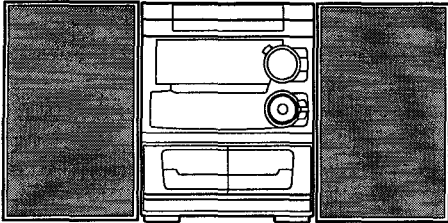

NSX-MT320 NSX-MT321



COMPACT DISC STEREO
CASSETTE RECEIVER

- BASIC TAPE MECHANISM : 6ZM-3 PR1NM
- BASIC CD MECHANISM : 4ZG-1 Z3DSHNM

• TYPE : U

SYSTEM	SUB WOOFER	CD - CASSEIVER	SPEAKER	REMOTE CONTROLLER
NSX-MT320	-	CX-NMT320	SX-NA302 SX-R275 SX-C605	RC-8AS
NSX-MT321	TS-W35			

•If requiring information about the CD mechanism, see Service Manual of 4ZG-1,
S/M Code No. 09-983-249-30T.

•If requiring information about the Sub woofer, see Service Manual of original.
S/M Code No. 09-976-204-001.

TABLE OF CONTENTS

SPECIFICATIONS	3
PROTECTION OF EYES FROM LASER BEAM DURING SERVICING	4
PRECAUTION TO REPLACE OPTICAL BLOCK	4
NOTE ON BEFORE STARTING REPAIR	5, 6
ELECTRICAL MAIN PARTS LIST	7 ~ 10
TRANSISTOR ILLUSTRATION	11
BLOCK DIAGRAM – 1 (TUNER)	12
BLOCK DIAGRAM – 2 (MAIN / FRONT / PRO).....	13 ~ 15
SCHEMATIC DIAGRAM – 1 (MAIN 1/2).....	16 ~ 18
WIRING – 1 (MAIN)	19, 20
WIRING – 2 (FRONT)	21, 22
SCHEMATIC DIAGRAM – 2 (FRONT)	23 ~ 25
SCHEMATIC DIAGRAM – 3 (TUNER FRONT END)	26
IC BLOCK DIAGRAM – 1.....	26, 27
SCHEMATIC DIAGRAM – 4 (PRO)	27 ~ 28
WIRING – 3 (PRO).....	29, 30
SCHEMATIC DIAGRAM – 5 (MAIN 2/2).....	31, 32
WIRING – 4 (AC)	33
WIRING – 5 (DECK)	34
FL GRID ASSIGNMENT AND ANODE CONNECTION.....	35
IC BLOCK DIAGRAM – 2.....	36, 38
IC DESCRIPTION	39 ~ 41
ADJUSTMENT <TUNER / DECK>	42, 43
PRACTICAL SERVICE FIGURE.....	44
MECHANICAL EXPLODED VIEW 1 / 1.....	45, 46
MECHANICAL PARTS LIST 1 / 1	47
TAPE MECHANISM EXPLODED VIEW 1 / 1	48, 49
TAPE MECHANISM PARTS LIST 1 / 1	50
SPRING APPLICATION POSITION	51
SPEAKER DISASSEMBLY INSTRUCTIONS	52
SPEAKER PARTS LIST.....	53
ACCESSORIES / PACKAGE LIST	53
REFERENCE NAME LIST	54

SPECIFICATIONS

<FM Tuner section>

Tuning range 87.5 MHz to 108 MHz
Usable sensitivity (IHF) 13.2 dBf
Antenna terminals 75 ohms (unbalanced)

<AM Tuner section>

Tuning range 531 kHz to 1602 kHz (9 kHz step)
 530 kHz to 1710 kHz (10 kHz step)
Usable sensitivity 350 μ V/m
Antenna Loop antenna

<Amplifier section>

Power output
Front
 30 W + 30 W (50 Hz – 20 kHz,
 THD less than 1%, 6 ohms)
Rear (Surround)
 Rated : 10 W +10 W
 (1 kHz, THD less than 1%, 8 ohms)
Center
 20 W (1 kHz, THD less than 1%,
 8 ohms)

Inputs
 VIDEO/AUX : 150 mV (adjustable)
 MIC : 1.8 mV (10 kohms)

Outputs
 SPEAKERS: accept speakers of
 6 ohms or more
 SURROUND SPEAKERS :
 accept speakers of 8 ohms to
 16 ohms
 CENTER SPEAKER : accept
 speakers of 8 ohms or more
 PHONES (stereo jack) :
 accepts headphones of 32 ohms
 or more

<Cassette deck section>

Track format 4 tracks, 2 channels stereo
Frequency response 50 Hz – 15000 Hz
Recording system AC bias
Heads Deck 1 : Playback head x 1
 Deck 2 : Recording/playback/
 erase head x 1

<Compact disc player section>

Laser Semiconductor laser ($\lambda = 780$ nm)
D-A converter 1 bit dual
Signal-to-noise ratio 85 dB (1 kHz, 0 dB)
Harmonic distortion 0.05% (1 kHz, 0 dB)
Wow and flutter Unmeasurable

<Speaker system SX-NA302>

Cabinet type 3 way, bass reflex (magnetic
 shielded type)

Speakers
Woofer :
 160 mm ($6\frac{3}{8}$ in.) cone type
Tweeter :
 80 mm ($3\frac{1}{4}$ in.) cone type
Super tweeter :
 20 mm ($1\frac{3}{16}$ in.) ceramic type

Impedance 6 ohms
Output sound pressure level 87 dB/W/m
Dimensions (W x H x D) 240 x 324 x 283 mm
 ($9\frac{1}{2}$ x $12\frac{7}{8}$ x $11\frac{1}{4}$ in.)
Weight 5.2 kg (11 lbs 7 oz.)

<General>

Power requirements 120 V AC, 60Hz
Power consumption 120 W
Dimensions of main unit 260 x 330 x 346 mm
 (W x H x D) ($10\frac{1}{4}$ x 13 x $13\frac{5}{8}$ in.)
Weight of main unit 6.9 kg (15 lbs 3 oz.)

- Design and specifications are subject to change without notice.
- Manufactured under license from Dolby Laboratories Licensing Corporation.
 "DOLBY" and "PRO LOGIC" are trademarks of Dolby Laboratories Licensing Corporation.

PROTECTION OF EYES FROM LASER BEAM DURING SERVICING

This set employs laser. Therefore, be sure to follow carefully the instructions below when servicing.

WARNING!!

WHEN SERVICING, DO NOT APPROACH THE LASER EXIT WITH THE EYE TOO CLOSELY. IN CASE IT IS NECESSARY TO CONFIRM LASER BEAM EMISSION. BE SURE TO OBSERVE FROM A DISTANCE OF MORE THAN 30cm FROM THE SURFACE OF THE OBJECTIVE LENS ON THE OPTICAL PICK-UP BLOCK.

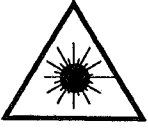

- Caution: Invisible laser radiation when open and interlocks defeated avoid exposure to beam.
- Advarsel: Usynlig laserstråling ved åbning, når sikkerhedsafbrydere er ude af funktion. Undgå udsættelse for stråling.

VAROITUS!

Laitteen Käyttäminen muulla kuin tässä käyttöohjeessa mainitulla tavalla saattaa altistaa käyttäjän turvallisuusluokan 1 ylittävälle näkymättömälle lasersäteilylle.

WARNING!

Om apparaten används på annat sätt än vad som specificeras i denna bruksanvisning, kan användaren utsättas för osynlig laserstrålning, som överskrider gränsen för laserklass 1.

CAUTION

Use of controls or adjustments or performance of procedures other than those specified herein may result in hazardous radiation exposure.

ATTENTION

L'utilisation de commandes, réglages ou procédures autres que ceux spécifiés peut entraîner une dangereuse exposition aux radiations.

ADVARSEL!

Usynlig laserstråling ved åbning, når sikkerhedsafbrydere er ude af funktion. Undgå udsættelse for stråling.

This Compact Disc player is classified as a CLASS 1 LASER product.

The CLASS 1 LASER PRODUCT label is located on the rear exterior.

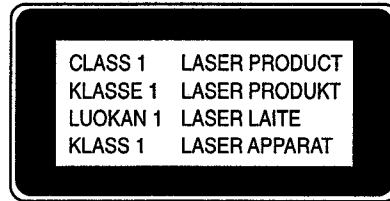

Precaution to replace Optical block

(KSS - 213F)

Body or clothes electrostatic potential could ruin laser diode in the optical block. Be sure ground body and workbench, and use care the clothes do not touch the diode.

- 1) After the connection, remove solder shown in right figure.

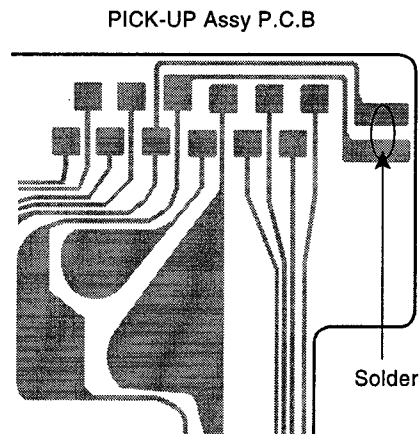

NOTE ON BEFORE STARTING REPAIR

1. Forced discharge of electrolytic capacitor of power supply block

When repair is going to be attempted in the set that uses relay circuit in the power supply block, electric potential is kept charged across the electrolytic capacitors (C101, 102) even though AC power cord is removed. If repair is attempted in this condition, the secondary defect can occur.

In order to prevent the secondary trouble, perform the following measures before starting repair work.

Discharge procedure

- ① Remove the AC power cord.
- ② Connect a discharging resistor at an end of lead wire that has clips at both ends. Connect the other end of the lead wire to metal chassis.
- ③ Contact the other end of the discharging resistor to the positive (+) side (+VH) of C101. (For two seconds)
- ④ Contact the same end of the discharging resistor as step ③ to the negative (-) side (-VH) of C102 in the same way. (For two seconds)
- ⑤ Check that voltage across C101 and C102 has decreased 1 V or less using a multimeter or an oscilloscope.

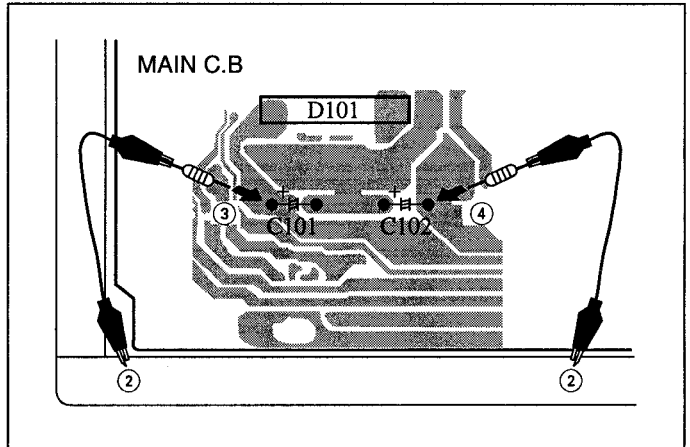

Fig-1

Select a discharging resistor referring to the following table.

Charging voltage (V) (C101, 102)	Discharging resistor (Ω)	Rated power (W)	Parts number
25-48	100	3	87-A00-247-090
49-140	220	5	87-A00-232-090

Note: The reference numbers (C101, C102) of the electrolytic capacitors can change depending on the models. Be sure to check the reference numbers of the charging capacitors on schematic diagram before starting the discharging work.

2. Check items before exchanging the MICROCOMPUTER

Be sure to check the following items before exchanging the MICROCOMPUTER. Exchange the MICROCOMPUTER after confirming that the MICROCOMPUTER is surely defective.

2-1. Regarding the HOLD terminal of the MICROCOMPUTER

When the HOLD terminal (INPUT) of the MICROCOMPUTER is "H", the MICROCOMPUTER is judged to be operating correctly. When this terminal is "L", the main power cannot be turned on. Therefore, be sure to check the terminal voltage of the HOLD terminal before exchange.

When the MICROCOMPUTER is not defective, the HOLD terminal can also go "L" when the POWER AMPLIFIER has any abnormalities that triggers the abnormality detection circuit on the MAIN C. B. that sets the HOLD terminal to "L".

- Good or no good judgement of the MICROCOMPUTER

- ① Turn on the AC main power.
- ② Confirm that the main power is turned on and the HOLD terminal of the MICROCOMPUTER keeps the "H" level or not.
- ③ When the HOLD terminal is "L" level, the abnormality detection circuit is judged to be working correctly and the MICROCOMPUTER is judged to be good.

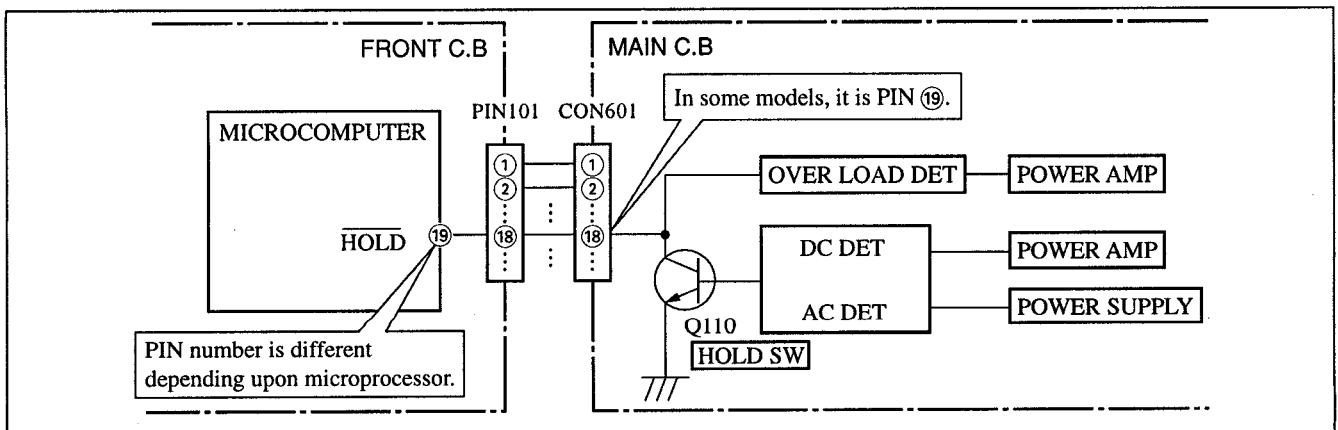

Fig-2-1

In such a case, check also if the POWER AMPLIFIER circuit or power supply circuit has any abnormalities or not.

2-2. Regarding reset

There are cases that the machine does not work correctly because the MICROCOMPUTER is not reset even though the AC power cord is re-inserted, or the software reset (pressing the STOP key + POWER key) is performed.

When the above described phenomenon occurs, it can lead to wrong judgement as if the MICROCOMPUTER is defective and to exchange the MICROCOMPUTER. In such a case, perform the forced-reset by the following procedure and check good or no good of the MICROCOMPUTER.

- ① Remove the AC power cord.

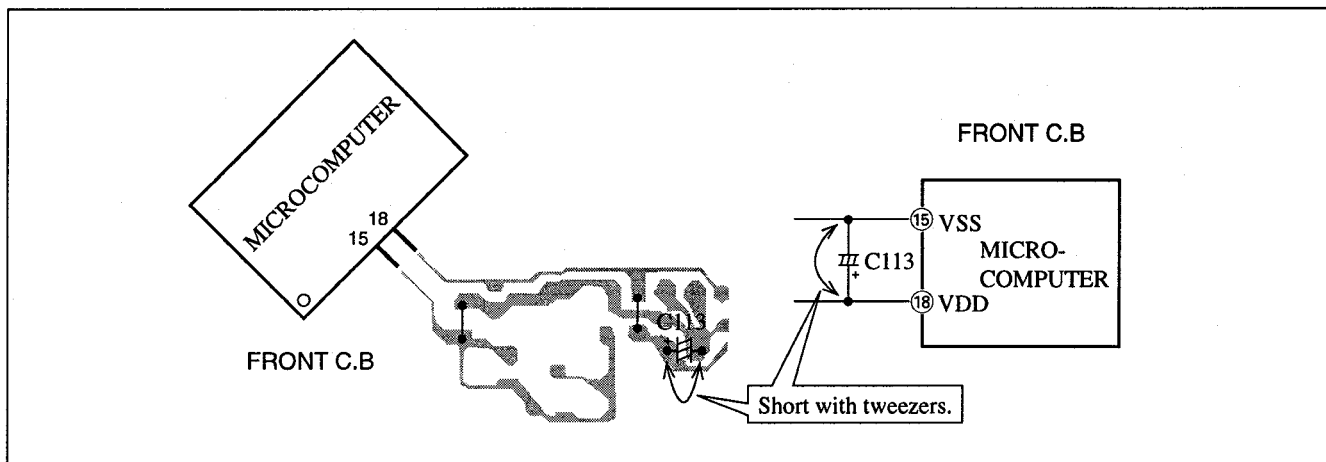

Fig-2-2

- ② Short both ends of the electrolytic capacitor C113 that is connected to VDD of the MICROCOMPUTER with tweezers.
- ③ Connect the AC power cord again. If the MICROCOMPUTER returns to the normal operation, the MICROCOMPUTER is good.

Note: The reference number or MICROCOMPUTER pin number of transistor (Q110) and electrolytic capacitor (C113) can change depending on the models. Be sure to check the reference numbers on schematic diagram before starting the discharging work.

2-3. Confirmation of soldering state of MICROCOMPUTER

Check the soldering state of the MICROCOMPUTER in addition to the above described procedures. Be sure to exchange the MICROCOMPUTER after surely confirming that the trouble is not caused by poor soldering but the MICROCOMPUTER itself.

ELECTRICAL MAIN PARTS LIST

If can't understand for Description please kindly refer to "REFERENCE NAME LIST".

REF. NO.	PART NO.	KANRI NO.	DESCRIPTION	REF. NO.	PART NO.	KANRI NO.	DESCRIPTION
IC				C115	87-010-407-080		CAP, ELECT 33-50V
	87-A20-083-010		IC,BA3835S	C116	87-010-407-080		CAP, ELECT 33-50V
	88-NFV-602-010		C-IC,UPD780228-019-3BA	C117	87-010-430-080		CAP, ELECT 100-63
	87-NF8-614-010		IC,SPS-442-1-W	C118	87-010-263-080		CAP, ELECT 100-10V
	87-017-915-080		IC,BU4094BCF	C119	87-010-260-080		CAP, ELECT 47-25V
	87-A20-783-040		C-IC,BA7762AFS	C120	87-010-403-080		CAP, ELECT 3.3-50V
	87-017-888-080		IC,NJM4558MD	C121	87-012-140-080		CAP 470P
	87-A20-954-040		C-IC,M62445FP-601	C122	87-010-263-080		CAP, ELECT 100-10V
	86-NFZ-655-010		IC,LC72131D(2)	C123	87-010-247-080		CAP, ELECT 100-50V
	87-A20-438-010		IC,LA1837	C124	87-010-112-080		CAP, ELECT 100-16V
	87-020-454-010		IC,DN6851	C125	87-010-235-080		CAP,E 470-16 SME
	87-A20-853-010		C-IC,M62463FP	C153	87-010-917-090		CAP,E 3300-50 M SMG
				C154	87-010-917-090		CAP,E 3300-50 M SMG
				C209	87-010-546-080		CAP, ELECT 0.33-50V
				C210	87-010-546-080		CAP, ELECT 0.33-50V
TRANSISTOR				C211	87-010-185-080		C-CAP,S 3900P-50 B
	89-213-702-010		TR,2SB1370 (1.8W)	C212	87-010-185-080		C-CAP,S 3900P-50 B
	87-026-610-080		TR,KTC3198GR	C213	87-010-186-080		CAP,CHIP 4700P
	87-A30-076-080		C-TR,2SC3052F	C214	87-010-186-080		CAP,CHIP 4700P
	87-A30-196-080		TR,2SC4115SRS	C215	87-010-403-080		CAP, ELECT 3.3-50V
	87-A30-075-080		C-TR,2SA1235F	C216	87-010-403-080		CAP, ELECT 3.3-50V
	87-026-609-080		TR,KTA1266GR	C217	87-010-260-080		CAP, ELECT 47-25V
	87-A30-198-080		TR,KTC3199GR	C218	87-010-260-080		CAP, ELECT 47-25V
	87-A30-074-080		C-TR,RT1P 141C	C229	87-A10-812-080		C-CAP,S 220P-200 J CH
	87-A30-071-080		C-TR,RT1N 144C	C230	87-A10-812-080		C-CAP,S 220P-200 J CH
	87-A30-087-080		C-FET,2SK2158	C233	87-010-544-080		CAP, ELECT 0.1-50V
	87-A30-107-070		C-TR,CMBT5401	C234	87-010-544-080		CAP, ELECT 0.1-50V
	87-026-263-080		C-TR,RN1410	C237	87-012-368-080		C-CAP,S 0.1-50 F
	87-A30-190-080		TR,CC5551	C238	87-012-368-080		C-CAP,S 0.1-50 F
	87-A30-106-070		C-TR,CMBT5551	C239	87-012-368-080		C-CAP,S 0.1-50 F
	87-A30-109-010		TR,2SD2495	C240	87-012-368-080		C-CAP,S 0.1-50 F
	87-A30-108-010		TR,2SB1626	C280	87-010-188-080		C-CAP,S 6800P-50 B
	87-A30-221-080		C-TR,DTA114WK	C301	87-010-318-080		C-CAP,S 47P-50 CH
	87-A30-159-080		C-TR,KTA1298Y	C302	87-010-318-080		C-CAP,S 47P-50 CH
	89-112-965-080		TR,2SA1296 (0.75W)	C303	87-012-157-080		C-CAP,S 330P-50 CH
	87-A30-073-080		C-TR,RT1N 141C	C304	87-012-157-080		C-CAP,S 330P-50 CH
	87-A30-105-080		C-TR,RT1P 441C	C305	87-012-145-080		CAP, CHIP S 270P CH
	87-026-238-080		C-TR,DTC144WK	C306	87-012-145-080		CAP, CHIP S 270P CH
	89-327-143-080		C-TR,2SC2714 (0.1W)	C307	87-010-196-080		CHIP CAPACITOR,0.1-25
	87-A30-072-080		C-TR,RT1P 144C	C309	87-010-196-080		CHIP CAPACITOR,0.1-25
	87-A30-214-010		TR,2SB1344	C310	87-010-196-080		CHIP CAPACITOR,0.1-25
	87-A30-215-010		TR,2SD2025	C311	87-010-198-080		CAP, CHIP 0.022
	87-A30-086-070		C-TR,CSD1306E	C312	87-010-198-080		CAP, CHIP 0.022
				C313	87-010-180-080		CAP,CHIP S 1500P-50 KB
				C314	87-010-180-080		CAP,CHIP S 1500P-50 KB
DIODE				C315	87-010-182-080		CHIP CAP 2200P-50 KB
	87-002-225-010		DIODE,DBF40C-K10	C316	87-010-182-080		CHIP CAP 2200P-50 KB
	87-A40-505-040		C-DIODE,KDS181	C321	87-016-492-080		C-CAP,S 0.33-16 FZ
	87-A40-504-040		C-DIODE,KDS184	C322	87-016-492-080		C-CAP,S 0.33-16 FZ
	87-070-274-080		DIODE,1N4003 SEM	C324	87-010-260-080		CAP, ELECT 47-25V
	87-A40-435-080		ZENER,MTZJ30D	C325	87-010-370-080		CAP,E 330-6.3 SME
	87-A40-345-080		ZENER,MTZJ10C	C327	87-010-404-080		CAP, ELECT 4.7-50V
	87-A40-004-080		ZENER,MTZJ16A	C328	87-010-404-080		CAP, ELECT 4.7-50V
	87-A40-470-080		DIODE,1SS254	C332	87-010-196-080		CHIP CAPACITOR,0.1-25
	87-A40-509-080		ZENER,MTZJ6.8C	C335	87-010-401-080		CAP, ELECT 1-50V
	87-A40-488-080		DIODE,1SS244	C336	87-010-401-080		CAP, ELECT 1-50V
	87-017-932-080		ZENER,MTJ6.2B	C337	87-010-196-080		CHIP CAPACITOR,0.1-25
	87-A40-002-080		ZENER,MTZJ5.1C	C339	87-010-196-080		CHIP CAPACITOR,0.1-25
	87-A40-438-080		ZENER,MTZJ4.7A	C340	87-010-196-080		CHIP CAPACITOR,0.1-25
	87-A40-234-080		ZENER,MTZJ5.6A	C351	87-012-140-080		CAP 470P
	87-A40-116-060		DIODE,RS403L-B-D-5L	C352	87-012-140-080		CAP 470P
				C354	87-010-175-080		CAP 560P
				C355	87-012-349-080		C-CAP,S 1000P-50 CH
				C356	87-010-260-080		CAP, ELECT 47-25V
				C357	87-010-197-080		CAP, CHIP 0.01 DM
				C358	87-010-183-080		C-CAP,S 2700P-50 B
				C359	87-010-183-080		C-CAP,S 2700P-50 B
				C360	87-010-183-080		C-CAP,S 2700P-50 B
				C370	87-010-196-080		CHIP CAPACITOR,0.1-25
				C373	87-016-083-080		C-CAP,S 0.15-16 RK
MAIN C.B				C109	87-010-196-080		CHIP CAPACITOR,0.1-25
	87-010-196-080		CHIP CAPACITOR,0.1-25	C110	87-010-196-080		CHIP CAPACITOR,0.1-25
	87-010-196-080		CHIP CAPACITOR,0.1-25	C111	87-010-196-080		CHIP CAPACITOR,0.1-25
	87-010-196-080		CHIP CAPACITOR,0.1-25	C112	87-010-196-080		CHIP CAPACITOR,0.1-25
	87-010-407-080		CAP, ELECT 33-50V	C113	87-010-407-080		CAP, ELECT 33-50V
	87-010-407-080		CAP, ELECT 33-50V	C114	87-010-407-080		CAP, ELECT 33-50V

REF. NO.	PART NO.	KANRI NO.	DESCRIPTION	REF. NO.	PART NO.	KANRI NO.	DESCRIPTION
C150	87-010-196-080		CHIP CAPACITOR, 0.1-25	S405	87-A90-680-080		SW, TACT KSM0612BTS
C153	87-010-196-080		CHIP CAPACITOR, 0.1-25	S406	87-A90-680-080		SW, TACT KSM0612BTS
C154	87-010-196-080		CHIP CAPACITOR, 0.1-25	S407	87-A90-680-080		SW, TACT KSM0612BTS
C170	87-010-194-080		CAP, CHIP 0.047	S408	87-A90-680-080		SW, TACT KSM0612BTS
C171	87-010-196-080		CHIP CAPACITOR, 0.1-25	S409	87-A90-680-080		SW, TACT KSM0612BTS
C172	87-010-406-040		CAP, E 22-50 M SME	S410	87-A90-680-080		SW, TACT KSM0612BTS
C173	87-010-194-080		CAP, CHIP 0.047	S411	87-A90-680-080		SW, TACT KSM0612BTS
C201	87-018-205-080		CAP, CERA-SOL 0.022	S412	87-A90-680-080		SW, TACT KSM0612BTS
C202	87-010-198-080		CAP, CHIP 0.022	S413	87-A90-680-080		SW, TACT KSM0612BTS
C203	87-010-198-080		CAP, CHIP 0.022	S414	87-A90-680-080		SW, TACT KSM0612BTS
C204	87-012-140-080		CAP 470P	S415	87-A90-680-080		SW, TACT KSM0612BTS
C205	87-010-316-080		C-CAP, S 33P-50 CH	S416	87-A90-680-080		SW, TACT KSM0612BTS
C206	87-010-318-080		C-CAP, S 47P-50 CH	S417	87-A90-680-080		SW, TACT KSM0612BTS
C207	87-010-312-080		C-CAP, S 15P-50 CH	S418	87-A90-680-080		SW, TACT KSM0612BTS
C208	87-010-196-080		CHIP CAPACITOR, 0.1-25	S419	87-A90-680-080		SW, TACT KSM0612BTS
C209	87-010-494-040		CAP, E 1-50 GAS	S420	87-A90-680-080		SW, TACT KSM0612BTS
C210	87-A10-189-040		CAP, E 220-10	S421	87-A90-680-080		SW, TACT KSM0612BTS
C211	87-010-194-080		CAP, CHIP 0.047	S423	87-A90-680-080		SW, TACT KSM0612BTS
C212	87-010-555-040		CAP, E 100-10 GAS	S425	87-A90-680-080		SW, TACT KSM0612BTS
C213	87-010-196-080		CHIP CAPACITOR, 0.1-25	SW201	87-A90-535-010		SW, RTRY EC16B24304
C214	87-010-405-040		CAP, E 10-50	SW202	88-NF8-615-010		SW, RTRY EC16B24204L=25
C215	87-012-156-080		C-CAP, S 220P-50 CH	X201	87-A70-075-080		VIB, CER 4.19MHZ CRHF
C216	87-012-156-080		C-CAP, S 220P-50 CH				
C217	87-010-197-080		CAP, CHIP 0.01 DM				
C250	87-010-196-080		CHIP CAPACITOR, 0.1-25	PRO C.B			
C270	87-010-196-080		CHIP CAPACITOR, 0.1-25	C101	87-012-368-080		C-CAP, S 0.1-50 Z F
C307	87-015-686-040		CAP, E 22-25 M 7L SRA	C102	87-012-368-080		C-CAP, S 0.1-50 Z F
C354	87-010-196-080		CHIP CAPACITOR, 0.1-25	C103	87-016-051-090		CAP, E 2200-35 M SMG
C355	87-010-196-080		CHIP CAPACITOR, 0.1-25	C104	87-016-051-090		CAP, E 2200-35 M SMG
C373	87-010-196-080		CHIP CAPACITOR, 0.1-25	C106	87-010-196-080		C-CAP, S 0.1-25 Z F
C376	87-012-158-080		C-CAP, S 390P-50 CH	C111	87-010-178-080		C-CAP, S 1000P-50 K B
C378	87-010-196-080		CHIP CAPACITOR, 0.1-25	C207	87-010-545-080		CAP, E 0.22-50 M SME
C401	87-010-405-040		CAP, E 10-50	C209	87-010-180-080		C-CAP, S 1500P-50 K B
C402	87-010-405-040		CAP, E 10-50	C211	87-010-404-080		CAP, E 4.7-50 M SME
C404	87-010-194-080		CAP, CHIP 0.047	C217	87-010-406-080		CAP, E 22-50 M SME
C405	87-010-246-040		CAP, E 47-35 SME	C219	87-A10-596-080		C-CAP, S 100P-100 J CH
C406	87-010-197-080		CAP, CHIP 0.01 DM	C221	87-A10-899-080		CAP, E 47-25 M BP
C501	87-010-401-040		CAP, E 1-50 SME	C223	87-010-544-080		CAP, E 0.1-50 M SME
C502	87-010-177-080		C-CAP, S 820P-50 SL	C225	87-010-993-080		C-CAP, S 0.056-25 K B
C504	87-010-546-040		CAP, E 0.33-50 SME	C227	87-010-196-080		C-CAP, S 0.1-25 Z F
C505	87-010-321-080		CHIP CAPACITOR, 82P(J)	C229	87-A10-799-080		C-CAP, S 5600P-16 J B
C506	87-010-405-040		CAP, E 10-50	C230	87-A10-799-080		C-CAP, S 5600P-16 J B
C508	87-010-248-040		CAP, E 220-10 SME	C233	87-010-263-080		CAP, E 100-10 SME
C509	87-010-545-040		CAP, E 0.22-50 SME	C234	87-010-235-080		CAP, E 470-16 SME
C511	87-010-406-040		CAP, E 22-50 SME	C307	87-010-545-080		CAP, E 0.22-50 M SME
C513	87-010-405-040		CAP, E 10-50	C309	87-010-181-080		C-CAP, 1800P-50 K B
C514	87-010-186-080		CAP, CHIP 4700P	C311	87-010-404-080		CAP, E 4.7-50 M SME
CON102	87-099-015-010		CONN, 13P 6216V	C317	87-010-408-080		CAP, E 47-50 M SME
CON301	87-099-013-010		CONN, 11P 6216 V	C319	87-A10-596-080		C-CAP, S 100P-100 J CH
CON601	87-099-016-010		CONN, 14P 6216V	C321	87-A10-899-080		CAP, E 47-25 M BP
EMI501	87-008-372-080		FILTER, EMI BL OIRNI	C323	87-010-544-080		CAP, E 0.1-50 M SME
FL401	88-NF8-603-010		FL, SVA-11MM12	C325	87-010-993-080		C-CAP, S 0.056-25 K B
J501	87-A60-284-010		JACK, 3.5MO (MSC)	C327	87-010-196-080		C-CAP, S 0.1-25 Z F
LED208	87-070-281-080		LED, SLZ736A-25H-S-T1 P-GRN	C329	87-A10-799-080		C-CAP, S 5600P-16 J B
LED209	87-070-281-080		LED, SLZ736A-25H-S-T1 P-GRN	C333	87-010-263-080		CAP, E 100-10 SME
LED210	87-070-281-080		LED, SLZ736A-25H-S-T1 P-GRN	C501	87-010-176-080		C-CAP, S 680P-50 J SL
LED211	87-070-281-080		LED, SLZ736A-25H-S-T1 P-GRN	C502	87-010-176-080		C-CAP, S 680P-50 J SL
LED213	87-070-281-080		LED, SLZ736A-25H-S-T1 P-GRN	C503	87-A10-804-080		C-CAP, S 0.1-25 J B
LED222	87-070-201-080		LED, SLP9118C-51-S RED	C504	87-A10-804-080		C-CAP, S 0.1-25 J B
LED223	87-070-201-080		LED, SLP9118C-51-S RED	C505	87-A10-804-080		C-CAP, S 0.1-25 J B
LED224	87-070-201-080		LED, SLP9118C-51-S RED	C506	87-A10-804-080		C-CAP, S 0.1-25 J B
LED225	87-070-201-080		LED, SLP9118C-51-S RED	C509	87-010-112-080		CAP, E 100-16 M SME
LED226	87-070-201-080		LED, SLP9118C-51-S RED	C510	87-010-221-080		CAP, E 470-10 M SME
LED227	87-070-201-080		LED, SLP9118C-51-S RED	C511	87-A10-891-080		CAP, E 4.7-25 SME(K)
LED228	87-070-201-080		LED, SLP9118C-51-S RED	C512	87-A10-800-080		C-CAP, S 6800P-16 J B
LED229	87-070-201-080		LED, SLP9118C-51-S RED	C513	87-010-374-080		CAP, E 47-10 M SME
S401	87-A90-680-080		SW, TACT KSM0612BTS	C514	87-010-196-080		C-CAP, S 0.1-25 Z F
S402	87-A90-680-080		SW, TACT KSM0612BTS	C515	87-010-400-080		CAP, E 0.47-50 M SME
S403	87-A90-680-080		SW, TACT KSM0612BTS	C516	87-010-400-080		CAP, E 0.47-50 M SME
S404	87-A90-680-080		SW, TACT KSM0612BTS	C519	87-010-544-080		CAP, E 0.1-50 M SME

REF. NO.	PART NO.	KANRI NO.	DESCRIPTION	REF. NO.	PART NO.	KANRI NO.	DESCRIPTION
C520	87-010-546-080		CAP,E 0.33-50 SME				
C522	87-018-209-080		CAP,TC U 0.1-50 Z F				
C524	87-010-374-080		CAP,E 47-10 M SME				
C526	87-010-196-080		C-CAP,S 0.1-25 Z F				
C530	87-010-544-080		CAP,E 0.1-50 M SME				
C531	87-010-546-080		CAP,E 0.33-50 SME				
C532	87-010-971-080		C-CAP,S 4700P-50 J B				
C533	87-012-349-080		C-CAP,S 1000P-50 J CH				
C538	87-010-971-080		C-CAP,S 4700P-50 J B				
C539	87-012-349-080		C-CAP,S 1000P-50 J CH				
C540	87-010-401-080		CAP,E 1-50 M SME				
C541	87-010-401-080		CAP,E 1-50 M SME				
C542	87-A10-799-080		C-CAP,S 5600P-16 J B				
C543	87-A10-802-080		C-CAP,S 0.047-16 J B				
C544	87-A10-229-080		C-CAP,S 0.68-10 K				
C545	87-012-393-080		C-CAP,S 0.22-16 K				
C546	87-012-393-080		C-CAP,S 0.22-16 K				
C547	87-010-404-080		CAP,E 4.7-50 M SME				
C548	87-010-404-080		CAP,E 4.7-50 M SME				
C549	87-012-393-080		C-CAP,S 0.22-16 K				
C550	87-012-393-080		C-CAP,S 0.22-16 K				
C551	87-016-081-080		C-CAP,S 0.1-16 K R				
C552	87-A10-802-080		C-CAP,S 0.047-16 J B				
C553	87-A10-802-080		C-CAP,S 0.047-16 J B				
C554	87-016-081-080		C-CAP,S 0.1-16 K R				
C555	87-016-081-080		C-CAP,S 0.1-16 K R				
C556	87-A10-801-080		C-CAP,S 0.022-16 J B				
C557	87-A10-801-080		C-CAP,S 0.022-16 J B				
C558	87-016-081-080		C-CAP,S 0.1-16 K R				
C579	87-010-402-080		CAP,E 2.2-50 M SME				
C580	87-010-402-080		CAP,E 2.2-50 M SME				
J202	87-A60-605-010		JACK,3P W/R/O YKC21-3948				
L201	87-003-383-010		COIL,1UH K				
L202	87-003-383-010		COIL,1UH K				
L301	87-003-383-010		COIL,1UH K				
R243	87-A00-258-080		RES,M/F 0.22-1W J				
R245	87-A00-258-080		RES,M/F 0.22-1W J				
R343	87-A00-258-080		RES,M/F 0.22-1W J				
R345	87-A00-258-080		RES,M/F 0.22-1W J				
R509	87-022-214-080		C-RES,S 100K-1/10W F				
				AC1 C.B			
				F101	87-035-416-010		FUSE,3A 250V T 239
				FC101	87-A90-505-080		FUSE CLAMP,TP00351-51
				FC102	87-A90-505-080		FUSE CLAMP,TP00351-51
				PT101	88-NFV-604-010		PT,8NF-28U
				T101	87-A60-317-010		TERMINAL, 1P MSC
				T102	87-A60-317-010		TERMINAL, 1P MSC
				AC2 C.B			
				PR101	87-026-691-080		FUSE,10A 125V 251
				PR102	87-026-691-080		FUSE,10A 125V 251
				PR105	87-A90-210-080		FUSE,7A 125V 251
				PR106	87-A90-210-080		FUSE,7A 125V 251
				W104	85-NF5-628-010		F-CABLE 7P-2.5
				DECK C.B			
				CON105	87-099-753-019		CONN,11P H 9604
				CON301	86-ZM3-604-219		CON ASSY,3P-PB
				CON351	86-ZM3-605-119		CON ASSY,8P-RPB
				SFR1	87-024-581-089		SFR,3.3K DIA 6H
				SOL1	82-ZM1-618-410		SOL ASSY,27
				SOL2	82-ZM1-618-410		SOL ASSY,27
				SW1	87-A90-248-010		SW,MICRO ESE11SH2CX0
				SW2	87-A90-248-010		SW,MICRO ESE11SH2CX0
				SW3	87-A90-248-010		SW,MICRO ESE11SH2CX0
				SW4	87-A90-248-010		SW,MICRO ESE11SH2CX0
				SW5	87-A90-248-010		SW,MICRO ESE11SH2CX0
				W1	82-ZM3-601-019		RBN-CORD,4P-75

○ チップ抵抗部品コード / CHIP RESISTOR PART CODE

チップ抵抗部品コードの成り立ち
Chip Resistor Part Coding

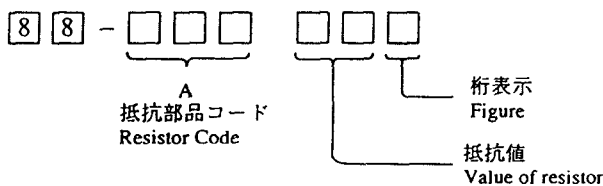

チップ抵抗
Chip resistor

容量 Wattage	種類 Type	許容誤差 Tolerance	記号 Symbol	寸法 / Dimensions (mm)			抵抗コード : A Resistor Code: A	
				外形 / Form	L	W		t
1/16W	1608	±5%	CJ		1.6	0.8	0.45	108
1/10W	2125	±5%	CJ		2	1.25	0.45	118
1/8W	3216	±5%	CJ		3.2	1.6	0.55	128

TRANSISTOR ILLUSTRATION



E C B

KTC3198
KTA1266



E C B

CC5551



B C E

2SB1370



E C B

KTC3199



B C E

2SA1296



B C E

2SB1626
2SB1344
2SD2025
2SD2495



B C E

2SC4115S

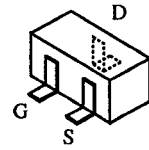

2SK2158

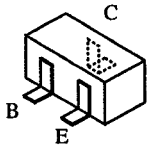

DTA114WK RN1410
DTC144WK RT1N141C
CSD1306E RT1N144C
CMBT5551 RT1P141C
CMBT5401 RT1P441C
2SA1235F RT1P144C
2SC3052F KTA1298Y
2SC2714(O)

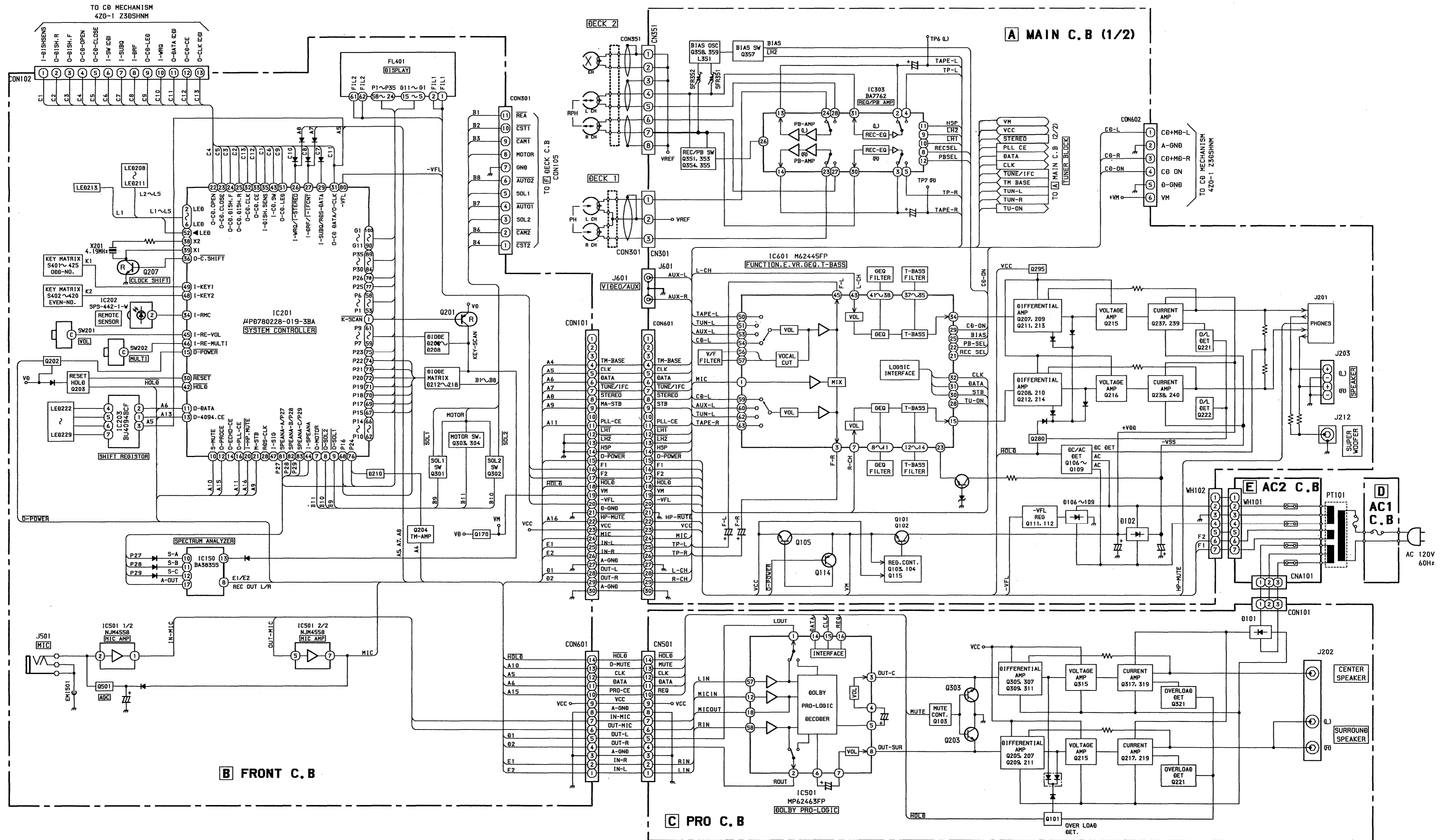

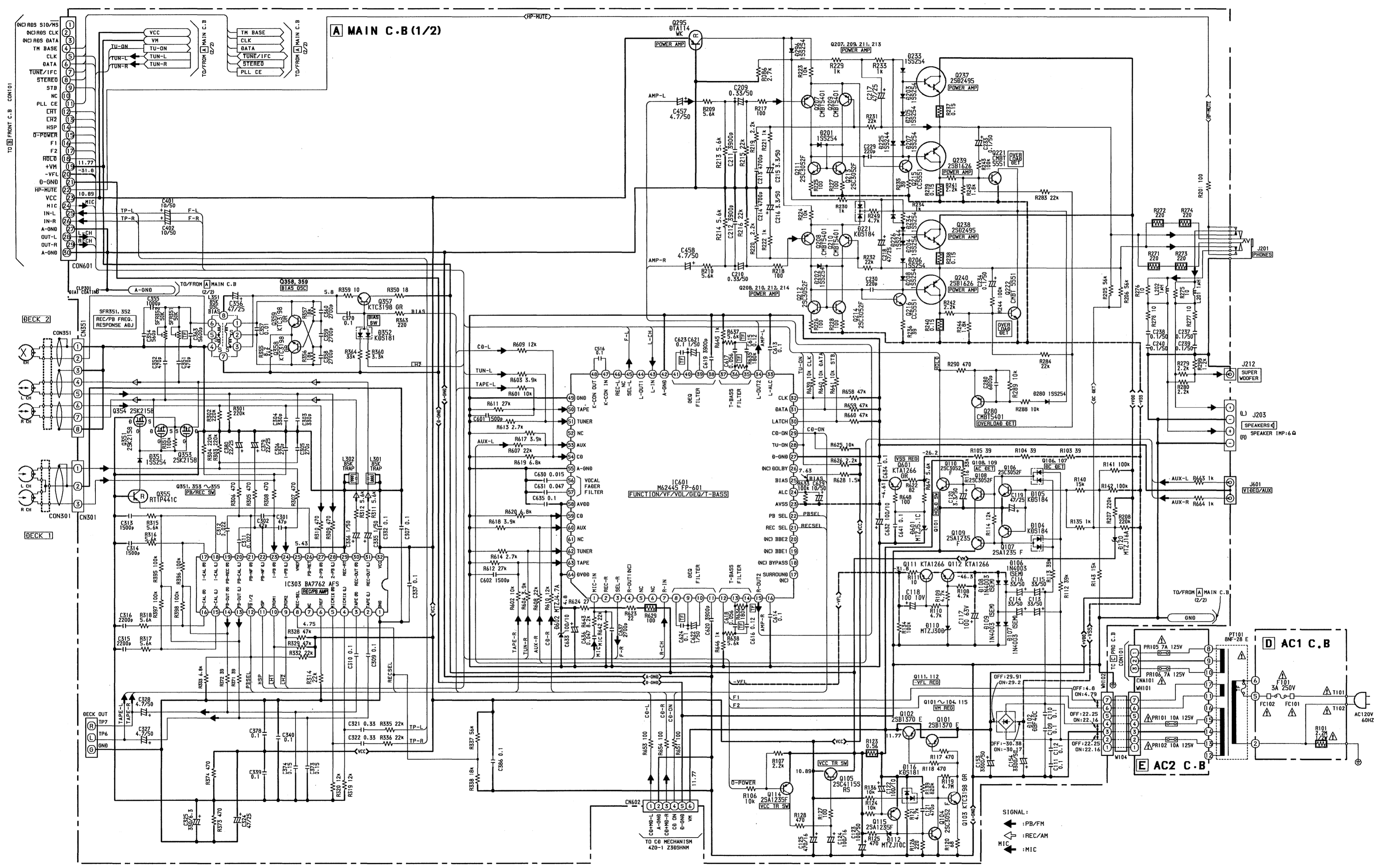

A MAIN C.B

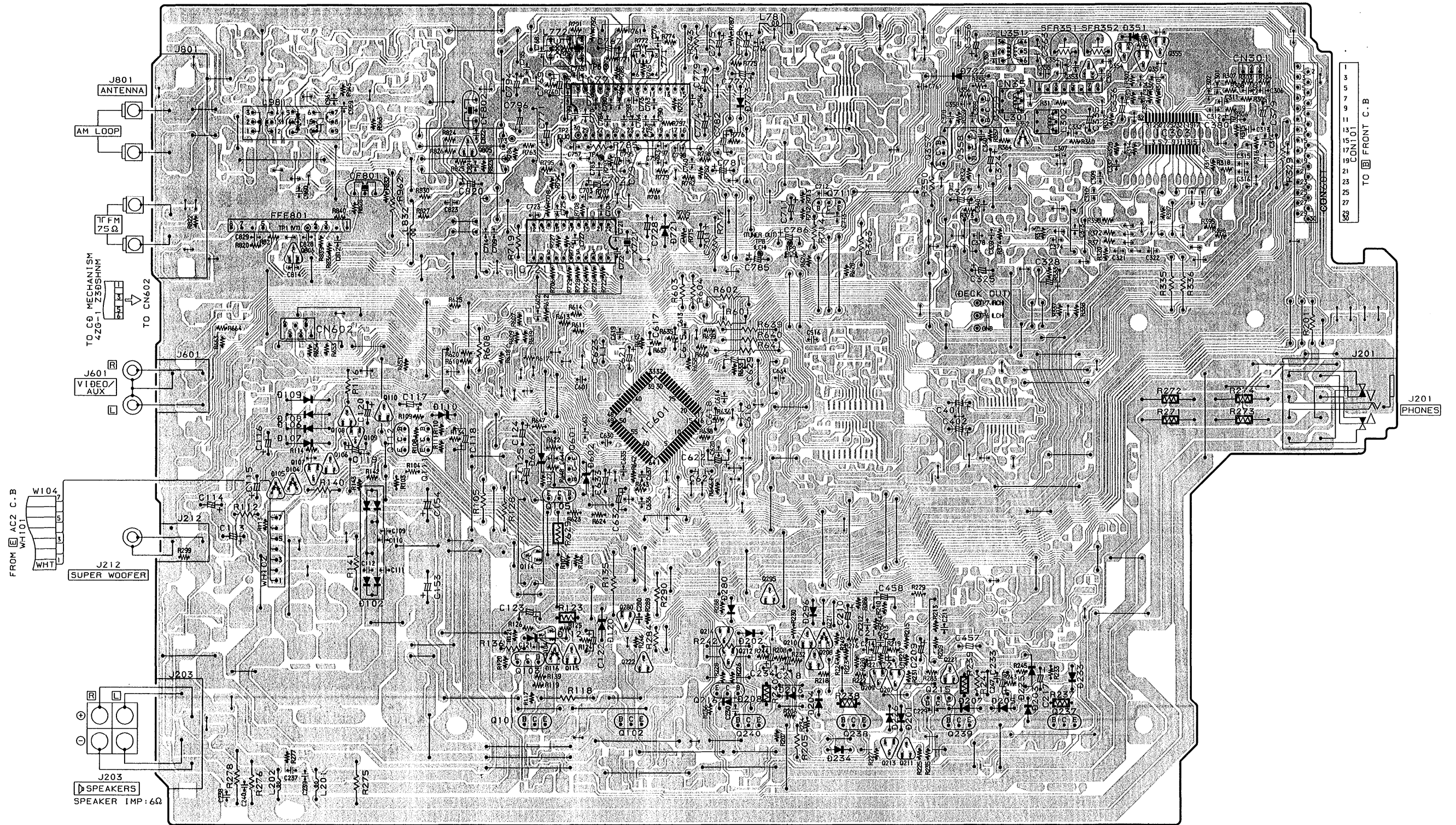

1 2 3 4 5 6 7 8 9 10 11 12 13 14

A
B
C
D
E
F
G
H
I
J

B FRONT C. B

LE0227, 226 3 STEREO
 LE0225, 224 PHANTOM
 LE0223, 222 NORMAL
 LE0228, 229 DOLBY PRO LOGIC

SW201 VOLUME
 S425 DOLBY PRO LOGIC
 S402 CD
 S405 VIDEO/AUX
 FL401 (DISPLAY)
 S403 TUNER BAND
 S401 TAPE DECK 1/2
 IC202 (REMOTE SENSOR)

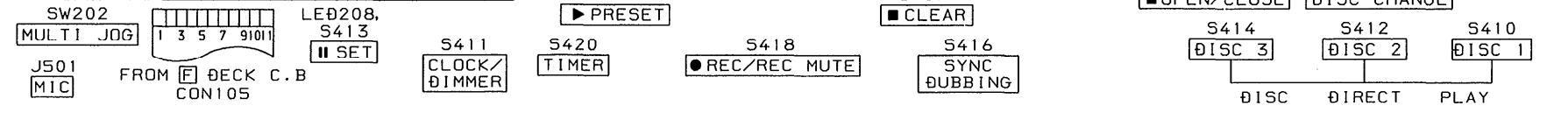
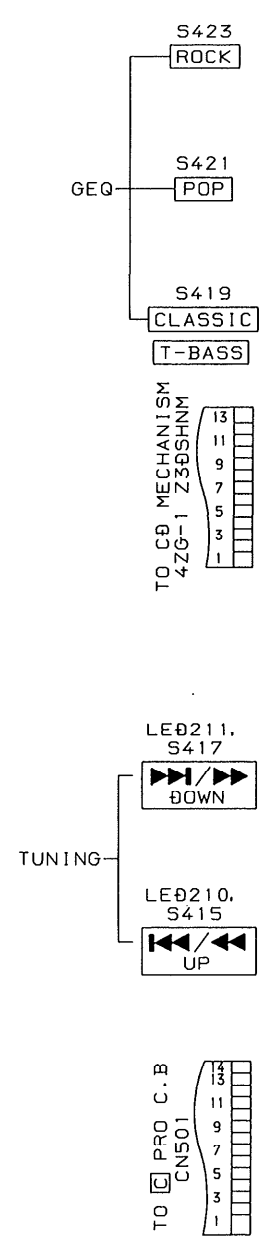
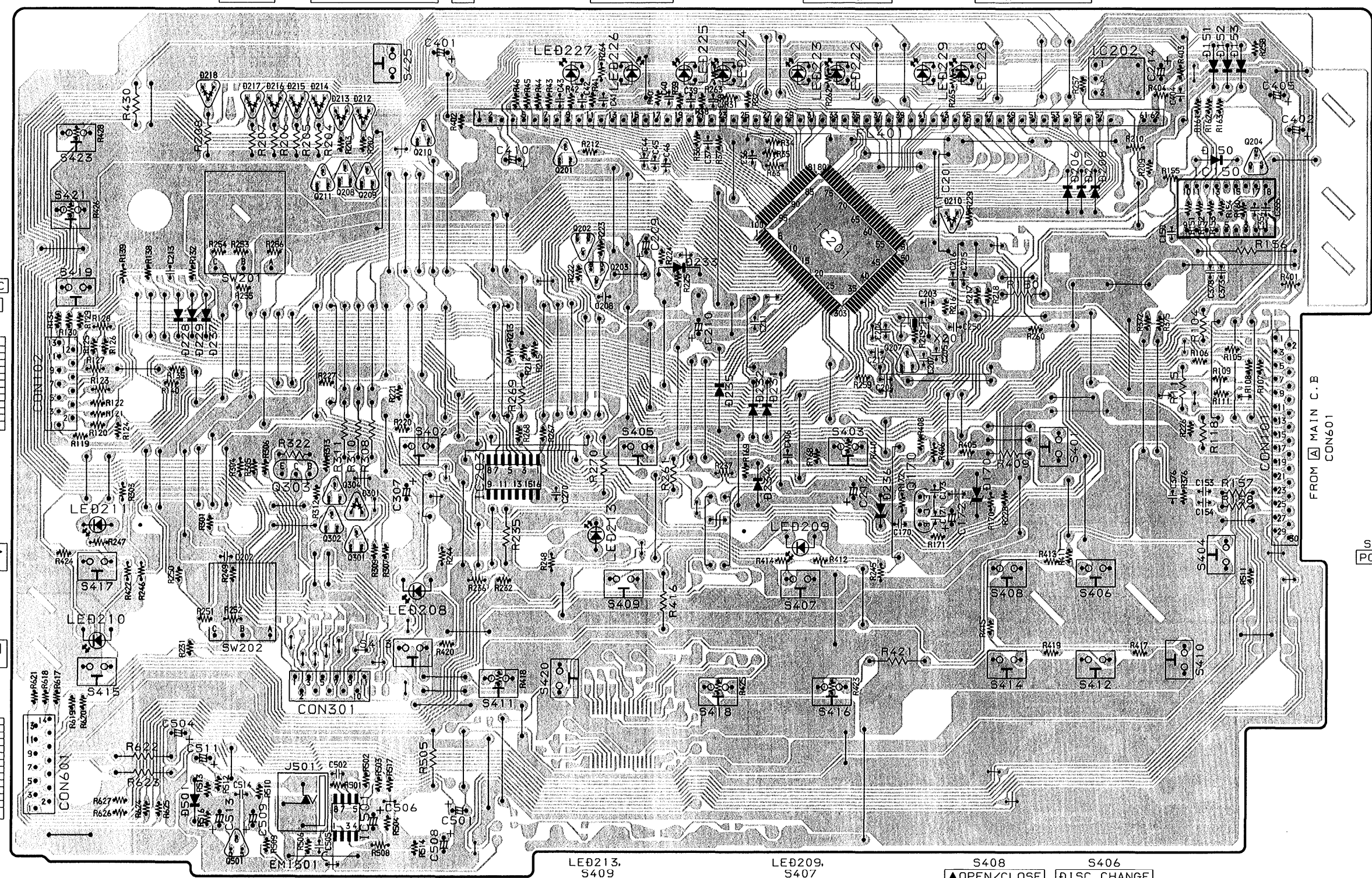

FROM MAIN C. B. CON601

S404 POWER

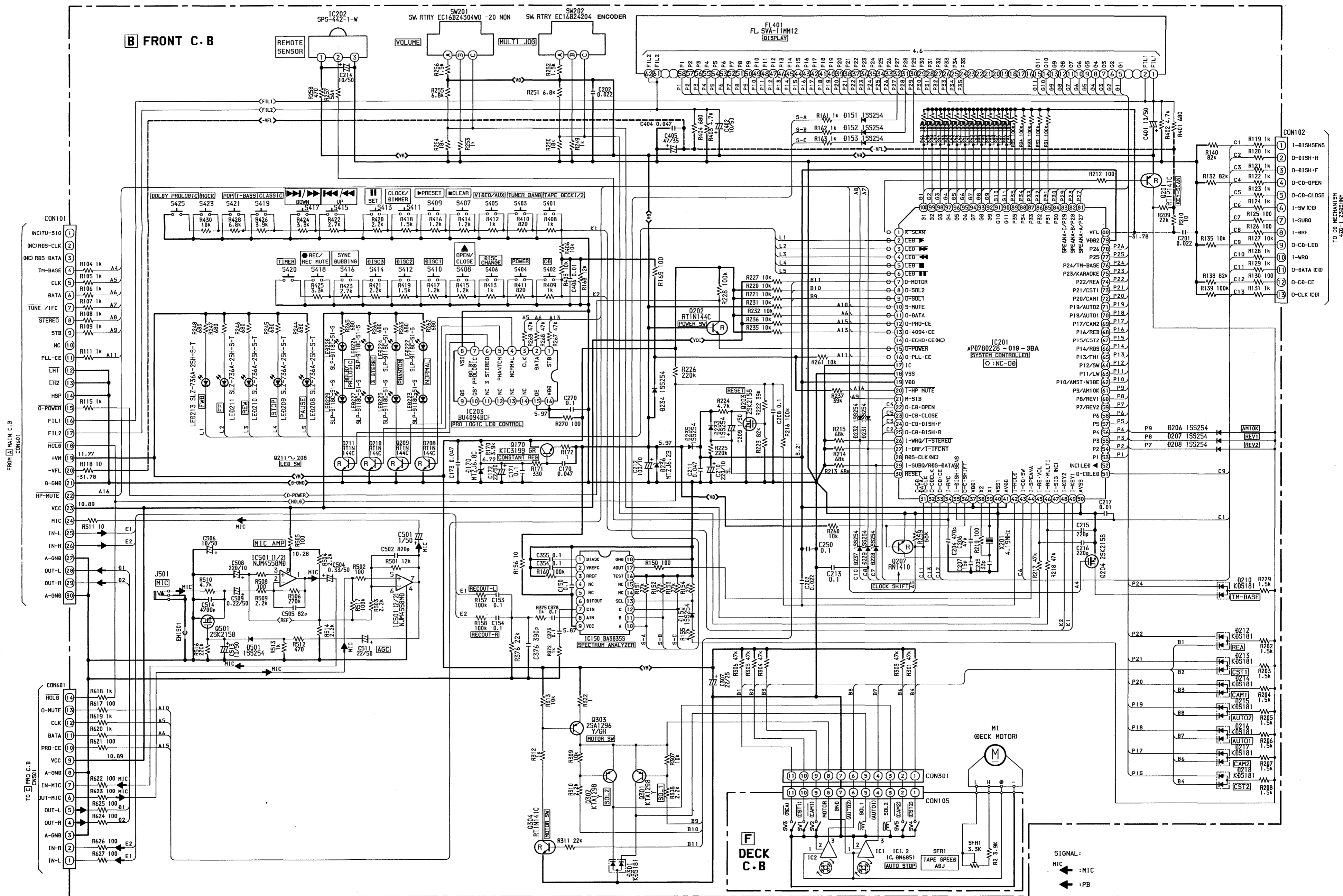

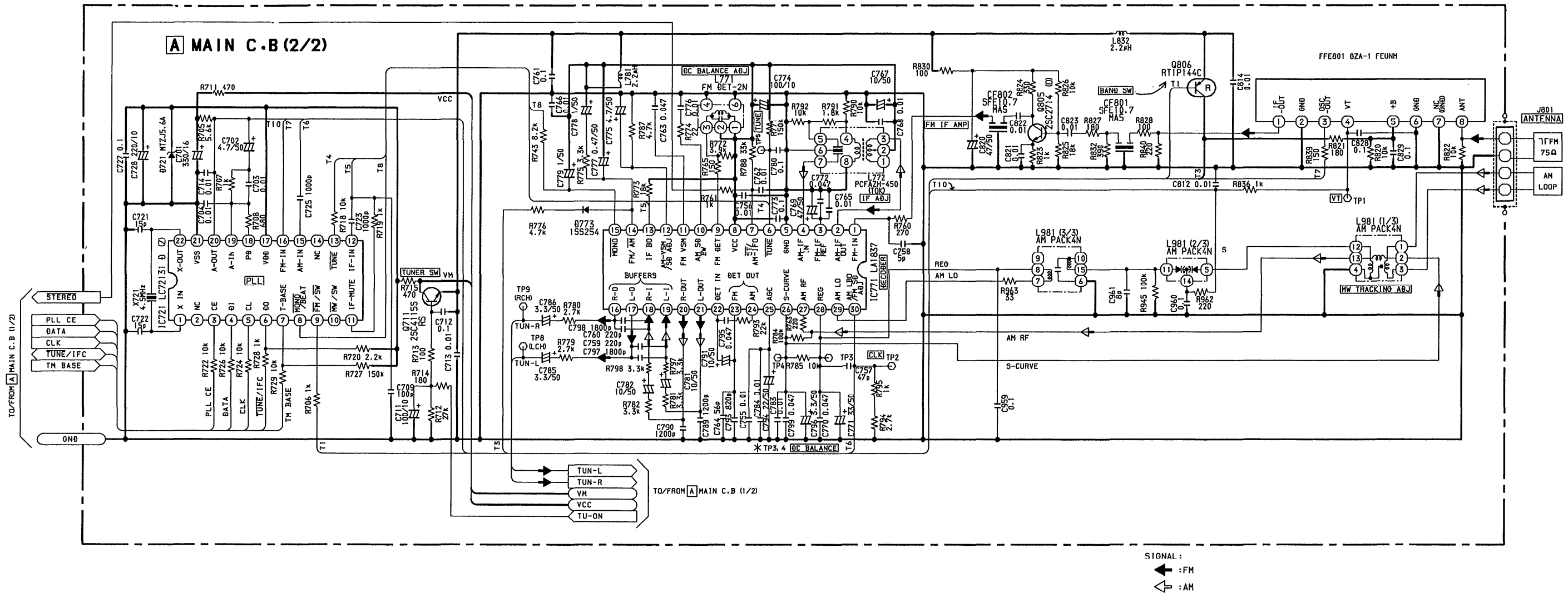

WIRING - 4 (AC)

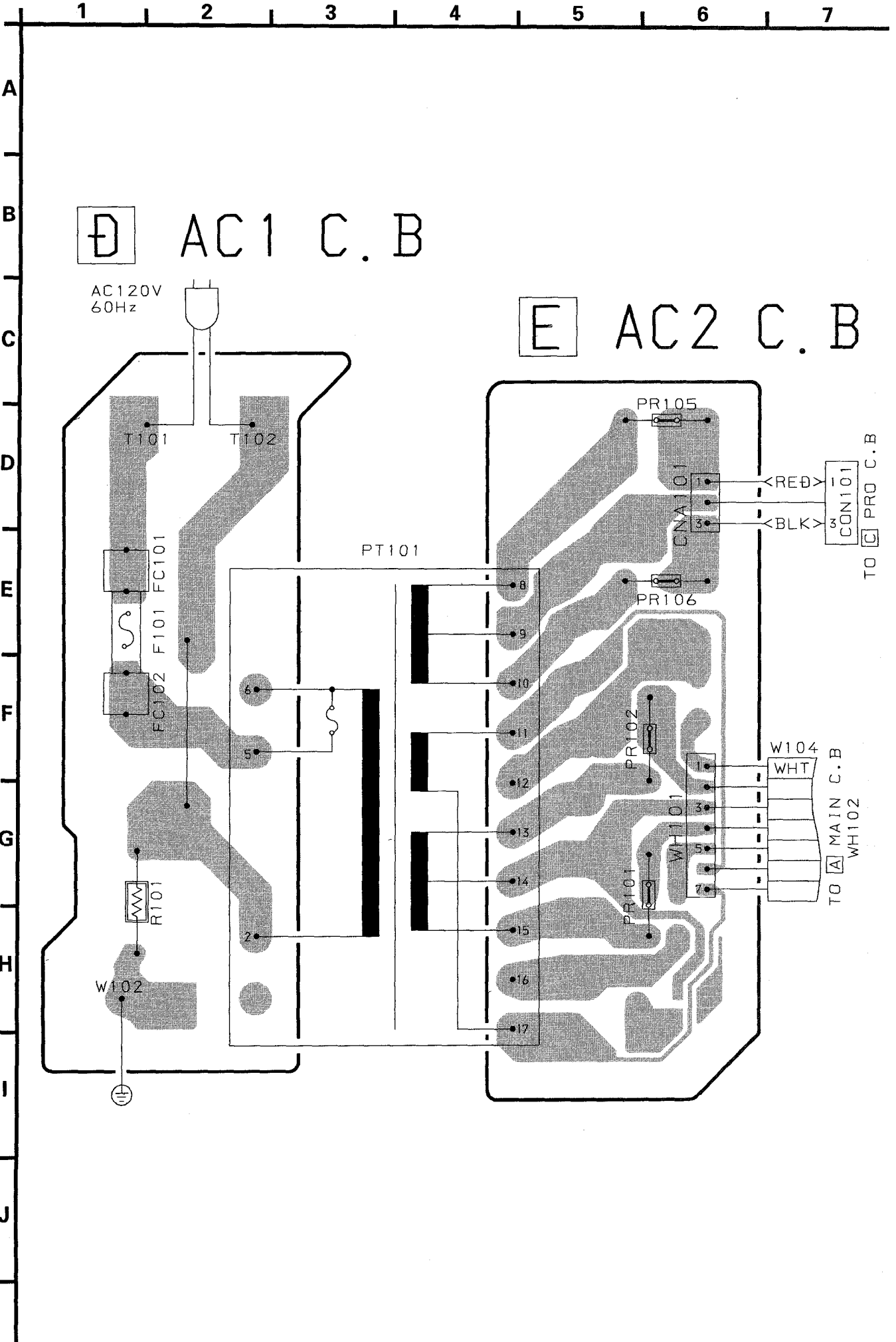

WIRING - 5 (DECK)

1 2 3 4 5 6 7

A
B
C
D
E
F
G
H
J

FROM [B] FRONT C.B.
CON301

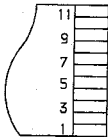

F DECK C. B.

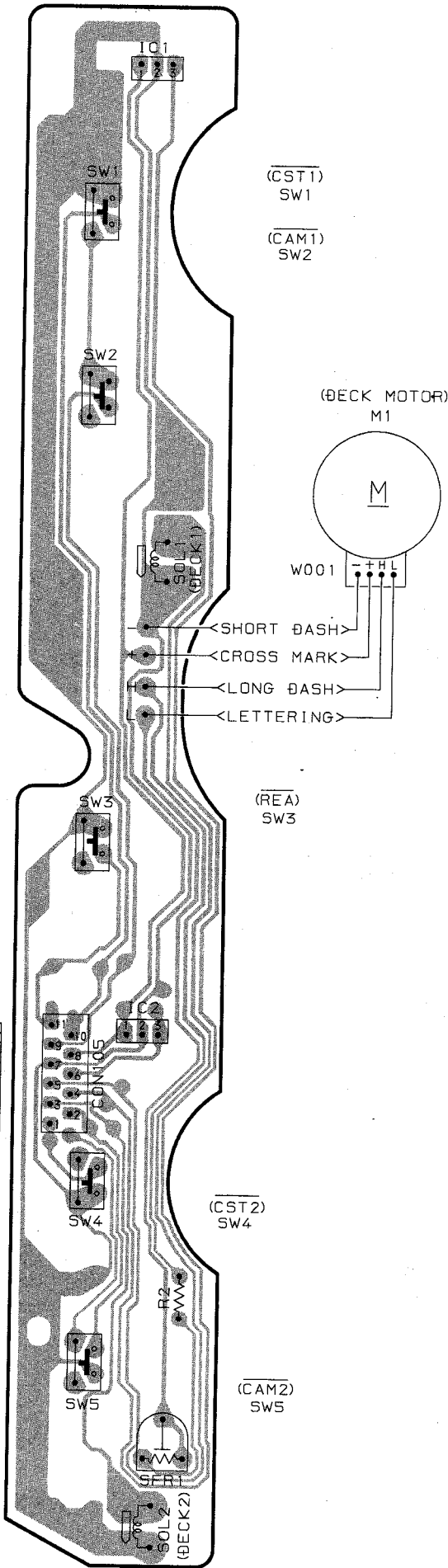

FL GRID ASSIGNMENT AND ANODE CONNECTION

GRID ASSIGNMENT

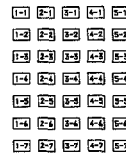
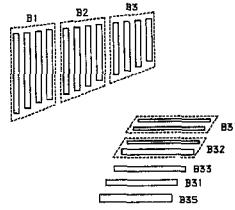
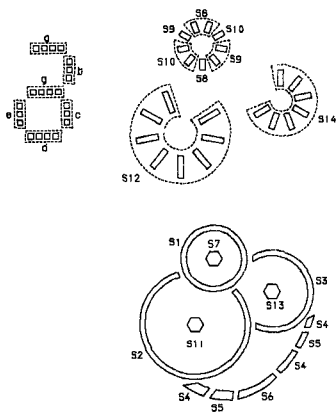
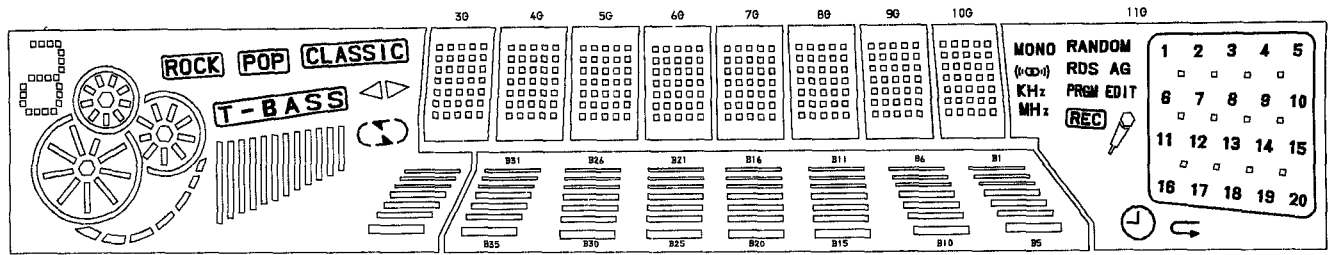

(3G-10G)

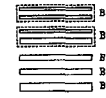

(2G)

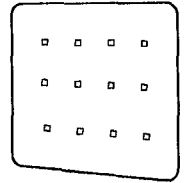

(11G)

ANODE CONNECTION

	1G	2G	3G-10G	11G
P1	a, g, d	B35	1-1	MONO
P2	b	B30	2-1	((∞∞))
P3	c	B25	3-1	KHz
P4	e	B20	4-1	MHz
P5	S1	B15	5-1	
P6	S7	B10	1-2	RANDOM
P7	S8	B5	2-2	
P8	S9	B34	3-2	
P9	S10	B29	4-2	
P10	S2	B24	5-2	EDIT
P11	S11	B19	1-3	REC
P12	S12	B14	2-3	
P13	S3	B9	3-3	
P14	S13	B4	4-3	
P15	S14	B33	5-3	S15
P16	S4	B28	1-4	20
P17	S5	B23	2-4	19
P18	S6	B18	3-4	18

	1G	2G	3G-10G	11G
P19	ROCK	B13	4-4	17
P20	POP	B8	5-4	16
P21	CLASSIC	B3	1-5	15
P22		B32	2-5	14
P23		B27	3-5	13
P24		B22	4-5	12
P25		B17	5-5	11
P26		B12	1-6	10
P27	T-BASS	B7	2-6	9
P28	B1	B2	3-6	8
P29	B2	B31	4-6	7
P30	B3	B26	5-6	6
P31	B31	B21	1-7	5
P32	B32	B16	2-7	4
P33	B33	B11	3-7	3
P34	B34	B6	4-7	2
P35	B35	B1	5-7	1

IC BLOCK DIAGRAM - 2

IC, BA3835S

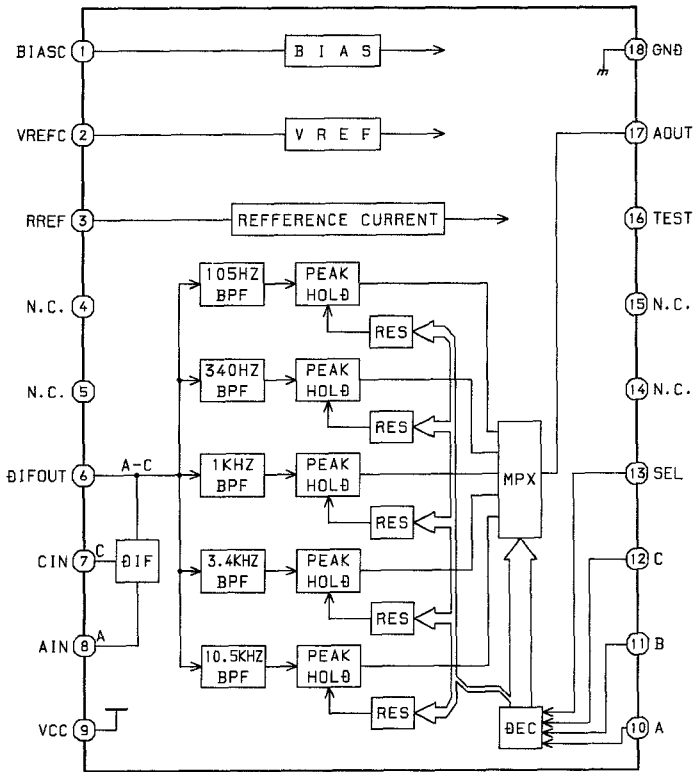

IC, BU4094BCF

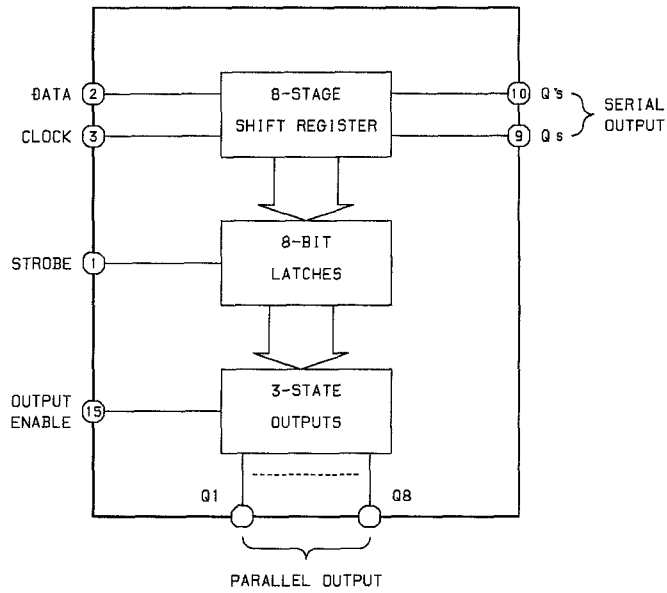

TRUTH TABLE

CLOCK	OUTPUT ENABLE	STROBE	DATA	PARALLEL OUTPUTS		SERIAL OUTPUTS	
				Q1	Qn	Qs	Q's
	L	X	X	Z	Z	Q7	NO Chg.
	L	X	X	Z	Z	No Chg.	Qs
	H	L	X	No Chg.	No Chg.	Q7	No Chg.
	H	H	L	L	Qn-1	Q7	No Chg.
	H	H	H	H	Qn-1	Q7	No Chg.
	H	X	X	No Chg.	No Chg.	No Chg.	Qs

Z=High Impedance

X=Don't Care

IC, LC72131D

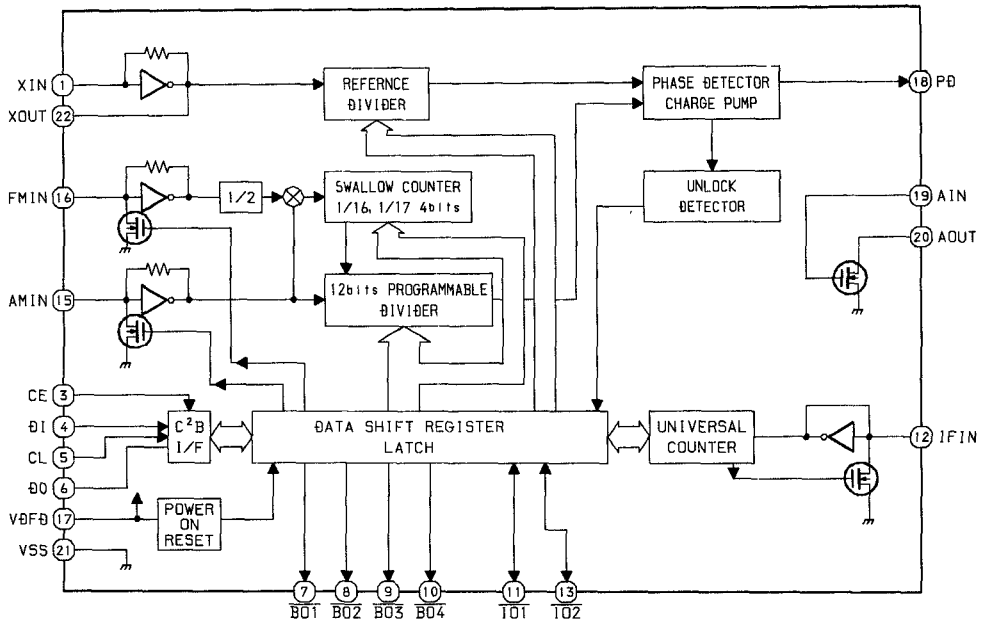

IC, LA1837

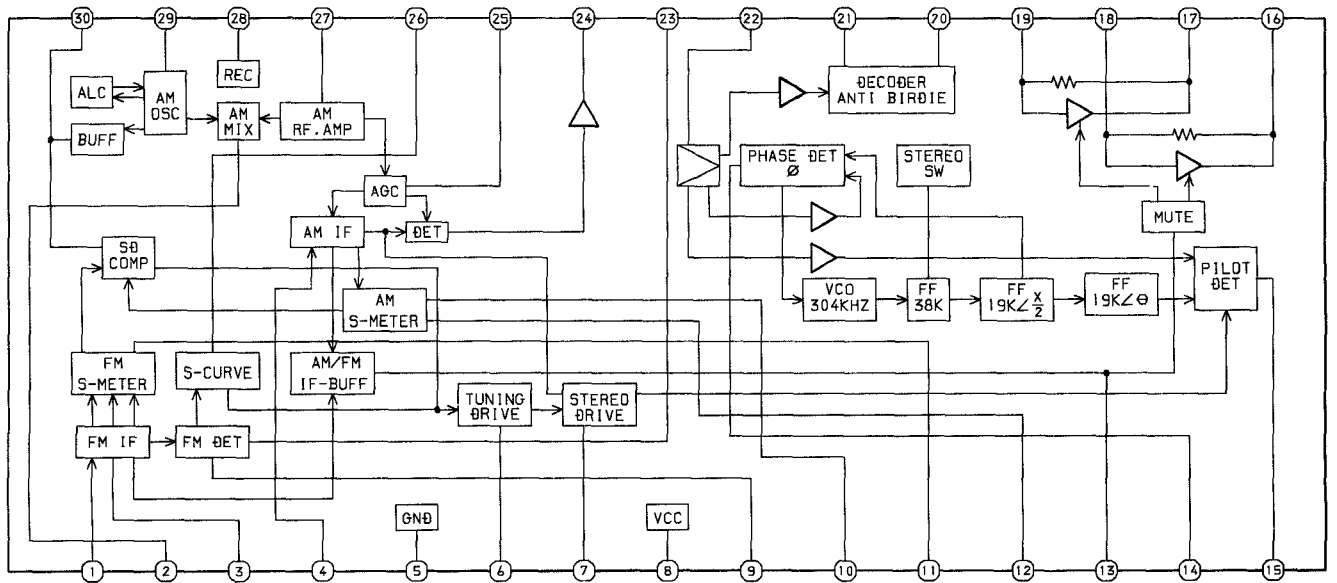

IC, M62463FP

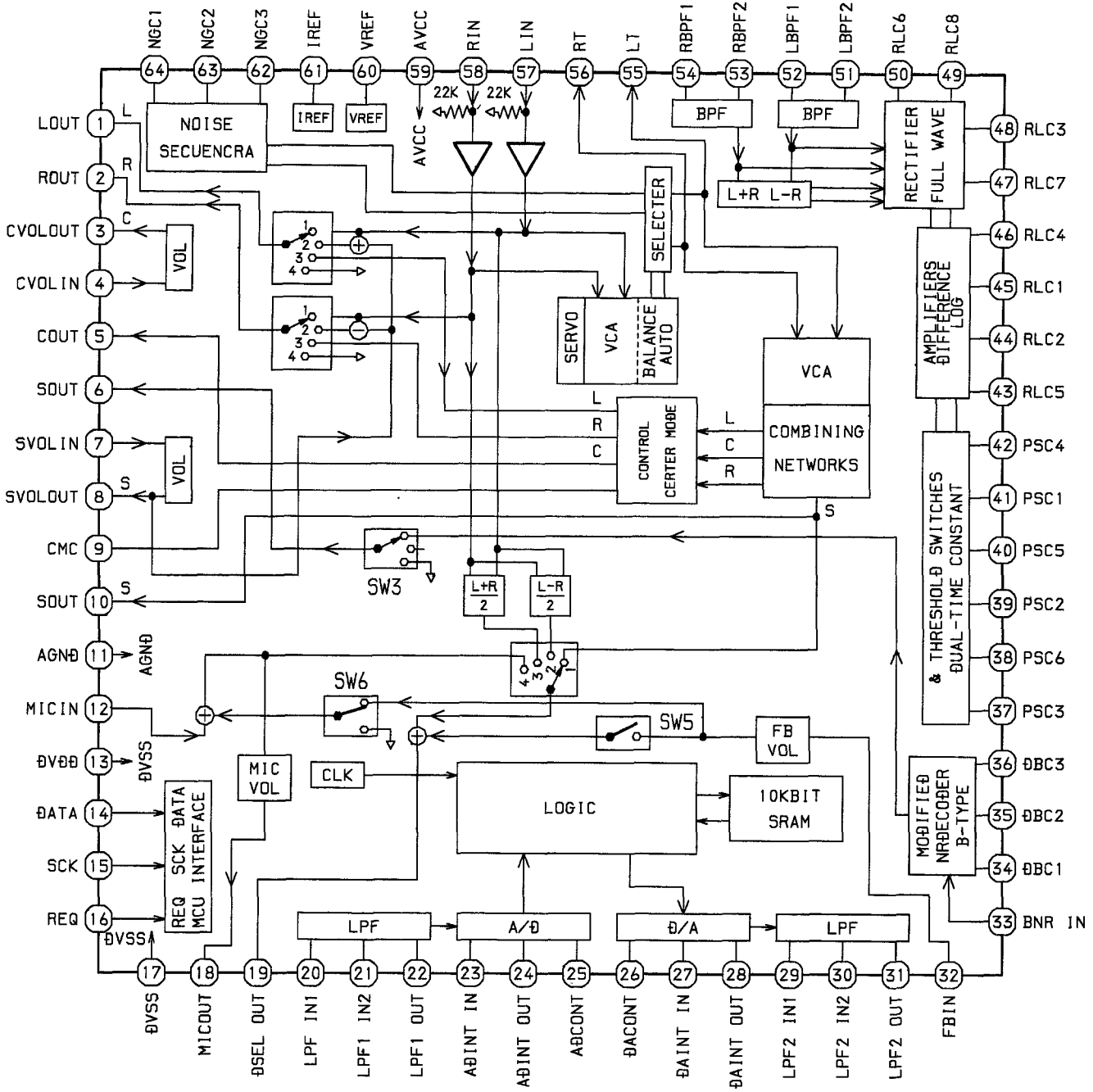

IC DESCRIPTION

IC, μ PD780228

Pin No.	Pin Name	I/O	Description
1	$\overline{\text{K-SCAN}}$	O	Key scan output.
2	$\overline{\text{LED}} \blacktriangleright$	O	\blacktriangleright LED $\overline{\text{ON/OFF}}$ output.
3	$\overline{\text{LED}} \blacktriangleright\blacktriangleright$	O	$\blacktriangleright\blacktriangleright$ LED $\overline{\text{ON/OFF}}$ output.
4	$\overline{\text{LED}} \blacktriangleleft\blacktriangleleft$	O	$\blacktriangleleft\blacktriangleleft$ LED $\overline{\text{ON/OFF}}$ output.
5	$\overline{\text{LED}} \blacksquare$	O	\blacksquare LED $\overline{\text{ON/OFF}}$ output.
6	$\overline{\text{LED}} \parallel$	O	\parallel LED $\overline{\text{ON/OFF}}$ output.
7	O-MOTOR	O	DECK MOTOR ON/OFF output.
8	$\overline{\text{O-SOL2}}$	O	DECK 2 solenoid output.
9	$\overline{\text{O-SOL1}}$	O	DECK 1 solenoid output.
10	S-MUTE	O	Surround mute output.
11	O-DATA	O	Data output for MAIN,FRONT,PRO C.B.
12	O-PRO-CE	O	Prologic IC chip enable output.
13	O-4094.CE	O	Latch strobe output to shift register IC.
14	O-ECHO.CE (N.C)	-	Not connected.
15	$\overline{\text{O-POWER}}$	O	System power supply $\overline{\text{ON/OFF}}$ output.
16	O-PLL.CE	O	PLL IC chip enable output.
17	IC	-	Internal connection.(Connected to GND.)
18	VSS	-	GND.
19	VDD	-	Power supply input.
20	$\overline{\text{I-HP MUTE}}$	I	"L" input prologic DSP off.
21	M-STB	O	Latch strobe output for MAIN C.B.
22	O-CD.OPEN	O	CD tray open data output.
23	O-CD.CLOSE	O	CD tray close data output.
24	O-CD.DISH.F	O	CD turntable forward rotation output.
25	O-CD.DISH.R	O	CD turntable reverse rotation output.
26	$\overline{\text{I-WRQ/I-STEREO}}$	I	CD WRQ input/Tuner stereo input.
27	$\overline{\text{I-DRF/I-IFCNT}}$	I	CD DRF input/Tune IF count serial data input.
28	RDS CLK (N.C)	I	Tuner RDS clock input.(Not connected.)
29	$\overline{\text{I-SUBQ/RDS-DATA}}$	I	CD SUBQ data input/RDS data input.
30	$\overline{\text{RESET}}$	I	System reset.
31	O-CD DATA/O-CLK	O	CD data output/Main PLL shift register clock output.
32	O-CDCLK	O	CD clock output.
33	O-CD.CE	O	CD enable output.
34	I-RMC	I	System remote control input.
35	$\overline{\text{I.DISH.SENSE}}$	I	CD turntable photo sensor input.
36	$\overline{\text{O-C.SHIFT}}$	O	Micon clock shift output.
37	VDD1	-	Power supply input.
38,39	X2,X1	-	4.19MHz oscillator circuit.
40	VSS1	-	GND.
41	AVDD	-	Power supply input.
42	$\overline{\text{I-HOLD}}$	I	Power failure detected input "L" to stop clock and main memory. "H" for normal operation.
43	$\overline{\text{I-CD.SW}}$	I	CD mecha switch input.

Pin No.	Pin Name	I/O	Description
44	I-SPEANA	I	A/D input for spectrum analyser display.
45	I-RE.VOL	I	Volume jog AD input.
46	I-RE.MULTI	I	Multi jog AD input.
47	I-SIG (N.C)	I	RDS Tuner signal input. (Not connected.)
48,49	I-KEY2,1	I	Key2,1 input.
50	AVSS	-	GND.
51	O-CDLED	O	CD flash window LED ON/OFF output.
52	LED ◀	O	◀ LED switch ON/OFF output.
53~58	P1~P6	O	FL segment P1~6 output.
59	P7/REV2	I/O	FL segment P7 output / REV2 data input.
60	P8/REV1	I/O	FL segment P8 output / REV1 data input.
61	P9/AM10K	I/O	FL segment P9 output / AM10K data input.
62	P10/AMST.WIDE	I/O	FL segment P10 output / AMSTWIDE data input.
63	P11/LW	I/O	FL segment P11 output / LW mode data input.
64	P12/SW	I/O	FL segment P12 output / SW mode data input.
65	P13/FM1	I/O	FL segment P13 output / FM1 data input.
66	P14/RDS	I/O	FL segment P14 output / RDS data input.
67	P15/CST2	I/O	FL segment P15 output / DECK2 cassette detect switch data input.
68	P16/REB	I/O	FL segment P16 output / DECK2 side B record OK switch data input.
69	P17/CAM2	I/O	FL segment P17 output / DECK2 CAM switch data input.
70	P18/AUTO1	I/O	FL segment P18 output / DECK1 AUTO stop switch data input.
71	P19/AUTO2	I/O	FL segment P19 output / DECK2 AUTO stop switch data input.
72	P20/CAM1	I/O	FL segment P20 output / DECK1 CAM stop switch data input.
73	P21/CST1	I/O	FL segment P21 output / DECK1 cassette detect switch data input.
74	P22/REA	I/O	FL segment P22 output / DECK2 side A record OK switch data input.
75	P23/KARAOKE	I/O	FL segment P23 output / KARAOKE data input.
76	P24/TM-BASE	I/O	FL segment P24 output / TM-BASE data input.
77,78	P25,P26	O	FL segment P25,P26 output.
79	VDD2	-	Power supply input.
80	-VFL	-	Power supply for FL display.
81	SPEANA-A/P27	O	FL segment P27 output / Spectrum analyser band switching data output.
82	SPEANA-B/P28	O	FL segment P28 output / Spectrum analyser band switching data output.
83	SPEANA-C/P29	O	FL segment P29 output / Spectrum analyser band switching data output.
84~89	P30~P35	O	FL segment P30~35 output.
90~100	G11~G1	O	FL grid G11~1 output.

IC, LC72131

Pin No.	Pin Name	I/O	Description																								
1	XIN	I/O	A crystal oscillator (4.5MHz) is connected between these pins.																								
22	XOUT																										
2	NC	-	Not used.																								
3	CE	I	To enable the IC. Active "H".																								
4	DI	I	Digital data input from CPU (μ PD780228) when relevant key is operated. Active "H".																								
5	CL	I	To clock in the data DI.																								
6	DO	O	Digital data output to CPU (μ PD780228).																								
7	T-BASE	O	Outputs a reference clock signal (8Hz) for the clock.																								
8	MONO / BEAT	O	Outputs "H" when MONO / BEAT is switched.																								
9	$\overline{\text{FM}} / \overline{\text{SW}}$	O	Output "L" or "H" as follows: <table border="1" style="margin-left: 20px;"> <thead> <tr> <th colspan="2">2 BAND</th> <th colspan="3">3 BAND</th> <th colspan="3">3 BAND</th> </tr> <tr> <th>AM</th> <th>FM</th> <th>LW</th> <th>MW</th> <th>FM</th> <th>MW</th> <th>SW</th> <th>FM</th> </tr> </thead> <tbody> <tr> <td>H</td> <td>L</td> <td>H</td> <td>H</td> <td>L</td> <td>H</td> <td>L</td> <td>L</td> </tr> </tbody> </table>	2 BAND		3 BAND			3 BAND			AM	FM	LW	MW	FM	MW	SW	FM	H	L	H	H	L	H	L	L
2 BAND		3 BAND			3 BAND																						
AM	FM	LW	MW	FM	MW	SW	FM																				
H	L	H	H	L	H	L	L																				
10	$\overline{\text{MW}}/\overline{\text{SW}}$	O	Outputs "L" or "H" as follows: <table border="1" style="margin-left: 20px;"> <thead> <tr> <th colspan="2">2 BAND</th> <th colspan="3">3 BAND</th> <th colspan="3">3 BAND</th> </tr> <tr> <th>AM</th> <th>FM</th> <th>LW</th> <th>MW</th> <th>FM</th> <th>MW</th> <th>SW</th> <th>FM</th> </tr> </thead> <tbody> <tr> <td>L</td> <td>L</td> <td>H</td> <td>L</td> <td>L</td> <td>L</td> <td>H</td> <td>L</td> </tr> </tbody> </table>	2 BAND		3 BAND			3 BAND			AM	FM	LW	MW	FM	MW	SW	FM	L	L	H	L	L	L	H	L
2 BAND		3 BAND			3 BAND																						
AM	FM	LW	MW	FM	MW	SW	FM																				
L	L	H	L	L	L	H	L																				
11	IF-MUTE	O	To control internal counter.																								
12	IF-IN	I	General purpose counter input.																								
13	$\overline{\text{TUNE}}$	I	Receives "L" when station is tuned.																								
14	NC	-	Not used.																								
15	AM-IN	I	Receives the AM local oscillator frequency signal.																								
16	FM-IN	I	Receives the FM local oscillator frequency signal.																								
17	VDD	-	Supply power to IC (+5V).																								
18	PD	O	PLL charge pump output.																								
19	A-IN	I	The MOS transistor for PLL active low pass filter.																								
20	A-OUT	O																									
21	VSS	-	Ground.																								

ADJUSTMENT <TUNER / DECK>

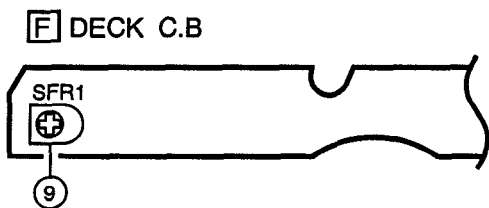
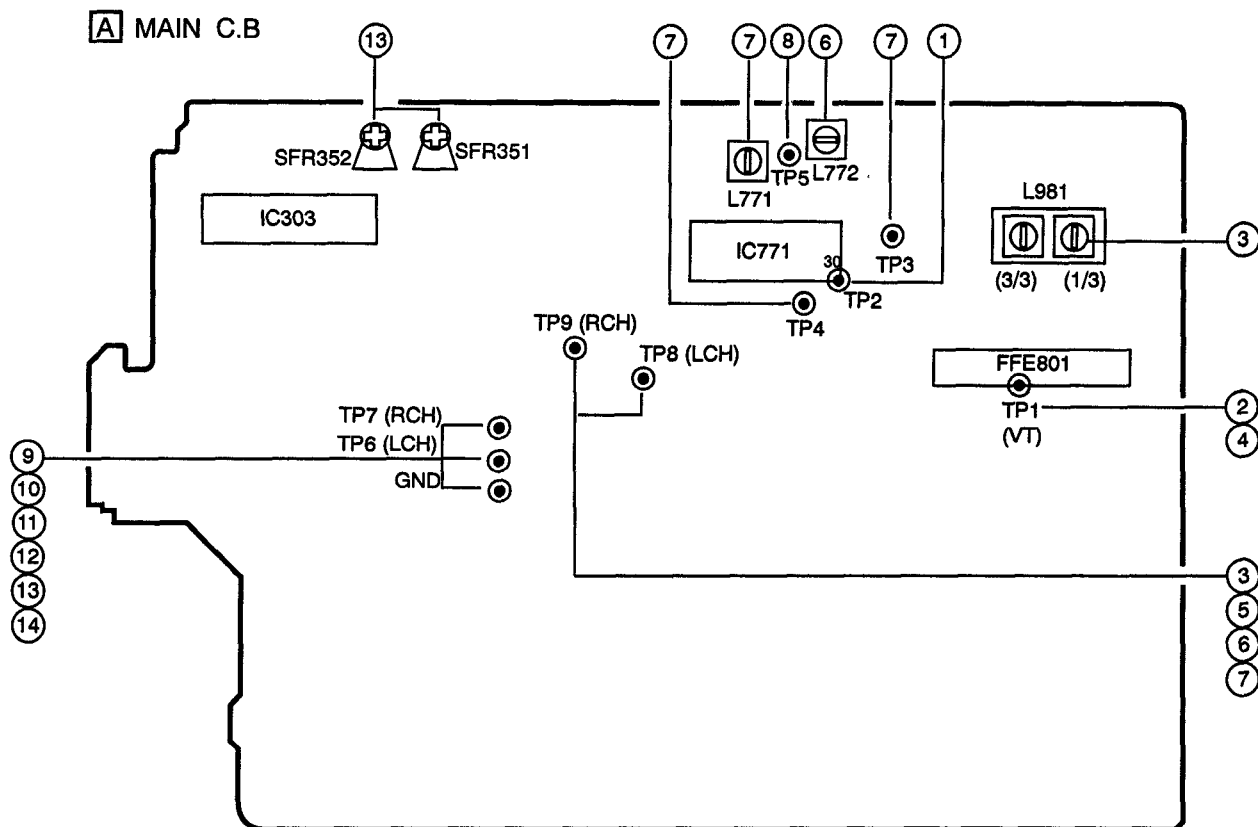

DECK-1 P, DECK-2 R / P / E HEAD

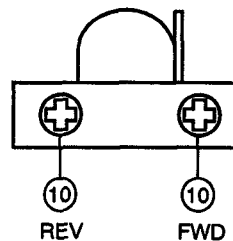

< TUNER SECTION >

- 1. Clock Frequency Check**
 Settings : • Test point : TP2
 Method : Set to AM 1710kHz and check that the test point is 2160kHz \pm 45Hz.
- 2. AM VT Check**
 Settings : • Test point : TP1
 Method : Set to AM 1710kHz and AM 530kHz and check that the test point is less than 8.5V(1710kHz) and more than 0.6V(530kHz).
- 3. AM Tracking Adjustment**
 Settings : • Test point : TP8(Lch), TP9(Rch)
 • Adjustment location :
 L981(1/3) 1000kHz
 Method : Set to AM 1000kHz and adjust L981(1/3) so that the test point is max.
- 4. FM VT Check**
 Settings : • Test point : TP1
 Method : Set to FM 108.0MHz and check that the test point is less than 8.0V.
 Set to FM 87.5MHz and check that the test point is more than 0.5V.

5. FM Tracking Check
 Settings : • Test point : TP8(Lch), TP9(Rch)
 Method : Set to FM 98.0MHz and check that the test point is less than 9.0dB.
6. AM IF Adjustment
 Settings : • Test point : TP8(Lch), TP9(Rch)
 • Adjustment location :
 L772 450kHz
7. DC Balance / Mono Distortion Adjustment
 Settings : • Test point : TP3, TP4 (DC Balance)
 TP8, TP9 (Distortion)
 • Adjustment location : L771
 • Input level : 54dB
 Method : Set to FM 98.0MHz and adjust L771 so that the voltage between TP3 and TP4 becomes $0V \pm 0.04V$.
 Next, check that the distortion is less than 1.3%
8. Auto Stop Level Check
 AM
 Settings : • Input level : 52dB
 • Test point : TP5
 Method : Set to AM 1000kHz and check that the auto stop is at 37 ~ 62dB.
- FM
 Settings : • Input level : 25dB
 • Test point : TP5
 Method : Set to FM 98.0MHz and check that the auto stop is at $25dB \pm 10dB$.

< DECK SECTION >

9. Tape Speed Adjustment
 Settings : • Test tape : TTA-100
 • Test point : TP6(Lch), TP7(Rch)
 • Adjustment location : SFR1
 Method : Play back the test tape and adjust SFR1 so that the frequency counter reads $3000Hz \pm 5Hz$.
10. Head Azimuth Adjustment
 Settings : • Test tape : TTA-300
 • Test point : TP6(Lch), TP7(Rch)
 • Adjustment location : Head azimuth adjustment screw
 Method : Play back (FWD) the 10kHz signal of the test tape and adjust screw so that the output becomes maximum.
 Next, perform on REV PLAY mode.
11. PB Frequency Response Check (DECK 1, DECK 2)
 Settings : • Test tape : TTA-300
 • Test point : TP6(Lch), TP7(Rch)
 Method : Play back the 315Hz and 10kHz signals of the test tape and check that the output ratio of the 10kHz signal with respect to that of the 315Hz signal is within 5dB.
12. PB Sensitivity Check (DECK 1, DECK 2)
 Settings : • Test tape : TTA-200
 • Test point : TP6(Lch), TP7(Rch)
 Method : Play back the test tape and check that the output level at TP6, TP7 becomes $120mV \pm 3.0dB$.
13. REC/PB Frequency Response Adjustment
 Settings : • Test tape : TTA-602
 • Test point : TP6(Lch), TP7(Rch)
 • Input signal : 1kHz / 10kHz (LINE IN)
 • Adjustment location : SFR351 (Lch)
 SFR352 (Rch)
 Method : Apply a 1kHz signal and REC mode. Then adjust OSC attenuator so that the output level at the TP6, TP7 becomes -28 dBV. Record and play back the 1kHz and 10kHz signals and adjust SFRs so that the output of the 10kHz signals becomes $0dB \pm 0.5dB$ with respect to that of the 1kHz signal.
14. REC/PB Sensitivity Check
 Settings : • Test tape : TTA-602
 • Test point : TP6(Lch), TP7(Rch)
 • Input signal : 1kHz (LINE IN)
 Method : Apply a 1kHz signal and REC mode. Then adjust OSC attenuator so that the output level at the TP6, TP7 becomes -8 dBV. Record and play back the 1kHz signals and check that the output is $0 \pm 3.5dB$.

PRACTICAL SERVICE FIGURE

<TUNER SECTION>

- <FM SECTION>
 IHF Sensitivity : Less than 10 / 9 / 9dB
 (THD 3%) [at 87.5 / 98.0 / 108.0MHz]
 S/N 50dB Quieting sensitivity :
 Less than 35dB
 [at 98.0MHz]
 Signal to noise ratio : Mono : More than 68dB
 Stereo : More than 66dB
 [at 98.0MHz]
 Distortion : Mono : Less than 1.2%
 Stereo : Less than 2.0%
 [at 98.0MHz]
 Auto stop level : $25dB \pm 10dB$ [at 98.0MHz]
 Stereo separation : More than 30dB [at 98.0MHz]
 Intermediate frequency : 10.7MHz

<AM SECTION>

- Sensitivity : Less than 60dB
 [at 600kHz]
 Less than 58dB
 [at 1000kHz]
 Less than 58dB
 [at 1400kHz]
 Signal to noise ratio : More than 36dB
 [at 1000kHz]
 Distortion : Less than 1.5%
 [at 1000kHz]
 Auto stop level : $52dB +10/-15dB$
 [at 1000kHz]
 Intermediate frequency : 450kHz

<DECK SECTION>

- Tape speed : $3000Hz \pm 45Hz$
 Wow & flutter : Less than 0.25% (W.R.M.S)
 Take-up torque : 30 ~ 55g-cm (FWD, REV)
 F.F torque : 75 ~ 180g-cm
 REW torque : 75 ~ 180g-cm
 Back tension : 2 ~ 7g-cm (FWD, REV)
 PB output level : $2.8V \pm 2dB$ (SP OUT 2V)
 REC/PB output level : $0 \pm 3.0dB$ (NORM)
 Distortion (REC/PB) : Less than 2.0% (NORM)
 Noise level (PB) : Less than 25mV(NORM)
 Noise level (REC/PB) : Less than 30mV(NORM)
 Erasing ratio : More than 60dB
 (at 125Hz, +10VU, NORM)
 Test tape : TTA-602 (NORM)

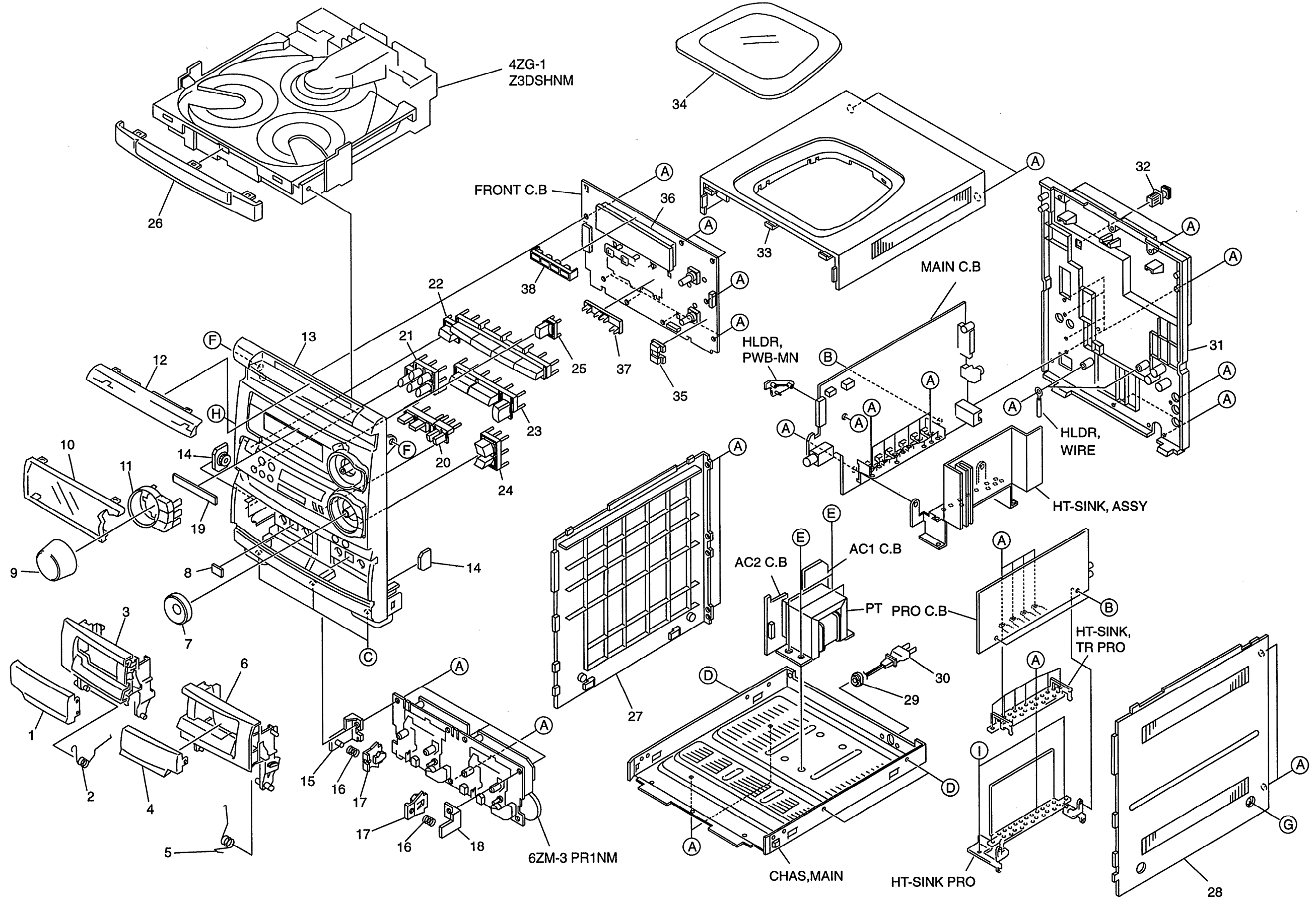

MECHANICAL PARTS LIST 1 / 1

If can't understand for Description please kindly refer to "REFERENCE NAME LIST".

REF. NO.	PART NO.	KANRI NO.	DESCRIPTION	REF. NO.	PART NO.	KANRI NO.	DESCRIPTION
1	87-NB8-012-010		WINDOW,CASS 1	26	88-NF8-046-010		PANEL,TRAY
2	82-NF5-218-010		SPR-T,EJECT 1 (SIN)	27	87-NB8-051-010		PANEL,LEFT U
3	88-NF8-044-010		BOX,CASS 1 1WAY	28	88-NF8-048-010		PANEL,RIGHT 2 U
4	87-NB8-013-010		WINDOW,CASS 2	29	87-085-189-010		BUSHING, CORD (U)
5	82-NF5-219-010		SPR-T,EJECT 2 (SIN)	△ 30	87-050-053-010		AC CORD ASSY,U-2
6	88-NF8-043-010		BOX,CASS 2 1WAY	31	88-NFV-021-010		CABI,REAR USTNM MT320
7	88-NF8-016-010		KNOB,RTRY JOG	32	84-ZG1-245-210		CAP,OPTICAL
8	81-532-080-010		LABEL, CASS. COMPT	33	87-NF9-055-010		PANEL, TOP
9	87-NB8-015-010		KNOB,RTRY VOL	34	86-NF2-001-010		WINDOW, TOP
10	88-NFV-011-010		WINDOW,DISPLAY U	35	88-NF8-207-010		GUIDE,FF
11	88-NFV-007-010		KEY,GEQ PRO	36	88-NF8-205-010		GUIDE,FL
12	87-NB8-009-010		WINDOW,CD	37	88-NF8-208-010		GUIDE,PLAY 1WAY
13	88-NFV-001-010		CABI,FR U	38	88-NFV-201-010		GUIDE,PRO
14	87-NF8-220-010		DMPR,150	A	87-067-703-010		TAPPING SCREW, BVT2+3-10
15	87-NF4-216-010		HLDR,LOCK 1	B	87-NF4-224-010		S-SCREW,IT3B+3-8 CU
16	86-NF9-224-010		SPR-C,LOCK	C	87-067-688-010		BVTT+3-6
17	82-NF5-229-010		PLATE,LOCK	D	87-721-096-410		QT2+3-10 GLD
18	87-NF4-217-010		HLDR,LOCK 2	E	87-078-019-010		S-SCREW,IT+4-6
19	88-NFV-010-010		PLATE,PRO	F	87-721-097-410		QT2+3-12 GLD
20	88-NF8-006-210		KEY,REC	G	87-067-641-010		UTT2+3-8(W/O SLOT)BL
21	88-NF8-014-110		KEY,CD	H	87-723-096-410		QT2+3-10W/O SLOT BL
22	88-NF8-007-010		KEY,FUNCTION	I	87-067-579-010		TAPPING SCREW, BVT2+3-8
23	88-NF8-019-010		KEY,PLAY 1WAY ASSY				
24	88-NF8-013-010		KEY,ASSY FF				
25	88-NFV-006-010		KEY,PRO				

TAPE MECHANISM EXPLODED VIEW 1 / 1

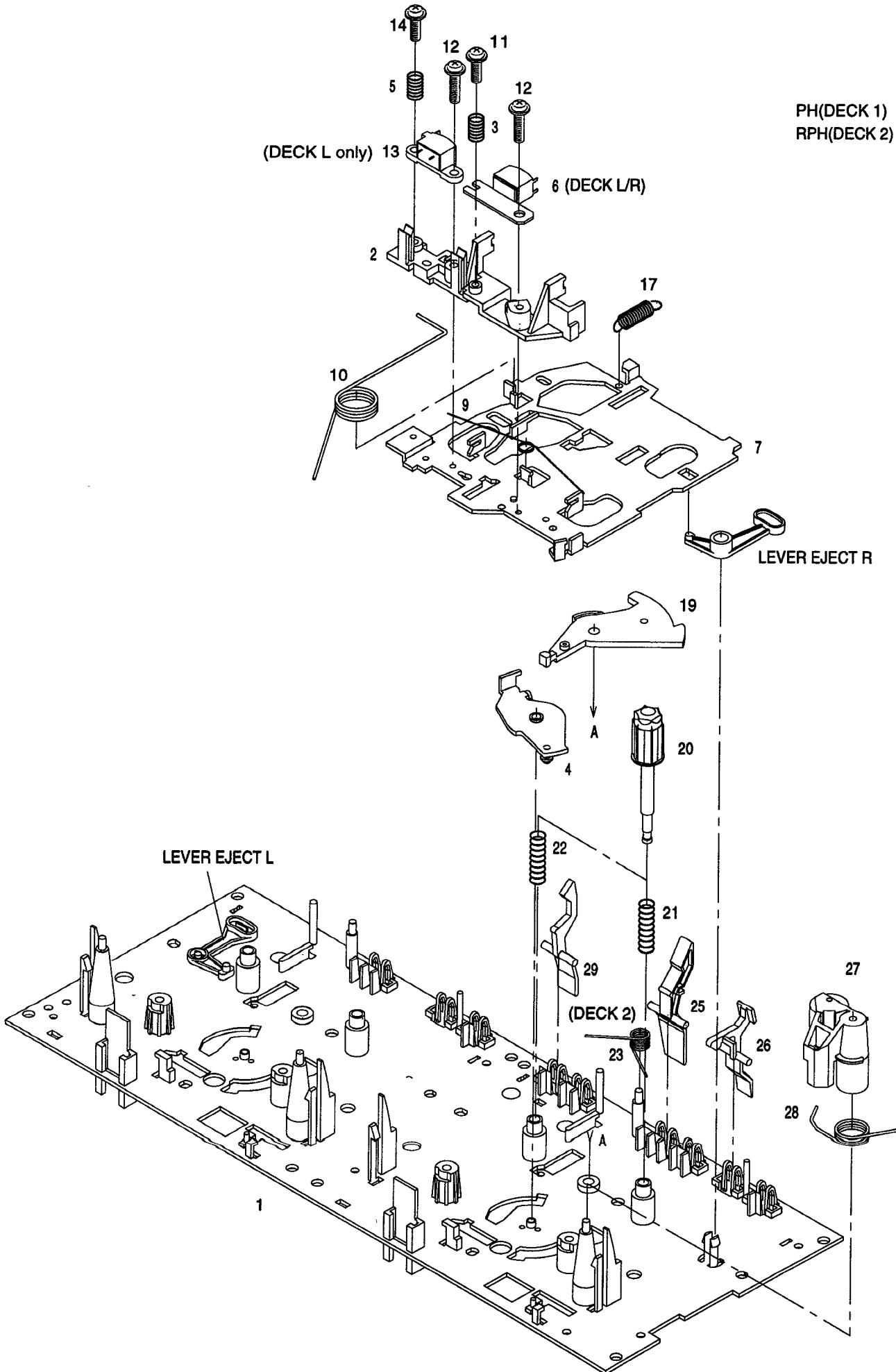

TAPE MECHANISM PARTS LIST 1 / 1

If can't understand for Description please kindly refer to "REFERENCE NAME LIST".

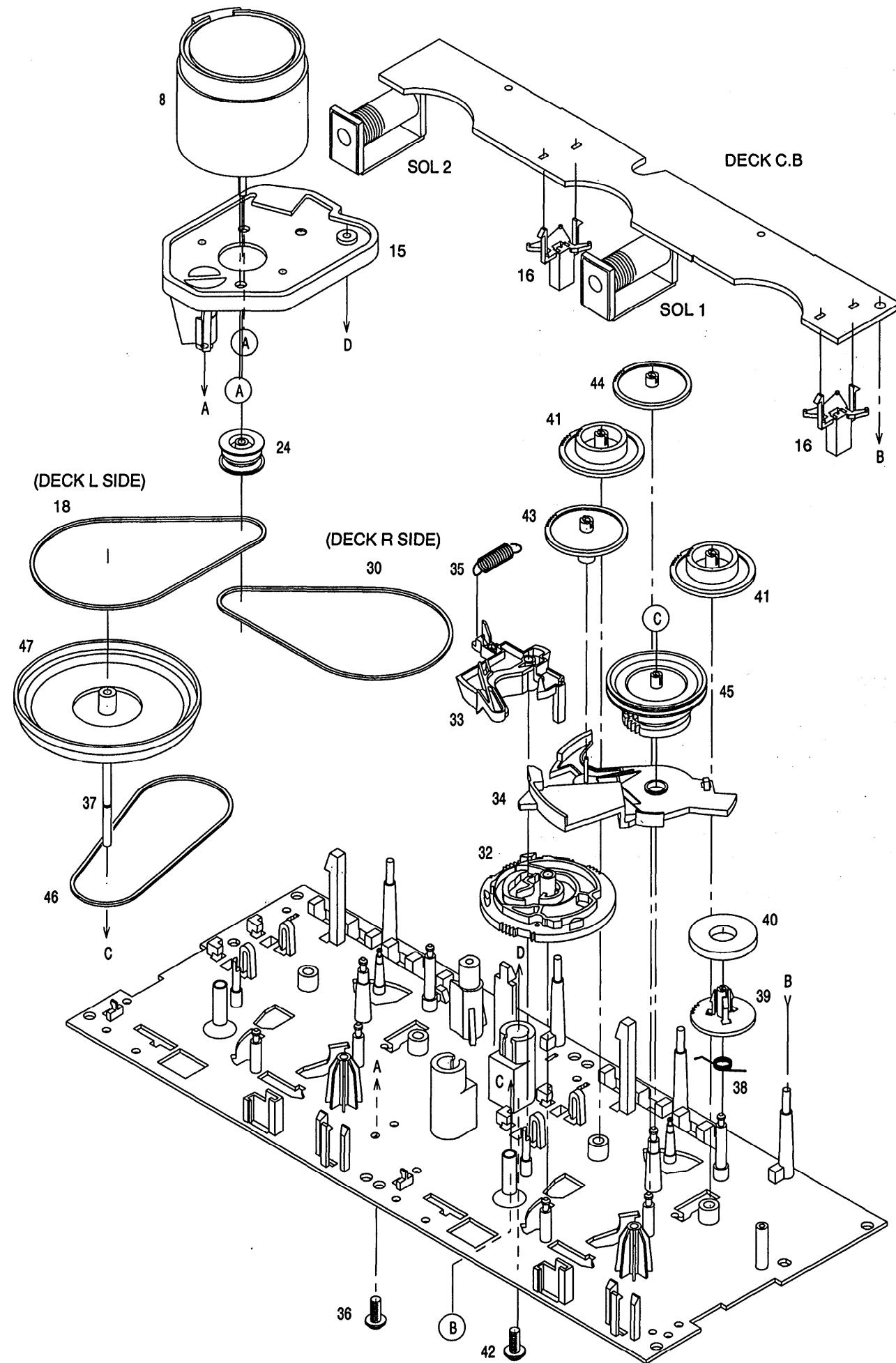

REF. NO.	PART NO.	KANRI NO.	DESCRIPTION	REF. NO.	PART NO.	KANRI NO.	DESCRIPTION
1	86-ZM3-212-010		CHAS ASSY,SS	26	82-ZM1-243-019		LVR,STOP
2	86-ZM3-202-010		BASE,HEAD S	27	82-ZM1-344-119		LVR ASSY,PINCH
3	86-ZM3-205-010		SPR-C,RPH S	28	86-ZM3-204-010		SPR-T,PINCHDS
4	82-ZM1-333-210		PLATE,LINK 2	29	82-ZM1-240-119		LVR,REC (DECK 2)
5	86-ZM3-206-010		SPR-C,EH S	30	86-ZM3-210-010		BELT,PS
6	87-A90-403-019		HEAD,RPH MS15R	31	82-ZM1-223-010		GEAR,PLAY
7	86-ZM3-201-010		CHAS,HEAD S	32	82-ZM3-305-019		GEAR,CAM M2
8	87-045-347-019		MOT,SHU2L 70(M1)	33	82-ZM1-227-319		LVR,TRIG
9	82-ZM1-269-219		SPR-T,BRG	34	82-ZM3-306-110		LVR,FR M2
10	82-ZM3-323-119		SPR-T,LINK	35	82-ZM1-265-119		SPR-E,TRIG
11	86-ZM3-209-010		S-SCREW,ASIMUTHS	36	85-ZM3-203-019		S-SCREW MOTOR M3
12	86-ZM3-207-010		S-SCREW,RPH	37	82-ZM1-236-019		CAPSTAN N 2-41.5
13	87-A90-404-019		HEAD,EH LE15B	37	82-ZM1-239-019		CAPSTAN N 2.2-41.7
14	86-ZM3-208-010		S-SCREW,EH	38	82-ZM1-322-019		SPR-T,FR60
15	86-ZM3-203-010		HLDR,MOTS	39	82-ZM1-220-219		GEAR,IDLER
16	82-ZM1-245-210		HLDR,IC	40	82-ZM3-616-019		RING MAGNET 4
17	82-ZM1-218-019		SPR-E,HB	41	82-ZM1-216-319		GEAR,REEL
18	86-ZM3-211-010		BELT,RS	42	85-ZM3-213-010		S-SCREW,HLDR MOT 3
19	82-ZM1-222-219		LVR,PLAY	43	82-ZM1-225-219		GEAR,FR
20	82-ZM1-217-419		REEL, TABLE	44	82-ZM1-226-019		GEAR,REW
21	82-ZM1-244-519		SPR-C,BT	45	82-ZM3-333-210		SLIP DISK ASSY 2
22	82-ZM1-285-410		SPR-C,BT L	46	82-ZM1-338-010		BELT FR4
23	82-ZM1-257-019		SPR-T,CAS	47	82-ZM1-349-019		FLY-WHL RW (DECK L)
24	82-ZM3-221-010		PULLEY,MOT 2M	47	82-ZM3-331-019		FLY-WHL R2W (DECK R)
25	82-ZM1-242-019		LVR,CAS	A	87-251-071-417		U+2.6-4
				B	80-ZM6-243-019		SH,1.75-3.6-0.5 SLT

SPRING APPLICATION POSITION

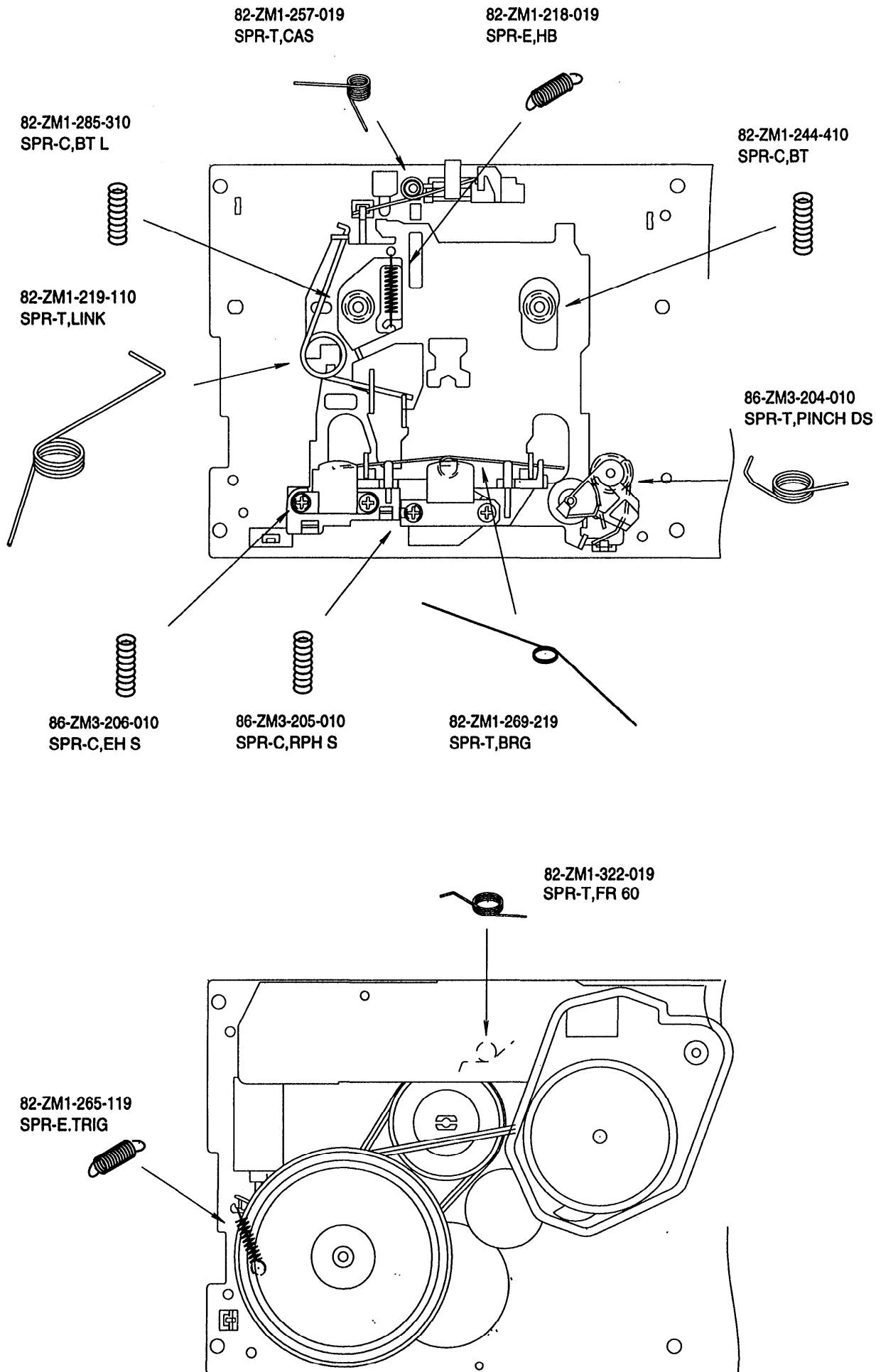

SPEAKER DISASSEMBLY INSTRUCTIONS

Type.1

矢印の位置にマイナスドライバーを差し込んで、パネルを外します。各々のスピーカーユニットのビスを取り、スピーカーユニットを外してください。

Insert a flat-bladed screwdriver into the position indicated by the arrows and remove the panel. Remove the screws of each speaker unit and then remove the speaker units.

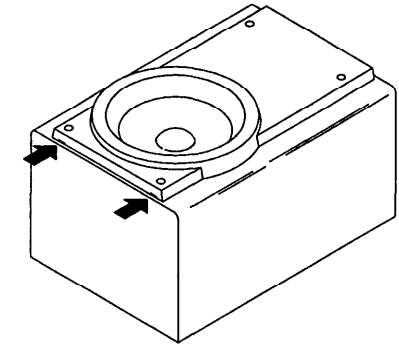

Type.2

グリルフレームを外し、4個のゴムキャブをマイナスドライバーで端の方から持ち上げて外すと中にビスが有りますので、ビスを取り外します。矢印の位置にマイナスドライバーを差し込んで、パネルを外します。各々のスピーカーユニットのビスを取り、スピーカーユニットを外してください。

Remove the grill frame and four pieces of rubber caps by pulling out with a flat-bladed screwdriver. Remove the screws from hole where installed rubber caps. Insert a flat-bladed screwdriver into the position indicated by the arrows and remove the panel. Remove the screws of each speaker unit and then remove the speaker units.

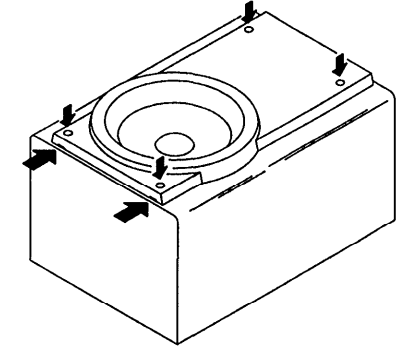

Type.3

矢印の位置にマイナスドライバーを差し込んで、パネルを外します。各々のスピーカーユニットの凹にマイナスドライバーを差し込んで、反時計方向に回転させスピーカーユニットを外してください。スピーカーユニット交換後は時計方向にクリック音がするまで、回転させて取り付けます。

Insert a flat-bladed screwdriver into the position indicated by the arrows and remove the panel. Turn the speaker unit to counter-clockwise direction while inserting a flat-bladed screwdriver into one of the hollows around speaker unit, and then remove the speaker unit. After replacing the speaker unit, install it turning to clockwise direction until "click" sound comes out.

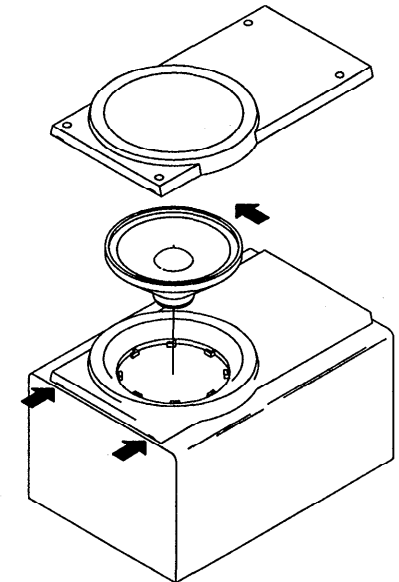

SPEAKER PARTS LIST (SX-NA302<AUST>)

If can't understand for Description please kindly refer to "REFERENCE NAME LIST".

REF. NO.	PART NO.	KANRI NO.	DESCRIPTION
1	86-NS5-012-010		BADGE, AIWA 35
2	87-NS7-611-010		CORD, SPKR
3	87-NSH-612-010		SPKR, CERAMIC ASSY
4	87-NSJ-602-010		SPKR 120
5	88-NSJ-001-010		PANEL, FR

SPEAKER PARTS LIST (SX-R275<YUST>)

If can't understand for Description please kindly refer to "REFERENCE NAME LIST".

REF. NO.	PART NO.	KANRI NO.	DESCRIPTION
1	87-YS1-004-010		GRILLE FRAME ASSY
2	87-YS6-002-010		SPKR, CORD Y
3	87-YS6-601-010		SPKR, 100

SPEAKER PARTS LIST (SX-C605<YUST>)

If can't understand for Description please kindly refer to "REFERENCE NAME LIST".

REF. NO.	PART NO.	KANRI NO.	DESCRIPTION
1	83-NSM-010-010		SPEAKER CORD
2	87-YS3-001-010		PANEL, FRONT ST(C600)
3	87-YS3-003-010		GRILL FRAME ASSY(C600)
4	87-YS7-602-010		SPKR, 100

ACCESSORIES / PACKAGE LIST

If can't understand for Description please kindly refer to "REFERENCE NAME LIST".

REF. NO.	PART NO.	KANRI NO.	DESCRIPTION
1	88-NFV-903-010		IB, U(ESF)M
2	87-006-225-010		AM LOOP ANT NC2
3	87-A90-064-010		FEEDER-ANT, FM(SHS)
4	88-NFV-605-010		RC UNIT, RC-8AS

REFERENCE NAME LIST

ELECTRICAL SECTION

DESCRIPTION	REFERENCE NAME
ANT	ANTENNAS
C-	CHIP
C-CAP	CAP, CHIP
C-CAP TN	CAP, CHIP TANTALUM
C-COIL	COIL, CHIP
C-DI	DIODE, CHIP
C-DIODE	DIODE, CHIP
C-FET	FET, CHIP
C-FOTR	FILTER, CHIP
C-JACK	JACK, CHIP
C-LED	LED, CHIP
C-RES	RES, CHIP
C-SFR	SFR, CHIP
C-SLIDE SW	SLIDE SWITCH, CHIP
C-SW	SWITCH, CHIP
C-TR	TRANSISTOR, CHIP
C-VR	VOLUME, CHIP
C-ZENER	ZENER, CHIP
CAP, CER	CAP, CERA-SOL
CAP, E	CAP, ELECT
CAP, M/F	CAP, FILM
CAP, TC	CAP, CERA-SOL
CAP, TC-U	CAP, CERA-SOL SS
CAP, TN	CAP, TANTALUM
CERA FIL	FILTER, CERAMIC
CF	FILTER, CERAMIC
DL	DELAY LINE
E/CAP	CAP, ELECT
FILT	FILTER
FLTR	FILTER
FUSE RES	RES, FUSE
MOT	MOTOR
P-DIODE	PHOTO DIODE
P-SNSR	PHOTO SENSER
P-TR	PHOTO TRANSISTOR
POLY VARI	VARIABLE CAPACITOR
PPCAP	CAP, PP
PT	POWER TRANSFORMER
PTR, RES	PTR, MELF
RC	REMOTE CONTROLLER
RES NF	RES, NON-FLAMMABLE
RESO	RESONATOR
SHLD	SHIELD
SOL	SOLENOID
SPKR	SPEAKER
SW, LVR	SWITCH, LEVER
SW, RTRY	SWITCH, ROTARY
SW, SL	SWITCH, SLIDE
TC CAP	CAP, CERA-SOL
THMS	THERMISTOR
TR	TRANSISTOR
TRIMER	CAP, TRIMMER
TUN-CAP	VARIABLE CAPACITOR
VIB, CER	RESONATOR, CERAMIC
VIB, XTAL	RESONATOR, CRYSTAL
VR	VOLUME
ZENER	DIODE, ZENER

MECHANICAL SECTION

DESCRIPTION	REFERENCE NAME
ADHESHIVE	SHEET ADHESHIVE
AZ	AZIMUTH
BAR-ANT	BAR-ANTENNA
BAT	BATTERY
BATT	BATTERY
BRG	BEARING
BTN	BUTTON
CAB	CABINET
CASS	CASSETTE
CHAS	CHASSIS
CLR	COLLAR
CONT	CONTROL
CRSR	CURSOR
CU	CUSHION
CUSH	CUSHION
DIR	DIRECTION
DUBB	DUBBING
FL	FRONT LOADING
FLY-WHL	FLYWHEEL
FR	FRONT
FUN	FUNCTION
G-CU	G-CUSHION
HDL	HANDOL
HIMERON	CLOTH
HINGE, BAT	HINGE, BATTERY
HLDR	HOLDER
HT-SINK	HEAT SINK
IB	INSTRUCTION BOOKLET
IDLE	IDLER
IND, L-R	INDICATOR, L-R
KEY, CONT	KEY, CONTROL
KEY, PRGM	KEY, PROGRAM
KNOB, SL	KNOB, SLIDE
LBL	LABEL
LID, BATT	LID, BATTERY
LID, CASS	LID, CASSETTE
LVR	LEVER
P-SP	P-SPRING
PANEL, CONT	PANEL, CONTROL
PANEL, FR	PANEL, FRONT
PRGM	PROGRAM
PULLY, LOAD MO	PULLY, LOAD MOTOR
RBN	RIBBON
S-	SPECIAL
SEG	SEGMENT
SH	SHEET
SHLD-SH	SHIELD-SHEET
SL	SLIDE
SP	SPRING
SP-SCREW	SPECIAL-SCREW
SPACER, BAT	SPACER, BATTERY
SPR	SPRING
SPR-P	P-SPRING
SPR-PC-PUSH	P-SPRING, C-PUSH
T-SP	T-SPRING
TERM	TERMINAL
TRIG	TRIGGER
TUN	TUNING
VOL	VOLUME
W	WASHER
WHL	WHEEL
WORM-WHL	WORM-WHEEL

サービス技術ニュース	
番号	連絡内容
G-	-
G-	-
G-	-

アイワ株式会社
AIWA CO.,LTD.

9620450, 750038

Tokyo Japan

〒110-8710 東京都台東区池之端1-2-11 ☎03 (3827) 3111 (代表)

Printed in Singapore