



Download kit

*Free documentation & blueprints for Aquapioneers Kit
Part III - Electrical & Monitoring system - The Nervous System*





VISIT:

www.aquapioneers.io

FOLLOW:

@aquapioneers (Twitter / Instagram / Youtube)

COMMENT:

<http://aquapioneers.io/community-forum/>

LIKE:

<https://www.facebook.com/aquapioneers/>

MAKE:

<https://github.com/aquapioneers/Aquapioneers-Kit-Barcelona-Design>



AQUAPIONEERS KIT MAIN FEATURES

The Aquapioneers Ecosystem is a thoughtfully crafted fun, educational, and rewarding experience.

At the intersection of hardware and ecology, it allows you to grow fresh and tasty food all year round. This little piece of nature, will engage and inspire you, your family and your friends.

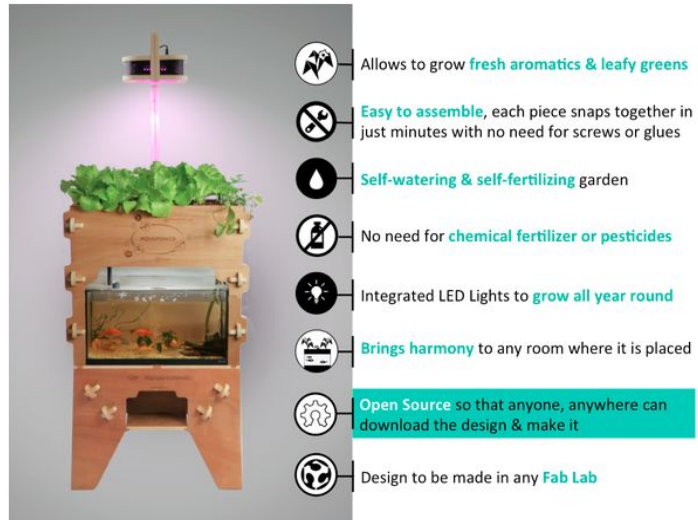

You can watch the following 30s timelapse [Youtube video](#) that sum up the overall assembly process and show a one month growing period with lettuces.



*Please note that the blueprints for Aquapioneers Kit v1.6 and v2 have been designed for a **specific aquarium dimension (60x30x30cm) which is the most common in Europe**. Please make sure you can find these dimensions in your area before you proceed. If you can not source an aquarium with these dimensions, you will have to modify the structure design to be compatible.*



SOME HERBS & LEAFY GREENS YOU CAN GROW



LETTUCE



STRAWBERRY



PARSLEY



MINT



BASIL



SHIZO

SOME SPECIES OF FISH THAT CAN INHABIT YOUR ECOSYSTEM



GOLD FISH



GUPPY



HEMICHROMIS



TETRA NEON

Contents

Project Overview	6
AQUAPIONEERS - What is this ?	6
Open Source Non Commercial - Why ?	6
Project toolkit	8
Project Goals	9
AQUAPIONEERS ECOSYSTEM ANATOMY	10
THE ELECTRICAL SYSTEM	14
• STEP 1: MAKING THE AQUARIUM LED LIGHT STRIP	15
• STEP 2: THE ELECTRICAL BOX	22
• STEP 3: CONNECTING THE ELECTRICAL SYSTEM	28
THE AQUAPIONEERS MONITORING SYSTEM	32
HARDWARE: How to make your monitoring kit	36
• ASSEMBLY 1: The Aquapioneers board	36
• ASSEMBLY 2: The 3D printed ultrasonic sensor case	39
• ASSEMBLY 3: The SHT-31 and Digital Light sensor	43
• ASSEMBLY 4: The board case and the sensors	49
SOFTWARE : How to setup your monitoring kit	58



Project Overview



AQUAPIONEERS - What is this ?

AQUAPIONEERS is a Barcelona based social enterprise that aims to combine the unbeatable advantages of Aquaponics as a sustainable method of urban agriculture and the power of Digital Fabrication to unlock social innovation. Locally we develop creative services around aquaponics for schools, businesses and individuals and globally spread the word using open source tools.

The Aquapioneers Ecosystem is our first open source product. Its design and user manual documentation release has been possible thanks to our 248 backers that supported our [crowdfunding on ULULE](#) closed on July 2017.

This document contains the information you will need to download, fabricate, assemble and use the Aquapioneers ecosystem v1.6 and v2 with confidence and grow aromatics all year round.



Open Source Non Commercial - Why ?

The CC-BY-NC license we have chosen gives anyone the right to download, edit and remix their own versions of the AQUAPIONEERS ECOSYSTEM designs. We think participation in design is something to be actively encouraged. By adapting, improving and creating new variations of the ecosystem we hope to encourage research, innovation and a spirit of collaboration. Because empowering people is one of the fundamental pillars of our project, we believe that everybody should have free access to this documentation to explore aquaponics and digital fabrication. Unfortunately in 2017 it is not yet possible to make a living out of free work.. this is why we have decided to limit the free use of our work to individuals. While we hope to inspire sustainable innovation with our work, we believe that economic value created from inventions should also benefit the inventors. This is why commercial use of this documentation will only be permitted through formal collaboration agreements. If you are interested in making commercial use of this work, please get in touch with us and we'll do our best to find a way to work together!



You are free to Under the following terms

SHARE — copy and redistribute the material in any medium or format

ATTRIBUTION— You must give [appropriate credit](#), provide a link to the license, and [indicate if changes were made](#). You may do so in any reasonable manner, but not in any way that suggests the licensor endorses you or your use.

ADAPT— remix, transform, and build upon the material

NON COMMERCIAL — You may not use the material for [commercial purposes](#).

The licensor cannot revoke these freedoms as long as you follow the license terms.





No additional restrictions — You may not apply legal terms or [technological measures that](#) legally restrict others from doing anything the license permits.

More info about this licence

<https://creativecommons.org/licenses/by-nc/3.0/>



Project toolkit

	
<h2 data-bbox="359 593 598 631">Download-kit</h2> <p data-bbox="277 683 679 712">Free documentation & blueprints</p> <p data-bbox="188 766 769 983">Starting an aquaponic system can be tricky, because quality information is rare and scattered all over the web. By open sourcing our design and its user guide, we want to break down the barriers of entry by ensuring that you work with the same system as the entire community and benefit from our collective experience.</p> <p data-bbox="188 1025 769 1303">We use Github to host our designs and file repositories. It allows anyone access to download files, make changes, “fork” new versions and work in a distributed and networked fashion. If you’d like to contribute to the project, Github is the place to make comments and add your work: https://github.com/aquapioneers/Aquapioneers-Kit-Barcelona-Design</p>	<h2 data-bbox="1024 611 1139 649">Forum</h2> <p data-bbox="874 683 1289 712">A place to meet & help each other</p> <p data-bbox="791 766 1375 1010">If we don’t share what we know, how can we learn from each other? We would like to encourage all participants to contribute what they can to improve the project. This might be peer review, debugging existing designs, creating entirely new design, sharing tips to grow amazing vegs, and collectively study the mystery of aquaponics.</p> <p data-bbox="791 1050 1375 1171">This forum is a place to share pictures, skills, knowledge and interests through ongoing conversation: http://aquapioneers.io/community-forum/</p>
	
<h2 data-bbox="284 1585 671 1630">Local Manufacturing</h2> <p data-bbox="236 1655 722 1686">+1200 maker spaces to build your kit</p> <p data-bbox="188 1740 769 1839">Check out these links to locate one in your city: www.themakermap.com. The Fablabs network: www.fablabs.io and also www.fabhub.io</p>	<h2 data-bbox="999 1592 1166 1630">Tutorials</h2> <p data-bbox="826 1666 1342 1697">Video tutorials to grow with confidence</p> <p data-bbox="799 1749 1265 1780">Youtube channel : https://bit.ly/2IElaDe</p>



Project Goals

- 1** **Developing open source aquaponics designs that are suitable for local and digital manufacturing and that can be optimised for locality.**
 - Developing a number of aquaponics designs that are used as a base for adaptation.

- 2** **Creating a public library of aquaponic recipes through innovative forms of citizen science.**
 - Imagine a public library of aquaponic recipes, where each recipe is associated to a particular plant and tells you how to set your ecosystem (i.e. fish density, lighting and environmental conditions, etc) to suit this plant's needs. Just like a cooking book!
 - Together we are smarter! This library will be collaborative, meaning that each user will be encouraged to share his cultivation experience with the community. This way we can use our collective intelligence to figure out the best aquaponic recipes for each plant. The more the community participates, the better the recipes will be!
 - Develop protocols and pathways for 'Citizen Science'.

- 3** **Bridging the information gap between aquaponics enthusiasts and maker communities**
 - Encouraging information sharing between people with differing backgrounds and expertise.
 - Developing a range of communication tools (forum, tutorials, download kit, tutorials) to facilitate innovation in local aquaponic farming.



AQUAPIONEERS ECOSYSTEM ANATOMY

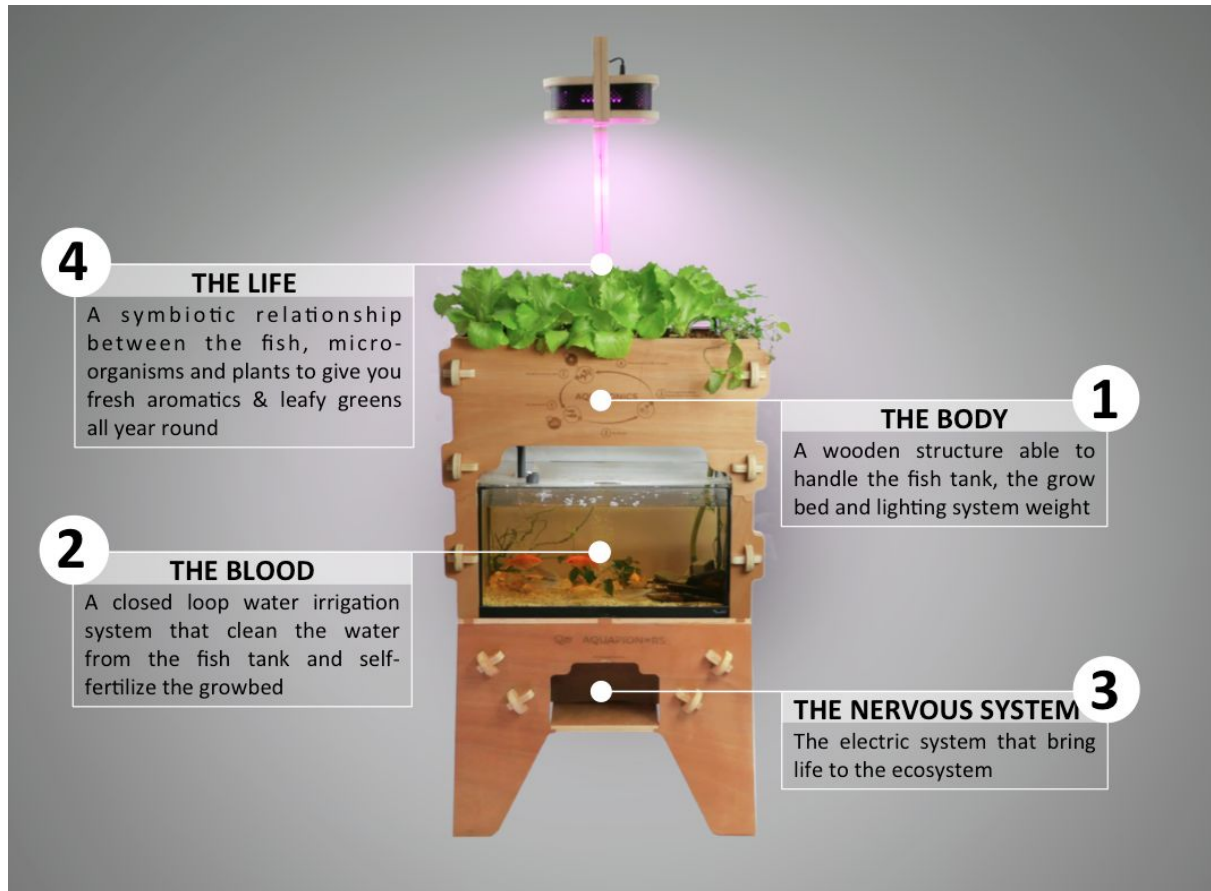

The user manual has been divided into four blocks following the Aquapioneers Ecosystem anatomy to ease its construction, assembly and use.

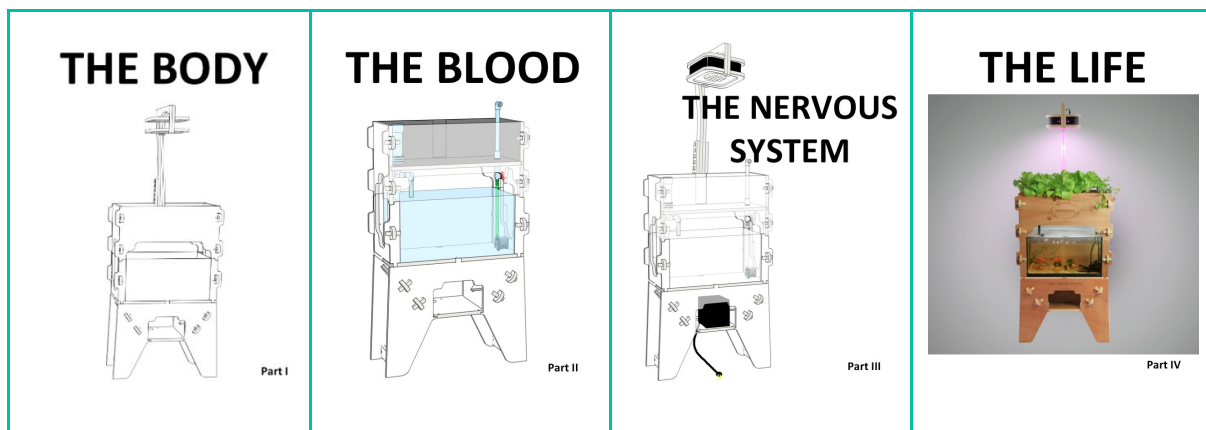

THE NERVOUS SYSTEM

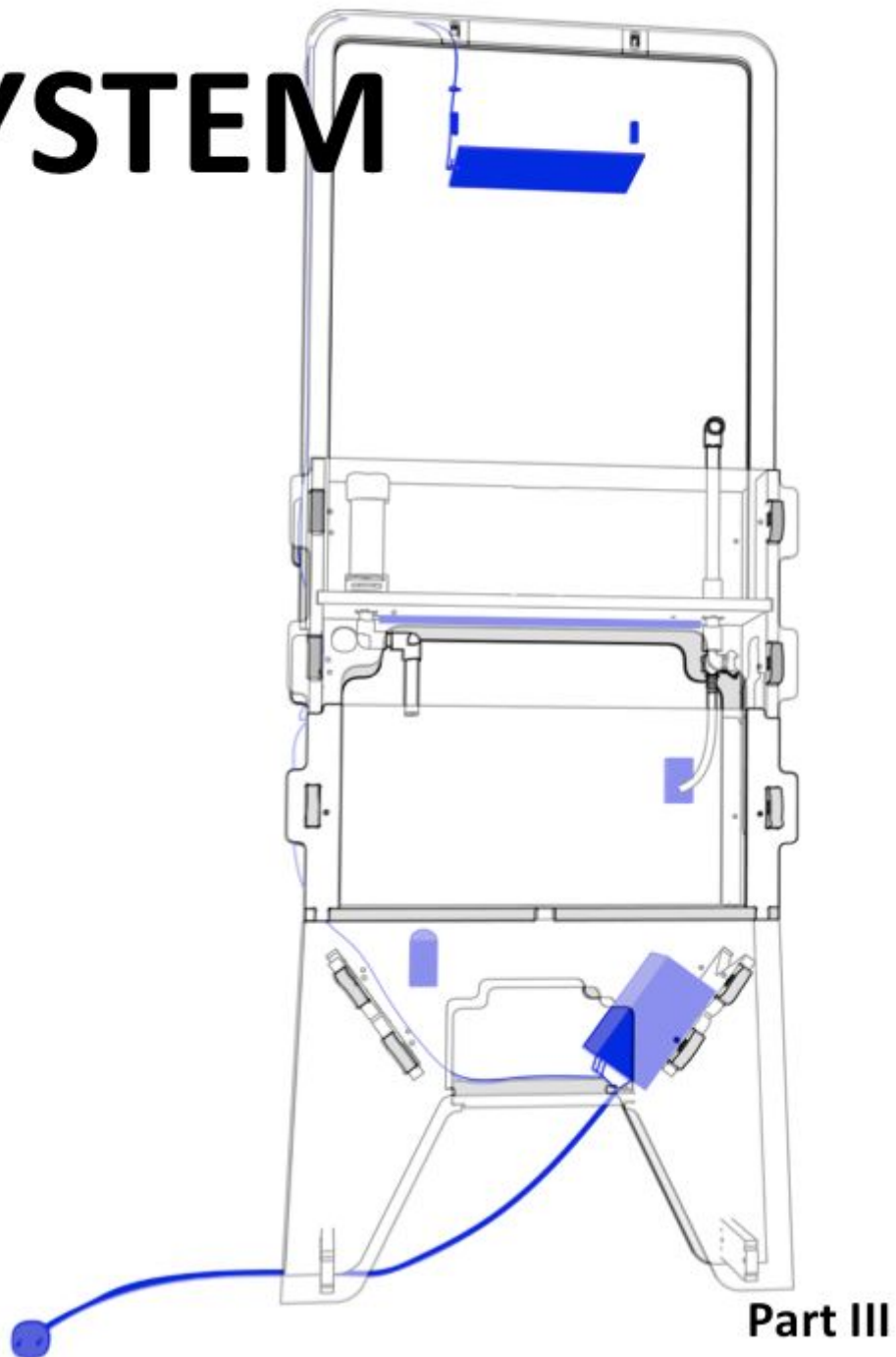

+

THE ELECTRICAL SYSTEM

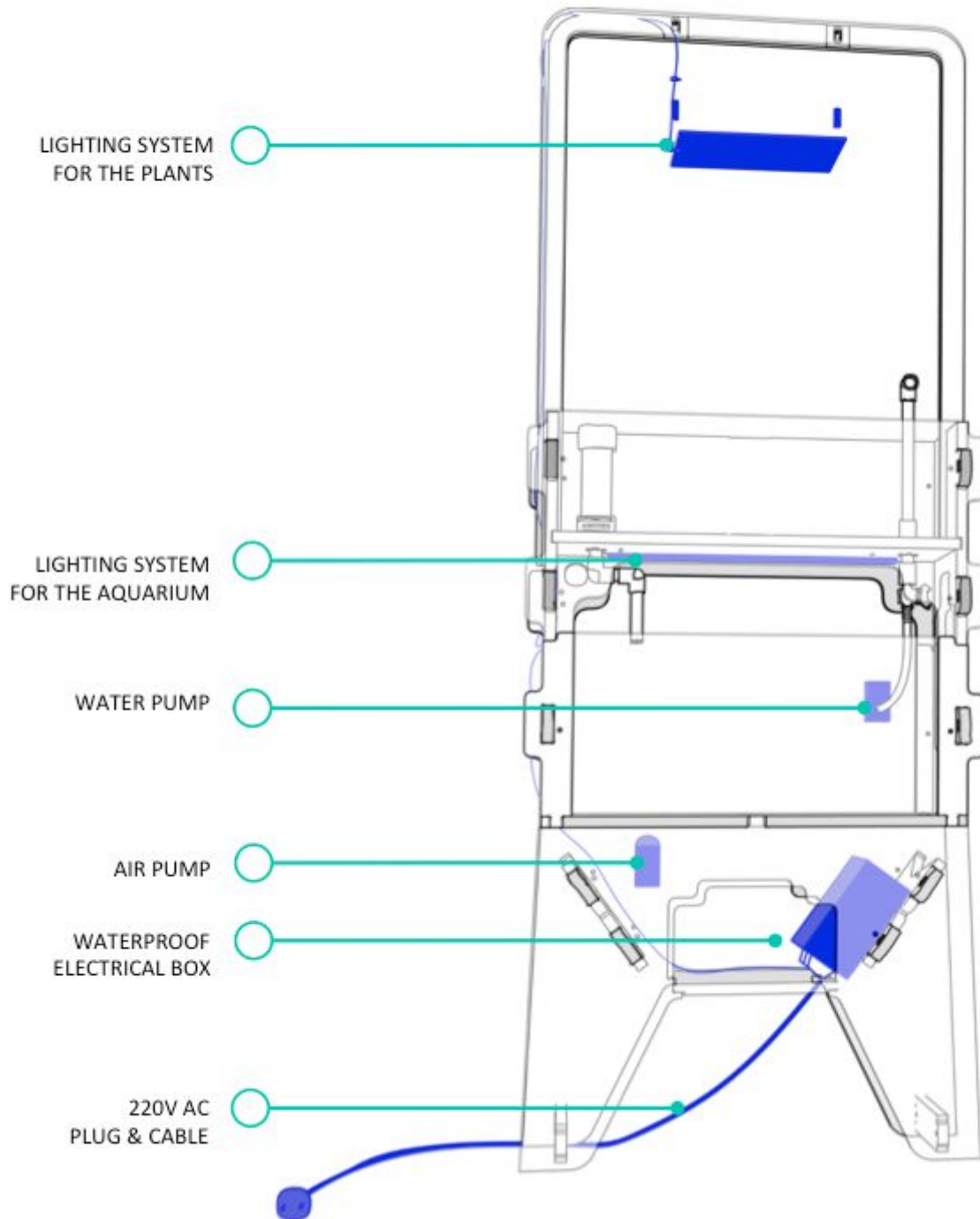

BILL OF MATERIALS

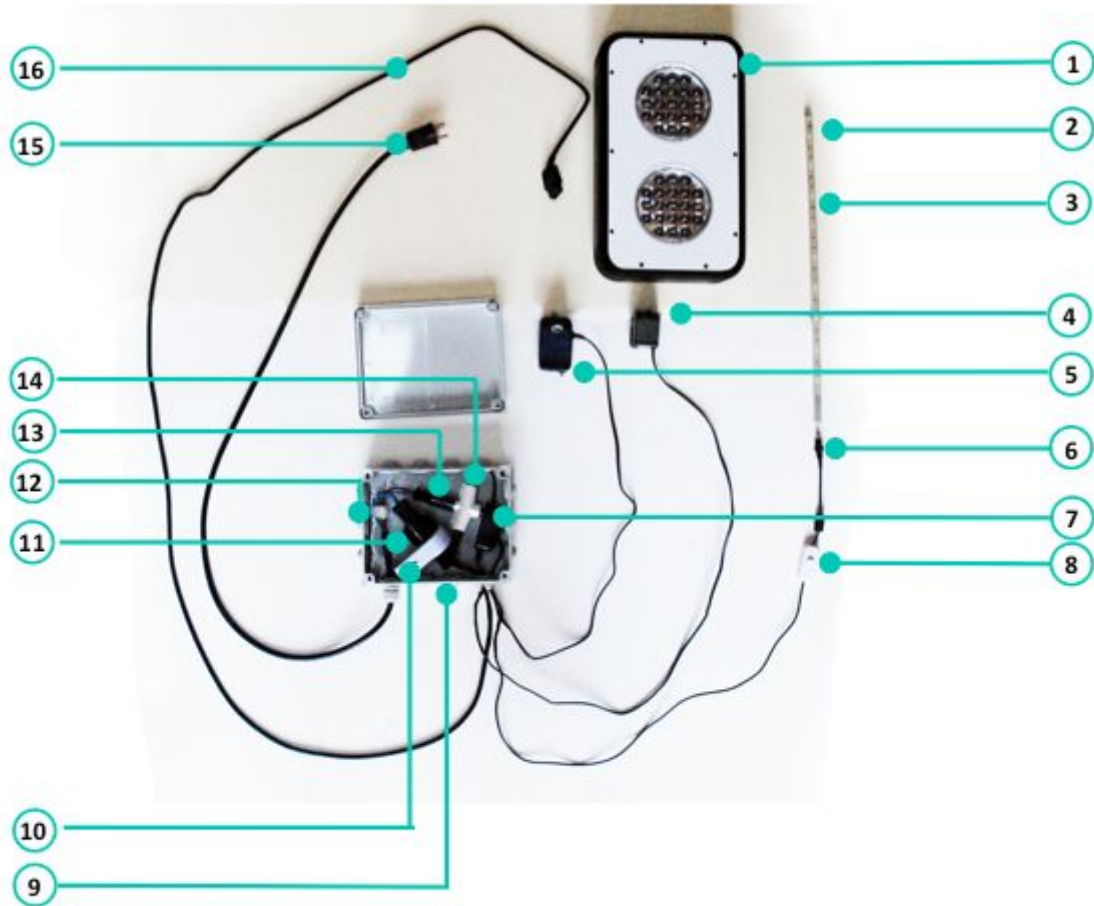

COMPONENTS					
1	120 W GROWING LED	x1	9	24cm x 19cm x 10cm Waterproof electrical box	
2	50cm x 1cm x 1cm Aluminium profile	x1	10	Aquarium light timer	
3	50 cm x 12 V White LED strip	x1	11	220 V Male plug	
4	600 L / h water pump	x1	12	Male rewirable 2 Pin grounded Plug	
5	140 L / h air pump	x1	13	Male rewirable 2 Pin Plug	
6	Connector Jack DC 12v		14	Multiple socket - 3 inputs	
7	220V AC/ 12V 1A DC adapter for LED strip		15	220V AC Plug & 1.3m grounded cable	
8	12v switch		16	120 W LED Growlight	

SAFETY NOTE: THE FOLLOWING ELECTRICAL ASSEMBLY PART SHOULD BE PERFORMED ONLY BY USERS EXPERIENCED WITH ELECTRICAL SETUPS. IF YOU ARE NOT FAMILIAR WITH ELECTRICITY WORK, ASK FOR PROFESSIONAL HELP. ELECTRICITY WORK IS DANGEROUS AND CAN BE FATAL IF DONE INCORRECTLY. AQUAPIONEERS DECLINES ALL RESPONSIBILITY IN CASE OF DAMAGES OR INJURIES.

STEP 1: MAKING THE AQUARIUM LED LIGHT STRIP

Time expected	Expected cost
30 min	6€

For this you will need the following:

7 mm diameter Heat shrink tube	50cmx1cmx1cm Square aluminium profile	30W-60W soldering iron	50 cm white 12V 9.5 W/m waterproof LED strip	12 Volt Female & Male connectors
				
Price: 0.02€	Price: 1€	-	Price: 1,5€	Price: 1 €

Step by step, please follow the next steps:

PREPARING THE LED STRIP BEFORE SOLDERING

1

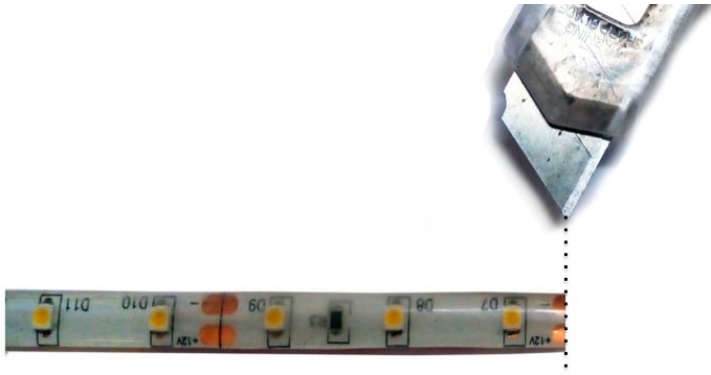

Since the LED strip can only be cut every third LED, you may have to go slightly under the 50cm desired specification. To cut your waterproof LED Strip Light it is first of all important to have a sharp pair of scissors or cutter. Each waterproof strip light will have a cut mark between the two pairs of copper connection pads. Once you have located this cut line you can then cut your LED Strip Light to the desired length. Be certain to make a clean straight cut without putting any additional stress on the PC Board, doing so can break the board making that 3 LED Section un-usable. Cut exactly along the black line to leave sufficient exposed copper for soldering.

2

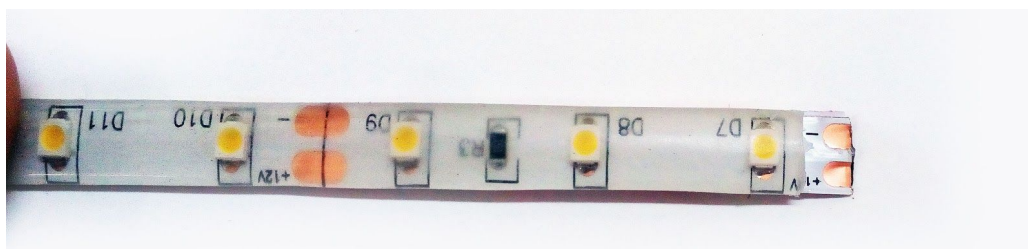

In order to solder wire to your waterproof LED strip light you must first cut back the TPU coating to expose the copper connection pads on your LED strip light. Use a sharp blade to cut back the TPU coating, be very careful not to cut through the PC Board on the LED Strip light. We recommend only cutting off the top half of the TPU coating and leaving the bottom half for support of the PC board like you see in the picture to the right.

3

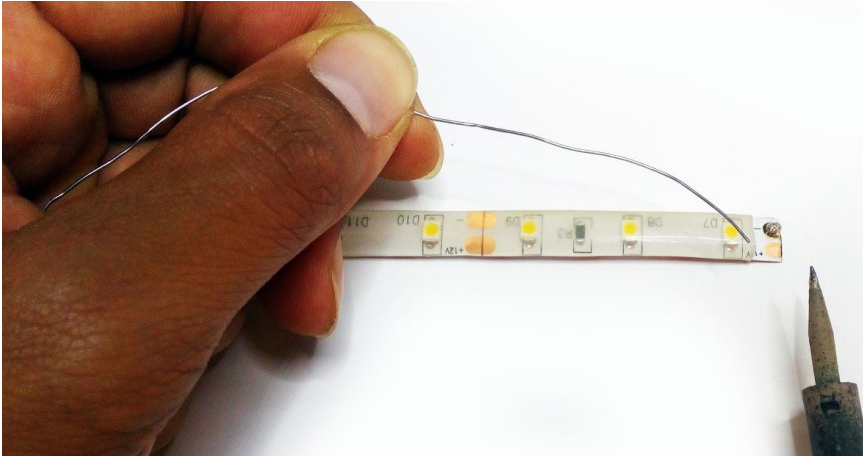

The next step is to tin the copper dots on your LED Strip Light by melting a small amount of solder directly onto the copper dots.

MAKING THE LED STRIP FEMALE CONNECTOR

4

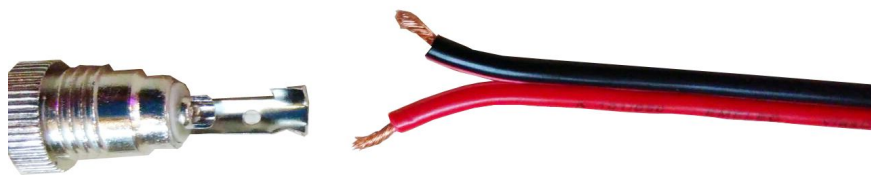

Prepare a 2-wire cable for soldering on your female jack connector. The positive lead (red) should be slightly longer as it will be soldered to the cup-like terminal at the center of the connector, while the negative lead (black) will be soldered to the thin section connected to the outer casing, via the hole provided for this purpose.

5



As you solder both leads, make sure you don't accidentally connect the positive with the negative ports which would short-circuit your LED. As both terminals are very close together, this can easily happen if you are not careful.

6



Cover up your solder joint with heat shrinking material. Use a heat gun or a lighter to shrink your heat shrink to protect your solder joints and then test one more time to be certain of a proper connection. Before moving on, test your positive and negative connector parts for continuity with the free ends of the wires to ensure the soldering was successful.

7



8

Screw on the insulating plastic casing of the connector, carefully without damaging the fragile soldered connections.



Once you have tinned both the wire and the copper dots on your LED Strip Light you can now mate the two together. Be careful to match your positive and negative wires to the (+) and (-) signs printed next to the corresponding soldering dots. Once again, make sure there is no connection between the + and - dots. Individually place the wire to the copper dots and then place the soldering iron over both in order to heat up each solder enough to melt and become one. Be sure to hold long enough to not create a "cold solder." Once dry, connect your freshly soldered LED Strip to a proper power source and test your connection.

9



Cover up your solder joint with heat shrinking material. Use a heat gun or a lighter to shrink your heat shrink to protect your solder joints and then test one more time to be certain of a proper connection.

10

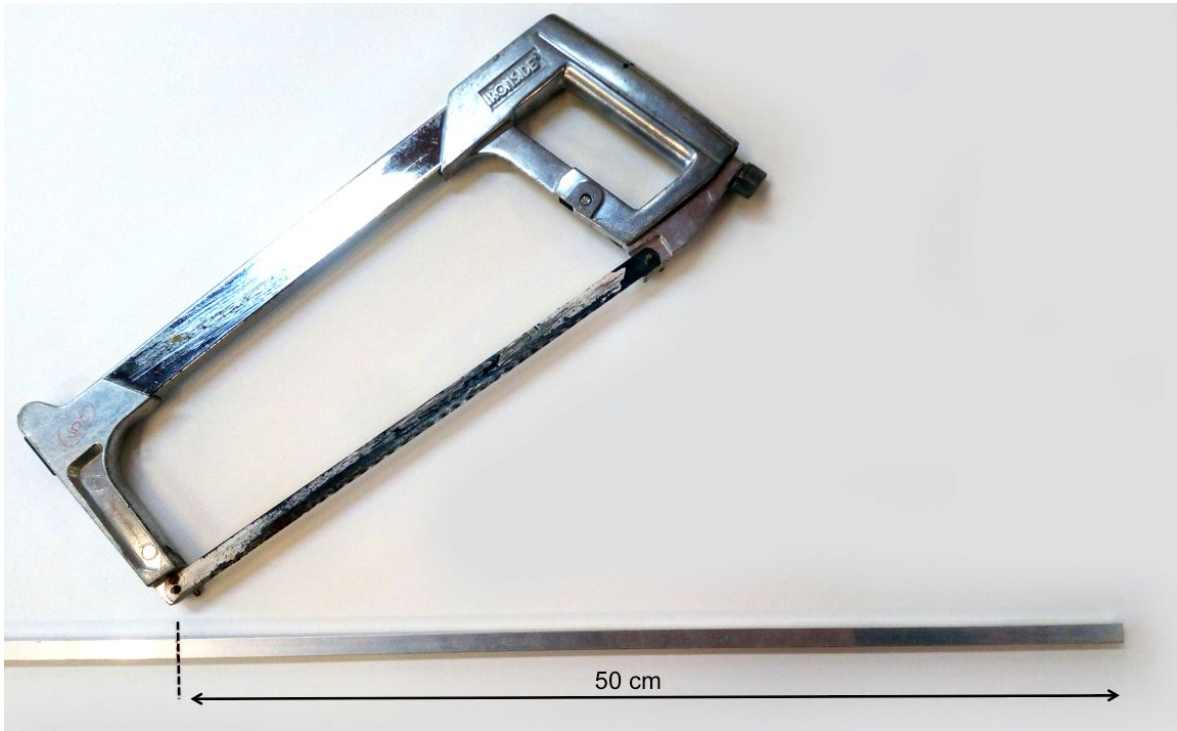

Cut your aluminium profile to 50cm length with a metal hand saw and smoothen the cut edges to avoid injuring yourself with the exposed metal.

11



Clean the aluminum surface with alcohol to create a smooth clean surface, then simply stick the LED strip light onto the aluminium profile.

12

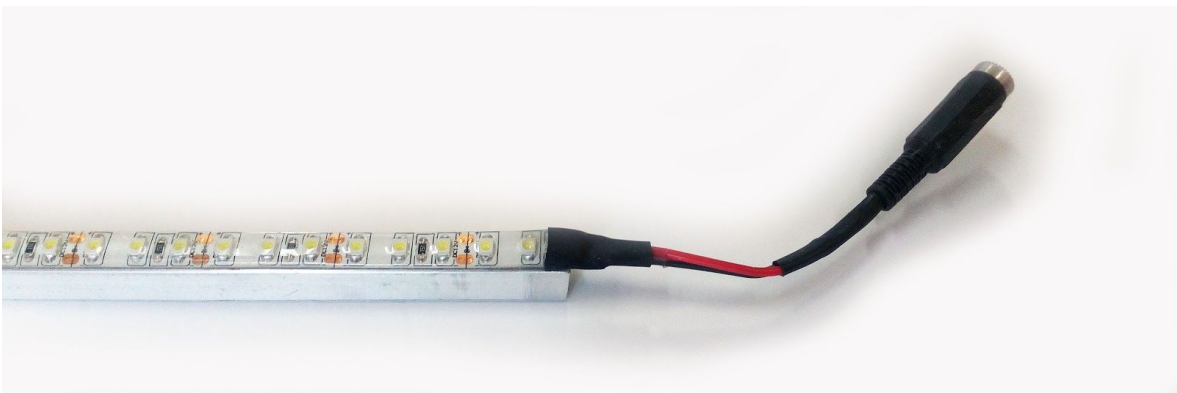

Make sure your solder joint is positioned at the end of the aluminium profile.

13

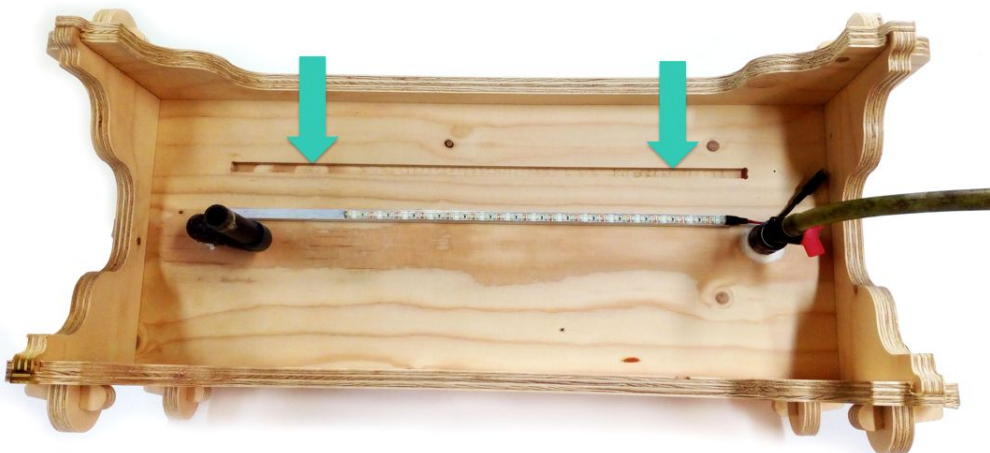

Below the growbed, you will see a pocketing in which we will fit the aluminium profile.

14

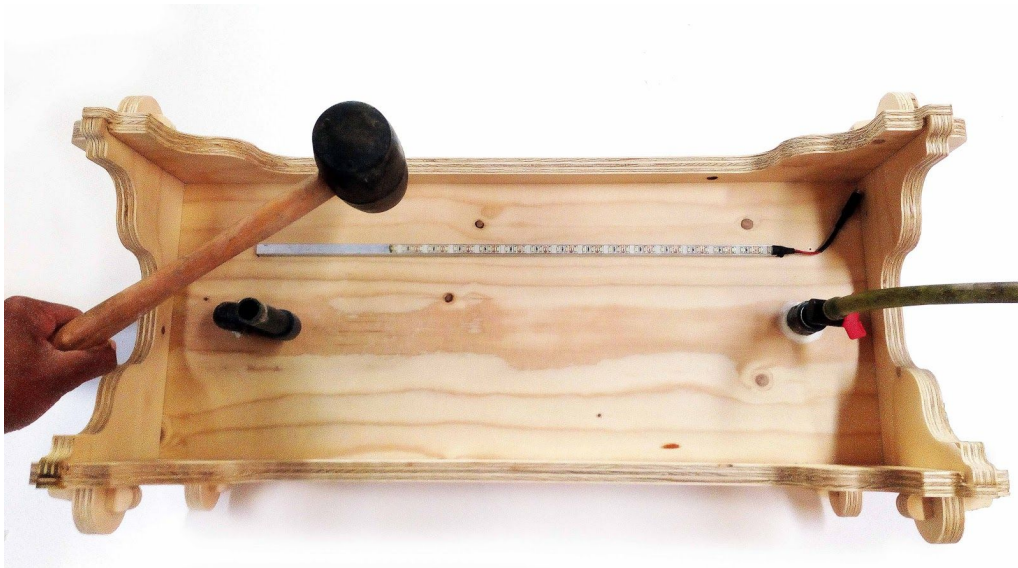

Depending on the precision of the CNC milling you have been using, you will be able to press fit with your fingers or with the help of a RUBBER hammer. Never use a regular hammer as it will destroy your LED's. Pay attention to the orientation of the connector, which should face the same side as the red valve.

15



Once in place, the aluminum profile will look like this.

16

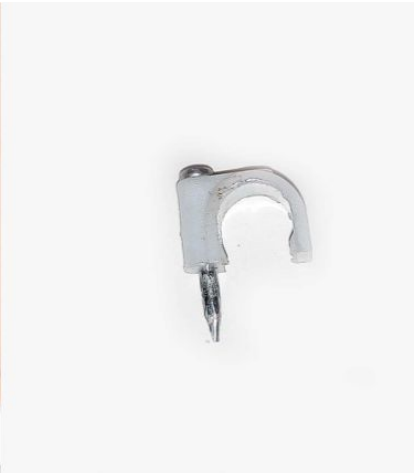
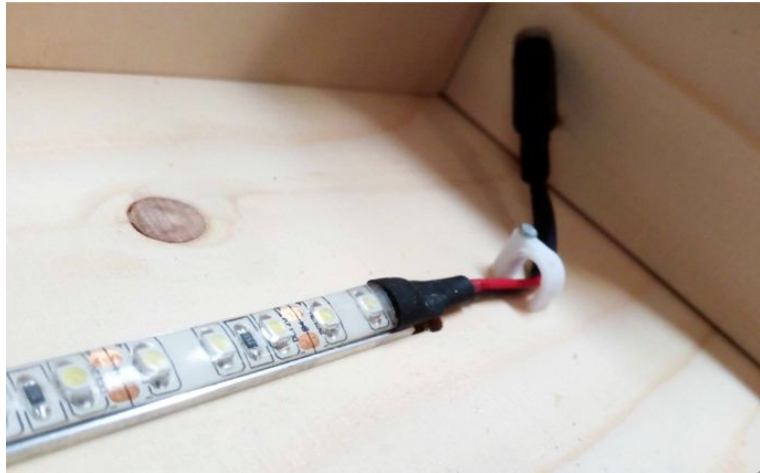





To protect your soldering connection, nail a wire gripper over the wire.

STEP 2: THE ELECTRICAL BOX

Time expected	Expected cost
30 min	170 €

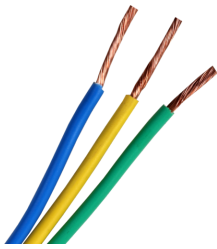
For this you will need the following materials:

22 x 17 x 8 cm IP65 Waterproof box	3 connector strip	electrical wires (3 colors)	220V AC to 12V 1A DC adaptor charger for LED strip	120 W LED Grow Light
				
Price: 5€	Price: 0,50€	Price: 0,50€	Price: 3€	Price: 150€
Male rewireable 2 Pin grounded Plug	Power cable for GrowLight 2.5m	3-socket splitter	Analog Timer	2-Pin-DIY-Rewirabl e-socket-EU female

				
Price: 1€	Price: 6€	Price: 2,5€	Price: 3,5€	Price: 1€
2-Pin-DIY-Rewireable-socket-EU female shuko	3G1. 5 mm2 black cable 1.5m long			
				
Price: 1€	Price: 2€			

Part by part, please follow the next steps:

17

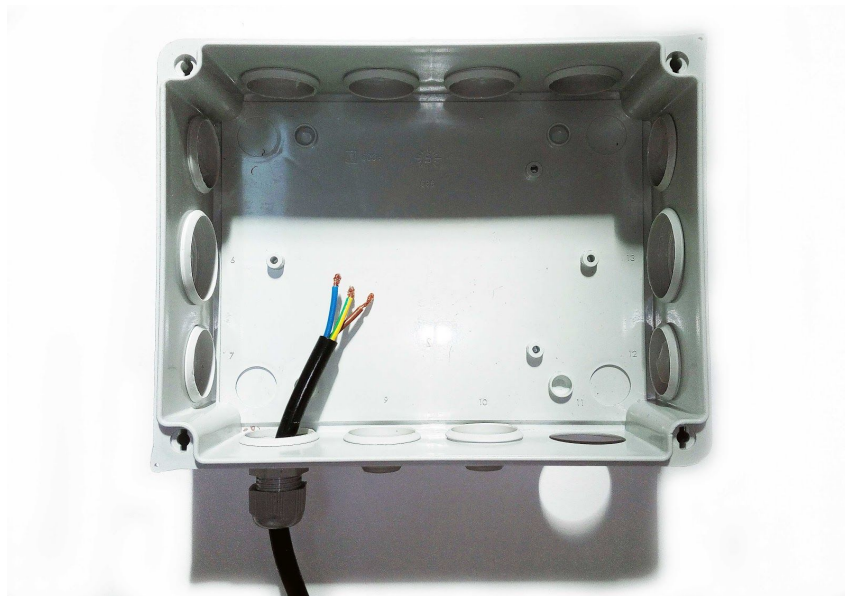

Remove 5 cm of rubber insulation to be able to use the wires of the the 3G1. 5 mm2 black triple wire cable before inserting it inside the electric box.

18

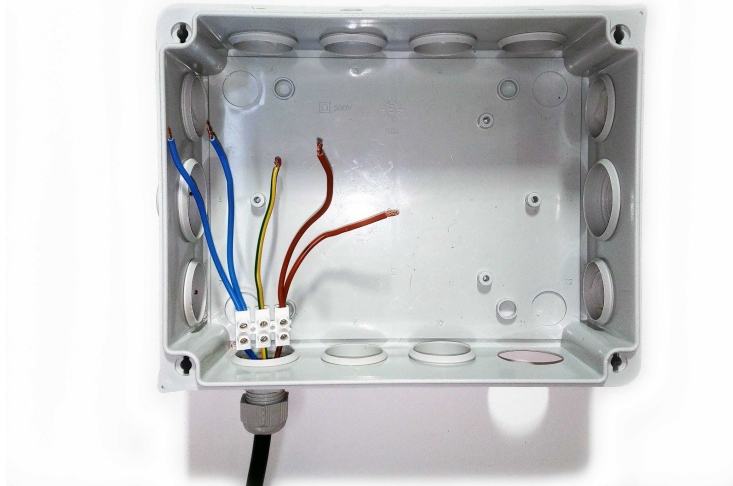

Use a 3 connectors strip to connect the single 12cm leads to the 1,5G cable, making sure to match wire colors. The live (brown) and blue (neutral) need to be split into 2 wires each since there will be two separate sockets in the box: 1 on timer for the growlight, and 1 for the remaining devices. Only 1 ground wire (green & yellow) is needed since the only grounded device used in the system is the growlight.

19

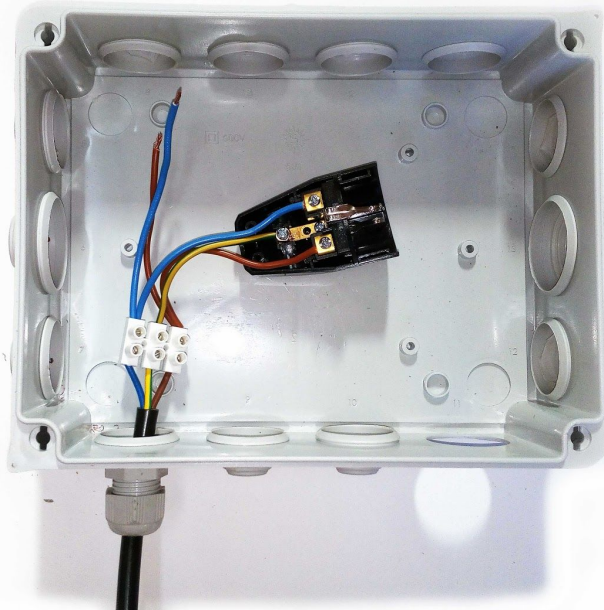

As illustrated above, connect the grounded socket to each of the leads. Be sure to connect the ground lead (green & yellow) to the appropriate terminal with the grounding symbol.

20

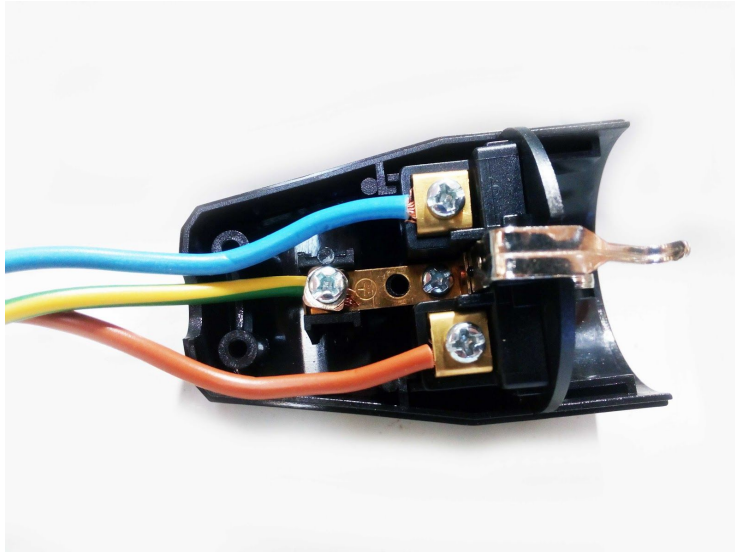

Detailed view of the wiring.

5.



Repeat the wiring for the non-grounding connector with the remaining brown and blue leads.

21

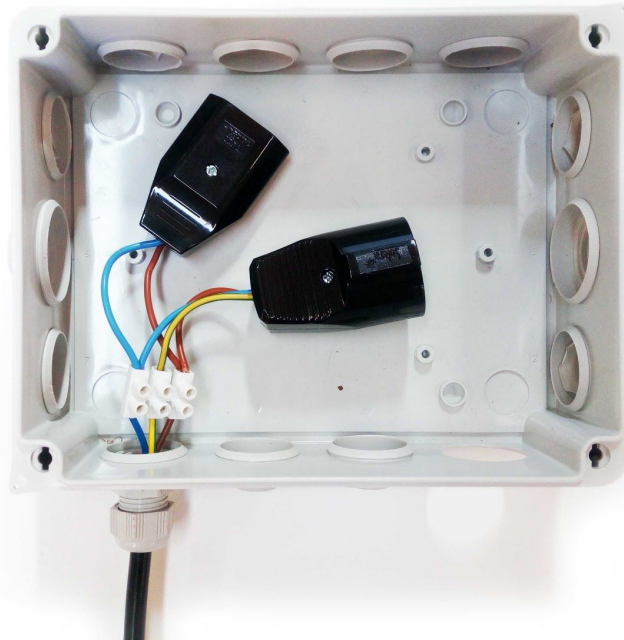

With the help of a screwdriver, close the two sockets.

22

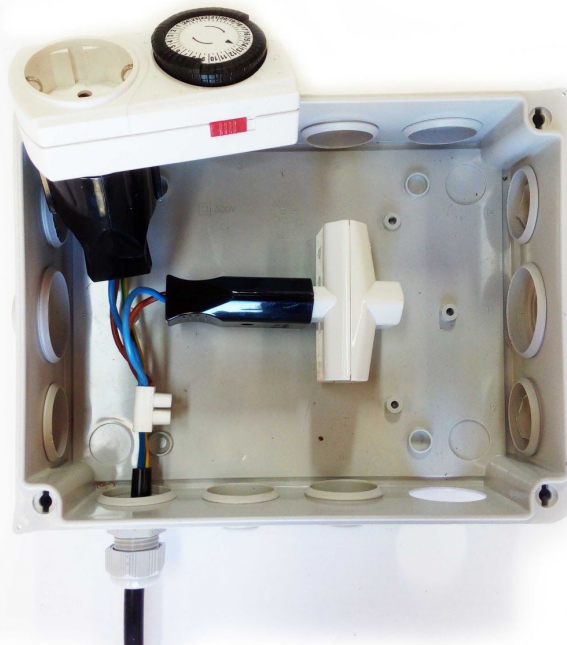

Connect the timer to the grounded socket, and the 3-way splitter to the other socket.

23

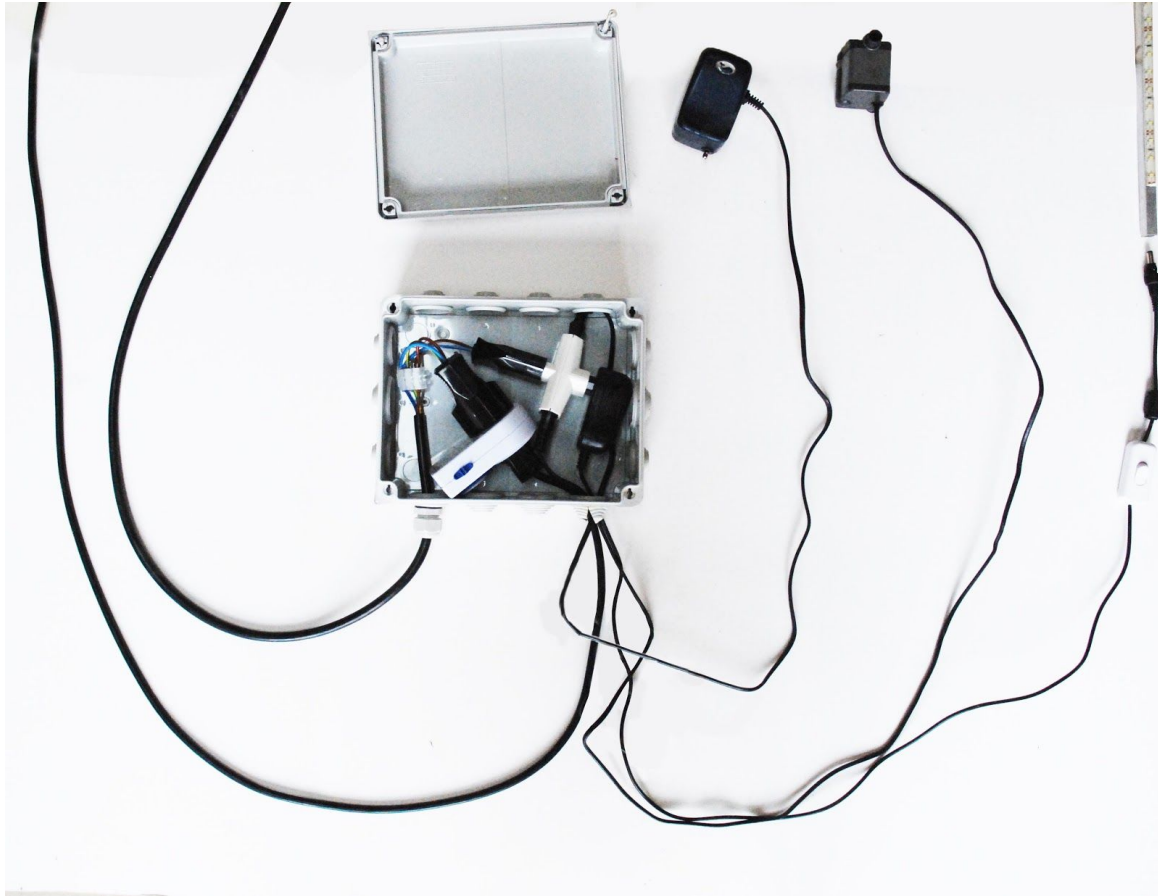

Then following the illustration above, connect the water pump, the air pump, the LED strip and the growing LED lighting system. Make sure your setup entirely fits into the box without forcing. Be especially careful not to jam the rotating timer as this would interfere with the proper light cycle for your plants. Set the timer to 14 to 16 daily light hours. Depending on your preferences, you can choose to run your lights during the day or during the night.

STEP 3: CONNECTING THE ELECTRICAL SYSTEM

24

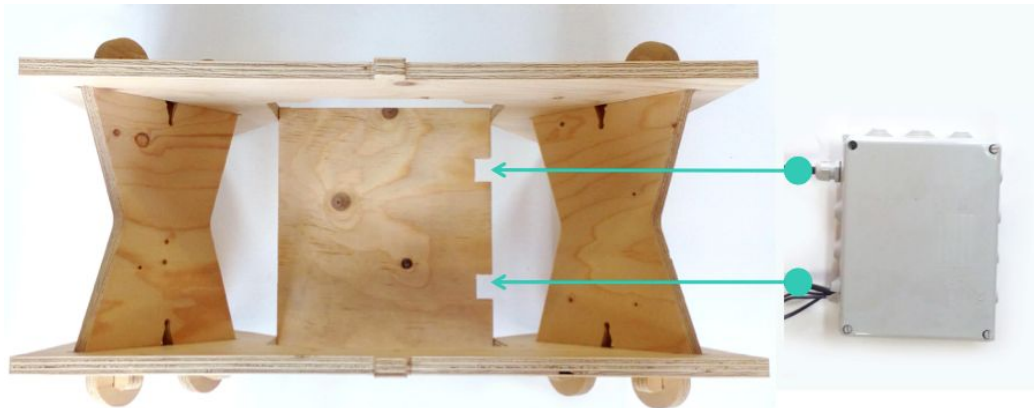

Place the waterproof electric box on the right hand side of the legs plate as in the above picture to ensure that the electrical wires can be well positioned.

25

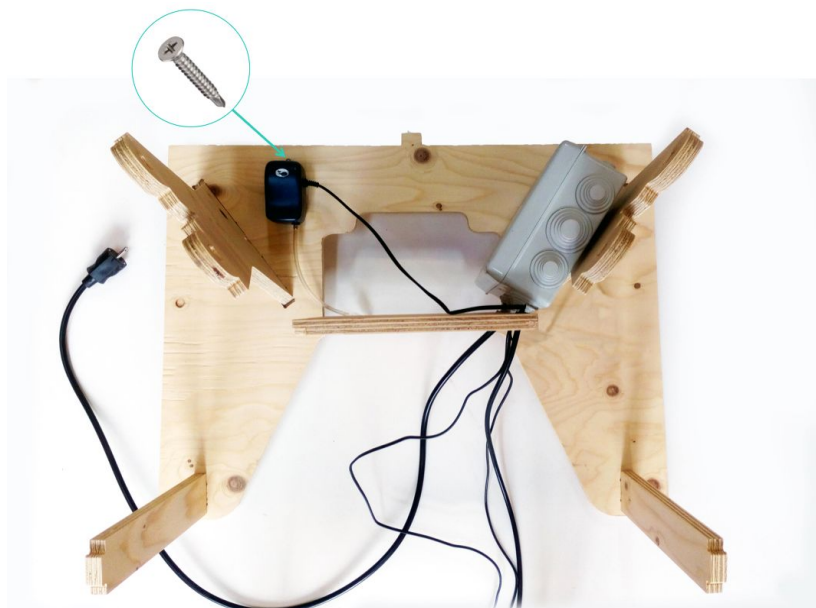

In order to avoid noise issues coming from the vibration of the air pump, we recommend you to fix the air pump with a screw on the left hand side of the back leg.

26

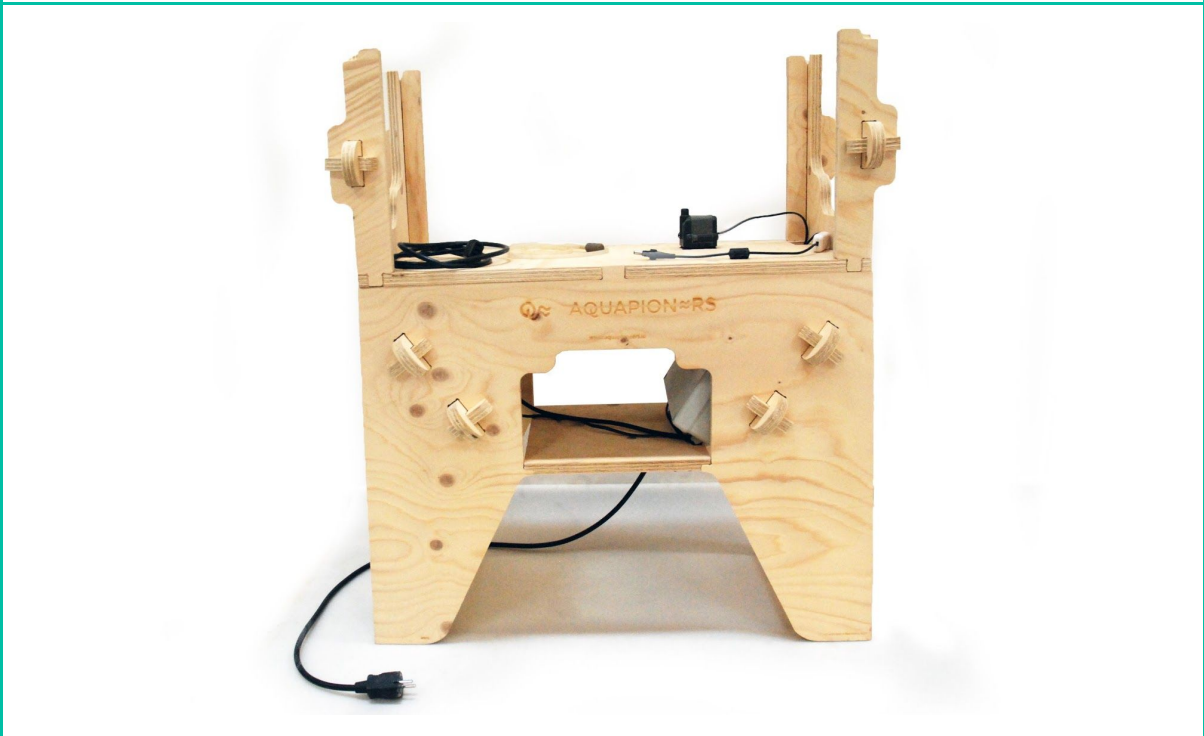

Then add the aquarium base plate and pass the water pump cable and LED strip cable through the left hand plate hole and the growing LED cable and air pump tube through the right hand hole as shown below.

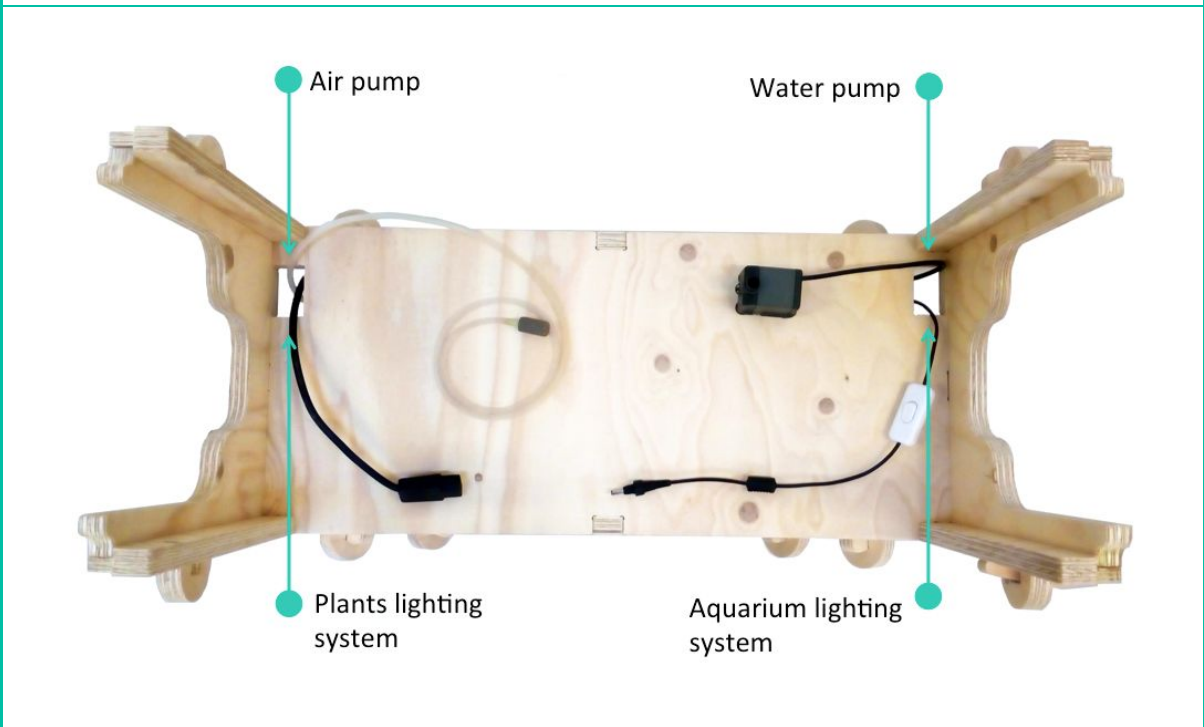

27

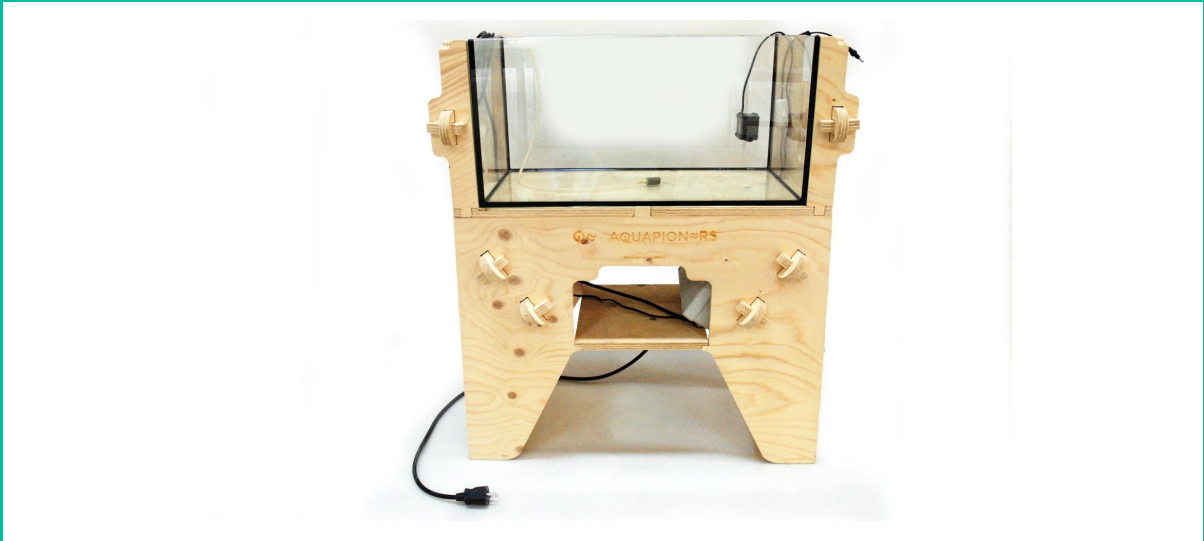

Then place the aquarium on a highly recommended 5mm foam-like protection layer (You could use cardboard as well) to avoid possible damage to it. Glass aquariums are very fragile and should be handled with maximum care. This will ensure your tank lies completely flat and doesn't risk cracking. Cut a piece of "60 x 30 cm" and place it between the aquarium side panels to fit the outer perimeter of the aquarium support frame. Carefully slide the aquarium between the side pieces and be sure it fits the outer perimeter of the 5mm insulation layer. Then place the water pump and air diffuser inside the aquarium.

28



Carefully place the growbed on top of the aquarium side panels and be sure it fits correctly. Then connect the flexible pipe to the water pump connector and the 12 Volts LED strip Female - Male socket together as shown on the picture below.

29



Make sure to run the LED cable the furthest to the corner as possible, in order not to interfere with the use of the red flow valve.

30

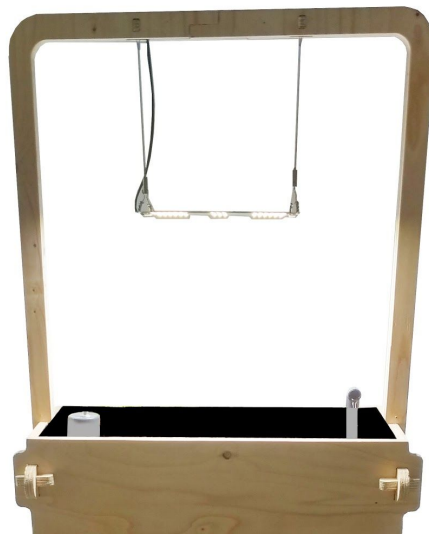

Last but not the least, add the growing light wooden frame above the media bed. Then pass the electrical cable into the pocketing space and connect it to LED light as described above.

The entire electrical system is now in place, but **“Do not plug your system to the mains power”** until there is water in the fish tank, as this will run your water pump dry and possibly destroy it. Make sure your electrical box is sealed before you connect your system.

You are almost ready to add water in it and start cycle your ecosystem. This information is available in the fourth part of our documentation manual aka « The Life ». You will be able to find more info on how to maintain the ecosystem thanks to several video tutorials on our Youtube channel:
<https://www.youtube.com/playlist?list=PLUFhb7gQAOXpYI2u4EjyPYbu-uKQxILc> .

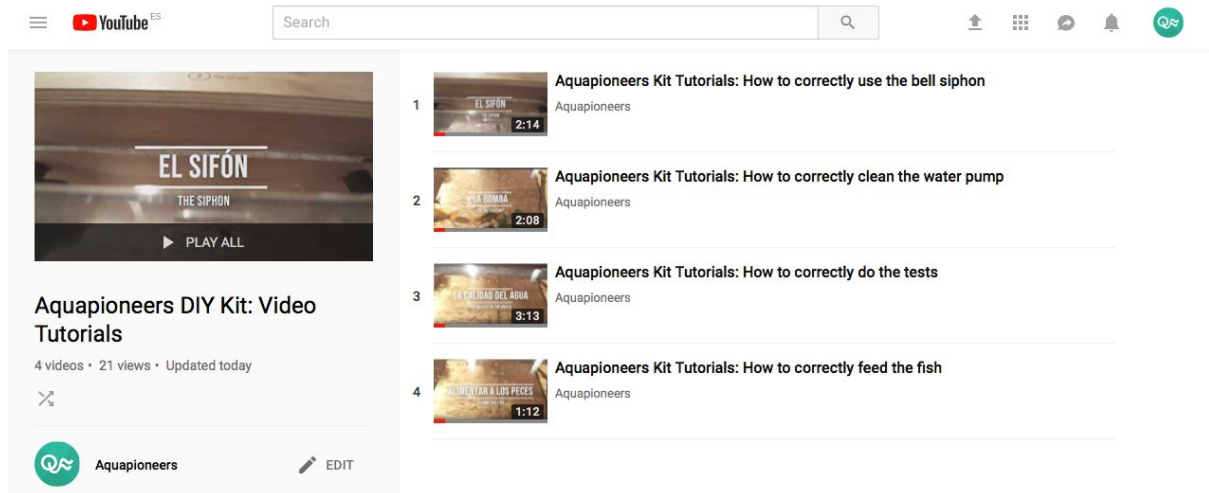

The screenshot shows a YouTube playlist page for the channel 'Aquapioneers'. The page title is 'Aquapioneers DIY Kit: Video Tutorials' with 4 videos and 21 views. The main video thumbnail is titled 'EL SIFÓN THE SIPHON' and has a 'PLAY ALL' button. To the right, a list of four video thumbnails is shown with their titles and durations:

- 1. Aquapioneers Kit Tutorials: How to correctly use the bell siphon (2:14)
- 2. Aquapioneers Kit Tutorials: How to correctly clean the water pump (2:08)
- 3. Aquapioneers Kit Tutorials: How to correctly do the tests (3:13)
- 4. Aquapioneers Kit Tutorials: How to correctly feed the fish (1:12)

The channel name 'Aquapioneers' and an 'EDIT' button are visible at the bottom of the playlist area.



THE AQUAPIONEERS MONITORING SYSTEM

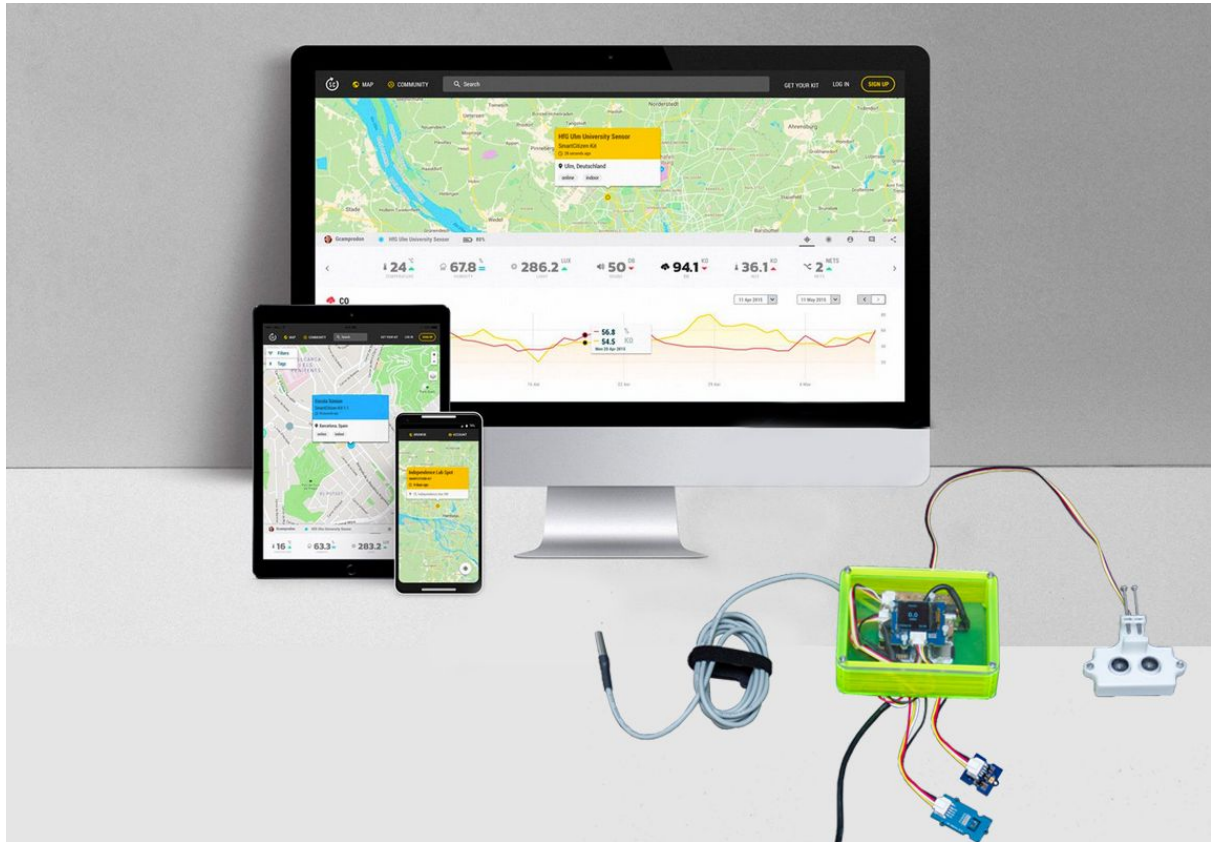

The goal of the Monitoring kit is to be able to check the state of the Aquaponics kit remotely from your smartphone or computer and also on the optional display. **This monitoring kit is optional on Aquapioneers kit and is not required for correct functioning of the ecosystem.** However, it can provide insightful data on the environmental parameters of your system such as air & water temperature, air humidity, water level and light intensity. This information can help you to describe your environmental settings to the Aquapioneers community, help you troubleshoot your system as well as optimize environmental parameters for optimal plant growth and fish health.

*** If this section is not relevant for you, you may go ahead and enjoy your fully functional aquaponic kit!**



BILL OF MATERIALS

The Aquapioneers Citizen Kit is built upon the Open Source Smart Citizen 1.5 environmental kit and data visualization platform and made out of different parts.

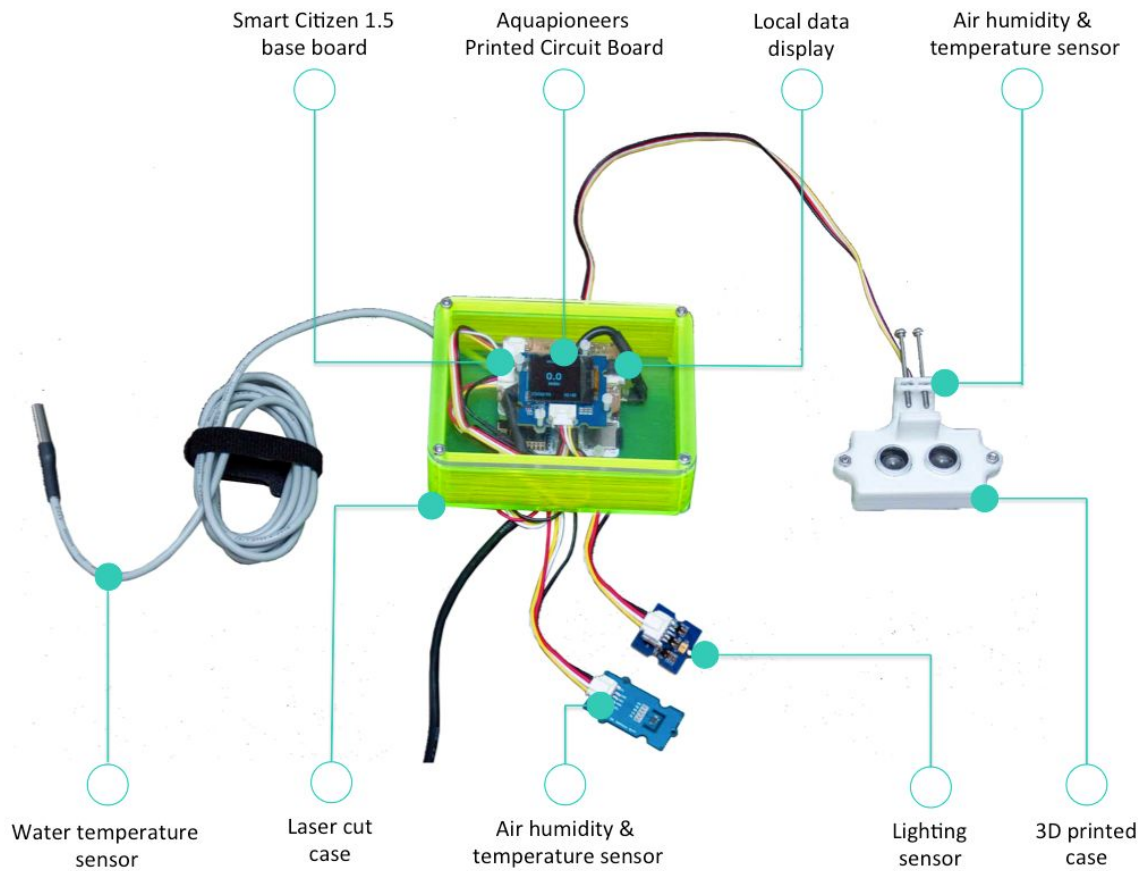

THE BOARDS

The Smart Citizen 1.5 Base board

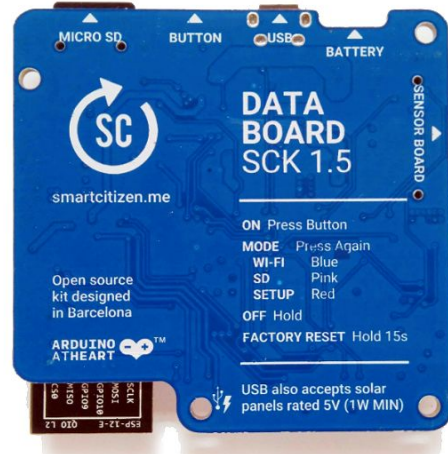
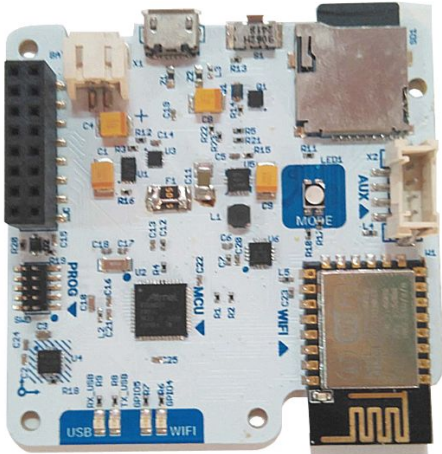

Price: 45 €

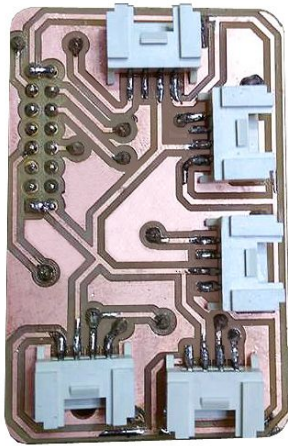

The Aquapioneers Printed Circuit Board

Price: 0 € - Fab Lab made



THE SENSORS

SHT-31		Ambient Humidity and Temperature	https://www.seeedstudio.com/Grove-Temperature%26amp%3BHumidity-Sensor-%28SHT31%29-p-2655.html	<table border="1" style="margin: auto;"> <tr><td style="padding: 2px;">GND</td></tr> <tr><td style="padding: 2px;">VCC</td></tr> <tr><td style="padding: 2px;">SDA</td></tr> <tr><td style="padding: 2px;">SCL</td></tr> </table>	GND	VCC	SDA	SCL	\$11.90
GND									
VCC									
SDA									
SCL									
Ultra sonic ranger		Water level Water filling and emptying times	https://www.seeedstudio.com/Grove-Ultrasonic-Ranger-p-960.html	<table border="1" style="margin: auto;"> <tr><td style="padding: 2px;">GND</td></tr> <tr><td style="padding: 2px;">VCC</td></tr> <tr><td style="padding: 2px;">NC</td></tr> <tr><td style="padding: 2px;">SIG</td></tr> </table>	GND	VCC	NC	SIG	\$3.90
GND									
VCC									
NC									
SIG									
1 Wire Temperature Sensor		Water temperature	https://www.seeedstudio.com/One-Wire-Temperature-Sensor-p-1235.html	<table border="1" style="margin: auto;"> <tr><td style="padding: 2px;">GND</td></tr> <tr><td style="padding: 2px;">VCC</td></tr> <tr><td style="padding: 2px;">NC</td></tr> <tr><td style="padding: 2px;">DQ</td></tr> </table>	GND	VCC	NC	DQ	\$7.50
GND									
VCC									
NC									
DQ									
TSL2561		Luminous flux on the plants	https://www.seeedstudio.com/Grove-OLED-Display-1.12%27%27-V2-p-3031.html	<table border="1" style="margin: auto;"> <tr><td style="padding: 2px;">GND</td></tr> <tr><td style="padding: 2px;">VCC</td></tr> <tr><td style="padding: 2px;">SDA</td></tr> <tr><td style="padding: 2px;">SCL</td></tr> </table>	GND	VCC	SDA	SCL	\$14.90
GND									
VCC									
SDA									
SCL									
OLED display 1.12		Data display	https://www.seeedstudio.com/Grove-Digital-Light-Sensor-p-1281.html	<table border="1" style="margin: auto;"> <tr><td style="padding: 2px;">GND</td></tr> <tr><td style="padding: 2px;">VCC</td></tr> <tr><td style="padding: 2px;">SDA</td></tr> <tr><td style="padding: 2px;">SCL</td></tr> </table>	GND	VCC	SDA	SCL	\$9.90
GND									
VCC									
SDA									
SCL									

THE CASES

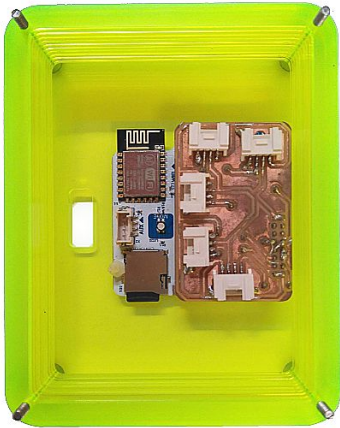

A laser cut boards case



A 3D printed Ultrasonic Ranger case

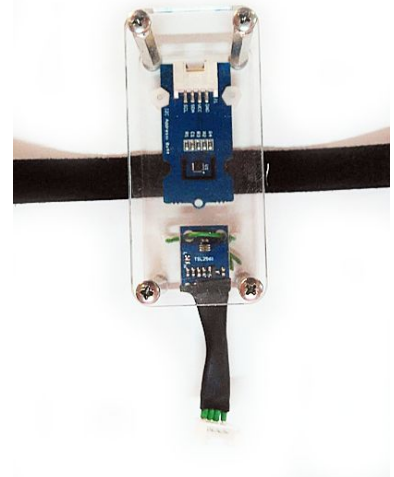







A laser cutted the SHT31 and Light sensor case

ASSEMBLY

ASSEMBLY 1: The Aquapioneers board

Tools you will need for this part:

A PC	A compact milling machine (ex:SRM-20)	Soldering iron	Grove connectors	Breakway Male header Pin headers (2.54mm)	Resistors
					

1

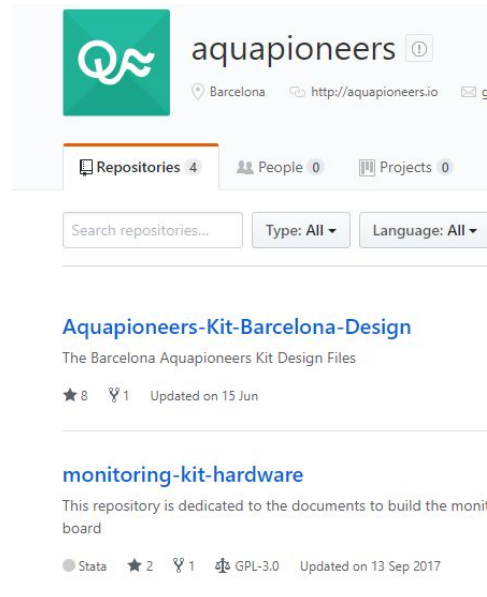

Connect to our Github at <https://github.com/aquapioneers> and download the .png of the Aquapioneers Board files.

2

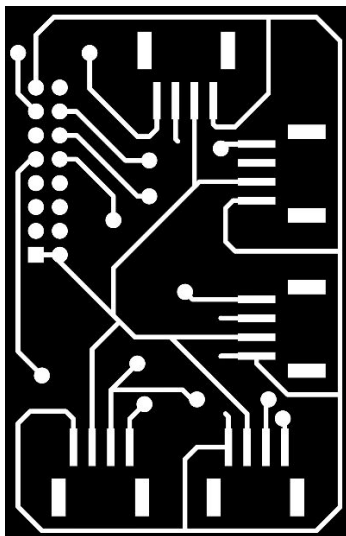

.png trace A

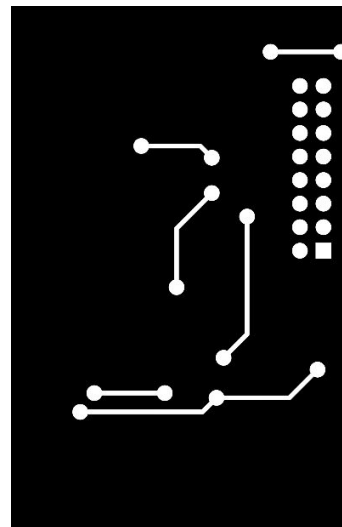

.png trace B

Mill the PCB by following the Fab academy tutorial :

http://fabacademy.org/2018/docs/FabAcademy-Tutorials/week4_electronic_production/srm20_windows.html

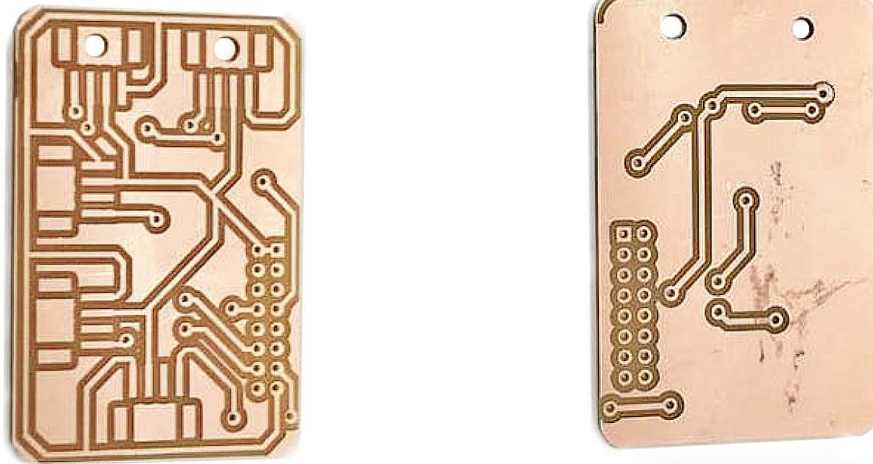

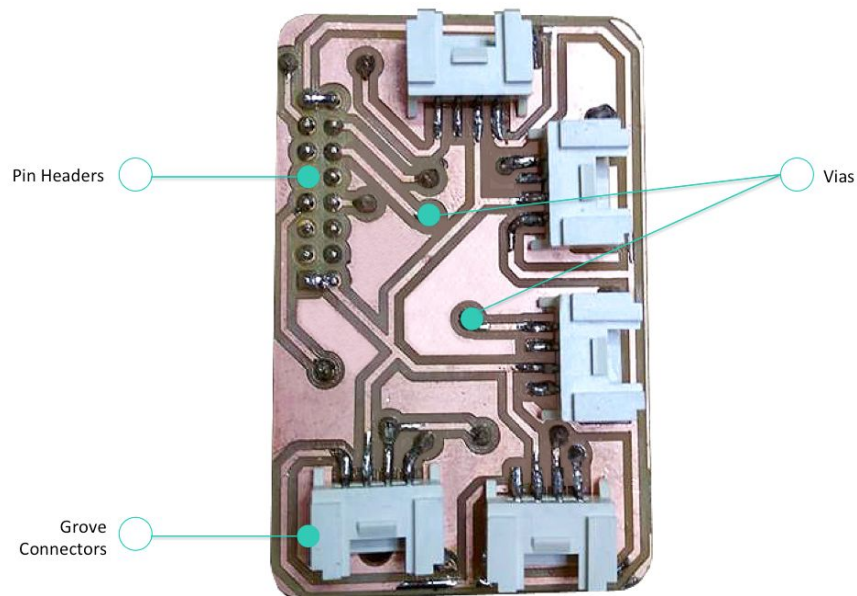

3



Solder Vias using Resistors lead connectors to make a connection between both sides.
Solder Pin headers and Grove connectors on board.

ASSEMBLY 2: The 3D printed ultrasonic sensor case

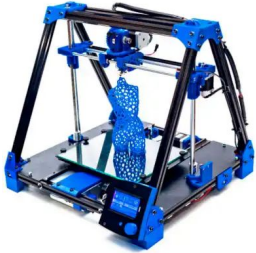
Tools you will need for this part:

3D printer	2 bolts and 2 nuts M3, 10mm long 2 bolts and 2 nuts M3 40mm long
	

4

Go on our Github at <https://github.com/aquapioneers> and download the .png of the Aquapioneers Board files.

5

The files contain Solidworks files so that you can modify the dimensions if you used a different sensor

6

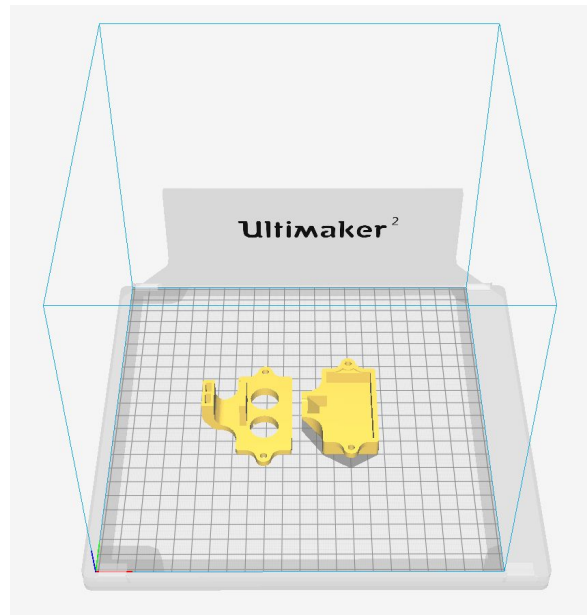

Open the STL files with the software Cura. Rotate and move them so that they fit.

7

A screenshot of a blue button with the text "Save to File" in white. The button is centered within a light gray rectangular frame.

Use recommended settings for your machine, or customized if you prefer, and transfer on SD card by clicking Save to File

8

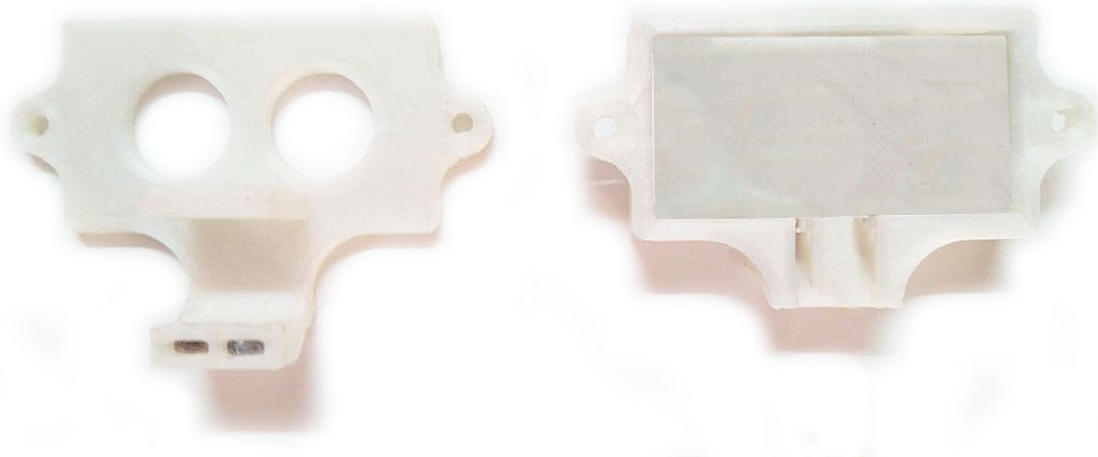

Print files on your 3D printing machine

9

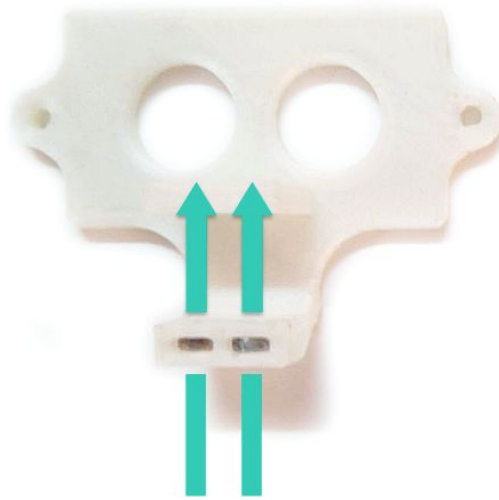

Insert bolts in bottom part

10



Add Ultrasonic ranger in top part of the casing with the Grove cable

11

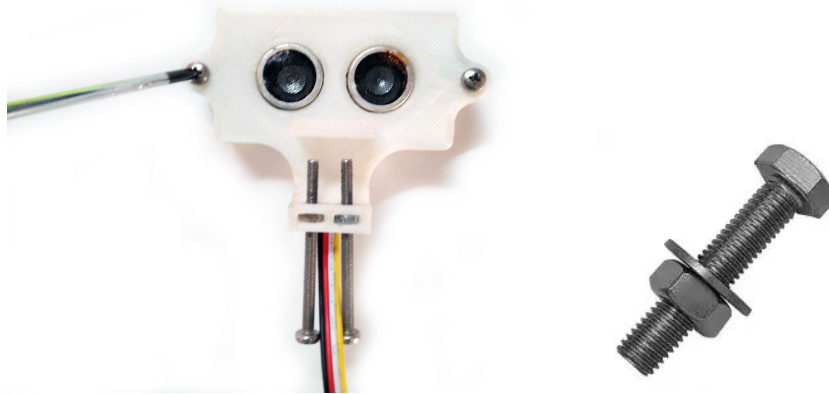

Screw both parts together using bolts and nuts

12

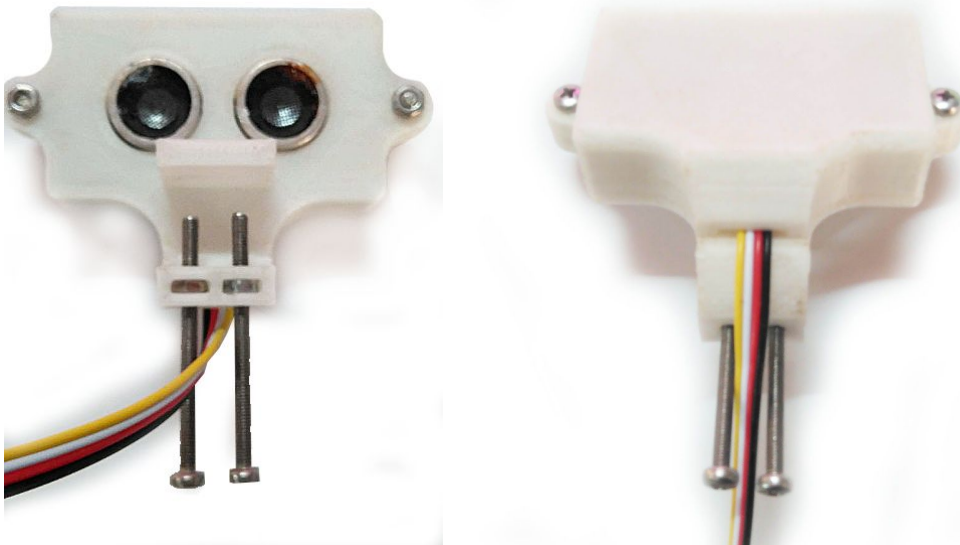

Screw in 40mm bolts on case

13

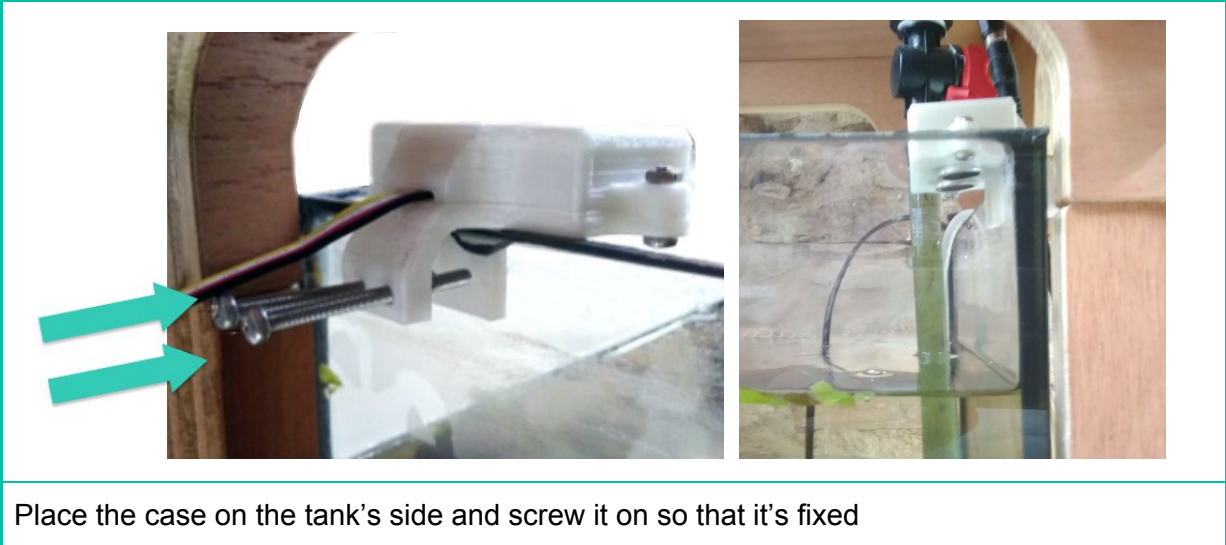

ASSEMBLY 3: The SHT-31 and Digital Light sensor

Tools you will need for this part:

Laser cutting machine	8 M3 bolts	4 M3 spacers	12 mm x 20 cm Velcro strap	Plastic bolts M2 and nuts for electronics	Screwdriver

14

Get Nesting files from Github

15



Laser cut the two parts on acrylic sheet

16



Insert velcro strap through hole in bottom part of casing

17

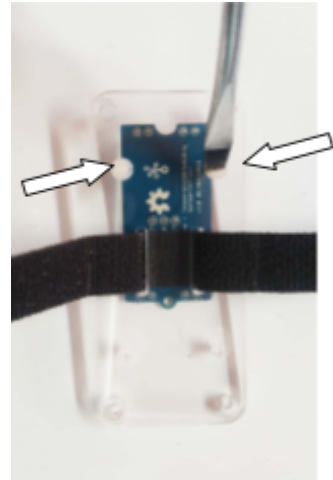
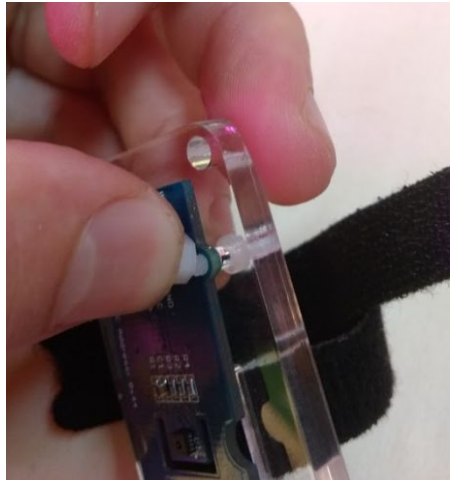
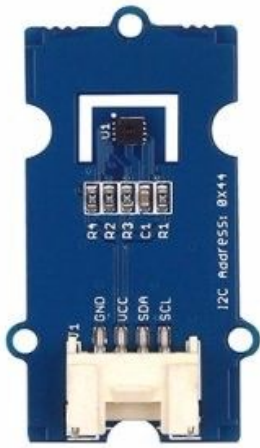

Screw plastics bolts to fix SHT-31 sensor to the back of the casing

18

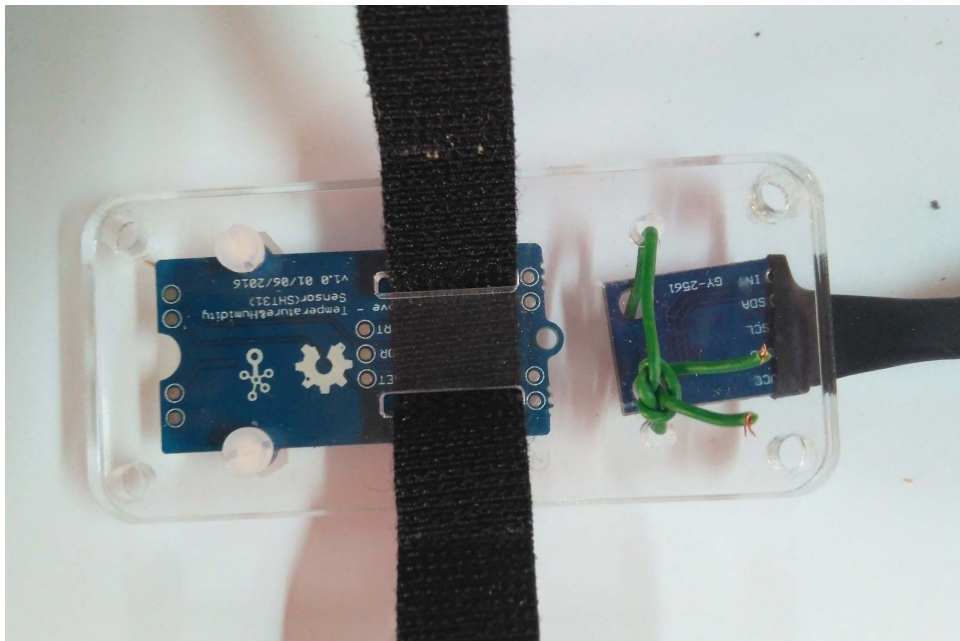

Fix the light sensor to the back of the casing

19

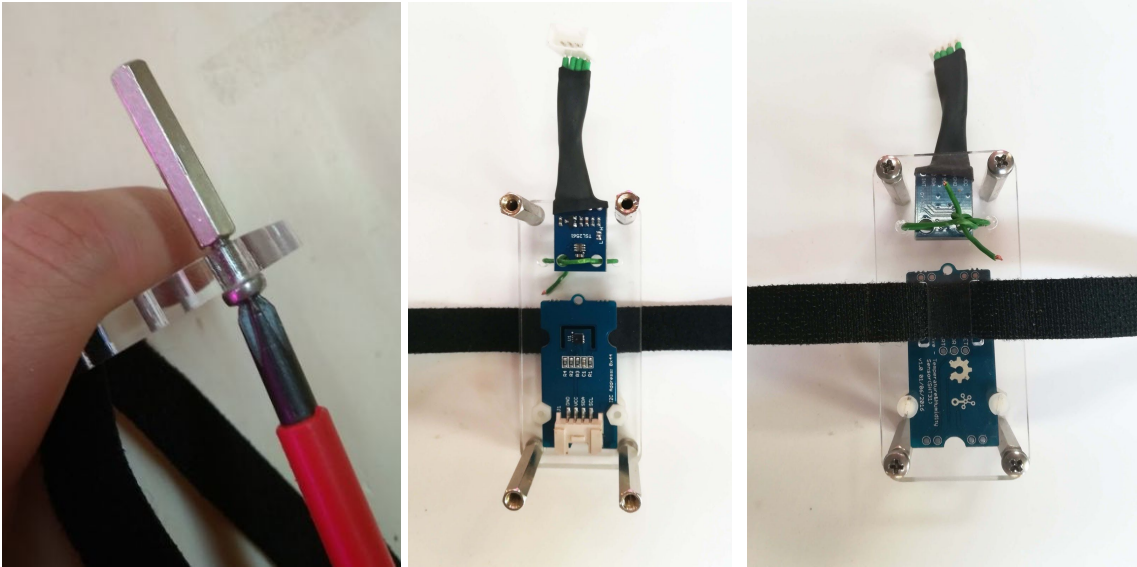

Insert metal bolts in each corner of the back of the casing. Screw on spacers

20

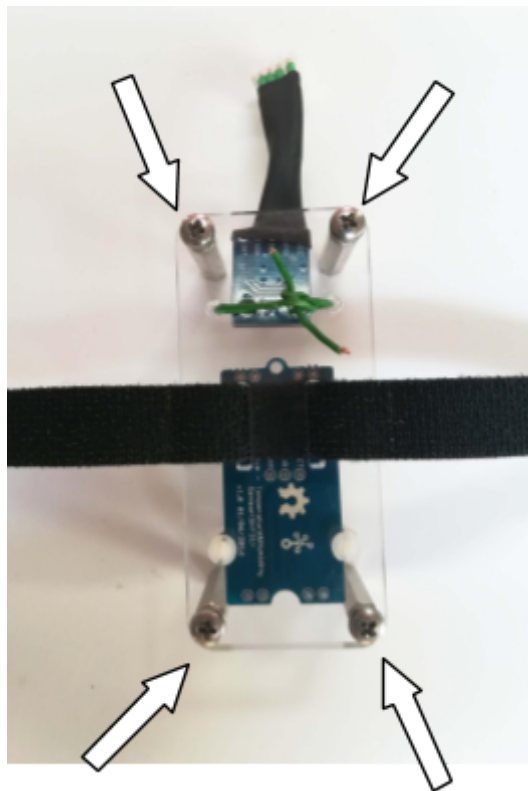

Repeat same procedure with the top part of the casing

21

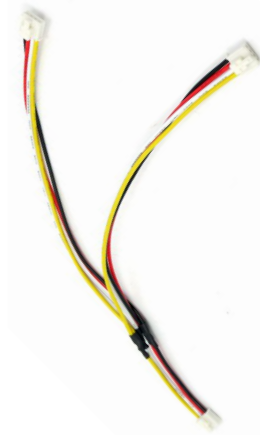

Get Grove Branch cable ready.

22



Separate slightly the two parts of the lamp frame.

23



Insert cables through the gap between the two parts.



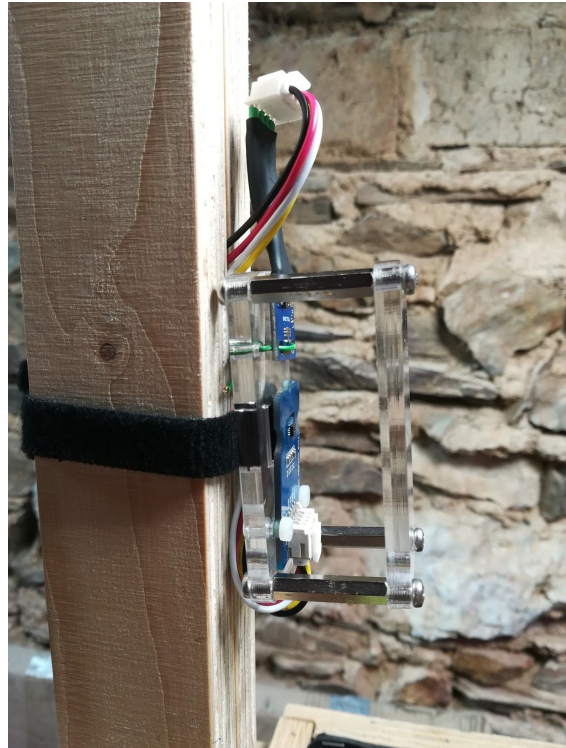

24









Attach the casing on the frame using the velcro strap

ASSEMBLY 4: The board case and the sensors

Tools you will need for this part:

Laser cutting machine	4 bolts and 4 nuts M3, 40mm long	Plastic bolts m2 and nuts for electronics	Screwdriver
			

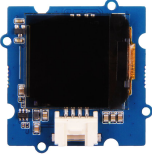
You will also need the different sensors:

SHT-31	Ultra sonic ranger in its casing	1 Wire Temperatu re Sensor	TSL2561	OLED display 1.12	Grove cables	Grove Branch cable
						

THE BOARDS CASE

25

Get files from Github

26



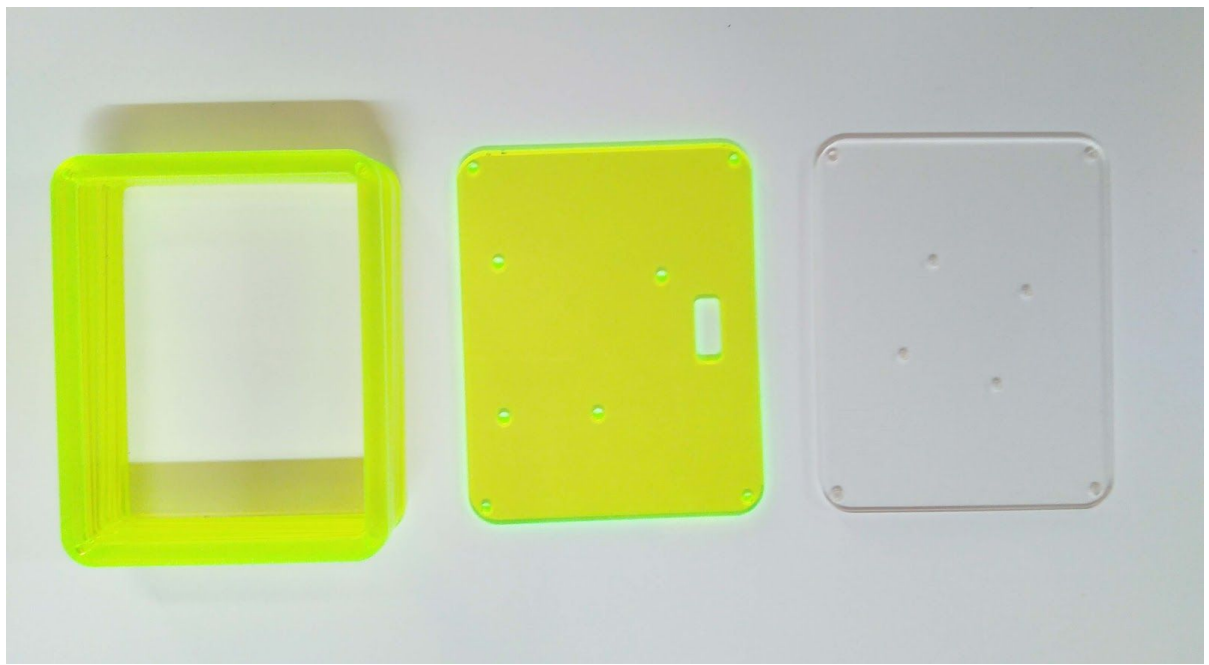

Use nesting files to cut 3mm thick acrylic with laser cutting machine. You can use whichever color you want. There should be 10 layers in between the top and bottom layers

27

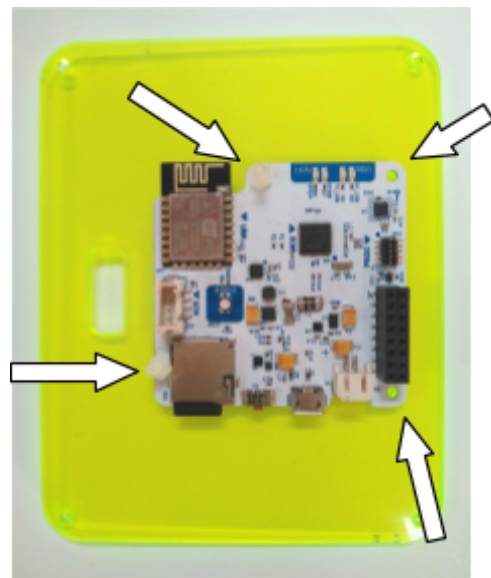
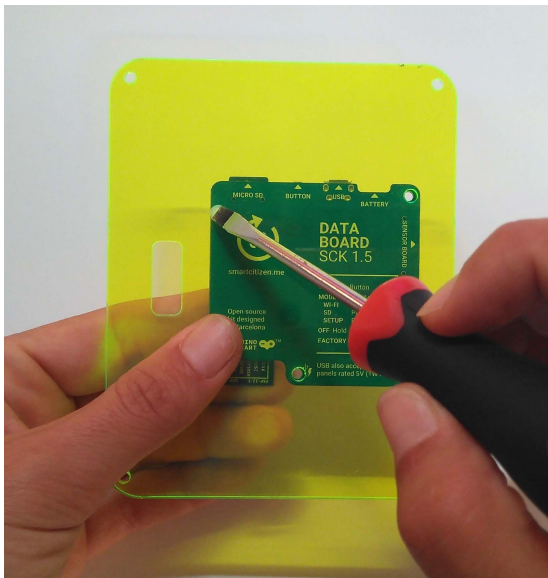

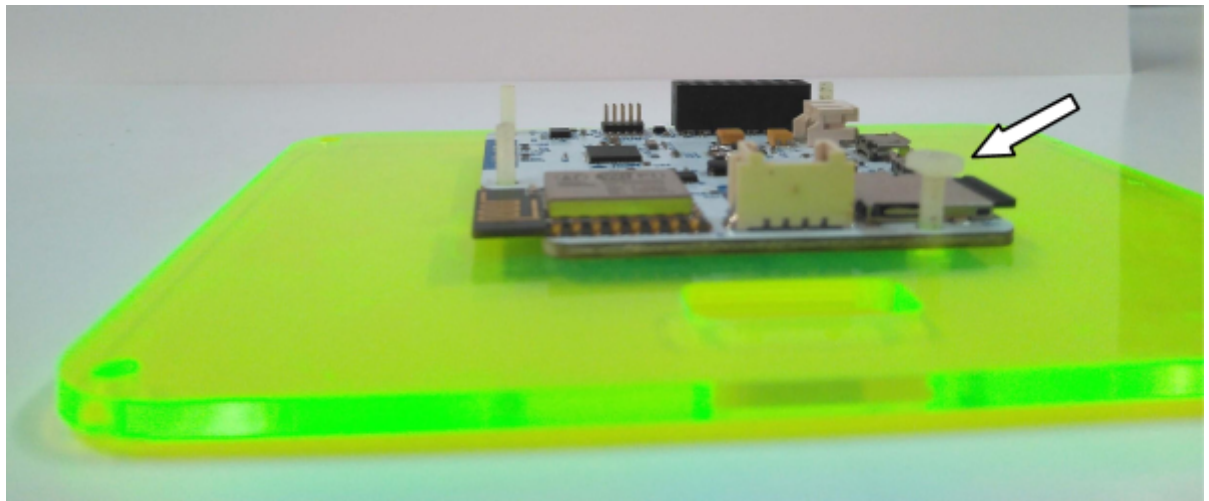

Screw the Base board on the bottom layer using the plastic bolts and screws

28

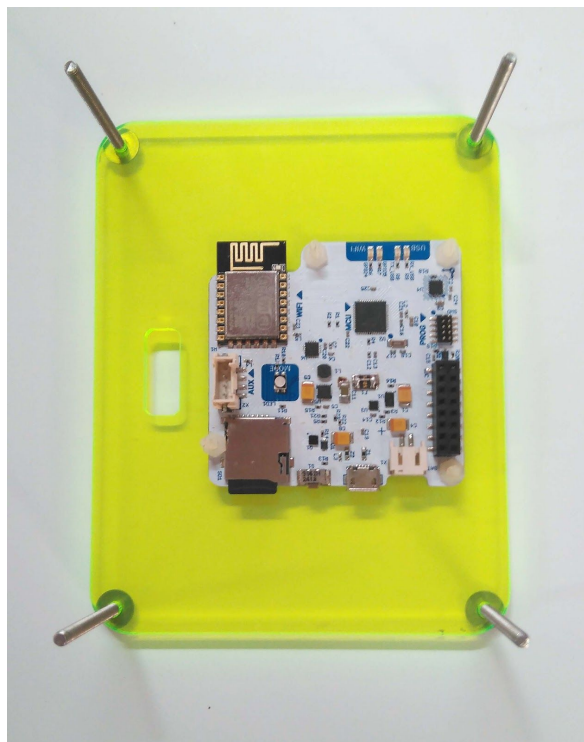

Add metal bolts underneath bottom layer

29

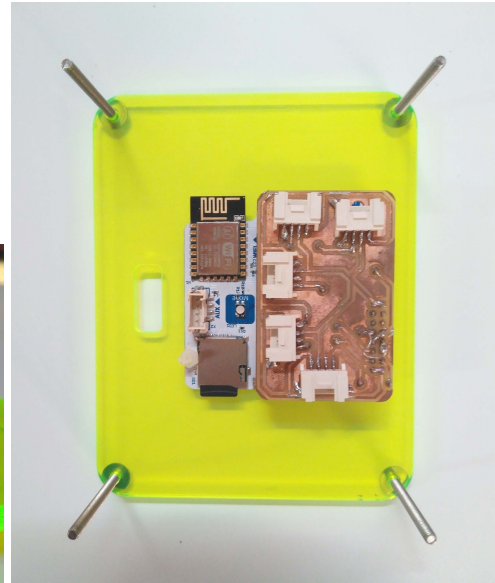
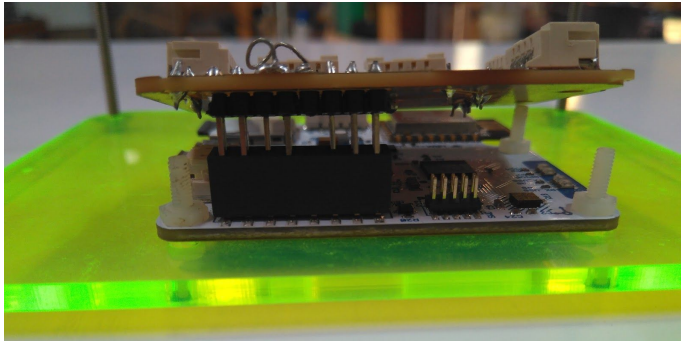

Plug in the Aquapioneers board onto the base board

30

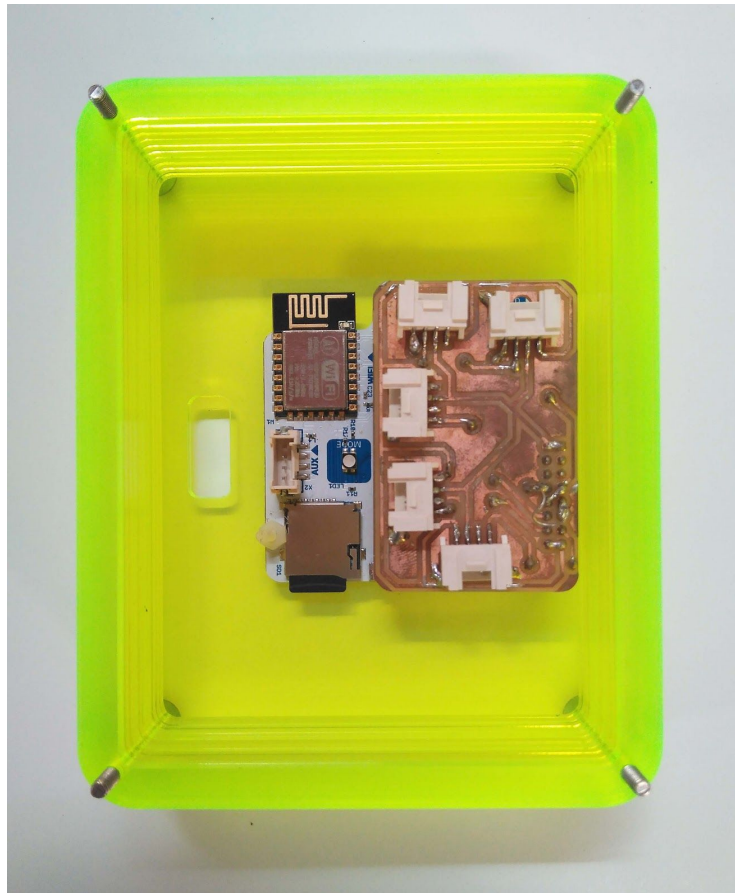

Slide intermediate layers of acrylic on the bolts

The sensors

31



Connect Grove cable to OLED screen.

32

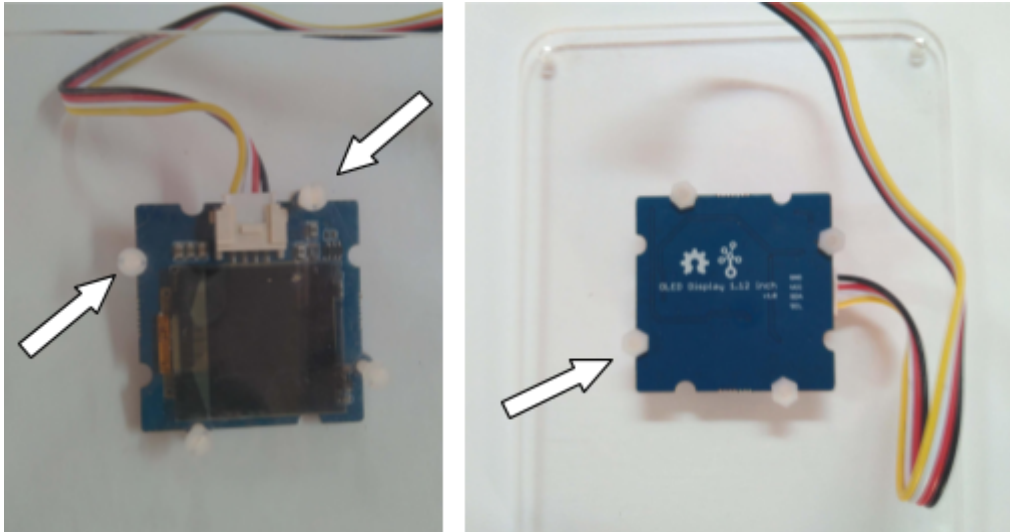

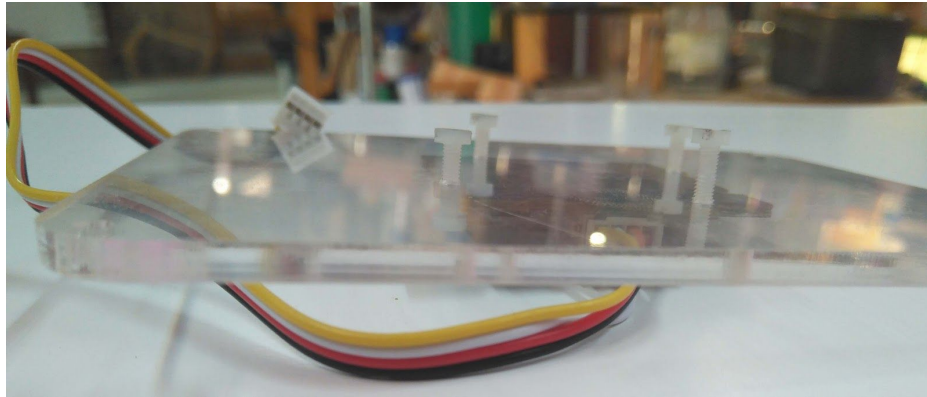

Take front part of the case and screw the screen. Be sure that the screen is touching the plastic.

33

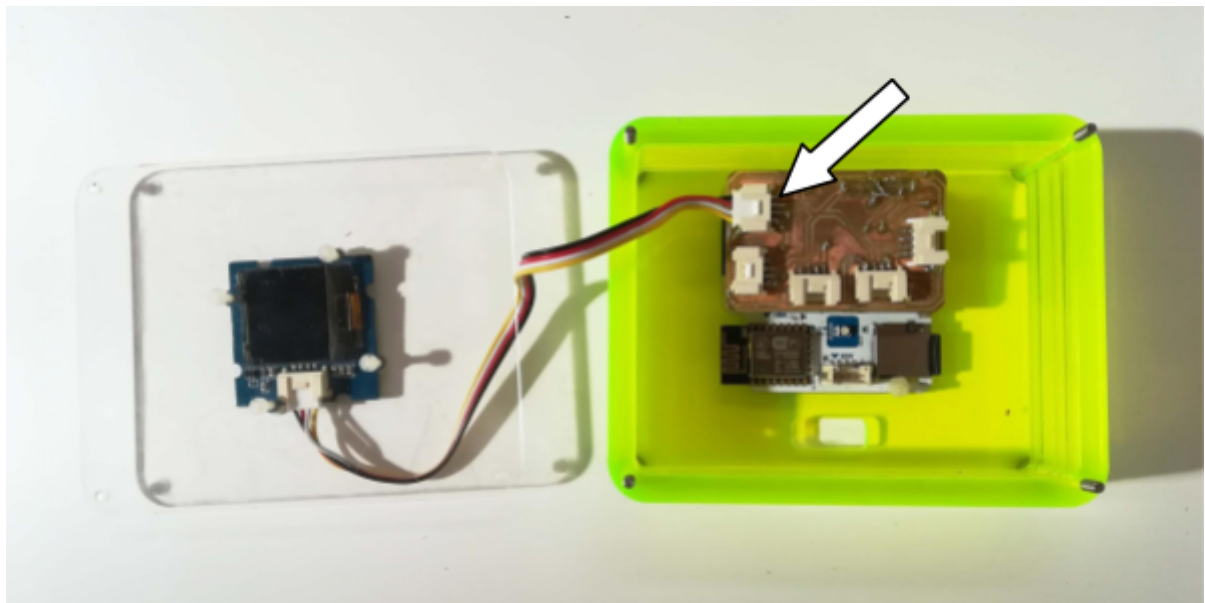

Plug in the OLED screen cable in the indicated connector.

34

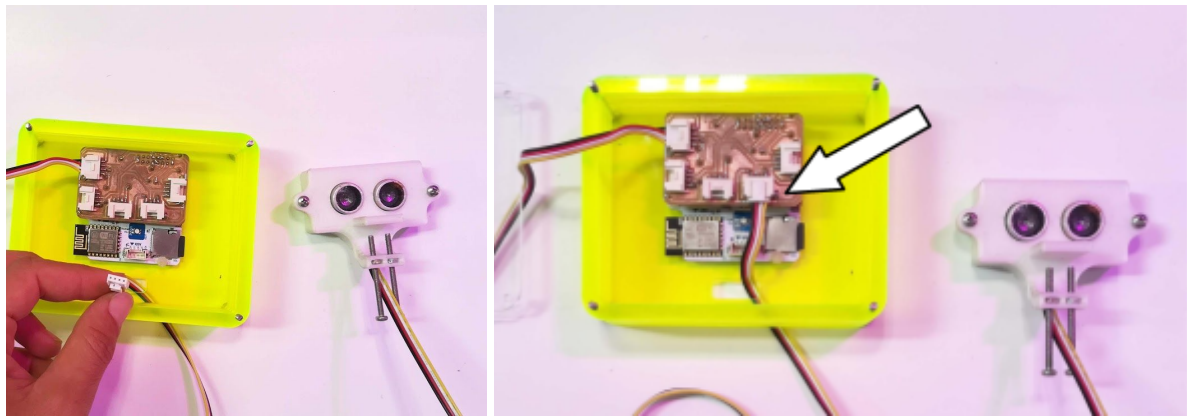

Plug the ultrasonic sensor cable in the indicated connector.

35

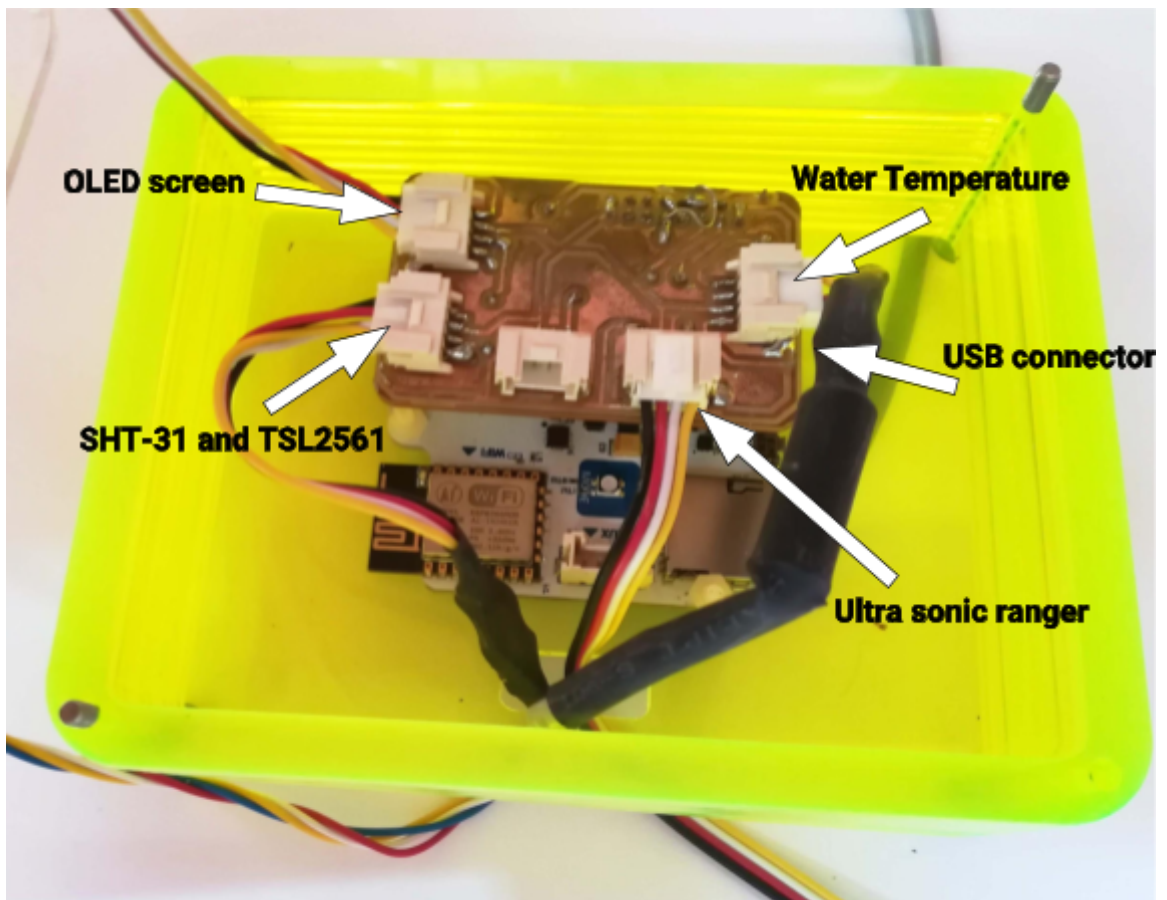

Plug in all the connectors onto the Aquapioneers board as shown above. There are one extra connector for an extra sensor.

36

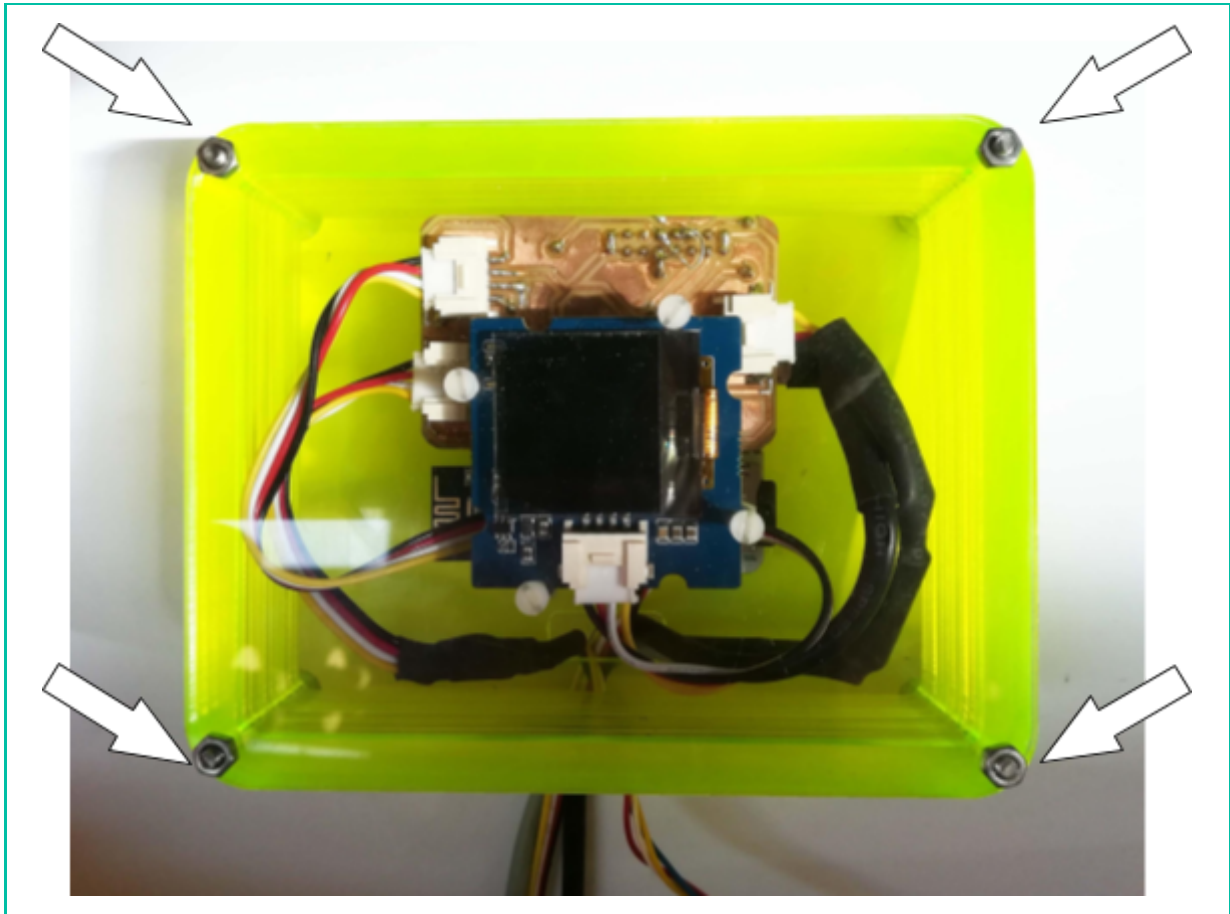

Screw top layer onto the case.

37

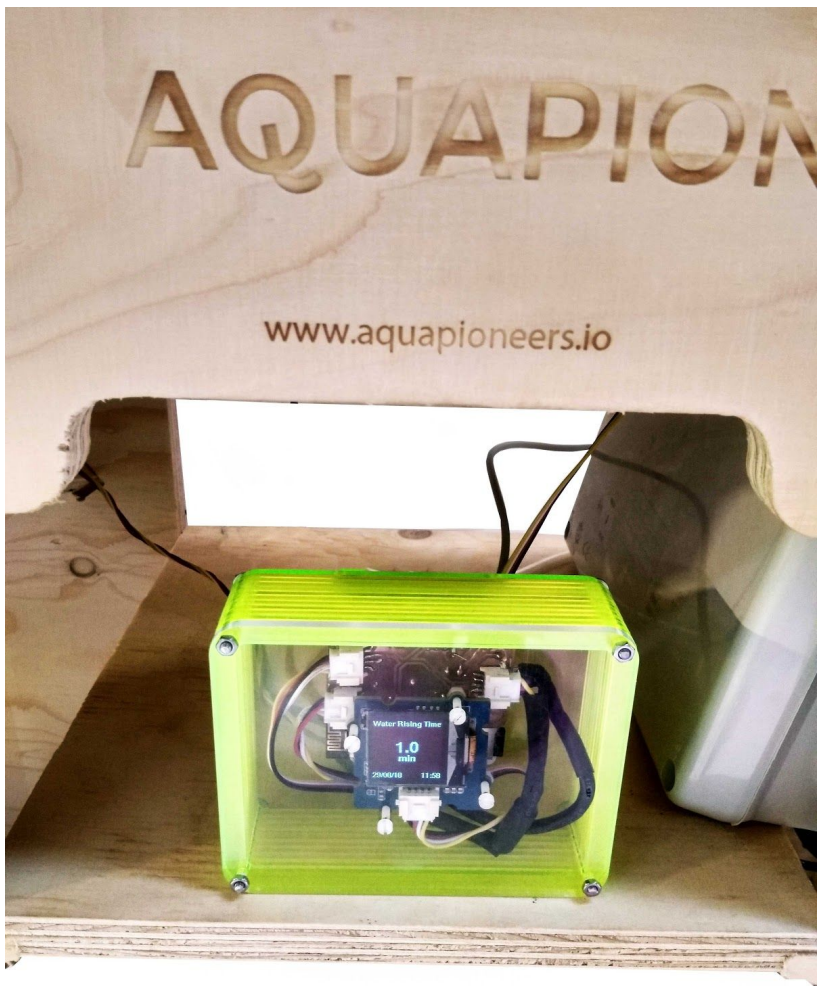

SOFTWARE : How to setup your Monitoring Kit

Once the sensors are mounted, you should connect the Aquapioneers kit to your computer through a USB cable to upload the source code.

 Check the source code

39 Downloading the firmware

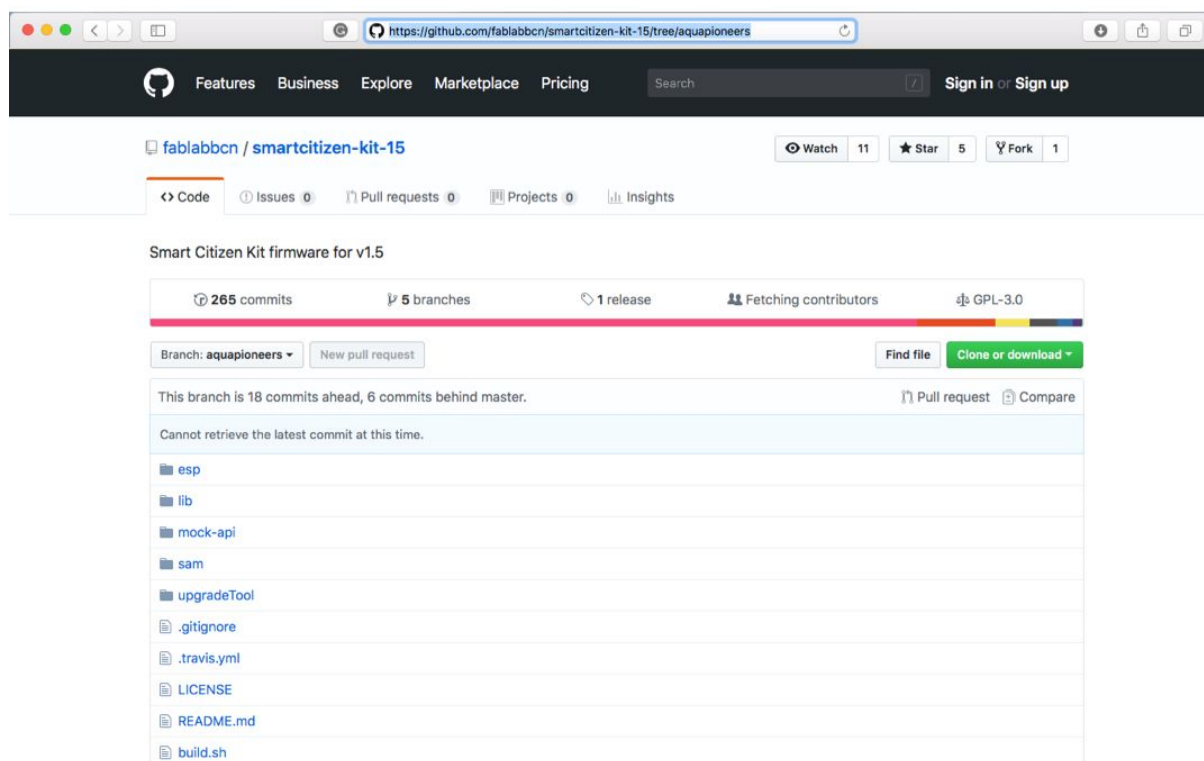

Aquapioneers Monitoring Kit firmware could be downloaded from the Smart Citizen / Aquapioneers Github branch: <https://github.com/fablabbcn/smartcitizen-kit-15/tree/aquapioneers>



40 Uploading the firmware



PlatformIO IDE

The next-generation integrated development environment for IoT

[Install for VSCode](#) [Looking for Atom?](#)

It's built on top of GitHub's Atom and Microsoft's Visual Studio Code – free, open source, and MIT licensed editors

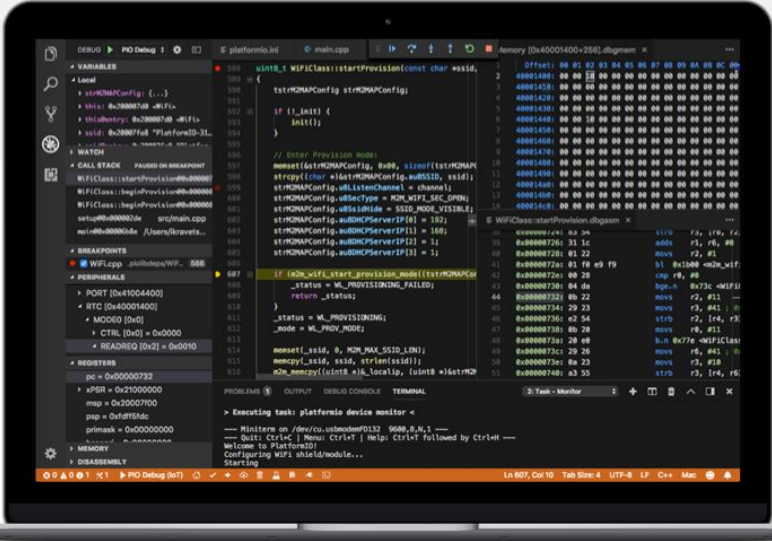

To upload the firmware to the Aquapioneers citizen kit, you will need to use “PlatformIO IDE” that can be download here: <https://platformio.org>. Then follow the next steps.

1. In folder `./sam/` do:

```
pio run -t upload
```

2. in folder `./esp/` do:

```
pio run -t upload
```

3. To upload the Frontend website code to the filesystem do:

```
pio run -t uploadfs
```

41 Configure & connect to WIFI

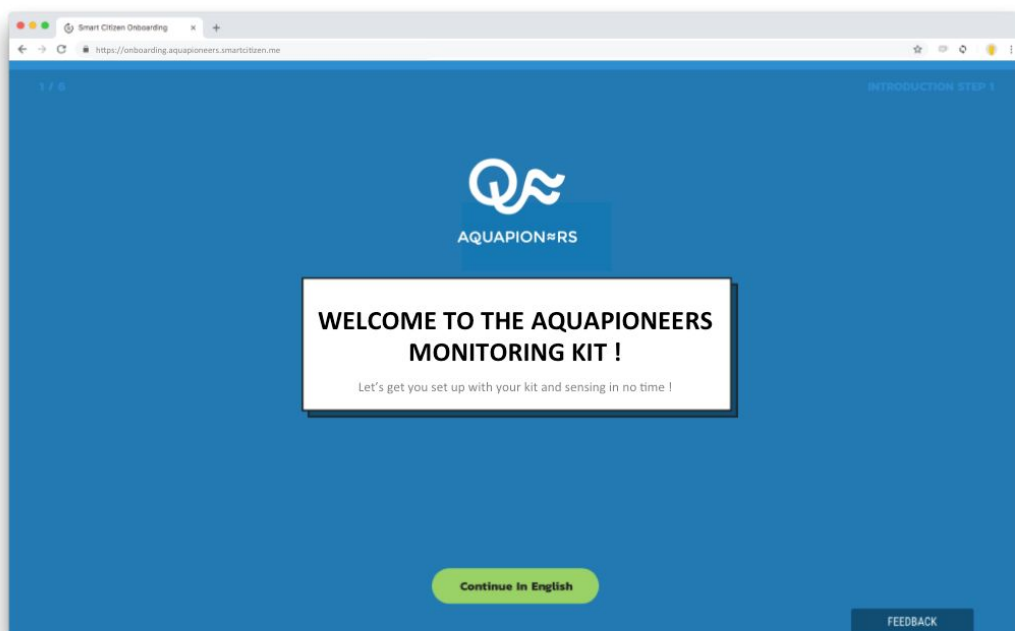

You will be able to configure it by following the instructions at <https://onboarding.aquapioneers.smartcitizen.me/>

42 Visualize your datas

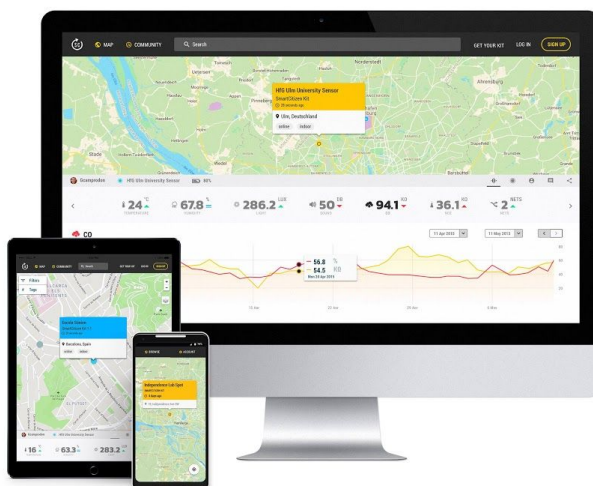

After the configuration your data will be available on the SmartCitizen platform (<https://smartcitizen.me/kits/>). You can explore the data there or download it using the **CSV Download** option.



43 Troubleshooting

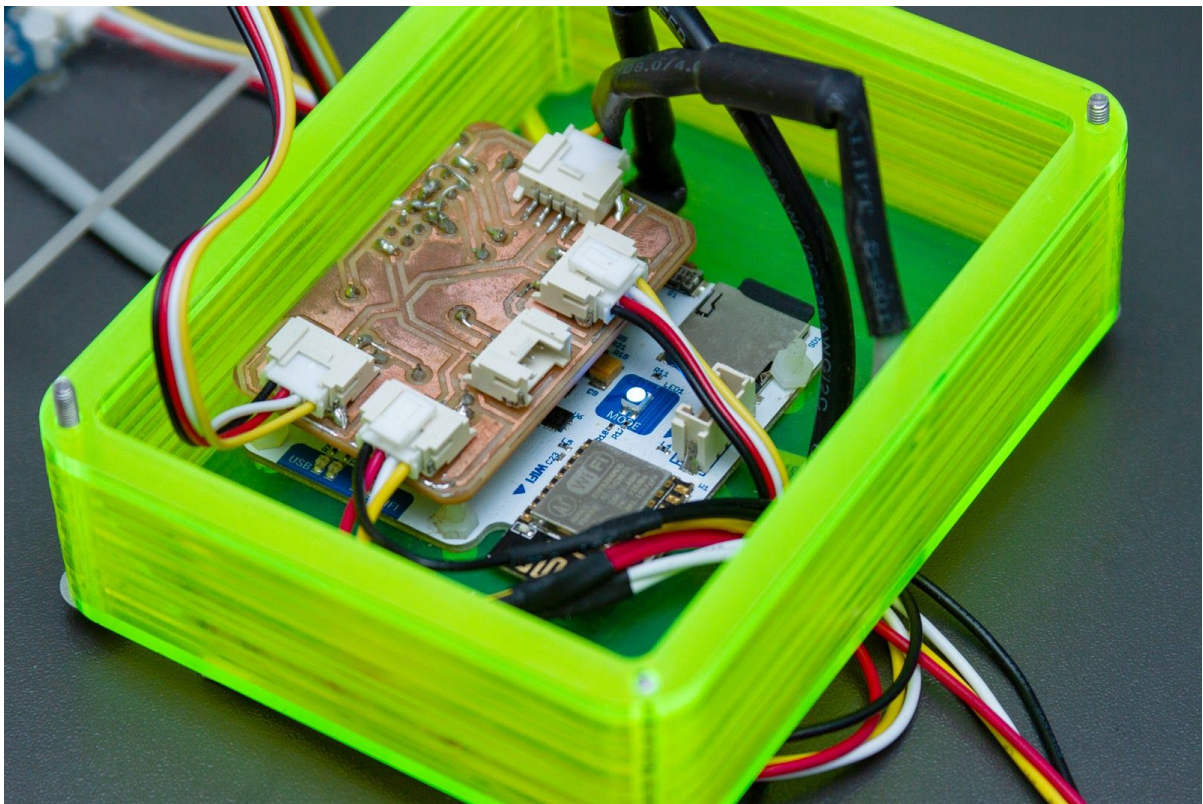

For any other FAQs related to:

- the state of the monitoring kit
- operation modes
- troubleshooting
- SD card mode (offline)

Please check the Smart Citizen sensors documentation on:

<https://docs.iscape.smartcitizen.me/Citizen%20Kit/> or contact the smart citizen team at support@smartcitizen.me.

Thanks to OPEN MAKER EU H2020 project that makes the “*Aquapioneers Kit - User Manual - Part III - The nervous system*” deliverable possible

<https://openmaker.eu/>



This project has received funding from the European Union's Horizon 2020 research and innovation programme under grant agreement No. 687941



We also want to thanks all our ULULE backers that make the “*Aquapioneers Kit - User Manual - Part I - The Body*” and “ the “*Aquapioneers Kit - User Manual - Part II - The Blood*” possible



<https://www.ulule.com/aquapioneers/>

Dinis Mendes	Miren Garrido	'Marco Sanalidro	Benny Krimeur	Pascale TEYSSIE
Miriam Hernandez	Thomas Jourdan	J Armand Figeac	Adriana Alvarez Caballero	Albert Siurana Saumell
Linda Sunnen	Kathleen Stewart	Anouk Le goueff	michaelboeckle3	Marcio Barrios
ginnygin	Diana Moret	Gaby Xocolata	Mayo Fuster Morell	David Castillo Santander



Gabi Masfarre Pinto	Thiebault Mura	Romain Flattet	Felipe Agudelo Jaramillo	Visual Cabin
Marlene Clement	Glauca Loebmann	Pierre Gachet	David Centeno	David Gomez Fontanills
Pablo Castellano	Anna Serena	Laurent Dussart	Jason Renoux	Fundacion Uxio Novoneyra
Lorenzi Nathalie	Mara Balestrini	Hong Park	Martine Neyen	Masanet Patrick
Anne Guimonnet	Aude Omerin	Isabel Wiseler-Lima	Mathieu Geiler	Goran Blazic
Helena Lahellen	Alexandre Benassar	Farrah Baut-Carlier	Albert Neyen	Vanessa Martnez
Pierre Tabary	Naoise Golden	Alexandre Curtelin	Kostia Belkin	Juan Manuel Umber rossello
Javier Verba	Roque Federico Dorfman	Gabriel Samso	Josh Edler	Robert Guia
Eva Miguelez Ortiz	Raf Sasan	Guillaume Teyssie	PATRICIA BASSE	Eileen Arnold
Patrice Boimond	Constance Dangy	Hugo Cabos	Charbel Aoun	julien bonnaud
Andrea Barbiero	AMPA La Sagrera AMPA La Sagrera	Olgui Fuertes	Mariana Quintero	Tania Sande
nith nith	Pierre Jean Nedergaard	Sergio Gutierrez	Alessio Verdolino	Walter D. Michaels
Anne Delacour	Anna Dalmasas Trias	Yola Perez	Jose Francisco Pelaez	Jeanne Streng
CoworkingLille	Bruno Le Hen Ortega	Yola Perez	Muriel Chevallet	Oriol Cela
Alexia Mellor	Bruno Le Hen Ortega	Lydia Fraga	Roci,Silvia, Rocio SAN, Inigo,Guillem	Simon Burin des Roziers
Kevin Tang	Bruno Le Hen Ortega	Eduard Hernandez	Julia Cruz	Beryl Navarro
Yoshi Yasu Hirano	Marion Schuppe	Emilia Caba	Charles Labatut	Loic Fievet
ANDREW GREGSON	Josep Carrizo	Eva Del Barrio	Paul VERZY	Raquel Jimenez
Alberto Perez	Marie Tavera	Simon Malfiarage	Igor Garcia Barbero	Etienne Guyon
Elena Canas	noemie rousselet	Martin Gutmann	Agustin Vargas	Xavier Dominguez Aparicio
Daniel Carbonell Rubio	Isaac pierre racine	Katherine Woodhouse	Edmond Capart	lolilola50

Miren Garrido	Anna Garrofe	Fra Mousel	Bobby Marchand	Quentin Govignon
Guillaume & Loic	Gerard Chatelier	Justo Fab	Ivn Gutierrez	Francois DESORMEAU
Yasmine Abdelaziz	Gai Boro	Jaume Miro	Jean-Marie Guyon	acanigueral
Benjamin Whipker	Thomas Zannoni	Marie Scheid	Daniel Reznikov	Valentin Albinet
Michel Coqblin	Paul-Henri Petit	Dimitrios Savvopoulos	margaux tiberghien	Jean Christophe THUAN
Yee man annie Leung	Murielle Bagniet	Cales Laure	Cloud Coworking	Cecile Delacour Delhay
Julien Morey	PaCha	Tristan Copley Smith	Vicente Guallart	jordivalsfoix
Pierre Willieme	Constance Martel	Stef Denamps Gomez	Vicente Guallart	Ricardo Iglesias Meijome
Keith Anderle	Renee Teyssie	Laura Dayan	Joaquin Baraibar	Julius Brenn
jeremy Lizandier	Nicole Dorrell	marcel kellner	Emi_ouiwin	Anya Popova
Bea Nina Tartaruga	Pierre Paslier	Constance Dangy	Claudine Perla	philippa young
Matthieu Napoli	Arnau Arn	v25a	Adria Casas Gimeno	Martine Neyen
Harvey Dunham	Roger Delacour	Regis Declaire	Luciana Asinari	Maxime Le Goueff
clem sayyeah	Paul Deshayes	Breny Aceituno	Jesus Badenas	Martine Neyen
Amaya Pou	jean louis teyssie	Pierre-Francois Delacour	Guillaume Dardelin	Ivan Loza
Pauline Grenier	Johanne Greenwood	Mathieu PAUWELS	Maria Serrano Basterra	Guillaume & Loic
Andrea Ruani	Ana maria Gibert	Shai Erev Levi	Jean-marc Streng	Gerard Llorach
Jose Ivan Gonzalez Estrada	stephan le goueff	Gabriel Dulac-Arnold	Areti Markopoulou	javier baraibar molina
L.J. Eiben	simona-1	samantha raez	Linda Carlson	Thomas GAUTHIER
marcin wolynski	Stephanie Ah Tchou	Antoine Desjonqueres	Silvia Brandi	Aude Omerin
Regis Largillier	Pascual Llanes	Corey Ellis	Lucas Cappelli	Jonathan Minchin
David Bertet	Angeles Ribes	Anahi Lacanna	Ana Vida	Alexandre Dubor
codeman	Tim Willemen	Charly Goerend	Gregoire Durrens	Helena Gibert
Adria Garcia I	Anaick Crozon	rieultecher	Naiara Chaler	Gaby Xocolata



Mateu				
Ricard Jornet	Caro Vignoli			

This Publication accompanies the Barcelona Aquapioneers ecosystem files or Assembly kit. It was designed and tested by the Aquapioneers team at Valldaura Labs in Barcelona, Spain, with the generous support of Valldaura Labs, IAAC and Fab Lab Barcelona.

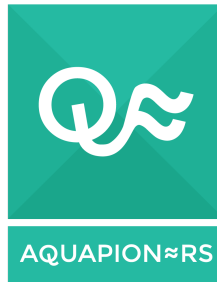

CONTACT:

info@aquapioneers.io

VISIT:

www.aquapioneers.io

FOLLOW:

@aquapioneers (Twitter/Instagram/Youtube/Linkedin)

COMMENT:

<http://aquapioneers.io/community-forum/>

LIKE:

<https://www.facebook.com/aquapioneers/>



MAKE:

<https://github.com/aquapioneers/Aquapioneers-Kit-Barcelona-Design>

