

# ASTRO® Digital Spectra® and Digital Spectra Plus

Mobile Radios

W3 / W4 / W5 / W7 / W9  
Control Head Models  
Service Manual







# ASTRO® Digital Spectra® and Digital Spectra Plus

Mobile Radios

## W3/W4/W5/W7/W9 Control Head Models Service Manual

# Foreword

This manual covers the ASTRO® Digital Spectra® and Digital Spectra Plus control heads (Models W3, W4, W5, W7, and W9), unless otherwise specified. This manual provides sufficient information to enable qualified service shop technicians to troubleshoot and repair ASTRO® Digital Spectra® and Digital Spectra Plus control heads to the component level.

For details on radio operation, refer to the applicable manuals available separately. A list of related publications is provided in the section, "Related Publications," on page ix.

## Product Safety and RF Exposure Compliance

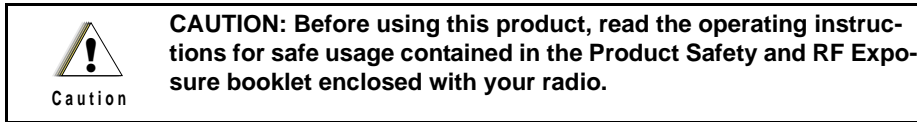

### ATTENTION!

**The radio that comes with this control head is restricted to occupational use only to satisfy FCC RF energy exposure requirements. Before using this product, read the RF energy awareness information and operating instructions in the Product Safety and RF Exposure booklet enclosed with your radio (Motorola Publication part number 68P81095C99) to ensure compliance with RF energy exposure limits.**

**For a list of Motorola-approved antennas, batteries, and other accessories, visit the following web site which lists approved accessories: <http://www.motorola.com/cgiss/index.shtml>**

## Manual Revisions

Changes which occur after this manual is printed are described in FMRs (Florida Manual Revisions). These FMRs provide complete replacement pages for all added, changed, and deleted items. To obtain FMRs, contact the Radio Parts Services Division (refer to "Appendix A, Replacement Parts Ordering").

## Computer Software Copyrights

The Motorola products described in this manual may include copyrighted Motorola computer programs stored in semiconductor memories or other media. Laws in the United States and other countries preserve for Motorola certain exclusive rights for copyrighted computer programs, including, but not limited to, the exclusive right to copy or reproduce in any form the copyrighted computer program. Accordingly, any copyrighted Motorola computer programs contained in the Motorola products described in this manual may not be copied, reproduced, modified, reverse-engineered, or distributed in any manner without the express written permission of Motorola. Furthermore, the purchase of Motorola products shall not be deemed to grant either directly or by implication, estoppel, or otherwise, any license under the copyrights, patents or patent applications of Motorola, except for the normal non-exclusive license to use that arises by operation of law in the sale of a product.

## Document Copyrights

No duplication or distribution of this document or any portion thereof shall take place without the express written permission of Motorola. No part of this manual may be reproduced, distributed, or transmitted in any form or by any means, electronic or mechanical, for any purpose without the express written permission of Motorola.

## Disclaimer

The information in this document is carefully examined, and is believed to be entirely reliable. However, no responsibility is assumed for inaccuracies. Furthermore, Motorola reserves the right to make changes to any products herein to improve readability, function, or design. Motorola does not assume any liability arising out of the applications or use of any product or circuit described herein; nor does it cover any license under its patent rights nor the rights of others.

## Trademarks

MOTOROLA, the Stylized M logo, ASTRO, and Spectra are registered in the US Patent & Trademark Office. All other product or service names are the property of their respective owners.

# Table of Contents

**Foreword ..... ii**

- Product Safety and RF Exposure Compliance ..... ii
- Manual Revisions ..... ii
- Computer Software Copyrights ..... ii
- Document Copyrights ..... ii
- Disclaimer ..... ii
- Trademarks ..... ii

**Commercial Warranty ..... xi**

- Limited Warranty ..... xi
  - MOTOROLA COMMUNICATION PRODUCTS ..... xi
    - I. What This Warranty Covers And For How Long ..... xi
    - II. General Provisions ..... xi
    - III. State Law Rights ..... xii
    - IV. How To Get Warranty Service ..... xii
    - V. What This Warranty Does Not Cover ..... xii
    - VI. Patent And Software Provisions ..... xiii
    - VII. Governing Law ..... xiii

**Chapter 1 Introduction ..... 1-1**

- 1.1 Notations Used in This Manual ..... 1-1
- 1.2 Control Head Features ..... 1-2
- 1.3 Control Heads ..... 1-2
  - 1.3.1 W3 Control Head ..... 1-2
    - 1.3.1.1 W3 Controls ..... 1-3
  - 1.3.2 W4, W5, W7, and W9 Control Heads ..... 1-4
    - 1.3.2.1 W4, W5, W7, and W9 Controls ..... 1-6

**Chapter 2 Basic Maintenance ..... 2-1**

- 2.1 Inspection ..... 2-1
- 2.2 Cleaning ..... 2-1
  - 2.2.1 Cleaning External Plastic Surfaces ..... 2-1
  - 2.2.2 Cleaning Internal Circuit Boards and Components ..... 2-1
- 2.3 Handling Precautions ..... 2-2

**Chapter 3 Theory of Operation ..... 3-1**

- 3.1 W3 Control Head ..... 3-1
  - 3.1.1 SB9600 Serial Bus Interface ..... 3-1
  - 3.1.2 Display Circuit ..... 3-1
  - 3.1.3 Keypad Side Keys and Top Keys ..... 3-2
  - 3.1.4 Microphone Preamplifier and PTT ..... 3-2

3.1.5	On-/Off-Hook Control .....	3-3
3.1.6	Backlight Circuit .....	3-3
3.1.7	Power Supply .....	3-3
3.1.8	Status LEDs .....	3-3
3.1.9	Jumper Selection .....	3-3
3.1.10	Power On/Off .....	3-4
3.1.11	Miscellaneous Functions.....	3-4
3.2	W4, W5, and W7 Control Heads.....	3-4
3.2.1	Power Switch/Ignition.....	3-4
3.2.2	Voltage Regulator .....	3-5
3.2.3	Microcomputer .....	3-5
3.2.4	Interface Circuitry.....	3-5
3.2.5	Reset.....	3-6
3.2.6	Bus Busy.....	3-6
3.2.7	Serial Bus Data .....	3-6
3.2.8	Push-To-Talk (PTT) .....	3-7
3.2.9	Hang-Up Button (HUB) .....	3-7
3.2.10	Ignition Sense Circuitry .....	3-7
3.2.11	Keypad Scan.....	3-7
3.2.12	Vacuum Fluorescent (VF) Voltage Converter Circuitry.....	3-7
3.2.13	Vacuum Fluorescent Display Driver IC .....	3-8
3.2.14	Vacuum Fluorescent Display .....	3-8
3.2.15	Backlight LEDs.....	3-8
3.3	W9 Control Head .....	3-8
3.3.1	Display .....	3-8
3.3.2	W9 Controls and Indicators.....	3-9
3.3.3	Control Board.....	3-9
3.3.3.1	Microprocessor .....	3-9
3.3.3.2	Watchdog Timer.....	3-9
3.3.3.3	Bus Transceiver .....	3-10
3.3.3.4	Vacuum Fluorescent Voltage Converter .....	3-10
3.3.3.5	Vehicle Interface Ports.....	3-10
3.3.3.6	Power Supply.....	3-10
3.3.3.7	Ignition Sense Circuits .....	3-10
3.3.3.8	EEPROM Write-Protect Circuit .....	3-11
3.3.4	Display Board.....	3-11
3.3.4.1	VF Display.....	3-11
3.3.4.2	VF Display Driver .....	3-11
3.3.4.3	Status LEDs.....	3-11
3.3.4.4	Backlight LEDs.....	3-11
3.3.5	Default Jumper Settings.....	3-11
3.4	Vehicle Interface Port (VIP) .....	3-12
3.4.1	W4, W5, and W7 Control Heads.....	3-12
3.4.1.1	VIP Output Connections .....	3-12
3.4.1.1.1	Dash-Mount Installations .....	3-12
3.4.1.1.2	Remote-Mount Installations .....	3-13
3.4.1.2	VIP Input Connections (Remote-Mount Only).....	3-13
3.4.2	W9 Control Heads.....	3-14
3.4.2.1	VIP Output Connections .....	3-14
3.4.2.2	VIP Input Connections .....	3-14

## Chapter 4 Test Equipment and Service Aids ..... 4-1

4.1	Recommended Test Equipment and Service Aids .....	4-1
<b>Chapter 5</b>	<b>Troubleshooting.....</b>	<b>5-1</b>
5.1	Required Tools and Supplies.....	5-1
5.2	Troubleshooting Waveforms .....	5-2
5.2.1	ASTRO Digital Spectra Waveforms.....	5-2
5.3	Replacing the Vacuum Fluorescent Display (W4, W5, and W7 Control Heads) .....	5-5
5.3.1	Removing the Display .....	5-5
5.3.2	Installing the Display .....	5-5
5.4	Replacing the Remote Back-Housing Interface Board .....	5-5
5.4.1	W4, W5, and W7 Control Heads.....	5-5
5.5	Replacing the Remote Interconnect Board.....	5-6
5.5.1	Low-/Mid-Power Radios.....	5-6
5.5.2	High-Power Radios .....	5-6
5.6	Replacing the Control-Head Board.....	5-7
5.6.1	W3 Control Heads .....	5-7
5.6.2	W4, W5, and W7 Control Heads.....	5-8
5.6.3	W9 Control Heads .....	5-10
5.7	Final Reassembly–W3 Control Head.....	5-11
5.8	Troubleshooting Charts .....	5-12
<b>Chapter 6</b>	<b>Radio Connectors .....</b>	<b>6-1</b>
6.1	Radio Connectors .....	6-2
6.2	Radio Connector Locations .....	6-3
6.3	Extender Cable (P501) .....	6-4
6.4	Control-Head Cabling Diagram.....	6-4
<b>Chapter 7</b>	<b>Exploded Views and Parts Lists .....</b>	<b>7-1</b>
7.1	Model W3 Hand-Held Control Head Exploded View .....	7-2
7.2	W4 Rotary Control Head Exploded View.....	7-3
7.3	W5 and W7 Pushbutton Control Head Exploded View .....	7-4
7.4	W9 Pushbutton Control Head Exploded View .....	7-5
7.5	HMN1080A, HMN1061A, HMN1079A Microphone Exploded View .....	7-6
7.6	Small Pushbutton Parts .....	7-7
7.7	Large Pushbutton Parts.....	7-7
<b>Chapter 8</b>	<b>Schematics, Overlays, and Parts Lists .....</b>	<b>8-1</b>
8.1	List of Schematics, Component Location Diagrams, and Parts Lists .....	8-1
<b>Appendix A</b>	<b>Replacement Parts Ordering.....</b>	<b>A-1</b>
A.1	Basic Ordering Information .....	A-1
A.2	Motorola Online .....	A-1
A.3	Mail Orders .....	A-1
A.4	Telephone Orders.....	A-2

---

A.5	Fax Orders .....	A-2
A.6	Parts Identification .....	A-2
A.7	Product Customer Service .....	A-2

<b>Index</b> .....	<b>Index-1</b>
--------------------	----------------



---

## List of Figures

Figure 1-1.	Typical W3 Hand-Held Control Head .....	1-3
Figure 1-2.	Typical W4 Rotary Control Head.....	1-4
Figure 1-3.	Typical W5 Pushbutton Control Head .....	1-4
Figure 1-4.	Typical W7 Pushbutton Control Head .....	1-5
Figure 1-5.	Typical W9 Pushbutton Control Head .....	1-5
Figure 3-1.	Astro Spectra Control Head Block Diagram.....	3-4
Figure 3-2.	Cabling Interconnect Diagram for Dash Mount.....	3-13
Figure 3-3.	Cabling Interconnect Diagram for Remote Mount.....	3-13
Figure 5-1.	Replacing the Vacuum Fluorescent Display .....	5-5
Figure 5-2.	Model W4 Rotary Control Head Assembly Screw and Snap Sequence.....	5-8
Figure 5-3.	Models W5 and W7 Pushbutton Control Head Assembly Screw Sequence .....	5-8
Figure 5-4.	W9 Control Head Control Board and Display Board.....	5-10
Figure 6-1.	J0103 Remote-Mount Control Head Connector.....	6-2
Figure 6-2.	J5 Control Cable for Remote-Mount Control Head.....	6-2
Figure 6-3.	J6 Radio Operations Connector.....	6-2
Figure 6-4.	J2 Rear Accessory Connector .....	6-2
Figure 6-5.	P104 Microphone Jack .....	6-2
Figure 6-6.	Dash-Mount Radio Connector Locations .....	6-3
Figure 6-7.	Remote-Mount Radio Connector Locations.....	6-3
Figure 6-8.	Command Board Connector Locations.....	6-3
Figure 6-9.	VOCON Board Connector Locations .....	6-3
Figure 6-10.	P501 Extender Cable.....	6-4
Figure 6-11.	Control-Head Cabling Diagram.....	6-4
Figure 7-1.	W3 Hand-Held Control Head Exploded View .....	7-2
Figure 7-2.	W4 Rotary Control Head Exploded View .....	7-3
Figure 7-3.	W5 and W7 Pushbutton Control Head Exploded View .....	7-4
Figure 7-4.	W9 Pushbutton Control Head Exploded View .....	7-5
Figure 7-5.	HMN1080A, HMN1061A, HMN1079A Microphone Exploded View.....	7-6

## List of Tables

Table 1-1.	ASTRO Digital Spectra/Spectra Plus Basic Features .....	1-2
Table 1-2.	12-Button Keypad (W7 and W9) .....	1-7
Table 3-1.	W3 Jumper Selection .....	3-3
Table 3-2.	Types of Operations .....	3-4
Table 3-3.	Serial Data Bus Logic.....	3-6
Table 3-4.	PTT Logic States.....	3-7
Table 3-5.	HUB Logic States .....	3-7
Table 3-6.	Standard Jumper Configurations.....	3-11
Table 3-7.	VIP Output Connections .....	3-14
Table 3-8.	VIP Input Connections .....	3-14
Table 4-1.	Recommended Motorola Test Equipment and Service Aids .....	4-1
Table 5-1.	Required Tools and Supplies .....	5-1
Table 7-1.	Exploded Views.....	7-1
Table 7-2.	W3 Hand-Held Control Head Exploded View Parts List.....	7-2
Table 7-3.	Model W4 Rotary Control Head Parts List .....	7-3
Table 7-4.	W5 and W7 Pushbutton Control Head Parts List.....	7-4
Table 7-5.	W9 Pushbutton Control Head Parts List .....	7-5
Table 7-6.	HMN1080A, HMN1061A, HMN1079A Microphone Parts List.....	7-6
Table 7-7.	Small Pushbutton Parts List .....	7-7
Table 7-8.	Large Pushbutton Parts List.....	7-7

---

## Related Publications

ASTRO Digital Spectra and Digital Spectra Plus Model W3 User's Guide .....	6881090C61
ASTRO Digital Spectra and Digital Spectra Plus Models W4, W5, W7, and W9 User's Guide ..	6881090C62
ASTRO Digital Spectra Hand-Held Control Head User's Guide (Model W3) .....	6881073C25
ASTRO Digital Spectra (Model W4, W5, W7, and W9) User's Guide.....	6881074C80
ASTRO Digital Spectra and Digital Spectra Plus Mobile Radios Detailed Service Manual .....	6881076C25
ASTRO Digital Spectra Mobile Radios Dual Control Head Radio System Service Manual.....	6881091C78
ASTRO Spectra and Digital Spectra FM Two-Way Mobile Radios Installation Manual .....	6881070C85
ASTRO Spectra Motorcycle Radios Supplemental Installation Manual.....	6880103W01
CPS Programming Installation Guide .....	6881095C44
KVL 3000 User's Manual .....	6881131E16

---

**Notes**

# Commercial Warranty

## Limited Warranty

### MOTOROLA COMMUNICATION PRODUCTS

#### I. What This Warranty Covers And For How Long

MOTOROLA INC. ("MOTOROLA") warrants the MOTOROLA manufactured Communication Products listed below ("Product") against defects in material and workmanship under normal use and service for a period of time from the date of purchase as scheduled below:

ASTRO Digital Spectra and Digital Spectra Plus Units	One (1) Year
Product Accessories	One (1) Year

Motorola, at its option, will at no charge either repair the Product (with new or reconditioned parts), replace it (with a new or reconditioned Product), or refund the purchase price of the Product during the warranty period provided it is returned in accordance with the terms of this warranty. Replaced parts or boards are warranted for the balance of the original applicable warranty period. All replaced parts of Product shall become the property of MOTOROLA.

This express limited warranty is extended by MOTOROLA to the original end user purchaser only and is not assignable or transferable to any other party. This is the complete warranty for the Product manufactured by MOTOROLA. MOTOROLA assumes no obligations or liability for additions or modifications to this warranty unless made in writing and signed by an officer of MOTOROLA. Unless made in a separate agreement between MOTOROLA and the original end user purchaser, MOTOROLA does not warrant the installation, maintenance or service of the Product.

MOTOROLA cannot be responsible in any way for any ancillary equipment not furnished by MOTOROLA which is attached to or used in connection with the Product, or for operation of the Product with any ancillary equipment, and all such equipment is expressly excluded from this warranty. Because each system which may use the Product is unique, MOTOROLA disclaims liability for range, coverage, or operation of the system as a whole under this warranty.

#### II. General Provisions

This warranty sets forth the full extent of MOTOROLA'S responsibilities regarding the Product. Repair, replacement or refund of the purchase price, at MOTOROLA's option, is the exclusive remedy. THIS WARRANTY IS GIVEN IN LIEU OF ALL OTHER EXPRESS WARRANTIES. IMPLIED WARRANTIES, INCLUDING WITHOUT LIMITATION, IMPLIED WARRANTIES OF MERCHANTABILITY AND FITNESS FOR A PARTICULAR PURPOSE, ARE LIMITED TO THE DURATION OF THIS LIMITED WARRANTY. IN NO EVENT SHALL MOTOROLA BE LIABLE FOR DAMAGES IN EXCESS OF THE PURCHASE PRICE OF THE PRODUCT, FOR ANY LOSS OF USE, LOSS OF TIME, INCONVENIENCE, COMMERCIAL LOSS, LOST PROFITS OR SAVINGS OR OTHER INCIDENTAL, SPECIAL OR CONSEQUENTIAL DAMAGES ARISING OUT OF THE USE OR INABILITY TO USE SUCH PRODUCT, TO THE FULL EXTENT SUCH MAY BE DISCLAIMED BY LAW.

### III. State Law Rights

SOME STATES DO NOT ALLOW THE EXCLUSION OR LIMITATION OF INCIDENTAL OR CONSEQUENTIAL DAMAGES OR LIMITATION ON HOW LONG AN IMPLIED WARRANTY LASTS, SO THE ABOVE LIMITATION OR EXCLUSIONS MAY NOT APPLY.

This warranty gives specific legal rights, and there may be other rights which may vary from state to state.

### IV. How To Get Warranty Service

You must provide proof of purchase (bearing the date of purchase and Product item serial number) in order to receive warranty service and, also, deliver or send the Product item, transportation and insurance prepaid, to an authorized warranty service location. Warranty service will be provided by Motorola through one of its authorized warranty service locations. If you first contact the company which sold you the Product, it can facilitate your obtaining warranty service. You can also call Motorola at 1-888-567-7347 US/Canada.

### V. What This Warranty Does Not Cover

- A. Defects or damage resulting from use of the Product in other than its normal and customary manner.
- B. Defects or damage from misuse, accident, water, or neglect.
- C. Defects or damage from improper testing, operation, maintenance, installation, alteration, modification, or adjustment.
- D. Breakage or damage to antennas unless caused directly by defects in material workmanship.
- E. A Product subjected to unauthorized Product modifications, disassemblies or repairs (including, without limitation, the addition to the Product of non-Motorola supplied equipment) which adversely affect performance of the Product or interfere with Motorola's normal warranty inspection and testing of the Product to verify any warranty claim.
- F. Product which has had the serial number removed or made illegible.
- G. Rechargeable batteries if:
  - any of the seals on the battery enclosure or cells are broken or show evidence of tampering.
  - the damage or defect is caused by charging or using the battery in equipment or service other than the Product for which it is specified.
- H. Freight costs to the repair depot.
- I. A Product which, due to illegal or unauthorized alteration of the software/firmware in the Product, does not function in accordance with MOTOROLA's published specifications or the FCC type acceptance labeling in effect for the Product at the time the Product was initially distributed from MOTOROLA.
- J. Scratches or other cosmetic damage to Product surfaces that does not affect the operation of the Product.
- K. Normal and customary wear and tear.

## VI. Patent And Software Provisions

MOTOROLA will defend, at its own expense, any suit brought against the end user purchaser to the extent that it is based on a claim that the Product or parts infringe a United States patent, and MOTOROLA will pay those costs and damages finally awarded against the end user purchaser in any such suit which are attributable to any such claim, but such defense and payments are conditioned on the following:

- A. that MOTOROLA will be notified promptly in writing by such purchaser of any notice of such claim;
- B. that MOTOROLA will have sole control of the defense of such suit and all negotiations for its settlement or compromise; and
- C. should the Product or parts become, or in MOTOROLA's opinion be likely to become, the subject of a claim of infringement of a United States patent, that such purchaser will permit MOTOROLA, at its option and expense, either to procure for such purchaser the right to continue using the Product or parts or to replace or modify the same so that it becomes noninfringing or to grant such purchaser a credit for the Product or parts as depreciated and accept its return. The depreciation will be an equal amount per year over the lifetime of the Product or parts as established by MOTOROLA.

MOTOROLA will have no liability with respect to any claim of patent infringement which is based upon the combination of the Product or parts furnished hereunder with software, apparatus or devices not furnished by MOTOROLA, nor will MOTOROLA have any liability for the use of ancillary equipment or software not furnished by MOTOROLA which is attached to or used in connection with the Product. The foregoing states the entire liability of MOTOROLA with respect to infringement of patents by the Product or any parts thereof.

Laws in the United States and other countries preserve for MOTOROLA certain exclusive rights for copyrighted MOTOROLA software such as the exclusive rights to reproduce in copies and distribute copies of such Motorola software. MOTOROLA software may be used in only the Product in which the software was originally embodied and such software in such Product may not be replaced, copied, distributed, modified in any way, or used to produce any derivative thereof. No other use including, without limitation, alteration, modification, reproduction, distribution, or reverse engineering of such MOTOROLA software or exercise of rights in such MOTOROLA software is permitted. No license is granted by implication, estoppel or otherwise under MOTOROLA patent rights or copyrights.

## VII. Governing Law

This Warranty is governed by the laws of the State of Illinois, USA.

## Notes



---

# Chapter 1 Introduction

ASTRO® Digital Spectra® and Digital Spectra Plus control heads are available in five radio models: W3, W4, W5, W7, and W9. This chapter describes the control heads used with these radios.

## 1.1 Notations Used in This Manual

Throughout the text in this publication, you will notice the use of note, caution, warning, and danger notations. These notations are used to emphasize that safety hazards exist, and care must be taken and observed.

**NOTE:** An operational procedure, practice, or condition that is essential to emphasize.



**Caution**

CAUTION indicates a potentially hazardous situation which, if not avoided, might result in equipment damage.



**WARNING**

WARNING indicates a potentially hazardous situation which, if not avoided, could result in death or injury.



**DANGER**

DANGER indicates an imminently hazardous situation which, if not avoided, will result in death or injury.

---

## 1.2 Control Head Features

The table below outlines the basic features of the five control heads covered in this manual.

Table 1-1. ASTRO Digital Spectra/Spectra Plus Basic Features

Feature	W3	W4	W5	W7	W9
Display	2 line/ 14 characters Liquid-Crystal Display (LCD) with 8 Status Annunciators	1 line/ 8 characters Vacuum Fluorescent Display	1 line/ 8 characters Vacuum Fluorescent Display	1 line/ 8 characters Vacuum Fluorescent Display	1 line/ 11 characters Vacuum Fluorescent Display
Mode & Volume Controls	Rocker Switches	Rotary Mode & Volume Controls	Rocker Switch Mode & Volume Controls	Rocker Switch Mode & Volume Controls	Rocker Switch Mode & Volume Controls
Numeric Keypad	Yes	No	No	Yes	Yes
Channel Capability (Digital Spectra)	255	128	128	255	255
Channel Capability (Digital Spectra Plus)	512	128	128	512	512
Remote Mount	Available	Available	Available	Available	Available
Dash Mount	Available	Available	Available	Available	Not Available

## 1.3 Control Heads

The control heads used with ASTRO Digital Spectra and Digital Spectra Plus radios have microprocessor circuitry that operates the standard and optional features built into the system. The control-head design allows for installation in even the smallest of vehicles. The control head may be field-programmed to add options or alter the information stored in certain areas of its electronic memory.

The following sections describe the control head used by each of the five models.

### 1.3.1 W3 Control Head

The W3 Hand-Held Control Head (HHCH) is shown below. The HHCH has been designed as an alternative to the standard radio control-head approach. It can emulate most radio control-head functions, including LCD display, volume control, power On/Off, and mode. The HHCH can either replace the radio control head or be used in dual-control applications, either in conjunction with a radio control head or another HHCH.

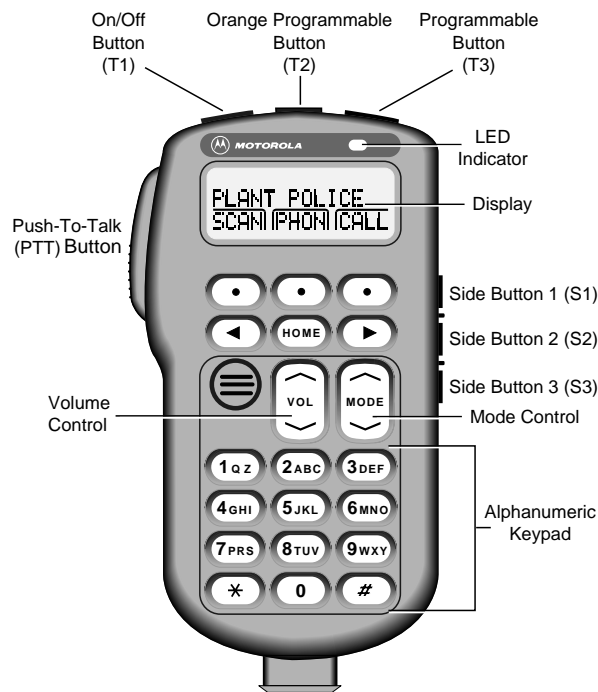

Figure 1-1. Typical W3 Hand-Held Control Head

### 1.3.1.1 W3 Controls

**On/Off Button (T1):** Turns the radio on and off. Can be used as an additional programmable button if the on/off function is not used.

**Orange Programmable Button (T2):** Programmed at the factory for emergency use. Field programmable by a qualified radio technician.

**Programmable Button (T3):** Field programmable by a qualified radio technician.

**LED Indicator:** Green/red light-emitting diode. Indicates operating status.

**Display:** 2-line by 14-character display. Provides visual information about many radio features.

**Keypad.** Provides control of, and data interface with, many features.

**Programmable Side Button 1 (S1):** Field programmable by a qualified radio technician.

**Programmable Side Button 2 (S2):** Field programmable by a qualified radio technician.

**Programmable Side Button 3 (S3):** Field programmable by a qualified radio technician.

**Mode Control:** Used for selecting modes and programming menus.

**Volume Control:** Used for selecting volume level, editing names, and making certain radio adjustments.

**Push-To-Talk (PTT) Button:** Engages the transmitter.

### 1.3.2 W4, W5, W7, and W9 Control Heads

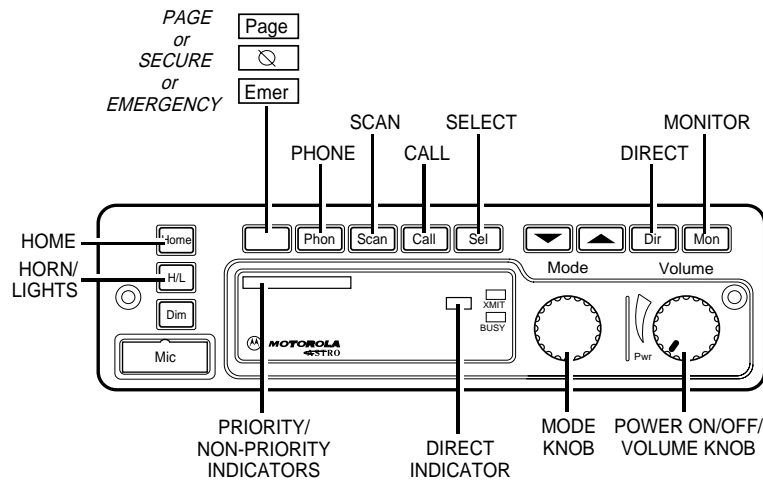

Figure 1-2. Typical W4 Rotary Control Head

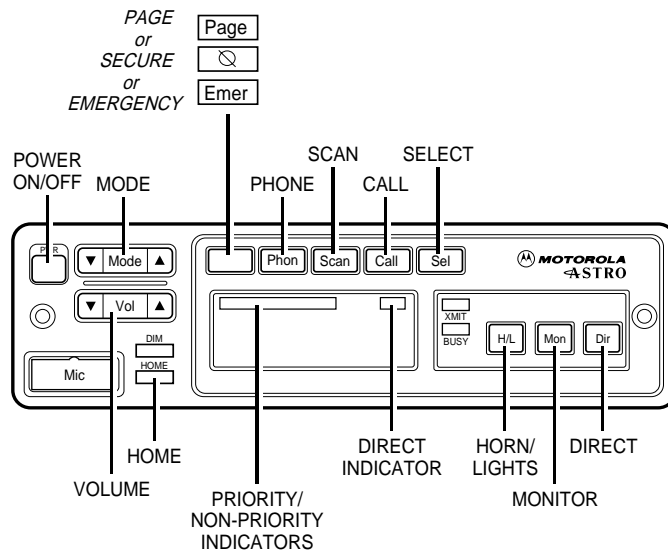

Figure 1-3. Typical W5 Pushbutton Control Head

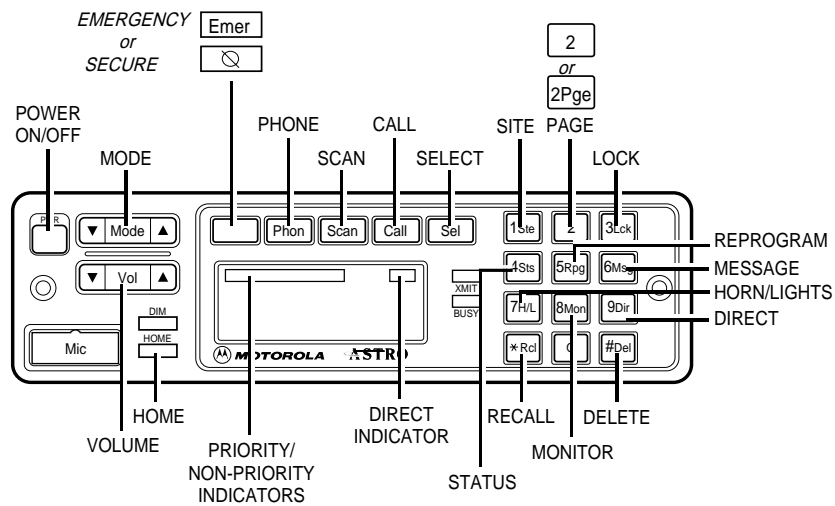
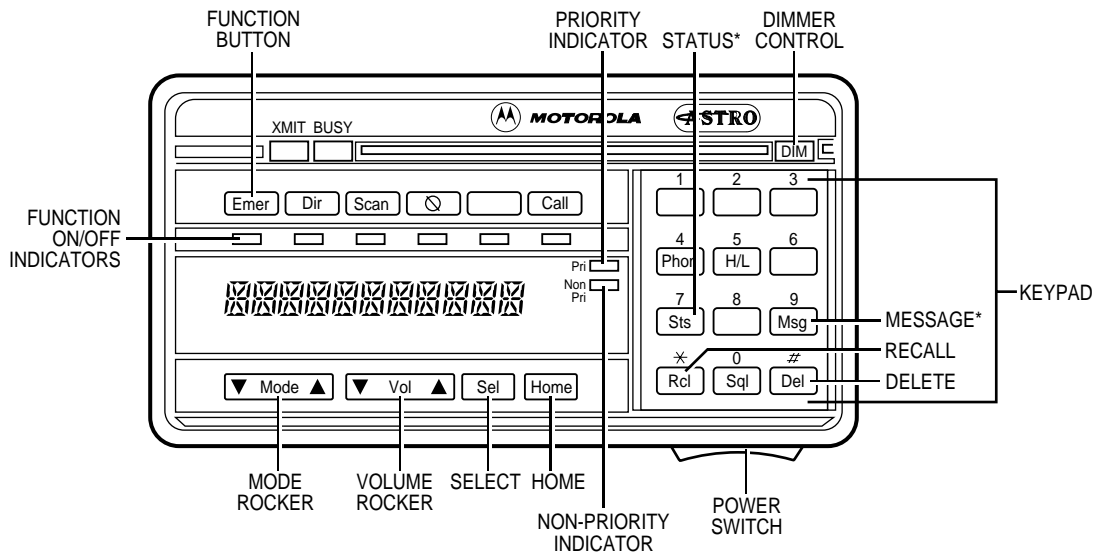

Figure 1-4. Typical W7 Pushbutton Control Head



\* Optional buttons (included but not installed or programmed)

Figure 1-5. Typical W9 Pushbutton Control Head

### 1.3.2.1 W4, W5, W7, and W9 Controls

**Power Switch (PWR):** Turns the radio and its accessories on or off. The Power switch is part of the rotary volume knob on the W4 model, a push-type switch on the W5 and W7 models, and a slide switch on the right-hand bottom surface of the W9 model.

**Mode Switch:** Used for selecting modes and programming menus. The Mode switch is a rotary switch on the W4 model and a rocker switch on the W5, W7, and W9 models. Press the right side of the rocker switch to *increase* the mode number and the left side to *decrease* the mode number. Press and hold the switch to scroll the mode number up or down. The mode names appear in the display window.

**Volume Switch:** Used for selecting the volume level, editing names, and making certain radio adjustments. The Volume switch is a rotary switch on the W4 model and a rocker switch on the W5, W7, and W9 models. On the pushbutton models, pressing and releasing the Volume switch checks the volume setting. Your display will show "VOLUME\_\_" and a number value (0-15). Pressing and holding the left side decreases the volume. The number value scrolls up or down to your desired level. The Volume rocker switch also controls the volume level of the public address (PA) and external radio speaker (Ex Rd) options when they are enabled. The display window shows "PA VOL \_\_" when public address is on and the Volume rocker switch is pressed.

**Dim Button:** Used to control the brightness of the display and button backlighting. When you turn on the system, the display comes on at the brightness level it was on before the system was last turned off. Press the DIM button once to reduce the brightness of the display to medium level and twice for low brightness level. Press the DIM button a third time to turn the display and button backlighting off. This is called the "surveillance" mode.

**Home Button:** Used for restoring preprogrammed mode, establishing programmed mode, selecting programming entries, etc. Press the Home button to go to the radio's preprogrammed "home" mode. On the W7 models, you can use the Home button instead of the Mode switch to change modes. Hold the Home button until a beep sounds to enter the configuration state. The display shows an entry prompt. Use the keypad to enter your new mode choice and press the Home button again. Your mode is now changed without scrolling.

**Select Button:** Used to configure radio options.

**Option Buttons:** Used for turning options on and off, such as Phone, Scan, Emergency Call, and Secure.

**Display:** The vacuum fluorescent (VF) display's primary function is to display mode numbers, mode names, volume level, and the status of options. It also functions as an on-off indicator for the entire system and plays an integral role in the operator's reconfiguration of options. The display is 8 characters on W4, W5, and W7 models and 11 characters on the W9 model.

**XMIT and BUSY Indicators:** The XMIT indicator lights when the radio is transmitting. The BUSY indicator lights when the selected channel is busy.

**Scan Indicators:** When scan operation detects activity on a non-priority (NON-PRI) channel, the NON-PRI indicator light comes on. Activity on a second priority channel causes the priority (PRI) indicator to light. First priority channel activity causes PRI to flash.

**12-Button Keypad (W7 and W9):** Used to change the status of options and for entering numbers. Several keys serve multiple functions. The following buttons can be programmed to W7 and W9 control heads. The table below describes the buttons preinstalled on the W7 model. (See the ASTRO Digital Spectra or Digital Spectra Plus User's Guide for a complete description of keypad operation.)

Table 1-2. 12-Button Keypad (W7 and W9)

Key	Description
#1 key Site ( <b>STE</b> )	Forces the radio to scan for a new site when the automatic multiple-site select (AMSS) feature for wide-area coverage is in use.
#2 Key Page ( <b>2</b> or <b>2Pge</b> )	Initiates a Call Alert page or enters Call ID list programming.
#3 key Lock ( <b>Lck</b> )	Locks the radio onto the current site when the AMSS feature is in use.
#4 key Status ( <b>Sts</b> )	Used alone or in conjunction with other keypad buttons and the <b>Sel</b> button to send a status transmission, indicating a predetermined condition change.
#5 key Regroup ( <b>Rpg</b> )	Requests a change in the radio's talkgroup assignment when the dynamic regrouping feature is used.
#6 key Message ( <b>Msg</b> )	Used alone or in conjunction with other keypad buttons and the <b>Sel</b> button to transmit a message, indicating a response or temporary condition.
#7 key Horn/Lights ( <b>H/L</b> )	Selects/enables radio external alarms.
#8 key Monitor ( <b>Mon</b> )	Monitors the radio for channel traffic.
#9 key Direct/Simplex ( <b>Dir</b> )	Used for talkaround (mobile-to-mobile) conversations.
* key Recall ( <b>Rcl</b> )	Reviews modes in scan and phone lists.
# key Delete ( <b>Del</b> )	Used when editing stored lists.

## Notes



---

## Chapter 2 Basic Maintenance

This chapter describes inspection, cleaning, and handling precautions for the control heads. Each of these topics provides information vital to the successful operation and maintenance of your radio.

### 2.1 Inspection

Check that the external surfaces of the control head are clean, and that all external controls and switches are functional. A detailed inspection of the interior electronic circuitry is not needed.

### 2.2 Cleaning

The following procedures describe the recommended cleaning agents and the methods to be used when cleaning the external and internal surfaces of the control head. These surfaces should be cleaned whenever a periodic visual inspection reveals the presence of smudges, grease, and/or grime. Internal surfaces should be cleaned only when the control head is disassembled for servicing or repair.

The only recommended agent for cleaning the external control head surfaces is a 0.5% solution of a mild dishwashing detergent in water. The only factory recommended liquid for cleaning the printed circuit boards and their components is isopropyl alcohol (70% by volume).



Caution

The effects of certain chemicals and their vapors can have harmful results on certain plastics. Aerosol sprays, tuner cleaners, and other chemicals should be avoided.

#### 2.2.1 Cleaning External Plastic Surfaces

The detergent-water solution should be applied sparingly with a stiff, non-metallic, short-bristled brush to work all loose dirt away from the control head. A soft, absorbent, lint-free cloth or tissue should be used to remove the solution and dry the control head. Make sure that no water remains entrapped near the connectors, cracks, or crevices.

#### 2.2.2 Cleaning Internal Circuit Boards and Components

Isopropyl alcohol may be applied with a stiff, non-metallic, short-bristled brush to dislodge embedded or caked materials located in hard-to-reach areas.

Alcohol is a high-wetting liquid and can carry contamination into unwanted places if an excessive quantity is used. Make sure that controls or tunable components are not soaked with the liquid. Do not use high-pressure air to hasten the drying process, since this could cause the liquid to puddle and collect in unwanted places.

Upon completion of the cleaning process, use a soft, absorbent, lint-free cloth to dry the area.

**NOTE:** Always use a fresh supply of alcohol and a clean container to prevent contamination by dissolved material (from previous usage).

---

## 2.3 Handling Precautions



### Caution

Components used in this equipment can be damaged by accumulated static charge. Avoid unnecessary handling. When handling devices, use a group strap, conductive benches, and floor mats to ensure that a static charge does not develop on component terminals. Always pick up components by the body when possible, avoiding the electrical terminals. Exposed connections should be shorted together via conductive foam when not in use.

Use grounded equipment when performing tests. **DO NOT** connect components to or disconnect components from test equipment while power is applied.

Complementary metal-oxide semiconductor (CMOS) devices, and other high-technology devices, are used in this family of radios. While the attributes of these devices are many, their characteristics make them susceptible to damage by electrostatic discharge (ESD) or high-voltage charges. Damage can be latent, resulting in failures occurring weeks or months later. Therefore, special precautions must be taken to prevent device damage during disassembly, troubleshooting, and repair. Handling precautions are mandatory for this radio, and are especially important in low-humidity conditions. **DO NOT** attempt to disassemble the radio without observing the following handling precautions:

- Eliminate static generators (plastics, Styrofoam, etc.) in the work area.
- Remove nylon or double-knit polyester jackets, roll up long sleeves, and remove or tie back loose-hanging neckties.
- Store and transport all static-sensitive devices in ESD-protective containers.
- Disconnect all power from the unit before ESD-sensitive components are removed or inserted unless otherwise noted.
- Use a static-safeguarded workstation through the use of an anti-static kit (Motorola part number 01-80386A82). This kit includes a wrist strap, two ground cords, a static-control table mat and a static-control floor mat.

**NOTE:** Be sure that the table and floor mats are properly grounded.

When these items are not readily available, observing the following techniques will minimize the chance of damage:

- If a static-sensitive device is to be temporarily set down, use a conductive surface for placement of the device.
- Make skin contact with a conductive work surface first and maintain this contact when the device is set down or picked up.
- Always wear a conductive wrist strap when servicing this equipment. The Motorola part number for a replacement wrist strap that connects to the table mat is 42-80385A59

---

## Chapter 3 Theory of Operation

This chapter describes the operational theory of the control heads for the W3, W4, W5, W7, and W9 radio models. It includes vehicular interface port (VIP) information.

### 3.1 W3 Control Head

The W3 Hand-Held Control Head (HHCH) contains the U3 microcomputer, which runs on a 4 MHz clock and performs the following basic functions:

- SB9600 data encode and decode for communication to host radio.
- Liquid-crystal display (LCD) drive comprising two rows of 14 dot-matrix characters plus 10 annunciators.
- Scans a 22-key keypad.
- Scans three side keys and three top keys.
- Determines what type of radio is connected from the bus data and selects either portable or mobile/vehicle adaptor (VA) modes.
- Scans the PTT switch.
- Provides display drive and programmable adjustment for display contrast.
- Provides display and keypad backlight control.
- Activates the red PTT LED and yellow status LED as required.
- Provides remote keying of the microphone via the SB9600 serial bus as required.
- Detects off-hook/on-hook conditions in mobile/VA mode.
- Provides SPI serial communications to U8 for serial-to-parallel output expansion, U12 for parallel-to-serial input compression, U14 for analog-to-serial input compression, and option connector J2.

#### 3.1.1 SB9600 Serial Bus Interface

The serial interface circuit, comprising transistors Q1, Q2, and Q8, and comparator U2, provides an interface between the microphone/message and a host radio for two-way SB9600 serial bus communications. This is necessary to control the radio from the HHCH and have radio status messages displayed on the HHCH. The interface circuit performs the following functions:

- Buffering of the input and output data by Q1 and U2 to improve isolation and drive capability.
- Conversion of balanced to unbalanced SB9600 data input to SB96 bus interface by Q1, U2.
- Bidirectional busy control through U3-20, -21, and -41 to J 1-3. U320 and -21 are paralleled to provide increased drive capability.

#### 3.1.2 Display Circuit

The display is a liquid-crystal display (LCD) and comprises two rows of 14 dot-matrix characters and 10 annunciators. The display circuit consists of sections involving character generation, backplane drive, negative voltage generation, temperature compensation, and contrast control. A 200 kHz clock is derived from U4-25, which also supplies U14.

---

Operation of the circuit is complex; a brief description is detailed below:

- Display data exits U3-5/12 as eight bits of parallel data. This data addresses a character look-up table in LCD driver/controller U4. This provides the relevant segment output data from U4, as well as LCD drivers U5, U6, and U7, to activate the relevant display dots that form the characters as defined in the look-up table.
- The LCD is multiplexed with eight backplanes that are driven separately by U4-47 to -54. Each backplane is driven sequentially, one after the other, by a stepped a.c. voltage of between approximately -2 volts and +5 volts. LCD dots are displayed when a maximum or minimum of one of the backplane drives coincides with a minimum or maximum, respectively, of the relevant segment drive voltage.
- Negative voltage generation necessary for correct operation of the display is derived from a timed clock output from U3-38. This is fed to a voltage doubler comprising C21, C22, and D30. The d.c. output of the doubler is fed to voltage divider R16 to R20. This divider provides evenly spaced voltage increments from approximately -2 volts to +5 volts, which are then fed to U4, U5, U6, and U7 to form the stepped backplane and segment drive voltages.
- Temperature compensation is provided by U3 and U14 in conjunction with D32. This diode provides a temperature-dependent voltage to analog input pin 1 of A/D converter U14. This is sent as serial data input to U3-34, where it is compared to a reference in U3. The amount of deviation from this reference determines the duty cycle of the output drive voltage from U3-38. This results in a change to the drive voltage across C22, which is fed to analog input pin 6 of U14 via voltage divider R26 and R2, which is then fed to U3 as serial data. U3 checks this voltage for accuracy, using the temperature-dependent voltage at U14-1 as a reference, and corrects the drive duty cycle accordingly.
- Contrast control is achieved by adjusting the display drive duty cycle U3-38 by either keypad control or radio programming via the SB9600 bus. U3 contains a reference that presets the drive duty cycle to an average value when first connected to a new radio. Adjustment of the contrast setting will set up a new reference, which will be retained by the radio in EEPROM for future use so that the new setting will be retained if the microphone is turned off.

### 3.1.3 Keypad Side Keys and Top Keys

The HHCH keypad is configured as a matrix of five columns by six rows. The keyboard is scanned by taking each column output low in turn (each one 1 ms) and reading the corresponding row inputs through the data input latch, U10. After all five columns have been scanned, the row data is then decoded to see which keys, if any, are pressed. The HHCH then waits for debounce until the keypad is scanned again. The keypad is scanned every 25 ms. If the same key is still pressed, the key register value is determined from a key table. If the SB9600 serial bus is not busy, a serial-bus "BUTCTL" message transmission is initiated. The same process also applies when a key is released.

### 3.1.4 Microphone Preamplifier and PTT

PTT is achieved by activating switch S1. This places a ground on the microphone pre-amplifier circuit, comprising Q6 and associated components, and effectively turns it on. Activation of S7 also places a low on U10-6 input, which is passed on to U3 and transmitted as an SB9600 message back to the radio. When this message is received by the radio, (if required) an SB9600 message is sent back to the microphone and detected by U3, and the PTT LED is activated through U8. However, illumination of the PTT LED is under radio control and is therefore dependent upon radio programming. Q7 is also connected across the PTT line. Its purpose is to remotely enable the microphone pre-amplifier through a received SB9600 serial-bus message, as required.

Microphone cartridge M1 contains a capacitive transducer coupled to a FET amplifier. Microphone audio is obtained from the output of M1 and fed to Q6-b via C28, which provides either 0dB of gain in portable mode or 20dB in mobile mode, during transmit. This gain change is achieved by the action of Q5, which is turned on in mobile mode only, and bypasses R71. (Note that this gain is with respect to a radio input impedance of 2k.Ω for portables and 600Ω for mobiles.)

### 3.1.5 On-/Off-Hook Control

The on-/off-hook control circuit comprises U8 and Hall switch U9. This circuit is only active in mobile mode, during which the output at U8-6 and -7 is driven high by U3. This provides supply volts for U9, the output of which still remains in its normally high state, provided that the microphone is off-hook. During the on-hook condition, when the microphone is retained in its hang-up bracket, a magnet in the hang-up bracket activates the Hall switch, which in turn pulls U9-3 low. This is detected by U3, which then sends an appropriate SB9600 message back to the radio. When the microphone is removed from the hang-up bracket, U9-3 returns high, causing U3 to send another SB9600 message back to the radio.

### 3.1.6 Backlight Circuit

The backlight circuit comprises U3, U15, Q3, Q4, and LEDs D3 to D17. U3 enables the backlights, as required, by placing a low at U3-16. This, in turn, turns on Q3 and Q4, causing the LEDs to turn on. The action of D35 and R34 provides a constant current source for the LEDs over a supply voltage range of 5.5 to 17 volts. U15 provides current balance between the individual pairs of LEDs, and R34 controls the total current to about 60 mA.

### 3.1.7 Power Supply

The power supply consists of a 5-volt linear regulator, U1, which provides the necessary 5-volt supply for all of the digital circuits. It has a low drop-out voltage to enable operation from an input voltage of about 5 volts up to 17 volts. This regulator also contains internal current-limiting protection, which will normally protect against damage from short-circuit faults. In addition, current is supplied directly from the unregulated input to the backlight LEDs for power dissipation reasons.

### 3.1.8 Status LEDs

D22 is provided as a status LED for programmable radio functions. It is activated by an SB9600 message from the radio which is detected by U3, resulting in a high at U8-2 and -3. In addition, the PTT LED, D21, can provide flashing radio status messages and can also be activated at the same time as D22.

### 3.1.9 Jumper Selection

The only jumpers that may normally be installed are JU10, JU11, and JU12. When these jumpers are installed, the ground provided is passed on to U3. These jumpers indicate whether a speaker is installed in the unit, the SB9600 serial-bus device address, and single- or dual-control head control, as defined in the table below.

Table 3-1. W3 Jumper Selection

Jumper	IN	OUT
JU10	Internal Speaker	No internal speaker
JU11	SB9600 address = 6	BS9600 address = 5
JU12	Dual control	Single control

### 3.1.10 Power On/Off

The HHCH has the ability to turn a host radio on or off by activating S6, which then places a momentary logic low on the Mic Hi line. This is detected by appropriate circuitry in the host radio, which then reverses the power on/off state of the radio. Since the microphone power is supplied by a switched Opt B+ line from the radio, the microphone power on/off state follows that of the radio.

### 3.1.11 Miscellaneous Functions

If TP1 contacts are momentarily shorted or certain key combinations are pressed simultaneously, the HHCH is placed in its test mode to carry out various diagnostic checks.

Transient protection diodes D24, D25, D37, D38, and D39 provide electrostatic transient protection for sensitive components within the HHCH by preventing voltages from going outside the specified ranges for these components.

## 3.2 W4, W5, and W7 Control Heads

The following pages describe the operational theory of the components of the W4, W5, and W7 control heads. Refer to Figure 3-1 for the control-head components.

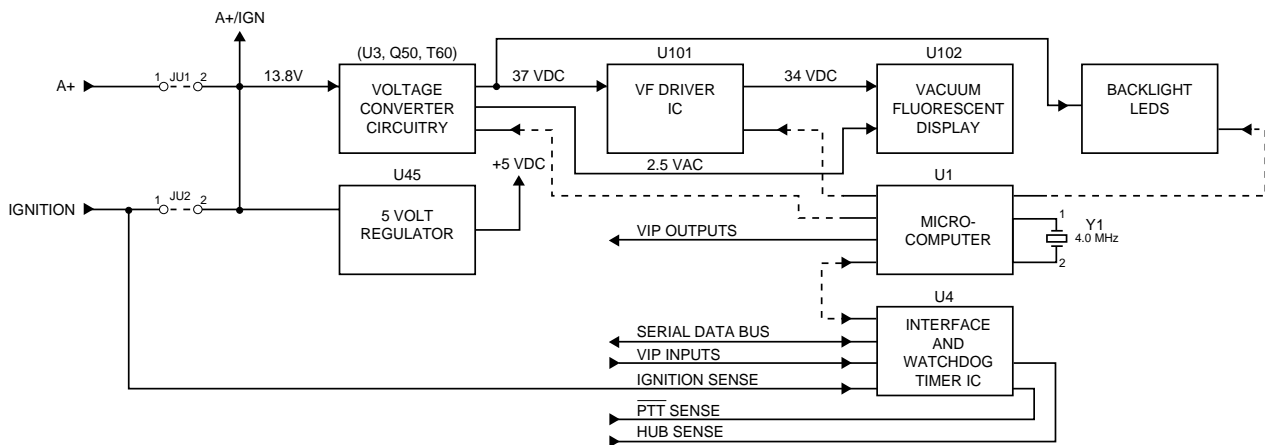

Figure 3-1. Astro Spectra Control Head Block Diagram

### 3.2.1 Power Switch/Ignition

For dash-mounted radios, a pushbutton On/Off switch (S1) (or rotary knob on the W4 control head) on the front panel controls power to the radio and accessories. In addition to this switch, you can wire the vehicle’s ignition and add or remove control-head jumpers to further control radio operation.

Table 3-2. Types of Operations

Type	How it Operates	Control Head Jumper/Status	Ignition Wiring
1	RECEIVE and TRANSMIT enabled via control head ON/OFF switch (ignition has no effect).	JU1OUT; JU2/IN	Connect ignition cable to “Battery Hot” at fuse block.
2	RECEIVE and TRANSMIT enabled only when ignition switch is ON.	JU1/OUT; JU2/IN	Connect ignition cable to “Ignition” at fuse block.

Table 3-2. Types of Operations (Continued)

Type	How it Operates	Control Head Jumper/Status	Ignition Wiring
3	RECEIVE enabled by control head ON/OFF switch; TRANSIT enabled only when ignition switch is ON.	JU1 IN; JU2 OUT	Connect ignition cable to "ignition" at fuse block. Enable "TX inhibit" ignition switch setting in RSS or CPS.

The ignition cable is the fused wire attached to the accessory connector. The control head is shipped with jumper JU1 OUT and jumper JU2 IN. The three options are:

1. Connect the ignition cable to "Battery Hot" on the fuse block to TRANSMIT and RECEIVE via the front panel pushbutton On/Off switch, regardless of the ignition setting.  
OR
2. Connect the ignition cable to "Ignition" at the fuse block to disable TRANSMIT and RECEIVE except when the ignition is on. This method is more convenient because you need only to switch off your ignition; the radio will not drain your car's battery when you leave the radio switch on.
3. To allow receive via front panel On/Off, but inhibit transit when the ignition is off, control head jumpers and radio software settings must be changed. Follow the disassembly procedures in Chapter 5 to remove the control head PC board from its housing, and then locate JU1 and JU2 using the board overlays in Chapter 8. Carefully unsolder JU2 from the board and solder it in a JU1. Change the "ignition switch" field in CPS (Radio Wide/Advanced) or RSS (F4/F3/F3/F3) to "TX inhibit."

For remote mounted radios, the same options of operation are available to the customer. The fused GREEN wire coming from the control-head end of the interconnect cable is connected to "Battery Hot." The ignition cable is the fused ORANGE wire also coming from the interconnect cable. The control head is shipped with jumper JU1 OUT and JU2 IN. Configured this way, connections to the ignition cable are made following options (1) or (2) above.

### 3.2.2 Voltage Regulator

Switch B+ is applied to U45, a 5-volt regulator. C45 and C58 filter SWB+ and the 5-volt line to ensure U45 operated properly. CR90 protects against accidental reverse-polarity connections during installation. The 5-volt supply operates the microcomputer circuitry, interface circuitry, vacuum fluorescent (VF) driver U101, and comparator U3.

### 3.2.3 Microcomputer

The microcomputer, U1, operates on the 5-volt supply and is filtered by L1. A resonator, Y1, oscillates at 4 MHz to provide a stable clock for microcomputer timing. U1 handles all communication with the radio command board over the serial bus, scans the keyboard for button presses, and generates the display information needed by the VF driver (U101) to drive the VF display (U102).

### 3.2.4 Interface Circuitry

The bulk of the interface circuitry is contained in bipolar, custom IC, U4. This IC includes watchdog timer circuits, serial-bus communication drive circuits, and input buffer circuits to protect microprocessor U1.

### 3.2.5 Reset

On initial power-up, the RESET line to U1-1 is held low by U4 for approximately 120 milliseconds before going high. This resets U1 and starts it operating properly. Then, a pulse train generated at U1-38 sends tickle pulses to the watchdog timer circuitry in U4 and sends a STROBE signal to the VF display driver, U101. Capacitor C6 charges to about 3.3 volts and triggers a reset as described above. Any time a reset occurs, U4-9 goes high, causing radio circuitry in the command board to also reset. Should radio circuitry initiate the reset, pin 23 of the control unit PC board connector is forced high, triggering the same events described above. The control head can reset the radio command board, and vice-versa, via the reset line. See Table 3-3.

### 3.2.6 Bus Busy

The control head prepares to send data on the serial bus when U-15 ( $\overline{\text{BUSY OUT}}$ ) goes low, causing U4-10 to go high. This signals the radio command board that the control head has data to send. U4-11 ( $\text{BUSY IN}$ ) goes low whenever U4-10 goes high. This informs the control-head microcomputer that the serial bus is in use. See Table 3-3.

Table 3-3. Serial Data Bus Logic

Data Line	No Bus Activity (Normal Receiving Data)	Bus Activity (Sending or Receiving Data)	In Reset*
Busy	Low	High	Low
$\overline{\text{BUSY IN}}$	High	Low	High
$\overline{\text{BUSY OUT}}$	High	Low*	High
BUS+	High	Low and High	High
BUS-	Low	High and Low	Low
TX DATA	High	Low and High**	High
RX DATA	High	Low and High	High
RESET	Low	Low	High
$\overline{\text{RESET}}$	High	High	Low

\* Bus activity will occur immediately after a reset.

\*\* Sending only.

### 3.2.7 Serial Bus Data

See Table 3-3 for Serial Data Bus Logic. Two lines, BUS+ and BUS-, send data between the control head and the radio command board. Under the normal condition of inactivity, BUS+ is high and BUS- is low. This is the "inactive state" on the serial bus. When the two lines invert (BUS+ goes low, BUS- goes high), the serial bus is in the "active state."

The control head uses the TX DATA line (U1-33) to send data over the serial bus. When TX DATA goes low, the bus is placed in the active state by U4; when TX DATA goes high, the bus returns to the inactive state.

Data is sent to the microcomputer on the RX DATA line (U1-32). Whenever the serial bus is in the active state, RX DATA is low. An inactive state on the bus causes RX DATA to go high.



### 3.2.8 Push-To-Talk (PTT)

The PTT line from the microphone keys the transmitter. This line (U4-37) is normally biased at 5 volts, but goes to DIG GND when the microphone PTT button is pressed. This causes the PTT line (U1-21) to go high. The transmit command is then sent over the serial bus to the radio command board. Releasing the PTT reverses this process. There is no PTT hardware connection from the control head to the radio command board. See Table 3-4.

Table 3-4. PTT Logic States

Microphone Push-to-Talk	$\overline{\text{PTT}}$	PTT
PRESSED	Low	High
RELEASED	High	Low

### 3.2.9 Hang-Up Button (HUB)

The control head senses when the microphone is off-hook by monitoring the HUB line from the microphone. When the microphone is on-hook, the HUB line (U4-31) is connected to ground, placing a high on the inverted HUB line (U1-20) and sending the on-hook command over the serial bus. When the microphone is off-hook, U4-31 biases to 5 volts, reversing the process and sending the off-hook command over the serial bus. See Table 3-5.

Table 3-5. HUB Logic States

Microphone Hang-Up Button	HUB Line	Inverted HUB
ON-HOOK	Low	High
OFF-HOOK	High	Low

### 3.2.10 Ignition Sense Circuitry

Ignition sense voltage is sensed by U4-28. When this voltage is high, U4-29 goes low, resulting in U1-39 going low, and sending the "ignition-on" command over the serial bus. When the ignition voltage drops off, the process is reversed.

### 3.2.11 Keypad Scan

U1 scans the keypad switches for a button press by sending out periodic low-going pulses in sequence on pins 8 through 12. Keypad sense lines connect back to U1 on pins 13 through 17. Resistors R120 through R124 ensure that the sense lines are high until a key is pressed. When a button is pressed, keypad contacts close, allowing the low-going pulse to return to the microcomputer on the appropriate sense line. This informs U1 that a particular button was pressed.

### 3.2.12 Vacuum Fluorescent (VF) Voltage Converter Circuitry

Voltage for the VF display is generated by a fixed-frequency, variable duty-cycle controlled, flyback voltage converter. The switching frequency is about 210 kHz. One half of U3, pins 5-7, forms a 210 kHz sawtooth oscillator. The sawtooth waveform is produced at U3-6 and is applied to pin 3 of the other half of U3. This portion of U3 is a duty-cycle controlled comparator.

U1-6 controls the entire voltage converter. During startup, U1-6 pulls to ground, biasing U3-2 to about 1.85 volts via R51 and R52. U3-1 and R61 then begin to switch Q50 on and off at a 210 kHz rate. This allows current to flow through T60, building a magnetic field, then collapsing it. When the field collapses, the back EMF (flyback) forward biases CR51 and charges C52 (after a few cycles) to about 37 volts, causing zener diode VR50 to conduct. The high voltage is regulated by the effect that VR50 has on the bias voltage at U3-2. If the high-voltage supply increases, VR50 pulls U3-2 higher in voltage resulting in a decreased duty-cycle for Q50 (the switching frequency remains constant; only the duty-cycle of on-time versus off-time decreases). Less power is up-converted to C52 when the duty cycle decreases; hence, regulation is maintained.

The voltage converter also produces an a.c. filament voltage for the VF display across T60 pins 4 and 6. R101 drops this voltage to approximately 2.4 Vrms. This a.c. voltage rides on a positive d.c. offset due to R50, depending on brightness. The positive offset allows a VF display grid to be reverse-biased with respect to the filament when that particular grid is supposed to be shut off. This prevents "character ghosting." Display dimming is exclusively controlled by multiplexing information sent from U1 to the VF driver IC, U101. Display dimming has no effect on the voltage converter circuitry except in the OFF mode. In this mode, U1-6 goes high, resulting in U3-2 going to +5 volts. This keeps U3-1 low and Q50 turned off. The high-voltage supply drops to about 12 volts and the a.c. filament voltage drops to zero, shutting off the display.

### 3.2.13 Vacuum Fluorescent Display Driver IC

The VF driver IC, U101, receives data directly from the microcomputer for multiplexing the VF display. All of the grid and anode driver lines from U101 are either at, or about, 34 volts (ON) or ground (OFF).

### 3.2.14 Vacuum Fluorescent Display

The VF display is an 8-character, 14-segment device. Anodes are the actual phosphorescent segments, and grids are the wire-mesh structures located over each character. Multiplexing allows character generation with a minimum of interconnecting lines between display and driver. Anodes and grids operate at, or about, 34 volts when ON and are at zero when OFF. The filament operates on ac at about 2.4 Vrms, with current flow at 100 mA through the filament. The d.c. current flowing from anodes and grids to the filament and through R50 to ground increases filament voltage by up to 5 Vdc.

### 3.2.15 Backlight LEDs

Most buttons on the control head are backlit by ten LEDs for easy night-time viewing. In medium and low brightness level settings, U1-19 goes high, turning on Q131 and causing a fixed current to flow through the LEDs.

In the OFF mode and the maximum brightness mode, U1-19 goes low, turning off Q131 and the LEDs. Microprocessor U1 does not duty-cycle change the brightness level of the backlighting LEDs.

## 3.3 W9 Control Head

The W9 control head has solid-state microprocessor circuitry that operates the standard and optional features built into the system. The control-head design allows installation in even the smallest of down-sized vehicles.

### 3.3.1 Display

The control head has an 11-character alphanumeric VF display for indicating the following:

- Zone/Mode names
- Squelch level

- Volume level
- Status codes
- Message codes
- Telephone numbers
- Identification numbers
- Alarm displays
- Option status

### 3.3.2 W9 Controls and Indicators

The W9 control head 12-button keypad contains traditional alphanumeric keys. These keys double as function keys for options. Six ON/OFF option buttons and indicator lights above the display window tell whether these options are on or off. All buttons are backlit to allow operation in low-light conditions.

Other indicators include BUSY, XMIT, Pri, and Non-Pri. The BUSY indicator lights when activity is detected on the channel. The XMIT (transmit) indicator lights when you are transmitting. The Non-Pri (non-priority) or Pri (priority) indicators light when activity occurs during scanning. If the detected activity is in the non-priority mode, the Non-Pri indicator lights. If the activity is in the priority mode, the Pri indicator lights (steady on for second priority mode, and flashing for first priority mode).

### 3.3.3 Control Board

**NOTE:** Refer to the W9 control head foldout block diagram and schematic diagram for the following discussion.

The control board's microprocessor unit (MPU) communicates on the serial bus, receives and interprets keypad data, and controls the volume. The MPU (U2) sends data to a driver to control the display and sends data to turn the LEDs on or off. The control board has a watchdog timer that senses the need for a system reset. The vehicle interface ports are also controlled on this board.

#### 3.3.3.1 Microprocessor

The MPU operates in expanded bus mode with internal Read-Only Memory (ROM) active. The clock frequency is 7.9488 MHz, which results in an internal operating frequency of 1987 kHz. The limited number of I/O ports is augmented by using a serial-to-parallel shift register (U6) to scan the keypad and to switch the VIP drivers Q71, Q72, and Q73.

#### 3.3.3.2 Watchdog Timer

The watchdog timer is on the serial input/output integrated circuit (SIOIC) U4. On system power-up, capacitor C6 pulls U4, pin 43, high while the RESET output at pin 4 goes low, and the microprocessor resets.

As C6 charges, the voltage on U4, pin 43, drops, causing the output to go high and the microprocessor to start operating. At this point, the bias on U4, pin 43, shifts toward positive, causing the voltage to begin to rise, eventually causing another reset cycle. A high on U4, pin 9, (RESET input) also initiates a reset.

When the microprocessor operates correctly, the microprocessor sends "tickle" pulses to U4-2. These pulses tickle the watchdog timer and keep the voltage on U4, pin 43, low enough to prevent reset. If the tickle pulses stop for more than 250 ms, the reset cycle repeats.

The watchdog timer can be disabled by shorting U4, pin 43, to ground.

### 3.3.3.3 Bus Transceiver

The serial bus transceiver is on SIOIC U4. The timer on SIOIC U4, pins 10, 16, and 17, connects to the external bus. Pins 11, 13, 19, and 20 connect to MPO 2. These pins act as a serial-communication buffer.

### 3.3.3.4 Vacuum Fluorescent Voltage Converter

Voltage for the vacuum fluorescent (VF) display filaments is generated by a fixed-frequency, variable-duty-cycle-driven, flyback voltage converter. Dual Comparator U3B, with resistors R56 through R60, form a triangle-wave generator that has an output swing between 1.5 and 3.2 volts at a frequency of 160 kHz. The output of this triangle goes to U3A-3, where it is compared to a feedback signal on U3A-2. The d.c. feedback signal comes from the voltage converter output through diode CR51 and is regulated by VR50 to 43 volts. The U3A output voltage increases or decreases as its input voltage rises or falls. Consequently, the duty cycle seen at the gate of MOSFET transistor Q50 varies inversely with the triangle output voltage. The output of Q50, varying at 160 kHz, is applied to the primary of transformer T60, pins 1 and 3. The secondary of T60, pins 4 and 6, supplies 3.5 Vac for the VF display (U102) filaments.

### 3.3.3.5 Vehicle Interface Ports

The control-head connector, P103, provides connections for three vehicle interface port (VIP) inputs and three VIP outputs.

The three VIP inputs enter the control head at P103, pins 4, 3, and 37. Zener diodes YR10, YR9, and YR8 limit the input voltages to 15 volts. VIP input 2 can be strapped through jumper JU11 to provide various control functions connected to P103, pins 41, 43, and 44. The three inputs are connected to SIOIC U4 at pins 25, 22, and 35. The input signals are buffered in U4 and are output on pins 24, 21, and 36. From U4, the signals are fed through 10K resistors R44, R14, and R15 to the MPU, U2. The MPU directs the signals as required by programming.

Programmable switches on the control head are connected through J101, pins 11, 10, 9, 8, and 7 (KRI through KRS, respectively) to CPU U2, pins 49, 44, 46, 48, and 50. The other contacts of the switches are connected through J101, pins 14, 15, 16, 17, and 19 (KSI through KSS), to CMOS shift register U6, pins 4, 5, 6, 7, and 14.

Shift register U6 outputs, pins 13, 12, and 11, go to Darlington transistors Q71, Q72, and Q73. These three transistors drive the VIP outputs (up to 300 mA each) through control-head connector P103, pins 2, 1, and 34. Primarily, these transistors control external relays. VIP outputs 1 and 2 are connected to jumpers JU12 and JU13 to provide control functions connected to P103, pins 28 and 29. VIP output 1 can also be connected through JU22 to MIC-PTT, pin 24.

### 3.3.3.6 Power Supply

The +5-volt power supply U46 is a three-terminal regulator IC that regulates the 12-volt SWB+ down to +5 volts for the digital logic circuits. The regulated +5 volts enters the control-head PC board through connector J101, pin 4.

### 3.3.3.7 Ignition Sense Circuits

SIOIC U4 senses the vehicle ignition's state through its pin 28, disabling transmit when the ignition is off. For negative-ground systems, the orange lead is typically connected to +12 volts. For more information, see the cable kit section in the Detailed Service Manual 68P80102W61.

**NOTE:** Q40 supplies an inverting path for positive-ground ignition service.

### 3.3.3.8 EEPROM Write-Protect Circuit

Transistors Q161, Q162, and associated circuitry guard against inadvertently writing into the EEPROM U5 by inhibiting the Write Enable input. The circuitry guarantees the EEPROM is protected during reset and when shift register U6 is not in the proper programming state.

### 3.3.4 Display Board

The display board contains the main operator interface points of the system, including the vacuum fluorescent display, the status indicator LEDs, and the user keypad.

**NOTE:** Refer to the foldout schematic diagram of the display board for this discussion.

#### 3.3.4.1 VF Display

The (VF) display is an 11-digit, 14-segment display that needs two separate voltages to operate. The anode and grids use +43 volts to accelerate electrons from the cathode, and the filament uses 3.5 vac at 80 mA. These voltages are obtained from the VF voltage converter on the controller board.

#### 3.3.4.2 VF Display Driver

VF display driver U101 receives 14-segment display data, digit enable data, and indicator state data from the microprocessor on the controller circuit board. This data is clocked using CLOCK (pin 23) and DATA-IN (pin 43) lines, then framed using LATCH-ENABLE (pin 24) and STROBE (pin 21) to control brightness. The 32-bit data frame is updated every millisecond so that a coherent display is maintained and totally updated every 11 ms.

#### 3.3.4.3 Status LEDs

Status LEDs CR111 through CR120 are driven by the display driver as though they were decimal points on the VF display. Level-shifting transistors are required for this since the display driver uses 43 volts for control signals.

#### 3.3.4.4 Backlight LEDs

The same signal (VF-CONTROL) that turns the VF voltage converter on and off also operates the backlight LEDs. Transistor Q134 supplies base current to the individual driver transistors. The driver transistors act as current sources to the LEDs. Backlight LEDs CR131 through CR134 are connected to thermistor RT133 via Q132. This circuit allows more current to flow through these LEDs at room temperature and reduces current as the temperature rises.

### 3.3.5 Default Jumper Settings

The factory installs jumpers in each control head according to customer-ordered options. See Table 3-6 for the standard jumper configurations. See the diagrams on the foldout pages for other configurations.

*Table 3-6. Standard Jumper Configurations*

Jumper Number	Normally
JU1	IN
JU2	OUT
JU3	IN
JU4	OUT

Table 3-6. Standard Jumper Configurations (Continued)

Jumper Number	Normally
JU5	IN
JU7	IN
JU8	OUT
JU9	OUT
JU10	OUT
JU11	OUT
JU12	OUT
JU13	OUT
JU16	OUT
JU17	OUT
JU18	IN
JU19	IN
JU20	IN
JU21	OUT
JU22	OUT

### 3.4 Vehicle Interface Port (VIP)

The vehicle interface port (VIP) allows the control head to control outside circuits in the vehicle and to receive inputs from outside the control head. This results in greater flexibility and ease of installation when interfacing to other systems in the vehicle. There are up to three VIP outputs that can be used for relay control. There are also up to three VIP inputs that can accept input from switches, etc.

#### 3.4.1 W4, W5, and W7 Control Heads

The VIP outputs are controlled by microcomputer U1 pins 26, 27, and 28. A high level causes the associated transistors Q71-73 to conduct up to 300 mA of current to ground. Primarily, these transistors control external relays. The relay coil is connected between the VIP output pin and SWB+. See the installation manual for connection details.

The VIP input lines connect to U4, pins 22, 25, and 35. U4 acts as an inverting stage, passing the VIP input signals to U1, pins 29-31, to be read by the microcomputer. VIP inputs normally connect to ground via a normally open or normally closed switch.

##### 3.4.1.1 VIP Output Connections

###### 3.4.1.1.1 Dash-Mount Installations

Two VIP outputs are available in dash-mount installations. VIP OUT 1 is on pin 12 of the rear accessory connector; VIP OUT 2 is on pin 3. These connections are used to control relays. Connect one terminal of the relay coil to SWB+ (Rear Accessory Connector pin 4). Connect the other relay coil terminal to one of the VIP outputs. See the installation manual for the horn and lights connection.

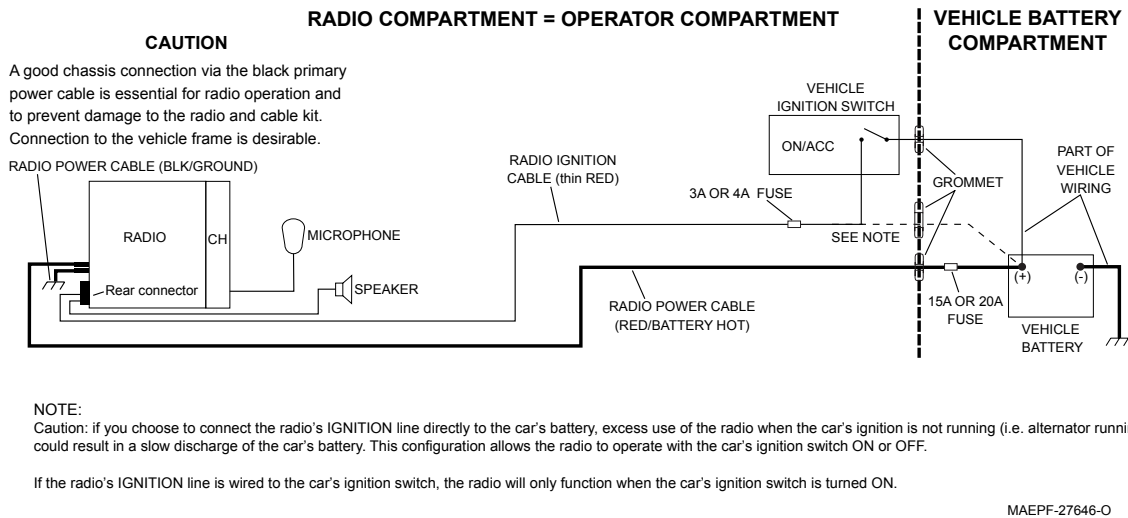

Figure 3-2. Cabling Interconnect Diagram for Dash Mount

### 3.4.1.1.2 Remote-Mount Installations

VIP outputs function exactly the same in remote-mount installations as the dash mount. However, three VIP outputs are available at the remote-mount accessory cable connector. VIP OUT 1 is on pin 12, VIP OUT 2 is on pin 3, and VIP OUT 3 is on pin 15.

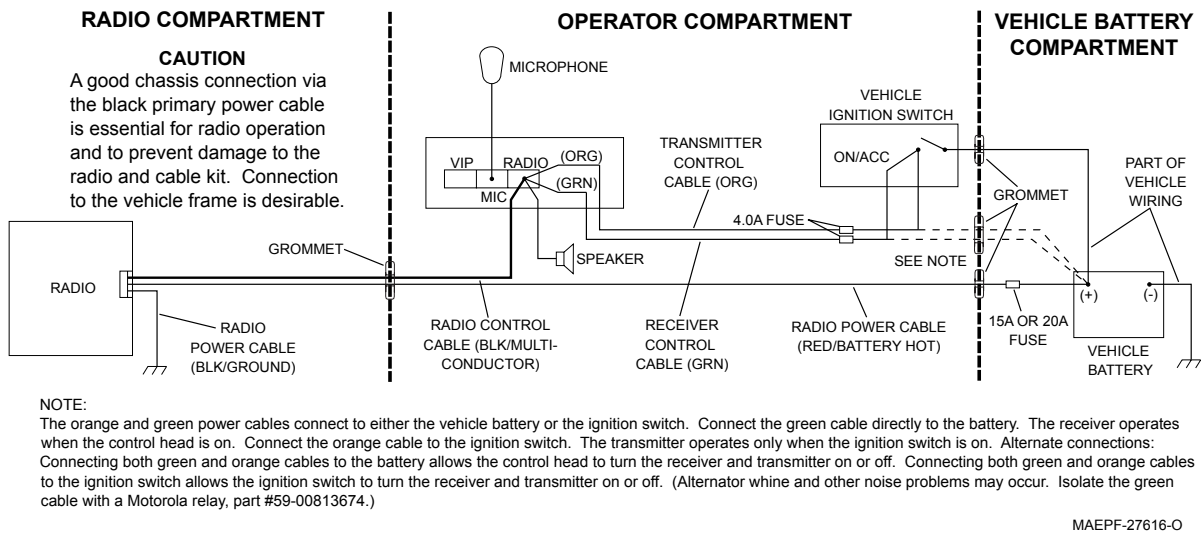

Figure 3-3. Cabling Interconnect Diagram for Remote Mount

### 3.4.1.1.2 VIP Input Connections (Remote-Mount Only)

Three VIP input lines are also available in remote-mount installations. VIP IN 1 is on pin 14, VIP IN 2 is on pin 10, and VIP 3 is on pin 9. These connections are used to accept input from switches or other circuits in the vehicle. The VIPs are biased at about 5 volts, and to be activated the inputs are switched to ground. Normally, a switch is connected from a VIP input line to ground. The switch can be normally open or normally closed, depending on VIP programming and the particular function being performed.

### 3.4.2 W9 Control Heads

The VIPs allow the W9 control head to operate outside circuits and to receive inputs from outside the control head. There are three VIP outputs that are used for relay control. There are also three VIP inputs that accept inputs from switches. See the cable kit section for typical connections of VIP input switches and VIP output relays.

#### 3.4.2.1 VIP Output Connections

The VIP output pins are located on the back of the control head below the area labeled VIP. These connections are used to control relays. One end of the relay should be connected to switched B+, while the other side is connected to a software-controlled on/off switch inside the control head. The relay can be normally On or normally Off depending on how the VIP outputs are configured. The control-head connector P103 pins that are connected to the external relays are listed in Table 3-7.

Table 3-7. VIP Output Connections

VIP Output No.	Switched B+ Pin No.	VIP Output Pin No.	Default Function Is Changed with Field Programmer
1	18	2	Horn Relay (Alarm)
2	19	1	Light Relay (Alarm)
3	35	34	Siren-Horn Transfer

The function of the VIP outputs can be defined by field programming of the control head. Typical applications for VIP outputs are external horn/lights alarm and horn-ring transfer relay control.

#### 3.4.2.2 VIP Input Connections

The VIP input pins are located on the back of the control head below the area labeled VIP. These connections accept inputs from switches. One side of the switch is connected to ground while the other side is connected to a buffered input to the control head. The switch can be normally closed or normally open, depending on how the VIP inputs are configured. The control head provides three VIP input connections. The control-head connector P103 pins that are connected to the external switches are listed in Table 3-8.

Table 3-8. VIP Input Connections

VIP Input No.	Switched B+ Pin No.	VIP Output Pin No.	Default Function Is Changed with Field Programmer
1	20	4	Siren; Horn Ring
2	21	3	Emergency (if option is present)
3	36	37	None

The function of the VIP inputs is defined by field programming of the control head. Typical applications for the VIP inputs are for a foot switch or a horn ring switch.



---

## Chapter 4 Test Equipment and Service Aids

### 4.1 Recommended Test Equipment and Service Aids

The list of equipment contained in Table 4-1 includes most of the standard test equipment required for servicing Motorola control heads. The *Characteristics* column is included so that equivalent equipment can be substituted; however, when no information is provided in this column, the specific Motorola model listed is either a unique item or no substitution is recommended.

Table 4-1. Recommended Motorola Test Equipment and Service Aids

Motorola Model Number	Description	Characteristics	Application
6032A*	DC power supply (Agilent)	0-20 Vdc, 0-50 A current-limited	Bench supply for 13.8 Vdc
FLUKE 87*	Digital Multimeter	True RMS metering, 200 kHz frequency counter, 32-segment bar graph with backlit display	Recommended for AC/DC voltage and current measurements
54622A*	Oscilloscope (Agilent)	Two-channel, 100 MHz bandwidth, 200 MSa/s sample rate, 2 MB memory/channel	Waveform Measurements
3080369B99 (dash mount) 3080369B97 (remote mount)	Extender Cable— Allows operation of control head while extended from radio		Control head troubleshooting

\* or equivalent

---

**Notes**

---

# Chapter 5 Troubleshooting

This chapter, along with the theory of operation in Chapter 3 and the schematics, overlays, and parts lists in Chapter 8, will aid you in troubleshooting a malfunctioning ASTRO Digital Spectra or Digital Spectra Plus control head. If the board is severely damaged or otherwise non-repairable, refer to the board replacement instructions in the section, "Replacing the Control Head Board" on page 5-7.

**NOTE:** To access W9 control-head boards for troubleshooting, remove them from the plastic housing using the procedure on page 5-10. To access W4, W5, and W7 control-head boards, use a control-head extender cable and the procedure on page 5-8. (Refer to the chapter, "Recommended Test Equipment and Service Aids" on page 4-1 for the appropriate Motorola test equipment and service aids part numbers.)

## 5.1 Required Tools and Supplies

Table 5-1 lists the tools and supplies needed for basic troubleshooting.

*Table 5-1. Required Tools and Supplies*

<b>Tools and Supplies</b>
Small, flat-blade screwdriver
2.5 mm hex-key driver
Torx® T8, T10, and T15 drivers
3.0 mm Allen wrench

## 5.2 Troubleshooting Waveforms

This section contains images of waveforms that might be useful in verifying operation of certain parts of the circuitry. These waveforms are for reference only; the actual data depicted will vary depending upon the operating conditions.

### 5.2.1 ASTRO Digital Spectra Waveforms

#### Waveform W1: Oscillator Out, U4 Pin 42

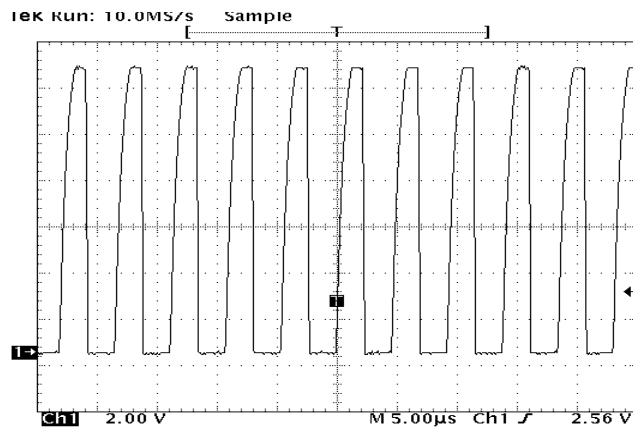

#### Waveform W2: Sawtooth Oscillator: U3 Pin 3

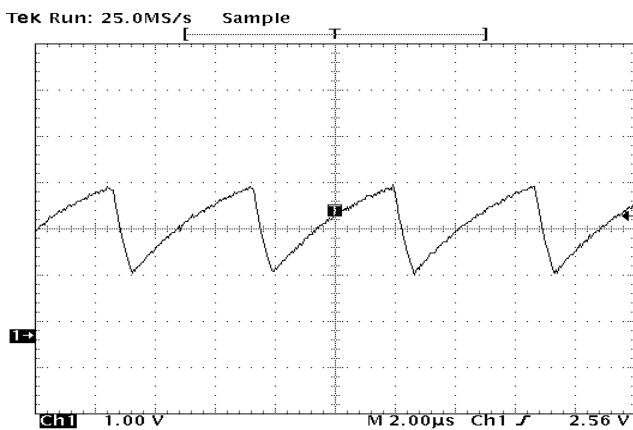

### Waveform W3: U3 Output: U3 pin 1 (output to Q50)

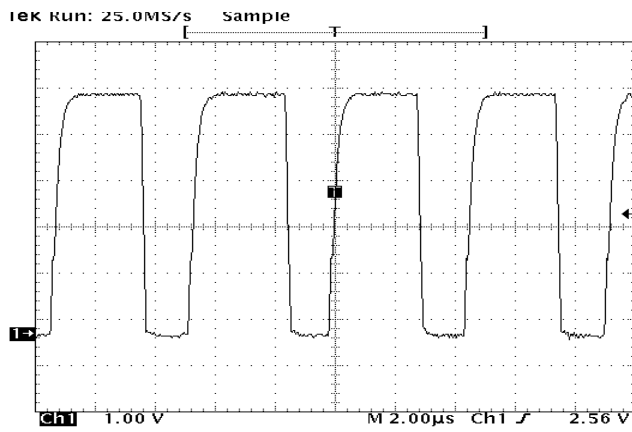

### Waveform W4: Q50 Drain

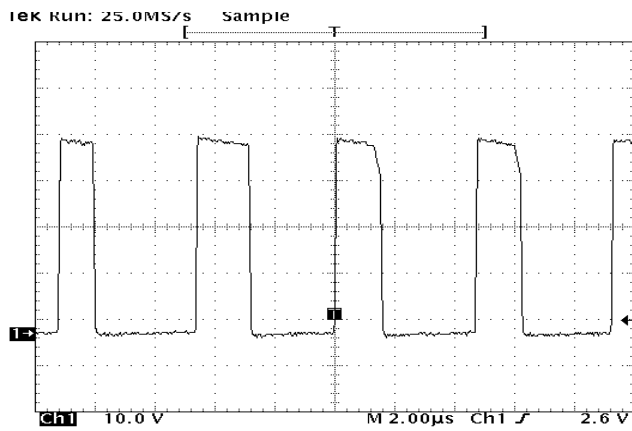

**Waveform W5: Transmit / Receive Data: U4 pins 19 and 20**

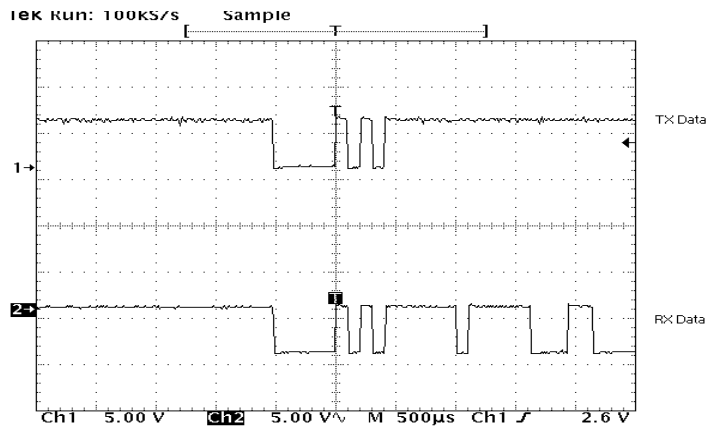

**Waveform W6: Serial Bus lines: U1 pins 17, 16, 10**

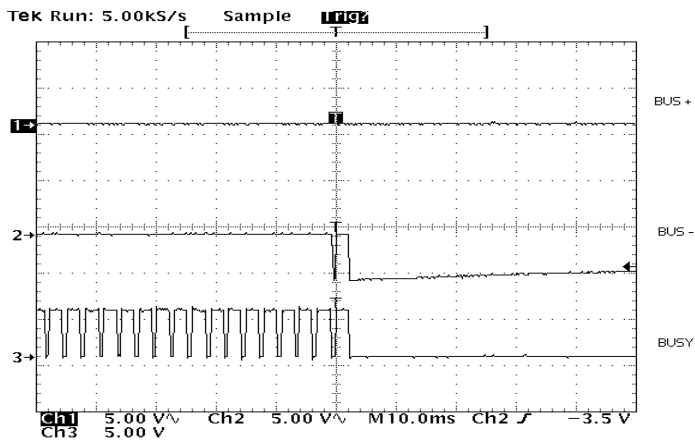

**NOTE:** Serial bus data can be seen during power up and button presses.

## 5.3 Replacing the Vacuum Fluorescent Display (W4, W5, and W7 Control Heads)

### 5.3.1 Removing the Display

1. Figure 5-1 below, Detail A, shows the removal procedure. Cut through the shock pad located opposite the side of the display with the soldered leads.

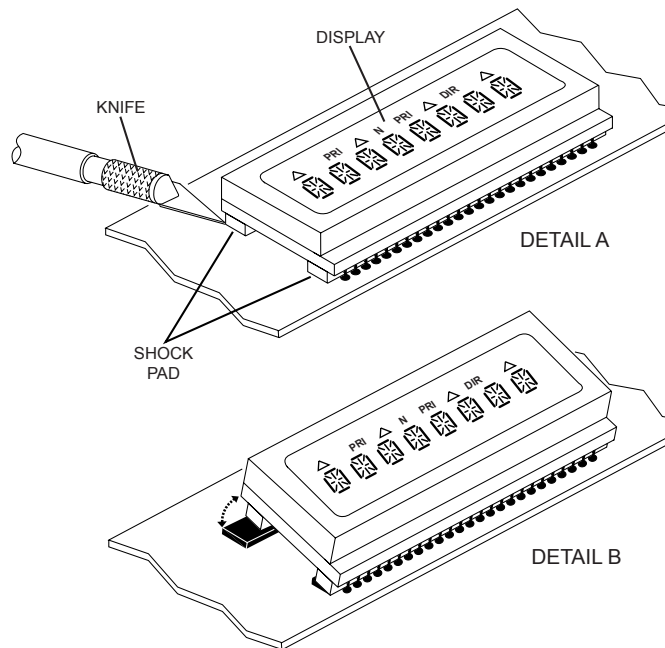

Figure 5-1. Replacing the Vacuum Fluorescent Display

2. Wear finger protection to prevent cutting your fingers on the sharp edges of the glass. Pull up on the edge of the display (see Figure 5-1 above, Detail B), bending the solder leads. Then cut through the remaining shock pad.
3. Unsolder the leads from the PC board to remove the display. Use organic solvent to remove the remaining shock pad and adhesive residue from the board.

### 5.3.2 Installing the Display

1. Apply the adhesive-backed shock pads to the new display. Carefully align the solder leads and insert the display into the PC board.
2. Solder the leads of the new display to the PC board. Do not reuse the old display.

## 5.4 Replacing the Remote Back-Housing Interface Board

### 5.4.1 W4, W5, and W7 Control Heads

1. Unplug the microphone.
2. Disconnect the control cable from the control head on remote models.
3. Remove the two front-panel screws using a 2.5 mm hex-key driver.
4. Grasp the front panel firmly, and carefully unplug the control-head assembly from the radio or remote control-head back housing.
5. Remove the two remote back-housing interface attachment screws.
6. Remove the remote control-head interface board from the remote control-head back housing.

7. Before installing a new Interface PC board (P/N 0105950T92), check to ensure that all gaskets are in place. Gasket (P/N 3205197X01) fits the perimeter of the plastic housing on the bottom surface, and is placed against the sealing rim in back housing. Gasket (P/N 3205198X01) fits inside the pin-out area on bottom of plastic housing. Gasket (P/N 3205082E90) O-rings (2) fit into recessed areas around the bottom of the screw clearance holes.
8. Attach the new interface PC board to the back housing with the two screws: torqued to 6-8 in.-lbs.

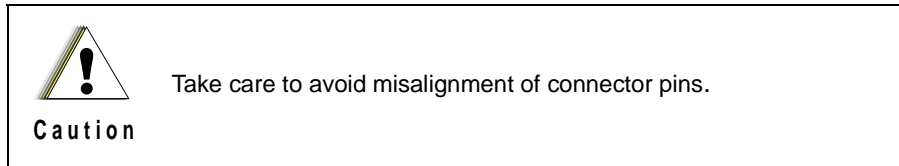

9. Reassemble the back housing to the front housing with the two screws: torqued to 4-6 in.-lbs.

## 5.5 Replacing the Remote Interconnect Board

### 5.5.1 Low-/Mid-Power Radios

1. Remove the two front panel screws using a 2.5 mm hex-key driver.
2. Grasp the front panel firmly, and carefully unplug it from the radio.
3. Remove the three screws that hold the remote interconnect board to the front panel using a Torx T10 driver.
4. Install the new remote interconnect board onto the front panel, and replace the screws. Torque the screws to 6-8 in.-lbs.

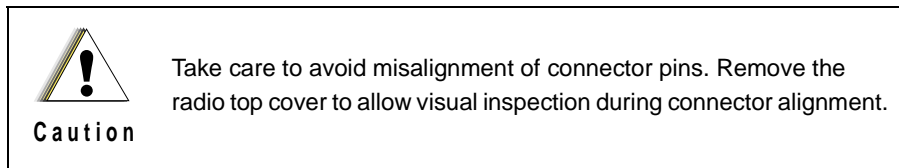

5. Reassemble the front panel into the radio and replace the screws.
6. Torque the screws to 4-6 in.-lbs.

### 5.5.2 High-Power Radios

1. Use a Torx T15 driver to remove the two screws in the radio top cover and then remove the radio top cover.
2. Remove the ribbon cable (38-conductor) from between the command board and the interconnect board by first disconnecting the cable at the command board side and then at the interconnect board.
3. Disengage the retaining wire on the back of the interconnect board at the chassis side.
4. Use the radio key to unlatch the radio handle, and use a Torx T15 driver to remove the two interconnect board screws that are inside the handle.
5. Turn the radio upside down and use a Torx T15 driver to remove the four bottom-cover screws. Remove the bottom cover.
6. Remove the RF-board shield and unplug the coaxial cable that comes up from the other side of the radio. Move the end of the coaxial cable out from behind the interconnect board.



7. Pull the retaining wire up into position so that the interconnect board can be slid back away from the front of the radio, and then up and out from the radio chassis.
8. Remove the rubber gasket from the front of the interconnect board by pulling it up and over the D-connectors.
9. Gently pry each of the arms on the interconnect board spacer so that the snap feature on the arms can be slid past the interconnect board.
10. Place the interconnect board spacer onto the new interconnect board, making sure that each arm is aligned in the proper slot and snaps securely into place.
11. Replace the rubber gasket, retaining wire, coaxial cable, bottom cover (torque four screws to 6-8 in.-lbs), and interconnect board screws (torque two screws to 10-12 in.-lbs).
12. Turn the radio top side up and re-insert the ribbon cable (38-conductor) by first connecting the command board side and then the interconnect board side. This cable is connected to two 38-pin connectors. The cable is keyed so that the cable fits only in the correct position.
13. Fold the ribbon cable down flat. Replace the top cover and torque the two screws to 6-8 in.-lbs. These screws are self-tapping and caution should be used so that the screws properly enter the previously cut threads.

## 5.6 Replacing the Control-Head Board

### 5.6.1 W3 Control Heads

**NOTE:** Numbers shown in brackets in the following procedure refer to item numbers in Figure 7-1, "W3 Hand-Held Control Head Exploded View," on page 7-2, and in Table 7-2, "W3 Hand-Held Control Head Exploded View Parts List," on page 7-2.

1. Remove the strain-relief boot (part of cable assembly [15]) from the housing assembly [7] by applying downward pressure on the boot and pulling it away from the control head until they are completely separated.
2. Carefully remove the rubber seal (part of cable assembly [15]) from the housing assembly [7] opening.

**NOTE:** Take care to avoid damaging this seal.

3. Using a small screwdriver, remove the seal support wedge [14] from the control head.
4. Using a small screwdriver to depress the telco lever, remove the telco connector (part of cable assembly [15]) from the control head, and pull the cable assembly away from the housing (like a telephone jack).
5. Remove the rear-cover assembly [2] from the control head.
6. Locate the recesses in the lower portion of the housing on both sides of the rear-cover's snap features and, prying the snaps until the two parts separate, remove the rear cover from the unit.
7. Remove the two snap retainers [4] from between the circuit board [5] and the housing assembly [7].
8. Disconnect the microphone assembly [8] connector from the circuit board [5].
9. Carefully remove the microphone cable assembly from the keypad [6].
10. Carefully pry the housing's snap features from the circuit board [5].

**NOTE:** Be careful to avoid damaging circuit-board components.

There are seven snaps locking the circuit board to the housing. As the snap features are deflected, push the circuit board upward, using the keypad, to release the circuit board from the snap features.

11. Remove the circuit-board assembly from the housing.
12. Remove the keypad [6] from the housing assembly [7].

### 5.6.2 W4, W5, and W7 Control Heads

**NOTE:** For the following procedure, refer to *Chapter 7: Exploded Views and Parts Lists*, beginning on page 7-1, for the exploded view and associated parts list applicable to the model being disassembled.

1. Unplug the microphone.
2. Remove the two front-panel screws using a 2.5 mm hex-key driver.
3. Disconnect the control cable on remote models.
4. Grasp the front panel firmly, and carefully unplug the control-head assembly from the radio or remote control-head back housing.
5. Lay the control head face down on a clean, flat surface, being careful not to scratch or mar the display.
6. Using a Torx T10 driver, remove the control-head screws:
  - W4 Control Head: four screws [callouts 5-8], as shown in Figure 5-2.

The W4 control head has, in addition to the screws, four snap features [callouts 1-4], which are shown in Figure 5-2.

  - W5 and W7 Control Heads: seven screws, as shown in Figure 5-3.

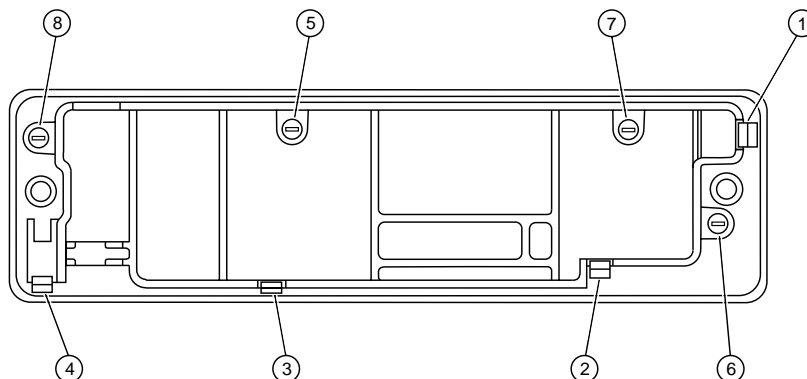

Figure 5-2. Model W4 Rotary Control Head Assembly Screw and Snap Sequence

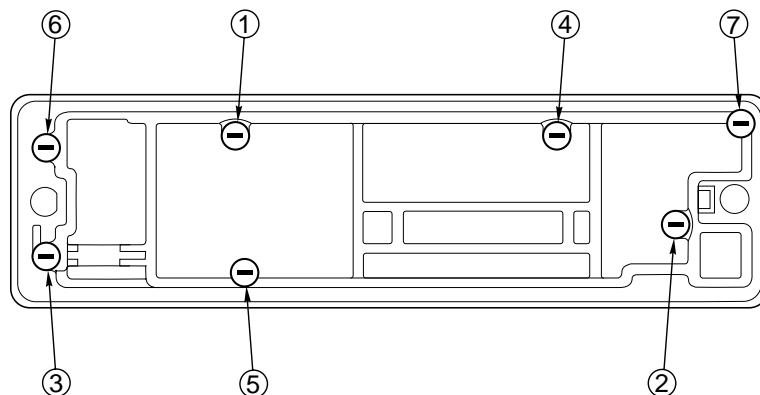



Figure 5-3. Models W5 and W7 Pushbutton Control Head Assembly Screw Sequence

7. Carefully separate the PC board, internal spacer, and elastomer keypad assembly from the front panel.
  - On rotary control-head models, care must be taken not to damage the flex circuit when separating the printed circuit board from the front housing. Do not disturb the buttons in the front panel.
  - On rotary control-head models, the flex circuit must also be unplugged.
8. On rotary control-head models, desolder the XMIT and BUSY LED before removing the elastomer keypad.
9. Remove the elastomer keypad from the PC board.
 

**NOTE:** Before you unsnap the PC board, note that the board slips under a hook on the right and snaps on the left. This will facilitate the assembly.
10. Remove the PC board from the internal spacer. The PC board snaps into and out of the spacer.
11. To reassemble, snap the PC board into the internal spacer. Before you press the elastomer keypad into the board, make sure that the conductive pads in the board and the elastomer keypad are clean and free of any foreign material.
12. On rotary control head models, solder the XMIT and Busy LEDs onto the PC board.
 

**NOTE:** On rotary control head models, the flex circuit must be connected to the PC board prior to attaching the PC board to the spacer.
13. Install the PC board internal spacer and elastomer keypad assembly into the front panel. Replace the screws and torque them to 6-8 in.-lbs.

 <p><b>Caution</b></p>	<p>Take care to avoid misalignment of connector pins. On dash mount radios, remove the radio top cover to allow visual inspection during connector alignment.</p>
---	---

14. Do one of the following:
  - For dash-mounted radios, plug the interconnect board into the radio, and then plug in the control-head assembly and fasten it with the two front-panel screws (torqued to 4-6 in.-lbs).
  - For remote-mount control heads, replace the front panel into the remote control-head back housing, make sure the gasket is in place, and then torque the screws to 4-6 in.-lbs. Replace any plugs and cables on the rear of the control head.

### 5.6.3 W9 Control Heads

**NOTE:** Before disassembling the W9 control head, note the location of the labeled buttons.

**NOTE:** Refer to Figure 7-4, “W9 Pushbutton Control Head Exploded View,” on page 7-5 and Table 7-5, “W9 Pushbutton Control Head Parts List,” on page 7-5 for the callout numbers in this section.

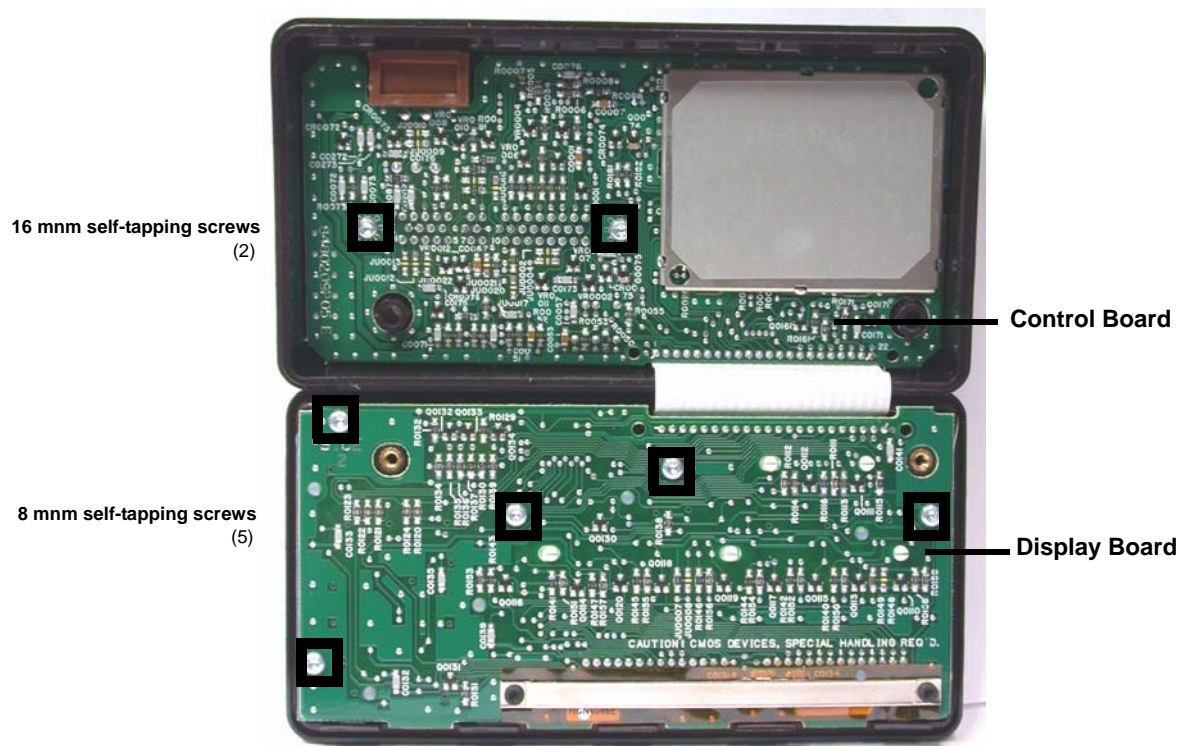



Figure 5-4. W9 Control Head Control Board and Display Board

1. Using a Torx T15 driver, remove the two 30 mm machine screws [29] from the back housing [31] of the control head.
2. Fold the front housing [41] over so that the front housing is face down and the back housing is on your working surface with the flex cable [18] attached.
3. Using a Torx T10 driver, remove the five 8 mm self-tapping screws [17] from the Display Board Kit [37], the two 10 mm captive screws [12] with the leaf assembly spring [11], and the two 16 mm tapping screws [38] from the control PC board.
4. Remove the Command Board Kit [36] from the back housing and the Display Board Kit [37] from the front housing.
5. Remove the elastomer keypad [7], ON/OFF switch gasket [34], the “D” Connector Gasket [33], the solder-side shield [16], and the component-side shield [19] from the PC boards.

 <b>Caution</b>	<p>Be careful to not bend the tabs on the shields when removing them and align them carefully when replacing the shields. When working with chips and SOT (small-outline transistor) parts, use extreme caution when heating. Never reuse a chip or SOT part; always replace with the correct Motorola part.</p>
---	--

6. Install the new PC board with the elastomer keypad, the ON/OFF switch gasket, the “D” Connector Gasket, the “D” Connector O-ring, the solder-side shield, and the component-side shield in the appropriate locations.
7. Reassemble the Command Board Kit [36] into the back housing [31], making sure that the power switch is in the proper location and then replace the two tapping screws [38], torquing them to 6-8 in.-lbs.
8. Reassemble the Display Board Kit [37] into the front housing [41], making sure that the elastomer keypad [7] is in the proper location.
9. Replace the captive screws [12] and the leaf assembly spring [11] in the front housing, and then torque them to 6-8 in.-lbs.

**NOTE:** Before assembling the leaf assembly spring, ensure that the insulator [10] on the board is present. Also ensure that the leaf assembly spring and captive screws are aligned properly to prevent stripping the front housing screw bosses.

10. Close the assembly by replacing the front housing [41] and the two screws in the back housing [31]. Torque the screws to 6-8 in.-lbs.

## 5.7 Final Reassembly–W3 Control Head

When reassembling the control head, make sure the microphone pins are properly inserted through the elastomeric keypad. Also make sure the elastomeric keypad inserts are secured to the PC board.

**NOTE:** Numbers shown in parentheses in the following procedure refer to item numbers in Table 7-2, “W3 Hand-Held Control Head Exploded View Parts List,” on page 7-2.

1. To reassemble the housing assembly [7]:
  - A. Insert the transmit indicator [11] into the housing. Ensure that the top surface of the lightpipe is below the label recess of the housing.
  - B. Attach the nameplate label [13] to the front of the housing. Ensure that the label is securely attached.
  - C. Install the PTT actuator [9] into the housing. Ensure that its lip is seated in the groove in the housing.
  - D. Install the PTT lever [10] and the PTT boot [12] into the housing. Ensure that the lever is seated in its nest and the boot is located properly in the recesses in the housing.
  - E. Install the keypad [6] into the housing. Ensure that all of the keys are located in the correct openings in the housing.
2. Install the microphone assembly [8] into the keypad. Ensure that the front surface of the cartridge is located up against the keypad membrane.
 

**NOTE:** The membrane is the rain seal and is very sensitive to puncture by sharp objects.
3. Connect the microphone cable connector to the mating location on the circuit board [5].

4. Install the circuit board [5] into the housing assembly [7] as follows:
  - A. Hold the housing assembly so that its key openings face downward and its top faces away from you.
  - B. Pivot the circuit board's display down under the retention features in the housing and rotate the board downward, ensuring that the board is positioned between the snap features. Ensure that the microphone assembly's [8] wire passes through the opening in the circuit board.
  - C. Press downward firmly on the board until the seven snap features lock the board into place.
5. Install the two snap retainers [4] between the circuit board and the side wall of the housing assembly [7], one on each side.
6. Install the main seal [3] onto the rear cover assembly [2], placing the seal under the retainer features around the perimeter of the cover.
7. Install the rear cover assembly [2] onto the housing assembly [7].

Starting at the top of the cover, pivot the cover toward the housing and squeeze the two halves together until the snap features at the lower end of the rear cover engage the housing's features and snap closed.

8. Insert the cable assembly's [15] telco connector into the opening in the bottom of the housing, and ensure that it is correctly oriented.
9. Press the telco connector in place until it snaps in (like a phone plug).
10. Place the seal-support wedge [14] into the housing's opening, orienting it so that its long portion is under the telco connector lever, and then push until it is properly seated.
11. Push the rubber seal (part of the cable assembly [15]) into the housing's opening and ensure that it is properly seated.

**NOTE:** This seal must be inserted completely into the housing to ensure the rain seal.
12. Push the strain-relief boot (part of the cable assembly [15]) into the housing and ensure that it is properly seated.
13. Insert the kit label [1] into the recess on the rear cover, and ensure that it is securely attached.

## 5.8 Troubleshooting Charts

This section contains detailed troubleshooting flowcharts. These charts should be used as a guide in determining the problem areas. They are not a substitute for knowledge of circuit operation and astute troubleshooting techniques. It is advisable to refer to the related detailed circuit descriptions in the theory section prior to troubleshooting a radio.

CONTROL UNIT POWERS UP  
PROPERLY BUT BUTTON PRESSES  
DO NOT WORK.

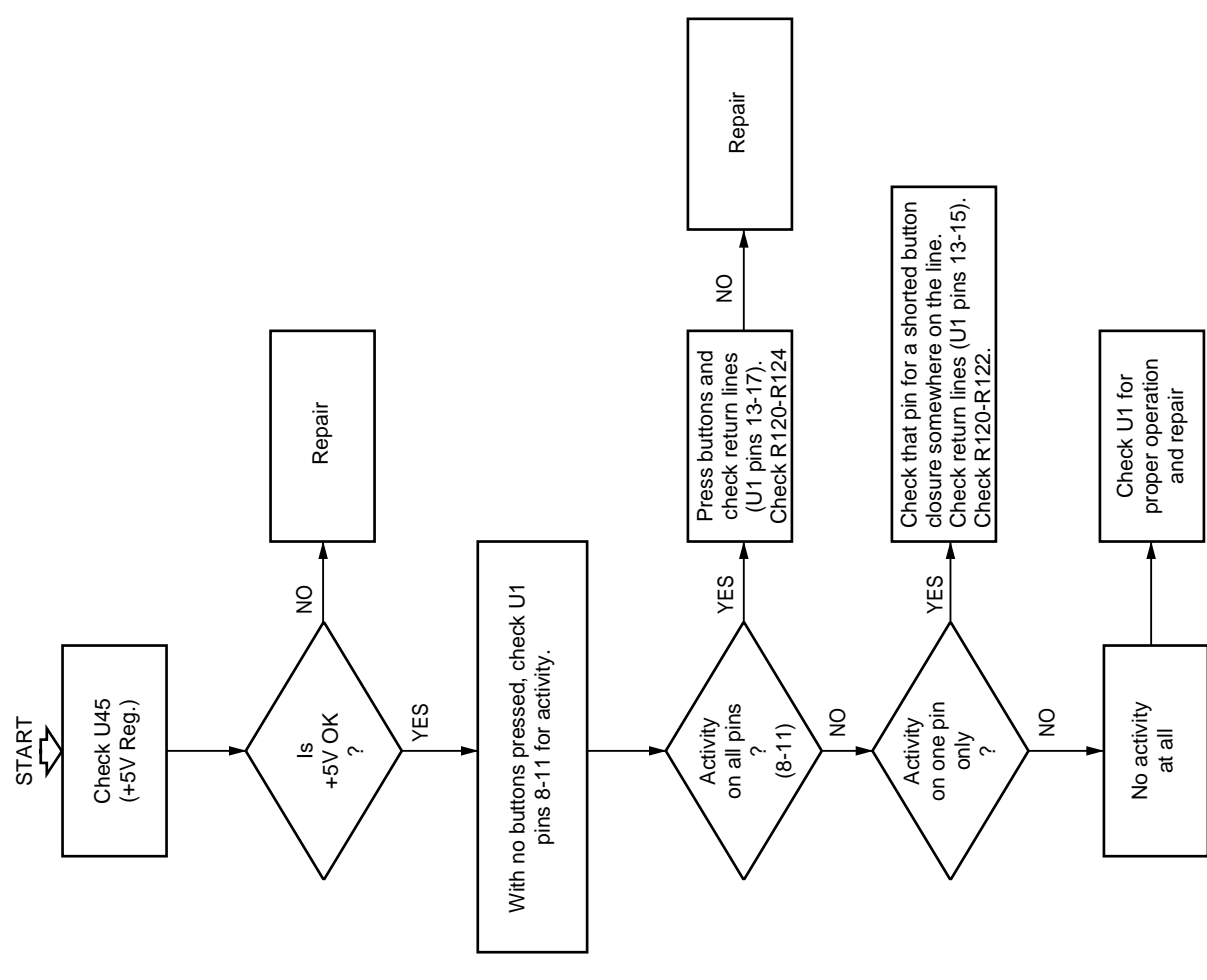

MAEPF-22619-A

Figure 5-5. W4 Control Head (Sheet 1 of 2)

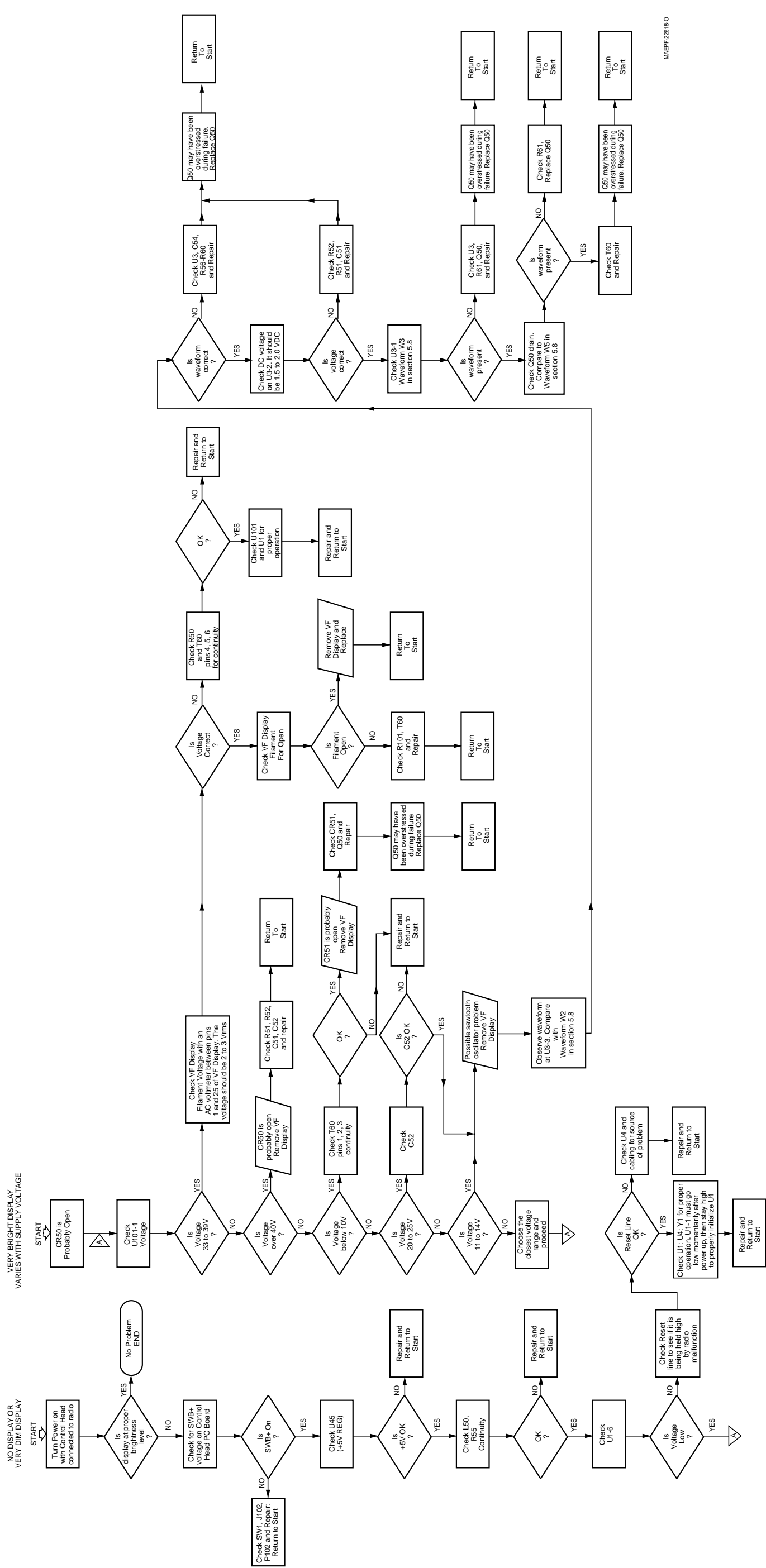

MAEPF-22818-0

Figure 5-6. W4 Control Head (Sheet 2 of 2)



---

## Chapter 6 Radio Connectors

This chapter contains the ASTRO Digital Spectra and Digital Spectra Plus connector locations.

---

### 6.1 Radio Connectors

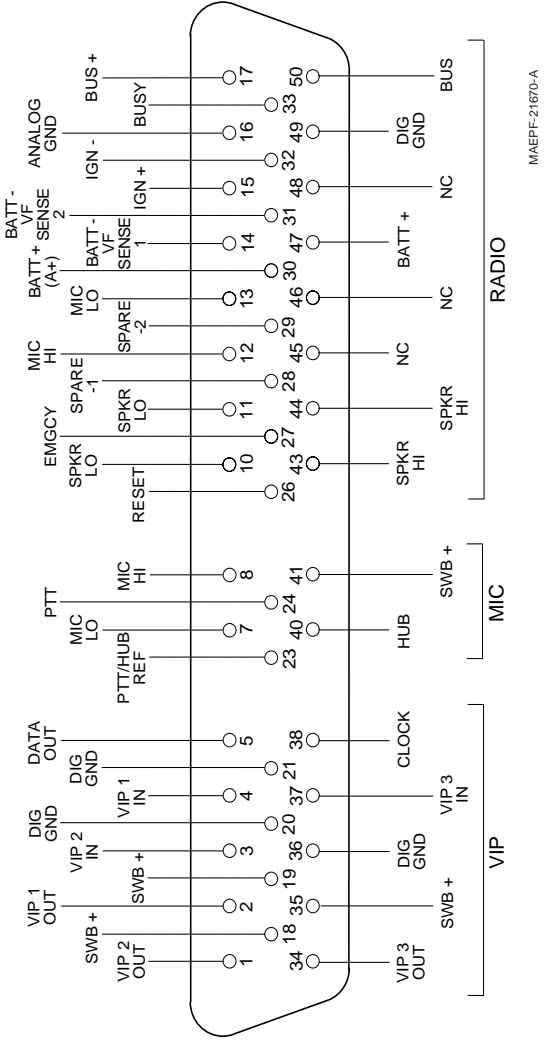

Figure 6-1. J0103 Remote-Mount Control Head Connector

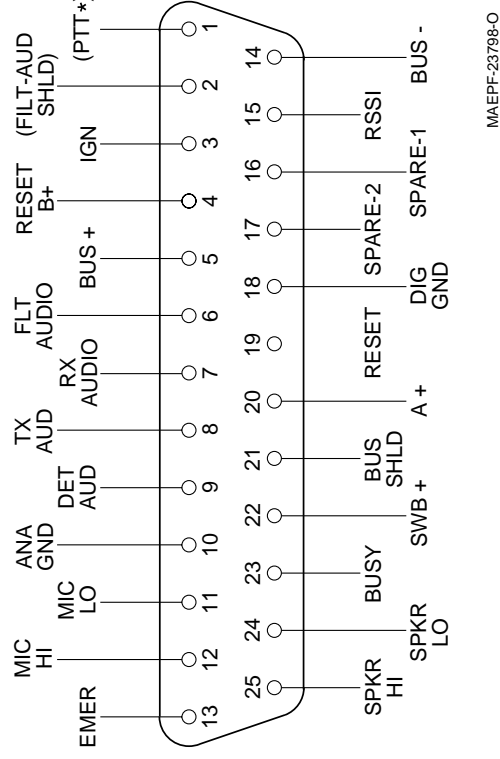

Figure 6-2. J5 Control Cable for Remote-Mount Control Head

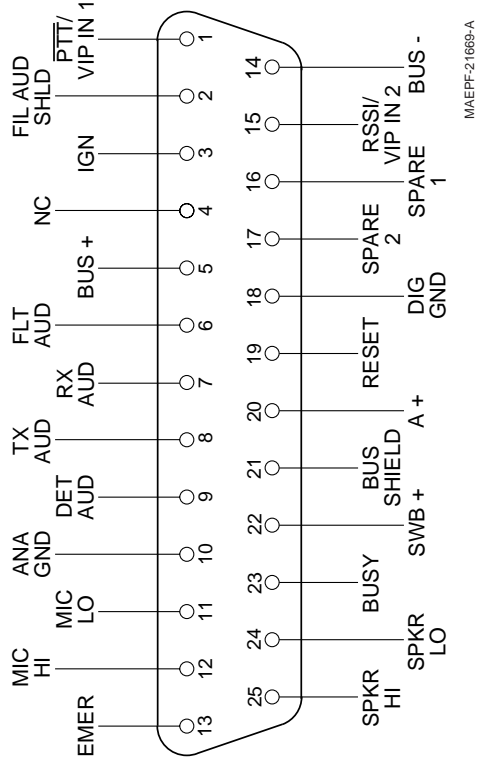

Figure 6-3. J6 Radio Operations Connector

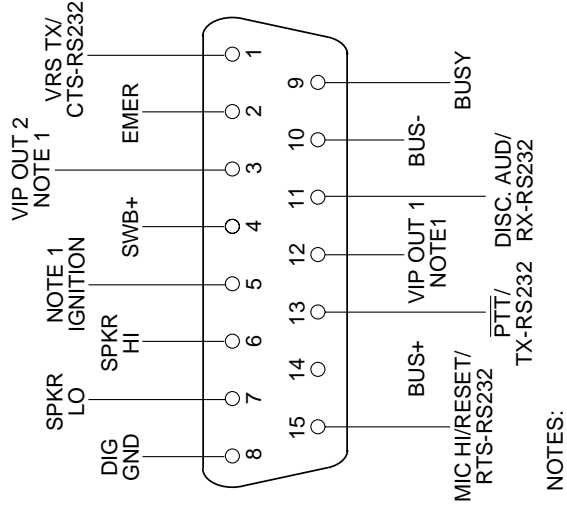

Figure 6-4. J2 Rear Accessory Connector

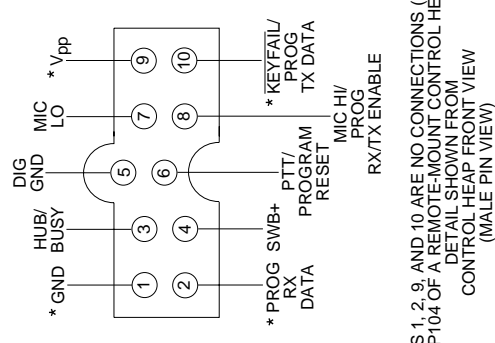

Figure 6-5. P104 Microphone Jack

## 6.2 Radio Connector Locations

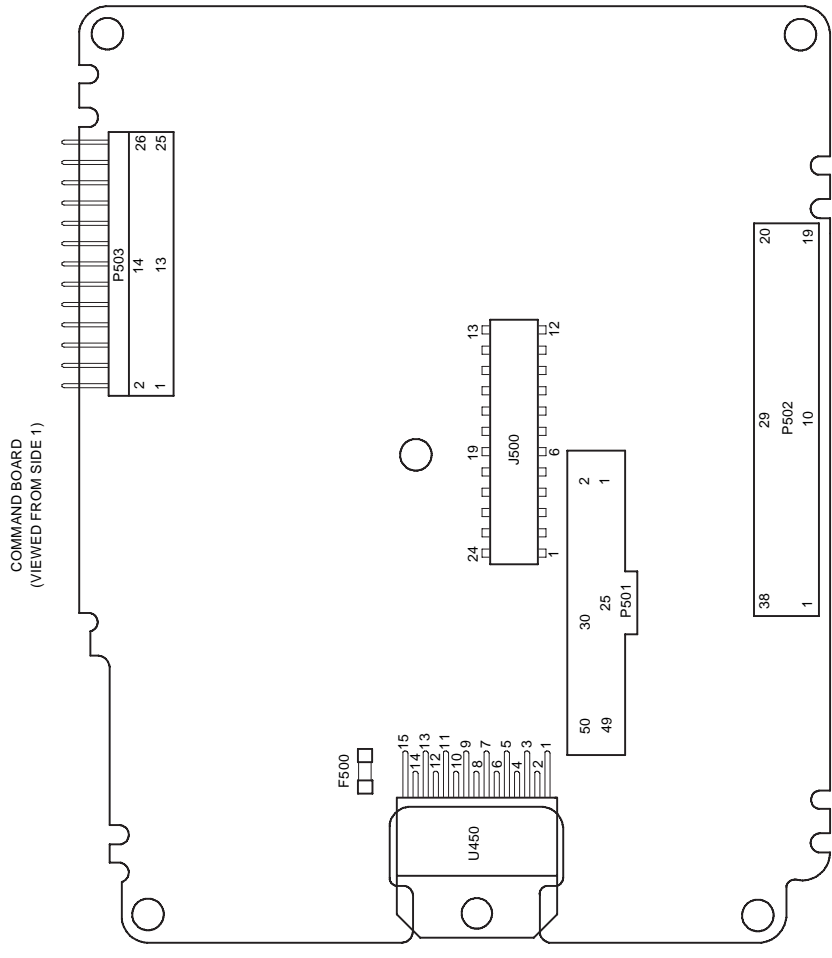

Figure 6-8. Command Board Connector Locations

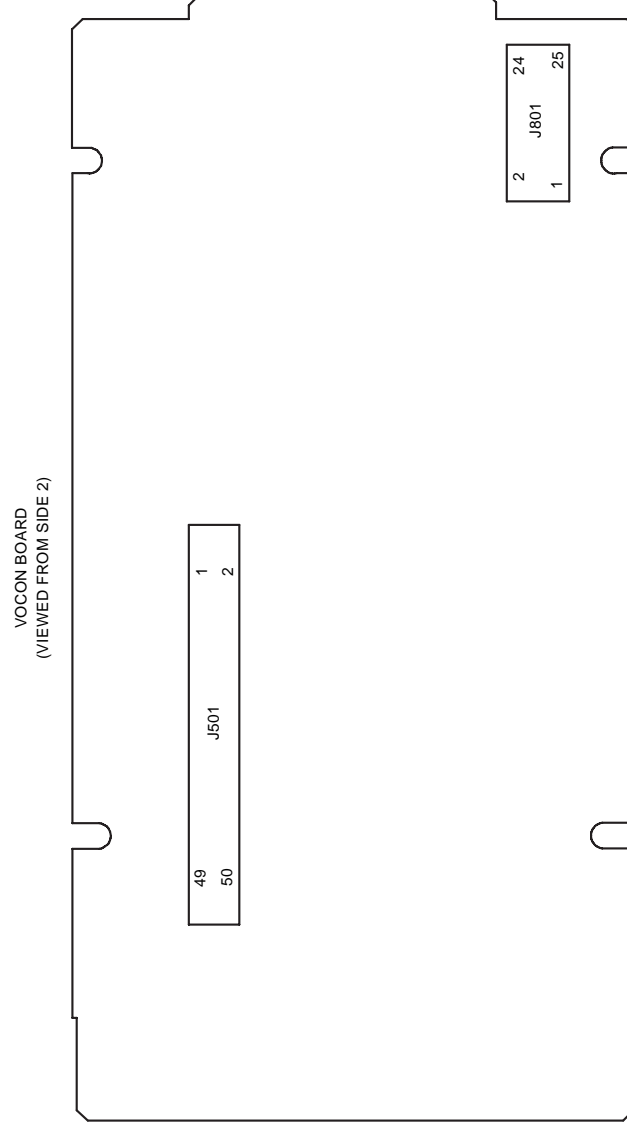
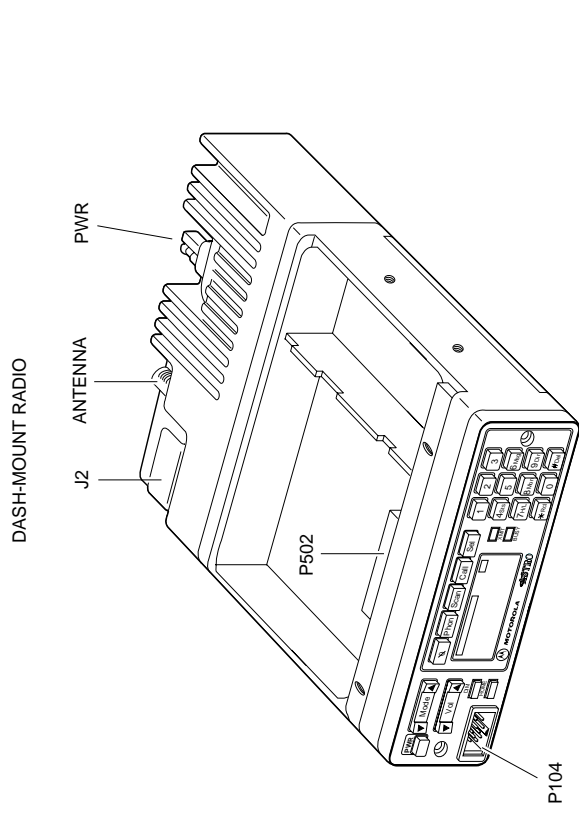
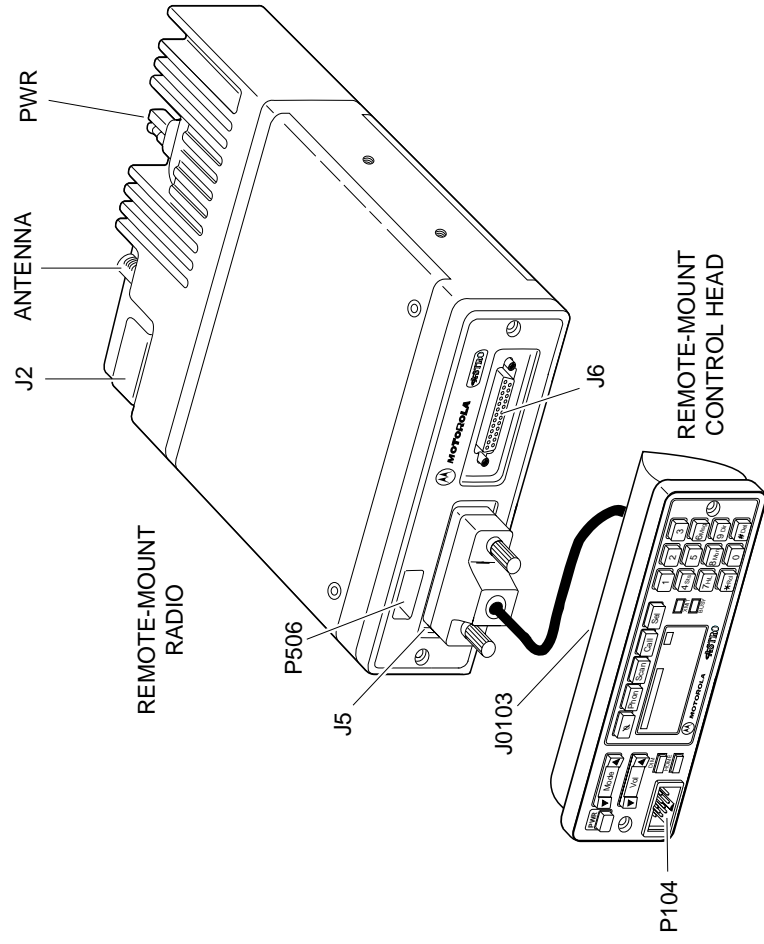

Figure 6-9. VOCON Board Connector Locations



MAEPF-24496-O

Figure 6-6. Dash-Mount Radio Connector Locations



MAEPF-24497-A

Figure 6-7. Remote-Mount Radio Connector Locations

### 6.3 Extender Cable (P501)

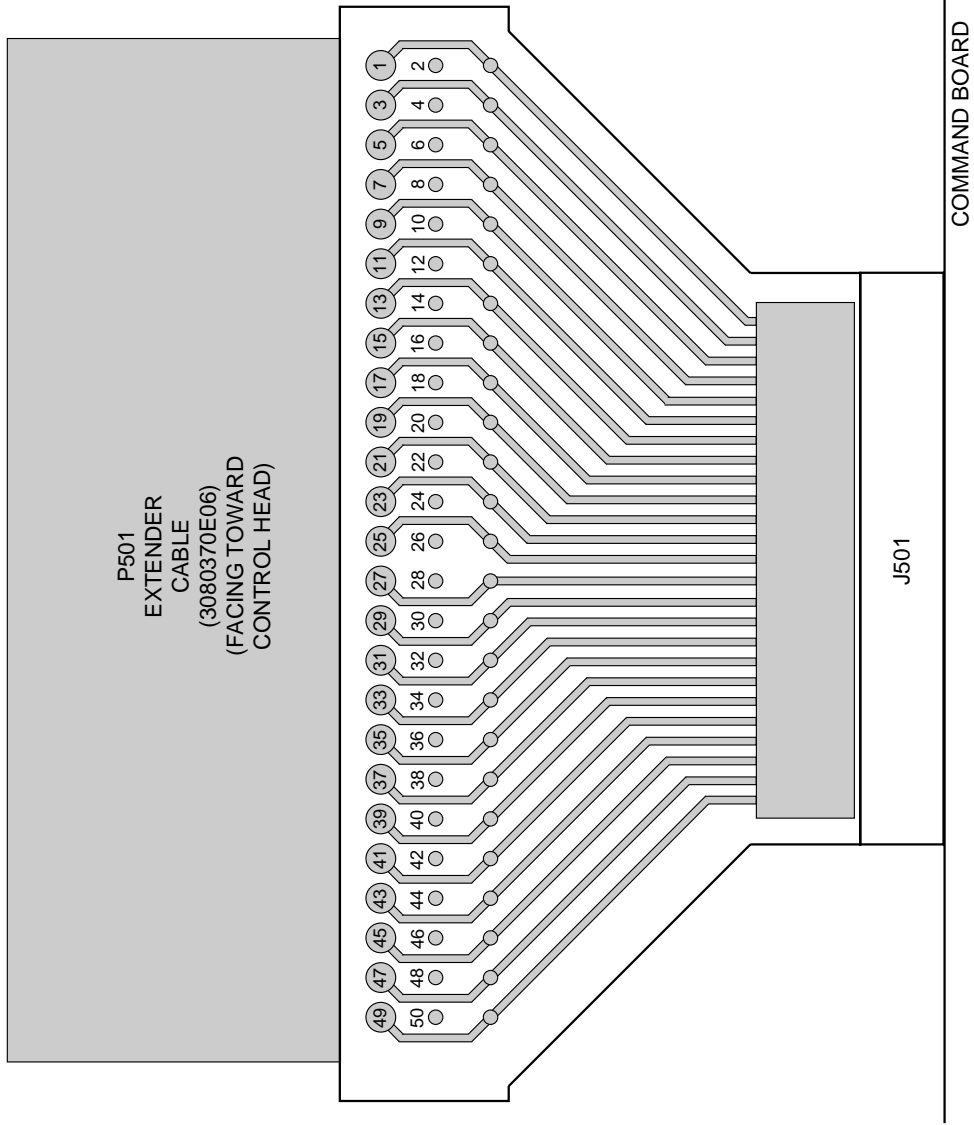

Figure 6-10. P501 Extender Cable

### 6.4 Control-Head Cabling Diagram

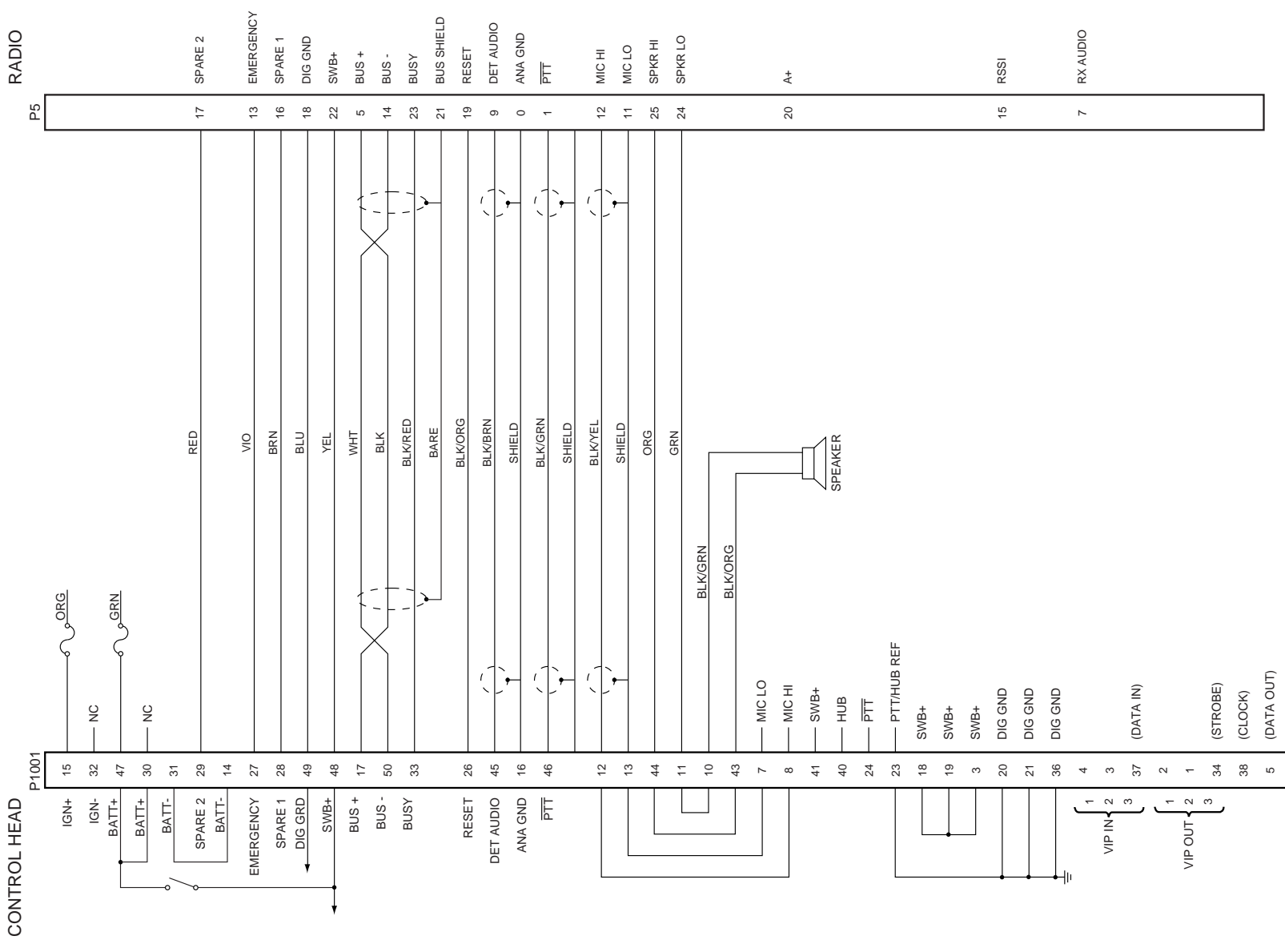

Figure 6-11. Control-Head Cabling Diagram

---

## Chapter 7 Exploded Views and Parts Lists

This chapter contains the exploded views and associated parts lists for each of the ASTRO Digital Spectra and Digital Spectra Plus control heads. Tables containing pushbutton parts lists are also included.

Table 7-1. Exploded Views

Fig #	Description	Page #
Figure 7-1	W3 Hand-Held Control Head Exploded View	7-2
Figure 7-2	W4 Rotary Control Head Exploded View	7-3
Figure 7-3	W5 and W7 Pushbutton Control Head Exploded View	7-4
Figure 7-4	W9 Pushbutton Control Head Exploded View	7-5
Figure 7-5	HMN1080A, HMN1061A, HMN1079A Microphone Exploded View	7-6

## 7.1 Model W3 Hand-Held Control Head Exploded View

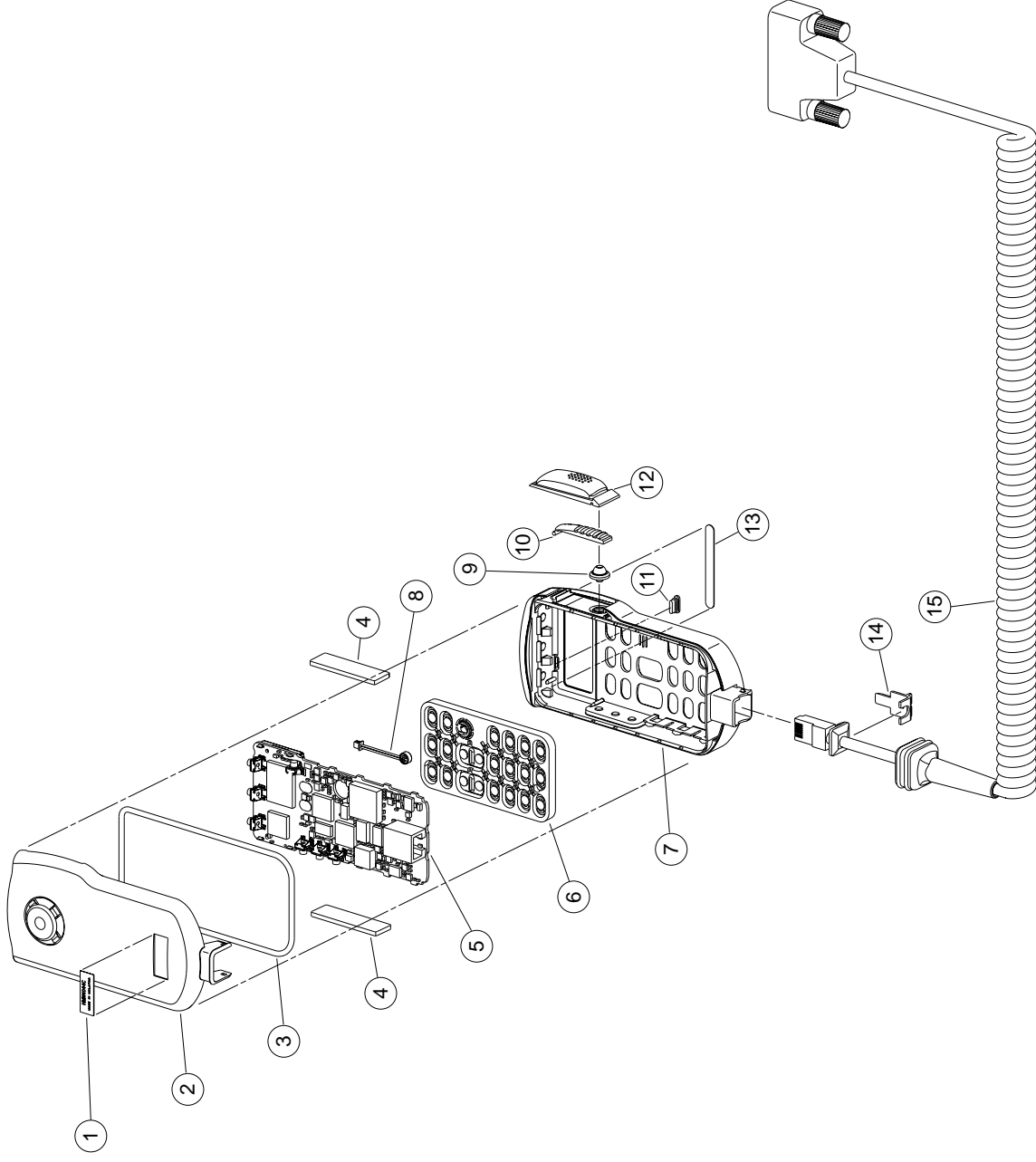

Figure 7-1. W3 Hand-Held Control Head Exploded View

Table 7-2. W3 Hand-Held Control Head Exploded View Parts List

Item No.	Motorola Part No.	Description
1	Not available	LABEL
2	0105955T26	ASSEMBLY, Rear Cover
3	3205082E93	SEAL, Main
4	4205343Y01	RETAINER, Snap (Qty 2)
5	0102707D81	BOARD, SB9600 Circuit
6	7505832X01	KEYPAD (Part of Item 7)
7	0102707D86	ASSEMBLY, Housing (Includes Items 6 and 9 thru 13)
8	0102708D08	ASSEMBLY, Microphone
9	7505618V02	ACTUATOR, PTT (Part of Item 7)
10	4505850X01	LEVER, PTT (Part of Item 7)
11	3205839X01	INDICATOR, Transmit (Part of Item 7)
12	3805835X01	BOOT, PTT (Part of Item 7)
13	3305409X17	LABEL (Part of Item 7)
14	3205274V01	WEDGE, Seal Support
15	HKN6095_	ASSEMBLY, Cable
<b>Note:</b> _ = The latest version kit. When ordering, refer to your specific kit for this suffix letter.		

## 7.2 W4 Rotary Control Head Exploded View

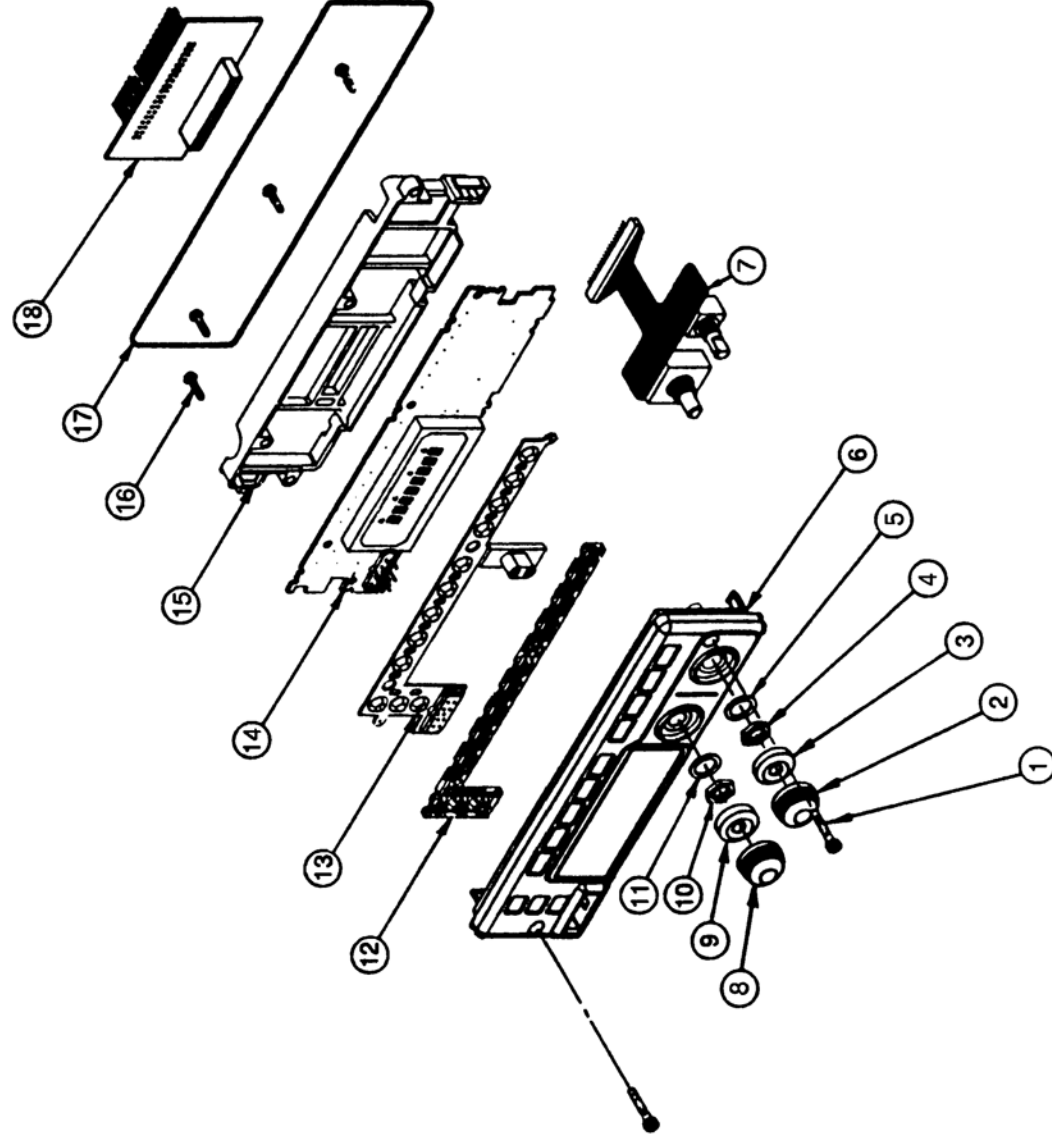

Figure 7-2. W4 Rotary Control Head Exploded View

Table 7-3. Model W4 Rotary Control Head Parts List

Item No.	Motorola Part No.	Description
1	0380077M01	SCREW, Control Head Mounting (Qty 2)
2	3602113Z05	KNOB, Volume Control
3	3205805V01	GASKET, W4 Shaft (Qty 2)
4	0284218M01	NUT, Volume Switch
5	0484219M01	LOCKWASHER, Volume Switch
6	1502117Z07 or 1502117Z08	HOUSING, Front Cover (Mobile) HOUSING, Front Cover (Motorcycle)
7	0102709J83	ASSEMBLY, Volume and Rotary Switch
8	3602113Z03	KNOB, Mode Control
9	3205805V01	GASKET, W4 Shaft (Qty 2)
10	0284218M02	NUT, Mode Switch
11	0484219M02	LOCKWASHER, Mode Switch
12	6105129X01	LIGHTPIPE
13	7505128X01	KEYPAD
14	AAHN4045_ or PMLN4019_	ASSEMBLY, Circuit Board (Mobile) ASSEMBLY, Circuit Board (Motorcycle)
15	4302112Z02	SPACER, Internal
16	0310945A14	SCREW, Machine (Qty 4)
17	3280289L02	GASKET, Housing
18	HLLN6401_	ASSEMBLY, Circuit Board Interconnect

**Notes:** \_ = The latest version kit. When ordering, refer to your specific kit for this suffix letter.  
The HKN4356\_ Radio Cable is used to remote mount the W4 Control Head.

### 7.3 W5 and W7 Pushbutton Control Head Exploded View

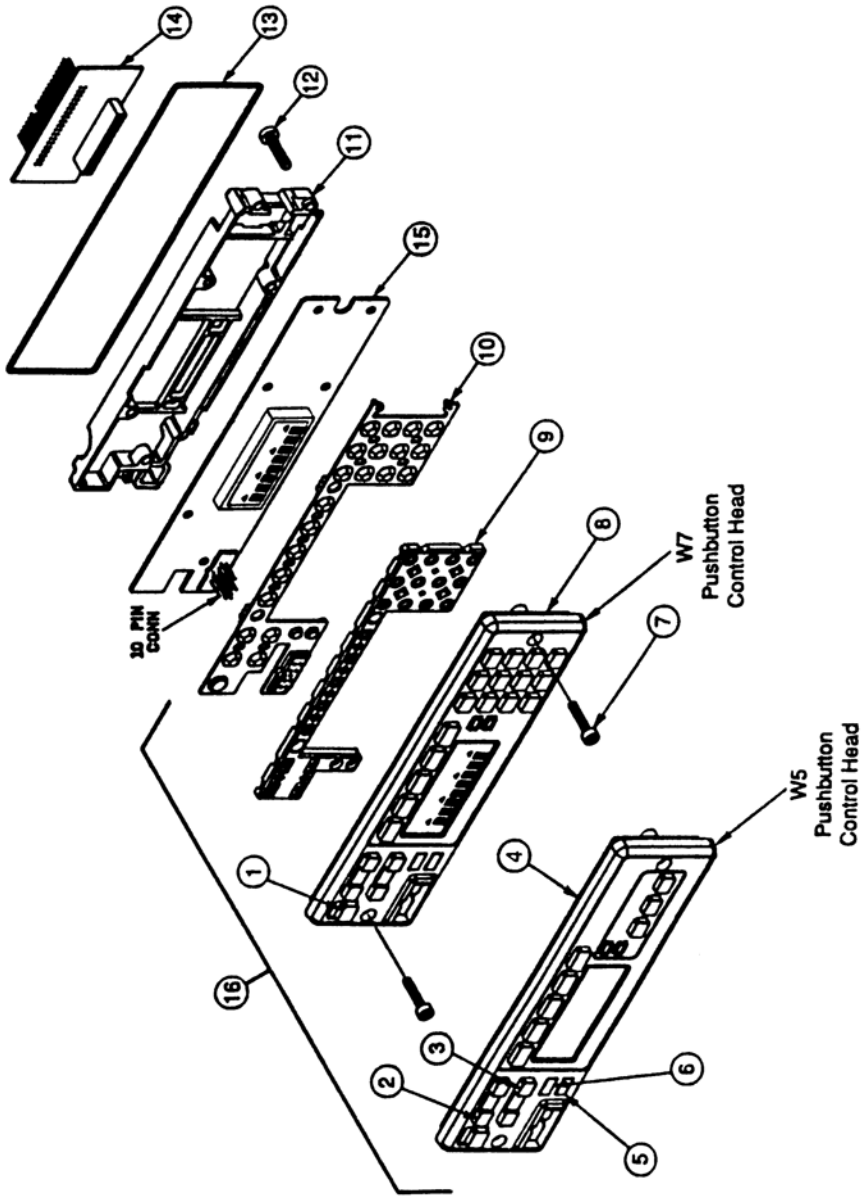

Figure 7-3. W5 and W7 Pushbutton Control Head Exploded View

Table 7-4. W5 and W7 Pushbutton Control Head Parts List

Item No.	Motorola Part No.	Description
1	3880227M04	SWITCH, On/Off Cap
2	3880009P01	SWITCH, Mode Rocker
3	3880009P02	SWITCH, Volume Rocker
4	1580020S17 or 1580020S19	HOUSING, W5 Front Cover (Mobile) HOUSING, W5 Front Cover (Motorcycle)
5	3880092J05	PUSHBUTTON, HOME
6	3880092J05	PUSHBUTTON, DIM
7	0380077M01	SCREW, (Qty 2)
8	1580020S16 or 1580020S18	HOUSING, W7 Front Cover (Mobile) HOUSING, W7 Front Cover (Motorcycle)
9	6180017S01	LIGHTPIPE
10	7580012S03	KEYPAD
11	4380019S02	SPACER, Internal Frame
12	0310945A14	SCREW, Tapping (Qty 7)
13	3280289L02	GASKET, Housing
14	HLN6401_	BOARD, Interconnect
15	HLN6396_ or HLN6563_	BOARD, Control Head (Mobile) BOARD, Control Head (Motorcycle)
16	0180049S09 or 0180049S11 or 0180049S08 or 0180049S10	ASSEMBLY, W5 Front Cover (Mobile) ASSEMBLY, W5 Front Cover (Motorcycle) ASSEMBLY, W7 Front Cover (Mobile) ASSEMBLY, W7 Front Cover (Motorcycle) Item 16 includes items 1, 2, 3, 4 or 8, 5, 6, 9, and 10
<p><b>Notes:</b> _ = The latest version kit. When ordering, refer to your specific kit for this suffix letter. The HKN4356_ Radio Cable is used to remote mount the W5 and W7 Control Head.</p>		



### 7.4 W9 Pushbutton Control Head Exploded View

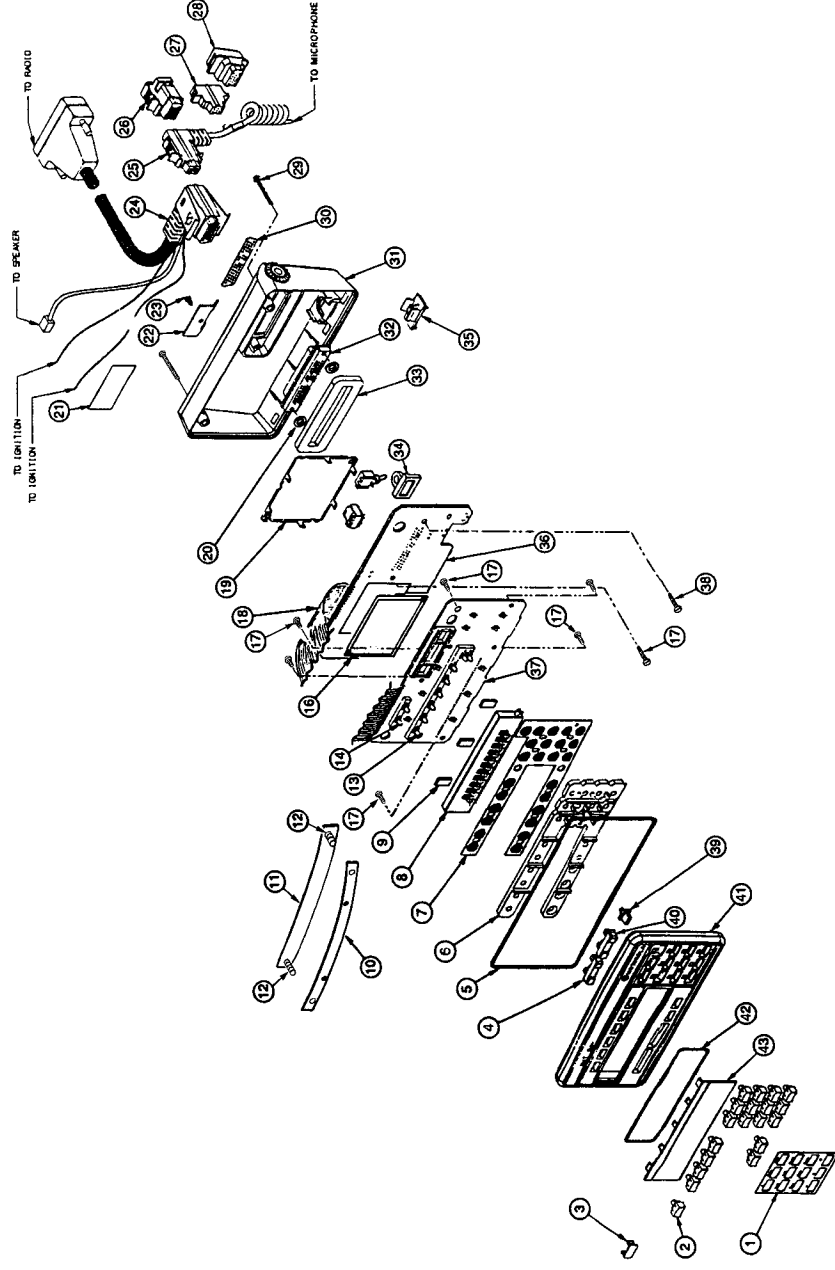

Figure 7-4. W9 Pushbutton Control Head Exploded View

Table 7-5. W9 Pushbutton Control Head Parts List

Item No.	Motorola Part No.	Description
1	1380087J01	ESCUTCHEON
2	HLN5083_	BUTTON, Emergency
	HLN5091_	BUTTON, Dir
	HLN5066_	BUTTON, Scan
	HLN5256_	BUTTON, Strch
	HLN5074_	BUTTON, Call
	HLN5268_	BUTTON, Page
	HLN5259_	BUTTON, RPGM
	HLN5258_	BUTTON, Site
	HLN5090_	BUTTON, PHON
	HLN5072_	BUTTON, H/L
	HLN5257_	BUTTON, Lock
	HLN5076_	BUTTON, RCL
	HLN5085_	BUTTON, SQL
	HLN5078_	BUTTON, Del
HLN5087_	BUTTON, Home	
HLN5079_	BUTTON, Sel	
HLN5095_	BUTTON, Blank	
3	3880253K01	PLUG
4	3880195P03	SWITCH, Mode Rocker

Table 7-5. W9 Pushbutton Control Head Parts List (Continued)

Item No.	Motorola Part No.	Description
5	3205145X01	GASKET, Internal Frame
6	6105126X01	LIGHTPIPE, Keypad
7	7505127X01	KEYPAD
8	7280242J01	DISPLAY, VF
9	7580094M05	PAD, Shock (Qty 3)
10	1405410X01	INSULATOR
11	4180042S01	SPRING, Leaf Assy
12	0380041S01	SCREW, Captive (Qty 4)
13	6180026R02	SPACER, LED (8-Position)
14	6180027R02	SPACER, LED (2-Position)
16	2680190P02	SHIELD, Solder Side (Includes two 1480269K01 insulators)
17	0310945A11	SCREW, Tapping (Qty 5)
18	3080034K01	CABLE, Flex
19	2680190P02	SHIELD, Component Side
20	3205082E90	O-RING "D" Connector (Qty 2)
21	3380178M01	NAMEPLATE
22	0784323C01	BRACKET, Strain Relief
23	0310908A18	SCREW, Machine
24	HKN4356_	CABLE, Radio
25	HMN1050_ or HMN1080_ or HMN1061_	KIT, Microphone
26	1580221J01	HOUSING, VIP Connector (Optional)
27	7502118Z01	COVER, Rubber Dust (MIC)
28	7502118Z02	COVER, Rubber Dust (VIP)
29	0310908A33	SCREW, Machine (Qty 2)
30	3205198X01	GASKET, Face
31	1505199X01	HOUSING, Back
32	2805778W01	CONNECTOR, Mini "D" 50 Contact
33	3205143X01	GASKET, "D" Connector
34	3205143X01	GASKET, On/Off Switch
35	3880128J01	KEY, On/Off
36	HCN4046_	BOARD KIT, Command (includes Display Board)
37	HCN4046_	BOARD KIT, Display (includes Command Board)
38	0310945A14	SCREW, Tapping (Qty 2)
39	3880092J05	KEY, Blank
40	3880195P02	SWITCH, Volume Rocker
41	1505125X09	HOUSING, Front
42	3205144X01	GASKET, Lens
43	6105146X01	LENS, VF Display

**Note:** \_ = The latest version kit. When ordering, refer to your specific kit for this suffix letter.

## 7.5 HMN1080A, HMN1061A, HMN1079A Microphone Exploded View

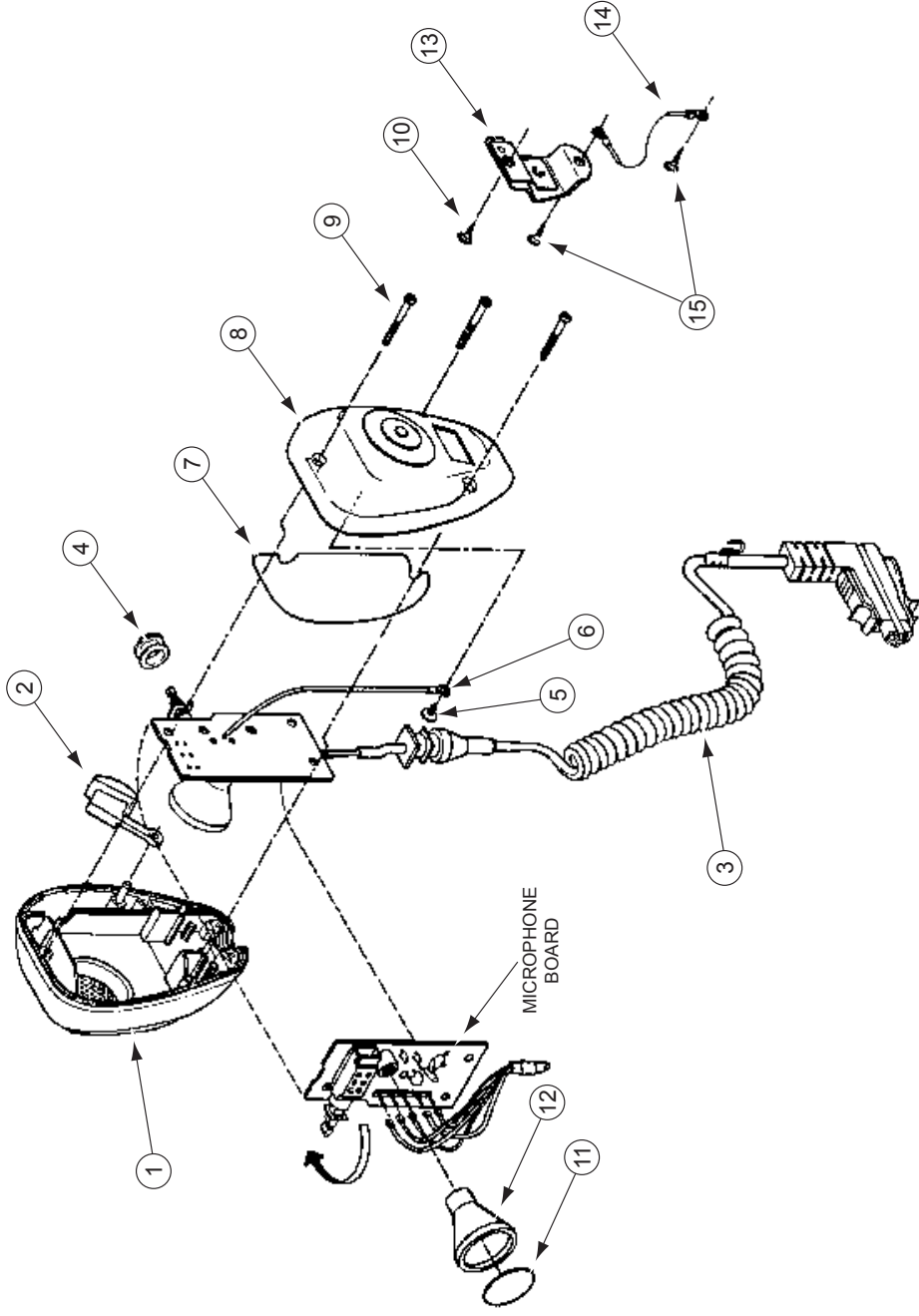

MMAEPF-27700-0

Figure 7-5. HMN1080A, HMN1061A, HMN1079A Microphone Exploded View

Table 7-6. HMN1080A, HMN1061A, HMN1079A Microphone Parts List

Item No.	Motorola Part No.	Description
1	1580127D05	Microphone Front Housing
2	3880144D05	Microphone PTT Button
3	3080223J05 or 3080210P01 or 3080223J01	HMN1080A Coiled 6 Cond HMN1079A Coiled 6 Cond HMN1061A Coiled 6 Cond
4	0580221K01	PTT Switch Grommet
5	0310943M09	Tapping Screw (3 x 0.5 x 6)
6	3080206L01	PCB to Mic Weight Wire
7	3280058H03	Housing Gasket
8	0180750T91	Microphone Rear Housing
9	0380076E04	Hi-Io Metric Screw
10	0312002C01	Screw, Self-drilling, 6-20 x 1/2"
11	3580089D01	Microphone Felt Baffle
12	0580148D01	Microphone Grommet
13	0180743T91	Hangup Clip
14	0180750T52	Ground Wire
15	0300138015	Screw, Self-drilling, 8-18 x 1/2"

### 7.6 Small Pushbutton Parts

Table 7-7. Small Pushbutton Parts List

Part Number	Graphic Legend	Part Number	Graphic Legend
3805671X02	1	3805671X21	9wxy
3805671X03	2	3805671X22	* Rcl
3805671X04	3	3805671X23	#Del
3805671X05	4	3805671X24	1Ste
3805671X06	5	3805671X25	2Pge
3805671X07	6	3805671X26	3Lck
3805671X08	7	3805671X27	4Sts
3805671X09	8	3805671X28	5Rpg
3805671X10	9	3805671X29	6Msg
3805671X11	0	3805671X30	7H/L
3805671X12	*	3805671X31	8Mon
3805671X13	#	3805671X32	9Dir
3805671X14	2abc	3805671X33	Mon
3805671X15	3def	3805671X34	H/L
3805671X16	4ghi	3805671X35	DIR
3805671X17	5jkl	3805671X36	Urg
3805671X18	6mno	3805671X37	RTT
3805671X19	7prs	3805671X38	Home
3805671X20	8tuv	3805671X39	Dim

### 7.7 Large Pushbutton Parts

Table 7-8. Large Pushbutton Parts List

Part Number	Graphic Legend	Part Number	Graphic Legend
3805672X01	-	3805672X10	H/L
3805672X02	MPL	3805672X11	Sts
3805672X03	Scan	3805672X12	Call
3805672X04	DVP	3805672X13	Msg
3805672X05	PA	3805672X14	Rcl
3805672X06	Sirn	3805672X15	Mode
3805672X07	Wail	3805672X16	ExRd
3805672X08	Hi/Lo	3805672X17	Del
3805672X09	Man	3805672X18	Sel
3805672X19	Mon	3805672X52	Emer
3805672X20	DTMF	3805672X53	Stdy
3805672X21	Yelp	3805672X54	ECC
3805672X22	MVS	3805672X55	Rptr
3805672X23	Play	3805672X56	State
3805672X24	Rply	3805672X57	Reg
3805672X25	Rord	3805672X58	AirHn
3805672X26	Emer	3805672X59	TB Scn
3805672X27	Ext	3805672X60	SCC
3805672X28	F/R	3805672X61	Srch
3805672X29	Alt	3805672X62	Lock
3805672X30	Tel	3805672X63	Page
3805672X31	Sqj	3805672X64	Rear
3805672X32	DES	3805672X65	Xfer
3805672X33	Txt	3805672X66	ST
3805672X34	Indv	3805672X67	VHF
3805672X35	Pvt	3805672X68	UHF
3805672X36	Site	3805672X69	Aux
3805672X37	AA	3805672X70	QC II
3805672X38	Sub	3805672X71	Mute
3805672X39	Home	3805672X72	Pri

Table 7-8. Large Pushbutton Parts List (Continued)

Part Number	Graphic Legend	Part Number	Graphic Legend
3805672X40	Menu	3805672X73	Blu
3805672X41	Rpgm	3805672X74	Div
3805672X42	Step	3805672X75	RTT
3805672X43		3805672X76	Send
3805672X44	Phon	3805672X77	Front
3805672X45	Dir	3805672X78	Bid
3805672X46	Text	3805672X79	ZONE
3805672X47	Rvw	3805672X80	TRBL
3805672X48	Sec	3805672X81	OVHD
3805672X49	Ø	3805672X82	UNGD
3805672X50	L/S	3805672X83	RSSI
3805672X51	S/S	3805672X84	VRS
3805672X85	A/B	3805669X12	ETrp
3805672X86	Chan	3805669X13	LvTe
3805672X87	PRTT	3805669X14	ArTe
3805672X88	RiRn	3805669X15	LvGg
3805672X89	Emp#	3805669X16	ArGg
3805672X90	Pass	3805669X17	P/in
3805672X91	Cir	3805669X18	P/out
3805672X92	URG	3805669X19	Serv
3805672X93	A	3805669X20	O/S
3805672X94	B	3805669X21	Rev
3805672X95	C	3805669X22	Stby
3805672X96	D	3805669X23	Sts 1
3805672X97	E	3805669X24	Sts 2
3805672X98	F	3805669X25	Sts 3
3805672X99	G	3805669X26	Sts 4
3805669X01	K	3805669X27	Sts 5
3805669X02	L	3805669X28	Sts 6
3805669X03	T/Z	3805669X29	Sts 7
3805669X04	30	3805669X30	Sts 8

Table 7-8. Large Pushbutton Parts List (Continued)

Part Number	Graphic Legend	Part Number	Graphic Legend
3805669X05	Entr	3805669X31	Drv
3805669X06	MWTT	3805669X32	Bdg#
3805669X07	MAck	3805669X33	LnBI
3805669X08	Time	3805669X34	RtBI
3805669X09	SRun	3805669X35	LnRn
3805669X10	ERun	3805669X36	s
3805669X11	STrp	3805669X37	t
3800028M01 "Emer Housing"		3800029M01 "Emer Plunger"	

**Notes**

## Chapter 8 Schematics, Overlays, and Parts Lists

### 8.1 List of Schematics, Component Location Diagrams, and Parts Lists

The following table lists the schematics, component location diagrams, and parts lists contained in this chapter.

*Table 8-1. List of Schematics, Component Location Diagrams, and Parts Lists*

Figure Title	Page
HMN4044E W3 Control Head Schematic	8-2
HMN4044E W3 Control Head Component Location Diagram	8-3
HMN4044E W3 Control Head Component Location Diagram	8-4
HMN4044E Parts List	8-5
HKN6096B Remote "Y" Cable Wiring Diagram	8-6
AAHN4045F/G (Standard), HLN4071A/B (Rear), PMLN4019C/D (Motorcycle) W4 Control Head Schematic (Sheet 1 of 2)	8-7
AAHN4045F/G (Standard), HLN4071A/B (Rear), PMLN4019C/D (Motorcycle) W4 Control Head Schematic (Sheet 2 of 2)	8-8
AAHN4045 (Standard), HLN4071 (Rear), PMLN4019 (Motorcycle) W4 Control Head Component Location Diagram	8-9
AAHN4045G Standard Parts List	8-10
HCN4071B Rear Parts List	8-12
PMLN4019D Motorcycle Parts List	8-14
HLN6396F/G/H (Standard), HLN6814A/B/C (Rear), HLN6563B/C/D (Motorcycle) W5/W7 Control Head Schematic (Sheet 1 of 2)	8-16
HLN6396F/G/H (Standard), HLN6814A/B/C (Rear), HLN6563B/C/D (Motorcycle) W5/W7 Control Head Schematic (Sheet 2 of 2)	8-17
HLN6396F/G (Standard), HLN6814A/B (Rear), HLN6563B/C (Motorcycle) W5/W7 Control Head Component Location Diagram (Viewed from Side 1)	8-18
HLN6396F/G (Standard), HLN6814A/B (Rear), HLN6563B/C (Motorcycle) W5/W7 Control Head Component Location Diagram (Viewed from Side 2)	8-18

*Table 8-1. List of Schematics, Component Location Diagrams, and Parts Lists (Continued)*

Figure Title	Page
HLN6396H_HLN6814C_HLN6563C W5/W7 Control Head Component Location Diagram (Viewed from Side 1)	8-19
HLN6396H_HLN6814C_HLN6563C W5/W7 Control Head Component Location Diagram (Viewed from Side 2)	8-19
HLN6396H Standard Parts List	8-20
HLN6814C Rear Parts List	8-22
HLN6563D Motorcycle Parts List	8-24
HCN1078J (Standard), HCN1121D (Rear) W9 Control Head Schematic (Side 1 of 2)	8-26
HCN1078J (Standard), HCN1121D (Rear) W9 Control Head Schematic (Side 2 of 2)	8-27
HCN1078J (Standard), HCN1121D (Rear) W9 Control Head Component Location Diagram (Viewed from Side 1)	8-28
HCN1078J (Standard), HCN1121D (Rear) W9 Control Head Component Location Diagram (Viewed from Side 2)	8-29
HCN1078J (Standard), HCN1121D (Rear) Parts List	8-30
W4, W5, and W7 Control Head Low-/Mid-Power Interconnection Diagram	8-33
W4, W5, and W7 High Power Interconnection Diagram	8-34
W5 and W7 Control Head Interface Board Schematic	8-35
HLN6432D W5/W7 Control Head Interface Board Component Location Diagram	8-36
HLN6401A Control Head Interconnect Board, (Dash-Mount)	8-37
HLN6486D/E High Power Standard Interconnect Board	8-38
HLN6486D/E High-Power Interconnect Board (Viewed from Side 1)	8-39
HLN6486D/E High-Power Interconnect Board (Viewed from Side 2)	8-39
HLN6486E Standard Interconnect Parts List	8-40
HLN6574E W3 Control Head High-Power Interconnect Board Schematic Design	8-41

*Table 8-1. List of Schematics, Component Location Diagrams, and Parts Lists (Continued)*

Figure Title	Page
HLN6574E W3 High Power Interconnect Board Component Location Diagrams	8-42
HLN6574E W3 High-Power Interconnect Parts List	8-43
HLN6459D, HLN6344E, and HLN6365E Low-Power Interconnect Board Schematic	8-45
HLN6459D, HLN6344E, and HLN6365E Low-Power Interconnect Component Location Diagram	8-46
HLN6459D W3 Low-Power Interconnect Parts List	8-47
HLN6365E Motorcycle Interconnect Parts List	8-49
HLN6344E Standard Interconnect Parts List	8-50
HMN1080A, HMN1061A, HMN1079A Microphone Board Overlay	8-51
HMN1080A, HMN1061A, HMN1079A Microphone Schematic	8-51
HMN1080A, HMN1061A, HMN1079A Microphone Parts List	8-51

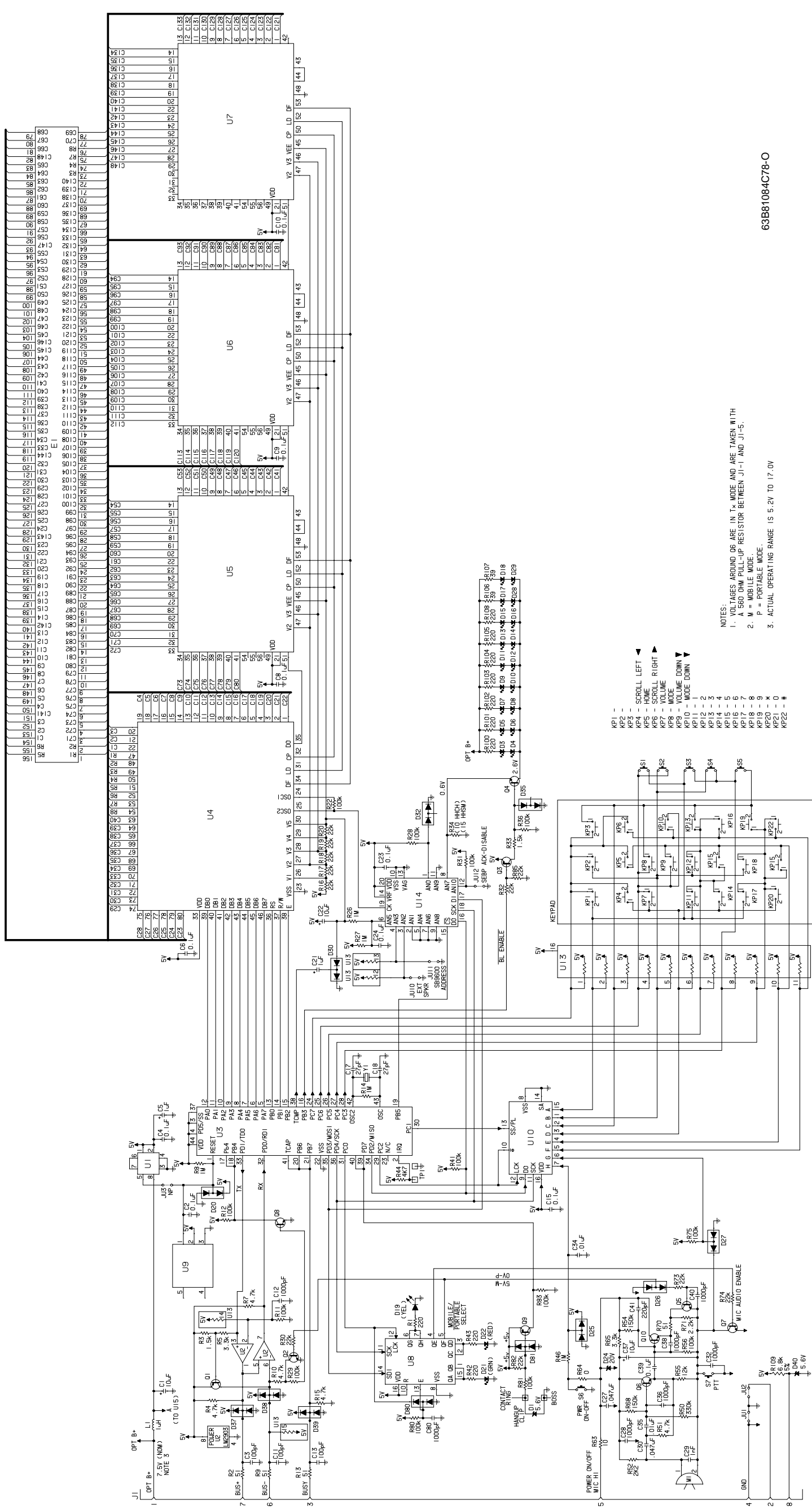

- KP1 -
- KP2 -
- KP3 -
- KP4 - SCROLL LEFT
- KP5 - SCROLL RIGHT
- KP6 -
- KP7 - VOLUME
- KP8 - MODE
- KP9 - VOLUME DOWN
- KP10 - MODE DOWN
- KP11 -
- KP12 -
- KP13 -
- KP14 -
- KP15 -
- KP16 -
- KP17 -
- KP18 -
- KP19 -
- KP20 -
- KP21 -
- KP22 -

NOTES:  
 1. VOLTAGES AROUND 06 ARE IN TX MODE AND ARE TAKEN WITH A 560 OHM PULL-UP RESISTOR BETWEEN J1-1 AND J1-5.  
 2. M = MOBILE MODE.  
 3. ACTUAL OPERATING RANGE IS 5.2V TO 17.0V

63B81084C78-0

Figure 8-1. HMN4044E W3 Control Head Schematic (For reference only - board is not field-repairable)

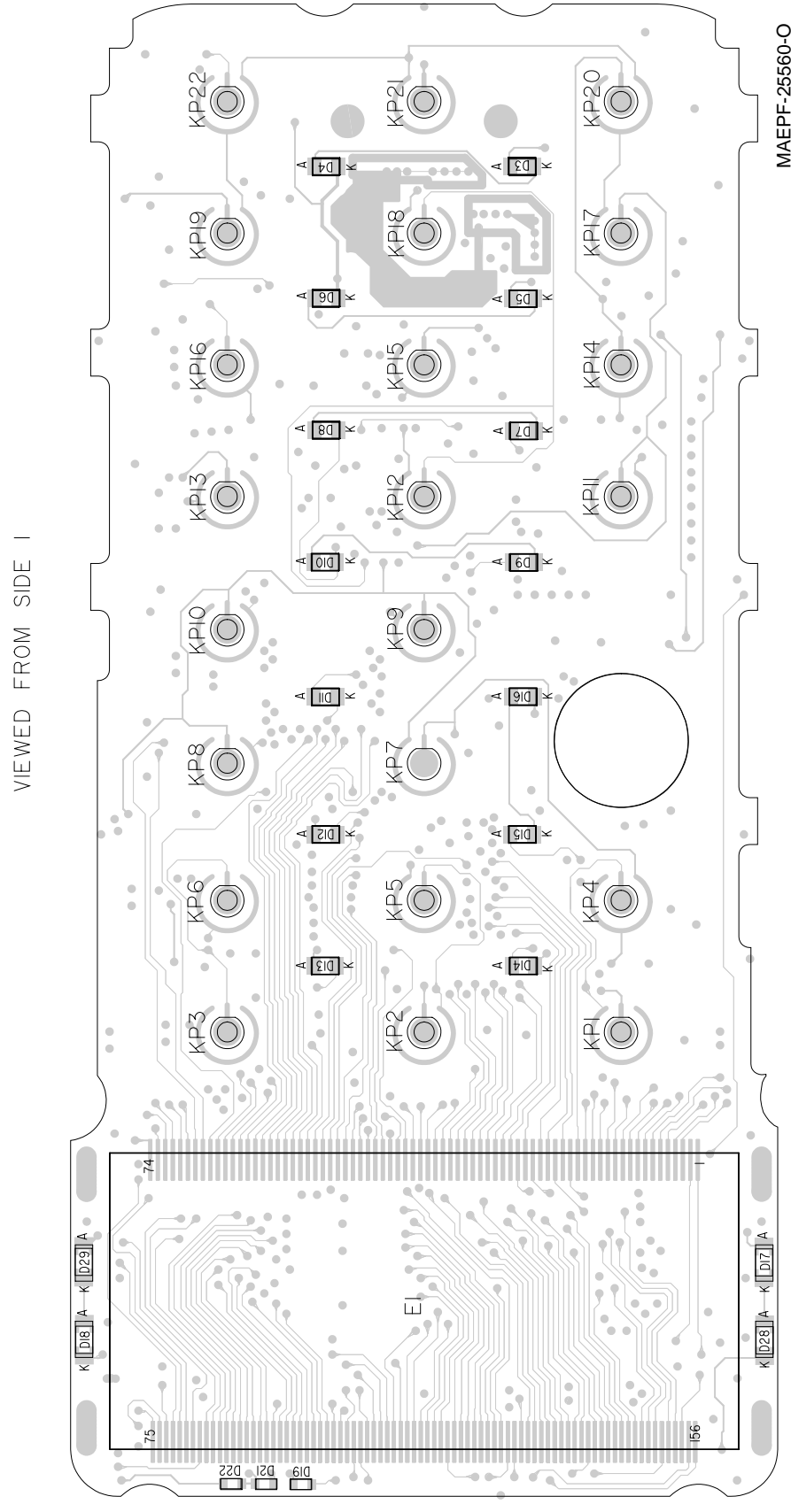

*(Viewed from Side 1)  
 (For reference only - board is not field-repairable)*

Figure 8-2. HMN4044E W3 Control Head Component Location Diagram

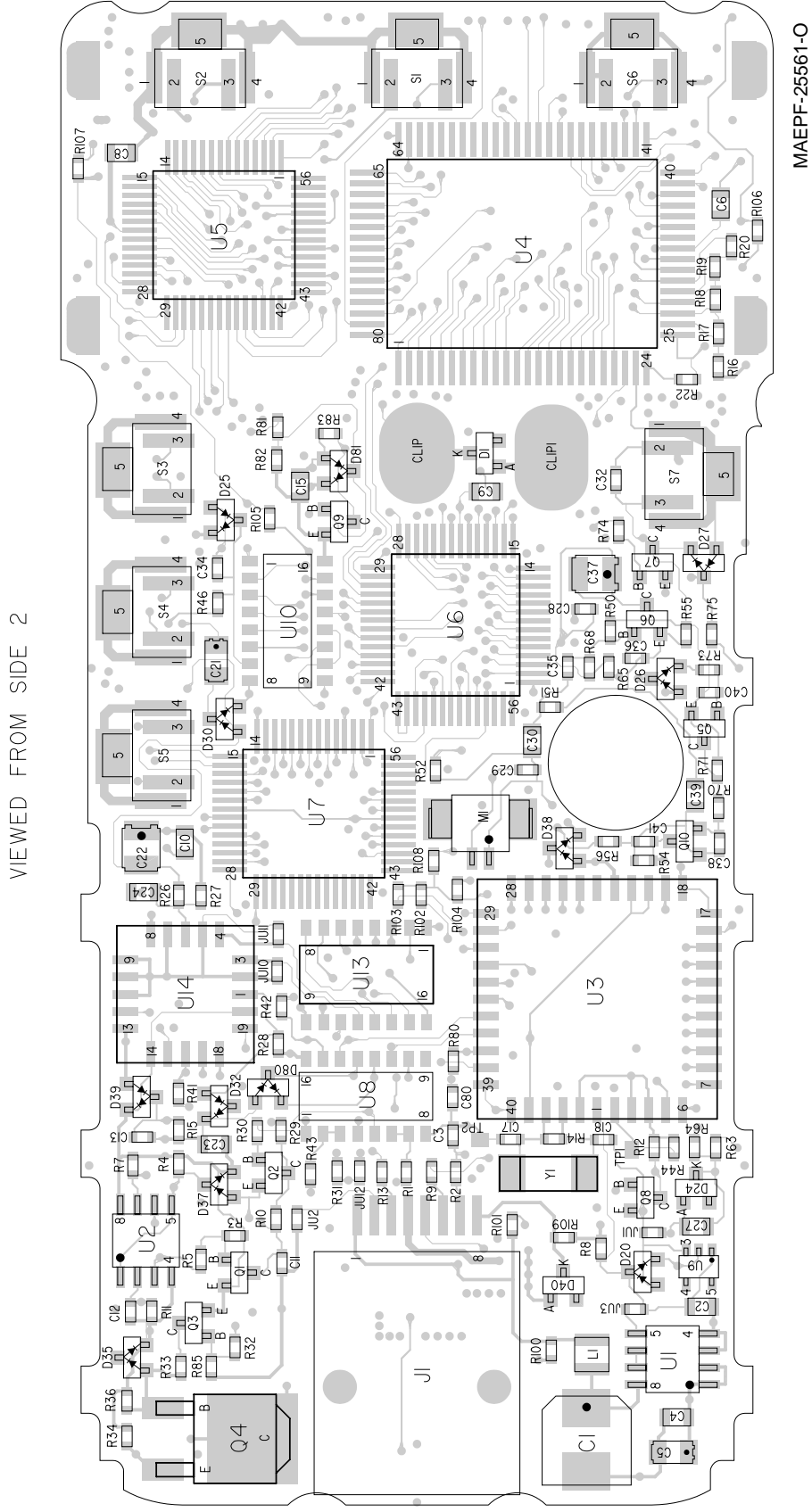

*(Viewed from Side 2)  
(For reference only - board is not field-repairable)*

Figure 8-3. HMN4044E W3 Control Head Component Location Diagram



**HMN4044E Parts List**  
**(For reference only - board is not field-repairable)**

ITEM	MOTOROLA PART NUMBER	DESCRIPTION
C1	2380090M24	10µF ± 20%; 50V
C2	2113743A19	0.1µF
C3	2113740F51	100pF
C4	2113743A19	0.1µF
C5	2311049A07	1µF ± 1%; 16V
C6	2113743A19	0.1µF
C8-C10	2113743A19	0.1µF
C11	2113740F51	100pF
C12	2113741F25	1000pF
C13	2113740F51	100pF
C15	2113743A19	0.1µF
C17-C18	2113740F37	27pF
C21	2311049A07	1µF ± 1%; 16V
C22	2311049A57	10µF ±1%;
C23	2113743A19	0.1µF
C24	2113743A19	0.1µF
C27	2113741A61	.047µF
C28-C29	2113741F25	1000pF
C30	2113741A61	.047µF
C32	2113741F25	1000pF
C34-C35	2113741F49	.010µF
C36	2113741F25	1000pF
C37	2311049A57	10µF ±1%; 16V
C38	2113741F25	1000pF
C39	2113743A19	0.1µF
C40	2113741F25	1000pF
C41	2113740F59	220pF
C80	2113741F25	1000pF
D1	4813830A15	Zener; 5.6V
D3-D16	4805729G75	LED Green
D17-D18	4805729G85	LED Green
D19	4805729G82	LED Yellow

ITEM	MOTOROLA PART NUMBER	DESCRIPTION
D21	4805729G83	LED Green
D22	4805729G81	LED Red
D24	4880140L25	20V
D25-D27	4813833C05	Dual; 70V
D28-D29	4805729G85	LED Green
D30	4813833C05	Dual; 70V
D32	4813833C05	Dual; 70V
D35	4813833C05	Dual; 70V
D37-D39	4813833C05	Dual; 70V
D80-D81	4813833C05	Dual; 70V
J1	0984875T03	Jack
L1	2480140E01	1.2µH
P1	2809926G01	Header
Q1	4805128M12	SOT
Q2	4880214G02	MMBT 3904
Q3	4805128M12	SOT
Q4	4805780V01	
Q5-Q8	4880214G02	MMBT 3904
Q9	4805128M12	SOT
Q10	4880214G02	MMBT 3904
R1	0662057A33	220
R2	0662057A18	51
R3	0662057A53	1.5k
R4	0662057A65	4.7k
R5	0662057A61	3.3k
R7	0662057A65	4.7k
R8	0662057A75	12k
R9	0662057A18	51
R10	0662057A65	4.7k
R11-R12	0662057A97	100k
R13	0662057A18	51
R14	0662057A97	100k
R15	0662057A65	4.7k

ITEM	MOTOROLA PART NUMBER	DESCRIPTION
R16-R20	0662057A81	22k
R22	0662057A97	100k
R26-R27	0662057B22	1M
R28-R29	0662057A97	100k
R30	0662057A81	22k
R31	0662057A97	100k
R32	0662057A81	22k
R33	0662057A53	1.5k
R34	0662057A01	10
R36	0662057A97	100k
R41	0662057A97	100k
R42-R43	0662057A33	220
R44	0662057A65	4.7k
R46	0662057B22	1M
R50	0662057B10	330k
R51	0662057A65	4.7k
R52	0662057A57	2.2k
R54	0662057B02	150k
R55	0662057A75	12k
R56	0662057A97	100k
R63	0662057A01	10
R64	0662057B47	0
R65	0662057A61	3.3k
R68	0662057B02	150k
R70	0662057A15	39
R71	0662057A57	2.2k
R73-R74	0662057A81	22k
R75	0662057A53	1.5k
R80-R81	0662057A97	100k
R82	0662057A81	22k
R83	0662057A97	100k
R100-R105	0662057A33	220
R106-R107	0662057A15	39

ITEM	MOTOROLA PART NUMBER	DESCRIPTION
R108	0662057A33	220
R109	0662057A69	6.8k
S1-S7	4005840X01	
U1	5105469E65	Voltage Regulator
U2	51056663U34	IC Comparator
U3	5113802A07	IC Comparator µP
U4	5102074D01	LDC
U5-U7	5102074D01	Driver
U8	5113805A75	8-Bit Shift Register
U9	5105625U63	IC Voltage Detector
U10	5113805A74	Shift Register
U13	0604267J01	In-line Resistor Package
U14	5102073D01	Analog/Digital Converter
Y1	4880065M01	Resonator; 4.0 MHz

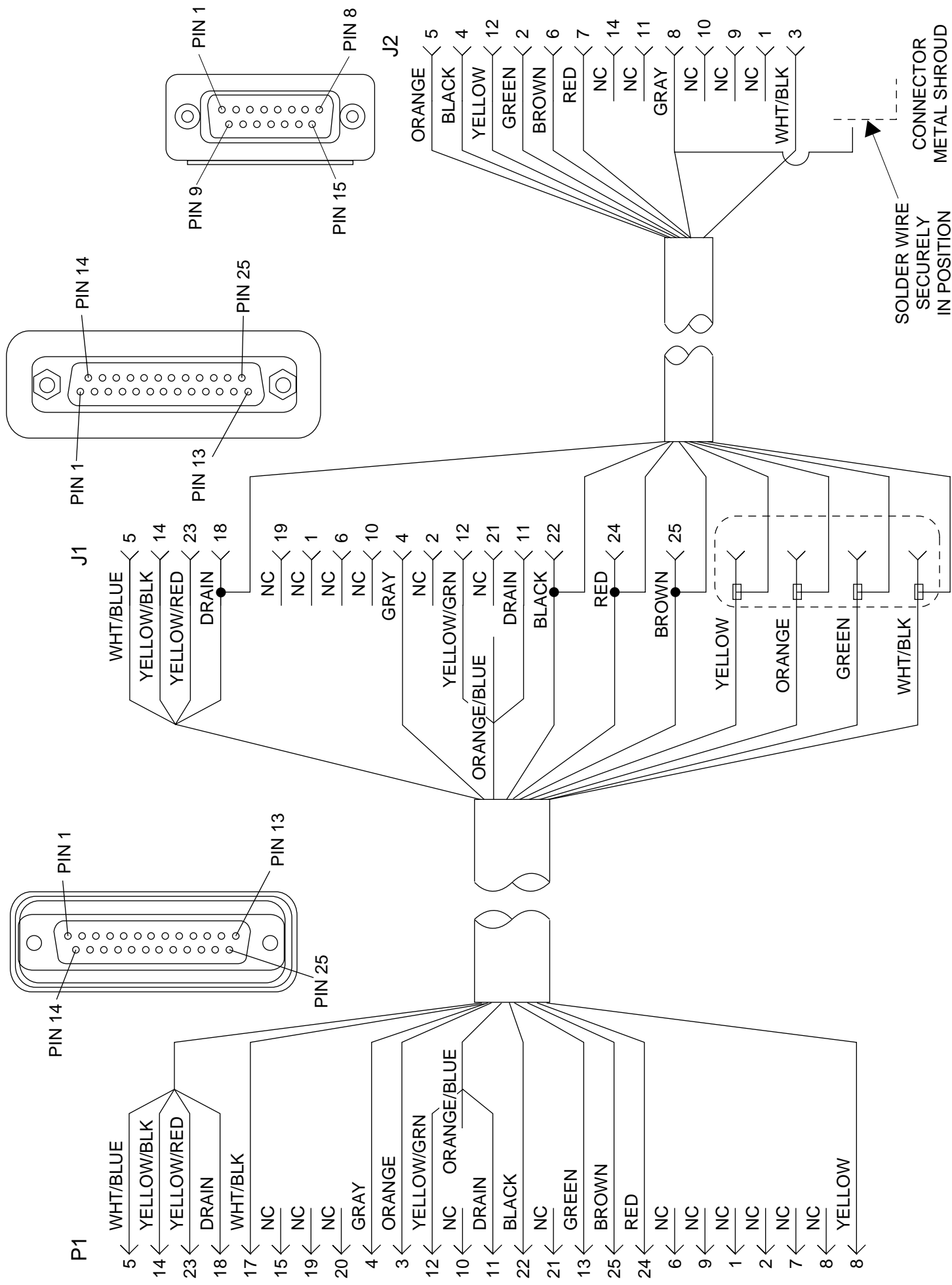
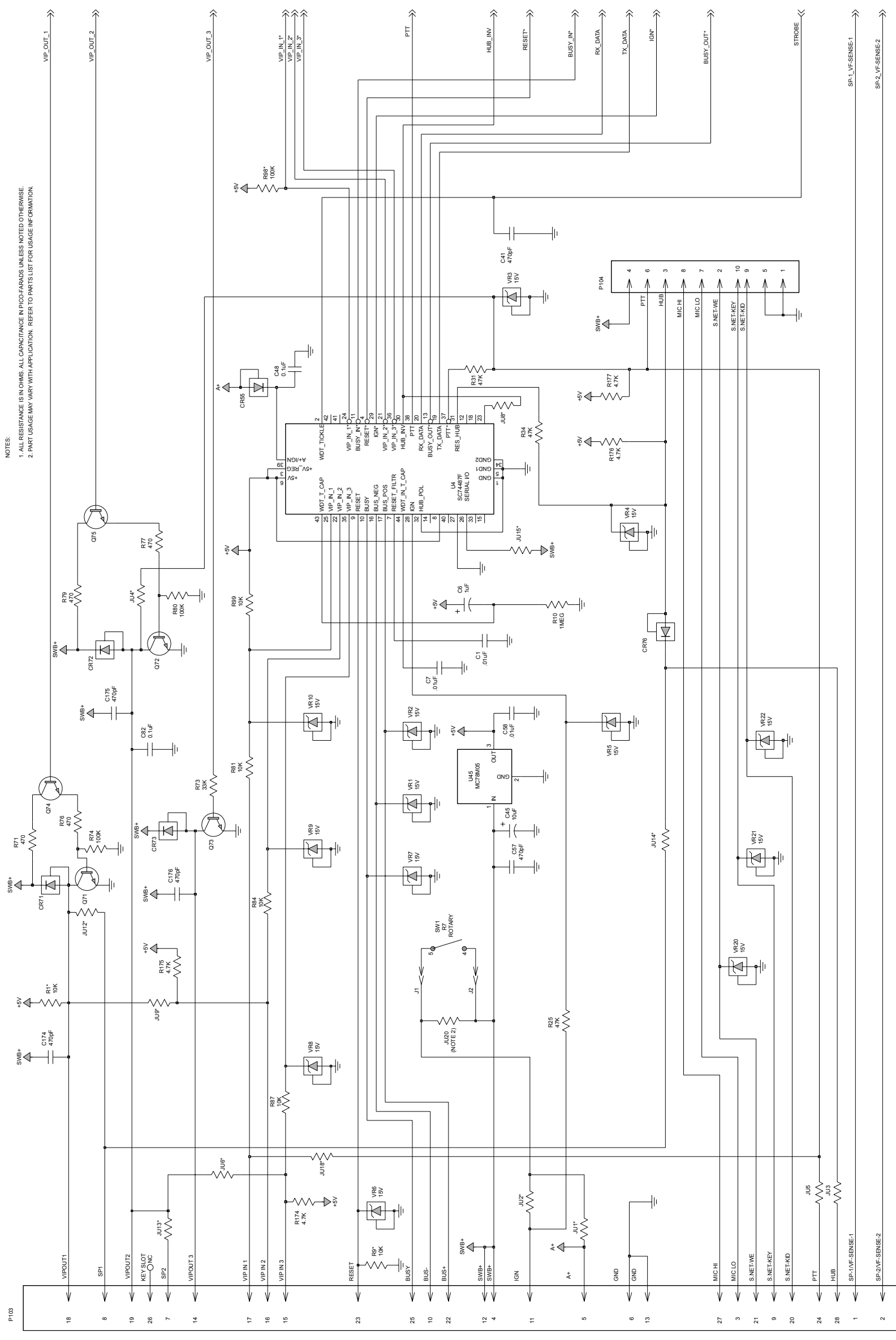

Figure 8-4. HKN6096B Remote "Y" Cable Wiring Diagram



NOTES:  
 1. ALL RESISTANCE IS IN OHMS. ALL CAPACITANCE IN PICO-FARADS, UNLESS NOTED OTHERWISE.  
 2. PART USAGE MAY VARY WITH APPLICATION. REFER TO PARTS LIST FOR USAGE INFORMATION.

Figure 8-5. AAHN4045F/G (Standard), HLN4071A/B (Rear), PMLN4019C/D (Motorcycle) W4 Control Head Schematic (Sheet 1 of 2)

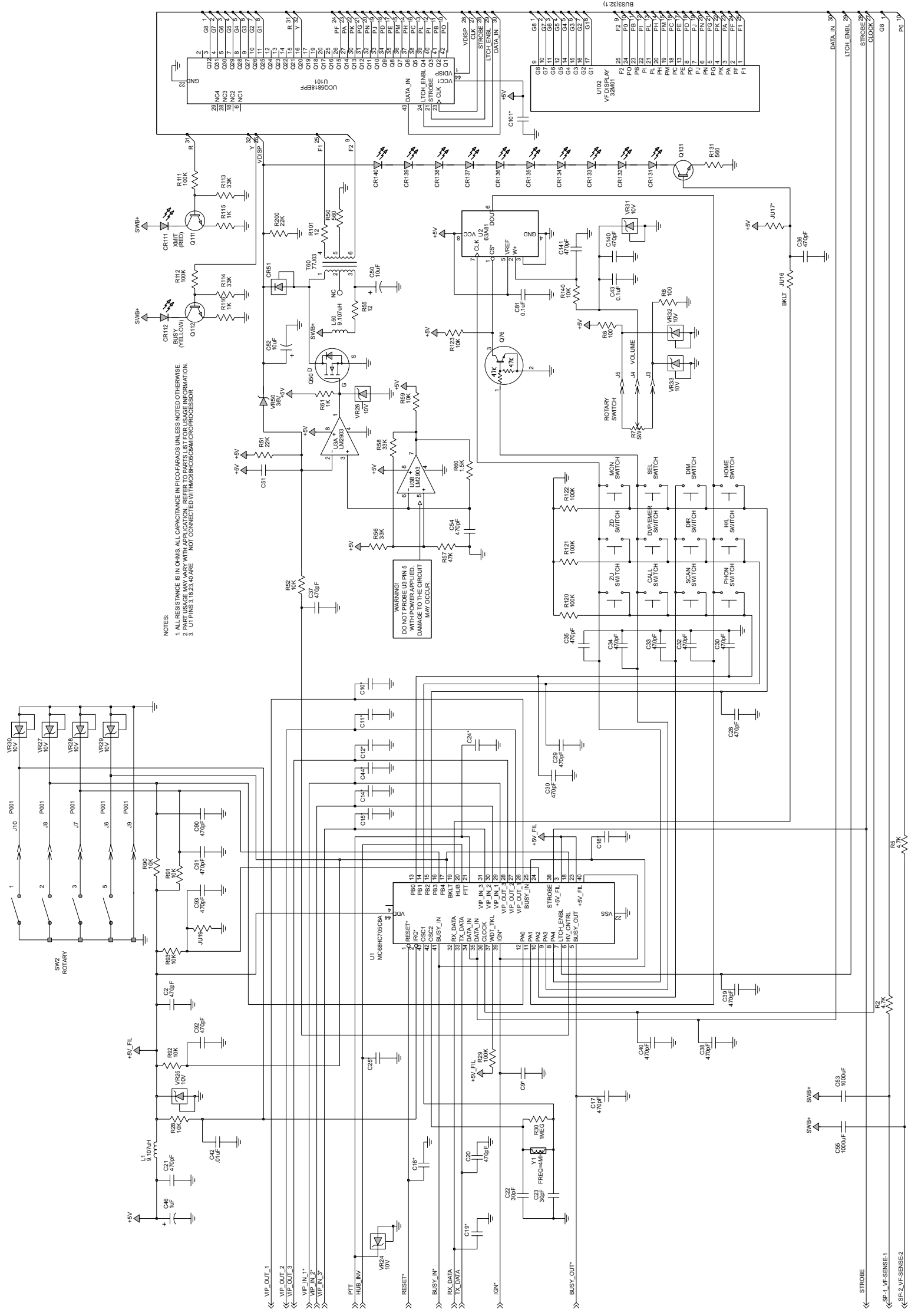
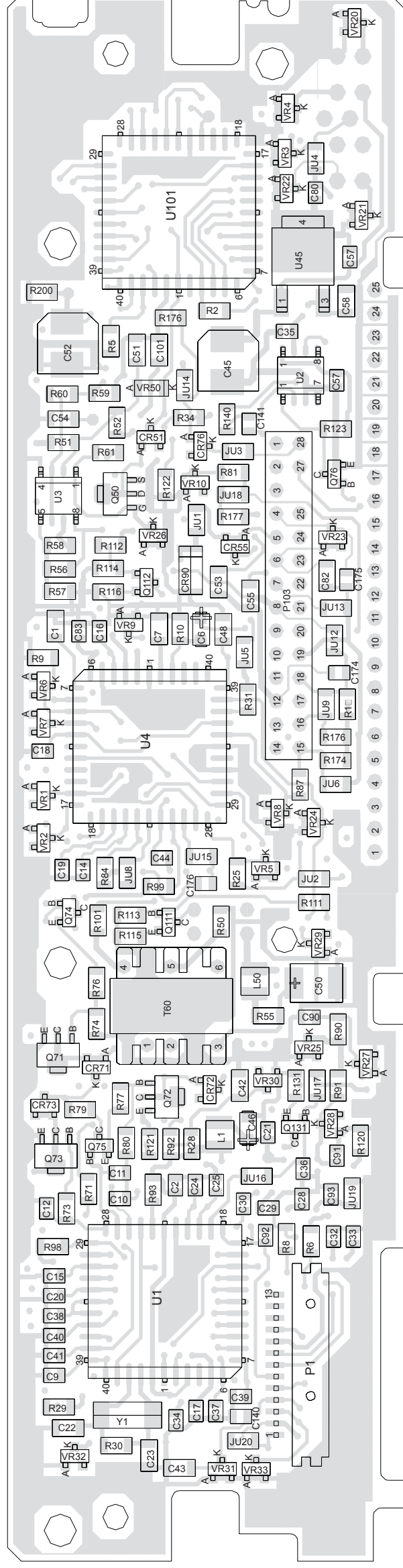

Figure 8-6. AAHN4045F/G (Standard), HLN4071A/B (Rear), PMLN4019C/D (Motorcycle) W4 Control Head Schematic (Sheet 2 of 2)

**SIDE 1**



**SIDE 2**

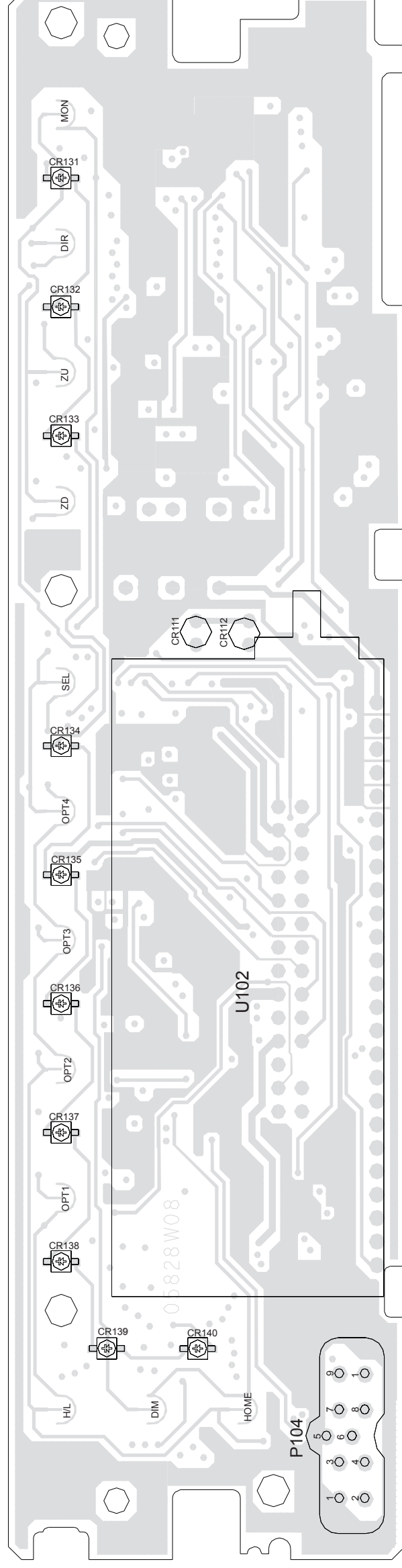

Figure 8-7. AAHN4045 (Standard), HLN4071 (Rear), PMLN4019 (Motorcycle) W4 Control Head Component Location Diagram

## AAHN4045G Standard Parts List

ITEM	MOTOROLA PART NUMBER	DESCRIPTION
C1	2113741N45	CAP CHIP CL2 X7R 10% 10000
C10	2113741M13	CAP CHIP CL2 X7R 10% 470
C101	2113740B65	CAP CHIP REEL CL1 +/-30 470
C11	2113741M13	CAP CHIP CL2 X7R 10% 470
C12	2113741M13	CAP CHIP CL2 X7R 10% 470
C14	2113741M13	CAP CHIP CL2 X7R 10% 470
C140	2113741M13	CAP CHIP CL2 X7R 10% 470
C141	2113741M13	CAP CHIP CL2 X7R 10% 470
C15	2113741M13	CAP CHIP CL2 X7R 10% 470
C16	2113741M13	CAP CHIP CL2 X7R 10% 470
C17	2113741M13	CAP CHIP CL2 X7R 10% 470
C174	2113741M13	CAP CHIP CL2 X7R 10% 470
C175	2113741M13	CAP CHIP CL2 X7R 10% 470
C176	2113741M13	CAP CHIP CL2 X7R 10% 470
C18	2113741M13	CAP CHIP CL2 X7R 10% 470
C19	2113741M13	CAP CHIP CL2 X7R 10% 470
C2	2113741M13	CAP CHIP CL2 X7R 10% 470
C20	2113741M13	CAP CHIP CL2 X7R 10% 470
C21	2113741M13	CAP CHIP CL2 X7R 10% 470
C22	2113740B36	CAP CHIP REEL CL1 +/-30 30
C23	2113740B36	CAP CHIP REEL CL1 +/-30 30
C24	2113741M13	CAP CHIP CL2 X7R 10% 470
C25	2113741M13	CAP CHIP CL2 X7R 10% 470
C28	2113741M13	CAP CHIP CL2 X7R 10% 470
C29	2113741M13	CAP CHIP CL2 X7R 10% 470
C30	2113741M13	CAP CHIP CL2 X7R 10% 470
C32	2113741M13	CAP CHIP CL2 X7R 10% 470
C33	2113741M13	CAP CHIP CL2 X7R 10% 470
C34	2113741M13	CAP CHIP CL2 X7R 10% 470
C35	2113741M13	CAP CHIP CL2 X7R 10% 470
C36	2113741M13	CAP CHIP CL2 X7R 10% 470
C37	2113741M13	CAP CHIP CL2 X7R 10% 470

ITEM	MOTOROLA PART NUMBER	DESCRIPTION
C38	2113741M13	CAP CHIP CL2 X7R 10% 470
C39	2113741M13	CAP CHIP CL2 X7R 10% 470
C40	2113741M13	CAP CHIP CL2 X7R 10% 470
C41	2113741M13	CAP CHIP CL2 X7R 10% 470
C42	2113741N45	CAP CHIP CL2 X7R 10% 10000
C43	2113741N69	CAP CHIP CL2 X7R 10%
C44	2113741M13	CAP CHIP CL2 X7R 10% 470
C45	2380090M24	CAP ALU 10 20 50V SURF MT
C46	2311049A37	CAP TANT CHIP 1 20 20
C48	2113741N69	CAP CHIP CL2 X7R 10%
C50	2311049A95	CAP TANT CHIP 10 UF 25V 10%
C51	2113741N21	CAP CHIP CL2 X7R 10% 1000
C52	2380090M24	CAP ALU 10 20 50V SURF MT
C53	2113741N21	CAP CHIP CL2 X7R 10% 1000
C54	2113740B65	CAP CHIP REEL CL1 +/-30 470
C55	2113741N21	CAP CHIP CL2 X7R 10% 1000
C57	2113741M13	CAP CHIP CL2 X7R 10% 470
C58	2113741N45	CAP CHIP CL2 X7R 10% 10000
C6	2311049A37	CAP TANT CHIP 1 20 20
C7	2113741N45	CAP CHIP CL2 X7R 10% 10000
C80	NOTPLACED	64AM DUMMY PART NUMBER
C81	2113743A19	CAP CHIP .100 UF 10% X7R
C82	NOTPLACED	64AM DUMMY PART NUMBER
C83	2113743A19	CAP CHIP .100 UF 10% X7R
C9	2113741M13	CAP CHIP CL2 X7R 10% 470
C90	2113741M13	CAP CHIP CL2 X7R 10% 470
C91	2113741M13	CAP CHIP CL2 X7R 10% 470
C92	2113741M13	CAP CHIP CL2 X7R 10% 470
C93	2113741M13	CAP CHIP CL2 X7R 10% 470
CR0076	4813833C09	DIODE GEN PURP .1A 100V 'DX'
CR111	4880026P01	DIODE LED RED

ITEM	MOTOROLA PART NUMBER	DESCRIPTION
CR112	4880026P02	DIODE LED YELLOW
CR131	4880052R03	DIODE LIGHT EMITTING GRN
CR132	4880052R03	DIODE LIGHT EMITTING GRN
CR133	4880052R03	DIODE LIGHT EMITTING GRN
CR134	4880052R03	DIODE LIGHT EMITTING GRN
CR135	4880052R03	DIODE LIGHT EMITTING GRN
CR136	4880052R03	DIODE LIGHT EMITTING GRN
CR137	4880052R03	DIODE LIGHT EMITTING GRN
CR138	4880052R03	DIODE LIGHT EMITTING GRN
CR139	4880052R03	DIODE LIGHT EMITTING GRN
CR140	4880052R03	DIODE LIGHT EMITTING GRN
CR51	4813833C09	DIODE GEN PURP .1A 100V 'DX'
CR55	4813833C09	DIODE GEN PURP .1A 100V 'DX'
CR71	4813833C09	DIODE GEN PURP .1A 100V 'DX'
CR72	4813833C09	DIODE GEN PURP .1A 100V 'DX'
CR73	4813833C09	DIODE GEN PURP .1A 100V 'DX'
CR90	4882960R02	DIODE RECT 48R82960R01 A/P
JU1	NOTPLACED	64AM DUMMY PART NUMBER
JU12	NOTPLACED	64AM DUMMY PART NUMBER
JU13	NOTPLACED	64AM DUMMY PART NUMBER
JU14	NOTPLACED	64AM DUMMY PART NUMBER
JU15	NOTPLACED	64AM DUMMY PART NUMBER
JU16	0611077A01	RES CHIP JUMPER
JU17	NOTPLACED	64AM DUMMY PART NUMBER
JU18	NOTPLACED	64AM DUMMY PART NUMBER
JU19	NOTPLACED	64AM DUMMY PART NUMBER
JU2	0611077A01	RES CHIP JUMPER
JU20	NOTPLACED	64AM DUMMY PART NUMBER
JU3	0611077A01	RES CHIP JUMPER
JU4	NOTPLACED	64AM DUMMY PART NUMBER
JU5	0611077A01	RES CHIP JUMPER

ITEM	MOTOROLA PART NUMBER	DESCRIPTION
JU6	NOTPLACED	64AM DUMMY PART NUMBER
JU8	NOTPLACED	64AM DUMMY PART NUMBER
JU9	NOTPLACED	64AM DUMMY PART NUMBER
L1	2480140E16	INDUCTOR CHIP 10UH
L50	2480140E16	INDUCTOR CHIP 10UH
P001	0905573P02	SKT 13 POSTN
P103	2880102M07	PLUG VERTICAL 28 POSITION
P104	2880068M01	HEADER MIC
Q111	4813824A10	TSTR NPN 40V .2A GEN PURP
Q112	4813824A10	TSTR NPN 40V .2A GEN PURP
Q131	4813824A10	TSTR NPN 40V .2A GEN PURP
Q50	4880053M03	TSTR N/CH SOT 89 200V B ST 84
Q71	4880053M02	TSTR NPN MXT2222A
Q72	4880053M02	TSTR NPN MXT2222A
Q73	4880053M02	TSTR NPN MXT2222A
Q74	4813824A10	TSTR NPN 40V .2A GEN PURP
Q75	4813824A10	TSTR NPN 40V .2A GEN PURP
Q76	4880048M01	TSTR NPN DIG 47K/47K
R1	NOTPLACED	64AM DUMMY PART NUMBER
R10	0611077B47	RES CHIP 1 MEG 5 1/8W
R101	0611077A28	RES CHIP 12 5 1/8W
R111	0611077B23	RES CHIP 100K 5 1/8W
R112	0611077B23	RES CHIP 100K 5 1/8W
R113	0611077B11	RES CHIP 33K 5 1/8W
R114	0611077B11	RES CHIP 33K 5 1/8W
R115	0611077A74	RES CHIP 1000 5 1/8
R116	0611077A74	RES CHIP 1000 5 1/8
R120	0611077B23	RES CHIP 100K 5 1/8W
R121	0611077B23	RES CHIP 100K 5 1/8W
R122	0611077B23	RES CHIP 100K 5 1/8W
R123	0611077A98	RES CHIP 10K 5 1/8W
R131	0611077A68	RES CHIP 560 5 1/8W
R140	0611077A98	RES CHIP 10K 5 1/8W

ITEM	MOTOROLA PART NUMBER	DESCRIPTION
R174	0611077A90	RES CHIP 4700 5 1/8
R175	0611077A90	RES CHIP 4700 5 1/8
R176	0611077A90	RES CHIP 4700 5 1/8
R177	0611077A90	RES CHIP 4700 5 1/8
R2	0611077A90	RES CHIP 4700 5 1/8
R200	0611077B07	RES CHIP 22K 5 1/8W
R25	0611077B15	RES CHIP 47K 5 1/8W
R28	0611077A98	RES CHIP 10K 5 1/8W
R29	0611077B23	RES CHIP 100K 5 1/8W
R30	0611077B47	RES CHIP 1 MEG 5 1/8W
R31	0611077B15	RES CHIP 47K 5 1/8W
R34	0611077B15	RES CHIP 47K 5 1/8W
R5	0611077A90	RES CHIP 4700 5 1/8
R50	0611077A68	RES CHIP 560 5 1/8W
R51	0611077B07	RES CHIP 22K 5 1/8W
R52	0611077A98	RES CHIP 10K 5 1/8W
R55	0611077A28	RES CHIP 12 5 1/8W
R56	0611077B11	RES CHIP 33K 5 1/8W
R57	0611077B15	RES CHIP 47K 5 1/8W
R58	0611077B11	RES CHIP 33K 5 1/8W
R59	0611077A98	RES CHIP 10K 5 1/8W
R6	0611077A50	RES CHIP 100 5 1/8W
R60	0611077A78	RES CHIP 1500 5 1/8
R61	0611077A74	RES CHIP 1000 5 1/8
R71	0611077A66	RES CHIP 470 5 1/8W
R73	0611077B11	RES CHIP 33K 5 1/8W
R74	0611077B23	RES CHIP 100K 5 1/8W
R76	0611077A66	RES CHIP 470 5 1/8W
R77	0611077A66	RES CHIP 470 5 1/8W
R79	0611077A66	RES CHIP 470 5 1/8W
R8	0611077A50	RES CHIP 100 5 1/8W
R80	0611077B23	RES CHIP 100K 5 1/8W
R81	0611077A98	RES CHIP 10K 5 1/8W

ITEM	MOTOROLA PART NUMBER	DESCRIPTION
R84	0611077A98	RES CHIP 10K 5 1/8W
R87	0611077A98	RES CHIP 10K 5 1/8W
R9	NOTPLACED	64AM DUMMY PART NUMBER
R90	0611077A98	RES CHIP 10K 5 1/8W
R91	0611077A98	RES CHIP 10K 5 1/8W
R92	0611077A98	RES CHIP 10K 5 1/8W
R93	0611077A98	RES CHIP 10K 5 1/8W
R98	NOTPLACED	64AM DUMMY PART NUMBER
R99	0611077A98	RES CHIP 10K 5 1/8W
T60	2580277J03	XFMR VLTG CONVERSION
U1	0104002J91	PRGMD MICROP ASSEM
U101	5180236C05	IC VF DRVR SN75518FN
U102	7280032M01	DSPLY VF 14 SEG 8 CHAR BLUGRN
U2	5185963A81	MODE 8-BIT SER I/O TLC0831DR
U3	5113820A02	IC DUJAL SING SPLY LO PWR 2903
U4	5180057S04	"IC CUST SER I/O 13" REEL"
U45	5113816G04	IC +5V REG 78M05
VR1	4813830A28	DIODE 15V 5% 225MW MMBZ5245B_
VR10	4813830A28	DIODE 15V 5% 225MW MMBZ5245B_
VR2	4813830A28	DIODE 15V 5% 225MW MMBZ5245B_
VR20	4813830A28	DIODE 15V 5% 225MW MMBZ5245B_
VR21	4813830A28	DIODE 15V 5% 225MW MMBZ5245B_
VR22	4813830A28	DIODE 15V 5% 225MW MMBZ5245B_
VR23	NOTPLACED	64AM DUMMY PART NUMBER
VR24	4813830A23	DIODE 10V 5% 225MW MMBZ5240B_
VR25	4813830A23	DIODE 10V 5% 225MW MMBZ5240B_
VR26	4813830A23	DIODE 10V 5% 225MW MMBZ5240B_

ITEM	MOTOROLA PART NUMBER	DESCRIPTION
VR27	4813830A23	DIODE 10V 5% 225MW MMBZ5240B_
VR28	4813830A23	DIODE 10V 5% 225MW MMBZ5240B_
VR29	4813830A23	DIODE 10V 5% 225MW MMBZ5240B_
VR3	4813830A28	DIODE 15V 5% 225MW MMBZ5245B_
VR30	4813830A23	DIODE 10V 5% 225MW MMBZ5240B_
VR31	4813830A23	DIODE 10V 5% 225MW MMBZ5240B_
VR32	4813830A23	DIODE 10V 5% 225MW MMBZ5240B_
VR33	4813830A23	DIODE 10V 5% 225MW MMBZ5240B_
VR4	4813830A28	DIODE 15V 5% 225MW MMBZ5245B_
VR5	4813830A28	DIODE 15V 5% 225MW MMBZ5245B_
VR50	4813830C41	DIODE 36V 'M3' MMSZ5258BT1
VR6	4813830A28	DIODE 15V 5% 225MW MMBZ5245B_
VR7	4813830A28	DIODE 15V 5% 225MW MMBZ5245B_
VR8	4813830A28	DIODE 15V 5% 225MW MMBZ5245B_
VR9	4813830A28	DIODE 15V 5% 225MW MMBZ5245B_
Y1	4880065M01	RESONTR CERAMIC 4.00 MHZ

## HCN4071B Rear Parts List

ITEM	MOTOROLA PART NUMBER	DESCRIPTION
C1	2113741N45	CAP CHIP CL2 X7R 10% 10000
C10	2113741M13	CAP CHIP CL2 X7R 10% 470
C101	2113740B65	CAP CHIP REEL CL1 +/-30 470
C11	2113741M13	CAP CHIP CL2 X7R 10% 470
C12	2113741M13	CAP CHIP CL2 X7R 10% 470
C14	2113741M13	CAP CHIP CL2 X7R 10% 470
C140	2113741M13	CAP CHIP CL2 X7R 10% 470
C141	2113741M13	CAP CHIP CL2 X7R 10% 470
C15	2113741M13	CAP CHIP CL2 X7R 10% 470
C16	2113741M13	CAP CHIP CL2 X7R 10% 470
C17	2113741M13	CAP CHIP CL2 X7R 10% 470
C174	2113741M13	CAP CHIP CL2 X7R 10% 470
C175	2113741M13	CAP CHIP CL2 X7R 10% 470
C176	2113741M13	CAP CHIP CL2 X7R 10% 470
C18	2113741M13	CAP CHIP CL2 X7R 10% 470
C19	2113741M13	CAP CHIP CL2 X7R 10% 470
C2	2113741M13	CAP CHIP CL2 X7R 10% 470
C20	2113741M13	CAP CHIP CL2 X7R 10% 470
C21	2113741M13	CAP CHIP CL2 X7R 10% 470
C22	2113740B36	CAP CHIP REEL CL1 +/-30 30
C23	2113740B36	CAP CHIP REEL CL1 +/-30 30
C24	2113741M13	CAP CHIP CL2 X7R 10% 470
C25	2113741M13	CAP CHIP CL2 X7R 10% 470
C28	2113741M13	CAP CHIP CL2 X7R 10% 470
C29	2113741M13	CAP CHIP CL2 X7R 10% 470
C30	2113741M13	CAP CHIP CL2 X7R 10% 470
C32	2113741M13	CAP CHIP CL2 X7R 10% 470
C33	2113741M13	CAP CHIP CL2 X7R 10% 470
C34	2113741M13	CAP CHIP CL2 X7R 10% 470
C35	2113741M13	CAP CHIP CL2 X7R 10% 470
C36	2113741M13	CAP CHIP CL2 X7R 10% 470
C37	2113741M13	CAP CHIP CL2 X7R 10% 470

ITEM	MOTOROLA PART NUMBER	DESCRIPTION
C38	2113741M13	CAP CHIP CL2 X7R 10% 470
C39	2113741M13	CAP CHIP CL2 X7R 10% 470
C40	2113741M13	CAP CHIP CL2 X7R 10% 470
C41	2113741M13	CAP CHIP CL2 X7R 10% 470
C42	2113741N45	CAP CHIP CL2 X7R 10% 10000
C43	2113741N69	CAP CHIP CL2 X7R 10%
C44	2113741M13	CAP CHIP CL2 X7R 10% 470
C45	2380090M24	CAP ALU 10 20 50V SURF MT
C46	2311049A37	CAP TANT CHIP 1 20 20
C48	2113741N69	CAP CHIP CL2 X7R 10%
C50	2311049A95	CAP TANT CHIP 10 UF 25V 10%
C51	2113741N21	CAP CHIP CL2 X7R 10% 1000
C52	2380090M24	CAP ALU 10 20 50V SURF MT
C53	2113741N21	CAP CHIP CL2 X7R 10% 1000
C54	2113740B65	CAP CHIP REEL CL1 +/-30 470
C55	2113741N21	CAP CHIP CL2 X7R 10% 1000
C57	2113741M13	CAP CHIP CL2 X7R 10% 470
C58	2113741N45	CAP CHIP CL2 X7R 10% 10000
C6	2311049A37	CAP TANT CHIP 1 20 20
C7	2113741N45	CAP CHIP CL2 X7R 10% 10000
C80	NOTPLACED	64AM DUMMY PART NUMBER
C81	2113743A19	CAP CHIP .100 UF 10% X7R
C82	NOTPLACED	64AM DUMMY PART NUMBER
C83	2113743A19	CAP CHIP .100 UF 10% X7R
C9	2113741M13	CAP CHIP CL2 X7R 10% 470
C90	2113741M13	CAP CHIP CL2 X7R 10% 470
C91	2113741M13	CAP CHIP CL2 X7R 10% 470
C92	2113741M13	CAP CHIP CL2 X7R 10% 470
C93	2113741M13	CAP CHIP CL2 X7R 10% 470
CR0076	4813833C09	DIODE GEN PURP .1A 100V 'DX'
CR111	4880026P01	DIODE LED RED

ITEM	MOTOROLA PART NUMBER	DESCRIPTION
CR112	4880026P02	DIODE LED YELLOW
CR131	4880052R03	DIODE LIGHT EMITTING GRN
CR132	4880052R03	DIODE LIGHT EMITTING GRN
CR133	4880052R03	DIODE LIGHT EMITTING GRN
CR134	4880052R03	DIODE LIGHT EMITTING GRN
CR135	4880052R03	DIODE LIGHT EMITTING GRN
CR136	4880052R03	DIODE LIGHT EMITTING GRN
CR137	4880052R03	DIODE LIGHT EMITTING GRN
CR138	4880052R03	DIODE LIGHT EMITTING GRN
CR139	4880052R03	DIODE LIGHT EMITTING GRN
CR140	4880052R03	DIODE LIGHT EMITTING GRN
CR51	4813833C09	DIODE GEN PURP .1A 100V 'DX'
CR55	4813833C09	DIODE GEN PURP .1A 100V 'DX'
CR71	4813833C09	DIODE GEN PURP .1A 100V 'DX'
CR72	4813833C09	DIODE GEN PURP .1A 100V 'DX'
CR73	4813833C09	DIODE GEN PURP .1A 100V 'DX'
CR90	4882960R02	DIODE RECT 48R82960R01 A/P
JU1	0611077A01	RES CHIP JUMPER
JU12	NOTPLACED	64AM DUMMY PART NUMBER
JU13	NOTPLACED	64AM DUMMY PART NUMBER
JU14	NOTPLACED	64AM DUMMY PART NUMBER
JU15	NOTPLACED	64AM DUMMY PART NUMBER
JU16	0611077A01	RES CHIP JUMPER
JU17	NOTPLACED	64AM DUMMY PART NUMBER
JU18	NOTPLACED	64AM DUMMY PART NUMBER
JU19	0611077A01	RES CHIP JUMPER
JU2	0611077A01	RES CHIP JUMPER
JU20	0611077A01	RES CHIP JUMPER
JU3	0611077A01	RES CHIP JUMPER
JU4	NOTPLACED	64AM DUMMY PART NUMBER
JU5	0611077A01	RES CHIP JUMPER

ITEM	MOTOROLA PART NUMBER	DESCRIPTION
JU6	NOTPLACED	64AM DUMMY PART NUMBER
JU8	NOTPLACED	64AM DUMMY PART NUMBER
JU9	NOTPLACED	64AM DUMMY PART NUMBER
L1	2480140E16	INDUCTOR CHIP 10UH
L50	2480140E16	INDUCTOR CHIP 10UH
P001	0905573P02	SKT 13 POSTN
P103	2880102M07	PLUG VERTICAL 28 POSITION
P104	2880068M01	HEADER MIC
Q111	4813824A10	TSTR NPN 40V .2A GEN PURP
Q112	4813824A10	TSTR NPN 40V .2A GEN PURP
Q131	4813824A10	TSTR NPN 40V .2A GEN PURP
Q50	4880053M03	TSTR N/CH SOT 89 200V B ST 84
Q71	4880053M02	TSTR NPN MXT2222A
Q72	4880053M02	TSTR NPN MXT2222A
Q73	4880053M02	TSTR NPN MXT2222A
Q74	4813824A10	TSTR NPN 40V .2A GEN PURP
Q75	4813824A10	TSTR NPN 40V .2A GEN PURP
Q76	4880048M01	TSTR NPN DIG 47K/47K
R1	NOTPLACED	64AM DUMMY PART NUMBER
R10	0611077B47	RES CHIP 1 MEG 5 1/8W
R101	0611077A28	RES CHIP 12 5 1/8W
R111	0611077B23	RES CHIP 100K 5 1/8W
R112	0611077B23	RES CHIP 100K 5 1/8W
R113	0611077B11	RES CHIP 33K 5 1/8W
R114	0611077B11	RES CHIP 33K 5 1/8W
R115	0611077A74	RES CHIP 1000 5 1/8
R116	0611077A74	RES CHIP 1000 5 1/8
R120	0611077B23	RES CHIP 100K 5 1/8W
R121	0611077B23	RES CHIP 100K 5 1/8W
R122	0611077B23	RES CHIP 100K 5 1/8W
R123	0611077A98	RES CHIP 10K 5 1/8W
R131	0611077A68	RES CHIP 560 5 1/8W
R140	0611077A98	RES CHIP 10K 5 1/8W



ITEM	MOTOROLA PART NUMBER	DESCRIPTION
R174	0611077A90	RES CHIP 4700 5 1/8
R175	0611077A90	RES CHIP 4700 5 1/8
R176	0611077A90	RES CHIP 4700 5 1/8
R177	0611077A90	RES CHIP 4700 5 1/8
R2	0611077A90	RES CHIP 4700 5 1/8
R200	0611077B07	RES CHIP 22K 5 1/8W
R25	0611077B15	RES CHIP 47K 5 1/8W
R28	0611077A98	RES CHIP 10K 5 1/8W
R29	0611077B23	RES CHIP 100K 5 1/8W
R30	0611077B47	RES CHIP 1 MEG 5 1/8W
R31	0611077B15	RES CHIP 47K 5 1/8W
R34	0611077B15	RES CHIP 47K 5 1/8W
R5	0611077A90	RES CHIP 4700 5 1/8
R50	0611077A68	RES CHIP 560 5 1/8W
R51	0611077B07	RES CHIP 22K 5 1/8W
R52	0611077A98	RES CHIP 10K 5 1/8W
R55	0611077A28	RES CHIP 12 5 1/8W
R56	0611077B11	RES CHIP 33K 5 1/8W
R57	0611077B15	RES CHIP 47K 5 1/8W
R58	0611077B11	RES CHIP 33K 5 1/8W
R59	0611077A98	RES CHIP 10K 5 1/8W
R6	0611077A50	RES CHIP 100 5 1/8W
R60	0611077A78	RES CHIP 1500 5 1/8
R61	0611077A74	RES CHIP 1000 5 1/8
R71	0611077A66	RES CHIP 470 5 1/8W
R73	0611077B11	RES CHIP 33K 5 1/8W
R74	0611077B23	RES CHIP 100K 5 1/8W
R76	0611077A66	RES CHIP 470 5 1/8W
R77	0611077A66	RES CHIP 470 5 1/8W
R79	0611077A66	RES CHIP 470 5 1/8W
R8	0611077A50	RES CHIP 100 5 1/8W
R80	0611077B23	RES CHIP 100K 5 1/8W
R81	0611077A98	RES CHIP 10K 5 1/8W

ITEM	MOTOROLA PART NUMBER	DESCRIPTION
R84	0611077A98	RES CHIP 10K 5 1/8W
R87	0611077A98	RES CHIP 10K 5 1/8W
R9	NOTPLACED	64AM DUMMY PART NUMBER
R90	0611077A98	RES CHIP 10K 5 1/8W
R91	0611077A98	RES CHIP 10K 5 1/8W
R92	0611077A98	RES CHIP 10K 5 1/8W
R93	0611077A98	RES CHIP 10K 5 1/8W
R98	NOTPLACED	64AM DUMMY PART NUMBER
R99	0611077A98	RES CHIP 10K 5 1/8W
T60	2580277J03	XFMR VLTG CONVERSION
U1	0104002J91	PRGMD MICROP ASSEM
U101	5180236C05	IC VF DRVR SN75518FN
U102	7280032M01	DSPLY VF 14 SEG 8 CHAR BLUGRN
U2	5185963A81	MODE 8-BIT SER I/O TLC0831DR
U3	5113820A02	IC DUJAL SING SPLY LO PWR 2903
U4	5180057S04	"IC CUST SER I/O 13" REEL"
U45	5113816G04	IC +5V REG 78M05
VR1	4813830A28	DIODE 15V 5% 225MW MMBZ5245B_
VR10	4813830A28	DIODE 15V 5% 225MW MMBZ5245B_
VR2	4813830A28	DIODE 15V 5% 225MW MMBZ5245B_
VR20	4813830A28	DIODE 15V 5% 225MW MMBZ5245B_
VR21	4813830A28	DIODE 15V 5% 225MW MMBZ5245B_
VR22	4813830A28	DIODE 15V 5% 225MW MMBZ5245B_
VR23	NOTPLACED	64AM DUMMY PART NUMBER
VR24	4813830A23	DIODE 10V 5% 225MW MMBZ5240B_
VR25	4813830A23	DIODE 10V 5% 225MW MMBZ5240B_
VR26	4813830A23	DIODE 10V 5% 225MW MMBZ5240B_

ITEM	MOTOROLA PART NUMBER	DESCRIPTION
VR27	4813830A23	DIODE 10V 5% 225MW MMBZ5240B_
VR28	4813830A23	DIODE 10V 5% 225MW MMBZ5240B_
VR29	4813830A23	DIODE 10V 5% 225MW MMBZ5240B_
VR3	4813830A28	DIODE 15V 5% 225MW MMBZ5245B_
VR30	4813830A23	DIODE 10V 5% 225MW MMBZ5240B_
VR31	4813830A23	DIODE 10V 5% 225MW MMBZ5240B_
VR32	4813830A23	DIODE 10V 5% 225MW MMBZ5240B_
VR33	4813830A23	DIODE 10V 5% 225MW MMBZ5240B_
VR4	4813830A28	DIODE 15V 5% 225MW MMBZ5245B_
VR5	4813830A28	DIODE 15V 5% 225MW MMBZ5245B_
VR50	4813830C41	DIODE 36V 'M3' MMSZ5258BT1
VR6	4813830A28	DIODE 15V 5% 225MW MMBZ5245B_
VR7	4813830A28	DIODE 15V 5% 225MW MMBZ5245B_
VR8	4813830A28	DIODE 15V 5% 225MW MMBZ5245B_
VR9	4813830A28	DIODE 15V 5% 225MW MMBZ5245B_
Y1	4880065M01	RESONTR CERAMIC 4.00 MHZ

## PMLN4019D Motorcycle Parts List

ITEM	MOTOROLA PART NUMBER	DESCRIPTION
C1	2113741N45	CAP CHIP CL2 X7R 10% 10000
C10	2113741M13	CAP CHIP CL2 X7R 10% 470
C101	2113740B65	CAP CHIP REEL CL1 +/-30 470
C11	2113741M13	CAP CHIP CL2 X7R 10% 470
C12	2113741M13	CAP CHIP CL2 X7R 10% 470
C14	2113741M13	CAP CHIP CL2 X7R 10% 470
C140	2113741M13	CAP CHIP CL2 X7R 10% 470
C141	2113741M13	CAP CHIP CL2 X7R 10% 470
C15	2113741M13	CAP CHIP CL2 X7R 10% 470
C16	2113741M13	CAP CHIP CL2 X7R 10% 470
C17	2113741M13	CAP CHIP CL2 X7R 10% 470
C174	2113741M13	CAP CHIP CL2 X7R 10% 470
C175	2113741M13	CAP CHIP CL2 X7R 10% 470
C176	2113741M13	CAP CHIP CL2 X7R 10% 470
C18	2113741M13	CAP CHIP CL2 X7R 10% 470
C19	2113741M13	CAP CHIP CL2 X7R 10% 470
C2	2113741M13	CAP CHIP CL2 X7R 10% 470
C20	2113741M13	CAP CHIP CL2 X7R 10% 470
C21	2113741M13	CAP CHIP CL2 X7R 10% 470
C22	2113740B36	CAP CHIP REEL CL1 +/-30 30
C23	2113740B36	CAP CHIP REEL CL1 +/-30 30
C24	2113741M13	CAP CHIP CL2 X7R 10% 470
C25	2113741M13	CAP CHIP CL2 X7R 10% 470
C28	2113741M13	CAP CHIP CL2 X7R 10% 470
C29	2113741M13	CAP CHIP CL2 X7R 10% 470
C30	2113741M13	CAP CHIP CL2 X7R 10% 470
C32	2113741M13	CAP CHIP CL2 X7R 10% 470
C33	2113741M13	CAP CHIP CL2 X7R 10% 470
C34	2113741M13	CAP CHIP CL2 X7R 10% 470
C35	2113741M13	CAP CHIP CL2 X7R 10% 470
C36	2113741M13	CAP CHIP CL2 X7R 10% 470
C37	2113741M13	CAP CHIP CL2 X7R 10% 470

ITEM	MOTOROLA PART NUMBER	DESCRIPTION
C38	2113741M13	CAP CHIP CL2 X7R 10% 470
C39	2113741M13	CAP CHIP CL2 X7R 10% 470
C40	2113741M13	CAP CHIP CL2 X7R 10% 470
C41	2113741M13	CAP CHIP CL2 X7R 10% 470
C42	2113741N45	CAP CHIP CL2 X7R 10% 10000
C43	2113741N69	CAP CHIP CL2 X7R 10%
C44	2113741M13	CAP CHIP CL2 X7R 10% 470
C45	2380090M24	CAP ALU 10 20 50V SURF MT
C46	2311049A37	CAP TANT CHIP 1 20 20
C48	2113741N69	CAP CHIP CL2 X7R 10% 100000
C50	2311049A95	CAP TANT CHIP 10 UF 25V 10%
C51	2113741N21	CAP CHIP CL2 X7R 10% 1000
C52	2380090M24	CAP ALU 10 20 50V SURF MT
C53	2113741N21	CAP CHIP CL2 X7R 10% 1000
C54	2113740B65	CAP CHIP REEL CL1 +/-30 470
C55	2113741N21	CAP CHIP CL2 X7R 10% 1000
C57	2113741M13	CAP CHIP CL2 X7R 10% 470
C58	2113741N45	CAP CHIP CL2 X7R 10% 10000
C6	2311049A37	CAP TANT CHIP 1 20 20
C7	2113741N45	CAP CHIP CL2 X7R 10% 10000
C80	NOTPLACED	64AM DUMMY PART NUMBER
C81	2113743A19	CAP CHIP .100 UF 10% X7R
C82	2113741N69	CAP CHIP CL2 X7R 10% 100000
C83	2113743A19	CAP CHIP .100 UF 10% X7R
C9	2113741M13	CAP CHIP CL2 X7R 10% 470
C90	2113741M13	CAP CHIP CL2 X7R 10% 470
C91	2113741M13	CAP CHIP CL2 X7R 10% 470
C92	2113741M13	CAP CHIP CL2 X7R 10% 470
C93	2113741M13	CAP CHIP CL2 X7R 10% 470
CR0076	4813833C09	DIODE GEN PURP .1A 100V 'DX'
CR111	4880026P01	DIODE LED RED

ITEM	MOTOROLA PART NUMBER	DESCRIPTION
CR112	4880026P02	DIODE LED YELLOW
CR131	4880052R03	DIODE LIGHT EMITTING GRN
CR132	4880052R03	DIODE LIGHT EMITTING GRN
CR133	4880052R03	DIODE LIGHT EMITTING GRN
CR134	4880052R03	DIODE LIGHT EMITTING GRN
CR135	4880052R03	DIODE LIGHT EMITTING GRN
CR136	4880052R03	DIODE LIGHT EMITTING GRN
CR137	4880052R03	DIODE LIGHT EMITTING GRN
CR138	4880052R03	DIODE LIGHT EMITTING GRN
CR139	4880052R03	DIODE LIGHT EMITTING GRN
CR140	4880052R03	DIODE LIGHT EMITTING GRN
CR51	4813833C09	DIODE GEN PURP .1A 100V 'DX'
CR55	4813833C09	DIODE GEN PURP .1A 100V 'DX'
CR71	4813833C09	DIODE GEN PURP .1A 100V 'DX'
CR72	NOTPLACED	64AM DUMMY PART NUMBER
CR73	4813833C09	DIODE GEN PURP .1A 100V 'DX'
CR90	4882960R02	DIODE RECT 48R82960R01 A/P
JU1	0611077A01	RES CHIP JUMPER
JU12	NOTPLACED	64AM DUMMY PART NUMBER
JU13	NOTPLACED	64AM DUMMY PART NUMBER
JU14	0611077A01	RES CHIP JUMPER
JU15	NOTPLACED	64AM DUMMY PART NUMBER
JU16	NOTPLACED	64AM DUMMY PART NUMBER
JU17	0611077A01	RES CHIP JUMPER
JU18	0611077A01	RES CHIP JUMPER
JU19	NOTPLACED	64AM DUMMY PART NUMBER
JU2	NOTPLACED	64AM DUMMY PART NUMBER
JU20	NOTPLACED	64AM DUMMY PART NUMBER
JU3	0611077A01	RES CHIP JUMPER
JU4	NOTPLACED	64AM DUMMY PART NUMBER
JU5	0611077A01	RES CHIP JUMPER

ITEM	MOTOROLA PART NUMBER	DESCRIPTION
JU6	0611077A01	RES CHIP JUMPER
JU8	NOTPLACED	64AM DUMMY PART NUMBER
JU9	NOTPLACED	64AM DUMMY PART NUMBER
L1	2480140E16	INDUCTOR CHIP 10UH
L50	2480140E16	INDUCTOR CHIP 10UH
P001	0905573P02	SKT 13 POSTN
P103	2880102M07	PLUG VERTICAL 28 POSITION
P104	2880068M01	HEADER MIC
Q111	4813824A10	TSTR NPN 40V .2A GEN PURP
Q112	4813824A10	TSTR NPN 40V .2A GEN PURP
Q131	4813824A10	TSTR NPN 40V .2A GEN PURP
Q50	4880053M03	TSTR N/CH SOT 89 200V B ST 84
Q71	4880053M02	TSTR NPN MXT2222A
Q72	NOTPLACED	64AM DUMMY PART NUMBER
Q73	4880053M02	TSTR NPN MXT2222A
Q74	4813824A10	TSTR NPN 40V .2A GEN PURP
Q75	4813824A10	TSTR NPN 40V .2A GEN PURP
Q76	4880048M01	TSTR NPN DIG 47K/47K
R1	NOTPLACED	64AM DUMMY PART NUMBER
R10	0611077B47	RES CHIP 1 MEG 5 1/8W
R101	0611077A28	RES CHIP 12 5 1/8W
R111	0611077B23	RES CHIP 100K 5 1/8W
R112	0611077B23	RES CHIP 100K 5 1/8W
R113	0611077B11	RES CHIP 33K 5 1/8W
R114	0611077B11	RES CHIP 33K 5 1/8W
R115	0611077A74	RES CHIP 1000 5 1/8
R116	0611077A74	RES CHIP 1000 5 1/8
R120	0611077B23	RES CHIP 100K 5 1/8W
R121	0611077B23	RES CHIP 100K 5 1/8W
R122	0611077B23	RES CHIP 100K 5 1/8W
R123	0611077A98	RES CHIP 10K 5 1/8W
R131	0611077A68	RES CHIP 560 5 1/8W
R140	0611077A98	RES CHIP 10K 5 1/8W

ITEM	MOTOROLA PART NUMBER	DESCRIPTION
R174	0611077A90	RES CHIP 4700 5 1/8
R175	0611077A90	RES CHIP 4700 5 1/8
R176	0611077A90	RES CHIP 4700 5 1/8
R177	0611077A90	RES CHIP 4700 5 1/8
R2	0611077A90	RES CHIP 4700 5 1/8
R200	0611077B07	RES CHIP 22K 5 1/8W
R25	0611077B15	RES CHIP 47K 5 1/8W
R28	0611077A98	RES CHIP 10K 5 1/8W
R29	0611077B23	RES CHIP 100K 5 1/8W
R30	0611077B47	RES CHIP 1 MEG 5 1/8W
R31	0611077B15	RES CHIP 47K 5 1/8W
R34	0611077B15	RES CHIP 47K 5 1/8W
R5	0611077A90	RES CHIP 4700 5 1/8
R50	0611077A68	RES CHIP 560 5 1/8W
R51	0611077B07	RES CHIP 22K 5 1/8W
R52	0611077A98	RES CHIP 10K 5 1/8W
R55	0611077A28	RES CHIP 12 5 1/8W
R56	0611077B11	RES CHIP 33K 5 1/8W
R57	0611077B15	RES CHIP 47K 5 1/8W
R58	0611077B11	RES CHIP 33K 5 1/8W
R59	0611077A98	RES CHIP 10K 5 1/8W
R6	0611077A50	RES CHIP 100 5 1/8W
R60	0611077A78	RES CHIP 1500 5 1/8
R61	0611077A74	RES CHIP 1000 5 1/8
R71	0611077A66	RES CHIP 470 5 1/8W
R73	0611077B11	RES CHIP 33K 5 1/8W
R74	0611077B23	RES CHIP 100K 5 1/8W
R76	0611077A66	RES CHIP 470 5 1/8W
R77	0611077A66	RES CHIP 470 5 1/8W
R79	0611077A66	RES CHIP 470 5 1/8W
R8	0611077A50	RES CHIP 100 5 1/8W
R80	0611077B23	RES CHIP 100K 5 1/8W
R81	NOTPLACED	64AM DUMMY PART NUMBER

ITEM	MOTOROLA PART NUMBER	DESCRIPTION
R84	0611077A98	RES CHIP 10K 5 1/8W
R87	0611077A98	RES CHIP 10K 5 1/8W
R9	NOTPLACED	64AM DUMMY PART NUMBER
R90	0611077A98	RES CHIP 10K 5 1/8W
R91	0611077A98	RES CHIP 10K 5 1/8W
R92	0611077A98	RES CHIP 10K 5 1/8W
R93	0611077A98	RES CHIP 10K 5 1/8W
R98	NOTPLACED	64AM DUMMY PART NUMBER
R99	0611077A98	RES CHIP 10K 5 1/8W
T60	2580277J03	XFMR VLTG CONVERSION
U1	0104002J91	PRGMD MICROP ASSEM
U101	5180236C05	IC VF DRVR SN75518FN
U102	7280032M01	DSPLY VF 14 SEG 8 CHAR BLUGRN
U2	5185963A81	MODE 8-BIT SER I/O TLC0831DR
U3	5113820A02	IC DUJAL SING SPLY LO PWR 2903
U4	5180057S04	"IC CUST SER I/O 13" REEL"
U45	5113816G04	IC +5V REG 78M05
VR1	4813830A28	DIODE 15V 5% 225MW MMBZ5245B_
VR10	4813830A28	DIODE 15V 5% 225MW MMBZ5245B_
VR2	4813830A28	DIODE 15V 5% 225MW MMBZ5245B_
VR20	4813830A28	DIODE 15V 5% 225MW MMBZ5245B_
VR21	4813830A28	DIODE 15V 5% 225MW MMBZ5245B_
VR22	4813830A28	DIODE 15V 5% 225MW MMBZ5245B_
VR23	NOTPLACED	64AM DUMMY PART NUMBER
VR24	4813830A23	DIODE 10V 5% 225MW MMBZ5240B_
VR25	4813830A23	DIODE 10V 5% 225MW MMBZ5240B_
VR26	4813830A23	DIODE 10V 5% 225MW MMBZ5240B_

ITEM	MOTOROLA PART NUMBER	DESCRIPTION
VR27	4813830A23	DIODE 10V 5% 225MW MMBZ5240B_
VR28	4813830A23	DIODE 10V 5% 225MW MMBZ5240B_
VR29	4813830A23	DIODE 10V 5% 225MW MMBZ5240B_
VR3	4813830A28	DIODE 15V 5% 225MW MMBZ5245B_
VR30	4813830A23	DIODE 10V 5% 225MW MMBZ5240B_
VR31	4813830A23	DIODE 10V 5% 225MW MMBZ5240B_
VR32	4813830A23	DIODE 10V 5% 225MW MMBZ5240B_
VR33	4813830A23	DIODE 10V 5% 225MW MMBZ5240B_
VR4	4813830A28	DIODE 15V 5% 225MW MMBZ5245B_
VR5	4813830A28	DIODE 15V 5% 225MW MMBZ5245B_
VR50	4813830C41	DIODE 36V 'M3' MMSZ5258BT1
VR6	4813830A28	DIODE 15V 5% 225MW MMBZ5245B_
VR7	4813830A28	DIODE 15V 5% 225MW MMBZ5245B_
VR8	4813830A28	DIODE 15V 5% 225MW MMBZ5245B_
VR9	4813830A28	DIODE 15V 5% 225MW MMBZ5245B_
Y1	4880065M01	RESONTR CERAMIC 4.00 MHZ

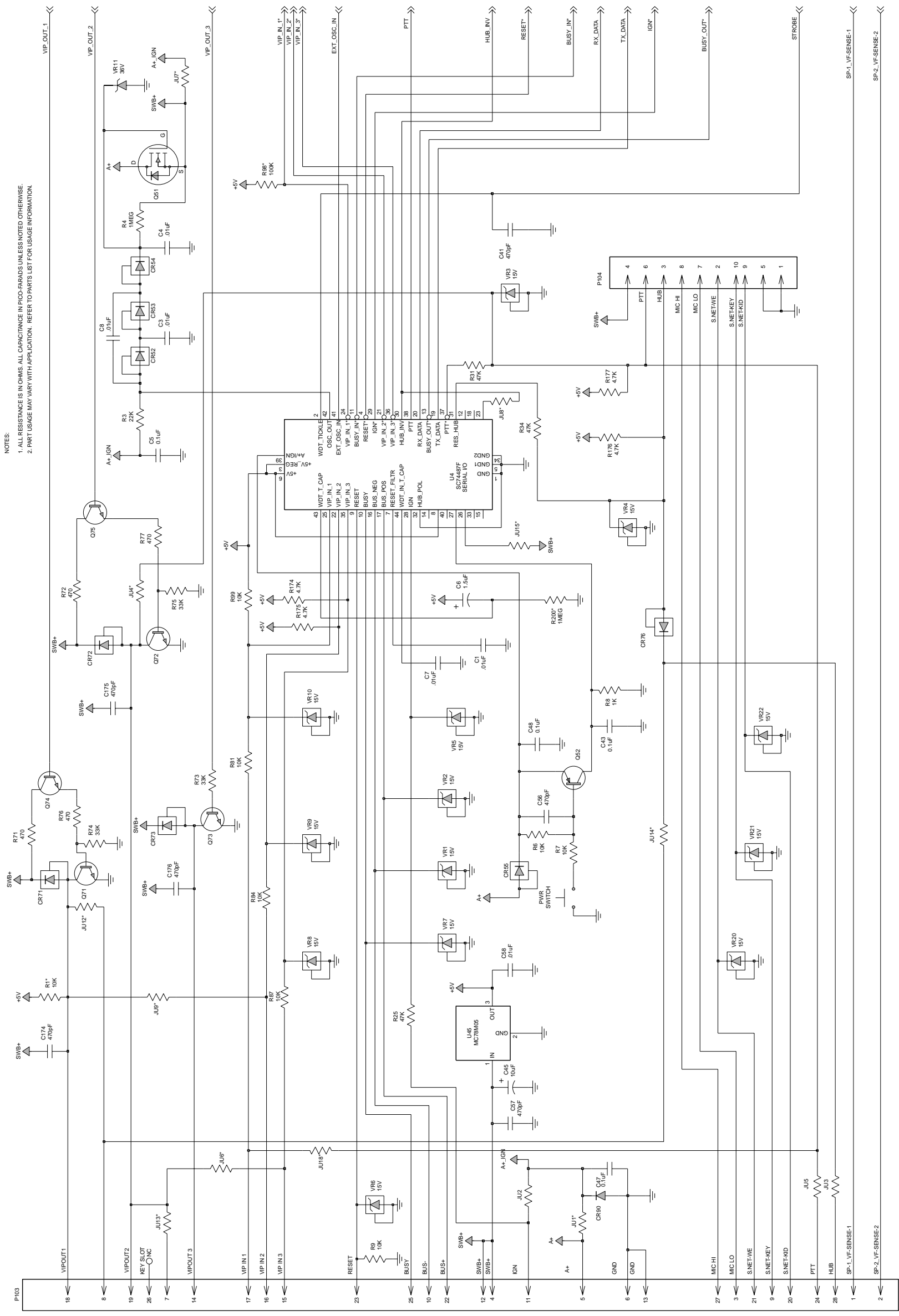

Figure 8-8. HLN6396F/G/H (Standard), HLN6814A/B/C (Rear), HLN6563B/C/D (Motorcycle) W5/W7 Control Head Schematic (Sheet 1 of 2)

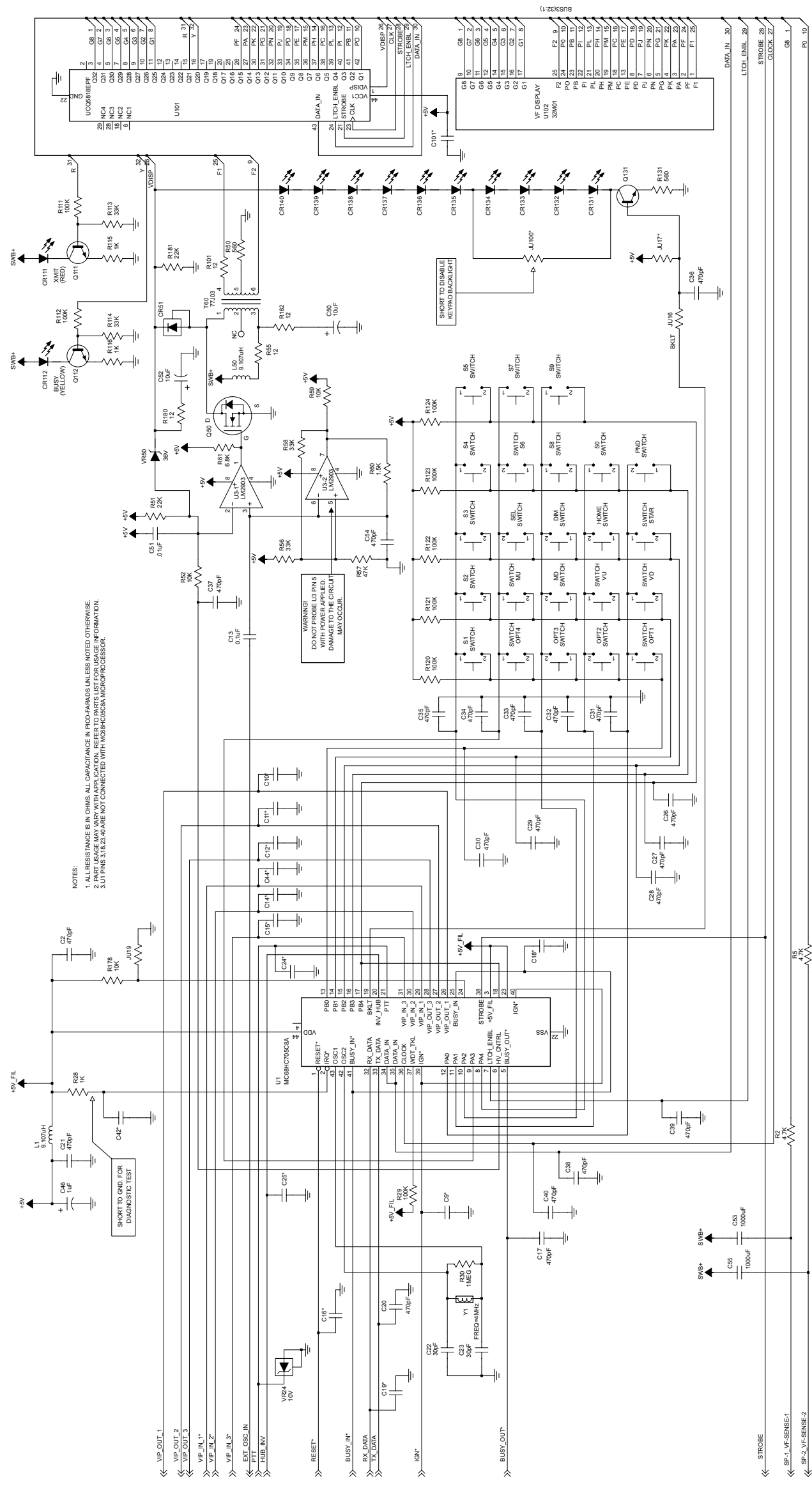

Figure 8-9. HLN6396F/G/H (Standard), HLN6814A/B/C (Rear), HLN6563B/C/D (Motorcycle) W5/W7 Control Head Schematic (Sheet 2 of 2)

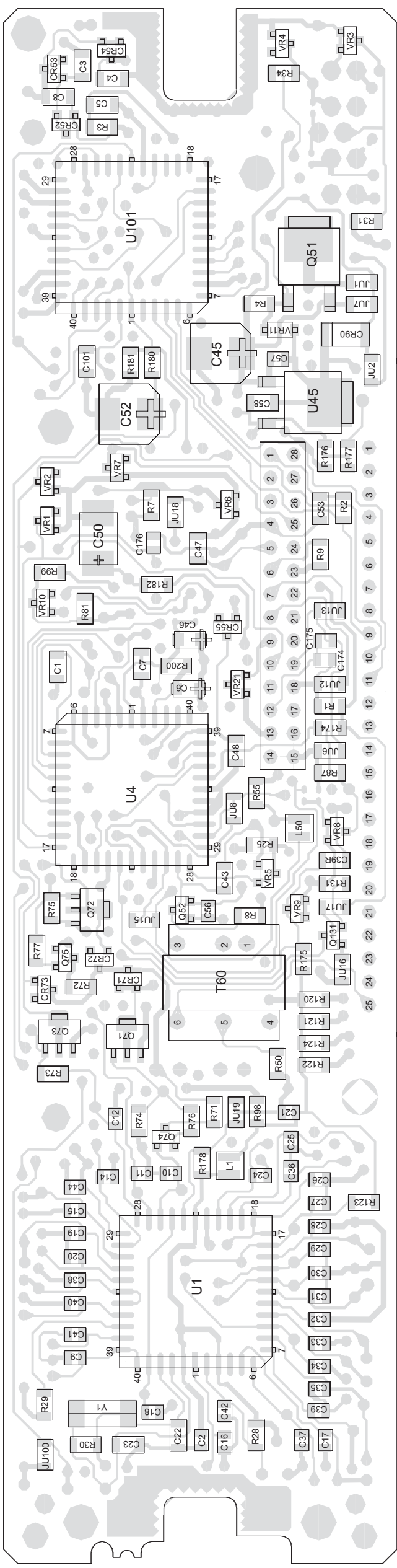

Figure 8-10. HLN6396F/G (Standard), HLN6814A/B (Rear), HLN6563B/C (Motorcycle) W5/W7 Control Head Component Location Diagram (Viewed from Side 1)

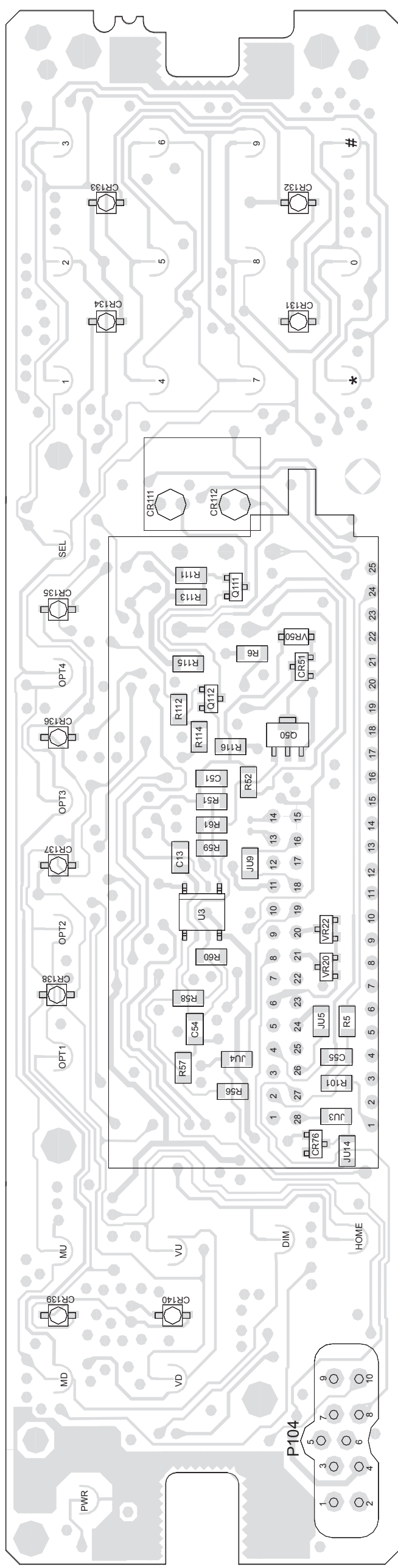

Figure 8-11. HLN6396F/G (Standard), HLN6814A/B (Rear), HLN6563B/C (Motorcycle) W5/W7 Control Head Component Location Diagram (Viewed from Side 2)

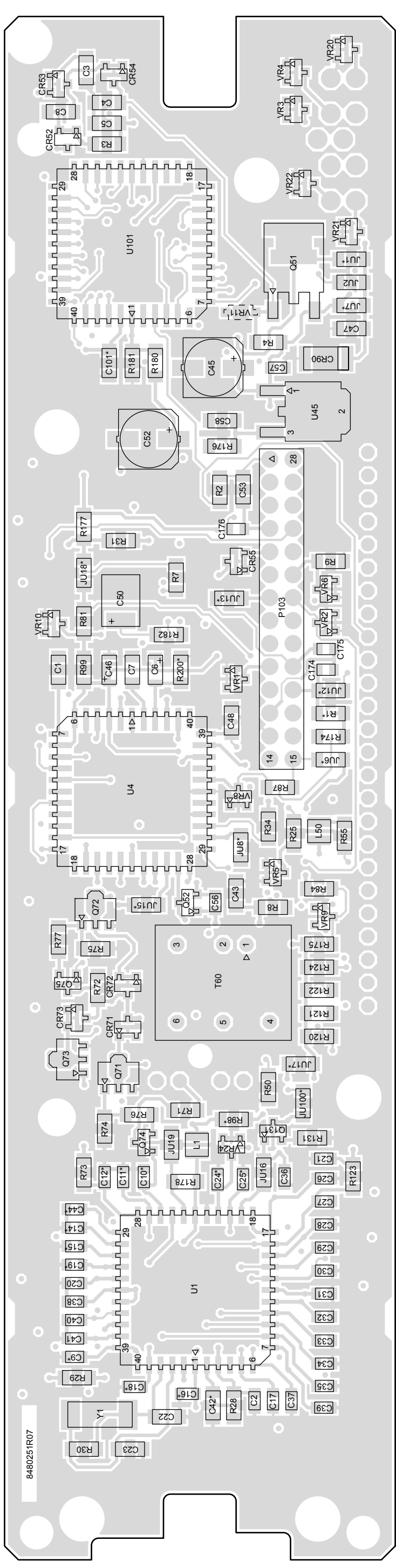

Figure 8-12. HLN6396H\_HLN6814C\_HLN6563C W5/W7 Control Head Component Location Diagram (Viewed from Side 1)

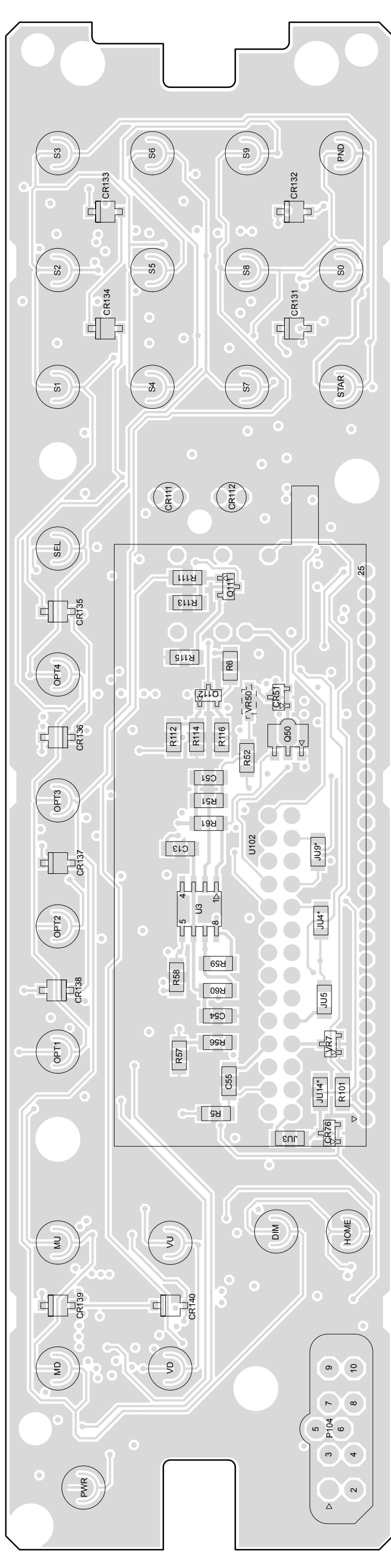

Figure 8-13. HLN6396H\_HLN6814C\_HLN6563C W5/W7 Control Head Component Location Diagram (Viewed from Side 2)

## HLN6396H Standard Parts List

ITEM	MOTOROLA PART NUMBER	DESCRIPTION
C0053	2113741N21	CAP CHIP CL2 X7R 10% 1000
C0055	2113741N21	CAP CHIP CL2 X7R 10% 1000
C1	2113741N45	CAP CHIP CL2 X7R 10% 10000
C10	NOTPLACED	64AM DUMMY PART NUMBER
C101	NOTPLACED	64AM DUMMY PART NUMBER
C11	NOTPLACED	64AM DUMMY PART NUMBER
C12	NOTPLACED	64AM DUMMY PART NUMBER
C13	2113741N69	CAP CHIP CL2 X7R 10%
C14	NOTPLACED	64AM DUMMY PART NUMBER
C15	NOTPLACED	64AM DUMMY PART NUMBER
C16	NOTPLACED	64AM DUMMY PART NUMBER
C17	2113741M13	CAP CHIP CL2 X7R 10% 470
C174	2113741M13	CAP CHIP CL2 X7R 10% 470
C175	2113741M13	CAP CHIP CL2 X7R 10% 470
C176	2113741M13	CAP CHIP CL2 X7R 10% 470
C18	NOTPLACED	64AM DUMMY PART NUMBER
C19	NOTPLACED	64AM DUMMY PART NUMBER
C2	2113741M13	CAP CHIP CL2 X7R 10% 470
C20	2113741M13	CAP CHIP CL2 X7R 10% 470
C21	2113741M13	CAP CHIP CL2 X7R 10% 470
C22	2113740B36	CAP CHIP REEL CL1 +/-30 30
C23	2113740B36	CAP CHIP REEL CL1 +/-30 30
C24	NOTPLACED	64AM DUMMY PART NUMBER
C25	NOTPLACED	64AM DUMMY PART NUMBER
C26	2113741M13	CAP CHIP CL2 X7R 10% 470
C27	2113741M13	CAP CHIP CL2 X7R 10% 470
C28	2113741M13	CAP CHIP CL2 X7R 10% 470
C29	2113741M13	CAP CHIP CL2 X7R 10% 470
C3	2113741N45	CAP CHIP CL2 X7R 10% 10000
C30	2113741M13	CAP CHIP CL2 X7R 10% 470
C31	2113741M13	CAP CHIP CL2 X7R 10% 470
C32	2113741M13	CAP CHIP CL2 X7R 10% 470

ITEM	MOTOROLA PART NUMBER	DESCRIPTION
C33	2113741M13	CAP CHIP CL2 X7R 10% 470
C34	2113741M13	CAP CHIP CL2 X7R 10% 470
C35	2113741M13	CAP CHIP CL2 X7R 10% 470
C36	2113741M13	CAP CHIP CL2 X7R 10% 470
C37	2113741M13	CAP CHIP CL2 X7R 10% 470
C38	2113741M13	CAP CHIP CL2 X7R 10% 470
C39	2113741M13	CAP CHIP CL2 X7R 10% 470
C4	2113741N45	CAP CHIP CL2 X7R 10% 10000
C40	2113741M13	CAP CHIP CL2 X7R 10% 470
C41	2113741M13	CAP CHIP CL2 X7R 10% 470
C42	NOTPLACED	64AM DUMMY PART NUMBER
C43	2113741N69	CAP CHIP CL2 X7R 10%
C44	NOTPLACED	64AM DUMMY PART NUMBER
C45	2380090M24	CAP ALU 10 20 50V SURF MT
C46	2311049A37	CAP TANT CHIP 1 20 20
C47	2113741N69	CAP CHIP CL2 X7R 10%
C48	2113741N69	CAP CHIP CL2 X7R 10%
C5	2113741N69	CAP CHIP CL2 X7R 10%
C50	2311049A95	CAP TANT CHIP 10 UF 25V 10%
C51	2113741N45	CAP CHIP CL2 X7R 10% 10000
C52	2380090M24	CAP ALU 10 20 50V SURF MT
C54	2113740B65	CAP CHIP REEL CL1 +/-30 470
C56	2113741M13	CAP CHIP CL2 X7R 10% 470
C57	2113741M13	CAP CHIP CL2 X7R 10% 470
C58	2113741N45	CAP CHIP CL2 X7R 10% 10000
C6	2311049A38	CAP TANT CHIP 1.5 10 16
C7	2113741N45	CAP CHIP CL2 X7R 10% 10000
C8	2113741N45	CAP CHIP CL2 X7R 10% 10000
C9	NOTPLACED	64AM DUMMY PART NUMBER
CR111	4880026P01	DIODE LED RED
CR112	4880026P02	DIODE LED YELLOW

ITEM	MOTOROLA PART NUMBER	DESCRIPTION
CR131	4880052R03	DIODE LIGHT EMITTING GRN
CR132	4880052R03	DIODE LIGHT EMITTING GRN
CR133	4880052R03	DIODE LIGHT EMITTING GRN
CR134	4880052R03	DIODE LIGHT EMITTING GRN
CR135	4880052R03	DIODE LIGHT EMITTING GRN
CR136	4880052R03	DIODE LIGHT EMITTING GRN
CR137	4880052R03	DIODE LIGHT EMITTING GRN
CR138	4880052R03	DIODE LIGHT EMITTING GRN
CR139	4880052R03	DIODE LIGHT EMITTING GRN
CR140	4880052R03	DIODE LIGHT EMITTING GRN
CR51	4811058B11	DIODE 48S11058A11 A/P
CR52	4811058B11	DIODE 48S11058A11 A/P
CR53	4811058B11	DIODE 48S11058A11 A/P
CR54	4811058B11	DIODE 48S11058A11 A/P
CR55	4811058B11	DIODE 48S11058A11 A/P
CR71	4811058B11	DIODE 48S11058A11 A/P
CR72	4811058B11	DIODE 48S11058A11 A/P
CR73	4811058B11	DIODE 48S11058A11 A/P
CR76	4811058B11	DIODE 48S11058A11 A/P
CR90	4882960R02	DIODE RECT 48R82960R01 A/P
JU0003	0611077A01	RES CHIP JUMPER
JU0005	0611077A01	RES CHIP JUMPER
JU0016	0611077A01	RES CHIP JUMPER
JU0017	NOTPLACED	64AM DUMMY PART NUMBER
JU1	NOTPLACED	64AM DUMMY PART NUMBER
JU100	NOTPLACED	64AM DUMMY PART NUMBER
JU12	NOTPLACED	64AM DUMMY PART NUMBER
JU13	NOTPLACED	64AM DUMMY PART NUMBER
JU14	NOTPLACED	64AM DUMMY PART NUMBER
JU15	NOTPLACED	64AM DUMMY PART NUMBER
JU18	NOTPLACED	64AM DUMMY PART NUMBER
JU19	NOTPLACED	64AM DUMMY PART NUMBER
JU2	0611077A01	RES CHIP JUMPER

ITEM	MOTOROLA PART NUMBER	DESCRIPTION
JU4	NOTPLACED	64AM DUMMY PART NUMBER
JU6	NOTPLACED	64AM DUMMY PART NUMBER
JU7	NOTPLACED	64AM DUMMY PART NUMBER
JU8	NOTPLACED	64AM DUMMY PART NUMBER
JU9	NOTPLACED	64AM DUMMY PART NUMBER
L1	2480140E16	INDUCTOR CHIP 10UH
L50	2480140E16	INDUCTOR CHIP 10UH
MP0103	4380290L01	SPACER LED
MP0106	5480004N01	LABEL BARCODE
P0103	2880102M07	PLUG VERTICAL 28 POSITION
P0104	2880068M01	HEADER MIC
Q111	4880141L02	TSTR NPN SOT23 LO PROFILE TAPE
Q112	4880141L02	TSTR NPN SOT23 LO PROFILE TAPE
Q131	4880141L02	TSTR NPN SOT23 LO PROFILE TAPE
Q50	4880053M03	TSTR N/CH SOT 89 200V B ST 84
Q51	4813821A30	MOSFET N-CH 60V 15A
Q52	4880141L01	TSTR PNP SOT23 LO PROFILE TAPE
Q71	4880053M02	TSTR NPN MXT2222A
Q72	4880053M02	TSTR NPN MXT2222A
Q73	4880053M02	TSTR NPN MXT2222A
Q74	4880141L02	TSTR NPN SOT23 LO PROFILE TAPE
Q75	4880141L02	TSTR NPN SOT23 LO PROFILE TAPE
R0002	0611077A90	RES CHIP 4700 5 1/8
R0005	0611077A90	RES CHIP 4700 5 1/8
R1	NOTPLACED	64AM DUMMY PART NUMBER
R101	0611077A28	RES CHIP 12 5 1/8W
R111	0611077B23	RES CHIP 100K 5 1/8W
R112	0611077B23	RES CHIP 100K 5 1/8W
R113	0611077B11	RES CHIP 33K 5 1/8W



ITEM	MOTOROLA PART NUMBER	DESCRIPTION
R114	0611077B11	RES CHIP 33K 5 1/8W
R115	0611077A74	RES CHIP 1000 5 1/8
R116	0611077A74	RES CHIP 1000 5 1/8
R120	0611077B23	RES CHIP 100K 5 1/8W
R121	0611077B23	RES CHIP 100K 5 1/8W
R122	0611077B23	RES CHIP 100K 5 1/8W
R123	0611077B23	RES CHIP 100K 5 1/8W
R124	0611077B23	RES CHIP 100K 5 1/8W
R131	0611077A68	RES CHIP 560 5 1/8W
R174	0611077A90	RES CHIP 4700 5 1/8
R175	0611077A90	RES CHIP 4700 5 1/8
R176	0611077A90	RES CHIP 4700 5 1/8
R177	0611077A90	RES CHIP 4700 5 1/8
R178	0611077A98	RES CHIP 10K 5 1/8W
R180	0611077A28	RES CHIP 12 5 1/8W
R181	0611077B07	RES CHIP 22K 5 1/8W
R182	0611077A28	RES CHIP 12 5 1/8W
R200	0611077B47	RES CHIP 1 MEG 5 1/8W
R25	0611077B15	RES CHIP 47K 5 1/8W
R28	0611077A74	RES CHIP 1000 5 1/8
R29	0611077B23	RES CHIP 100K 5 1/8W
R3	0611077B07	RES CHIP 22K 5 1/8W
R30	0611077B47	RES CHIP 1 MEG 5 1/8W
R31	0611077B15	RES CHIP 47K 5 1/8W
R34	0611077B15	RES CHIP 47K 5 1/8W
R4	0611077B47	RES CHIP 1 MEG 5 1/8W
R50	0611077A68	RES CHIP 560 5 1/8W
R51	0611077B07	RES CHIP 22K 5 1/8W
R52	0611077A98	RES CHIP 10K 5 1/8W
R55	0611077A28	RES CHIP 12 5 1/8W
R56	0611077B11	RES CHIP 33K 5 1/8W
R57	0611077B15	RES CHIP 47K 5 1/8W
R58	0611077B11	RES CHIP 33K 5 1/8W

ITEM	MOTOROLA PART NUMBER	DESCRIPTION
R59	0611077A98	RES CHIP 10K 5 1/8W
R6	0611077A98	RES CHIP 10K 5 1/8W
R60	0611077A78	RES CHIP 1500 5 1/8
R61	0611077A94	RES CHIP 6.8K 5 1/8
R7	0611077A98	RES CHIP 10K 5 1/8W
R71	0611077A66	RES CHIP 470 5 1/8W
R72	0611077A66	RES CHIP 470 5 1/8W
R73	0611077B11	RES CHIP 33K 5 1/8W
R74	0611077B11	RES CHIP 33K 5 1/8W
R75	0611077B11	RES CHIP 33K 5 1/8W
R76	0611077A66	RES CHIP 470 5 1/8W
R77	0611077A66	RES CHIP 470 5 1/8W
R8	0611077A74	RES CHIP 1000 5 1/8
R81	0611077A98	RES CHIP 10K 5 1/8W
R87	0611077A98	RES CHIP 10K 5 1/8W
R9	0611077A98	RES CHIP 10K 5 1/8W
R98	NOTPLACED	64AM DUMMY PART NUMBER
R99	0611077A98	RES CHIP 10K 5 1/8W
U0102	7280032M01	DSPLY VF 14 SEG 8 CHAR BLUGRN
U1	0104002J91	PRGMD MICROP ASSEM
U101	5180236C05	IC VF DRVR SN75518FN
U3	5113820A02	IC DUAL SING SPLY LO PWR 2903
U4	5180057504	"IC CUST SER I/O 13" REEL"
U45	5113816G04	IC +5V REG 78M05
VR0011	4813830C41	DIODE 36V 'M3' MMSZ5258BT1
VR08	4813830A28	DIODE 15V 5% 225MW MMBZ5245B_
VR09	4813830A28	DIODE 15V 5% 225MW MMBZ5245B_
VR1	4813830A28	DIODE 15V 5% 225MW MMBZ5245B_
VR10	4813830A28	DIODE 15V 5% 225MW MMBZ5245B_

ITEM	MOTOROLA PART NUMBER	DESCRIPTION
VR2	4813830A28	DIODE 15V 5% 225MW MMBZ5245B_
VR20	4813830A28	DIODE 15V 5% 225MW MMBZ5245B_
VR21	4813830A28	DIODE 15V 5% 225MW MMBZ5245B_
VR22	4813830A28	DIODE 15V 5% 225MW MMBZ5245B_
VR3	4813830A28	DIODE 15V 5% 225MW MMBZ5245B_
VR4	4813830A28	DIODE 15V 5% 225MW MMBZ5245B_
VR5	4813830A28	DIODE 15V 5% 225MW MMBZ5245B_
VR50	4813830C41	DIODE 36V 'M3' MMSZ5258BT1
VR6	4813830A28	DIODE 15V 5% 225MW MMBZ5245B_
VR7	4813830A28	DIODE 15V 5% 225MW MMBZ5245B_
Y1	4880065M01	RESONTR CERAMIC 4.00 MHZ

## HLN6814C Rear Parts List

ITEM	MOTOROLA PART NUMBER	DESCRIPTION
C0053	2113741N21	CAP CHIP CL2 X7R 10% 1000
C0055	2113741N21	CAP CHIP CL2 X7R 10% 1000
C1	2113741N45	CAP CHIP CL2 X7R 10% 10000
C10	NOTPLACED	64AM DUMMY PART NUMBER
C101	NOTPLACED	64AM DUMMY PART NUMBER
C11	NOTPLACED	64AM DUMMY PART NUMBER
C12	NOTPLACED	64AM DUMMY PART NUMBER
C13	NOTPLACED	64AM DUMMY PART NUMBER
C14	NOTPLACED	64AM DUMMY PART NUMBER
C15	NOTPLACED	64AM DUMMY PART NUMBER
C16	NOTPLACED	64AM DUMMY PART NUMBER
C17	2113741M13	CAP CHIP CL2 X7R 10% 470
C174	2113741M13	CAP CHIP CL2 X7R 10% 470
C175	2113741M13	CAP CHIP CL2 X7R 10% 470
C176	2113741M13	CAP CHIP CL2 X7R 10% 470
C18	NOTPLACED	64AM DUMMY PART NUMBER
C19	NOTPLACED	64AM DUMMY PART NUMBER
C2	2113741M13	CAP CHIP CL2 X7R 10% 470
C20	2113741M13	CAP CHIP CL2 X7R 10% 470
C21	2113741M13	CAP CHIP CL2 X7R 10% 470
C22	2113740B36	CAP CHIP REEL CL1 +/-30 30
C23	2113740B36	CAP CHIP REEL CL1 +/-30 30
C24	NOTPLACED	64AM DUMMY PART NUMBER
C25	NOTPLACED	64AM DUMMY PART NUMBER
C26	2113741M13	CAP CHIP CL2 X7R 10% 470
C27	2113741M13	CAP CHIP CL2 X7R 10% 470
C28	2113741M13	CAP CHIP CL2 X7R 10% 470
C29	2113741M13	CAP CHIP CL2 X7R 10% 470
C3	NOTPLACED	64AM DUMMY PART NUMBER
C30	2113741M13	CAP CHIP CL2 X7R 10% 470
C31	2113741M13	CAP CHIP CL2 X7R 10% 470
C32	2113741M13	CAP CHIP CL2 X7R 10% 470

ITEM	MOTOROLA PART NUMBER	DESCRIPTION
C33	2113741M13	CAP CHIP CL2 X7R 10% 470
C34	2113741M13	CAP CHIP CL2 X7R 10% 470
C35	2113741M13	CAP CHIP CL2 X7R 10% 470
C36	2113741M13	CAP CHIP CL2 X7R 10% 470
C37	2113741M13	CAP CHIP CL2 X7R 10% 470
C38	2113741M13	CAP CHIP CL2 X7R 10% 470
C39	2113741M13	CAP CHIP CL2 X7R 10% 470
C4	NOTPLACED	64AM DUMMY PART NUMBER
C40	2113741M13	CAP CHIP CL2 X7R 10% 470
C41	2113741M13	CAP CHIP CL2 X7R 10% 470
C42	NOTPLACED	64AM DUMMY PART NUMBER
C43	NOTPLACED	64AM DUMMY PART NUMBER
C44	NOTPLACED	64AM DUMMY PART NUMBER
C45	2380090M24	CAP ALU 10 20 50V SURF MT
C46	2311049A37	CAP TANT CHIP 1 20 20
C47	2113741N69	CAP CHIP CL2 X7R 10%
C48	NOTPLACED	64AM DUMMY PART NUMBER
C5	NOTPLACED	64AM DUMMY PART NUMBER
C50	2311049A95	CAP TANT CHIP 10 UF 25V 10%
C51	2113741N45	CAP CHIP CL2 X7R 10% 10000
C52	2380090M24	CAP ALU 10 20 50V SURF MT
C54	2113740B65	CAP CHIP REEL CL1 +/-30 470
C56	NOTPLACED	64AM DUMMY PART NUMBER
C57	2113741M13	CAP CHIP CL2 X7R 10% 470
C58	2113741N45	CAP CHIP CL2 X7R 10% 10000
C6	2311049A38	CAP TANT CHIP 1.5 10 16
C7	2113741N45	CAP CHIP CL2 X7R 10% 10000
C8	NOTPLACED	64AM DUMMY PART NUMBER
C9	NOTPLACED	64AM DUMMY PART NUMBER
CR111	4880026P01	DIODE LED RED
CR112	4880026P02	DIODE LED YELLOW
CR131	4880052R03	DIODE LIGHT EMITTING GRN

ITEM	MOTOROLA PART NUMBER	DESCRIPTION
CR132	4880052R03	DIODE LIGHT EMITTING GRN
CR133	4880052R03	DIODE LIGHT EMITTING GRN
CR134	4880052R03	DIODE LIGHT EMITTING GRN
CR135	4880052R03	DIODE LIGHT EMITTING GRN
CR136	4880052R03	DIODE LIGHT EMITTING GRN
CR137	4880052R03	DIODE LIGHT EMITTING GRN
CR138	4880052R03	DIODE LIGHT EMITTING GRN
CR139	4880052R03	DIODE LIGHT EMITTING GRN
CR140	4880052R03	DIODE LIGHT EMITTING GRN
CR51	4811058B11	DIODE 48S11058A11 A/P
CR52	NOTPLACED	64AM DUMMY PART NUMBER
CR53	NOTPLACED	64AM DUMMY PART NUMBER
CR54	NOTPLACED	64AM DUMMY PART NUMBER
CR55	4811058B11	DIODE 48S11058A11 A/P
CR71	4811058B11	DIODE 48S11058A11 A/P
CR72	4811058B11	DIODE 48S11058A11 A/P
CR73	4811058B11	DIODE 48S11058A11 A/P
CR76	4811058B11	DIODE 48S11058A11 A/P
CR90	NOTPLACED	64AM DUMMY PART NUMBER
JU0003	0611077A01	RES CHIP JUMPER
JU0005	0611077A01	RES CHIP JUMPER
JU0016	0611077A01	RES CHIP JUMPER
JU0017	NOTPLACED	64AM DUMMY PART NUMBER
JU1	0611077A01	RES CHIP JUMPER
JU100	NOTPLACED	64AM DUMMY PART NUMBER
JU12	NOTPLACED	64AM DUMMY PART NUMBER
JU13	NOTPLACED	64AM DUMMY PART NUMBER
JU14	NOTPLACED	64AM DUMMY PART NUMBER
JU15	NOTPLACED	64AM DUMMY PART NUMBER
JU18	NOTPLACED	64AM DUMMY PART NUMBER
JU19	0611077A01	RES CHIP JUMPER
JU2	NOTPLACED	64AM DUMMY PART NUMBER
JU4	NOTPLACED	64AM DUMMY PART NUMBER

ITEM	MOTOROLA PART NUMBER	DESCRIPTION
JU6	NOTPLACED	64AM DUMMY PART NUMBER
JU7	0611077A01	RES CHIP JUMPER
JU8	NOTPLACED	64AM DUMMY PART NUMBER
JU9	NOTPLACED	64AM DUMMY PART NUMBER
L1	2480140E16	INDUCTOR CHIP 10UH
L50	2480140E16	INDUCTOR CHIP 10UH
MP0101	7580094M05	"SHOCK PAD, VF"
MP0102	7580094M05	"SHOCK PAD, VF"
MP0103	7580094M05	"SHOCK PAD, VF"
MP0106	5480004N01	LABEL BARCODE
P0103	2880102M07	PLUG VERTICAL 28 POSITION
P0104	2880068M01	HEADER MIC
Q111	4880141L02	TSTR NPN SOT23 LO PRO-FILE TAPE
Q112	4880141L02	TSTR NPN SOT23 LO PRO-FILE TAPE
Q131	4880141L02	TSTR NPN SOT23 LO PRO-FILE TAPE
Q50	4880053M03	TSTR N/CH SOT 89 200V B ST 84
Q51	NOTPLACED	64AM DUMMY PART NUMBER
Q52	NOTPLACED	64AM DUMMY PART NUMBER
Q71	4880053M02	TSTR NPN MXT2222A
Q72	4880053M02	TSTR NPN MXT2222A
Q73	4880053M02	TSTR NPN MXT2222A
Q74	4880141L02	TSTR NPN SOT23 LO PRO-FILE TAPE
Q75	4880141L02	TSTR NPN SOT23 LO PRO-FILE TAPE
R0002	0611077A90	RES CHIP 4700 5 1/8
R0005	0611077A90	RES CHIP 4700 5 1/8
R1	NOTPLACED	64AM DUMMY PART NUMBER
R101	0611077A28	RES CHIP 12 5 1/8W
R111	0611077B23	RES CHIP 100K 5 1/8W
R112	0611077B23	RES CHIP 100K 5 1/8W
R113	0611077B11	RES CHIP 33K 5 1/8W

ITEM	MOTOROLA PART NUMBER	DESCRIPTION
R114	0611077B11	RES CHIP 33K 5 1/8W
R115	0611077A74	RES CHIP 1000 5 1/8
R116	0611077A74	RES CHIP 1000 5 1/8
R120	0611077B23	RES CHIP 100K 5 1/8W
R121	0611077B23	RES CHIP 100K 5 1/8W
R122	0611077B23	RES CHIP 100K 5 1/8W
R123	0611077B23	RES CHIP 100K 5 1/8W
R124	0611077B23	RES CHIP 100K 5 1/8W
R131	0611077A68	RES CHIP 560 5 1/8W
R174	0611077A90	RES CHIP 4700 5 1/8
R175	0611077A90	RES CHIP 4700 5 1/8
R176	0611077A90	RES CHIP 4700 5 1/8
R177	0611077A90	RES CHIP 4700 5 1/8
R178	0611077A98	RES CHIP 10K 5 1/8W
R180	0611077A28	RES CHIP 12 5 1/8W
R181	0611077B07	RES CHIP 22K 5 1/8W
R182	0611077A28	RES CHIP 12 5 1/8W
R200	0611077B47	RES CHIP 1 MEG 5 1/8W
R25	NOTPLACED	64AM DUMMY PART NUMBER
R28	0611077A74	RES CHIP 1000 5 1/8
R29	0611077B23	RES CHIP 100K 5 1/8W
R3	NOTPLACED	64AM DUMMY PART NUMBER
R30	0611077B47	RES CHIP 1 MEG 5 1/8W
R31	0611077B15	RES CHIP 47K 5 1/8W
R34	0611077B15	RES CHIP 47K 5 1/8W
R4	NOTPLACED	64AM DUMMY PART NUMBER
R50	0611077A68	RES CHIP 560 5 1/8W
R51	0611077B07	RES CHIP 22K 5 1/8W
R52	0611077A98	RES CHIP 10K 5 1/8W
R55	0611077A28	RES CHIP 12 5 1/8W
R56	0611077B11	RES CHIP 33K 5 1/8W
R57	0611077B15	RES CHIP 47K 5 1/8W
R58	0611077B11	RES CHIP 33K 5 1/8W

ITEM	MOTOROLA PART NUMBER	DESCRIPTION
R59	0611077A98	RES CHIP 10K 5 1/8W
R6	NOTPLACED	64AM DUMMY PART NUMBER
R60	0611077A78	RES CHIP 1500 5 1/8
R61	0611077A94	RES CHIP 6.8K 5 1/8
R7	NOTPLACED	64AM DUMMY PART NUMBER
R71	0611077A66	RES CHIP 470 5 1/8W
R72	0611077A66	RES CHIP 470 5 1/8W
R73	0611077B11	RES CHIP 33K 5 1/8W
R74	0611077B11	RES CHIP 33K 5 1/8W
R75	0611077B11	RES CHIP 33K 5 1/8W
R76	0611077A66	RES CHIP 470 5 1/8W
R77	0611077A66	RES CHIP 470 5 1/8W
R8	NOTPLACED	64AM DUMMY PART NUMBER
R81	0611077A98	RES CHIP 10K 5 1/8W
R84	NOTPLACED	64AM DUMMY PART NUMBER
R87	0611077A98	RES CHIP 10K 5 1/8W
R9	0611077A98	RES CHIP 10K 5 1/8W
R98	NOTPLACED	64AM DUMMY PART NUMBER
R99	0611077A98	RES CHIP 10K 5 1/8W
T60	2580277J03	XFMR VLTG CONVERSION
U0102	7280032M01	DSPLY VF 14 SEG 8 CHAR BLUGRN
U1	0104002J91	PRGMD MICROP ASSEM
U101	5180236C05	IC VF DRVR SN75518FN
U3	5113820A02	IC DUAL SING SPLY LO PWR 2903
U4	5180057S04	"IC CUST SER I/O 13" REEL"
U45	5113816G04	IC +5V REG 78M05
VR0011	NOTPLACED	64AM DUMMY PART NUMBER
VR1	4813830A28	DIODE 15V 5% 225MW MMBZ5245B_
VR10	4813830A28	DIODE 15V 5% 225MW MMBZ5245B_
VR2	4813830A28	DIODE 15V 5% 225MW MMBZ5245B_

ITEM	MOTOROLA PART NUMBER	DESCRIPTION
VR20	4813830A28	DIODE 15V 5% 225MW MMBZ5245B_
VR21	4813830A28	DIODE 15V 5% 225MW MMBZ5245B_
VR22	4813830A28	DIODE 15V 5% 225MW MMBZ5245B_
VR3	4813830A28	DIODE 15V 5% 225MW MMBZ5245B_
VR4	4813830A28	DIODE 15V 5% 225MW MMBZ5245B_
VR5	NOTPLACED	64AM DUMMY PART NUMBER
VR50	4813830C41	DIODE 36V 'M3' MMSZ5258BT1
VR6	4813830A28	DIODE 15V 5% 225MW MMBZ5245B_
VR7	4813830A28	DIODE 15V 5% 225MW MMBZ5245B_
VR8	4813830A28	DIODE 15V 5% 225MW MMBZ5245B_
VR9	4813830A28	DIODE 15V 5% 225MW MMBZ5245B_
Y1	4880065M01	RESONTR CERAMIC 4.00 MHZ

## HLN6563D Motorcycle Parts List

ITEM	MOTOROLA PART NUMBER	DESCRIPTION
C0053	2113741N21	CAP CHIP CL2 X7R 10% 1000
C0055	2113741N21	CAP CHIP CL2 X7R 10% 1000
C1	2113741N45	CAP CHIP CL2 X7R 10% 10000
C10	NOTPLACED	64AM DUMMY PART NUMBER
C101	NOTPLACED	64AM DUMMY PART NUMBER
C11	NOTPLACED	64AM DUMMY PART NUMBER
C12	NOTPLACED	64AM DUMMY PART NUMBER
C13	2113741N69	CAP CHIP CL2 X7R 10%
C14	NOTPLACED	64AM DUMMY PART NUMBER
C15	NOTPLACED	64AM DUMMY PART NUMBER
C16	NOTPLACED	64AM DUMMY PART NUMBER
C17	2113741M13	CAP CHIP CL2 X7R 10% 470
C174	2113741M13	CAP CHIP CL2 X7R 10% 470
C175	2113741M13	CAP CHIP CL2 X7R 10% 470
C176	2113741M13	CAP CHIP CL2 X7R 10% 470
C18	NOTPLACED	64AM DUMMY PART NUMBER
C19	NOTPLACED	64AM DUMMY PART NUMBER
C2	2113741M13	CAP CHIP CL2 X7R 10% 470
C20	2113741M13	CAP CHIP CL2 X7R 10% 470
C21	2113741M13	CAP CHIP CL2 X7R 10% 470
C22	2113740B36	CAP CHIP REEL CL1 +/-30 30
C23	2113740B36	CAP CHIP REEL CL1 +/-30 30
C24	NOTPLACED	64AM DUMMY PART NUMBER
C25	NOTPLACED	64AM DUMMY PART NUMBER
C26	2113741M13	CAP CHIP CL2 X7R 10% 470
C27	2113741M13	CAP CHIP CL2 X7R 10% 470
C28	2113741M13	CAP CHIP CL2 X7R 10% 470
C29	2113741M13	CAP CHIP CL2 X7R 10% 470
C3	2113741N45	CAP CHIP CL2 X7R 10% 10000
C30	2113741M13	CAP CHIP CL2 X7R 10% 470
C31	2113741M13	CAP CHIP CL2 X7R 10% 470
C32	2113741M13	CAP CHIP CL2 X7R 10% 470

ITEM	MOTOROLA PART NUMBER	DESCRIPTION
C33	2113741M13	CAP CHIP CL2 X7R 10% 470
C34	2113741M13	CAP CHIP CL2 X7R 10% 470
C35	2113741M13	CAP CHIP CL2 X7R 10% 470
C36	2113741M13	CAP CHIP CL2 X7R 10% 470
C37	2113741M13	CAP CHIP CL2 X7R 10% 470
C38	2113741M13	CAP CHIP CL2 X7R 10% 470
C39	2113741M13	CAP CHIP CL2 X7R 10% 470
C4	2113741N45	CAP CHIP CL2 X7R 10% 10000
C40	2113741M13	CAP CHIP CL2 X7R 10% 470
C41	2113741M13	CAP CHIP CL2 X7R 10% 470
C42	NOTPLACED	64AM DUMMY PART NUMBER
C43	2113741N69	CAP CHIP CL2 X7R 10%
C44	NOTPLACED	64AM DUMMY PART NUMBER
C45	2380090M24	CAP ALU 10 20 50V SURF MT
C46	2311049A37	CAP TANT CHIP 1 20 20
C47	2113741N69	CAP CHIP CL2 X7R 10%
C48	2113741N69	CAP CHIP CL2 X7R 10%
C5	2113741N69	CAP CHIP CL2 X7R 10%
C50	2311049A95	CAP TANT CHIP 10 UF 25V 10%
C51	NOTPLACED	64AM DUMMY PART NUMBER
C52	2380090M24	CAP ALU 10 20 50V SURF MT
C54	2113740B65	CAP CHIP REEL CL1 +/-30 470
C56	2113741M13	CAP CHIP CL2 X7R 10% 470
C57	2113741M13	CAP CHIP CL2 X7R 10% 470
C58	2113741N45	CAP CHIP CL2 X7R 10% 10000
C6	2311049A38	CAP TANT CHIP 1.5 10 16
C7	2113741N45	CAP CHIP CL2 X7R 10% 10000
C8	2113741N45	CAP CHIP CL2 X7R 10% 10000
C9	NOTPLACED	64AM DUMMY PART NUMBER
CR111	4880026P01	DIODE LED RED
CR112	4880026P02	DIODE LED YELLOW

ITEM	MOTOROLA PART NUMBER	DESCRIPTION
CR131	4880052R03	DIODE LIGHT EMITTING GRN
CR132	4880052R03	DIODE LIGHT EMITTING GRN
CR133	4880052R03	DIODE LIGHT EMITTING GRN
CR134	4880052R03	DIODE LIGHT EMITTING GRN
CR135	4880052R03	DIODE LIGHT EMITTING GRN
CR136	4880052R03	DIODE LIGHT EMITTING GRN
CR137	4880052R03	DIODE LIGHT EMITTING GRN
CR138	4880052R03	DIODE LIGHT EMITTING GRN
CR139	4880052R03	DIODE LIGHT EMITTING GRN
CR140	4880052R03	DIODE LIGHT EMITTING GRN
CR51	4811058B11	DIODE 48S11058A11 A/P
CR52	4811058B11	DIODE 48S11058A11 A/P
CR53	4811058B11	DIODE 48S11058A11 A/P
CR54	4811058B11	DIODE 48S11058A11 A/P
CR55	4811058B11	DIODE 48S11058A11 A/P
CR71	4811058B11	DIODE 48S11058A11 A/P
CR72	NOTPLACED	64AM DUMMY PART NUMBER
CR73	4811058B11	DIODE 48S11058A11 A/P
CR76	4811058B11	DIODE 48S11058A11 A/P
CR90	4882960R02	DIODE RECT 48R82960R01 A/P
E0001	8480251R06	BD CKT CTRL HD
JU0003	NOTPLACED	64AM DUMMY PART NUMBER
JU0005	NOTPLACED	64AM DUMMY PART NUMBER
JU0016	NOTPLACED	64AM DUMMY PART NUMBER
JU0017	0611077A01	RES CHIP JUMPER
JU1	0611077A01	RES CHIP JUMPER
JU100	NOTPLACED	64AM DUMMY PART NUMBER
JU12	NOTPLACED	64AM DUMMY PART NUMBER
JU13	NOTPLACED	64AM DUMMY PART NUMBER
JU14	0611077A01	RES CHIP JUMPER
JU15	NOTPLACED	64AM DUMMY PART NUMBER
JU18	0611077A01	RES CHIP JUMPER
JU19	NOTPLACED	64AM DUMMY PART NUMBER

ITEM	MOTOROLA PART NUMBER	DESCRIPTION
JU2	NOTPLACED	64AM DUMMY PART NUMBER
JU4	NOTPLACED	64AM DUMMY PART NUMBER
JU6	0611077A01	RES CHIP JUMPER
JU7	NOTPLACED	64AM DUMMY PART NUMBER
JU8	NOTPLACED	64AM DUMMY PART NUMBER
JU9	NOTPLACED	64AM DUMMY PART NUMBER
L1	2480140E16	INDUCTOR CHIP 10UH
L50	2480140E16	INDUCTOR CHIP 10UH
MP0101	7580094M05	"SHOCK PAD, VF"
MP0102	7580094M05	"SHOCK PAD, VF"
MP0103	7580094M05	"SHOCK PAD, VF"
MP0106	5480004N01	LABEL BARCODE
P0103	2880102M07	PLUG VERTICAL 28 POSITION
P0104	2880068M01	HEADER MIC
Q111	4880141L02	TSTR NPN SOT23 LO PROFILE TAPE
Q112	4880141L02	TSTR NPN SOT23 LO PROFILE TAPE
Q131	4880141L02	TSTR NPN SOT23 LO PROFILE TAPE
Q50	4880053M03	TSTR N/CH SOT 89 200V B ST 84
Q51	4813821A30	MOSFET N-CH 60V 15A
Q52	4880141L01	TSTR PNP SOT23 LO PROFILE TAPE
Q71	4880053M02	TSTR NPN MXT2222A
Q72	NOTPLACED	64AM DUMMY PART NUMBER
Q73	4880053M02	TSTR NPN MXT2222A
Q74	4880141L02	TSTR NPN SOT23 LO PROFILE TAPE
Q75	4880141L02	TSTR NPN SOT23 LO PROFILE TAPE
R0002	0611077A90	RES CHIP 4700 5 1/8
R0005	0611077A90	RES CHIP 4700 5 1/8
R1	NOTPLACED	64AM DUMMY PART NUMBER
R101	0611077A28	RES CHIP 12 5 1/8W

ITEM	MOTOROLA PART NUMBER	DESCRIPTION
R111	0611077B23	RES CHIP 100K 5 1/8W
R112	0611077B23	RES CHIP 100K 5 1/8W
R113	0611077B11	RES CHIP 33K 5 1/8W
R114	0611077B11	RES CHIP 33K 5 1/8W
R115	0611077A74	RES CHIP 1000 5 1/8
R116	0611077A74	RES CHIP 1000 5 1/8
R120	0611077B23	RES CHIP 100K 5 1/8W
R121	0611077B23	RES CHIP 100K 5 1/8W
R122	0611077B23	RES CHIP 100K 5 1/8W
R123	0611077B23	RES CHIP 100K 5 1/8W
R124	0611077B23	RES CHIP 100K 5 1/8W
R131	0611077A68	RES CHIP 560 5 1/8W
R174	0611077A90	RES CHIP 4700 5 1/8
R175	0611077A90	RES CHIP 4700 5 1/8
R176	0611077A90	RES CHIP 4700 5 1/8
R177	0611077A90	RES CHIP 4700 5 1/8
R178	0611077A98	RES CHIP 10K 5 1/8W
R180	0611077A28	RES CHIP 12 5 1/8W
R181	0611077B07	RES CHIP 22K 5 1/8W
R182	0611077A28	RES CHIP 12 5 1/8W
R200	0611077B47	RES CHIP 1 MEG 5 1/8W
R25	0611077B15	RES CHIP 47K 5 1/8W
R28	0611077A74	RES CHIP 1000 5 1/8
R29	0611077B23	RES CHIP 100K 5 1/8W
R3	0611077B07	RES CHIP 22K 5 1/8W
R30	0611077B47	RES CHIP 1 MEG 5 1/8W
R31	0611077B15	RES CHIP 47K 5 1/8W
R34	0611077B15	RES CHIP 47K 5 1/8W
R4	0611077B47	RES CHIP 1 MEG 5 1/8W
R50	0611077A68	RES CHIP 560 5 1/8W
R51	0611077B07	RES CHIP 22K 5 1/8W
R52	0611077A98	RES CHIP 10K 5 1/8W
R55	0611077A28	RES CHIP 12 5 1/8W

ITEM	MOTOROLA PART NUMBER	DESCRIPTION
R56	0611077B11	RES CHIP 33K 5 1/8W
R57	0611077B15	RES CHIP 47K 5 1/8W
R58	0611077B11	RES CHIP 33K 5 1/8W
R59	0611077A98	RES CHIP 10K 5 1/8W
R6	0611077A98	RES CHIP 10K 5 1/8W
R60	0611077A78	RES CHIP 1500 5 1/8
R61	0611077A94	RES CHIP 6.8K 5 1/8
R7	0611077A98	RES CHIP 10K 5 1/8W
R71	0611077A66	RES CHIP 470 5 1/8W
R72	0611077A66	RES CHIP 470 5 1/8W
R73	0611077B11	RES CHIP 33K 5 1/8W
R74	0611077B11	RES CHIP 33K 5 1/8W
R75	0611077B11	RES CHIP 33K 5 1/8W
R76	0611077A66	RES CHIP 470 5 1/8W
R77	0611077A66	RES CHIP 470 5 1/8W
R8	0611077A74	RES CHIP 1000 5 1/8
R81	NOTPLACED	64AM DUMMY PART NUMBER
R84	NOTPLACED	64AM DUMMY PART NUMBER
R87	0611077A98	RES CHIP 10K 5 1/8W
R9	0611077A98	RES CHIP 10K 5 1/8W
R98	NOTPLACED	64AM DUMMY PART NUMBER
R99	0611077A98	RES CHIP 10K 5 1/8W
U0102	7280032M01	DSPLY VF 14 SEG 8 CHAR BLUGRN
U1	0104002J91	PRGMD MICROP ASSEM
U101	5180236C05	IC VF DRVR SN75518FN
U3	5113820A02	IC DUAL SING SPLY LO PWR 2903
U4	5180057S04	"IC CUST SER I/O 13" REEL"
U45	5113816G04	IC +5V REG 78M05
VR1	4813830A28	DIODE 15V 5% 225MW MMBZ5245B_
VR10	4813830A28	DIODE 15V 5% 225MW MMBZ5245B_
VR11	4813830C41	DIODE 36V 'M3' MMSZ5258BT1

ITEM	MOTOROLA PART NUMBER	DESCRIPTION
VR2	4813830A28	DIODE 15V 5% 225MW MMBZ5245B_
VR20	4813830A28	DIODE 15V 5% 225MW MMBZ5245B_
VR21	4813830A28	DIODE 15V 5% 225MW MMBZ5245B_
VR22	4813830A28	DIODE 15V 5% 225MW MMBZ5245B_
VR3	4813830A28	DIODE 15V 5% 225MW MMBZ5245B_
VR4	4813830A28	DIODE 15V 5% 225MW MMBZ5245B_
VR5	4813830A28	DIODE 15V 5% 225MW MMBZ5245B_
VR50	4813830C41	DIODE 36V 'M3' MMSZ5258BT1
VR6	4813830A28	DIODE 15V 5% 225MW MMBZ5245B_
VR7	4813830A28	DIODE 15V 5% 225MW MMBZ5245B_
VR8	4813830A28	DIODE 15V 5% 225MW MMBZ5245B_
VR9	4813830A28	DIODE 15V 5% 225MW MMBZ5245B_
Y1	4880065M01	RESONTR CERAMIC 4.00 MHZ

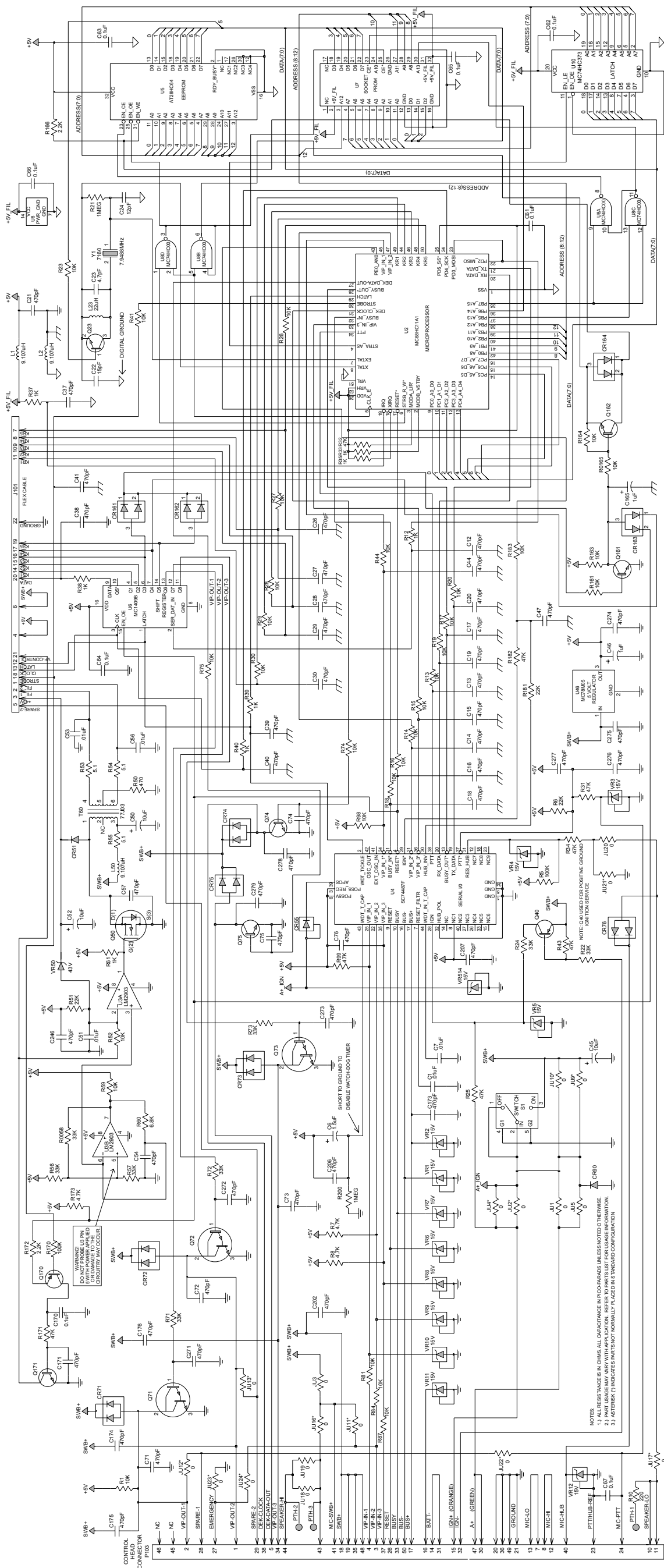

Figure 8-14. HCN1078J (Standard), HCN1121D (Rear) W9 Control Head Schematic (Side 1 of 2)

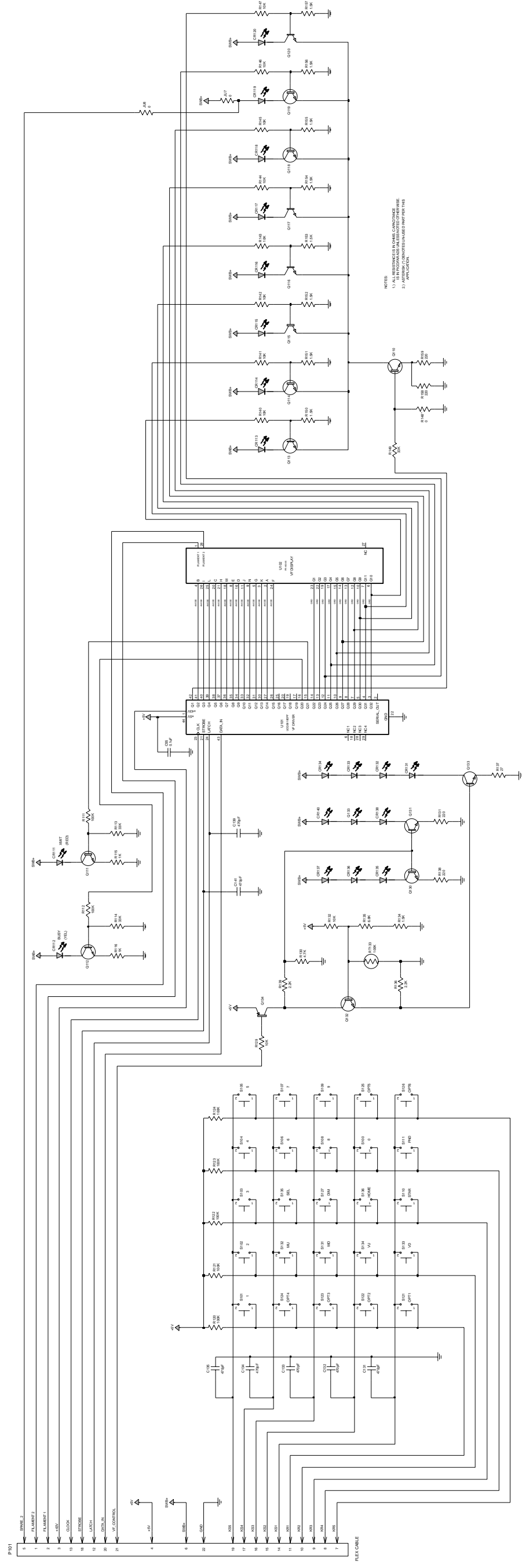

Figure 8-15. HCN1078J (Standard), HCN1121D (Rear) W9 Control Head Schematic (Side 2 of 2)

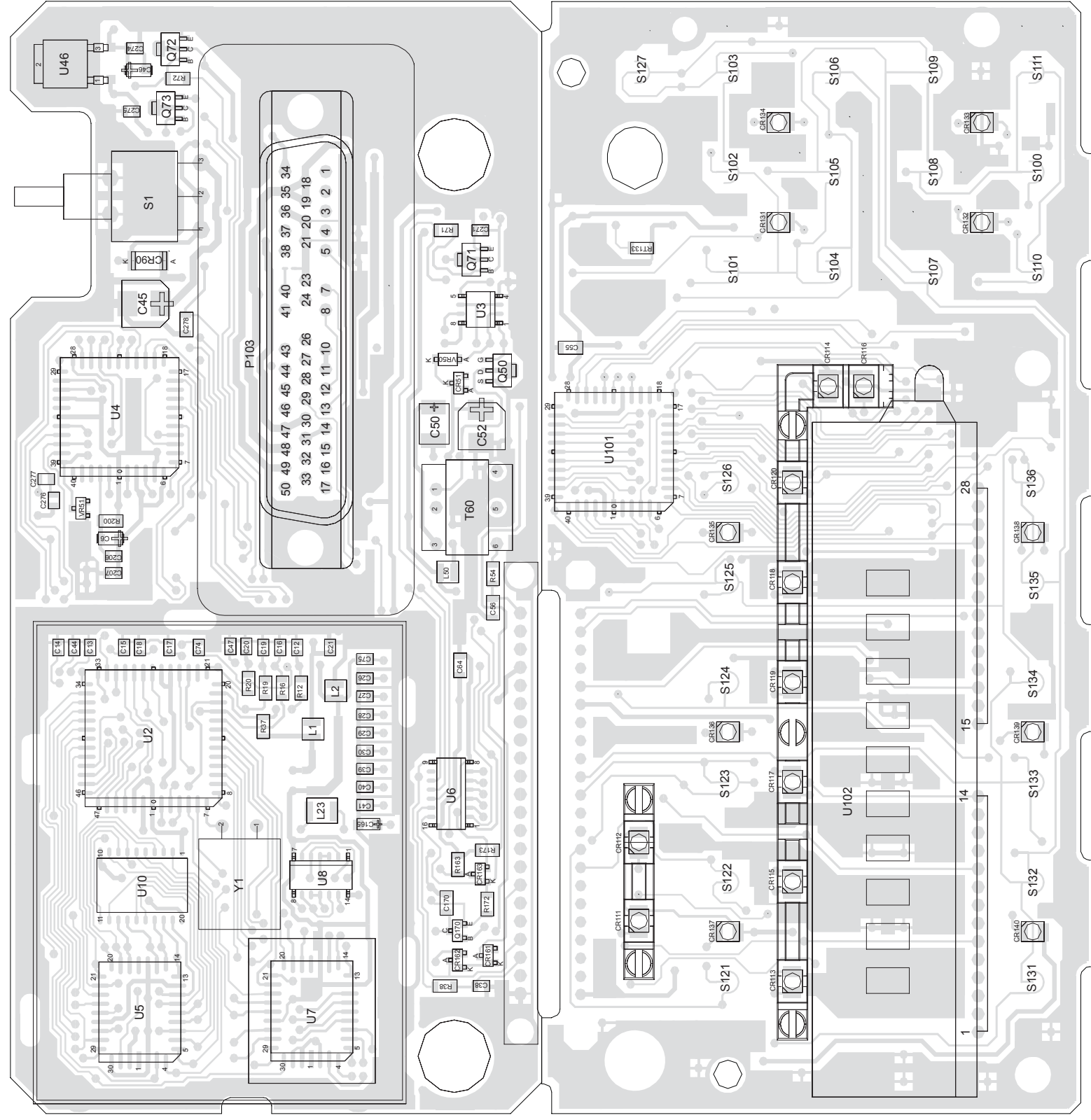

Figure 8-16. HCN1078J (Standard), HCN1121D (Rear) W9 Control Head Component Location Diagram (Viewed from Side 1)



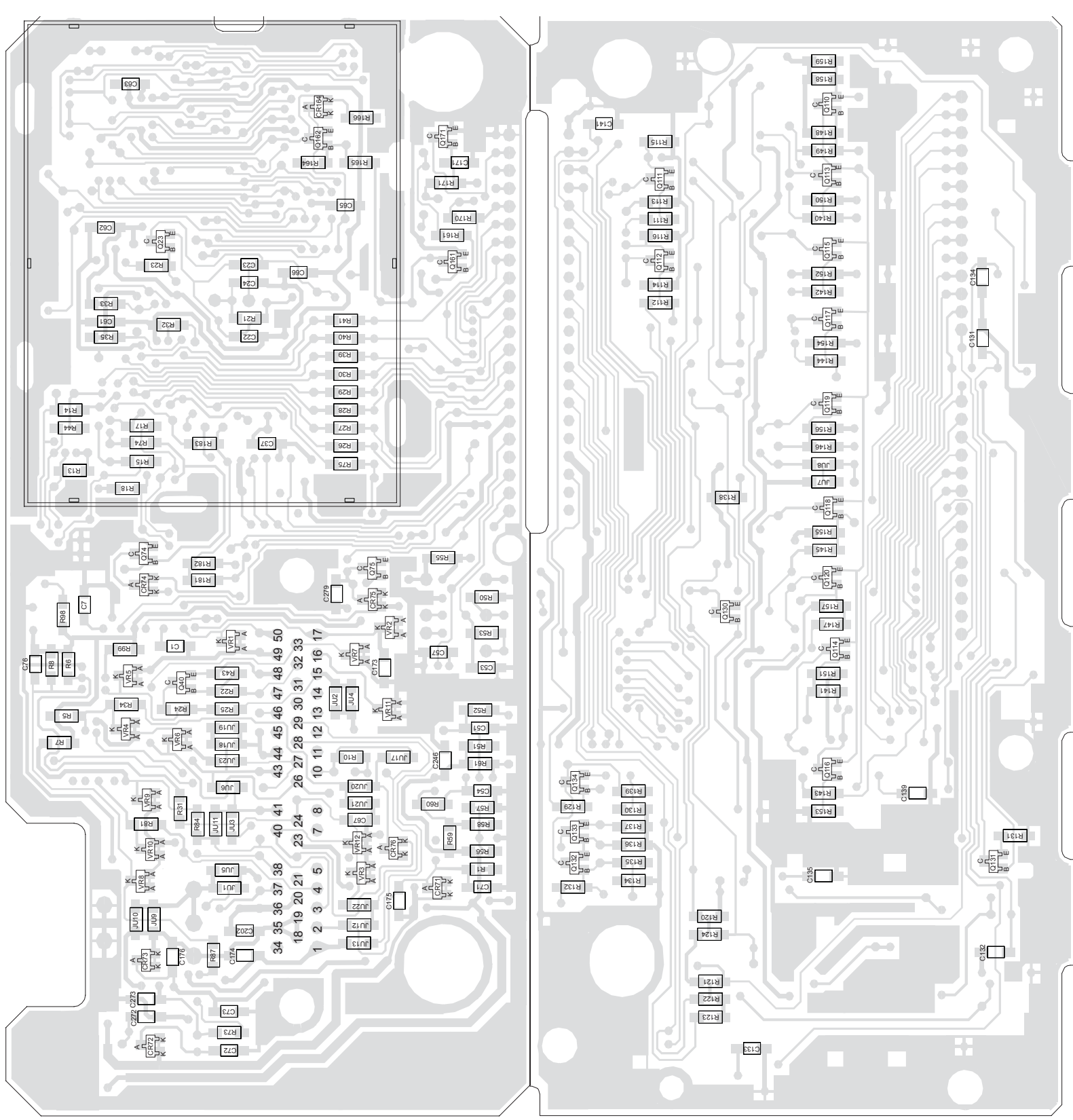

Figure 8-17. HCN1078J (Standard), HCN1121D (Rear) W9 Control Head Component Location Diagram (Viewed from Side 2)

## HCN1078J (Standard), HCN1121D (Rear) Parts List

ITEM	MOTOROLA PART NUMBER	DESCRIPTION
C1	2113741N45	CAP CHIP CL2 X7R 10% 10000
C12	2113741M13	CAP CHIP CL2 X7R 10% 470
C13	2113741M13	CAP CHIP CL2 X7R 10% 470
C131	2113740B65	CAP CHIP REEL CL1 +/-30 470
C132	2113740B65	CAP CHIP REEL CL1 +/-30 470
C133	2113740B65	CAP CHIP REEL CL1 +/-30 470
C134	2113740B65	CAP CHIP REEL CL1 +/-30 470
C135	2113740B65	CAP CHIP REEL CL1 +/-30 470
C139	2113740B65	CAP CHIP REEL CL1 +/-30 470
C14	2113741M13	CAP CHIP CL2 X7R 10% 470
C141	2113740B65	CAP CHIP REEL CL1 +/-30 470
C15	2113741M13	CAP CHIP CL2 X7R 10% 470
C16	2113741M13	CAP CHIP CL2 X7R 10% 470
C165	2311049A37	CAP TANT CHIP 1 20 20
C17	2113741M13	CAP CHIP CL2 X7R 10% 470
C170	2113741N69	CAP CHIP CL2 X7R 10% 10000
C171	2113740B65	CAP CHIP REEL CL1 +/-30 470
C173	2113740B65	CAP CHIP REEL CL1 +/-30 470
C174	2113740B65	CAP CHIP REEL CL1 +/-30 470
C175	2113740B65	CAP CHIP REEL CL1 +/-30 470
C176	2113740B65	CAP CHIP REEL CL1 +/-30 470
C18	2113741M13	CAP CHIP CL2 X7R 10% 470
C19	2113741M13	CAP CHIP CL2 X7R 10% 470
C20	2113741M13	CAP CHIP CL2 X7R 10% 470
C202	2113740B65	CAP CHIP REEL CL1 +/-30 470
C206	2113741M13	CAP CHIP CL2 X7R 10% 470
C207	2113741M13	CAP CHIP CL2 X7R 10% 470
C21	2113741M13	CAP CHIP CL2 X7R 10% 470
C22	2113740B29	CAP CHIP REEL CL1 +/-30 15
C23	2113740B17	CAP CHIP REEL CL1 +/-30 4.7
C24	2113740B27	CAP CHIP REEL CL1 +/-30 12
C246	2113740B65	CAP CHIP REEL CL1 +/-30 470

ITEM	MOTOROLA PART NUMBER	DESCRIPTION
C26	2113741M13	CAP CHIP CL2 X7R 10% 470
C27	2113741M13	CAP CHIP CL2 X7R 10% 470
C271	2113741M13	CAP CHIP CL2 X7R 10% 470
C272	2113740B65	CAP CHIP REEL CL1 +/-30 470
C273	2113740B65	CAP CHIP REEL CL1 +/-30 470
C274	2113741M13	CAP CHIP CL2 X7R 10% 470
C275	2113741M13	CAP CHIP CL2 X7R 10% 470
C277	2113741M13	CAP CHIP CL2 X7R 10% 470
C278	2113740B65	CAP CHIP REEL CL1 +/-30 470
C279	2113740B65	CAP CHIP REEL CL1 +/-30 470
C28	2113741M13	CAP CHIP CL2 X7R 10% 470
C29	2113741M13	CAP CHIP CL2 X7R 10% 470
C30	2113741M13	CAP CHIP CL2 X7R 10% 470
C300	2113741M13	CAP CHIP CL2 X7R 10% 470
C301	2113741M13	CAP CHIP CL2 X7R 10% 470
C37	2113740B65	CAP CHIP REEL CL1 +/-30 470
C38	2113741M13	CAP CHIP CL2 X7R 10% 470
C39	2113741M13	CAP CHIP CL2 X7R 10% 470
C40	2113741M13	CAP CHIP CL2 X7R 10% 470
C41	2113741M13	CAP CHIP CL2 X7R 10% 470
C44	2113741M13	CAP CHIP CL2 X7R 10% 470
C45	2380090M24	CAP ALU 10 20 50V SURF MT
C46	2311049A37	CAP TANT CHIP 1 20 20
C47	2113741M13	CAP CHIP CL2 X7R 10% 470
C50	2311049J27	CAP TANT CHIP 10 10 25
C51	2113741N45	CAP CHIP CL2 X7R 10% 10000
C52	2380090M24	CAP ALU 10 20 50V SURF MT
C53	2113741N45	CAP CHIP CL2 X7R 10% 10000
C54	2113740B65	CAP CHIP REEL CL1 +/-30 470
C55	2113741N69	CAP CHIP CL2 X7R 10% 10000
C56	2113741N45	CAP CHIP CL2 X7R 10% 10000
C57	2113740B65	CAP CHIP REEL CL1 +/-30 470
C6	2311049A38	CAP TANT CHIP 1.5 10 16

ITEM	MOTOROLA PART NUMBER	DESCRIPTION
C61	2113741N69	CAP CHIP CL2 X7R 10% 10000
C62	2113741N69	CAP CHIP CL2 X7R 10% 10000
C63	2113741N69	CAP CHIP CL2 X7R 10% 10000
C64	2113741N69	CAP CHIP CL2 X7R 10% 10000
C65	2113741N69	CAP CHIP CL2 X7R 10% 10000
C66	2113741N69	CAP CHIP CL2 X7R 10% 10000
C67	2113741N69	CAP CHIP CL2 X7R 10% 10000
C7	2113741N45	CAP CHIP CL2 X7R 10% 10000
C71	2113740B65	CAP CHIP REEL CL1 +/-30 470
C72	2113740B65	CAP CHIP REEL CL1 +/-30 470
C73	2113740B65	CAP CHIP REEL CL1 +/-30 470
C74	2113741M13	CAP CHIP CL2 X7R 10% 470
C75	2113741M13	CAP CHIP CL2 X7R 10% 470
C76	2113740B65	CAP CHIP REEL CL1 +/-30 470
CR111	4880052R01	DIODE LIGHT EMITTING RED
CR112	4880052R02	DIODE LIGHT EMITTING YEL
CR113	4880052R01	DIODE LIGHT EMITTING RED
CR114	4880052R01	DIODE LIGHT EMITTING RED
CR115	4880052R01	DIODE LIGHT EMITTING RED
CR116	4880052R02	DIODE LIGHT EMITTING YEL
CR117	4880052R01	DIODE LIGHT EMITTING RED
CR118	4880052R01	DIODE LIGHT EMITTING RED
CR119	4880052R01	DIODE LIGHT EMITTING RED
CR120	4880052R01	DIODE LIGHT EMITTING RED
CR131	4880052R03	DIODE LIGHT EMITTING GRN
CR132	4880052R03	DIODE LIGHT EMITTING GRN
CR133	4880052R03	DIODE LIGHT EMITTING GRN
CR134	4880052R03	DIODE LIGHT EMITTING GRN
CR135	4880052R03	DIODE LIGHT EMITTING GRN

ITEM	MOTOROLA PART NUMBER	DESCRIPTION
CR136	4880052R03	DIODE LIGHT EMITTING GRN
CR137	4880052R03	DIODE LIGHT EMITTING GRN
CR138	4880052R03	DIODE LIGHT EMITTING GRN
CR139	4880052R03	DIODE LIGHT EMITTING GRN
CR140	4880052R03	DIODE LIGHT EMITTING GRN
CR161	4880236E08	DIODE DUAL SOT 23
CR162	4880236E08	DIODE DUAL SOT 23
CR163	4880236E08	DIODE DUAL SOT 23
CR164	4880236E08	DIODE DUAL SOT 23
CR51	4813833C09	DIODE GEN PURP .1A 100V 'DX'
CR71	4880236E08	DIODE DUAL SOT 23
CR72	4880236E08	DIODE DUAL SOT 23
CR73	4880236E08	DIODE DUAL SOT 23
CR74	4880236E08	DIODE DUAL SOT 23
CR75	4880236E08	DIODE DUAL SOT 23
CR76	4880236E08	DIODE DUAL SOT 23
CR90	4882960R02	DIODE RECT 48R82960R01 A/P
JU1	0611077A01	RES CHIP JUMPER
JU18	0611077A01	RES CHIP JUMPER
JU19	0611077A01	RES CHIP JUMPER
JU20	0611077A01	RES CHIP JUMPER
JU23	0611077A01	RES CHIP JUMPER
JU3	0611077A01	RES CHIP JUMPER
JU5	0611077A01	RES CHIP JUMPER
JU7	0611077A01	RES CHIP JUMPER
L1	2480140E16	INDUCTOR CHIP 10UH
L2	2480140E16	INDUCTOR CHIP 10UH
L23	2480289M16	COIL IF 22UH 1611 CS 223
L50	2480140E16	INDUCTOR CHIP 10UH
P7	0980049R01	SOCKET PLCC 32 PIN
Q110	4880141L02	TSTR NPN SOT23 LO PROFILE TAPE
Q110	4880141L04	TSTR NPN SOT23 LO PROFILE TAPE

ITEM	MOTOROLA PART NUMBER	DESCRIPTION
Q111	4880141L02	TSTR NPN SOT23 LO PROFILE TAPE
Q112	4880141L02	TSTR NPN SOT23 LO PROFILE TAPE
Q113	4880141L02	TSTR NPN SOT23 LO PROFILE TAPE
Q114	4880141L02	TSTR NPN SOT23 LO PROFILE TAPE
Q115	4880141L02	TSTR NPN SOT23 LO PROFILE TAPE
Q116	4880141L02	TSTR NPN SOT23 LO PROFILE TAPE
Q117	4880141L02	TSTR NPN SOT23 LO PROFILE TAPE
Q118	4880141L02	TSTR NPN SOT23 LO PROFILE TAPE
Q119	4880141L02	TSTR NPN SOT23 LO PROFILE TAPE
Q120	4880141L02	TSTR NPN SOT23 LO PROFILE TAPE
Q130	4880141L02	TSTR NPN SOT23 LO PROFILE TAPE
Q131	4880141L02	TSTR NPN SOT23 LO PROFILE TAPE
Q132	4880141L02	TSTR NPN SOT23 LO PROFILE TAPE
Q133	4880141L02	TSTR NPN SOT23 LO PROFILE TAPE
Q134	4880141L01	TSTR PNP SOT23 LO PROFILE TAPE
Q161	4880141L02	TSTR NPN SOT23 LO PROFILE TAPE
Q162	4880141L02	TSTR NPN SOT23 LO PROFILE TAPE
Q170	4880141L01	TSTR PNP SOT23 LO PROFILE TAPE
Q171	4880141L02	TSTR NPN SOT23 LO PROFILE TAPE
Q23	4880141L02	TSTR NPN SOT23 LO PROFILE TAPE
Q40	4880141L01	TSTR PNP SOT23 LO PROFILE TAPE

ITEM	MOTOROLA PART NUMBER	DESCRIPTION
Q50	4880053M03	TSTR N/CH SOT 89 200V B ST 84
Q71	4880052M01	TSTR NPN DRLNGTN MXTA27
Q72	4880052M01	TSTR NPN DRLNGTN MXTA27
Q73	4880052M01	TSTR NPN DRLNGTN MXTA27
Q74	4880141L04	TSTR NPN SOT23 LO PROFILE TAPE
Q75	4880141L04	TSTR NPN SOT23 LO PROFILE TAPE
R1	0611077A98	RES CHIP 10K 5 1/8W
R10	0611077A58	RES CHIP 220 5 1/8W
R111	0611077B23	RES CHIP 100K 5 1/8W
R112	0611077B23	RES CHIP 100K 5 1/8W
R113	0611077B11	RES CHIP 33K 5 1/8W
R114	0611077B11	RES CHIP 33K 5 1/8W
R115	0611077A74	RES CHIP 1000 5 1/8
R116	0611077A74	RES CHIP 1000 5 1/8
R12	0611077A74	RES CHIP 1000 5 1/8
R120	0611077B23	RES CHIP 100K 5 1/8W
R121	0611077B23	RES CHIP 100K 5 1/8W
R122	0611077B23	RES CHIP 100K 5 1/8W
R123	0611077B23	RES CHIP 100K 5 1/8W
R124	0611077B23	RES CHIP 100K 5 1/8W
R129	0611077A98	RES CHIP 10K 5 1/8W
R13	0611077A98	RES CHIP 10K 5 1/8W
R130	0611077A90	RES CHIP 4700 5 1/8
R131	0611077A58	RES CHIP 220 5 1/8W
R132	0611077A98	RES CHIP 10K 5 1/8W
R134	0611077A78	RES CHIP 1500 5 1/8
R135	0611077A94	RES CHIP 6800 5 1/8
R136	0611077A82	RES CHIP 2200 5 1/8
R137	0611077A36	RES CHIP 27 5 1/8W
R138	0611077A58	RES CHIP 220 5 1/8W
R139	0611077A82	RES CHIP 2200 5 1/8
R14	0611077A98	RES CHIP 10K 5 1/8W

ITEM	MOTOROLA PART NUMBER	DESCRIPTION
R140	0611077A98	RES CHIP 10K 5 1/8W
R141	0611077A98	RES CHIP 10K 5 1/8W
R142	0611077A98	RES CHIP 10K 5 1/8W
R143	0611077A98	RES CHIP 10K 5 1/8W
R144	0611077A98	RES CHIP 10K 5 1/8W
R145	0611077A98	RES CHIP 10K 5 1/8W
R146	0611077A98	RES CHIP 10K 5 1/8W
R147	0611077A98	RES CHIP 10K 5 1/8W
R149	0611077B11	RES CHIP 33K 5 1/8W
R15	0611077A98	RES CHIP 10K 5 1/8W
R150	0611077A78	RES CHIP 1500 5 1/8
R151	0611077A78	RES CHIP 1500 5 1/8
R152	0611077A78	RES CHIP 1500 5 1/8
R153	0611077A82	RES CHIP 2200 5 1/8
R154	0611077A78	RES CHIP 1500 5 1/8
R155	0611077A78	RES CHIP 1500 5 1/8
R156	0611077A78	RES CHIP 1500 5 1/8
R157	0611077A78	RES CHIP 1500 5 1/8
R158	0611077A58	RES CHIP 220 5 1/8W
R159	0611077A58	RES CHIP 220 5 1/8W
R16	0611077A98	RES CHIP 10K 5 1/8W
R161	0611077A98	RES CHIP 10K 5 1/8W
R163	0611077A98	RES CHIP 10K 5 1/8W
R164	0611077A98	RES CHIP 10K 5 1/8W
R165	0611077A98	RES CHIP 10K 5 1/8W
R166	0611077A82	RES CHIP 2200 5 1/8
R17	0611077A98	RES CHIP 10K 5 1/8W
R170	0611077B23	RES CHIP 100K 5 1/8W
R171	0611077B15	RES CHIP 47K 5 1/8W
R172	0611077A82	RES CHIP 2200 5 1/8
R173	0611077A90	RES CHIP 4700 5 1/8
R18	0611077A98	RES CHIP 10K 5 1/8W
R181	0611077B07	RES CHIP 22K 5 1/8W

ITEM	MOTOROLA PART NUMBER	DESCRIPTION
R182	0611077B15	RES CHIP 47K 5 1/8W
R183	0611077A98	RES CHIP 10K 5 1/8W
R19	0611077A98	RES CHIP 10K 5 1/8W
R20	0611077A98	RES CHIP 10K 5 1/8W
R200	0611077B47	RES CHIP 1 MEG 5 1/8W
R21	0611077B47	RES CHIP 1 MEG 5 1/8W
R22	0611077B11	RES CHIP 33K 5 1/8W
R23	0611077A98	RES CHIP 10K 5 1/8W
R24	0611077B11	RES CHIP 33K 5 1/8W
R25	0611077B15	RES CHIP 47K 5 1/8W
R26	0611077A98	RES CHIP 10K 5 1/8W
R27	0611077A98	RES CHIP 10K 5 1/8W
R28	0611077A98	RES CHIP 10K 5 1/8W
R29	0611077A98	RES CHIP 10K 5 1/8W
R30	0611077A98	RES CHIP 10K 5 1/8W
R31	0611077B15	RES CHIP 47K 5 1/8W
R32	0611077B15	RES CHIP 47K 5 1/8W
R33	0611077A74	RES CHIP 1000 5 1/8
R34	0611077B15	RES CHIP 47K 5 1/8W
R35	0611077A74	RES CHIP 1000 5 1/8
R37	0611077A74	RES CHIP 1000 5 1/8
R38	0611077A74	RES CHIP 1000 5 1/8
R39	0611077A98	RES CHIP 10K 5 1/8W
R40	0611077A74	RES CHIP 1000 5 1/8
R41	0611077A98	RES CHIP 10K 5 1/8W
R43	0611077B15	RES CHIP 47K 5 1/8W
R44	0611077A98	RES CHIP 10K 5 1/8W
R5	0611077B23	RES CHIP 100K 5 1/8W
R50	0611077A66	RES CHIP 470 5 1/8W
R51	0611077B07	RES CHIP 22K 5 1/8W
R52	0611077A98	RES CHIP 10K 5 1/8W
R53	0611077A19	RES CHIP 5.1 5 1/8W
R54	0611077A19	RES CHIP 5.1 5 1/8W

ITEM	MOTOROLA PART NUMBER	DESCRIPTION
R55	0611077A28	RES CHIP 12 5 1/8W
R56	0611077B11	RES CHIP 33K 5 1/8W
R57	0611077B11	RES CHIP 33K 5 1/8W
R58	0611077B11	RES CHIP 33K 5 1/8W
R59	0611077A98	RES CHIP 10K 5 1/8W
R6	0611077B07	RES CHIP 22K 5 1/8W
R60	0611077A94	RES CHIP 6800 5 1/8
R61	0611077A74	RES CHIP 1000 5 1/8
R7	0611077A90	RES CHIP 4700 5 1/8
R71	0611077B11	RES CHIP 33K 5 1/8W
R72	0611077B11	RES CHIP 33K 5 1/8W
R73	0611077B11	RES CHIP 33K 5 1/8W
R74	0611077A98	RES CHIP 10K 5 1/8W
R75	0611077A98	RES CHIP 10K 5 1/8W
R8	0611077A90	RES CHIP 4700 5 1/8
R81	0611077A98	RES CHIP 10K 5 1/8W
R84	0611077A98	RES CHIP 10K 5 1/8W
R87	0611077A98	RES CHIP 10K 5 1/8W
R98	0611077A98	RES CHIP 10K 5 1/8W
R99	0611077B15	RES CHIP 47K 5 1/8W
RT133	0680149M02	THERMISTOR CHIP 100K OHM
U10	5180177M02	WIDE BODY SOLC OCTAL LATCH
U101	5180236C05	IC VF DRVR SN75518FN
U102	7280242J01	DISPLAY VF
U2	5113802A01 (HCN1078 only)	IC 68HC11 W/SCI SPI A/D 512
U3	5113820A02	IC DUAL SING SPLY LO PWR 2903
U4	5180057S04	"IC CUST SER I/O 13" REEL"
U46	5113816G04	IC +5V REG 78M05
U5	5197014A10	IC SPECTRA MEMORY BD
U6	5184704M54	IC CMOS REGISTER
U7	Not Available	IC PROM

ITEM	MOTOROLA PART NUMBER	DESCRIPTION
U8	5180177M03	QUAD NAND GATE
VR1	4813830A28	DIODE 15V 5% 225MW MMBZ5245B_
VR10	4813830A28	DIODE 15V 5% 225MW MMBZ5245B_
VR11	4813830A28	DIODE 15V 5% 225MW MMBZ5245B_
VR12	4813832C28	ZENER BPLR 15V FOR ESD SOT23
VR2	4813830A28	DIODE 15V 5% 225MW MMBZ5245B_
VR3	4813830A28	DIODE 15V 5% 225MW MMBZ5245B_
VR4	4813832C28	ZENER BPLR 15V FOR ESD SOT23
VR5	4813830A28	DIODE 15V 5% 225MW MMBZ5245B_
VR50	4813830C43	DIODE 43V 'M5' MMSZ5260BT1
VR514	4813830A28	DIODE 15V 5% 225MW MMBZ5245B_
VR6	4813830A28	DIODE 15V 5% 225MW MMBZ5245B_
VR7	4813830A28	DIODE 15V 5% 225MW MMBZ5245B_
VR8	4813830A28	DIODE 15V 5% 225MW MMBZ5245B_
VR9	4813830A28	DIODE 15V 5% 225MW MMBZ5245B_

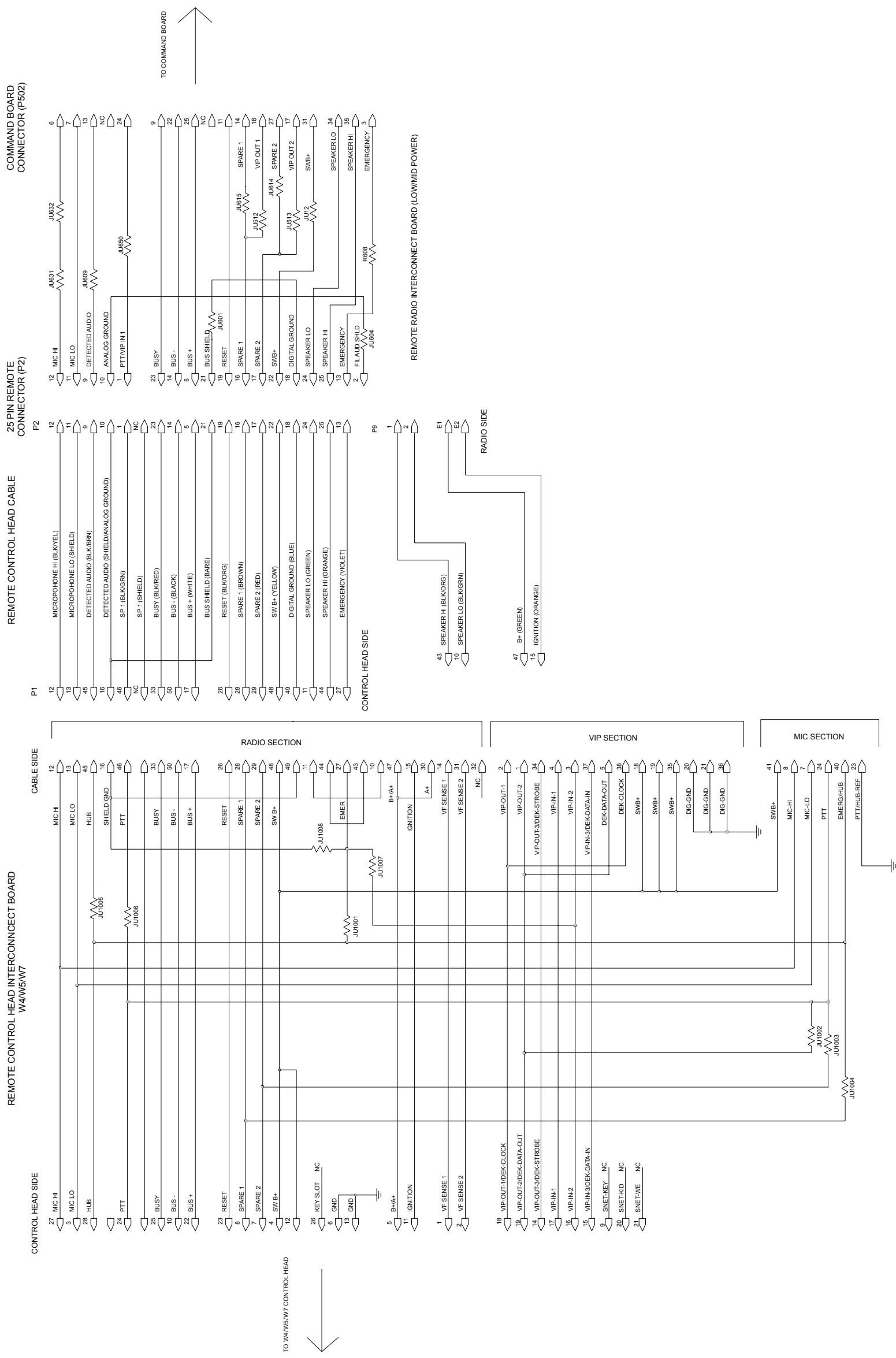

Figure 8-18. W4, W5, and W7 Control Head Low-/Mid-Power Interconnection Diagram

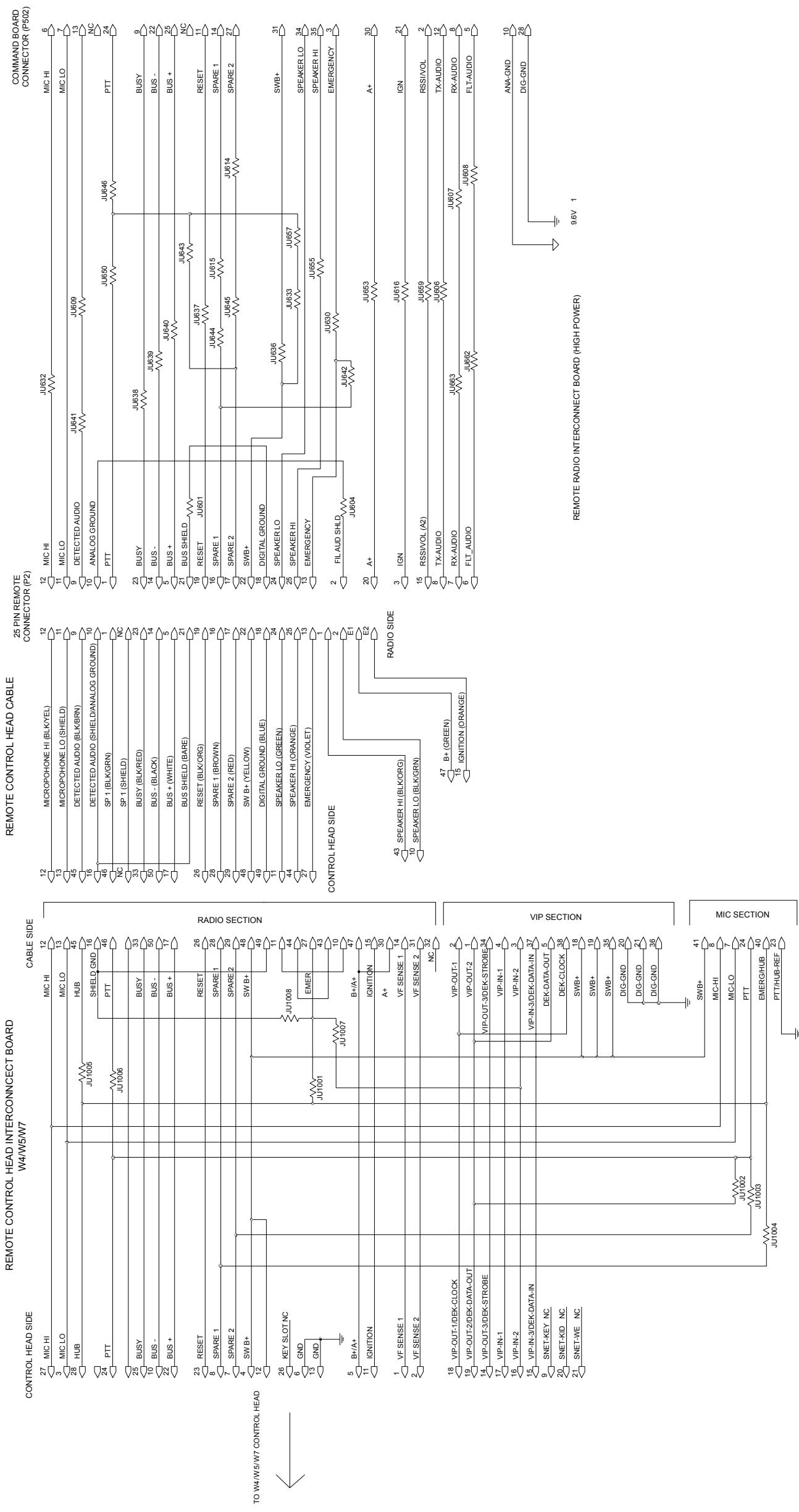
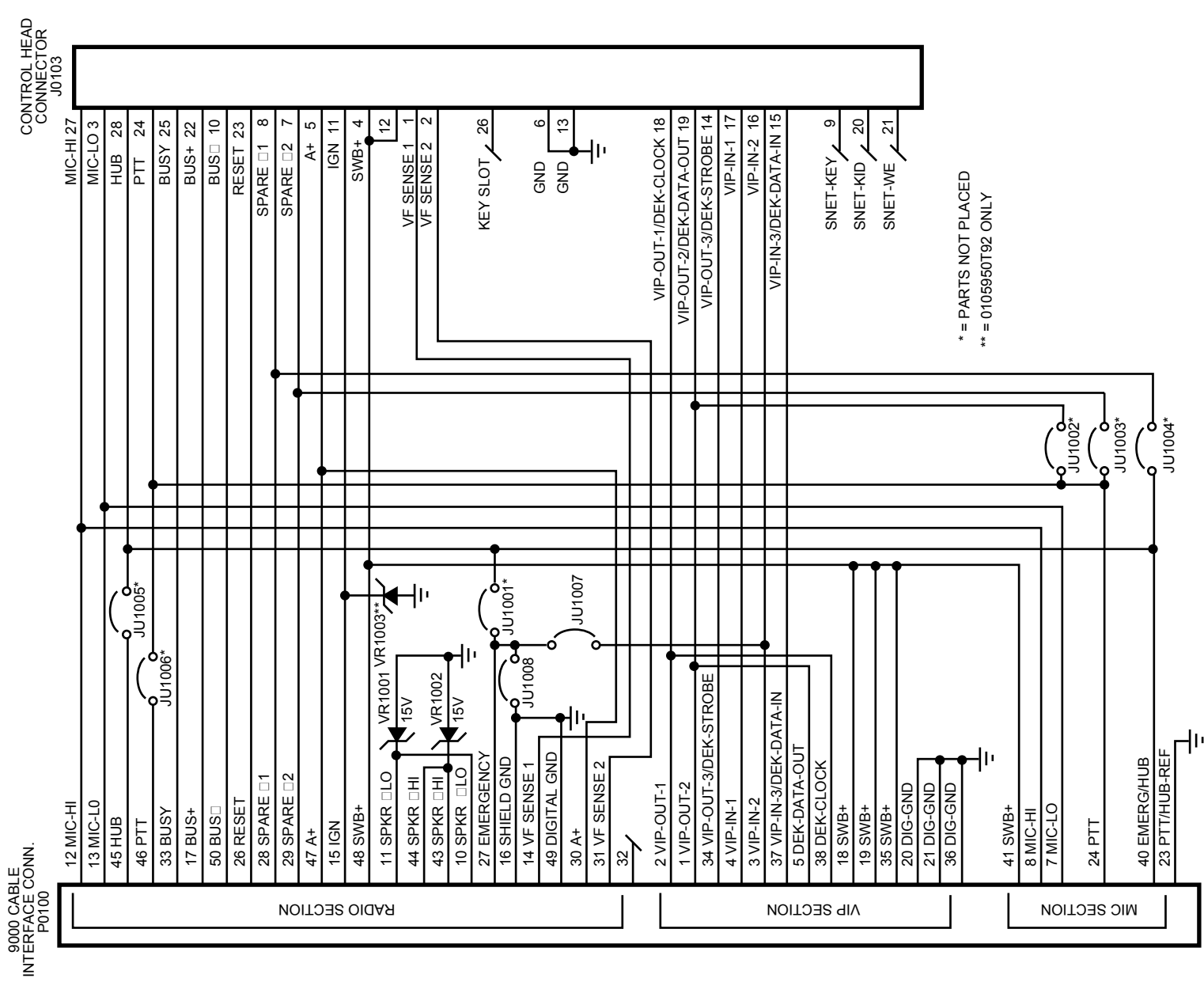

Figure 8-19. W4, W5, and W7 High Power Interconnection Diagram

### HLN6432D W5/W7 CONTROL HEAD INTERFACE BOARD



MAEPF-23570-A

Figure 8-20. W5 and W7 Control Head Interface Board Schematic

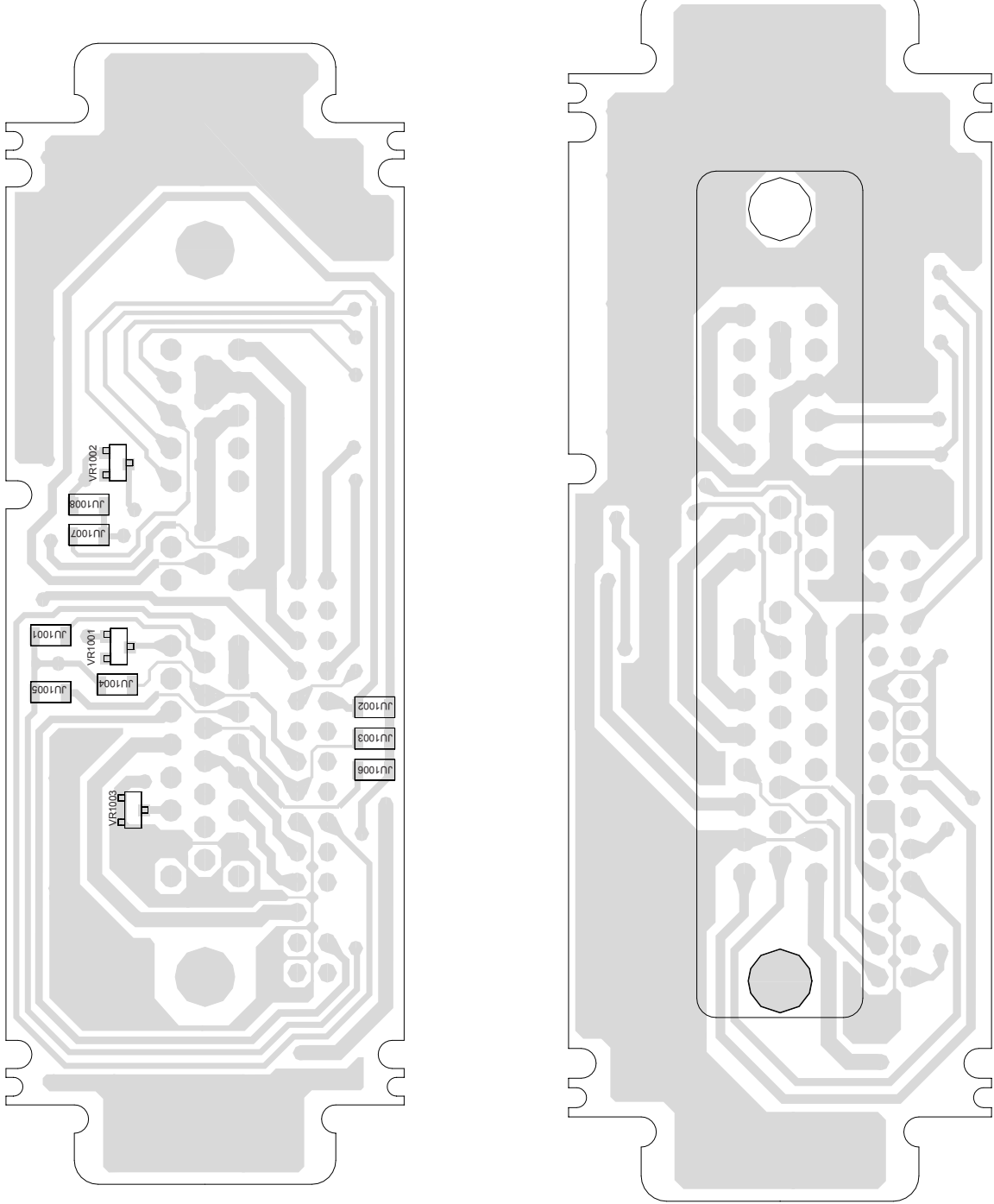

HLN6432D W5/W7 Parts List

Item	Motorola Part Number	Description
JU1001	NOTPLACED	64AM DUMMY PART NUMBER
JU1002	NOTPLACED	64AM DUMMY PART NUMBER
JU1003	NOTPLACED	64AM DUMMY PART NUMBER
JU1004	NOTPLACED	64AM DUMMY PART NUMBER
JU1005	NOTPLACED	64AM DUMMY PART NUMBER
JU1006	NOTPLACED	64AM DUMMY PART NUMBER
JU1007	0611077A01	RES CHIP JUMPER
JU1008	0611077A01	RES CHIP JUMPER
VR1001	4813830A28	DIODE 15V 5% 225MW MMBZ5245B_
VR1002	4813830A28	DIODE 15V 5% 225MW MMBZ5245B_
VR1003	NOTPLACED	64AM DUMMY PART NUMBER

Figure 8-21. HLN6432D W5/W7 Control Head Interface Board Component Location Diagram



**HLN6401A  
CONTROL HEAD INTERCONNECT BOARD  
(Dash Mount)**

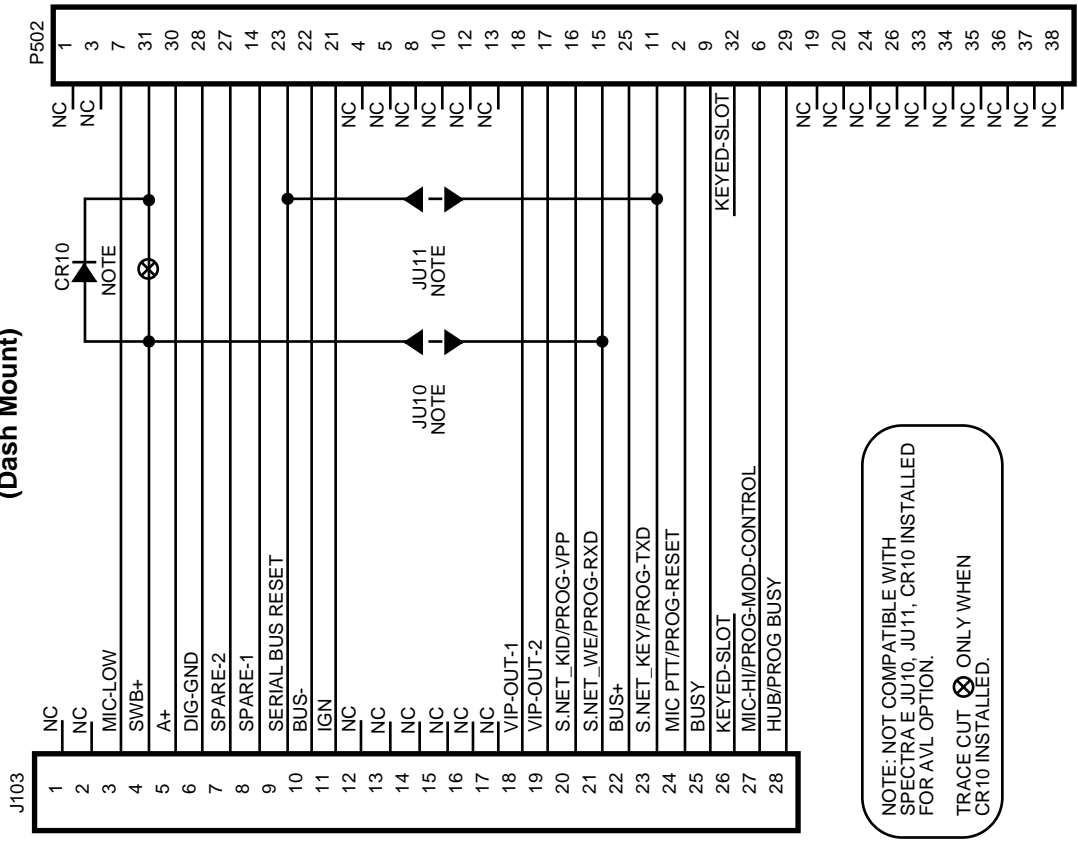

NOTE: NOT COMPATIBLE WITH SPECTRA JU10, JU11, CR10 INSTALLED FOR AVL OPTION.  
TRACE CUT ONLY WHEN CR10 INSTALLED.

MAEPF-23575-O

Figure 8-22. HLN6401A Control Head Interconnect Board, (Dash-Mount)

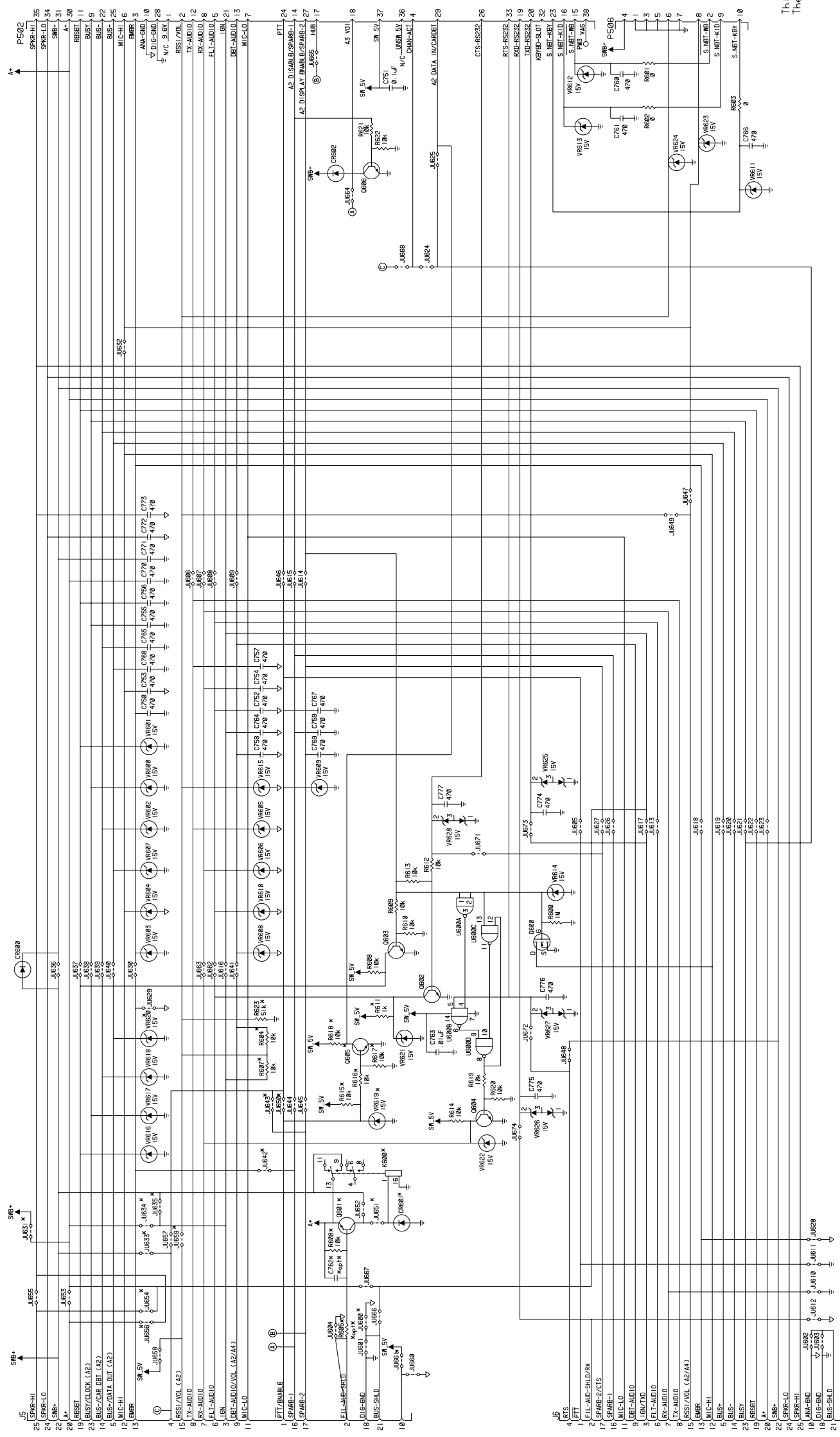

This is only a drawing.  
The Board Layout is done in CADS 4X

Figure 8-23. HLN6486D/E High Power Standard Interconnect Board

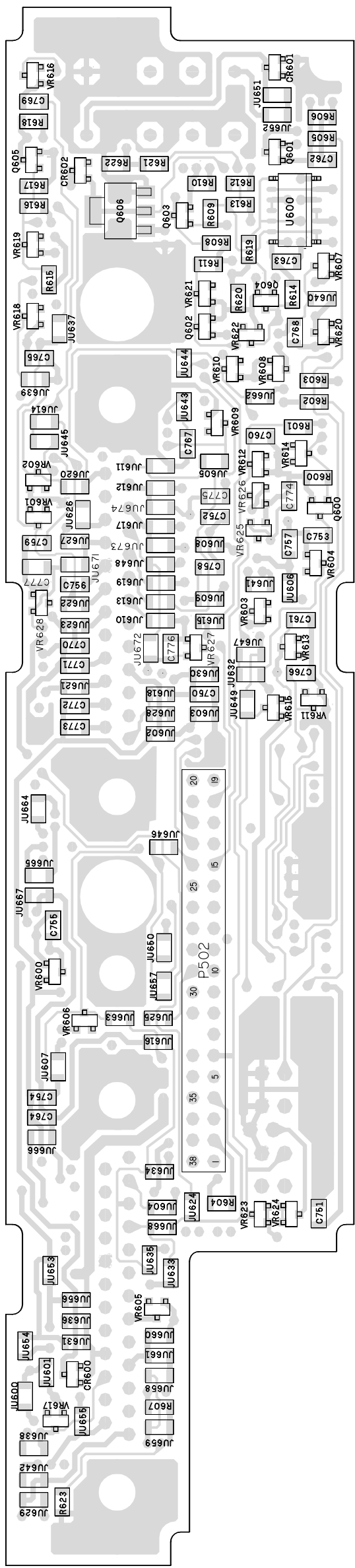

Figure 8-24. HLN6486D/E High-Power Interconnect Board (Viewed from Side 1)

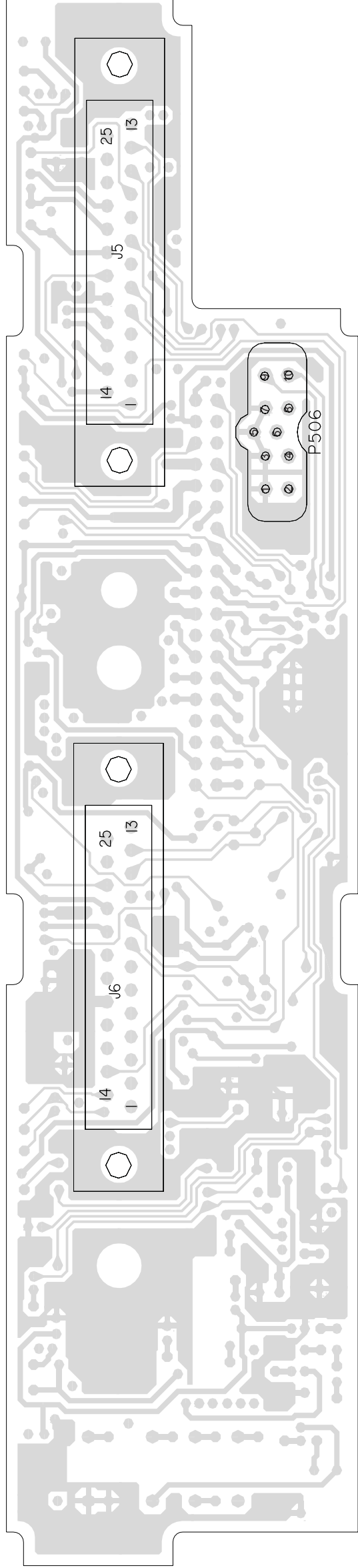

Figure 8-25. HLN6486D/E High-Power Interconnect Board (Viewed from Side 2)

## HLN6486E Standard Interconnect Parts List

ITEM	MOTOROLA PART NUMBER	DESCRIPTION
C750	2113740B49	CAP CHIP REEL CL1 +/-30 100
C751	2113741N69	CAP CHIP CL2 X7R 10% 100000
C752	2113740B49	CAP CHIP REEL CL1 +/-30 100
C754	2113740B49	CAP CHIP REEL CL1 +/-30 100
C755	2113740B49	CAP CHIP REEL CL1 +/-30 100
C756	2113740B49	CAP CHIP REEL CL1 +/-30 100
C757	2113740B49	CAP CHIP REEL CL1 +/-30 100
C763	2113741N45	CAP CHIP CL2 X7R 10% 10000
C764	2113740B49	CAP CHIP REEL CL1 +/-30 100
C765	2113740B49	CAP CHIP REEL CL1 +/-30 100
C768	2113740B49	CAP CHIP REEL CL1 +/-30 100
C770	2113740B49	CAP CHIP REEL CL1 +/-30 100
C771	2113740B49	CAP CHIP REEL CL1 +/-30 100
C772	2113740B49	CAP CHIP REEL CL1 +/-30 100
C773	2113740B49	CAP CHIP REEL CL1 +/-30 100
C774	2113740B65	CAP CHIP REEL CL1 +/-30 470
C775	2113740B65	CAP CHIP REEL CL1 +/-30 470
C776	2113740B65	CAP CHIP REEL CL1 +/-30 470
C777	2113740B65	CAP CHIP REEL CL1 +/-30 470
H0001	0300139581	SCR MCH 4-40X5/16 PHLPAN STL
H0002	0300139581	SCR MCH 4-40X5/16 PHLPAN STL
H0003	0300139581	SCR MCH 4-40X5/16 PHLPAN STL
H0004	0300139581	SCR MCH 4-40X5/16 PHLPAN STL
J0005	0980159P02	CONNECTOR 25-PIN
J0006	0980159P02	CONNECTOR 25-PIN
JU601	0611077A01	RES CHIP JUMPER
JU604	0611077A01	RES CHIP JUMPER
JU606	0611077A01	RES CHIP JUMPER
JU607	0611077A01	RES CHIP JUMPER
JU608	0611077A01	RES CHIP JUMPER

ITEM	MOTOROLA PART NUMBER	DESCRIPTION
JU609	0611077A01	RES CHIP JUMPER
JU613	0611077A01	RES CHIP JUMPER
JU618	0611077A01	RES CHIP JUMPER
JU619	0611077A01	RES CHIP JUMPER
JU620	0611077A01	RES CHIP JUMPER
JU621	0611077A01	RES CHIP JUMPER
JU622	0611077A01	RES CHIP JUMPER
JU623	0611077A01	RES CHIP JUMPER
JU626	0611077A01	RES CHIP JUMPER
JU629	0611077A01	RES CHIP JUMPER
JU630	0611077A01	RES CHIP JUMPER
JU632	0611077A01	RES CHIP JUMPER
JU636	0611077A01	RES CHIP JUMPER
JU637	0611077A01	RES CHIP JUMPER
JU638	0611077A01	RES CHIP JUMPER
JU639	0611077A01	RES CHIP JUMPER
JU640	0611077A01	RES CHIP JUMPER
JU644	0611077A01	RES CHIP JUMPER
JU645	0611077A01	RES CHIP JUMPER
JU646	0611077A01	RES CHIP JUMPER
JU652	0611077A01	RES CHIP JUMPER
JU653	0611077A01	RES CHIP JUMPER
JU655	0611077A01	RES CHIP JUMPER
JU657	0611077A01	RES CHIP JUMPER
JU658	0611077A01	RES CHIP JUMPER
JU662	0611077A01	RES CHIP JUMPER
JU664	0611077A01	RES CHIP JUMPER
JU665	0611077A01	RES CHIP JUMPER
JU666	0611077A01	RES CHIP JUMPER
JU671	0611077A01	RES CHIP JUMPER
JU672	0611077A01	RES CHIP JUMPER
JU673	0611077A01	RES CHIP JUMPER
JU674	0611077A01	RES CHIP JUMPER

ITEM	MOTOROLA PART NUMBER	DESCRIPTION
P0502	2880267M04	PLUG RIGHT ANGLE HDR 38 POS
P0506	2880068M01	HEADER MIC
R601	0611077A01	RES CHIP JUMPER
R602	0611077A01	RES CHIP JUMPER
R603	0611077A01	RES CHIP JUMPER
R614	0611077A98	RES CHIP 10K 5 1/8W
VR600	4813830A28	DIODE 15V 5% 225MW MMBZ5245B_
VR601	4813830A28	DIODE 15V 5% 225MW MMBZ5245B_
VR602	4813830A28	DIODE 15V 5% 225MW MMBZ5245B_
VR603	4813830A28	DIODE 15V 5% 225MW MMBZ5245B_
VR604	4813830A28	DIODE 15V 5% 225MW MMBZ5245B_
VR605	4813830A28	DIODE 15V 5% 225MW MMBZ5245B_
VR606	4813830A28	DIODE 15V 5% 225MW MMBZ5245B_
VR610	4813830A28	DIODE 15V 5% 225MW MMBZ5245B_
VR611	4813830A28	DIODE 15V 5% 225MW MMBZ5245B_
VR612	4813830A28	DIODE 15V 5% 225MW MMBZ5245B_
VR613	4813830A28	DIODE 15V 5% 225MW MMBZ5245B_
VR615	4813830A28	DIODE 15V 5% 225MW MMBZ5245B_
VR616	4813830A28	DIODE 15V 5% 225MW MMBZ5245B_
VR617	4813830A28	DIODE 15V 5% 225MW MMBZ5245B_
VR618	4813830A28	DIODE 15V 5% 225MW MMBZ5245B_
VR623	4813830A28	DIODE 15V 5% 225MW MMBZ5245B_
VR624	4813830A28	DIODE 15V 5% 225MW MMBZ5245B_

ITEM	MOTOROLA PART NUMBER	DESCRIPTION
VR625	4813832C28	ZENER BPLR 15V FOR ESD SOT23
VR626	4813832C28	ZENER BPLR 15V FOR ESD SOT23
VR627	4813832C28	ZENER BPLR 15V FOR ESD SOT23
VR628	4813832C28	ZENER BPLR 15V FOR ESD SOT23

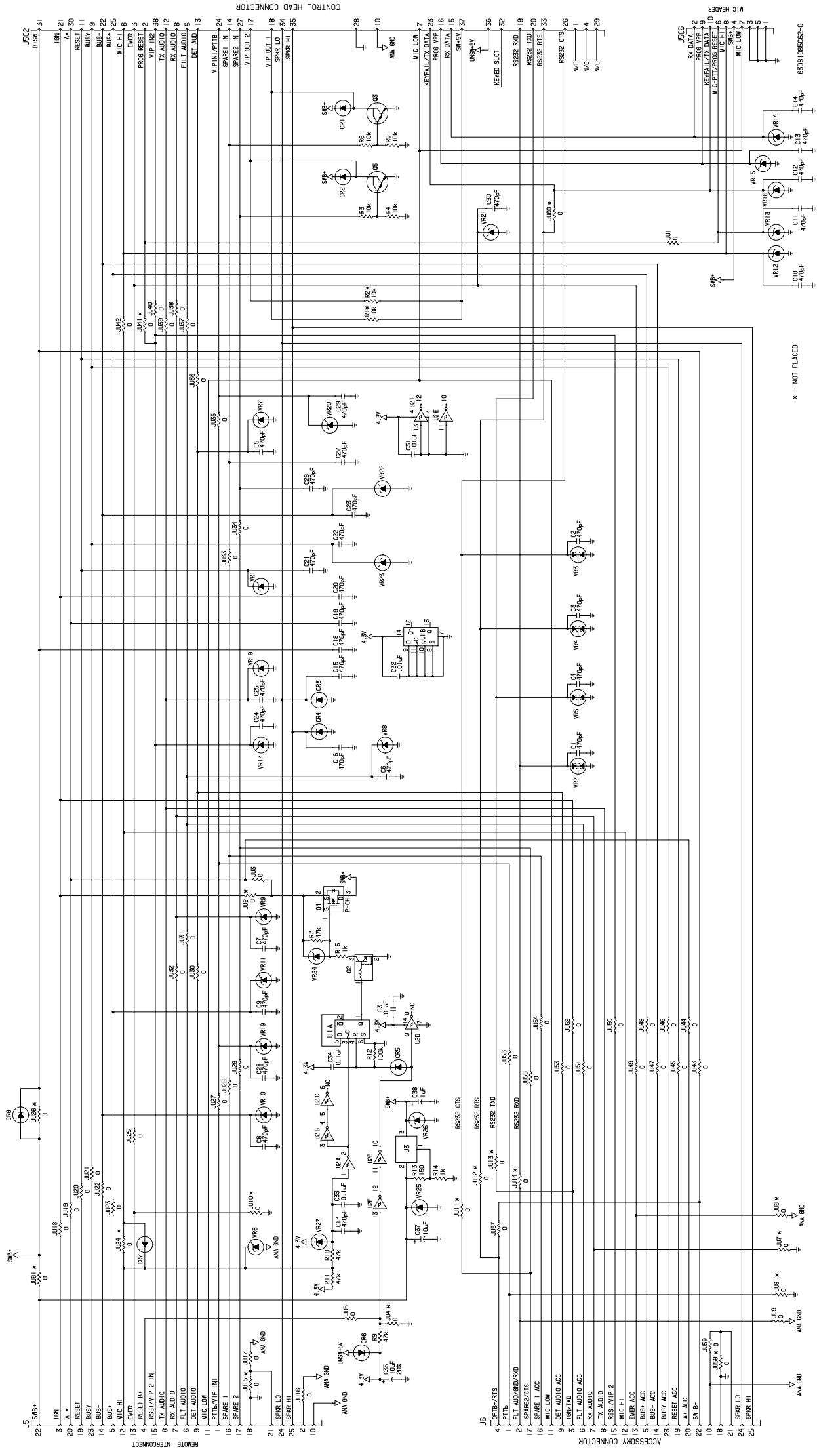
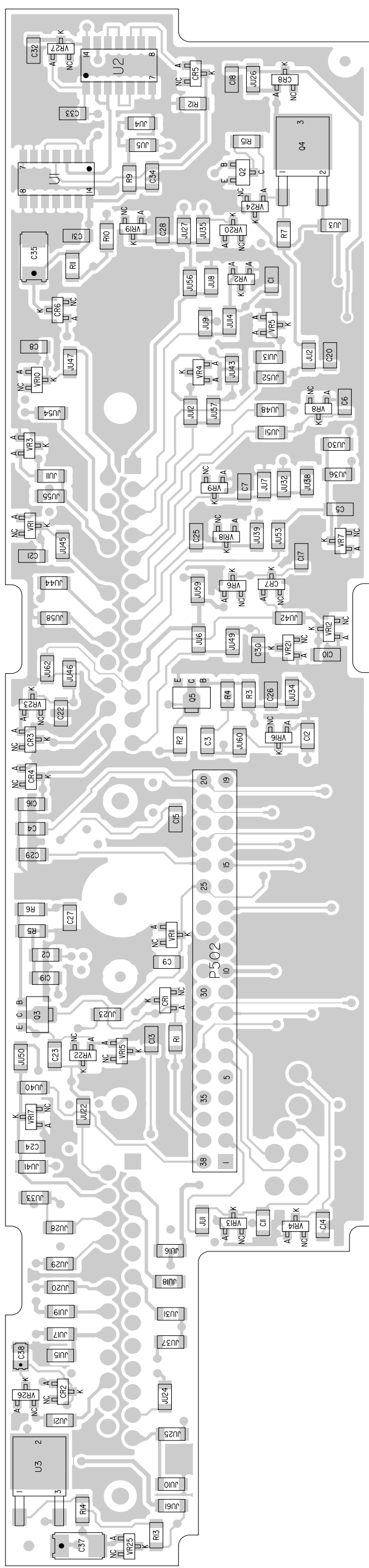

Figure 8-26. HLN6574E W3 Control Head High-Power Interconnect Board Schematic Design

VIEWED FROM SIDE 1



MAEPF-25697-O

VIEWED FROM SIDE 2

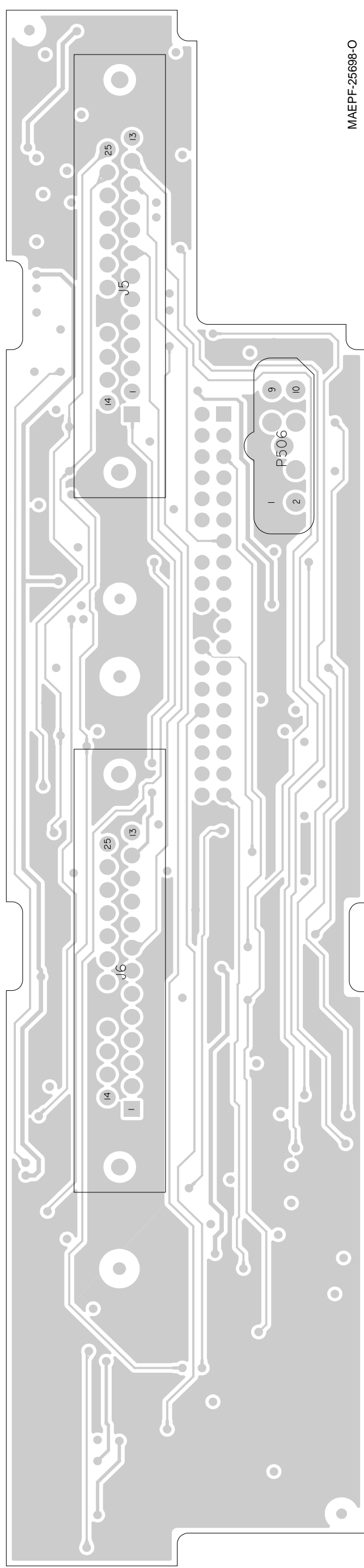

MAEPF-25698-O

Figure 8-27. HLN6574E W3 High Power Interconnect Board Component Location Diagrams

## HLN6574E W3 High-Power Interconnect Parts List

ITEM	MOTOROLA PART NUMBER	DESCRIPTION
C1	2113740B65	CAP CHIP REEL CL1 +/-30 470
C10	2113740B65	CAP CHIP REEL CL1 +/-30 470
C11	2113740B65	CAP CHIP REEL CL1 +/-30 470
C12	2113740B65	CAP CHIP REEL CL1 +/-30 470
C13	2113740B65	CAP CHIP REEL CL1 +/-30 470
C14	2113740B65	CAP CHIP REEL CL1 +/-30 470
C15	2113740B49	CAP CHIP REEL CL1 +/-30 100
C16	2113740B49	CAP CHIP REEL CL1 +/-30 100
C17	2113740B49	CAP CHIP REEL CL1 +/-30 100
C18	2113740B49	CAP CHIP REEL CL1 +/-30 100
C19	2113740B49	CAP CHIP REEL CL1 +/-30 100
C2	2113740B65	CAP CHIP REEL CL1 +/-30 470
C20	2113740B49	CAP CHIP REEL CL1 +/-30 100
C21	2113740B49	CAP CHIP REEL CL1 +/-30 100
C22	2113740B49	CAP CHIP REEL CL1 +/-30 100
C23	2113740B49	CAP CHIP REEL CL1 +/-30 100
C24	2113740B49	CAP CHIP REEL CL1 +/-30 100
C25	2113740B49	CAP CHIP REEL CL1 +/-30 100
C26	2113740B65	CAP CHIP REEL CL1 +/-30 470
C27	2113740B65	CAP CHIP REEL CL1 +/-30 470
C28	2113740B65	CAP CHIP REEL CL1 +/-30 470
C29	2113740B65	CAP CHIP REEL CL1 +/-30 470
C3	2113740B65	CAP CHIP REEL CL1 +/-30 470
C30	2113740B65	CAP CHIP REEL CL1 +/-30 470
C31	2113741N45	CAP CHIP CL2 X7R 10% 10000
C32	2113741N45	CAP CHIP CL2 X7R 10% 10000
C33	2113741N69	CAP CHIP CL2 X7R 10% 100000
C34	2113741N69	CAP CHIP CL2 X7R 10% 100000
C35	2311049J26	CAP TANT CHIP 10 20 16
C37	2311049J26	CAP TANT CHIP 10 20 16
C38	2311049A37	CAP TANT CHIP 1 20 20

ITEM	MOTOROLA PART NUMBER	DESCRIPTION
C4	2113740B65	CAP CHIP REEL CL1 +/-30 470
C5	2113740B49	CAP CHIP REEL CL1 +/-30 100
C6	2113740B49	CAP CHIP REEL CL1 +/-30 100
C7	2113740B49	CAP CHIP REEL CL1 +/-30 100
C8	2113740B49	CAP CHIP REEL CL1 +/-30 100
C9	2113740B49	CAP CHIP REEL CL1 +/-30 100
CR1	4813833C10	DIODE GEN PUR 70V MMBD6050
CR2	4813833C10	DIODE GEN PUR 70V MMBD6050
CR3	4813833C10	DIODE GEN PUR 70V MMBD6050
CR4	4813833C10	DIODE GEN PUR 70V MMBD6050
CR5	4813833C10	DIODE GEN PUR 70V MMBD6050
CR6	4813833C10	DIODE GEN PUR 70V MMBD6050
CR7	4813833C10	DIODE GEN PUR 70V MMBD6050
CR8	NOTPLACED	64AM DUMMY PART NUMBER
H0001	0300139581	SCR MCH 4-40X5/16 PHLPAN STL
H0002	0300139581	SCR MCH 4-40X5/16 PHLPAN STL
H0003	0300139581	SCR MCH 4-40X5/16 PHLPAN STL
H0004	0300139581	SCR MCH 4-40X5/16 PHLPAN STL
HU3	NOTPLACED	64AM DUMMY PART NUMBER
J5	0980159P02	CONNECTOR 25-PIN
J6	0980159P02	CONNECTOR 25-PIN
JU1	0611077A01	RES CHIP JUMPER
JU10	NOTPLACED	64AM DUMMY PART NUMBER
JU11	0611077A01	RES CHIP JUMPER
JU12	0611077A01	RES CHIP JUMPER
JU13	0611077A01	RES CHIP JUMPER
JU14	0611077A01	RES CHIP JUMPER

ITEM	MOTOROLA PART NUMBER	DESCRIPTION
JU15	NOTPLACED	64AM DUMMY PART NUMBER
JU16	0611077A01	RES CHIP JUMPER
JU17	0611077A01	RES CHIP JUMPER
JU18	0611077A01	RES CHIP JUMPER
JU19	0611077A01	RES CHIP JUMPER
JU2	0611077A01	RES CHIP JUMPER
JU20	0611077A01	RES CHIP JUMPER
JU21	0611077A01	RES CHIP JUMPER
JU22	0611077A01	RES CHIP JUMPER
JU23	0611077A01	RES CHIP JUMPER
JU24	NOTPLACED	64AM DUMMY PART NUMBER
JU25	0611077A01	RES CHIP JUMPER
JU26	0611077A01	RES CHIP JUMPER
JU27	0611077A01	RES CHIP JUMPER
JU28	0611077A01	RES CHIP JUMPER
JU29	0611077A01	RES CHIP JUMPER
JU30	0611077A01	RES CHIP JUMPER
JU31	0611077A01	RES CHIP JUMPER
JU32	0611077A01	RES CHIP JUMPER
JU33	0611077A01	RES CHIP JUMPER
JU34	0611077A01	RES CHIP JUMPER
JU35	0611077A01	RES CHIP JUMPER
JU36	0611077A01	RES CHIP JUMPER
JU37	0611077A01	RES CHIP JUMPER
JU38	0611077A01	RES CHIP JUMPER
JU39	0611077A01	RES CHIP JUMPER
JU4	2113741N69	CAP CHIP CL2 X7R 10% 100000
JU40	0611077A01	RES CHIP JUMPER
JU41	NOTPLACED	64AM DUMMY PART NUMBER
JU42	0611077A01	RES CHIP JUMPER
JU43	0611077A01	RES CHIP JUMPER
JU44	0611077A01	RES CHIP JUMPER
JU45	0611077A01	RES CHIP JUMPER

ITEM	MOTOROLA PART NUMBER	DESCRIPTION
JU46	0611077A01	RES CHIP JUMPER
JU47	0611077A01	RES CHIP JUMPER
JU48	0611077A01	RES CHIP JUMPER
JU49	0611077A01	RES CHIP JUMPER
JU5	0611077A74	RES CHIP 1000 5 1/8
JU50	0611077A01	RES CHIP JUMPER
JU51	0611077A01	RES CHIP JUMPER
JU52	NOTPLACED	64AM DUMMY PART NUMBER
JU53	0611077A01	RES CHIP JUMPER
JU54	0611077A01	RES CHIP JUMPER
JU55	NOTPLACED	64AM DUMMY PART NUMBER
JU56	0611077A01	RES CHIP JUMPER
JU57	NOTPLACED	64AM DUMMY PART NUMBER
JU58	NOTPLACED	64AM DUMMY PART NUMBER
JU59	0611077A01	RES CHIP JUMPER
JU6	NOTPLACED	64AM DUMMY PART NUMBER
JU60	NOTPLACED	64AM DUMMY PART NUMBER
JU61	NOTPLACED	64AM DUMMY PART NUMBER
JU62	0611077A01	RES CHIP JUMPER
JU7	NOTPLACED	64AM DUMMY PART NUMBER
JU8	NOTPLACED	64AM DUMMY PART NUMBER
JU9	NOTPLACED	64AM DUMMY PART NUMBER
P502	2880267M04	PLUG RIGHT ANGLE HDR 38 POS
P506	2880068M01	HEADER MIC
Q2	4880048M01	TSTR NPN DIG 47K/47K
Q3	4880052M01	TSTR NPN DRINGTN MXTA27
Q4	4813821A32	TSTR P-CH PWR FET 60V 5A
Q5	4880052M01	TSTR NPN DRINGTN MXTA27
R1	NOTPLACED	64AM DUMMY PART NUMBER
R10	0611077B15	RES CHIP 47K 5 1/8W
R11	0611077B15	RES CHIP 47K 5 1/8W
R12	0611077B23	RES CHIP 100K 5 1/8W
R13	0611077A54	RES CHIP 150 5 1/8W

ITEM	MOTOROLA PART NUMBER	DESCRIPTION
R14	0611077A74	RES CHIP 1000 5 1/8
R15	0611077A74	RES CHIP 1000 5 1/8
R2	NOTPLACED	64AM DUMMY PART NUMBER
R3	0611077A98	RES CHIP 10K 5 1/8W
R4	0611077A98	RES CHIP 10K 5 1/8W
R5	0611077A98	RES CHIP 10K 5 1/8W
R6	0611077A98	RES CHIP 10K 5 1/8W
R7	0611077B15	RES CHIP 47K 5 1/8W
R9	0611077B15	RES CHIP 47K 5 1/8W
U1	5113806A05	IC FLIP-FLOP,DUAL D
U2	5113806A37	IC SCHMITT TRIGGER,HEX
U3	5113816A19	IC ADJ LO DROPOUT POS REG .8A
VR1	4813830A28	DIODE 15V 5% 225MW MMBZ5245B_
VR10	4813830A28	DIODE 15V 5% 225MW MMBZ5245B_
VR11	4813830A28	DIODE 15V 5% 225MW MMBZ5245B_
VR12	4813830A28	DIODE 15V 5% 225MW MMBZ5245B_
VR13	4813830A28	DIODE 15V 5% 225MW MMBZ5245B_
VR14	4813830A28	DIODE 15V 5% 225MW MMBZ5245B_
VR15	4813830A28	DIODE 15V 5% 225MW MMBZ5245B_
VR16	4813830A28	DIODE 15V 5% 225MW MMBZ5245B_
VR17	4813830A28	DIODE 15V 5% 225MW MMBZ5245B_
VR18	4813830A28	DIODE 15V 5% 225MW MMBZ5245B_
VR19	4813830A28	DIODE 15V 5% 225MW MMBZ5245B_
VR2	4813832C28	ZENER BPLR 15V FOR ESD SOT23
VR20	4813830A28	DIODE 15V 5% 225MW MMBZ5245B_

ITEM	MOTOROLA PART NUMBER	DESCRIPTION
VR21	4813830A28	DIODE 15V 5% 225MW MMBZ5245B_
VR22	4813830A28	DIODE 15V 5% 225MW MMBZ5245B_
VR23	4813830A28	DIODE 15V 5% 225MW MMBZ5245B_
VR24	4813830A28	DIODE 15V 5% 225MW MMBZ5245B_
VR25	4813830A28	DIODE 15V 5% 225MW MMBZ5245B_
VR26	4880140L23	DIODE SOT ZENER 18V TAPE&REEL
VR27	4813830A28	DIODE 15V 5% 225MW MMBZ5245B_
VR3	4813832C28	ZENER BPLR 15V FOR ESD SOT23
VR4	4813832C28	ZENER BPLR 15V FOR ESD SOT23
VR5	4813832C28	ZENER BPLR 15V FOR ESD SOT23
VR6	4813830A28	DIODE 15V 5% 225MW MMBZ5245B_
VR7	4813830A28	DIODE 15V 5% 225MW MMBZ5245B_
VR8	4813830A28	DIODE 15V 5% 225MW MMBZ5245B_
VR9	4813830A28	DIODE 15V 5% 225MW MMBZ5245B_



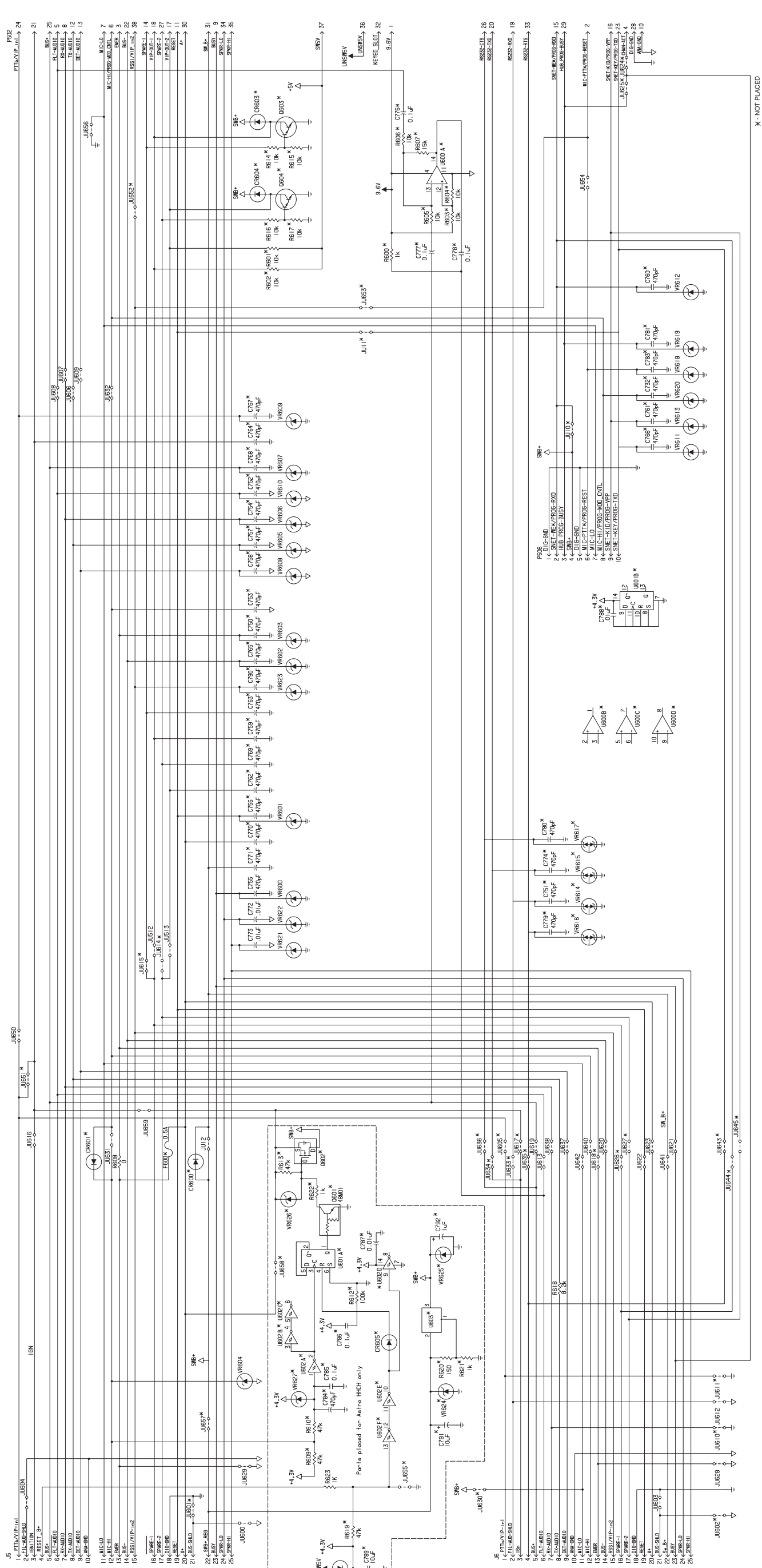
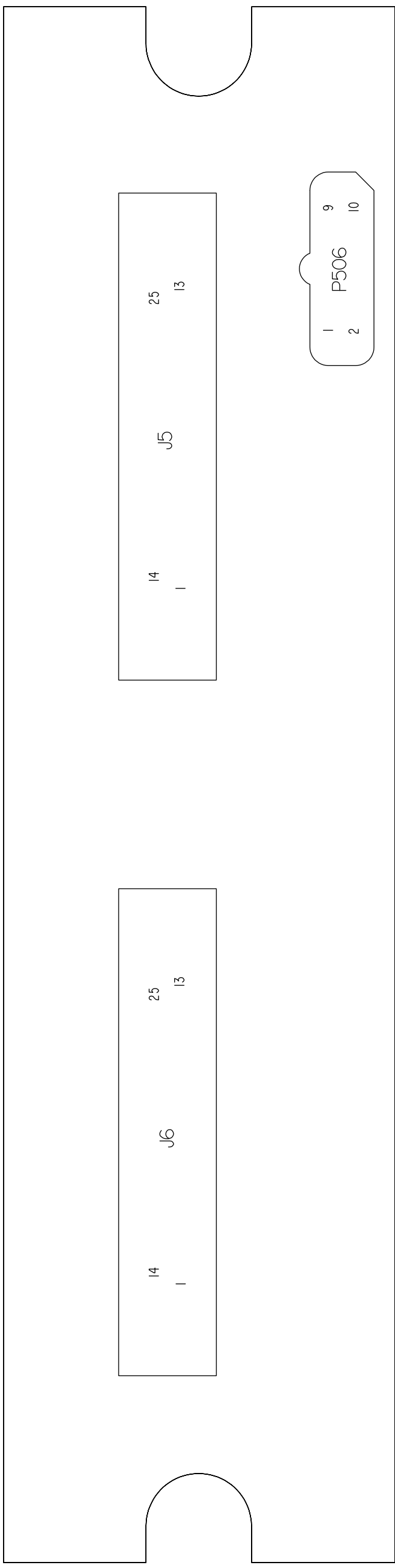

Figure 8-28. HLN6459D, HLN6344E, and HLN6365E Low-Power Interconnect Board Schematic

VIEWED FROM SIDE 2



MAEPF-27093-O

VIEWED FROM SIDE 1

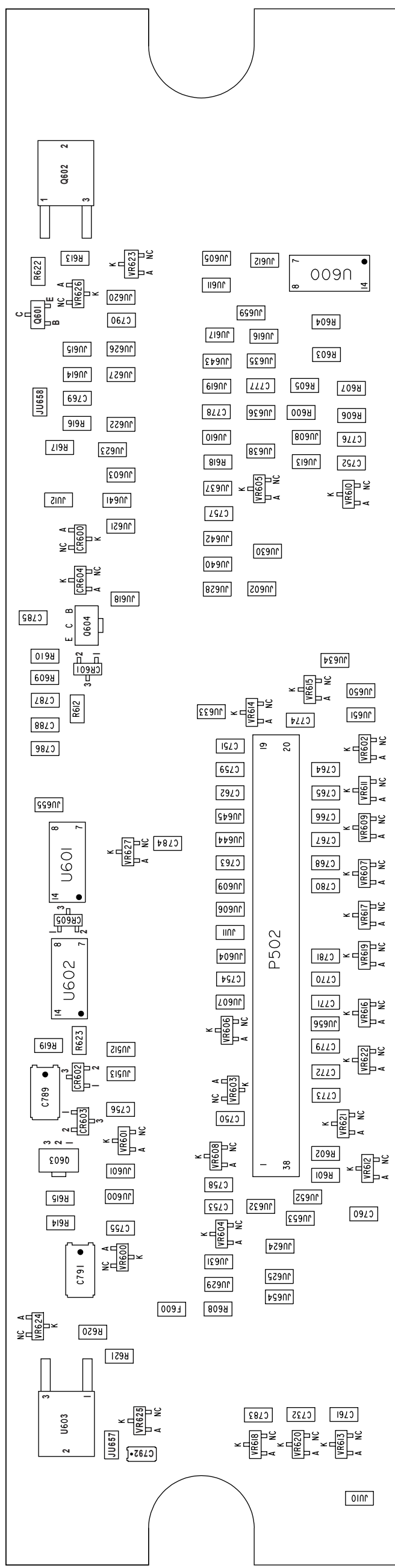

MAEPF-27703-O

Figure 8-29. HLN6459D, HLN6344E, and HLN6365 Low-Power Interconnect Component Location Diagram

## HLN6459D W3 Low-Power Interconnect Parts List

ITEM	MOTOROLA PART NUMBER	DESCRIPTION
C732	2113740B65	CAP CHIP REEL CL1 +/-30 470
C750	2113740B65	CAP CHIP REEL CL1 +/-30 470
C751	2113740B65	CAP CHIP REEL CL1 +/-30 470
C752	2113740B65	CAP CHIP REEL CL1 +/-30 470
C753	2113740B65	CAP CHIP REEL CL1 +/-30 470
C754	2113740B65	CAP CHIP REEL CL1 +/-30 470
C755	2113740B65	CAP CHIP REEL CL1 +/-30 470
C756	2113740B65	CAP CHIP REEL CL1 +/-30 470
C757	2113740B65	CAP CHIP REEL CL1 +/-30 470
C758	2113740B65	CAP CHIP REEL CL1 +/-30 470
C759	2113740B65	CAP CHIP REEL CL1 +/-30 470
C760	2113740B65	CAP CHIP REEL CL1 +/-30 470
C761	2113740B65	CAP CHIP REEL CL1 +/-30 470
C762	2113740B65	CAP CHIP REEL CL1 +/-30 470
C763	2113740B65	CAP CHIP REEL CL1 +/-30 470
C764	2113740B65	CAP CHIP REEL CL1 +/-30 470
C765	2113740B65	CAP CHIP REEL CL1 +/-30 470
C766	2113740B65	CAP CHIP REEL CL1 +/-30 470
C767	2113740B65	CAP CHIP REEL CL1 +/-30 470
C768	2113740B65	CAP CHIP REEL CL1 +/-30 470
C769	2113740B65	CAP CHIP REEL CL1 +/-30 470
C770	2113740B65	CAP CHIP REEL CL1 +/-30 470
C771	2113740B65	CAP CHIP REEL CL1 +/-30 470
C772	2113740B65	CAP CHIP REEL CL1 +/-30 470
C773	2113740B65	CAP CHIP REEL CL1 +/-30 470
C774	2113740B65	CAP CHIP REEL CL1 +/-30 470
C776	NOTPLACED	64AM DUMMY PART NUMBER
C777	NOTPLACED	64AM DUMMY PART NUMBER
C778	NOTPLACED	64AM DUMMY PART NUMBER
C779	2113740B65	CAP CHIP REEL CL1 +/-30 470
C780	2113740B65	CAP CHIP REEL CL1 +/-30 470
C781	2113740B65	CAP CHIP REEL CL1 +/-30 470

ITEM	MOTOROLA PART NUMBER	DESCRIPTION
C783	2113740B65	CAP CHIP REEL CL1 +/-30 470
C784	2113740B65	CAP CHIP REEL CL1 +/-30 470
C785	2113741N69	CAP CHIP CL2 X7R 10% 100000
C786	2113741N69	CAP CHIP CL2 X7R 10% 100000
C787	2113741N45	CAP CHIP CL2 X7R 10% 10000
C788	2113741N45	CAP CHIP CL2 X7R 10% 10000
C789	2311049J26	CAP TANT CHIP 10 20 16
C790	2113740B65	CAP CHIP REEL CL1 +/-30 470
C791	2311049J26	CAP TANT CHIP 10 20 16
C792	2311049A37	CAP TANT CHIP 1 20 20
CR600	4813833C10	DIODE GEN PUR 70V MMBD6050
CR601	4813833C10	DIODE GEN PUR 70V MMBD6050
CR602	4813833C10	DIODE GEN PUR 70V MMBD6050
CR603	4813833C10	DIODE GEN PUR 70V MMBD6050
CR604	4813833C10	DIODE GEN PUR 70V MMBD6050
CR605	4813833C10	DIODE GEN PUR 70V MMBD6050
F600	NOTPLACED	64AM DUMMY PART NUMBER
HD001	0300139581	SCR MCH 4-40X5/16 PHLPAN STL
HD002	0300139581	SCR MCH 4-40X5/16 PHLPAN STL
HD003	0300139581	SCR MCH 4-40X5/16 PHLPAN STL
HD004	0300139581	SCR MCH 4-40X5/16 PHLPAN STL
J5	0980159P02	CONNECTOR 25-PIN
J6	0980159P02	CONNECTOR 25-PIN
JU10	NOTPLACED	64AM DUMMY PART NUMBER
JU11	NOTPLACED	64AM DUMMY PART NUMBER
JU12	NOTPLACED	64AM DUMMY PART NUMBER
JU512	NOTPLACED	64AM DUMMY PART NUMBER

ITEM	MOTOROLA PART NUMBER	DESCRIPTION
JU513	NOTPLACED	64AM DUMMY PART NUMBER
JU600	0611077A01	RES CHIP JUMPER
JU601	NOTPLACED	64AM DUMMY PART NUMBER
JU602	0611077A01	RES CHIP JUMPER
JU603	NOTPLACED	64AM DUMMY PART NUMBER
JU604	0611077A01	RES CHIP JUMPER
JU605	NOTPLACED	64AM DUMMY PART NUMBER
JU606	0611077A01	RES CHIP JUMPER
JU607	0611077A01	RES CHIP JUMPER
JU608	0611077A01	RES CHIP JUMPER
JU609	0611077A01	RES CHIP JUMPER
JU610	NOTPLACED	64AM DUMMY PART NUMBER
JU611	NOTPLACED	64AM DUMMY PART NUMBER
JU612	0611077A01	RES CHIP JUMPER
JU613	NOTPLACED	64AM DUMMY PART NUMBER
JU614	0611077A01	RES CHIP JUMPER
JU615	0611077A01	RES CHIP JUMPER
JU616	0611077A01	RES CHIP JUMPER
JU617	NOTPLACED	64AM DUMMY PART NUMBER
JU618	0611077A01	RES CHIP JUMPER
JU619	0611077A01	RES CHIP JUMPER
JU620	0611077A01	RES CHIP JUMPER
JU621	0611077A01	RES CHIP JUMPER
JU622	0611077A01	RES CHIP JUMPER
JU623	0611077A01	RES CHIP JUMPER
JU624	NOTPLACED	64AM DUMMY PART NUMBER
JU625	NOTPLACED	64AM DUMMY PART NUMBER
JU626	0611077A01	RES CHIP JUMPER
JU627	0611077A01	RES CHIP JUMPER
JU628	NOTPLACED	64AM DUMMY PART NUMBER
JU629	NOTPLACED	64AM DUMMY PART NUMBER
JU630	NOTPLACED	64AM DUMMY PART NUMBER
JU631	NOTPLACED	64AM DUMMY PART NUMBER

ITEM	MOTOROLA PART NUMBER	DESCRIPTION
JU632	0611077A01	RES CHIP JUMPER
JU633	NOTPLACED	64AM DUMMY PART NUMBER
JU634	NOTPLACED	64AM DUMMY PART NUMBER
JU635	NOTPLACED	64AM DUMMY PART NUMBER
JU636	NOTPLACED	64AM DUMMY PART NUMBER
JU637	0611077A01	RES CHIP JUMPER
JU638	0611077A01	RES CHIP JUMPER
JU640	0611077A01	RES CHIP JUMPER
JU641	0611077A01	RES CHIP JUMPER
JU642	0611077A01	RES CHIP JUMPER
JU643	NOTPLACED	64AM DUMMY PART NUMBER
JU644	NOTPLACED	64AM DUMMY PART NUMBER
JU645	NOTPLACED	64AM DUMMY PART NUMBER
JU650	0611077A01	RES CHIP JUMPER
JU651	NOTPLACED	64AM DUMMY PART NUMBER
JU652	0611077A01	RES CHIP JUMPER
JU653	NOTPLACED	64AM DUMMY PART NUMBER
JU654	0611077A01	RES CHIP JUMPER
JU655	2113741N69	CAP CHIP CL2 X7R 10% 100000
JU656	0611077A01	RES CHIP JUMPER
JU657	NOTPLACED	64AM DUMMY PART NUMBER
JU658	NOTPLACED	64AM DUMMY PART NUMBER
JU659	0611077A01	RES CHIP JUMPER
P502	2880102M09	PLUG VERTICAL 38 POSITION
P506	2880068M01	HEADER MIC
Q601	4880048M01	TSTR NPN DIG 47K/47K
Q602	4813821A32	TSTR P-CH PWR FET 60V 5A
Q603	4880052M01	TSTR NPN DRNGTN MXTA27
Q604	4880052M01	TSTR NPN DRNGTN MXTA27
R600	NOTPLACED	64AM DUMMY PART NUMBER
R601	NOTPLACED	64AM DUMMY PART NUMBER
R602	NOTPLACED	64AM DUMMY PART NUMBER
R603	NOTPLACED	64AM DUMMY PART NUMBER

ITEM	MOTOROLA PART NUMBER	DESCRIPTION
R604	NOTPLACED	64AM DUMMY PART NUMBER
R605	NOTPLACED	64AM DUMMY PART NUMBER
R606	NOTPLACED	64AM DUMMY PART NUMBER
R607	NOTPLACED	64AM DUMMY PART NUMBER
R608	0611077A01	RES CHIP JUMPER
R609	0611077B15	RES CHIP 47K 5 1/8W
R610	0611077B15	RES CHIP 47K 5 1/8W
R612	0611077B23	RES CHIP 100K 5 1/8W
R613	0611077B15	RES CHIP 47K 5 1/8W
R614	0611077A98	RES CHIP 10K 5 1/8W
R615	0611077A98	RES CHIP 10K 5 1/8W
R616	0611077A98	RES CHIP 10K 5 1/8W
R617	0611077A98	RES CHIP 10K 5 1/8W
R618	0611077A96	RES CHIP 8200 5 1/8
R619	0611077B15	RES CHIP 47K 5 1/8W
R620	0611077A54	RES CHIP 150 5 1/8W
R621	0611077A74	RES CHIP 1000 5 1/8
R622	0611077A74	RES CHIP 1000 5 1/8
R623	0611077A74	RES CHIP 1000 5 1/8
U600	NOTPLACED	64AM DUMMY PART NUMBER
U601	5113806A05	IC FLIP-FLOP,DUAL D
U602	5113806A37	IC SCHMITT TRIGGER,HEX
U603	5113816A19	IC ADJ LO DROPOUT POS REG .8A
VR600	4813830A28	DIODE 15V 5% 225MW MMBZ5245B_
VR601	4813830A28	DIODE 15V 5% 225MW MMBZ5245B_
VR602	4813830A28	DIODE 15V 5% 225MW MMBZ5245B_
VR603	4813830A28	DIODE 15V 5% 225MW MMBZ5245B_
VR604	4813830A28	DIODE 15V 5% 225MW MMBZ5245B_
VR605	4813830A28	DIODE 15V 5% 225MW MMBZ5245B_

ITEM	MOTOROLA PART NUMBER	DESCRIPTION
VR606	4813830A28	DIODE 15V 5% 225MW MMBZ5245B_
VR607	4813830A28	DIODE 15V 5% 225MW MMBZ5245B_
VR608	4813830A28	DIODE 15V 5% 225MW MMBZ5245B_
VR609	4813830A28	DIODE 15V 5% 225MW MMBZ5245B_
VR610	4813830A28	DIODE 15V 5% 225MW MMBZ5245B_
VR611	4813830A28	DIODE 15V 5% 225MW MMBZ5245B_
VR612	4813830A28	DIODE 15V 5% 225MW MMBZ5245B_
VR613	4813830A28	DIODE 15V 5% 225MW MMBZ5245B_
VR614	4813832C28	ZENER BPLR 15V FOR ESD SOT23
VR615	4813832C28	ZENER BPLR 15V FOR ESD SOT23
VR616	4813832C28	ZENER BPLR 15V FOR ESD SOT23
VR617	4813832C28	ZENER BPLR 15V FOR ESD SOT23
VR618	4813830A28	DIODE 15V 5% 225MW MMBZ5245B_
VR619	4813830A28	DIODE 15V 5% 225MW MMBZ5245B_
VR620	4813830A28	DIODE 15V 5% 225MW MMBZ5245B_
VR621	4813830A28	DIODE 15V 5% 225MW MMBZ5245B_
VR622	4813830A28	DIODE 15V 5% 225MW MMBZ5245B_
VR623	4813830A28	DIODE 15V 5% 225MW MMBZ5245B_
VR624	4813830A28	DIODE 15V 5% 225MW MMBZ5245B_
VR625	4880140L23	DIODE SOT ZENER 18V TAPE&REEL
VR626	4813830A28	DIODE 15V 5% 225MW MMBZ5245B_
VR627	NOTPLACED	64AM DUMMY PART NUMBER

## HLN6365E Motorcycle Interconnect Parts List

ITEM	MOTOROLA PART NUMBER	DESCRIPTION
C754	2113740B65	CAP CHIP REEL CL1 +/-30 470
C755	2113740B65	CAP CHIP REEL CL1 +/-30 470
C772	2113741N45	CAP CHIP CL2 X7R 10% 10000
C773	2113741N45	CAP CHIP CL2 X7R 10% 10000
GS1	4205747Z01	CLIP GRND
GS2	4205747Z01	CLIP GRND
J5	0980159P02	CONNECTOR 25-PIN
JU12	0611077A01	RES CHIP JUMPER
JU512	0611077A01	RES CHIP JUMPER
JU513	0611077A01	RES CHIP JUMPER
JU600	0611077A01	RES CHIP JUMPER
JU601	0611077A01	RES CHIP JUMPER
JU603	0611077A01	RES CHIP JUMPER
JU604	0611077A01	RES CHIP JUMPER
JU606	0611077A01	RES CHIP JUMPER
JU607	0611077A01	RES CHIP JUMPER
JU608	0611077A01	RES CHIP JUMPER
JU609	0611077A01	RES CHIP JUMPER
JU612	0611077A01	RES CHIP JUMPER
JU613	0611077A01	RES CHIP JUMPER
JU619	0611077A01	RES CHIP JUMPER
JU620	0611077A01	RES CHIP JUMPER
JU621	0611077A01	RES CHIP JUMPER
JU622	0611077A01	RES CHIP JUMPER
JU623	0611077A01	RES CHIP JUMPER
JU631	0611077A01	RES CHIP JUMPER
JU632	0611077A01	RES CHIP JUMPER
JU637	0611077A01	RES CHIP JUMPER
JU638	0611077A01	RES CHIP JUMPER
JU640	0611077A01	RES CHIP JUMPER
JU641	0611077A01	RES CHIP JUMPER
JU642	0611077A01	RES CHIP JUMPER

ITEM	MOTOROLA PART NUMBER	DESCRIPTION
JU651	0611077A01	RES CHIP JUMPER
JU654	0611077A01	RES CHIP JUMPER
JU656	0611077A01	RES CHIP JUMPER
JU657	0611077A01	RES CHIP JUMPER
JU659	0611077A01	RES CHIP JUMPER
P502	2880102M09	PLUG VERTICAL 38 POSITION
P506	2880068M01	HEADER MIC
R608	0611077A74	RES CHIP 1000 5 1/8
R618	0611077A96	RES CHIP 8200 5 1/8
VR600	4813830A28	DIODE 15V 5% 225MW MMBZ5245B_
VR601	4813830A28	DIODE 15V 5% 225MW MMBZ5245B_
VR602	4813830A28	DIODE 15V 5% 225MW MMBZ5245B_
VR603	4813830A28	DIODE 15V 5% 225MW MMBZ5245B_
VR604	4813830A28	DIODE 15V 5% 225MW MMBZ5245B_
VR605	4813830A28	DIODE 15V 5% 225MW MMBZ5245B_
VR606	4813830A28	DIODE 15V 5% 225MW MMBZ5245B_
VR607	4813830A28	DIODE 15V 5% 225MW MMBZ5245B_
VR608	4813830A28	DIODE 15V 5% 225MW MMBZ5245B_
VR609	4813830A28	DIODE 15V 5% 225MW MMBZ5245B_
VR610	4813830A28	DIODE 15V 5% 225MW MMBZ5245B_
VR611	4813830A28	DIODE 15V 5% 225MW MMBZ5245B_
VR612	4813830A28	DIODE 15V 5% 225MW MMBZ5245B_
VR613	4813830A28	DIODE 15V 5% 225MW MMBZ5245B_
VR618	4813830A28	DIODE 15V 5% 225MW MMBZ5245B_

ITEM	MOTOROLA PART NUMBER	DESCRIPTION
VR619	4813830A28	DIODE 15V 5% 225MW MMBZ5245B_
VR620	4813830A28	DIODE 15V 5% 225MW MMBZ5245B_
VR621	4813830A28	DIODE 15V 5% 225MW MMBZ5245B_
VR622	4813830A28	DIODE 15V 5% 225MW MMBZ5245B_

## HLN6344E Standard Interconnect Parts List

ITEM	MOTOROLA PART NUMBER	DESCRIPTION
C754	2113740B65	CAP CHIP REEL CL1 +/-30 470
C755	2113740B65	CAP CHIP REEL CL1 +/-30 470
C772	2113741N45	CAP CHIP CL2 X7R 10% 10000
C773	2113741N45	CAP CHIP CL2 X7R 10% 10000
J5	0980159P02	CONNECTOR 25-PIN
J6	0980159P02	CONNECTOR 25-PIN
JU12	0611077A01	RES CHIP JUMPER
JU512	0611077A01	RES CHIP JUMPER
JU513	0611077A01	RES CHIP JUMPER
JU600	0611077A01	RES CHIP JUMPER
JU601	0611077A01	RES CHIP JUMPER
JU603	0611077A01	RES CHIP JUMPER
JU604	0611077A01	RES CHIP JUMPER
JU606	0611077A01	RES CHIP JUMPER
JU607	0611077A01	RES CHIP JUMPER
JU608	0611077A01	RES CHIP JUMPER
JU609	0611077A01	RES CHIP JUMPER
JU612	0611077A01	RES CHIP JUMPER
JU613	0611077A01	RES CHIP JUMPER
JU619	0611077A01	RES CHIP JUMPER
JU620	0611077A01	RES CHIP JUMPER
JU621	0611077A01	RES CHIP JUMPER
JU622	0611077A01	RES CHIP JUMPER
JU623	0611077A01	RES CHIP JUMPER
JU628	0611077A01	RES CHIP JUMPER
JU629	0611077A01	RES CHIP JUMPER
JU631	0611077A01	RES CHIP JUMPER
JU632	0611077A01	RES CHIP JUMPER
JU637	0611077A01	RES CHIP JUMPER
JU638	0611077A01	RES CHIP JUMPER
JU640	0611077A01	RES CHIP JUMPER
JU641	0611077A01	RES CHIP JUMPER

ITEM	MOTOROLA PART NUMBER	DESCRIPTION
JU642	0611077A01	RES CHIP JUMPER
JU650	0611077A01	RES CHIP JUMPER
JU654	0611077A01	RES CHIP JUMPER
JU656	0611077A01	RES CHIP JUMPER
JU657	0611077A01	RES CHIP JUMPER
JU659	0611077A01	RES CHIP JUMPER
P502	2880102M09	PLUG VERTICAL 38 POSITION
P506	2880068M01	HEADER MIC
R608	0611077A01	RES CHIP JUMPER
R618	0611077A96	RES CHIP 8200 5 1/8
VR600	4813830A28	DIODE 15V 5% 225MW MMBZ5245B_
VR601	4813830A28	DIODE 15V 5% 225MW MMBZ5245B_
VR602	4813830A28	DIODE 15V 5% 225MW MMBZ5245B_
VR603	4813830A28	DIODE 15V 5% 225MW MMBZ5245B_
VR604	4813830A28	DIODE 15V 5% 225MW MMBZ5245B_
VR605	4813830A28	DIODE 15V 5% 225MW MMBZ5245B_
VR606	4813830A28	DIODE 15V 5% 225MW MMBZ5245B_
VR607	4813830A28	DIODE 15V 5% 225MW MMBZ5245B_
VR608	4813830A28	DIODE 15V 5% 225MW MMBZ5245B_
VR609	4813830A28	DIODE 15V 5% 225MW MMBZ5245B_
VR610	4813830A28	DIODE 15V 5% 225MW MMBZ5245B_
VR611	4813830A28	DIODE 15V 5% 225MW MMBZ5245B_
VR612	4813830A28	DIODE 15V 5% 225MW MMBZ5245B_
VR613	4813830A28	DIODE 15V 5% 225MW MMBZ5245B_
VR618	4813830A28	DIODE 15V 5% 225MW MMBZ5245B_

ITEM	MOTOROLA PART NUMBER	DESCRIPTION
VR619	4813830A28	DIODE 15V 5% 225MW MMBZ5245B_
VR620	4813830A28	DIODE 15V 5% 225MW MMBZ5245B_
VR621	4813830A28	DIODE 15V 5% 225MW MMBZ5245B_
VR622	4813830A28	DIODE 15V 5% 225MW MMBZ5245B_

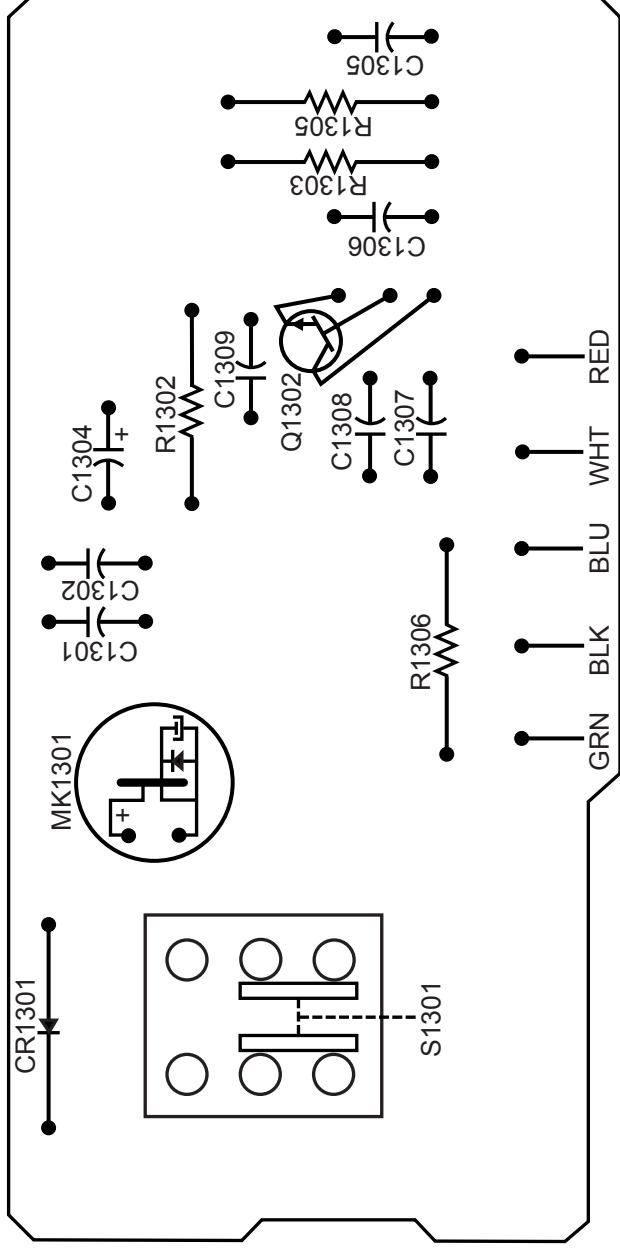

MAEPF-27698-O

Figure 8-30. HMN1080A, HMN1061A, HMN1079A Microphone Board Overlay

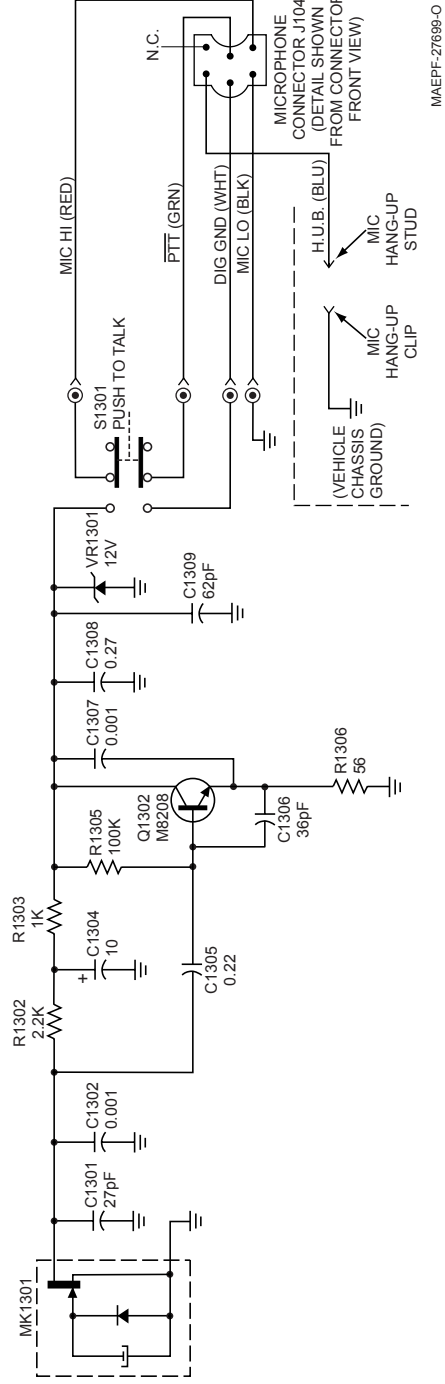

MAEPF-27699-O

Figure 8-31. HMN1080A, HMN1061A, HMN1079A Microphone Schematic

HMN1080A, HMN1061A, HMN1079A Microphone Parts List

ITEM	MOTOROLA PART NUMBER	DESCRIPTION
C1301	2111038H35	CAP 27pF 50V
C1302, C1307	2111039B13	CAP 1000 50V
C1304	2311048C10	CAP 10 50V
C1305	0811051A15 0811051A11	CAP .22 63V (HMN1080A & HMN1079A only) CAP .047 63V (HMN1061A only)
C1306	2182133G39 2111038P50	CAP 36 500V (HMN1080A & HMN1079A only) CAP 220 50V (HMN1061A only)
C1308	2382397D25 0811051A14	CAP .27pF 20V (HMN1080A & HMN1079A only) CAP .15 63V (HMN1061A only)
C1309	2111014H44	CAP 62pF 100V
CR1301	4811034A36	12V Zener
MK1301	5080258E06	ELECTRET MIC CTRG
Q1302	4811043C05	NPN
R1302	0611009C57	RES 2200 1/4
R1303	0611009C49	RES 1000 1/4
R1305	0611009C97	RES 100K 1/4
R1306	0611009C19	RES 56 5 1/4
S1301	4080065E02	SW MOMENTARY

## Notes



---

# Appendix A Replacement Parts Ordering

## A.1 Basic Ordering Information

When ordering replacement parts or equipment information, the complete identification number should be included. This applies to all components, kits, and chassis. If the component part number is not known, the order should include the number of the chassis or kit of which it is a part, and sufficient description of the desired component to identify it.

Crystal orders should specify the crystal type number, crystal and carrier frequency, and the model number in which the part is used.

The ASTRO Digital Spectra/Digital Spectra Plus Mobile Radios Control Head Manual (Motorola publication part number 6881096C77) includes complete parts lists and parts numbers.

## A.2 Motorola Online

Motorola Online users can access our online catalog at

<https://www.motorola.com/businessonline>

To register for online access:

- Domestic customers: please call 800-814-0601 (U.S. and Canada).
- International customers: please go to <https://www.motorola.com/businessonline> and click on "Sign Up Now."

## A.3 Mail Orders

Send written orders to the following addresses:

**Replacement Parts/  
Test Equipment/Manuals/  
Crystal Service Items:**

Motorola Inc.  
Radio Products Services Division\*  
Attention: Order Processing  
2200 Galvin Drive  
Elgin, IL 60123  
U.S.A.

**Federal Government Orders:**

Motorola Inc.  
U.S. Federal Government  
Markets Division  
Attention: Order Processing  
7230 Parkway Drive  
Landover, MD 21076  
U.S.A.

**International Orders:**

Motorola Inc.  
Radio Products Services Division\*  
Attention: Order Processing  
2200 Galvin Drive  
Elgin, IL 60123  
U.S.A.

\*The Radio Products Services Division (RPSD) was formerly known as the Customer Care and Services Division (CCSD) and/or the Accessories and Aftermarket Division (AAD).

---

## **A.4 Telephone Orders**

Radio Products Services Division\*  
(United States and Canada)  
7:00 AM to 7:00 PM (Central Standard Time)  
Monday through Friday (Chicago, U.S.A.)  
1-800-422-4210  
1-847-538-8023 (International Orders)

U.S. Federal Government Markets Division (USFGMD)  
1-800-826-1913 Federal Government Parts - Credit Cards Only  
8:30 AM to 5:00 PM (Eastern Standard Time)

## **A.5 Fax Orders**

Radio Products Services Division\*  
(United States and Canada)  
1-800-622-6210  
1-847-576-3023 (International)

USFGMD  
(Federal Government Orders)  
1-800-526-8641 (For Parts and Equipment Purchase Orders)

## **A.6 Parts Identification**

Radio Products Services Division\*  
(United States and Canada)  
1-800-422-4210, menu 3

## **A.7 Product Customer Service**

Customer Response Center  
(Non-technical Issues)  
1-800-247-2346  
FAX:1-800-247-2347

\*The Radio Products Services Division (RPSD) was formerly known as the Customer Care and Services Division (CCSD) and/or the Accessories and Aftermarket Division (AAD).

# Index

## C

- cable, P501 extender 6-4
- cautions 1-1
- charts, troubleshooting 5-12
- cleaning
  - circuit boards 2-1
  - components 2-1
  - external surfaces 2-1
- component location diagrams 8-1
- control heads
  - cabling 6-4
  - Model W3 1-2
  - Models W4, W5, W7, W9 1-4
  - overview 1-2
  - replacing 5-7
    - Model W3 5-7
    - Model W4, W5, W7 5-8
    - Model W9 5-10
  - vehicle interface port (VIP) 3-12
- controls
  - Model W3 1-3
  - Model W4, W5, W7, W9 1-6
- copyrights
  - computer software ii
  - document ii

## E

- extender cable, P501 6-4

## H

- handling precautions 2-2

## J

- jumper configurations 3-11

## M

- maintenance
  - cleaning 2-1
  - inspection 2-1
- manual
  - notations 1-1
  - revisions ii
- Microphone
  - exploded view 7-6
  - parts list 7-6
- Model W3
  - backlight circuit 3-3
  - display circuit 3-1
  - exploded view 7-2
  - final reassembly 5-11
  - jumper selection 3-3
  - keypad side keys and top keys 3-2
  - microphone preamplifier and PTT 3-2

- On/Off hook control 3-3
- operation 3-1
- parts list 7-2
- power On/Off 3-4
- power supply 3-3
- replacing the control head 5-7
- SB9600 Serial Bus Interface 3-1
- status LEDs 3-3
- Model W9
  - control board 3-9
    - bus transceiver 3-10
    - EEPROM write-protect circuit 3-11
    - ignition sense circuits 3-10
    - microprocessor 3-9
    - power supply 3-10
    - vacuum fluorescent voltage converter 3-10
    - vehicle interface ports 3-10
    - watchdog timer 3-9
  - controls and indicators 3-9
  - default jumper settings 3-11
  - display 3-8
  - display board 3-11
    - backlight LEDs 3-11
    - status LEDs 3-11
  - vacuum fluorescent display 3-11
  - vacuum fluorescent display driver 3-11
- exploded view 7-5
- operation 3-8
- parts list 7-5
- replacing the control head 5-10
- vehicle interface port (VIP) 3-14
- Models W4, W5, W7
  - backlight LEDs 3-8
  - bus busy 3-6
  - hang-up button (HUB) 3-7
  - ignition sense circuitry 3-7
  - interface circuitry 3-5
  - keypad scan 3-7
  - microcomputer 3-5
  - Model W4 exploded view 7-3
  - Model W4 parts list 7-3
  - Models W5, W7 exploded view 7-4
  - Models W5, W7 parts list 7-4
  - operation 3-4
  - power switch/ignition 3-4
  - push-to-talk (PTT) 3-7
  - replacing the control head 5-8
  - replacing the remote back housing
    - interface board 5-5
  - replacing the vacuum fluorescent display 5-5
  - reset 3-6
  - serial bus data 3-6
  - vacuum fluorescent display 3-8
  - vacuum fluorescent display driver IC 3-8
  - vacuum fluorescent voltage converter circuitry 3-7
  - vehicle interface port 3-12
  - voltage regulator 3-5

## N

- notations 1-1

## P

- parts list 8-1
  - large pushbutton parts 7-7
  - Microphone 7-6
  - Model W3 7-2
  - Model W4 7-3
  - Model W5 7-4
  - Model W7 7-4
  - Model W9 7-5
  - small pushbutton parts 7-7
- parts, ordering replacement A-1
- product safety information ii
- PTT (push-to-talk) 3-7

## R

- reassembly, final 5-11
  - Model W3 5-11
- remote back housing interface board, replacing 5-5
- remote interconnect board, replacing 5-6
- replacement parts, ordering A-1
- replacing
  - control head 5-7
  - remote back housing interface board 5-5
  - remote interconnect board 5-6
  - vacuum fluorescent display 5-5
- RF exposure compliance information ii

## S

- schematics 8-1
- Serial Bus Data 3-6

## T

- test equipment and service aids 4-1
- trademark information ii
- troubleshooting 5-1
  - charts 5-12
  - final reassembly 5-11
  - replacing the control head 5-7
  - replacing the remote back housing interface board 5-5
  - replacing the remote interconnect board 5-6
  - replacing the vacuum fluorescent display 5-5
  - tools and supplies 5-1
  - waveforms 5-2

## V

- vacuum fluorescent display, replacing 5-5
- vehicle interface port (VIP) 3-12
  - Model W4, W5, W7 3-12
  - VIP input connections 3-13
  - VIP output connections 3-12
- Model W9 3-14
  - VIP input connections 3-14
  - VIP output connections 3-14
- VIP output connections
  - dash-mount installations 3-12
  - remote-mount installations 3-13

## W

- warranty xi
- waveforms
  - troubleshooting 5-2





Motorola, Inc.  
8000 West Sunrise Boulevard  
Ft. Lauderdale, FL 33322

MOTOROLA, the Stylized M Logo, ASTRO, and Spectra are registered in the U.S. Patent and Trademark Office. All other product or service names are the property of their respective owners.  
© Motorola, Inc. 2003  
All rights reserved. Printed in U.S.A.



**6881096C77-O**