



Hardware Guide for Avaya Communication Manager

555-245-207
Issue 1.1
December 2003

**Copyright 2003, Avaya Inc.
All Rights Reserved**

Notice

Every effort was made to ensure that the information in this document was complete and accurate at the time of printing. However, information is subject to change.

Warranty

Avaya Inc. provides a limited warranty on this product. Refer to your sales agreement to establish the terms of the limited warranty. In addition, Avaya's standard warranty language as well as information regarding support for this product, while under warranty, is available through the following Web site: <http://www.avaya.com/support>.

Preventing Toll Fraud

"Toll fraud" is the unauthorized use of your telecommunications system by an unauthorized party (for example, a person who is not a corporate employee, agent, subcontractor, or is not working on your company's behalf). Be aware that there may be a risk of toll fraud associated with your system and that, if toll fraud occurs, it can result in substantial additional charges for your telecommunications services.

Avaya Fraud Intervention

If you suspect that you are being victimized by toll fraud and you need technical assistance or support, in the United States and Canada, call the Technical Service Center's Toll Fraud Intervention Hotline at 1-800-643-2353.

How to Get Help

For additional support telephone numbers, go to the Avaya support Web site: <http://www.avaya.com/support>. If you are:

- Within the United States, click the *Escalation Management* link. Then click the appropriate link for the type of support you need.
- Outside the United States, click the *Escalation Management* link. Then click the *International Services* link that includes telephone numbers for the international Centers of Excellence.

Providing Telecommunications Security

Telecommunications security (of voice, data, and/or video communications) is the prevention of any type of intrusion to (that is, either unauthorized or malicious access to or use of) your company's telecommunications equipment by some party.

Your company's "telecommunications equipment" includes both this Avaya product and any other voice/data/video equipment that could be accessed via this Avaya product (that is, "networked equipment").

An "outside party" is anyone who is not a corporate employee, agent, subcontractor, or is not working on your company's behalf. Whereas, a "malicious party" is anyone (including someone who may be otherwise authorized) who accesses your telecommunications equipment with either malicious or mischievous intent.

Such intrusions may be either to/through synchronous (time-multiplexed and/or circuit-based) or asynchronous (character-, message-, or packet-based) equipment or interfaces for reasons of:

- Utilization (of capabilities special to the accessed equipment)
- Theft (such as, of intellectual property, financial assets, or toll facility access)
- Eavesdropping (privacy invasions to humans)
- Mischief (troubling, but apparently innocuous, tampering)
- Harm (such as harmful tampering, data loss or alteration, regardless of motive or intent)

Be aware that there may be a risk of unauthorized intrusions associated with your system and/or its networked equipment. Also realize that, if such an intrusion should occur, it could result in a variety of losses to your company (including but not limited to, human/data privacy, intellectual property, material assets, financial resources, labor costs, and/or legal costs).

Responsibility for Your Company's Telecommunications Security

The final responsibility for securing both this system and its networked equipment rests with you - Avaya's customer system administrator, your telecommunications peers, and your managers. Base the fulfillment of your responsibility on acquired knowledge and resources from a variety of sources including but not limited to:

- Installation documents
- System administration documents
- Security documents
- Hardware-/software-based security tools
- Shared information between you and your peers
- Telecommunications security experts

To prevent intrusions to your telecommunications equipment, you and your peers should carefully program and configure:

- Your Avaya-provided telecommunications systems and their interfaces
- Your Avaya-provided software applications, as well as their underlying hardware/software platforms and interfaces
- Any other equipment networked to your Avaya products

TCP/IP Facilities

Customers may experience differences in product performance, reliability and security depending upon network configurations/design and topologies, even when the product performs as warranted.

Standards Compliance

Avaya Inc. is not responsible for any radio or television interference caused by unauthorized modifications of this equipment or the substitution or attachment of connecting cables and equipment other than those specified by Avaya Inc. The correction of interference caused by such unauthorized modifications, substitution or attachment will be the responsibility of the user. Pursuant to Part 15 of the Federal Communications Commission (FCC) Rules, the user is cautioned that changes or modifications not expressly approved by Avaya Inc. could void the user's authority to operate this equipment.

Product Safety Standards

This product complies with and conforms to the following international Product Safety standards as applicable:

Safety of Information Technology Equipment, IEC 60950, 3rd Edition including all relevant national deviations as listed in Compliance with IEC for Electrical Equipment (IECEE) CB-96A.

Safety of Information Technology Equipment, CAN/CSA-C22.2 No. 60950-00 / UL 60950, 3rd Edition

Safety Requirements for Customer Equipment, ACA Technical Standard (TS) 001 - 1997

One or more of the following Mexican national standards, as applicable: NOM 001 SCFI 1993, NOM SCFI 016 1993, NOM 019 SCFI 1998

The equipment described in this document may contain Class 1 LASER Device(s). These devices comply with the following standards:

- EN 60825-1, Edition 1.1, 1998-01
- 21 CFR 1040.10 and CFR 1040.11.

The LASER devices operate within the following parameters:

- Maximum power output: -5 dBm to -8 dBm
- Center Wavelength: 1310 nm to 1360 nm

Luokan 1 Laserlaitte
Klass 1 Laser Apparat

Use of controls or adjustments or performance of procedures other than those specified herein may result in hazardous radiation exposures. Contact your Avaya representative for more laser product information.

Electromagnetic Compatibility (EMC) Standards

This product complies with and conforms to the following international EMC standards and all relevant national deviations:

Limits and Methods of Measurement of Radio Interference of Information Technology Equipment, CISPR 22:1997 and EN55022:1998.

Information Technology Equipment – Immunity Characteristics – Limits and Methods of Measurement, CISPR 24:1997 and EN55024:1998, including:

- Electrostatic Discharge (ESD) IEC 61000-4-2
- Radiated Immunity IEC 61000-4-3
- Electrical Fast Transient IEC 61000-4-4
- Lightning Effects IEC 61000-4-5
- Conducted Immunity IEC 61000-4-6
- Mains Frequency Magnetic Field IEC 61000-4-8
- Voltage Dips and Variations IEC 61000-4-11
- Powerline Harmonics IEC 61000-3-2
- Voltage Fluctuations and Flicker IEC 61000-3-3

Federal Communications Commission Statement

Part 15:

Note: This equipment has been tested and found to comply with the limits for a Class A digital device, pursuant to Part 15 of the FCC Rules. These limits are designed to provide reasonable protection against harmful interference when the equipment is operated in a commercial environment. This equipment generates, uses, and can radiate radio frequency energy and, if not installed and used in accordance with the instruction manual, may cause harmful interference to radio communications. Operation of this equipment in a residential area is likely to cause harmful interference in which case the user will be required to correct the interference at his own expense.

Part 68: Answer-Supervision Signaling

Allowing this equipment to be operated in a manner that does not provide proper answer-supervision signaling is in violation of Part 68 rules. This equipment returns answer-supervision signals to the public switched network when:

- answered by the called station,
- answered by the attendant, or
- routed to a recorded announcement that can be administered by the customer premises equipment (CPE) user.

This equipment returns answer-supervision signals on all direct inward dialed (DID) calls forwarded back to the public switched telephone network. Permissible exceptions are:

- A call is unanswered.
- A busy tone is received.
- A reorder tone is received.

Avaya attests that this registered equipment is capable of providing users access to interstate providers of operator services through the use of access codes. Modification of this equipment by call aggregators to block access dialing codes is a violation of the Telephone Operator Consumers Act of 1990.

REN Number

For MCC1, SCC1, CMC1, G600, and G650 Media Gateways:

This equipment complies with Part 68 of the FCC rules. On either the rear or inside the front cover of this equipment is a label that contains, among other information, the FCC registration number, and ringer equivalence number (REN) for this equipment. If requested, this information must be provided to the telephone company.

For G350 and G700 Media Gateways:

This equipment complies with Part 68 of the FCC rules and the requirements adopted by the ACTA. On the rear of this equipment is a label that contains, among other information, a product identifier in the format US:AAAEQ##TXXXX. The digits represented by ## are the ringer equivalence number (REN) without a decimal point (for example, 03 is a REN of 0.3). If requested, this number must be provided to the telephone company.

For all media gateways:

The REN is used to determine the quantity of devices that may be connected to the telephone line. Excessive RENs on the telephone line may result in devices not ringing in response to an incoming call. In most, but not all areas, the sum of RENs should not exceed 5.0. To be certain of the number of devices that may be connected to a line, as determined by the total RENs, contact the local telephone company. REN is not required for some types of analog or digital facilities.

Means of Connection

Connection of this equipment to the telephone network is shown in the following tables.

For MCC1, SCC1, CMC1, G600, and G650 Media Gateways:

Manufacturer's Port Identifier	FIC Code	SOC/REN/A.S. Code	Network Jacks
Off premises station	OL13C	9.0F	RJ2GX, RJ21X, RJ11C
DID trunk	02RV2-T	0.0B	RJ2GX, RJ21X
CO trunk	02GS2	0.3A	RJ21X
	02LS2	0.3A	RJ21X
Tie trunk	TL31M	9.0F	RJ2GX
Basic Rate Interface	02IS5	6.0F, 6.0Y	RJ49C
1.544 digital interface	04DU9-BN	6.0F	RJ48C, RJ48M
	04DU9-IKN	6.0F	RJ48C, RJ48M
	04DU9-ISN	6.0F	RJ48C, RJ48M
120A4 channel service unit	04DU9-DN	6.0Y	RJ48C

For G350 and G700 Media Gateways:

Manufacturer's Port Identifier	FIC Code	SOC/REN/A.S. Code	Network Jacks
Ground Start CO trunk	02GS2	1.0A	RJ11C
DID trunk	02RV2-T	AS.0	RJ11C
Loop Start CO trunk	02LS2	0.5A	RJ11C
1.544 digital interface	04DU9-BN	6.0Y	RJ48C
	04DU9-DN	6.0Y	RJ48C
	04DU9-IKN	6.0Y	RJ48C
	04DU9-ISN	6.0Y	RJ48C
Basic Rate Interface	02IS5	6.0F	RJ49C

For all media gateways:

If the terminal equipment (for example, the media server or media gateway) causes harm to the telephone network, the telephone company will notify you in advance that temporary discontinuance of service may be required. But if advance notice is not practical, the telephone company will notify the customer as soon as possible. Also, you will be advised of your right to file a complaint with the FCC if you believe it is necessary.

The telephone company may make changes in its facilities, equipment, operations or procedures that could affect the operation of the equipment. If this happens, the telephone company will provide advance notice in order for you to make necessary modifications to maintain uninterrupted service.

If trouble is experienced with this equipment, for repair or warranty information, please contact the Technical Service Center at 1-800-242- 2121 or contact your local Avaya representative. If the equipment is causing harm to the telephone network, the telephone company may request that you disconnect the equipment until the problem is resolved.

A plug and jack used to connect this equipment to the premises wiring and telephone network must comply with the applicable FCC Part 68 rules and requirements adopted by the ACTA. A compliant telephone cord and modular plug is provided with this product. It is designed to be connected to a compatible modular jack that is also compliant. It is recommended that repairs be performed by Avaya certified technicians.

The equipment cannot be used on public coin phone service provided by the telephone company. Connection to party line service is subject to state tariffs. Contact the state public utility commission, public service commission or corporation commission for information.

This equipment, if it uses a telephone receiver, is hearing aid compatible.

Canadian Department of Communications (DOC) Interference Information

This Class A digital apparatus complies with Canadian ICES-003. Cet appareil numérique de la classe A est conforme à la norme NMB-003 du Canada.

This equipment meets the applicable Industry Canada Terminal Equipment Technical Specifications. This is confirmed by the registration number. The abbreviation, IC, before the registration number signifies that registration was performed based on a Declaration of Conformity indicating that Industry Canada technical specifications were met. It does not imply that Industry Canada approved the equipment.

Declarations of Conformity

United States FCC Part 68 Supplier's Declaration of Conformity (SDoC)

Avaya Inc. in the United States of America hereby certifies that the equipment described in this document and bearing a TIA TSB-168 label identification number complies with the FCC's Rules and Regulations 47 CFR Part 68, and the Administrative Council on Terminal Attachments (ACTA) adopted technical criteria.

Avaya further asserts that Avaya handset-equipped terminal equipment described in this document complies with Paragraph 68.316 of the FCC Rules and Regulations defining Hearing Aid Compatibility and is deemed compatible with hearing aids.

Copies of SDoCs signed by the Responsible Party in the U. S. can be obtained by contacting your local sales representative and are available on the following Web site: <http://www.avaya.com/support>.

All Avaya media servers and media gateways are compliant with FCC Part 68, but many have been registered with the FCC before the SDoC process was available. A list of all Avaya registered products may be found at: <http://www.part68.org> by conducting a search using "Avaya" as manufacturer.

European Union Declarations of Conformity



Avaya Inc. declares that the equipment specified in this document bearing the "CE" (*Conformité Européenne*) mark conforms to the European Union Radio and Telecommunications Terminal Equipment Directive (1999/5/EC), including the Electromagnetic Compatibility Directive (89/336/EEC) and Low Voltage Directive (73/23/EEC). This equipment has been certified to meet CTR3 Basic Rate Interface (BRI) and CTR4 Primary Rate Interface (PRI) and subsets thereof in CTR12 and CTR13, as applicable.

Copies of these Declarations of Conformity (DoCs) can be obtained by contacting your local sales representative and are available on the following Web site: <http://www.avaya.com/support>.

Japan

This is a Class A product based on the standard of the Voluntary Control Council for Interference by Information Technology Equipment (VCCI). If this equipment is used in a domestic environment, radio disturbance may occur, in which case, the user may be required to take corrective actions.

この装置は、情報処理装置等電波障害自主規制協議会（VCCI）の基準に基づくクラスA情報技術装置です。この装置を家庭環境で使用すると電波妨害を引き起こすことがあります。この場合には使用者が適切な対策を講ずるよう要求されることがあります。

To order copies of this and other documents:

Call: Avaya Publications Center
Voice 1.800.457.1235 or 1.207.866.6701
FAX 1.800.457.1764 or 1.207.626.7269

Write: Globalware Solutions
200 Ward Hill Avenue
Haverhill, MA 01835 USA
Attention: Avaya Account Management

E-mail: totalware@gwsmail.com

For the most current versions of documentation, go to the Avaya support Web site: <http://www.avaya.com/support>.

Contents

Overview	25
• Document Overview	25
• Avaya media servers	25
• Avaya media gateways	26
• Avaya Integrated Management	26
• Avaya communications devices	27
• DEFINITY Server CSI	29
Overview	29
Detailed description	29
Configuration information	29
Reliability and recovery	30
System capacity	31
Avaya Communication Manager	31
Adjuncts	32
• Avaya S8100 Media Server with a CMC1 or G600 Media Gateway	33
Overview	33
Detailed description	33
S8100 Media Server with a CMC1 or G600 Media Gateway	33
Standard components	34
Optional components	35
Reliability	35
Recoverability	36
Administration	36
Peer Web server	37
Telnet session	37
Avaya Integrated Management	37
Avaya Communication Manager	37
• Avaya S8300 Media Server and an Avaya G700 Media Gateway	39
Overview	39
Detailed description	39
Configuration description	39
Server features	40
Avaya G700 Media Gateway	41
LEDs	45
Maintenance software	46

Avaya media modules	46
LEDs	47
MM710 T1/E1 media module	47
MM711 Analog media module	48
MM712 DCP media module	49
MM720 BRI media module	49
MM760 VoIP media module	50
S8300 Media Server in an LSP configuration	50
IP addressing	51
Preservation of customer translations	51
IA770 INTUITY AUDIX messaging	51
Call center	52
G700 announcement software	53
Customer configuration options	55
System management	55
Avaya Integrated Management	55
S8300 Media Server Web interface	56
Adjuncts	56
International information	56
Digital trunks and CO trunks	58
• Avaya S8500 Media Server	59
Detailed description	59
Backing up an S8500 Media Server	60
Port-network connectivity	61
Media gateways	61
Remote Supervisor Adapter (RSA)	62
Modems	64
S8500 Media Server reliability	66
Migrating to an S8500 Media Server	66
RAM disk	68
High-level capabilities	68
System management	69
Avaya Integrated Management suite	69
Avaya S8500 Media Server Web interface	69
• Avaya S8700 Media Server with an Avaya G650 Media Gateway	70
Detailed description	70
Configuration information	70
S8700 Media Server control complex	70

S8700 Media Server	71
IPSI Circuit Pack (TN2312BP)	71
Ethernet switch	72
UPS or power backup	73
USB modem	73
Media gateways	73
Reliability	79
Reliability when sending voice bearer over IP	79
Reliability when sending voice bearer over ATM or CSS	83
Connectivity	88
Connectivity when sending voice bearer over ATM or CSS	88
Connectivity when sending voice bearer over IP	89
S8700 recoverability	89
S8300 Media Server in an LSP mode	89
Power outages	89
Survivable Remote EPN (voice bearer over CSS only)	90
High-level capabilities	90
BHCC capacity for S8700 Media Server	91
System management	93
Avaya Integrated Management suite	93
S8700 Media Server Web interface	93
Adjuncts	94
• DEFINITY Server SI	95
Overview	95
Detailed description	96
Configuration information	96
Options	101
Expansion Port Network	101
IP Media Processor	101
DEFINITY IP Solutions	101
Trunks	102
Connectivity	103
LAN Gateway	103
C-LAN	103
IP Asynchronous Links using C-LAN	104
Switch Client Applications	104
Switch Server Applications	104
Reliability	105

BHCCI	105
Adjuncts	106
• DEFINITY Server R	107
Overview	107
Detailed description	108
Configuration information	109
Trunks	115
Connectivity	115
Reliability	120
BHCC	121
Adjuncts	121
Media gateways	123
• Avaya G350 Media Gateway	123
Features	123
Deployment modes	124
Physical description	124
G350 capabilities	125
• G600 Media Gateway	127
G600 Media Gateway cooling	127
Required circuit packs for a G600 Media Gateway and an S8700 Media Server	128
IP Server Interface (TN2312BP)	128
C-LAN (TN799DP)	128
IP Media Processor (TN2302AP)	129
Required circuit packs for a G600 Media Gateway and an S8100 Media Server	129
TN2314 Processor (S8100)	129
TN744E Call Classifier and Tone Detector	130
• Avaya G650 Media Gateway	131
Overview	131
Mounting G650s	132
Mounting a single G650	132
Mounting multiple G650s	132
Carrier addressing	132
I/O connections	135
I/O adapters	135
Fan assembly	135

655A power supply	135
Input power	135
655A faceplate LEDs	136
655A ring generation	137
• Avaya G700 Media Gateway	139
Expansion modules	140
X330 WAN Access routing module	140
Avaya P330 LAN expansion module	141
P330 stacking fabric (Octaplane)	142
Power supply	142
Motherboard	142
Fans	143
LEDs	143
Media module LEDs	143
System-level LEDs	143
Gateway software	144
Maintenance software	144
Connectivity	144
Media modules	145
• CMC1 Media Gateway	147
• SCC1 Media Gateway	150
Carriers	153
Basic control cabinet for a DEFINITY Server SI	153
Duplicated control cabinet for a DEFINITY Server SI	154
Expansion control cabinet for a DEFINITY Server SI, DEFINITY Server R, S8700 Media Server, or S8500 Media Server	155
Port cabinet for a DEFINITY Server SI, DEFINITY Server R, S8700 Media Server, or S8500 Media Server	156
• MCC1 Media Gateway	159
Auxiliary cabinet	161
Port network cabinet for DEFINITY Server R or SI	161
Port network cabinet for Avaya S8700 Media Server	161
Port network cabinet for Avaya S8500 Media Server	163
Expansion port network cabinet for DEFINITY Server R or SI	163
Carriers	164
Control carrier for DEFINITY Server SI	164

Duplicated control carrier for DEFINITY Server SI	166
Processor carrier for DEFINITY Server R or SI	166
Expansion Control Carrier for all server models	167
Port carrier for DEFINITY Server SI or R, S8700 Media Server, or S8500 Media Server	169
Switch node carrier for DEFINITY Server R or S8700 Media Server	170
Circuit packs and power supplies	173
• 1217A AC power supply	173
• 631DA1 AC power unit	173
• 631DB1 AC power unit	173
• 649A DC power unit	174
• 650A AC power unit	174
• 655A power supply	175
Input power	175
AC power	175
DC power	175
Serial bus	175
655A faceplate LEDs	176
655A ring generation	176
676C DC power supply	177
982LS current limiter	177
CFY1B current limiter	177
ED-1E568 DEFINITY AUDIX R4	177
J58890MA-1 Multiapplication Platform for DEFINITY (MAPD)	177
NAA1 fiber-optic cable adaptor	178
TN429D Incoming Call Line Identification (ICLID)	178
TN433 Speech Synthesizer	178
TN436B Direct Inward Dialing Trunk (8 ports)	178
TN438B Central Office Trunk (8 ports)	178
TN439 Tie Trunk (4 ports)	178
TN457 Speech Synthesizer	179
TN459B Direct Inward Dialing Trunk (8 ports)	179
TN464GP DS1 Interface, T1 (24 channels) or E1 (32 channels)	179
TN465C Central Office Trunk (8 ports)	180
TN479 Analog Line (16 ports)	180
TN497 Tie Trunk (4 ports)	180
TN553 Packet Data Line	181

TN556D ISDN-BRI 4-Wire S/T-NT Interface (12 ports)	181
TN568 DEFINITY AUDIX 4.0 Voice Mail System (part of ED-1E568)	181
TN570D Expansion Interface	182
TN572 Switch-Node Clock	182
TN573B Switch-Node Interface for DEFINITY R	182
TN577 Packet Gateway	182
TN725B Speech Synthesizer	183
TN726B Data Line (8 ports)	183
TN735 MET Line (4 ports)	183
TN744E Call Classifier and Tone Detector (8 ports)	184
TN746B Analog Line (16 ports)	184
TN747B Central Office Trunk (8 ports)	185
TN750C Recorded Announcement (16 channels)	185
TN753B Direct Inward Dialing Trunk (8 ports)	186
TN754C DCP Digital Line (4-wire, 8 ports)	186
TN755B Neon Power Unit	186
TN758 Pooled Modem (2 ports)	187
TN760E Tie Trunk (4-wire, 4 ports)	187
TN762B Hybrid Line (8 ports)	187
TN763D Auxiliary Trunk (4 ports)	187
TN767E DS1 Interface, T1 (24 channels)	187
TN769 Analog Line (8 ports)	188
TN771DP Maintenance and Test	189
TN775C Maintenance	189
TN780 Tone Clock	190
TN787K Multimedia Interface	190
TN788C Multimedia Voice Conditioner	190
TN789B Radio Controller	191
TN791 Analog Guest Line (16 ports)	191
TN792 Duplication Interface	192
TN793B Analog Line with Caller ID (24 ports)	192
TN797 Analog Trunk or Line Circuit Pack (8 ports)	193
TN799DP Control LAN (C-LAN) Interface	193
TN801 MAPD (LAN Gateway Interface)	194
TN802B MAPD (IP Interface Assembly)	194
TN1648B System Access and Maintenance (SYSAM)	194
TN1650B Memory	195
TN1654 DS1 Converter, T1 (24 channels) and E1 (32 channels)	195

TN1655 Packet Interface	195
TN1657 Disk Drive	196
TN2138 Central Office Trunk (8 ports)	196
TN2139 Direct Inward Dialing Trunk(8 ports)	196
TN2140B Tie Trunk (4-wire, 4 ports)	196
TN2146 Direct Inward Dialing Trunk (8 ports)	196
TN2147C Central Office Trunk (8 ports)	197
TN2181 DCP Digital Line (2-wire, 16 ports)	197
TN2182C Tone Clock, Tone Detector, and Call Classifier (8 ports)	197
TN2183/TN2215 Analog Line for multiple countries (16 ports)	197
TN2184 DIOD Trunk (4 ports)	198
TN2185B ISDN-BRI S/T-TE Interface (4-wire, 8 ports)	198
TN2198B ISDN-BRI U Interface (2-wire, 12 ports)	199
TN2199 Central Office Trunk (3-wire, 4 ports)	199
TN2202 Ring Generator	200
TN2207 DS1 Interface, T1 (24 channels) and E1 (32 channels)	200
TN2209 Tie Trunk (4-wire, 4 ports)	200
TN2211 Optical Drive	201
TN2214B DCP Digital Line (2-wire, 24 ports)	201
TN2215/TN2183 Analog Line for Multiple Countries (16 ports) (International Offers or Offer B only for US and Canada)	202
TN2224B DCP Digital Line (2-wire, 24 ports)	203
TN2242 Digital Trunk	203
TN2301 Logic Switch	203
TN2302AP IP Media Processor	203
TN2305B ATM-CES Trunk/Port-Network Interface for multimode fiber	204
TN2306B ATM-CES Trunk/Port-Network Interface for single-mode fiber	204
TN2308 Direct Inward Dialing Trunk (8 ports)	204
TN2312BP IP Server Interface	204
I/O adapters	206
Compatibility	206
Number of IPSI circuit packs per configuration	207
TN2313AP DS1 Interface (24 channels)	207
TN2314 S8100 Media Server	207
TN2401 Network Control/Packet Interface for SI	208
TN2401/TN2400 Network Packet Interface complex assembly for SI upgrades	208

TN2402 Processor	208
TN2404 Processor	209
TN2464BP DS1 Interface with Echo Cancellation, T1/E1	209
TN2501AP Voice Announcements over LAN (VAL)	210
TN2793B Analog Line with Caller ID (24 ports)	210
TNCCSC-1 PRI to DASS Converter	211
TNCCSC-2 PRI to DPNSS Converter	211
TNCCSC-3 PRI to DPNSS Converter	211
TN-C7 PRI to SS7 Converter	211
TN-CIN Voice, FAX and Data Multiplexer	211
UN330B Duplication Interface	212
UN331C Processor	212
UN332C Mass Storage/Network Control for R	213
Media modules	215
• MM312 DCP media module	215
• MM314 LAN media module	216
• MM340 E1/T1 media module	217
• MM342 USP WAN media module	218
• MM710 T1/E1 media module	219
Echo cancellation	219
CSU function	220
Loopback/BERT functions	220
E1 impedance	220
Bantam jacks	220
LEDs	220
DB 25 DCE connector	221
Loopback jack	221
• MM711 Analog media module	222
External interfaces: CO trunk side	222
Caller ID	223
Analog line interface requirements	223
Companding	223
• MM712 DCP media module	224
Hardware interface	224
• MM714 Analog media module	225
• MM720 BRI media module	226

- MM722 BRI media module 227
- MM760 VoIP media module 228
 - Ethernet interface 228
 - Voice compression 228

Optional components 229

- Optional components for an S8100 Media Server 229
 - Media gateways 229
 - Circuit packs 229
 - Power circuit packs 229
 - Line circuit packs 229
 - Trunk circuit packs 230
 - Control circuit packs 230
 - Service circuit packs 230
 - Application circuit packs 231
 - Port circuit packs 231
 - Adapters 231
 - Avaya telephones 231
 - IP telephones 231
 - Digital telephones 231
 - Soundstation speakerphones 232
 - Analog phones 232
 - Avaya Explosive Atmosphere telephones 232
 - Wireless 232
 - Consoles 232
- Optional components: S8300 Media Server with a G700 Media Gateway 233
 - Media gateways 233
 - Media modules for a G700 Media Gateway 233
 - Avaya telephones 233
 - IP telephones 233
 - Digital telephones 233
 - Analog telephones 234
 - Wireless telephone 234
 - Speakerphones 234
- Optional components: S8500 235
 - Media gateways 235
 - Circuit packs 235
 - Power 235

Line circuit packs	235
Trunk circuit packs	236
Control circuit packs	236
Service circuit packs	237
Application circuit packs	237
Port circuit packs	237
Avaya telephones	237
IP telephones	237
Digital telephones	238
SoundStation speakerphones	238
Analog telephones	238
Avaya Explosive Atmosphere telephone	238
Wireless telephone	238
Consoles	238
• Optional components for an S8700 Media Server in an IP Connect configuration	239
Media gateways	239
Circuit packs	239
Line circuit packs	239
Trunk circuit packs	239
Control circuit packs	240
Service circuit packs	240
Application circuit packs	240
Port circuit packs	240
Avaya telephones	241
IP telephones	241
Digital telephones	241
SoundStation speakerphones	241
Avaya Explosive Atmosphere telephone	241
Wireless telephone	241
Consoles	242
• Optional components: S8700 – Voice Bearer Over CSS or ATM	243
Media gateways	243
Circuit packs	243
Power	243
Line circuit packs	243
Trunk circuit packs	244
Control circuit packs	244

Service circuit packs	245
Application circuit packs	245
Port circuit packs	245
Avaya telephones	245
IP telephones	245
Digital telephones	246
SoundStation speakerphones	246
Analog telephones	246
Avaya Explosive Atmosphere telephones	246
Wireless telephone	246
Consoles	246
• Optional components for DEFINITY Server CSI	247
Media gateways	247
Circuit packs for DEFINITY Server CSI	247
Power circuit packs	247
Line circuit packs	247
Trunk circuit packs	247
Control circuit packs	248
Service circuit packs	248
Application circuit packs	248
Port circuit packs	249
Adapter	249
Avaya telephones for DEFINITY Server CSI	249
IP telephones	249
Digital telephones	249
SoundStation speakerphones	250
Analog telephones	250
Explosive Atmosphere telephones	250
Wireless telephone	250
Consoles	250
• Optional components for DEFINITY Server SI	251
Media gateways	251
Circuit packs for DEFINITY Server SI	251
Power Circuit Packs	251
Line Circuit Packs	251
Trunk Circuit Packs	252
Control Circuit Packs	252
Service Circuit Packs	253

Application Circuit Packs	253
Port Circuit Packs	253
Avaya telephones for DEFINITY Server SI	253
IP telephones	253
Digital telephones	254
Soundstation speakerphones	254
Analog phones	254
Avaya Explosive Atmosphere telephones	254
Wireless	254
Consoles	254
• Optional components for DEFINITY Server R	255
Media gateways	255
Circuit packs	255
Power circuit packs	255
Line circuit packs	255
Trunk circuit packs	256
Control circuit packs	256
Service circuit packs	257
Application circuit packs	257
Port circuit packs	257
Avaya telephones	257
IP telephones	257
Digital telephones	258
Soundstation speakerphones	258
Analog phones	258
Avaya Explosive Atmosphere telephones	258
Wireless	258
Consoles	258
Telephones and speakerphones	259
• Avaya telephones	259
Avaya IP telephones	259
Avaya 4602 IP telephone	259
Avaya 4602SW IP telephone	260
Avaya 4606 IP telephone	260
Avaya 4610SW IP telephone	261
Avaya 4612 IP telephone	262

Avaya 4620 IP telephone	263
Avaya 4620SW IP telephone	264
Avaya 4624 IP telephone	264
Avaya 4630 IP Screenphone	266
Avaya 4630SW IP telephone	267
Avaya digital telephones	267
Avaya 2402 Digital Telephone	267
Avaya 2420 digital telephone	268
Avaya 6402 and 6402D digital telephones	268
Avaya 6408D+ digital telephone	269
Avaya 6416D+M digital telephone	270
Avaya 6424D+M digital telephone	271
Avaya Callmaster IV (603F) digital telephone	272
Avaya Callmaster V (607A) digital telephone	273
Avaya Callmaster VI (606A) digital telephone	273
Avaya attendant consoles	274
Avaya 302D attendant console	274
Avaya Softconsole	275
Avaya analog telephones	276
Avaya 2500 and 2554 analog terminals	276
Avaya 6211 Analog Telephone	277
Avaya 6219 analog telephone	278
Avaya 2520B Explosive Atmosphere telephone	279
Avaya wireless telephones	279
Avaya TransTalk 9040	279
• Power for Avaya IP telephones	281
Power for Avaya 4602 and Avaya 4620 IP telephones	281
Power for Avaya 4606, 4612, and 4624 IP telephones	281
Power for Avaya 4630 IP telephones	282
• SoundPoint and SoundStation speakerphones	283
3127 SoundPoint Speakerphone	283
Highlights	283
Models	283
3127 SoundStation speakerphone	283
Highlights	284
Models	284
3127 SoundStation Premier audioconferencing speakerphone	285
Highlights	285
Models	285

Avaya UPS Units 287

- Avaya Series 1 (AS1) UPS 287
 - AS1 1000 VA 120 V Online Uninterruptible Power Supply (UPS) 287
 - 1000 VA 120 V models include the following accessories: 287
 - AS1 1000VA 230V Online UPS 287
 - 1000VA 230 V models include the following accessories: 288
 - AS1 1500VA 120V Online UPS 288
 - The AS1 1500 VA model includes the following accessories: 288
 - AS1 1500VA 230V Online UPS 288
 - 1500 VA 230 V models include the following accessories: 289
 - UPS Add-on Modules 289
 - Extended Battery Module-EBM24 1000 VA 289
 - UPS Extended Battery Module-EBM48 1500-2000 VA 289
 - SNMP MODULE 1000-2000 VA 289
 - BYPASS DISTRIBUTION MODULE 120V 1000-1500 VA 290
 - PWR UPS BYPASS DISTR MOD S1 1000VA-2K VA 290

Avaya Ethernet Switches 291

- Avaya P330 Ethernet Switches 291
 - Features of the Avaya P330 Product Line 291
 - Auto-Negotiation 292
 - Congestion Control 292
 - VLANs 292
 - Multiple VLANs per Port 292
 - Leaky VLAN 292
 - Port Classification 292
 - Network TIME Acquiring Protocols 293
 - MAC Security 293
 - Link Aggregation Group (LAG) 293
 - IP Multicast Filtering 293
 - Radius Security 293
 - Port Redundancy 293
 - Intermodule Redundancy 294
 - Stack Redundancy 294
 - Hot-Swappable 294
 - Backup Power Supply 294
 - Fans 294
 - Network Management Agent (NMA) Redundancy 294

Software Download	294
P330 Standards Supported by Avaya	295
IEEE	295
IETF	295
Avaya P330 Network Management	295
Avaya P330 Device Manager (Embedded Web)	295
Avaya P330 Command Line Interface (CLI)	295
CajunView	295
Avaya P330 Network Monitoring	296
Port Mirroring	296
SMON	296
• Avaya P133 and P134 Ethernet Switches	297
Avaya P133G2	297
Avaya P134G2	297
General Features of the P133G2 and P134G2 Switches	297
Interfaces	298
Standards Supported	298
Physical Characteristics	298
Environmental Conditions	298
Power Consumption	298
Agency Approval	298

Site requirements 301

• Rack mounting, temperature and humidity information for the G600 Media Gateway	301
• Heat dissipation for the G600 Media Gateway	302
Typical G600 Media Gateway heat-dissipation specifications	302
• G650 specifications	303
Power requirements	303
AC power	303
DC power	303
Power output	303
Dimensions	304
Operating conditions	304
• Environmental considerations for the G700 Media Gateway	305
• Power requirements for the G700 Media Gateway	306
Thermal Protection	306
Manual Reset	306

AC and Load Center Circuit Breakers	306
AC power distribution	306
AC Grounding/Protective Grounds	306
• S8500 Media Server environmental specifications	308
• Altitude, air pressure and air purity for the S8700 Media Server	309
Air Purity	309
• Temperature and humidity for the S8700 Media Server	310
• EMI and RFI specifications for the S8700 Media Server	311
• Power supply specifications for the S8700 Media Server	312
BTU	312
• Regulatory certification for an S8700 Media Server	313
Product-safety standards and approvals	313
Electromagnetic-compatibility (EMC) standards and approvals	313
• Data rack mounting and media gateway floor loading for an S8700 Multi-Connect	314
19-Inch Rack	314
S8700 Media Server	314
Avaya 700VA or 1500VA UPS Units	314
Avaya Ethernet switches	315
Media gateways	315
• Site requirements for DEFINITY	316
Altitude, air pressure, and air purity for DEFINITY	316
Altitude and air pressure	316
Air purity	316
• Cabinet dimensions and clearances	317
• Floor load requirements	318
• Power requirements	319
Global AC MCC power supply	319
AC power	319
50-Hz power sources in DEFINITY R	320
DC power	322
Circuit-breaker sizes for AC and DC cabinets	323
MCC1 power system	323
AC power distribution	324
Circuit breaker	325
48-VDC batteries	325
Battery charger	325

DC power relay	326
EMI filters	326
Ring generator	326
Fuses	326
Power backup	326
UPS	327
AC power-distribution unit (J58890CH-1)	327
Power backup	327
Small batteries	327
Large batteries	328
DC power distribution	329
DC power-distribution unit (J58890CF-2)	329
Ground isolation	330
DC power converter (649A)	331
AC and DC grounding	332
Approved grounds	332
Protective grounds	332
Approved floor grounds	332
Coupled bonding conductor	333
SCC1 power systems	333
AC power supply (1217A)	333
DC power supply (676C)	334
DC power-distribution unit (J58890CG)	334
Enhanced DC rectifier cabinet (J58890R)	334
CMC1 AC power supply (650A)	334
CMC1 UPS	335
Cabinet cooling fans	335
CMC1 fan unit	335
MCC1 fans	335
SCC1 fan unit	336
System protection	336
Protection from hazardous voltages	336
Overvoltage protection	336
Sneak current protection	336
Lightning protection	337
Earthquake protection	337
• Temperature and humidity for DEFINITY	338

Customer configurations	339
• Small businesses	339
• Medium-sized business solution	341
• Large businesses	342
• Branch Office and Multi-Site Configurations	344
Branch Office Configuration	344
Multi-Site Environment	346
Index	347

Overview

Document Overview

Avaya's portfolio of MultiVantage™ applications enables a business to harness the power of a converged IP-based voice/data network and put it to work for the business. Driven by Avaya's rock-solid Communication Manager application, this portfolio operates with Avaya's media servers, media gateways, Integrated Management (network-management tools), and communication devices.

Using Avaya's MultiVantage applications, an enterprise can review the operation of its existing communication networks, rethink where IP telephony can maximize returns on investment, and then reshape the network to realize those goals. The choices are nearly unlimited, given Avaya's flexible, modular architecture and our commitment to standards-based software and hardware.

While Avaya brings continuous voice-application innovation to the enterprise, Communication Manager delivers massive new scalability to provide network devices for as few as 20 users, or up to a million. Avaya's Communication Manager application is also highly scalable and reliable voice-application software with

- Rich call-processing and contact-center features
- A widely accepted application-programming interface (API) supporting both 3rd-parties' and Avaya's own applications

Avaya's media servers and media gateways provide smart ways to rethink networking by adding top-tier scalability and reliability, while supporting mission-critical applications in a distributed, yet secure, multivendor environment. To provide businesses with maximum flexibility, the server and gateway components in Avaya's family of MultiVantage applications follow a modular mix-and-match approach. A wide range of custom configurations can be deployed to meet a broad spectrum of business needs:

- From a single location (upgrading to a converged IP network for 200 employees)
- To a complex multinational converged network (capable of supporting 10,000-plus voice/data users)

Avaya media servers

Avaya's line of media servers provides a robust application platform based on industry-standard operating systems to support distributed IP networking and centralized call processing across multiprotocol networks. These servers are available as an integrated solution with other servers or can operate independently.

Avaya media servers have the following features and benefits:

- Redundant, survivable call processing and media processing supports crucial business continuity.
- Standards-based computing supports Linux, Microsoft Windows, and Avaya's DEFINITY® operating system.
- Distributed survivable IP networking supports campus, global-multisite, and branch environments.

Avaya media gateways

Avaya media gateways are stackable and modular hardware elements that deliver applications – enabling data, voice, FAX, video, and messaging capabilities to your network. Avaya media gateways support both bearer and signaling traffic that is routed between packet- and circuit-switched networks. These gateways are optimized for enterprise-class telephony. Avaya media gateways provide a variety of flexible deployment options, including 100%-IP environments and blended environments such as IP and TDM.

Avaya media gateways have the following features and benefits:

- Interoperable with standards-based data networks
- Stackable, modular, and configurable component solutions
- Redundant capabilities
- Distributed networking
- Compatible with cabinets in traditional Avaya systems

Avaya Integrated Management

Designed for a converged network environment, Avaya's Integrated Management provides a comprehensive set of standards-based software tools to facilitate management of a complex network infrastructure (including both voice and data communications) through a common web-based user interface. This enables you to improve your network's uptime, increase your staff's productivity, and reduce your operating costs.

Integrated Management has the following features and benefits:

- Web-based system view – Of Avaya media servers, media gateways, and IP phones
- Voice-over-IP monitoring – Based on endpoint information, provides industry-leading, centralized monitoring of network quality
- Directory-enabled [Lightweight Directory Access Protocol (LDAP)] platform – Enables integration of management activities with business processes
- On-demand phone and feature management – Provides users with necessary customization tools

Avaya communications devices

Innovative and standards-based, providing new mobility opportunities – Avaya offers a wide choice of flexible, intelligent, mobile, and easy-to-use communication devices to meet your company's unique needs. With analog, digital, and IP telephones, the spectrum is covered. Highlights of the portfolio include:

- Avaya IP Softconsole – A software attendant console that brings features and functionality of a high-end attendant console to your converged network.
- Avaya IP Softphone for pocket PC – Brings the full functionality of an Avaya office phone to your hand-held pocket PC.
- Avaya 4630 Screenphone – A full-color touch-screen phone with Web access.

Avaya IP communication devices are supported without special power requirements.

DEFINITY Server CSI

Overview

Avaya's Communication Manager on a DEFINITY[®] Server CSI is a solution for a medium-sized office location that has from 50 to 900 stations. This solution uses DEFINITY TN circuit packs, Avaya Communication Manager, and the CMC1 Media Gateway. It is easy and cost-effective for a company to migrate from the DEFINITY Server CSI to another Avaya solution as the company grows. Initial investment is protected since every DEFINITY CSI application and most of the hardware can still be re-used.

The DEFINITY Server CSI can be used at a single site or be networked in multiple locations. For example, DEFINITY Server CSI might provide a solution for a satellite office within a larger business or a branch locations around the world. Multisite companies can use remote diagnostics and alarming to maintain the DEFINITY Server CSI from a central location. An administrator can centrally administer the system from a central location by using a system administration tool.

Detailed description

High-level description of the DEFINITY Server CSI:

- Ideal for small single sites, multi-site locations, and branch locations
- Supports up to 1300 ports
- Supports 400 trunks and 900 stations
- Uses Avaya Communication Manager
- Consistent administration over a customer's network when using an all-Avaya solution
- Consistent user interface over a customer network when using an all-Avaya solution

Configuration information

A DEFINITY Server CSI consists of the following main components:

- TN2402 Processor board
- TN2182 Tone Clock
- CMC1 Media Gateway

The following sections describe each component.

TN2402 Processor board

A TN2402 Processor board resides in slot one of cabinet A. This board contains 32 MB of DRAM memory and 32 MB of flash memory. The software is stored on flash memory and on removable memory through Flash-ROM that plugs directly into the TN2402 processor board. The memory on the Processor board contains the generic program and the system translations. The cartridge contains a copy of the system translations and error log. The TN2402 also provides:

- A 5-volt ATA PC-card Memory Card interface
- Three external RS232 interfaces [CD1]

- A SAT terminal interface
- An SMDR/Printer or other DTE interface
- A connection for an external modem to dial out alarms

Tone-Clock (TN2182)

For any system-reliability configuration, a TN2182B Tone-Clock integrates the tone-generation, tone-detection/call-classification, system-clocking, and synchronization functions onto a single circuit pack. The TN2182 supports eight ports for tone detection and allows gain or loss applied to PCM signals that are received from the bus.

CMC1 Media Gateway

A CMC1 Media Gateway has the following characteristics:

- The size is 25.5 inches wide, 24.5 inches high, and 11.3 inches deep. It is designed for wall mounting. Mounted on the floor or on a table where required.
- Ten universal port slots plus one power supply slot per CMC1.
- Standard-reliability option only.
- Is limited to one PN that is made up of a maximum of three CMC1 Media Gateways. A PN consists of a control CMC1 that is designated "A". The second and third CMC1s are optional and are designated cabinets "B" and "C" respectively. Cabinet address ID within the PN is set using the DIP switch on the backplane.
- Circuit packs are inserted and removed from the left side. Cabinet I/O is from the right side.
- The CMC1s in a port network are interconnected via shielded TDM/LAN bus cables.
- The CMC1 is AC-powered only. There are no internal batteries, and no DC power option.
- Two 12-volt DC variable-speed fans integrated into the bottom of the cabinet provide CMC1 cooling. The fans force air through a filter and up through the cabinet. Air exits from the back of the cabinet. Speed control is provided by the 650A Global Power supply. The 650A varies the fan input voltage between 8VDC and 14VDC depending on a temperature sensor that is mounted in the power supply. The fan assembly includes the two fans, a frame to which the fans are attached, wiring, and a connector that plugs into the backplane. The assembly is easily installed and removed. The entire assembly must be replaced as a unit if a fan fails.

A fan failure will result in the following conditions:

- An alarm through the power supply that will appear to the system
- The remaining fan goes to high speed
- The red LED on the 650A Global Power supply faceplate lights

Reliability and recovery

DEFINITY Server CSI provides the following capabilities:

- Can survive minor power surges, including lightning-induced surges up to 2500 Volts peak, without service interruption. Surge protectors can be purchased for increased coverage
- Can operate in conditions that include above-average temperatures and humidity.
- In case of a power failure, automatically restores the last saved version of user translations and runs them at system restart.

- Supports the remote diagnostics capability, which enables quick troubleshooting and maintenance.
- Conducts self-diagnostics and can self corrects many system errors. If further technical assistance is required, DEFINITY Server CSI uses an external modem to place a call for support.
- Conducts standard maintenance routines automatically.
- Backs up all the user translations every day at midnight by default.
- The single-processor configuration provides 99.9% reliability.

System capacity

Type	Capacity
Maximum trunks	400
Maximum stations	900
Maximum ports	1300 (limited by slots, not software)
Maximum IP endpoints	390

Avaya Communication Manager

The DEFINITY Server CSI uses Avaya Communication Manager for call processing solutions in large and small customer environments. For more information on these solutions, see the Overview for Avaya Communication Manager.

Avaya Communication Manager is an open, scalable, highly reliable and secure telephony software application. Avaya Communication Manager provides user functionality, and system management functionality, intelligent call routing, application integration and extensibility, and enterprise communications networking. Communication Manager offers over 500 features, in the following categories.

- Call center
- Telephony features
- Localization
- Collaboration
- Mobility
- Messaging
- Telecommuting
- System management
- Reliability
- Security, privacy and safety
- Hospitality
- Attendant features
- Networking

- Intelligent call routing
- Application programming interfaces

Adjuncts

The following is a partial list of the adjuncts that Avaya provides:

- Voice messaging and response such as INTUITY AUDIX
- Call center tools such as Avaya Call Management System, NICE Analyzer, Avaya Call Recording, Avaya Visual Vectors and Avaya Basic Call Management System Reporting Desktop
- System printer
- Journal printer
- Call Accounting Systems
- Call Detail Recording (CDR)
- Avaya Site Administration (ASA)
- DEFINITY Network Management (DNM)
- DEFINITY Translator ATM Manager (DTA)s

Avaya S8100 Media Server with a CMC1 or G600 Media Gateway

Overview

The Avaya S8100 Media Server with a CMC1 or G600 Media Gateway is a complete solution for small- to medium-sized offices, including branch offices of companies with multiple locations. The S8100 Media Server uses the Windows 2000 operating system. Avaya Communication Manager, Avaya MultiVantage INTUITY™ AUDIX® messaging application, and Avaya Site Administration are coresident applications on the platform. An optional Ethernet connection from the S8100 Media Server to the customer's LAN provides an easy access for administration.

The S8100 Media Server delivers a full range of global communications capabilities, including traditional voice and trunking needs and voice-over-IP (VoIP) technology. The S8100 Media Server with the G600 or the CMC1 Media Gateway supports up to 450 stations and 300 trunks.

Detailed description

This section includes information about the following:

- [S8100 Media Server with a CMC1 or G600 Media Gateway](#)
- [Standard components](#)
- [Optional components](#)
- [Reliability](#)
- [Recoverability](#)
- [Administration](#)

S8100 Media Server with a CMC1 or G600 Media Gateway

- Coresident applications
 - Avaya INTUITY AUDIX – An integrated voice mail system with eight ports and 100 hours of storage.
 - Avaya Communication Manager – For information about Avaya Communication Manager, see the Overview for Avaya Communication Manager, 555-233-767.
 - Dynamic Host Configuration Protocol (DHCP) servers and Trivial File Transfer Protocol (TFTP) servers
- Customer configurations
 - Single sites
 - Multiple sites and branch offices – The Communication Manager allows for a consistent, common user experience across a customer's network
- VoIP technology. With the addition of a CLAN and IP Media Processor boards, the S8100 Media Server with the CMC1 Media Gateway provides complete IP gateway and IP gatekeeper functions to support 100% VoIP capabilities

- Call center – Up to 100 agents
 - Avaya CMS and Basic Call Management Reporting Desktop
 - On-board announcement functionality – The Avaya S8100 Media Server supports eight ports of integrated announcements and 1 hour of noncompressed speech via an on-board speech and signal processor. These announcements are stored on the hard drive of the S8100 Media Server and can be backed up like Communication Manager system translations files are. In addition, standard *.wav files may be imported and used for system announcements.
- Network connectivity
 - Asynchronous Transfer Mode (ATM)
 - Internet Protocol (IP)
 - Supports Integrated Services Digital Network Primary Rate Interface (ISDN-PRI) access, Distributed Communications System (DCS), and QSIG private networking

Standard components

The S8100 Media Server with the CMC1 Media Gateway or the G600 Media Gateway has the following components:

- A TN744E Call Classifier circuit pack that integrates tone generation, tone detection, call classification, system clocking, and synchronization. (The tone-generation function puts tones on time slots of the TDM bus.)
- A Robotics 839 Sportster modem can be ordered separately.
- The S8100 Media Server has the following characteristics:
 - TN2314 Processor circuit pack
 - Windows 2000 operating system
 - Occupies two slots in either the CMC1 Media Gateway or the G600 Media Gateway
 - Intel Pentium III (500-MHz) and Motorola processors
 - 256 MB of synchronous dynamic RAM (SDRAM)
 - An Ethernet RJ45 jack on the faceplate for a services interface to facilitate switch installation and maintenance
 - An RS232 port for an external modem for INADS access during the warranty period, and when a maintenance contract is purchased
 - A 20-GB hard disk drive
 - Virtual ports for INTUITY™ AUDIX® and system announcements
 - Connectors for an optional, customer-provided keyboard, monitor, and mouse
- A G600 Media Gateway has the following characteristics
 - The ability to connect up to three G600 Media Gateways together in one location
 - Seven universal slots for circuit packs in the first G600 Media Gateway
 - Ten universal slots for circuit packs in the second and third G600 Media Gateways
 - A choice of floor mounting or rack mounting
 - A weight of 40 pounds to 50 pounds metric (18 to 22.5 kilograms)
 - Dimensions of 12 × 19 × 22 inches (30 × 48 × 55 centimeters)

- A CMC1 Media Gateway has the following characteristics:
 - The ability to connect up to three CMC1 Media Gateways together in one location.
 - The first CMC1 contains the S8100 Media Server and the TN744E Tone Clock board. These two packs take up three slots leaving seven universal slots available for circuit packs.
 - Ten universal slots available in the second and third CMC1 Media Gateways for circuit pack placement.
 - The CMC1 Media Gateway weighs from 50 to 60 pounds.
 - The dimensions of the CMC1 Media Gateway is 11 × 25 × 25 inches.
 - A choice of floor mounting or wall mounting.

Optional components

The S8100 Media Server with the CMC1 Media Gateway or the G600 Media Gateway can also use the following optional components:

- Avaya circuit packs with a "TN" prefix
- The following circuit packs for VoIP:
 - Control-LAN also called C-LAN (TN799DP) that provides TCP/IP connectivity over Ethernet or Point-to-Point Protocol (PPP) connectivity to adjuncts.
 - IP Media Processor (TN2302AP) provides media stream processing.
- Supported Avaya telephones:
 - Analog telephones include the 6200-, 7100-, and 8100-series telephones.
 - Digital telephones include the 6400- and 8400-series telephones.
 - IP telephones include the 4600-series telephones.
- Avaya recommends the use of an uninterruptible power system (UPS) to provide more dependable power between an AC power source and the S8100 Media Server. In addition to better power dependability, a UPS provides battery backup for a graceful shutdown if a power failure occurs.
- An Ethernet switch.

Reliability

Avaya incorporates high reliability and availability into the S8100 Media Server. The media server's platform:

- Detects and corrects errors as they occur
- Minimizes the number of components that can cause a system-wide outage
- Simplifies fault isolation to a replaceable component

The S8100 Media Server provides error detection and correction, system reconfiguration, and escalation paths for alarms to necessary performance elements. The software recovers from intermittent failures and continues providing service with minimal disruption.

The maintenance subsystem manages three categories of maintenance objects (MOs): hardware maintenance objects, software processes, and data relationships. Hardware MOs are tested, alarmed and

removed from service by the software. When the hardware problem is isolated, the object is replaced. If a software process encounters trouble, the process is recovered or restarted. Data relationships are audited and corrected.

The following design elements help ensure high availability of the Windows 2000 operating system on the S8100 Media Server:

- A secondary on-board processor complex supports initialization, monitoring, and recovery functions for every application that runs on the Windows 2000 Server operating system. When a problem is detected, the secondary processor complex takes corrective action to minimize user impact.
- Executive Software's DiskKeeper code is incorporated and runs regularly to eliminate disk fragmentation problems.
- The operating system is closed to any applications other than the ones that the manufacturer provides. Every application is thoroughly pretested to ensure proper performance.
- The Windows 2000 Server event log is proactively scanned for potential service-affecting items. If service-affecting items are found, alarms are generated which may result in a service technician's site visit.

For further reliability, the G600 Media Gateway uses a fan unit, an assembly consisting of three hot-swappable fans. The fan unit automatically senses temperature and adjusts each fan's operating speed accordingly. If one fan fails, the:

- The system generates an alarm, notifying a technician to replace the fan unit
- Other two fans speed up, providing sufficient cooling for up to several weeks

Recoverability

The S8100 Media Server with a CMC1 or G600 Media Gateway provides the following recoverability:

- System survival of minor power disruptions without service interruption
 - Automatic restoration of the last saved version of the customer translations following a power outage
 - Scheduled centralized backups of critical system information at remote sites
- During an emergency, multiple copies of translations, INTUITY AUDIX subscriber information, and the Windows 2000 Server registry are available. This saved information can be quickly restored. Backups can be saved either to the provided PCMCIA card or to another server over the LAN.
- Emergency transfer equipment is an option that cuts up to six analog lines directly through to analog trunks in the central office (CO).

Administration

Several methods can be used to administer the S8100:

- The peer Web server
- A Telnet session
- Avaya Integrated Management Suite

Peer Web server

The Avaya S8100 Media Server can be administered through a Web interface that uses a Peer Web server through a LAN connection. The administrator can download software, such as Message Manager, connect to INTUITY AUDIX, schedule a backup, or view backup results and restore from a backup.

Telnet session

A terminal emulation access can be used via a Telnet session.

Avaya Integrated Management

Avaya Integrated Management offers a comprehensive set of Web-based network and system management solutions that support the Avaya converged voice solutions. Integrated Management combines individual applications into 5 offers:

- Standard Management
- Standard Management Solutions Plus
- MultiService Network Management
- Enhanced Converged Management
- Advanced Converged Management

For more detailed information on Avaya Integrated Management see:

<http://www.avaya.com> > Products and Services > Products A-Z

Avaya Communication Manager

The S8100 Media Server uses Avaya Communication Manager software for call processing solutions in large and small customer environments. Avaya Communication Manager is an open, scalable, highly reliable and secure telephony application. Avaya Communication Manager provides user and system-management functionality, intelligent call routing, application integration and extensibility, and enterprise communications networking. Communication Manager offers over 500 features, in the following categories:

- Call center
- Telephony
- Localization
- Collaboration
- Mobility
- Messaging
- Telecommuting
- System management
- Reliability
- Security, privacy, and safety
- Hospitality

- Attendant features
- Networking
- Intelligent call routing
- Application programming interfaces

For more information about these solutions, see the Overview for Avaya Communication Manager.

Avaya S8300 Media Server and an Avaya G700 Media Gateway

Overview

An Avaya S8300 Media Server with a G700 Media Gateway and its media modules converges voice and data into one infrastructure. Using the same form factor as a media module, an S8300 Media Server is a Pentium-based processor residing in a G700 Media Gateway. An S8300 Media Server can also be configured as a Local Survivable Processor (LSP). A G700 Media Gateway is based on an Avaya P330 switch, which contains VoIP resources and modular interface connectivity. The media modules provide analog, digital, T1/E1, BRI, and additional VoIP capabilities.

The following figure shows an S8300 Media Server and media modules in a G700 Media Gateway.

Figure 1: S8300 Media Server, G700 Media Gateway, and media modules

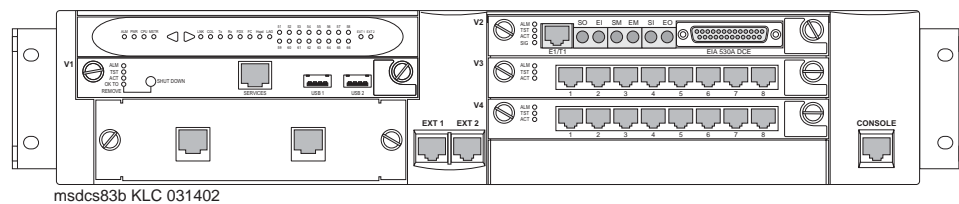

Detailed description

This section contains information about the following:

- [Configuration description](#)
- [Server features](#)
- [Avaya G700 Media Gateway](#)
- [LEDs](#)
- [Maintenance software](#)

Configuration description

The following components can be used with an S8300 Media Server and a G700 Media Gateway:

- Avaya media modules:
 - MM710 T1/E1 Media Module
 - MM711 Analog Media Module
 - MM712 DCP Media Module
 - MM720 BRI Media Module
 - MM760 VoIP Media Module

- Avaya Communication Manager
For information about Avaya Communication Manager, refer to the "Overview for Avaya Communication Manager," 555-233-767.
- Avaya P330 expansion modules
- Avaya WAN Access router modules for the Avaya P330 stackable switching system

An S8300 Media Server, the G700 Media Gateways, and all other components are described in more detail in the following sections.

Server features

An S8300 Media Server is a Pentium-based processor running the Linux Red Hat operating system and residing in Slot V1 of a G700 Media Gateway. It comes standard with the following:

- Avaya Communication Manager application software
For a description of Communication Manager, refer to:
 - For customer access – www.avaya.com
 - For business partner access – <http://avaya.com/businesspartner>
Click solutions, products, and services.
 - For internal access – <http://support.avaya.com>
- A 20-GB hard disk
- 256 MB RAM

NOTE:

The S8300B Media Server, when available, will have 512 MB RAM.

- A Web server used for the following:
 - Backups and restores of customer data
 - Easy access to view current alarms
 - The ability to perform server maintenance including busy out and release busyout, shutdown, and status of an S8300 Media Server.
 - Security commands to enable and disable the modem, start and stop the FTP server, and view the software license
 - SNMP access to configure trap destinations and to stop and start the master agent
 - Configuration information about an S8300 Media Server
 - Upgrade access to an S8300 Media Server
- Linux Red Hat operating system
- Trivial File Transfer Protocol (TFTP) server
- H.248 Media Gateway Signaling Protocol
- Control messages tunneled over H.323 Signaling Protocol
- Two USB ports and a 10/100 Base-T port
- One services port.

The S8300 supports a maximum of:

- 900 total ports (combination of trunks and stations)
 - 450 IP, non-IP, or a combination of IP and non-IP stations
 - 450 trunks
- 50 G700 Media Gateways

The following figure shows an S8300 Media Server and media modules in a G700 Media Gateway.

Figure 2: S8300 Media Server in a G700 Media Gateway

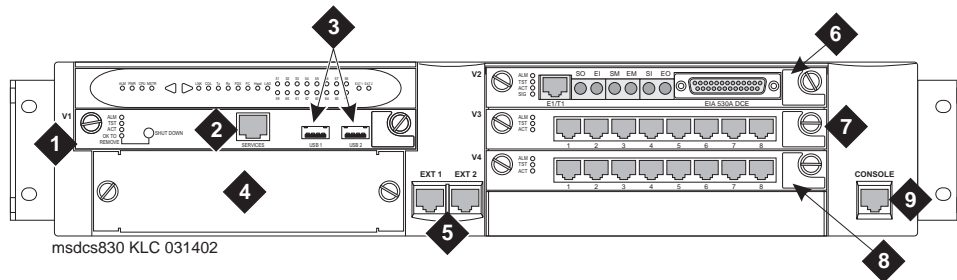

- 1 S8300 Media Server in Slot V1.
- 2 Services port
- 3 Two USB ports
- 4 Slot for an Avaya expansion module
- 5 Dual 10/100 Base-T Ethernet switch ports
- 6 Media module, Slot V2
- 7 Media module, Slot V3
- 8 Media module, Slot V4
- 9 Console connection for on-site administration.

Avaya G700 Media Gateway

An Avaya G700 Media Gateway is scalable and offers options. It is functional on its own or with other G700 Media Gateways. Up to 50 G700 Media Gateways can be supported using an S8300 Media Server. Up to 250 G700 Media Gateways can be supported using an S8500 Media Server or an S8700 Media Server. The G700 is also functional in a stack that is mixed with Avaya P330 devices such as the P333T, P333R, and P334.

To power IP telephones without additional cables, stack the G700 Media Gateways with the Avaya P333T-PWR.

The following list describes the basic architecture of the G700 Media Gateway:

- Intel i960 controller that hosts the base switch control and management software
- Supports 15 ports of tone detection
- Fits in an EIA-310-D standard 19-inch data rack
- Can sit on a desk top

- Contains four slots for media modules
- One slot for an Avaya P330 expansion module
- One slot for an Avaya P330 Octaplane stacking fabric
- Contains an internal motherboard described in detail later in this section
- Standards-based 10/100 Ethernet Interface connection types
- Internal global AC power supply that provides low-voltage DC power to the fans, motherboard, and media modules
- Four internal fans that provide cooling for the internal components
- A LED board that indicates system-level status
- A serial port for command-line access
- A VoIP engine that supports up to 64 G.711 single-channel calls
- An 8-port layer-2 switch

The G700 Media Gateway has a similar physical design to the Avaya stackable switching products. The following figure shows the G700 Media Gateway with two Avaya P330 switches. The G700 is shown at the top of the stack.

Figure 3: G700 Media Gateway with two Avaya P330 switches

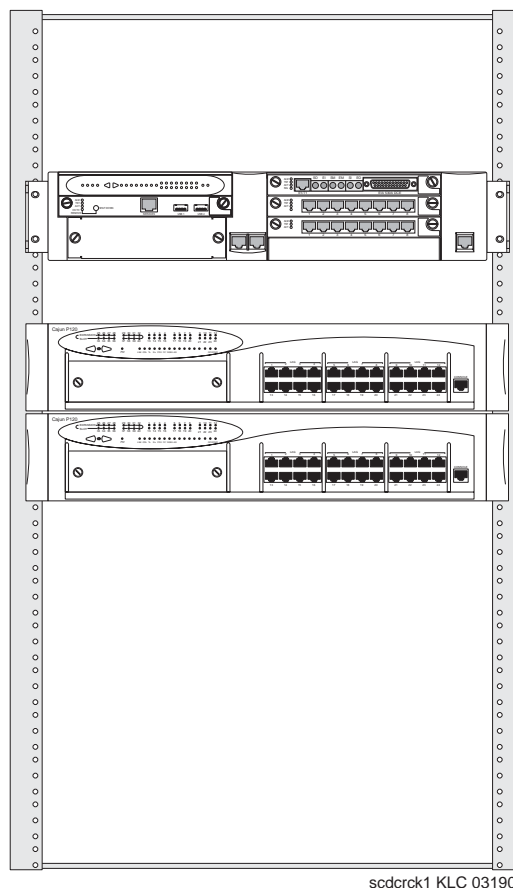

Expansion modules

A G700 Media Gateway is architecturally based on the Avaya P330 switch. Therefore, customers can use any of the P330's expansion modules with the G700 Media Gateway. Additional Avaya local-area network (LAN) and wide-area network (WAN) expansion modules connect directly to the G700 Media Gateway without requiring additional hardware. Two expansion modules are available from Avaya:

- X330 WAN Access routing module
- P330 LAN expansion modules

X330 WAN Access routing module

Customers with multiple branch offices need network solutions that are simple, flexible, and scalable. An Avaya X330 WAN Access routing module allows customers to deploy a unified, high-performance LAN/WAN infrastructure in one data stack.

Highlights of an X330 WAN Access router:

- Provides integrated WAN access that can be used with external firewalls or VPN Gateways
- Works with the following WAN and routing protocols:
 - Point-to-Point Protocol (PPP) over channeled E1/T1
 - Frame Relay
 - Routing Information Protocol (RIP) v1 and v2
 - Single-area Open Shortest Path First (OSPF)
 - VRRP Redundancy
 - Throughput: wire-speed WAN routing
- Congestion control
- Standard auto-negotiation
- Link redundancy
- 802.1Q/p virtual LAN (VLAN) and priority

P330 LAN expansion module

Highlights of a P330 LAN expansion module:

- Maximum flexibility to the data stack
- Standard auto-negotiation
- Link Aggregation Group (LAG)
- LAG redundancy
- Link redundancy
- Congestion control
- 802.1Q/p VLAN and priority



CAUTION:

Avaya expansion modules and Octaplane stacking modules are not hot-swappable. Turn off the system before you remove or insert an expansion module.

P330 Stacking Fabric (Octaplane)

Octaplane is an Avaya hardware capability to bundle stackable components using bidirectional 4-Gbps transmission. This technology combines separate units into a larger logical switch using different lengths of cables that are connected to the expansion slots behind the units. The cables are wired in a ring configuration, providing redundancy to the stack. If a single unit should fail, the stack's integrity is maintained. You can also remove or replace a single unit without disrupting operation or without first reconfiguring the stack.

Table 1: Octaplane cabling

Cable	Description and function	Length	Length (metric)
X330SC short Octaplane cable (30 cm)	Short Octaplane cable – light-colored, used to connect adjacent switches or switches separated by one backup universal power supply (BUPS) unit.	1 foot	0.3 m
X330LC long Octaplane cable (2 m)	Long Octaplane cable – light-colored, used to connect switches from two different physical stacks	6 feet	2 m
X330RC redundant Octaplane cable (2 m)	Redundant cable – black, used to connect the top and bottom switches of a stack.	6 feet	2 m
X330L-LC extra-long Octaplane cable (8 m)	Extra-long Octaplane cable – light-colored, used to connect switches from two different physical stacks	24 feet	8 m
X330L-RC long redundant Octaplane cable (8 m)	Long Redundant cable – black, used to connect the top and bottom switches of a stack.	24 feet	8 m

Power supply

A G700 Media Gateway uses an internal AC power supply that converts AC input power to voltages.

Motherboard

A motherboard resides in a G700 Media Gateway. This board controls the following:

- The VoIP Engine which supports up to 64 channels. If more than 64 channels are needed, a VoIP media module is required. The VoIP Engine performs the following functions:
 - IP/UDP/RTP processing
 - Echo cancellation
 - G.711 A- μ -Law
 - G.729 and G723.1 encode/decode
 - FAX relay
 - Silence suppression
 - Jitter buffer management
 - Packet loss concealment

- The gateway's processor complex controls every resource inside the gateway. The processor's functions include managing the media modules, and controlling the Tone Clock and H.248 signaling.
- An Avaya P330 processor complex is based on the Avaya P330 data-switch architecture. This complex provides an 8-port layer-2 switch function and manages the Expansion and Cascade modules.
- The electrical and physical connectivity for the four media module's slots.

NOTE:

The motherboard cannot be replaced in the field.

For more information about the VoIP media module, see [MM760 VoIP media module](#).

Fans

The G700 Media Gateway contains four 12-volt fans. These fans are monitored and can be alarmed via SNMP to a management station.

Gateway software

Gateway software is responsible for:

- Individual media-gateway operations
- Terminating H.248 on the G700 Media Gateway
- Interacting with maintenance operations

LEDs

An S8300 Media Server with a G700 Media Gateway uses two types of LEDs:

- Media module
- System-level.

Media module LEDs

A media module's LEDs have the following characteristics:

- Three or more LEDs reside on each media module to provide status information about the media module, its ports, and its current maintenance or administration mode.
- Every LED on each media module has a fixed user-visible location, spacing, and labeling.

System-level LEDs

An LED board visually indicates status of the system and its Ethernet data ports, and allows the customer to change between status-indication modes. The LED board resides in the upper left front of each G700 Media Gateway. The board's LEDs reside in an oblong fascia panel.

You must remove the LED board when you install or remove either an S8300 Media Server or an LSP-configured S8300 Media Server. An S8300 Media Server and its LED board must be installed or removed as a unit.

NOTE:

The LED panel is not the same size as standard slots for media modules. You cannot insert a media module into the LED board's slot, or vice versa.

Maintenance software

An S8300 Media Server with a G700 Media Gateway has a dual maintenance strategy. Maintenance software runs on both the G700 Media Gateway's platform and the S8300 Media Server for subsystems on the platform. This platform software performs initialization and motherboard maintenance, along with internal environmental monitoring.

In contrast, media modules are tested and brought into service by the S8300 Media Server's maintenance software after a G700 Media Gateway registers with the S8300 Media Server. While the G700 Media Gateway's maintenance software is aware of its own media modules, these modules and their associated ports are controlled by the S8300 Media Server. Error logs are also maintained on the S8300 Media Server.

Avaya media modules

Media modules reside in a G700 Media Gateway and interact with the motherboard and backplane.

The G700 supports the following media modules:

- MM710 T1/E1 Media Module
- MM711 Analog Media Module
- MM712 DCP Media Module
- MM720 BRI Media Module
- MM760 VoIP Media Module

The following figure shows a top view of a media module.

Figure 4: Top view of media module

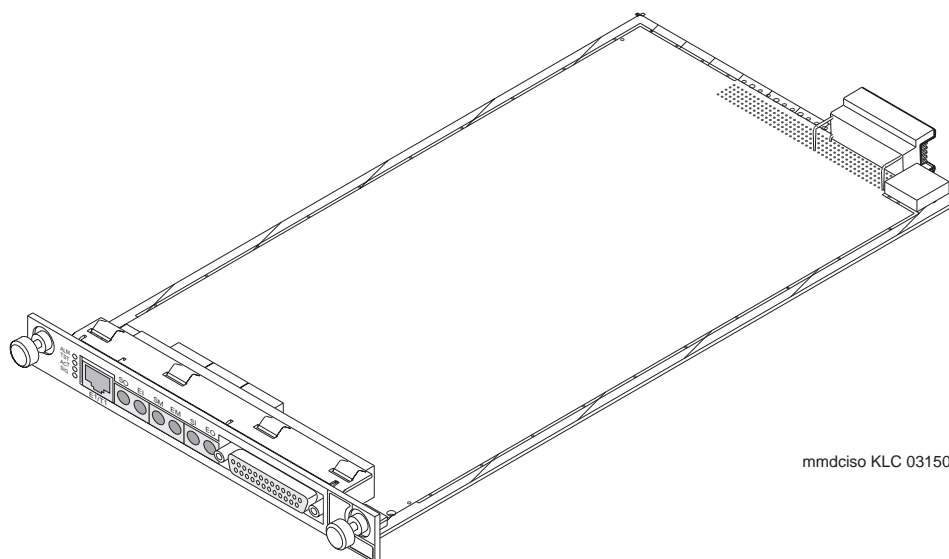

LEDs

Although some media modules have additional LEDs, a standard 3-LED pattern on each of their faceplates indicates the following conditions:

- Red – Fault condition
This LED also lights when the media module is physically inserted, and should turn off when the board initializes.
- Green – Test condition
- Yellow – In-use condition

See the following figure for the LEDs on the media module.

Figure 5: Media modules LEDs

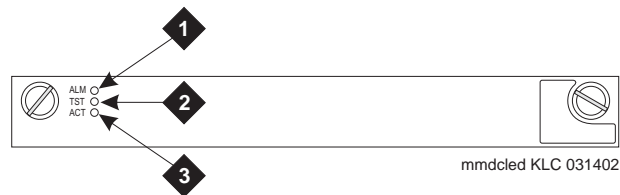

Figure notes

- | | |
|---|------------------|
| 1 | ALM – Alarm LED |
| 2 | TST – Test LED |
| 3 | ACT – Active LED |

MM710 T1/E1 media module

An MM710 terminates a T1 or E1 connection. The MM710 has built-in channel-service unit (CSU) so an external CSU is not necessary. The CSU is only used for the T1 circuit.

The attributes of an MM710 include:

- Software-selectable T1 or E1 operation
- Integrated CSU for T1 circuit only
- A-law (E1) and μ -law (T1) companding
- Gain control and echo cancellation
- D4, ESF, or CEPT framing
- ISDN-PRI capability (23B + D or 30B + D)
- Line coding – AMI, ZCS, B8ZS (T1) or HDB3 (E1)
- Trunk signaling to support US and International CO or tie trunks
- Echo cancellation in either direction
- Fractional T1 support
- OIC DB 25-pin interface
- A Bantam loop-back jack for testing T1 or E1 circuits

The following figure shows an MM710 media module.

Figure 6: MM710 T1/E1 media module

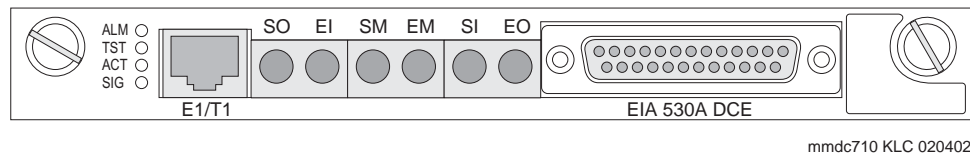

For more information, see [MM710 T1/E1 media module](#).

MM711 Analog media module

An MM711 provides analog trunk and telephone features and functionality. Up to four 8-port M711 media modules can reside in one G700 Media Gateway.

An administrator can assign each analog port of an MM711 as follows:

- Central Office trunk, either loop- or ground-start
- Direct Inward Dialing (DID) trunks, either wink- or immediate-start
- 2-wire outgoing CAMA E911 trunks, with MF signaling for connectivity to the PSTN
- Tip/ring devices such as single-line telephones, with or without LED message-waiting indication

The MM711 also supports:

- Three ringer loads (ringer equivalency number) for up to 2000 feet for all eight ports
- Up to eight simultaneously-ringing ports

NOTE:

The media gateway achieves this number of ports by staggering the ringing and pauses between two sets of up to four ports.

- Type-1 and -2 Caller ID
- Ring-voltage generation for a variety of international frequencies and cadences

The following figure shows an MM711 media module.

Figure 7: MM711 Analog media module

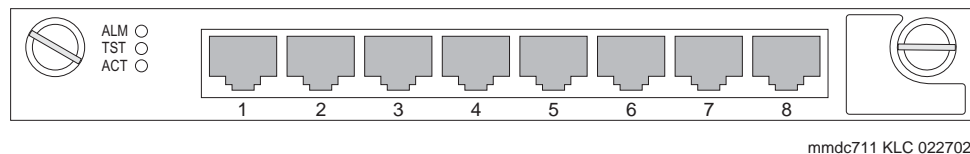

For more information, see [MM711 Analog media module](#).

MM712 DCP media module

An MM712 allows you to connect up to eight 2-wire Digital Communications Protocol (DCP) voice terminals.

The following figure shows an MM712 media module.

Figure 8: MM712 DCP media module

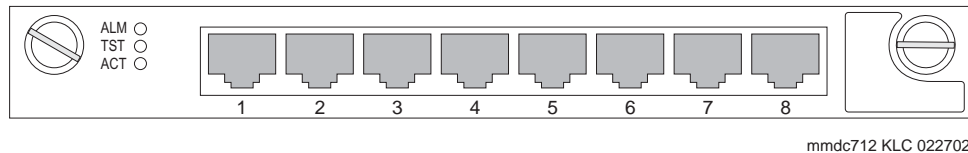

For more information, see [MM712 DCP media module](#) on page 224.

MM720 BRI media module

Each port of an 8-port MM720 provides an interface to the central office at the ISDN T reference point. Information is communicated in two ways:

- Over two 64-kbps channels called B1 and B2
 - Can be circuit-switched simultaneously
- Over a 16-kbps channel called the D channel
 - Used for signaling
 - Occupies one time slot for all eight D channels

The circuit-switched connections have an A- or μ -law companding option for voice operation. When in the data mode, the circuit-switched connections operate as 64-kbps clear channels.

The MM720 does not support the following:

- BRI stations
- Combining both B channels together to form a 128-kbps channel

The following figure shows an MM720 media module.

Figure 9: MM720 BRI media module

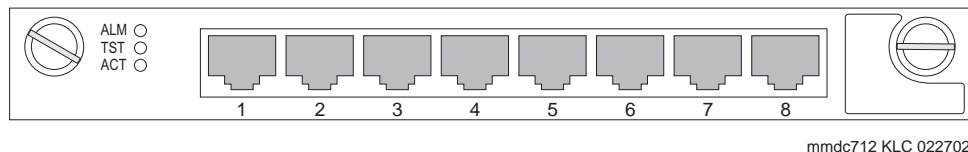

For more information, see [MM720 BRI media module](#) on page 226.

MM760 VoIP media module

An MM760 is a clone of the motherboard's VoIP engine. The MM760 provides an additional 64 VoIP channels with G.711 compression.

The capacity is 64 G.711 TDM/IP simultaneous calls, or 32 compression codec, G.729 or G.723, TDM/IP simultaneous calls. These call types can be mixed on the same resource; in other words, the simultaneous call capacity of the resource is 64 G.711 equivalent calls.

The following figure shows an MM760 media module.

Figure 10: MM760 VoIP media module

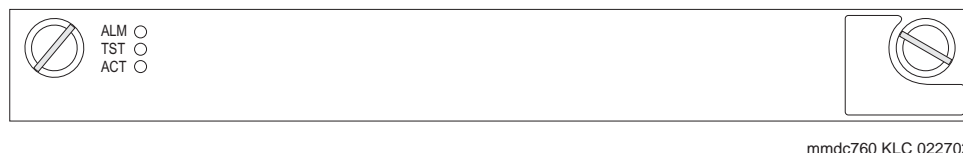

For more information, see [MM760 VoIP media module](#) on page 228.

S8300 Media Server in an LSP configuration

An S8300 Media Server in a Local Survivable Processor (LSP) configuration uses the S8300 hardware component and a software license to activate a standby feature. This software allows the LSP with a G700 Media Gateway to be a survivable call-processing server for remote and branch locations. The number of LSPs that can be supported in a configuration depends on the controlling media server. An S8500 Media Server or S8700 Media Server can support up to 50 LSPs. An S8300 Media Server can support up to 10 LSPs. An S8300 Media Server and the LSP cannot reside in the same G700 Media Gateway.

The difference between an S8300 configured as a primary controller (ICC) and an S833 configured as an LSP is entirely in software. Therefore, the hardware installation is identical for both configurations. On the G700, the S8300 board is restricted to slot V1 under the LED panel. The S8300 board and the LED panel must be inserted or removed together, as a single unit.

If for any reason communication between a G700 Media Gateway and its primary controller stops, an LSP activates. This "fail-over" from the primary controller to the LSP is an automatic process without human intervention. The LSP assumes control of any IP telephone provided that telephone has the LSP in its list of controllers. Not every call is preserved during a fail-over. IP-to-IP shuffled calls are preserved; any other calls end.

The fail-back from the LSP to the primary controller is manual, requiring a reset on the LSP. This reset breaks the communication between the LSP and every registered endpoint and causes the endpoints to register with the primary controller. During fail-back to the primary controller, every call is dropped with the exception of IP-to-IP calls.

IP addressing

IP telephones obtain their own IP address from a DHCP server. The DHCP server also sends a list of controllers, LSPs, and their associated IP addresses. The IP telephone then registers with the controller corresponding to the first IP address in this list. When connectivity is lost between the controller and the endpoint, the endpoint registers with the second IP address in the list, and so on. This list is administrable for telephones on the DHCP server.

Preservation of customer translations

An automatic process copies customer translation changes made on the primary server to every LSP.

IA770 INTUITY AUDIX messaging

IA770 INTUITY™ AUDIX® messaging is an optional voice mail system used with an S8300 Media Server. IA770 requires a small circuit board that plugs directly into a connector on the media server. The IA770's software and Communication Manager communicate over a TDM-bus connection that exists between the circuit board and the media server.

INTUITY AUDIX uses the circuit board to:

- Convert messages to the code-excited linear prediction (CELP) format
- Convert text to speech
- Process touch tones and FAX signals

The IA770 can be a stand-alone solution for one location or networked with other voice mail systems using TCP/IP, AMIS, and Avaya Interchange.

Highlights of an IA770:

- Available in two sizes:
 - Four ports with up to 100 local users
 - Eight ports with up to 300 local users
- Up to 500,000 remote messaging subscribers
- Up to eight networking channels
- INTUITY AUDIX LX
- Message Manager
 - Up to 500 clients
 - Up to 64 simultaneous sessions, four when using text-to-speech
- Internet Messaging
- 35 different languages are available for prompts
- Backup of translations and messages over LAN and WAN
- Message storage of up to:
 - 30 minutes for each mailbox
 - 300 total hours

An IA770 uses many resources of the S8300 Media Server and the G700 Media Gateway where it resides. The following outlines the S8300's shared resources used by the IA770:

- Hard drive for data storage and retrieval
- TFTP server for:
 - Downloading and updating the license file
 - Backing up and restoring data
 - Updating and upgrading software
- IP address for administration access
- License file for feature activation
- General Alarm Manager for alarm display
- Web interface to start and stop the system

The IA770 also shares the same switch-tone parameters established for the S8300 Media Server. The following countries require country-specific switch-tone parameters:

- Brazil
- Canada – uses the same parameters as the United States
- China
- France
- Germany
- Hong Kong
- Italy
- Japan
- Korea
- Mexico
- United Kingdom
- United States

Additional countries will be added in the near future.

Call center

An S8300 Media Server provides an excellent solution for a small call center. An S8300 Media Server with a G700 Media Gateway supports the following call-center capabilities:

- All three Avaya call-center packages: Avaya Call Center Basic, Avaya Call Center Deluxe, and Avaya Call Center Elite
- Supports up to 250 agents
- Supports a maximum of 16 ASAI links
- Avaya G700 announcement software

G700 announcement software

Voice announcements are used in a call-center environment to announce delays, direct customers to different departments, entertain and inform calling parties. The announcement capability is standard and coresident on a G700. The G700's announcement software has many capabilities of the TN2501AP VAL circuit pack.

The following table compares the G700 Announcement software and the VAL circuit pack.

Area description	TN2501AP (VAL) circuit pack	G700 announcement software
Requires hardware	Yes	No
Maximum storage time per board for TN750 or TN2501AP	Up to 60 minutes at 64-kbps sample rate	Up to 20 minutes at 64-kbps uncompressed speech
Concurrent Calls per Announcement	50 when using a DEFINITY Server SI or DEFINITY Server CSI 1,000 when using the DEFINITY Server R or S8700 Media Server	1,000
Backup and restore over LAN	Yes	Yes
Recording Method	Use PC or telephone	Use PC or telephone
File portability to multiple DEFINITY or Avaya servers	Yes	Yes
Playback quality	Toll quality	Toll quality
Backup speed	2.6 seconds for each 60 seconds of announcement time	2.6 seconds for each 60 seconds of announcement time
Reliability	High	High
Firmware downloadable	Yes	Yes
Number boards or G700 announcement software per configuration	5 with the DEFINITY® CSI and DEFINITY SI 10 with the DEFINITY R and S8700 Media Server	250 when using the S8700 Media Server 50 when using the S8300 Media Server
Announcements per board	256	256
Maximum number of announcements in a configuration	128 DEFINITY Server CSI or DEFINITY Server Si 1,000 DEFINITY Server R 3,000 S8700 Media Server	6,400 when using the S8700 Media Server 1280 when using the S8300 Media Server
Format	CCITT A- or μ -law companding	CCITT A- or μ -law companding

Area description	TN2501AP (VAL) circuit pack	G700 announcement software
Sample bits	eight	eight
Sample rate	8,000 Hz	8,000 Hz
Channels	Mono	Mono

Customer configuration options

An S8300 Media Server with a G700 Media Gateway provides a standards-based, IP communications infrastructure without compromising the customer's applications, reliability, and multiservice networking. This solution can be installed for either small customers or large customers with branch offices or a multisite configuration.

An S8300 Media Server with G700 Gateways provides the following networking benefits:

- Feature transparency across the network via QSIG or DCS+
- A consistent user experience with the same user interface
- Unified system management
- Applications controlled by Avaya's Communication Manager, yet offering a rich enterprise feature set administered using an H.248-based control interface
- Ease of moves, adds, and changes using the same administration interface

For examples of configurations see:

- [Small-business solution using the Avaya S8300 Media Server in the G700 Media Gateway](#)
- [Branch Office Configuration](#)
- [Multi-Site Environment](#)

System management

Avaya Integrated Management

Avaya Integrated Management offers a comprehensive set of Web-based network and system management solutions that support the Avaya converged voice solutions. Integrated Management combines individual applications into five offers:

- Standard Management
- Standard Management Solutions Plus
- MultiService Network Management
- Enhanced Converged Management
- Advanced Converged Management

For more detailed information on the Avaya Integrated Management suite see:

- <http://www.avaya.com> >Products and Services>Products A-Z

S8300 Media Server Web interface

The Web browser-based tool on the S8300 Media Server uses a graphical user interface (GUI) interface to perform server-administration tasks such as:

- Backing up and restoring customer data
- Viewing current alarms
- Maintaining the media server including:
 - Checking the media server's status
 - Busying out and releasing busy out the media server
 - Shutting down the media server
- Executing security commands to enable and disable the modem, start and stop the FTP server, and view the license
- Accessing SNMP to configure trap destinations and to stop and start the master agent
- Accessing the media server to acquire configuration information and upgrade access

The media server's Web interface contains an extensive help system that describes every Web screen and its procedures.

Adjuncts

The following are some Avaya-provided adjuncts:

- A system printer is supported when a terminal server is used.
- A journal printer is supported when a terminal server is used.
- Call Detail Recording (CDR) is supported when a terminal server is used.
- External INTUITY AUDIX
- Avaya Business Communication Management System
- Avaya Call Management System

International information

An S8300 Media Server is available in the following countries:

- Argentina
- Australia
- Austria
- Bahamas
- Belgium
- Bermuda
- Brazil
- Bolivia
- Canada
- Chile

- China
- Colombia
- Costa Rica
- France
- Germany
- Guatemala
- Hong Kong
- Ireland
- Israel
- Italy
- Jamaica
- Japan
- Korea
- Mexico
- Panama
- Paraguay
- Peru
- Puerto Rico
- The Netherlands
- New Zealand
- Nordics
- Russia
- Singapore
- Spain
- Sweden
- Switzerland
- Taiwan
- Trinidad
- Tobago
- United Kingdom
- United States
- Uruguay
- Venezuela

Digital trunks and CO trunks

The following table contains digital- and CO-trunk information for each country.

Country	Digital trunk	CO trunk	AC power (see note)	Plug type	DC power ¹	Companding	ICID	R2MFC over
Argentina	E1	LS	220 V	B, C, E	-48 V	A-law	- ²	E1
Australia	E1	LS DID	220 V	C	-	A-law	-	-
Austria	E1	LS	220 V	B, E	-48 V	A-law	-	-
Belgium	E1	LS	220 V	A, B, E	-60 V	A-law	-	-
Brazil	E1	LS	110/220 V	A, B, D, E	-48 V	A-law	-	E1
Canada	T1	LS GS DID	110 V	A	-	A-law	Bellcore FSK	-
China	E1	LS	220 V	B, C, E	-48 V	A-law	-	E1
Denmark	E1	-	220 V	B, E	-60 V	A-law	-	-
Finland	E1	-	220 V	B, E	-60 V	A-law	-	-
France	E1	LS	220 V	B, E	-60 V	A-law	-	-
Germany	E1	LS	220 V	B, E	-60 V	A-law	-	-
Hong Kong	T1	LS	220 V	D, E, I	-	μ-law	Bellcore FSK	-
Ireland	E1	LS	220 V	B, D, E	-60 V	A-law	-	-
Israel	E1	LS DID E&M	220 V	B, G	-48 V	A-law	-	-
Italy	E1	LS E&M	220 V	B, F	-60 V	A-law	-	-
Japan	T1	LS DID	100 V	A	-	μ-law	NTT Clip	-
Korea	E1	LS DID	110/220 V	A, B	-	A-law	-	-
Mexico	E1	LS	110 V	A	-60 V	A-law	Bellcore FSK	E1
Netherlands	E1	LS	220 V	B, E	-60 V	A-law	-	-
New Zealand	E1	LS DID	220 V	C	-	A-law	-	-
Norway	E1	-	220 V	B, E	-60 V	A-law	-	-
Russia								
Singapore	E1	LS DID	220 V	B, D, E, I	-	A-law	Bellcore FSK	-
Spain	E1	LS	220 V	A, B, E	-48 V	A-law	-	-
Sweden	E1	-	220 V	B, E	-60 V	A-law	-	-
Switzerland	E1	LS	220 V	B, E	-60 V	A-law	-	-
Taiwan	E1	LS DID	110 V	A	-48 V	μ-law	-	-
U.K.	E1	LS	220 V	D, E	-60	A-law	-	-
U.S.	T1	LS GS DID	110 V	A	-	μ-law	Bellcore FSK	-

1 DC power is only a TA issue in China.

2 Indicates that the feature is not important or applicable.

NOTE:

These are nominal voltages. In general, a reference to 110 V applies to a range from 100 to 160 V. Whereas, a reference to 220 V applies to a range from 220 to 240 V.

Avaya S8500 Media Server

The Avaya S8500 Media Server is a rack mounted telephony server, running Red Hat Linux 8.0 Operating System, and featuring the Avaya world class call processing application, Communication Manager. The S8500 is capable of supporting both Internet Protocol (IP) and traditional endpoints enabling new technology, and the ease of migration from legacy Avaya systems. The S8500 Media Server is a perfect solution for mid-sized customers, with growth of up to 3200 ports. See the following figure for an example of the front of the S8500 Media Server.

Figure 11: S8500 Media Server (front)

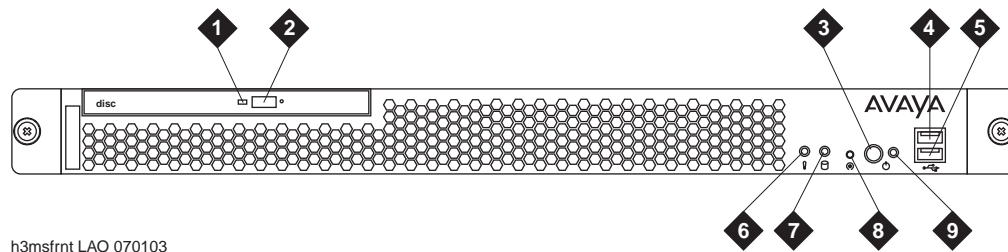

h3msfrnt LAO 070103

Figure notes

Number	Description	
1	CD-ROM drive activity LED	When this LED is lit, the CD-ROM drive is in use.
2	CD eject button	Press this button to release a CD from the CD-ROM drive.
3	Power-control button	Press this button to turn the server on or off manually
4	USB connector 1	This USB port configures automatically and uses a serial interface standard for telephony and multimedia devices.
5	USB connector 2	This USB port configures automatically and uses a serial interface standard for telephony and multimedia devices.
6	System-error LED	This amber LED lights when a system error occurs.
7	Hard disk drive activity LED	When this LED is flashing, it indicates that the associated hard disk drive is in use.
8	Reset button	Press this button to reset the server and run the power-on self-test (POST).
9	Power-on LED	When this LED is lit, it indicates that the server is turned on.

Detailed description

The S8500 Media Server comes standard with the following hardware components:

- Pentium IV 512 KB Level-2 cache and MMX (MMX2) technology Microprocessor.
- 512 MB RAM
- IDE CD-ROM

- 40-GB (minimum) hard drive
- Two USB ports
- One serial port
- A keyboard port
- A mouse port
- Two 10/100/1000Base-T Ethernet ports
- A Remote Supervisor Adapter (RSA)
- An external Compact Flash Memory Reader
- A Compact Flash 120 MB industry media (optional)
- One USB modem
- One serial modem
- AC or DC powered (seperate models)
- Includes RAM disk.

NOTE:

An optional dual-NIC card can be added to the configuration when the network control is sent over a dedicated LAN.

Backing up an S8500 Media Server

You can backup the S8500 Media Server to a server on the LAN or to the compact flash memory reader that is installed in one of the USB ports. The compact flash memory reader uses a 128-MB compactflash. Avaya recommends that use of the industrial grade compactflash for the following reasons:

- Improved data integrity and reliability
 - Powerful error correction
- Extreme endurance
 - 2,000,000 program/erase cycles per block
- Increased reliability
 - Mean time between failures (MTBF) greater than 3 million hours
- Industry-leading 7-year warranty
- Enhanced durability
 - New RTV silicone for added strength and stability

The industrial grade compactflash is available through Avaya and Avaya business partners.

Port-network connectivity

The S8500 Media Server uses IP connectivity between the Port Networks (PNs). Forms of traditional network connectivity such as Center Stage Switch (CSS) and ATM port-network connectivity (ATM-PNC) are not supported. Also traditional options of survivability such as the Survivable Remote Processor or the ATM WAN Spare Processor are not supported.

Port Network connectivity is provided by the IPSI-2 (TN2312BP) circuit packs and the IP Media Processor (TN2302AP) circuit pack. Direct connection between expansion interface boards is available for systems migrating from a DEFINITY G3r or DEFINITY G3si. The S8500 Media Server configurations with four or more PNs requires a IP PNC.

Media gateways

The G650 Media Gateway is used for new S8500 Media Server configurations. The following media gateways are supported in a migration from an existing Avaya solution to the S8500 Media Server:

- CMC1
- SCC1
- MCC1
- G600

NOTE:

The G700 Media Gateway and the G350 Media Gateway are supported through the CLAN board mounted in a CMC1, SCC1, MCC1, G600, or G650 Media Gateway.

NOTE:

Media Gateway types cannot be mixed within the same PN.

G650 Media Gateway

The Avaya G650 Media Gateway is a fourteen slot, rack mounted carrier configured for TN format circuit packs. The G650 is 8U high (14 inches (35.6 centimeters)) and mounts in a standard 19 inch (48.3 centimeters) data rack. The G650 uses one or two 655A power supplies, operating on either AC and DC input power. Either power supply can provide all the power needed by the G650. When two power supplies exist, they share the power load. One power supply can operate on AC power and the other on DC power. The system will always use AC power if available.

See [Figure 12, G650 Media Gateway](#), on page 62 for an example of a G650 Media Gateway.

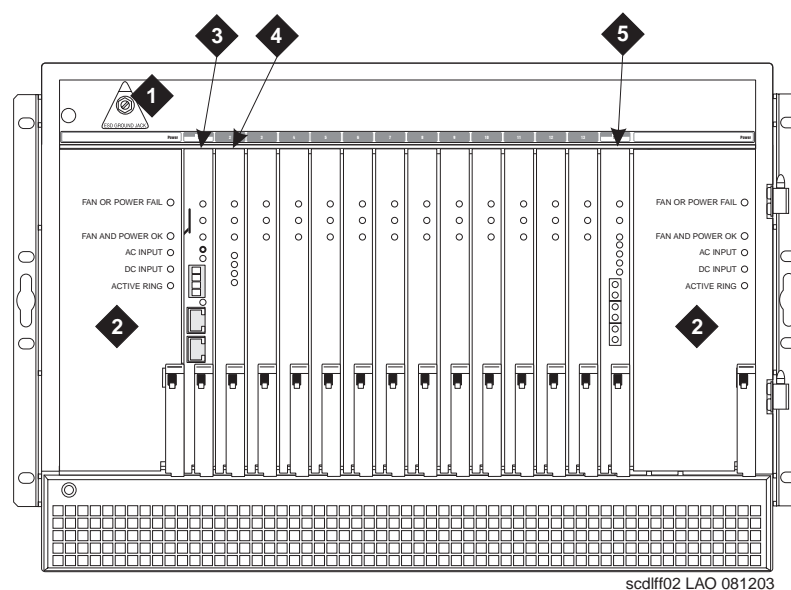
Figure 12: G650 Media Gateway**Figure notes**

Number	Description
1	EDS ground jack
2	655A power supply
3	TN2312BP IP server interface (IPSI)
4	TN799DP CLAN
5	TN2302 IP media processor

For more information on the G650 Media Gateway, see [Avaya G650 Media Gateway](#) on page 131.

Remote Supervisor Adapter (RSA)

A Remote Supervisor Adapter (RSA) is installed in PCI-X slot 1 of the S8500 Media Server. It monitors and reports alarms on S8500 components and provides control to power-on and power-off the S8500. Administration of the RSA is accomplished through the Advanced System Management (ASM) Web interface using a browser.

See [Figure 13, RSA](#), on page 63 for an example of the RSA.

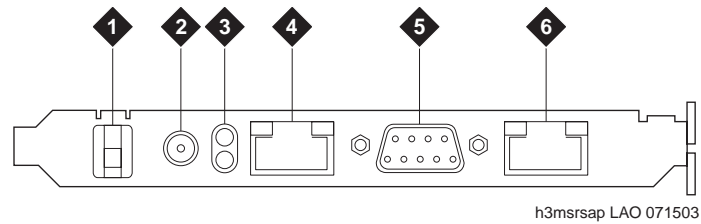
Figure 13: RSA**Figure notes**

RSA Component	Description
1 Clip	Power cord retaining clip
2 External power-supply connector	Connect the power-supply adapter to this connector. A power cord connects from the power-supply adapter to the power source. This connection provides power to the RSA that is independent of the S8500 Media Server power supply.
3 Power and error LEDs	The green LED: Shows the status of the power connection. The amber LED: Shows that an error condition exists on the RSA.
4 Ethernet RJ-45 connector	A 10/100 Mbps connector for LAN connectivity.
5 Serial connector	Used for serial modem connectivity.
6 ASM RS-485 RJ-14 connector	Not used in the S8500 Media Server configuration.

Standard features of the RSA are:

- Continuous health monitoring and control of the S8500 Media Server
- Automatic notification and alerts
- Event log showing time-stamped entries
- Remote access through the LAN and serial modem
- Simple Network Management Protocol (SNMP) trap support
- Domain Name System (DNS) server support
- Dynamic Host Configuration Protocol (DHCP) support
- Remote power control
- Remote firmware updates

NOTE:

The S8500 Media Server monitors the health of the RSA and generates an alarm if a failure condition is detected.

RSA power

The RSA obtains power from an external power source or from the S8500 Media Server. Avaya recommends that an external power source on a different circuit from the S8500 be provided for the RSA. For external power, plug the cord from the power-supply adapter into the power connector on the RSA. For domestic installations a 3 pronged power cord will be plugged from the power-supply adapter into the power source. For international installations a power cord with a male IEC320 connector is used. The RSA can only be plugged into a AC power source. A power LED on the RSA lights when one or both of the following conditions are met:

- The RSA is receiving power from the external power-supply adapter.
- The RSA is receiving power from the S8500 Media Server in which it is installed.

Modems

The S8500 Media Server is equipped with two modems for remote alarming. One modem connects to the USB port on the front of the S8500 Media Server and is used for Communication Manager alarms. The other modem connects to the RS232 port on the RSA and is used for S8500 O/S and environmental alarms. The RSA modem provides remote access for diagnostics for the S8500. See [Figure 14, Modem connectivity to the S8500](#), on page 65 for an example of modem connectivity to the S8500.

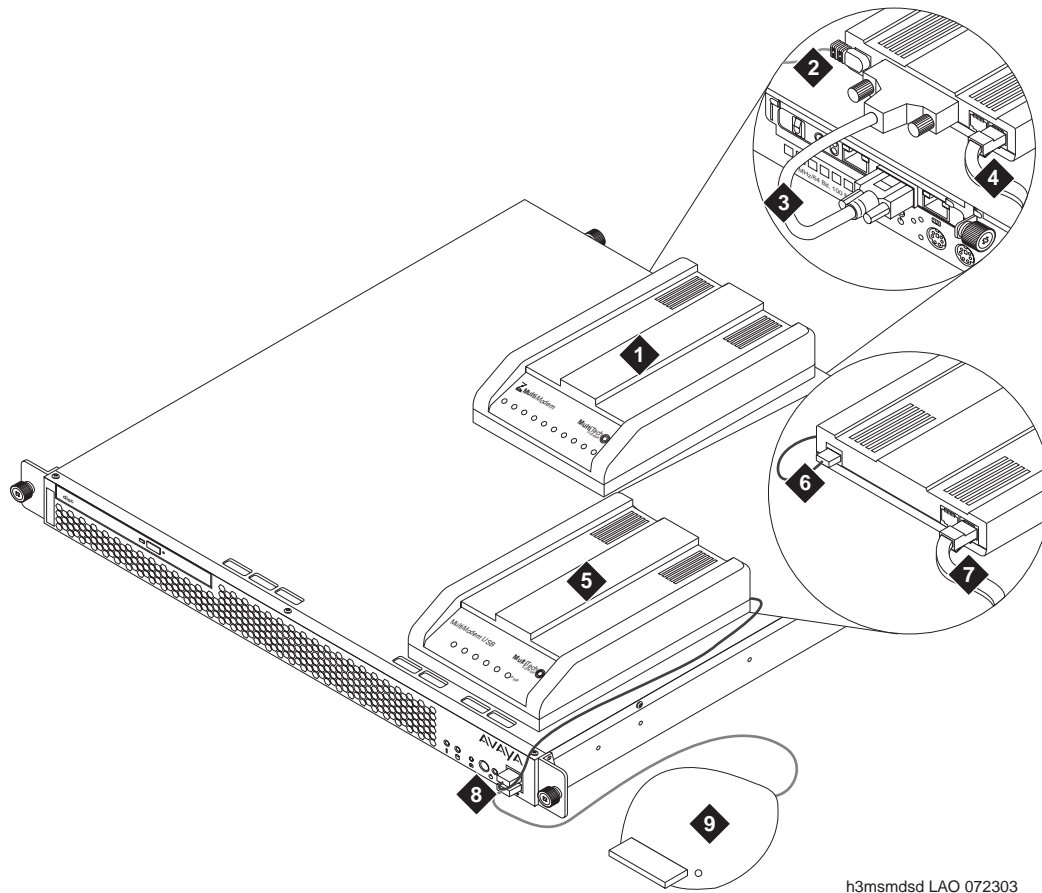
Figure 14: Modem connectivity to the S8500

h3msmdsd LAO 072303

Figure notes

Number	Description
1	Serial modem: used for the RSA.
2	Serial modem cable: connects a serial modem to an RS-232 port on the RSA
3	Serial modem cable: connects a serial modem to an RS-232 port on the RSA
4	Telephone line: connects the serial modem to the CO line
5	USB modem: used for Communication Manager
6	USB cable: connects a USB modem to a USB port in front of the server.
7	Telephone line: connects a USB modem to the CO line
8	Two USB ports on the front of the server: one for the USB modem, the other for the compact flash memory reader.
9	Compact flash memory reader: connects to a USB port in front of the server.

NOTE:

Avaya recommends that an external power source on a different circuit from the S8500 be provided for the RSA. If the RSA and the S8500 Media Server are powered by the same power supply, the ability to access the RSA may be prohibited in the case of a power failure.

S8500 Media Server reliability

The S8500 Media Server supports a simplex-reliability configuration. See the following figure for an example of a simplex configuration.

Figure 15: S8500 simplex configuration

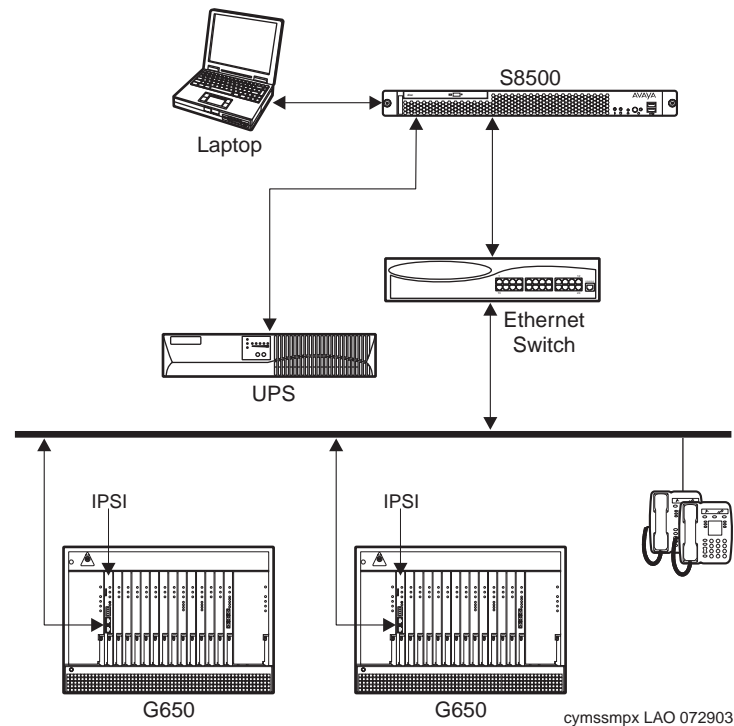

Migrating to an S8500 Media Server

Migrations from the DEFINITY R, DEFINITY SI, DEFINITY CSI and S8100 Media Server are supported to a S8500 Media Server configuration. The following describes a high-level migration from the DEFINITY R, DEFINITY SI, DEFINITY CSI and S8100 Media Server platforms:

- DEFINITY R simplex:
 - Direct-connect configurations only
 - All control circuit packs will be removed and replaced with an IPSI (TN2312BP) circuit pack.
 - Voice announcements must be on a VAL board or migrate to a VAL board.
 - The PPN control carrier must be replaced with an EPN control carrier.
- DEFINITY SI:
 - Direct-connect configurations only
 - SCC1 EPN cabinet will migrate to a SCC1 PN
 - SCC1-SPE cabinet will be removed and replaced with a SCC1 EPN or the G50 Media Gateway.

- SI processor, Net Pkt (TN2401), and Tone Clock (TN2182), are removed and replaced with an IPSI (TN2312BP).
- Voice announcements must be on a VAL board or migrate to a VAL board.
- **DEFINITY CSI:**
 - The CSI Media Server (TN798 or the TN2402) and the Tone Clock (TN2182) will be removed and an IPSI (TN2312BP) circuit pack will be installed in slot 2.
 - Voice announcements must be on a VAL board or migrate to a VAL board.
- **S8100 Media Server in a G600 Media Gateway or a CMC1 Media Gateway:**
 - The S8100 Media Server (TN795) will be removed and replaced with a IPSI (TN2312BP) circuit pack.
 - The Tone Detector (TN744) will be removed.
 - The S8100 Media Server runs Intuity Audix co-resident. In the event of a migration the subscriber data and voice files must be retranslated to an external voice messaging solution.
 - Voice announcement must be on a VAL board or migrate to a VAL board.

See [Figure 16, S8500 Media Server in a direct-connect configuration](#), on page 67 for an example of the S8500 Media Server in a direct-connect configuration.

Figure 16: S8500 Media Server in a direct-connect configuration

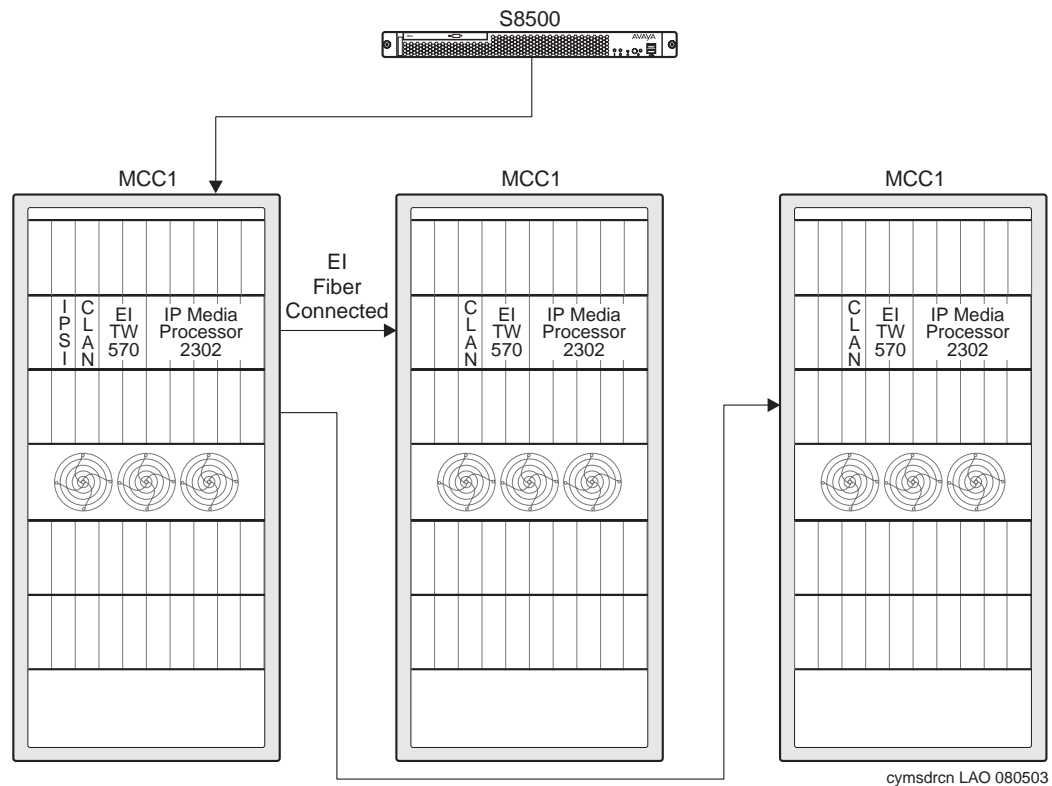

RAM disk

RAM disk is a portion of memory used as a disk partition. Under normal circumstances RAM disk and the hard disk drive are both used by the S8500. In the event of a disk failure, the S8500 Media Server, using only RAM disk, will continue to provide call processing for up to 72 hours. Administration, and backups will be prohibited.

High-level capabilities

The following table presents a subset of high-level capabilities for the S8500 Media Server. For more detailed system capacity information refer to the Avaya MultiVantage Solutions System Capacities Table (555-233-605). The Capacities Table can be found on the <http://support.avaya.com> Web site.

Table 2: High-level capabilities

Capability	S8500 Media Server
Call processing feature set	Avaya Communication Manager 2.0
Maximum number of stations	2400 (IP or TDM)
Maximum number of trunks	800
Reliability options	Simplex
Port-network connectivity	IP and direct connect
Supported media gateways	G650, G700, G350 (new installs); G600, CMC1, SCC1, MCC1 (migrations only)
Maximum number of supported gateways	250
Maximum locations	64 G650 port networks, plus up to 250 G700/G350 Media Gateways
Survivability options	G350 and G700 with S8300 LSP
Number of LSPs in one configuration	Maximum of 50 LSPs
Port networks per IPSI	One

System management

Avaya Integrated Management suite

The Avaya Integrated Management suite offers a comprehensive set of Web-based network and system management solutions that support the Avaya converged voice solutions. Integrated Management combines individual applications into five offers:

- Standard Management
- Standard Management Solutions Plus
- MultiService Network Management
- Enhanced Converged Management
- Advanced Converged Management

For more detailed information on the Avaya Integrated Management suite see:

- <http://www.avaya.com> >Products and Services>Products A-Z

Avaya S8500 Media Server Web interface

The S8500 Media Server uses a media server Web interface to perform a wide variety of functions. This browser-based tool uses a Graphical User Interface (GUI) for performing server administration tasks such as:

- Backups and restores for customer data
- Provides easy access to view current alarms
- The ability to perform server maintenance including busy out and release busy out, shutdown, and status of the S8500 Media Server.
- Security commands that will enable and disable the modem, start and stop FTP server, and view license.
- SNMP access to configure trap destinations, stop and start the master agent.
- S8500 Media Server configuration information and upgrade access.

The Web interface contains an extensive help system that describes all the Web screens and fields.

Avaya S8700 Media Server with an Avaya G650 Media Gateway

The Avaya S8700 Media Server uses a standard microprocessor engine with an Intel based processor on a commercial server. The S8700 Media Server uses high-speed connections to route voice, data, and video between analog and digital trunks, data lines that are connected to host computers, data-entry terminals, personal computers, and internet addresses

See [Figure 17, S8700 Media Server](#), on page 70 for an example of the S8700 Media Server.

Figure 17: S8700 Media Server

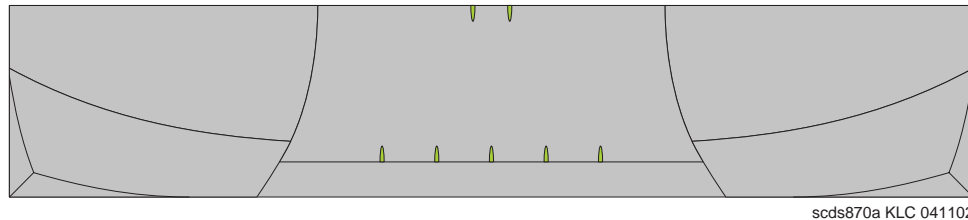

Detailed description

The S8700 Media Server uses a Redhat Linux platform on an Intel-based server. The S8700 Media Server is derived from the DEFINITY® processor, has fewer physical components, and provides most of the same features and functionality with increased capacity.

Configuration information

The S8700 Media Server is available in two configurations:

- Voice bearer over IP (IP-Connect): An all-IP configuration.
- Voice bearer over Asynchronous Transfer Mode (ATM) or Center Stage Switch (CSS) (Multi-Connect): In this configuration the bearer paths and control paths are separate. The control information for port networks travels over either a dedicated, through the Ethernet, switch (private LAN) or non-dedicated (over customer LAN) control network and terminates on the S8700 Media Server at one end and an IPSI circuit pack on the other.

S8700 Media Server control complex

The S8700 Media Server configuration uses the following components and software:

- Two media servers
- An IP Server Interface (IPSI) circuit pack (TN2312BP)
- An Avaya Ethernet Switch P133 or P134 or P333 or P334 or customer Ethernet switch
- An Avaya 700VA/1500VA online UPS
- An Abstract Control Model (ACM) compliant Universal Serial Bus (USB) modem

- Avaya media gateways
- Avaya Communication Manager

For information about Avaya Communication Manager, see the "Overview for Avaya Communication Manager", 555-233-767.

The following sections describe each of the main components.

S8700 Media Server

Characteristics of the S8700 Media Server:

- 10/100 Ethernet ports to support IPSI network control links, services access, duplication, administration and alarming.
- An IDE hard disk
- An IDE CD-ROM
- Support for global power ranging from 100V to 250V
- Storage media for the operating system, customer translations, and maintenance software
- Support for USB port connectivity for modem
- A 128 MB Flash Card for removable media
- Support for remote call out alarming from either server
- SNMP alarming

The S8700 Media Server must be mounted in an open 19-inch rack that is EIA-310-D compliant.

IPSI Circuit Pack (TN2312BP)

The TN2312BP IP Server Interface (IPSI) provides environmental maintenance and is the only IP server interface that is supported in the G650. A TN2312BP IPSI placed in a G650 with a carrier address set to A acts as the serial bus master. (A TN2312BP IPSI can only be placed in a G650 with a carrier address set to A or B. Only a TN2312BP IPSI in a G650 with a carrier address set to A can function as a serial bus master).

The TN2312BP IPSI is backward compatible with other media gateways, but provides environmental maintenance only when used in a G650. The TN2312BP IPSI always provides tone detection, call classification, tone generation, and clock functions.

When the TN2312BP IPSI is used in an MCC1 or SCC1, a TN755D provides the environmental maintenance.

The TN2312BP IPSI provides maintenance functions for the G650. This includes:

- Power supply, cabinet, and ring generator maintenance
- External device alarm detection
- Emergency transfer control
- Customer-provided alarm device control

For configurations where voice bearer is over CSS or ATM, each IPSI typically controls five port networks by tunneling control messages over the bearer network to PNs that do not have IPSIs. An IPSI cannot be placed in:

- a PN that has a Stratum-3 clock interface
- A Survivable Remote Expansion Port Network (SREPN)

To determine the number of IPSI-connected PNs that are recommended to support a S8700 configuration divide the total number of PNs in the configuration by five and add one. The additional IPSI provides fault tolerance.

For configurations where voice bearer is over IP, there must be one IPSI in each PN.

A direct connect configuration only supports one IPSI connected PN.

See [Figure 18, IPSI faceplate](#), on page 72 for an example of the IPSI faceplate

Figure 18: IPSI faceplate

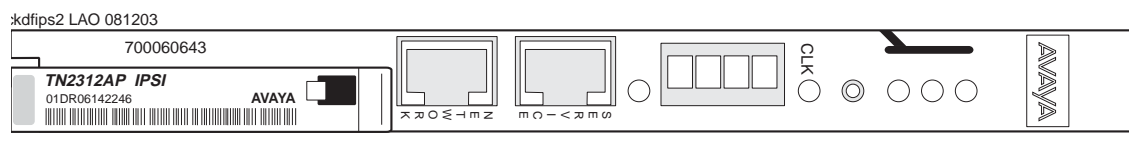

For more information on the IP Server Interface, see [TN2312BP IP Server Interface](#) on page 204.

Ethernet switch

An Ethernet switch provides the connectivity between the servers and the IPSI circuit packs that reside in some PNs. For duplex reliability, one Ethernet switch is provided. For high and critical reliability, the Ethernet switches are duplicated. The S8700 Media Server supports two Ethernet connections to the Ethernet switch in the control network.

The S8700 Media Server always requires an Avaya (P13X or P33X) Ethernet switch as part of the control complex. The Avaya Ethernet switch extends Ethernet connectivity to the PN where it connects to an IPSI. One Ethernet switch is required for duplex reliability. Two are required for high or critical reliability (voice bearer over CSS or ATM only). If desired, customer-provided non-Avaya Ethernet switches can be substituted for Avaya Ethernet switches.

Although the S8700 Media Server control network does not have to be a dedicated one, an installation that uses a dedicated set of Ethernet switches provides simplicity and greater reliability.

See [Figure 19, Avaya Ethernet switch](#), on page 73 for an example of an Avaya Ethernet switch.

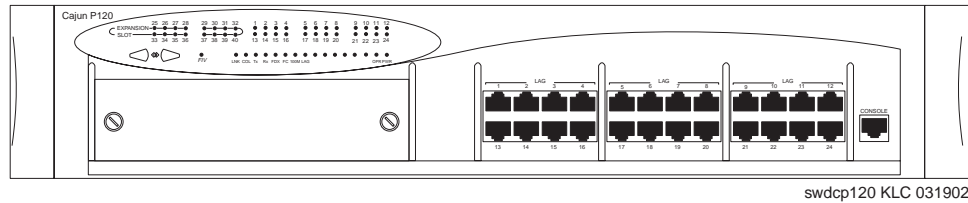
Figure 19: Avaya Ethernet switch

UPS or power backup

S8700 Media Servers always require power backup. Power backup is required to avoid power problems and to ensure graceful shutdown of the system processes if the power fails. The Avaya 700-VA UPS provides approximately 30 minutes of power backup. Combinations of battery extension modules and a 1500-VA UPS provide up to eight hours of power backup. See Avaya UPS's section for more information.

The Avaya UPS units use SNMP traps to send an alarm when power fails. Before the batteries are completely drained, an SNMP trap is sent that initiates a graceful shutdown process of the Linux server, including the call processing software. When a separate 48V-DC battery string is used, it might be possible to send an alarm when voltage is below a threshold but shutdown will not be mechanized.

USB modem

Each S8700 Media Server requires a Universal Serial Bus (USB) modem for maintenance access and to call out an alarm. The modems can share a common phone line if the S8700 Media Servers are co-located. When the S8700 Media Servers are separated an additional phone line will be required. Incoming calls are answered by the on-line server. The callers can access the off-line server via a telnet session. Each modem connects to a USB port on the S8700 Media Server. The USB modems used must conform to the Communication Device Class (CDC) specification, and usually to the Abstract Control Model (ACM) sub-class. Any modem that does not comply with the specification will not work with the driver that the S8700 Media Server provides.

Media gateways

The Avaya G650 Media Gateway is the preferred gateway for new installations of the S8700 Media Server. For migrations from an existing Avaya solution, and additions to an existing Avaya solution, the type of gateway that will be supported depends on the configuration. For the voice bearer over CSS or ATM, the G350, G650, MCC1, SCC1, and G700 media gateways are supported. For the voice bearer over IP the G350, G650, G600, G700, and CMC1 media gateways are supported. The following section offers a high-level description of each of the media gateways.

The G650 Media Gateway

The Avaya G650 Media Gateway is a fourteen slot, rack mounted carrier configured for TN format circuit packs. The G650 is 8U high (14 inches (35.6 centimeters)) and mounts in a standard 19 inch (48.3 centimeters) data rack. The G650 uses one or two 655A power supplies, operating on either AC and DC input power. Either power supply can provide all the power needed by the G650. When two power supplies exist, they share the power load. One power supply can operate on AC power and the other on DC power. The system will always use AC power if available.

See [Figure 20, G650 Media Gateway](#), on page 74 for an example of a stack of G650 Media Gateways mounted in a data rack.

Figure 20: G650 Media Gateway

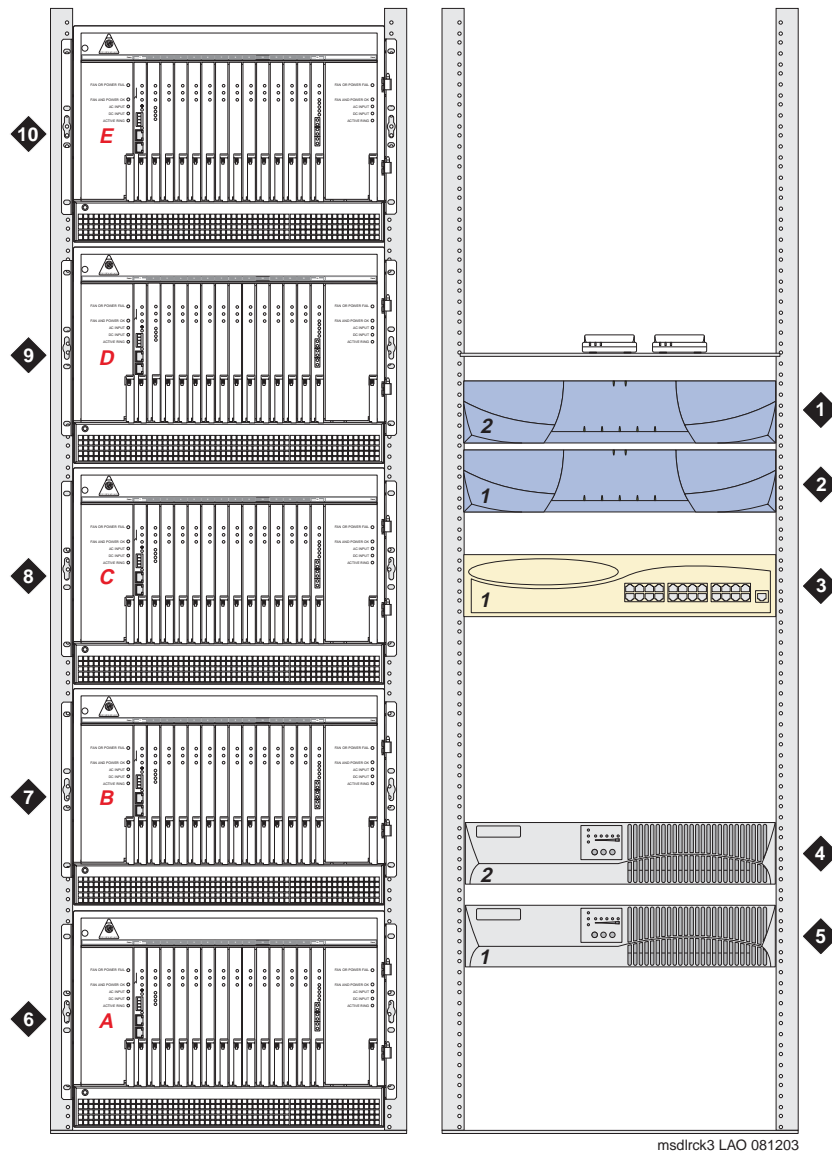

Figure notes

Number	Description
1 & 2	S8700 Media Servers
3	Ethernet switch
4 & 5	UPS units: one for each server
6	G650 Media Gateway: Carrier position "A"
7	G650 Media Gateway: Carrier position "B"
8	G650 Media Gateway: Carrier position "C"
9	G650 Media Gateway: Carrier position "D"
10	G650 Media Gateway: Carrier position "E"

For more information about the Avaya G650 Media Gateway, see [Avaya G650 Media Gateway](#).

The MCC1 Media Gateway (voice bearer over ATM or CSS only)

The MCC1 Media Gateway can contain up to five carriers. The MCC1 Media Gateway uses circuit packs. Doors on the front and on the rear of the cabinet protect internal equipment and allow easy access to circuit packs. The MCC1 Media Gateway can contain the following carriers:

- A Port Carrier can that contains one or more of the following:
 - Port circuit packs
 - IPSI
 - VoIP conversion resources
 - Service circuit packs
 - Tone clocks
 - Expansion Interface (EI) circuit packs
- A Switch Node Carrier that contains Switch Node Interface circuit packs that compose the Center Stage Switch (CSS).
- An Expansion Control Carrier that contains service slots and port slots.

See [Figure 21, MCC1 Media Gateway](#), on page 76 for an example of the MCC1 Media Gateway.

Figure 21: MCC1 Media Gateway

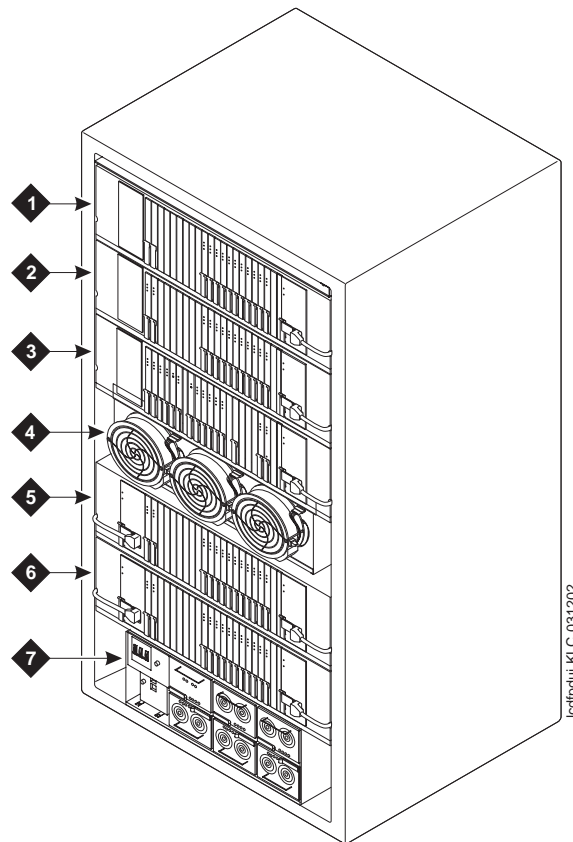

Figure notes

Number	Description
1	Carrier in position C
2	Carrier in position B
3	Carrier in position A
4	Fan unit
5	Carrier in position D
6	Carrier in position E
7	Power-distribution unit

For more information, see the [MCC1 Media Gateway](#).

SCC1 Media Gateway (voice bearer over ATM or CSS only)

The SCC1 Media Gateway consists of a single carrier. Up to four SCC1 Media Gateways can be connected together in one location to form a PN. The SCC1 Media Gateway provides vertical slots for circuit packs. Rear cabinet clips connect the cabinets together. A ground plate connects the stacked cabinets for ground integrity. There are two types of SCC1 Media Gateways:

- An Expansion Control Cabinet that contains service slots and port slots.
- A Port Cabinet that contains ports and interfaces to an Expansion Control Cabinet.

See [Figure 22, Typical SCC1 Media Gateway](#), on page 77 for an example of the SCC1 Media Gateway.

Figure 22: Typical SCC1 Media Gateway

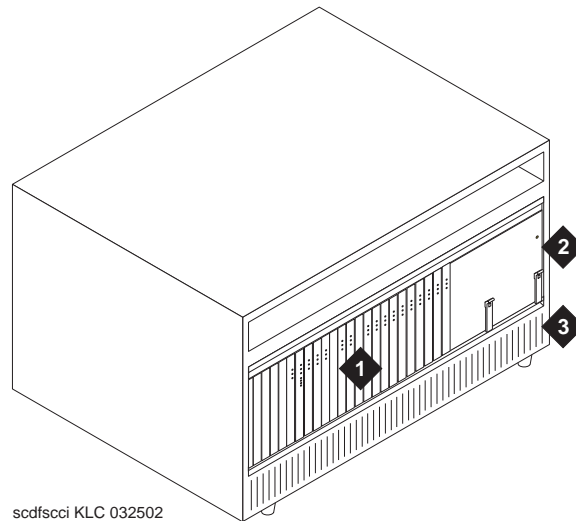
**Figure notes**

Number	Description
1	Circuit packs
2	Power converter
3	Air circulation vents

For more information, see [SCC1 Media Gateway](#) on page 150.

CMC1 Media Gateway (voice bearer over IP only)

The CMC1 Media Gateway can be mounted on a wall or on the floor, and uses an AC-only power supply. The control carrier contains two control slots, one for a processor (not used) and the other for the IPSI (TN2312BP). Slots 3 to 10 can contain optional port circuit packs and service circuit packs.

See [Figure 23, CMC1 Media Gateway](#), on page 78 for an example of the CMC1 Media Gateway.

Figure 23: CMC1 Media Gateway

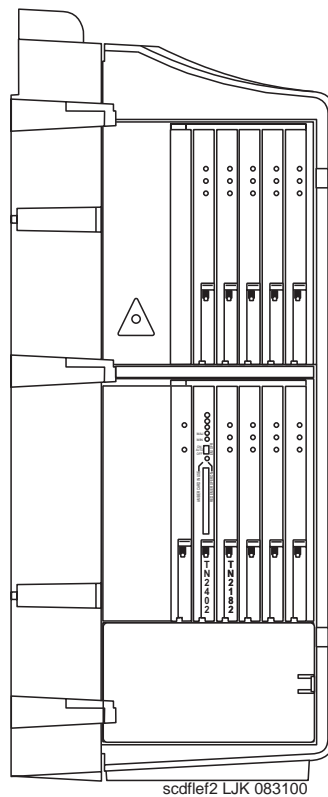

For more information on the CMC1 Media Gateway see [CMC1 Media Gateway](#) on page 147.

G600 Media Gateway (voice bearer over IP only)

A G600 Media Gateway has the following characteristics:

- 19 inches wide, 13 inches high, and 21 inches deep
- 10 universal slots and one power-supply slot
- AC-powered only

There are no internal batteries, and internal DC power is not an option. However, external DC powering or a UPS is supported.

- Its circuit packs are inserted and removed from the front of the cabinet.
- Cabinet I/O is through the back and through a front cable pass-through slot on the right.

A PN has the following characteristics:

- Contains up to 4 G600 Media Gateways
 - The first G600 is designated "A." Optional second, third, and fourth G600s are designated "B," "C," and "D" respectively.
 - Must reside in the same 19-inch data rack due to TDM-cable length
- A maximum of 64 port networks
- Recommended RJ45 patch panel for cross-connecting to LAN or 110 hardware.

The [Figure 24, G600 Media Gateway](#), on page 79 for an example of a G600 Media Gateway.

Figure 24: G600 Media Gateway

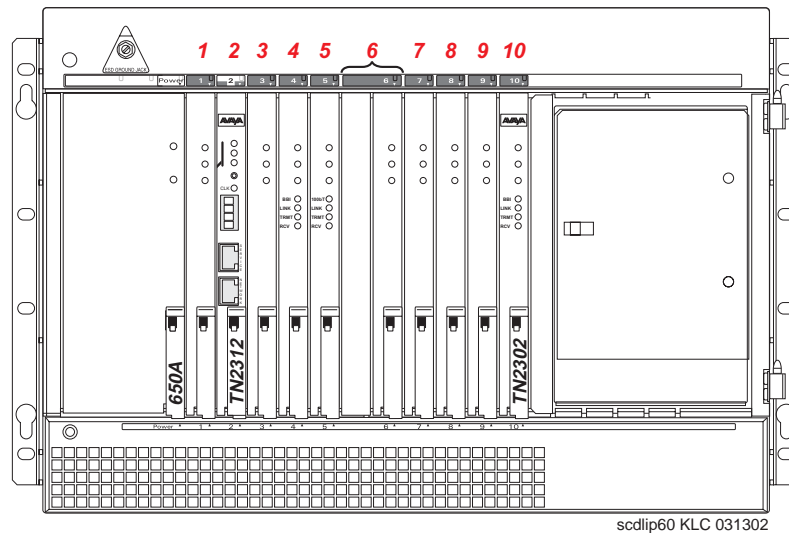

For more information, see [G600 Media Gateway](#) on page 127.

G700 Media Gateway

The G700 Media Gateway is not a PN by itself. The G700 Media Gateway is connected to the S8700 Media Server through the CLAN that resides in the SCC1, MCC1, CMC1, G600, or G650 Media Gateway. One S8700 Media Server can support a maximum of 250 G700 Media Gateways with up to 10 in one stack. The stack can be mixed with Avaya P330 devices such as the P333T, P333R, and P334.

For more information, see [Avaya G700 Media Gateway](#) on page 139.

Reliability

Reliability when sending voice bearer over IP

The following are supported with the S8700 Media Server when sending voice bearer over IP:

- Duplex reliability
- High reliability

Duplex-Reliability when sending voice bearer over IP

The S8700 Media Server is duplicated. Tone-Clock functionality is provided by the IPSI circuit pack in each PN. As an all-IP solution, only IP connected port networks are supported.

See [Figure 25, Duplex-reliability configuration when sending voice bearer over IP](#), on page 80 for an example of a duplex-reliability configuration when sending voice bearer over IP.

Figure 25: Duplex-reliability configuration when sending voice bearer over IP

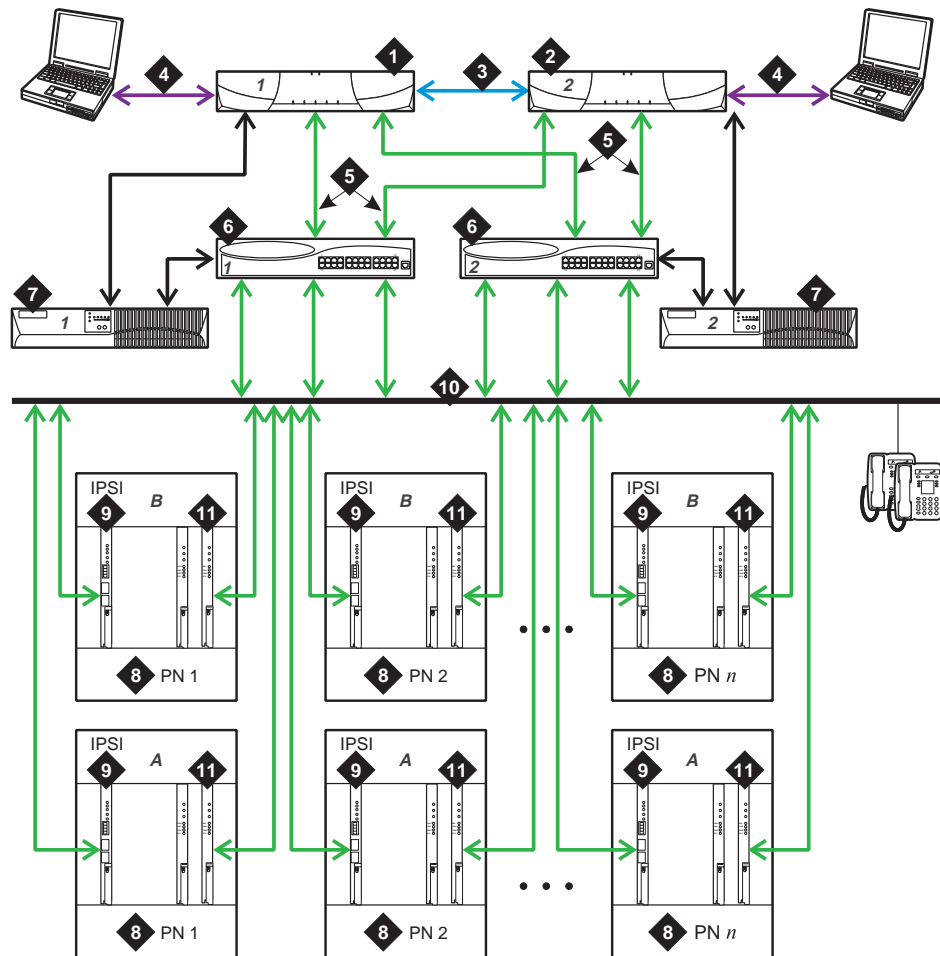

cyms0001 LAO 081203

Figure notes

Number	Description of Connection
1 & 2	S8700 Media Server pair. One in an active mode and the other on standby.
3	Duplication Links: The Ethernet connection default Ethernet 2 and the fiber link
4	A dedicated Ethernet connection to a laptop. This connection is active only during on-site administration or maintenance and the services interface can link to the standby server through a telnet session.
5	Connection from the servers to the Ethernet switch.
6	Ethernet Switch – A device that provides port multiplication on a LAN by creating more than one network segment. In an IP-Connect environment, the Ethernet switch should support 802.1 ip/Q, VLAN and 10-/100-Mbps.
7	Two UPS units
8	Port Network – An optional configuration of Media Gateways that provides increased port capacity.
9	IPSI – A circuit pack that transports control messages over IP. This IPSI circuit pack is used so the S8700 Media Server can communicate with the PNs.
10	Customer LAN
11	Control Lan Interface (C-LAN) - A circuit pack that provides call control for every IP endpoint that is connected to the media server using an Avaya media gateway.

High-reliability when sending voice bearer over IP

The high-reliability configuration option builds on the duplex reliability option. The high-reliability duplicates components so that no single point of failure exists in the control network. The high-reliability configuration consists of the following:

- Two S8700 Media Servers
- Two IPSI circuit packs in each IPSI-connected port network
- Two Ethernet switches
- Two UPS units

See [Figure 26, High-reliability when sending voice bearer over IP](#), on page 82 for an example of a high-reliability configuration when sending voice bearer over IP.

Figure 26: High-reliability when sending voice bearer over IP

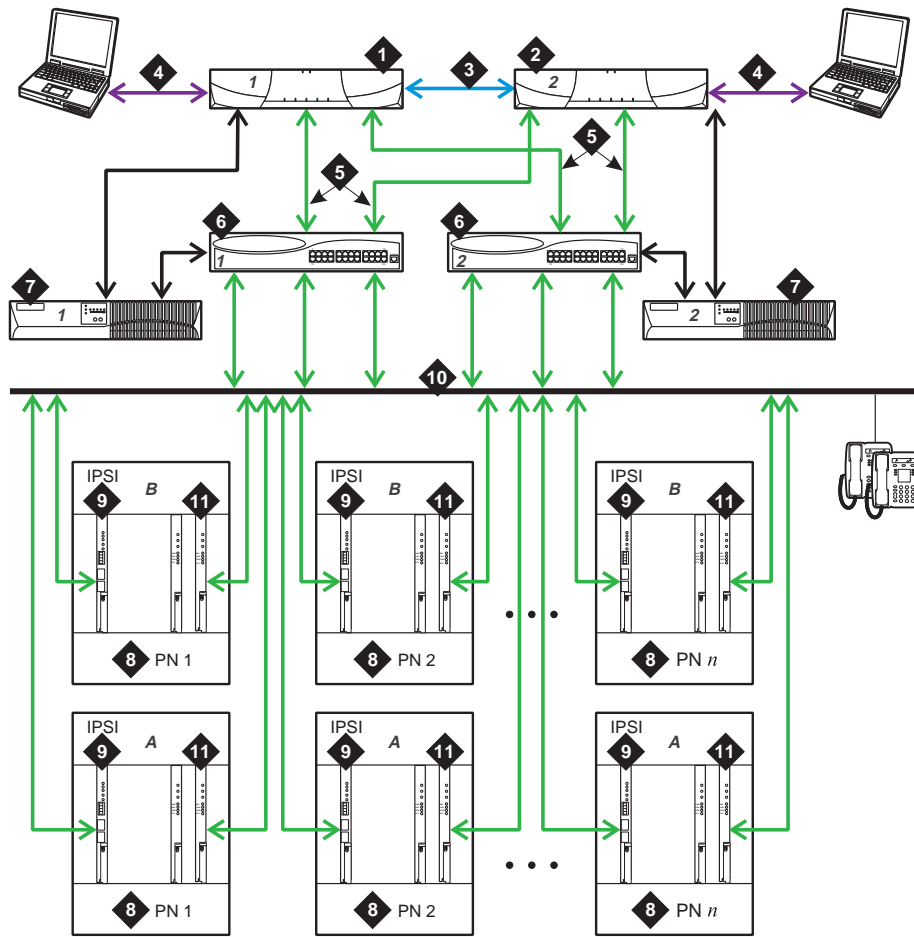

cyms0001 LAO 081203

Figure notes

Number	Description of Connection
1 & 2	S8700 Media Server pair. One in an active mode and the other on standby.
3	Duplication Links: The Ethernet connection default Ethernet 2 and the fiber link
4	A dedicated Ethernet connection to a laptop. This connection is active only during on-site administration or maintenance and the services interface can link to the standby server through a telnet session.
5	Connection from the servers to the Ethernet switch.
6	Ethernet Switch – A device that provides port multiplication on a LAN by creating more than one network segment. In an IP-Connect environment, the Ethernet switch should support 802.1 ip/Q, VLAN and 10-/100-Mbps.
7	Two UPS units
8	Port Network – An optional configuration of Media Gateways that provides increased port capacity.
9	IPSP – A circuit pack that transports control messages over IP. This IPSP circuit pack is used so the S8700 Media Server can communicate with the PNs.
10	Customer LAN
11	Control Lan Interface (C-LAN) - A circuit pack that provides call control for every IP endpoint that is connected to the media server using an Avaya media gateway.

Reliability when sending voice bearer over ATM or CSS

The following are supported with the S8700 Media Server when sending voice bearer over ATM or CSS:

- Duplex-reliability
- High-reliability
- Critical-reliability

Duplex-Reliability when sending voice bearer over CSS or ATM

The duplex-reliability option is the most basic option. A duplex-reliability configuration consists of the following:

- Two S8700 Media Servers
- One Ethernet switch
- One UPS unit for each S8700 Media Server. The use of two UPS units ensures that a single UPS failure or repair operation will not disable the system.
- One IPSI in each IPSI-connected port network.

Voice and data bearer traffic between port networks is carried on a simplex network that is made up of one Expansion Interface (EI) in each port network. Avaya offers different types of EI circuit packs, one for CSS, one for ATM. The EIs are cabled with lightguide fiber to either the Center Stage Switch (CSS) or an Asynchronous Transfer Mode (ATM) switch.

See [Figure 27, Duplex-reliability configuration when sending voice bearer over CSS or ATM](#), on page 84 for an example of a duplex-reliability when sending voice bearer over CSS or ATM.

Figure 27: Duplex-reliability configuration when sending voice bearer over CSS or ATM

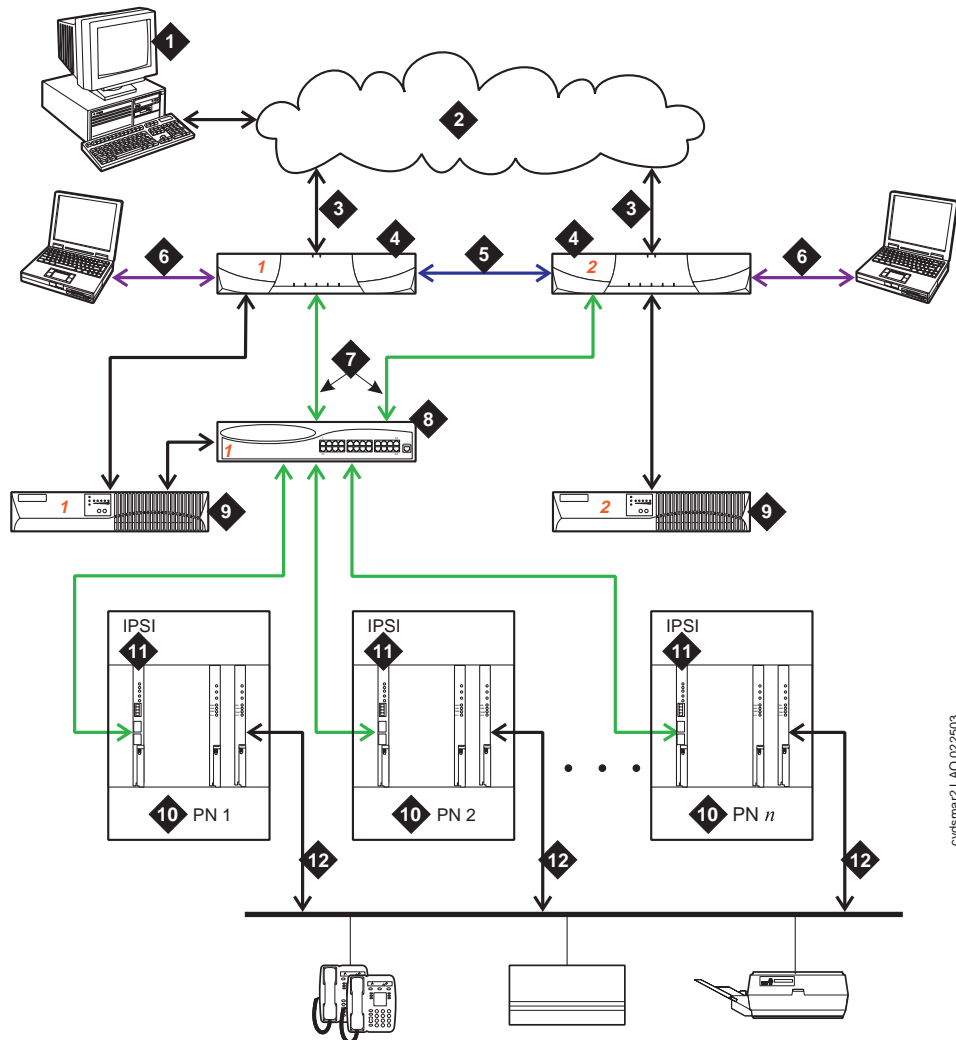

cydsmar2_LAO 02/25/03

Figure notes

Number	Description of the Connection
1	The Administration PC can be used to access the S8700 Media Server over the corporate LAN.
2	Corporate LAN.
3	Corporate LAN interface: default Ethernet 4— The Ethernet link from the S8700 Media Server to the LAN. Used for administration and can be used for alarming by way of Simple Network Message Protocol (SNMP) traps. The Ethernet connection to the corporate LAN in this figure is a non-dedicated network. IP addresses for the various components of the S8700 Media Server must be administered with care to prevent conflicts with other equipment that shares the LAN.
4	The S8700 Media Servers pair, one server in an active mode and the other server on standby.
5	Duplication links: The Ethernet link, default Ethernet 2, and the fiber link.

Figure notes

Number	Description of the Connection
6	Services interface: default Ethernet 1-The server's dedicated Ethernet connection from the S8700 Media Server to a laptop. This link is active only during on-site administration or onsite maintenance.
7	Network control A interface: default Ethernet 0-The server's Ethernet connection to one or two Ethernet switches. This private LAN carries the control signals for the PNs.
8	Ethernet switch — at least one Ethernet switch is required to support the S8700 Media Server's control network. If many PNs are present, two Ethernet switches may be daisy-chained together to provide sufficient Ethernet connections to the IPSI boards in the PNs.
9	UPS — Keeps the S8700 Media Servers and Ethernet switches functional during brief power outages.
10	PN — Provides the telecommunications functions of the S8700 Media Server.
11	IPSI — The IPSI circuit pack carries the control network signals to the PNs and provides tone clock functionality.
12	Bearer connectivity

High-Reliability when sending voice bearer over CSS or ATM

The high-reliability configuration option builds on the duplex reliability option. The high-reliability duplicates components so that no single point of failure exists in the control network. The high-reliability configuration consists of the following:

- Two S8700 Media Servers
- Two IPSI circuit packs in each IPSI-connected port network
- Two Ethernet switches
- Two UPS units

Voice and data bearer traffic between port networks is carried on a simplex network that is made up of one Expansion Interface (EI) in each port network. Avaya offers different types of EI circuit packs, one for CSS, one for ATM. The EIs are cabled with lightguide fiber to either the Center Stage Switch (CSS) or an Asynchronous Transfer Mode (ATM) switch.

See [Figure 28, High-reliability configuration when sending voice bearer over CSS or ATM](#), on page 86 for an example of a high-reliability configuration when sending voice bearer over CSS or ATM.

Figure 28: High-reliability configuration when sending voice bearer over CSS or ATM

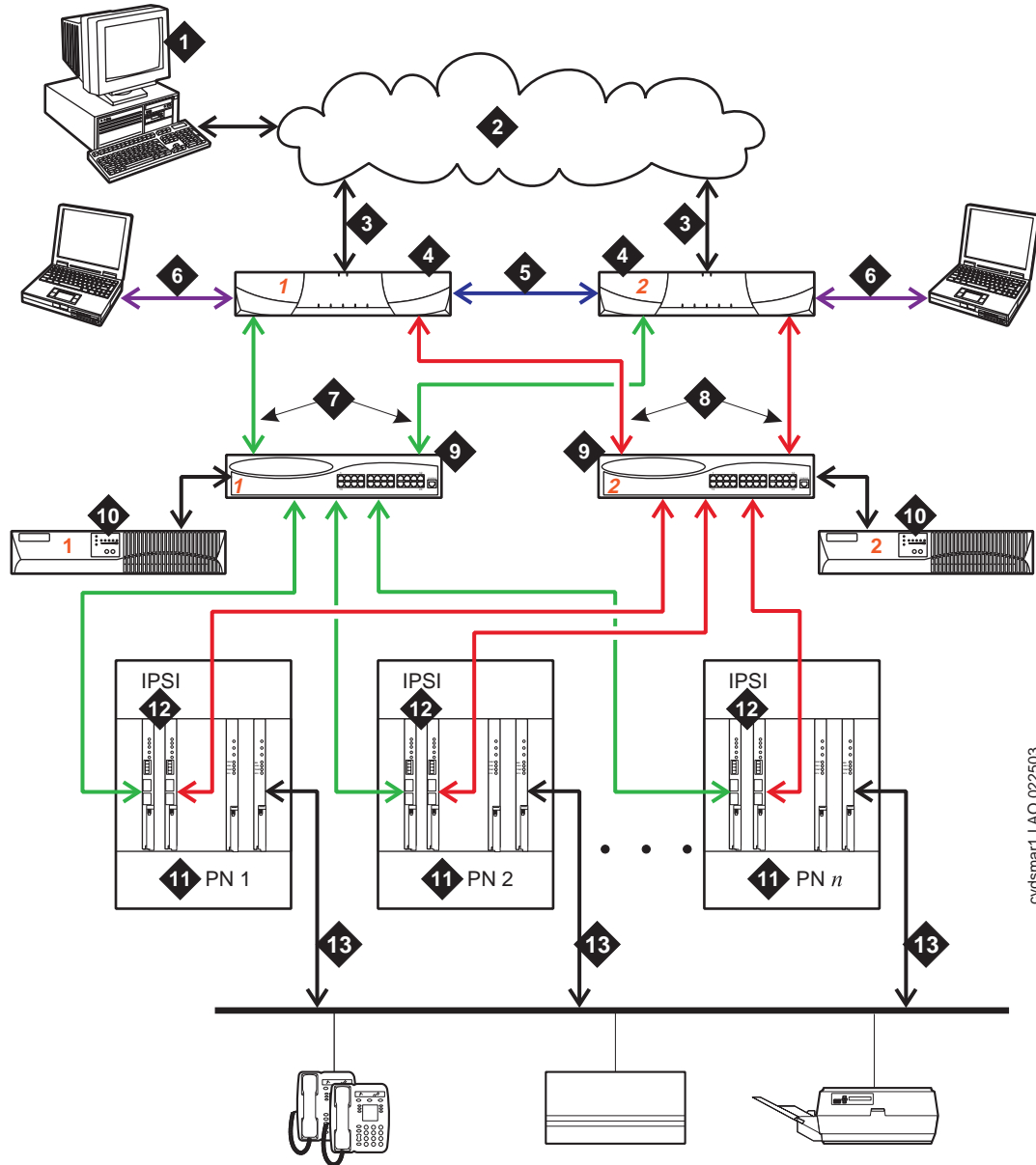

cydsmar1 LAO 022503

Figure notes

Number	Description of Connection
1	Administration PC — Used to access S8700 Media Server over the corporate LAN.
2	Corporate LAN.
3	Corporate LAN interface: default Ethernet 4 —The Ethernet link from the S8700 Media Server to the LAN. Used for administration and can be used for alarming by way of the Simple Network Message Protocol (SNMP) traps.
4	S8700 Media Server — Two are always present. One in active mode and the other on standby.

Figure notes

Number	Description of Connection
5	Duplication Links: The Ethernet link, default Ethernet 2, and the fiber link.
6	Services interface: default Ethernet 1-The server's dedicated Ethernet connection from the S8700 Media Server to a Services laptop. This link is active only during onsite administration or onsite maintenance.
7	Network control A interface: default Ethernet 0-The server's Ethernet connection to one or two Ethernet switches. This private LAN carries the control signals for the PNs when possible. Control network A is considered the primary control network because it connects to the primary IPSI board in a PN.
8	Network control B interface: default Ethernet 3-The S8700 Media Server's Ethernet connection to a duplicated set of Ethernet switches. This private LAN carries control signals for the PNs when the primary control network is unavailable. Control network B connects to the secondary IPSI board in a PN. When the problem is resolved, primary control is returned to control network A.
9	Ethernet switch — At least one is required to support each control network.
10	UPS — Keeps the S8700 Media Servers and Ethernet switches functional during brief power outages. Usually, UPS one powers server one and the Ethernet switch associated with it. UPS two powers server two and the Ethernet switch associated with it.
11	PN — Provides the telecommunications functions of the S8700 Media Server. For high reliability, each IPSI-connected PN contains a pair of IPSI circuit packs. This pair consists of, one primary circuit pack, and a duplicate secondary circuit pack as a backup. For critical reliability, the bearer network, among the port networks is also duplicated. Two EI circuit packs or two ATM circuit packs are present in each PN instead of just one.
12	IPSI — The IPSI circuit pack is duplicated in every IPSI-connected PN in a high- or critical-reliability configuration. The secondary IPSI is connected to control network B. The secondary IPSI takes over in case of problems with the primary control network. The S8700 Media Server regularly tests the duplicated IPSI to make sure it is ready for service.
13	Bearer Connectivity

Critical-Reliability when sending voice bearer over CSS or ATM

The critical-reliability configuration option is similar to the high-reliability configuration option. In addition, the critical-reliability configuration duplicates the bearer network channels among the PNs. Like the high-reliability configuration, the critical-reliability configuration consists of the following:

- Two S8700 Media Servers
- Two IPSI circuit packs in each IPSI-connected port network
- Two Ethernet switches
- Two UPS units

Voice and data bearer traffic between port networks is carried on a duplex network that is made up of two Expansion Interface (EI) in each port network. The EIs are cabled with lightguide fiber to either a duplicated Center Stage Switch (CSS) or a duplicated Asynchronous Transfer Mode (ATM) switch.

Connectivity

Connectivity for the S8700 Media Server depends on the method by which the voice bearer is being transmitted.

Connectivity when sending voice bearer over ATM or CSS

Port Networks

A new configuration consists of the G650 Media Gateways for all port networks. The MCC1 Media Gateway or the SCC1 Media Gateway are used for migrating configurations, and for configurations experiencing growth. For migrations from the DEFINITY® Server to the S8700 processor, the MCC1 cabinet that was the Processor Port Network (PPN) will be converted to a PN by replacing the control carriers with port carriers.

The IPSI extends Ethernet control by connecting the S8700 Media Server processor to the PNs. The IPSI replaces the TN2182B tone clock in each of the PNs that are connected by an IPSI. Not all PNs require the IPSI board. One IPSI-connected PN can control up to four other PNs.

CSS Network

The CSS is a connection hub that provides PN communication. A CSS can be used when more than three port networks are needed. Often the CSS is incorporated into smaller configurations to allow for growth. The CSS consists of from one to three switch nodes (SN). SNs are composed of one or two switch node carriers, depending on whether the solution is being duplicated for critical reliability. PN expansion depends on internal SN-to-SN traffic, according to the following guidelines:

- One SN expands from 1 to up to 15 PNs.
- Two SNs expands to up to 29 PNs.
- Three SNs expands to up to 44 PNs.

ATM Network

The Asynchronous Transfer Mode (ATM) switch is a replacement option for the CSS or for the direct-connect switch. Several Avaya ATM switch types can provide port network connectivity. Non-Avaya ATM switches that comply with the ATM standards that are set by the European Union can also provide port network connectivity.

When the voice bearer is sent over ATM, ATM port-network connectivity (ATM-PNC) allows any ATM switch or ATM network that complies with specified standards and capacities to serve as the means to connect to the PN. In this type of configuration, the ATM switch or network replaces the CSS. ATM-PNC is used to connect port networks within a single switch. The (WAN) spare processor is not supported.

Connectivity when sending voice bearer over IP

Sending the voice bearer over IP uses IP connectivity between PNs. An existing VOIP-ready IP infrastructure can be used. This solution saves customers the cost of building a separate telephony network.

S8700 recoverability

In addition to the high reliability of the duplicated S8700 Media Servers, the S8300 Media Server in a Local Survivable Processor (LSP) configuration and a survivable remote EPN can be used to provide survivability. Additional recovery capability is embedded in the Communication Manager software that resides on the S8700 Media Server.

S8300 Media Server in an LSP mode

The LSP is located in the G700 Media Gateway and provides survivability when the S8700 Media Server is inaccessible. Each S8700 Media Server can have up to 50 LSPs. The LSP has a copy of the S8700 Media Server customer translations. The translations are updated regularly from the S8700 Media Server using a virtual link through a IP network. Typically, all LSPs are in idle mode, where the LSP is not processing any calls. When the Media Gateway's Processor (MGP) or IP endpoints perceive the Avaya media server to be unreachable, the MGP or IP endpoints will attempt to register with an LSP. The LSP does not actively take over when the primary controller becomes unreachable, but waits for MGPs and IP endpoints to register with it. Switchback from the LSP to the primary Avaya media server is a manual operation requiring a reset 3 command on the LSP.

Power outages

In most cases an Avaya solution can recover from a power outage or other failure instantly, regardless of the source of the failure. Each PN includes a set of segmented, parallel buses. If one of the paired segments fails, the other bus segment continues to handle communications. The UPS units supply power to the control complex.

Survivable Remote EPN (voice bearer over CSS only)

The Survivable Remote Expansion Port Network (SREPN) allows either an MCC1 PN or SCC1 PN to provide service to the customer when connectivity links fail. When the links to the PN are restored and stable, a logic switch in the SREPN is manually reset and the PN is reconnected to the links from the switch. The logic switch can either be reset locally at the SREPN or reset remotely by way of a dial-up connection to the SREPN.

The SREPN must be administered separately, not as a duplicated PN, to be able to recover after a failure. It does not function as a SREPN without the administration of stations, trunks, and features to support its operation. SREPN is not compatible with ATM port-network connectivity (ATM-PNC).

An SREPN cannot be an IPSI connected PN.

High-level capabilities

The S8700 Media Server provides a large scale solution with a high number of endpoints. Specifically, it supports the following high-level capabilities.

The following table gives high-level information about S8700 Media Server capabilities.

Table 3: High-level capabilities

Capability	Description
Call processing feature set	Communication Manager
Duplication options available	Voice bearer over IP: Duplex, and high Voice bearer over CSS or ATM: Duplex, high, and critical
Port Network connectivity	Voice bearer over IP: IP Voice bearer over CSS or ATM: Center Stage Switch (CSS) or ATM, or Direct
Supported Media Gateways	Voice bearer over IP: G350, G650, G600, CMC1 and G700 Voice bearer over CSS or ATM: G350, G650, SCC1, MCC1 and G700
Maximum number of Port Networks (PN)	Voice bearer over IP: 64 Voice bearer over CSS or ATM: <ul style="list-style-type: none"> • 44 – Center Stage Switch (CSS) or • 64 – ATM-PNC
Survivability options	Voice bearer over IP: LSP Voice bearer over CSS or ATM: SRP and LSP
LSP options	S8300 Media Server in a Local Survivable Processor (LSP) configuration (maximum of 50)

Table 3: High-level capabilities

Capability	Description
Port Networks per IPSI	Up to five Note: A high- or critical-reliability configuration requires two IPSIs per IPSI-connected PN.
Modem calls	Supported
Wideband connections	Supported

For more detailed system capacity information refer to the Avaya MultiVantage Solutions System Capacities Table (555-233-605). The Avaya MultiVantage Solutions System Capacities Table can be found on the <http://support.avaya.com> Web site.

BHCC capacity for S8700 Media Server

The following is information about busy-hour call completion (BHCC) capacities for the S8700 Media Server. The values are based on current available data and may change as more data becomes available.

S8700 Media Server with MCC1/SCC1/G600 Media Gateways light call mix - 100% analog station-to-station

- 300,000 BHCC
- 250 Media Gateways
- 36,000 - analog stations
- 8,000 trunks.

S8700 Media Server with MCC1/SCC1/G600 Media Gateways general call mix - analog, DCP stations, and PRI trunks

- 220,000 BHCC
- 250 Media Gateways
- 36,000 analog and DCP stations
- 8,000 trunks.

S8700 Media Server with MCC1/SCC1/G600 Media Gateways - IP endpoints and PRI trunks

- 100,000 BHCC
- 250 Media Gateways
- 12,000 IP endpoints
- 450 IP endpoints per CLAN board.

S8700 Media Server with MCC1/SCC1/G600 Media Gateways and contact center - analog, DCP stations, and PRI trunks

- "Low" Contact Center Usage - 75,000 BHCC (low = simple vectors, minimal skill level use - skills-based routing is listed under "High")
- "Typical" Contact Center Usage - 40,000 BHCC
- "High" Contact Center Usage - 25,000 BHCC (high = pre-routed calls, BSR with many skill levels, heavily linked vectors, long speed to answer and many different announcements).

S8700 Media Server with MCC1/SCC1/G600 Media Gateways and contact center - IP endpoints and PRI trunks

- "Low" Contact Center Usage - 65,000 BHCC (low = simple vectors, minimal skill level use - skills-based routing is listed under "High")
- "Typical" Contact Center Usage - 35,000 BHCC
- "High" Contact Center Usage - 25,000 BHCC (high = pre-routed calls, BSR with many skill levels, heavily linked vectors, long speed to answer and many different announcements).

S8700 Media Server with G700 Media Gateway (IP endpoints) and MCC1/SCC1/G600 Media Gateways - (DCP stations) general call mix

- 90% MCC1/SCC1/G600 Media Gateway processing and 10% G700 processing - 202,000 BHCC (198,000 MCC1/SCC1/G600 Media Gateway BHCC and 4,000 BHCC G700 Media Gateway).
- 50% MCC1/SCC1/G600 Media Gateway processing and 50% G700 processing - 130,000 BHCC (110,000 MCC1/SCC1/G600 Media Gateway BHCC and 20,000 BHCC G700 Media Gateway).

S8700 Media Server with G700 Media Gateway - IP endpoints and PRI trunks

- 90% MCC1/SCC1/G600 Media Gateway processing and 10% G700 processing - 94,000 BHCC (90,000 MCC1/SCC1/G600 Media Gateway BHCC and 4,000 BHCC G700 Media Gateway).
- 50% MCC1/SCC1/G600 Media Gateway processing and 50% G700 processing - 70,000 BHCC (50,000 MCC1/SCC1/G600 Media Gateway BHCC and 20,000 BHCC G700 Media Gateway).

S8700 Media Server with G700 Media Gateway and MCC1/SCC1/G600 Media Gateways - contact center - low usage

- 90% MCC1/SCC1/G600 Media Gateway processing and 10% G700 processing - 71,000 BHCC (68,000 MCC1/SCC1/G600 Media Gateway BHCC and 3,000 BHCC G700 Media Gateway).
- 50% MCC1/SCC1/G600 Media Gateway processing and 50% G700 processing - 50,000 BHCC (37,000 MCC1/SCC1/G600 Media Gateway BHCC and 13,000 BHCC G700 Media Gateway).

NOTE:

Any configuration that includes IP Solutions applications such as Road Warrior, Telecommuter, or H.322 trunking, has an impact on the BHCCs and processor capacity. If a customer uses these applications in a high traffic solution, it is recommended that the Avaya Technology and Consulting (ATAC) team be involved to review any potential impact on traffic.

The information in this table represents the *maximum* number of calls the S8700 Media Server could execute, assuming it was unconstrained by other factors such as:

- TDM bus limitations
- Call duration
- Small number of telephones

We assume processor occupancy of 0.90, at which various delay criteria such as cut through is preserved, and is just at the threshold where call could no longer be processed.

System management

Avaya Integrated Management suite

The Avaya Integrated Management Suite offers a comprehensive set of Web-based network and system management solutions that support the Avaya converged voice solutions. Integrated Management combines individual applications into five offers:

- Standard Management
- Standard Management Solutions Plus
- MultiService Network Management
- Enhanced Converged Management
- Advanced Converged Management

For more detailed information on the Avaya Integrated Management Suite see:

- <http://www.avaya.com> >Products and Services > Products A-Z

S8700 Media Server Web interface

The S8700 Media Server uses a media server Web interface to perform a wide variety of functions. This browser-based tool uses a Graphical User Interface (GUI) for performing server administration tasks such as:

- Backups and restores for customer data
- Provides easy access to view current alarms
- The ability to perform server maintenance including busy out and release busy out, shutdown, and status of the S8700 Media Server.
- Security commands that will enable and disable the modem, start and stop FTP server, and view license.
- SNMP access to configure trap destinations, stop and start the master agent.
- S8700 Media Server configuration information and upgrade access.

The Web interface contains an extensive help system that describes all the Web screens and fields.

Adjuncts

This is a partial list of the adjuncts that Avaya provides:

- Voice messaging and response such as INTUITY AUDIX.
- Call center tools such as Avaya Call Management System, NICE Analyzer, Avaya Call Recording, Avaya Visual Vectors and Avaya Basic Call Management System Reporting Desktop.
- System printer is supported with the use of a terminal server.
- Journal printer is supported with the use of a terminal server.
- Call Accounting Systems is supported with the use of a terminal server.
- Call Detail Recording (CDR) is supported with the use of a terminal server.
- ASA is supported with the use of a terminal server.
- DEFINITY Network Management (DNM)
- DEFINITY Translator ATM Manager (DTA)

DEFINITY Server SI

Overview

Avaya™ Communication Manager on a DEFINITY® Server SI offers a high-level operating system, open interfaces, and distributed processing. DEFINITY Server SI provides circuit-switched voice communications and Internet Protocol (IP) telephony including voice and data network integration, unified messaging, and multimedia conferencing and collaboration. Because DEFINITY Server R is part of Avaya's Enterprise Class IP Solutions family, it is designed to work with other Avaya products to create a complete IP solution.

All major hardware is contained in a multicarrier cabinet (MCC1) that hold up to five carriers or stackable single-carrier cabinets (SCC1s). The solution enables high-speed connections between analog and digital trunks, data lines connected to host computers, data-entry terminals, personal computers, and IP network addresses. See the following figure for an example of a DEFINITY Server SI solution.

Figure 29: DEFINITY Server SI with Communication Manager

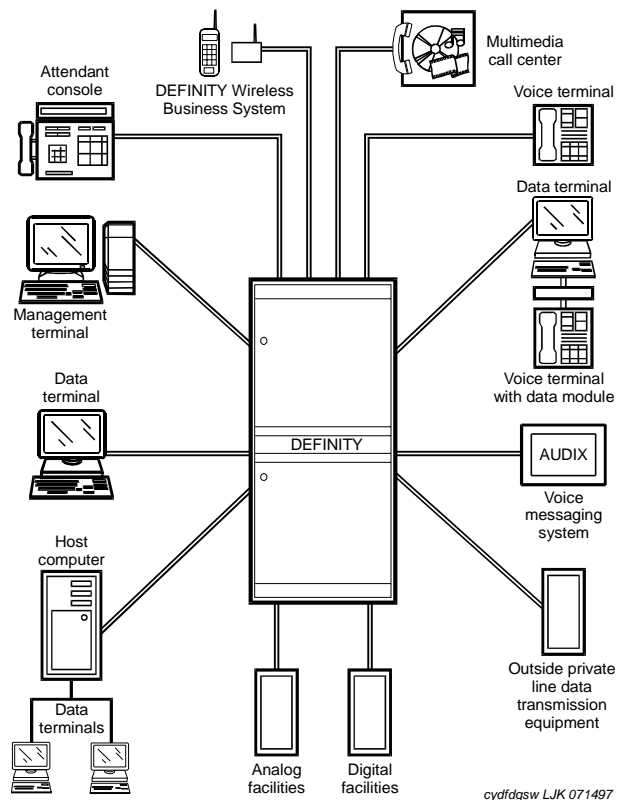

Detailed description

The DEFINITY Server SI with Avaya Communication Manager provides a common architecture platform across all supported line sizes. The Processor Port Network (PPN) is the master controller of the system. The Expansion Port Network (EPN) contains line ports and trunk ports. The universal port hardware allows station circuit packs, trunk circuit packs, and service circuit packs to be installed in any available slot.

DEFINITY Server SI with Communication Manager provides:

- Scalable applications for messaging, conferencing, collaboration, call centers, mobility, and remote users.
- Control of operational costs through the use of networking and management solutions
- A simple process for adding features. Add a circuit pack and use the graphical user interface (GUI) to administer it.
- Cost-effective and distributed switching arrangements in both LANs and WANs.
- Converged network environments through the use of IP and Asynchronous Transfer Mode (ATM) protocols and services
- Time Division Multiplex (TDM) transmission and switching infrastructures for both LANs and WANs. TDM supports analog, digital, and IP endpoints, both trunking and station, and an IP interface to a LAN or WAN.

Configuration information

The following are main system components:

- Avaya Communication Manager. For information about Avaya Communication Manager, see the Overview for Avaya Communication Manager, 555-233-767.
- A Processor Port Network (PPN) with a Switch Processing Element (SPE) and Port Network (PN).
- The 631DA power unit and 631DB power unit for AC power.
- The 649A power unit for DC power
- The Control Carrier
- The DEFINITY Server SI can use the following Media Gateways:
 - SCC1, including power supplies for AC power or DC power
[SCC1 Media Gateway](#) on page 150
 - MCC1, including power supplies for AC power or DC power
[MCC1 Media Gateway](#) on page 159
- Circuit Packs
 - The TN2404 processor
 - The TN2401 network control and packet interface (NetPkt)
 - TN768, TN780, or TN2182 tone clock

Each of the main components is described in the following section.

Processor Port Network and Switch Processing Element

The PPN is a DEFINITY Server SI configuration of carriers that contains the following control complex SPE of the system and port interfaces. The control complex consists of three circuit packs:

- The TN2404 RISC processor
- The TN2401 Network controller
- The TN2182, TN780 or TN768 tone clock board.

All of the control circuit packs reside in the control carrier within the PPN. Additional optional circuit packs might be needed such as the TN799DP C-LAN board which provides TCP/IP connectivity and the TN765 Processor Interface for BX.25 connectivity. For high- and critical-reliability systems, the TN792 Duplication Interface pack is used.

When a telephone goes off-hook or signals call initiation, the SPE receives a signal from the port circuit that is connected to the device. The digits of the called number are collected, and the switch is set up to make a connection between the calling device and the called devices.

The following figure shows a direct-connect system with an SPE in the PPN. Buses route voice and data calls between external trunks and external lines.

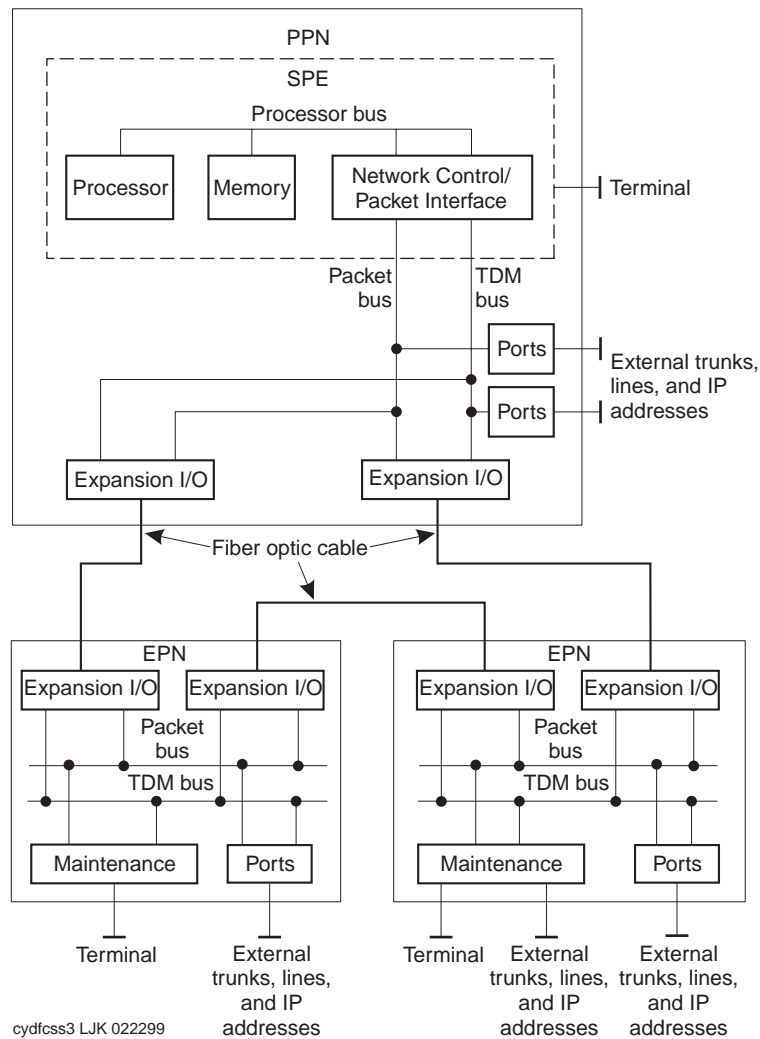
Figure 30: Components of a DEFINITY Server SI Configuration

Port Network

The Port Network (PN) consists of the following components:

- Time Division Multiplexing (TDM) bus:** The TDM bus has 484 time slots, 23 B channels, and 1 D channel available per bus. The TDM bus runs internally throughout each PN and terminates on each end. The TDM bus consists of two 8-bit parallel buses, bus A and bus B. Bus A and bus B carry switched digitized voice and data signals and control signals to all port circuits and between port circuits and the SPE. The port circuits place digitized voice signals and data signals on a TDM bus. Bus A and bus B are typically active simultaneously.
- Packet bus:** The packet bus runs internally throughout each PN and terminates on each end. The packet bus is an 18-bit parallel bus that carries logical links and control messages from the SPE, through port circuits, to endpoints such as terminals and adjuncts. The packet bus carries logical links for both on-switch and off-switch control between some specific port circuits in the system; for example, D-channels, X.25, and remote management terminals.

- *Port circuits*: The port circuits form analog/digital interfaces between the PN and external trunks and devices that provide links between these devices and the TDM bus and packet bus. Incoming analog signals are converted to pulse-code modulated (PCM) digital signals and placed on the TDM bus by port circuits. Port circuits convert outgoing signals from PCM to analog for external analog devices. All port circuits connect to the TDM bus. Only specific ports connect to the packet bus.
- *Interface circuits*: Interface circuits are types of port circuits that reside in the PPN and each EPN. Interface circuits terminate fiber optic cables that connect TDM buses and the packet bus from the PPN cabinet to the TDM bus and packet bus of each EPN cabinet.
- An Expansion Interface (EI) circuit pack also terminates:
 - Each end of a cable connecting the PPN to an EPN
 - Each end of a cable that connects an EPN to another EPN
 - The PN end of a cable connected between a PN carrier and an SN carrier.
- A Switch Node Interface (SNI) circuit pack terminates the SN carrier end of a cable that is connected between an SN carrier and a PN.
- Service circuits connect to an external terminal to monitor, maintain, and troubleshoot the system. Service circuits also provide tone production and detection, call classification, recorded announcements, and speech synthesis.

Carriers

Carriers hold circuit packs and connect them to power, the TDM bus, and the packet bus. There are five types:

- Control carrier (PPN cabinet only)
- Optional duplicated control carrier (PPN cabinet only)
- Optional port carrier (PPN and/or EPN cabinets)
- Optional expansion control carrier (EPN cabinets only)
- Optional switch node carrier (PPN and/or EPN cabinets)

Cabinets

The system cabinets contain the carriers and all other components, including the power supply. A cabinet contains at least one carrier in an enclosed shelf with vertical slots to hold circuit packs. The circuit packs fit into connectors that attach to the rear of the slots. There are two cabinet types:

- Single-carrier cabinet (SCC1)
- Multicarrier cabinet (MCC1)

Single-carrier cabinets

Up to three single-carrier cabinets (SCC1s) can be stacked to form a single PN. Refer to the following figure.

Single-carrier cabinets come in any of four configurations:

- A basic control cabinet that contains a TN2404 processor, tone clock, and a power converter
- An expansion control cabinet that contains additional port circuit packs, interfaces to the PPN, a maintenance interface, and a power converter
- A duplicated control cabinet that contains the same equipment as the basic control cabinet
- A port cabinet that contains port circuit packs and a power converter

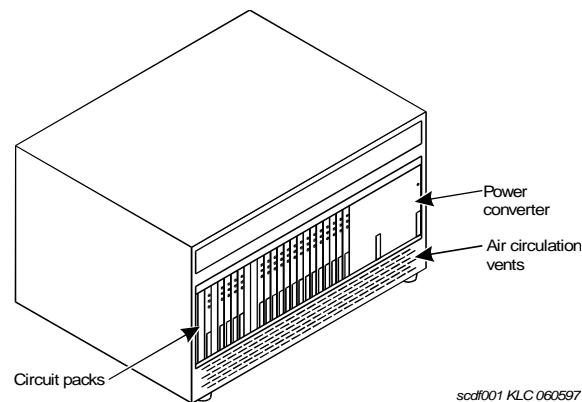
Figure 31: Typical single-carrier cabinet (SCC1)**Multicarrier cabinets**

A multicarrier cabinet (MCC1) is a 70-in. (178-cm) cabinet that has up to five carriers. See the following figure for an example of an MCC1. The following are the three types of multicarrier cabinets:

- A PPN cabinet that contains the ports, SPE, an interface to an EPN cabinet, and/or a CSS.
- An EPN cabinet that contains additional ports, interfaces to the PPN and other EPN cabinets, the maintenance interface, optional interfaces to other EPN cabinets, a switch node (in an SN in a CSS-connected system), or an ATM switch.
- An auxiliary cabinet that contains that is equipment used for optional, system-related hardware, such as rack-mounted equipment.

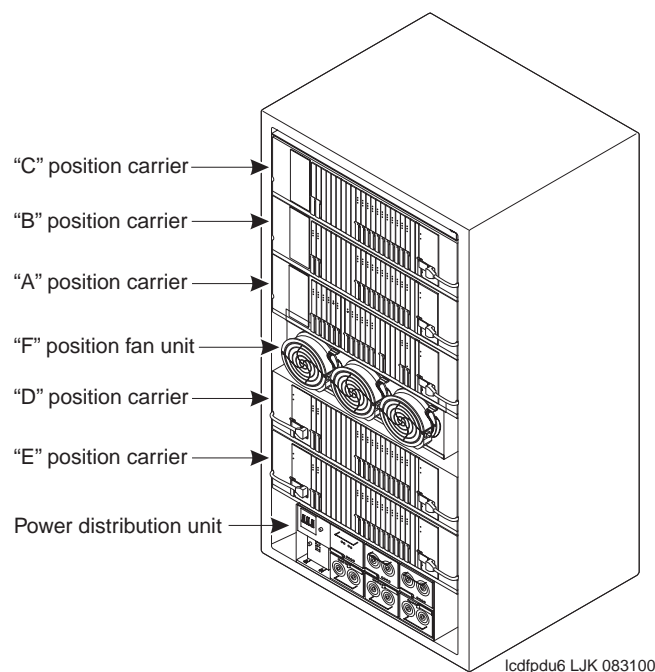
Figure 32: Typical multicarrier cabinet (MCC1)

Network Control and Packet Interface

The Network control and Packet interface communicates control channel messages between the processor circuit pack and the distributed network of port circuit packs on the TDM bus. The NetPkt circuit pack (TN2401) provides eight asynchronous data channels that process and route information directly from the processor circuit pack to customer-connected equipment.

Options

Expansion Port Network

An Expansion Port Network (EPN) contains additional ports that increase the number of connections to trunks and lines.

IP Media Processor

The IP Media Processor provides voice over internet protocol (VoIP) audio access to the switch for local stations and outside trunks. The IP Media Processor provides audio processing for between 32 and 64 voice channels and supports hairpin connections, as well as shuffling of calls between IP direct connections. The IP Media Processor can perform echo cancellation, silence suppression, FAX relay service, and DTMF detection. The IP Media Processor can be updated using the firmware download feature.

DEFINITY IP Solutions

DEFINITY IP Solutions brings together the flexibility of IP networks with the full feature functionality of Communication Manager. IP Solutions provides:

- Investment protection and optimization in IP and PSTN networks.
- Full software applications, features, and management capabilities are carried into the IP environment using Communication Manager.
- Enhanced quality of service
- Remote workers have full access to Communication Manager features from their PCs.

IP Solutions offers a feature that enables users to specify the quality of voice communications. With the Quality of Service feature, users can administer and download the Differentiated Services Type-of-Service value to optimize voice quality. The Quality of Service feature implements buffers in the audio-processing circuit pack to reduce latency and helps some routers to prioritize audio traffic.

IP Solutions also introduces hairpin and IP-IP direct connections, two features that make voice communications more efficient. Hairpin connections route the voice channel connecting two IP endpoints so that the voice goes through the IP Media Processor circuit pack in IP format, thereby bypassing the TDM bus. IP-IP direct connections route the voice channel connecting two IP endpoints by sending the voice directly through the LAN or WAN between the two endpoints, instead of carrying a mixed connection of IP signaling and TDM bus signaling

The following figure shows the trunk connects and line connections available with IP Solutions.

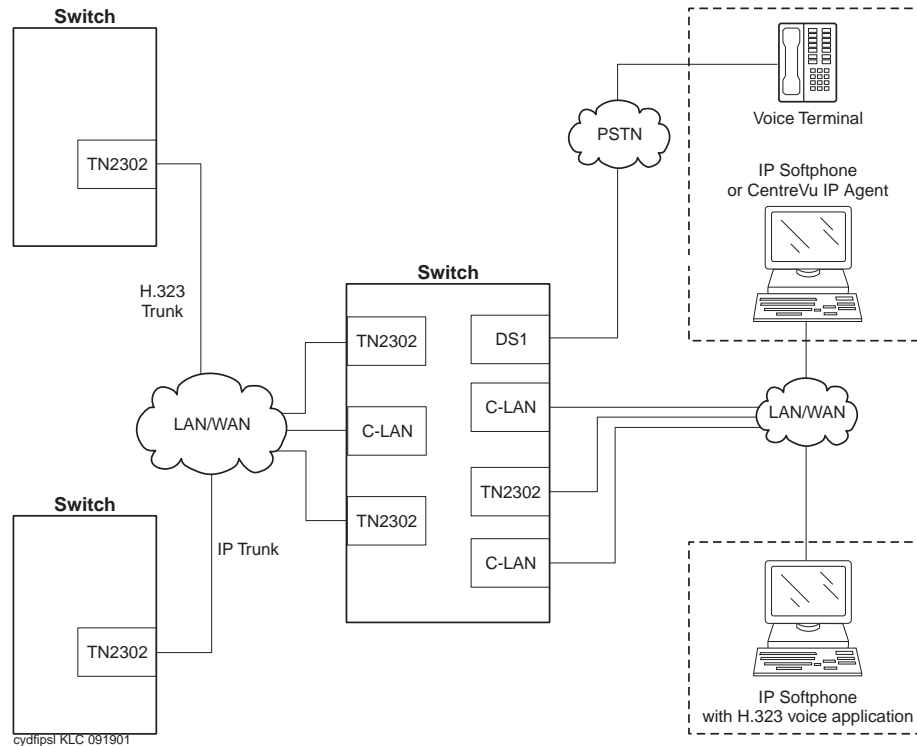
Figure 33: IP Solutions

The figure shows IP Solutions supports connectivity for IP trunks, IP softphones, and IP telephones.

DEFINITY IP Solutions is implemented using the TN2302AP, an IP Media Processor circuit pack inside the switch. The TN2302AP IP Media Processor provides H.323 trunk connections and H.323 voice processing for IP telephones. The features that use the TN2302AP circuit pack also require the TN799 C-LAN circuit pack.

NOTE:

The IP trunk that is used in R7 and the current TN2302AP H.323 trunks are not interoperable. The TN2302AP H.323 in trunk mode cannot communicate with an R7 IP trunk. However, the TN2302AP H.323 trunk can communicate with a TN802B circuit pack.

Trunks

DEFINITY IP Solutions supports two trunk configurations:

- H.323 IP trunk (IP Solutions mode)
- IP trunk mode

IP trunks reduce expenses for long distance voice and FAX, facilitating global communications, provide a full-function network with data and voice convergence, and use available network resources to optimize investments.

H.323 IP Trunk (IP Solutions mode)

The IP Media Processor circuit pack (TN2302AP) supports the H.323 version 2 protocol and operates with H.323 version 2 endpoints, including stations, trunks, and gateways. An IP Media Processor circuit pack uses IP connectivity between two DEFINITY or Avaya servers to enable H.323 trunk service using IP connectivity. H.323 trunk groups can be configured as DEFINITY-specific tie trunks that support:

- ISDN trunk features such as DCS+ and QSIG
- Generic tie trunks that permit interconnection with H.323 v2-compliant switches from other vendors
- Direct-inward-dial (DID) type of “public” trunks providing access to the switch for unregistered users.

The TN2302AP requires the TN799 for signaling.

The TN2302AP IP Media Processor is also used for H.323 VoIP applications.

IP Trunk mode

The IP Trunk mode allows trunk groups to be defined as DS1 tie lines between DEFINITY systems over a customer’s data network. Each IP Interface circuit pack in IP Trunk mode provides a basic 12-port package that can be expanded up to 30 ports.

Each TN802 or TN802B circuit pack in IP Trunk mode requires:

- A connection to a modem
- An incoming line for Avaya remote access
- Direct access to the NT server on the hard disk using pcANYWHERE, version 8 or later.

The TN2302AP circuit pack does not require:

- A connection to a modem
- An incoming line
- Access using pcANYWHERE.
- A TN799B circuit pack

Connectivity

LAN Gateway

With the optional J58890MA-1List 2 LAN Gateway circuit pack assembly installed, the switch works with PC/LAN-based communications applications that support the CallVisor Adjunct-Switch Application Interface (ASAI).

C-LAN

TCP/IP connectivity is provided over Ethernet or Point-to-Point Protocol (PPP) to adjuncts such as CMS or INTUITY™ AUDIX®, and for DCS connectivity. The C-LAN circuit pack (TN799DP) provides a “bridge” from the TDM bus to the packet bus on a DEFINITY server.

IP Asynchronous Links using C-LAN

The IP Asynchronous Links feature enables the switch to transfer existing asynchronous adjunct connectivity to an Ethernet network using TCP/IP protocol. IP Asynchronous Links is a simple, session-layer, proprietary protocol that creates value for the customer in the following ways:

- Reduces the cost to connect the switch to various adjuncts
- Allows for an open architecture to transport information and increases the speed at which data is transferred
- Allows customers to manage applications from both on site and remote locations
- Allows for several system management applications to run on a single PC and thus reducing hardware requirements
- Provides “IP Services” forms to support more flexible administration
- Guarantees data delivery through a reliable session-layer protocol
- Supports customers’ existing investment in serial hardware through use of Network Terminal Servers

IP Asynchronous Links supports switch client applications and server applications as described in the following sections.

Switch Client Applications

Client applications with Asynchronous Links allow you to use TCP/IP to connect adjunct equipment to the switch via the C-LAN board.

Asynchronous TCP/IP links can be used to connect call detail recording (CDR) devices, property management systems (PMS) and printers. Maintenance parameters can be set to allow the switch to report alarms over a TCP/IP link.

A device that does not support a direct TCP/IP connection, but that does support an RS232 interface, can connect to the C-LAN board through a terminal server or router.

Switch Server Applications

IP Asynchronous Links provides a telnet server to interconnect C-LAN Ethernet clients to system management applications on the switch via TCP/IP or TCP/IP and RS232 signals. IP Asynchronous Links supports the following server applications:

- System administration terminal (SAT)
- Avaya Site Administration (formerly DEFINITY Site Administration, or DSA)
- DEFINITY Network Management (DNM)
- Proxy Agent
- Enterprise Directory Gateway

Server applications send data to the switch, and the telnet server supports 80 kbps data throughput. Current application screen interactions, and current simultaneous session limits on the switch are also supported. The telnet server satisfies all current terminal emulation modes for example, 51x, 4410, 4425, vt220, hp262x, and pctt.

Access security for system management applications over TCP/IP is provided by the existing Access Security Gateway (ASG) feature. Through either a local or a remote node or port, users can specify the remote client IP address and port number from which the switch can accept service requests. ASG must be enabled on the system-parameters customer-options form. ASG must also be enabled for at least one customer login. The user can administer a timeout period that ranges from 5 to 999 minutes, but there is currently no provision for data encryption over the LAN.

Reliability

Duplication is a strategy to create fully redundant systems that are highly reliable. Duplication minimizes single failure points that can interrupt call processing. Three options are available for system reliability and duplication:

- Standard reliability – does not duplicate the tone clocks, the control carrier, or any inter-PN connectivity.
- High reliability – duplicates the hardware that is associated with the SPE. The Control Carrier is duplicated, which provides duplicate SPEs and tone clocks. Inter-PN connectivity and EPN tone clocks are not duplicated. The strategy is to duplicate items that are associated with the SPE so that a single fault will not cause the loss of the SPE.
- Critical reliability – requires the full duplication of the SPE, inter-PN connectivity, and the tone clocks.

As duplication increases, the maximum number of port carriers and port circuit packs per cabinet decreases.

BHCCI

The following table shows busy-hour call completion capacities for DEFINITY Server SI.

Type of call	DEFINITY Server SI
All analog	20,000
General business	20,000
ISDN	20,000
ACD	20,000
ICM	20,000
OCM	20,000
CTI/ASAI	20,000
Wireless	20,000
IP telephones, non-IP trunks	18,000
DCP telephones, IP trunks	13,500
IP telephones, IP trunks	7,500

Adjuncts

The following is a partial list of the adjuncts that Avaya provides:

- Voice messaging and response such as INTUITY AUDIX
- Call center tools such as Avaya Call Management System, NICE Analyzer, Avaya Call Recording, Avaya Visual Vectors and Avaya Basic Call Management System Reporting Desktop
- System printer
- Journal printer
- Call Accounting Systems
- Call Detail Recording (CDR)
- Avaya Site Administration (ASA)
- DEFINITY Network Management (DNM)
- DEFINITY Translator ATM Manager (DTA)

DEFINITY Server R

Overview

NOTE:

The UN331C processor server circuit pack used in The DEFINITY Server R will not be sold after November 3, 2003. The UN331C processor server circuit pack cannot be upgraded to Avaya Communication Manager 2.0, but upgrades to Avaya Communication Manager 1.3.x will be sold until November, 2004. Please consult "Upgrades and Additions for Avaya DEFINITY Server R," 555-233-115, for information about upgrading to Communication Manager 1.3.

Avaya Communication Manager on a DEFINITY[®] Server R offers a high-level operating system, open interfaces, and distributed processing. DEFINITY Server R provides circuit-switched voice communications and Internet Protocol (IP) telephony including voice and data network integration, unified messaging, and multimedia conferencing and collaboration. Because DEFINITY Server R is part of Avaya's Enterprise Class IP Solutions family, it is designed to work with other Avaya products to create a complete IP solution.

All major hardware is contained in a multicarrier cabinet (MCC1) that hold up to five carriers or stackable single-carrier cabinets (SCC1s). The solution enables high-speed connections between analog and digital trunks, data lines connected to host computers, data-entry terminals, personal computers, and IP network addresses. See the following figure for an example of a DEFINITY Server R solution.

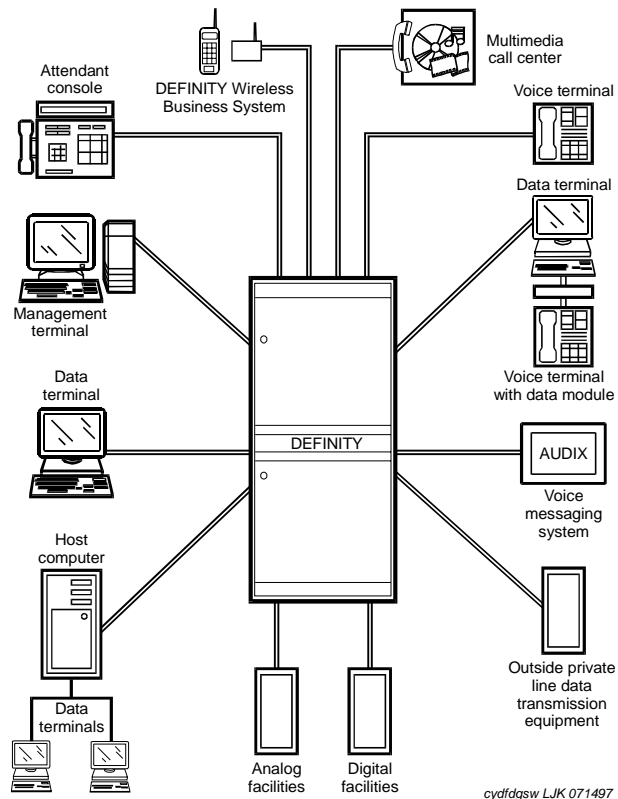
Figure 34: DEFINITY Server R

Detailed description

The DEFINITY Server R with Avaya Communication Manager, provides a common architecture platform across all supported DEFINITY product lines. It gives large customers with multiple locations the same user and administration interfaces across their enterprise network including international locations.

DEFINITY Server R provides:

- Scalable applications for messaging, conferencing, collaboration, call centers, mobility, and remote users.
- Control of operational costs through the use of networking and management solutions
- A simple process for adding features. Add a circuit pack and use the graphical user interface (GUI) to administer it.
- Cost-effective and distributed switching arrangements in both LANs and WANs.
- Converged network environments through the use of IP and Asynchronous Transfer Mode (ATM) protocols and services.
- Time Division Multiplex (TDM) transmission and switching infrastructures for both LANs and WANs. TDM supports analog, digital, and IP endpoints, both trunking and station, and an IP interface to a LAN or a WAN.

Configuration information

The DEFINITY Server R contains the following main components:

- Avaya Communication Manager: For information about Avaya Communication Manager, see the Overview for Avaya Communication Manager, 555-233-767.
- Processor Port Network (PPN) with a Switch Processing Element (SPE) and Port Network (PN).
- The 631DA power unit and 631DB power unit for AC power.
- The 649A power unit for DC power.
- The Control Carrier
- The DEFINITY Server R can use the following Media Gateways:
 - MCC1 Media Gateway- including power supplies for AC power or DC power [MCC1 Media Gateway](#) on page 159
 - SCC1 Media Gateways- including power supplies for AC power or DC power [SCC1 Media Gateway](#) on page 150
- Circuit packs
 - The UN331C processor
 - Four TN1650 memory circuit packs
 - A TN1648 SYSAM
 - A TN1655 packet interface
 - A UN332C mass storage system and network control (MSS/NET CONT)
 - The TN2211 optical drive
 - The TN1657 disk drive
 - The TN768, TN780, or TN2182 tone clock

Each of the main components, is described in the following section.

Processor Port Network and Switch Processing Element

The Processor Port Network (PPN) is a DEFINITY configuration of carriers that contains the control complex SPE of the system and port interfaces. The control complex consists of:

- the UN331C processor, four TN1650 memory packs
- A TN1648 SYSAM board, a TN1655 packet interface
- A UN332C suffix mass storage system and network control board
- A TN 2211 optical drive
- A TN1657 disk drive
- A TN768, TN780 or TN2182 tone clock.

Additional optional circuit packs might be needed such as the UN330B for duplication interface in high- and critical-reliability systems.

When a device such as a telephone, goes off-hook or signals call initiation, the SPE receives a signal from the port circuit that is connected to the device. The digits of the called number are collected, and the switch is set up to make a connection between the calling and the called devices.

The following figure shows a direct-connect system with an SPE in the PPN. Buses route voice calls and data calls between external trunks and external lines.

Figure 35: Components of a DEFINITY Server R

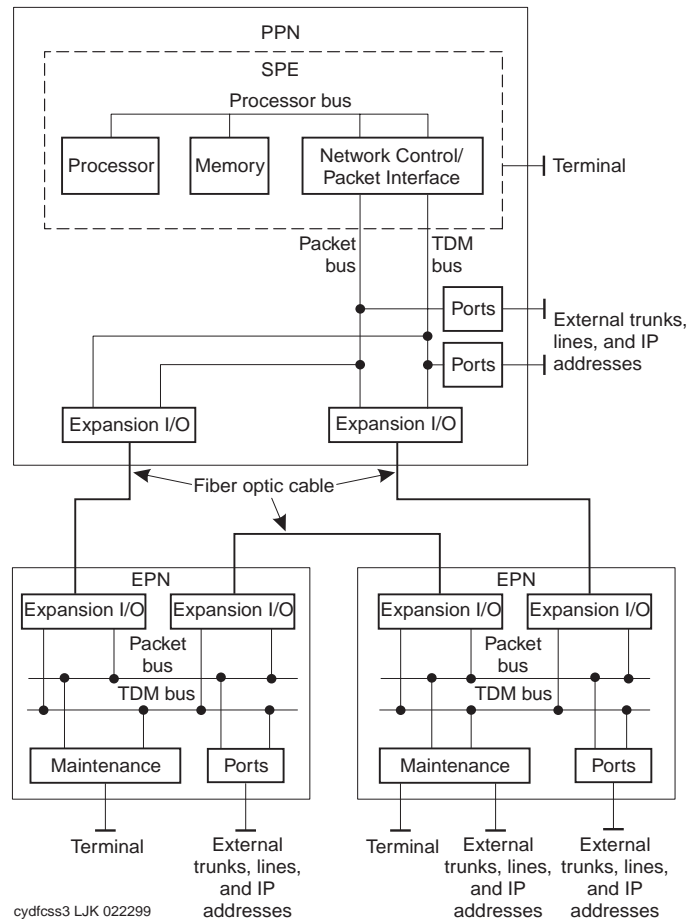

Port network

A port network (PN) consists of the following components:

- **Time Division Multiplexing (TDM) bus:** The TDM bus has 484 time slots, 23 B channels, and 1 D channel available per bus. The TDM bus runs internally throughout each PN and terminates on each end. The TDM bus consists of two 8-bit parallel buses, bus A and bus B. Bus A and bus B carry switched digitized voice and data signals and control signals to all port circuits and between port circuits and the SPE. The port circuits place digitized voice signals and data signals on a TDM bus. Bus A and bus B are typically active simultaneously.
- **Packet bus:** The packet bus runs internally throughout each PN and terminates on each end. The packet bus is an 18-bit parallel bus that carries logical links and control messages from the SPE, through port circuits, to endpoints such as terminals and adjuncts. The packet bus carries logical links for both on-switch and off-switch control between some specific port circuits in the system; for example, D-channels, X.25, and remote management terminals.

- *Port circuits:* The port circuits form analog/digital interfaces between the PN and external trunks and devices that provide links between these devices and the TDM bus and packet bus. Incoming analog signals are converted to pulse-code modulated (PCM) digital signals and placed on the TDM bus by port circuits. Port circuits convert outgoing signals from PCM to analog for external analog devices. All port circuits connect to the TDM bus. Only specific ports connect to the packet bus.
- *Interface circuits:* Interface circuits are types of port circuits that reside in the PPN and each EPN. Interface circuits terminate fiber optic cables that connect TDM buses and the packet bus from the PPN cabinet to the TDM bus and packet bus of each EPN cabinet.

Carriers

Carriers hold circuit packs and connect them to power, the TDM bus, and the packet bus. There are five types:

- Control Carrier (PPN cabinet only)
- Optional Duplicated Control Carrier (PPN cabinet only)
- Optional port carrier (PPN and/or EPN cabinets)
- Optional expansion control carrier (EPN cabinets only)
- Optional switch node carrier (PPN and/or EPN cabinets)

Cabinets

The system cabinets contain the carriers and all other components, including the power supply. A cabinet contains at least 1 carrier in an enclosed shelf with vertical slots to hold circuit packs. The circuit packs fit into connectors that attach to the rear of the slots. There are two cabinet types:

- Single-carrier cabinet (SCC1)
- Multicarrier cabinet (MCC1)

Single-carrier cabinets

Up to four single-carrier cabinets (SCC1s) can be stacked to form a single PN.

Single-carrier cabinets come in any of four configurations:

- An expansion control cabinet that contains additional port circuit packs, interfaces to the PPN, a maintenance interface and a power converter
- A port cabinet that contains port circuit packs and a power converter
- See the following figure for an example of a SCC1.

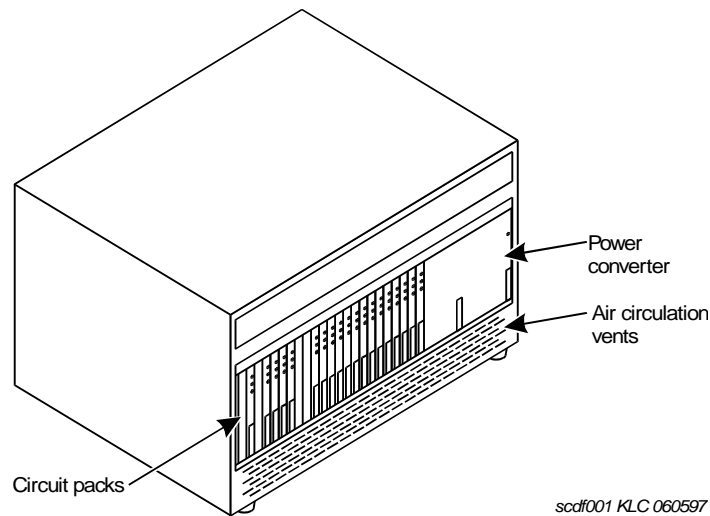
Figure 36: Typical single-carrier cabinet (SCC1)

Multicarrier cabinets

A multicarrier cabinet (MCC1) is a 70-inch (178-cm) cabinet that has up to five carriers. The three types of multicarrier cabinets are as follows:

- A PPN cabinet contains the ports, SPE, an interface to an EPN cabinet, or a CSS.
- An EPN cabinet contains additional ports, interfaces to the PPN and other EPN cabinets, the maintenance interface, optional interfaces to other EPN cabinets, a switch node in an SN in a CSS-connected system, or an ATM switch.
- Auxiliary cabinet contains equipment used for optional, system-related hardware, such as rack-mounted equipment.

See the following figure for an example of a typical MCC1.

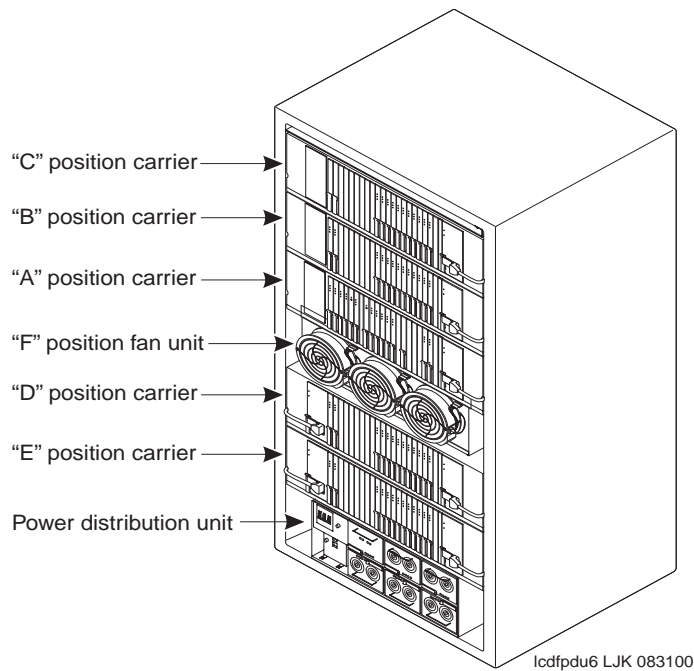
Figure 37: Typical multicarrier cabinet (MCC1)***Expansion port network***

An optional expansion port network (EPN) contains additional ports that increase the number of connections to trunks and lines. An EPN can be configured to provide service to users when the fiber or T1/E1 link to the main processor fails or is severed, or when the processor or center stage fails. This service requires that special standby remote-processor equipment be collocated with the EPN to provide SPE processor capabilities to the EPN.

Avaya MultiVantage applications

Avaya's MultiVantage applications bring together the flexibility of IP networks with the full feature functionality of Communication Manager. MultiVantage applications provide:

- Investment protection and optimization in IP and PSTN networks.
- Full software applications, features, and management capabilities are carried into the IP environment using Communication Manager.
- Enhanced quality of service
- Remote workers have full access to Communication Manager features from their PCs.

Avaya's portfolio of MultiVantage applications enables users to specify the quality of voice communications. Using the Quality of Service feature, users can administer and download the Differentiated Services Type-of-Service value to optimize voice quality. The Quality of Service feature implements buffers in the audio-processing circuit pack to reduce latency and help some routers to prioritize audio traffic.

MultiVantage applications provide hairpinned and IP-to-IP direct connections to improve the efficiency of voice communications. Hairpinned connections route the voice channel connecting two IP endpoints so that the voice goes through the IP Media Processor circuit pack in IP format, thereby bypassing the

TDM bus. IP-to-IP direct connections route the voice channel connecting two IP endpoints by sending the voice directly through the LAN or WAN between the two endpoints, instead of carrying a mixed connection of IP signaling and TDM-bus signaling.

The following figure shows the trunk connects and line connections available with Avaya's MultiVantage applications.

Figure 38: IP solutions

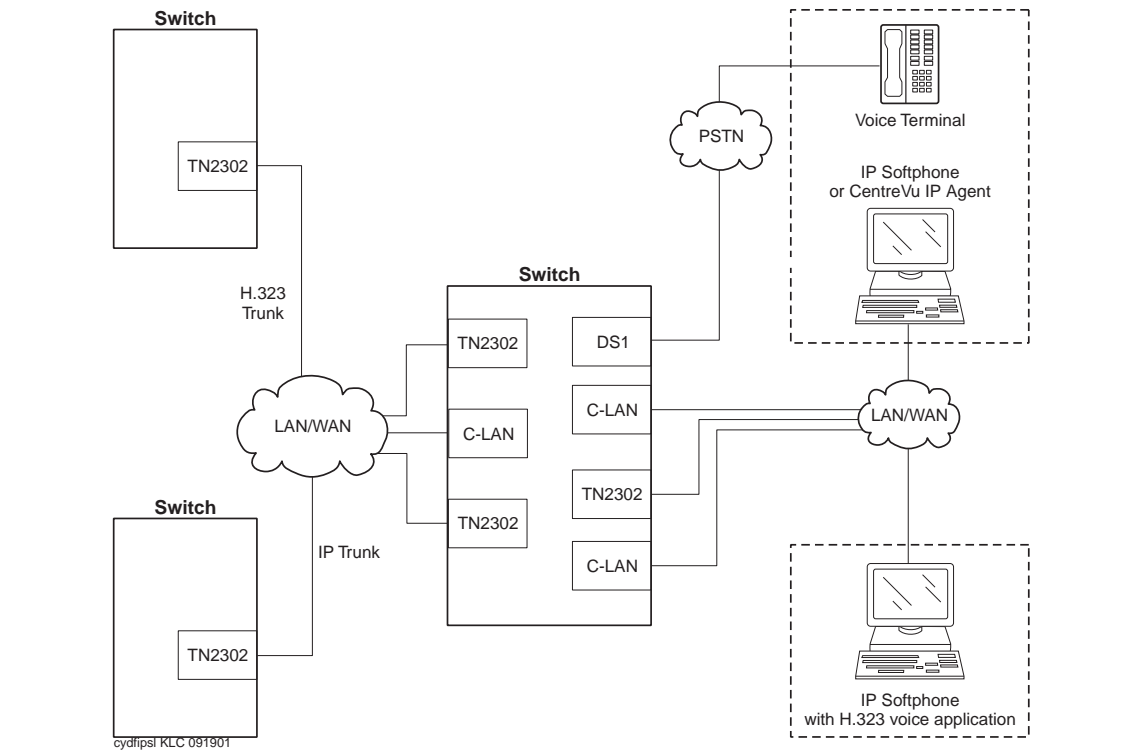

As the The figure shows IP Solutions supports connectivity for IP trunks, IP softphones, and IP telephones.

DEFINITY IP Solutions is implemented using the TN2302AP, an IP Media Processor circuit pack inside the switch. The TN2302AP IP Media Processor provides H.323 trunk connections and H.323 voice processing for IP telephones. The features that use the TN2302AP circuit pack also require the TN799 C-LAN circuit pack.

NOTE:

The IP trunk that is used in R7 and the current TN2302AP H.323 trunks are not interoperable. The TN2302AP H.323 in trunk mode cannot communicate with an R7 IP trunk. However, the TN2302AP H.323 trunk can communicate with a TN802B circuit pack.

Trunks

DEFINITY IP Solutions supports two trunk configurations:

- H.323 IP trunk (IP Solutions mode)
- IP trunk mode

IP trunks reduce expenses for long distance voice and FAX, facilitating global communications, provide a full-function network with data and voice convergence, and use available network resources to optimize investments.

H.323 IP Trunk (IP Solutions mode)

The IP Media Processor circuit pack (TN2302AP) supports the H.323 version 2 protocol and operates with H.323 version 2 endpoints, including stations, trunks, and gateways. An IP Media Processor circuit pack uses IP connectivity between two DEFINITY or Avaya servers to enable H.323 trunk service using IP connectivity. H.323 trunk groups can be configured as DEFINITY-specific tie trunks that support:

- ISDN trunk features such as DCS+ and QSIG
- Generic tie trunks that permit interconnection with H.323 v2-compliant switches from other vendors
- Direct-inward-dial (DID) type of “public” trunks providing access to the switch for unregistered users.

The TN2302AP requires the TN799 for signaling.

The TN2302AP IP Media Processor is also used for H.323 VoIP applications.

IP Trunk mode

The IP Trunk mode allows trunk groups to be defined as DS1 tie lines between DEFINITY systems over a customer’s data network. Each IP Interface circuit pack in IP Trunk mode provides a basic 12-port package that can be expanded up to 30 ports.

Each TN802 or TN802B circuit pack in IP Trunk mode requires:

- A connection to a modem
- An incoming line for Avaya remote access
- Direct access to the NT server on the hard disk using pcANYWHERE, version 8 or later.

The TN2302AP circuit pack does not require:

- A connection to a modem
- An incoming line
- Access using pcANYWHERE.
- A TN799B circuit pack

Connectivity

The following sections describe connectivity using TCP/IP, CSS and ATM.

Connectivity using TCP/IP

LAN Gateway With the optional J58890MA-1List 2 LAN Gateway circuit pack assembly installed, the switch works with PC/LAN-based communications applications that support the CallVisor Adjunct-Switch Application Interface (ASAI).

C-LAN TCP/IP connectivity is provided over Ethernet or Point-to-Point Protocol (PPP) to adjuncts such as CMS or INTUITY™ AUDIX®, and for DCS connectivity. The C-LAN circuit pack (TN799DP) provides a “bridge” from the TDM bus to the packet bus on a DEFINITY server.

IP Asynchronous Links using C-LAN The IP Asynchronous Links feature enables the switch to transfer existing asynchronous adjunct connectivity to an Ethernet network using TCP/IP protocol. IP Asynchronous Links is a simple, session-layer, proprietary protocol that creates value for the customer in the following ways:

- Reduces the cost to connect the switch to various adjuncts
- Allows for an open architecture to transport information and increases the speed at which data is transferred
- Allows customers to manage applications from both on site and remote locations
- Allows for several system management applications to run on a single PC and thus reducing hardware requirements
- Provides “IP Services” forms to support more flexible administration
- Guarantees data delivery through a reliable session-layer protocol
- Supports customers’ existing investment in serial hardware through use of Network Terminal Servers

IP Asynchronous Links supports switch client applications and server applications as described in the following sections.

Switch client applications Client applications with Asynchronous Links allow you to use TCP/IP to connect adjunct equipment to the switch via the C-LAN board.

Asynchronous TCP/IP links can be used to connect call detail recording (CDR) devices, property management systems (PMS) and printers. Maintenance parameters can be set to allow the switch to report alarms over a TCP/IP link.

A device that does not support a direct TCP/IP connection, but that does support an RS232 interface, can connect to the C-LAN board through a terminal server or router.

Switch server applications IP Asynchronous links provide a telnet server to interconnect C-LAN Ethernet clients to system management applications on the switch via TCP/IP or TCP/IP and RS232 signals. IP Asynchronous Links supports the following server applications:

- System administration terminal (SAT)
- Avaya Site Administration (formerly DEFINITY Site Administration, or DSA)
- DEFINITY Network Management (DNM)
- Proxy agent
- Enterprise Directory Gateway

Server applications send data to the switch, and the telnet server supports 80 kbps data throughput. Current application screen interactions, and current simultaneous session limits on the switch are also supported. The telnet server satisfies all current terminal emulation modes for example, 51x, 4410, 4425, vt220, hp262x, and ptt.

Access security for system management applications over TCP/IP is provided by the existing Access Security Gateway (ASG) feature. Through either a local or a remote node or port, users can specify the remote client IP address and port number from which the switch can accept service requests. ASG must be enabled on the system-parameters customer-options form. ASG must also be enabled for at least one customer login. The user can administer a timeout period that ranges from 5 to 999 minutes, but there is currently no provision for data encryption over the LAN.

Center stage switch

A Center stage switch (CSS) is optional for three PNs or less in the DEFINITY Server R. The CSS is the central interface between the PPN and the EPNs. The CSS consists of one, two, or three switch nodes (SN). One SN can expand the system from 1 EPN to up to 15 EPNs. Two SNs can expand the system to up to 29 EPNs. Three SNs can expand the system to up to 43 EPNs.

NOTE:

The number of EPNs that can be connected with two or three SNs might be less than the numbers given, depending on the internal SN-to-SN traffic.

The following figure shows a system with the added CSS to route voice calls and data calls between external trunks and external lines.

Figure 39: Components of a CSS-connected system

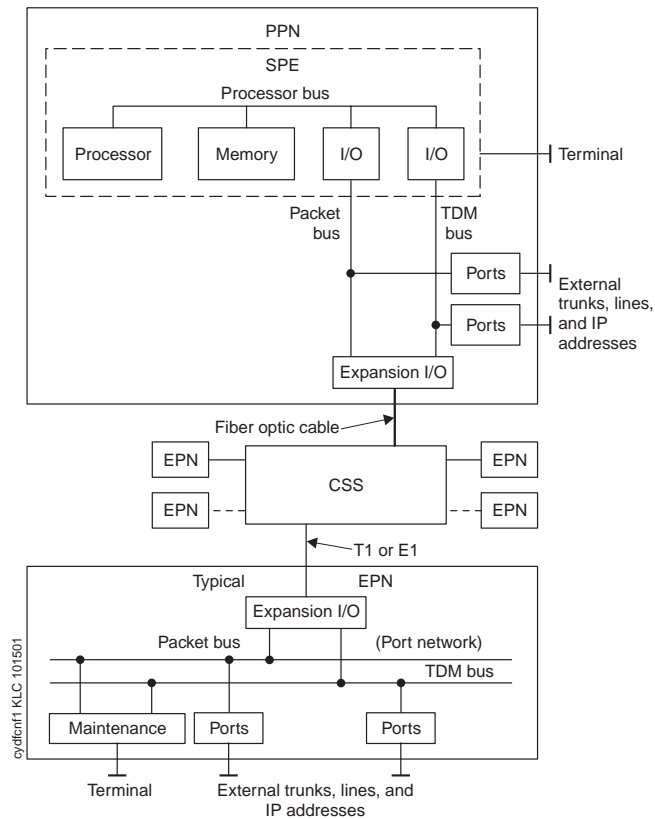

The following figure shows the CSS that links the PPN to EPNs by the SNI circuit packs in an SN carrier. An SN acts as a hub to distribute cables and thus reduces the amount of interconnect cabling between the PPN and the EPNs.

A system that uses a CSS can connect from 3 to 43 PNs. The CSS can consist of up to three SN carriers. The CSS can also consist of two, four, or six SN duplicated carriers in a critical-reliability system.

Each SN contains from 1 to 16 SNI circuit packs. Each interface uses fiber-optic cable to connect to a PPN or to a SN. One interface always connects to the PPN and one connects to each EPN.

Figure 40: CSS with Switch Nodes (SNs)

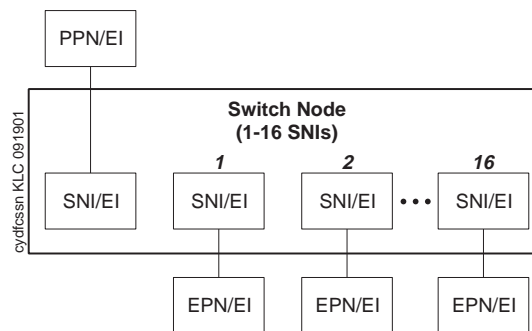

In a high-reliability system with a duplicated processor, two SNI circuit packs connect to the PPN. Depending on the chosen configuration this allows up to 15 PNs to connect to one SN, up to 29 PNs to connect to two SNs, and up to 43 PNs to connect to three SNs.

Connecting with ATM

ATM switch The Asynchronous Transfer Mode (ATM) switch is a replacement option for the CSS. Several Avaya ATM switch types can provide switch port network connectivity. Non-Avaya ATM switches that comply with the ATM standards set by the ITU can also provide port network connectivity. In this configuration, TN2305 multi-mode or TN2306 single-mode ATM circuit packs are installed on the port networks and connected to the ATM switch with the multi- or single-mode fiber that is specified for the ATM switch.

NOTE:

The components of an ATM-connected system are similar to those shown in the previous figure. However, in an ATM-connected system, the CSS is replaced with an ATM switch or switches and each expansion I/O is replaced with a TN2305 circuit pack or TN2306 circuit pack.

ATM-PNC ATM port network connectivity (ATM-PNC) provides an alternative to the CSS configurations for connecting the PPN to one or more EPNs. ATM-PNC replaces the CSS in a DEFINITY Server R network with an ATM switch or network. ATM-PNC is available with all three reliability options—standard, high, and critical. An ATM-PNC also offers duplication.

ATM-PNC integrates delivery of voice, video, and data via ATM over a converged large-bandwidth network, thus ATM-PNC provides reduced infrastructure cost and improved network manageability. ATM-PNC uses standards-based open interfaces that can be provisioned with either new DEFINITY Server or existing DEFINITY systems.

ATM-CES ATM Circuit-Emulation Service (CES) lets the switch emulate ISDN-PRI trunks on an ATM facility. These virtual trunks can serve as integrated access, tandem, or tie trunks. ATM-CES trunk emulation consolidates trunking to maximize port network capacities. For example, the CES interface can define up to 10 virtual circuits for tie-line connectivity, and consolidates network connectivity that typically requires multiple circuit packs into one circuit card.

ATM WAN Spare Processors An ATM WAN Spare Processor (WSP) provides a disaster recovery option for DEFINITY Server R expansion port networks that are deployed over an ATM WAN. An ATM WSP acts as a PPN in the event of a catastrophic failure in the network. That is, a WSP functions as a PPN if the main PPN is not functional or is not communicating to one or more of the other EPNs.

DEFINITY Server R is highly reliable, but when DEFINITY Server R overlays a converged network infrastructure, the reliability and availability depend on the entire infrastructure, not just its own hardware and software of the switch. ATM WSPs can be placed in a switch, ATM port network configuration to provide a backup arrangement of PPNs, and thus maintain the availability of the features and functions of the switch

A WSP continually monitors a connection to the main PPN to determine if the PPN is actively communicating with the EPNs. From 1 to 15 WSPs can be established in an ATM port network, and each is given a priority role to avoid its contending with other EPNs for control. Each WSP will become active if the WSP cannot establish communications with both the main PPN and a WSP of higher priority. The WSP will wait an administered interval of 5 to 99 minutes and then take control within approximately 15 minutes. Although calls are not preserved while the switch takes place, the WSP enables customers to be back in service within a reasonable amount of time.

Returning to normal operation under control of the PPN requires a manual restart sequence. When control is returned to the PPN, the WSP returns to a standby status. Calls are not preserved during the return to normal operation; you may therefore want to schedule the return to normal operation for a time when it will be least disruptive.

NOTE:

ATM WSPs cannot be used for critical reliability switches. It also cannot be used with a conventional CSS.

Reliability

Duplication is a strategy to create fully redundant systems that are highly reliable. Duplication minimizes single failure points that can interrupt call processing. Four options are available for system reliability and duplication:

- Standard reliability – does not duplicate the tone clocks, the control carrier, or any inter-PN connectivity.
- High reliability – duplicates the hardware that is associated with the SPE. The Control Carrier is duplicated, which provides duplicate SPEs and tone clocks. Inter-PN connectivity and EPN tone clocks are not duplicated. The strategy is to duplicate items that are associated with the SPE so that a single fault will not cause the loss of the SPE.
- Critical reliability – requires the full duplication of the SPE, inter-PN connectivity, and the tone clocks.
- ATM Network Duplication – requires full duplication of the inter-PN connectivity and the tone clocks.

As duplication increases, the maximum number of port carriers and port circuit packs per cabinet decreases.

BHCC

The following table shows busy-hour call-completion (BHCC) capacities:

Type of call	DEFINITY Server R
All analog	135,000
General business	100,000
ISDN	40,000
ACD	70,000
ICM	30,000
OCM	44,000
CTI/ASAI	70,000
Wireless	70,000
IP telephones, non-IP trunks	24,000
DCP telephones, IP trunks	18,000
IP telephones, IP trunks	10,000

Adjuncts

The following is a partial list of the adjuncts that Avaya provides:

- Voice messaging and response such as INTUITY AUDIX
- Call center tools such as Avaya Call Management System, NICE Analyzer, Avaya Call Recording, Avaya Visual Vectors and Avaya Basic Call Management System Reporting Desktop
- System printer
- Journal printer
- Call Accounting Systems
- Call Detail Recording (CDR)
- Avaya Site Administration (ASA)
- DEFINITY Network Management (DNM)
- DEFINITY Translator ATM Manager (DTA)

Media gateways

Avaya G350 Media Gateway

The Avaya G350 Media Gateway forms part of Avaya Enterprise Connect, Avaya's solution for extending communication capabilities from the headquarters of an organization to all collaborative branch locations. Avaya Enterprise Connect helps you provide the same high quality services to all organization members regardless of their location.

The G350 is a high-performance converged telephony and networking device that sits in a small branch location, providing all infrastructure needs in one box — telephone exchange and data networking. The G350 is designed for use in a 16-24 user environment but can support up to 40 users. The G350 features a VoIP engine, WAN router and Power over Ethernet LAN switch and provides full support for legacy digital and analog telephones.

The G350 integrates seamlessly with Avaya media servers S8700, S8500 and S8300 running Avaya Communication Manager call processing software to provide the same top quality telephony services to the small branch office as to the headquarters of the organization. The media server can be located at the headquarters and serve the G350 remotely.

The G350 can optionally house an internal Avaya S8300 media server as a local survivable processor or as the main media server for standalone deployment.

In addition to advanced and comprehensive telephony services, the G350 provides full data networking services, precluding the need for a WAN router or LAN switch.

The G350 is a modular device, adaptable to support different combinations of endpoint devices. Pluggable media modules provide interfaces for different types of telephones and trunks. A combination is selected to suit the needs of the branch.

A LAN media module with PoE standard compliant Ethernet ports provides support for IP telephones as well as all other types of data devices. A range of telephony modules provides full support for legacy equipment such as analog and digital telephones..

NOTE:

The G350 Media Gateway does not support Call Center. Customers who require Call Center should purchase the G700 Media Gateway.

Features

The G350 features:

- VoIP Media Gateway services
- Survivability features for continuous voice services
- WAN connectivity
- WAN routing

- Power-over-Ethernet LAN Switching
- Support for traditional telephones and trunks.

Deployment modes

The G350 is a modular device with multiple configuration possibilities to meet specific individual needs. Six slots in the G350 chassis house a customized selection of media modules, which connect to different types of circuit switched phones, trunks and data devices. One of the slots can house an internal media server. A major configuration choice is of which type of media server to deploy. The media server may be a media module or a standalone device.

The G350 can be deployed in one of two basic working modes:

- **Distributed Avaya Enterprise Connect.** In this mode, the G350 is controlled by an external media server. This may be a standalone media server, such as the S8500 or the S8700, or a separate media gateway in a standalone configuration. The G350 may also house an S8300 Media Server module to function as a Local Survivable Processor (LSP), which can take over control of the G350 if the external media server stops serving the G350.
- **Standalone.** In this mode, the G350 is controlled by an internally housed S8300 Media Server module.

Multiple G350s may be deployed in many remote branches of a large organization. Large branches or main offices may deploy an Avaya G700 Media Gateway, which provides similar functionality to the G350 for a larger number of users. Up to 250 G350 and G700 Media Gateways may be controlled by a single external S8700 Media Server.

Physical description

The following figure shows the G350 chassis.

Figure 41: G350 chassis

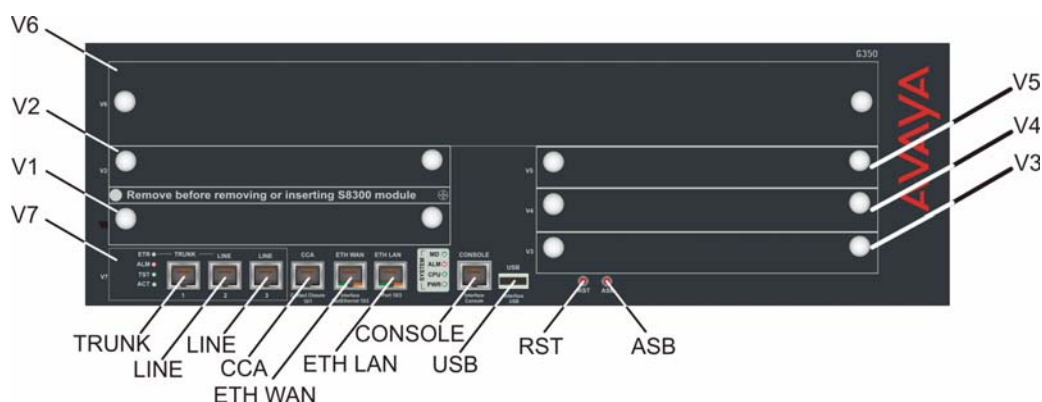

Table 4: Ports on the G350 chassis

Port	Description
TRK	An analog trunk port. Part of an integrated analog media module.
LINE 1, LINE 2	Analog telephone ports of the integrated analog media module. An analog relay between TRK and LINE 1 provides Emergency Transfer Relay (ETR) feature.
CC	RJ-45 port for ACS (308) contact closure adjunct box.
WAN 1	RJ-45 10/100 Base TX Ethernet port.
LAN 1	RJ-45 Ethernet LAN switch port.
CON	Console port for direct connection of CLI console. RJ-45s connector.
USB	USB port, not supported in this release.

Table 5: Buttons on the G350

Button	Description
RST	Reset button. Resets chassis configuration.
ASB	Alternate Software Bank button. Reboots the G350 with the software image in the alternate bank.

G350 capabilities

The following table outlines the capacities of various G350 services.

Description	Capacity*	Comments
Media Gateway Limits		
Maximum number of G350 Media Gateways controlled by an external S8300, S8500, or S8700 Media Server	250	This number also applies if a combination of Avaya G700 Media Gateways and G350 Media Gateways are controlled by the same external media server.
Maximum number of G350 Media Gateways controlled by a S8300 media server installed in an external media gateway.	50	
VoIP		
Maximum number of IP telephones	40	Limited by the number of VoIP resources used and the calling patterns (VoIP to VoIP conferencing, VoIP to non-VoIP etc.)

Description	Capacity*	Comments
Simultaneous two-way conversations from IP phone to legacy telephone or trunk.	32 – G.711 16 – G.729a/G723	Simultaneous two-way conversations limited by the VoIP engine, including call progress tones.
Transcoding from G.711 to G.729 for IP phones	16	Simultaneous 2-way conversations
Transcoding from TDM phones to G.729 IP phones	16	Simultaneous 2-way conversations. The quantity of 16 applies to conversations where one end of each conversation is on a G350 and transcoding occurs for that endpoint on the G350. If transcoding must occur on both ends of the conversation, the quantity of conversations is 10.
Maximum number of PSTN trunks	17 (analog) 15 (digital)	
Miscellaneous		
Fax capacity	8	Simultaneous fax transmissions using VoIP resources
Touch-tone recognition (TTR)	15	
Tone Generation	15	
Announcements (VAL)	6 Playback, 1 Record	

For more information about the G350 Media Gateway see 555-245-201, "Overview of the Avaya G350 Media Gateway."

G600 Media Gateway

The Avaya G600 Media Gateway is used in new installations of the S8700 Media Server and the S8100 Media Server, and in migrations to the S8500 Media Server. The G600 Media Gateway has the following characteristics:

- There is a maximum of 64 port networks when used with the S8700 and the S8500.
- A maximum of four G600 Media Gateways can be in each Port Network (PN) with the S8700 and S8500 media servers. The four G600 Media Gateways must be in one data rack due to TDM cable length.
- The S8100 Media Server can support up to three G600 Media Gateways in a single port network.
- A PN consists of a control G600 Media Gateway that is designated A, and second, third, and fourth optional G600 Media Gateways that are designated as B, C, and D, respectively.
- The dimensions of the G600 Media Gateway is 19 inches wide, 13 inches high and 21 inches deep.
- There are 10 universal slots plus one power supply.
- Circuit packs are inserted and removed from the front of the cabinet. Cabinet I/O is through the back and through a front cable pass-through slot.
- G600 Media Gateway is AC powered only. There are no internal batteries. DC power is not an option.
- An RJ45 patch panel is recommended for cross-connecting to a LAN or a wall field.

G600 Media Gateway cooling

Cooling for the G600 Media Gateway is provided by three 12-volt DC variable-speed fans that are integrated into the back of the cabinet. The fans pull air through the front and left sides and up through the cabinet. Air exits from the back of the cabinet. The 650A Global Power supply controls the speed. The 650A Global Power supply varies the fan input voltage between 8VDC and 14VDC depending on a temperature sensor that is mounted in the power supply.

The fan assembly includes the three fans, a base plate to which the fans are attached, wiring, and an AMP connector that plugs into a cable that connects to the backplane. The assembly is easily installed and removed. You must replace the entire assembly if a fan fails. If a fan fails the following events will take place:

- An alarm through the power supply is detected as a power alarm.
- The remaining fans go into high speed.
- The red LED on the 650A Global Power supply faceplate lights up.

See the following figure for an example of the G600 Media Gateway.

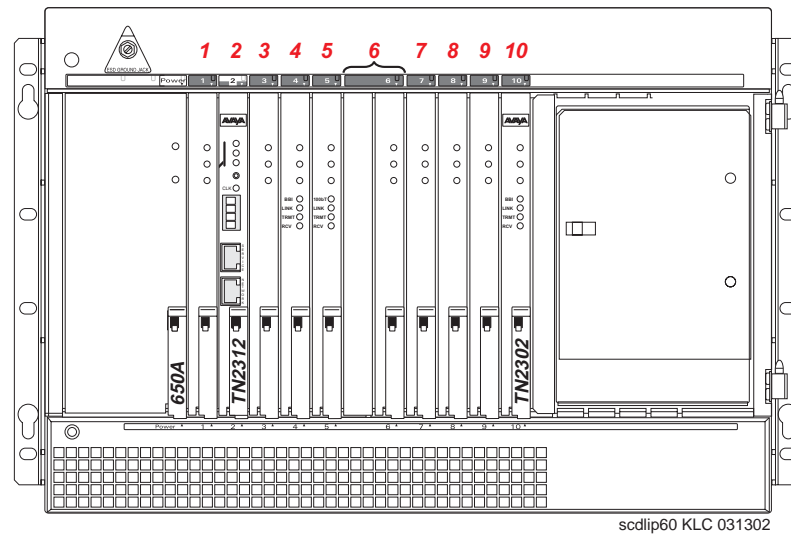
Figure 42: G600 Media Gateway

Required circuit packs for a G600 Media Gateway and an S8700 Media Server

When the G600 Media Gateway is connected to an S8500 Media Server or an S8700 Media Server, the following circuit packs are required:

IP Server Interface (TN2312BP)

The IP Server Interface (IPSI) provides transport of control messages over IP allowing the media server to communicate with the PNs. The IPSI is required to provide control network signaling over the customer's LAN and WAN. Tone generation, tone detection, global call classification, as well as stratum 4 type clock generation are provided on the IPSI board.

C-LAN (TN799DP)

The C-LAN circuit pack, TN799DP provides call control for every IP endpoints that is connected to the media server in an IP Connect configuration. A maximum number of 64 C-LANs per configuration is supported. The number of C-LANs that are required depends on the number of devices that are connected and the options that the endpoint is using. It might be advantageous to segregate IP voice control traffic from device control traffic as a safety measure.

To determine the default value for C-LAN socket usage of H.323 tie trunks, you must divide the total number of H.323 Tie Trunk that use sharing by 31. Each IP endpoint requires the use of some number of C-LAN sockets, which is the software object that is used to connect a TN799 board to the IP network. The TN799DP circuit pack supports up to 500 sockets.

The C-LAN differs from an IP Media Processor in that the C-LAN controls the call and the processor provides the codecs used for the audio on the call.

To take advantage of downloadable firmware capability there must be at least one TN799DP C-LAN and access to the public Internet for firmware downloads to other downloadable circuit packs. Downloads and instructions are posted to:

<http://www.avaya.com/support/>

Click on Online Services > Download Software Needed.

IP Media Processor (TN2302AP)

The media server in an IP Connect configuration requires resources on a IP Media Processor (TN2302AP) circuit pack for bearer communications within the same PN. The TN2302AP is also used for bearer communications with IP endpoints on both systems. The TN2302AP includes a 10/100 BaseT Ethernet interface to support H.323 endpoints for IP trunks and H.323 end-points. The TN2302AP can perform echo cancellation, silence suppression, dual-tone multi-frequency (DTMF) detection, and conferencing.

The TN2302AP, beginning with vintage 32, supports the following conversion resources for codec for voice, conversion between codecs, and FAX detection:

- G.711 (A- or μ -law, 64 kbps)
- G.723.1 (6.3 kbps or 5.3 kbps audio)
- G.729A (8 kbps audio)
- G.729, G.729B, G.729AB

Required circuit packs for a G600 Media Gateway and an S8100 Media Server

When the G600 Media Gateway is connected to the S8100 Media Server the following circuit packs are required:

TN2314 Processor (S8100)

The S8100 Media Server supports voice stations with co-resident voice switching, voice and FAX messaging and system applications run on a Microsoft Windows 2000 operating system. The communication between the firmware and the software is done by an Ethernet connection. An Intel processor Message Link (IML) is the Ethernet control link between the Pentium processor and the MPC860 processor. The link allows for the message based communication between the two processors.

The S8100 Media Server has the following characteristics:

- Processor – The processor is a 500-MHz Pentium III.
- RAM – There are two slots for SDRAM memory modules, with a minimum of 256-MB of RAM and a maximum of 512-MB of RAM.
- Front panel ethernet access – Services can access the switch via an RJ45 Ethernet jack on the circuit pack faceplate.
- Hard disk – The circuit pack has a 20-GB hard disk.

TN744E Call Classifier and Tone Detector

The TN744 call classifier and tone detector circuit pack has eight ports of tone detection on the TDM bus. The TN744 circuit pack does not support call progress tone generation or clocking. The tone detectors are used in vector prompting, outgoing call management (OCM), and call prompting applications in the United States and Canada and call classifier options for various countries. The TN744 detects special intercept tones used in network intercept tone detection in OCM. The TN744 circuit pack also detects tones when a CO answers a call.

The TN744 circuit pack provides tone generation and detection for R2-MFC DID signaling that is used in non-United States installations. The TN744 circuit pack also allows gain or loss to be applied to pulse code modulation (PCM) signals that are received from the bus and supports A-Law and μ -Law companding. The TN744 circuit pack detects 2025-Hz, 2100-Hz, or 2225-Hz modem answerback tones and provides normal broadband and wide broadband dial tone detection.

The TN744 circuit pack supports digital signal processing of PCM signals on each port to detect, recognize, and classify tones and other signals. Generation of signaling tones is also supported for applications such as R2-MFC, Spain MF, and Russia MF. Gain or loss and conferencing can be applied to PCM signals received from the TDM bus. Additional support includes DTMF detectors to collect address digits during dialing, and A-Law and μ -Law companding.

In normal operation, a port on the TN744 circuit pack can serve as an incoming register for Russia MFR (multi-frequency shuttle register signaling). Use the TN744 with the TN429C analog line central office trunk for CAMA/E911.

Avaya G650 Media Gateway

Overview

The Avaya G650 Media Gateway, is a fourteen slot, rack mounted carrier configured for TN format circuit packs. The G650 is 8U high (14 inches (35.6 centimeters)) and mounts in standard 19 inch (48.3 centimeters) data racks. The G650 can use one or two 655A power supplies that can have both AC and DC input power present. Either power supply can provide all the power needed by the G650.

See [Figure 43, G650 Media Gateway](#), on page 131 for an example of the G650 Media Gateway.

Figure 43: G650 Media Gateway

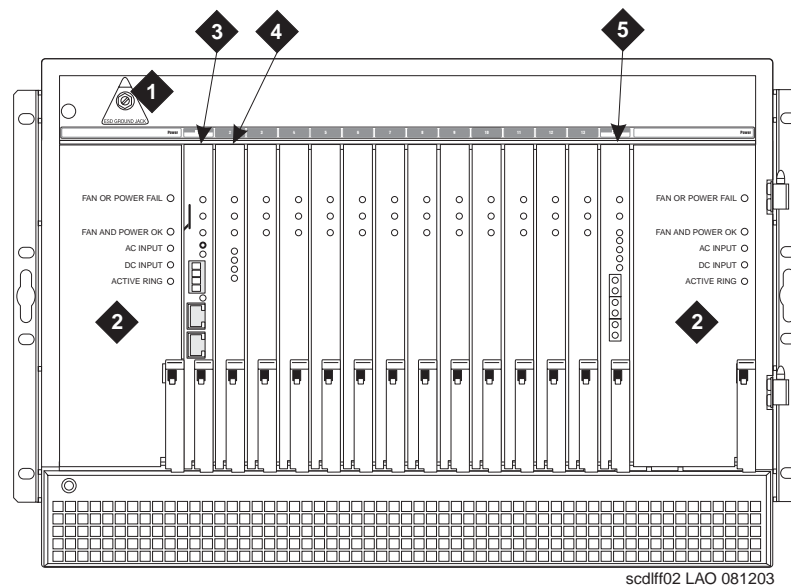

Figure notes

Number	Description
1	EDS ground jack
2	655A power supply
3	TN2312BP IP server interface (IPSI)
4	TN799DP CLAN
5	TN2302 IP media processor

Mounting G650s

The G650 can be rack mounted or, in single G650 configurations, table or floor mounted. Multiple G650s (up to five) can be mounted in a rack and connected by TDM cables to create a G650 stack.

The G650 is mounted in industry standard EIA-310 19 inch open racks. The G650 provides options for front or mid mounting. Although the G650 can be mounted in a 19 inch (48.3 centimeters) four-post data rack it does not mount simultaneously to all four posts. When mounted in a four-post rack, the G650 uses the front mounting position.

Mounting a single G650

A single G650, equipped with feet, can be table or floor mounted. Side-by-side G650s, connected by TDM cables, are not supported. In a single configuration, the G650 always has an A carrier address.

Mounting multiple G650s

Multiple G650s (up to five) can be mounted in a rack and connected by TDM cables to create a G650 stack. Multiple G650s must be vertically adjacent and their front panels must align in the same vertical plane. For example, carrier A is always below carrier B, which is always below carrier C, and so on through carrier E. Note that existing TDM cables used for the G600 cabinets are not compatible with the G650.

Multiple G650s (up to five) can be mounted in a rack but **not** connected by TDM cables. In this case each G650 is defined as a media gateway (a cabinet or port network) and each requires its own interface hardware (EI, ATM-EI, TN2312BP IPSI). Note that with this configuration, all of the G650s have a carrier address of A.

Carrier addressing

The carrier position (A through E) must be set on all G650s. The carrier address is set using a small printed circuit card that is plugged into one of five (A through E) connectors inside the carrier.

See [Figure 44, Printed circuit card](#), on page 133 for an example and location of the printed circuit card.

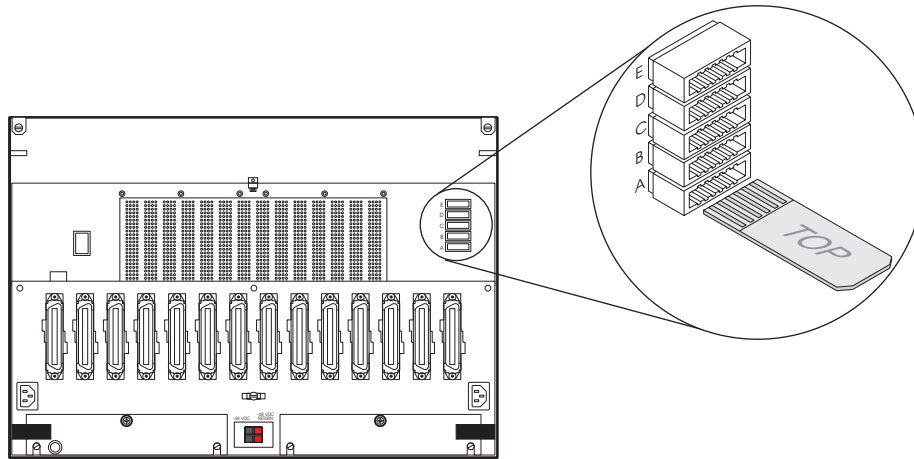
Figure 44: Printed circuit card

swdlpdle LAO 072403

When five G650s in a rack are connected together with TDM cables, the G650 in the bottom position in the rack has a carrier address of A, and the G650 in the top position in the rack has a carrier address of E. When the five G650s in a rack are not connected together with TDM cables, each G650 has a carrier address of A.

Multiple G650s can be rack mounted with some connected by TDM cables, and others not connected by TDM cables. For example, a customer can request that the G650 in the bottom of the rack not be connected to another G650. The carrier address of the G650 in the bottom of the rack is A. The customer can request that the next two G650s in the rack be connected together by a TDM cable. The carrier address of the lower of these two G650s is A, and the address of the upper G650 is B. And the customer can request that two additional G650s be placed in the rack and be connected by a TDM cable. The carrier address of the lower of these two G650s is A and the address of the upper G650 is B. In this example, the rack has one G650 with an A carrier address, and two G650 stacks with both an A and B carrier address.

The carrier address of an individual rack mounted, table mounted, or floor mounted G650 is A.

See [Figure 45, G650 stack](#), on page 134 for an example of a G650 stack.

Figure 45: G650 stack

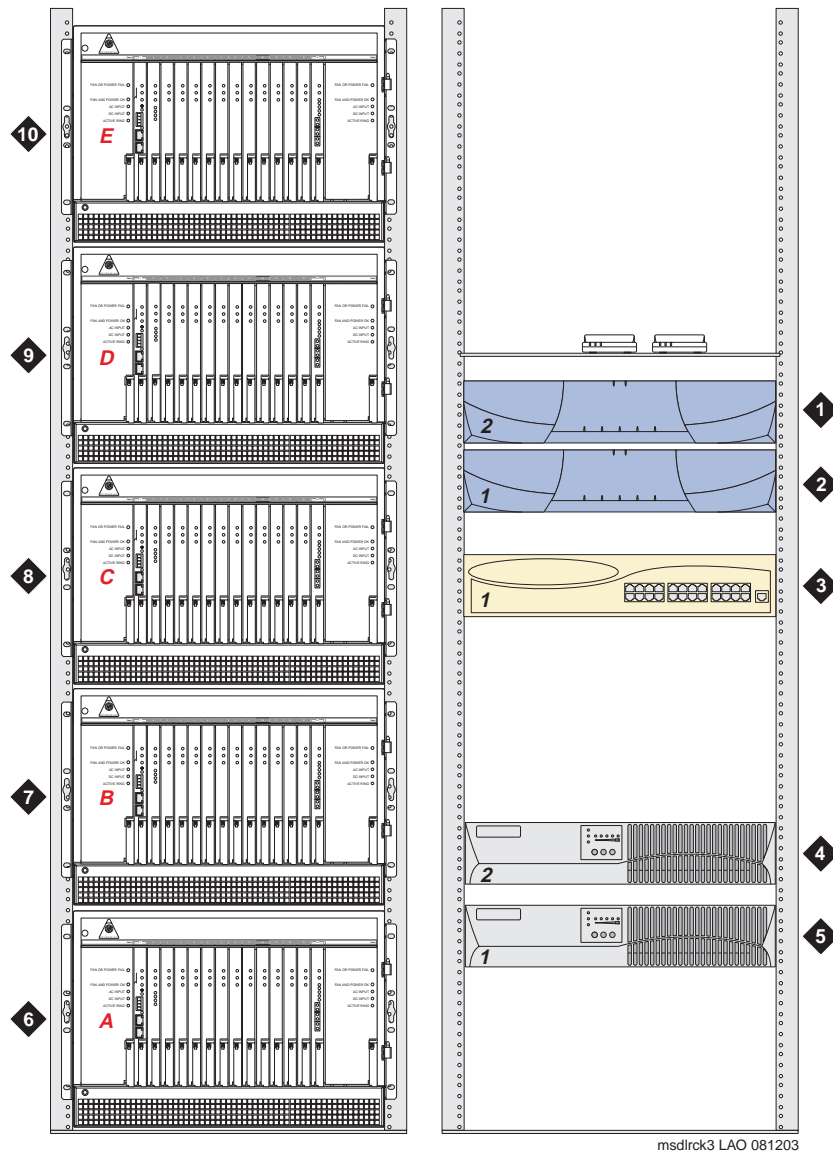

msdirck3 LAO 081203

Figure notes

Number	Description
1 & 2	S8700 Media Servers
3	Ethernet switch
4 & 5	UPS units: one for each server
6	G650 Media Gateway: Carrier position "A"
7	G650 Media Gateway: Carrier position "B"
8	G650 Media Gateway: Carrier position "C"
9	G650 Media Gateway: Carrier position "D"
10	G650 Media Gateway: Carrier position "E"

I/O connections

The fourteen slots of the G650 are equipped with twisted pair cables from the backplane to the 25-pair type D, metal shelled I/O connector panel mounted on the rear of the carrier. The power supply slots (0 and 15) do not provide external I/O connections.

I/O adapters

You can use any existing adapter for input and output if the associated TN circuit pack is supported in the G650.

Fan assembly

The three-fan unit can operate at two different speeds:

- Mid speed for normal cooling
- High speed when a temperature threshold is exceeded or a fan failure is detected

655A power supply

The G650 can use one or two 655A power supplies that can have both AC and DC input power present. Either power supply can provide all the power needed by the G650. When there are two power supplies, they share the power load. One power supply can operate on AC power and the other on DC power, although if AC power is available, the system always uses AC power. The 655A power supply is:

- The only power supply supported in the G650
- Not backward compatible to other carrier types

If you use only one 655A power supply, place it in slot 0. If you are using two power supplies, place them in slots 0 and 15.

NOTE:

You can insert or remove a **redundant** power supply and not affect the G650 if the other 655A power supply is operating.

Input power

The 655A power supply is capable of operating on either AC or DC input power, although AC power is always used if it is available. One power supply can operate on AC power, and the other on DC power. The power supplies use AC power first and switch to DC power if AC power fails or is not present.

AC power

Commercial AC is the primary input power source. Both slot 0 and slot 15 have dedicated AC input. The 655A power supply can operate on AC input of 90 to 264 VAC at 47 to 63 Hz. The nominal ranges for AC power are:

- 100 to 120 VAC at 50 or 60 Hz
- 200 to 240 VAC at 50 or 60 Hz

DC power

Minus 48VDC power can be supplied simultaneously as backup power. One -48VDC power input point is provided on the G650 backplane and is distributed through the backplane to each power supply.

655A faceplate LEDs

The five LEDs on the faceplate of the 655A power supply are in a vertical line with the red LED on top. These five LEDs provide the following status:

- Red - This LED:
 - Lights when there is a failure in either the power supply or the fans. (For a G650 with redundant power supplies, a failure in the fan assembly results in this LED being lit on **both** power supplies.)
 - Flashes off once per second when the software shuts down the ring voltage output of a power supply
- Yellow - This LED:
 - Lights when the status of the power supply and fans is OK
 - Flashes once per second when the software shuts down a single power supply, in a carrier with operational redundant power supplies
- Green - Lights when there is AC power applied to the power supply
- Green - Lights when there is DC power applied to the power supply
- Green - Lights when the power supply is supplying ringing to the G650

See [Figure 46, 655A faceplate LEDs](#), on page 137 for an example of 655A faceplate LEDs

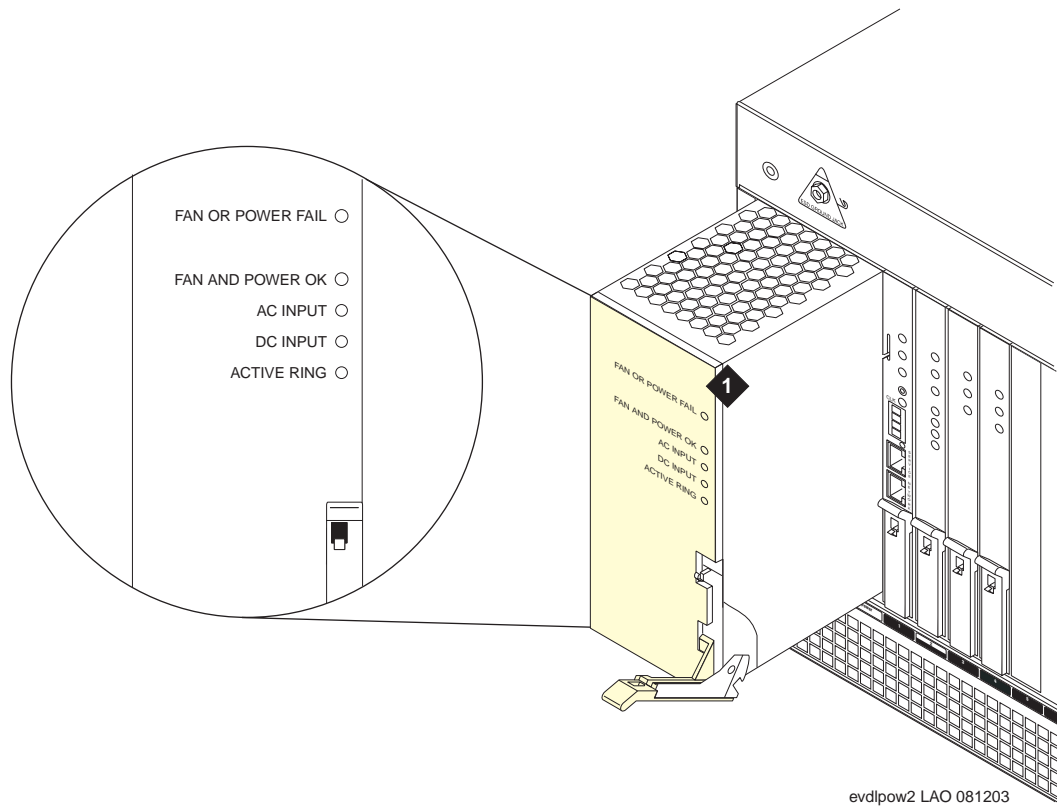
Figure 46: 655A faceplate LEDs

evdipow2 LAO 081203

655A ring generation

The 655A provides either North American ringing (20Hz) or European/International (25Hz) ringing. It also has a setting to provide no ringing when the customer supplies a ring generator that is external to the power supply. A TN2202 (French ringing circuit pack) is an example of an external ring generator.

The 655A power supply provides a physical slide switch to select the frequency of the ring generator. The options are:

- 20Hz — North American
- 25Hz — European and international
- Other — No ringing output when an external ring generator is used such as the TN2202 French ringing circuit pack.

You must remove the power supply from the G650 when you change the ringing frequency selection. The ringing frequency selection switch is on the back of the power supply.

Only one 655A supplies ringing to the G650. The power supply in slot 0 in the G650 with an A carrier address is the default for ringing. The system uses this default 655A unless it has failed or the software has commanded it to shut down. When a G650 carrier has redundant power supplies, one supply automatically supplies ringing if the other power supply fails.

A 655A provides ringing to only one G650 carrier. For example, the 655A power supplies in carrier A supply ringing to carrier A only, and the power supplies in carrier D supply ringing to carrier D only. If the ring generation in both of a carrier's power supplies fail, no other power supply provides ringing for the carrier.

Avaya G700 Media Gateway

The G700 Media Gateway is designed to be scalable and offer options. It is functional on its own or with other G700 Media Gateways. The G700 is also functional in combination with other G700 Media Gateways and Avaya P330 devices such as the P333T, P333R, and P334.

A maximum of 50 G700 Media Gateways can be supported using the S8300 Media Server. A maximum of 250 G700 Media Gateways can be supported using the S8700 Media Server or the S8500 Media Server.

To provide power to IP telephones without additional cables, stack the G700 Media Gateways with the Avaya P333T-PWR.

The following list describes the basic architecture of the G700 Media Gateway:

- Intel i960 controller that hosts all of the base switch-control and management software.
- Fits in a EIA-310-D standard 19-inch rack.
- Supports 15 ports of tone detection.
- Contains four media-module slots.
- One Avaya P330 expansion-module slot.
- One slot for the Avaya P330 Octaplane stacking fabric.
- Can sit on a desktop or be rack-mounted.
- Contains an internal motherboard. For more information, see [Motherboard](#).
- Standard based 10/100 Ethernet Interface connection types. A wall field or breakout panel is not required.
- Internal power supply that provides low-voltage DC power to the fans, motherboard, and media modules.
- Four internal fans that provide cooling for the internal components.
- A LED board that indicates system-level status.
- A serial port for command-line access.
- A VoIP engine that supports up to 64 G.711 single-channel calls.
- Eight-port layer-2 switch.

The G700 Media Gateway has a physical design that is similar to the Avaya stackable switching products. The following figure shows the G700 Media Gateway with two Avaya P330 switches. The G700 is shown at the top of the stack.

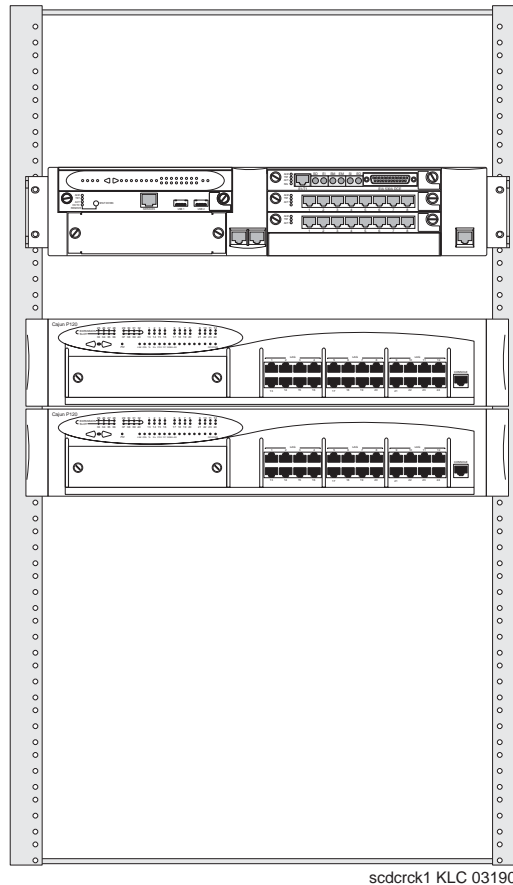
Figure 47: G700 Media Gateway with two Avaya P330 switches

Expansion modules

The G700 Media Gateway is architecturally based on the Avaya P330 switch. Therefore, customers can use any of the Avaya Expansion Modules with the G700 Media Gateway. Additional Avaya LAN/WAN expansion modules connect directly to the G700 Media Gateway without requiring additional hardware. Two expansion modules are available from Avaya:

- Avaya X330 WAN Access routing module
- Avaya P330 LAN expansion modules

X330 WAN Access routing module

Customers with multiple branch offices need network solutions that are simple flexible and scalable. The Avaya X330 WAN Access routing module allows customers to deploy a unified, high-performance LAN/WAN infrastructure in one data stack.

Highlights of the Avaya X330 WAN Access Router

- Provides integrated WAN access that can be used with external firewalls or VPN Gateways
- Works with the following WAN and routing protocols

- Point-to-Point (PPP) over channeled E1/T1
- Frame Relay
- Routing Information Protocol (RIP) v1/v2
- Single-Area Open Shortest Path First (OSPF)
- VRRP Redundancy
- Throughput: wire-speed WAN routing
- Congestion control
- Standard auto-negotiation
- Link redundancy
- 802.1Q/p VLAN and priority
- Hot-swappable

Avaya P330 LAN expansion module

Highlights of the Avaya P330 LAN expansion module

- Maximum flexibility to the data stack
- Standard auto-negotiation
- Link Aggregation Group (LAG)
- LAG redundancy
- Link redundancy
- Congestion control
- 802.1Q/p VLAN and priority
- Hot-swappable



CAUTION:

Avaya expansion modules and Octaplane stacking modules are not hot-swappable. The system must be turned off to before you remove or insert an expansion module.

P330 stacking fabric (Octaplane)

"Octaplane" is a name for an Avaya hardware capability to bundle stackable components using 4-Gbps communication in each direction. This technology combines separate units into a larger logical switch using different lengths of cables that are connected to the expansion slots in the rear of the units. These cables are wired in a ring configuration, providing redundancy to the stack. In the event that a single unit should fail, the stack integrity is maintained. You can remove, or replace, any single unit without disrupting operation or performing stack-level reconfiguration.

Table 6: Octaplane cabling

Cable	Description and function	Length	Length (metric)
X330SC Short Octaplane cable (30 cm)	Short Octaplane cable – light-colored, used to connect adjacent switches or switches separated by one backup universal power supply (BUPS) unit.	12 inches	30 cm
X330LC Long Octaplane cable (2 m)	Long Octaplane cable – light-colored, used to connect switches from two different physical stacks	6 feet	2 m
X330RC Redundant Octaplane cable (2 m)	Redundant cable – black, used to connect the top and bottom switches of a stack.	6 feet	2 m
X330L-LC Extra Long Octaplane cable (8 m)	Extra-long Octaplane cable – light-colored, used to connect switches from two different physical stacks	24 feet	8 m
X330L-RC Long redundant Octaplane cable (8 m)	Long redundant cable – black, used to connect the top and bottom switches of a stack.	24 feet	8 m

Power supply

The G700 Media Gateway uses an AC power supply. A power supply located in the G700 Media Gateway converts AC input power to voltages needed by the system.

Motherboard

The motherboard resides within the G700 Media Gateway. This board controls the following:

- The VoIP Engine which performs IP/UDP/RTP processing, echo cancellation, G.711 A-/μ-law, G.729 and G723.1 encode/decode, FAX relay, silence suppression, jitter buffer management, and packet-loss concealment. The VoIP Engine supports 64 channels. If more than 64 channels are needed, a VoIP Media Module is required.
- The Gateway Processor complex, which controls all the resources inside the Gateway. The Gateway Processor functions include the Media Module Manager, Tone-Clock, and H.248 signaling to the Gateway Controller.

- An Avaya P330 processor complex is based on the Avaya P330 data-switch architecture. This complex provides an 8-port layer-2 switch function and manages the Expansion and Cascade modules.
- Provides the electrical and physical connectivity for the four media-module slots.

NOTE:

The motherboard cannot be replaced in the field.

For more information about the VoIP Media Module, see [MM760 VoIP media module](#) on page 228.

Fans

The G700 Media Gateway contains four 12-volt fans. These fans are monitored and can be reported by SNMP to a management station.

LEDs

The S8300 Media Server with the G700 Media Gateway uses two types of LEDs:

- Media module
- System-level

Media module LEDs

Media-module LEDs have the following characteristics:

- Each media module has at least three LEDs to indicate module and port status or maintenance and administration modes.
- The location, spacing, and labeling is fixed for all LEDs on every media module.
- The LEDs are mounted on the media module's printed wiring board, and placed so that they show through an opening.

System-level LEDs

An LED board visually indicates both system and Ethernet-port status by allowing customers to change between these status-indication modes. The LEDs reside in the board's oblong fascia panel. In turn, the LED board resides in the upper-left front of each G700 Media Gateway.

You must remove the LED board when you install or remove either the active or standby S8300 Media Server. The two components must be installed or removed as a unit.

NOTE:

The LED panel is not the same size as a standard media module. You cannot insert a media module into the LED board's slot, or vice versa.

Gateway software

Gateway software is responsible for:

- Individual media-gateway operations
- Terminating H.248 on the G700 Media Gateway
- Interacting with maintenance operations.

Maintenance software

An Avaya media server with a G700 Media Gateway has a dual maintenance strategy. Maintenance software runs on both the G700 Media Gateway's and the media server's platform for each platform's subsystems.

The G700 media gateway's maintenance software performs its own initialization and motherboard maintenance, along with internal environmental monitoring. Whereas, after the G700 Media Gateway registers with the media server, the server's maintenance software tests and initializes the gateway's media modules. Although the media gateway's maintenance software is aware of its own media modules, these modules and their associated ports are controlled by the media server. Error logs are also maintained on the media server.

Connectivity

The G700 Media Gateway connects through a LAN to a TN799DP C-LAN circuit board mounted in a media gateway. The following figure is an example of G700 Media Gateway connectivity.

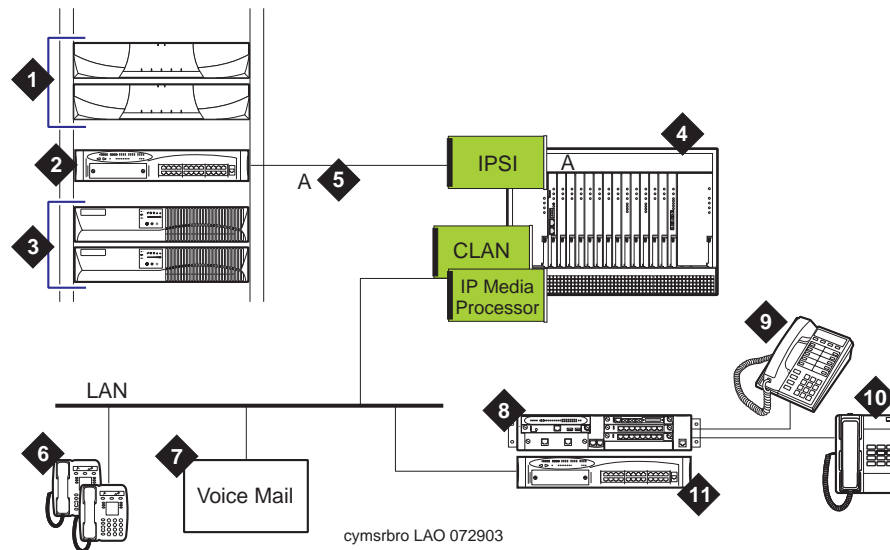
Figure 48: The G700 Media Gateway connecting to the S8700 Media Server**Figure notes**

Number	Description
1	Two S8700 Media Servers
2	Ethernet switch – Must be Avaya-provided
3	Two UPS units – One for each server
4	G650 Media Gateway
5	Dedicated LAN connectivity to the media gateway's IPSI board
6	IP phones off the customer's LAN
7	Voice Mail – INTUITY™ AUDIX® is shown connected via IP.
8	A G700 Media Gateway is connected via the LAN to the C-LAN board located in a G650 Media Gateway. The S8300 Media Server in an LSP configuration is located in the G700 Media Gateway. In the event of a loss in communication between the S8700 and the G700, the LSP will provide a backup for its registered endpoints.
9	DCP Phones – Avaya multifunction digital phones
10	Analog connectivity – Including analog telephones, lines, and trunks
11	Ethernet switch (optional)

Media modules

Avaya media modules convert the voice path of the traditional circuits (such as analog trunk, T1/E1, and DCP) to a TDM bus. The VOIP engine then converts the voice path from the TDM bus to packetized VoIP (compressed or uncompressed) on an Ethernet connection.

The media modules reside in the G700 Media Gateway and interact with the motherboard and backplane.

There are five media modules:

- MM710 T1/E1 – For information, see [MM710 T1/E1 media module](#) on page 219.
- MM711 Analog – For information, see [MM711 Analog media module](#) on page 222.
- MM712 DCP – For information, see [MM712 DCP media module](#) on page 224.
- MM720 BRI – For information, see [MM712 DCP media module](#) on page 224.
- MM760 VoIP – For information, see [MM760 VoIP media module](#) on page 228.

CMC1 Media Gateway

The CMC1 Media Gateway supports the DEFINITY® Server CSI and Avaya S8100, S8700, and S8500 Media Servers. It can be mounted on a wall or on the floor, and uses an AC-only power supply. The control carrier contains two control slots, one for the processor and the other for the tone clock. Slots 3 to 10 can contain optional port circuit packs and service circuit packs. See the following figure for an example of the CMC1 Media Gateway.

Figure 49: CMC1 Media Gateway, left side

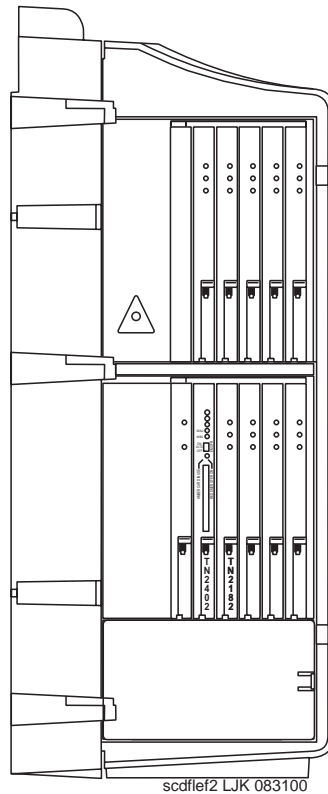

The following figure shows the connections on the right side of the cabinet. From 1 to 10 25-pair connectors provide an interface between port circuit packs and the cross-connect field or a cable access panel.

Figure 50: CMC1 Media Gateway, right side

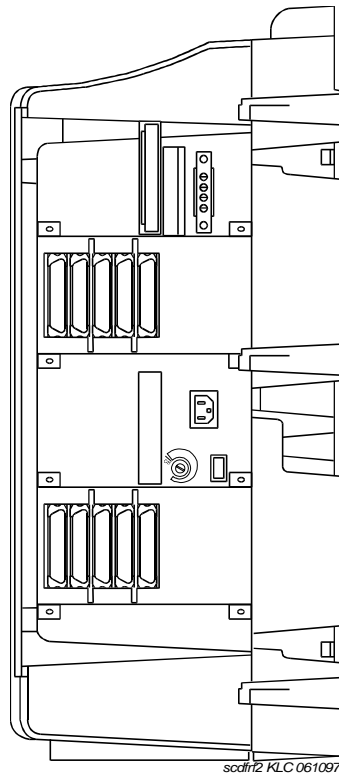

An S8100 Media Server can support up to three CMC1 Media Gateways. Whereas, a DEFINITY Server CSI can support up to four. In the CMC1 Media Gateway that contains the server and Tone-Clock circuit packs, some slots are unavailable for port and service circuit packs. Whereas, in every other connected CMC1 Media Gateway, every slot is available for a port or service circuit pack.

Figure 51: Typical vertical installation, front view of the CMC1 Media Gateway

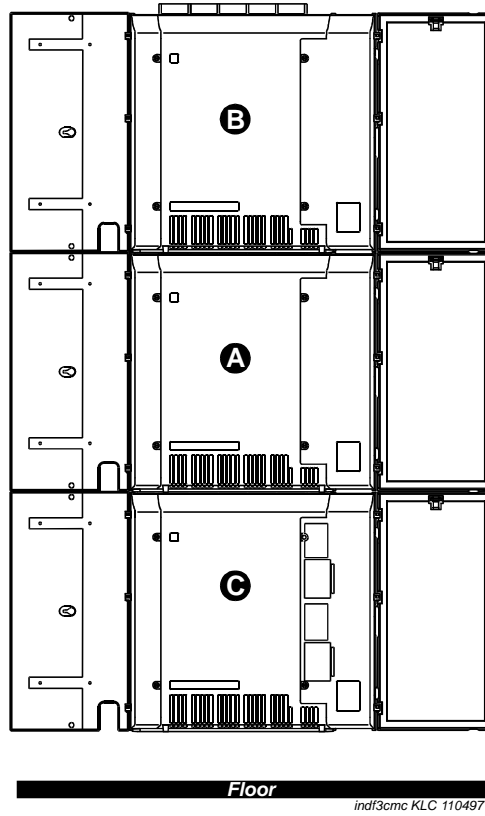

SCC1 Media Gateway

This section describes the SCC1 Media Gateway. Each SCC1 Media Gateway has vertical slots that hold circuit packs. A blank faceplate covers each unused slot. The following figure shows a typical SCC1 Media Gateway.

Figure 52: Typical SCC1 Media Gateway

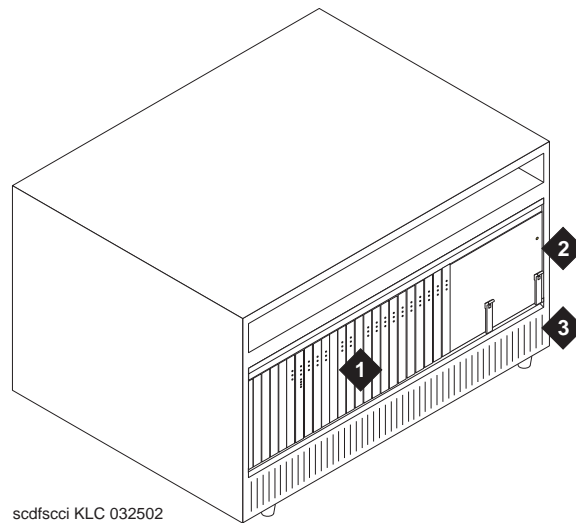

Figure notes

Number	Description
1	Circuit packs
2	Power converter
3	Air circulation vents

A maximum of four SCC1 Media Gateways can be stacked on top of each other. The cabinet positions are labeled A through D. The position of the basic control cabinet or expansion control cabinet is always labeled A. Additional port-cabinet positions are labeled B, C, and D, sequentially.

The duplicated control cabinet used for the DEFINITY servers is labeled B. See the following figure for an example of a stack of SCC1 Media Gateways.

Figure 53: Typical SCC1 stack

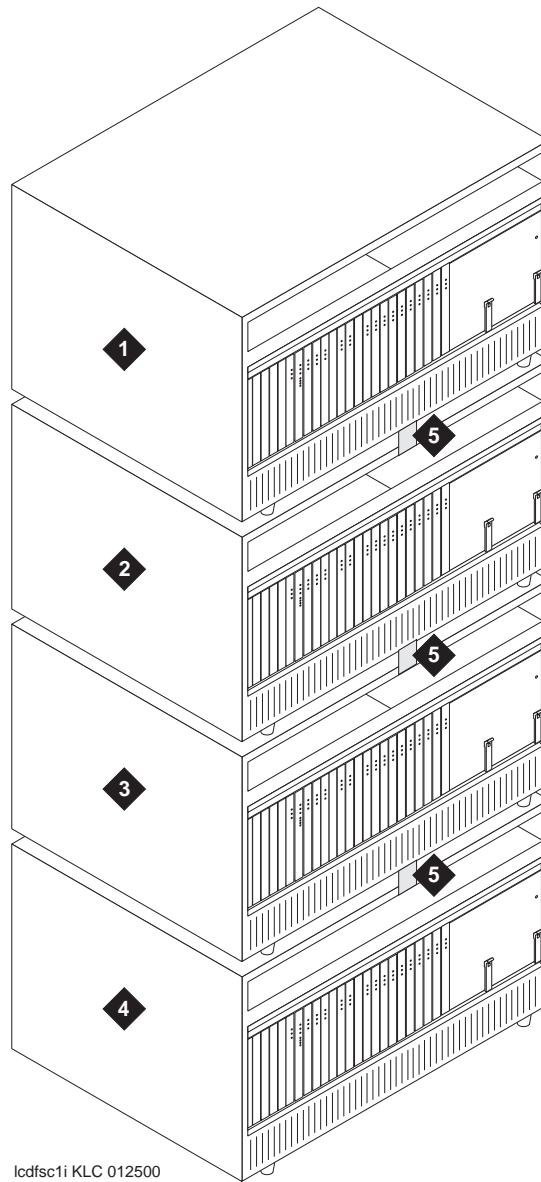

lcdfsc1i KLC 012500

Figure notes

Number	Description
1	Port cabinet in the D position
2	Port cabinet in the C position
3	Port cabinet or duplicated control cabinet in the B position
4	Basic control cabinet or expansion control cabinet
5	Cabinet clips

For DEFINITY Servers:

- Each stack of SCC1 Media Gateways requires one basic or expansion control cabinet at the bottom of the stack.
- The maximum number of SCC1 Media Gateway stacks or port networks:
 - Three for the DEFINITY Server SI
 - 44 for the DEFINITY Server R.

Cabinet clips connect the cabinets together. At the rear of the cabinets, a ground plate connects between cabinets for ground integrity.

For Avaya Media Servers:

- S8500 - SCC1 Media Gateways are supported for migrations only
 - Maximum number of SCC1 stacks or PNs is 64.
- S8700 - SCC1 Media Servers are supported in a multi-connect configuration only
 - Maximum number of SCC1 stacks or PNs is 64.

Table 7: Cabinet circuit-pack slots

Type	Description	Server
Port	A port slot is colored purple or labeled with a gray rectangle. A port slot can accept any purple or gray-labeled circuit pack	DEFINITY Server R, SI, S8700 Media Server, and S8500 Media Server
Control	A control slot is colored white or labeled with a outlined white rectangle. A port slot can accept any purple or gray-labeled circuit pack.	DEFINITY Server R and SI
Service	A service slot is colored purple or labeled with a gray rectangle. A service slot accepts a special type of circuit pack that does not have an I/O connector	DEFINITY Server R, SI, S8700 Media Server, and S8500 Media Server

The purple- and white-colored circuit packs and slots have been replaced by circuit packs and slots that are labeled with gray and white rectangles, respectively. A label with a solid gray rectangle indicates a slot for a port circuit pack. A label with an outlined white rectangle indicates a slot for a control circuit pack.

Each port slot in a port carrier, an expansion control carrier, or a control carrier attaches to a 25-pair connector on the carrier’s rear panel. A cable attaches to each connector and routes to the cross-connect field.

Blank faceplates cover empty carrier slots, as follows:

- 158J covers the area to the left of slot 1 in port cabinets (4 in/9.2 cm)
- 158P (0.75 in/1.9 cm) covers any unused slot.
- 158N (0.50 in/1.27 cm) is used with the LAN Gateway in DEFINITY AUDIX Release 3 and CallVisor ASAI installations
- 158G (0.25 in/0.63 cm) is used with the TN755 or the TN2202 circuit pack

In the following figure, a balanced ring generator (BRG) is shown below the power unit slot in certain carriers. This means that the power unit slot can include a 50-Hz BRG when optioned for France.

Carriers

Basic control cabinet for a DEFINITY Server SI

The basic control cabinet is in the PN only and is only used by DEFINITY Servers. This cabinet contains ports, a control complex to perform call processing, and an interface to an optional duplicated control cabinet. The basic control cabinet also interfaces to an optional Stratum-3 clock.

The basic control cabinet has dedicated white circuit-pack slots that contain specific control circuit packs. Dual-colored slots can contain any port circuit pack or the designated white circuit packs (such as an expansion interface or power unit). AC or DC power units supply power to the carrier. The following figure shows an example of the basic control cabinet.

Figure 54: SCC1 basic control cabinet (front)

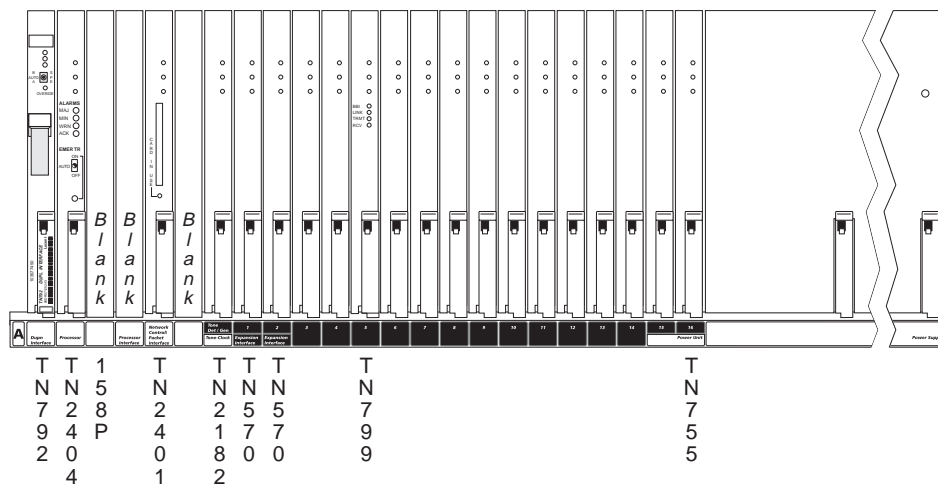

ccdf8l KLC 081601

The following table describes the connectors in the basic control carrier.

Connector	Function
1 to 16 (A1 to A16)	25-pair connectors that provide interfaces between connect port circuit packs and the cross-connect field or a fiber transceiver
AUX (auxiliary)	Provides interfaces for customer alarms, attendant console power, emergency power-transfer panels, and an internal modem that is used for remote maintenance.
PI (processor interface)	Provides a BX.25 protocol interface for communication between the circuit pack and external DCE equipment. This connection is only used with the standard-reliability option.

The following table lists a duplicated control cabinet's connectors and their functions.

Connector	Function
01 to 16 (A01 to A16)	25-pair connectors that provide interfaces between port circuit packs to the cross-connect field or a fiber transceiver
TERMINAL	Can connect to the processor circuit pack in the duplicated control cabinet in the event the duplication interface circuit pack fails in the control carrier.

Expansion control cabinet for a DEFINITY Server SI, DEFINITY Server R, S8700 Media Server, or S8500 Media Server

The expansion control cabinet contains ports, an interface to a port cabinet, a maintenance interface, and a tone-clock. The tone-clock, which is replaced by an IPSI, is not needed when using the S8700 Media Server or the S8500 Media Server in an IPSI-controlled port network.

An expansion control cabinet is the first in an expansion PN stack of SCC1 Media Gateways. An expansion control cabinet has optional port circuit packs in port slots 2 to 17. An AC or DC power supply resides in the right side of the cabinet.

Figure 56: Expansion control cabinet

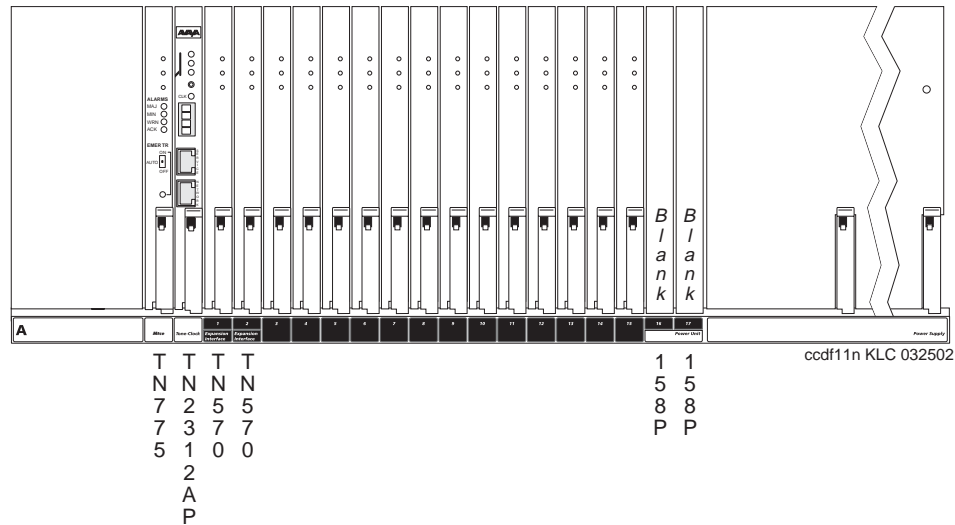

The following table describes the connectors of the expansion control cabinet.

Connector	Function
1 (A1)	Provides a fiber-optic cable interface to an expansion interface (EI) circuit pack in slot 1 ¹ or a copper cable interface for a DS1 Converter.
2 to 17 (A2 to A17)	25-pair connectors that provide interface between the port circuit packs and the cross-connect field or a fiber transceiver.
AUX (auxiliary)	Provides interfaces for customer alarms, attendant console power, and emergency power transfer panels.
TERM (terminal)	Connects an administration terminal to the maintenance circuit pack and used for the DEFINITY Server SI and DEFINITY Server R. This is not used for the S8700 Media Server or the S8500 Media Server.

¹ In systems that use ATM-PNC, the fiber connectors for the OC-3/STM-1 interfaces to the ATM switches reside on the faceplates of the TN2305 circuit pack or the TN2306 circuit pack.

Port cabinet for a DEFINITY Server SI, DEFINITY Server R, S8700 Media Server, or S8500 Media Server

Port cabinets reside in the PN and in expansion PNs. A port cabinet contains ports and an interface to an expansion control cabinet. A port cabinet has optional port circuit packs in port slots 1 to 18. In a critical-reliability system, these can include a Tone-Clock circuit pack in slot 1 and an expansion interface circuit packs in slots 2 and 3. A neon power unit can be installed in slots 17 and 18.

An AC or DC power supply resides in the right side of each cabinet. The following figure shows an example of a port cabinet.

MCC1 Media Gateway

An MCC1 Media Gateway can be used as a port network (PN) cabinet. Doors in front of and behind the MCC1 Media Gateway protect the internal equipment and allow easy access to the circuit packs. Each MCC1 Media Gateway contains casters. Leveling feet keep the cabinet from rolling. Each lower corner of a MCC1 Media Gateway can bolt to the floor, if required.

See [Figure 58, Typical MCC1 Media Gateway layout](#), on page 160 for an example of the MCC1 Media Gateway layout.

Figure 58: Typical MCC1 Media Gateway layout

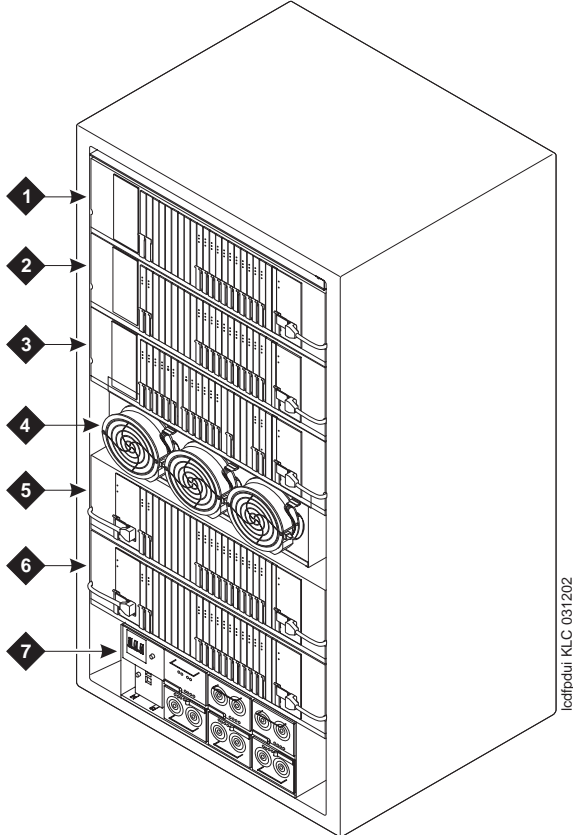

Figure notes

Number	Description
1	Carrier in position C
2	Carrier in position B
3	Carrier in position A
4	Fan unit
5	Carrier in position D
6	Carrier in position E
7	Power-distribution unit

Auxiliary cabinet

The auxiliary cabinet contains the hardware to install optional equipment. The cabinet allows carrier, rack (width: 23 in.; 58.4 cm), and panel types of mounting. An auxiliary cabinet contains the following:

- A fuse panel (J58889AB) that distributes -48 VDC to fused cabinet circuits
- An AC power receptacle strip that provides switched and unswitched 120-VAC receptacles
- A DC connector block for cabinets powered by either an external DC source or by an AC-to-DC converter that:
 - Accepts AC power from a switched outlet of an AC power strip
 - Sends converted DC power onto the required DC connector block

Port network cabinet for DEFINITY Server R or SI

A port network cabinet contains the following components

For a DEFINITY Server SI:

- One to four port carriers (J58890BB)
- One control carrier (J58890AH)
- One duplicated control carrier (J58890AJ) in a high- or critical-reliability configuration

For a DEFINITY Server R:

- One to four port carriers (J58890BB)
- One processor carrier (J58890AP) in a high-reliability configuration. Two processor carriers in a critical-reliability configuration.
- Minimum of one switch node (SN) carrier (J58890SA) in a standard- or high-reliability configuration with a center stage switch (CSS). Minimum of 2 SN carriers in a critical-reliability configuration.

Port network cabinet for Avaya S8700 Media Server

- One to four port carriers (J58890BB)
- In a configuration with Asynchronous Transfer Mode (ATM), an ATM Interface card
- Minimum of one switch node (SN) carrier (J58890SA) in a standard- or high-reliability configuration with a center stage switch (CSS). Minimum of 2 SN carriers in a critical-reliability configuration

See [Figure 59, Typical PN Cabinet for all server models](#), on page 162 for an example of a typical PN cabinet.

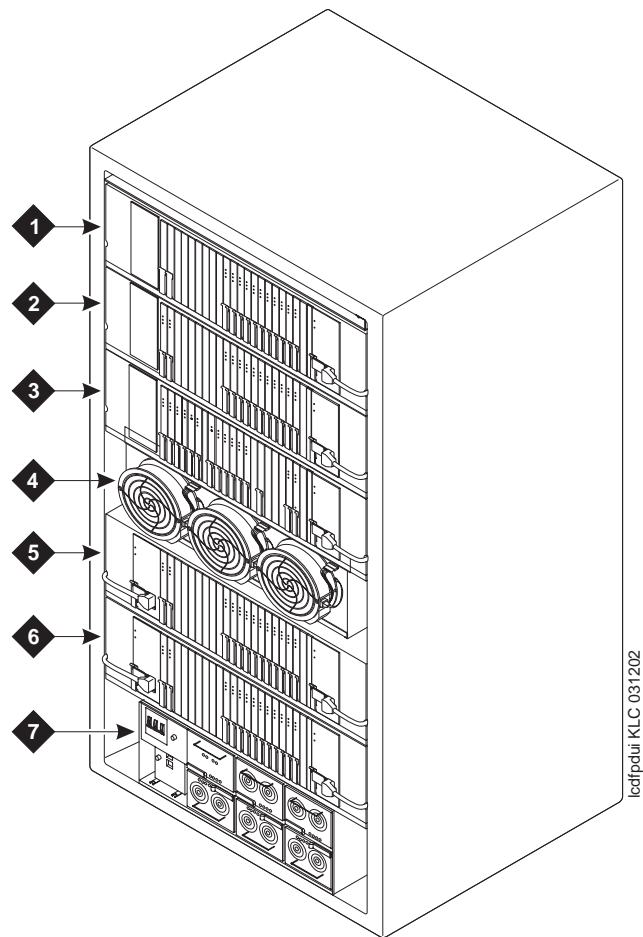
Figure 59: Typical PN Cabinet for all server models**Figure notes**

Number	Description
1	Port carrier in position C
2	Port, control, or processor carrier in position B
3	Control, processor, or expansion control carrier in position A
4	Fan units
5	Port or switch node (SN) carrier in position D
6	Port or SN carrier in position E
7	Power-distribution unit

Port network cabinet for Avaya S8500 Media Server

The Avaya S8500 Media Server supports the MCC1 Media Gateway in migrations from a DEFINITY R simplex configuration. A maximum of three Port Networks are supported in a direct connect configuration only.

Expansion port network cabinet for DEFINITY Server R or SI

An expansion port network (EPN) cabinet contains the following carriers:

- One to four port carriers (J58890BB)
- One expansion control carrier (J58890AF)
- Zero, one, or two SN carriers (J58890SA) in CSS-connected R model as required

See [Figure 60, MCC1 EPN cabinet](#), on page 163 for an example of an MCC1 EPN cabinet.

Figure 60: MCC1 EPN cabinet

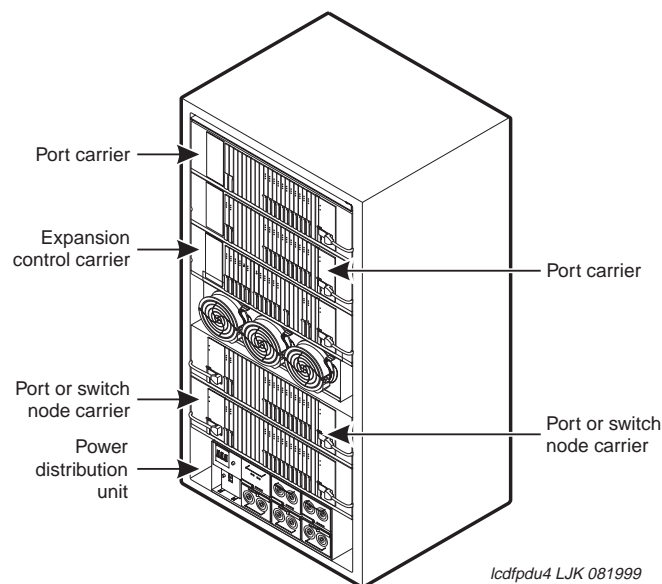

In a minimal dual-EPN cabinet configuration, the A, B, and C carrier positions are intended for the first port network in the cabinet. The D and E carrier positions are intended for the second port network in the cabinet. When a cabinet has two PNs, carrier position E must be used and populated first. Carrier position D is added and populated second.

Carriers

The following table lists the types of carriers that can be installed in the MCC1 Media Gateway with the DEFINITY Server R, the DEFINITY Server SI, the S8700 Media Server, and the S8500 Media Server. Each carrier will be described in greater detail later in this section.

Description	Cabinet	Server
Control Carrier – Contains the processor circuit packs to perform call processing and maintenance	PN	DEFINITY Server SI
Processor Carrier – Contains the processing circuit packs to perform call processing, maintenance, and administration. These carriers do not contain port circuit packs. Two J58890AP carriers are in the PN for high- and critical-reliability, duplicate processor, systems.	PN	DEFINITY Server SI and DEFINITY Server R
Port Carrier (optional) – Contains the port, service, Tone-Clock, and EI circuit packs.	PN or EPN	DEFINITY Server SI and DEFINITY Server R
Expansion control carrier – Contains extra port Tone-Clock, maintenance interface, and EI circuit packs.	EPN	DEFINITY Server R, DEFINITY Server SI, S8700 Media Server, and S8500 Media Server
Switch node carrier – Contains the SNI circuit packs that make up the CSS.	EPN or PPN	DEFINITY Server R and S8700 Media Server
Duplicated control carrier (optional) – Contains the duplicate processor circuit packs to perform call processing, maintenance, and administration identical to that of the control carrier. This carrier can also contain port circuit packs.	PN	DEFINITY Server SI

Control carrier for DEFINITY Server SI

The control carrier is used for a DEFINITY Server SI. This carrier is not used for an S8700 Media Server or an S8500 Media Server.

See [Figure 61, Control carrier \(front\)](#), on page 165 for an example of a control carrier.

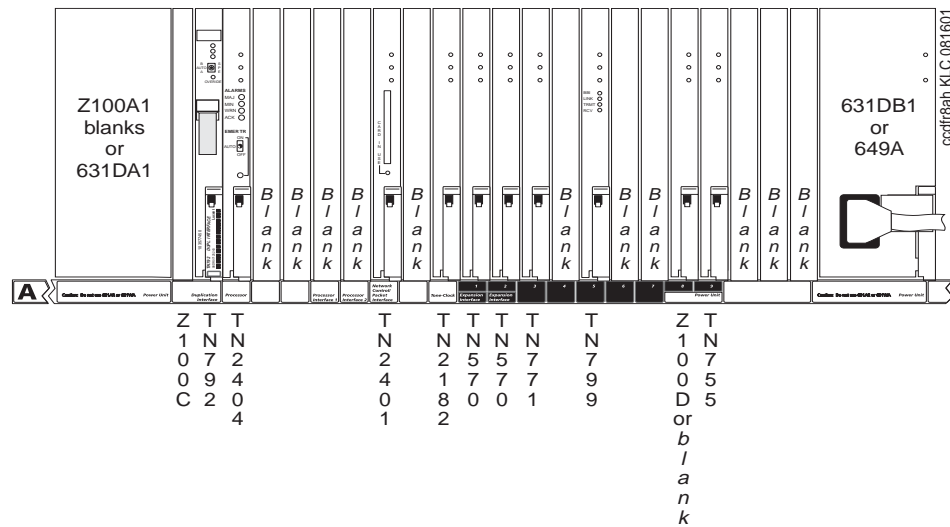
Figure 61: Control carrier (front)

The control carrier (J58890AH) has dedicated white-colored circuit pack slots that always contain specific control circuit packs. Dual-colored slots can contain any port circuit pack or the designated white circuit pack, such as an EI or power unit. AC or DC power units supply power to the carrier.

The following table describes the connectors in the control carrier.

Connector	Function
1 to 9 (A1 to A9)	25-pair connectors provide interfaces between port circuit packs and the cross-connect field or fiber transceiver.
AUX (Auxiliary)	Provide an interface for alarms, attendant console power, emergency power transfer panels, and an internal modem that is used for remote maintenance.
Processor interface for standard-reliability configurations	Connects directly to the PI circuit pack. Provides a BX.25 protocol interface for communication between the circuit pack and external DCE equipment.
Duplication option terminal	Used in high- and critical-reliability systems to connect an administration terminal to the active processor from the duplication interface slot position.
Terminal	Connects a management terminal to the processor in a standard-reliability system. In a critical-reliability system, connects a terminal to the processor in the control carrier.
P1	Provides a position indicator of the carrier, power to fans, and access to alarm and control circuits
P2	Provides control signals to the carrier
Data communications equipment	Connects the processor to CDR equipment, a system printer, or an external modem that is used for remote maintenance. This connector can be used with any reliability option.

Duplicated control carrier for DEFINITY Server SI

A duplicated control carrier (J58890AJ) contains the following colored slots:

- Dedicated white-colored circuit-pack slots that always contain specific control circuit packs.
- Gray and purple slots can contain port circuit packs.
- Dual-colored slots of white, gray, or purple can contain port circuit packs or designated white circuit packs, such as an expansion interface or power unit.

AC or DC power units reside at each end of a duplicated control carrier.

The following table describes the connectors in a duplicated control carrier.

Connector	Function
1 to 9 (B1 to B9)	25-pair connectors provide interfaces between port circuit packs and the cross-connect field or fiber transceiver.
Terminal	Connects a management terminal to the processor in the duplicated control carrier
P1	Provides a position indicator of the carrier, and access to alarm and control circuits

Processor carrier for DEFINITY Server R or SI

The processor carrier contains only dedicated slots for control circuit packs. A processor carrier does not contain slots for port circuit packs. The following figure shows an example.

This carrier always contains four memory circuit packs and one Packet Interface circuit pack. AC or DC power units reside at each end of a processor carrier.

See [Figure 62, Processor Carrier](#), on page 167 for an example of a processor carrier.

Figure 62: Processor Carrier

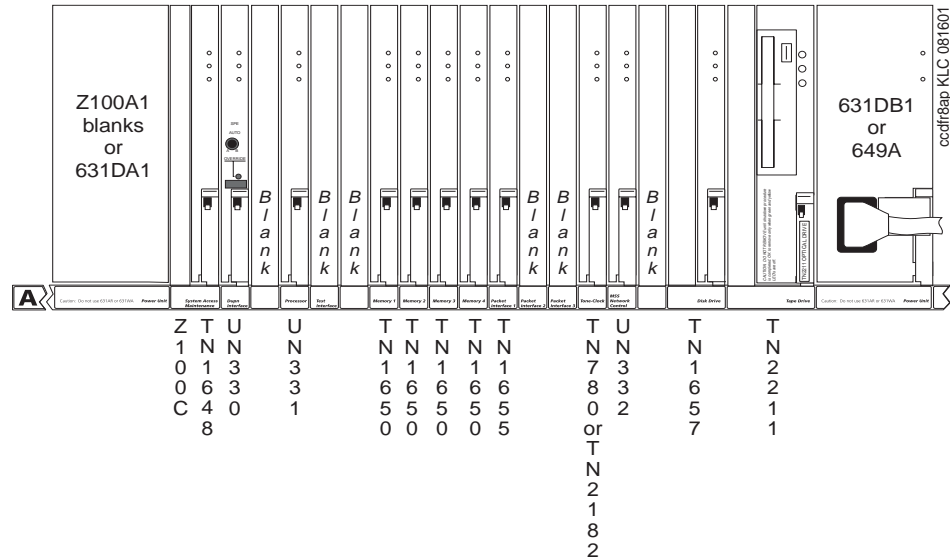

The following table describes the connectors in a processor carrier.

Connector	Function
Clock (Stratum-3)	The stratum-3 clock provides an interface for digital frame timing. (This is not a time-of-day clock.)
AUX (Auxiliary)	The AUX carrier provides an interface for customer alarms, attendant console power, emergency power-transfer panels, and an internal modem interface for remote maintenance.
Terminal active	Connects a management terminal to the system access and maintenance (SYSAM) circuit pack in the active processor carrier.
Terminal standby	Used only with duplicated processors to connect a management terminal to the standby processor carrier.
P1	Provides a position indicator of the carrier and access to alarm and control circuits
P2	Provides control signals to the carrier

Expansion Control Carrier for all server models

The expansion control carrier contains an EI or ATM Interface circuit pack in port slots 1 and 2. An expansion control carrier is used in a fiber-optic cabling path to another cabinet or the CSS in the same cabinet. The slots in an expansion control carrier may contain optional port circuit packs.

An expansion control carrier also contains port slots 3 to 19 and AC or DC power units. The Maintenance and Tone-Clock circuit packs are also shown. An optional neon power unit can be in slot 18 or 19.

See [Figure 63, Expansion Control Carrier \(Front\)](#), on page 168 for an example of an expansion control carrier.

Figure 63: Expansion Control Carrier (Front)

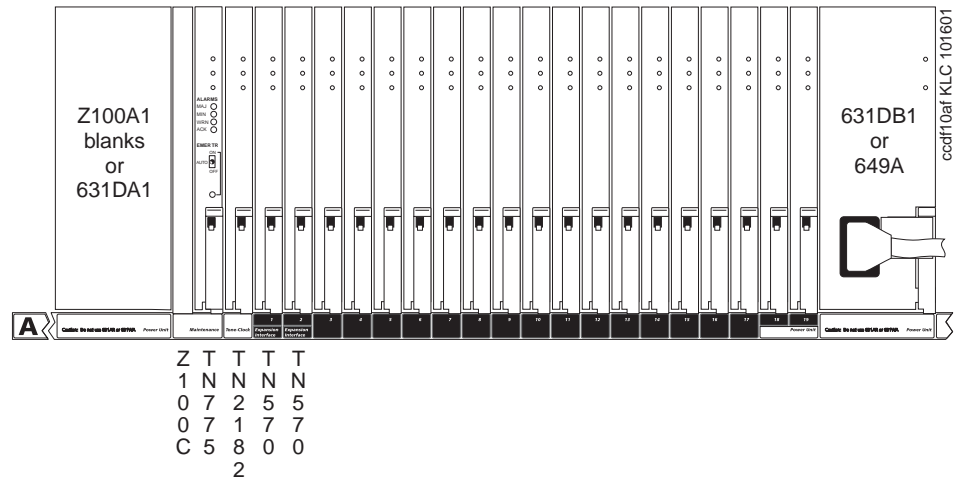

The following table describes the connectors of an expansion control carrier.

Connector	Function
1 and 2 A1 and A2	Provides a fiber-optic cable interface to an Expansion Interface (EI) circuit pack in slot 1 ¹ or a copper cable interface for a DS1 converter
1 to 19 A1 to A19	25-pair connectors provide interfaces between port circuit packs and the cross-connect field or fiber transceiver
Auxiliary (AUX)	Provides interfaces for customer alarms, attendant console power, and emergency power transfer panels
TERMINAL	Connects a management terminal to the Maintenance circuit pack in an expansion control carrier
P1	Provides a position indicator of the carrier and access to alarm and control circuits
P2	Connects ringing voltage from the ring generator to the carrier and produces control signals

¹ In systems that use ATM-PNC, the fiber connectors for the OC-3/STM-1 interfaces to the ATM switches reside on the faceplates of the TN2305 or the TN2306 circuit packs.

Port carrier for DEFINITY Server SI or R, S8700 Media Server, or S8500 Media Server

A port carrier contains the following slots:

- Port slot locations 1 to 20 for the port circuit packs. Slot 1 might contain a Tone-Clock circuit pack when the port carrier is in the B position of an EPN cabinet in a critical-reliability system. Slot 2 contains an optional EI or ATM Interface circuit pack for a critical-reliability system.
- A power unit service slot in which a power unit circuit pack or service circuit pack can be installed.
- AC or DC power units reside at each end of the carrier.

See [Figure 64, Port carrier \(front\)](#), on page 169 for an example of a port carrier.

Figure 64: Port carrier (front)

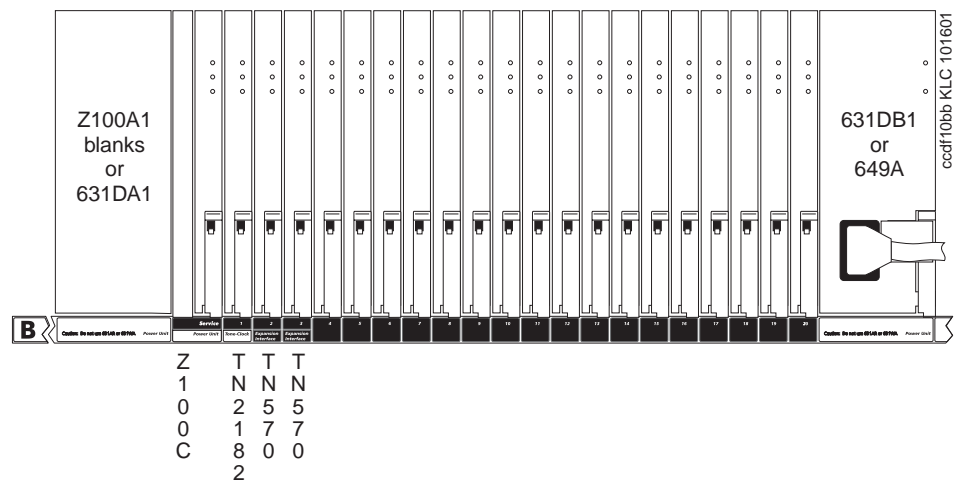

The following table describes the connectors in the processor carrier.

Connector	Function
1 to 20	25-pair connectors that provide interfaces between port circuit packs and the cross-connect field or fiber transceiver
P1	Provides a position indicator of the carrier and access to alarm and control circuits

Switch node carrier for DEFINITY Server R or S8700 Media Server

The switch node carrier (SNC) (J58890SA) can contain:

- One or two switch node clocks
- Up to 16 Switch Node Interface (SNI) circuit packs
- One or two DS1 converter circuit packs
- One EI circuit pack
- Two AC or DC power units

An AC or DC power unit resides at each end of an SNC. An SNC can be used when connecting from one to 44 PNs, but must be used when connecting three or more EPNs.

See [Figure 65, Switch node carrier \(front\)](#), on page 170 for an example of a switch node carrier.

Figure 65: Switch node carrier (front)

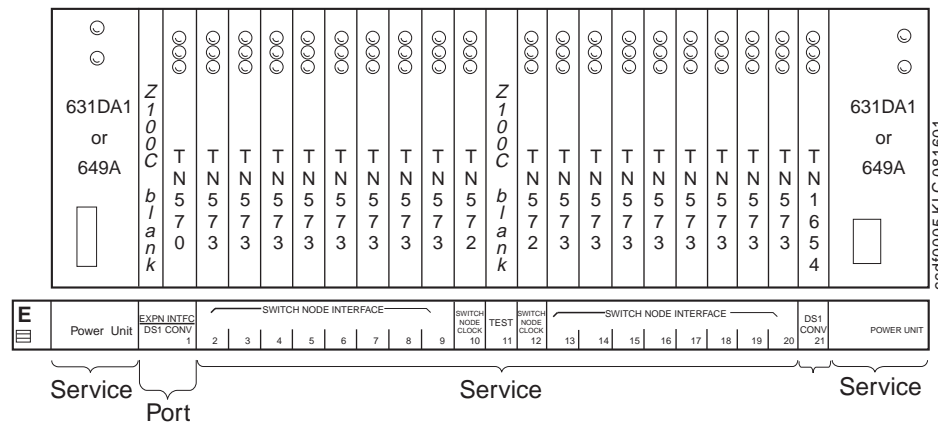

The following table describes the connectors in a switch node carrier.

Connector	Function
1 (E1)	EI connector for the cable between the EI circuit pack in slot 1 and the Switch Node Interface (SNI) circuit pack in slot 2 for a duplicated PN only. Also used for a DS1 Converter circuit pack in slot 1.
2 to 9 and 13 to 20 (E2 to E19 and E13 to E20)	SN ports that are fiber-optic cabling interfaces to the SNI circuit packs and other circuit packs that are connected to SN ports or circuit packs in expansion PNs.
21 (E21)	Interface to connect the DS1 Converter circuit pack to the cross-connect field and an SNI circuit pack.
P1	Provides the position indicator of the SN carrier and provides access to alarm circuits and control circuits.

Table 8: Carrier circuit pack slots

Type	Description	Server
Port	A port slot is colored purple or labeled with a gray rectangle. A port slot can accept any purple- or gray-labeled circuit pack.	DEFINITY Server R, SI, and S8700 Media Server
Control	A control slot is colored white or labeled with a outlined white rectangle. A port slot can accept any purple- or gray-labeled circuit pack.	DEFINITY Server R and SI
Service	A service slot is colored purple or labeled with a gray rectangle. A service slot accepts special circuit packs that do not have an I/O connector.	DEFINITY Server R, SI and S8700 Media Server

The purple- and white-colored circuit packs and slots have been replaced by circuit packs and slots that are labeled with gray and white rectangles, respectively. A label with a solid gray rectangle indicates a slot for a port circuit pack. A label with an outlined white rectangle indicates a slot for a control circuit pack. Each port slot attaches to a 50-pin (25-pair) connector on the rear panel of the carrier. A cable attaches to each connector and is routed to the cross-connect field. Each slot that contains a fiber-optic interface circuit pack (EI or SNI) uses a fiber-optic transceiver on the rear panel of the carrier.

A current limiter board (CFY1B) plugs into the backplane of the carrier located in the A position. The board supplies the following:

- Emergency transfer logic
- Current-limited power
- 5 VDC to trip the main circuit breaker in an over-temperature condition
- The ringing transfer relay

Terminators on the backplane terminate each end of the processor expansion bus.

The following apparatus blank faceplates (with widths) cover unused circuit pack slots in the carriers to maintain proper air flow:

- Z100A1, 0.75 inches (1.9 cm)
- Z100C, 0.5 inches (1.27 cm)
- Z100D, 0.25 inches (0.64 cm)

Circuit packs and power supplies

1217A AC power supply

A 1217A power supply is used only with an SCC1 Media Gateway. This power supply provides additional protection to your equipment in the event of an overload. An overload triggers a power-supply alarm, but the system's cooling fans continue to run, and the power supply continues to function. This power supply replaces the WP-51193 L3 and L4-25 and is fully backward compatible.

This power factor-corrected supply accepts 50- or 60-Hz AC input, while auto-ranging between 90- and 264-VAC input. This multiple-output power supply provides regulated DC outputs and AC ringer outputs that are switch-selectable 20- or 25-Hz AC . The 1217A power supply meets the:

- Harmonic-distortion requirements of IEC1000-3-2 (PFC)
- Immunity requirements of IEC 1000-4
- Safety requirements of IEC 950
- Current UL requirements and CSA requirements

The 1217A power supply mounts in a carrier's power supply slot. A power cord with a 3-prong plug on one end connects the supply to a dedicated AC power source.

631DA1 AC power unit

A 631DA1 power unit accepts 60-Hz, 120-VAC input power and provides DC power at +5V and up to 60A for the backplanes of an MCC1 Media Gateway's carriers.

If AC input power fails, the power unit can convert 144 VDC from optional batteries in an AC power-distribution unit to +5 VDC. A circuit in the optional battery charger detects the higher equivalent (AC- or DC-input) voltage and switches in the correct input voltage.

631DB1 AC power unit

A 631DB1 power unit accepts 60-Hz, 120-VAC input power and provides DC power at both:

- -48 V at 8 A
- -5 V at 6 A

for the backplanes of an MCC1 Media Gateway's carriers. The DC output of -48 V also drives the cabinet's fans.

If AC input power fails, the power unit can convert 144 VDC from optional batteries in an AC power-distribution unit to +5 VDC. A circuit in the optional battery charger detects the higher equivalent (AC- or DC-input) voltage and switches in the correct input voltage.

649A DC power unit

A 649A power converter converts a DC input of -48 V into DC outputs of:

- -48 V at 10 A
- ± 5 V at 6 A

for an MCC1 Media Gateway. Within a carrier, these outputs are distributed to the circuit packs' slots. Only one 649A converter is required per carrier except for SN carriers. SN carriers require two converters, one on each end. The use of the 649A power unit also allows an increase in the number of telephones supported by each carrier.

650A AC power unit

This global power factor-corrected supply accepts 47- to 63-Hz AC input, while auto-ranging between 85- and 264-VAC input. While providing 330 Watts of total output, the 650A power unit provides multiple DC outputs as follows:

- +5.1 VDC at 28 A
- -5.1 VDC at 1.0 A
- -48 VDC at 4.5 A
- +8- to +14 VDC at 1.6 A (fan-speed control)

This output (+12 VDC nominal) controls the fans' speed. The voltage varies with the temperature of the ambient air at the inlet below the power supply. If this voltage reaches +14 VDC, the system activates a FANALM signal.

- -115 to -150 VDC at 200 mA (neon bus)

The 650A power unit has three switch-selectable outputs for ringing:

- 20-Hz AC output at 85 V RMS and 80 mA, — centered about -48 VDC at 180 mA
- 25-Hz AC output at 72 V RMS and 8 to 80 mA, — centered about -48 VDC at 180 mA
- Two 50-Hz AC outputs at 28 V RMS (effectively 56 V) and 220 mA, — biased about -48 and 0 VDC at 70 mA balanced

655A power supply

The G650 can use one or two 655A power supplies. Either power supply can provide all the power needed by the G650. When there are two power supplies, they share the power load. The 655A power supply is:

- The only power supply supported in the G650
- Not backward compatible to other carrier types

If one G655A power supply is used it will be located in slot 0 of the G650 Media Gateway. If two G655A power units are used, they will be located in slots 0 and 15.

NOTE:

You can insert or remove a **redundant** power supply and not affect the G650 if the other 655A power supply is operating.

Input power

The 655A power supply is capable of operating on either AC or DC input power. AC power is always used if available. One power supply can operate on AC power, and the other on DC power. The power supplies use AC power first and switch to DC power if AC power fails or is not present.

AC power

Commercial AC is the primary input power source. Both slot 0 and slot 15 have dedicated AC input. The 655A power supply can operate on AC input of 90- to 264-VAC at 47 to 63 Hz. The nominal ranges for AC power are:

- 100- to 120-VAC at 50 or 60 Hz
- 200- to 240-VAC at 50 or 60 Hz

DC power

Minus 48VDC power can be supplied simultaneously as backup power. One -48VDC power input point is provided on the G650 backplane and is distributed through the backplane to each power supply.

Serial bus

The 655A power supply interfaces to the serial bus that is implemented on the G650 cabinet backplane. The 655A responds to commands and queries from the TN2312BP IPSI serial bus master.

655A faceplate LEDs

The five LEDs on the faceplate of the 655A power supply are in a vertical line with the red LED on top. These five LEDs provide the following status:

- Red – This LED:
 - Lights when there is a failure in either the power supply or the fans. (For a G650 with redundant power supplies, a failure in the fan assembly results in this LED being lit on **both** power supplies.)
 - Flashes off once per second when the software shuts down the ring voltage output of a power supply
- Yellow – This LED:
 - Lights when the status of the power supply and fans is OK
 - Flashes once per second when the software shuts down a single power supply, in a carrier with operational redundant power supplies
- Green – Lights when there is AC power applied to the power supply
- Green – Lights when there is DC power applied to the power supply
- Green – Lights when the power supply is supplying ringing to the G650

655A ring generation

The 655A provides either North American ringing (20 Hz) or European/International (25 Hz) ringing. It also has a setting to provide no ringing when the customer supplies a ring generator that is external to the power supply. A TN2202 (French ringing circuit pack) is an example of an external ring generator.

The 655A power supply provides a physical slide switch to select the frequency of the ring generator. The options are:

- 20 Hz – North American
- 25 Hz – European and international
- Other – No ringing output when an external ring generator is used such as the TN2202 French ringing circuit pack.

You must remove the power supply from the G650 when you change the ringing frequency selection.

Only one 655A supplies ringing to the G650. The power supply in slot 0 in the G650 is the default for ringing. The system uses this default 655A unless it has failed or the software has commanded it to shut down. When a G650 carrier has redundant power supplies, one supply automatically supplies ringing if the other power supply fails.

A 655A provides ringing to only one G650 carrier. For example, the 655A power supplies in carrier A supply ringing only to carrier A, and the power supplies in carrier D supply ringing only to carrier D. If the ring generation in both of a carrier's power supplies fail, no other power supply provides ringing for the carrier.

676C DC power supply

A -48 VDC source supplies power to the DC power supply at up to 25 A. The 676C power supply for the SCC1 Media Gateway, produces DC outputs of +5, -5, -48, and +12 VDC. The DC outputs are distributed across the cabinet's backplane to each circuit pack's slot. The output value and frequency of the AC ringing voltage depend on the country of use. The power supply has circuit breakers and electromagnetic interference (EMI) filtering.

982LS current limiter

The 982LS current limiter connects behind the Processor circuit pack's slot only in the processor port network (PPN) of a DEFINITY SI system. The 982LS provides current-limited accessory 48-VDC, emergency transfer logic, current-limited 5-VDC to trip main circuit breaker if high temperature is detected, and duplicated 48-VDC to fans in the PPN cabinet.

CFY1B current limiter

The CFY1B current limiter is used only in the DEFINITY R system only.

The CFY1B circuit pack supports the PPN and the MCC1 and SCC1 Media Gateway EPNs. The CFY1B current limiter connects behind the Maintenance circuit pack's slot and provides current-limited accessory 48-VDC, emergency transfer logic, current-limited 5-VDC to trip the main circuit breaker if high temperature is detected, and duplicated 48-VDC to fans in an EPN cabinet.

ED-1E568 DEFINITY AUDIX R4

For information about ED-1E568 DEFINITY AUDIX R4, see [TN568 DEFINITY AUDIX 4.0 Voice Mail System \(part of ED-1E568\)](#) on page 181.

J58890MA-1 Multiapplication Platform for DEFINITY (MAPD)

The J58890MA-1 is a variation of the MAPD platform that transports ASAI links between a DEFINITY LAN gateway system and an Ethernet LAN. The J58890MA-1 circuit-pack assembly uses the TN801B MAPD (LAN Gateway Interface) which is a circuit pack that is built from industry-standard PC processors, interfaces, buses, and ISA/PCI expansion boards. The J58890MA-1 takes up three adjacent slots in the carrier. In a CMC1 Media Gateway the J58890MA uses only two slots if placed in slot six or seven. There are different lists of the J58890MA which is indicated by a number at the end after the dash. A list represents different hardware configurations of the same board.

The following describes the capabilities of the different lists for the J58890MA:

- J58890MA-2 supports CallVisor ASAI and LAN Gateway
- J58890MA-10 supports IP trunking
- J58890MA-20 supports CallVisor ASAI, Avaya Computer Telephony, and Basic Call Management System Reporting Desktop
- J58890MA-30 supports IP solutions

NAA1 fiber-optic cable adaptor

The NAA1 adapter reroutes fiber-optic cable from the front of an ATM circuit pack to the rear of a CMC1 Media Gateway. While the NAA1 fiber-optic cable adaptor looks like a circuit pack, it is electrically and optically passive.

TN429D Incoming Call Line Identification (ICLID)

The TN429 Incoming Call Line Identification (ICLID) circuit pack provides eight ports for direct inward/outward dialing (DIOD) trunks. Each port provides a 2-wire interface to the central office (CO) public exchange for incoming calls and outgoing calls. The CO provides caller names and numbers to the circuit pack, which displays them on digital telephones (DCP and BRI) equipped with a 32- or 40-character alphanumeric display. In the United States the ICLID supports name and number. In Japan, and other countries that comply with requirements the ICLID displays the number only.

This ICLID is required for the Japan ANI feature where the calling number passes through to the switch. An in-band detector/converter may be required. Contact your Avaya representative more information.

The ICLID provides the required CO disconnect functions as well as the interface to CAMA/E911.

TN433 Speech Synthesizer

The TN433 speech synthesizer for Italian provides four ports that retrieve fixed messages for leave word calling, automatic wake up, and attendant console features for the visually impaired. These fixed messages include: good morning, time-of-day, and extension number. Each of the ports has touch-tone detection. The TN433 speech synthesizer has administrable A- and μ -Law companding capabilities.

TN436B Direct Inward Dialing Trunk (8 ports)

The TN436B Direct Inward Dialing (DID) trunk for Australia provides eight ports for DID. These ports are independently connected to a public network. Each port is an interface between a 2-wire analog line from a CO and the 4-wire TDM network in the system. The TN436B DID for Australia has administrable timers.

TN438B Central Office Trunk (8 ports)

The TN438B CO trunk for Australia provides eight ports for loop-start CO trunks. Each of the eight ports has tip and ring signal lead. The TN438B can detect 12-kHz and 50-Hz periodic metering pulses from the CO. Additional features include call still held timing and automatic guard fault-detection circuitry.

TN439 Tie Trunk (4 ports)

The TN439 Tie Trunk circuit pack for Australia and Japan provides four ports for 2-wire tie trunks with loop disconnect signaling. The TN439 has administrable A- and μ -Law companding and administrable timers.

TN457 Speech Synthesizer

The TN457 speech synthesizer or British English provides four ports that retrieve fixed messages for leave word calling, automatic wake up, and attendant console features for the visually impaired, that are spoken with a UK accent. Examples of messages are: good morning, time-of-day, and extension number. Each of the ports has touch-tone detection. The TN457 has administrable A- and μ -Law companding capabilities.

TN459B Direct Inward Dialing Trunk (8 ports)

The TN459B DID circuit pack for the United Kingdom provides eight ports for immediate- or wink-start DID trunks. Each port has tip and ring signal leads. Each port is an interface between a 2-wire analog line from a CO and the 4-wire TDM network in the system. The TN459B has administrable timers and a backward busy circuit that complies with signaling requirements.

TN464GP DS1 Interface, T1 (24 channels) or E1 (32 channels)

The TN464GP circuit pack provides:

- Board-level, administrable A- or μ -Law companding
- CRC-4 generation and checking (E1 only)
- Stratum-3 clock capability
- ISDN-PRI T1 or E1 connectivity
- Line-out (LO) and line-in (LI) signal leads (unpolarized, balanced pairs)
- Support for CO, TIE, DID, and off-premises station (OPS) port types that use robbed-bit signaling protocol, proprietary bit-oriented signaling (BOS) 24th-channel signaling protocol, or DMI-BOS 24th-channel signaling protocol
- Support for Russian incoming ANI
- Support for universal, digital, signal level-1 equipment in wideband ISDN-PRI applications
- Test-jack access to the DS1 or E1 line and support of the 120A integrated channel-service unit (ICSU) module
- Support for the enhanced maintenance capabilities of the ICSU. These circuit packs can communicate with CONVERSANT[®]. See [TN2185B ISDN-BRI S/T-TE Interface \(4-wire, 8 ports\)](#) on page 198.
- Downloadable firmware
- Support for echo cancellation. To enable this capability, the customer must purchase an Echo Cancellation Software Right-to-Use feature in addition to the hardware.

The echo cancellation capability of the TN464GP is selectable on a per-channel basis. The TN464GP DS1 interface automatically turns off echo cancellation when it detects a 2100-Hz phase-reversed tone generated by high-speed modems (56-kbps), but not when it detects a 2100-Hz straight tone generated by low-speed modems (9.6-kbps). Echo cancellation improves a low-speed data call.

The TN464GP DS1 interface is intended for customers who are likely to encounter echo over circuits that are connected to the public network. The occurrence of echo is higher if the switch is configured for ATM, IP, or other complex services and interfaces to local service providers who do not routinely install echo cancellation equipment in all their circuits. A common source of echo is “hybrid” circuits, where conversions between 2-wire analog and 4-wire digital circuits take place. The TN464GP DS1 interface cancels echo with delays of up to 96 ms.

TN465C Central Office Trunk (8 ports)

The TN465C CO Trunk circuit pack supports multiple countries.

This circuit pack contains eight analog CO trunk ports, loop-start trunk signaling, 12- and 16-kHz periodic pulse metering (PPM) detection and counting, administrable timers, battery-reversed signaling, and multicountry selectable signaling. For more information about a TN465C, contact your Avaya representative.

TN479 Analog Line (16 ports)

The TN479 analog line circuit pack has 16 ports and supports three ringer loads and three simultaneous ringing ports. Only one telephone can have an LED message-waiting indicator (neon message-waiting indicators are not supported). The TN479 supports μ -Law companding.

The following table lists the TN479-supported telephones and shows each of their wiring sizes and ranges.

Telephone	Wire size (metric area/diameter)	Maximum range (feet)
500-type	24 AWG (0.2 mm ² /0.5 mm)	3,000 (914 m)
2500-type	24 AWG (0.2 mm ² /0.5 mm)	3,000 (914 m)
7100-series	24 AWG (0.2 mm ² /0.5 mm)	3,000 (914 m)
7101A	not supported	not supported
7103A	not supported	not supported
8100-series	24 AWG (0.2 mm ² /0.5 mm)	2,500 (762 m)
9100-series	24 AWG (0.2 mm ² /0.5 mm)	2,500 (762 m)

TN497 Tie Trunk (4 ports)

The TN497 tie trunk circuit pack for Italy has four ports for 2-wire tie trunks with loop disconnect signaling. Each port can be administered for A- or μ -Law companding, timers, Translate Giunzione Unscante (TGU) (outgoing tie), Translate Giunzione Entrante (TGE) (incoming tie), and Translate Giunzione Interno (TGI) (internal tie).

TN553 Packet Data Line

The TN553 packet data line circuit pack has 12 ports that can connect through a cross-connect field to a TN726B circuit pack and provides software-administrable connections between the Switch Processing Element (SPE) and system access ports. Inside the system, the TN553 connects to the packet bus and converts mode-2 to mode-3 protocol which connects the TN726B circuit pack to the TDM bus for asynchronous EIA connections to adjuncts.

TN556D ISDN-BRI 4-Wire S/T-NT Interface (12 ports)

The TN556D ISDN-BRI circuit pack has 12 ports that connect to ISDN-BRI terminals. Each port on a TN556 ISDN-BRI circuit pack has TXT, TXR, PXT, and PXR signal leads. Up to eight ports can be used for Adjunct Switch Application Interface (ASAI) links. Each port operates at 192 kbps and has 2 B channels and 1 D channel.

The TN556D ISDN-BRI circuit pack has a maximum range of up to 1900 feet (579 m) from the system to the telephone when connected with 24-AWG (0.20 mm²/0.51 mm) wire, and uses standard ANSI T1.605 protocol. Up to 24 terminals can be connected, where each terminal uses 1 B channel and shares the D channel. The TN556 also has multipoint support. Capacity for the multipoint support depends on the protocol. In countries that do not support Service Profile Identifier (SPID) there is a limitation of one BRI phone per port.

The TN556D ISDN-BRI circuit pack supports A- or μ -Law companding. The TN556D ISDN-BRI circuit pack also functions as a trunk when connecting to a TE interface, for example a TN2185B in another switch. It can be used for lines and trunks simultaneously. The TN556D ISDN-BRI circuit pack provides end-to-end outpulse signaling when the circuit pack is in tie-trunk mode with a [TN2185B ISDN-BRI S/T-TE Interface \(4-wire, 8 ports\)](#).

TN568 DEFINITY AUDIX 4.0 Voice Mail System (part of ED-1E568)

The TN568 circuit pack is a component of the ED-1E568 that supports an DEFINITY AUDIX voice mail system using an embedded 386EX processor. The DEFINITY AUDIX systems can be interconnected to create large voice-mail networks that support up to 100,000 subscribers and store up to 100 hours of messages. Each circuit pack has eight ports available for calls when networking is enabled. Without networking, 12 ports are available.

The TN568 DEFINITY AUDIX voice mail system takes up two adjacent slots.

The TN568 DEFINITY AUDIX circuit pack includes a writable magneto-optical disk drive for backing up and upgrading system software and a hard disk for storing messages. The TN568 DEFINITY AUDIX circuit pack also includes an RS-232 connection for a maintenance and administration terminal, an Ethernet port (for the Message Manager PC desktop application), an Amphenol connection to the switch, and an RS-232 port for an external modem that is used for maintenance.

TN570D Expansion Interface

The TN570 Expansion Interface (EI) is an interface between the TDM bus and packet bus, and fiber-optic links that interconnect the cabinets. The TN570D circuit pack is used in a port network (PN) between a PN and another PN in a direct-connect system, and between a PN and an SNI in a switch node carrier in a CSS-connected system.

The TN570 circuit pack provides control-channel applications and time-slot interchanging between the PPN and EPNs. It is used when ISDN-BRI and/or ASAI is connected in an EPN.

The TN570 circuit pack carries circuit-switched data, packet-switched data, network control, timing control, and DS1 control. The TN570 circuit pack also communicates with an EPN's TN775B Maintenance circuit pack to send the EPN's environmental and alarm status to the SPE.

The TN570 circuit pack is replaced by the TN2305 circuit pack or TN2306 circuit pack when an ATM switch replaces the CSS.

The TN570 circuit pack is used in an EPN that is supported by a Survivable Remote Processor (SRP).

TN572 Switch-Node Clock

The TN572 switch-node clock circuit pack is used in DEFINITY R only.

The TN572 circuit pack distributes the timing signals that synchronize the SN carrier. The TN572 circuit pack also receives maintenance data.

TN573B Switch-Node Interface for DEFINITY R

The TN573B Switch Node Interface (SNI) routes circuit, packet, and control messages. The TN573B circuit pack is an interface installed in a SN carrier in a CSS. The TN573B circuit pack terminates a fiber-optic link from:

- A SNI in an SN carrier to an SNI in another SN carrier
- An EI in a PPN, and an EI in an EPN.

One TN573B is used per PN and supports the TN574 DS1 converter circuit pack.

The TN573B circuit pack vintage B and higher provides an interface to the single-mode fiber optic transceiver and supports the TN1654 circuit pack and TN574 DS1 converter circuit pack.

TN577 Packet Gateway

The TN577 packet gateway (PGATE) circuit pack is used in DEFINITY R only.

The TN577 circuit pack provides four RS-423 physical ports for X.25 protocol interfaces between the system and adjuncts. The PGATE functions as the data communications interface unit providing protocol conversion between the X.25 protocol and the mode 3 protocol carried across the LAN bus.

The X.25 protocol (Levels 1 and 2) is terminated and the data is reformatted into the ISDN packet mode protocol for transport across the LAN bus. Supported adjuncts include AUDIX, CMS, and Message Server Adjunct (MSA).

The TN577 also supports Distributed Communications System (DCS) by providing X.25 signaling through:

- One of the RS-423 physical ports
- Through the system using the TDM bus to the appropriate DS1 or tie trunk circuit pack.

TN725B Speech Synthesizer

The TN725B speech synthesizer supports English and is used in the United States.

The TN725B speech synthesizer circuit pack has four ports that send voice message information to telephones to activate leave word calling, automatic wake up, voice message retrieval, and Do Not Disturb features. The ports can detect tones.

TN726B Data Line (8 ports)

The TN726B data line circuit pack has eight serial asynchronous EIA ports with modem interfaces that are connected through asynchronous data units (ADUs) to EIA ports (such as RS-232) on DTE. The TN726B circuit pack uses Mode 2 or Mode 3 data transfer protocol. The DTE can be adjuncts and peripheral equipment such as data terminals, printers, host computers, personal computers (PCs), graphics and facsimile systems, and call detail acquisition and processing systems (CDAPSs).

With software-administered system access ports, a TN726B circuit pack connects through a cross-connect field to a TN553 packet data line circuit pack. The TN553 circuit pack then converts mode 2 protocol to mode 3 protocol that transfers the TN726B circuit pack from the packet bus to the TDM bus for EIA connections.

Each port on a TN726B circuit pack has TXT (terminal, transmit, and tip), TXR (terminal, transmit, and ring), PXT (port, transmit, and tip), and PXR (port, transmit, and ring) signal leads.

TN735 MET Line (4 ports)

The TN735 MET line circuit pack has four ports that connect to multibutton electronic telephone (MET) sets. Each port has tip and ring (analog voice) and digital signals to control terminals such as BT, BR, LT and LR.

TN744E Call Classifier and Tone Detector (8 ports)

The TN744 call classifier and tone detector circuit pack has eight ports of tone detection on the TDM bus. The TN744 circuit pack does not support call progress tone generation or clocking. The tone detectors are used in vector prompting, outgoing call management (OCM), and call prompting applications in the United States and Canada and call classifier options for various countries. The TN744 detects special intercept tones used in network intercept tone detection in OCM. The TN744 circuit pack also detects tones when a CO answers a call.

The TN744 circuit pack provides tone generation and detection for R2-MFC DID signaling that is used in non-United States installations. The TN744 circuit pack also allows gain or loss to be applied to pulse code modulation (PCM) signals that are received from the bus and supports A- and μ -Law companding. The TN744 circuit pack detects 2025-, 2100-, or 2225-Hz modem answerback tones and provides normal broadband and wide broadband dial-tone detection.

The TN744 circuit pack supports digital signal processing of PCM signals on each port to detect, recognize, and classify tones and other signals. Generation of signaling tones is also supported for applications such as R2-MFC, Spain MF, and Russia MF. Gain or loss and conferencing can be applied to PCM signals received from the TDM bus. Additional support includes DTMF detectors to collect address digits during dialing, and A- and μ -Law companding.

In normal operation, a port on the TN744 circuit pack can serve as an incoming register for Russia MFR (multifrequency shuttle register signaling). Use the TN744 with the TN429C analog line central office trunk for CAMA/E911.

TN746B Analog Line (16 ports)

The TN746B analog line circuit pack has 16 ports. Each port supports one telephone. Auxiliary equipment such as FAX machines, answering machines, modems, and amplifier handsets is supported.

The TN746B circuit pack supports on-premises building wiring with either touch-tone or rotary dialing and with or without the LED and neon message waiting indicators. The TN746B circuit pack supports off-premises wiring (out-of-building only with certified protection equipment) with either DTMF dialing or rotary dialing. LED or neon message waiting indicators are not supported off-premises. The TN746B circuit pack provides -48 V DC current in the off-hook state. Ringing voltage is -90 V DC.

The TN746B, along with a TN755B neon power unit per carrier or per single-carrier cabinet, supports on-premises telephones that are equipped with neon message waiting indicators. The TN746B circuit pack supports three ringer loads, only one telephone can have an LED or neon message waiting indicator.

TN746B supports A- and μ -Law companding and administrable timers. The TN746B supports:

- Queue warning-level lights associated with the DDC features and the UCD features
- Recorded announcements associated with the Intercept Treatment feature
- PagePac paging system for the Loudspeaker Paging feature.

Additional support is provided for external alerting devices associated with the TAAS feature, neon message waiting indicators, and modems. Secondary lightning protection is provided on the TN746B circuit pack. The TN746B circuit pack supports up to eight simultaneous ports ringing; four on ports one through eight, and four on ports 9 through 16.

Combined conversion of Modem Pooling requires a port on a TN754 and a port on a TN742, TN746B or TN769 Analog circuit pack for each combined resource that is to be supported.

The following table lists the TN746B-supported telephones and shows each of their wiring sizes and ranges.

Telephone	Wire size (AWG)	Maximum range (feet)
500-type	24 (0.2 mm ² /0.5 mm)	20,000 (6,096 m)
2500-type	24 (0.2 mm ² /0.5 mm)	20,000 (6,096 m)
7100-series	24 (0.2 mm ² /0.5 mm)	20,000 (6,096 m)
7101A	24 (0.2 mm ² /0.5 mm)	15,200 (4,633 m)
7103A	24 (0.2 mm ² /0.5 mm)	15,200 (4,633 m)
8100-series	24 (0.2 mm ² /0.5 mm)	12,000 (3,657 m)
9100-series	24 (0.2 mm ² /0.5 mm)	12,000 (3,657 m)

TN747B Central Office Trunk (8 ports)

The TN747B CO trunk circuit pack has eight ports for loop- or ground-start CO, foreign exchange (FX), and wide area telecommunications service (WATS) trunks. Each port has tip and ring signal leads. A port can connect to a PagePac paging system. The TN747B supports the abandoned call search feature in automatic call distribution (ACD) applications (if the CO has this feature). Vintage 12 or greater of the TN747B circuit pack also provides battery-reversed signaling.

TN750C Recorded Announcement (16 channels)

NOTE:

The TN2501AP circuit pack has replaced the TN750 circuit pack. However, the TN750 circuit pack is still supported.

The TN750 recorded announcement circuit pack records and stores announcements to be played back on demand as part of a calling feature. The TN750 circuit pack has sampling rates of 16, 32, or 64 kbps. The TN750 circuit pack records announcement messages from on-premises or off-premises telephones and can store up to 128 recorded announcements of a maximum of eight minutes total. The TN750 circuit pack has 16 channels and each can play any announcement. Up to 25 call connections can listen to each channel.

A total of 10 TN750C circuit packs in a system provides an announcement capacity of 42.6 minutes (at 32 kbps) and 160 ports. In other words, 160 announcements can play simultaneously. The 16 kbps compression rate, which is adequate for VDN of origin announcements, provides a total capacity of 85.3 minutes. Use of multiple TN750C circuit packs allows a more efficient method of providing many kinds of announcements and provides improved management of integrated announcements.

TN753B Direct Inward Dialing Trunk (8 ports)

The TN753B DID trunk circuit pack has eight ports used for immediate- or wink-start direct inward dialing (DID) trunks. Each port has tip and ring signal leads. For the Slovak Republic, vintage 17 (or greater) is required. The TN753B circuit pack supports A- and μ -Law companding with vintage 17 or greater.

The TN753B circuit pack is required to support Brazil Block Collect Call.

TN754C DCP Digital Line (4-wire, 8 ports)

The TN754C DCP digital line circuit pack has eight asynchronous, 4-wire DCP ports that can connect to 7400- and 8400-series digital telephones, 302A/B/C attendant consoles, or data modules. The TN754 circuit pack has administrable A- and μ -Law companding.

The following table lists the TN754-supported equipment and shows each of their wiring sizes and ranges.

Table 9: Maximum range of 7400- and 8400-series equipment

Supported equipment	Wire sizes (AWG)	Maximum range (feet)
7400 data modules	24 (0.2 mm ² /0.5 mm)	5000 (1524 m)
7400 data modules	26	4000 (1219 m)
7400-series telephones	24 (0.2 mm ² /0.5 mm)	3500 (1067 m)
7400-series telephones	26	2200 (670 m)
8400-series data modules	24 (0.2 mm ² /0.5 mm)	3500 (1067 m)
8400-series telephones	24 (0.2 mm ² /0.5 mm)	3500 (1067 m)

The TN754 circuit pack provides greater call-handling capacity for high-traffic applications and supports the group paging feature.

Combined conversion of Modem Pooling requires a port on a TN754 circuit pack and a port on a TN746B circuit pack or TN769 analog circuit pack for each combined resource that is to be supported.

TN755B Neon Power Unit

The TN755B neon power unit circuit pack is used in with all DEFINITY servers except the DEFINITY CSI. The TN755B circuit pack produces 150 VDC to operate neon message waiting lights on terminals that are connected to TN746B analog line circuit packs.

A TN755B circuit pack is required for each carrier where neon message waiting indicators are connected.

This circuit pack and the neon message waiting function are not available on systems that use the TN2202 ring generator circuit pack for France balanced-ringing.

TN758 Pooled Modem (2 ports)

The TN758 pooled modem circuit pack has two conversion resources ports (such as a trunk data module) for switched connections between digital data endpoints (data modules) and analog data endpoints (modems). A TN758 circuit pack is required for each two conversion resources provided with the integrated type of modem pool. The TN758 circuit pack supports μ -Law companding only.

TN760E Tie Trunk (4-wire, 4 ports)

The TN760 tie trunk circuit pack has four ports that are used for Type 1 or Type 5 4-wire E & M lead signaling tie trunks. Trunk types include automatic, immediate-start, wink-start, and delay-dial. Each port on a TN760 circuit pack has T, R, T1, R1, E, and M signal leads. The TN760 circuit pack provides release link trunks required for the CAS feature and has administrable A- and μ -Law companding. The TN760 circuit pack supports outgoing, Multilevel Precedence and Preemption (MLPP).

Option switches on each TN760 circuit pack port can select connections to Type 1 E & M standard unprotected format, Type 1 E & M compatible unprotected format, Type 1 E & M compatible protected format, and Type 5 simplex format.

For Belgium, the Slovak Republic, the Commonwealth of Independent States, and the Netherlands, vintage 11 or greater is required.

TN762B Hybrid Line (8 ports)

The TN762B hybrid line circuit pack has eight ports that connect to multiappearance hybrid analog and digital telephones. The TN762B can connect to 7300-series telephones, an MDC-9000 cordless telephones, and an MDW-9000 cordless telephone with separate base station and charging stations.

Each port on a TN762B circuit pack has VT and VR (analog voice), CT, CR, P-, and P+ (digital signals that control terminals) signal leads.

TN763D Auxiliary Trunk (4 ports)

The TN763 auxiliary trunk has four ports. Each port has T, R, SZ, SZ1, S, and S1 signal leads. The TN763D circuit pack is used to access on-premises applications such as music on hold, loudspeaker paging, code calling, and recorded telephone dictation. The TN763 circuit pack supports external recorded announcement equipment, and is administrable to select A- or μ -Law companding.

TN767E DS1 Interface, T1 (24 channels)

The TN767 DS1 interface circuit pack provides a DSX1-level physical interface to the DS1 facility and require a TN464 DS1 interface circuit pack. The TN767 circuit pack has unpolarized line out (LO) and line in (LI) signal lead pairs.

The TN767 circuit pack supports DS1 rate digital facility connectivity. The circuit pack supports CO, Tie, DID, and off-premises stations (OPS) port types that use the robbed-bit signaling protocol. This circuit pack also supports ISDN-PRI connectivity. For these applications, the signaling D channel can connect from the TN767 circuit pack to the processor interface by a permanent switched call over the TDM bus.

The TN767 circuit pack is used to communicate with Avaya IVR and to provide the enhanced maintenance capabilities of the 120A channel-service unit (CSU) and the enhanced integrated channel-service unit (ICSU).

DS1 tests include loopback tests at the DS1 board edge or the 120A (if used), bit error rate (BER) loopback tests at the far-end CSU, and BER 1-way DS1 facility tests. Other tests include loopback testing specifically designed to locate DS1 facility faults.

TN769 Analog Line (8 ports)

The TN769 analog line circuit pack has eight ports, each with tip and ring signal leads. The TN769 circuit pack supports:

- On-premises or off-premises wiring with either touch-tone or rotary dialing and with or without LED or neon message waiting indicators
- Three ringer loads, such as three telephones with one ringer load each
- Up to four simultaneous ports ringing
- Queue warning-level lights that are associated with the DDC feature and UCD feature
- Recorded announcements for the intercept treatment feature
- Dictation machines for the recorded telephone dictation access feature
- PagePac paging system for the loudspeaker paging feature
- External alerting devices for the trunk answer any station (TAAS) feature
- Modems

The TN769 circuit pack does not support off-premises message waiting indicators.

The TN769 circuit pack provides secondary lightning protection, and supports μ -Law companding.

Each carrier with neon message indicators requires the TN769 circuit pack, along with a TN755B neon power circuit pack to support neon message waiting indicators. Only one telephone can have an LED or neon message waiting indicator.

Combined conversion of Modem Pooling requires a port on a TN754B circuit pack and a port on a TN746B circuit pack or TN769 analog circuit pack for each combined resource that is to be supported.

The following table lists the TN769-supported telephones and shows each of their wiring sizes and ranges.

Telephone	Wire size (AWG)	Maximum range (feet)
500-type	24 (0.2 mm ² /0.5 mm)	20,000 (6,096 m)
2500-type	24 (0.2 mm ² /0.5 mm)	20,000 (6,096 m)
7102-series	24 (0.2 mm ² /0.5 mm)	20,000 (6,096 m)
7101A	24 (0.2 mm ² /0.5 mm)	15,200 (4,633 m)
7103A	24 (0.2 mm ² /0.5 mm)	15,200 (4,633 m)
8100-series	24 (0.2 mm ² /0.5 mm)	10,000 (3,048 m)
9100-series	24 (0.2 mm ² /0.5 mm)	10,000 (3,048 m)

TN771DP Maintenance and Test

The TN771DP maintenance test circuit pack performs maintenance functions. These functions include packet bus reconfiguration that allows diagnosis and correction of recoverable packet bus failures before the link access procedure on the D channel (LAPD) links fail. LAPD is a link-layer protocol on the ISDN-BRI and ISDN-PRI data link layer (level 2). LAPD provides data transfer between two devices and error and flow control on multiple logical links. LAPD swaps spare leads with the malfunctioning leads to recover packet bus failures involving up to three malfunctioning leads (1 or 2 data or parity leads and one control lead).

Other maintenance functions include ISDN-PRI testing that originates and terminates loopback tests on ISDN facilities. The testing provides bit and block error rate information indicating ISDN facility quality.

The TN771DP circuit pack can be updated using the firmware download feature, which requires use of the TN799 C-LAN circuit pack interface.

A TN771DP circuit pack is required:

- Any CSI system that is using a TN2198 BRI circuit pack. Otherwise, a TN771DP circuit pack is not required.
- An SI system PPN that is equipped with packet endpoints (ISDN-BRI lines or trunks, ISDN-PRI trunks, IP trunks, IP stations, ATM-CES, and ASAI) or is a critical-reliability (or fully duplicated) system. A critical-reliability system with packet endpoints requires a TN771DP circuit pack in each EPN. Otherwise, a TN771DP circuit pack is not required.
- All R system PPNs. A critical-reliability R system requires a TN771DP circuit pack in each EPN. An R system with ATM network duplication requires a TN771DP circuit pack in each PPN and EPN.
- All CSI models when using a TN2198 BRI circuit pack

A maximum of one TN771DP circuit pack is allowed in any port network.

A TN771DP circuit pack is never used with the S8100 Media Server.

TN775C Maintenance

The TN775C circuit pack is used in maintenance to monitor power failure signals in an EPN cabinet. The TN775C circuit pack also monitors the clock, monitors and controls the power supplies and battery charger, and monitors air flow and high-temperature sensors. The TN775C circuit pack provides two serial links to communicate with Expansion Interface (EI) circuit packs, and provides an RS-232 interface for connection to an administration terminal. Each circuit pack contains a 3-position switch to control emergency power transfer.

The TN775C contains a DC-to-DC power converter and is used in maintenance to monitor the processor in an EPN that is supported by a Survivable Remote Processor (SRP).

TN780 Tone Clock

The TN780 tone clock circuit pack connects to and monitors an optional external stratum-3 clock for digital frame timing. The TN780 circuit pack also couples the clock output to local clocks. The TN780 circuit pack supplies master timing to the system and produces the following tones: call-progress tones, touch tones, answer-back tones, and trunk-transmission test tones. The TN780 circuit pack has 2-MHz, 160-kHz, and 8-kHz clocks. The TN780 circuit pack can transmit the system clock and tones on either TDM bus A, TDM bus B, or both.

The TN780 circuit pack is administrable to produce five tone plans. For countries outside the United States six tones can be customized in each plan. The TN780 circuit pack supports A- or μ -Law companding.

A TN780 circuit pack is never used with the S8100 Media Server.

TN787K Multimedia Interface

The TN787 multimedia interface circuit pack is used in conjunction with the TN788 multimedia voice conditioner circuit pack to provide service circuit functionality for the Multimedia Call Handling (MMCH) feature. This feature provides both voice and multimedia data service between multimedia complex endpoints. Up to six endpoints can conference to a single multimedia call occurrence.

The TN787 circuit pack provides a TDM-bus interface and a DS1 adjunct cable interface. The TN787 circuit pack routes the H.221 multimedia information to the DS1 interface to free more TDM-bus timeslots. Freeing more timeslots allows the system to carry more audio, video, and data bit streams between multimedia complex endpoints. The TN787 circuit pack provides support for multiple PNs.

TN788C Multimedia Voice Conditioner

The TN788C multimedia voice conditioner circuit pack is used in conjunction with the TN787F/G multimedia interface circuit pack to provide service circuit functionality for the MMCH feature. This feature provides both voice service and multimedia data service between multimedia complex endpoints.

NOTE:

A TN788C V1 circuit pack only supports μ -Law companding. A TN788C V2 or later supports A- and μ -Law.

The TN788C circuit pack is the audio processor for the Px64 multimedia conference bridge. The TN788C circuit pack contains eight digital signal processors; four for encoding and four for decoding. Each encoder/decoder pair is assigned to a Px64 endpoint to process its audio channel. Connection to and from the endpoint's audio is by way of a TN787 multimedia interface port. This connection is through the TDM-bus timeslots.

Each of the eight digital signal processors communicate with the main on-board processor through eight individual dual-port random access memory (DPRAMs). No read-only memory (ROM) is available on this circuit pack. The DPRAM is used for program download.

TN789B Radio Controller

The TN789B radio controller circuit pack is an interface between a switch and two Wireless Fixed Base (WFB) radio units for the DEFINITY Wireless Business System. The TN789B circuit pack contains a main processor to handle data line circuit (DLC) and upper medium access (MAC) layers of firmware. The TN789B circuit pack also contains two lower MAC processors. one processor for each radio interface. Each radio interface is referred to as an I2 interface.

The I2 link is the connection between the Radio Controller (RC) and the WFB. The RC supports up to two I2 links, each link consisting of three pairs of twisted-pair cable: the transmit pair, the receive pair, and the local power pair. The transmit pair transfers WFB control and frame information from the RC to the WFB. The receive pair transfers status and frame information from the WFB to the RC. If the RC cannot provide power to the WFB, a third pair (to the WFB) can supply local power. When possible, the transmit pair and the receive pair provide phantom power from the RC to the WFB.

Each TN789B circuit pack includes a standard TDM-bus interface from a system, two radio interfaces to two separate radio units, and two synchronization ports. In addition, two RS-232 interfaces provide for a debug terminal and for setting up the wireless terminal.

TN791 Analog Guest Line (16 ports)

The TN791 is a 16 port analog guest line circuit pack that is used for international offers, United States and Canada in offer category B only. Each of the 16 ports support one telephone, such as 500 (rotary dial) and 2500 terminals (DTMF dial). LED and neon message waiting indicators are supported. A separate power supply is required for neon message indicators.

The TN791 circuit pack supports on-premises wiring with either touch-tone or rotary dialing and with or without the LED and neon message waiting indicators.

The TN791 circuit pack supports three ringer loads. Only one telephone can have an LED or neon message waiting indicator. The TN791 supports up to eight simultaneous ports ringing; four on ports one through eight, and four on ports 9 through 16.

The TN791 circuit pack supports A- and μ -law companding and administrable timers. Secondary lightning protection is provided. The TN791 circuit pack supports up to eight simultaneous ports ringing.

The following table lists the TN791-supported telephones and shows each of their wiring sizes and ranges.

Telephone	Wire size (AWG)	Maximum range (feet)
500-type	24 (0.2 mm ² /0.5 mm)	20,000 (6,096 m)
2500-type	24 (0.2 mm ² /0.5 mm)	20,000 (6,096 m)
6200-type	24 (0.2 mm ² /0.5 mm)	12,000 (3,657 m)
7100-series	24 (0.2 mm ² /0.5 mm)	20,000 (6,096 m)
7101A	24 (0.2 mm ² /0.5 mm)	15,200 (4,633 m)
7103A	24 (0.2 mm ² /0.5 mm)	15,200 (4,633 m)
8100-series	24 (0.2 mm ² /0.5 mm)	12,000 (3,657 m)
9100-series	24 (0.2 mm ² /0.5 mm)	12,000 (3,657 m)

TN792 Duplication Interface

In a high- or critical-reliability DEFINITY SI system, a duplication interface copies the contents of memory from the primary Switch Processing Element (SPE) to a standby SPE, so that the latter can take over immediately when the former fails. The TN792 duplication interface (DUPINT) uses the Enhanced M-Bus of the DEFINITY SI TN2404 processor for this memory shadowing function. The Enhanced M-bus supports 32-bit addressing and data access (vs. 16-bit for the M-bus), so it transfers data faster and shadows a larger area of memory than the older bus. The M-bus is still supported.

You need two TN792 circuit packs, one for the primary control carrier and one for the standby. You can replace TN772 duplication interfaces with TN792s, but you must replace them in pairs. A TN772 circuit pack cannot communicate with a TN792 circuit pack.

A new duplex optical cable connects the TN792 circuit packs. This cable eliminates the additional electromagnetic emissions that would otherwise result from the doubled data rate on the bus. The optical cable interface to the new DUPINT is on the front faceplate of the circuit pack.

The TN792 circuit pack is compatible with existing duplication cables.

TN793B Analog Line with Caller ID (24 ports)

The TN793B is a dual coded, analog line 24-port circuit pack that supports Caller ID telephones and Caller ID devices. Each port supports one telephone, such as 500 (rotary dial) and 2500 telephones (DTMF dial). Use TN793B Vintage 1 or greater.

The TN793B supports on-premises (in-building) wiring with either touch-tone or rotary dialing and with or without the LED and neon Message Waiting Indicators. The TN793B circuit pack supports off-premises wiring with either DTMF or rotary dialing, but LED or neon message waiting indicators are not supported off-premises.

The TN793B circuit pack, along with a TN755B neon power circuit pack supports on-premise telephones that are equipped with neon message waiting indicators. The TN793B supports three ringer loads, only one telephone can have an LED or neon message waiting indicator. The TN793B circuit pack allows a maximum of 12 simultaneous ports ringing; four on ports 1 through 8, four on ports 9 through 16, and four on ports 17 through 24.

The TN793B circuit pack supports A- and μ -law companding and administrable timers. The TN793 circuit pack supports queue warning level lights associated with the DDC and the UCD features, recorded announcements associated with the Intercept Treatment feature, and PagePac paging system for the Loudspeaker Paging feature. Additional support is provided for external alerting devices that are associated with the TAAS feature, neon message waiting indicators, and modems. The TN793B also supports secondary lightning protection. The TN793B provides -48 V DC current in the off-hook state. Ringing voltage is -90 VDC.

The following table lists the TN793B-supported telephones and shows each of their wiring sizes and ranges.

Telephone	Wire size (AWG)	Maximum range (feet)
500-type	24 (0.2 mm ² /0.5 mm)	20,000 (6,096 m)
2500-type	24 (0.2 mm ² /0.5 mm)	20,000 (6,096 m)
6200-type	24 (0.2 mm ² /0.5 mm)	12,000 (3,657 m)
7100-series	24 (0.2 mm ² /0.5 mm)	20,000 (6,096 m)
8100-series	24 (0.2 mm ² /0.5 mm)	12,000 (3,657 m)
9100-series	24 (0.2 mm ² /0.5 mm)	12,000 (3,657 m)

TN797 Analog Trunk or Line Circuit Pack (8 ports)

Provides a combination 8-port analog trunk and line circuit pack for the United States, Canada, and other countries that have the same analog standards. The TN797 circuit pack provides you with the capability to administer any of the eight ports as a loop start or ground start CO trunk, a CAMA E911 trunk, a wink- or immediate-start DID trunk, or as an on or off-premises analog line with or without LED Message Waiting Indication. It does not support ICLID on the analog trunk to the CO, nor Caller ID on the line side to the telephone.

TN799DP Control LAN (C-LAN) Interface

The TN799DP control LAN (C-LAN) interface provides TCP/IP connectivity over Ethernet or Point to Point Protocol (PPP) to adjuncts such as Avaya CMS, INTUITY AUDIX, DCS, printers, call detail recording (CDR), and property management systems (PMS). The C-LAN is required to support the TN2302AP IP Media Interface for H.323 functionality, and to support ATM interfaces and WAN PNC.

The C-LAN operates at 10 or 100 Mbps and full or half duplex, both of which are administrable. The C-LAN provides connectionless UDP sockets for IP solutions support. The C-LAN will also support 500 remote sockets, with support for 4-Kbyte UDP sockets. The C-LAN supports variable-length ping and the **traceroute** and **netstat** network testing commands.

The C-LAN circuit pack provides call control for every IP endpoint that is connected to the S8700 Media Server using the G600 Media Gateway. A maximum number of 64 C-LANs can be used for each configuration. The number of C-LANs that are required depends on the number of devices that are connected as well as the options that are being utilized by the endpoint. It might be advantageous to segregate IP voice control traffic from device control traffic as a safety measure.

To determine the default value for C-LAN socket usage of H.323 Tie Trunks divide the total number of H.323 Tie Trunk that use sharing by 31. Each IP endpoint requires the use of some number of C-LAN sockets, which is the software object that is used to connect a C-LAN to the IP Network. The C-LAN circuit pack supports a maximum of 500 sockets.

The C-LAN differs from an IP Media Processor in that the C-LAN controls the call and the IP Media Processor provides the codecs that are used for the audio on the call.

To take download firmware there must be at least one C-LAN and access to the public Internet.

Downloads and instructions have been posted to:

<http://www.avaya.com/support/>

Click on Online Services and then Download Software needed.

TN801 MAPD (LAN Gateway Interface)

The TN801 LAN gateway interface is part of the Multiapplication Platform DEFINITY (MAPD). It allows direct integration of PC-based application into the switch. The TN801 circuit pack works as the interface for solutions such as CTI, CallVisor and PC/LAN. The TN801 circuit pack provides packet bus and TDM-bus interfacing, physical mounting for a CPU, external interfaces, and mapping of circuit-switched connections between the TDM bus and the expansion circuit pack.

TN802B MAPD (IP Interface Assembly)

The TN802 IP interface circuit pack supports voice calls and FAX calls from the switch across a corporate intranet or the Internet. This circuit pack is still supported, but has been replaced with the [TN2302AP IP Media Processor](#) on page 203. The IP trunking software runs on an embedded PC that runs Windows NT. The TN802 circuit pack supports IP Solutions including IP trunking and MedPro (H.323) with IP softphones.

The TN802 IP Interface operates in two modes: IP Trunk and Media Processor (MedPro/H.323). The TN802 defaults to IP Trunk mode. To use it in MedPro mode, you activate it through administration to use the H.323 trunking feature related to IP softphones.

TN1648B System Access and Maintenance (SYSAM)

The TN1648B is an SPE component that is used for maintenance on a DEFINITY R configuration. A processor in the TN1648B circuit pack runs control routines that connect to maintenance software. The TN1648B circuit pack has an alarm panel with five LEDs and a toggle switch to manually inhibit automatic emergency transfer of PPN analog lines.

The TN1648B circuit pack provides two RS-232 interfaces for connection to an administration terminal and, with duplication, connection to a standby maintenance terminal. The TN1648B circuit pack also provides a tip and ring port with a built-in modem to allow a remote administration terminal to access the system.

The TN1648B circuit pack allows connection to the management terminal and connection to and termination of one end of the processor bus. Other maintenance items include:

- PPN alarm monitors and outputs including auxiliary alarms for auxiliary equipment and environmental monitoring for over-temperature conditions
- Power supply sense and control for the carriers

- Emergency transfer control for catastrophic failure. The circuit consists of a 3-position toggle switch. The switch can be moved into the manual on position, manual off position, or automatic position.
- Non volatile memory that contains the time-of-day clock, the telephone number for the Initialization and Administration System (INADS), login password, and product identification
- Alarm panel information with major, minor, and warning LEDs, an ACKnowledge LED, and an emergency transfer LED

The TN1648B circuit pack increases the speed of the internal modem and external modem from 2400 bps to 9600 bps with error control implementation. Appropriate software administration is added to choose between external modem access to the maintenance port, and direct loop start trunk access. The external modem access is used in countries that do not support the analog loop signaling protocol supplied by the internal modem.

For use outside the United States use a cable from the TN1648B that connects directly to an external modem. When the external modem is selected, the internal modem is disabled. The TN1648B circuit pack is backward-compatible with the TN1648 circuit pack.

TN1650B Memory

The TN1650B memory circuit pack is used only in the DEFINITY R configurations. The 1650B circuit pack contains 32 MB of Dynamic Random Access Memory (DRAM) and error detection and correction circuitry to ensure information integrity. The TN1650B is used for system software, customer translations, and call-processing maintenance. All new systems are shipped with four memory boards and a TN1657 disk drive. All upgrades to R10 require a fourth memory board and a TN1657 disk drive V9 or later.

TN1654 DS1 Converter, T1 (24 channels) and E1 (32 channels)

The TN1654 converter installs in place of the conventional fiber and supports from one to four T1 or E1 facilities, providing a total of 92 T1 channels, or 120 E1 channels, in each direction between the PPN and an EPN. This capacity is enough for the EPN to easily support several hundred stations.

The switch architecture provides for EPNs that are remotely located from the PPN. An EPN within five miles (8 km) of the PPN may be coupled using multimode fiber-optic cable or within 22 miles (35.4 km) of the PPN using single-mode fiber-optic cable. Connect using a DS1 converter complex when the distance between the PPN and an EPN exceeds five miles (8 km) for multimode cable, or 22 miles (35.4 km) for single-mode cable, or private right-of-way is unavailable. One DS1 circuit pack is placed on each end of the DS1 converter complex.

The TN1654 DS1 converter requires a new set of Y-cables to connect to a TN570B Expansion Interface circuit pack.

TN1655 Packet Interface

The TN1655 packet interface provides the communication path between the SPE and the packet bus in the PPN for DEFINITY R configurations. The packet bus connects to EI circuit packs in the PPN that communicate with EPNs and the CSS.

The TN1655 provides the link access procedure on the D channel (LAPD) for up to 8,192 links at a sustained rate of 2 Mbps. The link access is the digital multiplexed interface (DMI) mode-3 terminations of communication links across the packet bus that link to the processor circuit pack. Some data communication will use the X.25 data phase protocol at level 3.

The TN1655 provides termination for ISDN-BRI and ISDN-PRI signaling links, expansion archangel links that connect the processor to the expansion archangels on EI circuit packs in each PN, and center stage control network links that connect the processor with SNI circuit packs in the CSS.

The TN1655 supports firmware downloading. It also provides X.25 termination to the DCS links and to adjuncts such as CDR and AUDIX.

TN1657 Disk Drive

The TN1657 contains a 180 MB small computer system interface (SCSI) disk drive that is used for the DEFINITY R configurations. The TN1657 disk drive reduces the time it takes to reboot the system, stores translations, bootstrap image, and core dumps

TN2138 Central Office Trunk (8 ports)

The TN2138 central office trunk circuit pack provides eight analog loop start CO trunk ports for Italy. Each port has a tip and ring signal lead. The TN2138 has 50-Hz, 12-kHz, and 16-kHz periodic pulse metering (PPM).

TN2139 Direct Inward Dialing Trunk(8 ports)

The TN2139 direct inward dialing trunk for Italy provides eight analog direct inward dialing (DID) trunk ports for analog DID signaling. Each of the eight ports has a tip and ring signal lead.

TN2140B Tie Trunk (4-wire, 4 ports)

The TN2140B tie trunk is used in Hungary and Italy. The TN2140B provides four ports for 4-wire E&M lead signaling tie trunks. The TN2140 provides continuous E&M signaling and discontinuous E&M signaling. Administrable A- and μ -Law companding and standard Type 1 and Type 5 signaling is provided. The TN2140B is required for Hungary.

TN2146 Direct Inward Dialing Trunk (8 ports)

The TN2146 provides eight analog DID trunk ports for Belgium and the Netherlands. Each of the eight ports has tip and ring signal lead. The TN2146 uses four Dual Subscriber Line Audio processing Circuits (DSLACs). One DSLAC is used for each pair of ports. The circuits are administered to meet trunk transmission characteristics. The DSLACs can be set to either a resistive or complex balance impedance in the voice or AC talk path on the trunk interfaces. The DSLACs convert analog signals to digital signals and vice-versa to match the analog DID trunks to the system's digital TDM bus. The TN2146 circuit pack can provide either A-Law or μ -Law companding.

TN2147C Central Office Trunk (8 ports)

The TN2147 has eight analog CO trunk ports. Each port has tip and ring signal leads. The TN2147 uses four (1 for each pair of ports) Dual Subscriber Line Audio processing Circuits (DSLACs) to be administered to meet a given transmission and impedance requirement. The DSLACs convert analog signals to digital signals and digital signals to analog signals to interface the analog CO trunks to the system's digital TDM bus.

The TN2147C provides multicountry signaling based on trunk type of either: loop-start, ground start, or battery reverse loop-start.

TN2181 DCP Digital Line (2-wire, 16 ports)

The TN2181 circuit pack has 16 DCP ports that can connect to 2-wire terminals such as the 6400-, 8400-, and 9400-series digital telephones and the 302C and 302D attendant console. The maximum range of the 8400- and 9400-series terminals using 24-AWG (0.5 mm) wire is 3,500 feet (1067 m).

The TN2181 circuit pack supports either A- or μ -Law companding. The TN2181 also supports 8400-series data modules.

TN2182C Tone Clock, Tone Detector, and Call Classifier (8 ports)

The TN2182 tone clock integrates the tone generator, tone detection-call classifier, system clock, and synchronization functions onto one circuit pack for all system-reliability configurations. The TN2182 supports 8 ports for tone detection and allows gain or loss applied to PCM signals received from the bus. The TN2182 provides stratum-4 enhanced clock accuracy, supports MFC signaling (such as Russia MF), supports Russia MFR (multifrequency shuttle register signaling), and supports A- and μ -Law companding.

The TN2182CP provides continuous cadenced and mixed tones, allows administrable setting of tone frequency and level, detects 2025-Hz, 2100-Hz, or 2225-Hz modem answerback tones, and provides normal and wide broadband dial-tone detection.

In most configurations, the 2- or 3-circuit pack combination of tone generator, tone detector, and/or call classifier can be replaced with this one circuit pack to free one or two port slots.

Use the TN2182CP circuit pack with the TN429D analog line central office trunk for CAMA/E911 and ICLID. A TN2182 is required for the on-board tone detection or for additional tones to support CCRON, Russian ANI, and others.

TN2183/TN2215 Analog Line for multiple countries (16 ports)

See [TN2215/TN2183 Analog Line for Multiple Countries \(16 ports\) \(International Offers or Offer B only for US and Canada\)](#) on page 202.

TN2184 DIOD Trunk (4 ports)

The TN2184 is a Direct Inward/Outward Dialing (DIOD) trunk circuit pack used for Germany. The TN2184 circuit pack contains four port circuits. Each circuit interfaces a 2-wire analog CO trunk with the TDM switching network of the system. Each port allows incoming calls and outgoing calls to include addressing information that is being received from the CO for incoming calls and addressing information that is being sent to the CO for outgoing calls. The TN2184 detects periodic pulse metering (PPM) signals for call-charge accounting on outgoing calls.

The TN2184 combines the features of both a CO trunk and a DID trunk to provide both outgoing and incoming calls with addressing information in both directions.

TN2185B ISDN-BRI S/T-TE Interface (4-wire, 8 ports)

The TN2185B supports eight 4-wire ISDN BRI line S interfaces. Each interface operates at 192 kbps, with two B channels (64 kbps) and one D channel (16 kbps). The TN2185B interfaces to the LAN bus and to the TDM bus to provide the TE side of the BRI interface.

The TN2185B is similar to the TN2198 except that the TN2185B is a 4-wire S-interface instead of a 2-wire U-interface. Another difference is the function of the SCOTCH/NPE and SAKI are replaced by the network control element (NCE).

For each port, information communicates over two 64-kbps bearer channels called B1 and B2, and over a 16-kbps channel called the demand channel, or D channel. The D channel is used for signaling. Channels B1 and B2 can be circuit-switched simultaneously, or either of them may be packet-switched, but not both at once. The D channel is always packet-switched. The circuit-switched connections have a μ -Law or A-Law option on a per-board basis, for voice operation and operate as 64-kbps clear channels when in the data mode. The packet-switched channels support the LAPD protocol. However, the TN2185B does not terminate on LAPD protocol. The S-interface does not support switching of both B channels together as a 128-kbps wideband channel.

The TN2185B has a maximum range up to 18,000 feet (5486 m) from the system to the NT1 device. In an environment with multiple telephones, the B channels are shared only on a per-call basis. For example, if Channel B2 is for data, then the use of this channel by one telephone excludes the others from having access to it. When a used device communicates over the D channel to access B1 or B2, that channel is owned until the call is taken down. The D channel is always shared among the terminals. The TN2185B circuit pack can be used as an alternative to the TN464 circuit pack or the TN2464 circuit pack.

The ability of outpulse in-band DTMF signals or end-to-end signaling is supported by the TN2185B.

QSIG Call Completion is supported, however, QSIG Supplementary Services are not. ISDN-BRI trunks can be used as inter-PBX tie lines that use the QSIG peer protocol.

TN2198B ISDN-BRI U Interface (2-wire, 12 ports)

The TN2198 circuit pack allows connection to the ANSI standard 2-wire U-Interface. The 2-wire interface from the TN2198 connects to an NT1 network interface. The 4-wire interface on the other side of the NT1 may connect to one or two telephones. The TN2198 does not provide a trunk-side interface. Unlike the TN2185 circuit pack.

The TN2198 contains 12 ports that interface at the ISDN U reference point. For each port, information communicates over two 64-kbps bearer channels called B1 and B2, and over a 16-kbps channel called the demand channel, or D channel. The D channel is used for signaling. Channels B1 and B2 can be circuit-switched simultaneously. The D channel is always packet-switched. The TN2198 requires a packet control circuit pack. Each port supports one telephone, such as the 500 rotary dial analog telephone and 2500 DTMF dial telephones.

The D channel supports the LAPD protocol and is consistent with the CCITT Q.920 recommendations for D-channel signaling.

In an environment with multiple telephones, the B channels are shared only on a per-call basis. For example, if the B2 channel is used for data, then the use of B2 by one telephone excludes the other telephones from having access to it. When a device communicates over the D channel to access B1 or B2, that channel is owned until the call is taken. The D channel is always shared among the telephones. The TN2198 interfaces with the TDM bus and the packet bus in the switch backplane and terminates with 12 ISDN basic access ports.

The TN2198 has a maximum range of 18,000 feet (5486 m) from the system to the NT1 device and uses standard protocol ANSI T1.601. The TN2198 has a 160-kbps line rate, that consists of:

- Two bearer channels at 64 kbps each
- A D channel at 16 kbps
- Framing at 12 kbps
- Maintenance at 4 kbps

The TN2198 supports a maximum of 24 telephones or data modules.

The TN2198 is not offered as a BRI Tie Trunk.

TN2199 Central Office Trunk (3-wire, 4 ports)

The TN2199 central office trunk circuit pack is designed for use in Russia.

The TN2199 is a 4-port, 3-wire, loop-start trunk circuit pack that can be used as:

- A DID trunk
- A 2-way, 1-way incoming, or 1-way outgoing CO trunk

The TN2199 combines the functionality of a DID trunk and a 1-way outgoing CO trunk (DIOD trunk). To accomplish MF shuttle signaling, the TN2199 circuit pack must be combined with a TN744D Call Classifier circuit pack.

The TN2199 circuit pack supports incoming ANI.

TN2202 Ring Generator

The TN2202 ring generator circuit pack is designed for use in France.

The TN2202 ring generator circuit pack supplies 50-Hz ringing power. The TN2202 supplies balanced ringing, by a modified backplane, to telephones that connect to the TN2183 multi country analog line circuit pack when administered for France analog transmission.

The TN2202 plugs into the power unit slot and is required for each carrier that contains analog lines. A 1-lead modification is required in a carrier backplane that uses the TN2202. This modification is required for all products made for France. The TN2202 produces two symmetrical voltages (typically 28V RMS) with respect to ground, and takes -48 VDC, -5 VDC, and ground from the backplane and generates 2 × 28V RMS with added -48 VDC.

TN2207 DS1 Interface, T1 (24 channels) and E1 (32 channels)

The TN2207 circuit pack supports digital signal level 1 (DS1) rate (24-channel) and E1 rate (32-channel) digital facility connectivity. All TN2207 suffixes support CO, Tie, DID, and off-premises station (OPS) port types that use the following protocols:

- Robbed-bit signaling
- Proprietary bit-oriented signaling (BOS) 24th-channel signaling
- DMI-BOS 24th-channel signaling

The circuit packs also support ISDN-PRI connectivity T1 or E1.

In a 24-channel DS1 mode, a DS1 interface is provided to the DS1 facility. The TN2207 circuit packs provide board-level administrable A- and μ -Law companding, CRC-4 generation and checking for E1 only, and stratum-3 clock capability.

The TN2207 provides test jack access to the DS1 or E1 line and supports the 120A integrated channel-service unit (CSU).

All suffixes have line-out (LO) and line-in (LI) signal leads. The line-out and line-in leads are unpolarized balanced pairs.

The TN2207 has additional hardware to support direct cabling to a TN787 MMI circuit pack.

TN2209 Tie Trunk (4-wire, 4 ports)

The TN2209 tie trunk was designed for use in Russia.

The TN2209 tie trunk has four ports used for Type 1 or Type 5 4-wire E&M lead signaling tie trunks. The tie trunks can be one of four types: automatic, immediate-start, wink-start, and delay-dial. The TN2209 provides an interface between these four frequency signaling tie trunk lines and the switch TDM network. Based on a TN760D each port has modified E&M signal leads for universal hardware compatibility. The TN2209 provides release link trunks required for the CAS feature and has administrable A- and μ -Law companding.

TN2211 Optical Drive

The TN2211 Optical Drive provides removable storage for the DEFINITY R configurations. The TN2211 supports software upgrades, translation backups, announcement file backups, core dumps, and so on. The Optical Drive has several advantages over tape drive technology:

- Writing to the optical disk is considerably shorter than writing to tape. A full backup takes approximately 20 minutes, versus the tape drive takes that takes up to 95 minutes.
- Writing to the optical disk is more reliable because of:
 - Block allocation
 - The number of accesses to the media

The UN332C MSSNET must be used with the TN2211.

TN2214B DCP Digital Line (2-wire, 24 ports)

The TN2214B is designed to be used in the United States, Canada and international countries for offer B only.

The TN2214 has 24 DCP ports that can connect to 2-wire digital telephones such as 6400-, 8400-, or 9400-series telephones and the 302C and the 302D attendant console.

The TN2214 supports either A- or μ -Law companding.

The following table lists the TN2214B-supported telephones and shows each of their wiring sizes and ranges.

Telephone	Wire size (AWG)	Maximum range (feet)
302C/D console	24 (0.2 mm ² /0.5 mm)	3,500 (1,067 m)
6400-series	24 (0.2 mm ² /0.5 mm)	3,500 (1,067 m)
8400-series	24 (0.2 mm ² /0.5 mm)	3,500 (1,067 m)
9400-series	24 (0.2 mm ² /0.5 mm)	3,500 (1,067 m)

TN2215/TN2183 Analog Line for Multiple Countries (16 ports) (International Offers or Offer B only for US and Canada)

The TN2215 and the TN2183 analog line circuit packs are designed for international offers or offer B only for the United States and Canada.

The TN2215 and the TN2183 provide 16 analog port interfaces. Each port supports one telephone, such as 500 (rotary dial) and 2500 telephones (DTMF dial) from a tip/ring pair. Each port also sends or receives signaling to and from a device, such as an analog telephone, answering machine, FAX and loop-start CO port. The TN2215 and the TN2183 provides rotary digit 1 recall, ground-key recall, and programmable flash timing. Additional support is provided for selectable ringing patterns, LED message waiting, and secondary lightning protection.

The TN2215 and TN2183 supports on-premises wiring with either touch-tone or rotary dialing and with or without the LED message waiting indicators. The TN2215 and TN2183 supports off-premises wiring with either DTMF or rotary dialing. LED message waiting indicators are not supported off-premises. Neon message waiting indicators are not supported.

A maximum of six to eight simultaneous ringing ports is allowed depending on the ringing cadence selected. The TN2215 and the TN2183 supports A- and μ -Law companding and administrable timers.

The TN2215 and the TN2183 also supports balanced ringing. When balanced ringing is configured for France the TN2202 ring generator circuit pack must be used.

The TN2215 and the TN2183 supports DTMF sending levels appropriate for Avaya IVR.

The TN2215 and the TN2183 is impedance and gain selectable for multiple countries. For more information, contact your Avaya representative.

The following table lists the TN2215- and TN2183-supported telephones and shows each of their wiring sizes and ranges.

Telephone	Wire size (AWG)	Maximum range (feet)
500-type	24 (0.2 mm ² /0.5 mm)	20,000 (6,096 m)
2500-type	24 (0.2 mm ² /0.5 mm)	20,000 (6,096 m)
6200-type	24 (0.2 mm ² /0.5 mm)	12,000 (3,657m)
7102A-series	24 (0.2 mm ² /0.5 mm)	3,100 (945 m)
8100-series	24 (0.2 mm ² /0.5 mm)	12,000 (3,657m)

TN2224B DCP Digital Line (2-wire, 24 ports)

The TN2224 has 24 DCP ports that can connect to 2-wire digital telephones such as the 6400-, 8400-, or 9400-series telephones and the 302C or 302D attendant console.

The TN2224 circuit pack supports either A-Law or μ -Law companding.

The following table lists the TN2224-supported telephones and shows each of their wiring sizes and ranges.

Telephone	Wire size (AWG)	Maximum range (feet)
302C/D console	24 (0.2 mm ² /0.5 mm)	3,500 (1,067 m)
6400-series	24 (0.2 mm ² /0.5 mm)	3,500 (1,067 m)
8400-series	24 (0.2 mm ² /0.5 mm)	3,500 (1,067 m)
9400-series	24 (0.2 mm ² /0.5 mm)	3,500 (1,067 m)

TN2242 Digital Trunk

The TN2242 digital trunk circuit pack supports versions of channel-associated signaling and ISDN-PRI signaling that are peculiar to the TTC private networking environment used in Japan. It supports the special line-coding and framing used on 2.048-Mbps Japanese trunks. The TN2242 connects the switch with other vendor equipment and with other DEFINITY switches via the TDM device that is commonly used throughout Japan for this purpose.

TN2301 Logic Switch

The TN2301 logic switch is used with the DEFINITY R only. The TN2301 provides service to the customer when the link to the main processor fails or is severed, or when the processor or Center Stage Switch (CSS) fails. The TN2301 Survivable Remote Switch (SRS) circuit pack connects the EPN links (fiber or T1/E1) to the appropriate PPN for call processing. It does this under control of the TN775C Maintenance circuit pack which monitors the health of the expansion interface TN570B.

The TN2301 logic switch circuit pack is not used in an ATM-PNC.

TN2302AP IP Media Processor

The TN2302AP provides VoIP audio access to the switch for local stations and for outside trunks. The TN2302AP can perform echo cancellation, silence suppression, FAX relay service, and DTMF detection. The TN2302AP is the H.323 audio platform, includes a 10/100 BaseT Ethernet interface, supports the T.30 and T.38 standards for FAX transmission, and is firmware downloadable.

The TN2302AP provides audio processing for between 32 and 64 voice channels, depending on the CODECs in use. The TN2302AP supports hairpin connections and shuffling of calls between TDM connections and IP-to-IP direct connections.

TN2305B ATM-CES Trunk/Port-Network Interface for multimode fiber

The TN2305 provides an ATM-based replacement for the [TN570D Expansion Interface](#). The interface uses OC-3c or STM-1 155-Mbps multimode fiber. The TN2305 supports both trunk and port-network connectivity. As a trunk, the TN2305 uses Circuit Emulation Service (CES) to emulate up to eight ISDN-PRI trunks on an ATM facility. As a port-network expansion interface, the TN2305 connects port networks to an ATM switch that provides port-network connectivity. The TN2305 provides echo cancellation.

The TN2305 does not support hybrid port networks that use both ATM and CSS simultaneously. TN2305s must connect all port networks through the ATM switch. Direct connect EPNs are not supported. Category B offers are not supported.

TN2306B ATM-CES Trunk/Port-Network Interface for single-mode fiber

The TN2306 circuit pack has the same features as the [TN2305B ATM-CES Trunk/Port-Network Interface for multimode fiber](#) but supports single-mode fiber. The TN2306B is not available with Category B offers.

TN2308 Direct Inward Dialing Trunk (8 ports)

The TN2308 uses eight ports for immediate- or wink-start direct inward dialing (DID) trunks for Brazil. Each port has tip and ring signal leads.

The switch requires the TN2308 to support Brazil Block Collect Call. The TN2308 transmission characteristics comply with Brazilian telecom standards for PBXs.

TN2312BP IP Server Interface

The TN2312BP IP Server Interface (IPSI) provides environmental maintenance and is the only IP server interface that is supported in the G650. A TN2312BP IPSI placed in a G650 with a carrier address set to A acts as the serial bus master. (A TN2312BP IPSI can only be placed in a G650 with a carrier address set to A or B. Only a TN2312BP IPSI in a G650 with a carrier address set to A can function as a serial bus master).

The TN2312BP IPSI is backward compatible with other media gateways, but provides environmental maintenance only when used in a G650. The TN2312BP IPSI always provides tone detection, call classification, tone generation, and clock functions.

When the TN2312BP IPSI is used in an MCC1 or SCC1, a TN755D provides the environmental maintenance.

The TN2312BP IPSI provides environmental maintenance for the G650. This includes:

- Power supply, cabinet, and ring generator maintenance
- External device alarm detection

- Emergency transfer control
- Customer-provided alarm device control

The TN2312BP IPSI and the 655A power supply provide the following information to the G650:

- **Environment maintenance**

- Inlet temperature – Inlet temperature of the G650 (sensor is in the 655A power supply)
- Exhaust temperature – G650 carrier exhaust air sensor
- Hot Spot temperature status – 655A power supply sensor
- Voltage
 - +5VDC
 - 5VDC
 - 48VDC
- Fan Control – The speed at which the fans are operating:
 - Undr – indicates that the fan voltage is under 12VDC.
 - Mid (normal) – indicates that the fan voltage is +12VDC.
 - High – indicates that the fan voltage is +14VDC.
 - Over – indicates that the fan voltage is above 14 to 15VDC.
- Fan Alarm – Detection of a blocked or failed fan
- Ring Status – OK, overload, shorted, or failed
- Ring Control – Active, standby, disabled, off (shorted or failed)
- Ringer Setting – 20Hz, 25Hz, or other
- Ring Detection – Reports if the power supply detects ring on the backplane ring leads
- Input Power – Indicates the type of power present and in use, AC or DC

- **External device alarm detection**

The external device alarm detection uses two external leads. External devices such as an uninterruptible power supply (UPS) or voice messaging system can use these leads to generate alarms using the Avaya Communication Manager alarm reporting capability. Ground potential on either of these leads results in an alarm being generated. You can administer the alarm level (major, minor, or warning), product ID, alternate name, and alarm description for each lead.

- **Emergency transfer control**

Emergency transfer control provides -48VDC to operate an external emergency transfer panel. The Communication Manager controls the state of the emergency transfer. (Note that, in the past, hardware boards or alarm panels provided a 3-position physical switch to control emergency transfer.)

You can use the following Communication Manager SAT commands for emergency transfer:

- set emergency-transfer on|off|auto – Use this to set emergency transfer to **on** (not in emergency transfer), **off** (in emergency transfer), or **auto** (emergency transfer is controlled by Communication Manager).
- status cabinet nn – Use this to verify the current setting of emergency transfer.

When the emergency transfer is set to other than **auto** an alarm is generated.

- **Customer-provided alarm device (CPAD) control**

CPAD provides a contact closure across a pair of external leads that can be used to control a customer-provided alarm device or an alarm indicator. The level of alarm (major, minor, warning, or none) that causes a contact closure can be administered system wide. When the alarm level matches the alarm level that was administered, the TN2312BP IPSI closes this contact for all G650s with a carrier address set to A. When the TN2312BP IPSI is in emergency transfer, this contact is closed to activate the CPAD.

- **Tone Detection / Call Classification**

The TN2312BP IPSI provides eight ports of tone detection and call classification. The TN2312AP IPSI provides the same.

- **Tone/Clock functions**

The TN2312BP generates tones and provides clock functions for the port network in which it is placed. This functionality is equivalent to the TN2182B Tone/Clock circuit pack.

I/O adapters

The TN2312BP IPSI requires a new adapter that provides for the alarm input, CPAD, and emergency transfer leads. This adapter, like the existing TN2312AP IPSI adapter, also allows the IPSI Ethernet connection to be made to the back of the IPSI slot.

Compatibility

The TN2312BP IPSI can replace the TN2312AP IPSI in the SCC1, MCC1, CMC1, and G600. However, the TN2312BP IPSI acts only as a tone clock for these media gateways. It does not provide environmental maintenance.

When the TN2312BP is installed in a CMC1 or G600 media gateway with Communication Manager 2.0 cabinet environment maintenance is provided by monitoring of the AuxSig backplane lead. This lead sends an alarm if a failure is detected in either the power supply or fan assembly. The CMC1 and G600 are only supported in an IP connect configuration with Communication Manager 2.0.

See the following table for IPSI and media gateway compatibility.

Media Gateway	Communication Manager 1.x	Communication Manager 2.0	DEFINITY R10	Environmental maintenance provided by:
SCC1	Yes	Yes	Yes	TN775D
MCC1	Yes	Yes	Yes	TN775D
CMC1		Yes		Monitoring the AuxSig backplane lead
G600		Yes		Monitoring the AuxSig backplane lead
G650		Yes		TN2312BP IPSI

Number of IPSI circuit packs per configuration

For configurations where voice bearer is over CSS or ATM, each IPSI typically controls five port networks by tunneling control messages over the bearer network to PNs that do not have IPSIs. An IPSI cannot be placed in:

- A PN that has a Stratum-3 clock interface
- A remote PN that is using a DS1 converter
- A Survivable Remote Expansion Port Network (SREPN)

To determine the number of IPSI-connected PNs that are recommended to support a S8700 configuration divide the total number of PNs in the configuration by five and add one. The additional IPSI provides fault tolerance.

For example, if you have 20 PNs, divide 20 by 5 to get 4, then add 1. You need a minimum of five IPSIs to support the 20 PNs.

For configurations where voice bearer is over IP, there must be one IPSI in each PN.

A direct connect configuration only supports one IPSI connected PN.

TN2313AP DS1 Interface (24 channels)

The TN2313AP DS1 port board interfaces a DS1 trunk to the switch backplane via port slots that are standard for DEFINITY products. The TN2313AP is compatible with previous 24-channel DS1 circuit packs, including the TN464F (V19 and below), the TN2464 (V19 and below), and the TN767E DS1, except that it does not provide for packet adjunct capabilities. The TN2313AP supports a variety of applications, including networking of DEFINITY switches, international trunk types, video teleconferencing, and wideband data transmission.

The TN2313AP DS1 interface can be configured as 24 channels at 1.544 Mbps. The TN2313 can supply two 8-kHz reference signals to the switch backplane for optional use by the tone clock board in synchronizing the system clock to the received line clock.

The TN2313AP is firmware downloadable.

TN2314 S8100 Media Server

The S8100 Media Server supports voice stations with co-resident voice switching, voice and FAX messaging and system applications run on a Microsoft Windows 2000 operating system. The communication between the firmware and the software is done by an Ethernet connection. An Intel processor Message Link (IML) is the Ethernet control link between the Pentium processor and the MPC860 processor. The link allows for the message-based communication between the two processors.

The S8100 Media Server has the following characteristics:

- Processor – The processor is a 500-MHz Pentium III.
- RAM – There are two slots for SDRAM memory modules, with a minimum of 256-MB of RAM and a maximum of 512-MB of RAM.

- Front panel ethernet access – Services can access the switch via an RJ45 Ethernet jack on the circuit pack faceplate.
- Hard disk – The circuit pack has a 20-GB hard disk.

TN2401 Network Control/Packet Interface for SI

The TN2401 network control and packet interface is used with DEFINITY SI only.

The TN2401 Net/Pkt interface circuit pack provides the network control interface (NETCON), the packet interface (PACCON), and, if BX.25 connectivity is not required, the processor interface (PI). The TN2401 provides eight asynchronous data channels. The TN2401 does not include modems. The TN2401 is required for the SI model to save translations to the 5-volt ATA flash memory card.

TN2401/TN2400 Network Packet Interface complex assembly for SI upgrades

The TN2401/TN2400 network packet interface complex provides:

- A network control interface (NETCON)
- A packet interface (PACCON)
- A processor interface (PI) if BX.25 connectivity is not required
- Eight asynchronous data channels

The TN2401/TN2400 does not include modems.

The TN2401/TN2400 is required for the SI model to save translations to the 5-volt ATA flash memory card.

The TN2401/TN2400 complex and the TN2404 processor is required for the following upgrades:

- A G1 or G3iV1 MCC1 with a TN773 Processor
- An SI system with a TN786B Processor when reusing the existing control carrier cabinet
- An SI system with a TN790 or 790B Processor. Any R5 or R6 system will have the old control carrier backplane and will require the TN2401/TN2400. For R7 and R8 systems, it is possible to have the old control carrier backplane or the new control carrier backplane. The backplane type must be verified before the upgrade order is placed so that the right characteristic selection can be made. If the type of carrier is not known, a visual inspection of the R7 or R8 system will be required. The old backplane is being used if the system has a TN794/TN2400 in the Network Control and Packet Control Slots. If nothing is in the Packet Control Slot the new backplane exists.

TN2402 Processor

The TN2402 processor platform runs at 25 MHz. The TN2402 includes a 32-bit RISC CPU complex and a maintenance processor complex that provides serial communications and maintenance functions for DEFINITY CSI. In addition, the TN2402 also terminates ISDN LAPD signaling over the TDM bus from PRI and BRI trunk circuit packs.

The RISC CPU complex provides four to 32 MB of Flash PROM. The DRAM is provided via one SIMM. The TN2402 contains 32 MB of DRAM. The flash is not interleaved. The TN2402 processor does not provide X.25 communications or a duplication option. The TN2402 does not contain an on-board modem. Instead, an external modem must be connected to the RS-232E port that was previously used for the internal modem.

The TN2402 is required for the CSI model to save translations to the 5-Volt ATA flash memory card.

TN2404 Processor

The TN2404 processor circuit pack has 32 MB of DRAM memory and flash memory. The TN2404 processor for DEFINITY SI is designed to handle errors that are associated with the EM-BUS and must be used with the C-LAN (TN799) and the Net/Pkt (TN2401) in DEFINITY SI configurations.

TN2464BP DS1 Interface with Echo Cancellation, T1/E1

The TN2464BP DS1 circuit pack is designed for international use in both category A and category B. The TN2464BP has echo cancellation circuitry and firmware download capability. The TN2464BP supports T1 (24-channel) and E1 (32-channel) digital facilities. In ISDN-PRI applications, the ISDN D channel connects the [TN1655 Packet Interface](#) via the LAN bus. The TN2464BP has the same functionality as the TN464GP, which is for US and Canada offers only.

The TN2464BP circuit pack provides:

- Test jack access to the T1/E1 line
- Board-level administrable A- μ -Law companding
- CRC-4 generation and checking (E1 only)
- Stratum-3 clock capability
- Support for the 120A channel service unit module
- CO, TIE, DID, off-premises station (OPS) port types that use robbed-bit signaling protocol, proprietary bit-oriented signaling (BOS) 24th-channel signaling protocol, or DMI-BOS 24th-channel signaling protocol
- Unpolarized, balanced-pair, line-out (LO) and line-in (LI) signal leads
- Support for Russian incoming ANI
- Support for the enhanced maintenance capabilities of the enhanced integrated channel service unit (ICSU)
- Support for Avaya IVR
- Channel-associated signaling protocols for many countries (for details, contact your Avaya representative)

The TN2464BP can be updated using the firmware download feature, which requires use of the TN799 C-LAN interface.

TN2501AP Voice Announcements over LAN (VAL)

The TN2501AP is an integrated announcement circuit pack that:

- Offers up to 1 hour of announcement storage capacity
- Provides shorter backup and restore times
- Is firmware downloadable
- Plays announcements over the TDM bus, similar to the TN750C circuit pack
- Has 33 ports, including
 - One dedicated telephone access port for recording and playing back announcements using port number 1
 - One Ethernet port using port number 33
 - 31 playback ports using ports 2 through 32
- Uses a 10-/100-Mbps ethernet interface to allow portability of announcements and firmware files over LAN
- Uses announcement files that are in ".wav" format (CCITT A- and μ -law, 8 kHz, 8-bit mono)

TN2793B Analog Line with Caller ID (24 ports)

The TN2793B is a dual coded, analog line 24-port circuit pack. Each port supports one telephone, such as the rotary dial 500 telephone and the DTMF dial 2500 telephones.

The TN2793B supports on-premises wiring with either touch-tone or rotary dialing and with or without the LED and neon message waiting indicators. The TN2793B supports off-premises wiring with either DTMF dialing or rotary dialing. LED or neon message waiting indicators are not supported off-premises.

Along with a TN755B neon power unit per carrier or per single-carrier cabinet, the TN2793B supports telephones equipped with neon message waiting indicators (on-premises use only). The TN2793B supports three ringer loads, only one telephone can have an LED or neon message waiting indicator. The TN2793B allows a maximum of 12 simultaneous ports ringing; four on ports 1 through 8, four on ports 9 through 16, and four on ports 17 through 24.

The TN2793B supports A- and μ -law companding and administrable timers. The TN2793B supports queue warning level lights associated with the DDC and the UCD features, recorded announcements associated with the Intercept Treatment feature, and PagePac paging system for the Loudspeaker Paging feature. Additional support is provided for external alerting devices associated with the TAAS feature, neon message waiting indicators, and modems. The TN2793B also supports secondary lightning protection. The TN2793B provides -48 VDC current in the off-hook state and -90 VDC ringing voltage.

The following table lists the TN2793B-supported telephones and shows each of their wiring sizes and ranges.

Telephone	Wire size (AWG)	Maximum range (feet)
500-type	24 (0.2 mm ² /0.5 mm)	20,000 (6,096 m)
2500-type	24 (0.2 mm ² /0.5 mm)	20,000 (6,096 m)
6200-type	24 (0.2 mm ² /0.5 mm)	12,000 (3,657 m)
7102A-series	24 (0.2 mm ² /0.5 mm)	20,000 (6,096 m)
8100-series	24 (0.2 mm ² /0.5 mm)	12,000 (3,657 m)

TNCCSC-1 PRI to DASS Converter

The TNCCSC-1 circuit pack converts ISDN-PRI to a DASS interface. DASS is a 2-Mbps interface that uses a 75-Ohm coaxial transmission facility. One TNCCSC-1 circuit pack can support up to two TN464 DS1 interface circuit packs. A Y-cable and an 888B 75-Ohm coaxial adapter connect to the public network facility.

TNCCSC-2 PRI to DPNSS Converter

The TNCCSC-2 circuit pack converts ISDN-PRI to a DPNSS interface. DPNSS is a 2-Mbps interface that uses a 75-Ohm coaxial transmission facility. One TNCCSC-2 circuit pack can support up to two TN464 DS1 interface circuit packs. A Y-cable connects to the public network facility.

TNCCSC-3 PRI to DPNSS Converter

The TNCCSC-3 circuit pack is the same as the TNCCSC-2 circuit pack with a 120-Ohm twisted pair interface.

TN-C7 PRI to SS7 Converter

The TN-C7 Provides a gateway interface between the TN464 circuit pack and the public signaling network. The TN-C7 integrates DASS, DPNSS and SS7 into a single board type. The TN-C7 supports international service provider call center customers. It is not designed for operation in the US or Canada.

TN-CIN Voice, FAX and Data Multiplexer

The TN-CIN Provides QSIG and private networking transparency on demand across a switched network. The TN-CIN integrates up to three G.728 LD-CELP voice or FAX circuits, six CAFT voice or FAX and two data circuits over a single separate digital link. The three or six voice or FAX circuits are presented as a G.703 E1 data stream that uses either QSIG peer-to-peer or channel-associated signaling.

All voice or FAX circuits support low bit rate voice compression at 8 to 16 kbps when they use CAFT, or at 16 kbps when they use LD-CELP. LD-CELP voice compression supports FAX at V.29 (7200 bps).

CAFT voice compression supports FAX at V.27ter (4800 bps). The Composite port supports V.11 and V.35 at speeds up to 128 kbps.

The TN-CIN features an on-demand voice networking mode for use with time-based communications links like ISDN. A high-speed data port using V.24 or V.11 or V.35 at up to 115.2 kbps synchronous or V.24 at up to 115.2 kbps asynchronous, that incorporates dynamic bandwidth allocation (variable data clocking) is available for data applications. A low-speed V.24 data port of up to 96 kbps synchronous or 57.6 kbps asynchronous is available for data applications.

UN330B Duplication Interface

The UN330B duplication interface is used for the DEFINITY R configurations only.

In a high- or critical-reliability system with two SPEs, one UN330B resides in each SPE and connects to the other UN330B. The UN330Bs provide control and communication paths between the SPEs to keep the standby SPE ready to assume control if the active SPE fails. The UN330Bs select active/ standby mode for the two SPEs, shadow (copy) the active SPE memory writes into the standby SPE memory, and support inter-SPE communications.

The duplication channel is a bidirectional high-speed path between the 2 SPEs. When memory shadowing is active, all shadowed memory writes on the active processor's bus are sent across the link and written into the memory of the standby processor. Standby memory writes are not sent to the active processor.

UN331C Processor

The UN331C processor circuit pack is used in the DEFINITY R configurations only.

The UN331C controls the system and executes stored programs that perform call-processing activity and maintenance. The UN331C is a RISC that is designed around a MIPS R3000A CPU that operates at 33 MHz. It employs 32-bit address and data buses to obtain and execute instructions at a rate approaching one instruction per clock cycle. The 256-Kbyte instruction cache with burst-mode refill and 256-Kbyte data cache are key to the performance of the processor. A read and write buffer chip tailors the UN331C to the call-processing environment.

Peripheral devices residing on the UN331C are positioned outside the CPU cache structure and interface to the CPU through the read/write buffers. These peripherals include:

- 512 Kbytes of ROM for the monitor
- Counters and timers
- UARTs
- Control, status and error registers
- Logic for bus arbitration and the Bus Time-Out feature

The UN331C interfaces to the 32-bit multiplexed address/data processor bus (PM-Bus) and the 32-bit processor expansion bus (PX-Bus). The PM-Bus is for all processor write operations and single-word (4-byte) read operations. Multiple-word or burst reads are performed using the PM-Bus to transfer the address to main memory. The words of the burst are then returned using both the PM-Bus and PX-Bus.

UN332C Mass Storage/Network Control for R

The UN332 provides an interface between the UN331C processor and the SCSI bus for access to the mass storage system (MSS) such as a disk drive. The UN332 also provides TDM network control for the PPN, and terminates one end of the processor-multiplexed bus.

The UN332C allows the interface of the switch to the TN2211 optic disk drive. The UN332C circuit pack includes the SCSI Host Adapter, the ArchAngel, and the tone clock switching logic.

Circuit packs and power supplies

655A power supply

Media modules

MM312 DCP media module

The Avaya MM312 Media Module provides 24 Digital Communications Protocol (DCP) ports with RJ-45 jacks. The MM312 supports simultaneous operation of all 24 ports. Each port can be connected to a 2-wire DCP telephone. The MM312 does not support 4-wire DCP telephones.

NOTE:

The MM312 is not supported in the G700 Media Gateway.

MM314 LAN media module

The Avaya MM314 Media Module provides:

- 24 Ethernet 10/100 Base-T Ethernet access ports with inline Power over Ethernet (PoE).
- One Gigabit Ethernet Small Form-Factor Pluggables (SFP) GigaBit Interface Converter (GBIC) slot which supports any of the following SFP GBICs: 1000-SX, 1000-LX, 1000-ELX or 1000-TX.

NOTE:

The MM314 is not supported in the G700 Media Gateway.

The MM314 supports 48V DC inline power provided over standard category 5 UTP cables (up to 100-m range) on each PoE port.

The MM314 features:

- Priority power budgeting with configurable priorities
- Automatic load detection on ports
- Automatic device discovery
- Enable/disable port powering option
- Port monitoring
- Automatic recovery from overload shutdown
- Automatic recovery from no-load shutdown

See the following figure for an example of the MM314.



MM340 E1/T1 media module

The Avaya MM340 Media Module provides one WAN access port for the connection of an E1 or T1 WAN.

NOTE:

The MM340 is not supported in the G700 Media Gateway.

See the following figure for an example of the MM340.



MM342 USP WAN media module

The Avaya MM342 Media Module provides one USP WAN access port. MM342 supports the following WAN protocols:

- V.35/ RS449
- X.21

For these connections, one of the following cables is necessary:

- Avaya Serial Cable DTE V.35 (USP to V.35)
- Avaya Serial Cable DTE X.21 (USP to X.21)

NOTE:

The MM324 is not supported in the G700 Media Gateway.

MM710 T1/E1 media module

The Avaya MM710 Media Module terminates a T1/E1 connection. The MM710 has a built-in Channel Service Unit (CSU) so that an external CSU is not necessary. See the following figure for an example of the MM710.

Figure 66: Avaya MM710 T1/E1 Media Module

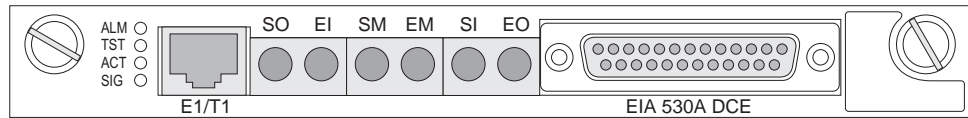

mmdc710 KLC 020402

NOTE:

The MM710 is supported in both the G700 and G350 Media Gateways.

Highlights of the MM710:

- Software selectable T1 or E1 operation
- An integrated CSU
- Both A-law (E1) and μ -law (T1) gain control and echo cancellation ability
- D4, ESF, or CEPT framing
- ISDN PRI capability (23B + D or 30B + D)
- AMI, ZCS, B8ZS (T1) or HDB3 (E1) line coding
- Trunk signaling to support US and international CO or tie trunks
- Echo cancellation in either direction
- Fractional T1 support
- An OIC DB 25-pin interface
- A Bantam loopback jack that is used for testing of T1 or E1 circuits.

The MM710 supports the universal DS1 that conforms to the ANSI T1.403 1.544 Mbps T1 standard and to the ITU-T G.703 2.048 Mbps E1 standard.

NOTE:

The MM710 does not support Code Mark Inversion line coding used in Japan.

Echo cancellation

The MM710 can cancel echoes in either direction for any DS0. The MM710 can cancel echoes with tail-end delays up to 96 milliseconds. It is compatible with either A- or μ -law code.

CSU function

The CSU functionality built into the MM710 has the following capabilities:

- Capable of long-haul or short-haul transmission
- Can receive signals as low as -36 dB
- Can compensate for distances up to 655 feet in short-haul operation
- Attenuation up to -22.5 dB can be programmed when driving repeaters for long-haul transmission.

Loopback/BERT functions

The loopback/BERT functionality in the MM710 has the following characteristics:

- Provides a passive loopback for the far-end in an un-powered state
- Can be set up for line or payload loopbacks.
- Supports incoming and outgoing ESF FDL requests
- Can generate and respond to in-band loop up and loop down codes per ANSI-T1.403
- Supports the generation and detection of test patterns as well as injection of bit errors for Bit Error Rate Testing

E1 impedance

By itself, the MM710 can be configured for balanced 120-ohm E1 operation. An external balun is required for 75-ohm unbalanced operation.

Bantam jacks

Six bantam jacks on the faceplate provide access to the incoming and outgoing T1 signals or E1 signals:

- SM permits passive monitoring of the incoming line.
- EM permits passive monitoring of the outgoing line.
- SO permits intrusive monitoring of the incoming signal from the network. When used, the SO jack breaks the connection of that signal to the framer.
- EI permits injection of a signal towards the framer. When used, the EI jack isolates the network Rx signal.
- SI permits injection of a signal towards the network. When used, the SI jack isolates the framer Tx signal from going out to the network.
- EO permits intrusive monitoring of the signal from the framer. When used, the EO jack breaks the connection of that signal to the network jack, RJ48C.

LEDs

Four LEDs are supported on the faceplate. These include the three standard Media Module LEDs and the SIG LED that indicates the MM710 Media Module is receiving a valid signal

DB 25 DCE connector

This connector can be used to connect a DSU (data service unit) in a future release.

Loopback jack

When you order a MM710, Avaya recommends that you include the optional 700A loop back jack. With the loop back jack installed you can loop back the T1 up to the network facility without a dispatch. If the MM710 is sold with an Avaya Service Agreement, the jack must be ordered and installed to save time and money on service calls.

The jack is typically used for CO trunk installations. The jack is inserted as close to the network or telco T1 facility as possible. When the jack is activated from the G700 Media Gateway, it sets up loopbacks in both directions. The G700 Media Gateway can then send and receive a test pattern to verify the function of the MM710 and T1 cable up to the network T1 facility. In normal operation, the jack passes the T1 signals through undisturbed in both directions.

MM711 Analog media module

The Avaya MM711 Media Module provides analog trunk and telephone features and functionality. See the following figure for an example of the MM711.

Figure 67: Avaya™ MM711 Analog Media Module

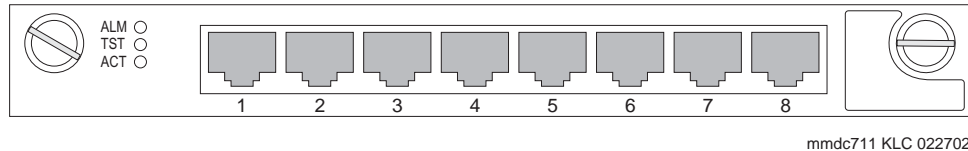

NOTE:

The MM711 is supported in both the G700 and G350 Media Gateways.

The MM711 provides the administrator with the capability to configure any of the eight ports of this analog circuit pack as:

- A loop start or a ground start central office trunk
 - Loop current 18-120mA
- A wink start or a immediate start Analog Direct Inward Dialing (DID) trunk
- A 2-wire analog Outgoing CAMA E911 trunk, for connectivity to the PSTN
 - MF signaling is supported for CAMA ports
- Analog, tip/ring devices such as single-line telephones with or without LED message waiting indication

The MM711 also supports:

- Three ringer loads (ringer equivalency number) for up to 2000 feet for all eight ports
- Up to eight simultaneously-ringing ports

NOTE:

The media gateway achieves this number of ports by staggering the ringing and pauses between two sets of up to four ports.

If more than four ports

- Type 1 and Type 2 Caller ID
- Ring voltage generation for a variety of international frequencies and cadences
- A hard-wired ground wire is added for each IROB-to-earth ground

External interfaces: CO trunk side

The following requirements apply to the external interfaces on the CO trunk side:

- The tip and ring default input impedance is 600 ohms. The default impedance can be configured to accommodate other tip and ring impedances such as 900 ohms used in Brazil and the complex impedance that is used in the European Union.
- A hard-wired ground wire is added for each IROB-to-earth ground.
- The MM711 supports DTMF, MF, and Pulsing.
- The MM711 supports R2MFC address signaling, and provides -48 VDC for ports that are set up as DID.
- CO trunk acceptable loop range is 18-60 mA
- The MM711 supports DIOD for Japan.

The following trunk types are supported:

- Loop start and ground start CO trunks
- DID
- CAMA

Caller ID

The MM711 supports ICLID on analog CO loop-start trunks for all supported countries that require this feature. It supports Type 1 CID devices, and firmware signaling requirements are implemented on a per-port basis. The firmware supports these formats:

- Single Data Message Format (SDMF)
- Multiple Data Message Format (MDMF)
- Caller ID generation on Line Ports

The MM711 accommodates on-hook transmission, necessary to receive caller ID signals.

On an ICLID administered trunk, absence of ICLID information or error in transmission of ICLID information will not prevent the call from being terminated, with the exception of Japan.

Analog line interface requirements

The MM711 provides pass through for FAX signals.

The MM711 supports analog telephone sets with:

- An impedance range of R_s : 215 to 300 ohms; R_p : 750 to 1000 ohms; C_p : 115 to 220pF
- A ringing frequency range of 20 Hz, 25 Hz, or 50 Hz
- A DC current range of 20 to 60 mA
- A hook flash range of 90 to 1000 ms

Companding

MM711 allows for A- or μ -law selection at installation. This is a software-selectable capability that applies to every port on the MM711.

MM712 DCP media module

The Avaya MM712 Media Module allows connectivity of up to eight 2-wire Digital Communications Protocol (DCP) voice terminals. See the following figure for an example of the MM712.

Figure 68: Avaya™ MM712 DCP Media Module

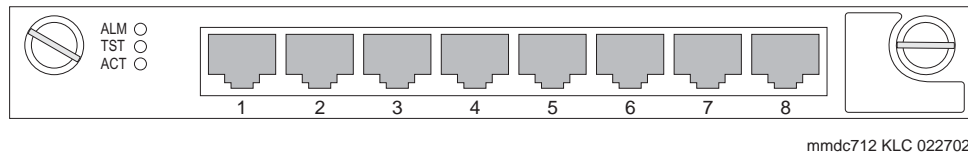

NOTE:

The MM712 is supported in both the G700 and G350 Media Gateways.

Hardware interface

Signal timing specifications for the MM712 support TDM Bus Timing in receive and transmit modes. The G700 Media Gateway supplies only +5 VDC and -48 VDC to the MM712 Media Module. Any other required voltages must be derived on the module.

Loop range secondary protection is provided on the MM712. The MM712 is also self-protecting from an over current condition on a tip and ring interface.

MM714 Analog media module

The Avaya MM714 Media Module provides four analog telephone ports and four analog trunk ports.

NOTE:

The MM714 is not supported in the G700 Media Gateway.

See the following figure for an example of the MM714.



MM720 BRI media module

The Avaya MM720 Media Module contains eight ports that interface to the central office at the ISDN T reference point. Information is communicated in two ways:

- Over two 64-kbps channels called B1 and B2
 - Can be circuit-switched simultaneously
- Over a 16-kbps channel called the D channel
 - Used for signaling
 - Occupies one time slot for all eight D channels

The circuit-switched connections have an A- or μ -law option for voice operation. The circuit-switched connections operate as 64-kbps clear channels when in the data mode.

NOTE:

The MM720 is supported in both the G350 and the G700 Media Gateways.

The MM720 does not support the following:

- BRI stations
- Combining both B channels together to form a 128-kbps channel

See the following figure for an example of the MM720.



MM722 BRI media module

The Avaya MM722 Media Module provides two 4-wire S/T ISDN BRI (Basic Rate Interface) 2B+D access ports with RJ-45 jacks. Each port interfaces to the central office at the ISDN T reference point. Information is communicated in the same manner as for the MM720.

NOTE:

The MM722 is not supported in the G700 Media Gateway.

MM760 VoIP media module

The Avaya MM760 Media Module is a clone of the motherboard VoIP engine. The MM760 provides an additional 64 VoIP channels with G.711 compression.

NOTE:

The MM760 is not supported in the G350 Media Gateway.

See the following figure for an example of a MM760.

Figure 69: Avaya™ MM760 VoIP Media Module



mmdc760 KLC 022702

The capacity of the MM760 is 64 G.711 TDM/IP simultaneous calls, or 32 compression codec, G.729 or G.723, TDM/IP simultaneous calls. These call types can be mixed on the same resource. In other words, the simultaneous call capacity of the resource is 64 G.711 Equivalent Calls.

NOTE:

Customers who want an essentially non-blocking system must add an additional MM760 Media Module if they use more than two MM710 Media Modules in a single chassis. The additional MM760 provides an additional 64 channels.

Ethernet interface

The MM760 must have its own Ethernet address. The MM760 requires a 10/100 Base T Ethernet interface to support H.323 endpoints for DEFINITY® IP trunks and stations from another G700 Media Gateway.

Voice compression

The MM760 supports on-board resources for compression and decompression of voice for G.711 (A- and μ -law), G.729 and 729B, and G.723 (5.3K and 6.3K).

The VoIP engine supports the following functionality:

- RTP and RTCP interfaces
- Dynamic jitter buffers
- DTMF detection
- Hybrid echo cancellation
- Silence suppression
- Comfort noise generation
- Packet loss concealment

Optional components

Optional components for an S8100 Media Server

Media gateways

[G600 Media Gateway](#) on page 127

[CMC1 Media Gateway](#) on page 147

Circuit packs

Power circuit packs

[650A AC power unit](#) on page 174

Line circuit packs

[TN479 Analog Line \(16 ports\)](#) on page 180

[TN556D ISDN-BRI 4-Wire S/T-NT Interface \(12 ports\)](#) on page 181

[TN746B Analog Line \(16 ports\)](#) on page 184

[TN762B Hybrid Line \(8 ports\)](#) on page 187

[TN769 Analog Line \(8 ports\)](#) on page 188

[TN791 Analog Guest Line \(16 ports\)](#) on page 191

[TN793B Analog Line with Caller ID \(24 ports\)](#) on page 192

[TN797 Analog Trunk or Line Circuit Pack \(8 ports\)](#) on page 193

[TN2181 DCP Digital Line \(2-wire, 16 ports\)](#) on page 197

[TN2183/TN2215 Analog Line for multiple countries \(16 ports\)](#) on page 197

[TN2185B ISDN-BRI S/T-TE Interface \(4-wire, 8 ports\)](#) on page 198

[TN2198B ISDN-BRI U Interface \(2-wire, 12 ports\)](#) on page 199

[TN2214B DCP Digital Line \(2-wire, 24 ports\)](#) on page 201

[TN2215/TN2183 Analog Line for Multiple Countries \(16 ports\) \(International Offers or Offer B only for US and Canada\)](#) on page 202

[TN2224B DCP Digital Line \(2-wire, 24 ports\)](#) on page 203

[TN2793B Analog Line with Caller ID \(24 ports\)](#) on page 210

Trunk circuit packs

- [TN429D Incoming Call Line Identification \(ICLID\)](#) on page 178
- [TN459B Direct Inward Dialing Trunk \(8 ports\)](#) on page 179
- [TN464GP DS1 Interface, T1 \(24 channels\) or E1 \(32 channels\)](#) on page 179
- [TN465C Central Office Trunk \(8 ports\)](#) on page 180
- [TN747B Central Office Trunk \(8 ports\)](#) on page 185
- [TN753B Direct Inward Dialing Trunk \(8 ports\)](#) on page 186
- [TN760E Tie Trunk \(4-wire, 4 ports\)](#) on page 187
- [TN763D Auxiliary Trunk \(4 ports\)](#) on page 187
- [TN767E DS1 Interface, T1 \(24 channels\)](#) on page 187
- [TN1654 DS1 Converter, T1 \(24 channels\) and E1 \(32 channels\)](#) on page 195
- [TN2140B Tie Trunk \(4-wire, 4 ports\)](#) on page 196
- [TN2146 Direct Inward Dialing Trunk \(8 ports\)](#) on page 196
- [TN2147C Central Office Trunk \(8 ports\)](#) on page 197
- [TN2184 DIOD Trunk \(4 ports\)](#) on page 198
- [TN2199 Central Office Trunk \(3-wire, 4 ports\)](#) on page 199
- [TN2207 DS1 Interface, T1 \(24 channels\) and E1 \(32 channels\)](#) on page 200
- [TN2209 Tie Trunk \(4-wire, 4 ports\)](#) on page 200
- [TN2242 Digital Trunk](#) on page 203
- [TN2305B ATM-CES Trunk/Port-Network Interface for multimode fiber](#) on page 204
- [TN2306B ATM-CES Trunk/Port-Network Interface for single-mode fiber](#) on page 204
- [TN2308 Direct Inward Dialing Trunk \(8 ports\)](#) on page 204
- [TN2313AP DS1 Interface \(24 channels\)](#) on page 207
- [TN2464BP DS1 Interface with Echo Cancellation,T1/E1](#) on page 209

Control circuit packs

- [TN771DP Maintenance and Test](#) on page 189
- [TN799DP Control LAN \(C-LAN\) Interface](#) on page 193
- [TN744E Call Classifier and Tone Detector \(8 ports\)](#) on page 184
- [TN2302AP IP Media Processor](#) on page 203
- [TN2314 S8100 Media Server](#) on page 207

Service circuit packs

- [TN433 Speech Synthesizer](#) on page 178
- [TN725B Speech Synthesizer](#) on page 183
- [TN788C Multimedia Voice Conditioner](#) on page 190
- [TNCCSC-1 PRI to DASS Converter](#) on page 211
- [TNCCSC-2 PRI to DPNSS Converter](#) on page 211

[TNCCSC-3 PRI to DPNSS Converter](#) on page 211

[TN-C7 PRI to SS7 Converter](#) on page 211

[TN-CIN Voice, FAX and Data Multiplexer](#) on page 211

Application circuit packs

[TN2501AP Voice Announcements over LAN \(VAL\)](#) on page 210

Port circuit packs

[TN2302AP IP Media Processor](#) on page 203

[TN789B Radio Controller](#) on page 191

Adapters

[NAA1 fiber-optic cable adaptor](#) on page 178

Avaya telephones

IP telephones

[Avaya 4602 IP telephone](#) on page 259

[Avaya 4602SW IP telephone](#) on page 260

[Avaya 4606 IP telephone](#) on page 260

[Avaya 4610SW IP telephone](#) on page 261

[Avaya 4612 IP telephone](#) on page 262

[Avaya 4620 IP telephone](#) on page 263

[Avaya 4620SW IP telephone](#) on page 264

[Avaya 4630 IP Screenphone](#) on page 266

[Avaya 4630SW IP telephone](#) on page 267

Digital telephones

[Avaya 2402 Digital Telephone](#) on page 267

[Avaya 2420 digital telephone](#) on page 268

[Avaya Callmaster IV \(603F\) digital telephone](#) on page 272

[Avaya Callmaster V \(607A\) digital telephone](#) on page 273

[Avaya 6402 and 6402D digital telephones](#) on page 268

[Avaya 6402 and 6402D digital telephones](#) on page 268

[Avaya 6408D+ digital telephone](#) on page 269

[Avaya 6416D+M digital telephone](#) on page 270

[Avaya 6424D+M digital telephone](#) on page 271

Optional components

Optional components for an S8100 Media Server

Soundstation speakerphones

[3127 SoundPoint Speakerphone](#) on page 283

[3127 SoundStation speakerphone](#) on page 283

[3127 SoundStation Premier audioconferencing speakerphone](#) on page 285

Analog phones

[Avaya 2500 and 2554 analog terminals](#) on page 276

[Avaya 6211 Analog Telephone](#) on page 277

[Avaya 6219 analog telephone](#) on page 278

Avaya Explosive Atmosphere telephones

[Avaya 2520B Explosive Atmosphere telephone](#) on page 279

Wireless

[Avaya TransTalk 9040](#) on page 279

Consoles

[Avaya 302D attendant console](#) on page 274

[Avaya Softconsole](#) on page 275

Optional components: S8300 Media Server with a G700 Media Gateway

Media gateways

[Avaya G700 Media Gateway](#) on page 139

Media modules for a G700 Media Gateway

[MM710 T1/E1 media module](#) on page 219

[MM711 Analog media module](#) on page 222

[MM712 DCP media module](#) on page 224

[MM760 VoIP media module](#) on page 228

[MM720 BRI media module](#) on page 226

Avaya telephones

IP telephones

[Avaya 4602 IP telephone](#) on page 259

[Avaya 4602SW IP telephone](#) on page 260

[Avaya 4606 IP telephone](#) on page 260

[Avaya 4610SW IP telephone](#) on page 261

[Avaya 4612 IP telephone](#) on page 262

[Avaya 4620 IP telephone](#) on page 263

[Avaya 4620SW IP telephone](#) on page 264

[Avaya 4630 IP Screenphone](#) on page 266

[Avaya 4630SW IP telephone](#) on page 267

Digital telephones

[Avaya 2402 Digital Telephone](#) on page 267

[Avaya 2420 digital telephone](#) on page 268

[Avaya 6402 and 6402D digital telephones](#) on page 268

[Avaya 6408D+ digital telephone](#) on page 269

[Avaya 6416D+M digital telephone](#) on page 270

[Avaya 6424D+M digital telephone](#) on page 271

[Avaya Callmaster IV \(603F\) digital telephone](#) on page 272

[Avaya Callmaster V \(607A\) digital telephone](#) on page 273

Optional components: S8300 Media Server with a G700 Media Gateway

[Avaya Callmaster VI \(606A\) digital telephone](#) on page 273

[Avaya 302D attendant console](#) on page 274

Analog telephones

[Avaya 6211 Analog Telephone](#) on page 277

[Avaya 6219 analog telephone](#) on page 278

[Avaya 2500 and 2554 analog terminals](#) on page 276

Wireless telephone

[Avaya TransTalk 9040](#) on page 279

Speakerphones

[3127 SoundPoint Speakerphone](#) on page 283

[3127 SoundStation speakerphone](#) on page 283

Optional components: S8500

Media gateways

[Avaya G650 Media Gateway](#) on page 131

[G600 Media Gateway](#) on page 127

[Avaya G700 Media Gateway](#) on page 139

[Avaya G350 Media Gateway](#) on page 123

[CMC1 Media Gateway](#) on page 147

[MCC1 Media Gateway](#) on page 159

[SCC1 Media Gateway](#) on page 150

Circuit packs

Power

[655A power supply](#) on page 175

[1217A AC power supply](#) on page 173

[649A DC power unit](#) on page 174

[676C DC power supply](#) on page 177

[TN755B Neon Power Unit](#) on page 186

[CFY1B current limiter](#) on page 177

[TN2202 Ring Generator](#) on page 200

Line circuit packs

[TN479 Analog Line \(16 ports\)](#) on page 180

[TN556D ISDN-BRI 4-Wire S/T-NT Interface \(12 ports\)](#) on page 181

[TN746B Analog Line \(16 ports\)](#) on page 184

[TN754C DCP Digital Line \(4-wire, 8 ports\)](#) on page 186

[TN762B Hybrid Line \(8 ports\)](#) on page 187

[TN769 Analog Line \(8 ports\)](#) on page 188

[TN791 Analog Guest Line \(16 ports\)](#) on page 191

[TN793B Analog Line with Caller ID \(24 ports\)](#) on page 192

[TN797 Analog Trunk or Line Circuit Pack \(8 ports\)](#) on page 193

[TN2181 DCP Digital Line \(2-wire, 16 ports\)](#) on page 197

[TN2183/TN2215 Analog Line for multiple countries \(16 ports\)](#) on page 197

[TN2185B ISDN-BRI S/T-TE Interface \(4-wire, 8 ports\)](#) on page 198

[TN2198B ISDN-BRI U Interface \(2-wire, 12 ports\)](#) on page 199

[TN2214B DCP Digital Line \(2-wire, 24 ports\)](#) on page 201

[TN2215/TN2183 Analog Line for Multiple Countries \(16 ports\) \(International Offers or Offer B only for US and Canada\)](#) on page 202

[TN2224B DCP Digital Line \(2-wire, 24 ports\)](#) on page 203

[TN2793B Analog Line with Caller ID \(24 ports\)](#) on page 210

Trunk circuit packs

[TN429D Incoming Call Line Identification \(ICLID\)](#) on page 178

[TN459B Direct Inward Dialing Trunk \(8 ports\)](#) on page 179

[TN464GP DS1 Interface, T1 \(24 channels\) or E1 \(32 channels\)](#) on page 179

[TN465C Central Office Trunk \(8 ports\)](#) on page 180

[TN747B Central Office Trunk \(8 ports\)](#) on page 185

[TN753B Direct Inward Dialing Trunk \(8 ports\)](#) on page 186

[TN760E Tie Trunk \(4-wire, 4 ports\)](#) on page 187

[TN763D Auxiliary Trunk \(4 ports\)](#) on page 187

[TN767E DS1 Interface, T1 \(24 channels\)](#) on page 187

[TN1654 DS1 Converter, T1 \(24 channels\) and E1 \(32 channels\)](#) on page 195

[TN2140B Tie Trunk \(4-wire, 4 ports\)](#) on page 196

[TN2146 Direct Inward Dialing Trunk \(8 ports\)](#) on page 196

[TN2147C Central Office Trunk \(8 ports\)](#) on page 197

[TN2184 DIOD Trunk \(4 ports\)](#) on page 198

[TN2199 Central Office Trunk \(3-wire, 4 ports\)](#) on page 199

[TN2207 DS1 Interface, T1 \(24 channels\) and E1 \(32 channels\)](#) on page 200

[TN2209 Tie Trunk \(4-wire, 4 ports\)](#) on page 200

[TN2242 Digital Trunk](#) on page 203

[TN2308 Direct Inward Dialing Trunk \(8 ports\)](#) on page 204

[TN2313AP DS1 Interface \(24 channels\)](#) on page 207

[TN2464BP DS1 Interface with Echo Cancellation, T1/E1](#) on page 209

Control circuit packs

[TN570D Expansion Interface](#) on page 182

[TN744E Call Classifier and Tone Detector \(8 ports\)](#) on page 184

[TN771DP Maintenance and Test](#) on page 189

[TN775C Maintenance](#) on page 189

[TN780 Tone Clock](#) on page 190

[TN799DP Control LAN \(C-LAN\) Interface](#) on page 193

[TN2182C Tone Clock, Tone Detector, and Call Classifier \(8 ports\)](#) on page 197

[TN2302AP IP Media Processor](#) on page 203

[TN2312BP IP Server Interface](#) on page 204

Service circuit packs

[TN433 Speech Synthesizer](#) on page 178

[TN725B Speech Synthesizer](#) on page 183

[TN744E Call Classifier and Tone Detector \(8 ports\)](#) on page 184

[TNCCSC-1 PRI to DASS Converter](#) on page 211

[TNCCSC-2 PRI to DPNSS Converter](#) on page 211

[TNCCSC-3 PRI to DPNSS Converter](#) on page 211

[TN-C7 PRI to SS7 Converter](#) on page 211

[TN-CIN Voice, FAX and Data Multiplexer](#) on page 211

Application circuit packs

[TN568 DEFINITY AUDIX 4.0 Voice Mail System \(part of ED-1E568\)](#) on page 181

[TN801 MAPD \(LAN Gateway Interface\)](#) on page 194

[TN2501AP Voice Announcements over LAN \(VAL\)](#) on page 210

Port circuit packs

[TN2302AP IP Media Processor](#) on page 203

[TN789B Radio Controller](#) on page 191

Avaya telephones

IP telephones

[Avaya 4602 IP telephone](#) on page 259

[Avaya 4602SW IP telephone](#) on page 260

[Avaya 4606 IP telephone](#) on page 260

[Avaya 4610SW IP telephone](#) on page 261

[Avaya 4612 IP telephone](#) on page 262

[Avaya 4620 IP telephone](#) on page 263

[Avaya 4620SW IP telephone](#) on page 264

[The 4620SW IP telephone has the same feature set as the 4620 with the addition of the following:](#)
on page 264

[Avaya 4630 IP Screenphone](#) on page 266

[Avaya 4630SW IP telephone](#) on page 267

Digital telephones

- [Avaya 2402 Digital Telephone](#) on page 267
- [Avaya 2420 digital telephone](#) on page 268
- [Avaya Callmaster IV \(603F\) digital telephone](#) on page 272
- [Avaya Callmaster V \(607A\) digital telephone](#) on page 273
- [Avaya 6402 and 6402D digital telephones](#) on page 268
- [Avaya 6402 and 6402D digital telephones](#) on page 268
- [Avaya 6408D+ digital telephone](#) on page 269
- [Avaya 6416D+M digital telephone](#) on page 270
- [Avaya 6424D+M digital telephone](#) on page 271

SoundStation speakerphones

- [3127 SoundPoint Speakerphone](#) on page 283
- [3127 SoundStation speakerphone](#) on page 283
- [3127 SoundStation Premier audioconferencing speakerphone](#) on page 285

Analog telephones

- [Avaya 2500 and 2554 analog terminals](#) on page 276
- [Avaya 6211 Analog Telephone](#) on page 277
- [Avaya 6219 analog telephone](#) on page 278

Avaya Explosive Atmosphere telephone

- [Avaya 2520B Explosive Atmosphere telephone](#) on page 279

Wireless telephone

- [Avaya TransTalk 9040](#) on page 279

Consoles

- [Avaya 302D attendant console](#) on page 274
- [Avaya Softconsole](#) on page 275

Optional components for an S8700 Media Server in an IP Connect configuration

Media gateways

[G600 Media Gateway](#) on page 127

[Avaya G700 Media Gateway](#) on page 139

Circuit packs

Line circuit packs

[TN479 Analog Line \(16 ports\)](#) on page 180

[TN556D ISDN-BRI 4-Wire S/T-NT Interface \(12 ports\)](#) on page 181

[TN746B Analog Line \(16 ports\)](#) on page 184

[TN762B Hybrid Line \(8 ports\)](#) on page 187

[TN769 Analog Line \(8 ports\)](#) on page 188

[TN791 Analog Guest Line \(16 ports\)](#) on page 191

[TN793B Analog Line with Caller ID \(24 ports\)](#) on page 192

[TN797 Analog Trunk or Line Circuit Pack \(8 ports\)](#) on page 193

[TN2181 DCP Digital Line \(2-wire, 16 ports\)](#) on page 197

[TN2183/TN2215 Analog Line for multiple countries \(16 ports\)](#) on page 197

[TN2185B ISDN-BRI S/T-TE Interface \(4-wire, 8 ports\)](#) on page 198

[TN2198B ISDN-BRI U Interface \(2-wire, 12 ports\)](#) on page 199

[TN2214B DCP Digital Line \(2-wire, 24 ports\)](#) on page 201

[TN2215/TN2183 Analog Line for Multiple Countries \(16 ports\) \(International Offers or Offer B only for US and Canada\)](#) on page 202

[TN2224B DCP Digital Line \(2-wire, 24 ports\)](#) on page 203

[TN2793B Analog Line with Caller ID \(24 ports\)](#) on page 210

Trunk circuit packs

[TN429D Incoming Call Line Identification \(ICLID\)](#) on page 178

[TN459B Direct Inward Dialing Trunk \(8 ports\)](#) on page 179

[TN464GP DS1 Interface, T1 \(24 channels\) or E1 \(32 channels\)](#) on page 179

[TN465C Central Office Trunk \(8 ports\)](#) on page 180

[TN747B Central Office Trunk \(8 ports\)](#) on page 185

[TN753B Direct Inward Dialing Trunk \(8 ports\)](#) on page 186

[TN760E Tie Trunk \(4-wire, 4 ports\)](#) on page 187

- [TN763D Auxiliary Trunk \(4 ports\)](#) on page 187
- [TN767E DS1 Interface, T1 \(24 channels\)](#) on page 187
- [TN1654 DS1 Converter, T1 \(24 channels\) and E1 \(32 channels\)](#) on page 195
- [TN2140B Tie Trunk \(4-wire, 4 ports\)](#) on page 196
- [TN2146 Direct Inward Dialing Trunk \(8 ports\)](#) on page 196
- [TN2147C Central Office Trunk \(8 ports\)](#) on page 197
- [TN2184 DIOD Trunk \(4 ports\)](#) on page 198
- [TN2199 Central Office Trunk \(3-wire, 4 ports\)](#) on page 199
- [TN2207 DS1 Interface, T1 \(24 channels\) and E1 \(32 channels\)](#) on page 200
- [TN2209 Tie Trunk \(4-wire, 4 ports\)](#) on page 200
- [TN2242 Digital Trunk](#) on page 203
- [TN2308 Direct Inward Dialing Trunk \(8 ports\)](#) on page 204
- [TN2313AP DS1 Interface \(24 channels\)](#) on page 207
- [TN2464BP DS1 Interface with Echo Cancellation,T1/E1](#) on page 209

Control circuit packs

- [TN771DP Maintenance and Test](#) on page 189
- [TN799DP Control LAN \(C-LAN\) Interface](#) on page 193
- [TN2302AP IP Media Processor](#) on page 203
- [TN2312BP IP Server Interface](#) on page 204

Service circuit packs

- [TN433 Speech Synthesizer](#) on page 178
- [TN725B Speech Synthesizer](#) on page 183
- [TN744E Call Classifier and Tone Detector \(8 ports\)](#) on page 184
- [TNCCSC-1 PRI to DASS Converter](#) on page 211
- [TNCCSC-2 PRI to DPNSS Converter](#) on page 211
- [TNCCSC-3 PRI to DPNSS Converter](#) on page 211
- [TN-C7 PRI to SS7 Converter](#) on page 211
- [TN-CIN Voice, FAX and Data Multiplexer](#) on page 211

Application circuit packs

- [TN801 MAPD \(LAN Gateway Interface\)](#) on page 194
- [TN2501AP Voice Announcements over LAN \(VAL\)](#) on page 210

Port circuit packs

- [TN2302AP IP Media Processor](#) on page 203
- [TN789B Radio Controller](#) on page 191

Avaya telephones

IP telephones

- [Avaya 4602 IP telephone](#) on page 259
- [Avaya 4602SW IP telephone](#) on page 260
- [Avaya 4606 IP telephone](#) on page 260
- [Avaya 4610SW IP telephone](#) on page 261
- [Avaya 4612 IP telephone](#) on page 262
- [Avaya 4620 IP telephone](#) on page 263
- [Avaya 4620SW IP telephone](#) on page 264
- [Avaya 4630 IP Screenphone](#) on page 266
- [Avaya 4630SW IP telephone](#) on page 267

Digital telephones

- [Avaya 2402 Digital Telephone](#) on page 267
- [Avaya 2420 digital telephone](#) on page 268
- [Avaya Callmaster IV \(603F\) digital telephone](#) on page 272
- [Avaya Callmaster V \(607A\) digital telephone](#) on page 273
- [Avaya 6402 and 6402D digital telephones](#) on page 268
- [Avaya 6402 and 6402D digital telephones](#) on page 268
- [Avaya 6408D+ digital telephone](#) on page 269
- [Avaya 6416D+M digital telephone](#) on page 270
- [Avaya 6424D+M digital telephone](#) on page 271

SoundStation speakerphones

- [3127 SoundPoint Speakerphone](#) on page 283
 - [3127 SoundStation speakerphone](#) on page 283
 - [3127 SoundStation Premier audioconferencing speakerphone](#) on page 285
- Analog telephones
- [Avaya 2500 and 2554 analog terminals](#) on page 276
 - [Avaya 6211 Analog Telephone](#) on page 277
 - [Avaya 6219 analog telephone](#) on page 278

Avaya Explosive Atmosphere telephone

- [Avaya 2520B Explosive Atmosphere telephone](#) on page 279

Wireless telephone

- [Avaya TransTalk 9040](#) on page 279

Consoles

[Avaya 302D attendant console](#) on page 274

[Avaya Softconsole](#) on page 275

Optional components: S8700 – Voice Bearer Over CSS or ATM

Media gateways

[Avaya G650 Media Gateway](#) on page 131

[Avaya G350 Media Gateway](#) on page 123

[Avaya G700 Media Gateway](#) on page 139

[SCC1 Media Gateway](#) on page 150

[MCC1 Media Gateway](#) on page 159

Circuit packs

Power

[655A power supply](#) on page 175

[1217A AC power supply](#) on page 173

[649A DC power unit](#) on page 174

[676C DC power supply](#) on page 177

[TN755B Neon Power Unit](#) on page 186

[CFY1B current limiter](#) on page 177

[TN2202 Ring Generator](#) on page 200

Line circuit packs

[TN479 Analog Line \(16 ports\)](#) on page 180

[TN556D ISDN-BRI 4-Wire S/T-NT Interface \(12 ports\)](#) on page 181

[TN746B Analog Line \(16 ports\)](#) on page 184

[TN754C DCP Digital Line \(4-wire, 8 ports\)](#) on page 186

[TN762B Hybrid Line \(8 ports\)](#) on page 187

[TN769 Analog Line \(8 ports\)](#) on page 188

[TN791 Analog Guest Line \(16 ports\)](#) on page 191

[TN793B Analog Line with Caller ID \(24 ports\)](#) on page 192

[TN797 Analog Trunk or Line Circuit Pack \(8 ports\)](#) on page 193

[TN2181 DCP Digital Line \(2-wire, 16 ports\)](#) on page 197

[TN2183/TN2215 Analog Line for multiple countries \(16 ports\)](#) on page 197

[TN2185B ISDN-BRI S/T-TE Interface \(4-wire, 8 ports\)](#) on page 198

[TN2198B ISDN-BRI U Interface \(2-wire, 12 ports\)](#) on page 199

[TN2214B DCP Digital Line \(2-wire, 24 ports\)](#) on page 201

[TN2215/TN2183 Analog Line for Multiple Countries \(16 ports\) \(International Offers or Offer B only for US and Canada\)](#) on page 202

[TN2224B DCP Digital Line \(2-wire, 24 ports\)](#) on page 203

[TN2793B Analog Line with Caller ID \(24 ports\)](#) on page 210

Trunk circuit packs

[TN429D Incoming Call Line Identification \(ICLID\)](#) on page 178

[TN459B Direct Inward Dialing Trunk \(8 ports\)](#) on page 179

[TN464GP DS1 Interface, T1 \(24 channels\) or E1 \(32 channels\)](#) on page 179

[TN465C Central Office Trunk \(8 ports\)](#) on page 180

[TN747B Central Office Trunk \(8 ports\)](#) on page 185

[TN753B Direct Inward Dialing Trunk \(8 ports\)](#) on page 186

[TN760E Tie Trunk \(4-wire, 4 ports\)](#) on page 187

[TN763D Auxiliary Trunk \(4 ports\)](#) on page 187

[TN767E DS1 Interface, T1 \(24 channels\)](#) on page 187

[TN1654 DS1 Converter, T1 \(24 channels\) and E1 \(32 channels\)](#) on page 195

[TN2140B Tie Trunk \(4-wire, 4 ports\)](#) on page 196

[TN2146 Direct Inward Dialing Trunk \(8 ports\)](#) on page 196

[TN2147C Central Office Trunk \(8 ports\)](#) on page 197

[TN2184 DIOD Trunk \(4 ports\)](#) on page 198

[TN2199 Central Office Trunk \(3-wire, 4 ports\)](#) on page 199

[TN2207 DS1 Interface, T1 \(24 channels\) and E1 \(32 channels\)](#) on page 200

[TN2209 Tie Trunk \(4-wire, 4 ports\)](#) on page 200

[TN2242 Digital Trunk](#) on page 203

[TN2305B ATM-CES Trunk/Port-Network Interface for multimode fiber](#) on page 204

[TN2306B ATM-CES Trunk/Port-Network Interface for single-mode fiber](#) on page 204

[TN2308 Direct Inward Dialing Trunk \(8 ports\)](#) on page 204

[TN2313AP DS1 Interface \(24 channels\)](#) on page 207

[TN2464BP DS1 Interface with Echo Cancellation, T1/E1](#) on page 209

Control circuit packs

[TN570D Expansion Interface](#) on page 182

[TN744E Call Classifier and Tone Detector \(8 ports\)](#) on page 184

[TN771DP Maintenance and Test](#) on page 189

[TN775C Maintenance](#) on page 189

[TN780 Tone Clock](#) on page 190

[TN799DP Control LAN \(C-LAN\) Interface](#) on page 193

[TN2182C Tone Clock, Tone Detector, and Call Classifier \(8 ports\)](#) on page 197

[TN2302AP IP Media Processor](#) on page 203

[TN2312BP IP Server Interface](#) on page 204

Service circuit packs

[TN433 Speech Synthesizer](#) on page 178

[TN725B Speech Synthesizer](#) on page 183

[TN787K Multimedia Interface](#) on page 190

[TN788C Multimedia Voice Conditioner](#) on page 190

[TNCCSC-1 PRI to DASS Converter](#) on page 211

[TNCCSC-2 PRI to DPNSS Converter](#) on page 211

[TNCCSC-3 PRI to DPNSS Converter](#) on page 211

[TN-C7 PRI to SS7 Converter](#) on page 211

[TN-CIN Voice, FAX and Data Multiplexer](#) on page 211

Application circuit packs

[TN568 DEFINITY AUDIX 4.0 Voice Mail System \(part of ED-1E568\)](#) on page 181

[TN801 MAPD \(LAN Gateway Interface\)](#) on page 194

[TN2501AP Voice Announcements over LAN \(VAL\)](#) on page 210

Port circuit packs

[TN2302AP IP Media Processor](#) on page 203

[TN789B Radio Controller](#) on page 191

Avaya telephones

IP telephones

[Avaya 4602 IP telephone](#) on page 259

[Avaya 4602SW IP telephone](#) on page 260

[Avaya 4606 IP telephone](#) on page 260

[Avaya 4612 IP telephone](#) on page 262

[Avaya 4620 IP telephone](#) on page 263

[Avaya 4620SW IP telephone](#) on page 264

[Avaya 4624 IP telephone](#) on page 264

[Avaya 4630 IP Screenphone](#) on page 266

[Avaya 4630SW IP telephone](#) on page 267

Digital telephones

[Avaya 2402 Digital Telephone](#) on page 267

[Avaya 2420 digital telephone](#) on page 268

[Avaya Callmaster IV \(603F\) digital telephone](#) on page 272

[Avaya Callmaster V \(607A\) digital telephone](#) on page 273

[Avaya Callmaster VI \(606A\) digital telephone](#) on page 273

[Avaya 6402 and 6402D digital telephones](#) on page 268

[Avaya 6408D+ digital telephone](#) on page 269

[Avaya 6416D+M digital telephone](#) on page 270

[Avaya 6424D+M digital telephone](#) on page 271

SoundStation speakerphones

[3127 SoundPoint Speakerphone](#) on page 283

[3127 SoundStation speakerphone](#) on page 283

[3127 SoundStation Premier audioconferencing speakerphone](#) on page 285

Analog telephones

[Avaya 2500 and 2554 analog terminals](#) on page 276

[Avaya 6211 Analog Telephone](#) on page 277

[Avaya 6219 analog telephone](#) on page 278

Avaya Explosive Atmosphere telephones

[Avaya 2520B Explosive Atmosphere telephone](#) on page 279

Wireless telephone

[Avaya TransTalk 9040](#) on page 279

Consoles

[Avaya 302D attendant console](#) on page 274

[Avaya Softconsole](#) on page 275

Optional components for DEFINITY Server CSI

Media gateways

[CMC1 Media Gateway](#) on page 147

Circuit packs for DEFINITY Server CSI

Power circuit packs

[650A AC power unit](#) on page 174

Line circuit packs

[TN479 Analog Line \(16 ports\)](#) on page 180

[TN746B Analog Line \(16 ports\)](#) on page 184

[TN762B Hybrid Line \(8 ports\)](#) on page 187

[TN769 Analog Line \(8 ports\)](#) on page 188

[TN791 Analog Guest Line \(16 ports\)](#) on page 191

[TN793B Analog Line with Caller ID \(24 ports\)](#) on page 192

[TN797 Analog Trunk or Line Circuit Pack \(8 ports\)](#) on page 193

[TN2181 DCP Digital Line \(2-wire, 16 ports\)](#) on page 197

[TN2183/TN2215 Analog Line for multiple countries \(16 ports\)](#) on page 197

[TN2185B ISDN-BRI S/T-TE Interface \(4-wire, 8 ports\)](#) on page 198

[TN2198B ISDN-BRI U Interface \(2-wire, 12 ports\)](#) on page 199

[TN2214B DCP Digital Line \(2-wire, 24 ports\)](#) on page 201

[TN2215/TN2183 Analog Line for Multiple Countries \(16 ports\) \(International Offers or Offer B only for US and Canada\)](#) on page 202

[TN2224B DCP Digital Line \(2-wire, 24 ports\)](#) on page 203

[TN2793B Analog Line with Caller ID \(24 ports\)](#) on page 210

Trunk circuit packs

[TN429D Incoming Call Line Identification \(ICLID\)](#) on page 178

[TN459B Direct Inward Dialing Trunk \(8 ports\)](#) on page 179

[TN464GP DS1 Interface, T1 \(24 channels\) or E1 \(32 channels\)](#) on page 179

[TN465C Central Office Trunk \(8 ports\)](#) on page 180

[TN747B Central Office Trunk \(8 ports\)](#) on page 185

[TN753B Direct Inward Dialing Trunk \(8 ports\)](#) on page 186

[TN760E Tie Trunk \(4-wire, 4 ports\)](#) on page 187

- [TN763D Auxiliary Trunk \(4 ports\)](#) on page 187
- [TN767E DS1 Interface, T1 \(24 channels\)](#) on page 187
- [TN1654 DS1 Converter, T1 \(24 channels\) and E1 \(32 channels\)](#) on page 195
- [TN2140B Tie Trunk \(4-wire, 4 ports\)](#) on page 196
- [TN2146 Direct Inward Dialing Trunk \(8 ports\)](#) on page 196
- [TN2147C Central Office Trunk \(8 ports\)](#) on page 197
- [TN2184 DIOD Trunk \(4 ports\)](#) on page 198
- [TN2199 Central Office Trunk \(3-wire, 4 ports\)](#) on page 199
- [TN2207 DS1 Interface, T1 \(24 channels\) and E1 \(32 channels\)](#) on page 200
- [TN2209 Tie Trunk \(4-wire, 4 ports\)](#) on page 200
- [TN2242 Digital Trunk](#) on page 203
- [TN2305B ATM-CES Trunk/Port-Network Interface for multimode fiber](#) on page 204
- [TN2306B ATM-CES Trunk/Port-Network Interface for single-mode fiber](#) on page 204
- [TN2308 Direct Inward Dialing Trunk \(8 ports\)](#) on page 204
- [TN2313AP DS1 Interface \(24 channels\)](#) on page 207
- [TN2464BP DS1 Interface with Echo Cancellation,T1/E1](#) on page 209

Control circuit packs

- [TN744E Call Classifier and Tone Detector \(8 ports\)](#) on page 184
- [TN799DP Control LAN \(C-LAN\) Interface](#) on page 193
- [TN2182C Tone Clock, Tone Detector, and Call Classifier \(8 ports\)](#) on page 197
- [TN2302AP IP Media Processor](#) on page 203
- [TN2402 Processor](#) on page 208

Service circuit packs

- [TN433 Speech Synthesizer](#) on page 178
- [TN725B Speech Synthesizer](#) on page 183
- [TN788C Multimedia Voice Conditioner](#) on page 190
- [TNCCSC-1 PRI to DASS Converter](#) on page 211
- [TNCCSC-2 PRI to DPNSS Converter](#) on page 211
- [TNCCSC-3 PRI to DPNSS Converter](#) on page 211
- [TN-C7 PRI to SS7 Converter](#) on page 211
- [TN-CIN Voice, FAX and Data Multiplexer](#) on page 211

Application circuit packs

- [TN568 DEFINITY AUDIX 4.0 Voice Mail System \(part of ED-1E568\)](#) on page 181

[TN750C Recorded Announcement \(16 channels\)](#) on page 185

[TN801 MAPD \(LAN Gateway Interface\)](#) on page 194

[TN2501AP Voice Announcements over LAN \(VAL\)](#) on page 210

Port circuit packs

[TN2302AP IP Media Processor](#) on page 203

[TN789B Radio Controller](#) on page 191

Adapter

[NAA1 fiber-optic cable adaptor](#) on page 178

Avaya telephones for DEFINITY Server CSI

IP telephones

[Avaya 4602 IP telephone](#) on page 259

[Avaya 4602SW IP telephone](#) on page 260

[Avaya 4606 IP telephone](#) on page 260

[Avaya 4610SW IP telephone](#) on page 261

[Avaya 4612 IP telephone](#) on page 262

[Avaya 4620 IP telephone](#) on page 263

[Avaya 4620SW IP telephone](#) on page 264

[Avaya 4630 IP Screenphone](#) on page 266

[Avaya 4630SW IP telephone](#) on page 267

Digital telephones

[Avaya 2402 Digital Telephone](#) on page 267

[Avaya 2420 digital telephone](#) on page 268

[Avaya Callmaster IV \(603F\) digital telephone](#) on page 272

[Avaya Callmaster V \(607A\) digital telephone](#) on page 273

[Avaya Callmaster VI \(606A\) digital telephone](#) on page 273

[Avaya 6402 and 6402D digital telephones](#) on page 268

[Avaya 6402 and 6402D digital telephones](#) on page 268

[Avaya 6408D+ digital telephone](#) on page 269

[Avaya 6416D+M digital telephone](#) on page 270

[Avaya 6424D+M digital telephone](#) on page 271

SoundStation speakerphones

[3127 SoundPoint Speakerphone](#) on page 283

[3127 SoundStation speakerphone](#) on page 283

[3127 SoundStation Premier audioconferencing speakerphone](#) on page 285

Analog telephones

[Avaya 2500 and 2554 analog terminals](#) on page 276

[Avaya 6211 Analog Telephone](#) on page 277

[Avaya 6219 analog telephone](#) on page 278

Explosive Atmosphere telephones

[Avaya 2520B Explosive Atmosphere telephone](#) on page 279

Wireless telephone

[Avaya TransTalk 9040](#) on page 279

Consoles

[Avaya 302D attendant console](#) on page 274

[Avaya Softconsole](#) on page 275

Optional components for DEFINITY Server SI

Media gateways

[SCC1 Media Gateway](#) on page 150

[MCC1 Media Gateway](#) on page 159

Circuit packs for DEFINITY Server SI

Power Circuit Packs

[1217A AC power supply](#) on page 173

[631DA1 AC power unit](#) on page 173

[631DB1 AC power unit](#) on page 173

[649A DC power unit](#) on page 174

[676C DC power supply](#) on page 177

[982LS current limiter](#) on page 177

[TN755B Neon Power Unit](#) on page 186

[CFY1B current limiter](#) on page 177

[TN2202 Ring Generator](#) on page 200

Line Circuit Packs

[TN479 Analog Line \(16 ports\)](#) on page 180

[TN556D ISDN-BRI 4-Wire S/T-NT Interface \(12 ports\)](#) on page 181

[TN746B Analog Line \(16 ports\)](#) on page 184

[TN754C DCP Digital Line \(4-wire, 8 ports\)](#) on page 186

[TN762B Hybrid Line \(8 ports\)](#) on page 187

[TN769 Analog Line \(8 ports\)](#) on page 188

[TN791 Analog Guest Line \(16 ports\)](#) on page 191

[TN793B Analog Line with Caller ID \(24 ports\)](#) on page 192

[TN797 Analog Trunk or Line Circuit Pack \(8 ports\)](#) on page 193

[TN2181 DCP Digital Line \(2-wire, 16 ports\)](#) on page 197

[TN2183/TN2215 Analog Line for multiple countries \(16 ports\)](#) on page 197

[TN2185B ISDN-BRI S/T-TE Interface \(4-wire, 8 ports\)](#) on page 198

[TN2198B ISDN-BRI U Interface \(2-wire, 12 ports\)](#) on page 199

[TN2214B DCP Digital Line \(2-wire, 24 ports\)](#) on page 201

[TN2215/TN2183 Analog Line for Multiple Countries \(16 ports\) \(International Offers or Offer B only for US and Canada\)](#) on page 202

[TN2224B DCP Digital Line \(2-wire, 24 ports\)](#) on page 203

[TN2793B Analog Line with Caller ID \(24 ports\)](#) on page 210

Trunk Circuit Packs

[TN429D Incoming Call Line Identification \(ICLID\)](#) on page 178

[TN459B Direct Inward Dialing Trunk \(8 ports\)](#) on page 179

[TN464GP DS1 Interface, T1 \(24 channels\) or E1 \(32 channels\)](#) on page 179

[TN465C Central Office Trunk \(8 ports\)](#) on page 180

[TN747B Central Office Trunk \(8 ports\)](#) on page 185

[TN753B Direct Inward Dialing Trunk \(8 ports\)](#) on page 186

[TN760E Tie Trunk \(4-wire, 4 ports\)](#) on page 187

[TN763D Auxiliary Trunk \(4 ports\)](#) on page 187

[TN767E DS1 Interface, T1 \(24 channels\)](#) on page 187

[TN1654 DS1 Converter, T1 \(24 channels\) and E1 \(32 channels\)](#) on page 195

[TN2140B Tie Trunk \(4-wire, 4 ports\)](#) on page 196

[TN2146 Direct Inward Dialing Trunk \(8 ports\)](#) on page 196

[TN2147C Central Office Trunk \(8 ports\)](#) on page 197

[TN2184 DIOD Trunk \(4 ports\)](#) on page 198

[TN2199 Central Office Trunk \(3-wire, 4 ports\)](#) on page 199

[TN2207 DS1 Interface, T1 \(24 channels\) and E1 \(32 channels\)](#) on page 200

[TN2209 Tie Trunk \(4-wire, 4 ports\)](#) on page 200

[TN2242 Digital Trunk](#) on page 203

[TN2305B ATM-CES Trunk/Port-Network Interface for multimode fiber](#) on page 204

[TN2306B ATM-CES Trunk/Port-Network Interface for single-mode fiber](#) on page 204

[TN2308 Direct Inward Dialing Trunk \(8 ports\)](#) on page 204

[TN2313AP DS1 Interface \(24 channels\)](#) on page 207

[TN2464BP DS1 Interface with Echo Cancellation,T1/E1](#) on page 209

Control Circuit Packs

[TN570D Expansion Interface](#) on page 182

[TN744E Call Classifier and Tone Detector \(8 ports\)](#) on page 184

[TN771DP Maintenance and Test](#) on page 189

[TN775C Maintenance](#) on page 189

[TN780 Tone Clock](#) on page 190

[TN792 Duplication Interface](#) on page 192

[TN799DP Control LAN \(C-LAN\) Interface](#) on page 193

[TN2182C Tone Clock, Tone Detector, and Call Classifier \(8 ports\)](#) on page 197

[TN2302AP IP Media Processor](#) on page 203

[TN2401 Network Control/Packet Interface for SI](#) on page 208

[TN2404 Processor](#) on page 209

Service Circuit Packs

[TN433 Speech Synthesizer](#) on page 178

[TN725B Speech Synthesizer](#) on page 183

[TN787K Multimedia Interface](#) on page 190

[TN788C Multimedia Voice Conditioner](#) on page 190

[TNCCSC-1 PRI to DASS Converter](#) on page 211

[TNCCSC-2 PRI to DPNSS Converter](#) on page 211

[TNCCSC-3 PRI to DPNSS Converter](#) on page 211

[TN-C7 PRI to SS7 Converter](#) on page 211

[TN-CIN Voice, FAX and Data Multiplexer](#) on page 211

Application Circuit Packs

[TN568 DEFINITY AUDIX 4.0 Voice Mail System \(part of ED-1E568\)](#) on page 181

[TN750C Recorded Announcement \(16 channels\)](#) on page 185

[TN801 MAPD \(LAN Gateway Interface\)](#) on page 194

[TN2501AP Voice Announcements over LAN \(VAL\)](#) on page 210

Port Circuit Packs

[TN2302AP IP Media Processor](#) on page 203

[TN789B Radio Controller](#) on page 191

Avaya telephones for DEFINITY Server SI

IP telephones

[Avaya 4602 IP telephone](#) on page 259

[Avaya 4602SW IP telephone](#) on page 260

[Avaya 4606 IP telephone](#) on page 260

[Avaya 4610SW IP telephone](#) on page 261

[Avaya 4612 IP telephone](#) on page 262

[Avaya 4620 IP telephone](#) on page 263

[Avaya 4620SW IP telephone](#) on page 264

[Avaya 4630 IP Screenphone](#) on page 266

[Avaya 4630SW IP telephone](#) on page 267

Digital telephones

- [Avaya 2402 Digital Telephone](#) on page 267
- [Avaya 2420 digital telephone](#) on page 268
- [Avaya Callmaster IV \(603F\) digital telephone](#) on page 272
- [Avaya Callmaster V \(607A\) digital telephone](#) on page 273
- [Avaya 6402 and 6402D digital telephones](#) on page 268
- [Avaya 6402 and 6402D digital telephones](#) on page 268
- [Avaya 6408D+ digital telephone](#) on page 269
- [Avaya 6416D+M digital telephone](#) on page 270
- [Avaya 6424D+M digital telephone](#) on page 271

Soundstation speakerphones

- [3127 SoundPoint Speakerphone](#) on page 283
- [3127 SoundStation speakerphone](#) on page 283
- [3127 SoundStation Premier audioconferencing speakerphone](#) on page 285

Analog phones

- [Avaya 2500 and 2554 analog terminals](#) on page 276
- [Avaya 6211 Analog Telephone](#) on page 277
- [Avaya 6219 analog telephone](#) on page 278

Avaya Explosive Atmosphere telephones

- [Avaya 2520B Explosive Atmosphere telephone](#) on page 279

Wireless

- [Avaya TransTalk 9040](#) on page 279

Consoles

- [Avaya 302D attendant console](#) on page 274
- [Avaya Softconsole](#) on page 275

Optional components for DEFINITY Server R

Media gateways

[SCC1 Media Gateway](#) on page 150

[MCC1 Media Gateway](#) on page 159

Circuit packs

Power circuit packs

[1217A AC power supply](#) on page 173

[631DA1 AC power unit](#) on page 173

[631DB1 AC power unit](#) on page 173

[649A DC power unit](#) on page 174

[676C DC power supply](#) on page 177

[TN755B Neon Power Unit](#) on page 186

[CFY1B current limiter](#) on page 177

[TN2202 Ring Generator](#) on page 200

Line circuit packs

[TN479 Analog Line \(16 ports\)](#) on page 180

[TN556D ISDN-BRI 4-Wire S/T-NT Interface \(12 ports\)](#) on page 181

[TN726B Data Line \(8 ports\)](#) on page 183

[TN746B Analog Line \(16 ports\)](#) on page 184

[TN754C DCP Digital Line \(4-wire, 8 ports\)](#) on page 186

[TN762B Hybrid Line \(8 ports\)](#) on page 187

[TN769 Analog Line \(8 ports\)](#) on page 188

[TN791 Analog Guest Line \(16 ports\)](#) on page 191

[TN793B Analog Line with Caller ID \(24 ports\)](#) on page 192

[TN797 Analog Trunk or Line Circuit Pack \(8 ports\)](#) on page 193

[TN2181 DCP Digital Line \(2-wire, 16 ports\)](#) on page 197

[TN2183/TN2215 Analog Line for multiple countries \(16 ports\)](#) on page 197

[TN2185B ISDN-BRI S/T-TE Interface \(4-wire, 8 ports\)](#) on page 198

[TN2198B ISDN-BRI U Interface \(2-wire, 12 ports\)](#) on page 199

[TN2214B DCP Digital Line \(2-wire, 24 ports\)](#) on page 201

[TN2215/TN2183 Analog Line for Multiple Countries \(16 ports\) \(International Offers or Offer B only for US and Canada\)](#) on page 202

[TN2224B DCP Digital Line \(2-wire, 24 ports\)](#) on page 203

[TN2793B Analog Line with Caller ID \(24 ports\)](#) on page 210

Trunk circuit packs

[TN429D Incoming Call Line Identification \(ICLID\)](#) on page 178

[TN459B Direct Inward Dialing Trunk \(8 ports\)](#) on page 179

[TN464GP DS1 Interface, T1 \(24 channels\) or E1 \(32 channels\)](#) on page 179

[TN465C Central Office Trunk \(8 ports\)](#) on page 180

[TN747B Central Office Trunk \(8 ports\)](#) on page 185

[TN753B Direct Inward Dialing Trunk \(8 ports\)](#) on page 186

[TN760E Tie Trunk \(4-wire, 4 ports\)](#) on page 187

[TN763D Auxiliary Trunk \(4 ports\)](#) on page 187

[TN767E DS1 Interface, T1 \(24 channels\)](#) on page 187

[TN1654 DS1 Converter, T1 \(24 channels\) and E1 \(32 channels\)](#) on page 195

[TN2140B Tie Trunk \(4-wire, 4 ports\)](#) on page 196

[TN2146 Direct Inward Dialing Trunk \(8 ports\)](#) on page 196

[TN2147C Central Office Trunk \(8 ports\)](#) on page 197

[TN2184 DIOD Trunk \(4 ports\)](#) on page 198

[TN2199 Central Office Trunk \(3-wire, 4 ports\)](#) on page 199

[TN2207 DS1 Interface, T1 \(24 channels\) and E1 \(32 channels\)](#) on page 200

[TN2209 Tie Trunk \(4-wire, 4 ports\)](#) on page 200

[TN2242 Digital Trunk](#) on page 203

[TN2305B ATM-CES Trunk/Port-Network Interface for multimode fiber](#) on page 204

[TN2306B ATM-CES Trunk/Port-Network Interface for single-mode fiber](#) on page 204

[TN2308 Direct Inward Dialing Trunk \(8 ports\)](#) on page 204

[TN2313AP DS1 Interface \(24 channels\)](#) on page 207

[TN2464BP DS1 Interface with Echo Cancellation,T1/E1](#) on page 209

Control circuit packs

[TN570D Expansion Interface](#) on page 182

[TN572 Switch-Node Clock](#) on page 182

[TN573B Switch-Node Interface for DEFINITY R](#) on page 182

[TN771DP Maintenance and Test](#) on page 189

[TN744E Call Classifier and Tone Detector \(8 ports\)](#) on page 184

[TN775C Maintenance](#) on page 189

[TN780 Tone Clock](#) on page 190

[TN799DP Control LAN \(C-LAN\) Interface](#) on page 193

[TN1648B System Access and Maintenance \(SYSAM\)](#) on page 194

- [TN1650B Memory](#) on page 195
- [TN1655 Packet Interface](#) on page 195
- [TN1657 Disk Drive](#) on page 196
- [TN2182C Tone Clock, Tone Detector, and Call Classifier \(8 ports\)](#) on page 197
- [TN2211 Optical Drive](#) on page 201
- [TN2302AP IP Media Processor](#) on page 203
- [UN330B Duplication Interface](#) on page 212
- [UN331C Processor](#) on page 212
- [UN332C Mass Storage/Network Control for R](#) on page 213

Service circuit packs

- [TN433 Speech Synthesizer](#) on page 178
- [TN725B Speech Synthesizer](#) on page 183
- [TN787K Multimedia Interface](#) on page 190
- [TN788C Multimedia Voice Conditioner](#) on page 190
- [TNCCSC-1 PRI to DASS Converter](#) on page 211
- [TNCCSC-2 PRI to DPNSS Converter](#) on page 211
- [TNCCSC-3 PRI to DPNSS Converter](#) on page 211
- [TN-C7 PRI to SS7 Converter](#) on page 211
- [TN-CIN Voice, FAX and Data Multiplexer](#) on page 211

Application circuit packs

- [TN568 DEFINITY AUDIX 4.0 Voice Mail System \(part of ED-1E568\)](#) on page 181
- [TN750C Recorded Announcement \(16 channels\)](#) on page 185
- [TN801 MAPD \(LAN Gateway Interface\)](#) on page 194
- [TN2501AP Voice Announcements over LAN \(VAL\)](#) on page 210

Port circuit packs

- [TN577 Packet Gateway](#) on page 182
- [TN2302AP IP Media Processor](#) on page 203
- [TN789B Radio Controller](#) on page 191

Avaya telephones

IP telephones

- [Avaya 4602 IP telephone](#) on page 259
- [Avaya 4602SW IP telephone](#) on page 260
- [Avaya 4606 IP telephone](#) on page 260

[Avaya 4610SW IP telephone](#) on page 261

[Avaya 4612 IP telephone](#) on page 262

[Avaya 4620 IP telephone](#) on page 263

[Avaya 4620SW IP telephone](#) on page 264

[Avaya 4630 IP Screenphone](#) on page 266

[Avaya 4630SW IP telephone](#) on page 267

Digital telephones

[Avaya 2402 Digital Telephone](#) on page 267

[Avaya 2420 digital telephone](#) on page 268

[Avaya Callmaster IV \(603F\) digital telephone](#) on page 272

[Avaya Callmaster V \(607A\) digital telephone](#) on page 273

[Avaya Callmaster VI \(606A\) digital telephone](#) on page 273

[Avaya 6402 and 6402D digital telephones](#) on page 268

[Avaya 6402 and 6402D digital telephones](#) on page 268

[Avaya 6408D+ digital telephone](#) on page 269

[Avaya 6416D+M digital telephone](#) on page 270

[Avaya 6424D+M digital telephone](#) on page 271

Soundstation speakerphones

[3127 SoundPoint Speakerphone](#) on page 283

[3127 SoundStation speakerphone](#) on page 283

[3127 SoundStation Premier audioconferencing speakerphone](#) on page 285

Analog phones

[Avaya 2500 and 2554 analog terminals](#) on page 276

[Avaya 6211 Analog Telephone](#) on page 277

[Avaya 6219 analog telephone](#) on page 278

Avaya Explosive Atmosphere telephones

[Avaya 2520B Explosive Atmosphere telephone](#) on page 279

Wireless

[Avaya TransTalk 9040](#) on page 279

Consoles

[Avaya 302D attendant console](#) on page 274

[Avaya Softconsole](#) on page 275

Telephones and speakerphones

Avaya telephones

Avaya IP telephones

Avaya 4602 IP telephone

The Avaya 4602 is an entry-level IP telephone with 2 call appearances.

The following are characteristics of an Avaya 4602 IP telephone:

- 2 × 24-character display
- 2 call appearances
- Ready to be sold and used world wide
- Fixed button for voice mail retrieval
- 1-way speaker
- Seven fixed feature buttons that include the following:
 - Speaker
 - Mute
 - Hold
 - Transfer
 - Conference
 - Drop
 - Redial
- Supports power over Ethernet
- Supports Quality-of-Service features including RTCP and RSVP'
- Wall or desk mount
- 10/100Base-T Ethernet network connection with RJ-45 interface
- Integrated Ethernet repeater hub for optional PC connection
- Supports G.711, G.729A, and G.729B audio voice coders
- Supports H.323 V2
- IP address assignment using DHCP or statically configured
- Downloadable firmware for future upgrades
- Native support that provides the user with the capability to administer and maintain the 4602 IP telephone
- 12-button touch-tone dial pad with raised bar on the button labeled five for the visually impaired

- FCC and CISPR Class B
- Message waiting light (LED)
- Hearing aid compatible
- Adjustable volume control
- Available in dark gray

Avaya 4602SW IP telephone

The 4602SW IP telephone has the same feature set as the 4602 with the addition of a built-in Ethernet switch instead of the hub.

Avaya 4606 IP telephone

The 4606 IP telephone is a fully Internet-capable set supporting Internet Protocol (IP) standards, providing extensive telephone features and functionality in both the handset and speakerphone.

The following are characteristics of the Avaya 4606 IP telephone:

- Six programmable appearance or feature buttons with dual red and green LEDs
- Four fixed feature buttons that include: the speaker button, the mute button, the hold button, the volume button
- Three fixed feature buttons under display which include: the conference button, the transfer button, and the redial button
- 2-line by 16-character LCD display
- Full duplex speakerphone with echo cancellation
- 10/100Base-T Ethernet network connection with RJ-45 interface
- Integrated Ethernet repeater hub for optional PC connection
- Supports G.711, G.729A, and G.729B audio voice coders
- Supports H.323 V2
- IP address assignment using DHCP or statically configured
- Infrared port to support IR dialing and other applications
- Downloadable firmware for future upgrades
- Supports CTI applications from the Avaya Softphone, and is CTI ready for other applications
- Supports power over Ethernet
- Supports Quality of Service features including RTCP and RSVP
- Hearing aid compatible
- 12-button touch-tone dial pad with raised bar on the button labeled five for the visually impaired
- Message waiting light (LED)
- Integrated RJ-11 headset jack for direct connection of headset
- Adjustable volume control for the handset, speaker, and ringer
- Eight personalized ringing options
- K-style handset with 9-foot modular cord

- 14-foot modular line cord
- Available in black or white

Optional available components:

- 12-foot modular handset cord
- 25-foot modular line cord
- Base stand (15-degree angle)
- Avaya headsets
- Amplifier handset
- Noisy environment handset
- Push-to-talk handset

Avaya 4610SW IP telephone

The Avaya 4610SW IP telephone provides advanced feature functionality with an intuitive and innovative user interface. The Avaya 4610SW provides telephony, speed dial, call log, and Web browsing functionality. It uses both the resident and thin-client approach. Many of the 4610SW's applications "reside" in the telephone itself, while "thin-client" applications, such as the Directory application that is invoked through the telephone's Web browser, reside outside the 4610SW.

The following are characteristics of the Avaya 4610SW IP telephone:

- High-end feature set
- Medium screen graphic display (80 × 132 pixel, 4 grayscale)
- Advanced user interface that supports 48 speed dialing buttons, 45 call log entries, and up to six redial buttons on display
- Avaya Call Processing label editing
- Speed Dial entry editing
- EU24 label-button editing
- User screen options
- Call log
- WML browser capability
- Full-duplex speakerphone with echo cancellation
- 10/100Base-T Ethernet network connection with RJ-45 interface
- Integrated Ethernet switch for optional PC connection
- Supports G.711, G.729A, and G.729B audio voice coders
- Supports H.323 V2
- IP address assignment using DHCP or statically configured
- Infrared port to support IR dialing and other applications
- Downloadable firmware for future upgrades
- 24 call appearance or feature buttons with downloadable labels
- Adjustable desk stand

Telephones and speakerphones

Avaya telephones

- Global icons
- Hearing aid compatible
- 12-button touch-tone dial pad with raised bar on the button labeled five for the visually impaired
- Message waiting light (LED)
- Adjustable volume control
- Supports CTI applications from the Avaya Softphone and is CTI-ready for other applications
- Supports power over Ethernet
- Supports Quality of Service features including RTCP and RSVP
- FCC and CISPR Class B
- Can display network audio quality information during calls
- Native support that will give the customer the ability to administer and maintain the telephone
- Four softkeys, located under the display, that enhance the user interface
- Available in dark gray.

Avaya 4612 IP telephone

The 4612 IP telephone is a fully Internet-capable set supporting IP standards, providing extensive telephone features and functionality in both the handset and speakerphone.

The following are characteristics of the Avaya 4612 IP telephone:

- 12 Programmable appearance or feature buttons with dual red and green LEDs
- Eight fixed feature buttons which include: the speaker button, the mute button, the hold button, the transfer button, the conference button, the redial button, and the volume control button
- Softkeys that reside under the display for the browser user interface
- 2-line by 24-character LCD display
- Full duplex speakerphone with echo cancellation
- 10/100 Base-T Ethernet network connection with RJ-45 interface
- Integrated Ethernet repeater hub for optional PC connection
- G.711, G.729A, and G.729B audio voice coders
- H.323 V2
- IP address assignment using DHCP or statically configured.
- Infrared port to support IR dialing and other applications
- Supports CTI applications from the Avaya Softphone and is CTI ready for other applications
- Supports power over Ethernet
- Supports Quality of service features including RTCP and RSVP
- Supports external 30A Switched Hub adapter
- Downloadable firmware for future upgrades
- Hearing aid compatible
- A 12-button touch-tone dial pad with raised bar on the button labeled five for the visually impaired.

- A message waiting light (LED)
- An integrated RJ-11 headset jack for direct connection of headset
- Adjustable volume control for the handset, speaker, and ringer.
- Eight personalized ringing options
- K-style handset with 9-foot modular cord
- 14-foot modular line cord
- Available in black or white

Optional available components:

- 12-foot modular handset cord
- 25-foot modular line cord
- Base stand (15-degree angle)
- Avaya headsets
- Amplifier handset
- Noisy environment handset
- Push-to-talk handset

Avaya 4620 IP telephone

Avaya 4620 IP telephone provides advanced feature functionality with an intuitive and innovative user interface. The Avaya 4620 can provide telephony, speed dial, call log, and Web browsing functionality. The Avaya 4620 can use either the resident or thin-client approach. With the resident or thick-client software installed, the Avaya 4620 holds the complete software for all the applications. The Avaya server handles the call control. With thin-client software installed, a Avaya server still handles call control. A separate application server in conjunction with Communication Manager controls most of the display.

The following are characteristics of the Avaya 4620 IP telephone:

- High-end feature set
- Large screen graphic display (168-by-132 pixel 4-grayscale)
- Advanced user interface, supporting 108 speed dialing buttons, 90 call log entries and up to six redial buttons on the display
- Avaya Call Processing label editing
- Speed Dial entry editing
- EU24 label-button editing
- User screen options
- Local call log and speed dial productivity applications
- WML browser capability
- Full duplex speakerphone with echo cancellation
- 10/100Base-T Ethernet network connection with RJ-45 interface
- Integrated Ethernet switch for optional PC connection
- Supports G.711, G.729A, and G.729B audio voice coders
- H.323 V2

Telephones and speakerphones

Avaya telephones

- IP address assignment using DHCP or statically configured
- Infrared port to support IR dialing and other applications
- Downloadable firmware for future upgrades
- 24 call appearance or feature buttons with downloadable labels
- Integrated Ethernet switch
- Adjustable desk stand
- Function key expansion unit jack to support optional 24 button feature expansion unit (EU24)
- Global Icons
- Hearing aid compatible
- A 12-button touch-tone dial pad with raised bar on the button labeled five for the visually impaired.
- A message waiting light (LED)
- Adjustable volume control
- Supports CTI applications from the Avaya Softphone and is CTI ready for other applications
- Supports power over Ethernet
- Supports Quality of Service features including RTCP and RSVP
- FCC and CISPR Class B
- Can display network audio quality information during calls
- Native support that will give the customer the capability to administer and maintain the 4620 IP telephone
- Four softkeys that reside under the display to enhance the user interface
- Available in dark gray.

Avaya 4620SW IP telephone

The 4620SW IP telephone has the same feature set as the 4620 with the addition of the following:

- Support of multi-byte fonts
- Available in white.

Avaya 4624 IP telephone

The 4624 IP telephone is a fully Internet-capable set supporting IP standards, providing extensive telephone features and functionality.

The following are characteristics of the Avaya 4624 IP telephone:

- 24 Programmable appearance or feature buttons with dual red and green LEDs
- Eight fixed feature buttons which include: the speaker button, the mute button, the hold button, the transfer button, the conference button, the redial button, and volume control button
- Four fixed navigation buttons which include: the menu button, the exit button, the previous and next buttons
- Four softkeys that reside under the display

- Full duplex speakerphone with echo cancellation
- 10/100 Base-T Ethernet network connection with RJ-45 interface
- Integrated ethernet repeater hub for optional PC connection
- G.711, G.729A, and G.729B audio voice coders
- H.323 V2
- Supports CTI applications from the Avaya Softphone and is CTI ready for other applications
- Supports power over Ethernet
- Supports Quality of Service features including RTCP and RSVP
- Supports external 30A Switched Hub adapter
- IP Address assignment using DHCP or statically configured
- Infrared port to support IR dialing and other applications
- Downloadable firmware for future upgrades
- Hearing aid compatible
- 12-button touch-tone dial pad with raised bar on the number five for the visually impaired
- Message waiting light (LED)
- Integrated RJ-11 headset jack for direct connection of headset
- Adjustable volume control for the handset, speaker, and ringer
- Eight personalized ringing options
- K-style handset with 9-foot modular cord
- 14-foot modular line cord
- Available in black or white

Optional available components:

- 12-foot modular handset cord
- 25-foot modular line cord
- Base stand (15-degree angle)
- Avaya headsets
- Amplifier handset
- Noisy environment handset
- Push-to-talk handset

Avaya 4630 IP Screenphone

The Avaya 4630 Screenphone is a fully Internet-capable IP appliance that supports IP standards. The Avaya 4630 IP Screenphone provides a user-friendly window into IP enabled applications, a full suite of Communication Manager features, Lightweight Directory Access Protocol (LDAP) directory, and INTUITY™ AUDIX® voice mail features. Up to seven telephony related applications are provided through a unique user interface, developed with ease-of-use and minimal touch access in mind.

The following are characteristics of the Avaya 4630 Screenphone:

- 1/4 VGA color touch-screen display with user screen options
- Five fixed feature buttons which include: the speaker button, the mute button, the hold button, the headset button, and the volume control button
- Full duplex speakerphone with echo cancellation
- 120 total speed dial buttons organized into groups for easier access
- 100 total entries in the call log of incoming and outgoing calls
- Up to eight redial buttons can be presented on the display
- 10/100 Base-T Ethernet network connection with RJ-45 interface
- Directory access to corporate telephone directory information on a LDAP server
- Voice mail access to Web based voice mail messaging capabilities of UCC's Avaya Web Messaging
- User-customizable stock ticker
- Access to Web-based information, including support for downloading Java applets
- G.711, G.729A, and G.729B audio voice coders
- H.323 V2
- IP address assignment using DHCP or statically configured
- Infrared port to support IR dialing and other applications
- Supports CTI applications from the Avaya Softphone and is CTI ready to other applications
- Supports power over Ethernet
- Supports Quality of Service features including RTCP and RSVP
- Supports external 30A Switched Hub adapter
- Can display network audio quality information during calls
- Downloadable firmware for future upgrades
- Hearing aid compatible
- 12-button touch-tone dial pad with raised bar on the number five for the visually impaired
- Message waiting light (LED)
- Integrated RJ-11 headset jack for direct connection of headset
- Adjustable volume control for the handset, speaker, and ringer
- K-style handset with 9-foot modular cord
- 14-foot modular line cord
- Available in black or white

Optional available components:

- 12-foot modular handset cord
- 25-foot modular line cord
- Base stand
- Avaya headsets
- Amplifier handset
- Noisy environment handset
- Push-to-talk handset

Avaya 4630SW IP telephone

The 4630SW IP telephone has the same feature set as the 4630 with the addition of a built-in Ethernet switch and compliance with FCC and CISPR Class B.

Avaya digital telephones

Avaya 2402 Digital Telephone

The Avaya 2402 is a low-cost, low function, 2-wire digital telephone. The 2402 can be aliased as a 6402 telephone.

The following are characteristics of the Avaya 2402 telephone:

- 2 line × 24 character LCD
- 2 call appearance buttons
- Handset and 12-button dialpad
- Wall mountable
- Display of downloaded extension number
- Highly visible message-waiting indicator
- Message button for expedited access to voice mail
- Conference, transfer, drop, hold, and redial buttons
- Built-in one-way speaker with group listen operation
- Speaker, feature, and mute buttons, each with LED indicators
- Feature button allows access, by way of the dialpad, to 12 Communication Manager features that do not require indicators
- Volume up or down buttons for handset, speaker, and ringer
- Electronically stored part ID and serial number for use with Automatic Customer Telephone Rearrangement
- 9-foot phone cord and 14-foot gray, modular line cord
- Stand included

Avaya 2420 digital telephone

The Avaya 2420 is a 2-wire digital telephone. The display of the Avaya 2420 consists of a monochrome liquid crystal display (LCD) which is 29 characters wide by 7 lines tall. Display characters are defined by a 5-column by 8-row matrix of dots which is used to support 5- × 7-dot European or Katakana characters.

The following are characteristics of the Avaya 2420 telephone:

- 7-line × 29 character LCD
- Handset and 12-button dialpad
- Adjustable viewing angle
- Wall mountable
- Eight general purpose buttons to access up to 24 system call appearance or features
- Downloaded call appearance or feature button labels
- Four local softkey feature buttons
- Exit, previous, and next buttons for display navigation
- Highly visible message waiting indicator
- Message button for expedited access to voice mail
- Conference, transfer, drop, hold, and redial buttons
- Headset jack that is separate from the handset jack
- Built-in speakerphone with group listen operation
- Speaker, headset, mute buttons, each with LED indicators
- Volume up or down buttons for handset, headset, speakerphone and ringer
- 100 Entry Call Log (total incoming answered, incoming unanswered, and outgoing calls)
- Downloadable firmware for future upgrades
- Automatic Gain Control on all audio interfaces
- Electronically stored part ID and serial number for use with Automatic Customer Telephone Rearrangement
- Optional 24 button feature key expansion unit
- Optional analog interface application module
- Native support that allows users the capability to administer and maintain the 2420 using the associated Feature Expansion Module

Avaya 6402 and 6402D digital telephones

The Avaya 6402 and 6402D are single-line digital telephones. The difference between the Avaya 6402 and the 6402D is the Avaya 6402D is equipped with a 2-line by 24-character display.

The following are characteristics of the Avaya 6402 telephone:

- Built-in group listening speaker
- Six Fixed buttons which include: the speaker button, the feature button, the hold button, the redial button, the transfer button, and the conference button

- The feature button allows access by way of the dialpad, to 12 Communication Manager features that do not require indicators or display messages.
- Adjustable volume control for the handset, speaker, and ringer.
- 2-wire connectivity through a digital line circuit packs.
- Internal self test for the LEDs.
- Choice of eight ringing patterns.
- Can be used with or without the stand.
- Desk or wall mountable.
- Matching 9-foot (2.7-m) handset cord and a 7-foot (2.1-m) modular line cord.
- Available in dark gray and white.
- No Adjunct jack interface for external speakerphones or headset modules
- Headsets must be connected through the handset.

Avaya 6408D+ digital telephone

The 6408D+ is a digital telephone with eight buttons.

The following are characteristics of the 6408D+ telephone:

- 2-line by 24-character LCD display showing time and date when the telephone is in an idle status
- Tiltable display with three viewing angles.
- Eight call appearance and feature buttons with dual LEDs (two color buttons).
- Built-in 2-way speakerphone which can also be optioned as a 1-way group listening speaker.
- Six fixed buttons which include: the speaker button, the mute button, the hold button, the redial button, the transfer button, and the conference button.

NOTE:

Drop must be administered on a softkey.

- Twelve system features can be administered on softkeys associated with the display.
- Four buttons to access softkey features such as: the menu button, the exit button, the previous button, and the next button
- When the headset feature is administered, it is no longer necessary to take handset off hook to answer a call.
- Adjustable volume control for the handset, speaker, and ringer.
- Message Waiting Light (LED)
- 2-wire connectivity through 2-wire Digital line circuit packs only.
- Accepts download from Communication Manager of voice and touchtone transmission parameters as required by each country
- Internal self test to determine if LEDs light
- Choice of eight ringing patterns
- Line powered
- Can be used with or without stand.

Telephones and speakerphones

Avaya telephones

- Desk or wall mountable
- Matching 9-foot (2.7-m) handset cord and a 7-foot (2.1-m) modular line cord.
- Available in dark gray and white.

Avaya 6416D+M digital telephone

The Avaya 6416D+M telephone is a multi-appearance digital telephone with 16 call appearances or feature buttons.

The Avaya 6416D+M comes equipped with a modular plug that allows you to install a 100A tip and ring module to the desktop stand on the telephone for increased set functionality. The 100A tip and ring module provides a connection to adjuncts such as answering machines, FAX machines, modems, analog speakerphones, and hearing impaired TDD machines.

A XM24 expansion module can be connected to any Avaya 6416D+M telephone to expand the number of buttons you can use. However, when the expansion module is connected you must connect an auxiliary power supply to the telephone. An 1151B1 local power supply or an 1151B2 local power supply with battery holdover is recommended.

The following are characteristics of the Avaya 6416D+M telephone:

- 24 Call appearance or feature buttons with dual LEDs
- 10 fixed features buttons which include: the speaker button, the mute button, the conference button, the transfer button, the hold button, the redial button, the menu button, the exit button, the previous button, and the next button
- 12 assignable soft key features associated with the display
- A built-in two-way programmable speakerphone can be optioned by user on an individual call basis for group listening
- Headset jack for direct connection of headset
- Adjustable volume control for the handset, speaker, and ringer
- 12-button touch-tone dial pad with raised bar for the visually impaired
- Message waiting light (LED)
- Eight personalized ringing options
- K-style handset with 9-foot modular cord
- 14-foot modular line cord
- Pull-out feature reference card tray
- Can be wall or desk mounted
- International portability
- Downloadable transmission parameters
- Available in gray or white
- Meets Class B requirements for use in residential locations

Optional available components:

- 12-foot modular handset cord
- 25-foot modular line cord

- HIC-1 headset interface cord
- Headset modular base unit M12LUCM
- Avaya headset
- Amplifier handset
- Noisy environment handset

The approximate dimensions of the 6416D+M are:

- Width = 10.35 inches (26.35 cm)
- Depth (front to back) = 8.5 inches (21.59 cm)
- Height (with deskstand and handset in place) = 4.75 inches (12.07 cm)

Avaya 6424D+M digital telephone

The Avaya 6424D+M telephone is a multi-appearance digital telephone with 24 call appearances and feature buttons.

The Avaya 6424D+M comes equipped with a modular plug that allows you to install a 100A tip and ring module to the desktop stand on the telephone for increased set functionality. Through the 100A tip and ring module you can connect adjuncts such as, answering machines, FAX machines, modems, analog speakerphones, and hearing impaired TDD machines.

A XM24 expansion module can be connected to any Avaya 6416D+M telephone to expand the number of buttons you can use. However, when the expansion module is connected you must connect an auxiliary power supply to the telephone. An 1151B1 local power supply or an 1151B2 local power supply with battery holdover is recommended.

The following are characteristics of the 6424D+M telephone:

- 2-line × 24-character LCD display showing time and date when the telephone is in an idle status.
- A tiltable display with three viewing angles.
- A 24 call appearance and feature buttons with dual LEDs
- Built-in 2-way speakerphone which can also be optioned as 1-way group listening speaker
- Six fixed feature buttons which include: the speaker button, the mute button, the hold button, the redial button, the transfer button, and the conference buttons.
- Twelve system features that can be administered on the softkeys associated with the display.
- Four buttons to access softkey features such as menu, exit, previous, and next.
- Only one next button that is used with the softkeys and the directory function.
- A ribbon connector under the telephone to connect optional modules that fit into the stand.
- Headset jack under telephone, next to handset jack, for direct connection of headset.
 - When the headset feature is administered, it is not necessary to take handset off hook to answer telephone when using a headset.
 - When using headset via headset feature button, handset becomes listen-only for monitoring until headset button turned off.
- No adjunct jack interface for external S201/S203 speakerphone adjuncts or headset adjuncts

Telephones and speakerphones

Avaya telephones

- When system administrator provides the user with permission, a user may add, remove or rearrange the certain features on their call appearance and feature buttons.
- Adjustable volume control for the handset, speaker and ringer.
- Message waiting light
- Supports optional XM24 expansion module that allows for an additional 24 call appearance and feature buttons with dual LEDs.
- 2-wire connectivity through 2-wire digital line circuit packs only
- Internal self test
- Choice of eight ringing patterns
- Can be used with or without stand when the 100A Analog Interface module not in stand.
- Desk or wall mountable. If 100A Analog Interface Module is connected, the telephone can not be wall mounted.
- Available in dark gray and white.
- Meets Class B requirements for use in residential location.

The Avaya 6424D+M telephone is powered from the system it is connected to. Adjunct station or closet power is necessary only when connecting an XM24 expansion module or the 100A Analog Interface Module. If both modules are connected to the 6424D+M, only one power supply is necessary. The 6424D+M will continue to work if the auxiliary power is interrupted, but the modules will not work.

Avaya Callmaster IV (603F) digital telephone

The Avaya Callmaster IV is engineered to support applications involving the Automatic Call Distribution (ACD) feature. The ergonomic design of the Avaya Callmaster IV enables agents to handle large volumes of calls more quickly and efficiently. VuStats, a display of agent and call center statistics on the Avaya Callmaster IV, provides agents with real-time information.

The Avaya Callmaster IV will work in either a 4-wire or 2-wire environment. The Avaya Callmaster IV can automatically detect whether it is plugged into a 2-wire or 4-wire circuit. This detection provides for an easy transition to either the 2-wire or 4-wire environment, as well as reduced wiring expenses and installation change adjustments.

The Avaya Callmaster IV includes as standard a built-in Recorder Interface Module (RIM) that supports both 2-wire and 4-wire connections to agent recording equipment.

The Avaya Callmaster IV meets FCC and CISPR Class B requirements allowing the telephone to be used in home office environments with a DEFINITY® Extender.

The following are characteristics of the Avaya Callmaster IV:

- Six rubber-domed administrable call appearance or flexible feature buttons
- 15 rubber-domed administrable flexible feature buttons
- Eight fixed feature buttons such as: the conference button, the transfer button, the drop button, the hold button, the mute button, the volume button, the release button, and the login button
- 80-character alphanumeric LCD display
- 12-button touch-tone dial pad with raised bar on the number five for the visually impaired
- Message waiting light (LED)

- Recorder interface module
- Adjunct jack for speakerphone
- Dual headset jacks
- Eight personalized ringing options
- Receiver and ringer volume control
- Stand for desk
- International portability
- Amplifier handset

Avaya Callmaster V (607A) digital telephone

The Avaya Callmaster V has been specially designed to support applications involving the ACD feature. The ergonomic design of the Avaya Callmaster V enables agents to handle large volumes of calls more quickly and efficiently. VuStats display of agent and call center statistics on the Avaya Callmaster V provides agents with real-time information.

The Avaya Callmaster V has the same look and feel of the 6400-series telephones. There are two significant additional features that maximize the value of this telephone in a Call Center environment:

- **2 built-in headset jacks**
- **Built-in Recorder Interface Module (RIM) with Warning Tone.** The RIM will support recording of both the agent's and caller's voice on a voice activated analog tape recorder. A soft beep warning tone is repeated every 13.5 seconds to notify the agent and calling party that the call is being recorded. The warning tone may be de-activated by the user.

The Avaya Callmaster V meets FCC and CISPR Class B requirements allowing the telephone to be used in home office environments with a DEFINITY Extender.

The following are characteristics of the Callmaster V telephone:

- 16 dual-LED call appearance or feature buttons
- An adjustable 48-character liquid crystal display
- 10 fixed feature buttons such as: the speaker button, the mute button, the conference button, the transfer button, the hold button, the redial button, the menu button, the exit button, the previous button, and the next button
- 12 assignable soft key features associated with the display
- One-way listen-only speaker for group listening, dialing while the handset in place, or hands free listening
- Adjustable volume control for the handset, speaker, and ringer
- Works in a 2-wire environment

Avaya Callmaster VI (606A) digital telephone

The Callmaster VI is a small digital voice telephone used with the application software running on a PC. Powered from the PBX, the Callmaster VI connects to the PC by way of a standard EIA or TIA-574 serial port interface.

The following are the characteristics of the Avaya Callmaster VI:

- Two headset input jacks, both usable at the same time
- Optional headset with custom cable
- Message waiting indicator
- Five pre-set buttons:
 - Headset on and off
 - Mute
 - Two call appearances
 - Release
- Three administrable feature buttons
- Voice announcement recording feature:
 - Up to six announcements that are 9.6 seconds in length
 - Announcements can be played automatically for incoming calls
- FCC and CISPR Class B

Avaya attendant consoles

Avaya 302D attendant console

The Avaya 302D Attendant Console is a 2-wire unit with an optional 26C expansion module. The Avaya 302D cannot be used in a 4-wire environment.

The following are characteristics of the Avaya 302D attendant console:

- Comes in three colors: dark gray, black and white
- Power is required from the desktop or the telephone closet
- All 302D Attendant Consoles are desk mounted only.
- Supports optional 26C Selector Console:
 - Has 20 Hundreds group buttons and 100 Tens group buttons. Each Hundreds group button is assigned the first digit or first two digits of each group of 100 extension (room) numbers. The Tens group buttons are automatically assigned a tens and ones digit. The buttons can be used for 3- or 4-digit extensions.

For an example of 4-digit extensions, if you have rooms numbered from 7000 to 7099, you can have a Hundreds button labeled "70" and a tens group button labeled "01." Pressing "70", then "01", dials extension 7001 with only two button presses.
 - Has busy or idle status display for each button
- The display is 1 × 40 and supports Katakana, Roman and Euro font Character set. Label Languages are Japanese, English, French, Dutch, Spanish Latin America, Italian, German, Canadian French, Brazilian Portuguese. Two labels are included with each 302D console.
- Handset/Headset connection is moved to the front and is a single modular plug. For headset an H1C or M12L is Optional.

- Service observing must be done through the Communication Manager via the feature of Service Observing. An optional Training-Y connector can be used in conjunction with headset connection for desktop listen only supervisor support.

Avaya Softconsole

Avaya Softconsole is a software attendant console solution. Avaya Softconsole is available for industry standard IP and Avaya Digital Communications Protocol (DCP). IP connectivity is available in both Voice over IP configuration (road warrior) and dual connection (telecommuter) for toll quality audio.

The following are characteristics of the Avaya Softconsole:

- Busy Lamp Fields (BLF), directory and display windows may all be on the same screen and the same time.
- Flexible screen arrangement for the attendant that is saved from session to session.
- Application window scales intelligently from a minimum useful size to full screen. Useful information is added to the display as the attendant increases the window size.
- On request line status such as on and off-hook displayed for the selected entry in the directory window.
- Queue status display
- Feature buttons offered as tools in multiple tool bars with pop-up, full word, tool tip displays for each.
- 32-bit Application
- Maximum of 100 directories
- Ability to generate e-mail to users at the click of a tool bar button or keyboard command
- Step-by-step wizard for both installation and initial administration with help and warning text presented with each step.
- Targeted to reduce service call volumes for installation assistance.

MasterDirectory Data Manager

MasterDirectory Data Manager is included as part of Avaya Softconsole. It is a database application that is specifically designed for directory data management. It serves as an information management tool—importing and consolidating directory information from voice and data systems, and exporting it to directory-enabled applications. MasterDirectory can import/export and transfer data via standards-based protocols, including the following:

- ODBC – Open Data Base Connectivity
- LDAP – Lightweight Directory Access Protocol
- FTP – File Transfer Protocol
- SMTP – Simple Mail Transfer Protocol
- CSV – text delimited files

Using these protocols MasterDirectory can:

- Extract data from multiple sources
- Apply filters and business logic to consolidate data
- Populate directory services and databases for use by applications

For example, MasterDirectory can collect information from multiple Avaya Media Servers, consolidate the data with Human Resource databases, and send the processed data to an LDAP directory service used by phone attendant applications, Internet white and yellow pages, and other applications.

Avaya analog telephones

Avaya 2500 and 2554 analog terminals

The Avaya 2500 and the Avaya 2554-series telephones are made up of several analog telephones that are basically the same but are equipped with small different attributes. These models include:

- 2500 MMGN desk model telephone
- 2500 MMGL desk model telephone
- 2500 YMGL desk model telephone
- 2500 YMGP desk model telephone
- 2500 MMGM desk model telephone
- 2554 MMGN wall model telephone
- 2554 MMGM wall model telephone
- 2554 YMGP wall model telephone
- 2554 YMGM wall model telephone

All Avaya 2500 and 2554 telephones are single appearance analog telephones with conventional touch-tone dialing. The 2500 MMGL, 2500 MMGM and 2554 MMGM telephones have NO feature buttons. The 2500 YMGL, 2500 YMGM, 2554 YMGP, and 2554 YMGM telephones are equipped with a flash button, a message waiting light, a redial button, a hold button and a mute button. All six of these telephone models provide access to features through the use of the * or # dial pad keys and the appropriate feature access codes.

The following are physical features of the Avaya 2500 and Avaya 2554 telephones:

- The 2500 MMGN and 2554 MMGN telephones are manufactured without Positive Disconnect and without a FLASH button. The 2500 YMGP and 2554 YMGP have Positive Disconnect permanently enabled. When the FLASH button is depressed, access is provided to switch features. When the switchhook is depressed, the call is automatically disconnected and a dial tone is provided for a completely new call. Older models have a Positive Disconnect switch on the bottom of the telephone with two positions: ON and OFF:
 - The ON position hangs up the telephone for approximately two seconds, even if the switchhook depression is less. This prevents inadvertent switchhook flashes. To initiate switchhook flash in this mode, press the FLASH button.
 - In the OFF position, the switchhook will function normally
- K-type handset
- All of the 2500-series telephones are equipped with a 12-button touch-tone dial pad.
- All of the 2500-series telephones contain two jacks. The handset cord jack is on the left side of the telephone. The line cord jack is on the right rear of the set.
- All of the 2554-series telephones have one jack and one mounting cord. The handset cord jack is on the bottom of the telephone. The line cord is on the rear of the telephone to plug into the wall outlet.

- Two cords are supplied with all four of these 2500-series model telephones: a coiled 6-foot modular handset cord and a 7-foot modular line cord. Optional longer cords are available: a 12-foot handset cord, and 14-foot and 25-foot line cords. Two cords are supplied with 2554-series model telephones: a coiled 6-foot modular handset cord and a permanently attached 4-inch modular mounting cord. An optional longer 12-foot handset cord is available.
- All of the 2500-series telephones have an electronic tone ringer. There is a 3-position ringer volume control located on the bottom of the 2500 telephone and the side of the 2554 telephone.
- The 2500 MMGL, 2500 MMGM, 2500 YMGP, and 2500 YMGM telephones can only be desk-mounted. They cannot be wall-mounted. The 2554 MMGL, 2554 MMGM and 2554 YMGP telephones are wall-mounted telephones. They cannot be desk-mounted.
- All of the 2500-series telephones are available in black or misty cream.
- All of the Avaya 2500- and 2554-series telephones are powered by the tip and ring leads. The telephones do not require any external power supply.
- All of the Avaya 2500- and 2554-series telephones can be used as an emergency station during power failure transfer conditions. The 2554 sets can ONLY be used as a Power Failure set in a Loop Start environment; the 2500 sets can be used as a Power Failure set in either a Loop Start or a Ground Start environment. Use in a Ground Start environment required the optional Modular Ground Start button.
- These 2500 and 2554 telephones are FCC-registered.

Avaya 6211 Analog Telephone

The Avaya 6211 telephone is a single line analog telephone.

The following are characteristics of the Avaya 6211 telephone:

- 7-foot modular line cord
- Handset volume control
- Ringer volume control
- Message waiting light
- Flash button
- Set hold button with LED Indicator
- Last number re-dial button
- A 12-button touch-tone dial pad with raised bar on the number five for the visually impaired
- Positive disconnect via switchhook
- Can be desk or wall mounted
- RJ-11 data jack
- FCC approved for emergency power failure transfers
- Line powered
- Available in gray or white

Telephones and speakerphones

Avaya telephones

Optional available components:

- A 12-foot handset cord
- A 14-foot line cord
- A 25-foot line cords
- Avaya headsets

Avaya 6219 analog telephone

The Avaya 6219 telephone is a single line analog telephone.

The following are characteristics of the Avaya 6219 telephone:

- A 7-foot modular line cord
- Handset volume control
- Ringer volume control
- Message waiting light
- Flash button
- Set hold button with LED Indicator
- Last number redial button
- A 12-button touch-tone dial pad with raised bar on the number five for the visually impaired
- Positive disconnect via switchhook
- Desk and wall mounting available
- RJ-11 Data jack
- FCC approved for emergency power failure transfers
- Line powered
- Available in gray or white
- Ten repertory dialing buttons
- Personalized ringing

Optional available components:

- 2-foot handset cord
- 14- and 25-foot modular line cords
- Avaya headsets

Avaya 2520B Explosive Atmosphere telephone

Explosive Atmosphere telephones are listed by Underwriters Laboratories, Inc. (UL) for the following explosive atmosphere classifications and conditions:

- Class I explosive gas or vapors, group B, C, and D
- Class II combustible dusts, group E, F, and G

They are not to be installed in locations where acetylene gas may become present in the atmosphere.

The following are characteristics of the 2520B Explosive Atmosphere telephones:

- Comes with a 4-foot handset cord
- 9-foot cord can be ordered as an option
- Standard 12-button touch-tone dialpad with a raised bar on button labeled five for the visually impaired
- No handset volume control, in compliance with the FCC Waiver
- Designed for wall mounting
- Available in black only

Avaya wireless telephones

Avaya TransTalk 9040

The Avaya TransTalk 9040 is a small wireless telephone with a full feature set, and alphanumeric display give users complete control of their wireless communications.

The following are characteristics of the TransTalk 9040:

- A 1 × 16 alphanumeric display shows internal calling party information and the external called number.
 - The backlit display includes three rows for line or intercom terminations and one-button feature access.
 - Icons such as out-of-range, low battery, and message waiting are visible on the display.
- Weighs just eight ounces
- Dimensions are 6" × 2" × 1"
- A maximum of 12 virtual button appearances for lines, intercoms, and features.
- Redial button: fixed redial for busy numbers.
- Replaceable Antenna: customers can replace their own antennas in case of breakage.
- Headset Option: works with the Supra (over-the-head) or Radium (over-the-ear) mobility headsets. Can be used with the wireless headset for the MDW 9000 and MDW 9010 with an adaptor. New 2.5-mm jack makes connecting a headset to the 9040 easier than ever. Backlit display: for easier use in poorly lit areas such as warehouses and manufacturing plants.

Telephones and speakerphones

Avaya telephones

- Vibrator Alert: for times when a ringing telephone would be intrusive (standard on all Pocket Phones).
- Field registration: If a handset becomes needs to be replaced, only the handset needs to be returned (i.e. the corresponding Radio Module does not have to be shipped back with the handset). When a new handset is received, the user or technician simply registers it with the appropriate Dual Radio Module (DRM).

The following are the characteristics of the battery charge

- Batteries charge fully in 1.5 hours
- Batteries are discharged and recharged, which eliminates the memory effect that reduces battery life (spare is automatically reconditioned; handset battery is reconditioned in the cradle if manually selected)
- Users get 3.5 hours of talk time, and over 22 hours of standby time
- Users can continue to screen calls because the upright position keeps the display clearly visible
- An optional extended-use battery, will provide up to eight hours of talk time and 72 hours of standby time.

Power for Avaya IP telephones

Power for Avaya 4602 and Avaya 4620 IP telephones

An Avaya 4602 or an Avaya 4620 IP telephone is powered through the RJ45 jack that resides on the telephone. There are two methods of powering the telephone through the RJ45 jack:

- Centralized power provided by an Avaya P333T-PWR switch or an 1152A1 mid-span power-distribution unit. If the Avaya P333T-PWR switch is used the Gen-1 IP phone adapter is required.
- Local power using the 1151B1 or 1151B2 power supply

Power for Avaya 4606, 4612, and 4624 IP telephones

There are two generations of Avaya 4606, 4612, and 4624 IP telephones. Power for the three models depends on the generation of the telephone. First generation (Gen-1) IP telephones support power over pins 7 & 8 or by the barrel connector beneath the phone. The second generation (Gen-2) IP telephones adhere to the current IEEE Draft 802.3af specifications and will accept power on either the data pairs or the spare pairs. The Gen-2 telephones add power over Ethernet to the Gen-1 power capabilities.

There are two ways to identify the generation of an Avaya IP telephone:

- Label identification – The product label beneath an IP telephone contains a 12-character (US only), or 16-character (international) model number or apparatus code. The model number indicates the generation by either a 01A (Gen-1) or 02A (Gen-2) identifier attached to the number of the phone.
- Display identification – The model for an IP telephone can be retrieved via the display after the telephone has been powered up.

There are three methods to power an Avaya 4606, 4612, or 4624 IP telephone:

- Centralized power (power over Ethernet) provided by the Avaya P333T-PWR switch for new installations. The 1152A1 mid-span power-distribution unit is used for Avaya configurations that use the DEFINITY R, SI, or CSI Media Servers.
 - The Gen-1 IP Phone adapter is required for every Gen-1 IP telephone in a centralized power environment.
- Local power refers to a configuration where power is supplied at an immediate location to an IP telephone. Local power requires a 120- to 240-VAC outlet located within six feet of the IP telephone.
- Legacy power is the least preferred method for powering an IP telephone.
 - Within the US and Canada, legacy power is provided via the AUX power supply of the IP telephone and a barrel connector. The barrel connects to a jack on the bottom of the IP telephone. The 1151A1 or 1151A2 power supplies with split cords are an alternative method of power.
 - Internationally, legacy power is provided by the 1151A1 or 1151A2 power supply with the required split cords. A 30A switch can also be used with the 1151A1 or 1151A2 local power supply. In this configuration two special cords are required.

Power for Avaya IP telephones

- A 1145B bulk power supply can also provide power over pins 7 and 8 utilizing a special cord.

Power for Avaya 4630 IP telephones

An Avaya 4630 IP telephone must be powered locally using the barrel connector beneath the telephone. The power supply for an Avaya 4630 is provided with the telephone.

SoundPoint and SoundStation speakerphones

3127 SoundPoint Speakerphone

The SoundPoint speakerphone adjunct connects to a telephone and provides high quality audioconferencing for desktop environments. The Analog version plugs into any standard analog phone jack. The DCP version plugs into the adjunct port of the 7400-, 7500-, 8400-, and 8500-series terminals.

The full-duplex operation eliminates the clipping of speech and the de-reverberation technology helps to reduce the hollow, “bottom of the well” sound associated with common speakerphones.

SoundPoint automatically adapts itself to both the room and line conditions in order to ensure the best full-duplex operation. This is especially critical when you have multi-party international conference calls operating over a bridge. Additionally, this adaptation is an automatic and continuous process to accommodate for changing room conditions.

Highlights

- 180° of microphone coverage – ideal for desktop applications
- Tabletop, user installable solution for ease of setup and use
- Neodymium speaker tuned to reproduce the human voice
- Avaya DM1000 Directional Microphone for best voice clarity
- Auto Answer capable for hands free applications
- Microphone muting for privacy
- Dual color LED for on and mute display lights

Models

3127-ATR: AVAYA SOUNDPOINT ANALOG

The analog version of SoundPoint plugs into any analog port or terminal and comes with all appropriate cabling. In Addition, the analog version of SoundPoint can automatically answer (Auto-Answer) calls placed to its extension.

3127-DCP: AVAYA SOUNDPOINT DCP

Connects to the adjunct port of the 7400-, 7500-, 8400-, and 8500-series terminals for added convenience. Comes with all appropriate cabling.

3127 SoundStation speakerphone

The SoundStation speakerphone has three microphones providing 360 degree of coverage for offices and small conference rooms. The amplified speaker provides enough audio for groups of up to 10 people. The analog version plugs into any standard analog phone jack. The DCP version plugs into the adjunct port of the 7102, 8102, and 7400- and 8400-series terminals.

The full-duplex operation eliminates the clipping of speech and the Acoustic Clarity Technology helps to eliminate background noise. SoundStation automatically adapts itself to both the room and line conditions in order to ensure the best full-duplex operation. This is especially critical when you have multi-party international conference calls operating over a bridge. Additionally, this adaptation is an automatic and continuous process to accommodate for changing room conditions.

Highlights

- 360° of microphone coverage – ideal for desktop applications
- Digitally tuned speaker with Acoustic Clarity Technology™
- Full Duplex Operation – talk and listen at the same time
- Tabletop, user installable solution for ease of setup and use
- Extension microphones available for up to 20 people
- Integrated dial pad
- Microphone muting for privacy
- Dual color LED for on and mute display
- Wireless, lapel microphone available for stand-up presenters

Models

3127-STD: AVAYA SOUNDSTATION ANALOG

The analog version of SoundStation plugs into any analog port or terminal and comes with all appropriate cabling. Requiring just an analog line and a power outlet, this system is easy to install and use. Good for groups of up to 10 people.

3127-EXP: AVAYA SOUNDSTATION EX ANALOG

This analog version of SoundStation includes two extension microphones, which can be used to enhance the room coverage to support up to 15 people. Plugs directly into an analog port.

3127-DCS: AVAYA SOUNDSTATION DCP

The DCP version connects to the adjunct port of the 7102, 8102, and 7400- and 8400-series terminals. **This SoundStation does not work with a 6400-series terminal.** Comes with all appropriate cabling and is user installable. Good for groups of up to 10 people.

3127-DCE: AVAYA SOUNDSTATION EX DCP w/Mics

This DCP version of SoundStation includes two extension microphones, which can be used to enhance the room coverage to support up to 15 people. The DCP version connects to the adjunct port of the 7102, 8102, and 7400- and 8400-series terminals. **This SoundStation does not work with a 6400-series terminal.** Comes with all appropriate cabling and is user installable.

3127 SoundStation Premier audioconferencing speakerphone

The SoundStation Premier speakerphone has three microphones providing 360° of coverage for offices and small conference rooms. The amplified speaker provides enough audio for groups of up to 25 people.

The analog version plugs into any standard analog phone jack, the DCP version plugs into the adjunct port of the 7102, 8102, and 7400- and 8400-series terminals and the 6400-SSDP version plugs directly into a DCP jack.

The full-duplex operation eliminates the clipping of speech and the Acoustic Clarity Technology helps to eliminate background noise. In addition, SoundStation Premier focuses a microphone on the main speaker, effectively eliminating the hollow sound common with standard speakerphones. Also included is a full feature remote control and Display.

SoundStation Premier automatically adapts itself to both the room and line conditions in order to ensure the best full-duplex operation. This is especially critical when you have multi-party international conference calls operating over a bridge. This adaptation is an automatic and continuous process to accommodate for changing room conditions.

Highlights

- 360° of microphone coverage – ideal for desktop applications
- Digitally tuned speaker accurately reproduces the human voice
- Full Duplex Operation – talk and listen at the same time
- De-reverberation – reduces the hollow, bottom of the well sound
- Tabletop, user installable solution for ease of setup and use
- Extension microphones available to support up to 25 people
- Integrated dial-pad and full-featured remote control
- Microphone muting for privacy
- Dual color LED for on and mute display
- Wireless, lapel microphone optional for stand-up presenters

Models

3127-APE: AVAYA SOUNDSTATION PREMIER EX ANALOG

The analog version of SoundStation Premier plugs into any analog port or terminal and comes with all appropriate cabling. Expansion ports are available for adding on the optional extension microphones. Requiring just an analog line and a power outlet, this system is easy to install and use. Good for groups of up to 15 people.

3127-APX: AVAYA SOUNDSTATION PREMIER EX/MICS ANALOG

This analog version of SoundStation Premier EX/Mics includes two extension microphones, which can be used to enhance the room coverage to support up to 25 people. Plugs directly into an analog port.

3127-DPE: AVAYA SOUNDSTATION PREMIER DCP EX

A DCP version of SoundStation Premier EX connects to the adjunct port of the 7102, 8102, and 7400- and 8400-series terminals. **(Does not work with a 6400-series terminal.)** Expansion ports are available for adding on the optional extension microphones. Comes with all appropriate cabling and is user installable. Good for groups of up to 15 people.

3127-DPX: AVAYA SOUNDSTATION PREMIER DCP EX w/Mics

This DCP version of SoundStation Premier EX includes two extension microphones, which can be used to enhance the room coverage to support up to 25 people. The DCP version connects to the adjunct port of the 7102, 8102, and 7400- and 8400-series terminals. **(Does not work with a 6400-series terminal.)** Comes with all appropriate cabling and is user installable. Good for groups of up to 25 people.

3127-DDP: AVAYA 6400-SSDP – SOUNDSTATION DCP PREMIER EX

A DCP version of SoundStation Premier EX that connects directly into a DCP jack. It can work with or without a terminal. It can work with any 6400-, 7400-, or 8400-series terminal. Expansion ports are available for adding on the optional extension microphones. Comes with all appropriate cabling and is user installable. Good for groups of up to 15 people.

3127-DDX: AVAYA 6400-SSDP – SOUNDSTATION DCP PREMIER w/Mics

This 6400-SSDP includes two extension microphones, which can be used to enhance the room coverage to support up to 25 people. The 6400-SSDP connects directly into a DCP jack. It can work or without a terminal. It can work with any 6400-, 7400- or 8400-series terminal. Comes with all appropriate cabling and is user installable.

3127-MIC: AVAYA SOUNDSTATION WIRELESS LAPEL MIC

This clip-on microphone is designed for stand-up presenters. Consisting of a small transmit/receive pack that clips onto your belt and collar, this microphone has a 100' range and comes in two individual frequencies.

3127-PMI: EXTENSION MICROPHONES FOR SOUNDSTATION PREMIER

Two extension microphones to enhance and expand room coverage. Compatible with 3127-APE, 3127-DPE and 3127-DDP

Avaya UPS Units

Avaya Series 1 (AS1) UPS

AS1 1000 VA 120 V Online Uninterruptible Power Supply (UPS)

The 1000 VA 120 V Online UPS provides 1000 VA/490 Watts/8.3 Amps at 120 Volts AC and battery holdover of five minutes at full load. Two optional Extended Battery Modules (EBM24) extend the run time to 104 minutes at full load. The UPS groups the six available 5-15R receptacles into two groups of three to make it possible for users to shutdown one set of loads to allow longer run times for more critical loads during a power failure. Power management is included. The UPS chassis can be installed in a tower or mounted in a data rack. Serial interface capabilities and DEFINITY alarm contacts are standard.

1000 VA 120 V models include the following accessories:

- Extended Battery Module (EBM24)
- Bypass Distribution Module 1000-1500VA 120V
- SNMP Module

Safety Compliance: UL, CSA, NOM

EMC Compliance: FCC Class B, VCCI Class II.

Input: 120 Vac, 45-65 Hz, auto sensing; user-selectable 100 or 127 VAC; 6-foot attached cord with 5-15 P

Output: Six 5-15 R receptacles in two load segments; sine wave; voltage +/- 3% of nominal.

Battery: Two 12 V 9 A/H sealed, lead-acid; maintenance free

Dimensions: (H x W x D) 89 mm x 432 mm x 494 mm = 3.5" x 17" x 19.4"

Weight: 15 kg = 34 pounds

AS1 1000VA 230V Online UPS

The 1000 VA 230 V Online UPS provides up to 700 Watts and basic battery holdover of five minutes at full load. Output current for 208/220/230/240 volts is 4.8/4.5/4.3/4.2 Amps. Two optional Extended Battery Modules (EBM24) extend the run time to 104 minutes at full load. By grouping the six available 5-15 R receptacles into two groups of three, the UPS allows users to shutdown one set of loads to allow longer run times for more critical loads during a power failure. Power management is included. The UPS can be installed as a tower or mounted in a data rack. Serial interface capabilities and DEFINITY alarm contacts are standard.

1000VA 230 V models include the following accessories:

- Extended Battery Module (EBM24)
- Bypass Distribution Module 700-2000 VA 230 V
- SNMP Module

Safety Compliance: UL, CSA, NOM, CE

EMC Compliance: FCC Class B, EN 50091-2, VCCI Class II, IECS-003

Input: 230Vac, 50/60 Hz, auto sensing, user-selectable 220, 240; 2-meter cord with unterminated plug-end.

Output: Six 5-15 R receptacles in two load segments; sine wave; voltage +/- 3% of nominal.

Battery: Two 12V 9 A/H sealed, lead-acid; maintenance free

Dimensions: (H x W x D) 89 mm x 432 mm x 494 mm = 3.5" x 17" x 19.4"

Weight: 15 kg = 34 pounds

AS1 1500VA 120V Online UPS

The AS1 1500 VA 120 V Online UPS provides 1500 VA/1050 Watts/12.5 Amps at 120 Volts AC and battery holdover of eight minutes at full load. Four optional Extended Battery Modules-EBM48 extend the run time to 144 minutes at full load. By grouping the six available 5-15 R receptacles into two groups of three, the UPS allows users to shutdown one set of loads to allow longer run times for more critical loads during a power failure. Power management software is included. The UPS can be installed as a tower or mounted in a data rack. Serial interface capabilities and DEFINITY alarm contacts are standard.

The AS1 1500 VA model includes the following accessories:

- Extended Battery Module (EBM48)
- Bypass Distribution Module AS1 1000-1500 VA 120 V
- SNMP Module

Safety Compliance: UL, CSA, NOM

EMC Compliance: FCC Class B, VCCI Class II.

Input: 120 Vac, 45-65Hz, auto sensing; user-selectable 110, 127 VAC; 6-foot attached cord with 5-15P.

Output: Six 5-15 R receptacles in two load segments; sine wave; voltage +/- 3% of nominal.

Battery: Four 12V 9 A/H sealed, lead-acid; maintenance free

Dimensions: (H x W x D) 89 mm x 432 mm x 494 mm = 3.5" x 17" x 19.4"

Weight: 23 kg = 50 pounds

AS1 1500VA 230V Online UPS

The AS1 1500 VA 230 V Online UPS provides up to 1050 Watts and basic battery holdover of eight minutes at full load. Output current for 208/220/230/240 volts is 7.2/6.8/6.5/6.2 Amps. Four optional Extended Battery Modules (EBM48) extend the run time to 144 minutes at full load. By grouping the six available 5-15 R receptacles into two groups of three, the UPS allows users to shutdown one set of loads to allow longer run times for more critical loads during a power failure. Power management is included. The UPS can be installed as a tower or mounted in a data rack. Serial interface capabilities and DEFINITY alarm contacts are standard.

1500 VA 230 V models include the following accessories:

- Extended Battery Module (EBM48)
- Bypass Distribution Module 1000-2000VA 230V
- SNMP Module

Safety Compliance: UL, CSA, NOM, CE

EMC Compliance: FCC Class B, EN 50091-2, VCCI Class II, IECS-003

Input: 230 Vac, 50/60 Hz, auto sensing, user-selectable 220, 240; 2-meter cord with unterminated plug-end.

Output: Six 5-15 R receptacles in two load segments; sine wave; voltage +/- 3% of nominal.

Battery: Four 12V 9 A/H sealed, lead-acid; maintenance free

Dimensions: (H x W x D) 89 mm x 432 mm x 494 mm = 3.5" x 17" x 19.4"

Weight: 23 kg = 50 pounds

UPS Add-on Modules

Extended Battery Module-EBM24 1000 VA

The Extended Battery Module-EBM24 supports the 1000 VA Online UPS with a 24v battery string to extend the run time (see table for run times). The EBM chassis is suitable for tower and rack-mounted installations in a compact 2U height. No other battery module or cabinet is compatible with the 1000 VA Online UPS.

Maximum: Up to two Extended Battery Module (EBM24) per 1000VA Online UPS.

Safety Compliance: UL, CSA, NOM.

EMC Compliance: FCC Class B, VCCI Class II.

Dimensions: (H x W x D) 89 mm x 432 mm x 494 mm = 3.5" x 17" x 19.4"

Weight: 29.5 kg = 65 pounds

UPS Extended Battery Module-EBM48 1500-2000 VA

The UPS Extended Battery Module-EBM48 supports the 1500 VA and 2000 VA online UPS with a 48v battery string to extend the run time up to 144 minutes at full load. The EBM chassis is suitable for tower and rack-mounted installations in a compact 2U height.

Maximum: Up to four Extended Battery Module-EBM48 per 1500 or 2000 VA Online UPS.

Safety Compliance: UL, CSA, NOM.

EMC Compliance: FCC Part 15 (Class B) and VCCI Class II.

Dimensions: (H x W x D) 89 mm x 432 mm x 494 mm = 3.5" x 17" x 19.4"

Weight: 29kg = 65 pounds

SNMP MODULE 1000-2000 VA

The SNMP module is included in the 1000 VA package, adding direct control and monitoring capabilities in SNMP-based networks. The module is hot-swappable with the standard serial interface module.

Dimensions: (H x W X D) 4.5" x 4" x 1"

Weight: 0.2 pounds

BYPASS DISTRIBUTION MODULE 120V 1000-1500 VA

The bypass distribution module (BDM) allows for replacement of the UPS or internal batteries without shutting down the connected load.

Dimensions: (H x W X D) 12" x 5" x 4"

Weight: 5.0 pounds

PWR UPS BYPASS DISTR MOD S1 1000VA-2K VA

The bypass distribution module (BDM) allows for replacement of the UPS or internal batteries without shutting down the connected load.

Dimensions: (H x W X D) 12" x 5" x 4"

Weight: 5.0 pounds

Avaya Ethernet Switches

Avaya P330 Ethernet Switches

The Avaya P330 family of stackable Ethernet workgroup switches include:

- A range of modules with 10/100/1000 Mbps ports
- A Layer 3 capability
- ATM Expansion sub-module.

The Avaya g2T switch has 24x10/100 Mbps ports and an Expansion sub-module slot. The optional expansion sub-modules provide additional Ethernet, Fast Ethernet, and Gigabit Ethernet connectivity.

An Avaya P330 stack can contain up to 10 switches and up to three backup power supply units. The stacked switches connect using the Avaya X330STK stacking sub-modules that plug into a slot in the back of the Avaya P330. If the stack is split between two racks you can connect the P330 by using the X330SC or X330LC cables. The Avaya X330RC cable connects the top and bottom switches in the stack and provides redundancy and hot-swappability in the same way that modules can be swapped in a modular switching chassis.

When two or more layer 2 switches are connected together, VLAN numbering consistency is maintained by creating a trunk port that is logically connected to multiple VLANs. The numbering is kept consistent through the use of 802.1Q tags. The Avaya P330 is fully compliant with IEEE standards for VLAN Tagging, Gigabit Ethernet, Spanning Tree and Flow Control. This full standards-compliance, combined with auto-negotiation for 10/100/1000 Mbps and half/full duplex facilitates the expansion of your network to match your company's growing needs.

Features of the Avaya P330 Product Line

- You can connect up to 10 Avaya P330 switches in a stack. Moreover, this stack can be either in one rack or split over several racks using the X330LC Long Cable.
- Avaya X330STK is stacking sub-module that is used to connect Avaya P330 switches in a stack by way of the Octaplane.
- Avaya P330 BUPS is the back-up power supply module. The Avaya P330 BUPS can support up to four Avaya P330 switches.
- One RJ45/RS232 front panel console connector for both terminal and modem sessions.
- Each switch is equipped with two fan units with operation sensors.
- One virtual IP address for managing the whole stack that allows the P330 stack to be managed as a single entity.
- The ability to hot-swap one switch at a time by activation of the redundant cable:
 - Does not disrupt the operation of other Avaya P330 switches.
 - Does not change stack configuration.
 - Does not require network downtime.

- Connection through Telnet from the front panel ports of any switch:
 - multiple levels of password protection
 - login and inactivity timeouts

Auto-Negotiation

Every 10/100 port on the Avaya P330 supports Auto-Negotiation. Auto-Negotiation automatically detects and supports the operating mode and speed of a connected device. Auto-negotiation is also supported on the Gigabit Ethernet ports for flow control mode only. You can simply connect the Avaya P330 to Ethernet or Fast Ethernet equipment at full or half duplex without pre-configuration.

Congestion Control

Congestion control is a key element of maintaining network efficiency. Congestion control is used to prevent resource overload. The Avaya P330 supports congestion control on all Ethernet ports by using the following:

- Back Pressure in half duplex mode
- IEEE 802.3x Flow Control in full duplex mode

VLANs

The Avaya P330 VLANs are fully IEEE 802.1Q compliant and can handle up to 1k tagged VLANs.

Multiple VLANs per Port

The Avaya P330 provides the ability to set multiple (1K) VLANs per port. The three available Port Multi-VLAN binding modes are:

- Bound to All - the port is programmed to support the entire 3K VLANs range. Traffic from any VLAN is forwarded through a port defined as Bound to All.
- Bound to Configured - the port supports all the VLANs configured in the switch/stack. These may be either Port VLAN IDs (PVID) or VLANs that were manually added to the switch.
- Statically Bound - the port supports VLANs manually configured on it.

Leaky VLAN

Leaky VLAN provides the ability to send unicast traffic between two ports on different VLANs. Leaky VLAN will function only on modules (and sub-modules) with C/S 2.0 and higher.

Port Classification

With the Avaya P330, you can classify any port as regular or valuable. Setting a port to valuable means that a link fault trap can be sent even when the port is disabled. This feature is particularly useful for the software redundancy application, where you need to be informed about a link failure on the dormant port.

Network TIME Acquiring Protocols

The Avaya P330 supports the SNTP Protocol over UDP port 123. You can choose between SNTP or TIME protocol over UDP port 37.

MAC Security

To prevent the P330 from learning an new MAC address you can define a port as secure. If an unknown MAC or station tries to access the secure port an intruder alarm is sent to the management station.

Link Aggregation Group (LAG)

LAG provides increased bandwidth and redundancy for critical high-bandwidth applications such as inter-stack links and connections to servers. You can aggregate the bandwidth of up to eight 10/100Base-Tx ports, two 100Base-FX or 1000Base-X ports. Load sharing ensures that if one of the port connections fails, the other connections will assume the load seamlessly. Load balancing guarantees that the traffic load at any level will be evenly divided among all the LAG links.

IP Multicast Filtering

IP Multicast allows you to send a single copy of an IP packet to multiple destinations, and can be used for various applications including video streaming and video conferencing. On LANs, IP Multicast packets are transmitted in MAC Multicast frames. Traditional LAN switches flood these Multicast packets to all stations in the VLAN. Multicast filtering functions may be added to the Layer 2 switches to avoid sending Multicast packets where they are not required. Layer 2 switches capable of Multicast filtering send the Multicast packets only to ports that connect members of that Multicast group. In order for this feature to operate correctly, you need in your network a router issuing IGMP queries.

NOTE:

IP Multicast filtering will function only based on the port's VLAN ID and not based on any VLAN bound to the port.

Radius Security

The Remote Authentication Dial-In User Service (RADIUS) is an IETF standard (RFC 2138) client/server security protocol. Security and login information is stored in a central location known as the RADIUS server. RADIUS clients such as the Avaya P330, communicate with the RADIUS server to authenticate users.

All transactions between the RADIUS client and server are authenticated through the use of a "shared secret" which is not sent over the network. The shared secret is an authentication password configured on both the RADIUS client and its RADIUS servers. The shared secret is stored as clear text in the client's file on the RADIUS server, and in the non-volatile memory of the Avaya P330. In addition, user passwords are sent between the client and server are encrypted for increased security.

Port Redundancy

Redundancy can be implemented between any two ports in the same stack at the link level. You can also assign redundancy between any two LAGs in the stack or between a LAG and a port. One port or LAG is

defined as the primary port, and the other as the secondary port. In case the primary port link fails, the secondary port takes over.

Intermodule Redundancy

Intermodule redundancy includes all Port Redundancy functionality, and additionally maintains port integrity even when the primary port link fails as the result of a failure of the module. If the module on which the active port in an Intermodule Port Redundancy pair is located is powered down or removed from the stack, the secondary port in the Intermodule Port Redundancy pair takes over. Only one pair per stack can be set for Intermodule Port Redundancy.

Stack Redundancy

In the unlikely event that an Avaya P330 switch or Octaplane link should fail, stack integrity is maintained if the redundant cable is connected to the stack. The broken link is bypassed and data transmission continues uninterrupted. The single management IP address for the stack is also preserved for uninterrupted management and monitoring.

Hot-Swappable

You can remove or replace any module within the stack without disrupting operation or performing stack-level reconfiguration. You can therefore adapt the P330 to your requirements on the fly and with a downtime which is second to none. When you remove an expansion module from the stack, all configuration definitions on expansion modules are lost.

Backup Power Supply

Each Avaya P330 module comes with a Backup Power Supply (BUPS) connector. If the internal power supply should fail, the Avaya P330 BUPS (available separately,) will automatically supply power to the switch for uninterrupted operation.

Fans

The Avaya P330 module fans have integrated sensors which provide advance warnings of fan failure by way of the management.

Network Management Agent (NMA) Redundancy

Since each Avaya P330 module has an integral SNMP agent, any module in a stack can serve as the stack NMA while other NMAs act as redundant agents in hot standby. If the live NMA fails then a backup is activated instantaneously.

Software Download

Avaya P330 includes a safe software download procedure in which backup code is always present. You should perform a reset after downloading software to the Module.

P330 Standards Supported by Avaya

The Avaya P330 complies with the following standards.

IEEE

- 802.3x Flow Control on all ports
- 802.1Q VLAN Tagging support on all ports and 802.1p compatible
- 802.1D Bridges and STA
- 803.2z Gigabit Ethernet ports
- 803.2u Ethernet/Fast Ethernet ports

IETF

- MIB-II - RFC 1213
- Bridge MIB for Spanning Tree - RFC 1492
- RMON - RFC 1757
- SMON - RFC 2613
- Bridge MIB Groups - RFC 2674 dot1dBase and dot1dStp fully implemented. Support for relevant MIB objects: dot1q (dot1qBase, dot1qVlanCurrent)

Avaya P330 Network Management

Comprehensive network management is a key component of today's networks. Therefore we have provided multiple ways of managing the Avaya P330 to suit your needs.

Avaya P330 Device Manager (Embedded Web)

The built-in Avaya P330 Device Manager (Embedded Web Manager) allows you to manage an Avaya P330 stack using a Web browser without purchasing additional software. This application works with the Microsoft® Internet Explorer and Netscape® Navigator Web browsers and Sun Microsystems Java™ Plug-in.

Avaya P330 Command Line Interface (CLI)

The Avaya P330 CLI provides a terminal type configuration tool for local or remote configuration of Avaya P330 features and functions.

CajunView

When you need extra control and monitoring or wish to manage other Cajun Campus equipment, then the CajunView network management suite is the answer. This suite provides the ease-of-use and features necessary for optimal network utilization.

- CajunView is available for Windows® NT®/2000 and Solaris 8.
- CajunView can operate in Stand-Alone mode with Windows® NT®/2000.
- CajunView operates under HP OpenView for Windows® NT®/2000 and Solaris 8.

Avaya P330 Network Monitoring

RMON MIBs - RFC 1757

- RMON support for groups 1,2,3 and 9.
 - Statistics
 - History
 - Alarms
 - Events

SMON MIBs - RFC 2613

- SMON support for groups
 - Data Source Capabilities
 - Port Copy
 - VLAN and Priority Statistics

Bridge MIB Groups - RFC 2674

- dot1dBase and dot1dStp fully implemented.
- Support for relevant MIB objects: dot1q (dot1qBase, dot1qVlanCurrent)

Port Mirroring

The Avaya P330 provides port mirroring for additional network monitoring functionality. You can filter the traffic and mirror either incoming traffic to the source port or both incoming and outgoing traffic. This allows you to monitor the network traffic you need. Ports which are members in a Link Aggregation Group (LAG) can also be used as Port Mirroring Destination or Source ports.

SMON

The Avaya P330 supports Avaya's ground-breaking SMON Switched Network Monitoring, which the IETF has now adopted as a standard (RFC2613). SMON provides an unprecedented top-down monitoring of switched network traffic at the following levels:

- Enterprise Monitoring
- Device Monitoring
- VLAN Monitoring
- Port-level Monitoring

This top-down approach gives you rapid troubleshooting and performance trending to keep the network running optimally.

NOTE:

CajunView is required to run SMON monitoring. You need to purchase one SMON License per Avaya P330 Stack.

Avaya P133 and P134 Ethernet Switches

The Avaya P133G2 and P134G2 are part of the Avaya Switch Portfolio line of cost effective Workgroup Ethernet switches. The Avaya P133G2 and P134G2 provide all the features needed at the network to implement emerging applications and yet are simple to install, operate and manage.

Installing the Avaya P133G2 and P134G2 Ethernet switches at the network edge or a small enterprise allows customers to easily build a network fully featured to meet their requirements. The switch's integrated uplinks enable connectivity to the network Backbone and you can scale up as you grow: stack up to four P130 switches to create a single logical switch.

For the P133G2 and P134G2 products, application configuring, network operation and network monitoring are straightforward tasks due to the user-friendly Web management capabilities. The P133G2 and P134G2 products have the same management and monitoring capabilities as other Avaya Cajun switches and therefore can also be centrally managed by the widely acclaimed CajunView(tm) network management suite of applications.

Like all Avaya MultiService Network products, the new P133G2 and P134G2 products are DayOne Ready for Voice, Video and Data Networking; Day One Ready means these products offer application optimization for converged voice, video and data networks. These products are designed to support a superior data network environment with capabilities for QoS, Policy Management and redundancy support that provides superior operational reliability and network availability.

Avaya P133G2

The P133G2 is a workgroup switch with 24 Fast Ethernet and 2 SFP GBIC slots for uplink and cascading. This unit has a 8.8 Gbps wire speed switching and forwarding rate.

Avaya P134G2

The P134G2 configuration provides 48 Fast Ethernet ports and 2 SFP GBIC slots.

General Features of the P133G2 and P134G2 Switches

- 802.3 compliant ports for full/half duplex traffic, auto-negotiation, and flow control
- 802.1Q VLAN tagging
- Port based VLAN
- QoS Support
- Transparent IEEE 802.1p
- Per-port basis
- Congestion control per port
- Link Redundancy
- Link Aggregate Group (LAG) Supports both load sharing and redundancy as an incremental way to scale link bandwidth

- LAG Redundancy
- IEEE 802.1d Spanning Tree
- Load-Sharing Back-up Power Supply (BUPS)
- Port mirroring
- SMON (RFC2613) IETF SMON standard for Layer 2

Interfaces

- 24 x 10/100Base-TX ports with RJ connectors
- 2 x SFP GBIC connectors
- RS-232 for terminal setup/modem and PPP

Standards Supported

- IEEE 802.3x Flow control on all ports
- IEEE 802.1Q/p VLAN Tagging and priority on all ports
- IEEE 802.1D Spanning Tree protocol
- IEEE 802.3z Gigabit Ethernet ports
- IETF MIB-II, Bridge MIB, RMON, SMON

Physical Characteristics

- Dimensions 2U (3.5"/88 mm) x 19", (h, w, d): (482.6 mm) x 13.8" (350 mm), Weight 11.4 lb (5.2 kg)

Environmental Conditions

- Operating Temp: 23 to 122 o F (-5 to 50 o C)
- Humidity: 5% to 95% non-condensing

Power Consumption

- Power Entry (AC): 100-240 VAC, 1A, 50/60 Hz
- Power Consumption: 75W maximum

Agency Approval

- EMC Emission:
 - US - FCC Part 15, Subpart B, Class A
 - Europe - EN55022 class A and EN61000-3-2
 - Japan - VCCI-A
- Immunity: Approved according to EN55024 and EN61000-3-3

- Safety:
 - UL for US approved according to UL1950 Std.
 - C-UL (UL for Canada) approved according to C22.2 No.950 Std.
 - CE for Europe approved according to EN 60950 Std
- CLEI Code According to Telcordia (Bellcore) KS-22022 standard NEBS Level 3 Certified

Site requirements

Rack mounting, temperature and humidity information for the G600 Media Gateway

The G600 Media Gateway can be mounted in a standard 19-inch data rack that has been properly pre-installed and secured as per the EIA 464 (or equivalent) standards. The G600 Media Gateway can be front mounted (as shipped) or mounted at its midpoint.

The customer must provide the rack and have it installed and secured prior to the G600 Media Gateway installation. The customer must also provide AC power to the rack. The technicians who install the G600 Media Gateway do not typically have the tools or proper training for data rack installation.

Installation requires 1 foot (30 cm) of clearance in the rear, and 18 inches (45 cm) of clearance in the front, which is consistent with the EIA 310 standards. In a 2-cabinet configuration, the dimensions of the TDM/LAN cable require that you mount the B cabinet directly over the A cabinet.

The G600 Media Gateway must be installed in a well-ventilated area. Maximum equipment performance is achieved at an ambient temperature between 40 and 120° F (4 and 49° C) for a short-term operation of not more than 72 consecutive hours or 15 days in one year. A continuous operation requires up to 110° F (43° C).

The relative humidity range is 10 to 95% at up to 84° F (29° C). Above this, maximum relative humidity decreases from 95% down to 32% at 120° F (49° C). Installations outside these limits may reduce system life or affect operation. The recommended temperature and humidity range is 65 to 85° F (18 to 29° C) at 20 to 60% relative humidity.

Table 10: Cabinet power source information

Cabinet style and power-distribution unit	Power sources	Power input receptacles
G600 Media Gateway – *AC power supply (650A integrated power supply)	Single-phase 120-VAC with neutral Single-phase 240-VAC with neutral	120-VAC, 60-Hz NEMA 5-15R 24-VAC, 50-Hz IEC 320 Japan installations use country-specific receptacles for 100 VAC and 200 VAC, 50/60 Hz
*There is no integrated DC power supply. DC rectifiers can be used if desired; follow manufacturer's instructions.		

Table 11: Circuit breakers for AC-powered G600 Media Gateway

G600 Media Gateway	Circuit Amperes
120 VAC, 60 Hz	15
240 VAC, 50 Hz	10

Heat dissipation for the G600 Media Gateway

The amount of heat dissipated required by a G600 Media Gateway configuration is described below. These estimates are highly dependent on the inclusion of telephones with the Media Gateways as well as the amount of time that the telephones are off-hook.

NOTE:

Typical systems assume typical trunking, sparing, call rate, and a typical mixture of high-function and low function telephones. The following table shows estimates of heat dissipation for the G600 Media Gateway. Worst-case systems assumes typical trunking and call rate, but no spare slots and all ports configured with high functioning terminals. The G600 Media Gateway that was tested used the worst case of 16 port analog circuit packs fully populated with analog sets.

Typical G600 Media Gateway heat-dissipation specifications

BTU per hour	# of G600 Media Gateways only	G600 with terminals
1	400	1000
2	900	2200
3	1400	3475
4	1900	4700
Worst case	3200	5150

G650 specifications

Power requirements

AC power

Commercial AC is the primary input power source. Both slot 0 and slot 15 have dedicated AC input. The 655A power supply can operate on AC input of 90 - 264VAC at 47 - 63Hz. The nominal ranges for AC power are:

- 100 - 120VAC at 50 or 60Hz
- 200 - 240VAC at 50 or 60Hz

DC power

Minus 48VDC power can be supplied simultaneously as backup power. One -48VDC power input point is provided on the G650 backplane and is distributed through the backplane to each power supply.

Power output

Power supply output voltage measurements—+5VDC, -5VDC, and -48VDC

See the following table for power source information.

Table 12: Chassis power source information for the G650

Chassis style and power-distribution unit	Power source options	Power input receptacles
<ul style="list-style-type: none"> • AC or DC power supply (Apparatus Code 655A) • A 655A power supply is required in slot 0. • A 655A power supply is optional in slot 15. 	<ul style="list-style-type: none"> • Single phase 120 VAC with neutral wire • Single phase 240 VAC with neutral wire • -48VDC 	<ul style="list-style-type: none"> • 120 VAC, 60 Hz NEMA 5-15R • 240 VAC, 50 Hz IEC 320 • When installing G650s in Japan, use country specific receptacles for 100 and 200 VAC, 50/60 Hz. • When installing G650s in Mexico, use country specific receptacles for 127 VAC.

See [Table 13, Circuit breakers for AC-powered chassis](#), on page 304 for circuit breaker information for AC-powered chassis

Table 13: Circuit breakers for AC-powered chassis

Chassis type	Circuit breaker size
Rack mount chassis (120 VAC) 60 Hz	15 A
Rack mount chassis (240 VAC) 50 Hz	10 A

Dimensions

The G650 Media Gateway has the following dimensions:

- 14h x 22d x 19w (inches)
- 36h x 56d x 48w (centimeters)
- height in rack: 8 U
- weight: 35 - 39 pounds, 16 - 18 kg

The G650 requires 12 inches (30 centimeter) of clearance in the rear and 18 inches (45 centimeters) of clearance in the front for adequate ventilation and to conform with EIA3 10D data rack standards. In a multiple G650 configuration, the G650s are placed in a rack without any space between them. If the G650s are not correctly placed in the rack, the TDM/LAN cables cannot connect them.

Operating conditions

The normal operating conditions for the G650 are the following:

- 41° Fahrenheit (5° Celsius) to 104° Fahrenheit (40° Celsius)
- 10 percent to 90 percent relative humidity, non-condensing below 10,617 feet (3,236 meters).

Environmental considerations for the G700 Media Gateway

The following table lists the environmental considerations for the G700 Media Gateway.

Table 14: Environmental considerations for the G700 Media Gateway

Consideration	Description
Heat dissipation	The unit uses global AC, 100-240 VAC, 50/60 Hz, 1.5 to 4.9 A, which translates to 360 to 400 Watts. However, some is passed out the front, via -48VDC (up to 32 ports at 1.5 Watts each for a total of 48 Watts).
Altitude and air pressure	Functions at altitudes of minus 197 feet to 10,000 feet. Air pressure is not specified.
Temperature and humidity	Long term operation at +5 to +40 C at 5 to 85% humidity. Short term operation at -5 to 50 C, at 5 to 90% humidity, non condensing.
Air purity	Indoor environments that are suitable for continuous human occupancy.
Lightning	The user is protected under the UL codes against over voltage in the system. However, the system itself is susceptible to over voltage (i.e. lightning) depending on the configuration. The loss of service due to an over voltage condition can result in the loss of one or more of the following: <ul style="list-style-type: none"> • Terminal loss • Port loss • Media Module loss • Power supply within the G700
Acoustic noise generated by unit	50dBA maximum
Electromagnetic compatibility standards	Conforms to the electromagnetic compatibility standards for the countries in which it operates.
European union standards	Approved to Safety Standard EN60950.
Air flow with a single fan failure	In front of the backplane is 264 linear feet per minute average. If a fan fails in front of the backplane, 174 lfpm average, with a range from 42 to 340 lfpm.
Air flow with the power supply fan failure	Minimal air flow at power supply if power supply fan fails.

Power requirements for the G700 Media Gateway

The power supply complies with FCC Part 15, Subpart B Class B and EN55022 Class B requirements for conducted and radiated electromagnetic interferences (EMI). When you use the power supply in a single or multiple G700 Media Gateway system, the power supply must allow the system to comply with Class B requirements with +6 dB of margin.

This power unit can be a single power supply or multiple modules that are sized and scalable for the load. The Avaya Ethernet switches have a power unit that meets the 802.3 AF standard and provides remote power for the telephone. The power supply meets all applicable global standards for safety, immunity, and emissions, and is verified by in-country testing.

Thermal Protection

Thermal protection shuts down the power supply if the internal temperature exceeds the maximum rated safe operating temperature. The minimum thermal shutdown point is determined at an ambient temperature of 50 degrees C at 10,000 feet elevation or 60 degrees C at sea level under all input and load conditions. You must consider the effects of component tolerances when defining the shutdown point. This consideration ensures that the supply does not shut down at ambient temperatures that are less than those specified above, with forced air flowing from input to output at a nominal rate of 46 CFM (300 LFM).

Manual Reset

The power supply requires reset when it manually when it shuts down because of over voltage or overheating. To reset the power supply recycle the AC input power.

AC and Load Center Circuit Breakers

For AC power, each of the G700 Media Gateways has a detachable AC power cord that plugs into a wall socket or into a power strip on the rack. This circuit must be protected by a circuit breaker for the panel that serves the outlet.

As a result, the G700 Media Gateway itself does not have circuit breakers or on/off switches. However, any customer AC load center must have circuit breakers protecting the power feeds to the G700 Media Gateways as required by electric codes.

AC power distribution

AC power distribution is plugged into an outlet or power strip and can be backed up by an optional UPS

AC Grounding/Protective Grounds

The G700 Media Gateway contains a grounding screw on the back of the chassis. You must maintain ground connection whether you connect the G700 Media Gateway directly to the branch circuit or to a

power distribution strip. The G700 Media Gateway also requires a cabinet ground connection directly to an approved ground.

S8500 Media Server environmental specifications

The following table outlines the environmental specifications of the S8500 Media Server. For a complete feature and specification table refer to the S8500 Installation Manual.

NOTE:

Some values are shown at maximum configuration. Avaya values will be slightly lower than maximum.

Table 15: S8500 Environmental Specifications

Type	Description
Acoustical Noise Emissions	<ul style="list-style-type: none"> • Sound power, idling: 6.5 bel maximum • Sound power, operating: 6.5 bel maximum
Environment: Air Temperature	<p>Server on:</p> <ul style="list-style-type: none"> • 10 to 35 degrees C (50.0 to 95.0 degrees F) • Altitude: 0 to 914 m (2998.7 ft) <p>Server off:</p> <ul style="list-style-type: none"> • -40 to 60 degrees C (-104 to 140 F) • Maximum altitude: 2133 m (6998.0 ft)
Environment: Humidity	<p>Server on:</p> <ul style="list-style-type: none"> • 8% to 80% <p>Server off:</p> <ul style="list-style-type: none"> • 8% to 80%
Heat Output	<p>BTU output per hour (approximate):</p> <ul style="list-style-type: none"> • Maximum configuration: 512 BTU (150 watts)
Electrical Input	<ul style="list-style-type: none"> • Sine-wave input (47-63 Hz) required • Input voltage low range: <ul style="list-style-type: none"> • Minimum: 100 V ac • Maximum: 127 V ac • Input voltage high range: <ul style="list-style-type: none"> • Minimum: 200 V ac • Maximum: 240 V ac • Input kilovolt-amperes (kVA) (approximate): <ul style="list-style-type: none"> • Minimum: 0.0870 kVA • Maximum: 0.150 kVA • Receptacle U.S.: XXXX 87=NEMA 5-15 • Circuit breaker: XXXX 87=15 amp • Pole: XXXX 87=1 • Amp Draw: XXXX 87=3

Altitude, air pressure and air purity for the S8700 Media Server

The normal operating air pressure for the S8700 Media Server is from 9.4 to 15.2 psi (648 to 1048 millibars). For altitudes above 5,000 feet, reduce the maximum short-term temperature limit by 1 °F or for 1,000 feet of elevation above 5,000 feet. At 10,000 feet, for example, the maximum short-term temperature limit is 115 °F.

Air Purity

Do not install the equipment in an area where the air may be contaminated with any of the following:

- Excessive dust, lint, carbon particles, paper fiber contaminants, or metallic contaminants
- Corrosive gases, such as sulfur and chlorine

Contaminant	Average
Particulate matter	185 microgram/m ³
Nitrate in particulate matter	12 microgram/m ³
Total hydrocarbons equivalent to methane	10 ppm
Sulfur dioxide	0.20 ppm
Oxides of nitrogen	0.30 ppm
Total oxidants equivalent to ozone	0.05 ppm
Hydrogen sulfide	0.10 ppm

NOTE:

Avaya recommends that the S8700 Media Server and related equipment not be collocated with copiers, printers, or plain paper FAX machines because of the fine dust these devices produce.

Temperature and humidity for the S8700 Media Server

The S8700 Media Server should be installed in an area that is well-ventilated. Maximum equipment performance is obtained at an ambient temperature between 40 to 110 degrees Fahrenheit (4 and 43 degrees Celsius) for continuous operation and between 40 and 120 degrees Fahrenheit (4 and 49 degrees Celsius) for short term operation. The system equipment can operate at the short-term operational limits for a period not to exceed 72 consecutive hours or a total of not more than 15 days in a year.

The relative humidity range is 10 to 95 percent up to 84 degrees Fahrenheit (29 degrees Celsius). Above 84 degrees Fahrenheit (29 degrees Celsius), maximum relative humidity decreases from 95 percent down to 32 percent at 120 degrees Fahrenheit (49 degrees Celsius). Installations outside these limits may reduce system life or impede operation.

The following table correlates room temperature with allowable relative humidity.

Recommended temperature range (degrees Fahrenheit)	Recommended temperature range (degrees Celsius)	Recommended humidity range (in %)
65 to 85	18 to 29	20 to 60
40 to 84	4.4 to 28.8	10 to 95
86	30.0	10 to 89
88	31.1	10 to 83
90	32.2	10 to 78
92	33.3	10 to 73
94	34.4	10 to 69
96	35.6	10 to 65
98	36.7	10 to 61
100	37.8	10 to 58
102	38.9	10 to 54
104	40.0	10 to 51
106	41.1	10 to 48
108	42.2	10 to 45
110	43.3	10 to 43
112	44.4	10 to 40
114	45.6	10 to 38
116	46.7	10 to 36
118	47.8	10 to 34
120	48.9	10 to 32

EMI and RFI specifications for the S8700 Media Server

Country	Specification
USA	FCC74 CFR Parts 2 and 15 Verified Class A limit
Canada	IC ICES-003 Class A limit
Europe	EMC Directive, 89/336/EEC; EN55022, Class A Limit, Radiated and Conducted Emissions; EN55024, Immunity Standard for Information Technology Equipment; EN61000-3-2 Harmonic Currents; EN61000-3-3 Voltage Flicker
Australia and New Zealand	AS/NZS 3548 Class A limit
Japan	VCCI, Class A ITE (CISPR 22, Class A Limit); IEC 1000-3-2; Harmonic Currents
Taiwan	BSMI Class A (CISPR 22)
Russia	Gost approval
International	CISPR-22 Class A limit

Power supply specifications for the S8700 Media Server

Power	Voltage and frequency
AC	100 to 127 VAC 200 to 240 VAC
DC	200 Watts
+5 VDC	22 A maximum
+5 VDC standby	1.0 A maximum
+12 VDC	3.5 A maximum
+3.3 VDC	13.0 A maximum
-12 VDC	0.25 A maximum

BTU

British thermal units (BTUs) are standard for measuring the thermal output of a device. One BTU equals the heat that will raise the temperature of one pound of water by one degree Fahrenheit. In physical terms, one BTU equals 1054 joules. The maximum BTU output of the Intel SRTR1 server is 988 BTU's. This rating represents a SRTR1 with the following components:

- SRTR1 server board
- Front panel board
- PCI riser board
- One 80-mm fan
- Three 40-mm fans
- 850-MHz Pentium III with heat sink fan
- Four Micron 32-Mb × 72 (256-Mb) DIMM modules
- IDE hard drive
- Slimline CD-ROM drive
- Slimline floppy drive
- Three PCI cards

NOTE:

The BTU number is rated at the lowest efficiency or worst case of the power supply. Under normal conditions the power supply should perform above the 70% efficiency level, which will lower the BTU ratings.

Regulatory certification for an S8700 Media Server

Product-safety standards and approvals

Country	Safety standards and approval summary
US and Canada	UL 1960, CSA 22.2, No. 950M95, 3 rd edition
Europe	Low Voltage Directive, 73/23/EEC TUV/GS to EN60950 2 nd Edition with Amendments, A1 + A2 + A3 + A4 + A11
International	CB Certificate and Report to IEC 60950, 2 nd edition including EMKO-TSE (74-SEC) 207/94 and other national deviations

Electromagnetic-compatibility (EMC) standards and approvals

Country	EMC standards and approvals
US	FCC 47 CFR Parts 2 and 15, Verified Class A Limit
Canada	IC ICES-003 Class A Limit
Europe	EMC Directive, 89/336/EEC EN55022, Class A Limit, Radiated and Conducted Emissions EN55024, Immunity Standard for Information Technology Equipment EN61000-3-2 Harmonic Currents EN61000-3-3 Voltage Flicker
Australia and New Zealand	C-Tick; AS/NZS 3548, Class A Limit
Japan	VCCI Class A ITE (CISPR 22, Class A Limit) IEC 61000-3-2; Harmonic Currents
Taiwan	BSMI Class A (CISPR 22)
Russia	Gost Approval
International	CISPR 22, Class A Limit

Data rack mounting and media gateway floor loading for an S8700 Multi-Connect

Hardware components of the S8700 Media Server with Multi-Connect are, the S8700 Media Servers, an Ethernet Switch, a modem and the two UPS units. All components are installed in a 19 inch open data rack.

19-Inch Rack

The customer provides a data rack that is used to hold equipment not necessarily specified or provided by Avaya. The footprint of the data rack is 19 inches by 21 inches.

S8700 Media Server

The two S8700 Media Servers are designed for mounting in an open 19-inch data rack. S8700 Media Servers weigh approximately 25 pounds.

Avaya 700VA or 1500VA UPS Units

For configurations that require 28 to 410 minutes of battery holdover the Avaya 700VA UPS can be used. The 700VA is available in the following voltages:

- 700VA 120-V for US and Canada
- 700 VA 230-V Online for International
- 700 VA 100-V and 200-V for Japan

The physical characteristics of the Avaya 700VA are:

- Width: 17 inches (43.2 cm)
- Depth: 19 inches (48.2 cm)
- Height: 3.5 inches (8.9 cm)
- Weight: 34 pounds (15 kg)

For configurations that require 411 to 480 minutes of battery holdover the Avaya 1500VA UPS can be used. The 1500VA is available in the following voltages:

- 1500VA 120 V for US and Canada
- 1500 VA 230 V Online for International
- 1500 VA 100V and 200V for Japan

The physical characteristics of the Avaya 1500VA are:

- Width: 17 inches (43.2 cm)
- Depth: 24 inches
- Height: 3.5 inches (8.9 cm)
- Weight: 50 pounds

Avaya Ethernet switches

The P133G2 and the P134G2 equipped with CCS PNC:

- The height, weight, and length of the P133G2 and the P134G2 is:
2μ (3.5"/88 mm) × 19" (482.6 mm) × 13.8" (350 mm)
- The weight of the P133G2 is 11.4 pounds (5.2 kg)
- The weight of the P134G2 is 13.2 pounds (6.0 kg)

The P333T and the P334T equipped with ATM PNC:

- The height, weight and length of the P333T and the P334T is:
2μ (3.5"/88 mm) × 19 inches (482.6 mm) × 17.7 inches (450 mm)
- The weight of the P333T and the P334T is 16.5 pounds (7.5 kg)

Media gateways

The floor of the equipment room must meet the loading code of a commercial floor of at least 50 pounds per square foot (242 kg per square meter). Floor plans typically allocate space around the front, the ends, and the rear of the cabinets, for maintenance access. Additional equipment room floor support may be required if the floor load is greater than 50 pounds per square foot (242 kg per square meter).

The following table shows the weight and floor loading of the media gateways.

Media gateway	Weight	Floor loading
SCC1	125 lb. (56 kg)	31 lb./sq. ft. (148.9 kg/m ²)
MCC1	200 to 800 lb. (90 to 363 kg)	130 lb./sq. ft. (624.2 kg/m ²)
G700	16.5 lbs (7.5 kg)	19-inch rack-mounted – floor loading depends on load on the rack

Site requirements for DEFINITY

Altitude, air pressure, and air purity for DEFINITY

Altitude and air pressure

At altitudes above 5,000 feet (1,525 meters), the maximum short-term temperature limit reduces by 1° Fahrenheit for each 1,000 feet (305 meters) of elevation above 5,000 feet (1,525 meters). For example: at sea level, the maximum short-term temperature limit is 120° F (49° Celsius). At 10,000 feet (3,050 meters), the maximum short-term temperature limit is 115° F (46° C).

The normal operating air pressure range is: 9.4 to 15.2 psi (pounds per square inch) (648 to 1,048 millibars).

Air purity

The CMC1, SCC1, and MCC1 Media Gateways contain an air filter to reduce the flow of particulates through the equipment. Do not install the Media Gateways where the air might be contaminated by excessive dust, lint, carbon particles, paper fiber contaminants, or metallic contaminants. For example, do not install the cabinet near paper handling equipment such as copiers and high-speed printers, which introduce paper dust and print particles into the environment. Avoid Corrosive gases above the levels in the following table.

Table 16: Allowable concentrations of atmospheric contaminants

Contaminant	Average concentration not to exceed
All particulate matter	185 micrograms/cubic meter
Nitrate	12 micrograms/cubic meter
Total hydrocarbons equivalent to methane	10 ppm (parts per million)
Sulphur dioxide	0.20 ppm (parts per million)
Oxides of nitrogen	0.30 ppm (parts per million)
Total oxidants equivalent to ozone	0.05 ppm (parts per million)
Hydrogen sulfide	0.10 ppm (parts per million)

Cabinet dimensions and clearances

Floor plans typically allocate space around the front, ends, and rear of the cabinets for maintenance purposes. Floor area requirements vary between cabinets. The following table lists the dimensions and clearances for the SCC1 Media Gateway and the MCC1 Media Gateway.

Table 17: Dimensions and clearance for the MCC1 Media Gateway and the SCC1 Media Gateway

Cabinet type	Height	Width	Depth	Clearance
SCC1 1-cabinet	20 in. (51 cm)	27 in. (69 cm)	22 in. (56 cm)	38 inch (97 cm) between cabinet and wall
2-cabinets	39 in. (99 cm)	27 in. (69 cm)	22 in. (56 cm)	
3-cabinets	58 in. (1.5 m)	27 in. (69 cm)	22 in. (56 cm)	
4-cabinets	77 in. (2 m)	27 in. (69 cm)	22 in. (56 cm)	
MCC1 ¹	70 in. (1.8 m)	32 in. (81 cm)	28 in. (71 cm)	Rear 38 in. (97 cm) Front 36 in. (91 cm)
Cable slack manager ²	7 in. (18 cm)	32 in. (81 cm)	38 in. (97 cm)	
DC power cabinet ³	20 in. (51 cm)	27 in. (69 cm)	22 in. (56 cm)	38 in. (97 cm) Front and Rear
Large battery cabinet 100 Amp	27 in. (69 cm)	55 in. (140 cm)	21 in. (53 cm)	38 in. (97 cm) Front and Rear
200 Amp	42 in. (107 cm)	55 in. (140 cm)	21 in. (53 cm)	
300 Amp	42 in. (107 cm)	55 in. (140 cm)	21 in. (53 cm)	
400 Amp	57 in. (145 cm)	55 in. (140 cm)	21 in. (53 cm)	

1 This row includes the auxiliary cabinet, the global AC cabinet, and the global DC cabinet.

2 Cable slack manager is used with MCC1 Media Gateway and the SCC1 Media Gateway.

3 DC power cabinet requires a floor area of eight square feet (0.74 square inches). The DC power cabinet also requires 38 inches (97 cm) between the cabinet and the wall.

Floor load requirements

The equipment room floor must meet the commercial floor loading code of at least 50 pounds per square foot (242 kg per square meter). Floor plans typically allocate space around the front, ends, and rear (if necessary) for maintenance access of the Media Gateways. Additional equipment room floor support may be required if the floor load is greater than 50 pounds per square foot (242 kg per square meter). See the following table for Media Gateway and battery information concerning weight and floor loading.

Type	Weight	Floor loading	Remarks
SCC1 Media Gateway	125 pounds (56 kg)	31 pounds per square foot (148.9 kg/m ²)	
MCC1 Media Gateway	200-800 pounds (90-363 kg)	130 pounds per square foot (624.2 kg/m ²)	Includes auxiliary, global AC and global DC cabinets
100-A battery	maximum 400 pounds (181 kg)	180 pounds per square foot (871.2 kg/m ²)	
200-A battery	maximum 815 pounds (370 kg)	328 pounds per square foot.(1587.5 kg/m ²)	
300-A battery	maximum 1480 pounds (671 kg)	476 pounds per square foot (2303.8 kg/m ²)	
400-A battery	maximum 1580 pounds (717kg)	625 pounds per square foot (3025 kg/m ²)	

Power requirements

This section describes AC-power and DC-power source requirements for the cabinet.

Global AC MCC power supply

The Global MCC (GMCC) power supply is for use in both US and international systems. The GMCC replaces the existing AC MCC1 cabinet configuration that is used in the US, and thus reducing the number of power supplies and distribution units that are associated with the MCC1 platform.

The GMCC automatically accepts 200- to 240-VAC power at 50 or 60 Hz. The GMCC complies with all emissions and safety requirements for customer applications worldwide. the GMCC power system consists of:

- NP850 rectifier that consists of cabinet-level power units located in the power-distribution unit at the bottom of the MCC1
- 649A power supplies that are DC/DC converters that provide carrier-level power
- One battery interface and alarm unit
- Battery connections
- Alarm outputs
- One cabinet input cord, NEMA 6-30P in the US.

The GMCC power architecture offers both short-term and long-term power backup. Batteries inside the MCC1 provide short-term backup. External battery cabinets provide long-term backup. Because of its long-term power backup capabilities, the GMCC significantly reduces or eliminates the need for UPS and DC battery plants for most customer applications.

AC power

Power feeders from a dedicated power source that is typically located outside the building connect to an AC load center. These feeders do not provide power to other equipment. The AC load center distributes the power to receptacles. The power cords from the AC power-distribution unit in each MCC1 and AC power supply in each SCC1 plugs into a receptacle.

60-Hz power sources in DEFINITY R

Each of the following power sources can supply 60-Hz power to the AC load in R7 and later systems. See the following figures for information on 120- to 240-VAC power sources.

Figure 70: Single-phase, 120- to 240-VAC, 60-Hz source

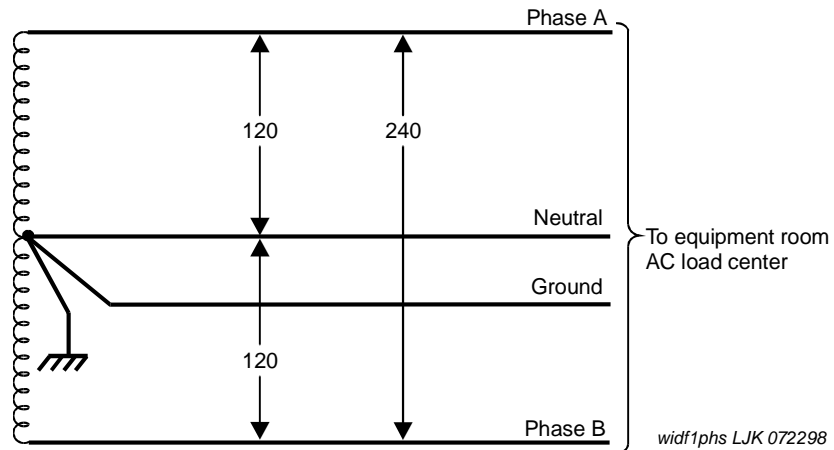
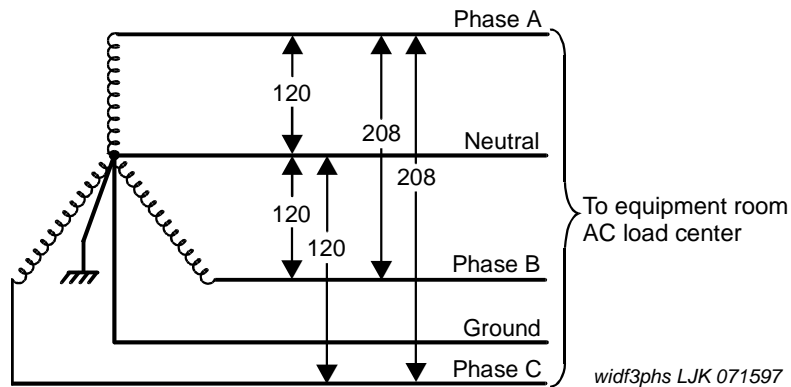

Figure 71: 3-phase, 120- to 208-VAC, 60-Hz source



50-Hz power sources in DEFINITY R

Either of the following power sources can supply 50-Hz power to the AC load in R7 and later systems. See the following figures for 220-VAC power source.

NOTE:

For type of power see:

- MCC1 is shown on the cabinet's rear door
- SCC1 is shown on the cabinet's rear cover
- CMC1 is shown on the right door

Figure 72: International, 3-phase, 220- to 380-VAC, 50-Hz source

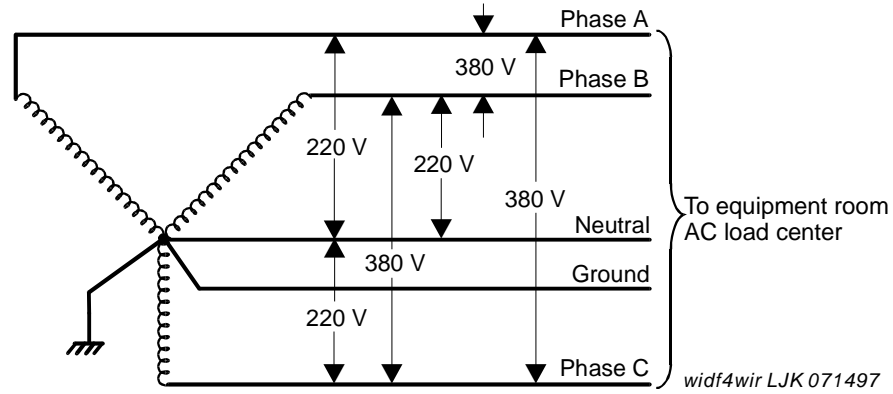
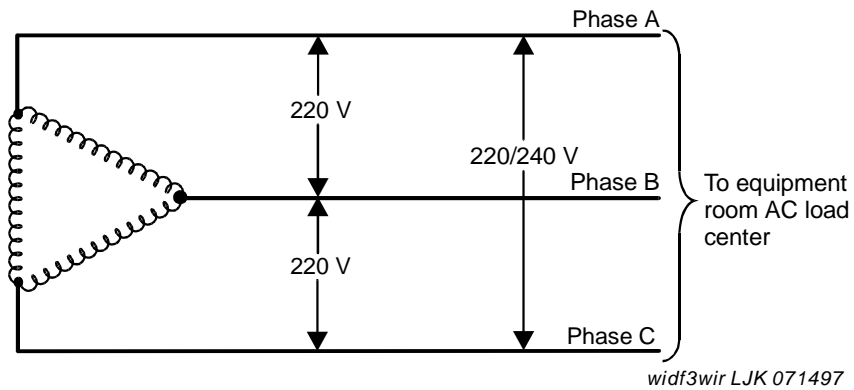

Figure 73: International delta, 220- or 240-VAC, 50-Hz source



The following table lists the AC power sources that can supply power to an AC load in a cabinet. A NEMA receptacle or its equivalent, connects to the wires from the unit. The AC power cord from the power input of each unit plugs into a receptacle.

Contact your Avaya representative for ordering information.

Table 18: Cabinet AC power sources

Cabinet style and power-distribution unit	Power sources	Power input receptacles
CMC AC power supply (650A power unit)	Single phase 120 VAC with neutral	120 VAC, 60 Hz NEMA 5-15R
	Single phase 240 VAC with neutral	240 VAC, 50 Hz IEC 320 Note: Configurations installed in Japan use country specific receptacles for 100 and 200 VAC, 50/60 Hz
MCC1 AC power distribution	Single phase 120 VAC with neutral	120 VAC, 60 Hz NEMA 5-50R or
	Single phase 240 VAC with neutral, or single phase of 3-phase, 208 VAC with neutral	208/240 VAC, 60 Hz NEMA
MCC1 AC power distribution	Single phase 176-264 VAC	200-240 Volts, 50-60 Hz NEMA L6-30R. Configurations that are installed outside the United States require a receptacle suitable for use in the country of installation.
SCC1 AC power supply (1217A power unit)	Single phase 120 VAC with neutral	120 VAC, 60 Hz NEMA 5-20R or 5-15R
	Single phase of 220 VAC or Single phase of 240 VAC	220-VAC to 240-VAC at a country-specific receptacle

DC power

DC-powered cabinets that contains a J58890CF power-distribution unit require a -42.5 to -56 VDC source at up to 75 A.

Circuit-breaker sizes for AC and DC cabinets

The following tables list the circuit-breaker sizes for every AC- and DC-powered cabinet.

Table 19: Circuit breakers for AC-powered cabinets

Cabinet	Circuit breaker size (A)
CMC1 (120 VAC) 60 Hz	15
CMC1 (240 VAC) 50 Hz	10
MCC1 (120 VAC) 60 Hz	50
MCC1 (208 VAC) 60 Hz	30
MCC1 (240 VAC) 60 Hz	30
MCC1 (200-240 VAC) 50 to 60 Hz	30
SCC1 (120 VAC)	15 or 20
Auxiliary cabinet (120 VAC)	20

Table 20: Circuit breakers for DC-powered cabinets

Cabinet (-48 VDC)	Circuit breaker size (A)
MCC1	75
SCC1	25
Auxiliary	20

MCC1 power system

The MCC1 power system consist of an AC power or DC power-distribution unit in the bottom of each cabinet and cables to distribute output voltages to power unit circuit packs in the carriers. These power systems also consist of power-converter circuit packs in the carriers. These circuit packs supply DC power to the circuit pack slots. The following tables list the input voltages and the output voltages of power unit circuit packs in the carriers of MCC1s.

Table 21: Power Units in the MCC1: Inputs

Model	Inputs		
	120 VAC	144 VDC	-48 VDC
AC 631DA1	Yes	Yes	No
AC 631DB1	Yes	Yes	No
DC 644A	No	No	Yes
DC 645B	No	No	Yes
DC 649A	No	No	Yes

Table 22: Power Units in the MCC1: Outputs

Model	Outputs		
	+5 VDC 60 A	-5 VDC 6 A	-48 VDC 8 A
AC 631DA1	Yes	No	No
AC 631DB1	No	Yes	Yes
DC 644A	Yes	No	No
DC 645B	No	Yes	Yes
DC 649A	Yes	Yes	10 A

AC power distribution

A typical AC power-distribution unit for an MCC1 contains:

- Circuit breakers
- Ring generator
- Optional batteries
- Optional battery charger

The power distribution cables carry 120-VAC during normal operation and 144-VDC from optional batteries if AC power fails. Another cable connects 120-VAC to the battery charger.

The following figure shows an AC power-distribution unit and battery charger (J58890CE-2 List 15 or later). The AC power-distribution unit and the battery charger sits at the bottom of some MCC1s.

Figure 74: AC power-distribution unit (J58890CE-2) (front)

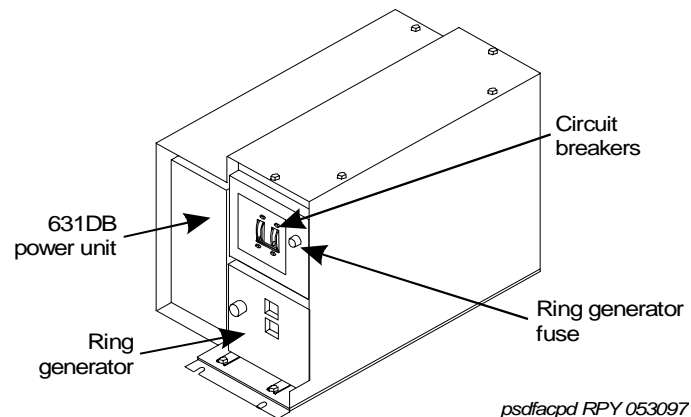

The AC power-distribution unit contains the following additional components that are not shown in the figure:

- Electromagnetic interference (EMI) filter
- AC input fuse

- Five circuit breakers (1 for each carrier)
- 20-A fuses
- A signal connector
- -48 VDC fan power

The optional battery charger sits at the bottom of some MCC1s.

Figure 75: Battery Charger (Optional Part of J58890CE-2) (Front)

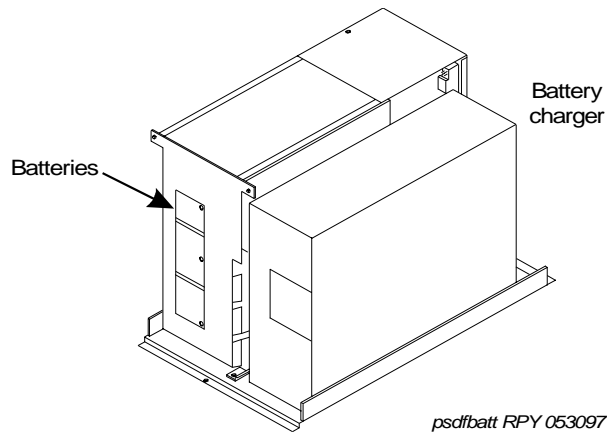

The battery charger is used only without an uninterruptible power supply (UPS). The charger contains:

- Three 48-VDC batteries for backup power to the cabinet
- A DC-power relay to connect the batteries into the power circuit if a main power failure is detected

Circuit breaker

The circuit breaker protects the AC input power to the cabinet and serves as the main AC input disconnect switch. The circuit breaker has two poles for 120-VAC or three poles for 208/240 VAC. If a problem develops, the circuit breaker automatically opens and removes the AC power input.

48-VDC batteries

The three series-connected 48-VDC batteries produce a nominal 144-VDC that is fused at 20 A. The batteries are trickle-charged from the battery charger.

Battery charger

When AC power restores after an outage, the battery charger converts a 120-VAC input to a DC voltage that recharges the batteries. The batteries typically recharge within 24 hours.

DC power relay

The DC power relay disconnects the batteries from a system that is using AC power. The relay also disconnects the batteries if power fails for more than:

- 10 minutes in a standard-reliability system
- 5 minutes in high- and critical-reliability systems
- 10 minutes in an expansion port network (EPN)

This protects the batteries from over discharging.

EMI filters

The Electromagnetic interference (EMI) filters suppress noise voltage on the AC input line to the MCC1 cabinet.

Ring generator

The ring generator converts the -48 VDC input to a 67 to 100-VAC, 20 or 25-Hz ringing voltage. The analog line circuit packs use this AC voltage output to ring telephones. The AC outputs are routed from the ring generator to port carriers, expansion control carriers, and control carriers.

Fuses

20-A fuses protect the power on each cable that goes from the AC power-distribution unit to power converters in the carriers.

The following figure shows AC power distribution in some MCC1s. The DC power-distribution cables are on both sides of the cabinet. These cables supply power to each of the carriers. The optional battery charger is at the right side of the power-distribution unit.

Figure 76: AC power distribution in MCC1 cabinets

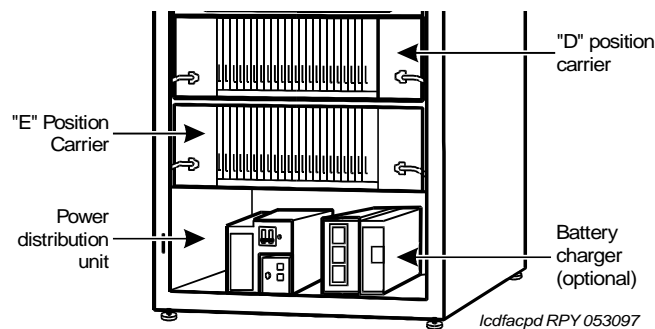

Power backup

If AC power fails, three 48-VDC batteries power the system for:

- 10 seconds in a PPN cabinet

- 15 seconds in an EPN cabinet
- 10 minutes in the control carrier of a standard-reliability system
- 5 minutes in a control carrier of a high- or critical-reliability system
- 10 minutes in the expansion control carrier in the A position of an EPN cabinet for a DEFINITY R configuration only

UPS

An external, uninterruptible power supply (UPS) provides a longer backup time than holdover batteries which have holdover times that vary from less than 10 minutes to up to 8 hours. The UPS can replace the batteries and battery charger. The UPS connects from the AC power source to a AC power cord on the cabinet. If AC power fails, the UPS supplies its own AC power to the cabinet.

AC power-distribution unit (J58890CH-1)

The following figure shows a typical AC power-distribution unit that is used in some MCC1 cabinets. The AC power-distribution unit sits at the bottom of an MCC1 cabinet.

Figure 77: AC power-distribution unit (J58890CH-1) (front)

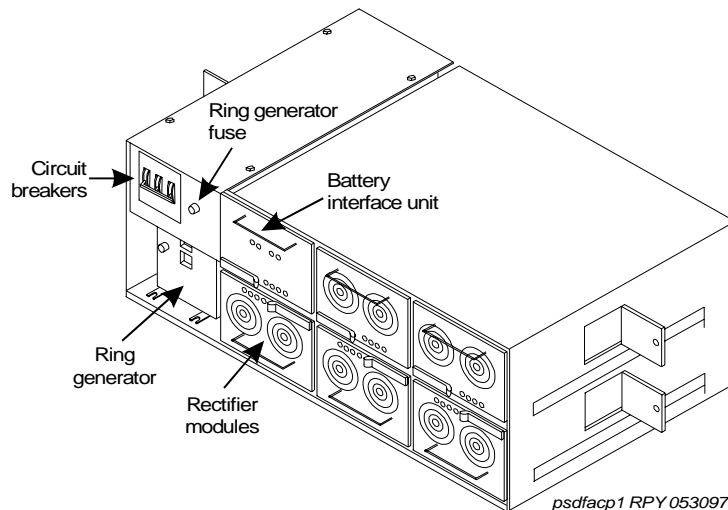

Power backup

There are 2 types of battery assemblies used for power backup: small and large. The small batteries are typically located at the center rear of a MCC1 gateway. The large batteries are typically located inside the battery cabinet.

Small batteries

The small batteries are an 8 AH (Amp-hour) batteries fused for short circuit protection and charged by the J58890CH-1. The batteries also contain a thermal sensor that changes the charging voltage depending on battery temperature. See the following figure for an example of the small batteries.

The small batteries provide short-term battery holdover. If AC power fails, 48 VDC batteries supply system power for:

- 10 seconds in a PPN cabinet
- 15 seconds in an EPN cabinet
- 10 minutes in the control carrier in a standard-reliability system
- 5 minutes in the control carrier in high and critical-reliability systems
- 10 minutes in the expansion control carrier in the A position of an EPN cabinet for a DEFINITY R configuration only

Figure 78: Small Battery Assembly

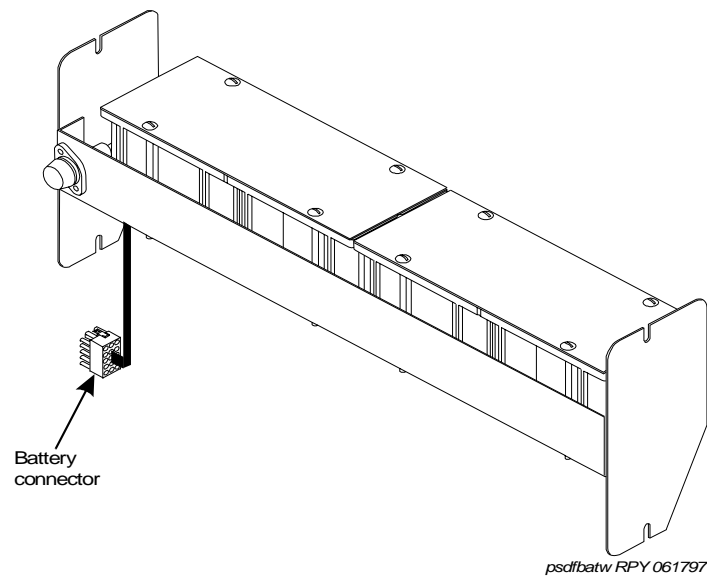

Large batteries

The large batteries provide holdover times of 2 to 8 hours, depending on the number of batteries. To use large battery holdover one battery cabinet is required per system. The 24-cell battery cabinet must have a float voltage of 54.2-VDC. The 23-cell battery cabinet must have a float voltage of 51.75-VDC. The batteries are circuit breaker protected and are charged by the J58890CH-1.

The batteries also contain a thermal sensor that changes the charging voltage, depending on the battery temperature. The following table shows the battery holdover and recharge times for a typical 2500-Watt load.

Table 23: Battery holdover and recharge times

Battery cabinet (A)	Holdover time (hours)	Recharge time (hours)
100	2	7
200	4	13
300	6	20
400	8	26

The following figure shows a typical large battery cabinet, (200 A).

Figure 79: Typical large battery cabinets

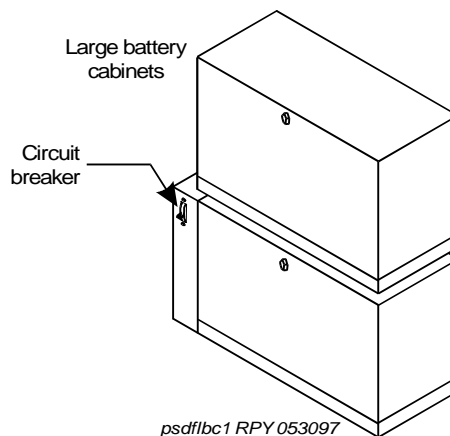

DC power distribution

The typical DC distribution system has a DC power converter and cables to provide the power to the system circuit packs. DC-powered cabinets require -42.5 to -56-VDC.

DC power-distribution unit (J58890CF-2)

The following figure shows a power-distribution unit that is used in some DC-powered MCC1 cabinets. The DC power unit sits at the bottom of the MCC1 cabinet and contains the ring generator, 20-amp circuit breakers, terminal blocks, and system fan power.

Figure 80: DC power-distribution unit (J58890CF-2) (front view)

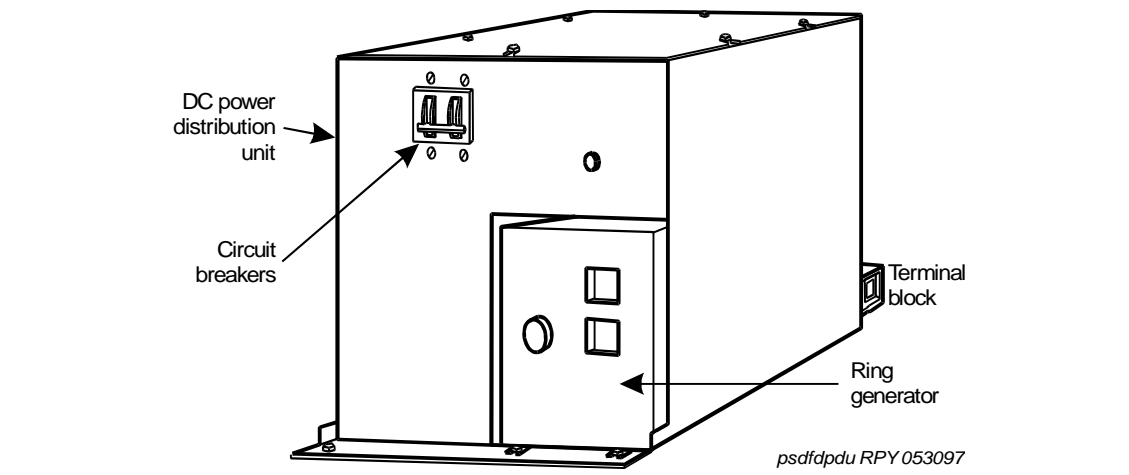

Ground isolation

Each peripheral device that is connected to a system by the asynchronous (EIA) RS-232 interface, requires either a 105C, a 105D, or a 116A isolator interface. The interface isolates ground between the system and external adjuncts.

The isolator interface sits behind a PPN control carrier or behind an EPN expansion control carrier. The isolator interface is installed at the RS-232 interface between the peripheral equipment and the interface connector.

The following figure shows the power distribution in some MCC1s with small battery, short term battery holdover. In DEFINITY R systems, the power distribution cables are on the right side of the cabinet because that is where the 649A DC power converter circuit pack is located. Switch node (SN) carriers require two 649 DC power converters and two cables.

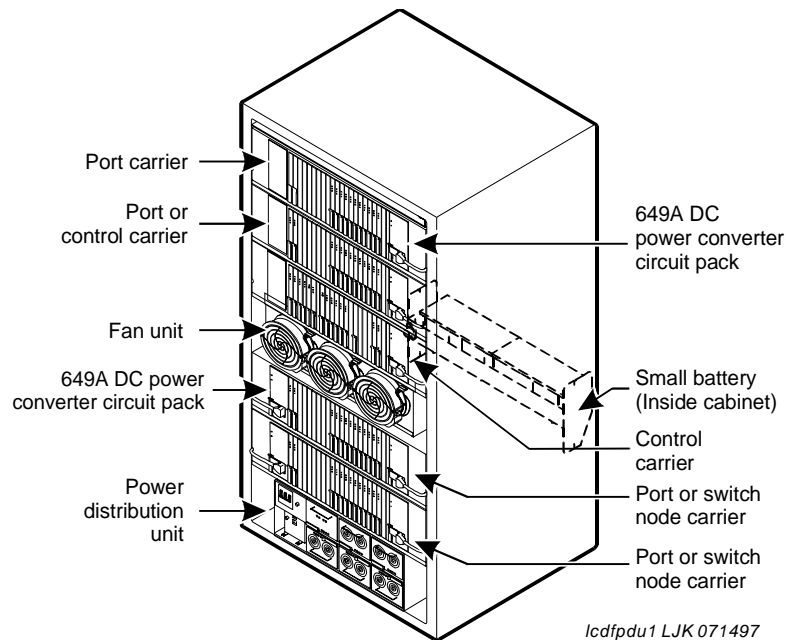
Figure 81: Power distribution in MCC1

The following figure shows the DC-power distribution in some MCC1s with large batteries or extended battery backup. In DEFINITY R configurations, the power distribution cables are on the right side of the cabinet only because that is where the 649A DC power converter circuit pack is located. Switch node (SN) carriers require two 649 DC power converters and two cables.

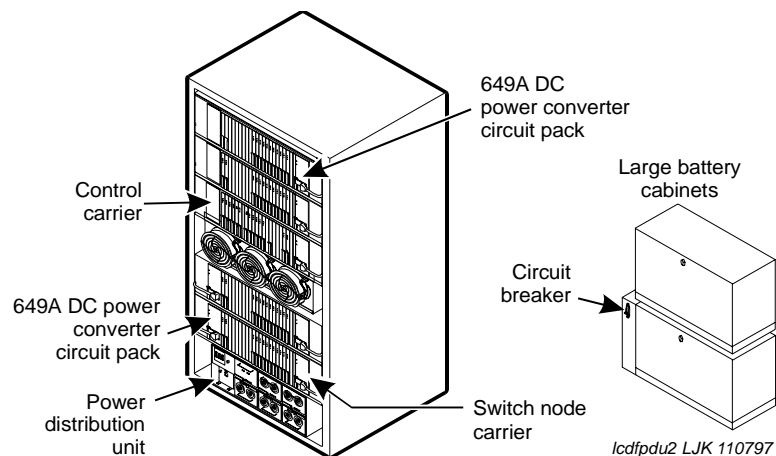
Figure 82: DC power distribution in MCC1s

DC power converter (649A)

The 649A converts the -48 VDC from the power-distribution unit to outputs of -48 VDC at 10 A, $+5$ VDC at 60 A, and -5 VDC at 6 A. These outputs distribute power to circuit pack slots in the carriers.

AC and DC grounding

Approved grounds

An approved ground is the closest acceptable medium for grounding the building entrance protector or the entrance cable shield, or for a single-point ground of the system.

If more than one type of approved ground is available on the premises, bond the grounds together. Follow the instructions in Section 250-81 of the National Electrical Code, or the applicable electrical code in the country where the equipment is installed.

Protective grounds

Acceptable grounds include the following:

- Grounded building steel — The metal frame of the building where it is grounded by one of the following: acceptable metallic water pipe, concrete encased ground, or a ground ring.
- Acceptable Water Pipe — An underground water pipe, at least 1/2 inch (1.3 cm) in diameter, and in direct contact with the earth for at least 10 feet (3 meters). The pipe must be electrically continuous to the point where the protector ground wire is connected. The pipe can also be made electrically continuous by bonding around insulated joints, plastic pipe, or plastic water meters.
- Concrete encased ground — An electrode that is encased by at least 2 in. (5 cm) of concrete and located within and near the bottom of a concrete foundation or footing in direct contact with the earth. The electrode must be at least 20 feet (6 meters) of one or more steel reinforcing bars or rods 1/2 inch (1.3 cm) in diameter, or at least 20 feet (6 meters) of bare, solid copper, 4 AWG (26 mm²) wire.
- Ground ring — A buried ground that encircles a building or structure at a depth of at least 2.5 feet (0.8 meter) below the surface of the earth. The ground ring must be at least 20 feet (6 meters) of 2AWG (35 mm²), bare, copper wire.

If these grounds are not available, the water pipe ground can be supplemented by one of the following types of grounds:

- Other local metal underground systems or structures — Local underground structures such as tanks and piping systems
- Rod and pipe electrodes — A 5/8 inch (1.6 cm) solid rod or 3/4-inch (1.9-cm) conduit or pipe electrode that is driven to a minimum depth of 8 feet (2.5 meters)
- Plate electrodes — Must have a minimum of two square feet (0.18 square meters) of metallic surface exposed to the exterior soil

A metallic underground water pipe must be supplemented by the metal frame of the building, a concrete-encased ground, or a ground ring.

Approved floor grounds

WARNING:

If you can only access the approved ground or approved floor ground from within a dedicated power equipment room, then a licensed electrician must make the connections.

Approved floor grounds are those grounds on each floor of a high-rise building that are suitable for connection to the ground terminal in the riser closet and to the cabinet equipment single-point ground terminal. Approved floor grounds might include the following:

- Building steel
- The grounding conductor for the secondary side of the power transformer that feeds the floor
- Metallic water pipes
- Power feed metallic conduit that supplies panel boards on the floor
- A point that is specifically provided in the building design for grounding

NOTE:

You must ensure that you electrically connect all protective grounds together to form a single grounding electrode system.

Coupled bonding conductor

When you use a coupled bonding conductor (CBC) grounding in an AC-powered cabinet, you must maintain a minimum 1 ft. (0.3 m) space between the CBC power and other power and ground leads.

In AC-powered systems, locate the system single-point ground terminal block on the AC load or AC protector cabinet.

SCC1 power systems

Each SCC1 has one AC or one DC power supply that distributes DC power and AC ringing voltage to the circuit pack slots in the cabinet.

AC power supply (1217A)

In an AC-powered cabinet, the power supply slot contains, a single, plug-in, multi-output AC power supply. A power cord, with a three-prong plug on one end and an appliance connector on the other end, connects the supply to a dedicated AC power source.

The 1217A power supply is a global power unit for SCC1s. The 1217A power supply has a wide input voltage operating range of 90 to 264-VAC and a 50 or 60 Hz auto-ranging input, multi-output power supply that provides regulated DC output. The 1217A also has a selectable 20 or 25 Hz AC ringer.

The 1217A power supply uses one of the following inputs, depending on the version:

- 120-VAC, 60-Hz, 15-A to 20-A; three wires in the power cord: one hot wire, one neutral wire, and one ground wire
- 220-VAC or 240-VAC, 50-Hz, 10-Amp; three wires in the power cord: one hot wire, one neutral wire, and one ground wire

The AC power supply produces the following DC outputs: +5 VDC, -5 VDC, -48 VDC, +12 VDC, and a battery-charging voltage. The DC outputs distribute power on the cabinet backplane to the circuit pack slots. Additionally, the -48 VDC output current capacity has been increased from 6.85 amps to 8.25 A. A 50 A load inrush requirement has been added to the -48 VDC output

A holdover circuit in the power supply allows a system to operate normally during AC power interruptions. If AC input power fails, reserve batteries supply power to the memory and processor circuit packs and fans for two minutes. All port circuit packs are inactive during this time. The power supply contains a battery charger to charge the holdover batteries.

DC power supply (676C)

In a DC-powered SCC, the power slots contain a single, plug-in multi-output DC power supply.

The 676C DC power supply has a wide input voltage operating range of -42 to -60 VDC at up to 22 A. The 676C power supply produces the following outputs: +5.1 VDC at 0 to 55 A, -5.1 VDC at 0 to 5.5A, +12 VDC at 0 to 2 A (surge to 2.8 A for 350 ms), -48 VDC at 0 to 8.25 A. The outputs distribute power on the cabinet backplane to the slots for the circuit packs. The value and frequency of the AC ringing voltage output value depend on the country of use. The power supply has circuit breakers and EMI filtering.

DC power-distribution unit (J58890CG)

The J58890CG is used with SCC1s. Individual DC output connectors can power up to four SCC1s. Each output connector is separately fused at 25 A. The fuses are inside the unit the DC power-distribution unit. The input for the DC distribution unit is from the DC power cabinet.

The J58890CG DC power-distribution unit is required when the distance between the DC power cabinet and the cabinet stack is greater than 30 feet (9 m).

Enhanced DC rectifier cabinet (J58890R)

The J58890R enhanced DC rectifier cabinet is used with SCC1s. Each rectifier assembly in the DC rectifier cabinet can supply up to 50 A of DC current. You can install a minimum of two rectifiers install in each DC cabinet to supply a total of 100 A. A third rectifier assembly is used as a backup only.

Each SCC1 can draw up to 15 A. Up to three DC cabinets can be stacked to supply power to single-carrier cabinets stacks.

Each output connector is separately fused at 25 A. The fuses are inside each DC rectifier assembly.

NOTE:

A J58890CG DC power-distribution unit is required if the distance between the DC cabinet and the cabinet stack is greater than 30 feet (9 m).

CMC1 AC power supply (650A)

In the CMC1, a power cord with a 3-prong plug on one end and an appliance connector on the other end that connects the supply to a dedicated AC power source. The power supply is a global power factor corrected AC/DC converter that provides multiple DC outputs and AC ring outputs. It is auto ranging 85 to 264 VAC, 47 to 63 Hz, at 330 Watts, 4.5 A (100 to 120-VAC) or 2.3 A (200 to 240-VAC) at 500-VA.

The inputs to the power supply can be:

- 120 VAC, 50-Hz to 60-Hz, 6-Amp; 3 wires in the power cord: 1 hot wire, 1 neutral wire, and 1 ground wire

- 220 VAC or 240 VAC, 50-Hz to 60-Hz, 3-Amp; 3 wires in the power cord: 1 hot wire, 1 neutral wire, and 1 ground wire

The AC power supply produces the following outputs: +5 VDC, -5 VDC, and -48 VDC. The outputs distribute power on the cabinet backplane to the circuit pack slots. The AC ringing voltage output value and frequency depend on the country of use. The 650A also supplies power for neon message-waiting lamps (150 VDC). The power supply has EMI filtering.

CMC1 UPS

The uninterruptible power supply (UPS) provides surge protection for all connected cabinets.

- Connect the UPS to an electrical outlet that can handle the power requirements of all cabinets. To calculate the number of amps drawn, use the following formulas.
 - a. For 100 to 200-VAC, multiply 3.5 A times the number of cabinets.
 - b. For 200 to 240-VAC, multiply 1.8 A times the number of cabinets.
- Cabinet A (control carrier) is always connected to an *unswitched* or *always on* electrical outlet on the UPS.

Cabinet cooling fans

CMC1 fan unit

Two variable-speed fans are at the bottom of the cabinet. The fans receive +8 to +14 VDC from the power supply. An air filter, which can be removed and cleaned or replaced, is located above the fans. Air flows from the outside, into the bottom of the cabinet, around the circuit packs, and out through the top of the cabinet.

If the cabinet temperature reaches 158°F (70°C), the temperature sensor in the power supply shuts the system down and invokes the emergency transfer.

MCC1 fans

A fan unit that consists of six fans, mounts near the center of the cabinet. The three front fans blow up and the three rear fans blow down. A removable air filter is provided above and below each fan unit. Four sensors monitor the cabinet temperature; three sensors are inside the cabinet top and 1 sensor is inside the cabinet bottom. One of the top sensors affects the speed of the front fans and the bottom sensor affects the speed of the rear fans. A speed control and thermal alarm circuit in each fan monitors the sensors. When a sensor indicates a change in cabinet temperature, the circuit in a fan changes the speed for that fan.

A power cable from the power-distribution unit connects -48 VDC to each fan, +5 VDC to the speed control and thermal alarm circuit in each fan, and temperature sensor signals to the equivalent circuit in each fan. One pair of wires is routed to each fan circuit. Alarm signals are also routed to the equivalent circuit in each fan. One pair of wires routes to each fan circuit.

A minor alarm is sent to the processor circuit pack in the PPN cabinet and the maintenance circuit pack in an EPN cabinet if any fan's speed drops below minimum. A minor alarm occurs if a fan stops due to loss of -48 VDC. One of the cabinet top thermal sensors sends an alarm if the exhaust temperature reaches 149°F (65°C).

Another cabinet top sensor senses if the exhaust temperature reaches 158 °F (70 °C). If the temperature reaches 158°F the system shuts down and the Emergency Transfer is invoked.

SCC1 fan unit

Four constant-speed fans at the top rear of the cabinet receive -48 VDC from the backplane. An air filter is located below the fan unit. Air flows down through the filter over the circuit packs. The filter is removable and can be cleaned or replaced when necessary.

If the cabinet temperature reaches 158° F (70° C), the temperature sensor in the power supply causes the system to shut down and invokes the Emergency Transfer.

System protection

Protections are established to keep the switch active and on line. The following 4 types of system protection are provided:

- Overvoltage
- Sneak current
- Lightning
- Earthquake

Protection from hazardous voltages

Protection from hazardous voltages and currents is required for all off-premises trunks, lines, and terminal installations. Both over-voltage protection from lightning, power induction, and so on, and sneak current protection are required.

Overvoltage protection

The following devices protect the system from over voltages:

- Analog trunks use the 507B Sneak Protector. The local telephone company normally provides over voltage protection.
- Analog voice and 2-wire DCP terminals can use one of the following types of combined protection against over voltage and sneak current or the equivalent of one of the following types:
 - Carbon block with heat coil for UL code 4B1C
 - Gas tube with heat coil for UL code 4B1E-W
 - Solid state with heat coil for UL code 4C1S
- DCP and ISDN-BRI terminals use the solid state 4C3S-75 with heat coil protector, or equivalent.
- DS1/E1/T1 circuits require isolation from exposed facilities. A CSU (T1), LIU (E1), or other equipment provides this isolation.

Sneak current protection

Sneak current protection uses fuses to protect building wiring between the network interface and trunk circuits when exposed to extraneous power. The fuses also protect the circuit packs.

All incoming trunks and outgoing trunks and off-premises station lines pass through the sneak fuses. 507B Sneak fuse panels. These panels are install on the system side of the network interface.

Sneak current protectors must be either UL-listed or CSA-certified or must comply with local safety standards. Sneak current protectors must have a maximum rating of 350 mA and a minimum voltage rating of 600 V, or as required by local regulations.

Lightning protection

A Coupled Bonding Conductor (CBC) in the cabinet ground wiring protects the system from lightning. The CBC runs adjacent to wires in a cable and causes mutual coupling between itself and the wires. The mutual coupling reduces the voltage difference between ground and the switch.

Be sure that the CBC connects to telecommunication cable that is firmly connected to an approved ground. In multiple-story buildings, be sure to connect the CBC to an approved ground at each floor.

The CBC can be a 10 AWG (5.3 mm²/2.6 mm) ground wire, a continuous cable sheath surrounding wires within a cable, or six unused pairs of wire within a cable that are twisted and soldered together. The CBC connects from the cabinet single-point ground bar in an AC-powered cabinet or the ground discharge bar in a DC-powered cabinet to the terminal bar at the cross-connect field.

When there is an auxiliary cabinet, a 6 AWG (13.3 mm²/4.1 mm) wire connects the system cabinet single-point ground block to the Auxiliary cabinet ground block. The ground wire routes as closely as possible to the cables that connect the system cabinet to the Auxiliary cabinet.

If equipment is not present in the Auxiliary cabinet, plug the power supply for this equipment into one of the two convenience outlets on the rear of the MCC1, to preserve ground integrity. The convenience outlets are fused at 5 A. A dedicated maintenance terminal plugs into the other convenience outlet.

Earthquake protection

For earthquake or disaster bracing, the cabinets bolt to the floor. Other areas may require additional bracing. Contact your Avaya representative for earthquake requirements at the location of the system installation.

Temperature and humidity for DEFINITY

Install the DEFINITY equipment in a well-ventilated area. Maximum equipment performance is achieved at an ambient room temperature between 40 and 120° Fahrenheit (4° and 49° Celsius) for short term operation (not more than 72 consecutive hours or 15 days in a year) and up to 110° Fahrenheit (43° Celsius) for continuous operation.

The relative humidity range is 10 to 95 percent at up to 84° Fahrenheit (29° Celsius). Above 84 degrees Fahrenheit the maximum relative humidity decreases from 95 percent down to 32 percent at 120° Fahrenheit (49° Celsius). Installations outside these limits may reduce system life or impede operations. The recommended temperature and humidity range is 65° to 85° Fahrenheit (18° to 29° Celsius) at 20 to 60 percent relative humidity.

The following table correlates room temperature with allowable relative humidity.

Table 24: Temperature and relative humidity

Recommended room temperature (degrees Fahrenheit)	Recommended room temperature (degrees Celsius)	Recommended relative humidity (%)
40 to 84	4.4 to 28.8	10 to 95
86	30.0	10 to 89
88	31.1	10 to 83
90	32.2	10 to 78
92	33.3	10 to 73
94	34.4	10 to 69
96	35.6	10 to 65
98	36.7	10 to 61
100	37.8	10 to 58
102	38.9	10 to 54
104	40.0	10 to 51
106	41.1	10 to 48
108	42.2	10 to 45
110	43.3	10 to 43
112	44.4	10 to 40
114	45.6	10 to 38
116	46.7	10 to 36
118	47.8	10 to 34
120	48.9	10 to 32

Customer configurations

Small businesses

Figure 83: Small-business solution using the Avaya S8300 Media Server in the G700 Media Gateway

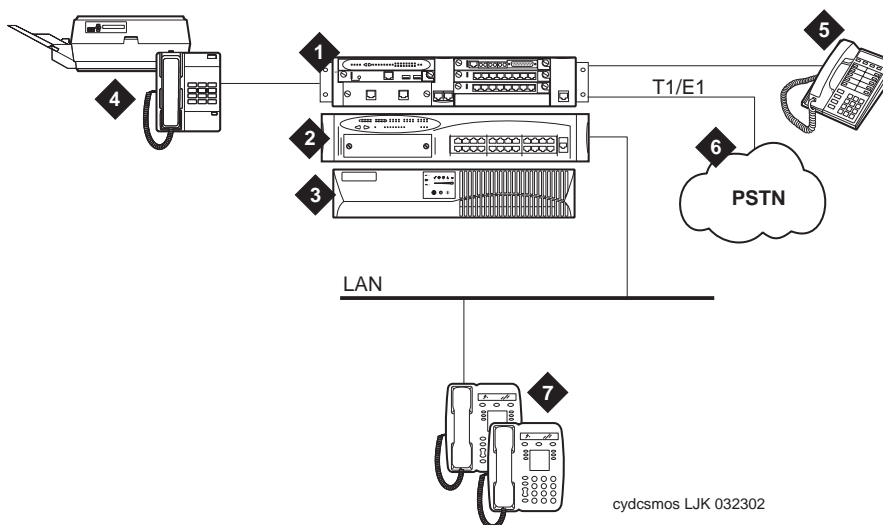
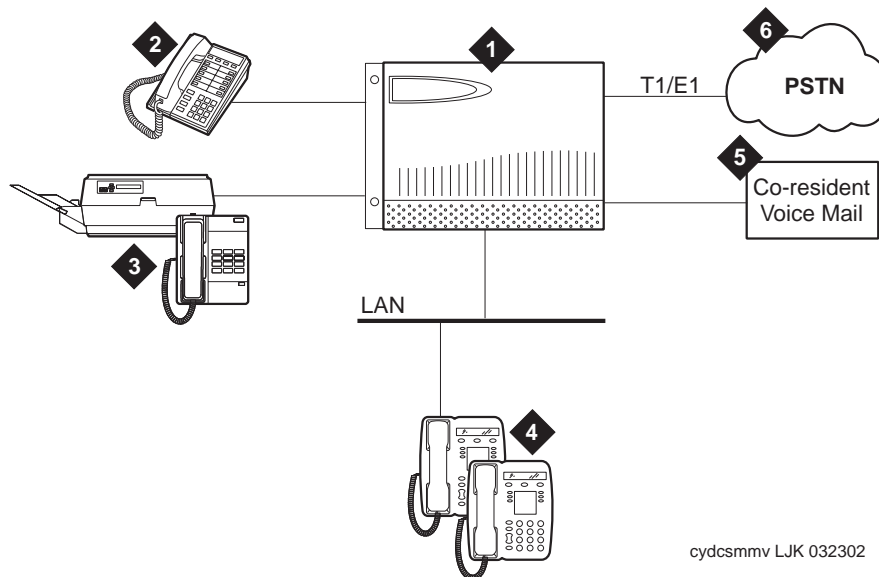

Figure notes

Number	Description
1	This figure shows a G700 Media Gateway with an S8300 Media Server installed in the upper right hand slot. This configuration is using the T1/E1, DCP and analog media modules.
2	Ethernet Switch: Can be customer provided or Avaya™ provided. This device provides for port multiplication by having more than one network segment.
3	UPS: Avaya™ suggests a UPS be provided to allow for a graceful shutdown of the server during a power outage.
4	Analog connectivity such as, analog trunks, stations and lines.
5	DCP phones: Avaya multifunction digital phones.
6	T1/E1 connectivity: <ul style="list-style-type: none"> The T1 (or T-1) carrier is the most commonly used digital line in the United States, Canada and Japan. The E1 (or E-1) is a European digital transmission format. It is the equivalent of the North American T-carrier system format.
7	Avaya IP telephones

Figure 84: Small-business solution using the Avaya S8100 Media Server and the G600 Media Gateway



cydcsmmv LJK 032302

Figure notes

Number	Description
1	This figure shows the S8100 Media Server with a G600 Media Gateway: The S8100 Media Server is a two slot processor running the WINDOWS 2000 operating system with co-resident applications such as Communication Manager, INTUITY™ AUDIX® and Avaya Site Administration.
2	DCP phones: Supports 2- and 4-wire Avaya multifunction phones.
3	Analog connectivity such as, analog trunks, stations and FAX machines.
4	IP phones: Avaya 4600-series phones.
5	Voice Mail: Co-resident INTUITY™ AUDIX® eight port voice mail or an external Voice Mail system (external shown).
6	T1/E1 Capability: <ul style="list-style-type: none">• The T1 (or T-1) carrier is the most commonly used digital line in the United States, Canada, or Japan.• The E1 (or E-1) carrier is a European digital transmission format. It is the equivalent of the North American T-carrier system format.

Medium-sized business solution

Figure 85: Medium-sized business solution using the Avaya S8500 Media Server and the G650 Media Gateway

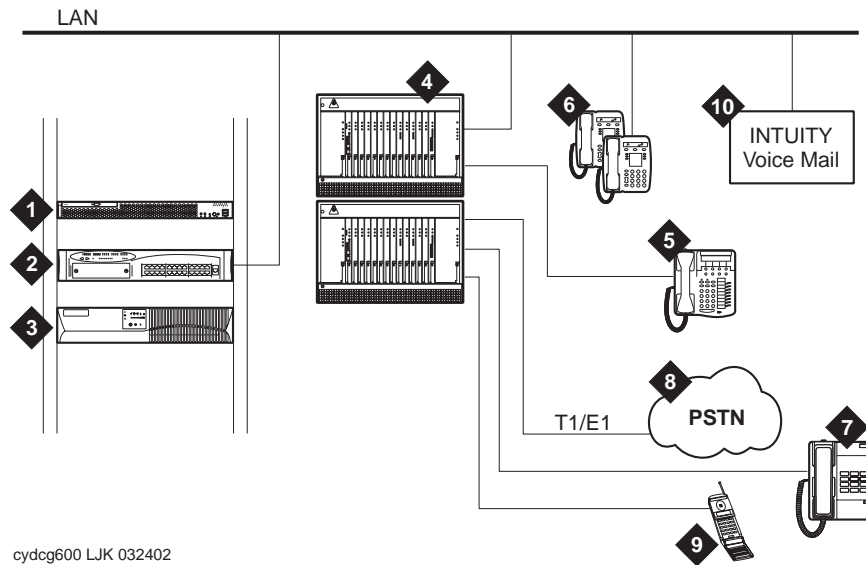
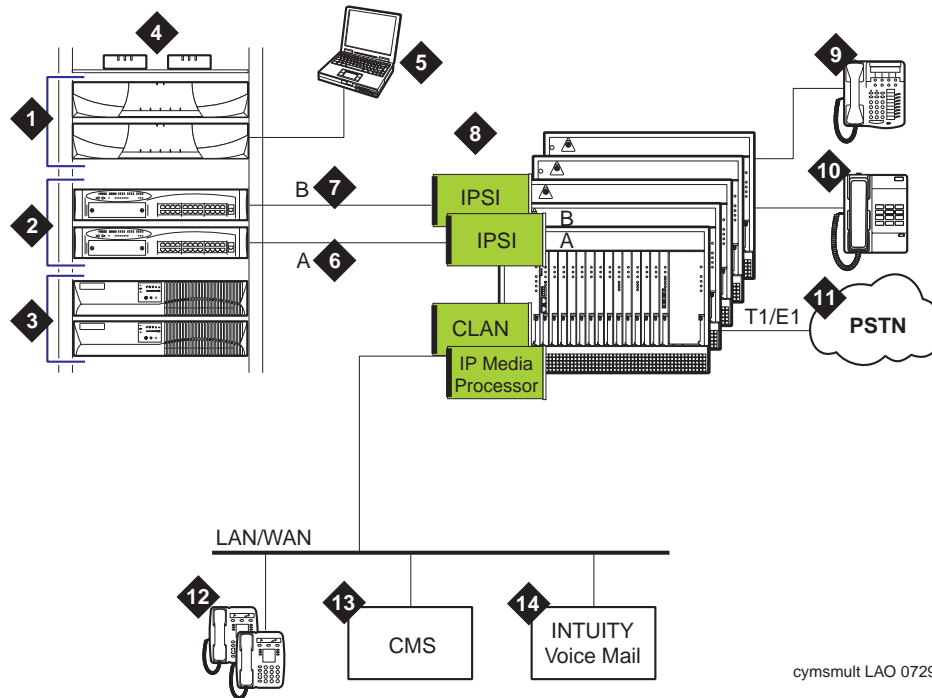

Figure notes

Number	Description
1	S8500 Media Server
2	Ethernet Switch: A device that provides for port multiplication by having more than one network segment. The Ethernet Switch could be provided by Avaya or already exists in the customer's network.
3	UPS: Used to provide power during an outage and allow for a graceful shutdown of the server.
4	G650 Media Gateways: Connected to the S8500 Media Server by IP.
5	DCP phones: Supports 2- and 4-wire Avaya multifunction phones.
6	IP phones: Avaya 4600-series IP phones.
7	Analog connectivity such as analog stations, lines, trunks and FAX machines
8	T1/E1 Connectivity: <ul style="list-style-type: none"> The T1 (or T-1) carrier is the most commonly used digital line in the United States, Canada, and Japan. The E1 (or E-1) carrier is a European digital transmission format. It is the equivalent of the North American T-carrier system format.
9	Wireless
10	Voice Mail System: INTUITY™ AUDIX® is shown connecting via IP.

Large businesses

Figure 86: Large-business solution using the Avaya S8700 Media Server and the MCC1 Media Gateway



cysmult LAO 072903

Figure notes

Number	Description
1	The S8700 Media Server and a MCC1 Media Gateway
2	Ethernet must be Avaya provided.
3	UPS: Provides power hold over when commercial power shuts down. The UPS units are duplicated in this configuration (one for each server).
4	Modems for services access.
5	Services connectivity.
6	Dedicated LAN A for control data.
7	Dedicated LAN B for control data.
8	Port networks consisting of G650 Media Gateways.
9	DCP Phones: Avaya multifunction digital terminals.
10	Analog connectivity such as, analog phones, FAX machines and trunks.

Figure notes

Number	Description
11	T1/E1 Connectivity: <ul style="list-style-type: none">• The T1 (or T-1) carrier is the most commonly used digital line in the United States, Canada and Japan.• The E1 (or E-1) carrier is a European digital transmission format. It is the equivalent of the North American T-carrier system format.
12	IP phones: Avaya 4600-series IP phones.
13	Avaya Call Management System (CMS): Used in a call center environment to collect and store data for reports and management.
14	Voice Mail: INTUITY™ AUDIX® shown in this configuration connecting via IP.

Branch Office and Multi-Site Configurations

Branch Office Configuration

A remote branch office location is a part of a larger enterprise network. In this configuration the S8700 Media Server resides in the main location and controls the G700 Media Gateway in the remote location. It is highly desirable for the branch office to be survivable in the event of lost connectivity to the S8700 Media Server. Survivability is accomplished with the use of the S8300 Media Server in an LSP configuration

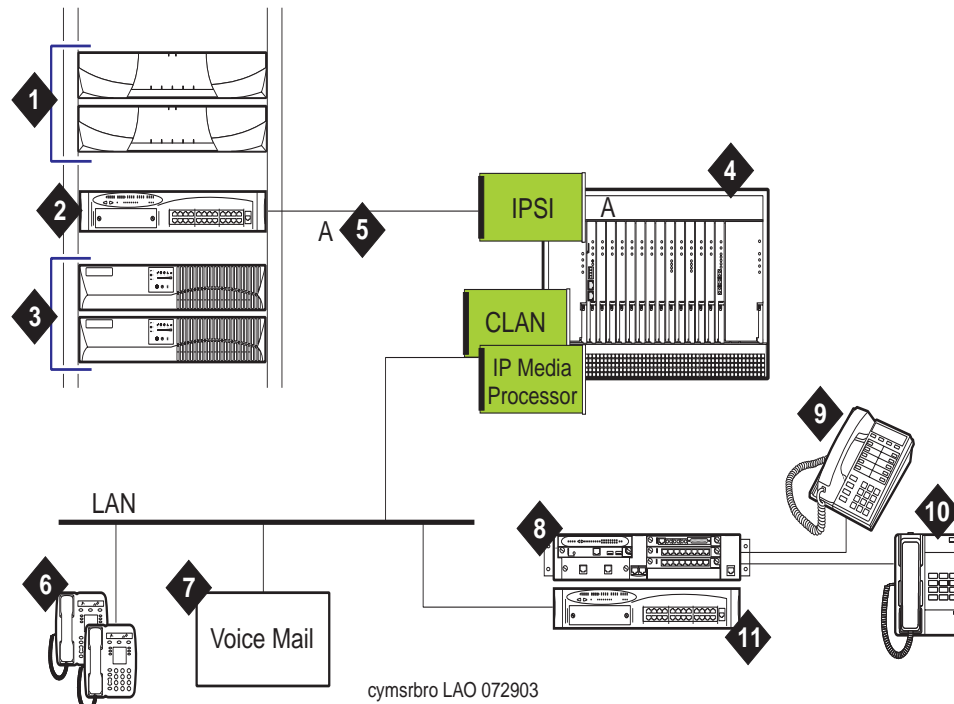
Figure 87: Branch Office Configuration**Figure notes**

Number	Description
--------	-------------

- | | |
|----|--|
| 1 | Duplicated S8700 Media Servers |
| 2 | Ethernet switch must be Avaya provided. |
| 3 | UPS units: Two UPS units one for each server. |
| 4 | G650 Media Gateways |
| 5 | LAN connectivity to the IPSI in the G650 Media Gateway. |
| 6 | IP Phones off of the customer's LAN |
| 7 | Voice Mail: INTUITY™ AUDIX® shown connected via IP. |
| 8 | The G700 Media Gateway is connected via the LAN to the C-LAN board located in the G650 Media Gateway. The S8300 Media Server in an LSP configuration is located in the G700 Media Gateway. In the event of a loss in communication between the S8700 and the G700 the LSP will provide a backup for the endpoints that register with it. |
| 9 | DCP Phones: Avaya Multi-Function Digital Phones. |
| 10 | Analog connectivity such as, analog phones, lines and trunks. |

Multi-Site Environment

The following figure shows the S8700 Media Server (top middle) connected to two sites with S8300 Media Servers in G700 Media Gateways.

Figure 88: Multi-Site Configuration

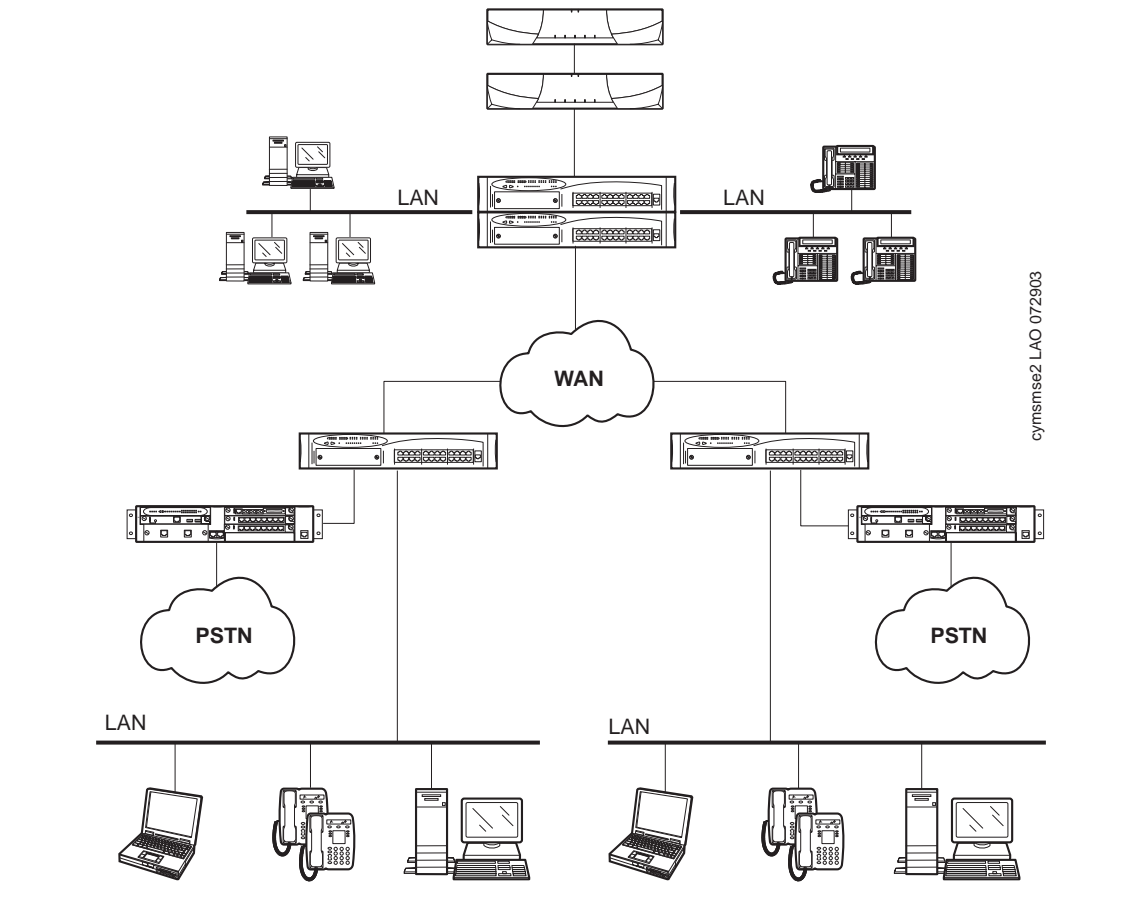

In a multi-site environment there are a number of standalone solutions connected together using protocols such as QSIG or DCS. Each location has its own processing capability and separate managed configurations. These configurations can be a mix of different solutions. Voice mail can be shared or connected to a network.

Index

Numerics

4-wire S/T-NT interfaces, [181](#)
4C3S-75 solid state protectors, [336](#)
1217A Power Supply, [173](#)
48-VDC batteries, [325](#)
507B sneak fuse panels, [336](#), [337](#)
631DA1/B1 AC power units, [173](#), [323](#)
649A DC power units, [174](#), [331](#)
676B DC power units, [334](#)
676C DC Power, [177](#)
982LS Current Limiter for DEFINITY SI, [177](#)

A

AC power
 battery chargers, [324](#)
 circuit breakers, [323](#)
 distribution units, [324](#)
 grounding, [332](#)
 power feeders, [319](#)
 supply
 WP-91153, [333](#)
 units
 631DA1/B1, [173](#), [323](#)
acoustic noise levels, [319](#)
Adjunct Systems, [56](#)
Analog Trunk/Telephone Media Module (MM711), [48](#)
approved grounds, [332](#)
AS1 UPS
 1500VA 120V, [288](#)
 1500VA 230V, [288](#)
 700 VA 120V, [287](#)
 700VA 230V, [287](#)
 Add-on Modules, [289](#)
ASB button, [125](#)
ATM
 switch, [89](#)
ATM-CES, [119](#)
ATM-PNC, [119](#)
auxiliary cabinets, [100](#)
Avaya Solutions
 Large Business, [342](#)
 Medium Sized Business, [340](#), [341](#)
 Small Business, [339](#)
Avaya Telephones
 Analog, [276](#)
 2500 and 2554, [276](#)
 2520B, [279](#)
 6211, [277](#)
 6219, [278](#)
 Attendant Consoles, [274](#)
 302D, [274](#)

 Softconsole, [275](#)
 Digital Communications Protocol (DCP) Telephone
 2402, [267](#)
 Digital Telephones, [267](#)
 2420, [268](#)
 6402 and 6402D, [268](#)
 6408D+, [269](#)
 6416D+M, [270](#)
 6424D+M, [271](#)
 Callmaster IV, [272](#)
 Callmaster V, [273](#)
 Callmaster VI, [273](#)
 IP Telephones
 4602, [259](#)
 4602SW, [260](#)
 4606, [260](#)
 4610SW, [261](#)
 4612, [262](#)
 4620, [263](#)
 4620SW, [264](#)
 4624, [264](#)
 4630, [266](#)
 Wireless, [279](#)
 Transtalk 9040, [279](#)

B

backup power, [325](#), [327](#)
batteries
 48 VDC, [325](#)
 chargers, [325](#)
 small assemblies, [327](#)
BCCs (J58890L), [99](#)

C

cabinets
 AC-powered, [333](#)
 auxiliary (J58886N), [161](#)
 CBCs, [333](#)
 cooling fans, [335](#)
 DC-powered, [337](#)
 dimensions/clearances, [317](#)
 earthquake protections, [337](#)
 lightning protection, [337](#)
 power sources, [319](#)
CallVisor ASAI, [152](#), [177](#)
CBCs, [333](#), [337](#)
CC port, [125](#)
center stage switches, [88](#)
CFY1B Current Limiter for DEFINITY R, [177](#)

Index

D

CFY1B current limiters, [171](#)
circuit breakers, [323](#), [325](#)
circuit packs
 sneak current protection, [336](#)
CMC1 Media Gateway, [147](#)
CMC1 Media Gateway for DEFINITY CSI, [30](#)
CMCs (J58890T), [99](#)
 dimensions, [317](#)
 fan units, [335](#)
commercial floor loading code, [318](#)
CON port, [125](#)
concrete encased grounds, [332](#)
conduit, as ground, [333](#)
cooling fans, [335](#)
corrosive gas contaminants, [316](#)
coupled bonding conductor (for grounding), [333](#)
CSS, [117](#), [118](#)
Current Limiter, [177](#)
current limiters
 CFY1B, [171](#)
Customer Configuration Options for the S8300 Media Server with G700 Media Gateway, [55](#)

D

DC power
 circuit breakers, [323](#)
 distribution units
 J58890CF, [329](#)
 J58890CG, [334](#)
 grounding, [332](#)
 relays, [325](#), [326](#)
 requirements, [322](#), [329](#)
 units
 649A, [174](#), [331](#)
 676B, [334](#)
DCP Media Module (MM712), [49](#)
DEFINITY CSI
 Detailed description, [29](#)
 Overview, [29](#)
 overview, [29](#)
 Reliability and recovery, [30](#)
 Required System Components, [29](#)
 CMC1 Media Gateway, [30](#)
 TN2182 Tone Clock, [30](#)
 TN2402 Processor board, [29](#)
DEFINITY R
 Adjunct Systems, [121](#)
 Cabinets, [111](#)
 Multicarrier cabinets (MCC1s), [112](#)
 Single-carrier cabinets (SCC1s), [111](#)
 Carriers, [111](#)
 Connectivity, [115](#)
 ATM, [119](#)
 ATM WAN spare processors
 ATM WAN spare processors, [119](#)
 TCP/IP, [116](#)
 Detailed description, [108](#)
 Optional Components
 ATM Switch, [119](#)
 Center Stage Switch (CSS), [117](#)

 Expansion Port Network, [113](#)
 IP Solutions, [113](#)
 Overview, [107](#)
 Port Network, [110](#)
 Processor Port Network and Switch Processing Element, [109](#)
 Reliability, [120](#)
DEFINITY Server CSI
 Adapter, [249](#)
 Avaya Telephones, [249](#)
 Analog, [250](#)
 Consoles, [250](#)
 Digital, [249](#)
 Explosive Atmosphere, [250](#)
 IP, [249](#)
 SoundStation, [250](#)
 Wireless, [250](#)
 Circuit Packs, [247](#)
 Application, [248](#)
 Control, [248](#)
 Line, [247](#)
 Port, [249](#)
 Power, [247](#)
 Service, [248](#)
 Trunk, [247](#)
 Media Gateways, [247](#)
DEFINITY Server R
 Avaya Telephones, [257](#)
 Analog, [258](#)
 Consoles, [258](#)
 Digital, [258](#)
 Explosive Atmosphere, [258](#)
 IP, [257](#)
 Wireless, [258](#)
 Circuit Packs, [255](#)
 Application, [257](#)
 Control, [256](#)
 Line, [255](#)
 Port, [257](#)
 Power, [255](#)
 Trunk, [256](#)
 Circuit Packs
 Service, [257](#)
 Media Gateways, [255](#)
DEFINITY Server SI
 Avaya Telephones, [253](#)
 Analog, [254](#)
 Consoles, [254](#)
 Digital, [254](#)
 Explosive Atmosphere, [254](#)
 IP, [253](#)
 SoundStation, [254](#)
 Wireless, [254](#)
 Circuit Packs, [251](#)
 Application, [253](#)
 Control, [252](#)
 Line, [251](#)
 Port, [253](#)
 Power, [251](#)
 Service, [253](#)

Trunk, [252](#)
 Media Gateways, [251](#)
 DEFINITY SI
 Adjunct Systems, [32](#), [94](#), [106](#)
 Cabinets, [99](#)
 Multicarrier cabinets (MCC1s), [100](#)
 Single-carrier cabinet (SCC1), [99](#)
 Carriers, [99](#)
 Connectivity, [103](#)
 C-LAN, [103](#), [116](#)
 IP Asynchronous Links, [104](#), [116](#)
 TCP/IP, [103](#)
 Detailed description, [96](#)
 H.323 IP Trunk, [103](#), [115](#)
 IP Trunk, [103](#), [115](#)
 Network Control/Packet Interface, [101](#)
 Optional Components, [101](#)
 Expansion Port Network, [101](#)
 IP Media Processor, [101](#)
 IP Solutions, [101](#)
 Port Network, [98](#)
 Processor Port Network and Switch Processing
 Element, [97](#)
 Reliability, [105](#)
 Required System Components, [96](#)
 System capacity, [105](#)
 DIGITAL Server R
 Avaya Telephones
 SoundStation, [258](#)
 duplicated control cabinets (J58890M), [99](#)
 duplication interfaces
 UN330B, [212](#)

E

earth, [332](#)
 earthquake protections, [337](#)
 electrical components, power distribution units, [324](#)
 EMI filters, [326](#)
 enhanced DC rectifier cabinet, [334](#)
 EPN cabinets (J58890A), [100](#), [163](#)
 EPNs, [101](#)
 Ethernet Switch for S8700 Multi-Connect, [72](#)
 expansion control cabinets
 J58890AF, [163](#)
 SCCs, [99](#)
 expansion port carriers (J58890BB), [163](#)

F

Features, [123](#)
 Fixed ports
 CC, [125](#)
 CON, [125](#)
 LAN 1, [125](#)
 LINE 2, [125](#)
 LINE1, [125](#)
 TRK, [125](#)
 USB, [125](#)

WAN 1, [125](#)
 floor grounds, [333](#)
 floor loads, [318](#)
 Front panel buttons, [125](#)
 fuse panels (J58889AB), [161](#)
 fuses
 20-amp, [326](#)
 sneak current protectors, [337](#)

G

G350
 features, [123](#)
 G600 Media Gateway, [127](#)
 G700 Media Gateway, [41](#), [139](#)
 Cabling, [44](#), [142](#)
 Expansion Module, [43](#), [140](#)
 Gateway Software, [45](#), [144](#)
 LEDs, [45](#), [143](#)
 Maintenance Software, [46](#), [144](#)
 Media Modules, [46](#)
 Motherboard, [44](#), [142](#)
 Power Supply, [44](#), [142](#)
 Stacking Module, [44](#), [142](#)
 System-Level LEDs, [45](#), [143](#)
 G700 Media Gateway for S8700 Multi-Connect, [79](#)
 ground isolation, [330](#)
 ground ring, [332](#)
 ground wiring, [323](#)
 grounding, AC and DC, [332](#), [333](#)

H

hardware
 center stage switches, [88](#)
 humidity, [338](#)

I

international requirements, [322](#), [329](#)
 IP Server Interface for S8700 Multi-Connect, [71](#)
 IP Solutions, [101](#), [113](#)
 implementation, [102](#), [114](#)
 trunks
 H.323, [103](#), [115](#)
 IPSI for S8700 Multi-Connect, [71](#)
 isolator interfaces, [330](#)

J

J58886N auxiliary cabinets, [161](#)
 J58889AB fuse panels, [161](#)
 J58890A EPN/PPN cabinet, [163](#)
 J58890AF expansion control cabinets, [163](#)
 J58890AP processor carriers, [166](#)
 J58890BB port carriers, [161](#), [163](#)

Index

K

J58890CE-2 AC power distribution units/battery chargers, [324](#)
J58890CF-2 DC power distribution units, [329](#)
J58890CG DC power distribution units, [334](#)
J58890CH-1 AC power distribution units, [327](#)
J58890H port cabinets, [99](#)
J58890L BCCs, [99](#)
J58890R enhanced DC rectifier cabinets, [334](#)
J58890SA SN carriers, [164](#)

K

KS-21906, L9 48 VDC battery, [325](#)

L

LAN 1 port, [125](#)
large battery power backup, [328](#)
lightning protection, [337](#)
LINE 1 port, [125](#)
LINE 2 port, [125](#)
Local Survivable Processor (LSP), [50](#)

M

MCC1 Media Gateway, [159](#), [164](#)
MCC1 Media Gateway for S8700 Multi-Connect, [75](#)
MCCs (multicarrier cabinets)
 auxiliary cabinets, [161](#)
 carrier types, [100](#)
 DC power distribution, [330](#)
 fan units, [335](#)
 ground integrity, [337](#)
 power distribution, [326](#), [327](#)
 power systems, [323](#)
Media Gateway
 CMC1, [147](#)
 G600, [127](#)
 G700, [139](#)
 MCC1, [159](#)
 SCC1, [150](#)
Media Gateways for S8700 Multi-Connect, [73](#)
Media Module
 Analog, [222](#)
 BRI, [226](#)
 DCP, [224](#)
 T1/E1, [219](#)
 VoIP, [228](#)
Media Module LEDs, [45](#), [143](#)
Media Modules, [46](#)
 Analog Trunk/Telephone Media Module (MM711), [47](#), [48](#)
 DCP Media Module (MM712), [49](#)
 T1/E1 Media Module (MM710), [47](#)
 VoIP Media Module (MM760), [50](#)
MM 712 DCP Media Module, [49](#)
MM710, [219](#)
MM710 T1/E1 Media Module, [47](#)

MM711, [222](#)
MM711 Analog Trunk/Telephone Media Module, [48](#)
MM712, [224](#)
MM720, [226](#)
MM760, [228](#)
MM760 VoIP Media Module, [50](#)
Modem for S8700 Multi-Connect, [73](#)

N

NAA1 Fiber Optic Cable Adaptor (CMC1 Media Gateway), [178](#)
non-US power requirements, [322](#), [329](#)

O

overvoltage protections, [336](#)

P

P133G2 and P134G2
 Features, [297](#)
 Agency Approval, [298](#)
 Environmental Information, [298](#)
 Interfaces, [298](#)
 Physical Characteristics, [298](#)
 Power Consumption, [298](#)
 Supported Standards, [298](#)
 Overview, [297](#)
P133G2 Ethernet Switch, [297](#)
P134G2 Ethernet Switch, [297](#)
P330 Ethernet Switch, [291](#)
 Features, [291](#)
 Auto-Negotiation, [292](#)
 Backup Power Supply, [294](#)
 CajunView, [295](#)
 Command Line Interface, [295](#)
 Congestion Control, [292](#)
 Device Manager, [295](#)
 Fans, [294](#)
 Intermodule Redundancy, [294](#)
 IP Multicast Filtering, [293](#)
 Leaky VLANs, [292](#)
 Link Aggregation Group, [293](#)
 MAC Security, [293](#)
 Multiple VLANs per Port, [292](#)
 Network Management, [295](#)
 Network Management Agent Redundancy, [294](#)
 Network Monitoring, [296](#)
 Network TIME Acquiring Protocols, [293](#)
 Port Classification, [292](#)
 Port Mirroring, [296](#)
 Port Redundancy, [293](#)
 Radius Security, [293](#)
 SMON, [296](#)

- Software Download, [294](#)
- Stack Redundancy, [294](#)
- Standards, [295](#)
- VLANs, [292](#)
- peripherals, ground isolation, [330](#)
- pipe grounds, [332](#)
- port cabinets, [99](#)
- port carriers, [161](#), [163](#)
- power
 - backup, [326](#), [327](#)
 - current limited, [171](#)
 - DC requirements, [322](#), [329](#)
 - feeders, [319](#)
 - global requirements, [322](#), [329](#)
 - outages, [89](#)
 - sources, [319](#)
 - transformers, [333](#)
- Power Backup for S8700 Multi-Connect, [73](#)
- power converters
 - 631DA1/B1, [173](#), [323](#)
 - 649A, [174](#), [331](#)
- Power Supply, AC, WP-1217A, [173](#)
- power units
 - AC
 - 631DA1/B1, [173](#), [323](#)
 - J58890CE-2, [324](#)
 - DC
 - 649A, [174](#), [331](#)
 - 676B, [334](#)
 - distribution, [324](#)
 - distribution (J58890CH-1), [327](#)
 - electrical components, [324](#)
 - inputs, [323](#)
 - outputs, [324](#)
- PPNs
 - cabinets, [100](#)
- processors
 - J58890AP carriers, [166](#)
- protections, system, [336](#)
- protective grounds, [332](#)

R

- relays, DC power, [325](#), [326](#)
- requirements
 - international, [322](#)
- ring generators, [326](#)
- RST button, [125](#)
- Russia
 - MFR (TN2182C), [197](#)
 - MFR (TN744B/C/D), [130](#), [184](#)

S

- S8100 Media Server
 - Adapters, [231](#)
 - Administration, [36](#)
 - Avaya Telephones, [231](#)
 - Analog, [232](#)

- Consoles, [232](#)
- Digital Telephones, [231](#)
- Explosive Atmosphere Telephones, [232](#)
- IP Telephones, [231](#)
- Soundstation Speakerphones, [232](#)
- Wireless, [232](#)
- Circuit Packs, [229](#)
 - Application, [231](#)
 - Control, [230](#)
 - Line, [229](#)
 - Port, [231](#)
 - Power, [229](#)
 - Service, [230](#)
 - Trunk, [230](#)
- CMC1 Media Gateway, [35](#)
- Detailed Description, [33](#)
- G600 Media Gateway, [34](#)
- Main components, [34](#)
- Media Gateways, [229](#)
- MultiVantage Software, [37](#)
- Overview, [33](#)
- Recoverability, [36](#)
- Reliability, [35](#)
- S8100 Media Server Optional Components, [229](#)
- S8300 Media Server
 - Avaya Telephones, [233](#)
 - Analog Telephones, [234](#)
 - Digital Telephones, [233](#)
 - IP Telephones, [233](#)
 - SoundStation, [234](#)
 - Wireless, [234](#)
 - Media Gateways, [233](#)
- S8300 Media Server in a Local Survivable Processor Mode with an S8700 Multi-Connect, [89](#)
- S8300 Media Server in an LSP Configuration, [50](#)
- S8300 Media Server Web Interface, [56](#)
- S8300 Media Server with G700 Media Gateway
 - Configuration Description, [39](#)
 - Customer Configuration Options, [55](#)
 - Detailed Description, [39](#)
 - Media Server Web Interface, [56](#)
 - Overview, [39](#)
 - S8300 Media Server in an LSP Configuration, [50](#)
 - System Management, [55](#)
- S8700 Media Server, [71](#)
 - Circuit Packs
 - Line, [235](#), [239](#)
 - Trunk, [236](#), [239](#)
- S8700 Media Server IP Connect
 - Avaya Telephones, [237](#), [241](#)
 - Analog, [238](#), [241](#)
 - Consoles, [238](#), [242](#)
 - Digital, [238](#), [241](#)
 - Explosive Atmosphere, [238](#), [241](#)
 - IP, [237](#), [241](#)
 - SoundStation, [238](#), [241](#)
 - Wireless, [238](#), [241](#)
 - Circuit Packs, [235](#), [239](#)
 - Application, [237](#), [240](#)
 - Control, [236](#), [240](#)
 - Port, [237](#), [240](#)

- Service, [237](#), [240](#)
 - Media Gateways, [235](#), [239](#)
 - S8700 Media Server Multi-Connect
 - Avaya Telephones, [245](#)
 - Analog, [246](#)
 - Consoles, [246](#)
 - Digital, [246](#)
 - Explosive Atmosphere, [246](#)
 - IP, [245](#)
 - SoundStation, [246](#)
 - Wireless, [246](#)
 - Circuit Packs, [243](#)
 - Application, [245](#)
 - Control, [244](#)
 - Line, [243](#)
 - Port, [245](#)
 - Power, [243](#)
 - Service, [245](#)
 - Trunk, [244](#)
 - Media Gateways, [243](#)
 - S8700 Multi-Connect
 - Communication Complex Configuration, [71](#)
 - Connectivity, [88](#)
 - ATM Network, [89](#)
 - CSS Network, [88](#)
 - Detailed Description, [70](#)
 - Ethernet Switch, [72](#)
 - G700 Media Gateway, [79](#)
 - High-level capabilities, [90](#)
 - IP Server Interface (TN2312AP), [71](#)
 - MCC1 Media Gateway, [75](#)
 - Media Gateways, [73](#)
 - Overview, [70](#)
 - Recoverability, [89](#)
 - Reliability, [83](#), [88](#), [89](#)
 - Critical Reliability, [88](#)
 - Duplex Reliability, [83](#)
 - High Reliability, [85](#)
 - Required System Components, [70](#)
 - S8300 Media Server in a Local Survivable Processor Mode, [89](#)
 - S8700 Media Server, [71](#)
 - SCC1 Media Gateway, [77](#)
 - Survivable Remote EPN, [90](#)
 - System Capacity, [91](#)
 - System Management, [93](#)
 - UPS or Power Backup, [73](#)
 - USB Modem, [73](#)
 - S8700 Multi-Connect Connectivity, [88](#)
 - ATM Network, [89](#)
 - CSS Network, [88](#)
 - S8700 Multi-Connect Detailed Description, [70](#)
 - S8700 Multi-Connect Recoverability, [89](#)
 - S8700 Multi-Connect Reliability, [83](#), [88](#), [89](#)
 - Critical Reliability, [88](#)
 - Duplex Reliability, [83](#)
 - High Reliability, [85](#)
 - S8700 Required System Components, [70](#)
 - SCC1 Media Gateway, [150](#)
 - SCC1 Media Gateway for S8700 Multi-Connect, [77](#)
 - SCCs (single carrier cabinets)
 - acoustic noise levels, [319](#)
 - DC power supply (676B), [334](#)
 - fan units, [336](#)
 - power systems, [333](#)
 - SCSI drives, [196](#)
 - single point ground terminals, [333](#)
 - small battery power backup, [327](#)
 - SN carriers, [164](#)
 - SN clock circuit packs, [182](#)
 - sneak fuse panels (507B), [337](#)
 - sneak protectors, [336](#)
 - SNIs (TN573/B), [170](#), [182](#)
 - solid state voltage protection, [336](#)
 - SPEs, [98](#), [110](#)
 - Survivable Remote EPN in an S8700 Multi-Connect, [90](#)
 - system
 - protections, [336](#)
-
- ## T
- T1/E1 Media Module (MM710), [47](#)
 - TCP/IP
 - connectivity
 - C-LAN, [193](#)
 - terminals
 - grounding, [333](#)
 - TN1648 System Access and Maintenance (SYSAM), [194](#)
 - TN1650B Memory for DEFINITY R, [195](#)
 - TN1654 DS1 Converter, T1 (24 channel) and E1 (32 channel), [195](#)
 - TN1655 Packet Interface for DEFINITY R, [195](#)
 - TN1657 Disk Drive for DEFINITY R, [196](#)
 - TN2138 CO Trunk for Italy (8 ports), [196](#)
 - TN2139 DID Trunk for Italy (8 ports), [196](#)
 - TN2140BTie Trunk for Hungary and Italy (4-wire, 4 ports), [196](#)
 - TN2146 DID Trunk for Belgium and the Netherlands (8 port), [196](#)
 - TN2147C CO Trunk for Multiple Countries (8 ports), [197](#)
 - TN2181 DCP Digital Line (2-wire, 16 ports), [197](#)
 - TN2182C Tone-Clock, Tone Detector, and Call Classifier (8 ports), [197](#)
 - TN2183/TN2215 Analog Line for Multiple Countries (16 ports), [202](#)
 - TN2184 DIOD Trunk for Germany (4 ports), [198](#)
 - TN2185 ISDN-BRI S/T-TE Interface (4-wire), [198](#)
 - TN2198 ISDN-BRI U Interface (2-wire), [199](#)
 - TN2199 CO Trunk for Russia (3-wire, 4 ports), [199](#)
 - TN2202 Ring Generator for France, [200](#)
 - TN2207 DS1 Interface, T1 (24-channel) and E1 (32-channel), [200](#)
 - TN2209 Tie Trunk for Russia (4-wire, 4 ports), [200](#)
 - TN2211 Optical Drive for DEFINITY R, [201](#)
 - TN2214B DCP Digital Line (2-wire, 24 ports), [201](#)
 - TN2215/TN2183 Analog Line for Multiple Countries (16 ports), [202](#)
 - TN2224B DCP Digital Line (2-wire, 24 ports), [203](#)
 - TN2242 Digital Trunk (Japan 2MB TTC), [203](#)
 - TN2301 Logic Switch for DEFINITY R, [203](#)
 - TN2302 IP media processor, [203](#)
 - TN2302AP IP Media Processor, [203](#)

- TN2305 ATM-CES Trunk/Port-Network Interface for Multi-Mode Fiber, [204](#)
TN2306 ATM-CES Trunk/Port-Network Interface for Single-Mode Fiber, [204](#)
TN2308 DID Trunk for Brazil (8 ports), [204](#)
TN2313AP DS1 interface, [207](#)
TN2313AP DS1 Interface (24-channel), [207](#)
TN2314 S8100 Media Server, [129](#), [207](#)
TN2401 Net/Pkt, [208](#)
TN2401 Network Control/Packet Interface for DEFINITY SI, [208](#)
TN2401/2400 Net/Pkt sandwich board, [208](#)
TN2401/TN2400 Net/Pkt Interface sandwich board assembly for DEFINITY SI/I upgrades, [208](#)
TN2402 Processor for DEFINITY CSI, [208](#)
TN2404 Processor for DEFINITY SI, [209](#)
TN2464BP DS1 Interface with Echo Cancellation, T1/E1, [209](#)
TN2501AP Voice Announcements over LAN (VAL), [210](#)
TN2793B Analog Line with Caller ID (24 ports), [210](#)
TN572 SN clock, [182](#)
TN573/B SNI, [182](#)
TN2202 ring generator, [326](#)
TN429D DIOD or Central Office Trunk (8 ports), [178](#)
TN433 speech synthesizer Italy, [178](#)
TN436B DID Trunk for Australia (8 ports), [178](#)
TN438B CO trunk for Australia (8 port), [178](#)
TN439 Tie Trunk for Australia and Japan, [178](#)
TN457 Speech Synthesizer for British English, [179](#)
TN459B DID Trunk for the United Kingdom, [179](#)
TN464C/D/E/F DS1 Interface, [179](#)
TN465C CO Trunk for Multiple Countries (8 port), [180](#)
TN479 Analog Line (16 ports), [180](#)
TN497 Tie Trunk for Italy TGU, TGE, and TGI (4 ports), [180](#)
TN553 Packet Data Line, [181](#)
TN556D ISDN-BRI 4-Wire Interface (12 ports), [181](#)
TN568 DEFINITY AUDIX 4.0 Voice Mail System, [181](#)
TN570D Expansion Interface, [182](#)
TN572 Switch-Node Clock for DEFINITY R, [182](#)
TN573/B SNI, [170](#)
TN573B Switch Node Interface, [182](#)
TN577 Packet Gateway (PGATE), [182](#)
TN725B Speech Synthesizer for United States English, [183](#)
TN726B Data Line (8 ports), [183](#)
TN735 MET Line (4 ports), [183](#)
TN744E Call Classifier Tone Detector for Multiple Countries (8 ports), [130](#), [184](#)
TN746B Analog Line (16 ports), [184](#)
TN747B CO Trunk (8 ports), [185](#)
TN750C Recorded Announcement (16 channels), [185](#)
TN753B DID Trunk (8 ports), [186](#)
TN755B Neon Power Unit, [186](#)
TN758 Pooled Modem, [187](#)
TN760E Tie Trunk (4-wire, 4 ports), [187](#)
TN762B Hybrid Line (8 ports), [187](#)
TN763D Auxiliary Trunk (4 ports), [187](#)
TN767E DS1 Interface, T1 (24 channel), [187](#)
TN769 Analog Line (8 ports), [188](#)
TN771DP Maintenance/Test, [189](#)
TN771DP maintenance/test board with firmware download, [189](#)
TN775C Maintenance board, [189](#)
TN780 Tone Clock, [190](#)
TN787K Multimedia Interface, [190](#)
TN788C Multimedia Voice Conditioner, [190](#)
TN789B Radio Controller, [191](#)
TN791 Analog Guest Line (16 ports), [191](#)
TN792 Duplication Interface for TN2404 Processor for DEFINITY SI, [192](#)
TN793B Analog Line with Caller ID (24 ports), [192](#)
TN797 US Analog Trunk or Line Circuit Pack (8 ports), [193](#)
TN799/B/C CLAN interface, [193](#)
TN801 LAN Gateway interface, [194](#)
TN801 MAPD (LAN Gateway Interface), [194](#)
TN801B MAPD LAN Gateway Interface, [177](#)
TN802B MAPD IP Interface Assembly, [194](#)
TN-C7 ISDN-PRI to SS7 Converter, [211](#)
TNCCSC-1 ISDN-PRI to DASS Converter, [211](#)
TNCCSC-2 ISDN-PRI to DPNSS Converter, [211](#)
TNCCSC-3 ISDN-PRI to DPNSS Converter, [211](#)
TN-CIN Voice/Fax/Data Multiplexer, [211](#)
TRK port, [125](#)
trunks
H.323, [103](#), [115](#)
-
- ## U
- UN330B duplication, [212](#)
UN330B Duplication Interface for DEFINITY R, [212](#)
UN331C Processor for DEFINITY R, [212](#)
UN332C Mass Storage/Network Control for DEFINITY R, [213](#)
UPS, [325](#), [327](#)
UPS for S8700 Multi-Connect, [73](#)
USB Modem for S8700 Multi-Connect, [73](#)
USB port, [125](#)
-
- ## V
- VoIP Media Module (MM760), [50](#)
-
- ## W
- WAN 1 port, [125](#)
WP-1217A Power Supply, [173](#)
WP-91153 AC power, [333](#)

