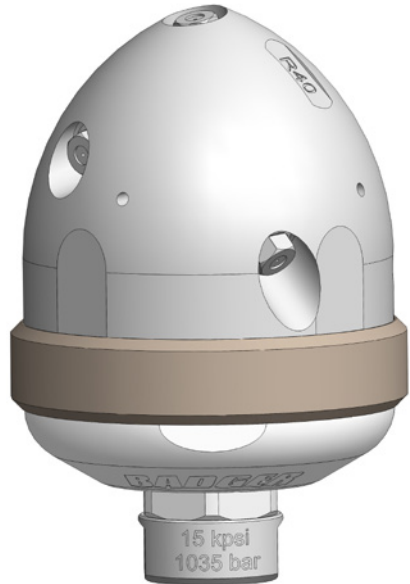


# BADGER FAMILY SELF ROTARY SWIVELS USER MANUAL

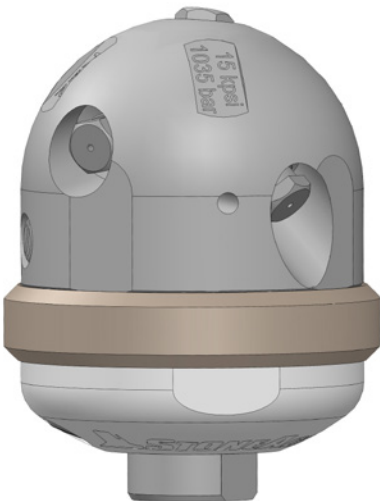
*\*EXCLUDES BA-H6 4" 40K MODEL*



**2 INCH**



**6 INCH**



**4 INCH**

# TABLE OF CONTENTS

<b>MANUFACTURER'S INFORMATION</b> .....	<b>3</b>
SPECIFICATIONS FOR ALL MODELS .....	3
KEY FEATURES FOR ALL MODELS .....	3
GENERAL JETTING INFORMATION .....	4
<b>2" BADGER</b> .....	<b>5</b>
TOOL DESCRIPTION AND INTENDED USE .....	5
OPERATION .....	6
TROUBLESHOOTING .....	7
TOOL SERVICE INFORMATION .....	8
ASSEMBLY AND PARTS .....	9
<b>4" BADGER</b> .....	<b>10</b>
TOOL DESCRIPTION AND INTENDED USE .....	10
WARNING AND SAFETY INSTRUCTIONS .....	11
OPERATION .....	12
TROUBLESHOOTING .....	13
TOOL SERVICE INFORMATION .....	14
LUBRICATION REPLACEMENT INSTRUCTIONS .....	15
DISASSEMBLY .....	16
ASSEMBLY .....	17
PART NAMES/NUMBERS .....	20
SERVICE KITS .....	21
<b>6" BADGER</b> .....	<b>22</b>
TOOL DESCRIPTION AND INTENDED USE .....	22
WARNING AND SAFETY INSTRUCTIONS .....	23
OPERATION .....	24
TROUBLESHOOTING .....	25
TOOL SERVICE INFORMATION .....	26
LUBRICATION REPLACEMENT INSTRUCTIONS .....	27
DISASSEMBLY .....	28
ASSEMBLY .....	30
PART NAMES/NUMBERS .....	32
SERVICE KITS .....	33
<b>TERMS AND CONDITIONS AND WARRANTY</b> .....	<b>34</b>

This manual must be used in accordance with all applicable national laws. The manual shall be regarded as a part of the machine and shall be kept for reference until the final dismantling of the machine, as defined by applicable national law(s). Updated manuals can be downloaded at:

<https://www.stoneagetools.com/manuals>

# MANUFACTURER'S INFORMATION

StoneAge Inc.  
466 S. Skylane Drive  
Durango, CO 81303, USA  
Phone: 970-259-2869  
Toll Free: 866-795-1586  
www.stoneagetools.com

StoneAge Europe  
Unit 2, Britannia Business Centre  
Britannia Way  
Malvern WR14 1GZ  
United Kingdom  
Phone: +44 (0) 1684 892065

## Badger Model Specifications

Tool Size	Tool Model Number	Pressure Range	Flow Range	Inlet Connection	Weight	Rotation Speed	Max Water Temperature
2"	BA-LK-P4 BA-LK-BSPP4	2-15k psi 140-1000 bar	3-20 gpm 11-76 l/min	1/4 NPT or 1/4 BSPP	0.45 lb 0.20 kg	High Speed	250 °F 120 °C
	BA-LK-MP9L BA-LK-MP9R	12-22k psi 830-1500 bar	3-15 gpm 11-57 l/min	9/16 MP or M24	0.45 lb 0.20 kg	High Speed	250 °F 120 °C
4"	BA-P6 BA-BSPP6	2-15k psi 140-1000 bar	13-30 gpm 49-110 l/min	3/8 NPT 3/8 BSPP	3.0 lbs 1.4 kg	20-100 rpm (Slow Fluid) 75-250 rpm (Fast Fluid)	250 °F 120 °C
	BA-TM12	12-22k psi 830-1500 bar	12-25 gpm 45-95 l/min	3/4 Type M Male	3.0 lbs 1.4 kg	20-100 rpm (Slow Fluid) 75-250 rpm (Fast Fluid)	250 °F 120 °C
	BA-H6 (Not included in this manual)	44k psi 3000 bar	4.5-12 gpm 17-45.5 l/min	3/8 HP Female	4.0 lbs 1.8 kg	100-400 rpm	250 °F 120 °C
6"	BA-MP9 BA-M24	12-22k psi 840-1500 bar	14-43 gpm 53-163 l/min	9/16 MP or M24	8.0 lbs 3.6 kg	50-300 rpm (Adjustable)	250 °F 120 °C
	BA-P8	2-15k psi 140-1000 bar	15-55 gpm 57-208 l/min	1/2 NPT	8.0 lbs 3.6 kg	50-300 rpm (Adjustable)	250 °F 120 °C

## Badger Model Features

2"	<ul style="list-style-type: none"> <li>The only self-rotary tool on the market that can navigate 2 in. (50 mm) pipes with bends and comes with head locking technology for increased safety</li> <li>Multiple jetting options allow the tool to be optimized for a variety of pump pressures and flows - unplug, polish, or run longer lines based on jetting</li> <li>Optional fairing available to streamline tool during retrieval</li> </ul>
4"	<ul style="list-style-type: none"> <li>Different jetting configurations allow for more or less pull and forward hitting power</li> <li>Navigates elbows as small as 4 in. (102 mm) at up to 44k psi (3000 bar)</li> <li>Self-rotary, speed controlled head provides complete internal coverage with optimum jet delivery</li> <li>Two speeds to choose from to maximize cleaning by choosing slower speeds for hard to clean or plugged pipes, and faster speeds for polishing easy to clean pipes with a single tool</li> <li>Multiple jetting options optimize the tool for a variety of pumps pressures and flows - unplug, polish, or run longer lines based on jetting</li> <li>Designed to easily pair with the AutoBox ABX-500 hose tractor for hands-free pipe cleaning.</li> </ul>
6"	<ul style="list-style-type: none"> <li>Only rotary pipe cleaning tool on the market with adjustable speed control for fine-tuning to specific requirements</li> <li>Different jetting configurations allow for more or less pull and forward hitting power and optimize the tool for a variety of pumps pressures and flows.</li> <li>Navigates elbows as small as 6 in. (152 mm)</li> <li>Speed controlled rotary tools provide complete internal coverage with optimum jet delivery</li> <li>Maximize cleaning by choosing slower speeds for hard to clean or plugged pipes, and faster speeds for polishing easy to clean pipes with a single tool</li> <li>Centralizer options for larger pipe sizes available</li> </ul>

## GENERAL JETTING INFORMATION

### DETERMINING JET SIZES:

Badger tools come from the factory with installed nozzles, selected based on customer pressure and flow requirements. Jet thrust is used to pull the tool through the pipe. An estimate of the amount of pulling force required is useful and depends on the number of elbows and any vertical climbs that must be made. On a horizontal run with no elbows, 1 pound of pull is required for every ten feet. When climbing vertically, the pulling force must equal the weight of the tool and the hose. Typically, larger jet sizes using 50 to 80 percent of the total flow are used in the back ports. As little as 10 percent of the total flow is given to the front jet, because it pushes the wrong direction and is only used to open up blockages. The remaining flow goes to the side ports, which help pull as well as clean. Jetting assistance is available on our jetting app at: <http://jetting.stoneagetools.com> or through one of our StoneAge customer service reps at 1-866-795-1586.

See the “Assembly” section of this manual for instructions on to how to install new nozzles.

## 2" BADGER TOOL DESCRIPTION AND INTENDED USE

### 2" BADGER MODELS DESCRIPTION AND INTENDED USE

The BA-LK-P4 / BA-LK-BSPP4 / BA-LK-MP6R / BA-LK-MP9L / BA-LK-MP9R is a self-rotating swivel designed for cleaning 2" to 4" tubes and pipes with bends and long radius elbows, such as U-Tubes and process lines. The P4 and BSPP4 tools can be used at operating pressures up to 15,000 psi (1035 bar) and the MP6R, MP9L and MP9R tools at up to 22,000 psi (1500 bar). The P4 and BSPP4 have either a 1/4" NPT or 1/4" BSPP female pipe thread inlet. If a standard 1/4" NPT or BSPP hose end is used, they can pass through elbows in 3" and larger pipe. If using the tool in 2" pipe a special shorter hose end is required to allow tool to travel through elbows. Contact StoneAge for more information on the hose requirements. The MP6R tool has a 3/8" female right-hand medium pressure inlet. The MP9L tool has a 9/16" female left-hand medium pressure inlet and the MP9R has a 9/16" female right-hand medium pressure inlet. The tools do not use any bearings, seals, or lubricating fluid. Rotation is powered by the jet thrust. The nozzle inserts used in the head determine the flow rate and the pulling force.

\*An OPTIONAL BA 530 Fairing Assembly is available for all 2" Badger models when using hose sizes up to 6mm. The fairing is designed to be attached to the back of the 2" Badger to help prevent the rear edge of the tool from getting caught on obstructions during withdrawal from tubes or pipes.



BA 530 FAIRING



## 2" BADGER OPERATION

### NOTICE

The most important items in maintaining the Badger tool;

- Keep debris from entering the tool and preventing it from rotating by flushing high pressure hoses before use.

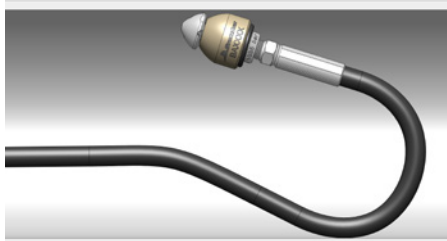
#### OPERATION

- Make sure the operator has a controlled dump in the system and it is operated by the person closest to the job. Test the dump prior to beginning the job.
- Flush out the high pressure hoses before connecting the Badger to eliminate debris.
- Attach tool to the end of the hose. Use Parker Thread Mate and Teflon tape on all pipe thread connections (P4, BSPP4); use anti-seize on all straight thread connections (MP6R, MP9L, MP9R) to the swivel inlet.
- The 2" Badger has a large O-Ring (WV 008) around the inlet. This O-Ring helps prevent the tool from getting caught on the rear edge when pulling the tool back out of the line. *An optional Fairing Assembly (BA 530) will also help prevent snagging during tool removal.*

BA 530  
FAIRING



- It is recommended that the hose be marked a few feet from the end with a piece of tape so the operator knows when to stop on the way back out.
- Position the tool in the pipe opening.
- Close the dump and slowly bring the pump up to pressure the first time to make sure no nozzles are plugged and the jet thrust is correct. The Badger™ should begin to slowly rotate.
- Once operating pressure is reached, feed the tool into the pipe to begin the cleaning job.
- Allow the jets time to do their work by feeding the hose out at a controlled rate.
- 2" BADGER ONLY- After the Badger is removed from the hose, blow out water with compressed air and spray a light oil such as WD-40 into the tool.



### ⚠ DANGER

If the 2" BADGER is being used in pipes larger than 4 inch diameter, a rigid stinger should be installed between the tool inlet and the hose end; otherwise the tool can turn around and come back toward the operator, causing serious injury or death.

Operations with this equipment can be potentially hazardous. Caution must be exercised prior to and during machine and water jet tool use. Please read and follow all of these instructions, in addition to the guidelines in the WJTA Recommended Practices handbook, available online at [www.wjta.org](http://www.wjta.org). Deviating from safety instructions and recommended practices can lead to severe injury and/or death.

### HEAD WILL NOT ROTATE:

- First, make sure the head (BA 044-LK) is still tightened into the shaft (BA 501-LK). A safety feature built into the shaft stops the tool from rotating if the head comes loose.
- If the head isn't loose, try spraying a light oil such as WD-40 into the tool and rotate head by hand until it turns freely again.
- Make sure that the jets in the head are not plugged.
- If the tool still does not rotate after trying the steps above, it may need to be disassembled and cleaned on the inside. To do this requires a spanner wrench (available in StoneAge Tool Kit BA-P4 612) inserted into the rear of the shaft to remove the head from the shaft. Begin by removing the O-ring (WV 008) and the Retaining Ring (WV 010). Pull the Inlet Nut (BA 002-P4,-BSPP4,BA 502-MP9L,BA 502-MP9R) out of the Body (BA 503). Using a spanner wrench, unscrew the Shaft (BA 501) from the Head (BA 044). Make sure the two small holes in the side of the shaft are cleaned out; debris plugging these holes is the most likely cause of the tool not rotating. If the outside of the shaft is badly worn, it needs to be replaced.
- See the "2" Badger Tool Service Information" and the "2" Badger Assembly and Parts" pages in this manual for more detailed information about service.

## 2" BADGER TOOL SERVICE INFORMATION

### TOOL SERVICE

\*\*\*Product training and proper tools are required to service this nozzle. If you are uncomfortable performing the service, bring the nozzle to your authorized dealer.\*

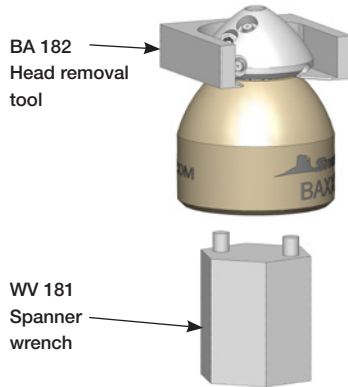
The use of a bench vice is highly helpful. Take care throughout the entire procedure to keep the internals clean and free from grit, lint, and contamination. Failure to do so could result in premature failure after service.

#### LIST OF TOOLS:

- Bench Vice (recommended)
- 7/8" socket
- 3/8" drive torque wrench
  
- BA 612-LK Tool Kit (For 2" Badger Includes)
  - BA 182 Head Removal Tool
  - WV 181 Spanner Wrench

#### LIST OF MATERIALS:

- Clean lint free rags or blue shop towels
- BA 185 Red Loctite® 262



### NOZZLES

The nozzle head has forward jets at 15°, 30°, 45°, two side jets at 90°, and two back jets at 132°. StoneAge recommends replacing the entire head assembly with the nozzles installed at the factory.

### ASSEMBLY

If assembling tool, apply 2-4 drops of Loctite #262 Red (StoneAge p/n BA 185) around the circumference of the threads on the Head prior to screwing it into the Shaft. Care must be taken NOT to allow into the internal shaft bore below the female threads or onto the tapered external surface of the shaft. Torque to 100 in-lbs using 7/8" socket on the spanner wrench (available from StoneAge as p/n WV 181). Also replace Retaining Ring (WV 010) with a new one during each reassembly.

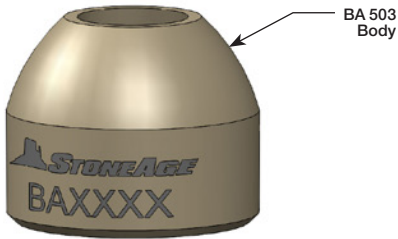
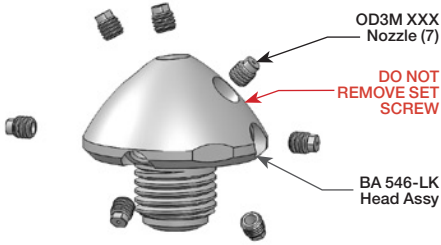
If you do not have the required tools or you are not confident in performing these procedures please send the tools back to StoneAge for maintenance and repairs.

Loctite® is a registered trademark of Henkel AG & Co. KGaA.

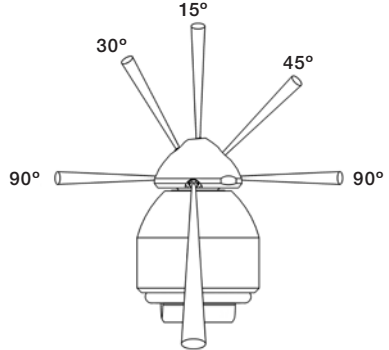


# 2" BADGER ASSEMBLY AND PARTS

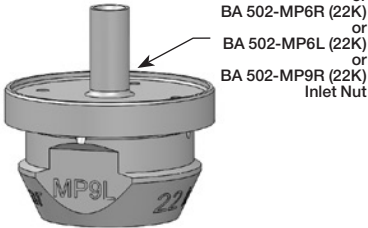
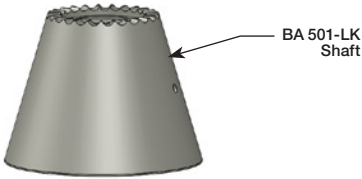
## Part Diagram



## Nozzle Locations



2 x 132°  
 7 Ports:  
 1 @ 15°  
 1 @ 30°  
 1 @ 45°  
 2 @ 90°  
 2 @ 132°



## Accessories



GP 200-BSPP4  
 Copper Seal Ring .250  
 REQUIRED FOR BSPP  
 INLETS ONLY



\*Optional  
 BA 530 Fairing

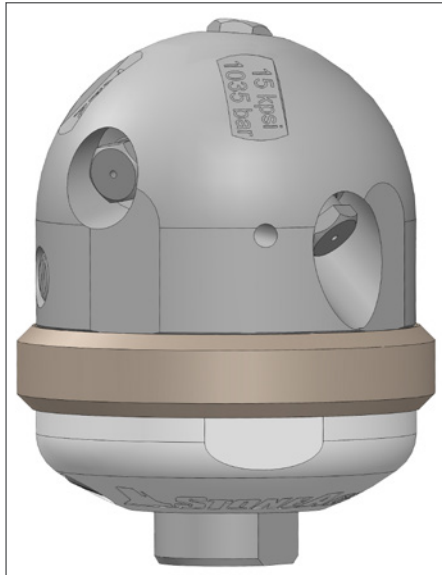
## 4" BADGER TOOL DESCRIPTION AND INTENDED USE

### 4" BADGER MODELS DESCRIPTION AND INTENDED USE

The Badger™ Rotary Waterblast Nozzle was designed for waterblast cleaning of pipes as small as 4 inch with elbows. The BA-P6 has a 3/8 NPT female inlet connection and a maximum operating pressure of 15,000 psi (1035 bar). The BA-BSPP6 has a 3/8 BSPP female inlet connection and a maximum operating pressure of 15,000 psi (1035 bar). The BA-TM12 has a 3/4 type M male inlet connection and a maximum operating pressure of 22,000 psi (1500 bar). Two rotation speed ranges are available for each tool; a thick fluid is used for rotation speeds of 20 to 100 rpm, and a thinner fluid is used for rotation speeds of 75 to 250 rpm. The fluid in the swivel can be changed to provide either fast or slow rotation. The Badger™ heads have 1/8 NPT ports; one at 15 degrees, two at 100 degrees, and two at 135 degrees.

Engraved on each head is R16 or R22; this number is the offset of the head that makes it rotate.

The flow range for each head is given in the table; nozzle sizes must be selected to fit within this flow range. If the flow is less than the range shown, the tool will not rotate; if it is more than the allowable the tool will rotate too fast and wear out the seals and bearings.



4" BADGER FLOW RANGE PER HEAD OFFSET CHART		
PRESSURE	R22	R16
10,000 PSI (690 bar)	13-21 GPM (50-80 l/min)	20-30 GPM (76-114 l/min)
15,000 PSI (1035 bar)	13-17 GPM (50-65 l/min)	18-30 GPM (68-114 l/min)
22,000 PSI (1500 bar)	12-18 GPM (45-68 l/min)	15-25 GPM (57-95 l/min)

## 4" BADGER WARNING AND SAFETY INSTRUCTIONS

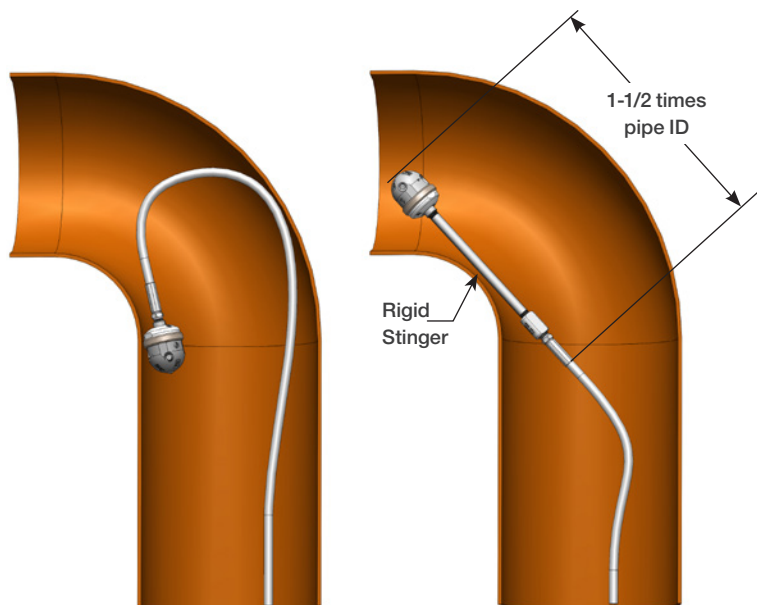
### ⚠ WARNING

Because of the short length of the Badger, the tool can turn around in large pipes and come back at the operator at a high rate of speed. If cleaning larger pipes, a rigid "stinger" should be used between the hose and the tool. It is recommended that the rigid length of the tool including hose end is 1-1/2 times the inside diameter of the pipe being cleaned (see below).

Make sure there is an operator controlled dump in the system, operated by the person closest to the cleaning job. Flush out the high pressure hoses before connecting the Badger. It is recommended that the hose be marked a few feet from the end with a piece of tape so the operator knows when to stop when retracting the tool. Position the tool in the pipe opening. Close the dump and slowly bring up to pressure the first time to make sure no nozzles are plugged and the jet thrust is correct. The Badger should begin to slowly rotate. Once operating pressure is reached, feed the tool into the pipe to begin the cleaning job. Allow the jets time to do their work by feeding the hose out at a controlled rate. The StoneAge ABX-500 Hose Control Device can be used to achieve consistent feed rates for pipe cleaning. When the work is complete and the tool is connected from the hose, blow out all water to prolong the life of the tool. A small amount of oil can be blown into the tool as well as an added measure to maximize tool life.

### ⚠ DANGER

Operations with this equipment can be potentially hazardous. Caution must be exercised prior to and during machine and water jet tool use. Please read and follow all of these instructions, in addition to the guidelines in the WJTA Recommended Practices handbook, available online at [www.wjta.org](http://www.wjta.org). Deviating from safety instructions and recommended practices can lead to severe injury and/or death.



**IMPROPER USE:**  
Badger will turn around in  
large diameter pipe  
**VERY DANGEROUS!**

**PROPER USE:**  
Badger with rigid "stinger"  
to prevent turnaround, still  
able to pass through elbows.

## 4" BADGER OPERATION

### OPERATION:

- Make sure the operator has a controlled dump in the system and it is operated by the person closest to the job. Test the dump prior to beginning the job.
- Flush out the high pressure hoses before connecting the Badger™ to eliminate debris.

## NOTICE

*The two most important items in maintaining the Badger tools;*

*- Keep debris from entering the tool and preventing it from rotating by flushing high pressure hoses before use.*

*- Keep the 4" and 6" models full of viscous fluid to maintain control and rotation speed. When the viscous fluid is lost or contaminated, the rotation speed of the tool will increase, which reduce the life of the high pressure seal and bearing.*

- Attach tool to the end of the hose.
- It is recommended that the hose be marked a few feet from the end with a piece of tape so the operator knows when to stop on the way back out.
- Position the tool in the pipe opening.
- Close the dump and slowly bring the pump up to pressure the first time to make sure no nozzles are plugged and the jet thrust is correct. The Badger should begin to slowly rotate.
- Once operating pressure is reached, feed the tool into the pipe to begin the cleaning job.
- Allow the jets time to do their work by feeding the hose out at a controlled rate.
- When the work is complete and the tool is disconnected from the hose, blow out all water to prolong the life of the tool.
- 4" & 6" BADGERS ONLY- A small amount of 3-IN-ONE or equivalent lubricant can be blown into the tool as well.

### HIGH-PRESSURE WATER SEALS LEAK:

- The high pressure seal may leak initially at lower pressures, but should pop closed as pressure is increased. A continuous leak at operating pressure from the weep holes indicates the need to replace the HP Seal and Seat. HP Seals wearing out too quickly can be an indication that the shaft bore is worn, the HP Seat is installed upside-down, or the tool is over spinning. Over spinning is caused by low or contaminated viscous fluid, water in the fluid chamber (replace shaft seals), or too much jet torque. Refilling the viscous fluid every 30-40 hours of operation is important for proper speed control. Only use StoneAge recommended viscous fluid.

### TOOL WILL NOT ROTATE:

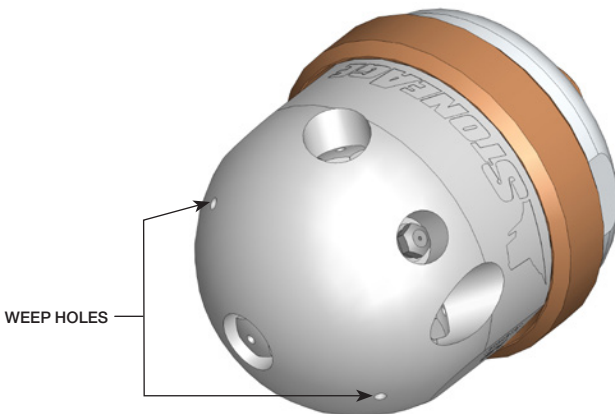
- Check the nozzles for plugging or wear (nozzles have to be removed to check for obstructions), Check that the nozzle sizes are correct for the desired flow and that the desired flow matches the head flow range. Check that the nozzle sizes are installed in a balanced configuration. If the tool feels rough when manually rotating the head, this indicates internal damage. Replace bearings, shaft seals, viscous fluid, and check the Inner and Outer Discs for flatness. These discs can be deformed if tool is reassembled when discs are not properly aligned with BA 018 Pins.

### TOOL SPINS TOO FAST:

- A significant increase in rotation speed means that the speed control mechanism in the tool has lost functionality. This can be a result of viscous fluid loss or fluid contamination. Operation of the tool in this state can cause damage to other components and accelerated wear of the high pressure seal. If this occurs, the first step is to flush the tool with new viscous fluid as shown below.

### LOCK-UP TROUBLESHOOTING TIP:

- Rotate in reverse 1 1/4 to 1 1/2 turns to unlock braking mechanism. If tool rotates smoothly then redress may not be required.
- Verify jetting at <http://jetting.stoneagetools.com/#/> or contact your factory authorized StoneAge® Inc.



## 4" BADGER TOOL SERVICE INFORMATION

### TOOL SERVICE

\*\*\*Product training and proper tools are required to service this nozzle. If you are uncomfortable performing the service, bring the nozzle to your authorized dealer.\*

The use of a bench vice and an arbor press is highly helpful. Take care throughout the entire procedure to keep the internals clean and free from grit, lint, and contamination. Failure to do so could result in premature failure after service.

### LIST OF TOOLS:

- Bench Vice (recommended)
- Arbor Press (recommended)
- 18" Adjustable Wrench (such as Crescent® C718 Automatic Adjustable Pipe Wrench)
- Medium size flat-head screw driver
- Pick
- Bearing Splitter
- 3/8 Drive Ratchet with 3" Extension
- BA 612 Tool Kit (For 4" Badger Includes)
  - BA 100 Retaining Ring Pliers
  - BA 105 Seal Press Tool

### LIST OF MATERIALS:

- Clean lint free rags or blue shop towels
- Anti-Seize - StoneAge PN (GP 043 Blue Goop)
- Lithium Soap Grease – StoneAge PN (GP 048 Grease)
- Blue Loctite® 242
- Isopropyl Alcohol or Denatured Alcohol

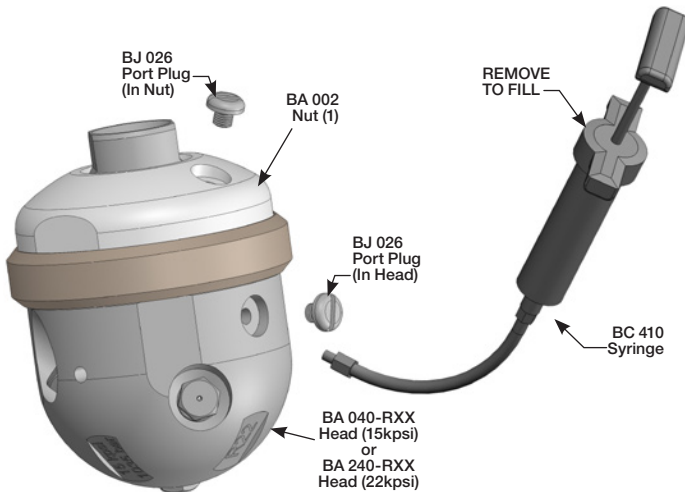
Blue Goop® is a registered trademark of the Swagelock® Corporation.

Loctite® is a registered trademark of Henkel AG & Co. KGaA.

## 4" BADGER LUBRICATION REPLACEMENT INSTRUCTIONS

### VISCOUS FLUID FLUSH INSTRUCTIONS (4" BADGER)

1. Remove the Port Plugs (BJ 026) in the Nut (BA 002) and Head (BA 040-RXX) / (BA 240-RXX) (see below).
2. Fill the Syringe (BC 410) with viscous fluid by removing the end near the handle, pulling out the plunger, and pouring the Viscous Fluid (BJ 048-F) in to fill the Syringe Body. With plunger re-installed, purge air out of Syringe hose.
3. Thread the syringe end into the port in the Head, and squeeze fresh Viscous Fluid in until clean Viscous Fluid comes out the port in the Nut. Hold the tool so the port in the Nut is the highest point. If air bubbles come out of the port on the nut, keep flushing new fluid until air bubbles stop.
4. Install Port Plug into Nut first. Remove the Syringe and install the Port Plug in the Head.



*Viscous Fluid Flush*

# 4" BADGER DISASSEMBLY

## DISASSEMBLY

1. Unscrew the Nut (BA 002) from the Head (BA 040/240)
2. Pull the Shaft (BA 001/ BA 001-BSPP6/ BA 201) out of the head.

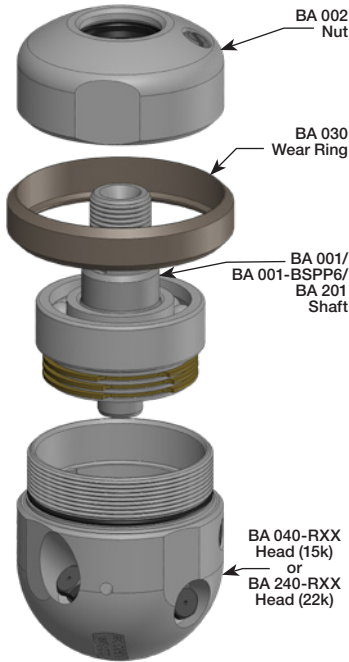


Figure 1: For Steps 1-2

3. Remove the Seat (RJ 011/RJ 011-KC) and H.P. Seal (RJ 012-TO/RJ 012-KTO) from the bore of the Shaft.

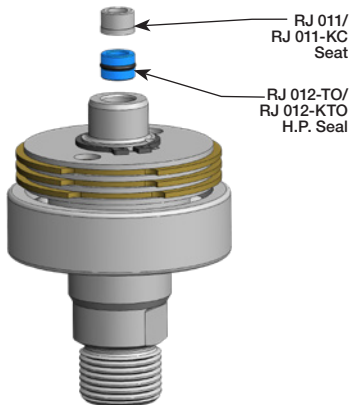


Figure 2: For Step 3

4. Remove Retaining Ring (BA 017) from the shaft.
5. Pull the Discs (BA 015, BA 016) and O-Rings (SM 016) off of the Shaft.

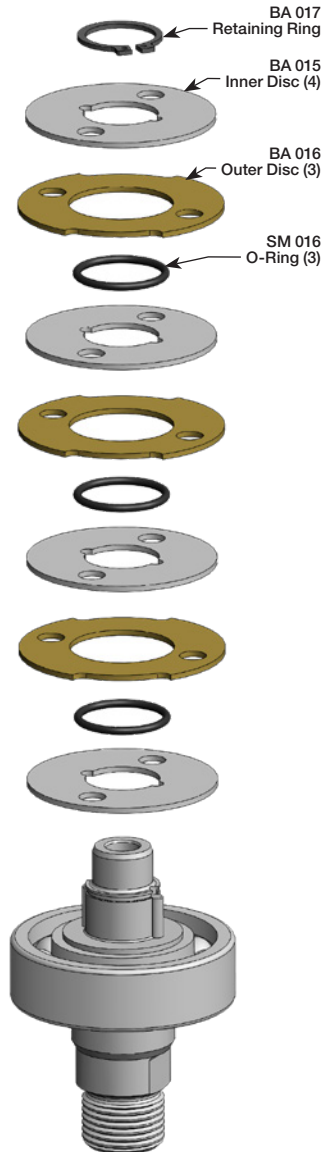


Figure 3: For Step 4-5



## 4" BADGER DISASSEMBLY

6. Press the Bearing (UH 009) off of the Shaft.
7. There is no need to remove the Pins (BA 018) from the Shaft; however, if they fall out do not lose them.

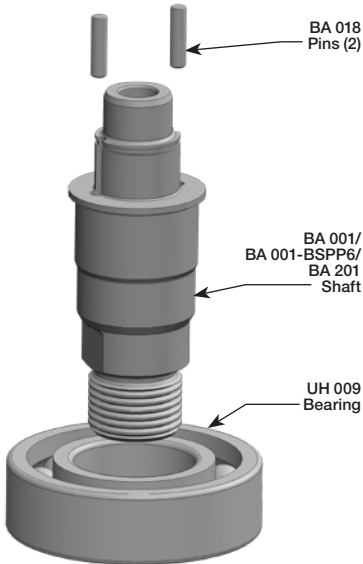


Figure 4: For Steps 6-7

8. Remove the Shaft Seal (BA 007) if it is damaged.
9. Remove the Port Plug (BJ 026) from the Nut.

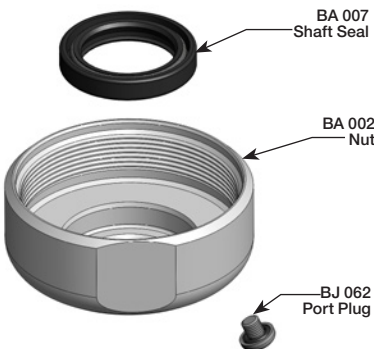


Figure 5: For Steps 8-9

10. Remove the Port Plug (BJ 026) from the Head.
11. Remove the Shaft Seal (BA 006) and O-Ring (WG 008) if they are damaged.
12. There is no need to remove the Pins (BA 018); however, if they fall out, do not lose them.

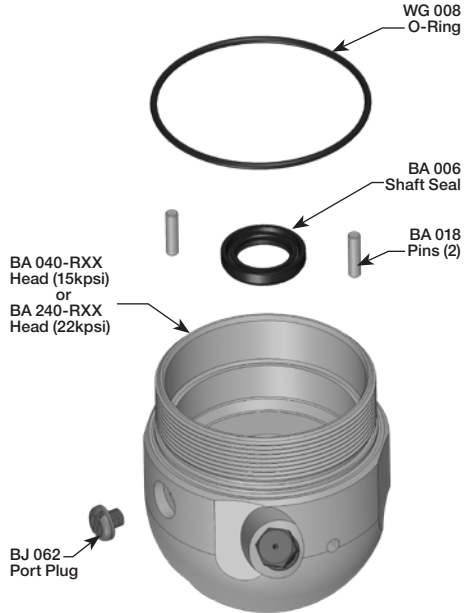


Figure 6: For Steps 10-12

# 4" BADGER ASSEMBLY

## ASSEMBLY

1. Press Bearing (UH 009) onto Shaft (BA 001 / BA 001-BSPP6)
2. Check that Pins (BA 018) are installed in Shaft.

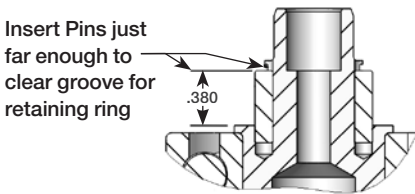
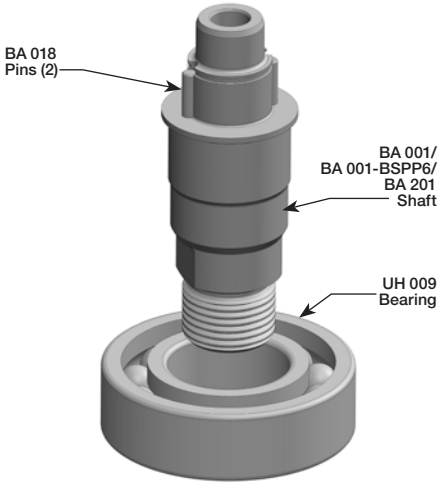


Figure 7: For Steps 1-2

3. Place an Inner Disc (BA 015) on Shaft, aligning with pins.
4. Place an O-Ring (SM 016) on top of this Disc, stretched around Pins.
5. Place an Outer Disc (BA 016) on top of this.
6. Repeat these steps until there are three Outer Discs and four Inner Discs on the Shaft.
7. Push down on top disc and install the Retaining Ring (BA 017) in the groove around the Shaft.

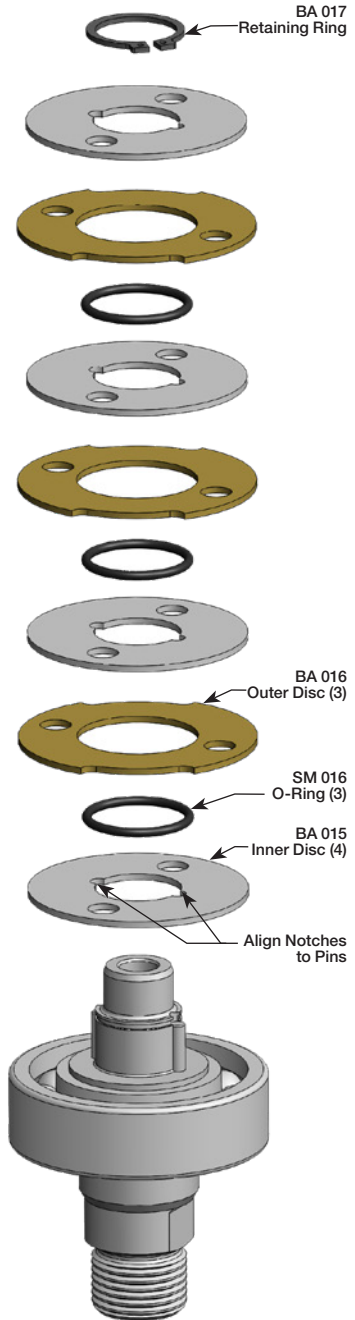
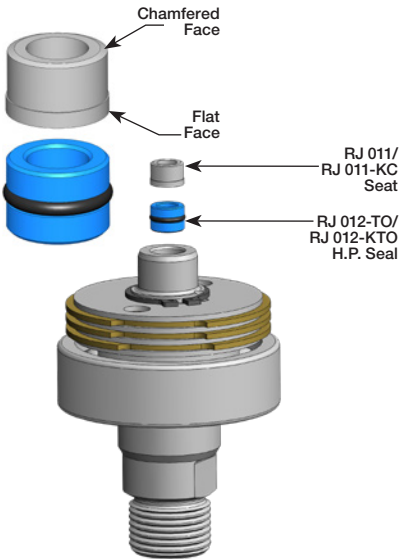


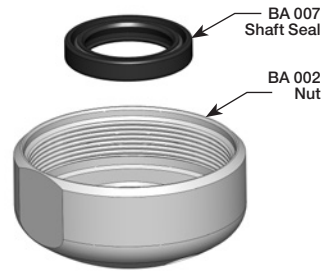
Figure 8: For Step 3-7

8. Apply grease to and install the H.P. Seal (RJ 012-TO/RJ 012-KTO) in the bore of the Shaft.
9. Apply grease to the face of the Seat (RJ 011/ RJ 011-KC) and place in bore of Shaft, on top of Seal, as shown.

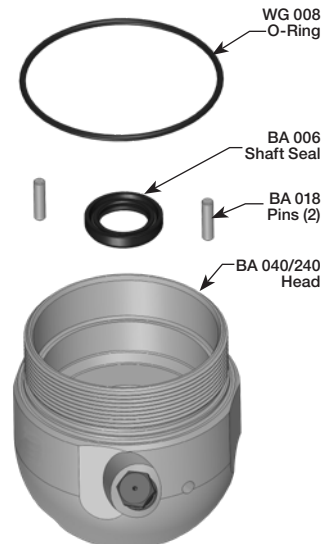


**Figure 9: For Steps 8-9**

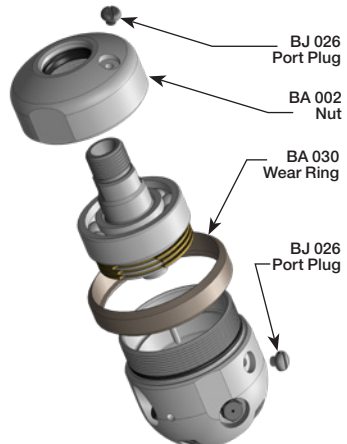
10. Install Shaft Seals (BA 007 and BA 006) in the Nut (BA 002) and Head (BA 040/240) as shown.
11. Place O-Ring (WG 008) over threads and into groove of Head.
12. Check that the Pins (BA 018) are installed in the Head.
13. Align the notches on the Outer Discs with the pins in the Head; slide shaft assembly into the Head.
14. Apply anti-seize to threads on Head; install Wear Ring (BA 030) onto the Nut (BA 002); thread the Nut onto the Head. Tighten to 50 ft-lb.
15. Use syringe to fill the tool with viscous fluid as shown in the "Lubricant Replacement Instructions" Section: install Port Plugs (BJ 026).



**Figure 10: For Step 10**

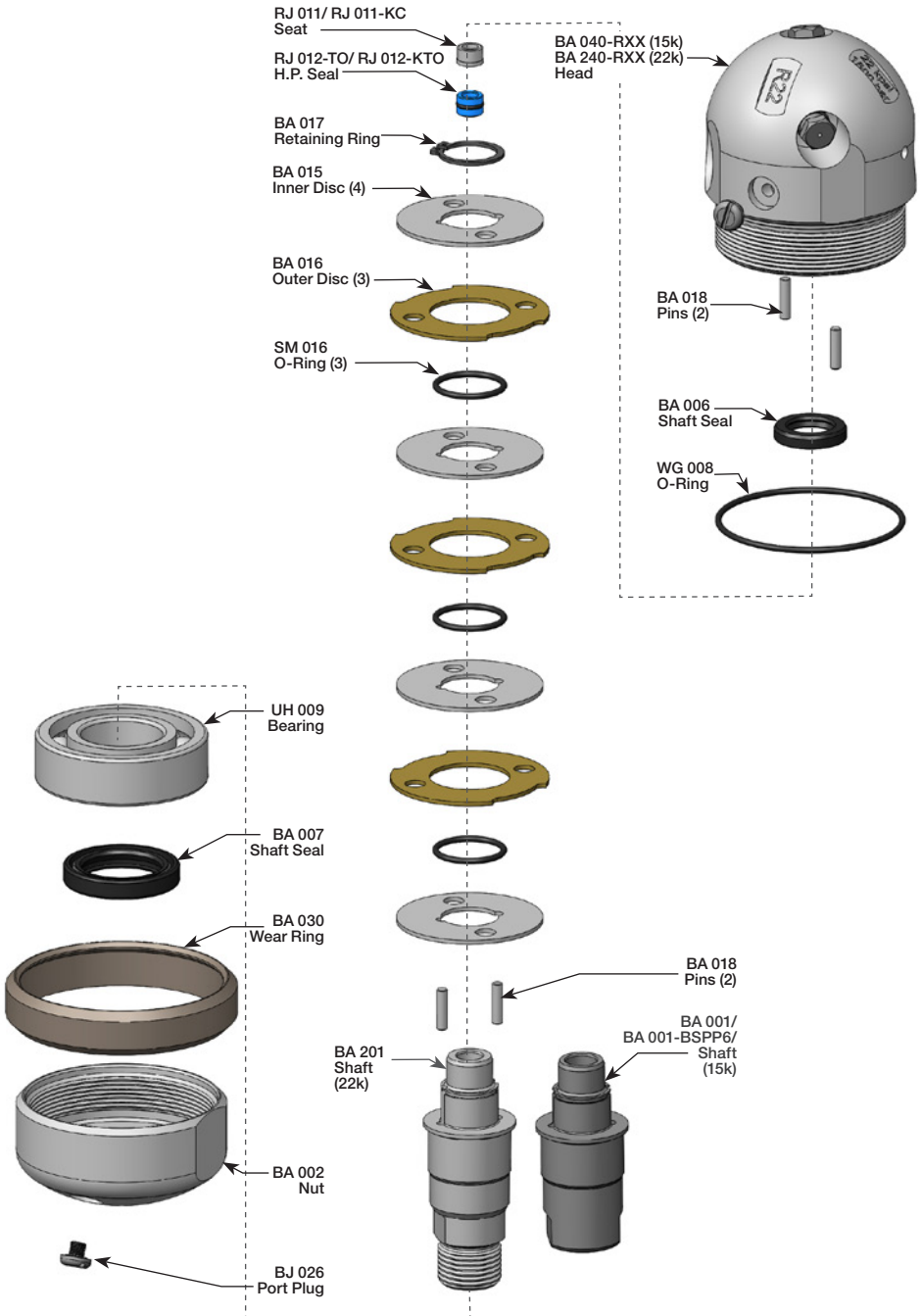


**Figure 11: For Steps 10-12**



**Figure 12: For Steps 13-15**

# 4" BADGER PART NAMES/NUMBERS



## 4" BADGER SERVICE KITS

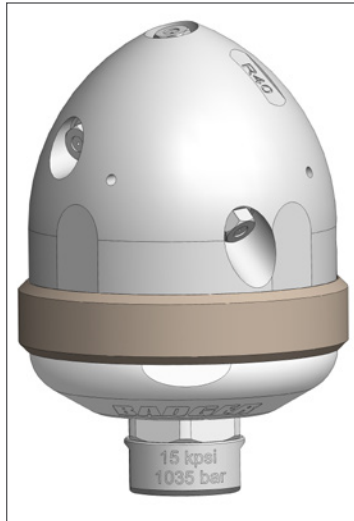
4" BADGER MODELS	KITS AND KIT CONTENTS		
<b>BA-P6 / BA-BSPP6 (15K)</b>	<b>BA 600-F SERVICE KIT (FAST)</b>	<b>BA 600-S SERVICE KIT (SLOW)</b>	<b>BA 602 H.P. SEAL KIT</b>
	1 BJ 048-F Visc Fluid, Fast, 6oz 1 BJ 062-S Anti-seize, 2g 1 RJ 011 Brass Seat 1 RJ 012-TO H.P. Seal and O-Ring 1 BC 410 Syringe Assembly 1 GP 025-P2SS Hex Socket Plug, 1/8 NPT Male, SS 1 PL 663 BA Manual	1 BJ 048-S Visc Fluid, Slow, 6oz 1 BJ 062-S Anti-seize, 2g 1 RJ 011 Brass Seat 1 RJ 012-TO H.P. Seal and O-Ring 1 BC 410 Syringe Assembly 1 GP 025-P2SS Hex Socket Plug, 1/8 NPT Male, SS 1 PL 663 BA Manual	1 RJ 011 Brass Seat 1 RJ 012-TO H.P. Seal and O-Ring
<b>BA-TM12 (20K)</b>	<b>BA 610-F OVERHAUL KIT (FAST)</b>	<b>BA 610-S OVERHAUL KIT (SLOW)</b>	<b>BA 612 TOOL KIT</b>
	1 BA 006 Seal 1 BA 007 Seal 1 BA 017 Retaining Ring, External .688 1 BJ 026 Port Plug 1 BJ 048-F Visc Fluid, Fast, 6oz 1 PL 663 BA Manual 1 RJ 01 Brass Seat 1 RJ 012-TO H.P. Seal and O-Ring 1 SM 016 Seal, O-Ring 1 UH 009 Bearing, Ball 1 WG 008 O-Ring	1 BA 006 Seal 1 BA 007 Seal 1 BA 017 Retaining Ring, External .688 1 BJ 026 Port Plug 1 BJ 048-S Visc Fluid, Slow, 6oz 1 PL 663 BA Manual 1 RJ 011-KC Brass Seat 1 RJ 012-KTO H.P. Seal and O-Ring 1 SM 016 Seal, O-Ring 1 UH 009 Bearing, Ball 1 WG 008 O-Ring	1 BA 100 Retaining Ring Pliers 1 BA 105 Tool
<b>BA-TM12 (20K)</b>	<b>BA 600-TM12-F SERVICE KIT (FAST)</b>	<b>BA 600-TM12-S SERVICE KIT (SLOW)</b>	<b>BA 602-TM12 H.P. SEAL KIT</b>
	1 BJ 048-F Visc Fluid, Fast, 6oz 1 BJ 062-S Anti-seize, 2g 1 RJ 011-KC Carbide 1 RJ 012-KTO H.P. Seal and O-Ring 1 BC 410 Syringe Assembly 1 GP 025-P2SS Hex Socket Plug, 1/8 NPT Male, SS 1 PL 663 BA Manual	1 BJ 048-S Visc Fluid, Slow, 6oz 1 BJ 062-S Anti-seize, 2g 1 RJ 011-KC Carbide 1 RJ 012-KTO H.P. Seal and O-Ring 1 BC 410 Syringe Assembly 1 GP 025-P2SS Hex Socket Plug, 1/8 NPT Male, SS 1 PL 663 BA Manual	1 RJ 011-KC Carbide 1 RJ 012-KTO H.P. Seal and O-Ring
<b>BA-TM12 (20K)</b>	<b>BA 610-TM12-F OVERHAUL KIT (FAST)</b>	<b>BA 610-TM12-S OVERHAUL KIT (SLOW)</b>	<b>BA 612 TOOL KIT</b>
	1 BA 006 Seal 1 BA 007 Seal 1 BA 017 Retaining Ring, External .688 1 BJ 026 Port Plug 1 BJ 048-F Visc Fluid, Fast, 6oz 1 PL 663 BA Manual 1 RJ 011-KC Carbide 1 RJ 012-KTO H.P. Seal and O-Ring 1 SM 016 Seal, O-Ring 1 UH 009 Bearing, Ball 1 WG 008 O-Ring	1 BA 006 Seal 1 BA 007 Seal 1 BA 017 Retaining Ring, External .688 1 BJ 026 Port Plug 1 BJ 048-S Visc Fluid, Slow, 6oz 1 PL 663 BA Manual 1 RJ 011-KC Carbide 1 RJ 012-KTO H.P. Seal and O-Ring 1 SM 016 Seal, O-Ring 1 UH 009 Bearing, Ball 1 WG 008 O-Ring	1 BA 100 Retaining Ring Pliers 1 BA 105 Tool

## 6" BADGER DESCRIPTION AND INTENDED USE

### 6" BADGER MODELS DESCRIPTION AND INTENDED USE

The Badger™ P8, MP9 and M24 Rotary Waterblast Nozzles were designed to waterblast clean pipes as small as 6 inches with elbows. The BA-P8 has a 1/2 NPT female inlet connection and a maximum working pressure of 15,000 psi (1035 bar). The BA-MP9 has a 9/16 medium pressure female inlet connection and a maximum working pressure of 22,000 psi (1500 bar). The BA-M24 has a metric M24x1.5 female face seal inlet connection and a maximum working pressure of 22,000 psi (1500 bar). The Badger™ has an adjustable speed mechanism that allows rotation speed to be changed. For the fastest speed setting, the Shaft Adjust Sleeve (BA 303) is backed out all the way against the shoulder of the shaft. The slowest speed setting is about 1-1/4 turn inward. Do not force the adjustment in this direction. To adjust the speed, hold the wrench flats on the shaft while turning the Shaft Adjust Sleeve with wrench (BA 300). This Badger uses fast viscous fluid for speed control and bearing lubrication.

The Badger™ heads have 1/4 NPT ports; one at 15 degrees, two at 100 degrees, and two at 135 degrees. Engraved on each head is R21, R31 or R40; this number is the offset of the head that makes it rotate. The flow range for each head is given in the table; nozzle sizes must be selected to fit within this flow range. If the flow is less than the range shown, the tool will not rotate; it is okay to use more than the allowable, but the tool **MUST** be slowed down using the adjustable speed mechanism to prevent over-speeding and damaging the tool.



6" BADGER FLOW RANGE PER HEAD OFFSET CHART			
PRESSURE	R40	R31	R21
10,000 (690 bar)	15-24 GPM (57-91 l/min)	21-31 GPM (80-117 l/min)	31-55 GPM (117-208 l/min)
15,000 (1035 bar)	15-24 GPM (57-91 l/min)	23-33 GPM (87-125 l/min)	33-55 GPM (125-208 l/min)
22,000 (1500 bar)	14-21 GPM (53-80 l/min)	21-30 GPM (80-114 l/min)	30-43 GPM (114-163 l/min)

## 6" BADGER WARNING AND SAFETY INSTRUCTIONS

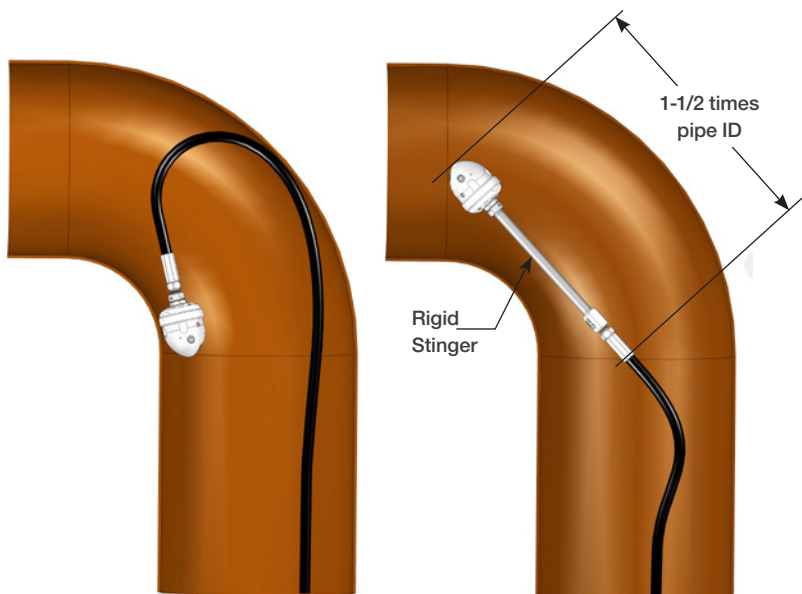
### ⚠ WARNING

Because of the short length of the Badger, the tool can turn around in large pipes and come back at the operator at a high rate of speed. If cleaning larger pipes, a rigid "stinger" should be used between the hose and the tool. It is recommended that the rigid length of the tool including hose end is 1-1/2 times the inside diameter of the pipe being cleaned (see below).

Make sure there is an operator controlled dump in the system, operated by the person closest to the cleaning job. Flush out the high pressure hoses before connecting the Badger. It is recommended that the hose be marked a few feet from the end with a piece of tape so the operator knows when to stop when retracting the tool. Position the tool in the pipe opening. Close the dump and slowly bring up to pressure the first time to make sure no nozzles are plugged and the jet thrust is correct. The Badger should begin to slowly rotate. Once operating pressure is reached, feed the tool into the pipe to begin the cleaning job. Allow the jets time to do their work by feeding the hose out at a controlled rate. The StoneAge ABX-500 Hose Control Device can be used to achieve consistent feed rates for pipe cleaning. When the work is complete and the tool is connected from the hose, blow out all water to prolong the life of the tool. A small amount of oil can be blown into the tool as well as an added measure to maximize tool life.

### ⚠ DANGER

Operations with this equipment can be potentially hazardous. Caution must be exercised prior to and during machine and water jet tool use. Please read and follow all of these instructions, in addition to the guidelines in the WJTA Recommended Practices handbook, available online at [www.wjta.org](http://www.wjta.org). Deviating from safety instructions and recommended practices can lead to severe injury and/or death.



**IMPROPER USE:**  
Badger will turn around in  
large diameter pipe  
**VERY DANGEROUS!**

**PROPER USE:**  
Badger with rigid "stinger"  
to prevent turnaround, still  
able to pass through elbows.

## 6" BADGER OPERATION

### OPERATION:

- Make sure the operator has a controlled dump in the system and it is operated by the person closest to the job. Test the dump prior to beginning the job.
- Flush out the high pressure hoses before connecting the Badger™ to eliminate debris.

## NOTICE

*The two most important items in maintaining the Badger tools;*

*- Keep debris from entering the tool and preventing it from rotating by flushing high pressure hoses before use.*

*- Keep the 4" and 6" models full of viscous fluid to maintain control and rotation speed. When the viscous fluid is lost or contaminated, the rotation speed of the tool will increase, which reduce the life of the high pressure seal and bearing.*

- Attach tool to the end of the hose.
- It is recommended that the hose be marked a few feet from the end with a piece of tape so the operator knows when to stop on the way back out.
- Position the tool in the pipe opening.
- Close the dump and slowly bring the pump up to pressure the first time to make sure no nozzles are plugged and the jet thrust is correct. The Badger should begin to slowly rotate.
- Once operating pressure is reached, feed the tool into the pipe to begin the cleaning job.
- Allow the jets time to do their work by feeding the hose out at a controlled rate.
- When the work is complete and the tool is disconnected from the hose, blow out all water to prolong the life of the tool.
- 4" & 6" BADGERS ONLY- A small amount of 3-IN-ONE or equivalent lubricant can be blown into the tool as well.



## HIGH-PRESSURE WATER SEALS LEAK:

- The high pressure seal may leak initially at lower pressures, but should pop closed as pressure is increased. A continuous leak at operating pressure from the weep holes indicates the need to replace the HP Seal and Seat. HP Seals wearing out too quickly can be an indication that the shaft bore is worn, the HP Seat is installed upside-down, or the tool is over spinning. Over spinning is caused by low or contaminated viscous fluid, water in the fluid chamber (replace shaft seals), or too much jet torque. Refilling the viscous fluid every 30-40 hours of operation is important for proper speed control. Only use StoneAge recommended viscous fluid.

## TOOL WILL NOT ROTATE:

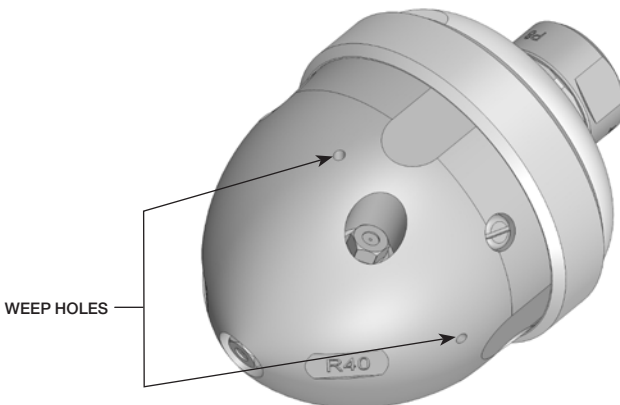
- Check the nozzles for plugging or wear (nozzles have to be removed to check for obstructions), Check that the nozzle sizes are correct for the desired flow and that the desired flow matches the head flow range. Check that the nozzle sizes are installed in a balanced configuration. If the tool feels rough when manually rotating the head, this indicates internal damage. Replace bearings, shaft seals, viscous fluid, and check the Inner and Outer Discs for flatness. These discs can be deformed if tool is reassembled when discs are not properly aligned with BA 018 Pins.

## TOOL SPINS TOO FAST:

- A significant increase in rotation speed means that the speed control mechanism in the tool has lost functionality. This can be a result of viscous fluid loss or fluid contamination. Operation of the tool in this state can cause damage to other components and accelerated wear of the high pressure seal. If this occurs, the first step is to flush the tool with new viscous fluid as shown below.

## LOCK-UP TROUBLESHOOTING TIP:

- Rotate in reverse 1 1/4 to 1 1/2 turns to unlock braking mechanism. If tool rotates smoothly then redress may not be required.
- Verify jetting at <http://jetting.stoneagetools.com/#/> or contact your factory authorized StoneAge® Inc.



# 6" TOOL SERVICE INFORMATION

## TOOL SERVICE

\*\*\*Product training and proper tools are required to service this nozzle. If you are uncomfortable performing the service, bring the nozzle to your authorized dealer.\*

The use of a bench vice and an arbor press is highly helpful. Take care throughout the entire procedure to keep the internals clean and free from grit, lint, and contamination. Failure to do so could result in premature failure after service.

### LIST OF TOOLS:

- Bench Vice (recommended)
- Arbor Press (recommended)
- 18" Adjustable Wrench (such as Crescent® C718 Automatic Adjustable Pipe Wrench)
- Medium size flat-head screw driver
- Pick
- Bearing Splitter
- 3/8 Drive Ratchet with 3" Extension
- BA 612-P8/M9 Tool Kit (For 6" Badger Includes)
  - BA 100 Retaining Ring Pliers
  - BA 105 Seal Press Tool

### LIST OF MATERIALS:

- Clean lint free rags or blue shop towels
- Anti-Seize - StoneAge PN (GP 043 Blue Goop)
- Lithium Soap Grease – StoneAge PN (GP 048 Grease)
- Blue Loctite® 242
- Isopropyl Alcohol or Denatured Alcohol

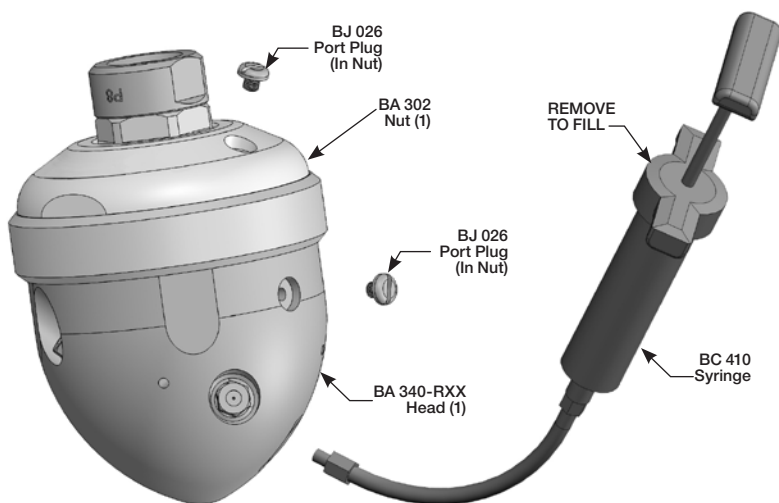
Blue Goop® is a registered trademark of the Swagelock® Corporation.

Loctite® is a registered trademark of Henkel AG & Co. KGaA.

## 6" BADGER LUBRICANT REPLACEMENT INSTRUCTIONS

### VISCOUS FLUID FLUSH INSTRUCTIONS (6" BADGER)

1. Remove the Port Plugs (BJ 026) in the Nut (BA 302) and Head (BA 340-RXX) (see below).
2. Fill the Syringe (BC 410) with viscous fluid by removing the end near the handle, pulling out the plunger, and pouring the Viscous Fluid (BJ 048-F) in to fill the Syringe Body. With plunger re-installed, purge air out of Syringe hose.
3. Thread the syringe end into the port in the Head, and squeeze fresh Viscous Fluid in until clean Viscous Fluid comes out the port in the Nut. Hold the tool so the port in the Nut is the highest point. If air bubbles come out of the port on the nut, keep flushing new fluid until air bubbles stop.
4. Install Port Plug into Nut first. Remove the Syringe and install the Port Plug in the Head.



*Viscous Fluid Flush*

# 6" BADGER DISASSEMBLY

## DISASSEMBLY

1. Unscrew the Nut (BA 302) from the Head (BA 340).
2. Pull the Shaft (BA 301-P8/M9/M24x1.5) out of the Head.

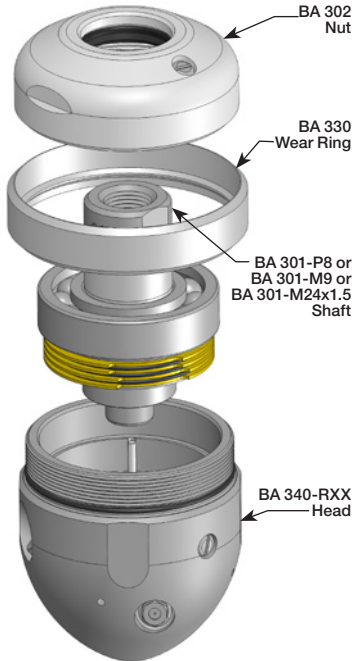


Figure 1: For Steps 1-2

3. Remove the Seat (BJ 011-C), H.P. Seal (BJ 012-TRO), and Wave Spring (BA 313) from the bore of the Shaft.

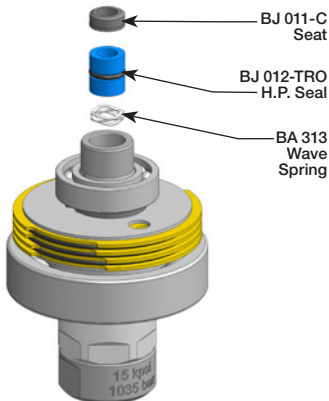


Figure 2: For Step 3

4. Remove the Bearing (BA 311) and Retaining Ring (CST 141) from the Shaft.
5. Pull the Discs (BA 315, BA 316) and O-Rings (SM 116 & BJ 008) off of the Shaft.

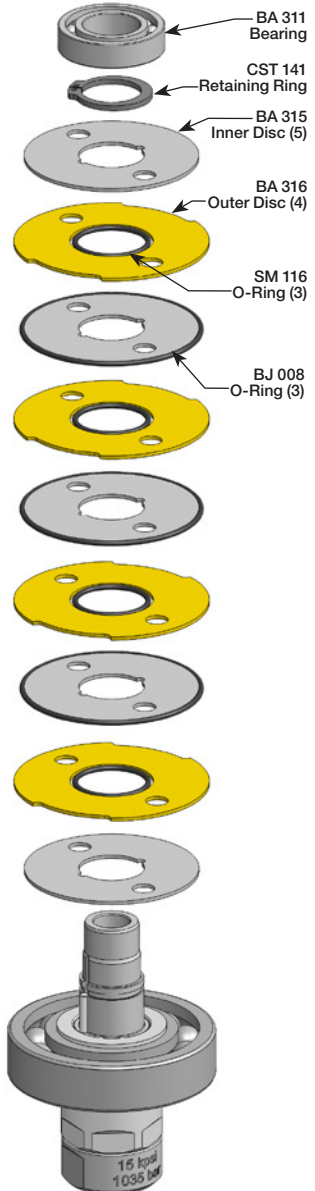


Figure 3: For Step 4-5

## 6" BADGER DISASSEMBLY

6. Press the Bearing (BA 309) off of the Shaft Adjust Sleeve.
7. There is no need to remove the Pins (BA 318) from the Shaft; however, if they fall out do not lose them.
8. If the Shaft Adjust Sleeve (BA 303) fails to remain in the set position while the tool is in use, it may be necessary to unscrew the Shaft (BA 301-P8/MP9/M24x1.5) from the Shaft Adjust Sleeve in order to replace the (2) O-Rings (BA 310). Normally it is not necessary to disassemble the Shaft from the Adjust Sleeve.

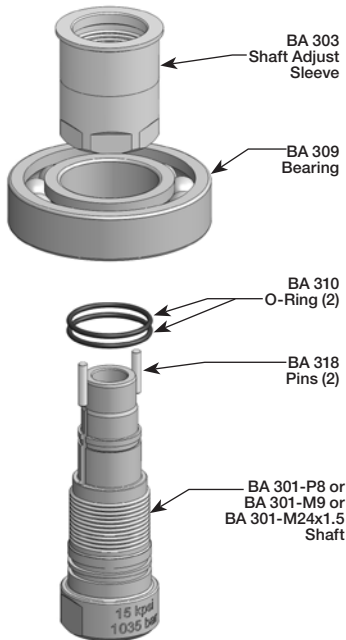


Figure 4: For Steps 6-8

9. Remove the Shaft Seal (BA 308) if it is damaged.
10. Remove the Port Screw (BJ 026) from the Nut.

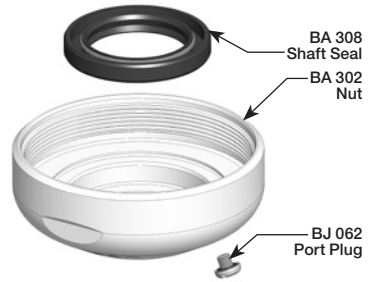


Figure 5: For Steps 9-10

11. Remove the Port Screw (BJ 026) from the Head.
12. Remove the Shaft Seal (BA 307) and O-Ring (BA 312) if they are damaged.
13. There is no need to remove the Pins (BA 318); however, if they fall out, do not lose them.

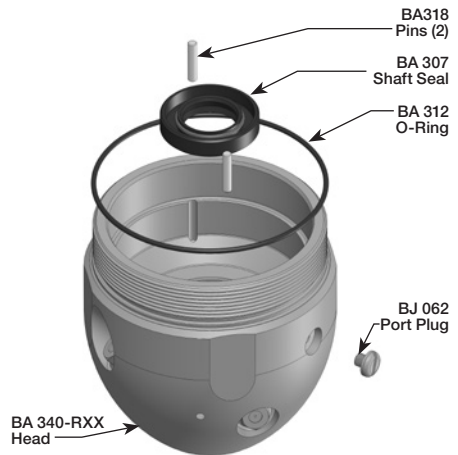


Figure 6: For Steps 11-13

# 6" BADGER ASSEMBLY

## ASSEMBLY

1. Press Bearing (BA 309) onto Shaft Adjust Sleeve (BA 303)
2. Check that Pins (BA 318) are installed in Shaft.

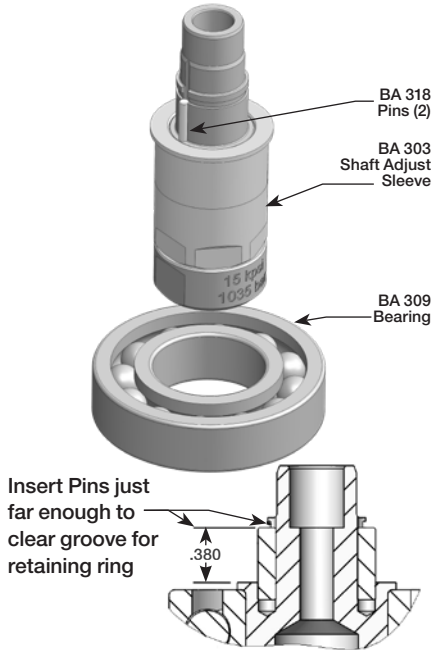


Figure 7: For Steps 1-2

3. Place an Inner Disc (BA 315) on Shaft, aligning with pins.
4. Place an O-Ring (SM 116) on top of this Disc, stretched around the pins.
5. Place an Outer Disc (BA 316) around the outside of this O-Ring
6. Place another Inner Disc, and also place an O-Ring (BJ 008) around the outer edge of this Disc.
7. Repeat steps 3 through 6, until there are four Outer Discs and five Inner Discs on Shaft. Note that there is no outer O-Ring on the Inner Discs at each end of the stack.
8. Push down on top disc and install the Retaining Ring (CST 141) in the groove around Shaft. Install Bearing (BA 311) on shaft.

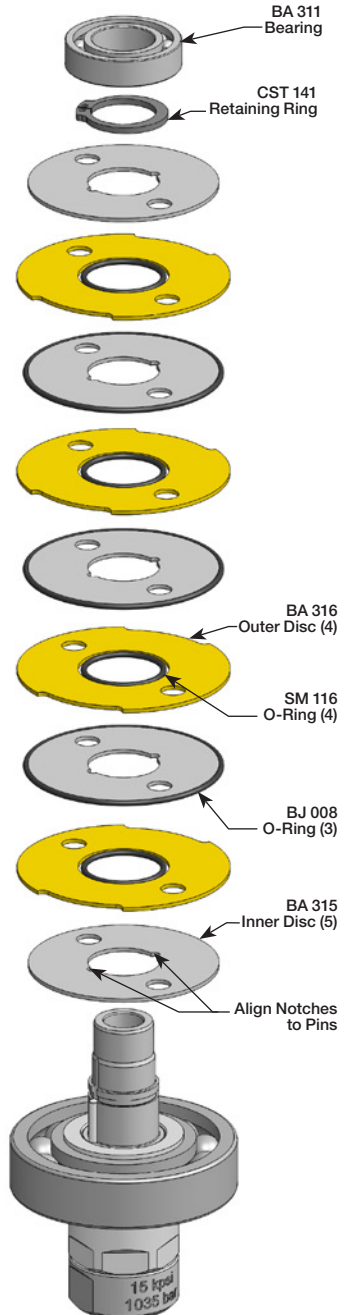


Figure 8: For Step 3-8

9. Insert Wave Spring (BA 313) into bore of Shaft. Apply grease to and install the H.P. Seal (BJ 012-TRO) in bore of Shaft.
10. Apply grease to the flat face of the Seat (BJ 011-C) and place in bore of Shaft, on top of Seal, as shown.

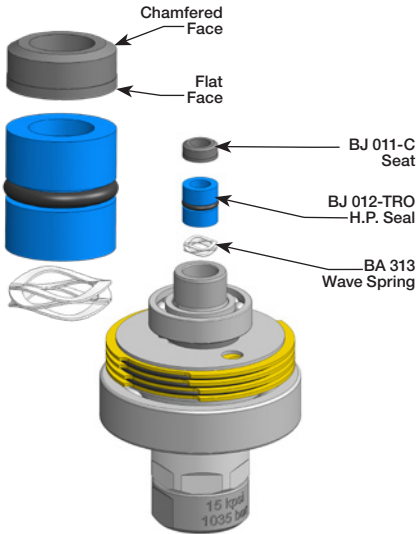


Figure 9: For Steps 9-10

11. Install Shaft Seals (BA 308) in the Nut (BA 302) as shown.

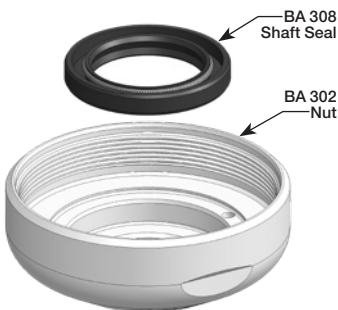


Figure 10: For Step 11

12. Install Shaft Seals (BA 307) in the Head (BA 340-RXX) as shown.
13. Place O-Ring (BA 312) over threads and into groove of Head.
14. Check that the Pins (BA 318) are installed in the Head.

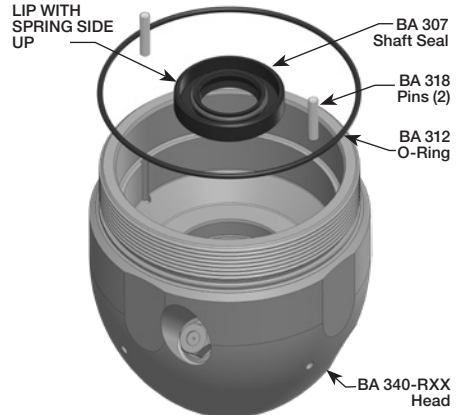


Figure 11: For Step 12-14

15. Align the notches on the Outer Discs with the pins in the Head; slide shaft assembly into the Head, taking care that the outer O-Rings remain captured between the Discs.
16. Apply anti-seize to threads on Head; install Wear Ring (BA 330) onto the Nut (BA 302); thread the Nut onto the Head. **Tighten to 50 ft-lbs.**
17. Use syringe to fill the tool with viscous fluid as shown in the "Lubrication Replacement Instructions" Section; install the Port Screws (BJ 026).

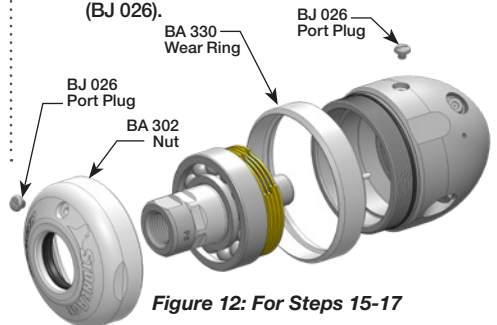
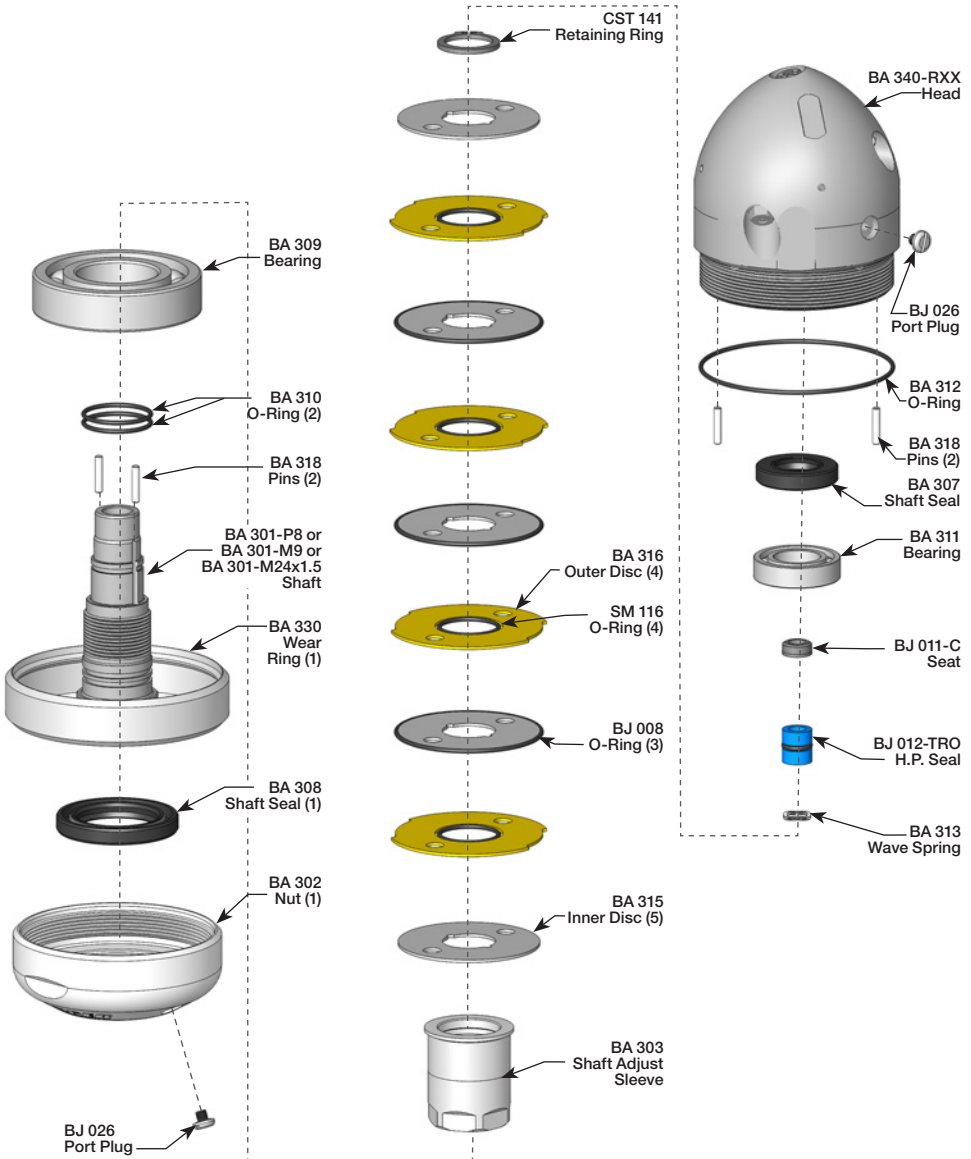


Figure 12: For Steps 15-17

# 6" BADGER PART NAMES/NUMBERS





<b>6" BADGER KITS AND KIT CONTENTS</b>		
<b>BA-P8/ MP9</b>	<b>BA 600-P8/MP9 SERVICE KIT (FAST)</b>	<b>BA 602-P8/MP9 H.P. SEAL KIT</b>
	<ul style="list-style-type: none"> <li>1 BA 313 Wave Spring</li> <li>1 BC 410 Syringe Assembly</li> <li>1 BJ 011-C Carbide Seat</li> <li>1 BJ 012-TRO H.P. Seal and O-Ring</li> <li>1 BJ 026 Port Plug</li> <li>1 BJ 048-F Visc Fluid, Fast, 6oz</li> <li>1 PL 663 BA Manual</li> </ul>	<ul style="list-style-type: none"> <li>1 BJ 011-C Carbide Seat</li> <li>1 BJ 012-TRO H.P. Seal and O-Ring</li> </ul>
	<b>BA 610-P8/MP9 OVERHAUL KIT (FAST)</b>	<b>BA 612 P8/MP9 TOOL KIT</b>
	<ul style="list-style-type: none"> <li>1 BA 307 Seal</li> <li>1 BA 308 Seal</li> <li>1 BA 309 Bearing, Ball, JEM</li> <li>2 BA 310 O-Ring</li> <li>1 BA 311 Bearing, Ball, Open</li> <li>1 BA 312 O-Ring</li> <li>1 BA 313 Wave Spring</li> <li>3 BJ 008 O-Ring</li> <li>1 BJ 011-C Carbide Seat</li> <li>1 BJ 012-TRO H.P. Seal &amp; O-Ring</li> <li>2 BJ 026 Port Plug</li> <li>1 BJ 048-F Viscous Fluid, Fast - 6oz.</li> <li>1 CST 141 Retaining Ring, HD External .875</li> <li>4 SM 116 O-Ring, Sealing</li> <li>1 PL 663 Consumable, BA Manual</li> </ul>	<ul style="list-style-type: none"> <li>1 BA 100 Retaining Ring Pliers</li> <li>1 BA 305 Tool (6" Badger Elbow)</li> </ul>

# TERMS AND CONDITIONS AND WARRANTY INFORMATION

**1. Acceptance of Terms and Conditions.** Receipt of these Terms and Conditions of Sale ("Terms and Conditions") shall operate as the acceptance by StoneAge, Inc. ("Seller") of the order submitted by the purchaser ("Buyer"). Such acceptance is made expressly conditional on assent by Buyer to these Terms and Conditions. Such assent shall be deemed to have been given unless written notice of objection to any of these Terms and Conditions (including inconsistencies between Buyer's purchase order and this acceptance) is given by Buyer to Seller promptly on receipt hereof.

Seller desires to provide Buyer with prompt and efficient service. However, to individually negotiate the terms of each sales contract would substantially impair Seller's ability to provide such service. Accordingly, the product(s) furnished by Seller are sold only according to the terms and conditions stated herein and with the terms and conditions stated in any effective StoneAge Dealer Agreement or StoneAge Reseller Agreement, if applicable. Notwithstanding any terms and conditions on Buyer's order, Seller's performance of any contract is expressly made conditional on Buyer's agreement to these Terms and Conditions unless otherwise specifically agreed to in writing by Seller. In the absence of such agreement, commencement of performance, shipment and/or delivery shall be for Buyer's convenience only and shall not be deemed or construed to be an acceptance of Buyer's terms and conditions.

**2. Payment/Prices.** Unless other arrangements have been made in writing between Seller and Buyer, payment for the product(s) shall be made upon receipt of invoice. The prices shown on the face hereof are those currently in effect. Prices invoiced shall be per pricelist in effect at the time of shipment. Prices are subject to increase for inclusion of any and all taxes which are applicable and which arise from the sale, delivery or use of the product(s), and the collection of which Seller is or may be responsible to provide to any governmental authority, unless acceptable exemption certificates are provided by Buyer in accordance with applicable law. Buyer shall pay all charges for transportation and delivery and all excise, order, occupation, use or similar taxes, duties, levies, charges or surcharges applicable to the product(s) being purchased, whether now in effect or hereafter imposed by any governmental authority, foreign or domestic.

**3. Warranty.** SELLER MAKES NO WARRANTIES OR REPRESENTATIONS AS TO THE PERFORMANCE OF ANY PRODUCT EXCEPT AS SET FORTH IN THE STONEAGE LIMITED WARRANTY PROVIDED WITH THE PRODUCT.

**4. Delivery.** Seller is not obligated to make delivery by a specified date, but will always use its best efforts to make delivery within the time requested. The proposed shipment date is an estimate. Seller will notify Buyer promptly of any material delay and will specify the revised delivery date as soon as practicable. UNDER NO CIRCUMSTANCES SHALL SELLER HAVE ANY LIABILITY WHATSOEVER FOR LOSS OF USE OR FOR ANY DIRECT OR CONSEQUENTIAL DAMAGES RESULTING FROM DELAY REGARDLESS OF THE REASON(S).

All product(s) will be shipped F.O.B. point of origin, unless specifically agreed otherwise, and Buyer shall pay all shipping costs and insurance costs from that point. Seller, in its sole discretion, will determine and arrange the means and manner of transportation of the product(s). Buyer shall bear all risk of loss commencing with the shipment or distribution of the product(s) from Seller's warehouse. Order shortages or errors must be reported within fifteen (15) business days from receipt of shipment to secure adjustment. No product(s) may be returned without securing written approval from Seller.

**5. Modification.** These Terms and Conditions are intended by Seller and Buyer to constitute a final, complete and exclusive expression of agreement relating to the subject matter hereof and cannot be supplemented or amended without Seller's prior written approval.

**6. Omission.** Seller's waiver of any breach or Seller's failure to enforce any of these Terms and Conditions at any time, shall not in any way affect, limit or waive Seller's right thereafter to enforce and compel strict compliance with every term and condition hereof.

**7. Severability.** If any provision of these Terms and Conditions is held to be invalid or unenforceable, such invalidity or unenforceability shall not affect the validity or enforceability of the other portions hereof.

## TERMS AND CONDITIONS AND WARRANTY INFORMATION

**8. Disputes.** Seller and Buyer shall attempt in good faith to promptly resolve any dispute arising under these Terms and Conditions by negotiations between representatives who have authority to settle the controversy. If unsuccessful, Seller and Buyer shall further attempt in good faith to settle the dispute by nonbinding third-party mediation, with fees and expenses of such mediation apportioned equally to each side. Any dispute not so resolved by negotiation or mediation may then be submitted to a court of competent jurisdiction in accordance with the terms hereof. These procedures are the exclusive procedures for the resolution of all such disputes between the Seller and Buyer.

**9. Governing Law.** All sales, agreements for sale, offers to sell, proposals, acknowledgments and contracts of sale, including, but not limited to, purchase orders accepted by Seller, shall be considered a contract under the laws of the State of Colorado and the rights and duties of all persons, and the construction and effect of all provisions hereof shall be governed by and construed according to the laws of such state.

### STONEAGE TRADEMARK LIST

View the list of StoneAge's trademarks and service marks and learn how the trademarks should be used. Use of StoneAge trademarks may be prohibited, unless expressly authorized.

<http://www.StoneAgetools.com/trademark-list/>

### STONEAGE PATENT DATA

View the list of StoneAge's current U.S. patent numbers and descriptions.

<http://www.sapatents.com>

### STONEAGE TERMS AND WARRANTY

View StoneAge's Terms and Warranty Conditions online.

<http://www.stoneagetools.com/terms>

<http://www.stoneagetools.com/warranty>

**10. Jurisdiction and Venue.** Seller and Buyer agree that the state or federal courts located within the City and County of Denver, Colorado shall have sole and exclusive jurisdiction over any litigation concerning any dispute arising under these Terms and Conditions not otherwise resolved pursuant to Section 9 as well as any alleged defects of any Products or damages sustained as a result of such alleged defects. Seller and Buyer further agree that should any litigation be commenced in connection with such a dispute, it shall only be commenced in such courts. Seller and Buyer agree to the exclusive jurisdiction of such courts and neither will raise any objection to the jurisdiction and venue of such courts, including as a result of inconvenience.

**11. Attorney's Fees.** If any litigation is commenced between Seller and Buyer, or their personal representatives, concerning any provision hereof, the party prevailing in the litigation shall be entitled, in addition to such other relief that is granted, to a reasonable sum as and for their attorneys' fees and costs in such litigation or mediation.

## WARRANTY:

Warranties set forth herein extend only to End-Users, meaning customers acquiring, or that have previously acquired, a product manufactured by StoneAge ("Product") for their own use and not for resale, either directly from StoneAge Inc. ("StoneAge") or from a StoneAge Authorized Dealer or Reseller ("Dealer"). No warranty of any kind or nature is made by StoneAge beyond those expressly stated herein.

**1. LIMITED WARRANTY PERIOD.** Subject to the limitations and conditions hereinafter set forth, StoneAge warrants its Product to be free from defects in workmanship and material for a period of one (1) year from the date of purchase by the End-User, provided that the end of the limited warranty period shall not be later than eighteen (18) months from the date of shipment of the Product to the Dealer or the End-User by StoneAge ("Limited Warranty Period"). All replacement parts which are furnished under this Limited Warranty and properly installed shall be warranted to the same extent as the original Product under this Limited Warranty if, and only if, the original parts were found to be defective within the original Limited Warranty Period covering the original Product. Replacement parts are warranted for the remainder of the original Limited Warranty Period. This Limited Warranty does not cover any component part of any Product not manufactured by StoneAge. Any such component part is subject exclusively to the component manufacturer's warranty terms and conditions.

**2. LIMITED WARRANTY COVERAGE.** StoneAge's sole obligation under this Limited Warranty shall be, at StoneAge's option and upon StoneAge's inspection, to repair, replace or issue a credit for any Product which is determined by StoneAge to be defective in material or workmanship. StoneAge reserves the right to examine the alleged defective Product to determine whether this Limited Warranty is applicable, and final determination of limited warranty coverage lies solely with StoneAge. No statement or recommendation made by a StoneAge representative, Dealer or agent to End-User shall constitute a warranty by StoneAge or a waiver or modification to any of the provisions hereof or create any liability for StoneAge.

**3. WARRANTY SERVICE PROVIDERS.** Service and repair of the Product is to be performed only by StoneAge authorized service representatives, including Dealers who are authorized repair centers, with StoneAge approved parts. Information about StoneAge authorized service representatives can be obtained through the StoneAge website at [www.stoneagetools.com/service](http://www.stoneagetools.com/service). Unauthorized service, repair or

modification of the Product or use of parts not approved by StoneAge will void this Limited Warranty. StoneAge reserves the right to change or improve the material and design of the Product at any time without notice to End-User, and StoneAge is not obligated to make the same improvements during warranty service to any Product previously manufactured.

**4. WARRANTY EXCLUSIONS.** This Limited Warranty does not cover, and StoneAge shall not be responsible for the following, or damage caused by the following: (1) any Product that has been altered or modified in any way not approved by StoneAge in advance in writing; (2) any Product that has been operated under more severe conditions or beyond the rated capacity specified for that Product; (3) depreciation or damage caused by normal wear and tear, failure to follow operation or installation instructions, misuse, negligence or lack of proper protection during storage; (4) exposure to fire, moisture, water intrusion, electrical stress, insects, explosions, extraordinary weather and/or environmental conditions including, but not limited to lightning, natural disasters, storms, windstorms, hail, earthquakes, acts of God or any other force majeure event; (5) damage to any Product caused by any attempt to repair, replace, or service the Product by persons other than StoneAge authorized service representatives; (6) costs of normal maintenance parts and services; (7) damage sustained during unloading, shipment or transit of the Product; or (8) failure to perform the recommended periodic maintenance procedures listed in the Operator's Manual accompanying the Product.

**5. REQUIRED WARRANTY PROCEDURES.** To be eligible for warranty service, the End-User must: (1) report the Product defect to the entity where the Product was purchased (i.e. StoneAge or the Dealer) within the Limited Warranty Period specified in this Limited Warranty; (2) submit the original invoice to establish ownership and date of purchase; and (3) make the Product available to a StoneAge authorized service representative for inspection to determine eligibility for coverage under this Limited Warranty. This Limited Warranty shall not extend to any person or entity who fails to provide proof of original purchase from StoneAge or a Dealer. No Product may be returned for credit or adjustment without prior written permission from StoneAge.

## TERMS AND CONDITIONS AND WARRANTY INFORMATION

6. **DISCLAIMER OF IMPLIED WARRANTIES AND OTHER REMEDIES.** EXCEPT AS EXPRESSLY STATED HEREIN (AND TO THE FULLEST EXTENT ALLOWED UNDER APPLICABLE LAW), STONEAGE HEREBY DISCLAIMS ALL OTHER WARRANTIES, EXPRESS OR IMPLIED, INCLUDING WITHOUT LIMITATION ALL IMPLIED WARRANTIES OF MERCHANTABILITY OR FITNESS FOR A PARTICULAR PURPOSE, AND ANY AND ALL WARRANTIES, REPRESENTATIONS OR PROMISES AS TO THE QUALITY, PERFORMANCE OR FREEDOM FROM DEFECT OF THE PRODUCT COVERED BY THIS LIMITED WARRANTY. STONEAGE FURTHER DISCLAIMS ALL IMPLIED INDEMNITIES.

7. **LIMITATION OF LIABILITY.** End-User specifically acknowledges that the Product may be operated at high speeds and/or pressures, and that as such it may be inherently dangerous if not used correctly. End-User shall familiarize itself with all operation materials provided by StoneAge and shall at all times use and require its agents, employees and contractors to use all necessary and appropriate safety devices, guards and proper safe operating procedures. In no event shall StoneAge be responsible for any injuries to persons or property caused directly or indirectly by the operation of the Product if End-User or any agent, employee, or contractor of End-User: (1) fails to use all necessary and appropriate safety devices, guards and proper safe operating procedures; (2) fails to maintain in good working order such safety devices and guards; (3) alters or modifies the Product in any way not approved by StoneAge in advance in writing; (4) allows the Product to be operated under more severe conditions or beyond the rated capacity specified for the Product; or (5) otherwise negligently operates the Product. End-User shall indemnify and hold StoneAge harmless from any and all liability or obligation incurred by or against StoneAge, including costs and attorneys' fees, to or by any person so injured.

TO THE FULL EXTENT ALLOWED BY APPLICABLE LAW, STONEAGE SHALL NOT BE LIABLE FOR ANY INDIRECT, SPECIAL, INCIDENTAL, CONSEQUENTIAL, OR PUNITIVE DAMAGES (INCLUDING WITHOUT LIMITATION, LOSS OF PROFITS, LOSS OF GOODWILL, DIMINUTION OF VALUE, WORK STOPPAGE, INTERRUPTION OF BUSINESS, RENTAL OF SUBSTITUTE PRODUCT, OR OTHER COMMERCIAL LOSS EVEN TO THE EXTENT SUCH DAMAGES WOULD CONSTITUTE DIRECT DAMAGES), WITH RESPECT TO THE COVERED STONEAGE PRODUCT, OR OTHERWISE IN CONNECTION WITH THIS LIMITED WARRANTY, REGARDLESS OF WHETHER STONEAGE HAS BEEN

ADVISED OF THE POSSIBILITY OF SUCH DAMAGES.

IT IS UNDERSTOOD THAT STONEAGE'S LIABILITY, WHETHER IN CONTRACT, IN TORT, UNDER ANY WARRANTY, IN NEGLIGENCE, OR OTHERWISE SHALL NOT EXCEED THE AMOUNT OF THE PURCHASE PRICE PAID BY THE END-USER FOR THE PRODUCT. STONEAGE'S MAXIMUM LIABILITY SHALL NOT EXCEED, AND END-USER'S REMEDY IS LIMITED TO EITHER (1) REPAIR OR REPLACEMENT OF THE DEFECTIVE WORKMANSHIP OR MATERIAL OR, AT STONEAGE'S OPTION, (2) REFUND OF THE PURCHASE PRICE, OR (3) ISSUANCE OF A CREDIT FOR THE PURCHASE PRICE, AND SUCH REMEDIES SHALL BE END-USER'S ENTIRE AND EXCLUSIVE REMEDY.

YOU, THE END-USER, UNDERSTAND AND EXPRESSLY AGREE THAT THE FOREGOING LIMITATIONS ON LIABILITY ARE PART OF THE CONSIDERATION IN THE PRICE OF THE STONEAGE PRODUCT YOU PURCHASED.

Some jurisdictions do not allow the limitation or exclusion of liability for certain damages, so the above limitations and exclusions may not apply to you. This Limited Warranty gives you specific legal rights, and you may also have other rights which vary from jurisdiction to jurisdiction. If any provisions of this Limited Warranty is held to be invalid or unenforceable, such invalidity or unenforceability shall not affect the validity or enforceability of the other portions hereof.

# NOTES

THIS PAGE LEFT INTENTIONALLY BLANK

THIS PAGE LEFT INTENTIONALLY BLANK



1-866-795-1586 • [www.STONEAGETOOLS.com](http://www.STONEAGETOOLS.com)

© 2018 StoneAge, Inc. All Rights Reserved