

# BUSH HOG®

## Model 278 Rotary Cutter Operator's Manual



**BUSH HOG®**  
Performance You Can Count On™

**OPERATION ● MAINTENANCE**

# CONGRATULATIONS!

You have invested in the best implement of its type on the market today.

The care you give your Bush Hog implement will greatly determine your satisfaction with its performance and its service life. We urge a careful study of this manual to provide you with a thorough understanding of your new implement before operating, as well as suggestions for operation and maintenance.

If your manual should become lost or destroyed, Bush Hog will be glad to provide you with a new copy. Order from Bush Hog, 2501 Griffin Ave., Selma, Alabama, 36703. Most of our manuals can also be downloaded from our website at [www.bushhog.com](http://www.bushhog.com).

As an authorized Bush Hog dealer, we stock genuine Bush Hog parts which are manufactured with the same precision and skill as our original equipment. Our trained service personnel are well informed on methods required to service Bush Hog equipment, and are ready and able to help you.

Should you require additional information or assistance, please contact us.

YOUR AUTHORIZED  
BUSH HOG DEALER

BECAUSE BUSH HOG MAINTAINS AN ONGOING PROGRAM OF PRODUCT IMPROVEMENT, WE RESERVE THE RIGHT TO MAKE IMPROVEMENTS IN DESIGN OR CHANGES IN SPECIFICATIONS WITHOUT INCURRING ANY OBLIGATION TO INSTALL THEM ON UNITS PREVIOUSLY SOLD.

BECAUSE OF THE POSSIBILITY THAT SOME PHOTOGRAPHS IN THIS MANUAL WERE TAKEN OF PROTOTYPE MODELS, PRODUCTION MODELS MAY VARY IN SOME DETAIL. IN ADDITION, SOME PHOTOGRAPHS MAY SHOW SHIELDS REMOVED FOR PURPOSES OF CLARITY. **NEVER OPERATE THIS IMPLEMENT WITHOUT ALL SHIELDS IN PLACE.**

# 278 SERIES

## ROTARY CUTTER OPERATOR'S MANUAL

---

### TABLE OF CONTENTS

SECTION / PARA	PAGE	SECTION / PARA	PAGE
Warranty .....	2	IV Maintenance .....	9
Dealer Preparation Check List .....	3	4-1 Maintenance Check List .....	9
Safety Precautions .....	4	4-2 Lubrication .....	9
Introduction and Description .....	5	4-3 Gearbox Removal .....	11
I 1-1 Introduction .....	5	4-4 Gearbox Installation .....	12
1-2 Description .....	5	4-5 Blade Replacement .....	12
II Preparation for use .....	6	4-6 Adjusting Gearbox Angle .....	12
2-1 Attaching to Tractor (Pull Type) .....	6	4-7 Slip Clutch Operation Check .....	13
2-2 Attaching to Tractor (Lift Type) .....	6	4-8 Slip Clutch Adjustment .....	13
III Operating Instructions .....	8	4-9 Troubleshooting .....	13
3-1 General Safety .....	8	V Assembly .....	14
3-2 Adjusting for Work .....	8	5-1 3 Point Hitch Model .....	14
3-2.1 Cutting Height Adjustment (3-Point Hitch Models) .....	8	5-1.1 Center Mount .....	14
3-2.2 Cutting Height Adjustment (Pull Type) .....	8	5-1.2 Offset Mount .....	14
3.3 Operation .....	8	5-2 Pull Models .....	15
3-4 Transporting .....	9	5-3 Optional Safety Chain Installation .....	16
		5-3.1 Rear Chains .....	16
		5-3.2 Front Chains .....	16
		Safety Decals .....	17

---

### RETAIL CUSTOMER'S RESPONSIBILITY UNDER THE BUSH HOG WARRANTY

It is the Retail Customer and/or Operator's responsibility to read the Operator's Manual, to operate, lubricate, maintain and store the product in accordance with all instructions and safety procedures. Failure of the operator to read the Operator's Manual is a misuse of this equipment.

It is the Retail Customer and/or Operator's responsibility to inspect the product and to have any part(s) repaired or replaced when continued operation would cause damage or excessive wear to other parts or cause a safety hazard.

It is the Retail Customer's responsibility to deliver the product to the authorized Bush Hog Dealer, from whom he purchased it, for service or replacement of defective parts which are covered by warranty. Repairs to be submitted for warranty consideration must be made within forty-five (45) days of failure.

It is the Retail Customer's responsibility for any cost incurred by the Dealer for traveling to or hauling of the product for the purpose of performing a warranty obligation or inspection.



# MODEL 278 LIMITED WARRANTY



Bush Hog warrants to the original purchaser of any new Bush Hog equipment, purchased from an authorized Bush Hog dealer, that the equipment be free from defects in material and workmanship for a period of one (1) year for non-commercial, state, and municipalities' use and ninety (90) days for commercial use from date of retail sale.

Replacement or repair parts installed in the equipment covered by this limited warranty are warranted for ninety (90) days from the date of purchase of such part or to the expiration of the applicable new equipment warranty period, whichever occurs later. Warranted parts shall be provided at no cost to the user at an authorized Bush Hog dealer during regular working hours. Bush Hog reserves the right to inspect any equipment or parts which are claimed to have been defective in material or workmanship.

## DISCLAIMER OF IMPLIED WARRANTIES & CONSEQUENTIAL DAMAGES

Bush Hog's obligation under this limited warranty, to the extent allowed by law, is in lieu of all warranties, implied or expressed, **INCLUDING IMPLIED WARRANTIES OF MERCHANTABILITY AND FITNESS FOR A PARTICULAR PURPOSE** and any liability for incidental and consequential damages with respect to the sale or use of the items warranted. Such incidental and consequential damages shall include but not be limited to: Transportation charges other than normal freight charges; cost of installation other than cost approved by Bush Hog; duty; taxes; charges for normal service or adjustment; loss of crops or any other loss of income; rental of substitute equipment, expenses due to loss, damage, detention or delay in the delivery of equipment or parts resulting from acts beyond the control of Bush Hog.

### THIS LIMITED WARRANTY SHALL NOT APPLY:

1. To vendor items which carry their own warranties, such as engines, tires, and tubes.
2. If the unit has been subjected to misapplication, abuse, misuse, negligence, fire or other accident.
3. If parts not made or supplied by Bush Hog have been used in connection with the unit, if, in the sole judgement of Bush Hog such use affects its performance, stability or reliability.
4. If the unit has been altered or repaired outside of an authorized Bush Hog dealership in a manner which, in the sole judgement of Bush Hog, affects its performance, stability or reliability.
5. To normal maintenance service and normal replacement items such as gearbox lubricant, hydraulic fluid, worn blades, or to normal deterioration of such things as belts and exterior finish due to use or exposure.
6. To expendable or wear items such as teeth, chains, sprockets, belts, springs and any other items that in the company's sole judgement is a wear item.

NO EMPLOYEE OR REPRESENTATIVE OF BUSH HOG IS AUTHORIZED TO CHANGE THIS LIMITED WARRANTY IN ANY WAY OR GRANT ANY OTHER WARRANTY UNLESS SUCH CHANGE IS MADE IN WRITING AND SIGNED BY BUSH HOG'S SERVICE MANAGER, 2501 GRIFFIN AVE., SELMA, ALABAMA 36703.



Record the model number, serial number and date purchased. This information will be helpful to your dealer if parts or service are required.

MAKE CERTAIN THE WARRANTY HAS BEEN FILED WITH BUSH HOG / SELMA, ALABAMA

MODEL NUMBER \_\_\_\_\_

SERIAL NUMBER \_\_\_\_\_

DATE OF RETAIL SALE \_\_\_\_\_

# DEALER PREPARATION CHECK LIST

## 278 ROTARY CUTTERS

BEFORE DELIVERING MACHINE — The following check list should be completed.  
Use the Operator's Manual as a guide.

- 1. Assembly completed.
- 2. Gearbox filled with oil.
- 3. All fittings lubricated.
- 4. All shields in place and in good condition.
- 5. All fasteners torqued to specifications given in Torque Chart.
- 6. Slip clutches have been checked for proper operation.
- 7. All decals in place and readable. (See decal page.)
- 8. Overall condition good (i.e. paint, welds)
- 9. Operators manual has been delivered to owner and he has been instructed on the safe and proper use of the cutter.
- 10. Warranty information registered with Bush Hog.
- 11. Purchaser or dealer elects to delete deflectors. (front chains)

Explanation: \_\_\_\_\_

### WARNING

Deflector kit or chain shielding is standard equipment. Must be used for all non-agricultural uses or in areas where the possibility of thrown objects could be hazardous to persons or property. Use 5/16" double row highway chains for all roadside mowing operations.

Dealer's  
Signature \_\_\_\_\_

Purchaser's  
Signature \_\_\_\_\_

THIS CHECKLIST TO REMAIN IN OWNER'S MANUAL  
It is the responsibility of the dealer to complete the procedures listed  
above before delivery of this implement to the customer.

# IMPORTANT SAFETY PRECAUTIONS

**This symbol is used to call attention to safety precautions that should be followed by the operator to avoid accidents. When you see this symbol, carefully read the message that follows and heed its advice. Failure to comply with safety precautions could result in serious bodily injury.**



In addition to the design and configuration of equipment, hazard control and accident prevention are dependent upon the awareness, concern, prudence and proper training of personnel in the operation, transport, maintenance and storage of equipment. Lack of attention to safety can result in accident, personal injury, reduction of efficiency and worst of all loss of life. Watch for safety hazards and correct deficiencies promptly. Use the following safety precautions as a general guide to safe operations when using this machine. Additional safety precautions are used throughout this manual for specific operating and maintenance procedures. Read this manual and review the safety precautions often until you know the limitations.

1. Read the Operator's Manual. Failure to read the Operator's Manual is considered a misuse of this equipment.
2. Become familiar with all the machine's controls and all the caution, warning and danger decals affixed to the machine before attempting to start or operate.
3. Before starting or operating the machine, make a walk around inspection and check for obvious defects such as loose mounting bolts and damaged components. Correct any deficiency before starting.
4. Do not allow children to operate the cutter. Do not allow adults to operate it without proper instruction.
5. Do not carry passengers.
6. Keep the area of operation clear of all persons, particularly small children and pets. The operator should cease mowing whenever anyone comes within the operating area.
7. Clear the work area of objects which might be picked up and thrown.
8. Use a piece of cardboard or wood rather than hands to search for hydraulic leaks. Escaping hydraulic oil under pressure can penetrate skin. If fluid is injected into the skin, it must be surgically removed within a few hours by a doctor familiar with this form of injury or gangrene may result.
9. Do not operate without all guards and shields in place and in good condition.
10. Lower implement to ground, stop tractor engine, apply parking brake, and allow blades to completely stop before leaving the tractor.
11. Keep hands and feet away from blades.
12. This cutter is not to be operated along highways or in any area where people may be present unless all sides of the unit are enclosed by permanent bands, safety chains or other factory approved safety shields that are in good repair.
13. Wear personal protective equipment such as, but not limited to, protection for eyes, ears, feet, hands and head when operating or repairing the equipment. Do not wear loose clothing or jewelry that may catch on equipment moving parts.
14. When performing adjustments or maintenance on the cutter, first lower it to the ground or block it securely at a workable height.
15. Never stand between tractor and cutter while tractor is being backed to the cutter hitch.
16. Reduce speed when transporting cutter to avoid bouncing and momentary loss of steering.
17. Use tractor flashing warning lights, day or night, when transporting cutter on road or highways unless prohibited by law.
18. In the event that someone other than yourself will operate this equipment we firmly suggest that all SAFETY references be discussed prior to operation.
19. It is recommended that tractor be equipped with Rollover Protective System (ROPS) and seat belt be used in all mowing operations.

Fig. 1-1 Offset, Pull Type Model 278

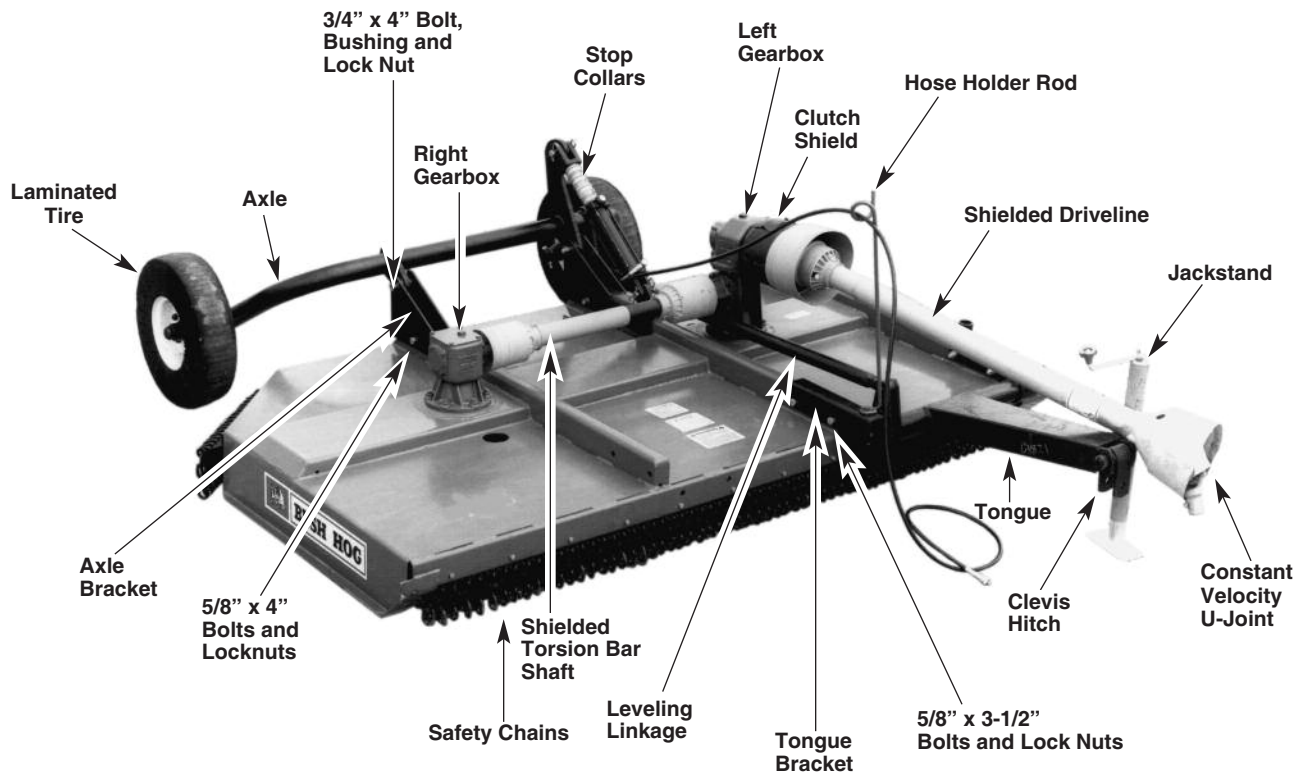

## SECTION I INTRODUCTION AND DESCRIPTION

### 1-1 INTRODUCTION

We are pleased to have you as a Bush Hog customer. Your 278 Series Rotary Cutter has been carefully designed to give maximum service with minimum down time. This manual is provided to give you the necessary operating and maintenance instructions for keeping your rotary cutter in top operating condition. Please read this manual thoroughly. Understand what each control is for and how to use it. Observe all safety precautions decaled on the machine and noted throughout the manual for safe operation of implement. If any assistance or additional information is needed, contact your authorized Bush Hog dealer.

#### NOTE

All references made in this manual to right, left, front, rear, top, or bottom is as viewed facing the direction of forward travel from the tractor operator's seat with implement properly attached to tractor.

### 1-2 DESCRIPTION

The 278 series cutters (Figure 1-1) are available in the following configurations: 3-point hitch or drawbar pulled, offset or center mount, 540 RPM or 1000 RPM. These cutters have an eight foot cutting width achieved using dual spindles. Each spindle has two free swinging uplift blades designed to cut grass and light brush. Free swinging blades reduce the shock of impact when a stationary object is hit. Additional protection is provided by a slip clutch installed on the driveline and a torsion shaft between the gearboxes.

#### TABLE 1-1 TECHNICAL SPECIFICATIONS

Cutting Width	.96 in. (243.8cm)
Transport Width	.101 in. (256.5cm)
Length (Pull Model)	.130 in. (330.2cm)
Length (3-pt. Hitch model)	.091 in. (231.1cm)
Hitch	.3-Pt. Category 2 or Drawbar
Cutting Height (Pull Model)	.2-1/2 -12 in. (6.3-30cm)
Cutting Height (3-pt. Hitch Model)	.2-1/2 -10 in. (6.3-25cm)
Maximum Cutting Capacity	.2 in. (51mm) dia.
Blades	.Uplift 1/2 x 4 in. (12.7 x 76.2 mm)
Blade Tip Speed	.13,500 fpm
Gearbox HP	.70 (Main), 50 (Outboard)
Minimum Required HP	.40 Pull, 55 Lift

## SECTION II PREPARATION FOR USE

### IMPORTANT

The minimum PTO horsepower requirement for cutter operation is 40 HP for pull models and 55 HP for lift models.

### 2-1 ATTACHING TO TRACTOR (Pull Models)

- A. Raise rear of cutter approximately 1"- 2" (25-51mm) off ground. Block securely in position.
- B. Attach jackstand (optional) to tongue of cutter. Extend jackstand to support weight of tongue.
- C. Remove pin securing self-leveling linkage to axle. Retain roll pin for reinstallation.
- D. Adjust tractor drawbar length to dimension shown in Figure 2-1. Incorrect drawbar length will change angle of driveline causing possible damage to constant velocity joint. See tractor operator's manual for drawbar adjustment procedures.

Figure 2-1 Tractor Drawbar Adjustment

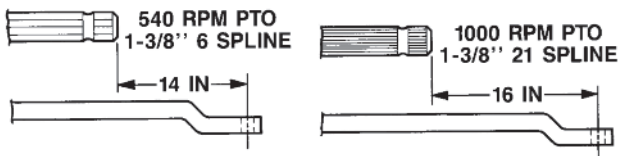

- E. Connect cutter to tractor drawbar using 7/8 Inch (22.2mm) diameter approved pin with linch pin retainer or equivalent.
- F. Loosen locknut on self-leveling linkage. Adjust linkage in or out as necessary to connect to axle.
- G. Pin linkage to axle securing with roll pin. Tighten locknut.
- H. Install driveline on tractor and cutter. Pull on each driveline section to be sure yokes lock into place. Make certain driveline shielding is in place and in good condition.

! DANGER

**• PTO ADAPTERS SHOULD NOT BE USED WITH ANY BUSH HOG EQUIPMENT**

- The PTO adapter length will cause an unshielded shaft area between the tractor master shield and the driveline shield.
- Contact with and entanglement in the unshielded rotating PTO adaptor area can cause serious injury or death.
- The use of a PTO adapter can cause equipment overspeed, driveline failures and damage to tractor and implement.

I. If equipped with optional hydraulic cylinder route hydraulic line through hose holder on tongue bracket. and connect to tractor auxiliary hydraulics quick disconnect. Make certain line is not twisted or kinked.

### ⚠ CAUTION

**USE A PIECE OF CARDBOARD OR WOOD RATHER THAN HANDS AND WEAR EYE PROTECTION WHEN SEARCHING FOR HYDRAULIC LEAKS. ESCAPING HYDRAULIC OIL UNDER PRESSURE CAN PENETRATE SKIN. IF OIL IS INJECTED INTO SKIN, IT MUST BE SURGICALLY REMOVED WITHIN A FEW HOURS BY A DOCTOR OR GANGRENE MAY RESULT.**

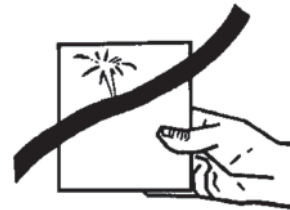

### 2- 2 ATTACHING TO TRACTOR (3-Point Hitch Models)

A. Attach cutter to tractor 3-point hitch per tractor operator's manual. Do not attach driveline at this time.

#### IMPORTANT

Tractor top link pin securing 3-point hitch top link to cutter must conform to dimension shown in Figure 2-2 to avoid interference with A-frame.

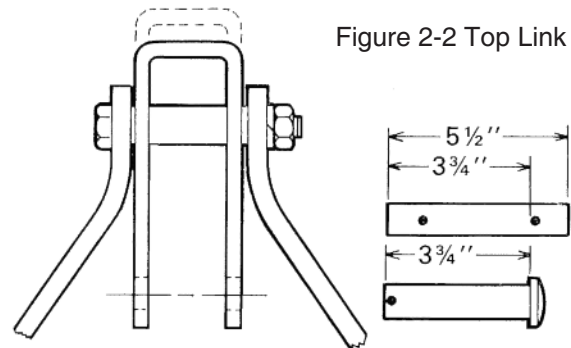

Figure 2-2 Top Link Pin

B. Raise 3-point hitch until front of cutter is approximately 1-2 inches (25-51 mm) lower than rear. Shut down tractor. Securely block cutter in position.

C. Adjust top link of 3-point hitch to position flex link as shown in Figure 2-3.

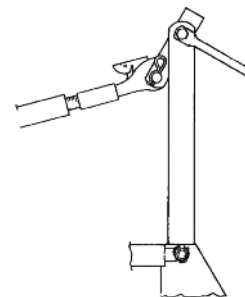

Figure 2-3 Flex- Link

#### NOTE

Due to the many variations in tractor/implement hitch points and corresponding differences in distances between tractor PTO shafts and implement input shafts, drivelines may need to be shortened as described in the following steps:

D. Raise and lower cutter to determine position with shortest distance between the tractor PTO shaft and gearbox input shaft. Shut down tractor leaving cutter in position of shortest distance. **Securely block cutter in position.**

E. Pull driveline apart. Attach outer (female) section to tractor PTO shaft. Pull on driveline section to be sure that yoke locks into place.

F. Hold driveline sections parallel to each other to determine if too long. Each section should end approximately 3 inches (76mm) short of reaching universal joint shield on opposite section. If too long, measure 3 inches (76mm) back from universal joint shield and mark on opposite section. (Figure 2-4). Do this for both sections.

Figure 2-4

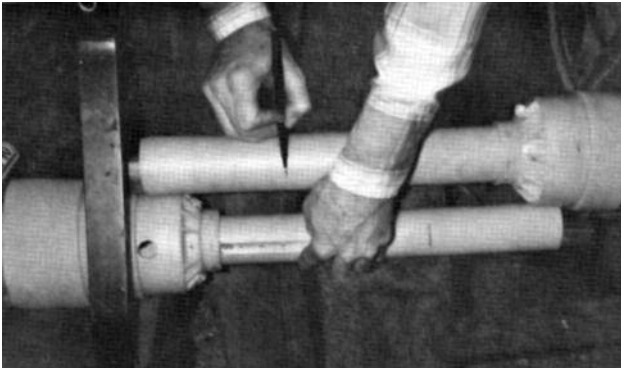

G. Raise and lower cutter to determine position with greatest distance between PTO shaft and gearbox input shaft. Shut down tractor leaving cutter in position of greatest distance. **Securely block cutter in position.**

H. Hold driveline sections parallel to each other and check for minimum 6 inches (15cm) overlap. (Figure 2-5). If driveline has been marked for cutting, overlap will be the distance between two marks. If driveline has less than minimum overlap, do not use. Contact authorized Bush Hog dealer.

Figure 2-5

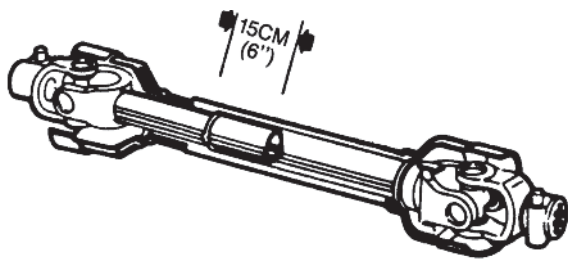

#### NOTE

If driveline is the correct length, omit the following steps "I" through "L" and proceed to step "M".

I. Clamp driveline in a well padded vice to prevent damage to the shield. Cut off shield where marked. (Figure 2-6).

Figure 2-6

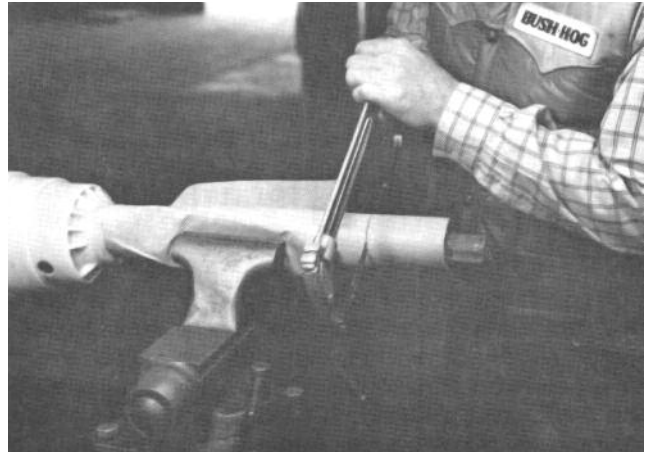

J. Using cut off section of shield as a guide, cut shaft the same amount. (Figure 2-7).

Figure 2-7



K. Repeat steps "I" and "J" to other driveline section.

L. Deburr ends of driveline sections and clean away all chips filings. (Figure 2-8).

Figure 2-8



M. Apply multi-purpose grease to inside of outer (female) driveline section. Assemble driveline and install on tractor and cutter. Pull on each driveline section to be sure yokes lock into place. Make certain driveline shielding is in place and in good condition.

N. Adjust lower lift arm to level cutter right to left. Refer to tractor operator's manual for instructions.

## SECTION III

### OPERATING INSTRUCTIONS

#### 3-1 GENERAL SAFETY

Only qualified people should operate this machine. Operator should wear hard hat, safety glasses, and safety shoes. It is recommended that tractor be equipped with Rollover Protective Systems (ROPS) and a seat belt be used. Before beginning operating, clear work area of objects that may be picked up and thrown. Check for ditches, stumps, holes, or other obstacles that could upset tractor or damage cutter. Always turn off tractor engine, set parking brake, and allow cutter blades to come to a complete stop before dismounting tractor.

#### 3-2 ADJUSTING FOR WORK

The cutter should be operated at the highest position which will give desired cutting results. This will help prevent the blades from striking the ground, reducing blade wear and undue strain on the machine. For best results under heavier cutting conditions, always tilt the cutter approximately 2 inches (51 mm) lower in the front. This tilt decreases horsepower requirements and increases potential ground speed. When fine shredding is desired, adjust cutter deck level or slightly lower in the rear. This will keep the foliage under cutter until thoroughly shredded. More power is required for shredding.

##### 3-2.1 Cutting Height Adjustment (3-Point Hitch Models)

One of four height adjustments may be selected. These are approximately 2-1/2", 5", 7-1/2", or 10" (63.5mm, 127mm, 190.5mm, 254mm). Adjust as follows:

A. Raise cutter using 3-point lift until tailwheel(s) lift off ground. Turn off tractor. **Block cutter in position.**

Figure 3-1 Height Adjustment

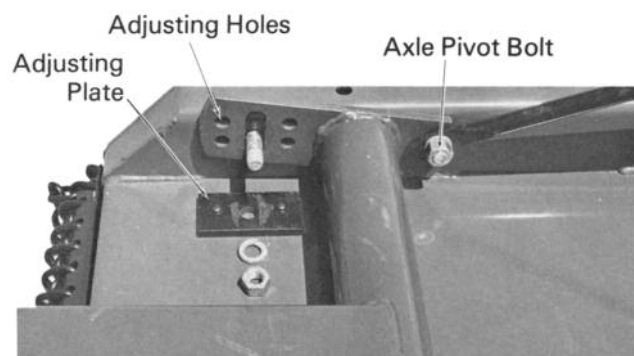

B. Loosen but don't remove axle pivot bolts. (Figure 3-1)

C. Remove adjusting plate retaining nuts.

D. Position adjusting plates for desired cutting height. Rotate plates 180° for two additional height adjustments. Secure plates with nuts and lockwashers.

E. Tighten axle pivot bolts.

##### 3-2.2 Cutting Height Adjustment (Pull Models)

Two methods of height adjustment are available on pull type cutters - a single acting hydraulic cylinder or a ratchet. Stop collars are supplied with the hydraulic cylinder. These are used to stop cylinder at desired cutting height. (Figure 3-2). When height is adjusted, the self-leveling linkage will adjust tongue height automatically. The cutter deck front to rear tilt may be changed by adjusting tongue height with the self-leveling linkage. To adjust, disconnect cutter from tractor and perform steps "A" through "G" in paragraph 2-1.

Figure 3-2

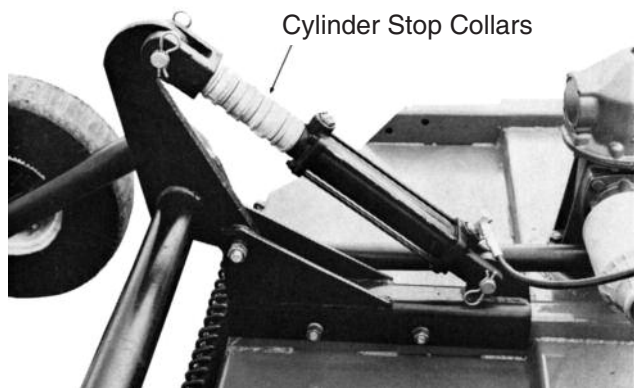

#### 3-3 OPERATION

A. Perform BEFORE EACH USE maintenance listed in paragraph 4-1.

B. Make certain jackstand is stored for work. (Pull models only).

C. Start tractor.

D. Adjust cutter to working position.

E. With tractor at idle speed, engage PTO drive.



**STAY CLEAR OF ROTATING DRIVELINE. DO NOT OPERATE WITHOUT DRIVELINE SHIELDS IN PLACE AND IN GOOD CONDITION. FAILURE TO HEED THESE WARNING MAY RESULT IN PERSONAL INJURY OR DEATH.**

F. Set tractor throttle for appropriate PTO speed (540 RPM or 1000 RPM).

## **DANGER**

**ROTATING CUTTER BLADES. STAND CLEAR UNTIL ALL MOTION HAS STOPPED. TO AVOID AN ACCIDENTAL FALL FROM THE TRACTOR AND POSSIBLE INJURY BY THE MOWER, IT IS RECOMMENDED THAT THE TRACTOR BE EQUIPPED WITH ROPS (ROLLOVER PROTECTIVE SYSTEM) AND THAT A SEAT BELT BE USED BY THE OPERATOR FOR ALL MOWING OPERATIONS.**

G. Place tractor in gear and begin cutting. Tractor forward speed should be controlled by gear selection, not engine speed. For maximum cutting efficiency, forward speed should allow cutter to maintain a constant, maximum blade speed. Do not exceed 5 mph (8 kph). If PTO drive is disengaged due to cutter stalling or tractor engine bogging, cutter must be moved to a "cut" area and tractor throttle reduced to idle before re-engaging. Always cut up and down the face of slopes, never across.

## **WARNING**

**ALL ROTARY CUTTERS HAVE THE ABILITY TO DISCHARGE OBJECTS AT HIGH SPEEDS WHICH COULD RESULT IN SERIOUS INJURY TO BYSTANDERS OR PASSERS-BY.**

**THEREFORE, THIS CUTTER IS NOT TO BE OPERATED ALONG HIGHWAYS OR IN ANY AREA WHERE PEOPLE MAY BE PRESENT UNLESS ALL SIDES OF THE UNIT ARE ENCLOSED BY PERMANENT BANDS, SAFETY CHAINS, OR OTHER FACTORY APPROVED SAFETY SHIELDS THAT ARE IN GOOD REPAIR.**

### **3-4 TRANSPORTING**

When implement is transported on road or highway, day or night, use tractor flashing warning lights unless prohibited by law. A slow moving vehicle (SMV) sign must be visible from the rear by approaching vehicles. Do not exceed 15 mph (24 kph) when traveling. Fully raise implement before transporting. If equipped with hydraulic cylinder, install all stop collars. (Figure 3-2).

---

---

## **SECTION IV MAINTENANCE**

### **4-1 MAINTENANCE CHECK LIST**

Perform scheduled maintenance as outlined below. Lower machine to ground, turn off tractor and set parking brake before doing maintenance inspections or work. Some checks may require raising machine off ground and supporting with blocks. All bolts should be torqued as recommended in Torque Specifications as listed on page 18 of this manual.

#### **BEFORE EACH USE**

1. Check tractor tire air pressure. Refer to tractor operator's manual.
2. Check blades and spindle to be sure that no foreign objects such as wire or steel strapping bands are wrapped around them.
3. Check blade bolts for tightness. Tighten to 450 ft./lbs. (609Nm).
4. Clean all debris from machine especially underside of deck.
5. Inspect blades for wear. Replace if necessary per paragraph 4-5. Always replace both blades on spindle with two blades equal in weight. Use only genuine Bush Hog replacement blades.
6. Make certain chains and/or side bands are in good repair.
7. Make certain driveline shields are in place and in good repair.
8. Inspect wheel(s) for wear, damage, or foreign objects. Repair or replace if necessary.
9. Inspect hydraulic lines and fittings for wear or leaks. (Pull Model). Repair or replace if needed.

## **CAUTION**

**USE A PIECE OF CARDBOARD OR WOOD RATHER THAN HANDS AND WEAR EYE PROTECTION WHEN SEARCHING FOR HYDRAULIC LEAKS. ESCAPING HYDRAULIC OIL UNDER PRESSURE CAN PENETRATE THE SKIN. IF OIL IS INJECTED INTO THE SKIN, IT MUST BE SURGICALLY REMOVED WITHIN A FEW HOURS BY A DOCTOR OR GANGRENE MAY RESULT.**

10. Perform BEFORE EACH USE lubrication per paragraph 4-2.

11. During operation, listen for abnormal sounds which might indicate loose parts, damaged bearings, or other damage.

### **4-2 LUBRICATION (Figure 4-1)**

The multipurpose grease referenced in this section is an NLGI Grade 2 type Grease.

#### **BEFORE EACH USE**

1. Driveline Universal Joints - Apply multi-purpose grease with grease gun.
2. Wheel Bearings (3-Point Hitch Models) - Apply multi-purpose grease with grease gun.
3. Wheel Pivots (3-Point Hitch Models) - Apply multi-purpose grease with grease gun.
4. Driveline Guard - Apply 2-3 shots of multi-purpose grease with grease gun to plastic fitting.
5. Constant Velocity (CV) Joint (Pull Models) - Position CV joint as straight as possible to be sure grease will penetrate to ball joint.

Lubricate the central body with a minimum of 30 shots of grease every 8 hours. Lubricate telescoping members with 10 shots every 8 hours and clean telescoping members every 40 hours and completely coat with grease.

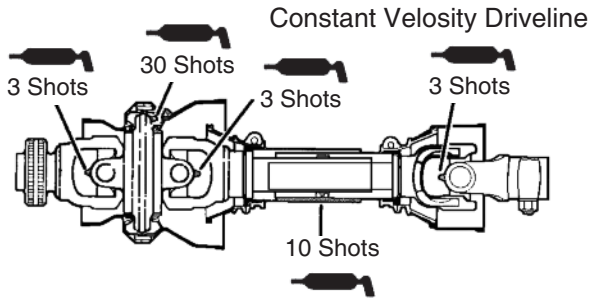

6. PTO Driveline - Disconnect PTO driveline, pull the two sections apart, apply thin coat of multipurpose grease to inside of outer (female) section. Pull each section to be sure driveline and shields are securely connected. Make certain PTO shielding is in good condition.

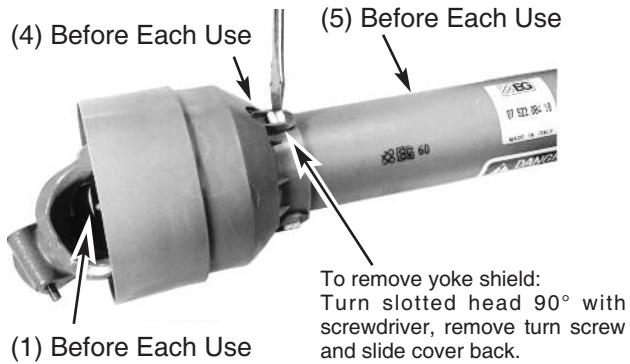

7. Gearboxes - Add EP80W-90 gear oil as necessary to bring oil level to bottom notch on dipstick. Capacity for left gearbox is 3 qts. (2.85 l) and for right gearbox is 1.7 qts. (1.6 l).

120 HOURS

8. Wheel Bearings (pull models) -Apply multi-purpose grease with grease gun.

Figure 4-1

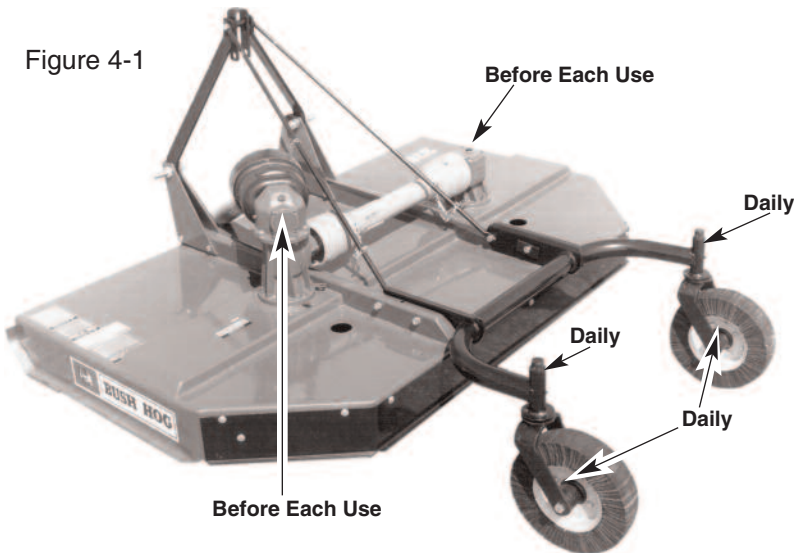

### 4-3 GEARBOX REMOVAL

- A. Disconnect PTO driveline from gearbox (if applicable).
- B. Remove cotter pin and lower shaft nut. (Figure 4-2).
- C. Wearing heavy gloves, grasp blade holder assembly and pull off shaft. If stuck, align blade bolt with access hole in top of cutter deck and carefully tap off with hammer and bat. Care should be taken not to damage threads.
- D. Push in tab and slide universal joint covers back. (Figure 4-3).
- E. Remove roll pin. Retain for reinstallation (Figure 4-3).
- F. Push in yoke quick disconnect pins, slide yokes securely connected. Make certain PTO shielding towards middle of bar. Lift out torsion bar assembly carefully. Keep yokes on bar so they will remain synchronized (aligned).
- G. Remove bolts securing gearbox to deck. Remove gearbox

Figure 4-2 Blade Timing

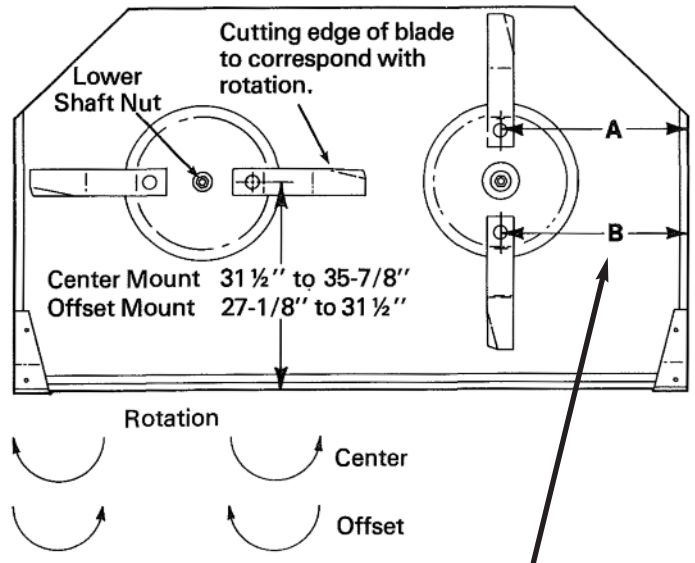

**NOTE: Dimensions "A" and "B" must be equal.**

Figure 4-3 Yoke Synchronization

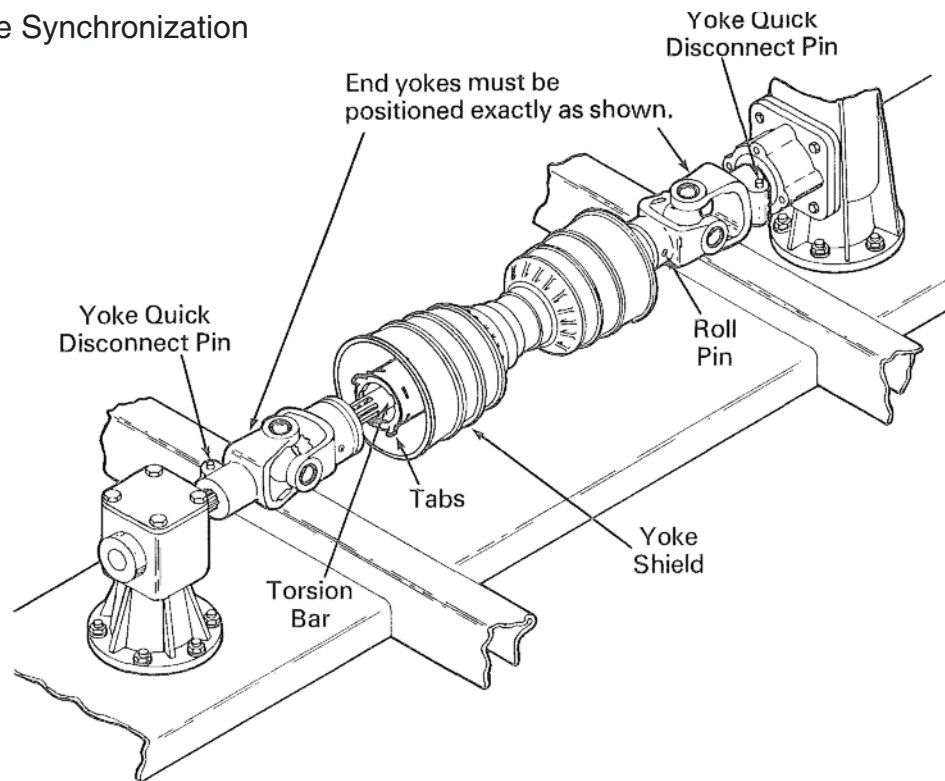

#### 4-4 GEARBOX INSTALLATION

- A. Bolt gearbox to cutter deck.
- B. Synchronize (align) yokes on torsion bar as shown in Figure 4-3. Yokes must be synchronized to prevent excessive vibration.
- C. Slide yokes toward middle of bar, press yoke quick disconnect pins, and install on gearbox shafts.
- D. Align roll pin hole in torsion bar with hole in yoke. Install roll pin.
- E. Pull on each yoke to make sure it is securely connected.
- F. Install blade holder assembly onto gearbox shaft securing with nut. Blade holder must be timed using shaft splines during installation as shown in Figure 4-2 to prevent blade contact during operation. Measurement from center of inside blade bolt to front most point on cutter deck must be between 31-1/2" and 35-7/8" (80cm and 91 cm) on center units and between 27-1/8" and 31-1/2" (69cm and 80cm) on offset units.
- G. Torque lower shaft nut to 450 ft./lbs. (609.7Nm). Install cotter pin. It may be necessary to back off nut to install pin.

#### 4-5 BLADE REPLACEMENT

- It is not necessary to remove the complete blade holder assembly to replace the blades. Blade bolts are accessible through a hole in the top of the cutter deck. Always replace both blades on a spindle using two blades having the same weight. Use only genuine Bush Hog replacement blades.
- A. Remove nuts from blade bolts.
  - B. Inspect blade bolt shoulder for wear. Replace if necessary.
  - C. Assemble new blades to blade holder using blade bolts, nuts, and lockwashers. Tighten nuts to 450 ft./lbs. (609.7Nm).
  - D. Check to be sure blades swing 360° freely. If blades will not swing freely, remove, locate problem, and repair. Operating cutter when blades will not swing freely will cause excessive vibration, damaging implement.

## 4- 6 ADJUSTING GEARBOX ANGLE

The left (main) gearbox input shaft angle must correspond to cutter configuration for proper cutter operation. This angle is adjusted by removing bolts securing gearbox head (top section) to the body and rotating head. See Figure 4-4 for correct settings. Reinstall bolts using a thread locking adhesive and torque to 40-60 ft. lbs. (54-81 Nm).

Figure 4-4

### Offset Lift & Pull Models

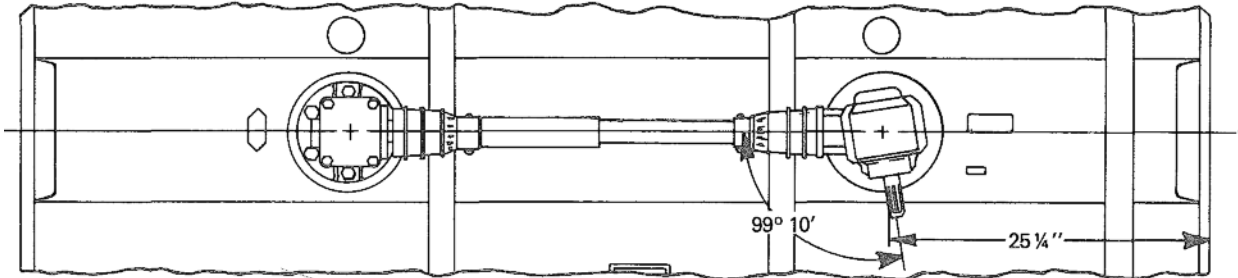

### Center Lift Model

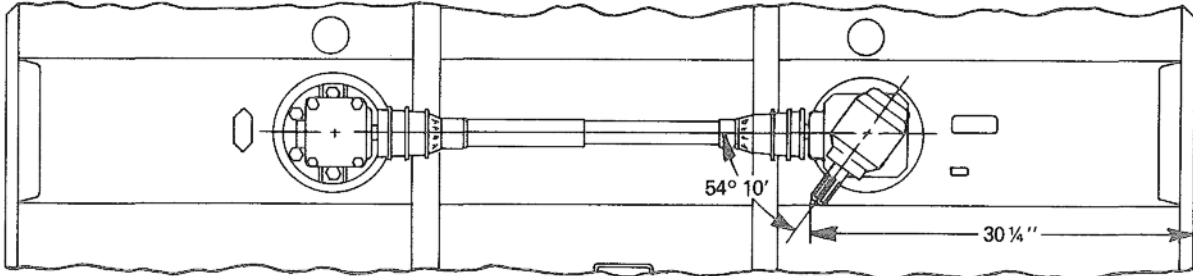

### Center Pull Model

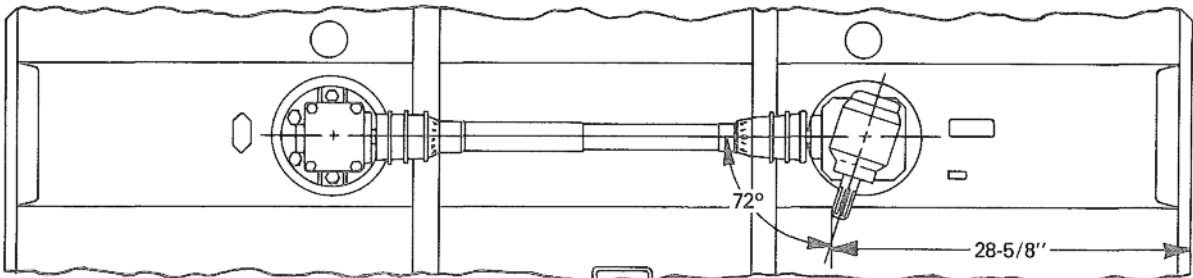

#### 4-7 SUP CLUTCH OPERATION CHECK

After the implement has been stored 30 days or more, perform the following operational check:

A. Loosen eight nuts retaining clutch springs 1/3 turn or until spring can be turned with fingers.

B. With tractor at idle speed, engage tractor PTO drive for 2-3 seconds. Clutch should slip without turning blades. If clutch does not slip, contact your authorized Bush Hog dealer.

C. Retighten nuts to within 1/64" of original position. Initial spring length is shown in Figure 4-5.



#### CAUTION

**FAILURE TO RETIGHTEN SPRING NUTS TO ORIGINAL POSITION MAY CAUSE DAMAGE TO IMPLEMENT AND/OR TRACTOR DUE TO IMPROPER SLIP CLUTCH TORQUE SETTING.**

#### 4-8 SUP CLUTCH ADJUSTMENT

The slip clutch is factory preset to the correct torque for protecting implement and tractor. Periodic adjustment is recommended; refer to section 4-7. Should adjustment be needed, first check to be sure all spring lengths are the same. Initial spring length is shown in Figure 4-5. If necessary, adjust nut on any spring that is unequal. Adjust all eight spring retaining nuts 1/3 of a turn (2 flats on a nut) and check clutch slippage. If further adjustment is necessary, do so in 1/3 turn increments. Adjust only to provide sufficient torque to prevent slippage under normal conditions. Occasional slippage is normal for drive train protection. If satisfactory results cannot be obtained, consult your Bush Hog Dealer.

Figure 4-5 Spring Length

"BP" Clutch 1-1/8" (28.5mm)  
"EG" Clutch 1-5/16" (33.5mm)

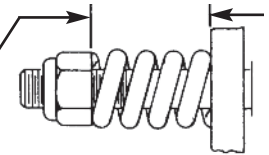

#### 4-9 TROUBLESHOOTING

Troubleshooting procedures are listed in Table 4-2. If the problem cannot be solved, or replacement parts are necessary, contact your authorized Bush Hog dealer. Please have ready your machine name, model number, serial number, purchase date, and exact cause or description of problem.

TABLE 4-2 GENERAL TROUBLESHOOTING

PROBLEM	PROBABLE CAUSE	REMEDY
Uneven Cut	Cutter not level side to side or front to rear	Refer to SECTION II
	Worn or bent blades	Replace blades per paragraph 4-5.
Stripping or Windrowing	Possible build up of material under cutter	Clean Cutter
	Cutter not level	Refer to SECTION II
	Worn Blades	Replace per paragraph 4-5
Noisy Cutter	Loose Components	Check all bolts for tightness
	Low oil in gearboxes	Check for proper oil level. Refer to paragraph 4-2.
Rapid Blade Wear (Cutting Edge)	Blade contacting the ground	Adjust cutter to operate at a height that will eliminate ground contact
Rapid Blade Wear (Bolt Hole)	Cutter not being operated at rated RPM speed	Reduce Ground Speed or Set tractor throttle for proper PTO speed
Poor shredding Job	Incorrect deck Tilt	Adjust per paragraph 3-2
	Excessive ground speed	Reduce ground speed
	Worn blades	Replace blades per paragraph 4-5
Cutter Vibration	Blades or yoke not synchronized	See paragraph 4-4
	Excessive universal joint angle	Refer to paragraph 4-8
	Cutter not being operated at rated RPM speed	Set tractor throttle to proper PTO speed

# SECTION V

## ASSEMBLY

### NOTE

Make certain left gearbox is correct for cutter configuration. Refer to paragraph 4-6.

### 5-1 3 POINT HITCH MODEL

#### 5-1.1 Center Mount (Figure 5-1)

A. Bolt strut weldment to front of cutter using two 5/8" x 3-3/4" bolts, nuts, lockwashers on top and two 5/8" x 3-1/2" bolts, nuts and lockwashers on the front.

B. Using Category 2 pins as bolts, attach "A"-frame sections to struts using pins, nuts and lockwashers.

C. Bolt top of "A"-frame together using 5/8" x 6" bolt and locknut. Flex link and spacer attach between "A"-frame sections, support rods on outside.

D. Attach axle and "A"-frame support rods to cutter deck using two 5/8" x 3-3/4" bolts, nuts and lockwashers. Do not tighten nuts.

E. Place 4" washers on wheel spindles. Install wheels into axle securing with roll pins.

F. Bolt adjusting plates to axle and cutter deck using two 5/8" x 3-3/4" bolts, nuts and lockwashers. Tighten other two bolts securing axle to deck.

G. Bolt clutch shield to gearbox with inspection cover up. Use four 8mm x 15mm bolts, flatwashers.

H. Remove two clamp bolts from female splined end of clutch. Remove inspection cover on clutch shield.

I. Slide clutch onto gearbox input shaft aligning bolt holes with slots in input shaft. Install clamp bolts, nuts and lockwashers, inserting bolts from opposite directions.

J. Fill gearbox to oil level - check plug with EP80W-90 gear oil. Capacity for left gearbox is 3 Qts.. (2.85L) and for the right gearbox is 1.7 Qts.. (1.6L).

#### 5-1.2 Offset Mount

A. Perform steps "A" through "C" in paragraph 5-1.1.

B. Attach left "A"-frame support rod to left cutter deck brace using a 5/8" x 3-1/2" bolt, nut and lockwasher.

C. Attach axle and right "A"-frame support rod to cutter deck using 5/8" x 3-1/2" and 5/8" x 3-3/4" bolts, nuts and lockwashers. Do not tighten nuts.

D. Perform steps "E" through "J" in paragraph 5-1.1.

### QUICK HITCH ASSEMBLY (Optional)

Assemble quick hitch components in place of the standard hitch as illustrated at right.

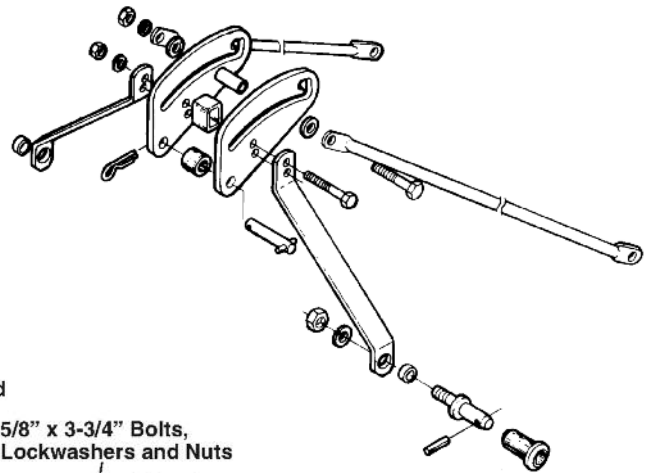
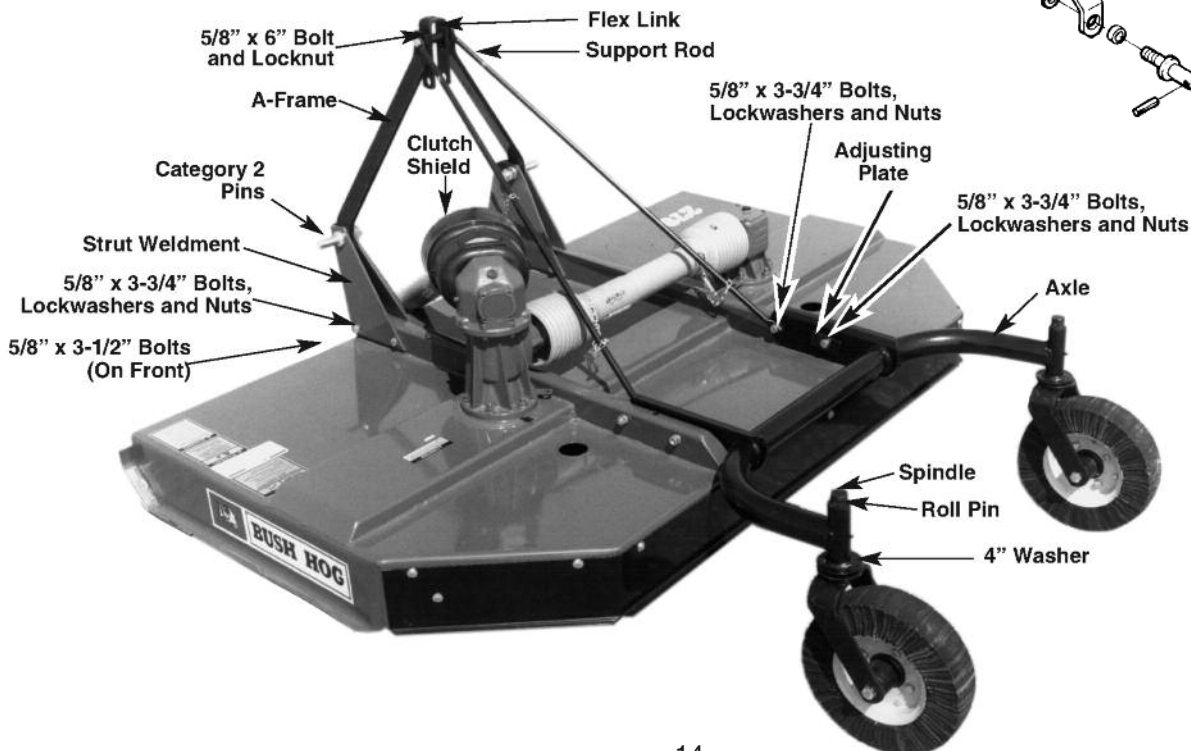

Figure 5-1



## 5-2 PULL MODELS (FIGURE 5-2)

A. Attach one tongue bracket to cutter deck using three 5/8" x 3-1/2" bolts and locknuts.

B. Place end of tongue in installed bracket. Place second bracket on opposite end of tongue then secure bracket to cutter deck using three 5/8" x 3-1/2" bolts and locknuts.

C. Attach axle brackets to cutter deck using 5/8" x 4" bolts and locknuts. The one piece bracket with cylinder mounting lug should be mounted on the left side on offset models and right side on center models.

D. Mount axle to brackets using two 3/4" x 4" bolts, locknuts and bushings.

E. If equipped with laminated tires, mount tires to hub.

F. Mount wheel/spindle assembly to axle using one 1/2" x 3-1/4" bolt and locknut per assembly. Mount wheels toward outside of machine.

G. Connect hydraulic cylinder or ratchet jack from axle bracket to axle.

### IMPORTANT

Use a single acting hydraulic cylinder only. A double acting cylinder can damage the cutter.

H. Connect tongue leveling linkage from axle to tongue using two pins and four roll pins.

I. Attach hose holder to tongue using a 1/2" x 2" bolt, flatwasher and locknut.

J. Attach clutch shield to gearbox with inspection cover up. Use four 8mm x 15mm bolts and flatwashers.

K. Remove two clamp bolts from female spline end of clutch. Remove inspection cover on clutch shield.

L. Slide clutch onto gearbox input shaft, aligning bolt holes with slots in input shaft. Install clamp bolts, nuts and lockwashers, inserting bolts from opposite directions.

M. Plumb hydraulic cylinder as shown in Figure 5-3. Do not over tighten fittings. Do not use teflon tape.

### CAUTION

**USE A PIECE OF CARDBOARD OR WOOD RATHER THAN YOUR HANDS AND WEAR PROTECTIVE EYEWEAR WHEN SEARCHING FOR HYDRAULIC LEAKS. ESCAPING HYDRAULIC OIL UNDER PRESSURE CAN PENETRATE THE SKIN. IF OIL IS INJECTED INTO THE SKIN, IT MUST BE SURGICALLY REMOVED WITHIN A FEW HOURS BY A DOCTOR OR GANGRENE MAY RESULT.**

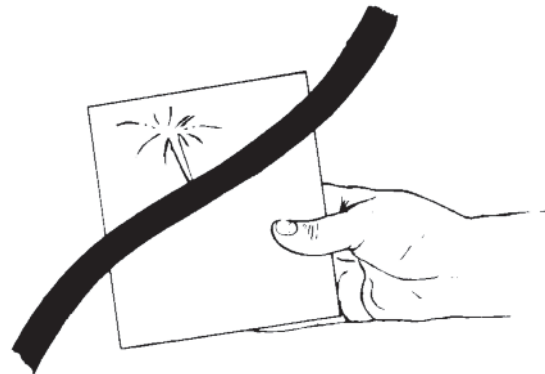

N. Fill gearboxes to oil level - check plug with EP80W-90 gear oil. Capacity for left gearbox is 3 Qts. (2.85 L) and for the right gearbox is 1.7 Qts. (1.6 L).

Figure 5-2

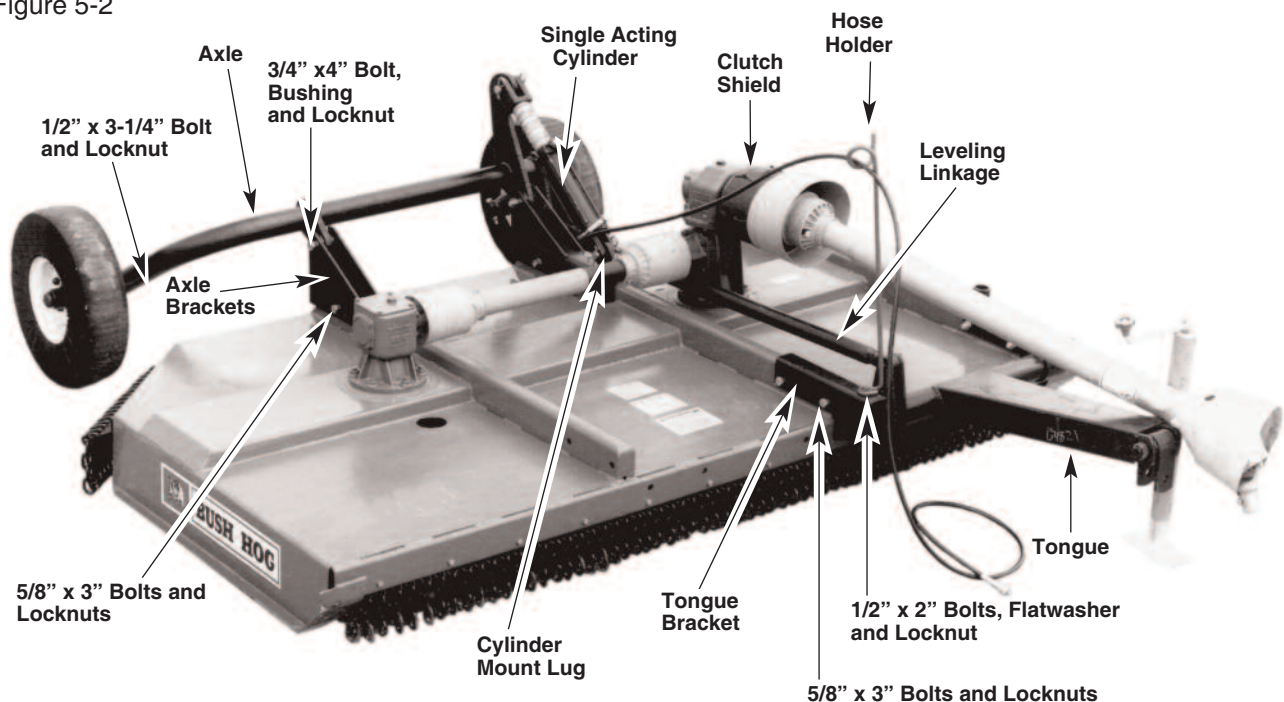
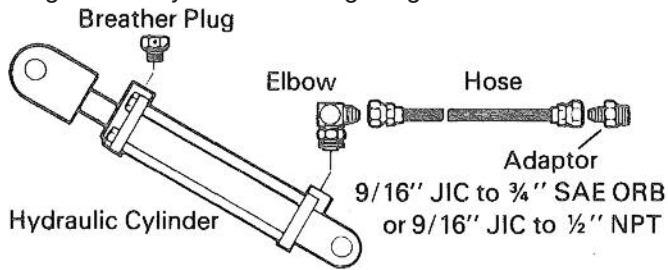

Figure 5-3 Cylinder Plumbing Diagram



### 5-3 OPTIONAL SAFETY CHAIN INSTALLATION

#### CAUTION

#### USE ONLY FACTORY APPROVED SAFETY CHAINS!

Raise cutter off ground to a convenient working height. **Block into position securely to prevent falling while working around cutter.**

#### 5-3.1 Rear Chains

A. Using a straight edge to determine the top surface of deck, measure  $3/4$ " (19 mm) down the rear band. Mark a line across rear band at this position parallel to top of the deck.

Figure 5-4 Correct Measurement

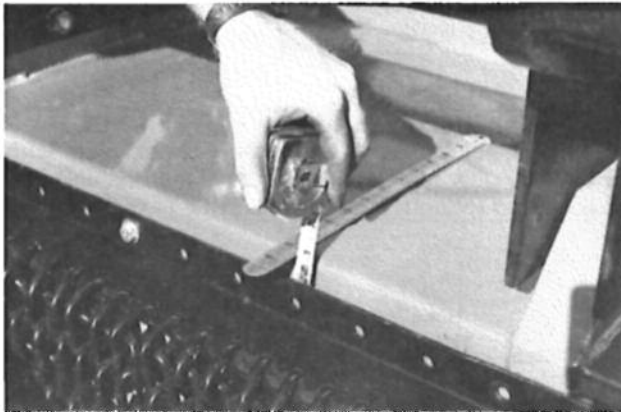
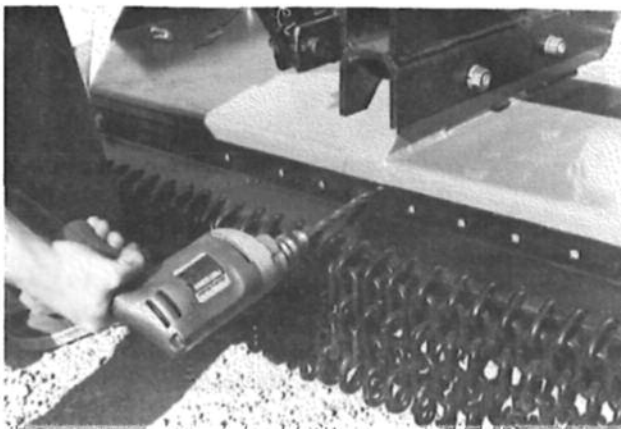

Figure 5-5 Drill Chains



B. Center middle section of chain assembly on rear band, aligning top edge with line. Clamp in this position.

C. Using holes in chain assembly as a pattern, drill one hole at each end and three holes at equal intervals in center of middle chain section (Figure 5-5). Use  $13/32$ " drill bit.

D. Secure chains using  $3/8$ " x 1" bolts, flatwashers and locknuts. A flatwasher is used on the outside of chain assembly and on inside of rear band.

E. Carefully bend chain assembly around corner of deck (figure 5-6). Check for  $3/4$ " (19 mm) distance from top of cutter deck to top of each outside chain assembly section.

F. Drill and bolt each end section of chain assembly as described in preceding steps using two bolts per section.

#### 5-3.2 Front Chains

A. Loosely attach chain retainer to inside of front band using  $3/8$ " x 3" bolts and locknuts (Figure 5-7).

B. Slide chains into slot formed by chain retainer by doubling each piece and using center link to suspend the two ends.

C. With all chains evenly spaced, tighten all bolts.

Figure 5-6 Bending Chains



Figure 5-7 Front Chain Installation

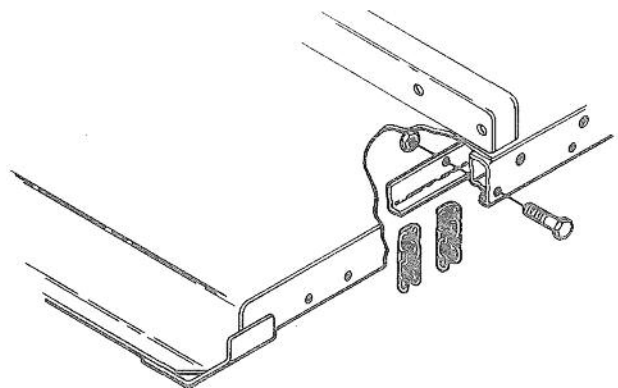

# SAFETY DECALS

To promote safe operation, Bush Hog supplies safety decals on all products manufactured. Because damage can occur to safety decals either through shipment, use or reconditioning, Bush Hog will, upon request, provide safety decals for any of our products in the field at no charge. Contact your authorized Bush Hog dealer for more information.

**⚠ DANGER**

**KEEP AWAY - ROTATING BLADES**

TO AVOID SERIOUS INJURY OR DEATH FROM BLADE CONTACT:

- LOWER IMPLEMENT, STOP ENGINE AND PTO, ALLOW ALL MOVING PARTS TO STOP, AND REMOVE KEY BEFORE DISMOUNTING FROM TRACTOR.
- ALLOW NO RIDERS ON TRACTOR OR MOWER.
- KEEP ALL PERSONS CLEAR OF OPERATING MOWER AND MOWING AREA.
- KEEP CLEAR OF ROTATING BLADES, PARTS, AND DRIVELINES.

**PREVENT FALL OFF INTO ROTATING BLADES**

TO PREVENT ACCIDENTAL FALL OFF FROM TRACTOR AND SERIOUS INJURY OR DEATH FROM RUN OVER OR ROLLOVER BY TRACTOR OR MOWER:

- USE ROPS (ROLLOVER PROTECTIVE STRUCTURES) AND SEAT BELT EQUIPPED TRACTORS FOR MOWING OPERATIONS.
- BUCKLE UP SEAT BELT.
- KEEP ALERT FOR STUMPS, HOLES, RUTS AND UNEVEN TERRAIN.

50029417

**⚠ WARNING**

**ROTARY CUTTERS CAN DISCHARGE OBJECTS SEVERAL HUNDREDS OF FEET. TO AVOID SERIOUS INJURY OR DEATH TO BYSTANDERS FROM THROWN OBJECTS:**

- CLEAR MOWING AREA OF VISIBLE DEBRIS AND USE EXTRA CAUTION WHERE ROCKS OR DEBRIS MAY BE PRESENT.
- DO NOT OPERATE CUTTER ALONG ROADWAYS OR IN THE VICINITY OF OTHER PERSONS WITHOUT ENCLOSED SIDES, PERMANENT BANDS, BELTING, HIGHWAY CHAINS OR OTHER FACTORY APPROVED DISCHARGE SHIELDS IN PLACE AND IN GOOD WORKING ORDER.
- KEEP ALL PERSONS WELL CLEAR OF MOWER WHEN IN OPERATION.

**⚠ CAUTION**

THIS IMPLEMENT IS DESIGNED TO OPERATE AT 540 RPM MAXIMUM TRACTOR PTO SPEED.

ALL DRIVE LINE SHIELDS MUST BE KEPT IN PLACE.

**⚠ WARNING**

**TO AVOID SERIOUS INJURY OR DEATH:**

- READ OPERATOR'S MANUAL BEFORE OPERATING AND FOLLOW ALL PRECAUTIONS. (CONTACT DEALER FOR MANUAL)
- KEEP SHIELDS AND GUARDS IN PLACE. KEEP CLEAR OF DRIVES AND BELTS.
- LOWER IMPLEMENT, STOP ENGINE AND PTO, ALLOW ALL MOVING PARTS TO STOP, AND REMOVE KEY BEFORE DISMOUNTING FROM TRACTOR.
- KNOW HOW TO STOP TRACTOR AND EQUIPMENT QUICKLY IN AN EMERGENCY.
- ALLOW NO CHILDREN OR UNQUALIFIED PERSONS TO OPERATE EQUIPMENT.
- BE CAREFUL ON UNEVEN TERRAIN. DECREASE SPEED WHEN TURNING.
- DO NOT OPERATE MOWER IN TRANSPORT POSITION.

**⚠ WARNING**

**IMPLEMENT CAN FALL FROM HYDRAULIC SYSTEM RELEASE. TO AVOID SERIOUS INJURY OR DEATH:**

- SHUT OFF TRACTOR ENGINE, REMOVE KEY, SECURE TRACTOR PARKING BRAKE AND BLOCK UP OR SECURELY SUPPORT IMPLEMENT BEFORE WORKING UNDERNEATH.
- PURGE ALL AIR FROM HYDRAULIC SYSTEM BEFORE ATTEMPTING TO RAISE OR LOWER THIS IMPLEMENT.
- STAND CLEAR IF LOWERING OR RAISING IMPLEMENT.
- DO NOT USE HAND OR SKIN TO CHECK FOR HYDRAULIC LEAKS. USE CARDBOARD OR WOOD.
- HIGH PRESSURE OIL LEAKS CAN PENETRATE SKIN CAUSING SERIOUS INJURY AND GANGRENE. CONSULT A PHYSICIAN IMMEDIATELY.
- LOWER THE IMPLEMENT AND RELEASE HYDRAULIC PRESSURE BEFORE LOOSENING FITTINGS.
- REFER TO OWNER'S MANUAL FOR DETAILS.

50029419

**⚠ DANGER**

**KEEP AWAY - ROTATING BLADES**

TO AVOID SERIOUS INJURY OR DEATH FROM BLADE CONTACT:

- LOWER IMPLEMENT, STOP ENGINE AND PTO, ALLOW ALL MOVING PARTS TO STOP, AND REMOVE KEY BEFORE DISMOUNTING FROM TRACTOR.
- ALLOW NO RIDERS ON TRACTOR OR MOWER.
- KEEP ALL PERSONS CLEAR OF OPERATING MOWER AND MOWING AREA.
- KEEP CLEAR OF ROTATING BLADES, PARTS, AND DRIVELINES.

**PREVENT FALL OFF INTO ROTATING BLADES**

TO PREVENT ACCIDENTAL FALL OFF FROM TRACTOR AND SERIOUS INJURY OR DEATH FROM RUN OVER OR ROLLOVER BY TRACTOR OR MOWER:

- USE ROPS (ROLLOVER PROTECTIVE STRUCTURES) AND SEAT BELT EQUIPPED TRACTORS FOR MOWING OPERATIONS.
- BUCKLE UP SEAT BELT.
- KEEP ALERT FOR STUMPS, HOLES, RUTS AND UNEVEN TERRAIN.

**⚠ WARNING**

**ROTARY CUTTERS CAN DISCHARGE OBJECTS SEVERAL HUNDREDS OF FEET. TO AVOID SERIOUS INJURY OR DEATH TO BYSTANDERS FROM THROWN OBJECTS:**

- CLEAR MOWING AREA OF VISIBLE DEBRIS AND USE EXTRA CAUTION WHERE ROCKS OR DEBRIS MAY BE PRESENT.
- DO NOT OPERATE CUTTER ALONG ROADWAYS OR IN THE VICINITY OF OTHER PERSONS WITHOUT ENCLOSED SIDES, PERMANENT BANDS, BELTING, HIGHWAY CHAINS OR OTHER FACTORY APPROVED DISCHARGE SHIELDS IN PLACE AND IN GOOD WORKING ORDER.
- KEEP ALL PERSONS WELL CLEAR OF MOWER WHEN IN OPERATION.

**⚠ CAUTION**

THIS IMPLEMENT IS DESIGNED TO OPERATE AT 1000 RPM MAXIMUM TRACTOR PTO SPEED.

ALL DRIVE LINE SHIELDS MUST BE KEPT IN PLACE.

50029418

**⚠ DANGER**

**ROTATING DRIVELINE CONTACT CAN CAUSE DEATH. KEEP AWAY!**

**DO NOT OPERATE WITHOUT -**

- ALL DRIVELINE GUARDS, TRACTOR AND EQUIPMENT SHIELDS IN PLACE
- DRIVELINES SECURELY ATTACHED AT BOTH ENDS
- DRIVELINE GUARDS THAT TURN FREELY ON DRIVELINE

**BONDIOLO & PAVESI**

78608

**⚠ DANGER**

**GUARD MISSING DO NOT OPERATE**

**⚠ DANGER**

**GUARD MISSING DO NOT OPERATE**

**⚠ DANGER**

78786

# TORQUE SPECIFICATIONS

Proper torque for American fasteners used on Bush Hog equipment.  
Recommended Torque in Foot Pounds (Newton Meters).\*

## AMERICAN

Bolt Head Markings

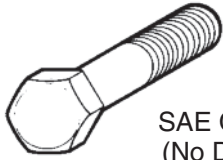

SAE Grade 2  
(No Dashes)

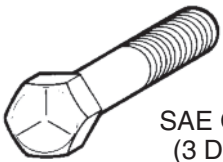

SAE Grade 5  
(3 Dashes)

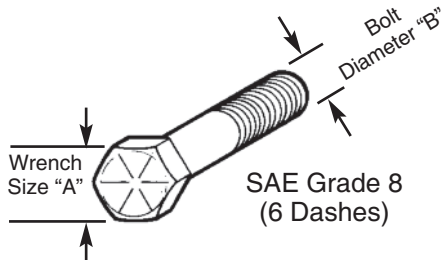

SAE Grade 8  
(6 Dashes)

WRENCH SIZE (IN.) "A"	BOLT DIAMETER (IN.) "B" AND THREAD SIZE	SAE GRADE 2	SAE GRADE 5	SAE GRADE 8
7/16	1/4 - 20 UNC	6 (7)	8 (11)	12 (16)
7/16	1/4 - 28 UNF	6 (8)	10 (13)	14 (18)
1/2	5/16 - 18 UNC	11 (15)	17 (23)	25 (33)
1/2	5/16 - 24 UNF	13 (17)	19 (26)	27 (37)
9/16	3/8 - 16 UNC	20 (27)	31 (42)	44 (60)
9/16	3/8 - 24 UNF	23 (31)	35 (47)	49 (66)
5/8	7/16 - 14 UNC	32 (43)	49 (66)	70 (95)
5/8	7/16 - 20 UNF	36 (49)	55 (75)	78 (106)
3/4	1/2 - 13 UNC	49 (66)	76 (103)	106 (144)
3/4	1/2 - 20 UNF	55 (75)	85 (115)	120 (163)
7/8	9/16 - 12 UNC	70 (95)	109 (148)	153 (207)
7/8	9/16 - 18 UNF	79 (107)	122 (165)	172 (233)
15/16	5/8 - 11 UNC	97 (131)	150 (203)	212 (287)
15/16	5/8 - 18 UNF	110 (149)	170 (230)	240 (325)
1-1/8	3/4 - 10 UNC	144 (195)	266 (360)	376 (509)
1-1/8	3/4 - 16 UNF	192 (260)	297 (402)	420 (569)
1-5/16	7/8 - 9 UNC	166 (225)	430 (583)	606 (821)
1-5/16	7/8 - 14 UNF	184 (249)	474 (642)	668 (905)
1-1/2	1 - 8 UNC	250 (339)	644 (873)	909 (1232)
1-1/2	1 - 12 UNF	274 (371)	705 (955)	995 (1348)
1-1/2	1 - 14 UNF	280 (379)	721 (977)	1019 (1381)
1-11/16	1-1/8 - 7 UNC	354 (480)	795 (1077)	1288 (1745)
1-11/16	1-1/8 - 12 UNF	397 (538)	890 (1206)	1444 (1957)
1-7/8	1-1/4 - 7 UNC	500 (678)	1120 (1518)	1817 (2462)
1-7/8	1-1/4 - 12 UNF	553 (749)	1241 (1682)	2013 (2728)
2-1/16	1-3/8 - 6 UNC	655 (887)	1470 (1992)	2382 (3228)
2-1/16	1-3/8 - 12 UNF	746 (1011)	1672 (2266)	2712 (3675)
2-1/4	1-1/2 - 6 UNC	870 (1179)	1950 (2642)	3161 (4283)
2-1/4	1-1/2 - 12 UNF	979 (1327)	2194 (2973)	3557 (4820)

## METRIC

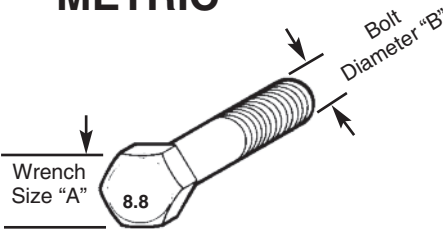

Numbers appearing on bolt heads indicate ASTM class.

Proper torque for metric fasteners used on Bush Hog equipment.  
Recommended torque in foot pounds (newton Meters).\*

WRENCH SIZE (mm) "A"	BOLT DIA. (mm) "B"	ASTM 4.6	ASTM 8.8	ASTM 9.8	ASTM 10.9
8	5	1.8 (2.4)		5.1 (6.9)	6.5 (8.8)
10	6	3 (4)		8.7 (12)	11.1 (15)
13	8	7.3 (10)		21.1 (29)	27 (37)
16	10	14.5 (20)		42 (57)	53 (72)
18	12	25 (34)	74 (100)	73 (99)	93 (126)
21	14	40 (54)	118 (160)	116 (157)	148 (201)
24	16	62 (84)	167 (226)	181 (245)	230 (312)
30	20	122 (165)	325 (440)		449 (608)
33	22		443 (600)		611 (828)
36	24	211 (286)	563 (763)		778 (1054)
41	27		821 (1112)		1138 (1542)
46	30	418 (566)	1119 (1516)		1547 (2096)

\*Use 75% of the specified torque value for plated fasteners. Use 85% of the specified torque values for lubricated fasteners.

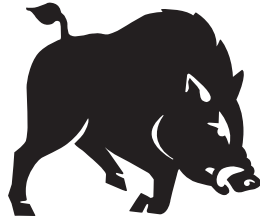

**BUSH HOG<sup>®</sup>**  
**Performance You Can Count On<sup>SM</sup>**

2501 Griffin Ave. • Selma, AL 36703  
Telephone (334) 874-2700 • [www.bushhog.com](http://www.bushhog.com)