



BOILER TUBE CLEANER™ (BTC-200-CAM-PKG) USER MANUAL

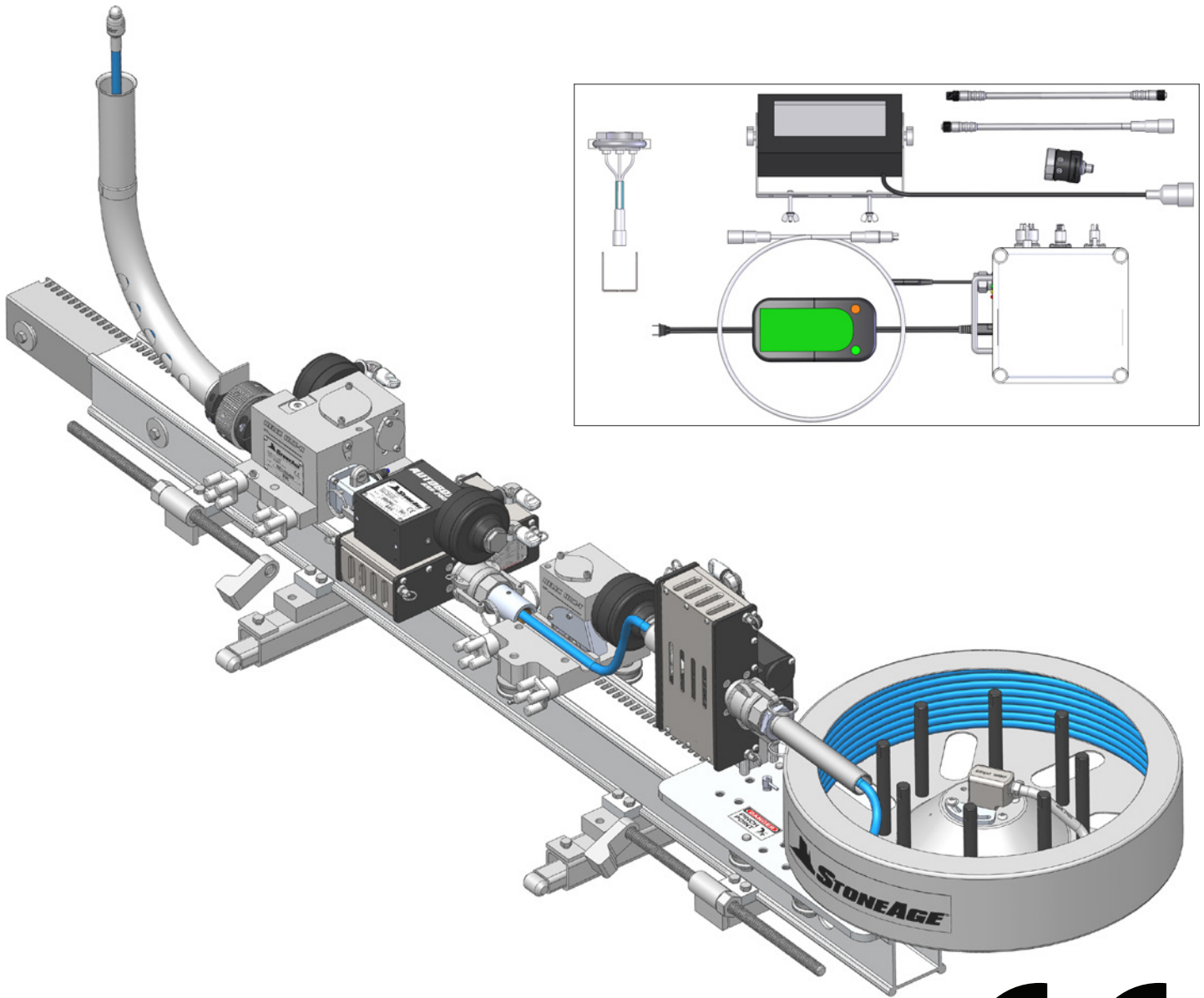

TABLE OF CONTENTS

MANUFACTURER'S INFORMATION 4

SPECIFICATIONS	4
DESCRIPTION OF EQUIPMENT AND INTENDED USE	4
KEY FEATURES	4
CE DECLARATION OF INCORPORATION	5

WARNING AND SAFETY INSTRUCTIONS 6

OPERATOR TRAINING	6
PERSONAL PROTECTIVE EQUIPMENT REQUIREMENTS	6
PRE-RUN SAFETY CHECK	7

PACKAGE CONTENTS 8

BTC-200-CAM-PKG CONTENTS	8
BASE PACKAGE OPTIONS	9

SYSTEM ASSEMBLY - OVERVIEW 10

BTC-200-001 BOILER TUBE CLEANER	10
CB-BTC-200 CONTROL BOX	11

BTC-200-001 STEP BY STEP SET-UP ON RAIL 12

RAILS AND SUPPORT TO MUD DRUM	12
JOIN RAIL EXTENSIONS AND CLAMP TO MUD DRUM	13
HLXR-100-001 ROTATOR AND ABX-PRO TRACTOR TO RAIL	14
HLXT-100-001 TRACTOR TO RAIL	15
HCS-BTC-200 HOSE CONTAINMENT SYSTEM AND INSTALLATION	16
HIGH PRESSURE HOSE INSTALLATION	17
WATERBLAST TOOL INSTALLATION	18

CONTROL BOX SET-UP 19

CONTROL BOX DETACHABLE LEGS	19
PNEUMATIC SUPPLY LINES	20
CAMERA AND LIGHT CONNECTION TO BATTERY BOX	21

OPERATION 22

CONTROL PANEL	22
PNEUMATIC DUMP CONTROL AND AIR SUPPLY FITTING	22
PRE-RUN SAFETY CHECK	23
TEST RUN PROCEDURE	23

MAINTENANCE, STORAGE, TRANSPORTATION, AND HANDLING 24

MANUAL TUBE LOCATION INSTRUCTIONS 25

ABX-PRO TRACTOR ROLLER REPLACEMENT 26

ROLLER REMOVAL INSTRUCTIONS 26

POLY ROLLER INSTALLATION INSTRUCTIONS 27

HELIX ROLLER INSTALLATION INSTRUCTIONS 28

PARTS DIAGRAMS 30

TERMS AND CONDITIONS 54

MANUFACTURER'S INFORMATION

StoneAge Inc.
 466 S. Skylane Drive
 Durango, CO 81303
 Phone: 970-259-2869
 Toll Free: 866-795-1586
 www.stoneagetools.com

StoneAge Europe
 Unit 2, Britannia Business Centre
 Britannia Way
 Malvern WR14 1GZ
 United Kingdom
 Phone: +44 (0) 1684 892065

This manual must be used in accordance with all applicable national laws. The manual shall be regarded as a part of the machine and shall be kept for reference until the final dismantling of the machine, as defined by applicable national law(s).

COMPONENT SPECIFICATIONS	Weight	Air Volume	Speed	Dimensions	Connections
ABX-PRO Tractor	20 lb (9 kg)	20 cfm	9-50 FT./MIN.		1.25 inch Camlock
BTC Tractor	20 lb (9 kg)	10 cfm	5 IPM		Rollers on Box Rail
BTC Rotator	20 lb (9 kg)	10 cfm	2 RPM		Rollers on Box Rail
Hose Containment	40 lb (18 kg)	5 cfm		24 inch diameter x 12 inch high	Position Held by Pin
Control Panel	30 lb (13.6 kg)	90 psi air, 20 cfm			
Video Camera	2 lb (.9 kg)			5x7 inch display	12v Battery or 120v AC

TRAVEL: UP TO 5 FEET PER MINUTE CONTROLLED BY VALVE HANDLE POSITION

ROTATION: 2 RPM CONTROLLED BY VALVE HANDLE POSITION

HOSE FEED SPEED: CONTROLS WILL MOVE THE HOSE IN THE FORWARD DIRECTION AT 9-50 FT/MIN, AND INDEPENDENTLY IN THE REVERSE DIRECTION AT 9-65 FT/MIN.

DESCRIPTION OF EQUIPMENT AND INTENDED USE

The BTC-200-V2 Boiler Tube Cleaner was developed as a safe and efficient alternative to manual cleaning requiring vessel entry and cleaning of tube bundles such as steam generator tubes in fossil fueled boilers. Specifically designed for the mud drum of small package boilers that are used for process steam in chemical and petroleum refining plants. The Boiler Tube Cleaner can be adapted to fit other types of boilers by modifying the size of a few components.

This system automates the cleaning process, increasing both safety and efficiency, yet remains flexible, portable, and fast.

KEY FEATURES:

- Cleans vertical and horizontal tubing
- Removes thin, hard scale and corrosion.
- Will work with manways as small as 16 inches wide
- Camera System gives the Operator the ability to quickly align with each boiler tube inside of the mud drum.
- Capable of accommodates Helix hose with a Helix Roller Kit.
- Optimally paired with 5mm or 6mm hose with Blast-Pro fitting.
- Can be paired with any StoneAge rotary pipe or tube cleaning tool. StoneAge recommends utilizing the 2" Badger or the 25mm Banshee Beetle Rotating Nozzle for boiler tube cleaning. Both tools are capable of navigating the bends commonly found in boiler tubes

Tool Benefits:

- Safely operated from outside the water blast zone
- Requires a single operator to run

EU DECLARATION OF CONFORMITY

Manufacturer: StoneAge Incorporated
466 South Skylane Drive
Durango, CO 81303
USA

Authorized Representative: StoneAge Europe
Unit 2, Britannia Business Centre
Britannia Way
Malvern WR14 1GZ
United Kingdom
Steve Ellis, Director StoneAge Europe

Declare that: **Boiler Tube Cleaner (BTC-200)
for high pressure water cleaning of system parts.**

Is compliant with the following Directives and Standards:

Directive 2006/42/EC (Machinery Directive)

EN ISO 12100:2010 (E) Safety of machinery – General principles for design – Risk assessment and risk reduction

The Technical File for Boiler Tube Cleaner (BTC-200)

is maintained at: StoneAge Incorporated, 466 South Skylane Drive, Durango, CO 81303, USA and was compiled by the Engineering Manager. The Technical File is available through the Authorized Representative.

This Declaration of Conformity is issued under the exclusive responsibility of StoneAge Incorporated.

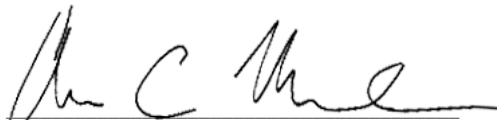

StoneAge Incorporated, Durango, CO, USA
Adam Markham, Engineering Manager, Robotics

02/11/2019
Date



WARNING AND SAFETY INSTRUCTIONS

OPERATOR TRAINING

Managers, supervisors, and operators **MUST** be trained in Health and Safety Awareness of High-pressure Water Jetting and hold a copy the Water Jetting Association (WJA) Code of Practice, or equivalent (see www.waterjetting.org.uk).

Operators **MUST** be trained to identify and understand all applicable standards for the equipment supplied. Operators should be trained in manual handling techniques to prevent bodily injury.

Operators **MUST** read, understand, and follow the Operational and Training Requirements (Section 7.0) of WJTA-IMCA's Recommended Practices For The Use Of High-pressure Waterjetting Equipment, or equivalent.

Operators **MUST** read, understand and follow the Warnings, Safety Information, Assembly, Installation, Connection, Operation, Transport, Handling, Storage, and Maintenance Instructions detailed in this manual.

StoneAge has designed and manufactured this equipment considering all hazards associated with its operation. StoneAge assessed these risks and incorporated safety features in the design. StoneAge **WILL NOT** accept responsibility for the results of misuse.

IT IS THE RESPONSIBILITY OF THE INSTALLER/OPERATOR to conduct a job specific risk assessment prior to use. Job specific risk assessment **MUST** be repeated for each different set up, material, and location.

The risk assessment **MUST** conform to the Health and Safety at Work Act 1974 and other relevant Health and Safety legislation.

The risk assessment **MUST** consider potential material or substance hazards including:

- Aerosols
- Biological and microbiological (viral or bacterial) agents
- Combustible materials
- Dusts
- Explosion
- Fibers
- Flammable substances
- Fluids
- Fumes
- Gases
- Mists
- Oxidizing Agents

PERSONAL PROTECTIVE EQUIPMENT REQUIREMENTS

Use of Personal Protective Equipment (PPE) is dependent on the working pressure of water and the cleaning application. Managers, Supervisors, and Operators **MUST** carry out a job specific risk assessment to define the exact requirements for PPE. See Protective Equipment for Personnel (Section 6) of WJTA-IMCA's Recommended Practices For The Use Of High-pressure Waterjetting Equipment for additional information.

Hygiene - Operators are advised to wash thoroughly after all operations to remove any waterblast residue which may contain traces of harmful substances.

First aid provision - users **MUST** be provided with suitable first aid facilities at the operation site.

PPE may include:

- **Eye protection:** Full face visor
- **Foot protection:** Kevlar® brand or steel toe capped, waterproof, non-slip safety boots
- **Hand protection:** Waterproof gloves
- **Ear protection:** Ear protection for a minimum of 85 dBA
- **Head protection:** Hard hat that accepts a full face visor and ear protection
- **Body protection:** Multi-layer waterproof clothing approved for waterjetting
- **Hose protection:** Hose shroud
- **Respiratory protection:** May be required; refer to job specific risk assessment

▲ WARNING

Operations with this equipment can be potentially hazardous. Caution **MUST** be exercised prior to and during machine and water jet tool use. Please read and follow all of these instructions, in addition to the guidelines in the WJTA Recommended Practices handbook, available online at www.wjta.org. Deviating from safety instructions and recommended practices can lead to severe injury and/or death.

- Do not exceed the maximum operating pressure specified for any component in a system. The immediate work area **MUST** be marked off to keep out untrained persons.
- Inspect the equipment for visible signs of deterioration, damage, and improper assembly. Do not operate until repaired. Make sure all threaded connections are tight and free of leaks.
- Users of the Boiler Tube Cleaner™ (BTC) **MUST** be trained and/or experienced in the use and application of high-pressure technology and cleaning, as well as all associated safety measures, according to the WJTA Recommended Practices for the use of High-pressure Waterjetting Equipment.
- The Control Box should be located in a safe location where the operator has good visibility of the mud drum entrance. The Boiler Tube Cleaner™ (BTC) and Control Box **MUST** be supervised at all times and should never be left unattended.
- Always de-energize the system before attempting to service or replace any parts. Failure to do so can result in severe injury and/or death.

▲WARNING

Operations with this equipment can be potentially hazardous. Caution MUST be exercised prior to and during machine and water jet tool use. Please read and follow all of these instructions, in addition to the guidelines in the WJTA Recommended Practices handbook, available online at www.wjta.org. Deviating from safety instructions and recommended practices can lead to severe injury and/or death.







- Do not exceed the maximum operating pressure specified for any component in a system.
- The immediate work area MUST be marked off to keep out untrained persons.
- Inspect the equipment for visible signs of deterioration, damage, and improper assembly. Do not operate if damaged, until repaired.
- Make sure all threaded connections are tight and free of leaks.
- Use Blue Goop® by Swagelock® or equivalent on all straight thread connections.
- Use Loctite® 567, Teflon tape, or equivalent, on all pipe thread connections.
- Users of the Boiler Tube Cleaner™ (BTC-200-001) Hose Tractor MUST be trained and/or experienced in the use and application of high pressure technology and cleaning, as well as all associated safety measures, according to the WJTA Recommended Practices for the use of High pressure Water jetting Equipment.
- An anti-withdrawal device (back-out preventer) MUST be used at all times. The back-out prevention device is the Hose Stop Collet located within the Hose Guide Assembly. StoneAge offers several different size Hose Stop Collets. The Collet Size Reference guide is located on the Hose Guide Assembly.
- The Control Box should be located in a safe location where the Operator has good visibility of the tool entering the exchanger tubes. The Boiler Tube Cleaner™ (BTC-200-001) Hose Tractor and Control Box MUST be supervised at all times and should never be left unattended.
- Do not fully release the hose clamp (decreasing pressure to zero) during operation, or the Boiler Tube Cleaner™ (BTC-200-001) Hose Tractor will release the hose and may create a dangerous runaway hose condition, which can result in severe injury and/or death.
- Always de-energize the system before opening the door to service or replace any parts. Failure to do so can result in severe injury and/or death.
- When moving the Boiler Tube Cleaner™ (BTC-200-001) Hose Tractor lift with care to prevent bodily injury.
- Do not operate the Boiler Tube Cleaner™ (BTC-200-001) Hose Tractor while either side door is open.

PRE-RUN SAFETY CHECK

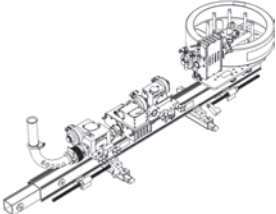
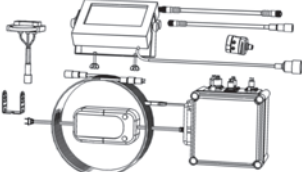
Refer to WJTA-IMCA's, Recommended Practices For The Use Of High pressure Waterjetting Equipment and/or The Water Jetting Association's, WJA Code of Practice for additional safety information.

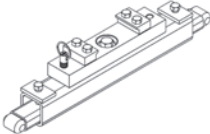
- Complete a job specific risk assessment and act on the resulting actions.
- Adhere to all site specific safety procedures.
- Ensure the waterblasting zone is properly barricaded and that warning signs are posted.
- Ensure the work place is free of unnecessary objects (e.g. loose parts, hoses, tools).
- Ensure all Operators are using the correct Personal Protective Equipment (PPE).
- Check that the air hoses are properly connected and tight.
- Check all hoses and accessories for damage prior to use. Do not use damaged items. Only high quality hoses intended for waterblast applications should be used as high pressure hoses.
- Check all high pressure threaded connections for tightness.
- **Ensure that an anti-withdrawal device (back-out preventer), whip checks (hose whips), and all other applicable safety devices are installed and set-up properly.**
- Ensure the doors of the Boiler Tube Cleaner™ (BTC-200-001) Hose Tractor are closed and securely latched.
- Test the Control Box before operating the Boiler Tube Cleaner™ (BTC-200-001) Hose Tractor with high pressure water to verify the control valves move the hose in the intended direction, and that the high pressure dump valve and hose clamp are working properly.
- Ensure that Operators never connect, disconnect, or tighten hoses, adapters, or accessories with the high pressure water pump unit running.
- Ensure no personnel are in the hydroblasting zone.

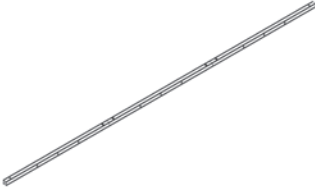
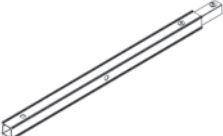
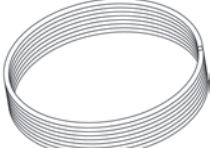
BTC-200-CAM-PKG CONTENTS

	QTY.	DESCRIPTION	PART ID
	1	BOILER TUBE CLEANER ASSEMBLY	BTC-200-001
	1	BTC CAMERA SYSTEM ASSEMBLY (THE CAMERA AND LED CABLES INCLUDED IN THIS KIT ALLOW FOR THE CAMERA SYSTEM TO BE USED INDEPENDENTLY OF THE BTC-200-001.)	CAM-200-BTC
	1	BTC 200 CONTROL BOX (CB 061 HOSE BUNDLE INCLUDED WITH THE CB-BTC-200 IS USED TO CONNECT THE CONTROL BOX, CAMERA, AND LED TO THE BTC ASSEMBLY)	CB-BTC-200
	2	SUPPORT ASSEMBLY	BTC 140-7-14
	1	FLARE KIT INCLUDES: 1", 3", AND 7" FOR 24"-36" DRUMS	HLXR 015-K
	1	30' DRIVE RAIL ASSEMBLY	BTC 570-30
	1	10' RAIL KIT EXTENSION	BTC 580-10
	1	85' HOSE 5/4, 9/16TM X 3/8 RHM, FLEX LANCE	ACHO H54085FTM6NZRM
	1	BEETLE TUBE SPINNER, 22K PSI (12-15 GPM)	BT25-MP6R-C
	1	20K AIR DUMP VALVE KIT INCLUDES: ACDA 61020019-K 20K DUMP VALVE ACHO H134H010FTMSC HOSE, 134H, 1TM X 1TM, 10FT, W/ABRASIVE COVER AF 063-MP9 ADAPTER, 1-12 TYPE-M X MP9 ACWC NY-31 NYLON HOSE WHIP RESTRAINT	ACDK 620

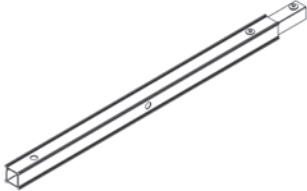
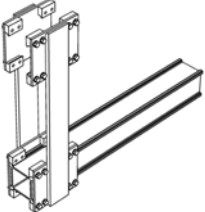
	QTY.	DESCRIPTION	PART ID
	1	10' RAIL KIT EXTENSION	BTC 580-10
	1	HANGING HOSE CONTAINMENT SYSTEM BRACKET ASSEMBLY	HCS 150

**SEE "PART DIAGRAM" SECTION AT THE BACK OF THIS MANUAL FOR MORE DETAILED PART BREAK DOWNS.

OVERVIEW- BTC-200-001 BOILER TUBE CLEANER AND CAM-BTC-200

BTC-200-001 BOILER TUBE CLEANER COMPONENTS

ABX-PRO TRACTOR

The Drive will feed or retract the Hose through the assembly into the boiler tube ports. The Drive can exert up to 50 lbs (23 Kg) of push when needed to clear plugged tubes or travel long distances.

ABX-PRO-5 HOSE CONTAINMENT DRIVE

The Hose Containment Drive is a hose drive with an air motor driving rollers to take up slack in the hose and push it into the containment drum.

HCS-BTC-200 HOSE CONTAINMENT SYSTEM

The Hose Containment System remains outside of the boiler and is designed to keep the Hose managed and protected.

HLXR-100-001 ROTATOR

The Rotator aligns the Hose and water jet tool with the boiler tubes. The Rotator is comprised of an air motor drive, double worm gear reduction, overload slip clutch, and elbow. The Hose and water jet tool exit the HLXR 040 Rotator Elbow and enter the boiler tubes. Rotator extension tubes are available through StoneAge to match the internal diameter of the boiler tube. The Rotator and the Tractor allow the operator to align the Hose with each individual boiler tube before launching the Hose.

HLXT-100-001 TRACTOR DRIVE ASSEMBLY

The Tractor moves the entire Boiler Tube Cleaner unit forward and backward along the rail.

HOSE TYPES- STANDARD POLY OR HELIX

The Boiler Tube Cleaner comes standard with Poly rollers and 5/4 Poly hose. It can also be retrofit to accommodate Helix hose with HLXD 625 Helix Roller Kits installed in the ABX-PRO Tractor and the ABX-PRO-5 Hose Containment Drive.

NOTE: If there is any question about the appropriate hose size for the flow limit or water jet tool being used, please contact your StoneAge Customer Service Representative. 1-866-795-1586

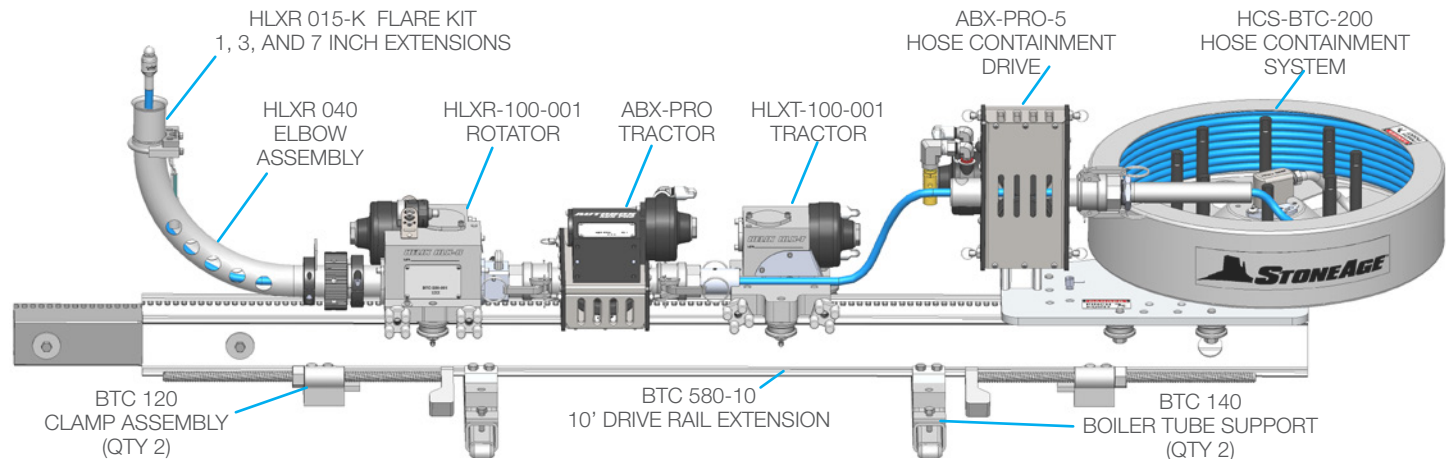

CAM-200-BTC CAMERA ASSEMBLY

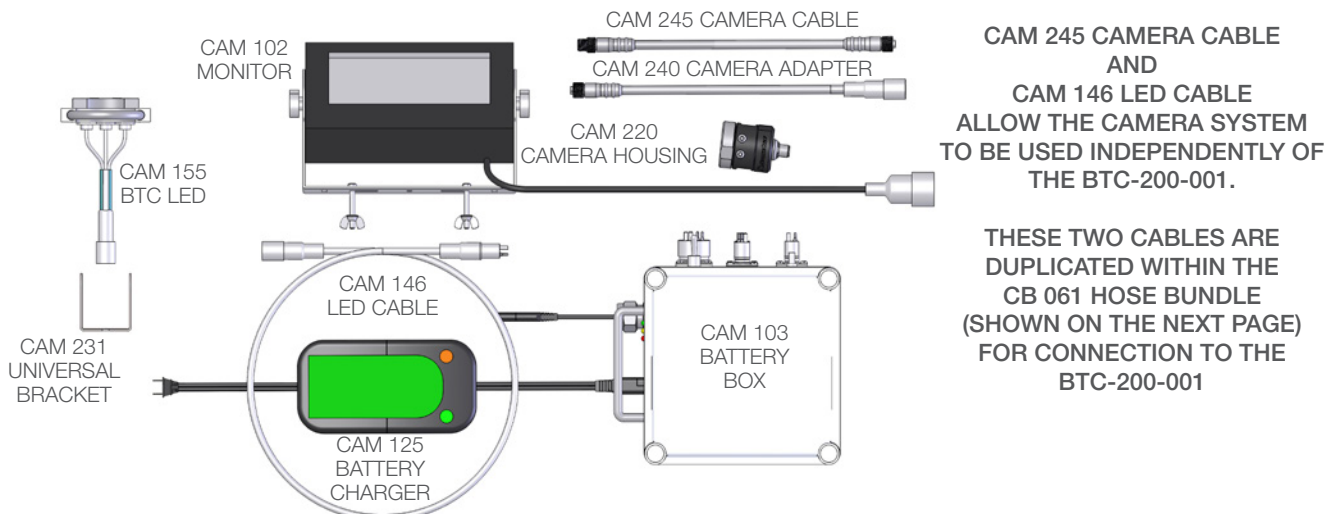

CB-BTC-200 CONTROL BOX

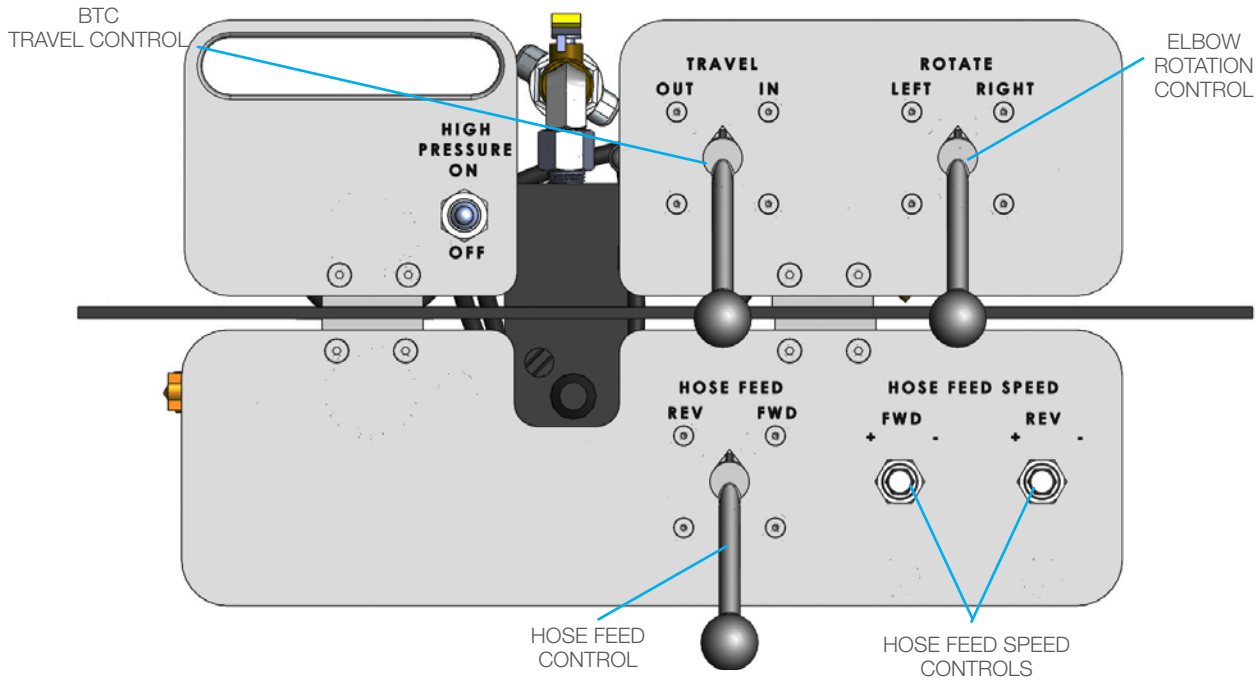

CONTROL BOX FRONT VIEW

CONTROL BOX REAR VIEW

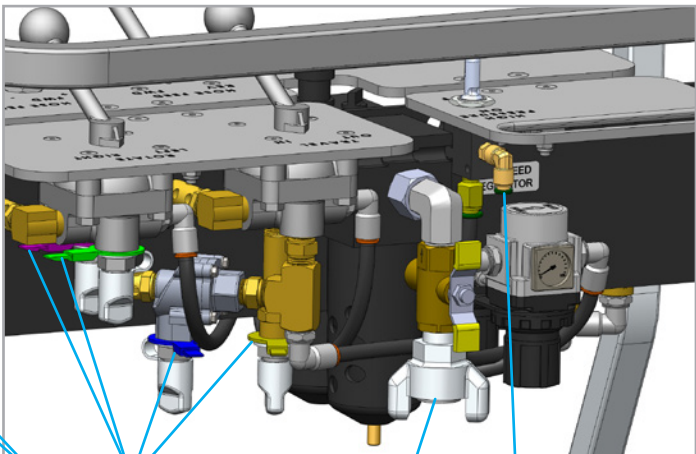
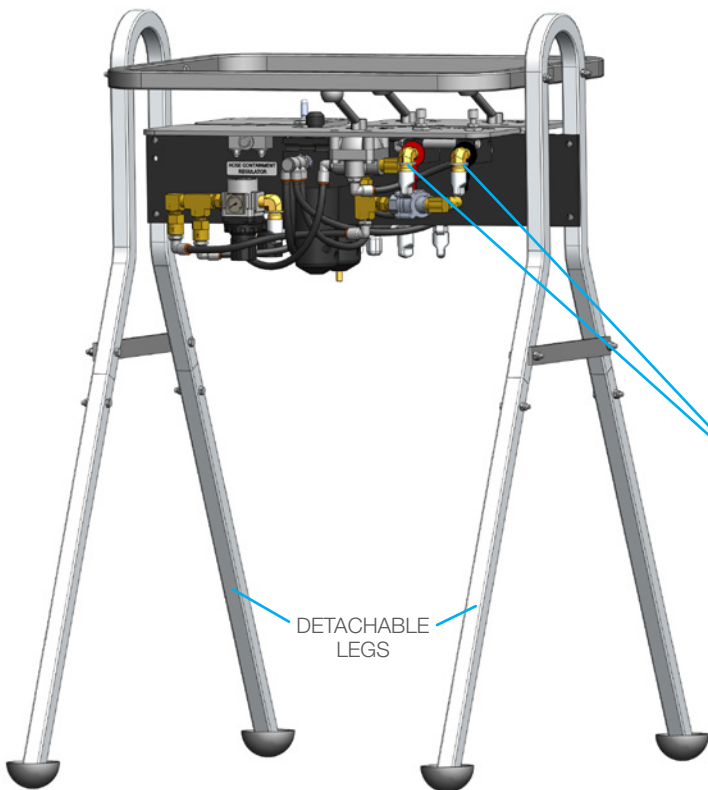

****SEE "PART DIAGRAM" SECTION AT THE BACK OF THIS MANUAL FOR MORE DETAILED PART BREAK DOWNS.**



BTC-200-001 STEP BY STEP ASSEMBLY ON RAIL

BTC 580-10 DRIVE RAIL EXTENSION

The slotted box rail with BTC 140 Support and BTC 120 Clamps act as the support for the BTC-200-001 system components. Rails are available to match the length of any mud drum. The BTC will ship mounted to a 6ft rail.

BTC 140 SUPPORT

1. Before attaching to the rail, set the BTC 140 Support in the drum. Check the height of the bearing surface to be sure it is level with the manway. Adjust the extendable feet if needed to level the support 6" (15.24 cm) below the drum centerline. Attach to rail with rail slots positioned on the right and Spring Plungers on the left, when looking into the mud drum.
2. Pull up on the ring of the Spring Plunger Pin to unlock the swivel mechanism of the BTC-140 Support.
3. Swivel the Support until it allows for insertion into the mud drum.
4. Insert the BTC 140 Support and the rail into the mud drum with the extendable feet facing down.
5. Swivel the Support so the feet touch the sides of the mud drum and lock the Spring Plunger Pin in place.
6. The distance you insert the rail into the mud drum is dependent on the length of the mud drum. If the rail span exceeds 20 ft. (6096 mm), use two supports evenly spaced.

NOTE: If the manway is higher than 12" (30.48 cm), block up the rail to center the HLXR-100-001 Rotator.

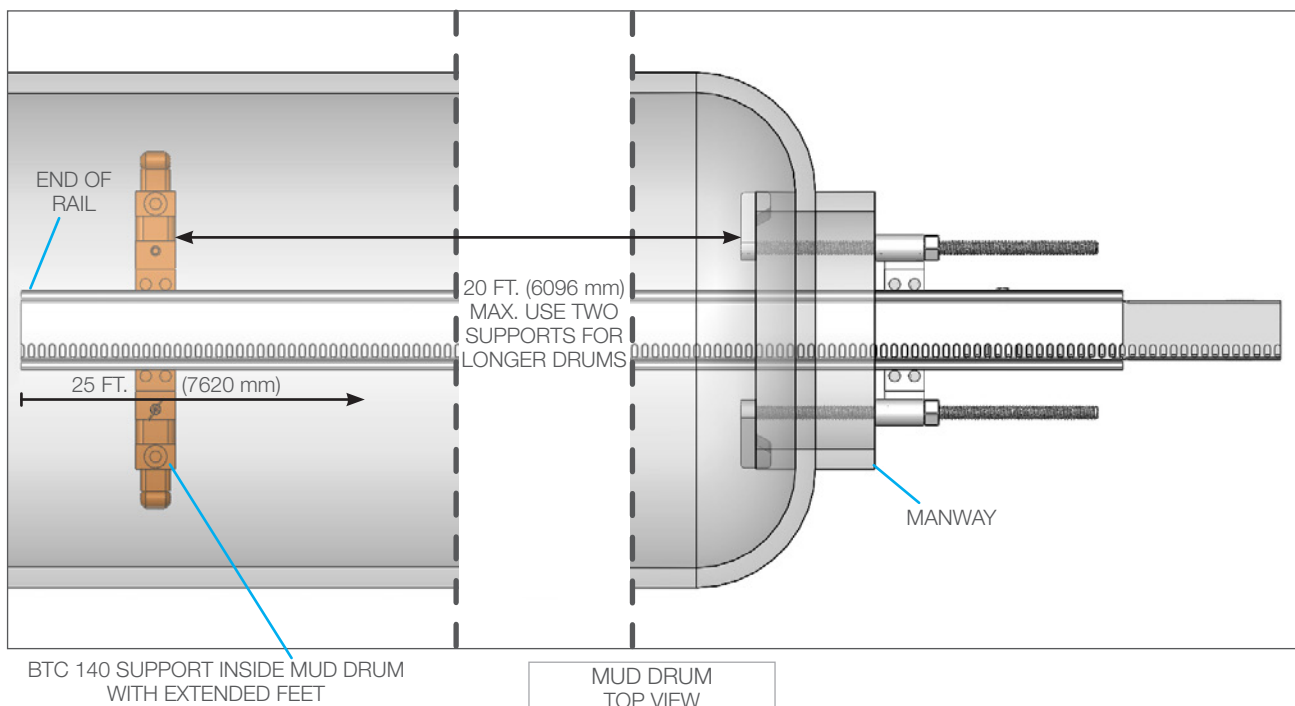
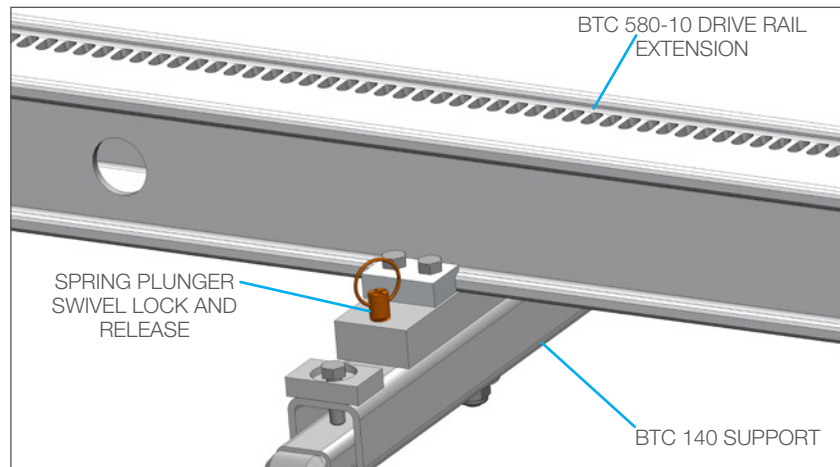

JOINING RAILS

Additional rail length may be needed when the assembly is slid into the inside of the mud drum. Tighten the wedge bolts evenly to synchronize the rail slots.

1. Slide Rail Extension over the Splice Tube. When joining multiple rails, it is important to align the drive slots as illustrated.
2. Make sure the slots are clear to allow the gears of the Boiler Tube Cleaner to engage freely.
3. Install Wedge Bolt through both Rail and Splice Tube and tighten the bolt to expand the diameter and secure the rails together. Make sure the rail edges are match to allow rollers to travel freely across joints.
4. There must be at least 6 ft. (1829 mm) of rail outside the manway to allow the Elbow, Rotator, Tractor, Hose Drive, and Hose Containment System to be assembled. Setup on site is easier if all components are installed on a rail section.

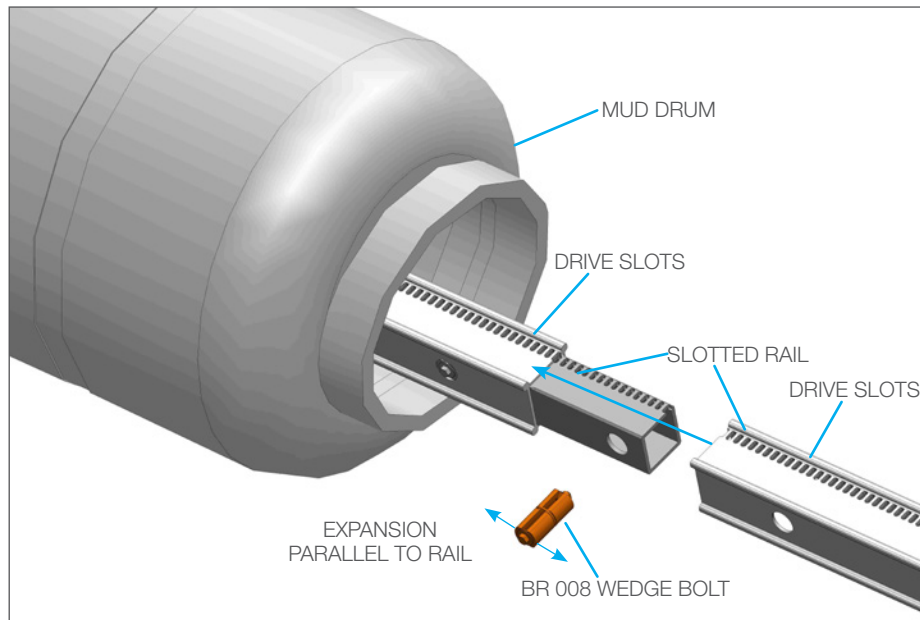

BTC-120 CLAMP

1. Place the BTC 120 Clamp under the rail at the point where the rail contacts the man way. Make sure the clamp end is outside the manway and the hook end is inside the man way. Hook the clamps inside the manway flange.
2. Hand-tighten the two Acme nuts onto the threaded rods to pull the BTC 120 Clamp against the face of the man way. Use a wrench to tighten the two clamps to 100 in-lb (11.3 Nm).

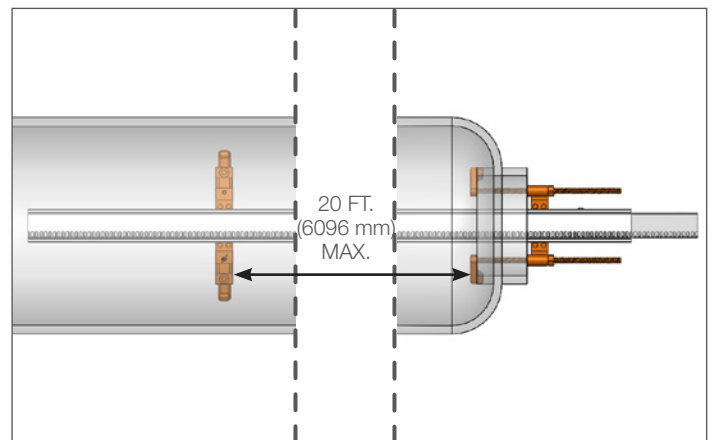
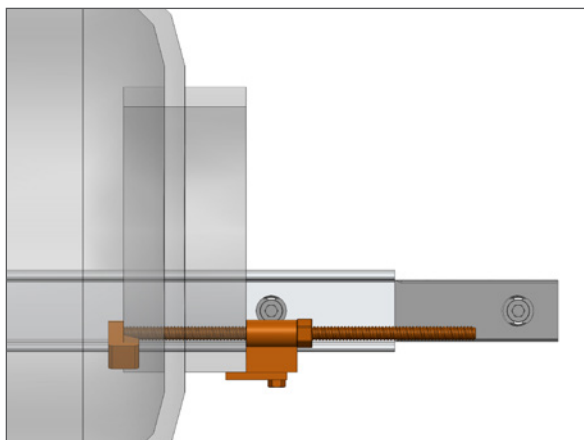

BTC-200-001 STEP BY STEP ASSEMBLY ON RAIL

HLXR-100-001 ROTATOR TO RAIL ASSEMBLY

NOTICE

Before assembling the BTC-200-001 be sure the desired rollers (Poly or Helix) are installed in the ABX-PRO and ABX-PRO-5. See the Roller Replacement section of this manual for instructions on how to change out the rollers.

1. To install the HLXR-100-001 Rotator on the rail, loosen the bar knobs on the Chassis Clamp and slide the Rotator on the rail into position. Tighten the bar knobs to 50 in-lbs (5.65 Nm). Make sure the roller grooves engage the rail and the Chassis Clamp is completely closed. **(Figures 1 & 2)**

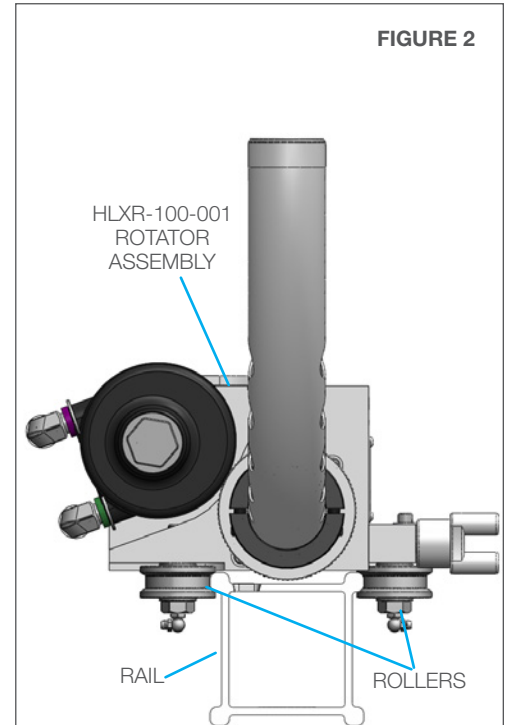
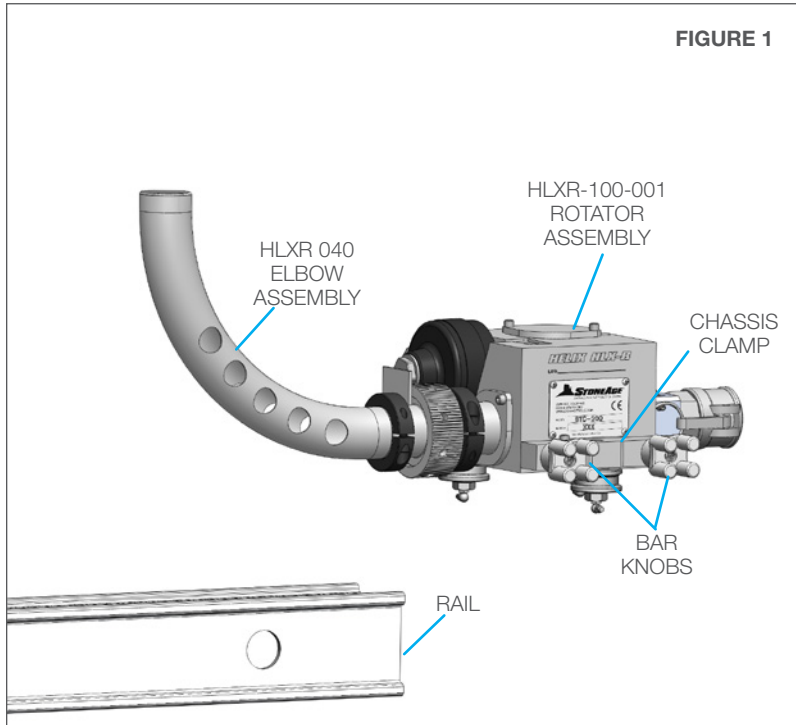

ABX-PRO TRACTOR TO HLXR-100-001 ROTATOR

2. Slide the hose guide on the ABX-PRO Tractor into the Female Camlock on the HLXR-100-001 Rotator and engage the Camlock lever lock pins. Make sure the air fittings are pointed away from the Rotator and the AUTOBOX label is facing up. **(Figure 3)**

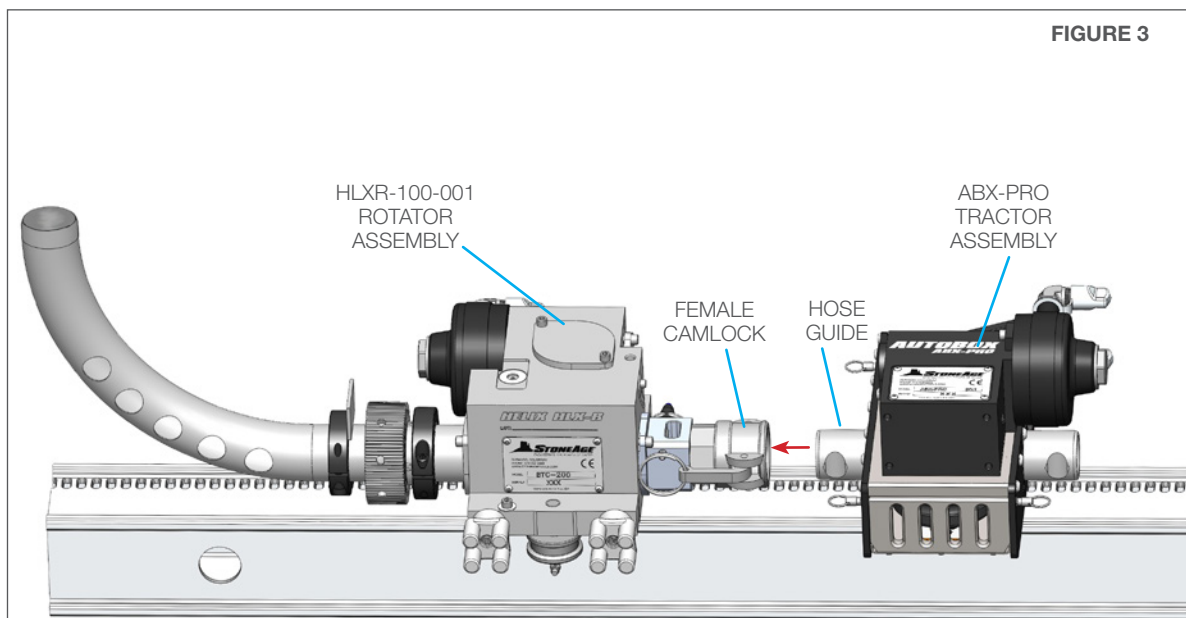

HLXT-100-001 TRACTOR TO ABX-PRO TRACTOR

- To install the HLXT-100-001 Tractor on the rail, loosen the bar knobs on the Chassis Clamp and slide the HLXT-100-001 Tractor on the rail onto the Hose Guide on the ABX-PRO (Tractor). Tighten the bar knobs to 50 in-lbs (5.65 Nm). Make sure the roller grooves engage the rail and the Chassis Clamp is completely closed. **(Figures 4)**

FIGURE 4

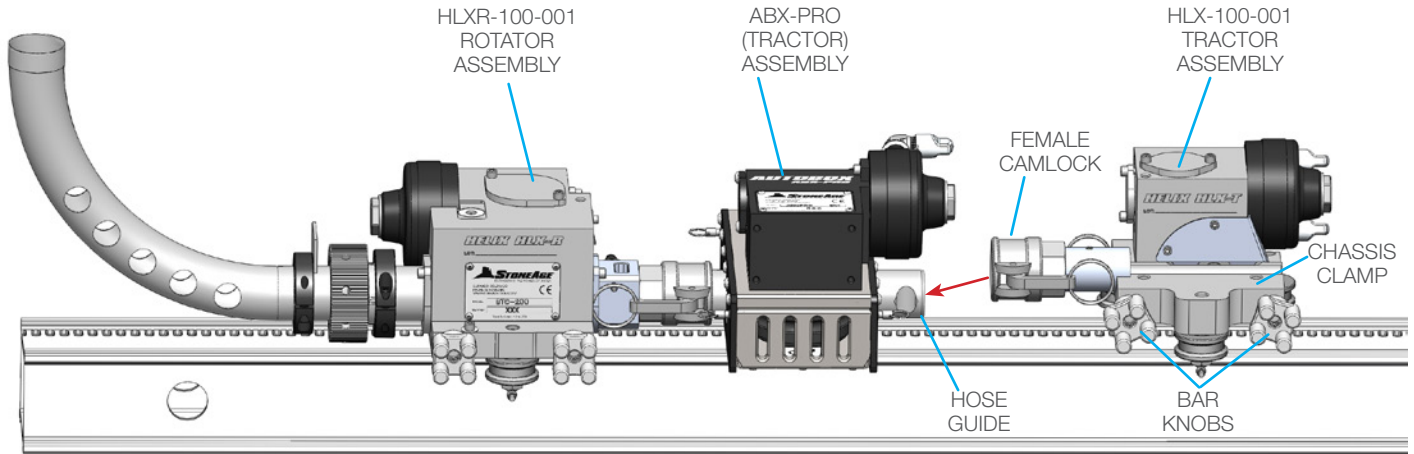

CAM 220 CAMERA TO BTC-200-001

- Attach the CAM 220 Camera Assembly by placing the CAM 231 Universal Bracket into the slot on the Rotator until it engages with the CAM 161 Magnet. **(Figure 5)**
- Choose the HLXR 015 Flare length from the chart below, based on the Interior Diameter of the boiler tube. The BTC-200-CAM Package comes with 1", 3", and 7" lengths. Additional lengths may be purchased through StoneAge®.
- Attach the HLXR 015-XX Flare with the CAM 155 BTC LED Bracket Assembly. **(Figure 5)**

FIGURE 5

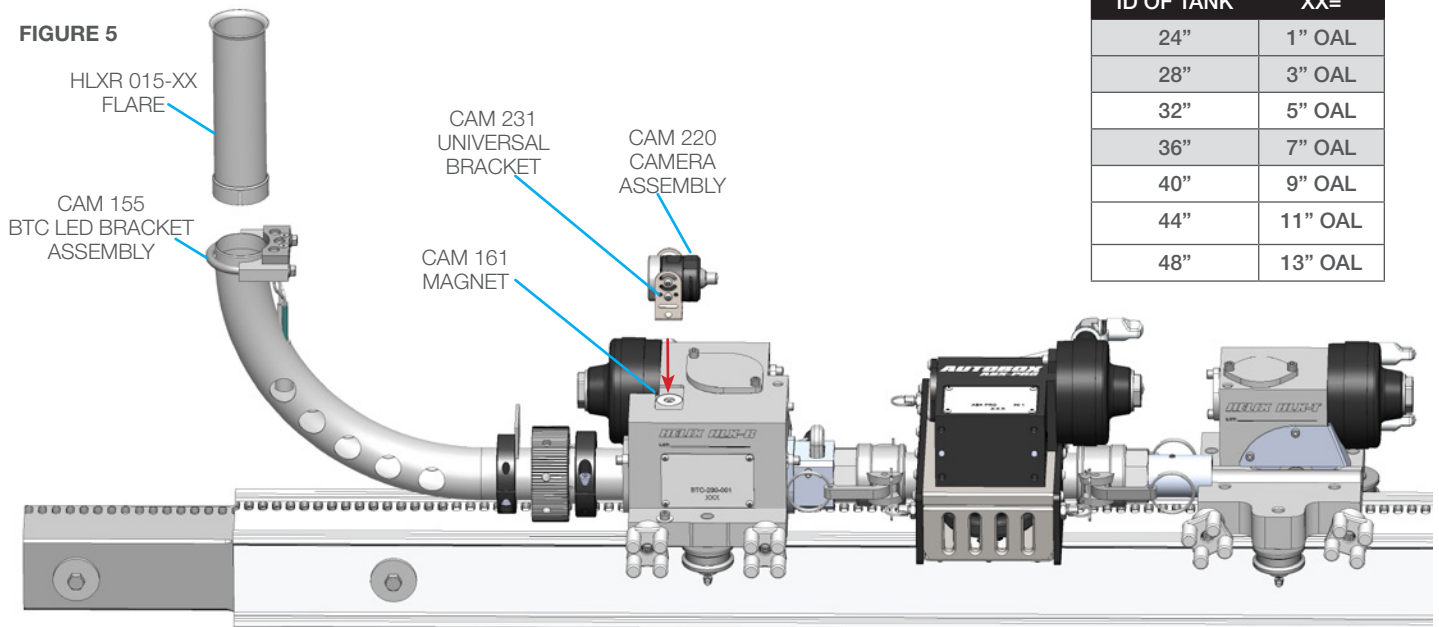

HLXR 015 FLARE CHART	
ID OF TANK	XX=
24"	1" OAL
28"	3" OAL
32"	5" OAL
36"	7" OAL
40"	9" OAL
44"	11" OAL
48"	13" OAL

BTC-200-001 STEP BY STEP ASSEMBLY ON RAIL

HCS-BTC-200 HOSE CONTAINMENT SYSTEM TO BTC-200-001

- To install the HCS-BTC-200 Hose Containment System, release the Retractable Spring Plunger on the drum plate and slide the Hose Containment System onto the rail until the edge of the Drum Plate lines up with the end of the rail. **(Figure 6)**
Lock the Retractable Spring Plunger into a slot in the Rail. **(Figure 6.1)**

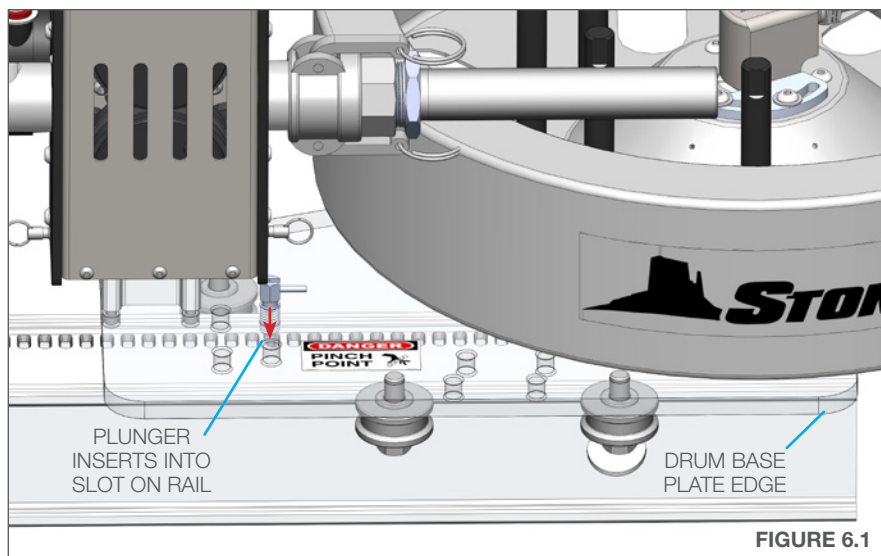
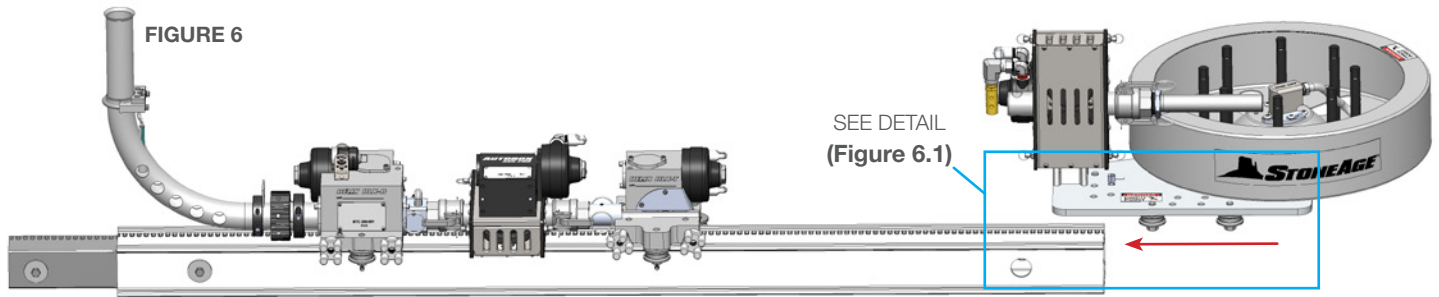

HIGH PRESSURE HOSE CONNECTION TO HCS-BTC-200 HOSE CONTAINMENT SYSTEM

- Thread the female swivel end of the high pressure hose onto the HCS 108 Drum Tube and wrap the remainder of the hoses around the rods, in the direction of the red arrow **(Figure 7)**

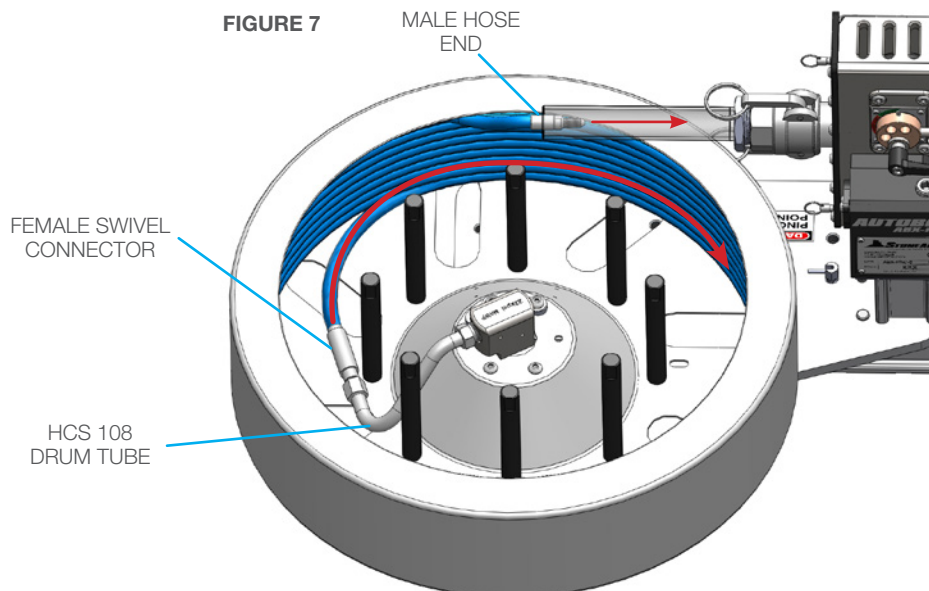

LOADING THE HIGH-PRESSURE HOSE

NOTICE

Only high quality hoses intended for waterblast applications should be used as high-pressure hoses. Pressure rating of high-pressure hoses MUST NEVER be exceeded. Do not use a shrouded hose or hose with a steel protective cover. This will cause severe damage to the Rollers.

- To load a hose, release the Adjustable Handle and rotate the Cam Lever until the Indicator Pin is in the "Disengaged" position. This opens up the space between the rollers. (Figure 8) This will need to be done at the ABX-PRO-5 (Tractor) and the ABX-PRO (Tractor). (Figure 8.1)

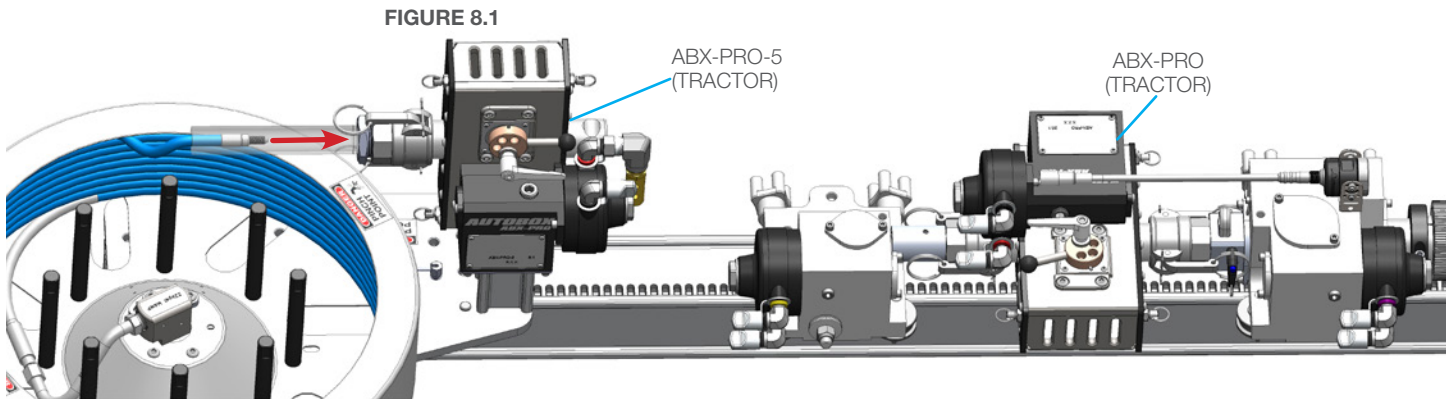
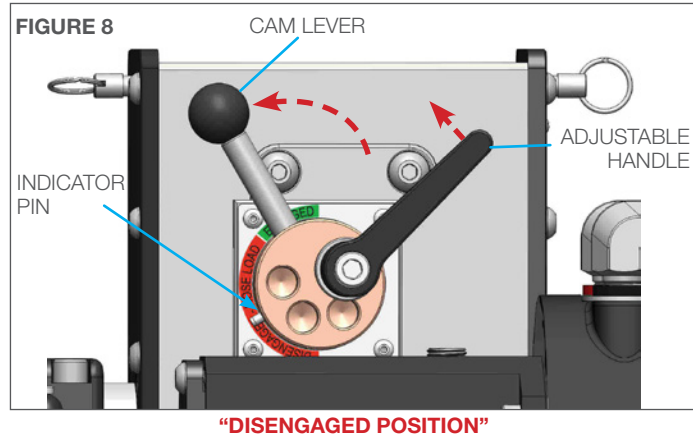

- Continue to feed the male hose end of the high pressure hose through the ABX-PRO-5, HLXT-100-001, ABX-PRO, HLXR-100-001, and the HLXR 040 Elbow Assembly, in the direction of the red arrow shown below. Pull out the Quick Release Pin and insert the FF-121-XX Collet just behind the HLXR-100-001 Rotator. (Figure 9)

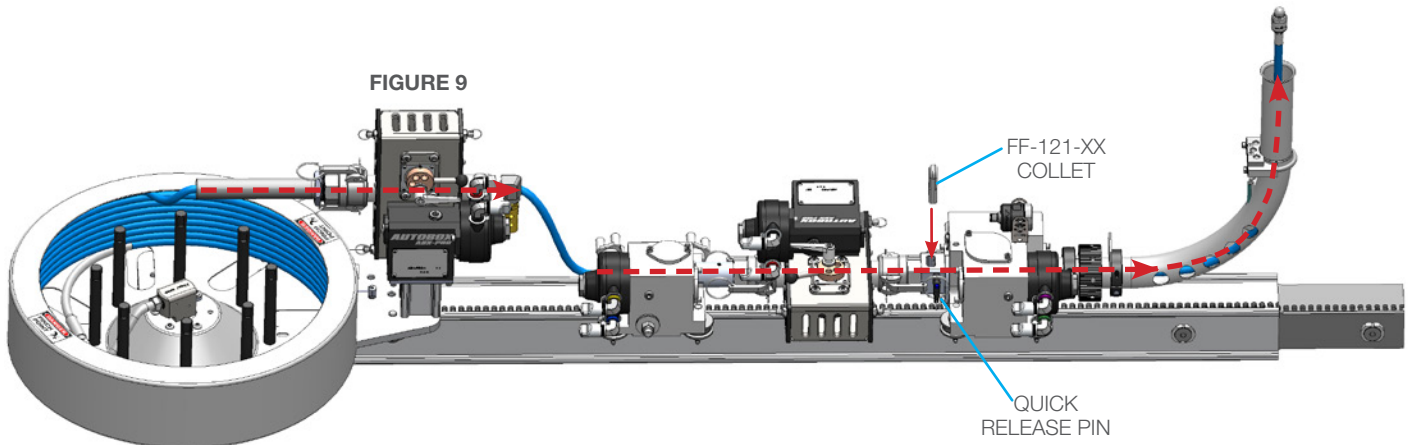

BTC-200-001 STEP BY STEP ASSEMBLY ON RAIL

11. When the male end of the High Pressure hose projects out of the Elbow, rotate the Cam Levers clockwise on both the ABX-PRO-5 and ABX-PRO (Tractors) until the Indicator Pin is in the **“Engaged”** position. Then rotate the Adjustable Handle clockwise to increase tension on the hose. **(Figure10)**

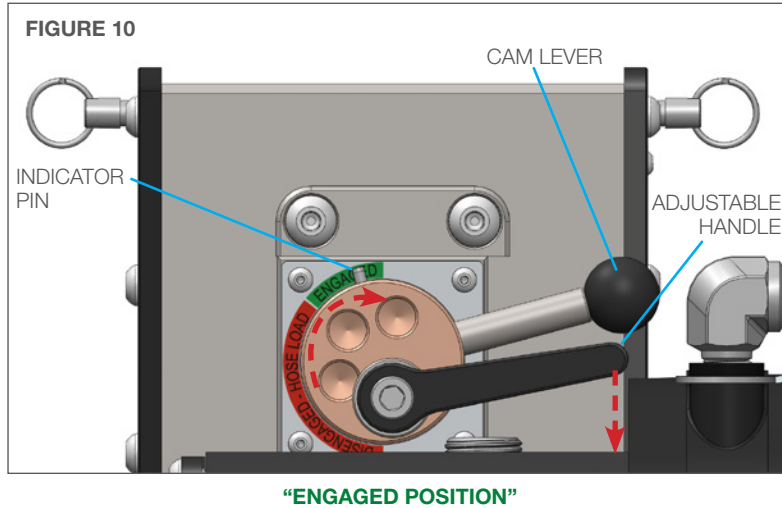

INSTALL TOOL

12. Thread the Banshee® Beetle BT25-XXX onto the male hose end. **(Figure 11)**

NOTICE

Use Blue Goop® by Swagelok® or equivalent on all straight thread connections.

Never use Pipe Wrenches or Pliers to install or maintain the Banshee® Beetle. After each use, always blow water out of the tool and fill with light oil such as WD-40

FIGURE 11

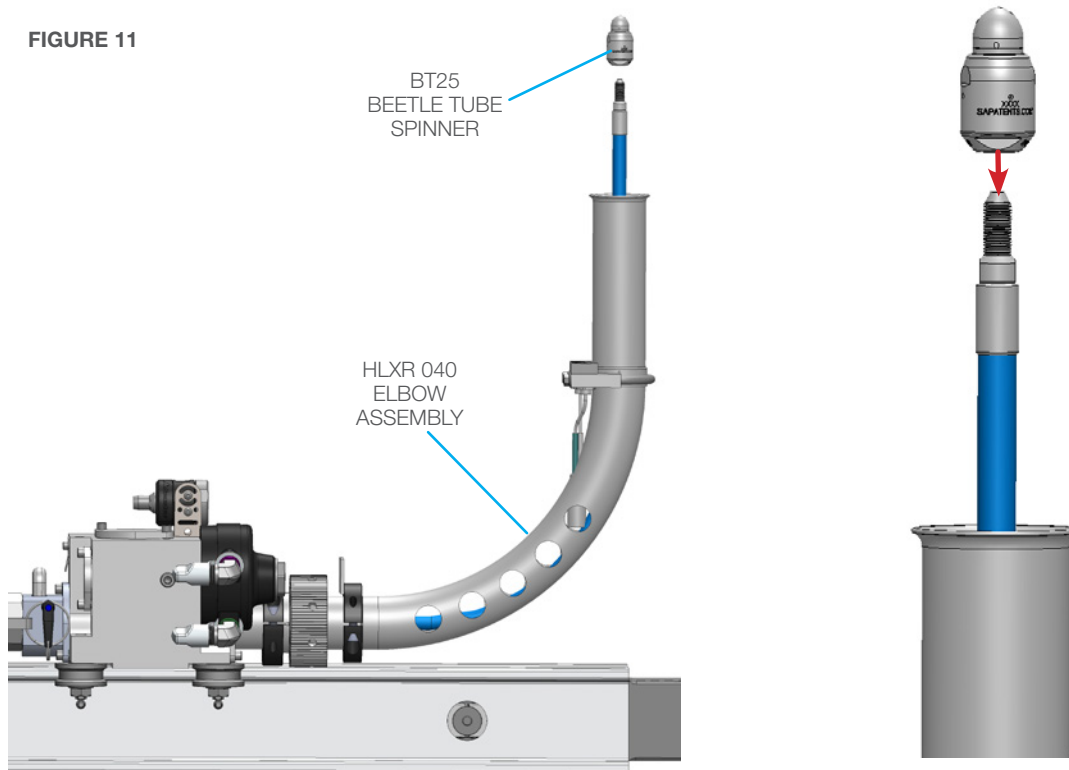

CB-BTC-200 CONTROL BOX

The Control Box may be operated with or without installing the detachable legs. Remove the legs for portability or to operate the Control Box in smaller spaces.

1. Remove the lower bolts and nuts from the Control Box frame.
2. Install the detachable legs onto the tube inserts.
3. Install the lower bolts and nuts through the legs and tube inserts. Use a 7/16 in wrench and socket to tighten the bolts.



CONTROL BOX CONNECTION TO THE BTC-200-001

PNEUMATIC SUPPLY LINES

1. Remove the dust caps from the Joint Industry Council (JIC) fittings on the Control Box and the motors on the BTC-200-001.
2. Following the "Pneumatic Supply Line Color Chart", connect the equally bundled hose ends to the fittings on the Control Box. Assuming the air supply is connected to the Control Box, blow out the hoses before connecting to them to the motors on the BTC-200-001 to remove any debris.
3. Immediately following the blow out procedure, connect the other end to the motors on the BTC-200-001 using the color coding on the JIC fittings. Use a 7/8 in. wrench to tighten the JIC Swivel nuts.
4. Test the Control Box before operating the BTC with high-pressure water to verify the control valves move the hose in the intended direction, and that the dump valve is working properly.

PNEUMATIC SUPPLY LINE COLOR CHART

HCS-BTC-200
HOSE CONTAINMENT SYSTEM
HOSE FEED

ABX-PRO (TRACTOR)

HLXR-100-001 ROTATOR

HLXT-100-001 TRACTOR

■ HOSE FEED
SPEED REVERSE
■ HOSE FEED
SPEED FORWARD

■ RIGHT
■ LEFT

■ IN
■ OUT

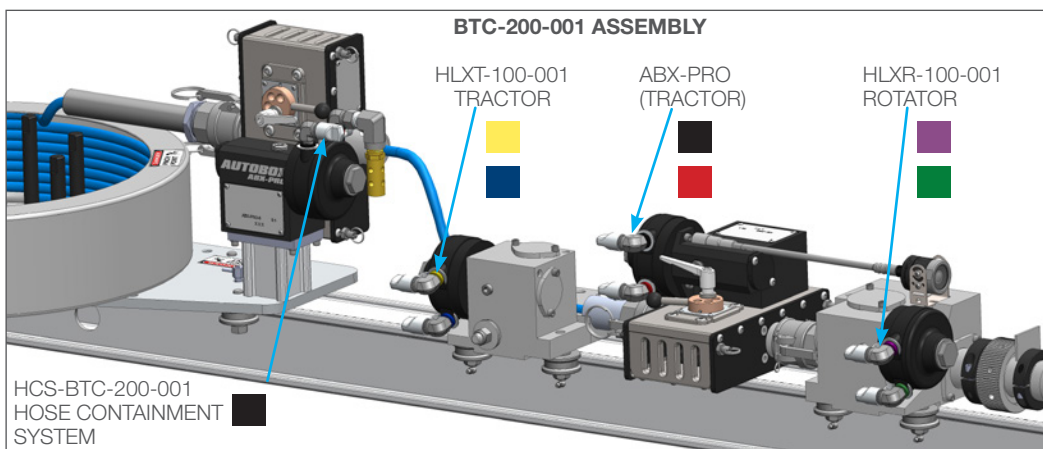
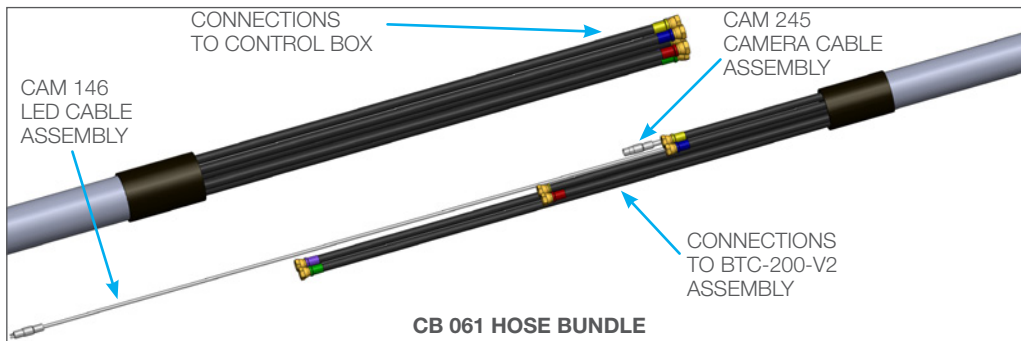
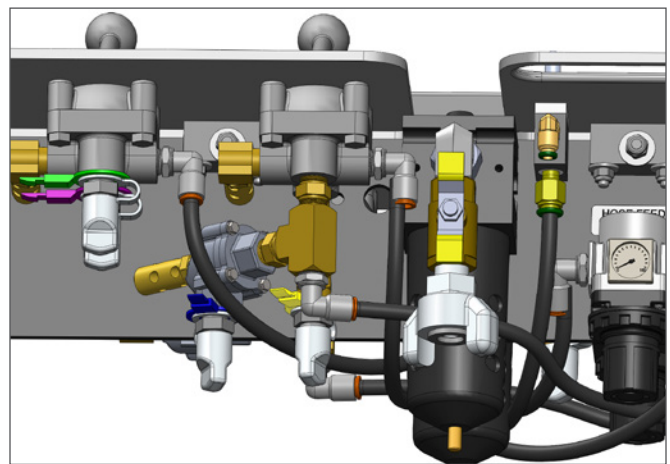
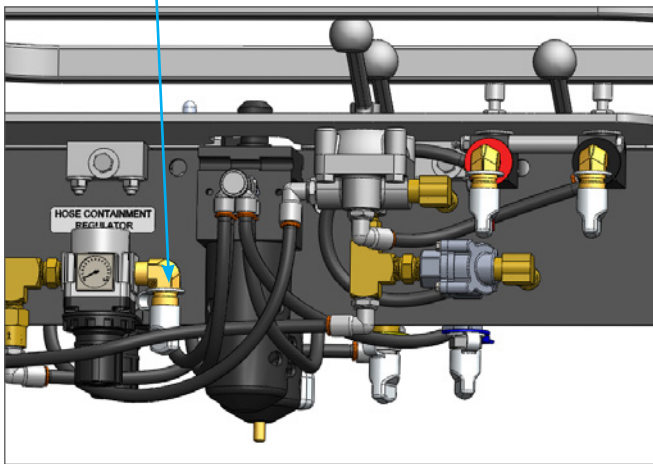

CAMERA AND LIGHT CONNECTION TO BATTERY BOX

CAMERA, LIGHT, BATTERY, AND BTC CONNECTIONS

1. Fasten the CAM 102 Monitor Assembly to the Control Box Frame with the provided screws and wing nuts, as shown below.
2. Follow the connection diagram below to connect the Camera and Light to the Battery Box and BTC-200-001.

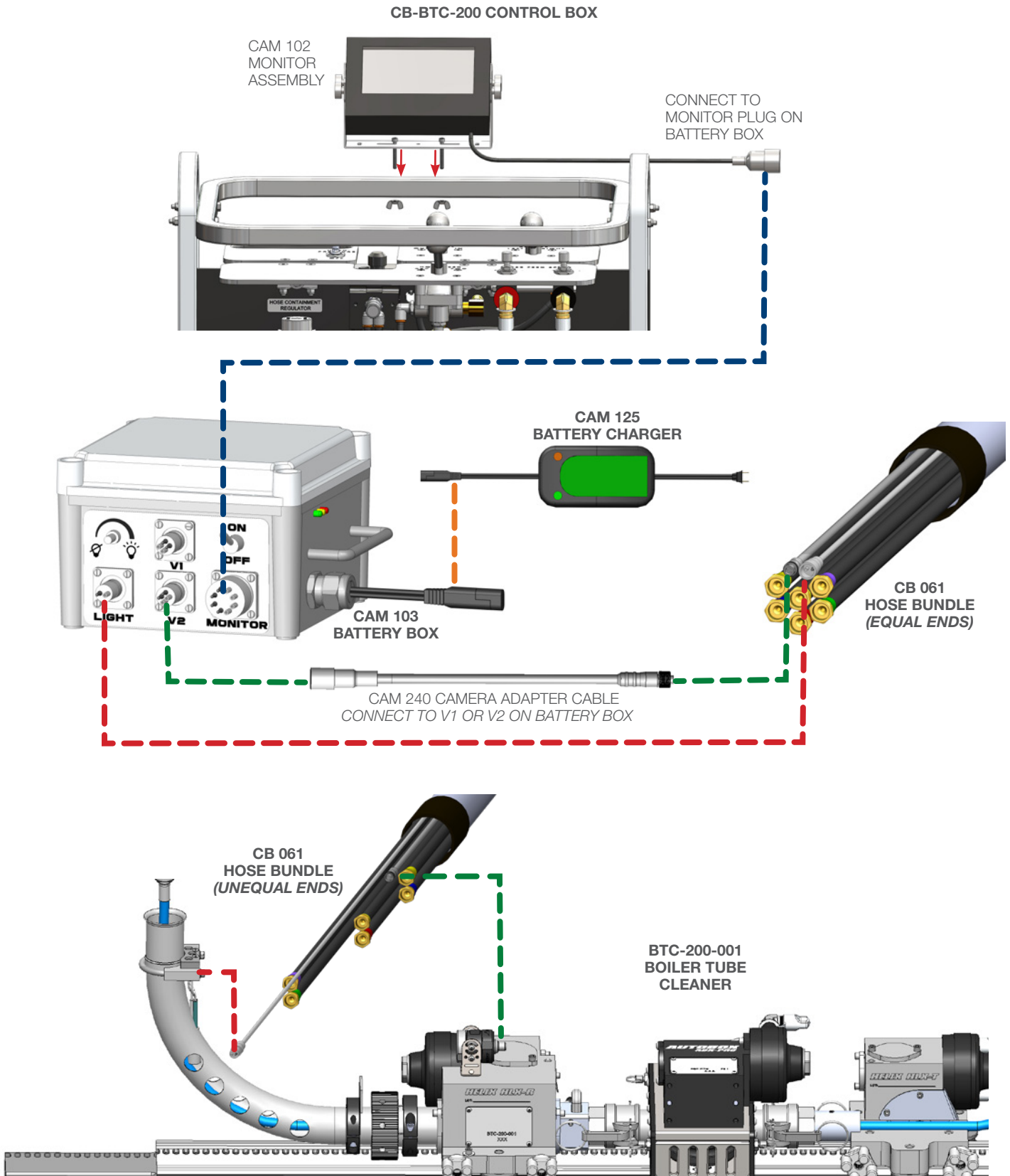

OPERATION

CB-BTC CONTROL PANEL

The **TRAVEL CONTROL** moves the BTC-200-001 Assembly in and out of the mud drum along the rail. The **OFF** position is at the 12 O'clock position.

The **ROTATE CONTROL** rotates the elbow. There is a stop on the Elbow that will contact the rail and activate the internal slip clutch if you over-rotate the elbow to either side. This prevents damage to the tool. Adjust the elbow length, so you can see the tool move out of the tube and there is a gap between the elbow and the tube.

NOTE: Do not travel or rotate while the hose is extended into a boiler tube. This can damage hose. Always retract the tool into the elbow before moving the Helix Tractor or Helix Rotator controls.

The **HOSE FEED CONTROL** will move the hose in the forward (feeding) and reverse (retracting) directions. The **OFF** position is at the 12 O'clock position.

NOTE: Ensure that the elbow is lined up with a boiler tube before advancing the hose. Use remote camera to line up elbow. A manual tube locating instruction is in the "Maintenance" section of this manual.

The **HOSE FEED SPEED CONTROLS** will move the hose in the forward direction at 9-50 ft/min, and independently in the reverse direction at 9-65 ft/min. The control acts on the motor exhaust in the return hoses. Turn the controls clockwise to decrease the feed rate, and counter-clockwise to increase the feed rate.

To use the **MOMENTARY PNEUMATIC DUMP CONTROL TOGGLE**, hold it in the **HIGH PRESSURE ON** position to route the high-pressure water to the tool. Release the toggle to the **OFF** position to release the high-pressure water away from the tool.

NOTE: Ensure that the tool end is inside a boiler tube before going to high pressure

To pause the system, turn the **HOSE FEED CONTROL** to the **CENTER**, 12 O'clock position and release the **MOMENTARY PNEUMATIC DUMP CONTROL TOGGLE** to the **OFF** position. This will stop the assembly from moving and reroute the high-pressure water away from the BTC-200-001.

Set the **HOSE CONTAINMENT PRESSURE REGULATOR** to 60 PSI with the fitting plugged. Plugging the fitting prevents air flow so that maximum pressure is achieved. If there is no cap, you can kink the connected hose to stop the flow. See diagram below.

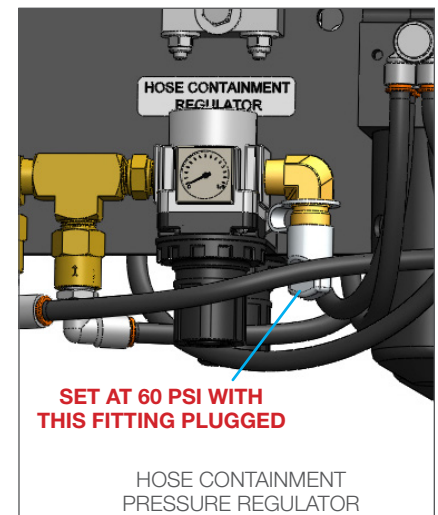
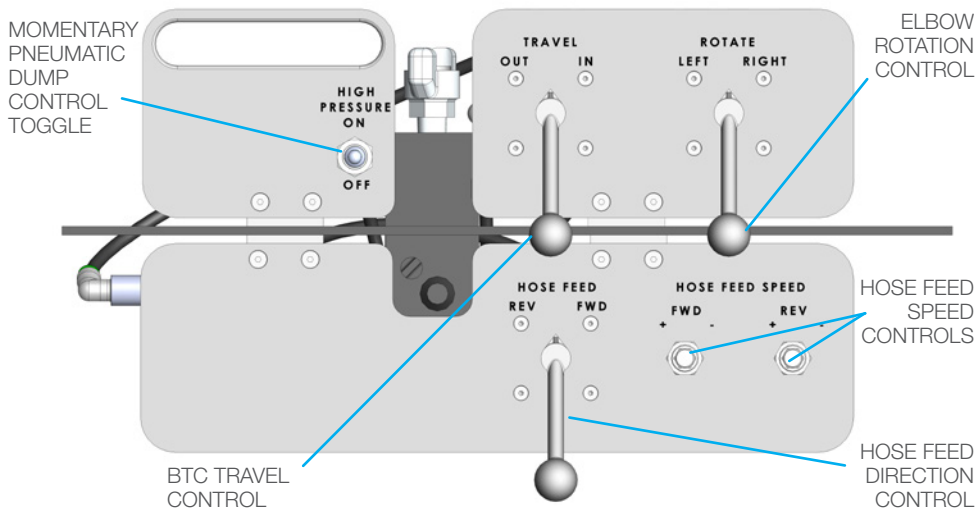

AIR SUPPLY FITTING

A universal **AIR SUPPLY FITTING** (Chicago style) is located on the back of the Control Box. Connect a compatible compressed air line (not included) according to the manufacturer's instructions. If another pneumatic connection is preferred, this fitting can be removed and any male 1/2 in NPT fitting may be used.

PNEUMATIC DUMP CONTROL FITTING AND LINE

A **MOMENTARY PNEUMATIC DUMP CONTROL TOGGLE** is located on the control panel and should be set up to control the ACDK 620 air actuated dump valve kit. Install 1/4 in OD tubing (included in the kit) by pushing the tubing into the fitting to connect the **PNEUMATIC DUMP CONTROL FITTING** to the pneumatic dump valve.

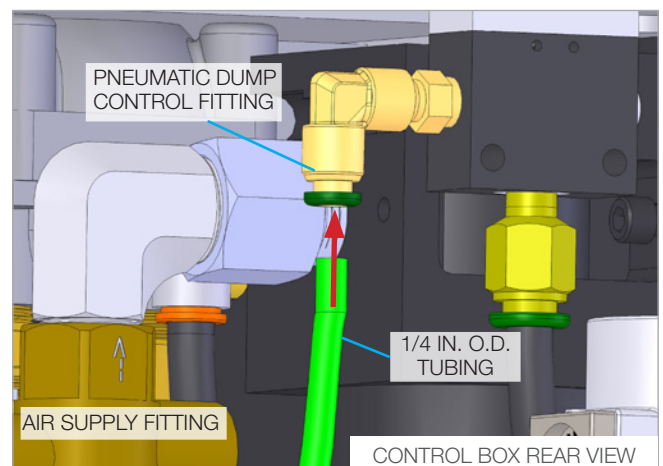

PRE-RUN SAFETY CHECK

Refer to WJTA-IMCA's, Recommended Practices For The Use Of High-pressure Waterjetting Equipment and/or The Water Jetting Association's, WJA Code of Practice for additional safety information.

- Complete a job specific risk assessment and act on the resulting actions.
- Ensure the waterblasting zone is properly barricaded and that warning signs are posted.
- Adhere to all site safety procedures.
- Ensure no personnel are in the hydroblasting zone.
- Ensure the work place is free of unnecessary objects (e.g. loose parts, hoses, tools).
- Ensure all operators are using the correct Personal Protective Equipment (PPE).
- Ensure whip checks (hose whip restraints), and all other applicable safety devices are installed and set-up properly.
- Check that the air hoses are properly connected and tight.
- Check all hoses and accessories for damage prior to use. Do not use damaged items. Only high quality hoses intended for waterblast applications should be used as high-pressure hoses.
- Ensure that operators never connect, disconnect, or tighten hoses, adapters, or accessories with the high-pressure water pump unit running.
- Test the Control Box before operating the BTC-200-001 with high-pressure water to verify the control valves move the hose in the intended direction, and that the dump valve is working properly.
- Check that the BTC-200-001 is anchored securely for the application and pressure of the waterjet tool being used.
- Check all high-pressure threaded connections for tightness.
- Check - air supply attachment, high pressure pump function, air controlled dump function

⚠ WARNING

Always turn off pump system before servicing or replacing any parts. Failure to do so can result in severe injury and/or death.

INSERTING ASSEMBLY THROUGH MANWAY

- Use the HLXR 050 spanner tool to loosen the knurled nut that holds the elbow onto the Helix Rotator.
- Rotate and/or tilt the elbow into a position that will allow it to fit through the manway, into the mud drum.
- Drive the BTC-200-001 into the drum slightly.
- Once the elbow is inside the mud drum, the elbow can return to it's operating position. Tighten the knurled nut to hold the elbow in position.
- **TORQUING THE KNURLED NUT.** THE SLIP CLUTCH IN THE ROTATOR IS DESIGNED TO PROTECT THE ROTATOR IF THE ELBOW ENCOUNTERS AN OBSTRUCTION. OVER TIGHTENING THE KNURLED NUT MAY NOT ALLOW THE ROTATOR TO SLIP AND WILL CAUSE DAMAGE. TEST THIS BY ROTATING THE ELBOW ALL THE WAY DOWN AND MAKING SURE THE ROTATOR SLIPS. IF IT DOES NOT SLIP, LOOSEN THE KNURLED NUT WITH THE SPANNER UNTIL IT DOES.
- **NOTE:** The end of the elbow should be approximately 2 1/2" from the inside surface of the 24" mud drum. The boiler tubes may project 1/2" inside the drum. There should be 2" clearance between the end of the elbow and the tubes. Depending on field conditions, you may need to shorten or lengthen the elbow. This can be easily done by adding length to the elbow, or saw off and form flare. StoneAge has HLXR-015 Flares available in custom lengths.

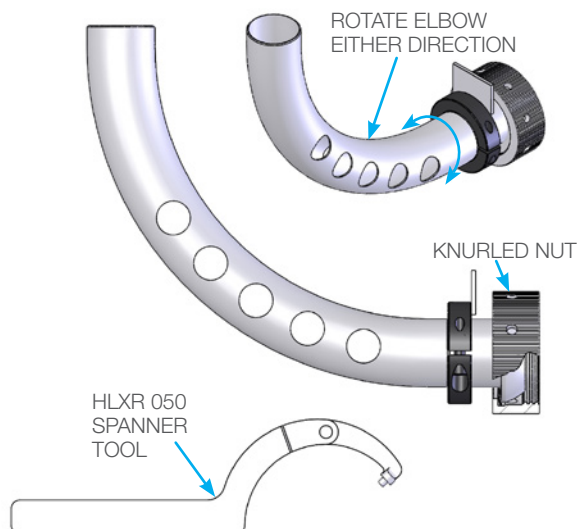

- When beginning the cleaning process, run the "train" ALL the way into the drum and index BACKWARDS to avoid clogging of the rail slots.

TEST RUN PROCEDURE

- Adjust the hose feed speed controls. Proper forward and reverse speeds will vary, depending on the type of material being removed. Adjustment of the hose feed speed controls may be necessary during operation in order to optimize cleaning and overall productivity.
- Operate the high-pressure water at full pressure and use the **MOMENTARY PNEUMATIC DUMP CONTROL TOGGLE** to verify that the dump valve is working properly.

MAINTENANCE

Maintenance Item	Frequency	Maintenance Required
Gearbox oil level for HLXT-100-001, HLXR-100-001, ABX-PRO AND ABX-PRO-5 Tractors	Every 100 Hours of use	Drain the refill with Mobil® SCH™ 634 synthetic gear oil. See individual part diagram pages for gearbox fill orientations.
All air fittings	Before each use	Inspect threads for wear or damage.
All air fittings	After each use	Apply a small amount of air tool oil directly into the forward and reverse fittings. Then, briefly operate the controls at slow speed for a short duration in each direction to coat the interior parts of the motor. Install the dust caps onto all fittings to keep moisture and dirt out.
Carriage rollers	Every 100 Hours of use	Lubricate Zerks on all Carriage Rollers using any multipurpose NLGI 2 grease. Carriage rollers will continue to function normally after some wear. Roller replacement is required when wear begins to affect the Drive movement in forward or reverse.
Drive Rollers inside both the ABX-PRO and ABX-PRO-5	When Needed	The BTC-200-001 BOILER TUBE CLEANER comes with two pairs of the PRO 174-46 installed in the ABX-PRO and ABX-PRO-5 TRACTORS. Inspect for wear and replace if damaged. See the "Roller Replacements Instructions" section in this manual.

Contact StoneAge for Safety Data Sheets for material usage, a complete list of spare part numbers, and service instructions for the Boiler Tube Cleaner BTC-200-001 Boiler Tube Cleaner and CB-BTC-200 Control Box.

Mobil® and SCH™ are registered trademarks and/or trademarks of Exxon Mobil®. Loctite® and Threadlocker Blue 242® are registered trademarks of Henkel AG & Co. KGaA.

STORAGE, TRANSPORTATION, AND HANDLING

- When moving the BTC-200-001 and any of its components, lift with care to prevent bodily injury.
- When storing the unit, use compressed air to blow out the air lines to remove debris and moisture. Use mild soapy water to clean the machine in order to remove corrosive materials.
- Store unit in a clean and dry area.
- Apply a small amount of air tool oil directly into the motor forward and reverse fittings. Then, briefly operate the controls at slow speed for a short duration in each direction to coat the interior parts of the motor. Install the dust caps onto all fittings to keep moisture and dirt out.

BTC-200-001 BOILER TUBE MANUAL LOCATING INSTRUCTIONS

It is possible to track the depth of the BTC inside the boiler using a flexible tape measure. If at any time during a job the BTC needs to be retracted from the boiler, it is a huge benefit to know exactly how far in the unit is in order to pick up where you left off. This may also be useful if the Camera System malfunctions.

1. Align the end of the tape measure with the center of the flange on the top end of the elbow. Fasten the tape where it lies on the HLXR-100 Rotator to the socket head cap screw and washer on the HLXR-100 Rotator. It should measure approximately 18" +/- at the washer.
2. Zip tie the end of the tape measure back onto itself, so that it does not get caught up in the assembly.
3. Once the tape is fastened to the HLXR-100 Rotator, drape the other end over the frame of the control box and clip it to the frame. The distance measurement should be checked at the face of the mud drum. For a tutorial on this procedure go to the YouTube page below.

StoneAge® Boiler Tube Cleaner BTC-200-001 Training
<https://www.youtube.com/watch?v=17SZ34so9L4>

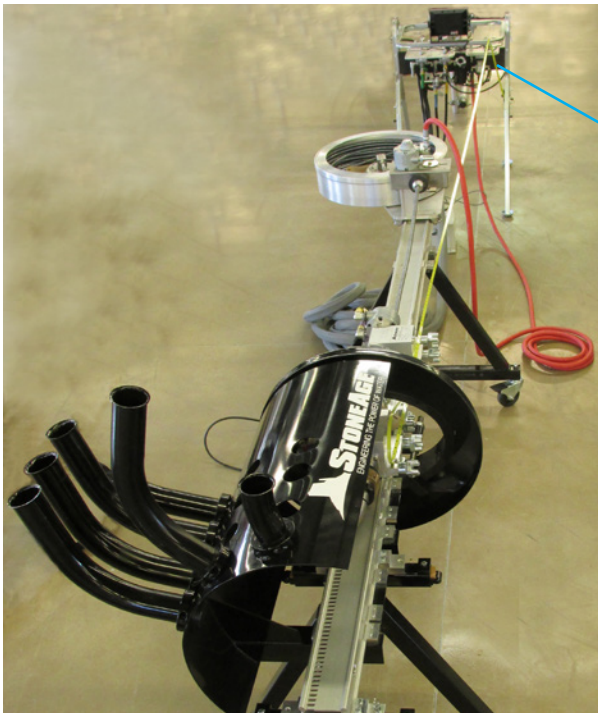

DRAPE TAPE
MEASURE OVER
CONTROL BOX
FRAME

FASTEN TAPE
MEASURE
HERE AND ZIP
TIE IT BACK
ONTO ITSELF.

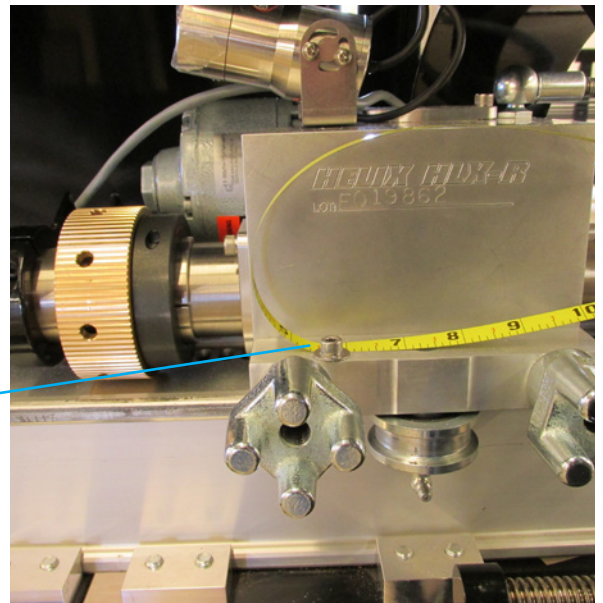

ROLLER REPLACEMENT INSTRUCTIONS

ROLLER REPLACEMENT

It will be necessary to replace rollers when they are worn or if changing to a Helix hose. The following steps will be typical for Poly and Helix Roller replacements for both ABX-PRO Tractor and ABX-PRO-5 Tractor Assemblies. The ABX-PRO Tractor must be removed from the BTC-200-001 Assembly to access the Rollers inside the tractor housing. Removing the ABX-PRO Tractor is a simple process. Remove the waterblast tool from the end of the hose. Retract the hose into the Hose Containment. Release both Camlocks on the ABX-PRO-5 Tractor to release it from the BTC-200-001 Assembly. The roller replacement on the ABX-PRO-5 Tractor can be done in place.

⚠ WARNING

Always de-energize the system before servicing or replacing any parts. Failure to do so can result in severe injury and/or death. Keep hands, hair, and clothing clear of rotating parts.

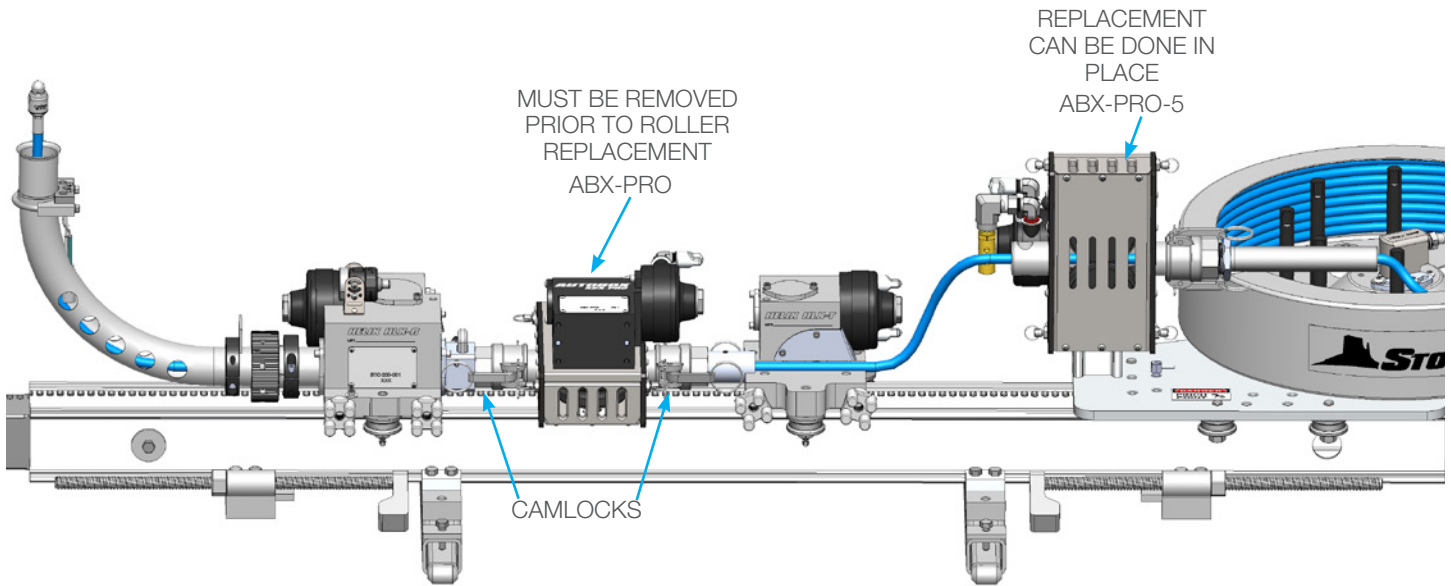

ROLLER REMOVAL

1. Open the back cover of the tractor by pulling the top two Quick Release Pins in the outward direction. (Figure 1)
2. Push the Adjustable Handle in the counterclockwise direction to loosen the CAM Lever and bushing. Next, push the Eccentric Lever in the counterclockwise direction, moving the indicator pin to "Disengaged". (Figure 2)

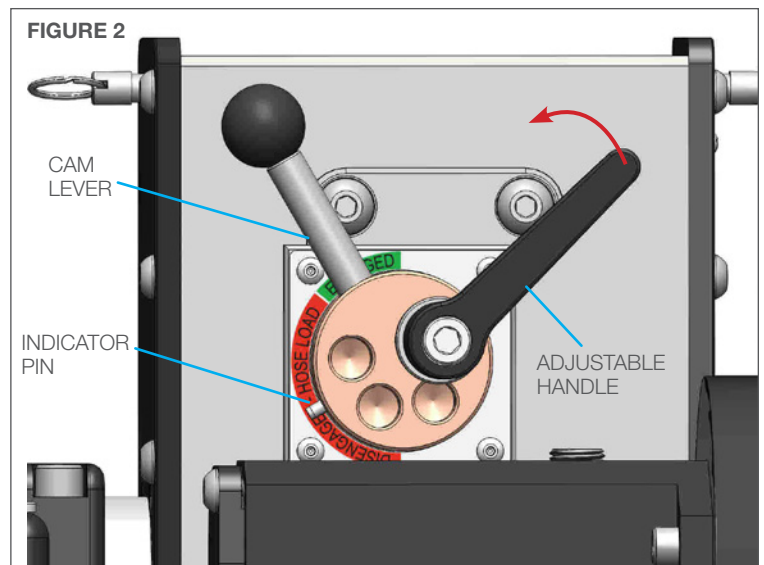
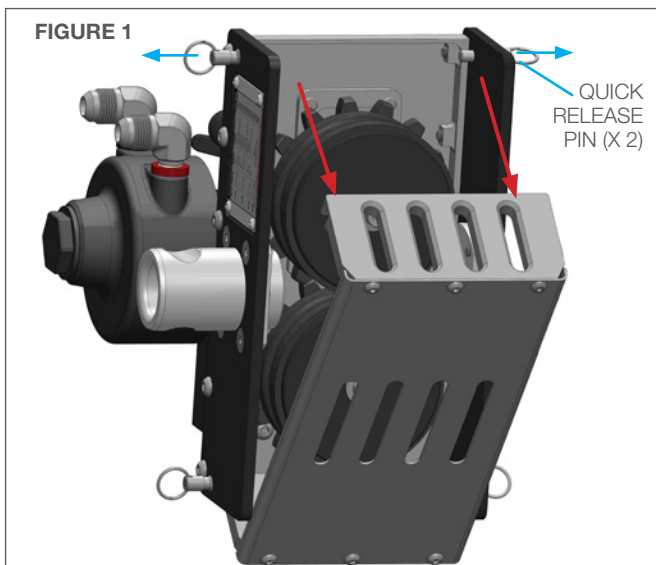

ROLLER REPLACEMENT INSTRUCTIONS

- Loosening the Cam Lever opens up the space between the Spline Roller Assemblies. **(Figure 3)**
- Remove the two socket head cap screws, Roller Washers, Hub Outer Plates and Rollers. **(Figure 4)**

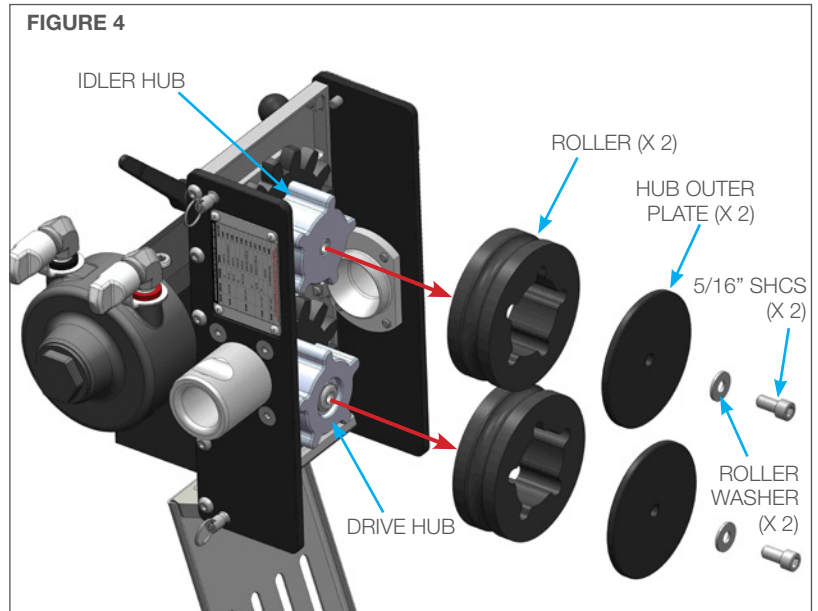
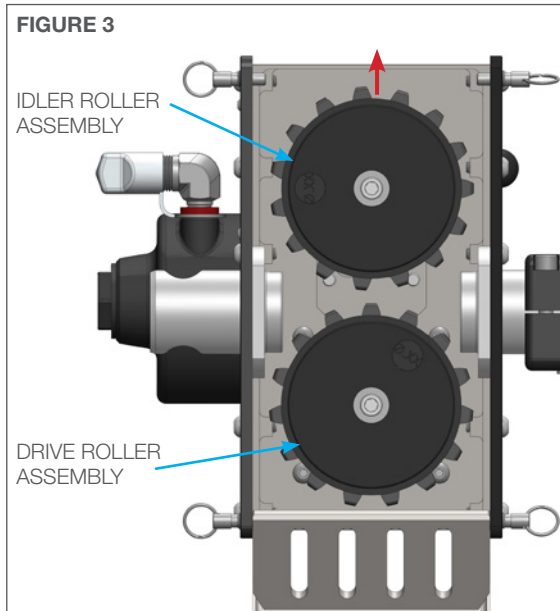

POLY ROLLER INSTALLATION (See the Step 6 for Helix Roller Kit installation)

- Slide the new Poly Rollers onto the Hubs. Be sure to align the holes in Hub Outer Plates so the size inscription on the Poly Roller shows through. **(Figure 6)** Then fasten the Hub Outer Plates and Roller Washers onto the Hubs with the two 5/16" socket head cap screws. Lightly coat the threads with Blue Goop® a Swagelok Brand Anti-seize. An equivalent alternative is acceptable. **(Figure 5)**
Skip to Step 9.

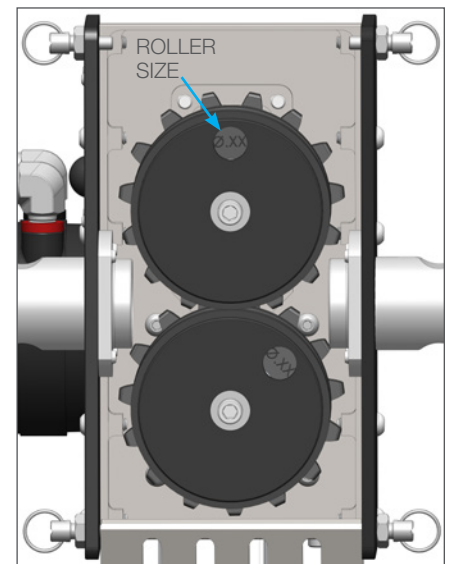
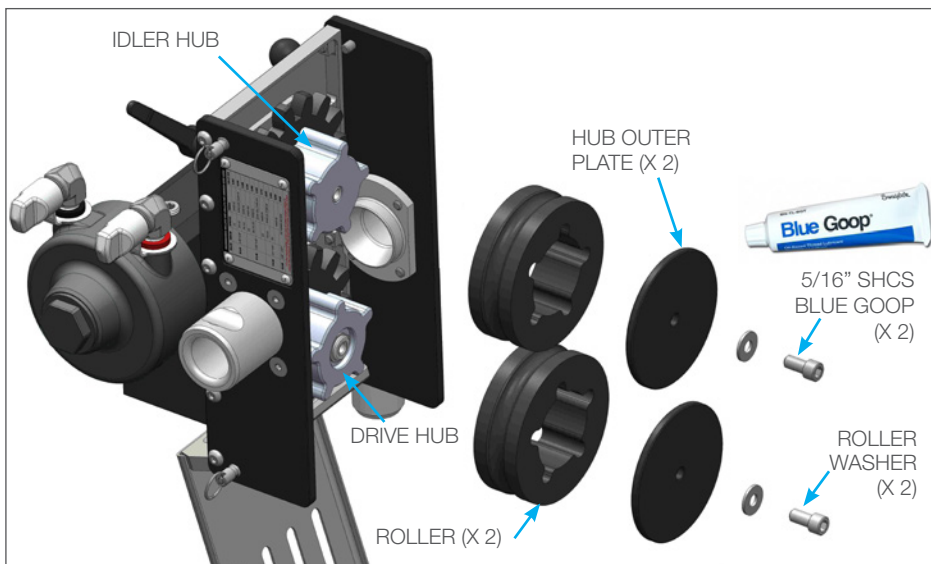

ROLLER REPLACEMENT INSTRUCTIONS

HELIX ROLLER KIT INSTALLATION

6. If installing the Helix Roller Kit, align the timing marks on Spacers and Sprockets as shown in **(Figure 7)** and slide a set onto each Hub.

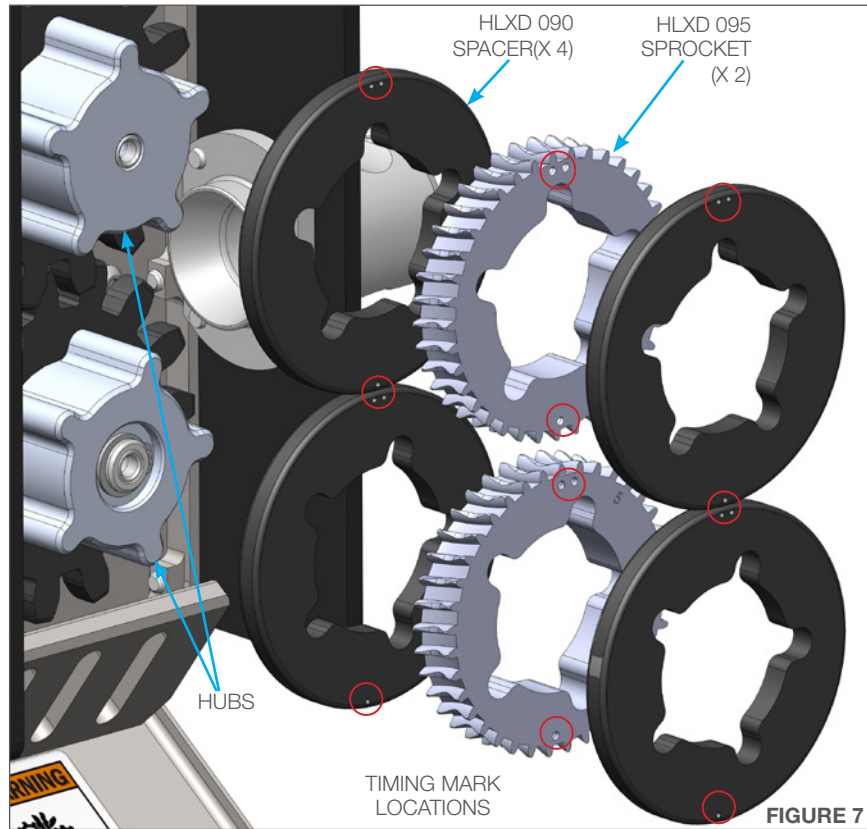

7. The dots must also be aligned between the 2 sprockets when the tractor lever is set into the **“ENGAGED”** range. **(Figures 8 &9)** This alignment is crucial to the sprockets engaging the helix wrap correctly. The drive will jam if sprockets not aligned.

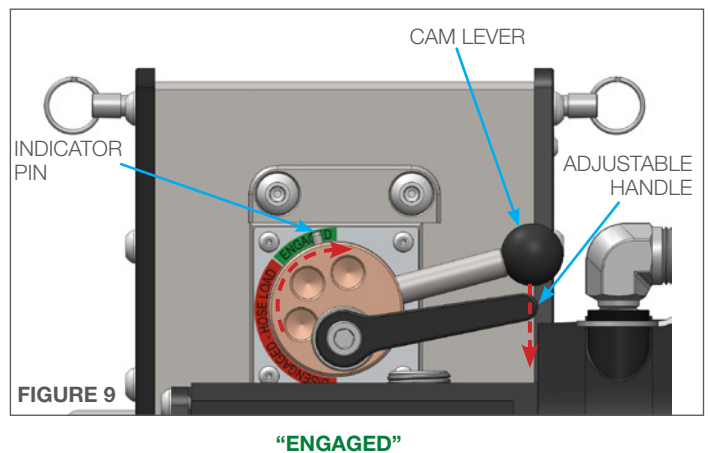
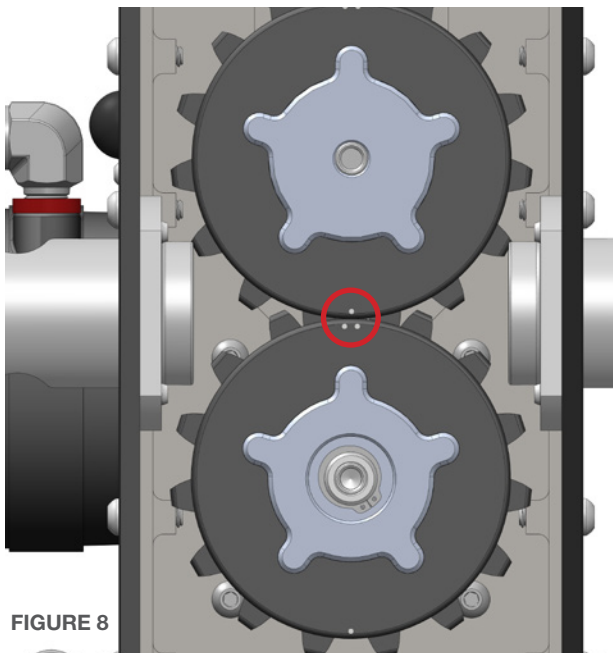

ROLLER REPLACEMENT INSTRUCTIONS

- Fasten the Hub Outer Plates and Roller Washers onto the Hubs with the two 5/16" socket head cap screws. Lightly coat the threads with Blue Goop® a Swagelock Brand Anti-seize. An equivalent alternative is acceptable. **(Figure 10)**

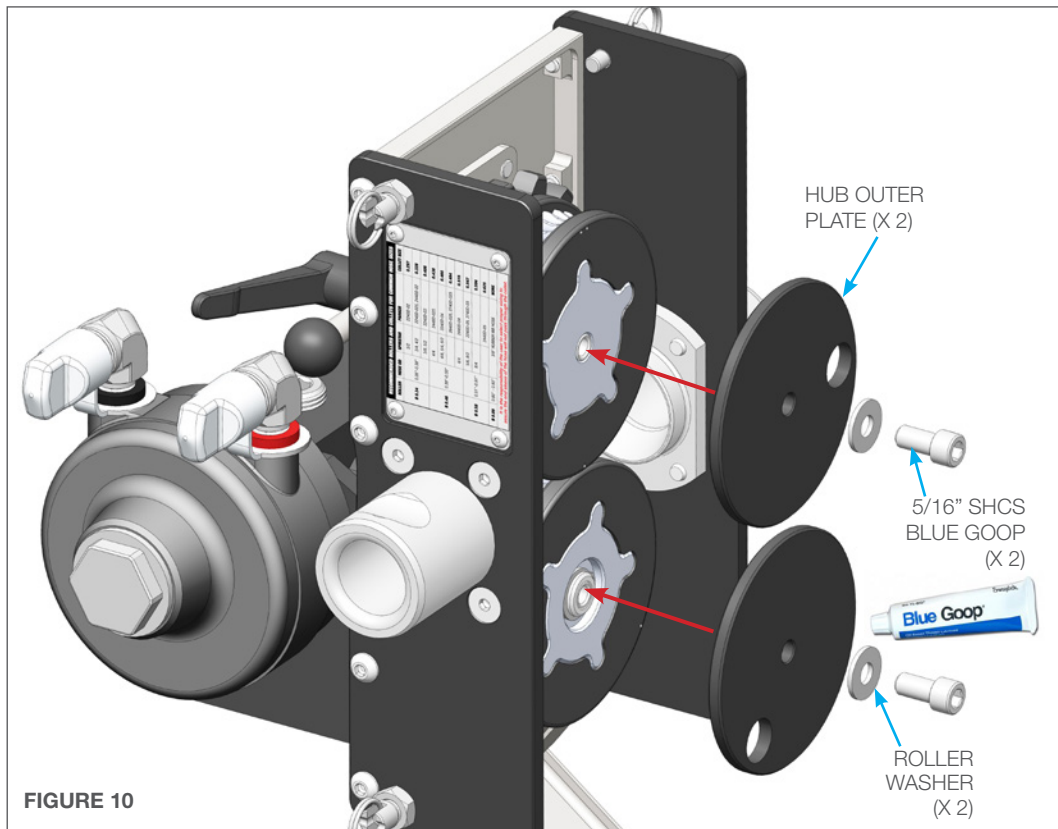

- Push the back cover back into the closed position and secure the two Quick Release Pins on the top of the tractor. **(Figure 11)**

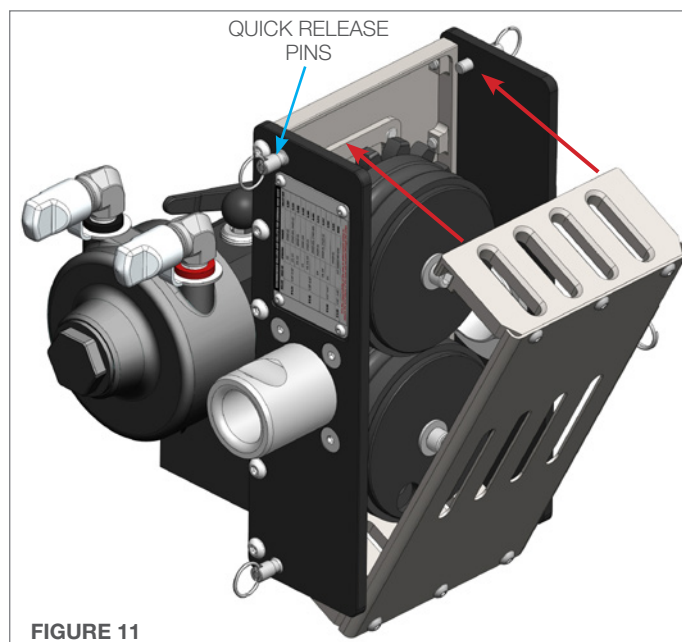

PARTS DIAGRAM

ABX-PRO AUTOBOX® TRACTOR ASSEMBLY

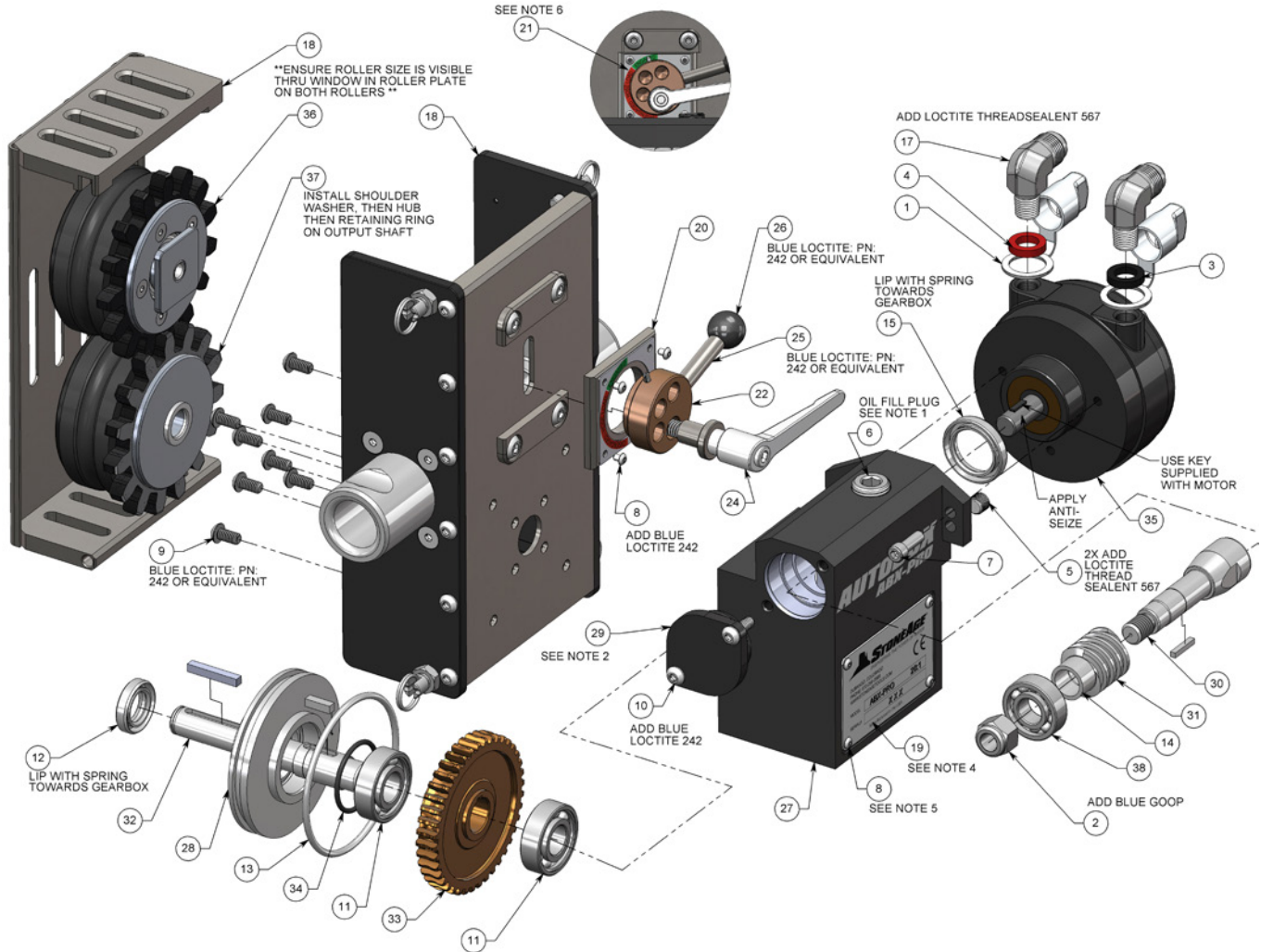

NOTE:

1. ADD 5.0 OUNCES OF MOBIL SYNTHETIC OIL SCH 634 (SA# GP 146.1)
2. THIS WORM CAP WILL BOTTOM ON BEARING, WILL NOT BOTTOM ON HOUSING WHEN TIGHTENED
3. ADD PRELUBE TO ALL SHAFTS, GEARS, BEARINGS, AND SEALS.
4. CLEAN SURFACE PRIOR TO INSTALLING SERIAL PLAQUE. STAMP IN ACCORDANCE WITH WORK INSTRUCTIONS.
5. 4X ADD RED LOCTITE: PN: 262 OR EQUIVALENT.
6. ORIENT GRAPHIC PLATE AS SHOWN.

#	PART NUMBER	QTY.
1	BR 167 90° DUST CAP	2
2	GN 550-L NYLOK NUT	1
3	GP 013-BK BLACK ID BAND, SM	1
4	GP 013-R RED ID BAND, SM	1
5	GP 025-P2SS HEX SOCKET PLUG	1
6	GP 025-P8SS HEX SOCKET PLUG	1
7	GS 325-03 SHCS .25-20 X .75 SS (TB 050)	2
8	GSB 313-0075 BHCS 6-32 X .188 LG SS	8
9	GSB 325-02 BHCS .25-20 X .50 LG SS	8
10	GSB 325-03 BHCS .25-20 X .75 LG SS	2
11	HLXD 002 BEARING, OUTPUT	2
12	HLXD 003 SEAL, OUTPUT	1

13	HLXD 006 O-RING, OUTPUT	1
14	HLXD 011 SPACER	1
15	HLXD 013 SEAL, INPUT	1
16	HLXD 017 CAP O-RING, INPUT	1
17	HRS 552 FITTING, ELBOW OUTLET P4J8 90°	2
18	PRO 101 HOUSING ASSEMBLY	1
19	PRO 109 CE SERIAL PLATE	1
20	PRO 112 CAM PLATE	1
21	PRO 113 CAM PLATE, DECAL	1
22	PRO 114 CAM BUSHING	1
23	PRO 115 ROLL PIN	1
24	PRO 116 ADJUSTABLE HANDLE ASSEMBLY	1

25	PRO 117 CAM LEVER SHAFT	1
26	PRO 118 CAM LEVER KNOB	1
27	PRO 130 GEARBOX HOUSING	1
28	PRO 131 BULKHEAD, OUTPUT	1
29	PRO 132 INPUT CAP	1
30	PRO 133 INPUT SHAFT	1
31	PRO 134 WORM 20-1	1
32	PRO 136 OUTPUT SHAFT	1
33	PRO 137 WORM GEAR 20-1	1
34	PRO 138 O-RING	1
35	PRO 155-001 AIR MOTOR	1
36	PRO 170 IDLER ROLLER ASSEMBLY	1
37	PRO 181 DRIVE ROLLER ASSEMBLY	1
38	RJ 009 BEARING	1

ABX-PRO-5
AUTOBOX® TRACTOR ASSEMBLY 5:1 RATIO

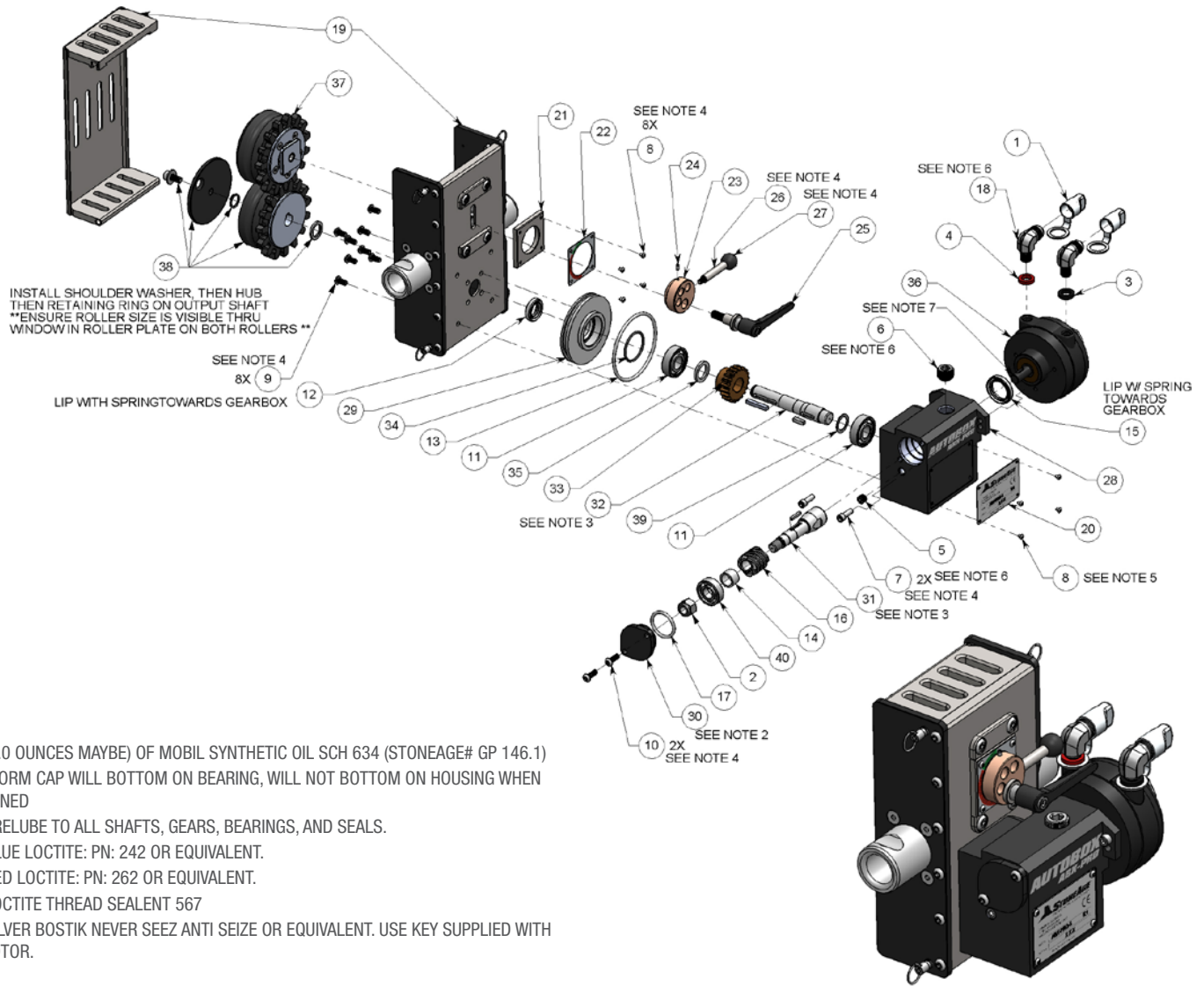

NOTES:

1. ADD (5.0 OUNCES MAYBE) OF MOBIL SYNTHETIC OIL SCH 634 (STONEAGE# GP 146.1)
2. THIS WORM CAP WILL BOTTOM ON BEARING, WILL NOT BOTTOM ON HOUSING WHEN TIGHTENED
3. ADD PRELUBE TO ALL SHAFTS, GEARS, BEARINGS, AND SEALS.
4. ADD BLUE LOCTITE: PN: 242 OR EQUIVALENT.
5. ADD RED LOCTITE: PN: 262 OR EQUIVALENT.
6. ADD LOCTITE THREAD SEALANT 567
7. ADD SILVER BOSTIK NEVER SEEZ ANTI SEIZE OR EQUIVALENT. USE KEY SUPPLIED WITH AIR MOTOR.

#	PART NUMBER	QTY.			
1	BR 167 90° DUST CAP	2	13	HLXD 006 O-RING, OUTPUT	1
2	GN 550-L NYLOK NUT	1	14	HLXD 011 SPACER	1
3	GP 013-BK BLACK ID BAND, SM	1	15	HLXD 013 SEAL, INPUT	1
4	GP 013-R RED ID BAND, SM	1	16	HLXD 014 WORM, INPUT	1
5	GP 025-P2SS HEX SOCKET PLUG	1	17	HLXD 017 CAP O-RING, INPUT	1
6	GP 025-P8SS HEX SOCKET PLUG	1	18	HRS 552 FITTING, ELBOW OUTLET P4J8 90°	2
7	GS 325-03 SHCS .25-20 X .75 SS (TB 050)	2	19	PRO 101 HOUSING ASSEMBLY	1
8	GSB 313-0075 BHCS 6-32 X .188 LG SS	8	20	PRO 109-5 CE SERIAL PLATE	1
9	GSB 325-02 BHCS .25-20 X .50 LG SS	8	21	PRO 112 CAM PLATE	1
10	GSB 325-03 BHCS .25-20 X .75 LG SS	2	22	PRO 113 CAM PLATE, DECAL	1
11	HLXD 002 BEARING, OUTPUT	2	23	PRO 114 CAM BUSHING	1
12	HLXD 003 SEAL, OUTPUT	1	24	PRO 115 ROLL PIN	1
			25	PRO 116 ADJUSTABLE HANDLE ASSEMBLY	1
			26	PRO 117 CAM LEVER SHAFT	1
			27	PRO 118 CAM LEVER KNOB	1
			28	PRO 130-5 GEARBOX	1
			29	PRO 131 BULKHEAD, OUTPUT	1
			30	PRO 132 INPUT CAP	1
			31	PRO 133 INPUT SHAFT	1
			32	PRO 136 OUTPUT SHAFT	1
			33	PRO 137-5 WORM GEAR 5-1	1
			34	PRO 138 O-RING	1
			35	PRO 139 SPACER	1
			36	PRO 155-001 AIR MOTOR	1
			37	PRO 170 IDLER ROLLER ASSEMBLY	1
			38	PRO 181 DRIVE ROLLER ASSEMBLY	1
			39	PRO 193 WASHER	1
			40	RJ 009 BEARING	1

PARTS DIAGRAM

ACDK 620
20K AIR DUMP VALVE KIT

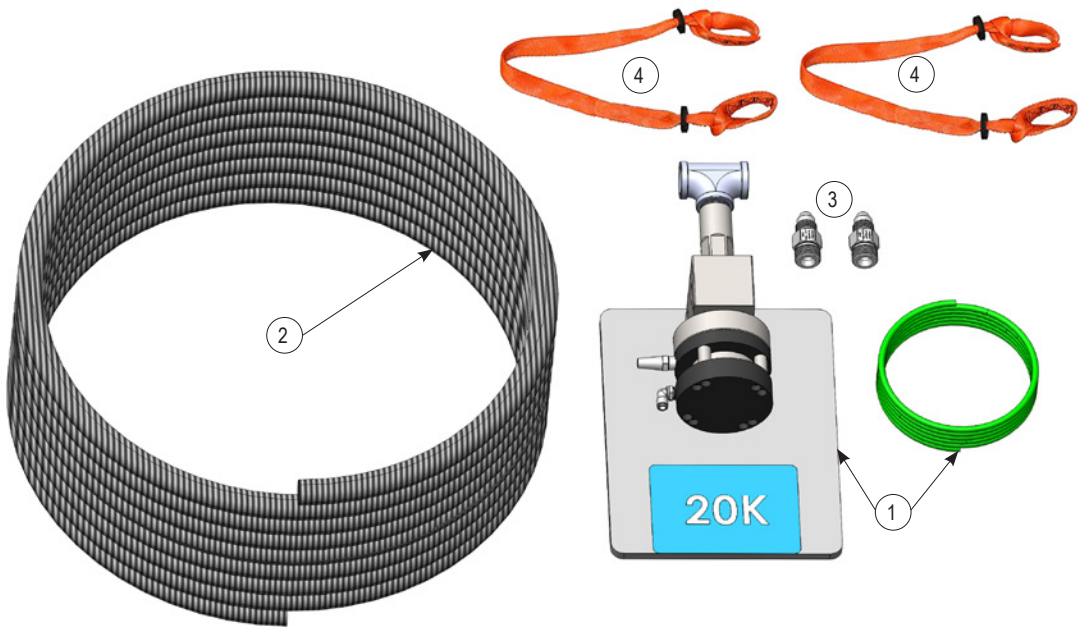
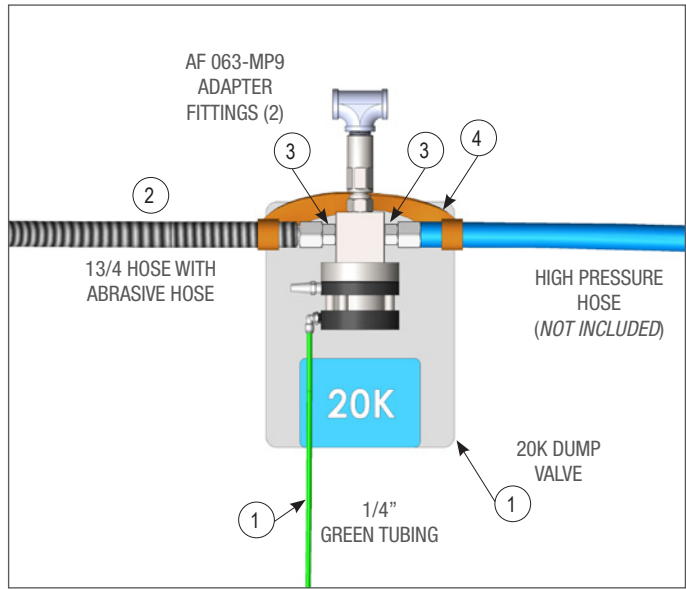

#	PART NUMBER	QTY
1	ACDA 61020019-K KIT, DUMP VALVE, 20K, W/ AIR FITTINGS	1
2	ACHO H134H010FTMSC HOSE, 134H, 1TM X 1TM, 10FT, W/ABRASIVE COVER	1
3	AF 063-MP9 ADAPTER, 1-12 TYPE-M X MP9	2
4	ACWC NY-31 NYLON HOSE WHIP RESTRAINT	2

BTC 120
CLAMP ASSEMBLY

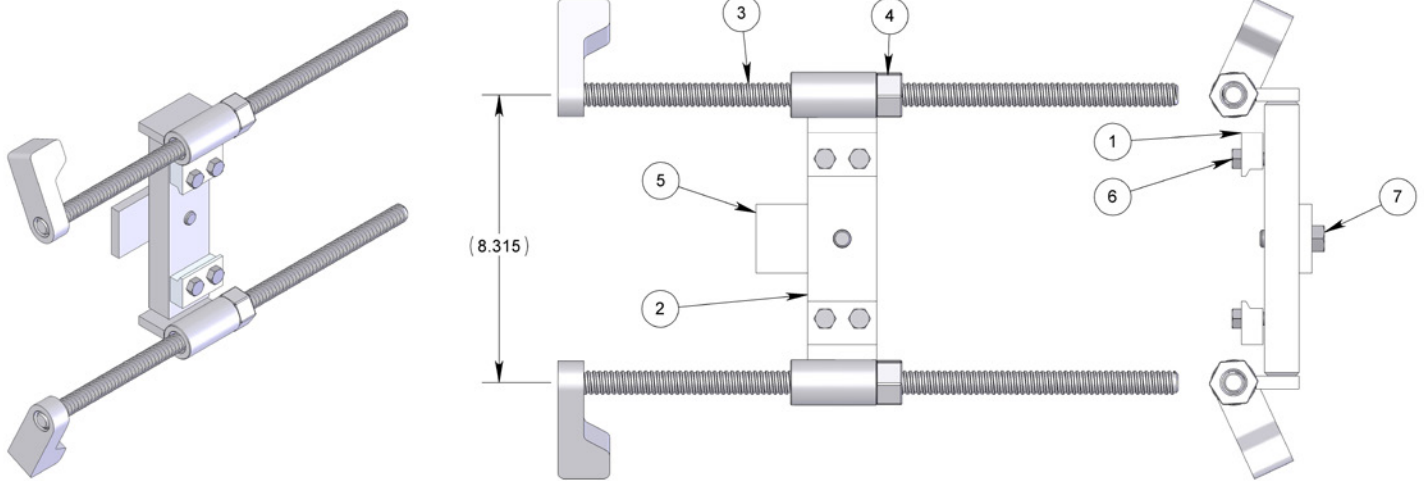

#	PART NUMBER	QTY.
1	BR 060-D RAIL CLAMP, DRILLED	2
2	BTC 121 CLAMP WELDMENT	1
3	BTC 122 ACME WELDMENT	2
4	BTC 123 ACME NUT	2
5	BTC 124 SUPPORT PLATE	1
6	GB 537-04 BOLT, HEX .37-16 X 1.00	4
7	GB 550-06 BOLT, HEX .50-13 X 1.50	1

BTC 140-XX-XX
SUPPORT ASSEMBLY

INCLUDED IN
BTC-200-CAM-PKG

BTC 140-XX-XX	ID OF TANK	BTC 142-XX	BTC 141-XX
BTC 140-7-14	24-28	BTC 142-7	BTC 141-14
BTC 140-7-24	32-36	BTC 142-7	BTC 141-24
BTC 140-17-24	40-48	BTC 142-17	BTC 141-24

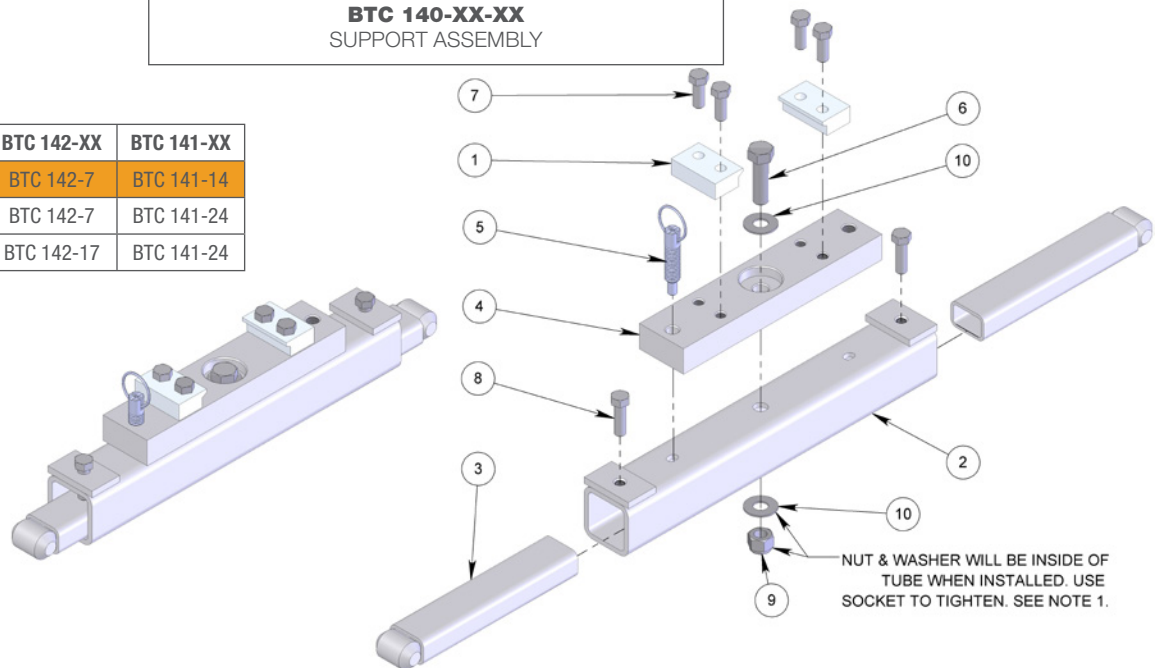

#	PART NUMBER	QTY.
1	BR 060-D RAIL CLAMP, DRILLED	2
2	BTC 141-XX TUBE, OUTER WELDMENT	1
3	BTC 142-XX TUBE, INNER WELDMENT	2
4	BTC 143 PIVOT PLATE	1
5	BTC 144 SPRING PLUNGER	1

6	GB 350-07 BOLT, HEX .50-13 X 1.75 SS	1
7	GB 537-04 BOLT, HEX .37-16 X 1.00	4
8	GB 537-05 BOLT, HEX .37-16 X 1.25	2
9	GN 550-L NYLOK NUT	1
10	GW 343-F FLAT WASHER SS	2

PARTS DIAGRAM

BTC-200-001
BOILER TUBE CLEANER

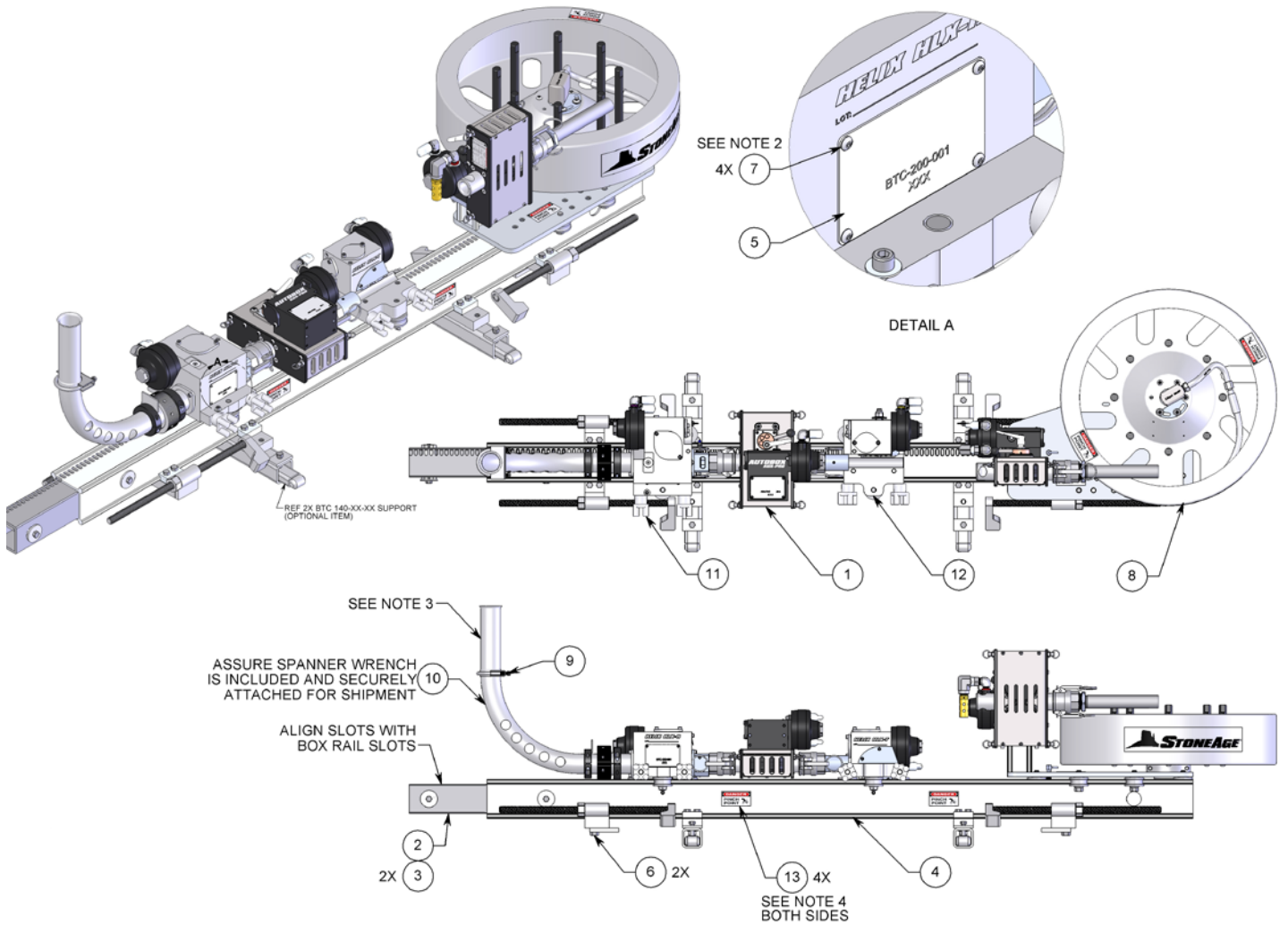

NOTES:

1. ITEMS THAT CAN BE INCLUDED WITH THE BTC PER CUSTOMER REQUESTS: HIGH-PRESSURE WATER HOSE, COLLETS, TOOLS, TOOL FAIRING, ADDITIONAL SLOTTED BOX RAIL, HELIX HOSE, AND HELIX SPROCKETS.
2. ADD BLUE LOCTITE: PN: 242 OR EQUIVALENT INSTALL AT APPROXIMATE ORIENTATION AND LOCATION AT ROOM TEMPERATURE.
3. FLARED EXTENSION TUBE (HLXR 015-XX) IS AN OPTIONAL ITEM AND CAN BE ORDERED IN CUSTOM LENGTHS. IT IS SHOWN FOR REFERENCE ONLY.
4. CLEAN ALL DEBRIS & OILS BEFORE INSTALLING. INSTALL AT APPROXIMATE ORIENTATION AND LOCATION & AT ROOM TEMP.

#	PART NUMBER	QTY.
1	ABX-PRO AUTOBOX TRACTOR ASSEMBLY	1
2	BR 006-BU-001 SPLICE TUBE	1
3	BR 008-BU-001 WEDGE BOLT	2
4	BTC 004-6 BOX RAIL EXTENSION	1
5	BTC 103 CE SERIAL PLATE	1
6	BTC 120 CLAMP	2

7	GSB 313-0075 BHCS 6-32 X .188 LG SS	4
8	HCS-BTC-200 HOSE CONTAINMENT SYSTEM	1
9	HLXR 014 U-BOLT CLAMP	1
10	HLXR 040 ELBOW ASSEMBLY	1
11	HLXR-100-001 ROTATOR DRIVE ASSEMBLY	1
12	HLXT-100-001 TRACTOR DRIVE ASSEMBLY	1
13	PL 160 PINCH POINT 1.5X3.0 DECAL	4

BTC 570-30
DRIVE RAIL ASSEMBLY, 30'

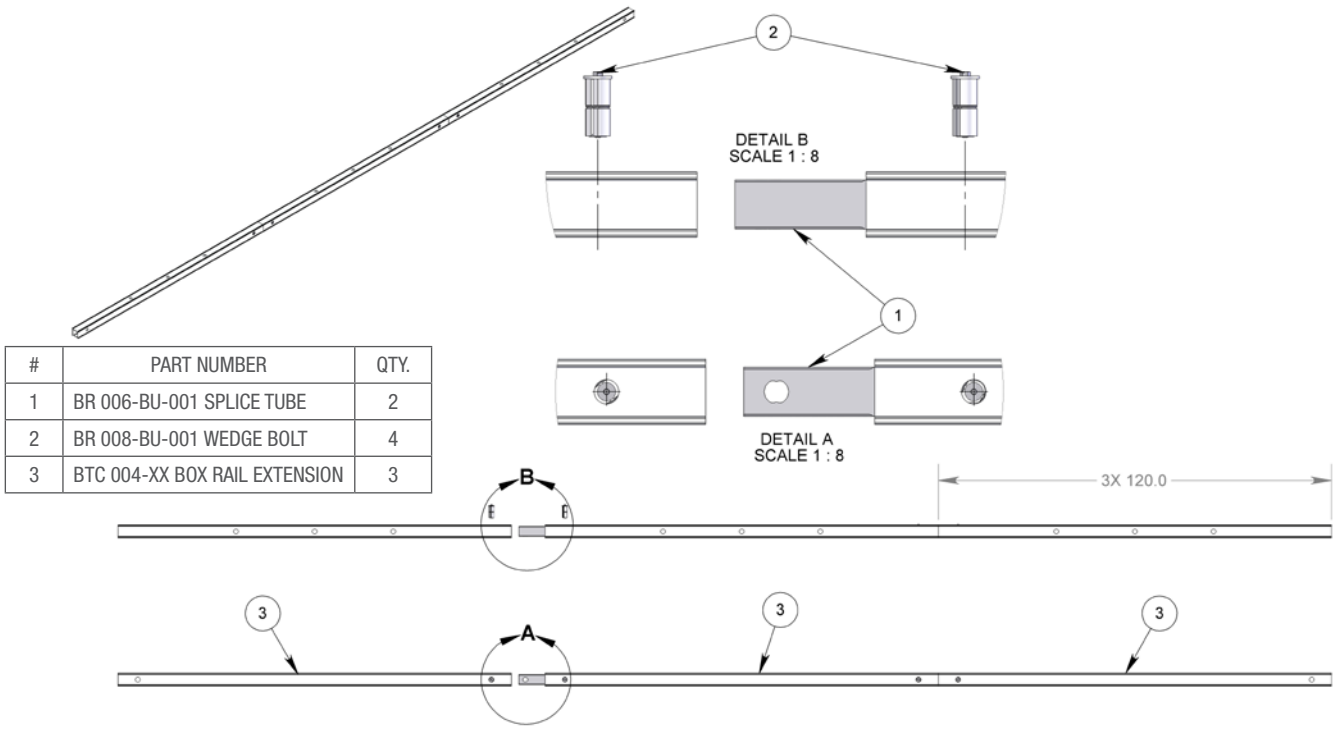

BTC 580-10
RAIL KIT EXTENSION 10'

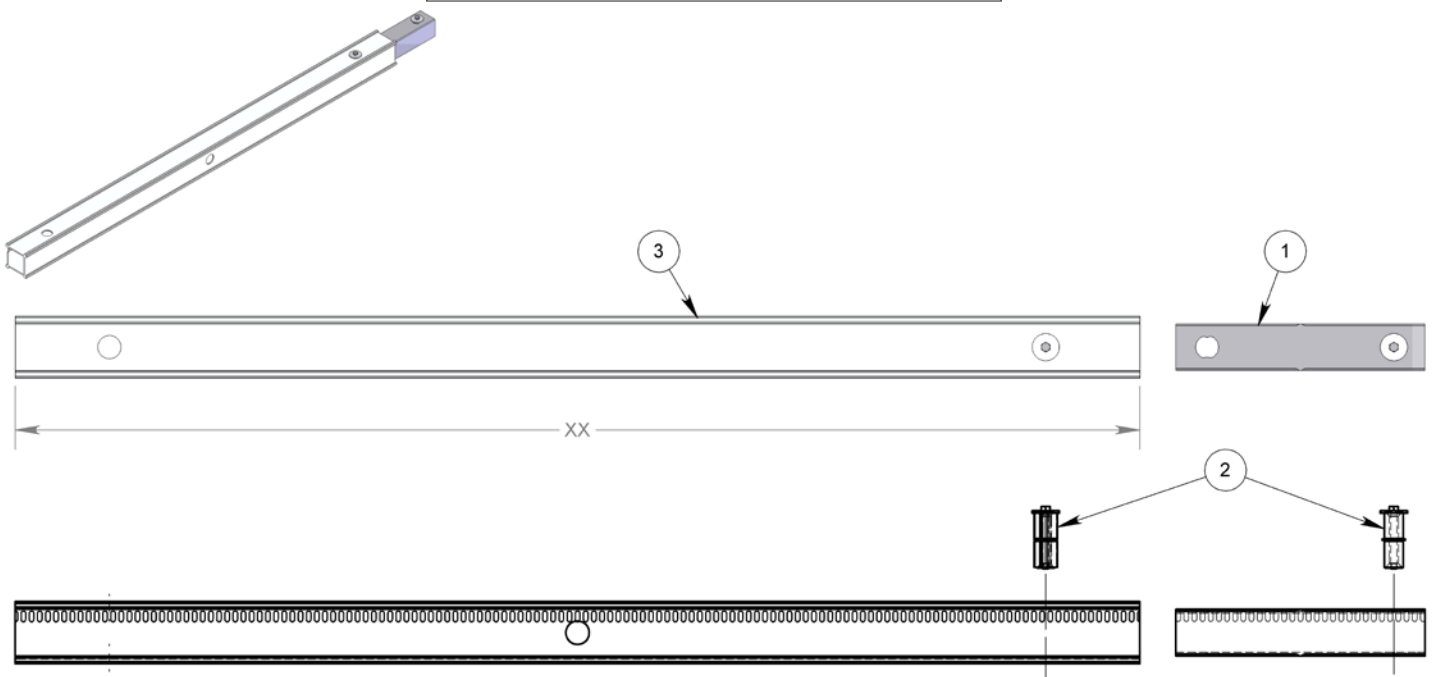

PARTS DIAGRAM

CAM-200-BTC BOILER TUBE CLEANER CAMERA SYSTEM

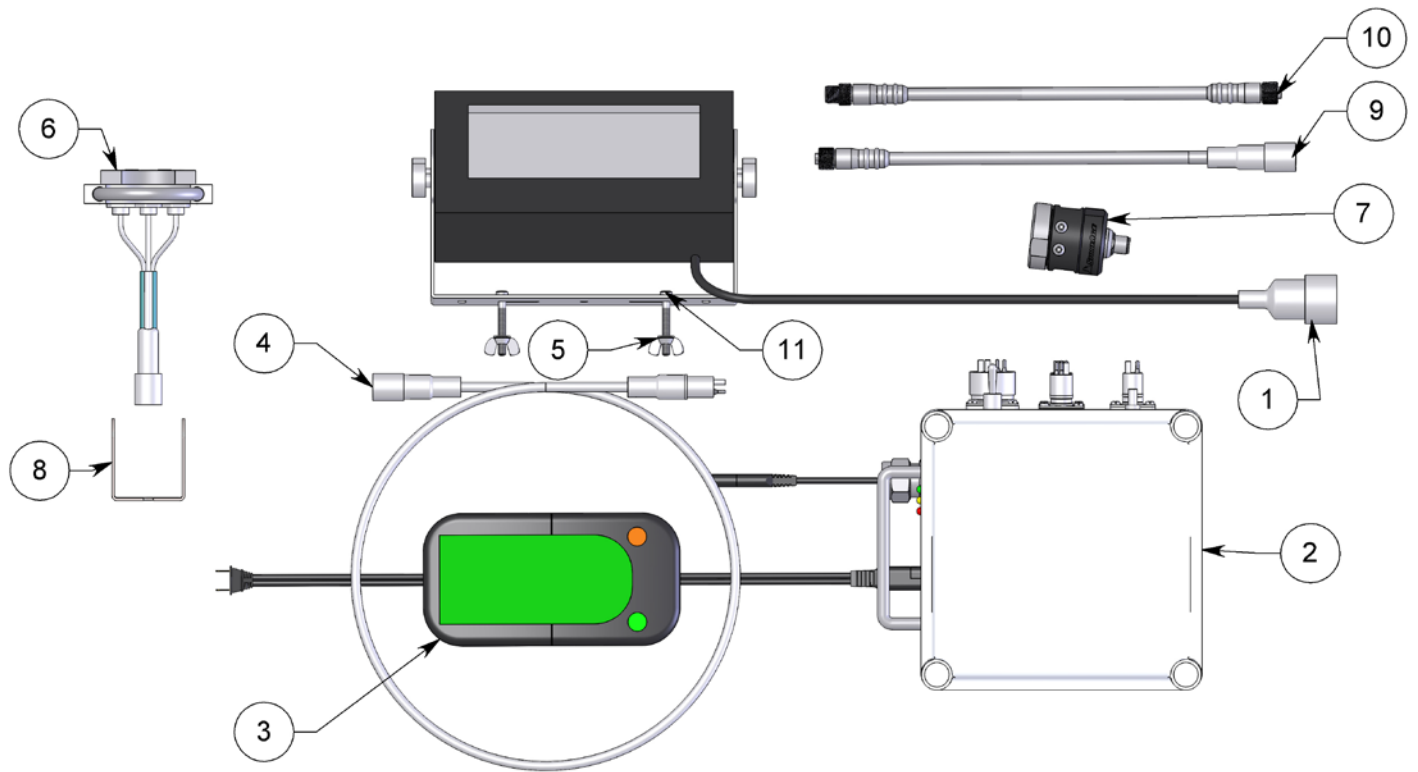

#	PART NUMBER	QTY.
1	CAM 102 MONITOR ASSEMBLY	1
2	CAM 103 BATTERY BOX ASSY	1
3	CAM 125 BATTERY CHARGER COMPLETE	1
4	CAM 146 LED CABLE ASSEMBLY	1
5	CAM 149 10-24 WING NUT	2
6	CAM 155 BTC LED BRACKET ASSY	1
7	CAM 220 CAMERA HOUSING ASSEMBLY	1
8	CAM 231 UNIVERSAL CAMERA BRACKET	1
9	CAM 240 CAMERA ADAPTER CABLE	1
10	CAM 245 CAMERA CABLE	1
11	GS 319-06 SHCS .19-24 X 1.50 SS	2
12	GW 319-F FLAT WASHER SS	2

CB-BTC-200
BTC CONTROL BOX (DIAGRAM 1)

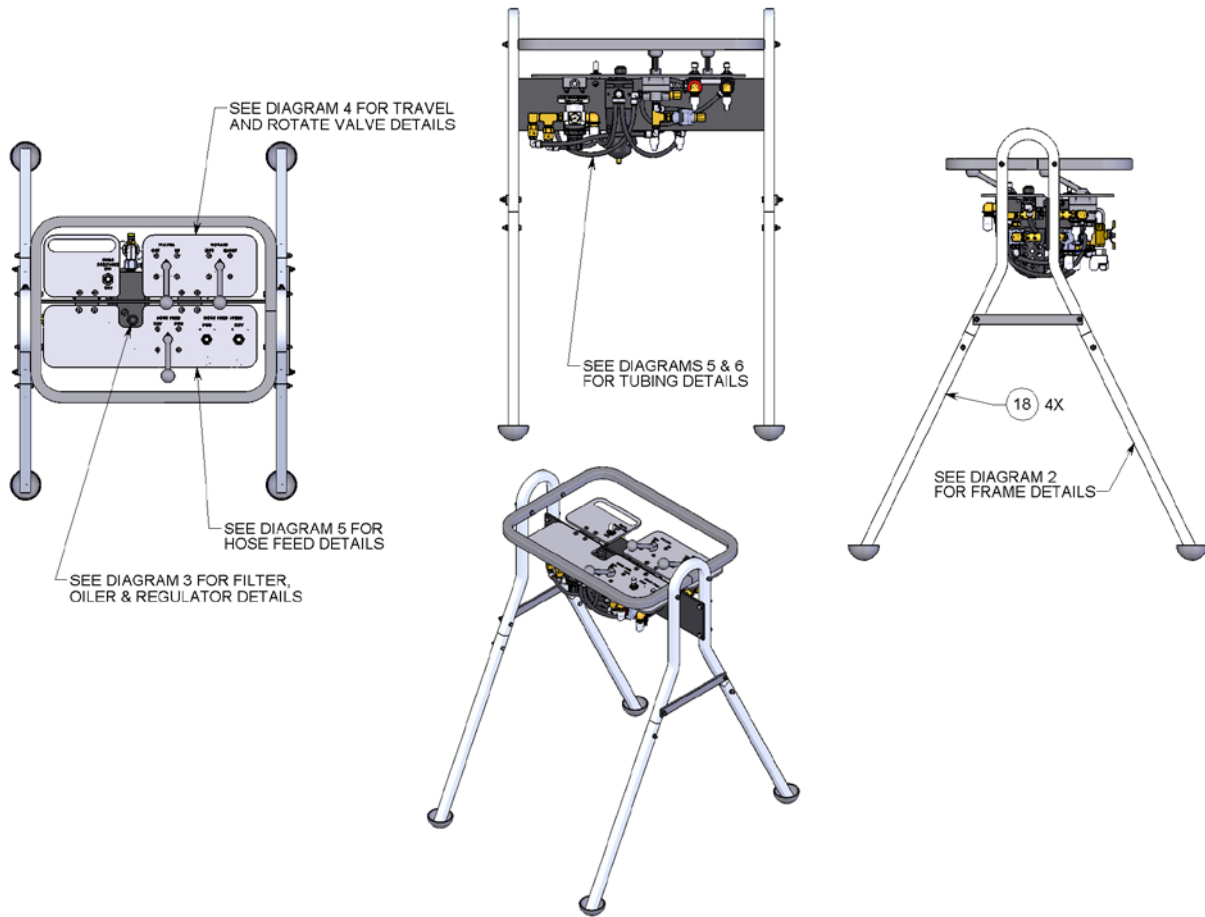

#	PART NUMBER	QTY	#	PART NUMBER	QTY	#	PART NUMBER	QTY
1	BR 154 MUFFLER, P6M	5	20	CB 122 FTG, NIPPLE P6 JIC8	4	40	GN 531-L NUT 5/16 LOCK ZINC	6
2	BR 167 DUST CAP	7	21	CB 126 FTG, ELBOW 90 P6M JIC8	3	41	GP 009-B PLASTIC ID WASHER, P6, BLUE	1
3	CB 004-BTC MOUNTING PLATE	1	22	CB 142 VALVE SELECTOR	3	42	GP 009-BK PLASTIC ID WASHER, P6, BLACK	1
4	CB 006 MOUNTING BLOCK	4	23	CB 352 FTG P6PL6 SWIVEL ELBO	13	43	GP 009-G PLASTIC ID WASHER, P6, GREEN	1
5	CB 011-001 QUICK EXHAUST VALVE, P6	2	24	CB 508 FSHCS, 1/4-20 X 1-3/4" SS	8	44	GP 009-P PLASTIC ID WASHER, P6, PURPLE	1
6	CB 020 FILTER	1	25	CB 513 DUMP PLATE, ABX	1	45	GP 009-R PLASTIC ID WASHER, P6, RED	1
7	CB 021 SHCS, 1/4-20 X 1-1/4 BLK	2	26	CB 514 SPACER	1	46	GP 009-Y PLASTIC ID WASHER, P6, YELLOW	1
8	CB 022 OILER	1	27	CB 515 TOGGLE 3 WAY, MOM, MOM	1	47	GP 025-P2SS HEX SOCKET PLUG, 1/8 NPT, SS	1
9	CB 026 FTG, NIPPLE P6	5	28	CB 516 FTG, 4 WAY MANIFOLD, P6M X PL6	1	48	GW 525-F WASHER, 1/4 FLAT ZINC	8
10	CB 032 AIR REGULATOR	2	29	CB 528 FLOW CONTROL VALVE, P6	2	49	GW 531-F WASHER, 5/16 FLAT ZINC	4
11	CB 033 MOUNTING BRACKET FOR K33 AIR REGULATOR	2	30	CB 532 MAIN PLATE	1	50	HRS 563 FTG, ELBOW 90 P2M PL4	1
12	CB 034 FTG, NIPPLE, P6, 2.5"L, BRASS	1	31	CB 533 POSITION PLATE	1	51	ML 077-P8 ADAPTER, MALE-FEMALE P8P8	1
13	CB 035 FTG, ELBOW, P6F X P6M, BRASS	5	32	CB 555 FSHCS 10-24 X .50 SS	12	52	PGC 315 P8P6 REDUCER BUSHING	1
14	CB 036 FTG, TEE, P6F, BRASS	3	33	CB 792 VALVE, AUTO DRAIN, P8	1	53	PL 158 DECAL, HCS REGULATOR	1
15	CB 037 CHECK VALVE, P6F X P6M, BRASS	1	34	DB 251 FITTING, BUSHING P2-PL6	1	54	PL 159 DECAL, HOSE FEED REGULATOR	1
16	CB 039 CHECK VALVE, P6F X P6M, BRASS	2	35	GB 525-19 BOLT, HEX .25-20 X 4.75	1	55	SBT 292.1 FTG, 90° ELBOW P8MP8M	1
17	CB 100 FRAME SUBASSEMBLY	1	36	GB 525-035 BOLT 1/4-20 X 7/8 ZINC	2			
18	CB 107 LEG WELDMENT	4	37	GB 531-07 BOLT 5/16-18 X 2-3/4 ZINC	4			
19	CB 114 INLET FITTING W/ PIN	1	38	GB 531-11 NUT 1/4 LOCK ZINC	2			
			39	GN 525-L NUT 1/4 LOCK ZINC	13			

PARTS DIAGRAM

CB-BTC-200
BTC CONTROL BOX
(DIAGRAM 2)

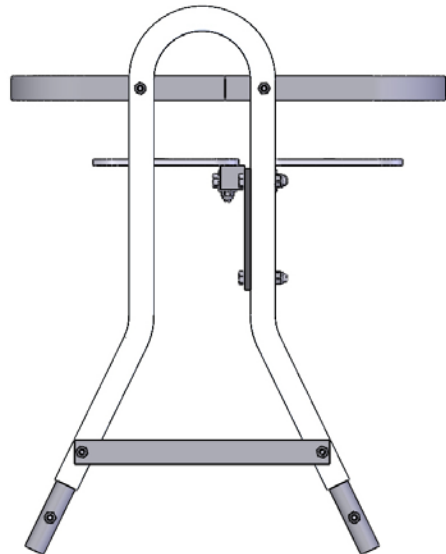
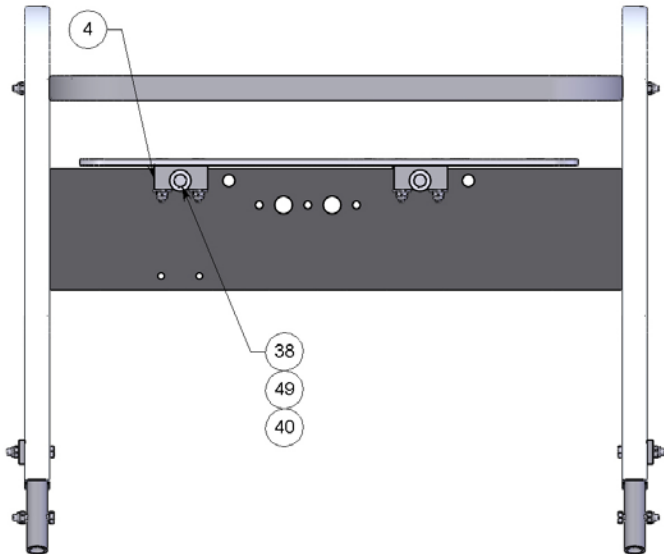
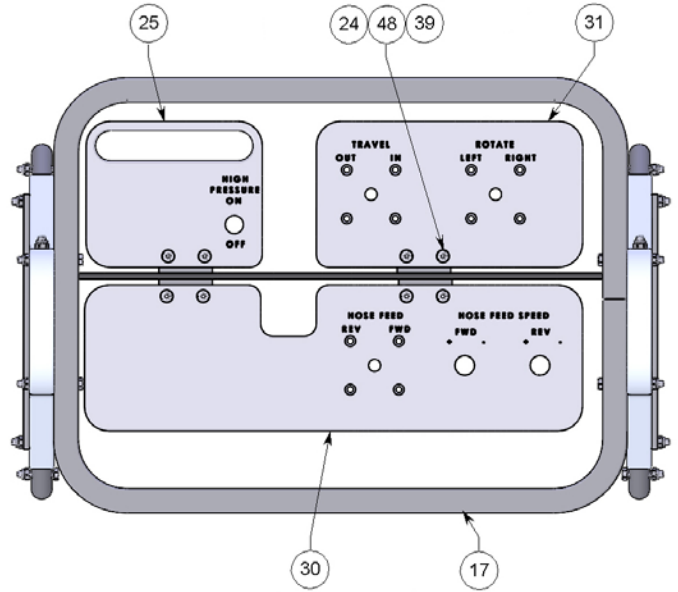
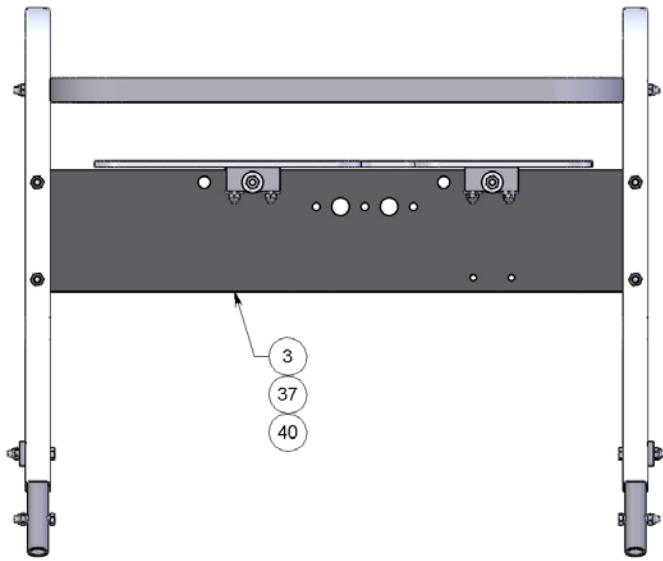

CB-BTC-200
BTC CONTROL BOX
(DIAGRAM 3)

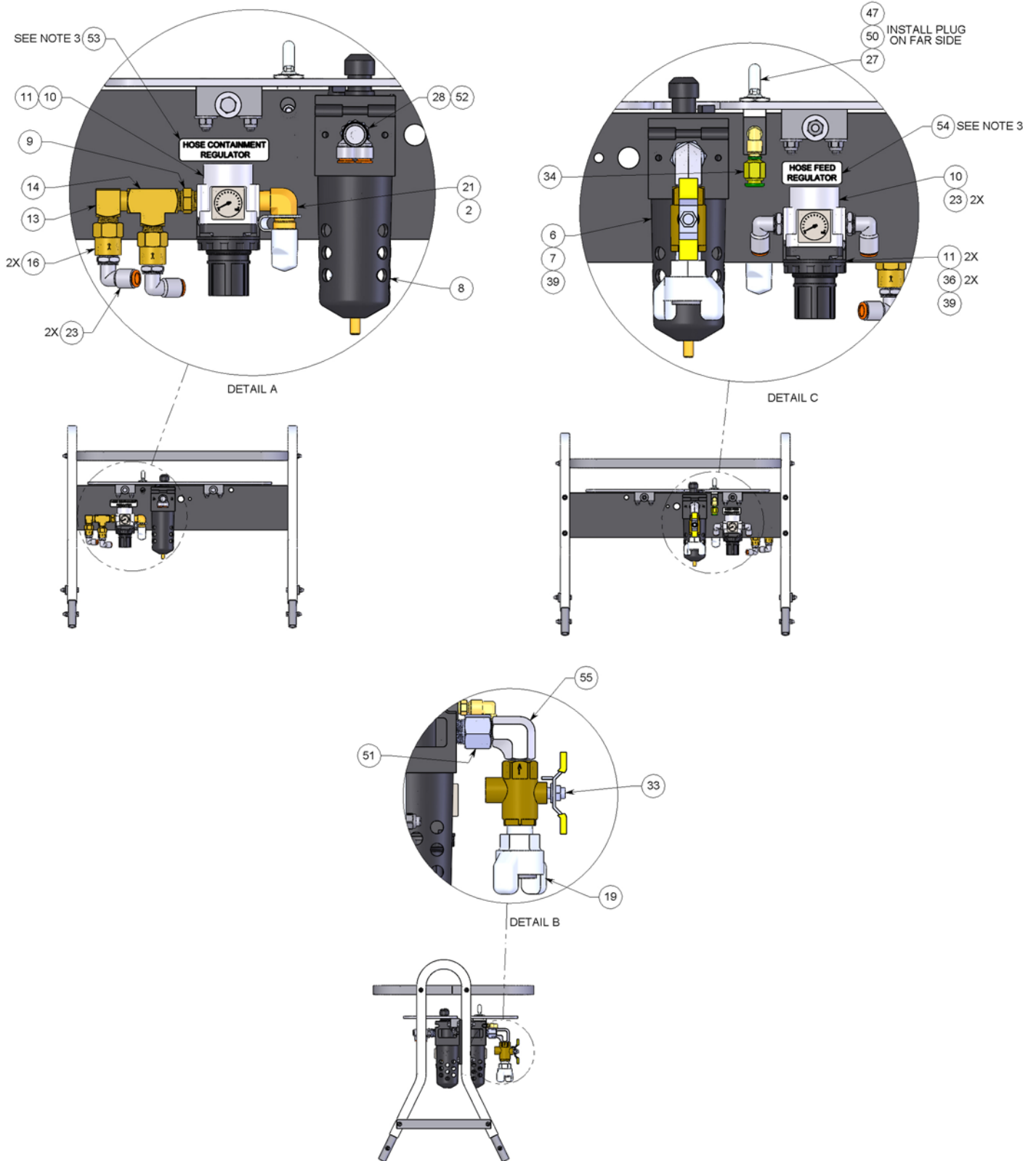

CB-BTC-200
BTC CONTROL BOX
(DIAGRAM 4)

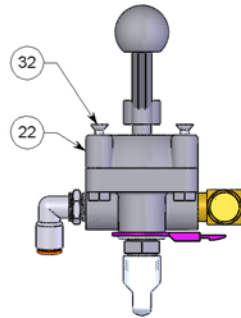
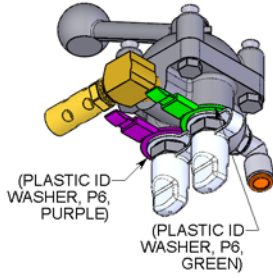
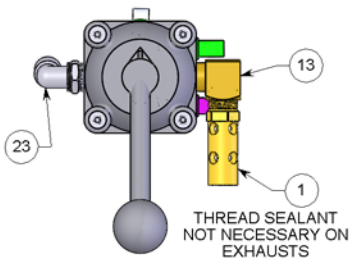

"ROTATE" VALVE ASSEMBLY

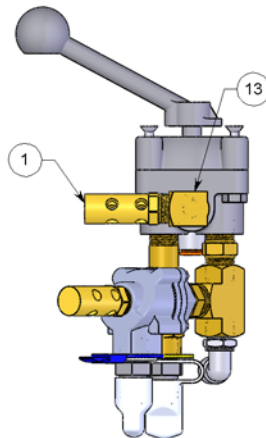
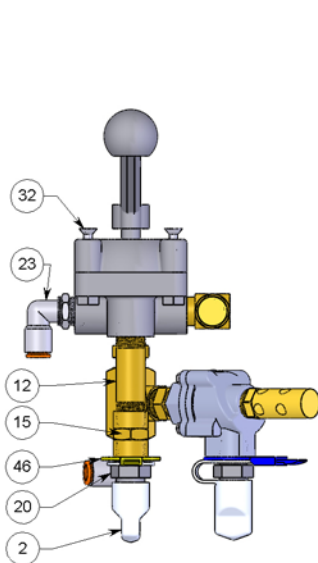
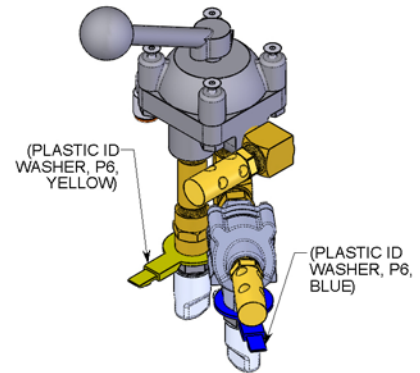
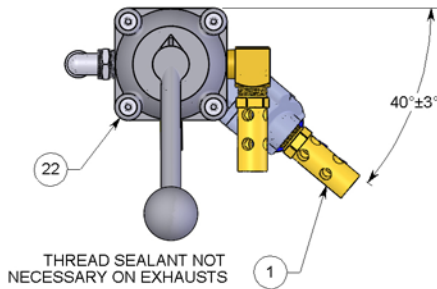
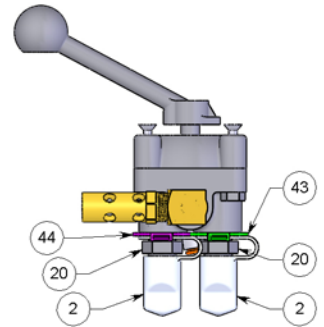

"TRAVEL" VALVE ASSEMBLY

RECOMMENDED ORDER OF ASSEMBLY STEPS:
1) MUFFLER AND FITTING ON SIDES OF VALVE BODY
2) FITTINGS LEADING TO THE BLUE ID TAG
3) FITTINGS LEADING TO THE YELLOW ID TAG

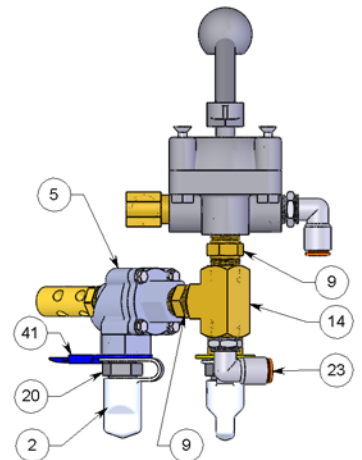

CB-BTC-200
BTC CONTROL BOX
(DIAGRAM 5)

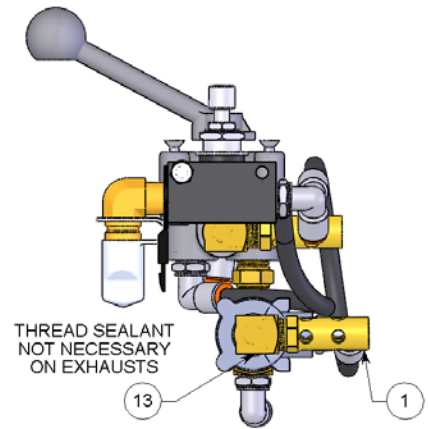
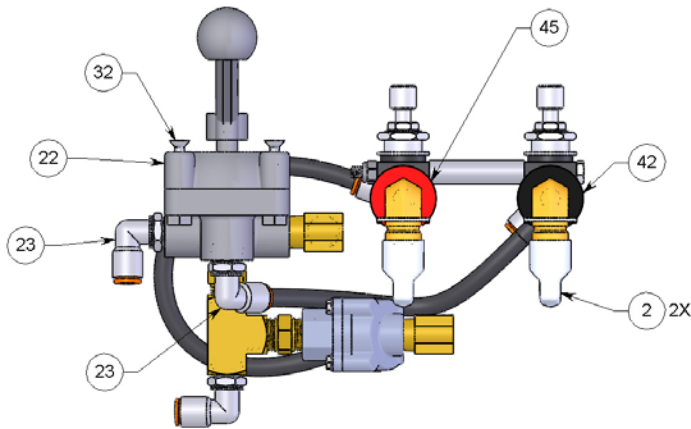
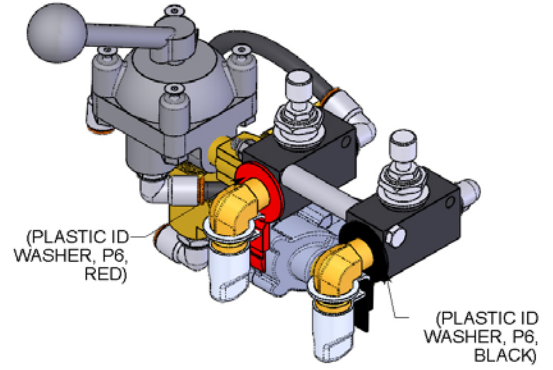
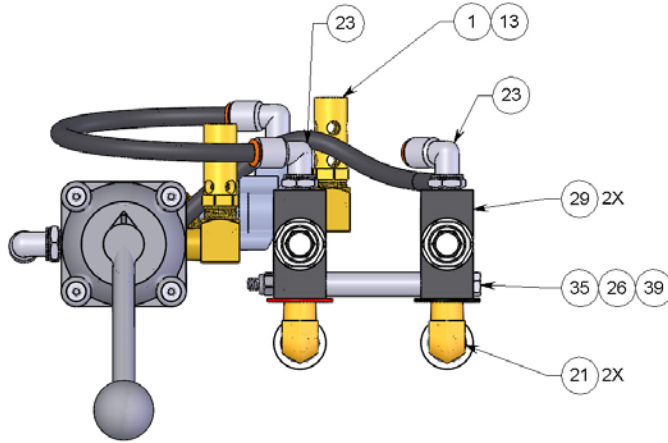

"HOSE FEED" VALVE AND FLOW CONTROL ASSEMBLIES

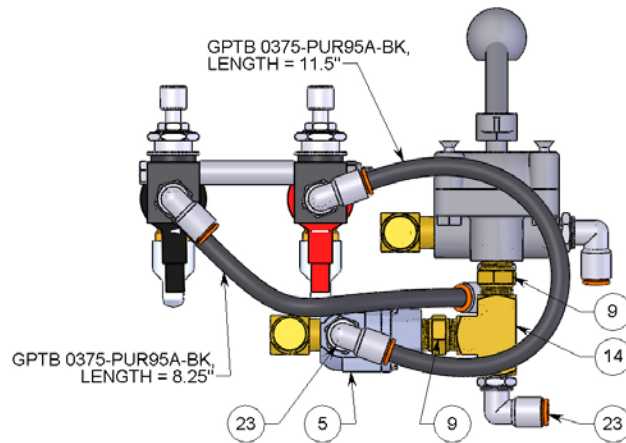

PARTS DIAGRAM

CB-BTC-200 BTC CONTROL BOX (DIAGRAM 6)

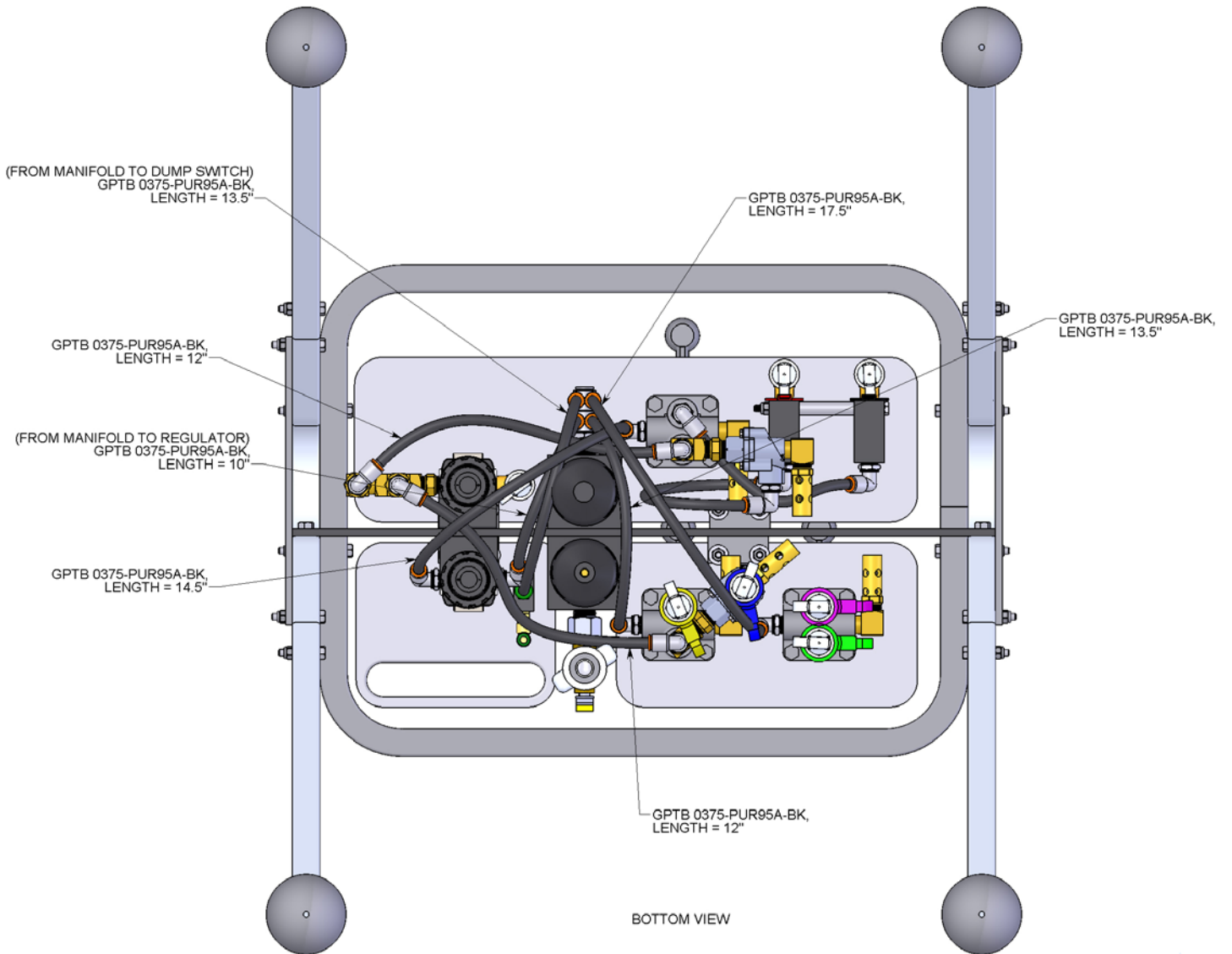

CB 061
HOSE BUNDLE ASSEMBLY

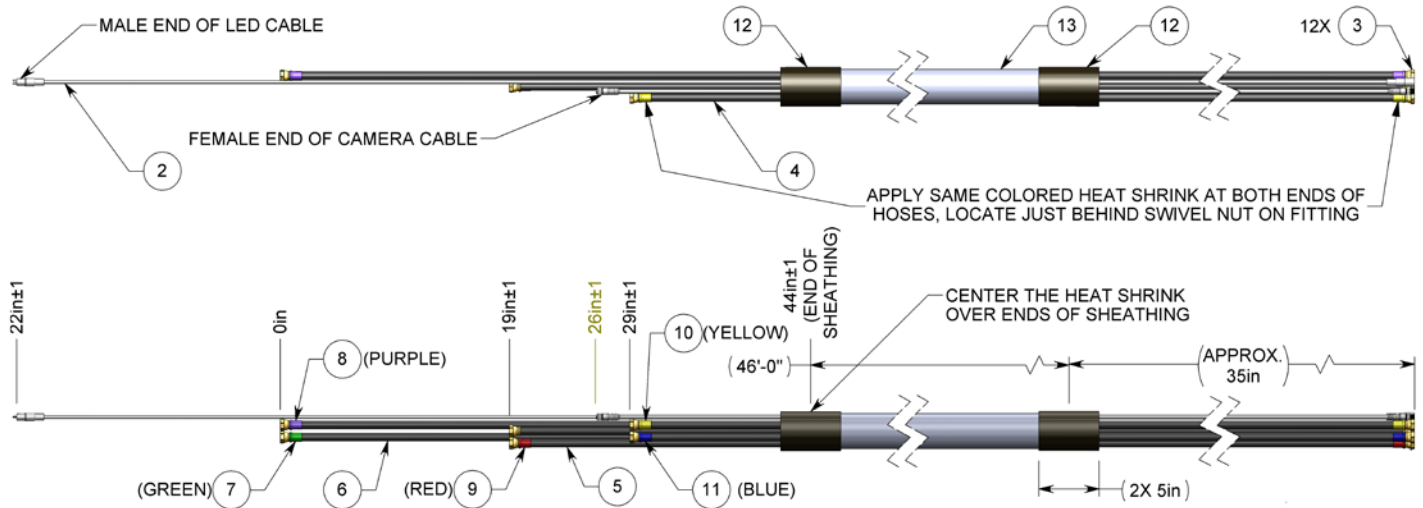

#	PART NUMBER	DESCRIPTION	QTY.	LENGTH
1	CAM 245 CAMERA CABLE ASSEMBLY	CAMERA CABLE ASSEMBLY	1	N/A
2	CAM 146 LED CABLE ASSEMBLY	LED CABLE ASSEMBLY	1	N/A
3	CB 063 FTG, BARBED, JIC8F HB6	JIC8F X HB6 PUSH-ON BRASS HOSE FITTING	12	N/A
4	GPHO 0375-RUB-BK	3/8ID X 5/8OD PUSH-ON AIR HOSE, BUNA-N RUBBER, 250PSI, BLACK ("REF" MC 5288K12-BLACK)	2	50'-0" ±3"
5	GPHO 0375-RUB-BK	3/8ID X 5/8OD PUSH-ON AIR HOSE, BUNA-N RUBBER, 250PSI, BLACK (REF MC 5288K12-BLACK)	2	50'-10" ±3"
6	GPHO 0375-RUB-BK	3/8ID X 5/8OD PUSH-ON AIR HOSE, BUNA-N RUBBER, 250 , BLACK (REF MC 5288K12-BLACK)	2	52'-5" ±3"
7	GPHS 1000-B2-GN	1.00 OD HEAT SHRINK TUBE, GREEN ("REF" HEATSHRINK.COM 5121015)	2	2" +0.5"
8	GPHS 1000-B2-PR	1.00 OD HEAT SHRINK TUBE, PURPLE ("REF" HEATSHRINK.COM 5121017)	2	2" +0.5"
9	GPHS 1000-B2-RD	1.00 OD HEAT SHRINK TUBE, RED ("REF" HEATSHRINK.COM 5121012)	2	2" +0.5"
10	GPHS 1000-B2-YL	1.00 OD HEAT SHRINK TUBE, YELLOW ("REF" HEATSHRINK.COM 5121014)	2	2" +0.5"
11	GPHS 1000-B2-BL	1.00 OD HEAT SHRINK TUBE, BLUE ("REF" HEATSHRINK.COM 5121016)	2	2" +0.5"
12	GPHS 3000-OLE-A-BK	3.00 DIA HEAVY DUTY MOISTURE SEAL HEAT-SHRINK ("REF" MC 7270K87)	2	5" ±0.5"
13	GPSL 3000-NYL-G-BK	3.0 DIA BRAIDED EXPANDABLE HEAVY DUTY NYLON ("REF" TECHFLEX GORILLA SLEEVE NHN3.00BK)	1	46'-0" ±3"

PARTS DIAGRAM

FF 121-XXX
COLLET STOPS

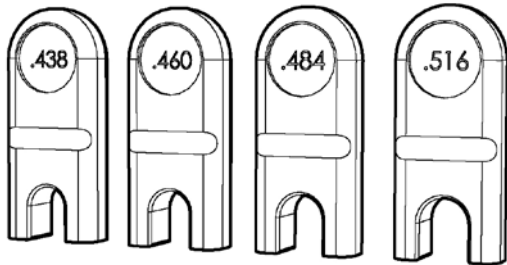

PRO174-46
HOSE DRIVE ROLLER

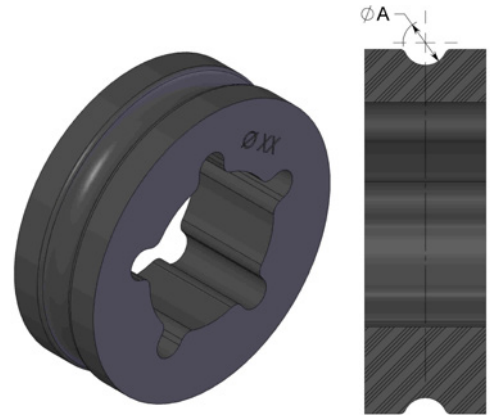

The BTC-200-001 BOILER TUBE CLEANER comes with one customer specified FF 121-XXX Collet installed in the BOP 030 Collet Block Assembly. It is necessary to change the Collet size when changing to a different diameter hose. THE REPLACEMENTS SHOWN IN THE CHART BELOW ARE THE ONLY SIZES TO BE USED WITH THE BTC-200-001 ASSEMBLY.

ROLLER INSIDE ABX-PRO	HOSE O.D.	SPIR STAR	PARKER	COLLET SIZE	STONEAGE PART NUMBER
PRO 174-46 Ø 0.46 IN.	0.39 - 0.50 IN.	4/4	2440D-025	0.438 in. / 11.0 mm	FF 121-438
		5/4		0.460 in. / 11.7 mm	FF 121-460
			2440D-03	0.484 in. / 12.3 mm	FF 121-484
		6/4	2440D-04	0.516 in. / 13.0 mm	FF 121-516

HLXD 625
HELIX DRIVE ROLLER KIT

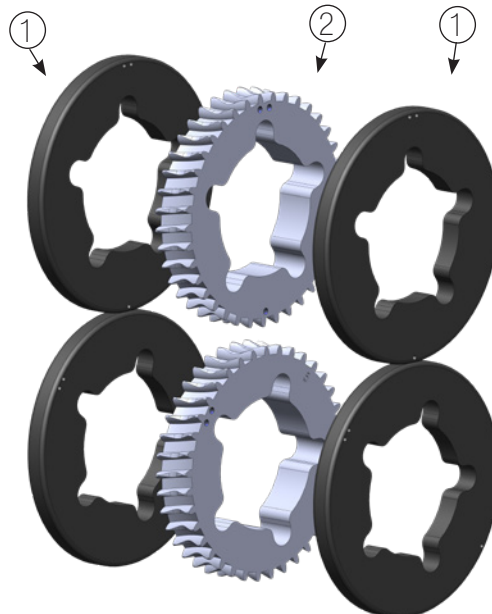

#	PART NUMBER	QTY.
1	HLXD 090 HLX 5 SPACER	4
2	HLXD 095 HLX 5 SPROCKET	2

If changing rollers on both the ABX-PRO Tractor and the ABX-PRO-5 Hose Containment Drive, order a quantity of two HLXD 625 kits.

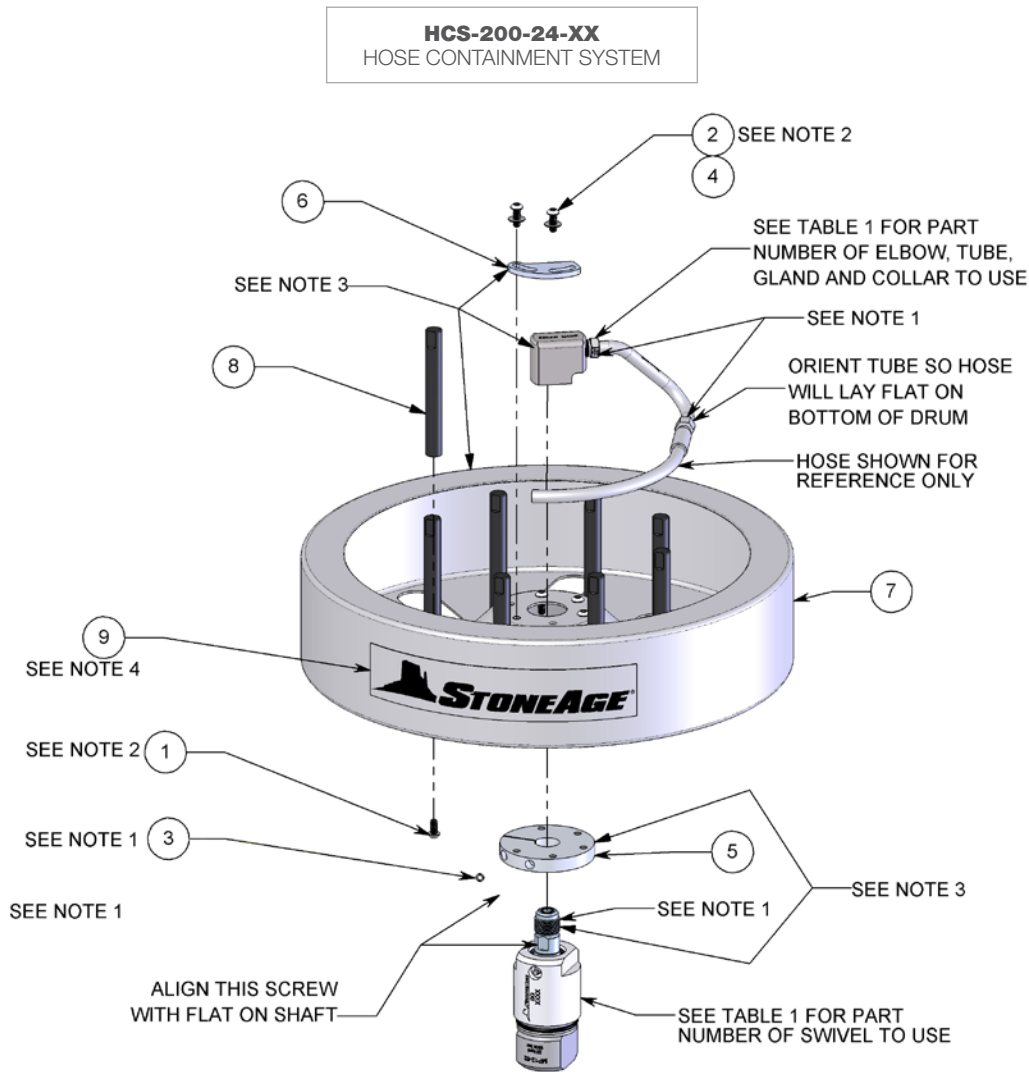

TABLE 1					
ASSEMBLY NUMBER	PART NUMBERS OF:				
	SWIVEL	ELBOW	TUBE	GLAND	COLLAR
HCS-100-P12TM9-24	SG-P12K-62-90	HCS 105	HCS 108	AF 070-MP9	AF 071-MP9
HCS-100-MP12TM9-24	SG-MP12K-62-90	HCS 105	HCS 108	AF 070-MP9	AF 071-MP9
HCS-100-MP12TM12-24	SG-MP12K-62-90	HCS 106	HCS 109	AF 070-MP12	AF 071-MP12

#	PART NUMBER	QTY.
1	GSB 331-025 BHCS .31-18 X .62 LG SS	8
2	GSB 331-03 BHCS .31-18 X .75 LG SS	5
3	GW 325-L-HC LOCK WASHER SS	1
4	GW 331-F FLAT WASHER SS	2
5	HCS 103 DRUM ADAPTER FLANGE	1
6	HCS 120 ELBOW LOCKING PLATE	1
7	HCS 206 HOSE DRUM	1
8	HCS 207 ROD, INNER DRUM	8
9	PL 180 GENERIC STONEAGE DECAL 2.5X13	1

1. ADD BLUE GOOP, IT IS A SWAGelok BRAND ANTI-SEIZE. AN EQUIVALENT ALTERNATIVE IS ACCEPTABLE.
2. ADD BLUE LOCTITE: PN: 242 OR EQUIVALENT
3. SWIVEL, FLANGE, DRUM, ELBOW & LOCKING PLATE INSTALLATION:
 - A) SLIDE ADAPTER FLANGE FULLY ONTO SWIVEL SHAFT (PROFILED SIDE TOWARD SWIVEL), ALIGN SCREW WITH FLAT ON SWIVEL SHAFT AND TIGHTEN BOTH SCREWS SECURELY.
 - B) PLACE DRUM ON ADAPTER FLANGE (5 OF THE 6 HOLES WILL BE USED). ATTACH DRUM TO ADAPTER FLANGE WITH ALL 5 SCREWS.
 - C) (CRITICAL) TIGHTEN ELBOW ONTO SWIVEL. (CRITICAL)
 - D) PLACE FLAT SIDE OF LOCKING PLATE UP AGAINST ONE OF THE SIDES OF ELBOW. DETERMINE THE BEST SIDE AND ORIENTATION OF PLATE BY ASSURING 2 SCREWS CAN SECURE THE PLATE. REMOVE THOSE 2 SCREWS, PLACE PLATE FIRMLY AGAINST THE SIDE OF THE ELBOW, ADD FLAT WASHERS AND REINSTALL SCREWS. SEE SECTION VIEW A-A SHOWING EXAMPLE OF PLATE INSTALLED.
4. CLEAN ALL DEBRIS & OILS BEFORE INSTALLING. INSTALL AT APPROXIMATE ORIENTATION AND LOCATION & AT ROOM TEMP.

PARTS DIAGRAM

HCS-BTC-200 HOSE CONTAINMENT SYSTEM

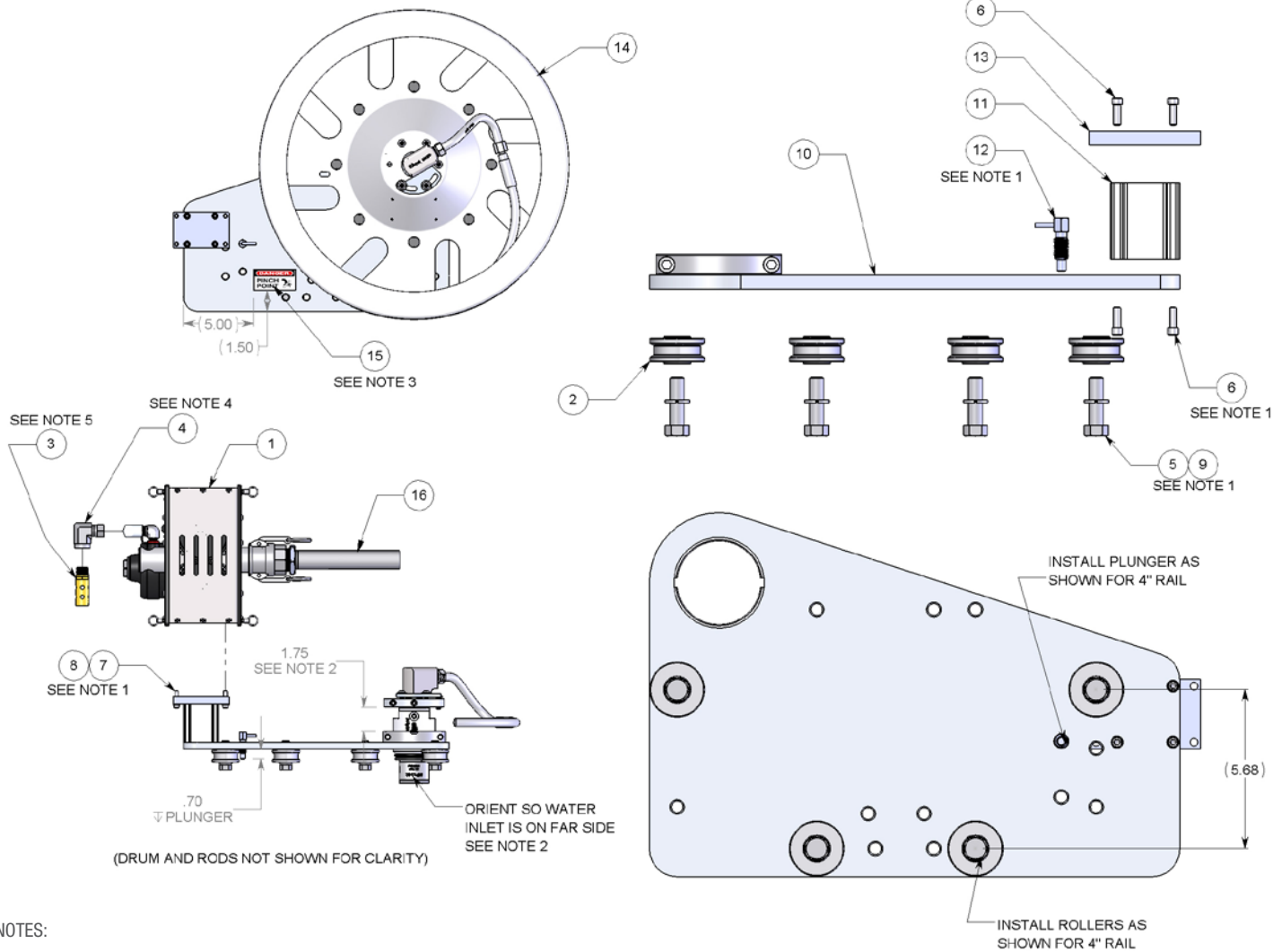

NOTES:

1. ADD BLUE LOCTITE: PN: 242 OR EQUIVALENT TO ALL THREADED HARDWARE
2. SECURE SWIVEL WITHIN CLAMP ON BASE PLATE AT HEIGHT & ORIENTATION SHOWN IN SIDE VIEW.
3. CLEAN ALL DEBRIS & OILS BEFORE INSTALLING. INSTALL AT APPROXIMATE ORIENTATION AND LOCATION & AT ROOM TEMP.
4. ADD BLUE GOOP, IT IS A SWAGelok BRAND ANTI-SEIZE. AN EQUIVALENT ALTERNATIVE IS ACCEPTABLE.
5. ADD LOCTITE THREAD SEALANT © 567 OR EQUIVALENT TO ALL NPT THREADS.

#	PART NUMBER	QTY.		
1	ABX-PRO-5 AUTOBOX PRODRIVE TRACTOR ASSEMBLY	1	8	GW 325-L LOCK WASHER SS 4
2	BR 055-SS ROLLER ASSY	4	9	GW 350-L LOCK WASHER SS 4
3	BR 155 MUFFLER	1	10	HCS 101-001 DRUM BASE PLATE WELDMENT 1
4	CB 162 FTG, P8FJ8F 90DEG ELBOW	1	11	HCS 102-001 2.5IN BOX RAIL, CUT AND TAPPED 1
5	GB 350-07 BOLT, HEX .50-13 X 1.75 SS	4	12	HCS 115 RETRACTABLE SPRING PLUNGER 1
6	GS 325-03 SHCS .25-20 X .75 SS	8	13	HCS 124 TOP PLATE, MOUNT 1
7	GS 325-04 SHCS .25-20 X 1.00 SS (BC 053)	4	14	HCS-200-24-MP12TM9 1
			15	PL 160 PINCH POINT 1.5X3.0 DECAL 1
			16	PRO 190-08 GUIDE ASSEMBLY 1

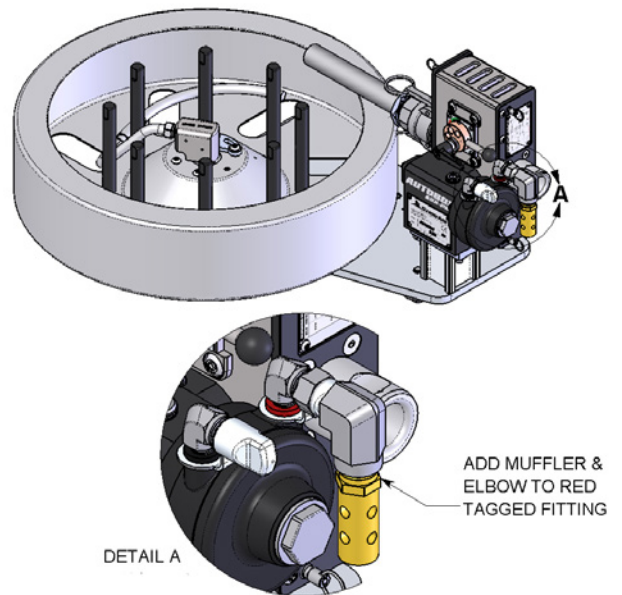

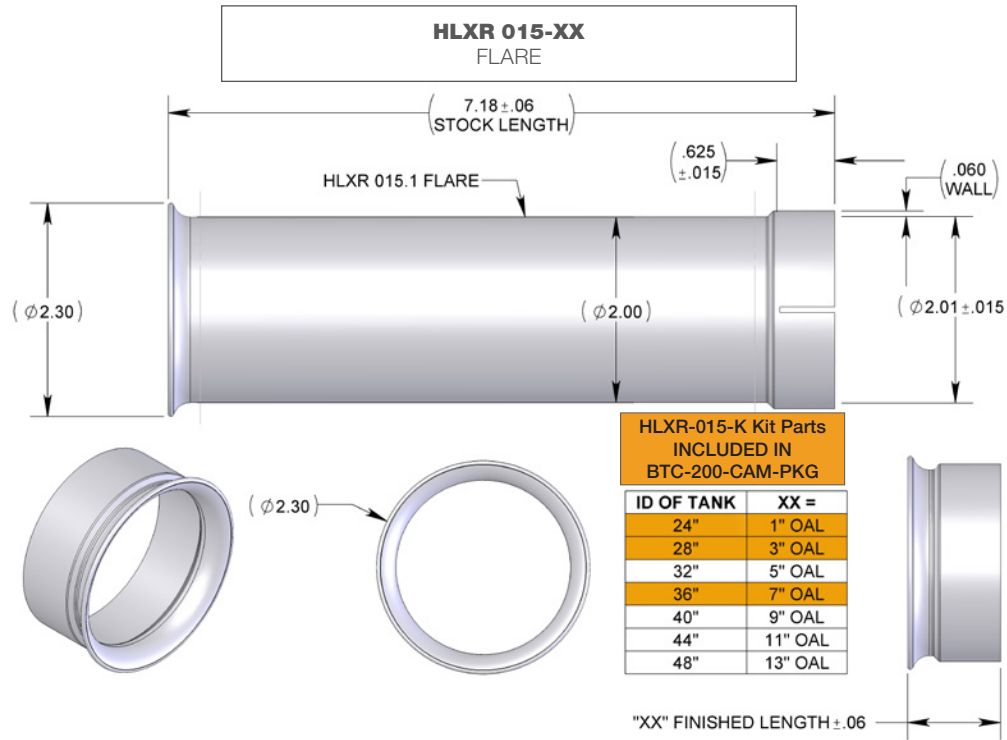

HLXR 040
ELBOW ASSEMBLY

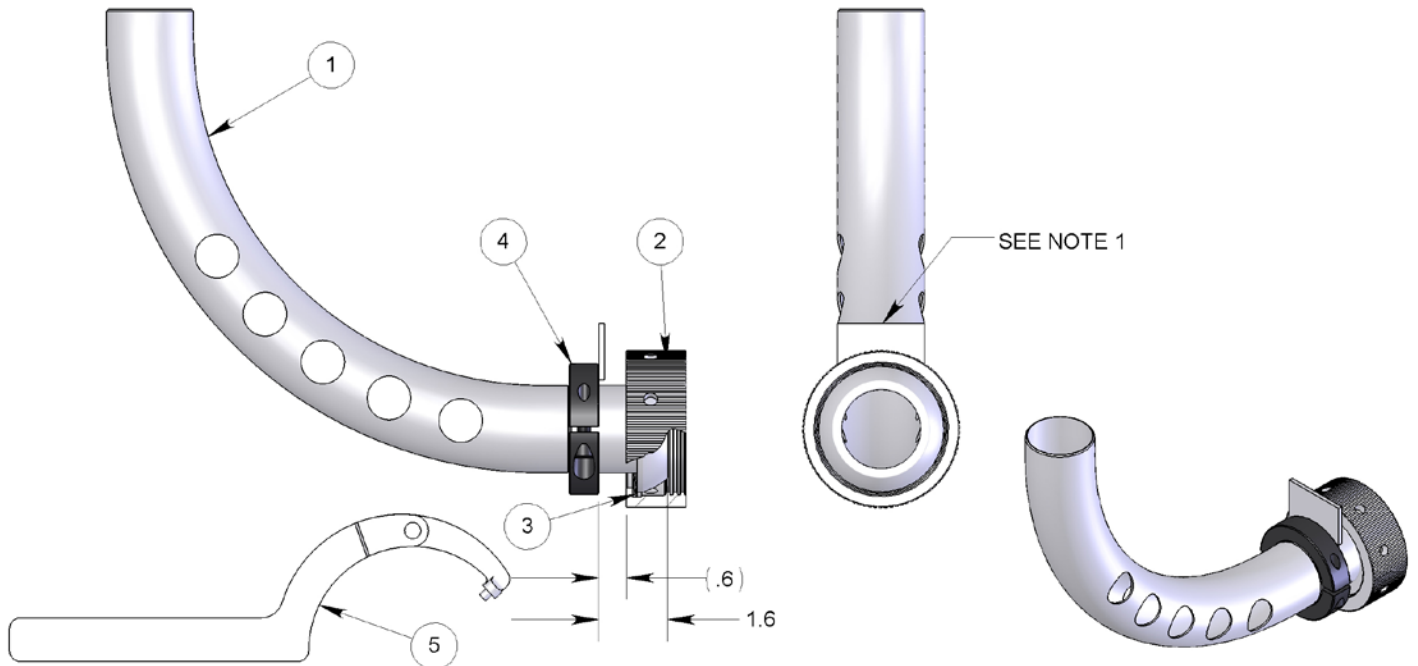

NOTES:

1. ALIGN ELBOW STOP VERTICALLY TO ELBOW BY VISUAL ESTIMATE, APPROXIMATELY AS SHOWN.

#	PART NUMBER	QTY.
1	HLXR 010 ELBOW, WELDMENT	1
2	HLXR 011 KNURLED NUT	1
3	HLXR 012 WAVE SPRING, ELBOW	1
4	HLXR 013 STOP, ELBOW	1
5	HLXR 050 TOOL	1

PARTS DIAGRAM

HLXR-100-001 ROTATOR (PAGE 1)

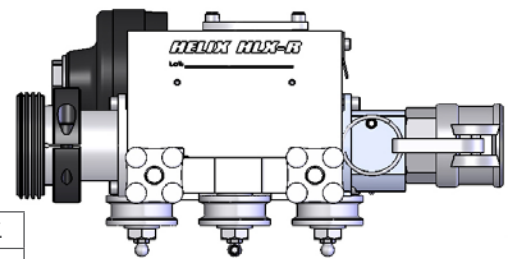
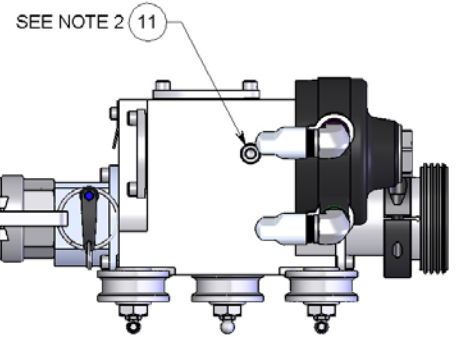
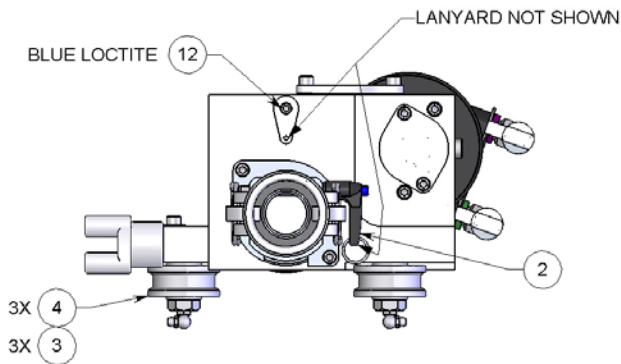
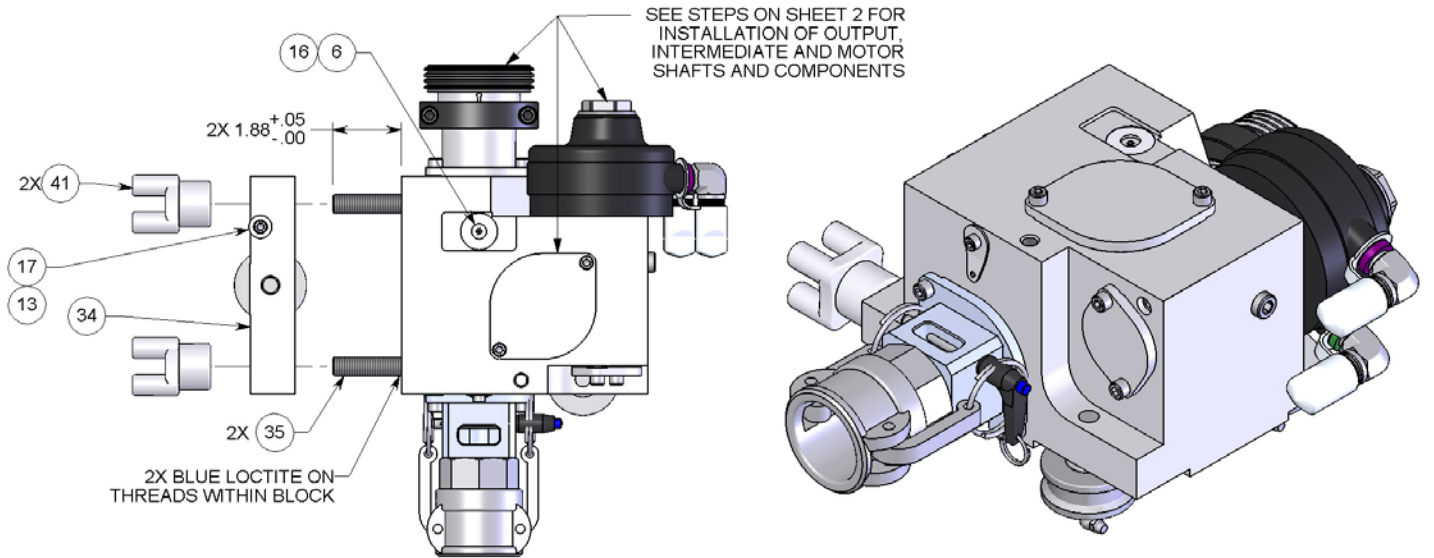

NOTES:

1. APPLY A THIN COAT OF GENERAL PURPOSE GREASE TO O-RINGS PRIOR TO INSTALLATION.
2. LAST STEP: ADD 2.5 OUNCES OF MOBIL SYNTHETIC OIL SCH 634 (SA# GP 146.1), THEN INSTALL PLUG.
3. THIS WORM CAP WILL BOTTOM ON BEARING, WILL NOT BOTTOM ON HOUSING WHEN TIGHTENED.

#	PART NUMBER	QTY.
2	BOP 033 QUICK PIN	1
3	BR 052-2.0-90 AXLE-ZERK	3
4	BR 055 ROLLER ASSY	3
6	CAM 161 MAGNET	1
11	GP 025-P4SS HEX SOCKET PLUG	1
12	GS 319-015 SHCS .19-24 X .38 SS	1
13	GS 325-02 SHCS .25-20 X .50 SS	1
16	GSF 319-03 FHCS .19-24 X .75 LG SS	1
17	GW 325-F FLAT WASHER SS	1
34	HLXR 031 SPLIT CLAMP	1
35	HLXR 033 .50-13 THREADED ROD SS	2
41	HLXT 038 BAR KNOB-.50	2

HLXR-100-001
ROTATOR (PAGE 2)

STEP 1: BEARING

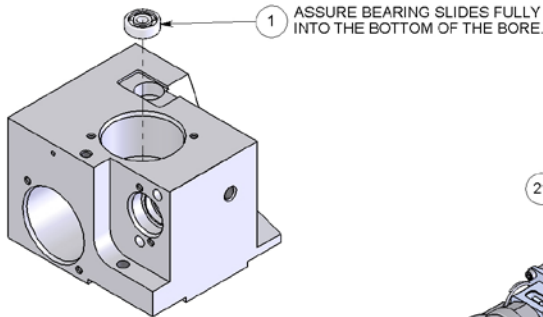

STEP 2: OUTPUT SHAFT

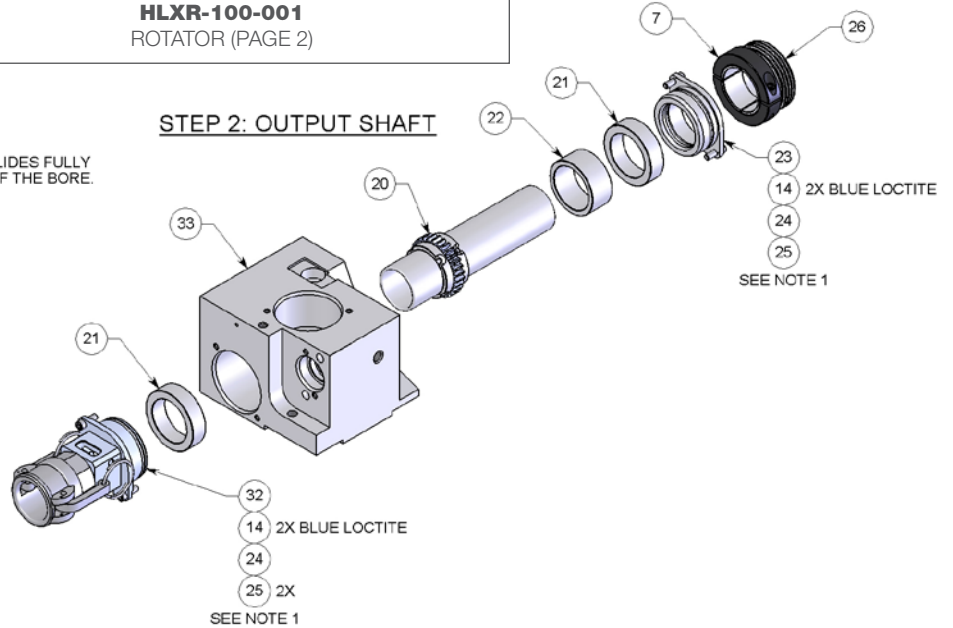

STEP 3: INTERMEDIATE SHAFT

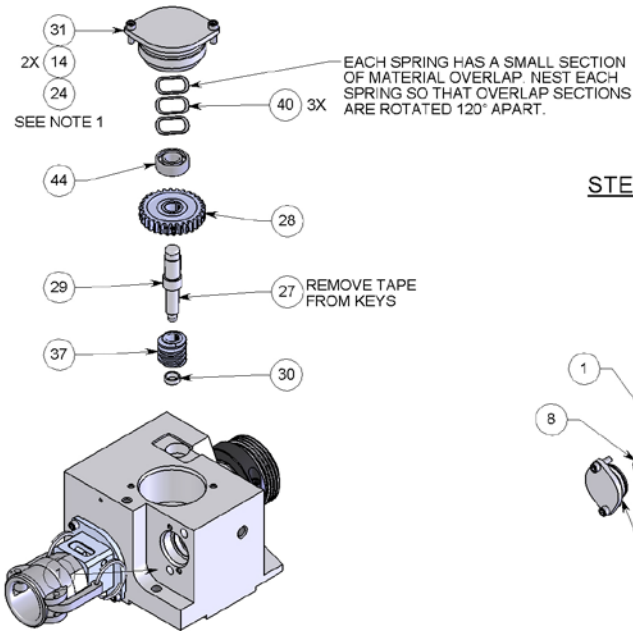

STEP 4: MOTOR SHAFT

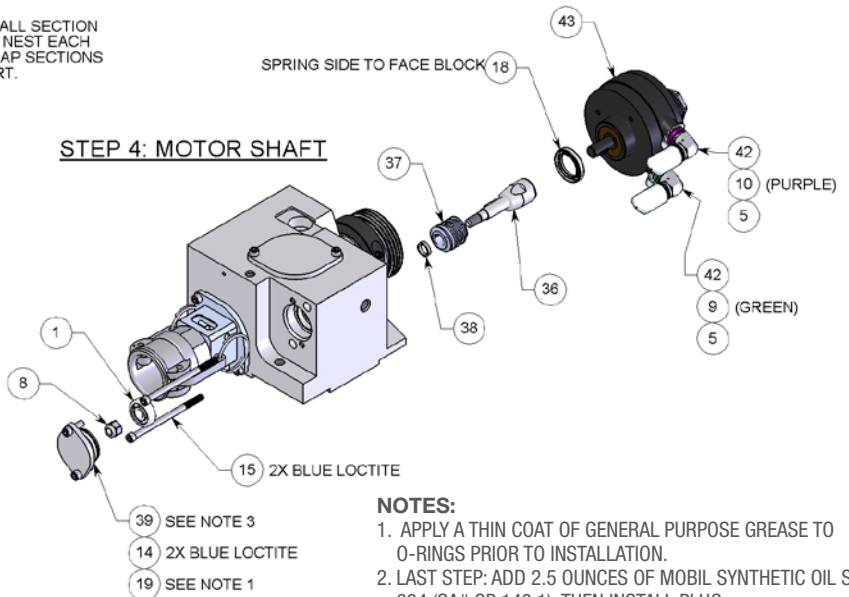

NOTES:

1. APPLY A THIN COAT OF GENERAL PURPOSE GREASE TO O-RINGS PRIOR TO INSTALLATION.
2. LAST STEP: ADD 2.5 OUNCES OF MOBIL SYNTHETIC OIL SCH 634 (SA# GP 146.1), THEN INSTALL PLUG.
3. THIS WORM CAP WILL BOTTOM ON BEARING, WILL NOT BOTTOM ON HOUSING WHEN TIGHTENED.

#	PART NUMBER	QTY.	#	PART NUMBER	QTY.	#	PART NUMBER	QTY.
1	BC 009 BEARING	2	20	HLXR 001-001 DRIVE TUBE, OUTPUT WELDMENT	1	31	HLXR 025 WORM CAP, MID	1
5	BR 167 90° DUST CAP	2	21	HLXR 004 BUSHING, OUTPUT	2	32	HLXR 026 WORM CAP CAMLOCK WELDMENT	1
7	GC SP-36-F COLLAR ASSY	1	22	HLXR 005 SPACER, OUTPUT	1	33	HLXR 030 HOUSING	1
8	GN 337-L NYLOK NUT SS	1	23	HLXR 006 WORM CAP, OUTPUT	1	36	HLXT 015-001 AXLE, INPUT	1
9	GP 013-G GREEN ID BAND, SM	1	24	HLXR 007 O-RING OUTER, FINAL	3	37	HLXT 016 WORM, MID-MAIN	2
10	GP 013-PR PURPLE ID BAND, SM	1	25	HLXR 008 O-RING INNER, FINAL	3	38	HLXT 017 SPACER, INPUT	1
14	GS 325-03 SHCS .25-20 X .75 SS (TB 050)	8	26	HLXR 009 PIVOT COLLET	1	39	HLXT 018 WORM CAP, INPUT	1
15	GS 325-16 SHCS .25-20 X 4.00 SS	2	27	HLXR 021 AXLE DRIVE, MID	1	40	HLXT 025 WAVE SPRING, MID	3
18	HLXD 013 SEAL, INPUT	1	28	HLXR 022 WORM GEAR, MID	1	42	HRS 552 FITTING, ELBOW OUTLET P4J8 90°	2
19	HLXD 017 CAP O-RING, INPUT	1	29	HLXR 023 SPACER UPPER, MID	1	43	PRO 155-001 AIR MOTOR	1
			30	HLXR 024 SPACER LOWER, MID	1	44	RJ 009 BEARING	1

PARTS DIAGRAM

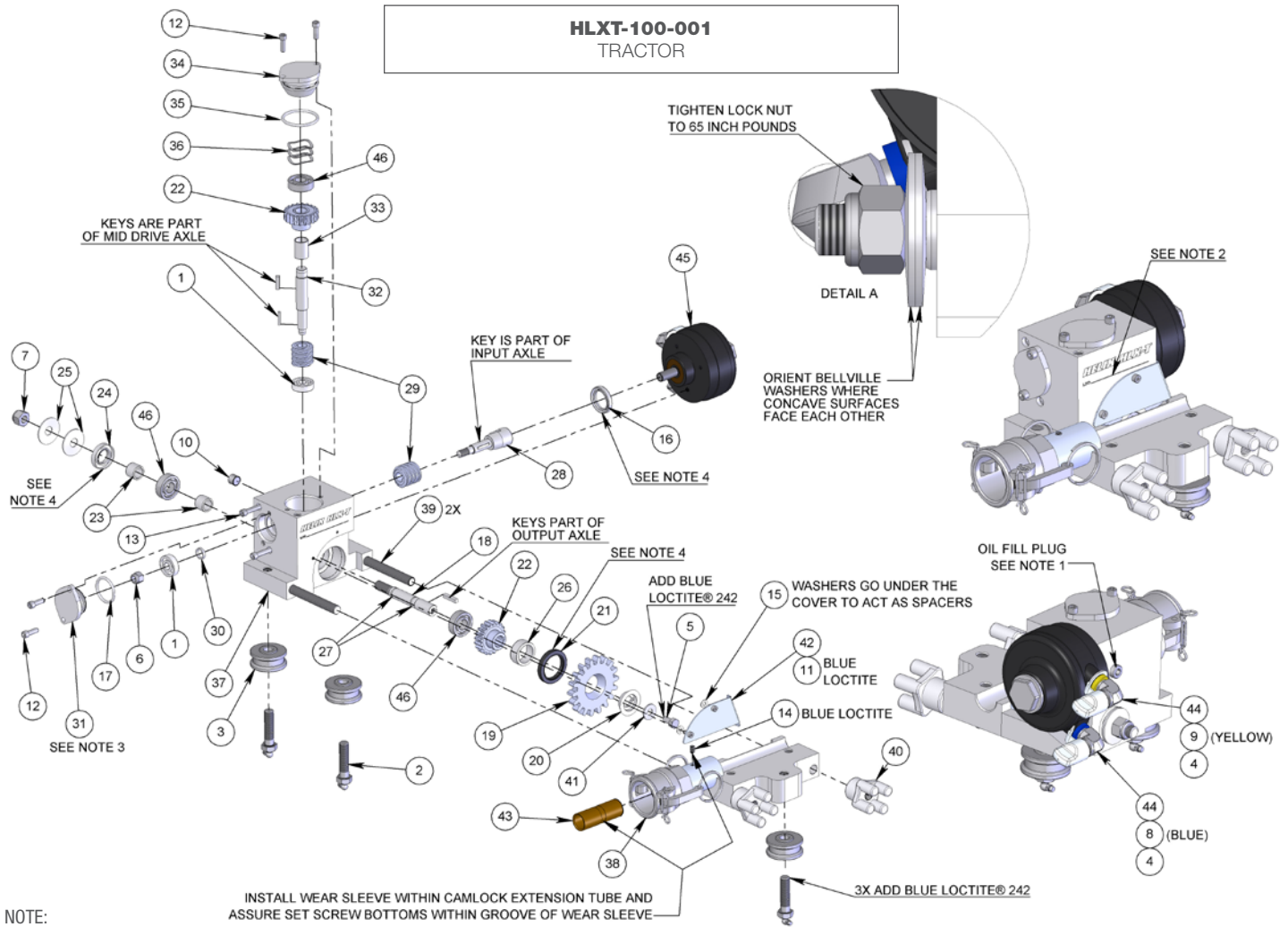

NOTE:

1. ADD 1.5 OUNCES OF MOBIL SYNTHETIC OIL SCH 634 (SA# GP 146.1)
2. LOT# TO BE ADDED BY STONEAGE.
3. THIS WORM CAP WILL BOTTOM ON BEARING, WILL NOT BOTTOM ON HOUSING WHEN TIGHTENED
4. ALL SEALS MUST HAVE LIP WITH SPRING FACING GEAR BOX.

#	PART NUMBER	QTY.	15	GW 319-F FLAT WASHER SS	2	31	HLXT 018 WORM CAP, INPUT	1
1	BC 009 BEARING	2	16	HLXD 013 SEAL, INPUT	1	32	HLXT 021 AXLE, MID	1
2	BR 052-2.0-90 AXLE-ZERK	3	17	HLXD 017 CAP O-RING, INPUT	1	33	HLXT 022 GEAR SPACER, MID	1
3	BR 055 ROLLER ASSY	3	18	HLXT 001 AXLE, OUTPUT	1	34	HLXT 023 WORM CAP, MID	1
4	BR 167 90° DUST CAP J8	2	19	HLXT 002 SPUR GEAR, OUTPUT	1	35	HLXT 024 O-RING, MID	1
5	GB 331-025 BOLT, HEX .31-18 X .625 SS	1	20	HLXT 003 BUSHING, OUTPUT	1	36	HLXT 025 WAVE SPRING, MID	3
6	GN 337-L NYLOK NUT SS	1	21	HLXT 004 34 X 48 X 7 TC SEAL, FINAL	1	37	HLXT 030 HOUSING	1
7	GN 350-L-20 NYLOK NUT SS	1	22	HLXT 005 WORM GEAR, OUTPUT	2	38	HLXT 031-001 LOWER CHASSIS CLAMP WELDMENT	1
8	GP 013-B BLUE ID BAND, SM	1	23	HLXT 006 SPACER, OUTPUT	2	39	HLXT 033 .50-13 THREADED ROD	2
9	GP 013-Y YELLOW ID BAND, SM	1	24	HLXT 007 20 X 36 X 7 TC SEAL, FINAL	1	40	HLXT 038 BAR KNOB-.50	2
10	GP 025-P4SS HEX SOCKET PLUG	1	25	HLXT 008 BELLVILLE WASHER	2	41	HLXT 042-FLAT WASHER. .375 SS	1
11	GS 319-015 SHCS .19-24 X .38 SS	2	26	HLXT 009 SEAL SLEEVE, OUTPUT	1	42	HLXT 043 GEAR COVER	1
12	GS 325-03 SHCS .25-20 X .75 SS (TB 050)	4	27	HLXT 010 O-RING, FINAL	2	43	HLXT 044 WEAR SLEEVE	1
13	GS 325-16 SHCS .25-20 X 4.00 SS	2	28	HLXT 015-001 AXLE, INPUT	1	44	HRS 552 FTG, ELBOW 90 P4M J8M	2
14	GSS 325-20-37CU SET SCREW, CUP PT SS	1	29	HLXT 016 WORM, MID-MAIN	2	45	PRO 155-001 AIR MOTOR	1
			30	HLXT 017 SPACER, INPUT	1	46	RJ 009 BEARING	3

TERMS AND CONDITIONS

1. Acceptance of Terms and Conditions. Receipt of these Terms and Conditions of Sale ("Terms and Conditions") shall operate as the acceptance by StoneAge, Inc. ("Seller") of the order submitted by the purchaser ("Buyer"). Such acceptance is made expressly conditional on assent by Buyer to these Terms and Conditions. Such assent shall be deemed to have been given unless written notice of objection to any of these Terms and Conditions (including inconsistencies between Buyer's purchase order and this acceptance) is given by Buyer to Seller promptly on receipt hereof.

Seller desires to provide Buyer with prompt and efficient service. However, to individually negotiate the terms of each sales contract would substantially impair Seller's ability to provide such service. Accordingly, the product(s) furnished by Seller are sold only according to the terms and conditions stated herein and with the terms and conditions stated in any effective StoneAge Dealer Agreement or StoneAge Reseller Agreement, if applicable. Notwithstanding any terms and conditions on Buyer's order, Seller's performance of any contract is expressly made conditional on Buyer's agreement to these Terms and Conditions unless otherwise specifically agreed to in writing by Seller. In the absence of such agreement, commencement of performance, shipment and/or delivery shall be for Buyer's convenience only and shall not be deemed or construed to be an acceptance of Buyer's terms and conditions.

2. Payment/Prices. Unless other arrangements have been made in writing between Seller and Buyer, payment for the product(s) shall be made upon receipt of invoice. The prices shown on the face hereof are those currently in effect. Prices invoiced shall be per price list in effect at the time of shipment. Prices are subject to increase for inclusion of any and all taxes which are applicable and which arise from the sale, delivery or use of the product(s), and the collection of which Seller is or may be responsible to provide to any governmental authority, unless acceptable exemption certificates are provided by Buyer in accordance with applicable law. Buyer shall pay all charges for transportation and delivery and all excise, order, occupation, use or similar taxes, duties, levies, charges or surcharges applicable to the product(s) being purchased, whether now in effect or hereafter imposed by any governmental authority, foreign or domestic.

3. Warranty. SELLER MAKES NO WARRANTIES OR REPRESENTATIONS AS TO THE PERFORMANCE OF ANY PRODUCT EXCEPT AS SET FORTH IN THE STONEAGE LIMITED WARRANTY PROVIDED WITH THE PRODUCT.

4. Delivery. Seller is not obligated to make delivery by a specified date, but will always use its best efforts to make delivery within the time requested. The proposed shipment date is an estimate. Seller will notify Buyer promptly of any material delay and will specify the revised delivery date as soon as practicable. UNDER NO CIRCUMSTANCES SHALL SELLER HAVE ANY LIABILITY WHATSOEVER FOR LOSS OF USE OR FOR ANY DIRECT OR CONSEQUENTIAL DAMAGES RESULTING FROM DELAY REGARDLESS OF THE REASON(S).

All product(s) will be shipped F.O.B. point of origin, unless specifically agreed otherwise, and Buyer shall pay all shipping costs and insurance costs from that point. Seller, in its sole discretion, will determine and arrange the means and manner of transportation of the product(s). Buyer shall bear all risk of loss commencing with the shipment or distribution of the product(s) from Seller's warehouse. Order shortages or errors must be reported within fifteen (15) business days from receipt of shipment to secure adjustment. No product(s) may be returned without securing written approval from Seller.

5. Modification. These Terms and Conditions are intended by Seller and Buyer to constitute a final, complete and exclusive expression of agreement relating to the subject matter hereof and cannot be supplemented or amended without Seller's prior written approval.

6. Omission. Seller's waiver of any breach or Seller's failure to enforce any of these Terms and Conditions at any time, shall not in any way affect, limit or waive Seller's right thereafter to enforce and compel strict compliance with every term and condition hereof.

7. Severability. If any provision of these Terms and Conditions is held to be invalid or unenforceable, such invalidity or unenforceability shall not affect the validity or enforceability of the other portions hereof.

8. Disputes. Seller and Buyer shall attempt in good faith to promptly resolve any dispute arising under these Terms and Conditions by negotiations between representatives who have authority to settle the controversy. If unsuccessful, Seller and Buyer shall further attempt in good faith to settle the dispute by nonbinding third-party mediation, with fees and expenses of such mediation apportioned equally to each side. Any dispute not so resolved by negotiation or mediation may then be submitted to a court of competent jurisdiction in accordance with the terms hereof. These procedures are the exclusive procedures for the resolution of all such disputes between the Seller and Buyer.

9. Governing Law. All sales, agreements for sale, offers to sell, proposals, acknowledgments and contracts of sale, including, but not limited to, purchase orders accepted by Seller, shall be considered a contract under the laws of the State of Colorado and the rights and duties of all persons, and the construction and effect of all provisions hereof shall be governed by and construed according to the laws of such state.

10. Jurisdiction and Venue. Seller and Buyer agree that the state or federal courts located within the City and County of Denver, Colorado shall have sole and exclusive jurisdiction over any litigation concerning any dispute arising under these Terms and Conditions not otherwise resolved pursuant to Section 9 as well as any alleged defects of any Products or damages sustained as a result of such alleged defects. Seller and Buyer further agree that should any litigation be commenced in connection with such a dispute, it shall only be commenced in such courts. Seller and Buyer agree to the exclusive jurisdiction of such courts and neither will raise any objection to the jurisdiction and venue of such courts, including as a result of inconvenience.

11. Attorney's Fees. If any litigation is commenced between Seller and Buyer, or their personal representatives, concerning any provision hereof, the party prevailing in the litigation shall be entitled, in addition to such other relief that is granted, to a reasonable sum as and for their attorneys' fees and costs in such litigation or mediation.

STONEAGE TRADEMARK LIST

View the list of StoneAge's trademarks and service marks and learn how the trademarks should be used. Use of StoneAge trademarks may be prohibited, unless expressly authorized.

<http://www.StoneAgetools.com/trademark-list/>

STONEAGE PATENT DATA

View the list of StoneAge's current U.S. patent numbers and descriptions.

<http://www.sapatents.com>

STONEAGE TERMS AND WARRANTY

View StoneAge's Terms and Warranty Conditions online.

<http://www.stoneagetools.com/terms>

<http://www.stoneagetools.com/warranty>

Warranties set forth herein extend only to End-Users, meaning customers acquiring, or that have previously acquired, a product manufactured by StoneAge ("Product") for their own use and not for resale, either directly from StoneAge Inc. ("StoneAge") or from a StoneAge Authorized Dealer or Reseller ("Dealer"). No warranty of any kind or nature is made by StoneAge beyond those expressly stated herein.

1. LIMITED WARRANTY PERIOD. Subject to the limitations and conditions hereinafter set forth, StoneAge warrants its Product to be free from defects in workmanship and material for a period of one (1) year from the date of purchase by the End-User, provided that the end of the limited warranty period shall not be later than eighteen (18) months from the date of shipment of the Product to the Dealer or the End-User by StoneAge ("Limited Warranty Period"). All replacement parts which are furnished under this Limited Warranty and properly installed shall be warranted to the same extent as the original Product under this Limited Warranty if, and only if, the original parts were found to be defective within the original Limited Warranty Period covering the original Product. Replacement parts are warranted for the remainder of the original Limited Warranty Period. This Limited Warranty does not cover any component part of any Product not manufactured by StoneAge. Any such component part is subject exclusively to the component manufacturer's warranty terms and conditions.

2. LIMITED WARRANTY COVERAGE. StoneAge's sole obligation under this Limited Warranty shall be, at StoneAge's option and upon StoneAge's inspection, to repair, replace or issue a credit for any Product which is determined by StoneAge to be defective in material or workmanship. StoneAge reserves the right to examine the alleged defective Product to determine whether this Limited Warranty is applicable, and final determination of limited warranty coverage lies solely with StoneAge. No statement or recommendation made by a StoneAge representative, Dealer or agent to End-User shall constitute a warranty by StoneAge or a waiver or modification to any of the provisions hereof or create any liability for StoneAge.

3. WARRANTY SERVICE PROVIDERS. Service and repair of the Product is to be performed only by StoneAge authorized service representatives, including Dealers who are authorized repair centers, with StoneAge approved parts. Information about StoneAge authorized service representatives can be obtained through the StoneAge website at www.stoneagetools.com/ service. Unauthorized service, repair or modification of the Product or use of parts not approved by StoneAge will void this Limited Warranty. StoneAge reserves the right to change or improve the material and design of the Product at any time without notice to End-User, and StoneAge is not obligated to make the same improvements during warranty service to any Product previously manufactured.

4. WARRANTY EXCLUSIONS. This Limited Warranty does not cover, and StoneAge shall not be responsible for the following, or damage caused by the following: (1) any Product that has been altered or modified in any way not approved by StoneAge in advance in writing; (2) any Product that has been operated under more severe conditions or beyond the rated capacity specified for that Product; (3) depreciation or damage caused by normal wear and tear, failure to follow operation or installation instructions, misuse, negligence or lack of proper protection during storage; (4) exposure to fire, moisture, water intrusion, electrical stress, insects, explosions, extraordinary weather and/or environmental conditions including, but not limited to lightning, natural disasters, storms, windstorms, hail, earthquakes, acts of God or any other force majeure event; (5) damage to any Product caused by any attempt to repair, replace, or service the Product by persons other than StoneAge authorized service representatives; (6) costs of normal maintenance parts and services; (7) damage sustained during unloading, shipment or transit of the Product; or (8) failure to perform the recommended periodic maintenance procedures listed in the Operator's Manual accompanying the Product.

5. REQUIRED WARRANTY PROCEDURES. To be eligible for warranty service, the End-User must: (1) report the Product defect to the entity where the Product was purchased (i.e. StoneAge or the Dealer) within the Limited Warranty Period specified in this Limited Warranty; (2) submit the original invoice to establish ownership and date of purchase; and (3) make the Product available to a StoneAge authorized service representative for inspection to

determine eligibility for coverage under this Limited Warranty. This Limited Warranty shall not extend to any person or entity who fails to provide proof of original purchase from StoneAge or a Dealer. No Product may be returned for credit or adjustment without prior written permission from StoneAge.

6. DISCLAIMER OF IMPLIED WARRANTIES AND OTHER REMEDIES. EXCEPT AS EXPRESSLY STATED HEREIN (AND TO THE FULLEST EXTENT ALLOWED UNDER APPLICABLE LAW), STONEAGE HEREBY DISCLAIMS ALL OTHER WARRANTIES, EXPRESS OR IMPLIED, INCLUDING WITHOUT LIMITATION ALL IMPLIED WARRANTIES OF MERCHANTABILITY OR FITNESS FOR A PARTICULAR PURPOSE, AND ANY AND ALL WARRANTIES, REPRESENTATIONS OR PROMISES AS TO THE QUALITY, PERFORMANCE OR FREEDOM FROM DEFECT OF THE PRODUCT COVERED BY THIS LIMITED WARRANTY. STONEAGE FURTHER DISCLAIMS ALL IMPLIED INDEMNITIES.

7. LIMITATION OF LIABILITY. End-User specifically acknowledges that the Product may be operated at high speeds and/or pressures, and that as such it may be inherently dangerous if not used correctly. End-User shall familiarize itself with all operation materials provided by StoneAge and shall at all times use and require its agents, employees and contractors to use all necessary and appropriate safety devices, guards and proper safe operating procedures. In no event shall StoneAge be responsible for any injuries to persons or property caused directly or indirectly by the operation of the Product if End-User or any agent, employee, or contractor of End-User: (1) fails to use all necessary and appropriate safety devices, guards and proper safe operating procedures; (2) fails to maintain in good working order such safety devices and guards; (3) alters or modifies the Product in any way not approved by StoneAge in advance in writing; (4) allows the Product to be operated under more severe conditions or beyond the rated capacity specified for the Product; or (5) otherwise negligently operates the Product. End-User shall indemnify and hold StoneAge harmless from any and all liability or obligation incurred by or against StoneAge, including costs and attorneys' fees, to or by any person so injured.

TO THE FULL EXTENT ALLOWED BY APPLICABLE LAW, STONEAGE SHALL NOT BE LIABLE FOR ANY INDIRECT, SPECIAL, INCIDENTAL, CONSEQUENTIAL, OR PUNITIVE DAMAGES (INCLUDING WITHOUT LIMITATION, LOSS OF PROFITS, LOSS OF GOODWILL, DIMINUTION OF VALUE, WORK STOPPAGE, INTERRUPTION OF BUSINESS, RENTAL OF SUBSTITUTE PRODUCT, OR OTHER COMMERCIAL LOSS EVEN TO THE EXTENT SUCH DAMAGES WOULD CONSTITUTE DIRECT DAMAGES), WITH RESPECT TO THE COVERED STONEAGE PRODUCT, OR OTHERWISE IN CONNECTION WITH THIS LIMITED WARRANTY, REGARDLESS OF WHETHER STONEAGE HAS BEEN ADVISED OF THE POSSIBILITY OF SUCH DAMAGES.

IT IS UNDERSTOOD THAT STONEAGE'S LIABILITY, WHETHER IN CONTRACT, IN TORT, UNDER ANY WARRANTY, IN NEGLIGENCE, OR OTHERWISE SHALL NOT EXCEED THE AMOUNT OF THE PURCHASE PRICE PAID BY THE END-USER FOR THE PRODUCT. STONEAGE'S MAXIMUM LIABILITY SHALL NOT EXCEED, AND END-USER'S REMEDY IS LIMITED TO EITHER (1) REPAIR OR REPLACEMENT OF THE DEFECTIVE WORKMANSHIP OR MATERIAL OR, AT STONEAGE'S OPTION, (2) REFUND OF THE PURCHASE PRICE, OR (3) ISSUANCE OF A CREDIT FOR THE PURCHASE PRICE, AND SUCH REMEDIES SHALL BE END-USER'S ENTIRE AND EXCLUSIVE REMEDY.

YOU, THE END-USER, UNDERSTAND AND EXPRESSLY AGREE THAT THE FOREGOING LIMITATIONS ON LIABILITY ARE PART OF THE CONSIDERATION IN THE PRICE OF THE STONEAGE PRODUCT YOU PURCHASED.

Some jurisdictions do not allow the limitation or exclusion of liability for certain damages, so the above limitations and exclusions may not apply to you. This Limited Warranty gives you specific legal rights, and you may also have other rights which vary from jurisdiction to jurisdiction. If any provisions of this Limited Warranty is held to be invalid or unenforceable, such invalidity or unenforceability shall not affect the validity or enforceability of the other portions hereof.



1-866-795-1586 • www.STONEAGETOOLS.com

© 2014 StoneAge, Inc. All Rights Reserved