

# The BattIR Project

*Since the author has no control over the quality or skill level of the persons building up this project, there needs to be the following disclaimer.*

*The software is provided "As Is" with the author not being responsible for any claim, damages or similar issues on the use of this project.*

## HOW IT WORKS

The BattIR project uses 14 electronic relays to connect each battery cell in succession to the same PicChip A/D input. This way there is no variation in the PicChip between different A/D inputs since only one PicChip channel is used.

So far, 31 BattIR meters have been built, all work very well. (I did miss a solder joint on one meter)

A precision 0.2% Voltage reference, part U2 has been added to the original design in order to improve basic DC voltage accuracy, as compared to the original BattIR meters.

In addition, each cell voltage is read 10 times, and an average is taken of those voltage readings. .

The multiple cell voltage readings eliminates voltage "jitter" on the last digit of the four digit display of the battery voltage. Tests on the three prototypes shows that the voltage read out is accurate to around 0.3% on voltages between 2.5 VDC and 4.5 VDC as compared to my Fluke 87V meter while using its Hi Res feature. These units should hold plus/minus 1% on the measured cell voltages.

The BattIR meter first connects a 5 Ohm 1% resistor across the battery pack, then reads and saves the individual cell voltage readings to the first table. Next, it connects a 2.00 Ohm 1% resistor to the battery pack, and reads and saves the individual voltage readings to a second table.

Last, the BattIR meter applies both the 5.00 and 2.00 Ohm resistors in parallel to the battery pack, and again reads and saves the voltage readings to a third table.

The individual cell IR calculation is:

**IR = (Volts Low Amps- Volts Hi Amps)**

**Divided by (High Amps - Low Amps)**

The first and third voltage readings are used to calculate the individual cell IR values and displays them to the LCD display.

Example, a cell measuring 3.71 Volts at 4.45 Amps and measuring 3.58 Volts at 15.1 Amps would have a cell resistance of 12.2 MilliOhms. This meter has a maximum of 999 MilliOhms range.

The software also has commands to preset the batteries Mah rating and uses the Mah rating to calculate the maximum safe current for the battery.

Credit must be given to Forsyth, Julian, and Giles for their work in testing countless LiPo batteries, and coming up with the formula that is used to calculate the maximum safe current for the given LiPo or LiFe/A123 battery pack. These names are included on the BattIR LCD display.

Last but not least, the test currents that are applied to the battery pack are derived by the batteries voltage divided by the resistance of the power resistors.

If the 1% 5 ohm and 2 ohm power resistors are not available, 5% units can be substituted with a slight loss of IR accuracy.

One feature of this setup is that the 5, 6 or 7 cell packs will pull higher test currents through the power resistors, compared to much lower test currents that occur with the 1, 2 or 3 cell LiPo packs.

As a result, those usually smaller 2 cell 200 Mah battery packs are tested at current levels of around 5 Amps, compared to the test current of around 15 Amps for the higher voltage big battery packs.

This meter also has the capability of displaying the individual cell voltage of the battery pack on each of the load currents applied to the pack. It can also display all cell voltages while connected to an ESC and motor under full power as an example.

## Time to start the project! (Equipment Needed)

This project uses a number of surface mounted resistors in its design. Surface mounted resistors might be a bit scary for someone that has not worked with them. But, with a bit of practice, assembly of a project like this goes much faster than through hole resistors.

Note the required equipment in the photo at right that will be used to build up the circuit board. An old cookie sheet will aid in finding any surface mounted parts accidentally dropped. For older folks, a magnifying visor helps a lot. Then a needle pointed soldering iron is used along with tweezers to place and solder the components. I use 0.040 sized rosin cored solder for these type projects.

What I've learned over the years, is to place a

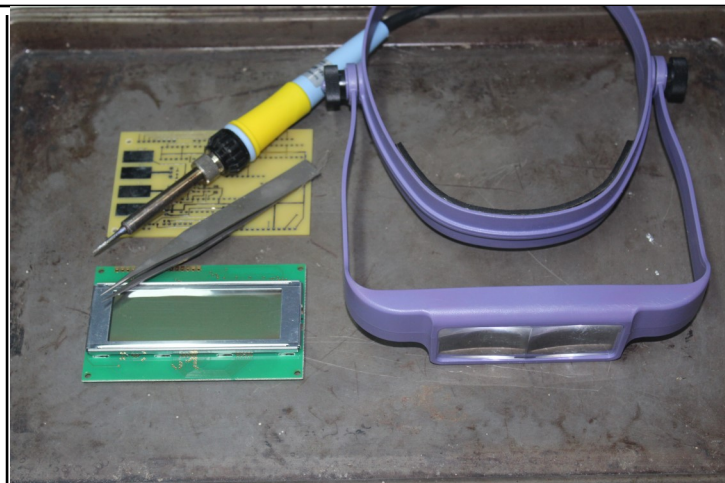

tiny bit of solder on ONE of the pads of the resistor as an example.

Then, place the iron on that bit of solder, and, using the tweezers, “slide” the surface mounted resistor into that tiny bit of solder. Wait for the solder to cool off, then solder the other end of the resistor. This takes longer to describe than actually doing it.

At the right is the components as received from [www.digikey.com](http://www.digikey.com). All components are placed in individual bags, properly marked with component type and value.

Order extra resistors and capacitors. Most 10 parts for under 50 cents.

These correspond with the parts list that is part of the [www.expresspcb.com](http://www.expresspcb.com) schematic that is included along with the PCB layout that can be downloaded from [github](https://github.com).



## Install the electronic relays

Next, insert each of the 16 electronic relays into the circuit board. Be careful to not have any of the relay pins bent under the relay, rather than going into their respective holes. Also, pay attention to the small dot on these relays showing which is pin #1. Next, install and solder up the resistor networks that are used with the electronic relays.

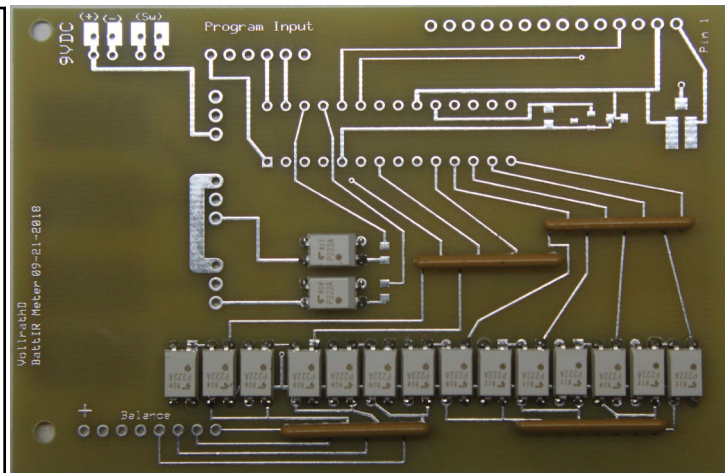

## Install the 0.2% voltage reference

with its associated resistor and capacitor. Next, install the potentiometer that is used to set the LCD display Contrast.

Note the PCB layout on the voltage reference has been changed. The author placed the circuit board order through [www.expresspcb.com](http://www.expresspcb.com). This web site repeatedly warns to verify that the proper PCB layout is attached.

And, of course, I didn't include the proper layout! The PCB layout plans in this project has the corrected circuit board layout.

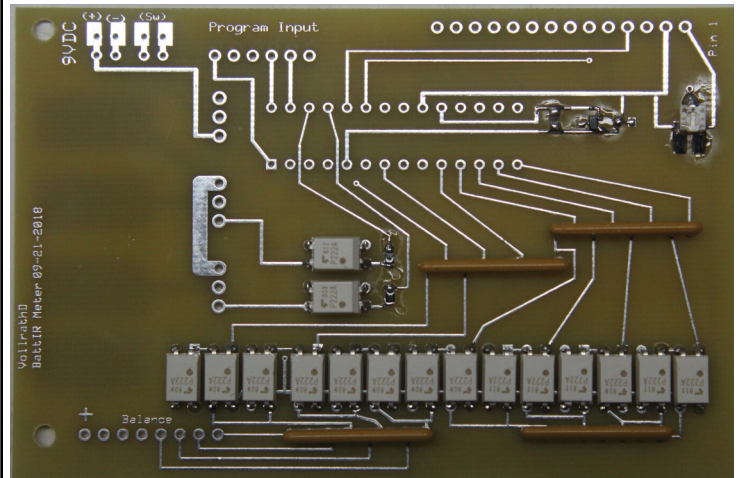

## Install The Microcontroller

Here we install the microcontroller, along with the 5 Volt regulator that powers the project, along with the two MosFets that are used to connect the battery under test to the load resistors.

Be very careful not to fold any of the microcontroller pins under the chip. If this happens it will be difficult to fix after the chip is soldered. Again, be aware of the location of the dot on the microcontroller, it should be located to the bottom left on the photo. (The PCB Pin#1 hole

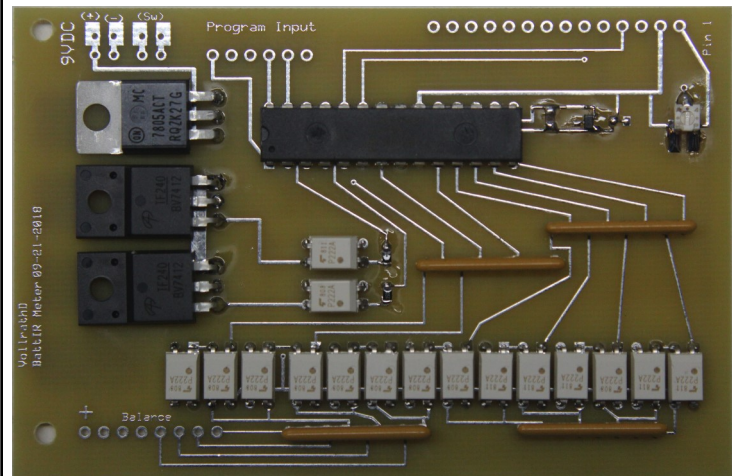

## Install the surface mounted parts on the back of the PCB

Time to install the parts on the back of the PCB, paying particular attention to the part number, part value, and location on the PCB.

***For those interested in this project, the author will make available a limited supply of the circuit board plus the programmed microcontroller for 20% over cost of the two items, plus shipping cost, USA only.***

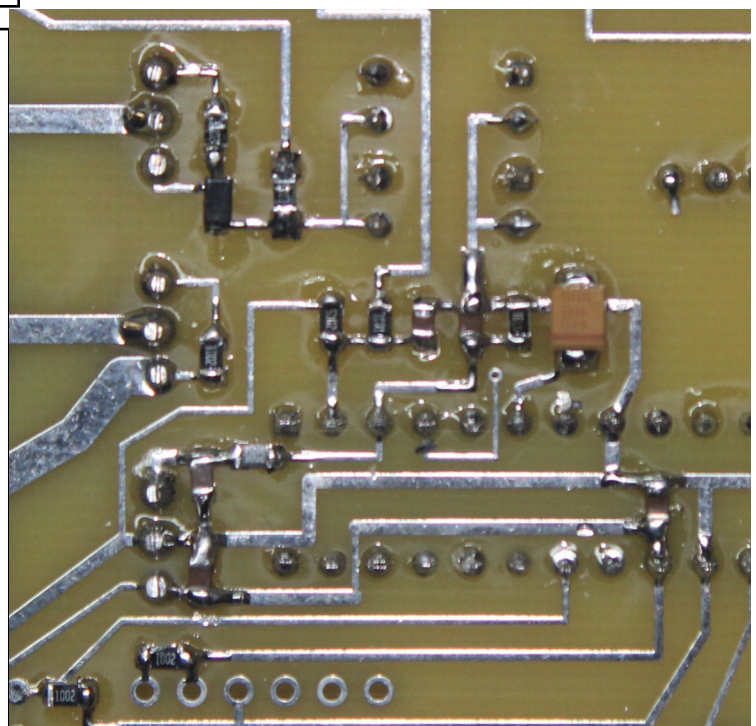

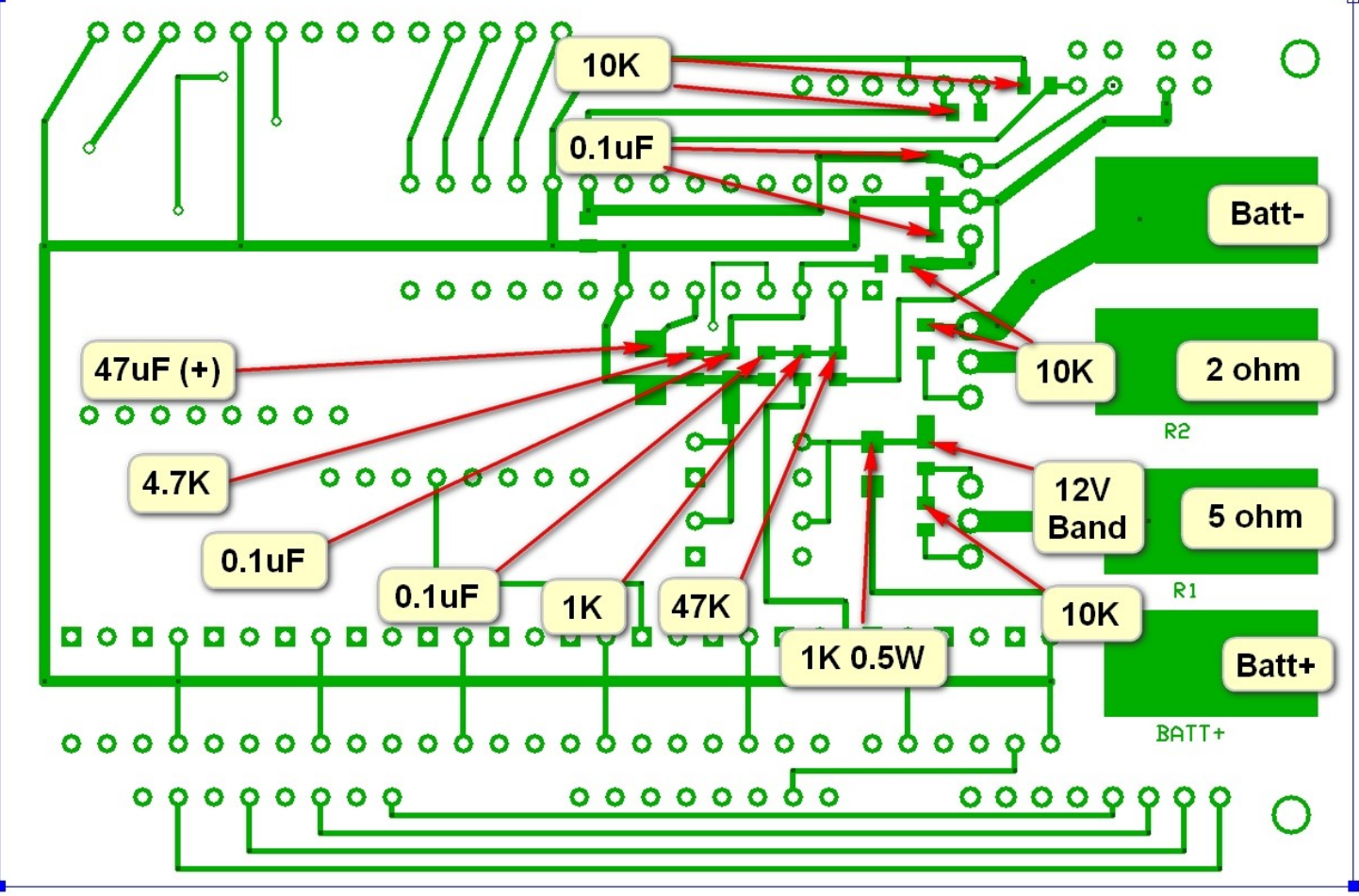
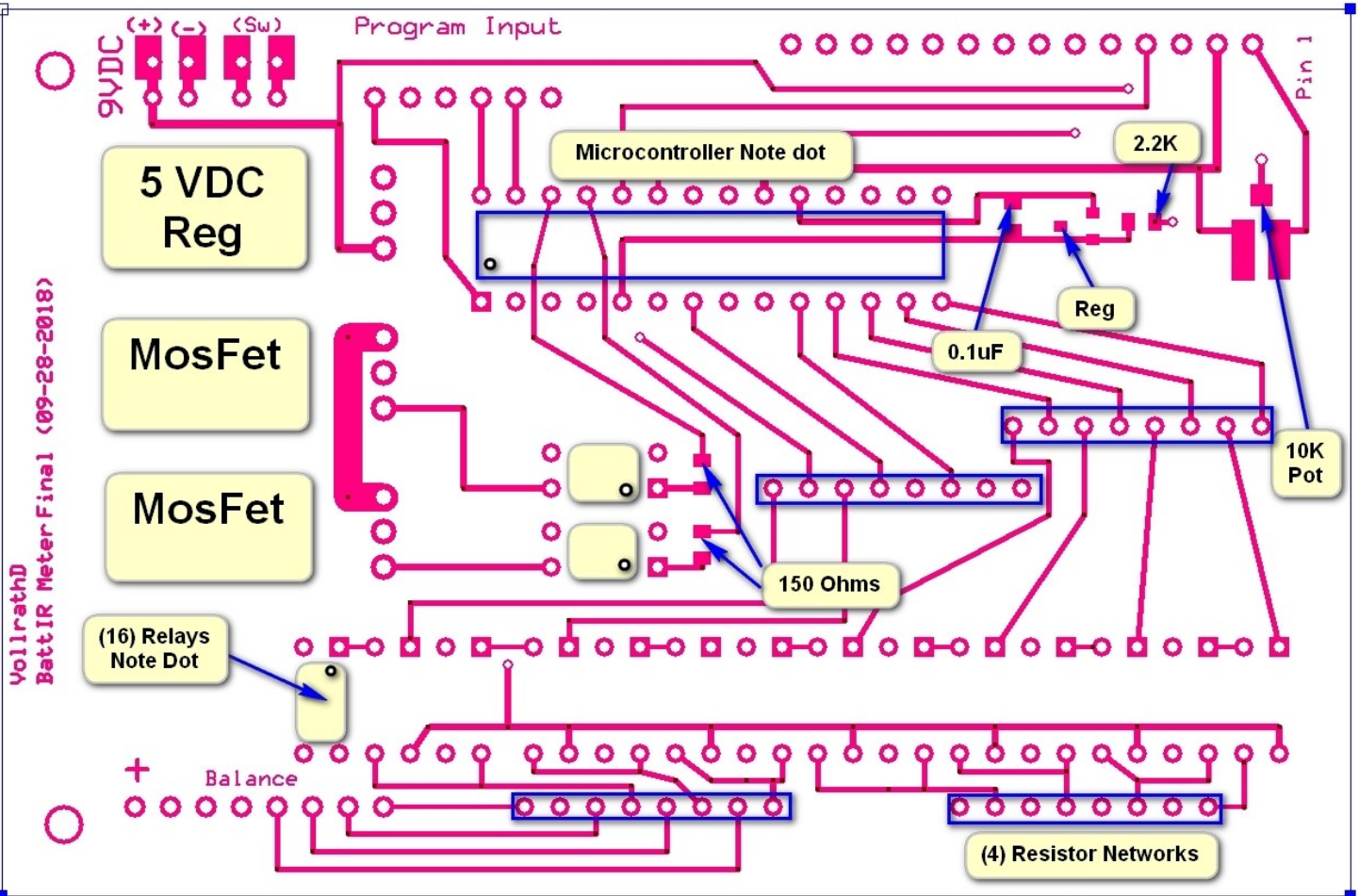

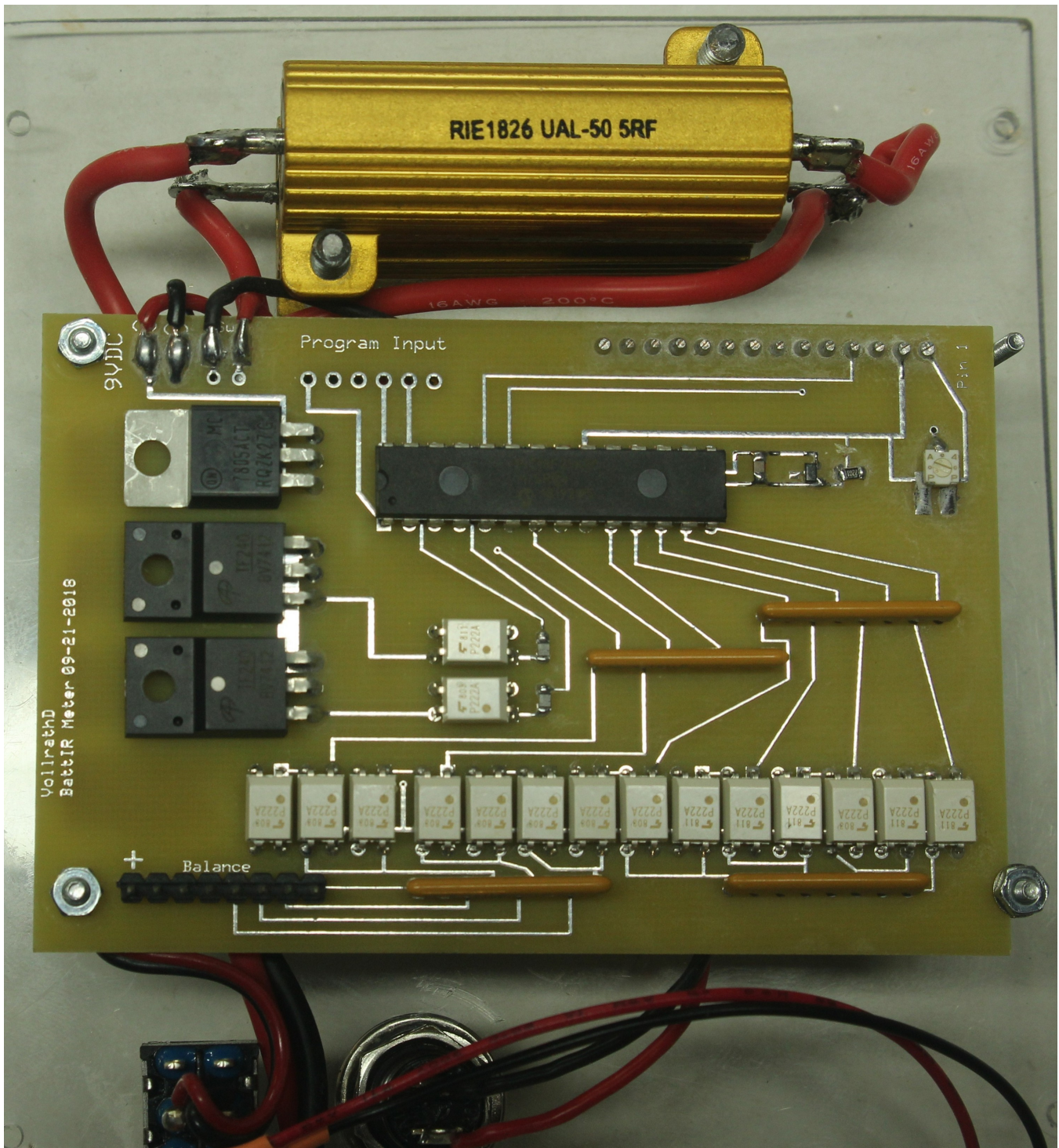

The final project as installed on a piece of Luan sheet found at the local lumberyard.

The PCB is mounted along with the LCD display by four one inch long 2-56 screws, along with nuts and washers. Note that the PCB is slightly smaller than the LCD display, requiring the bottom right screw holding the PCB with a couple of washers.

The power resistor mounting brackets were

tapped and installed with 6-32 screws. The flat pads on the PCB are used to connect the #16 wire for the power test lead to the battery under test, along with connections to the two power resistors.

When first powered up, the LCD display will be blank. The top right potentiometer must be turned counter clockwise until the LCD display properly displays the information.

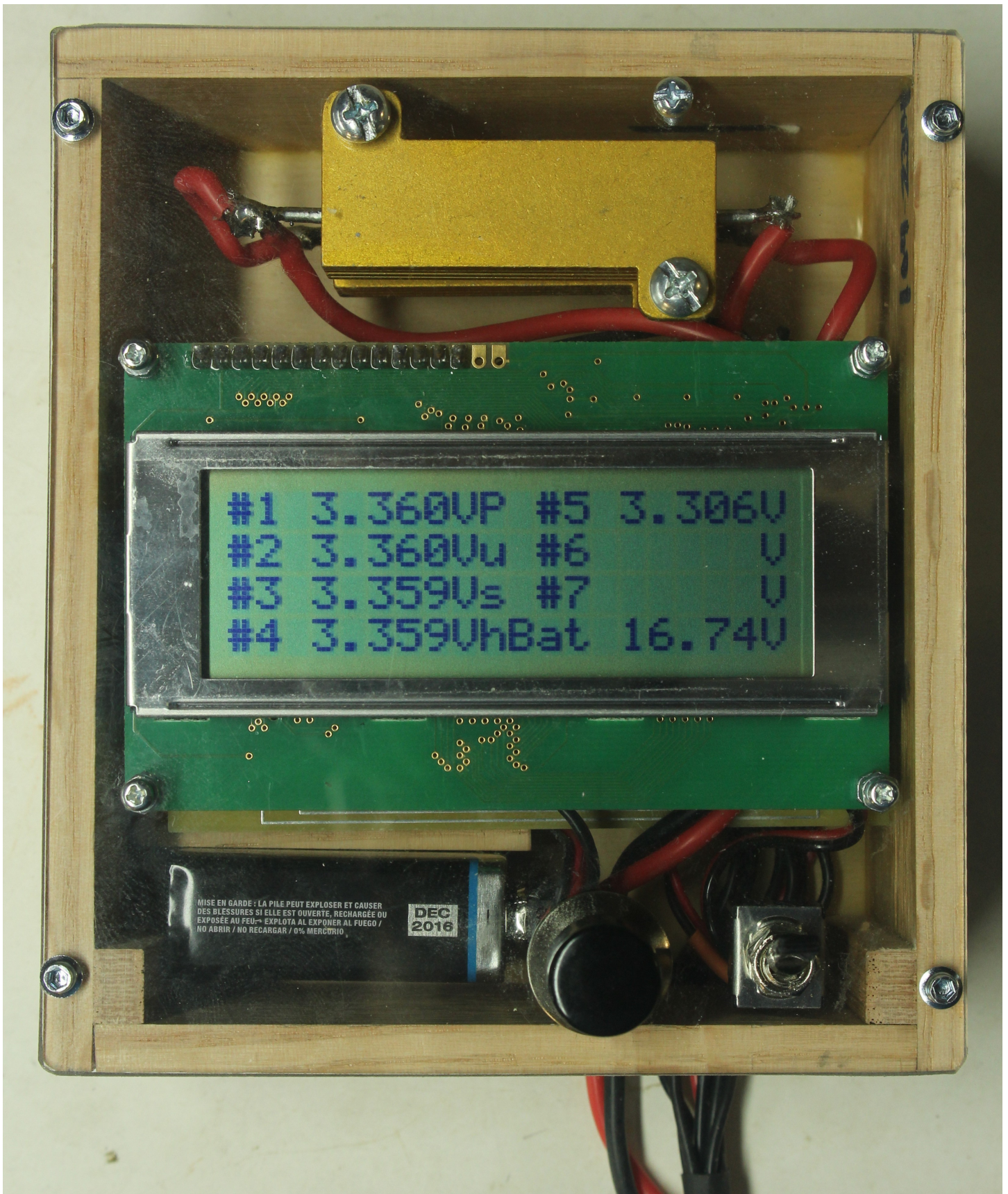

**The final project.** The case was built up from some 1/4 by 2 inch Oak trim pieces from the local lumber yard. This project will also fit into a commercial 6X4X2 plastic project box available from many sources.