

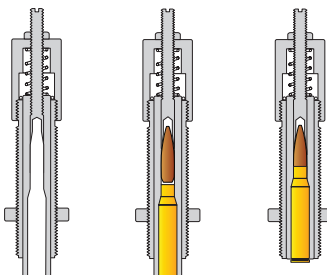

Bench Rest® Seater Dies

Individual Dies

Bench Rest Reloading Die	Features	Reloader Experience Level
Seater Dies		
Seater Die 	<ul style="list-style-type: none"> Our innovative, caliber-specific sliding die chamber holds the bullet, case and seating stem in perfect alignment while the bullet is seated. Available individually or as a set with a Full Length Sizing Die. Non-crimping style provides accuracy, consistency, and virtually flawless alignment. 	 <p style="text-align: center; font-size: small;">*Bench Rest Seater Die is shown.</p>
Ultra Micrometer Seater Die 	<ul style="list-style-type: none"> Our innovative, caliber-specific sliding Die chamber holds the bullet, case and seating stem in perfect alignment while the bullet is seated. Micrometer fine tunes your precise seating depth requirements. Use if you like to experiment with various bullets and loads for many different shooting applications. Non-crimping style provides accuracy, consistency and virtually flawless alignment. 	

Introducing our Bench Rest Die Set

One Full Length Sizing Die and one Bench Rest Seater Die



For every rifle caliber you own, we recommend that you have a Full Length Sizing Die and a Bench Rest Seater Die. The Bench Rest Die Set includes one Full Length Sizing Die and one Bench Rest Seater Die, all packaged in our Deluxe Die Box. See listings on pages 6-7.

Custom Machining Services



We can manufacture custom versions of any of five Reloading Dies to your specifications.



310 East Lanark Avenue
Lanark, Illinois 61046
P: 815-493-6360 • F: 815-493-2371
forsterproducts.com

WARRANTY

All Forster Products are warranted against defects in materials and workmanship for the life of the product. Parts which, by nature of their function, are subject to normal wear (such as springs, pins, etc.) and parts which have been altered, abused or neglected, are excluded from the warranty. If the product is deemed defective by workmanship or materials, it will be repaired, reconditioned or replaced (at Forster's option). This warranty supersedes all other warranties for Forster Products whether written or oral.

ISO 9001: 2008 accredited

HG0001 Issue 2, August 2016