

**INSTRUCTION
MANUAL**

**DURA-TRAK 90A SERIES
CARTRIDGE MACHINES**

December, 1993

IM No. 597-9100-001

BROADCAST ELECTRONICS, INC.



IMPORTANT INFORMATION

EQUIPMENT LOST OR DAMAGED IN TRANSIT

When delivering the equipment to you, the truck driver or carrier's agent will present a receipt for your signature. Do not sign it until you have (a) inspected the containers for visible signs of damage and (b) counted the containers and compared with the amount shown on the shipping papers. If a shortage or evidence of damage is noted, insist that notation to that effect be made on the shipping papers before you sign them.

Further, after receiving the equipment, unpack it and inspect thoroughly for concealed damage. If concealed damage is discovered, immediately notify the carrier, confirming the notification in writing, and secure an inspection report. This item should be unpacked and inspected for damage WITHIN 15 DAYS after receipt. Claims for loss or damage will not be honored without proper notification of inspection by the carrier.

TECHNICAL ASSISTANCE AND REPAIR SERVICE

Technical assistance is available from Broadcast Electronics by letter or prepaid telephone or telegram. Equipment requiring repair or overhaul should be sent by common carrier, prepaid, insured and well protected. Do not mail equipment. We can assume no liability for inbound damage, and necessary repairs become the obligation of the shipper. Prior arrangement is necessary. Contact Customer Service Department for a Return Authorization.

FOR TECHNICAL ASSISTANCE

Phone (217) 224-9600 Customer Service

WARRANTY ADJUSTMENT

Broadcast Electronics, Inc. warranty is included in the Terms and Conditions of Sale. In the event of a warranty claim, replacement or repair parts will be supplied F.O.B. factory. At the discretion of Broadcast Electronics, the customer may be required to return the defective part or equipment to Broadcast Electronics, Inc. F.O.B. Quincy, Illinois. Warranty replacements of defective merchandise will be billed to your account. This billing will be cleared by a credit issued upon return of the defective item.

RETURN, REPAIR AND EXCHANGES

Do not return any merchandise without our written approval and Return Authorization. We will provide special shipping instructions and a code number that will assure proper handling and prompt issuance of credit. Please furnish complete details as to circumstances and reasons when requesting return of merchandise. All returned merchandise must be sent freight prepaid and properly insured by the customer.

REPLACEMENT PARTS

Emergency and Warranty Replacement Parts may be ordered from the address below. Be sure to include equipment model and serial number and part description and part number. Non-Emergency Replacement Parts may be ordered directly from the Broadcast Electronics stock room by Fax at the number shown below.

EMERGENCY AND WARRANTY REPLACEMENT PARTS

Broadcast Electronics, Inc.
4100 N. 24th St., P.O. Box 3606
Quincy, Illinois 62305
Tel: (217) 224-9600
Telex: 25-0142
Fax: (217) 224-9607

NON-EMERGENCY REPLACEMENT PARTS

Fax: (217) 224-9609

PROPRIETARY NOTICE

This document contains proprietary data of Broadcast Electronics, Inc. No disclosure, reproduction, or use of any part thereof may be made except by prior written permission.

MODIFICATIONS

Broadcast Electronics, Inc. reserves the right to modify the design and specifications of the equipment in this manual without notice. Any modifications shall not adversely affect performance of the equipment so modified.

TECHNICAL MANUAL

BROADCAST ELECTRONICS

DURA-TRAK 90A SERIES

TAPE CARTRIDGE MACHINES

597-9100-001

© Broadcast Electronics 1990
ALL RIGHTS RESERVED
Printed in the U.S.A.

GENERAL INFORMATION	1
INSTALLATION	2
OPERATION	3
THEORY OF OPERATION	4
MAINTENANCE	5
PARTS LISTS AND DRAWINGS	6

TECHNICAL MANUAL

BROADCAST ELECTRONICS, INC.

DURA-TRAK 90A SERIES CARTRIDGE MACHINES



DT-90A RECORD/PLAYBACK

DT-90A PLAYBACK

MODEL	PART NO.	DESCRIPTION
DT-90AP	900-9100-001	Single-Deck Monophonic Playback Cartridge Machine with Primary, Secondary, and Tertiary Detection Circuitry. NAB A or AA Cartridge Operation, 117V ac 50/60 Hz Power Supply.
DT-90AP	900-9100-301	Single-Deck Monophonic Playback Cartridge Machine with Primary, Secondary, and Tertiary Detection Circuitry. NAB A or AA Cartridge Operation, 220V ac 50/60 Hz Power Supply.
DT-90ARP	900-9101-001	Single-Deck Monophonic Record/Playback Cartridge Machine with Primary, Secondary, and Tertiary Detection Circuitry. NAB A or AA Cartridge Operation, 117V ac 50/60 Hz Power Supply.
DT-90ARP	900-9101-301	Single-Deck Monophonic Record/Playback Cartridge Machine with Primary, Secondary, and Tertiary Detection Circuitry. NAB A or AA Cartridge Operation, 220V ac 50/60 Hz Power Supply.
DT-90APS	900-9102-001	Single-Deck Stereophonic Playback Cartridge Machine with Primary, Secondary, and Tertiary Detection Circuitry. NAB A or AA Cartridge Operation, 117V ac 50/60 Hz Power Supply.
DT-90APS	900-9102-301	Single-Deck Stereophonic Playback Cartridge Machine with Primary, Secondary, and Tertiary Detection Circuitry. NAB A or AA Cartridge Operation, 220V ac 50/60 Hz Power Supply.

- DT-90ARPS 900-9103-001 Single-Deck Stereophonic Record/Playback Cartridge Machine with Primary, Secondary, and Tertiary Detection Circuitry. NAB A or AA Cartridge Operation, 117V ac 50/60 Hz Power Supply.
- DT-90ARPS 900-9103-301 Single-Deck Stereophonic Record/Playback Cartridge Machine with Primary, Secondary, and Tertiary Detection Circuitry. NAB A or AA Cartridge Operation, 220V ac 50/60 Hz Power Supply.

TABLE OF CONTENTS

PARAGRAPH		PAGE NO.
SECTION I		
GENERAL INFORMATION		
1-1	Introduction	1-1
1-3	Equipment Description	1-1
1-5	Electrical Description	1-1
1-8	Mechanical Description	1-1
1-11	Options and Accessories	1-1
1-13	Equipment Specifications	1-1
SECTION II		
INSTALLATION		
2-1	Introduction	2-1
2-3	Unpacking	2-1
2-6	Installation	2-1
2-7	Placement	2-1
2-9	DT-90A Circuit Board Programming	2-1
2-11	Start Lock-Out and Stop Indicator Flasher Operation	2-1
2-12	Automatic Fast Forward Operation	2-2
2-13	Primary Cue Tone Operation	2-2
2-14	EOM Mute Operation	2-2
2-15	Automatic Fast Forward/Record Drop-Out Jumper	2-2
2-16	VU Meter Operation	2-2
2-17	Motor Speed	2-3
2-18	Audio Interfacing	2-3
2-19	Audio Output Connections	2-3
2-20	Record Input Connections	2-3
2-21	Remote Functions	2-3
2-23	Playback Remote Functions	2-4
2-33	Record Remote Functions	2-6
2-37	Automatic Audio Muting	2-7
2-39	Automatic Start Sequencing	2-7
2-41	Sequence	2-7
2-42	Motor Operation	2-8
2-44	Ground Connections	2-10
2-46	AC Power Connection	2-11
2-50	Electrical Adjustments	2-11
2-51	Audio Output Level Adjustment	2-11
2-52	Optional Equipment Installation	2-11
SECTION III		
OPERATION		
3-1	Introduction	3-1
3-3	Controls and Indicators	3-1
3-5	Operation	3-1
3-6	Playback Operation	3-1
3-12	Stop Indicator Flashing/Deck Start Lock-Out	3-5
3-14	Manual Fast Forward	3-5
3-15	Automatic Fast Forward	3-5

© Broadcast Electronics 1990
 ALL RIGHTS RESERVED
 Printed in the U.S.A.

PARAGRAPH		PAGE NO.
3-16	Terminating The Fast Forward Mode	3-5
3-17	Maintenance Mode Operation	3-5
3-18	Record Operation	3-5
3-19	Preliminary Set-Up	3-5
3-24	Record Level Adjustment	3-6
3-29	Recording Program Material	3-6
3-34	Secondary and Tertiary Cue Tone Recording	3-6
SECTION IV	THEORY OF OPERATION	
4-1	Introduction	4-1
4-3	Functional Description	4-1
4-4	Playback Circuitry	4-1
4-6	Audio Processing Circuits	4-1
4-14	Cue Tone Detection Circuits	4-2
4-23	Start/Stop Logic Circuit	4-2
4-34	Flasher Logic Circuit	4-7
4-39	Fast Forward Logic Circuit	4-8
4-47	Mute Logic Circuit	4-8
4-53	Solenoid and Power Supply Circuits	4-9
4-60	Motor Control Circuit Board	4-10
4-62	Reference Circuit	4-11
4-66	Tachometer Processing Circuit	4-11
4-67	Frequency Comparator Circuit	4-11
4-70	Motor Driver Circuit	4-12
4-71	Motor Protection Circuit	4-12
4-73	Motor Lock Detector Circuit	4-12
4-74	Motor Commutator Control Circuit	4-12
4-77	Vari-Speed Circuit	4-15
4-79	Power Supply Circuit	4-15
4-80	Record Circuitry	4-15
4-82	Record Audio Processing Circuits	4-15
4-88	Metering Circuits	4-19
4-92	Program Bias Circuit	4-19
4-96	Cue Bias Circuit	4-20
4-99	Cue Tone Generator Circuits	4-20
4-104	Record/Primary Cue Tone Logic Circuits	4-20
4-116	Secondary/Tertiary Cue Tone Logic Circuits	4-21
SECTION V	MAINTENANCE	
5-1	Introduction	5-1
5-3	Safety Considerations	5-1
5-5	First Level Maintenance	5-1
5-7	General	5-1
5-9	Electrical	5-1
5-11	Mechanical	5-1
5-14	Second Level Maintenance	5-2
5-17	Mechanical Adjustments	5-2
5-20	Motor Alignment Procedure	5-2
5-29	Pressure Roller Indentation Adjustment	5-4
5-36	Solenoid Response Adjustment	5-6
5-41	Head Adjustments	5-7
5-114	Electrical Adjustments	5-13

PARAGRAPH		PAGE NO.
5-117	Playback Adjustments	5-13
5-118	Output Level Adjustment	5-13
5-127	Playback Equalization Adjustment	5-14
5-137	Cue Tone Detection Adjustment	5-15
5-149	Motor Drive-Pulse Adjustment	5-15
5-158	Record Adjustments	5-17
5-159	Record Equalization	5-17
5-174	Program Bias Level Adjustment	5-18
5-184	Cue Bias Level Adjustment	5-19
5-194	Cue Tone Record Level Adjustments	5-20
5-227	Meter Calibration	5-21
5-248	Mechanical Parts Replacement Procedures	5-22
5-251	Pressure Roller Replacement Procedure	5-23
5-257	Head Replacement	5-23
5-266	Motor Replacement	5-23
5-276	Conversion Kit Installation	5-24
5-278	Front-Panel Disassembly	5-24
5-287	Circuit Board Installation	5-25
5-290	Record Head Installation	5-25
5-302	Troubleshooting	5-26
5-306	Component Replacement	5-26
5-312	Integrated Circuits	5-31

SECTION VI PARTS LISTS AND DRAWINGS

6-1	Introduction	6-1
-----	--------------	-----

LIST OF TABLES

TABLE NO.	DESCRIPTION	PAGE NO.
1-1	DT-90A Series Cartridge Machine Options and Accessories	1-2
1-2	DT-90A Series Cartridge Machine Specifications	1-3
3-1	Controls and Indicators	3-3
5-1	DT-90A Playback Logic Circuit Board Troubleshooting	5-27
5-2	DT-90A Record Logic Circuit Board Troubleshooting	5-28
6	Parts Lists and Drawings	6-1

LIST OF ILLUSTRATIONS

FIGURE NO.	DESCRIPTION	PAGE NO.
2-1	Playback Circuit Board Jumper Programming	2-2
2-2	Record Circuit Board Jumper Programming	2-3
2-3	Motor Control Circuit Board Jumper Programming	2-4
2-4	Playback Remote Control Receptacle Connections	2-5
2-5	Record Remote Control Receptacle Connections	2-6
2-6	Automatic Audio Muting	2-8
2-7	DT-90A Cartridge Machine Start Sequencing	2-9
2-8	Motor Operation	2-10
3-1	DT-90A Controls and Indicators	3-2
4-1	Playback Circuit Board Simplified Schematic	4-3
4-2	Power Supply and Solenoid Circuits	4-10
4-3	Motor Control Circuit Board Simplified Schematic	4-13
4-4	Record Circuit Board Simplified Schematic	4-16
5-1	Cartridge Deck Assembly	5-3
5-2	Motor Mounting Screws	5-4
5-3	Motor Alignment	5-5
5-4	Pressure Roller Indentation Adjustment	5-6
5-5	Head and Tape Guide Adjustments	5-8
5-6	Head Adjustment Controls	5-9
5-7	Height Cartridge Tape Tracking	5-10
5-8	Stereophonic Phase Response Lissajous Patterns	5-12
5-9	Playback Logic Circuit Board Controls	5-14
5-10	Motor Control Circuit Board Control	5-16
5-11	Motor Drive-Pulse Duty Cycle	5-17
5-12	Record Logic Circuit Board Controls	5-18
5-13	Tape Head Configurations	5-24
5-14	Troubleshooting Tree, No Motor Operation	5-30

SECTION I

GENERAL INFORMATION

1-1. INTRODUCTION.

1-2. Information presented by this section provides a general description of the Broadcast Electronics DT-90A series cartridge machines and lists equipment specifications.

1-3. EQUIPMENT DESCRIPTION.

1-4. The Broadcast Electronics DT-90A series cartridge machines are professional single-deck playback and record/playback units designed for continuous operation. The DT-90A series includes monophonic and stereophonic models equipped with secondary and tertiary cue tone detection circuitry. All models are designed to accept NAB A or AA size cartridges. A wide range of assemblies and accessories provide the flexibility required for any type of installation.

1-5. ELECTRICAL DESCRIPTION.

1-6. All DT-90A cartridge machines are equipped with a plug-in playback logic circuit board. The playback logic circuit board contains the deck control logic, audio amplifier circuitry, and the cue channel detection circuitry. NAB primary (1 kHz), secondary (150 Hz), and tertiary (8 kHz) cue tone detection is standard on all models. An automatic/manual fast forward feature is incorporated into the control logic design for rapid tape advance. The automatic fast forward circuitry can be defeated by a programmable jumper. A complete remote control system is incorporated into the circuitry for external manual control.

1-7. All DT-90A record/playback models are equipped with an additional plug-in record logic circuit board. The record logic circuit board contains the record amplifier and bias circuitry, the record control logic, and the cue tone generator circuitry. The front-panel circuit board contains the LED VU meter display(s) and record control switches.

1-8. MECHANICAL DESCRIPTION.

1-9. The cartridge machine deck is equipped with a cartridge guidance system, an air-damped solenoid, and the Broadcast Electronics PHASE LOK V head assembly. The cartridge guidance system is designed with spring-loaded components to channel and lock a cartridge into the proper play position. An air-damped solenoid provides a rapid response to start commands. The PHASE LOK V head assembly provides the tape heads with a secure and stable environment. The head assembly is designed to permit independent adjustment of the head height/zenith, and head azimuth.

1-10. The DT-90A series cartridge machine also features a direct-drive dc servo motor for precise tape movement. The motor is mounted to the half-inch thick rigid aluminum deck.

1-11. OPTIONS AND ACCESSORIES.

1-12. Refer to Table 1-1 for options and accessories available for the DT-90A series cartridge machines.

1-13. EQUIPMENT SPECIFICATIONS.

1-14. Refer to Table 1-2 for the electrical, mechanical, physical, and environmental specifications of the Broadcast Electronics DT-90A series cartridge machines.

TABLE 1-1. DT-90A SERIES CARTRIDGE MACHINE OPTIONS AND ACCESSORIES
(Sheet 1 of 2)

OPTIONS AND ACCESSORIES	PART NUMBER
CONVERSION KIT OPTIONS	
<p>MODEL DT-90A</p> <p>Description:</p> <p>The DT-90A conversion kit will convert a monophonic playback cartridge machine into a record/playback unit.</p>	970-0118
<p>MODEL DT-90A</p> <p>Description:</p> <p>The DT-90A conversion kit will convert a stereophonic playback cartridge machine into a record/playback unit.</p>	970-0119
TELEPHONE ANSWERING EQUIPMENT	
<p>MODEL PC-1 TELEPHONE INTERFACE.</p> <p>Description:</p> <p>The PC-1 telephone interface provides cartridge machine/telephone network communication. The unit answers incoming telephone calls and enables a cartridge machine for the purpose of transmitting a pre-recorded message.</p>	900-0010
RACK MOUNTING ACCESSORIES	
RACK MOUNT SHELF FOR EIA 19 INCH RACK, 7 INCH HEIGHT.	900-9013
1/3 RACK FILLER PANEL FOR 7 INCH RACK SHELF.	900-9014
SPARE PARTS KIT FOR DT-90A SERIES CARTRIDGE MACHINES.	970-0117
TEST EQUIPMENT	
50-PIN EXTENDER CIRCUIT BOARD AND CABLE ASSEMBLY, DT-90A PLAYBACK OR RECORD/PLAYBACK UNITS.	941-0017
TAPE HEAD AND TAPE GUIDE ALIGNMENT GAUGE KIT.	970-0102
MOTOR ALIGNMENT GAUGE KIT.	970-0103
CARTRIDGE MACHINE TEST TAPES:	
NAB Monophonic Reproduce Alignment Test Tape, 160 nWb/m.	800-1005-001
NAB Stereophonic Reproduce Alignment Test Tape, 160 nWb/m.	800-1005
NAB Cue Tone Calibration Cartridge	800-1095
Cut-Away Tape Alignment Test Cartridge	710-0132

**TABLE 1-1. DT-90A SERIES CARTRIDGE MACHINE OPTIONS AND ACCESSORIES
(Sheet 2 of 2)**

OPTIONS AND ACCESSORIES	PART NUMBER
<p>SPLICE-TRAK 90</p> <p>Description:</p> <p>The ST-90 provides high speed tape splice detection and tape erasing for A or AA sizes cartridges.</p>	<p>900-9120-000</p>

**TABLE 1-2. DT-90A SERIES CARTRIDGE MACHINE SPECIFICATIONS
(Sheet 1 of 3)**

PARAMETER	SPECIFICATIONS
<p>ELECTRICAL</p> <p>MOTOR</p> <p>TAPE SPEED</p> <p>TAPE SPEED ACCURACY</p> <p>TAPE TRANSPORT SYSTEM STOP TIME</p> <p>TAPE TRANSPORT SYSTEM START TIME</p> <p>WOW AND FLUTTER</p> <p>AUDIO OUTPUT IMPEDANCE</p> <p>AUDIO OUTPUT LEVEL</p> <p>AUDIO INPUT IMPEDANCE</p> <p>AUDIO INPUT LEVEL</p> <p>DISTORTION</p> <p>Record/Playback System</p> <p>Reproduce Amplifier</p>	<p>DC Servo.</p> <p>Programmable for 3.75 Inches/Second, 7.5 Inches/Second, or 15 Inches/Second operation. Factory programmed at 7.5 Inches/Second.</p> <p>±0.2%.</p> <p>80 msec Maximum at 7.5 Inches/Second Operation.</p> <p>120 msec or less with Minimum Damping.</p> <p>0.12% Maximum DIN. Referenced at 7.5 Inches/Second.</p> <p>75 Ohms, Source Impedance, 600 Ohms, Termination Impedance.</p> <p>-10 dBm to +10 dBm, Continuously Variable.</p> <p>Greater than 10 k Ohms, Balanced, Floating.</p> <p>-18 dBm to +20 dBm, Continuously Variable.</p> <p>1.5% or Less Total-Harmonic-Distortion. Reference: 1 kHz at 250 nWb/m.</p> <p>0.5% or Less Total-Harmonic-Distortion.</p>

**TABLE 1-2. DT-90A SERIES CARTRIDGE MACHINE SPECIFICATIONS
(Sheet 2 of 3)**

PARAMETER	SPECIFICATIONS
NOISE (See Note)	
Hum and Noise	
Monophonic	-58 dB. Reference: 1 kHz at 250 nWb/m.
Stereophonic	-56 dB. Reference: 1 kHz at 250 nWb/m.
CROSSTALK	-50 dB or greater, Program Channel-to-Program Channel or Program Channel-to-Cue Channel at 1kHz.
FREQUENCY RESPONSE (See Note)	±2 dB, 40 Hz to 16 kHz.
EQUALIZATION	
Standard	1975 NAB.
Optional	I.E.C., CCIR, 1965 NAB.
POWER REQUIREMENTS	
Standard	105V ac to 132V ac, 50/60 Hz.
Optional	210V ac to 264V ac, 50/60 Hz.
CUE TONES	1kHz (Primary), 150 Hz (Secondary), 8 kHz (Tertiary).
MECHANICAL	
NUMBER OF DECKS	One.
CARTRIDGE DECK SIZE	A or AA Size Cartridges.
TRANSPORT TYPE	Direct Drive Capstan.
PHYSICAL	
WEIGHT (Unpacked)	
Playback	19.3 Pounds (8.7 kg).
Record/Playback	19.7 Pounds (8.9 kg).
MOUNTING	
Standard	Desk-Top.
Optional	Rack Mount. 19 Inch (48.3 cm) EIA rack.
 NOTE: Specifications measured using 1975 NAB Standard Equalization.	

**TABLE 1-2. DT-90A SERIES CARTRIDGE MACHINE SPECIFICATIONS
(Sheet 3 of 3)**

PARAMETER	SPECIFICATIONS
DIMENSIONS	
Height	5.25 Inches (13.3 cm).
Width	5.75 Inches (14.6 cm).
Depth	16.5 Inches (41.9 cm).
ENVIRONMENTAL	
AMBIENT OPERATING TEMPERATURE	32°F to 122°F (0°C to 50°C).
HUMIDITY	95% Maximum. Non-Condensing.

1

SECTION II INSTALLATION

2-1. INTRODUCTION.

2-2. This section contains the information required for the installation of the Broadcast Electronics DT-90A series cartridge machines.

2-3. UNPACKING.

2-4. The equipment becomes the property of the customer when the equipment is delivered to the carrier. Carefully unpack the cartridge machine. Perform a visual inspection to determine that no apparent damage has been incurred during shipment. All shipping materials should be retained until it is determined that the unit has not been damaged. Claims for damaged equipment must be promptly filed with the carrier or the carrier may not accept the claim.

2-5. The contents of the shipment should be as indicated on the packing list. If the contents are incomplete, or if the unit is damaged electrically or mechanically, notify both the carrier and Broadcast Electronics, Inc.

2-6. INSTALLATION.

2-7. PLACEMENT.

2-8. The standard DT-90A cartridge machine is designed for desk-top placement. However, the unit may be installed in a 19 inch EIA rack assembly if desired. To provide adequate structural support, it is recommended that rack mounted units be installed in a DT-90A rack shelf. Refer to illustration 597-9100-160 in SECTION VI for rack installation information. Install the cartridge machine by observing the following requirements and placing the unit in any convenient location.

- A. Place the cartridge machine within reach of signal and power cables.
- B. Do not place the cartridge machine near heat generating equipment.
- C. To minimize noise, do not place the cartridge machine near equipment generating excessive 50 Hz or 60 Hz radiation.
- D. For rack mounted cartridge machines, allow one inch of rack space above and below the unit for heat dissipation.



WARNING ***ENSURE NO PRIMARY POWER IS CONNECTED TO THE UNIT BEFORE PROCEEDING.***

WARNING

2-9. DT-90A CIRCUIT BOARD PROGRAMMING.

2-10. The DT-90A series cartridge machines are designed with programmable operating characteristics to meet any installation requirement. The following text presents DT-90A control and operating parameters. Perform the circuit board programming and connection procedures as required for the desired operating or control parameter.

2-11. **START LOCK-OUT AND STOP INDICATOR FLASHER OPERATION.** A start lock-out circuit is provided to prevent duplicate on-air cartridge play. Start lock-out operation is initiated when cartridge play is terminated by a primary (1 kHz) stop tone and indicated by the stop indicator flashing at a 1 Hz rate. The playback logic circuit board is shipped from the factory with J213 installed. If start lock-out and stop indicator flasher operation is not desired, refer to Figure 2-1 and program the circuit board as required.

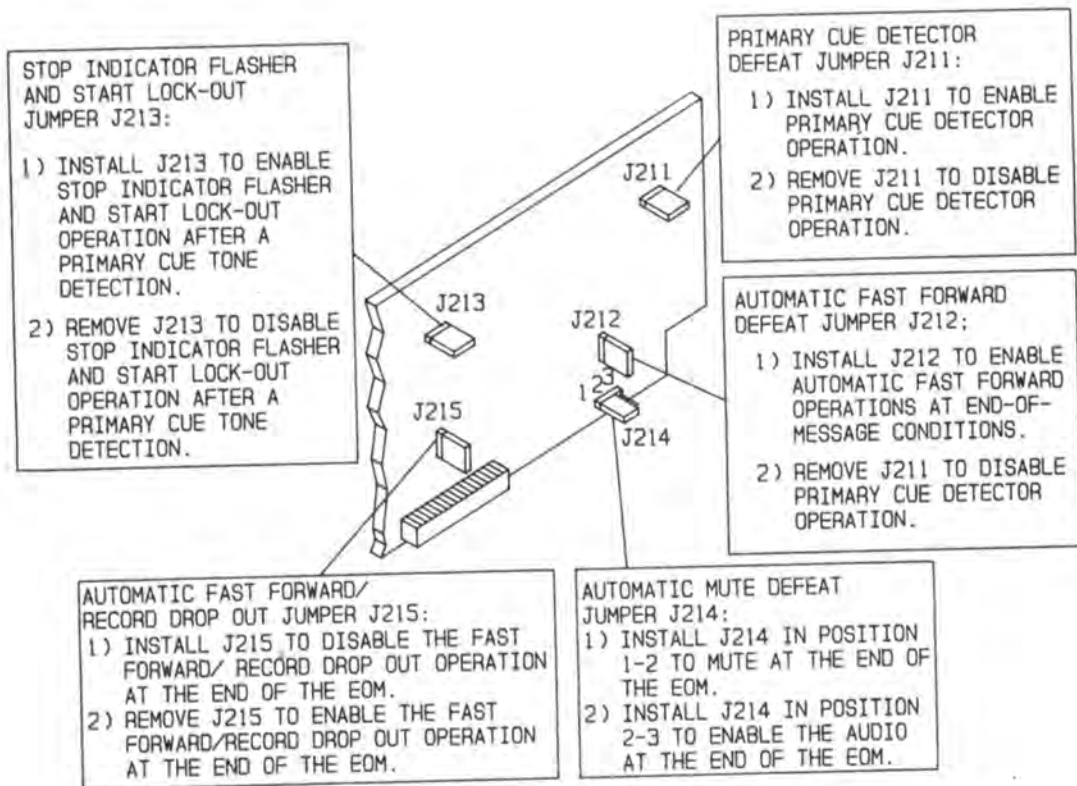

COPYRIGHT © 1990 BROADCAST ELECTRONICS, INC
597-9100-1

FIGURE 2-1. PLAYBACK CIRCUIT BOARD JUMPER PROGRAMMING

- 2-12. **AUTOMATIC FAST FORWARD OPERATION.** Fast forward advance is automatically initiated during EOM operations. The playback logic circuit board is shipped from the factory with J212 installed. If automatic fast forward operation is not desired, refer to Figure 2-1 and program the circuit board as required.
- 2-13. **PRIMARY CUE TONE OPERATION.** The primary cue tone detector circuit may be disabled to continuously reproduce program material. The playback logic circuit board is shipped from the factory with J211 installed. If continuous reproduction is desired, refer to Figure 2-1 and program the circuit board as required.
- 2-14. **EOM MUTE OPERATION.** Programmable jumper J214 on the playback logic circuit board provides automatic muting at the end of the EOM. The circuit board is shipped from the factory with J214 configured for automatic muting. If automatic muting is not desired, refer to Figure 2-1 and program the circuit board as required.
- 2-15. **AUTOMATIC FAST FORWARD/RECORD DROP-OUT JUMPER.** Programmable jumper J215 on the playback logic circuit board provides automatic fast forward/record drop-out at the end of the EOM during a record operation. The circuit board is shipped from the factory with J215 installed. If automatic fast forward/record drop-out is desired, refer to Figure 2-1 and program the circuit board as required.
- 2-16. **VU METER OPERATION.** Programmable jumper J311 on the record logic circuit board selects playback or record level meter indications during the record mode. The circuit board is shipped from the factory with J311 programmed for playback level indications. If playback level indications are not desired, refer to Figure 2-2 and program the circuit board as required.

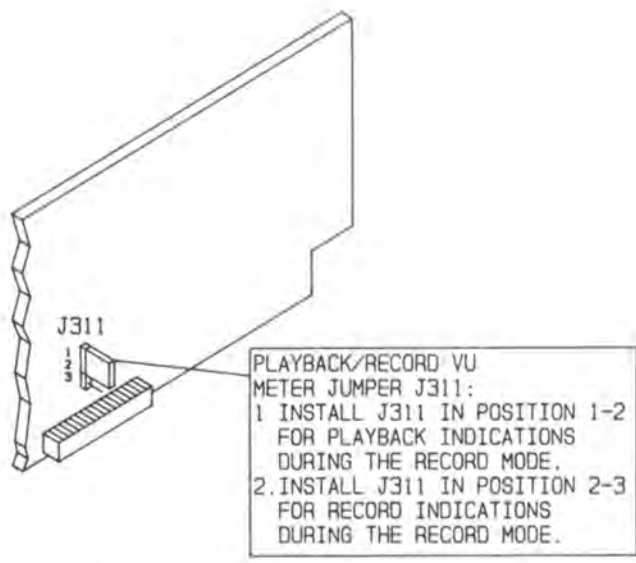

COPYRIGHT © 1990 BROADCAST ELECTRONICS, INC.
597-9100-161

FIGURE 2-2. RECORD CIRCUIT BOARD JUMPER PROGRAMMING

- 2-17. **MOTOR SPEED.** The cartridge machine motor speed is determined by circuitry on the motor control circuit board. The unit is shipped from the factory for 7.5 inches-per-second (IPS) operation. Playback units may be programmed for 3.75 IPS or 15 IPS operation. Record/playback units may be programmed for 3.75 IPS operation. Refer to Figure 2-3 to program the motor control circuit board as required for the desired motor speed.
- 2-18. **AUDIO INTERFACING.**
- 2-19. **AUDIO OUTPUT CONNECTIONS.** D-type playback connector J105 on the rear-panel provides interfacing to external equipment (refer to Figure 2-4). D-type mating receptacles are supplied with the unit for interface cable construction (located in the accessory parts kit). Refer to Figure 2-4 and construct audio output interfacing cables using the mating receptacles and 2-conductor shielded audio cable such as Belden 8451 or equivalent.
- 2-20. **RECORD INPUT CONNECTIONS.** D-type record connector J106 on the rear-panel provides interfacing to external equipment (refer to Figure 2-5). D-type mating receptacles are supplied with the unit for interface cable construction (located in the accessory parts kit). Refer to Figure 2-5 and construct record audio input interfacing cables using the mating receptacles and 2-conductor shielded audio cable such as Belden 8451 or equivalent.
- 2-21. **REMOTE FUNCTIONS.**
- 2-22. The DT-90A series cartridge machines are equipped with playback and record remote control and status systems. Playback remote control and status interfacing is accessible at rear-panel remote connector J105. Record remote control and status interfacing is accessible at rear-panel remote connector J106. Remote mating connectors are supplied with the unit for interface cable construction (located in the accessory parts kit).

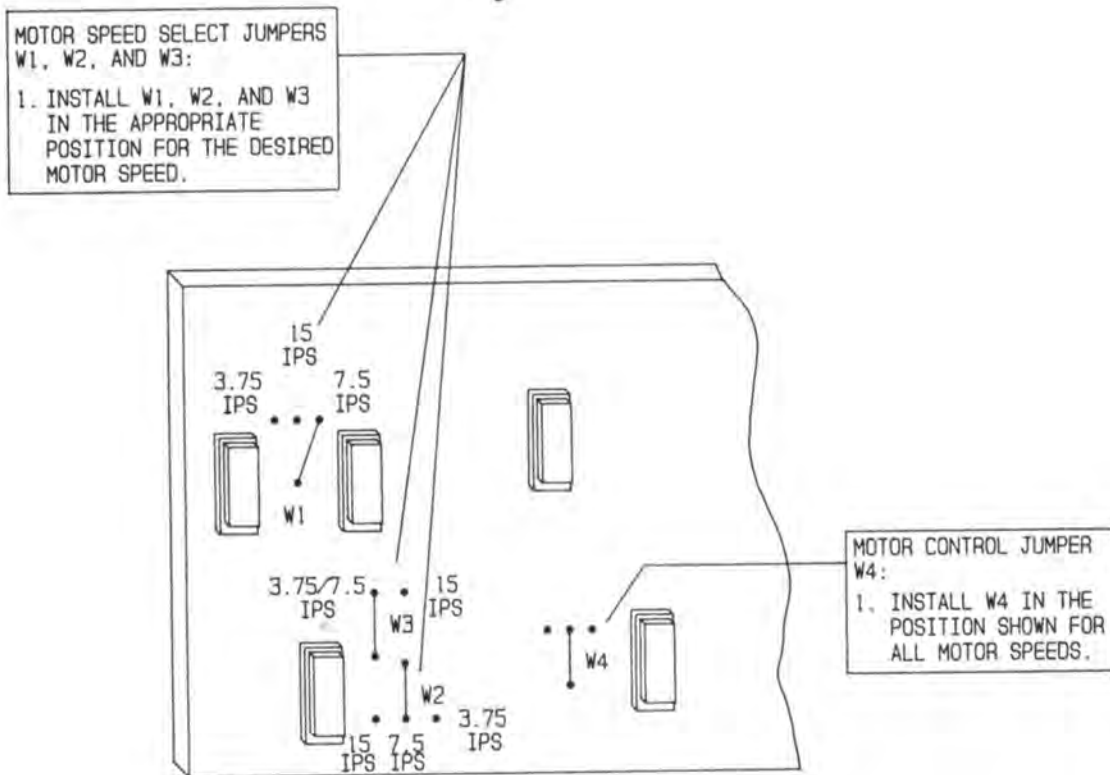

COPYRIGHT © 1990 BROADCAST ELECTRONICS, INC.
597-9100-20

FIGURE 2-3. MOTOR CONTROL CIRCUIT BOARD JUMPER PROGRAMMING

- 2-23. **PLAYBACK REMOTE FUNCTIONS.** If playback remote functions are desired, refer to Figure 2-4 and the following text to connect remote control and status interfacing circuitry to rear-panel PLAYBACK receptacle J105 as required.
- 2-24. **Start Operation And Indications.** Remote start control is accessible at J105 pin 1. A momentary contact to ground is required to initiate a remote start operation. Remote start indications are available at J105 pin 3. The unit will output a logic LOW to indicate a start operation. Attach the appropriate interface circuitry to connector J105 as required.
- 2-25. **Stop Operation And Indications.** Remote stop control is accessible at J105 pin 2. A momentary contact to ground is required to initiate a remote stop operation. Remote stop indications are available at J105 pin 4. The unit will output a logic LOW to indicate the termination of deck operation. Attach the appropriate interface circuitry to connector J105 as required.
- 2-26. **Audio Mute Operation.** Remote audio muting is accessible at J105 pin 5. A momentary contact to ground is required to initiate an audio mute operation.
- 2-27. **Secondary Cue Tone Relay Contacts And Indications.** Secondary cue tone relay contacts are accessible at J105 pins 13 and 25 for control of external equipment. The relay contacts are rated for 100V dc at 0.5 amperes maximum. Remote secondary cue tone indications are available at J105 pin 9. The unit will output a logic LOW to indicate a secondary cue tone detection. Attach the appropriate interface circuitry to connector J105 as required.

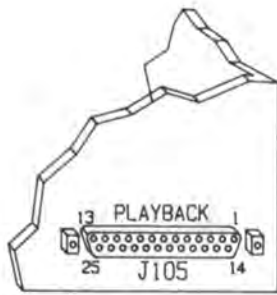

PLAYBACK
CONNECTOR
J105 PIN NO.

PLAYBACK CONNECTOR J105 PIN NO.	DESCRIPTION	CIRCUIT APPLICATION
1	START COMMAND	-REMOTE CONTROL COMMANDS- MOMENTARY CONTACT TO GROUND REQUIRED TO ACTIVATE FUNCTION.
2	STOP COMMAND	
3	START INDICATOR	
4	STOP INDICATOR	
5	AUDIO MUTE COMMAND	-REMOTE CONTROL COMMAND- MOMENTARY CONTACT TO GROUND REQUIRED TO ACTIVATE FUNCTION.
6	+ RIGHT AUDIO OUTPUT	RIGHT CHANNEL AUDIO OUTPUT CONNECTIONS
7	RIGHT SIGNAL GROUND	
8	- RIGHT AUDIO OUTPUT	
9	SECONDARY CUE TONE INDICATOR	REMOTE STATUS INDICATORS- LOGIC 0 WHEN ACTIVE
10	TERTIARY CUE TONE INDICATOR	
11	+28V dc SUPPLY	+28V dc SUPPLY
12	TERTIARY CUE TONE CONTACT	CUE TONE RELAY CONNECTIONS- 100V dc AT 0.5 AMPERES MAXIMUM
13	SECONDARY CUE TONE CONTACT	
14	POWER SUPPLY GROUND	
15	FAST FORWARD COMMAND	-REMOTE CONTROL COMMAND- MOMENTARY CONTACT TO GROUND REQUIRED TO ACTIVATE FUNCTION.
16	FAST FORWARD INDICATOR	REMOTE STATUS INDICATOR LOGIC 0 WHEN ACTIVE
17	AUXILIARY START PULSE OUTPUT	-AUXILIARY START PULSE OUTPUT- A LOW ACTIVE PULSE FOR EXTERNAL START OPERATIONS.
18	POWER SUPPLY GROUND	POWER SUPPLY GROUND
19	+ LEFT AUDIO OUTPUT	LEFT CHANNEL AUDIO OUTPUT CONNECTIONS
20	LEFT SIGNAL GROUND	
21	- LEFT AUDIO OUTPUT	
22	CUE AUDIO OUTPUT	CUE AUDIO OUTPUT CONNECTIONS
23	CUE AUDIO GROUND	
24	TERTIARY CUE TONE RELAY CONTACT	CUE TONE RELAY CONNECTIONS- 100V dc AT 0.5 AMPERES MAXIMUM
25	SECONDARY CUE TONE RELAY CONTACT	

COPYRIGHT © 1990 BROADCAST ELECTRONICS, INC
597-9100-2

FIGURE 2-4. PLAYBACK REMOTE CONTROL RECEPTACLE CONNECTIONS

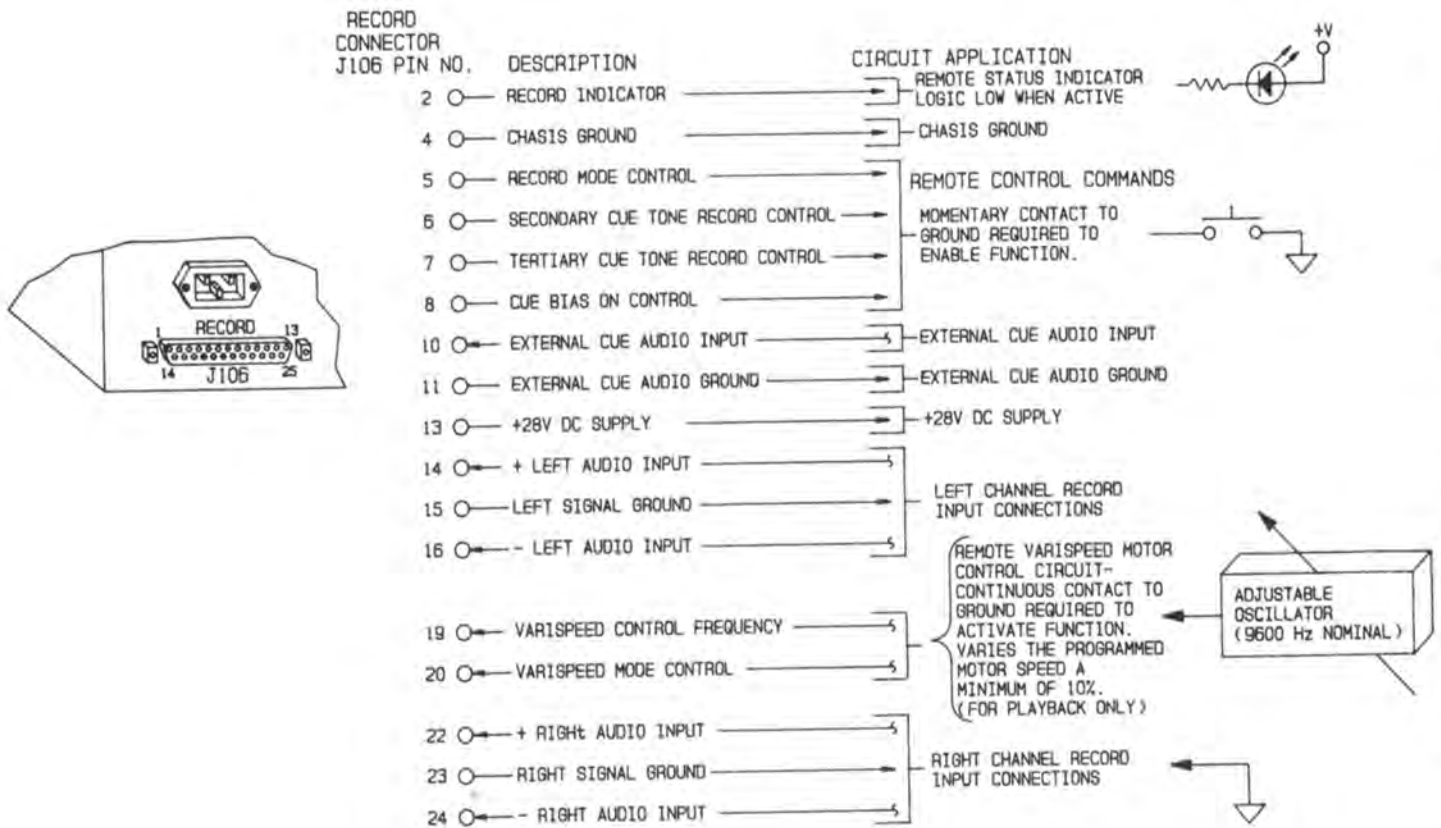

COPYRIGHT © 1990 BROADCAST ELECTRONICS, INC
597-9100-3

FIGURE 2-5. RECORD REMOTE CONTROL RECEPTACLE CONNECTIONS

- 2-28. **Tertiary Cue Tone Relay Contacts And Indications.** Tertiary cue tone relay contacts are accessible at J105 pins 12 and 24 for control of external equipment. The relay contacts are rated for 100V dc at 0.5 amperes maximum. Remote tertiary cue tone indications are available at J105 pin 10. The unit will output a logic LOW to indicate a tertiary cue tone detection. Attach the appropriate interface circuitry to connector J105 as required.
- 2-29. **Fast Forward Operation And Indications.** Remote fast forward control is accessible at remote connector J105 pin 15. A momentary contact to ground is required to initiate a fast forward operation. Remote fast forward indications are available at J105 pin 16. The unit will output a logic LOW to indicate a fast forward operation. Attach the appropriate interface circuitry to connector J105 as required.
- 2-30. **Auxiliary Start Pulse Output.** An auxiliary start pulse is accessible at J105 pin 17 for control of external equipment. The unit will output a logic LOW for external start applications.
- 2-31. **Cue Audio Output.** Cue audio is accessible at J105 pins 22 and 23 for remote monitoring applications. Attach the appropriate interface circuitry to connector J105 as required.
- 2-32. **Vari-Speed Motor Operation.** The DT-90A series cartridge machines are equipped with a vari-speed feature which allows the operator to vary the cartridge machine motor speed a minimum of $\pm 10\%$ (refer to Figure 2-5). An Adjustable 9600 Hz reference is required at J106 pin 19 for motor control. Refer to Figure 2-5 and connect a LOW to J106 pin 20 to initiate vari-speed operation. When vari-speed operation is initiated and the motor reference is varied (example: 10%), the control circuitry will act to vary the programmed motor speed a corresponding amount (10%).
- 2-33. **RECORD REMOTE FUNCTIONS.** If record remote functions are desired, refer to Figure 2-5 and the following text to connect remote control and status interfacing circuitry to rear-panel RECORD receptacle J106 as required.

- 2-34. **Record Control and Indications.** Remote record mode control is accessible at J106 pin 5. A momentary contact to ground is required to initiate a remote record operation. Remote record indications are available at J106 pin 2. The unit will output a logic LOW to indicate a record mode operation. Attach the appropriate interface circuitry to connector J106 as required.
- 2-35. **Secondary and Tertiary Cue Tone Record Control.** Secondary and tertiary cue tone remote record control is accessible at remote connector J106. A momentary contact to ground is required to initiate a remote record operation. Attach the appropriate interface circuitry to connector J106 as required. The following list presents secondary and tertiary cue tone record control pin locations.

RECORD CONNECTOR J106 PIN NO.	DESCRIPTION
6	Secondary Cue Tone Record Control
7	Tertiary Cue Tone Record Control

- 2-36. **External Cue Record.** An external cue tone record feature is incorporated into the remote control circuit design. The external cue record circuit includes an external cue control and a cue tone audio input. If external cue record operations are desired, connect a momentary contact to ground switch to the cue bias on terminal at J106 pin 8. Connect the external cue audio to J106 pin 10.
- 2-37. **AUTOMATIC AUDIO MUTING.**
- 2-38. An automatic audio muting feature is incorporated into the DT-90A control circuit design. The feature will automatically mute associated cartridge machines without the assistance of an audio switcher in multiple unit installations. Audio will be muted in all cartridge machines with the exception of the on-air unit. If automatic audio muting is desired, refer to Figure 2-6 and connect the units as shown.
- 2-39. **AUTOMATIC START SEQUENCING.**
- 2-40. All DT-90A cartridge machines may be configured for automatic start sequencing. The following text presents wiring procedures for a typical start sequence. However, the sequence may be modified as required to achieve any start sequence.
- 2-41. **SEQUENCE.** Figure 2-7 presents wiring connections for a start sequence described in the following text. Refer to Figure 2-7 and connect the units as shown.

START SEQUENCE

- A. Cartridge machine 1 will start cartridge machine 2.
- B. Cartridge machine 2 will start cartridge machine 3.
- C. Cartridge machine 3 will start cartridge machine 4.
- D. Cartridge machine 4 will start cartridge machine 5.
- E. Cartridge machine 5 will start cartridge machine 1.

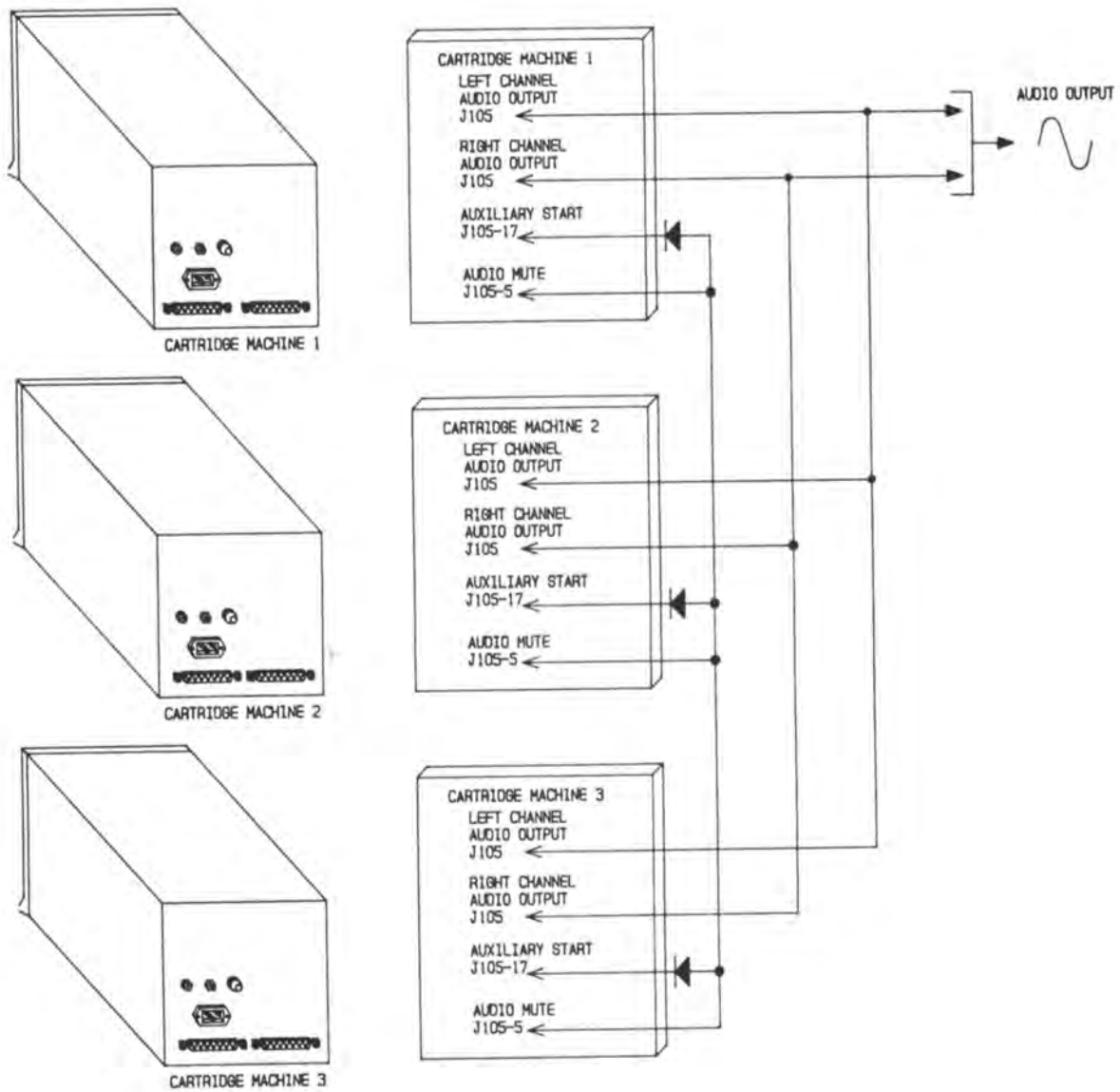

COPYRIGHT © 1990 BROADCAST ELECTRONICS, INC
597-9100-4

FIGURE 2-6. AUTOMATIC AUDIO MUTING

2-42. **MOTOR OPERATION.**

- 2-43. The DT-90A servo motor is wired to operate continuously when shipped from the factory. The motor can be configured to operate only when the deck switch is activated. If motor operation is desired only when a cartridge is inserted, refer to Figure 2-8 and connect wire No. 13 to pin 6 of J104 as indicated.

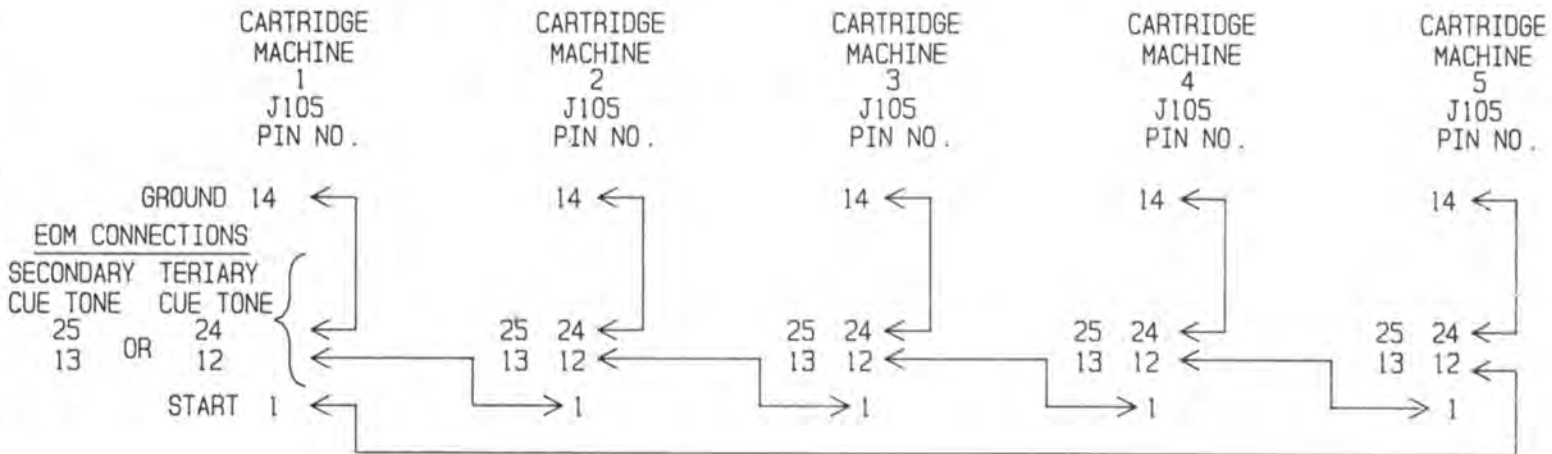
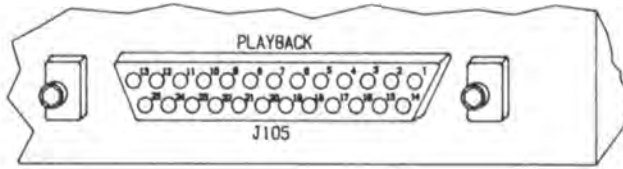

START SEQUENCE

1. CARTRIDGE MACHINE 1 WILL START CARTRIDGE MACHINE 2.
2. CARTRIDGE MACHINE 2 WILL START CARTRIDGE MACHINE 3.
3. CARTRIDGE MACHINE 3 WILL START CARTRIDGE MACHINE 4.
4. CARTRIDGE MACHINE 4 WILL START CARTRIDGE MACHINE 5.
5. CARTRIDGE MACHINE 5 WILL START CARTRIDGE MACHINE 1.

NOTE:

1. THE START SEQUENCE MAY BE MODIFIED TO ACHIEVE ANY START SEQUENCE REQUIREMENT.
2. FOR SECONDARY CUE TONE EOM ASSIGNMENTS, CONNECT JUMPERS TO PINS 25 AND 13. FOR TERTIARY CUE TONE EOM ASSIGNMENTS, CONNECT JUMPERS TO PINS 24 AND 12.

COPYRIGHT © 1990 BROADCAST ELECTRONICS, INC.
597-9100-5

FIGURE 2-7. DT-90A CARTRIDGE MACHINE START SEQUENCING

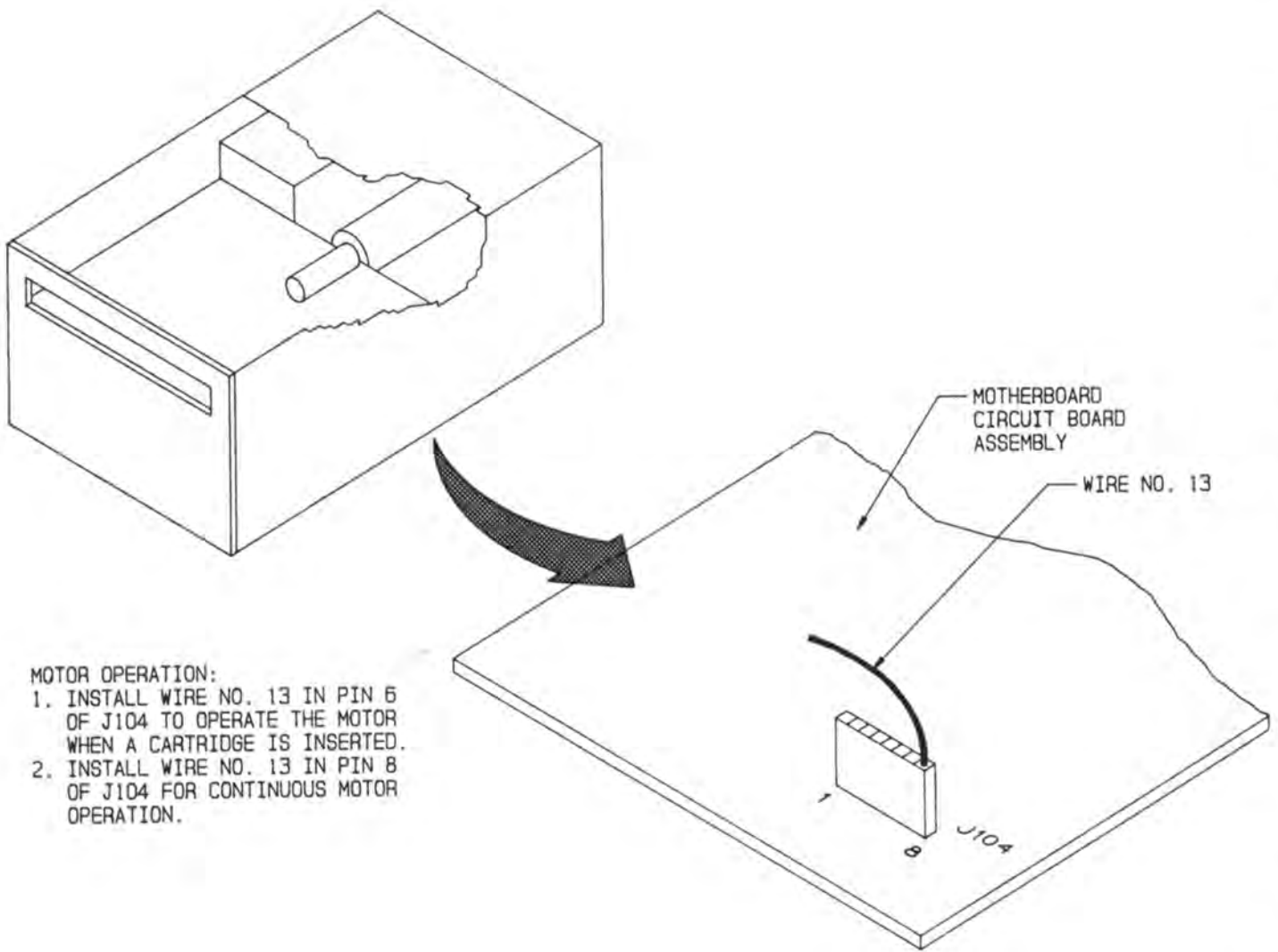

COPYRIGHT © 1990 BROADCAST ELECTRONICS, INC
597-9100-21

FIGURE 2-8. MOTOR OPERATION

2-44. **GROUND CONNECTIONS.**

2-45. An important consideration in assuring low noise performance from the cartridge machine is the grounding and shielding of the various audio interconnections. First, ensure the cartridge machine circuit ground and any required internal ground terminal is connected to an earth ground using a braided or solid copper conductor. Second, the shields from audio conductors must be grounded to prevent the coupling of extraneous noise. Generally, the shields are grounded at the studio audio console. However, the shields may require grounding at the cartridge machine or at a point between the cartridge machine and the studio audio console. Particular care must be exercised to avoid ground loops at patch panels, external switching equipment, uninsulated jacks on associated equipment, and grounded racks or cabinets.

2-46. AC POWER CONNECTION.



WARNING **ENSURE ALL PRIMARY POWER IS DISCONNECTED
BEFORE PROCEEDING.**

WARNING

- 2-47. Terminal strip TB1 on the inside rear-panel of the DT-90A is wired for the proper power supply voltage when shipped from the factory. The operating voltage requirement for the unit is indicated on the cartridge machine identification plate which is located on the cartridge machine side-panel. If an alternate operating voltage is desired, refer to schematic SD900-9100-000 in SECTION VI, PARTS LISTS AND DRAWINGS and connect TB1 as required.
- 2-48. Remove the fuse from the rear-panel fuse-holder. For playback and record/playback units, ensure the fuse is a slow-blow type rated at 1.0A for 105V to 132V operation or 0.5A for 210V to 264V operation.
- 2-49. Ensure the rear-panel power switch is operated to OFF and connect the cartridge machine line cord to the appropriate power source.
- 2-50. **ELECTRICAL ADJUSTMENTS.**
- 2-51. **AUDIO OUTPUT LEVEL ADJUSTMENT.** The cartridge machine audio output level is factory adjusted to 0 dBm. If an alternate output level is required, refer to the **ELECTRICAL ADJUSTMENTS** procedures in SECTION V, MAINTENANCE and perform the **OUTPUT LEVEL ADJUSTMENT** procedure.
- 2-52. **OPTIONAL EQUIPMENT INSTALLATION.**
- 2-53. The following list presents related publications which provide data required for the installation of options and accessories associated with the DT-90A series cartridge machines.

OPTION OR ACCESSORY	PUBLICATION NUMBER
Model PC-1 Telephone Interface	597-0047

SECTION III OPERATION

3-1. INTRODUCTION.

3-2. This section identifies all controls and indicators associated with the DT-90A series cartridge machines and provides standard operating procedures.

3-3. CONTROLS AND INDICATORS.

3-4. Refer to Figure 3-1 for the location of all controls and indicators associated with the unit. The function of each control or indicator is described in Table 3-1.

3-5. OPERATION.



NOTE

THE FOLLOWING PROCEDURE ASSUMES THAT THE CARTRIDGE MACHINE IS COMPLETELY INSTALLED AND IS FREE OF ANY DISCREPANCIES.

NOTE

3-6. PLAYBACK OPERATION.

3-7. Operate the rear-panel **PWR ON/OFF** switch to the ON position. The capstan motor will operate if the motor is wired as shipped from the factory.

3-8. Insert an NAB A or AA size tape cartridge into the deck. The deck **STOP** switch/indicator will illuminate.

3-9. Depress the deck **START** switch/indicator to begin cartridge play operation. When the **START** switch/indicator is depressed, the following events will occur:

- A. The deck **START** switch/indicator will illuminate.
- B. The deck **STOP** switch/indicator will extinguish.
- C. The **AUD** indicator will illuminate.
- D. On record/playback models, the VU meter display will begin operation.

3-10. The deck will operate until a primary (1 kHz) stop tone is detected or the deck **STOP** switch/indicator is depressed. When deck operation is terminated, the following events will occur:

- A. The **START** switch/indicator will extinguish.
- B. The **AUD** indicator will extinguish.
- C. On record/playback models, the VU meter display will terminate operation.
- D. The **STOP** switch/indicator will illuminate or flash.

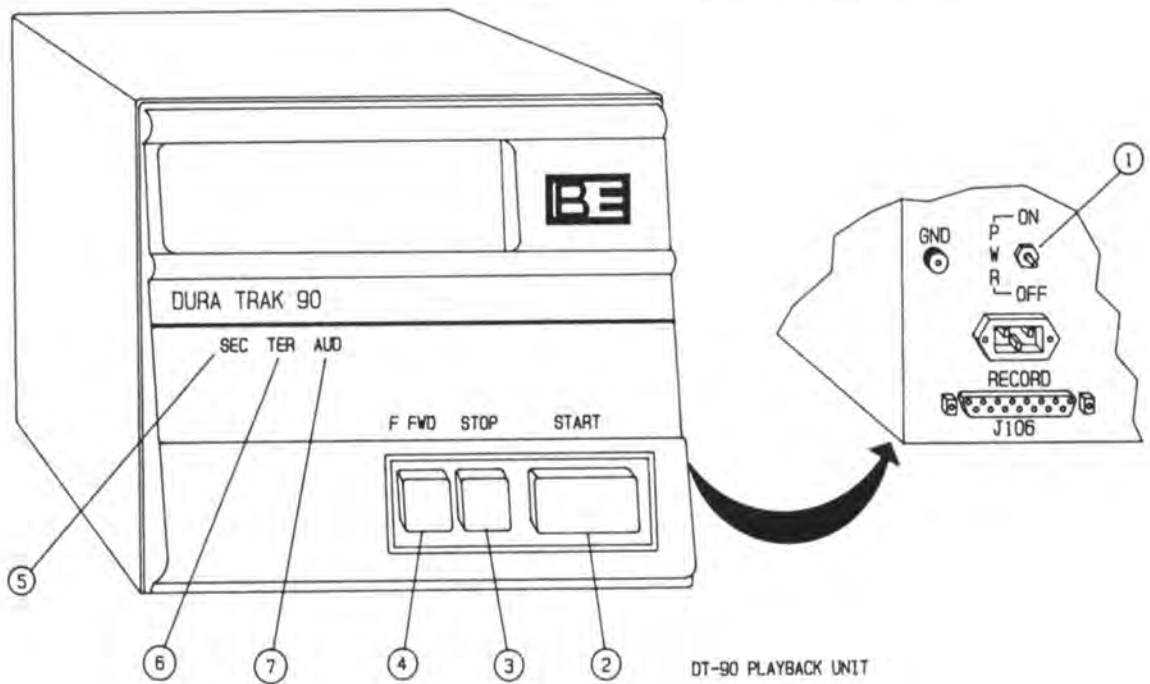
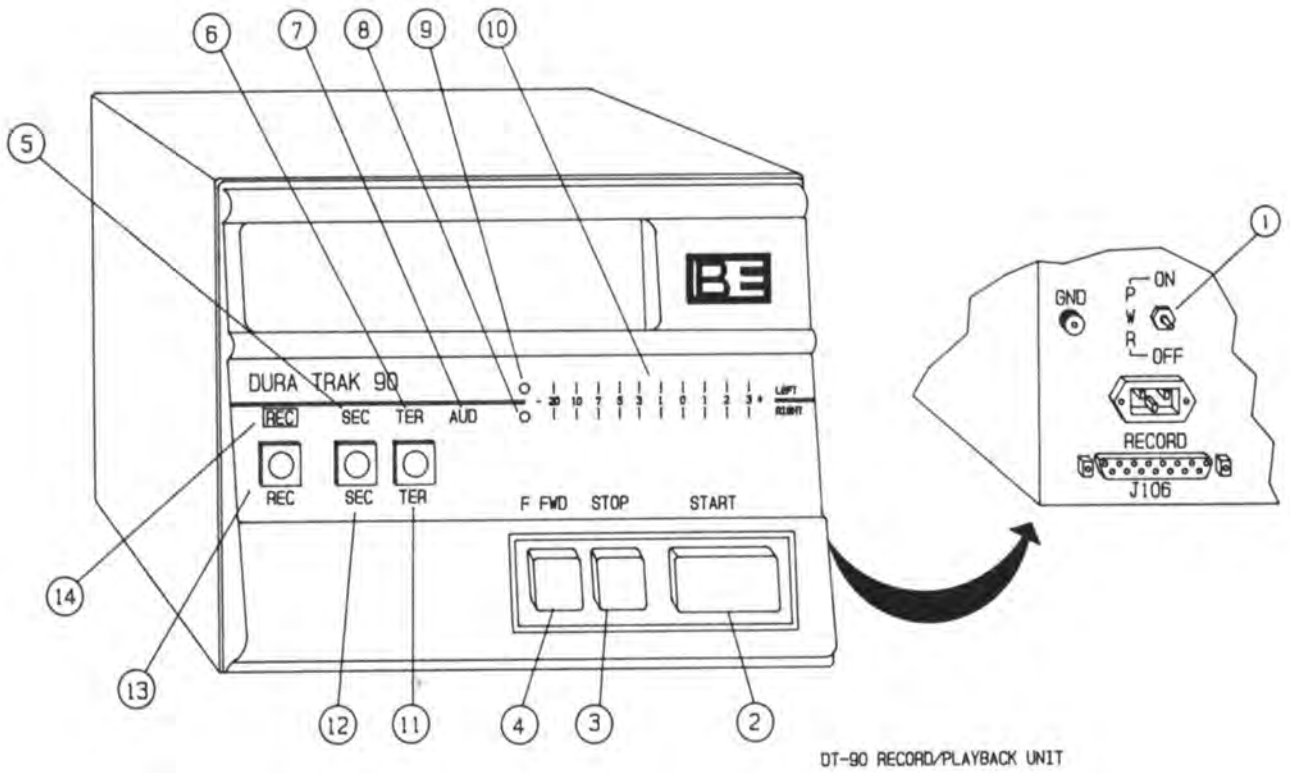

- STEREPHONIC MODELS ONLY
- OPTIONAL

COPYRIGHT © 1990 BROADCAST ELECTRONICS, INC
597-9100-6

FIGURE 3-1. DT-90A CONTROLS AND INDICATORS

TABLE 3-1. CONTROLS AND INDICATORS
(Sheet 1 of 2)

INDEX NO.	NOMENCLATURE	FUNCTION
1	Power Switch	Controls the application of ac power to the unit.
2	START Switch/ Indicator	<p>SWITCH:</p> <ul style="list-style-type: none"> A. Initiates tape movement for playback and/or record operations. B. When momentarily depressed during fast forward operation, returns the unit to the normal operating speed and audio is enabled. C. Initiates maintenance mode operation when simultaneously operated with the STOP switch/indicator. The solenoid will remain energized until the STOP switch/indicator is again depressed. <p>INDICATOR: Illuminates to indicate deck operation.</p>
3	STOP Switch/ Indicator	<p>SWITCH:</p> <ul style="list-style-type: none"> A. Terminates deck operation. B. Initiates maintenance mode operation when simultaneously operated with the START switch/indicator. The solenoid will remain energized until the STOP switch/indicator is again depressed. C. Resets start lock-out conditions. D. Resets stop indicator flashing conditions. <p>INDICATOR:</p> <ul style="list-style-type: none"> A. Illuminates to indicate the unit is in the ready mode (unit energized with a cartridge completely inserted into the deck). B. Flashes once per second to indicate a cartridge played condition.
4	F FWD Switch/ Indicator	<p>SWITCH: When depressed, initiates fast forward operation. Tape advances at three times the normal speed until a 1 kHz stop tone is detected or the STOP switch/indicator is depressed. Audio is muted when the switch is released.</p> <p>INDICATOR: Illuminates to indicate the unit is in the fast forward mode.</p>

3

TABLE 3-1. CONTROLS AND INDICATORS
(Sheet 2 of 2)

INDEX NO.	NOMENCLATURE	FUNCTION
5	SEC Indicator	Illuminates to indicate a secondary (150 Hz) cue tone detection.
6	TER Indicator	Illuminates to indicate a tertiary (8 kHz) cue tone detection.
7	AUD Indicator	Illuminates to indicate audio is enabled.
8	Right Record Input Level Control	Adjusts the right channel record input level.
9	Left Record Input Level Control	Adjusts the left channel record input level.
10	VU Meter Display	A stereophonic multi-color LED display containing VU meter ballistics. Normal display operation provides level indications of record input audio and playback audio.
11	TER Switch	Records an 8 kHz tertiary cue tone on the cue channel for the duration of switch operation. The tertiary cue tone may be recorded when the unit is operating in the playback or record modes.
12	SEC Switch	Records a 150 Hz secondary cue tone on the cue channel for the duration of switch operation. The secondary cue tone may be recorded when the unit is operating in the playback or record modes.
13	REC Switch	<p>A. Configures the unit to the record mode with 1 kHz primary cue tone record operation when depressed once.</p> <p>B. Configures the unit to the record mode without 1 kHz primary cue tone record operation when depressed twice.</p>
14	REC Indicator	<p>A. Illuminates to indicate the unit is configured to the record mode with 1 kHz primary cue tone record operation.</p> <p>B. Flashes to indicate the unit is configured to the record mode without 1 kHz primary cue tone record operation.</p>

- 3-11. The DT-90A cartridge machines are equipped with secondary and tertiary cue tone detection indication circuitry. Cue tone detection is indicated as follows:
- A. The **SEC** indicator will illuminate to indicate the detection of a secondary (150 Hz) cue tone.
 - B. The **TER** indicator will illuminate to indicate the detection of a tertiary (8 kHz) cue tone.
- 3-12. **STOP INDICATOR FLASHING/DECK START LOCK-OUT.** The **STOP** indicator circuitry is designed to indicate a special operating condition. If the function is enabled, the **STOP** indicator will flash once per second to indicate a cartridge played and start lock-out condition to prevent duplicate on-air cartridge play.
- 3-13. To reset the **STOP** indicator flashing and start lock-out circuitry, remove the cartridge or depress the **STOP** switch/indicator.
- 3-14. **MANUAL FAST FORWARD.** The manual fast forward feature may be operated with the muting circuit enabled or disabled. To operate the unit in the manual fast forward mode with audio muted, momentarily depress the front-panel **F FWD** switch/indicator. To operate the unit in the manual fast forward mode with audio enabled, continuously depress the **F FWD** switch/indicator. The **F FWD** switch/indicator will illuminate to indicate the fast forward mode.
- 3-15. **AUTOMATIC FAST FORWARD.** To operate the unit in the automatic fast forward mode, the appropriate circuitry on the playback logic circuit board must be enabled. Insert the cartridge into the deck and initiate playback operation. When the end of the EOM is detected, the unit will operate to fast forward advance with audio muted. The **F FWD** switch/indicator will illuminate to indicate the fast forward mode.
- 3-16. **TERMINATING THE FAST FORWARD MODE.** When initiated, the fast forward mode will continue until a stop tone is detected, the **STOP** switch/indicator is depressed, or the **START** switch/indicator is depressed. If the **STOP** switch/indicator is depressed or a stop tone is detected, the **STOP** switch/indicator will illuminate or flash. If the **START** switch/indicator is depressed, the unit will return to the playback mode.
- 3-17. **MAINTENANCE MODE OPERATION.** All DT-90A cartridge machines are equipped with a maintenance mode feature which energizes the solenoid to allow routine pressure roller and capstan shaft cleaning. To generate a maintenance mode command, remove any tape cartridge and simultaneously depress the **START** and **STOP** switch/indicators and release the **STOP** switch/indicator prior to the **START** switch/indicator.
- 3-18. **RECORD OPERATION.**
- 3-19. **PRELIMINARY SET-UP.** Select the program material to be recorded. Ensure the playback system output level is within the input level specifications.
- 3-20. Operate the rear-panel **PWR ON/OFF** switch to the ON position.
- 3-21. Select a bulk erased cartridge that is approximately 2 seconds longer than the selected material to be recorded.
- 3-22. Insert the cartridge into the deck. The **STOP** switch/indicator will illuminate.
- 3-23. Depress the **START** switch/indicator and play the tape for several seconds to align the tape in the guides and to locate the tape splice. Stop the deck just beyond the tape splice to avoid recording over the splice.

- 3-24. **RECORD LEVEL ADJUSTMENT.** To adjust the record level, proceed as follows:
3-25. Ensure the bulk erased cartridge is inserted into the deck.



NOTE *THE CARTRIDGE MACHINE WILL NOT OPERATE TO THE RECORD MODE UNLESS A CARTRIDGE IS INSERTED IN THE DECK.*

NOTE

THE CARTRIDGE MACHINE RECORD CIRCUITRY IS SHIPPED FROM THE FACTORY FOR A RECORD LEVEL OF 0 dBm WHEN THE VU METERS INDICATE 0 VU.

- 3-26. Operate the cartridge machine to the record mode by depressing the **REC** switch. The **REC** indicator will illuminate.
- 3-27. Start the program material and adjust the record level control(s) until the VU meter(s) indicate 0 VU.
- 3-28. Stop and re-cue the program material and the bulk erased cartridge.
- 3-29. **RECORDING PROGRAM MATERIAL.** Program material can be recorded with or without a 1 kHz primary cue tone record operation. To select a record operation with a primary cue tone, operate the **REC** switch to illuminate the **REC** indicator. To select a record operation without a primary cue tone, depress the **REC** switch again. The **REC** indicator will flash.
- 3-30. Depress the deck **START** switch/indicator. The **START** switch/indicator and **AUD** indicator will illuminate.
- 3-31. Wait approximately one-half second, then start the program material. If the **REC** indicator is illuminated, a stop tone will be automatically recorded on the cue channel. The VU meter(s) will indicate record input audio.



NOTE *THE RECORDING PROCESS MAY BE MONITORED IF DESIRED BY CONNECTING A SPEAKER SYSTEM TO THE PLAYBACK DECK OUTPUT.*

NOTE

- 3-32. At the end of the record operation, deck operation will terminate automatically when a 1 kHz cue tone is detected. To terminate deck operation manually, depress the **STOP** switch/indicator.
- 3-33. When deck operation is terminated, the following events will occur:
- A. The **START** switch/indicator will extinguish.
 - B. The **REC** indicator will extinguish.
 - C. The **AUD** indicator will extinguish.
 - D. The **STOP** switch/indicator will illuminate or flash.
 - E. The unit will be automatically operated to the playback mode.
- 3-34. **SECONDARY AND TERTIARY CUE TONE RECORDING.** Secondary and tertiary cue tones may be recorded in the playback or record modes of operation. If secondary and tertiary cue tone recording is desired, proceed as follows:
- 3-35. Start the recording system in the playback mode or record mode of operation. Depress the **SEC** or **TER** switch for the amount of time the tone is desired.

SECTION IV

THEORY OF OPERATION

4-1. INTRODUCTION.

4-2. This section presents the theory of operation for the Broadcast Electronics DT-90A cartridge machines.

4-3. FUNCTIONAL DESCRIPTION.

4-4. PLAYBACK CIRCUITRY.

4-5. Figure 4-1 presents a simplified schematic diagram of the playback logic circuit board. Refer to Figure 4-1 as required for a description of the following circuits.

- A. Audio Processing Circuits
- B. Cue Tone Detection Circuits
- C. Start/Stop Logic Circuit
- D. Flasher Logic Circuit
- E. Fast Forward Logic Circuit
- F. Mute Logic Circuit

4-6. **AUDIO PROCESSING CIRCUITS.** Stereophonic units are equipped with left and right channel audio circuits. Monophonic units are equipped with only the left channel audio circuit. The left and right channel audio circuits are identical; therefore, only the left channel circuit will be discussed.

4-7. **Audio Input Circuit.** Left channel audio from the tape head is applied to operational amplifier U1B. U1B operates as an audio amplifier and equalization stage with a gain of approximately 50 dB. Potentiometer R4 provides ± 10 dB of high frequency equalization. Potentiometer R9 provides ± 6 dB of low frequency equalization. The output of U1B is routed to an audio/mute selector.

4-8. On record/playback models, the output of inverter U1B is routed to the record logic circuit board for metering applications.

4-9. **Audio/Mute Selector Operation.** Intergrated circuit U20 will select one of the following modes of operation as determined by the mute control and fast forward control signals. U20 operates in the playback audio mode when both control signals are logic LOW. The left channel audio output of U20 is applied to mute switch Q1.

- A. Playback audio.
- B. Fast forward audio.
- C. Muted audio.

4-10. Left mute switch Q1 is a series field-effect-transistor. When audio muting is required, a HIGH from the mute control line is applied to Q1 which will bias Q1 off to mute the audio signal.

4-11. **Output Amplifier Circuit.** Audio from the mute switch is applied to amplifier U1A. Potentiometer R19 provides left channel output level adjustment. The output of U1A is applied to the left channel output amplifier network consisting of inverter U3A and amplifier stages U4A/B and U3B.

- 4-12. Audio from U1A is routed through inverter U3A and applied to the amplifier stage in an inverted and non-inverted format. Inverted audio is applied to amplifier stage U4A. Non-inverted audio is applied to amplifier U4B. Together, U4A and U4B operate as a balanced audio output amplifier with a gain of two. Amplifier U3B functions as a monitoring and gain stage for a shorted audio output condition.
- 4-13. When the audio output impedance is balanced, the input to U3B is at virtual ground which isolates the stage from the circuit. When either the positive or negative output terminal is grounded, an audio signal will be applied to U3B. U3B will output a signal to increase the gain of the remaining output amplifier network. Consequently, the network will maintain full output into an unbalanced load condition.
- 4-14. **CUE TONE DETECTION CIRCUITS.** The cue tone detection circuits consist of: 1) a cue input amplifier circuit, 2) cue tone filter circuits, and 3) individual cue tone detector circuits.
- 4-15. **Cue Input Amplifier Circuit.** Cue audio information from the tape head is applied to an input amplifier circuit consisting of U7A and U7B which provides approximately 30 dB of gain. The output of the amplifier circuit is routed to a rear-panel connector for external applications. Cue audio is also applied to the cue tone filter circuits.
- 4-16. **Cue Tone Filter Circuits.** The cue tone filters consist of integrated circuits U8A, U8B, U9A, and U9B which operate as active bandpass filters. These filters will convert valid cue information into dc levels for application to individual detector circuits.
- 4-17. **Primary Detector Circuit.** The primary cue tone output from the filter circuit is routed to comparator U10C through 1 kHz level control R78. When the output from the filter exceeds the reference level at U10C, the output of U10C will go HIGH. This HIGH is inverted by U19D for application to the primary cue tone detection bus.
- 4-18. **3 KHZ Detector Circuit.** The 1 kHz primary cue tone will be detected at 3 kHz when the unit is operated in the fast forward mode. A HIGH applied to the fast forward control line will: 1) inhibit the primary, secondary, and tertiary cue tone detector circuits, and 2) operate the audio/mute selector to enable the input of comparator U10A.
- 4-19. The 3 kHz cue tone output from the filter circuit is routed to comparator U10A through 3 kHz level control R139. When the output from the filter circuit exceeds the reference level at comparator U10A, the output of U10A will go HIGH. This HIGH is inverted by U19A for application to the primary cue tone detection bus.
- 4-20. **Secondary Detector Circuit.** The secondary cue tone output from the filter circuit is routed to comparator U10B through 150 Hz level control R66. When the output from the filter exceeds the reference level at U10B, the output of U10B will go HIGH. This HIGH is inverted by U11A/U11B to energize secondary relay K1, and illuminate the front-panel and remote indicators.
- 4-21. The HIGH from comparator U10B is also applied to the secondary cue tone detection bus, and end-of-tone detector U19B/C. The end-of-tone detector provides a momentary LOW for application to the END of EOM tone bus.
- 4-22. **Tertiary Detector Circuit.** The operation of the tertiary detector circuit and secondary detector circuit is identical with the exception of an end-of-tone detector circuit.
- 4-23. **START/STOP LOGIC CIRCUIT.** The start/stop logic circuit controls deck start, auxiliary start, start indicator, manual and automatic stop, start lock-out, maintenance mode, and primary cue tone inhibit operations.

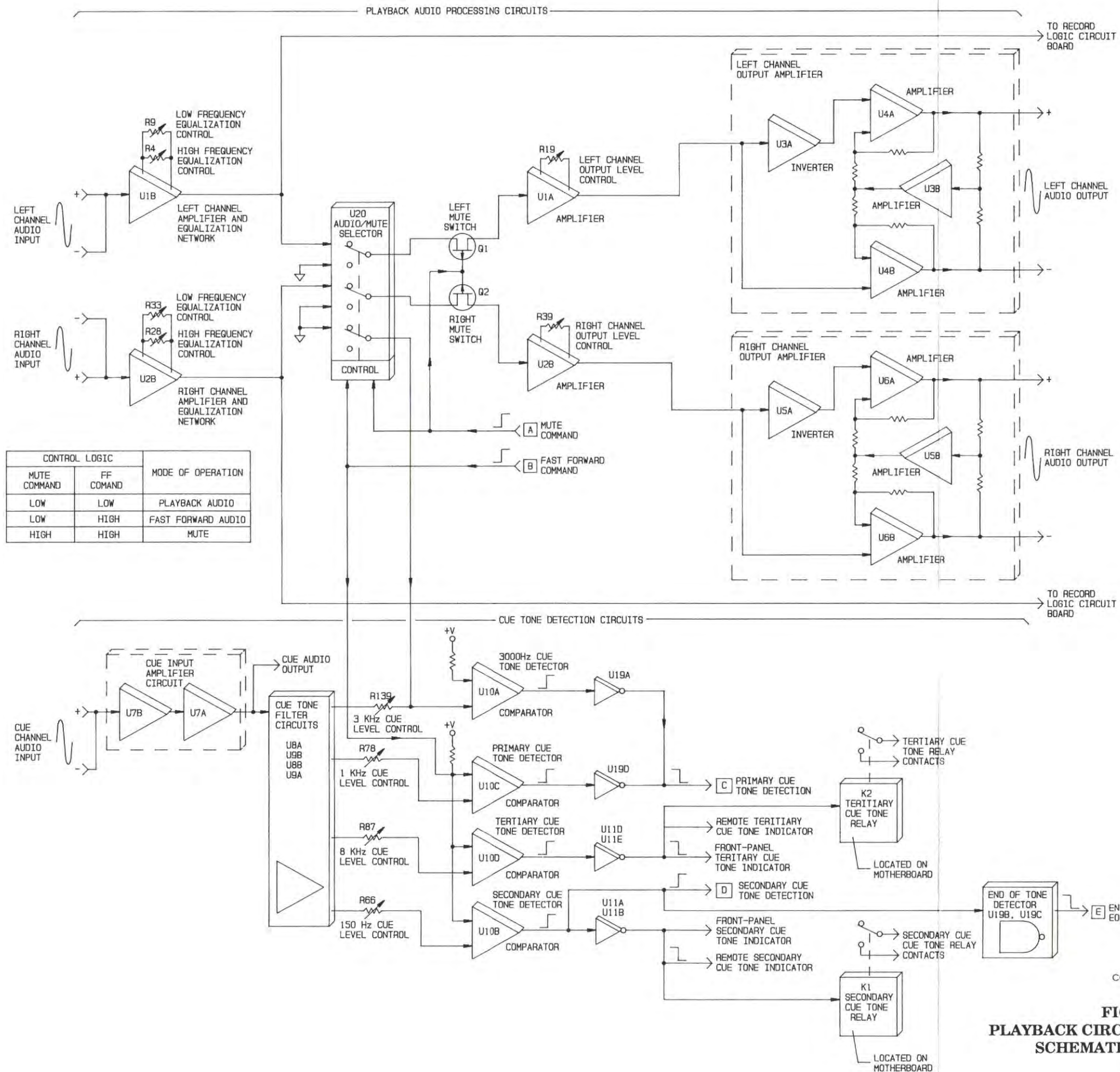

COPYRIGHT © 1990 BROADCAST ELECTRONICS, INC.
597-9100-7A

FIGURE 4-1.
PLAYBACK CIRCUIT BOARD SIMPLIFIED
SCHEMATIC (Sheet 1 of 2)

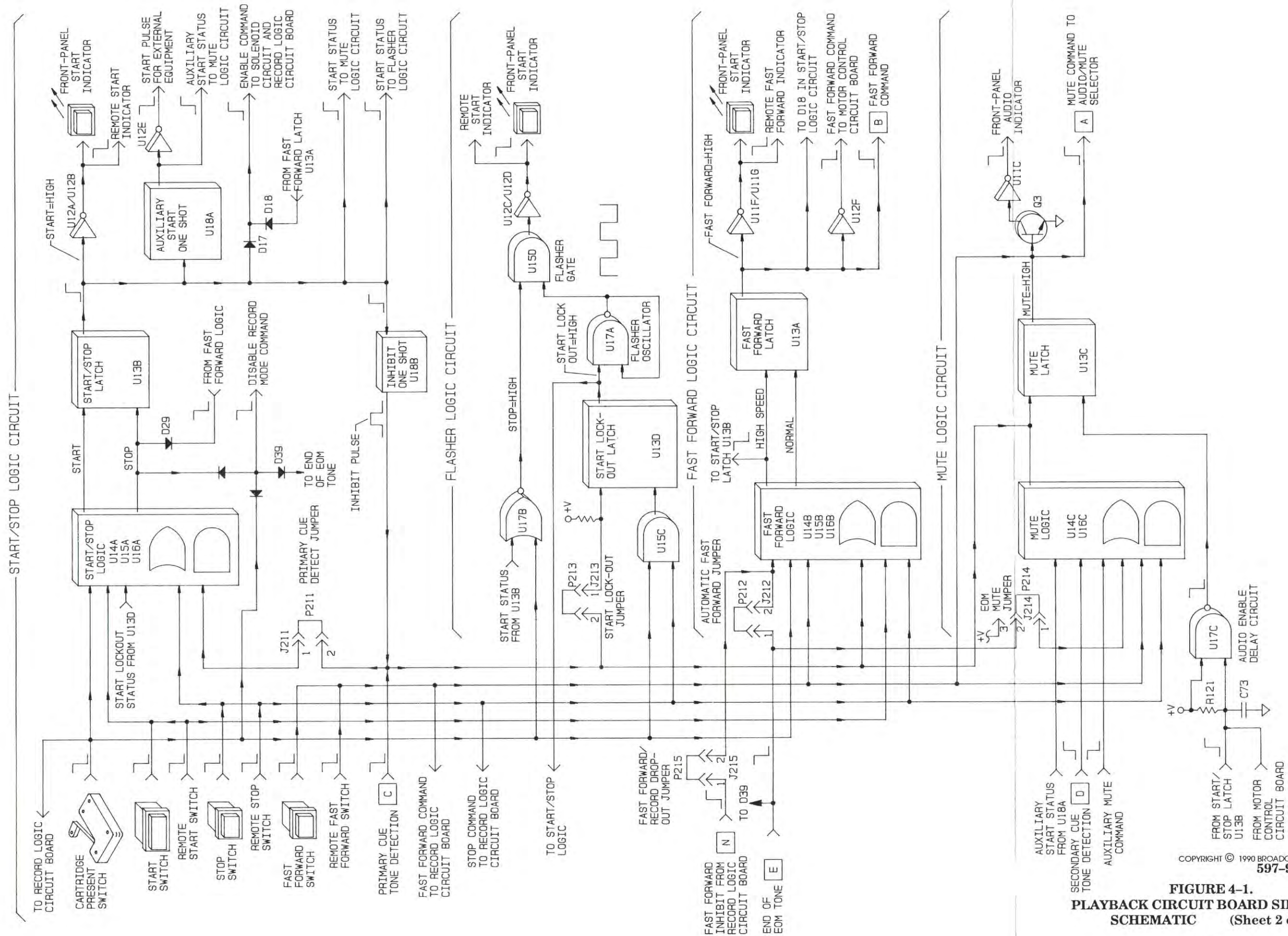

COPYRIGHT © 1990 BROADCAST ELECTRONICS, INC.
597-9100-7B

FIGURE 4-1.
PLAYBACK CIRCUIT BOARD SIMPLIFIED
SCHEMATIC (Sheet 2 of 2)

- 4-24. The start/stop logic circuit consists of: 1) start/stop logic U14A, U15A, and U16A, 2) start/stop latch U13B, 3) auxiliary start one-shot U18A, 4) inhibit one-shot U18B, and 5) inverters U12A/U12B.
- 4-25. **Start and Start Lock-out Operations.** A start operation is initiated when the front-panel start switch/indicator is depressed. A LOW from the start switch/indicator is applied to the start/stop logic for decoding. If the start lock-out and cartridge present switch status lines are LOW, the start output line of the start/stop logic will apply a LOW to start/stop latch U13B.
- 4-26. With the LOW from the start/stop logic, U13B will output a continuous HIGH through diode D17 to energize the solenoid. This HIGH is also routed to the primary cue inhibit circuit, auxiliary start circuit, start indicator circuit, mute logic circuit, and flasher logic circuit.
- 4-27. A start lock-out condition will occur when deck operation is terminated by a primary cue tone detection and the start lock-out status line from the flasher logic circuit is HIGH. This HIGH indicates a cartridge played condition and is applied to the start/stop logic to prevent consecutive start operations.
- 4-28. **Start Indicator Operation.** With the HIGH from the start/stop latch, inverters U12A/U12B will output a LOW to illuminate the start and remote start indicator.
- 4-29. **Auxiliary Start Operation.** With the HIGH from the start/stop latch, the auxiliary start one-shot will apply a momentary HIGH to the mute logic circuit and inverter U12E. U12E will output a momentary LOW for external equipment operations.
- 4-30. **Manual and Automatic Stop Operation.** A manual stop operation is initiated when the stop switch is depressed. A LOW from the stop switch is routed to the start/stop logic for decoding. The stop output line of the start/stop logic will apply a LOW to start/stop latch U13B. U13B will toggle LOW to disable the solenoid and extinguish the start indicators.
- 4-31. An automatic stop operation is initiated when a primary cue tone is detected. A HIGH from the primary cue tone status line is routed through primary cue detect jumper J211 to the start/stop logic for decoding. The stop output line will go LOW to terminate deck operations. This LOW is also routed to the record logic circuit board through diode D36 to terminate a record operation.
- 4-32. **Primary Cue Inhibit Operation.** During a start operation, a HIGH from the start/stop latch is applied to inhibit one-shot U18B. The output of U18B is connected to the primary cue detection status line. U18B will apply a momentary HIGH for approximately 1.75 seconds to the primary cue status line to delay a stop operation.
- 4-33. **Maintenance Mode Operation.** The start/stop logic will also decode a special maintenance mode command to energize the solenoid without a cartridge inserted into the deck. This command is applied to the start/stop logic when the start and stop switches are simultaneously depressed and the stop switch released prior to the start switch.
- 4-34. **FLASHER LOGIC CIRCUIT.** The flasher logic circuit generates the start lock-out status and controls the operation of the stop indicator depending on start lock-out jumper J213. This circuit consists of NOR gate U17B, AND gates U15C and U15D, inverters U12C/U12D, latch U13D, and NAND gate U17A.
- 4-35. **Jumper Installed.** When jumper J213 is installed, the start lock-out operation is enabled. A LOW from the primary cue tone detection status line will be applied to start lock-out latch U13D. U13D will apply a HIGH to the start/stop logic and flasher oscillator U17A. U17A will apply pulses at a 1 Hz rate to flasher gate U15D.
- 4-36. With the unit in the stop mode, U17B will gate a LOW from U13B and a LOW from the cartridge present switch status line to output a HIGH to U15D. U15D will gate the oscillator pulses from U17A for application to the stop indicator through inverters U12C/U12D. The stop indicator will flash at a 1 Hz rate for a cartridge played condition.

- 4-37. The start lock-out latch is cleared by AND gate U15C. The stop switch and cartridge present switch status lines are applied to U15C. With a LOW from either the stop switch or cartridge present switch, U15C will output a LOW to reset to latch U13D.
- 4-38. **Jumper Removed.** When jumper J213 is removed, the start lock-out function is disabled. U13D will apply a continuous LOW to U17A which will output a HIGH to U15D. With the unit in the stop mode, U17B will apply a HIGH to U15D which outputs a continuous HIGH through inverters U12C/U12D to illuminate the stop indicator.
- 4-39. **FAST FORWARD LOGIC CIRCUIT.** The fast forward logic circuit controls the speed of the capstan motor and operation of the solenoid. Depending on jumper J212, the automatic fast forward operation is enabled or disabled. The fast forward logic circuit consists of: 1) fast forward logic U14B, U15B, and U16B, 2) fast forward latch U13A, and 3) inverters U12F and U11F/U11G.
- 4-40. **Automatic Fast Forward Operation.** The automatic fast forward function is enabled when jumper J212 is installed. A fast forward operation is initiated when a secondary cue tone is detected. A LOW from the END of EOM tone status line will be applied to the fast forward logic for decoding.
- 4-41. With the LOW from the END of EOM tone status line and a LOW from the cartridge present switch status line, the fast forward output line of the fast forward logic will output a LOW to start/stop latch U13B through diode D29, and fast forward latch U13A. The LOW at U13B will extinguish only the start indicator. U13A will output a HIGH through diode D18 to maintain solenoid operation.
- 4-42. The HIGH fast forward command from U13A is also routed to inverters U11F/U11G to illuminate the fast forward indicator and the motor control circuit board through inverter U12F.
- 4-43. In a record/playback unit, a HIGH applied to the fast forward logic through J215 inhibits a fast forward function when an END of EOM tone is detected during a record operation. With J215 removed during a record operation, an END of EOM tone will initiate a fast forward function and also disable the record operation by applying a LOW through diode D39.
- 4-44. **Manual Fast Forward Operation.** A manual fast forward operation is identical to an automatic except the manual operation is initiated when the fast forward switch is depressed. A LOW from the fast forward switch will be applied to the fast forward logic to begin a fast forward operation.
- 4-45. **Automatic/Manual Termination of Fast Forward Operation.** Automatic termination of the fast forward operation is initiated when a LOW from the primary cue tone detection line is applied to the fast forward logic for decoding. The normal output line of the fast forward logic will apply a LOW to U13A. U13A will route a LOW to the motor control circuit board to terminate the fast forward operation.
- 4-46. Manual termination of the fast forward operation is identical to an automatic except the manual operation is initiated when the start switch is depressed. A LOW from the start switch will be applied to the fast forward logic to begin a termination operation.
- 4-47. **MUTE LOGIC CIRCUIT.** The mute logic circuit generates the mute command, controls the operation of the audio indicator, and provides an audio delay. This circuit consists of mute logic U14C and U16C, mute latch U13C, NAND gate U17C, transistor Q3, and inverter U11C.
- 4-48. **Mute Operation.** A mute operation is initiated when a LOW from the stop switch bus, or the fast forward switch bus is applied to the mute logic for decoding. A LOW from the END of EOM through J214 will also initiate a mute operation. The mute logic will apply a LOW to U13C. U13C will output a HIGH to the audio/mute selector and transistor Q3. The HIGH will bias Q3 ON which routes a LOW through inverter U11C to extinguish the audio indicator.

- 4-49. A mute operation is also initiated by a LOW on the primary cue tone detection bus. This LOW is directly applied to mute latch U13C which outputs a mute command.
- 4-50. In addition, an auxiliary mute bus provides external mute operations. If both the secondary cue tone detection and auxiliary start status lines are LOW, the mute logic will decode a LOW on the auxiliary mute bus to generate a mute command.
- 4-51. **Audio Enable Operation.** The motor control circuit board applies a LOW to the input of U17C which momentarily inhibits audio until the motor attains proper speed. When the start switch is depressed, a HIGH from start/stop latch U13B will be applied to U17C and C73. U17C will output a momentary LOW to U13C for a duration established by capacitor C73 and resistor R121. This LOW resets U13C to enable the audio.
- 4-52. Audio can also be enabled during a fast forward operation. When the fast forward switch is continuously depressed, a LOW is directly applied to the output of mute latch U13C to enable the audio.
- 4-53. **SOLENOID AND POWER SUPPLY CIRCUITS.** Figure 4-2 presents a simplified schematic diagram of the solenoid and power supply circuits. Refer to Figure 4-2 as required for a description of the circuits.
- 4-54. **Solenoid Operation.** Prior to solenoid operation, transistor Q3 is biased ON which routes +28 volts through the solenoid winding to the collector of transistor Q1 and the base of transistor Q2. With a HIGH from the start/stop latch, Q1 will conduct to rapidly operate the solenoid.
- 4-55. With Q1 conducting, a LOW is applied to the base of Q2 which biases Q2 Off. The collector of Q2 will go HIGH which disables Q3 and allows +12 volts from solenoid driver U3 to be applied to the solenoid.
- 4-56. **Power Supply Circuit.** Primary power is applied to the DT-90A through line fuse F1 and switch S1 to the primary of power transformer T1. The secondaries of T1 provide 25 volt, 40 volt, and 9 volt ac potentials.
- 4-57. The 40 volt ac potential is routed to a full-wave rectifier and filter network to provide +20 volt and -20 volt dc potentials at the output. The +20 volt dc is applied to the input of regulator U1 which supplies a regulated +16 volts to the logic circuit board, front-panel switches, and cue relays. The -20 volt dc is applied to the input of regulator U2 which supplies a regulated -16 volts to the logic circuit board.
- 4-58. The 9 volt ac potential is routed to a full-wave rectifier and filter network to provide an unregulated +10 volt supply for front-panel status indicators.
- 4-59. The 25 volt ac potential is routed to a full-wave rectifier and filter network to provide an unregulated +28 volt supply for solenoid operation. +28 volts is also routed to a lamp driver which supplies +28 volts to the rear-panel for external applications, and operating voltage for front-panel switch/indicators.

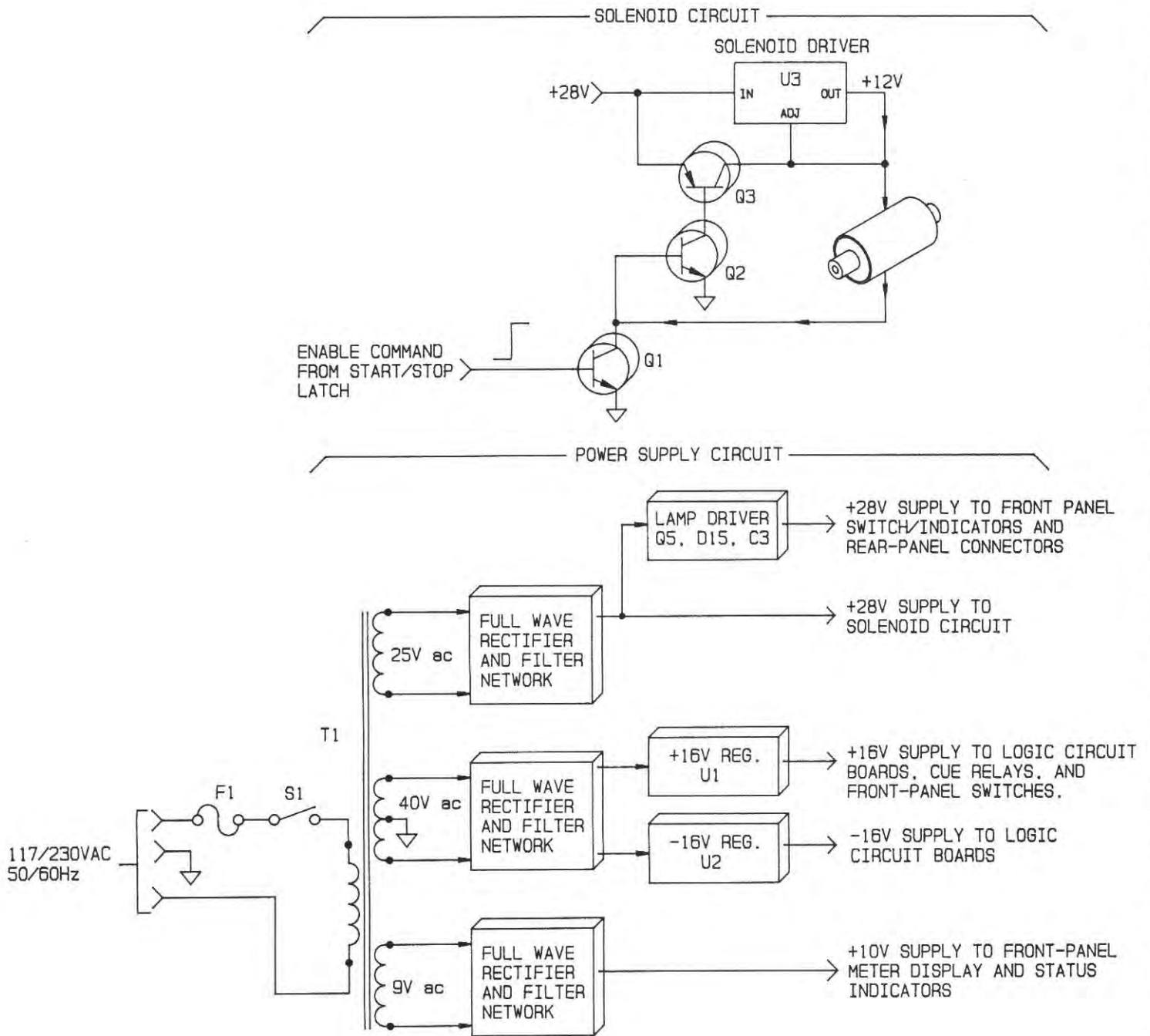

COPYRIGHT © 1990 BROADCAST ELECTRONICS, INC
597-9100-7C

FIGURE 4-2. POWER SUPPLY AND SOLENOID CIRCUITS

4-60. **MOTOR CONTROL CIRCUIT BOARD.**

4-61. Figure 4-3 presents a simplified schematic diagram of the motor control circuit board. Refer to Figure 4-3 as required for a description of the following circuits.

- A. Reference Circuit.
- B. Tachometer Processing Circuit.
- C. Frequency Comparator Circuit.
- D. Motor Driver Circuit.
- E. Motor Protection Circuit.
- F. Motor Lock Detector Circuit.
- G. Motor Commutator Control Circuit.
- H. Vari-Speed Circuit.
- J. Power Supply Circuit.

- 4-62. **REFERENCE CIRCUIT.** A precision reference signal for servo circuit operation is generated by a 460.8 kHz crystal controlled oscillator circuit consisting of crystal Y1, capacitors C30, C31, and resistor R54. The oscillator circuit output is applied to divider U11.
- 4-63. Divider U11 is designed to generate motor frequency references. The output of U11 and motor speed jumper network W1 is applied to divide-by-three stage U12A/B. The output of divider U12A/B is routed to multiplexer network U13A/B. U13A/B is designed to switch between normal and fast forward motor frequency references. Jumper network W3 provides input information for the multiplexer network. The output of multiplexer U13A/B is routed for application to a frequency comparator circuit. The following list provides motor reference frequencies and corresponding motor speeds.

MOTOR REFERENCE FREQUENCY (Hz)		MOTOR SPEED (Inches-Per-Second)	
NORMAL	FAST FORWARD	NORMAL	FAST FORWARD
1200	3600	15	—
600	1800	7.5	22.5
300	900	3.75	11.25

- 4-64. **Normal/Fast Forward Operation.** With the unit in the normal mode and programmed for 7.5 IPS operation, divider U11 will output an 1800 Hz reference to divider U12A/B and multiplexer U13A/B via jumper network W3. U12A/U12B will output a 600 Hz reference to multiplexer U13A/B. The vari-speed and fast forward control lines will be HIGH to instruct multiplexer U13A/B to output a 600 Hz motor reference frequency for application to a frequency comparator circuit.
- 4-65. When the unit is operated to the fast forward mode, the fast forward control line will go LOW. The LOW instructs multiplexer U13A/B to output an 1800 Hz reference for application to a frequency comparator circuit.
- 4-66. **TACHOMETER PROCESSING CIRCUIT.** An indication of cartridge machine motor speed is generated by a tachometer winding. When the unit is programmed for 7.5 IPS operation and the motor is at full speed, the tachometer will output a sinusoidal 600 Hz signal to high gain amplifier stage U2A. U2A is configured for a gain of approximately 1000. The output of U2A is applied to inverter U15G. U15G generates square-wave tachometer pulses for application to a frequency comparator circuit.
- 4-67. **FREQUENCY COMPARATOR CIRCUIT.** The frequency comparator circuit consists of a one-shot network, a frequency comparator, and a shift register. The one-shot network consists of integrated circuits U3A/B. The reference circuit output (600 Hz for 7.5 IPS operation) is applied to one-shot U3B. The motor tachometer reference is applied to one-shot U3A. The one-shots are designed to generate precision square-wave signals for application to the frequency comparator.

- 4-68. The frequency comparator network consists of NAND gates U4A/B/C. The circuit compares the applied frequencies and generates corresponding shift and clock signals to shift register U5 and a rectifier network. Shift register U5 will generate four outputs which represent operating parameters such as motor load and speed. The outputs provide information for a motor driver circuit, a motor brake control circuit, and a motor protection circuit.
- 4-69. **Motor Run Circuit.** The $\overline{\text{CLR}}$ input of shift register U5 determines motor operation. When the deck switch is open (cartridge not present), a LOW is applied to the $\overline{\text{CLR}}$ input to inhibit motor operation. When the deck switch is closed (cartridge present), a HIGH is applied to the $\overline{\text{CLR}}$ input to initiate motor operation.
- 4-70. **MOTOR DRIVER CIRCUIT.** One output from shift register U5 is filtered into a dc level by a passive low-pass filter consisting of resistors R7, R8, R9 and capacitors C9 and C10. The dc level is buffered by operational amplifier U6A and applied to amplifier stage U6B. U6B will output a varying bias voltage to motor driver transistor Q1. Q1 is designed to provide a dc supply voltage which controls the speed of the motor. Potentiometer R16 provides motor drive calibration.
- 4-71. **MOTOR PROTECTION CIRCUIT.** The motor is monitored for loss of tachometer signals and over-current conditions by a protection circuit. A rectifier circuit consisting of diodes D2 and D13 and operational amplifier U7A function as a tachometer monitor network. With the application of tachometer signals, the output of U7A will be HIGH to allow normal motor drive operation. With the loss of tachometer pulses, the output of U7A will go LOW to bias Q1 off and terminate motor operation.
- 4-72. Motor over-current conditions are monitored by a circuit consisting of a passive low-pass filter, comparator U7C, and latch U7D. A motor current sample is filtered into a dc level by a low-pass filter consisting of resistors R39, R40, and capacitor C26. The dc signal is applied to comparator U7C and latch U7D. When the motor current sample is below the reference level at U7C, U7C will output a HIGH to latch U7D. U7D will output a HIGH to allow normal motor drive operation. When the motor current sample increases above the comparator reference level, U7C will output a LOW to latch U7D. U7D will output a LOW to bias Q1 off and terminate motor operation. A timing circuit consisting of inverter U15B, transistor Q8, and capacitor C29 disables the over-current protection circuit for approximately 3 seconds during initial motor operation.
- 4-73. **MOTOR LOCK DETECTOR CIRCUIT.** Samples from U5 are monitored for motor unlocked conditions by inverter U2B, diode D4, and flip-flop U9B. When the motor is operating in a locked condition, a HIGH is applied to inverter U2B and a LOW to Diode D4. U2B will output a LOW to frequency lock detector U9B. The output of U9B will go LOW. The LOW is routed to inverter U15C which outputs a HIGH to the playback circuit board. When an unlocked condition exists, the output of U2B will go HIGH or diode D4 will conduct to generate a clock pulse for flip-flop U9B. The output U9B will go HIGH. Inverter U15C will route a LOW to the playback circuitry to inhibit audio output until the motor speed is synchronized.
- 4-74. **MOTOR COMMUTATOR CONTROL CIRCUIT.** The motor commutator control circuit consists of a stator control/driver network and a brake control circuit. Multiplexer U10A/B/C and transistors Q2 through Q7 operate together to control the direction of the motor stators. Divider U8 and motor brake control flip-flop U9A initiate motor braking operations when: 1) the motor is operating at a fast forward rate and required to return to the normal operating speed and 2) at motor termination.

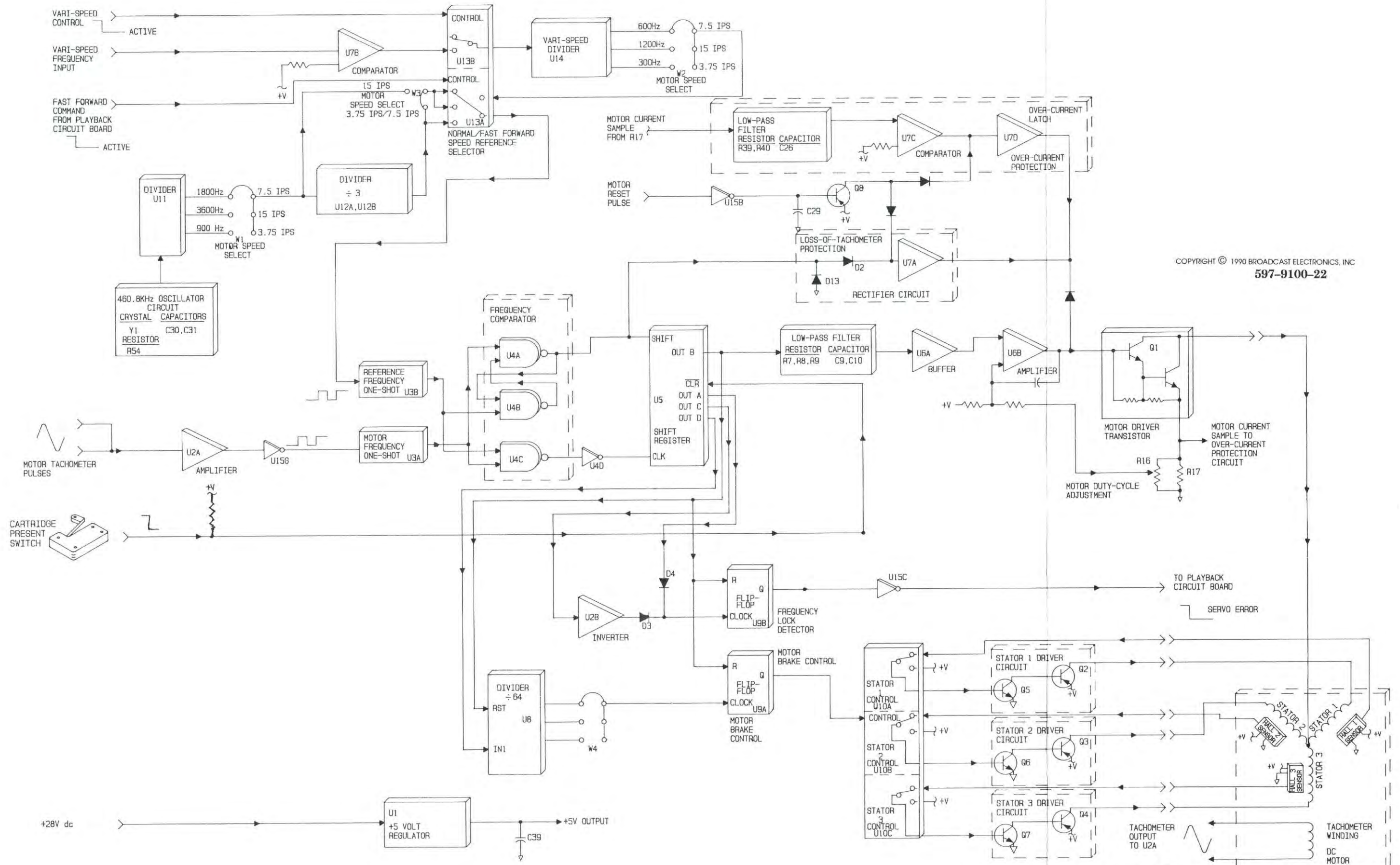

COPYRIGHT © 1990 BROADCAST ELECTRONICS, INC
597-9100-22

FIGURE 4-3. MOTOR CONTROL CIRCUIT BOARD SIMPLIFIED SCHEMATIC
4-13/4-14

- 4-75. When the motor is in normal or fast forward operation, output samples from U5 will force the output of divider U8 LOW. The LOW is applied to motor brake control flip-flop U9A. The output of U9A will go LOW. With the output of U9A LOW, stator control logic U10A/B/C and the transistor driver circuits operate individually to control each motor stator. A signal from hall effect sensor 1 will be routed through stator control device U10A to the stator 1 driver circuit. The driver circuit will output the signal to control the operation of stator 1. Stator 2 and 3 control/driver networks operate in an identical manner. The stator control/driver circuitry will respond in the appropriate sequence to initiate and control motor commutator rotation.
- 4-76. When a motor braking operation is required, the motor drive samples from U5 will produce a square-wave clock signal from U8. The clock signal is applied to flip-flop U9A which outputs a corresponding square-wave control signal to the stator control logic. The stator control logic will respond by simultaneously applying a +28 volt pulse to each stator to provide a motor braking action. When the motor returns to a locked condition, the output of U9A will go LOW to terminate motor braking operation and provide normal stator control.
- 4-77. **VARI-SPEED CIRCUIT.** The cartridge machine motor may be varied a minimum $\pm 10\%$ for special audio applications by a vari-speed feature. The vari-speed circuitry consists of comparator U7B, divider U14, and jumper network U2. The circuit operates from a nominal 9600 Hz external signal source.
- 4-78. The vari-speed signal source is applied to comparator U7B. U7B is designed to generate a square-wave reference signal for application to multiplexer U13B. When a LOW is applied to the vari-speed control line, multiplexer U13B will route the reference signal to divider U14. U14 will output a corresponding reference signal for application to U13A and the reference circuitry.
- 4-79. **POWER SUPPLY CIRCUIT.** The motor control circuit board power supply circuit consists of regulator U1 and capacitor C39. U1 and capacitor C39 regulate the +28V dc voltage into a +5 volt supply for circuit operations.
- 4-80. **RECORD CIRCUITRY.**
- 4-81. Figure 4-4 presents a simplified schematic diagram of the record logic circuit board. Refer to Figure 4-4 as required for a description of the following circuits.
- A. Record Audio Processing Circuits.
 - B. Metering Circuits.
 - C. Program Bias Circuit.
 - D. Cue Bias Circuit.
 - E. Cue Tone Generator Circuits.
 - F. Record/Primary Cue Tone Logic Circuits.
 - G. Secondary/Tertiary Cue Tone Logic Circuits.
- 4-82. **RECORD AUDIO PROCESSING CIRCUITS.** Stereophonic units are equipped with left and right channel record audio circuits. Monophonic units are equipped with only the left channel audio circuit. The left and right channel audio circuits are identical; therefore, only the left channel record circuit will be discussed.
- 4-83. **Input Amplifier Circuit.** Left channel record audio from the rear-panel record connector is applied to a 600 Ohm impedance matching network. Audio from the impedance network is applied to integrated circuits U1A, U1B and U1D which operate as an instrumentation amplifier. The amplifier provides maximum noise rejection with a gain of one.

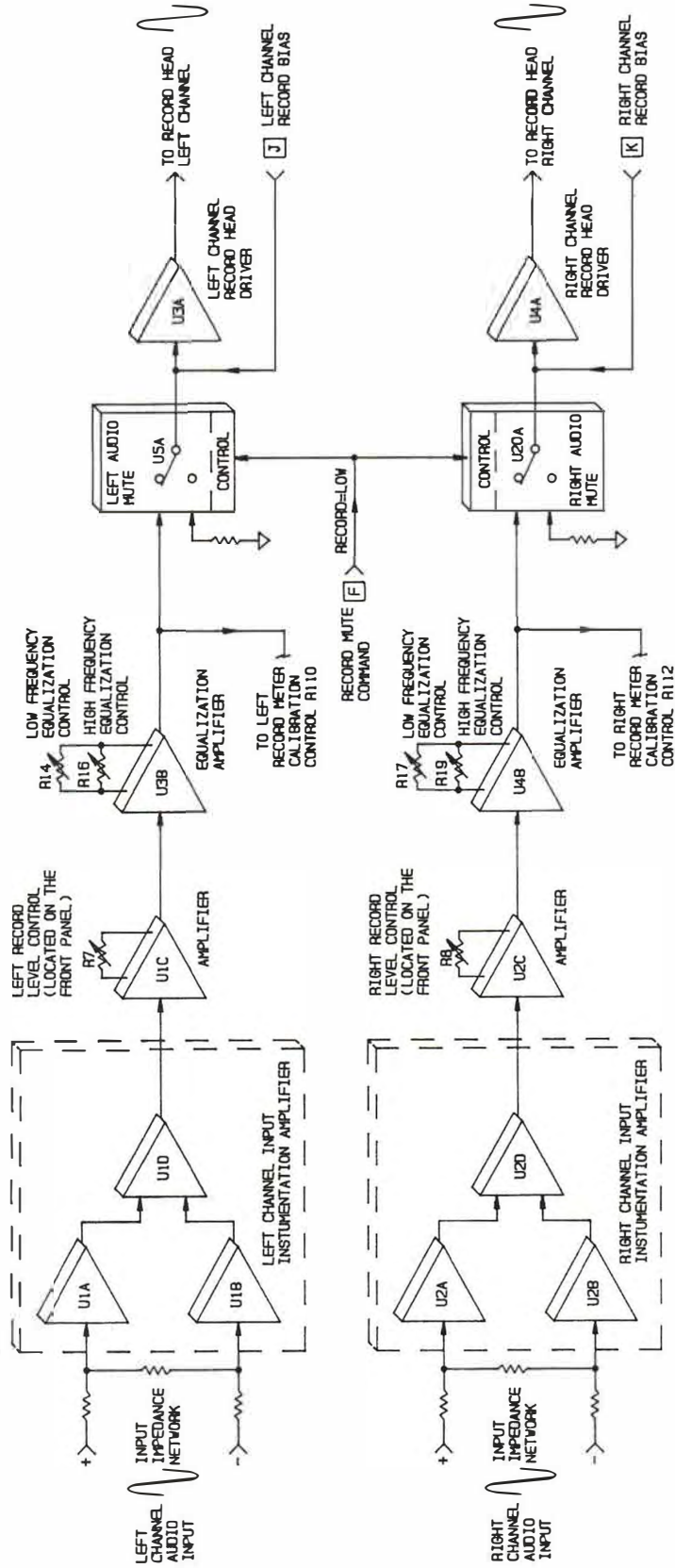

METER CIRCUITS

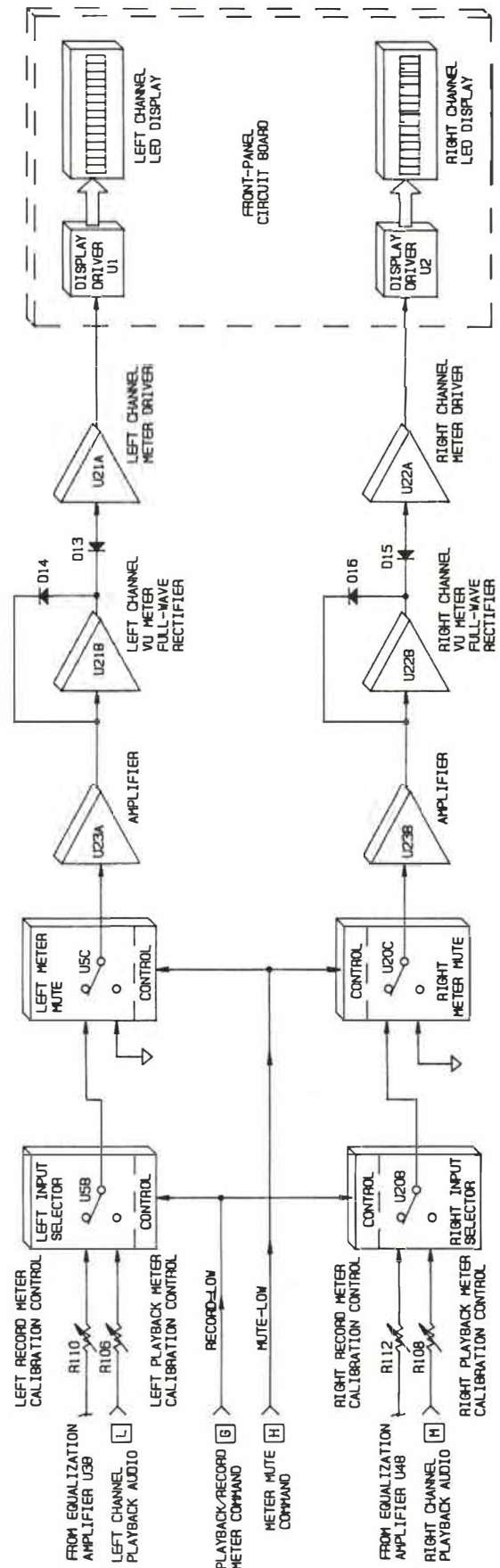

FIGURE 4-4. RECORD CIRCUIT BOARD SIMPLIFIED SCHEMATIC
(Sheet 1 of 2)

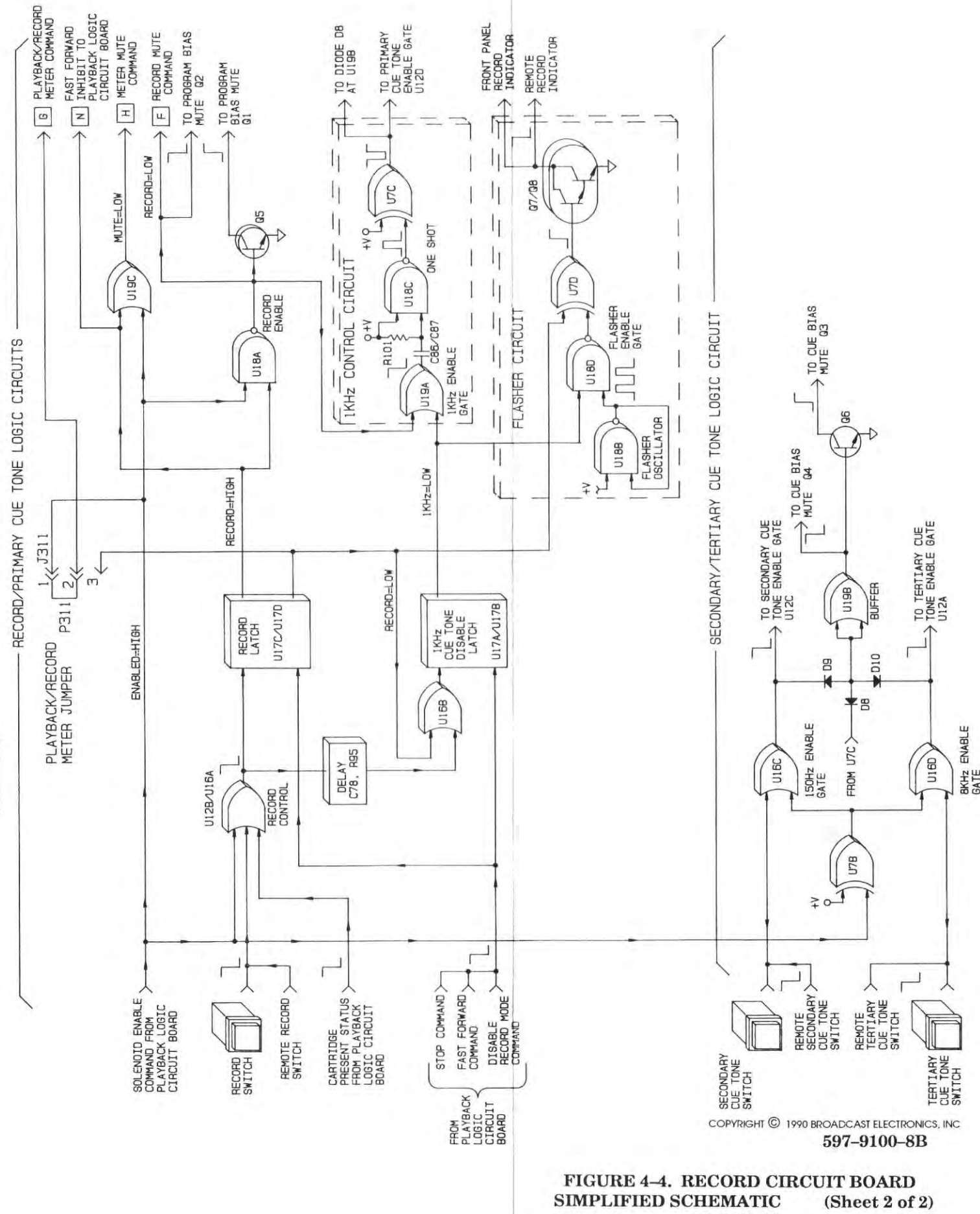
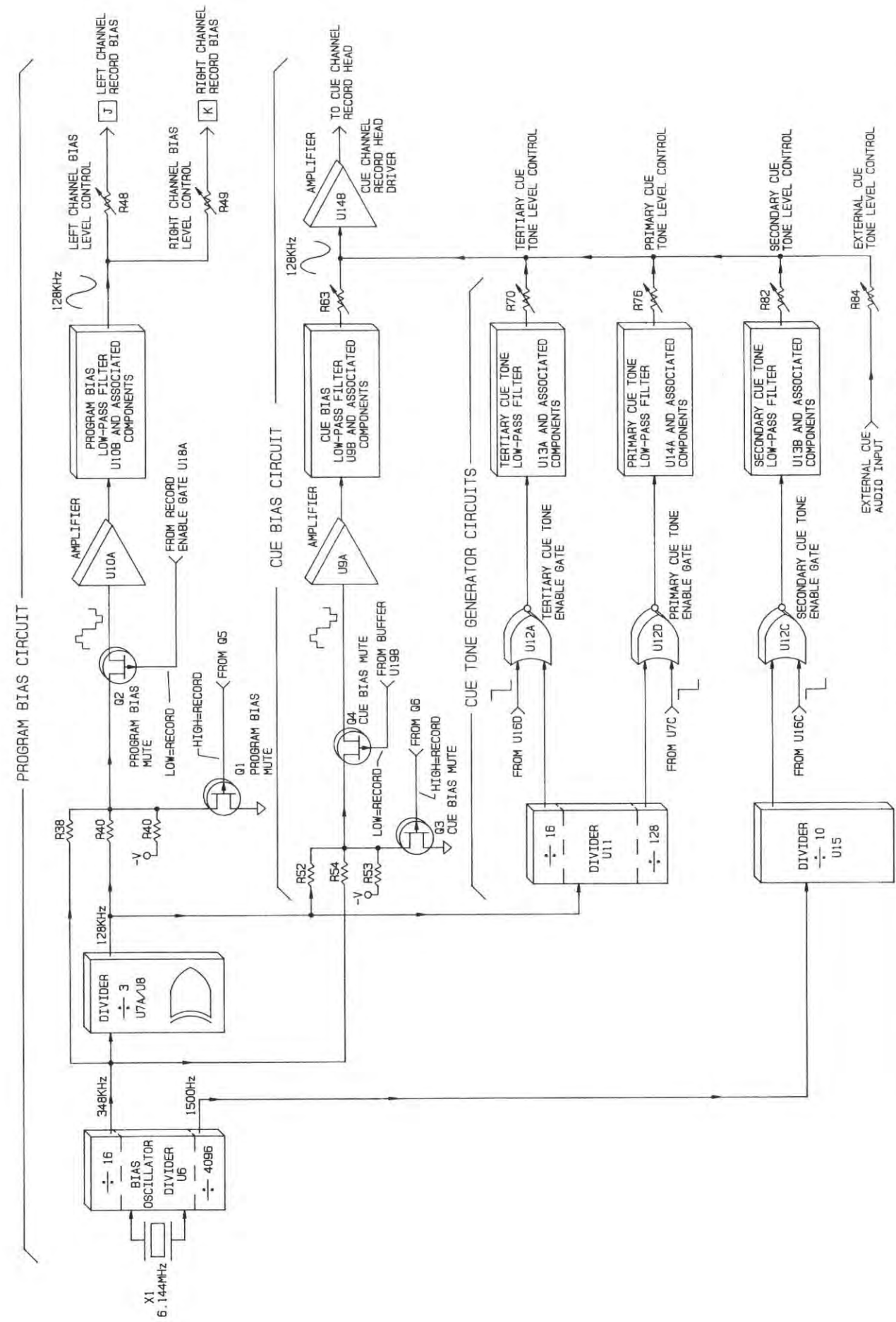

FIGURE 4-4. RECORD CIRCUIT BOARD SIMPLIFIED SCHEMATIC (Sheet 2 of 2) 4-17/4-18

COPYRIGHT © 1990 BROADCAST ELECTRONICS, INC. 597-9100-8B

- 4-84. Audio from the input amplifier is applied to an amplifier and input level control stage consisting of U1C and front-panel potentiometer R7. U1C and R7 provide an input level range from -20 dBm to +20 dBm.
- 4-85. **Equalization Amplifier Circuit.** The output of U1C is applied to equalization amplifier stage U3B which provides unity gain. Potentiometer R14 provides ± 5 dB of low frequency equalization. Potentiometer R16 provides ± 3 dB of high frequency equalization. The output of U3B is routed to the metering circuit and the audio/mute selector.
- 4-86. **Audio/Mute Selector Operation.** Intergrated circuit U5A will mute or enable the audio depending on the record mute command. When the mute command is LOW, U5A will enable the audio. The output of U5A is applied to the record head driver.
- 4-87. **Record Head Driver Circuit.** Intergrated circuit U3A operates as a constant current amplifier to drive the record head. Left channel record bias is applied at the input of U3A which eliminates the necessity for a bias trap circuit.
- 4-88. **METERING CIRCUITS.** Stereophonic units are equipped with left and right channel metering circuits. Monophonic units are equipped with only the left channel metering circuit. The left and right metering circuits are identical; therefore, only the left channel circuit will be discussed.
- 4-89. Audio from the left record amplifier is applied to left input selector U5B through calibration control R110. Audio from the left playback amplifier is applied to U5B through calibration control R106. With a LOW on the playback/record meter command line, U5B will route record audio to the left meter mute.
- 4-90. Left meter mute U5C will mute or enable the metering circuit depending on the meter mute command. When the meter mute command is HIGH, U5C will route audio to U21B through amplifier U23A. Full-wave rectifier circuit U21B converts the audio into dc for application to the left channel meter driver.
- 4-91. Left channel meter driver U21A and associated components establish the meter ballistics. The output of U21A is applied to a display driver. The display driver contains a resistive ladder network and comparator circuits which sequentially activate output lines in response to the input voltage. The output lines of the display driver are applied to a moving bar LED display which illuminate when the lines are activated.
- 4-92. **PROGRAM BIAS CIRCUIT.** The program bias circuit provides an accurate 128 kHz signal for application to the record head program channels. A 6.144 MHz frequency from crystal X1 is applied to bias oscillator/divider U6. U6 will divide the input signal by 4096 to provide a 1500 Hz signal to the cue tone generator circuit.
- 4-93. U6 also divides the 6.144 MHz input signal by 16 to provide a 348 kHz signal to divide-by-three counter U7A/U8 and the input of program bias mute Q2 through summing resistor R38. The output of U7A/U8 applies a 128 kHz signal to Q2 through summing resistor R40.
- 4-94. Program bias mute Q2 operates to the record mode when a LOW is applied to the gate. Program bias mute Q1 operates to the record mode when a HIGH is applied to the gate. With Q1 and Q2 in the record mode, a stepped sine-wave is applied to the input of amplifier U10A.
- 4-95. The output of U10A is applied to a low-pass filter consisting of U10B and associated components. The filter will convert the stepped sine-wave into a 128 kHz sinusoidal signal. The output of the filter is routed through bias level control R48 for application to the left record amplifier circuit. Program bias for the right record amplifier circuit is routed through bias level control R49.

- 4-96. **CUE BIAS CIRCUIT.** The cue bias circuit generates a 128 kHz signal for application to the record head cue channel. The output of bias oscillator/divider U6 applies a 348 kHz signal to cue bias mute Q4 through summing resistor R54. Divide-by-three counter U7A/U8 applies a 128 kHz signal to Q4 through summing resistor R52.
- 4-97. Cue bias mute Q4 operates to the record mode when a LOW is applied to the gate. Cue bias mute Q3 operates to the record mode when a HIGH is applied to the gate. With Q3 and Q4 in the record mode, a stepped sine-wave is applied to the input of amplifier U9A.
- 4-98. The output of U9A is applied to a low-pass filter consisting of U9B and associated components. The filter will convert the stepped sine-wave into a 128 kHz sinusoidal signal. The output of the filter is applied to head driver U14B through cue bias level control R63. Cue tone audio is also applied at the input of U14B. The output of U14B is applied to the record head cue channel.
- 4-99. **CUE TONE GENERATOR CIRCUITS.** The primary, secondary, and tertiary cue tone generator circuits are contained on the record logic circuit board. Circuitry is also provided for external cue tone applications.
- 4-100. **Primary Cue Tone Circuit.** A 128 kHz signal from divide-by-three counter U7A/U8 is applied to divider U11. U11 will divide the input signal by 128 to output a 1 kHz signal to OR gate U12D. With a LOW from U7C, U12D will route the 1 kHz signal to a primary cue tone low-pass filter consisting of U14A and associated components. The sinusoidal output of the filter is applied to head driver U14B through primary cue tone level control R76.
- 4-101. **Tertiary Cue Tone Circuit.** Integrated circuit U11 will also divide the 128 kHz input signal by 16 to output an 8 kHz signal to OR gate U12A. With a LOW from U16D, U12A will route the 8 kHz signal to a tertiary cue tone low-pass filter consisting of U13A and associated components. The sinusoidal output of the filter is applied to head driver U14B through tertiary cue tone level control R70.
- 4-102. **Secondary Cue Tone Circuit.** Integrated circuit U15 will divide the 1500 Hz input signal by 10 to output a 150 Hz signal to OR gate U12C. With a LOW from U16C, U12C will route the 150 Hz signal to a secondary cue tone low-pass filter consisting of U13B and associated components. The sinusoidal output of the filter is applied to head driver U14B through secondary cue tone level control R82.
- 4-103. **External Cue Tone Circuit.** The record logic circuit board provides for external cue operations. External cue audio from the rear-panel is routed to record head driver U14B through external cue tone level control R84.
- 4-104. **RECORD/PRIMARY CUE TONE LOGIC CIRCUITS.** The record and primary cue tone logic circuits generate commands to control the program bias mute, and meter mute circuits. These circuits also control primary cue tone record and front-panel record indicator operations.
- 4-105. **Record Operation.** A record operation is initiated when the record switch is depressed. With a LOW on the solenoid enable command line and cartridge present switch status line, record control U12B/U16A will gate a LOW from the record switch to record latch U17C/U17D. The record control also applies a momentary LOW to OR gate U16B through a one-shot circuit consisting of C78 and R95.
- 4-106. With the LOW from the record control, the record latch will output a HIGH to NAND gate U18A, OR gate U19C, and the playback logic circuit board. The record latch also outputs a LOW to OR gate U16B.
- 4-107. When a start operation is initiated, a HIGH on the solenoid enable command line is applied to record enable U18A and OR gate U19C. U18A will output a LOW to operate audio mute logic U5A, U20A, and program bias mute Q2 to the record mode.
- 4-108. The LOW from U18A is also applied to transistor Q5 which outputs a HIGH to operate program bias mute Q1 to the record mode. With a HIGH from either the record latch or solenoid enable command line, U19C will output a HIGH to enable the meter circuit.

- 4-109. **Primary Cue Tone Record Operation.** A primary cue tone record operation is initiated when the record switch is depressed. The record latch applies a LOW to OR gate U16B which outputs a HIGH to 1 kHz cue tone disable latch U17A/U17B. The latch will apply a LOW to 1 kHz enable gate U19A.
- 4-110. With the LOW from U17A/U17B and LOW from U18A during a start operation, U19A will output a LOW to NAND gate U18C. U18C will output a momentary HIGH to exclusive OR gate U7C for a duration established by components C86/C87 and R101. U7C will apply a momentary LOW to activate primary cue tone enable gate U12D. A momentary LOW is also routed to the secondary/tertiary cue tone logic circuit to operate cue bias mute logic Q3 and Q4 to the record mode.
- 4-111. **Primary Cue Tone Record Inhibit Operation.** When a record operation is initiated, a momentary LOW from the one-shot circuit is applied to U16B prior to the continuous LOW from the record latch. When the record switch is depressed again, U16B will gate the momentary LOW to 1 kHz cue tone disable latch U17A/U17B.
- 4-112. The output of U17A/U17B will apply a HIGH to U19A to disable the 1 kHz control circuit. This HIGH is also applied to U18D to enable the flasher circuit. U18B generates pulses at a 1 Hz rate for application to flasher enable gate U18D. U18D applies the pulses to the input of exclusive OR gate U7D. With a LOW from the record latch during a record operation, U7D will gate pulses to transistors Q7/Q8. The output of Q7/Q8 will flash the record indicator at a 1 Hz rate for a 1 kHz cue tone inhibit condition.
- 4-113. **Record Disable Operation.** A record operation is terminated when a LOW on the stop, fast forward, or disable record command line is applied to the record latch and 1 kHz cue tone disable latch. The output of the record latch will go LOW to disable a record operation. The output of the cue tone disable latch will go LOW to enable a 1 kHz cue tone record operation.
- 4-114. **Meter Operation.** The front-panel meters will indicate record levels or playback levels during a record operation depending on programmable jumper J311. When the solenoid is deenergized, a LOW from the solenoid command line operates the meter select circuits on the playback circuit board for record level indications.
- 4-115. If J311 is in position 1-2 and deck operation is initiated, a HIGH from the solenoid command line operates the meters for playback level indications. However, if J311 is in position 2-3 and deck operation is initiated, a LOW from the record latch assures the meter select circuits are operated for record level indications.
- 4-116. **SECONDARY/TERTIARY CUE TONE LOGIC CIRCUITS.** The secondary and tertiary cue tone logic circuits generate the cue bias mute control signals and the tertiary and secondary cue tone enable signals. The secondary and tertiary circuits operate identically; therefore, only the secondary circuit will be discussed.
- 4-117. With a HIGH applied from the solenoid enable command line, exclusive OR gate U7B will output a LOW to 150 Hz enable gate U16C. When the secondary cue tone switch is depressed, a LOW is applied to U16C. U16C will output a LOW to activate secondary cue tone enable gate U12C.
- 4-118. The LOW from U16C is also routed to buffer U19B through steering diode D9. U19B will output a LOW to operate cue bias mute Q4 to the record mode. The LOW is also applied to transistor Q6. Q6 will output a HIGH to operate cue bias mute Q3 to the record mode.

SECTION V MAINTENANCE

5-1. INTRODUCTION.

5-2. This section provides general maintenance information, mechanical and electrical adjustment procedures, and troubleshooting information for the Broadcast Electronics DT-90A series cartridge machines.

5-3. SAFETY CONSIDERATIONS.

5-4. Low voltages are used throughout DT-90A cartridge machine playback and record circuit board assemblies. Maintenance with power energized is always considered hazardous and caution should be observed. Good judgment, care, and common sense must be practiced to prevent accidents. The procedures contained in this section should be performed only by experienced and trained maintenance personnel.

5-5. FIRST LEVEL MAINTENANCE.

5-6. First level maintenance consists of precautionary procedures applied to the equipment to prevent future failures. The procedures are performed on a regular basis and the results recorded in a maintenance log.



WARNING *DISCONNECT ALL CARTRIDGE MACHINE PRIMARY
POWER BEFORE ATTEMPTING ANY EQUIPMENT
MAINTENANCE.*

5-7. GENERAL.

5-8. Periodically remove abrasions from the cartridge machine chassis with a cloth moistened with a mild household cleaner. Remove dust from the chassis exterior with a brush and vacuum cleaner as required.

5-9. ELECTRICAL.

5-10. The cartridge machine circuitry should be periodically cleaned of accumulated dust using a brush and vacuum cleaner. Check the circuit boards for improperly seated semiconductors and components damaged by overheating.

5-11. MECHANICAL.



WARNING *MOST SOLVENTS WHICH REMOVE TAPE RESIDUE
ARE VOLATILE AND TOXIC BY NATURE AND MUST
BE APPLIED IN SMALL AMOUNTS IN A WELL VENTI-
LATED AREA. OBSERVE THE SOLVENT CONTAINER
SAFETY INFORMATION AND DO NOT USE THE SOL-
VENT NEAR FLAME, CIGARETTES, AND HOT SOLDER-
ING IRONS.*

5-12. Each day clean the heads, tape guides, pressure roller, and capstan shaft with a cleaning solvent to remove accumulated oxide. Recommended cleaning solvents include: 1) Broadcast Electronics head cleaning kit 979-0064 and 2) isopropal alcohol. The pressure roller and capstan shaft may be cleaned utilizing the cartridge machine maintenance mode operation (refer to MAINTENANCE MODE OPERATION in SECTION III, OPERATION).

- 5-13. Approximately once a week, demagnetize the heads and other ferrous components in the tape path. Perform the demagnetizing with an appropriate degausser. Observe the degausser operating instructions to prevent damage to the heads.
- 5-14. **SECOND LEVEL MAINTENANCE.**
- 5-15. Second level maintenance consists of procedures required to restore a DT-90A cartridge machine to operation after a fault has occurred. The procedures are divided into mechanical adjustments, electrical adjustments, mechanical component replacement procedures, electrical component replacement procedures, and troubleshooting.
- 5-16. The DT-90A cartridge machine maintenance philosophy consists of isolating a problem to a specific assembly with subsequent troubleshooting to isolate defective components. The defective components may be repaired locally or the entire assembly may be returned to Broadcast Electronics, Inc. for repair or replacement.
- 5-17. **MECHANICAL ADJUSTMENTS.**
- 5-18. The following text provides adjustment procedures for mechanical components associated with the DT-90A series cartridge machines. The procedures are presented in the following order.

ADJUSTMENT PROCEDURES

- A. Motor Alignment Procedure.
 - B. Pinch Roller Indentation Adjustment.
 - C. Solenoid Response Adjustment.
 - D. Head Adjustments.
- 5-19. The following test equipment is required for the mechanical adjustment procedures. Refer to the following list as required for each procedure.

TEST EQUIPMENT

- A. Calibrated Oscilloscope, 5 MHz Bandwidth, Dual Channel With Lissajous Display of Inputs.
 - B. Calibrated Low Distortion Audio Generator, 600 Ohm Output, 20 Hz to 20 kHz Audio Range.
 - C. Tape Head and Tape Guide Alignment Gauge (BE P/N 300-0002).
 - D. Motor Alignment Gauge (BE P/N 300-0700).
 - E. Pressure Roller Indentation Gauge (BE P/N 300-0013).
 - F. Allen Wrenches (supplied with the Cartridge Machine).
 - G. Tape Alignment Cut-Away Test Cartridge (BE P/N 710-0132).
 - H. Stereophonic/Monophonic Reproduce Alignment Tape (BE P/N 808-0004).
 - I. No. 1 Phillips Screwdriver, 4 Inch (10.2 cm) Blade.
- 5-20. **MOTOR ALIGNMENT PROCEDURE.** The deck pressure roller operates in conjunction with the motor capstan shaft to provide tape movement. The pressure roller and the motor capstan shaft must be properly aligned to prevent improper tape movement across the heads.

- 5-21. **Procedure.** To align the cartridge machine motor and deck solenoid, proceed as follows:
- 5-22. Disconnect the cartridge machine primary power.
- 5-23. Manually retract the deck solenoid plunger (refer to Figure 5-1) and remove the pressure roller E-ring, pressure roller, and the nylon washers.

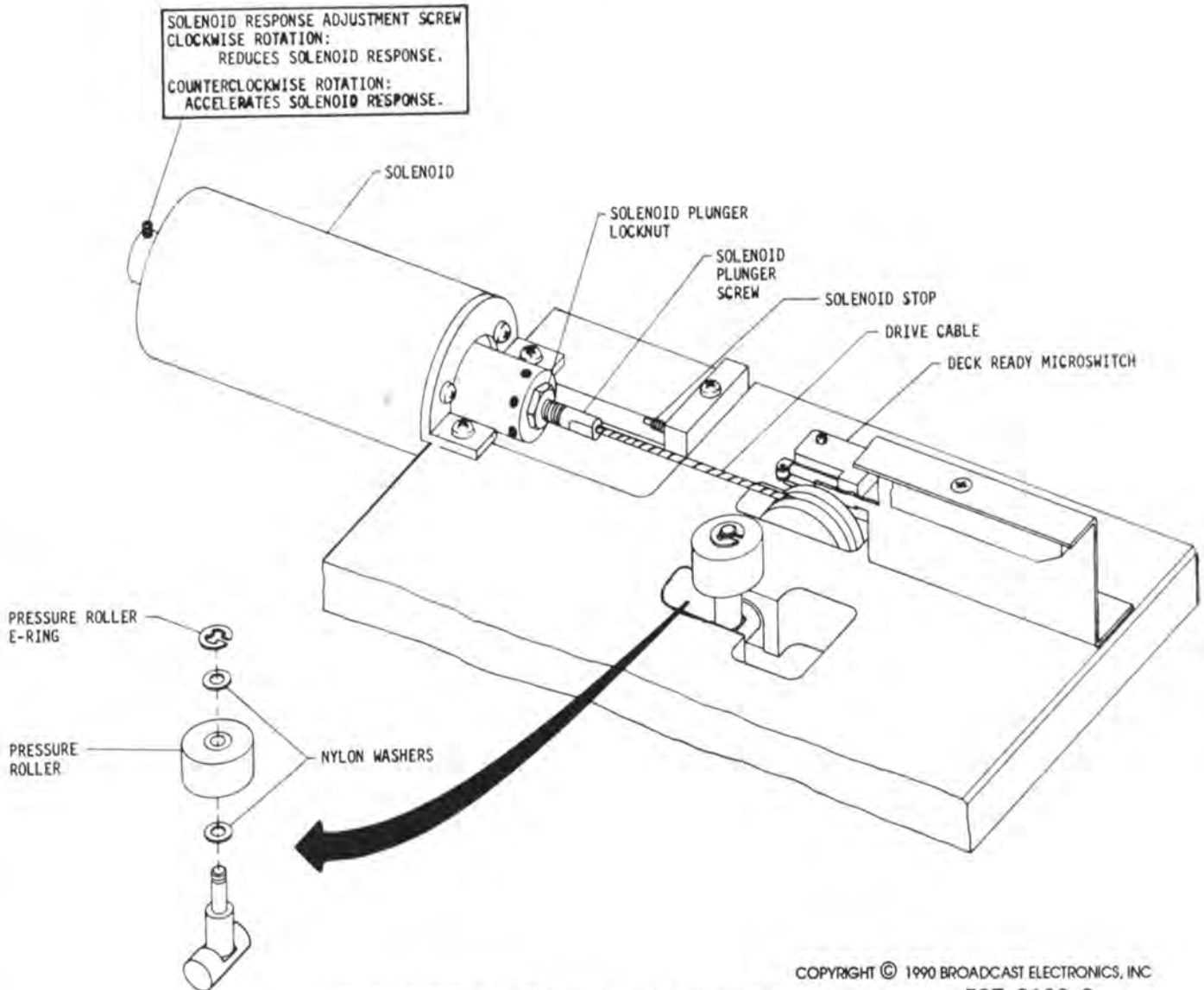

COPYRIGHT © 1990 BROADCAST ELECTRONICS, INC

597-9100-9

FIGURE 5-1. CARTRIDGE DECK ASSEMBLY

- 5-24. Refer to Figure 5-2 and loosen the two motor mounting screws to allow movement of the motor assembly.
- 5-25. Refer to Figure 5-3A and place motor alignment gauge 300-0700 on the deck pressure roller shaft.
- 5-26. Refer to Figure 5-3A and move the motor assembly until the capstan shaft is tangent with the alignment gauge.
- 5-27. Secure the two motor mounting screws. Secure the screws alternately to ensure correct motor alignment. Remove the alignment gauge.
- 5-28. Refer to Figure 5-1 and re-install the pressure roller, the nylon washers, and the pressure roller E-ring.

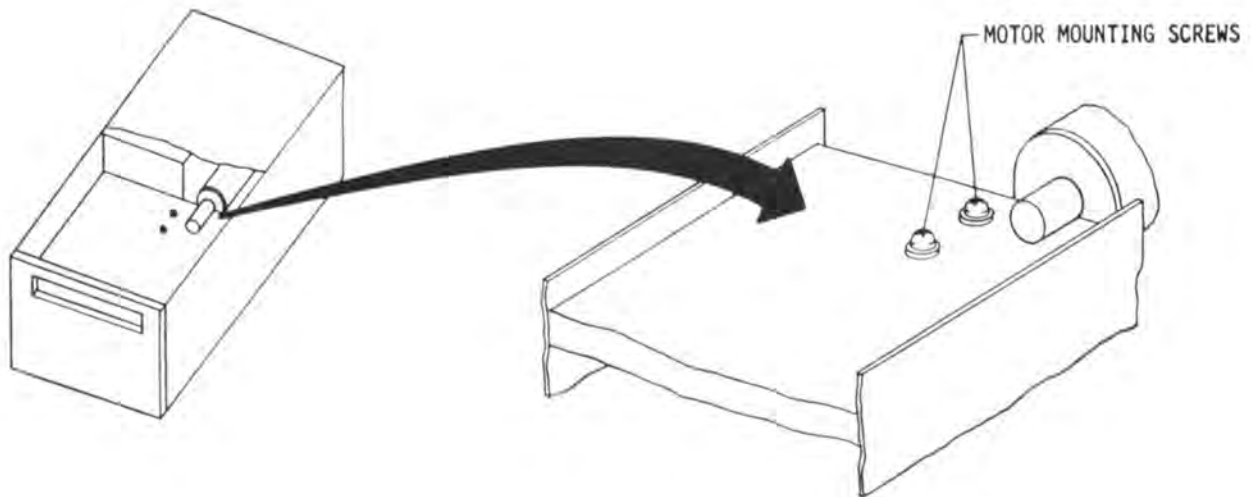

COPYRIGHT © 1990 BROADCAST ELECTRONICS, INC.

597-9100-10

FIGURE 5-2. MOTOR MOUNTING SCREWS

- 5-29. **PRESSURE ROLLER INDENTATION ADJUSTMENT.** This procedure adjusts the correct pressure roller indentation. Proper pressure roller indentation determines the amount of tape pull. Refer to Figure 5-3 and coarse adjust the solenoid plunger as follows:
- A. Disconnect the cartridge machine primary power.
 - B. Loosen the solenoid plunger locknut.
 - C. Rotate the solenoid plunger clockwise or counterclockwise as required until the plunger front-surface is aligned with the solenoid bracket.
 - D. Finger tighten the solenoid plunger locknut.



CAUTION

WHEN OPERATING THE DECK SWITCH TO THE ON POSITION, DO NOT USE A METALLIC OBJECT.

CAUTION

- 5-30. Temporarily operate the deck switch to the ON position.
- 5-31. Apply power to the cartridge machine. Depress the deck **START** switch/indicator to energize the solenoid.



WARNING

MAINTENANCE WITH MOVING PARTS IS ALWAYS CONSIDERED HAZARDOUS AND CAUTION SHOULD BE OBSERVED. DO NOT TOUCH THE CAPSTAN SHAFT OR THE PRESSURE ROLLER SHAFT WITH THE PARTS IN MOTION.

WARNING

- 5-32. Fine adjustment of the pressure roller indentation is accomplished by using the pressure roller indentation gauge as shown in Figure 5-4. Insert the gauge between the capstan shaft and pressure roller shaft in the direction indicated while maintaining the gauge perpendicular to the deck surface.

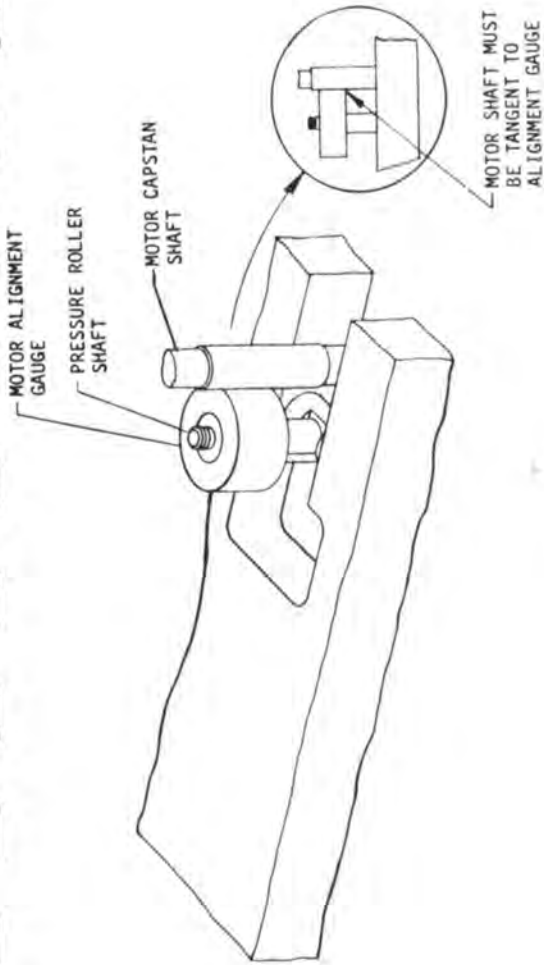

A
MOTOR ALIGNMENT

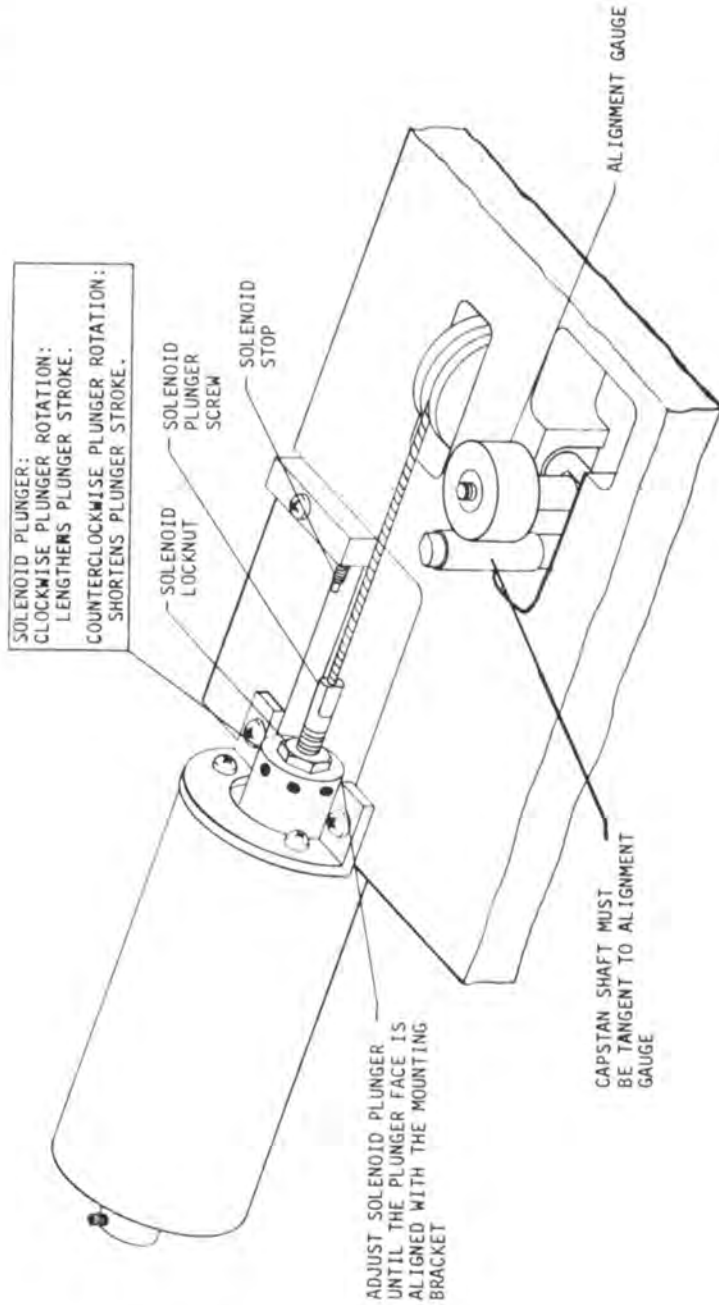

B
SOLENOID PLUNGER STROKE ADJUSTMENT

COPYRIGHT © 1990 BROADCAST ELECTRONICS, INC
597-9100-11

FIGURE 5-3. MOTOR ALIGNMENT

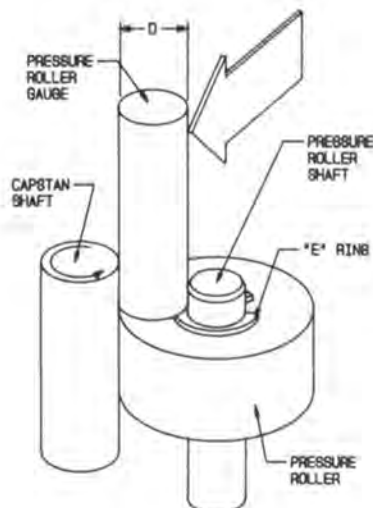

COPYRIGHT © 1990 BROADCAST ELECTRONICS, INC
597-9100-12

FIGURE 5-4. PRESSURE ROLLER INDENTATION ADJUSTMENT

- 5-33. Refer to Figure 5-4 and adjust the pressure roller indentation by rotating the solenoid plunger clockwise to decrease distance D or counterclockwise to increase distance D as required. Correct adjustment is obtained when the gauge will pass between the shafts with a slight resistance. Deenergize the solenoid between measurements to allow the solenoid to stabilize.
- 5-34. Once the correct pressure roller indentation is obtained, refer to Figure 5-1 and adjust the solenoid plunger stop until the pressure roller is just below the deck surface when the solenoid is deenergized.
- 5-35. Disconnect the cartridge machine primary power. Secure the solenoid plunger locknut and restore the deck switch to normal operation.
- 5-36. **SOLENOID RESPONSE ADJUSTMENT.** The solenoid is equipped with a control to adjust the response of the plunger. The control adjusts the rate of air movement through a relief valve to establish the response of the plunger and the level of noise generated. The control is factory adjusted for a compromise between response and noise level. Generally, the solenoid response will not require adjustment. However, the response may be adjusted to obtain any individual requirements. The solenoid response is adjusted as follows.
- 5-37. **Procedure.** To adjust the solenoid response, proceed as follows:
- 5-38. Disconnect the cartridge machine primary power.
- 5-39. Refer to Figure 5-1 and adjust solenoid response adjustment screw clockwise 1/4 of a revolution to reduce the response and decrease the noise level of the solenoid. Adjust the solenoid response control counterclockwise 1/4 of a revolution to accelerate the response and increase the noise level of the solenoid.
- 5-40. Perform an operational test to ensure the deck performs as desired. If required, repeat the procedure to obtain the desired results.



CAUTION
CAUTION

TO PREVENT DAMAGE TO THE PHASE LOK V HEAD ASSEMBLY, PERFORM ALL HEAD ASSEMBLY ADJUSTMENTS USING THE ALLEN WRENCH PROVIDED WITH THE UNIT.

- 5-41. **HEAD ADJUSTMENTS.** The head adjustments involve the alignment of the tape guide height, head height, head zenith, head azimuth, and head phase response parameters. The head parameters are presented as individual adjustment procedures. Due to the design of the PHASE LOK V head bracket, only head azimuth and the related electrical parameters will require periodic adjustment (example: prior to extensive continuous operation). The following list presents the procedures required for periodic maintenance. When a replacement head is installed, all head adjustment procedures must be performed (refer to the HEAD REPLACEMENT PROCEDURE specific replacement information).

PERIODIC PLAYBACK HEAD ADJUSTMENT PROCEDURES

MONOPHONIC CARTRIDGE MACHINES

STEREOPHONIC CARTRIDGE MACHINES

- A. The Playback Head Azimuth Adjustment Procedure.
- B. The **PLAYBACK EQUALIZATION** Procedure.

- A. The Playback Head Azimuth Procedure.
- B. The Playback Phase Response Adjustment Procedure.
- C. The **PLAYBACK EQUALIZATION** Procedure.

PERIODIC RECORD HEAD ADJUSTMENT PROCEDURES

STEREOPHONIC CARTRIDGE MACHINES

- A. The Record Head Azimuth Adjustment Procedure.
- B. The Record Head Phase Response Adjustment Procedure.

- 5-42. The following text presents adjustment procedures for the playback, dummy, and record heads. For playback only models, align the playback head before adjusting the dummy head. For record/playback models, align the playback head before adjusting the record head.
- 5-43. An adjustment tool (located in the Accessory Parts Kit) is provided with the unit for head assembly alignment. Perform all head alignment procedures using the adjustment tool.
- 5-44. **Tape Guide Height Adjustment Procedure.** To ensure proper tape movement, perform the tape guide height adjustment procedure for each tape guide. To adjust the tape guide height, proceed as follows:
- 5-45. Refer to Figure 5-5A and check the tape guide height. The inside edge of the upper tape guide must be aligned with the top surface of the alignment gauge as shown.
- 5-46. If adjustment is required, refer to Figure 5-6 and loosen the tape guide adjustment screws.
- 5-47. Adjust the tape guide to obtain proper alignment.
- 5-48. Secure the tape guide adjustment screws.

A
TAPE GUIDE ADJUSTMENT
THE INSIDE EDGE OF UPPER TAPE
GUIDE MUST BE ALIGNED WITH
THE T-END OF ALIGNMENT GAUGE.

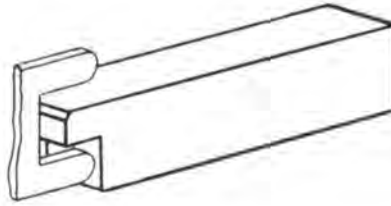

B
HEAD HEIGHT ADJUSTMENT
THE UPPER HEAD POLE
MUST BE ALIGNED WITH THE
TOP OF THE ALIGNMENT GAUGE.

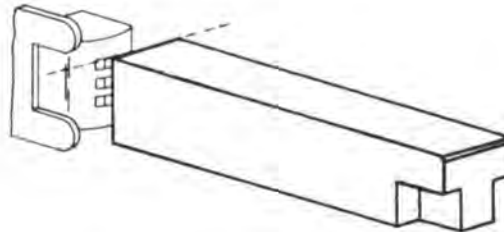

C
ZENITH ADJUSTMENT
THE HEAD MUST BE
PERPENDICULAR TO
DECK SURFACE.

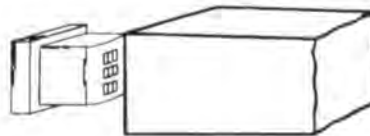

COPYRIGHT © 1990 BROADCAST ELECTRONICS, INC
597-9100-13

FIGURE 5-5. HEAD AND TAPE GUIDE ADJUSTMENTS

- 5-49. **Head Height Adjustment Procedure.** To adjust the playback, record, or dummy head height, proceed as follows:
- 5-50. Refer to Figure 5-5B and check the playback or record head height. The head upper pole must be aligned with the top of the alignment gauge.
- 5-51. Insert the tape alignment cut-away test cartridge into the cartridge deck and begin deck operation to visually inspect the tape movement across the heads. The magnetic tape must cover the top and bottom of the head poles (refer to Figure 5-7).
- 5-52. If adjustment is required, refer to Figure 5-6 and loosen the appropriate head height/zenith lock-screw.
- 5-53. Refer to Figure 5-6 and adjust the appropriate front and rear head height/zenith adjustment screws as required to obtain the proper head height. The height/zenith screws must be adjusted equally to retain the zenith adjustment.
- 5-54. Secure the head height/zenith lock-screw.

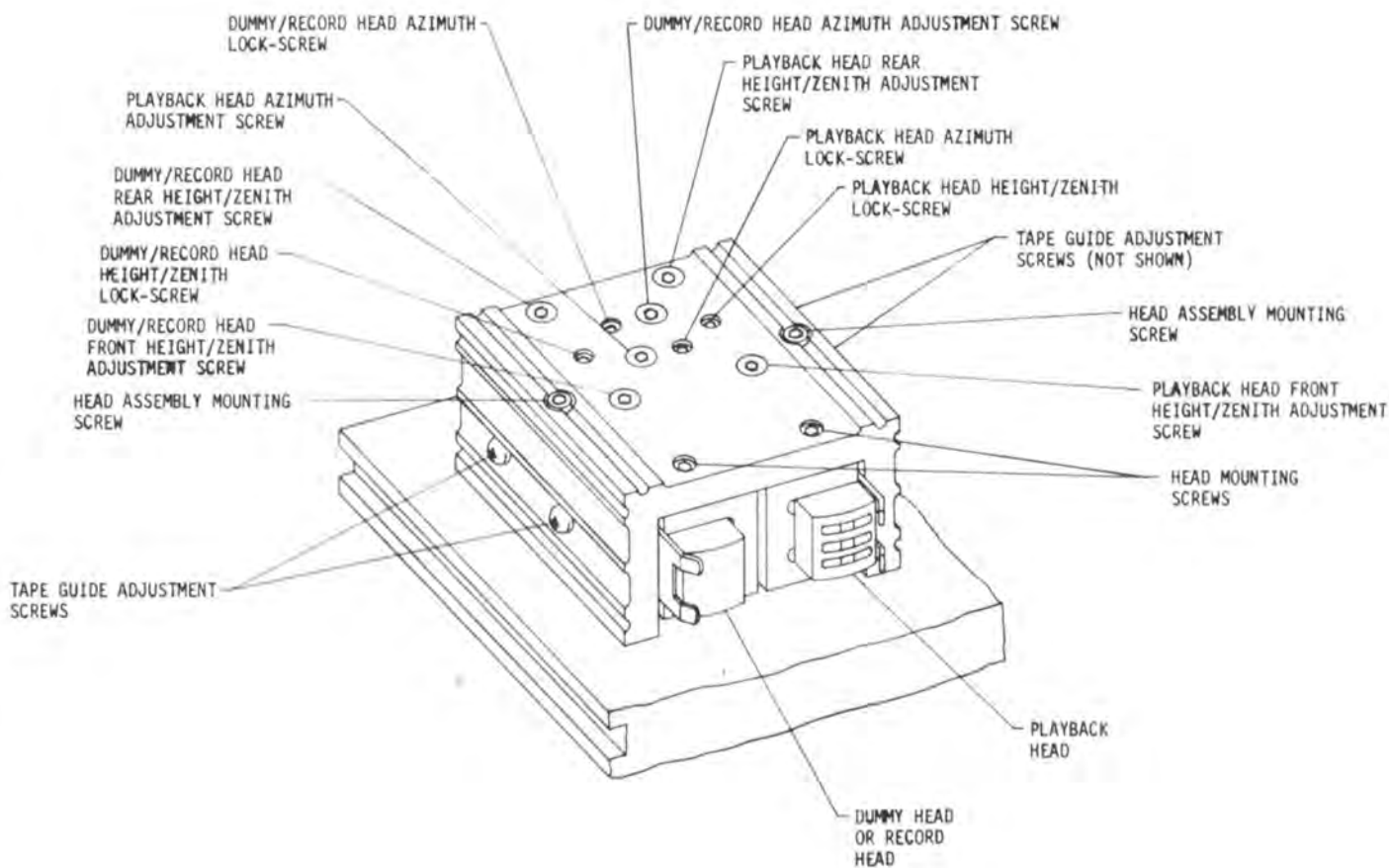

COPYRIGHT © 1990 BROADCAST ELECTRONICS, INC.
597-9100-14

FIGURE 5-6. HEAD ADJUSTMENT CONTROLS

- 5-55. For playback only cartridge machines, the top of the dummy head must be aligned with the top of the playback head. For record/playback units, the top of the record head must be aligned with the top of the playback head. Visually inspect the tape head heights. If required, adjust the dummy head or record head height as required. Refer to Figure 5-6 for the location of the dummy/record head height/zenith adjustment screws.
- 5-56. **Head Zenith Adjustment Procedure.** To adjust the playback, record, or dummy head zenith, proceed as follows:
- 5-57. Refer to Figure 5-5C and check the playback or record head zenith. The head must be perpendicular to the deck surface.
- 5-58. If adjustment is required, refer to Figure 5-6 and loosen the appropriate head height/zenith lock-screw.
- 5-59. Refer to Figure 5-6 and adjust the appropriate head front or rear height/zenith screw to obtain the proper alignment.
- 5-60. Refer to the **Head Height Adjustment Procedure** and check the head height. If required, re-adjust the head height.
- 5-61. Repeat the procedure until the head zenith and the head height is properly adjusted.
- 5-62. Secure the head height/zenith lock-screw.

MONOPHONIC STANDARD

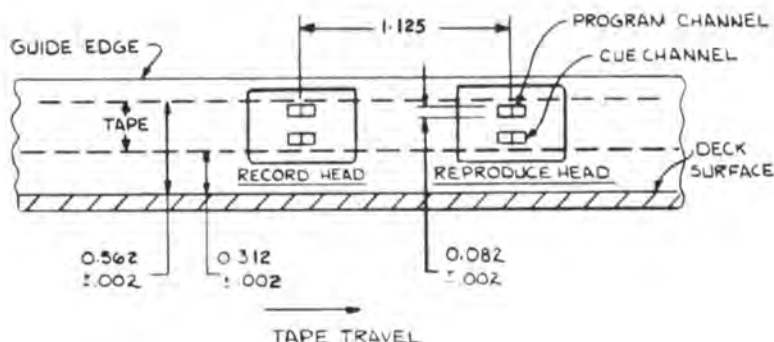

STEREOPHONIC STANDARD

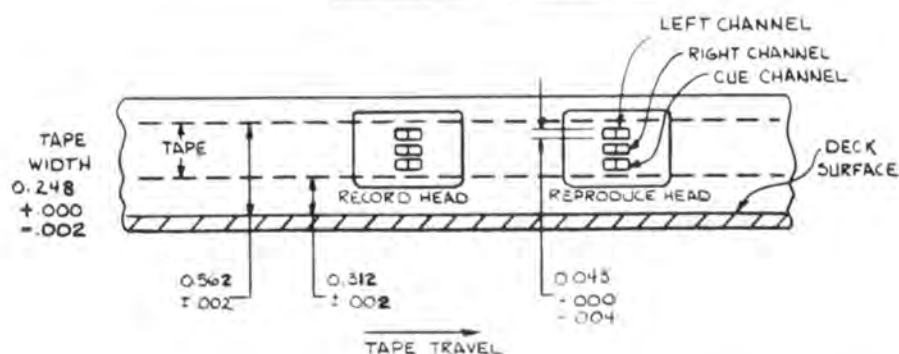

COPYRIGHT © 1990 BROADCAST ELECTRONICS, INC.
597-9100-15

FIGURE 5-7. HEIGHT CARTRIDGE TAPE TRACKING

- 5-63. For playback only cartridge machines, repeat the procedure for the dummy head. Refer to Figure 5-6 for the location of the dummy head height/zenith adjustment screws.
- 5-64. **Playback Head Azimuth Adjustment Procedure.** To adjust the playback head azimuth, proceed as follows:
- 5-65. Disconnect the cartridge machine primary power.
- 5-66. Demagnetize the playback head, the dummy/record head, and all surrounding ferrous components.
- 5-67. Refer to the **OUTPUT LEVEL ADJUSTMENT** procedure (located in the **ELECTRICAL ADJUSTMENT** procedures) and calibrate the cartridge deck for the desired output level.
- 5-68. Refer to Figure 2-2 in SECTION II, INSTALLATION and connect an oscilloscope to the left channel output terminals of rear-panel **PLAYBACK** receptacle J105.
- 5-69. Refer to Figure 5-6 and loosen the playback head azimuth lock-screw.
- 5-70. Apply power to the cartridge machine.
- 5-71. Insert the reproduce alignment test tape into the cartridge deck and reproduce the 12.5 kHz test tone.
- 5-72. Refer to Figure 5-6 and adjust the playback head azimuth screw for a maximum peak-to-peak voltage indication on the oscilloscope.

- 5-73. Secure the playback head azimuth lock-screw.
- 5-74. Disconnect power from the cartridge machine, remove the test equipment.
- 5-75. **Record Head Azimuth Adjustment Procedure.** To adjust the record head azimuth, proceed as follows:
- 5-76. Disconnect the cartridge machine primary power.
- 5-77. Demagnetize the record head, playback head, and all surrounding ferrous components.
- 5-78. Refer to the **OUTPUT LEVEL ADJUSTMENT** procedure (located in the **ELECTRICAL ADJUSTMENT** procedures) and calibrate the cartridge deck for the desired output level.
- 5-79. Refer to Figure 2-3 in SECTION II, INSTALLATION and connect an audio generator to the left channel input terminals of rear-panel **RECORD** receptacle J106.
- 5-80. Refer to Figure 2-2 in SECTION II, INSTALLATION and connect an oscilloscope to the left channel output terminals of rear-panel **PLAYBACK** receptacle J105.
- 5-81. Refer to Figure 5-6 and loosen the record head azimuth lock-screw.
- 5-82. Apply power to the cartridge machine.
- 5-83. Adjust the audio generator for a 12.5 kHz output at 0 dBm.
- 5-84. Operate the record/playback unit in the record mode and begin recording the 12.5 kHz tone.
- 5-85. Refer to Figure 5-6 and adjust the record head azimuth screw for a maximum peak-to-peak voltage indication on the oscilloscope.
- 5-86. Secure the record head azimuth lock-screw.
- 5-87. Disconnect power from the cartridge machine and remove the test equipment.
- 5-88. **Playback Head Phase Response Adjustment Procedure.** (For Stereophonic Cartridge Machines Only). The playback phase adjustment involves the fine alignment of the playback head azimuth for maximum phase response. To adjust the playback head phase response, proceed as follows:
- 5-89. Disconnect the cartridge machine primary power.
- 5-90. Demagnetize the playback head, the dummy/record head, and all surrounding ferrous components.
- 5-91. Refer to the **OUTPUT LEVEL ADJUSTMENT** procedure (located in the **ELECTRICAL ADJUSTMENT** procedures) and calibrate the cartridge deck for the desired output level.
- 5-92. Refer to Figure 2-2 in SECTION II, INSTALLATION and connect an oscilloscope to the left and right channel output terminals of rear-panel **PLAYBACK** receptacle J105.
- 5-93. Refer to Figure 5-6 and loosen the playback head azimuth lock-screw.
- 5-94. Apply power to the cartridge machine.
- 5-95. Operate the oscilloscope for lissajous display of inputs.
- 5-96. Insert the reproduce alignment test tape into the cartridge deck and reproduce the 15 kHz test tone.
- 5-97. Refer to Figure 5-6 and adjust the playback head azimuth screw for a 0° lissajous pattern as shown in Figure 5-8.

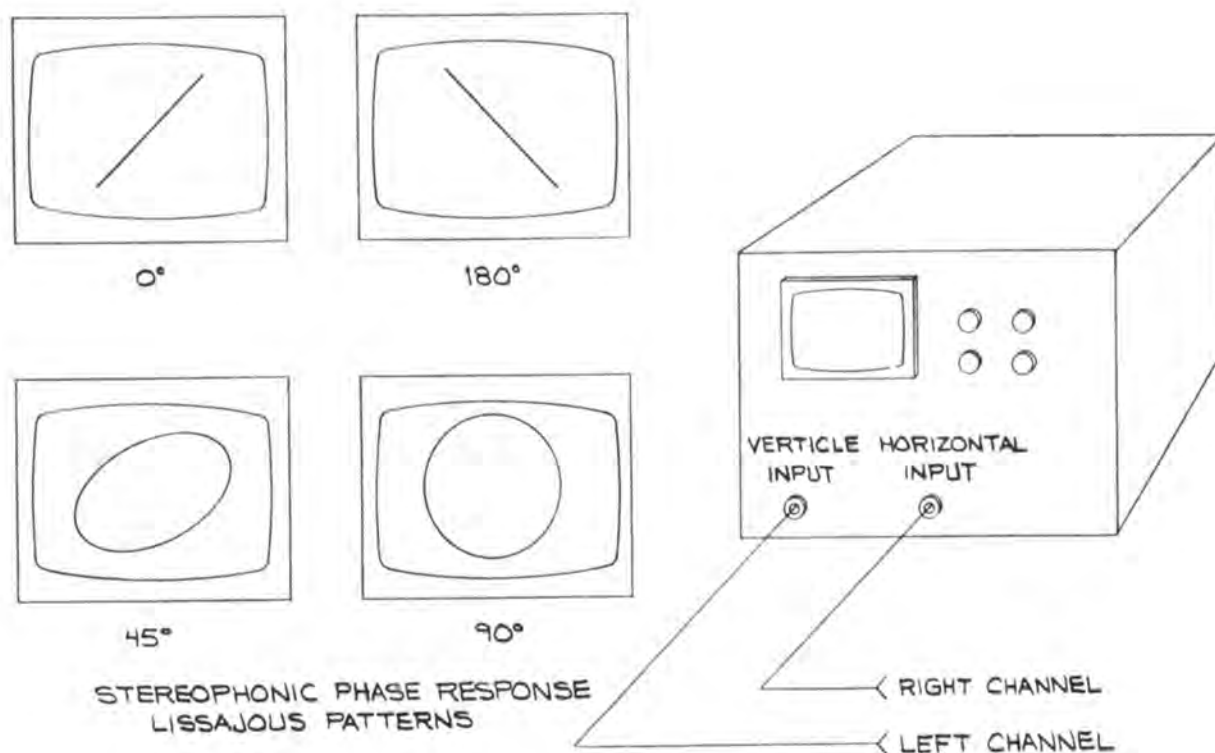

COPYRIGHT © 1990 BROADCAST ELECTRONICS, INC
597-9100-16

FIGURE 5-8. STEREOPHONIC PHASE RESPONSE LISSAJOUS PATTERNS

- 5-98. Secure the playback head azimuth lock-screw.
- 5-99. Disconnect power from the cartridge machine and remove the test equipment.
- 5-100. **Record Phase Adjustment Procedure** (For Stereophonic Record/Playback Models Only). The record phase adjustment involves the fine alignment of the record head azimuth for maximum phase response. To adjust the record head phase response, proceed as follows:
 - 5-101. Disconnect the cartridge machine primary power.
 - 5-102. Demagnetize the record head, the playback head, and all surrounding ferrous components.
 - 5-103. Refer to the **OUTPUT LEVEL ADJUSTMENT** procedure (located in the **ELECTRICAL ADJUSTMENT** procedures) and calibrate the cartridge deck for the desired output level.
 - 5-104. Refer to Figure 2-3 in SECTION II, INSTALLATION and connect an audio generator to the left and right channel input terminals of rear-panel **RECORD** receptacle J106.
 - 5-105. Refer to Figure 2-2 in SECTION II, INSTALLATION and connect an oscilloscope to the left and right channel output terminals of rear-panel **PLAYBACK** receptacle J105.
 - 5-106. Refer to Figure 5-6 and loosen the record head azimuth lock-screw.
 - 5-107. Apply power to the cartridge machine.
 - 5-108. Operate the oscilloscope for a lissajous display of inputs.
 - 5-109. Adjust the audio generator for a 12.5 kHz output at 0 dBm.
 - 5-110. Operate the record/playback unit in the record mode and begin recording the 12.5 kHz tone.

- 5-111. Refer to Figure 5-6 and adjust the record head azimuth screw for a θ° lissajous pattern as shown in Figure 5-8.
- 5-112. Secure the record head azimuth lock-screw.
- 5-113. Disconnect power from the cartridge machine and remove the test equipment.
- 5-114. **ELECTRICAL ADJUSTMENTS.**
- 5-115. The following text provides electrical adjustment procedures for all controls associated with the DT-90A cartridge machines. The procedures are presented in the following order:
- A. **PLAYBACK ADJUSTMENTS.**
 1. Output Level Adjustment.
 2. Playback Equalization Adjustment.
 3. Cue Tone Detection Adjustment.
 4. Motor Drive-Pulse Adjustment.
 - B. **RECORD ADJUSTMENTS.**
 1. Record Equalization.
 2. Program Bias Level Adjustment.
 3. Cue Bias Level Adjustment.
 4. Cue Tone Record Level Adjustment.
 5. Meter Calibrations.
- 5-116. The following equipment is required for the electrical adjustment procedures:
- A. Frequency Counter.
 - B. Calibrated Oscilloscope, 5 MHz Bandwidth, Dual Channel with Lissajous Display of Inputs.
 - C. DC Voltmeter.
 - D. VU Meter (or decibel calibrated voltmeter).
 - E. Extender Circuit Board and Cable Assembly (BE P/N 941-0017).
 - F. Monophonic/Stereophonic Reproduce Alignment Test Tape (BE P/N 800-1005).
 - G. Insulated Non-Metallic Adjustment Tool.
 - H. Cue Tone Calibration Cartridge (BE P/N 800-1095).
 - I. Audio Signal Generator (audio range: 20 Hz to 20 kHz).
 - J. Audio Analyzer.
- 5-117. **PLAYBACK ADJUSTMENTS.**
- 5-118. **OUTPUT LEVEL ADJUSTMENT.** Left channel level control R19 and right channel level control R39 on the playback logic circuit board adjust the output level of the cartridge machine. The output level control(s) are adjusted as follows.
- 5-119. **Procedure.** To adjust the cartridge deck output level, proceed as follows:

- 5-120. Disconnect the cartridge machine primary power and remove the top-panel.
- 5-121. Refer to Figure 2-2 in SECTION II, INSTALLATION and connect a VU meter to the left channel output terminals of rear-panel **PLAYBACK** receptacle J105.
- 5-122. Apply power to the cartridge machine.
- 5-123. Insert the reproduce alignment test tape into the deck and reproduce the operating level portion of the test tape.
- 5-124. Refer to Figure 5-9 and adjust **L OUT** control R19 for the desired output level.
- 5-125. For stereophonic cartridge machines, repeat the procedure for the right channel. Refer to Figure 5-9 and adjust the right channel with **R OUT** control R39 for the desired level.
- 5-126. Disconnect the cartridge machine primary power and remove the test equipment.

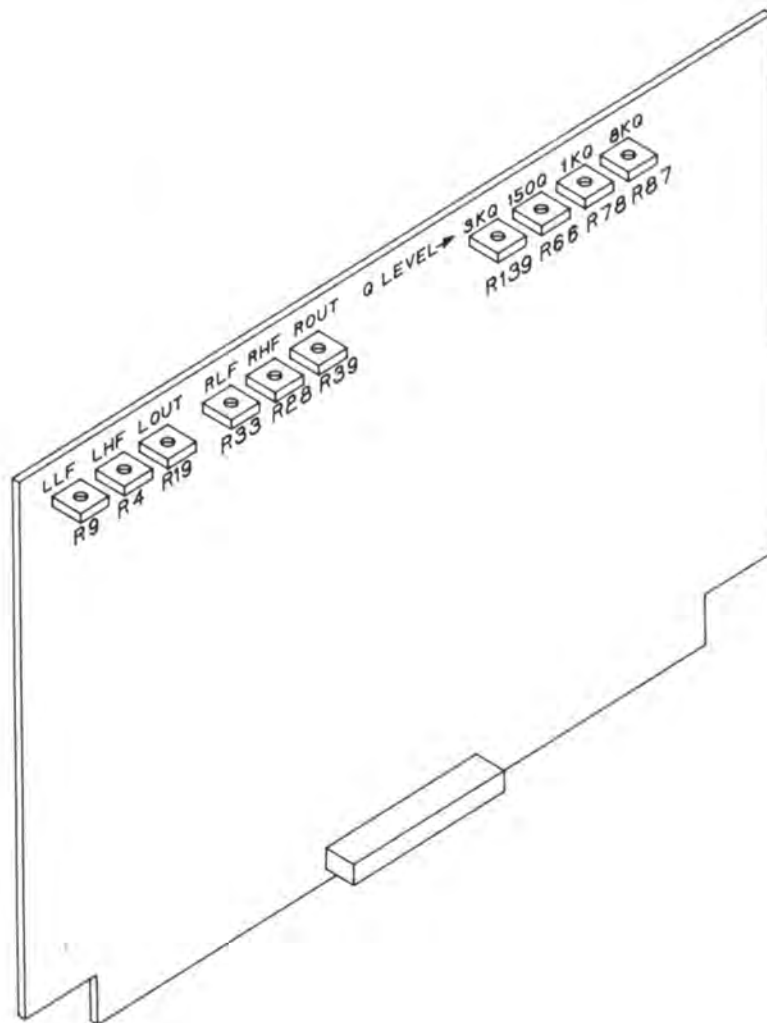

COPYRIGHT © 1990 BROADCAST ELECTRONICS, INC
597-9100-17

FIGURE 5-9. PLAYBACK LOGIC CIRCUIT BOARD CONTROLS

- 5-127. **PLAYBACK EQUALIZATION ADJUSTMENT.** Equalization controls R4, R9, R28, and R33 on the playback logic circuit board adjust the left channel and right channel playback response. The playback equalization circuitry is adjusted as follows.

- 5-128. **Procedure.** To adjust the equalization controls, proceed as follows:
- 5-129. Refer to the **OUTPUT LEVEL ADJUSTMENT** procedure in the preceding text and calibrate the cartridge deck for the desired level.
- 5-130. Disconnect the cartridge machine primary power and remove the top-panel.
- 5-131. Refer to Figure 2-2 in SECTION II, INSTALLATION and connect a VU meter to the left channel output terminals of rear-panel **PLAYBACK** receptacle J105.
- 5-132. Insert the reproduce alignment tape and reproduce the test tones portion of the tape.
- 5-133. At the 50 Hz test tone, adjust **LLF** control R9 (refer to Figure 5-9) until the VU meter indicates a level within -1 dB to 0 dB of the reference tone level.
- 5-134. At the 12.5 kHz test tone, adjust **LHF** control R4 (refer to Figure 5-9) until the VU meter indicates the level of the reference tone.
- 5-135. For stereophonic cartridge machines, repeat the procedure for the right channel. Refer to Figure 5-9 and adjust the right channel equalization with **RLF** control R33 and **RHF** control R28.
- 5-136. Disconnect the cartridge machine primary power and remove the test equipment.
- 5-137. **CUE TONE DETECTION ADJUSTMENT.** The cue tone controls on the playback logic circuit board adjust the sensitivity of the 1 kHz, 3 kHz, 150 Hz, and 8 kHz cue tone detection circuits. The cue tone detection controls are adjusted as follows.
- 5-138. **Procedure.** To adjust the cue tone detection controls, proceed as follows:
- 5-139. Remove the top-panel.
- 5-140. Insert the cue tone calibration cartridge into the deck and reproduce the 1 kHz test tones.
- 5-141. Refer to Figure 5-9 and adjust **Q LEVEL 1KQ** control R78 to terminate deck operation during a test tone.
- 5-142. Insert the cue tone calibration cartridge into the deck. Depress the **F FWD** switch/indicator to reproduce the 1 kHz cue tone at 3 kHz.
- 5-143. Refer to Figure 5-9 and adjust **Q LEVEL 3KQ** control R139 to terminate deck operation during a cue test tone.
- 5-144. Insert the cue tone calibration cartridge into the deck and reproduce the 150 Hz test tones.
- 5-145. Refer to Figure 9 and adjust **Q LEVEL 150Q** control R66 until the front-panel **SEC** indicator illuminates.
- 5-146. Insert the cue tone calibration cartridge into the deck and reproduce the 8 kHz test tones.
- 5-147. Refer to Figure 5-9 and adjust **Q LEVEL 8KQ** control R87 until the front-panel **TER** indicator illuminates.
- 5-148. Replace the top-panel.
- 5-149. **MOTOR DRIVE-PULSE ADJUSTMENT.** Motor control potentiometer R16 on the motor control circuit board calibrates the duty cycle of the motor drive-pulse. Adjustment of the motor control circuit is not required unless replacement components are installed in the circuit or the complete motor control circuit board is replaced. The motor drive-pulse circuit is adjusted as follows.
- 5-150. **Procedure.** To adjust the motor drive-pulse, proceed as follows:

- 5-151. Disconnect the cartridge machine primary power.
- 5-152. Refer to Figure 5-10 and connect an oscilloscope test probe to TP1 on the motor control circuit board. Adjust the oscilloscope as follows:
 - A. Input: 1 Meg Ohm
 - B. Mode: Triggered
 - C. Vertical Sensitivity: 1V/Div
 - D. Horizontal Rate: 0.5 ms/Div
- 5-153. Apply power to the cartridge machine.
- 5-154. Momentarily depress the **STOP** switch/indicator to operate the unit to the motor maintenance mode . The motor will operate for approximately 90 seconds.

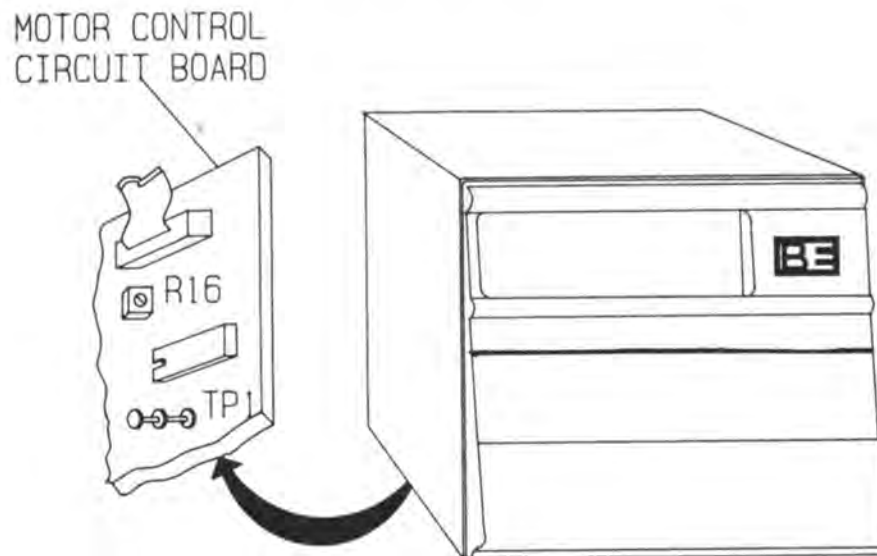

COPYRIGHT © 1990 BROADCAST ELECTRONICS, INC
597-9100-12

FIGURE 5-10. MOTOR CONTROL CIRCUIT BOARD CONTROL

- 5-155. Refer to Figure 5-10 and adjust motor drive-pulse control R16 until the front-panel SVO indicator just illuminates, then adjust R16 to extinguish the SVO indicator and to produce the oscilloscope waveform presented in Figure 5-11.
- 5-156. Disconnect the cartridge machine primary power.
- 5-157. Remove the test equipment.
- 5-158. **RECORD ADJUSTMENTS.**
- 5-159. **RECORD EQUALIZATION.** Potentiometers R14, R16, R17, and R19 on the record logic circuit board adjust the record equalization to obtain the proper record response. The record equalization controls are adjusted as follows.
- 5-160. **Procedure.** To adjust the record equalization controls, proceed as follows:
- 5-161. Calibrate the cartridge machine record circuitry for a -10 dBm record level by performing the procedure described in the **PROGRAM BIAS LEVEL ADJUSTMENT.**

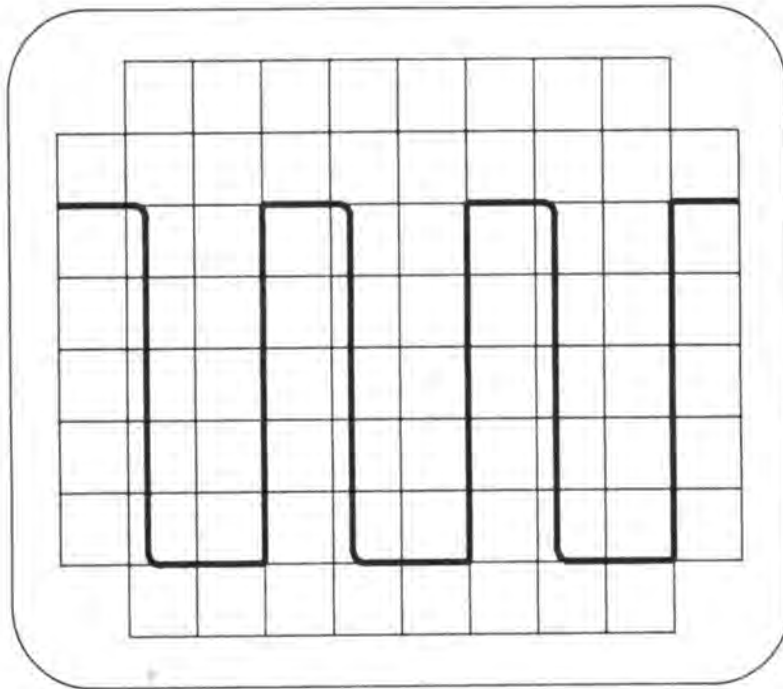

COPYRIGHT © 1990 BROADCAST ELECTRONICS, INC
597-9100-24

FIGURE 5-11. MOTOR DRIVE-PULSE DUTY CYCLE

- 5-162. Disconnect power from the cartridge machine.
- 5-163. Refer to Figure 2-3 in SECTION II, INSTALLATION and connect an audio generator to the left channel input terminals of rear-panel **RECORD** receptacle J106.
- 5-164. Refer to Figure 2-2 in SECTION II, INSTALLATION and connect a VU meter to the left channel output terminals of rear-panel **PLAYBACK** receptacle J105.
- 5-165. Apply power to the cartridge machine.
- 5-166. Adjust the audio generator for a 50 Hz output at -10 dBm.
- 5-167. Operate the unit to the record mode and begin recording the 50 Hz tone.
- 5-168. Refer to Figure 5-12 and adjust **LLF** control R14 until the external VU meter indicates -10 dBm.
- 5-169. Adjust the audio generator for a 12 kHz output at -10 dBm.
- 5-170. Refer to Figure 5-12 and adjust **LHF** control R16 until the external VU meter indicates -10 dBm.
- 5-171. Repeat the procedure for the right channel. Adjust the right channel equalization with **RLF** control R17 and **RHF** control R19 (refer to Figure 5-12).
- 5-172. Re-calibrate the record circuitry for a 0 dBm record level by performing the **Record Meter Calibrations** procedure in the following text.
- 5-173. Disconnect power from the cartridge machine and remove the test equipment.

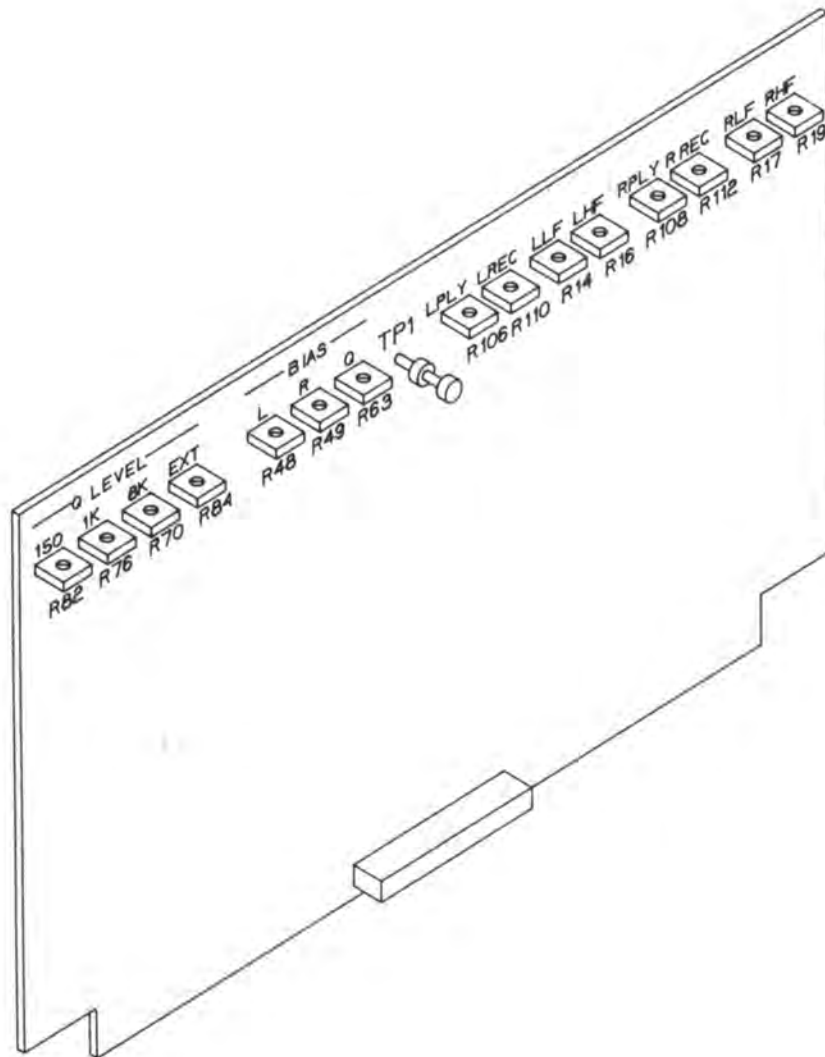

COPYRIGHT © 1990 BROADCAST ELECTRONICS, INC
597-9100-18

FIGURE 5-12. RECORD LOGIC CIRCUIT BOARD CONTROLS

- 5-174. **PROGRAM BIAS LEVEL ADJUSTMENT.** L BIAS control R48 and R BIAS control R49 on the record logic circuit board adjust the level of program bias. The bias level controls are adjusted as follows.
- 5-175. **Procedure.** To adjust the controls, proceed as follows:
- 5-176. Calibrate the cartridge machine record circuitry for a -10 dBm record level as follows:
- A. Disconnect power from the cartridge machine.
 - B. Refer to Figure 2-3 in SECTION II, INSTALLATION and connect an audio generator to the left channel input terminals of rear-panel RECORD receptacle J106.
 - C. Refer to Figure 2-2 in SECTION II, INSTALLATION and connect a VU meter to the left channel output terminals of rear-panel PLAYBACK receptacle J105.
 - D. Apply power to the cartridge machine.
 - E. Adjust the audio generator for a 1 kHz output at -20 dBm.
 - F. Operate the record circuitry and begin recording the 1 kHz tone.
 - G. Adjust the cartridge machine left channel level control until the external VU meter indicates -10 dBm.

- H. Depress the deck **STOP** switch/indicator.
 - I. For stereophonic cartridge machines, repeat steps A through H for the right channel.
 - J. Disconnect power from the cartridge machine and remove the VU meter.
- 5-177. Refer to Figure 2-2 in SECTION II, INSTALLATION and connect an oscilloscope to the left channel output terminals of rear-panel **PLAYBACK** receptacle J105.
- 5-178. Apply power to the cartridge machine.
- 5-179. Operate the unit to the record mode and begin recording the 1 kHz tone.
- 5-180. Refer to Figure 5-12 and adjust **L BIAS** control R48 for a maximum peak-to-peak 1 kHz waveform without distortion.
- 5-181. For stereophonic cartridge machines, repeat the procedure for the right channel. Adjust the right channel bias level with **R BIAS** control R49 (refer to Figure 5-12).
- 5-182. Re-calibrate the record circuitry for a 0 dBm record level by performing the **Record Meter Calibrations** procedure in the following text.
- 5-183. Disconnect power from the cartridge machine and remove the test equipment.
- 5-184. **CUE BIAS LEVEL ADJUSTMENT.** Potentiometer R63 on the record logic circuit board adjusts the cue bias level. The cue bias level is adjusted as follows.
- 5-185. **Procedure.** To adjust the cue bias level, proceed as follows:
- 5-186. Disconnect the cartridge machine primary power.
- 5-187. Refer to Figure 2-3 in SECTION II, INSTALLATION and perform the following:
 - A. Activate the cue bias by connecting a jumper between pin 4 and pin 8 on rear-panel **RECORD** receptacle J106.
 - B. Connect an audio signal generator to **RECORD** receptacle J106 pin 10.
- 5-188. Refer to Figure 2-2 in SECTION II, INSTALLATION and connect an oscilloscope to the cue channel audio output on **PLAYBACK** receptacle J105.
- 5-189. Apply power to the cartridge machine.
- 5-190. Adjust the audio generator for a 1 kHz output at -10 dBm.
- 5-191. Operate the unit to the record mode and begin recording the 1 kHz cue tone.
- 5-192. Refer to Figure 5-12 and adjust **Q BIAS** level control R63 for a maximum peak-to-peak 1 kHz waveform without distortion.
- 5-193. Disconnect power from the cartridge machine, remove all test equipment, and remove the jumper from **RECORD** receptacle J106.
- 5-194. **CUE TONE RECORD LEVEL ADJUSTMENTS.** Primary cue tone control R76, secondary cue tone control R82, tertiary cue tone control R70 and external cue tone control R84 adjust the individual cue tone record levels. The cue tone record levels are adjusted as follows.
- 5-195. **1 kHz Cue Tone Record Level Adjustment.** To adjust the 1 kHz cue tone level, proceed as follows:
- 5-196. Measure the NAB 1 kHz cue tone level standard as follows:
 - A. Disconnect the cartridge machine primary power.

- B. Refer to Figure 2-2 in SECTION II, INSTALLATION and connect an oscilloscope to the cue channel audio output on **PLAYBACK** receptacle J105.
- C. Apply power to the cartridge machine.
- D. Insert the cue tone calibration cartridge into the deck.
- E. Reproduce the reference level 1 kHz cue tone and record the peak-to-peak voltage indication _____.
- F. Depress the deck **STOP** switch/indicator and remove the cue tone calibration cartridge.



WARNING **DISCONNECT PRIMARY POWER TO THE CARTRIDGE MACHINE BEFORE PROCEEDING.**

WARNING

- 5-197. Disconnect primary power to the cartridge machine.
- 5-198. Remove the top-panel and record logic circuit board.
- 5-199. To activate the 1 kHz oscillator and cue bias circuits, refer to Figure 5-12 and connect a jumper between TP1 and ground.
- 5-200. Replace the logic circuit board.
- 5-201. Apply primary power to the cartridge machine.
- 5-202. Insert a bulk erased tape cartridge into the deck and operate the unit in the playback mode.
- 5-203. Refer to Figure 5-12 and adjust **1K Q LEVEL** control R76 for the recorded NAB standard level.
- 5-204. Disconnect the cartridge machine primary power, remove all test equipment, and the temporary jumper.
- 5-205. **150 Hz Cue Tone Record Level Adjustment.** To adjust the 150 Hz cue tone level, proceed as follows:
- 5-206. Measure the NAB 150 Hz cue tone level standard by performing the level measurement procedure described in the **1 kHz Cue Tone Record Level Adjustment** procedure. Record the peak-to-peak voltage indication _____.
- 5-207. Insert a bulk erased tape cartridge into the deck and operate the unit in the playback mode.
- 5-208. Continuously depress the front-panel **SEC** switch and observe the oscilloscope indication.
- 5-209. Refer to Figure 5-12 and adjust **150 Hz Q LEVEL** control R82 for the recorded NAB standard level.
- 5-210. Disconnect the cartridge machine primary power and remove all test equipment.
- 5-211. **8 kHz Cue Tone Record Level Adjustment.** To adjust the 8 kHz cue tone level, proceed as follows:
- 5-212. Measure the NAB 8 kHz cue tone level standard by performing the level measurement procedure described in the **1 kHz Cue Tone Record Level Adjustment** procedure. Record the peak-to-peak voltage indication _____.

- 5-213. Insert a bulk erased tape cartridge into the deck and operate the unit in the playback mode.
- 5-214. Continuously depress the front-panel **TER** switch and observe the oscilloscope indication.
- 5-215. Refer to Figure 5-12 and adjust **8 kHz Q LEVEL** control R70 for the recorded NAB standard level.
- 5-216. Disconnect the cartridge machine primary power and remove all test equipment.
- 5-217. **External Cue Audio Level Adjustment.** Potentiometer R84 on the record logic circuit board adjusts the external cue audio level. The external cue audio level is adjusted as follows.
- 5-218. **Procedure.** To adjust the external cue audio level, proceed as follows:
- 5-219. Disconnect the cartridge machine primary power.
- 5-220. Refer to Figure 2-3 in SECTION II, INSTALLATION and perform the following:
- A. Activate the cue bias by connecting a jumper between pin 4 and pin 8 on **RECORD** receptacle J106.
 - B. Connect the audio signal generator between **RECORD** receptacle J106 pins 10 and 11.
- 5-221. Refer to Figure 2-2 in SECTION II, INSTALLATION and connect an external VU meter to the cue channel audio output on **PLAYBACK** receptacle J105.
- 5-222. Apply power to the cartridge machine and insert a bulk erased tape cartridge into the deck.
- 5-223. Adjust the audio generator for a 1 kHz output at -10 dBm.
- 5-224. Operate the unit in the playback mode and begin recording the 1 kHz cue tone.
- 5-225. Refer to Figure 5-12 and adjust **EXT Q LEVEL** control R84 for a -10 dBm external VU meter indication.
- 5-226. Disconnect power from the cartridge machine, remove all test equipment, and remove the jumper from **RECORD** receptacle J106.
- 5-227. **METER CALIBRATION.** Potentiometers R106, R110, R108, and R112 calibrate the DT-90A record/playback unit front-panel VU meters. The front-panel VU meters are calibrated as follows.
- 5-228. **Playback Meter Calibrations.** To calibrate the playback VU meter parameters, proceed as follows:
- 5-229. Refer to the **OUTPUT LEVEL ADJUSTMENT** procedure in the preceding text and calibrate the cartridge machine for the desired output level.
- 5-230. Disconnect the cartridge machine primary power.
- 5-231. Refer to Figure 2-2 in SECTION II, INSTALLATION and connect a VU meter to the left channel output terminals of rear-panel **PLAYBACK** receptacle J105.
- 5-232. Apply power to the cartridge machine.
- 5-233. Insert the reproduce alignment test tape into the deck and reproduce the 1 kHz tone.
- 5-234. Refer to Figure 5-12 and adjust **L PLY** meter calibration control R106 until the front-panel VU meter left channel display is equal to the output level indicated on the external VU meter.

- 5-235. For stereophonic record/playback models, repeat the procedure for the right channel. Adjust the right channel VU meter with **R PLY** calibration control R108 (refer to Figure 5-12).
- 5-236. Disconnect the cartridge machine primary power and remove the external VU meter.
- 5-237. **Record Meter Calibrations.** To calibrate the record VU meter parameters, proceed as follows:
- 5-238. Disconnect the cartridge machine primary power.
- 5-239. Refer to Figure 2-2 in SECTION II, INSTALLATION and connect a VU meter to the left channel output terminals of rear-panel **PLAYBACK** receptacle J105.
- 5-240. Refer to Figure 2-3 in SECTION II, INSTALLATION and connect an audio generator to the left channel input terminals of rear-panel **RECORD** receptacle J106.
- 5-241. Apply power to the cartridge machine.
- 5-242. Adjust the audio signal generator for a 1 kHz output at 0 dBm.
- 5-243. Insert a bulk erased tape into the deck and operate the unit to begin recording the 1 kHz tone.
- 5-244. Refer to Figure 3-1 and adjust the front-panel left channel level control until the external VU meter indication is equal to the playback audio level.
- 5-245. Refer to Figure 5-12 and adjust left channel **L REC** control R110 until the front-panel VU meter left channel display is equal to the output level indicated on the external VU meter.
- 5-246. Repeat the procedure for the right channel. Adjust the right channel using right channel **R REC** control R112 (refer to Figure 5-12).
- 5-247. Disconnect the cartridge machine primary power.
- 5-248. **MECHANICAL PARTS REPLACEMENT PROCEDURES.**
- 5-249. The following text provides mechanical parts replacement procedures. The procedures are presented in the following order.
 - A. Pressure Roller Replacement.
 - B. Head Replacement.
 - C. Motor Replacement.
- 5-250. The following equipment is required for the replacement procedures. Refer to the list as required for each procedure.

EQUIPMENT

- A. No. 1 Phillips Screwdriver, 4 Inch (10.2 cm) Blade.
- B. Needle-nose pliers.
- C. Allen Wrenches (supplied with the cartridge machine).

- 5-251. **PRESSURE ROLLER REPLACEMENT PROCEDURE.** To replace a cartridge deck pressure roller, proceed as follows:
- 5-252. Disconnect the cartridge machine primary power.
- 5-253. Refer to Figure 5-1 and manually retract the solenoid plunger.
- 5-254. Remove the pressure roller E-ring, the pressure roller, and the nylon washers (refer to Figure 5-1).
- 5-255. Refer to Figure 5-1 and replace the washers, the pressure roller, and the pressure roller E-ring.
- 5-256. Check the solenoid plunger stroke by performing the plunger adjustment steps described in the **PRESSURE ROLLER INDENTATION ADJUSTMENT** procedure.
- 5-257. **HEAD REPLACEMENT.** To replace a tape head, proceed as follows:
- 5-258. Disconnect the cartridge machine primary power.
- 5-259. Loosen the head assembly mounting screws (refer to Figure 5-6) and remove the entire head assembly from the cartridge deck.
- 5-260. Refer to Figure 5-6 and loosen the defective tape head mounting screw.
- 5-261. Remove the defective head from the head assembly and disconnect the head leads.
- 5-262. Refer to Figure 5-13 and connect the head leads to the replacement head.
- 5-263. Firmly seat the replacement head into the head assembly and secure the mounting screw.
- 5-264. Replace the head assembly and secure the mounting screws.
- 5-265. Align the head by performing all the **HEAD ADJUSTMENTS** and associated **ELECTRICAL ADJUSTMENT** procedures.
- 5-266. **MOTOR REPLACEMENT.** To replace the cartridge machine motor, proceed as follows:
- 5-267. Disconnect the cartridge machine primary power.
- 5-268. Remove the cartridge machine top-panel and bottom-panel.
- 5-269. Place the cartridge machine on a side-panel.
- 5-270. Refer to the cartridge machine final assembly diagram in SECTION VI, PARTS LISTS AND DRAWINGS and disconnect motor power supply connector P601 from the motor control board (located near the motor).
- 5-271. Refer to Figure 5-2 and locate the motor mounting screws. While supporting the motor, remove the motor mounting screws and carefully remove the motor from the cartridge machine chassis.

MONOPHONIC PLAYBACK/RECORD HEAD



STEREOPHONIC PLAYBACK/RECORD HEAD



P= PROGRAM TRACK (MONO)
 Q= CUE TRACK
 L= LEFT PROGRAM TRACK (STEREO)
 R= RIGHT PROGRAM TRACK (STEREO)

COPYRIGHT © 1990 BROADCAST ELECTRONICS, INC
 597-9100-19

FIGURE 5-13. TAPE HEAD CONFIGURATIONS



CAUTION
CAUTION

EXERCISE CARE WHEN HANDLING THE CARTRIDGE MACHINE MOTOR TO AVOID DAMAGING THE BEARINGS. NEVER HANDLE THE MOTOR BY THE CAPSTAN SHAFT.

- 5-272. Carefully insert the new motor into the cartridge machine chassis and replace the motor mounting screws. Do not tighten the motor mounting screws at this time.
- 5-273. Reconnect the motor power supply connector P601 to the motor control circuit board.
- 5-274. Align the motor by performing the **MOTOR ALIGNMENT PROCEDURE** and **PRESSURE ROLLER INDENTATION ADJUSTMENT** procedure described in the preceding text.
- 5-275. Replace the cartridge machine top-panel and bottom-panel.
- 5-276. **CONVERSION KIT INSTALLATION.**
- 5-277. Optional field installation kits are available for converting monophonic and stereophonic playback cartridge machines into record/playback units. To convert a playback machine into a record/playback unit, refer to the following procedures and the final assembly diagram in SECTION VI, PARTS LISTS AND DRAWINGS, as required.
- 5-278. **FRONT-PANEL DISASSEMBLY.** To disassemble the front-panel circuit board and status panel, proceed as follows:



WARNING **DISCONNECT THE PRIMARY POWER FROM THE DT-90A BEFORE PROCEEDING.**

WARNING

- 5-279. Disconnect the primary power from the DT-90A.
- 5-280. Remove the top-cover and bottom-panel as shown.
- 5-281. Disconnect P401 from J401 on the front-panel circuit board as shown.
- 5-282. Remove the four front-panel mounting screws. With light pressure, carefully pull the front-panel from the side-panels as indicated.
- 5-283. Disconnect P402 from J402 on the front-panel circuit board.
- 5-284. Remove the three front-panel mounting nuts. Lift the front-panel circuit board from the mounting studs as indicated.
- 5-285. By applying light pressure to the mounting studs, separate the status panel from the front-panel casting as shown.
- 5-286. Install the new status panel and front-panel circuit board by following the procedure for disassembly in reverse order. Do not install the top-cover or remove the protective cling film from the status panel until installation is complete.
- 5-287. **CIRCUIT BOARD INSTALLATION.** To install the record logic circuit board, proceed as follows:



WARNING **DISCONNECT THE PRIMARY POWER FROM THE DT-90A BEFORE PROCEEDING.**

WARNING

- 5-288. Disconnect the primary power from the DT-90A.
- 5-289. Install the record circuit board as shown. Ensure the connector on the record circuit board and mating connector on the motherboard circuit board are properly seated.
- 5-290. **RECORD HEAD INSTALLATION.** To install the record head, proceed as follows:



WARNING **DISCONNECT THE PRIMARY POWER FROM THE DT-90A BEFORE PROCEEDING.**

WARNING

- 5-291. Disconnect the primary power from the DT-90A.
- 5-292. Disconnect the playback head leads from the playback circuit board.
- 5-293. Loosen the head assembly mounting screws and remove the entire head assembly from the cartridge deck.
- 5-294. Loosen the head locking screw and remove the dummy head from the head assembly.
- 5-295. Refer to Figure 5-13 and connect the head leads to the record head as shown.
- 5-296. Firmly seat the record head into the head assembly and secure the head locking screw.
- 5-297. Replace the head assembly and secure the mounting screws.

- 5-298. Refer to drawing AD910-0112/-001 in SECTION VI, PARTS LISTS AND DRAWINGS, and connect the record head leads to the record circuit board.
- 5-299. Refer to drawing AD910-0113/-001 in SECTION VI, PARTS LISTS AND DRAWINGS, and connect the playback head leads to the playback circuit board.
- 5-300. Align the record head by performing all the **HEAD ADJUSTMENT** and associated **RECORD ADJUSTMENT** procedures.
- 5-301. Replace the DT-90A top-cover, and remove the cling film from the status panel.
- 5-302. **TROUBLESHOOTING.**
- 5-303. Low voltages are used throughout the DT-90A series cartridge machine playback and control circuitry. The power supply circuitry contains primary ac line voltage. Therefore, do not perform any maintenance or troubleshooting procedures on the power supply circuitry with power energized. Troubleshooting with power energized is always considered hazardous and caution should be observed. Good judgment, care, and common sense must be practiced to prevent accidents.
- 5-304. The troubleshooting philosophy for the DT-90A cartridge machines consists of isolating a problem to a specific circuit board. The problem may be isolated by referencing Tables 5-1 and 5-2 which present the DT-90A series cartridge machine troubleshooting.



WARNING ***DISCONNECT ALL CARTRIDGE MACHINE PRIMARY POWER BEFORE REMOVING OR INSERTING PRINTED CIRCUIT BOARDS OR REPLACING ANY COMPONENTS.***

WARNING



CAUTION ***INADVERTENT CONTACT BETWEEN ADJACENT COMPONENTS OR CIRCUIT BOARDS WITH TEST EQUIPMENT MAY CAUSE SERIOUS DAMAGE TO THE CARTRIDGE MACHINE.***

CAUTION

- 5-305. Once trouble is isolated and power is totally deenergized, refer to the schematic diagrams and the theory of operation to assist in problem resolution. The defective component may be repaired locally or the entire device may be returned to Broadcast Electronics Inc. for repair or replacement.



WARNING ***DISCONNECT POWER BEFORE REMOVING OR REPLACING CIRCUIT BOARDS OR COMPONENTS.***

WARNING



CAUTION ***WHEN REPLACING A COMPONENT MOUNTED ON A HEAT-SINK, ENSURE A THIN FILM OF A ZINC-BASED HEAT-SINK COMPOUND IS USED TO ASSURE GOOD HEAT DISSIPATION.***

CAUTION

- 5-306. **COMPONENT REPLACEMENT.** The circuit boards used in the DT-90A cartridge machines are double-sided with plated-through holes. Due to the plated-through hole design, solder fills the holes by capillary action. This condition requires that defective components be removed carefully to avoid damage to the circuit board.

TABLE 5-1. DT-90A PLAYBACK LOGIC CIRCUIT BOARD TROUBLESHOOTING
(Sheet 1 of 2)

SYMPTOM	DEFECT
NO MOTOR, SOLENOID, AND INDICATOR OPERATION	<ol style="list-style-type: none"> 1. Check the ac line fuse on the DT-90A rear-panel.
NO NORMAL SPEED MOTOR OPERATION	<ol style="list-style-type: none"> 1. Check motor relay K1 on the side-panel.
.	<ol style="list-style-type: none"> 2. Check fast forward latch U13A. 3. Check integrated circuits U12G and U17D.
NO FAST FORWARD MOTOR OPERATION	<ol style="list-style-type: none"> 1. Check solid state motor relays K1 and K2 on the motherboard circuit board. 2. Check fast forward latch U13A. 3. Check integrated circuits U14B and U15B. 4. Check integrated circuit U12F. 5. Check front-panel FAST FORWARD switch/indicator S2.
NO MOTOR OPERATION	<ol style="list-style-type: none"> 1. Check the capstan motor. 2. Refer to Figure 5-14 and troubleshoot the motor control circuit board.
NO SOLENOID OPERATION	<ol style="list-style-type: none"> 1. Check front-panel START switch/indicator S1. 2. Check start latch U13B. 3. Check integrated circuit U14A. 4. Check transistor Q1 on the motherboard circuit board. 5. Check the deck solenoid. 6. Check the deck microswitch.
NO LEFT CHANNEL AUDIO OUTPUT	<ol style="list-style-type: none"> 1. Check input amplifier U1B. 2. Check audio selector U20A and mute transistor Q1. 3. Check amplifier circuit U1A. 4. Check output amplifier circuits U3 and U4.
NO AUDIO OUTPUT	<ol style="list-style-type: none"> 1. Check the playback head. 2. Check mute latch U13C. 3. Check audio delay circuit U17C and associated components. 4. Check integrated circuits U14C and U16C.

5

TABLE 5-1. DT-90A PLAYBACK LOGIC CIRCUIT BOARD TROUBLESHOOTING
(Sheet 2 of 2)

SYMPTOM	DEFECT
NO 1 KHZ STOP OPERATION	<ol style="list-style-type: none"> 1. Check integrated circuits U9B, U10C, and U19D. 2. Check primary cue tone inhibit jumper J211.
NO CUE TONE OPERATIONS	<ol style="list-style-type: none"> 1. Check cue input amplifier U7. 2. Check the playback head.
NO START LOCK-OUT OPERATION	<ol style="list-style-type: none"> 1. Check start lock-out jumper J213. 2. Check flasher latch U13D. 3. Check integrated circuit U15C.
NO MUTE OPERATION	<ol style="list-style-type: none"> 1. Check integrated circuit U16C. 2. Check mute latch U13C.

TABLE 5-2. DT-90A RECORD LOGIC CIRCUIT BOARD TROUBLESHOOTING
(Sheet 1 of 2)

SYMPTOM	DEFECT
NO RECORD OPERATION	<ol style="list-style-type: none"> 1. Check front-panel RECORD switch S6. 2. Check integrated circuits U12B and U16A. 3. Check record latch U17C/U17D. 4. Check integrated circuit U18A and transistor Q5. 5. Check the record head.
NO PROGRAM BIAS	<ol style="list-style-type: none"> 1. Check program bias mute circuits Q1 and Q2. 2. Check integrated circuit U10.
NO CUE BIAS	<ol style="list-style-type: none"> 1. Check cue bias mute circuits Q3 and Q4. 2. Check integrated circuit U9.
NO PROGRAM BIAS, CUE BIAS AND CUE TONE AUDIO	<ol style="list-style-type: none"> 1. Check bias oscillator U6. 2. Check crystal X1.

**TABLE 5-2. DT-90A RECORD LOGIC CIRCUIT BOARD TROUBLESHOOTING
(Sheet 2 of 2)**

SYMPTOM	DEFECT
NO PRIMARY CUE TONE RECORD OPERATION	<ol style="list-style-type: none"> 1. Check 1 kHz enable gate U19A. 2. Check 1 kHz timer circuit U18C. 3. Check integrated circuit U7C. 4. Check integrated circuit U12D. 5. Check low-pass filter U14A and associated components.
NO PRIMARY CUE TONE INHIBIT OPERATION	<ol style="list-style-type: none"> 1. Check one shot U16B and associated circuitry. 2. Check 1 kHz inhibit latch U17A and U17B.
NO RECORD INDICATOR FLASHER OPERATION	<ol style="list-style-type: none"> 1. Check flasher oscillator U18B.
NO CUE TONE RECORD OPERATION	<ol style="list-style-type: none"> 1. Check buffer circuit U19B. 2. Check transistor Q6. 3. Check the record head cue channel.
NO LEFT CHANNEL RECORD METER OPERATION	<ol style="list-style-type: none"> 1. Check left input meter selector U5B.
NO LEFT CHANNEL METER OPERATION	<ol style="list-style-type: none"> 1. Check left meter mute U5C. 2. Check left meter amplifier U23A. 3. Check left meter rectifier stage U21B. 4. Check left meter driver U21A. 5. Check left display driver U1 and LED display on the front-panel circuit board.
NO METER OPERATION	<ol style="list-style-type: none"> 1. Check integrated circuit U19C.
NO RECORD AUDIO	<ol style="list-style-type: none"> 1. Check integrated circuit U18A.
NO LEFT RECORD AUDIO	<ol style="list-style-type: none"> 1. Check left input amplifier circuits U1A, U1B, and U1D. 2. Check left amplifier circuits U1C and U3B. 3. Check left audio mute U5A. 4. Check left head driver U3A.

5

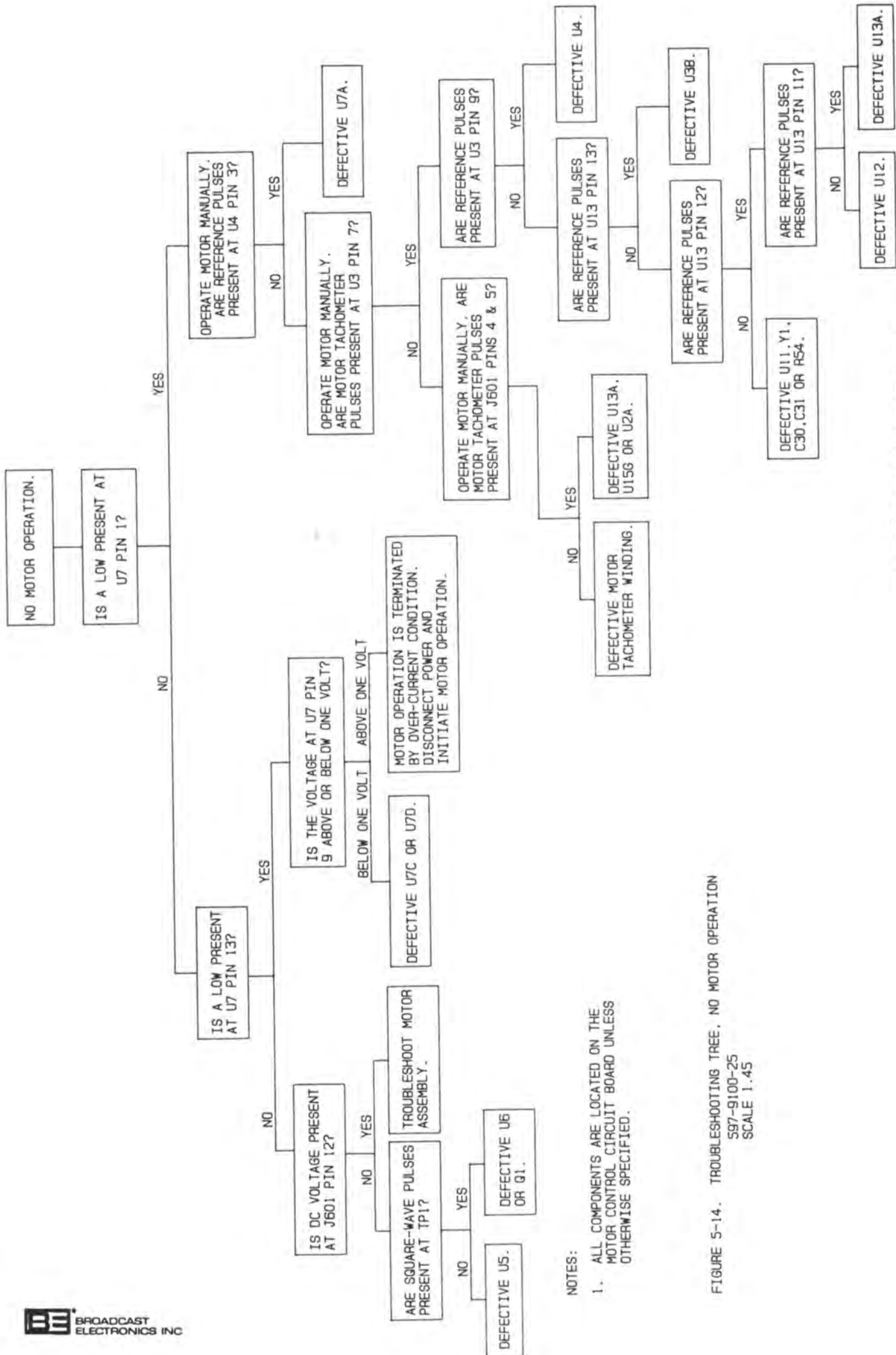

NOTES:
1. ALL COMPONENTS ARE LOCATED ON THE MOTOR CONTROL CIRCUIT BOARD UNLESS OTHERWISE SPECIFIED.

FIGURE 5-14. TROUBLESHOOTING TREE. NO MOTOR OPERATION
597-9100-25
SCALE 1.45

- 5-307. On all circuit boards, the adhesion between the copper trace and the circuit board fails at almost the same temperature as solder melts. A circuit board trace can be destroyed by excessive heat or lateral movement during soldering. Use of a small soldering iron with steady pressure is required for circuit board repairs.
- 5-308. To remove a soldered component from a circuit board, cut the leads from the body of the defective component while the device is still soldered to the board. Grip a component lead with needle-nose pliers. Touch the soldering iron to the lead at the solder connection on the circuit side of the board. When the solder begins to melt, push the lead through the back side of the board and cut off the clinched end of the lead. Each lead may now be heated independently and pulled out of each hole. The holes may be cleared by careful re-heating with a low wattage iron and removing the residual solder with a soldering vacuum tool.
- 5-309. Install the new component and apply solder from the circuit side of the board. If no damage has been incurred to the plated-through holes, soldering of the component side of the board will not be required.



WARNING *MOST SOLVENTS WHICH REMOVE ROSIN FLUX ARE VOLATILE AND TOXIC BY NATURE AND SHOULD BE USED ONLY IN SMALL AMOUNTS IN A WELL VENTILATED AREA AWAY FROM FLAME, CIGARETTES, AND HOT SOLDERING IRONS.*



WARNING *OBSERVE THE MANUFACTURERS CAUTIONARY INSTRUCTIONS.*

- 5-310. After soldering, remove residual flux with a suitable solvent. Rubbing alcohol is highly diluted and is not effective.
- 5-311. The board should be checked to ensure the flux has been completely removed. Rosin flux is not normally corrosive, however in time, the flux will absorb enough moisture to become conductive and create problems.
- 5-312. **INTEGRATED CIRCUITS.** Special care should be exercised with integrated circuits. Each integrated circuit must be installed by matching the integrated circuit notch with the notch on the socket. Do not attempt to remove an integrated circuit from a socket with your fingers. Use an integrated circuit puller to lightly pry the component from the socket.

SECTION VI

PARTS LISTS AND DRAWINGS

6-1. INTRODUCTION.

- 6-2. This section provides parts lists and drawings for the Broadcast Electronics DT-90A cartridge machine. The parts lists provide descriptions and part numbers of electrical components, assemblies, and selected mechanical parts required for maintenance. Each parts list entry in this section is indexed by reference designators appearing on the applicable schematic diagrams. The DT-90A drawings presented in this section include: 1) assembly diagrams, 2) wiring diagrams, and 3) schematic diagrams.
- 6-3. Table 6 presents the parts lists and drawings contained in the section. The section is organized by assemblies. Each assembly contains all applicable drawings and parts lists.

TABLE 6. PARTS LISTS AND DRAWINGS
(Sheet 1 of 2)

ASSEMBLY	DESCRIPTION	PART NO.
FINAL ASSEMBLY		
FIGURE 6-1A	SCHEMATIC DIAGRAM, DT-90A OVERALL	SD900-9100-001
FIGURE 6-1B	ASSEMBLY DIAGRAM, DT-90A OVERALL	597-9100-71
TABLE 6-1	PARTS LIST, DT-90A CARTRIDGE MACHINE FINAL ASSEMBLY	900-910X-X01
TABLE 6-1A	PARTS LIST, DT-90A ACCESSORY KIT	979-0086
TABLE 6-1B	PARTS LIST, HEAD BOX ASSEMBLY	950-0302
TABLE 6-1C	PARTS LIST, DECK ASSEMBLY	950-0190
TABLE 6-1D	PARTS LIST, CABLE ASSEMBLY	940-0035/ -0036
TABLE 6-1E	PARTS LIST, SOLENOID ASSEMBLY	950-0303-001
TABLE 6-1F	PARTS LIST, DT-90A MOTOR ASSEMBLY	950-0037
MOTHERBOARD		
FIGURE 6-2	SCHEMATIC DIAGRAM, MOTHERBOARD	SD910-0115
FIGURE 6-2A	ASSEMBLY DIAGRAM, MOTHERBOARD	AD910-0115
TABLE 6-2	PARTS LIST, MOTHERBOARD CIRCUIT BOARD ASSEMBLY	910-0115
PLAYBACK LOGIC CIRCUIT BOARD		
FIGURE 6-3	SCHEMATIC DIAGRAM, PLAYBACK LOGIC CIRCUIT BOARD	SD910-0112/-001
FIGURE 6-3A	ASSEMBLY DIAGRAM, PLAYBACK LOGIC CIRCUIT BOARD	AD910-0112/-001
TABLE 6-3	PARTS LIST, PLAYBACK LOGIC CIRCUIT BOARD	910-0112/-001

TABLE 6. PARTS LISTS AND DRAWINGS
(Sheet 2 of 2)

ASSEMBLY	DESCRIPTION	PART NO.
RECORD LOGIC CIRCUIT BOARD		
FIGURE 6-4	SCHEMATIC DIAGRAM, RECORD LOGIC CIRCUIT BOARD	SD910-0113/-001
FIGURE 6-4A	ASSEMBLY DIAGRAM, RECORD LOGIC CIRCUIT BOARD	AD910-0113/-001
TABLE 6-4	PARTS LIST, RECORD LOGIC CIRCUIT BOARD	910-0113/-001
FRONT-PANEL CIRCUIT BOARD		
FIGURE 6-5	SCHEMATIC DIAGRAM, FRONT-PANEL CIRCUIT BOARD	SD910-0111
FIGURE 6-5A	ASSEMBLY DIAGRAM, FRONT-PANEL CIRCUIT BOARD	AC910-0111
TABLE 6-5	PARTS LIST, RECORD/PLAYBACK FRONT-PANEL CIRCUIT BOARD	910-0111/-001
TABLE 6-5A	PARTS LIST, PLAYBACK FRONT-PANEL CIRCUIT BOARD	910-0111/-002
MOTOR CONTROL CIRCUIT BOARD		
FIGURE 6-6	SCHEMATIC DIAGRAM, MOTOR CONTROL CIRCUIT BOARD	SD910-9005
FIGURE 6-6A	ASSEMBLY DIAGRAM, MOTOR CONTROL CIRCUIT BOARD	AC910-9005
TABLE 6-6	PARTS LIST, MOTOR CONTROL CIRCUIT BOARD	910-9005
MISCELLANEOUS		
FIGURE 6-7	DT-90A RACK ASSEMBLY DIAGRAM	597-9100-160

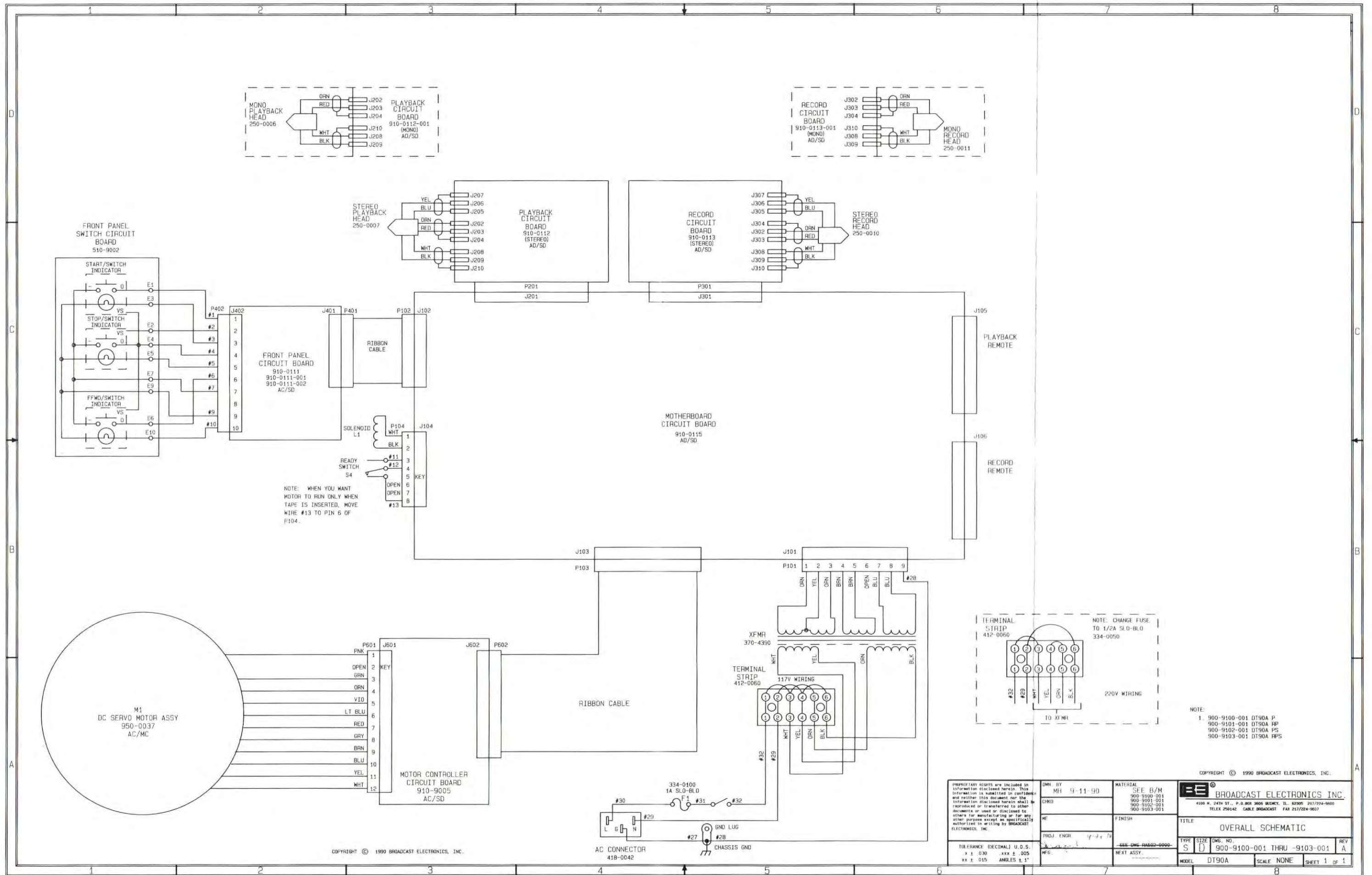

NOTE: WHEN YOU WANT MOTOR TO RUN ONLY WHEN TAPE IS INSERTED, MOVE WIRE #13 TO PIN 6 OF P104.

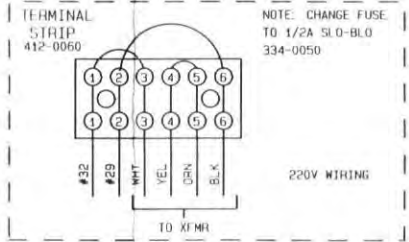

- NOTE:
- 1. 900-9100-001 DT90A P
 - 900-9101-001 DT90A RP
 - 900-9102-001 DT90A PS
 - 900-9103-001 DT90A RPS

COPYRIGHT © 1990 BROADCAST ELECTRONICS, INC.

PROPRIETARY RIGHTS ARE INCLUDED IN INFORMATION DISCLOSED HEREIN. THIS INFORMATION IS SUBMITTED IN CONFIDENCE AND NEITHER THIS DOCUMENT NOR THE INFORMATION DISCLOSED HEREIN SHALL BE REPRODUCED OR TRANSFERRED TO OTHER DOCUMENTS OR USED OR DISCLOSED TO OTHERS FOR MANUFACTURING OR FOR ANY OTHER PURPOSE EXCEPT AS SPECIFICALLY AUTHORIZED IN WRITING BY BROADCAST ELECTRONICS, INC.	DWN. BY MH 9-11-90	MATERIAL SEE B/M 900-9100-001 900-9101-001 900-9102-001 900-9103-001	BROADCAST ELECTRONICS, INC. 4100 N. 24TH ST., P.O. BOX 3606 GAITHERSBURG, MD. 20878 217/974-9600 TEL: 250-142 CABLE: BROADCAST FAX: 217/224-9607		
	DWN. 	FINISH 		TITLE OVERALL SCHEMATIC	
	PROJ. ENGR.	SEE DWG HAS00-0000-		TYPE SIZE Dwg. NO. S D 900-9100-001 THRU -9103-001	REV A
	MFG.	NEXT ASSY.		MODEL DT90A	SCALE NONE SHEET 1 OF 1
TOLERANCE (DECIMAL) U.O.S. .X ± 0.30 .XXX ± 0.05 XX ± 0.15 ANGLES ± 1°					

COPYRIGHT © 1990 BROADCAST ELECTRONICS, INC.

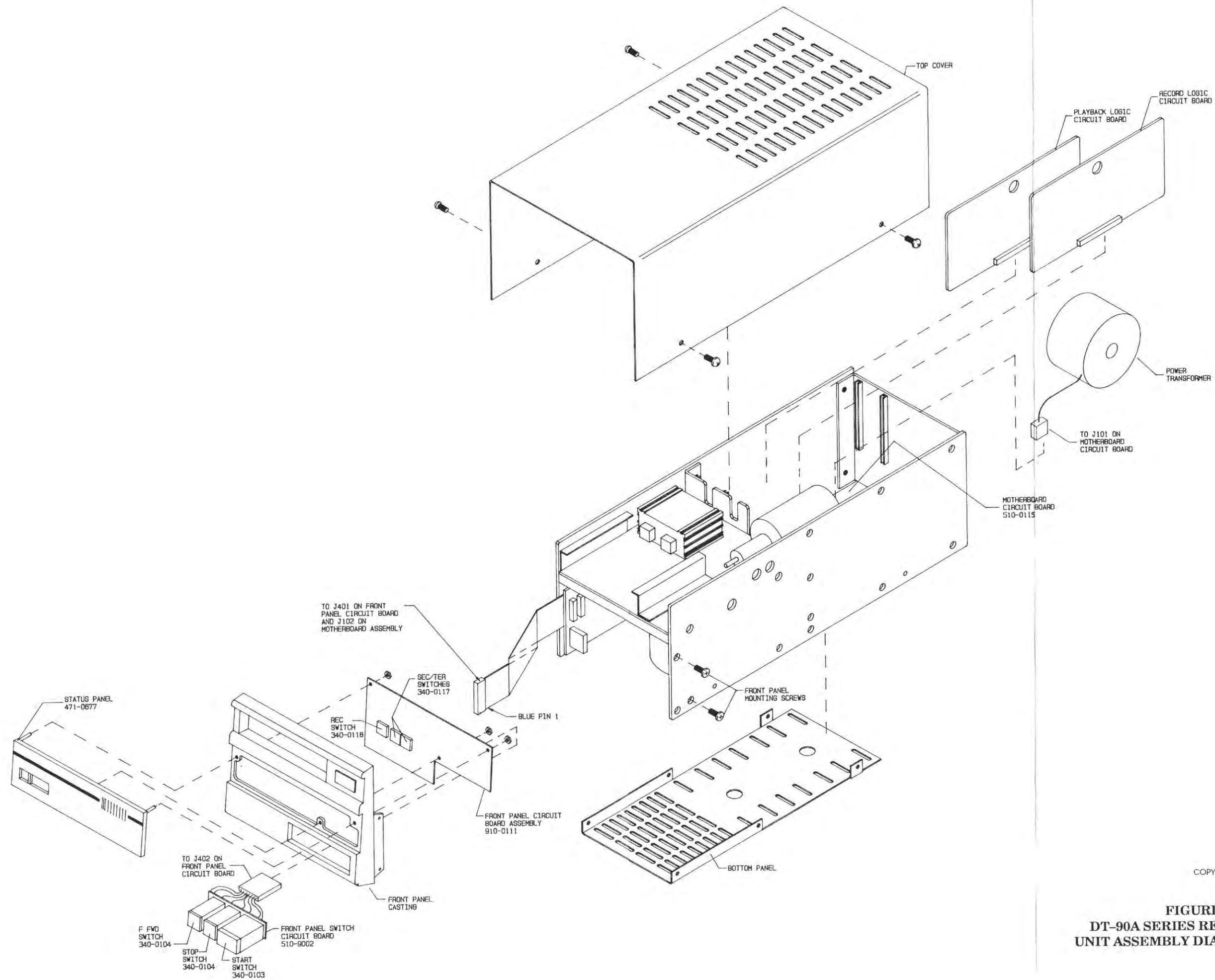

COPYRIGHT © 1990 BROADCAST ELECTRONICS, INC.
597-9100-71A

FIGURE 6-1B.
DT-90A SERIES RECORD/PLAYBACK
UNIT ASSEMBLY DIAGRAM (Sheet 1 of 4)

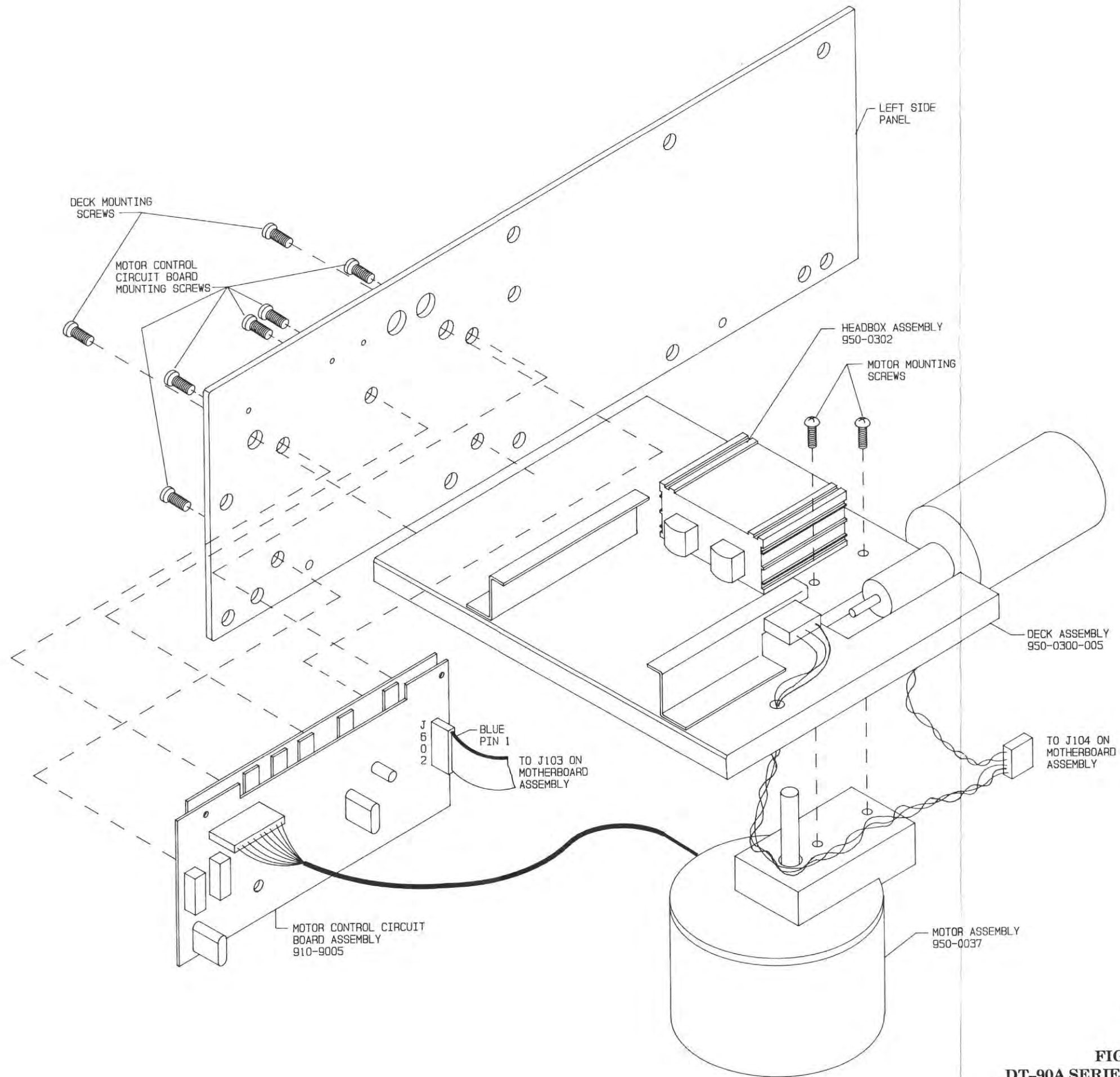

COPYRIGHT © 1990 BROADCAST ELECTRONICS, INC.
597-9100-71B

FIGURE 6-1B.
DT-90A SERIES RECORD/PLAYBACK
UNIT ASSEMBLY DIAGRAM (Sheet 2 of 4)

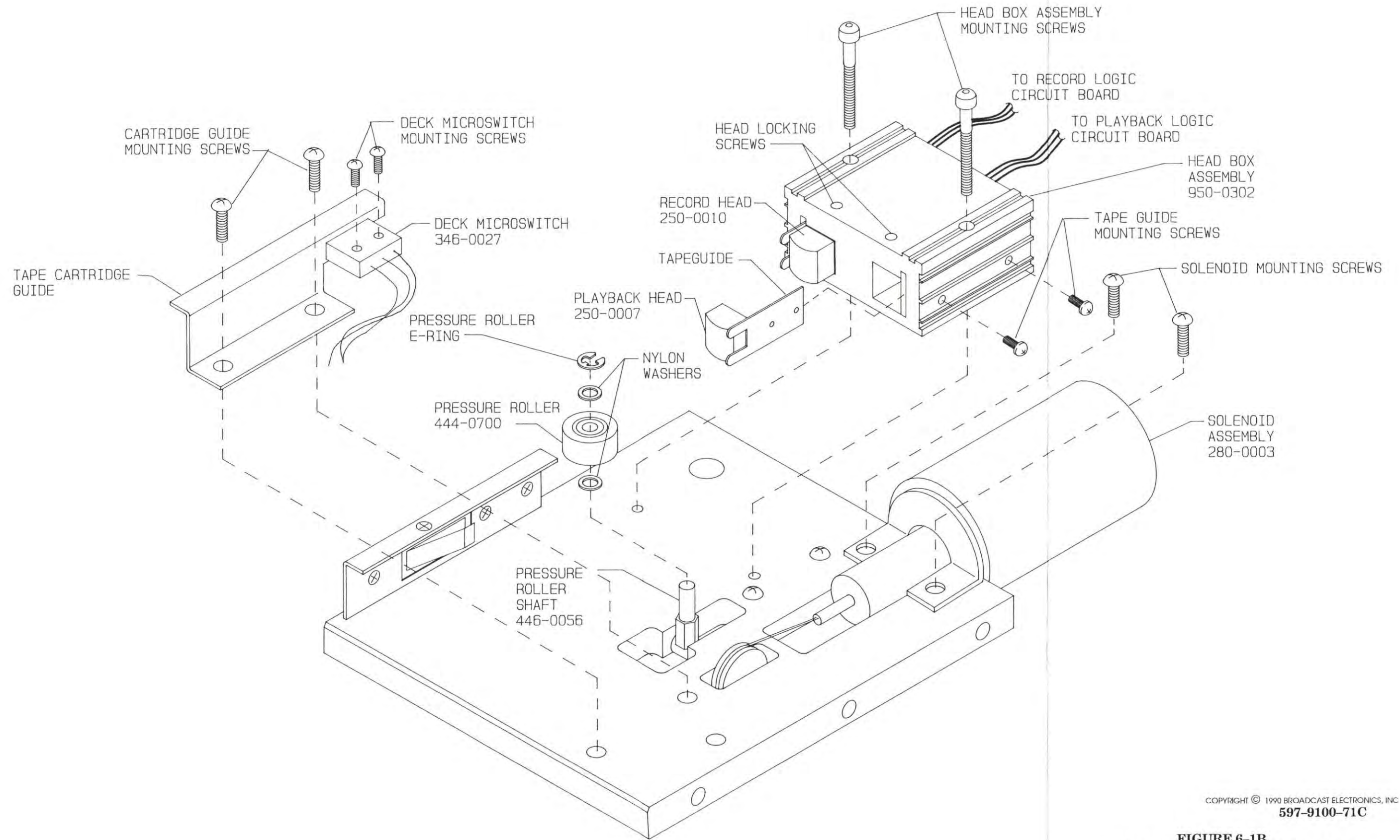

COPYRIGHT © 1990 BROADCAST ELECTRONICS, INC
 597-9100-71C

FIGURE 6-1B.
DT-90A SERIES RECORD/PLAYBACK
UNIT ASSEMBLY DIAGRAM (Sheet 3 of 4)

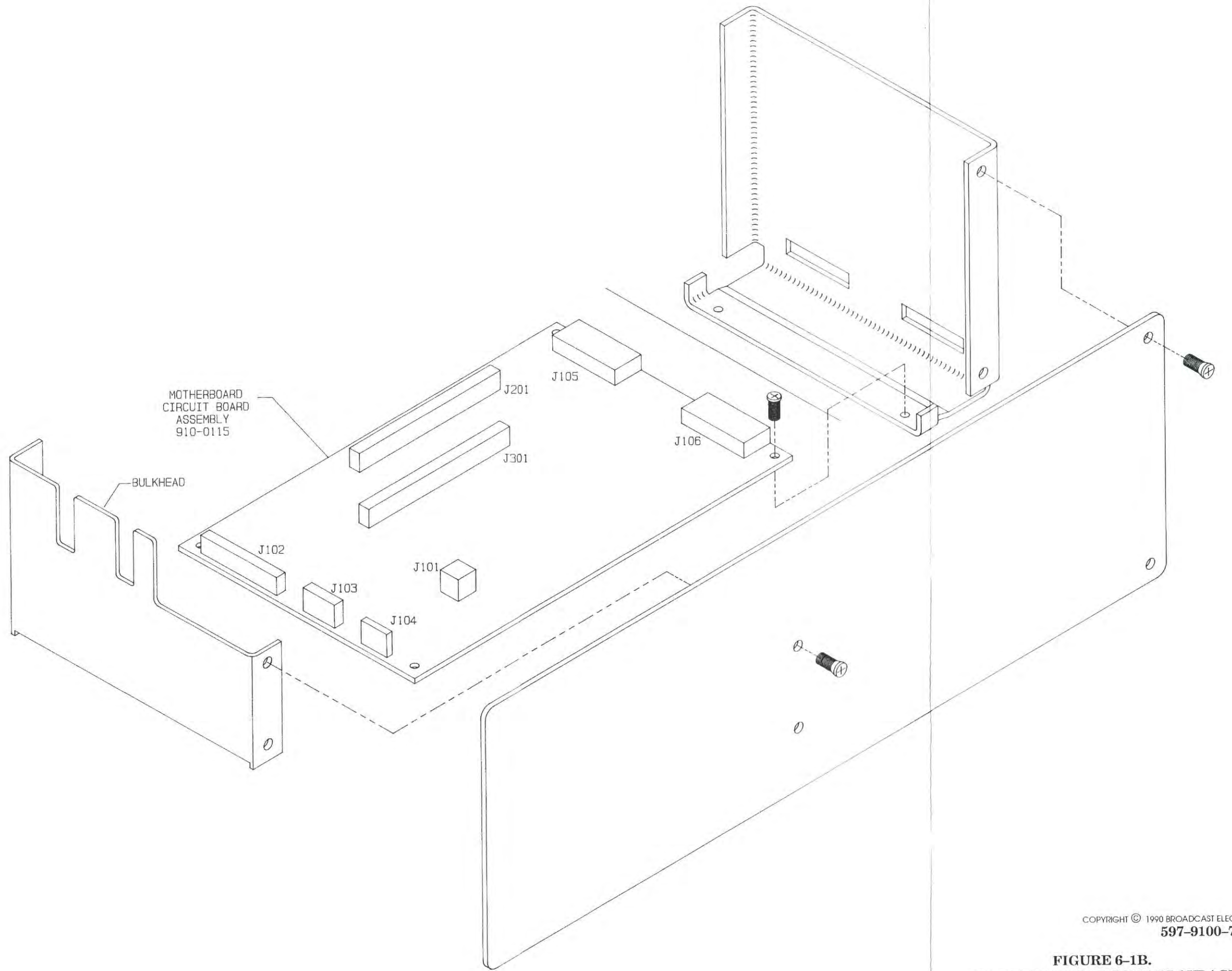

COPYRIGHT © 1990 BROADCAST ELECTRONICS, INC.
597-9100-71D

FIGURE 6-1B.
DT-90A SERIES RECORD/PLAYBACK
UNIT ASSEMBLY DIAGRAM (Sheet 4 of 4)

TABLE 6-1. DT-90A CARTRIDGE MACHINE FINAL ASSEMBLY - 900-910X-X01
(Sheet 1 of 2)

REF. DES.	DESCRIPTION	PART NO.	QTY.
117V 50/60 Hz			
F1	Fuse, AGC, 1 Ampere, 250V, Slow-Blow (for 115V Operation)	334-0100	1
—	AC Line Cord, 3 Conductor	682-0001	1
220V 50/60 Hz			
F1	Fuse, AGC, 1/2 Ampere, Slow-Blow	330-0050	1
—	AC Line Cord, 3 Conductor	682-0003	1
S1	Switch, Pushbutton, Rectangular, Momentary Contact, Illuminated, (START Switch)	340-0103	1
S2,S3	Switch, Pushbutton, Square, Momentary Contact, Illuminated, (F FWD and STOP Switches)	340-0104	2
T1	Transformer, Toroid Primary: 115V AC 50/60 Hz 0.68 Ampere 230V AC 50/60 Hz 0.34 Ampere Secondary: 1) 20V AC 0.40 Ampere 2) 25V AC 1.0 Ampere 3) 9V AC 150 mA	370-4390	1
TB1	Barrier Strip, 6 Terminals	412-0060	1
P101	Connector, 9-Pin (for Transformer T1)	417-0059	1
—	Connector, Power, AC Input	418-0042	1
—	Pins, Connector for P101	417-0053	8
—	Fuse Holder, AGC	415-2012	1
—	Switch, Miniature, Toggle, SPDT, 5A @ 120V ac or 2A @ 250V ac (PWR)	348-7101	1
—	Switch Cap, Green, Rectangular (START)	340-0089	1
—	Switch Cap, Blue, Square (F FWD)	340-0059	1
—	Switch Cap, Yellow, Square (STOP)	340-0014	1
—	Lamp, Wedge Base, No. 85, 28V @ 0.04 Amperes	321-0085	3
—	Blank Circuit Board, Front-panel Switch	510-9002	1
—	Motherboard Circuit Board Assembly	910-0115	1
—	Deck Assembly	950-0190	1
—	Head Box Assembly	950-0302	1
—	Kit, Final Assembly	950-0189	1
—	Accessory Kit	979-0086	1
—	Motor Control Circuit Board Assembly	910-9005	1
—	DT-90A Motor Assembly	950-0037	1
—	DT-90A, Motor Replacement Kit	950-0207	1

ADDITIONAL PARTS FOR MONOPHONIC PLAYBACK
900-9100-X01

—	Head Playback, Monophonic, 2-Channel, Model NPD1484 Inductance at 1 kHz: 475 mH Impedance at 1 kHz: 3.3 Ohms DC Resistance: 500 Ohms	250-0006	1
—	Head, Dummy, H801016	407-0001	1
—	Front-Panel Circuit Board Assembly	910-0111-002	1
—	Playback Logic Circuit Board Assembly	910-0112-001	1
—	Playback Cable Assembly	940-0036	1

**TABLE 6-1. DT-90A CARTRIDGE MACHINE FINAL ASSEMBLY - 900-910X-X01
(Sheet 2 of 2)**

REF. DES.	DESCRIPTION	PART NO.	QTY.
ADDITIONAL PARTS FOR MONOPHONIC RECORD/PLAYBACK 900-9101-X01			
—	Head Playback, Monophonic, 2-Channel, Model NPD1484 Inductance at 1 kHz: 475 mH Impedance at 1 kHz: 3.3 Ohms DC Resistance: 500 Ohms	250-0006	1
—	Head Record, Monophonic, 2-Channel, Model F53B9302 Inductance at 1 kHz: 0.10 mH Impedance at 1 kHz: 3.0 Ohms DC Resistance: 3.6 Ohms	250-0012	1
—	Front-Panel Circuit Board Assembly	910-0111-001	1
—	Playback Logic Circuit Board Assembly	910-0112-001	1
—	Record Logic Circuit Board Assembly	910-0113-001	1
—	Playback Cable Assembly	940-0035	1
ADDITIONAL PARTS FOR STEREOPHONIC PLAYBACK 900-9103-X01			
—	Head, Playback, Stereophonic, 3-Channel, Model NPD1496 Inductance at 1 kHz: 475 mH Impedance at 1 kHz: 3.3 Ohms DC Resistance: 500 Ohms	250-0007	1
—	Head, Dummy, H801016	407-0001	1
—	Front-Panel Circuit Board Assembly	910-0111-002	1
—	Playback Logic Circuit Board Assembly	910-0112	1
—	Playback Cable Assembly	940-0036	1
ADDITIONAL PARTS FOR STEREOPHONIC RECORD/PLAYBACK 900-9103-X01			
—	Head, Playback, Stereophonic, 3-Channel, Model NPD1496 Inductance at 1 kHz: 475 mH Impedance at 1 kHz: 3.3 Ohms DC Resistance: 500 Ohms	250-0007	1
—	Head, Record, Stereophonic, 3-Channel, Model F38B9303 Inductance at 1 kHz: 0.10 mH Impedance at 1 kHz: 4.6 Ohms DC Resistance: 4.9 Ohms	250-0010	1
—	Front-Panel Circuit Board Assembly	910-0111	1
—	Playback Logic Circuit Board Assembly	910-0112	1
—	Record Logic Circuit Board Assembly	910-0113	1
—	Playback Cable Assembly	940-0035	1

TABLE 6-1A. DT-90A ACCESSORY KIT - 979-0086

REF. DES.	DESCRIPTION	PART NO.	QTY.
P105	Connector, 25-Pin (PLAYBACK)	417-0251	1
P106	Connector, 25-Pin (RECORD)	417-0252	1
—	Pins, Connector (RECORD)	417-0158	25
—	Pins, Connector (PLAYBACK)	418-0048	25
—	Housing, Connector With Clamp	418-2501	2
—	Pressure Roller Indentation Gauge	300-0013	1
—	Fuse, AGC, 1 Ampere, Slow-Blow	334-0100	1
60 Hz ASSEMBLY			
—	AC Line Cord, N.E.M.A. 3-Wire North American Plug	682-0001	1
50 Hz ASSEMBLY			
—	AC Line Cord, CEE 7/7 3-Wire European Plug	682-0003	1

TABLE 6-1B. HEAD BOX ASSEMBLY - 950-0302

REF. DES.	DESCRIPTION	PART NO.	QTY.
—	Tape Guide	445-0004	2
—	Spring, Head Box	430-0012	6

TABLE 6-1C. DECK ASSEMBLY - 950-0190

REF. DES.	DESCRIPTION	PART NO.	QTY.
—	Solenoid Assembly	950-0303-001	1
—	Switch, Micro, Roller Actuator, SPDT, 5 Amperes @ 125V ac	346-0027	1
—	Pressure Roller	444-0700	1
—	Pressure Roller Shaft	446-0056	1
—	Pressure Roller Cross Shaft	446-0049	1
—	Retainer "E" Ring	454-3318	1
—	Solenoid Return Spring	430-0014	1
—	Cartridge Guide, Right	445-0006	1
—	Cartridge Guide, Left	445-0008	1
—	Pressure Pad, Cartridge Guide	459-0123	1
—	Spring, Pressure Pad	430-0011	2
—	Spring, Left Cartridge Guide	430-0010	1
—	Washer, Nylon (for Pressure Roller)	423-5008	1
	Outside Diameter: 0.312 Inches (0.792 cm)		
	Inside Diameter: 0.190 Inches (0.483 cm)		
	Height: 0.010 Inches (0.254 cm)		
—	Washer, Nylon (for Pressure Roller)	423-5009	1
	Outside Diameter: 0.312 Inches (0.792 cm)		
	Inside Diameter: 0.190 Inches (0.483 cm)		
	Height: 0.015 Inches (0.381 cm)		

TABLE 6-1D. CABLE ASSEMBLY - 940-0035/-0036

REF. DES.	DESCRIPTION	PART NO.	QTY.
P102,P401	Plug Ribbon Cable, 26-Pin Dual In-Line	418-2600	2
—	Connector Housing, 8-Pin (for P104)	417-0046	1
—	Connector Housing, 16-Pin (for P103, P602)	417-0131	2
—	Connector Housing, 10-Pin (for P402)	417-0148	1
—	Pins, Connector	417-0053	1
—	Pins, Crimp Type	417-8766	12

**ADDITIONAL PARTS FOR PLAYBACK CABLE ASSEMBLY
940-0035**

—	Pins, Connector	417-0142	9
---	-----------------	----------	---

**ADDITIONAL PARTS FOR RECORD/PLAYBACK CABLE ASSEMBLY
940-0036**

—	Pins, Connector	417-0142	18
---	-----------------	----------	----

TABLE 6-1E. SOLENOID ASSEMBLY - 950-0303-001

REF. DES.	DESCRIPTION	PART NO.	QTY.
L1	Solenoid, 32V dc, 1.75 Diameter, Resistance: 37.5 Ohms $\pm 10\%$ at 25°C	280-0003	1
—	Pins, Crimp Type	417-8766	2

TABLE 6-1F. DT-90A MOTOR ASSEMBLY - 950-0037

REF. DES.	DESCRIPTION	PART NO.	QTY.
M1	Motor, DC Servo Operating Supply: +24V $\pm 1.2V$ dc, +5V $\pm 0.2V$ dc Tachometer: 80 Hz per 1 RPS Operating Torque: 10 oz/in. Maximum Operating Current: 1.1A Maximum Operating Speed: Programmable Model: 58FPAK8003	380-0009	1
—	Bearing, Ball, 609ZZ (Upper Bearing) Outside Diameter: 0.9348 Inches (2.37 cm) Inside Diameter: 0.355 Inches (0.902 cm) Height: 0.275 Inches (0.698 cm)	442-0609	1
—	Bearing, Ball, 699ZZ (Lower Bearing) Outside Diameter: 0.7873 Inches (1.99 cm) Inside Diameter: 0.355 Inches (0.902 cm) Height: 0.2346 Inches (0.596 cm)	442-1023	1
—	Connector Housing, 12-Pin	417-1202	1
—	Pins, Crimp Type	417-8766	11

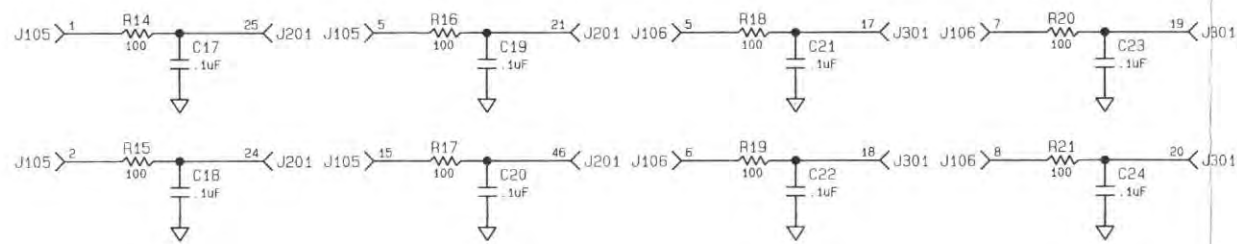
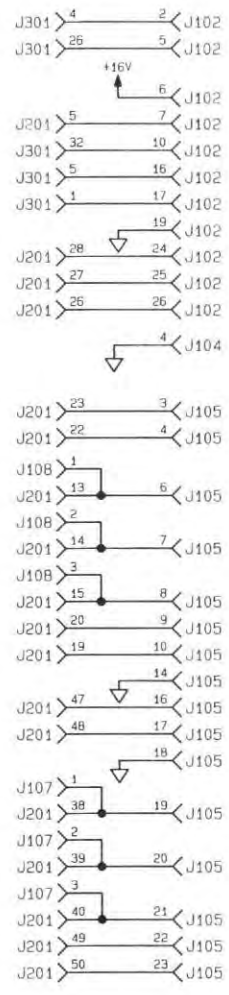
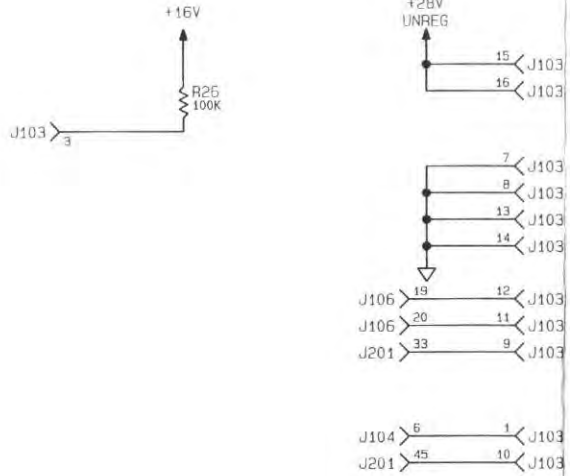
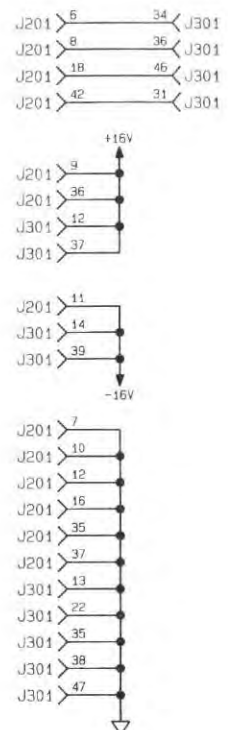
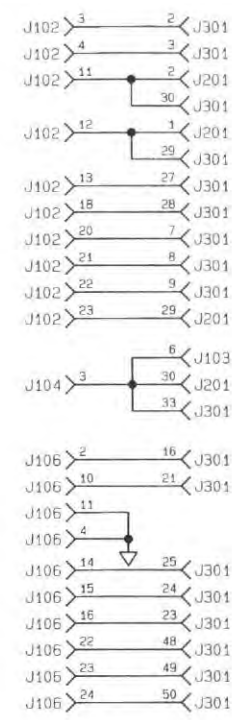
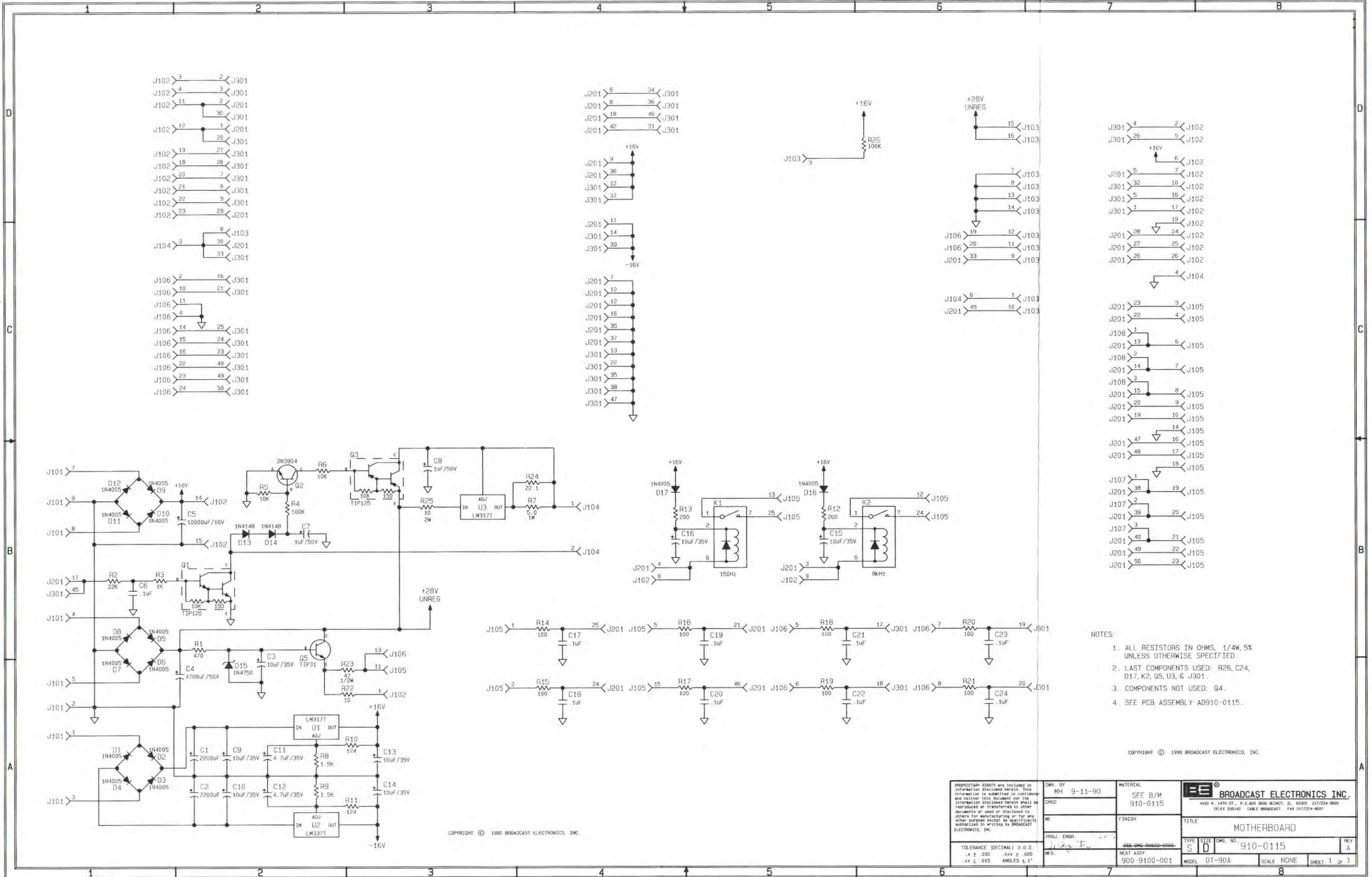

- NOTES:
1. ALL RESISTORS IN OHMS, 1/4W, 5% UNLESS OTHERWISE SPECIFIED.
 2. LAST COMPONENTS USED: R26, C24, D17, K2, G5, U3, & J301.
 3. COMPONENTS NOT USED: G4.
 4. SEE PCB ASSEMBLY AD910-0115.

COPYRIGHT © 1990 BROADCAST ELECTRONICS, INC.

COPYRIGHT © 1990 BROADCAST ELECTRONICS, INC.

PROPRIETARY RIGHTS ARE INCLUDED IN INFORMATION DISCLOSED HEREIN. THIS INFORMATION IS SUBMITTED IN CONFIDENCE AND NEITHER THIS DOCUMENT NOR THE INFORMATION DISCLOSED HEREIN SHALL BE REPRODUCED OR TRANSFERRED TO OTHER DOCUMENTS OR USED OR DISCLOSED TO OTHERS FOR MANUFACTURING OR FOR ANY OTHER PURPOSE EXCEPT AS SPECIFICALLY AUTHORIZED IN WRITING BY BROADCAST ELECTRONICS, INC.		DWN. BY MH 9-11-90	MATERIAL SEE B/M 910-0115	BROADCAST ELECTRONICS INC. <small>4100 N. 24TH ST., P.O. BOX 3606 QUINCY, IL 62305 217/224-3600 TELEX 250142 CABLE BROADCAST FAX 217/224-9807</small>
CHRD	FINISH	TITLE MOTHERBOARD	TYPE SIZE DWS. NO. S D 910-0115	
ME	PROJ. ENGR.	SEE DWS 9100-0000	TITLE 910-0115	REV A
TOLERANCE (DECIMAL) U.O.S. .X ± .030 .XXX ± .005 .XX ± .015 ANGLES ± 1°	NEXT ASST 900-9100-001	MODEL DT-90A	SCALE NONE	SHEET 1 OF 1

COPYRIGHT © 1990 BROADCAST ELECTRONICS, INC.

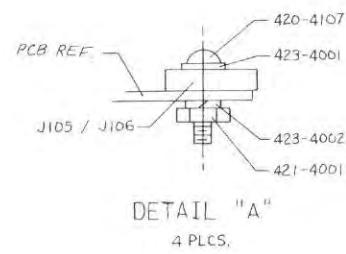
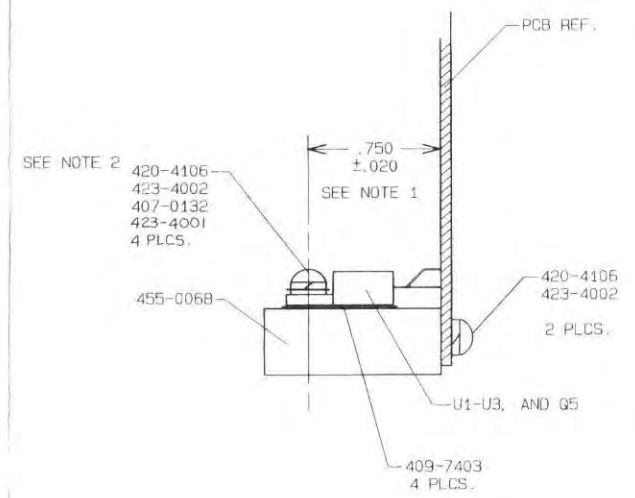
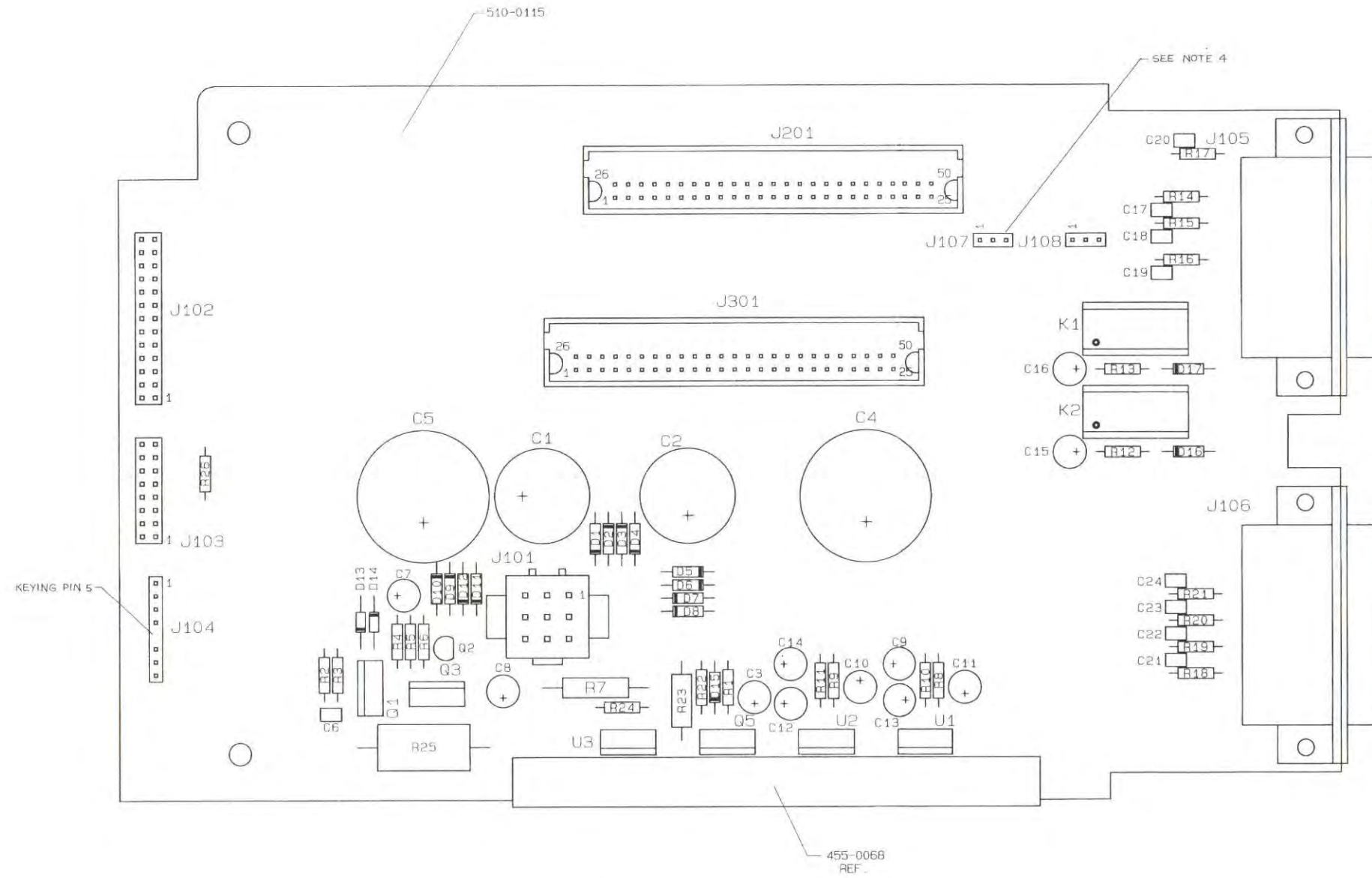

DETAIL "A"
4 PLCS.

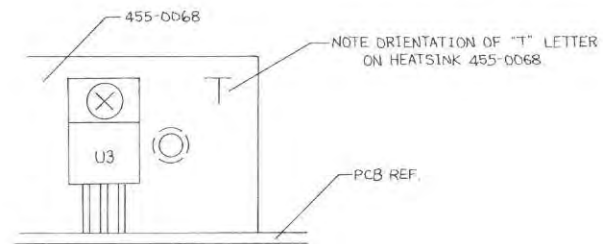

DETAIL "B"

NOTE:

1. U1-U3, AND Q5 MUST BE LOCATED TO DIMENSION SHOWN BEFORE SOLDERING TO P.C. BOARD.
2. 420-4106, 6 PLCS. TO BE TORQUED 5-6 IN.-LBS.
3. AFTER COMPONENTS ON COMPONENT SIDE OF BOARD ARE WAX SOLDERED, THEN INSTALL J201 AND J301. THEY ARE TO BE INSTALLED USING APPROPRIATE SEATING TOOLS AS PER ANY APPLICATION SPECIFICATION NO. 04-9004 REV. 0 SHEET 1 THRU 8.
4. J107 AND J108 ARE OPTIONAL. THEY DO NOT NEED TO BE INSERTED IN BOARD.

COPYRIGHT © 1990 BROADCAST ELECTRONICS, INC.

PROPRIETARY RIGHTS are included in information disclosed herein. This information is submitted in confidence and neither this document nor the information disclosed herein shall be reproduced or transferred to other documents or used or disclosed to others for manufacturing or for any other purpose except as specifically authorized in writing by BROADCAST ELECTRONICS, INC.	DWN BY KLS 7-20-90	MATERIAL SEE B/M 910-0115	BROADCAST ELECTRONICS, INC. 4100 N. 24TH ST., P.O. BOX 3606, QUINCY, IL 62305-2177/2124-9600 TELEX 250142 GABLE BROADCAST FAX 217/224-9607
	CHECKED ME PRD. ENGR.	FINISH NEXT ASSY	
TOLERANCE DECIMAL U.O.S. .X ± .030 XXX ± .005 .XX ± .015 ANGLES ± °			

TABLE 6-2. MOTHERBOARD CIRCUIT BOARD ASSEMBLY - 910-0115
(Sheet 1 of 2)

REF. DES.	DESCRIPTION	PART NO.	QTY.
C1,C2	Capacitor, Electrolytic, 2200 uF, 35V	014-2293	2
C3	Capacitor, Electrolytic, 10 uF, 35V	023-1076	1
C4	Capacitor, Electrolytic, 4700 uF ±20%, 50V	020-4794	1
C5	Capacitor, Electrolytic, 10,000 uF ±20%, 16V	020-1094	1
C6	Capacitor, Monolythic Ceramic, 0.1 uF ±20%, 50V	003-1054	1
C7,C8	Capacitor, Electrolytic, 1 uF, 50V	024-1064	2
C9,C10	Capacitor, Electrolytic, 10 uF, 35V	023-1076	2
C11,C12	Capacitor, Electrolytic, 4.7 uF, 35V, Low Leakage	024-4753	2
C13 THRU C16	Capacitor, Electrolytic, 10 uF, 35V	023-1076	4
C17 THRU C24	Capacitor, Monolythic Ceramic, 0.1 uF ±20%, 50V	003-1054	8
D1 THRU D12	Diode, 1N4005, Silicon, 600V @ 1 Ampere	203-4005	12
D13,D14	Diode, 1N4148, Silicon, 75V @ 0.3 Amperes	203-4148	2
D15	Diode, 1N4750A, Zener, 27V ±10%, 1 Watt	200-0027	1
D16,D17	Diode, 1N4005, Silicon, 600V @ 1 Ampere	203-4005	2
J101	Connector, 9-Pin	418-0900	1
J102	Receptacle, Male, 13-Pin Dual In-Line	417-2600	1
J103	Receptacle, Header, 16-Pin Dual In-Line	417-1603	1
J104	Receptacle, Male, 20-Pin In-Line	417-0200	1
J105	Connector, 25-Pin D-Type	418-2500	1
J106	Connector, 25-Pin	417-0153	1
J201,J301	Connector Header, 50-Pin Dual In-line	417-0146	2
K1,K2	Relay, Coil: 12V dc, 800 Ohms Contacts: 100V dc @ 0.5 Amperes Maximum	270-0056	2
Q1	Transistor, TIP 120, NPN Darlington-Connected Silicon Power, 65W @ 25°C Case	210-0120	1
Q2	Transistor, 2N3904, NPN, Silicon, TO-92 Case	211-3904	1
Q3	Transistor, TIP125, Silicon, PNP, Darlington, TO-220 Case	210-0125	1
Q5	Transistor, TIP31A, Silicon, NPN, TO-220 AB Case	219-0031	1
R1	Resistor, 470 Ohm ±5%, 1/4W	100-4733	1
R2	Resistor, 22 k Ohm ±5%, 1/4W	100-2253	1
R3	Resistor, 1 k Ohm ±5%, 1/4W	100-1043	1
R4	Resistor, 100 k Ohm ±5%, 1/4W	100-1063	1
R5,R6	Resistor, 10 k Ohm ±5%, 1/4W	100-1053	2
R7	Resistor, 10 k Ohm ±5%, 1/4W	120-5011	1
R8,R9	Resistor, 1.5 k Ohm ±1%, 1/4W	103-1504	2
R10,R11	Resistor, 124 Ohm ±1%, 1/4W	103-1241	2
R12,R13	Resistor, 200 Ohm ±5%, 1/4W	100-2033	2
R14 THRU R21	Resistor, 100 Ohm ±5%, 1/4W	100-1033	8
R22	Resistor, 10 Ohm ±5%, 1/4W	100-1023	1
R23	Resistor, 47 Ohm ±5%, 1/2W	110-4723	1
R24	Resistor, 22.1 Ohm ±1%, 1/4W	103-2212	1
R25	Resistor, 10 Ohm ±5%, 2W	130-1023	1
R26	Resistor, 100 k Ohm ±5%, 1/4W	100-1063	1
U1	Integrated Circuit, LM317T, Adjustable Positive Voltage Regulator, 1.2V to 37V, 1.5 Ampere, TO-220 Case	227-0317	1
U2	Integrated Circuit, LM337T, Adjustable Negative Voltage Regulator, 1.2V to 37V, 1.5 Ampere, TO-220 Case	227-0337	1

TABLE 6-2. MOTHERBOARD CIRCUIT BOARD ASSEMBLY - 910-0115
(Sheet 2 of 2)

REF. DES.	DESCRIPTION	PART NO.	QTY.
U3	Integrated Circuit, LM317T, Adjustable Positive Voltage Regulator, 1.2V to 37V, 1.5 Ampere, TO-220 Case	227-0317	1
—	Blank Motherboard Circuit Board	510-0115	1

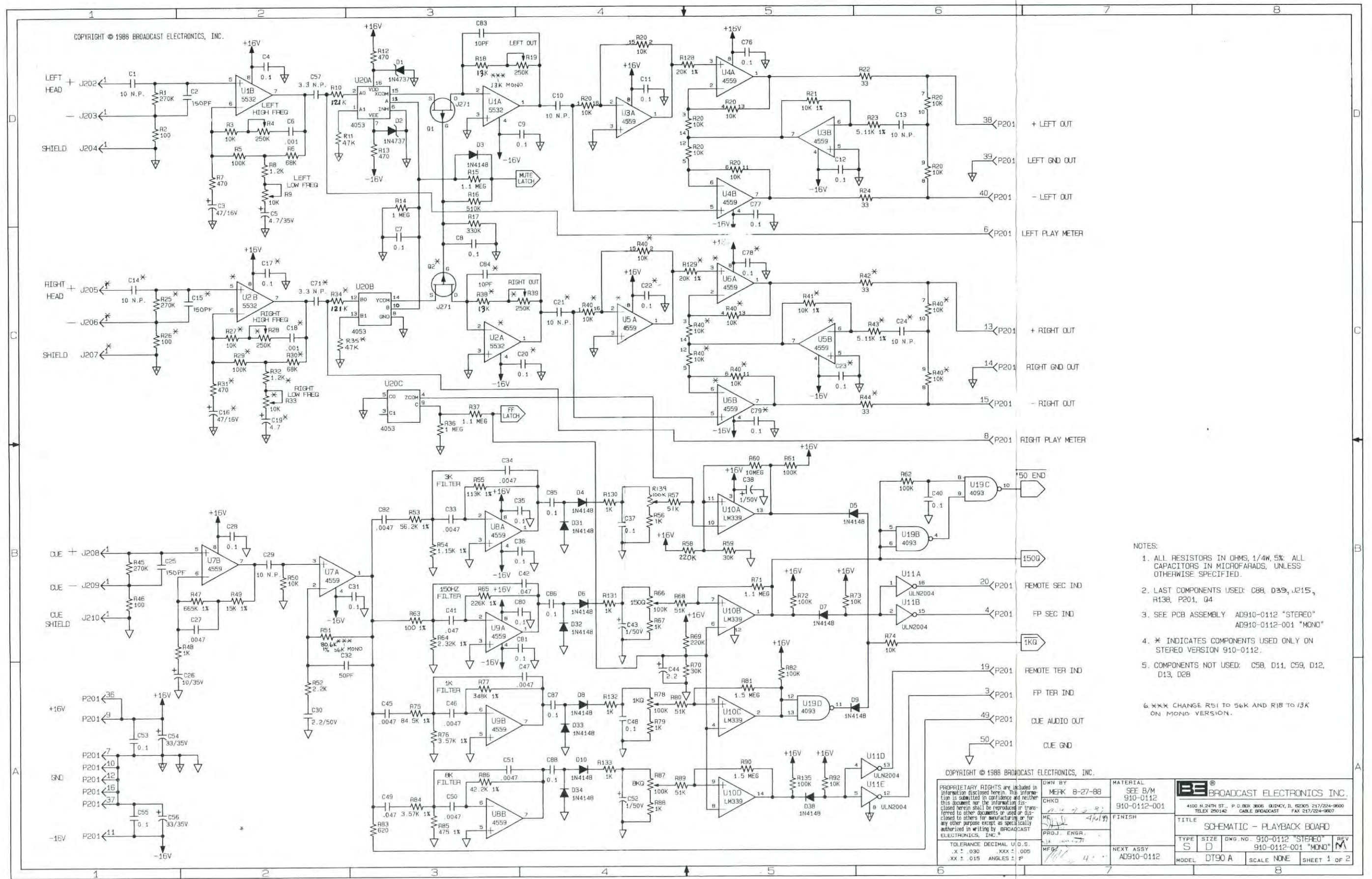

- NOTES:
1. ALL RESISTORS IN OHMS, 1/4W, 5%; ALL CAPACITORS IN MICROFARADS, UNLESS OTHERWISE SPECIFIED.
 2. LAST COMPONENTS USED: C88, D39, J215, R138, P201, Q4
 3. SEE PCB ASSEMBLY AD910-0112 "STEREO" AD910-0112-001 "MONO"
 4. * INDICATES COMPONENTS USED ONLY ON STEREO VERSION 910-0112.
 5. COMPONENTS NOT USED: C58, D11, C59, D12, D13, D28
 6. *** CHANGE R51 TO 56K AND R18 TO 13K ON MONO VERSION.

COPYRIGHT © 1988 BROADCAST ELECTRONICS, INC.

OWN BY MFK 8-27-88	MATERIAL SEE B/M 910-0112	 BROADCAST ELECTRONICS, INC. 4100 N. 24TH ST., P. O. BOX 3606, QUINCY, IL 62205 217/224-9600 TELEX 290140 CABLE BROADCAST FAX 217/224-9807
CHKD	910-0112-001	
DATE 8/27/88	FINISH	TITLE SCHEMATIC - PLAYBACK BOARD
PROJ. ENGR.		TYPE S D
DATE 8/27/88	NEXT ASSY AD910-0112	SIZE DWG. NO. 910-0112 "STEREO" 910-0112-001 "MONO"
		MODEL DT90 A
		SCALE NONE
		SHEET 1 OF 2

COPYRIGHT © 1988 BROADCAST ELECTRONICS, INC.

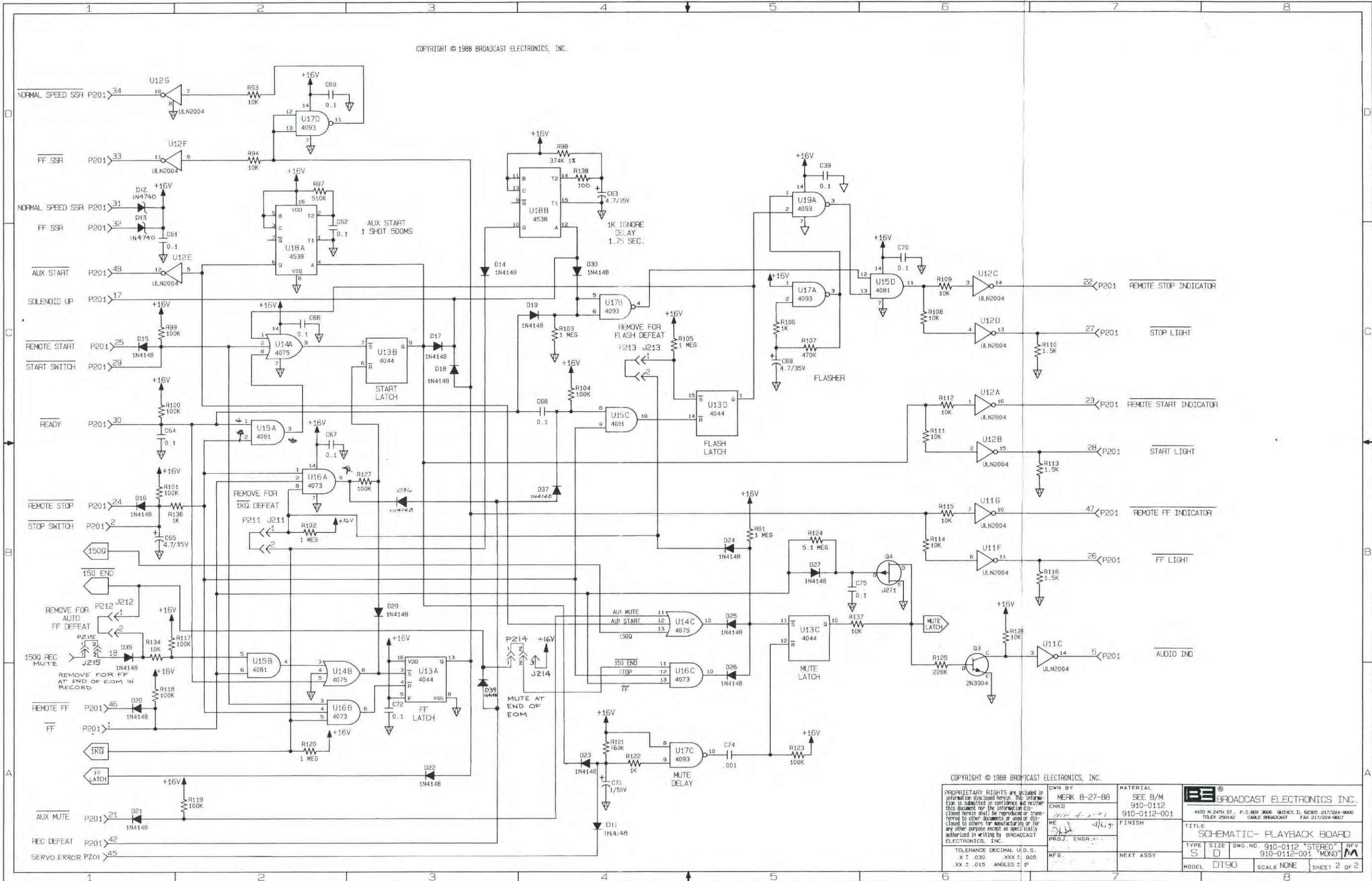

COPYRIGHT © 1988 BROADCAST ELECTRONICS, INC.

PROPRIETARY RIGHTS are included in information disclosed herein. This information is submitted in confidence and neither this document nor the information disclosed herein shall be reproduced or transferred to other documents or used or disclosed to others for manufacturing or for any other purpose except as specifically authorized in writing by BROADCAST ELECTRONICS, INC.		TOLERANCE DECIMAL U.D.S. X ± .030 .XXX ± .005 .XX ± .015 ANGLES ± 1°	DWN BY MERK 8-27-88 CHKD ME PROJ. ENGR.	MATERIAL SEE B/M 910-0112 910-0112-001	FINISH	NEXT ASSY
TITLE SCHEMATIC- PLAYBACK BOARD		TYPE S D	DWG. NO. 910-0112 "STEREO"	REV 910-0112-001 "MONO"	MODEL DT90	SCALE NONE
SHEET 2 OF 2						

COPYRIGHT © 1988 BROADCAST ELECTRONICS, INC.

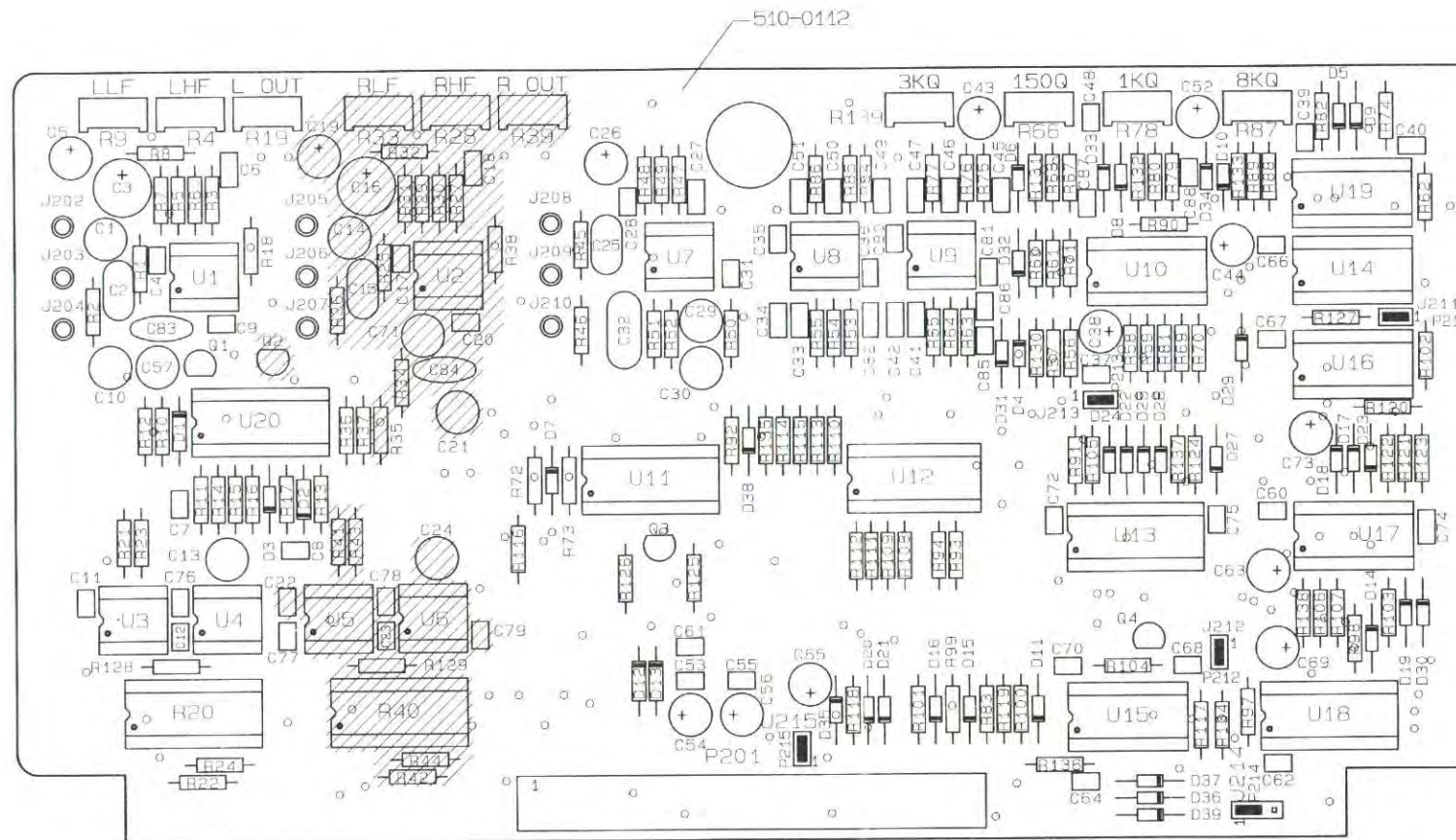

NOTE:

1. SEE SCHEMATIC SD910-0112.
2. 910-0112 "STEREO"
910-0112-001 "MONO"
3. AREA SHADED ON DRAWING REPRESENTS COMPONENTS
USED ONLY ON STEREO VERSION - 910-0112.

COPYRIGHT © 1988 BROADCAST ELECTRONICS, INC.

<small>PROPRIETARY RIGHTS are included in information disclosed herein. This information is submitted in confidence and neither this document nor the information disclosed herein shall be reproduced or transmitted to other documents or used or disclosed to others for manufacturing or for any other purpose except as specifically authorized in writing by BROADCAST ELECTRONICS, INC.</small>	DWN BY MERK 9-9-88	MATERIAL SEE B/M 910-0112	BROADCAST ELECTRONICS, INC. 4100 N 24TH ST., P.O. BOX 3600 GUILFORD, IL 62526 217/224-9600 TELEX 250142 CABLE BROADCAST FAX 217/224-9607
	CHKD MH 4-6-89	910-0112-001	
	ME JHS 4-6-89	FINISH 	TITLE PCB ASSEMBLY- PLAYBACK BOARD
	PROJ. ENGR. JRC 4-6-89	NEXT ASSY 	TYPE SIZE DWG. NO. 910-0112 "STEREO" REV A D 910-0112-001 "MONO"
<small>TOLERANCE DECIMAL U. S. S. .X ± .030 .XXX ± .005 .XX ± .015 ANGLES ± 1°</small>	MFG. PFB 4-6-89	MODEL DT90 A	SCALE 2:1
		SHEET 1 OF 1	

TABLE 6-3. MONOPHONIC/STEREOPHONIC PLAYBACK CIRCUIT BOARD ASSEMBLY
910-0112/-001 (Sheet 1 of 6)

REF. DES.	DESCRIPTION	PART NO.	QTY.
C1	Capacitor, Electrolytic, 10 uF, 25V, Non-Polarized	023-1075	1
C3	Capacitor, Electrolytic, 47 uF, 16V	013-4750	1
C4	Capacitor, Monolythic Ceramic, 0.1 uF ±20%, 50V	003-1054	1
C5	Capacitor, Electrolytic, 4.7 uF, 35V, Low Leakage	024-4753	1
C6	Capacitor, Ceramic, 0.001 uF ±10%, 200V	030-1033	1
C7,C8,C9	Capacitor, Monolythic Ceramic, 0.1 uF ±20%, 50V	003-1054	3
C10	Capacitor, Electrolytic, 10 uF, 25V, Non-Polarized	023-1075	1
C11,C12	Capacitor, Monolythic Ceramic, 0.1 uF ±20%, 50V	003-1054	2
C13	Capacitor, Electrolytic, 10 uF, 25V, Non-Polarized	023-1075	1
C26	Capacitor, Electrolytic, 10 uF, 35V	023-1076	1
C27	Capacitor, Monolythic Ceramic, 0.0047 uF ±5%, 100V	003-4723	1
C28	Capacitor, Monolythic Ceramic, 0.1 uF ±20%, 50V	003-1054	1
C29	Capacitor, Electrolytic, 10 uF, 25V, Non-Polarized	023-1075	1
C30	Capacitor, Electrolytic, 2.2 uF, 50V	020-2264	1
C31	Capacitor, Monolythic Ceramic, 0.1 uF ±20%, 50V	003-1054	1
C32	Capacitor, Mica, 50 pF ±5%, 500V	040-5013	1
C33,C34	Capacitor, Monolythic Ceramic, 0.0047 uF ±5%, 100V	003-4723	2
C35 THRU C37	Capacitor, Monolythic Ceramic, 0.1 uF ±20%, 50V	003-1054	3
C38	Capacitor, Electrolytic, 1 uF, 50V	024-1064	1
C39,C40	Capacitor, Monolythic Ceramic, 0.1 uF ±20%, 50V	003-1054	2
C41,C42	Capacitor, Monolythic Ceramic, 0.047 uF ±5% 50V	003-4733	2
C43	Capacitor, Electrolytic, 1 uF, 50V	024-1064	1
C44	Capacitor, Electrolytic, 2.2 uF, 25V dc	013-2064	1
C45 THRU C47	Capacitor, Monolythic Ceramic, 0.0047 uF ±5%, 100V	003-4723	3
C48	Capacitor, Monolythic Ceramic, 0.1 uF ±20%, 50V	003-1054	1
C49	Capacitor, Monolythic Ceramic, 0.047 uF ±5% 50V	003-4733	1
C50,C51	Capacitor, Monolythic Ceramic, 0.0047 uF ±5%, 100V	003-4723	2
C52	Capacitor, Electrolytic, 1 uF, 50V	024-1064	1
C53	Capacitor, Monolythic Ceramic, 0.1 uF ±20%, 50V	003-1054	1
C54	Capacitor, Electrolytic, 33 uF, 35V	024-3335	1
C55	Capacitor, Monolythic Ceramic, 0.1 uF ±20%, 50V	003-1054	1
C56	Capacitor, Electrolytic, 33 uF, 35V	024-3335	1
C57	Capacitor, Electrolytic, 3.3 uF ±20%, 50V, Non-Polarized	024-3364	1
C60 THRU C62	Capacitor, Monolythic Ceramic, 0.1 uF ±20%, 50V	003-1054	3
C63	Capacitor, Electrolytic, 4.7 uF, 35V, Low Leakage	024-4753	1
C64	Capacitor, Monolythic Ceramic, 0.1 uF ±20%, 50V	003-1054	1
C65	Capacitor, Electrolytic, 4.7 uF, 35V, Low Leakage	024-4753	1
C66 THRU C68	Capacitor, Monolythic Ceramic, 0.1 uF ±20%, 50V	003-1054	3
C69	Capacitor, Electrolytic, 4.7 uF, 35V, Low Leakage	024-4753	1
C70, C72	Capacitor, Monolythic Ceramic, 0.1 uF ±20%, 50V	003-1054	2
C73	Capacitor, Electrolytic, 1 uF, 50V	024-1064	1
C74	Capacitor, Ceramic, 0.001 uF ±10%, 200V	030-1033	1
C75 THRU C77,C80,C81	Capacitor, Monolythic Ceramic, 0.1 uF ±20%, 50V	003-1054	5
C82	Capacitor, Monolythic Ceramic, 0.0047 uF ±5%, 100V	003-4723	1
C83	Capacitor, Ceramic Disc, 10 pF ±10%, 1kV, Non-Polarized	001-1014	1

TABLE 6-3. MONOPHONIC/STEREOPHONIC PLAYBACK CIRCUIT BOARD ASSEMBLY
910-0112/-001 (Sheet 2 of 6)

REF. DES.	DESCRIPTION	PART NO.	QTY.
C85 THRU C88	Capacitor, Monolithic Ceramic, 0.1 uF ±20%, 50V	003-1054	4
D1,D2	Diode, 1N4737, Zener, 7.5V ±10%, 1W	200-4737	2
D3 THRU 11,	Diode, 1N4148, Silicon, 75V @ 0.3 Amperes	203-4148	9
D12,D13	Diode, Zener, 1N4740, 10V ±10%, 1W	200-4740	2
D14 THRU D27,D29 THRU D39	Diode, 1N4148, Silicon, 75V @ 0.3 Amperes	203-4148	25
J202 THRU J210	Receptacle, Single Pin	417-0071-001	9
J211,J212, J213	Receptacle, Male, 2-Pin In-line	417-4004	3
J214	Connector, Header, 3-Pin	417-0003	1
J215	Receptacle, Male, 2-Pin In-line	417-4004	1
P201	Receptacle, 50-Pin Dual In-line	417-0147	1
P211 THRU P215	Jumper, Programmable, 2-Pin	340-0004	5
Q1	Field Effect Transistor, J271, P-Channel JFET, TO-92 Case	210-0271	1
Q3	Transistor, 2N3904, NPN, Silicon, TO-92 Case	211-3904	1
Q4	Field Effect Transistor, J271, P-Channel JFET, TO-92 Case	210-0271	1
R1	Resistor, 270 k Ohm ±5%, 1/4W	100-2763	1
R2	Resistor, 100 Ohm ±5%, 1/4W	100-1033	1
R3	Resistor, 10 k Ohm ±5%, 1/4W	100-1053	1
R4	Potentiometer, 250 k Ohm ±10%, 1/2W	180-0001	1
R5	Resistor, 100 k Ohm ±5%, 1/4W	100-1063	1
R6	Resistor, 68 k Ohm ±5%, 1/4W	100-6853	1
R7	Resistor, 470 Ohm ±5%, 1/4W	100-4733	1
R8	Resistor, 1.2 k Ohm ±5%, 1/4W	100-1243	1
R9	Potentiometer, 10 k Ohm ±10% 1/2W	178-1054	1
R10	Resistor, 121 k Ohm ±1%, 1/4W	103-1261	1
R11	Resistor, 47 k Ohm ±5%, 1/4W	100-4753	1
R12,R13	Resistor, 470 Ohm ±5%, 1/4W	100-4733	2
R14	Resistor, 1 Meg Ohm ±5%, 1/4W	100-1073	1
R15	Resistor, 1.1 Meg Ohm ±5%, 1/4W	100-1173	1
R16	Resistor, 510 k Ohm ±5%, 1/4W	100-5163	1
R17	Resistor, 330 k Ohm ±5%, 1/4W	100-3363	1
R19	Potentiometer, 250 k Ohm ±10%, 1/2W	180-0001	1
R20	Resistor Network, 8-10 k Ohm ±1%, 1/4W, 16-Pin DIP	226-1055	1
R21	Resistor, 10 k Ohm ±1%, 1/4W	100-1051	1
R22	Resistor, 33 Ohm ±5%, 1/4W	100-3323	1
R23	Resistor, 5.11 k Ohm ±1%, 1/4W	103-5141	1
R24	Resistor, 33 Ohm ±5%, 1/4W	100-3323	1
R36	Resistor, 1 Meg Ohm ±5%, 1/4W	100-1073	1
R37	Resistor, 1.1 Meg Ohm ±5%, 1/4W	100-1173	1
R45	Resistor, 270 k Ohm ±5%, 1/4W	100-2763	1
R46	Resistor, 100 Ohm ±5%, 1/4W	100-1033	1
R47	Resistor, 665 k Ohm ±1%, 1/4W	103-6654	1
R48	Resistor, 1 k Ohm ±5%, 1/4W	100-1043	1
R49	Resistor, 15 k Ohm ±5%, 1/4W	100-1551	1

**TABLE 6-3. MONOPHONIC/STEREOPHONIC PLAYBACK CIRCUIT BOARD ASSEMBLY
910-0112/-001 (Sheet 3 of 6)**

REF. DES.	DESCRIPTION	PART NO.	QTY.
R50	Resistor, 10 k Ohm $\pm 5\%$, 1/4W	100-1053	1
R52	Resistor, 2.2 k Ohm $\pm 5\%$, 1/4W	100-2243	1
R53	Resistor, 56.2 k Ohm $\pm 1\%$, 1/4W	103-5651	1
R54	Resistor, 1.15 k Ohm $\pm 1\%$, 1/4W	103-1156	1
R55	Resistor, 113 k Ohm $\pm 5\%$, 1/4W	103-1136	1
R56	Resistor, 1 k Ohm $\pm 5\%$, 1/4W	100-1043	1
R57	Resistor, 51.1 k Ohm $\pm 5\%$, 1/4W	100-5153	1
R58	Resistor, 220 k Ohm $\pm 5\%$, 1/4W	100-2263	1
R59	Resistor, 30.1 k Ohm $\pm 1\%$, 1/4W	100-3051	1
R60	Resistor, 1 Meg Ohm $\pm 5\%$, 1/4W	100-1073	1
R61,R62	Resistor, 100 k Ohm $\pm 5\%$, 1/4W	100-1063	2
R63	Resistor, 100 k Ohm $\pm 5\%$, 1/4W	103-1062	1
R64	Resistor, 2.32 k Ohm $\pm 1\%$, 1/4W	103-2341	1
R65	Resistor, 226 k Ohm $\pm 1\%$, 1/4W	103-2276	1
R66	Potentiometer, 100 k Ohm $\pm 10\%$, 1/2W	178-1064	1
R67	Resistor, 1 k Ohm $\pm 5\%$, 1/4W	100-1043	1
R68	Resistor, 51.1 k Ohm $\pm 5\%$, 1/4W	100-5153	1
R69	Resistor, 220 k Ohm $\pm 5\%$, 1/4W	100-2263	1
R70	Resistor, 30.1 k Ohm $\pm 1\%$, 1/4W	100-3051	1
R71	Resistor, 1.1 Meg Ohm $\pm 5\%$, 1/4W	100-1173	1
R72	Resistor, 100 k Ohm $\pm 5\%$, 1/4W	100-1063	1
R74	Resistor, 10 k Ohm $\pm 5\%$, 1/4W	100-1053	1
R75	Resistor, 84.5 k Ohm $\pm 5\%$, 1/4W	103-8456	1
R76	Resistor, 3.57 k Ohm $\pm 1\%$, 1/4W	103-3574	1
R77	Resistor, 348 k Ohm $\pm 1\%$, 1/4W	103-3486	1
R78	Potentiometer, 100 k Ohm $\pm 10\%$, 1/2W	178-1064	1
R79	Resistor, 1 k Ohm $\pm 5\%$, 1/4W	100-1043	1
R80	Resistor, 51.1 k Ohm $\pm 5\%$, 1/4W	100-5153	1
R81	Resistor, 1.5 Meg Ohm $\pm 5\%$, 1/4W	100-1573	1
R82	Resistor, 100 k Ohm $\pm 5\%$, 1/4W	100-1063	1
R83	Resistor, 620 Ohm $\pm 5\%$, 1/4W	100-6233	1
R84	Resistor, 3.57 k Ohm $\pm 1\%$, 1/4W	103-3574	1
R85	Resistor, 475 Ohm $\pm 1\%$, 1/4W	103-4753	1
R86	Resistor, 42.2 k Ohm $\pm 5\%$, 1/4W	103-4225	1
R87	Potentiometer, 100 k Ohm $\pm 10\%$, 1/2W	178-1064	1
R88	Resistor, 1 k Ohm $\pm 5\%$, 1/4W	100-1043	1
R89	Resistor, 51.1 k Ohm $\pm 5\%$, 1/4W	100-5153	1
R90	Resistor, 1.5 Meg Ohm $\pm 5\%$, 1/4W	100-1573	1
R91	Resistor, 1 Meg Ohm $\pm 5\%$, 1/4W	100-1073	1
R92 THRU R94	Resistor, 10 k Ohm $\pm 5\%$, 1/4W	100-1053	3
R97	Resistor, 510 k Ohm $\pm 5\%$, 1/4W	100-5163	1
R98	Resistor, 374 k Ohm $\pm 1\%$, 1/4W	103-3746	1
R99 THRU R101	Resistor, 100 k Ohm $\pm 5\%$, 1/4W	100-1063	3
R102,R103	Resistor, 1 Meg Ohm $\pm 5\%$, 1/4W	100-1073	2
R104	Resistor, 100 k Ohm $\pm 5\%$, 1/4W	100-1063	1

**TABLE 6-3. MONOPHONIC/STEREOPHONIC PLAYBACK CIRCUIT BOARD ASSEMBLY
910-0112/-001 (Sheet 4 of 6)**

REF. DES.	DESCRIPTION	PART NO.	QTY.
R105	Resistor, 1 Meg Ohm $\pm 5\%$, 1/4W	100-1073	1
R106	Resistor, 1 k Ohm $\pm 5\%$, 1/4W	100-1043	1
R107	Resistor, 470 k Ohm $\pm 5\%$, 1/4W	100-4763	1
R108,R109	Resistor, 10 k Ohm $\pm 5\%$, 1/4W	100-1053	2
R110	Resistor, 1.5 k Ohm $\pm 5\%$, 1/4W	100-1543	1
R111,R112	Resistor, 10 k Ohm $\pm 5\%$, 1/4W	100-1053	2
R113	Resistor, 1.5 k Ohm $\pm 5\%$, 1/4W	100-1543	1
R114,R115	Resistor, 10 k Ohm $\pm 5\%$, 1/4W	100-1053	2
R116	Resistor, 1.5 k Ohm $\pm 5\%$, 1/4W	100-1543	1
R117 THRU R119	Resistor, 100 k Ohm $\pm 5\%$, 1/4W	100-1063	3
R120	Resistor, 1 Meg Ohm $\pm 5\%$, 1/4W	100-1073	1
R121	Resistor, 220 k Ohm $\pm 5\%$, 1/4W	100-2263	1
R122	Resistor, 1 k Ohm $\pm 5\%$, 1/4W	100-1043	1
R123	Resistor, 100 k Ohm $\pm 5\%$, 1/4W	100-1063	1
R124	Resistor, 5.1 Meg Ohm $\pm 5\%$, 1/4W	100-5173	1
R125	Resistor, 220 k Ohm $\pm 5\%$, 1/4W	100-2263	1
R126	Resistor, 10 k Ohm $\pm 5\%$, 1/4W	100-1053	1
R127	Resistor, 100 k Ohm $\pm 5\%$, 1/4W	100-1063	1
R128	Resistor, 20.0 k Ohm $\pm 1\%$, 1/4W	103-2051	1
R130 THRU R133	Resistor, 1 k Ohm $\pm 5\%$, 1/4W	100-1043	4
R134	Resistor, 10 k Ohm $\pm 5\%$, 1/4W	100-1053	1
R135	Resistor, 100 k Ohm $\pm 5\%$, 1/4W	100-1063	1
R136	Resistor, 1 k Ohm $\pm 5\%$, 1/4W	100-1043	1
R137	Resistor, 10 k Ohm $\pm 5\%$, 1/4W	100-1053	3
R138	Resistor, 100 Ohm $\pm 5\%$, 1/4W	100-1033	1
R139	Potentiometer, 100 k Ohm $\pm 10\%$, 1/2W	178-1064	1
U1	Integrated Circuit, NE5532A, Dual Low Noise Operational Amplifier, 8-Pin DIP	221-5532	1
U3,U4,U7, U8,U9	Integrated Circuit, RC4559NB, Operational Amplifier, 8-Pin DIP	221-4559	5
U10	Integrated Circuit, LM339AN, Quad Comparator, 14-Pin DIP	221-0339	1
U11,U12	Integrated Circuit, ULN2004, 7 NPN Darlington Driver Pack, 16-Pin DIP	226-2004	2
U13	Integrated Circuit, MC14044BP, Quad NAND R-S Latch, CMOS, 16-Pin DIP	228-4044	1
U14	Integrated Circuit, CD4075BE, RCA	225-0006	1
U15	Integrated Circuit, CD4081B, Quad 2-Input AND Gate, CMOS, 14-Pin DIP	225-0008	1
U16	Integrated Circuit, MC14073B, Tripple 3-Input AND Gate, CMOS, 14-Pin DIP	228-4073	1
U17	Integrated Circuit, MC14093B, CMOS, Quad 2-Input NAND Schmitt Trigger, 14-Pin DIP	220-4093	1
U18	Integrated Circuit, MC14538B, Dual Retriggerable, Resettable Monostable Multivibrator, CMOS, 16-Pin DIP	228-4538	1
U19	Integrated Circuit, MC14093B, CMOS, Quad 2-Input NAND Schmitt Trigger, 14-Pin DIP	220-4093	1
U20	Integrated Circuit, MC14053B, Analog Multiplexers/Demulti- plexers, CMOS MSI, 16-Pin DIP	220-4053	1
XU1,XU3, XU4,XU7, XU8,XU9	Socket, 8-Pin DIP	417-0804	6

TABLE 6-3. MONOPHONIC/STEREOPHONIC PLAYBACK CIRCUIT BOARD ASSEMBLY
910-0112/-001 (Sheet 5 of 6)

REF. DES.	DESCRIPTION	PART NO.	QTY.
XU10	Socket, 14-Pin DIP	417-1404	1
XU11,XU12, XU13	Socket, 16-Pin DIP	417-1604	3
XU14 THRU XU17	Socket, 14-Pin DIP	417-1404	4
XU18	Socket, 16-Pin DIP	417-1604	1
XU19	Socket, 14-Pin DIP	417-1404	1
XU20	Socket, 16-Pin DIP	417-1604	1
—	Blank Playback Circuit Board	510-0112	1

ADDITIONAL PARTS FOR STEREOPHONIC PLAYBACK
910-0112

C2	Capacitor, Mica, 150 pF $\pm 5\%$, 500V	040-1522	1
C14	Capacitor, Electrolytic, 10 uF, 25V, Non-Polarized	023-1075	1
C15	Capacitor, Mica, 150 pF $\pm 5\%$, 500V	040-1522	1
C16	Capacitor, Electrolytic, 47 uF, 16V	013-4750	1
C17	Capacitor, Monolythic Ceramic, 0.1 uF $\pm 20\%$, 50V	003-1054	1
C18	Capacitor, Ceramic, 0.001 uF $\pm 10\%$, 200V	030-1033	1
C19	Capacitor, Electrolytic, 4.7 uF, 35V, Low Leakage	024-4753	1
C20	Capacitor, Monolythic Ceramic, 0.1 uF $\pm 20\%$, 50V	003-1054	1
C21	Capacitor, Electrolytic, 10 uF, 25V, Non-Polarized	023-1075	1
C22,C23	Capacitor, Monolythic Ceramic, 0.1 uF $\pm 20\%$, 50V	003-1054	2
C24	Capacitor, Electrolytic, 10 uF, 25V, Non-Polarized	023-1075	1
C25	Capacitor, Mica, 150 pF $\pm 5\%$, 500V	040-1522	1
C71	Capacitor, Electrolytic, 3.3 uF $\pm 20\%$, 50V, Non-Polarized	024-3364	1
C78,C79	Capacitor, Monolythic Ceramic, 0.1 uF $\pm 20\%$, 50V	003-1054	2
Q2	Field Effect Transistor, J271, P-Channel JFET, TO-92 Case	210-0271	1
R18	Resistor, 13 k Ohm $\pm 1\%$, 1/4W	103-1305	1
R25	Resistor, 270 k Ohm $\pm 5\%$, 1/4W	100-2763	1
R26	Resistor, 100 Ohm $\pm 5\%$, 1/4W	100-1033	1
R27	Resistor, 10 k Ohm $\pm 5\%$, 1/4W	100-1053	1
R28	Potentiometer, 250 k Ohm $\pm 10\%$, 1/2W	180-0001	1
R29	Resistor, 100 k Ohm $\pm 5\%$, 1/4W	100-1063	1
R30	Resistor, 68 k Ohm $\pm 5\%$, 1/4W	100-6853	1
R31	Resistor, 470 Ohm $\pm 5\%$, 1/4W	100-4733	1
R32	Resistor, 1.2 k Ohm $\pm 5\%$, 1/4W	100-1243	1
R33	Potentiometer, 10 k Ohm $\pm 10\%$ 1/2W	178-1054	1
R34	Resistor, 121 k Ohm $\pm 1\%$, 1/4W	103-1261	1
R35	Resistor, 47 k Ohm $\pm 5\%$, 1/4W	100-4753	1
R38	Resistor, 13 k Ohm $\pm 1\%$, 1/4W	103-1305	1
R39	Potentiometer, 250 k Ohm $\pm 10\%$, 1/2W	180-0001	1
R40	Resistor Network, 8-10 k Ohm $\pm 1\%$, 1/4W, 16-Pin DIP	226-1055	1
R41	Resistor, 10 k Ohm $\pm 1\%$, 1/4W	100-1051	1
R42	Resistor, 33 Ohm $\pm 5\%$, 1/4W	100-3323	1
R43	Resistor, 5.11 k Ohm $\pm 1\%$, 1/4W	103-5141	1
R44	Resistor, 33 Ohm $\pm 5\%$, 1/4W	100-3323	1
R51	Resistor, 80.6 k Ohm $\pm 1\%$, 1/4W	103-8065	1

**TABLE 6-3. MONOPHONIC/STEREOPHONIC PLAYBACK CIRCUIT BOARD ASSEMBLY
910-0112/-001 (Sheet 6 of 6)**

REF. DES.	DESCRIPTION	PART NO.	QTY.
R73	Resistor, 10 k Ohm $\pm 5\%$, 1/4W	100-1053	1
R129	Resistor, 20.0 k Ohm $\pm 1\%$, 1/4W	103-2051	1
U2	Integrated Circuit, NE5532A, Dual Low Noise Operational Amplifier, 8-Pin DIP	221-5532	1
U5,U6	Integrated Circuit, RC4559NB, Operational Amplifier, 8-Pin DIP	221-4559	2
XU2,XU5, XU6	Socket, 8-Pin DIP	417-0804	3

**ADDITIONAL PARTS FOR MONOPHONIC PLAYBACK
910-0112-001**

C2,C25	Capacitor, Mica, 150 pF $\pm 5\%$, 500V	040-1522	2
R18	Resistor, 13 k Ohm $\pm 1\%$, 1/4W	103-1305	1
R51	Resistor, 56 k Ohm $\pm 5\%$, 1/4W	100-5653	1

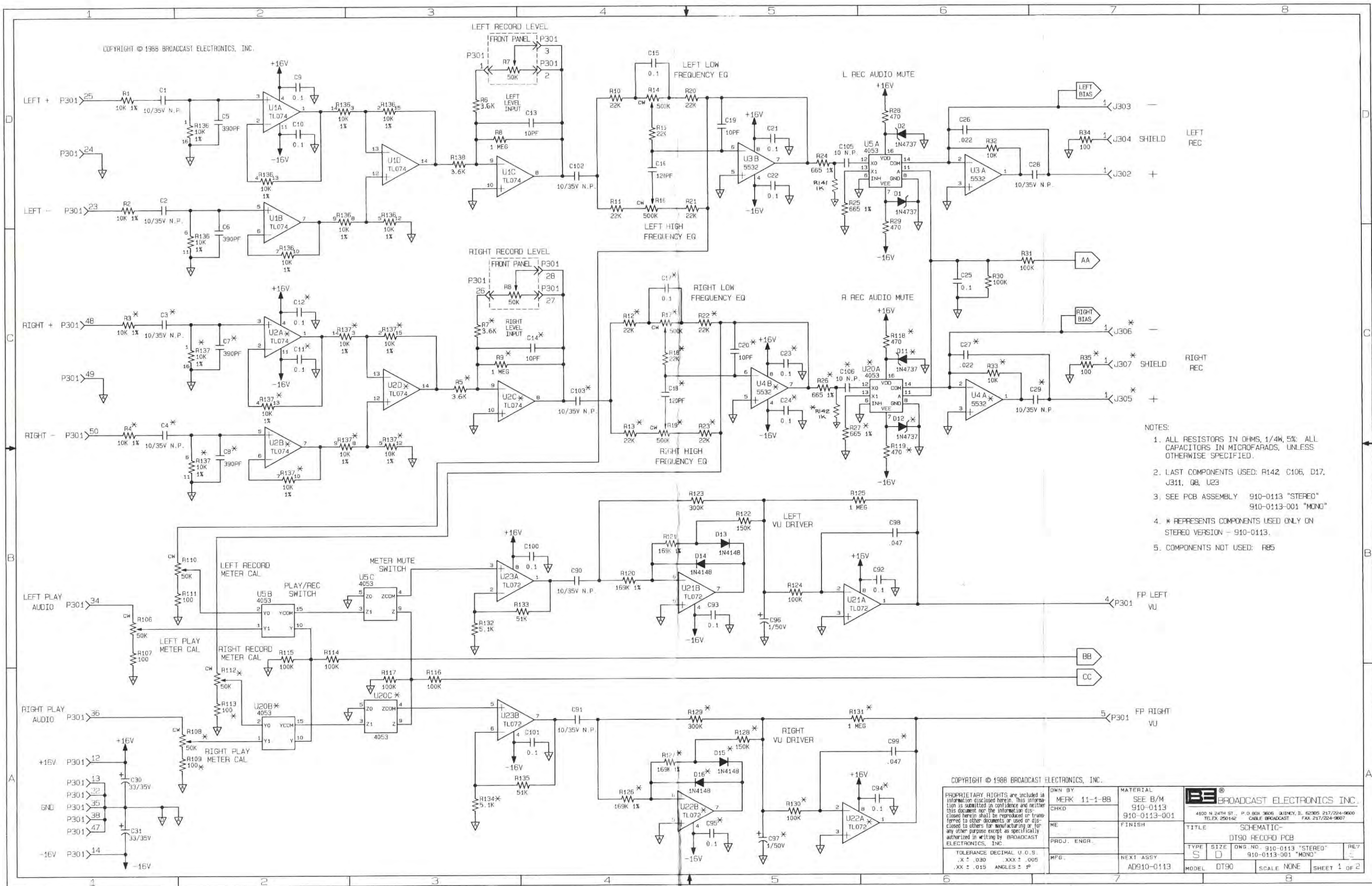

- NOTES:
1. ALL RESISTORS IN OHMS, 1/4W, 5%; ALL CAPACITORS IN MICROFARADS, UNLESS OTHERWISE SPECIFIED.
 2. LAST COMPONENTS USED: R142, C106, D17, J311, Q8, U23
 3. SEE PCB ASSEMBLY 910-0113 "STEREO" 910-0113-001 "MONO"
 4. * REPRESENTS COMPONENTS USED ONLY ON STEREO VERSION - 910-0113.
 5. COMPONENTS NOT USED: R85

PROPRIETARY RIGHTS are included in information disclosed herein. This information is submitted in confidence and neither this document nor the information disclosed herein shall be reproduced or transmitted to other documents or used or disclosed to others for manufacturing or for any other purpose except as specifically authorized in writing by BROADCAST ELECTRONICS, INC. TOLERANCE DECIMAL U.O.S. .X ± .030 .XXX ± .005 .XX ± .015 ANGLES ± P	DWN BY MEK 11-1-BB	MATERIAL SEE B/M 910-0113 910-0113-001	BROADCAST ELECTRONICS INC. 4100 N. 24TH ST., P.O. BOX 9606, GAINESVILLE, FL 32609 217/224-9600 TELEX 250142 CABLE BROADCAST FAX 217/224-9607
	CHKD ME PROJ. ENGR. MFG.	FINISH TITLE DT90 RECORD PCB	
	NEXT ASSY AD910-0113	MODEL DT90	SCALE NONE SHEET 1 OF 2

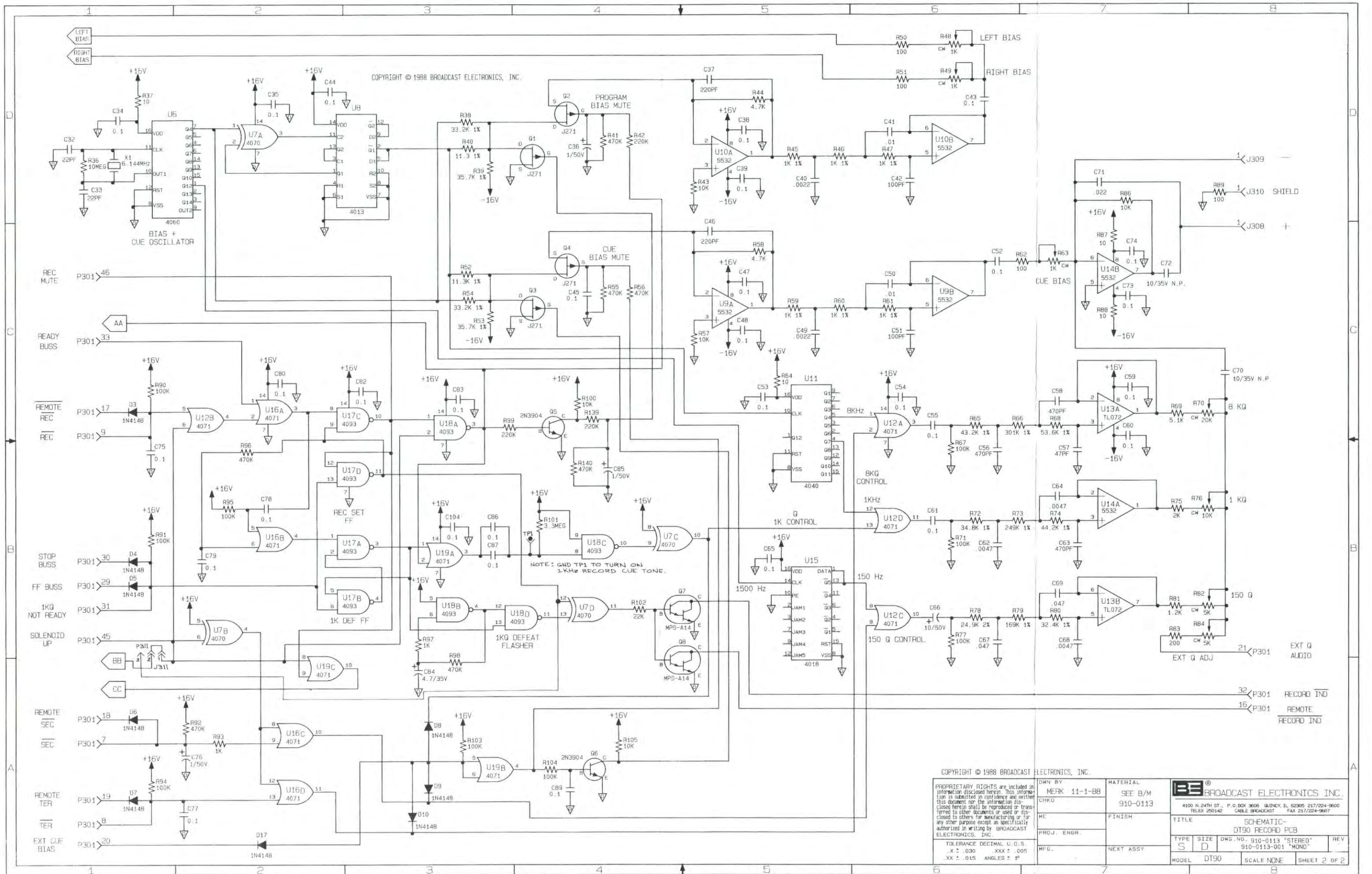

COPYRIGHT © 1988 BROADCAST ELECTRONICS, INC.

PROPRIETARY RIGHTS are included in information disclosed herein. This information is submitted in confidence and neither this document nor the information disclosed herein shall be reproduced or transferred to other documents or used or disclosed to others for manufacturing or for any other purpose except as specifically authorized in writing by BROADCAST ELECTRONICS, INC.

TOLERANCE DECIMAL U.O.S.
 .X ± .030 .XXX ± .005
 .XX ± .015 ANGLES ± °

OWN BY MERK 11-1-88	MATERIAL SEE B/M 910-0113	 BROADCAST ELECTRONICS, INC. 4100 N. 24TH ST., P.O. BOX 3606, QUINCY, IL 62305 217/224-9600 TELEX 250142 CABLE BROADCAST FAX 217/224-9607
CHKD	FINISH	
ME	NEXT ASSY	TITLE SCHEMATIC- DT90 RECORD PCB
PROJ. ENGR.		TYPE SIZE DWG. NO. 910-0113 "STEREO" REV
MPG.		S D 910-0113-001 "MONO" REV
		MODEL DT90 SCALE NONE SHEET 2 OF 2

COPYRIGHT © 1988 BROADCAST ELECTRONICS, INC.

* NOTE *

INSTALL "PEM" STANDOFFS BEFORE ANY OTHER COMPONENTS. TO BE INSTALLED FROM SOLDER SIDE OF PCB. 3 PLCS.
B.E. NO. 426-4004

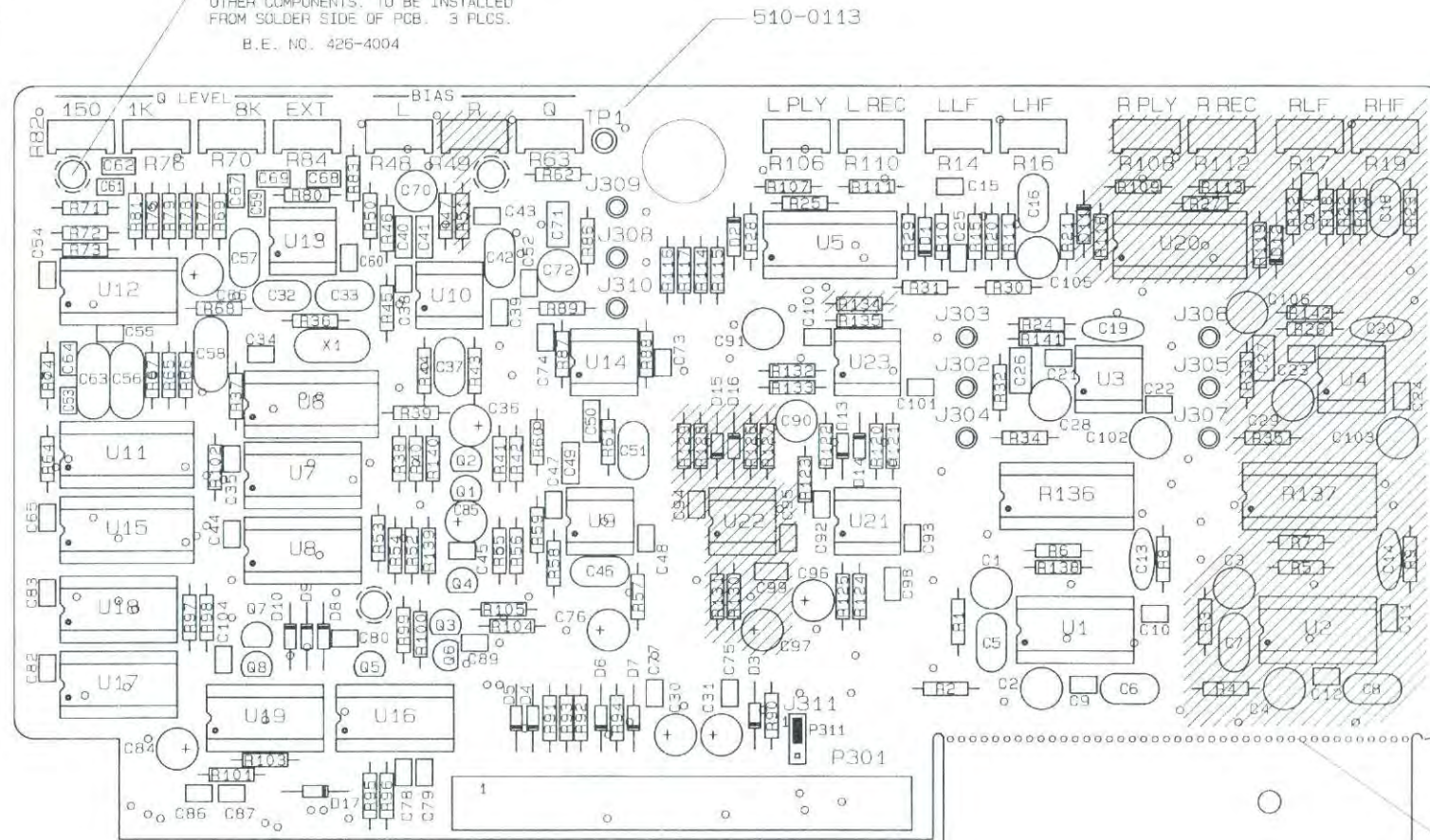
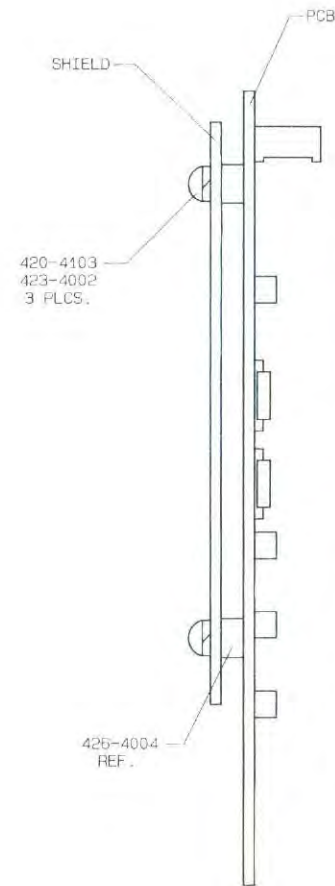

NOTES:

1. INSTALL "PEM" STANDOFFS FIRST.
2. SEE SCHEMATIC SD910-0113.
3. 910-0113 "STEREO"
910-0113-001 "MONO"
4. AREA SHADED ON DRAWING REPRESENTS COMPONENTS USED ONLY ON STEREO VERSION - 910-0113.

BREAK SHIELD OFF BEFORE FLOW SOLDER
SEE SIDE DETAIL FOR MOUNTING OF SHIELD TO PCB

SHIELD FOR 510-0113

COPYRIGHT © 1988 BROADCAST ELECTRONICS, INC.

PROPRIETARY RIGHTS are included in information disclosed herein. This information is submitted in confidence and neither this document nor the information disclosed herein shall be reproduced or transferred to other documents or used or disclosed to others for manufacturing or for any other purpose except as specifically authorized in writing by BROADCAST ELECTRONICS, INC.

TOLERANCE DECIMAL U.O.S.
X ± .030 XXX ± .005
.XX ± .015 ANGLES ± °

OWN BY: MEHK 11-5-88
CHKD: MH 4-6-89
RE: JHS 4-6-89
PROJ. ENGR: JRC 4-6-89
MFG: PRB 4-6-89

MATERIAL: SEE B/M 910-0113
910-0113-001
FINISH:
NEXT ASSY:

BROADCAST ELECTRONICS INC.
4100 N. 24TH ST., P.O. BOX 3606 GAITHERSBURG, MD 20878-3606
TELEX 250142 CABLE BROADCAST FAX 301/724-9607

TITLE: PCB ASSEMBLY- RECORD BOARD
TYPE: A D
SIZE: DT90
DWG. NO.: 910-0113 "STEREO"
910-0113-001 "MONO"
SCALE: 2:1
SHEET 1 OF 1

**TABLE 6-4. MONOPHONIC/STEREOPHONIC RECORD CIRCUIT BOARD ASSEMBLY
910-0113/-001 (Sheet 1 of 6)**

REF. DES.	DESCRIPTION	PART NO.	QTY.
C1,C2	Capacitor, Electrolytic, 10 uF, 35V	023-1075	2
C5,C6	Capacitor, Mica, 390 pF \pm 5%, 100V	042-3922	2
C9,C10	Capacitor, Monolythic Ceramic, 0.1 uF \pm 20%, 50V	003-1054	2
C13	Capacitor, Ceramic Disc, 10 pF \pm 10%, 1kV, Non-Polarized	001-1014	1
C15	Capacitor, Monolythic Ceramic, 0.1 uF \pm 20%, 50V	003-1054	1
C16	Capacitor, Mica, 120 pF \pm 5%, 500V	042-1222	1
C19	Capacitor, Ceramic Disc, 10 pF \pm 10%, 1kV, Non-Polarized	001-1014	1
C21,C22	Capacitor, Monolythic Ceramic, 0.1 uF \pm 20%, 50V	003-1054	2
C25	Capacitor, Monolythic Ceramic, 0.1 uF \pm 20%, 50V	003-1054	1
C26	Capacitor, Mylar Film, 0.022 uF \pm 10%, 100V	031-2243	1
C28	Capacitor, Electrolytic, 10 uF, 35V	023-1075	1
C30,C31	Capacitor, Electrolytic, 33 uF, 35V	024-3335	2
C32,C33	Capacitor, Mica, 22 pF \pm 5%, 500V	042-2212	1
C34,C35	Capacitor, Monolythic Ceramic, 0.1 uF \pm 20%, 50V	003-1054	2
C36	Capacitor, Electrolytic, 1 uF, 50V	024-1064	1
C37	Capacitor, Mica, 220 pF \pm 5%, 500V	040-2223	1
C38,C39	Capacitor, Monolythic Ceramic, 0.1 uF \pm 20%, 50V	003-1054	2
C40	Capacitor, Polyester, 0.0022 uF \pm 10%, 100V	031-2033	1
C41	Capacitor, Mylar, 0.01 uF \pm 10%, 100V	031-1043	1
C42	Capacitor, Silvered Mica, 100 pF \pm 5%, 500V	040-1022	1
C43 THRU C45	Capacitor, Monolythic Ceramic, 0.1 uF \pm 20%, 50V	003-1054	3
C46	Capacitor, Mica, 220 pF \pm 5%, 500V	040-2223	1
C47,C48	Capacitor, Monolythic Ceramic, 0.1 uF \pm 20%, 50V	003-1054	2
C49	Capacitor, Polyester, 0.0022 uF \pm 10%, 100V	031-2033	1
C50	Capacitor, Mylar, 0.01 uF \pm 10%, 100V	031-1043	1
C51	Capacitor, Silvered Mica, 100 pF \pm 5%, 500V	040-1022	1
C52 THRU C55	Capacitor, Monolythic Ceramic, 0.1 uF \pm 20%, 50V	003-1054	4
C56	Capacitor, Mica, 470 pF \pm 1%, 500V	040-4721	1
C57	Capacitor, Mica, 47 pF \pm 5%, 500V	040-4713	1
C58	Capacitor, Mica, 470 pF \pm 1%, 500V	040-4721	1
C59 THRU C61	Capacitor, Monolythic Ceramic, 0.1 uF \pm 20%, 50V	003-1054	3
C62	Capacitor, Monolythic Ceramic, 0.0047 uF \pm 5%, 100V	003-4723	1
C63	Capacitor, Mica, 470 pF \pm 1%, 500V	040-4721	1
C64	Capacitor, Monolythic Ceramic, 0.0047 uF \pm 5%, 100V	003-4723	1
C65	Capacitor, Monolythic Ceramic, 0.1 uF \pm 20%, 50V	003-1054	1
C66	Capacitor, Electrolytic, 10 uF, 35V	023-1076	1
C67	Capacitor, Monolythic Ceramic, 0.047 uF \pm 5%, 50V	003-4733	1
C68	Capacitor, Monolythic Ceramic, 0.0047 uF \pm 5%, 100V	003-4723	1
C69	Capacitor, Monolythic Ceramic, 0.047 uF \pm 5%, 50V	003-4733	1
C70	Capacitor, Electrolytic, 10 uF, 35V	023-1075	1
C71	Capacitor, Mylar Film, 0.022 uF \pm 10%, 100V	031-2243	1
C72	Capacitor, Electrolytic, 10 uF, 35V	023-1075	1
C73 THRU C75	Capacitor, Monolythic Ceramic, 0.1 uF \pm 20%, 50V	003-1054	3
C76	Capacitor, Electrolytic, 1 uF, 50V	024-1064	1

**TABLE 6-4. MONOPHONIC/STEREOPHONIC RECORD CIRCUIT BOARD ASSEMBLY
910-0113/-001 (Sheet 2 of 6)**

REF. DES.	DESCRIPTION	PART NO.	QTY.
C77 THRU C80,C82,C83	Capacitor, Monolythic Ceramic, 0.1 uF \pm 20%, 50V	003-1054	6
C84	Capacitor, Electrolytic, 4.7 uF, 35V, Low Leakage	024-4753	1
C85	Capacitor, Electrolytic, 1 uF, 50V	024-1064	1
C86,C87,C89	Capacitor, Monolythic Ceramic, 0.1 uF \pm 20%, 50V	003-1054	3
C90,C91	Capacitor, Electrolytic, 10 uF, 35V	023-1075	2
C92,C93	Capacitor, Monolythic Ceramic, 0.1 uF \pm 20%, 50V	003-1054	2
C96	Capacitor, Electrolytic, 1 uF, 50V	024-1064	1
C98	Capacitor, Monolythic Ceramic, 0.047 uF \pm 5%, 50V	003-4733	1
C100,C101	Capacitor, Monolythic Ceramic, 0.1 uF \pm 20%, 50V	003-1054	2
C102	Capacitor, Electrolytic, 10 uF, 35V	023-1075	1
C104	Capacitor, Monolythic Ceramic, 0.1 uF \pm 20%, 50V	003-1054	1
C105	Capacitor, Electrolytic, 10 uF, 35V	023-1075	1
D1,D2	Diode, 1N4737, Zener, 7.5V \pm 10%, 1W	200-4737	2
D3 THRU D10,D13,D14, D17	Diode, 1N4148, Silicon, 75V @ 0.3 Amperes	203-4148	11
J302 THRU J310	Receptacle, Single Pin	417-0071-001	9
J311	Connector, Header, 3-Pin	417-0003	1
P301	Receptacle, 50-Pin Dual In-line	417-0147	1
P311	Jumper, Programmable, 2-Pin	340-0004	1
Q1 THRU Q4	Field Effect Transistor, J271, P-Channel JFET, TO-92 Case	210-0271	4
Q5,Q6	Transistor, 2N3904, NPN, Silicon, TO-92 Case	211-3904	2
Q7,Q8	Transistor, MPS-A14, Silicon, NPN, Darlington, TO-92 Case	211-0014	2
R1,R2	Resistor, 10 k Ohm \pm 1%, 1/4W	100-1051	2
R6	Resistor, 3.6 k Ohm \pm 5%, 1/4W	100-3643	1
R8	Resistor, 1 Meg Ohm \pm 5%, 1/4W	100-1073	1
R10,R11	Resistor, 22 k Ohm \pm 5%, 1/4W	100-2253	2
R14	Potentiometer, 500 k Ohm \pm 10%, 1/2W	178-5064	1
R15	Resistor, 22 k Ohm \pm 5%, 1/4W	100-2253	1
R16	Potentiometer, 500 k Ohm \pm 10%, 1/2W	178-5064	1
R20,R21	Resistor, 22 k Ohm \pm 5%, 1/4W	100-2253	2
R24,R25	Resistor, 665 Ohm \pm 1%, 1/4W	103-6653	2
R28,R29	Resistor, 470 Ohm \pm 5%, 1/4W	100-4733	2
R30,R31	Resistor, 100 k Ohm \pm 5%, 1/4W	100-1063	2
R32	Resistor, 10 k Ohm \pm 5%, 1/4W	100-1053	1
R34	Resistor, 100 Ohm \pm 5%, 1/4W	100-1033	1
R36	Resistor, 10 Meg Ohm \pm 5%, 1/4W	100-1083	1
R37	Resistor, 10 Ohm \pm 5%, 1/4W	100-1023	1
R38	Resistor, 33.2 k Ohm \pm 1%, 1/4W	103-3325	1
R39	Resistor, 35.7 k Ohm \pm 1%, 1/4W	103-3575	1
R40	Resistor, 11.3 k Ohm \pm 1%, 1/4W	103-1135	1
R41	Resistor, 470 k Ohm \pm 5%, 1/4W	100-4763	1
R42	Resistor, 220 k Ohm \pm 5%, 1/4W	100-2263	1
R43	Resistor, 10 k Ohm \pm 5%, 1/4W	100-1053	1
R44	Resistor, 4.7 k Ohm \pm 5%, 1/4W	100-4743	1
R45 THRU R47	Resistor, 1 k Ohm \pm 1%, 1/4W	100-1041	3
R48	Potentiometer, 1 k Ohm \pm 10%, 1/2W	178-1044	1

TABLE 6-4. MONOPHONIC/STEREOPHONIC RECORD CIRCUIT BOARD ASSEMBLY
910-0113/-001 (Sheet 3 of 6)

REF. DES.	DESCRIPTION	PART NO.	QTY.
R50	Resistor, 100 Ohm $\pm 5\%$, 1/4W	100-1033	1
R52	Resistor, 11.3 k Ohm $\pm 1\%$, 1/4W	103-1135	1
R53	Resistor, 35.7 k Ohm $\pm 1\%$, 1/4W	103-3575	1
R54	Resistor, 33.2 k Ohm $\pm 1\%$, 1/4W	103-3325	1
R55,R56	Resistor, 470 k Ohm $\pm 5\%$, 1/4W	100-4763	2
R57	Resistor, 10 k Ohm $\pm 5\%$, 1/4W	100-1053	1
R58	Resistor, 4.7 k Ohm $\pm 5\%$, 1/4W	100-4743	1
R59 THRU R61	Resistor, 1 k Ohm $\pm 1\%$, 1/4W	100-1041	3
R62	Resistor, 100 Ohm $\pm 5\%$, 1/4W	100-1033	1
R63	Potentiometer, 1 k Ohm $\pm 10\%$, 1/2W	178-1044	1
R64	Resistor, 10 Ohm $\pm 5\%$, 1/4W	100-1023	1
R65	Resistor, 43.2 k Ohm $\pm 1\%$, 1/4W	103-4325	1
R66	Resistor, 301 k Ohm $\pm 1\%$, 1/4W	103-3061	1
R67	Resistor, 100 k Ohm $\pm 5\%$, 1/4W	100-1063	1
R68	Resistor, 53.6 k Ohm $\pm 1\%$, 1/4W	103-5365	1
R69	Resistor, 5.1 k Ohm $\pm 5\%$, 1/4W	100-5143	1
R70	Potentiometer, 20 k Ohm $\pm 10\%$, 1/2W	178-2054	1
R71	Resistor, 100 k Ohm $\pm 5\%$, 1/4W	100-1063	1
R72	Resistor, 34.8 k Ohm $\pm 1\%$, 1/4W	103-3485	1
R73	Resistor, 294 k Ohm $\pm 1\%$, 1/4W	103-2946	1
R74	Resistor, 44.2 k Ohm $\pm 1\%$, 1/4W	103-4425	1
R75	Resistor, 2 k Ohm $\pm 5\%$, 1/4W	100-2043	1
R76	Potentiometer, 10 k Ohm $\pm 10\%$, 1/2W	178-1054	1
R77	Resistor, 100 k Ohm $\pm 5\%$, 1/4W	100-1063	1
R78	Resistor, 24.9 k Ohm $\pm 1\%$, 1/4W	103-2495	1
R79	Resistor, 169 k Ohm $\pm 1\%$, 1/4W	103-1696	1
R80	Resistor, 32.4 k Ohm $\pm 1\%$, 1/4W	103-3245	1
R81	Resistor, 1.2 k Ohm $\pm 5\%$, 1/4W	100-1243	1
R82	Potentiometer, 5 k Ohm $\pm 20\%$, 3/4W	178-5044	1
R83	Resistor, 200 Ohm $\pm 5\%$, 1/4W	100-2033	1
R84	Potentiometer, 5 k Ohm $\pm 20\%$, 3/4W	178-5044	1
R86	Resistor, 10 k Ohm $\pm 5\%$, 1/4W	100-1053	1
R87,R88	Resistor, 10 Ohm $\pm 5\%$, 1/4W	100-1023	2
R89	Resistor, 100 Ohm $\pm 5\%$, 1/4W	100-1033	1
R90,R91	Resistor, 100 k Ohm $\pm 5\%$, 1/4W	100-1063	2
R92	Resistor, 470 k Ohm $\pm 5\%$, 1/4W	100-4763	1
R93	Resistor, 1 k Ohm $\pm 5\%$, 1/4W	100-1043	1
R94,R95	Resistor, 100 k Ohm $\pm 5\%$, 1/4W	100-1063	2
R96	Resistor, 470 k Ohm $\pm 5\%$, 1/4W	100-4763	1
R97	Resistor, 1 k Ohm $\pm 5\%$, 1/4W	100-1043	1
R98	Resistor, 470 k Ohm $\pm 5\%$, 1/4W	100-4763	1
R99	Resistor, 220 k Ohm $\pm 5\%$, 1/4W	100-2263	1
R100	Resistor, 10 k Ohm $\pm 5\%$, 1/4W	100-1053	1
R101	Resistor, 3.3 Meg Ohm $\pm 5\%$, 1/4W	100-3373	1
R102	Resistor, 22 k Ohm $\pm 5\%$, 1/4W	100-2253	1

**TABLE 6-4. MONOPHONIC/STEREOPHONIC RECORD CIRCUIT BOARD ASSEMBLY
910-0113/-001 (Sheet 4 of 6)**

REF. DES.	DESCRIPTION	PART NO.	QTY.
R103,R104	Resistor, 100 k Ohm $\pm 5\%$, 1/4W	100-1063	2
R105	Resistor, 10 k Ohm $\pm 5\%$, 1/4W	100-1053	1
R106	Potentiometer, 10 k Ohm $\pm 10\%$ 1/2W	178-1054	1
R107	Resistor, 100 Ohm $\pm 5\%$, 1/4W	100-1033	1
R110	Potentiometer, 10 k Ohm $\pm 10\%$ 1/2W	178-1054	1
R111	Resistor, 100 Ohm $\pm 5\%$, 1/4W	100-1033	1
R114 THRU R117	Resistor, 100 k Ohm $\pm 5\%$, 1/4W	100-1063	4
R120,R121	Resistor, 169 k Ohm $\pm 1\%$, 1/4W	103-1696	2
R122	Resistor, 150 k Ohm $\pm 5\%$, 1/4W	100-1563	1
R123	Resistor, 300 k Ohm $\pm 5\%$, 1/4W	100-3063	1
R124	Resistor, 100 k Ohm $\pm 5\%$, 1/4W	100-1063	1
R125	Resistor, 1 Meg Ohm $\pm 5\%$, 1/4W	100-1073	1
R132	Resistor, 5.1 k Ohm $\pm 5\%$, 1/4W	100-5143	1
R133	Resistor, 51.1 k Ohm $\pm 5\%$, 1/4W	100-5153	1
R136	Resistor Network, 8-10 k Ohm $\pm 1\%$, 1/4W, 16-Pin DIP	226-1055	1
R138	Resistor, 3.6 k Ohm $\pm 5\%$, 1/4W	100-3643	1
R139	Resistor, 220 k Ohm $\pm 5\%$, 1/4W	100-2263	1
R140	Resistor, 470 k Ohm $\pm 5\%$, 1/4W	100-4763	1
R141	Resistor, 1 k Ohm $\pm 5\%$, 1/4W	100-1043	1
TP1	Terminal, Turret, Double Shoulder	417-1597	1
U1	Integrated Circuit, TLO74CN, Quad JFET-Input Operational Amplifier, 14-Pin DIP	221-0074	1
U3	Integrated Circuit, NE5532AP, Dual Low Noise Operational Amplifier, 8-Pin DIP	221-5532-001	1
U5	Integrated Circuit, MC14053B, Analog Multiplexers/Demultiplexers, CMOS MSI, 16-Pin DIP	220-4053	1
U6	Integrated Circuit, MC14060B, 14-Bit Binary Counter and Oscillator, CMOS MSI, 16-Pin DIP	220-4060	1
U7	Integrated Circuit, MC14070BCP, Quad Exclusive OR Gate, CMOS, 14-Pin DIP	228-4071	1
U8	Integrated Circuit, MC14013BCP, Dual D-Type Flip-Flop, CMOS, 14-Pin DIP	228-4013	1
U9,U10	Integrated Circuit, NE5532AP, Dual Low Noise Operational Amplifier, 8-Pin DIP	221-5532-001	2
U11	Integrated Circuit, MC14040B, CMOS MSI, 12-Bit Binary Counter, 16-Pin DIP	220-4040	1
U12	Integrated Circuit, CD4071B, OR Gate, CMOS, 14-Pin DIP	225-0005	1
U13	Integrated Circuit, TL072CP, Dual JFET-Input Operational Amplifier, 8-Pin DIP	221-0072	1
U14	Integrated Circuit, NE5532AP, Dual Low Noise Operational Amplifier, 8-Pin DIP	221-5532-001	1
U15	Integrated Circuit, MC14018BP, Presettable Divide-By-N Counter, CMOS, 16-Pin DIP	220-4018	1
U16	Integrated Circuit, CD4071B, OR Gate, CMOS, 14-Pin DIP	225-0005	1
U17,U18	Integrated Circuit, MC14093B, Quad 2-Input NAND Schmitt Trigger, CMOS, 14-Pin DIP	220-4093	2
U19	Integrated Circuit, CD4071B, OR Gate, CMOS, 14-Pin DIP	225-0005	1
U21	Integrated Circuit, TL072CP, Dual JFET-Input Operational Amplifier, 8-Pin DIP	221-0072	1
U23	Integrated Circuit, TL072CP, Dual JFET-Input Operational Amplifier, 8-Pin DIP	221-0072	1
X1	Crystal, 6.144 MHz $\pm 0.01\%$ from 0°C to +70°C, 30 pF Load Capacitance, HC-18 Case	390-0020	1

**TABLE 6-4. MONOPHONIC/STEREOPHONIC RECORD CIRCUIT BOARD ASSEMBLY
910-0113/-001 (Sheet 5 of 6)**

REF. DES.	DESCRIPTION	PART NO.	QTY.
XU1	Socket, 14-Pin DIP	417-1404	1
XU3	Socket, 8-Pin DIP	417-0804	1
XU5,XU6	Socket, 16-Pin DIP	417-1604	2
XU7,XU8	Socket, 14-Pin DIP	417-1404	2
XU9,XU10	Socket, 8-Pin DIP	417-0804	2
XU11	Socket, 16-Pin DIP	417-1604	1
XU12	Socket, 14-Pin DIP	417-1404	1
XU13,XU14	Socket, 8-Pin DIP	417-0804	2
XU15	Socket, 16-Pin DIP	417-1604	1
XU16 THRU XU19	Socket, 14-Pin DIP	417-1404	4
XU21,XU23	Socket, 8-Pin DIP	417-0804	2
—	Blank Record Circuit Board	510-0113	1

**ADDITIONAL PARTS FOR STEREOPHONIC RECORD CIRCUIT BOARD
910-0113**

C3,C4	Capacitor, Electrolytic, 10 uF, 35V	023-1075	2
C7,C8	Capacitor, Mica, 390 pF $\pm 5\%$, 100V	042-3922	2
C11,C12	Capacitor, Monolythic Ceramic, 0.1 uF $\pm 20\%$, 50V	003-1054	2
C14	Capacitor, Ceramic Disc, 10 pF $\pm 10\%$, 1kV, Non-Polarized	001-1014	1
C17	Capacitor, Monolythic Ceramic, 0.1 uF $\pm 20\%$, 50V	003-1054	1
C18	Capacitor, Mica, 120 pF $\pm 5\%$, 500V	042-1222	1
C20	Capacitor, Ceramic Disc, 10 pF $\pm 10\%$, 1kV, Non-Polarized	001-1014	1
C23,C24	Capacitor, Monolythic Ceramic, 0.1 uF $\pm 20\%$, 50V	003-1054	2
C27	Capacitor, Mylar Film, 0.022 uF $\pm 10\%$, 100V	031-2243	1
C29	Capacitor, Electrolytic, 10 uF, 35V	023-1075	1
C94,C95	Capacitor, Monolythic Ceramic, 0.1 uF $\pm 20\%$, 50V	003-1054	2
C97	Capacitor, Electrolytic, 1 uF, 50V	024-1064	1
C99	Capacitor, Monolythic Ceramic, 0.047 uF $\pm 5\%$, 50V	003-4733	1
C103,C106	Capacitor, Electrolytic, 10 uF, 35V	023-1075	2
D11,D12	Diode, 1N4737, Zener, 7.5V $\pm 10\%$, 1W	200-4737	2
D15,D16	Diode, 1N4148, Silicon, 75V @ 0.3 Amperes	203-4148	2
R3,R4	Resistor, 10 k Ohm $\pm 1\%$, 1/4W	100-1051	2
R5,R7	Resistor, 3.6 k Ohm $\pm 5\%$, 1/4W	100-3643	2
R9	Resistor, 1 Meg Ohm $\pm 5\%$, 1/4W	100-1073	1
R12,R13	Resistor, 22 k Ohm $\pm 5\%$, 1/4W	100-2253	2
R17	Potentiometer, 500 k Ohm $\pm 10\%$, 1/2W	178-5064	1
R18	Resistor, 22 k Ohm $\pm 5\%$, 1/4W	100-2253	1
R19	Potentiometer, 500 k Ohm $\pm 10\%$, 1/2W	178-5064	1
R22,R23	Resistor, 22 k Ohm $\pm 5\%$, 1/4W	100-2253	2
R26,R27	Resistor, 665 Ohm $\pm 1\%$, 1/4W	103-6653	2
R33	Resistor, 10 k Ohm $\pm 5\%$, 1/4W	100-1053	1
R35	Resistor, 100 Ohm $\pm 5\%$, 1/4W	100-1033	1
R49	Potentiometer, 1 k Ohm $\pm 10\%$, 1/2W	178-1044	1
R51	Resistor, 100 Ohm $\pm 5\%$, 1/4W	100-1033	1
R108	Potentiometer, 10 k Ohm $\pm 10\%$ 1/2W	178-1054	1
R109	Resistor, 100 Ohm $\pm 5\%$, 1/4W	100-1033	1

**TABLE 6-4. MONOPHONIC/STEREOPHONIC RECORD CIRCUIT BOARD ASSEMBLY
910-0113/-001 (Sheet 6 of 6)**

REF. DES.	DESCRIPTION	PART NO.	QTY.
R112	Potentiometer, 10 k Ohm $\pm 10\%$ 1/2W	178-1054	1
R113	Resistor, 100 Ohm $\pm 5\%$, 1/4W	100-1033	1
R118,R119	Resistor, 470 Ohm $\pm 5\%$, 1/4W	100-4733	2
R126,R127	Resistor, 169 k Ohm $\pm 1\%$, 1/4W	103-1696	2
R128	Resistor, 150 k Ohm $\pm 5\%$, 1/4W	100-1563	1
R129	Resistor, 300 k Ohm $\pm 5\%$, 1/4W	100-3063	1
R130	Resistor, 100 k Ohm $\pm 5\%$, 1/4W	100-1063	1
R131	Resistor, 1 Meg Ohm $\pm 5\%$, 1/4W	100-1073	1
R134	Resistor, 5.1 k Ohm $\pm 5\%$, 1/4W	100-5143	1
R135	Resistor, 51.1 k Ohm $\pm 5\%$, 1/4W	100-5153	1
R137	Resistor Network, 8-10 k Ohm $\pm 1\%$, 1/4W, 16-Pin DIP	226-1055	1
R142	Resistor, 1 k Ohm $\pm 5\%$, 1/4W	100-1043	1
U2	Integrated Circuit, TLO74CN, Quad JFET-Input Operational Amplifier, 14-Pin DIP	221-0074	1
U4	Integrated Circuit, NE5532AP, Dual Low Noise Operational Amplifier, 8-Pin DIP	221-5532-001	1
U20	Integrated Circuit, MC14053B, Analog Multiplexers/Demultiplexers, CMOS MSI, 16-Pin DIP	220-4053	1
U22	Integrated Circuit, TL072CP, Dual JFET-Input Operational Amplifier, 8-Pin DIP	221-0072	1
XU2	Socket, 14-Pin DIP	417-1404	1
XU4	Socket, 8-Pin DIP	417-0804	1
XU20	Socket, 16-Pin DIP	417-1604	1
XU22	Socket, 8-Pin DIP	417-0804	1

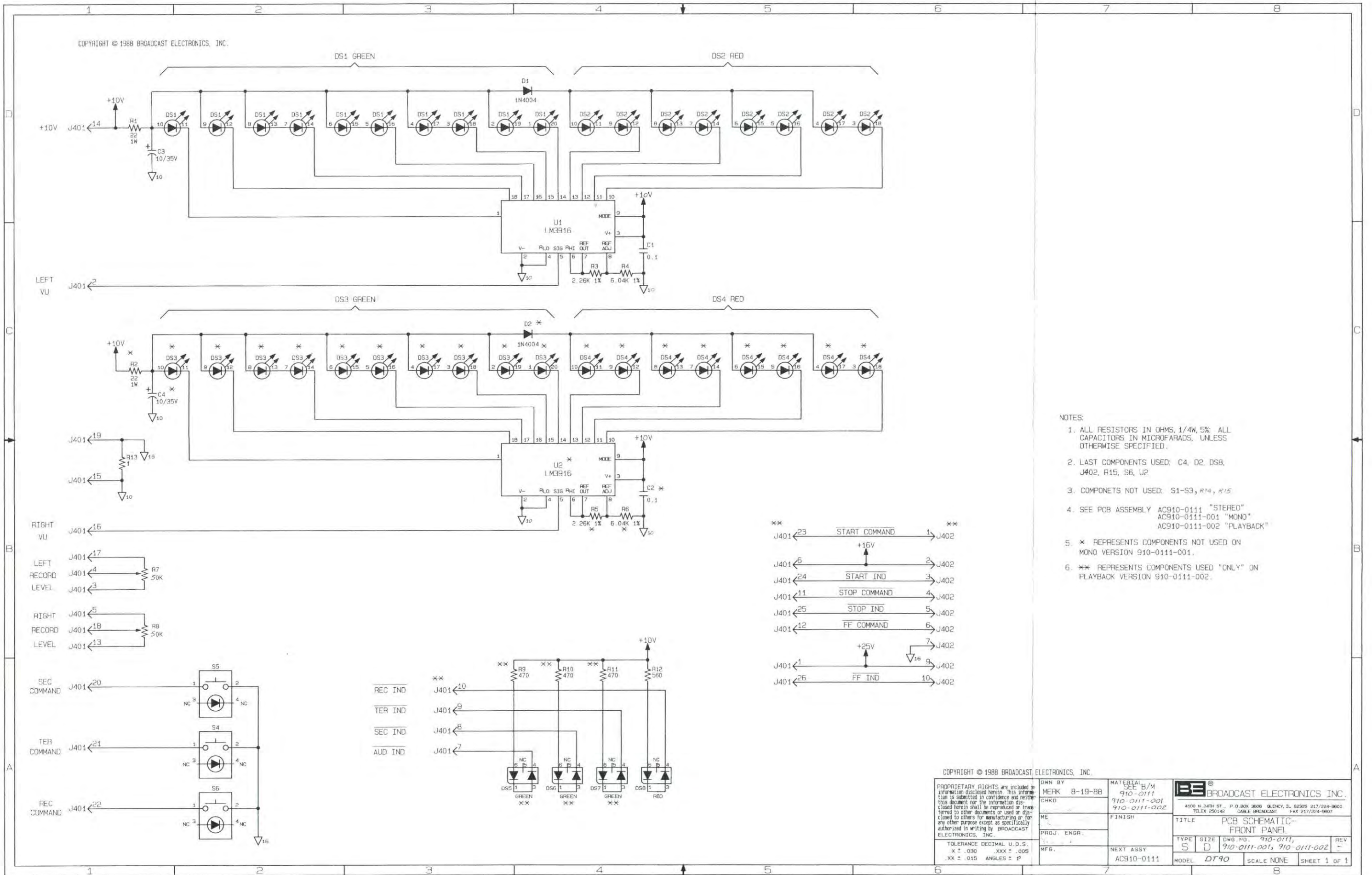

- NOTES:
1. ALL RESISTORS IN OHMS, 1/4W, 5% ALL CAPACITORS IN MICROFARADS, UNLESS OTHERWISE SPECIFIED.
 2. LAST COMPONENTS USED: C4, D2, DS8, J402, R15, S6, U2
 3. COMPONENTS NOT USED: S1-S3, R14, R15
 4. SEE PCB ASSEMBLY AC910-0111 "STEREO" AC910-0111-001 "MONO" AC910-0111-002 "PLAYBACK"
 5. * REPRESENTS COMPONENTS NOT USED ON MONO VERSION 910-0111-001.
 6. ** REPRESENTS COMPONENTS USED "ONLY" ON PLAYBACK VERSION 910-0111-002.

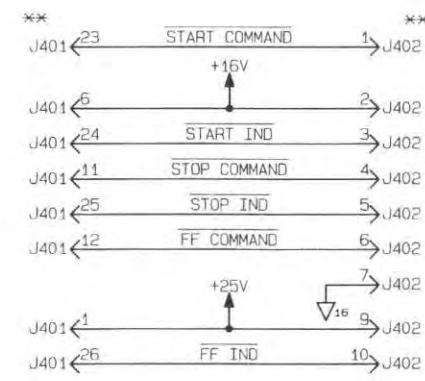

COPYRIGHT © 1988 BROADCAST ELECTRONICS, INC.

PROPRIETARY RIGHTS are included in information disclosed herein. This information is submitted in confidence and neither this document nor the information disclosed herein shall be reproduced or transferred to other documents or used or disclosed to others for manufacturing or for any other purpose except as specifically authorized in writing by BROADCAST ELECTRONICS, INC.	DWN BY MERK 8-19-88 CHKD ME PROJ. ENGR. MFB.	MATERIAL SEE B/M 910-0111 910-0111-001 910-0111-002 FINISH NEXT ASSY AC910-0111	BROADCAST ELECTRONICS, INC. 4100 N. 24TH ST., P.O. BOX 3606 QUINCY, IL 62305 217/224-9600 TELEX 250142 GBLF BROADCAST FAX 217/224-9607 TITLE PCB SCHEMATIC- FRONT PANEL TYPE SIZE DWG. NO. 910-0111, 910-0111-001, 910-0111-002 MODEL DT90 SCALE NONE SHEET 1 OF 1
---	---	--	---

TOLERANCE DECIMAL U.D.S.
 .X ± .030 .XXX ± .005
 .XX ± .015 ANGLES ± 1°

COPYRIGHT © 1988 BROADCAST ELECTRONICS, INC.

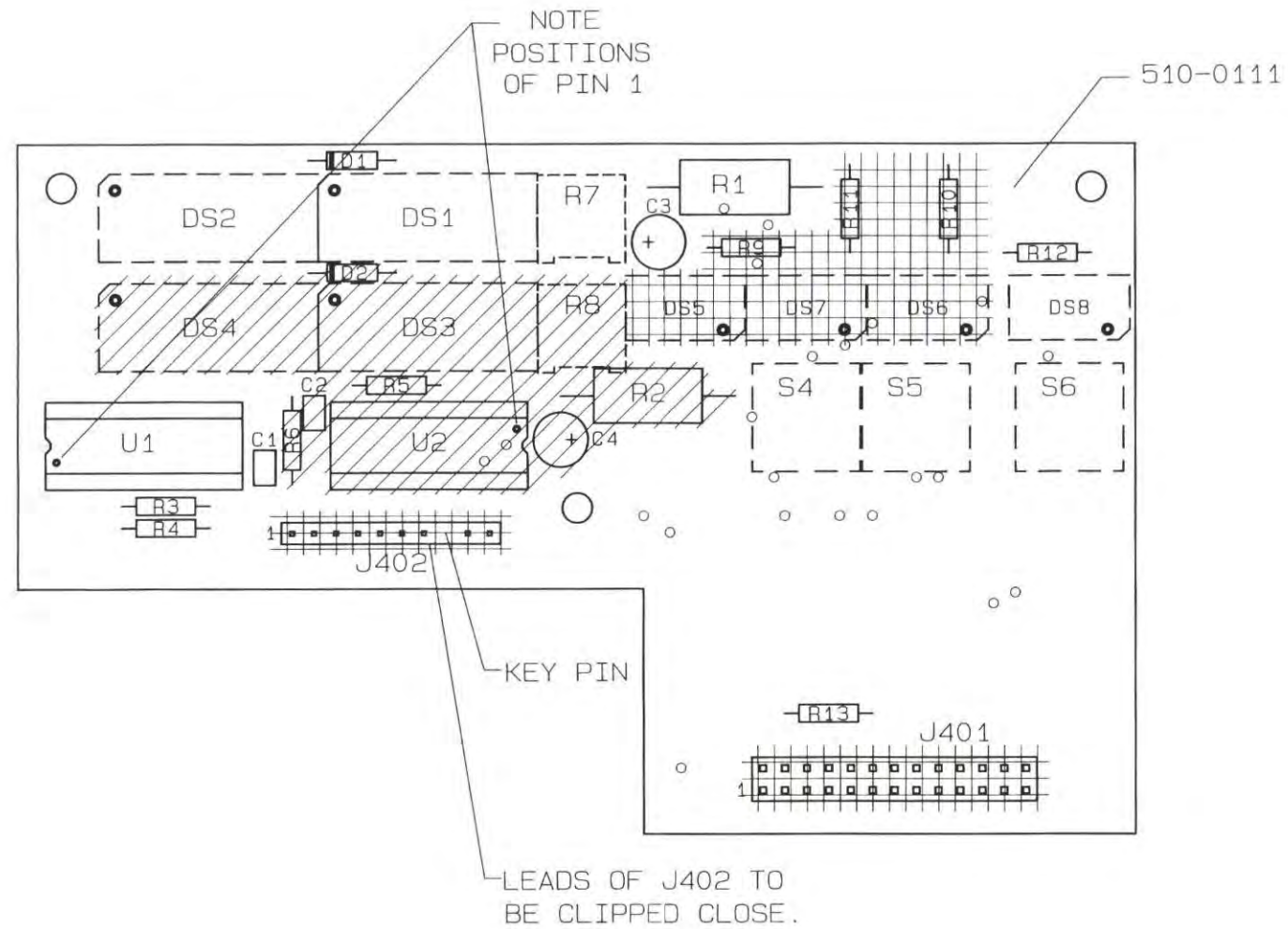

- NOTE:
1. FOR STEREO VERSION - 910-0111 - USE ALL COMPONENTS SHOWN.
 2. AREA SHADED WITH REPRESENTS COMPONENTS NOT USED ON MONO VERSION - 910-0111-001.
 3. AREA SHADED WITH REPRESENTS COMPONENTS USED "ONLY" ON PLAYBACK VERSION - 910-0111-002.
 4. SEE SCHEMATIC AD910-0111.
 5. CUT PIN 8 OF J402.
 6. DASHED COMPONENTS MOUNTED TO OPPOSITE SIDE SHOWN.
 7. SEE B/M: 910-0111 "STEREO"
910-0111-001 "MONO"
910-0111-002 "PLAYBACK"

COPYRIGHT © 1988 BROADCAST ELECTRONICS, INC.

PROPRIETARY RIGHTS are included in information disclosed herein. This information is submitted in confidence and neither this document nor the information disclosed herein shall be reproduced or transferred to other documents or used or disclosed to others for manufacturing or for any other purpose except as specifically authorized in writing by BROADCAST ELECTRONICS, INC. TOLERANCE DECIMAL U.O.S. .X ± .030 .XXX ± .005 .XX ± .015 ANGLES ± 4°	DWN BY MERK 8-17-88	MATERIAL SEE NOTE 7	BROADCAST ELECTRONICS INC. 4100 N. 24TH ST., P.O. BOX 3606 QUINCY, IL 62305 217/224-9600 TELEX 250142 CABLE BROADCAST FAX 217/224-9607	
	CHKD MH 4-6-89	FINISH		TITLE PCB ASSEMBLY- FRONT PANEL
	ME JHS 4-6-89	PROJ. ENGR. 4-6-89 JR CARPENTER	NEXT ASSY	TYPE SIZE DWG. NO. REV A C 910-0111-001, 910-0111-002 B
	MFG. PR BROSE	4-6-89		MODEL DT-90A SCALE 2:1 SHEET 1 OF 1

**TABLE 6-5. RECORD/PLAYBACK FRONT-PANEL CIRCUIT BOARD ASSEMBLY
910-0111/-001**

REF. DES.	DESCRIPTION	PART NO.	QTY.
DS5 THRU DS7	LED, Green, MV54173, Light Intensity I	320-0016	3
DS8	LED, Red, MV57173, Light Intensity G	320-0017	1
J401	Receptacle, Male, 13-Pin Dual In-Line	417-2600	1
J402	Receptacle, Male, 20-Pin In-Line	417-0200	1
R9 THRU R11	Resistor, 470 Ohm $\pm 5\%$, 1/4W	100-4733	3
R12	Resistor, 560 Ohm $\pm 5\%$, 1/4W	100-5633	1
R13	Resistor, 1 Ohm $\pm 5\%$, 1/4W	100-1013	1
S4,S5	Switch, Push, Illuminated, SN10601Hz, , Contacts: SPST, N.O., 50V ac at 125 mA Nominal (SEC and TER Switches)	340-0141	2
S6	Switch, Push, SN10202N1, Contacts: SPST, N.O., 24V dc at 125 mA Nominal (REC Switch)	340-0118	1
—	Blank Circuit Board	510-0111	1

**ADDITIONAL PARTS FOR STEREOPHONIC RECORD/PLAYBACK
910-0111**

C2	Capacitor, Monolythic Ceramic, 0.1 uF $\pm 20\%$, 50V	003-1054	1
C4	Capacitor, Electrolytic, 10 uF, 35V	023-1076	1
D2	Diode, 1N4004, Silicon, 400V @ 30 uA	203-4004	1
DS3	LED, Green, MV54164, High Efficiency 10-Segment Bar Graph Array	320-4164	1
DS4	LED, Red, MV57164, High Efficiency 10-Segment Bar Graph Array	320-7164	1
R2	Resistor, 22 Ohm $\pm 5\%$, 1W	120-2223	1
R5	Resistor, 2.26 k Ohm $\pm 1\%$, 1/4W	103-2264	1
R6	Resistor, 6.04 k Ohm $\pm 1\%$, 1/4W	103-6044	1
R8	Potentiometer, 50 k Ohm $\pm 10\%$, 1/2W	177-5054	1
U2	Integrated Circuit, LM3916N, Dot/Bar Display Driver, 18-Pin DIP	220-3916	1
XU2	Socket, 18-Pin DIP	417-1804	1

**ADDITIONAL PARTS FOR MONOPHONIC RECORD/PLAYBACK
910-0111-001**

C1	Capacitor, Monolythic Ceramic, 0.1 uF $\pm 20\%$, 50V	003-1054	1
C3	Capacitor, Electrolytic, 10 uF, 35V	023-1076	1
D1	Diode, 1N4004, Silicon, 400V @ 30 uA	203-4004	1
DS1	LED, Green, MV54164, High Efficiency 10-Segment Bar Graph Array	320-4164	1
DS2	LED, Red, MV57164, High Efficiency 10-Segment Bar Graph Array	320-7164	1
R1	Resistor, 22 Ohm $\pm 5\%$, 1W	120-2223	1
R3	Resistor, 2.26 k Ohm $\pm 1\%$, 1/4W	103-2264	1
R4	Resistor, 6.04 k Ohm $\pm 1\%$, 1/4W	103-6044	1
R7	Potentiometer, 50 k Ohm $\pm 10\%$, 1/2W	177-5054	1
U1	Integrated Circuit, LM3916N, Dot/Bar Display Driver, 18-Pin DIP	220-3916	1
XU1	Socket, 18-Pin DIP	417-1804	1

**TABLE 6-5A. PLAYBACK FRONT-PANEL CIRCUIT BOARD ASSEMBLY
910-0111-002**

REF. DES.	DESCRIPTION	PART NO.	QTY.
DS5 THRU DS7	LED, Green, MV54173, Light Intensity I	320-0016	3
J401	Receptacle, Male, 13-Pin Dual In-Line	417-2600	1
J402	Receptacle, Male, 20-Pin In-Line	417-0200	1
R9 THRU R11	Resistor, 470 Ohm $\pm 5\%$, 1/4W	100-4733	3
—	Blank Front-Panel Circuit Board	510-0111	1

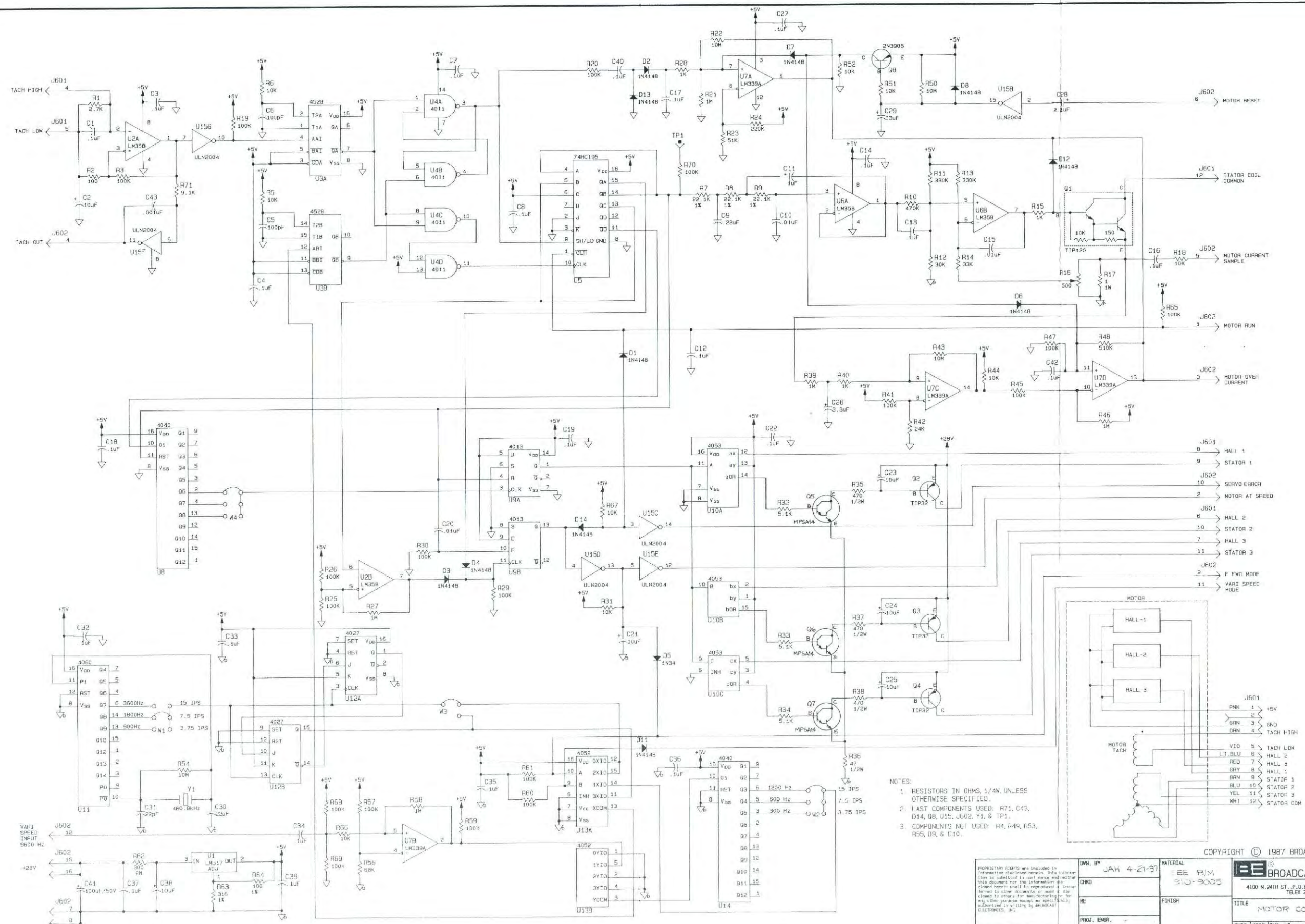

NOTES:

1. RESISTORS IN OHMS, 1/4W, UNLESS OTHERWISE SPECIFIED.
2. LAST COMPONENTS USED: R71, C43, D14, Q8, U15, J602, Y1, & TP1.
3. COMPONENTS NOT USED: R4, R49, R53, R55, D9, & D10.

COPYRIGHT © 1987 BROADCAST ELECTRONICS, INC.

COPYRIGHT © 1987 BROADCAST ELECTRONICS, INC.

IMPROPER HANDLING OF THIS PRODUCT MAY BE DANGEROUS TO LIFE AND PROPERTY. THIS PRODUCT IS NOT TO BE USED IN LIFE SUPPORT OR OTHER CRITICAL APPLICATIONS. THE USER SHALL BE RESPONSIBLE FOR OBTAINING THE NECESSARY TRAINING AND QUALIFICATION FOR THE PROPER USE OF THIS PRODUCT.		DWG. BY: JAH 4-21-97 CHKD: REV. ENGR. MFG.	MATERIAL: EEE B1M 910-9005 FINISH: SEE DWG BASED-0000 NEXT ASSY.	BROADCAST ELECTRONICS INC. 4100 N. 24TH ST., P.O. BOX 3606 QUINCY, IL 62305 217/224-3600 TELEF 250142 CABLE BROADCAST TITLE: MOTOR CONTROL PCB ASSY TYPE: S D SIZE: 3 1/2 X 5 1/2 DWG. NO.: 910-9005 REV: 1 MODEL: 9000 SERIES SCALE: SHEET 1 OF 1
--	--	---	---	---

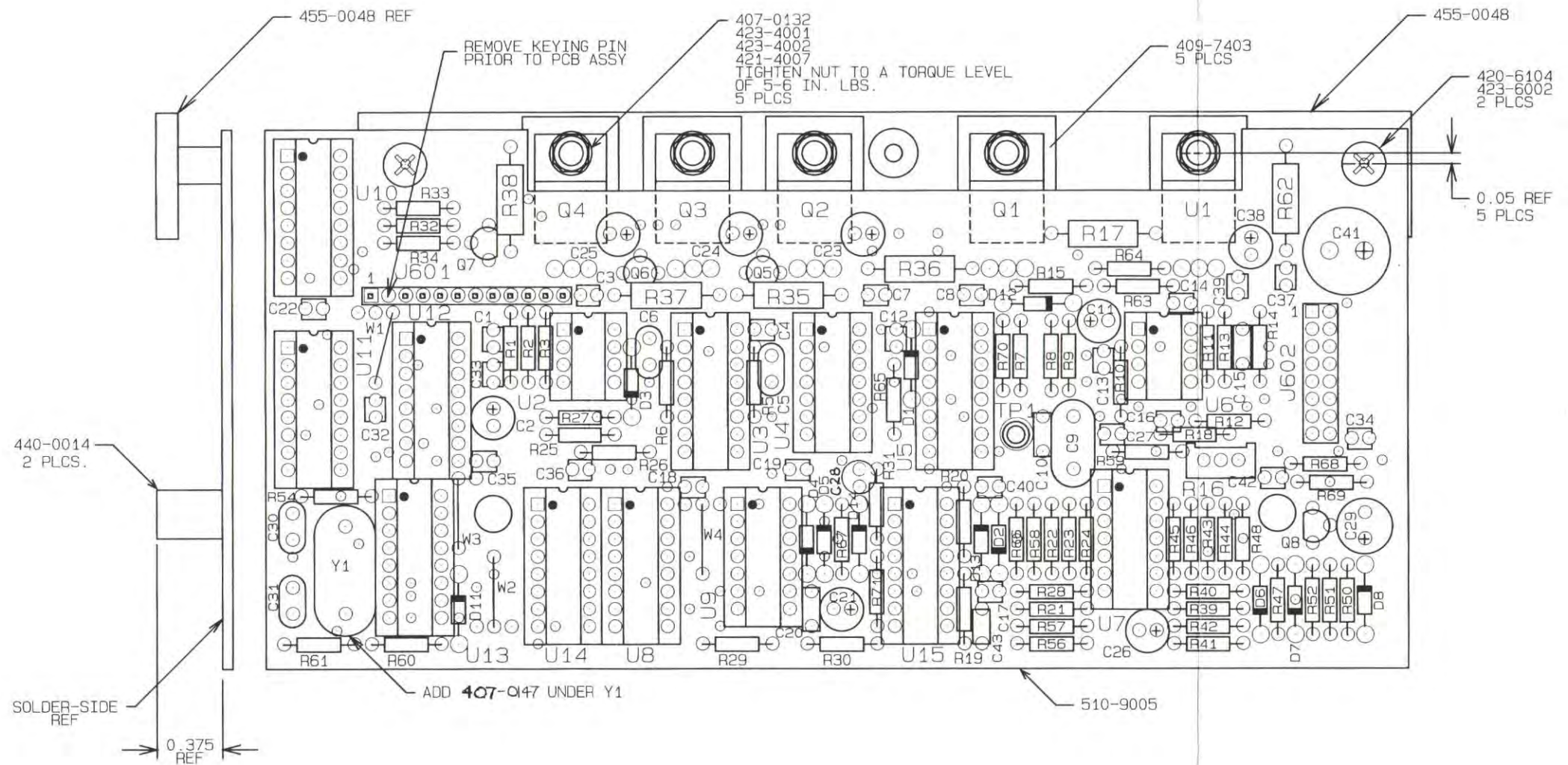

- NOTES:
 1. SEE SCHEMATIC NO. SD910-9005.

COPYRIGHT © 1986 BROADCAST ELECTRONICS, INC.

PROPRIETARY RIGHTS ARE INCLUDED IN INFORMATION DISCLOSED HEREIN. THIS INFORMATION IS SUBMITTED IN CONFIDENCE AND NEITHER THIS DOCUMENT NOR THE INFORMATION DISCLOSED HEREIN SHALL BE REPRODUCED OR TRANSFERRED TO OTHER DOCUMENTS OR USED OR DISCLOSED TO OTHERS FOR MANUFACTURING OR FOR ANY OTHER PURPOSE EXCEPT AS SPECIFICALLY AUTHORIZED IN WRITING BY BROADCAST ELECTRONICS, INC.	DWN BY DATE M. HAYDEN 11-19-86 CHKD	MATERIAL SEE B/M 910-9005	 BROADCAST ELECTRONICS INC. 4100 N. 24TH ST. QUINCY, IL. 62305 217/224-9600 TELEX 250142 CABLE "BROADCAST"
	ME PROJ ENGR MFG	FINISH NEXT ASSY	
TOLERANCE DECIMAL U.O.S. .X ± .030 .XXX ± .005 .XX ± .015 ANGLES ± 1°	TYPE A	SIZE C	DWG. NO. 910-9005
			REV D
		MODEL PT90	SCALE 2/1
			SHEET 1 OF 1

TABLE 6-6. MOTOR CONTROL CIRCUIT BOARD ASSEMBLY
910-9005 (Sheet 1 of 3)

REF. DES.	DESCRIPTION	PART NO.	QTY.
C1	Capacitor, Monolythic Ceramic, 0.1 uF ±20%, 50V	003-1054	1
C2	Capacitor, Electrolytic, 10 uF, 35V	023-1076	1
C3,C4	Capacitor, Monolythic Ceramic, 0.1 uF ±20%, 50V	003-1054	2
C5,C6	Capacitor, Silvered Mica, 100 pF ±5%, 500V	040-1022	2
C7,C8	Capacitor, Monolythic Ceramic, 0.1 uF ±20%, 50V	003-1054	2
C9	Capacitor, Mylar Film, 0.22 uF ±10%, 100V	030-2253	1
C10	Capacitor, Mylar Film, 0.01 uF ±10%, 100V	031-1043	1
C11	Capacitor, Electrolytic, 1 uF, 50V	024-1064	1
C12,C13,C14	Capacitor, Monolythic Ceramic, 0.1 uF ±20%, 50V	003-1054	3
C15	Capacitor, Mylar Film, 0.01 uF ±10%, 100V	031-1043	1
C16 THRU C19	Capacitor, Monolythic Ceramic, 0.1 uF ±20%, 50V	003-1054	4
C20	Capacitor, Mylar Film, 0.01 uF ±10%, 100V	031-1043	1
C21	Capacitor, Electrolytic, 10 uF, 35V	023-1076	1
C22	Capacitor, Monolythic Ceramic, 0.1 uF ±20%, 50V	003-1054	1
C23,C24,C25	Capacitor, Electrolytic, 10 uF, 35V	023-1076	3
C26	Capacitor, Electrolytic, 3.3 uF, 50V	020-3363	1
C27	Capacitor, Monolythic Ceramic, 0.1 uF ±20%, 50V	003-1054	1
C28	Capacitor, Electrolytic, 2.2 uF, 25V	013-2064	1
C29	Capacitor, Electrolytic, 33 uF, 35V	024-3374	1
C30,C31	Capacitor, Mica, 22 pF ±5%, 500V	040-2213	2
C32 THRU C37	Capacitor, Monolythic Ceramic, 0.1 uF ±20%, 50V	003-1054	6
C38	Capacitor, Electrolytic, 10 uF, 35V	023-1076	1
C39,C40	Capacitor, Monolythic Ceramic, 0.1 uF ±20%, 50V	003-1054	2
C41	Capacitor, Electrolytic, 100 uF, 50V	020-1083	1
C42	Capacitor, Monolythic Ceramic, 0.1 uF ±20%, 50V	003-1054	1
C43	Capacitor, Ceramic, 0.001 uF ±10%, 200V	030-1033	1
D1 THRU D4	Diode, 1N4148, Silicon, 75V @ 0.3 Amperes	203-4148	4
D5	Diode, 1N34, Germanium, 8.5 mA, 10V	202-0034	1
D6 THRU D8, D11 THRU D14	Diode, 1N4148, Silicon, 75V @ 0.3 Amperes	203-4148	7
J601	Connector, Header, 20-Pin In-Line	417-0200	0.6
J602	Connector, Header, 8-Pin Dual In-line	417-1603	1
Q1	Transistor, T1P120, NPN Darlington-Connected Silicon Power, 65W @ 25°C Case	210-0120	1
Q2,Q3,Q4	Transistor, T1P32A, Silicon, PNP, TO-220 AB Case	218-0032	3
Q5,Q6,Q7	Transistor, MPS-A14, Silicon, NPN Darlington, TO-92 Case	211-0014	3
Q8	Transistor, 2N3906, Silicon, PNP, TO-92 Case	210-3906	1
R1	Resistor, 2.7 k Ohm ±5%, 1/4W	100-2743	1
R2	Resistor, 100 Ohm ±5%, 1/4W	100-1033	1
R3	Resistor, 100 k Ohm ±5%, 1/4W	100-1063	1
R5,R6	Resistor, 10 k Ohm ±5%, 1/4W	100-1053	2
R7,R8,R9	Resistor, 22.1 k Ohm ±1%, 1/4W	103-2211	3
R10	Resistor, 470 k Ohm ±5%, 1/4W	100-4763	1
R11	Resistor, 330 k Ohm ±5%, 1/4W	100-3363	1
R12	Resistor, 30 k Ohm ±5%, 1/4W	100-3053	1
R13	Resistor, 330 k Ohm ±5%, 1/4W	100-3363	1
R14	Resistor, 33 k Ohm ±5%, 1/4W	100-3353	1

TABLE 6-6. MOTOR CONTROL CIRCUIT BOARD ASSEMBLY
910-9005 (Sheet 2 of 3)

REF. DES.	DESCRIPTION	PART NO.	QTY.
R15	Resistor, 1 k Ohm $\pm 5\%$, 1/4W	100-1043	1
R16	Potentiometer, 500 Ohm, 1/2W	178-5030	1
R17	Resistor, 1 Ohm $\pm 1\%$, 1W	120-1013	1
R18	Resistor, 10 k Ohm $\pm 5\%$, 1/4W	100-1053	1
R19,R20	Resistor, 100 k Ohm $\pm 5\%$, 1/4W	100-1063	2
R21	Resistor, 1 Meg Ohm $\pm 5\%$, 1/4W	100-1073	1
R22	Resistor, 10 Meg Ohm $\pm 5\%$, 1/4W	100-1083	1
R23	Resistor, 51 k Ohm $\pm 5\%$, 1/4W	100-5153	1
R24	Resistor, 220 k Ohm $\pm 5\%$, 1/4W	100-2263	1
R25,R26	Resistor, 100 k Ohm $\pm 5\%$, 1/4W	100-1063	2
R27	Resistor, 1 Meg Ohm $\pm 5\%$, 1/4W	100-1073	1
R28	Resistor, 1 k Ohm $\pm 5\%$, 1/4W	100-1043	1
R29,R30	Resistor, 100 k Ohm $\pm 5\%$, 1/4W	100-1063	2
R31	Resistor, 10 k Ohm $\pm 5\%$, 1/4W	100-1053	1
R32,R33,R34	Resistor, 5.1 k Ohm $\pm 5\%$, 1/4W	100-5143	3
R35	Resistor, 470 Ohm $\pm 5\%$, 1/2W	110-4733	1
R36	Resistor, 47 Ohm $\pm 5\%$, 1/2W	110-4723	1
R37,R38	Resistor, 470 Ohm $\pm 5\%$, 1/2W	110-4733	2
R39	Resistor, 1 Meg Ohm $\pm 5\%$, 1/4W	100-1073	1
R40	Resistor, 1 k Ohm $\pm 5\%$, 1/4W	100-1043	1
R41	Resistor, 100 k Ohm $\pm 5\%$, 1/4W	100-1063	1
R42	Resistor, 24 k Ohm $\pm 5\%$, 1/4W	100-2453	1
R43	Resistor, 10 Meg Ohm $\pm 5\%$, 1/4W	100-1083	1
R44	Resistor, 10 k Ohm $\pm 5\%$, 1/4W	100-1053	1
R45	Resistor, 100 k Ohm $\pm 5\%$, 1/4W	100-1063	1
R46	Resistor, 1 Meg Ohm $\pm 5\%$, 1/4W	100-1073	1
R47	Resistor, 100 k Ohm $\pm 5\%$, 1/4W	100-1063	1
R48	Resistor, 510 k Ohm $\pm 5\%$, 1/4W	100-5163	1
R50	Resistor, 10 Meg Ohm $\pm 5\%$, 1/4W	100-1083	1
R51,R52	Resistor, 10 k Ohm $\pm 5\%$, 1/4W	100-1053	2
R54	Resistor, 10 Meg Ohm $\pm 5\%$, 1/4W	100-1083	1
R56	Resistor, 68 k Ohm $\pm 5\%$, 1/4W	100-6853	1
R57	Resistor, 100 k Ohm $\pm 5\%$, 1/4W	100-1063	1
R58	Resistor, 1 Meg Ohm $\pm 5\%$, 1/4W	100-1073	1
R59,R60,R61	Resistor, 100 k Ohm $\pm 5\%$, 1/4W	100-1063	3
R62	Resistor, 300 Ohm $\pm 5\%$, 2W, W/W	130-3004	1
R63	Resistor, 316 Ohm $\pm 1\%$, 1/4W	103-3163	1
R64	Resistor, 100 Ohm $\pm 1\%$, 1/4W	100-1031	1
R65	Resistor, 100 k Ohm $\pm 5\%$, 1/4W	100-1063	1
R66,R67	Resistor, 10 k Ohm $\pm 5\%$, 1/4W	100-1053	2
R68,R69,R70	Resistor, 100 k Ohm $\pm 5\%$, 1/4W	100-1063	3
R71	Resistor, 9.1 k Ohm $\pm 5\%$, 1/4W	100-9143	1
U1	Integrated Circuit, LM317T, Adjustable Positive Voltage Regulator, 1.2V to 37V, 1.5 Ampere, TO-220 Case	227-0317	1
U2	Integrated Circuit, LM358N, Dual Operational Amplifier, 8-Pin DIP	221-0358	1
U3	Integrated Circuit, MC14528BCP, Dual Monostable Multi-vibrator, CMOS, 16-Pin DIP	224-4528	1

**TABLE 6-6. MOTOR CONTROL CIRCUIT BOARD ASSEMBLY
910-9005 (Sheet 3 of 3)**

REF. DES.	DESCRIPTION	PART NO.	QTY.
U4	Integrated Circuit, MC14011BCP, Quad 2-Input NAND Gate, CMOS, 14-Pin DIP	228-4011	1
U5	Integrated Circuit, MC54/74HC195, 4-Bit Universal Shift Register, CMOS, 16-Pin DIP	220-0195	1
U6	Integrated Circuit, LM358N, Dual Operational Amplifier, 8-Pin DIP	221-0358	1
U7	Integrated Circuit, LM339AN, Quad Comparator, 14-Pin DIP	221-0339	1
U8	Integrated Circuit, MC14040BCP, 12-Bit Binary Counter, CMOS, 16-Pin DIP	220-4040	1
U9	Integrated Circuit, MC14013BCP, Dual D-Type Flip-Flop, CMOS, 14-Pin DIP	228-4013	1
U10	Integrated Circuit, MC14053B, Analog Multiplexers/Demultiplexers, CMOS, 16-Pin DIP	220-4053	1
U11	Integrated Circuit, MC14060B, 14-Bit Binary Counter and Oscillator, CMOS, 16-Pin DIP	220-4060	1
U12	Integrated Circuit, CD4027BE, Dual J-K Master-Slave Flip-Flop, CMOS, 16-Pin DIP	225-0003	1
U13	Integrated Circuit, MC14052B, Dual 4-Channel Analog Multiplexers/Demultiplexers, CMOS, 2P4T, 16-Pin DIP	220-4052	1
U14	Integrated Circuit, MC14040BCP, 12-Bit Binary Counter, CMOS, 16-Pin DIP	220-4040	1
U15	Integrated Circuit, ULN2004, 7 NPN Darlington Driver Pack, 16-Pin DIP	226-2004	1
XU2	Socket, 8-Pin DIP	417-0804	1
XU3	Socket, 16-Pin DIP	417-1604	1
XU4	Socket, 14-Pin DIP	417-1404	1
XU5	Socket, 16-Pin DIP	417-1604	1
XU6	Socket, 8-Pin DIP	417-0804	1
XU7	Socket, 14-Pin DIP	417-1404	1
XU8	Socket, 16-Pin DIP	417-1604	1
XU9	Socket, 14-Pin DIP	417-1404	1
XU10 THRU XU15	Socket, 16-Pin DIP	417-1604	6
Y1	Crystal, 460.80 kHz \pm 0.01% from θ° C to 50 $^{\circ}$ C, R/DT Cut, NE33D Case	390-0019	1
—	Blank Circuit Board	510-9005	1

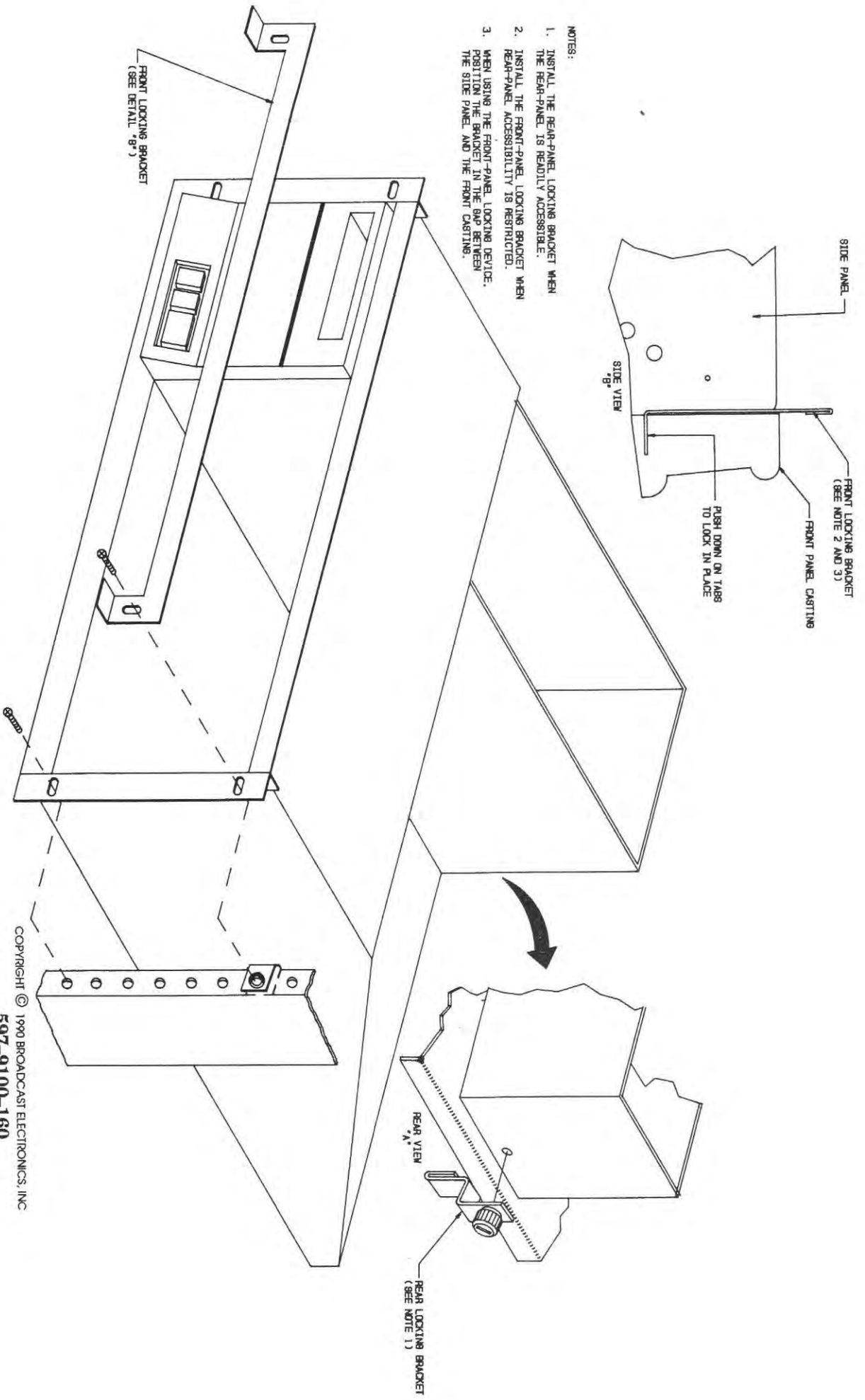

- NOTES:
1. INSTALL THE REAR-PANEL LOCKING BRACKET WHEN THE REAR-PANEL IS READILY ACCESSIBLE.
 2. INSTALL THE FRONT-PANEL LOCKING BRACKET WHEN REAR-PANEL ACCESSIBILITY IS RESTRICTED.
 3. WHEN USING THE FRONT-PANEL LOCKING DEVICE, POSITION THE BRACKET IN THE ONE DENIED POSITION THE SIDE PANEL AND THE FRONT CASTING.

FIGURE 6-7. DT-90A RACK ASSEMBLY DIAGRAM

COPYRIGHT © 1990 BROADCAST ELECTRONICS, INC.
597-9100-160

PRODUCT WARRANTY

LIMITED TWO YEAR

While this warranty gives Purchaser specific legal rights, which terminate two (2) years (one year on turntable, cartridge and blower motors) from the date of shipment, Purchaser may also have other rights which vary state to state.

Broadcast Electronics, Inc. ("Seller") hereby warrants cartridge machines, consoles, and other new Equipment manufactured by Seller against any defects in material or workmanship at the time of delivery thereof, that develop under normal use within a period of two (2) years (one year for turntable, cartridge and blower motors) from the date of shipment, as such term is defined herein. Other manufacturer's and suppliers' Equipment and services, if any, including electronic tubes, solid state devices, transmission line, antennas, towers, related equipment and installation and erection services, shall carry only such manufacturer's or suppliers' standard warranty. This warranty extends to the original user and any subsequent purchaser during the warranty period. Seller's sole responsibility with respect to any equipment or parts not conforming to this warranty is to replace such equipment or parts upon the return thereof F.O.B. Seller's factory or authorized repair depot within the period aforesaid.

In the event of replacement pursuant to the foregoing warranty, only the unexpired portion of the warranty from the time of the original purchase will remain in effect for any such replacement. However, the warranty period will be extended for the length of time that Purchaser is without the services of the Equipment due to its being serviced pursuant to this warranty. The terms of the foregoing warranty shall be null and void if the Equipment has been altered or repaired without specific written authorization of Seller, or if Equipment is operated under environmental conditions or circumstances other than those specifically described in Seller's product literature or instruction manual which accompany the Equipment. Seller shall not be liable for any expense of any nature whatsoever incurred by the original user without prior written consent of Seller.

Seller shall not be liable to Purchaser for any and all incidental or consequential damages for breach of either expressed or implied warranties. However, some states do not allow the exclusion or limitation of incidental or consequential damages, so the above limitation or exclusion may not apply to Purchaser. All express and implied warranties shall terminate at the conclusion of the period set forth herein. Any card which is enclosed with the equipment will be used by Seller for survey purposes only.

If the Equipment is described as used, it is sold as is and where is. If the contract covers equipment not owned by Seller at this date, it is sold subject to Seller's acquisition of possession and title.

EXCEPT AS SET FORTH HEREIN, AND EXCEPT AS TO TITLE, THERE ARE NO WARRANTIES, OR ANY AFFIRMATIONS OF FACT OR PROMISES BY SELLER, WITH REFERENCE TO THE EQUIPMENT, OR TO MERCHANTABILITY, FITNESS FOR A PARTICULAR APPLICATION, SIGNAL COVERAGE, INFRINGEMENT, OR OTHERWISE, WHICH EXTEND BEYOND THE DESCRIPTION OF THE EQUIPMENT ON THE FACE HEREOF.

BROADCAST ELECTRONICS, INC.

4100 North 24th Street, P.O. Box 3606, Quincy, Illinois 62305

