

INSTALLATION, OPERATING AND SERVICE INSTRUCTIONS FOR V7 SERIES OIL FIRED BOILER KNOCKDOWN & PACKAGED HEATING UNITS



As an ENERGY STAR® Partner, Burnham Corporation has determined that the V73WR (0.60 GPH), V74WR (0.80 GPH), V75WR (0.90 GPH), and V76WR (1.15 GPH) meet the ENERGY STAR® guidelines for Energy efficiency established by the United States Environmental Protection Agency (EPA).



These instructions have been reviewed by ULC and found suitable for use in the installation of ULC labeled V-7 Series Boilers.



The ULC label or listed marking on a product is the only evidence provided by Underwriters' Laboratories of Canada to identify products which have been produced under the listing and follow-up service.

For service or repairs to boiler, call your heating contractor. When seeking information on boiler, provide Boiler Model Number and Serial Number as shown on Rating Label.

Boiler Model Number _ V7 _ - _	Boiler Serial Number 6 _ _ _ _ _	Installation Date
Heating Contractor		Phone Number
Address		



IMPORTANT INFORMATION - PLEASE READ THIS PAGE CAREFULLY

1. THIS BOILER HAS LIMITED WARRANTIES, COPIES OF WHICH ARE PRINTED ON THE BACK COVER OF THIS MANUAL.
2. THIS BOILER IS SUITABLE FOR INSTALLATION ON COMBUSTIBLE FLOORING. BOILER CANNOT BE INSTALLED ON CARPETING.
3. ALL BOILERS MUST BE INSTALLED IN ACCORDANCE WITH NATIONAL, STATE AND LOCAL PLUMBING, HEATING AND ELECTRICAL CODES AND THE REGULATIONS OF THE SERVING UTILITIES WHICH MAY DIFFER FROM THIS MANUAL. AUTHORITIES HAVING JURISDICTION SHOULD BE CONSULTED BEFORE INSTALLATIONS ARE MADE.

IN ALL CASES, REFERENCE SHOULD BE MADE TO THE FOLLOWING STANDARDS:

USA BOILERS

- A. Current Edition of American National Standard ANSI/NFPA 31, "Installation of Oil Burning Equipment", for clearances between boiler, vent connector and combustible material.
- B. Current Edition of American National Standard ANSI/NFPA 211, "Chimneys, Fireplaces, Vents, and Solid Fuel Burning Appliances", For Chimney requirements, type of venting material and clearances between vent connector pipe and combustible materials.
- C. Current Edition of American Society of Mechanical Engineers ASME CSD-1, "Controls and Safety Devices for Automatically Fired Boilers", for assembly and operations of controls and safety devices.

CANADA BOILERS

- A. Current Edition of Canadian Standards Association CSA B139, "Installation Code for Oil Burning Equipment", for recommended Installation Practices.
4. ALL HEATING SYSTEMS SHOULD BE DESIGNED BY COMPETENT CONTRACTORS AND ONLY PERSONS KNOWLEDGEABLE IN THE LAYOUT AND INSTALLATION OF HYDRONIC HEATING SYSTEMS SHOULD ATTEMPT INSTALLATION OF ANY BOILER.
 5. THE BOILER MUST BE CONNECTED TO AN APPROVED CHIMNEY IN GOOD CONDITION. SERIOUS PROPERTY DAMAGE COULD RESULT IF THE BOILER IS CONNECTED TO A DIRTY OR INADEQUATE CHIMNEY. THE INTERIOR OF THE CHIMNEY FLUE MUST BE INSPECTED AND CLEANED BEFORE THE START OF THE HEATING SEASON AND SHOULD BE INSPECTED PERIODICALLY THROUGHOUT THE HEATING SEASON FOR ANY OBSTRUCTIONS. A CLEAN AND UNOBSTRUCTED CHIMNEY FLUE IS NECESSARY TO ALLOW NOXIOUS FUMES THAT COULD CAUSE INJURY OR LOSS OF LIFE TO VENT SAFELY AND WILL CONTRIBUTE TOWARD MAINTAINING THE BOILER'S EFFICIENCY.
 6. READ THE LITERATURE ENCLOSED BY THE MANUFACTURER WITH THE VARIOUS ACCESSORY DEVICES. THESE ACCESSORY DEVICES MUST BE INSTALLED AND USED ACCORDING TO THE RECOMMENDATIONS OF THE MANUFACTURER.
 7. IT IS THE RESPONSIBILITY OF THE INSTALLING CONTRACTOR TO SEE THAT ALL CONTROLS ARE CORRECTLY INSTALLED AND ARE OPERATING PROPERLY WHEN THE INSTALLATION IS COMPLETED.
 8. FOR OPTIMUM PERFORMANCE AND SERVICEABILITY FROM THIS BOILER ADHERE TO THE FOLLOWING RECOMMENDATIONS:
 - A. DO NOT TAMPER WITH THE BOILER OR CONTROLS. Retain your contractor or a competent serviceman to assure that the boiler is properly adjusted and maintained.
 - B. Clean flueways at least once a year - preferably at the end of the heating season to remove soot and scale. Inside of firebox should also be cleaned at the same time.
 - C. Have oil burner and controls checked at least once a year or as may be necessitated.

WARNING

This boiler is designed to burn No. 2 fuel oil only. Do not use gasoline, crankcase drainings, or any oil containing gasoline. Never burn garbage or paper in this boiler. Do not convert to any solid fuel (i.e. wood, coal) or gaseous fuel (i.e. natural gas, LP/propane). All flammable debris, rags, paper, wood scraps, etc., should be kept clear of the boiler at all times. Keep the boiler area clean and free of fire hazards.

WARNING

All boilers equipped with burner swing door have a potential hazard which can cause severe property damage, personal injury or loss of life if ignored. Before opening swing door, turn off service switch to boiler to prevent accidental firing of burner outside the combustion chamber. Be sure to tighten swing door fastener completely when service is completed.

WARNING

High water temperatures increase the risk of burns or scalding injury. Install an automatic tempering (mixing) valve at the tankless heater outlet to avoid excessively hot water at the fixtures.

IMPORTANT

Before starting to install this oil boiler, read these instructions carefully. Keep instructions in legible condition and posted near oil boiler for reference by owner and service technician.

TABLE OF CONTENTS

I. General Information	3	IV. Operating Instructions	21
II. Knockdown Boiler Assembly	7	V. Boiler Cleaning	29
III. Installation Instructions	12	VI. Repair Parts	31
		Burner Specifications	46

SECTION I: GENERAL INFORMATION

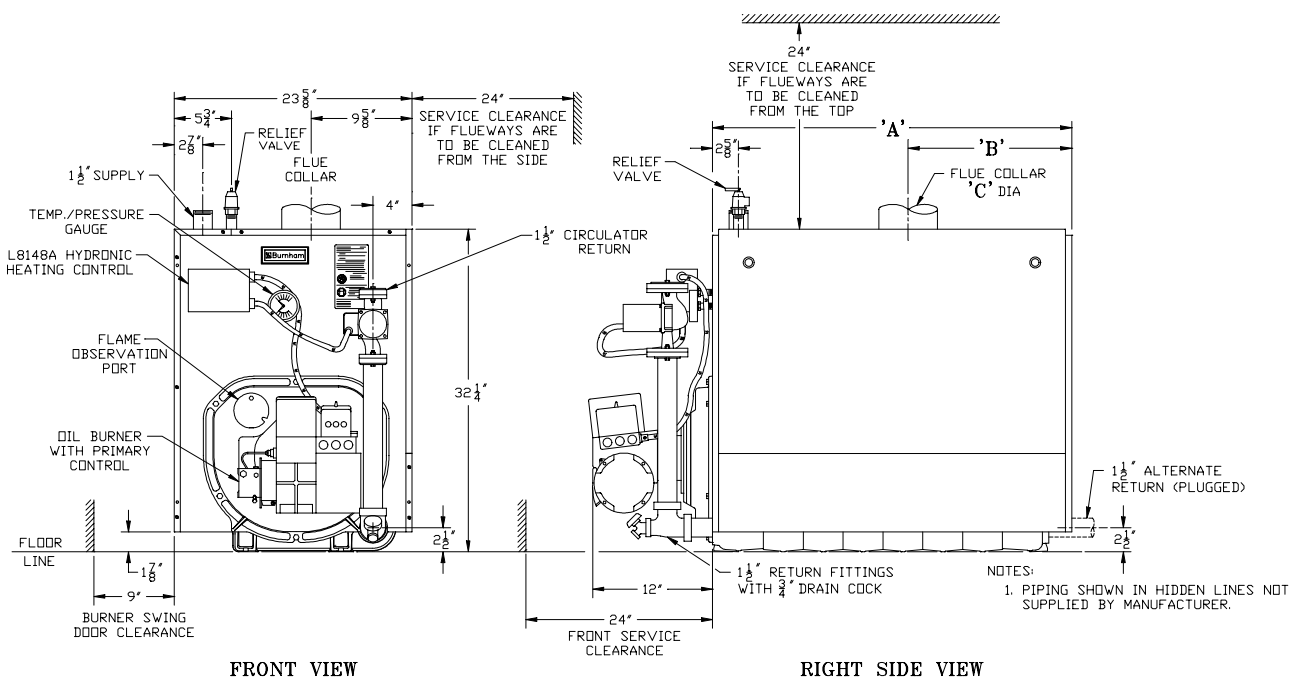

Figure 1A: V72 thru V79 Water Boiler Without Tankless Heater (WB)

TABLE 1: DIMENSIONAL DATA (SEE FIGURES 1A THRU 1E)

Boiler Model No.	Dimensions			Minimum Chimney Size	Water Content - Gallons		Heat Transfer Surface Area - Sq. Ft.	Approximate Shipping Weight (LB.)
	"A"	"B"	"C"		Steam Boiler	Water Boiler	Steam Boiler	
V72	11-3/8"	6-3/8"	5"	8" x 8" x 15'	----	10.6	----	381
V713	16"	8-3/4"	6"	8" x 8" x 15'	----	13.5	----	524
V73	15-3/8"	8-3/8"	6"	8" x 8" x 15'	10.8	13.2	13.8	478
V714	20"	10-3/4"	6"	8" x 8" x 15'	----	15.9	----	580
V74	19-3/8"	10-3/8"	6"	8" x 8" x 15'	13.5	15.9	19.7	575
V75	23-3/8"	12-3/8"	7"	8" x 8" x 15'	16.1	18.5	25.6	674
V76	27-3/8"	14-3/8"	7"	8" x 8" x 15'	18.6	21	31.4	773
V77	31-3/8"	16-3/8"	8"	8" x 12" x 15'	21.2	23.6	37.3	872
V78	35-3/8"	18-3/8"	8"	8" x 12" x 15'	23.8	26.2	43.1	971
V79	39-3/8"	20-3/8"	8"	8" x 12" x 15'	26.4	28.8	49.0	1070

NOTE: 1. Maximum Working Pressure 15 PSI (Steam) and 30 PSI (Water)
 2. The V72, V713 and V714 Boilers are available as packaged water boilers only
 3. The V713 and V714 are not ULC listed Models

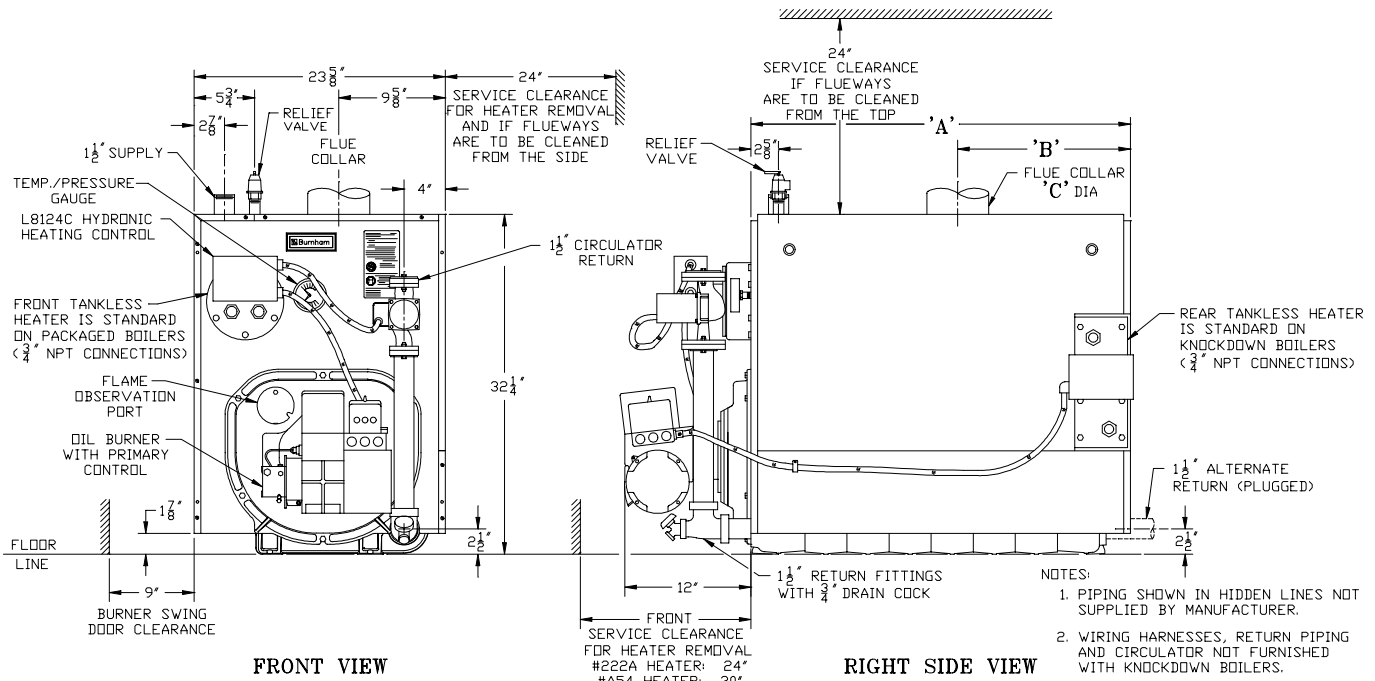

Figure 1B: V73 thru V79 Water Boiler with Tankless Heater (WBT)

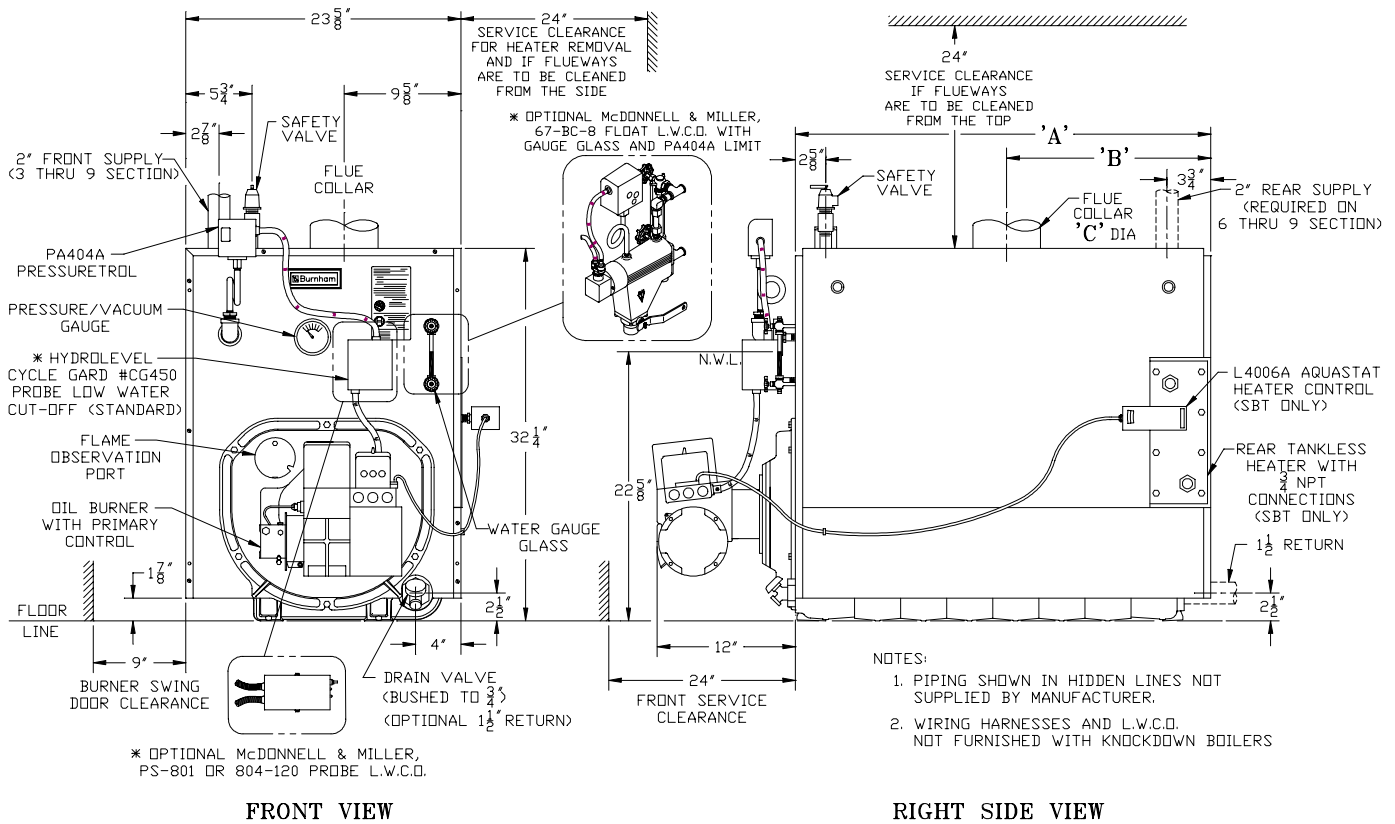

Figure 1C: V73 thru V79 Steam Boiler with or without Tankless Heater ("SBT" or "SB")

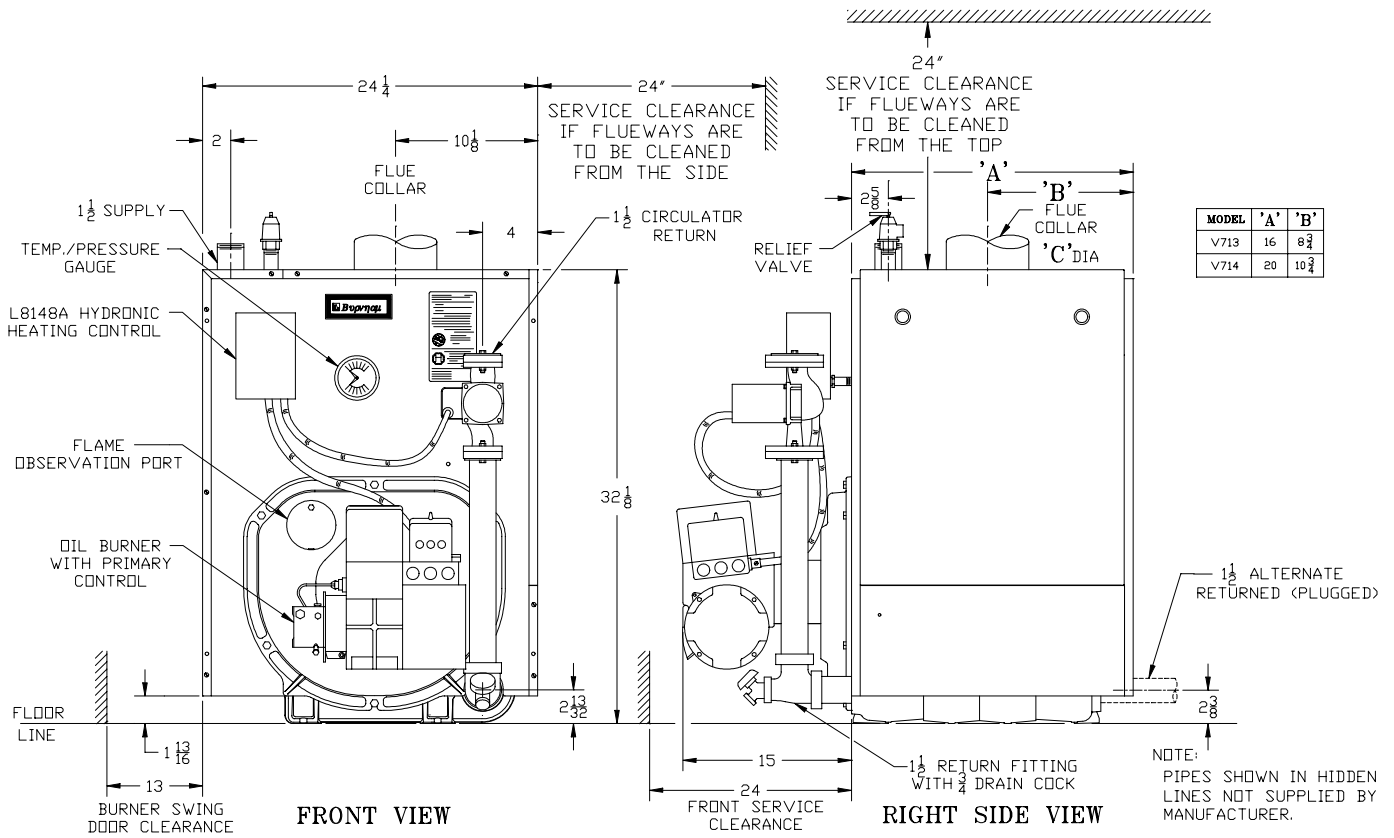

Figure 1D: V713 and V714 Packaged Water Boiler Less Tankless Heater (WB)

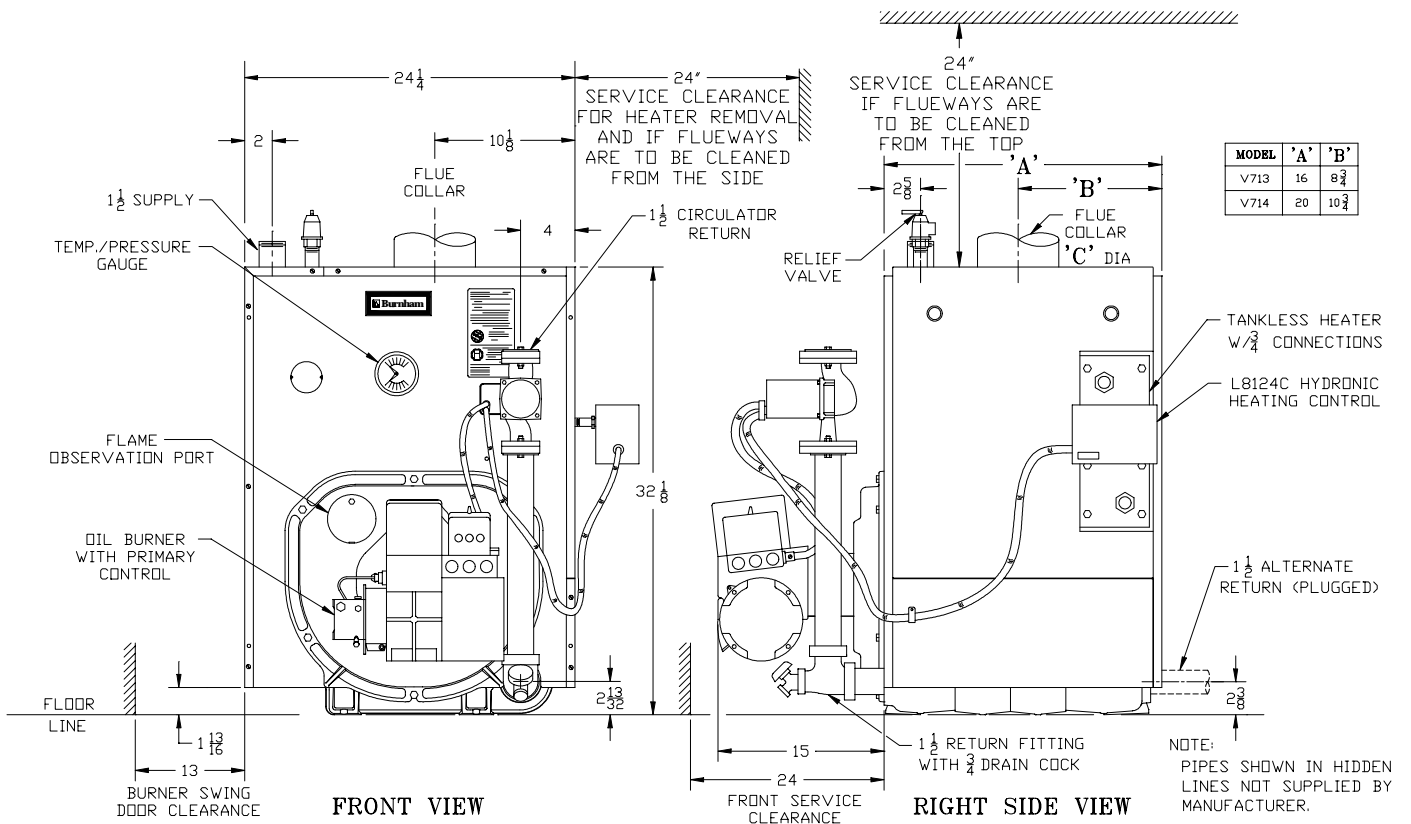

Figure 1E: V713 and V714 Packaged Water Boiler with Tankless Heater (WBT)

A. INSPECT SHIPMENT carefully for any signs of damage.

1. ALL EQUIPMENT is carefully manufactured, inspected and packed. Our responsibility ceases upon delivery of crated boiler to the carrier in good condition.
2. ANY CLAIMS for damage or shortage in shipment must be filed immediately against the carrier by the consignee. No claims for variances from, or shortage in orders, will be allowed by the manufacturer unless presented within sixty (60) days after receipt of goods.

B. LOCATE BOILER in front of final position before removing crate. See Figures 1A thru 1E.

1. LOCATE so that smoke pipe connection to chimney will be short and direct. BOILER IS SUITABLE FOR INSTALLATION ON COMBUSTIBLE FLOOR. Boiler cannot be installed on carpeting.

2. FOR BASEMENT INSTALLATION, provide a solid base, such as concrete, if floor is not level, or if water may be encountered on floor around boiler.
3. PROVIDE SERVICE CLEARANCE of at least 24" on right side of boiler for removal of rear tankless heater. Provide at least 24" clearance from front jacket panel for servicing and removal of front tankless heater (increase to 30" for #A54 heater). Provide at least 24" clearance from right side of boiler **or** top of boiler for cleaning flueways. Boiler flueways may be cleaned either from the top **or** from the side.
4. For minimum clearances to combustibles materials. See Table 2.

C. PROVIDE AIR SUPPLY AND VENTILATION to accommodate proper combustion. If natural ventilation is inadequate, provide a screened opening or duct from the boiler room to the outside. The opening or duct must be sized so the boiler input will not exceed 4,000 BTUH/Sq. In. of free area. If other air consuming appliances are near the boiler, the air inlet should be larger. Consult respective manufacturers.

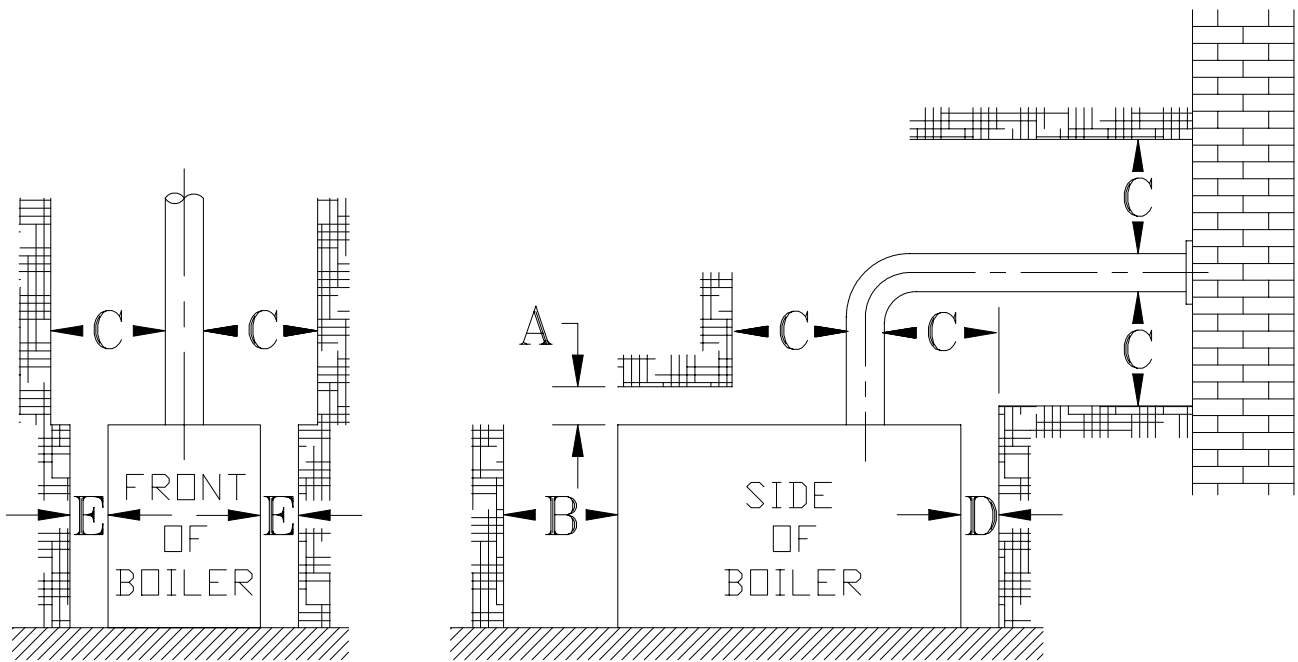

TABLE 2: Minimum Installation Clearances To Combustible Materials (Inches)

Boiler	A Above	B Front	C		
			Chimney Connector	D Rear	E Sides
V7	6	24	18	6	6

NOTE 1: Listed clearances comply with American National Standard ANSI/NFPA 31, Installation of Oil Burning Equipment.

NOTE 2: V7 Series boilers can be installed in rooms with clearances from combustible material as listed above. Listed clearances cannot be reduced for alcove or closet installations.

NOTE 3: For reduced clearances to combustible material, protection must be provided as described in the above ANSI/NFPA 31 standard.

SECTION II: KNOCKDOWN BOILER ASSEMBLY

Note: If Boiler is Packaged Go To Section III

A. REMOVAL OF BARE BOILER FROM SKID

1. Boiler is secured to base with 4 bolts, 2 on front and 2 on rear, see Figure 2. Remove all bolts.
2. Tilt boiler to right and to rear. Using right rear leg as pivot, rotate boiler 90° in a clockwise direction, and lower left side of boiler to floor. Tilt boiler and remove crate skid.

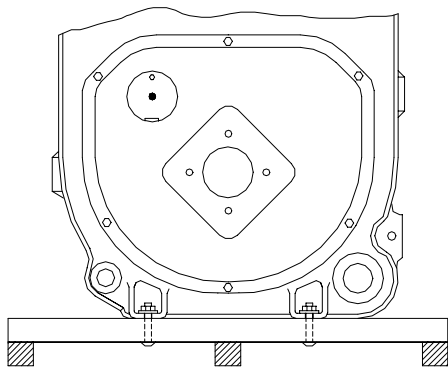

Figure 2

B. MOVE BOILER TO PERMANENT POSITION by sliding or walking.

C. TEST BOILER FOR LEAKS before installing controls, trim, and jacket, and before connecting to heating system.

1. Loosen nuts on tie rods until only finger tight.
2. Install pressure gauge (at least 30 P.S.I. capacity), a hose to the city water and a valve in the supply tapping. Plug remainder of tappings.
3. Fill boiler with water and apply a pressure of at least 10 pounds but no more than 30 pounds gauge pressure.
4. Examine Boiler carefully inside and outside for leaks or damage due to shipment or handling.

D. DRAIN WATER FROM BOILER. Remove gauge, valve and plugs from those tappings to be used. Leave other tappings plugged or bushed according to Figure 4.

E. INSPECT JOINTS BETWEEN SECTIONS. All joints are factory sealed. If there are any spaces due to shipment or handling, seal them with boiler putty.

F. INSPECT FLUE COVER PLATES for tightness. If loose, retighten mounting hardware. If flue plate or sealing insulation is damaged repair or replace as needed.

G. INSTALL AND SECURE CANOPY with cerafelt gasket and hardware provided to ensure gas tight seal — see Figure 3.

1. Cut two (2) strips 13 3/4" lg. from the roll of cerafelt gasket insulation. Place one (1) strip across the top of the front section and the other across the rear

section as shown in Fig. 3. Place gaskets so as not to allow any flueway blockage.

2. Cut the remainder of the roll into two (2) equal pieces. Place each piece along the sides, allowing the ends to overlap the front and rear pieces.

Do not allow any flueway blockage.

3. Position canopy body within the retaining bar which borders the flueway openings on top of the bare boiler block assembly.

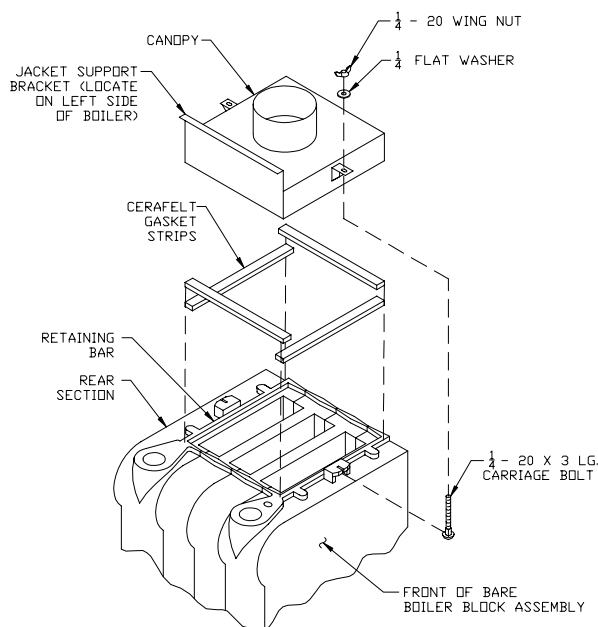

BOILER CANOPY INSTALLATION

Figure 3

IMPORTANT: Jacket support bracket must be facing left side of boiler — see Figure 3.

4. Secure canopy to boiler with two (2) 1/4" - 20 x 3" lg. carriage bolts, 1/4" flat washers and 1/4" - 20 wing nuts provided.

H. INSTALL the following steam or water trim that would be concealed or inaccessible after flush jacket is installed, see Figure 4 for boiler tapping locations and usage.

1. STEAM BOILER — Top tappings:

- a. Tapping "L" — Install 2" plug in rear section top supply tapping on boiler sizes V73 thru V75.
- b. Tapping "M" — Install 3/4" coupling and 3/4" x 8" long nipple into 3/4" tapping located next to front section top supply tapping — all boiler sizes.

2. WATER BOILER — Top tappings:

- a. Tapping "L" — Install 2" plug in rear section top supply tapping on boiler sizes V73 thru V79.

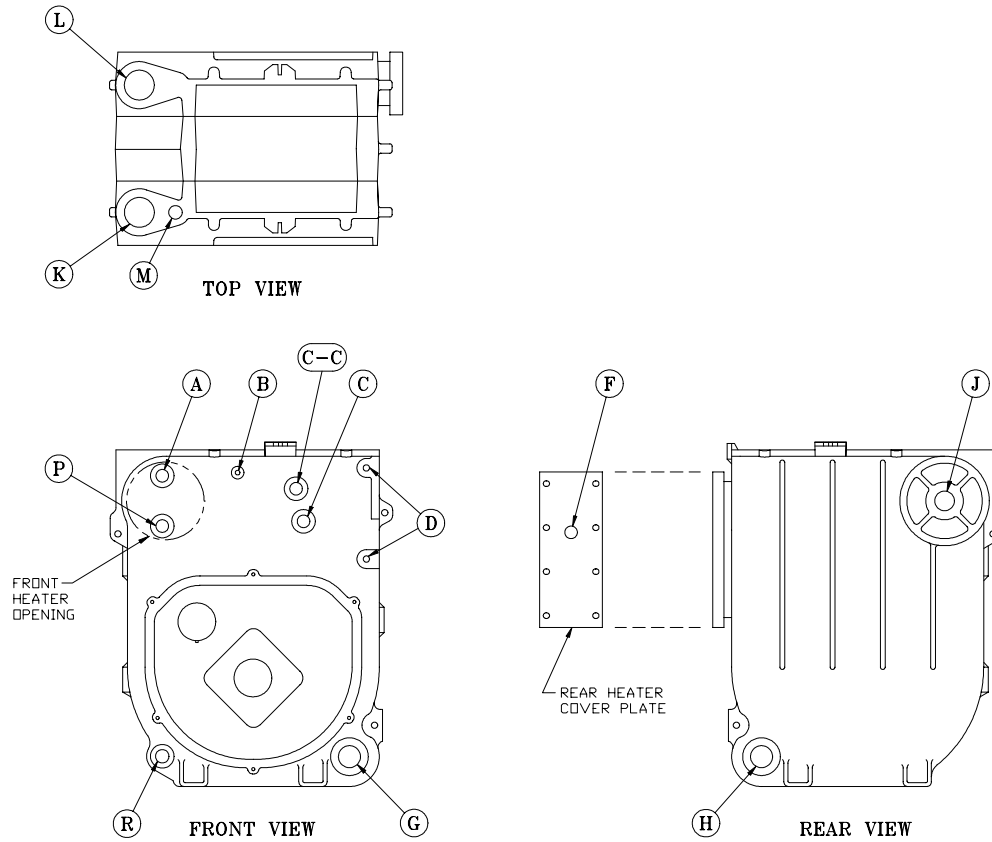

Figure 4: Boiler Tapping Locations and Usage (Knockdown Boilers Only)

PURPOSE OF TAPPINGS						
Tapping Location	Size	Steam Boiler		Water Boiler		
		Non-Heater	w/Heater	Non-Heater	Front Heater	Rear Heater
A	¾"	PA404A Pressuretrol (Probe LWCO) Plugged (Float LWCO)		L8148A Operating Control	L8124C Operating Control	Flush Plug
B	¾"	Pressure/Vacuum Gauge		Temperature/Pressure Gauge		
C	¾"	Probe LWCO Std. Plugged (Float LWCO)		Flush Plug		
C-C	¾"	Flush Plug	Flush Plug	Flush Plug		
D	½"	Water Gauge Glass (Probe LWCO) Water Gauge Glass, Pressuretrol, and LWCO (Float)		Flush Plug		
F	¾"	-----	L4006A Operating Control	-----	Disregard	L8124C Operating Control
G	1½"	Bushed to ¾" for Draincock (Optional Return)		Return		
H	1½"	Return		Bushed to ¾" for Draincock (Optional Return)		
J	1½"	Surface Blowoff - Plugged		Flush Plug		
K	2"	Front Supply (3 thru 9 Section)		Front Supply (3 thru 9 Section)		
L	2"	Plugged, Optional Second Supply (3 thru 5 Section) Required Second Supply (6 thru 9 Section)		Plugged (3 thru 9 Section)		
M	¾"	Safety Valve		Relief Valve		
P	¾"	Auxiliary Tapping - Plugged		Aux. Tapping - Plugged	Disregard	Aux. Tapping - Plugged
R	¾"	Auxiliary Tapping - Plugged		Auxiliary Tapping - Plugged		

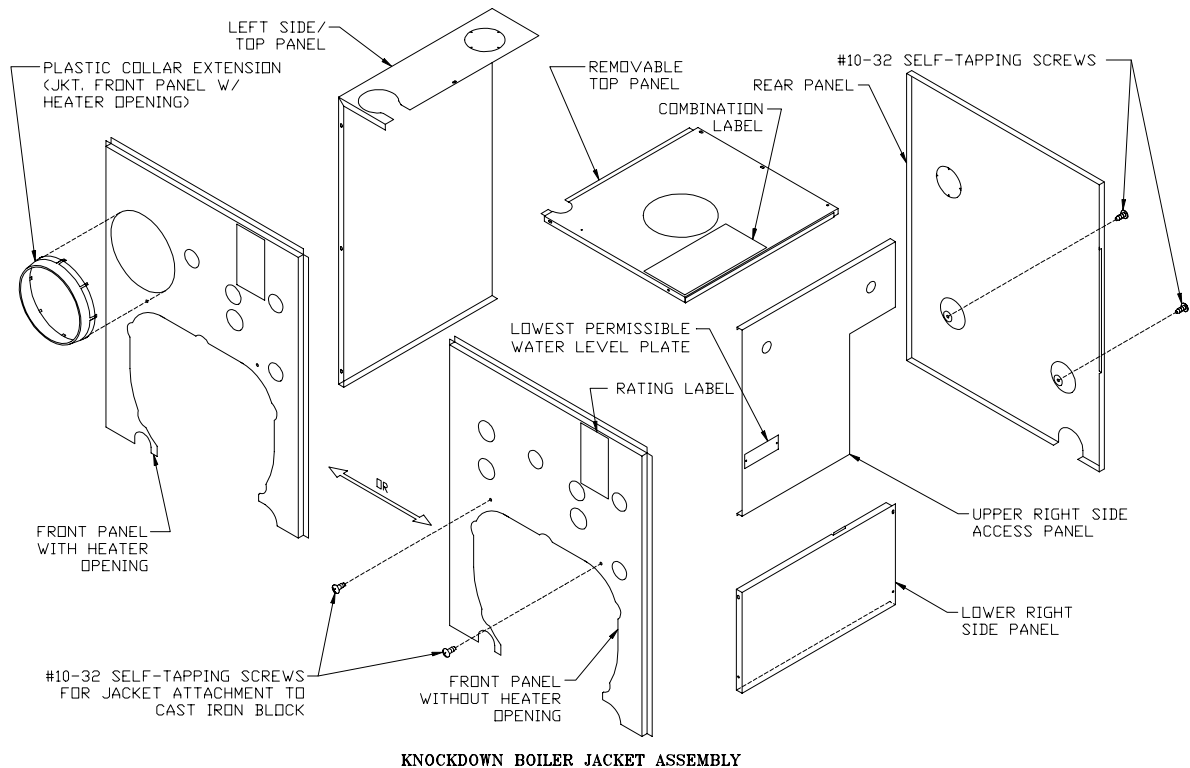
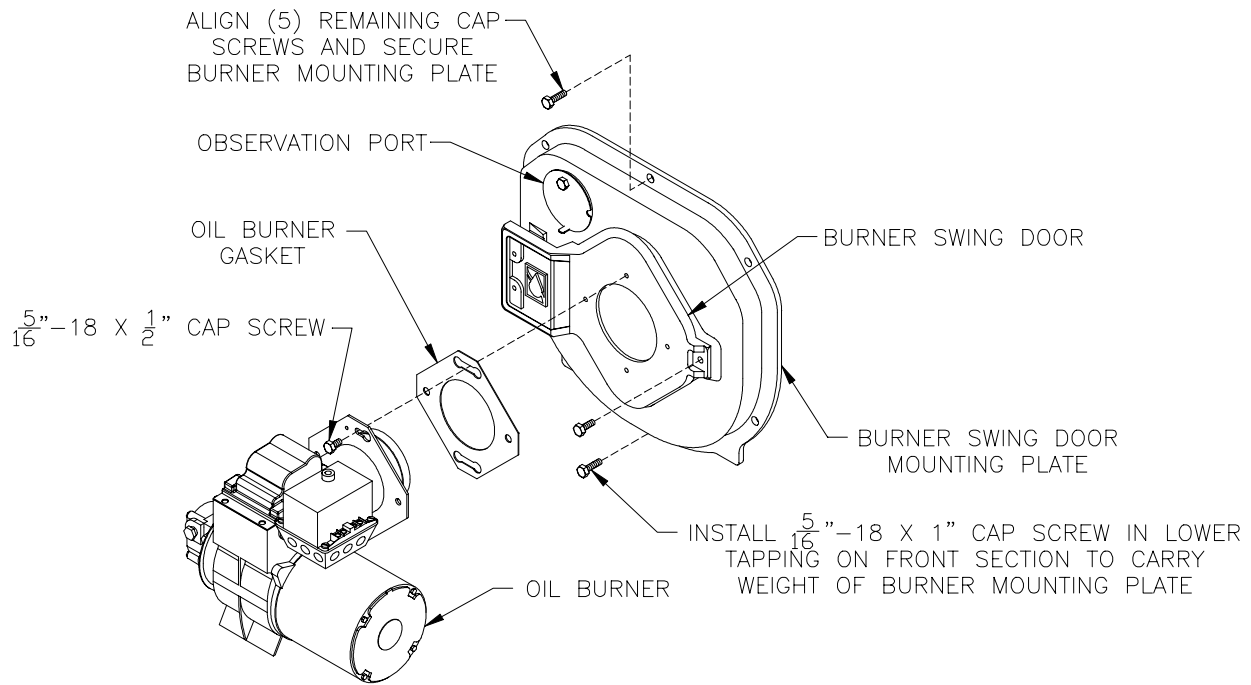

Figure 5: Knockdown Boiler Jacket Assembly

- b. Tapping "M" —Install $\frac{3}{4}$ " x 8" long nipple into $\frac{3}{4}$ " tapping located next to front section top supply tapping — all boiler sizes.
- I. INSTALL FLUSH JACKET (See Figure 5).**
1. Remove burner swing door mounting plate. Loosen the bottom bolt three full turns. Remove (5) remaining $\frac{5}{16}$ " bolts securing mounting plate to boiler sections.
Lift up and remove plate.
 2. Install rear jacket panel. Align two dimpled holes on jacket panel with the cast iron lugs. Secure with two #10 x $\frac{3}{8}$ " long self tapping screws.
 3. JACKET FRONT PANEL
 - a. Install black plastic collar extension to jacket front panels with 7-13/16" dia. heater opening. Engage two (2) retaining tabs over raw edge of opening. Provide support behind the panel with one hand while applying pressure on collar to snap each tab over edge of opening until all eight (8) tabs are securing collar.
 - b. Install front jacket panel. Locate two $\frac{3}{16}$ " diameter holes on front panel approximately 16" up from the bottom of the panel and $4\frac{1}{2}$ " in from each side. Align these holes with the similarly located cast iron lugs on the front section. Secure with two #10 x $\frac{3}{8}$ " long self-tapping screws.
 4. Install jacket left side panel. Fold panel at perforation keeping insulation inward. Align left side panel mounting holes with the front and rear panel holes. Secure with #8 x $\frac{1}{2}$ " long sheet metal screws.
 5. Install jacket top panel. Place jacket top panel on boiler and secure to front, rear and left side panels with #8 x $\frac{1}{2}$ " long sheet metal screws.
 6. Install jacket lower right side panel. Align right side panel mounting holes with front and rear panel holes. Secure with #8 x $\frac{1}{2}$ " long sheet metal screws.
 7. Install jacket upper right side access panel. Using the thumb holes, hold access panel 1" above lower right side panel. Engage flanges on access panel with surrounding panels and lower into position until access panel is resting flush with top panel and bottom flange is properly locked into position with lower right side panel.
 8. Attach the data labels shipped in the instruction envelope as follows: (see Figure 5).
 - a. Place the Rating Label (serialized) approximately $\frac{1}{4}$ " below the top edge and 3-1/2" from the right edge of the jacket front panel as shown. Mark outline of label on jacket with a pencil. Remove paper backing from label, realign label with pencil marks and apply label to jacket by using backing paper to rub across face of label.
 - b. Locate the Combination Label (P/N 8142756) on the front right corner of top panel, approximately $\frac{3}{8}$ " from each edge as shown. Mark the location and apply label in the same



BURNER MOUNTING

Figure 6

manner as rating label.

- c. On steam boilers, install the Lowest Permissible Water Level Plate, Form No. 1204 (shipped in Steam Trim Carton), on the jacket right side panel. Align the two holes in the plate with the two 1/8" dia. holes located near the front edge, in line with the lower sight glass tapping, and secure with #8 x 1/2" lg. sheet metal screws.

J. INSTALL OIL BURNER (See Figure 6).

1. Check target wall and cerafelt blanket in combustion chamber. If any damage or movement occurred during shipment, repair or replace as needed.
2. Check the burner mounting plate and swing door insulation pieces for damage and adhesion. If damaged, replace insulation. If loose, re-attach with RTV 732 or 736 silicone caulk.
3. Engage bottom slot on burner mounting plate with matching bolt in bottom tapping of front section. Align mounting holes and fasten the mounting plate to the boiler sections with (5) five 5/16" bolts and washers removed in step 8a. Fully tighten all bolts.
4. Place burner flange gasket on burner swing door and thread two 5/16" x 1/2" long bolts into vertical set of holes approximately three full turns.
5. Insert oil burner air tube into the opening of the burner swing door. Align keyhole slot with vertical set of bolts, engage hex head of bolts and rotate

burner to the left. Install two remaining 5/16" x 1/2" long bolts in horizontal sets of holes. Level burner and fully tighten all bolts.

K. INSTALL STEAM BOILER TRIM AND CONTROLS (See Figures 1C & 4).

1. Thread the combination pressure/vacuum gauge into the 1/4" tapping. Tighten with wrench applied to the square shank of the gauge. Do not apply pressure to the gauge case — this might destroy the calibration of the gauge.
2. Thread 1 1/2" x 3/4" bushing and a 3/4" drain cock into the 1/2" tapping located in the lower right corner of the front casting. Tighten with wrench.

NOTE: Lower rear section tapping "H" is used for standard condensate return on steam boilers.

3. Thread safety relief valve, as shown in Figure 1C, into 3/4" coupling and 3/4" x 8" nipple previously installed in step H. Tighten with wrench.

NOTE: Pipe discharge as shown in Figure 8.

4. Install probe type LWCO if so equipped. Thread probe into 3/4" tapping located on the front section directly above the protectorelay on the oil burner. Read the manufacturer's instructions packed with the probe LWCO for proper pipe dope application. DO NOT use Teflon tape on probe threads. Use of teflon can render the probe LWCO inoperational. Slip the LWCO control over the probe and clamp in place. Connect the wire(s) between the probe and control per the manufacturer's instructions. Install

the sight glass using the two 1/2" tapping to the right of the probe LWCO.

5. Install float-type Low Water Cutoff, if so equipped. See Figure below.
 - a. Install nipples and unions in Tappings D.
 - b. Mount hardware to low water cutoff body. Install assembly.
 - c. Install water gage glass on low water cutoff assembly's tee fittings.
6. Install Limit Control.
 - a. Probe LWCO: Install Limit in Tapping A using 3/4 NPT x 2" nipple, 3/4 NPT elbow, 3/4 NPT x 1/4 NPT bushing, and syphon. See Figure below right.
 - b. Float LWCO: Remove 1/4 NPT plug from top of Low Water Cutoff. Install Syphon and Limit into this tapping. See Figure below.
7. On units equipped with a tankless heater, install the aquastat controller well in the 3/4" tapping in tankless heater plate. Slip the bulb of the aquastat into the well and secure the control in place with the set screw.
8. Connect the field wiring to the pressure limit, the LWCO, the burner J-box, and from the aquastat control (if equipped with tankless heater) to the oil burner primary control's "T-T" terminals. Make the wiring connections as shown in Figures 17 thru 20.

L. INSTALL WATER TRIM AND CONTROLS
(See Figures 1B and 4).

1. Thread 1/2" pipe plugs into gauge glass tappings in the upper right side of front section.
2. Thread 3/4" pipe plug in probe low water cut off tapping (just left of gauge glass tappings).
3. Thread combination pressure/temperature gauge into 1/4" tapping. Tighten with wrench applied to the square shank of the gauge. Do not apply pressure to the gauge case - this might destroy the calibration of the gauge.

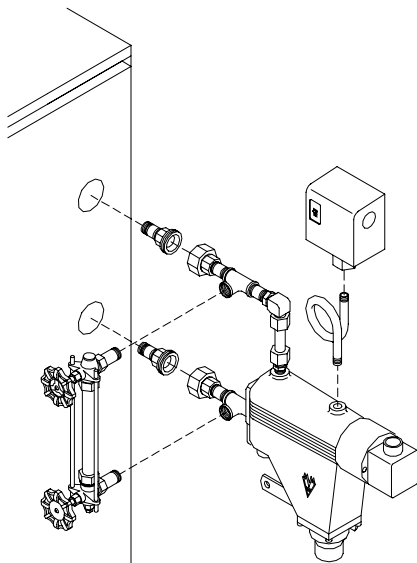

Float-type Low Water Cutoff Installation

4. Screw drain valve into 1/2" tapping in lower rear section using 1/2" x 3/4" bushing (note - lower front section tapping "G" (see Figure 4) is used for standard return on water boilers).
5. If CIRCULATOR (not supplied with boiler) is to be mounted directly to 1/2" boiler return tapping "G", use the piping arrangements outlined in steps a. thru e. as follows:
 - a. Thread 1/2" x 3" long nipple and 1/2" x 90° elbow into the return tapping and tighten with a pipe wrench.
 - b. Thread 1/2" NPT x 15" long pipe nipple into the 90° elbow and tighten with a pipe wrench.
 - c. Thread one of the circulator flange onto the pipe nipple and tighten with a pipe wrench. Position flange so that the bolt slots are perpendicular to the boiler front.
 - d. Place a flange gasket in the flange groove on the circulator and mount the circulator on the flange installed in step 3. Note that this is the return piping and the flow arrow on the circulator should point down ↓. Fasten circulator with 7/16" nuts and bolts.
 - e. Bolt second circulator flange and gasket to the circulator with 7/16" nuts and bolts.
6. Install pressure relief valve, as shown in Figure 1B, onto 3/4" x 8" nipple previously installed in Step H. Tighten with wrench.

NOTE: Pipe discharge as shown in Figure 9.

7. On units without a tankless heater, install the control well into the 3/4" tapping located on the front of the boiler in the upper left corner. Tighten the well and insert the control's bulb into the well. Secure the control with set screw on the control.
8. On units with a tankless heater, install the control well in the 3/4" tapping on the tankless heater plate. Tighten the well and insert the control's bulb into the well. Secure the control with set screw on the control.
9. Connect the field wiring from the circulator to the control and from the control to the burner J-Box. Make the wiring connections as shown on Figures 21 and 22.

NOTE: Proceed to Installation Instructions Section III, step E, to continue.

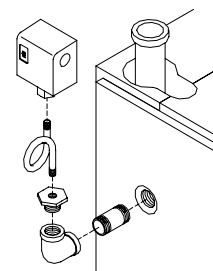

Limit Installation for Probe LWCO Equipped Boilers

SECTION III: INSTALLATION INSTRUCTIONS

A. REMOVE CRATE — (Packaged Boilers)

1. Remove all fasteners at crate skid.
2. Lift outside container and remove all other inside protective spacers and bracing. Remove draft regulator box and miscellaneous trim bag containing safety/relief valve, and pipe fittings.

B. REMOVAL OF BOILER FROM SKID

4. Packaged boilers with Probe style LWCO. Install Limit in Tapping A using $\frac{3}{4}$ NPT x 2" nipple, $\frac{3}{4}$ NPT elbow, $\frac{3}{4}$ NPT x $\frac{1}{4}$ NPT bushing, and syphon included in trim bag. See Figure on previous page. Connect wiring harness from Low Water Cutoff. See Figure below.

TS-39-126-A

TS-39-26-A

Fig. 7

1. Boiler is secured to base with 4 bolts, 2 on left side and 2 on right side, see Figure 7. Remove all bolts.
2. Tilt boiler to right and to rear. Using right rear leg as pivot, rotate boiler 90° in a clockwise direction, and lower left side of boiler to floor. Tilt boiler and remove crate skid. Care should be exercised to prevent damage to jacket or burner.

C. MOVE BOILER TO PERMANENT POSITION by sliding or walking.

D. INSPECT COMBUSTION TARGET WALL AND COMBUSTION CHAMBER LINER

1. OPEN FLAME OBSERVATION DOOR AND/OR BURNER SWING DOOR on front of boiler. Use flashlight to inspect target wall secured to rear section with silastic sealant. Inspect ceramic fiber blanket secured to floor of boiler with water glass adhesive. If either is damaged they must be replaced.

E. CONNECT SUPPLY AND RETURN PIPING TO HEATING SYSTEM.

CLEARANCES — Steam and hot water pipes shall have clearances of at least $\frac{1}{2}$ " from all combustible construction.

1. With STEAM HEATING, see Figure 8. Consult I = B = R Installation and Piping Guide No. 200.
2. With Forced Circulation HOT WATER HEATING, see Figure 9. Consult I = B = R Installation and Piping Guide No. 200.
3. Packaged boilers. Install Safety Valve in Tapping M. Use $\frac{3}{4}$ NPT x 8" nipple and $\frac{3}{4}$ NPT coupling included in trim bag. Safety Valve must be installed with spindle in vertical position.

5. If this boiler is used in connection with refrigeration systems, the boiler must be installed so that the chilled medium is piped in parallel with the heating boiler using appropriate valves to prevent the chilled medium from entering the boiler, see Figure 10. Also consult I = B = R Installation and Piping Guides.
6. If this boiler is connected to heating coils located in air handling units where they may be exposed to refrigerated air, the boiler piping must be equipped with flow control valves to prevent gravity circulation of boiler water during the operation of the cooling system.
7. Use a boiler bypass if the boiler is to be operated in a system which has a large volume or excessive radiation where low boiler water temperatures may be encountered (i.e. converted gravity circulation system, etc.).

Remove the circulator and install a pipe tee between the circulator and boiler return along with a second tee in the supply piping as shown in Figure 11. The bypass should be the same size as the supply and return lines with valves located in the bypass and supply outlet as illustrated in Figure 11 in order to regulate water flow for maintenance of higher boiler water temperature.

Set the by-pass and boiler supply valves to a half throttle position to start. Operate boiler until the system water temperature reaches its normal operating range.

Adjust the valves to maintain 180°F boiler water temperature. Adjust both valves simultaneously. Closing the boiler supply valve and opening the by-pass valve will raise the boiler water temperature and lower the supply temperature. Opening the boiler supply valve while closing the by-pass valve will lower the boiler water temperature and raise the supply temperature.

8. A hot water boiler installed above radiation level must be provided with a low water cutoff device as part of the installation.

TS-39-17-D

Fig 8: V73 Thru V79 Recommended Boiler Piping For Gravity Return Steam Boiler

TS-39-4-C

Fig. 9: V72 thru V79, V713 and V714 Recommended Boiler Piping for Series Loop Forced Hot Water System

TS-O-62-B

Fig. 10: Recommended Piping for Combination Heating & Cooling (Refrigeration) Systems Water Boilers

In order to insure long product life, oxygen sources should be eliminated. This can be accomplished by taking the following measures:

1. Repairing system leaks to eliminate the need for addition of make-up water.
 2. Eliminating open tanks from the system.
 3. Eliminating and/or repairing fittings which allow oxygen absorption.
 4. Use of non-permeable materials in the distribution system.
 5. Isolating the boiler from the system water by installing a heat exchanger.
- F. CONNECT TANKLESS HEATER PIPING AS SHOWN IN Figure 12. See Tables 3 and 3A for Tankless Heater Ratings.**

TS-39-7-A

Fig. 11: Recommended Bypass Piping Water Boilers

CAUTION

Oxygen contamination of boiler water will cause corrosion of iron and steel boiler components, and can lead to boiler failure. Burnham's standard warranty does not cover problems caused by oxygen contamination of boiler water.

There are many possible causes of oxygen contamination such as:

1. Addition of excessive make-up water as a result of system leaks.
2. Absorption through open tanks and fittings.
3. Oxygen permeable materials in the distribution system.

TS-0-63-B

Fig. 12: Schematic Tankless Heater Piping

THE FOLLOWING GUIDELINES SHOULD BE FOLLOWED WHEN PIPING THE TANKLESS HEATER:

1. **FLOW REGULATION** — If flow through the heater is greater than its rating, the supply of adequate hot water may not be able to keep up with the demand. For this reason a flow regulator matching the heater rating should be installed in the cold water line to the heater. The flow regulator should preferably be located below the inlet to the heater and a minimum of 3' away from the inlet so that the regulator is not subjected to excess temperatures that may occur during "off" periods when it is possible for heat to be conducted back through the supply line. The flow regulator also limits the flow of supply water regardless of inlet pressure variations in the range of 20 to 125 psi.
2. **TEMPERING OF HOT WATER** — Installation of an automatic mixing valve will lengthen the delivery of the available hot water by mixing some

TABLE 3: TANKLESS HEATER DATA: Rear Mounted Heater on Steam and Water Boilers

Boiler Model	Heater No.	Heater Rating (GPM)		Pressure Drop thru Heater (PSI)	
		Steam	Water	Steam	Water
V713	V1-2	---	3.25	---	5.6
V73	V1-2	2.75	3	3.9	4.7
V714	V1-1	---	3.5	---	4.4
	V1-2	---	4	---	8
V74	V1-2	3	3.25	4.7	5.6
V75	V1-2	3.25	3.5	5.6	6.4
V76	V1-2	3.75	3.75	7.2	7.2
V77	V1-2	3.75	4	7.2	8
V78	V1-2	4	4.5	8	9.8
V79	V1-2	4	4.5	8	9.8

TABLE 3A: TANKLESS HEATER DATA: Front Mounted Heater on Water Boilers

Boiler Model	Heater No.	Heater Rating (GPM)	Pressure Drop Thru Heater (PSI)
V73	222	3	22
V74	222	3.5	22
V75	222	4	30.5
V76	222	4.5	33
V77	222	4.6	33
	A54	5.5	36
V78	222	4.75	40
	A54	6	39.5
V79	222	4.75	40
	A54	6	39.5

cold water with the hot. This prevents excessive and possibly scalding hot water at the fixtures. In addition, savings of hot water will be achieved since the user will not waste as much hot water while seeking water temperature to his liking. Higher temperature hot water required by dishwashers and automatic washers is possible by piping the hot water from the heater prior to entering the mixing valve. The mixing valve should be “trapped” by installing it below the cold water inlet to heater to prevent lime formation in the valve.

WARNING

Install an automatic mixing valve at the tankless heater outlet to avoid risk of burns or scalding due to excessively hot water at the fixtures. Adjust and maintain the mixing valve in accordance with the manufacturer's instructions.

3. **FLUSHING OF HEATER** — All water contains some sediment which settles on the inside of the coil. Consequently, the heater should be periodically backwashed. This is accomplished by installing hose bibs as illustrated and allowing water at city pressure to run into hose bib A, through the heater, and out hose bib B until the discharge is clear. The tees in which the hose bibs are located should be the same size as heater connections to minimize pressure drop.
4. **HARD WATER** — A water analysis is necessary to determine the hardness of your potable water. This is applicable to some city water and particularly to well water. An appropriate water softener should be installed based on the analysis and dealer’s recommendation. This is not only beneficial to the tankless heater but to piping and fixtures plus the many other benefits derived from soft water.

NOTE: STEAM BOILERS

- a. During summertime operation, the normal water line should be raised 1”, from 22-5/8” to 23-5/8” (see Figure 1C) for improved tankless heater performance.
- G. INSTALL SMOKEPIPE** — The V7 should be vented into a fireclay tile-lined masonry chimney or chimney constructed from type L vent or a factory built chimney that complies with the type HT requirements of UL103. The chimney and vent pipe shall have a sufficient draft at all times, to assure safe proper operation of the boiler. See Figure 13 for recommended installation.
1. Install a draft regulator (supplied with boiler) following the instructions furnished with the regulator. See Figure 14 for alternate draft regulator locations.
 2. Consider the chimney overall. Chimneys that have a high heat loss may become less suitable as the heat loss of the home goes down and the efficiency of the boiler installed goes up. Most homes have a chimney appropriate for the fuel and the era in which the home was built. That may have been a coal fired or an inefficient oil fired boiler built into a home without insulation or storm windows. With increasing fuel prices that home probably has been insulated and fitted with storm windows so that the heat loss of the home has been reduced. This

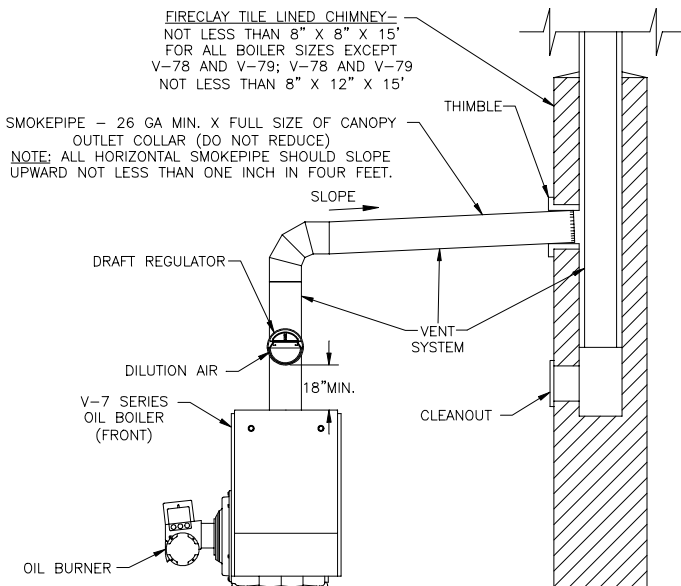

Fig. 13: Recommended Smokepipe Arrangement and Chimney Requirements

requires less fuel to be burned and sends less heat up the chimney.

A new boiler probably has a higher efficiency than the boiler being replaced. That probably means that the stack temperature from the new boiler will be lower than that from the old boiler and with less room air being drawn up the chimney to dilute the stack gases. The combination of a large uninsulated chimney, reduced firing rate, reduced firing time, lower stack temperature and less dilution air can, in some cases, contribute to the condensing of small amounts of water vapor in the chimney. Such condensation, when it occurs, can cause chimney deterioration. In extreme cases, condensed water may be visible on the outside of the breeching or chimney. In those extreme cases, the chimney may have to be lined to insulate the chimney and thus prevent the condensation. The addition of dilution air into the chimney may assist in drying the chimney interior surfaces.

A massive chimney on a cold, or exposed outside wall may have produced adequate draft when it was fired with a higher input and greater volumes of heated gases. With reduced input and volume, the draft may be severely affected. In one instance our research showed a new chimney of adequate sizing produced only $-.035''$ W.C. after 30 minutes of continuous firing at 13.0% CO_2 . Outside wall chimneys take longer to heat up and can have $.00''$ W.C. draft at burner startup. You may have to consider a special alloy chimney flue liner with insulation around it and a stabilizing draft cap or even a draft inducing fan in severe cases.

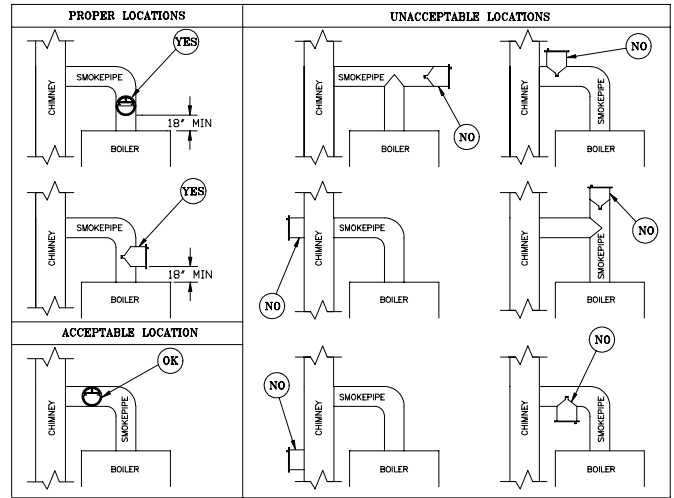

Fig. 14: Proper and Improper Locations of Draft Regulator

3. For the same reasons as in (2.) above, heat extractors mounted into the breeching are not recommended.

H. INSTALL ELECTRIC WIRING in accordance with National Electrical Code and local regulations. A separate **ELECTRICAL CIRCUIT** should be run from meter with a Fused Disconnect Switch in the Circuit. Wiring should conform to Figures 17 thru 23.

CANADA- Refer to CSA standard C22.2 Part 1, 1990, Electrical Features of Fuel Burning Equipment (Gas and Oil).

I. FUEL UNITS AND OIL LINES

SINGLE-PIPE OIL LINES - Standard burners are provided with single-stage 3450 rpm fuel units with the by-pass plug removed for single-pipe installations.

The single-stage fuel unit may be installed single-pipe with gravity feed or lift. Maximum allowable lift is 8 feet. See Figure 15.

TWO-PIPE OIL LINES - For two-pipe systems where more lift is required, the two-stage fuel unit is recommended. Table 4 (single-stage) and Table 5 (two-stage) show allowable lift and lengths of 3/8-inch and 1/2-inch OD tubing for both suction and return lines. Refer to Figure 16.

Be sure that all oil line connections are absolutely airtight. Check all connections and joints. Flared fittings are recommended. Do not use compression fittings or PTFE ("Teflon®") tape.

Open the air-bleed valve and start the burner. For clean bleed, slip a 3/16" ID hose over the end of the bleed valve and bleed into a container. Continue to bleed for 15 seconds after oil is free of air bubbles. Stop burner and close valve.

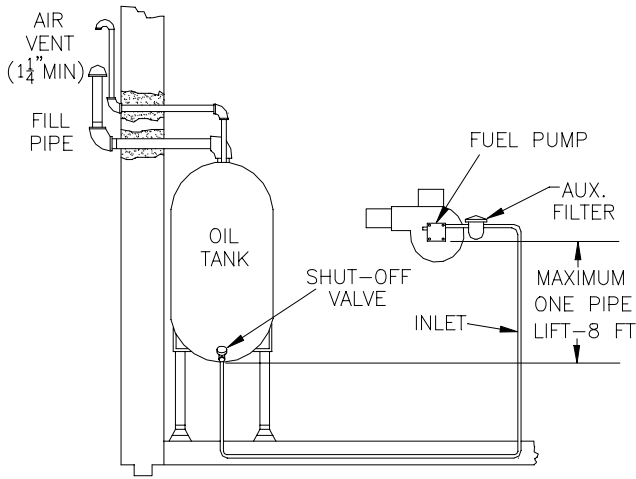

Figure 15

IMPORTANT

Single-pipe installations must be absolutely airtight or leaks or loss of prime may result. Bleed line and fuel unit completely.

TABLE 4: SINGLE-STAGE UNITS (3450 RPM) - TWO-PIPE SYSTEMS

Lift "H" (See Fig. 16)	Manimum Length of Tubing "H" + "R" (See Figure 16)	
	3/8" OD Tubing (3 GPH)	1/2" OD Tubing (3 GPH)
0'	84'	100'
1'	78'	100'
2'	73'	100'
3'	68'	100'
4'	63'	100'
5'	57'	100'
6'	52'	100'
7'	47'	100'
8'	42'	100'
9'	36'	100'
10'	31'	100'
11'	26'	100'
12'	21'	83'
13'	---	62'
14'	---	41'

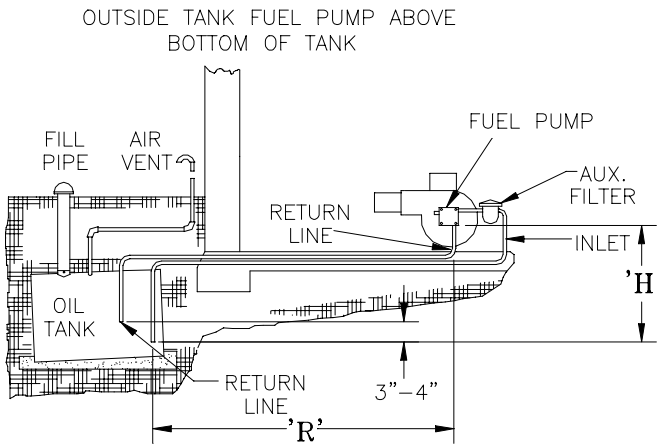

Figure 16

TABLE 5: TWO-STAGE UNITS (3450 RPM) - TWO-PIPE SYSTEMS

Lift "H" (See Fig. 16)	Maximum Length of Tubing "H" + "R" (See Figure 16)	
	3/8" OD Tubing (3 GPH)	1/2" OD Tubing (3 GPH)
0'	93'	100'
2'	85'	100'
4'	77'	100'
6'	69'	100'
8'	60'	100'
10'	52'	100'
12'	44'	100'
14'	36'	100'
16'	27'	100'
18'	---	76'

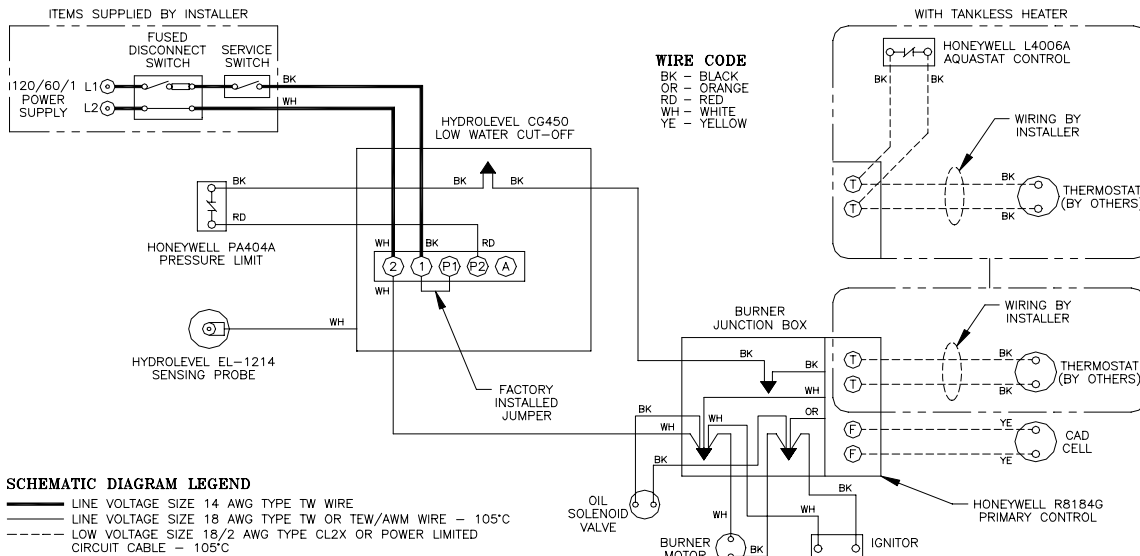

Fig. 17: Wiring Diagram for Steam Boilers with Standard Hydrolevel CG-450 Probe LWCO, Beckett AFG Burner and Controls, with or without Tankless Heater

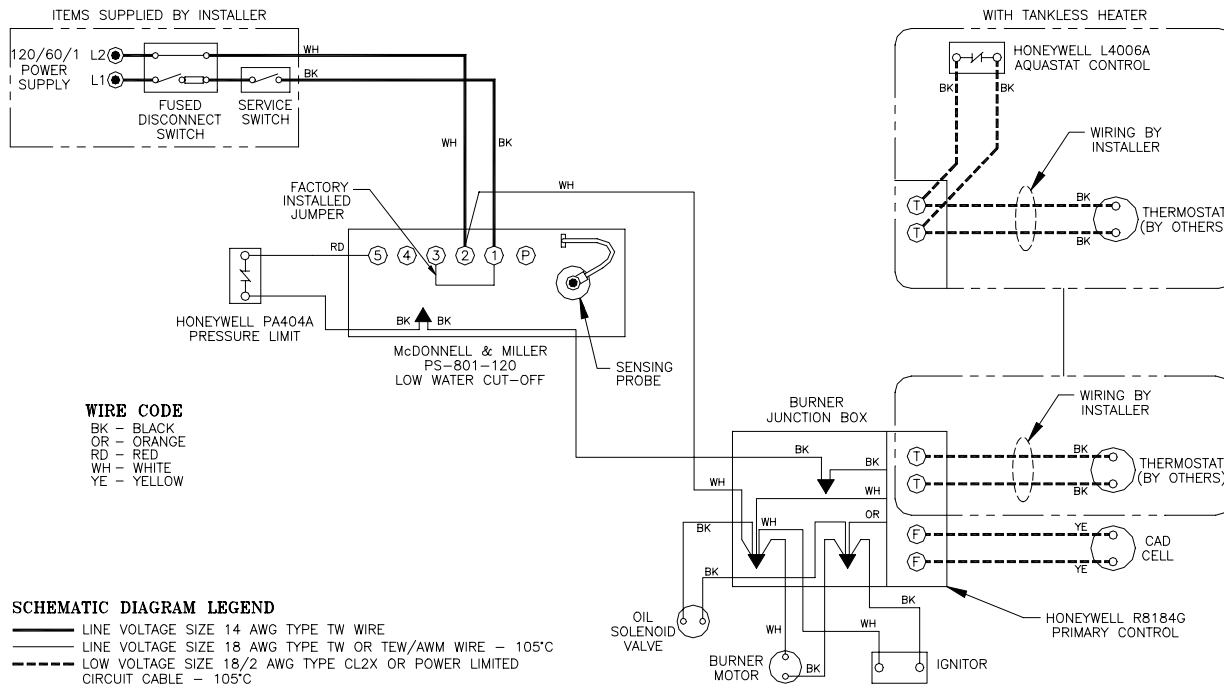

Fig. 18: Wiring Diagram for Steam Boilers with Optional McDonnell & Miller PS-801 Probe LWCO, Beckett AFG Burner and Controls, with or without Tankless Heater
BOILER SEQUENCE OF OPERATION WITH PROBE LWCO

When the thermostat calls for heat, it energizes the cad cell primary control, bringing on the burner. The burner will operate until the thermostat is satisfied or the limit setting on the high limit is reached. When the high limit control restores the circuit on a drop in pressure, the burner will start if the thermostat is still calling for heat.

Any of the probe low water cutoffs will shut down the burner after a 10-15 second delay, if the water level in the boiler drops too low. The Hydrolevel CG-450 and the McDonnell & Miller PS-804-120 low water cutoffs will shut down the burner for 90 seconds every 10 minutes of firing time to allow water level to stabilize. If the water level is too low the burner will not be allowed to restart.

Any of the probe low water cutoffs reset and restart the burner with a call for heat a few seconds after the water is returned to its normal level.

On burner start, if the cad cell does not see flame within approximately 45 seconds, primary control will lock out on safety and must be reset before burner can be restarted.

When there is no demand for heat, the operating control will maintain the boiler water temperature at the selected setting for proper operation of the domestic water heater, if equipped with optional tankless heater.

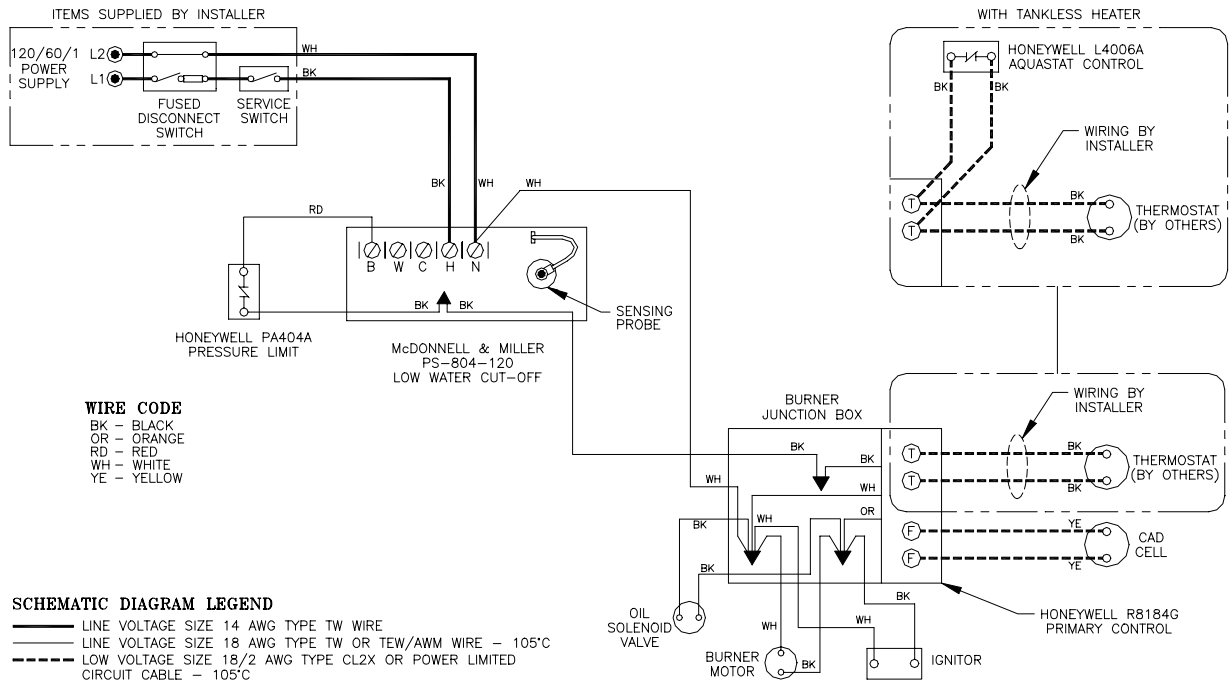

Fig. 19: Wiring Diagram for Steam Boilers with Optional McDonnell & Miller PS-804-120 Probe LWCO, Beckett AFG Burner and Controls, with or without Tankless Heater

NOTE: The McDonnell Miller low water cut off incorporates a 10 second delay to prevent nuisance burner cut-off due to rapid water level fluctuations. The LWCO also has a time delay of 15 seconds which allows additional fill time after water touches the probe. Red LED indicates a low water condition.

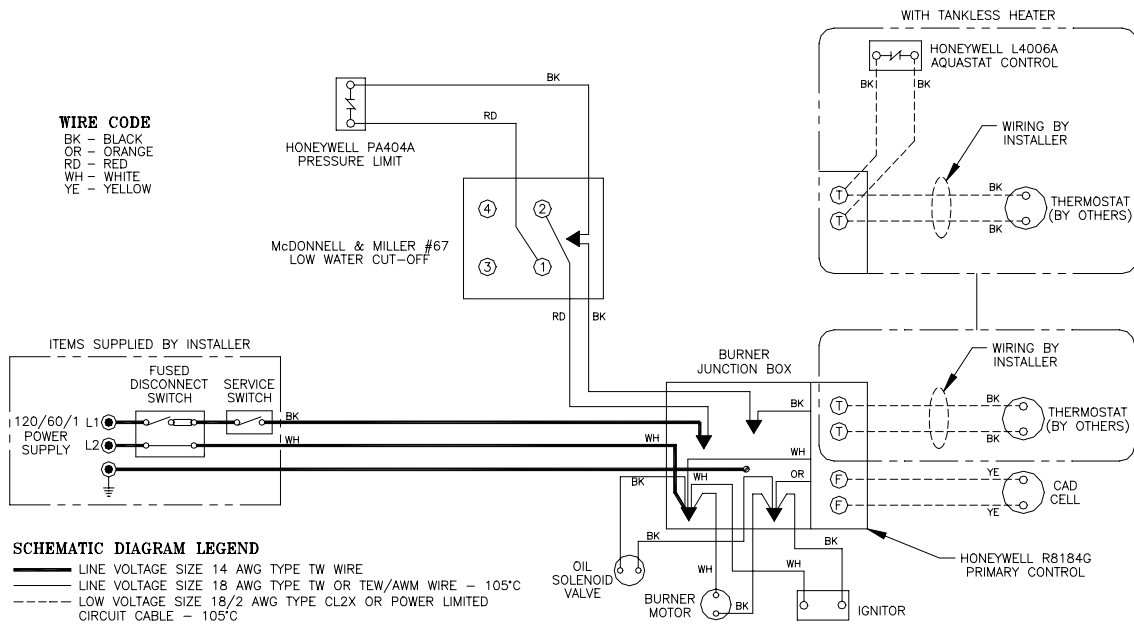

Fig. 20: Wiring Diagram for Steam Boilers with McDonnell & Miller #67 LWCO, Beckett AFG Burner and Controls, with or without Tankless Heater

BOILER SEQUENCE OF OPERATION WITH FLOAT LWCO

When the thermostat calls for heat, it energizes the cad cell primary control, bringing on the burner. The burner will operate until the thermostat is satisfied or the limit setting on the high limit is reached. When the high limit control restores the circuit on a drop in pressure, the burner will start if the thermostat is still calling for heat. The low water cut off will shut down the burner if the water level in the boiler drops too low. The control resets and restarts the burner with a call for heat a few seconds after the water is returned to its normal level.

On burner start, if the cad cell does not see flame within approximately 45 seconds, primary control will lock out on safety and must be reset before burner can be restarted.

When there is no demand for heat, the operating control will maintain the boiler water temperature at the selected setting for proper operation of the domestic water heater, if equipped with optional tankless heater.

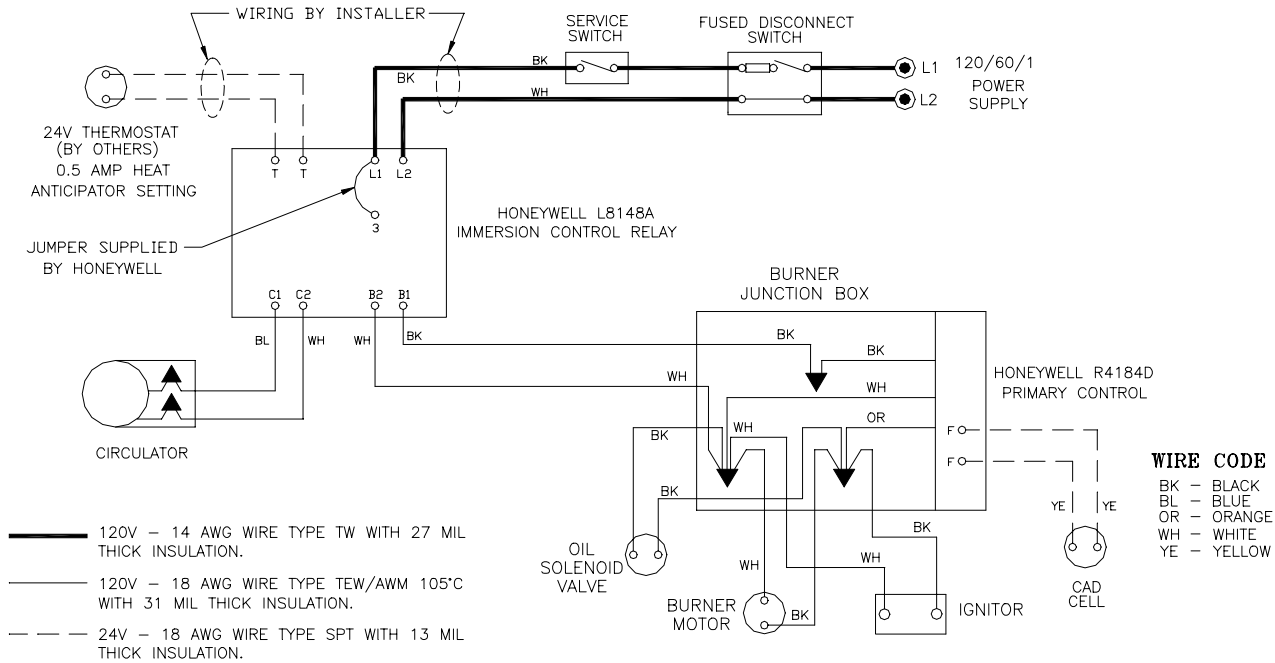

Fig. 21: Wiring Diagram for Water Boilers with Beckett AFG Burner and Controls, without Tankless Heater
SEQUENCE OF OPERATION

A call for heat by the thermostat energizes the L8148A control which in turn energizes the R4184D primary control to turn on the burner. If burner ignites within approximately 45 seconds and the cad cell sees flame, the burner will continue to operate until the call for heat is satisfied or the setting of the high limit is reached. The circulator will operate as long as the thermostat is calling for heat. If the thermostat is not satisfied and the high limit is reached, the circulator will continue to operate, and the burner will stop until the high limit is closed by a drop in boiler water temperature.

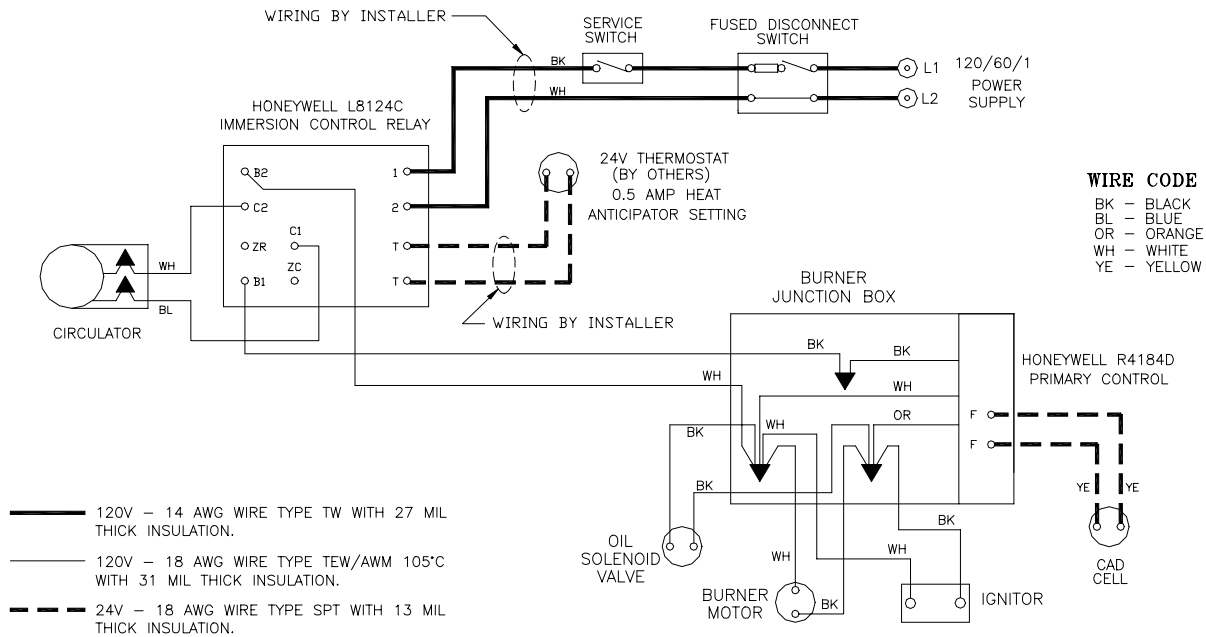

Fig. 22: Wiring Diagram for Water Boilers with Beckett AFG Burner and Controls, with Tankless Heater
SEQUENCE OF OPERATION

A call for heat by the thermostat energizes the L8124C control which in turn energizes the R4184D primary control to turn on the burner. If burner ignites within approximately 45 seconds and the cad cell sees flame the burner will continue to operate until the call for heat is satisfied. The circulator will also operate when the thermostat calls for heat if the boiler water temperature is up to the setting of the low limit in the L8124C control. If boiler water temperature is below the low limit setting the burner will operate but the circulator will not, giving preference to the domestic hot water demand.

On call for heat by the thermostat the burner will continue to operate until the thermostat is satisfied or the setting of the high limit is reached. If the thermostat is not satisfied when the high limit is reached the burner will stop but the circulator will continue to operate until the thermostat is satisfied. Any time the boiler water temperature drops below the setting of the low limit the burner will be energized in order to maintain domestic water temperature.

SECTION IV: OPERATING AND SERVICE INSTRUCTIONS

WARNING

All boilers equipped with burner swing door have a potential hazard which can cause severe property damage, personal injury or loss of life if ignored. Before opening swing door, turn off service switch to boiler to prevent accidental firing of burner outside the combustion chamber. Be sure to tighten swing door fastener completely when service is completed.

A. ALWAYS INSPECT INSTALLATION BEFORE STARTING BURNER.

B. FILL HEATING SYSTEM WITH WATER.

NOTE: It is important, especially in a steam system, to properly remove the oil and dirt from the system. Failure to clean the system can result in erratic water lines and surging.

CLEAN HEATING SYSTEM IF boiler water or condensate return water is dirty or if erratic water lines or surging exist after a few days of boiler operation.

Refer to step "N" for proper cleaning instructions for steam and water boilers.

1. STEAM BOILERS — Fill boiler to normal water line. Refer to Figure No. 1C.
2. HOT WATER BOILERS. Fill entire heating system with water and vent air from system. Use the following procedure on a series loop or multi-zoned system installed as per Figure 9, to remove air from system when filling:
 - a. Close isolation valve in boiler supply piping.
 - b. Isolate all circuits by closing zone valves or balancing valves.
 - c. Attach a hose to bib cock located just below isolation valve in boiler supply piping.
(Note - Terminate hose in five gallon bucket at a suitable floor drain or outdoor area).
 - d. Starting with one circuit, open zone valve.
 - e. Open bib cock.
 - f. Open fill valve (make-up water line should be located directly above isolation valve in boiler supply piping).
 - g. Allow water to overflow from bucket until discharge from hose is bubble free for 30 seconds.
 - h. Open zone valve to the second zone to be purged, then close the first. Repeat this step until all zones have been purged, but always have one zone open. At completion, open all zone valves.
 - i. Close bib cock, continue filling the system until the pressure gauge reads 12 psi. Close fill valve.

(Note - If make-up water line is equipped with pressure reducing valve, system will automatically fill to 12 psi. Leave globe valve open).

- j. Open isolation valve in boiler supply piping.
- k. Remove hose from bib cock.

C. CHECK CONTROLS, WIRING AND BURNER to be sure that all connections are tight and burner is rigid, that all electrical connections have been completed and fuses installed, and that oil tank is filled and oil lines have been tested.

D. LUBRICATION — Follow instruction on burner and circulator label to lubricate, if oil lubricated. Most motors currently used on residential type burners employ permanently lubricated bearings and thus do not require any field lubrication. Water lubricated circulators do not need field lubrication.

Do not over-lubricate. This can cause as much trouble as no lubrication at all.

E. SET CONTROLS with burner service switch turned "OFF".

1. SET ROOM THERMOSTAT about 10° above room temperature.
2. PRESS RED RESET BUTTON on primary control (R4184D/R8184G) and release.
3. On STEAM BOILERS, set cut-in pressure on PA404 pressuretrol for three (3) pounds and differential pressure for two (2) pounds. These pressures may be varied to suit individual requirements of installation.
4. On STEAM BOILERS WITH TANKLESS DOMESTIC WATER HEATERS, set boiler water temperature dial on L4006 operating control at 190°F (max.). Set differential at 10°.
5. On WATER BOILERS WITHOUT TANKLESS HEATERS, set high limit dial on L8148 at 210°F. This temperature may be varied to suit requirements of installation.
6. On WATER BOILERS WITH TANKLESS HEATERS, set operating control dial (low limit) on L8124 at 190°F and high limit dial at 210°F. Operating control (low limit) must be a minimum of 20° below high limit setting. Set differential at 25°.

NOTICE

Burner-specific references in the following instructions pertain to the Beckett AFG, supplied as standard equipment. For optional burners, Riello R40 and Carlin EZ-1HP and 102CRD-3, consult Table 6 at the rear of this manual for specifications, the instruction booklet shipped with the burner, and the appropriate Supplemental Instructions shipped with the boiler:

Supplemental Instructions for:	<u>Burnham Part Number</u>	
	Riello R40	8142761
	Carlin EZ-1HP	8142759
	Carlin 102CRD-3	8142760

F. REMOVE GUN ASSEMBLY

1. Items to be checked are nozzle size, type, and angle; head size (and setting on MD(V1)head); gun setting; and positioning of electrodes. This information is shown in Figures 23 and 24 and Table 6 (at rear of manual).
2. Reinstall gun assembly.

G. ADJUST OIL BURNER BEFORE STARTING.

1. SET BURNER AIR BAND AND AIR SHUTTER, see Table 6 at rear of manual.
2. OPEN ALL OIL LINE VALVES.
3. Attach a plastic hose to fuel pump vent fitting and provide a pan to catch the oil.
4. REMOVE GAUGE PORT PLUG from fuel pump and install pressure gauge capable of reading at least 150 PSI.
5. OPEN FLAME OBSERVATION DOOR on front of boiler.

H. START OIL BURNER.

1. Open vent fitting on fuel pump.
2. TURN 'ON' BURNER service switch and allow burner to run until oil flows from vent fitting in a SOLID stream without air bubbles for approximately 10 seconds.
3. Close vent fitting and burner flame should start immediately.

I. ADJUST OIL PRESSURE.

1. Locate oil pressure adjusting screw and turn screw to obtain 140 PSI pressure (100 PSI for V74R only).
2. DO NOT REMOVE PRESSURE GAUGE until later.

J. OTHER ADJUSTMENTS

1. ADJUST THE AIR BAND AND/OR AIR SHUTTER.
Adjust air supply by loosening lock screws and moving the air shutter and if necessary the air band. Refer to Table 6 for preliminary settings.
2. ADJUST THE COMBUSTION HEAD.

V72 thru V77; V713 and V714:

"L1" and "F" head burners have a fixed head which is non-adjustable. To check combustion head location refer to Figure 24.

V78 & V79:

"V1" (variable) head burners have the ability to control air by moving the head either forward or back.

Loosen the adjusting plate assembly hold down screw. Slide the head and plate to the required firing rate setting as shown in Figure 24. Tighten the screw and knurled nut.

It might be necessary to move the head forward or back one position at a time to optimize the smoke and CO₂ readings. See Figure 24.

3. ADJUST DRAFT REGULATOR for a draft of —.02" (water gauge) over the fire after chimney has reached operating temperature and while burner is running.
4. READJUST AIR BANDS on burner for a light orange colored flame while the draft over the fire is —.02". Use a smoke tester and adjust air for minimum smoke (not to exceed #1) with a minimum of excess air. Make final check using suitable instrumentation to obtain a CO₂ of 11.5 to 12.5% with draft of —.02" (water gauge) in fire box. These settings will assure a safe and efficient operating condition. If the flame appears stringy instead of a solid fire, try another nozzle of the same type. Flame should be solid and compact. After all adjustments are made recheck for a draft of —.02" over the fire.

**(Non-Burnham Drawing
Copy from other Manual)**

Fig. 23: "F" Head Electrode Positioning and Gun Setting (Beckett AFG)

(Non-Burnham Drawing,
Copy from LE Manual, 81433010R4, Page 13, without
"Figure 12A, 12B, 12C and 12D"; sample enclosed)

Fig. 24: "L1" and "V1" Head Electrode Positioning and Gun Setting (Beckett AFG)

5. TURN "OFF" BURNER and remove pressure gauge. Install gauge port plug and tighten. Start burner again.
6. CAD CELL LOCATION AND SERVICE
The burner is supplied with a cadmium sulfide flame detector mounted at the factory, mounted on the bottom of the ignitor. See Figure 25. To service cad cell or to replace the plug in portion, swing open the ignitor. After service is complete, be sure to fasten down the ignitor.
7. FLAME FAILURE
The V7 boiler controls operate the burner automatically. If for unknown reasons the burner ceases to fire and the reset button on the primary control has tripped, the burner has experienced ignition failure. Before pressing the reset button call your serviceman immediately.

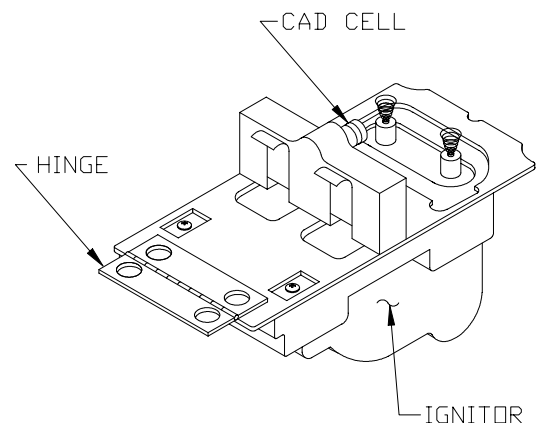

Figure 25: Cad Cell Location

CAD CELL TEST

- g. Open line switch. Clean cell face and see that cell is securely in socket. Reconnect leads. Reset safety switch.
- h. Close line switch. If burner starts and runs beyond safety switch cut-out time, cell is good. If not, install new cell.

3. **WARNING** — Check High Limit Control — Jumper Thermostat Terminals. Allow burner to operate until shut-down by limit. Installation is not considered complete until this check has been made.

REMOVE JUMPER.

4. Check low water cut off control with water level at normal water line (see Figure 1C). Raise thermostat setting to allow burner to operate. Open boiler drain to allow water level to drop to bottom of sight glass until burner operation is shut-down by low water cutoff.

Close boiler drain and refill to normal water line. Burner should automatically restart during fill. Lower thermostat setting.

5. Check operating control on boiler equipped with tankless heaters. With burner off, draw hot water until burner starts, then turn off hot water and check burner shut-down.

IF CONTROLS DO NOT MEET REQUIREMENTS OUTLINED IN PARAGRAPH L., REPLACE CONTROL AND REPEAT CHECK-OUT PROCEDURES.

M. MAINTENANCE OF LOW WATER CUTOFF DEVICES

IMPORTANT

Probe and float type low water cut-off devices require annual inspection and maintenance.

1. PROBE TYPE LOW WATER CUT-OFF

Although these devices are solid state in their operation, the probe is exposed to possible contamination in the boiler water and subject to fouling.

It is important to physically remove the probe from the boiler tapping annually and inspect that probe for accumulation of scale or sediment.

Follow these steps to inspect, clean and/or replace the probe:

- a. Turn off electric service to the boiler.
- b. Drain boiler water to a level below the tapping for the probe.
- c. Disconnect wiring connections between the low water cutoff control and the probe.

K. CHECK FOR CLEAN CUT OFF OF BURNER.

1. **AIR IN THE OIL LINE** between fuel unit and nozzle will compress when burner is on and will expand when burner stops, causing oil to squirt from nozzle at low pressure as burner slows down and causing nozzle to drip after burner stops. Usually cycling the burner operation about 5 to 10 times will rid oil line of this air.
2. **IF NOZZLE CONTINUES TO DRIP**, repeat step K.1.. If this does not stop the dripping, remove cutoff valve and seat, and wipe both with a clean cloth until clean, then replace and readjust oil pressure. If dripping or after burn persist replace fuel pump.

L. TEST CONTROLS.

WARNING

Before installation of the boiler is considered complete, the operation of the boiler controls should be checked, particularly the primary control and high limit control.

1. Check thermostat operation. Raise and lower thermostat setting as required to start and stop burner.
2. **VERIFY PRIMARY CONTROL SAFETY FEATURES** using procedures outlined in Instructions furnished with control (See back of control cover) or instructions as follows:

CHECKOUT PROCEDURE

CAUTION

FOR SERVICEMAN ONLY

- a. Check wiring connections. Close line switch. Check power at control.

PRIMARY RELAY TEST

- b. Disconnect cad cell leads (f-f). Reset safety switch.
- c. Set controller to call for heat. Burner should start.
- d. Jumper F-F terminal within 15 to 30 seconds. Burner should run.
- e. Remove F-F Jumper. Burner shuts down in approximately 15 to 60 seconds.
- f. If burner operates as described, relay is good. If not, install new relay.

- d. Dismount the low water cutoff control from the probe.
- e. Unscrew the probe from the boiler tapping.
- f. Inspect that portion of the probe that is exposed to the boiler water for a scale or sediment buildup.
- g. Light deposits may be removed by wiping the probe with a damp cloth. Wiping the probe with a cloth soaked in vinegar will remove more tenacious lime deposits. The most stubborn deposits may be removed from the probe by using a diluted amount, 3 parts of water to 1 part of phosphoric acid (H_2PO_4).

CAUTION

Exercise caution when handling phosphoric acid and follow the instruction label on its container.

- h. Clean the pipe threads of the probe to remove old, hardened pipe dope and other foreign matter.
- i. Apply a moderate amount of good quality pipe dope to the pipe threads on the probe, leaving the two end threads bare. Do not use PTFE (Teflon) tape.
- j. Screw the probe into the boiler tapping.
- k. Mount the low water cutoff control on the probe.
- l. Reconnect the control to probe wiring.
- m. Fill the boiler to its normal waterline.
- n. Add boiler water treatment compound as needed (refer to paragraph N.).
- o. Restore electric service to the boiler.
- p. Fire burner to bring the water in the boiler to a boil to drive off free oxygen.
- q. **WARNING — BEFORE RETURNING BOILER TO SERVICE:** Follow the low water cutoff check out procedure in step L.4..

2. FLOAT TYPE LOW WATER CUT-OFF

During the heating season, if an external low water cutoff is on the boiler, the blow off valve should be opened once a month (use greater frequency where conditions warrant), to flush out the sediment chamber so the device will be free to function properly.

Low-water cutoffs and water feeders should be dismantled annually by qualified personnel, to the extent necessary to insure freedom from obstructions and proper functioning of the working parts. Inspect connecting lines to boiler for accumulation of mud, scale, etc., and clean as

required. Examine all visible wiring for brittle or worn insulation and make sure electrical contacts are clean and that they function properly. Give special attention to solder joints on bellows and float when this type of control is used. Check float for evidence of collapse and check mercury bulb (where applicable) for mercury separation or discoloration. *Do not attempt to repair mechanisms in the field.* Complete replacement mechanisms, including necessary gaskets and installation instructions are available from the manufacturer.

N. BOILER AND SYSTEM CLEANING INSTRUCTIONS FOR TROUBLE FREE OPERATION.

1. STEAM BOILERS

- a. Oil, greases & sediments which accumulate in a new boiler and piping must be removed from the system in order to prevent an unsteady water line and carry over of the water into the supply main above boiler.

Operate the boiler with steam in the entire system for a few days allowing the condensate to return to the boiler. If the condensate can temporarily be wasted, operate boiler only for the length of time it takes for condensate to run clear. If the latter cannot be achieved or if the condensate is returned to the boiler, boil out the boiler using the SURFACE BLOWOFF connection, see Figure 4.

- i. Drain boiler until 1" of water is visible in gauge glass. Run temporary 1½" pipe line from the surface blowoff connection to an open drain or some other location where hot water may be discharged safely. Do not install valve in this line.
- ii. Drain about 5 gallons of hot water from boiler into a container and dissolve into it an appropriate amount of recommended boil out compound. Remove safety valve & add solution to boiler water thru exposed tapping using a funnel.

NOTICE

Check with local authorities or consult local water treatment services for acceptable chemical cleaning compounds.

- iii. Start burner and operate sufficiently to boil the water without producing steam pressure. Boil for about 5 hours. Open boiler feed pipe sufficiently to permit a steady trickle of water from the surface blowoff pipe.

- Continue this slow boiling and trickle of overflow for several hours until the water coming from the overflow is clear.
- iv. Stop burner and drain boiler in a manner and to a location that hot water can be discharged with safety.
 - v. Refill boiler to normal water line. If water in gauge glass does not appear to be clear, repeat steps (i. thru iii.) and boil out the boiler for a longer time.
- b. Low pressure steam boilers such as the V7 Series should be maintained with appropriate water treatment compounds. Add suitable water treatment compounds as recommended by your qualified water treatment company.
 - c. Remove temporary surface blowoff piping, plug tapping and reinstall safety valve. Boil or bring water temperature to 180°F promptly in order to drive off the dissolved gases in the fresh water.
 - d. If unsteady water line, foaming or priming persist, install gate valve in Hartford Loop and drain valves in return main and at boiler as shown in Figure 8 and proceed as follows:
 - i. Connect hoses from drain cocks to floor drain. Close gate valve in Hartford Loop and open drain cock in return main. Fill boiler to normal water level, turn on oil burner and operate boiler at this water level for at least 30 minutes after the condensate begins to run hot, then turn off burner.
Close all radiator valves. Remove all supply main air valves and plug the openings in supply main.
 - ii. Draw about 5 gallons of hot water from boiler into a container and dissolve into it the appropriate amount of a recommended boilout compound. Remove safety valve from boiler and pour this solution into boiler, then reinstall safety valve.
 - iii. Turn on oil burner and keep operating while feeding water to boiler slowly. This will raise water level in boiler slowly so that water will be boiling hot and will rise slowly into supply main and back through return main, flowing from drain hose at about 180°F. Continue until water runs clear from drain hose for at least 30 minutes.
 - iv. Stop feeding water to boiler but continue operating oil burner until excess water in boiler flows out through supply main and water lowers (by steaming) until it reaches normal level in boiler. Turn off oil burner. Drain boiler. Open all radiator valves. Reinstall all supply main air valves. Open gate valve in Hartford Loop.
 - v. When boiler has cooled down sufficiently (crown sheet of sections are not too hot to touch), close the drain cocks at boiler and in return main and feed water slowly up to normal level in boiler. Turn on oil burner and allow boiler to steam for 10 minutes, then turn off burner. Draw off one quart of water from bottom gauge glass fitting and discard. Draw off another quart sample and if this sample is not clear, repeat the cycle of draining the boiler and return main and refilling the boiler until sample is clear.
 - vi. If the boiler water becomes dirty again at a later date due to additional sediment loosened up in the piping, close gate valve in Hartford Loop, open drain cock in return main, turn on oil burner and allow Condensate to flow to drain until it has run clear for at least 30 minutes while feeding water to boiler so as to maintain normal water level. Turn off oil burner, drain boiler, open gate valve in Hartford Loop, then repeat step 1 above.
 - e. Make pH or Alkalinity Test.
After boiler and system have been cleaned and refilled as previously described, test the pH of the water in the system. This can easily be done by drawing a small sample of boiler water and testing with hydrion paper which is used in the same manner as litmus paper, except it gives specific readings. A color chart on the side of the small hydrion dispenser gives the reading in pH. Hydrion paper is inexpensive and obtainable from any chemical supply house or through your local druggist. The pH should be higher than 7, but lower than 11. Add some of the washout chemical (caustic soda), if necessary, to bring the pH within the specified range.
 - f. Boiler is now ready to be put into service.
- ## 2. WATER BOILERS
- a. *Filling of Boiler and System — General* — In a hot water heating system, the boiler and entire system (other than the expansion tank) must be full of water for satisfactory operation. Water should be added to the system until the boiler pressure gauge registers 12 psi. To insure that the system is full, water should come out of all air vents when opened.
 - b. *Boiling Out of Boiler and System.* The oil and grease which accumulate in a new hot water boiler can be washed out in the following manner.
 - i. Remove safety relief valve using extreme care to avoid damaging it.
 - ii. Add an appropriate amount of

recommended boil out compound.

- iii. Replace safety relief valve.
 - iv. Fill the entire system with water.
 - v. Start firing the boiler.
 - vi. Circulate the water through the entire system.
 - vii. Vent the system, including the radiation.
 - viii. Allow boiler water to reach operating temperature, if possible.
 - ix. Continue to circulate the water for a few hours.
 - x. Stop firing the boiler.
 - xi. Drain the system in a manner and to a location that hot water can be discharged with safety.
 - xii. Remove plugs from all available returns and wash the water side of the boiler as thoroughly as possible, using a high-pressure water stream.
 - xiii. Refill the system with fresh water.
- c. Add appropriate boiler water treatment compounds as recommended by your qualified water treatment company.
 - d. *Make pH or Alkalinity Test.*

After boiler and system have been cleaned and refilled as previously described, test the pH of the water in the system. This can easily be done by drawing a small sample of boiler water and testing with hydrion paper which is used in the same manner as litmus paper, except it gives specific readings. A color chart on the side of the small hydrion dispenser gives the reading pH. Hydrion paper is inexpensive and obtainable from any chemical supply house or thru your local druggist. The pH should be higher than 7 but lower than 11. Add appropriate water treatment chemicals, if necessary, to bring the pH within the specified range. With this lower level of protection, care must be exercised to eliminate all of the free oxygen in the system.

- e. Boiler is now ready to be put into service.

O. HINTS ON COMBUSTION

1. **NOZZLES** — Although the nozzle is a relatively inexpensive device, its function is critical to the successful operation of the oil burner. The selection of the nozzle supplied with the V7 boiler is the result of extensive testing to obtain the best flame shape and efficient combustion. Other brands of the same spray angle and spray pattern may be used but may not perform at the expected level of CO₂ and smoke. Nozzles are delicate and should be protected from dirt and abuse. Nozzles are mass-produced

and can vary from sample to sample. For all of those reasons a spare nozzle is a desirable item for a serviceman to have.

2. **FLAME SHAPE** — Looking into the combustion chamber through the observation door, the flame should appear straight with no sparklers rolling up toward the crown of the chamber. If the flame drags to the right or left, sends sparklers upward or makes wet spots on the target wall, the nozzle should be replaced. If the condition persists look for fuel leaks, air leaks, water or dirt in the fuel as described above.
3. **FUEL LEAKS** — Any fuel leak between the pump and the nozzle will be detrimental to good combustion results. Look for wet surfaces in the air tube, under the ignitor, and around the air inlet. Any such leaks should be repaired as they may cause erratic burning of the fuel and in the extreme case may become a fire hazard.
4. **AIR LEAKS** — Any such leaks should be repaired, as they may cause erratic burning of the fuel and in extreme cases may become a fire hazard.
5. **GASKET LEAKS** — If 11.5 to 12.5% CO₂ with a #1 smoke cannot be obtained in the breeching, look for air leaks around the burner mounting gasket, observation door, and canopy gasket. Such air leaks will cause a lower CO₂ reading in the breeching. The smaller the firing rate the greater effect an air leak can have on CO₂ readings.
6. **DIRT** — A fuel filter is a good investment. Accidental accumulation of dirt in the fuel system can clog the nozzle or nozzle strainer and produce a poor spray pattern from the nozzle. The smaller the firing rate, the smaller the slots become in the nozzle and the more prone to plugging it becomes with the same amount of dirt.
7. **WATER** — Water in the fuel in large amounts will stall the fuel pump. Water in the fuel in smaller amounts will cause excessive wear on the pump, but more importantly water doesn't burn. It chills the flame and causes smoke and unburned fuel to pass out of the combustion chamber and clog the flueways of the boiler.
8. **COLD OIL** — If the oil temperature approaching the fuel pump is 40°F or lower poor combustion or delayed ignition may result. Cold oil is harder to atomize at the nozzle. Thus, the spray droplets get larger and the flame shape gets longer. An outside fuel tank that is above grade or has fuel lines in a shallow bury is a good candidate for cold oil. The best solution is to bury the tank and lines deep enough to keep the oil above 40°F.
9. **HIGH ALTITUDE INSTALLATIONS**
Air openings must be increased at higher altitudes. Use instruments and set for 11.5 to 12.5% CO₂.

IMPORTANT

SUCTION LINE LEAKS - THE OIL MUST BE FREE OF AIR. Try bleeding the pump through a clear tube. There must be no froth visible. There are various test kits available to enable you to look at the oil through clear tubing adapted to the supply line at the pump fitting. Air eliminators are on the market that have potential. Also, electronic sight glasses are being used with good success. At times, new tubing must be run to the tank or new fittings put on. Just make sure you get the air out. Any air leaks in the fuel line will cause an unstable flame and may cause delayed ignition noises. Use only flare fittings in the fuel lines.

10. **START-UP NOISE** — Late ignition is the cause of start-up noises. If it occurs recheck for electrode settings, flame shape, air or water in the fuel lines.
11. **SHUT DOWN NOISE** — If the flame runs out of air before it runs out of fuel, an after burn with noise may occur. That may be the result of a faulty cut-off valve in the fuel pump, or it may be air trapped in the nozzle line. It may take several firing cycles for that air to be fully vented through the nozzle. Water in the fuel or poor flame shape can also cause shut down noises.

IMPORTANT

CHECK TEST PROCEDURE. A very good test for isolating fuel side problems is to disconnect the fuel system and with a 24" length of tubing, fire out of an auxiliary five gallon pail of clean, fresh, warm #2 oil from another source. If the burner runs successfully when drawing out of the auxiliary pail then the problem is isolated to the fuel or fuel lines being used on the jobsite.

P. ATTENTION TO BOILER WHILE NOT IN OPERATION.

1. IMPORTANT

IF BOILER IS NOT USED DURING WINTER TIME, IT MUST BE FULLY DRAINED TO PREVENT FREEZE DAMAGE.

2. Spray inside surfaces with light lubricating or crankcase oil using gun with extended stem so as to reach all corners.
3. With steam boilers, at end of season add sufficient water to fill boiler to top of water column and leave it that way until fall when water should be drained again to proper level. If at this time boiler water is dirty, drain water, flush out boiler, and refill with

clean water to prescribed water level.

4. Always keep the manual fuel supply valve shut off if the burner is shut down for an extended period of time.
5. To recondition the heating system in the fall season after a prolonged shut down, follow the instructions outlined in Section IV, Items A through M.

CAUTION

This boiler contains controls which may cause the boiler to shut down and not restart without service. If damage due to frozen pipes is a possibility, the heating system should not be left unattended in cold weather; or appropriate safeguards and alarms should be installed on the heating system to prevent damage if the boiler is inoperative.

Q. FREQUENT WATER ADDITION

A leaky system will increase the volume of make-up water supplied to the boiler which can significantly shorten the life of the boiler. Entrained in make-up water are dissolved minerals and oxygen. When the fresh, cool make-up water is heated in the boiler the minerals fall out as sediment and the oxygen escapes as a gas. Both can result in reduced boiler life. The accumulation of sediment can eventually isolate the water from contacting the cast iron. When this happens the cast iron in that area gets extremely hot and eventually cracks. The presence of free oxygen in the boiler creates a corrosive atmosphere which, if the concentration becomes high enough, can corrode the cast iron through from the inside. Since neither of these failure types are the result of a casting defect the warranty does not apply. Clearly it is in everyone's best interest to prevent this type of failure. The maintenance of system integrity is the best method to achieve this.

(Non-Burnham Drawing
Copy from other Manual)

AQUASTAT SWITCHING ACTION WITHIN L8124C CONTROL

The switching action within the L8124C control has three settings:

1. high limit
2. low limit
3. adjustable differential

HIGH LIMIT OPERATION —

The high limit opens and turns off the burner when the water temperature reaches the set point. The high limit automatically resets after the water temperature drops past the set point and through the 10°F differential.

Set the indicator at desired shutoff temperature.

LOW LIMIT OPERATION —

On a temperature rise, with the adjustable differential at the minimum setting of 10°F, the burner circuit (R-B) breaks and the circulator circuit (R-W) makes at the low limit set point. On a temperature drop of 10°F below the set point, the R-B circuit makes and the R-W circuit breaks.

ADJUSTABLE DIFFERENTIAL —

At any differential setting greater than 10°F, the R-B make temperature and R-W break temperature will remain the same-control setting minus 10°F. The R-B break and R-W make temperature will be the set point temperature plus the difference between the differential setting and 10°F.

EXAMPLE: Set point of 140°F; differential set at 25°F. On a temperature rise, R-B will break and R-W will make at 155°F. On a temperature fall, R-B will make and R-W will break at 130°F.

Set low limit indicator at the minimum temperature recommended for domestic hot water supply. This setting *must* be at least 20°F below high limit setting to prevent one switch from locking out the other.

Set the differential the desired number of degrees. 25°F differential gives longest burner cycles.

AQUASTAT SWITCHING ACTION WITHIN L8148A CONTROLS

The switching action in the L8148A control has one setting, the high limit. The switching relay is controlled by the low voltage room thermostat. On a call for heat, the relay contacts make to complete the line voltage circulator circuit and also the burner circuit if the boiler water temperature is below the high limit setting. The high limit switch shuts off the burner if boiler water temperature exceeds the high limit setting.

Set the indicator at the desired shutoff temperature.

SECTION V: BOILER CLEANING

WARNING

All boiler cleaning must be completed with burner service switch turned off. Boilers equipped with burner swing door have a potential hazard which can cause severe property damage, personal injury or loss of life if ignored. Before opening swing door, turn off service switch to boiler to prevent accidental firing of burner outside the combustion chamber. Be sure to tighten swing door fastener completely when service is completed.

A. CLEAN THE FLUEWAYS (See Figure 26).

1. Prior to cleaning boiler, lay a protective cloth or plastic over combustion chamber blanket to collect debris falling from flueways.
2. For access to firebox
On boilers *with* burner swing door and flexible fuel line(s), remove fastener securing door and swing door open. For full access to firebox, remove burner and swing door from mounting plate by pulling hairpin cotter from bottom of hinge pin and removing pin from hinge. Set burner aside. Remove swing door mounting plate, see Figure 6.

3. For cleaning from the side:

- a. Lift the jacket's upper right side access panel off to expose the flue cleanout plates.
- b. Loosen nuts securing the flue cleanout plates and remove the plates. The insulation should be removed with the plates taking care not to damage the insulation.

4. For cleaning from the top:

- a. Lift the jacket's upper right side access panel off to allow removal of the jacket top panel.
- b. Remove as much smokepipe as necessary to allow removal of the jacket top panel and canopy (smokebox).
- c. Remove the jacket top panel.
- d. Remove the canopy, being careful not to damage the ceramic fiber gasket.

5. Using a 1¼" diameter wire or fibre bristle brush (30" handle) clean the flueways. Brush from the top and/or side using horizontal and diagonal strokes for best results. **DO NOT** allow brush to strike the target wall or liner in the chamber.

B. CLEAN TOP OF BOILER SECTIONS (if cleaning from the top).

Brush and vacuum the tops of the boiler sections.

C. CLEAN THE FIREBOX.

Using wire or fibre bristle brush, clean crown of boiler and inside of water legs. **DO NOT** allow brush to strike target wall or blanket in the combustion chamber.

D. AFTER CLEANING, remove protective cloth with debris and vacuum as necessary, but be careful not to damage blanket. Inspect target wall, combustion chamber blanket, burner mounting plate insulation and burner swing door insulation for signs of damage. If damaged, replace as needed.

E. REASSEMBLE BOILER.

CAUTION: Do not start the burner unless canopy,

smokepipe, burner mounting plate, burner swing door and all flue plates are secured in place.

1. Install the canopy taking care to align the gaskets without blocking the flueways. If gasket is damaged, replace as needed.
2. Reinstall flue plates, making sure gasket on each plate is in place and forms gas tight seal. If damaged replace as needed.
3. Reinstall jacket top panel and secure with sheet metal screws. Replace jacket upper right side access panel.
4. Reinstall smokepipe on canopy and secure to collar with sheet metal screws.
5. Install swing door mounting plate to front section with fasteners, see Figure 6.
6. Reinstall burner in reverse order of disassembly outlined in paragraph A.2 above. For details, see Figure 6.

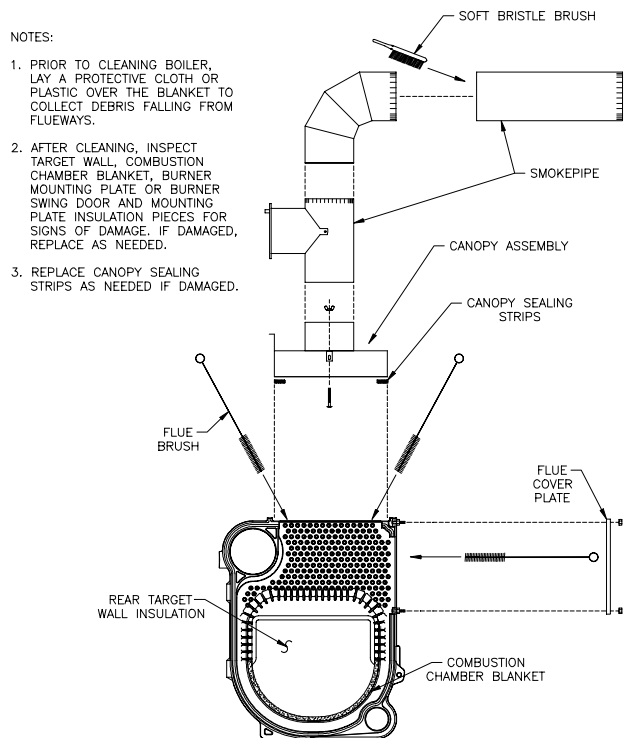

Figure 26: Cleaning of Boiler Flueways

WARNING

The boiler must be connected to an approved chimney in good condition. Serious property damage could result if the boiler is connected to a dirty or inadequate chimney. The interior of the chimney flue must be inspected and cleaned before the start of the heating season and should be inspected periodically throughout the heating season for any obstructions. A clean and unobstructed chimney flue is necessary to allow noxious fumes that could cause injury or loss of life to vent safely and will contribute toward maintaining the boiler's efficiency.

SECTION VI: REPAIR PARTS

All V7 Series Repair Parts may be obtained through your local Burnham Wholesale distributor. Should you require assistance in locating a Burnham Distributor in your area, or have questions regarding the availability of Burnham products or repair parts, please contact your Burnham Regional Sales Office as listed below.

Burnham Corporation Regional Offices

A. Burnham Corporation - Central & Western Regions P.O. Box 3079 Lancaster, PA 17604-3079 Phone: (717) 481-8400 FAX: (717) 481-8408	C. Burnham Corporation - Metropolitan Region P.O. Box 3079 Lancaster, PA 17604-3079 Phone: (717) 481-8400 FAX: (717) 481-8409
B. Burnham Sales Corporation - Northeast Region 19-27 Mystic Avenue Somerville, MA 02145 Phone: (617) 625-9735 FAX: (617) 625-9736	D. Burnham Corporation - Mid-Atlantic Region P.O. Box 3079 Lancaster, PA 17604-3079 Phone: (717) 481-8400 FAX: (717) 481-8409

Contact Regional Office Indicated for your State

Alabama	A	Nebraska	A	Oregon	A		
Alaska	A	Nevada	A	Pennsylvania	D		
Arizona	A	New Hampshire	B	Rhode Island	B		
Arkansas	A	New Jersey <i>Atlantic, Burlington, Camden, Cape May, Cumberland, Gloucester, Mercer, Monmouth, Ocean, Salem Counties All other Counties</i>	D C	South Carolina	A		
California	A			South Dakota	A		
Colorado	A			Tennessee	A		
Connecticut	B			Texas	A		
Delaware	D			Utah	A		
Florida	A			Vermont	B		
Georgia	A			Virginia <i>Arlington,Accomack,Clarke, Fairfax,Frederick,Fauquier, Loudoun,Northampton and Prince William Counties All other Counties</i>	D A	Washington	A
Hawaii	A					Washington, D.C.	D
Idaho	A					West Virginia	D
Illinois	A					Wisconsin	A
Indiana	A	Wyoming	A				
Iowa	A	Ohio <i>Athens, Belmont, Gallia, Jefferson, Lawrence, Meigs, Monroe, and Washington Counties All other Counties</i>	D A				
Kansas	A			North Carolina	A		
Kentucky	A			North Dakota	A		
Louisiana	A			Ohio			
Maine	B			Oklahoma	A		Canada
Maryland	D						
Massachusetts	B						
Michigan	A						
Minnesota	A						
Mississippi	A						
Missouri	A						
Montana	A						

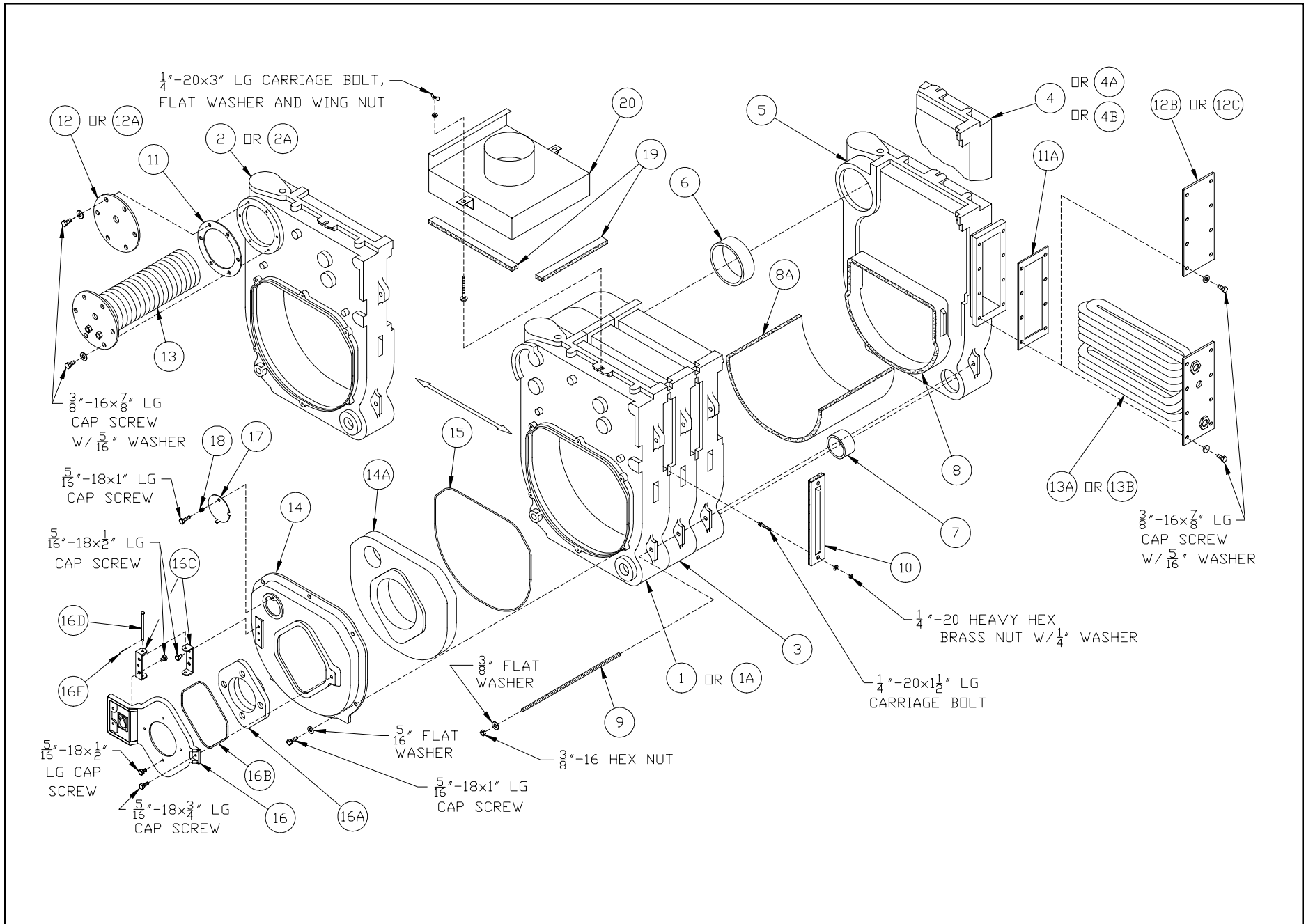

BARE BOILER ASSEMBLY

Item No.	Description	Part No.	V72	V713	V73	V714	V74	V75	V76	V77	V78	V79
BARE BOILER ASSEMBLY (See Page 32 for Illustration)												
1	Front Section (Non-Htr.), Machined Water	71727019	1	---	1	---	1	1	1	1	1	1
	Front Section (Non-Htr.), Machined Water	71727015	---	1	---	1	---	---	---	---	---	---
1A	Front Section (Non-Htr.), Machined Steam	71727018	---	---	1	---	1	1	1	1	1	1
2	Front Section w/Htr. Opening, Machined Water	71727016	---	---	1	---	1	1	1	1	1	1
2A	Front Section w/Htr. Opening, Machined Steam	71727017	---	---	1	---	1	1	1	1	1	1
3	Center Section	7172202	---	1	---	2	---	---	---	---	---	---
	Center Section	71727021	---	---	1	---	2	3	4	5	6	7
4	Narrow Back Section (Non-Htr.), Machined	7172204	---	1	---	1	---	---	---	---	---	---
4A	Wide Back Section (Non-Htr.), Machined Water	71727033	1	---	1	---	1	1	1	1	1	1
4B	Wide Back Section (Non-Htr.), Machined Steam	71727034	---	---	1	---	1	1	1	1	1	1
5	Rear Section w/Htr. Opening, Machined	7172203	---	1	---	1	---	---	---	---	---	---
	Rear Section w/Htr. Opening, Machined	71727036	---	---	1	---	1	1	1	1	1	1
6	5" Cast Iron Slip Nipple	7066003	1	---	2	---	3	4	5	6	7	8
7	2½" Cast Iron Slip Nipple	7066001	1	4	2	6	3	4	5	6	7	8
8	Rear Target Wall Insulation	8202701	1	1	1	1	1	1	1	1	1	1
8A	Combustion Chamber Liner, ½" x 23" x 4"	82027023	1	---	---	---	---	---	---	---	---	---
	Combustion Chamber Liner, ½" x 24" x 5"	82022033	---	1	---	---	---	---	---	---	---	---
	Combustion Chamber Liner, ½" x 23" x 8"	82027031	---	---	1	---	---	---	---	---	---	---
	Combustion Chamber Liner, ½" x 24" x 9"	82022043	---	---	---	1	---	---	---	---	---	---
	Combustion Chamber Liner, ½" x 23" x 12"	82027041	---	---	---	---	1	---	---	---	---	---
	Combustion Chamber Liner, ½" x 23" x 16"	82027051	---	---	---	---	---	1	---	---	---	---
	Combustion Chamber Liner, ½" x 23" x 20"	82027061	---	---	---	---	---	---	1	---	---	---
	Combustion Chamber Liner, ½" x 23" x 24"	82027071	---	---	---	---	---	---	---	1	---	---
	Combustion Chamber Liner, ½" x 23" x 28"	82027081	---	---	---	---	---	---	---	---	1	---
	Combustion Chamber Liner, ½" x 23" x 32"	82027091	---	---	---	---	---	---	---	---	---	1
9	Tie Rod, 3/8"-16 x 7¾" Lg.	80861072	2	---	---	---	---	---	---	---	---	---
	Tie Rod, 3/8"-16 x 12½" Lg.	80861010	---	2	2	---	---	---	---	---	---	---
	Tie Rod, 3/8"-16 x 17" Lg.	80861011	---	---	---	2	2	---	---	---	---	---
	Tie Rod, 3/8"-16 x 20¾" Lg.	80861012	---	---	---	---	---	2	---	---	---	---
	Tie Rod, 3/8"-16 x 25¼" Lg.	80861013	---	---	---	---	---	---	2	---	---	---
	Tie Rod, 3/8"-16 x 27½" Lg.	80861014	---	---	---	---	---	---	---	2	---	---
	Tie Rod, 3/8"-16 x 31½" Lg.	80861015	---	---	---	---	---	---	---	---	2	---
	Tie Rod, 3/8"-16 x 36½" Lg.	80861036	---	---	---	---	---	---	---	---	---	2

CONTINUED ON PAGES 34 AND 35

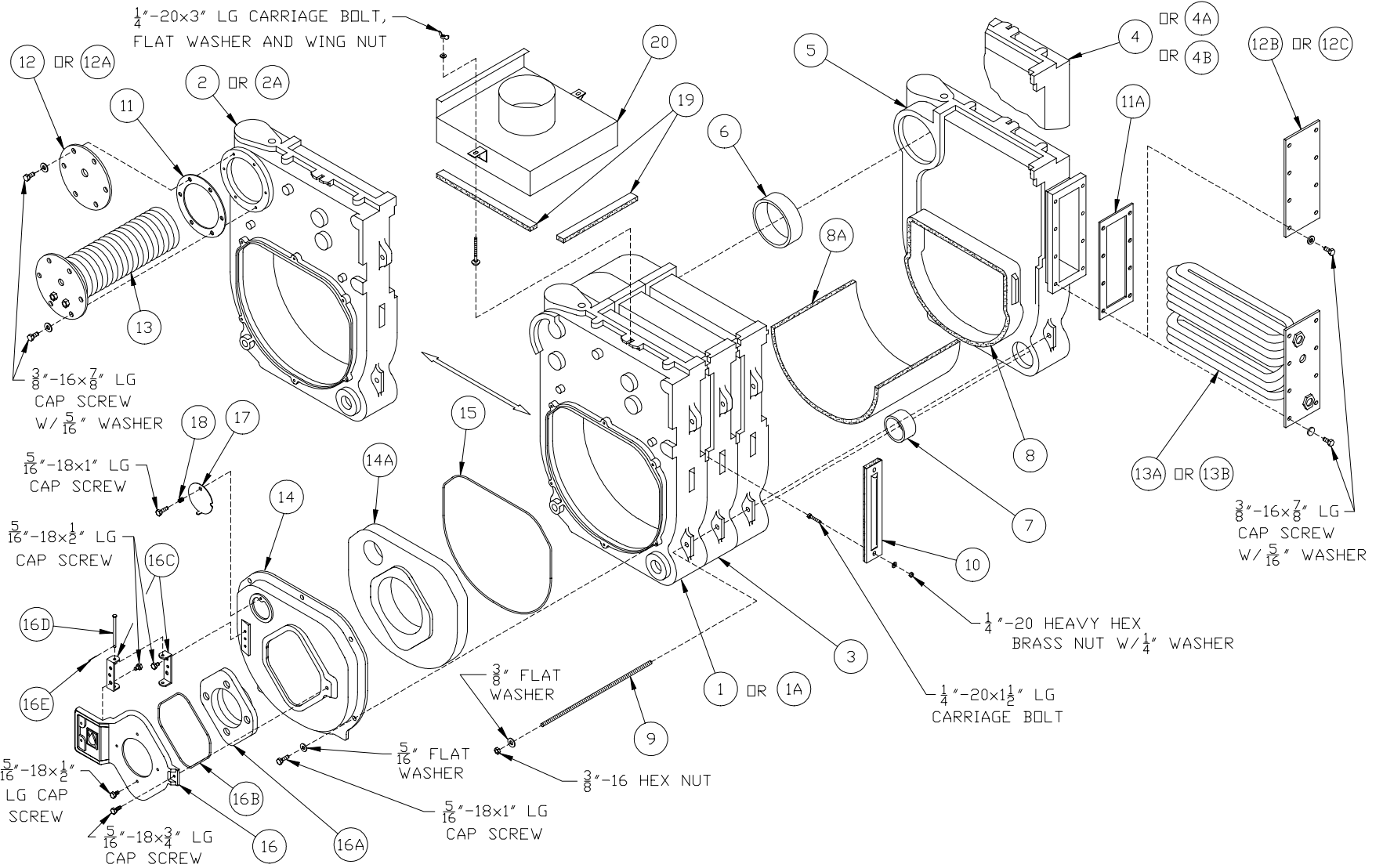

BARE BOILER ASSEMBLY (CONTINUED)

CONTINUED FROM PAGE 33

Item No.	Description	Part No.	V72	V713	V73	V714	V74	V75	V76	V77	V78	V79
BARE BOILER ASSEMBLY (See Page 34 for Illustration)												
10	Flue Cover Plate Assembly	6112214	1	2	2	3	3	4	5	6	7	8
11	Heater Cover Plate Gasket - Front Heater	8036068	---	---	1	---	1	1	1	1	1	1
11A	Heater Cover Plate Gasket - Rear Heater	8036058	---	1	1	1	1	1	1	1	1	1
12	Blank Heater Cover Plate (WB) - Front Heater	7036002	---	---	1	---	1	1	1	1	1	1
12A	Tapped Heater Cover Plate (WBTL) - Front Heater	7036001	---	---	1	---	1	1	1	1	1	1
12B	Blank Heater Cover Plate (SB & WB) - Rear Heater	7036020	---	---	1	---	1	1	1	1	1	1
12C	Tapped Heater Cover Plate (WBTL) - Rear Heater	7036021	---	1	1	1	1	1	1	1	1	1
13	222A Heater Carton Assy. - (WBT) Front Heater	6036036	---	---	1	---	1	1	1	1	1	1
	---OR--- A54 Heater Carton Assy. - (WBT) Front Heater	6031204	---	---	---	---	---	---	---	1	1	1
13A	V1-2 Heater Assy. - (SBT & WBT) - Rear Heater	6036031	---	1	1	---	1	1	1	1	1	1
13B	V1-1 Heater Carton Assy. - (WBT) Rear Heater	6036030	---	---	---	1	---	---	---	---	---	---
14	Burner Swing Door Mounting Plate	7172705	1	1	1	1	1	1	1	1	1	1
14A	Burner Swing Door Mounting Plate Insulation	82027021	1	1	1	1	1	1	1	1	1	1
15	Rope Gasket - Burner Mounting Plate - 53" Lg.	72027014	1	1	1	1	1	1	1	1	1	1
16	Burner Swing Door	7172706	1	1	1	1	1	1	1	1	1	1
16A	Burner Swing Door Insulation	82027022	1	1	1	1	1	1	1	1	1	1
16B	Rope Gasket (Burner Swing Door) - 28" Lg.	72027015	1	1	1	1	1	1	1	1	1	1
16C	Hinge	7022701	2	2	2	2	2	2	2	2	2	2
16D	Hinge Pin	80861614	1	1	1	1	1	1	1	1	1	1
16E	Hairpin Cotter	80861667	1	1	1	1	1	1	1	1	1	1
17	Observation Port Cover	7026001	1	1	1	1	1	1	1	1	1	1
18	Spring 3/8" I.D. x 1/2" Lg.	8026015	1	1	1	1	1	1	1	1	1	1
19	Canopy Sealing Strip (1/2" x 1" x 98")	7202710	1	1	1	1	1	1	1	1	1	1
20	V72 Canopy Assembly, Type II	611270211	1	---	---	---	---	---	---	---	---	---
	V713 Canopy Assembly	611270313	---	1	---	---	---	---	---	---	---	---
	V73 Canopy Assembly, Type II	611270311	---	---	1	---	---	---	---	---	---	---
	V714 Canopy Assembly	611270413	---	---	---	1	---	---	---	---	---	---
	V74 Canopy Assembly, Type II	611270411	---	---	---	---	1	---	---	---	---	---
	V75 Canopy Assembly, Type II	611270511	---	---	---	---	---	1	---	---	---	---
	V76 Canopy Assembly, Type II	611270611	---	---	---	---	---	---	1	---	---	---
	V77 Canopy Assembly, Type II	611270711	---	---	---	---	---	---	---	1	---	---
	V78 Canopy Assembly, Type II	611270811	---	---	---	---	---	---	---	---	1	---
V79 Canopy Assembly, Type II	611270911	---	---	---	---	---	---	---	---	---	1	

TS-39-112-D

V713 and V714 FLUSH JACKET

Item No.	Description	Part No.	V713	V714
V713 and V714 Flush Jacket Components - Items 1 thru 6 Include Insulation As Part of Assembly				
1	Jacket Front Panel Assembly	60427097	1	1
2	Jacket Rear Panel Assembly	60427096	1	1
3	Jacket Left Side/Top Panel Assembly	604270314	1	---
		604270414	---	1
4	Jacket Top Panel Assembly	604270322	1	---
		604270422	---	1
5	Jacket Lower Right Side Panel Assembly	604270337	1	---
		604270437	---	1
6	Jacket Upper Right Side Access Panel Assembly without Heater Opening (WB Only)	604270336	1	---
		604270436	---	1
	Jacket Upper Right Side Access Panel Assembly with Heater Opening (WBT Only)	604270335	1	---
		604270435	---	1
7	Jacket Bracket (WB Only)	7042715	1	1
	Jacket Bracket (WBT Only)	7042714		

TS-39-109-D

V72 Thru V79 FLUSH JACKET

Item No.	Description	Part No.	V72	V73	V74	V75	V76	V77	V78	V79
V72 Thru V79 Flush Jacket Components - Items 1 thru 7 Include Insulation As Part of Ass'y										
1	Jacket Front Panel Ass'y w/o Htr. Opg. (Wtr. Blr.)	60427090	1							
	Jacket Front Panel Ass'y w/o Htr. Opg. (Stm. Blr.)	60427091	---	1	1	1	1	1	1	1
	Jacket Front Panel Ass'y w/Htr. Opg. (Wtr. Blr.)	60427092	---							
	Jacket Front Panel Ass'y w/Htr. Opg. (Stm. Blr.)	60427094	---							
2	Plastic Collar Extension-Jkt. Frt. Panel w/Htr. Opg.	8032704	---		1	1	1	1	1	1
3	Jacket Rear Panel Assembly	60427093	1	1	1	1	1	1	1	1
4	Jacket Left Side/Top Panel Assembly	604270241	1	---	---	---	---	---	---	---
		604270341	---	1	---	---	---	---	---	---
		604270441	---	---	1	---	---	---	---	---
		604270541	---	---	---	1	---	---	---	---
		604270641	---	---	---	---	1	---	---	---
		604270741	---	---	---	---	---	1	---	---
		604270841	---	---	---	---	---	---	1	---
		604270941	---	---	---	---	---	---	---	1
5	Jacket Top Panel Assembly	604270221	1	---	---	---	---	---	---	---
		604270321	---	1	---	---	---	---	---	---
		604270421	---	---	1	---	---	---	---	---
		604270521	---	---	---	1	---	---	---	---
		604270621	---	---	---	---	1	---	---	---
		604270721	---	---	---	---	---	1	---	---
		604270821	---	---	---	---	---	---	1	---
		604270921	---	---	---	---	---	---	---	1
6	Jacket Lower Right Side Panel Assembly	604270234	1	---	---	---	---	---	---	---
		604270334	---	1	---	---	---	---	---	---
		604270434	---	---	1	---	---	---	---	---
		604270534	---	---	---	1	---	---	---	---
		604270634	---	---	---	---	1	---	---	---
		604270734	---	---	---	---	---	1	---	---
		604270834	---	---	---	---	---	---	1	---
		604270934	---	---	---	---	---	---	---	1
7	Jacket Upper Right Side Access Panel Assembly without Heater Opening	604270233	1	---	---	---	---	---	---	---
		604270333	---	1	---	---	---	---	---	---
		604270433	---	---	1	---	---	---	---	---
		604270533	---	---	---	1	---	---	---	---
		604270633	---	---	---	---	1	---	---	---
		604270733	---	---	---	---	---	1	---	---
		604270833	---	---	---	---	---	---	1	---
		604270933	---	---	---	---	---	---	---	1
	Jacket Upper Right Side Access Panel Assembly with Heater Opening	604270332	---	1	---	---	---	---	---	---
		604270432	---	---	1	---	---	---	---	---
		604270532	---	---	---	1	---	---	---	---
		604270632	---	---	---	---	1	---	---	---
		604270732	---	---	---	---	---	1	---	---
		604270832	---	---	---	---	---	---	1	---
604270932	---	---	---	---	---	---	---	1		

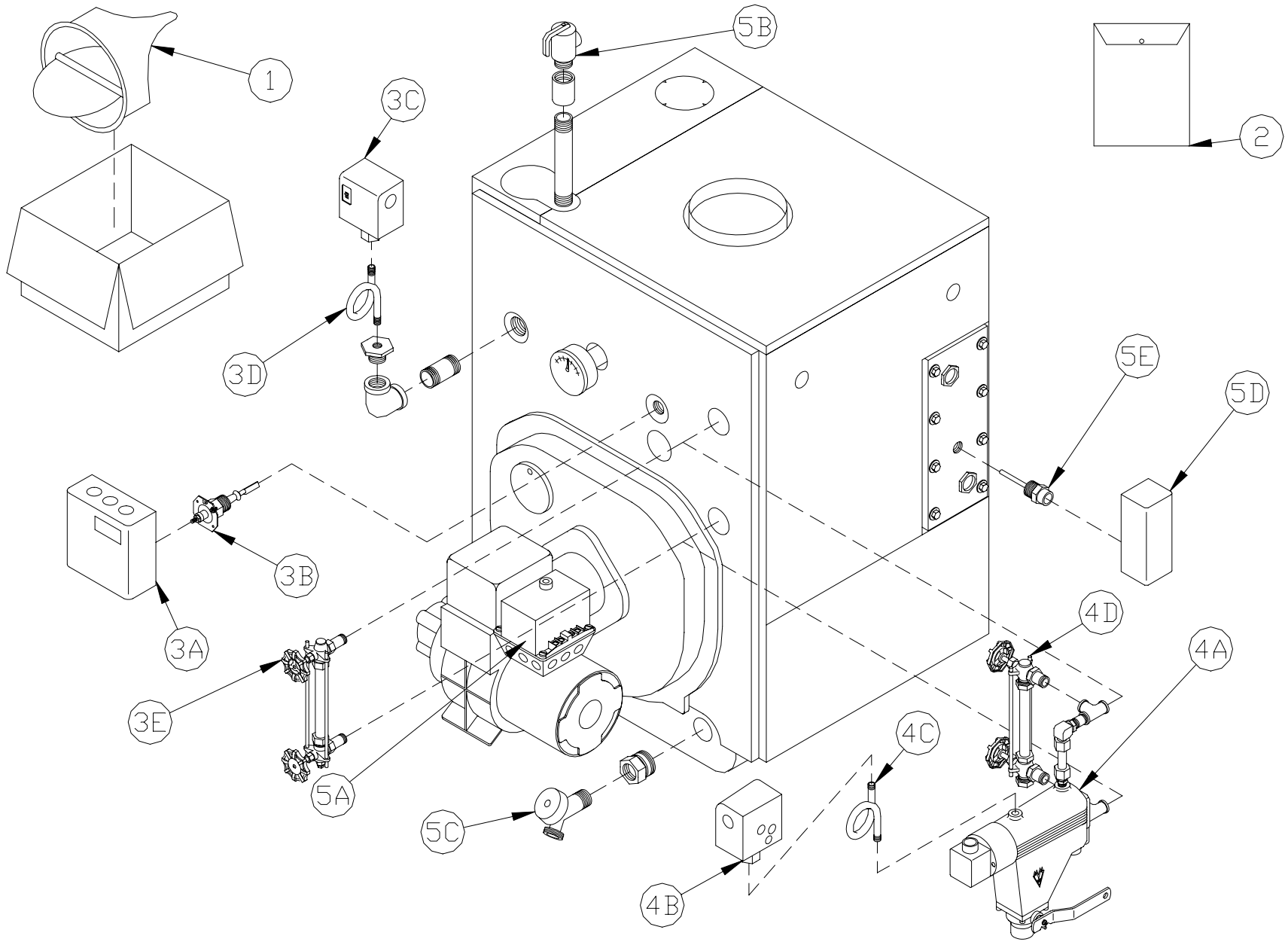

V73 Thru V79 STEAM BOILERS - TRIM AND CONTROLS

Item No.	Description	Part No.	V73	V74	V75	V76	V77	V78	V79
V73 Thru V79 STEAM BOILERS - TRIM AND CONTROLS (See Page 40 for Illustration)									
1. Draft Regulator									
1A	DR-6 Draft Regulator	8116029	1	1	1	1	---	---	---
1B	DR-7 Draft Regulator	8116001	---	---	---	---	1	1	1
2. Instruction Envelope Containing:									
2A	Installation and Operating Instructions	8142711	1	1	1	1	1	1	1
2B	10 Year Limited Warranty Mailer (Steam Boilers)	81460121	1	1	1	1	1	1	1
2C	I=B=R Pamphlet	81460061	1	1	1	1	1	1	1
3. Probe Low Water Cutoff									
3A	Low Water Cutoff, Hydrolevel CG450 (less probe)	80160628	1	1	1	1	1	1	1
	Low Water Cutoff, McDonnell & Miller PS-801-120	80160624							
	Low Water Cutoff, McDonnell & Miller PS-804-120	80160662							
3B	Probe, Hydrolevel EL-1214 (Hydrolevel CG450)	80160629	1	1	1	1	1	1	1
3C	Limit, Honeywell PA404A1009	80160300	1	1	1	1	1	1	1
3D	Syphon, ¼ NPT x 4" x 180°	806603030	1	1	1	1	1	1	1
3D1	Bushing, ¾ NPT x ¼ NPT	806600508	1	1	1	1	1	1	1
3D2	Elbow, ¾ NPT	806601520	1	1	1	1	1	1	1
3D3	Nipple, ¾ NPT x 2"	806600003	1	1	1	1	1	1	1
3E	Gage Glass Set, 6", ConBraCo 20-104-10	8056091	1	1	1	1	1	1	1
4. Float Low Water Cutoff									
4A	Low Water Cutoff, McDonnell & Miller 67	80160597	1	1	1	1	1	1	1
4B	Limit, Honeywell PA404A1009	80160300	1	1	1	1	1	1	1
4C	Syphon, ¼ NPT x 4" x 180°	806603030	1	1	1	1	1	1	1
4D	Gage Glass Set, 6", ConBraCo 20-104-10	8056091	1	1	1	1	1	1	1
5. Miscellaneous Trim and Controls									
5A	Oil Primary Control, Honeywell R8184G1286	80160416	1	1	1	1	1	1	1
5B	Safety Valve, ¾ NPT, 15 psi, ConBraCo 13-511-08	81660530	1	1	1	1	1	1	1
5B1	Coupling, ¾ NPT	806602561	1	1	1	1	1	1	1
5B2	Nipple, ¾ NPT x 8"	806600221	1	1	1	1	1	1	1
5C	Drain Valve, ¾ NPT, ConBraCo 31-606-02	806603011	1	1	1	1	1	1	1
5C1	Bushing, 1½ NPT x ¾ NPT	806600507	1	1	1	1	1	1	1
5D	Limit, Honeywell L4006A2015 (SBPT & SBFT)	80160400	1	1	1	1	1	1	1
5E	Well, ¾ NPT x 1½", Honeywell 123890A	80160426	1	1	1	1	1	1	1

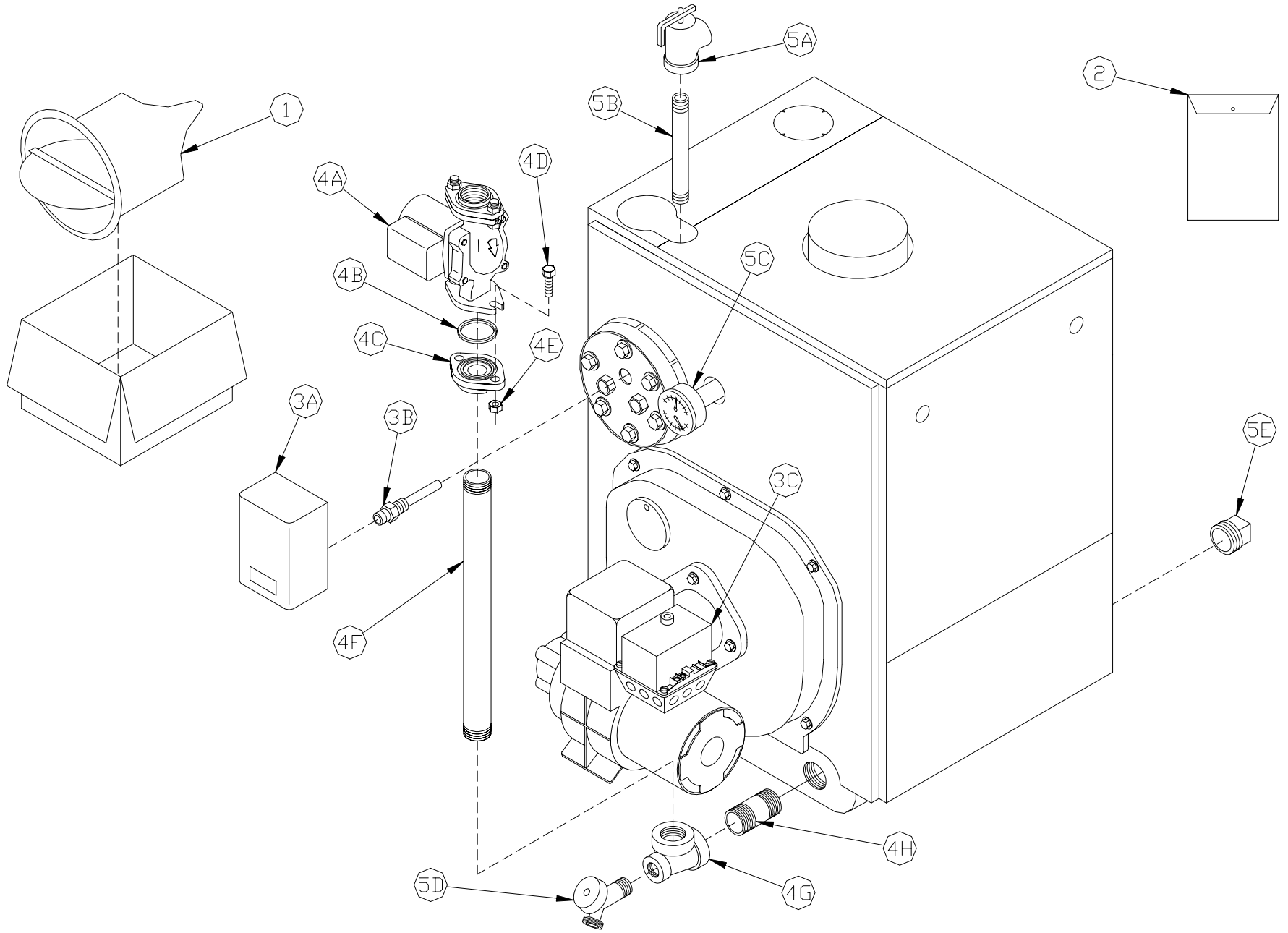

V72 Thru V79, V713 and V714 WATER BOILERS - TRIM AND CONTROLS

ITEM NO.	DESCRIPTION	Part No.	V72	V713	V73	V714	V74	V75	V76	V77	V78	V79
V72 Thru V79, V713 and V714 WATER BOILERS - TRIM AND CONTROLS (See Page 42 for Illustration)												
1. DRAFT REGULATOR												
1A	DR-6 Draft Regulator	8116029	1	1	1	1	1	1	1	----	----	----
1B	DR-7 Draft Regulator	8116001	----	----	----	----	----	----	----	1	1	1
2. INSTRUCTION ENVELOPE CONTAINING:												
2A	Installation and Operating Instructions	8142711	1	1	1	1	1	1	1	1	1	1
2B	Limited Warranty Mailer (Water Boilers)	81460135	1	1	1	1	1	1	1	1	1	1
2C	I=B=R Pamphlet	81460061	1	1	1	1	1	1	1	1	1	1
3. CONTROLS												
3A	Honeywell L8148A1090 Hi Limit, Circ. Relay (WB)	80160449U	1	1	1	1	1	1	1	1	1	1
	--OR-- Honeywell L8124C1102 Hi & Lo Limit, Circ. Relay (WBT)	80160406U	----	1	1	1	1	1	1	1	1	1
3B	Honeywell #123870A Immersion Well, ¾NPT x 1½ Insulation (WB)	80160426	1	1	1	1	1	1	1	1	1	1
	-- OR -- Honeywell #123872A Immersion Well, ½NPT x 3" Insulation (WBT)	80160497	----	1	1	1	1	1	1	1	1	1
3C	Honeywell R4184D (1027/1001) Protectorelay	80160473	1	1	1	1	1	1	1	1	1	1
4. CIRCULATOR & PIPING (Packaged Boiler Only)												
4A	Circulator, Taco 007F (position 2)	8056007	1	1	1	1	1	1	1	1	1	1
4B	Gasket, Taco "00" Series Circulator	806602006	2	2	2	2	2	2	2	2	2	2
4C	Circulator Flange, 1½"NPT	806602014	2	2	2	2	2	2	2	2	2	2
4D	Cap Screw, Hex Head, 7/16" -14 x 1½"	80861301	4	4	4	4	4	4	4	4	4	4
4E	Hex Nut, 7/16" - 14	80860406	4	4	4	4	4	4	4	4	4	4
4F	Nipple, 1½"NPT x18"	806600011	1	1	1	1	1	1	1	1	1	1
4G	Tee, 1½" x ¾" x 1½"NPT, Black	806601003	1	1	1	1	1	1	1	1	1	1
4H	Nipple, 1½"NPT x 3"	806600006	1	1	1	1	1	1	1	1	1	1
5. MISCELLANEOUS WATER TRIM												
5A	Relief Valve, ¾"NPT, F/F 30 LB, Conbraco 10-408-05	81660319	1	1	1	1	1	1	1	1	1	1
5B	Nipple, ¾"NPT x 8"	806600221	1	1	1	1	1	1	1	1	1	1
5C	Temp/Pressure Gauge, 2½" Dia., ENFM #41042.5210	8056169U	1	1	1	1	1	1	1	1	1	1
5D	Drain Cock, ¾"NPT Short Shank (WB and WBT), Conbraco #31-606-02	806603011	1	1	1	1	1	1	1	1	1	1
5E	Plug, Square Head, 1½"NPT (Packaged)	806603515	1	1	1	1	1	1	1	1	1	1
	Reducing Bushing, 1½" x ¾"NPT (Knockdown)	80660507										

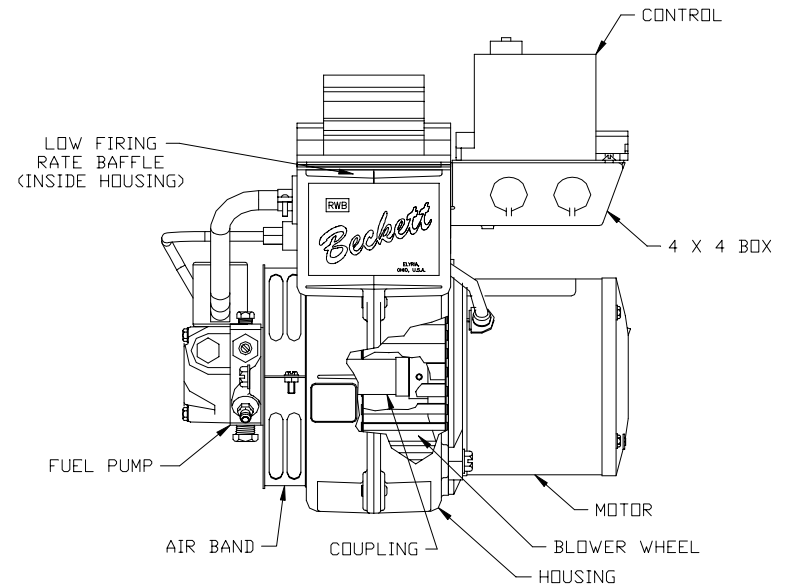
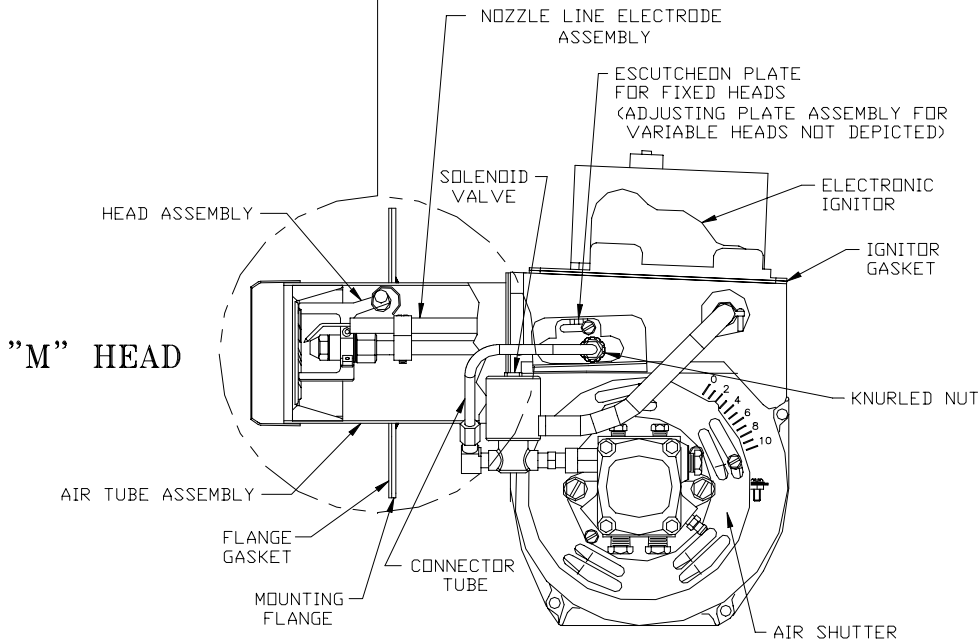
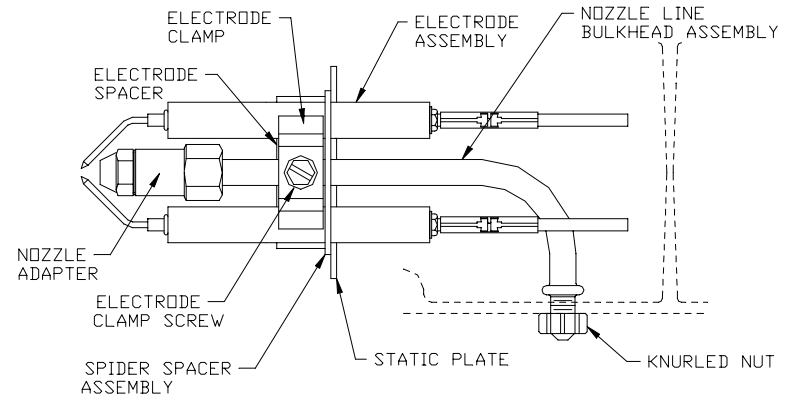
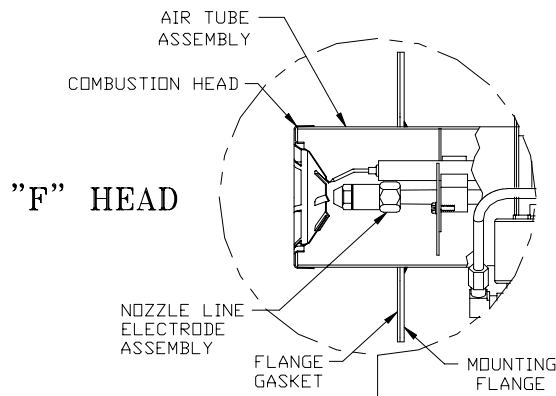

SIDE VIEW

FRONT VIEW

Beckett AFG Burner

BECKETT OIL BURNER PART NOS. FOR V7 SERIES BOILERS

NOTE: When ordering parts always give the serial and model numbers shown on the boiler and burner. Also provide the name of the part(s) and part number as listed below.

Boiler Model	V72	V713	V73	V714	V74	V75	V76	V77	V78	V79
Air Tube Combination	AFG70MB	AF72YH	AF44XN	AF72YY	AF44WH	AF44RA	AF44XO	AF72WK	AFG50MD	AFG50MD
Beckett's Spec No.	BCB6111	BCB6119	BCB6112	BCB6120	BCB6113	BCB6114	BCB6115	BCB6116	BCB6117	BCB6118
Air Band	3492	3492	3492	3492	3492	3492	3492	3492	3492	3492
Air Band Nut	4150	4150	4150	4150	4150	4150	4150	4150	4150	4150
Air Band Screw	4198	4198	4198	4198	4198	4198	4198	4198	4198	4198
Air Shutter	3709	3709	3709	3709	3709	3709	3709	3709	3709	3709
Air Shutter Screw	4198	4198	4198	4198	4198	4198	4198	4198	4198	4198
Blower	2999	2999	2999	2999	2999	2999	2999	2999	2999	2999
Coupling	2454	2454	2454	2454	2454	2454	2454	2454	2454	2454
Low Firing Rate Baffle	5880	5880	[1]	---	[1]	---	---	---	---	---
Bulkhead Knurled Locknut	3666	3666	3666	3666	3666	3666	3666	3666	3666	3666
Connector Tube Assembly	5636	5636	5636	5636	5636	5636	5636	5636	5636	5636
Electrode Clamp	149	149	149	149	149	149	149	149	149	149
Electrode Clamp Screw	4219	4219	4219	4219	4219	4219	4219	4219	4219	4219
Electrode Insulator Assembly	5780	5780	5780	5780	5780	5780	5780	5780	5780	5780
Spider Spacer Assembly	5503	5503	5503	5503	5503	5503	5503	5503	5503	5503
Escutcheon Plate	3493	3493	3493	3493	3493	3493	3493	3493	---	---
Adjusting Plate Assembly	---	---	---	---	---	---	---	---	5941	5941
Head	5912	360003	[4] 360004	360006	[5] 360004	[6] 360006	[7] 360012	360016	5913	5913
Head Screws	4221	4221	4221	4221	4221	4221	4221	4221	4221	4221
Flange Gasket	31498	31498	31498	31498	31498	31498	31498	31498	31498	31498
AFG Housing	5877	5877	5877	5877	5877	5877	5877	5877	5877	5877
Motor	2456	2456	2456	2456	2456	2456	2456	2456	2456	2456
Nozzle Adapter	213	213	213	213	213	213	213	213	213	213
Nozzle Line Electrode Assembly	NL72BN	NL72YH	NL44YH	NL72YY	NL44WP	NL44YB	NL44X0	NL72WK	NL50MD	NL50MD
Pump	2460	2460	2460	2460	2460	2460	2460	2460	2460	2460
Static Plate	3384	3384	[2] 3384	3384	[3] 3383P	3384	3383P	None	3383P	3383P
Ignitor	51771	51771	51771	51771	51771	51771	51771	51771	51771	51771
Ignitor Hinge Screw	4217	4217	4217	4217	4217	4217	4217	4217	4217	4217
Ignitor Holding Screw	4292	4292	4292	4292	4292	4292	4292	4292	4292	4292
Ignitor Gasket Kit	51304	51304	51304	51304	51304	51304	51304	51304	51304	51304
Wire Guard	10251	10251	10251	10251	10251	10251	10251	10251	10251	10251
Junction Box	5770	5770	5770	5770	5770	5770	5770	5770	5770	5770
Flame Detector	7006	7006	7006	7006	7006	7006	7006	7006	7006	7006
Oil Solenoid Valve	21789	21789	21789	21789	21789	21789	21789	21789	21789	21789

[1] 5880 in V73R, V73M and V74R [2] 3912 in V73M and V73R [3] 3384 in V74M and V74R [4] 360000 in V73R; 360003 in V73M
 [5] 360003 in V74R and V74M [6] 360003 in V75R; 360006 in V75M [7] 360006 in V76R; 360012 in V76M

Print word document

