

Haier

Air Cooled Module Water Chiller

Installation, operation and technical manual



Heat pump / Cooling only

R22 refrigerant

100KW

3PH, 380V, 50Hz

Haier Commercial Air Conditioning

MANUAL CODE: SYJS-035-06REV.2

2008-04-30

TABLE OF CONTENTS

1. Nomenclature.....3

2. Product character.....3

3. Specifications.....5

4. Dimension data.....7

5. Installation and debugging.....8

6. Refrigerant circuit.....10

7. Water system installation diagram.....11

8. Wiring diagrams.....13

9. Auxiliary electric heating function control.14

10. Water pump operation control(valid when water pump and the unit controlled simultaneously).....14

11. The terminal simultaneous control.....15

12. Wired controller functions.....16

14. Control functions.....28

14. Maintenance.....34

1. Nomenclature

Code Explanation for chiller

1	2		3	4	5	6	7		8		9		10			
chiller system	compressor type		capacity (for Centrifugal chiller: Rt; other: KW)				product type		unit character		suitable voltage		design number			
C	Centrifugal chiller		C	1	0	6	9	heat pump	R22	A	air cooled	A	100-115V, 60Hz	1	fixed frequency	A-G
	Screw chiller	air cooled		0	2	3	7		R407C	B	water cooled	W	220-240V, 50Hz	2	inverter	H-Q
		water cooled	I	0	0	1	2		R132	C	earth source	E	115-220V, 50/60Hz	3	DC inverter	R-Z
		earth source							R134a	D			220-220V, 60Hz	4		
		Air-cooled module chiller	A					R410a	E			110V, 50-60Hz	5			
	Light chiller	split-packaged	H					cooling only	R22	M			220V, 50-60Hz	6		
		single-packaged	R						R407C	N			127V, 60Hz	7		
	Water-cooled cabinet chiller		W						R123	O			240V, 50Hz	8		
	Hydronic system	Cassatte	B						R134a	P			110-220V, 50/60Hz	9		
		Duct	D						R410a	Q			330V, 50Hz	A		
		Cabinet	P										400V, 50Hz	B		
		Wall mounted	S									3300V, 50Hz	C			
											6600V, 50Hz	D				
											380-400V, 50Hz	N				
											415V, 50Hz	M				

2. Product character

- a. Installation conveniently, no need the special machine room and water tower; can be installed on the roof or out of the room. Widely application for cinema, hospital, hotel, school, commercial building, etc.
- b. Utilize flexible scroll compressor. And adopts three compressors in parallel technology. The master unit will control all compressors run or stop due to the water outlet temp. Optimum refrigerant distribution technique and minimum-deformation design. Adoption of rolling bearing and non-lubricated bearing. Excellent heating effect at low temperature. Broad range of working temperature and suitability for high condensation temperature.
- c. Shell & Tube and U type inner grooved finned coil heat exchanger.
High efficient water side heat exchanger: in cooling, the water side heat exchanger is as evaporator; in heating, it is as condenser. The freezed water flows outside of the pipe, and the refrigerant flows in the pipe. Optimum design, reliable operation, reasonable structure, perfect performance.
- d. Central control technology, indoor unit be connected with controller by dual core non-polar wire. The indoor units can be controlled individually or simultaneously, more convenient, more energy saving. One central air conditioning system can include max. 16 sets of module unit. Through the dip switch on PCB you can set unit No. of every module unit, and every unit is connected by RS485 port. Compact structure, convenient for electric installation.
- e. Fan coil simultaneous control technology: indoor fan coil can be controlled individually or centrally. Every indoor unit is connected to the individual controller or central controller through dual-core non-polar wire to realize the cental control. When one indoor starts up, the central air conditioning

system will start up automatically. When all indoors arrive the set temperature, the master unit will stop.
Energy saving.

- f. Auto check technology: The system can check the operation status automatically; all kinds of sensors will transmit the operation parameters to the chip. By pressing the buttons, all the parameters can display on the liquid crystal screen. When the unit occurs failure in operation, the failure will display on the LED so that the malfunction can be solved soon.
- g. Password control function: According to the user setting, the password control function can be used. Therefore the control to the unit will be more reliable and more flexible.
- h. Equipped with RS-485 physical connector, perfect network communication ability.
- i. Module structure design, the system can be produced or transported as module unit. Every system is independent, and they are spare part for each other, however which cooling circuit is abnormal, the other systems do not be affected by the abnormal system, and furthermore they will run in shape. Module structure can reduce the cost of transport and installation greatly, more convenient.
- j. Heat exchanger of air side is designed much larger, enlarge heat transmission area, lower the temperature drop of transmission. Consequently, the chiller can run in cool mode even at high temperature of 45celsius degree in summer, and also can run in heat mode at low ambient temperature of -15celsius degree in winter with good performance.
- k. Safety and protection devices: phase reverse protection device, high and low pressure switch, freeze protection device, overheat protection device, overload protection device, etc. Also, with Timer ON/OFF, AUTO operation, defrosting, etc. functions.

3. Specifications

Model			CA0100MANB	CA0100AANB
Nominal cooling capacity		KW	98	98
Nominal heating capacity		KW	/	105
Total power input		KW	32.25	32.25
Start current		A	164	164
Running current		A	21	21
Max. running current (in the electric control box)		A	67.5	67.5
Recommended circuit breaker		A	GV2-M22C (23A) /GV2-M16C (10)	GV2-M22C (23A) /GV2-M16C (10)
Power supply			3PH, 380V, 50Hz	
Running control method			fully automation	
Appearance colour			Haier gray	Haier gray
Capacity control step			3	3
Safety&functional protection			water-lackage delay protection,high and low pressure switch, freeze protection device, overheat protection device, overload protection device, phase loss & sequence protection	
Compressor	model		JT335D-Y1L	
	type/manufacture		hermetic scroll / DAIKIN	
	COP		3.41	
	quantity	set	3	3
	power input	KW	9.98Kw	9.98Kw
	rated power	KW	10.1*3	10.1*3
	power supply		3PH, 50Hz	
	running current	A	17	17
	starting current	A	159A(380V,50Hz)	159A(380V,50Hz)
	oil type		SUNISO4GSDID-K	
	oil charge	ml	3000	
	crankcase heater	W	72	72
	weight	kg	71	71
	rated speed	rpm	2900	2900
Fan	type		axial flow	
	quantity	set	3	3
	rated power	KW	0.75*3	0.75*3
	running current	A	2.5	2.5
	Air flow	m3/h	9000*3	9000*3
	Fan speed	rpm	960	960
External dimension	length	mm	2635	
	width	mm	1350	
	height	mm	2136	
Refrigerant charge(R22)		kg	30	30
Refrigeration system (circuit quantity)			3	3
Refrigeration control method			thermostatic expansion valve	
Water side heat exchanger			shell & tube heat exchanger, working pressure 1.0MPa	
Air side heat exchanger			cross finned coil, inner grooved copper pipe&dydrophilic aluminum finned coil	

Water flow		m ³ /h	18	18
Water resistance		kPa	50	50
Water pipe diameter		mm	65	65
Noise level		DB/(A)	66	66
Net weight		kg	1100	1100
Running weight		kg	1150	1150
Casing			polyester painted galvanized steel plate, Haier gray	

Nominal working condition (cooling):water inlet temp. 1°C, water outlet temp. 7°C, ambient temp. 35°C。

Nominal working condition (heating):water inlet temp. 40°C, water outlet temp. 45°C, ambient temp. (DB)7°C, (WB)6°C

The permitted range of voltage is 380±10%

The noise level will be measured in the third octave band limited values, using a Real Time Analyser calibrated sound intensity meter. The noise level is measured at 2meter in front of the unit, 1.5 meter high to the ground.

When starting up the complete unit, the compressor will start up one by one and will not start up together.

Variable condition cooling capacity & input power correct curve

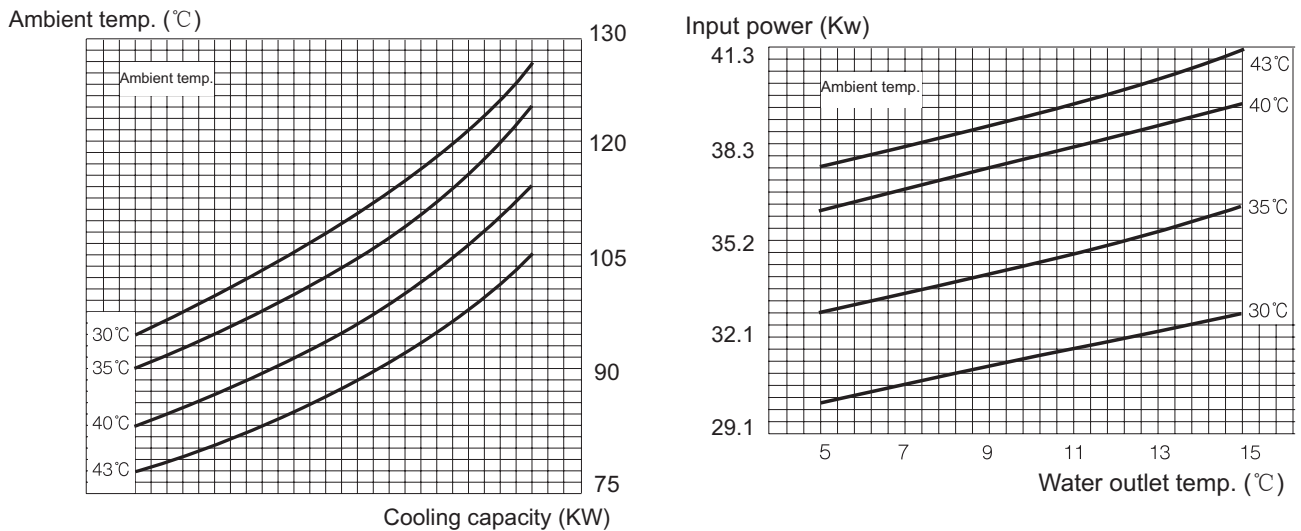

Variable condition heating capacity & input power correct curve

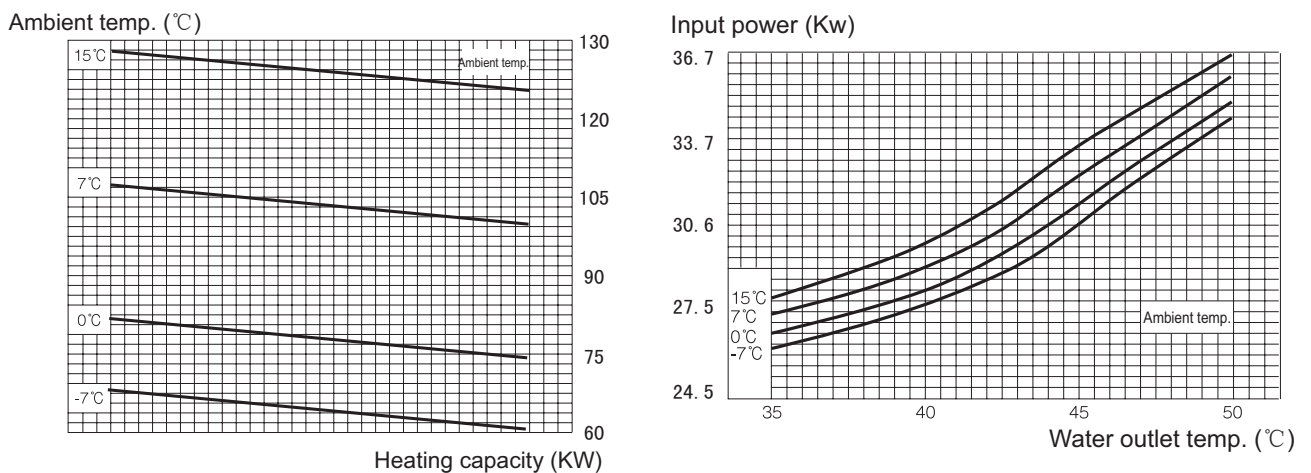

4. Dimension data

4.1 Installation dimension

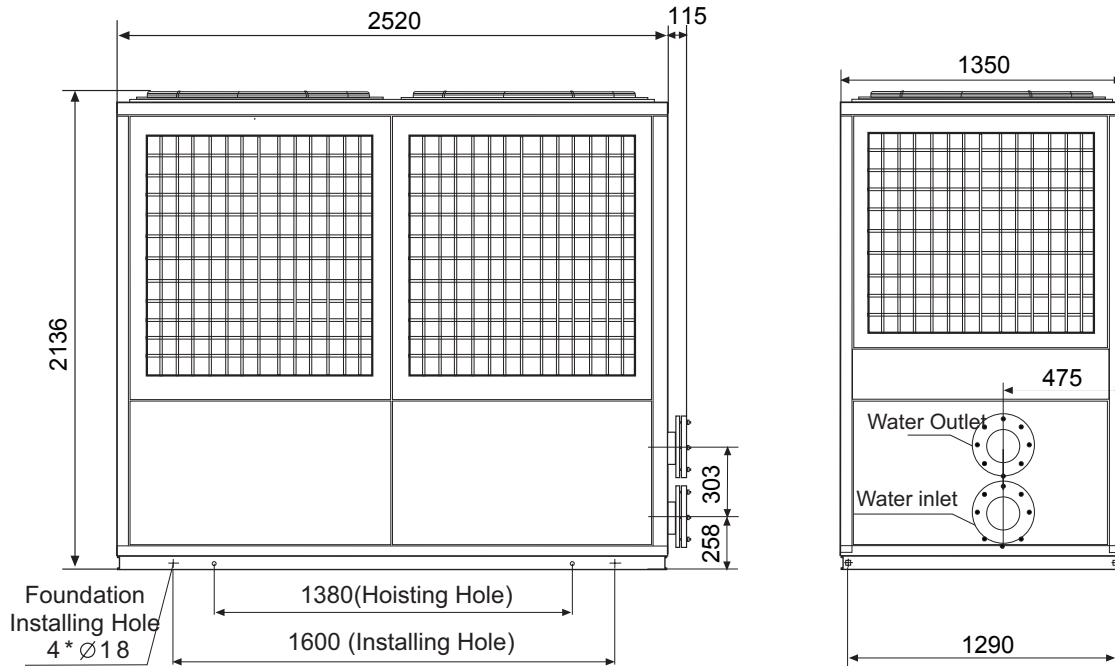

4.2 Foundation dimension

4.2.1 The bearing capacity of the foundation shall be designed according to the unit's operation weight.

4.2.2 The foundation can be beam channel (designed by the installer according to the unit outline dimension) or concrete structure, and the surface of the foundation shall be flat.

4.2.3 A 10~20mm rubber anti-vibration cushion shall be used between unit and foundation.

4.2.4 The unit can be fixed on the foundation by using anchor bolt with 16 or 18mm diameter.

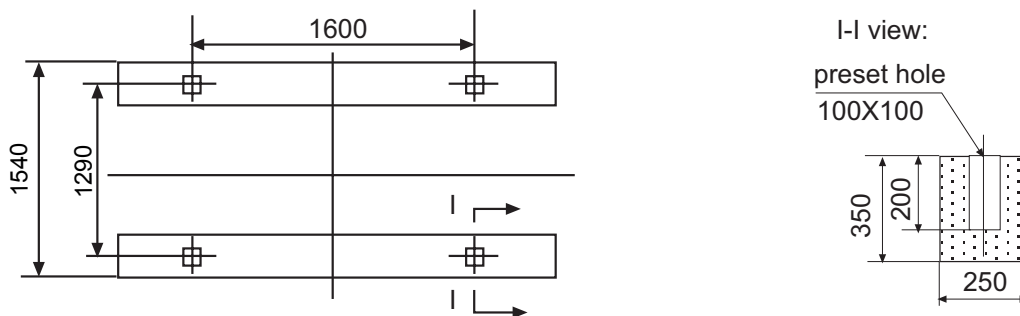

5. Installation and debugging

5.1 Freight Check

All the units are tightly fastened on the wooden pallet by the bolts. Before leaving factory, the units are all checked and pre-filled with refrigerant and refrigerant oil, both of which are the precise amount the unit operation needs.

When user receives the product, he shall check it carefully to confirm if there is product damage in transportation and to confirm all the pre-ordered parts are received. If there is any damage, he shall immediately inform the transportation person and claim for compensation according to relevant clauses. If there is problem except for surface damage, he shall immediately inform our company.

5.2 Transportation

In order to be convenient to carry the unit, the user shall use forklift or crane. When using crane, there shall be proper partition to protect the top and side panel of the unit (as Figure shown). During carrying, the unit shall be kept level, and the gradient shall not exceed 30° . Try to avoid units damage due to improper operation.

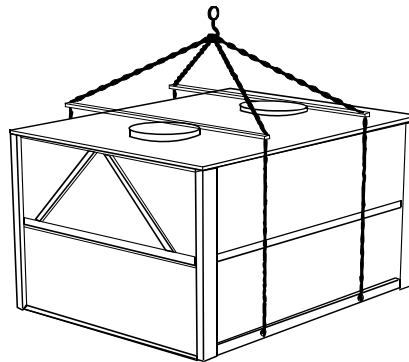

5.3 Unwrap the packaging

After putting the unit on the site, cut the packing strap and remove the outer crate. Unscrew the tightening bolt and remove the wood pallet from the bottom of the unit.

5.4 Selection of Installation Place

- 5.4.1 The installation place shall be plane, the foundation surface shall be flat, and the supporting surface can bear the operating weight of the unit.
- 5.4.2 The unit shall not be installed in a place where there is too much dust, corrosive gas, high humidity or insects gathers easily, fallen leaves and other contaminative matters.
- 5.4.3 Recommend that maintenance space among units should be over 400mm.
- 5.4.4 There shall be over 1.5m space around the unit to be convenient for ventilation and maintenance.
- 5.4.5 Try to keep the unit away from sunshine and rain, it is recommended to cover the unit with shed, but be sure there is a space over 3m above the air outlet for releasing heat easily.
- 5.4.6 An anti-vibration cushion about 10-20mm shall be equipped between the unit and the foundation. After adjusting level, fasten the anchor bolt.
- 5.4.7 For the heat pump unit, there shall be a drain for the condensate.

5.4.8 The installation and thermal insulation of the water pipes of the air conditioning system shall be designed and instructed by the professionals and shall implement the relevant regulations of the Installation Standard for HV & AC.

5.4.9 The external water pipe system must be equipped with anti-vibration hose, water filter, electronic water cleaner, check valve, drain valve, discharging valve, stop valve and expansion tank, etc. The expansion tank shall be installed 1-1.5m higher than the system top, and its capacity is about 1/10 of the total water amount of the system. The air release valve shall be installed between the top of the system and the expansion tank, and the water tank and the pipe shall be thermal insulated.

5.4.10 The water supply system must match the water pump with proper water flow and proper head to ensure the supply for the unit normally.

5.4.11 The unit must be equipped with a water filter in front of the water inlet pipe and use the mesh with 16~40-mesh filter.

5.4.12 The anti-vibration hose must be used between water pump and unit, between water pump and water pipe of system. At the same time, the pipes and the water pump shall have bracket to prevent the unit from receiving force.

5.4.13 Wash and thermal insulation of system water pipes shall be done before connecting the pipe with the unit.

5.5 Safety Precautions

5.5.1 The system pressure and electric parts will cause danger to the installation and maintenance of the air conditioner, so only the authorized personnel with qualification can perform the installation, operation and maintenance of the air conditioner.

5.5.2 Please comply with the protection measures and safety warnings marked on the documents, labels and nameplate on the unit.

5.5.3 Please comply with various safety regulations, wearing safety glasses and working gloves, and when welding, wear the fireproof clothes.

Warning: Before maintaining the unit, cut off the main power supply of the unit, otherwise electric shock will cause.

5.5.4 When maintaining, only the original parts shall be used and pay attention to correct installation, and the parts must be installed in their original position.

5.5.5 During unit operation, the temperature of some parts of the refrigerant circuit may exceed 70°C, so that the untrained personnel shall not make bold to remove the protection panel of the unit.

5.5.6 Unit shall not be installed in the air containing explosive gases.

5.5.7 If the heat pump type unit operates under the condition below 0°C, it must be installed in a place 300mm higher than the ground, which can not only prevent the bottom plate from freezing, but also prevent the accumulated snow from reaching this height to influence the unit's normal operation. The unit shall be installed on a flat surface (the max. deviation of the ground level shall not exceed 2mm/m.)

6. Refrigerant circuit

CA0100AANB

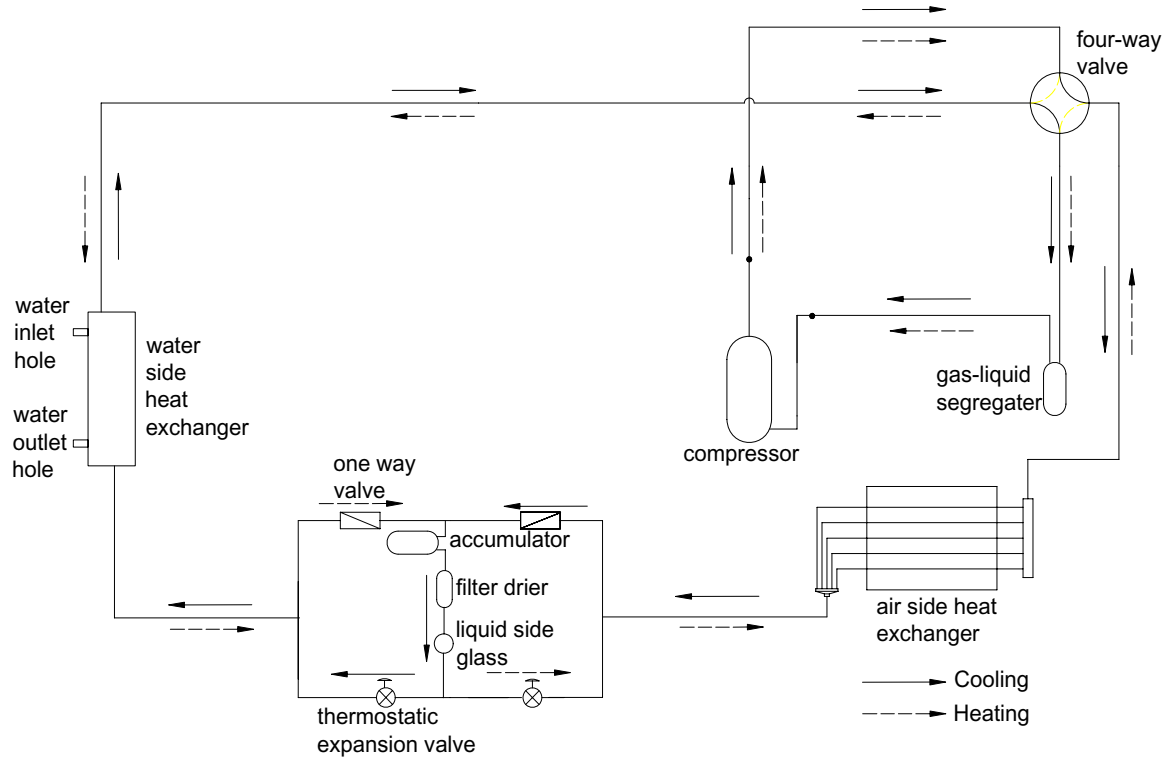

CA0100MANB

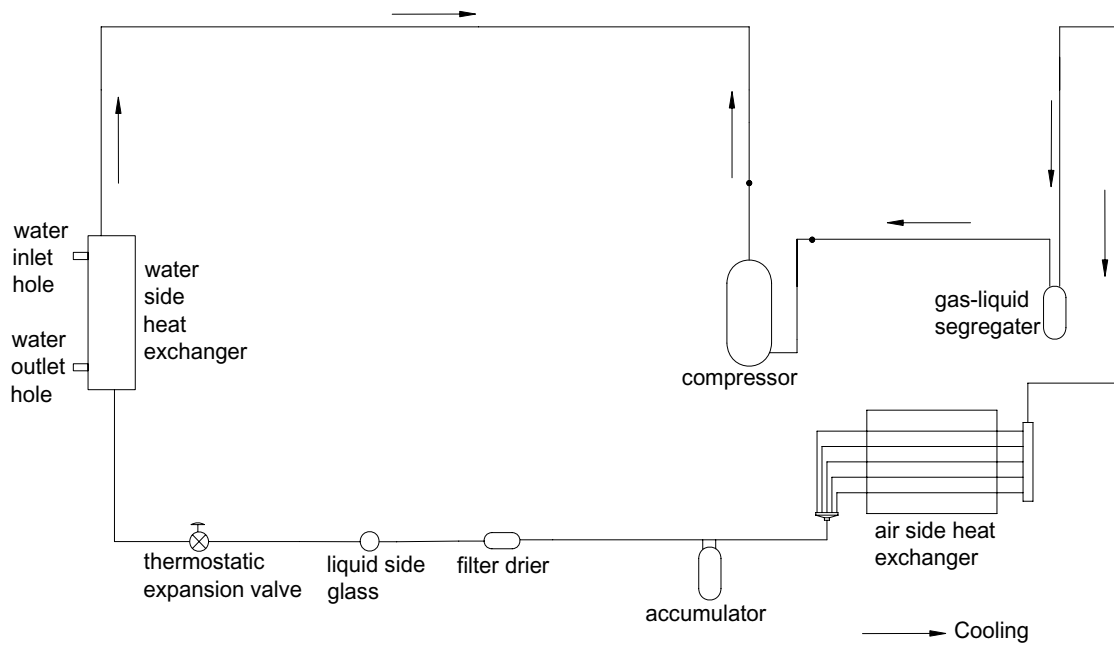

7. Water system installation diagram

Water System Installation Diagram

Diagram of water pipe connection between three units

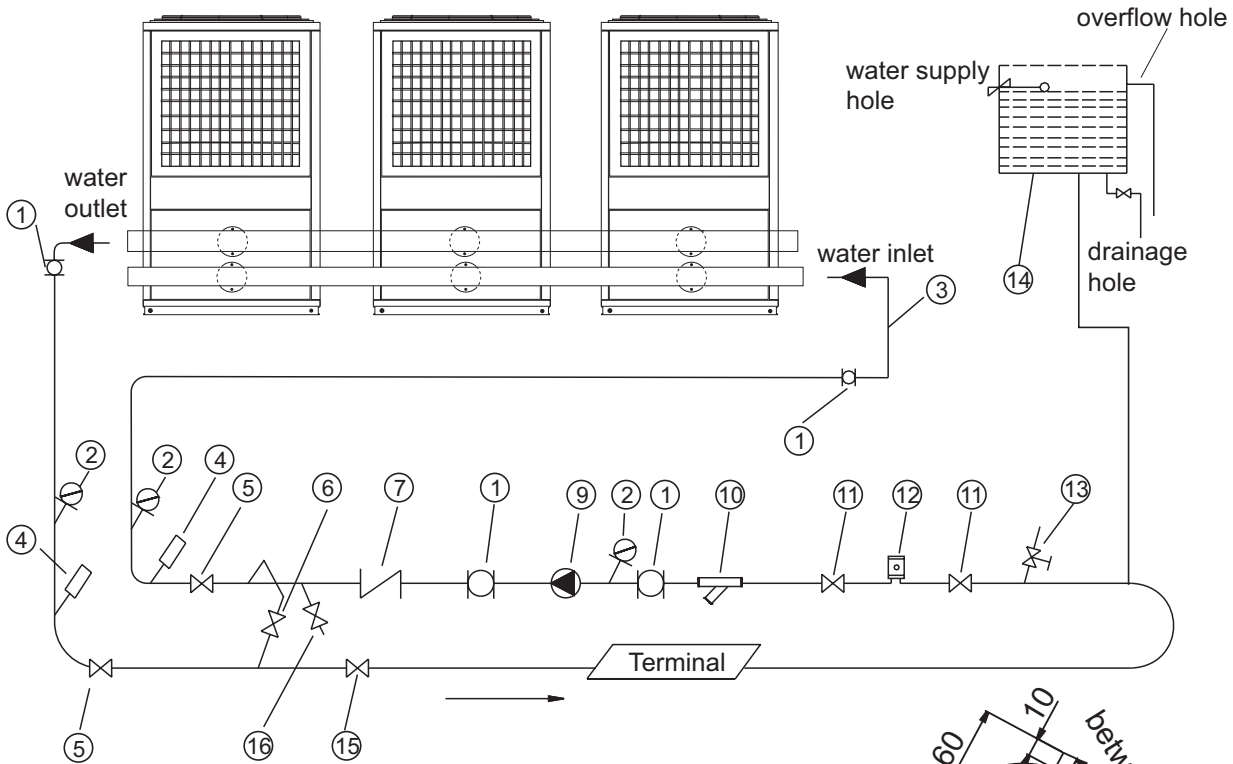

Note:

- | | |
|--|--|
| 1- Flexible hose joint | 2- Pressure gauge |
| 3- Total water return sensor install place | 4- Thermometer |
| 5. 11. 15- Stop valve | 6- By-pass valve |
| 7- One-way valve | 8- Flexible joint |
| 9- Water Pump | 10- Water strainer |
| 12- electrical water processor | 13- Auto discharging air valve (highest in the water system) |
| 14- Expansion water tank | 16- Drain valve |

When circulation water runs for the first time, close the inlet and outlet valve (No. 5) and open the by-pass valve (No.6). When water pump works for a while, clean the water filter screen. While ensuring that there is no impurity in the external circulation system, open inlet and outlet valve (No. 5) and close the by-pass valve (No.6). Then, the unit is in normal operation.

Note:

when the installation is over, the total water outlet temperature sensor in the main module must be fixed on the general water outlet pipeline. Pay attention that a section of blind pipe (Ø8, L=60mm) be reserved for the installation of temperature sensor during site design and that the insert length of blind pipe is 50mm. When installing the sensor, place the sensor beneath the blind pipe and inject some refrigerant oil into the blind pipe. The level of the refrigeration oil should be at least 10mm over the sensor. To minimize heat transfer error, it is necessary to adopt thermal insulation measures.

Typical Wiring and Pipe Connection

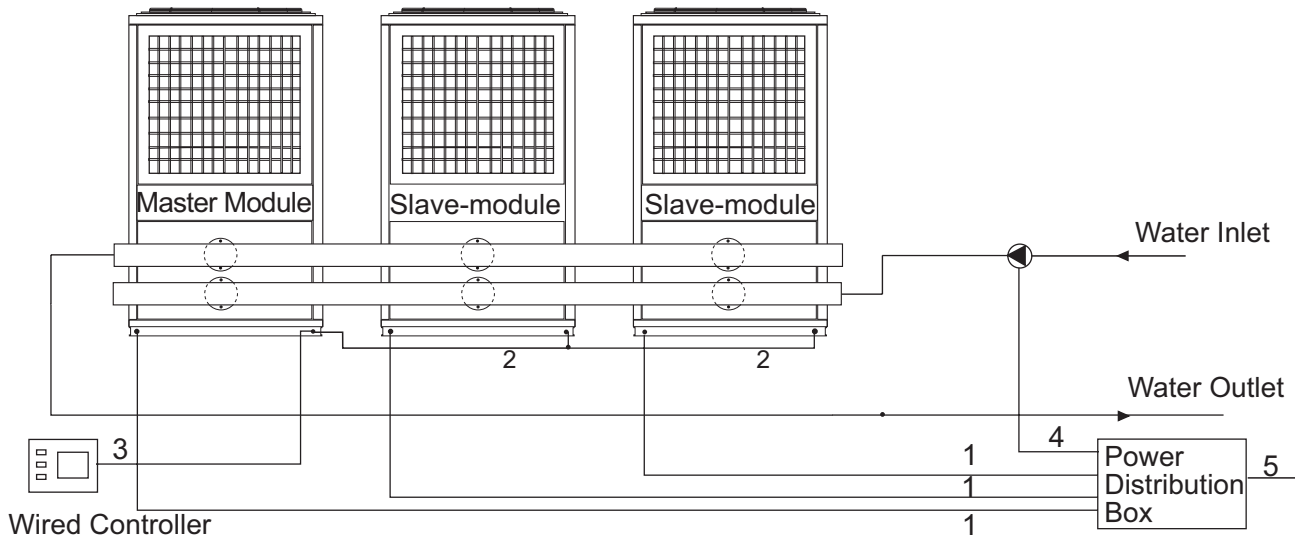

Note:

- 1. Unit Power Supply Cord
- 2. Module-based Unit Communication Wire
- 3. Unit Operation Controller Wiring
- 4. Water Pump Power Cord
- 5. Cable to Unit Power Distribution Box

Note:

1. The connecting wire of the unit only refer to the power wire for power supply and communication control wire. The control wire in the electric box attached with the unit had been connected properly before they left factory, the user shall not change by themselves.

2. The working currents of the unit are shown in the following table, when wiring, it must to ensure the unit can work normally.

Unit Model	Rate Current	Maximum Current	Locked-rotor Current	Reference Cable Sectional Area
CA0100AANB CA0100MANB	52.5A	67.5A	(130x3)A	5X25mm ²

8. Wiring diagrams

a. The unit wiring diagram

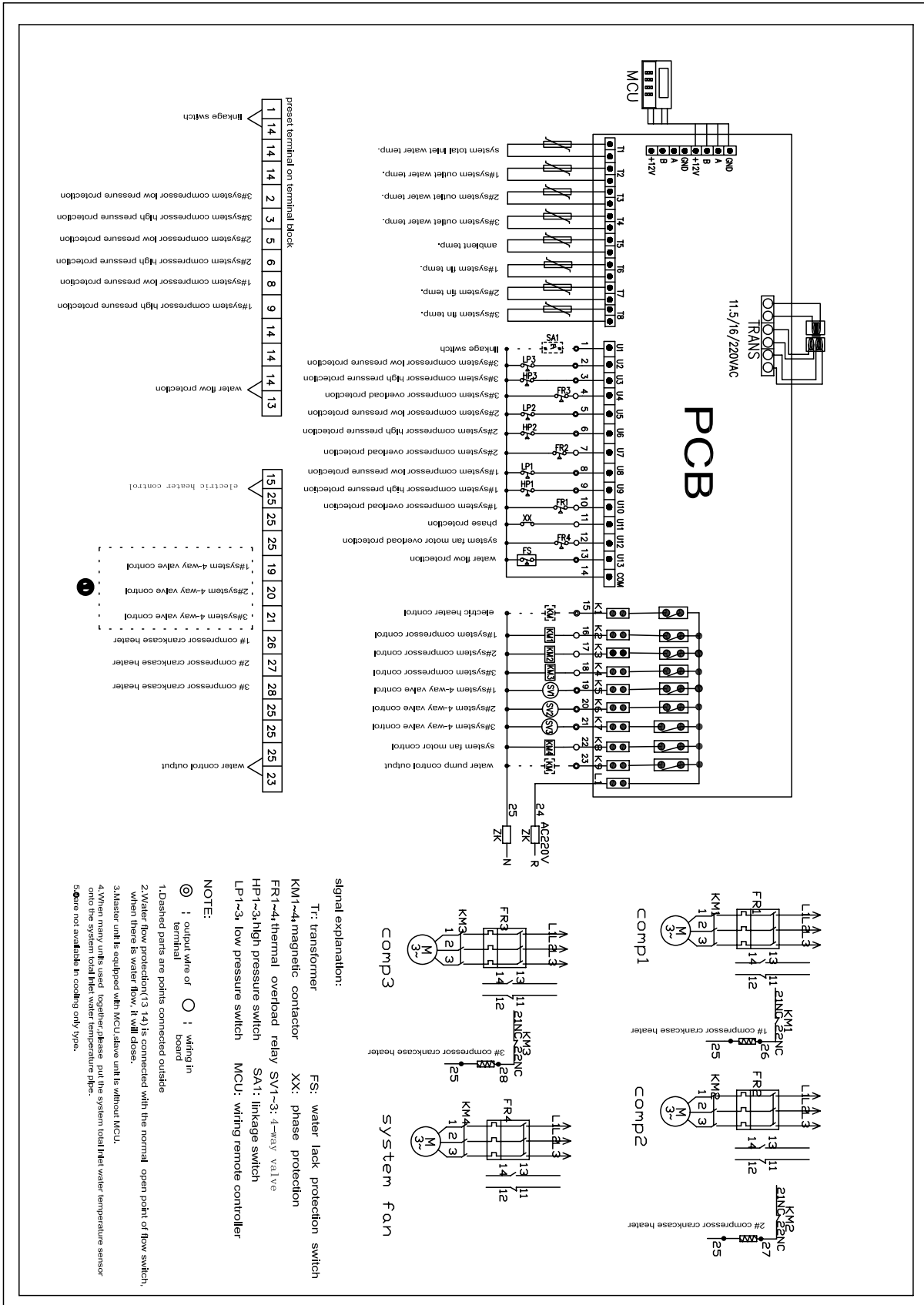

0010452203 for CA0100AANB

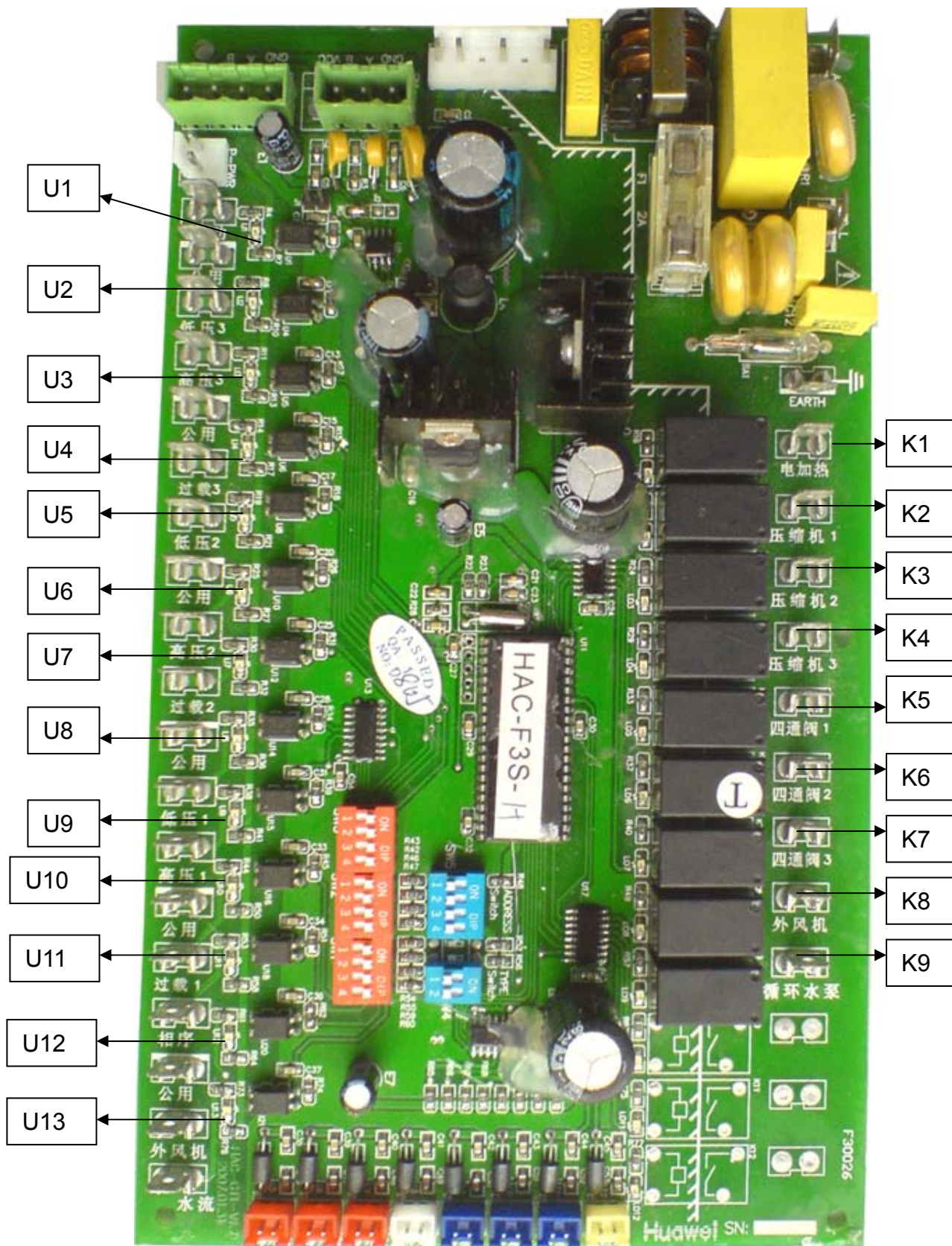

b. The driving wiring diagram

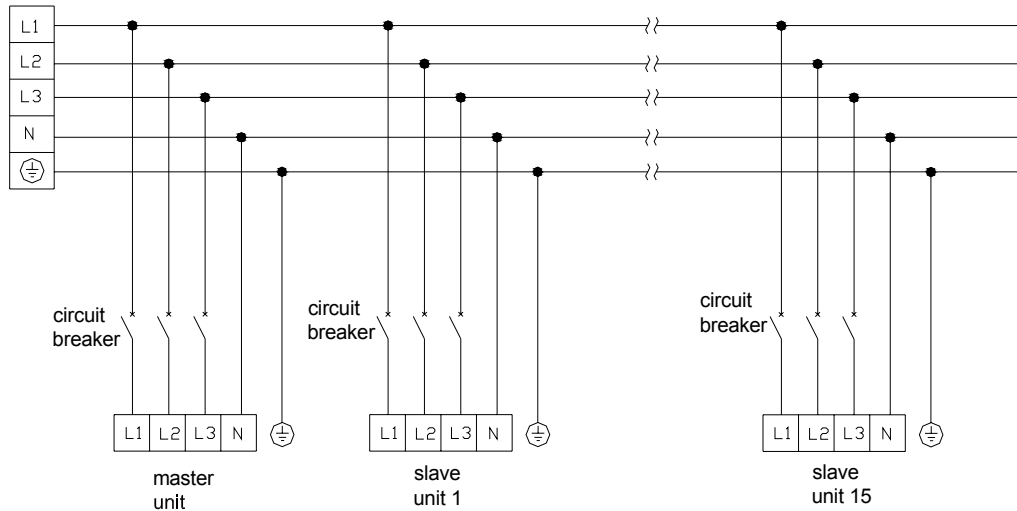

c. The communication wiring diagram

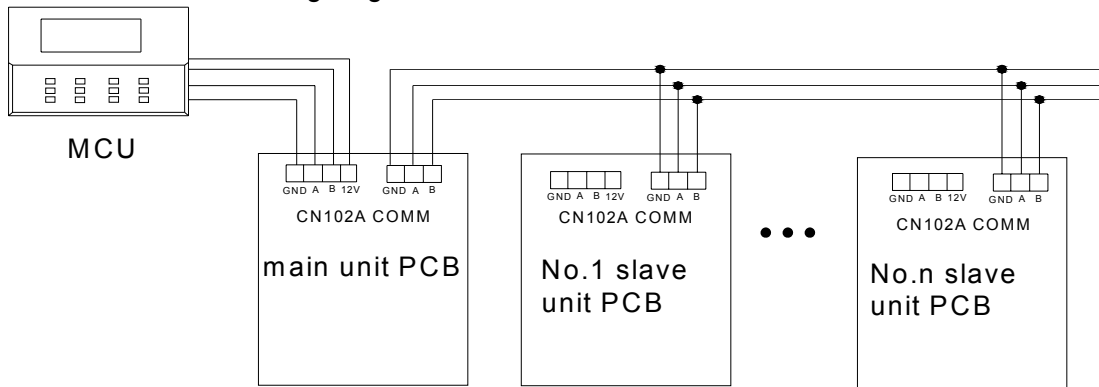

9. Auxiliary electric heating function control

The auxiliary electric heating function will be performed in low ambient temperature. Connect the water inlet/outlet pipe with auxiliary electric heater to the total water inlet/outlet pipe, in the electric control box of the master module, there is the control port of auxiliary electric heating (only with 220V output, not supply the electric heating control part).

10. Water pump operation control (valid when water pump and the unit controlled simultaneously)

In the electric control box, there is the frozen water pump simultaneous control port (only with 220V output, not supply the water pump control part). When the unit is in standby state, water pump will not start up; when the unit enters working state from standby state, start up water pump firstly; when the unit enters standby state from working state or stop state, 30seconds later, water pump will stop automatically. In stop state, when water outlet temp. is no more than 3 degree and more than 2 degree, the water pump will start up; when water outlet temp. is no more than 2 degree, start up one module in heating and stop until water temp. arrives 8 degree.

11. The terminal simultaneous control

Connect the passive port of the terminal controller to the simultaneous control port in the controller of the master module unit. When the unit is running and the controller is in simultaneous control state, when one of terminal unit starts up, the chiller system will start up automatically. When all the terminal units stop, the chiller system will stop later.

When in electric wiring, please pay attention to the following:

- a. The wires are the power supply cable and the communication wire. The wires with the unit have been fixed properly, and should not be modified by the user. Use four-core shield wire when install the communication wire and earth one end of the shield layer. Do not put the communication wire and high voltage wire together, or the communication error will occur.
- b. The unit running current is as below table:

model	Rated current	Max. current	Rocked current	Cable section for reference
CA0100*	52.5A	67.5A	(130*3)A	5*24mm ²

12. Wired controller functions

Display screen:

Panel display

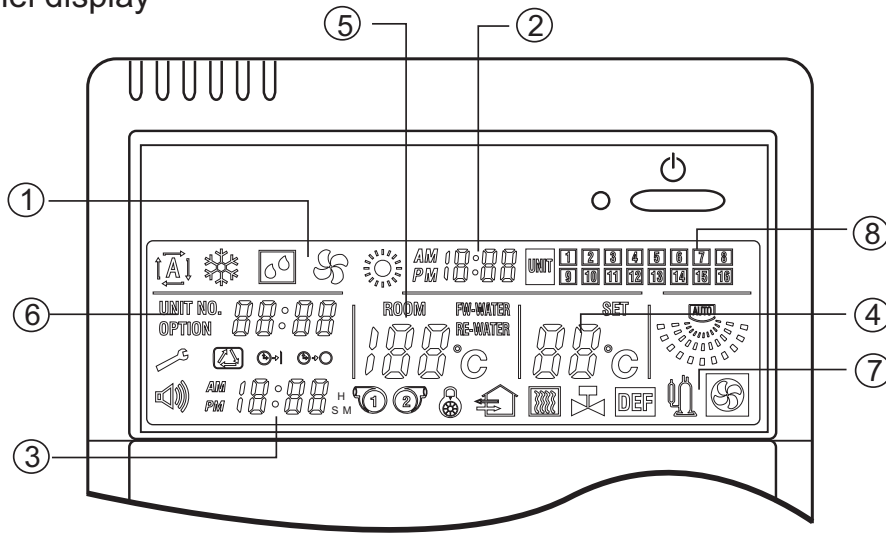

① Mode display



② Clock display



③ Timer setting display

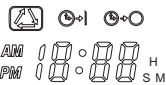

When the appliance is in search or setting mode and time parameter operation, this zone displays mode and time parameter.

④ Time-setting display



⑤ Temperature display



⑥ Code display

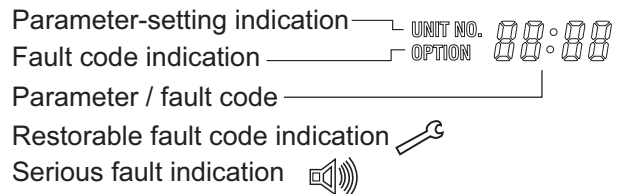

⑦ Output equipment display

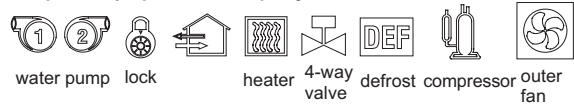

⑧ Unit number displaying zone



Keypad of wired controller

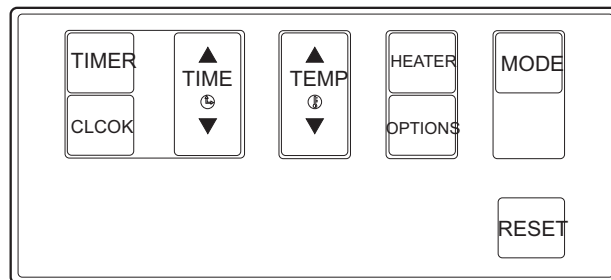

Controller system is constituted by 1 to 16 HAC-F3S-H PCB and one or many MCU. parallel connect each MCU when use many MCU.

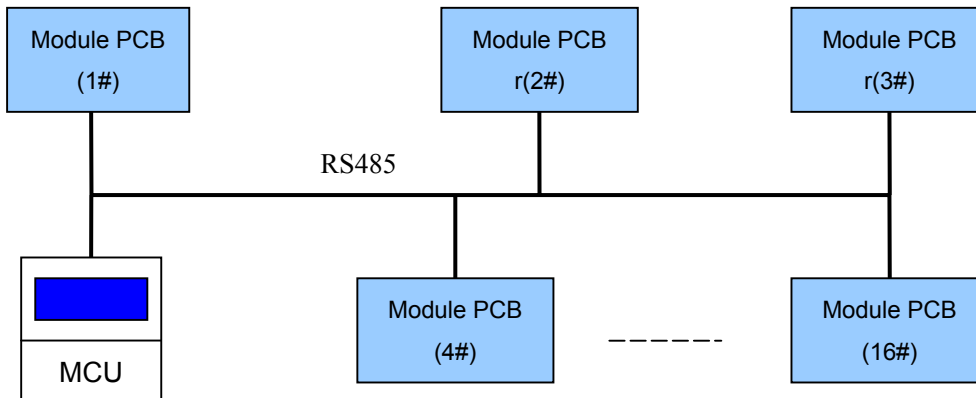

There should be at least one main module PCB in the system, the address of which is 0000 and the No. is 1#. From the module PCB can connect max. 15 and address can be setted from 0001 to 1111, set No. from 2# to 15#. Each PCB must be setted address differently in the system.

Setting method of module number

1. Press the DOWN, M and T button.
2. Input the password (0000) to come into the program.
3. Press S button after you input four zero.
4. The LED will display six code(A, B, C, D, E, F). They stand for six kind of data.
 A --- unfreeze data
 B --- work temp
 C --- protect
 D --- work data
 E --- password setting
 F --- number module setting
5. Press UP or DOWN to choose F and S to confirm it.
6. You will see an "A" symbol.
7. Press DOWN button, "B" will be added. And repeat press DOWN, "C" will be added. Repeat this process till A B C D E F displayed.
8. Press M button twice to quit the program.
9. The LED will display "---" after you quit the program and last 26 seconds or so. The program is resetting during this period.
10. Start the chiller according to normal process

12.1 Operation and guidance

There are 11 Touch buttons on the control panel for On/Off operation, mode selection, parameter query,

temperature setting, clock setting, timer setting, reset/dark. General layout of all touch buttons is illustrated in the above diagram. Press valid button once or receive signal by remote control, LCD will display the corresponding mode, backlight lightens, the buzzer gives a beep, and backlight is off 10 seconds later automatically.

12.2 Control functions

1. Working mode: cooling → heating
2. Working method: auto running operation
3. Monitor type: real time monitoring (resumable fault, serious fault protection): query display (real time temperature detection)
4. Intelligent operation when a sensor fault occurs.
5. LCD backlight (yellow/green light, blue light, white light)
6. Fault alarm
7. Remote receiving function (informed before being ordered)
8. Resumable fault protection
9. Serious fault protection.

12.3 Buttons operation instructions

12.3.1 Clock adjustment

Press [CLOCK] into the clock adjustment. Firstly the minute indicator flashes, which shows that you can adjust clock by pressing [▲] and [▼] keys. Press [▲] once, the number is increased by 1, press time key [▼] once, the number is decreased by 1. If pressing time [▲] and [▼] keys for a long time, the number will increase and decrease automatically.

Press [CLOCK] again in the minute setting mode to enter hour setting mode.

Time adjustment can be cycled by pressing [CLOCK] key. If the controller is not operated within a fixed period of time, it will quit time adjustment automatically.

12.3.2 Timer setting

Press [TIMER] to enter timer setting. Timer setting sequence is as follows: minute setting of TIMER ON, hour setting of TIMER ON, minute setting of TIMER OFF, hour setting of TIMER OFF, repeating/combination timer setting, cancellation of timer setting.

In the timer setting mode, the adjustment of [▲] and [▼] keys is as the same as clock adjustment.

12.3.3 On/Off operation

When unit is off, red indicator of controller lightens. Start up the unit by pressing [On/Off].

When unit is on, green indicator of controller lightens. Stop the unit by pressing [On/Off].

Caution: if the controller is used to set the interlink function of the indoor fan coil and the controller receives no interlink signal, green indicator of controller will lighten when the appliance is working. If serious faults are present, red indicator of controller will lighten.

12.3.4 Mode setting.

Press [MODE] to enter the mode setting. Controller recognizes controller mode automatically. Mode setting cycles between cooling and heating.

12.3.5 Temperature-setting

When the unit is on, you can adjust controller to set temperature. Press the [▲] and [▼] keys, the temperature will increase and decrease accordingly. The max and min temperature values are determined by controller.

12.3.6 Fault query

When a fault occurs, symbol of “unit” glitters and also fault code displays in the fault code displaying zone. Corresponding unit number also glitters at the interval of 2 seconds, press [query] key will display fault code in the fault code displaying zone.

If there are several faults, press [▲] and [▼] key, you can see fault codes in turns.

12.3.7 Temperature query

Press the [QUERY] key, you can check temperatures and unit state. On normal condition, unit number represents the running unit. Press the [QUERY] key, you can chose unit number that is activated, and the chosen unit number glitters quickly at the intervals of 0.5 second.

When the unit is in query mode, press time key [▲] and [▼], you can see fault code in turn. Press temperature key [▲] and [▼], you can see the temperatures of all units.

When the unit temperature is in query mode, the code of sensor from P01 to P08 is shown on the code displaying zone, temperature displaying zone presents the corresponding temperature. The sensor that is not equipped to the controller will not be displayed.

12.3.8 Output equipments status query

When the unit is in query mode, equipment output status will be shown on the controller.

12.4 Functions descriptions

12.4.1 System structure

- A. single unit system
- B. Multi units system: integrating an outdoor unit and several indoor units into a centralized controlling system by RS-485 bus. The multi system use one water system; the outdoor unit controls interlinked operation of system pump and other indoor units use the same water system. The master unit harmonizes the whole system, and the slave units are consistent with the master unit. When the working mode of the master unit changes, all slave units change accordingly. When the master unit is off, all slave units can't be turned on.

12.4.2 Unit number setting

The system is a central air conditioner controlling system consisting of one wired controller and 16 modules numbered from 1 to 16. Every controller panel is assigned with a different address according to

the number of system modules used. There is a dip switch which includes 4-digit set on the controlling panel, according to which we can set the module number of unit. After the communication between a module and the wired controller is established, there is one lighting dot representing it on the wired controller.

Diagram of module code number:

Switch 1	Switch 2	Switch 3	Switch 4	Controller No.
OFF	OFF	OFF	OFF	Outdoor unit
OFF	OFF	OFF	ON	Indoor unit 1
OFF	OFF	ON	OFF	Indoor unit 2
OFF	OFF	ON	ON	Indoor unit 3
OFF	ON	OFF	OFF	Indoor unit 4
OFF	ON	OFF	ON	Indoor unit 5
OFF	ON	ON	OFF	Indoor unit 6
OFF	ON	ON	ON	Indoor unit 7
ON	OFF	OFF	OFF	Indoor unit 8
ON	OFF	OFF	ON	Indoor unit 9
ON	OFF	ON	OFF	Indoor unit 10
ON	OFF	ON	ON	Indoor unit 11
ON	ON	OFF	OFF	Indoor unit 12
ON	ON	OFF	ON	Indoor unit 13
ON	ON	ON	OFF	Indoor unit 14
ON	ON	ON	ON	Indoor unit 15

Dip switch (TYPE ADDRESS) used to set the unit type

Switch 1	Switch 2	Function name	Function specification
ON	ON	Cooling only	Cooling Only mode
OFF	OFF	Heat pump +electric heat	Cooling, heating, auxiliary electric heating

Caution: Type must be set according to requirements.

12.4.3 Operation modes:

Cooling, heating

12.4.4 Control functions

a. Indoor fan coil interlink function

When setting the indoor fan interlink, control panel detects On/Off mode of the interlink switch at anytime. When one or more indoor fan coils open, interlink switch closes, the system is operates. When all the indoor fan coils close, interlink switch is disconnected for 30s, the system stop working now. When the interlink switch of one indoor fan closes and the indoor fan has been off for at least 3 minutes, the system will restart.

b. Timer On/Off

Timer on, timer off, cycling timer setting and combination timer setting can be chosen through wired controller. Each combination timer setting is valid for within 24 hours and cycling timer setting is valid all the time. The combination timer setting can be selected only when the code [SA09] is set as Off, and the cycling timer setting can be selected only when the code [SA09] is set On.

c. Temperature sensor compensation

In some special cases, if the sensor lead is too long or the installation of indoor fan is limited by installing space, the measured temperature of sensor needs compensation and correction. This function can be achieved by revising code [PC01] and [PC08]. If one code is set as cancelled "---", it means the respective temperature sensor is cancelled. Corresponding function and protection function will be cancelled as well.

d. Unit power-off memory**e. Fault alarm and query****f. Return water temperature, environment temperature and coil pipe temperature display and query.****g. Unit operating code set and reset****h. System clock set and display****i. Compressor operating average energy consumption**

The system records the operation time of every compressor separately, those with a shorter operation time will start first when the system starts, and those with a longer time will close first when the system closes.

j. Defrosting options**12.4.5 Protection and safety****a. Over-load protection for cooling operation**

The outdoor coil temp. will rise if the cooling load too high, when the temperature is higher than [EP02], over-load protection will be activated.

b. Over-temperature protection for heating operation

When the system is in the process of heating, in order to avoid fault of inner coil pipe due to over-temperature, if the return water temperature is higher than [EP04], over-temperature protection will be activated.

c. Frost-proof in winter

In order to avoid circulated water being frozen in the winter, controller will protect the system according to code [EP07]. Controller has 2-level frost-proof protection, the Level 1 protection starts the circulating pump, auxiliary electric heating at a fixed intervals. The Level 2 protection starts the heating system of compressor to heat the circulated water.

d. Flow protection switch

When there is no or little water flow in the pipe, the switch will cut off the control circuit to close the unit, protect the unit and compressor.

e. Overload protection of compressor

There is a crankcase-heater and a thermal overload relay equipped on the compressor. Crankcase-heater can preheat the lubrication oil to make sure that the compressor is adequately lubricated. Thermal overload relay can prevent damage of compressor.

12.5 Parameter-setting display and parameter-setting

12.5.1 Parameter display

When the appliance is operating or in standby mode, press “query” key to check the system temp.:

No.	Parameter code	Code number
1	P01	general return water temperature of the system
2	P02	Liquid pipe of 1# system
3	P03	Liquid pipe of 2# system
4	P04	Liquid pipe of 3# system
5	P05	Outdoor temperature
6	P06	1# coil pipe temperature
7	P07	2# coil pipe temperature
8	P08	3# coil pipe temperature

12.5.2 Parameter-setting method

When the appliance is off, pressing [query] key for 5 seconds until the wired controller gives a beep then let it go to enter code-setting operation.

12.5.3 System function parameter selection

Parameter name	Unit number	Original setup	ON	OFF
Defrost option	SA04	OFF	Defrosting during compressor operation	Defrosting at intervals of compressor operation
Mode option	SA07	OFF	Operating mode can be changed when the appliance is in stand-by mode or in operating mode	Operating mode can not be changed when the appliance is in operating mode
Power-failure compensation	SA08	OFF	Controller remains the original mode set after the power supply is restored.	Controller remains off after the power supply is restored.
Combination and cycling timer setting option	SA09	ON	Cycling timer setting (cycling every 24 hours)	Combination timer setting (timer-setting is valid for 24 hours)
Interlink function	SA10	OFF	Terminal interlink is allowed	Terminal interlink is not allowed

12.5.4 Temperature sensor compensation parameter

Parameter name	Unit number	Original setup	min	max	cancellation
General return water temperature	PC01	0 °C	-9 °C	9 °C	(1)
1# liquid pipe temperature	PC02	0 °C	-9 °C	9 °C	--
2# liquid pipe temperature	PC03	0 °C	-9 °C	9 °C	--
3# liquid pipe temperature	PC04	0 °C	-9 °C	9 °C	--
Outside environment temperature	PC05	0 °C	-9 °C	9 °C	--
1# external pipe temperature	PC06	0 °C	-9 °C	9 °C	--
2# external pipe temperature	PC07	0 °C	-9 °C	9 °C	--
3# external pipe temperature	PC08	0 °C	-9 °C	9 °C	--

12.5.5 System operating temperature parameter

Parameter name	Unit number	Original setup	Max	Min	cancellation
Loading water return difference temperature	SP01	2°C	5°C	1°C	
Unloading water return difference temperature	SP02	2°C	5°C	1°C	
Cooling external circuit temperature	SP05	15°C	50°C	0°C	--
Heating external circuit temperature	SP06	25°C	50°C	0°C	--

12.5.6 System operating temperature parameter

Parameter name	Unit number	Original setup	Max	Min	cancellation
Loading water return difference temperature	SP01	2°C	10°C	1°C	
Unloading water return difference temperature	SP02	2°C	10°C	1°C	
Electric-heating initiating water return temperature	SP03	50°C	70°C	20°C	
Cooling external circuit temperature	SP05	15°C	50°C	0°C	
Heating external circuit temperature	SP06	25°C	50°C	0°C	

12.5.7 System operating time parameter

Parameter name	Unit number	Original setup	Max	Min	Cancellation
Interval between temperature detections	SC01	10sec	120sec	1sec	
Interval between start-ups	SC02	30 sec	120sec	5sec	
Interval between stops	SC03	30 sec	120sec	5sec	
Pre-start time of outdoor fan	SC04	10 sec	60sec	1sec	
Delayed stop time of outdoor fan	SC05	5 sec	60sec	1sec	
Backlight illumination time	SC06	10sec	60sec	3sec	--
LCD illumination time during parameter searching	SC07	10sec	30sec	3sec	

12.5.8 Protection temperature parameter

Name	Unit number	Original setup	Max	Min	Cancellation
Cooling and frost-proof protection	EP01	4°C	10°C	-5°C	--
Heating and over-temperature protection	EP04	60°C	80°C	55°C	--
Winter frost-proof protection	EP07	3°C	8°C	-2°C	

12.5.9 Protection time parameter

Name	Unit number	Original setup	Max	Min	Cancellation
Time of compressor startup protection	EC01	3min	10 min	1 min	
Time of compressor operating	EC02	3min	10 min	1 min	
Time of shielded low-side pressure inspection	EC05	30sec	120 sec	0 sec	
Protection duration	EC06	3sec	10 sec	1 sec	
Time of flow switch inspection	EC07	10sec	60 sec	1 sec	

12.5.10 Defrost parameter

Name	Unit number	Original setup	max	min	Cancellation
Defrosting activating external circuit temperature	HF01	8°C	20°C	0°C	
Defrosting activating external and external pipe conditions	HF02	8°C	20°C	1°C	
Defrosting activating external pipe temperature	HF03	-8°C	0°C	-19°C	
Defrosting deactivating external pipe temperature	HF04	10°C	20°C	0°C	
Defrosting activating time condition (cumulative)	HF05	4min	90min	30min	
Defrosting deactivating time condition	HF06	8min	15min	2min	

Caution: The factory settings should not be changed without authorization. The manufacturer will not be responsible for any damages caused thereof.

12.6 Fault alarm and query

12.6.1 Fault parameter display and query

No.	Description	Fault code	Solution	Remarks
1	Transmission error	Eo : 00	Unit stops	Serious fault
2	Open/short circuit of general return water	Eo : 01	Unit stops	Serious fault
3	Main module phase sequence protection	Eo : 03	Unit stops	Serious fault
4	Main module flow protection	Eo : 04	Unit stops	Serious fault
5	1#compressor overload protection	Er: 01	1#compressor stops	Serious fault
6	2#compressor overload protection	Er: 02	2#compressor stops	Serious fault

7	3#compressor overload protection	Er: 03	3#compressor stops	Serious fault
8	1#system high pressure protection	Er: 04	System 1 stops	Serious fault
9	2#system high pressure protection	Er: 05	System 2 stops	Serious fault
10	3#system high pressure protection	Er: 06	System 3 stops	Serious fault
11	Secondary module flow protection	Er: 07	Secondary module stops	Serious fault
12	1#system low pressure protection	Er: 11	System 1 stops	Serious fault
13	2#system low pressure protection	Er: 12	System 2 stops	Serious fault
14	3#system low pressure protection	Er: 13	System 3 stops	Serious fault
15	Open/short circuit of temperature-sensing circuit of liquid pipe 1	Er: 14	System 1 stops	Serious fault
16	Open/short circuit of temperature-sensing circuit of liquid pipe 2	Er: 15	System 2 stops	Serious fault
17	Open/short circuit of temperature-sensing circuit of liquid pipe 3	Er: 16	System 3 stops	Serious fault
18	Outdoor fan overload protection	Er: 17	Unit stops	Serious fault
19	Secondary module phase sequence protection	Er: 18	Secondary module stops	Serious fault
20	Open/short circuit of temperature-sensing circuit of coil pipe 1	Pr: 01	Defrosting without inspection	Restorable
21	Open/short circuit of temperature-sensing circuit of coil pipe 2	Pr: 02	Defrosting without inspection	Restorable
22	Open/short circuit of temperature-sensing circuit of coil pipe 3	Pr: 03	Defrosting without inspection	Restorable
23	Cooling and frost-proof protection of 1 # system	Pr: 04	Protective operating (no maintenance needed)	Restorable
24	Cooling and frost-proof protection of 2 # system	Pr: 05	Protective operating (no maintenance needed)	Restorable
25	Cooling and frost-proof protection of 3 # system	Pr: 06	Protective operating (no maintenance needed)	Restorable
26	Open/short circuit of external circuit temperature-sensing circuit	Po; 01	Defrosting without inspection	Restorable
27	Frost-proof protection in winter	Po; 06	Protective operating (no maintenance needed)	Restorable

12.6.2 When a fault is present, controller gives an alarm and fault module number glisters. Pressing the query key now can show the fault code and the fault can be resolved automatically.

12.6.3 After the fault is resolved, the indication of a serious fault will still display, only after pressing the “reset/dark” key will the system return to operating condition before the fault occurred. As for restorable faults, such as temperature sensor fault, when the fault is resolved, the unit restores automatically.

12.7 Main technical parameter

12.7.1 Running voltage

Transformer of controller: primary side 220V/AC second side ① 16V/AC

Frequency 50HZ second side ② 11.5V/AC

12.7.2 Operation condition

Operation ambient temp.: -10°C — $+60^{\circ}\text{C}$

Preserved ambient temp.: -20°C — $+70^{\circ}\text{C}$

Relative humidity: 40%—98%

12.7.3 Temp. sensor

System total return water temp. sensor: $3470-502 \pm 1\%$

System total outlet water temp. sensor: $3470-502 \pm 1\%$

Module outlet water temp. sensor: $3470-502 \pm 1\%$

Outdoor ambient temp. sensor: $3470-502 \pm 1\%$

1# outdoor coil temp. sensor: $3470-502 \pm 1\%$

2# outdoor coil temp. sensor: $3470-502 \pm 1\%$

3# outdoor coil temp. sensor: $3470-502 \pm 1\%$

12.7.4 Precise

Sample temp. precise of each sensor: $\pm 1^{\circ}\text{C}$

Precise of temp. control: $\pm 1^{\circ}\text{C}$

Timer error in 24 hours is less than 20 seconds

12.7.5 Communication distance

Max. communication distance between controllers: 1.2km

Max. distance when MCU use the power from PCB: 100m

Max. distance when MCU use the power from local: 1.2km

12.7.6 Power output

Compressor: 5A*3 (AC contactor is connected outside)

Outdoor fan motor: 5A (AC contactor is connected outside)

Four-way valve: 5A*3

Cooling(heating) water pump: 5A (AC contactor is connected outside)

Electric heater: 5A (AC contactor is connected outside)

12.8 Inspection before operation

1. Voltage is consistent with requirement; phase voltage and phase current are balanced.
2. Inspecting the power source connection, especially section of the power cord, earthing and connecting terminal.
3. Water pipe must keep clean without impurities. At last, flush the pipe 2 or 3 times (bypassing the system), make sure that all the impurities and oxides have been washed out.
4. make sure that water source has been connected properly, if the water pump is not subject to interlock control, start water pump before starting the unit.
5. Check if the water circulating system works well, water system has enough water, and make sure

that there is no leakage and air bubbles.

12.9 Inspection of operation status

Please inspect the items as follows:

1. Temperature of water entering into the heat exchanger
2. Temperature of water returning from the heat exchanger
3. Flow rate at the exit of the heat exchanger
4. Operating current of compressor upon start-up or during stable operation
5. Operating current of fan upon start-up or during stable operation

When the appliance is in cooling process, please use a built-in spindle valve to inspect the saturated temperature (related to pressure) in the working mode

Referring to the requirements as follows:

1. High pressure side: saturated temperature is about 15-18°C higher than the temperature at the inlet of condenser.
2. Low pressure side: saturated temperature is about 5-7°C lower than temperature at the outlet of condenser.
3. When the appliance is the heating process, the water temperature should not be high than 50°C.

12.10 Operating range:

Cooling	Min	Max
Outdoor temperature	+ 25°C.	+50°C.
Return water temperature	+7°C.	+15°C.

Heating	Min	Max
Outdoor temperature	-10°C.	+25°C.
Water temperature at outlet	+25°C.	+55°C.

13. Control functions

13.1 Cooling mode

13.1.1 Enter cooling mode

Control the system total return water temp.: the setted temp. of cooling mode is 12°C;

Control the system total outlet water temp.: the setted temp. of cooling mode is 12°C;

13.1.2 Startup procedure in cooling condition

PCB will startup the unit as following procedure when PCB performs the start order from MCU, or more than one terminal work in simultaneous control, or time of Timer ON reached.

- a. Running lamp on the MCU changes from red to green;
- b. Main control cooling(heating) water pump start, detect the water flow switch continually;
- c. Module PCB upload or download by the determination of return water temp. or outlet water temp. after the water flow switch working normally.

13.1.3 Stop procedure in cooling condition

PCB will stop the unit as following procedure when PCB performs the stop order from MCU, or all terminals stop, or time of Timer OFF reached, or stops because of error.

- a. Running lamp on the MCU changes from green to red;
- b. Compressors ordinal stop, the interval time is 5 seconds;
- c. Outdoor fan motor time-delay [SC05] close when all the compressors in module have closed;
- d. Cooling(heating) water pump close 1 minute later.

13.1.4 Cooling temp. control procedure

MCU control the start/stop of compressor by comparing the total return or outlet water temp. $T_{tr/o}$ of the master module with the setting temp. T_s during cooling.

Control the system total return water temp.: the setted temp. of MCU is 10°C--25°C;

Control the system total outlet water temp.: the setted temp. of MCU is 5°C--25°C;

When $T_{tr/o} \geq T_s + [SP01]$, MCU enter upload area, compressor will begain cooling if it can meet the startup protect time $\geq [EC01]$; When $T_{tr/o} < T_s$, MCU enter download area, compressor will standby if it can meet the startup protect time $\geq [EC02]$; When $T_s \geq T_{tr/o} > T_s + [SP01]$, the compressor will keep its original state, there is a setted difference temp. [SP01] to prevent compressor from conversing ON/OFF frequently; When $T_{tr/o} < T_s - [SP01]$, PCB entering Emergency stop area and all stop at the 5 seconds interval.

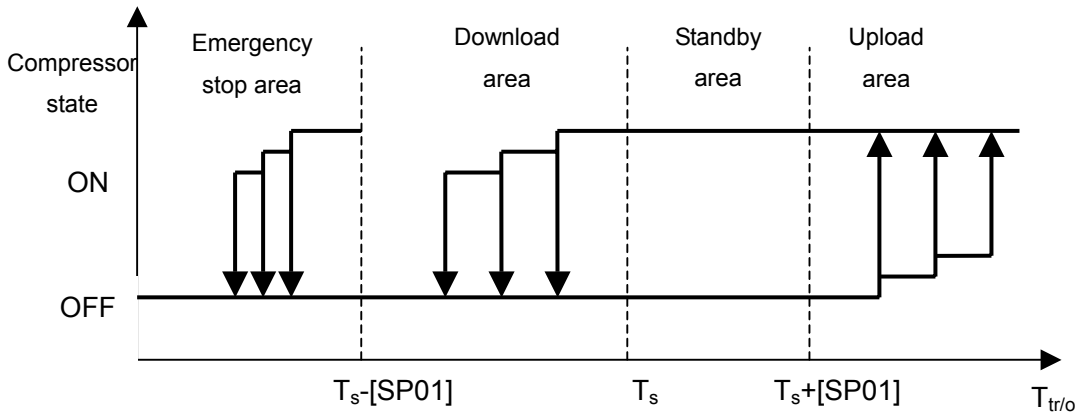

Fig. 14-1 Compressor running diagram in cooling mode

13.1.5 Cooling (heating) water pump running regulation

Cooling (heating) water pump will startup when PCB working or protection in winter, the working of pump is concerned with the state of water flow switch.

a. The water pump PCB detect water flow switch continually after the pump working for 10 seconds. If water flow switch OFF, enter normal running state.

b. When pump has started for 10 seconds or during working, if the water flow switch of master module keep opening for [EC07], all equipments of system will stop, [UNIT] will flash and display failure code [Eo:04]. if the water flow switch of slave module keep opening for [EC07], all equipments of this module will stop, the corresponding module No. will flash and display failure code [Eo:07].

13.1.6 Protection during cooling state

PCB will detect the possible failure when working and manage accordingly under cooling mode.

a. Anti-freeze protection (failure code [Pr:07])

Start conditions for anti-freeze protection:

- ① Compressor works;
- ② Water outlet temp. $T_{ou} < [EP01]$ and keeps for 1 minute.

When enter anti-freeze protection, the corresponding module No. will flash and display failure code [Pr:07] on MCU, all compressors in the corresponding module will stop for protection.

Quit conditions for anti-freeze protection:

- ① Water outlet temp. $T_{ou} \geq [EP01] + 3^\circ\text{C}$, failure disappear;
- ② Resume cooling after compressor meet the stop time of protection.

b. Temp. sensor failure protection

① When the system total return temp. sensor damage, the system [UNIT] will flash and display [Eo:01] code, system will stop for protection;

② When the system total outlet temp. sensor damage, the system [UNIT] will flash and display [Eo:02] code, module will stop for protection;

③ When the module total outlet temp. sensor damage, the corresponding module No. will flash and

display [Er:08] code, the corresponding module will stop for protection;

④ When the outdoor ambient temp. sensor damage, the system [UNIT] will flash and display [Po:01] code;

⑤ When the condenser coil temp. sensor of No.1 module damage, the corresponding module No. will flash and display [Pr:01] code;

⑥ When the condenser coil temp. sensor of No.2 module damage, the corresponding module No. will flash and display [Pr:02] code;

⑦ When the condenser coil temp. sensor of No.3 module damage, the corresponding module No. will flash and display [Pr:03] code;

13.2 Heating mode

13.2.1 Enter heating mode

Control the system total return water temp.: the setted temp. of heating mode is 40°C;

Control the system total outlet water temp.: the setted temp. of heating mode is 40°C;

13.2.2 Startup procedure in heating condition

PCB will startup the unit as following procedure when PCB performs the start order from MCU, or more than one terminal work in simultaneous control, or time of Timer ON reached.

- a. Running lamp on the MCU changes from red to green;
- b. Main control cooling(heating) water pump start, detect the water flow switch continually;
- c. The 4-way vlave will open and enter standby state after the water flow switch working normally.
- d. Module PCB upload or download by the determination of return water temp. or outlet water temp. after the water flow switch working normally.

13.2.3 Stop procedure in heating condition

PCB will stop the unit as following procedure when PCB performs the stop order from MCU, or all terminals stop, or time of Timer OFF reached, or stops because of error.

- a. Running lamp on the MCU changes from green to red;
- b. Compressors ordinal stop, the interval time is 5 seconds;
- c. Outdoor fan motor time-delay [SC05] close when all the compressors in module have closed;
- d. Cooling(heating) water pump and 4-way valve close 1 minute later.

13.2.4 Heating temp. control procedure

MCU control the start/stop of compressor by comparing the total return or outlet water temp. $T_{tr/o}$ of the master module with the setting temp. T_s during heating.

Control the system total return water temp.: the setted temp. of MCU is 25°C--45°C;

Control the system total outlet water temp.: the setted temp. of MCU is 25°C--50°C;

When $T_{tr/o} \leq T_s - [SP01]$, MCU enter upload area, compressor will begain heating if it can meet the startup protect time $\geq [EC01]$; When $T_{tr/o} > T_s$, MCU enter download area, compressor will standby if it can meet the

startup protect time \geq [EC02]; When $T_s - [SP01] < T_{tr/o} \leq T_s$, the compressor will keep its original state, there is a setted difference temp. [SP01] to prevent compressor from conversing ON/OFF frequently; When $T_{tr/o} > T_s + [SP02]$, PCB entering Emergency stop area.

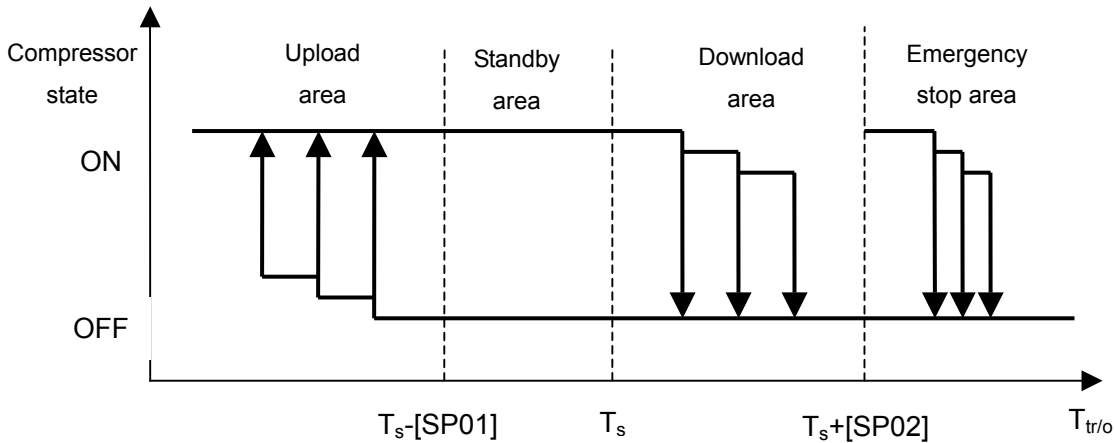

Fig. 14-2 Compressor running diagram in heating mode

13.2.5 Protection during heating state

PCB will detect the possible failure when working and manage accordingly under heating mode.

a. Overheating protection (failure code [Pr:08])

Start conditions for overheating protection:

① If water outlet temp. of module T_{ou} rise, when $T_{ou} \geq [EP04]$, enter overheating protection;

② When enter overheating protection, the corresponding module No. will flash and display failure code [Pr:08] on MCU, compressor and outdoor fan motor will stop, cooling (heating) water pump will keep running and will stop when $T_{ou} < [EP04] - 4^\circ\text{C}$, compressor will begin heating according to the flow when the start conditions of compressor are metted.

b. Auxiliary electric heating procedure

Auxiliary electric heating will work when all the following conditions are metted:

① Auxiliary electric heating has been allowed by MCU (electric heating is defaulted as working when unit start);

② When select heat pump+ electric heating mode, outdoor ambient temp. $T_{oa} < [EP06]$;

③ When select heat pump+ electric heating mode, $T_s - T_{tr/o} > 2^\circ\text{C}$.

Electric heating will stop if any condition as the following is metted:

① Water outlet temp. sensor damage;

② The temp. of stop condition is metted;

③ Overheating protection.

c. Temp. sensor failure protection

① When the system total return temp. sensor damage, the system [UNIT] will flash and display [Eo:01]

code, system will stop for protection;

② When the system total outlet temp. sensor damage, the system [UNIT] will flash and display [Eo:02] code, module will stop for protection;

③ When the module total outlet temp. sensor damage, the corresponding module No. will flash and display [Er:08] code, the corresponding module will stop for protection;

④ When the outdoor ambient temp. sensor damage, the system [UNIT] will flash and display [Po:01] code, cancel the enter condition of system defrost by outdoor ambient temp. sensor, system will enter defrost by judging the coil temp. sensor of condenser;

⑤ When condenser the coil temp. sensor of No.1 module damage, the corresponding module No. will flash and display [Pr:01] code, cancel the enter condition of corresponding module defrost by outdoor ambient temp. sensor, enter defrost as other modules;

⑥ When the condenser coil temp. sensor of No.2 module damage, the corresponding module No. will flash and display [Pr:02] code, cancel the enter condition of corresponding module defrost by outdoor ambient temp. sensor, enter defrost as other modules;

⑦ When the condenser coil temp. sensor of No.3 module damage, the corresponding module No. will flash and display [Pr:03] code, cancel the enter condition of corresponding module defrost by outdoor ambient temp. sensor, enter defrost as other modules.

Note: If all the condenser coil temp. sensors damage, defrost in timer defrost mode.

d. Anti-freeze protection in winter (failure code [Pr:06])

It is needed to use anti-freeze protection in winter to prevent heating or cooling water from freezing when unit stops during winter, Start conditions for anti-freeze protection:

① The unit stops;

② When the system water total return temp. T_{tr} or system water total outlet temp. $T_{tou} \leq [EP07] + 3^{\circ}\text{C}$, enter anti-freeze protection, cooling (heating) water pump start, run for 5 minutes and then stop for 30 minutes. When $T_{tou} \leq [EP07]$, compressor enter heating mode, auxiliary electric heating will working.

When enter anti-freeze protection, system [UNIT] will flash and display failure code [Po:06] on MCU, quit the protection when the following conditions are metted:

① Air conditioner startup;

② When the system water total return temp. T_{tr} and system water total outlet temp. $T_{tou} \geq [EP07] + 6^{\circ}\text{C}$, quit anti-freeze protection;

③ water flow abnormal.

13.3 Defrost operation

13.3.1 Start conditions for defrost

a. Compressor accumulative running time

The influence of outdoor ambient temp. can be selected to be considered or not when accumulate the running time according to [PC04] and [HF01] parameters.

If the compressor accumulative running time over the setted value [HF05], one of the enter conditions is metted.

b. Temp. difference condition between outdoor coil and outdoor ambient temp.

Outdoor coil temp. T_{oc} will be lower than outdoor ambient temp. T_{oa} for the heating operation of compressor, if set [HF02] parameter, defrost can be started when $T_{oa}-T_{oc} \geq [HF02]$. If [HF02] is setted cancel, Outdoor coil temp. sensor and outdoor ambient temp. sensor are damage, this condition is cancelled.

c. Outdoor coil temp. condition

Outdoor coil temp. condition is determined by [HF03] parameter. Deforst will not startup untill $T_{oc} \leq [HF03]$ is metted. If [HF02] and [HF03] are valid synchronously, enter defrost when both are metted. If neither [HF02] or [HF03] is cancelled or outdoor coil temp. sensor damage, enter defrost when time condition is metted.

13.3.2 Multi units defrost simultaneously

If one unit of the modules meet the above single unit deforst enter conditions, other units will enter defrost together and ignore the coil temp. condition.

13.3.3 Quit conditions for defrost

After entering defrost, running at least 3 minutes, then judge if deforst can be quited according to the transformation of compressor pressure, coil temp. and deforst time, deforst can be quited if any one of the conditions is metted.

a. Quit deforst when compressor in high pressure

When compressor defrost and cause pressure rise, after high pressure switch open, the unit will quit defrost.

b. Outdoor coil temp.

When compressor defrost and cause outdoor coil temp. rise, when $T_{oc} \geq [HF04]$, the unit will quit defrost.

c. Time condition for quit deforst

[HF06] has been setted the longest time for deforsting, when deforst exceed the setted time [HF06], deforst will quited no matter the outdoor coil has metted the setted value [HF04] or not.

13.3.4 Quit condition for multi units defrost simultaneously

if there are other units defrost when one unit meet the quit conditions, the unit will stop and standby untill all the units are quit seforst and then heating again.

13.3.5 Deforst procedure

[SA04] has setted two deforst procedure: when set [SA04] ON, compressor will change to defrost directly without stop; when set [SA04] OFF, compressor will stop firstly and began deforsting after 4-way valve has conversed.

14 Maintenance

Note: Before performing any maintenance and repair to the unit, please cut off power supply. Electricity leakage will cause body injury.

In order to exert the unit's performance fully, must pay attention to the following items:

a. Electric connection: The cables for communication must be shielded and protected by means of single-end earthing. Wiring of communication cables together with power cables is prohibited. the power supply provided should be within the compressor permitted range. Confirm there is no wrong connection in terminals and the main panel of AC contact, etc. Confirm all the electric connections are not loose; all the electric components (AC contactor and relay, etc.) are connected firmly and safely. Especially pay attention to the condition of the connecting wire between control components and electric control box and power cord. The power wire shall not be warped, and the insulation cover shall not have cracks and cut. Check the energy consumption in starting and operating the unit is in the permitted range.

b. Water system connection: confirm the water system does not leak water. If the unit has not been used for a long period, it is necessary to open the drain valve of the water pump to empty the water pump, tube pipe or shell pipe type heat exchanger and all the water in the pipes. If the ambient temperature may drop below 0°C, it is more necessary to be done. If the water in the unit is not emptied, the main switch of the power supply must keep close, and the unit is set in heating mode, thus it can prevent from freezing by the heating temperature sensor. Do be careful when cleaning the filter

c. Cleaning of tube in tube (shell&tube) heat exchanger: when using the unit, for example, when using hard water, sometimes it will produce dirty. In this condition, it is recommended to install the filter to remove dirty. The heat exchanger shall use cleaning solution to be washed; the solution can be weak acid solution, use pump to drive the cleaning solution in the heat exchanger.

In order to fulfill a better cleaning effect, the circulation flow speed of the acid solution shall be 1.5 times of normal water flow, if can use acid solution to wash the pipe in an opposite direction again, the effect will be better. Finally, use a large amount of water to repeatedly wash the acid solution clean. The unit shall be cleaned periodically, not until the unit is blocked. The cleaning frequency is determined by the water quality being used, but generally, once a year is rather reasonable.

d. Refrigerant circuit: Confirm the refrigerant and refrigerant oil does not leak from the compressor. Check if the pressure in the high/low pressure side is normal. Check the inside cleanness of the plate type heat exchanger by pressure drop.

e. Control: Check and the location of the total return water temperature sensor and the temperature difference, and then make adjustments accordingly. Check the operation of all relays, high/low pressure protection device and controls.

MAINTENANCE

a. Before replacing any component of the refrigeration circulation, make sure the refrigerant has been evacuated from both the high side and the low side of the unit. The control elements of refrigeration system are highly sensitive and they must be handled very carefully if a replacement is required. Make sure they are not overheated during the welding process by protecting them with wet cloth. The parts should not be exposed to the oxyacetylene flame directly.

b. If needing to replace the refrigerant of the unit, its quantity shall be in accordance with the data on the nameplate. Before replacing, the previous gas must be released as empty as possible.

c. During operation, all the panels must be installed properly, including the panel on the control box.

d. If it must cut the pipes of the refrigerant circuit, the pipe cutter must be used, do not use the tools that will produce copper scraps. All the pipes of the refrigerant circuit are copper pipes special for cooling.

Sincere Forever

Haier Group

Haier Industrial Park, No.1, Haier Road

266101, Qingdao, China

<http://www.haier.com>