



# Table of Contents

<b>Introduction</b>	<b>3</b>
<b>Important Notes on Servicing</b>	<b>3</b>
<b>Ordering Replacement Parts</b>	<b>3</b>
<b>Block Diagrams</b>	<b>4</b>
<b>Start up Procedure</b>	<b>5</b>
<b>Protection Modes and Indicators</b>	<b>6</b>
<b>Troubleshooting Guide</b>	<b>7</b>
<b>Output Transistors Testing and Replacement</b>	<b>8</b>
<b>Calibrations and Adjustments</b>	<b>9</b>
<b>Parts List</b>	<b>10</b>
<b>Updates</b>	<b>11</b>
<b>Fuses</b>	<b>12</b>
<b>Voltage Change</b>	<b>12</b>
<b>IR Interface Information</b>	<b>13</b>
<b>Schematics</b>	<b>14</b>

The contents of this document as well as the files associated with it contain confidential information that is proprietary to Classé Audio Incorporated and are intended solely for the purpose of servicing product. No part of its contents may be used, copied, disclosed, or conveyed to any party in any manner whatsoever without prior written permission from Classé Audio Incorporated.

# Introduction

Please read this manual carefully before commencing servicing!  
Only qualified and authorized personnel should attempt to service this product.



The lightning flash with arrowhead symbol, within an equilateral triangle, is intended to alert the user to the presence of uninsulated dangerous voltage within the product's enclosure that may be of sufficient magnitude to constitute a risk of electric shock to persons.



The exclamation point within an equilateral triangle is intended to alert the user to the presence of important operating and maintenance (servicing) instructions.

Classé has a global product support network. For product assistance or to order replacement parts please contact your nearest service center always quoting the unit serial number.

## North America

Phone: (978) 664-2870 E-mail: [classe@bwgroupusa.com](mailto:classe@bwgroupusa.com)

## Europe

Phone: 44 (0) 1903 221 700 E-mail: [classe@bwgroup.com](mailto:classe@bwgroup.com)

## Asia

Phone: (852) 2790 8903 E-mail: [classe@bwgroup.hk](mailto:classe@bwgroup.hk)

## Rest of the World

Phone: (514) 636-6384 E-mail: [cservice@classeaudio.com](mailto:cservice@classeaudio.com)

# Important Notes on Servicing

1. ALWAYS observe ESD precautions when handling electronic modules or PCBAs.
2. NEVER exchange boards with a different revision number, unless authorized by Classé.
3. ALWAYS use Classé original replacement parts. The use of generic parts may void the warranty of the unit.

# Ordering Replacement Parts

There may be a delay in processing incomplete requests. Please be sure to include all required information. Remember to quote the serial number of the unit on all replacement part orders and the Classé order number when returning defective parts for credit.

# Block diagrams

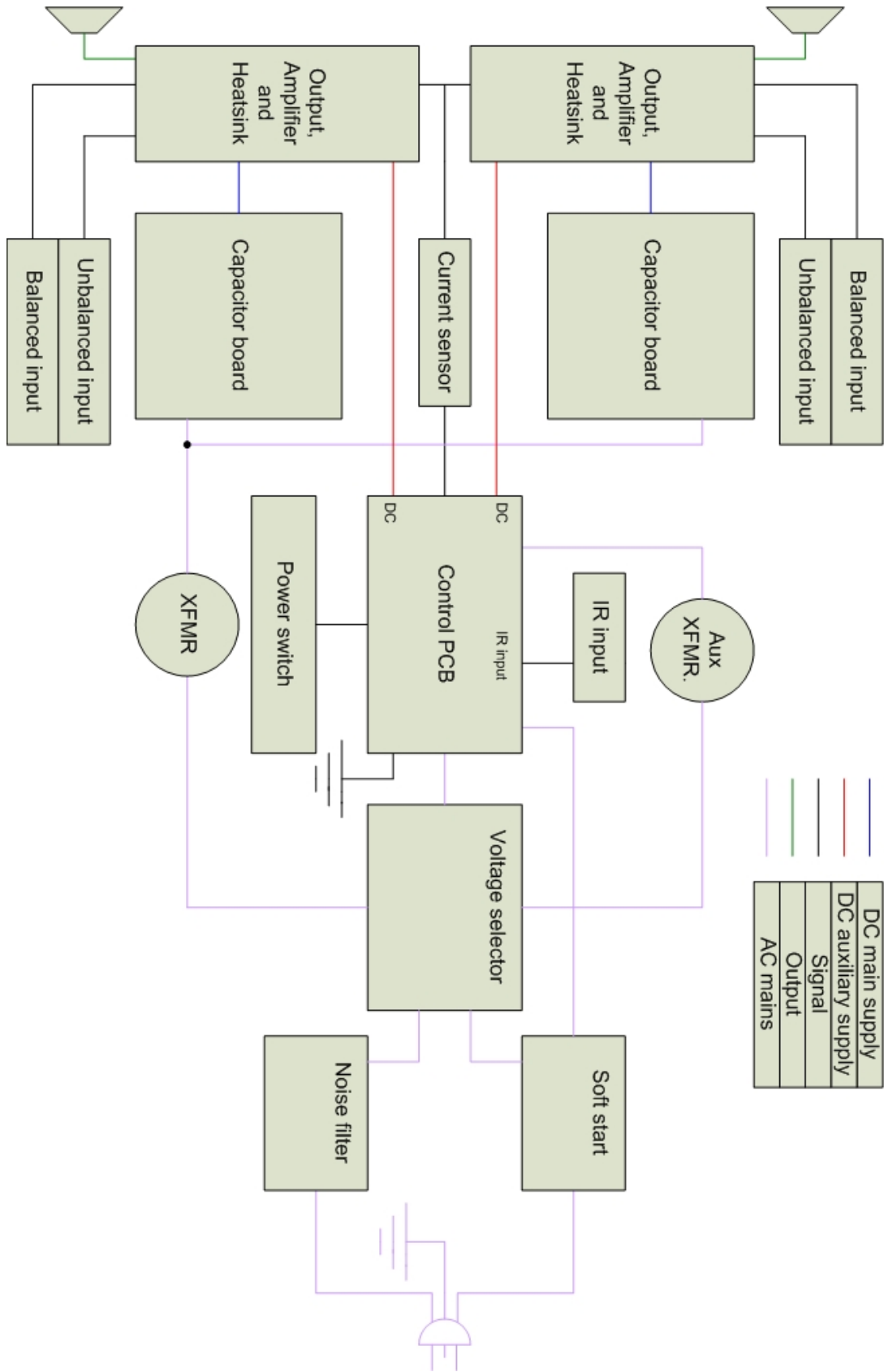

# Start Up Procedure

When receiving a unit, an assiduous visual inspection must be performed. Do not connect the unit without analysing the symptoms reported by the customer and the results of the inspection.

Using the troubleshooting guide, find the problem and proceed to the repair. Once this step is done, follow these steps, known as the start-up procedure, to ensure that everything in the unit is in working condition.

1. Proceed with a post repair visual inspection. Take the time to check if every wire is reconnected properly, every screw is bolted on, no soldering and/or metal residues lying in the unit, every fuse has been replaced, etc.
2. Connect the unit to a variable transformer, setted to 0Vac.
3. Turn the bias trimpot (RV1) counter clockwise until a click is heard.
4. Connect the bypass wire to the variable transformer. This bypass is a power cord, modified on the female side in order to bypass the soft start sequence. It is connected to the line tab on voltage selector PCB.
5. Slowly raise the voltage to 10Vac, and check positive and negative rails and pre-driver supply. Check fuses.
6. If one or more supply are not within specifications, return to the troubleshooting guide.
7. Slowly raise voltage until you hear relays click, this point is around 55Vac. Recheck every supply.
8. If one or more supply are not within specifications, return to the troubleshooting guide.
9. Raise voltage to 120Vac. Recheck every supply
10. If every supply is within specifications, unplug the unit and bypass from the variable transformer. Reconnect only the unit.
11. Report to calibration and adjustments to adjust bias and DC offset. Note that bias can be adjusted to 14mV, and the following tests can be performed before the unit is send to the burn-in bench for a 24 hours warm-up.
12. Connect the unit to a load, and to a source using balanced inputs and single ended inputs, independently.
13. Perform a test with a 200Hz, a 2kHz and a 20kHz tone, both sinus wave and square wave. Check the output with a oscilloscope, on 4 ohms and 8 ohms loads. Take special cares about oscillation and phase correlation between channels.
14. Connect the unit to a small speaker, and short the input. Check for any noise. Perform this step with single ended inputs and balanced inputs, independently.
15. Put the unit on a burn-in bench, and let it sit for 24 hours, then readjust bias. Let the unit on the burn-in bench for another 72 hours.
16. Redo steps 11 to 14 before shipping to the customer.

## Protection Modes and Indicators

The front LED shows the status of the amplifier. When starting up normally, the CAM350 will show a FLASHING RED LED for about 15 seconds and if all is normal, the LED will go SOLID RED. If there is a fault, the LED will go to a FLASHING GREEN LED. The CAM350 is equipped with four Mosfet protection fuses. In the event that one or more of these fuses would blow, the technician will first need to identify and cure the cause of failure (please report to troubleshooting guide). When the cause has been identified, disconnect the unit from the system including the AC power. Remove the top cover and look for damaged or burned components. If no other components than the fuses appear to be damaged, the technician can then replace the broken fuses with the same value and rating (please report to fuses section). The Mosfet fuses are located on the control board. When replacing fuses, please make sure that the fuse holder are holding the fuses very tightly. A loose fuse holder can translate into distortion on top of the signal.

# Troubleshooting Guide

Symptom	Possible cause
Unit won't turn on	Check connections; Check fuses; Check soft-start circuit; Check relays; Check power supply circuits (positive rail, negative rail, Mosfet supply).
Smoked and/or burned components	Check for short between components and ground; Check output transistors; Check output relays; Check power supply circuits (positive rail, negative rail, Mosfet supply).
Blown fuses	Check for short between fuse and ground; Check power supply circuits (positive rail, negative rail, Mosfet supply).
No output	Check connexions; Check output relays; Check power supply circuits (positive rail, negative rail, Mosfet supply); Check output transistors.
Unit turn into protection	Check for smoked and/or burned components; Check power supply circuits (positive rail, negative rail, Mosfet supply); Check source and load; Check protection circuit; Check sensor wires between sensor PCB and control PCB; Check outputs transistors and Mosfet drivers.
Excessive buzz and/or hum	Check electrical lines; Check for a ground loop in the system.
Oscillation	Check source; Check capacitors on main board; Check 4.7Ω resistor.
Intermittent signal	Check connections; Replace shield wires.

# Output Transistors Testing and Replacement



**PLEASE NOTE THAT THESE TESTS ARE ONLY EFFECTIVE ON BIPOLAR TRANSISTORS. DO NOT PERFORM THESE TESTS ON MOSFET DEVICES, AS THEY ARE LIKELY TO BECOME SHORT DURING THE TEST.**

You should check all pin combinations, as there is a chance that only one side of the transistor is short. When replacing outputs transistors, the technician should first disconnect both outputs and main board to check if the blown outputs were caused by a faulty component on the amplifier's base. Blown output transistors should be replaced by kits, not individually. These kits contains matched transistors for both rails of one channel. When replacing blown output transistors, you must also replace positive and negative Mosfet drivers and bias transistor. Carefully inspect 4.7Ω resistor and 10Ω soft start resistor, and replace if necessary. Replace any burnt component or board.

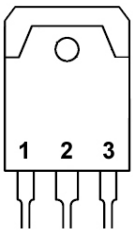

Pins : 1      Base  
         2      Collector  
         3      Emitter

You should have these results, if the transistor is good.

2SC3264 (NPN)

Positive lead	Negative lead	Result
B	C	Conductive
B	E	Conductive
C	B	Infinite
C	E	Infinite
E	B	Infinite
E	C	Infinite

2SA1295 (PNP)

Positive lead	Negative lead	Result
B	C	Infinite
B	E	Infinite
C	B	Conductive
C	E	Infinite
E	B	Conductive
E	C	Infinite



# Calibrations and Adjustments

## Bias adjustment:

Note: Bias adjustment should be made without any load connected to the amplifier's output, and no signal connected to the amplifier's input.

1. On positive heatsink, connect a multimeter to R111 leads and set the multimeter to mV scale.
2. Turn trimpot R104 counterclockwise until it reaches  $0\Omega$ . A click should be heard.
3. Turn on amplifier, and let it warm up for 15 minutes on idle.
4. Adjust trimpot R104 to get a 10mV reading.
5. Repeat procedure with negative heatsink.
6. Let the amplifier warm up for a 24 hours period with signal and load.
7. Remove signal and load, and reconnect the multimeter, setted to mV scale, to R112 leads.
8. Readjust R104 to get a 12mV reading.
9. Repeat procedure with negative heatsink.

## DC offset:

Note: DC offset adjustment should be made without any load connected to the amplifier's output, and no signal connected to the amplifier's input.

On these units, DC offset can't be adjusted. Measure DC offset using a voltmeter connected to the output posts, scale setted to mV. DC offset should be less than 10mV.

# Parts List

This is not a detailed part list. It is a list of major chassis parts and PCBs. If you need to order a specific part, please contact Classe Audio with the part location, PCB number, and model and serial number of the unit. If you need a complete PCB, please replace the (x) in the Classe part number with the revision number printed on the board.

Parts	Description	Classe part number
B1DAX	Complete PCB, power switch	B1DAXR(x)
B1D1X	Complete PCB, heatsink	B1D1XR(x)
B02AX	Complete PCB, amplifier	B02AXR(x)
B1B3X	Complete PCB, control	B1B3XR(x)
B1B1X	Complete PCB, capacitors	B1B1XR(x)
B016X	Complete PCB, AC	B016XR(x)
B258X	Complete PCB, input	B258XR(x)
B019X	Complete PCB, sensor	B019XR(x)
B01GX	Complete PCB, filter	B01GXR(x)
B1B2X	Complete PCB, supply	B1B2XR(x)

## Updates

1. On board B1D1X (both PCBs), replace R104 with Classe part number 3299X-1-202.
2. On board B1D1X (both PCBs), replace D101 and D103 with Classe part number 1N5333B.
3. On board B1B3X, replace P011XR02 to 040AR3, and drop rail voltage sensor from 500mV to 250mV.
4. Add a jumper from GND post on B1B1X PCB to relay GND on B1B3X PCB.

# Fuses



EXTRA PRECAUTIONS SHOULD BE TAKEN WHEN REPAIRING, MODIFYING, OR TROUBLESHOOTING IN THE POWER SUPPLY AREA. UNIT MUST BE DISCONNECT FROM MAIN SOURCE AND CAPACITORS MUST BE DISCHARGED USING A 100W INCANDESCENT BULB.



WHEN REPLACING FUSES, PLEASE MAKE SURE THAT THE FUSE HOLDERS ARE HOLDING THE FUSES VERY TIGHTLY. A LOOSE FUSE HOLDER CAN TRANSLATE INTO DISTORTION ON TOP OF THE SIGNAL.

Main fuses:

For 100 – 120v units: 10A slo-blo, Classe part number MDA-10A

For 220 – 240v units: 4A slo-blo, Classe part number MD

The main fuse is located at the back of the unit, on the rear panel.

Control board fuse: 0.50A, Classe part number 225.500

The control board fuse is located on top of the supply board (B1B2X)

Mosfet fuses: 0.75A, Classe part number 225.750

The Mosfet fuses are located on top of the supply board (B1B2X)

# Voltage Change



EXTRA PRECAUTIONS SHOULD BE TAKEN WHEN REPAIRING, MODIFYING, OR TROUBLESHOOTING IN THE POWER SUPPLY AREA. UNIT MUST BE DISCONNECT FROM MAIN SOURCE AND CAPACITORS MUST BE DISCHARGED USING A 100W INCANDESCENT BULB.

1. Set the primary wires of the main transformer as described below.
2. Replace the varistor, according to new line voltage, following Classe’s recommendations. If varistor is not available, remove old varistor and leave it empty.
3. Set the jumpers accordingly on the auxiliary transformer located at the back of the unit on the top main board on the left-hand side of the auxiliary transformer (see tables below)

Primary wires, main transformer

Mains	X1	X2	X3	X4	X5	X6	X7	X8	Varistor
100VAC	Grey	Yellow	Blue	Black	Orange	White	-	-	130
120VAC	Blue	Black	Grey	Yellow	Orange	White	-	-	130
220VAC	-	Yellow	Grey	Black	-	White	Blue	Orange	250
240VAC	-	Black	Grey	Yellow	-	White	Blue	Orange	250

Jumpers, auxiliary transformer

Mains	Position 1	Position 2	Position 3	Position 4	Position 5
100/120VAC	In	Out	Out	Out	In
220/240VAC	Out	Out	In	Out	Out

# IR Interface Information

Press and hold:

AMP +	LINE 1 =	Turns on Amplifier # 1
AMP +	LINE 2 =	Turns on Amplifier # 2
AMP +	LINE 3 =	Turns on Amplifier # 3
AMP +	BAL 1 =	Turns on Amplifier # 4
AMP +	BAL 2 =	Turns on Amplifier # 5
AMP +	BAL 3 =	Turns on Amplifier # 6

J3	J2	J1	J0	ADDRESS	RC Button	Auto ON	Note
X	X	X	X	0	Amp1	No	QC setting
X	X	X	Out	1	Amp2	No	
X	X	Out	X	2	Amp3	No	
X	X	Out	Out	3	Amp4	No	
X	Out	X	X	4	Amp5	No	
X	Out	X	Out	5	Amp6	No	
X	Out	Out	X	0	Amp1	No	
X	Out	Out	Out	0	Amp1	Yes	On with AC
Out	X	X	X	0	DC	No	
Out	X	X	Out	1	DC	No	
Out	X	Out	X	2	DC	No	
Out	X	Out	Out	3	DC	No	
Out	Out	X	X	4	DC	No	
Out	Out	X	Out	5	DC	No	
Out	Out	Out	X	0	DC	No	
Out	Out	Out	Out	0	DC	Yes	On with AC

6

5

4

3

2

1

REVISION RECORD			
LTR	ECO NO:	APPROVED:	DATE:

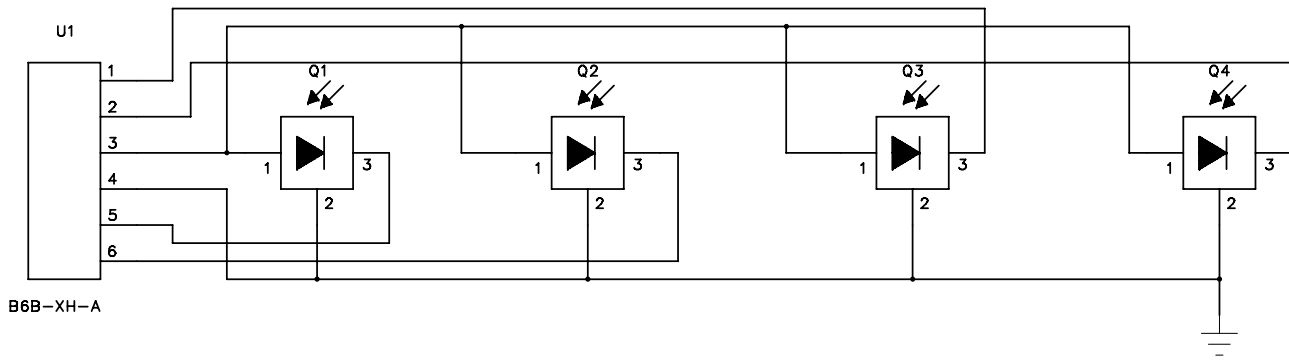

B6B-XH-A

COMPANY: CLASSE AUDIO INC.			
TITLE: SENSOR PCB			
CODE:	SIZE:	DRAWING NO:	REV:
		B019XR02_CA301	
SCALE:		JUNE 30, 2000	SHEET: 1 OF 1

DRAWN:	DATED:
CHECKED:	DATED:
QUALITY CONTROL:	DATED:
RELEASED:	DATED:

D

D

C

C

B

B

A

A

6

5

4

3

2

1

D

C

B

A

D

C

B

A

REVISION RECORD			
LTR	ECO NO:	APPROVED:	DATE:

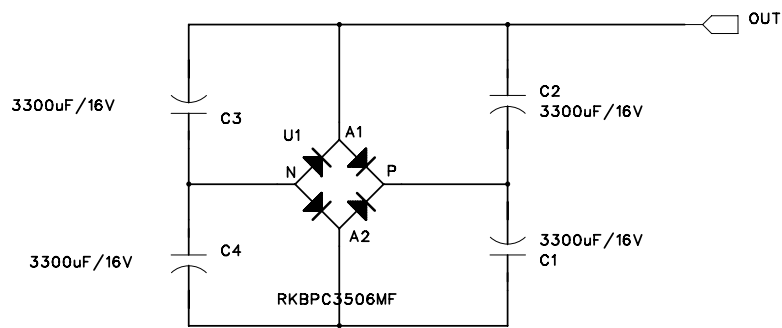

COMPANY:				Classé Audio Inc.					
TITLE:				NOISE FILER					
DRAWN:		DATED:		CODE:		DRAWING NO:		REV:	
CHECKED:		DATED:				B01GXR02			
QUALITY CONTROL:		DATED:							
RELEASED:		DATED:							
SCALE:				JUNE 23, 2000				SHEET: 1 of 1	

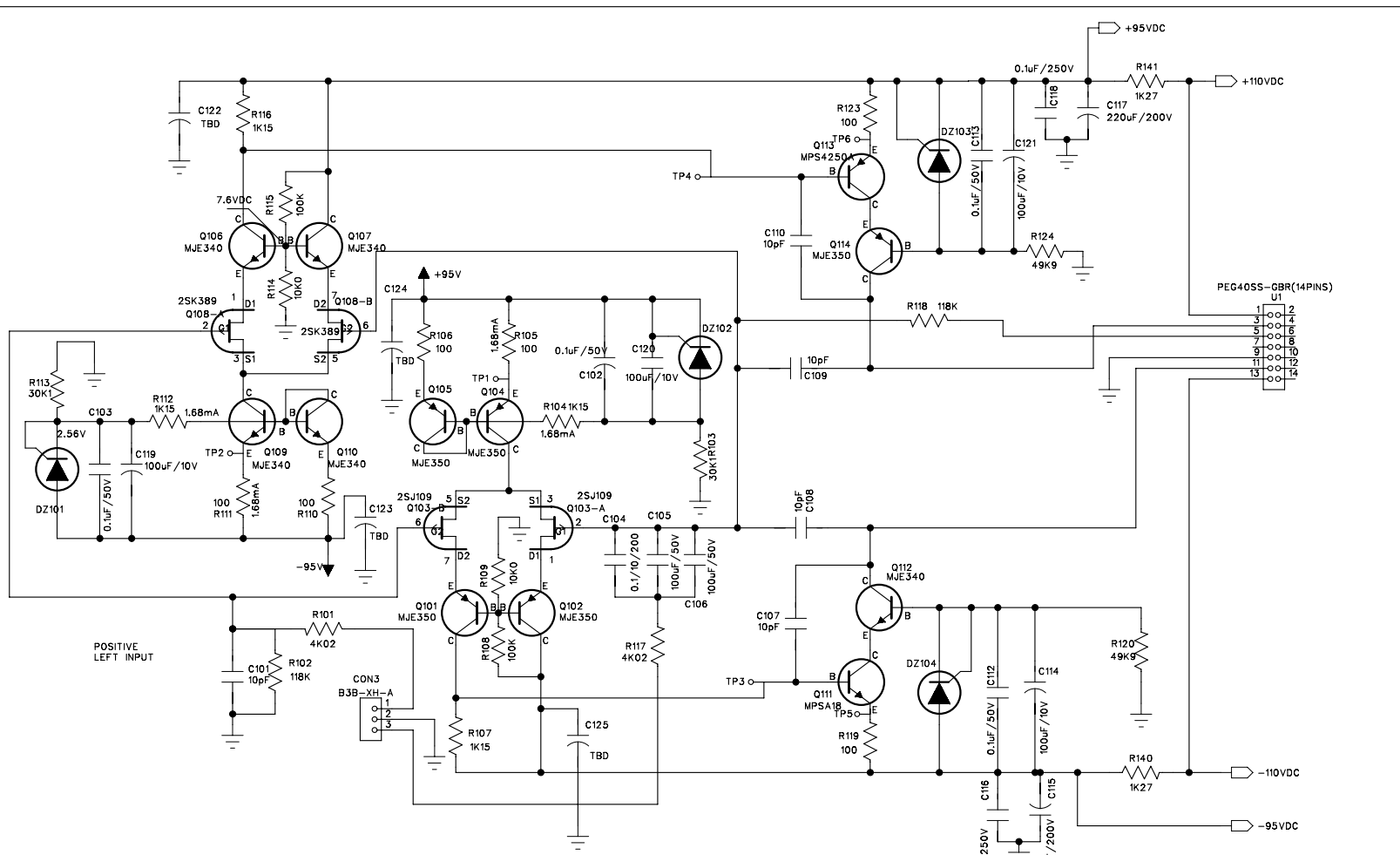

POSITIVE LEFT INPUT

COMPANY:	CLASSE AUDIO INC.
TITLE:	OMEGA AMPLIFIER
DESC:	CA301GAIN STAGE
DRAWING NO:	B02AXR00_CA301
DRAWN:	NDN
DATE:	NOV 17 1997
SHEET:	1 OF 1



6

5

4

3

2

1

REVISION RECORD			
LTR	ECO NO:	APPROVED:	DATE:

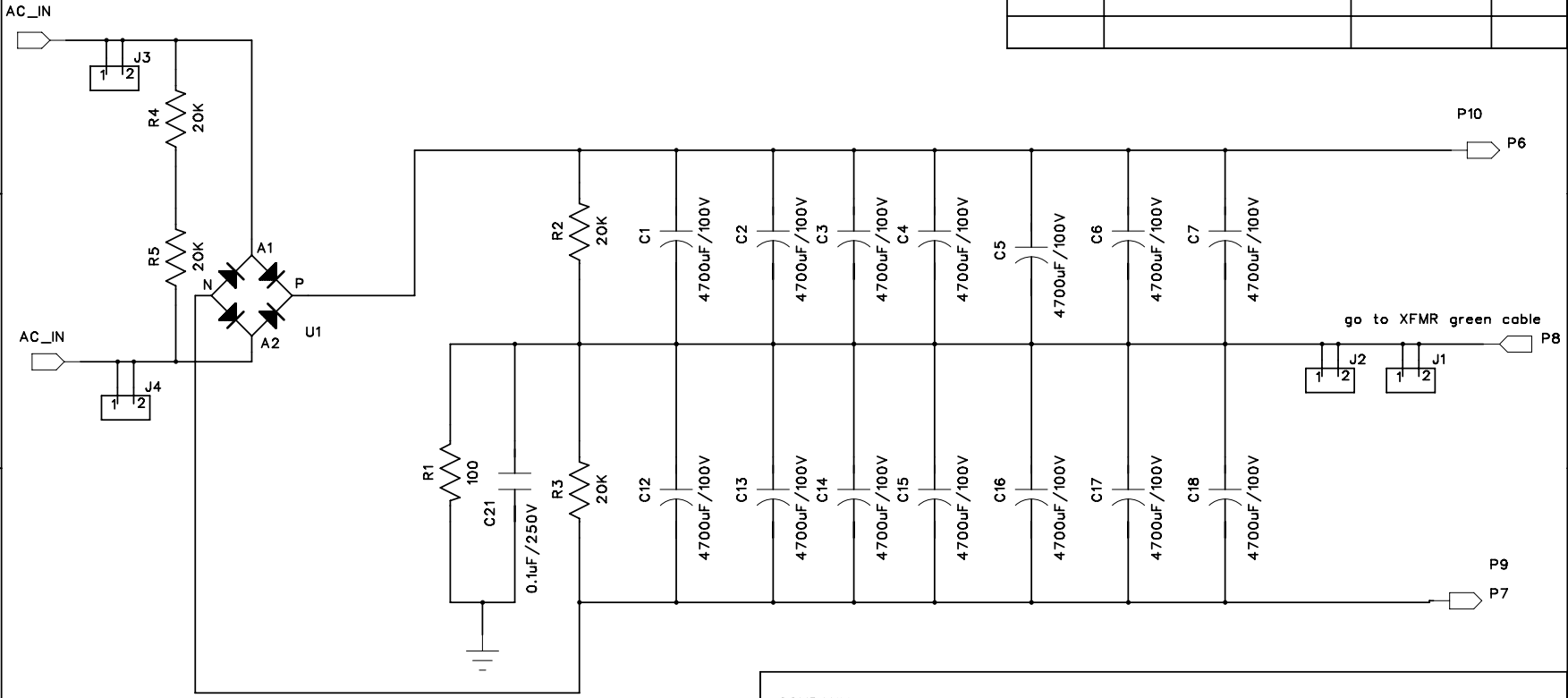

COMPANY:				<b>CLASSE AUDIO INC.</b>			
DRAWN:				TITLE:			
CHECKED:				<b>CAM350 CAP PCB</b>			
QUALITY CONTROL:		DATED:		CODE:	SIZE:	DRAWING NO:	REV:
RELEASED:		DATED:		<b>B1B1XR01</b>			
SCALE:						<b>JULY 4, 2000</b>	
						SHEET: 1 OF 1	

D

C

B

A

D

C

B

A

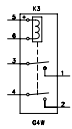
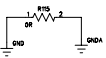
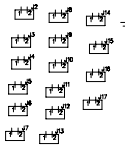
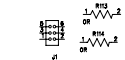
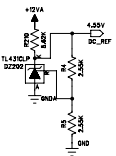
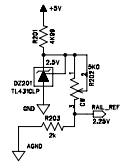
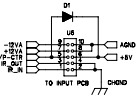
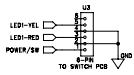
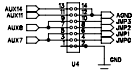
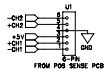
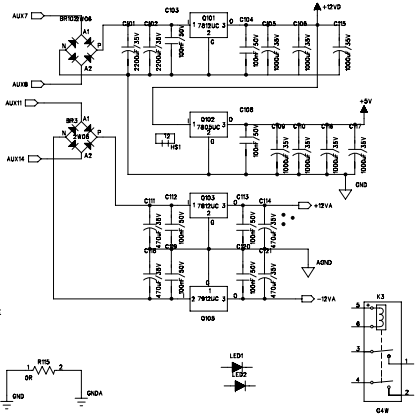
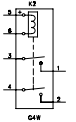
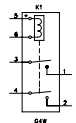
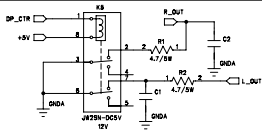

DATE:	DRAWING:	CHECKED:	EDD No:	REV:

COMPANY:  
**CLASSE AUDIO INC.**

TITLE:  
**CAM350 CONTROL CCT**

DRAWING No: **B1B3XR02**

SHEET 1 OF 3



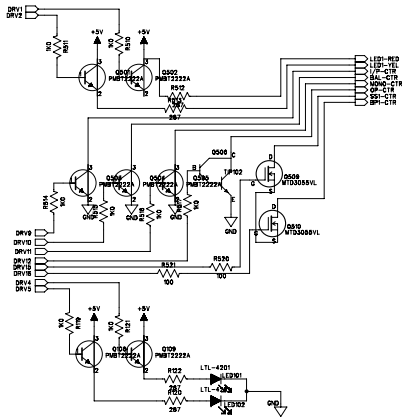
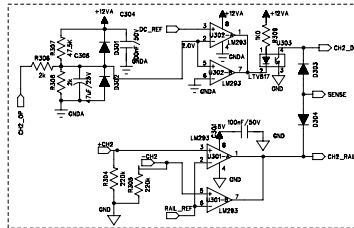
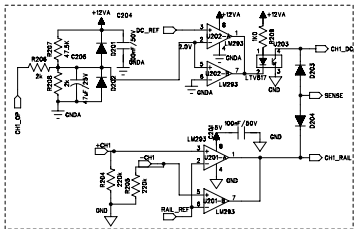

DATED:	DRAWN:	CHECKED:	ECO No:	REV:	COMPANY: CLASSE AUDIO INC.
4/4/97					
					TITLE: CAM 350 CONTROL CCT
					DRAWING No: B1B3XR02
					SHEET 3 of 3

SSW-107-01-GD

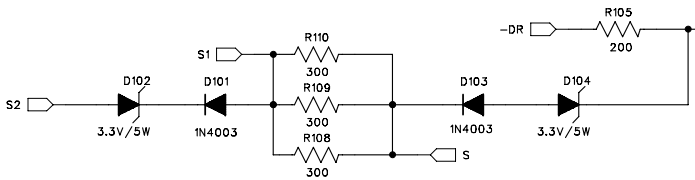
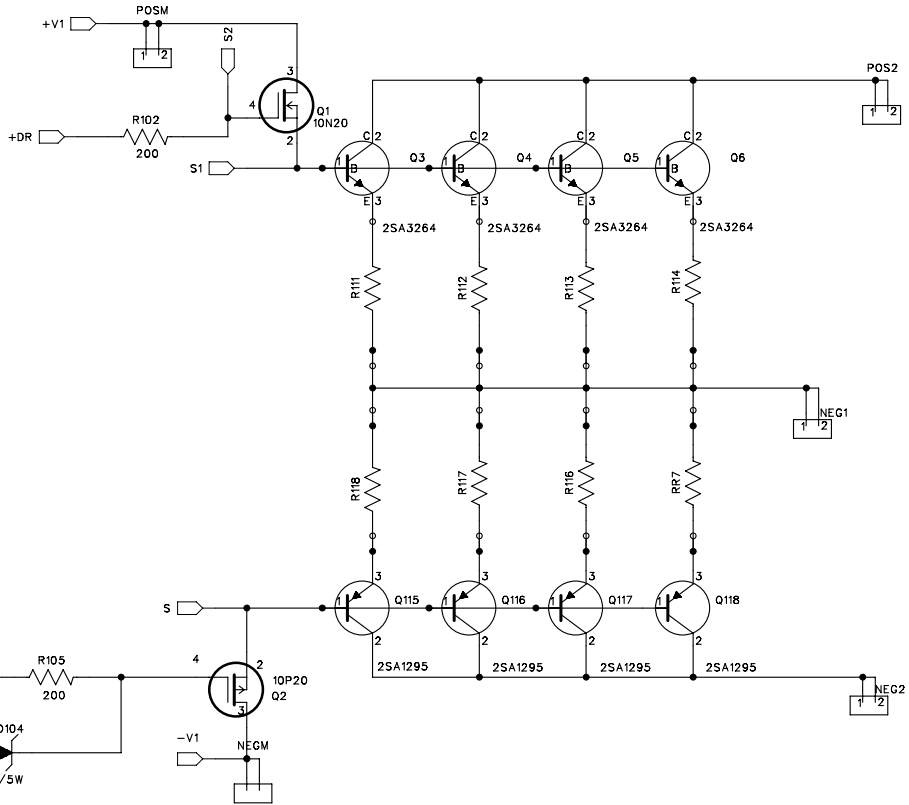
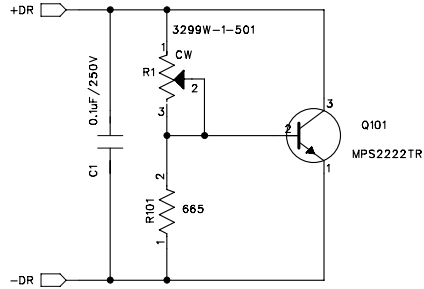
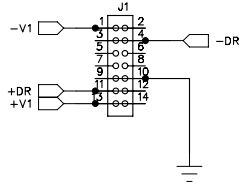

DATED:	DRAWN:	CHECKED:	ECO No:	REV:

COMPANY: CLASSE AUDIO INC.

TITLE: CAV500 DEVICES PCB

DRAWING No: B1D1XR02 SHEET 1 OF 1

B

A

6

5

4

3

2

1

D

D

C

C

B

B

A

A

REVISION RECORD			
LTR	ECO NO:	APPROVED:	DATE:

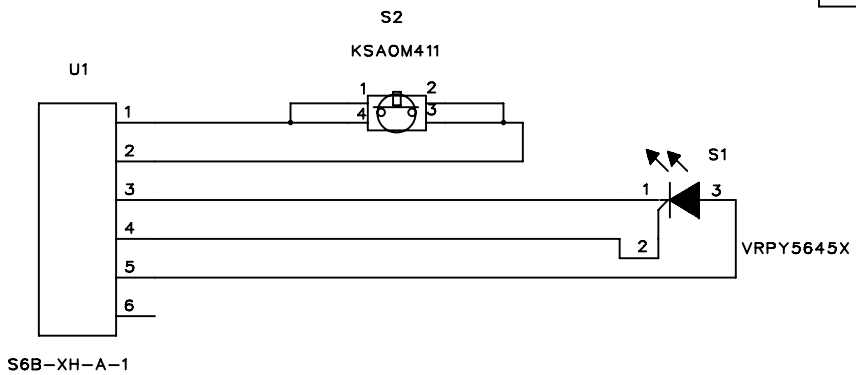

COMPANY:			
TITLE: <h1 style="text-align: center;">POWER SWITCH</h1>			
CODE:	SIZE:	DRAWING NO: <h2 style="text-align: center;">B1DAXR01_CA301</h2>	REV:
SCALE: JUNE 27, 2000		SHEET: OF	

DRAWN:	DATED:
CHECKED:	DATED:
QUALITY CONTROL:	DATED:
RELEASED:	DATED:

6

5

4

3

2

1

REVISION RECORD			
LTR	ECO NO:	APPROVED:	DATE:

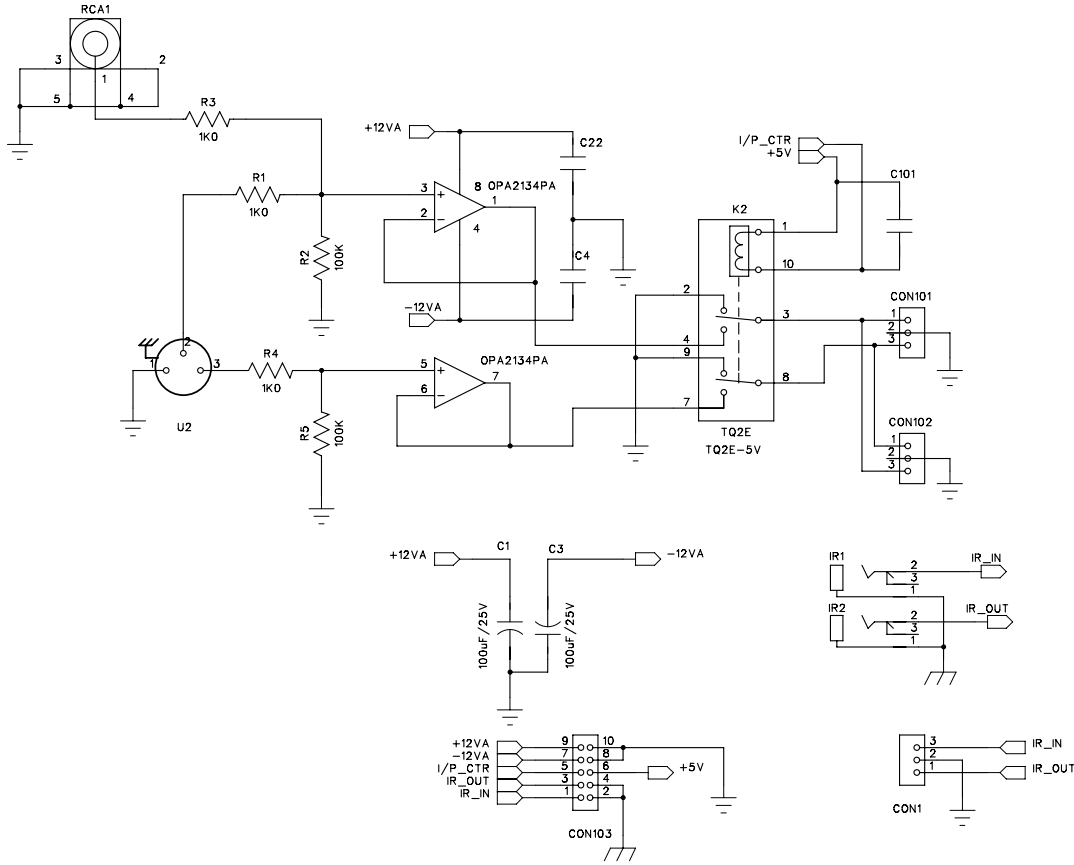

COMPANY:			
TITLE: CAM 200 INPUT PCB			
CODE:	SIZE:	DRAWING NO: B258XR00	REV:
SCALE:		SHEET: OF	

DRAWN:	DATED:
CHECKED:	DATED:
QUALITY CONTROL:	DATED:
RELEASED:	DATED:

D

C

B

A

D

C

B

A