

# COMPUTERS & STRUCTURES, INC.

STRUCTURAL AND EARTHQUAKE ENGINEERING SOFTWARE

**ETABS**® 2016  
Integrated Building Design Software

**Composite Beam Design Manual**

BS 5950-1990





# **Composite Beam Design Manual**

## **BS 5950-1990**

**For ETABS® 2016**

# Copyright

Copyright © Computers & Structures, Inc., 1978-2015  
All rights reserved.

The CSI Logo®, SAP2000®, ETABS®, and SAFE® are registered trademarks of Computers & Structures, Inc. Watch & Learn™ is a trademark of Computers & Structures, Inc.

The computer programs SAP2000® and ETABS® and all associated documentation are proprietary and copyrighted products. Worldwide rights of ownership rest with Computers & Structures, Inc. Unlicensed use of these programs or reproduction of documentation in any form, without prior written authorization from Computers & Structures, Inc., is explicitly prohibited.

No part of this publication may be reproduced or distributed in any form or by any means, or stored in a database or retrieval system, without the prior explicit written permission of the publisher.

Further information and copies of this documentation may be obtained from:

Computers & Structures, Inc.

<http://www.csiamerica.com/>

[info@csiamerica.com](mailto:info@csiamerica.com) (for general information)

[support@csiamerica.com](mailto:support@csiamerica.com) (for technical support)

# DISCLAIMER

CONSIDERABLE TIME, EFFORT AND EXPENSE HAVE GONE INTO THE DEVELOPMENT AND DOCUMENTATION OF THIS SOFTWARE. HOWEVER, THE USER ACCEPTS AND UNDERSTANDS THAT NO WARRANTY IS EXPRESSED OR IMPLIED BY THE DEVELOPERS OR THE DISTRIBUTORS ON THE ACCURACY OR THE RELIABILITY OF THIS PRODUCT.

THIS PRODUCT IS A PRACTICAL AND POWERFUL TOOL FOR STRUCTURAL DESIGN. HOWEVER, THE USER MUST EXPLICITLY UNDERSTAND THE BASIC ASSUMPTIONS OF THE SOFTWARE MODELING, ANALYSIS, AND DESIGN ALGORITHMS AND COMPENSATE FOR THE ASPECTS THAT ARE NOT ADDRESSED.

THE INFORMATION PRODUCED BY THE SOFTWARE MUST BE CHECKED BY A QUALIFIED AND EXPERIENCED ENGINEER. THE ENGINEER MUST INDEPENDENTLY VERIFY THE RESULTS AND TAKE PROFESSIONAL RESPONSIBILITY FOR THE INFORMATION THAT IS USED.

---

# Contents

---

<b>1</b>	<b>Introduction</b>	
1.1	Organization	1-2
1.2	Recommended Reading/Practice	1-3
<b>2</b>	<b>Design Prerequisites</b>	
2.1	Design Codes	2-1
2.2	Units	2-1
2.3	Preferences	2-2
2.4	Overwrites	2-2
2.5	Composite Beam Properties	2-2
2.5.1	Beam Properties	2-2
2.5.2	Metal Deck and Slab Properties	2-4
2.5.3	Shear Stud Anchor Properties	2-5
2.5.4	Cover Plates	2-6
2.6	Beams Designed as Composite Beams	2-6
2.6.1	Frame Elements Designed by Default as Composite Beams	2-7
2.6.2	Overwriting the Frame Design Procedure for a Composite Beam	2-8
2.7	How the Program Optimizes Design Groups	2-9
2.8	Analysis Sections and Design Sections	2-12
2.9	Output Stations	2-13
2.10	Effective Width of the Concrete Slab	2-13
2.10.1	Location Where Effective Slab Width Is Checked	2-14



2.10.2	Multiple Deck Types or Directions Along the Beam Length	2-15
2.10.3	Effect of Diagonal Beams on Effective Slab Width	2-19
2.10.4	Effect of Openings on Effective Slab Width	2-20
2.10.5	Effective Slab Width and Transformed Section Properties	2-21
2.11	Beam Unbraced Length and Design Check Locations	2-21
2.11.1	Determination of the Braced Points of a Beam	2-22
2.11.2	User Defined Unbraced Length of a Beam	2-23
2.12	Design Check Locations	2-24
2.13	Design Load Combinations	2-26
2.13.1	Special Live Load Patterning for Cantilever Back Spans	2-28
2.13.2	Special Live Load Patterning for Continuous Spans	2-30
2.14	Beam Deflection and Camber	2-32
2.14.1	Deflection	2-32
2.14.2	Deflection Reported for Cantilever Overhangs	2-33
2.14.3	Camber	2-33
2.15	Floor Vibration	2-34
2.15.1	Vibration Frequency	2-34
2.16	Distribution of Steel Headed Stud Anchors on a Composite Beam	2-40
2.16.1	Composite Beam Segments	2-41
2.16.2	How the Program Distributes Steel Headed Stud Anchors on a Beam	2-45
2.16.3	A Note About Multiple Design Load Combinations	2-51
2.17	Number of Shear Studs that Fit in a Composite Beam Segment	2-52
2.17.1	Solid Slab or Deck Ribs Oriented Parallel to Beam Span	2-53
2.17.2	Deck Ribs Oriented Perpendicular to Beam Span	2-57
2.18	User Defined Shear Connector Patterns	2-60
2.18.1	Specifying a User Defined Shear Connector Pattern	2-61

	2.18.2	Uniformly Spaced Shear Studs Over the Length of the Beam	2-61
	2.18.3	Additional Shear Studs in Specified Sections of Beam	2-63
	2.18.4	How the Program Checks a Beam with User Defined Shear Studs	2-67
2.19		Transformed Section Moment of Inertia	2-67
	2.19.1	Background	2-68
	2.19.2	Properties of Steel Beam (Plus Cover Plate) Alone	2-70
	2.19.3	Properties of the Composite Section	2-73
2.20		Effective Moment of Inertia for Partial Composite Connection	2-80
2.21		Composite Plastic Moment Capacity for Positive Bending	2-81
	2.21.1	Location of the Plastic Neutral Axis	2-84
	2.21.2	Plastic Moment Capacity for Positive Bending	2-95
2.22		Composite Moment Capacity of a Partially Composite Beam with a Plastic Stress Distribution	2-106
	2.22.1	Location of the Plastic Neutral Axis	2-106
	2.22.2	Determining the Effective Portion of the Concrete Slab	2-109
	2.22.3	Plastic Moment Capacity for Positive Bending	2-111
<b>3</b>		<b>Design Process</b>	
	3.1	Notation	3-1
	3.2	Design Methodology	3-13
	3.3	Design Load Combinations	3-18
	3.3.1	Strength Check for Construction Loads	3-19
	3.3.2	Strength Check for Final Loads	3-19
	3.3.3	Deflection Check for Final Loads	3-20
	3.4	Plastic, Compact, Semi-Compact Requirements	3-20
	3.4.1	Limiting Width-to-Thickness Ratios for Flanges	3-24
	3.4.2	Limiting Width-to-Thickness Ratios for Webs	3-24
	3.4.3	Limiting Width-to-Thickness Ratios for Cover Plates	3-26

3.5	Composite Plastic Moment Capacity for Positive Bending	3-27
3.6	Composite Section Elastic Moment Capacity	3-28
3.7	Moment Capacity for Steel Section Alone	3-28
3.7.1	Steel Beam Properties	3-29
3.7.2	Moment Capacity, $M_c$	3-30
3.7.3	Lateral-Torsional Buckling Moment Capacity, $M_b$	3-31
3.8	Shear Connectors	3-34
3.8.1	Shear Capacity of a Shear Stud Connector	3-34
3.8.2	Horizontal Shear for Full Composite Connection	3-37
3.8.3	Number of Shear Connectors	3-38
3.9	Beam Shear Capacity	3-39
3.9.1	Shear Capacity	3-39
3.9.2	Checking the Beam Shear	3-40
3.9.3	Limitations of Beam Shear Check	3-41
3.10	Deflection Check	3-41
3.11	Floor Vibration	3-42

**Appendix A**      **Preferences**

**Appendix B**      **Overwrites**

**Bibliography**



---

# Chapter 1

## Introduction

---

This manual assumes the reader has an engineering background in the general area of structural steel design and is already familiar with the BS 5950-1990 code.

Initiation of the design process, along with control of various design parameters, is accomplished using the Design menu. The design/check of composite beams is seamlessly integrated within the program.

Automated design at the object level is available for any one of a number of user-selected design codes, as long as the structures have first been modeled and analyzed by the program. Model and analysis data, such as material properties and member forces, are recovered directly from the model database, and no additional user input is required if the design defaults are acceptable.

The design is based on a set of user-specified loading combinations. However, the program provides default load combinations for each supported design code. If the default load combinations are acceptable, no definition of additional load combinations is required.

Composite beam design/check consists of calculating the flexural, axial, and shear forces or stresses at several locations along the length of a member, and then comparing those calculated values with acceptable limits. That comparison produces a demand/capacity ratio, which typically should not exceed a val-

ue of one if code requirements are to be satisfied. The program follows the same review procedures when it is checking a user-specified shape or when checking a shape selected by the program from a predefined list.

The program checks the requirements for strength and deflection limit states at service and construction time conditions. It also checks vibration for service time condition. It considers shoring-unshoring phases if shoring is used. It calculates camber if it is required.

The program can determine the number of steel headed stud anchors required to achieve the desired level of composite action. On the other hand, the program can check the adequacy if the profile—number and distribution—of the steel headed stud anchors is provided.

Program output can be presented graphically on the model, in tables for both input and output data, or in calculation sheets prepared for each member. For each presentation method, the output is in a format that allows the engineer to quickly study the stress conditions that exist in the structure, and in the event the member is not adequate, aid the engineer in taking appropriate remedial measures, including altering the design member without re-running the entire analysis.

The program supports a wide range of composite beam design codes, including many national building codes. This manual is dedicated to the use of the menu option "BS 5950-1990." This option covers the "BS 5950— Structural Use of Steelwork in Buildings. Part 3. Design in Composite Construction" (BS 5950-1990).

The design codes supported under "BS 5950-1990" are written in Newton-millimeter units. All the associated equations and requirements have been implemented in the program in Newton-millimeter units. The program has been enabled with unit conversion capability. This allows the users to enjoy the flexibility of choosing any set of consistent units during creating and editing models, exporting and importing the model components, and reviewing the design results.

## 1.1 Organization

This manual is designed to help you quickly become productive using the BS 5950-1990 composite beam design option. Chapter 2 addresses prerequisites related to modeling and analysis for a successful design in accordance with the code. Chapter 3 provides detailed descriptions of the specific requirements as implemented in the program for the code.

## 1.2 Recommended Reading/Practice

It is strongly recommended that you read this manual and review any applicable "Watch & Learn" Series™ tutorials, which are found on our web site, <http://www.csiamerica.com/>, before attempting to design a steel frame. Additional information can be found in the on-line Help facility available from within the program.

---

## Chapter 2

# Design Prerequisites

---

This chapter provides an overview of the basic assumptions, design preconditions, and some of the design parameters that affect composite beam design.

### 2.1 Design Codes

The design code can be set by the user when the model is started and changed at any time. Any one design code can be used in any one design run. A group of beams cannot be designed using one code and another set of beams designed for a different code in the same design run. However, different design codes can be used to perform different design runs without rerunning the analysis.

### 2.2 Units

For composite beam design in this program, any set of consistent units can be used for input. Typically, design codes are based on one specific set of units. The documentation in this manual is presented in Newton-millimeter-seconds units unless otherwise noted. However, any system of units can be used to define and design a building in the program.

## 2.3 Preferences

The Composite Beam Design Preferences are basic assignments that apply to all composite beam members. Default values are provided for all preference items. Thus, it is not necessary to specify or change any of the preferences. However, at least review the default values to ensure they are acceptable. Some of the preference items also are available as member specific overwrite items. The Preferences are described in Appendix A. The Overwrites are described in Appendix B. Overwritten values take precedence over the preferences.

## 2.4 Overwrites

The composite beam design Overwrites are basic assignments that apply only to those elements to which they are assigned. Default values are provided for all overwrite items. Thus, it is not necessary to specify or change any of the overwrites. However, at least review the default values to ensure they are acceptable. When changes are made to overwrite items, the program applies the changes only to the elements to which they are specifically assigned. Overwritten values take precedence over the preferences. See Appendix B for more information about Overwrites.

## 2.5 Composite Beam Properties

This section provides an overview of composite beam properties. Items described include beam properties, metal deck and concrete slab properties, shear connector properties, user-defined shear connector patterns, cover plate properties, effective slab width and beam unbraced length.

The many properties associated with composite beams are defined using various menus in the program. Other items related to the beam properties are specified in the composite beam preferences or overwrites.

### 2.5.1 Beam Properties

Figure 2-1 shows a typical composite beam for reference. The beam shown is a rolled beam section from the built-in section database.

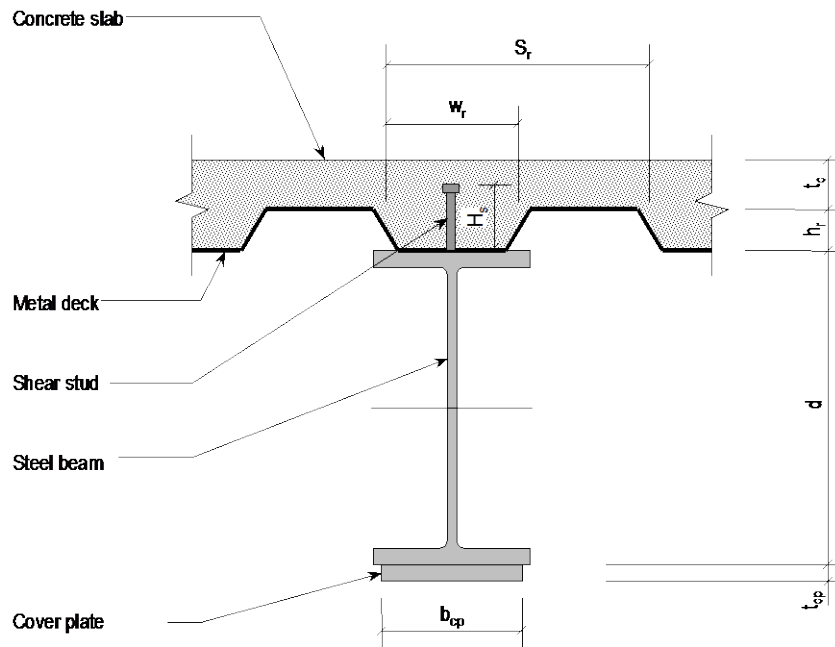

*Figure 2-1 Illustration of Composite Beam*

Basic steel beam properties can be user defined along with the basic geometry of the steel section, except for the cover plate, if it exists. Cover plates are specified in the composite beam Overwrites. When defining a beam, a material property that includes the yield stress for that beam is also assigned. That yield stress is assumed to apply to the beam and the cover plate unless it is revised in the beam overwrites.

The Composite Beam Design postprocessor designs beams that are I-shaped sections and channel sections only. The beam section for a composite beam can be any I-shaped section, or a channel. The I-shaped section can be defined by selecting a UB, UC and UKB shape from the built-in program steel section database, or by defining a user-specified I-shaped section. It is not necessary that the top and bottom flanges have the same dimensions in user-defined I-shaped sections used as composite beams. A channel section used as a composite beam can also be either user-defined or a section taken from one of the built-in program steel section databases.

Beam sections defined using Section Designer are considered as general sections, not I-shaped or channel-shaped sections (even if they really are I-shaped or channel-shaped), and cannot be designed using the Composite Beam Design postprocessor.

If the user defines a beam section by selecting it from the built-in section database, the program assumes that it is a rolled section and applies the design equations accordingly. If the user defines a section without selecting it from the built-in database, the program assumes it is a welded section and revises the design equations as necessary. The program does not check or design any of the welding for these welded beams.

## 2.5.2 Metal Deck and Slab Properties

Basic metal deck and concrete slab properties can be user defined. The geometry and the associated material properties of the metal deck, concrete slab, and shear connectors can be specified.

A beam designed using the Composite Beam Design postprocessor can have composite behavior only if it supports a deck section (not a slab or wall section).

The concrete slab over metal deck must be specified as a *deck section property* (not a slab section property) if the beam is to have composite behavior. If the slab is specified using a slab section property instead of a deck section property, the Composite Beam Design postprocessor designs the beams supporting that slab as non-composite beams.

A deck section can be specified as a Filled Deck (metal deck filled with concrete), an Unfilled Deck, or a Solid Slab (solid concrete slab with no metal deck). The specified metal deck geometry includes the following:

- **Slab Depth:** The depth of concrete fill above the metal deck. This item is labeled  $t_c$  in Figure 2-1.
- **Deck Depth:** The height of the metal deck ribs. This item is labeled  $h_r$  in Figure 2-1.
- **Rib Width:** The average width of the metal deck ribs. This item is labeled  $w_r$  in Figure 2-1.



- **Rib Spacing:** The center-to-center spacing of the metal deck ribs. This item is labeled  $S_r$  in Figure 2-1.

If the deck has been specified as Filled Deck or Solid Slab (not Unfilled Deck), a slab material must be specified for the concrete. This should be a previously specified concrete material property. This concrete material property is used to specify all material properties of the concrete, except in some code-specific cases.

If the deck has been specified as Unfilled Deck, a steel material property must be specified for the deck material, and an equivalent shear thickness must be specified for the deck. These two items are used by the program to determine the membrane shear stiffness of the deck.

The weight-per-unit-area of the deck,  $w_d$ , can be specified. The self-weight of the deck element representing the concrete slab over the metal deck is calculated using the weight-per-unit-area shown in the following equation.

$$\text{Weight-per-Unit-Area} = w_c \left( \frac{w_r h_r}{S_r} + t_c \right) + w_d$$

In the equation,  $w_c$  is the weight-per-unit-volume of concrete. The first term is the weight-per-unit-area of the concrete and the second term is the weight-per-unit-area of the metal deck.

Note that the program does not check the design of the metal deck itself.

### 2.5.3 Shear Stud Anchor Properties

As described in the previous section, shear studs can be user defined along with the deck properties. The properties specified for shear studs are the diameter,  $d_{sc}$ , the height,  $H_s$ , and the specified tensile strength of the shear stud,  $F_u$ . In this program, shear connector patterns can be user specified.

The specification of composite deck stud anchors can include the following items:

- **Diameter:** The diameter of the shear stud.
- **Height:** The height of the shear stud. This item is labeled  $H_s$  in Figure 2-1.

- **Tensile Strength,  $F_u$ :** The specified tensile strength of the shear stud.

The program automatically calculates the strength of a single shear connector based on the shear stud and concrete slab properties. Revise this value using the composite beam overwrites, if desired.

## 2.5.4 Cover Plates

In this program, full-length cover plates can be specified on the bottom flange of a composite beam. Cover plates are not defined as part of the beam properties. They can be specified in the overwrites only. Thus, to specify a beam with a cover plate, the beam is designed as it typically would be without the cover plate, and then the user should add the cover plate in the overwrites.

One consequence of this process is that the cover plate is not included for overall analysis of the building. However, the cover plate is considered both for resisting moments and deflections for design of the composite beam within the program's Composite Beam Design postprocessor.

The properties specified for a cover plate are the width,  $b_{cp}$ , the thickness,  $t_{cp}$ , and a yield stress,  $F_{ycp}$ . The width and thickness dimensions are illustrated in Figure 2-1. The program does not check or design any of the welding between the cover plate and the beam bottom flange. It also does not determine cutoff locations for the full length cover plate.

## 2.6 Beams Designed as Composite Beams

The program puts the following restrictions on the members that can be designed as composite beams.

### (a) Section Requirements

Only I-shaped and channel-shaped beams can be designed as composite beams by the program. The I-shaped and channel-shaped beams can be selected from the built-in program section database, or they can be user defined.

Note that beam sections that are defined in Section Designer are always treated as general sections. Thus, if an I-type or channel-type section is defined using Section Designer, the program will consider it to be a general section, not an I-

shaped or channel-shaped section and will *not* allow it to be designed as a composite beam.

**(b) Material Property Requirement**

If a beam is to be designed as a composite beam, the Type of Design associated with the Material Property Data assigned to the beam *must* be Steel.

**(c) Beam Orientation**

The line type associated with the frame object that represents a composite beam must be "Beam." In other words, the beam element must lie in a horizontal plane.

For composite beams, the beam local 2-axis must be vertical. The Local axis 2 Angle is displayed on the Geometry tab of the Beam Information form.

**(d) Support and Extent**

The frame object representing a composite beam should span from support to support. Composite beams should not be modeled using multiple, adjacent frame objects between supports for a single composite beam.

In the case of a cantilever beam overhang, the frame object should span from the overhang support to the end of the beam. The cantilever beam back span should be modeled using a separate frame object. If cantilever beams are not modeled in this way, the analysis results for moments and shears will still be correct but the design performed by the Composite Beam Design processor probably will not be correct.

## 2.6.1 Frame Elements Designed by Default as Composite Beams

The program will design certain frame elements using the design procedures documented in this manual by default. Those elements must meet the following restrictions:

- The beam must meet the section requirements described in the subsection entitled *Section Requirements* in this chapter.

- The beam must meet the material property requirement described in the subsection entitled *Material Property Requirement* in this chapter.
- The beam must meet the two other requirements described in the subsection entitled *Beam Orientation and Support and Extent* in this chapter.
- At least one side of the beam must support a deck that is specified as a Deck section (not a Slab or Wall section). The deck section can be filled, unfilled or a solid slab. When the deck is unfilled, the beam will still go through the Composite Beam Design postprocessor and will simply be designed as a non-composite beam.
- The beam must not frame continuously into a column or a brace. Both ends of the beam must be pinned for major axis bending (bending about the local 3 axis).

## 2.6.2 Overwriting the Frame Design Procedure for a Composite Beam

The three procedures possible for steel beam design are:

- Composite beam design
- Steel frame design
- No design

By default, steel sections are designed using either the composite beam design procedure or the steel frame design procedure. All steel sections that meet the requirements described in the previous subsection entitled *Frame Elements Designed by Default as Composite Beams* are by default designed using the composite beam design procedures. All other steel frame elements are by default designed using the steel frame design procedures.

Change the default design procedure used for a beam(s) by selecting the beam(s) and clicking the **Design menu > Overwrite Frame Design Procedure** command. This change is successful only if the design procedure assigned to an element is valid for that element. For example, if two steel beams, one an I-section and the other a tube section, are selected and an attempt is made to change the design procedure to Composite Beam Design, the change will be executed for the

I-section, but not for the tube section because it is not a valid section for the composite beam design procedure. A section is valid for the composite beam design procedure if it meets the requirements specified in the section entitled *Beams Designed as Composite Beams*, earlier in this chapter.

Note that the procedures documented for composite beam design allow for designing a non-composite beam. One of the overwrites available for composite beam design is to specify that selected beams are designed as composite as required, non-composite with a minimum number of shear studs specified, non-composite with no shear studs, or always composite. These overwrites do not affect the design procedure. Changing the overwrite to one of the non-composite designs does not change the design procedure from Composite Beam Design to Steel Frame Design. The non-composite design in this case is still performed from within the Composite Beam Design postprocessor.

Using the composite beam design procedure, out-of-plane bending is not considered and slender sections are not designed. This is different from the Steel Frame Design postprocessor. Thus, the design results obtained for certain beams may be different, depending on the design procedure used.

Finally, note that the user can specify that the composite beam design procedures are to be used for a beam even if that beam does not support any deck, or for that matter, even if no slab is specified. In these cases, the beam will be designed as a non-composite beam by the Composite Beam Design postprocessor.

## 2.7 How the Program Optimizes Design Groups

This section describes the process the program uses to select the optimum section for a design group. In this description, note the distinction between the term **section**, which refers to a beam section in an auto select section list, and the term **beam**, which refers to a specific element in the design group.

When considering design groups, the program first discards any beam in the design group that is not assigned an auto select section list.

Next, the program looks at the auto select section list assigned to each beam in the design group and creates a new list that contains the sections that are

common to all of the auto select section lists in the design group. The program sorts this new common section list in ascending order, from smallest section to largest section based on section weight (area).

When designing with design groups, the program attempts to quickly eliminate inadequate beams.

The program then finds the beam with the largest positive design moment in the design group, or the "pseudo-critical beam." The program then checks the design of the pseudo-critical beam for all sections in the common section list. Any sections in the common section list that are not adequate for the pseudo-critical beam are discarded from the common section list, making the list shorter. This new list is the shorter common section list. The shorter common section list is still in ascending order based on section weight (area).

Now the program checks all beams in the design group for the first section (smallest by weight [area]) in the shorter common section list. If the optimization is being performed on the basis of beam weight and the section is adequate for all beams in the design group, the optimum section has been identified. If the section is not adequate for a beam, the next higher section in the shorter common section list is tried until a section is found that is adequate for all beams in the design group.

If the optimization is based on price instead of weight, the program finds the first section in the shorter common section list (i.e., the one with the lowest weight) that is adequate for all beams. Next it calculates the cost of this first adequate section and then determines the theoretical heaviest section that could still have a cost equal to the adequate section by dividing the total price of the beam with the adequate section (steel plus camber plus shear connectors) by the unit price of the steel. This assumes that when the cost of the steel section alone is equal to or greater than the total cost of the adequate section, the section could not have a total cost less than the adequate section. The program then checks any other sections in the shorter common section list that have a weight less than or equal to the calculated maximum weight. If any of the other sections are also adequate, a cost is calculated for them. Finally, the section with the lowest associated cost is selected as the optimum section for the design group.

Regardless of whether the optimization is based on weight or cost, if all sections in the shorter common section list are tried and none of them are

adequate for all of the beams in the design group, the program proceeds to design each beam in the design group individually based on its own auto section list and ignores the rest of the design group. If for a particular beam none of the sections in the auto select section list are adequate, the program displays results for the section in the auto select list with the smallest controlling ratio shown in red. Note that the controlling ratio may be based on stress or deflection.

By default, the program selects the optimum composite beam size based on weight, not price. When a beam is optimized by weight, the program internally optimizes the beam based on area of steel (excluding the cover plate, if it exists). Thus, the weight density specified for the steel is irrelevant in such a case.

By default, when auto select section lists are assigned to beams, the program compares alternate acceptable composite beam designs based on the weight of the steel beam (not including the cover plate, if it exists) to determine the optimum section. The beam with the least weight is considered the optimum section. The choice of optimum section does not consider the number of shear connectors required or if beam camber is required.

In the Preferences, the user can request that the program use price to determine the optimum section and assign prices to steel, camber, and shear studs. If a price analysis is requested, the program compares alternate acceptable beam designs based on their price and selects the one with the least cost as the optimum section. By assigning different prices for steel, shear connectors and camber, the user can influence the choice of optimum section.

The costs for steel and cambering are specified on a unit weight of the beam basis; for example, a cost per pound of the beam. The shear connector cost is specified on a cost per connector. When a beam is optimized by price, the program determines the price associated with the steel by multiplying the volume of the beam (including the cover plate, if it exists) by the weight density of the beam by the price per unit weight specified in the material properties for the steel. The price associated with camber is determined by multiplying the volume of the beam (including the cover plate, if it exists) by the weight density of the beam by the specified price per unit weight for camber defined in the composite beam preferences. The price for shear connectors is determined by multiplying the total number of shear connectors



by the price per connector specified in the composite beam preferences. The total price for the beam is the sum of the prices for the steel, camber and shear connectors. Thus, when a beam is optimized by price, the weight density for the steel is important and must be correctly specified for the price to be correctly calculated.

The volume of the beam is calculated by multiplying the area of the steel beam (plus the area of the cover plate, if used) by the length of the beam from center-of-support to center-of-support.

## 2.8 Analysis Sections and Design Sections

It is important to understand the difference between analysis sections and design sections. Analysis sections are those section properties used to analyze the model when an analysis is run. The design section is whatever section has most currently been designed and thus designated the current design section.

It is possible for the last used analysis section and the current design section to be different. For example, an analysis may have been run using a W460X52 beam, and then it is determined in the design that a W410X46 beam worked better. In that case, the last used analysis section is the W460X52 and the current design section is the W410X46. Before the design process is complete, verify that the last used analysis section and the current design section are the same.

The program keeps track of the analysis section and the design section separately. Note the following about analysis and design sections:

- Assigning a beam a frame section property assigns the section as both the analysis section and the design section.
- Running an analysis always sets the analysis section to be the same as the current design section.
- Assigning an auto select list to a frame section initially sets the design section to be the beam with the median weight in the auto select list.
- Unlocking a model deletes the design results, but it does not delete or change the design section.

- Changing a design load combination deletes the design results, but it does not delete or change the design section.
- Changing any of the composite beam design preferences deletes the design results, but it does not delete or change the design section.
- Deleting the static nonlinear analysis results also deletes the design results for any load combination that includes static nonlinear forces. Typically, static nonlinear analysis and design results are deleted when one of the following actions is taken:
  - Redefine existing or define new hinges.
  - Redefine existing or define new static nonlinear load cases.
  - Add or delete hinges.

Again, note that these actions delete only results for load combinations that include static nonlinear forces.

## 2.9 Output Stations

Frame output stations are designated locations along a frame element. They are used as locations to report output forces and to perform design, and they are used as plotting points for graphic display of force diagrams. When force diagrams are plotted, exact forces are plotted at each output station, and then those points are connected by straight lines. Output stations occur at user-specified locations *and* at point load locations along a beam. Designate the output stations for a frame element using the Assign menu.

For composite beam design, the program checks the moments, shears and deflections at each output station along the beam. No checks are made at any points along the beam that are not output stations.

## 2.10 Effective Width of the Concrete Slab

This section explains how the program considers the effective width of the concrete slab separately on each side of the composite beam. This separation is carried through in all of the calculations. It allows different deck properties on the two sides of the beam.

The effective slab width on either side of the beam can be specified in the overwrites. The effective widths are specified on the left and right sides of the beam. As illustrated in Figure 2-2, when viewed from the I-end of the beam toward the J-end of the beam, the program assumes the right side of the beam to be on the right-hand side.

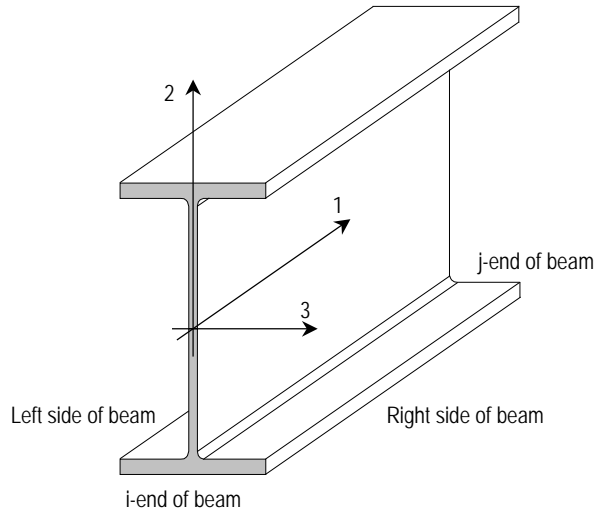

*Figure 2-2 Example of How the Program Defines the Left and Right Sides of the Beam*

### 2.10.1 Location Where Effective Slab Width is Checked

By default, the program checks the effective width of the beam over the entire middle 70% of the beam and uses the smallest value found as the effective width of the beam,  $b_{\text{eff}}$ , everywhere in the calculations for that beam. The 70% number is derived based on two assumptions:

- The capacity of the composite beam is approximately twice that of the steel beam alone.
- The steel beam alone is capable of resisting the entire moment in the composite beam for the last 15% of the beam length at each end of the beam. Note that for a uniformly loaded beam, the moment drops off to half of the maximum moment or less in the last 15% of the beam.

Redefine this default “middle range” of 70% in the composite beam design preferences, if desired (Appendix A).

## 2.10.2 Multiple Deck Types or Directions Along the Beam Length

For design calculations, the program assumes one deck type and deck direction on each side of the beam along the entire length of the beam, regardless of the actual number of types and directions of deck that may exist. The program allows different deck types and deck directions on the two sides of the beam in the calculations. Figure 2-3 shows examples of different deck types and different deck directions on the two sides of the beam.

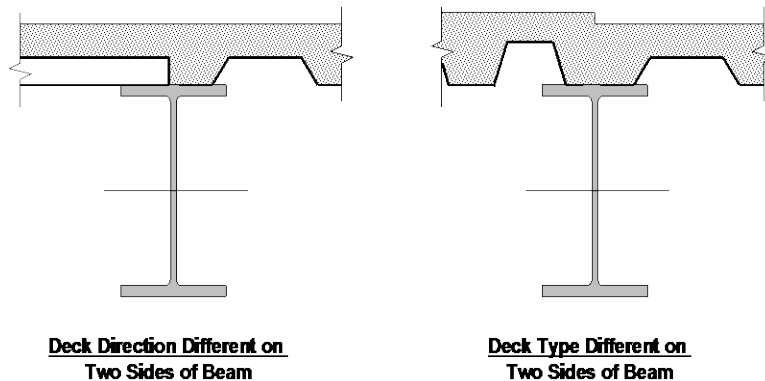

*Figure 2-3 Different Deck Types and Different Deck Directions on the Two Sides of the Beam*

The program checks the deck types and deck directions on each side of the composite beam within the specified middle range (see the previous subsection). When multiple deck types or deck directions occur on the same side of a composite beam, the program decides which single deck section and direction to use on that side of the beam.

The program goes through these steps in this order to choose the deck section.

1. The program calculates the product of  $t_c * f'_c$  for each deck where  $t_c$  is the depth of the concrete above the metal deck and  $f'_c$  is the concrete slab

compressive strength. It uses the deck section that has the *smallest* value of  $t_c * f'_c$  in the calculations for the beam.

2. If two or more deck sections have the same value of  $t_c * f'_c$  but the deck spans in different directions, the program uses the deck section that spans perpendicular to the beam.
3. If two or more deck sections span in the same direction and have the same value of  $t_c * f'_c$ , the program uses the deck section with the smaller  $t_c$  value.
4. If two or more deck sections span in the same direction and have the same values of  $t_c$  and  $f'_c$ , the program uses the first defined deck section.

In this program's composite beam design, the deck is assumed either parallel or perpendicular to the span of the beam. If the deck span is exactly parallel to the beam span or within 15 degrees of parallel to the beam span, the deck span is assumed to be parallel to the beam span. Otherwise, the deck span is assumed to be perpendicular to the beam span.

The assumed deck type and deck direction on each side of the beam can be specified using the composite beam overwrites.

Refer to the floor plan shown in Figure 2-4. The typical floor in this plan consists of 65 mm normal weight concrete over 75 mm metal deck that is designated Deck Type A. However, the upper left-hand quadrant of the floor consists of 90 mm normal weight concrete over 75 mm metal deck that is designated Deck Type B. Assume that the concrete compressive strength is 30 MPa for both deck types.

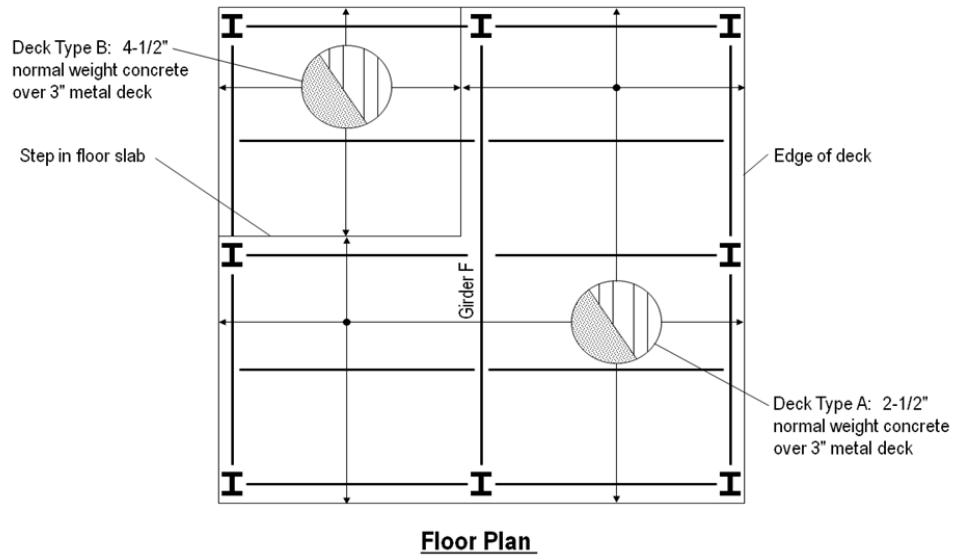

**Figure 2-4 Example of Different Deck Types  
on the Left and Right Sides of the Beam**

Now consider the beam labeled “Girder F” in the figure. Deck Type A exists along the entire length of the right-hand side of this beam. Thus, the program uses Deck Type A on the right side of the beam in the calculations. Both Deck Type A and Deck Type B exist along the left-hand side of the beam. The program uses the following method to determine which of these deck types to use on the left side of the beam in the calculations:

1. Determine the product of  $t_c * f'_c$  for each deck type.
  - a. For Deck Type A:  $t_c * f'_c = 65 * 30 = 1,950 \text{ N/mm}$ .
  - b. For Deck Type B:  $t_c * f'_c = 90 * 30 = 2,700 \text{ N/mm}$ .
2. Use Deck Type A on the left side of the girder in the composite beam calculations because it has the smaller value of  $t_c * f'_c$ .

Note that the loads applied to the beam are still based on the actual deck types. Thus, the load applied to the upper half of Girder F in Figure 2-4 would include the contribution from Deck Type B even though Deck Type B might not be used in calculating the composite beam properties.

A second example is shown in Figure 2-5. In this example, the deck type is the same throughout the floor, but the direction of the deck changes in the upper left-hand quadrant of the floor.

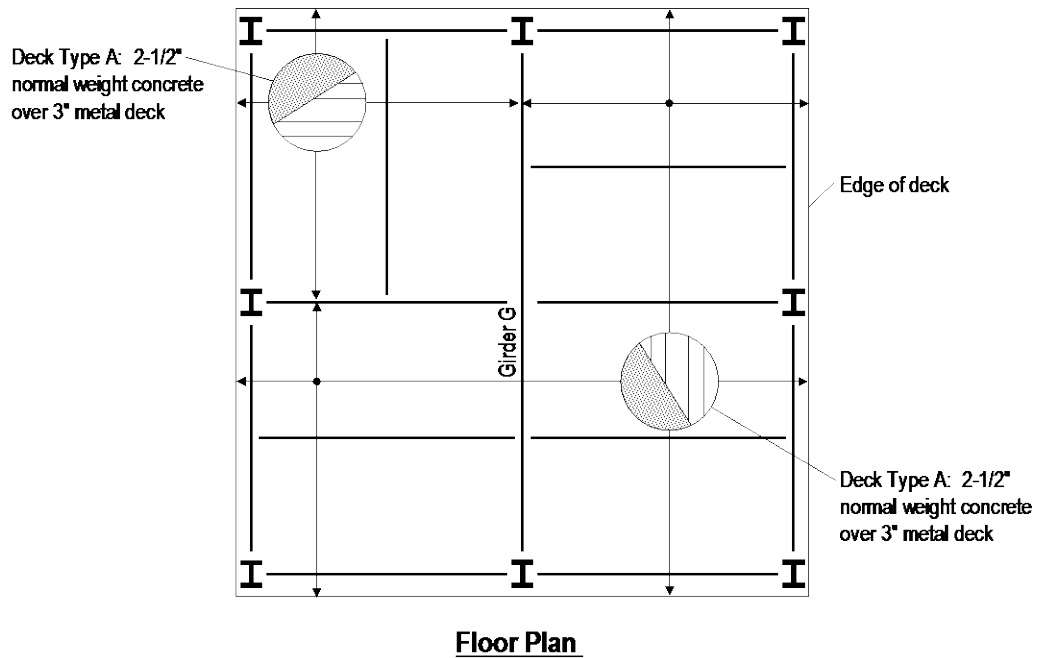

*Figure 2-5 Example of Different Deck Orientations on the Left and Right Sides of the Beam*

Now consider the beam labeled “Girder G” in the figure. The deck ribs are oriented parallel to the span of Girder G along the entire length of the right-hand side of this beam. Thus, the program uses Deck Type A oriented parallel to the span of Girder G on the right side of the beam in the calculations.

Deck ribs oriented both perpendicular and parallel to the span of Girder G exist along the left-hand side of the beam. Because only the deck direction is different along the left side of the beam, not the deck type (and thus  $t_c$  and  $f'_c$  do not change), the program uses the deck that spans perpendicular to Girder G on the left side of the beam.



### 2.10.3 Effect of Diagonal Beams on Effective Slab Width

Consider the example shown in Plan A of Figure 2-6. In Plan A, the length of Beam A is  $L_A$ . Assume that the effective width of this beam is controlled by the distance to the centerline of the adjacent beam. Also assume that the program checks the effective width of the slab over the default middle range (70%) of Beam A. If the variable labeled  $x_A$  in the figure is less than or equal to 0.15, the effective width of the concrete slab on the upper side of Beam A (i.e., the side between Beam A and Beam X) is controlled by the distance between Beam A and Beam X. On the other hand, if  $x_A$  is greater than 0.15, the effective width of the concrete slab on the upper side of Beam A is controlled by the distance between Beam A and Girder Y, at a location of  $0.15L_A$  from the left end of Beam A. This distance is measured along a line that is perpendicular to Beam A.

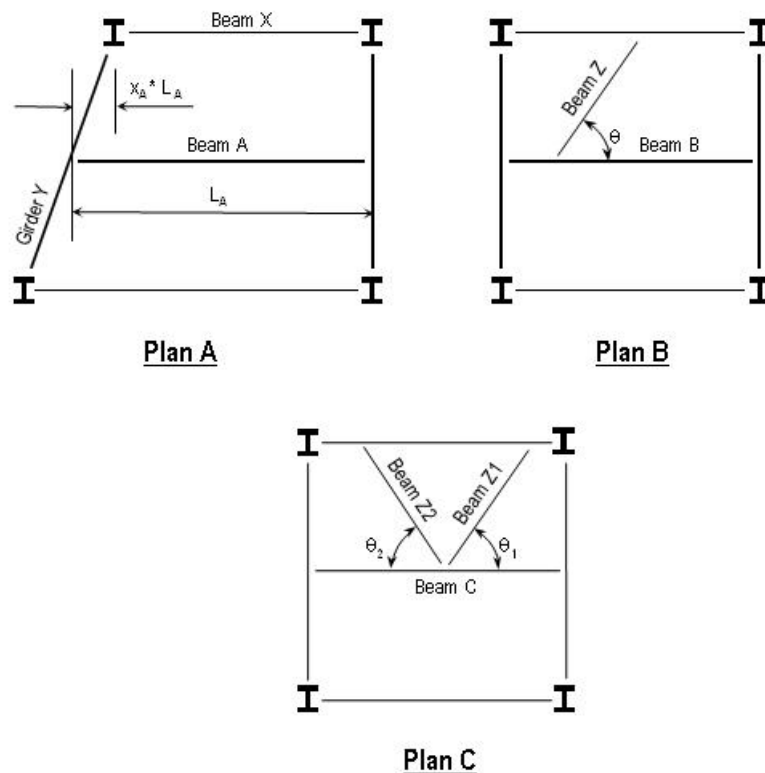

**Figure 2-6 Examples of the Effect of Diagonal Beams on Composite Beam Effective Width**

Now consider the example shown in Plan B of Figure 2-6. Assume that the effective width of Beam B is controlled by the distance to the centerline of the adjacent beam. When considering the perpendicular distance from Beam B to the adjacent beam on the upper side of Beam B, the program considers the diagonal beam labeled Beam Z when the angle  $\theta$  is less than 45 degrees. If the angle  $\theta$  is greater than or equal to 45 degrees, Beam Z is ignored when calculating the effective slab width on the upper side of Beam B.

Plan C in Figure 2-6 shows a special case where two diagonal beams frame into Beam C *at the same point*. In this special case, the program assumes that the effective width of the slab on the side of the beam where the two diagonals exist is zero. The user can, of course, change this in the overwrites. The program assumes the zero effective width because, although it is checking the effective width for Beam C, it is unable to determine whether a slab is actually between the two diagonal beams.

#### 2.10.4 Effect of Openings on Effective Slab Width

Now consider Plan D shown in Figure 2-7. In this case, there is an opening on both sides of the slab at the left end of Beam D.

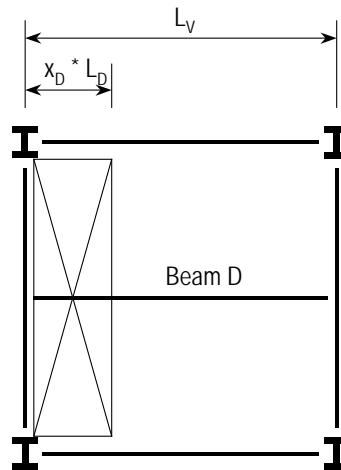

Plan D

*Figure 2-7 Example of the Effect of Openings on Composite Beam Effective Width*

Assume again that the effective width of this beam is controlled by the distance to the centerline of the adjacent beam, and also assume that the program checks the effective width of the slab over the default center 70% of the Beam D length. If the width of the opening,  $x_D * L_D$  is less than  $0.15L_D$ , the program bases the effective width of the concrete slab on the distance to the adjacent beams. On the other hand, if  $x_D * L_D$  exceeds  $0.15L_D$ , the program assumes the effective concrete slab width for Beam D to be zero; that is, it assumes a non-composite beam.

### 2.10.5 Effective Slab Width and Transformed Section Properties

When the program calculates the transformed section properties, the concrete is transformed to steel by multiplying  $b_{eff}$  by the ratio  $E_c / E_s$ . This ratio may be different on the two sides of the beam. See the section entitled *Transformed Section Moment of Inertia* for more information.

## 2.11 Beam Unbraced Length and Design Check Locations

The program considers the unbraced length for construction loading separately from that for final loads. For both types of loading, the unbraced length of the beam associated with buckling about the local 2-axis (minor) of the beam is used to determine the flexural capacity of the non-composite beam. The local 2-axis is illustrated in Figure 2-8.

By default, the program automatically determines the locations where the beam is braced for buckling about the local 2-axis. This information is then used to determine the unbraced length associated with any point on the beam. Instead of using the program calculated bracing points, the user can specify in the overwrites brace points for any beam.

For buckling about the local 2-axis, the program differentiates between bracing of the top flange of the beam and bracing of the bottom flange of the beam. The program automatically recognizes which flange of the beam is the compression flange at any point along the beam for any design load combination. With this ability and the program-determined or user-specified bracing point locations, the program can automatically determine the unbraced length of any segment

along the beam and can apply appropriate code-specified modification factors (e.g.,  $\omega_2$  factor for flexure) to the flexural strength of the beam.

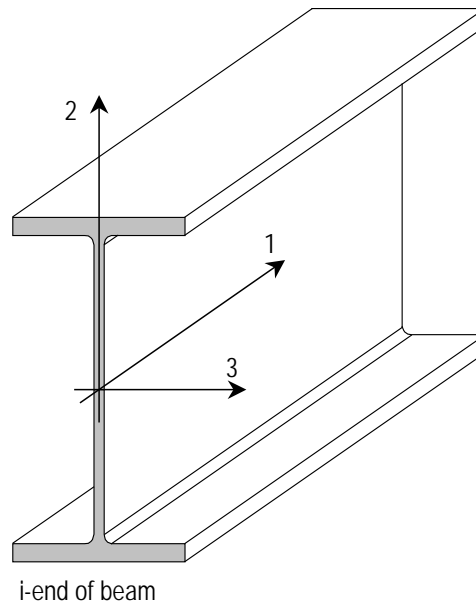

*Figure 2-8 Local 2Axis of a Beam*

### 2.11.1 Determination of the Braced Points of a Beam

The program considers the lateral bracing for the top and bottom flanges separately. In the Composite Beam Design postprocessor, the program assumes that beams can be braced by the deck section (or slab section) that they support and by other beams framing into the beam being considered. The program automatically determines the braced points of a beam for buckling about the local 2-axis as follows:

The top flange is assumed to be continuously laterally supported (unbraced length of zero) anywhere there is metal deck section with concrete fill framing into one or both sides of the beam or there is a slab section framing into both sides of the beam.

Metal deck sections with *no* concrete fill are assumed to continuously brace the top flange if the deck ribs are specified as oriented perpendicular to the beam

span. If the deck ribs are specified as oriented *parallel* to the beam span, the deck is assumed to *not* brace the top flange.

The top and bottom flange are assumed to be braced at any point where another beam frames into the beam being considered at an angle greater than 30 degrees, as shown in the sketch to the right. It is up to the user to provide appropriate detailing at this point to ensure that the bottom flange is adequately braced. If appropriate detailing is not provided, the user should redefine the brace points using one of the methods described in the next section.

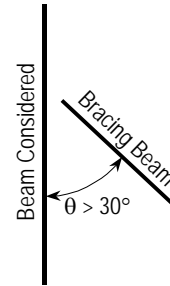

When the bracing is program calculated or brace points are user specified, the program *always* assumes that each end of the beam is braced at both the top and the bottom flange. If the unbraced length of a beam is longer than the actual beam, specify a user-defined unbraced length, not user-defined brace points.

## 2.11.2 User Defined Unbraced Length of a Beam

### 2.11.2.1 Overview

To use unbraced lengths other than those determined by the program, change the assumed unbraced length for any beam in the composite beam overwrites. This is true for both the construction loading unbraced lengths and the final loading unbraced lengths.

For buckling about the local 2-axis, specific bracing points can be specified along the beam that apply to the top flange, bottom flange, or both, or one maximum unbraced length can be specified that applies over the entire length of the beam to both the top and bottom flanges.

As soon as the user specifies any user defined bracing points or unbraced lengths for a beam, all of the program determined lateral bracing information on that beam is ignored. **Thus, if any bracing point is specified for a beam, all of the bracing points for that beam should be specified.**

### 2.11.2.2 User Specified Uniform and Point Bracing

If the user specifies bracing along the beam for buckling about the local 2-axis, the user can specify continuous bracing along a beam flange, bracing at specific points along a beam flange, or both.

#### 2.11.2.2.1 Point Braces

To define point braces, specify a distance along the beam that locates the brace point, and then indicate whether the top, bottom, or both flanges are braced at this location. Specify the distance as an actual distance or as a relative distance, both measured from the I-end of the beam. All distances are measured from the center of the support, not the physical end of the beam. The distances may be specified as either absolute (actual) distances or as relative distances. A relative distance to a point is the absolute distance to that point divided by the length of the beam measured from the center-of-support to center-of-support.

The user can change the default bracing assumed for a beam in the composite beam overwrites. The bracing specified can be different for construction loading and final loading.

#### 2.11.2.2.2 Uniform Braces

To define uniform or continuous bracing, specify a distance along the beam that locates the starting point of the continuous bracing, specify a second (longer) distance along the beam that locates the ending point of the continuous bracing, and then indicate whether the top, bottom, or both flanges are continuously braced over this length. The distances can be specified as absolute (actual) distances or as relative distances, both measured from the I-end of the beam. A relative distance to a point is the absolute distance to that point divided by the length of the beam measured from the center-of-support to center-of-support.

## 2.12 Design Check Locations

One of the first tasks the program performs when designing or checking a composite beam is to determine the design check locations for the design load combinations used for checking the strength of the beam to carry the final design loads. There may be many design check locations along a beam. The design check locations are determined as follows:

- The point of maximum positive moment for each design load combination used for checking the strength of the beam to carry the final design loads is a design check location. Note that there may be more than one of these design load combinations and thus there may be more than one point of maximum moment to consider.
- The point of maximum negative moment (if negative moment exists) for each design load combination used for checking the strength of the beam to carry the final design loads is a design check location.
- A point load or point moment location for any design load combination used for checking the strength of the beam to carry the final design loads is a design check location.
- The ends of a cover plate, if one is specified, are design check locations.
- The end or edge of the deck. This occurs, for example, at locations where the beam spans through an opening in the deck.

At each design check location the program checks the moment capacity of the composite beam and determines the number of shear connectors required between that location and the nearest point of zero moment (or in some special cases, the end of the slab).

The program determines one set of design check locations that applies to all design load combinations.

Consider, for example, a composite beam with two design load combinations used for checking the strength of the beam to carry the final design loads. Assume one of those load combinations is a uniform load over the full length of the beam and the other is a point load at the third point of the beam. Also assume there is positive moment only in the beam and no cover plate. In this example, the program considers the following design check locations:

- The point of maximum positive moment for the design load combination with uniform load only.
- The point of maximum positive moment for the design load combination with point loads at the third point.
- The location of the point load, that is, the third point of the beam.



The program checks the moment capacity and the number of shear connectors required between each of these four locations and the nearest point of zero moment for both of the design load combinations. Thus, for the design load combination with uniform load only, the program still checks how many shear studs are required between the location of the point load in the other design load combination and the nearest point of zero moment. This ensures that there is always a sufficient number of shear connectors in the appropriate location on the beam.

## 2.13 Design Load Combinations

The design load combinations are used for determining the various combinations of the load cases for which the structure needs to be designed/checked. The load combination factors to be used vary with the selected design code. The load combination factors are applied to the forces and moments obtained from the associated load cases and are then summed to obtain the factored design forces and moments for the load combination.

For multi-valued load combinations involving response spectrum, time history, moving loads and multi-valued combinations (of type enveloping, square-root of the sum of the squares or absolute) where any correspondence between interacting quantities is lost, the program automatically produces multiple sub combinations using maxima/minima permutations of interacting quantities. Separate combinations with negative factors for response spectrum cases are not required because the program automatically takes the minima to be the negative of the maxima for response spectrum cases and the previously described permutations generate the required sub combinations.

When a design combination involves only a single multi-valued case of time history, further options are available. The program has an option to request that time history combinations produce sub combinations for each time step of the time history.

For normal loading conditions involving static dead load, live load, snow load, wind load, and earthquake load, or dynamic response spectrum earthquake load, the program has built-in default loading combinations for each design code. These are based on the code recommendations and are documented for each code in the corresponding manuals.

For other loading conditions involving moving load, time history, pattern live loads, separate consideration of roof live load, snow load, and so on, the user must define design loading combinations either in lieu of or in addition to the default design loading combinations.

The default load combinations assume all load cases declared as dead load to be additive. Similarly, all cases declared as live load are assumed additive. However, each load case declared as wind or earthquake, or response spectrum cases, is assumed to be non additive with other similar cases and produces multiple lateral load combinations. Also wind and static earthquake cases produce separate loading combinations with the sense (positive or negative) reversed. If these conditions are not correct, the user must provide the appropriate design combinations.

The default load combinations are included in design if the user requests them to be included or if no other user-defined combination is available for composite beam design. If any default combination is included in design, all default combinations will automatically be updated by the program any time the design code is changed or if static or response spectrum load cases are modified.

Live load reduction factors can be applied to the member forces of the live load case on an element-by-element basis to reduce the contribution of the live load to the factored loading.

The user is cautioned that if moving load or time history results are not requested to be recovered in the analysis for some or all of the frame members, the effects of those loads will be assumed to be zero in any combination that includes them.

For Composite Beam Design, three separate types of load combinations are considered. They are:

- **Strength Check for Construction Loads:** Design load combination for checking the strength of the beam to carry construction loads. Note that this design load combination is considered only if the beam is specified to be unshored. Beams can be specified as shored or unshored in the preferences.
- **Strength Check for Final Loads:** Design load combinations for checking the strength of the beam to carry the final design loads.

- Deflection Check for Final Loads: Design load combinations for checking the deflection of the beam under final design loads.

The design load combinations are defined separately for each of the three conditions. The program automatically creates code-specific composite beam design load combinations for each of the three types of design load combinations based on the specified dead, superimposed dead, live and reducible live load cases. The user can add additional design load combinations and modify or delete the program-created load combinations.

None of the program default load combinations include the effect of lateral loads. If lateral loads need to be considered, the user should specify user-defined design load combinations. As many load combinations as needed can be specified. In addition, the program creates special live load patterns for cantilever beams.

### 2.13.1 Special Live Load Patterning for Cantilever Back Spans

For strength design of cantilever back spans, the program performs special live load patterning. *The live load patterning used for cantilever back spans is slightly different from what you might expect, so you should read this section carefully to understand what the program does.*

Each composite beam design load combination for a cantilever has a dead load (DL), superimposed dead load (SDL) and a live load plus reduced live load (LL + RLL) component. There may also be other types of load components as well. The nature of the other types of load components is not important. The DL, SDL, (LL + RLL) and other components are shown in Figure 2-9a.

The program internally creates a *simply supported* model of the cantilever back span. It applies a load to this simply supported span that is equal to a factor times the LL + RLL applied to the span. The factor used is specified in the composite beam design preferences as the Pattern Live Load Factor. This internally created model and loading is illustrated in Figure 2-9b. In the figure, PLLF is short for Pattern Live Load Factor.

Finally for strength design (final loads only) of cantilever back spans, the program considers the following two conditions for each design load combination:

- DL + SDL + LL + RLL (+ any other type of load if it exists) as specified over the full length (back span plus overhang) of the cantilever beam.
- DL + SDL (+ any other type of load if it exists) over the full length (back span plus overhang) of the cantilever beam plus the (LL + RLL) multiplied by the Pattern Live Load Factor applied to the simply supported back span.

These two conditions are shown in Figure 2-9c.

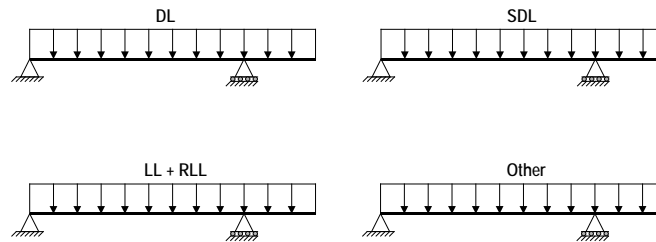

a) Components of a Design Load Combination

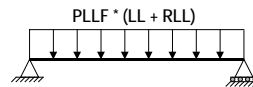

Note: PLLF = The Pattern Live Load Factor as specified on the Beam tab in the composite beam preferences.

b) Simply Supported Back Span with Factored LL + RLL Loading

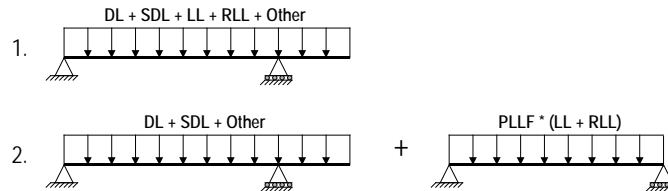

c) Two Conditions Considered for Each Design Load Combination

**Figure 2-9 Conditions Considered for Strength Design of a Cantilever Back Span**

Note that the conditions described herein are considered for strength design for final loads only. The program does not do any special pattern loading checks for deflection design or for construction loading design.

If load patterning different from that provided by the program is needed, the user should create a design load combination. When creating user-defined live load patterning, it typically works best to give the specially defined pattern live

load cases an “Other” design type instead of a “Live Load” design type. That way, the special pattern live load cases are not included in the automatically created default design load combinations, avoiding possible double counting of some live loads in those load combinations.

## 2.13.2 Special Live Load Patterning for Continuous Spans

For strength design of spans that are continuous at one or both ends, the program performs special live load patterning similar to that described in the previous section for back spans of cantilevers. *The live load patterning used for continuous spans is slightly different from what you might expect, so you should read this section carefully to understand what the program does.*

Each composite beam design load combination for a continuous span has a DL, SDL and (LL + RLL) component. There also may be other types of load components as well. The nature of the other types of load components is not important. The DL, SDL, (LL + RLL) and other components are shown in Figure 2-10a.

The program internally creates a *simply supported* model of the continuous span. It applies a load to this simply supported span that is equal to a factor times the LL + RLL applied to the span. The factor used is specified on the Beam tab in the composite beam design preferences as the Pattern Live Load Factor. This internally created model and loading is illustrated in Figure 2-10b. In the figure, PLLF is short for Pattern Live Load Factor.

Finally for strength design (final loads only) of continuous spans, the program considers the following two conditions for each design load combination:

- DL + SDL + LL + RLL (+ any other type of load if it exists) as specified with actual continuity.
- DL + SDL (+ any other type of load if it exists) as specified with actual continuity plus the (LL + RLL) multiplied by the Pattern Live Load Factor applied to the simply supported beam.

These two conditions are shown in Figure 2-10c.

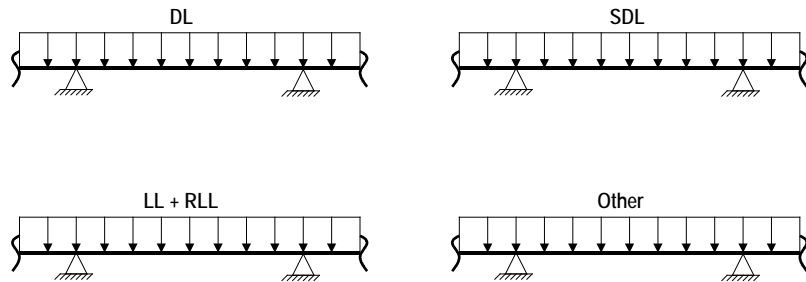

a) Components of a Design Load Combination

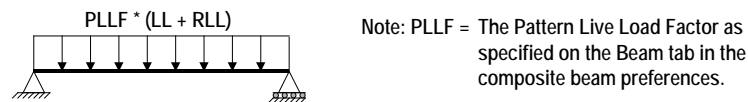

Note: PLLF = The Pattern Live Load Factor as specified on the Beam tab in the composite beam preferences.

b) Simply Supported Span with Factored LL + RLL Loading

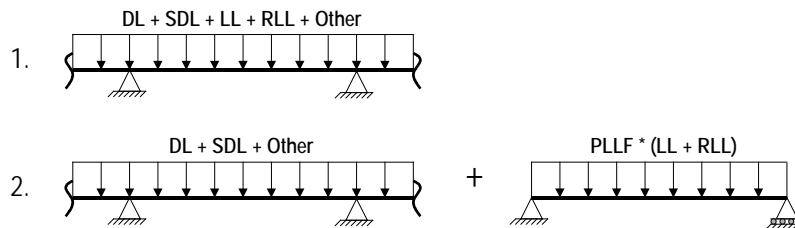

c) Two Conditions Considered for Each Design Load Combination

**Figure 2-10 Conditions Considered for Strength Design of a Continuous Span**

Note that the conditions described herein are considered for strength design for final loads only. The program does not do any special pattern loading checks for deflection design or for construction loading design.

If load patterning different from that provided by the program is needed, the user should create a design load combination. When creating user-defined live load patterning, it typically works best to give the specially defined pattern live load cases an “Other” design type instead of a “Live Load” design type. That way, the special pattern live load cases are not included in the automatically created default design load combinations, avoiding possible double counting of some live loads in those load combinations.

## 2.14 Beam Deflection and Camber

This section describes how the program calculates beam deflections and how it considers beam camber.

### 2.14.1 Deflection

In composite beam design, when a beam is shored, the deflection is calculated using the effective moment of inertia,  $I_{eff}$ , if there is composite action, or the moment of inertia of the steel beam alone,  $I_{bare}$ , if the beam is designed as non-composite or found to be a cantilever overhang. How  $I_{eff}$  is computed is described in section *Effective Moment of Inertia* later in this Chapter.

If a composite beam is unshored, the dead load deflection is always based on the moment of inertia of the steel section alone (plus cover plate, if it exists),  $I_{bare}$ . The deflection for all other loads is calculated using (a) the transformed moment of inertia,  $I_{tr}$ , if there is full (100%) composite connection, (b) the effective moment of inertia,  $I_{eff}$ , if there is partial composite connection, or (c) the moment of inertia of the steel beam alone,  $I_{bare}$ , if the beam is designed as non-composite or found to be a cantilever overhang.

When deflection is used as a criterion for selecting the optimum beam size, the program checks that the total load deflection minus the camber does not exceed the specified total load deflection limit. It also checks that the live load deflection does not exceed the specified live load deflection limit.

The program calculates composite beam deflections using a moment-area technique. An  $M/EI$  diagram is constructed by calculating  $M/EI$  values at each output station along the length of the beam and then connecting the  $M/EI$  values at those stations with straight-line segments. *The program assumes that the moment of inertia does not vary along the length of the beam (frame object).*

Deflections for the beam are calculated at each output station. The overall deflected shape of the beam is drawn by connecting the computed values of deflection at each output station with straight-line segments. Thus, the program assumes a linear variation of  $M/EI$  between output stations.

In this program's composite beam design, the reported deflection is the vertical displacement relative to a line drawn between the deflected position of the ends of the beam. For example, refer to the beam shown in Figure 2-11. Figure 2-11a shows the original undeformed beam and also shows an arbitrary point along the beam labeled A. Figure 2-11b shows the beam in its deformed position and illustrates the deflection that the Composite Beam Design postprocessor reports for the beam at point A.

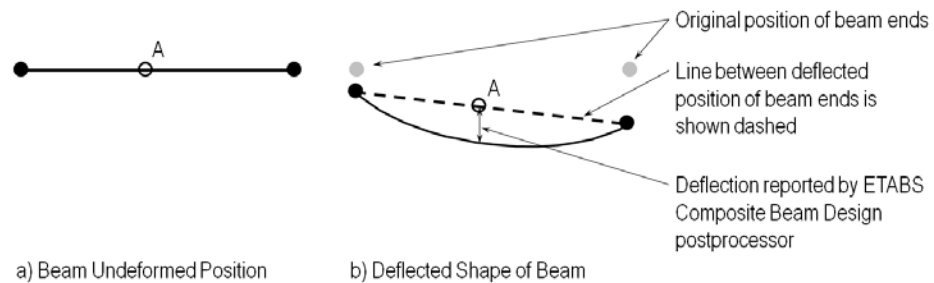

**Figure 2-11 Deflection Results Reported by the Composite Beam Design Postprocessor**

## 2.14.2 Deflection Reported for Cantilever Overhangs

For cantilever overhangs, the program's Composite Beam Design postprocessor reports the displacement of the beam relative to the deformed position of the supported end. *This displacement is calculated by the design postprocessor assuming that the supported end of the cantilever overhang is fixed against rotation.*

When reviewing the displacement at the end of the cantilever, the displacement is reported relative to the *undeformed* position of the end of the cantilever. In that case, the rotation at the supported end of the cantilever overhang is correctly taken into account. However, the displacements displayed are all based on the analysis section properties (non-composite moment of inertias).

## 2.14.3 Camber

When the beam is not shored during construction and beam camber is calculated, the amount of camber is based on a percentage of the dead load (not including superimposed dead load) deflection. By default, this percentage is 80%, but this value can be modified using the composite beam design



preferences. If the beam is shored during construction, the amount of camber calculated by ETABS is zero, reflecting the fact that the beam does not deflect when concrete is poured on the deck on top of it.

The minimum camber that the program specifies (other than zero) is 15 mm. The maximum camber the program specifies is 100 mm. The program specifies the camber in 5 mm increments. Table 2-1 shows how the program assigns camber to a beam based on the specified percentage of dead load deflection.

**Table 2-1 How the Program Specifies Camber**

CP * $\Delta_{DL}$ (mm)		Camber Specified by the Program (mm)	CP * $\Delta_{DL}$ (mm)		Camber Specified by the Program (mm)
$\geq$	<		$\geq$	<	
N.A.	13	0	53	58	55
13	18	15	58	63	60
18	23	20	63	68	65
23	28	25	68	73	70
28	33	30	73	78	75
33	38	35	78	83	80
38	43	40	83	88	85
43	48	45	88	93	90
48	53	50	93	98	95
			98	N.A.	100

In the table, CP is the specified percentage of dead load deflection upon which the camber is based. The CP \*  $\Delta_{DL}$  column is broken into two subcolumns labeled “ $\geq$ ” and “<”. These two subcolumns specify the range of CP \*  $\Delta_{DL}$  for which the program specifies a particular camber.

The program specifies camber for those beams for which the user requests it to specify camber, regardless of the beam depth or length. Review the beam cambers calculated by the program together with beam camber information related to the design code and any other information provided by the steel fabricator to make any necessary adjustments.

## 2.15 Floor Vibration

For BS 5950-1990, by default the program calculates the first natural vibration frequency for each beam and reports it in the output, but it does not by default

use this information to determine the adequacy of a composite beam section. This can be changed on the Preferences tab in the composite beam design preferences. An option is available to indicate that a beam section must satisfy the Murray minimum damping requirement to be considered acceptable.

## 2.15.1 Vibration Frequency

The program calculates the first natural vibration frequency of a beam using the Dunkerley relationship.

$$f = K_f \sqrt{\frac{g E_s I_t}{W L^3}} \quad (\text{DG11 Eqn. 3.1})$$

where,

- $f$  = First natural frequency of the beam in cycles per second.
- $K_f$  = A unitless coefficient typically equal to 1.57 unless the beam is the overhanging portion of a cantilever with a back span, in which case  $K_f$  is as defined in Figure 2-12 and digitized in Table 1, or the beam is a cantilever that is fully fixed at one end and free at the other end, in which case  $K_f$  is 0.56. Note that Figure 2-12 is based on a similar figure in Murray and Hendrick (1977)
- $g$  = Acceleration of gravity, 9.86 m/sec<sup>2</sup>
- $E_s$  = Modulus of elasticity of steel, MPa
- $I_t$  = Transformed section moment of inertia for the composite beam calculated assuming full (100%) composite connection, regardless of the actual percent composite connection, mm<sup>4</sup>
- $W$  = Total load supported by the beam, N. This is calculated by the program as the sum of all of the dead load and superimposed dead load supported by the beam, plus a percentage of all of the live load and reducible live load supported by the beam. The percentage of live load is specified in the composite beam preferences. The percentage is intended to be an estimate of

the sustained portion of the live load (about 10% to 25% of the total design live load). See Naeim (1991)

$L$  = Center-of-support to center-of-support length of the beam, mm

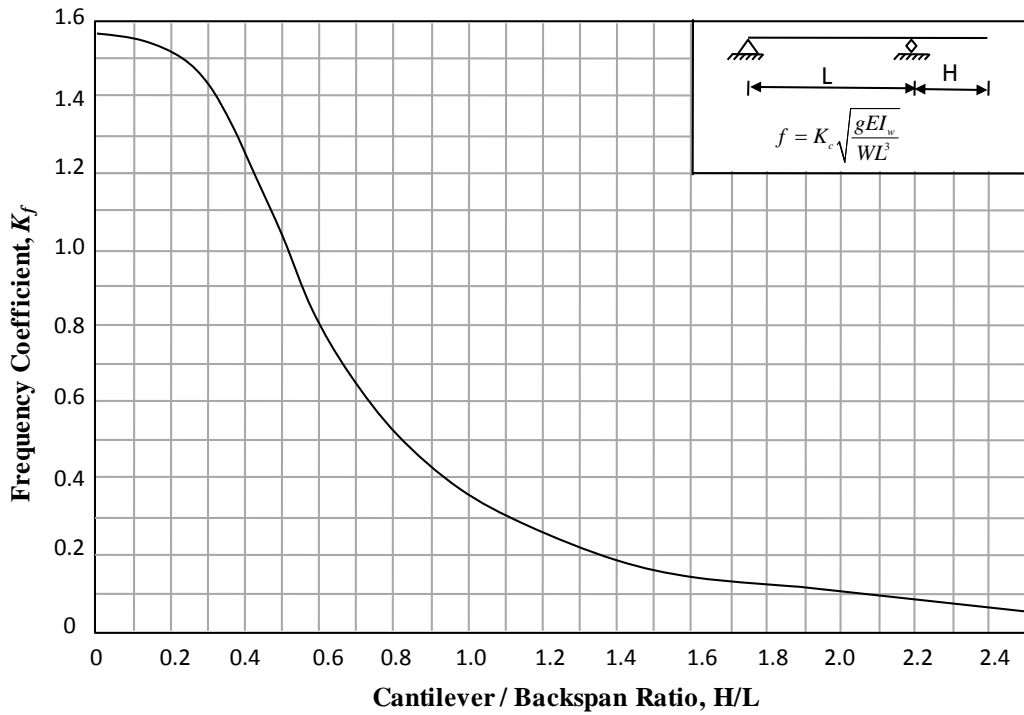

Figure 2-12  $K_f$  Coefficient for an Overhanging Beam for Use in the Preceding Equation  
(The definition of  $K_f$  is provided earlier in this section.)

Table 2-2 Digitization of Figure 2-12 as used by the Program

Point	H/L	$K_f$	Point	H/L	$K_f$	Point	H/L	$K_f$
1	0	1.57	11	0.6	0.8	21	1.6	0.15
2	0.05	1.57	12	0.7	0.64	22	1.7	0.14
3	0.1	1.56	13	0.8	0.52	23	1.8	0.13
4	0.15	1.55	14	0.9	0.43	24	1.9	0.12
5	0.2	1.53	15	1	0.37	25	2	0.11
6	0.25	1.5	16	1.1	0.31	26	2.1	0.1

---

7	0.3	1.44	17	1.2	0.27	27	2.2	0.09
8	0.35	1.35	18	1.3	0.22	28	2.3	0.08
9	0.4	1.25	19	1.4	0.2	29	2.4	0.07
10	0.5	1.03	20	1.5	0.17	30	2.5	0.06

---

### 2.15.1.1 Murray's Minimum Damping Requirement

In his paper entitled "Acceptability Criterion for Occupant-Induced Floor Vibrations," Thomas M. Murray (Murray 1981) proposed that a criterion for acceptable steel beam-concrete slab floor systems subject to human walking vibrations is as shown in the following equation:

$$D \geq 35 \frac{A_{sb}}{N_{eff}} f + 2.5$$

where,

$D$  = Damping ratio, percent critical damping inherent in the floor system, unitless. This item is specified on the Vibration tab in the composite beam preferences.

$A_{sb}$  = Initial displacement amplitude of a single beam resulting from a heel drop impact, mm.

$N_{eff}$  = The effective number of beams resisting the heel drop impact, unitless.

$f$  = First natural frequency of the beam in cycles per second.

If the damping ratio,  $D$ , is greater than the right side of the preceding equation, the beam is considered acceptable. Approximate damping ratio values for typical building configurations are published in the literature (see, for example, Allen 1974; Allen and Rainer 1976; Allen, Rainer and Pernica 1979; Murray 1975; and Murray 1991). The derivation of the initial displacement amplitude is described herein.

#### 2.15.1.1.1 Initial Displacement Amplitude

To calculate the initial displacement amplitude of a single beam,  $A_{sb}$ , first calculate the time to the maximum initial displacement,  $t_0$ , in seconds. This time is calculated using the following equation.

$$t_0 = \frac{1}{\pi f} \tan^{-1}(0.1\pi f)$$

where  $f$  is the first natural vibration frequency as determined from DG11 Eqn. 3.1 and  $\tan^{-1}(0.1\pi f)$  is evaluated in radians. After the value of  $t_0$  has been determined, the value of  $A_{sb}$  is calculated from either of the following equations, depending on the value of  $t_0$ .

$$A_{sb} = \frac{P_0 L^3}{2.4 E_s I_{tr}} (0.1 - t_0), \quad \text{if } t_0 \leq 0.05 \text{ sec}$$

$$A_{sb} = \frac{P_0 L^3}{2.4 E_s I_{tr}} * \frac{1}{2\pi f} * VF, \quad \text{if } t_0 > 0.05 \text{ sec}$$

where,

$$VF = \sqrt{2 \left[ 1 - 0.1\pi f \sin(0.1\pi f) - \cos(0.1\pi f) \right] + (0.1\pi f)^2}$$

In the preceding equation, the terms  $\sin(0.1\pi f)$  and  $\cos(0.1\pi f)$  are evaluated in radians.

In the preceding equations,

$A_{sb}$  = Initial displacement amplitude of a single beam resulting from a heel drop impact, mm.

$P_0$  = Heel drop force, kips. This force is taken as 290 N.

$L$  = Center-of-support to center-of-support length of the beam, mm.

$E_s$  = Steel modulus of elasticity, MPa.

$I_{tr}$  = Transformed section moment of inertia for the composite beam calculated assuming full (100%) composite connection, regardless of the actual percent composite connection, mm<sup>4</sup>.  $I_{tr}$  is calculated using the first equation in the previous section entitled *Beam Deflection and Camber*. If there is no deck supported by the beam,  $I_{bare}$  is used for this item.

$f$  = First natural frequency of the beam in cycles per second.

#### 2.15.1.1.2 Effective Number of Beams Resisting Heel Drop Impact

The program defaults to using an  $N_{eff}$  value of 1. Alternatively, specify a value of  $N_{eff}$  on the Vibration tab in the composite beam overwrites, if desired, or specify that the program calculate  $N_{eff}$  based on a user-specified beam spacing using the following equation.

Note the following about the program's implementation of the following equation:

- When calculating  $N_{eff}$  using the following equation, the program does not check or consider the number of parallel, equally spaced identical beams.
- The beam spacing used in the equation is user input in the composite beam overwrites.
- If the beam considered is a cantilever overhang, the program calculated value of  $N_{eff}$  is always set to 1.0.
- If the beam considered has deck on one side, or less, the program calculated value of  $N_{eff}$  is always set to 1.0.

$$N_{eff} = 2.967 - 0.05776 \left( \frac{s_b}{d_{avg}} \right) + 2.556 * 10^{-8} \left( \frac{L^4}{I_{tr}} \right) + 0.00010 \left( \frac{L}{s_b} \right)^3$$

where,

$N_{eff}$  = Effective number of beams resisting heel drop impact, unitless.

$s_b$  = Beam spacing as input by the user in the composite beam overwrites, mm.

$d_{avg}$  = Average depth of concrete slab including the concrete in the metal deck ribs, mm.

$L$  = Center-of-support to center-of-support length of the beam, mm.

$I_{tr}$  = Transformed section moment of inertia for the composite beam calculated assuming full (100%) composite connection regardless of

the actual percent composite connection, in<sup>4</sup>.  $I_{tr}$  is calculated using the first equation in the preceding section entitled *Beam Deflection and Camber*. If there is no deck supported by the beam,  $I_{bare}$  is used for this item.

The depth  $d_{avg}$  is calculated as:

$$d_{avg} = \frac{\left[ \left( \frac{w_{r\ left} h_{r\ left}}{S_{r\ left}} + t_{c\ left} \right) b_{eff\ left} + \left( \frac{w_{r\ right} h_{r\ right}}{S_{r\ right}} + t_{c\ right} \right) b_{eff\ right} \right]}{b_{eff\ left} + b_{eff\ right}}$$

where,

$w_r$  = Average width of the metal deck ribs, mm.

$h_r$  = Height of the metal deck ribs, mm.

$S_r$  = Center-to-center spacing of the metal deck ribs, mm.

$t_c$  = Depth of the concrete slab above the metal deck ribs or depth of the solid concrete slab, mm.

$b_{eff}$  = Effective slab width for composite design, mm.

Each of the preceding quantities may be different on the left and right sides of the beam.

## 2.16 Distribution of Steel Headed Stud Anchors on a Composite Beam

This section describes how the program calculates and reports the distribution of shear studs on a composite beam. It begins by introducing the term “composite beam segments.” Next it describes how the program calculates the shear stud distribution for a beam.

## 2.16.1 Composite Beam Segments

For the purposes of reporting the number of shear studs required on each composite beam, the program divides the top flange of each composite beam into segments. The segments extend along the length of the beam. Each composite beam consists of one or more composite beam segments.

A composite beam segment may span between any two of the following three items *provided that there is concrete on the beam, and the beam top flange is available over the full length of the segment*:

1. The physical end of the beam top flange.
2. Another beam in the program model that frames into the beam being considered.
3. The physical end of the concrete slab on top of the beam considered.

A composite beam segment cannot exist in locations where concrete is not over the beam or where the beam top flange has been coped. Figure 2-13 shows some examples of composite beam segments. The figure uses the following notation:

$L$  = Length of the composite beam measured from center-of-support to center-of-support, mm.

$L_{CBS}$  = Length of a composite beam segment, mm.

Note that a composite beam can have more than one composite beam segment, as shown in Figure 2-13c.



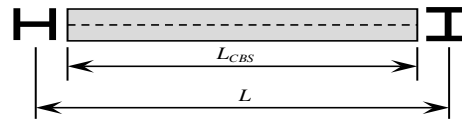

a)  $L_{CBS}$  for Beam Between Two Columns

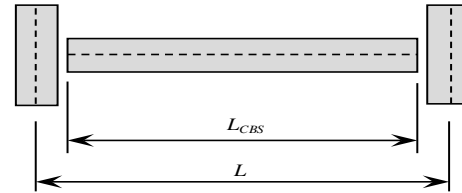

b)  $L_{CBS}$  for Beam Between Two Girders

**Figure 2-13 Examples of Composite Beam Segments,  $L_{CBS}$**

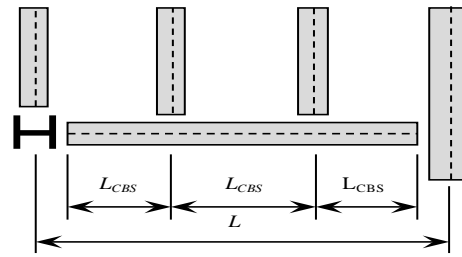

c)  $L_{CBS}$  when Beams Frame into Considered Beam

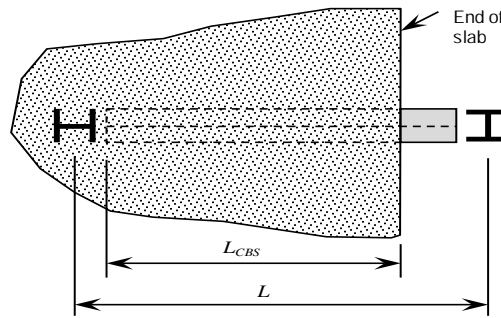

d)  $L_{CBS}$  when Slab Ends in Beam Span

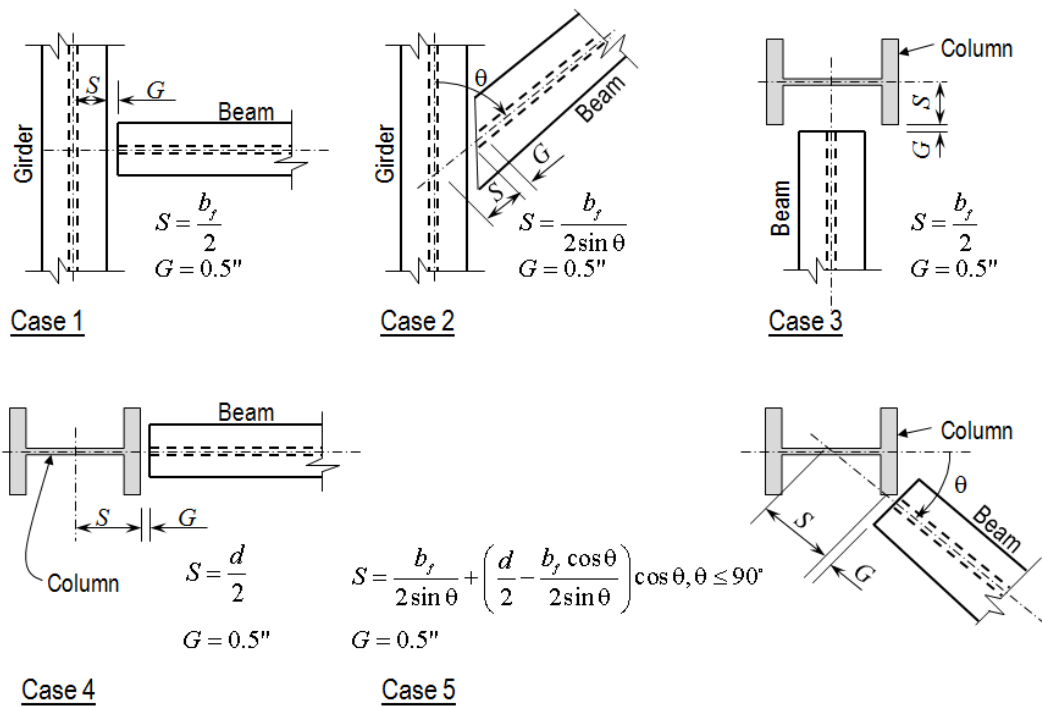
**Notes:**

1.  $S$  is the support distance.
2.  $G$  is the gap distance.
3. If a beam is supported by a wall or a point support, ETABS assumes that the dimension  $S$  is 0 mm.
4. The dimension  $b_f$  in Cases 1 and 2 is the top flange width of the supporting girder.
5. The dimension  $b_f$  in Cases 3 and 5 is the flange width of the supporting column (dimension parallel to the local 3-axis). If the two flanges have different widths, the larger flange width is used.
6. The dimension  $d$  in Cases 4 and 5 is the depth of the supporting column (dimension parallel to the local 2-axis).

**Figure 2-14 Examples of Support Distance  $S$  and Gap Distance  $G$**

### 2.16.1.1 Physical End of the Beam Top Flange

When one or both ends of a composite beam segment lie at the end of a composite beam, the program must assume the exact location of the end(s) of the beam top flange to calculate a length,  $L_{CBS}$ , for the composite beam segment.

When determining the location of the ends of the beam top flange, the program begins by assuming that the top flange extends from the center of the left support to the center of the right support. It then subtracts a support distance,  $S$ , from each end of the beam and a gap distance,  $G$ , from each end of the beam. The gap distance,  $G$ , is always 12 mm. The support distance varies depending on the type of support and the angle at which the beam frames into the support.

If the end of the beam is supported by a wall or a point support, the support distance,  $S$ , is assumed to be zero. If the end of the beam is supported by another beam, support distance  $S$  is determined as illustrated in Cases 1 and 2 in Figure 2-14, which show the beam supported by an I-shaped beam. A similar method is used in the unusual case of other types of support beams.

If the end of the beam is supported by a column,  $S$  is determined as illustrated in Cases 3, 4 and 5 in Figure 2-14, which show the beam supported by an I-shaped column. A similar method is used for box columns and in the very unusual case of some other column shape.

In the unusual case of some other column shape, the program draws a bounding rectangle around the shape. The sides of the rectangle are parallel to the local 2 and 3 axes of the shape. The beam is assumed to connect to the center of the bounding rectangle. The dimensions of the edges of the rectangle are assumed to be  $b_f$  and  $d$ , where  $b_f$  is the dimension parallel to the local 3 axis, and  $d$  is the dimension parallel to the local 2 axis.

### 2.16.1.2 Distribution of Shear Studs Within a Composite Beam Segment

The program *always* assumes a uniform intensity of shear studs within a composite beam segment. This is a convenient assumption that in some cases may lead to a slightly conservative number of shear studs.

## 2.16.2 How the Program Distributes Steel Headed Stud Anchors on a Beam

This section describes how the program calculates the shear stud distribution on a beam.

When determining the distribution of shear studs on a composite beam, the program considers the following output stations:

1. The output station with the maximum positive moment.
2. Any output station with a positive moment greater than 0.999 times the maximum positive moment.
3. Any output station that has a point load applied to it *for any load case defined in the program*. Even if the load case with the point load is not used in the design load combinations for composite beam design, the program will still consider the output station associated with the point load when it determines the shear stud distribution. It will not, however, in any way explicitly consider the loads in that unused load case when determining the shear stud distribution.

At each considered output station, the program begins by determining the distances  $L_{1 \text{ left}}$  and  $L_{1 \text{ right}}$ . These are illustrated in Figure 2-15 for a typical composite beam with positive moment only and with a concrete slab over the metal deck along its entire length. The following notation is used in the figure:

$L$  = Length of the composite beam measured from center-of-support to center-of-support, mm.

$L_{1 \text{ left}}$  = Distance from the output station considered to the closest point of zero moment or physical end of the beam top flange, or physical end of the concrete slab on the *left* side of the output station considered, mm.

$L_{1 \text{ right}}$  = Distance from the output station considered to the closest point of zero moment or physical end of the beam top flange, or physical end of the concrete slab on the *right* side of the output station considered, mm.

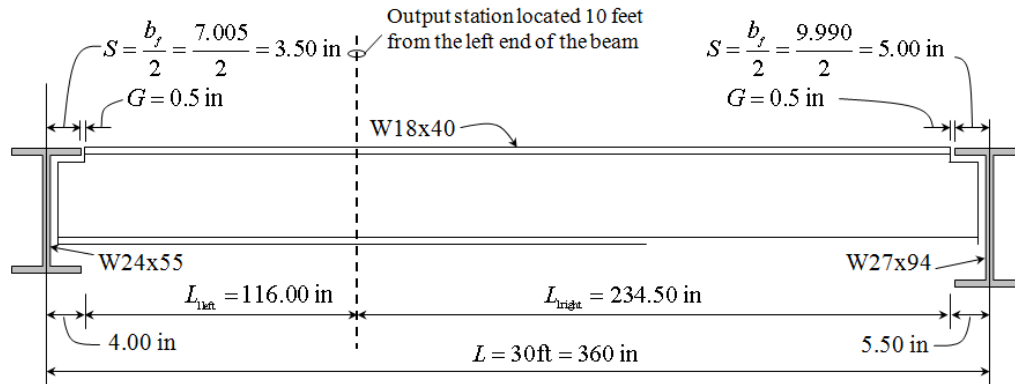

Figure 2-15 Illustration of  $L_{left}$  and  $L_{right}$

Next, the program calculates the number of shear studs,  $N$ , required within the lengths  $L_{left}$  and  $L_{right}$ . This is a code-specific calculation and is described in the next chapter.

The program works along the beam from left to right, making calculations at each considered output station along the way. These calculations are described later in this section. When there is more than one composite beam segment along the beam, the program must also work back along the beam from right to left, again making calculations at each considered output station along the way, after finishing the pass from left to right.

When the program completes the necessary calculations at each considered output station, it has determined the required uniformly spaced shear studs in each composite beam segment along the beam based on strength considerations. If the calculated number of studs is then found to be less than the minimum required number of studs on the beam, the program increases the number of studs on the beam accordingly. This check is described later in the subsection entitled *Minimum and Maximum Number of Shear Studs in a Composite Beam Segment*.

The program also checks if the number of shear studs required based on strength considerations or minimum stud requirements actually fit on the beam. This check is described in the section entitled *Number of Shear Studs that Fit in a Composite Beam Segment* later in this chapter. If the required number of

studs does not fit on the beam, the program considers the beam to be inadequate.

In the following description of the calculations the program performs as it steps along the beam and then back again, the terms  $L_{CBSn}$  and  $N_{CBSn}$  are used.  $L_{CBS}$  is the length of a composite beam segment, and  $N_{CBS}$  is the number of uniformly spaced shear studs required in a composite beam segment. The  $n$  is the composite beam segment number. The leftmost composite beam segment is always  $L_{CBS1}$ , and the numbering of composite beam segments then proceeds in order toward the right end of the beam.

The values we are ultimately interested in are the  $N_{CBSn}$  values. Note that the final  $N_{CBSn}$  values calculated are the values of interest. All other  $N_{CBSn}$  values are intermediate values.

Also in the equations used note that  $N_{CBSxPrev}$  is the value of  $N_{CBSx}$  calculated at the previously considered output station. Finally the term Roundup used in some of the equations means to calculate the indicated quantity and round it up to the next integer.

### 2.16.2.1 Equations Used When the Program Works from Left to Right

When the program is working from left to right along the beam, the equation used to calculate  $N_{CBSn}$  depends on the location of the output station considered.

#### (a) Output Station in Composite Beam Segment 1

When working along the beam from left to right and the output station considered falls in composite beam segment 1, or at the right end of composite beam segment 1, the following equation is used to determine the value of  $N_{CBS1}$ . Note that when there is only one composite beam segment along the beam, the following equation is used at each considered output station.

$$N_{CBS1} = \text{Roundup} \left[ \text{Max} \left( \frac{N}{L_{1\text{left}}}, \frac{N}{L_{1\text{right}}} \right) * L_{CBS1} \right] \geq N_{CBS1\text{Prev}}$$

Values of  $N_{CBSn}$  where  $n > 1$  (i.e., values of  $N_{CBS}$  for composite beam segments 2, 3, etc.) are not applicable and thus not calculated at these stations when

working along the beam from left to right. In the term  $N_{CBS1}$ , the "1" denotes composite beam segment 1.

**(b) Output Station in Composite Beam Segment  $n, n > 1$**

The equations in this subsection are used when the output station considered falls in composite beam segment  $n$ , where  $n > 1$ , and the program is working from left to right along the beam. Note that if the output station considered coincides with the right end of composite beam segment  $n$ , the output station is assumed to be in composite beam segment  $n$  (when working along the beam from left to right).

The following equation applies for composite beam segments  $i$ , where  $i$  is an integer less than  $n$ .

$$N_{CBSi} = \text{Roundup} \left( \frac{N}{L_{1\text{left}}} * L_{CBSi} \right) \geq N_{CBSi \text{ Prev}}$$

The next two equations apply for composite beam segment  $n$ .

If  $\frac{N}{L_{1\text{left}}} * \sum_{i=1}^{n-1} L_{CBSi} < \sum_{i=1}^{n-1} N_{CBSi}$ , use the following equation to calculate  $N_{CBSn}$ .

$$N_{CBSn} = \text{Roundup} \left( \frac{N - \sum_{i=1}^{n-1} N_{CBSi}}{L_{1\text{left}} - \sum_{i=1}^{n-1} L_{CBSi}} * L_{CBSn} \right) \geq N_{CBSn \text{ Prev}}$$

Otherwise use the next equation to calculate  $N_{CBSn}$ .

$$N_{CBSn} = \text{Roundup} \left( \frac{N}{L_{1\text{left}}} * L_{CBSn} \right) \geq N_{CBSn \text{ Prev}}$$

When  $i > n$ , values of  $N_{CBSi}$  are not applicable and thus are not calculated at those stations when working along the beam from left to right.

### 2.16.2.2 Equations Used When the Program Works from Right to Left

Recall that it is only necessary for the program to work back along the beam from right to left if there is more than one composite beam segment along the length of the beam. When the program is working back along the beam from right to left, the equation used to calculate  $N_{CBSn}$  again depends on the location of the output station considered.

#### (a) Output Station in Rightmost Composite Beam Segment

The equations in this subsection are used when working back along the beam from right to left and the output station considered falls in the rightmost composite beam segment, or at the left end of the rightmost composite beam segment. For the rightmost composite beam segment:

$$N_{CBS \text{ rightmost}} = \text{Roundup} \left[ \text{Max} \left( \frac{N}{L_{1 \text{ left}}}, \frac{N}{L_{1 \text{ right}}} \right) * L_{CBS \text{ rightmost}} \right],$$

$$N_{CBS \text{ rightmost}} \geq N_{CBS \text{ rightmost prev}}$$

For other composite beam segments that are not the rightmost composite beam segment, the following equation applies, where  $i$  represents the composite beam segment number.

$$N_{CBSi} = N_{CBSi \text{ Prev}}$$

#### (b) Output Station Not in Rightmost Composite Beam Segment

The equations in this subsection apply when working back along the beam from right to left. (Note that this implies that there is more than one composite beam segment along the beam.) In this section, assume that the output station considered falls within (or at the left end of) composite beam segment  $n$ .

The following equation applies for composite beam segments  $i$ , where  $i$  is an integer *greater* than  $n$ . For example, if the output station considered falls in composite beam segment 2, this equation applies to composite beam segments 3, 4, etc.



$$N_{CBSi} = \text{Roundup} \left( \frac{N}{L_{1 \text{ right}}} * L_{CBSi} \right) \geq N_{CBSi \text{ Prev}}$$

The following two equations apply for composite beam segment  $n$ . For example, if the output station considered falls in composite beam segment 2, the following two equations apply to composite beam segment 2 only.

If  $\frac{N}{L_{1 \text{ right}}} * \sum_{i=n+1}^{\text{rightmost}} L_{CBSi} < \sum_{i=n+1}^{\text{rightmost}} N_{CBSi}$ , use the following equation to calculate  $N_{CBSn}$ .

$$N_{CBSn} = \text{Roundup} \left( \frac{N - \sum_{i=n+1}^{\text{rightmost}} N_{CBSi}}{L_{1 \text{ right}} - \sum_{i=n+1}^{\text{rightmost}} L_{CBSi}} * L_{CBSn} \right) \geq N_{CBSn \text{ Prev}}$$

Otherwise, use this equation to calculate  $N_{CBSn}$ .

$$N_{CBSn} = \text{Roundup} \left( \frac{N}{L_{1 \text{ right}}} * L_{CBSn} \right) \geq N_{CBSn \text{ Prev}}$$

The following equation applies for composite beam segments  $i$ , where  $i$  is an integer less than  $n$ . For example, if the output station considered falls in composite beam segment 2, this equation applies to composite beam segment 1.

$$N_{CBSi} = N_{CBSi \text{ Prev}}$$

### 2.16.2.3 Minimum and Maximum Number of Shear Studs in a Composite Beam Segment

After the number of shear studs required in a composite beam segment has been calculated using the procedure described in the previous section, the program checks that the number of studs is not less than the required minimum. This required minimum,  $MS_{CBS}$ , is calculated based on the maximum longitudinal spacing of shear studs along the length of the beam,  $MaxLS$ , which is specified on the Shear Studs tab in the composite beam overwrites. This calculation is shown in the following equation.

$$MS_{CBS} = \text{Roundup}\left(\frac{L_{CBS}}{\text{MaxLS}}\right)$$

The program also checks that the number of studs required in a composite beam segment does not exceed the number that can actually fit in the segment. The section entitled *Number of Shear Studs that Fit in a Composite Beam Segment* describes how the program determines the maximum number of shear studs that can fit into a composite beam segment.

Note that the minimum number of shear studs required in a composite beam segment is calculated based on the maximum longitudinal spacing of shear studs specified on the Shear Studs tab in the overwrites.

### 2.16.3 A Note About Multiple Design Load Combinations

When there are multiple design load combinations on a composite beam, the program determines the stud distribution separately for each design load combination and then uses an intelligent algorithm to determine the final stud distribution that satisfies all design load combinations.

As an example, consider a beam with four composite beam segments (CBS1 through CBS4) and two separate design load combinations (1 and 2). Figure 2-16(a) shows the stud distribution obtained for the first design load combination, and Figure 2-16(b) shows the stud distribution obtained for the second design load combination. Note that the term  $N_{CBS}$  in the figure denotes the number of shear studs in the corresponding composite beam segment.

Figure 2-16(c) shows the final stud distribution that reports for this beam. Note that the intelligent algorithm allows the program to shift one of the five shear studs required in composite beam segment 2 for design load combination 1 into composite segment 1.

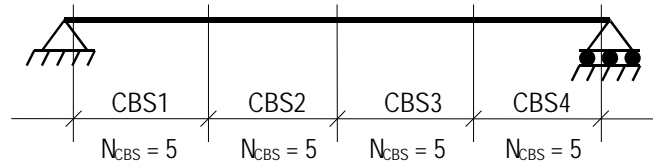

a) Shear Stud Distribution for Design Load Combination 1

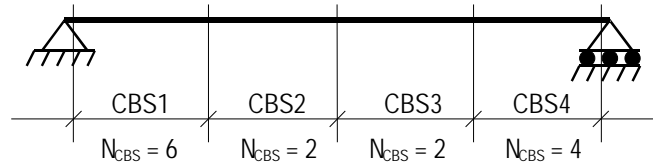

b) Shear Stud Distribution for Design Load Combination 2

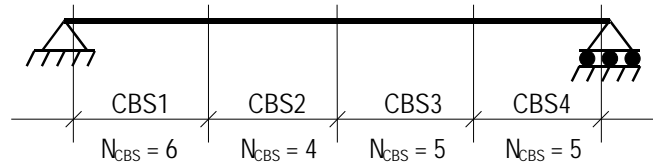

c) Final Shear Stud Distribution Reported by the Program

**Figure 2-16 Example of Shear Stud Distribution When Multiple Design Load Combinations Are Considered**

## 2.17 Number of Shear Studs that Fit in a Composite Beam Segment

Composite beam segments are defined in the subsection entitled *Composite Beam Segments* of the section entitled *Distribution of Shear Studs on a Composite Beam*. In short, a composite beam segment spans between any of the following: (1) physical end of the beam top flange; (2) another beam framing into the beam being considered; (3) physical end of the concrete slab on top of the beam. When the program designs a composite beam, it reports the required number of *uniformly spaced* shear studs in each composite beam segment.

For a beam section to be adequate in the program Composite Beam Design postprocessor, the stresses and deflections for the beam must be less than the allowable stresses and deflections, *and* the number of shear studs required in each composite beam segment must be less than or equal to the maximum number of shear studs that can fit in the composite beam segment. This section describes how the program calculates the maximum number of shear studs that fit in a composite beam segment.

The program uses the same process to determine the number of shear connectors that can fit on a composite beam when there is a solid slab with no metal deck and when the deck ribs span parallel to the beam span. The program uses a different process when the deck ribs span perpendicular to the beam. These conditions are described in the next two sections.

### 2.17.1 Solid Slab or Deck Ribs Oriented Parallel to Beam Span

When there is a solid slab with no metal deck, or when there is metal deck and the metal deck ribs are assumed to be oriented parallel to the beam span, the program uses the following process to determine the number of shear studs that can be placed within a composite beam segment. See the subsection entitled *Composite Beam Segments* of the section entitled *Distribution of Shear Studs on a Composite Beam* for a definition of a composite beam segment.

The number of shear studs that can fit in a row across the beam top flange may be limited by the width of the beam top flange, by the width of the deck ribs, or by the Max Studs per Row item specified on the Shear Studs tab in the composite beam overwrites.

1. The program determines the number of shear studs that can fit in a single row across the width of the top flange of the beam. When there is a solid slab (no metal deck), the number of shear studs is limited by the width or thickness of the beam flange (item 1a, which follows), or by the "Max Studs per Row" item specified on the Shear Studs tab in the composite beam overwrites. When the deck spans parallel to the beam, the number of shear studs may be limited by the width or thickness of the beam flange (item 1a, which follows), the width of the metal deck rib (item 1b, which follows), or by the "Max Studs per Row" item specified on the Shear Studs tab in the composite beam overwrites. Following is a description of each of these limits:

- a. When checking the number of shear studs that fit across the width of the beam flange, the program assumes that the studs are centered about the centerline (web) of the beam and that the center of a shear stud can be no closer than  $d_s$  or 25 mm, whichever is *larger*, to the edge of the beam flange. This is illustrated in the following sketch.

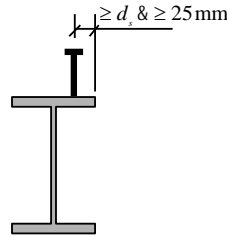

In the preceding paragraph and the sketch,  $d_s$  is the diameter of the shear stud. The clearance requirement means that the minimum clear distance from the face of a shear stud to the edge of the beam flange is equal to one-half of a shear stud diameter. For shear studs less than 25 mm in diameter (typically they are 19 mm diameter), the program clearance is slightly more than one-half of a shear stud diameter. This clear distance is provided by the program to allow for adequate welding of the shear stud.

- b. When checking the number of shear studs that fit within a metal deck rib, the program assumes that the studs and deck rib are centered about the centerline (web) of the beam and that the center of a shear stud can be no closer than  $d_s + h_r / 4$  to the edge of the beam flange. This is illustrated in the following sketch.

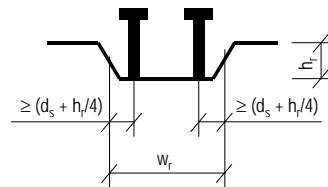

In the preceding paragraph and the sketch,  $d_s$  is the diameter of the shear stud, and  $h_r$  is the height of the metal deck ribs. The  $w_r$  dimension in the sketch is the average width of the deck ribs. The spacing between the shear studs is the “Min Tran. Spacing” item specified on

the Shear Studs tab in the composite beam design overwrites. The default value for this shear stud spacing is  $4d_s$ .

The dimension  $d_s + h_r/4$  is derived by assuming that the slope of the sides of the metal deck ribs is 2 to 1 and that the clear distance from the face of the shear stud to the point where the edge of the deck rib starts to rise is equal to one-half of a shear stud diameter. This clear distance is provided by the program to allow for adequate welding of the shear stud.

Regardless of the number of studs calculated to fit across the width of the beam flange in items 1a or 1b ( see preceding text), the program does not use a number of studs larger than the “Max Studs per Row” item specified on the Shear Studs tab in the composite beam design overwrites.

2. The program determines the number of rows of shear studs that can fit between the two considered points on the beam top flange. This number of rows is controlled by the “Min Long Spacing” item specified on the Shear Studs tab in the composite beam design overwrites.
3. The program multiplies the maximum number of shear studs in a single row, determined in item 1, by the number of rows of studs that can fit in a composite beam segment, determined in item 2, to calculate the maximum number of studs that can fit in the composite beam segment.

Figure 2-17 is a flowchart that illustrates the details of how the program calculates the maximum number of shear studs that fit in a composite beam segment when there is a solid slab or when the span of the metal deck is parallel to the beam span.

The term "Int" in the flowchart means to calculate the indicated quantity and round the result *down* to the nearest integer. The definitions of the variables used in the flowchart are:

$t_{f-top}$  = Thickness of beam top flange, mm.

$d_s$  = Diameter of a shear stud connector, mm.

$SPR_{max}$  = Maximum number of shear studs that can fit in one row across the top flange of a composite beam, unitless.

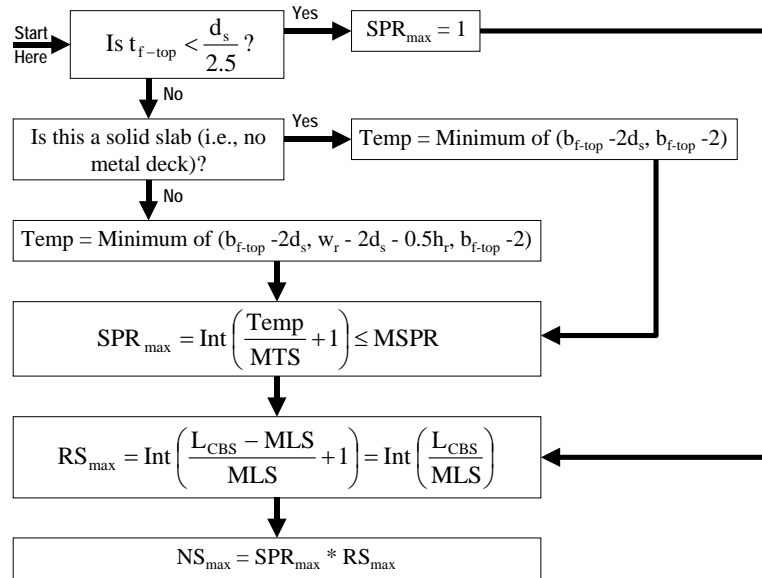

**Figure 2-17 Flowchart of the Method Used to Determine Maximum Number of Shear Studs that Can Fit within a Composite Beam Segment When There is a Solid Slab or the Metal Deck Ribs Are Oriented Parallel to the Beam Span (The term "Int" in the flowchart means to calculate the indicated quantity and round the result down to the nearest integer.)**

Temp = Temporary variable equal to the minimum of the 2 or 3 items specified in the parenthesis, mm. The items specified are separated by commas.

$b_{f-top}$  = Width of beam top flange, mm.

$w_r$  = Average width of metal deck rib, mm.

$h_r$  = Height of the metal deck rib, mm.

MTS = Minimum transverse spacing of shear studs across the beam top flange as specified on the Shear Studs tab in the composite beam overwrites, mm.

MSPR = Maximum shear studs per row across the beam top flange as specified on the Shear Studs tab in the composite beam overwrites, unitless.

$RS_{\max}$  = Maximum number of rows of shear studs that can fit in a composite beam segment, unitless.

$LCBS$  = Length of a composite beam segment, mm.

$MLS$  = Minimum longitudinal spacing of shear studs along the length of the beam as specified on the Shear Studs tab in the composite beam overwrites, mm.

$NS_{\max}$  = Maximum number of shear studs that fit in a composite beam segment, unitless.

Note that in the flowchart formulation, the studs located closest to the ends of the composite beam segment are located no closer than  $MLS/2$  to the ends of the composite beam segment. This helps prevent possible double-counting of shear studs in adjacent composite beam segments.

## 2.17.2 Deck Ribs Oriented Perpendicular to Beam Span

When the deck ribs are oriented perpendicular to the beam span, the program limits the number of rows of shear studs across the width of the beam flange in each metal deck rib to one. For a typical case with 19 mm diameter shear studs and an average width of the deck rib equal to 150 mm, it is difficult to fit more than one row of shear studs in a deck rib and still have adequate edge clearances. To have more than one row of shear studs in a single deck rib, specify a user-defined shear connector pattern for the beam.

The process used to determine the number of shear studs that can fit in a composite beam segment when the metal deck is assumed to span perpendicular to the beam span is described as follows.

1. The program determines the number of shear studs that can fit in a single row across the width of the top flange of the beam. This number of shear studs is limited by either the width or thickness of the beam flange, or by the "Max Studs per Row" item specified on the Shear Studs tab in the composite beam overwrites.



When checking the number of shear studs that fit across the width of the beam flange, the program assumes that the studs are centered about the centerline (web) of the beam and that the center of a shear stud can be no closer than either  $d_s$  or 25 mm, whichever is *larger*, to the edge of the beam flange. This is illustrated in the sketch to the right.

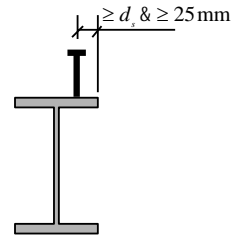

In the preceding paragraph and the sketch,  $d_s$  is the diameter of the shear stud. The clearance requirement means that the minimum clear distance from the face of a shear stud to the edge of the beam flange is equal to one-half of a shear stud diameter. For shear studs less than 25 mm in diameter (typically they are 19 mm in diameter), the program clearance is slightly more than one-half of a shear stud diameter. This clear distance is provided by the program to allow for adequate welding of the shear stud.

Some codes require that if the thickness of the beam flange is less than the diameter of the stud divided by 2.5, the shear studs must be located on top of the beam web. This means that only one stud can fit across the width of the beam flange if  $t_f < d_s / 2.5$ . The program checks the top flange thickness for this requirement when determining the number of studs that fit across the width of the beam flange.

2. The program determines how many deck ribs are available to receive shear studs within the length of the composite beam segment. To determine this, the program makes several assumptions, which are described as follows:
  - a. The mid-height of a side of the metal deck rib is assumed to align with one end of the composite beam segment, as shown in Figure 2-18. In other words, one end of the composite beam segment is always assumed to start with an "up" flute.
  - b. If one-half or more of the width of a metal deck rib down flute is within the length of the composite beam segment, the program assumes that the deck rib is available to receive shear studs. This is illustrated in Figure 2-18.

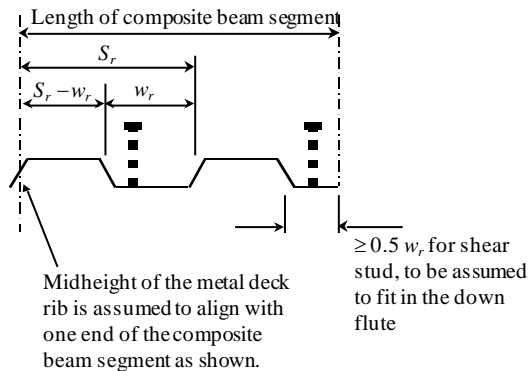

**Figure 2-18 Illustration of Some of the ETABS Assumptions Used to Determine the Number of Available Deck Ribs**

- c. The minimum longitudinal spacing of shear studs along the length of the beam as specified on the Shear Studs tab in the composite beam overwrites is assumed to apply when the deck ribs run perpendicular to the beam span. In some cases, this could cause deck ribs that are within the length of the composite beam segment to be unavailable to receive shear studs.
3. The program multiplies the maximum number of shear studs in a single row across the beam flange, determined as described in item 1, by the number of deck ribs within the length of the composite beam segment that are available to receive shear studs, determined as described in item 2, to calculate the maximum number of studs that can fit in the composite beam segment.

Figure 2-19 is a flowchart that illustrates the details of how the program calculates the maximum number of shear studs that fit in a composite beam segment when the span of the metal deck is perpendicular to the beam span.

The term "Int" in the flowchart means to calculate the indicated quantity and round the result *down* to the nearest integer. The definitions of the variables used in the flowchart are the same as those used in the Figure 2-17 flowchart, with the following additions:

$S_r$  = Center-to-center spacing of the metal deck ribs, mm.

$NR$  = Available number of metal deck ribs within the composite beam segment that are available to receive shear studs, unitless.

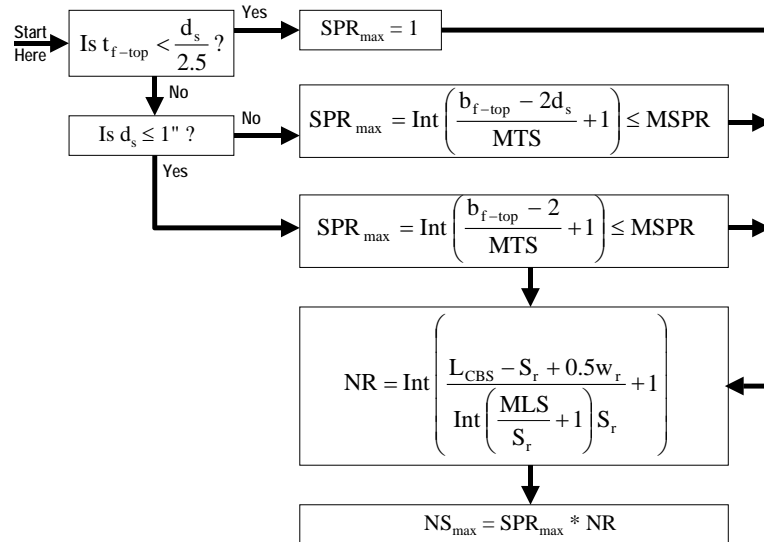

**Figure 2-19** Flowchart of the Method to Determine the Maximum Number of Shear Studs that Can Fit Within a Composite Beam Segment When the Metal Deck Ribs Are Oriented Perpendicular to the Beam Span (The term "Int" in the flowchart means to calculate the indicated quantity and round the result down to the nearest integer.)

### 2.17.2.1 Different Deck Type or Orientation on Beam Sides

When a different type or orientation of the metal deck exists on the two sides of the beam, the program determines the maximum number of shear studs that fit in the composite beam segment for each of the two deck types/orientations. The smaller maximum value obtained is used as the maximum number of shear studs that fit within the composite beam segment.

## 2.18 User Defined Shear Connector Patterns

This section explains how to specify the shear stud pattern rather than have the program determine the distribution of shear studs. This can be useful when checking an existing building, or if there is a certain shear stud pattern that is required, for example, one shear stud per foot of beam length.

## 2.18.1 Specifying a User Defined Shear Connector Pattern

User defined shear connector patterns are specified on the Shear Studs tab in the composite beam overwrites. See *Appendix B Overwrites* for more information.

The composite beam overwrites can be used to specify a uniform spacing of shear studs located on top of the beam web and centered along the length of the beam top flange, or to specify a starting and ending point for a beam section and the number of studs that are uniformly spaced within the beam section. Use one of these options or use the two options together to define the studs on a beam.

The term beam **section** is purposely used here to differentiate it from a composite beam **segment**. Do not confuse composite beam sections and composite beam segments. They are two entirely different items. Composite beam segments are described in the subsection entitled *Composite Beam Segments* of the section entitled *Distribution of Shear Studs on a Composite Beam* in this chapter. Beam sections are simply an arbitrary length of the beam, defined by a starting and ending location over which a certain number of uniformly spaced shear studs is specified.

The following two sections describe the two methods of specifying user defined shear studs.

## 2.18.2 Uniformly Spaced Shear Studs Over the Length of the Beam

When uniformly spaced user defined shear studs are specified over the length of the beam, the program treats the shear studs as if they are all in a single line along the beam web and disregards any checks for minimum longitudinal spacing requirements.

Figure 2-20 illustrates uniformly spaced user defined shear studs over the length of the beam. These shear studs are specified by inputting the spacing for the Uniform Spacing item on the Shear Studs tab in the composite beam overwrites.

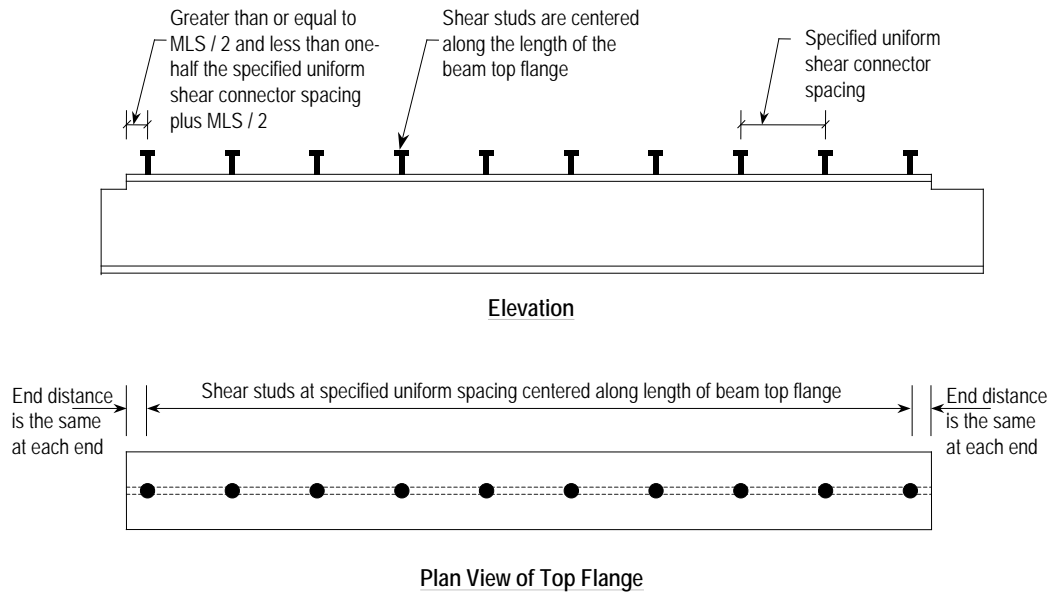

**Figure 2-20 Uniformly Spaced User Defined Shear Connectors Over the Length of the Beam, Specified Using the Uniform Spacing Item on the Shear Studs Tab in the Composite Beam Overwrites**

Note the following about these shear studs:

1. The shear studs are assumed to occur over the length of the top flange of the beam. In most cases, this is shorter than the center-of-support to center-of-support length of the beam.
2. There is assumed to be one shear stud per row. To use this option to specify 2 studs every 300 mm, specify a spacing of 150 mm. The 150 mm spacing gives the closest equivalent to two studs every 300 mm.
3. The program determines the exact distance from the end of the beam top flange (or end of the concrete slab) to the first shear stud, as shown in the following equation. In that equation the term "Int" means to calculate the indicated quantity and round the result *down* to the nearest integer, and the term "Specified Spacing" is the spacing input in the composite beam overwrites for the Uniform Spacing item.

$$ED = \frac{TFL - \text{Int} \left( \frac{TFL - MLS}{\text{Specified Spacing}} \right) * \text{Specified Spacing}}{2}$$

where,

*ED* = Distance from the end of the beam top flange (or end of the concrete slab) to the first shear stud, mm.

*TFL* = The length of the beam top flange available to receive shear studs, mm. This length is typically determined by subtracting the support distance and the gap distance at each end of the beam from the center-of-support to center-of-support length of the beam. In special cases, an additional distance can be subtracted if the slab does not exist over some portion of the beam.

*MLS* = Minimum longitudinal spacing of shear studs along the length of the beam, as specified on the Shear Studs tab in the composite beam overwrites, mm.

After the shear studs at the end of the beam top flange (or end of the concrete slab) have been located using the preceding equation, the program knows the exact location of each uniformly spaced shear stud along the length of the beam.

In the preceding equation, the studs at the ends of the beam are assumed to be no closer than  $MLS/2$  from the end of the beam top flange. The studs at the ends of the beam are also assumed to be no farther than  $(MLS + \text{Specified Spacing})/2$  from the end of the beam top flange. Finally, the distance from the studs at the ends of the beam to the end of the beam top flange is assumed to be the same at each end of the beam.

Similar to the preceding, if the concrete slab stops before the end of the beam, the first shear stud at that end of the beam is assumed to occur at a distance not less than  $MLS/2$  from the end of the slab and not more than  $(MLS + \text{the specified uniform spacing})/2$  from the end of the slab.

### 2.18.3 Additional Shear Studs in Specified Sections of Beam

When the user specifies the starting and ending points of a beam section and the number of uniformly spaced shear studs in the section, the program treats the shear connectors as if they are all in a single line and disregards any checks for minimum longitudinal spacing requirements.

### 2.18.3.1 Defining Additional Beam Sections

To define additional beam sections for specifying shear studs, simply specify a distance along the beam that locates the starting point of the beam section, specify a second (longer) distance along the beam that locates the ending point of the beam section, and then specify the total number of uniformly spaced shear studs that fall within the specified beam section.

Distances can be specified as absolute (actual) distances or relative distances, both measured from the I-end of the beam. A relative distance to a point is the absolute distance to that point divided by the length of the beam measured from the center-of- support to center-of-support.

Do not confuse beam sections with composite beam segments. See the section entitled *Specifying a User Defined Shear Connector Pattern* earlier in this section for more information.

Note the following about the shear studs specified for additional beam sections:

- The program assumes that the specified shear studs occur in a single line along the beam web within the specified length of the beam section. It further assumes that the end shear studs in the beam section are located one-half of the equal space from the ends of the specified beam section. These assumptions mean that the spacing of shear studs in a beam section is equal to the length of the beam top flange available to receive shear studs in the beam section divided by the specified number of shear studs. See Figure 2-21 for an example.

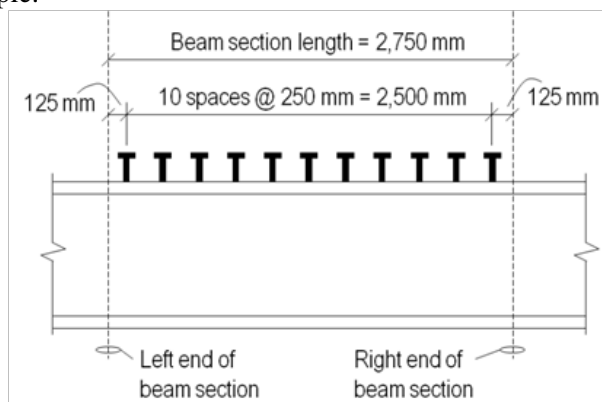

**Figure 2-21 Assumed Spacing of User Defined Shear Studs**

The figure shows a beam section that is 2750 mm long. Assume that 11 shear studs have been specified for this beam section. The spacing of shear studs in the beam section is equal to the beam section length divided by the number of studs, that is,  $2750 \text{ mm}/11 \text{ studs} = 250 \text{ mm/stud}$ . The end studs are located one-half of a space, that is,  $250 \text{ mm}/2 = 125 \text{ mm}$ , from each end of the beam section.

The program does not check shear stud spacing requirements for user defined shear stud patterns.

- Assume that a beam section is specified at the end of a beam and the beam top flange does not exist over a portion of that beam section length. This can often happen because, as described in the *Physical End of the Beam Top Flange* of the section entitled *Distribution of Shear Studs on a Composite Beam*, the program subtracts a support distance and a gap distance from the end of the beam when computing the length of the beam top flange.

In that case, the program places all of the specified shear studs on the portion of the top flange that does exist. See Figure 2-22 for an illustration.

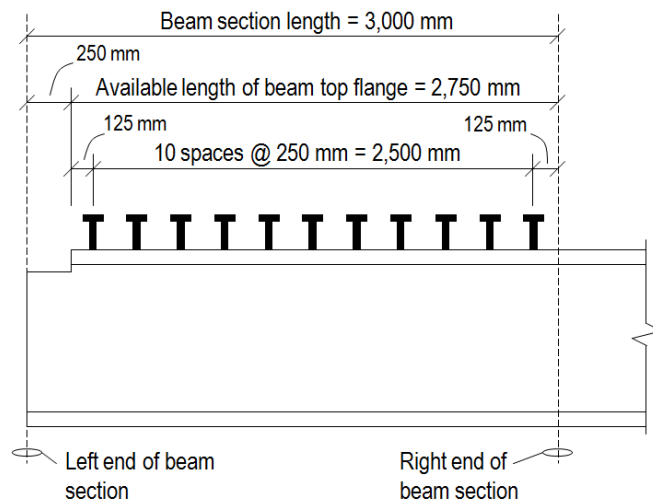

**Figure 2-22 Example Showing No Beam Top Flange Over a Portion of the Specified Beam Section Length**

The figure shows a beam section at the end of the beam that is 3000 mm long. The end of the beam top flange starts 250 mm from the specified left



end of the beam section. Thus, the actual length of top flange available for shear studs is 2750 mm. Assume that 11 shear studs have been specified for this beam section.

As previously mentioned, the spacing of shear studs in a beam section is equal to the length of the beam top flange available to receive shear studs in the beam section divided by the specified number of shear studs. In this case,  $2750 \text{ mm} / 11 \text{ studs} = 250 \text{ mm/stud}$ . The end studs are located one-half of a space, that is  $250 \text{ mm} / 2 = 125 \text{ mm}$ , from each end of the beam top flange within the beam section.

- If the beam top flange does not exist over the entire length of the specified beam section, the program ignores the shear studs that are specified for that beam section.

### 2.18.3.2 Example of a User Defined Shear Stud Pattern

Refer to the example shown in Figure 2-23. To specify the actual shear connector layout shown in Figure 2-23, three beam sections are specified. Table 2-3 shows how each of the three beam sections should be specified.

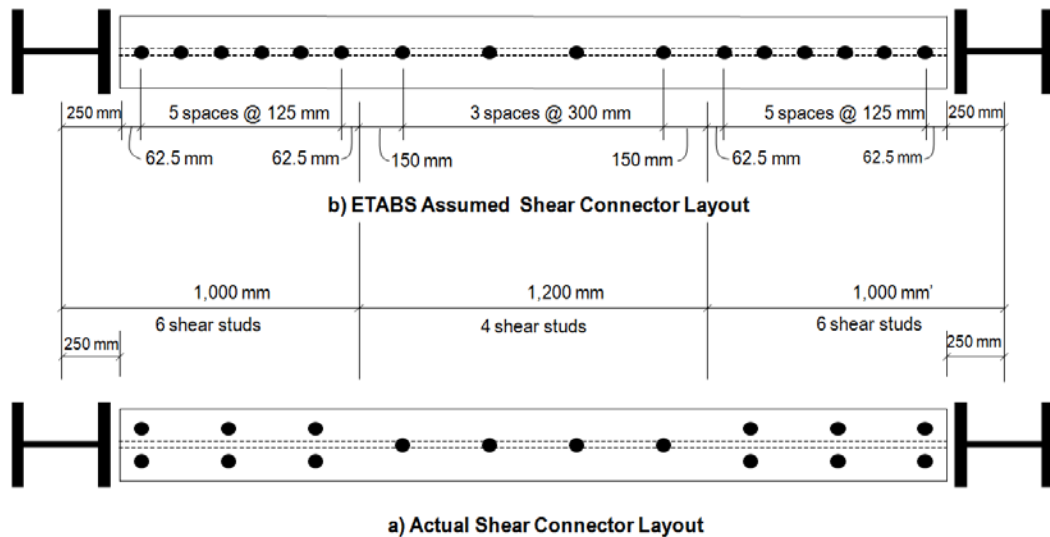

*Figure 2-23 Example of a User-Defined Shear Stud Pattern*

Figure 2-23b illustrates how the program interprets the stud pattern as specified in Table 2-3. The location and spacing of shear studs is as described in the bulleted items in the previous subsection entitled *Defining Additional Beam Sections*.

**Table 2-3 Specification of Beam Sections in the Example Shown in Figure 2-23**

Beam Section	Starting Point	Ending Point	Number of Studs
1	0 mm	1000 mm	6
2	1000 mm	2200 mm	4
3	2200 mm	3200 mm	6

### 2.18.4 How the Program Checks a Beam with User Defined Shear Studs

When the number and location of shear studs on a beam is defined, the program performs flexural design somewhat differently from how it is described elsewhere in this manual. For flexural design with user defined shear studs, the program calculates the percent composite connection (PCC) at each design output station based on the specified shear stud layout. The program then calculates the beam section properties for this PCC and derives a flexural stress ratio (actual stress divided by allowable stress).

## 2.19 Transformed Section Moment of Inertia

This section describes in general terms how the program calculates the transformed moment of inertia,  $I_{tr}$ , of the composite section of a beam subject to positive bending resulting in stresses in the elastic range. The value of  $I_{eff}$  used in deflection calculations differs. See *Effective Moment of Inertia* in the next section.

The program determines the transformed section moment of inertia separately for beam deflection check and beam vibration check because the two generally differ.

The deflection transformed section moment of inertia is based on the modulus of elasticity of concrete,  $E_c$ , defined by the user for the material definition.

The vibration transformed section moment of inertia is based on the enhanced short term modulus of elasticity of concrete due to the small strain range

involved in vibration:  $E_c$  is taken as the modulus of elasticity as defined by the user multiplied by an enhancement factor, which is 1.35 based on DG11.

Also, for deflection calculations, concrete is assumed to be effective only in compression, whereas for vibration calculations, it is considered effective in both tension and compression.

### 2.19.1 Background

Figure 2-24 shows a typical rolled steel composite floor beam with the metal deck ribs running parallel to the beam. Figure 2-25 shows a typical composite user defined steel beam with the metal deck ribs running parallel to the beam. Note that the user defined beam may have a different top and bottom flange size, and that no fillets are assumed in this beam.

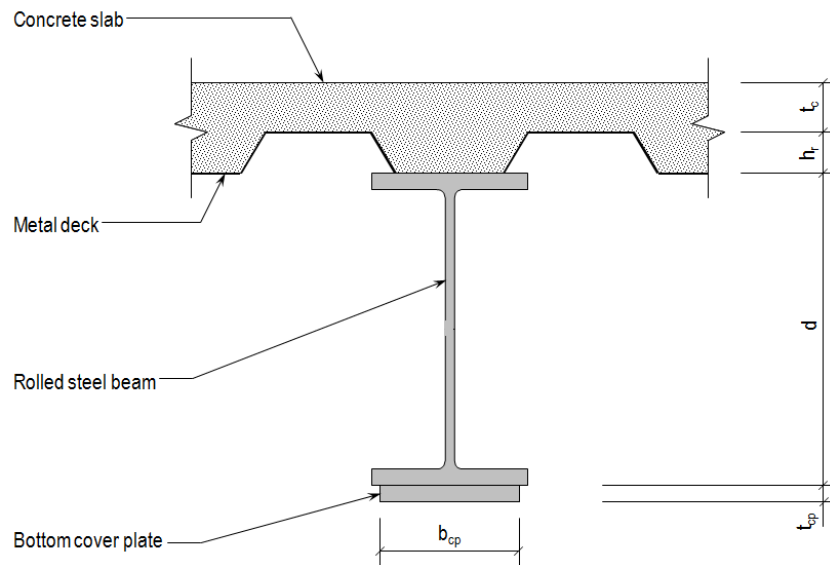

**Figure 2-24 Composite Rolled Steel Beam Shown with Metal Deck Ribs Running Parallel to the Beam**

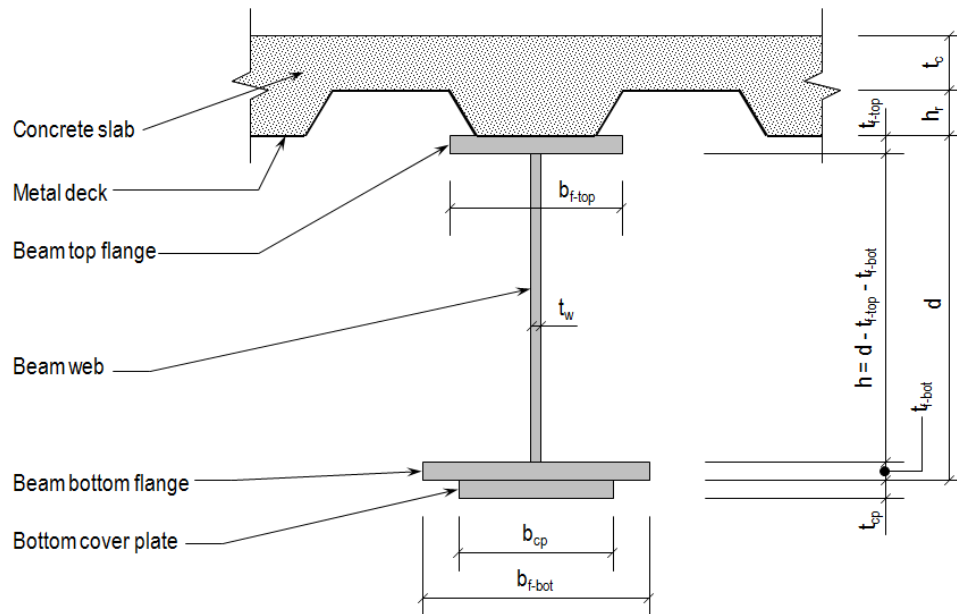

**Figure 2-25 Composite User Defined Steel Beam Shown with Metal Deck Rib Running Parallel to the Beam**

For each of these configurations the following items may or may not be included when calculating the transformed section moment of inertia:

**Concrete in the metal deck ribs:** The concrete in the metal deck ribs is included in the calculation when the deck ribs are oriented parallel to the beam (typically the case for girders). It is not included when the deck ribs are oriented perpendicular to the beam (typically the case for infill beams).

**Cover plate:** The cover plate is included only if one is specified by the user in the composite beam overwrites.

Note that the deck type and deck orientation may be different on the two sides of the beam as described in *Multiple Deck Types or Directions Along the Beam Length* in the section entitled *Effective Width of the Concrete Slab*.

Because composite behavior is considered for positive bending only, the transformed section moment of inertia is calculated for positive bending only (top of composite section in compression). Calculation of the transformed

section moment of inertia is greatly complicated by the requirement that the concrete resist no tension.

The first task in calculating the transformed section moment of inertia of the composite section is to compute properties for the steel beam alone (plus the cover plate, if it exists). The properties required are the total area,  $A_{bare}$ , the location of the ENA,  $y_{bare}$ , and the moment of inertia,  $I_s$ .

### 2.19.2 Properties of Steel Beam (Plus Cover Plate) Alone

The location of the Elastic Neutral Axis, ENA, for the steel beam alone (plus cover plate if applicable) is defined by the distance  $y_{bare}$ , where  $y_{bare}$  is the distance from the bottom of the bottom flange of the beam to the ENA, as shown in Figure 2-26. If there is a cover plate,  $y_{bare}$  is still measured from the bottom of the bottom flange of the beam, not the bottom of the cover plate.

Figure 2-26 also illustrates an example of the dimension  $y_1$  that is used in Tables 2-4 and 2-5. For a given element of a steel section, the dimension  $y_1$  is equal to the distance from the bottom of the beam bottom flange to the centroid of the element. Figure 2-26 illustrates the distance  $y_1$  for the beam top flange.

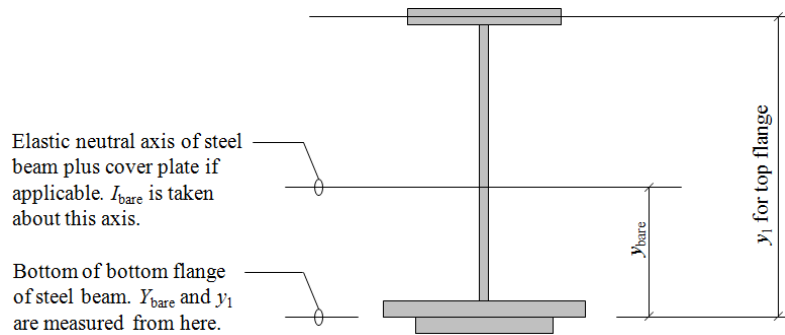

Figure 2- 26 Illustration of  $y_{bare}$  and  $y_1$

If the beam section is a rolled steel beam or channel chosen from the program section database,  $A_{bare}$ ,  $y_{bare}$  and  $I_{bare}$  are calculated as shown in Table 2-4 and using the subsequent three equations (after Table 2-5). If the beam section is a user defined (welded) beam, they are calculated using Table 2-5 and the subsequent three equations.

**Table 2-4 Section Properties for Rolled Steel Beam Plus Cover Plate**

Item	Area, $A$	$y_1$	$Ay_1$	$Ay_1^2$	$I_o$
Steel beam	$A_s$	$\frac{d}{2}$	$Ay_1$	$Ay_1^2$	$I_s$
Cover plate	$b_{cp}t_{cp}$	$-\frac{t_{cp}}{2}$	$Ay_1$	$Ay_1^2$	$\frac{b_{cp}t_{cp}^3}{12}$
<b>Sums</b>	$\sum A$		$\sum(Ay_1)$	$\sum(Ay_1^2)$	$\sum I_o$

**Table 2-5 Section Properties for User-Defined (Welded) Steel Beam Plus Cover Plate**

Item	Area, $A$	$y_1$	$Ay_1$	$Ay_1^2$	$I_o$
Top flange	$b_{f-top}t_{f-top}$	$d - \frac{t_{f-top}}{2}$	$Ay_1$	$Ay_1^2$	$\frac{b_{f-top}t_{f-top}^3}{12}$
Web	$ht_w$	$\frac{d}{2}$	$Ay_1$	$Ay_1^2$	$\frac{t_w h^3}{12}$
Bottom flange	$b_{f-bot}t_{f-bot}$	$\frac{t_{f-bot}}{2}$	$Ay_1$	$Ay_1^2$	$\frac{b_{f-bot}t_{f-bot}^3}{12}$
Cover plate	$b_{cp}t_{cp}$	$-\frac{t_{cp}}{2}$	$Ay_1$	$Ay_1^2$	$\frac{b_{cp}t_{cp}^3}{12}$
<b>Sums</b>	$\sum A$		$\sum(Ay_1)$	$\sum(Ay_1^2)$	$\sum I_o$

The area of the steel section (including the cover plate if it exists),  $A_{bare}$ , is given by the following equation

$$A_{bare} = \sum A.$$

The ENA of the steel section is located a distance  $y_{bare}$  from the bottom of the bottom flange of the steel beam section (not bottom of cover plate) where  $y_{bare}$  is determined from the following equation

$$y_{bare} = \frac{\sum(Ay_1)}{\sum A}.$$

The moment of inertia of the steel section (plus cover plate, if one exists) about its ENA,  $I_{bare}$ , is given by the following equation

$$I_{bare} = \sum(Ay_1^2) + \sum I_o - (\sum A)y_{bare}^2.$$

The following notations are used in the preceding Tables 2-4 and 2-5 and the preceding equations:

$A_{\text{bare}}$  = Area of the steel beam (plus cover plate, if one exists), in<sup>2</sup>.

$A_s$  = Area of the rolled steel section alone (without the cover plate even if one exists), mm<sup>2</sup>.

$I_{\text{bare}}$  = Moment of inertia of the steel beam (plus cover plate if one exists), mm<sup>4</sup>.

$I_O$  = The moment of inertia of an element of the beam section taken about the ENA of the element, mm<sup>4</sup>.

$I_s$  = Moment of inertia of the steel beam alone (without the cover plate even if one exists), mm<sup>4</sup>.

$b_{cp}$  = Width of the steel cover plate, mm.

$b_{f\text{-bot}}$  = Width of the bottom flange of a user defined steel beam, mm.

$b_{f\text{-top}}$  = Width of the top flange of a user defined steel beam, mm.

$d$  = Depth of the steel beam from the outside face of the top flange to the outside face of the bottom flange, mm.

$h$  = Clear distance between the flanges for user defined (welded) sections, mm.

$t_{cp}$  = Thickness of the cover plate, mm.

$t_{f\text{-bot}}$  = Thickness of the bottom flange of a user defined (welded) section, mm.

$t_{f\text{-top}}$  = Thickness of the top flange of a user defined (welded) section, mm.

$t_w$  = Thickness of the web of a user defined (welded) section, mm.

$y_{\text{bare}}$  = Distance from the bottom of the bottom flange of the steel section to the ENA of the steel beam (plus cover plate if it exists), mm.

$y_1$  = Distance from the bottom of the bottom flange of the steel beam section to the centroid of an element of the beam section, mm.

$\sum A$  = Sum of the areas of all of the elements of the steel beam section, mm<sup>2</sup>.

$\sum (Ay_1)$  = Sum of the product  $A$  times  $y_1$  for all of the elements of the steel beam section, mm<sup>3</sup>.

$\sum (Ay_1^2)$  = Sum of the product  $A$  times  $y_1^2$  for all of the elements of the steel beam section, mm<sup>4</sup>.

$\sum I_o$  = Sum of the moments of inertia of each element of the beam section taken about the ENA of the element, mm<sup>4</sup>.

### 2.19.3 Properties of the Composite Section

The first step, and potentially most calculation-intensive step in the process of determining the composite properties is to calculate the distance from the ENA of the steel beam (plus cover plate if it exists) to the ENA of the full composite section. This distance is designated  $y_e$  in Figure 2-27.



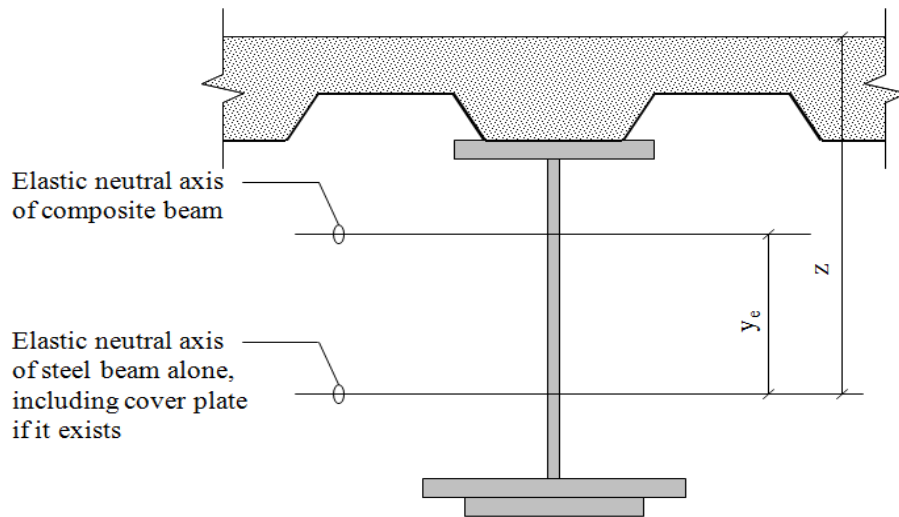

*Figure 2-27 Illustration of  $y_e$  and  $z$*

Recall that for the calculation of transformed section properties to be used for stress and deflection calculation, concrete in tension is ignored. But concrete is assumed effective for both tension and compression for vibration calculations. Because of the possibility that some of the concrete may be in tension, and because the amount of concrete that is in tension is initially unknown (if any), the process for calculating the distance  $y_e$  is iterative. After the distance  $y_e$  has been determined, the other calculations to determine the composite properties are relatively straightforward.

The program uses the following method to calculate the properties of the composite section.

The location of the ENA of the composite section, defined by  $y_e$  (see Figure 2-27), is calculated using the following iterative process:

- a. The program assumes (guesses) that the ENA of the composite section is within the height of the steel beam and uses the following equation to calculate the distance  $y_e$  that defines the location of the ENA for the composite section. Note that with this assumption, all of the concrete is above the ENA of the composite section, and thus it is all in compression and can be considered.

$$y_e = \frac{\sum (A_{\text{element}} d_{\text{element}})}{\sum A_{\text{element}}}$$

where,

$A_{\text{element}}$  = Equivalent area of an element in the composite section, ignoring any area of concrete that is in tension, if appropriate, and ignoring any concrete in the metal deck ribs when the metal deck span is perpendicular to the beam span.

For any element from the steel section (flange, fillet, or web), the equivalent area is taken as its own area unmodified. Any element from the concrete parts is adjusted to match the modulus of elasticity by multiplying the area by  $E_c/E_s$ .

$d_{\text{element}}$  = Distance from the ENA of the element considered to the ENA of the steel beam alone (including cover plate, if it exists), mm. Signs are considered for this distance. Elements located below the ENA of the steel beam alone (including cover plate, if it exists) have a negative distance and those above have a positive distance.

If the ENA as calculated is within the height of the steel beam, as assumed, the assumed location of the ENA is correct and the calculation for  $y_e$  is complete.

- b. If the calculated ENA is *not* within the height of the steel beam, as assumed in Step a, the assumed location of the ENA is incorrect and calculation for  $y_e$  continues.
  - i* Using the incorrect location of the ENA *calculated* in Step a, the program calculates the location of  $y_e$  again using the preceding equation for  $y_e$ .
  - ii* If the newly calculated location of the ENA is the same as the previously calculated location (Step *i*), the assumed location of the ENA has been identified and the calculation for  $y_e$  is complete.

- iii If the newly calculated location of the ENA is not the same as the previously calculated zone (Step i), the most recent assumed location of the ENA is incorrect and another iteration is made.
- iv The program repeats the iterations until the location of the ENA has been determined.

After the location of the ENA is known, the other calculations to determine the composite section moment of inertia are non-iterative and relatively straightforward. The other calculation steps are as follow.

1. Calculate the transformed section properties for full composite connection as illustrated in Table 2-6.

**Table 2-6 Transformed Section Properties for a Fully Composite Beam**

Item	Transformed				
	Area, $A_{tr}$	$y_1$	$A_{tr}y_1$	$A_{tr}y_1^2$	$I_o$
Concrete slab, left side	$\frac{b_{eff} t_c^* E_c}{E_s}$	$d + h_r + t_c - \frac{t_c^*}{2}$	$A_{tr}y_1$	$A_{tr}y_1^2$	$\frac{b_{eff} E_c t_c^{*3}}{12E_s}$
Concrete slab, right side	$\frac{b_{eff} t_c^* E_c}{E_s}$	$d + h_r + t_c - \frac{t_c^*}{2}$	$A_{tr}y_1$	$A_{tr}y_1^2$	$\frac{b_{eff} E_c t_c^{*3}}{12E_s}$
Concrete in metal deck ribs, left side	$\frac{b_{eff} h_r^* w_r E_c}{S_r E_s}$	$d + h_r - \frac{h_r^*}{2}$	$A_{tr}y_1$	$A_{tr}y_1^2$	$\frac{b_{eff} w_r E_c h_r^{*3}}{12S_r E_s}$
Concrete in metal deck ribs, right side	$\frac{b_{eff} h_r^* w_r E_c}{S_r E_s}$	$d + h_r - \frac{h_r^*}{2}$	$A_{tr}y_1$	$A_{tr}y_1^2$	$\frac{b_{eff} w_r E_c h_r^{*3}}{12S_r E_s}$
Steel beam plus cover plate	$A_{bare}$	$y_{bare}$	$A_{tr}y_1$	$A_{tr}y_1^2$	$I_{bare}$
<b>Sums</b>	$\sum A_{tr}$		$\sum (A_{tr}y_1)$	$\sum (A_{tr}y_1^2)$	$\sum I_o$

When reviewing this table, note the following:

- a. If the deck spans perpendicular to the beam span, the concrete in the metal deck ribs is ignored. If the deck spans parallel to the beam span, the concrete in the metal deck ribs is considered.
- b. The cover plate may or may not be present.
- c. The concrete slab and metal deck may not exist on one side of the beam or the other.

- d. The top of the concrete slab may be at a different elevation on the two sides of the beam.
- e. The appropriate modulus of elasticity of concrete,  $E_c$ , should be used. For vibration,  $E_c$  is increased by an enhanced factor.
- f. Concrete is considered effective for compression and considered ineffective for tension, while  $I_{tr}$  is calculated for deflection and stress calculations. While  $I_{tr}$  is calculated for vibration, concrete is considered effective for both compression and tension.

Following is a list of the variables introduced in Table 2-6 that have not been mentioned previously in this section.

$A_{tr}$  = Equivalent area of an element of the composite steel beam section, in<sup>2</sup>.

$h_r^*$  = Height of the metal deck ribs above the ENA used for calculating the transformed section properties, mm. Note that this could be different on the left and right sides of the beam.

If the deck ribs are oriented perpendicular to the beam span,  $h_r^* = 0$ .

If the deck ribs are oriented parallel to the beam span, one of the following four items applies:

1. If concrete is not needed to be ignored in tension, for example for calculation of  $I_{tr}$  for vibration,  $h_r^*$  is independent of the location of the ENA. In that case, it is taken as the full depth of the rib,  $h_r^* = h_r$ .
2. If the ENA is below the metal deck,  $h_r^* = h_r$ .
3. If the ENA is within the metal deck,  $h_r^*$  equals the height of the metal deck above the ENA.
4. If the ENA is above the metal deck,  $h_r^* = 0$ .

$t_c^*$  = Thickness of the concrete slab above the metal deck (or solid slab) that lies above the ENA that is used for calculating the transformed section properties, mm. Note that this could be different on the left and right sides of the beam. One of the following four items applies:

1. If concrete is not needed to be ignored in tension, for example for calculation of  $I_{rr}$  for vibration,  $t_c^*$  is independent of the location of the ENA. In that case, it is taken as the full thickness of the slab,  $t_c^* = t_c$ .
2. If the ENA is below the top of the metal deck (bottom of the concrete slab),  $t_c^* = t_c$ .
3. If the ENA is within the concrete slab,  $t_c^*$  equals the height of the concrete slab above the ENA.
4. If the ENA is above the concrete slab,  $t_c^* = 0$

$A_{\text{bare}}$  = Area of the steel beam (plus cover plate), mm<sup>2</sup>. This area does not include the concrete area.

$E_c$  = Modulus of elasticity of concrete slab, MPa. Note that this could be different on the left and right sides of the beam.

$E_s$  = Modulus of elasticity of steel, MPa.

$S_r$  = Center-to-center spacing of metal deck ribs, mm. Note that this may be different on the left and right sides of the beam.

$b_{\text{eff}}$  = Effective width of the concrete flange of the composite beam, mm. This width is code dependent. Note that this width may be different on the left and right sides of the beam. See the section entitled *Effective Width of the Concrete Slab* for additional information.

$d$  = Depth of the steel beam from the outside face of the top flange to the outside face of bottom flange, mm.

$h_r$  = Height of the metal deck rib, mm. Note that this may be different on the left and right sides of the beam.

$t_c$  = Thickness of the concrete slab, mm. If there is metal deck, this is the thickness of the concrete slab above the metal deck. Note that this may be different on the left and right sides of the beam.

$w_r$  = Average width of a metal deck rib, mm. Note that this may be different on the left and right sides of the beam.

- $y_{bare}$  = Distance from the bottom of the bottom flange of the steel beam to the ENA of the steel beam (plus cover plate, if it exists) alone, mm.
- $y_e$  = The distance from the ENA of the steel beam (plus cover plate, if it exists) alone to the ENA of the fully composite beam, mm.
- $z$  = Distance from the ENA of the steel beam (plus cover plate, if it exists) alone to the top of the concrete slab, mm. Note that this distance may be different on the left and right sides of the beam.
- $\sum A_{tr}$  = Sum of the areas of all of the elements of the composite steel beam section, mm<sup>2</sup>.
- $\sum (A_{tr}y_1)$  = Sum of the product  $A_{tr}$  times  $y_1$  for all of the elements of the composite steel beam section, mm<sup>3</sup>.
- $\sum (A_{tr}y_1^2)$  = Sum of the product  $A_{tr}$  times  $y_1^2$  for all of the elements of the composite steel beam section, mm<sup>4</sup>.

The neutral axis of the transformed composite section is located a distance  $\bar{y}$  from the bottom of the bottom flange of the steel beam section (not bottom of cover plate). The distance  $\bar{y}$  can be determined from either of the following equations. They both give the same result.

$$\bar{y} = \frac{\sum (A_{tr}y_1)}{\sum A_{tr}}$$

$$\bar{y} = y_{bare} + y_e$$

The distance  $\bar{y}$  is illustrated in Figure 2-28.

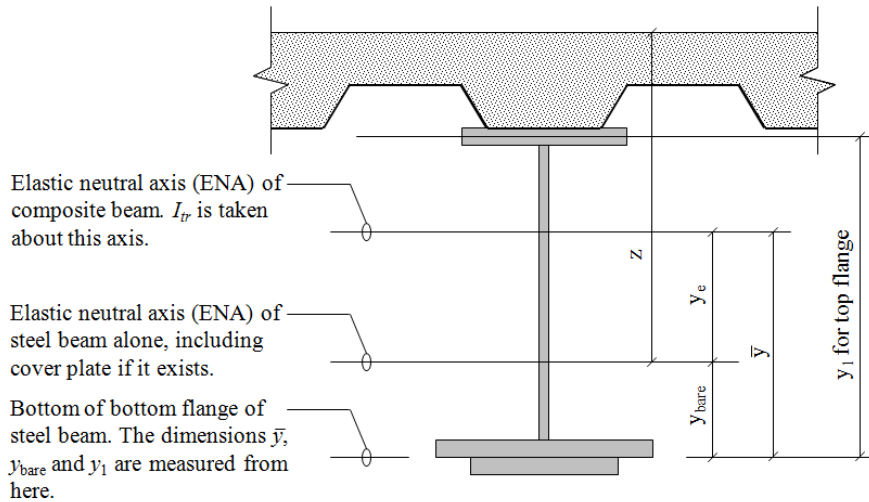

Figure 2-28 Illustration of  $\bar{y}$

The transformed section moment of inertia about the ENA of the composite beam,  $I_{tr}$ , is calculated using the following equation.

$$I_{tr} = \sum A_{tr} y_1^2 + \sum I_O - \left( \sum A_{tr} \right) \bar{y}^2$$

Figure 2-28 illustrates the axis about which  $I_{tr}$  is taken.

## 2.20 Effective Moment of Inertia for Partial Composite Connection

When there is partial composite connection, the number of shear connectors provided controls the amount of horizontal shear that can be transferred between the steel beam and the concrete slab. The effective moment of inertia of the composite section for positive bending in a partially composite beam is calculated in accordance with BS 5950-1990 6.1.4 as follows:

$$I_{eff} = \left[ \frac{I_{tr}}{1 + 0.5 \cdot (1 - PCC) \cdot \left( \frac{I_{tr}}{I_{bare}} - 1 \right)} \right] \quad \text{when the beam is shored}$$

or:

$$I_{eff} = \left[ \frac{I_{tr}}{1 + 0.3 \cdot (1 - PCC) \cdot \left( \frac{I_{tr}}{I_{bare}} - 1 \right)} \right] \quad \text{when the beam is not shored}$$

where:

$PCC$  = Percent composite connection, unitless. The percentage varies between 40% and 100% inclusive.

$I_{bare}$  = Moment of inertia of the steel beam alone plus cover plate, if it exists,  $\text{mm}^4$ .

$I_{eff}$  = Effective moment of inertia of a partially composite beam,  $\text{mm}^4$ .

$I_{tr}$  = Transformed section moment of inertia about ENA of the composite beam calculated as described in the section entitled *Transformed Section Moment of Inertia*,  $\text{mm}^4$ .

Note that, while BS 5950-1990 6.2 specifies that stresses must remain in the elastic range, this check is not currently performed by the program.

## 2.21 Composite Plastic Moment Capacity for Positive Bending

This section describes how the positive moment capacity of the composite beam using plastic stress distribution is calculated. It normally covers the plastic moment capacity for full composite connection. The minor modification that is needed for partial composite connection also is discussed.

Figure 2-31 illustrates a generic plastic stress distribution for positive bending.

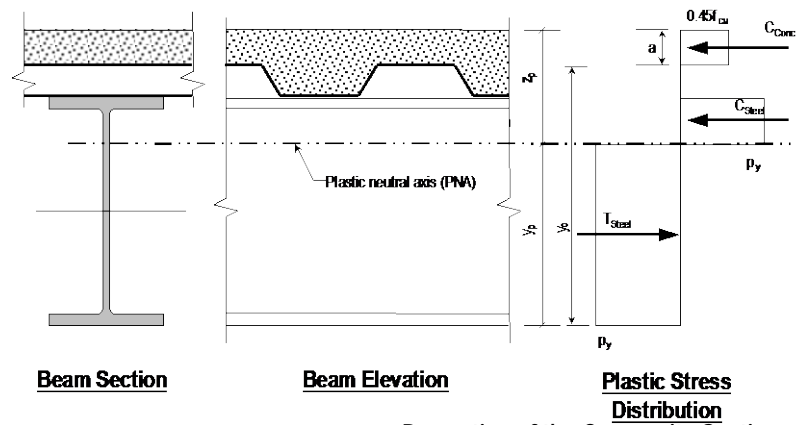



**Figure 2-29 Generic Plastic Stress Distribution for Positive Bending**

Note that the concrete is stressed to  $0.45 f_{cu}$  and the steel is stressed to  $F_y$ . The distance  $y_p$  is measured from the bottom of the beam bottom flange (not cover plate) to the plastic neutral axis (PNA). The distance  $z_p$  is measured from the top of the concrete slab to the PNA; it can be different on the two sides of the beam as described later. The illustrated plastic stress distribution is the basic distribution of stress used by the program when considering a plastic stress distribution for positive bending. Note that if the metal deck ribs are parallel to the beam, the concrete in the ribs is also considered.

Figure 2-32 illustrates how the program idealizes a steel beam for calculating the plastic stress distribution. Two different cases are shown, one for a rolled section and the other for a user defined section. The idealization for the rolled section considers the fillets whereas the idealization for the user defined section assumes there are no fillets because none are specified in the section definition. Although not shown in those figures, the deck type and orientation may be different on the left and right sides of the beam as shown in Figure 2-3 of the section entitled *Effective Width of the Concrete Slab* in this chapter.

For a rolled steel section, the fillets are idealized as a rectangular block of steel. The depth of this rectangular block,  $k_{\text{depth}}$ , is:

$$k_{\text{depth}} = k - t_f$$

The width of this rectangular block,  $k_{\text{width}}$ , is:

$$k_{\text{width}} = [A_s - 2b_f t_f - (d - 2k) t_w] / 2k_{\text{depth}}$$

The basic steps in computing the positive plastic moment capacity are as follows:

- Determine the location of the PNA using the subsection *Location of the Plastic Neutral Axis*.
- Calculate the plastic moment capacity of the composite section using the equation given in subsection *Plastic Moment Capacity for Positive Bending* together with the appropriate equation depending on the location of the PNA. Note that for user defined sections, the terms related to the top and bottom fillets are ignored.

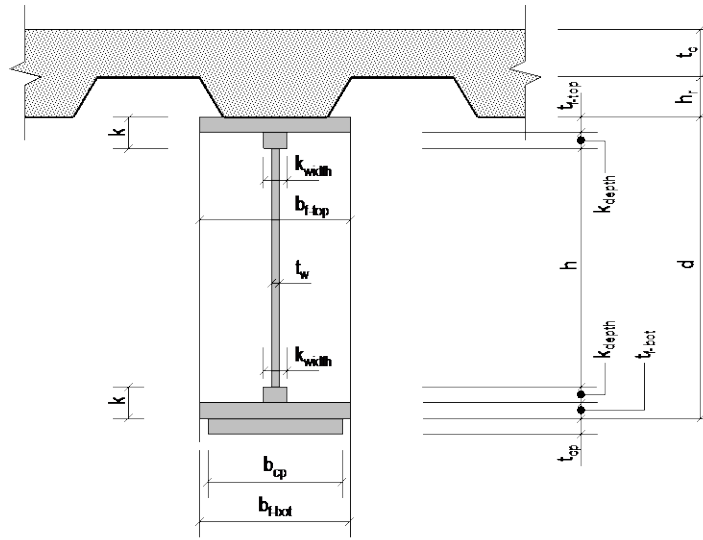

**Idealization for Rolled Section**

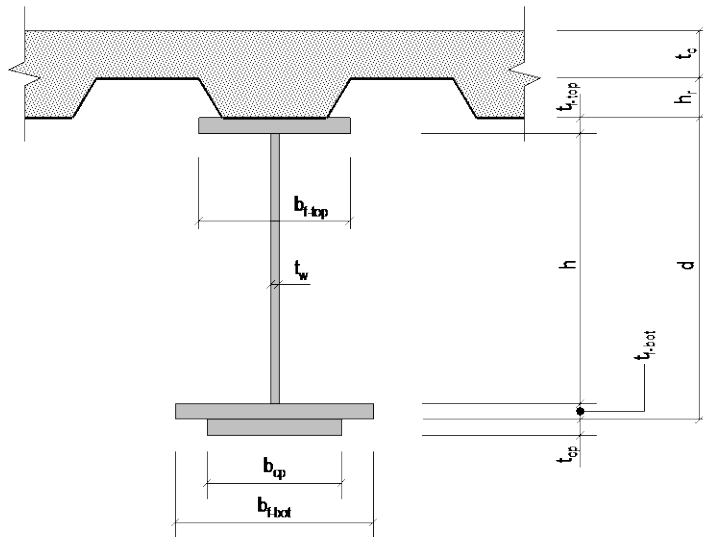

**Idealization for User-Defined Section**

*Figure 2-30 Idealization of a Rolled Section and a User Defined Section Used for Calculating the Plastic Stress Distribution*

## 2.21.1 Location of the Plastic Neutral Axis

The program determines the location of the PNA by comparing the maximum possible compressive force that can be developed in the concrete,  $MPF_{conc}$ , with the maximum possible tensile force that can be developed in the steel section (including the cover plate, if applicable),  $MPF_{steel}$ .

The maximum concrete force,  $MPF_{conc}$ , is calculated as follows if there is no metal deck, or if the metal deck ribs are oriented perpendicular to the beam span.

$$MPF_{conc} = \phi_{bcc} \left[ \left( \alpha_1 f'_c b_{eff} t_c \right)_{left} + \left( \alpha_1 f'_c b_{eff} t_c \right)_{right} \right]$$

If the deck ribs are oriented parallel to the beam span,  $MPF_{conc}$  is calculated as follows

$$MPF_{conc} = \phi_{bcc} \left[ \left( \alpha_1 f'_c b_{eff} \left\{ t_c + \frac{w_r h_r}{S_r} \right\} \right)_{left} + \left( \alpha_1 f'_c b_{eff} \left\{ t_c + \frac{w_r h_r}{S_r} \right\} \right)_{right} \right].$$

Note that the maximum concrete force has contributions from the left and right sides of the beam that are treated separately and may be different.

The maximum steel force,  $MPF_{steel}$ , is calculated as follows if the beam is a rolled section:

$$MPF_{steel} = \phi_{bcs} \left( A_s F_y + b_{cp} t_{cp} F_{ycp} \right).$$

$MPF_{steel}$ , is calculated as follows if the beam is a user defined section

$$MPF_{steel} = \phi_{bcs} \left( b_{f-top} t_{f-top} F_{yf-top} + t_w h + b_{f-bot} t_{f-bot} F_{yf-bot} + b_{cp} t_{cp} F_{ycp} \right).$$

Note that  $\phi_{bcc}$  and  $\phi_{bcs}$  are resistance factors defined by CSI, not in any conventional code. They are provided to give the user more control over section capacity, if desired or needed. They essentially allow different resistance factors for steel and concrete. Note the  $\phi_{bcc}$  factor is applied to the reinforcing steel in the concrete slab (if this steel is considered). By default, both of those resistance factors are set equal to 1.0.

When computing the location of the PNA, it is important to remember that the concrete is assumed to take no tension. Also, the concrete in the metal deck ribs is considered effective in compression only if the metal deck ribs are oriented parallel to the beam span.

The maximum concrete and steel forces are compared to determine whether the PNA is within the concrete slab or the steel section. If  $MPF_{conc} > MPF_{steel}$ , the PNA is within the concrete slab. If  $MPF_{steel} > MPF_{conc}$ , the PNA is within the steel section. If  $MPF_{steel} = MPF_{conc}$ , the PNA is at the top of the steel beam.

If the PNA is within the slab, the fact that the concrete slab can be different on each side of the beam complicates locating the PNA. If the PNA is within the steel section, there are several general locations for it. After the general locations have been identified, it is a straightforward process to determine the location of the PNA. The general locations are:

- Within the beam top flange.
- Within the beam top fillet (applies to rolled shapes from the program's section database only).
- Within the beam web.
- Within the beam bottom fillet (applies to rolled shapes from the program's section database only).
- Within the beam bottom flange.
- Within the cover plate (if one is specified).

Note it is very unlikely that the PNA would be below the beam web but there is nothing in the program to prevent it. This condition would require a very large beam bottom flange and/or cover plate. Each of the PNA locations in the steel section is described following the description of the PNA in the concrete slab.

### 2.21.1.1 PNA in the Concrete Slab Above the Steel Beam

The program considers the condition where the slab on the left and right sides of the beam are different. When the program determines that the PNA is above the top of the steel section, that is, when  $MPF_{conc} > MPF_{steel}$ , it puts the following four items in order, from highest elevation to lowest:

- Top of concrete slab on the left side of the beam.

- Top of concrete slab on the right side of the beam.
- Top of metal deck on the left side of the beam.
- Top of metal deck on the right side of the beam.

Next the program adds the compressive forces of those four items, starting with the item at the highest elevation and proceeding downward. As each item is added into the sum, the sum of compressive forces is compared with the maximum tension value, which is the sum of  $MPF_{steel}$ . As soon as the sum of forces exceeds  $MPF_{steel}$ , the program recognizes that the last location considered is below the PNA, and the second to last location considered is above the PNA. Using this information, the program can solve directly for the location of the PNA.

Figures 2-33 and 2-34 show the internal forces for a rolled steel section and a user defined steel section, respectively, for the condition where the PNA is in the concrete slab above the metal deck.

Figures 2-35 and 2-36 show the internal forces for a rolled steel section and a user defined steel section, respectively, for the condition where the PNA is within the height,  $h_r$ , of the metal deck ribs.

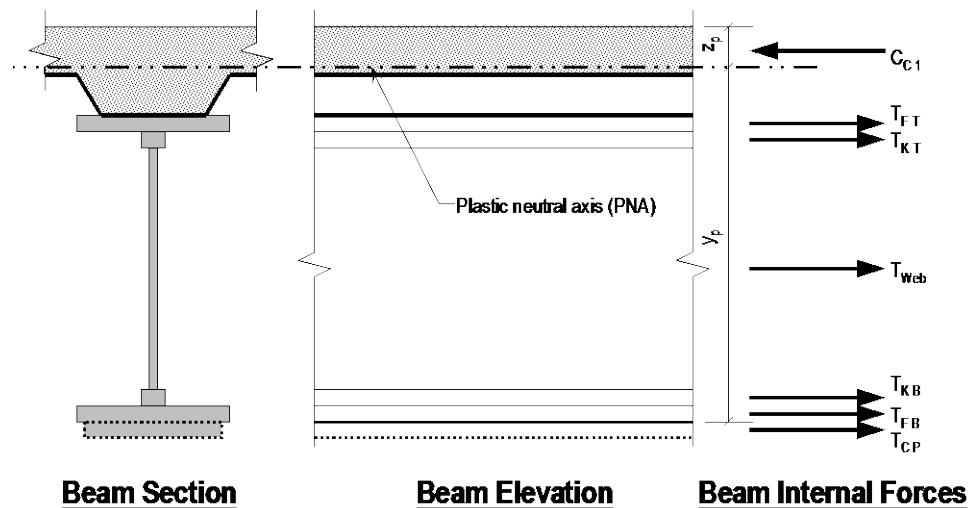

**Figure 2-31 Rolled Steel Section  
With PNA in the Concrete Slab Above the Metal Deck, Positive Bending**

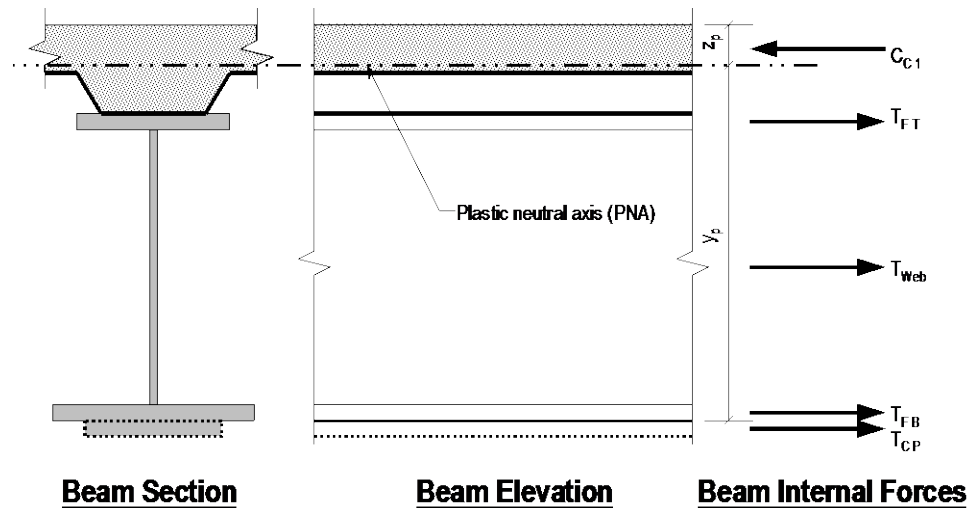

**Figure 2-32 User Defined Steel Section**  
 With PNA in the Concrete Slab Above the Metal Deck, Positive Bending

Note that in Figures 2-33 through 2-36 the concrete compression forces ( $C_{C1}$  and  $C_{C2}$ ) may have different magnitudes and locations (elevations) for the left and right sides of the beam.

Also note that the program ignores the rebar area for computing composite moment capacities.

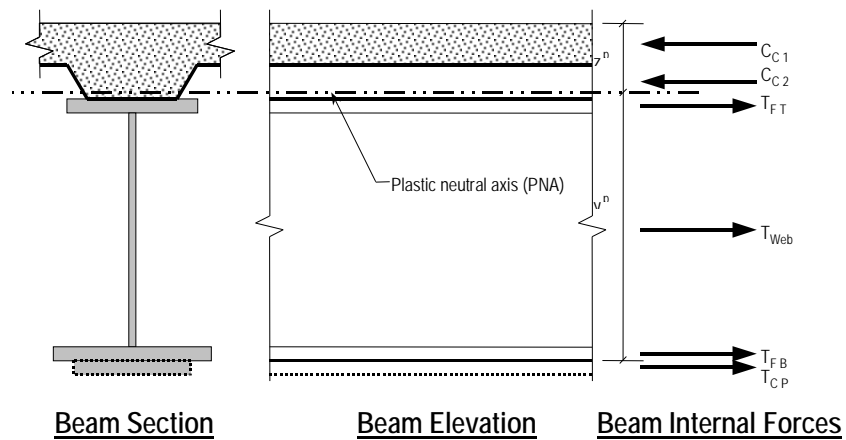

**Figure 2-33 Rolled Steel Section**  
 With PNA Within the Height,  $h_r$ , of the Metal Deck, Positive Bending

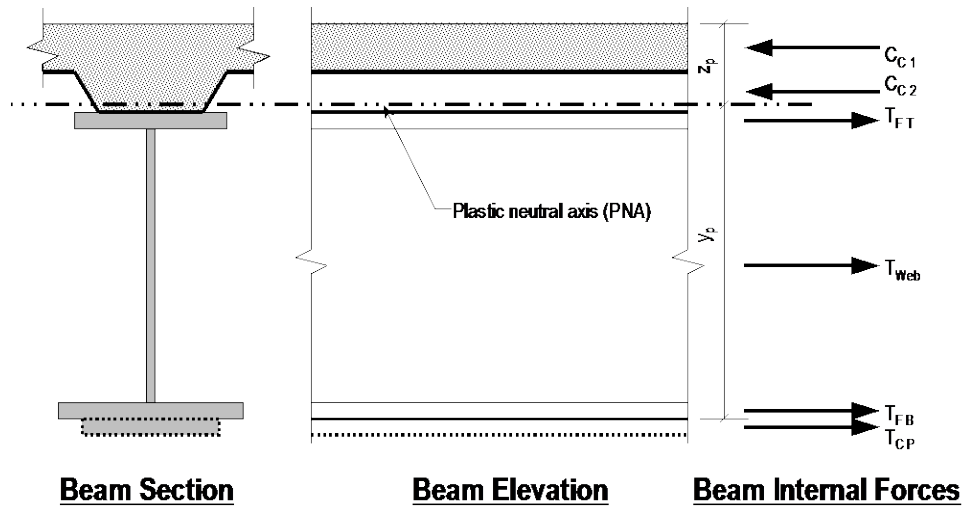

*Figure 2-34 UserDefined Steel Section  
With PNA Within the Height,  $h_r$ , of the Metal Deck, Positive Bending*

### 2.21.1.2 PNA within the Beam Top Flange

Figures 2-37 and 2-38 show the internal forces for a rolled steel section and a user defined steel section, respectively, for the condition where the PNA is within the beam top flange.

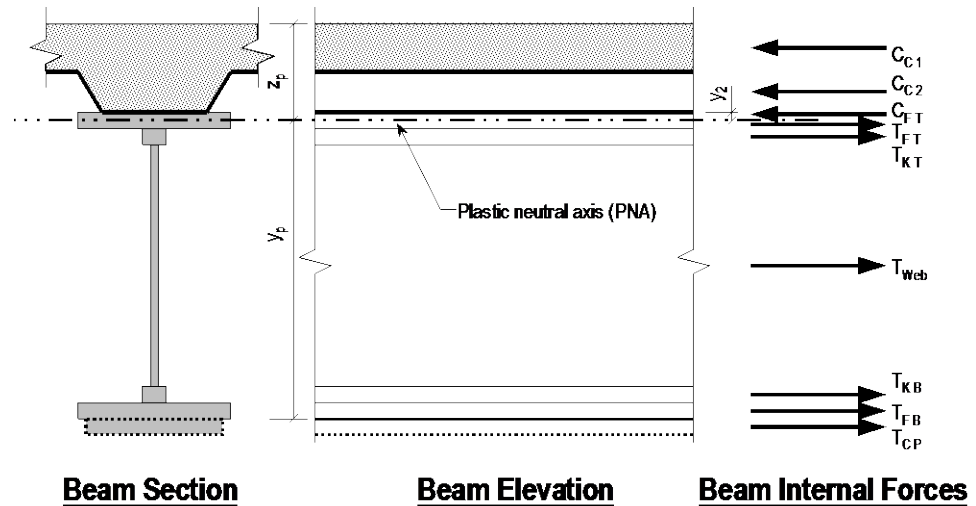

*Figure 2-35 Rolled Steel Section  
With PNA Within the Beam Top Flange, Positive Bending*

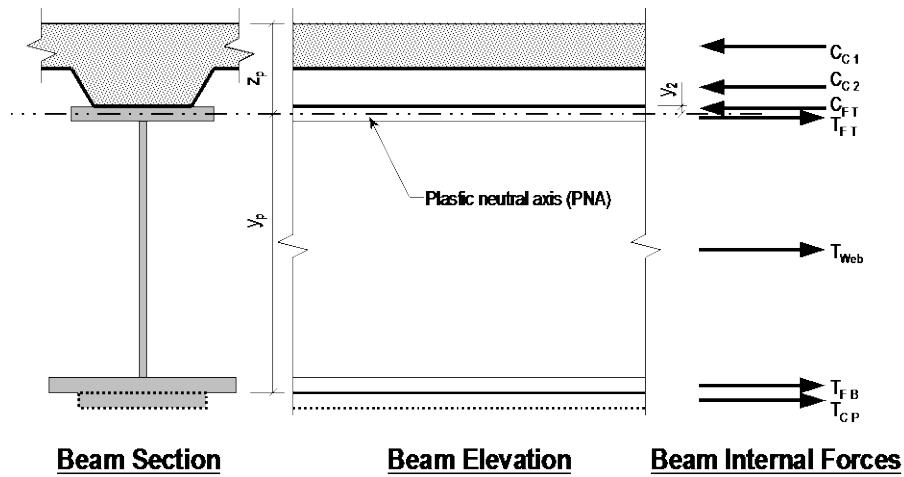

**Figure 2-36 UserDefined Steel Section  
With PNA Within the Beam Top Flange, Positive Bending**

The term  $y_2$ , which is the distance from the top of the steel beam to the PNA, is shown in these figures and is defined by the following equation

$$y_2 = \frac{MPF_{\text{steel}} - MPF_{\text{conc}}}{2\phi_{\text{bcs}} b_{f\text{-top}} F_{yf\text{-top}}}$$

### 2.21.1.3 PNA within the Beam Top Fillet

The PNA lies within the beam top fillet only if the beam section is a rolled section. Figure 2-39 shows the internal forces for this condition.

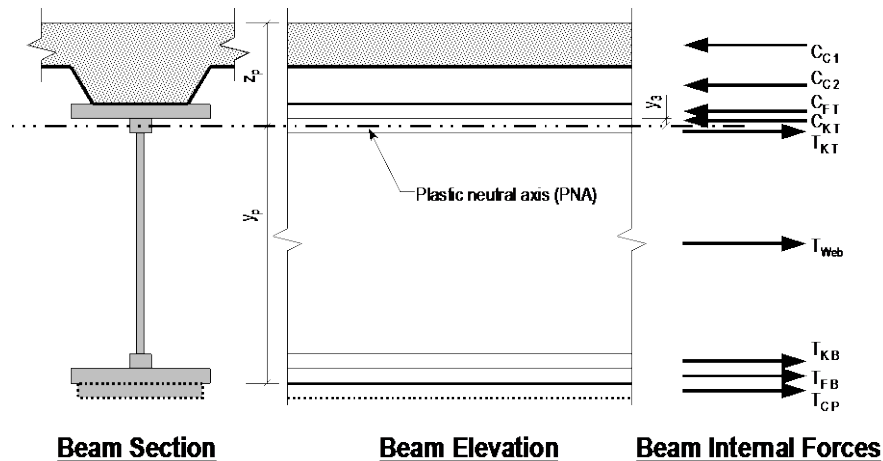

**Figure 2-37 Rolled Section With PNA Within the Beam Top Fillet, Positive Bending**



The term  $y_3$ , which is the distance from the bottom side of the beam top flange to the PNA, is shown in Figure 2-39 and is defined by the following equation.

$$y_3 = \frac{MPF_{\text{steel}} - MPF_{\text{conc}} - 2\phi_{\text{bcs}} b_{f\text{-top}} t_{f\text{-top}} F_{yf\text{-top}}}{2\phi_{\text{bcs}} k_{\text{width}} F_{yw}}$$

### 2.21.1.4 PNA within the Beam Web

Figures 2-40 and 2-41 show the internal forces for a rolled steel section and a user defined steel section, respectively, for the condition where the PNA is within the beam web. The term  $y_4$  for a rolled steel beam is the distance from the web toe of the top fillet to the PNA, and for a user defined beam  $y_4$  is the distance from the bottom side of the beam top flange to the PNA, as shown in Figures 2-40 and 2-41, and is defined by the following equation.

$$y_4 = \frac{MPF_{\text{steel}} - MPF_{\text{conc}} - 2\phi_{\text{bcs}} b_{f\text{-top}} t_{f\text{-top}} F_{yf\text{-top}}}{2\phi_{\text{bcs}} t_w F_{yw}} - \frac{2\phi_{\text{bcs}} k_{\text{width}} k_{\text{depth}} F_{yw}}{2\phi_{\text{bcs}} t_w F_{yw}}$$

The last term applies only to rolled steel beams; it reduces to zero for user defined beams.

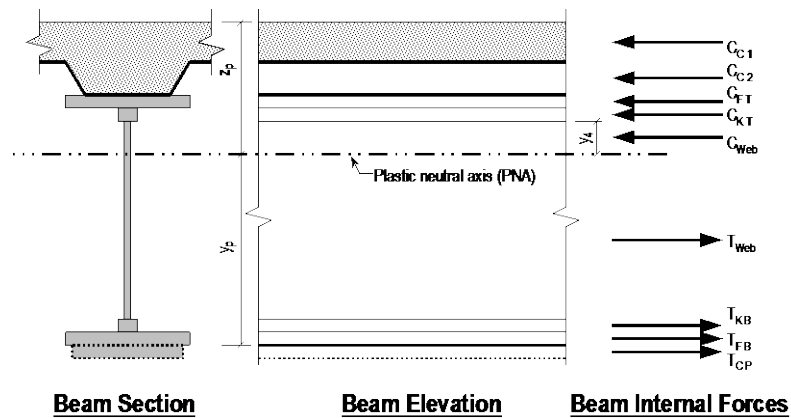
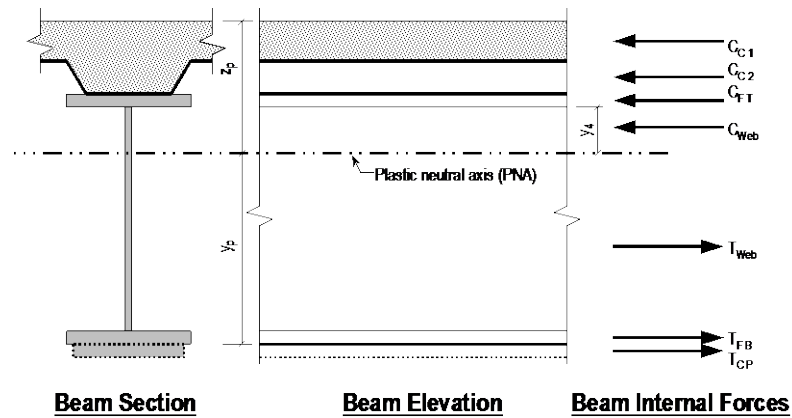

Figure 2-38 Rolled Steel Section With PNA Within the Beam Web, Positive Bending



*Figure 2-39 User Defined Steel Section  
With PNA Within the Beam Web, Positive Bending*

### 2.21.1.5 PNA within the Beam Bottom Fillet

The PNA is within the beam bottom fillet only if the beam section is a rolled section. Figure 2-42 shows the internal forces for this condition.

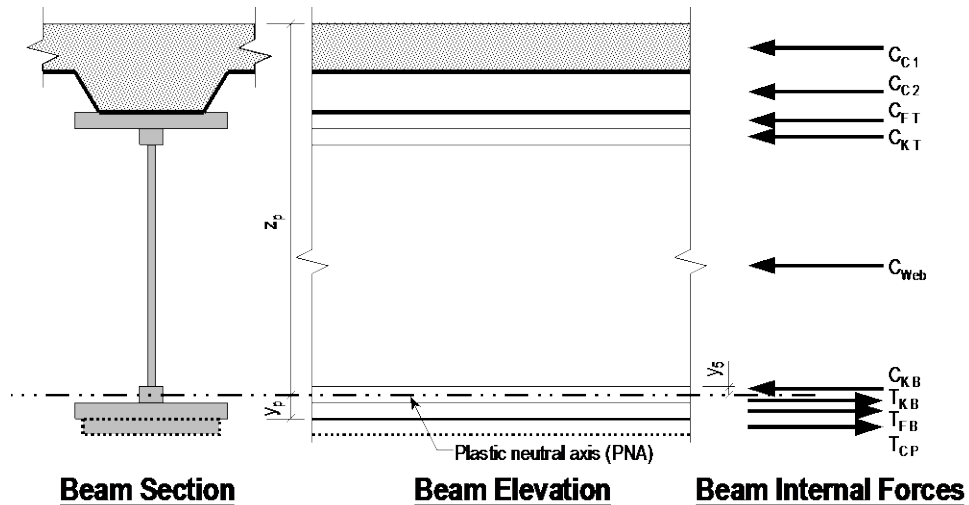

*Figure 2-40 Rolled Steel Section  
With PNA Within the Beam Bottom Fillet, Positive Bending*

The term  $y_5$ , which is the distance from the top side of the beam bottom fillet to the PNA, is shown in Figure 2-42 and is defined by the following equation.

$$y_5 = \frac{MPF_{\text{steel}} - MPF_{\text{conc}} - 2\phi_{\text{bcs}} b_{f\text{-top}} t_{f\text{-top}} F_{yf\text{-top}}}{2\phi_{\text{bcs}} k_{\text{width}} F_{yw}} - \frac{2\phi_{\text{bcs}} k_{\text{width}} k_{\text{depth}} F_{yw}}{2\phi_{\text{bcs}} k_{\text{width}} F_{yw}} - \frac{2\phi_{\text{bcs}} h t_w F_{yw}}{2\phi_{\text{bcs}} k_{\text{width}} F_{yw}}$$

Note that it is unlikely that the PNA will be this low. It requires a very large beam bottom flange and/or cover plate.

### 2.21.1.6 PNA within the Beam Bottom Flange

Figures 2-43 and 2-44 show the internal forces for a rolled steel section and a user defined steel section, respectively, for the condition where the PNA lies within the beam bottom flange. The term  $y_6$ , which is the distance from the top of the beam bottom flange to the PNA, is shown in Figures 2-43 and 2-44 and is defined by the following equation.

$$y_6 = \frac{MPF_{\text{steel}} - MPF_{\text{conc}} - 2\phi_{\text{bcs}} b_{f\text{-top}} t_{f\text{-top}} F_{yf\text{-top}}}{2\phi_{\text{bcs}} b_{f\text{-bot}} F_{yf\text{-bot}}} - \frac{4\phi_{\text{bcs}} k_{\text{width}} k_{\text{depth}} F_{yw}}{2\phi_{\text{bcs}} b_{f\text{-bot}} F_{yf\text{-bot}}} - \frac{2\phi_{\text{bcs}} h t_w F_{yw}}{2\phi_{\text{bcs}} b_{f\text{-bot}} F_{yf\text{-bot}}}$$

Note that it is unlikely that the PNA will be this low. It requires a very large beam bottom flange and/or cover plate.

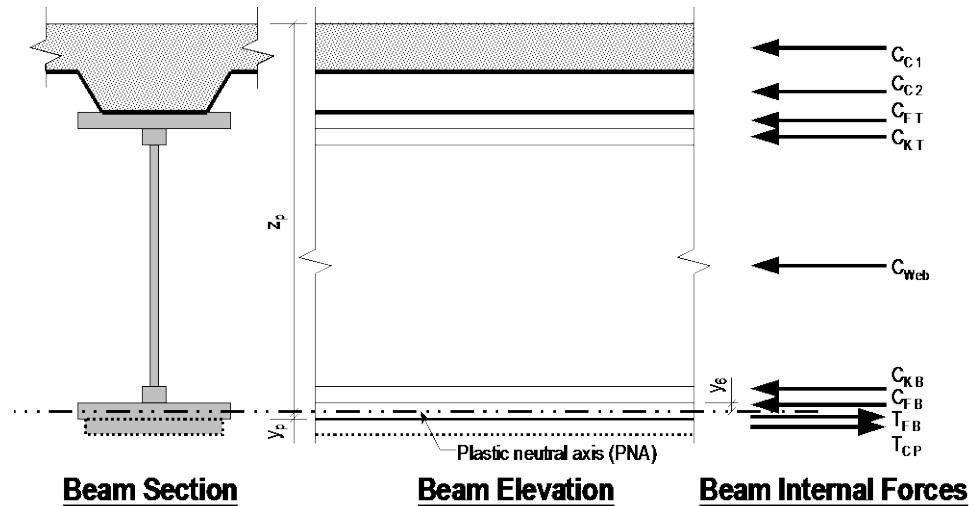
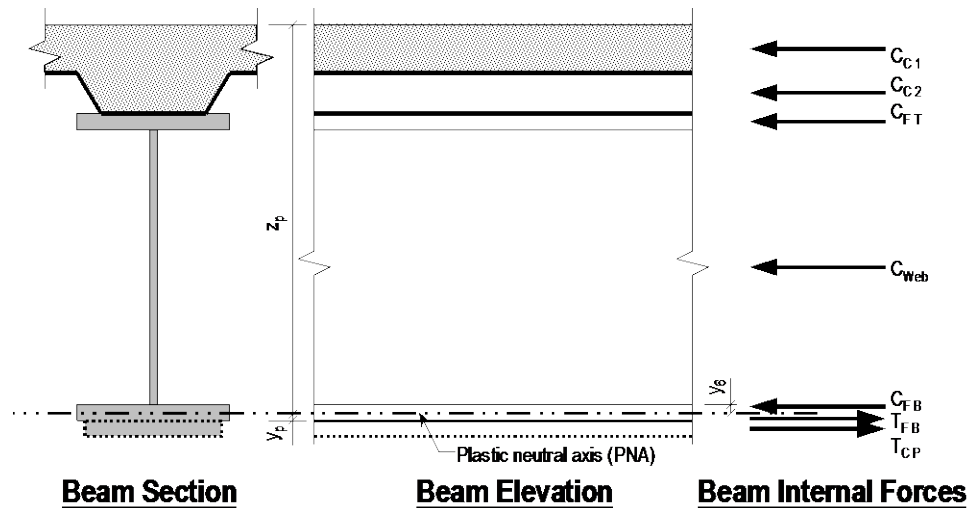

Figure 2-41 Rolled Steel Section with PNA Within the Beam Bottom Flange, Positive Bending



*Figure 2-42 UserDefined Steel Section with PNA Within the Beam Bottom Flange, Positive Bending*

### 2.21.1.7 PNA within the Cover Plate

Figures 2-45 and 2-46 show the internal forces for a rolled steel section and a user defined steel section, respectively, for the condition where the PNA lies within the cover plate.

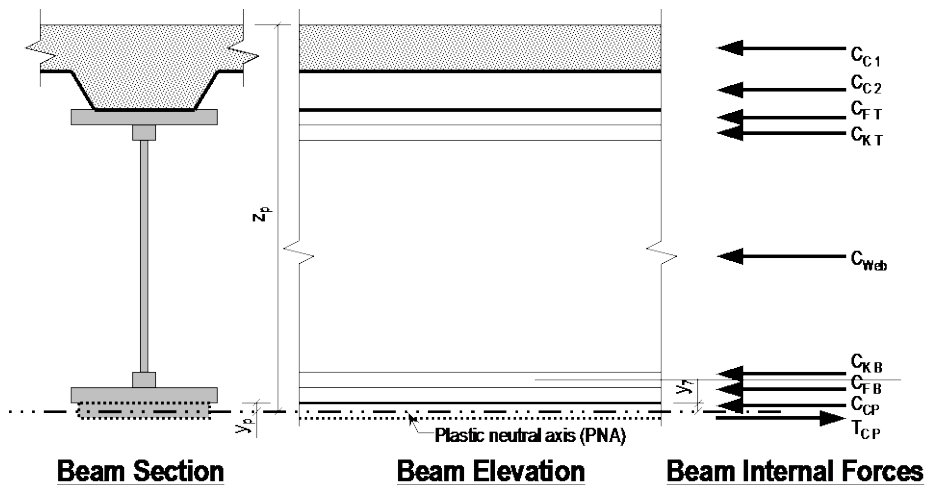

*Figure 2-43 Rolled Steel Section With PNA Within the Cover Plate, Positive Bending*

The term  $y_7$ , which is the distance from the top of the cover plate to the PNA, is shown in Figures 2-45 and 2-46 and is defined by the following equation.

$$y_7 = \frac{MPF_{steel} - MPF_{conc} - 2\phi_{bcs} b_{f-top} t_{f-top} F_{yf-top} - 4\phi_{bcs} k_{width} k_{depth} F_{yw} - 2\phi_{bcs} h_t F_{yw} - 2\phi_{bcs} b_{f-top} t_{f-top} F_{yf-top}}{2\phi_{bcs} b_{cp} F_{ycp}}$$

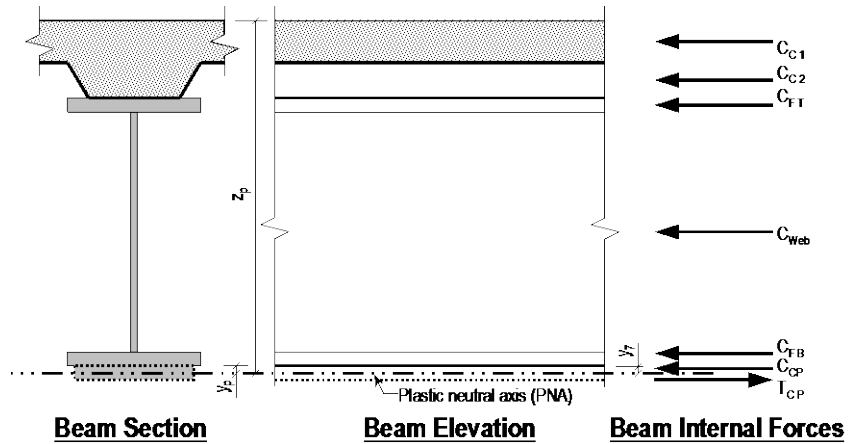

Figure 2-44 User Defined Steel Section with PNA Within the Cover Plate, Positive Bending

Note that it is unlikely that the PNA will be this low. It requires an extremely large cover plate. In the event the PNA was in the cover plate, the distance  $y_p$  would become negative.

### 2.21.1.8 Calculating the PNA Location

To calculate the location of the PNA for positive bending, the program starts by comparing the value of  $MPF_{conc}$  to that of  $MPF_{steel}$  to determine whether the PNA is in the steel section or in the concrete slab above the steel section. As described in an earlier subsection of this section, if  $MPF_{conc} > MPF_{steel}$ , the PNA is within the concrete slab. If  $MPF_{steel} > MPF_{conc}$ , the PNA is within the steel section. If  $MPF_{steel} = MPF_{conc}$ , the PNA is at the top of the steel beam.

If the PNA is in the concrete slab above the steel section, the procedure described in the previous subsection of this section entitled *PNA in the Concrete Slab Above the Steel Beam* is followed.

If the PNA is within the steel section, the program assumes that the PNA occurs in the top flange of the beam. The distance  $y_2$  is calculated as described previously for the PNA within the beam top flange. The calculated distance  $y_2$  is then checked to see if it actually is within the beam top flange. If it is, the location of the PNA has been identified.

If the calculated distance  $y_2$  is not within the beam top flange, the program continues by assuming that the PNA occurs in the beam top fillet. (Note that if the beam is a user defined beam, there is no top fillet and the program skips directly to assuming that the PNA is in the beam web.) The distance  $y_3$  is calculated as described previously for PNA within the beam top fillet. The calculated distance  $y_3$  is then checked to see if it actually is within the beam top fillet. If it is, the location of the PNA has been identified.

If the calculated distance  $y_3$  is not within the beam top fillet, the program continues by assuming that the PNA occurs in the beam web. The distance  $y_4$  is calculated as described previously for the PNA within the beam top fillet. The calculated distance  $y_4$  is then checked to see if it actually is within the beam web. If it is, the location of the PNA has been identified.

In any practical case, the PNA is not expected to be below the beam web. However, in the event the PNA has not yet been located, the program continues down the beam section through the bottom fillet, the bottom flange, and finally the cover plate until the location of the PNA has been identified.

## 2.21.2 Plastic Moment Capacity for Positive Bending

The plastic moment capacity for positive bending in a composite section is calculated from the following equation:

$$\phi_{bcpp} M_n = \phi_{bcpp} \sum_{\text{Piece}=1}^{10} T_{\text{piece}} x_{\text{PNA-piece}} + \phi_{bcpp} \sum_{\text{Piece}=1}^{10} C_{\text{piece}} x_{\text{PNA-piece}}$$

where:

$C_{\text{piece}}$  = Compression force in a piece of the composite beam, N.

$M_n$  = Plastic moment capacity for positive bending, N-mm.

$T_{\text{piece}}$  = Tension force in a piece of the composite beam, N.

$x_{\text{PNA-piece}}$  = Distance from centroid of tension or compression force in a piece of a composite beam to the PNA, mm.

$\phi_{bcpp}$  = Resistance factor for positive bending when plastic stress distribution is assumed, unitless.

In the preceding equation, the values used for  $T_{\text{piece}}$ ,  $C_{\text{piece}}$  and  $x_{\text{PNA-piece}}$  can assume the tension and compression values of ten constituent pieces of the composite section, and their respective centroidal distances from the PNA. The constituents parts are concrete above the metal deck on the left and right, concrete within the metal deck as ribs at the left and right, the beam top flange, the beam top fillet (of rolled shapes only), the beam web, the beam bottom fillet (of rolled shapes only), the beam bottom flange, and the cover plate. Note that the program ignores reinforcing bars in concrete. The corresponding compression forces are  $C_{C1}$ ,  $C_{C2}$ ,  $C_{FT}$ ,  $C_{KT}$ ,  $C_{\text{Web}}$ ,  $C_{KB}$ ,  $C_{FB}$ , and  $C_{cp}$ . The corresponding tensile forces are  $T_{C1}$ ,  $T_{C2}$ ,  $T_{FT}$ ,  $T_{KT}$ ,  $T_{\text{Web}}$ ,  $T_{KB}$ ,  $T_{FB}$ , and  $T_{cp}$ . (Please refer to Figures 2-33 to 2-46 for graphical representations of these forces.) Note that based on the assumption that concrete cannot take tension,  $T_{C1}$  and  $T_{C2}$  are always zero. For any piece from the steel shape, if  $C$  for a piece exists,  $T$  for that piece is zero unless the PNA falls within that piece.

Depending on the location of the PNA, the compression and tension forces and their corresponding  $x_{\text{PNA}}$  for all constituent pieces of the composite section are given as follows:

- **Concrete above the metal deck on the left side of the beam:** The concrete can carry a compression force only; tension is not allowed in the concrete. The following equations are used for the compression force in the concrete above the metal deck.

$$C_{C1} = \phi_{bcc} \alpha_1 f_c' b_{\text{eff}} z_p, \quad \text{if the PNA is above the metal deck,}$$

$$C_{C1} = \phi_{bcc} \alpha_1 f_c' b_{\text{eff}} t_c, \quad \text{if the PNA is below the solid slab.}$$

The following equations are used for the distance from the center of the force in the concrete above the metal deck to the PNA.

$$x_{\text{PNA}} = \frac{z_p}{2}, \quad \text{if the PNA is above the metal deck,}$$

$$x_{\text{PNA}} = z_p - \frac{t_c}{2}, \quad \text{if the PNA is below the solid slab.}$$

For partial composite connection, the PNA is always in the depth of the steel shape. In that case, the  $C_{C1}$  is determined based on the depth of the effective slab thickness as described in the subsection entitled *Location of Plastic Neutral Axis* of the section *Composite Moment Capacities of a Partially Composite Beam with a Plastic Stress Distribution*. If the bottom of the effective concrete in the concrete slab is above the metal deck,  $C_{C1}$  is based on the effective depth  $a_1$ , else it is based on total thickness.

$$C_{C1} = \phi_{bcc} \alpha_1 f_c' b_{\text{eff}} a_1, \quad \text{if the effective line is above the metal deck, } a_1 < t_c$$

$$C_{C1} = \phi_{bcc} \alpha_1 f_c' b_{\text{eff}} t_c, \quad \text{if the effective line is below the solid slab.}$$

For partial composite connection, the following equations are used for the distance from the center of the force in the concrete slab above the metal deck to the PNA.

$$x_{\text{PNA}} = z_p - \frac{a_1}{2}, \quad \text{if effective line is above the metal deck, } a_1 < t_c,$$

$$x_{\text{PNA}} = z_p - \frac{t_c}{2}, \quad \text{if effective line is below the solid slab.}$$

Note that the terms  $z_p$ ,  $t_c$ , and  $h_r$  in the preceding equations must be for the left side of the beam.

- **Concrete above the metal deck on the right side of the beam:** The concrete can carry a compression force only; tension is not allowed in the concrete. The following equations are used for the compression force in the concrete above the metal deck. Note that these equations are applied to each side of the beam separately.

$$C_{C1} = \phi_{bcc} \alpha_1 f_c' b_{\text{eff}} z_p, \quad \text{if the PNA is above the metal deck,}$$

$$C_{C1} = \phi_{bcc} \alpha_1 f_c' b_{\text{eff}} t_c, \quad \text{if the PNA is below the solid slab.}$$

The following equations are used for the distance from the center of the force in the concrete above the metal deck to the PNA.



$$x_{\text{PNA}} = \frac{z_p}{2}, \quad \text{if the PNA is above the metal deck,}$$
$$x_{\text{PNA}} = z_p - \frac{t_c}{2}, \quad \text{if the PNA is below the solid slab.}$$

For partial composite connection, the PNA is always in the depth of the steel shape. In that case,  $C_{C1}$  is determined based on the depth of the effective slab thickness as described in the subsection entitled *Location of Plastic Neutral Axis* of the section *Composite Moment Capacities of a Partially Composite Beam with a Plastic Stress Distribution*. If the bottom of the effective concrete in the concrete slab is above the metal deck,  $C_{C1}$  is based on the effective depth  $a_1$ ; else it is based on total thickness.

$$C_{C1} = \phi_{bcc} \alpha_1 f_c' b_{\text{eff}} a_1, \quad \text{if the effective line is above the metal deck, } a_1 < t_c,$$
$$C_{C1} = \phi_{bcc} \alpha_1 f_c' b_{\text{eff}} t_c, \quad \text{if the effective line is below the solid slab.}$$

For partial composite connection, the following equations are used for the distance from the center of the force in the concrete slab above the metal deck to the PNA.

$$x_{\text{PNA}} = z_p - \frac{a_1}{2}, \quad \text{if effective line is above the metal deck, } a_1 < t_c,$$
$$x_{\text{PNA}} = z_p - \frac{t_c}{2}, \quad \text{if effective line is below the solid slab.}$$

Note that the terms  $z_p$ ,  $t_c$ , and  $h_r$  in the preceding equations must be for the right side of the beam.

- **Concrete within height of metal deck on the left side of the beam:** The concrete can carry a compression force only; tension is not allowed in the concrete. The following two equations are used for the compression force in the concrete within the metal deck. Also note that these equations apply only if the span of the metal deck ribs is oriented parallel to the beam span. If the metal deck ribs are oriented perpendicular to the beam span, there is no compression force allowed on the concrete within the metal deck ribs.

$$C_{C2} = \phi_{bcc} \alpha_1 f_c' b_{eff} \frac{w_r (z_p - t_c)}{S_r}, \quad \text{if the PNA is within the metal deck ribs,}$$

$$C_{C2} = \phi_{bcc} \alpha_1 f_c' b_{eff} \frac{w_r h_r}{S_r}, \quad \text{if the PNA is below the metal deck ribs.}$$

The following equations are used for the distance from the center of the force in the concrete within the metal deck ribs to the PNA.

$$x_{\text{PNA}} = \frac{z_p - t_c}{2}, \quad \text{if the PNA is within the metal deck ribs,}$$

$$x_{\text{PNA}} = z_p - t_c - \frac{h_r}{2}, \quad \text{if the PNA is below the metal deck rib.}$$

For partial composite connection, the PNA is always in the depth of the steel shape. In that case,  $C_{C2}$  is determined based on the depth of the effective slab thickness as described in the subsection entitled *Location of Plastic Neutral Axis of the section Composite Beam with a Plastic Stress Distribution*. If the bottom of the effective concrete in the concrete slab is within the metal deck,  $C_{C2}$  is based on the effective depth  $a_2$ ; else it is based on the total rib depth.

$$C_{C2} = \phi_{bcc} \alpha_1 f_c' b_{eff} \frac{w_r a_2}{S_2}, \quad \text{if the effective line is within the metal deck rib,}$$

$$C_{C2} = \phi_{bcc} \alpha_1 f_c' b_{eff} \frac{w_r h_r}{S_2}, \quad \text{if the effective line is below the metal deck rib.}$$

For partial composite connection, the following equations are used for the distance from the center of the force in the concrete deck rib above the effective line.

$$x_{\text{PNA}} = z_p - \frac{t_c}{2} - \frac{a_2}{2}, \quad \text{if the effective line is within the metal deck ribs,}$$

$$x_{\text{PNA}} = z_p - \frac{t_c}{2} - \frac{h_r}{2}, \quad \text{if the effective line is below the metal deck rib.}$$

Note that the terms  $z_p$ ,  $t_c$ , and  $h_r$  in the preceding equations must be for the left side of the beam.

- **Concrete within height of metal deck on the right side of the beam:** The concrete can carry a compression force only; tension is not allowed in the

concrete. The following two equations are used for the compression force in the concrete within the metal deck. Also note that these equations apply only if the span of the metal deck ribs is oriented parallel to the beam span. If the metal deck ribs are oriented perpendicular to the beam span, there is no compression force allowed on the concrete within the metal deck ribs.

$$C_{C2} = \phi_{bcc} \alpha_1 f_c b_{eff} \frac{w_r (z_p - t_c)}{S_r}, \quad \text{if the PNA is within the metal deck ribs,}$$
$$C_{C2} = \phi_{bcc} \alpha_1 f_c b_{eff} \frac{w_r h_r}{S_r}, \quad \text{if the PNA is below the metal deck ribs.}$$

The following equations are used for the distance from the center of the force in the concrete within the metal deck ribs to the PNA.

$$x_{\text{PNA}} = \frac{z_p - t_c}{2}, \quad \text{if PNA is within the metal deck ribs,}$$
$$x_{\text{PNA}} = z_p - t_c - \frac{h_r}{2}, \quad \text{if PNA is below the metal deck rib.}$$

For partial composite connection, the PNA is always in the depth of the steel shape. In that case,  $C_{C2}$  is determined based on the depth of the effective slab thickness as described in the subsection entitled *Location of Plastic Neutral Axis* of the section *Composite Beam with a Plastic Stress Distribution*. If the bottom of the effective concrete in the concrete slab is within the metal deck,  $C_{C2}$  is based on the effective depth  $a_2$ ; else it is based on the total rib depth.

$$C_{C2} = \phi_{bcc} \alpha_1 f_c b_{eff} \frac{w_r a_2}{S_2}, \quad \text{if the effective line is within the metal deck rib,}$$
$$C_{C2} = \phi_{bcc} \alpha_1 f_c b_{eff} \frac{w_r h_r}{S_2}, \quad \text{if the effective line is below the metal deck rib.}$$

For partial composite connection, the following equations are used for the distance from the center of the force in the concrete deck rib above the effective line.

$$x_{\text{PNA}} = z_p - \frac{t_c}{2} - \frac{a_2}{2}, \quad \text{if the effective line is within the metal deck rib,}$$

$$x_{\text{PNA}} = z_p - \frac{t_c}{2} - \frac{h_r}{2}, \quad \text{if the effective line is below the metal deck rib.}$$

Note that the terms  $z_p$ ,  $t_c$ , and  $h_r$  in the preceding equations must be for the right side of the beam.

- **Beam top flange:** The force in the beam top flange can be tension, compression, or compression in the upper portion of the flange and tension in the lower portion. The following equations are used for the tension and compression forces in the beam top flange.

$$T_{FT} = \phi_{bcs} b_{f\text{-top}} t_{f\text{-top}} F_{yf\text{-top}}, \quad \text{if the PNA is above the top of the top flange,}$$

$$T_{FT} = \phi_{bcs} b_{f\text{-top}} (t_{f\text{-top}} - y_2) F_{yf\text{-top}}, \quad \text{if the PNA is within the top flange,}$$

$$T_{FT} = 0, \quad \text{if the PNA is below the bottom of the top flange,}$$

$$C_{FT} = 0, \quad \text{if the PNA is above the top of the top flange,}$$

$$C_{FT} = \phi_{bcs} b_{f\text{-top}} y_2 F_{yf\text{-top}}, \quad \text{if the PNA is within the top flange,}$$

$$C_{FT} = \phi_{bcs} b_{f\text{-top}} t_{f\text{-top}} F_{yf\text{-top}}, \quad \text{if the PNA is below the bottom of the top flange.}$$

The distance of tension force,  $T_{FT}$ , in the top flange to the PNA is given by the following equations.

$$x_{\text{PNA}} = y_p - d + \frac{t_{f\text{-top}}}{2}, \quad \text{if the PNA is above the top of the top flange,}$$

$$x_{\text{PNA}} = \frac{t_{f\text{-top}} - y_2}{2}, \quad \text{if the PNA is within the top flange,}$$

$$x_{\text{PNA}} = 0, \quad \text{if the PNA is below the bottom of the top flange.}$$

The distance of compression force,  $C_{FT}$ , in the top flange to the PNA is given by the following equations.

$$x_{\text{PNA}} = 0, \quad \text{if the PNA is above the top of the top flange,}$$

$$x_{\text{PNA}} = \frac{y_2}{2}, \quad \text{if the PNA is within the top flange,}$$

$$x_{\text{PNA}} = z_p - t_c - h_r - \frac{t_{f\text{-top}}}{2}, \quad \text{if the PNA is below the bottom of the top flange.}$$

Note the terms  $z_p$ ,  $t_c$ , and  $h_r$  in the preceding equations must all be for the left side of the beam or all for the right side of the beam. It does not matter which side of the beam is used, but all of the terms must be consistent.

- **Beam top fillet:** The force in the beam top fillet can be tension, compression, or compression in the upper portion of the fillet and tension in the lower portion. The following equations are used for the tension and compression forces in the beam top fillet. Note that these equations do not apply to user defined sections.

$$\begin{aligned}
 T_{KT} &= \phi_{bc} k_{width} k_{depth} F_{yw}, && \text{if the PNA is above the top of the top fillet,} \\
 T_{KT} &= \phi_{bc} k_{width} (k_{depth} - y_3) F_{yw}, && \text{if the PNA is within the top fillet,} \\
 T_{FT} &= 0, && \text{if the PNA is below the bottom of the top fillet,} \\
 C_{KT} &= 0, && \text{if the PNA is above the top of the top fillet,} \\
 C_{KT} &= \phi_{bc} k_{width} y_3 F_{yw}, && \text{if the PNA is within the top fillet,} \\
 C_{KT} &= \phi_{bc} k_{width} k_{depth} F_{yw}, && \text{if the PNA is below the bottom of the top fillet.}
 \end{aligned}$$

The distance of the tension force in the top fillet,  $T_{KT}$ , to the PNA is given by the following equations.

$$\begin{aligned}
 x_{PNA} &= y_p - d + t_{f-top} + \frac{k_{depth}}{2}, && \text{if the PNA is above the top of the top fillet,} \\
 x_{PNA} &= \frac{k_{depth} - y_3}{2}, && \text{if the PNA is within the top fillet,} \\
 x_{PNA} &= 0, && \text{if the PNA is below the bottom of the top fillet.}
 \end{aligned}$$

The distance of the compression force in the top fillet,  $C_{KT}$ , to the PNA is given by the following equations.

$$\begin{aligned}
 x_{PNA} &= 0, && \text{if the PNA is above the top of the top fillet,} \\
 x_{PNA} &= \frac{y_3}{2}, && \text{if the PNA is with the top fillet,} \\
 x_{PNA} &= z_p - t_c - h_r - r_d - t_{f-top} - \frac{k_{depth}}{2}, && \text{if the PNA is below the bottom of the top fillet.}
 \end{aligned}$$

Note the terms  $z_p$ ,  $t_c$ , and  $h_r$  in the preceding equation must all be for the left side of the beam or all for the right side of the beam. It does not matter which side of the beam is used, but all of the terms must be consistent.

- **Beam web:** The force in the beam web can be tension, compression, or compression in the upper portion of the web and tension in the lower portion. The following equations are used for the tension and compression forces in the beam web.

$$\begin{aligned}
 T_{\text{Web}} &= \phi_{bcs} t_w h F_{yw}, & \text{if the PNA is above the top of the web,} \\
 T_{\text{Web}} &= \phi_{bcs} t_w (h - y_4) F_{yw}, & \text{if the PNA is within the web,} \\
 T_{\text{Web}} &= 0, & \text{if the PNA is below the bottom of the web,} \\
 C_{\text{Web}} &= 0, & \text{if the PNA is above the top of the web,} \\
 C_{\text{Web}} &= \phi_{bcs} t_w y_4 F_{yw}, & \text{if the PNA is within the web,} \\
 C_{\text{Web}} &= \phi_{bcs} t_w h F_{yw}, & \text{if the PNA is below the bottom of the web.}
 \end{aligned}$$

The distance of the tension force in the web,  $T_{\text{Web}}$ , to the PNA is given by the following equations.

$$\begin{aligned}
 x_{\text{PNA}} &= y_p - d + t_{f\text{-top}} + k_{\text{depth}} + \frac{h}{2}, & \text{if the PNA is above the top of the web,} \\
 x_{\text{PNA}} &= \frac{h - y_4}{2}, & \text{if the PNA is within the web,} \\
 x_{\text{PNA}} &= 0, & \text{if the PNA is below the bottom of the web.}
 \end{aligned}$$

The distance of the compression force in the web,  $C_{\text{Web}}$ , to the PNA is given by the following equations.

$$\begin{aligned}
 x_{\text{PNA}} &= 0, & \text{if the PNA is above the top of the web,} \\
 x_{\text{PNA}} &= \frac{y_4}{2}, & \text{if the PNA is within the web,} \\
 x_{\text{PNA}} &= z_p - t_c - h_r - r_d - t_{f\text{-top}} - k_{\text{depth}} - \frac{h}{2} & \text{if the PNA is below the bottom of the web.}
 \end{aligned}$$

Note the terms  $z_p$ ,  $t_c$ , and  $h_r$  in the preceding equation must all be for the left side of the beam or all for the right side of the beam. It does not matter which side of the beam is used, but all of the terms must be consistent.

- **Beam bottom fillet:** The force in the beam bottom fillet can be tension, compression, or compression in the upper portion of the fillet and tension in the lower portion. The following equations are used for the tension and

compression forces in the beam bottom fillet. Note that these equations do not apply to user defined sections.

$$\begin{aligned}
 T_{KB} &= \phi_{bcs} k_{width} k_{depth} F_{yw}, & \text{if the PNA is above the top of the bottom fillet,} \\
 T_{KB} &= \phi_{bcs} k_{width} (k_{depth} - y_5) F_{yw}, & \text{if the PNA is within the bottom fillet,} \\
 T_{KB} &= 0, & \text{if the PNA is below the bottom fillet,} \\
 C_{KB} &= 0, & \text{if the PNA is above the top of the bottom fillet,} \\
 C_{KB} &= \phi_{bcs} k_{width} y_5 F_{yw}, & \text{if the PNA is within the bottom fillet,} \\
 C_{KB} &= \phi_{bcs} k_{width} k_{depth} F_{yw}, & \text{if the PNA is below the bottom fillet.}
 \end{aligned}$$

The distance of the tension force,  $T_{KB}$ , to the PNA is given by the following equations.

$$\begin{aligned}
 x_{PNA} &= y_p - d + t_{f-top} + \frac{3k_{depth}}{2} + h, & \text{if the PNA is above the top of the bottom fillet,} \\
 x_{PNA} &= \frac{k_{depth} - y_5}{2}, & \text{if the PNA is within the bottom fillet,} \\
 x_{PNA} &= 0, & \text{if the PNA is below the bottom fillet.}
 \end{aligned}$$

The distance of the compression force,  $C_{KB}$ , to the PNA is given by the following equations.

$$\begin{aligned}
 x_{PNA} &= 0, & \text{if the PNA is above the top of the bottom fillet,} \\
 x_{PNA} &= \frac{y_5}{2}, & \text{if the PNA is within the bottom fillet,} \\
 x_{PNA} &= z_p - t_c - h_r - r_d - t_{f-top} - \frac{3k_{depth}}{2} - h, & \text{if the PNA is below the bottom fillet.}
 \end{aligned}$$

Note the terms  $z_p$ ,  $t_c$ , and  $h_r$  in the preceding equation must all be for the left side of the beam or all for the right side of the beam. It does not matter which side of the beam is used, but all of the terms must be consistent.

- Beam bottom flange:** The force in the beam bottom flange can be tension, compression, or compression in the upper portion of the flange and tension in the lower portion. The following equations are used for the tension and compression forces in the beam bottom flange.

$$\begin{aligned}
T_{FB} &= \phi_{bcs} b_{f-bot} t_{f-bot} F_{yf-bot}, & \text{if the PNA is above the top of the bottom flange,} \\
T_{FB} &= \phi_{bcs} b_{f-bot} (t_{f-bot} - y_6) F_{yf-bot}, & \text{if the PNA is within the bottom flange,} \\
T_{FB} &= 0, & \text{if the PNA is below the bottom flange,} \\
C_{FB} &= 0, & \text{if the PNA is above the top of the bottom flange,} \\
C_{FB} &= \phi_{bcs} b_{f-bot} y_6 F_{yf-bot}, & \text{if the PNA is within the bottom flange,} \\
C_{FB} &= \phi_{bcs} b_{f-bot} t_{f-bot} F_{yf-bot}, & \text{if the PNA is below the bottom flange.}
\end{aligned}$$

The distance of the tension force in the bottom fillet,  $T_{FB}$ , to the PNA is given by the following equations.

$$\begin{aligned}
x_{PNA} &= y_p - d + t_{f-top} + 2k_{depth} + h + \frac{t_{f-bot}}{2}, & \text{if the PNA is above the top of the bottom flange,} \\
x_{PNA} &= \frac{t_{f-bot} - y_6}{2}, & \text{if the PNA is within the bottom flange,} \\
x_{PNA} &= 0, & \text{if the PNA is below the bottom of the bottom flange.}
\end{aligned}$$

The distance of the compression force in the bottom fillet,  $C_{FB}$ , to the PNA is given by the following equations.

$$\begin{aligned}
x_{PNA} &= 0, & \text{if the PNA is above the top of the bottom flange,} \\
x_{PNA} &= \frac{y_6}{2}, & \text{if the PNA is within the bottom flange,} \\
x_{PNA} &= z_p - t_c - h_r - r_d - t_{f-top} - 2k_{depth} - h - \frac{t_{f-bot}}{2}, & \text{if the PNA is below the bottom flange.}
\end{aligned}$$

Note the terms  $z_p$ ,  $t_c$ , and  $h_r$  in the preceding equation must all be for the left side of the beam or all for the right side of the beam. It does not matter which side of the beam is used, but all of the terms must be consistent.

- **Cover plate:** The force in the cover plate can be tension, or compression in the upper portion of the cover plate and tension in the lower portion. The following equations are used for the tension and compression forces in the cover plate.

$$\begin{aligned}
T_{CP} &= \phi_{bcs} b_{cp} t_{cp} F_{ycp}, & \text{if the PNA is above the top of the cover plate,} \\
T_{CP} &= \phi_{bcs} b_{cp} (t_{cp} - y_7) F_{ycp}, & \text{if the PNA is within the cover plate,} \\
C_{CP} &= 0, & \text{if the PNA is above the top of the cover plate,} \\
C_{CP} &= \phi_{bcs} b_{cp} y_7 F_{ycp}, & \text{if the PNA is within the cover plate.}
\end{aligned}$$



The distance of the tension force in the cover plate,  $T_{CP}$ , to the PNA is given by the following equations

$$x_{\text{PNA}} = y_p - d + t_{f\text{-top}} + 2k_{\text{depth}} + h + t_{f\text{-bot}} + \frac{t_{cp}}{2} \quad \text{if the PNA is above the top of the cover plate,}$$
$$x_{\text{PNA}} = \frac{t_{cp} - y_7}{2} \quad \text{if the PNA is within the cover plate.}$$

The distance of the compression force in the cover plate,  $C_{CP}$ , to the PNA is given by the following equations

$$x_{\text{PNA}} = 0 \quad \text{if the PNA is above the top of the cover plate,}$$
$$x_{\text{PNA}} = \frac{y_7}{2} \quad \text{if the PNA is within the cover plate.}$$

## 2.22 Composite Moment Capacity of a Partially Composite Beam with a Plastic Stress Distribution

This section describes how the positive moment capacity of the composite beam using a plastic stress distribution is calculated for partial composite connection.

### 2.22.1 Location of the Plastic Neutral Axis

The location of the PNA for partial composite connection with a plastic stress distribution is calculated using the method described in the subsection *Location of the Plastic Neutral Axis* of the section entitled *Composite Plastic Moment Capacity for Positive Bending* in this chapter, with the modifications described here.

The program determines the location of the PNA by comparing the maximum possible compressive force that can be developed in the concrete,  $MPF_{\text{conc}}$ , with the maximum possible tensile force that can be developed in the steel section (including the cover plate, if applicable),  $MPF_{\text{steel}}$ .

The maximum concrete force,  $MPF_{conc}$ , is calculated as follows if there is no metal deck, or if the metal deck ribs are oriented perpendicular to the beam span.

$$MPF_{conc} = \phi_{bcc} \left[ \left( 0.85 f'_c b_{eff} t_c \right)_{left} + \left( 0.85 f'_c b_{eff} t_c \right)_{right} \right] \leq p MPF_{steel}$$

If the deck ribs are oriented parallel to the beam span,  $MPF_{conc}$  is calculated as follows.

$$MPF_{conc} = \phi_{bcc} \left[ \left( 0.85 f'_c b_{eff} \left\{ t_c + \frac{w_r h_r}{S_r} \right\} \right)_{left} + \left( 0.85 f'_c b_{eff} \left\{ t_c + \frac{w_r h_r}{S_r} \right\} \right)_{right} \right] \leq p MPF_{steel}$$

Note that the maximum concrete force has contributions from the left and right sides of the beam that are treated separately and may be different.

The maximum steel force,  $MPF_{steel}$ , is calculated as follows if the beam is a rolled section:

$$MPF_{steel} = \phi_{bcs} \left( A_s F_y + b_{cp} t_{cp} F_{ycp} \right)$$

$MPF_{steel}$ , is calculated as follows if the beam is a user defined section.

$$MPF_{steel} = \phi_{bcs} \left( b_{f-top} t_{f-top} F_{yf-top} + t_w h + b_{f-bot} t_{f-bot} F_{yf-bot} + b_{cp} t_{cp} F_{ycp} \right)$$

Note that for a partial composite case, the expressions for  $MPF_{steel}$  remain the same. The expressions of  $MPF_{conc}$  have an upper limit based on steel's axial capacity. Here  $p$  is the partial composite connection (PCC), which theoretically ranges from 0 to 1.

When computing the location of the PNA, it important to remember that the concrete is assumed to take no tension. Also, the concrete in the metal deck ribs is considered effective in compression only if the metal deck ribs are oriented parallel to the beam span.

The maximum concrete and steel forces are compared to determine whether the PNA is within the concrete slab or the steel section. Since  $MPF_{steel} \geq MPF_{conc}$ , the PNA is within the steel section.

Since the PNA is within the steel section, there are several general locations for it. After the general locations have been identified, it is a straightforward

process to determine the location of the PNA. The general locations are as follows:

- Within the beam top flange.
- Within the beam top fillet (applies to rolled shapes from the program's section database only).
- Within the beam web.
- Within the beam bottom fillet (applies to rolled shapes from the program's section database only).
- Within the beam bottom flange.
- Within the cover plate (if one is specified).

Note it is very unlikely that the PNA would be below the beam web but there is nothing in the program to prevent it. This condition would require a very large beam bottom flange and/or cover plate. Each of the PNA locations in the steel section is described following the description of the PNA in the concrete slab.

With the known values of  $MPF_{\text{steel}}$  and  $MPF_{\text{conc}}$ , where  $MPF_{\text{conc}} \leq p(MPF_{\text{steel}})$ , the program uses the subsections of the section *Location of the Plastic Neutral Axis* to determine the exact location of the PNA by calculating  $y_2, y_3, y_4, y_5, y_6,$  and  $y_7$ .

Then, the program assumes that the PNA occurs in the top flange of the beam. The distance  $y_2$  is calculated as described previously for PNA within the beam top flange. The calculated distance  $y_2$  is then checked to see if it actually is within the beam top flange. If it is, the location of the PNA has been identified.

If the calculated distance  $y_2$  is not within the beam top flange, the program continues by assuming that the PNA occurs in the beam top fillet. (Note that if the beam is a user-defined beam, there is no top fillet and the program skips directly to assuming that the PNA is in the beam web.) The distance  $y_3$  is calculated as described previously for PNA within the beam top fillet. The calculated distance  $y_3$  is then checked to see if it actually is within the beam top fillet. If it is, the location of the PNA has been identified.

If the calculated distance  $y_3$  is not within the beam top fillet, the program continues by assuming that the PNA occurs in the beam web. The distance  $y_4$  is calculated as described previously for the PNA within the beam top fillet. The calculated distance  $y_4$  is then checked to see if it actually is within the beam web. If it is, the location of the PNA has been identified.

In any practical case, the PNA is not expected to be below the beam web. However, in the event the PNA has not yet been located, the program continues down the beam section through the bottom fillet, the bottom flange and finally the cover plate until the location of the PNA has been identified.

## 2.22.2 Determining the Effective Portion of the Concrete Slab

For partial composite connection, when different composite decks and or spans are specified on each side of the beam, the effective portion of the slab is determined as follows: The program first puts the following six items in order, from highest elevation to lowest, to determine how much of the concrete slab is effective for partial composite connection:

- Top of concrete slab on the left side of the beam.
- Top of concrete slab on the right side of the beam.
- Top of metal on the left side of the beam.
- Top of metal on the right side of the beam.
- Bottom of metal on the left side of the beam.
- Bottom of the metal on the right side of the beam.

Next the program sums the compressive forces of these eight items, starting with the item at the highest elevation and proceeding downward. As each item is added into the sum, the sum of the compressive forces is compared with the  $p(MPF_{steel})$  as determined in the previous subsection.

As soon as the sum of forces exceeds  $p(MPF_{steel})$ , the program recognizes that the last location considered is below the bottom of the effective concrete, and the second to last location considered is above the bottom of the effective concrete. Using this information, the program can solve directly for the location of the bottom of the effective concrete.

Figure 2-47 shows the internal concrete forces for a rolled steel section (a user defined steel section is similar) for the condition where the bottom of the effective concrete is in the concrete slab above the metal deck. In this case,  $a_1$  represents the distance from the top of the concrete slab to the bottom of the effective concrete. Note that the distance  $a_1$  can be different on the left and right sides of the beam.

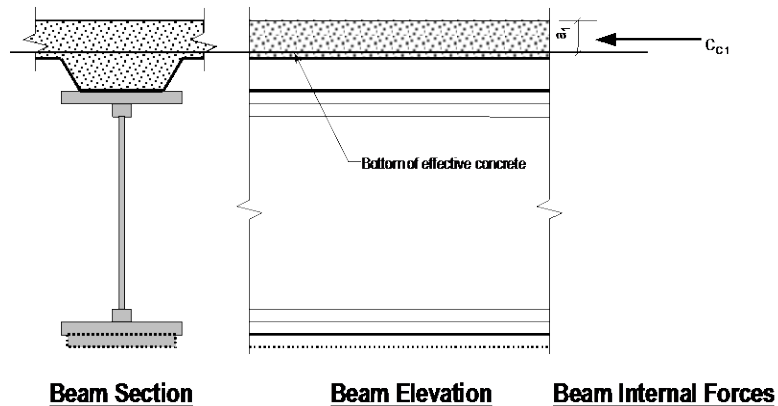
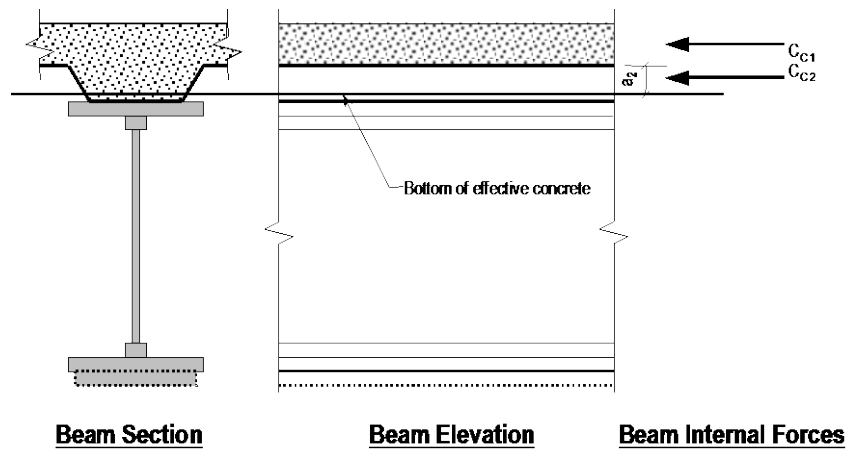

**Figure 2-45: Rolled Steel Section With Bottom of Effective Concrete in Concrete Slab Above Metal Deck, Positive Bending With Partial Composite Connection**

Figure 2-48 shows the internal concrete forces for a rolled steel section (a user defined steel section is similar) for the condition where the bottom of the effective concrete is within the height,  $h_r$ , of the metal deck ribs. In this case,  $a_2$  represents the distance from the top of the metal deck ribs to the bottom of the effective concrete. Note that the distance  $a_2$  can be different on the left and right sides of the beam.

The program obtains the distances  $a_1$  and  $a_2$  using an iterative solution technique.

If the bottom of effective concrete is in the concrete above the metal deck,  $a_2$  is set equal to 0. If the bottom of effective concrete is within the height of the metal deck,  $a_1$  is set equal to  $t_c$ .



**Figure 2-46: Rolled Steel Section With Bottom of Effective Concrete Within the Height,  $h_r$ , of the Metal Deck Ribs, Positive Bending With Partial Composite Connection**

### 2.22.3 Plastic Moment Capacity for Positive Bending

The plastic moment capacity for positive bending in a composite section is calculated from the following equation:

$$\phi_{bcpp} M_n = \phi_{bcpp} \sum_{\text{Piece}=1}^{12} T_{\text{piece}} x_{\text{PNA-piece}} + \phi_{bcpp} \sum_{\text{Piece}=1}^{12} C_{\text{piece}} x_{\text{PNA-piece}}$$

All of the preceding terms have been described in the subsection *Plastic Moment Capacity for Positive Bending* in the previous section entitled *Composite Plastic Moment Capacity for Positive Bending*. The exception is that the forces in the concrete slabs and concrete ribs in the metal decks, both at the left and right sides of the beam, are expressed in terms of  $a_1$  and  $a_2$  instead of  $z_p$  and  $h_r$  only. Also the corresponding  $x_{\text{PNA}}$ s have been expressed in terms of  $a_1$  and  $a_2$ . All of these exceptions have been described previously there.

When calculating the moment capacity, concrete or reinforcing steel below the bottom of the effective concrete is not considered in the calculation.

Note that the PNA for a partially composite beam always lies within the steel beam section, not the concrete slab. Thus it is not necessary to check for the PNA location within the concrete slab.

---

## Chapter 3 Design Process

---

This chapter provides a detailed description of the algorithms used by the programs in the design/check of structures in accordance with “BS 5950-1990 — Specifications for Structural Steel Building” (BS 5950). Subsequent references to this code are identified with the prefix “**BS.**”

### 3.1 Notation

$A_{bare}$	Area of the steel beam (plus cover plate) alone, mm <sup>2</sup> .
$A_c$	Area of concrete within the slab effective width that is above the elastic neutral axis (ENA) for full composite action, mm <sup>2</sup> . For beams with metal deck ribs running perpendicular to the beam span, only the concrete above the metal deck and above the ENA is included. For beams with metal deck ribs running parallel to the beam span, the concrete above the metal deck and the concrete in the deck ribs are included if it is above the ENA. This value may be different on the left and right sides of the beam.
$A_g$	Gross area of steel member, including area of cover plate if any, mm <sup>2</sup> .

$A_s$	Area of rolled steel section, or the total area (excluding cover plate) of a user defined steel section, mm <sup>2</sup> . Note that the total area of a userdefined steel section is found by summing the area of the top flange, web, and bottom flange.
$A_{sb}$	Initial displacement amplitude of a single beam resulting from a heel drop impact, mm. Used in vibration analysis.
$A_{v2}, A_{v3}$	Major and minor shear areas, mm <sup>2</sup> .
$A_{rr}$	Area of an element of the composite steel beam section, mm <sup>2</sup> .
$A_w$	Area of the web equal to the overall depth $d$ times the web thickness $t_w$ , mm <sup>2</sup> .
$B$	Actual physical width of the concrete flange, mm. Also full width of the steel flange, mm.
$B_{cp}$	Width of steel cover plate, mm.
$C_b$	Bending coefficient dependent on moment gradient, unitless.
$C_{bot}$	Cope depth at bottom of beam, mm.
$C_{C1}$	Compressive force in concrete slab above metal deck, N. If no metal deck exists, this is the compressive force in the slab.
$C_{C2}$	Compressive force in concrete that is in the metal deck ribs, N. This force occurs only when the metal deck ribs are oriented parallel to the steel beam, and the plastic neutral axis is below the top of the metal deck.
$C_{FT}$	Compressive force in the top flange of the steel beam, N. This force occurs only when the plastic neutral axis is below the top of the beam.
$C_{KT}$	Compressive force in the top fillets of a rolled steel beam, N. This force occurs only when the plastic neutral axis is below the bottom of the top flange of the beam.
$C_{top}$	Cope depth at top of beam, mm.



$C_{web}$	Compressive force in the steel beam web, N. This force occurs only when the plastic neutral axis is within the beam web.
$D$	Depth of steel beam from outside face of top flange to outside face of bottom flange, mm.
$D_p$	Overall depth of the profiled steel sheet
$E_c$	Modulus of elasticity of concrete slab, MPa. Note that this could be different on the left and right sides of the beam. Also note that this is different for stress calculations and deflection calculations.
$E_s$	Modulus of elasticity of steel, MPa.
$F_c, F_{stud}$	The design concrete force that can be generated in a concrete deck considering the effect of composite shear connection, N.
$F_u$	Minimum specified tensile strength of structural steel or shear stud, MPa.
$F_v$	Required shear strength, N.
$F_{v2}$	Major shear loads, N.
$F_y$	Minimum specified yield stress of structural steel, MPa.
$F_{ycp}$	Minimum specified yield stress of cover plate, MPa.
$F_v$	Required shear strength, N.
$F_{v2}, F_{v3}$	Major and minor shear loads, N.
$G$	Shear modulus of elasticity of steel, N/mm <sup>2</sup> .
$H$	Warping constant, mm <sup>6</sup> .
$I_{22}, I_{33}$	Minor and major moment of inertia, respectively, mm <sup>4</sup> .
$I_{bare}$	Moment of inertia of a steel section, including the cover plate if present, mm <sup>4</sup> . $I_{bare}$ becomes equal to $I_s$ if there is no cover plate welded to the beam.

$I_{eff}$	Effective moment of inertia of a partially composite beam, mm <sup>4</sup> .
$I_s$	Moment of inertia of the steel beam alone, mm <sup>4</sup> .
$I_{tr}$	Transformed moment of inertia if there is full (100%) composite connection
$J$	Torsional constant for the section, mm <sup>4</sup> .
$K_f$	A unitless coefficient typically equal to 1.57 unless the beam is the overhanging portion of a cantilever with a backspan, in which case $K_f$ is as defined in Figure 2-12 of Floor Vibration, or the beam is a cantilever that is fully fixed at one end and free at the other end, in which case $K_f$ is 0.56. This is used for vibration analysis.
$L$	Center-of-support to center-of-support length of the beam, mm.
$L_{CBS}$	Length of a composite beam segment, mm. A composite beam segment spans between any of the following: 1) physical end of the beam top flange; 2) another beam framing into the beam being considered; 3) physical end of concrete slab. Figure 2-13 of <i>Distribution of Steel Headed Stud Anchors on a Composite Beam</i> illustrates some typical cases for $L_{CBS}$ .
$L_1$	Distance from point of maximum moment to the closest point of zero moment or physical end of beam top flange, or physical end of concrete slab, mm.
$M$	Moment, N-mm.
$M_A$	Absolute value of moment at the quarter point of the unbraced beam segment, N-mm.
$M_B$	Absolute value of moment at the centerline of the unbraced beam segment, N-mm.
$M_C$	Absolute value of moment at the three-quarter point of the unbraced beam segment, N-mm.
$M_{cr}$	Elastic buckling moment, N-mm.

$M_b$	Lateral-torsional buckling moment capacity of a non-composite section, N-mm.
$M_c$	Moment capacity, N-mm.
$M_{c22}$	Minor moment capacity, N-mm.
$M_{c33}$	Major moment capacity, N-mm.
$M_{max}$	Maximum positive moment for a beam, N-mm.
$M_E$	Elastic critical moment of a non-composite section, N-mm.
$M_n$	Nominal flexural strength, N-mm.
$M_p$	Plastic bending moment, N-mm. Plastic moment capacity of a composite section for positive moment with an appropriate PCC, or for negative moment, as appropriate, N-mm
$M_s$	Moment resistance of the steel beam alone
$MPF_{conc}$	Maximum possible force that can be developed in the concrete slab, and rebar in slab, if applicable, N.
$MPF_{steel}$	Maximum possible force that can be developed in the steel section, and cover plate, if applicable, N.
$N$	Axial load, N.
$N_{CBS}$	The number of uniformly distributed shear connectors the program specifies for a composite beam segment, unitless.
$N_{eff}$	The effective number of beams resisting the heel drop impact, unitless.
$N_R$	Number of shear stud connectors in one rib at a beam intersection; not to exceed three in computations, although more than three studs may be installed, unitless.
$N_1$	Required number of shear connectors between the point of maximum moment and an adjacent point of zero moment (or end of slab), unitless.

$N_2$	Required number of shear connectors between a point load and a point of zero moment (or end of slab), unitless.
$NR$	Available number of metal deck ribs between two points, unitless.
$NS_{\max}$	Maximum number of shear stud connectors between two points a distance of $L_s$ apart, unitless.
$PCC$	Percent composite connection, unitless. The exact formula for this term is code dependent.
$P_{v2}, P_{v3}$	Major and minor shear capacities, N.
$Q_k$	Characteristic strength of one shear connector (shear stud), N.
$Q_n$	Nominal strength of one shear connector (shear stud or channel), N.
$Q_p$	Design strength of one shear connector (shear stud) for positive moment, N.
$RS_{\max}$	Maximum number of rows of shear stud connectors that can fit between two points a distance of $L_s$ apart, unitless.
$S$	Plastic section modulus of the steel beam alone plus cover plate if applicable, $\text{mm}^3$ .
$S_{33}, S_{22}$	Major and minor plastic section moduli, $\text{mm}^3$ .
$S_{\text{eff}}$	Effective section modulus of a partially composite beam referred to the extreme tension fiber of the steel beam section (including cover plate), $\text{mm}^3$ .
$S_r$	Center-to-center spacing of metal deck ribs, mm.
$S_{tr}$	Section modulus for the fully composite uncracked transformed section referred to the extreme tension fiber of the steel beam section (including cover plate), $\text{mm}^3$ .
$T$	Thickness of flange, mm.
$T_{\text{bot}}$	Thickness of bottom flange of a user-defined steel beam, mm.

---

$T_{top}$	Thickness of top flange of a user-defined steel beam, mm.
$t_{cp}$	Thickness of cover plate, mm.
$T_{CP}$	Tensile force in the cover plate, N.
$T_{FB}$	Tensile force in the bottom flange of a steel beam, N.
$T_{FT}$	Tensile force in the top flange of a steel beam, N.
$T_{KB}$	Tensile force in the bottom fillets of a rolled steel beam, N.
$T_{KT}$	Tensile force in the top fillets of a rolled steel beam, N.
$T_{Web}$	Tensile force in the web of a steel beam, N.
$Y_s$	Specified yield strength, N/mm <sup>2</sup> .
$Z_{33}, Z_{22}$	Section modulus about the 3-3 and 2-2 axes of the beam respectively, mm <sup>3</sup> .
$a$	Robertson constant, unitless. Also the depth of the concrete compression block, mm.
$a_1$	Distance from the top of the concrete to the bottom of the effective concrete for partial composite connection when the bottom of the effective concrete is within the slab above the metal deck (or there is a solid slab with no metal deck), mm.
$a_2$	Distance from the top of the metal deck to the bottom of the effective concrete for partial composite connection when the bottom of the effective concrete is within the height of the metal deck, mm.
$b$	Width, mm.
$b_{cp}$	Width of the steel cover plate, mm.
$b_{eff}$	Effective width of the concrete flange of the composite beam, mm.
$b_f$	Width of the flange of a rolled steel beam, mm.

$b_{f\text{-bot}}$	Width of the bottom flange of a user defined steel beam, mm.
$b_{f\text{-top}}$	Width of top flange of a user defined steel beam, mm.
$b_r$	Average width of concrete rib, mm.
$d$	Clear distance between flanges less the fillet or corner radius at each flange for rolled shapes and clear distance between flanges for welded shapes, mm.
$d_{\text{avg}}$	Average depth of the concrete slab, including the concrete in the metal deck ribs, mm.
$d_{sc}$	Diameter of a shear stud connector, mm.
$f$	First natural frequency of the beam in cycles per second.
$f'_c$	Specified compressive strength of concrete, MPa.
$f_{cu}$	Characteristic cube strength of concrete, N/mm <sup>2</sup> .
$g$	Acceleration of gravity, mm/seconds <sup>2</sup> .
$h$	Clear distance between flanges less the fillet or corner radius at each flange for rolled shapes and clear distance between flanges for other shapes, mm.
$h_r$	Height of metal deck rib, mm.
$h_s$	Length of shear stud connector after welding, mm.
$k$	Distance from the outer face of a rolled beam flange to the web toe of a fillet, mm.
$k_{\text{depth}}$	Distance from the inner face of a rolled beam flange to the web toe of a fillet, mm.
$k_{\text{width}}$	Width of the idealized fillet of a rolled beam section, mm.
$l$	Controlling laterally unbraced length of a member, mm.
$l_{e22}, l_{e33}$	Major and minor effective lengths, mm ( $K_{33}l_{33}, K_{22}l_{22}$ ).

$n$	Slenderness correction factor dependent on moment gradient, unitless. This factor modifies the slenderness to consider the effect of variation of moment along the length of the beam. This is used to calculate $M_b$ .
$p_y$	Minimum specified yield stress of structural steel, N/mm <sup>2</sup> .
$p_{ycp}$	Minimum specified yield stress of cover plate, N/mm <sup>2</sup> .
$r$	Governing radius of gyration, mm. Also the ratio of average axial stress in steel to yield stress of steel, unitless.
$r_{22}, r_{33}$	Radius of gyration about the local 2 and 3 axes of the beam respectively, mm.
$s_b$	Beam spacing, mm.
$t$	Thickness of web of steel beam, mm.
$t_c$	Thickness of concrete slab, mm. If there is metal deck, this is the thickness of the concrete slab above the metal deck.
$t_{cp}$	Thickness of the cover plate, mm.
$t_0$	Time to the maximum initial displacement of a single beam resulting from a heel drop impact, seconds. Used in vibration analysis.
$t_f$	Thickness of the steel beam flange, mm.
$t_{f-bot}$	Thickness of the bottom flange of a user defined steel beam, mm.
$t_{f-top}$	Thickness of the top flange of a user defined steel beam, mm.
$t_w$	Thickness of the web of a user defined steel beam, mm.
$u$	Buckling parameter.
$v$	Longitudinal shear force per unit length, N/mm.
$w_c$	Unit weight per volume of concrete, N/mm <sup>3</sup> .

$w_d$	Unit weight per area of metal deck, MPa.
$w_r$	Average width of the metal deck rib, mm.
$\bar{y}$	Distance from the bottom of the bottom flange of the steel beam section to the elastic neutral axis of the fully composite beam, mm.
$y_{bare}$	The distance from the bottom of the bottom flange of the steel beam to the neutral axis of the non-composite steel beam plus the cover plate if applicable, mm.
$y_e$	The distance from the elastic neutral axis of the bare steel beam alone (plus cover plate, if applicable) to the elastic neutral axis of the fully composite beam, mm.
$y_{eff}$	The distance from the bottom of the bottom flange of the steel beam to the neutral axis of the partially composite beam, mm.
$y_1$	Distance from the bottom of the bottom flange of the steel beam section to the centroid of an element of the composite beam section, mm.
$y_2$	Distance from the top of the top flange of the steel beam section to the plastic neutral axis when the plastic neutral axis is within the beam top flange, mm.
$y_3$	Distance from the bottom of the top flange of a rolled steel beam section to the plastic neutral axis when the plastic neutral axis is within the fillets, mm.
$y_4$	For a rolled steel beam, the distance from the bottom of the top fillet to the plastic neutral axis when the plastic neutral axis is within the beam web, mm. For a user defined steel beam, the distance from the bottom of the top flange to the plastic neutral axis when the plastic neutral axis is within the beam web, mm.
$y_p$	Distance from the plastic neutral axis of composite section to the bottom of the beam bottom flange (not cover plate), mm.



$z$	Distance from the elastic neutral axis of the steel beam (plus cover plate, if it exists) alone to the top of the concrete slab, mm. Note that this distance may be different on the left and right sides of the beam.
$z_p$	Distance from the plastic neutral axis of composite section to the top of the concrete slab, mm. Note that this distance may be different on the left and right sides of the beam.
$\sum A$	Sum of the areas of all of the elements of the steel beam section, mm <sup>2</sup> .
$\sum A_{tr}$	Sum of the areas of all of the elements of the composite steel beam section, mm <sup>2</sup> .
$\sum (A_{tr}y_1)$	Sum of the product $A_{tr}$ times $y_1$ for all of the elements of the composite steel beam section, mm <sup>3</sup> .
$\sum (Ay_1)$	Sum of the product $A$ times $y_1$ for all of the elements of the steel beam section, mm <sup>3</sup> .
$\sum (Ay_1^2)$	Sum of the product $A$ times $y_1^2$ for all of the elements of the steel beam section, mm <sup>4</sup> .
$\sum (A_{tr}y_1^2)$	Sum of the product $A_{tr}$ times $y_1^2$ for all of the elements of the composite steel beam section, mm <sup>4</sup> .
$\sum I_o$	Sum of the moments of inertia of each element of the composite steel beam section taken about the center of gravity of the element, mm <sup>4</sup> .
$\sum Q_n$	Sum of the nominal strength of the shear connectors (shear stud or channel) between the considered point and the point of zero moment, N.
$\sum Q_{n-pcc}$	Required nominal strength of the shear connectors (shear stud or channel) between the considered point and the point of zero moment for partial composite connection percentage, PCC, N.

$\sum Q_{n-100}$	Required nominal strength of the shear connectors (shear stud or channel) between the considered point and the point of zero moment for full (100%) composite action, N.
$\alpha$	Axial compression stress level indicator for classification of section.
$\alpha_b$	Constant, taken as 0.007; used in defining Perry coefficient.
$\phi_{bcc}$	Resistance factor defined by CSI to give the user more control over section capacity, unitless.
$\phi_{bcs}$	Resistance factor defined by CSI to give the user more control over section capacity, unitless.
$\varepsilon$	Constant $\left(\frac{275}{p_y}\right)^{1/2}$ .
$\lambda$	Slenderness parameter. It is the minor axis slenderness ratio $L_b / r_{22}$ for lateral-torsional buckling of non-composite beams. For composite beams, this parameter is not required.
$\lambda_c$	Column slenderness parameter, unitless.
$\lambda_{LT}$	Equivalent slenderness.
$\lambda_{LO}$	Limiting equivalent slenderness.
$\eta$	Perry factor.
$\eta_{LT}$	Perry coefficient.
$\nu$	Slenderness factor.
$\rho_1$	Proportion of the long term loading to the total loading in a load combination. This ratio is taken by considering the ratio of the corresponding moments in the program, unitless. It ranges between 0 and 1.
$\psi$	Monosymmetry index.

## 3.2 Design Methodology

The flowchart in Figure 3-1 shows the general methodology for composite beam design of a single beam element using the BS 5950-1990 specification. The numbered boxes in the flowchart correspond to the "Box" identifiers used in the text of this chapter. The flowchart is intended to convey the important features of the BS 5950-1990 design methodology. It should not be literally construed as a flowchart for the actual computer code included in the program.

### Box 1 - Start Here

To begin, note that the flowchart is set up for a single beam. Thus the flow process shown must be applied to each beam designed. Do not confuse the beam that is being designed with a trial section for that beam. The beam that is being designed is an actual element in the model. A trial section is simply a beam section size that is checked for the beam that is being designed.

### Box 2 - Design Load Combinations

The program creates default design load combinations for composite beam design using the BS 5950-1990 specification. Also any user-specified design load combinations can be interpreted and implemented. Refer to *Design Load Combinations* for a description of the BS 5950-1990 default design load combinations.

### Box 3 - Design Check Locations

The program determines all of the design check locations for a given beam. Also refer to *Beam Unbraced Length and Design Check Locations* in Chapter 2.

### Box 4 - Checking Order for Beams

If the beam is assigned an auto selection property, the checking order for the beam must be determined. The program considers the beams in the auto select list in the order described in the section entitled *How the Program Optimizes Design Groups* in Chapter 2.

### Box 5 - Trial Beam Section

The program allows the user to select the next trial beam section to be checked for conformance with the BS 5950-1990 specification and any additional user defined criteria. Refer to the section entitled *How the Program Optimizes Design Groups* in Chapter 2 for a description of this selection process.

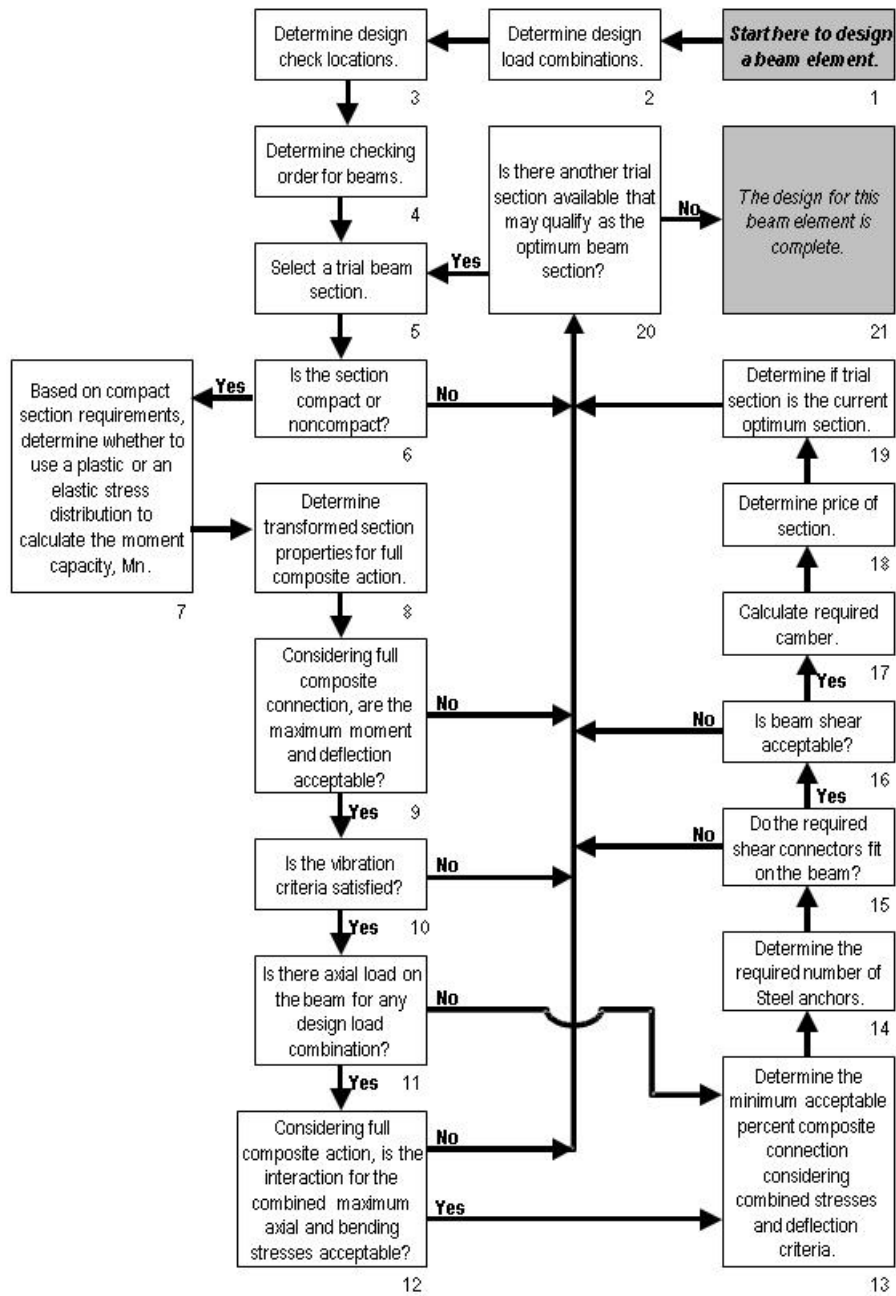

Figure 3-1 Flowchart for BS 5950-1990 Design of a Single Beam

**Box 6-Section Class Requirements**

For BS 5950-1990 design of composite beams, the program requires that the beam section be either Class 1 (Plastic), Class 2 (Compact) or Class 3 (Semi-Compact). Slender sections are not designed. The program checks to make sure the beam is not slender. Refer to *Plastic, Compact and Semi-Compact Requirements* later in this chapter for a description of how the program checks plastic, compact and semi-compact requirements.

**Box 7 - Stress Distribution Used to Calculate Moment Capacity**

The program determines whether to use a plastic or an elastic stress distribution when calculating the moment resistance for BS 5950-1990 design. See *Plastic, Compact and Semi-Compact Requirements* later in this chapter for more information.

**Box 8 - Transformed Section Properties**

The program computes the transformed section properties of the trial beam section. If there is only positive bending in the beam, only the transformed section properties for positive bending are calculated. Similarly, if there is only negative bending in the beam, only the transformed section properties for negative bending are calculated. If there is both positive and negative bending in the beam, transformed section properties for both positive and negative bending are calculated.

Refer to *Effective Width of the Concrete Slab* in Chapter 2 for a description of how the program calculates the effective width of the concrete slab for the composite beam. Refer to *Transformed Section Moment of Inertia* in Chapter 2 for a description of how the program calculates the transformed section properties.

In BS 5950-1990 design, the transformed section properties are used for calculating deflection, and they are used when the moment resistance is determined based on an elastic stress distribution.

**Box 9 - Initial Moment Resistance and Deflection Check**

The program checks that the moment resistance of the beam using full composite connection is greater than or equal to the applied factored moment. It also checks if the deflection using full composite connection is acceptable. The main purpose of this check is to quickly eliminate inadequate beam sections. Refer to *Bending Checks* later in this chapter for more information.

**Box 10 - Vibration Criteria Check**

The program calculates the vibration parameters. If vibration is specified to be used as one of the tools for selecting the optimum beam size, the program checks if the vibration parameters satisfy the specified limits. If the vibration check is satisfied, the design using the current trial section continues; otherwise, the design for this section is terminated. For more detailed information on the vibration checks, refer to *Floor Vibration* in Chapter 2.

**Box 11 - Axial Load**

The program checks if axial load exists on the beam for any design load combination. If so, the axial load resistance is determined and the interaction is subsequently checked, as indicated in Box 14. If there is no axial load on the beam, the axial resistance is not determined and the interaction check (Box 14) is skipped. Refer to *Plastic, Compact and Semi-Compact Requirements* later in this chapter for a description of how the program calculates axial load resistance.

**Box 12 - P-M Interaction Check**

If there is axial load on the beam, the program checks the P-M interaction equations. If the interaction check is satisfied, the design using the current trial section continues; otherwise, the design for this section is terminated. Refer to *Moment Capacity for Steel Section Alone* later in this chapter for more information.

**Box 13 - Partial Composite Action**

A significant amount of design is performed at this point in the process. The program determines the smallest amount of composite connection for which the beam is adequate. Both flexural checks and deflection checks are made at this point. In addition, the program considers axial load on the beam if it exists and is specified to be considered. Flexural checks are also made for the construction loads.

For more information refer to *Composite Moment Capacity of a Partially Composite Beam with a Plastic Stress Distribution* in Chapter 2 and *Bending Checks* later in this chapter. Also refer to the section entitled *Positive Moment Capacity with an Elastic Stress Distribution* in Chapter 2.

**Box 14 - Required Number of Shear Connectors**

The program calculates the required number of shear connectors on the beam and the distribution of those shear connectors. For more information refer to

*Steel Anchors* later in this chapter. Also refer to *Distribution of Steel Headed Stud Anchors on a Composite Beam and Number of Shear Studs that Fit in a Composite Beam Segment* in Chapter 2. Finally refer to *Effective Width of the Concrete Slab* in Chapter 2 for limitations associated with composite beams and formed metal deck.

**Box 15 - Checking if Shear Connectors Fit on the Beam**

The program checks if the number of shear connectors calculated (Box 14) actually fit on the beam. For more information refer to *Number of Shear Studs that Fit in a Composite Beam Segment* in Chapter 2. If the connectors fit on the beam, the design using the current trial section continues; otherwise, the design for this section is terminated.

**Box 16 - Beam Shear**

The program checks the beam shear for the reactions at each end of the beam. See *Beam Shear Capacity* later in this chapter for more information. If the beam shear check is satisfied, the design using the current trial section continues; otherwise, the design for this section is terminated.

**Box 17 - Camber**

The program determines the camber for the beam, if it is specified to have camber. Refer to *Beam Deflection and Camber* in Chapter 2 for more information.

**Box 18 - Section Price**

Determination of the price of a section applies only when price has been specified by the user as the method of selecting the optimum section. In such cases, the program determines the price of the current beam. Refer to the section entitled *How the Program Optimizes Design Groups* in Chapter 2 for more information.

**Box 19 - Check if a Section is the Current Optimum Section**

This check applies only if price has been specified as the method of selecting the optimum section. The program checks if the price of the current trial beam is less than that of any other beam that satisfies the design criteria. If so, the current beam section becomes the current optimum beam section. Refer to the section entitled *How the Program Optimizes Design Groups* in Chapter 2 for more information.

If the optimum beam size is to be selected by weight, this check becomes irrelevant because the beams are checked in order from the lightest to the heaviest beams and thus the first beam found to work is the optimum beam.

#### **Box 20 - Checking for Possible Additional Optimum Sections**

This check applies only if the beam has been assigned an auto selection property. The program checks if another section in the auto selection list might qualify as the optimum beam section. Refer to the section entitled *How the Program Optimizes Design Groups* in Chapter 2 for more information.

#### **Box 21 - Design Complete**

At this point, the design for this particular beam element is complete. If the beam has been assigned an auto select property, the current optimum section, assuming one has been found, is the optimum section for the beam. The program will indicate if no beam with an optimum section is included in the auto select list.

If the beam is assigned a regular, non-auto select property, the design for that beam property will be provided or the beam will be indicated to be inadequate.

There are some additional aspects included in the composite beam design module that are not directly addressed in the flowchart shown in Figure 3-1. Those include designing beams in groups and designing beams with partial length cover plates.

For more information on the design by group feature, refer to the section entitled *How the Program Optimizes Design Groups* in Chapter 2. The extension of the methodology described for designing by groups is relatively simple and is assumed to be apparent to the reader.

When a beam has a partial length cover plate, the program checks not only the design at the point of the maximum moment (Box 8 of Figure 3-1), but also the design at the point of the largest moment where the cover plate does not exist.

## **3.3 Design Load Combinations**

The default composite beam design load combinations can be used for design, or the user may define design load combinations, or both default combinations



and user defined combinations can be used. The default design load combinations can be modified or deleted.

### 3.3.1 Strength Check for Construction Loads

The program performs the check using the construction load design load combination only if the beam is unshored. If the beam is shored, the check for construction loads is not performed and any specified design load combinations for construction loads are not relevant.

The automatically created design load combination, using the BS 5950-1990 specification, for checking the strength of an unshored beam subjected to construction loads is given by the following equation (BS 5950 Part 3 Section 2.3.1, BS 5950 Part 1 Section 2.2, Table 2).

$$1.4 (\sum WDL) + 1.6 (\sum CL)$$

where:

$\sum WDL$  = The sum of all wet dead load (WDL) load cases defined for the model. Note that if a load case is simply defined as dead load, it is assumed to be a WDL load case.

$\sum CL$  = The sum of all construction load (CL) load cases defined for the model. Note that you need to explicitly define these.

### 3.3.2 Strength Check for Final Loads

The automatically created design load combinations for checking the strength of a composite beam under final loads are given by the following equations (BS 5950 Part 3 Section 2.4.1; BS 5950 Part 1 Section 2.2, Table 2).

$$1.4 (\sum WDL + \sum SDL)$$

$$1.4 (\sum WDL + \sum SDL) + 1.6 (\sum LL + \sum RLL)$$

where:

$\sum \text{SDL}$  = the sum of all superimposed dead load (SDL) load cases defined for the model,

$\sum \text{LL}$  = The sum of all live load (LL) load cases defined for the model.

$\sum \text{RLL}$  = The sum of all reducible live load (RLL) load cases defined for the model.

and the remainder of the terms are as defined previously in this section.

### 3.3.3 Deflection Check for Final Loads

The automatically created design load combination for checking the deflection of a composite beam under final loads is given by the following equation (BS 5950 Part 3 Section 2.4.1; BS 5950 Part 1 Section 2.2, Table 2).

$$\sum \text{WDL} + \sum \text{SDL} + \sum \text{LL} + \sum \text{RLL}$$

where all of the terms are as described previously. Note that all of the load factors for this serviceability check are 1.0.

If the beam is unshored, the WDL portion of the deflection is based on the moment of inertia of the steel beam alone and the remainder of the deflection is based on the effective moment of inertia of the composite section. If the beam is shored, the entire deflection is based on the effective moment of inertia of the composite section.

## 3.4 Plastic, Compact, Semi-Compact Requirements

In designing composite beams, under certain conditions, the beam must be designed as a non-composite beam. For example, when the deck or slab has an opening near the beam middle span, when the deck or slab is in tension because of negative moment, or when the user has explicitly requested the beam to be designed as a non-composite beam, the program designs the beam as non-composite. For checking steel sections for load at the construction stage, the section is always assumed to be a non-composite section. The program classifies the beam for non-composite requirements (BS 5950 Part 1 Section 3.5.1, BS Table 7) or for composite requirements (BS 5950 Part 3 Section 4.5, BS Table 2) as required for specific situations.

The program checks the sections according to Table 3-1. The section dimensions used in the table are given in Figure 3-2. The parameters  $r$ ,  $\alpha$  and  $\epsilon$  along with the slenderness ratios are the major factors in classification of sections. Those factors are defined in the next two sections.

**Table 3-1 Limiting Width-Thickness Ratios for Classification of Sections Based on BS 5950-90**

Description of Section	Ratio Checked	Common Criteria	Class 1 (Plastic)	Class 2 (Compact)	Class 3 (Semi-Compact)	
<b>I-SHAPE</b> (Non-Composite)	$b/T$	Rolled	$\leq 8.5 \epsilon$	$\leq 9.5 \epsilon$	$\leq 15 \epsilon$	
		Welded	$\leq 7.5 \epsilon$	$\leq 8.5 \epsilon$	$\leq 13 \epsilon$	
	$d/t$	$\alpha < 2$		$\leq \frac{79}{0.4 + 0.6\alpha} \epsilon$	$\leq \frac{98}{\alpha} \epsilon$	If $r > 0$ , $\leq \frac{120}{1 + 1.5r} \epsilon$ , and $\leq \left(\frac{41}{r} - 2\right) \epsilon$ (Rolled) or $\leq \left(\frac{41}{r} - 13\right) \epsilon$ (Welded), if $r = 0$ $\leq 120 \epsilon$ , if $r < 0$ $\leq \frac{120}{(1 + 4)^2} \epsilon$ and $\leq 250 \epsilon$
			$\alpha \geq 2$ , Rolled	$\leq 39 \epsilon$	$\leq 39 \epsilon$	$\leq 39 \epsilon$
			$\alpha \geq 2$ , Welded	$\leq 28 \epsilon$	$\leq 28 \epsilon$	$\leq 28 \epsilon$
<b>I-SHAPE</b> (Composite)	$b/T$	Solid Slab	Assumed Class 1 (Plastic)			
		Deck perpendicular, Rolled Shape	$\leq 9.5 \epsilon$	$\leq 15 \epsilon$	unconditional	
		Deck perpendicular, Welded Shape	$\leq 8.5 \epsilon$	$\leq 13 \epsilon$	unconditional	
		Deck parallel, $b_r \geq B/2$ , Rolled Shape	$\leq 9.5 \epsilon$	$\leq 15 \epsilon$	unconditional	
		Deck parallel, $b_r \geq B/2$ , Welded Shape	$\leq 8.5 \epsilon$	$\leq 13 \epsilon$	unconditional	
		Other cases	Sam as Non-Composite I-Shapes			

**Table 3-1 Limiting Width-Thickness Ratios for Classification of Sections Based on BS 5950-90**

Description of Section	Ratio Checked	Common Criteria	Class 1 (Plastic)	Class 2 (Compact)	Class 3 (Semi-Compact)
<b>I-SHAPE</b> (Composite) (continued)	$d / t$	None	$\leq \frac{64}{1+r} \epsilon$	$\leq \frac{76}{1+r} \epsilon$	If $r > -0.5$ , unconditional, if $-0.5 < r < 0$ , $\leq \frac{114(1+r)}{(1+2r)^{3/2}} \epsilon$ , if $0 \leq r < 0.66$ , $\leq \frac{114}{1+2r} \epsilon$ , if $r \geq 0.66$ and Rolled, $\leq \frac{114}{1+2r} \epsilon$ , if $r \geq 0.66$ and Welded, $\leq \left( \frac{41}{r} - 13 \right) \epsilon$
	$b_1 / T_{cp}$	$M \geq 0$	Assumed Class 1 (Plastic)		
		$M < 0$	$\leq 23 \epsilon$	$\leq 25 \epsilon$	$\leq 28 \epsilon$
	$b_2 / T_{cp}$	$M \geq 0$	Assumed Class 1 (Plastic)		
$M < 0$		$\leq 7.5 \epsilon$	$\leq 8.5 \epsilon$	$\leq 13 \epsilon$	
<b>CHANNEL</b> (Non-Composite)	$b / T$	As for I-Shapes	As for I-Shapes	As for I-Shapes	As for I-Shapes
	$d / t$	As for I-Shapes	As for I-Shapes	As for I-Shapes	As for I-Shapes
<b>CHANNEL</b> (Composite)	$b / T$	As for I-Shapes	As for I-Shapes	As for I-Shapes	As for I-Shapes
	$d / t$	As for I-Shapes	As for I-Shapes	As for I-Shapes	As for I-Shapes
	$b_1 / T_{cp}$	As for I-Shapes	As for I-Shapes	As for I-Shapes	As for I-Shapes
	$b / T_{cp}$	As for I-Shapes	As for I-Shapes	As for I-Shapes	As for I-Shapes

The program checks the limiting proportions of cross-section requirements at each design location along the beam for each design load combination separately. A beam section may be classified differently for different design load combinations. Three reasons that a beam may be classified differently for different design load cases are as follows:

- The limiting proportions of cross-section requirements for beam webs depend on the axial load in the beam. Different design load combinations may produce different axial loads in the beam.

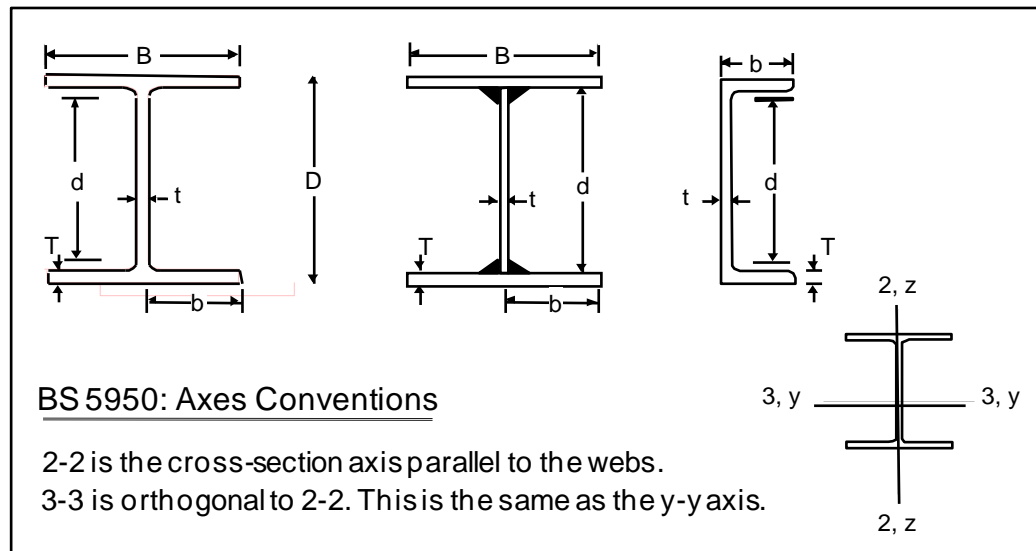

*Figure 3-2 BS 5950-90 Definition of Geometric Properties*

- The compression flange may be different for different design load combinations. If the sizes of the top and bottom flanges are not the same, classification of the section may depend on which flange is determined to be the compression flange.
- A beam may behave as a composite or non-composite beam, depending on the load combination.

At each design location, for each design load combination, the program first checks a beam section for the Class 1 (Plastic) section requirements for the compression flange, web, and cover plate (if present) as described herein. If the beam section meets all of those requirements, it is classified as Class 1 (Plastic) for that design load combination. If the beam section does not meet all of the Class 1 (Plastic) section requirements, it is checked for the Class 2 (Compact) requirements for the flanges, web, and cover plate (if present). If the beam section meets all of those requirements, it is classified as Class 2 (Compact) for that design load combination, and so on. If the beam section does not meet all of the Class 3 (Semi-Compact) section requirements, it is classified as Class 4 (Slender) for that design load combination. **Currently, the program does not check/design Class 4 (Slender) sections for composite beam design.**

### 3.4.1 Limiting Width-to-Thickness Ratios for Flanges

This section describes the limiting width-to-thickness ratios considered by the program for beam compression flanges. The width-to-thickness ratio for flanges is denoted  $b/T$ , and is equal to  $B/2T$  for I-shaped sections and  $b/T$  for channel sections.

For composite sections, the compression flange connected with the solid slab is taken as Class 1 (Plastic) regardless of its  $b/T$  ratio (BS 4.5.2.b). When the following conditions are met, the program promotes the flange class by one level above the class calculated according to BS 5950 Part 1 (BS 5950-1 3.5.2 BS 5950-1 Table 7): the steel compression flange is restrained by shear connectors to a composite decked slab where (a) the deck is perpendicular to the beam or (b) the deck is parallel to the beam but the average width of the deck rib is at least half of the flange width. That is, if BS 5950 Part 1 classifies the flange to be Class 2, the flange will be classified as Class 1 if the flange of the composite is laterally supported by deck satisfying either of the previous two conditions (BS 4.5.2.c). See Table 3-1 of this chapter for details. In that table, the limiting width-thickness ratios for flanges are expressed by  $\varepsilon$ , which is defined as follows:

$$\varepsilon = \left( \frac{275}{p_y} \right)^{1/2} \quad (\text{BS 5950-1 Table 7, BS 5950-3 Table 2})$$

### 3.4.2 Limiting Width-to-Thickness Ratios for Webs

This section describes the limiting width-to-thickness ratios considered by the program for beam webs.

When checking a beam web for limiting proportions for the purpose of classifying web, the width-to-thickness ratio used is  $d/t$ . See Figure 3-2 for the definition of  $d$  and  $t$ . The limiting values of this ratio for different classes of sections are given in Table 3-1 for both composite and non-composite beams (BS 5950-1 3.5.2, BS 5950-1 Table 7, BS 5950-1 3.5.4; BS 5950-3 4.5.2, BS 5950-3 Table 2, BS 5950-3 Appendix C). The three parameters,  $r$ ,  $\alpha$  and  $\varepsilon$  are used extensively in the table to define the limiting values. Among all of those parameters,  $\varepsilon$  is defined in the previous section.  $r$  and  $\alpha$  are described here.

$r$ , the web stress ratio, is the ratio of mean longitudinal stress in the web in a section to yield stress  $p_y$  of the section, with slight exceptions for composite sections. For non-composite sections,  $r$  is defined in the program as follows:

$$r = -\frac{N}{A_g p_y}, \quad (\text{BS 5950-1 3.5.4})$$

where  $N$  is the factored force taking tension as positive and compression as negative. For composite sections, the effect of composite action is considered in calculating the axial force in the steel section alone. It is related to the percent composite connection, axial compression capacity of the deck concrete and the axial tensile capacity of the steel section alone. For composite sections,  $r$  is defined as follows (BS 5950-3 4.5.2.c, BS 5950-3 Figure 1, BS 5950-3 5.5.2, BS 5950-3 Appendix C).

If the compression flange is determined to be classified as either Class 1 (Plastic) or Class 2 (Compact), plastic stress distribution is assumed. In such cases,  $r$  is defined as (BS 4.5.2.c, Figure 1, Appendix C1):

$$r = \begin{cases} -\frac{(N + F_c - T_{cp} B_{cp} p_{ycp})}{dt p_y}, & \text{for section with cover plate and } M > 0 \\ -\frac{(N + F_c + T_{cp} B_{cp} p_{ycp})}{dtp_y}, & \text{for section with cover plate and } M \leq 0 \\ -\frac{(N + F_c)}{dtp_y}, & \text{for section with no cover plate.} \end{cases} \quad (\text{BS C.1})$$

On the other hand, if the compression flange is determined to be classified as Class 3 (Semi-Compact), elastic stress distribution is assumed. In such cases,  $r$  is defined as (BS 4.5.2.c, Figure 1, Appendix C.2):

$$r = \begin{cases} -\frac{(N + F_c)}{A_g p_y}, & \text{for sections with no cover plate,} \\ -\frac{(N + F_c)}{A_g p_y} - \frac{M (D/2 - \bar{y})}{I_{bare} p_y}, & \text{for sections with cover plate.} \end{cases} \quad (\text{BS C.2})$$

In all cases, the absolute value of  $r$  is limited by 1.

$$-1 \leq r \leq 1 \quad (\text{BS 5950-1 3.5.4, BS 5950-3 C1, C3})$$

The parameter  $\alpha$  represents the ratio of the depth of the compression zone of the web under the current load combination to the depth of the compression zone under pure bending. In that case, plastic stress distribution is assumed. For a symmetric I section,  $\alpha$  assumes the value of 2 for full compression, 1 for bending with no axial force, and 0 for tension only load cases (BS 5950-1 Table 7). The value of  $\alpha$  is needed for non-composite sections only. It is defined for non-composite sections as follows:

$$\alpha = \frac{\gamma_c}{d/t}, \text{ where} \quad (\text{BS 5950-1 3.5.2, Table 7})$$

$$\gamma_c = \left( \frac{h}{2} - T \right) - \frac{P}{2p_y t}. \quad (\text{BS 5950-1 3.5.2, Table 7})$$

In calculating  $\gamma_c$ , the presence of any cover plate currently is ignored in the program.

In the preceding expressions,

$N$  = Factored axial force, tension is taken as positive,

$F_c$  = Compression in deck concrete, including the effect of rib concrete capacity if the deck is parallel to the beam, and partial composite connection;  $F_c$  is the same as  $F_{stud}$ .

$t_{cp}$  = Thickness of the cover plate,

$b_{cp}$  = Width of the cover plate,

$p_{ycb}$  = Yield strength of the cover plate,

$A_g$  = Gross area of steel section, including the area of cover plate, if any,

$I_{bare}$  = Gross moment of inertia of bare steel, including the effect of the cover plate, if any.

### 3.4.3 Limiting Width-to-Thickness Ratios for Cover Plates

The width-to-thickness checks made for the cover plate depend on the width of the cover plate compared to the width of the beam bottom flange. Figure 3-3 illustrates the conditions considered.



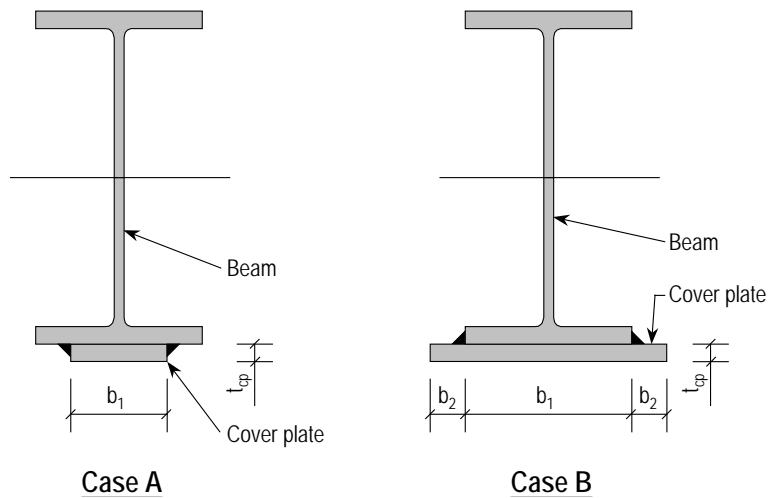

**Figure 3-3 Conditions Considered When Checking Width-to-Thickness Ratios of Cover Plates**

In Case A of the figure, the width of the cover plate is less than or equal to the width of the beam bottom flange. In that case, the width-to-thickness ratio is taken as  $b_1/t_{cp}$ , and it is checked as a flange cover plate.

In Case B of Figure 3-2, the width of the cover plate is greater than the width of the beam bottom flange. Two conditions are checked in that case. The first condition is the same as that shown in Case A, where the width-to-thickness ratio is taken as  $b_1/t_{cp}$  and is checked as a flange cover plate. The second condition checked in Case B takes  $b_2/t_{cp}$  as the width-to-thickness ratio and checks it as a plate projecting from a beam.

If the moment is positive, the cover plate will be in tension. In such a case, the cover plate will be classified as Class 1 (Plastic) regardless of the width thickness ratio. See Table 3-1 for details.

### 3.5 Composite Plastic Moment Capacity for Positive Bending

The plastic moment resistance for full composite connection,  $M_p$ , is calculated based on the section entitled *Composite Plastic Moment Capacity for Positive Bending* in Chapter 2.

The plastic moment resistance for partial composite beam,  $M_p$ , is calculated based on the section entitled *Composite Moment Capacity of a Partially Composite Beam with a Plastic Stress Distribution* in Chapter 2.

Figure 2-31 in Chapter 2 illustrates a generic plastic stress distribution for positive bending for both full and partial composite cases. Note that the concrete is stressed to  $0.45f_{cu}$  (BS 4.4.2.a). The illustrated plastic stress distribution is the basic distribution of stress used by the program when considering a plastic stress distribution for positive bending. Note that if the metal deck ribs are parallel to the beam, the concrete in the ribs is also considered.

It should be noted that for both full and partial composite cases, the concrete stress block is stressed to  $0.45f_{cu}$  (BS 4.4.2.a).

### 3.6 Composite Section Elastic Moment Capacity

To calculate the positive moment resistance with an elastic stress distribution, the program first calculates the location of the elastic neutral axis (ENA) and the transformed section moment of inertia. Information on how the program calculates the location of the ENA and the transformed section moment of inertia for full composite connection is provided in the section entitled *Transformed Section Moment of Inertia* in Chapter 2. Information on how the program calculates the location of the ENA and the transformed section moment of inertia for partial composite connection is provided in the section entitled *Effective Section Properties for Partial Composite Connection* in Chapter 2.

### 3.7 Moment Capacity for Steel Section Alone

This section describes how the program calculates the moment resistance of a non-composite steel beam, including a cover plate, if applicable.

The moment capacities of the section ( $M_{c22}$  and  $M_{c33}$ ) and the buckling moment resistance ( $M_b$ ) are computed for Class 1 (Plastic), Class 2 (Compact), and Class 3 (Semi-Compact) sections according to the following sections. By default, the program takes the design strength,  $p_y$ , to be 1.0 times the minimum yield strength of steel,  $Y_s$ , as specified by the user. In inputting values of the

yield strength, the user should ensure that the thickness and the ultimate strength limitations given in the code are satisfied (BS 5950-1 3.1.1).

**For Class 4 (Slender) sections, reduced section capacities may be applicable. The user must separately investigate this reduction if such elements are used. Currently the program does not check/design Class 4 (Slender) sections.**

### 3.7.1 Steel Beam Properties

If properties for the steel section alone are available directly from the program's section database, then those properties are used to compute the moment resistance. For other cases such as a user defined section or a section with a cover plate, the section properties are calculated in a manner similar to that described in *Transformed Section Moment of Inertia* in Chapter 2, except that there is no concrete or reinforcing steel to consider.

After the moment of inertia has been calculated, the section moduli and radius of gyration are calculated using standard formulae. This process is repeated to get properties about both axes. The torsional constant is determined by summing the torsional constants for the various components of the section. For example, it may be determined by summing the  $J$ 's of a rolled section and the cover plate, if applicable, or in a user defined section, by summing the  $J$ 's for the top flange, web, bottom flange and cover plate, if applicable.

**Table 3-2 Robertson Constant in BS 5950-90,  $a$**

Description of Section	Thickness (mm)	Axis of Bending	
		Major	Minor
<b>I-SHAPE</b> (rolled)	any	2.0	3.5
<b>I-SHAPE</b> (welded)	≤40	3.5	5.5
	>40	3.5	8.0
<b>CHANNEL</b>	any	5.5	5.5

## 3.7.2 Moment Capacity, $M_c$

The moment capacities in the major and minor directions,  $M_{c33}$  and  $M_{c22}$ , are based on the design strength and the section modulus, the co-existent shear and the possibility of local buckling of the cross-section. Local buckling is avoided by applying a limitation to the width/thickness ratios of elements of the cross-section. The moment capacities are calculated as follows (BS 5950-3 1.4; BS 5950-1 4.2).

### 3.7.2.1 Class 1 (Plastic) and Class 2 (Compact) Sections

For plastic and compact sections, the moment capacities about the major and the minor axes of bending depend on the shear force,  $F_v$ , and the shear capacity,  $p_v$ .

For bending about the major (3-3) axis of I and Channel sections, the moment capacities considering the effects of shear force are computed as

$$M_{c33} = p_y S_{33} \leq 1.2 p_y Z_{33}, \quad \text{for } F_v \leq 0.6 p_v, \quad (\text{BS 5950-1 4.2.5})$$

$$M_{c33} = p_y (S_{33} - S_{v33} \rho_l) \leq 1.2 p_y Z_{33}, \quad \text{for } F_v > 0.6 p_v, \quad (\text{BS 5950-1 4.2.6})$$

where

$S_{33}$  = Plastic modulus of the gross section about the major (3-3) axis.

$Z_{33}$  = Elastic modulus of the gross section about the major (3-3) axis.

$S_{v33}$  = Plastic modulus of the gross section about the relevant axis less the plastic modulus of that part of the section remaining after deduction of shear area, i.e., plastic modulus of shear area. For example, for rolled I-shapes,  $S_{v33}$  is taken to be  $tD^2/4$ , and for welded I-shapes, it is taken as  $td^2/4$ .

$p_v$  = The shear capacity.

$$\rho_l = \frac{2.5 F_{v2}}{P_{v2}} - 1.5.$$

The combined effect of shear and axial forces is not being considered because practical situations do not warrant this. In rare cases, however, the user may

need to investigate this independently, and if necessary, overwrite values of the section moduli.

For bending about the minor (2-2) axis of I and Channel sections, the reduction of moment capacities for the presence of shear force is not considered. The user should investigate the reduced moment capacity separately. The moment capacity for those cases is computed in the program as

$$M_{c22} = p_y S_{22} \leq 1.2 p_y Z_{22}. \quad (\text{BS 5950-1 4.2.5})$$

### 3.7.2.2 Class 3 (Semi-Compact) Sections

Reduction of moment capacity resulting from coexistent shear does not apply for semi-compact sections. The moment capacities for the major and minor axes of bending are determined as follows:

$$M_{c33} = p_y Z_{33} \quad (\text{BS 5950-1 4.2.5})$$

$$M_{c22} = p_y Z_{22} \quad (\text{BS 5950-1 4.2.5})$$

## 3.7.3 Lateral-Torsional Buckling Moment Capacity, $M_b$

The lateral-torsional buckling resistance moment,  $M_b$ , of a member is calculated from the following equations (BS 5950-3 1.4; BS 5950-1 4.3, B2). The program assumes the members to be uniform (of constant properties) throughout their lengths.

For I and Channel sections,  $M_b$  is obtained from

$$M_b = \frac{p_y S_{33} M_E}{\phi_B + (\phi_B^2 - p_y S_{33} M_E)^{1/2}}, \quad \text{where} \quad (\text{BS 5950-1 B2.1})$$

$$\phi_B = \frac{p_y S_{33} + (\eta_{LT} + 1) M_E}{2},$$

$$M_E = \text{The elastic critical moment, } \frac{S_{33} \pi^2 E}{\lambda_{LT}^2}, \quad \text{and} \quad (\text{BS 5950-1 B2.3})$$

$\eta_{LT}$  = The Perry coefficient.

The Perry coefficient,  $\eta_{LT}$  for rolled and welded sections is taken as follows:

For rolled sections

$$\eta_{LT} = \alpha_b(\lambda_{LT} - \lambda_{L0}) \geq 0, \text{ and} \quad (\text{BS 5950-1 B2.3})$$

for welded sections

$$\eta_{LT} = 2\alpha_b\lambda_{L0} \geq 0, \text{ with } \alpha_b(\lambda_{LT} - \lambda_{L0}) \leq \eta_{LT} \leq 2\alpha_b(\lambda_{LT} - \lambda_{L0}). \quad (\text{BS 5950-1 B2.2})$$

In the preceding definition of  $\eta_{LT}$ ,  $\lambda_{L0}$  and  $\lambda_{LT}$  are the limiting equivalent slenderness and the equivalent slenderness, respectively, and  $\alpha_b$  is a constant.  $\alpha_b$  is taken as 0.007 (BS 5950-1 2.3). For flanged members symmetrical about at least one axis and uniform throughout their length,  $\lambda_{L0}$  is defined as follows:

$$\lambda_{L0} = 0.4 \sqrt{\frac{\pi^2 E}{p_y}} \quad (\text{BS 5950-1 B2.4})$$

$\lambda_{LT}$  is defined as follows:

$$\lambda_{LT} = n u v \lambda \quad (\text{BS 5950-1 B2.5})$$

where,

- $\lambda$  is the slenderness and is equivalent to  $l_{b22}/r_{22}$ .
- $n$  is the slenderness correction factor to consider the effect of variation of moment along the length of the beam. For flanged members in general, not loaded between adjacent lateral restraints, and for cantilevers without intermediate lateral restraints,  $n$  is taken as 1.0. For members with equal flanges loaded between adjacent lateral restraints, a conservative value of  $n$  is given by the following formula. This, however, can be overwritten by the user for any member (BS 5950-1 Table 13).

$$n = \frac{1}{\sqrt{C_b}} \leq 1.0, \text{ where}$$

$$C_b = \frac{12.5 M_{\max}}{2.5 M_{\max} + 3 M_A + 4 M_B + 3 M_C}, \text{ and}$$

$M_{\max}$ ,  $M_A$ ,  $M_B$ , and  $M_C$  are absolute values of maximum moment, 1/4 point, center of span and 3/4 point major moments, respectively, in the member. The program also defaults  $C_b$  to 1.0 if the unbraced length,  $l$ , of the member is redefined by the user (i.e., it is not equal to the length of the member).  $C_b$  should be taken as 1.0 for cantilevers. However, the program is unable to detect whether the member is a cantilever. The user can overwrite the value of  $C_b$  for any member.

- $u$  is the buckling parameter.  $u$  is taken as

$$u = \begin{cases} \left( \frac{4 S_{33}^2 \gamma}{A^2 (D - t_f)^2} \right)^{1/4}, & \text{for I sections, and} \\ \left( \frac{I_{22} S_{33}^2 \gamma}{A^2 H} \right), & \text{for Channel sections, where} \end{cases} \quad (\text{BS 5950-1 B2.5b})$$

$$\gamma = \left( 1 - \frac{I_{22}}{I_{33}} \right). \quad (\text{BS 5950-1 B2.5b})$$

- $v$  is the slenderness factor and it is given by the following formula.

$$v = \frac{1}{\left[ \left\{ 4N(N-1) + \frac{1}{20} \left[ \frac{\lambda}{x} \right]^2 + \psi^2 \right\}^{1/2} + \psi \right]^{1/2}}, \text{ where} \quad (\text{BS 5950-1 B2.5d})$$

$$N = 0.5, \quad (\text{BS 59590-1 2.5.d})$$

$$\psi = 0.0, \quad (\text{BS 59590-1 2.5.d})$$

$$x = \begin{cases} 0.566 (D - T) \left( \frac{A}{J} \right)^{1/2} & \text{for I sections, and} \\ 1.132 \left( \frac{AH}{I_{22} J} \right)^{1/2} & \text{for Channel sections,} \end{cases} \quad (\text{BS 5950-1 B2.5b})$$

$\lambda$  is the slenderness and is taken as  $l_{b22} / r_{22}$ .

## 3.8 ShearConnectors

This section begins by defining the program's default allowable shear connector loads for BS 5950-1990 composite beam design. Shear connector capacities are defined for both shear studs and channel shear connectors. Next the equations used for determining the number of shear connectors on the beam are provided.

### 3.8.1 Shear Capacity of a Shear Stud Connector

The capacity of a single shear stud is taken in the program as follows (BS 5.4.3, 5.4.6, 5.4.7.2, 5.4.7.3, Table 5):

$$Q_p = kR_{LW}R_mQ_k, \quad (\text{BS 5.4.3})$$

where,

$Q_k$  = The characteristic resistance of the shear connector; the procedure to determine  $Q_k$  is described later in this section (BS 5.4.6, Table 5)

$R_m$  = Reduction factor for the sign of moment,

$$R_m = \begin{cases} 0.8, & \text{for positive moment, and} \\ 0.6, & \text{for negative moment,} \end{cases} \quad (\text{BS 5.4.3})$$

$R_{LW}$  = Reduction factor for the concrete aggregate

$$R_{LW} = \begin{cases} 1.0, & \text{for normal weight concrete, and} \\ 0.9, & \text{for light-weight concrete,} \end{cases} \quad (\text{BC 5.4.6})$$

$k$  = Reduction factor based on whether the stud is embedded in a solid slab, a ribbed slab with the ribs running parallel to the beam, or a ribbed slab with the ribs running perpendicular to the beam; the procedure to determine  $k$  is described later in this section (BS 5.4.3, 5.4.7.2, 5.4.7.3)

The program determines the characteristic resistance,  $Q_k$ , using the parameters identified in Table 3-3, which is adapted from BS 5950-3 Table 5 (BS 5.4.6, BS Table 5). The program bases strength on nominal stud diameter only,



except for studs with 19 mm diameter, in which case the nominal height of the stud is also considered.

**Table 3-3 Characteristic Resistance  $Q_k$  of Headed Studs, kN**

Dimensions of Studs		Characteristic Strength of Concrete, $f_{cu}$ , N/mm <sup>2</sup>					
Nominal Stud Diameter, mm	Nominal Stud Height, mm	0 N/mm <sup>2</sup>	25 N/mm <sup>2</sup>	30 N/mm <sup>2</sup>	35 N/mm <sup>2</sup>	40 N/mm <sup>2</sup>	≥40 N/mm <sup>2</sup>
13	any	0	44	47	49	52	52
16	any	0	70	74	78	82	82
19	≤75	0	82	87	91	96	96
19	≥100	0	95	100	104	109	109
22	any	0	119	126	132	139	139
25	any	0	146	154	161	168	168

If the concrete shear strength,  $f_{cu}$ , used in a model matches any of those specified in the column headings of Table 3-3 (i.e., 25, 30, 35, or 40 N/mm<sup>2</sup>), the program determines  $Q_k$  from Table 3-3. If  $f_{cu}$  equals a value other than any of those specified in Table 3-3, the program interpolates  $Q_k$  linearly within the table for  $f_{cu}$ . Note that  $f_{cu}$  is always assumed to be limited to a maximum value of 40 N/mm<sup>2</sup> (BS Table 7 Note 1).

If the stud nominal diameter does not match any of the diameters given in Table 3-3 (e.g., 13, 16, 19, or 22 mm), the program determines strength using the stud nominal diameter immediately larger than the diameter of the stud for which  $Q_k$  is being determined. Then the strength is adjusted in proportion to the stud nominal diameter.

For the calculation of  $Q_k$ , the nominal stud height is mostly ignored. The user should be careful. For studs of diameter 19 mm, the stud shear resistance is interpolated if the height of the stud is less 100 mm or more than 75 mm.

The reduction factor  $k$  is determined as follows (BS 5.4.3, 5.4.2):

For solid slabs:

$$k = 1 \quad (\text{BS 5.4.3})$$

For ribbed decks with ribs running perpendicular to the beam:

$$k = \begin{cases} 0.85 \frac{b_r}{D_p} \left( \frac{h_s}{D_p} - 1 \right) \leq 1 & \text{if } N_R \geq 1, \\ 0.60 \frac{b_r}{D_p} \left( \frac{h_s}{D_p} - 1 \right) \leq 0.8 & \text{if } N_R \geq 2, \\ 0.50 \frac{b_r}{D_p} \left( \frac{h_s}{D_p} - 1 \right) \leq 0.6 & \text{if } N_R \geq 3, \end{cases} \quad (\text{BS 5.4.7.2})$$

where,

$b_r$  = Average breadth of the concrete rib,

$D_p$  = Overall depth of the profiled steel sheet (depth of the rib),

$h_s$  = Overall height of the stud;  $h_s$  is taken as not more than  $2D_p$  and also not more than  $D_p + 75$  mm in the calculation (BS 5.4.7.2),

$$h_s \leq 2D_p, \quad (\text{BS 5.4.2.2})$$

$$h_s \geq D_p + 75 \text{ mm, and} \quad (\text{BS 5.4.7.2})$$

$N_R$  = Number of studs per rib.

For ribbed decks with ribs running parallel to the beam:

$$k = \begin{cases} 1.0 & \text{if } \frac{b_r}{D_p} \geq 1.5, \text{ and} \\ 0.6 \frac{b_r}{D_p} \left( \frac{h_s}{D_p} - 1 \right) \leq 1.0 & \text{if } \frac{b_r}{D_p} < 1.5, \end{cases} \quad (\text{BS 5.4.7.3})$$

where  $b_r$ ,  $D_p$  and  $h_s$  are as described previously.

The detrimental effect of eccentric placement of studs on the rib and the beneficial effect of staggered placement of studs is not considered in the program. The user should consult the code for more details (BS 5.4.7.2).

In general, the ribs can run at any angle to the beam, not just parallel or perpendicular. Ideally, the rib angle to the beam should be considered in determining the characteristic shear strength of the studs (BS 5.4.7.4).

However, the program considers the ribs to run either parallel or perpendicular, depending on the rib-to-beam angle.

If there are different decks on the left and right sides of the beam, the program calculates  $Q_p$  for each side of the beam, using the same procedure. Then the program uses the smaller value in the further calculations.

If any of the assumptions do not satisfy the user, the user can calculate the strength  $Q_p$  and use that value in the Overwrites to apply to any specific composite beam.

### 3.8.2 Horizontal Shear for Full Composite Connection

The total horizontal shear to be resisted between the point of maximum *positive* moment (where the concrete is in compression) and the points of zero moment for full composite connection,  $\sum Q_{n-100}$ , is given by the smaller of  $\sum Q_{n-100}^c$  and  $\sum Q_{n-100}^s$  as applicable.

The total maximum horizontal shear that can develop due to crushing of concrete,  $\sum Q_{n-100}^c$ , is given by

$$\sum Q_{n-100}^c = 0.45 f_{cu\text{left}} f'_{c\text{left}} A_{c\text{left}} + 0.45 f_{cu\text{right}} A_{c\text{right}}$$

The total maximum horizontal shear that can be developed due to tensile yielding of the steel section,  $\sum Q_{n-100}^s$ , is given by

$$\sum Q_{n-100}^s = A_s \rho_y + b_{cp} t_{cp} \rho_{ycp} \quad (\text{Rolled})$$

$$\sum Q_{n-100}^s = b_{f\text{-top}} t_{f\text{-top}} \rho_{yf\text{-top}} + h t_w \rho_{yw} + b_{f\text{-bot}} t_{f\text{-bot}} \rho_{yf\text{-bot}} + b_{cp} t_{cp} \rho_{ycp}$$

(Welded)

In the preceding equations,

$A_c$  = Area of concrete slab within the effective width. It may include the rib area if the rib is parallel to the beam, mm<sup>2</sup>.

$A_s$  = Area of steel cross-section, mm<sup>2</sup>.

### 3.8.3 Number of Shear Connectors

#### 3.8.3.1 Between Maximum Moment and Point of Zero Moment

For full composite action, the number of shear connectors between a point of maximum positive or negative moment and adjacent points of zero moment,  $N_1$ , is given as follows:

$$N_1 = \frac{\sum Q_{n-100}}{Q_n}.$$

In the preceding equation,  $\sum Q_{n-100}$  is as determined in the previous section entitled *Horizontal Shear for Full Composite Connection*, and  $Q_n$  is determined as described in the previous subsections.

For partial composite connection, the number of shear connectors between a point of maximum **positive** (not negative) moment and adjacent points of zero moment,  $N_1$ , is given as follows:

$$N_1 = \frac{\sum Q_{n-PCC}}{Q_n}$$

In the preceding equation,  $\sum Q_{n-PCC}$  is equal to the percent composite connection times  $\sum Q_{n-100}$ . For example, if there is 70% composite connection,  $\sum Q_{n-PCC} = 0.7 \sum Q_{n-100}$ . Thus, the percent composite connection,  $p$ , for BS 5950-1990 design is given as follows:

$$p = \frac{\sum Q_{n-PCC}}{\sum Q_{n-100}}.$$

#### 3.8.3.2 Between the Point Load and the Point of Zero Moment

The program uses the following equation to check that the number of shear connectors provided between a point load and a point of zero moment is sufficient. This equation is not specified by BS but is used by CSI as the LRFD equivalent of Equation I4-5 in the AISC-ASD89 specification.

$$N_2 = N_1 \left( \frac{M - M_s}{M_{c,100} - M_s} \right)$$

In the preceding equation,

$M_{c,100}$  = Maximum moment resistance of the composite beam, considering partial composite connection if applicable, N-mm.

$M_s$  = Moment resistance of the steel beam alone, N-mm.

$M$  = Moment at the point load location, N-mm.

$N_1$  = Number of shear connectors required between the point of maximum moment and the point of zero moment, or the end of the slab, unitless.

$N_2$  = Number of shear connectors required between the point load considered and the point of zero moment, or the end of the slab, unitless.

This equation is checked at each point load location.

## 3.9 Beam Shear Capacity

This section describes how the program calculates the allowable shear stress for BS 5950-1990 composite beam design.

### 3.9.1 Shear Capacity

For shear design of a composite beam, the program checks only the major (vertical) shear,  $F_{v2}$ . The shear capacity for the major shear in I and Channel sections is evaluated as follows (BS 5950-3 5.1.4; BS 5950-1 4.2.3):

$$P_{v2} = 0.6p_y A_{v2} \quad (\text{BS 5950-1 4.2.3})$$

The shear area  $A_{v2}$  for I and Channel sections is taken as follows (BS 5950-1 4.2.3):

$$A_{v2} = \begin{cases} Dt & \text{if rolled section, and} \\ (D - T_{\text{top}} - T_{\text{bot}})t & \text{if welded section,} \end{cases} \quad (\text{BS 5950-1 4.2.3})$$

where,

$D$  = full depth of the section,

$t$  = thickness of the web,

$T_{\text{top}}$  = thickness of the top flange, and

$T_{\text{bot}}$  = thickness of the bottom flange.

At the ends of the beam, coping of the beams may be needed, which reduces the shear capacity of the beam. If coping is needed, the program automatically calculates the required cope based on the joint geometry and minimum gap of 6 mm. For a coped beam, the shear area is taken from the above equation but with an upper limit given in the following equation:

$$A_{v2} \leq (D - C_{\text{top}} - C_{\text{bot}}) t, \quad \text{for rolled section, and}$$

$$A_{v2} \leq [D - \max(C_{\text{top}}, T_{\text{top}}) - \max(C_{\text{bot}}, T_{\text{bot}})] t, \quad \text{for welded section,}$$

where,

$C_{\text{top}}$  = Cope at the top of the beam, and

$C_{\text{bot}}$  = Cope at the bottom of the beam.

Under certain conditions, both the copes can be non-zero, or either of the copes can be non-zero.

Moreover, the shear capacity computed here is valid only if  $d/t \leq 63\epsilon$ , strictly speaking. For  $d/t > 63\epsilon$ , the shear buckling of the thin members should be checked independently by the user in accordance with the code (BS 5950-1 4.4.2, 4.4.5).

### 3.9.2 Checking the Beam Shear

The program checks the beam major (vertical) shear at all stations of the beam using the following equation.

$$\frac{F_{v2}}{P_{v2}} \leq 1.0$$

where,

$F_{v2}$  = The required shear strength; that is, the applied factored major (vertical) shear force, N

$P_{v2}$  = Shear capacity for the major (vertical) shear, N. The procedure for calculating this term is given in the previous section.

The shear capacity is checked only for the major shear (vertical) of a composite section. The horizontal shear capacity is not needed to check for composite section because the corresponding minor (horizontal) shear capacity is huge given the strength of the concrete deck. The minor (horizontal) shear capacity is not checked for non-composite beams, which may be unconservative if there is no deck. In such cases, the user should check minor shear independently.

### 3.9.3 Limitations of Beam Shear Check

Following are some limitations of the program's beam shear check for composite beams.

- No check is made for shear on the net section considering the bolt holes.
- The shear check used in the program is only valid for  $d/t \leq 63\epsilon$  (BS 59550-1 4.2.3, 4.4.5).

The minor direction shear is not checked for non-composite sections.

## 3.10 Deflection Check

Deflection is calculated as described in the section entitled *Beam Deflection and Camber* in Chapter 2. For full composite connection,  $I_{tr}$  is used in the deflection calculations. For partial composite connection,  $I_{eff}$  is used in the deflection calculations.

## 3.11 Floor Vibration

By default the program calculates the first natural vibration frequency for each beam and reports it in the output, but it does not by default use this information to determine the adequacy of a composite beam section. This can be changed on the Preferences tab in the composite beam preferences. An option also exists to indicate that a beam section must satisfy the Murray minimum damping requirement to be considered acceptable.

Please refer to *Floor Vibration* in Chapter 2 for more information.



---

## Appendix A Preferences

---

The composite beam design preferences are basic assignments that apply to all composite beams. Default values are provided for all composite beam design preference items. Thus, it is not necessary to specify or change any of the preferences. However, at least review the default values for the preference items to make sure they are acceptable.

### A1 Beam Tab

Table A1 lists the composite beam preference items available on the Beam tab in the Preferences form.

**Table A1: Composite Beam Preferences on the Beam Tab**

<b>Item</b>	<b>Possible Values</b>	<b>Default Value</b>	<b>Description</b>
Shored?	Yes/No	No	Toggle for shored or unshored construction.
Middle Range (%)	$\geq 0\%$	70%	Length in the middle of the beam over which the program checks the effective width on each side of the beam, expressed as a percentage of the total beam length.
Pattern Live Load Factor	$\geq 0$	0.75	Factor applied to live load for special pattern live load check for cantilever back spans and continuous spans.
Stress Ratio Limit	$>0$	1.0	The acceptable stress ratio limit. This item applies to design optimization only.

## A2 Shear Studs Tab

Table A2 lists the composite beam preference items available on the Shear Studs tab in the Preferences form.

**Table A2: Composite Beam Preferences on the Shear Studs Tab**

Item	Possible Values	Default Value	Description
Minimum PCC (%)	> 0	40	Minimum percent composite connection applied to the beams which require composite action to meet strength or deflection criteria. This percentage also applies to beams for which Force Composite is specified in the Overwrites.
Maximum PCC(%)	> 0	100	Maximum percent composite connection for the beams.
Single Segment?	Yes/No	No	Toggle for placement of steel headed stud anchors in a single segment. To place studs in a single segment with uniform spacing throughout the beam, select Yes. This factor has no effect on checking beams with user defined studs.
Min. Long. Spacing	> 0	$6d_s$ (i.e., six stud diameters)	Minimum longitudinal spacing of shear studs along the length of the beam.
Max. Long. Spacing	> 0	1000	Maximum longitudinal spacing of shear studs along the length of the beam. This setting applies to all beams composite or non-composite unless "NonComposite w/o Studs" is specified in the overwrites.
Min. Trans. Spacing	> 0	$4d_s$ (i.e., four stud diameters)	Minimum transverse spacing of shear studs across the beam flange.
Max. Studs per Row	>0	3	Maximum number of shear studs in a single row across the beam flange.

## A3 Camber Tab

Table A3 lists the composite beam preference items available on the Camber tab in the Preferences form.

**Table A3: Composite Beam Preferences on the Camber Tab**

<b>Item</b>	<b>Possible Values</b>	<b>Default Value</b>	<b>Description</b>
Calculate Camber?	Yes/No	Yes	Toggle for whether or not beams have a camber.
Camber DL, %	$\geq 0$	80	Percent of dead load (not including superimposed dead load) on which camber calculations are based.
Minimum Beam Depth for Camber	$\geq 0$	340 mm	Actual (not nominal) beam depth below which beams are never cambered.
Minimum Web Thick. for Camber	$\geq 0$	6 mm.	Web thickness below which beams are never cambered.
Minimum Beam Span for Camber	$\geq 0$	7 m	Minim beam span below which beams are never cambered.
Minimum Camber, abs.	$\geq 0$	15 mm	The limiting number in the current unit. If the calculated camber falls below this limit, the required camber will be reported as zero.
Minimum Camber, L/	$> 0$	900	The minimum camber limitation denominator. Inputting a value of 360 means that the maximum camber limit is $L/360$ . If the calculated camber falls below this limit, the required camber will be reported as zero.
Camber Abs Max Limit	$> 0$	150	The absolute maximum camber in the current unit. If the calculated camber is larger than this limit, the required camber will be reported as this limiting value.
Camber Max Limit, L/	$> 0$	180	The maximum camber limitation denominator. Inputting a value of 360 means that the maximum camber limit is $L/360$ . If the calculated camber is larger than this limit, the required camber will be reported as this limiting value.
Camber Increment	$> 0$	5 mm	The camber interval in the current unit. The camber is reported as an integer multiple of the interval. This is used for rounding purposes only.
Camber Rounding Down	Yes/No	Yes	Camber rounding procedure. If Yes is selected, camber is rounded down consistently to the next level; else camber is rounded to the nearest level.

See the section entitled *Beam Deflection and Camber* in Chapter 2 for a description of beam deflection and camber.

## A4 Deflection Tab

Table A4 lists the composite beam preference items available on the Deflection tab in the Preferences form.

**Table A4: Composite Beam Preferences on the Deflection Tab**

Item	Possible Values	Default Value	Description
PreComp DL Limit, L/	$\geq 0$	0	Pre-composite dead load deflection limitation denominator. Inputting a value of 120 means that the deflection limit is L/120. Inputting zero is special, since it means no check has to be made for this item.
Super DL+LL Limit, L/	$\geq 0$	240	Post-composite superimposed dead plus live load deflection limitation denominator. Inputting a value of 120 means that the deflection limit is L/120. Inputting zero is special, since it means no check has to be made for this item.
Live Load Limit, L/	$\geq 0$	360	Live load deflection limitation denominator. Inputting a value of 360 means that the deflection limit is L/360. Inputting zero is special, since it means no check has to be made for this item.
Total Camber Limit, L/	$\geq 0$	240	Net load deflection (total deflection minus camber) limitation denominator. Inputting a value of 240 means that the deflection limit is L/240. Inputting zero is special, since it means no check has to be made for this item. Camber is subtracted from the total load deflection before checking.

See the section entitle *Beam Deflection and Camber* in Chapter 2 for a description of beam deflection and camber.

## A5 Vibration Tab

Table A5 lists the composite beam preference items available on the Vibration tab in the Preferences form.

**Table A5: Composite Beam Preferences on the Vibration Tab**

Item	Possible Values	Default Value	Description
Vibration Criterion	Walking, Rhythmic, Sensitive Equipment, None	Walking	Vibration criterion to be considered in design.
Occupancy Category	Paper Office, Electronics Office, Residential	Paper Office	Occupancy category to be considered in the design. Selecting this item changes the default parameters for the damping ratio (DG11 Table 4.1) and vibrational acceleration due to gravity $a_0/g$ (DG11 Table 4.1). However, the default parameters can be changed here.
Damping Ratio	> 0	0.0250	Damping ratio of the system (DG11 Table 4.1, DG11 Section 5.2).
Acceleration Limit, $a_0/g$	> 0%	0.005	Vibrational acceleration limit as a fraction of acceleration due to gravity, $a_0/g$ for walking excitation (DG11 Table 4.1).

See *Floor Vibration* in Chapter 2 for a description of beam vibration.

## A6 Prices Tab

Table A6 lists the composite beam preference items available on the Price tab in the Preferences form.

**Table A6: Composite Beam Preferences on the Prices Tab**

Item	Possible Values	Default Value	Description
Optimize for Price?	Yes/No	No	Toggle to consider price rather than steel weight when selecting the optimum beam section from an auto select section list.
Steel Price (\$)	$\geq 0$	\$1 per pound	Price of steel per unit weight of steel beam (including cover plate if it exists).
Stud Price (\$)	$\geq 0$	\$0	Installed price for a single shear stud connector.
Camber Price (\$)	$\geq 0$	\$0	Camber price per unit weight of steel beam (including cover plate, if it exists).

See "*How the Program Optimizes Design Groups*" in Chapter 2 for additional information on the "Optimize for Price?" item.

---

## Appendix B Overwrites

---

The composite beam design overwrites are basic assignments that apply only to those composite beams to which they are assigned. Default values are provided for all composite beam overwrite items. Thus, it is not required that any of the overwrites be changed. However, at least review the default values for the overwrite items to make sure they are acceptable. When changes are made to overwrite items, the program applies the changes only to the elements to which they are specifically assigned; that is, to the elements that are selected when the overwrites are changed.

### B1 Beam

Table B-1 lists the composite beam overwrite items available.

**Table B-1: Composite Beam Overwrites**

<b>Item</b>	<b>Possible Values</b>	<b>Default Value</b>	<b>Description</b>
Restrict Beam Depth?	Yes/No	No	Toggle to select if the beam depth is to be considered in an auto select section list. If yes, maximum and minimum depths must be input.
Maximum Depth	> 0	1100 mm	Maximum actual (not nominal) beam depth to be considered in an auto select section list.

**Table B-1: Composite Beam Overwrites**

Item	Possible Values	Default Value	Description
Minimum Depth	$\geq 0$	0	Minimum actual (not nominal) beam depth to be considered in auto select section list.
Restrict Beam Width?	Yes/No	No	Toggle to select if the beam width is to be considered in an auto select section list. If yes, maximum and minimum width must be input.
Maximum Depth	$> 0$	460 mm	Maximum actual beam width to be considered in an auto select section list.
Minimum Width	$\geq 0$	0	Minimum actual beam width to be considered in auto select section list.
Shored Construction?	Yes/No	No (unshored)	Toggle for shored or unshored construction.
Beam $F_y$	$\geq 0$	Specified in Material Properties	Yield stress of the beam, $F_y$ . Specifying 0 in the overwrites means that $F_y$ is as specified in the material properties
Beam $F_u$	$\geq 0$	Specified in Material Properties	Minimum tensile strength of the beam, $F_u$ . Specifying 0 means that $F_u$ is as specified in the material properties
Cover Plate Present?	Yes/No	No	Toggle switch indicating if a full length cover plate exists on the bottom of the beam bottom flange.
Plate width	$\geq 0$	0	Width of cover plate, $b_{cp}$ .
Plate thickness	$\geq 0$	0	Thickness of cover plate, $t_{cp}$ .
Plate $F_y$	$> 0$	0	Cover plate yield stress, $F_{ycp}$ . Specifying 0 means that $F_{ycp}$ is set to that specified in the beam material properties

The Shored item affects both the deflection calculations and the flexural stress calculations for the beam. See the section entitled *Beam Deflection and Camber* in Chapter 2 for a description of beam deflection. If the beam is shored, no checks are performed for the construction loading design load combination.

Typically, when a beam is designed using the Composite Beam Design post-processor that beam is designed as a composite beam if it has a deck section

(not slab section) assigned along the full length of the specified Middle Range on at least one side of the beam.

When a beam is designed as non-composite with minimum shear studs, the beam is designed as a non-composite beam. Then steel stud anchors are specified for the beam with as large a spacing as possible, without exceeding the specified maximum longitudinal spacing. The maximum longitudinal spacing can be overwritten on the Steel Stud Anchor tab.

See *Effective Width of the Concrete Slab* in Chapter 2 for a description of the beam effective width.

The beam yield stress and the cover plate yield stress both default to the yield stress specified for the material property associated with the beam section.

In this program, the cover plate can have a yield stress that is different from that of the beam, if desired. See "*Cover Plates*" in the section entitled *Composite Beam Properties* in Chapter 2 for a description of cover plates.

## B2 Bracing (C) and Bracing

Tables B-2a, B-2b, and B-2c list the composite beam overwrite items available for bracing.

**Table B-2a: First Two Composite Beam Overwrite Items**

Item	Possible Values	Default Value	Description
n factor	$\geq 0$	Program calculated	Unitless factor used in determining allowable bending stress, $n$ . This is called the slenderness correction factor. This factor modifies the slenderness to consider the effect of variation of moment along the length of the beam. This is used to calculate design buckling moment. Specifying 0 in the overwrites means that this value is program calculated
Bracing Condition	Program calculated, bracing specified or length specified	Program calculated	This item defines how the unbraced lengths are determined for buckling about the beam local 2-axis. They are program calculated, based on user-specified uniform and point bracing, or based on a user-specified maximum unbraced length.



When the  $n$  factor is program calculated, the program uses BS Table 13 to calculate it unless you have specified the Bracing Condition as Length Specified.

$$n = \frac{1}{\sqrt{C_b}} \leq 1.0.$$

$$C_b = \frac{12.5M_{\max}}{2.5M_{\max} + 3M_A + 4M_B + 3M_C}. \quad (\text{BS Table 13})$$

where,

- $M_{\max}$  = maximum factored bending moment in unbraced segment
- $M_a$  = factored bending moment at one-quarter point of unbraced segment
- $M_b$  = factored bending moment at midpoint of unbraced segment
- $M_c$  = factored bending moment at three-quarter point of unbraced segment

The numeric value of  $n$  is 1.0 for cantilever overhangs.

When the  $n$  factor is program calculated and the Bracing Condition is set in the overwrites to Length Specified, the program uses 1.0 for  $n$ .

When the Bracing Condition is specified as Program Calculated, the program assumes the beam is braced as described in *Determination of the Braced Points of a Beam* in the section entitled *Beam Unbraced Length and Design Check Locations* in Chapter 2. Note that the program automatically considers the bracing for construction loading and for the final condition separately. For the construction loading condition, the program assumes that the concrete fill does assist in bracing the beam.

When the Bracing Condition is specified as Bracing Specified, two additional items may be specified in addition to those shown in Table B-2a. The two additional items are shown in Table B-2b.

**Table B-2b: Additional Composite Beam Overwrite Items When the Bracing Condition Is Specified as Bracing Specified**

<b>Item</b>	<b>Possible Values</b>	<b>Default Value</b>	<b>Description</b>
No. Point Braces	$\geq 0$	0	The number of user specified point brace locations. Clicking in this box opens the Point Braces form, which can be used to specify point braces.
No. Uniform Braces	$\geq 0$	0	The number of user specified uniform braces. Clicking in this box opens the Uniform Braces form, which can be used to specify the uniform braces.

The No. Point Braces and No. Uniform Braces items allows specification of the actual bracing for the beam. These items are described in *User-Specified Uniform and Point Bracing in Beam Unbraced Length and Design Check* locations in Chapter 2.

When the Bracing Condition is specified as Length Specified, two items may be specified in addition to those shown in Table B2a. The two additional items are shown in Table B2c.

**Table B2c: Additional Composite Beam Overwrite Items When the Bracing Condition Is Specified as Length Specified**

<b>Item</b>	<b>Possible Values</b>	<b>Default Value</b>	<b>Description</b>
Absolute Length?	Yes/No	No	Toggle switch for whether the maximum unbraced length is given as an absolute length or a relative length.
Unbraced L22	$\geq 0$ and $\leq$ beam length	Length of beam	Maximum unbraced length for buckling about the beam local 2 axis.

When the maximum unbraced length is specified as an absolute length, the actual maximum unbraced length is specified. When the maximum unbraced length is specified as a relative length, the value specified is equal to the maximum unbraced length divided by the length of the beam. The relative length specified is always between 0 and 1, inclusive.

See *Beam Unbraced Length and Design Check Locations* for additional information about the unbraced length of the beam.

## B3 Deck

Table B-3 lists the composite beam overwrite items available for the Deck.

**Table B-3: Composite Beam Overwrites for the Deck**

Item	Possible Values	Default Value	Description
Deck ID Left	Program calculated, any defined deck property, or None	Program calculated	Deck ID assigned to left side of beam.
Deck direction Left	Program calculated, parallel, or perpendicular	Program calculated	Span direction of the metal deck ribs on the left side of the beam relative to the span direction of the beam.
b-eff left Condition	Program calculated or user-defined	Program calculated	Toggle specifying how the effective width of the concrete slab on the left side of the beam is determined
b-eff left	$\geq 0$	Program calculated	User defined effective width of the concrete slab on the left side of beam, $b_{\text{eff left}}$ .
Deck ID Right	Program calculated, any defined deck property, or None	Program calculated	Deck ID assigned to right side of beam.
Deck direction Right	Program calculated, parallel, or perpendicular	Perpendicular	Span direction of the metal deck ribs on the right side of beam relative to the span direction of beam
b-eff right Condition	Program calculated or user-defined	Program calculated	Toggle specifying how the effective width of the concrete slab on the right side of the beam is determined
b-eff right	$\geq 0$	0	User defined effective width of concrete slab on the right side of the beam, $b_{\text{eff right}}$

When the Deck ID is program calculated, the user must refer to the output data to determine what the program assumed for this item. It is not shown in the overwrites.

If the deck direction is program calculated, do not overlook the important note about deck orientation in *Multiple Deck Types or Directions Along the Beam Length* in the section *Effective Width of the Concrete Slab* in Chapter 2.

## B4 Shear Studs

Table B-4 lists the composite beam overwrite items available for the Shear Studs.

**Table B-4: Composite Beam Overwrites for the Shear Studs**

Item	Possible Values	Default Value	Description
Beam Type	Composite, NC w studs, NC w/o studs, or Force Composite	Composite	Type of beam design. NC w studs is short for Noncomposite with minimum shear studs. NC w/o studs is short for Noncomposite without shear studs. Force Composite is short for always design with composite action.
Minimum PCC (%)	> 0	40	Minimum value of percent composite connection applied to beams which require composite action to meet strength or deflection design criteria. This percentage also applies to beams for which "Force Composite" is specified.
Maximum PCC(%)	> 0	100	Maximum percent composite connection considered for the beam.
User Pattern?	Yes/No	No	Toggle to indicate if a user defined steel headed stud anchor pattern is defined.
Uniform Spacing	$\geq 0$	0, indicating there are no uniformly spaced connectors	Uniform spacing of steel headed stud anchors along the beam. There is one shear stud per row along the beam.
No. Additional Sections	$\geq 0$	0, indicating there are no additional connectors specified	Number of sections in which additional uniformly spaced steel headed stud anchors are specified. Clicking in this box opens the Additional Sections form, which can be used to specify the section length and the number of uniformly spaced steel headed anchors in the section.

**Table B-4: Composite Beam Overwrites for the Shear Studs**

Item	Possible Values	Default Value	Description
Single Segment?	Yes/No	No	Toggle for placement of steel headed stud anchors in a single segment. To place studs in a single segment with uniform spacing throughout the beam, select Yes. This factor has no effect on checking beams with user defined studs.
Max. Studs per Row	>0	3	Maximum number of shear studs in a single row across the beam flange.
$Q_k$	Program calculated or > 0	Program calculated	Capacity of a single shear stud. Specifying 0 in the overwrites means that this value is program calculated.

The program default value for the minimum longitudinal spacing of steel headed stud anchors along the length of the beam is six shear stud diameters. Note that this item is input as an absolute length, not as a multiplier on the stud diameter.

The program default value for the maximum longitudinal spacing of steel headed stud anchors along the length of the beam is 1000 mm. This item is taken as an absolute length by the program, not as a multiplier on the total slab thickness as required by the code. The code specifies that the maximum longitudinal spacing of steel headed stud anchors along the length of the beam shall not exceed eight times the total slab thickness (rib height,  $h_r$ , plus the concrete slab above the metal deck,  $t_c$ ) or 1000 mm. If the total slab thickness is less than  $1000 \text{ mm}/6 = 167 \text{ mm}$ , the program default value may be unconservative and should be revised.

The program default value for the minimum transverse spacing of steel headed stud anchors across the beam flange is four shear stud diameters. Note that this item is input as an absolute length, not as a multiplier on the stud diameter. See the section entitled *Distribution of Steel Headed Stud Anchors on a Composite Beam* in Chapter 2 for an additional description of how steel headed stud anchors are distributed on composite beams.

The “Max Studs per Row” item indicates the maximum number of steel headed stud anchors that is allowed in a row across the beam flange. For wider beams, the Min Tran Spacing item might indicate that more steel anchors could be ac-

commodated across the beam flange but the Max Studs per Row item will limit the number of studs in any row. See the section entitled *Distribution of Steel Headed Stud Anchors on a Composite Beam* in Chapter 2 for an additional description of how steel anchors are distributed on beams.

See *Steel Headed Stud Connector* in the section entitled *Steel Anchors* in Chapter 2 for a description of how the program calculates the allowable shear load for a single steel anchor. Note that when a  $Q_k$  value is specified in the overwrites, the program assumes that the specified value of  $Q_k$  has already been modified by any applicable reduction factors for the metal deck. Finally, note that specifying 0 (zero) in the overwrites for this item means that the allowable shear stud load is calculated by the program, not that it is zero.

Steel anchors are described in more detail in the sections entitled *Distribution of Steel Headed Stud Anchors on a Composite Beam*, *Number of Shear Studs that Fit in a Composite Beam Segment*, and *User Defined Shear Connector Patterns* in Chapter 2.

## B5 Deflection

Table B-5 lists the composite beam overwrite items available for Deflection.

**Table B5: Composite Beam Overwrites for Deflection**

Item	Possible Values	Default Value	Description
Deflection Check Type	Ratio, Absolute, Both	Ratio	Toggle to consider live load and total load deflection limitations as absolute or as divisor of beam length (relative).
PreComp DL Limit, L/	$\geq 0$	0	Pre-composite dead load deflection limitation denominator. Inputting a value of 120 means that the deflection limit is L/120. Inputting zero is special, since it means no check has to be made for this item.
Super DL+LL Limit, L/	$\geq 0$	240	Post-composite superimposed dead plus live load deflection limitation denominator. Inputting a value of 120 means that the deflection limit is L/120. Inputting zero is special, since it means no check has to be made for this item.

**Table B5: Composite Beam Overwrites for Deflection**

<b>Item</b>	<b>Possible Values</b>	<b>Default Value</b>	<b>Description</b>
Live Load Limit, L/	$\geq 0$	360	Live load deflection limitation denominator. Inputting a value of 360 means that the deflection limit is L/360. Inputting zero is special, since it means no check has to be made for this item.
Total Camber Limit, L/	$\geq 0$	240	Net load deflection (total deflection minus camber) limitation denominator. Inputting a value of 240 means that the deflection limit is L/240. Inputting zero is special, since it means no check has to be made for this item. Camber is subtracted from the total load deflection before checking.
PreComp DL Limit, abs	$\geq 0$	0	Deflection limitation for pre-composite dead load. For absolute deflection the input value is taken as it is. Inputting zero is special, since it means no check has to be made for this item.
Super DL+LL Limit, abs	$\geq 0$	Beam Span / 240	Deflection limitation for post-composite superimposed dead plus live load. For absolute deflection the input value is taken as it is. Inputting zero is special, since it means no check has to be made for this item.
Live Load Limit, abs	$\geq 0$	Beam Span / 360	Deflection limitation for live load. For absolute deflection the input value is taken as it is. Inputting zero is special, since it means no check has to be made for this item.
Total Camber Limit, abs	$\geq 0$	240	Net load deflection (total deflection minus camber) limitation denominator. Inputting a value of 240 means that the deflection limit is L/240. Inputting zero is special, since it means no check has to be made for this item. Camber is subtracted from the total load deflection before checking.
Calculate Camber?	Yes/No	Yes	Toggle for the program to calculate beam camber.
Fixed Camber	$\geq 0$	0	User specified camber when the program does not calculate beam camber

See the section entitled *Beam Deflection and Camber* in Chapter 2 for a description of beam deflection and camber.

## B6 Vibration

Table B6 lists the composite beam overwrite items available for Vibration.

**Table B-6: Composite Beam Overwrites for Vibration**

<b>Item</b>	<b>Possible Values</b>	<b>Default Value</b>	<b>Description</b>
Neff Condition	User Defined or Program Calculated	User Defined	Toggle to select user defined or program calculated based on beam spacing, N effective.
No. Effective Beams	$\geq 1$	1.0	Effective number of beams resisting a heel drop impact.
Beam Spacing	$> 0$	2500	Beam spacing used to calculate number of effective beams.

See the section entitled *Floor Vibration* in Chapter 2 for a description of beam vibration.



---

## Bibliography

---

- Allen, D. E. and Murray, T. M., 1993, "Design Criterion for Vibrations due to Walking," *Engineering Journal*, 4th Qtr, AISC, pp. 117-129.
- Allen, D.E., J.H. Rainer, and G. Pernica. 1979. Vibration Criteria for Long Span Concrete Floors. *Vibrations of Concrete Structures*. Publication SP-60. American Concrete Institute. Detroit, MI.
- Allen, D. E., and J.H. Rainer. 1976. Vibration Criteria for Long Span Floors. *Canadian Journal of Civil Engineering*. Vol. 3, No.2. June.
- Allen, D.L. 1974. Vibrational Behavior of Long Span Floor Slabs. *Canadian Journal of Civil Engineering*. Vol. 1, No. 1. September.
- Boresi, A. P., 1985. *Advanced Mechanics of Materials*, John Wiley & Sons, Inc. ISBN 0-471-88392-1.
- British Standard Institution (BSI). 1990a. *British Standard Structural Use of Steelwork in Buildings. Part 1. Code of Practice for Design of Simple and Continuous Construction: Hot Rolled Sections*. 389 Chiswick High Road, London, U.K. W4 4AL.

- British Standard Institution (BSI). 1990b. British Standard Structural Use of Steelwork in Buildings. Part 3. Design in Composite Construction, Section 3.1 Code of Practice for Design of Simple and Continuous Composite Beams. 389 Chiswick High Road, London, U.K. W4 4AL.
- Murray, T.M. 1991. Building Floor Vibrations. *Engineering Journal*. American Institute of Steel Construction, Inc. Vol. 28, No. 3.
- Murray, T.M. 1981. Acceptability Criterion for Occupant-Induced Floor Vibrations. *Engineering Journal*. American Institute of Steel Construction, Inc. Vol. 18, No. 2.
- Murray, T.M. 1975. Design to Prevent Floor Vibration. *Engineering Journal*. American Institute of Steel Construction, Inc. Vol. 12, No. 3.
- Murray, T. M., Allen, D. E. and Unger, E. E., 1997, "Floor Vibrations due to Human Activity," AISC Steel Design Guide Series 11.
- Murray, T.M. and W.E. Hendrick. 1977. Floor Vibrations and Cantilevered Construction. *Engineering Journal*. American Steel Institute of Steel Construction, Inc. Vol. 14, No. 3.
- Naeim, F. 1991. Design Practice to Prevent Floor Vibration. *Steel Tips, Technical Information & Product Service*. Structural Steel Educational Council. September.
- Vogel, R. 1991. "LRFD-Composite Beam Design with Metal Deck," *Steel Tips, Technical Information & Product Service*, Steel Committee of California, March.