

Command Control Interface

01-46-03/02

User and Reference Guide

This document describes and provides instructions for using the Command Control Interface (CCI) software to configure and perform operations on the Hitachi RAID storage systems.

© 2018 Hitachi, Ltd. All rights reserved.

No part of this publication may be reproduced or transmitted in any form or by any means, electronic or mechanical, including copying and recording, or stored in a database or retrieval system for commercial purposes without the express written permission of Hitachi, Ltd., or Hitachi Vantara Corporation (collectively "Hitachi"). Licensee may make copies of the Materials provided that any such copy is: (i) created as an essential step in utilization of the Software as licensed and is used in no other manner; or (ii) used for archival purposes. Licensee may not make any other copies of the Materials. "Materials" mean text, data, photographs, graphics, audio, video and documents.

Hitachi reserves the right to make changes to this Material at any time without notice and assumes no responsibility for its use. The Materials contain the most current information available at the time of publication.

Some of the features described in the Materials might not be currently available. Refer to the most recent product announcement for information about feature and product availability, or contact Hitachi Vantara Corporation at https://support.hitachivantara.com/en_us/contact-us.html.

Notice: Hitachi products and services can be ordered only under the terms and conditions of the applicable Hitachi agreements. The use of Hitachi products is governed by the terms of your agreements with Hitachi Vantara Corporation.

By using this software, you agree that you are responsible for:

1. Acquiring the relevant consents as may be required under local privacy laws or otherwise from authorized employees and other individuals; and
2. Verifying that your data continues to be held, retrieved, deleted, or otherwise processed in accordance with relevant laws.

Notice on Export Controls. The technical data and technology inherent in this Document may be subject to U.S. export control laws, including the U.S. Export Administration Act and its associated regulations, and may be subject to export or import regulations in other countries. Reader agrees to comply strictly with all such regulations and acknowledges that Reader has the responsibility to obtain licenses to export, re-export, or import the Document and any Compliant Products.

Hitachi is a registered trademark of Hitachi, Ltd., in the United States and other countries.

AIX, AS/400e, DB2, Domino, DS6000, DS8000, Enterprise Storage Server, eServer, FICON, FlashCopy, IBM, Lotus, MVS, OS/390, PowerPC, RS/6000, S/390, System z9, System z10, Tivoli, z/OS, z9, z10, z13, z/VM, and z/VSE are registered trademarks or trademarks of International Business Machines Corporation.

Active Directory, ActiveX, Bing, Excel, Hyper-V, Internet Explorer, the Internet Explorer logo, Microsoft, the Microsoft Corporate Logo, MS-DOS, Outlook, PowerPoint, SharePoint, Silverlight, SmartScreen, SQL Server, Visual Basic, Visual C++, Visual Studio, Windows, the Windows logo, Windows Azure, Windows PowerShell, Windows Server, the Windows start button, and Windows Vista are registered trademarks or trademarks of Microsoft Corporation. Microsoft product screen shots are reprinted with permission from Microsoft Corporation.

All other trademarks, service marks, and company names in this document or website are properties of their respective owners.

Contents

Preface	xiv
Intended audience.....	xiv
Product version.....	xiv
Release notes.....	xiv
Changes in this revision.....	xv
Referenced documents.....	xv
Document conventions.....	xvi
Conventions for storage capacity values.....	xix
Accessing product documentation.....	xx
Getting help.....	xx
Comments.....	xx
Chapter 1: Overview	21
About Command Control Interface.....	21
CCI functions.....	22
CCI functions matrix.....	22
Provisioning functions.....	23
Asynchronous command processing.....	23
Command execution modes.....	23
Precheck function.....	24
Command execution by the in-band and out-of-band methods.....	26
User authentication mode.....	28
LDEV nickname function.....	28
LDEV grouping function.....	28
Resource group function.....	29
Resource locking function.....	29
CCI functions available on all RAID storage systems.....	29
In-system replication.....	29

Remote replication.....	30
Data protection.....	30
Chapter 2: CCI software environment.....	31
Overview of the CCI software environment.....	31
CCI components on the RAID storage system.....	32
Command device.....	32
Command device guarding.....	33
Alternate command device function.....	35
Remote command device.....	36
CCI and the SCSI command interface.....	37
Command competition.....	38
Command flow.....	38
Issuing commands for LDEVs within a LUSE device.....	38
CCI instance components on the host server.....	39
HORCM operational environment.....	39
CCI instance configurations.....	40
Host machines that can be paired.....	42
Configuration definition file.....	43
Configuration definition file settings.....	47
HORCM_MON.....	47
HORCM_CMD (in-band method).....	48
HORCM_CMD (out-of-band method).....	53
HORCM_DEV.....	56
HORCM_INST.....	59
HORCM_LDEV.....	60
HORCM_LDEVG.....	61
HORCM_INSTP.....	62
HORCM_ALLOW_INST.....	62
Correspondence of the configuration definition file for cascading volume and mirror descriptors.....	63
Correspondence of configuration file and mirror descriptors.....	63
Cascading connection and configuration files.....	67
ShadowImage.....	68

Cascading connections for TrueCopy and ShadowImage.....	69
CCI software files.....	72
CCI files supplied with the software.....	72
CCI files for UNIX-based systems.....	72
CCI files for Windows-based systems.....	74
CCI files for OpenVMS-based systems.....	77
CCI log and trace files.....	79
CCI log files.....	79
CCI trace files.....	82
CCI trace control command.....	82
Command logging for audit.....	82
Logging other than raidcom command.....	83
Logging raidcom command.....	85
User-created files.....	88
User environment variable.....	89

Chapter 3: CCI functions..... 90

System configuration using CCI.....	90
In-band system configurations and out-of-band system configurations.....	90
System configuration for connecting to a CCI server connected by the in-band method using the out-of-band method.....	92
Connecting to CCI server already connected by In-Band method using Out-of-Band method.....	93
Hardware requirements.....	94
I/O Traffic Control.....	94
Security setting.....	95
User authentication.....	96
Command operation authority and user authentication.....	97
Controlling User Role.....	97
Controlling user resources.....	98
Commands executed depending on operation authorities.....	101
Relation between resource groups and command operations.....	111
Resource lock function.....	115
Command execution modes.....	116

Overview.....	116
Context check.....	118
Checking contents before executing scripts.....	118
Details of check contents.....	118
Configuration check.....	125
Resource location and parameter.....	125
MP blade location and parameter.....	125
LDEV grouping function.....	127
Overview.....	127
Device group definition methods.....	130
Read operations and command device settings.....	130
Defining device groups.....	132
Creating device groups.....	133
Adding LDEVs to device groups.....	133
Deleting LDEVs from device groups.....	134
Deleting device groups.....	135
Copy group function.....	136
Creating copy groups.....	137
Adding LDEVs to copy groups.....	138
Deleting LDEVs from copy groups.....	139
Deleting copy groups.....	140
Pair operation by specifying a copy group.....	141
Pair operations with mainframe volumes.....	143
Using "dummy" LUs for mainframe LDEVs.....	143
Pair status and access permission for mainframe LDEVs.....	144
Operational differences for multiplatform volumes.....	147
Operational differences for replication commands.....	147
Global storage virtualization function.....	149
System configuration example with the global storage virtualization function.....	150
Using CCI with the global storage virtualization function.....	150
Configuration definition file settings with global storage virtualization.....	152
Example of the configuration definition files when specifying a virtual storage machine by HORCM_CMD.....	153

Specifying a virtual storage machine to HORCM_VCMD.....	155
Command operations to virtual storage machines.....	155
Operation target for <code>raidcom</code> commands when specifying the virtual storage machine in HORCM_VCMD.....	159
<code>raidcom</code> commands for volumes that belong to virtual storage machine for HORCM_CMD.....	167
Chapter 4: Starting up CCI.....	168
Starting up on UNIX systems.....	168
Starting up one instance of CCI on a UNIX system.....	168
Starting up two instances of CCI on a UNIX system.....	168
Starting up on Windows systems.....	169
Starting up one instance of CCI on a Windows system.....	169
Starting up two instances of CCI on a Windows system.....	170
Starting up on OpenVMS systems.....	170
Starting up one instance of CCI on an OpenVMS system.....	170
Starting up two instances of CCI on an OpenVMS system.....	171
Starting CCI as a service (Windows systems).....	172
Chapter 5: Provisioning operations with CCI.....	175
About provisioning operations.....	175
Overview of the configuration setting command.....	175
Synchronous command processing.....	176
Asynchronous command processing.....	176
Errors during asynchronous command processing.....	176
Workflow for executing asynchronous commands.....	177
Asynchronous commands.....	177
Help on configuration setting commands.....	180
LDEV nickname function.....	180
Available provisioning operations.....	180
Provisioning operations that can be performed on device groups.....	189
Operation method.....	190
Workflow for performing provisioning operations.....	192
Resource group operations.....	193
Creating resource groups.....	193

Deleting resource groups.....	194
Allocating resources to other resource groups.....	195
Execution example for registering LDEVs to the pools as device groups.	196
Internal volume operations.....	197
Creating internal volumes (open volumes).....	197
Script examples for internal volume operation (open volumes).....	199
Creating internal volumes (mainframe volumes).....	202
Script examples of internal volume (mainframe volumes) operations..	203
Virtual volume (Dynamic Provisioning) operations.....	204
Creating virtual volumes (Dynamic Provisioning).....	204
Script examples of virtual volume (Dynamic Provisioning) operation.....	207
Deleting a virtual volume for which capacity saving is enabled.....	209
Using the <code>-operation initialize_capacity_saving</code> option of the <code>raidcom delete ldev</code> command to delete a virtual volume.	209
Deleting a virtual volume by blocking, initializing, and then deleting the volume.....	210
Virtual volume (Dynamic Provisioning for Mainframe) operations.....	211
Creating virtual volumes (Dynamic Provisioning for Mainframe).....	211
Script examples of virtual volume (Dynamic Provisioning for Mainframe) operation.....	213
Virtual volume (Dynamic Tiering) operations.....	215
Operational flow.....	215
Creating virtual volumes (Dynamic Tiering).....	216
Script examples of virtual volume (Dynamic Tiering) operation.....	219
Configuring iSCSI virtual ports.....	222
Setting an iSCSI virtual port.....	222
Deleting an iSCSI virtual port.....	223
External volume operations.....	224
Creating external volumes (Fibre Channel).....	224
Creating external volumes (iSCSI).....	227
Script examples of external volume operations.....	232
Virtual Partition Manager operations.....	235
Performing Virtual Partition Manager operations.....	235

Displaying CLPR information.....	236
Migrating parity groups in a CLPR.....	236
Displaying parity group information.....	236
Moving parity groups.....	237
Checking result of CLPR transfer.....	237
Server Priority Manager operations.....	238
Configuring Server Priority Manager by specifying ports and WWNs of HBAs.....	238
Controlling the priority of I/O operations in storage systems on servers.....	239
Using and managing Server Priority Manager.....	239
Setting SPM names for WWNs and registering them to the SPM group.....	240
Configuring Server Priority Manager by specifying ports and WWNs of HBAs.....	241
Controlling server performance when the host group is not registered in the SPM group.....	241
Controlling server performance when the host group is registered in the SPM group (VSP only).....	243
Displaying the WWN of host bus adapters.....	245
Setting the priority on host bus adapters.....	245
Displaying the status of the prioritized WWN and the non-prioritized WWN settings.....	246
Setting SPM names for host bus adapters.....	247
Grouping multiple host bus adapters into one group.....	247
Obtaining monitoring information of the prioritized WWN and the non-prioritized WWN.....	247
Stopping performance control of server by using SPM function.....	248
Cautions about using Server Priority Manager.....	248
Cautions when using host groups after registering them in SPM groups (VSP only).....	251
Configuring Server Priority Manager by specifying LDEVs and WWNs or iSCSI names of HBAs.....	252
Virtual storage machine operations.....	255
Creating host groups in a virtual storage machine.....	255
Adding LDEVs to a virtual storage machine.....	256

Removing the virtual storage machine.....	256
Chapter 6: Data replication operations with CCI.....	259
About data replication operations.....	259
Features of paired volumes.....	260
Using CCI with ShadowImage and TrueCopy.....	261
Using CCI with Thin Image.....	261
Using CCI with global-active device.....	262
ShadowImage operations.....	262
ShadowImage duplicated mirroring.....	263
ShadowImage cascading pairs.....	264
Restrictions for ShadowImage cascading volumes.....	265
Restriction for TrueCopy/ShadowImage cascading volumes.....	266
TrueCopy operations.....	266
TrueCopy takeover commands.....	267
Takeover-switch function.....	269
Swap-takeover function.....	270
SVOL-takeover function.....	271
PVOL-takeover function.....	272
TrueCopy remote commands.....	273
TrueCopy local commands.....	274
TrueCopy, ShadowImage, and Universal Replicator operations.....	275
TrueCopy/ShadowImage volumes.....	275
TrueCopy/ShadowImage/Universal Replicator pair status.....	276
TrueCopy Async, TrueCopy Sync, Universal Replicator, and global-active device volumes.....	284
TrueCopy Async and Universal Replicator volume characteristics.....	286
Sidefile cache for TrueCopy Async.....	287
TrueCopy Async transition states and sidefile control.....	287
TrueCopy Async/Universal Replicator error state.....	290
TrueCopy Sync/TrueCopy Async and Universal Replicator/global-active device fence level settings.....	290
Setting the fence level.....	292
Copy-on-Write Snapshot operations.....	293

Copy-on-Write Snapshot volumes.....	294
Pair operations and commands for Copy-on-Write Snapshot and Thin Image.....	294
Creating a Copy-on-Write Snapshot pair.....	295
Copy-on-Write Snapshot pair status.....	295
Pair status relationship to Copy-on-Write Snapshot commands.....	296
Controlling Volume Migration.....	297
Specifications for Volume Migration.....	298
Commands to control Volume Migration.....	299
Relations between "cc" command issues and migration volume status.....	304
Restrictions for Volume Migration.....	305
Universal Replicator MxN configuration and control.....	305
Overview.....	305
Policy.....	306
Configuration definition file (horcm.conf).....	307
Command specifications.....	308
pairedisplay command.....	308
pairsplit command.....	309
Notice on system operation.....	311
Configuration examples.....	314
Duplication of CCI applications.....	315
Requirements for duplication of CCI.....	318
Note for duplication of CCI.....	319
Remote volume discovery.....	319
Discovering a remote volume.....	320
Import method by the startup of CCI (horcmstart.sh) on the remote host.....	321
Chapter 7: Data protection operations with CCI.....	323
Data protection operations.....	323
Data Retention Utility.....	323
Restrictions on Data Retention Utility volumes.....	324
Database Validator.....	325
Restrictions on Database Validator.....	325

Protection parameters and operations.....	326
Data Protection facility.....	327
Data Protection Facility specifications.....	328
Examples for configuration and protected volumes.....	329
Operation authority with CMD security enabled.....	331
Target commands for protection.....	332
permission command.....	332
New options for security.....	333
raidscan -find inst.....	333
raidscan -find verify [MU#].....	333
raidscan -f[d].....	334
pairedisplay -f[d].....	334
Permitting protected volumes.....	335
With a \$HORCMPerm file.....	335
Without a \$HORCMPerm file: Commands to run on different operating systems.....	337
Environment variables.....	338
\$HORCMPROMOD.....	338
\$HORCMPerm.....	338
Determining the protection mode command device.....	338
Chapter 8: Examples of using CCI commands	340
Group version control for mixed storage system configurations.....	340
LDM volume discovery and flushing for Windows.....	341
Volume discovery function.....	341
Mountvol attached to Windows 2012/2008/2003/2000 systems.....	344
System buffer flushing function.....	344
Special facilities for Windows systems.....	348
Signature changing facility for Windows systems.....	348
GPT disk for Windows.....	351
Directory mount facility for Windows systems.....	352
Host group control.....	355
Specifying a host group.....	355
Commands and options including a host group.....	356

Using CCI SLPR security.....	357
Specifying the SLPR protection facility.....	358
SLPR configuration examples.....	359
Single host.....	359
Dual Hosts.....	360
Chapter 9: Troubleshooting.....	363
General troubleshooting.....	363
Operational notes and restrictions for CCI operations.....	366
Error messages and error codes.....	370
System log messages.....	370
Command error messages	372
Generic error codes (horctakeover and pair commands).....	390
Generic error codes (raidscan, raidqry, raidar, horcctl).....	392
Specific error codes.....	393
SSB codes.....	395
SSB codes returned by the replication commands.....	395
SSB codes returned by the configuration setting command (raidcom). 397	
Other SSB codes indicating internal errors.....	628
Calling customer support.....	630
Glossary.....	631
Index.....	632

Preface

This document describes and provides instructions for using the Command Control Interface (CCI) software to configure and perform operations on RAID storage systems.

Please read this document carefully to understand how to use these products, and maintain a copy for your reference.

Intended audience

This document is intended for system administrators, Hitachi Vantara representatives, and authorized service providers who install, configure, and operate Hitachi Vantara RAID storage systems.

Readers of this document should be familiar with the following:

- Data processing and RAID storage systems and their basic functions.
- The Hitachi Vantara RAID storage system and the manual for the storage system (for example, *Hardware Guide for Hitachi Virtual Storage Platform G1000, G1500, and F1500*, *Hitachi Virtual Storage Platform User and Reference Guide*)
- The management software for the storage system (for example, Hitachi Command Suite, Hitachi Device Manager - Storage Navigator) and the applicable user manuals (for example, *Hitachi Command Suite User Guide* and *System Administrator Guide*).
- The host systems attached to the Hitachi Vantara RAID storage system.

Product version

This document revision applies to CCI version 01-46-03/02 or later.

Release notes

Read the release notes before installing and using this product. They may contain requirements or restrictions that are not fully described in this document or updates or corrections to this document. Release notes are available on Hitachi Vantara Support Connect: <https://knowledge.hitachivantara.com/Documents>.

Changes in this revision

- Updated the description of the resource lock function ([Resource lock function \(on page 115\)](#)).
- Updated the description of the suspending/deleting status for Universal Replicator MxN configurations ([Notice on system operation \(on page 311\)](#)).
- Updated the error code tables.

Referenced documents

Referenced documents

Command Control Interface documents:

- *Command Control Interface Installation and Configuration Guide*, MK-90RD7008
- *Command Control Interface User and Reference Guide*, MK-90RD7010

Hitachi Command Suite documents:

- *Hitachi Command Suite User Guide*, MK-90HC172

Hitachi Virtual Storage Platform F series and G series documents:

- *Hitachi Thin Image User Guide*, MK-92RD8011
- *Provisioning Guide*, MK-94HM8014
- *Provisioning Guide for Open Systems*, MK-92RD8014
- *System Administrator Guide*, MK-94HM8016
- *System Administrator Guide*, MK-92RD8016
- *Hitachi Device Manager - Storage Navigator Messages*, MK-94HM8017
- *Hitachi Device Manager - Storage Navigator Messages*, MK-92RD8017
- *Hitachi TrueCopy® User Guide*, MK-92RD8019
- *Hitachi ShadowImage® User Guide*, MK-92RD8021
- *Hitachi Universal Replicator User Guide*, MK-92RD8023
- *Hitachi Universal Volume Manager User Guide*, MK-92RD8024
- *Global-Active Device User Guide*, MK-92RD8072

Hitachi Unified Storage VM documents:

- *Provisioning Guide*, MK-92HM7012
- *Hitachi ShadowImage® User Guide*, MK-92HM7013
- *System Administrator Guide*, MK-92HM7016
- *Hitachi Device Manager - Storage Navigator Messages*, MK-92HM7017
- *Hitachi TrueCopy® User Guide*, MK-92HM7018
- *Hitachi Universal Replicator User Guide*, MK-92HM7019
- *Hitachi Universal Volume Manager User Guide*, MK-92HM7020

Hitachi Virtual Storage Platform documents:

- *Hitachi Copy-on-Write Snapshot User Guide*, MK-90RD7013
- *Provisioning Guide for Mainframe Systems*, MK-90RD7021
- *Provisioning Guide for Open Systems*, MK-90RD7022
- *Hitachi ShadowImage® for Mainframe User Guide*, MK-90RD7023
- *Hitachi ShadowImage® User Guide*, MK-90RD7024
- *Hitachi Storage Navigator User Guide*, MK-90RD7027
- *Hitachi Storage Navigator Messages*, MK-90RD7028
- *Hitachi TrueCopy® User Guide*, MK-90RD7029
- *Hitachi TrueCopy® for Mainframe User Guide*, MK-90RD7030
- *Hitachi Universal Replicator for Mainframe User Guide*, MK-90RD7031
- *Hitachi Universal Replicator User Guide*, MK-90RD7032
- *Hitachi Universal Volume Manager User Guide*, MK-90RD7033
- *Hitachi Thin Image User Guide*, MK-90RD7179

Document conventions

This document uses the following storage system terminology conventions:

Convention	Description
Hitachi Virtual Storage Platform family (VSP family)	Refers to the following storage systems: <ul style="list-style-type: none"> ▪ Hitachi Virtual Storage Platform ▪ Hitachi Virtual Storage Platform G1x00 ▪ Hitachi Virtual Storage Platform F1500 ▪ Hitachi Virtual Storage Platform G200 ▪ Hitachi Virtual Storage Platform G400



Convention	Description
	<ul style="list-style-type: none"> ▪ Hitachi Virtual Storage Platform G600 ▪ Hitachi Virtual Storage Platform G800 ▪ Hitachi Virtual Storage Platform F400 ▪ Hitachi Virtual Storage Platform F600 ▪ Hitachi Virtual Storage Platform F800
VSP G series	<p>Refers to the following storage systems:</p> <ul style="list-style-type: none"> ▪ Hitachi Virtual Storage Platform G1x00 ▪ Hitachi Virtual Storage Platform G200 ▪ Hitachi Virtual Storage Platform G400 ▪ Hitachi Virtual Storage Platform G600 ▪ Hitachi Virtual Storage Platform G800
VSP F series	<p>Refers to the following storage systems:</p> <ul style="list-style-type: none"> ▪ Hitachi Virtual Storage Platform F1500 ▪ Hitachi Virtual Storage Platform F400 ▪ Hitachi Virtual Storage Platform F600 ▪ Hitachi Virtual Storage Platform F800
VSP Gx00 models	<p>Refers to all of the following models, unless otherwise noted.</p> <ul style="list-style-type: none"> ▪ Hitachi Virtual Storage Platform G200 ▪ Hitachi Virtual Storage Platform G400 ▪ Hitachi Virtual Storage Platform G600 ▪ Hitachi Virtual Storage Platform G800
VSP Fx00 models	<p>Refers to all of the following models, unless otherwise noted.</p> <ul style="list-style-type: none"> ▪ Hitachi Virtual Storage Platform F400 ▪ Hitachi Virtual Storage Platform F600 ▪ Hitachi Virtual Storage Platform F800

This document uses the following typographic conventions:

Convention	Description
Bold	<ul style="list-style-type: none"> Indicates text in a window, including window titles, menus, menu options, buttons, fields, and labels. Example: Click OK. Indicates emphasized words in list items.
<i>Italic</i>	<ul style="list-style-type: none"> Indicates a document title or emphasized words in text. Indicates a variable, which is a placeholder for actual text provided by the user or for output by the system. Example: <pre>pairdisplay -g group</pre> <p>(For exceptions to this convention for variables, see the entry for angle brackets.)</p>
Monospace	Indicates text that is displayed on screen or entered by the user. Example: <code>pairdisplay -g oradb</code>
< > angle brackets	Indicates variables in the following scenarios: <ul style="list-style-type: none"> Variables are not clearly separated from the surrounding text or from other variables. Example: <pre>Status-<report-name><file-version>.csv</pre> Variables in headings.
[] square brackets	Indicates optional values. Example: [a b] indicates that you can choose a, b, or nothing.
{ } braces	Indicates required or expected values. Example: { a b } indicates that you must choose either a or b.
vertical bar	Indicates that you have a choice between two or more options or arguments. Examples: [a b] indicates that you can choose a, b, or nothing. { a b } indicates that you must choose either a or b.

This document uses the following icons to draw attention to information:

Icon	Label	Description
	Note	Calls attention to important or additional information.

Icon	Label	Description
	Tip	Provides helpful information, guidelines, or suggestions for performing tasks more effectively.
	Caution	Warns the user of adverse conditions and/or consequences (for example, disruptive operations, data loss, or a system crash).
	WARNING	Warns the user of a hazardous situation which, if not avoided, could result in death or serious injury.

Conventions for storage capacity values

Physical storage capacity values (for example, disk drive capacity) are calculated based on the following values:

Physical capacity unit	Value
1 kilobyte (KB)	1,000 (10^3) bytes
1 megabyte (MB)	1,000 KB or $1,000^2$ bytes
1 gigabyte (GB)	1,000 MB or $1,000^3$ bytes
1 terabyte (TB)	1,000 GB or $1,000^4$ bytes
1 petabyte (PB)	1,000 TB or $1,000^5$ bytes
1 exabyte (EB)	1,000 PB or $1,000^6$ bytes

Logical capacity values (for example, logical device capacity, cache memory capacity) are calculated based on the following values:

Logical capacity unit	Value
1 block	512 bytes
1 cylinder	Mainframe: 870 KB Open-systems: <ul style="list-style-type: none"> ▪ OPEN-V: 960 KB ▪ Others: 720 KB
1 KB	$1,024 (2^{10})$ bytes

Logical capacity unit	Value
1 MB	1,024 KB or 1,024 ² bytes
1 GB	1,024 MB or 1,024 ³ bytes
1 TB	1,024 GB or 1,024 ⁴ bytes
1 PB	1,024 TB or 1,024 ⁵ bytes
1 EB	1,024 PB or 1,024 ⁶ bytes

Accessing product documentation

Product user documentation is available on Hitachi Vantara Support Connect: <https://knowledge.hitachivantara.com/Documents>. Check this site for the most current documentation, including important updates that may have been made after the release of the product.

Getting help

[Hitachi Vantara Support Connect](#) is the destination for technical support of products and solutions sold by Hitachi Vantara. To contact technical support, log on to Hitachi Vantara Support Connect for contact information: https://support.hitachivantara.com/en_us/contact-us.html.

[Hitachi Vantara Community](#) is a global online community for Hitachi Vantara customers, partners, independent software vendors, employees, and prospects. It is the destination to get answers, discover insights, and make connections. **Join the conversation today!** Go to community.hitachivantara.com, register, and complete your profile.

Comments

Please send us your comments on this document to doc.comments@hitachivantara.com. Include the document title and number, including the revision level (for example, -07), and refer to specific sections and paragraphs whenever possible. All comments become the property of Hitachi Vantara Corporation.

Thank you!

Chapter 1: Overview

This chapter provides an overview of the Command Control Interface (CCI) software and CCI operations on the Hitachi RAID storage systems.

About Command Control Interface

The Command Control Interface software enables you to perform storage system configuration and data management operations by issuing commands to the RAID storage systems:

- Hitachi Virtual Storage Platform G200, G400, G600, G800
- Hitachi Virtual Storage Platform F400, F600, F800
- Hitachi Virtual Storage Platform F1500 (VSP F1500)
- Hitachi Unified Storage VM (HUS VM)
- Hitachi Virtual Storage Platform (VSP)
- Hitachi Universal Storage Platform V/VM (USP V/VM)
- Hitachi TagmaStore[®] Universal Storage Platform (TagmaStore USP)
- Hitachi TagmaStore[®] Network Storage Controller (TagmaStore NSC)

CCI continues to provide the proven functionality that has been available for the USP V/VM and previous storage system models, including in-system replication, remote replication, and data protection operations.

In addition, CCI for VSP and later provides command-line access to the same provisioning and storage management operations that are available in the GUI software (for example, Hitachi Command Suite, Storage Navigator). CCI commands can be used interactively or in scripts to automate and standardize storage administration functions, thereby simplifying the job of the storage administrator and reducing administration costs.



Note: If a storage system rejects CCI commands, verify the software licenses for the storage system (for example, TrueCopy) and the status of the software product and storage system.

CCI functions

CCI functions matrix

The following table lists and describes the CCI functions available on the RAID storage systems.

Function	Storage system					
	TagmaStore USP/ TagmaStore NSC	USP V/VM	VSP	HUS VM	VSP G1x00 VSP F1500	VSP Gx00 models, VSP Fx00 models
Local copy (open)	Yes	Yes	Yes	Yes	Yes	Yes
Local copy (mainframe)	No	No	Yes*	No	Yes	No
Remote copy (open)	Yes	Yes	Yes	Yes	Yes	Yes
Remote copy (mainframe)	No	No	Yes*	No	Yes	No
Data protection	Yes	Yes	Yes	Yes	Yes	Yes
VSS configuration	Yes	Yes	Yes	Yes	Yes	Yes
SRM SRA	Yes	Yes	Yes	Yes	Yes	Yes
Provisioning (raidcom)	No	No	Yes	Yes	Yes	Yes
Out-of-band method	No	No	Yes	Yes	Yes	Yes
User authentication	No	No	Yes	Yes	Yes	Yes
LDEV nickname	No	No	Yes	Yes	Yes	Yes
LDEV group	No	No	Yes	Yes	Yes	Yes
Resource group	No	No	Yes	Yes	Yes	Yes
Resource lock	No	No	Yes	Yes	Yes	Yes
*If DKCMAIN microcode version of the VSP storage system is 70-03-3x-xx/xx or later, the operation of TrueCopy for Mainframe, Universal Replicator for Mainframe, and ShadowImage for Mainframe can be performed from Command Control Interface.						

Provisioning functions

The **raidcom** configuration setting command enables you to perform provisioning functions, such as setting commands or creating LDEVs, from CCI. For information about the configuration setting command (**raidcom** command), see [Provisioning operations with CCI \(on page 175\)](#).

Asynchronous command processing

For the **raidcom** configuration setting commands, asynchronous command processing is used for operations that take time to process on the storage system. Once an asynchronous command has been issued, you can execute additional commands without having to wait for the asynchronous command to complete. You can also monitor the completion status of asynchronous commands by using a status reference command (for example, **raidcom get command_status**).

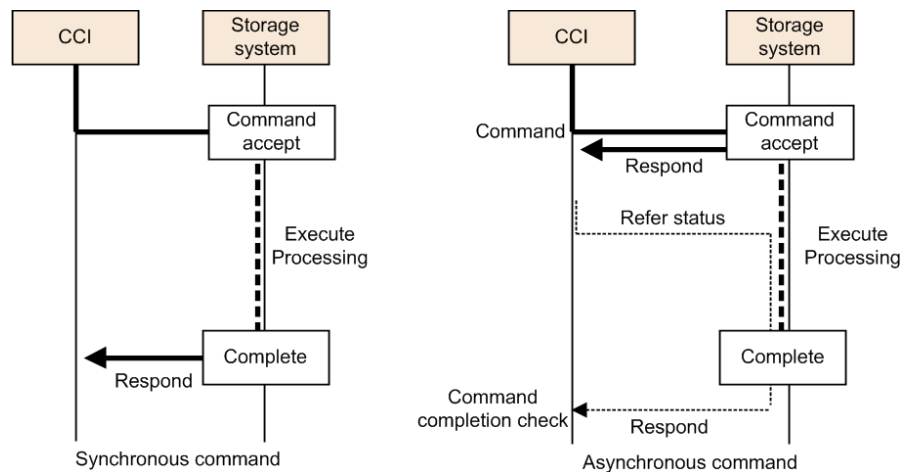

Command execution modes

CCI provides two command execution modes:

- Transaction mode, in which a script file is specified with the `-zt` option
- Line-by-line mode, in which commands are executed row-by-row for the configuration setting (**raidcom**) commands

You can use transaction mode to execute the following checking:

- **Context check:** This check is executed when a script file is specified by `-zt` option. It checks the context of preceding commands and determines whether a subsequent command can be executed.

Specifying example:

```
raidcom -zt <script_file>
```

- **Configuration check:** This check verifies that the actual storage system configuration is valid (implemented) for the resources specified in the commands (for example, LDEVs, ports, pools).

Syntax example:

```
raidcom get ldev -ldev_id -cnt 65280 -store<work_file>
```

```
raidcom -zt <script_file> -load<work_file>
```

Precheck function

CCI provides a precheck function for the configuration setting (**raidcom**) commands that checks the command before it is executed.

In earlier versions of CCI, an error was returned when the syntax of a command to be executed was not correct. The precheck function checks the command syntax before the command is executed. To use the precheck function, specify either the `-checkmode precheck` option or the `-zt` option.

The following table shows the summary of the checking function combinations between the precheck function and the transaction mode.

Command syntax	Syntax check	Context check	Config check	Execution
<code>raidcom <command></code>	Execute	Not execute	Not execute	Executed
<code>raidcom <command> -checkmode precheck</code>	Execute	Not execute	Not execute	Not executed
<code>raidcom -zt <script file></code>	Execute	Execute	Not execute	Executed

Command syntax	Syntax check	Context check	Config check	Execution
<pre>raidcom get ldev -ldev_id -cnt 65280 -store<work_file></pre>	Executed	Executed	Executed	Executed
<pre>raidcom -zt <script_file> -load <work_file></pre>				
<pre>raidcom -zt <script file> -checkmode precheck</pre>	Executed	Executed	Not executed	Not executed
<pre>raidcom get ldev -ldev_id -cnt 65280 -store<work_file></pre>	Executed	Executed	Executed	Not executed
<pre>raidcom -zt <script_file> -load <work_file> -checkmode precheck</pre>				

Command execution by the in-band and out-of-band methods

The two methods for issuing commands from a host are the in-band method and the out-of-band method:

- **In-band method:**

The method issues a command from a UNIX/PC host connected directly to a storage system via Fibre Channel or iSCSI. Older CCI versions (that do not support VSP) can only issue commands by using the in-band method. In this method, when a command is issued, it is sent to the dedicated LDEV (command device) of the storage system selected by the user via Fibre Channel or iSCSI from CCI on the host.

- **Out-of-band method:**

This method issues commands from a UNIX/PC host connected to the storage system via LAN. As shown in the following figure, CCI supporting VSP and later models can issue commands using the out-of-band method. Client PCs that are not connected directly to storage systems can execute the same scripts as the in-band method.

When a command is issued by using the out-of-band method, the command is sent to a virtual command device via LAN from CCI on the host. Virtual command devices are created when a command is executed using the out-of-band method. A virtual command device can be created by specifying the location to create a virtual command device in the configuration definition file. For details on how to create command devices, see HORCM_CMD (out-of-band method). Note, however, that the location you can create virtual command devices varies depending on the storage system models. For details about the location, see System configuration using CCI.



Note: If many commands are issued in a short period of time by using the out-of-band method, for example issuing commands in a configuration with VMware Site Recovery Manager (SRM), or from scripts, the command response might slow. In this case, issuing commands by using the in-band method is recommended.



Tip: For older versions of CCI that do not support VSP, if you want to issue a command from a client PC which is not connected to a storage system directly, you must write a remote shell script which is executed by your logging in to the CCI server of the in-band method via Telnet or SSH.

The following figure illustrates in-band and out-of-band CCI operations. For details about the in-band and out-of-band system configurations, see System configuration using CCI.

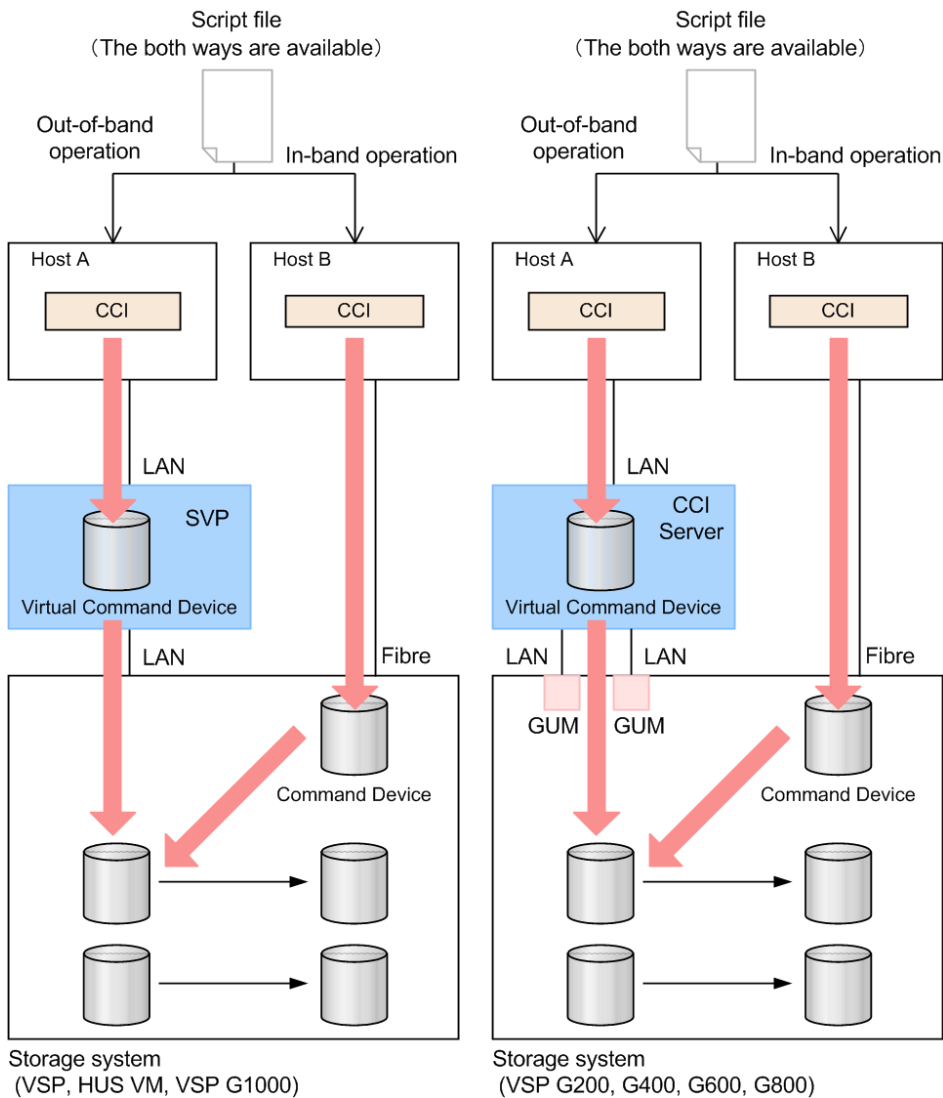

The following table provides a comparison of in-band and out-of-band operations.

Route	Command	Specification
In-band	Replication	The requirement for user authentication depends on the setting of user authentication.
	Provisioning	User authentication is required. User authentication mode of the command device must be enabled.
Out-of-band	Replication	User authentication is required. For virtual command devices, user authentication mode is always enabled.

Route	Command	Specification
	Provisioning	User authentication is required. For virtual command devices, user authentication mode is always enabled.

User authentication mode

You must enable the user authentication mode on the CCI command device. For the virtual command device the user authentication mode is always enabled.

When user authentication mode is enabled, use the user ID and password that you created using Device Manager - Storage Navigator or the maintenance utility to log in to the storage system.

LDEV nickname function

You can assign a unique nickname of up to 32 characters to an LDEV.

LDEV grouping function

In CCI versions prior to the Hitachi Virtual Storage Platform, you needed to define the copy groups in the CCI configuration definition file on each host. When the copy group information changed, the configuration definition file needed to be edited on each host. In CCI versions after the VSP, the information registered in the storage system can be used. This LDEV grouping function can minimize the description of the CCI configuration definition file on each host. When the copy group information changes, you need to update only one configuration definition file, saving time and eliminating the chance for error due to mismatching edits.

The LDEV grouping functionality is implemented using device names, device groups, and copy groups:

Device name

- A name that can be assigned to one LDEV per device group.
- Each name is associated with a device group to which the LDEV belongs.
- An LDEV nickname can be assigned to the LDEV as a unique name for the LDEV that is not related with a device group. Only one LDEV nickname can be assigned to each LDEV.

Device group

- A group of one or more LDEVs. One LDEV can belong to multiple device groups.
- A device group can belong to only one copy group.
- If you want to construct a mirror or cascade, you need to define a different device group and a device name in each copy group.

Copy group

A group that is defined by specifying two device groups: one device group at the primary site and one device group at the secondary site.

Resource group function

Using Resource Group function, the storage administrator for each resource group can access only the resources in the resource group. The storage administrator cannot access resources in other resource groups. This prevents the risk of destroying the data by another storage administrator in the other resource groups or of leaking out the data.

Resource locking function

The resource locking function prevents conflict among multiple users.

User scripts cannot be guaranteed to work correctly when multiple users are using the following different interfaces:

- Storage Navigator
- Device Manager - Storage Navigator
- SVP
- Maintenance utility (VSP Gx00 models and VSP Fx00 models)
- Maintenance PC

You can use the lock command while the script is running to ensure completion. To use the lock command, user authentication is required.

CCI functions available on all RAID storage systems

CCI provides the following functionality on all Hitachi Vantara RAID storage systems.

- In-system replication
- Remote replication
- Data protection

In-system replication

CCI provides command-line control for in-system (local) replication operations, including ShadowImage, Thin Image, and Copy-on-Write Snapshot. CCI displays local replication information and allows you to perform operations by issuing commands or by executing script files.

Remote replication

CCI provides command-line control for remote replication operations, including TrueCopy, Universal Replicator, and global-active device. CCI displays remote replication information and allows you to perform operations by issuing commands or by executing script files.

For remote copy operations, CCI interfaces with the system software and high-availability (HA) software on the host as well as the software on the RAID storage system. CCI provides failover operation commands that support mutual hot standby in conjunction with industry-standard failover products (for example, MC/ServiceGuard, HACMP, FirstWatch®). CCI also supports a scripting function for defining multiple operations in a script (or text) file. Using CCI scripting, you can set up and execute a large number of commands in a short period of time while integrating host-based high-availability control over copy operations.

Data protection

CCI supports data protection operations, including Hitachi Database Validator and Hitachi Data Retention Utility.

- Database Validator. The CCI software provides commands to set and verify parameters for volume-level validation checking of Oracle® database operations. Once validation checking is enabled, all write operations to the specified volumes must have valid Oracle checksums. CCI reports a validation check error to the syslog file each time an error is detected. Database Validator requires the operation of CCI software product but cannot be controlled via the Storage Navigator software.
- Data Retention Utility. The CCI software enables you to set and verify the parameters for guarding at the volume level. Once guarding is enabled, the RAID storage system conceals the target volumes from SCSI commands such as SCSI Inquiry and SCSI Read Capacity, prevents reading and writing to the volume, and protects the volume from being used as a copy volume (the TrueCopy, Universal Replicator, global-active device, or ShadowImage paircreate operation fails).

Chapter 2: CCI software environment

This chapter describes the CCI software environment.

Overview of the CCI software environment

The CCI software environment includes components on the Hitachi RAID storage systems and the CCI software on the host servers and/or on the Storage Navigator computer or management client. The CCI components on the storage systems include the user data volumes and CCI command devices.

Each CCI instance on a host server includes:

- CCI application files, referred to as **HORC Manager (HORCM)**
 - Log and trace files
 - A command server
 - Error monitoring and event reporting files
 - A configuration management feature
- Configuration definition file (user-defined)
- User execution environments for the Hitachi Vantara features, including the commands, a command log, and a monitoring function.

The CCI commands also have interface considerations (see CCI and the SCSI command interface).

CCI components on the RAID storage system

Command device

CCI commands are issued by the CCI software to the RAID storage system command device. The command device is a user-selected, dedicated logical volume on the storage system that functions as the interface to the CCI software on the host. The command device is dedicated to CCI communications and cannot be used by any other applications. The command device accepts CCI read and write commands that are issued by the storage system. The command device also returns read requests to the host. The volume designated as the command device is used only by the storage system and is blocked from the user. The command device uses 32 MB, and the remaining volume space is reserved for CCI and its utilities. The command device can be any OPEN-x device (for example, OPEN-V) that is accessible to the host. A LUN Expansion volume cannot be used as a command device. A Virtual LVI/Virtual LUN volume as small as 36 MB (for example, OPEN-3-CVS) can be used as a command device.



Warning: Make sure the volume to be selected as the command device does not contain any user data. The command device will be inaccessible to the host.

The CCI software on the host issues read and write commands to the command device. When CCI receives an error notification in reply to a read or write request to the RAID storage system, the CCI software switches to an alternate command device, if one is defined. If a command device is blocked (for example, for online maintenance), you can switch to an alternate command device manually. If no alternate command device is defined or available, all TrueCopy and ShadowImage commands terminate abnormally, and the host will not be able to issue commands to the storage system. Therefore, one or more alternate command devices (see Alternate command device function.) must be set to avoid data loss and storage system downtime.

Each command device must be set using the LUN Manager software on Storage Navigator. In addition, for using a Provisioning command, user authentication is required. Set the security attribute of the command device with user authentication. For information and instructions on setting a command device, see the *Provisioning Guide* for the storage system.

Each command device must also be defined in the HORCM_CMD section of the configuration definition file for the CCI instance on the attached host. If an alternate command device is not defined in the configuration definition file, the CCI software might not be able to use the device.

The CCI Data Protection Facility uses an enhanced command device that has an attribute to indicate protection ON or OFF.



Note:

- For Solaris operations, the command device must be labeled.

To enable dual path of the command device, make sure to include all paths to the command device on a single line in the HORCM_CMD section of the configuration definition file. The following shows an example with two controller paths to the command device. Putting the path information on separate lines might cause parsing issues, and failover might not occur unless the HORCM startup script is restarted.

```
HORCM_CMD #dev_name dev_name dev_name /dev/rdisk/c1t66d36s2 /dev/
rdsk/c2t66d36s2
```

Command device guarding

In the customer environment, a command device might be attacked by the maintenance program of the Solaris Server, after that usable instance will be exhausted, and CCI instance would not start up on all servers (except attacked server). This might happen due to incorrect operation of the maintenance personnel for the UNIX Server. In this case, the command device should be protected against operator error, as long as it can be seen as the device file from the maintenance personnel.

Thus, the RAID microcode (for the command device) and CCI support this protection in order to guard from similar access.

Guarding method

Currently, assignment of the instance via the command device is ONE phase. Therefore, if the command device reads a special allocation area of the instance through the maintenance tool and so on, then it causes a fault of full space of the instance, because the command device interprets as assignment of the instance from CCI.

CCI has TWO phases that it reads to acquire usable LBA, and writes with the acquired LBA in attaching sequence to the command device, so the command device can confirm whether it was required as the assignment for CCI or not, by detecting and adding two status bits to the instance assignment table.

The following figure shows the current assignment sequence.

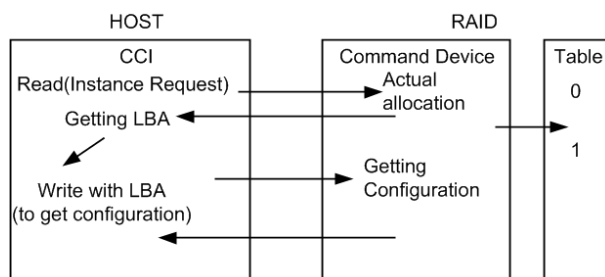

The following figure shows improved assignment sequence.

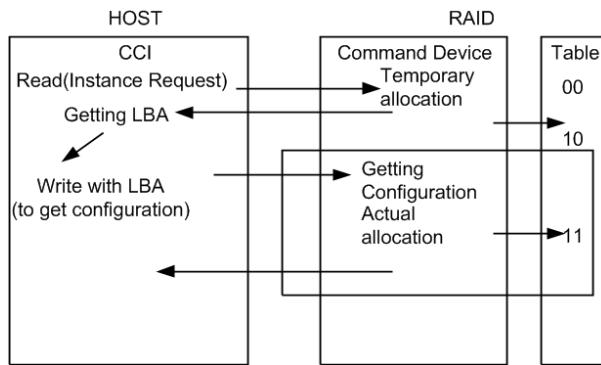

The command device performs the assignment of an instance through TWO phases that have "temporary allocation (1 0)" and "actual allocation (1 1)" to the instance assignment table.

If the command device is attacked, the instance assignment table is filled with "temporary allocation (1 0)". After that, the command device will detect a fault of full space as the instance assignment, clear up all "temporary allocation (1 0)", and then reassign the required instance automatically.

This does not require a service representative to switch the command device "OFF/ON" to clear up the instance table.

Verifying the CCI instance number

CCI provides a way to verify the number of "temporary allocations (1 0)" and "actual allocations (1 1)" on the instance table so that you can confirm validity of the CCI instance number in use. The `horcctl -DI` command shows the number of CCI instances since HORCM was started as follows.

Example without command device security:

```
# horcctl -DI
Current control device = /dev/rdisk/c0t0d0 AI = 14 TI = 0 CI = 1
```

Example with command device security:

```
# horcctl -DI
Current control device = /dev/rdisk/c0t0d0* AI = 14 TI = 0 CI = 1
```

- AI** NUM of actual instances in use
- TI** NUM of temporary instances in RAID
- CI** NUM of instances using current (own) instance

Alternate command device function

The CCI software issues commands to the command device via the UNIX/PC raw I/O interface. If the command device fails in any way, all CCI commands are terminated abnormally, and you cannot use any commands. Because the use of alternate I/O path is platform dependent, restrictions are placed upon it. For example, on HP-UX systems, only devices subject to the LVM can use the alternate path PV-LINK. To avoid command device failure, CCI supports an alternate command device function.



Note: When you set a redundant path to the command device by using alternate path software, make sure that path switching occurs only in case of a failure. For example, you cannot use round robin.

- **Definition of alternate command devices:** To use an alternate command device, you must define two or more command devices for the HORCM_CMD item in the configuration definition file. When two or more devices are defined, they are recognized as alternate command devices. Create all alternate command devices within the same resource group of the same storage system.
- **Timing of alternate command devices:** When the HORCM receives an error notification in reply from the operating system via the raw I/O interface, the alternate command device is used. You can also change to the alternate command device forcibly by using the `horcctl -C` switch command. However, if you specified HORCM_CMD for the volume belonging to a virtual storage machine, you cannot use the `horcctl -C` switch command, and therefore you cannot switch to the alternate command device forcibly.
- **Operation of alternating command:** If the command device is blocked due to online maintenance, the switch command should be issued in advance. If the switch command is issued again after completion of the online maintenance, the previous command device is activated.
- **Multiple command devices on HORCM startup:** If at least one command device is available during one or more command devices described to the configuration definition file, then HORCM can start with a warning message to the startup log by using the available command device. Confirm that all command devices can be changed by using the `horcctl -C` command option, or HORCM has been started without the warning message to the HORCM startup log.

The following figure shows the alternate command device function.

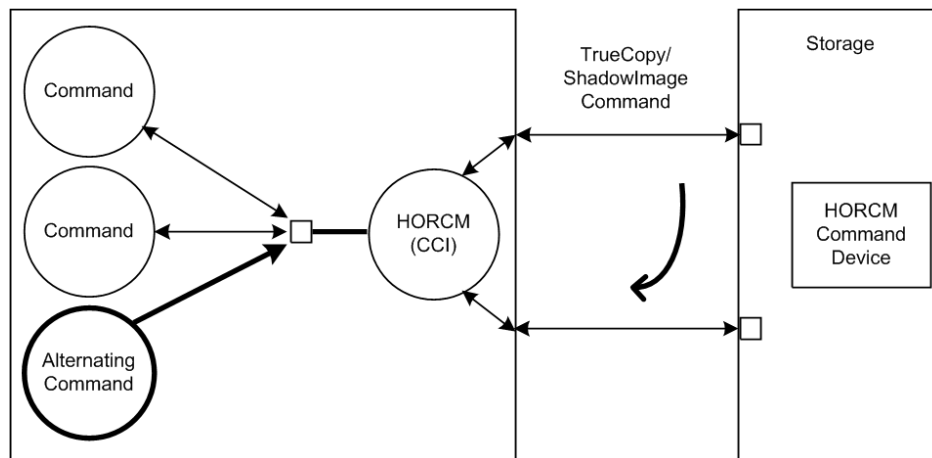

Remote command device

A remote command device is a command device on an external (UVM) storage system that is mapped as a command device of the local storage system. When commands are issued to a remote command device, the UR/URz journal operations are processed using the UVM FC path between the arrays. Use of a remote command device provides improved performance for 3DC configurations by providing separate paths for UR/URz journal processing and data replication.

The remote command device (RCD) requirements are:

- Virtual Storage Platform G1000, G1500, Virtual Storage Platform F1500:
 - RCD is required in 3DC TC/UR and 3DC TCz/URz configurations, including intermix configurations with VSP or USP V/VM.
 - RCD is required in 3DC URxUR and 3DC URzxURz configurations, including intermix configurations with VSP or USP V/VM.
 - RCD is not required in GAD 3DC delta resync (GAD+UR) configurations.
- Virtual Storage Platform G200, G400, G600, G800 and Virtual Storage Platform F400, F600, F800:
 - RCD is required in 3DC TC/UR and URxUR configurations.
 - RCD is not required in GAD 3DC delta resync (GAD+UR) configurations.
- Virtual Storage Platform: RCD is recommended in 3DC TC/UR and 3DC TCz/URz configurations. If there is intermix with VSP G1000, G1500 or VSP F1500, RCD is required.
- Hitachi Unified Storage VM: RCD is recommended in 3DC TC/UR configurations.

The remote command device is defined using Device Manager - Storage Navigator. For more information, see the *Hitachi Universal Volume Manager User Guide*.

CCI and the SCSI command interface

When CCI commands are converted into a special SCSI command format, a SCSI through driver that can send specially formatted SCSI commands to the RAID storage system is needed. As a result, OS support for CCI depends on the OS capabilities. It is necessary to use a read/write command that can easily be issued by many UNIX/PC server platforms. For example, `ioctl()` can be used for the following platforms: HP-UX, Linux, Solaris, Windows, IRIX64, OpenVMS and zLinux.

- **SCSI command format used:** Use a RD/WR command that can be used with special LDEVs, since they should be discriminated from the normal RD/WR command.
- **Recognition of the control command area (LBA#):** The host issues control commands through the raw I/O special file of a special LDEV. Since the specific LU (command device) receiving these commands is viewed as a normal disk by the SCSI interface, the OS can access its local control area. The RAID storage system must distinguish such accesses from the control command accesses. Normally, several megabytes of the OS control area are used starting at the initial LBA#. To avoid using this area, a specific LBA# area is decided and control commands are issued within this area. The command LBA# recognized by the storage system is shown below, provided the maximum OS control area is 16 MB.

The following figure shows the relationship of the special file to the special LDEV.

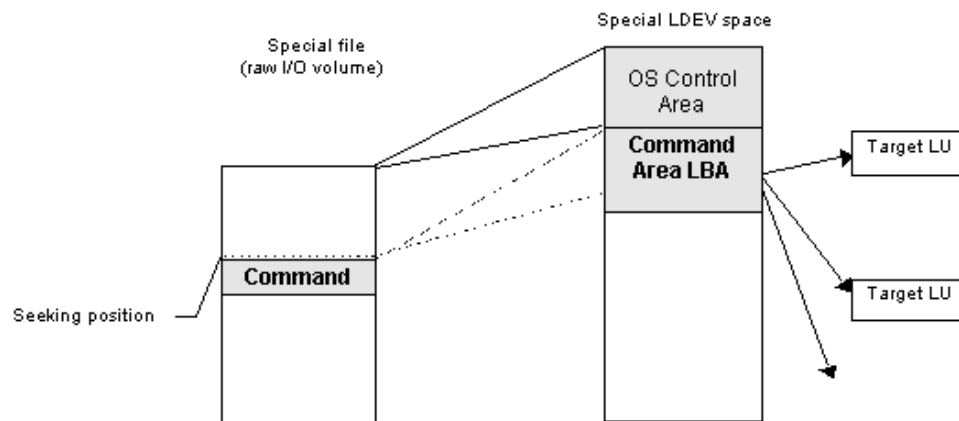

32,768 LBA# 32,768 * 2 (In "block" units, 512 bytes per block)
The host seeks 32,768 * 512 bytes and issues a command.

- **Acceptance of commands:** A command is issued in the LBA area of the special LDEV explained above. The RD/WR command meeting this requirement should be received especially as a CCI command. A command is issued in the form of WR or WR-RD. When a command is issued in the form of RD, it is regarded as an inquiry (equivalent to a SCSI inquiry), and a CCI recognition character string is returned.

Command competition

The CCI commands are asynchronous commands issued via the SCSI interface. As a result, if several processes issue these commands to a single LDEV, the storage system cannot take the proper action. To avoid such a problem, two or more write commands should not be issued to a single LDEV. The command initiators should not issue two or more write commands to a single LDEV unless the storage system can receive commands with independent initiator number * LDEV number simultaneously.

The following figure shows the HORCM and command issue process.

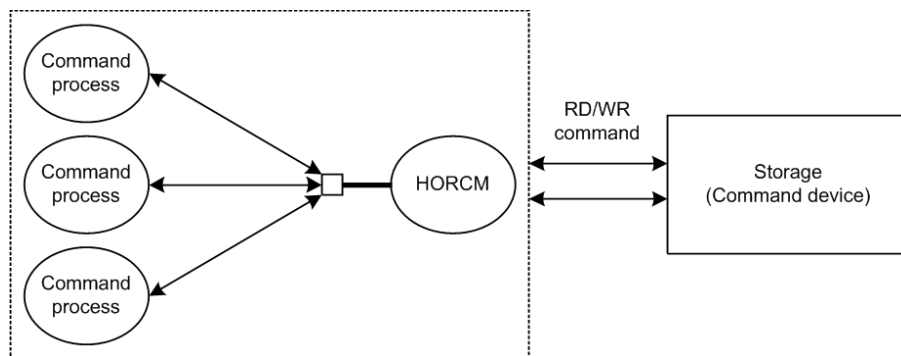

Command flow

This figure shows the flow of read/write command control for a specified LBA#.

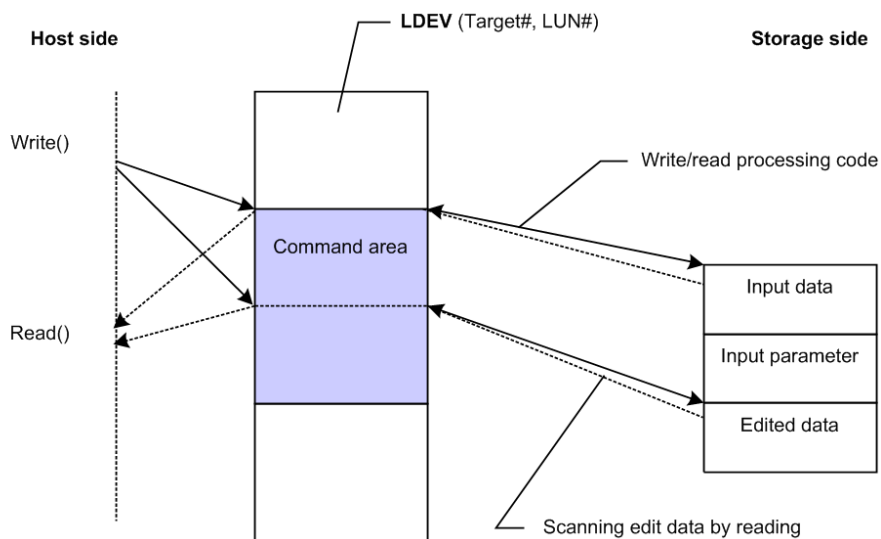

Issuing commands for LDEVs within a LUSE device

A LUSE device is a group of LDEVs regarded as a single logical unit. Because it is necessary to know the configuration of the LDEVs when issuing a command, a new command is used to specify a target LU and acquire LDEV configuration data, as shown in the following figure.

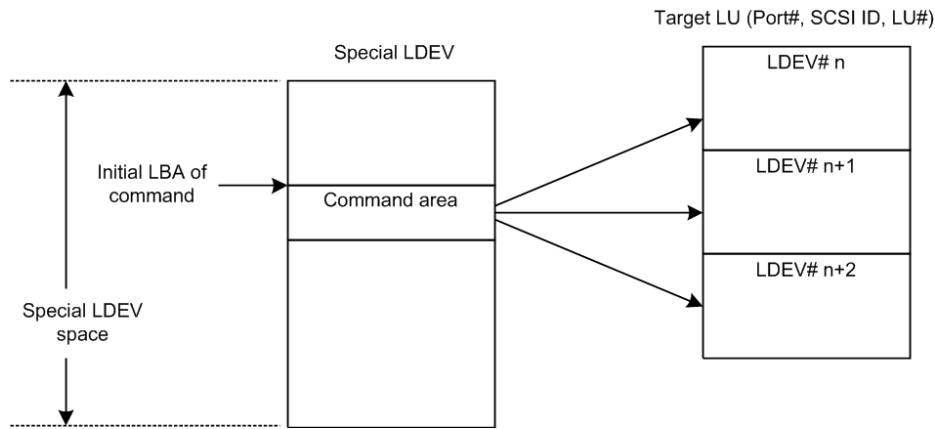

CCI instance components on the host server

HORCM operational environment

The HORCM operates as a daemon process on the host server and is activated either automatically when the server machine starts up or manually by the startup script. HORCM reads the definitions specified in the configuration file upon startup. The environment variable HORCM_CONF is used to define the location of the configuration file to be referenced. The following figure shows the HORCM operational environment.

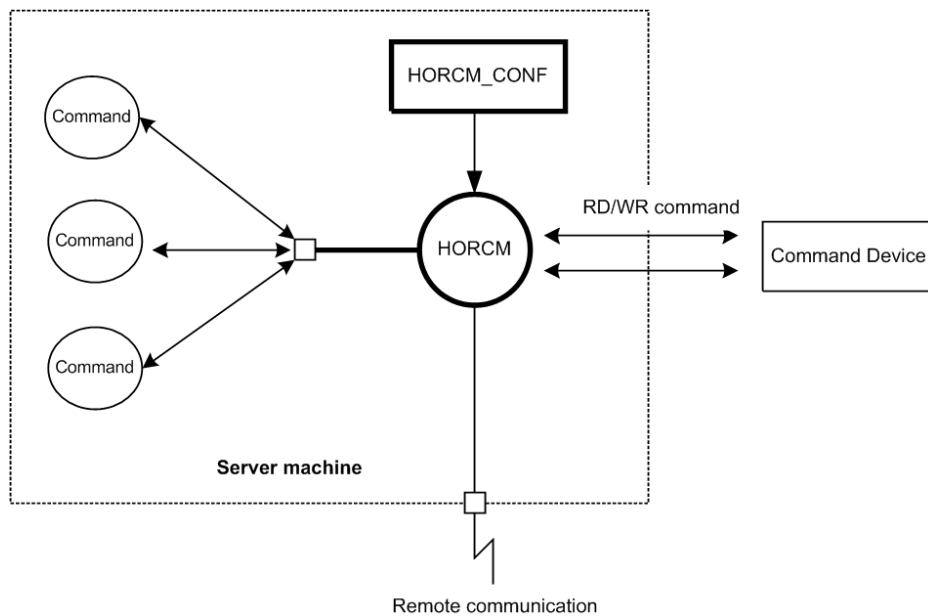

CCI instance configurations

The basic unit of the CCI software structure is the CCI instance. A CCI instance consists of HORC manager (HORCM), CCI commands, the user-defined configuration definition file, and the log function for maintenance. Each instance uses its own configuration definition file to manage volume relationships while maintaining awareness of the other CCI instances. Each CCI instance normally resides on separate servers (one node per instance). If two or more instances are run on a single server (for example, for test operations), it is possible to activate two or more instances using instance numbers. The CCI commands to be used are selected by the environment variable (HORCC_MRCF). The default command execution environment for CCI is TrueCopy.

The CCI instance shown in the following figure has a remote execution link and a connection to the RAID storage system. The remote execution link is a network connection to another PC to allow you to execute CCI functions remotely. The connection between the CCI instance and the storage system illustrates the connection between the CCI software on the host and the command device. The command device accepts CCI commands and communicates read and write I/Os between the host and the volumes on the storage system. The host does not communicate CCI commands directly to the volumes on the storage system -- the CCI commands always go through the command device.

The following figure illustrates CCI instance configuration and components.

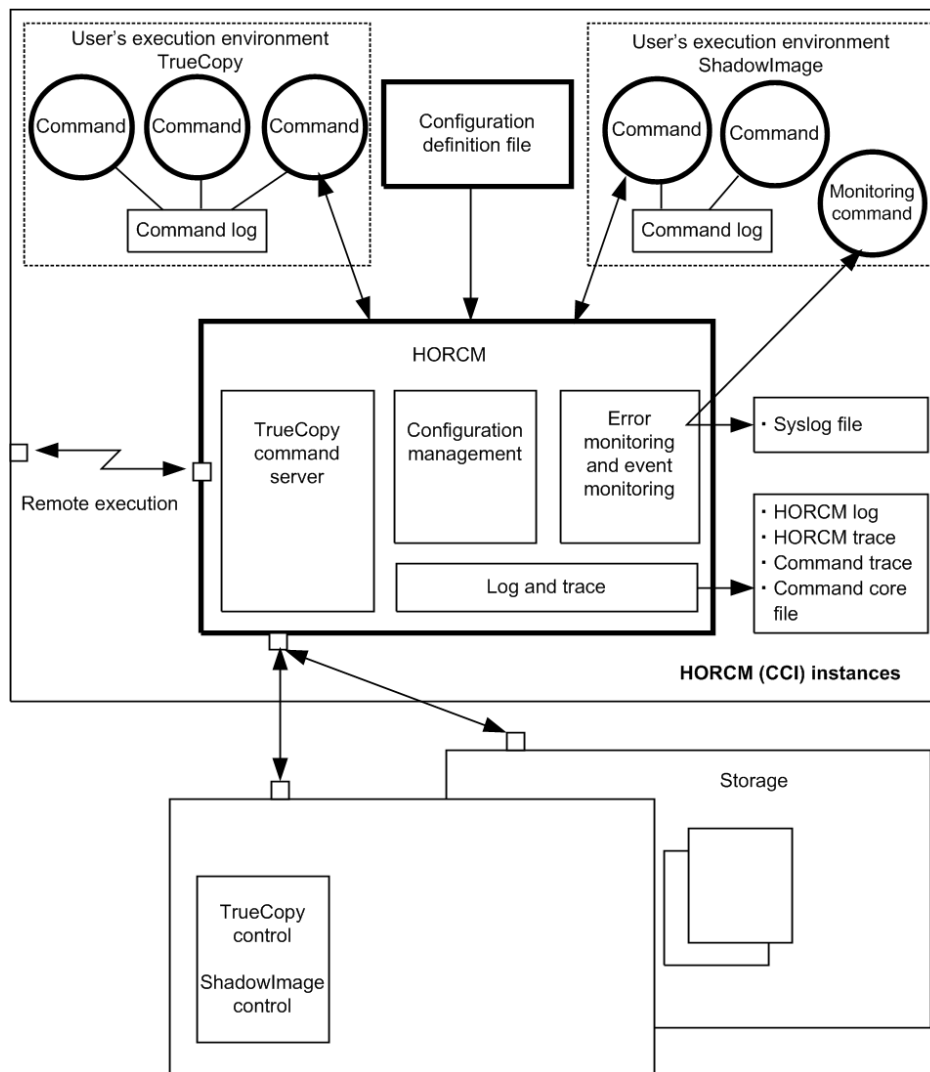

The four possible CCI instance configurations are:

- One host connected to one storage system:** Connecting one host to one storage system allows you to maintain multiple copies of your data for testing purposes or as an offline backup. Each CCI instance has its own operation manager, server software, and scripts and commands, and each CCI instance communicates independently with the command device. The RAID storage system contains the command device that communicates with the CCI instances as well as the primary and secondary volumes of both CCI instances.
- One host connected to two storage systems:** Connecting the host to two storage systems enables you to migrate data or implement disaster recovery by maintaining duplicate sets of data in two different storage systems. You can implement disaster recovery solutions by placing the storage systems in different geographic areas. Each CCI instance has its own operation manager, server software, and scripts and commands, and each CCI instance communicates independently with the command device. Each RAID storage system has a command device that communicates with each CCI instance independently. Each storage system contains the primary volumes of its connected CCI instance and the secondary volumes of the other CCI instance (located on the same host in this case).

- **Two hosts connected to one storage system:** Having two attached hosts to one storage system, one host for the primary volume and the other host for the secondary volume, allows you to maintain and administer the primary volumes while the secondary volumes can be taken offline for testing. The CCI instances of separate hosts are connected via the LAN so that they can maintain awareness of each other. The RAID storage system contains the command device that communicates with both CCI instances (one on each host) and the primary and secondary volumes of both CCI instances
- **Two hosts connected to two storage systems:** Two hosts connected to two storage systems also allows the most flexible disaster recovery plan, because both sets of data are administered by different hosts. This guards against storage system failure as well as host failure. The CCI instances of separate hosts are connected via the LAN so that they can maintain awareness of each other. Each RAID storage system has a command device that communicates with each CCI instance independently. Each storage system contains the primary volumes of its connected CCI instance and the secondary volumes of the other CCI instance (located on a different host in this case).

Host machines that can be paired

When you perform a pair operation, the version of CCI should be the same on the primary and secondary sites. As a particular application uses HORC, users sometimes use a HORC volume as the data backup volume for the server. In this case, CCI requires that the CCI instance correspond to each OS platform that is located on the secondary site for the pair operation of data backup on the primary servers of each OS platform.

However, it is possible to prepare only one server at a secondary site by supporting CCI communications among different OSs (including the converter for **little-endian** vs. **big-endian**).

The following figure represents CCI's communication among different OSs, and the table below shows the supported communication (32-bit, 64-bit) among different OSs. Please note the following terms that are used in the example:

- RM-H: Value of HORCMFCTBL environment variable for an HP-UX CCI instance on Windows
- RM-S: Value of HORCMFCTBL environment variable for a Solaris CCI instance on Windows

Restriction: CCI's communications among different operating systems is supported on HP-UX, Solaris, AIX, Linux, and Windows (this is not supported on Tru64 UNIX/Digital UNIX). Also, CCI does not require that the HORCMFCTBL environment variable be set—except for RM-H and RM-S instances (to ensure that the behavior of the operating system platform is consistent across different operating systems).

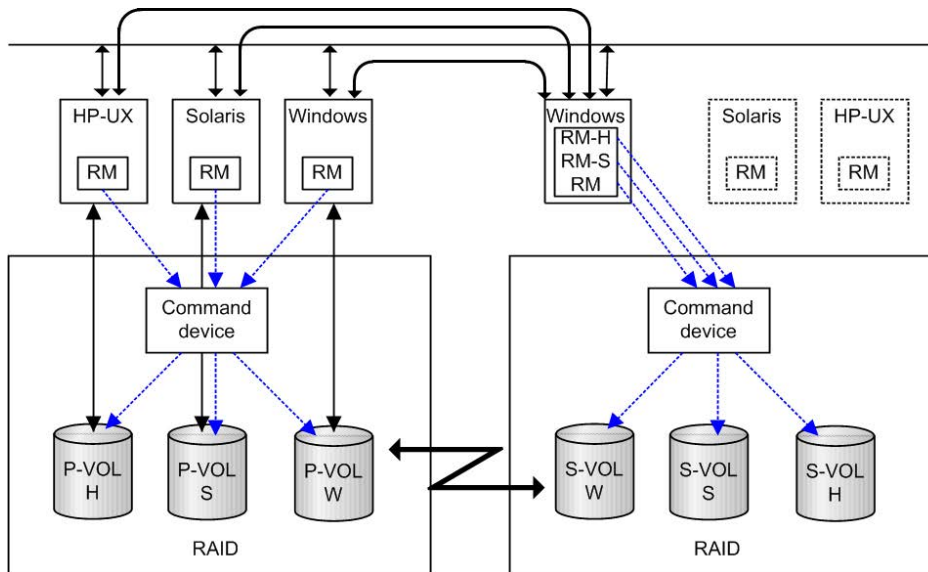

HORCM		HORCM 32 bit		HORCM 64 bit	
		little	big	little	big
32 bit	little	AV	AV	AV	-
	big	AV	AV	AV	-
64 bit	little	AV	AV	AV	-
	big	-	-	-	-

Configuration definition file

The CCI configuration definition file is a text file that defines a CCI instance. The connected hosts, volumes and groups known to the CCI instance are defined in the configuration definition file. Physical volumes (special files) used independently by the servers are combined when paired logical volume names and group names are given to them. The configuration definition file describes the correspondence between the physical volumes used by the servers and the paired logical volumes and the names of the remote servers connected to the volumes. See the *Command Control Interface Installation and Configuration Guide* for instructions on creating the CCI configuration definition file.

The following figure illustrates the configuration definition of paired volumes.

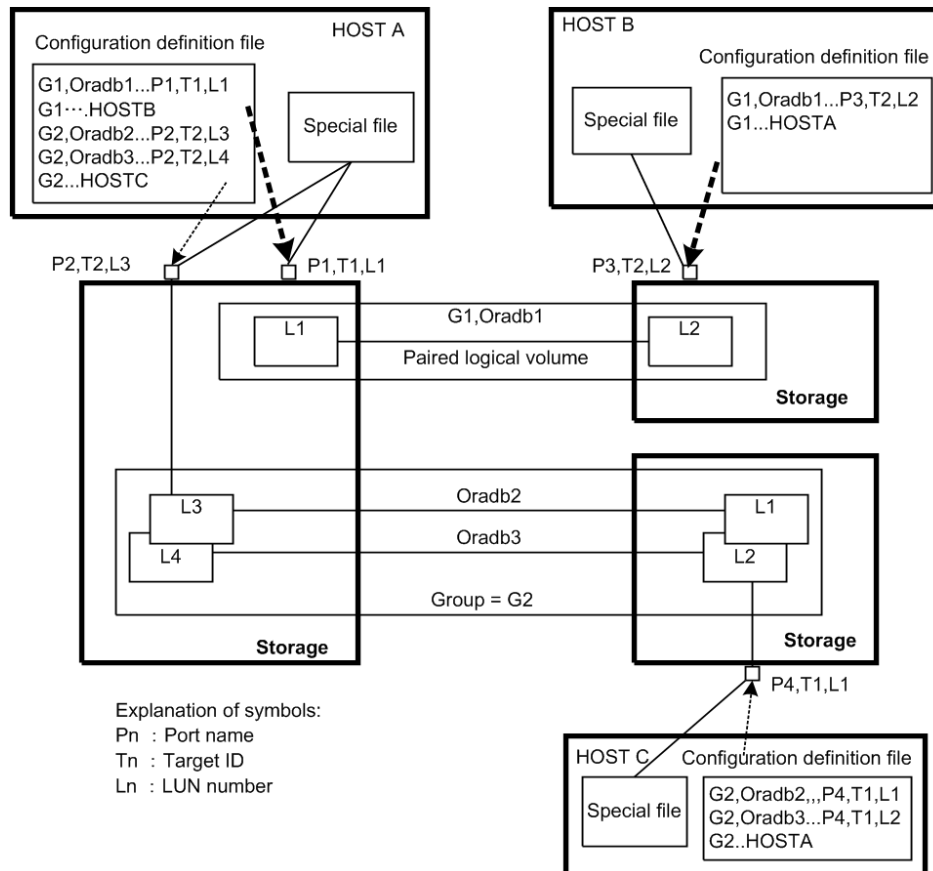

Configuration file example — UNIX-based servers

Note that # at the beginning of a line indicates a comment.

```

HORCM_MON
#ip_address service poll(10ms) timeout(10ms)
HST1      horcm 1000      3000

HORCM_CMD
#unitID 0... (seq#30014)
#dev_name dev_name dev_name
/dev/rdisk/c0t0d0
#unitID 1... (seq#30015)
#dev_name dev_name dev_name
/dev/rdisk/c1t0d0

HORCM_DEV
#dev_group dev_name port# TargetID LU# MU#
oradb      oradb1   CL1-A      3    1    0
oradb      oradb2   CL1-A      3    1    1
oralog     oralog1  CL1-A      5    0
oralog     oralog2  CL1-A1     5    0
oralog     oralog3  CL1-A1     5    1
oralog     oralog4  CL1-A1     5    1    h1

HORCM_INST
    
```

```
#dev_group ip_address service
oradb      HST2      horcm
oradb      HST3      horcm
oralog     HST3      horcm
```

Configuration file example — Windows servers

```
horcmU.conf - Notepad
File Edit Search Help
HORCM_MON
#ip_address      service      poll(10ms)      timeout(10ms)
POLLUX          horcm0        1000            3000

HORCM_CMD
#dev_name                dev_name                dev_name
\\.\PHYSICALDRIVE2

HORCM_DEV
#dev_group      dev_name      port#      TargetID      LU#
UG01           kate1        CL1-A      0             0
#UG02          kate2        CL1-C      4             0
#UG02          oradb3       CL1-B      2             4

HORCM_INST
#dev_group      ip_address      service
UG01           POLLUX          horcm1
```

The following table lists the parameters defined in the configuration file and specifies the default value, type, and limit for each parameter.

Parameter	Default	Type	Limit
ip_address	None	Character string	63 characters
Service	None	Character string or numeric value	15 characters
poll (10 ms)	1000	Numeric value ¹	None
timeout (10 ms)	3000	Numeric value ¹	None
dev_name for HORCM_CMD	None	Character string	63 characters Recommended value = 8 char. or fewer
dev_name for HORCM_DEV	None	Character string	31 characters
dev_group	None	Character string	31 characters

Parameter	Default	Type	Limit
			Recommended value = 8 char. or less
port #	None	Character string	31 characters
target ID	None	Numeric value ¹	7 characters
LU#	None	Numeric value ¹	7 characters
MU#	0	Numeric value ¹	7 characters
Serial# ²	None	Numeric value	12 characters
CU:LDEV(LDEV#)	None	Numeric value	6 characters
dev_name for HORCM_CMD	None	Character string	63 characters Recommended value = 8 char. or less
Notes:			
<ol style="list-style-type: none"> 1. Use decimal notation for numeric values (not hexadecimal). 2. For VSP G1x00 and VSP F1500, add a "3" at the beginning of the serial number. For example, for serial number 12345, enter 312345. 			

Do not edit the configuration definition file while CCI is running. Shut down CCI, edit the configuration file as needed, and then restart CCI.

When you change the system configuration, it is required to shut down CCI once and rewrite the configuration definition file to match with the change and then restart CCI.

When you change the storage system configuration (microprogram, cache capacity, LU path, and so on), you need to restart CCI regardless of the necessity of the configuration definition file editing.

When you restart CCI, confirm that there is no contradiction in the connection configuration by using the `-c` option of `pairdisplay` command and `raidqry` command. But you cannot confirm the consistency of the P-VOL and S-VOL capacity with the `-c` option of `pairdisplay` command. Confirm the capacity of each volume by using the `raidcom` command.

Do not mix pairs created with the "At-Time Split" option (`-m grp`) and pairs created without this option in the same group defined in the CCI configuration file. If you do, a `pairsplit` operation might end abnormally, or S-VOLs of the P-VOLs in the same consistency group (CTG) might not be created correctly at the time the `pairsplit` request is received.

Configuration definition file settings

This section describes the settings in the configuration definition file:

- [HORCM_MON \(on page 47\)](#)
- [HORCM_CMD \(in-band method\) \(on page 48\)](#)
- [HORCM_CMD \(out-of-band method\) \(on page 53\)](#)
- [HORCM_DEV \(on page 56\)](#)
- [HORCM_INST \(on page 59\)](#)
- [HORCM_LDEV \(on page 60\)](#)
- [HORCM_LDEVG \(on page 61\)](#)
- [HORCM_INSTP \(on page 62\)](#)
- [HORCM_ALLOW_INST \(on page 62\)](#)

HORCM_MON

The monitor parameter (HORCM_MON) defines the following values:

- **Ip_address:** Specifies the local host name or the IP address of the local host. When you specify the name of a local host that has multiple IP addresses, one of the IP addresses is selected at random and used. If you want to use all IP addresses, specify NONE for IPv4 or NONE6 for IPv6.
- **Service:** Specifies the UDP port name assigned to the HORCM communication path, which is registered in "/etc/services" ("%windir%\system32\drivers\etc\services" in Windows, "SYS\$SYSROOT:[000000.TCPIP\$ETC]SERVICES.DAT" in OpenVMS). If a port number is specified instead of a port name, the port number will be used.
- **Poll:** The interval for monitoring paired volumes. To reduce the HORCM daemon load, make this interval longer. If set to -1, the paired volumes are not monitored. The value of -1 is specified when two or more CCI instances run on a single machine.
- **Timeout:** The time-out period of communication with the remote server.

If HORCM_MON is not specified, then the following are set as defaults.

```
HORCM_MON
```

```
#ip_address    service        poll (10ms)    timeout (10ms)
```

```
NONE          default_port    1000           3000H
```

Default_port:

For none specified HORCM instance: "31000 + 0"

For instance HORCM X : "31000 + X + 1"

HORCM_CMD (in-band method)

When using the in-band method, define the UNIX device path or Windows physical device number and specify a command device that can be accessed by CCI for HORCM_CMD. You can specify multiple command devices in HORCM_CMD to provide failover in case the original command device becomes unavailable.



Tip: To enhance redundancy, you can make multiple command devices available for a single storage system. This configuration is called command device alternative configuration. For this configuration, command devices are listed horizontally in a line in the configuration definition file. CMD1 and CMD2 in the following example are command devices of the same storage system:

```
HORCM_CMD
CMD1 CMD2
```

Aside from the command device alternative configuration, to control multiple storage systems in one configuration definition file, you can list command devices of each storage system in one configuration definition file. In this case, command devices are listed vertically. CMD1 and CMD2 in the following example are command devices of different storage systems:

```
HORCM_CMD
CMD1
CMD2
```

The command device must be mapped to the iSCSI/Fibre using LUN Manager first. The mapped command devices can be identified by the "-CM" at the end of product ID displayed by the **inqraid** command. The following are the examples for the **inqraid** command.

Example for the **inqraid** command (UNIX host)

```
# ls /dev/rdisk/c1t0* | /HORCM/usr/bin/inqraid -CLI -sort
DEVICE_FILE PORT SERIAL LDEV CTG H/M/12 SSID R:Group PRODUCT_ID
```

```
c1t0d0s2 CL2-E 63502 576 - - - - OPEN-V-CM
```

```
c1t0d1s2 CL2-E 63502 577 - s/s/ss 0006 1:02-01 OPEN-V -SUN
```

```
c1t0d2s2 CL2-E 63502 578 - s/s/ss 0006 1:02-01 OPEN-V -SUN
```

The command device is `/dev/rdisk/c1t0d2s2`.

Example for the `inqraid` command (Windows host)

```
D:\HORCM\etc>inqraid $Phys -CLI
```

```
\\.\PhysicalDrive1:
```

```
# Harddisk1 -> [VOL61459_449_DA7C0D92] [OPEN-3 ]
```

```
\\.\PhysicalDrive2:
```

```
# Harddisk2 -> [VOL61459_450_DA7C0D93] [OPEN-3-CM ]
```

The command device is `\\.\PhysicalDrive2`.

After the process of command device mapping, set `HORCM_CMD` of the configuration definition file as follows.

```
\\.\CMD-<Serial Number>:<Device special file name>
```

<Serial Number>: Sets the serial number. For VSP G1x00 and VSP F1500, add a "3" at the beginning of the serial number. For example, for serial number 12345, enter 312345.

<Device special file name>: Sets the device special file name of a command device.

Example with serial number 64015 and device special file name, `/dev/rdisk/*` is specified:

```
HORCM_CMD
#dev_name dev_name dev_name
\\.\CMD-64015:/dev/rdsk/*
```



Caution: To enable dual path of the command device under UNIX systems, make sure to include all paths to the command device on a single line in the `HORCM_CMD` section of the configuration definition file. Entering path information on separate lines might cause syntax parsing issues, and failover might not occur unless the `HORCM` startup script is restarted on the UNIX system.

When two or more storage systems are connected, CCI identifies each storage system using unit IDs. The unit ID is assigned sequentially in the order described in `HORCM_CMD` of the configuration definition file. For a command device alternative configuration, a special file for multiple command devices is written.



Caution: When storage systems are shared by two or more servers, unit IDs and serial numbers must be consistent among the servers. List serial numbers of the storage systems in `HORCM_CMD` of the configuration definition file in the same order. The following figure illustrates unit IDs when multiple servers share multiple storage systems.

The following figure shows the configuration and unit IDs for multiple storage systems.

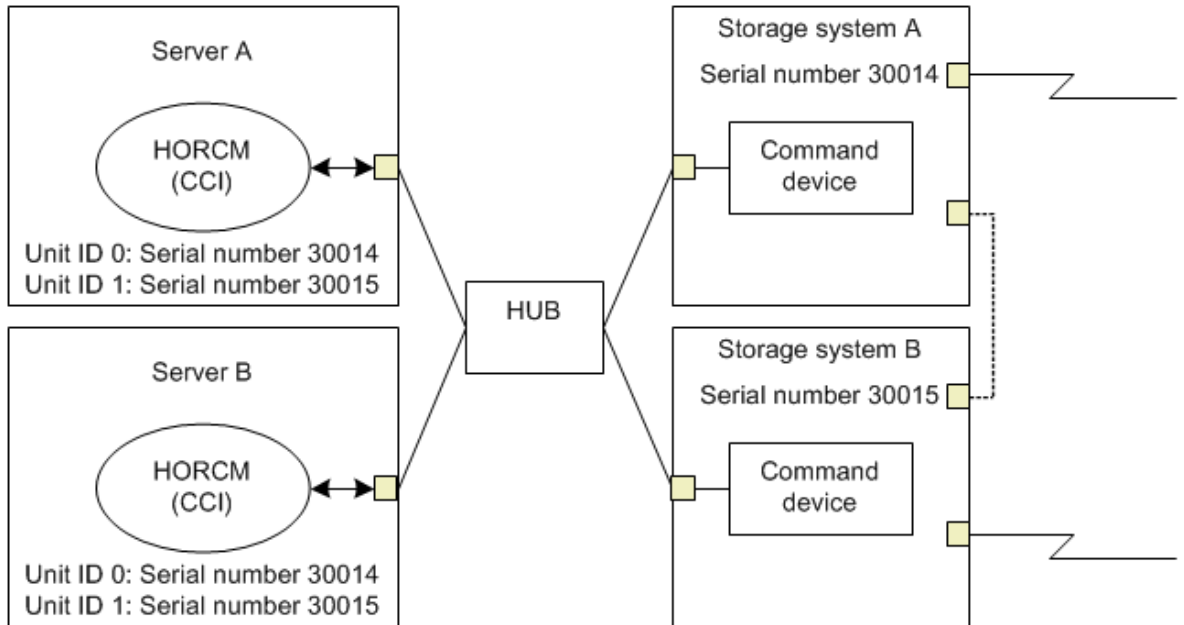

Specifying command devices for Windows 2000, 2003, 2008, and 2012

Normally, physical drives are specified for command devices in storage systems. However, CCI provides a method that is not affected by changes of physical drives in Windows 2000, 2003, 2008, and 2012 by using the following naming format to specify the serial number, LDEV number, and port number in that order:

```
\\.\CMD-Ser#-ldev#-Port#
```



Note: For VSP G1x00 and VSP F1500, add a "3" to the beginning of the serial number (for example, enter "312345" for serial number "12345").

The following example specifies 30095 for the storage system's serial number, 250 for the LDEV number, and CL1-A for the port number:

```
HORCM_CMD
#dev_name dev_name dev_name
\\.\CMD-30095-250-CL1-A
```

- **Minimum specification**

For the command device with serial number 30095, specify as follows:

```
\\.\CMD-30095
```

- **Command devices in the multi-path environment**

Specify serial number 30095, and LDEV number 250 as follows:

```
\\.\CMD-30095-250
```

- **Other specifications**

Specify serial number 30095, LDEV number 250, and port number CL1-A as follows:

```
\\.\CMD-30095-250-CL1-A
```

or

```
\\.\CMD-30095-250-CL1
```

Specifying command devices for UNIX

Device files are specified for command devices in UNIX. However, CCI provides a method that is not affected by changes of device files in UNIX by using the following naming format specifying the serial number, LDEV number, and port number in that order:

```
\\.\CMD-Ser#-ldev#-Port#:HINT
```



Note: For VSP G1x00 and VSP F1500, add a "3" to the beginning of the serial number (for example, enter "312345" for serial number "12345").

The following example specifies 30095 for the storage system's serial number, 250 for the LDEV number, and CL1-A for the port number:

```
HORCM_CMD
#dev_name dev_name dev_name
\\.\CMD-30095-250-CL1-A:/dev/rdisk/
```

HINT provides a path to scan and specifies a directory ending with a slash (/) or a name pattern including the directory. Device files are searched via a name filter similar to the `ingraid` command.

- To find command devices from `/dev/rdisk/`, enter: `' /dev/rdisk/*`
- To find command devices from `/dev/rdisk/c10`, enter: `' /dev/rdisk/c10*`
- To find command devices from `/dev/rhdisk`, enter: `' /dev/rhdisk*`

For a command device alternative configuration, HINT of the second command device can be omitted. In this case, command devices are searched from the device file that was scanned first.

```
HORCM_CMD
#dev_name dev_name dev_name
\\.\CMD-30095-CL1:/dev/rdisk/ \\.\CMD-30095-CL2
```

- **Minimum specification:** For the command device of a storage system with serial number 30095, specify as follows.

```
\\.\CMD-30095:/dev/rdisk/
```

- **Command devices in the multi-path environment:** Specify storage system's serial number 30095 and LDEV number 250 as follows.

```
\\.\CMD-30095-250:/dev/rdisk/
```

- **Other specifications:** An alternate path with storage system's serial number 30095 and LDEV number 250 can be specified as follows.

```
\\.\CMD-30095-250-CL1:/dev/rdisk/ \\.\CMD-30095-250-CL2
\\.\CMD-30095:/dev/rdisk/c1 \\.\CMD-30095:/dev/rdisk/c2
```



Note: If the hardware configuration is changed during the time an OS is running in Linux, the name of a special file corresponding to the command device might be changed. At this time, if HORCM was started by specifying the special file name in the configuration definition file, HORCM cannot detect the command device, and the communication with the storage system might fail.

To prevent this failure, specify the path name allocated by udev to the configuration definition file before booting HORCM. Use the following procedure to specify the path name. In this example, the path name for `/dev/sdgh` can be found.

1. Find the special file name of the command device by using `inqraid` command. Command example:

```
[root@myhost ~]# ls /dev/sd* | /HORCM/usr/bin/inqraid -
CLI | grep CM sda CL1-B 30095 0 - - 0000 A:00000 OPEN-V-
CM sdgh CL1-A 30095 0 - - 0000 A:00000 OPEN-V-CM
[root@myhost ~]#
```

2. Find the path name from the `by-path` directory. Command example:

```
[root@myhost ~]# ls -l /dev/disk/by-path/ | grep sdgh
lrwxrwxrwx. 1 root root 10 Jun 11 17:04 2015
pci-0000:08:00.0- fc-0x50060e8010311940-lun-0 -> ../../
sdgh [root@myhost ~]#
```

In this example, "pci-0000:08:00.0-fc-0x50060e8010311940-lun-0" is the path name.

3. Enter the path name to HORCM_CMD in the configuration definition file as follows.

```
HORCM_CMD /dev/disk/by-path/pci-0000:08:00.0-
fc-0x50060e8010311940-lun-0
```

4. Boot the HORCM instance as usual.

HORCM_CMD (out-of-band method)

When executing commands using the out-of-band method, use a virtual command device instead of a command device. By specifying the location to create a virtual command device in HORCM_CMD, you can create a virtual command device.

The location where the virtual command device can be created is different according to the type of the storage system. For details about locations, see System configuration using CCI.

To create a virtual command device on an SVP (VSP, HUS VM, VSP G1x00 and VSP F1500)

Specify the following to HORCM_CMD of the configuration definition file.

```
\\.\IPCMD-<SVP IP address>-<UDP communication port number>[-Unit ID]
```

- <SVP IP address>: Sets an IP address of SVP.
- <UDP communication port number>: Sets the UDP communication port number. This value (31001) is fixed.
- [-Unit ID]: Sets the unit ID of the storage system for the multiple units connection configuration. This can be omitted.

To create a virtual command device on the maintenance utility (VSP Gx00 models, VSP Fx00 models)

Specify the following to HORCM_CMD of the configuration definition file:

```
\\.\IPCMD-<GUM IP address>-<UDP communication port number>[-Unit ID]
```

- <GUM IP address>: Sets an IP address of the maintenance utility (GUM).
- <UDP communication port number>: Sets the UDP communication port number. These values (31001 and 31002) are fixed.
- [-Unit ID]: Sets the unit ID of the storage system for the multiple units connection configuration. This can be omitted.



Note: To use the maintenance utility, we recommend that you set the combination of all GUM IP addresses in the storage system and the UDP communication port numbers by an alternative configuration. See the following examples for how to set the combination.

Using a CCI server port as a virtual command device:

Specify the following in HORCM_CMD of the configuration definition file:

```
\\.\IPCMD-<CCI server IP address>-<CCI port number>[-Unit ID]
```

- <CCI server IP address>: Sets the IP address of the CCI server.
- <CCI port number>: Sets the CCI port number.
- [-Unit ID]: Sets the unit ID of the storage system for the multiple units connection configuration. This can be omitted.

Example for the case of IPv4

```
HORCM_CMD
#dev_name dev_name dev_name
\\.\IPCMD-158.214.135.113-31001
```

Example for the case of IPv6

```
HORCM_CMD
#dev_name dev_name dev_name
\\.\IPCMD-fe80::209:6bff:febe:3c17-31001
```

Example for the case when both the in-band and out-band methods are used

```
HORCM_CMD
#dev_name dev_name dev_name
\\.\CMD-64015:/dev/rdisk/*  \\.\IPCMD-158.214.135.113-31001
```

Example for the case when both the in-band and out-band methods are used in a command device alternative configuration

```
HORCM_CMD
#dev_name dev_name
\\.\CMD-64015:/dev/rdisk/*  \\.\IPCMD-158.214.135.113-31001
HORCM_CMD
#dev_name dev_name
\\.\IPCMD-158.214.135.113-31001  \\.\CMD-64015:/dev/rdisk/*
```

Example for the case of virtual command devices in a cascade configuration (three units)

```
HORCM_CMD
#dev_name dev_name dev_name
\\.\IPCMD-158.214.135.113-31001
\\.\IPCMD-158.214.135.114-31001
\\.\IPCMD-158.214.135.115-31001
```

Example for case of alternative configuration of the combination of all GUM IP addresses in the storage system and the UDP communication port numbers. In this case, enter the IP address without a line feed

```
HORCM_CMD
#dev_name dev_name dev_name
\\.\IPCMD-192.168.0.16-31001
\\.\IPCMD-192.168.0.17-31001
\\.\IPCMD-192.168.0.16-31002
\\.\IPCMD-192.168.0.17-31002
```

An IP address and a port number can be expressed using a host name and a service name.

HORCM_DEV

The device parameter (HORCM_DEV) defines the RAID storage system device addresses for the paired logical volume names. When the server is connected to two or more storage systems, the unit ID is expressed by port# extension. Each group name is a unique name discriminated by a server that uses the volumes, the attributes of the volumes (such as database data, redo log file, UNIX file), recovery level, etc. The group and paired logical volume names described in this item must reside in the remote server. The hardware iSCSI/Fibre port, target ID, and LUN as hardware components need not be the same.

The following values are defined in the HORCM_DEV parameter:

dev_group

Names a group of paired logical volumes. A command is executed for all corresponding volumes according to this group name.

dev_name

Names the paired logical volume within a group (that is, name of the special file or unique logical volume). The name of paired logical volume must be different to the dev name in another group.

Port#

Defines the RAID storage system port number of the volume that connects to the dev_name volume. The following "n" shows unit ID when the server is connected to two or more storage systems (for example, CL1-A1 = CL1-A in unit ID 1). If the "n" option is omitted, the unit ID is 0. The port is not case sensitive (for example, CL1-A = cl1-a = CL1-a = cl1-A).

-	Basic			Option				Option			Option					
CL1	A n	B n	C n	Dn	E n	F n	G n	Hn	Jn	K n	L n	Mn	Nn	P n	Qn	R n
CL2	A n	B n	C n	Dn	E n	F n	G n	Hn	Jn	K n	L n	Mn	Nn	P n	Qn	R n

The following ports can be specified only for the 9900V:

-	Basic			Option				Option			Option					
CL3	a n	b n	cn	dn	e n	fn	g n	hn	jn	k n	ln	mn	nn	p n	qn	rn
CL4	a n	b n	cn	dn	e n	fn	g n	hn	jn	k n	ln	mn	nn	p n	qn	rn

For 9900V, CCI supports four types of port names for host groups:

- Specifying the port name without a host group: CL1-A CL1-An, where n is the unit ID if there are multiple RAID storage systems
- Specifying the port name with a host group: CL1-A-g, where g is the host group CL1-An-g, where n-g is the host group g on CL1-A in unit ID=n

The following ports can be specified for USP V/VM and TagmaStore USP/
TagmaStore NSC:

-	Basic				Option				Option				Option			
CL5	a n	b n	cn	dn	e n	fn	g n	hn	jn	k n	ln	mn	nn	p n	q n	rn
CL6	a n	b n	cn	dn	e n	fn	g n	hn	jn	k n	ln	mn	nn	p n	q n	rn
CL7	a n	b n	cn	dn	e n	fn	g n	hn	jn	k n	ln	mn	nn	p n	q n	rn
CL8	a n	b n	cn	dn	e n	fn	g n	hn	jn	k n	ln	mn	nn	p n	q n	rn
CL9	a n	b n	cn	dn	e n	fn	g n	hn	jn	k n	ln	mn	nn	p n	q n	rn
CLA	a n	b n	cn	dn	e n	fn	g n	hn	jn	k n	ln	mn	nn	p n	q n	rn
CLB	a n	b n	cn	dn	e n	fn	g n	hn	jn	k n	ln	mn	nn	p n	q n	rn
CLC	a n	b n	cn	dn	e n	fn	g n	hn	jn	k n	ln	mn	nn	p n	q n	rn
CLD	a n	b n	cn	dn	e n	fn	g n	hn	jn	k n	ln	mn	nn	p n	q n	rn
CLE	a n	b n	cn	dn	e n	fn	g n	hn	jn	k n	ln	mn	nn	p n	q n	rn
CLF	a n	b n	cn	dn	e n	fn	g n	hn	jn	k n	ln	mn	nn	p n	q n	rn
CLG	a n	b n	cn	dn	e n	fn	g n	hn	jn	k n	ln	mn	nn	p n	q n	rn

Target ID

Defines the iSCSI/Fibre target ID (TID) number of the physical volume on the specified port.

LU#

Defines the iSCSI/Fibre logical unit number (LU#) of the physical volume on the specified target ID and port.



Note: In case of fibre channel, if the TID and LU# displayed on the system are different than the TID on the fibre address conversion table, then you must use the TID and LU# indicated by the **raidscan** command in the CCI configuration file.

MU# for ShadowImage (HOMRCF)

Defines the mirror unit number (0 - 2) to use the redundant mirror for the identical LU on the ShadowImage. If this number is omitted, it is assumed to be (MU#0). The cascaded mirroring of the S-VOL is expressed as virtual volumes using the mirror descriptors (MU#1-2) in the configuration definition file. The MU#0 of a mirror descriptor is used for connection of the S-VOL. The mirror descriptor (MU#0-2) can be used in ShadowImage and Copy-on-Write Snapshot. MU#3-63 can be used in Copy-on-Write Snapshot only.



Note: When you enter the MU number for a ShadowImage/Copy-on-Write Snapshot pair into the configuration definition file, enter only the number, for example, "0" or "1".

Feature	SMPL		P-VOL		S-VOL	
	MU#0-2	MU#3 - 63	MU#0-2	MU#3 - 63	MU#0	MU#1 - 63
ShadowImage	Valid	Not valid	Valid	Not valid	Valid	Not valid
Copy-on-Write Snapshot	Valid	Valid	Valid	Valid	Valid	Not valid

MU# for TrueCopy/Universal Replicator/global-active device

Defines the mirror unit number (0 - 3) if using redundant mirror for the identical LU on TC/UR/GAD. If this number is omitted, it is assumed to be (MU#0). You can specify only MU#0 for TrueCopy, and 4 MU numbers (MU#0 - 3) for Universal Replicator and global-active device.



Note: When you enter the MU number for a TC/UR/GAD pair into the configuration definition file, add an "h" before the number, for example, "h0" or "h1".

Feature	SMPL		P-VOL		S-VOL	
	MU#0	MU#1 - 3	MU#0	MU#1 - 3	MU#0	MU#1 - 3
TrueCopy	Valid	Not valid	Valid	Not valid	Valid	Not valid
UR	Valid	Valid	Valid	Valid	Valid	Valid

HORCM_INST

The instance parameter (HORCM_INST) defines the network address (IP address) of the remote server (active or standby). It is used to view or change the status of the paired volume in the remote server (active or standby). When the primary volume is shared by two or more servers, there are two or more remote servers using the secondary volume. Thus, it is necessary to describe the addresses of all of these servers.

The following values are defined in the HORCM_INST parameter:

dev_group

The server name described in dev_group of HORC_DEV.

ip_address

The network address of the specified remote server.

service

The port name assigned to the HORCM communication path (registered in the /etc/services file). If a port number is specified instead of a port name, the port number will be used.

A configuration for multiple networks can be found using the `raidqry -r <group>` command on each host. The current HORCM network address can be changed using `horcctl -NC <group>` on each host.

When you use all IP addresses of the local host in a configuration for multiple networks, specify NONE (for IPv4) or NONE6 (for IPv6) to the ip_address of the HORCM_MON parameter.

See the figure below for configuration for multiple networks.

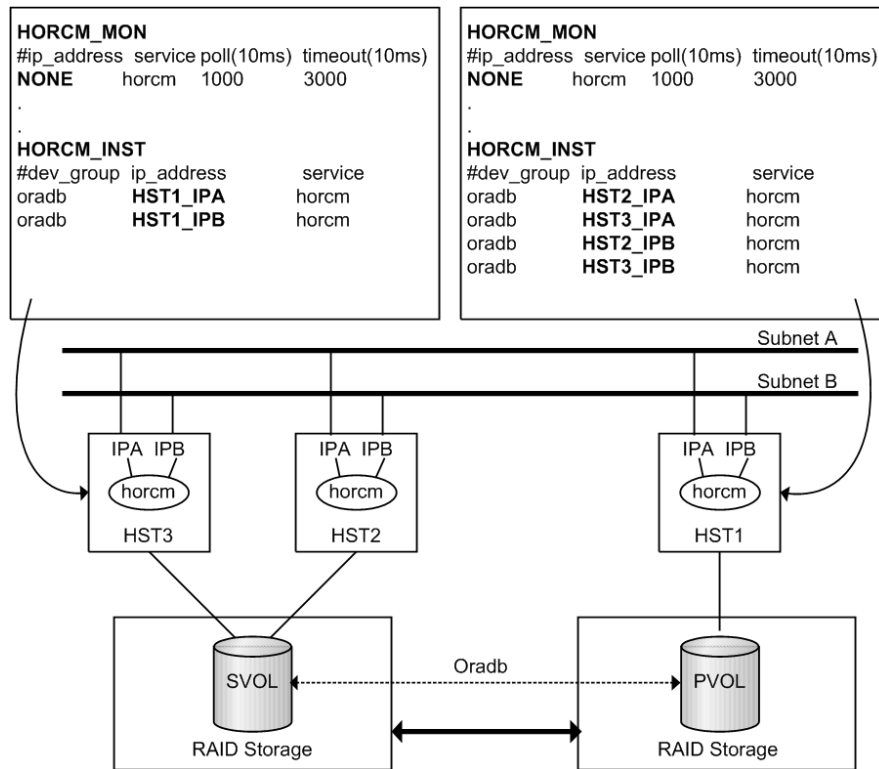

HORCM_LDEV

The HORCM_LDEV parameter is used for specifying stable LDEV# and Serial# as the physical volumes corresponding to the paired logical volume names. Each group name is unique and typically has a name fitting its use (for example, database data, Redo log file, UNIX file). The group and paired logical volume names described in this item must also be known to the remote server.

dev_group

This parameter is the same as HORCM_DEV parameter.

dev_name

This parameter is the same as HORCM_DEV parameter.

MU#

This parameter is the same as HORCM_DEV parameter.

Serial#

This parameter is used to specify the serial number of RAID box. For VSP G1x00 and VSP F1500, add a "3" at the beginning of the serial number. For example, for serial number 12345, enter 312345.

CU:LDEV(LDEV#)

This parameter is used to describe the LDEV number in the RAID storage system and supports three types of format as LDEV#.

#dev_group	dev_name	Serial#	CU:LDEV (LDEV#)	MU#
oradb	dev1	30095	02:40	0
oradb	dev2	30095	02:41	0

- Specifying "CU:LDEV" in hex.

Example for LDEV# 260:

01:04

- Specifying "LDEV" in decimal used by the CCI inqraid command.

Example for LDEV# 260:

260

- Specifying "LDEV" in hex used by the CCI inqraid command.

Example for LDEV# 260:

0x104



Note: The HORCM_LDEV format can only be used on the TagmaStore USP/TagmaStore NSC. LDEV# will be converted to "Port#, Targ#, Lun#" mapping to this LDEV internally, because the RAID storage system needs to specify "Port#, Targ#, Lun#" for the target device. This feature is TagmaStore USP/TagmaStore NSC microcode dependent; if HORCM fails to start, HORCM_DEV needs to be used.

HORCM_LDEVG

The HORCM_LDEVG parameter defines the device group information that the CCI instance reads. For details about device group, see LDEV grouping function.

The following values are defined.

Copy group

Specifies a name of copy group. This is equivalent to the dev_group of HORCM_DEV and HORCM_LDEV parameters.

CCI operates by using the information defined here.

ldev_group

Specifies a name of device group that the CCI instance reads.

Serial#:

Specifies a storage system serial number. For VSP G1x00 and VSP F1500, add a "3" at the beginning of the serial number. For example, for serial number 12345, enter 312345.

```
HORCM_LDEVG
#Copy_Group  ldev_group  Serial#
ora          grp1       64034
```

HORCM_INSTP

The HORCM_INSTP parameter is used when specifying a path ID for the link of TrueCopy/ Universal Replicator/global-active device as well as HORCM_INST parameter. You can specify from 1 to 255 for the path ID. If you do not specify the Path ID, the behavior is the same as when 'HORCM_INST' is used.

```
HORCM_INSTP
dev_group      ip_address      service  pathID
VG01           HSTA            horcm    1
VG02           HSTA            horcm    2
```



Note: The path ID can be specified at TrueCopy, Universal Replicator, Universal Replicator for Mainframe, and global-active device. However, the path ID cannot be specified at UR/URz when connecting USP V/VMM and USP/ NSC. The same path ID must be specified between the site of P-VOL and S-VOL because the path ID is used at the **paircreate** command.

HORCM_ALLOW_INST

The HORCM_ALLOW_INST parameter is used to restrict the users using the virtual command device. The allowed IP addresses and port numbers are as follows.

For IPv4

```
HORCM_ALLOW_INST
#ip_address      service
158.214.135.113  34000
158.214.135.114  34000
```

For IPv6

```
HORCM_ALLOW_INST
#ip_address      service
fe80::209:6bff:febe:3c17  34000
```



Note: Note: If CCI clients not defined HORCM_ALLOW_INST, HORCM instance starting up is rejected by SCSI check condition (SKEY=0x05, ASX=0xfe) and CCI cannot be started up.

Correspondence of the configuration definition file for cascading volume and mirror descriptors

The CCI software (HORCM) is capable of keeping a record of the multiple pair configurations per LDEV. CCI distinguishes the records of the each pair configuration by MU#. You can assign 64 MU#s for local copy products and 4 MU#s for remote copy products as the following figure, you can define up to 68 device groups (records of pair configuration) in the configuration definition file.

See the following figure for management of pair configuration by mirror descriptors.

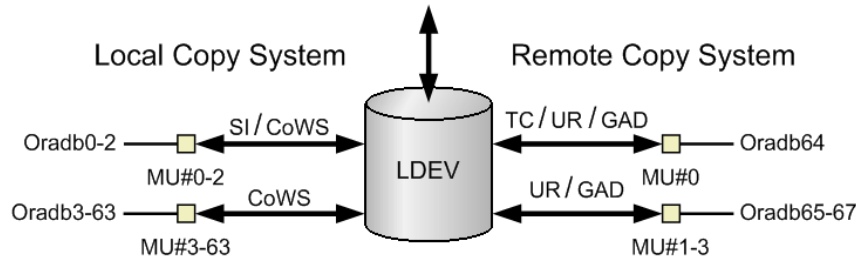

Legend

SI: ShadowImage CoWS: Copy-on-Write Snapshot
 TC: TrueCopy UR: Universal Replicator GAD: global-active device

Correspondence of configuration file and mirror descriptors

The group name and MU# that are noted in the HORCM_DEV section of the configuration definition file are assigned to the corresponding mirror descriptors. This outline is described in the following table. "Omission of MU#" is handled as MU#0, and the specified group is registered to MU#0 on ShadowImage/Copy-on-Write Snapshot and TrueCopy/Universal Replicator/global-active device. Also, when you note the MU# in HORCM_DEV, the sequence of the MU# can be random (for example, 2, 1, 0).

HORCM_DEV parameter in configuration file	MU#0		ShadowImage (Copy-on-Write Snapshot) only	UR/GAD
	TC/UR/GAD	SI	MU#1-#2 (MU#3-#63)	MU#1-#3
HORCM_DEV #dev_group dev_name port# TargetID LU# MU# Oradb oradev1 CL1-D 2 1	oradev1	oradev1	-	-
HORCM_DEV #dev_group dev_name port# TargetID LU# MU# Oradb oradev1 CL1-D 2 1 Oradb1 oradev11 CL1-D 2 1 1 Oradb2 oradev21 CL1-D 2 1 2	oradev1	oradev1	oradev11 oradev21	-

HORCM_DEV parameter in configuration file	MU#0		ShadowImage (Copy-on-Write Snapshot) only	UR/GAD
	TC/UR/GAD	SI	MU#1-#2 (MU#3-#63)	MU#1-#3
HORCM_DEV	oradev1	oradev11	oradev21	-
#dev_group dev_name port# TargetID LU# MU#			oradev31	
Oradb 1	oradev1	CL1-D	2	
Oradb1 1 0	oradev11	CL1-D	2	
Oradb2 1 1	oradev21	CL1-D	2	
Oradb3 1 2	oradev31	CL1-D	2	
HORCM_DEV	-	oradev1	-	-
#dev_group dev_name port# TargetID LU# MU#				
Oradb 1 0	oradev1	CL1-D	2	

HORCM_DEV parameter in configuration file	MU#0		ShadowImage (Copy-on-Write Snapshot) only	UR/GAD
	TC/UR/GAD	SI	MU#1-#2 (MU#3-#63)	MU#1-#3
HORCM_DEV #dev_group dev_name port# TargetID LU# MU# Oradb oradev1 CL1-D 2 1 h0	oradev1	-	-	-
HORCM_DEV #dev_group dev_name port# TargetID LU# MU# Oradb oradev1 CL1-D 2 1 0 Oradb1 oradev1 CL1-D 2 1 1 Oradb2 oradev21 CL1-D 2 1 2	-	oradev1	oradev11 oradev21	-

HORCM_DEV parameter in configuration file	MU#0		ShadowImage (Copy-on-Write Snapshot) only	UR/GAD
	TC/UR/GAD	SI	MU#1-#2 (MU#3-#63)	MU#1-#3
HORCM_DEV	oradev1	oradev11	-	oradev21
#dev_group dev_name port# TargetID LU# MU#				oradev31
Oradb1 oradev1 CL1-D 2				oradev41
Oradb11 oradev11 CL1-D 2				
Oradb21 oradev21 CL1-D 2				
Oradb31 oradev31 CL1-D 2				
Oradb41 oradev41 CL1-D 2				

Cascading connection and configuration files

A volume of the cascading connection describes entity in a configuration definition file on the same instance, and classifies connection of volume through the mirror descriptor. In case of TrueCopy/ShadowImage cascading connection, too, the volume entity describes to a configuration definition file on the same instance. The following figure shows an example.

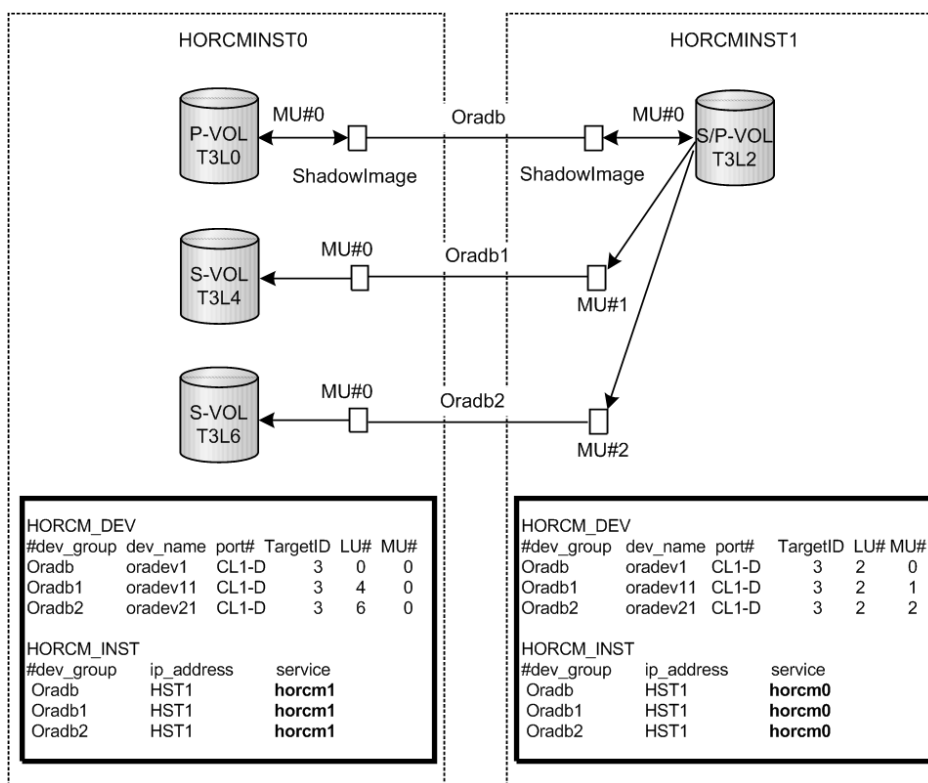

ShadowImage

Since ShadowImage is a mirrored configuration within one storage system, it can be described as a volume of the cascading connection according to two configuration definition files. For a ShadowImage-only cascading connection, the specified group is assigned to the mirror descriptor (MU#) of ShadowImage, specifically defining "0" as the MU# for ShadowImage. The following figures show ShadowImage cascading configurations and the **pairdisplay** information for each configuration.

Pairdisplay on HORCMINST0

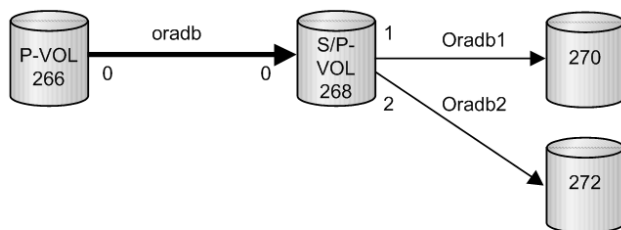

```
# pairdisplay -g oradb -m cas
Group PairVol(L/R) (Port#,TID,LU-M),Seq#,LDEV#.P/S,Status, Seq#,P-LDEV# M
oradb oradev1(L) (CL1-D, 3, 0-0) 30053 266..P-VOL PAIR,30053 268 -
oradb oradev1(R) (CL1-D, 3, 2-0) 30053 268..S-VOL PAIR,---- 266 -
oradb1 oradev11(R) (CL1-D, 3, 2-1) 30053 268..P-VOL PAIR,30053 270 -
oradb2 oradev21(R) (CL1-D, 3, 2-2) 30053 268..P-VOL PAIR,30053 272 -
```

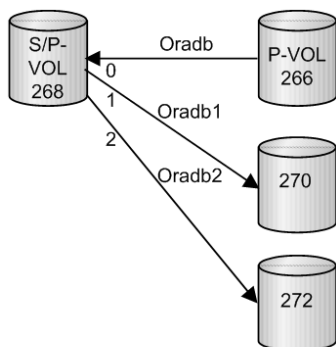
Pairedisplay on HORCMINST1

```
# pairedisplay -g oradb -m cas
Group PairVol(L/R) (Port#,TID,LU-M),Seq#,LDEV#.P/S,Status, Seq#,P-LDEV# M
oradb oradev1(L) (CL1-D , 3, 2-0)30053 268..S-VOL PAIR,----- 266 -
oradb1 oradev11(L) (CL1-D , 3, 2-1)30053 268..P-VOL PAIR,30053 270 -
oradb2 oradev21(L) (CL1-D , 3, 2-2)30053 268..P-VOL PAIR,30053 272 -
oradb oradev1(R) (CL1-D , 3, 0-0)30053 266..P-VOL PAIR,30053 268 -
```

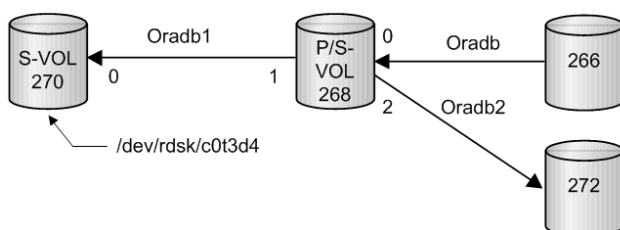
Pairedisplay on HORCMINST0

```
# pairedisplay -d /dev/rdisk/c0t3d4 -m cas
Group PairVol(L/R) (Port#,TID,LU-M),Seq#,LDEV#.P/S,Status, Seq#,P-LDEV# M
oradb1 oradev11(L) (CL1-D , 3, 4-0)30053 270..S-VOL PAIR,----- 268 -
oradb1 oradev11(R) (CL1-D , 3, 2-1)30053 268..P-VOL PAIR,30053 270 -
oradb oradev1(R) (CL1-D , 3, 2-0)30053 268..S-VOL PAIR,----- 266 -
oradb2 oradev21(R) (CL1-D , 3, 2-2)30053 268..P-VOL PAIR,30053 272 -
```

Cascading connections for TrueCopy and ShadowImage

The cascading connections for TrueCopy/ShadowImage can be set up by using three configuration definition files that describe the cascading volume entity in a configuration definition file on the same instance. The mirror descriptor of ShadowImage and TrueCopy definitely describe "0" as MU#, and the mirror descriptor of TrueCopy does not describe "0" as MU#.

TrueCopy/ShadowImage cascading connection and configuration file

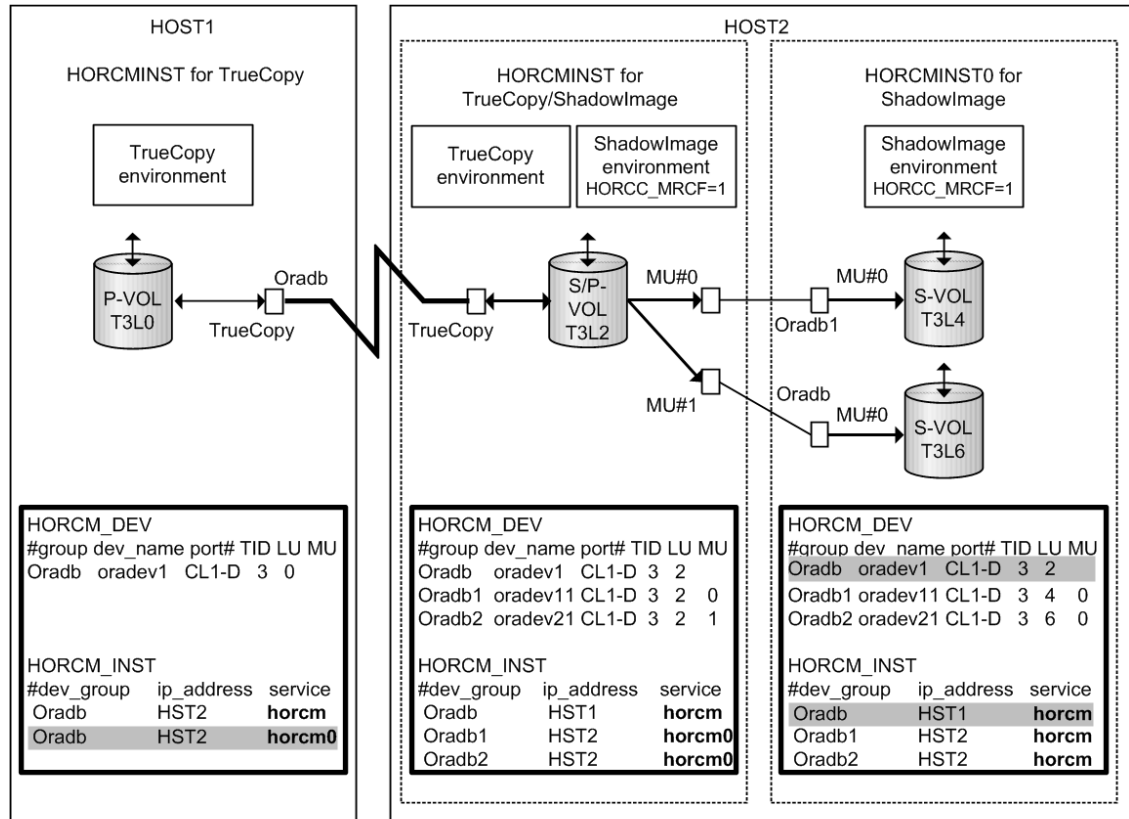

Note: Shaded portions: If HORCMINST0 needs to manage Hitachi TrueCopy's paired volume, and then "oradb" must describe that there is a connection to HST1 via HORCMINST0.

The following figures show TrueCopy/ShadowImage cascading configurations and the **pairedisplay** information for each configuration.

Pairedisplay for TrueCopy on HOST1

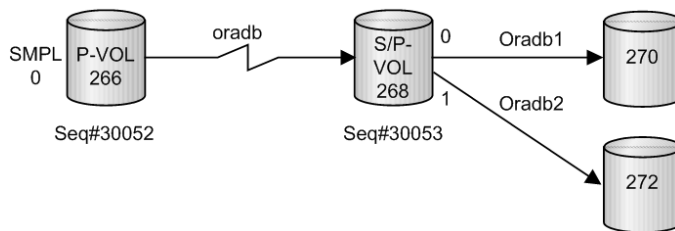

```

# pairedisplay -g oradb -m cas
Group PairVol(L/R) (Port#,TID,LU-M),Seq#,LDEV#.P/S,Status, Seq#,P-LDEV# M
oradb oradev1(L) (CL1-D, 3, 0-0) 30052 266..SMPL ----,---- -
oradb oradev1(L) (CL1-D, 3, 0) 30052 266..P-VOL COPY,30053 268 -
oradb1 oradev11(R) (CL1-D, 3, 2-0) 30053 268..P-VOL COPY,30053 270 -
oradb2 oradev21(R) (CL1-D, 3, 2-1) 30053 268..P-VOL PSUS,30053 272 W
oradb oradev1(R) (CL1-D, 3, 2) 30053 268..S-VOL COPY,---- 266 -
    
```

Pairedisplay for TrueCopy on HOST2 (HORCMINST)

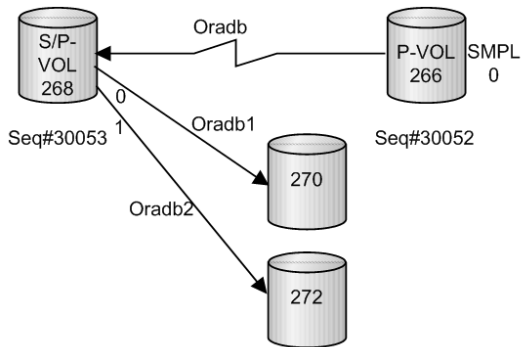

```
# pairedisplay -g oradb -m cas
Group PairVol(L/R) (Port#,TID,LU-M),Seq#,LDEV#.P/S,Status, Seq#,P-LDEV# M
oradb1 oradev11(L) (CL1-D , 3, 2-0) 30053 268..P-VOL PAIR,30053 270 -
oradb2 oradev21(L) (CL1-D , 3, 2-1) 30053 268..P-VOL PSUS,30053 272 W
oradb oradev1(L) (CL1-D , 3, 2) 30053 268..S-VOL PAIR, ---- 266 -
oradb oradev1(R) (CL1-D , 3, 0-0) 30052 266..SMPL ----, ---- -
oradb oradev1(R) (CL1-D , 3, 0) 30052 266..P-VOL PAIR, 30053 268 -
```

Pairedisplay for ShadowImage on HOST2 (HORCMINST)

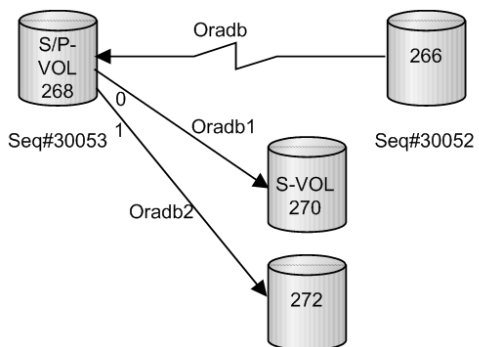

```
# pairedisplay -g oradb1 -m cas
Group PairVol(L/R) (Port#,TID,LU-M),Seq#,LDEV#.P/S,Status, Seq#,P-LDEV# M
oradb1 oradev11(L) (CL1-D , 3, 2-0) 30053 268..P-VOL PAIR,30053 270 -
oradb2 oradev21(L) (CL1-D , 3, 2-1) 30053 268..P-VOL PSUS,30053 272 W
oradb oradev1(L) (CL1-D , 3, 2) 30053 268..S-VOL PAIR, ---- 266 -
oradb oradev11(R) (CL1-D , 3, 4-0) 30053 270..S-VOL PAIR, ---- 268 -
```

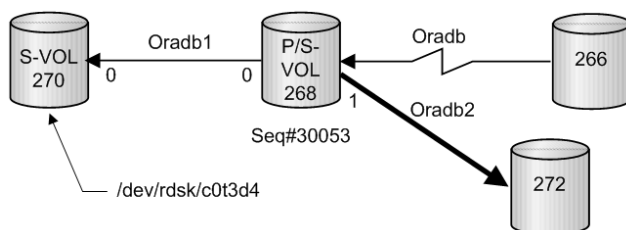
Pairedisplay for ShadowImage on HOST2 (HORCMINST0)

```
# pairedisplay -g oradb1 -m cas
Group PairVol(L/R) (Port#,TID,LU-M),Seq#,LDEV#,P/S,Status, Seq#,P-LDEV# M
oradb1 oradev11(L) (CL1-D , 3, 4-0) 30053 270..S-VOL PAIR,----- 268 -
oradb2 oradev11(R) (CL1-D , 3, 2-0) 30053 268..P-VOL PAIR, 30053 270 -
oradb2 oradev21(R) (CL1-D , 3, 2-1) 30053 268..P-VOL PSUS,30053 272 W
oradb oradev1 (R) (CL1-D , 3, 2) 30053 268..S-VOL PAIR, ----- 266 -

# pairedisplay -d /dev/rdsk/c0t3d4 -m cas
Group PairVol(L/R) (Port#,TID,LU-M),Seq#,LDEV#,P/S,Status, Seq#,P-LDEV# M
oradb1 oradev11(L) (CL1-D , 3, 4-0) 30053 270..S-VOL PAIR,----- 268 -
oradb2 oradev11(R) (CL1-D , 3, 2-0) 30053 268..P-VOL PAIR, 30053 270 -
oradb2 oradev21(R) (CL1-D , 3, 2-1) 30053 268..P-VOL PSUS,30053 272 W
oradb oradev1 (R) (CL1-D , 3, 2) 30053 268..S-VOL PAIR, ----- 266 -
```

CCI software files

The CCI software consists of files supplied with the software, log files created internally, and files created by the user. These files are stored on the local disk in the server machine.

- [CCI files supplied with the software \(on page 72\)](#)
- [CCI log and trace files \(on page 79\)](#)
- [User environment variable \(on page 89\)](#)

CCI files supplied with the software

- [CCI files for UNIX-based systems \(on page 72\)](#)
- [CCI files for Windows-based systems \(on page 74\)](#)
- [CCI files for OpenVMS-based systems \(on page 77\)](#)

CCI files for UNIX-based systems

Title	File name	Command name	Mode	User*	Group
HORCM	/etc/horcmgr	horcmd	0544	root	sys
HORCM_CONF	/HORCM/etc/horcm.conf	-	0444	root	sys
Takeover	/usr/bin/horctakeover	horctakeover	0544	root	sys

Title	File name	Command name	Mode	User*	Group
Accessibility check	/usr/bin/paircurchk	paircurchk	0544	root	sys
Pair generation	/usr/bin/paircreate	paircreate	0544	root	sys
Pair splitting	/usr/bin/pairsplit	pairsplit	0544	root	sys
Pair resynchronization	/usr/bin/pairresync	pairresync	0544	root	sys
Event waiting	/usr/bin/pairevtwait	pairevtwait	0544	root	sys
Error notification	/usr/bin/pairmon	pairmon	0544	root	sys
Volume check	/usr/bin/pairvolchk	pairvolchk	0544	root	sys
Pair configuration confirmation	/usr/bin/pairdisplay	pairdisplay	0544	root	sys
RAID scanning	/usr/bin/raidscan	raidscan	0544	root	sys
RAID activity reporting	/usr/bin/raidar	raidar	0544	root	sys
Connection confirming	/usr/bin/raidqry	raidqry	0544	root	sys
Trace control	/usr/bin/horcctl	horcctl	0544	root	sys
HORCM activation script	/usr/bin/horcstart.sh	horcstart.sh	0544	root	sys
HORCM shutdown script	/usr/bin/horcshutdown.sh	horcshutdow n.sh	0544	root	sys
Connection confirming	/HORCM/usr/bin/inraid	--	0544	root	sys
Synchronous waiting	/usr/bin/pairsyncwait	pairsyncwait	0544	root	sys
Configuration setting and confirming command	/HORCM/usr/bin/raidcfg	raidcfg	0544	root	sys

Title	File name	Command name	Mode	User*	Group
Text filtering	/HORCM/usr/bin/rmawk	rmawk	0544	root	sys
DB Validator setting	/usr/bin/raidvchkset	raidvchkset	0544	root	sys
DB Validator confirmation	/usr/bin/raidvchkdsp	raidvchkdsp	0544	root	sys
DB Validator confirmation	/usr/bin/raidvchkscan	raidvchkscan	0544	root	sys
Storage Replication Adapter	/HORCM/usr/bin/rmsra	rmsra	0544	root	sys
Configuration setting command	HORCM/usr/bin/raidcom	raidcom	0544	root	sys
A file for management	/HORCM/etc/Raidcom_Dic_Raid_RM_Patch.txt	-	0444	root	sys
A file for management	/HORCM/etc/Raidcom_Help_Raid_RM.txt	-	0444	root	sys
A file for management	/HORCM/etc/Raidcom_Dic_Raid_RM.txt	-	0444	root	sys
* For information and instructions for changing the UNIX user for the CCI software, see the <i>Command Control Interface Installation and Configuration Guide</i> .					

CCI files for Windows-based systems

Title	File name	Command name
HORCM	\HORCM\etc\horcmgr.exe	horcmd
HORCM_CONF	\HORCM\etc\horcm.conf	-
Takeover	\HORCM\etc\horctakeover.exe	horctakeover
Accessibility check	\HORCM\etc\paircurchk.exe	paircurchk
Pair generation	\HORCM\etc\paircreate.exe	paircreate
Pair split	\HORCM\etc\pairsplit.exe	pairsplit

Title	File name	Command name
Pair re-synchronization	\HORCM\etc\pairresync.exe	pairresync
Event waiting	\HORCM\etc\pairevtwait.exe	pairevtwait
Error notification	\HORCM\etc\pairmon.exe	pairmon
Volume checking	\HORCM\etc\pairvolchk.exe	pairvolchk
Pair configuration confirmation	\HORCM\etc\pairedisplay.exe	pairedisplay
RAID scanning	\HORCM\etc\raidscan.exe	raidscan
RAID activity reporting	\HORCM\etc\raidar.exe	raidar
Connection confirmation	\HORCM\etc\raidqry.exe	raidqry
Trace control	\HORCM\etc\horcctl.exe	horcctl
HORCM activation script	\HORCM\etc\horcmstart.exe	horcmstart
HORCM shutdown script	\HORCM\etc\horcmshutdown.exe	horcmshutd own
Synchronous waiting	\HORCM\etc\pairsyncwait.exe	pairsyncwait
Connection confirmation	\HORCM\etc\inqraid.exe	inqraid
Configuration setting and confirming command	\HORCM\Tool\mkconf.exe	mkconf
Text filtering	\HORCM\Tool\rmawk.exe	rmawk
Oracle Validation setting	\HORCM\etc\raidvchkset.exe	raidvchkset
Oracle Validation confirmation	\HORCM\etc\raidvchkdsp.exe	raidvchkdsp
Oracle Validation confirmation	\HORCM\etc\raidvchkscan.exe	raidvchkscan
Configuration setting command	\HORCM\etc\raidcom.exe	raidcom
A file for management	\HORCM\etc \Raidcom_Dic_Raid_RM_Patch.txt	-
A file for management	\HORCM\etc\Raidcom_Help_Raid_RM.txt	-
A file for management	\HORCM\etc\Raidcom_Dic_Raid_RM.txt	-
Tool	\HORCM\Tool\chgacl.exe	chgacl

Title	File name	Command name
Tool	\\HORCM\Tool\svcx.exe	svcx.exe
Sample script for svcx.exe	\\HORCM\Tool\HORCM0_run.txt	-
Tool	\\HORCM\Tool\TRCLOG.bat	TRCLOG
Storage Replication Adapter	\\HORCM\etc\rmsra.exe	rmsra
Takeover	\\HORCM\usr\bin\horctakeover.exe	horctakeover
Accessibility check	\\HORCM\usr\bin\paircurchk.exe	paircurchk
Pair generation	\\HORCM\usr\bin\paircreate.exe	paircreate
Pair split	\\HORCM\usr\bin\pairsplit.exe	pairsplit
Pair re-synchronization	\\HORCM\usr\bin\pairresync.exe	pairresync
Event waiting	\\HORCM\usr\bin\pairevtwait.exe	pairevtwait
Volume check	\\HORCM\usr\bin\pairvolchk.exe	pairvolchk
Synchronous waiting	\\HORCM\usr\bin\pairsyncwait.exe	pairsyncwait
Pair configuration confirmation	\\HORCM\usr\bin\pairdisplay.exe	pairdisplay
RAID scanning	\\HORCM\usr\bin\raidscan.exe	raidscan
Connection confirmation	\\HORCM\usr\bin\raidqry.exe	raidqry
Oracle Validation setting	\\HORCM\usr\bin\raidvchkset.exe	raidvchkset
Oracle Validation confirmation	\\HORCM\usr\bin\raidvchkdsp.exe	raidvchkdsp
Oracle Validation confirmation	\\HORCM\usr\bin\raidvchkscan.exe	raidvchkscan
Configuration setting and confirming command	\\HORCM\usr\bin\raidcfg.exe	raidcfg

**Note:**

- The \HORCM\etc\ commands are used from the console window. If these commands are executed without an argument, the interactive mode will start up.
- The \HORCM\usr\bin commands have no console window, and can therefore be used from the application.
- The \HORCM\usr\bin commands do not support the directory mounted volumes in subcommands.
- \HORCM\Tool\TRCLOG.bat is a troubleshooting tool. This tool is not usually used.
- \HORCM\etc\rmsra.exe is the binary data used for cooperation with VMware. This is used directly by VMware, not usually used by users.

CCI files for OpenVMS-based systems

Title	File name	Command name	User
HORCM	\$ROOT:[HORCM.etc]horcmgr.exe	horcmd	sys
HORCM_CONF	\$ROOT:[HORCM.etc]horcm.conf	-	sys
Takeover	\$ROOT: [HORCM.usr.bin]horctakeover.exe	horctakeover	sys
Volume accessibility check	\$ROOT: [HORCM.usr.bin]paircurchk.exe	paircurchk	sys
Pair generation	\$ROOT: [HORCM.usr.bin]paircreate.exe	paircreate	sys
Pair splitting	\$ROOT:[HORCM.usr.bin]pairsplit.exe	pairsplit	sys
Pair re-synchronization	\$ROOT: [HORCM.usr.bin]pairresync.exe	pairresync	sys
Event waiting	\$ROOT: [HORCM.usr.bin]pairevtwait.exe	pairevtwait	sys
Error notification	\$ROOT:[HORCM.usr.bin]pairmon.exe	pairmon	sys
Volume checking	\$ROOT: [HORCM.usr.bin]pairvolchk.exe	pairvolchk	sys
Pair config. confirmation	\$ROOT: [HORCM.usr.bin]pairdisplay.exe	pairdisplay	sys
RAID scan	\$ROOT:[HORCM.usr.bin]raidscan.exe	raidscan	sys
RAID activity report	\$ROOT:[HORCM.usr.bin]raidar.exe	raidar	sys

Title	File name	Command name	User
Connection confirmation	\$ROOT:[HORCM.usr.bin]raidqry.exe	raidqry	sys
Trace control	\$ROOT:[HORCM.usr.bin]horcctl.exe	horcctl	sys
HORCM activation script	\$ROOT: [HORCM.usr.bin]horcmstart.exe	horcmstart.sh	sys
HORCM shutdown script	\$ROOT: [HORCM.usr.bin]horcmshutdown.exe	horcmshutdown.sh	sys
Connection confirmation	\$ROOT:[HORCM.usr.bin]inqraid.exe	-	sys
Synchronous waiting	\$ROOT: [HORCM.usr.bin]pairsyncwait.exe	pairsyncwait	sys
Configuration file making	\$ROOT:[HORCM.usr.bin]mkconf.exe	-	sys
Text filtering	\$ROOT:[HORCM.usr.bin]rmawk.exe	-	sys
Database Validator setting	\$ROOT: [HORCM.usr.bin]raidvchkset.exe	raidvchkset	sys
DB Validator confirmation	\$ROOT: [HORCM.usr.bin]raidvchkdsp.exe	raidvchkdsp	sys
DB Validator confirmation	\$ROOT: [HORCM.usr.bin]raidvchkscan.exe	raidvchkscan	sys
Storage Replication Adapter	\$ROOT:[HORCM.usr.bin]rmsra.exe	rmsra	sys
Sample file for horcmstart	\$ROOT:[HORCM]loginhorcm*.com	-	sys
Sample file for horcmstart	\$ROOT:[HORCM]runhorcm*.com	-	sys

**Note:**

- \$ROOT is defined as SYS\$POSIX_ROOT. \$POSIX_ROOT is necessary when using C RTL.
- The user name for OpenVMS is "System".

CCI log and trace files

The CCI software (HORCM) maintains internal startup log files, execution log files, and trace files that can be used to identify the causes of errors and to keep records of the status transition history of the paired volumes.

- [CCI log files \(on page 79\)](#)
- [CCI trace files \(on page 82\)](#)
- [CCI trace control command \(on page 82\)](#)
- [Command logging for audit \(on page 82\)](#)

CCI log files

HORCM logs are classified into startup logs and execution logs.

- The startup logs contain data on errors that occur before HORCM becomes ready to provide services. Thus, if HORCM fails to start up due to improper environment setting, refer to the startup logs to resolve the problem.
- The HORCM execution logs (error log, trace, and core files) contain data on errors that are caused by software or hardware problems. These logs contain internal error data that does not apply to any user settings, therefore, you do not need to refer to the HORCM execution logs.
- When an error occurs in execution of a command, data on the error is collected in the command log file. Refer to the command log file if a command execution error occurs.

The following figure shows a graphical representation of the CCI log and trace files within the CCI configuration environment.

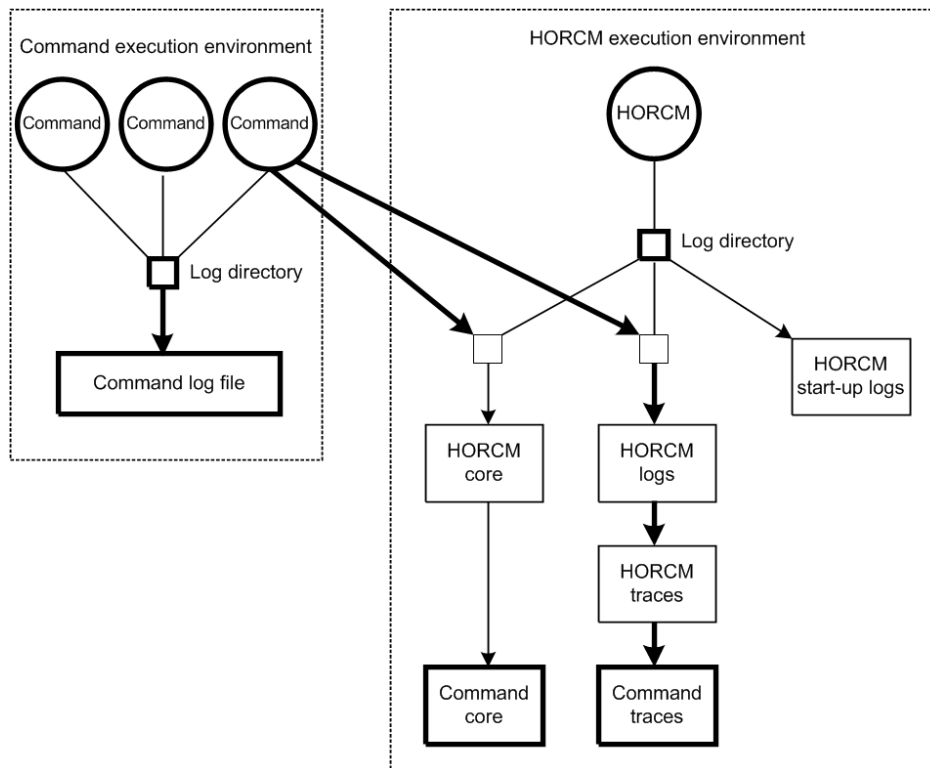

The startup log, error log, trace, and core files are stored as shown in the following table. Specify the directories for the HORCM and command log files using the HORCM_LOG and HORCC_LOG environment variables. If it is not possible to create the log files, or if an error occurs before the log files are created, the error logs are output in the system log file. If the HORCM activation fails, the system administrator should check the system log file and activation log, identify the error cause, and take the proper action. The system log file for UNIX-based systems is the syslog file. The system log file for Windows-based systems is the event log file.

File	UNIX-based systems	Windows-based systems
Start up log	HORCM startup log: \$HORCM_LOG/horcm_HOST.log Command log: \$HORCC_LOG/ horcc_HOST.log \$HORCC_LOG/horcc_HOST.oldlog	HORCM startup log: \$HORCM_LOG\horcm_HOST_log.txt Command log: \$HORCC_LOG \horcc_HOST_log.txt \$HORCC_LOG\horcc_HOST_oldlog.txt
Error log	HORCM error log: \$HORCM_LOG/horcmlog_HOST/ horcm.log	HORCM error log: \$HORCM_LOG\horcmlog_HOST \horcm_log.txt
Trace	HORCM trace: \$HORCM_LOG/horcmlog_HOST/ horcm_PID.trc	HORCM trace: \$HORCM_LOG\horcmlog_HOST \horcm_PID_trc.txt

File	UNIX-based systems	Windows-based systems
	Command trace: \$HORCM_LOG/horcmlog_HOST/ horcc_PID.trc	Command trace: \$HORCM_LOG\horcmlog_HOST \horcc_PID_trc.txt
Core	HORCM core: \$HORCM_LOG/core_HOST_PID/ core Command core: \$HORCM_LOG/core_HOST_PID/ core	HORCM core: \$HORCM_LOG \core_HOST_PID\core Command core: \$HORCM_LOG\core_HOST_PID\core



Note: HOST denotes the host name of the corresponding machine. PID denotes the process ID of that machine.

The location of the directory containing the log file depends on your command execution environment and the HORCM execution environment. The command trace file and core file reside together under the directory specified in the HORCM execution environment. A directory specified using the environment variable HORCM_LOG is used as the log directory in the HORCM execution environment. If no directory is specified, the directory /tmp is used. A directory specified using the environment variable HORCC_LOG is used as the log directory in the command execution environment. If no directory is specified, the directory /HORCM/log* is used (* = instance number). A nonexistent directory can be specified as a log directory using the environment variable.

The following table shows the environment variables for log directories.

Directory name	Definition
\$HORCM_LOG	A directory specified using the environment variable HORCM_LOG. The HORCM log file, trace file, and core file as well as the command trace file and core file are stored in this directory. If no environment variable is specified, "/HORCM/log/curlog" is used.
\$HORCC_LOG	A directory specified using the environment variable HORCC_LOG. The command log file is stored in this directory. If no environment variable is specified, the directory "/HORCM/log*" is used (* is the instance number). While the HORCM is running, the log files are stored in the \$HORCM_LOG directory shown in (a). When the HORCM starts up, the log files created in the operation are stored automatically in the \$HORCM_LOGS directory shown in (b). a. HORCM log file directory in operation \$HORCM_LOG = /HORCM/log*/curlog (* is instance number)

Directory name	Definition
	b. HORCM log file directory for automatic storing \$HORCM_LOGS = /HORCM/log*/tmplog (* is instance number)

CCI trace files

The command trace file is used for maintenance aiming at troubleshooting. It is not created normally. If a cause of an error cannot be identified using the log file, the environment variables or trace control commands with trace control parameters are issued to start tracing and the trace file is created. The trace control parameters include trace level, file size, mode, etc. More detailed tracing is enabled by increasing the trace level. Tracing is made in wraparound within the range of the file size. HORCM makes the trace file according to the trace level specified in the HORCM startup shell script set to activate the HORCM.

CCI trace control command

The trace control command (one of the HORCM control commands) sets or changes the trace control parameters. This command is used for troubleshooting and maintenance. If no trace control parameters can be specified using the environment variables in your command execution environment, it is possible to change the trace control parameters into the global parameters using this command. The following table lists and describes the parameters of the trace control command.

Parameter	Function
Trace level parameter	Specifies the trace level, range = 0 to 15.
Trace size parameter	Specifies the trace file size in KB.
Trace mode parameter	Specifies the buffer mode or non-buffer mode for writing data in the trace file.
Trace type parameter	Specifies the trace type defined internally.
Trace change instruction	Specifies the command or CCI instance for which the trace control parameters are changed.

Command logging for audit

- [Logging other than raidcom command \(on page 83\)](#)
- [Logging raidcom command \(on page 85\)](#)

Logging other than raidcom command

This section explains the logging other than the **raidcom** command described in Logging raidcom command..

CCI supports command logging, this logging function cannot be used for auditing the script issuing the command. Thus, CCI supports the function logging the result of the command executions by expanding the current logging.

This function has the following control parameters.

\$HORCC_LOGSZ variable

This variable is used to specify a maximum size (in units of KB) and normal logging for the current command. /HORCM/log*/horcc_HOST.log file is moved to the /HORCM/log*/horcc_HOST.oldlog file when reaching in the specified maximum size. If this variable is not specified or specified as 0, it is same as the current logging for only command error.

This variable is able to define to the environment variable and/or horcc_HOST.conf as discussed below.

For example setting 2MB size: HORCC_LOGSZ=2048 Export HORCC_LOGSZ

/HORCM/log*/horcc_HOST.conf file

This file is used to describe HORCC_LOGSZ variable and the masking variable for logging. If the HORCC_LOGSZ as the environment variable is not specified, then HORCC_LOGSZ variable of this file is used. If both variable is not specified, then it is same as the current logging for only command error.

HORCC_LOGSZ variable

This variable must be described as follows: HORCC_LOGSZ=2048

Masking variable

This variable is used to mask (disable) the logging by specifying a condition of the command and returned value (except inqraid or EX_XXX error code). This variable is valid for NORMAL exit.

If executing the **pairvolchk** command repeatedly at every interval (30 seconds), logging of this command might not be wanted. Therefore, you can mask it by specifying HORCC_LOGSZ=0 as shown below, and you might need to change your scripts if tracing is ON.

Example of masking **pairvolchk** on a script:

```
Export HORCC_LOGSZ=0 Pairvolchk -g xxx -s Unset HORCC_LOGSZ
```

The masking feature is to enable the tracing without changing their scripts. And this feature is available for all CCI commands (except **inqraid** or **EX_XXX error code**).

For example, if you want to mask pairvolchk (returns 22) and raidqry, specify the following:

```
pairvolchk=22 raidqry=0
```

You can track script performance, and then decide to mask by auditing the command logging file, as needed.

Relationship between an environment variable and horcc_HOST.conf

Logging depends on the \$HORCC_LOGSZ environment variable and/or the HORCC_HOST.conf file as shown below.

\$HORCC_LOGSZ	HORCC_HOST.conf	Performing
=value	Any (does not matter)	Tracing within this APP
=0		NO tracing within this APP
Unspecified	HORCC_LOGSZ=value	Global tracing within this CCI instance
	HORCC_LOGSZ=0	NO global tracing within this CCI instance
	Unspecified or nonexistent	Use the default value (0) The same as the current logging for only command error

Examples for execution: /HORCM/log* directory

```
[root@raidmanager log9]# ls -l
total 16
drwxr-xr-x  3 root root   4096 Oct 27 17:33 curlog
-rw-r--r--  1 root root   3936 Oct 27 17:36 horcc_raidmanager.log
-rw-r--r--  1 root root 2097452 Oct 27 17:29 horcc_raidmanager.oldlog
-rw-r--r--  1 root root     46 Oct 27 17:19 horcc_raidmanager.conf
drwxr-xr-x  3 root root   4096 Oct 27 17:19 tmplog
```

Examples for execution: /HORCM/log*/horcc_HOST.log file

```
COMMAND NORMAL : EUserId for HORC : root (0) Tue Nov  1 12:21:53 2005
CMDLINE : pairvolchk ss g URA
12:21:54-2d27f-10090- [pairvolchk][exit(32)]
COMMAND NORMAL : EUserId for HORC : root (0) Thu Oct 27 17:36:32 2005
CMDLINE : raidqry l
17:36:32-3d83c-17539- [raidqry][exit(0)]
COMMAND ERROR  : EUserId for HORC : root (0) Thu Oct 27 17:31:28 2005
CMDLINE : pairdisplay g UR
17:31:28-9a206-17514- ERROR:cm_sndrcv[rc < 0 from HORCM]
17:31:28-9b0a3-17514- [pairdisplay][exit(239)]
[EX_ENOGRP] No such group
[Cause ]:The group name which was designated or the device name
doesn't exist in the configuration file, or the network address
for remote communication doesn't exist.
[Action]:Please confirm if the group name exists in the
configuration file of the local and remote host
```

Examples for execution: /HORCM/log*/horcc_HOST.conf file

```
# For Example
HORCC_LOGSZ=2048
#The masking variable
#This variable is used to disable the logging by the command and exit code.
#For masking below log pairvolchk returned '32' (status is SVOL_COPY)
#COMMAND NORMAL : EUserId for HORC : root (0) Tue Nov 1 12:21:53 2005
#CMDLINE : pairvolchk ss g URA
#12:21:54-2d27f-10090- [pairvolchk] [exit(32)]
pairvolchk=32
pairvolchk=22
```

Logging raidcom command

The history of performing **raidcom** command can be stored in syslog server by outputting it to the syslog file. Since the information of what command was performed by who and when are recorded on the syslog file, this is available to use for audit log.

Output the syslog file by using syslog service on the host OS. For details, refer to the host OS manual.

**Caution:**

- The packet loss occurs on the syslog because the syslog uses UDP communication. The log is also lost when the server to be received the syslog is down because the server does not have a function to store the data until it recovered. If you want to record the same log at the client side by considering the lost of syslog at the syslog server, refer to the output setting of the syslog file.
- This syslog files are not deleted automatically. Delete unnecessary files accordingly, or make run the log rotation by installing such as the logrotate service separately.

The conditions to support the output of syslog file

The conditions to support this function are explained in the following:

Supported OS

This function is supported only when the OS of the host is one of the following (Windows is out of support):

- Solaris 2.5
- Solaris 10/x86
- HP-UX 10.20/11.0/11.2x
- AIX 4.3
- Red Hat Linux 6.0, 7.0, 8.0 AS/ES 2.1, 3.0, 4.0, 5.0
- AS/ES 2.1, 3.0 Update2, 4.0, 5.0 on EM64T / IA641

Target command

The following shows the **raidcom** command that is target to be output on the syslog file.

- Setting commands
- raidcom get command status
- Authentication commands (performing the authentication command at the prompt also becomes the target.)

However, if the command is not issued to the DKC by detecting the **raidcom** command execution error beforehand, the command becomes out of target even if it falls under the above items.

Output setting for the syslog file

A syslog file is output when "1" is set on the RAIDCOM_SYSLOG of environment variables. The syslog file is not output at the stage of initial setting.

How to set the syslog.conf:

The contents that can be set on the syslog.conf for the environment setting might vary in each OS. However, set basically according to the syslog.conf described in the following:

Setting example (It might vary by the host OS)

▪ Client side (extracts)

```
user.info                               /var/log/raidcomuser.err
                                       /var/log/raidcom.erruser.info
                                       @host1234user.err
@host1234
```

▪ Server side (extracts)

```
user.info                               /var/log/raidcomuser.err
                                       /var/log/raidcom.err
```

You can record the same log at the client side by considering the lost of syslog at the syslog server. In this case, add the following settings.

- facility:user
- level:info/err ("info" for the normal command operation; "err" for the abnormal command operation.)

Syslog file display information

Three kinds of information for one **raidcom** command are output on the syslog file.

- Title row (first row)
- Command row (second row)
- Result rows (3 - 132 rows): the number of rows changes depending on the issuing command.

Display information of the title row

Item	Output example
Syslog fixed output part (Including the host name)	Jun 27 10:15:13 rmsolx86 raidcom: [ID 702911 user.info] *It varies depending on the host OS.
Process ID	PID:1234
Command status	COMMAND NORMAL or COMMAND ERROR
Separation	:
User name Title	EUserId for HORC :
User name of the host	root
(user ID)	(0)
Time that performed raidcom	Wed Jun 27 10:15:13 2012

Display information of the command row

Item	Output example
Syslog fixed output part (Including the host name)	Jun 27 10:15:13 rmsolx86 raidcom: [ID 702911 user.info] *It varies depending on the host OS.
Process ID	PID:1234
Title for performed command	CMDLINE:
Performed command	raidcom modify ldev -ldev_id 1234 -status nml

Display information of the result rows

Item	Output example
Syslog fixed output part (Including the host name)	Jun 27 10:15:13 rmsolx86 raidcom: [ID 702911 user.info] *It varies depending on the host OS.
Process ID	PID:1234
[raidcom]	[raidcom]

Item	Output example
Rows for the error information	[EX_CMDRJE] An order to the control/command device was rejected It was rejected due to SKEY=0x05, ASC=0x26, ASCQ=0x00, SSB=0x2E11,0x2205 on Serial#(64568)
Result of get_command_status	HANDLE SSB1 SSB2 ERR_CNT Serial# Description 00c4 - - 0 200414 -
Rows for the returned values of a command	[exit(0)]

See the following display examples (It might vary depending on the host OS):

Logs: during normal operation

```
Aug 24 12:24:37 raidmanager raidcom: PID:06864 COMMAND NORMAL : EUserID
for HORC : root(0) Fri Aug 24 12:24:36 2012
Aug 24 12:24:37 raidmanager raidcom: PID:06864 CMDLINE : raidcom get
command_status -ldev_id 0001
Aug 24 12:24:37 raidmanager raidcom: PID:06864 [raidcom] HANDLE SSB1
SSB2 ERR_CNT Serial# Description
Aug 24 12:24:37 raidmanager raidcom: PID:06864 [raidcom] 00c3 -
- 0 64568 -
Aug 24 12:24:37 raidmanager raidcom: PID:06864 [raidcom] [exit(0)]
```

Logs: during abnormal operation

```
Aug 24 12:24:27 raidmanager raidcom: PID:06857 COMMAND ERROR : EUserID for
HORC : root(0) Fri Aug 24 12:24:19 2012
Aug 24 12:24:27 raidmanager raidcom: PID:06857 CMDLINE : raidcom get
command_status
Aug 24 12:24:27 raidmanager raidcom: PID:06857 [raidcom] User for
Serial#[64568] : user1234
Aug 24 12:24:27 raidmanager raidcom: PID:06857 [raidcom] User
authentication has failed on Serial#(64568).
Aug 24 12:24:27 raidmanager raidcom: PID:06857 [raidcom] [EX_ENAUTH]
Authentication failed with User
Aug 24 12:24:27 raidmanager raidcom: PID:06857 [raidcom] [exit(202)]
```

User-created files

CCI supports scripting to provide automated and unattended copy operations. A CCI script contains a list of CCI commands that describes a series of TrueCopy and/or ShadowImage operations. The scripted commands for UNIX-based platforms are defined in a shell script file. The scripted commands for Windows-based platforms are defined in a text file. The host reads the script file and sends the commands to the command device to execute the TrueCopy/ShadowImage operations automatically.

The CCI scripts are:

- **HORCM startup script (horcmstart.sh, horcmstart.exe):** A script that starts HORCM (/etc/horcmgr), sets environment variables as needed (for example, HORCM_CONF, HORCM_LOG, HORCM_LOGS), and starts HORCM.
- **HORCM shutdown script. (horcmshutdown.sh, horcmshutdown.exe):** A script for stopping the HORCM (/etc/horcmgr).
- **HA control script:** A script for executing takeover processing automatically when the cluster manager (CM) detects a server error.

When constructing the HORCM environment, the system administrator should make a copy of the `horcm.conf` file. The copied file should be set according to the system environment and registered as the following file (* is the instance number):

UNIX systems: `/etc/horcm.conf` or `/etc/horcm*.conf`

Windows systems: `%windir%\horcm.conf` or `%windir%\horcm*.conf`

User environment variable

When HORCM or command is invoked, environment variable can be specified.

Chapter 3: CCI functions

This chapter describes the CCI functions.

System configuration using CCI

This section describes system configurations using the in-band method or out-of-band method. In addition, a system configuration for connecting to an in-band CCI server by using the out-of-band method is also described. For an overview of the in-band and out-of-band methods, see [Command execution by the in-band and out-of-band methods](#).

In-band system configurations and out-of-band system configurations

Values to specify for HORCM_CMD in the configuration definition file are different between in-band and out-of-band method system configurations.

- **In-band method.** This method specifies the device special file of command device in the configuration definition file. For details about contents to specify for HORCM_CMD, see [HORCM_CMD \(in-band method\)](#) topic.
- **Out-of-band method.** This method specifies the SVP for creating virtual command devices or IP addresses of GUM in the command definition file. For details about contents to specify for HORCM_CMD, see [HORCM_CMD \(out-of-band method\)](#) topic.

The location of the virtual command device depends on the type of storage system. The following table lists the storage system types and indicates the allowable locations of the virtual command device.

Storage system type	Location of virtual command device		
	SVP	GUM	CCI server ¹
VSP Gx00 models, VSP Fx00 models	OK ²	OK	OK
VSP G1x00 and VSP F1500	OK	Not allowed	OK
HUS VM	OK	Not allowed	OK
VSP	OK	Not allowed	OK

1. A CCI server is a remote CCI server connected via LAN.
2. CCI on the SVP must be configured as a CCI server in advance.

The following figures show a system configuration example and a setting example of a command device and a virtual command device using the in-band and out-of-band methods.

Note: For the out-of-band method using the maintenance utility (GUM) of VSP Gx00 models and VSP Fx00 models, the command might time out if a controller with GUM is maintained. Before the maintenance, change command devices so that you use a virtual command device of the other GUM. For details about how to switch command devices, see Alternate command device function.

The following figure shows system configuration example of in-band and out-of-band methods (VSP).

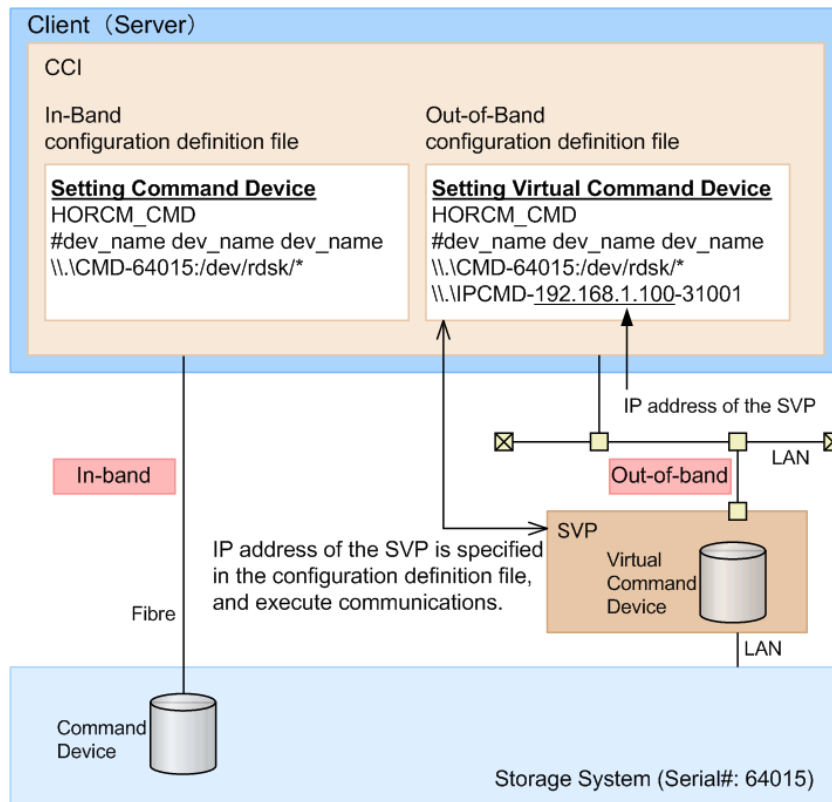

In the following figure, CCI B is the CCI server of CCI A. Users can issue a command from CCI A to a storage system via a virtual command device of CCI B. Commands can also be issued directly from CCI B without using CCI A.

The following figure shows a system configuration example of in-band and out-of-band methods (VSP G800, VSP F800).

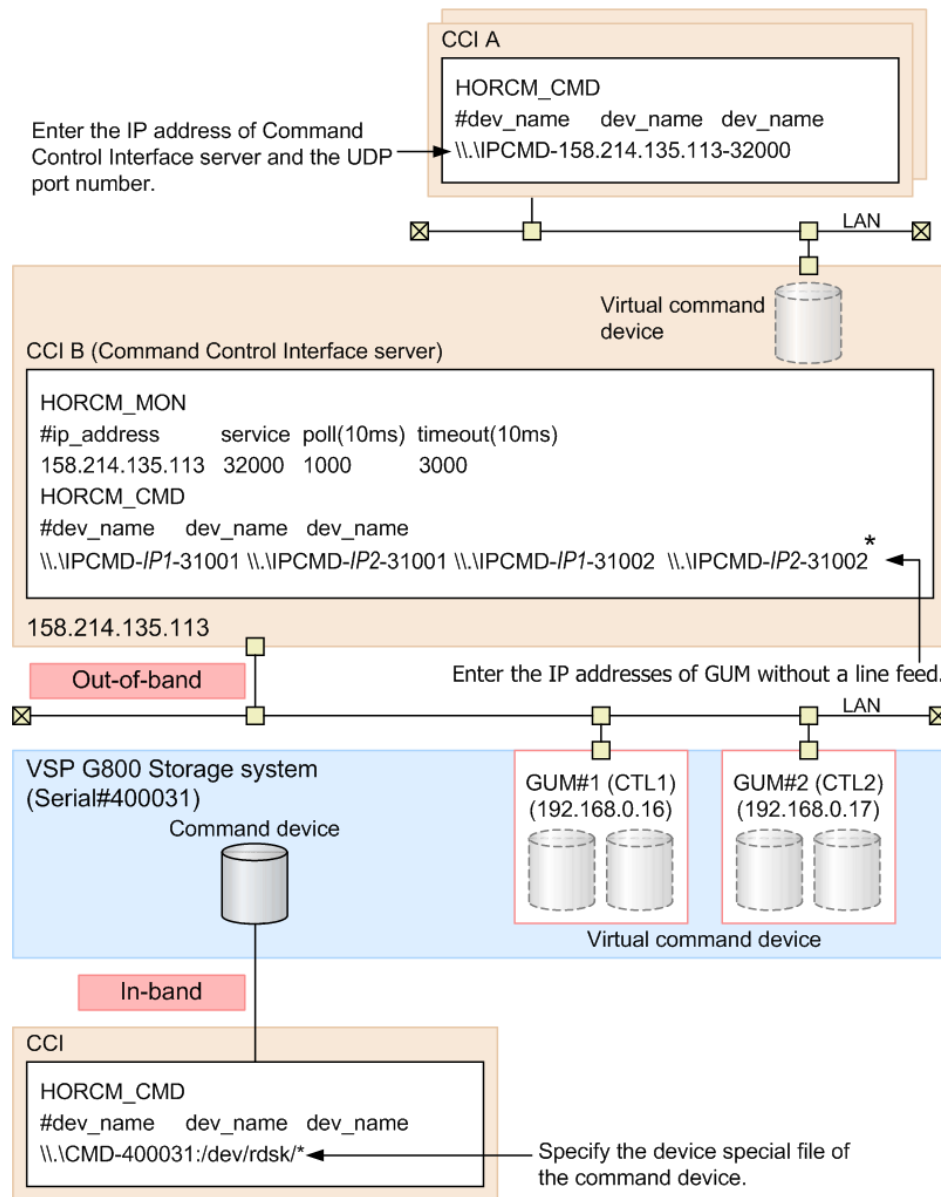

* When you write the configuration definition file, replace *IP1* with IP address of GUM#1 and *IP2* with IP address of GUM#2.



Note: In the out-of-band method using SVP of VSP G1x00 and VSP F1500, VSP, or HUS VM, a command times out if the microcode of the SVP is changed. Execute the command again after the microcode change completes.

System configuration for connecting to a CCI server connected by the in-band method using the out-of-band method

In the out-of-band method, CCI server ports can be specified as virtual command devices. Specifying a CCI server port as a virtual command device allows you to use the out-of-band method to connect to a CCI server connected to a storage system using the in-band method. For details about settings for HORCM_CMD in the configuration definition file of this configuration, see HORCM_CMD (out-of-band method) topic.

Tip: If you specify a CCI server port as a virtual command device, it achieves better performance than the out-of-band method which specifies SVP or GUM as a virtual command device.

The following figure shows a system configuration example when a CCI server is connected to a storage system using the in-band method.

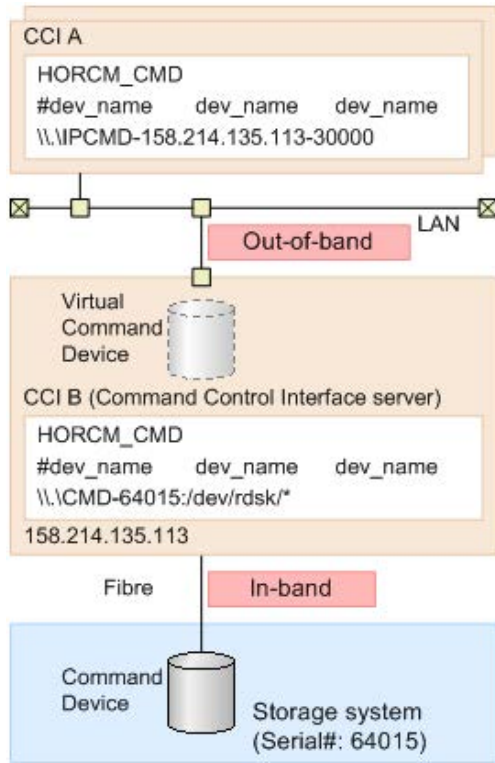

Connecting to CCI server already connected by In-Band method using Out-of-Band method

In Out-of-Band method, CCI server port can also be specified as a virtual command device. For this reason, CCI server which connected to a storage system in In-Band method can be connected in Out-of-Band method. If a CCI server is specified as a virtual command device, it provides better performance than the Out-of-Band method with specified SVP/GUM as a virtual command device.

Hardware requirements

CCI uses SCSI path through driver to issue I/O for command device. To use CCI server port as virtual command device, the virtual command device interface needs to be converted to the actual SCSI path through interface. Following is the environment for using CCI server port as a virtual command device.

- CCI server which can set virtual command devices

CCI support platform except Tru64UNIX and the environment can be used SCSI path through driver

- Client PC which can issue commands to virtual command devices

It must be CCI support platform.

- Initiator port

Initiator port is required on the following storage systems: Virtual Storage Platform, Unified Storage VM, Virtual Storage Platform G1000, Virtual Storage Platform G1500, and Virtual Storage Platform F1500.

Following is the default port number.

If not specified the instance number: 34000

If specified instance number (X): $34000 + X + 1$

If you change the default port number, use following environment variables.

`$HORCM_IPSCPORT=<services>*`

* <services>: port number or service name

For details about supported platforms, see the *Command Control Interface Installation and Configuration Guide*.

I/O Traffic Control

Synchronized I/O is issued from a virtual command device. The queueing time might occur because of the heavy I/O traffic because the virtual command device has to relay the command to the next virtual command device in the cascade configuration using the virtual command device. To improve the response in this environment, define the configuration so that asynchronous I/O is issued using the following environment variables.

```
$HORCM_IPSCPAIO=1
```

Security setting

Following security can be set.

- Specifying security of IP address and port number

By defining IP address and port number of the client PC that issues command to virtual command device to HORCM_ALLOW_INST in the configuration definition file, users who can use virtual command device can be restricted. For the details about the settings to HORCM_ALLOW_INST, please refer to "Configuration definition file".

- Security setting for virtual command device

By using the following environment variable, security can be set to virtual command device.

```
$HORCM_IPCMDSEC=<value>
```

Security setting for virtual command device

Specify the number (from 0 to 7) to <value> depending on the contents of the security which you want, in reference with the following table.

Value specified for <value>	Command device setting			
	Security setting	User authentication	Device group definition	Security to be set (see Notes)
0	OFF	OFF	OFF	No security
1	OFF	OFF	ON	Only HORCM_DEV allowed
2	OFF	ON	OFF	User authentication required
3	OFF	ON	ON	User authentication required Only HORCM_DEV allowed
4	ON	OFF	OFF	CMD security
5	ON	OFF	ON	CMD security Only HORCM_DEV allowed
6	ON	ON	OFF	CMD security User authentication required
7	ON	ON	ON	CMD security

Value specified for <value>	Command device setting			
	Security setting	User authentication	Device group definition	Security to be set (see Notes)
				User authentication required Only HORCM_DEV allowed
<p>Notes:</p> <ul style="list-style-type: none"> ▪ ON: Enabled ▪ OFF: Disabled ▪ Only HORCM_DEV allowed: the operation can be performed only for paired logical volumes described in HORCM_DEV. ▪ User authentication required: only commands issued by authorized users can be executed. ▪ CMD security: only devices recognizable from the host can be operated. For details about CMD security, see Data Protection facility (on page 327). 				

User authentication

CCI allows user authentication by using the operation authority of a user set by:

- Storage Navigator
- Device Manager - Storage Navigator
- Maintenance utility

User authentication is arbitrary in the Replication operation in the in-band method while the operation by user authentication is mandatory in the configuration information operation and in the out-of-band method.

To enable the user authentication function, the user authentication mode of the command device accessed by CCI must be enabled.

The user authentication function inputs a login command from the client (server) and, to authenticate the user ID and password sent from CCI and the same types of information maintained by the storage system, issues an authentication request to the authentication module (SVP/GUM).

If the user ID and password which are sent by CCI are authenticated, the storage system generates the session information. The storage system stores the session information, the user ID, and the client ID, and then sends back the session information to CCI. CCI stores the session information with the storage system ID. After that, the session information is added to all commands which are issued by CCI to the storage system. If the session information which is added to the command is valid, the storage system permits the command execution.

When the user logs out, the session information which is stored by CCI, and the user ID, the client ID, and the session information which are stored in the storage system are deleted.

A storage system can store only one session information for the same user ID and the same client ID at the same time. If the storage system received the login command with the user ID and client ID, corresponding to the session information which has already been stored, the storage system sends back the stored session information to CCI without authentication. During executing the login command, if another login command is input with the same user ID from the same client, the authentication result of the subsequent login command will be the same as the authentication result of login command being executed.



Note:

- The only function that can be used if the user authentication function is disabled is the Replication function (replication command). If the user authentication function is disabled, the Provisioning function (configuration setting command) cannot be used. If you use the global storage virtualization function, see the table in Controlling user resources. For details about global storage virtualization, see the *Provisioning Guide for Open Systems* or *Provisioning Guide*.
- If the specific user information or authority information is changed, perform the user authentication processing on CCI again.
- CCI stores the session information for each user ID (managed by OS) which is used for login to the client OS. Therefore, if users having the different user ID (managed by OS) use the same client, execute CCI login command for each user ID (managed by OS).

Command operation authority and user authentication

When CCI is used with the user authentication function enabled, commands are executed complying with the operation authority of a user set by:

- Storage Navigator
- Device Manager - Storage Navigator
- Maintenance utility (GUM)

Controlling User Role

CCI verifies whether or not the user executing the command on the host was already authenticated by checking the command device being in the authentication mode. After that, CCI obtains the execution authority of the command that is configured on the user role, and then compares the relevant command and the execution authority.

Checking the execution authority

If the configuring commands authenticated are compared with the execution authorities of commands configured on the user role and they do not correspond, CCI rejects the command with an error code "EX_EPPERM".

Normally, the user role needs to be the consistent and integrated authority among the large storage systems. In case of HORCM instances that are configured by the multiple large storage systems, the execution authorities are obtained by the serial number of the storage systems. If the user role is for the multiple storage systems and is not consistent among these storage systems, CCI makes the integrated authority by performing the logical AND of the execution authorities among the storage systems.

Target commands

CCI checks execution authorities on the following commands that use command devices.

- **horctakeover, horctakeoff**
- **paircreate, pairsplit, pairresync**
- **raidvchkset**

Controlling user resources

CCI verifies the user who executes the command has been authenticated already. After that, CCI obtains the access authority of the resource groups that are configured on the user roles, and then compares the access authority of the user and the specified resources.

Checking resource authorities

If the access is not permitted by comparing the access authorities of the resource groups configured on the user roles and the specified resource, CCI rejects the command with an error code "EX_EGPERM". If the resource groups are defined among the large storage systems, the specified resource is compared with the resource specified by obtaining the access authority configured to each large storage system.

Target commands

CCI checks resource authorities on the following commands that use command devices.

- **raidcom** commands (commands for setting configurations)
- **horctakeover, horctakeoff, paircurchk, paircreate, pairsplit, pairresync, pairvolchk, pairevtwait, pairsyncwait, pairmon**
- **raidscan** (-find verify, -find inst, -find sync except for [d]), **pairdisplay, raidar, raidqry** (except for -l and -r)
- **raidvchkset, raidvchkscan, raidvchkdsp**

Relation between user authentication and resource groups

In user authentication mode, CCI verifies the access authority of the target resource based on the user authentication and the role of it. Also, on the user authentication unnecessary mode and the undefined resource groups, CCI checks the access authorities shown in the following table.

Resources	Commands			
	pairXX ¹		raidcom	
	Not authenticated user ²	Authenticated user	Not authenticated user ²	Authenticated user
Undefined resource ³	Permitted	Permitted by the authority of resource ID 0	EX_EPPERM ⁴	Permitted by the authority of resource ID 0
Defined resource	EX_EGPERM ⁴	Permitted by the authority of the target resource ID	EX_EGPERM ⁴ EX_EPPERM	Permitted by the authority of the target resource ID
Virtual storage machine ⁵	Permitted ⁶	Permitted by the authority of the target resource ID	EX_EGPERM ⁴ EX_EPPERM	Permitted by the authority of the target resource ID

Notes:

1. Above-described commands except for the **raidcom** command.
2. User who uses the mode without the command authentication.
3. Undefined as the resource group.
4. Command execution is rejected by the relevant error.
5. The resource group that is defined as the virtual storage machine by the global storage virtualization function. For details about global storage virtualization, see the *Provisioning Guide* for the storage system.
6. When you specify a volume that belongs to meta_resource or a virtual command device for HORCM_VCMD in the configuration definition file, the resource operation for the entire resource group in the virtual storage machine which specifies HORCM_VCMD is permitted. If you do not specify the virtual storage system for HORCM_VCMD, EX_EGPERM is returned. When you specify a volume that belongs to the virtual storage machine for HORCM_CMD in the configuration definition file, the resource operation for the entire resource group in the virtual storage machine to which the volume belongs is permitted. For details about specifying the virtual storage machine to HORCM_VCMD, see Configuration definition file settings with global storage virtualization.

Checking the access authority when you operate a pair

When you use the commands other than `raidcom` commands, which are described in "Target commands" above, whether the user who executes the command has an access authority to the resource is checked. Usually, only one resource in the volumes which configures a pair is checked, the resource is managed by the instance which executes the pair operation command. However, when you operate a pair of a local copy, if the `HOMRCF_CHECK_RSGID` environment variable is defined, an access authority of the command execution user to both volumes which configure a pair can be checked.

The following figure shows an example of a pair operation when you do not define the `HOMRCF_CHECK_RSGID` environment variable. The command execution user can create a pair even if one of the volume which configures the pair is a resource to which the user does not have an authority.

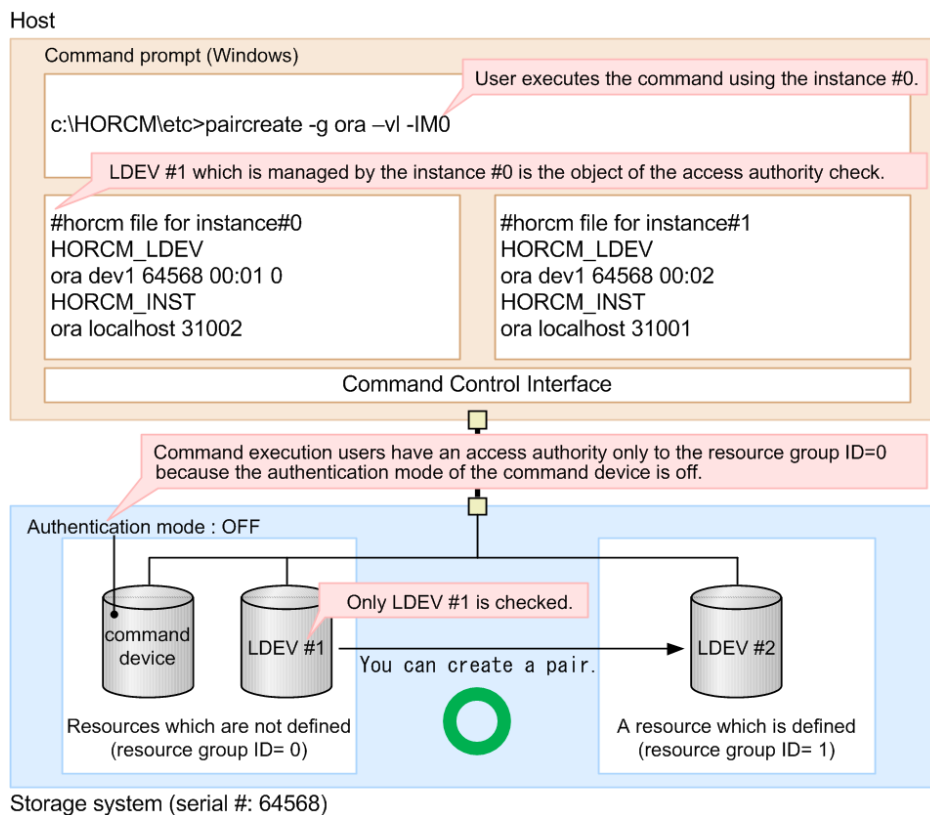

The following figure shows an example of a local copy pair operation when you define the `HOMRCF_CHECK_RSGID` environment variable. You can avoid creating a pair which includes the volume without authority, therefore whether the both volumes which configure a pair are authenticated or not is checked.

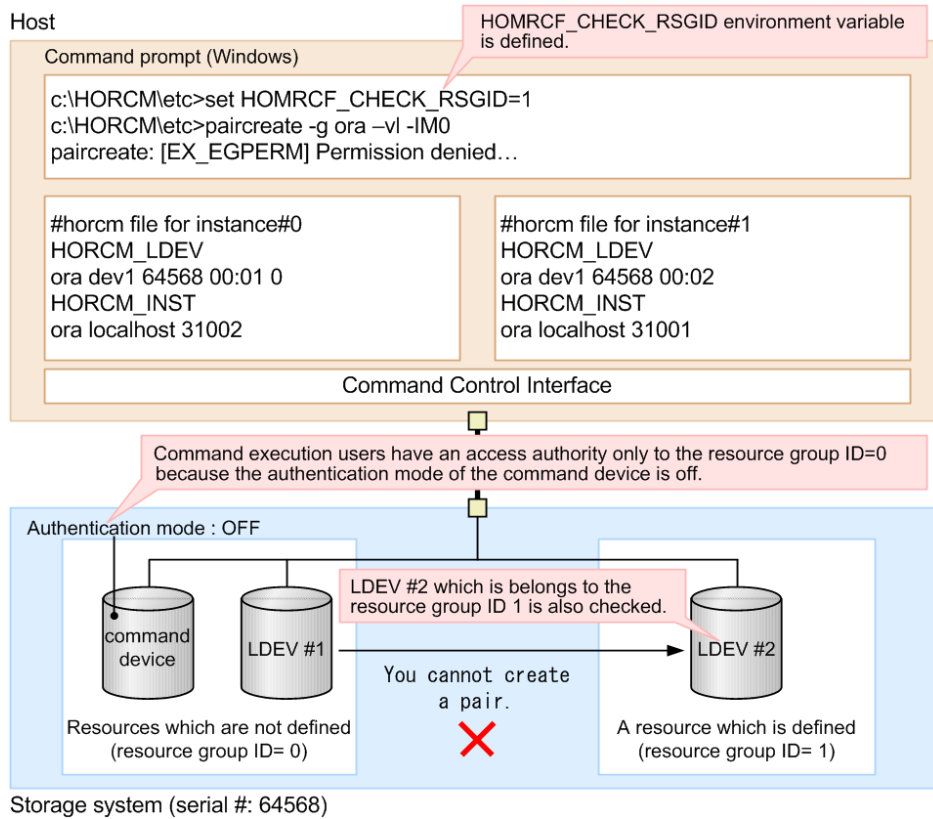

Target resources

The following objects are arbitrarily defined as the resource groups by each user.

- LDEV
- Physical port
- Host group
- RAID group
- External connection group

Commands executed depending on operation authorities

The following table lists the commands executed depending on operation authority of a user set by:

- Storage Navigator
- Device Manager - Storage Navigator
- Maintenance utility

For information about creating the user accounts, registering user accounts to user groups, and user group authorities, see the *Hitachi Command Suite User Guide* or the *System Administrator Guide* or *System Administrator Guide* for the storage system.

The following table shows the executable commands executed depending on operation authority of a user set by Storage Navigator, Device Manager - Storage Navigator, or maintenance utility.

Operation	Operation target	Authority	Executable command	Operation authority (Role)
Initial configuration	Program product	License management authority	<ul style="list-style-type: none"> ▪ raidcom add license (VSP G200, G400, G600, G800 and VSP F400, F600, F800 only) ▪ raidcom delete license (VSP G200, G400, G600, G800 and VSP F400, F600, F800 only) ▪ raidcom modify license (VSP G200, G400, G600, G800 and VSP F400, F600, F800 only) 	Storage Administrator (Initial configuration)
Overall setting	MP blade	MP blade setting authority	raidcom modify ldev raidcom modify journal raidcom modify external_grp	Storage Administrator (System Resource Management)
	CLPR	Parity group migration authority	raidcom modify clpr	
	Resource group	Resource group creation authority	raidcom add resource raidcom modify resource raidcom map resource	Storage Administrator (View & Modify)
	Resource group deletion authority	raidcom unmap resource		

Operation	Operation target	Authority	Executable command	Operation authority (Role)
			raidcom delete resource	
Resource creation, deletion	LDEV	LDEV creation authority raidcom add ldev	raidcom add ldev	Storage Administrator (Provisioning)
		LDEV deletion authority	raidcom delete ldev	Storage Administrator (Provisioning)
		LDEV format authority	raidcom initialize ldev -operation fmt raidcom initialize ldev -operation qfmt	Storage Administrator (Provisioning)
		LDEV shredding execution authority	raidcom initialize ldev -operation shrd raidcom initialize ldev -operation stop	Storage Administrator (Provisioning)
		HAM/GAD Pair creation authority	raidcom modify ldev - quorum_enable paircreate -f never - jq paircreate -f never - jp	Storage Administrator (Provisioning)
		HAM/GAD Pair deletion authority	raidcom modify ldev - quorum_disable pairsplit -S[F[V]] pairsplit -R[F[V]]	Storage Administrator (Provisioning)
	Parity group	LDEV shredding execution authority	raidcom initialize parity_grp	Storage Administrator (Provisioning)
		Parity group creation authority	raidcom modify parity_grp	Storage Administrator (Provisioning)

Operation	Operation target	Authority	Executable command	Operation authority (Role)
		Parity group creation authority	raidcom add parity_grp (VSP Gx00 models, VSP Fx00 models)	Storage Administrator (Provisioning)
		Parity group creation authority, encryption setting cancellation authority	raidcom add parity_grp - encryption (VSP Gx00 models, VSP Fx00 models)	Storage Administrator (Provisioning), Security Administrator (View & Modify)
		Parity group creation cancellation authority	raidcom delete parity_grp (VSP Gx00 models, VSP Fx00 models)	Storage Administrator (Provisioning)
		Parity group creation authority or parity group creation cancellation authority	raidcom modify drive -spare enable (VSP Gx00 models, VSP Fx00 models)	Storage Administrator (Provisioning)
			raidcom modify drive -spare disable (VSP Gx00 models, VSP Fx00 models)	Storage Administrator (Provisioning)
	External volume (Universal Volume Manager)	External volume creation authority	raidcom add external_grp	Storage Administrator (Provisioning)
		External path operation authority	raidcom check_ext_storage path	Storage Administrator (Provisioning)
			raidcom disconnect path	
	External volume disconnection authority	raidcom check_ext_storage external_grp raidcom disconnect external_grp	Storage Administrator (Provisioning)	

Operation	Operation target	Authority	Executable command	Operation authority (Role)
		External volume connection check and resumption authority		
		External volume mapping release authority	raidcom delete external_grp	Storage Administrator (Provisioning)
		UVM Attribute value setting authority	raidcom modify external_grp raidcom add external_iscsi_name raidcom delete external_iscsi_name raidcom modify external_chap_user raidcom modify initiator_chap_user	Storage Administrator (Provisioning)
		UVM path operation authority	raidcom delete path	Storage Administrator (Provisioning)
	Pool	Pool creation and capacity change authority	raidcom add dp_pool raidcom add snap_pool raidcom initialize pool	Storage Administrator (Provisioning)
		Pool deletion authority	raidcom delete pool	Storage Administrator (Provisioning)
	Dynamic Provisioning virtual volume	Dynamic Provisioning virtual volume creation authority	raidcom add ldev - pool raidcom extend ldev	Storage Administrator (Provisioning)

Operation	Operation target	Authority	Executable command	Operation authority (Role)
		Dynamic Provisioning virtual volume deletion authority	raidcom delete ldev	Storage Administrator (Provisioning)
	Copy-on-Write Snapshot virtual volume	Copy-on-Write Snapshot virtual volume creation authority	raidcom add ldev - pool	Storage Administrator (Provisioning)
		Copy-on-Write Snapshot virtual volume deletion authority	raidcom delete ldev	Storage Administrator (Provisioning)
	Port	LUN security setting authority	raidcom modify port - security_switch	Storage Administrator (System Resource Management) Storage Administrator (Provisioning)
	Host group	Host group creation authority	raidcom add host_grp	Storage Administrator (Provisioning)
		Host group deletion authority	raidcom delete host_grp	Storage Administrator (Provisioning)
	LUN	LU path creation authority	raidcom add lun	Storage Administrator (Provisioning)
		LU path deletion authority	raidcom delete lun	Storage Administrator (Provisioning)
	WWN / iSCSI name / CHAP user name	WWN addition authority	raidcom add hba_wwn raidcom add hba_iscsi	Storage Administrator (Provisioning)

Operation	Operation target	Authority	Executable command	Operation authority (Role)
			raidcom add chap_user	
		WWN deletion authority	raidcom delete hba_wwn raidcom delete hba_iscsi raidcom delete chap_user	Storage Administrator (Provisioning)
	LDEV group	Device group and Copy group creation authority	raidcom add device_grp raidcom add copy_grp	Storage Administrator (Provisioning)
		Device group and Copy group deletion authority	raidcom delete device_grp raidcom delete copy_grp	Storage Administrator (Provisioning)
	Local copy	Pair creation authority	paircreate raidcom add snapshot	Storage Administrator (Provisioning)
		Pair deletion authority	pairsplit -S raidcom delete snapshot	Storage Administrator (Provisioning)
		Volume Migration pair creation authority	paircreate	Storage Administrator (Provisioning)
		Volume Migration pair deletion authority	pairsplit -S	Storage Administrator (Provisioning)
		Local copy environmental setting authority	raidcom modify local_replica_opt	Storage Administrator (Local Copy)

Operation	Operation target	Authority	Executable command	Operation authority (Role)
	Remote copy	Pair creation authority	paircreate	Storage Administrator (Remote Copy)
		Pair deletion authority	pairsplit -S	Storage Administrator (Remote Copy)
Attribute change	External volume	External path setting authority	raidcom add path	Storage Administrator (Provisioning)
	Pool	Pool setting authority	raidcom modify pool raidcom rename pool	Storage Administrator (Provisioning)
		Pool monitoring and reallocation start and stop authority	raidcom reallocate pool raidcom monitor pool	Storage Administrator (Provisioning)
	Port	Port attribute setting authority	raidcom modify port -port_attribute	Storage Administrator (System Resource Management)
		Port setting authority	raidcom modify port -loop_id raidcom modify port -topology raidcom modify port -port_speed raidcom modify port -t10pi raidcom modify port -port <port#> [-mtu <value>]... raidcom modify port -port <port#> [-isns_mode {enable disable}]...	Storage Administrator (Provisioning)

Operation	Operation target	Authority	Executable command	Operation authority (Role)
	Host group	Host group setting authority	raidcom modify host_grp	Storage Administrator (Provisioning)
	LUN	LDEV setting authority	raidcom modify lun	Storage Administrator (Provisioning)
	WWN / iSCSI name / CHAP user name	WWN setting authority	raidcom set hba_wwn raidcom reset hba_wwn raidcom set hba_iscsi raidcom reset hba_iscsi raidcom set chap_user raidcom reset chap_user	Storage Administrator (Provisioning)
	LDEV nickname	LDEV nickname setting authority	raidcom modify ldev -ldev_name	Storage Administrator (Provisioning)
	SPM information	SPM setting authority	raidcom add spm_wwn raidcom add spm_group raidcom delete spm_wwn raidcom delete spm_group raidcom modify spm_wwn raidcom modify spm_group raidcom modify spm_ldev	Storage Administrator (System Resource Management)

Operation	Operation target	Authority	Executable command	Operation authority (Role)
			raidcom delete spm_ldev	
	Local copy	Pairsplit and resync authority	pairresync raidcom modify snapshot raidcom map snapshot raidcom unmap snapshot raidcom replace snapshot	Storage Administrator (Local Copy)
	Remote copy	Environment construction authority	raidcom add rcu raidcom delete rcu raidcom modify rcu raidcom add rcu_iscsi_port raidcom delete rcu_iscsi_port raidcom add rcu_path raidcom delete rcu_path raidcom add journal raidcom delete journal raidcom modify journal raidcom add ssid raidcom delete ssid	Storage Administrator (Remote Copy)
		Pairsplit and resync authority	pairresync	Storage Administrator (Remote Copy)
	Quorum disk	LDEV setting authority	raidcom modify quorum	Storage Administrator (Provisioning)

Operation	Operation target	Authority	Executable command	Operation authority (Role)
		HAM/GAD pair creation authority	raidcom replace quorum	Storage Administrator (Provisioning)
		HAM/GAD pair deletion authority		

Relation between resource groups and command operations

The operation for using resource groups are different by the command devices (the In-Band method) or the Out-of-Band method that are used when you start CCI.

You can create resource groups for each resource. And you can share them with multiple users. When user 10 and user 20 share the port like the following figure, the relation between the command devices and resource groups that user can use is given in the table below.

See the following figure given below for relation among user, command devices, and resource groups. The table given below shows the relation between resource groups and command devices.

Relation between resource groups and command operations

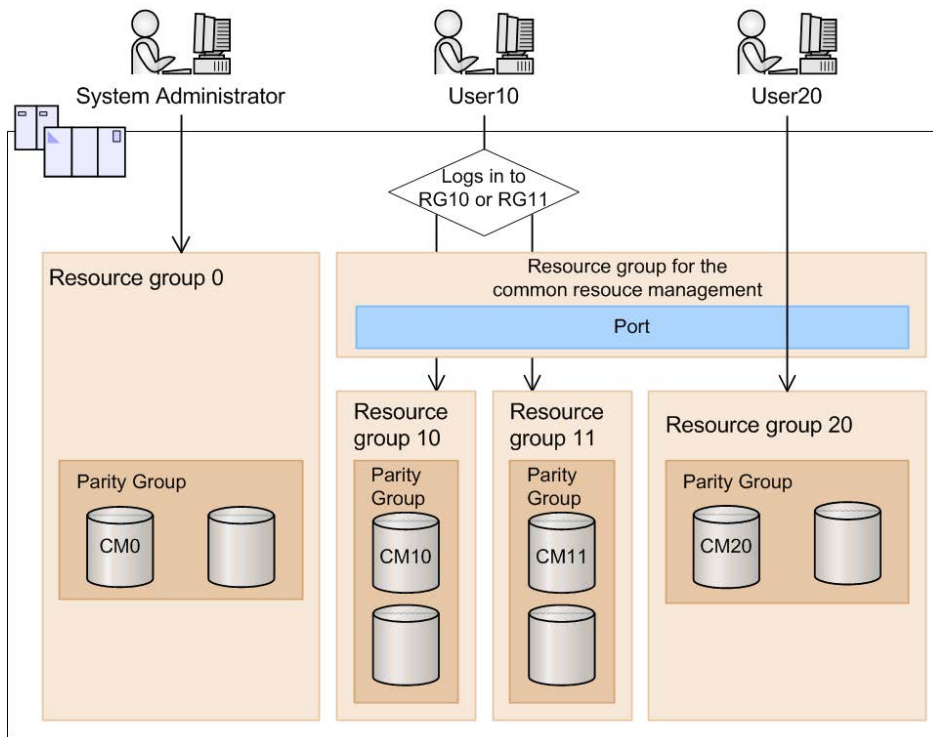

Legend



Login user	Command device	Operating range	Reference	Configuration change	Command operations using the out-of-band method
System administrator	CM0	Can operate all resource groups after logging in.	Operable	Operable	Operable
	CM10	Can operate only in the range of resource group 10, and the shared ports after logging in.	Operable	Operable	Inoperable
	CM11	Can operate only in the range of resource group 11, and the shared ports after logging in.	Operable	Operable	Inoperable

Login user	Command device	Operating range	Reference	Configuration change	Command operations using the out-of-band method
	CM20	Can operate only in the range of resource group 20, and the shared ports after logging in.	Operable	Operable	Inoperable
User 10	CM0	Can operate only in the range of resource group 10 and 11, and the shared ports after logging in.	Operable	Operable	Operable
	CM10	Can operate only in the range of resource group 10, and the shared ports after logging in.*	Operable	Operable	Inoperable
	CM11	Can operate only in the range of resource group 11, and the shared ports after logging in.*	Operable	Operable	Inoperable
	CM20	Cannot log in. Nothing is displayed or the operation authority error.		Operation authority error	Inoperable
User 20	CM0	Can operate only in the range of resource group 20, and the shared ports after logging in.	Operable	Operable	Operable
	CM10	Cannot log in. Nothing is displayed or the operation authority error.		Operation authority error	Inoperable
	CM11	Cannot log in. Nothing is displayed or the operation authority error.		Operation authority error	Inoperable

Login user	Command device	Operating range	Reference	Configuration change	Command operations using the out-of-band method
	CM20	Can operate only in the range of resource group 20, and the shared ports after logging in.	Operable	Operable	Inoperable
<p>* To use each resource group, the user must separately execute <code>raidcom -login</code> command. For details about the <code>raidcom -login</code> command, see <i>Command Control Interface Command Reference</i>.</p>					

As shown in the table above, the relation among users, command devices and operations of resource groups are the following.

- The range that can be operated by command device 0 (CM0) or Out-of-Band is the shared range (AND) of resource groups that are allocated to each user and all resource groups.
- The range that can be operated by command device 10 (CM10) is the shared range (AND) of resource groups that are allocated to each user and resource group 10 that the command devices are allocated.

Therefore, in the range of resource group 10 can be operated.

The following shows the example of the case that the execution results of the commands change by the case of having or not having the authority of the operated resources, specifies only the objects or specifies to the parameters.

When user has the authority using CL1-A, CL3-A and CL5-A ports, and CL1-A, CL2-A, CL3-A, CL4-A and CL5-A ports are implemented in the system, executes the following command.

When only the objects are specified:

```
# raidcom get port
```

The execution results of CL1-A, CL3-A and CL5-A are displayed. The execution results of CL2-A and CL4-A (the user does not have the authority of the resource) are not displayed (filtered).

When parameters are also specified:

```
# raidcom get port -port CL1-A
```

The execution result of CL1-A is only displayed.

```
# raidcom get port -port CL2-A
```

The error is displayed because the user does not have the execution authority.

The following shows the output example when -cnt that is used in get ldev is used.

The following command is executed when the user has the authorities of LDEV number 10 and 12.

```
# raidcom get ldev -ldev_id 10 -cnt 3
```

Execution results of LDEV number 10 and 12 are displayed. LDEV number 11 is not displayed because the user does not have the authority of the resource.

Resource lock function

When configuration changes from multiple user interfaces (CCI, HCS, Device Manager - Storage Navigator, or maintenance utility) are performed on the same resource at the same time, configurations are changed unexpectedly, and expected results might not occur. While a command is being executed, if another user changes the configuration, unexpected results can occur even though it is a viewing command.

To prevent users from changing the configuration of the same resource at the same time, the **resource lock** command is provided. When this command is used, the resource group can be locked to prevent other users from using the specified resource group. If the resource is not locked, all configuration change commands are performed. However, conflicting operations might cause an error.

The commands for performing the exclusive control and exclusive control release (lock and unlock) of resource groups are as follows.

- `raidcom lock resource -resource_name <resource group name > [-time <time(sec)>]`
(Locking a specified resource group)
- `raidcom unlock resource -resource_name <resource group name >` (Unlocking a specified resource group)

If multiple users (IDs) operate the same resource, you can prevent operation conflict for the target resource by using the **raidcom lock resource** command to confirm that no other user is using the resource.

After the configuration change is completed, release the lock status by the **raidcom unlock resource** command.

The user who locks a resource is identified by the session information. When the user logs out and the session information of the user is deleted from the storage system, the resource that has been locked by the user is automatically released. For details about the session information, see User authentication.

Command execution modes

Overview

Provisioning operations are performed using a configuration setting command. For details about the configuration setting command, see Overview of the configuration setting command or Command Control Interface Command Reference.

Two modes can be used for executing the configuration setting command:

- Line-by-line mode.

This mode executes commands input from the command line one at a time.

- Transaction mode.

Executes a script file specified by the -zt option.

When executing the configuration setting command, the following checks can be done depending on the above two mode types.

- **Syntax check:**

This function checks if there is no syntax error in the specified command. This is executed every time at the both line-by-line mode and transaction mode.

- **Context check:**

This function checks the consistency of one specified line in the script and the preceding lines in the order from the top. This function is available only at the Transaction mode. For details about context checking, see Context check topic.

- **Configuration check:**

Acquire the current configuration information to a configuration file, and then this function checks whether the resources specified in the script (LDEVs, ports, or host groups) are configured in the storage system or not. This function is available only at the transaction mode. For details about context checking, see configuration check topic.

The configuration setting command also has a execution option described in the following.

Precheck

Specify the checkmode precheck option. It operates checking only (it does not execute processing even if no error is detected.) This can be specified at the both line-by-line mode and transaction mode.

Execution modes and options of the configuration setting command (line-by-line mode)

The following tables show the overview of execution modes and options of the configuration setting command.

Command syntax	Syntax check	Context check	Configuration check	Command execution with no error	Remarks
raidcom <action>	Executed	Not executed	Not executed	Executed	Default
raidcom <action> -checkmode precheck	Executed	Not executed	Not executed	Not executed	Check only

Execution modes and options of the configuration setting command (transaction mode)

Command syntax	Syntax check	Context check	Configuration check	Command execution with no error	Remarks
raidcom -zt <script file>	Executed	Executed	Not executed	Executed	Default
raidcom -zt <script file> -load <work file>	Executed	Executed	Executed	Executed	With configuration check
raidcom -zt <script file> -checkmode precheck	Executed	Executed	Not executed	Not executed	Check only
raidcom -zt <script file> -load <work file> -checkmode precheck	Executed	Executed	Executed	Not executed	With configuration check Check only

Detailed description are provided in the following sections.



Caution: Observe the following cautions:

- For <script file>, specify an executable file name.
- For <script file>, either specify a full path name or store under the c:\HORCM\etc folder.
- For <work file>, either specify a full path name or store in the current directory.

Context check

This check can be performed to ensure consistent content of the created script file. For example, it can check if the script refers to an ldev_id that is already deleted in the preceding lines.

The script is executed only when no error is detected by the checking of whole script contents.

The following resources can be the target of the check:

- LDEV
- Port
- Host group

Checking contents before executing scripts

Checking the contents before executing the script helps reduce debugging after running the script.

Specify the script as follows to execute it.

```
raidcom -zt <created script file name>
```

```
raidcom -zt <created script file name> -load <configuration file>
```

```
raidcom -zt <created script file name> -checkmode precheck
```

```
raidcom -zt <created script file name> -load <configuration file> -  
checkmode precheck
```

Details of check contents

Details of Context check is described below. Checking contents before issuing a script can reduce load for the debug operation.

LDEV check

The check is performed from the following perspective. Note that checking for the object information that is related to the LDEV such as pool or device group, or an attribute of LDEV is not executed.

Check with the additional operation

The check is performed to ensure no identical LDEV as the existing LDEV is added. If the existing LDEV is attempted to be added, an error is detected.

If it is not clear whether the LDEV to be added exists or not, or if the target LDEV information does not exist in the configuration definition file, the error is not detected. Therefore, the script is executed and the LDEV is added.

The command as the target of the check is shown below.

```
raidcom add ldev {-parity_grp_id <gno-sgno>| -external_grp_id
  <gno-sgno> | -pool {<pool ID#> | <pool naming> | snap}}
  {-ldev_id <ldev#> | -tse_ldev_id <ldev#>} {-capacity <size>
  | -offset_capacity <size> | -cylinder <size>} [-emulation
  <emulation type>][-location <lba>][-mp_blade_id <mp#>]
  [-clpr <clpr#>]
```

Check with the attribute setting

The check is performed regardless of whether or not the operation is performed for the existing LDEV. If the operation is attempted to be performed for an LDEV that does not exist, an error is detected.

If it is not clear whether the LDEV as the target of the operation exists in the configuration definition file, or if the target LDEV information does not exist in the configuration definition file, the error is not detected.

The commands as the target of the check are shown below.

- `raidcom add lun -port <port#> [<host group name>] {-ldev_id <ldev#> [-lun_id<lun#>] | -grp_opt <group option> -device_grp_name <device group name> [<device name>]}`
- `raidcom delete lun -port <port#> [<host group name>] {-lun_id <lun#> | -ldev_id <ldev#> | -grp_opt <group option> -device_grp_name <device group name> [<device name>]}`
- `raidcom add journal -journal_id <journal ID#> {-ldev_id <ldev#> ...[-cnt<count>] | -grp_opt <group option> -device_grp_name <device group name> [<device name>]} [-mp_blade_id <mp#> | -timer_type <timer type>]`
- `raidcom delete journal -journal_id <journal ID#> [-ldev_id <ldev#> | -grp_opt <group option> -device_grp_name <device group name> [<device name>]]`
- `raidcom add snap_pool {-pool_id <pool ID#> [-pool_name <pool naming>] | -pool_name <pool naming> [-pool_id <pool ID#>] | -pool_id <pool ID#> -pool_name <pool naming>} {-ldev_id <ldev#> ...[-cnt<count>] | -grp_opt <group option> -device_grp_name <device group name> [<device name>]}[-user_threshold <%>]`
- `raidcom add dp_pool {{-pool_id <pool ID#> [-pool_name <pool naming>] | -pool_name <pool naming> [-pool_id <pool ID#>]} | -pool_id <pool ID#> -pool_name <pool naming>} {-ldev_id <ldev#> ...[-cnt <count>] | -grp_opt <group option> -device_grp_name <device group name> [<device name>]}[-user_threshold <threshold_1> [<threshold_2>]]`
- `raidcom extend ldev {-ldev_id <ldev#> | -grp_opt <group option> -device_grp_name <device group name> [<device name>]} -capacity <size> | -offset_capacity <size> | -cylinder <size>`
- `raidcom check_ext_storage external_grp {-external_grp_id <gno-sgno> | -ldev_id <ldev#> | -grp_opt <group option> -device_grp_name <device group name> [<device name>]}`
- `raidcom add device_grp -device_grp_name <ldev group name> <device name> -ldev_id <ldev#>... [-cnt <count>]`

- `raidcom delete device_grp -device_grp_name <device group name> -ldev_id<ldev#>... [-cnt <count>]`
- `raidcom modify ldev -ldev_id <ldev#> {-status <status> [<level>] | -ldev_name <ldev naming> | -mp_blade_id <mp#> | -ssid <value> | -command_device <y/n > [Security value]}`
- `raidcom initialize ldev {-ldev_id <ldev#> | -grp_opt <group option> -device_grp_name <device group name> [<device name>]} -operation <type>`

Check with the deletion operation

It is checked to ensure that the operation is not intended to be performed for the LDEV that is already deleted. If it is, an error is detected.

If it is not clear whether the LDEV as the target of the operation exists in the configuration definition file or not (if the target LDEV information does not exist in the configuration definition file), the error is not detected.

The command as the target of the check is shown below.

- `raidcom delete ldev {-ldev_id <ldev#> | -grp_opt <group option> -device_grp_name <device group name> [<device name>]}`

The example of the script where the existing LDEV is attempted to be added to the already created LDEV and the execution result of the context check is shown below.

Example of script

```
raidcom add ldev -parity_grp_id 01-01 -ldev_id 1 -capacity 100M
raidcom add ldev -parity_grp_id 01-01 -ldev_id 2 -capacity 100M
raidcom add ldev -parity_grp_id 01-01 -ldev_id 3 -capacity 100M
```

Execution result

```
C:\HORCM\etc>raidcom get ldev -ldev_id 1 -cnt 65280 -store ldevconf_65
> ldevconf_65.txt
C:\HORCM\etc>raidcom -zt 3_defined_ldev.bat -load ldevconf_65.dat
-checkmode precheck
C:\HORCM\etc>raidcom add ldev -parity_grp_id 01-01 -ldev_id 1 -capacity
100M
C:\HORCM\etc>raidcom add ldev -parity_grp_id 01-01 -ldev_id 2 -
capacity 100M
C:\HORCM\etc>raidcom add ldev -parity_grp_id 01-01 -ldev_id 3 -capacity
100M
```

Example of script (the text in bold indicates the invalid configuration definition.)

```
raidcom add ldev -parity_grp_id 01-01 -ldev_id 1 -capacity 100M
raidcom add ldev -parity_grp_id 01-01 -ldev_id 2 -capacity 100M
raidcom add ldev -parity_grp_id 01-01 -ldev_id 3 -capacity 100M
```



```

raidcom add ldev -parity_grp_id 01-01 -ldev_id 1 -capacity 100M
raidcom add ldev -parity_grp_id 01-01 -ldev_id 2 -capacity 100M
raidcom add ldev -parity_grp_id 01-01 -ldev_id 3 -capacity 100M
for /1 %i in (1,1,3) do (raidcom add ldev -parity_grp_id 01-01 -
ldev_id %i -capacity 100M)

for /1 %i in (1,1,3) do (
raidcom add ldev -parity_grp_id 01-01 -ldev_id %i -capacity 100M)

```

Execution result (the text in bold indicates the contents of the error accompanying the invalid configuration definition in the script.)

```

C:\HORCM\etc>raidcom get ldev -ldev_id 1 -cnt 65280 -store ldevconf_65 >
ldevconf_65.txt
C:\HORCM\etc>raidcom -zt 3_defined_ldev.bat -load ldevconf_65.dat
-checkmode precheck
C:\HORCM\etc>raidcom add ldev -parity_grp_id 01-01 -ldev_id 1 -capacity
100M
C:\HORCM\etc>raidcom add ldev -parity_grp_id 01-01 -ldev_id 2 -capacity
100M
C:\HORCM\etc>raidcom add ldev -parity_grp_id 01-01 -ldev_id 3 -capacity
100M
C:\HORCM\etc>raidcom add ldev -parity_grp_id 01-01 -ldev_id 1 -capacity
100M
raidcom: LDEV(1) is already existing as status is [1] on UnitID# 0.
raidcom_#5 : [EX_CTXCHK] Context Check error
C:\HORCM\etc>raidcom add ldev -parity_grp_id 01-01 -ldev_id 2 -capacity
100M
raidcom: LDEV(2) is already existing as status is [1] on UnitID# 0.
raidcom_#6 : [EX_CTXCHK] Context Check error
C:\HORCM\etc>raidcom add ldev -parity_grp_id 01-01 -ldev_id 3 -capacity
100M
raidcom: LDEV(3) is already existing as status is [1] on UnitID# 0.
raidcom_#7 : [EX_CTXCHK] Context Check error

```

The number in raidcom # of raidcom_#7: [EX_CTXCHK] Context Check error is the number of times of performing the raidcom command by using <work file>. The number of times is incremented each time the raidcom command is executed.

Port check

The check is performed from the following perspective. Note that checking for object information related to the port, such as external volume group or RCU, or an attribute of port, is not executed.

Checking for attribute setting

It is checked whether the operation is performed for the existing port. If the port does not exist, an error is detected.

If it is not clear whether the port as the target of the operation exists in the configuration definition file or not (if the target port information does not exist in the configuration definition file), the error is not detected.

The commands as the target of the check are shown below.

- `raidcom modify port -port <port#> {[-port_speed <value>] [-loop_id <value>][-topology <topology>] [-security_switch <y|n >] | -port_attribute <port attribute>}`
- `raidcom add external_grp -path_grp <path group#> -external_grp_id <gnosgno> -port <port#> -external_wwn <wwn strings> -lun_id <lun#> [-emulation <emulation type>] [-clpr <clpr#>]`
- `raidcom add path -path_grp <path group#> -port <port#> -external_wwn <wwn strings>`
- `raidcom delete path -path_grp <path group#> -port <port#> -external_wwn <wwn strings>`
- `raidcom check_ext_storage path -path_grp <path group#> -port <port#> -external_wwn <wwn strings>`
- `raidcom disconnect path -path_grp <path group#> -port <port#> -external_wwn <wwn strings>`
- `raidcom add rcu {-rcu <serial#> <mcu#> <rcu#> <id> -ssid <ssid> | -cu_free <serial#> <id> <pid>} -mcu_port <port#> -rcu_port <port#>`

For example, if a path is attempted to be added to a port that does not exist, an error is detected. An example of the script where the error is detected and the execution result of the actual Context check are shown below.

Example of script (the text in bold indicates the part of incorrect configuration definition.)

```
raidcom add path -path_grp 1 -port CL1-C -external_wwn 50060e80,06fc4180
raidcom add path -path_grp 1 -port CL1-D -external_wwn 50060e80,06fc4190
raidcom add path -path_grp 1 -port CL1-E -external_wwn 50060e80,06fc41a0
```

Execution result (the text in bold indicates the contents of the error accompanying the invalid configuration definition in the script.)

```
C:\HORCM\etc>raidcom get port -store portcnf_27.dat
PORT   TYPE  ATTR  SPD  LPID  FAB  CONN  SSW  SL  Serial#  WWN
CL1-A  FIBRE TAR   AUT   EF   N   FCAL  N    0   64539
06fc1b000000fc1b
CL1-B  FIBRE TAR   AUT   EF   N   FCAL  N    0   64539
50060e8006fc1b01
CL2-A  FIBRE TAR   AUT   EF   N   FCAL  N    0   64539
50060e8006fc1b10
CL2-B  FIBRE TAR   AUT   EF   N   FCAL  N    0   64539
50060e8006fc1b11
CL3-A  FIBRE TAR   AUT   E8   N   FCAL  N    0   64539
50060e8006fc1b20
```

```

CL3-B FIBRE TAR AUT E0 N FCAL N 0 64539
50060e8006fc1b21
CL4-A FIBRE TAR AUT D6 N FCAL N 0 64539
50060e8006fc1b30
CL4-B FIBRE TAR AUT D2 N FCAL N 0 64539
50060e8006fc1b31
CL5-A FIBRE TAR AUT E4 N FCAL N 0 64539
50060e8006fc1b40
CL5-B FIBRE TAR AUT DC N FCAL N 0 64539
50060e8006fc1b41
CL6-A FIBRE TAR AUT D5 N FCAL N 0 64539
50060e8006fc1b50
CL6-B FIBRE TAR AUT D1 N FCAL N 0 64539
50060e8006fc1b51
CL7-A FIBRE ELUN AUT E2 N FCAL N 0 64539
50060e8006fc1b60
CL7-B FIBRE ELUN AUT DA N FCAL N 0 64539
50060e8006fc1b61
CL8-A FIBRE TAR AUT D4 N FCAL N 0 64539
50060e8006fc1b70
CL8-B FIBRE TAR AUT CE N FCAL N 0 64539
50060e8006fc1b71
C:\HORCM\etc>raidcom -zt 4_no_port.bat -load portcnf_27.dat -checkmode
precheck
C:\HORCM\etc>raidcom add path -path_grp 1 -port CL1-C -external_wwn
50060e80,06fc4180
raidcom: PORT(2) does not exist as status is [2] on UnitID# 0.
raidcom_#2 : [EX_CTXCHK] Context Check error
C:\HORCM\etc>raidcom add path -path_grp 1 -port CL1-D -external_wwn
50060e80,06fc4190
raidcom: PORT(3) does not exist as status is [2] on UnitID# 0.
raidcom_#3 : [EX_CTXCHK] Context Check error
C:\HORCM\etc>raidcom add path -path_grp 1 -port CL1-E -external_wwn
50060e80,06fc41a0
raidcom: PORT(4) does not exist as status is [2] on UnitID# 0.
raidcom_#4 : [EX_CTXCHK] Context Check error

```

Host group check

The check is performed from the following perspective. Note that checking for an attribute of host group, or for a name of host group is not executed.

Check with the attribute setting

Checks whether the operation is performed for an existing host group. If the host group does not exist, an error is detected.

If it is not clear whether the target port or host group exists (if the target port or host group information does not exist in the configuration definition file), the error is not detected.

The commands as the target of the check are shown below.

- `raidcom modify host_grp -port <port#> [<host group name>] -host_mode <host mode> [-host_mode_opt <host mode option> ...]`
- `raidcom add hba_wwn -port <port#> [<host group name>] -hba_wwn <WWN strings>`
- `raidcom delete hba_wwn -port <port#> [<host group name>] -hba_wwn <WWN strings>`
- `raidcom set hba_wwn -port <port#> [<host group name>] -hba_wwn <WWN strings> -wwn_nickname <WWN Nickname>`
- `raidcom reset hba_wwn -port <port#> [<host group name>] -hba_wwn <WWN strings>`
- `raidcom add lun -port <port#> [<host group name>] {-ldev_id <ldev#> [-lun_id<lun#>] | -grp_opt <group option> -device_grp_name <device group name> [<device name>]}`
- `raidcom delete lun -port <port#> [<host group name>] {-lun_id <lun#> | -ldev_id <ldev#> | -grp_opt <group option> -device_grp_name <device group name> [<device name>]}`

Check with deletion operation

It is checked to ensure that the operation is not intended to be performed for the host group that is already deleted. If the host group is already deleted, an error is detected.

If it is not clear whether the target port or host group exists or not (if the target port or host group information does not exist in the configuration definition file), the error is not detected.

The command as the target of the check is shown below.

```
raidcom delete host_grp -port <port#> [<host group name>
```

For example, if the host group that does not exist is attempted to be deleted, an error is detected. An example of the script where the error is detected and the execution result of the actual context check are shown below.

Example of script (the text in bold indicates the part of incorrect configuration definition.)

```
raidcom delete host_grp -port CL1-A-0
raidcom delete host_grp -port CL1-A-1
raidcom delete host_grp -port CL1-A-2
```

Execution result (the text in bold indicates the contents of the error accompanying the invalid configuration definition in the script.)

```
C:\HORCM\etc>raidcom get host_grp -port CL1-A -store hostgrpcnf_27_cl1-
a.dat
PORT      GID      GROUP_NAME                               Serial# HMD      HMO_BITS
```

```

CL1-A    0    1A-G00                                64539 LINUX/IRIX
C:\HORCM\etc>raidcom -zt 6_no_hstgrp.bat -load hostgrpcnf_27_cl1-a.dat
-checkmode precheck
C:\HORCM\etc>raidcom delete host_grp -port CL1-A-0
C:\HORCM\etc>raidcom delete host_grp -port CL1-A-1
raidcom: PORT-HGRP(0-1) does not exist as status is [2] on UnitID# 0.
raidcom #3: [EX_CTXCHK] Context Check error
C:\HORCM\etc>raidcom delete host_grp -port CL1-A-2
raidcom: PORT-HGRP(0-2) does not exist as status is [2] on UnitID# 0.
raidcom #4 : [EX_CTXCHK] Context Check error

```

Configuration check

The contents of a script file can be checked whether the operation is performed for the existing resource or not.

Before performing the configuration check, execute the following command, acquire the current configuration information, and store it in the work file specified by the `-store` option.

Check the operation for LDEV

```

raidcom get ldev {-ldev_id <ldev#> ... [-cnt <count>] | -grp_opt
  <group option> -device_grp_name <device group name> [<device name>]}
-store <work file>

```

Check the operation for Port

```

raidcom get port -port -store <work file>

```

Check the operation for Host group

```

raidcom get host_grp -port <port#> -store <work file>

```

After acquiring the configuration information, execute the script by specifying the configuration file.

```

raidcom -zt <created script file name> -load <work file>

```

Resource location and parameter

MP blade location and parameter

To specify MP blade IDs by the `raidcom add ldev` command, specify the following IDs.

MP blade names and parameters for VSP G1x00 and VSP F1500

MP blade name	MP blade number	MP blade ID
MPB-1MA	0	0
MPB-1MB	1	1
MPB-1PE	2	2
MPB-1PF	3	3
MPB-2MA	4	4
MPB-2MB	5	5
MPB-2PE	6	6
MPB-2PF	7	7
MPB-1MC	8	8
MPB-1MD	9	9
MPB-1PL	10	10
MPB-1PM	11	11
MPB-2MC	12	12
MPB-2MD	13	13
MPB-2PL	14	14
MPB-2PM	15	15

MP blade names and parameters for VSP

MP blade name	MP blade number	MP blade ID
MPB-1MA	0	0
MPB-1MB	1	1
MPB-2MC	2	2
MPB-2MD	3	3
MPB-1ME	4	4
MPB-1MF	5	5
MPB-2MG	6	6

MP blade name	MP blade number	MP blade ID
MPB-2MH	7	7

MP unit names and parameters for HUS VM

MP unit name	MP blade number	MP blade ID
MPU-10	0	0
MPU-11	1	1
MPU-20	2	2
MPU-21	3	3

LDEV grouping function

The LDEV grouping function enables you to create a group of multiple LDEVs (device group function and copy group function).

Overview

CCI can be used to create a group of multiple LDEVs by defining copy groups, which are a group of copy pairs. This is accomplished in both the primary and secondary configuration definition files by defining the group names of the combined LDEVs (dev_name of HORCM_DEV or HORCM_LDEV).

To change copy group information, modify the primary and secondary configuration definition files. For example, to change the LDEV configuration of copy group dbA, change the LDEV information in configuration definition files A and B.

See the figure for LDEV grouping for USP V/VM and earlier.

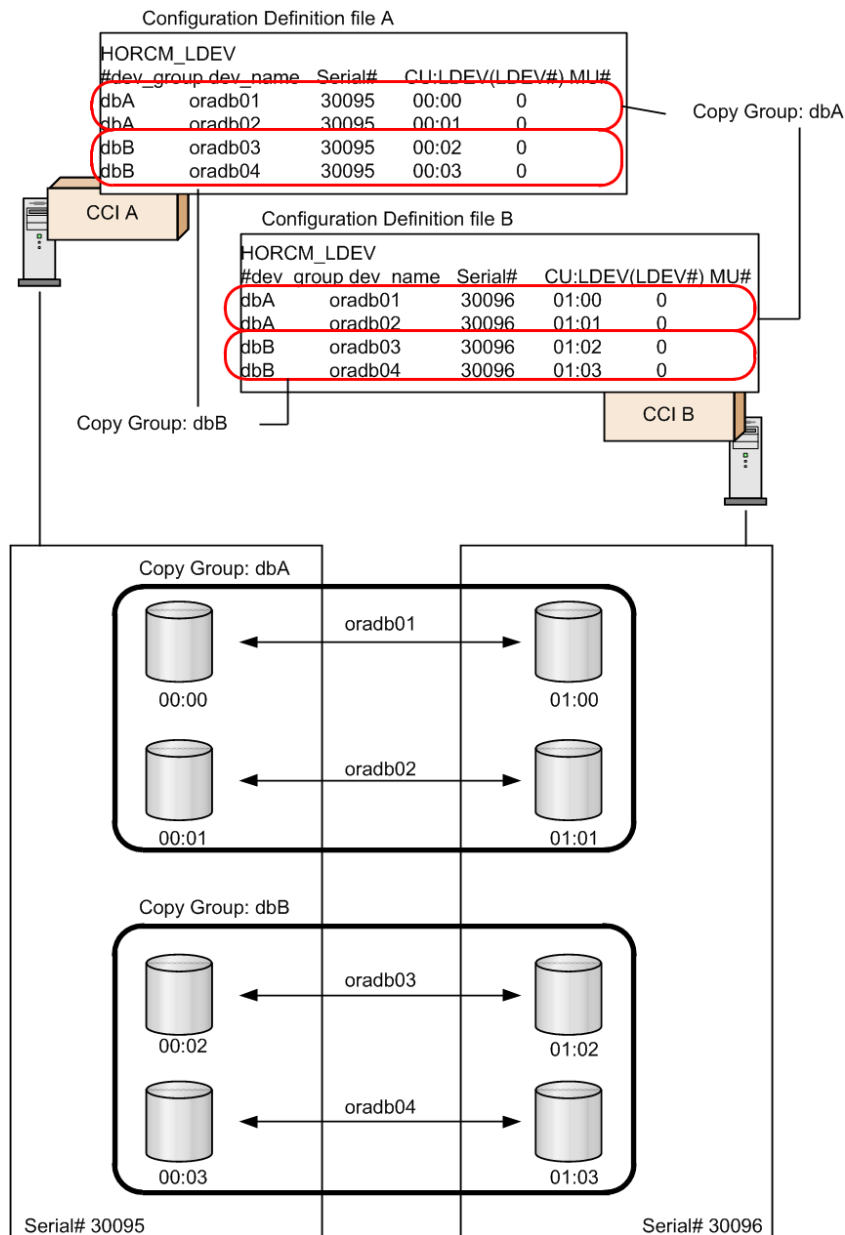

For Virtual Storage Platform and later, CCI can be used to create a group of multiple LDEVs by defining device groups. This is accomplished by defining device groups in either the primary or secondary configuration definition file, but not both. By defining a device group, LDEV information can be changed or defined in one operation. It is not required to modify LDEV information in both configuration definition files. For example, referencing LDEVs or creating pools can be executed at the same time, because all LDEVs in the device group are subjected to the operation.

See the figure for LDEV grouping for VSP and later (device group and copy group).

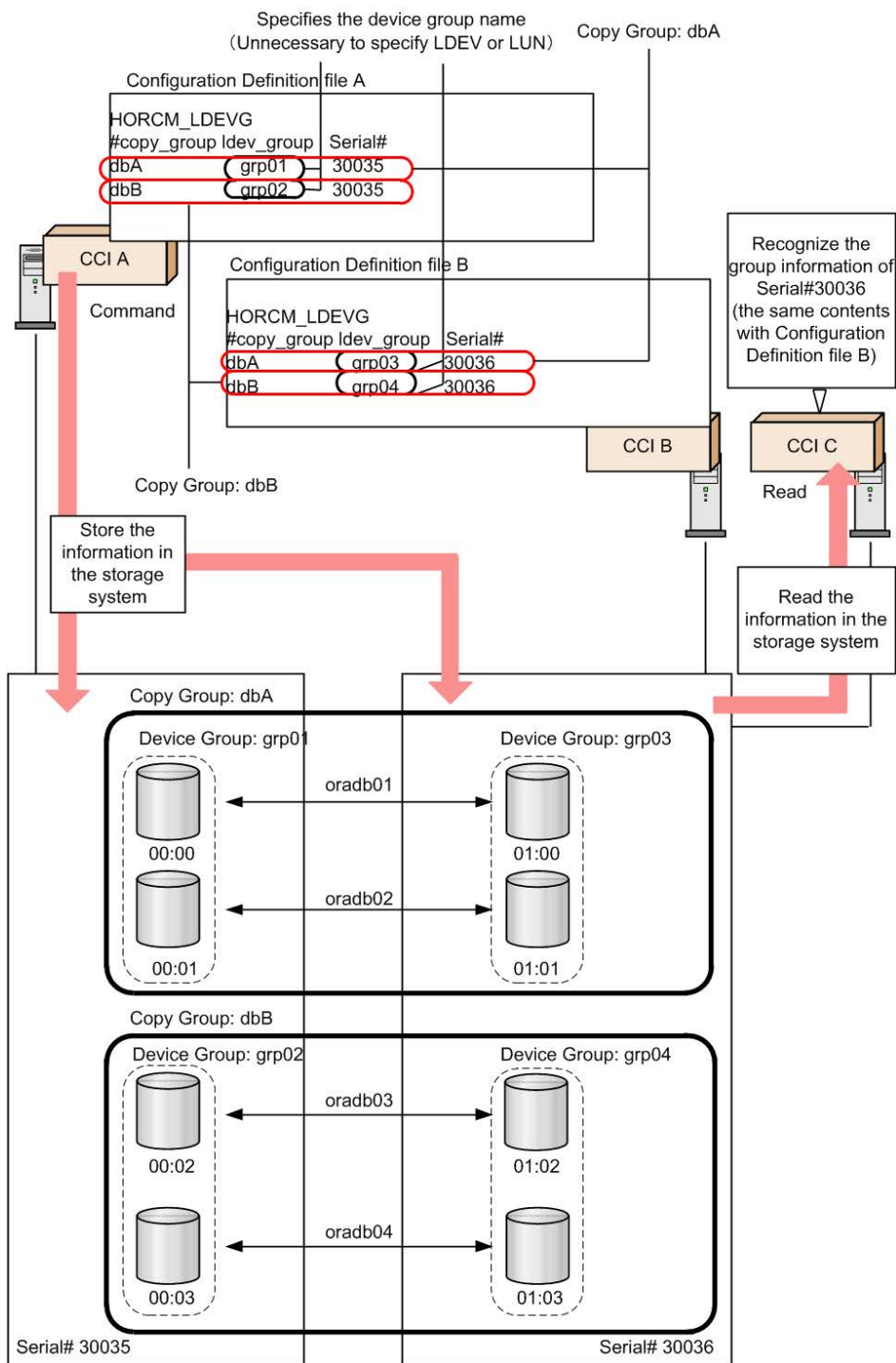

However, for executing replication function commands in CCI, two device groups must be combined and defined as a copy group.

When defining a device group or copy group by a command, the command can be issued from multiple CCI instances because the group information is defined in the storage system.

Device group definition methods

To define a device group or copy group in the CCI that supports Virtual Storage Platform or later, use one or both of following methods.

- **Execute a command:**

Create a device group with the `raidcom add device_grp` command, and execute the `raidcom add copy_grp` command specifying the name of the device group to define a copy group. When the command is executed, a description corresponding to HORCM_LDEV of CCI is defined in the storage system. Then, define HORCM LDEVG in the configuration file to incorporate it into the CCI instance. This can be executed at CCI that supports Virtual Storage Platform or later.

- **Define a configuration definition file:**

Define HORCM_LDEV or HORCM_DEV of the configuration definition files of the primary and secondary volumes. For definition details, see Configuration definition file.

A device name is a name given to an LDEV in each device group. This is equivalent to the `dev_name` definition of HORCM_DEV. A device name is not required, but it is convenient to use to specify device group or device name instead of LDEV number. However, to create a pool or a journal, specifying LDEV number is required.

The LDEVs that have the same device name are recognized as a pair in the primary and secondary device group. Therefore, make match the device name for the LDEV to be a pair. Also, the number of LDEVs in the device group must be the same at the primary and secondary sides. Pairs are operated in the ascending sequence of the LDEV numbers. If there is no corresponding device name of LDEV in the device group to be paired, an error might be occurred on the pair operation.

Read operations and command device settings

When grouping LDEVs, if HORCM_LDEVG on the primary side and secondary side is not defined, the read operation of CCI is different depending on the command device settings. The following table shows the details.

HORCM_LDEVG	Command device setting			Reading of device group or copy group information	Security to be set
	Security	User authentication	Group information acquisition		
Not defined	OFF	OFF	OFF	Do not read	No security
			ON	Do not read	Only HORCM_DEV allowed

HORCM_LDEVG	Command device setting			Reading of device group or copy group information	Security to be set	
	Security	User authentication	Group information acquisition			
	OFF	ON	OFF	Read ¹	User authentication required	
			ON	Do not read	User authentication required Only HORCM_DEV allowed	
	ON	OFF	OFF	Read ¹	CMD security	
			ON	Do not read	CMD security Only HORCM_DEV allowed	
	ON	ON	OFF	Read ¹	CMD security User authentication required	
			ON	Do not read	CMD security User authentication required Only HORCM_DEV allowed	
	Defined	-	-	-	Read ²	-
	Notes:					
<ol style="list-style-type: none"> 1. Read the entire group information in the storage system. 2. Read the information of device group and copy group from the contents of the configuration definition file regardless of the setting of the command device. 						

Defining device groups

A device group is created by specifying a device name and a device group name. Once a device group is created, the device group name, the LDEV number, and the information if there is copy group definition or not are stored in the storage system as configuration information.

The maximum number of device groups is 1,024 in one storage system. The maximum 65,279 LDEVs can be placed under the device group. And one LDEV can be placed in multiple device groups.

Notes when specifying a device name

- Multiple device names can be defined in one LDEV (Max: 1,024 names).
- The length of a device name must be up to 32 characters.
- In the device group that does not become an element of copy a group, the same device name can be used in the same device group.
- In the device group that becomes an element of a copy group, a device group name must be unique in the device group. It is because a pair is created between LDEVs that have same device names in respective primary and secondary volumes at the group operation of a replication series command.

Notes when specifying a device group name

- The length of a device group name must be up to 32 characters.
- A device group name must be unique within the storage system. The device group name cannot be duplicated in one storage system.
- When a device group name is specified by the **raidcom** command option and an LDEV to operate is specified by the device name, all devices that have the same name with the beginning of the specified name will be operated.

The contents of the following operations that can be executed for a device group are expressed hereafter with its use cases.

1. Device group creation
2. LDEV addition to device group
3. LDEV deletion from device group
4. Device group deletion



Note:

The following symbols are used in the use cases described hereafter.



: simplex volume



: device group



: copy group

Creating device groups

Specify the LDEV number and the device group name to create a device group.

Use cases

The following examples show use cases for creating a device group.

- Creating a device group configured of simplex volumes with different device names.

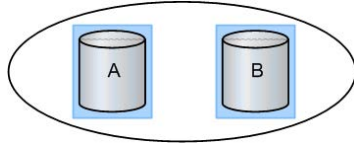

- Creating a device group configured of a simplex volume and a paired volume with different device names.

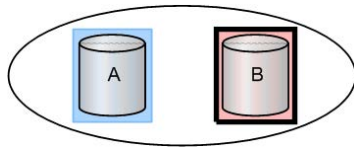

- Creating a device group configured of simplex volumes with same device names.

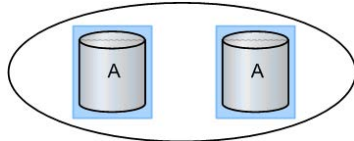

Adding LDEVs to device groups

Specify the device group name and the LDEV number to add the LDEV to the device group.

Use Cases

The following figures show use cases that can be added an LDEV to a device group.

- Adding an LDEV (simplex volume) with a different device name to a device group.

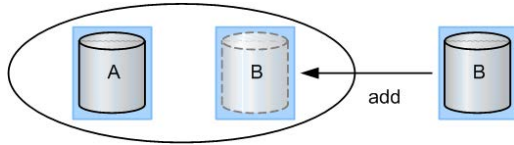

- Adding an LDEV (paired volume) with a different device name to a device group.

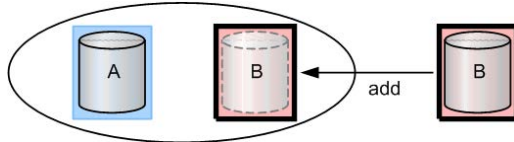

- Adding an LDEV to a device group already including the same device name.

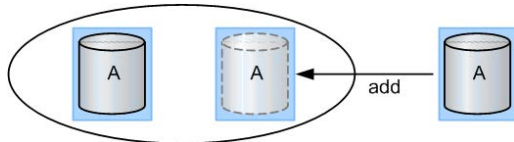

The device name can be duplicated in the case of not creating the copy group by specifying a device group.

Deleting LDEVs from device groups

Specify the device group name and the LDEV number to delete the LDEV from the device group.

LDEV can be deleted from the device group associating a copy group. The pair status does not change even if the LDEV is deleted from the device group.

Use Cases

The following figures show use cases that can be deleted an LDEV from a device group.

- Deleting an LDEV (simplex volume) not associated with a copy group from a device group.

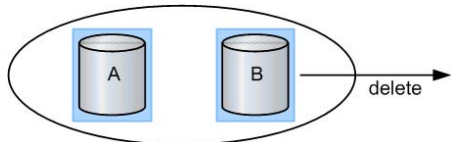

- Deleting an LDEV (paired volume) not associated with a copy group from a device group.

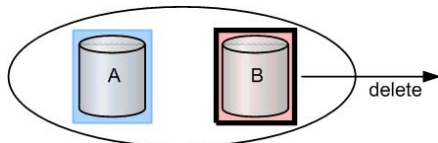

- Deleting an LDEV (simplex volume) associated with a copy group from a device group.

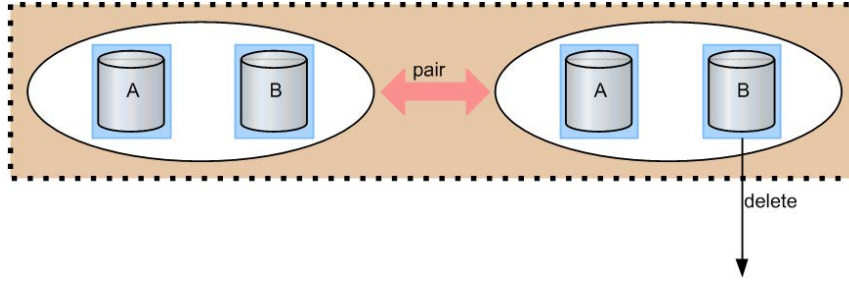

- Deleting an LDEV (paired volume) associated with a copy group from a device group.

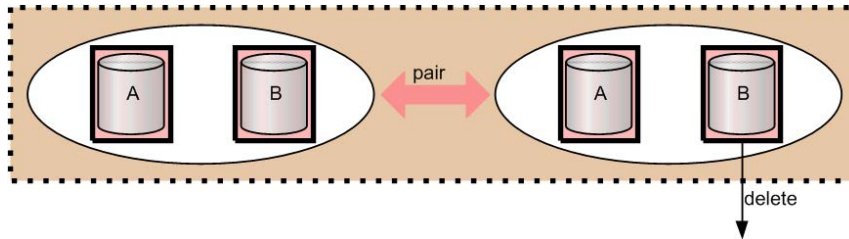

Deleting device groups

Specify the device group name and the LDEV number to delete the LDEV in the device group. If all of the LDEVs configuring the device group are deleted from the device, the relevant device group is deleted. And, even if a device group is deleted, the pair status of the pair in the device group does not change.

Use Cases

The following figures show use cases that can be deleted an LDEV from a device group.

- Deleting a device group configured of simplex volumes and not associated with a copy group.

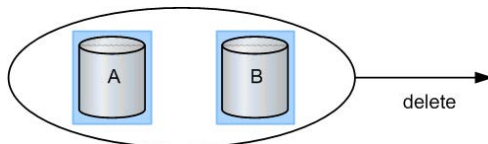

- Deleting a device group configured of a simplex volume and a paired volume and not associated with a copy group.

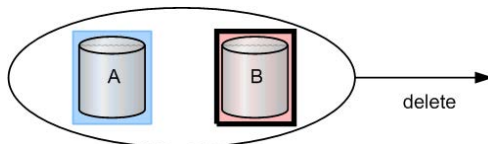

- Deleting a device group configured of simplex volumes and associated with a copy group.

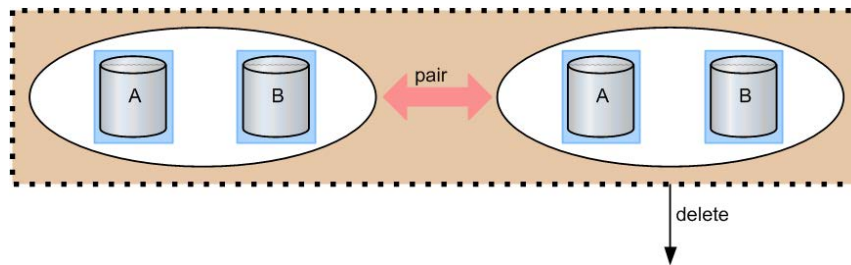

- Deleting a device group configured of paired volumes and associated with a copy group.

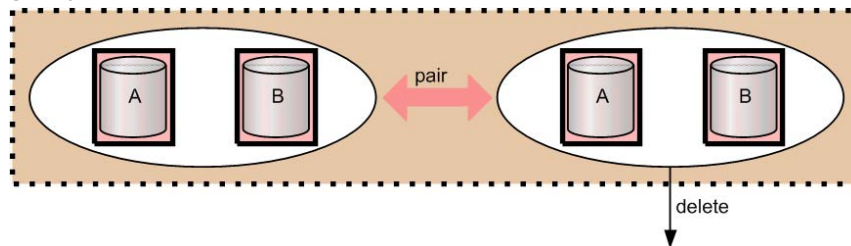

Copy group function

Defining a copy group by specifying two device groups: one device group from primary side and one device group from secondary side, whether they are inside or outside the storage system. A copy group cannot be defined by specifying more than one device group from just one side of primary or secondary.

When a copy group is created, which device group is primary and which is secondary cannot be specified. Therefore, it is specified at the time of actual pair creation. As configuration information, a copy group name, a device group name (primary and secondary), and an MU# are maintained in the storage system.

The notes when operating copy groups are shown below.

When creating a copy group

- In case of creating a copy group by executing a command, a copy group cannot be created through direct specification of multiple LDEVs. Create a copy group by specifying a device group.
- In one device group associated as a copy group, the same device name cannot be defined.
- Copy groups with the same name cannot be defined within the same storage system.
- One device group cannot be defined to multiple copy groups.
- The maximum number of copy groups per storage system is 16,384.
- At the time of consistency group creation (pair creation) and consistency group deletion (pair deletion), the collaboration with the group operations (device group creation/deletion, copy group creation/deletion) is not performed.

When deleting a copy group

- If a copy group is deleted, the association of two device groups is deleted. However, the actual pair status, the consistency group ID and others are not changed (not affected). Even if the pair status in the copy group is not single and the copy group is deleted, the copy group deletion processing is performed.
- If an LDEV is deleted from a device group associated as a copy group, the relevant LDEVs are deleted from all the associated copy groups.
- A copy group defines the relationship of device groups. Therefore, it is not possible to specify an LDEV and remove it from the copy group.
- Regardless of the pair status (copy status), it is possible to exclude LDEVs from device groups associated as a copy group.

The contents of the following operations that can be executed for a copy group are expressed hereafter with its use cases.

1. Copy group creation
2. LDEV addition to copy group
3. LDEV deletion from copy group
4. Copy group deletion
5. Pair operation by specifying a copy group



Note: The following symbols are used in the use cases described hereafter.



: symplex volume



: device group



: copy group

Creating copy groups

Specify the names of two device groups to create a copy group. The same device name must not be defined for any LDEVs in a specified device group. A copy group can be created whether the LDEV in the device group is paired status or not.

Use cases

The following shows use cases that can be created a copy group.

- Creating a copy group in cases where two device groups are configured of simplex volumes and the device names and the LDEV numbers in the respective device groups are the same.

In the following example, when a copy group is created, the LDEVs within the device names of A to A and B to B become a subject of pair operation.

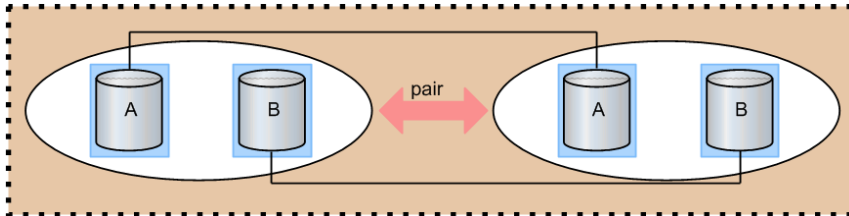

- Creating a copy group in cases where two device groups are configured of paired volumes and the device names and the LDEV numbers in the respective device groups are the same.

In the following example, although pairs have been created on the device names of A to A and B to B, a copy group can be created.

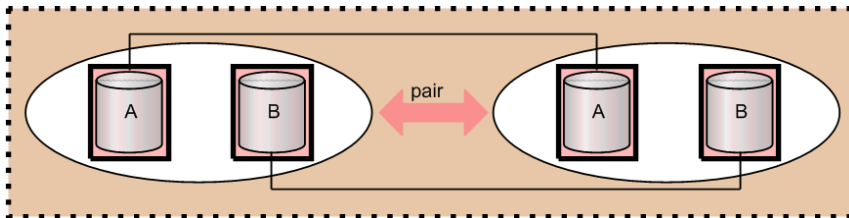

Adding LDEVS to copy groups

Specify the name of the device group for which you created a copy group to add an LDEV. It is not possible to add LDEVs directly to the copy group.

If the device group you want to specify has the same device name, you cannot add the LDEV.

Use cases

The following figures show use cases that can be added an LDEV to the device group associating a copy group.

- Adding an LDEV with a different device name (simplex volume) to a device group forming a copy group.

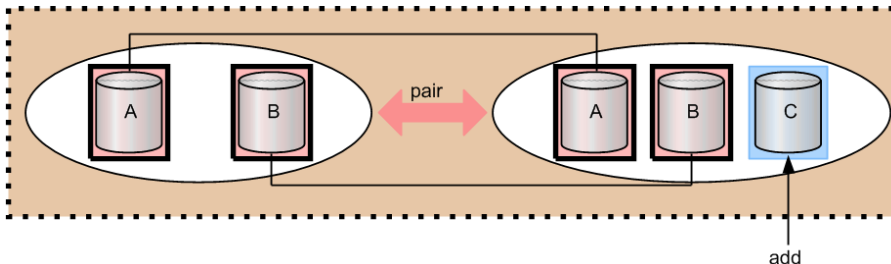

- Adding an LDEV with a different device name (paired volume) to a device group forming a copy group.

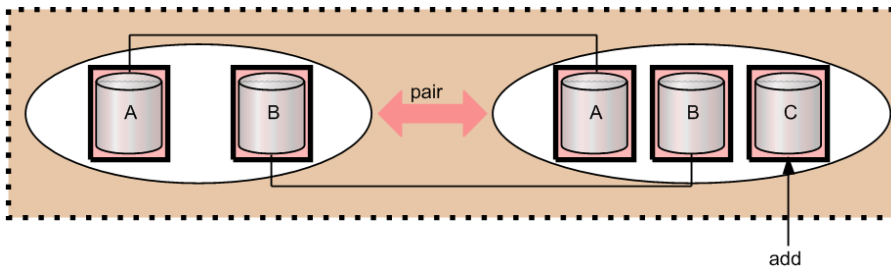

Deleting LDEVs from copy groups

Specify the device group name for which you created a copy group to delete an LDEV. You can delete either simplex volume or paired volume LDEVs.

It is not possible to delete LDEVs directly from the copy group.

Use cases

The following shows use cases that can be deleted LDEVs from the device group forming a copy group.

- Deleting an LDEV (simplex volume) from a device group forming a copy group.

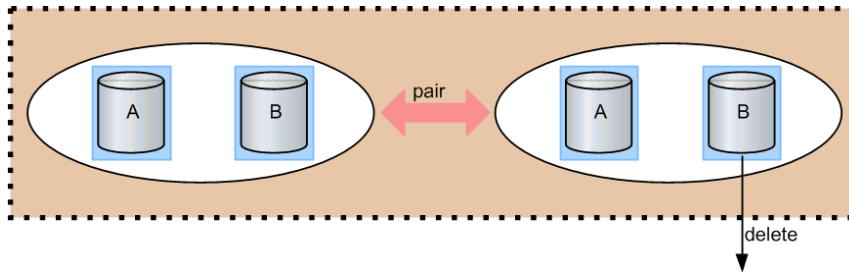

- Deleting an LDEV (paired volume) from a device group forming a copy group.

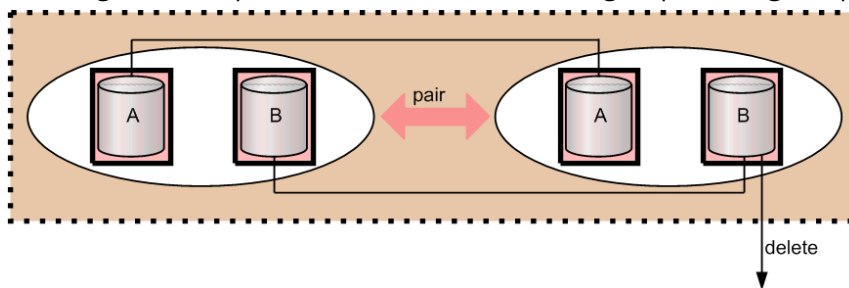
**Deleting copy groups**

Specify the defined copy group to delete it.

Use cases

A copy group can be deleted even if it is configured of simplex volumes or paired volumes.

The following shows use cases that can be deleted a copy group.

- Deleting a copy group configured of simplex volumes.

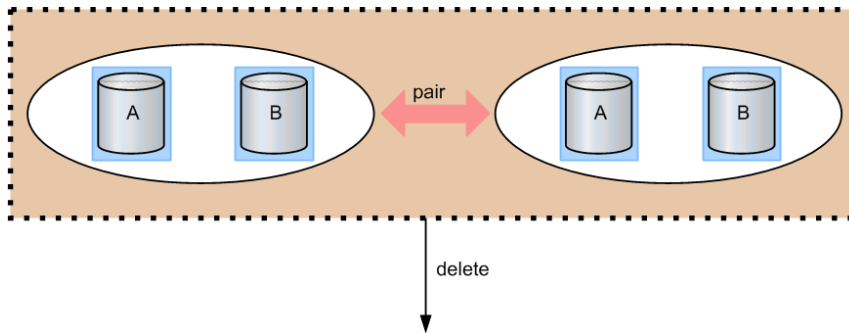

- Deleting a copy group configured of paired volumes.

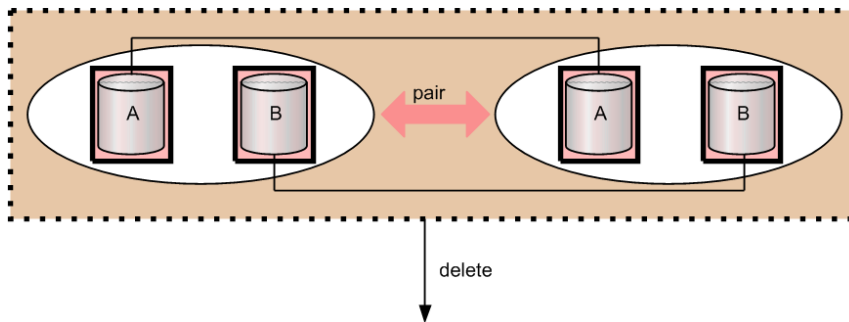

Pair operation by specifying a copy group

Specifying a copy group and creating a pair. Pairs are created for which the same device names of LDEV defined in respective device groups of the LDEVs. Therefore, it is required to give a same device name for the item to be operated as a pair.

If a consistency group attribute is valid and no consistency group ID is specified, automatically assign a consistency group ID (1 copy group=1 consistency group). If the automatic consistency group assignment is specified and the other pairs in a copy group already have consistency group IDs, assign the same consistency group ID.

If there is no target LDEV to be a pair in the copy group, the process is terminated by detecting an error.

Use cases

As an example of pair operation, the following shows use cases that can be created a pair by specifying a copy group.

- Creating a pair in cases where the device names and the numbers of LDEVs in two device groups in a copy group configured of simplex volumes are the same.

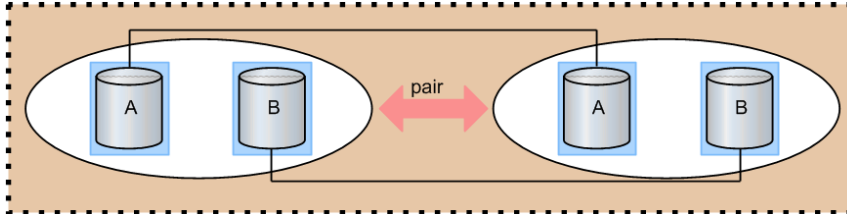

In the following example, pairs are created with LDEVs that have the same device name, A to A and B to B.

- Creating a pair in cases where the device names and the numbers of LDEVs in two device groups in a copy group configured of simplex volumes and paired volumes are the same.

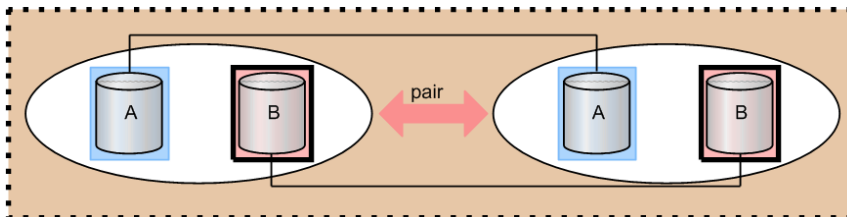

In the following example, a pair is created with LDEVs for the device name A. And no operation is performed for the volumes of device name B that are already formed into copy pairs.

- Creating a pair in cases where different device names exist in two device groups in a copy group configured of simplex volumes.

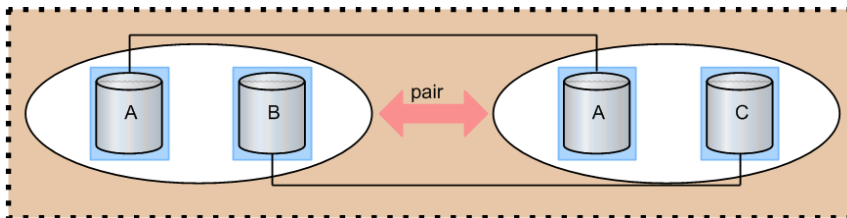

In the following example, a pair for device name A can be created, but not for device name B and C because they have different names.

- Creating a pair in cases where the device names in two device groups in a copy group configured of simplex volumes and paired volumes are different.

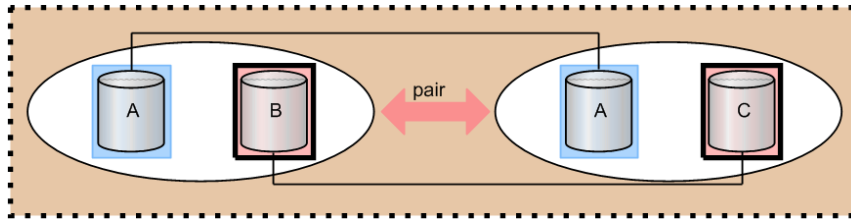

In the following example, a pair for device name A to A can be created. For the device name B and C, although it does not change the paired status, but an error occurs because they have different device names.

- Creating a pair in cases where the numbers of LDEVs in two device groups in a copy group configured of simplex volumes are different.

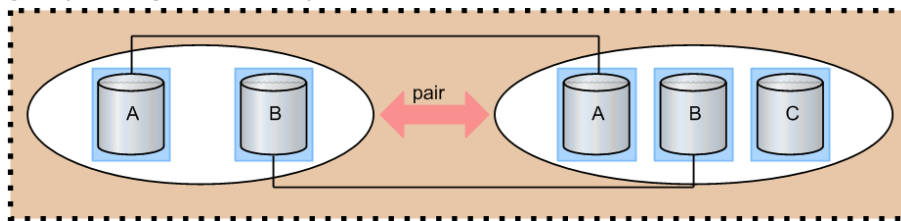

In the following example, pairs are created for the device name A to A and B to B.

Pair operations with mainframe volumes

You can create a pair with mainframe LDEVs using CCI. However, some of the replication functions are not available in CCI. For more detailed information, see the user manual for the replication function: *Hitachi TrueCopy® for Mainframe User Guide*, *Hitachi Universal Replicator for Mainframe User Guide*, or *Hitachi ShadowImage® for Mainframe User Guide*.

Using "dummy" LUs for mainframe LDEVs

Pseudo-LUs called "dummy" LUs are used to access mainframe LDEVs in CCI. The dummy LUs are unconditionally defined for all mainframe device emulation types. Since the dummy LUs are used only by CCI, other user interfaces such as Storage Navigator and host servers do not display the dummy LUs. Two dummy LUs are assigned to each mainframe LDEV. The port IDs of the mainframe PCBs are assigned as the port IDs for the dummy LUs. Host modes cannot be defined for dummy LUs.

```
# pairdisplay -g oradb
Group Pair Vol (L/R) (Port#,TID,LU-M), Seq#, LDEV#..P/S, Status, Fence, Seq#, P-LDEV# M
oradb oradb1 (L) (CL1-A, 1, 0) 30053 18..P-VOL PAIR Never, 30053 19 -
oradb oradb1 (R) (CL1-D, 1, 0) 30053 19..S-VOL PAIR Never, 30053 18 -
```

information on dummy LUs

To determine the port number for dummy LUs, use the following formula:

```
Port#:Installed Port#(*1) (LDEV# / 0x4000) × 32
      Installed Port#(*1) (LDEV# / 0x4000) × 32+1
```

*1: The lowest port number of the installed mainframe ports.

TID: (LDEV# & 03xFC0) / 64
 LU-M: (LDEV# & 0x3F)

To perform pair operations on mainframe volumes just like on open-system volumes, include the mainframe LDEV# in the HORCM_LDEV section of the configuration definition file. If you have mainframe pairs that already exist, you can verify their MU # using the **raidscan** command.

```
HORCM_LDEV
#dev_group dev_name Serial# CU:LDEV(LDEV#) MU
oradb      dev1      30095 00:12 0
oradb      dev2      30095 00:14 0
```

Define mainframe LDEV#.

Pair status and access permission for mainframe LDEVs

The pair status of mainframe LDEVs is displayed in the same way as for open-system LDEVs. However, access permissions to mainframe P-VOLs and S-VOLs are different from those of open volumes. The following tables show the pair status and access permissions for mainframe LDEVs. For more information about displayed pair status of open LDEVs, see TrueCopy/ShadowImage/Universal Replicator pair status.

Pair status and access permission for TrueCopy/TrueCopy for Mainframe

Pair status in Storage Navigator		Pair status in CCI		Access to mainframe P-VOL	Access to mainframe S-VOL	Notes
Open	Mainframe	Open	Mainframe			
SMPL	Simplex	SMPL	SMPL	Read/write enabled	Read/write enabled	not in pair
COPY	Pending	COPY	COPY	Read/write enabled	Reject	copying
PAIR	Duplex	PAIR	PAIR	Read/write enabled	Reject	pair
PSUS (pair suspended split)	Suspended	PSUS	PSUS	Read/write enabled	Reject ¹	suspend
PSUE (pair suspended error)	Suspended	PSUE	PSUE	Read/write enabled	Reject ¹	suspend by failure

Pair status in Storage Navigator		Pair status in CCI		Access to mainframe P-VOL	Access to mainframe S-VOL	Notes
Open	Mainframe	Open	Mainframe			
PDUB	-	PDUB	.2	-	-	inconsistency in LUSE status
SSWS	SSWS	SSWS	SSWS	-	Read/write enabled	HAM only/horctakeover only

Notes:

1. When the system option mode 20 is on, this is a read only volume.
2. PDUB (inconsistency in LUSE status) does not exist in the mainframe system.

Pair status and access permission for Universal Replicator/Universal Replicator for Mainframe

Pair status in Storage Navigator		Pair status in CCI		Access to mainframe P-VOL	Access to mainframe S-VOL	Notes
Open	Mainframe	Open	Mainframe			
SMPL	Simplex	SMPL	SMPL	Read/write enabled	Read/write enabled	not in pair
COPY	Pending	COPY	COPY	Read/write enabled	Reject	copying
PAIR	Duplex	PAIR	PAIR	Read/write enabled	Reject	pair
PSUS (pair suspended split)	Suspend	PSUS	PSUS	Read/write enabled	Reject*	suspend
PSUE (pair suspended error)	Suspend	PSUE	PSUE	Read/write enabled	Reject*	suspend
Suspending	Suspending	PAIR	PAIR	Read/write enabled	Reject	pair
Deleting	Deleting	PAIR / COPY	PAIR / COPY	Read/write enabled	Reject	pair/copying

Pair status in Storage Navigator		Pair status in CCI		Access to mainframe P-VOL	Access to mainframe S-VOL	Notes
Open	Mainframe	Open	Mainframe			
HOLD	Hold	PSUS	PSUS	Read/write enabled	Reject*	suspend
HOLDING	Holding	PSUS	PSUS	Read/write enabled	-	suspend
PSUS (HLDE)	Hold	PSUE	PSUE	Read/write enabled	Reject	suspend
PFUL	Suspend	PFUL	PFUL	Read/write enabled	Reject	suspend
PFUS	Suspend	PFUS	PFUS	Read/write enabled	Reject	suspend
SSWS	Suspend	SSWS	SSWS	-	Read/write enabled	suspend

*When system option mode 20 is on, this is a read-only volume.

Pair status and access permission for ShadowImage/ShadowImage for Mainframe

Pair status in Storage Navigator		Pair status in CCI		Access to mainframe P-VOL	Access to mainframe S-VOL	Notes
Open	Mainframe	Open	Mainframe			
SMPL	Simplex	SMPL	SMPL	Read/write enabled	Read/write enabled	simplex
COPY(PD)	Pending	COPY	COPY	Read/write enabled	Reject	copying
PAIR	Duplex	PAIR	PAIR	Read/write enabled	Reject	pair
COPY (SP)	SP-Pend	COPY	COPY	Read/write enabled	Reject	suspend (in COPY(SP) COPY-COPY)
PSUS (SP)	V-split	PSUS	PSUS	Read/write enabled	Read/write enabled	suspend (in Quick Split PSUS-COPY)

Pair status in Storage Navigator		Pair status in CCI		Access to mainframe P-VOL	Access to mainframe S-VOL	Notes
Open	Mainframe	Open	Mainframe			
PSUS (pair suspended split)	Split	PSUS	PSUS	Read/write enabled	Read/write enabled	suspend
PSUE (pair suspended error)	Suspend	PSUE	PSUE	Read/write enabled	Reject	suspend by failure
COPY (RS)	Resync	COPY	COPY	Read/write enabled	Reject	resynchronizing
COPY (RS-R)	Resync-R	RCPY	RCPY	Reject	Reject	restoring

Operational differences for multiplatform volumes

The following table shows the operational differences for TrueCopy, Universal Replicator, and ShadowImage multiplatform volumes.

LU path definition	LU path information reported to CCI	ShadowImage operations	TrueCopy operations	Universal Replicator operations
LU path is defined.	Actual LU path information is reported.	ShadowImage for Mainframe operations	Commands are rejected.	Commands are rejected.
LU path is not defined.	Dummy LU number is reported.	ShadowImage for Mainframe operations	Commands are rejected.	Commands are rejected.

Operational differences for replication commands

The following table shows the differences between open volumes and mainframe volumes in replication commands. For details on the differences, see the manual for each program product.

Command	Option	Description	Operation in open systems	Operation in mainframe systems	Notes
paircreate*	-c <size>	Specifies track size when copying.	TrueCopy: You can specify 1 to 15 tracks.	TrueCopy for Mainframe: 3 or 15 tracks When you specify the number 1 to 3, the copy speed is 3 tracks. When you specify the number 4 to 15, the copy speed is 15 tracks.	This option is not supported in Universal Replicator or Universal Replicator for Mainframe. There is no difference between ShadowImage and ShadowImage for Mainframe.
	-m grp [CTG ID]	If CTG ID is not specified, CTG ID is automatically assigned and a pair is registered to the consistency group. If CTG ID is specified, a pair is registered to the CTG ID in use.	You can specify this option.	You can specify this option.	ShadowImage pairs and ShadowImage for Mainframe pairs cannot be registered to the same CTG ID. If both ShadowImage pairs and ShadowImage for Mainframe pairs are registered to one group, the command ends abnormally.
pairsplit	-r -rw	Specifies access mode to S-VOL after splitting a pair.	-r: Read only -rw: Read/write enabled	The volume cannot be read regardless of the specified options.	This option is only for TrueCopy, TrueCopy for Mainframe, Universal Replicator, and Universal Replicator for Mainframe.

Command	Option	Description	Operation in open systems	Operation in mainframe systems	Notes
					You cannot specify this option in ShadowImage or ShadowImage for Mainframe.
<p>*If the capacity of the S-VOL is larger than that of the P-VOL, you cannot create a pair with CCI. To create a TrueCopy for Mainframe pair with volumes that differ in capacity, use Business Continuity Manager or Storage Navigator.</p> <p>Notes:</p> <ul style="list-style-type: none"> ▪ A mainframe primary volume can also be called a source volume or a main volume. ▪ A mainframe secondary volume can also be called a target volume or a remote volume. 					

Global storage virtualization function

The global storage virtualization function enables you to minimize rewrites of configuration definition files (horcm*.conf) when you operate volumes migrated from older models to the VSP G1000, VSP G1500, VSP F1500, VSP Gx00 models, or VSP Fx00 models. You can also minimize the modification of the script file that you used for the older models, when you operate volumes using the script file created by you. For details about the global storage virtualization function, see the *Provisioning Guide* for the storage system. Volume migration (nondisruptive migration) from older models by using the global storage virtualization function is supported only on the VSP G1000, VSP G1500, VSP F1500, VSP Gx00 models, and VSP Fx00 models.

System configuration example with the global storage virtualization function

This topic shows a system configuration with the global storage virtualization function. In this configuration, a virtual storage machine is created in two storage systems respectively. Volumes in the virtual storage machine are given virtual LDEV IDs.

- Primary site
 - Storage system: VSP G1000 (S/N: 67000)
 - Virtual storage machine: VSP (S/N: 65000)
 - LDEV ID of VSP G1000: 10:00 and 10:01
 - Virtual LDEV ID: 01:00 and 01:01
- Secondary site
 - Storage system: VSP G1000 (S/N: 68000)
 - Virtual storage machine: VSP (S/N: 66000)
 - LDEV ID of VSP G1000: 10:00 and 10:01
 - Virtual LDEV ID: 02:00 and 02:01

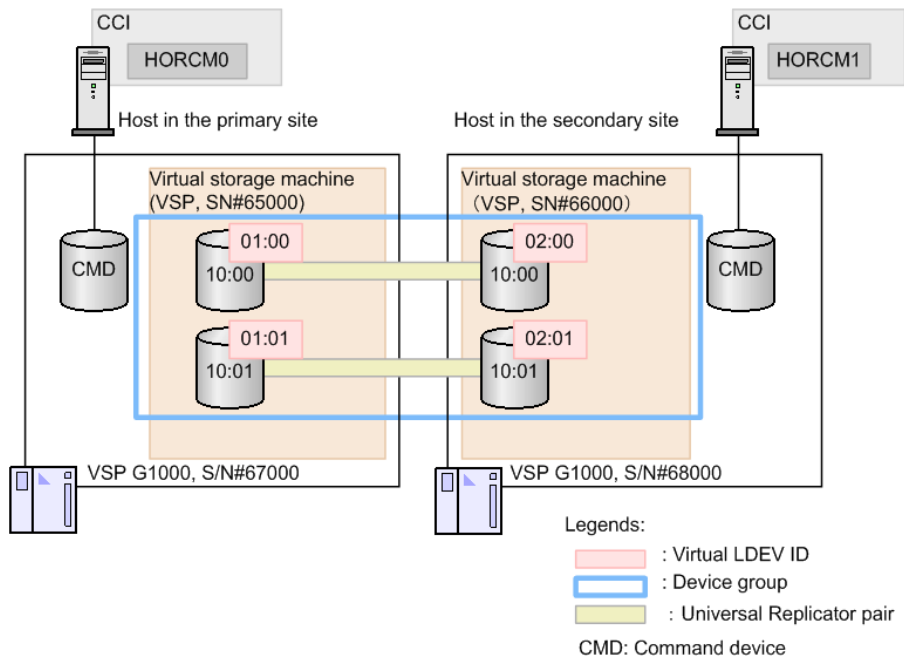

Using CCI with the global storage virtualization function

To use CCI with the system configuration using the global storage virtualization function, the following two methods can be used.

- Specifying a virtual storage machine to HORCM_VCMD in configuration definition files
- Specifying a virtual storage machine to command options (that is, `-s <seq#>` or `-u <unit id>`)

If you specify the virtual storage machine to HORCM_VCMD of the configuration file, the shell scripts can be used continuously, because you do not need to modify their scripts. However, if you define HORCM_VCMD, you cannot operate the virtual storage machine whose the serial number is not specified by HORC_VCMD. If you specify the virtual storage machine to the command options (that is, -s <seq#> or -u <unit id>) instead of specifying with HORCM_VCMD, you can also operate the virtual storage machine of the serial number not specifying to HORCM_VCMD.

After you change the virtual storage machine configuration with the **raidcom add resource** command or the **raidcom delete resource** command, restart HORCM.

Configuration definition file settings with global storage virtualization

This topic shows configuration definition file settings with the global storage virtualization function. For details on other parameters, see Configuration definition file. The global storage virtualization function is supported on the VSP G1000 storage system, VSP G1500, VSP F1500, VSP Gx00 models, and VSP Fx00 models.

- **HORCM_CMD:**

Specify a volume belonging to meta_resource or a virtual storage machine in the storage system as the command device. CCI obtains the virtual storage machine information defined in the storage system via the specified command device, and configures the virtual storage machine components.

When you specify a volume that belongs to a virtual storage machine, note the following:

- Use the serial number of the virtual storage machine and the virtual LDEV ID for the serial number and LDEV ID which you are specifying for HORCM_CMD.
- You cannot specify HORCM_VCMD to the same configuration definition file.
- You cannot define the volume that does not belong to the virtual storage machine to the HORCM_CMD of the same configuration definition file.
- When you specify multiple volumes of virtual storage machines associated with the same serial number, these volumes must belong to the same storage system.



Note: The `mkconf` command lets you create the configuration definition file by importing the special file name from the standard input. When you create a configuration definition file by using the `mkconf` command, make sure that the special file name of the volume that belongs to the virtual storage machine and the special file name of the volume that does not belong to the virtual storage machine are different.

- **HORCM_VCMD:**

In HORCM_VCMD, specify the serial number of the virtual storage machine to be operated by this instance.

You cannot operate the virtual storage machines whose serial numbers are not specified in HORCM_VCMD. To operate more than one virtual storage machine from a instance, specify each serial number of the virtual storage machines in a new line with HORCM_VCMD. To operate the virtual storage machine specified in the second or later of HORCM_VCMD, use the command options (for example, `-s <seq#>` or `-u <unit id>`). If you omit the options of the command, the virtual storage machine of which you first specified serial number is operated. Even if you specify the virtual storage machine of which the serial number is not specified in HORCM_VCMD with the command option (`-s <seq#>` or `-u <Unit ID>`), the error (EX_ENOUNT) occurs.

- **HORCM_LDEV:**

Specify volumes to be copied. Serial numbers of the virtual storage machine and virtual LDEV IDs must be specified. You cannot specify the volumes with HORCM_DEV in the system configuration with the global storage virtualization function. Specify the volumes with HORCM_LDEV.

- **HORCM_INST:**

Specify an IP address and a service name of the remote host as it is for not using the global storage virtualization function.

Example of the configuration definition files when specifying a virtual storage machine by HORCM_CMD

The following examples show when a volume belonging to meta_resource is specified for HORCM_CMD.



Note: The underlined parts indicate the information that needs to modify from the file of the old model.

Example of the configuration definition files (HORCM0)

```
#!/***** HORCM0 on PHOST *****/
HORCM_MON
#ip_address service poll(10ms) timeout(10ms)
NONE          horcm0          1000          3000

#!/***** For HORCM_CMD *****/
HORCM_CMD
#dev_name
\\.\CMD-367000:/dev/rdsk
HORCM_VCMD
# redefine Virtual DKC Serial# as unitIDs
65000

HORCM_LDEV
Ora          dev1          65000 01:00 h1
Ora          dev2          65000 01:01 h1

#!/***** For HORCM_INST *****/
HORCM_INST
#dev_group  ip_address  service
Ora         RHOST      horcm1
```

Example of the configuration definition files (HORCM1)

```
#!/***** HORCM1 on RHOST *****/
HORCM_MON
#ip_address service poll(10ms) timeout(10ms)
NONE          horcm1          1000          3000
```

```
#!/***** For HORCM_CMD *****/
HORCM_CMD
#dev_name
\\.\CMD-368000:/dev/rdisk
HORCM_VCMD
# redefine Virtual DKC Serial# as unitIDs
66000

HORCM_LDEV
Ora      dev1      66000  02:00  h1
Ora      dev2      66000  02:01  h1

#!/***** For HORCM_INST *****/
HORCM_INST
#dev_group ip_address  service
Ora      PHOST      horcm0
```

raidqry command display example

```
# raidqry -l
No Group  Hostname      HORCM_ver  Uid Serial# Micro_ver  Cache(MB)
1 ---    raidmanager  01-31-03/00  0   66000   80-01-00/00  81920
```

The following examples show when the storage system is VSP G1000 and a volume belonging to a virtual storage system is specified for HORCM_CMD.



Note: It is not necessary to change HORCM_CMD used in the previous model or to add HORCM_VCMD.

Example of the configuration definition files (HORCM0)

```
#!/***** HORCM0 on PHOST *****/
HORCM_MON
#ip_address service poll(10ms) timeout(10ms)
NONE horcm0 1000 3000
#!/***** For HORCM_CMD *****/
HORCM_CMD
#dev_name
\\ . \ CMD-65000:/dev/rdisk
HORCM_LDEV
Ora dev1 65000 01:00 h1
Ora dev2 65000 01:01 h1
#!/***** For HORCM_INST *****/
HORCM_INST
#dev_group ip_address service
Ora RHOST horcm1
```

Example of the configuration definition files (HORCM1)

```

#/***** HORCM1 on RHOST *****/
HORCM_MON
#ip_address service poll(10ms) timeout(10ms)
NONE horcm1 1000 3000
#/***** For HORCM_CMD *****/
HORCM_CMD
#dev_name
\\ . \ CMD-66000:/dev/rdsk
HORCM_LDEV
Ora dev1 66000 02:00 h1
Ora dev2 66000 02:01 h1
#/***** For HORCM_INST *****/
HORCM_INST
#dev_group ip_address service
Ora PHOST horcm0

```

Specifying a virtual storage machine to HORCM_VCMD

This section covers the following topics:

- [Command operations to virtual storage machines \(on page 155\)](#)
- [Operation target for raidcom commands when specifying the virtual storage machine in HORCM_VCMD \(on page 159\)](#)

Command operations to virtual storage machines

When HORCM starts, CCI obtains the virtual storage machine information from multiple storage systems, and configure each virtual storage machine component. CCI regards commands as the command to the virtual storage machine by the descriptions of the configuration definition file or the command options (i.e., -s <seq#> or -u <unit id>), and use their information. The following table shows how to issue the command to the virtual storage machine for each command.

Commands	How to issue the command to the virtual storage machine	Remarks
paircreate	Describe the virtual storage machine information in HORCM_LDEV in the configuration definition file.	---
pairsplit	Describe the virtual storage machine information in HORCM_LDEV in the configuration definition file.	---
pairresync	Describe the virtual storage machine information in HORCM_LDEV in the configuration definition file.	---

Commands	How to issue the command to the virtual storage machine	Remarks
pairevwait	Describe the virtual storage machine information in HORCM_LDEV in the configuration definition file.	---
pairvolchk	Describe the virtual storage machine information in HORCM_LDEV in the configuration definition file.	---
pairdisplay	Describe the virtual storage machine information in HORCM_LDEV in the configuration definition file.	---
paircurchk	Describe the virtual storage machine information in HORCM_LDEV in the configuration definition file.	---
horctakeover	Describe the virtual storage machine information in HORCM_LDEV in the configuration definition file.	---
raidvchkset	Describe the virtual storage machine information in HORCM_LDEV in the configuration definition file.	---
raidvchkdsp	Describe the virtual storage machine information in HORCM_LDEV in the configuration definition file.	---
pairsyncwait	Describe the virtual storage machine information in HORCM_LDEV in the configuration definition file.	---
pairmon	Describe the virtual storage machine information in HORCM_LDEV in the configuration definition file.	---
raidscan	<p>Specify the virtual storage machine by the -s <seq#> or the -p <port#> (to specify the unit ID) option.</p> <p>The virtual storage machine can be specified regardless of the description contents of the configuration definition file.</p>	<p>You cannot specify a virtual storage machine by the -u <unit ID> option of the raidscan command. Use the -s <seq#> option, or the -p <port#> to specify as "CL1-An" (<i>n</i> is the unit ID).</p>

Commands	How to issue the command to the virtual storage machine	Remarks
raidar	Specify the virtual storage machine by a unit ID by the command option (-p <port#>).	The raidar command has no option to specify a serial number nor a unit ID. Use the -p <port#> option as "CL1-An" (specify a unit ID in n).
raidqry	---	The information of VSP G1000, VSP G1500, VSP F1500, VSP Gx00 models, or VSP Fx00 models and the virtual storage machine is displayed.
raidvchksan	Specify the virtual storage machine by the command option (-s <seq#> or -u <unit ID>). The virtual storage machine can be specified regardless of the description contents of the configuration definition file.	If you are specifying a command device in a virtual storage machine for which user authentication is disabled to the HORCM_CMD, do not specify the -v jnl and -v pid option.
horcctl	Specify VSP G1000, VSP G1500, VSP F1500, VSP G200, G400, G600, G800, or VSP F400, F600, F800 information.	If you specify the virtual storage machine information, error (No such control device) occurs. This command cannot be used if you specify a volume belonging to a virtual storage machine to HORCM_CMD.

Commands	How to issue the command to the virtual storage machine	Remarks
raidcom	<p>Specify the virtual storage machine by the command option (-s <seq#> or -u <unit ID>).</p> <p>The virtual storage machine can be specified regardless of the description contents of the configuration definition file.</p>	<p>When you specify a volume that belongs to meta_resource for HORCM_CMD, if you specify the virtual storage machine for the command option, some commands can be executed using the virtual storage machine information (see Operation target for raidcom commands when specifying the virtual storage machine in HORCM_VCMD).</p> <p>When you specify a volume that belongs to a virtual storage machine for HORCM_CMD, there is a limitation of which command you can use. You can execute by using the virtual storage machine information if the raidcom command can be used and if you specify the virtual storage machine for the command option (see raidcom commands for volumes that belong to virtual storage machine for HORCM_CMD).</p>

Operation target for **raidcom** commands when specifying the virtual storage machine in HORCM_VCMD

The virtual storage machine specified in HORCM_VCMD becomes the operation target if you do not specify the **-s <seq#>** (serial number) and **-u <unit ID>** (unit ID of the command device) options of the **raidcom** commands. The operational targets according to the definition of HORCM_VCMD are shown in the table below.

- When you specify the virtual storage machine in HORCM_VCMD and the operation target for the **raidcom** command is a virtual storage machine, the operational target is: The virtual storage machine of the first serial number specified in HORCM_VCMD.
- When you specify the virtual storage machine in HORCM_VCMD and the operation target for the **raidcom** command is VSP G1x00 and VSP F1500, VSP Gx00 models, or VSP Fx00 models, the operational target is: VSP G1x00 and VSP F1500, VSP Gx00 models, or VSP Fx00 models for which the virtual storage machine of the first serial number specified in HORCM_VCMD is defined.
- When you specify the virtual storage machine in HORCM_VCMD and the operation target for the **raidcom** command is VSP Gx00 models or VSP Fx00 models, the operational target is: VSP Gx00 models or VSP Fx00 models for which the virtual storage machine of the first serial number specified in HORCM_VCMD is defined.

Operation type	Commands	Operation targets according to the definition of HORCM_VCMD
Copy group	raidcom get copy_grp	VSP G1x00 and VSP F1500, VSP Gx00 models, or VSP Fx00 models
	raidcom add copy_grp	VSP G1x00 and VSP F1500, VSP Gx00 models, or VSP Fx00 models
	raidcom delete copy_grp	VSP G1x00 and VSP F1500, VSP Gx00 models, or VSP Fx00 models
Device group	raidcom get device_grp	VSP G1x00 and VSP F1500, VSP Gx00 models, or VSP Fx00 models
	raidcom add device_grp	VSP G1x00 and VSP F1500, VSP Gx00 models, or VSP Fx00 models
	raidcom delete device_grp	VSP G1x00 and VSP F1500, VSP Gx00 models, or VSP Fx00 models
External volume group	raidcom get external_grp	VSP G1x00 and VSP F1500, VSP Gx00 models, or VSP Fx00 models
	raidcom add external_grp	VSP G1x00 and VSP F1500, VSP Gx00 models, or VSP Fx00 models
	raidcom delete external_grp	VSP G1x00 and VSP F1500, VSP Gx00 models, or VSP Fx00 models

Operation type	Commands	Operation targets according to the definition of <i>HORCM_VCMD</i>
	raidcom modify external_grp	VSP G1x00 and VSP F1500, VSP Gx00 models, or VSP Fx00 models
	raidcom disconnect external_grp	VSP G1x00 and VSP F1500, VSP Gx00 models, or VSP Fx00 models
Host group	raidcom get host_grp	VSP G1x00 and VSP F1500, VSP Gx00 models, or VSP Fx00 models
	raidcom add host_grp	VSP G1x00 and VSP F1500, VSP Gx00 models, or VSP Fx00 models
	raidcom delete host_grp	VSP G1x00 and VSP F1500, VSP Gx00 models, or VSP Fx00 models
	raidcom modify host_grp	VSP G1x00 and VSP F1500, VSP Gx00 models, or VSP Fx00 models
WWN	raidcom get hba_wwn	VSP G1x00 and VSP F1500, VSP Gx00 models, or VSP Fx00 models
	raidcom add hba_wwn	VSP G1x00 and VSP F1500, VSP Gx00 models, or VSP Fx00 models
	raidcom delete hba_wwn	VSP G1x00 and VSP F1500, VSP Gx00 models, or VSP Fx00 models
	raidcom set hba_wwn	VSP G1x00 and VSP F1500, VSP Gx00 models, or VSP Fx00 models
	raidcom reset hba_wwn	VSP G1x00 and VSP F1500, VSP Gx00 models, or VSP Fx00 models
iSCSI name and CHAP user name	raidcom get hba_iscsi	VSP G1x00 and VSP F1500, VSP Gx00 models, or VSP Fx00 models
	raidcom add hba_iscsi	VSP G1x00 and VSP F1500, VSP Gx00 models, or VSP Fx00 models
	raidcom delete hba_iscsi	VSP G1x00 and VSP F1500, VSP Gx00 models, or VSP Fx00 models
	raidcom set hba_iscsi	VSP G1x00 and VSP F1500, VSP Gx00 models, or VSP Fx00 models
	raidcom reset hba_iscsi	VSP G1x00 and VSP F1500, VSP Gx00 models, or VSP Fx00 models
	raidcom get chap_user	VSP G1x00 and VSP F1500, VSP Gx00 models, or VSP Fx00 models

Operation type	Commands	Operation targets according to the definition of HORCM_VCMD
	raidcom add chap_user	VSP G1x00 and VSP F1500, VSP Gx00 models, or VSP Fx00 models
	raidcom delete chap_user	VSP G1x00 and VSP F1500, VSP Gx00 models, or VSP Fx00 models
	raidcom set chap_user	VSP G1x00 and VSP F1500, VSP Gx00 models, or VSP Fx00 models
	raidcom reset chap_user	VSP G1x00 and VSP F1500, VSP Gx00 models, or VSP Fx00 models
	raidcom send ping	VSP G1x00 and VSP F1500, VSP Gx00 models, or VSP Fx00 models
Journal	raidcom get journal	VSP G1x00 and VSP F1500, VSP Gx00 models, or VSP Fx00 models
	raidcom add journal	VSP G1x00 and VSP F1500, VSP Gx00 models, or VSP Fx00 models
	raidcom delete journal	VSP G1x00 and VSP F1500, VSP Gx00 models, or VSP Fx00 models
	raidcom modify journal	VSP G1x00 and VSP F1500, VSP Gx00 models, or VSP Fx00 models
LDEV	raidcom get ldev	Virtual storage machine
	raidcom add ldev	VSP G1x00 and VSP F1500, VSP Gx00 models, or VSP Fx00 models
	raidcom delete ldev	VSP G1x00 and VSP F1500VSP G1x00 and VSP F1500, VSP Gx00 models, or VSP Fx00 models
	raidcom modify ldev	VSP G1x00 and VSP F1500, VSP Gx00 models, or VSP Fx00 models
	raidcom extend ldev	VSP G1x00 and VSP F1500, VSP Gx00 models, or VSP Fx00 models
	raidcom initialize ldev	VSP G1x00 and VSP F1500, VSP Gx00 models, or VSP Fx00 models
LUN	raidcom get lun	Virtual storage machine
	raidcom add lun	Virtual storage machine
	raidcom modify lun	Virtual storage machine

Operation type	Commands	Operation targets according to the definition of <i>HORCM_VCMD</i>
	raidcom delete lun	Virtual storage machine
External path	raidcom get path	VSP G1x00 and VSP F1500, VSP Gx00 models, or VSP Fx00 models
	raidcom add path	VSP G1x00 and VSP F1500, VSP Gx00 models, or VSP Fx00 models
	raidcom delete path	VSP G1x00 and VSP F1500, VSP Gx00 models, or VSP Fx00 models
	raidcom disconnect path	VSP G1x00 and VSP F1500, VSP Gx00 models, or VSP Fx00 models
	raidcom check_ext_storage path	VSP G1x00 and VSP F1500, VSP Gx00 models, or VSP Fx00 models
	raidcom check_ext_storage external_grp	VSP G1x00 and VSP F1500, VSP Gx00 models, or VSP Fx00 models
	raidcom discover external_storage	VSP G1x00 and VSP F1500, VSP Gx00 models, or VSP Fx00 models
	raidcom discover lun	VSP G1x00 and VSP F1500, VSP Gx00 models, or VSP Fx00 models
	raidcom get external_iscsi_name	VSP G1x00 and VSP F1500, VSP Gx00 models, or VSP Fx00 models
	raidcom add external_iscsi_name	VSP G1x00 and VSP F1500, VSP G1x00 and VSP F1500VSP Gx00 models, or VSP Fx00 models
	raidcom delete external_iscsi_name	VSP G1x00 and VSP F1500, VSP Gx00 models, or VSP Fx00 models
	raidcom modify external_chap_user	VSP G1x00 and VSP F1500, VSP Gx00 models, or VSP Fx00 models
	raidcom get initiator_iscsi_name	VSP G1x00 and VSP F1500, VSP Gx00 models, or VSP Fx00 models
	raidcom modify initiator_chap_user	VSP G1x00 and VSP F1500, VSP Gx00 models, or VSP Fx00 models
	raidcom discover external_iscsi_name	VSP G1x00 and VSP F1500, VSP Gx00 models, or VSP Fx00 models
raidcom check external_iscsi_name	VSP G1x00 and VSP F1500, VSP Gx00 models, or VSP Fx00 models	

Operation type	Commands	Operation targets according to the definition of HORCM_VCMD
Pool	raidcom get pool	VSP G1x00 and VSP F1500, VSP Gx00 models, or VSP Fx00 models
	raidcom get dp_pool	VSP G1x00 and VSP F1500, VSP Gx00 models, or VSP Fx00 models
	raidcom get snap_pool	VSP G1x00 and VSP F1500, VSP Gx00 models, or VSP Fx00 models
	raidcom add dp_pool	VSP G1x00 and VSP F1500, VSP Gx00 models, or VSP Fx00 models
	raidcom add snap_pool	VSP G1x00 and VSP F1500, VSP Gx00 models, or VSP Fx00 models
	raidcom delete pool	VSP G1x00 and VSP F1500, VSP Gx00 models, or VSP Fx00 models
	raidcom modify pool	VSP G1x00 and VSP F1500, VSP Gx00 models, or VSP Fx00 models
	raidcom reallocate pool	VSP G1x00 and VSP F1500, VSP Gx00 models, or VSP Fx00 models
	raidcom monitor pool	VSP G1x00 and VSP F1500, VSP Gx00 models, or VSP Fx00 models
	raidcom initialize pool	VSP G1x00 and VSP F1500, VSP Gx00 models, or VSP Fx00 models
Port	raidcom get port	VSP G1x00 and VSP F1500, VSP Gx00 models, or VSP Fx00 models
	raidcom modify port	VSP G1x00 and VSP F1500, VSP Gx00 models, or VSP Fx00 models
RCU	raidcom get rcu	VSP G1x00 and VSP F1500, VSP Gx00 models, or VSP Fx00 models
	raidcom add rcu	VSP G1x00 and VSP F1500, VSP Gx00 models, or VSP Fx00 models
	raidcom delete rcu	VSP G1x00 and VSP F1500, VSP Gx00 models, or VSP Fx00 models
	raidcom modify rcu	VSP G1x00 and VSP F1500, VSP Gx00 models, or VSP Fx00 models
Logical path to RCU	raidcom add rcu_path	VSP G1x00 and VSP F1500, VSP Gx00 models, or VSP Fx00 models

Operation type	Commands	Operation targets according to the definition of HORCM_VCMD
	raidcom delete rcu_path	VSP G1x00 and VSP F1500, VSP Gx00 models, or VSP Fx00 models
	raidcom add rcu_iscsi_port	VSP G1x00 and VSP F1500, VSP Gx00 models, or VSP Fx00 models
	raidcom delete rcu_iscsi_port	VSP G1x00 and VSP F1500, VSP Gx00 models, or VSP Fx00 models
	raidcom get rcu_iscsi_port	VSP G1x00 and VSP F1500, VSP Gx00 models, or VSP Fx00 models
Parity group	raidcom get parity_grp	VSP G1x00 and VSP F1500, VSP Gx00 models, or VSP Fx00 models
	raidcom initialize parity_grp	VSP Gx00 models or VSP Fx00 models
	raidcom modify parity_grp	VSP Gx00 models or VSP Fx00 models
	raidcom get parity_grp	VSP G1x00 and VSP F1500
	raidcom add parity_grp	VSP Gx00 models, or VSP Fx00 models
	raidcom delete parity_grp	VSP Gx00 models, or VSP Fx00 models
Drive	raidcom get drive	VSP Gx00 models, or VSP Fx00 models
	raidcom modify drive	VSP Gx00 models, or VSP Fx00 models
SSID	raidcom get ssid	VSP G1x00 and VSP F1500, VSP Gx00 models, or VSP Fx00 models
	raidcom add ssid	VSP G1x00 and VSP F1500, VSP Gx00 models, or VSP Fx00 models
	raidcom delete ssid	VSP G1x00 and VSP F1500, VSP Gx00 models, or VSP Fx00 models
Resource group	raidcom get resource	VSP G1x00 and VSP F1500, VSP Gx00 models, or VSP Fx00 models
	raidcom add resource	VSP G1x00 and VSP F1500, VSP Gx00 models, or VSP Fx00 models

Operation type	Commands	Operation targets according to the definition of <i>HORCM_VCMD</i>
	raidcom delete resource	VSP G1x00 and VSP F1500, VSP Gx00 models, or VSP Fx00 models
	raidcom lock resource	VSP G1x00 and VSP F1500, VSP Gx00 models, or VSP Fx00 models
	raidcom unlock resource	VSP G1x00 and VSP F1500, VSP Gx00 models, or VSP Fx00 models
	raidcom map resource	VSP G1x00 and VSP F1500, VSP Gx00 models, or VSP Fx00 models
	raidcom unmap resource	VSP G1x00 and VSP F1500, VSP Gx00 models, or VSP Fx00 models
CLPR	raidcom get clpr	VSP G1x00 and VSP F1500, VSP Gx00 models, or VSP Fx00 models
	raidcom modify clpr	VSP G1x00 and VSP F1500, VSP Gx00 models, or VSP Fx00 models
Thin Image	raidcom get snapshot	Virtual storage machine
	raidcom add snapshot	Virtual storage machine
	raidcom delete snapshot	Virtual storage machine
	raidcom modify snapshot	Virtual storage machine
Server Priority Manager	raidcom get spm_wwn	VSP G1x00 and VSP F1500, VSP Gx00 models, or VSP Fx00 models
	raidcom get spm_group	VSP G1x00 and VSP F1500, VSP Gx00 models, or VSP Fx00 models
	raidcom add spm_wwn	VSP G1x00 and VSP F1500, VSP Gx00 models, or VSP Fx00 models
	raidcom add spm_group	VSP G1x00 and VSP F1500, VSP Gx00 models, or VSP Fx00 models
	raidcom delete spm_wwn	VSP G1x00 and VSP F1500, VSP Gx00 models, or VSP Fx00 models
	raidcom delete spm_group	VSP G1x00 and VSP F1500, VSP Gx00 models, or VSP Fx00 models
	raidcom modify spm_wwn	VSP G1x00 and VSP F1500, VSP Gx00 models, or VSP Fx00 models

Operation type	Commands	Operation targets according to the definition of HORCM_VCMD
	raidcom modify spm_group	VSP G1x00 and VSP F1500, VSP Gx00 models, or VSP Fx00 models
	raidcom monitor spm_wwn	VSP G1x00 and VSP F1500, VSP Gx00 models, or VSP Fx00 models
	raidcom monitor spm_group	VSP G1x00 and VSP F1500, VSP Gx00 models, or VSP Fx00 models
	raidcom modify spm_ldev	VSP G1x00 and VSP F1500, VSP Gx00 models, or VSP Fx00 models
	raidcom delete spm_ldev	VSP G1x00 and VSP F1500, VSP Gx00 models, or VSP Fx00 models
	raidcom monitor spm_ldev	VSP G1x00 and VSP F1500, VSP Gx00 models, or VSP Fx00 models
	raidcom get spm_ldev	VSP G1x00 and VSP F1500, VSP Gx00 models, or VSP Fx00 models
Program product	raidcom add license	VSP Gx00 models or VSP Fx00 models
	raidcom delete license	VSP Gx00 models or VSP Fx00 models
	raidcom modify license	VSP Gx00 models or VSP Fx00 models
	raidcom get license	VSP G1x00 and VSP F1500, VSP Gx00 models, or VSP Fx00 models
Local replica option	raidcom modify local_replica_opt	VSP G1x00 and VSP F1500, VSP Gx00 models, or VSP Fx00 models
	raidcom get local_replica_opt	VSP G1x00 and VSP F1500, VSP Gx00 models, or VSP Fx00 models
Quorum disk	raidcom get quorum	VSP G1x00 and VSP F1500, VSP Gx00 models, or VSP Fx00 models
	raidcom modify quorum	VSP G1x00 and VSP F1500, VSP Gx00 models, or VSP Fx00 models
	raidcom replace quorum	VSP G1x00 and VSP F1500, VSP Gx00 models, or VSP Fx00 models
Others	raidcom get command_status	VSP G1x00 and VSP F1500, VSP Gx00 models, or VSP Fx00 models

Operation type	Commands	Operation targets according to the definition of HORCM_VCMD
	raidcom reset command_status	VSP G1x00 and VSP F1500, VSP Gx00 models, or VSP Fx00 models
	raidcom get error_message	VSP G1x00 and VSP F1500, VSP Gx00 models, or VSP Fx00 models

raidcom commands for volumes that belong to virtual storage machine for HORCM_CMD

You can use the following **raidcom** commands when you specify a volume that belongs to virtual storage machine in HORCM_CMD:

#	raidcom command
1	raidcom get ldev
2	raidcom delete ldev
3	raidcom add lun
4	raidcom get lun
5	raidcom modify port
6	raidcom get port
7	raidcom add host_grp
8	raidcom delete host_grp
9	raidcom get host_grp
10	raidcom modify host_grp
11	raidcom add hba_wwn
12	raidcom delete hba_wwn
13	raidcom get hba_wwn
14	raidcom get resource

Chapter 4: Starting up CCI

You can begin using the CCI software after you have installed the CCI software, set the command device, created the configuration definition file(s), and (for OpenVMS only) followed the porting requirements and restrictions. One or two instances of CCI can be used simultaneously in UNIX, Windows, and OpenVMS operating system environments.

Starting up on UNIX systems

Starting up one instance of CCI on a UNIX system

Procedure

1. Modify **/etc/services** to register the port name/number (service) of each configuration definition file. Make the port name/number the same on all servers:

```
horcm xxxxx/udp xxxxx = the port name/number for horcm.conf
```

2. If you want CCI to start automatically each time the system starts up, add **/etc/horcmstart.sh** to the system automatic startup file (for example, **/sbin/rc**).

3. Execute the **horcmstart.sh** script manually to start the CCI instances:

```
# horcmstart.sh
```

4. Set the log directory (**HORCC_LOG**) in the command execution environment as needed.

5. If you want to perform TrueCopy operations, do not set the **HORCC_MRCF** environment variable. If you want to perform ShadowImage operations, set the **HORCC_MRCF** environment variable for the CCI execution environment.

```
For B shell:# HORCC_MRCF=1 # export HORCC_MRCF
```

```
For C shell:# setenv HORCC_MRCF 1 # pairdisplay -g xxxx
```

Where xxxx = group name

Starting up two instances of CCI on a UNIX system

Procedure

1. Modify **/etc/services** to register the port name/number (service) of each configuration definition file. The port name/number must be different for each CCI instance.

```
horcm0 xxxxx/udp xxxxx = the port name/number for horcm0.conf horcm1  
yyyyy/udpyyyy = the port name/number for horcm1.conf
```

2. If you want CCI to start automatically each time the system starts up, add **/etc/horcmstart.sh 0 1** to the system automatic startup file (for example, **/sbin/rc**).

3. Execute the **horcmstart.sh** script manually to start the CCI instances:

```
# horcmstart.sh 0 1
```
4. Set an instance number to the command execution environment:
 For B shell:# HORCMINST=X # export HORCMINST
 X = instance number = 0 or 1
 For C shell:# setenv HORCMINST X
5. Set the log directory (**HORCC_LOG**) in the command execution environment as needed.
6. If you want to perform TrueCopy operations, do not set the **HORCC_MRCF** environment variable. If you want to perform ShadowImage operations, set the **HORCC_MRCF** environment variable for the CCI execution environment.
 For B shell:# HORCC_MRCF=1 # export HORCC_MRCF
 For C shell:# setenv HORCC_MRCF 1 # pairdisplay -g **xxxx**
 xxxx = group name

Starting up on Windows systems

Starting up one instance of CCI on a Windows system

Procedure

1. Modify **%windir%\system32\drivers\etc\services** to register the port name/number (service) of the configuration definition file. Make the port name/number the same on all servers:

```
horcm xxxxx/udp
```

 Where, xxxxx = the port name/number of horcm.conf
2. If you want CCI to start automatically each time the system starts up, add **\HORCM\etc\horcmstart** to the system automatic startup file (for example, **\autoexec.bat**).
3. Execute the **horcmstart** script manually to start CCI:

```
D:\HORCM\etc> horcmstart
```
4. Set the log directory (**HORCC_LOG**) in the command execution environment as needed.
5. If you want to perform TrueCopy operations, do not set the **HORCC_MRCF** environment variable. If you want to perform ShadowImage operations, set the **HORCC_MRCF** environment variable for the CCI execution environment:

```
D:\HORCM\etc> set HORCC_MRCF=1
```

```
D:\HORCM\etc> pairdisplay -g xxxx
```

 xxxx = group name

Starting up two instances of CCI on a Windows system

Procedure

1. Modify `%windir%\system32\drivers\etc\services` to register the port name/number (service) of the configuration definition files. Make sure that the port name/number is different for each instance:

```
horcm0 xxxxx/udp
```

xxxxx = the port name/number of horcm0.conf

```
horcm1 xxxxx/udp
```

xxxxx = the port name/number of horcm1.conf

2. If you want CCI to start automatically each time the system starts up, add **\HORCM\etc\horcmstart 0 1** to the system automatic startup file (for example, **\autoexec.bat**).

3. Execute the **horcmstart** script manually to start CCI:

```
D:\HORCM\etc> horcmstart 0 1
```

4. Set an instance number to the command execution environment:

```
D:\HORCM\etc> set HORCMINST=X
```

X = instance number = 0 or 1

5. Set the log directory (**HORCC_LOG**) in the command execution environment as needed.

6. If you want to perform TrueCopy operations, do not set the **HORCC_MRCF** environment variable. If you want to perform ShadowImage operations, set the **HORCC_MRCF** environment variable for the CCI execution environment:

```
D:\HORCM\etc> set HORCC_MRCF=1
```

```
D:\HORCM\etc> pairdisplay -g xxxx
```

xxxx = group name

Starting up on OpenVMS systems

Starting up one instance of CCI on an OpenVMS system

Procedure

1. Create the configuration definition file.

For a new installation, use the configuration definition sample file that is supplied (SYS\$POSIX_ROOT:[HORCM.etc]horcm.conf). Make a copy of the file:

```
$ COPY SYS$POSIX_ROOT:[HORCM.etc]horcm.conf SYS$POSIX_ROOT:[etc]
```

Edit this file according to your system configuration using a text editor (for example, `edit`). Register the port name (service) of the configuration definition file in

```
SYS$SYSROOT:[000000.TCPIP$ETC]SERVICES.DAT.horcm xxxxx/udp
```

xxxxx = port number

Use the same port number in all servers. The port number can be directly specified without registering it in "SYS\$SYSROOT:[000000.TCPIP\$ETC]SERVICES.DAT".

2. Manually execute the HORCM startup command.

```
$ spawn /nowait /process=horcm horcmstart
```



Note: The subprocess (HORCM) created by SPAWN is terminated when the terminal is LOGOFF or the session is terminated. If you want an independent process to the terminal LOGOFF, use the "RUN /DETACHED" command.

3. Confirm the configuration.

Set the log directory (HORCC_LOG) in the command execution environment as required.



Note: If the log directory under SYS\$POSIX_ROOT is shared with other nodes, the log directory of Horc Manager must be set for each node. The log directory of Horc Manager can be changed by setting the parameter of horcmstart. See the *Command Control Interface Command Reference* for information about horcmstart parameters.

If you want to perform ShadowImage operations, set the environment variable (HORCC_MRCF).

```
$ HORCC_MRCF:=1 $ pairdisplay -g xxxx
xxxx = group name
```

Next steps



Note: If a system configuration change or a RAID configuration change causes this file to change, (for example, cache size change or microcode change), these changes will not take effect until you stop HORCM (horcmshutdown) and restart HORCM (horcmstart). Use the "-c" option of the pairdisplay command to verify that there are no configuration errors.

Starting up two instances of CCI on an OpenVMS system

Procedure

1. Create the configuration definition files.

For a new installation, use the configuration definition sample file that is supplied (SYS\$POSIX_ROOT:[HORCM.etc]horcm.conf). Copy the file twice, once for each instance.

```
$ COPY SYS$POSIX_ROOT:[HORCM.etc]horcm.conf SYS$POSIX_ROOT:[etc]
horcm0.conf$ COPY SYS$POSIX_ROOT:[HORCM.etc]horcm.conf SYS
$POSIX_ROOT:[etc] horcm1.conf
```

Edit these two files according to your system configuration using a text editor (for example, eve). Register the port name (service) of the configuration definition file in

```
SYS$SYSROOT:[000000.TCPIP$ETC]SERVICES.DAT.horcm0 xxxxx/udp
```

xxxxx = port number horcm1 yyyyy/udp

yyyyy = port number.

Each instance should have a unique port number. The port number can be directly specified without registering it in "SYS\$SYSROOT:[000000.TCPIP\$ETC]SERVICES.DAT".

2. Execute the HORCM startup command.

```
$ spawn /nowait /process=horcm0 horcmstart 0 $ spawn /nowait /
process=horcm1 horcmstart 1
```



Note: The subprocess (HORCM) created by SPAWN is terminated when the terminal is LOGOFF or the session is terminated. If you want an independent process to the terminal LOGOFF, use "RUN /DETACHED" command.

3. Set the HORCM instance numbers in the environment in which the command is to be executed: `$ HORCMINST:=X`

X = instance number (0 or 1)

4. Confirm the configuration using a CCI command.

Set the log directory (**HORCC_LOG**) in the command execution environment as required.



Note: If the log directory under SYS\$POSIX_ROOT is shared with other nodes, the log directory of Horc Manager must be set for each node. The log directory of Horc Manager can be changed by setting the parameter of horcmstart. See the *Command Control Interface Command Reference* for information about horcmstart parameters.

If you want to perform ShadowImage operations, set the environment variable (**HORCC_MRCF**). `$ HORCC_MRCF:=1 $ pairdisplay -g xxxx`
xxxx denotes a group name.

Next steps



Note: If a system configuration change or a RAID configuration change causes this file to change (for example, cache size change, microcode change), these changes will not take effect until you stop HORCM (horcmshutdown 0 1) and restart HORCM (horcmstart 0 and horcmstart 1). Use the "-c" option of the pairdisplay command to verify that there are no configuration errors.

Starting CCI as a service (Windows systems)

Usually, CCI (HORCM) is started by executing the startup script from the Windows services. However, in the VSS environment, there is no interface to automatically start CCI. CCI provides the `svcexe.exe` command and a sample script file (HORCM0_run.txt) so that CCI can be started automatically as a service.

C:\HORCM\tool\ > svcxexe

- Usage for adding [HORCM_START_SVC]: svcxexe /A=command_path
 - for deleting [HORCM_START_SVC]: svcxexe /D
 - for specifying a service: svcxexe /S=service_name
 - for dependent services: svcxexe /C=service_name,service_name

This command example uses HORCM0 for registering the service name for HORCM instance#0:

- Example for adding [HORCM0]: svcxexe /S=HORCM0 "/A=C:\HORCM\tool\svcxexe.exe"
 - for deleting [HORCM0]: svcxexe /S=HORCM0 /D
 - for starting [HORCM0]:

: [1] make a C:\HORCM\tool\HORCM0_run.txt file.

: [2] set a user account to this service.

: [3] confirm to start using horcmstart 0.

: [4] confirm to stop using horcmshutdown 0.

: [5] start as a service by net start HORCM0.

The following procedure is about starting CCI as a service.

Procedure

1. Register the CCI (HORCM) instance as a service. The system administrator must add the CCI instance using the following command:

```
C:\HORCM\tool\ > svcxexe /S=HORCM0 "/A=C:\HORCM\tool\svcxexe.exe"
```

2. Customize a sample script file. The system administrator must customize the sample script file (HORCM0_run.txt) according to the CCI instance. For details, see the descriptions in the HORCM0_run.txt file.
3. Set the user account. The system administrator must set the user account for the CCI administrator as needed.

When using the GUI, use "Administrative Tools - Services - Select HORCM0 - Logon". When using the CUI, use "sc config" command as follows: C:\HORCM\tool\ > sc config HORCM0 obj= AccountName password= password If the system administrator uses the default account (LocalSystem), add "HORCM_EVERYCLI=1":

```
# **** For INSTANCE# X, change to HORCMINST=X as needed ****
START:
  set HORCM_EVERYCLI=1
  set HORCMINST=0
  set HORCC_LOG=STDERROUT
  C:\HORCM\etc\horcmstart.exe
  exit 0
```

4. Start the CCI instance from the service. After you have confirmed starting and stopping using "horcmstart 0" and "horcmshutdown 0", you must verify that HORCM0 starts from the service and that HORCM0 started automatically from REBOOT, using the following command:

```
C:\HORCM\tool\>net start HORCM0
```

- 5.** Stop CCI instance as a service. Instead of using the "horcmshutdown 0" command, you must use the following command to stop HORCM0:

```
C:\HORCM\tool\>net stop HORCM0
```

(By using the "horcmshutdown 0" command, the script written into HORCM0_run.txt will automatically restart HORCM0).

Chapter 5: Provisioning operations with CCI

This chapter describes storage provisioning operations with CCI.

About provisioning operations

You can use CCI to perform provisioning operations on the following storage systems:

- Hitachi Virtual Storage Platform G200, G400, G600, G800
- Hitachi Virtual Storage Platform F400, F600, F800
- Hitachi Virtual Storage Platform G1x00 or Hitachi Virtual Storage Platform F1500
- Hitachi Virtual Storage Platform
- Hitachi Unified Storage VM

For details about the provisioning operations, see the *Provisioning Guide* for the storage system.



Note: Be aware of the following when performing provisioning operations using CCI:

- When you execute provisioning operations using CCI, the operation of refreshing the window (Device Manager - Storage Navigator, SVP, GUM) might be delayed.
- During maintenance work on the storage system (Device Manager - Storage Navigator, maintenance utility, or Maintenance PC in modify mode), or when the configuration is being changed from the GUI, the CCI provisioning command might be rejected (2E10, 8000).
- When you execute commands for provisioning operations, host I/O performance might deteriorate because of increased working ratio of processor by updating processing of the configuration information of storage system. If you plan to execute many commands, take account of the impact on the I/O performance.

Overview of the configuration setting command

CCI functions enable provisioning operations such as host setting, LDEV creation, and device group creation. These operations are performed using the **raidcom** configuration setting command.

The configuration setting command is specified using the following syntax:

```
raidcom <action> <resource> <parameter>
```

The operation itself, such as add or delete, is specified in the action, and the resource object, such as LDEV or path, is specified in the resource. The necessary value to operate the resource object is specified in the parameter. For the details about the **raidcom** configuration setting command, see the *Command Control Interface Command Reference*.

Because some provisioning operations can take time to process, CCI provides two ways to execute the configuration setting command: synchronously or asynchronously.

See the figure for synchronous and asynchronous command processing.

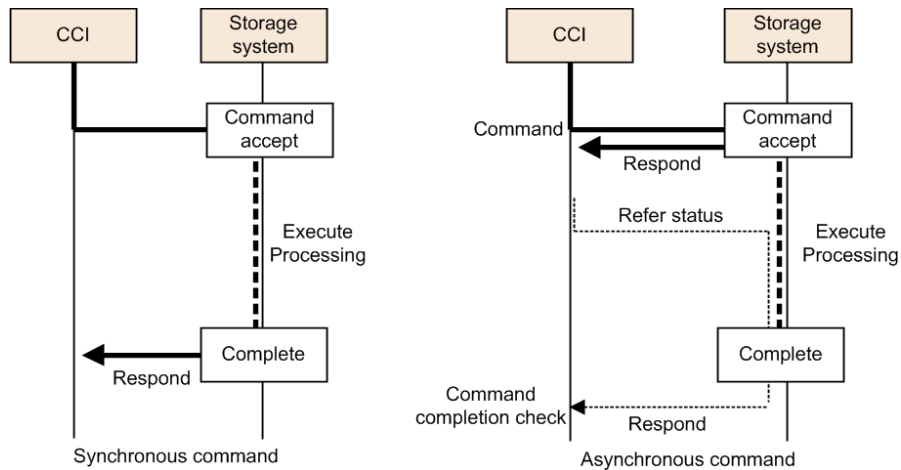

The processing difference between these two command types are described in Synchronous command processing and Asynchronous command processing.

Synchronous command processing

In addition to the replication commands, the process is executed by synchronizing with a command execution, and then returning a response after the processing is completed. When an error occurs, the error is returned to CCI at each occurrence.

Asynchronous command processing

When an asynchronous command is executed, the command is received at the storage system, and a response is returned before the processing is executed. The actual processing is executed asynchronously with command input.

The completion of the asynchronous command processing can be checked with the **raidcom get command_status** command. When you execute the **raidcom get command_status** command after executing an asynchronous command, the **raidcom get command_status** command is terminated after all asynchronous command processing has been completed.

Errors during asynchronous command processing

When an error occurs during asynchronous command processing, the error information, such as the total number of errors or error code (SSB1 and SSB2), is provided. After executing the asynchronous command, execute the **raidcom get command_status** command to check the error information if the asynchronous command processing completed normally.

Error codes SSB1 and SSB2 are stored only at the first error occurrence. For the second and subsequent occurrences, only the number of the error occurrence is stored with no error code. Therefore, before executing an asynchronous command, reset the error information in the storage system using the **raidcom reset command_status** command. You can check the information in SSB1 and SSB2 by using the **raidcom get error_message** command.

In asynchronous command processing, multiple commands received by the host are executed at the same time. Therefore, the total number of errors might not correspond with the unexecuted commands. If an error occurs in asynchronous commands, verify the system configuration using the reference commands. For details about the reference commands, see Available provisioning operations.

Workflow for executing asynchronous commands

When executing asynchronous commands, execute the command or script using the following procedure:

1. Execute the **raidcom reset command_status** command.
The error information of asynchronous command processing in the storage system is reset.
2. Execute the asynchronous command.
3. Execute the **raidcom get command_status** command to check if all asynchronous command processing is done or if no error occurred.

Asynchronous commands

The asynchronous commands associated with the **raidcom** configuration setting command provide provisioning functions. The following table lists the provisioning functions performed by asynchronous commands and describes the required syntax. For details about **raidcom** command syntax, see the *Command Control Interface Command Reference*.

Function	Command syntax
Blocking an LDEV	<code>raidcom modify ldev -ldev_id <ldev#> -status blk</code>
Adding an LDEV	<code>raidcom add ldev {-parity_grp_id <gno-sgno> -external_grp_id <gno-sgno> -pool {<pool ID#> <pool naming> snap}} -ldev_id <ldev#> { -capacity <size> -offset_capacity <size> -cylinder <size>} [-emulation <emulation type>][-location <lba>][-mp_blade_id <mp#>]</code>
Deleting an LDEV	<code>raidcom delete ldev {-ldev_id <ldev#> -grp_opt <group option> -device_grp_name <device group name> [<device name>]}</code>

Function	Command syntax
LDEV Quick Format	raidcom initialize ldev {-ldev_id <ldev#> -grp_opt <group option> -device_grp_name <device group name> [<device name>]} -operation qfmt
Restoring an LDEV	raidcom modify ldev -ldev_id <ldev#> -status nml
Creating virtual volume for HDP/, Dynamic Provisioning, Dynamic Provisioning for Mainframe, Dynamic Tiering, active flash, , active flash for mainframe, or Copy-on-Write Snapshot	raidcom add ldev -pool {<pool ID#> <pool naming> snap} -ldev_id <ldev#> -capacity <size>
Deleting virtual volume for Dynamic Provisioning, Dynamic Provisioning for Mainframe, Dynamic Tiering, active flash, , active flash for mainframe, or Copy-on-Write Snapshot	raidcom delete ldev {-ldev_id <ldev#> -grp_opt <group option> -device_grp_name <device group name> [<device name>]} [-operation initialize_capacity_saving] Note: The <code>-operation initialize_capacity_saving</code> option is available only for DP-VOLs for which capacity saving is enabled.
Creating a pool /adding a pool volume for Dynamic Provisioning or Dynamic Provisioning for Mainframe	raidcom add dp_pool {{-pool_id <pool ID#> [-pool_name <pool naming>] -pool_name <pool naming> [-pool_id <pool ID#>]} -pool_id <pool ID#> -pool_name <pool naming>}} {-ldev_id <ldev#> ...[-cnt<count>] -grp_opt <group option> -device_grp_name <device group name> [<device name>]}[-user_threshold <threshold_1> [<threshold_2>]]
Creating a pool /adding a pool volume for Copy-on-Write Snapshot	raidcom add snap_pool {{-pool_id <pool ID#> [-pool_name <pool naming>] -pool_name <pool naming> [-pool_id <pool ID#>]} -pool_id <pool ID#> -pool_name <pool naming>}} {-ldev_id <ldev#> ...[-cnt<count>] -grp_opt <group option> -device_grp_name <device group name> [<device name>]}[-user_threshold <%>]
Deleting or shrinking a pool	raidcom delete pool -pool {<pool ID#> <pool naming>}[-ldev <ldev#>]
Releasing a blocked pool	raidcom modify pool -pool {<pool ID#> <pool naming>} -status nml
RCU registration	raidcom add rcu -cu_free <serial#> <id> <pid> -mcu_port <port#> -rcu_port <port#>

Function	Command syntax
RCU logical path addition	raidcom add rcu_path -cu_free <serial#> <id> <pid> -mcu_port <port#> -rcu_port <port#>
RCU deletion	raidcom delete rcu -cu_free <serial#> <id> <pid>
RCU logical path deletion	raidcom delete rcu_path -cu_free <serial#> <id> <pid> -mcu_port <port#> -rcu_port <port#>
Creating journal/ Registering journal volume in the journal	raidcom add journal -journal_id <journal ID#> {-ldev_id <ldev#> ...[-cnt <count>] -grp_opt <group option> -device_grp_name <device group name> [<device name>]}
Deleting journal/ Deleting journal volume from the journal	raidcom delete journal -journal_id <journal ID#> [-ldev_id <ldev#> -grp_opt <group option> -device_grp_name <device group name> [<device name>]]
Restoration of path for the external path	raidcom check_ext_storage path -path_grp <path group#> -port <port#> -external_wwn <wwn strings>
Setting the external path	raidcom add path -path_grp <path group#> -port <port#> -external_wwn <wwn strings>
Mapping the external volume	raidcom add external_grp -path_grp <path group#> -external_grp_id <gno-sgno> -port <port#> -external_wwn <wwn strings> -lun_id <lun#> [-emulation <emulation type>]
Deleting the external path	raidcom delete path -path_grp <path group#> -port <port#> -external_wwn <wwn strings>
Releasing the mapping of external volume	raidcom delete external_grp -external_grp_id <gno-sgno> [-forcible]
Stopping the use of paths to the external volume	raidcom disconnect path -path_grp <path group#> -port <port#> -external_wwn <wwn strings>
Creating a parity group	raidcom add parity_grp {-parity_grp_id <gno-sgno> -concatenated_parity_grp_id <gno-sgno>... } -drive_location <drive location>... -raid_type <raid type> [-encryption {enable disable}] [-copy_back {enable disable}] [-accelerated_compression {enable disable}] [-clpr <clpr#>]
Deleting a parity group	raidcom delete parity_grp -parity_grp_id <gno-sgno>
Setting a spare drive or cancelling the setting	raidcom modify drive -drive_location <drive location> -spare {enable disable}

Help on configuration setting commands

To see the configuration setting command help, execute any command using the `-h` option, for example, `raidcom -h`.

```
raidcom -h
```

LDEV nickname function

As a function of configuration setting command, a nickname can be set for each LDEV. The details of the definition for the LDEV nickname function are shown below.

The maximum length of a name is 32 characters. For one LDEV, one nickname can be defined.

A nickname can be defined as follows:

```
raidcom modify ldev -ldev_id <ldev#> -ldev_name <ldev naming>
```

Available provisioning operations

The following provisioning operations can be performed using CCI.

Operation type	Description	Corresponding command
Login and logout	Log in.	<code>raidcom -login <user_name> <password></code>
	Log out.	<code>raidcom -logout</code>
Resource	Lock resource.	<code>raidcom lock resource -resource_name <resource group name > [-time <time(sec)>]</code>
	Unlock resource.	<code>raidcom unlock resource -resource_name <resource group name ></code>
	Display resource group information.	<code>raidcom get resource</code>
	Add resource group.	<code>raidcom add resource -resource_name <resource group name> [-resource_id <resource group_id > -ldev_id <ldev#> -port <port#> -port <port#> <host group name> -parity_grp_id <gno-sgno> -external_grp_id <gno-sgno>]</code>

Operation type	Description	Corresponding command
	Delete resource group.	raidcom delete resource -resource_name <resource group name> [-ldev_id <ldev#> -port <port#> -port <port#> <host group name> -parity_grp_id <gno-sgno> -external_grp_id <gno-sgno>]
Host (see the <i>Provisioning Guide</i>)	Create host group.	raidcom add host_grp -port <port#> -host_grp_name <host group name>
	Set host mode.	raidcom modify host_grp -port <port#> [<host group name>] -host_mode <host mode> [-host_mode_opt <host mode option> ...]
	Register a host to host group.	raidcom add hba_wwn -port <port#> [<host group name>] -hba_wwn <WWN strings>
	Delete host group.	raidcom delete host_grp -port <port#> [<host group name>]
	Display host group information.	raidcom get host_grp -port <port#> [<host group name>]
Port (see the <i>Provisioning Guide</i>)	Set port.	raidcom modify port -port <port#> {[-port_speed <value>] [-loop_id<value>] [-topology <topology>] [-security_switch <y/n >]}
	Set port attribute.	raidcom modify port -port <port#> -port_attribute <port attribute>
	Display port information.	raidcom get port [-port <port#>]
Internal volume (see the <i>Provisioning Guide</i>)	Create LDEV.	raidcom add ldev {-parity_grp_id <gno-sgno> -external_grp_id <gno-sgno> -pool {<pool ID#> <pool naming> snap}} -ldev_id <ldev#> {-capacity <size> -offset_capacity <size> -cylinder <size>} [-emulation <emulation type>][-location <lba>] [-mp_blade_id <mp#>]
	Display LDEV information.	raidcom get ldev {-ldev_id <ldev#> ... [-cnt <count>] -grp_opt <group option> -device_grp_name <device group name> [<device name>]} [-key <keyword>]
	Display parity group information.	raidcom get parity_grp [-parity_grp_id <gno-sgno>]

Operation type	Description	Corresponding command
	Create a parity group.	raidcom add parity_grp {-parity_grp_id <gnosgno> -concatenated_parity_grp_id <gnosgno>... } -drive_location <drive location>... -raid_type <raid type> [-encryption {enable disable}] [-copy_back {enable disable}] [-accelerated_compression {enable disable}] [-clpr <clpr#>]
	Delete a parity group.	raidcom delete parity_grp -parity_grp_id <gnosgno>
	Define SSID.	raidcom add ssid -rcu <serial#> <mcu#> <rcu#> <id> -ssid <ssid> raidcom delete ssid -rcu <serial#> <mcu#> <rcu#> -ssid <ssid>
	Display drive information.	raidcom get drive [-parity_grp_id <gnosgno> -usage <usage>]
	Set a spare drive, or cancel the setting.	raidcom modify drive -drive_location <drive location> -spare {enable disable}
Virtual volume (HDP, HDPz, HDT, HDTz, active flash, active flash for mainframe, or SS) (see the <i>Provisioning Guide</i>)	Create pool for HDP or HDPz.	raidcom add dp_pool {{-pool_id <pool ID#> [-pool_name <pool naming>] -pool_name <pool naming> [-pool_id <pool ID#>]} -pool_id <pool ID#> -pool_name <pool naming>}} {-ldev_id <ldev#> ...[-cnt<count>] -grp_opt <group option> -device_grp_name <device group name> [<device name>]}[-user_threshold <threshold_1> [<threshold_2>]]
	Create pool for SS.	raidcom add snap_pool {{-pool_id <pool ID#> [-pool_name <pool naming>] -pool_name <pool naming> [-pool_id <pool ID#>]} -pool_id <pool ID#> -pool_name <pool naming>}} {-ldev_id <ldev#> ...[-cnt<count>] -grp_opt <group option> -device_grp_name <device group name> [<device name>]}[-user_threshold <%>]
	Display pool information for HDP, HDPz, HDT, HDTz, active flash, active flash for mainframe, or SS.	raidcom get pool [-key <keyword>]

Operation type	Description	Corresponding command
	Delete pool for HDP, HDPz, HDT, HDTz, active flash, active flash for mainframe, or SS.	raidcom delete pool -pool {<pool ID#> <pool naming>}
	Change the threshold value of a pool for HDP, HDPz, HDT, HDTz, active flash, active flash for mainframe, or SS.	raidcom modify pool -pool {<pool ID#> <pool naming>} -user_threshold <threshold_1> [<threshold_2>]
	Restore a pool for HDP, HDPz, HDT, HDTz, active flash, active flash for mainframe, or SS.	raidcom modify pool -pool {<pool ID#> <pool naming>} -status nml
	Set the maximum rate of subscription of a pool for HDP, HDPz, HDT, HDTz, active flash, or active flash for mainframe.	raidcom modify pool -pool {<pool ID#> <pool naming>} -subscription <%>
	Change the pool for HDP to the pool for HDT.	raidcom modify pool -pool {<pool ID#> <pool naming>} -pool_attribute dt_manual
	Change the pool for HDT to the pool for HDP.	raidcom modify pool -pool {<pool ID#> <pool naming>} -pool_attribute dp
	Set the newly allocation free space percentage of the pool for HDT, HDTz, active flash, or active flash for mainframe.	raidcom modify pool -pool {<pool ID#> <pool naming>} -tier <Tier number><ratio>
	Create virtual volume for HDP, HDPz, HDT, HDTz, active flash, active flash for mainframe, or SS.	raidcom add ldev -pool {<pool ID#> <pool naming> snap} -ldev_id <ldev#> -capacity <size> [-emulation <emulation type>] [-location <lba>][-mp_blade_id <mp#>]

Operation type	Description	Corresponding command
	Extend capacity of virtual volume for HDP, HDPz, HDT, HDTz, active flash, or active flash for mainframe.	raidcom extend ldev{-ldev_id <ldev#> -grp_opt <group option> -device_grp_name <device group name> [<device name>]} -capacity <size>
	Set enabled or disabled of virtual volume tier reallocation for HDT, HDTz, active flash, or active flash for mainframe.	raidcom modify ldev -ldev_id <ldev#> -status {enable_reallocation disable_reallocation}
	Discard a page of virtual volume for HDP, HDPz, HDT, HDTz, active flash, or active flash for mainframe.	raidcom modify ldev -ldev_id <ldev#> -status discard_zero_page
	Display the information of a pool for HDP, HDPz, HDT, HDTz, active flash, or active flash for mainframe.	raidcom get dp_pool [-key <keyword>]
	Display the information of a pool for SS.	raidcom get snap_pool
	Extend the capacity of a pool for HDP, HDPz, HDT, HDTz, active flash, or active flash for mainframe.	raidcom add dp_pool {{-pool_id <pool ID#> [-pool_name <pool naming>] -pool_name <pool naming> [-pool_id <pool ID#>]} -pool_id <pool ID#> -pool_name <pool naming>}} {-ldev_id <ldev#> ... [-cnt<count>] -grp_opt <group option> -device_grp_name <device group name> [<device name>]}[-user_threshold <threshold_1> [<threshold_2>]]

Operation type	Description	Corresponding command
	Extend the capacity of a pool for SS.	raidcom add snap_pool {{-pool_id <pool ID#> [-pool_name <pool naming>] -pool_name <pool naming> [-pool_id <pool ID#>]} -pool_id <pool ID#> -pool_name <pool naming>}} {-ldev_id <ldev#> ...[-cnt<count>] -grp_opt <group option> -device_grp_name <device group name> [<device name>]}[-user_threshold <%>]
	Start or stop the performance monitor for HDT, HDTz, active flash, or active flash for mainframe.	raidcom monitor pool -pool {<pool ID#> <pool naming>} -operation <type>
	Start or stop the tier reallocation of a pool for HDT, HDTz, active flash, or active flash for mainframe.	raidcom reallocate pool -pool {<pool ID#> <pool naming>} -operation <type>
LU path (see the <i>Provisioning Guide</i>)	Set LU path.	raidcom add lun -port <port#> [<host group name>] {-ldev_id <ldev#> [-lun_id<lun#>] -grp_opt <group option> -device_grp_name <device group name> [<device name>]}
	Delete LU path.	raidcom delete lun -port <port#> [<host group name>] {-lun_id <lun#> -ldev_id <ldev#> -grp_opt <group option> -device_grp_name <device group name> [<device name>]}
	Display LU path information.	raidcom get lun -port <port#> [<host group name>]
External volume (UVM) (see the <i>Universal Volume Manager User Guide</i>)	Search external storage.	raidcom discover external_storage -port <port#>
	Search external volume.	raidcom discover lun -port <port#> -external_wwn <wwn strings>
	Map external volume.	raidcom add external_grp -path_grp <path group#> -external_grp_id <gno-sgno> -port <port#> -external_wwn <wwn strings> -lun_id <lun#> [-emulation <emulation type>]

Operation type	Description	Corresponding command
	Disconnect the connection for external volume.	raidcom disconnect external_grp {-external_grp_id <gno-sgno> -ldev_id <ldev#>}
	Check the connection for external volume and restore it.	raidcom check_ext_storage external_grp {-external_grp_id <gno-sgno> -ldev_id <ldev#>}
	Unmap external volume.	raidcom delete external_grp -external_grp_id <gno-sgno> [-forcible]
	Display mapped external volume information.	raidcom get external_grp [-external_grp_id <gno-sgno>]
	Create LDEV in external volume.	raidcom add ldev -external_grp_id <gno-sgno> -ldev_id <ldev#> -capacity <size> [-emulation <emulation type>][-location <lba>] [-mp_blade_id <mp#>]
	Display LDEV information created in external volume.	raidcom get ldev {-ldev_id <ldev#> ... [-cnt <count>] -grp_opt <group option> -device_grp_name <device group name> [<device name>]} [-key <keyword>]
	Change cache mode of external volume.	raidcom modify external_grp -external_grp_id <gno-sgno> -cache_mode <y n >
	Control cache write of external volume.	raidcom modify external_grp -external_grp_id <gno-sgno> -cache_inflow <y n >
	Modify ownership MP Blade of external volume.	raidcom modify external_grp -external_grp_id <gno-sgno> -mp_blade_id <mp#>
	Add external path.	raidcom add path -path_grp <path group#> -port <port#> -external_wwn <wwn strings>
	Delete external path.	raidcom delete path -path_grp <path group#> -port <port#> -external_wwn <wwn strings>
	Display external path information.	raidcom get path [-path_grp <path group#>]

Operation type		Description	Corresponding command
		Stop the usage of external path.	raidcom disconnect path -path_grp <path group#> -port <port#> -external_wwn <wwn strings>
		Restore the external path.	raidcom check_ext_storage path -path_grp <path group#> -port <port#> -external_wwn <wwn strings>
		Define SSID.	raidcom add ssid -rcu <serial#> <mcu#> <rcu#> <id> -ssid <ssid> raidcom delete ssid -rcu <serial#> <mcu#> <rcu#> -ssid <ssid>
Maintenance	Host	Add WWN of host path adapter.	raidcom add hba_wwn -port <port#> [<host group name>] -hba_wwn <WWN strings>
		Delete WWN of host path adapter.	raidcom delete hba_wwn -port <port#> [<host group name>] -hba_wwn <WWN strings>
		Set nickname for WWN of host path adapter.	raidcom set hba_wwn -port <port#> [<host group name>] -hba_wwn <WWN strings> -wwn_nickname <WWN Nickname>
		Delete nickname from WWN of host path adapter.	raidcom reset hba_wwn -port <port#> [<host group name>] -hba_wwn <WWN strings>
		Display registered WWN information of host path adapter.	raidcom get host_grp -port <port#> [<host group name>]
	LDEV	Blockade or restore LDEV.	raidcom modify ldev -ldev_id <ldev#> -status discard_zero_page
		Create nickname for LDEV.	raidcom modify ldev -ldev_id <ldev#> -ldev_name <ldev naming>
		Modify allocated MP Blade to LDEV.	raidcom modify ldev -ldev_id <ldev#> -mp_blade_id <mp#>
		Format LDEV.	raidcom initialize ldev {-ldev_id <ldev#> -grp_opt <group option> -device_grp_name <device group name> [<device name>]} -operation <type>
	Device group	Create device group.	raidcom add device_grp -device_grp_name <ldev group name> <device name> -ldev_id <ldev#>... [-cnt <count>]

Operation type		Description	Corresponding command
		Delete LDEV from device group.	raidcom delete device_grp - device_grp_name <device group name> - ldev_id <ldev#>... [-cnt <count>]
		Display device group information.	raidcom get device_grp [-device_grp_name <device group name>]
	Copy group	Create copy group.	raidcom add copy_grp -copy_grp_name <copy group name> <device group name> [device group name] [-mirror_id <mu#> -journal_id <journal ID#>]
		Delete copy group.	raidcom delete copy_grp -copy_grp_name <copy group name>
		Display copy group information.	raidcom get copy_grp
	CLPR	View CLPR configuration.	raidcom get clpr
		Modify CLPR (migrate LDEV, parity group, external group).	raidcom modify clpr
	Remote copy environment	RCU (see the manuals for TC, TCz, UR, and URz)	Register RCU.
Delete RCU.			raidcom delete rcu -cu_free <serial#> <id> <pid>
Set RCU attribute.			raidcom modify rcu -cu_free <serial#> <id> <pid> -rcu_option <mpth> <rto> <rtt>
Display RCU information.			raidcom get rcu [-cu_free <serial#> <id> <pid>]
RCU path (see the manuals for TC, TCz, UR, and URz)		Add RCU logical path.	raidcom add rcu_path -cu_free <serial#> <id> <pid> -mcu_port <port#> -rcu_port <port#>
		Delete RCU logical path.	raidcom delete rcu_path -cu_free <serial#> <id> <pid> -mcu_port <port#> -rcu_port <port#>

Operation type		Description	Corresponding command
Journal (see the manuals for UR and URz)	Register journal volume to Journal.	raidcom add journal -journal_id <journal ID#> [-ldev_id <ldev#> ...[-cnt <count>] -grp_opt <group option> -device_grp_name <device group name> [<device name>] [-mp_blade_id <mp#> -timer_type <timer type>]	
	Delete journal volume from Journal/ Delete journal.	raidcom delete journal -journal_id <journal ID#> [-ldev_id <ldev#> -grp_opt <group option> -device_grp_name <device group name> [<device name>]]	
	Change the UR option to be used at Journal.	raidcom modify journal -journal_id <journal ID#> {[-data_overflow_watch<time>][-cache_mode <y/n>][-timer_type <type>]} -path_blocked_watch <time> [-mirror_id <mu#>] -mp_blade_id <mp#>	
	Display journal information.	raidcom get journal [-key <keyword>]raidcom get journal[t]	

Provisioning operations that can be performed on device groups

You can use CCI to perform provisioning operations on device groups. When you specify a device group, you can perform operations on all LDEVs in the device group at the same time. For details about device groups, see LDEV grouping function.

The following table lists the provisioning operations that can be executed by specifying a device group.

Contents of operation	Command
Register a journal group to a journal	raidcom add journal
Delete a journal group from a journal/delete a journal	raidcom delete journal
Delete an LDEV/V-VOL	raidcom delete ldev
Extend the capacity of V-VOL for Dynamic Provisioning, Dynamic Provisioning for Mainframe, Dynamic Tiering, active flash, Dynamic Tiering for Mainframe, or active flash for mainframe	raidcom extend ldev
Display the LDEV information	raidcom get ldev

Contents of operation	Command
Format an LDEV	raidcom initialize ldev
Create an LU path	raidcom add lun
Delete an LU path	raidcom delete lun
Create a pool for Copy-on-Write Snapshot	raidcom add snap_pool
Extend the capacity of a pool for Copy-on-Write Snapshot	raidcom add snap_pool
Create a pool for Dynamic Provisioning, Dynamic Provisioning for Mainframe	raidcom add dp_pool
Extend the capacity of a pool for Dynamic Provisioning, Dynamic Provisioning for Mainframe, Dynamic Tiering, active flash, Dynamic Tiering for Mainframe, or active flash for mainframe	raidcom add dp_pool
Create a resource group	raidcom add resource
Delete a resource group	raidcom delete resource

Operation method

To execute a command on a device group, specify the name of the device group (max: 32 characters) and the device name in the device group (max: 32 characters).

The following shows an example of mapping the LDEVs in a device group to LUNs. When you specify both the device group name and the device name, the operation is executed for the LDEV that matches the specified device name in the specified device group. If you do not specify the device name, the operation is executed for all LDEVs in the device group.

Information of the device group

```
C:\HORCM\etc>raidcom get device_grp -device_grp_name grp1
LDEV_GROUP      LDEV_NAME      LDEV#      Serial#
grp1             data0          17000      64577
grp1             data0          17001      64577
grp1             data1          17002      64577
grp1             data1          17003      64577
```

Result of executing `raidcom add lun` command

The following shows the result of executing the `raidcom add lun` command and specifying device group name: `grp1` and device name: `data0`.

```
C:\HORCM\etc>raidcom add lun -port CL8-A -grp_opt ldev -device_grp_name
grp1 data0
```

```

GROUP = grp1, DEVICE = data0, UnitID = 0, LDEV = 17000(0x4268)[1], PORT =
CL8-A, LUN = none:
raidcom: LUN 0(0x0) will be used for adding.
done
GROUP = grp1, DEVICE = data0, UnitID = 0, LDEV = 17001(0x4269)[1], PORT =
CL8-A, LUN = none:
raidcom: LUN 1(0x1) will be used for adding.
done
C:\HORCM\etc>raidcom get lun -port CL8-A-0
PORT   GID  HMD           LUN  NUM    LDEV  CM   Serial#  HMO_BITS
CL8-A  0   LINUX/IRIX    0    1     17000 -    64577
CL8-A  0   LINUX/IRIX    1    1     17001 -    64577

```

The following shows the result of executing the **raidcom add lun** command and specifying device group name: **grp1** (omitting device name).

```

C:\HORCM\etc>>raidcom add lun -port CL8-A -grp_opt ldev -device_grp_name
grp1
GROUP = grp1 , DEVICE = data0 , UnitID = 0 , LDEV = 17000(0x4268)[1] , PORT
= CL8-A , LUN = none :
raidcom: LUN 0(0x0) will be used for adding.
done
GROUP = grp1 , DEVICE = data0 , UnitID = 0 , LDEV = 17001(0x4269)[1] , PORT
= CL8-A , LUN = none :
raidcom: LUN 1(0x1) will be used for adding.
done
GROUP = grp1 , DEVICE = data1 , UnitID = 0 , LDEV = 17002(0x426A)[1] , PORT
= CL8-A , LUN = none :
raidcom: LUN 2(0x2) will be used for adding.
done
GROUP = grp1 , DEVICE = data1 , UnitID = 0 , LDEV = 17003(0x426B)[1] , PORT
= CL8-A , LUN = none :
raidcom: LUN 3(0x3) will be used for adding.
done
C:\HORCM\etc>>raidcom get lun -port CL8-A-0
PORT   GID  HMD           LUN  NUM    LDEV  CM   Serial#  HMO_BITS
CL8-A  0   LINUX/IRIX    0    1     17000 -    64577
CL8-A  0   LINUX/IRIX    1    1     17001 -    64577
CL8-A  0   LINUX/IRIX    2    1     17002 -    64577
CL8-A  0   LINUX/IRIX    3    1     17003 -    64577

```

The following shows examples of specifying device groups and creating journal.

Examples

```
C:\HORCM\etc>raidcom add device_grp -device_grp_name dg_jnl1 data1 -
ldev_id 512 513 514 515
```

```
C:\HORCM\etc>raidcom get device_grp
```

LDEV_GROUP	Serial#
dg_jnl1	64539

```
C:\HORCM\etc>raidcom get device_grp -device_grp_name dg_jnl1
```

LDEV_GROUP	LDEV_NAME	LDEV#	Serial#
dg_jnl1	data1	512	64539
dg_jnl1	data1	513	64539
dg_jnl1	data1	514	64539
dg_jnl1	data1	515	64539

```
C:\HORCM\etc>raidcom add journal -journal_id 2 -grp_opt ldev -
device_grp_name dg_jnl1
```

```
GROUP = dg_jnl1 , DEVICE = data1 , UnitID = 0 , LDEV = 512(0x0200) [1] ,
PORT = none , LUN = none :done
GROUP = dg_jnl1 , DEVICE = data1 , UnitID = 0 , LDEV = 513(0x0201) [1] ,
PORT
= none , LUN = none :done
GROUP = dg_jnl1 , DEVICE = data1 , UnitID = 0 , LDEV = 514(0x0202) [1] ,
PORT
= none , LUN = none :done
GROUP = dg_jnl1 , DEVICE = data1 , UnitID = 0 , LDEV = 515(0x0203) [1] ,
PORT
= none , LUN = none :done
```

Workflow for performing provisioning operations

When you execute provisioning operations, perform the operations in the following order to log in and lock resources first and then unlock resources and view resource group information after performing operations.

Step	Operation	Description	Command
1	Login	Logs in.	<code>raidcom -login <user_name> <password></code>
2	Locking resources	Locks the resource group.	<code>raidcom lock resource - resource_name <resource group name> [-time <time(sec)>]</code>
3	Provisioning	Performs the desired provisioning operations.	--
4	Unlocking resources	Unlocks the resource group.	<code>raidcom unlock resource - resource_name <resource group name></code>
5	Displaying resource group information	Displays the resource group information to confirm the operations and lock information.	<code>raidcom get resource</code>
6	Logout	Logs out.	<code>raidcom -logout</code>

Resource group operations

Creating resource groups

To create resource groups, perform the following provisioning operations.

Step	Operation	Description	Command
1	Creating resource groups	Creates resource groups.	<code>raidcom add resource -resource_name <resource group name></code>

Step	Operation	Description	Command
2	Allocating resources to resource groups	Specifies resources that are allocated to meta_resource (resource group), and allocates resources to created resource groups.	<pre>raidcom add resource -resource_name <resource group name> [-ldev_id <ldev#> -port <port#> -port <port#> <host group name> -parity_grp_id <gno-sgno> -external_grp_id <gno-sgno>]</pre>
3	Displaying resource group information	Displays a resource group information, and confirms execution results of commands.	<pre>raidcom get resource</pre>

Deleting resource groups

To delete resource groups, perform the following provisioning operations.

Step	Operation	Description	Command
1	Deleting resources that are allocated to resource groups	Deletes resources that are allocated to resource groups. In other words, this operation allocates resources to resource group: meta_resource.	<pre>raidcom delete resource -resource_name <resource group name> [-ldev_id <ldev#> -port <port#> -port <port#> <host group name> -parity_grp_id <gno-sgno> -external_grp_id <gno-sgno>]</pre>
2	Confirming resource deletions	Confirms that resources are not allocated to resource groups that you want to delete. At that time, allocation of resources to the resource group: meta_resource must be finished.	<pre>raidcom get resource</pre>
3	Deleting resource groups	Deletes resource groups.	<pre>raidcom delete resource -resource_name <resource group name></pre>

Step	Operation	Description	Command
4	Displaying resource group information	Displays resource group information and confirms results of command executions.	<code>raidcom get resource</code>

Allocating resources to other resource groups

When you want to allocate resources that are already allocated to resource groups to other resource groups, resources must be once allocated to resource group: `meta_resource`. After that, allocate resources to the resource groups that you want to allocate. LDEVs that configure journals, pools, LUSEs or device groups must be allocated to resource groups particularly. The following shows the necessary provisioning operations.

Step	Operation	Description	Command
1	Deleting resources that are allocated to resource groups	Deletes resources that are allocated to resource groups. In other words, this operation allocates resources to resource group: <code>meta_resource</code> .	<code>raidcom delete resource -resource_name <resource group name> [-ldev_id <ldev#> -port <port#> -port <port#> <host group name> -parity_grp_id <gno-sgno> -external_grp_id <gno-sgno>]</code>
2	Confirming resource deletions	Confirms that resources are not allocated to resource groups that you want to delete. At that time, allocation of resources to the resource group: <code>meta_resource</code> must be finished.	<code>raidcom get resource</code>
3	Allocating resources to resource groups	Specifies resources that are allocated to <code>meta_resource</code> (resource group), and allocates resources to resource groups.	<code>raidcom add resource -resource_name <resource group name> [-ldev_id <ldev#> -port <port#> -port <port#> <host</code>

Step	Operation	Description	Command
			group name> -parity_grp_id <gno-sgno> -external_grp_id <gno-sgno>]
4	Displaying resource group information	Displays resource group information and confirms results of command executions.	raidcom get resource

LDEVs that are allocated to journals or pools must be migrated by users. We recommend that you register LDEVs that are allocated to journals or pools as device groups, and then operate after specifying them by the device groups.

Execution example for registering LDEVs to the pools as device groups

The following shows the execution example of registering LDEVs to the pool as device groups, creating resource groups in the device group unit and migrating created resource groups.

Example 1

```
C:\HORCM\etc>raidcom add device_grp -device_grp_name dg_jnl1 data1 -
ldev_id 512 513 514 515
```

```
C:\HORCM\etc>raidcom get device_grp
```

```
LDEV_GROUP          Serial#
dg_jnl1              64539
```

Example 2

```
C:\HORCM\etc>raidcom get device_grp -device_grp_name dg_jnl1
```

```
LDEV_GROUP          LDEV_NAME          LDEV#    Serial#
dg_jnl1             data1              512      64539
dg_jnl1             data1              513      64539
dg_jnl1             data1              514      64539
dg_jnl1             data1              515      64539
```

Example 3

```
C:\HORCM\etc>raidcom add resource -resource_name rsg002 -grp_opt ldev -
device_grp_name dg_jnl1
```

```
GROUP = dg_jnl1 , DEVICE = data1 , UnitID = 0 , LDEV = 512(0x0200) [1] ,
PORT = none , LUN = none :done
GROUP = dg_jnl1 , DEVICE = data1 , UnitID = 0 , LDEV = 513(0x0201) [1] ,
PORT
= none , LUN = none :done
GROUP = dg_jnl1 , DEVICE = data1 , UnitID = 0 , LDEV = 514(0x0202) [1] ,
PORT
= none , LUN = none :done
GROUP = dg_jnl1 , DEVICE = data1 , UnitID = 0 , LDEV = 515(0x0203) [1] ,
PORT
= none , LUN = none :done
```

Example 4

```
C:\HORCM\etc>raidcom delete resource -resource_name rsg002 -grp_opt ldev -
device_grp_name dg_jnl1
```

```
GROUP = dg_jnl1 , DEVICE = data1 , UnitID = 0 , LDEV = 512(0x0200) [1] ,
PORT = none , LUN = none :done
GROUP = dg_jnl1 , DEVICE = data1 , UnitID = 0 , LDEV = 513(0x0201) [1] ,
PORT
= none , LUN = none :done
GROUP = dg_jnl1 , DEVICE = data1 , UnitID = 0 , LDEV = 514(0x0202) [1] ,
PORT
= none , LUN = none :done
GROUP = dg_jnl1 , DEVICE = data1 , UnitID = 0 , LDEV = 515(0x0203) [1] ,
PORT
= none , LUN = none :done
```

Internal volume operations

Creating internal volumes (open volumes)

To create LDEVs of internal volumes (open volumes) and make the LDEVs available to the host, perform the following provisioning operations.

Step	Operation	Description	Command
1	Setting port	Enables LUN security of the port. Modify settings such as port topology and data transfer speed as needed.	<code>raidcom modify port -port <port#> -security_switch y</code>
2	Creating host group	Specifies port and create host group.	<code>raidcom add host_grp -port <port#> -host_grp_name <host group name></code>
3	Setting host mode	Specifies port and set host mode for host group.	<code>raidcom modify host_grp -port <port#> [<host group name>] -host_mode < host mode> [-host_mode_opt <host mode option> ...]</code>
4	Displaying host group information	Displays host group information and confirm result of executing command.	<code>raidcom get host_grp -port <port#> [<host group name>]</code>
5	Adding host to host group	Registers host to host group of the port.	<code>raidcom add hba_wnn -port <port#> [<host group name>] -hba_wnn <WWN strings></code>
6	Displaying WWN information	Displays WWN of connection host registered to the host group and confirm the result of executing the command.	<code>raidcom get hba_wnn -port <port#> [<host group name>]</code>
7	Creating LDEV	Specifies a parity group and create LDEV.	<code>raidcom add ldev -parity_grp_id <gno-sgno> -ldev_id <ldev#> -capacity <size> [-emulation <emulation type>] [-location <lba>] [-mp_blade_id <mp#>]</code>

Step	Operation	Description	Command
8	Formatting LDEV	Formats created LDEV.	<code>raidcom initialize ldev -ldev_id <ldev#> -operation <type></code>
9	Creating LDEV nickname (arbitrary)	Creates nickname for created LDEV. This operation is arbitrary.	<code>raidcom modify ldev -ldev_id <ldev#> -ldev_name <ldev naming></code>
10	Setting MP blade of LDEV	Sets MP blade of created LDEV.	<code>raidcom modify ldev -ldev_id <ldev#> -mp_blade_id <mp#></code>
11	Displaying LDEV information	Displays information of created LDEV and confirm the result of executing the command.	<code>raidcom get ldev -ldev_id <ldev#> ... [-cnt <count>] [-key <keyword>]</code>
12	Creating LU path	Specifies port, map LDEV to LUN and create an LU path.	<code>raidcom add lun -port <port#> [<host group name>] -ldev_id <ldev#> [-lun_id<lun#>]</code>
13	Displaying LU path information	Displays LU path information and confirm the result of executing the command.	<code>raidcom get lun -port <port#> [<host group name>]</code>

Script examples for internal volume operation (open volumes)

The following shows script examples of internal volume (open volume) operation.

Script examples of internal volume operation (open volume) (1/3)

```

raidcom -login USER01 PASS01           ;Log in with the user ID : USER01 and the
                                       ;password : PASS01.
raidcom lock resource -resource_grp_name ;Lock the resource group: meta_resource.
meta_resource                          ;
                                       ;
raidcom modify port -port CL1-A -security ;Turn ON the security switch of PortCL1-A and
_switch y                               ;PortCL2-A.
raidcom modify port -port CL2-A -security ;
_switch y                               ;
                                       ;
raidcom add host_grp -port CL1-A-0 -     ;Set the host group #0 to PortCL1-A, host
host_grp_name HP-UX-P                   ;group name: HP-UX-P, and the host group #0 to
raidcom add host_grp -port CL2-A-0 -     ;PortCL2-A, host group name: HP-UX-S.
host_grp_name HP-UX-S                   ;
                                       ;
raidcom modify host_grp -port CL1-A-0 -  ;Set the host mode: HP-UX to the host group#0
host_mode HP-UX                         ;of PortCL1-A and PortCL2-A.
raidcom modify host_grp -port CL2-A-0 -  ;
host_mode HP-UX                         ;
                                       ;
raidcom get host_grp -port CL1-A         ;Display the host group information that is
raidcom get host_grp -port CL2-A         ;set to PortCL1-A and PortCL2-A.
                                       ;
                                       ;
raidcom add hba_wwn -port CL1-A HP-UX-P - ;Set the connection host WWN:210000e0,8b0256f8
hba_wwn 210000e0,8b0256f8               ;to the PortCL1-A, host group HP-UX-P, and
raidcom add hba_wwn -port CL2-A HP-UX-S - ;the connection host WWN: 210000e0,8b0256f9 to
hba_wwn 210000e0,8b0256f9               ;the PortCL2-A, host group HP-UX-S.
                                       ;
                                       ;
raidcom get hba_wwn -port CL1-A HP-UX-P  ;Display the connection host WWN that is set
raidcom get hba_wwn -port CL2-A HP-UX-S  ;to PortCL1-A, host group HP-UX-P, and the
                                       ;connection host WWN that is set to PortCL2-A,
                                       ;host group HP-UX-S.
for /l %%i in (0,1,9) do (raidcom add ldev - ;Create each 10 of 10G Ldev to the
ldev_id %%i -capacity 10g -parity_grp_id 1-1 ;Parity_grp_id 1-1 (LDEV: 0 to 9).
)
raidcom get command_status               ;
raidcom reset command_status             ;
                                       ;
for /l %%i in (0,1,9) do (               ;Execute the quick format to LDEV:0 to 9.
raidcom initialize ldev -ldev_id %%i -operation ;
qfmt                                     ;
)
raidcom get command_status               ;
raidcom reset command_status             ;
                                       ;
for /l %%i in (0,1,9) do (               ;Give a nickname to LDEV:0 to 9.
raidcom modify ldev -ldev_id %%i -device_name ;(my_volume 0 to 9)
my_volume_%%i                           ;
)

```

Script examples of internal volume operation (open volume) (2/3)

```

for /l %%i in (0,1,9) do (
raidcom modify ldev -ldev_id %%i -mp_blade_id 2
)
:;Set the LDEV MP Blade ID of LDEV: 0 to 9 to
:;2.

raidcom get ldev -ldev_id 0 -cnt 10
:;Display the information of LDEV: 0 to
:;9(Internal VOL).

raidcom add dp_pool -pool_id 1 -ldev_id 0 -cnt
10
:;Create Pool:1 by using LDEV: 0 to 9.
raidcom get command_status
raidcom reset command_status
:;

for /l %%i in (10,1,19) do (
raidcom add ldev -ldev_id %%i
-capacity 10g -pool 1
)
:;Create each 10 of 10G VVOL to Pool_id 1.
:;(LDEV: 10 to 19, 20 to 29)

for /l %%i in (20,1,29) do (
raidcom add ldev -ldev_id %%i
-capacity 10g -pool 1
)
:;
raidcom get command_status
raidcom reset command_status
:;

for /l %%i in (10,1,29) do (
raidcom modify ldev -ldev_id %%i -device_name
my_virtual_volume_%%i
)
:;Give a nickname to VVOL: 10 to 29.
:;(my_virtual_volume 10 to 29)

for /l %%i in (10,1,29) do (
raidcom modify ldev -ldev_id %%i -mp_blade_id 2
)
:;Set the VVOL MP Blade ID of VVOL:10 to 29 to
:;2.

raidcom get ldev -ldev_id 10 -cnt 20
:;Display the information of VVOL: 10 to
:;29(virtual VOL).

for /l %%i in (10,1,19) do (
raidcom add device_grp -device_grp_name grp1
data%%i -ldev_id %%i
)
:;Give the device name: data 10 to 29 to VVOL:
:;10 to 29, and add it to the device group name
:;grp1(data10 to 19) and grp2(data20 to 29).
for /l %%i in (20,1,29) do (
raidcom add device_grp -device_grp_name grp2
data%%i -ldev_id %%i
)
:;
raidcom get command_status
raidcom reset command_status
:;

raidcom get device_grp -device_grp_name grp1
raidcom get device_grp -device_grp_name grp2
:;Display the device group information:grp1 and
:;grp2.

raidcom add copy_grp -copy_grp_name ora grp1
grp2
:;Create a copy group (ora) with the device
:;group (grp1 and grp2).

raidcom get command_status
raidcom reset command_status
:;

```

Step	Operation	Description	Command
4	Creating LDEV nicknames (arbitrarily)	Creates LDEV nicknames. This operation is optional.	<code>raidcom modify ldev -ldev_id <ldev#> -ldev_name <ldev naming></code>
5	Configuring MP blades of LDEVs	Configures MP blades of created LDEVs.	<code>raidcom modify ldev -ldev_id <ldev#> -mp_blade_id <mp#></code>
6	Displaying a LDEV information	Displays an information of created LDEV, and confirms an execution result of the command.	<code>raidcom get ldev -ldev_id <ldev#> ... [-cnt <count>] [-key <keyword>]</code>

Script examples of internal volume (mainframe volumes) operations

The following shows the script examples of internal volume (mainframe volume) operations.

```

raidcom -login USER01 PASS01                ;Log in with the User ID: USER01 and
                                             ;Password: PASS01.

raidcom lock resource -resource_grp_name    ;Lock the resource group: meta_resource
meta_resource                               ;
                                             ;
for /l %%i in (0,1,9) do (                  ;Create each 10 of 483078 cylinder LDEV to
raidcom add ldev -parity_grp_id 1-1 -emulation ;Parity_grp_id 1-1 (LDEV: 0 to 9)
3390-A -cylinder 483078 -ldev_id %%i       ;
)                                           ;
raidcom get command_status                 ;
raidcom reset command_status               ;
                                             ;
for /l %%i in (0,1,9) do (                  ;Execute Quick format to LDEV: 0 to 9
raidcom initialize ldev -ldev_id %%i -operation ;
qfmt                                       ;
)                                           ;
raidcom get command_status                 ;
raidcom reset command_status               ;
                                             ;
for /l %%i in (0,1,9) do (                  ;Give a nickname to LDEV: 0 to 9
raidcom modify ldev -ldev_id %%i -device_name ;(my_volume 0 to 9)
my_volume_%%i                             ;
)                                           ;
                                             ;
for /l %%i in (0,1,9) do (                  ;Set to 2 the MP blade ID of LDEV: 0 to 9
raidcom modify ldev -ldev_id %%i -mp_blade_id 2 ;
)                                           ;
                                             ;
raidcom get ldev -ldev_id 0 -cnt 10         ;Display the information of LDEV: 0 to
                                             ;9(Internal VOL).
                                             ;
for /l %%i in (0,1,9) do (                  ;Give the device name: data 0 to 9 to the
raidcom add device_grp -device_grp_name grp1 ;LDEV: 0 to 9, and add it to Device group name
data%%i -ldev_id %%i                       ;grp1(data0 to 9).
)                                           ;
                                             ;
raidcom get command_status                 ;
raidcom reset command_status               ;
                                             ;
raidcom get device_grp -device_grp_name grp1 ;Display the device group information: grp1.
                                             ;
raidcom add copy_grp -copy_grp_name ora grp1 ;Create a copy group (ora) by the device group
                                             ;(grp1).
                                             ;
raidcom get command_status                 ;
raidcom reset command_status               ;
                                             ;
raidcom get copy_grp                       ;Display the copy group information.
                                             ;
for /l %%i in (0,1,9) do (                  ;Defining paths of LDEV: 0 to 9 to Port: CL1-A
raidcom add lun -port CL1-A HP-UX-P -ldev_id %%i ;host group HP-UX-P
)                                           ;LU number is given automatically.
                                             ;
raidcom get lun -port CL1-A HP-UX-P         ;Display the path information that is set to
                                             ;PortCL1-A, host group HP-UX-P.
                                             ;
                                             ;
raidcom unlock resource -resource_grp_name  ;Unlock the resource group: meta_resource.
meta_resource                               ;
                                             ;
raidcom get resource                       ;Display the resource group information.
                                             ;
raidcom -logout                             ;Log out.

```

Virtual volume (Dynamic Provisioning) operations

Creating virtual volumes (Dynamic Provisioning)

Use the following provisioning operations to create LDEVs of virtual volumes (Dynamic Provisioning) and make the LDEVs available to the host.

Table 1 Operations and descriptions

Step	Operation overview	Description	Executed command
1	Setting port	Enable LUN security for the port. Modify settings such as port topology and data transfer speed as needed.	raidcom modify port -port <port#> -security_switch y
2	Creating host group	Specify port and create host group.	raidcom add host_grp -port <port#> -host_grp_name <host group name>
3	Setting host mode	Specify port and set host mode for host group.	raidcom modify host_grp -port <port#> [<host group name>] -host_mode <host mode> [-host_mode_opt <host mode option> ...]
4	Displaying host group information	Display host group information and confirm result of executing command.	raidcom get host_grp -port <port#> [<host group name>]
5	Adding host to host group	Register host to host group of the port.	raidcom add hba_wwn -port <port#> [<host group name>] -hba_wwn <WWN strings>
6	Displaying WWN information	Display WWN of connection host registered to the host group and confirm the result of executing the command.	raidcom get hba_wwn -port <port#> [<host group name>]
7	Creating LDEV	Specify a parity group and create LDEV.	raidcom add ldev -parity_grp_id <gno-sgno> -ldev_id <ldev#> {-capacity <size> -offset_capacity <size> -cylinder <size>} [-emulation <emulation type>][location <lba>] [-mp_blade_id <mp#>]
8	Formatting LDEV	Format created LDEV.	raidcom initialize ldev -ldev_id <ldev#> -operation <type>
9	Creating LDEV nickname (arbitrary)	Create nickname for LDEV. This operation is arbitrary.	raidcom modify ldev -ldev_id <ldev#> -ldev_name <ldev naming>
10	Setting MP blade of LDEV	Set MP blade of created LDEV.	raidcom modify ldev -ldev_id <ldev#> -mp_blade_id <mp#>

Step	Operation overview	Description	Executed command
11	Displaying LDEV information	Display information of created LDEV and confirm the result of executing the command.	<code>raidcom get ldev -ldev_id <ldev#> ... [-cnt <count>] [-key <keyword>]</code>
12	Creating pool (for Dynamic Provisioning)	Create pool (for Dynamic Provisioning).	<code>raidcom add dp_pool {{-pool_id <pool ID#> [-pool_name <pool naming>] -pool_name <pool naming> [-pool_id <pool ID#>]} -pool_id <pool ID#> -pool_name <pool naming>}} -ldev_id <ldev#> ... [-cnt <count>] [-user_threshold <threshold_1> [<threshold_2>]]</code>
13	Creating LDEV (V-VOL)	Specify pool and create an LDEV(V-VOL).	<code>raidcom add ldev -pool {<pool ID#> <pool naming> snap} -ldev_id <ldev#> {-capacity <size> -offset_capacity <size> -cylinder <size>} [-emulation <emulation type>] [-location <lba>] [-mp_blade_id <mp#>]</code>
14	Creating LDEV (V-VOL) nickname (arbitrary)	(Optional) Create nickname for the created LDEV.	<code>raidcom modify ldev -ldev_id <ldev#> -ldev_name <ldev naming></code>
15	Setting MP blade of LDEV (V-VOL)	Set MP blade of created LDEV (V-VOL).	<code>raidcom modify ldev -ldev_id <ldev#> -mp_blade_id <mp#></code>
16	Displaying LDEV information (V-VOL)	Display information of created LDEV (V-VOL) and confirm the result of executing the command.	<code>raidcom get ldev -ldev_id <ldev#> ... [-cnt <count>] [-key <keyword>]</code>
17	Creating LU path	Specify port, map LDEV to LUN and create an LU path.	<code>raidcom add lun -port <port#> [host group name] -ldev_id <ldev#> [-lun_id <lun#>]</code>
18	Displaying LU path information	Display LU path information and confirm the result of executing the command.	<code>raidcom get lun -port <port#> [<host group name>]</code>

Script examples of virtual volume (Dynamic Provisioning) operation

The following shows script examples of virtual volume (Dynamic Provisioning) operation.

Script examples of virtual volume operation (Dynamic Provisioning) (1/3)

```

raidcom -login USER01 PASS01                ;Log in with the user ID : USER01 and the
;password : PASS01.
raidcom lock resource -resource_grp_name    ;Lock the resource group: meta_resource.
meta_resource                               ;
;
raidcom modify port -port CL1-A -security   ;Turn ON the security switch of PortCL1-A and
_switch y                                   ;PortCL2-A.
raidcom modify port -port CL2-A -security   ;
_switch y                                   ;
;
raidcom add host_grp -port CL1-A-0 -        ;Set the host group #0 to PortCL1-A, host
host_grp_name HP-UX-P                       ;group name: HP-UX-P, and the host group #0 to
raidcom add host_grp -port CL2-A-0 -        ;PortCL2-A, host group name: HP-UX-S.
host_grp_name HP-UX-S                       ;
;
raidcom modify host_grp -port CL1-A-0 -     ;Set the host mode: HP-UX to the host group#0
host_mode HP-UX                             ;of PortCL1-A and PortCL2-A.
raidcom modify host_grp -port CL2-A-0 -     ;
host_mode HP-UX                             ;
;
raidcom get host_grp -port CL1-A            ;Display the host group information that is
raidcom get host_grp -port CL2-A            ;set to PortCL1-A and PortCL2-A.
;
raidcom add hba_wwn -port CL1-A HP-UX-P -   ;Set the connection host WWN:210000e0,8b0256f8
hba_wwn 210000e0,8b0256f8                   ;to the PortCL1-A, host group HP-UX-P, and
raidcom add hba_wwn -port CL2-A HP-UX-S -   ;the connection host WWN: 210000e0,8b0256f9 to
hba_wwn 210000e0,8b0256f9                   ;the PortCL2-A, host group HP-UX-S.
;
raidcom get hba_wwn -port CL1-A HP-UX-P    ;Display the connection host WWN that is set
raidcom get hba_wwn -port CL2-A HP-UX-S    ;to PortCL1-A, host group HP-UX-P, and the
;connection host WWN that is set to PortCL2-A,
;host group HP-UX-S.
for /l %%i in (0,1,9) do (raidcom add ldev -  ;Create each 10 of 10G Ldev to the
ldev_id %%i -capacity 10g -parity_grp_id 1-1 ;Parity_grp_id 1-1 (LDEV: 0 to 9).
)
raidcom get command_status                 ;
raidcom reset command_status               ;
;
for /l %%i in (0,1,9) do (                 ;Execute the quick format to LDEV:0 to 9.
raidcom initialize ldev -ldev_id %%i -operation ;
qfmt                                       ;
)
raidcom get command_status                 ;
raidcom reset command_status               ;
;
for /l %%i in (0,1,9) do (                 ;Give a nickname to LDEV:0 to 9.
raidcom modify ldev -ldev_id %%i -device_name ;(my_volume 0 to 9)
my_volume_%%i                             ;
)

```

Script examples of virtual volume operation (Dynamic Provisioning) (2/3)

```

for /l %%i in (0,1,9) do (
raidcom modify ldev -ldev_id %%i -mp_blade_id 2
)
:;Set the LDEV MP Blade ID of LDEV: 0 to 9 to
:;2.

raidcom get ldev -ldev_id 0 -cnt 10
:;Display the information of LDEV: 0 to
:;9(Internal VOL).

raidcom add dp_pool -pool_id 1 -ldev_id 0 -cnt
10
:;Create Pool:1 by using LDEV: 0 to 9.
raidcom get command_status
raidcom reset command_status
:;

for /l %%i in (10,1,19) do (
raidcom add ldev -ldev_id %%i
-capacity 10g -pool 1
)
:;Create each 10 of 10G VVOL to Pool_id 1.
:;(LDEV: 10 to 19, 20 to 29)

for /l %%i in (20,1,29) do (
raidcom add ldev -ldev_id %%i
-capacity 10g -pool 1
)
:;
raidcom get command_status
raidcom reset command_status
:;

for /l %%i in (10,1,29) do (
raidcom modify ldev -ldev_id %%i -device_name
my_virtual_volume_%%i
)
:;Give a nickname to VVOL: 10 to 29.
:;(my_virtual_volume 10 to 29)

for /l %%i in (10,1,29) do (
raidcom modify ldev -ldev_id %%i -mp_blade_id 2
)
:;Set the VVOL MP Blade ID of VVOL:10 to 29 to
:;2.

raidcom get ldev -ldev_id 10 -cnt 20
:;Display the information of VVOL: 10 to
:;29(virtual VOL).

for /l %%i in (10,1,19) do (
raidcom add device_grp -device_grp_name grp1
data%%i -ldev_id %%i
)
:;Give the device name: data 10 to 29 to VVOL:
:;10 to 29, and add it to the device group name
:;grp1(data10 to 19) and grp2(data20 to 29).

for /l %%i in (20,1,29) do (
raidcom add device_grp -device_grp_name grp2
data%%i -ldev_id %%i
)
:;
raidcom get command_status
raidcom reset command_status
:;

raidcom get device_grp -device_grp_name grp1
raidcom get device_grp -device_grp_name grp2
:;Display the device group information:grp1 and
:;grp2.

raidcom add copy_grp -copy_grp_name ora grp1
grp2
:;Create a copy group (ora) with the device
:;group (grp1 and grp2).

raidcom get command_status
raidcom reset command_status
:;

```

3. Check the status of the volume by executing the **raidcom get ldev** command.

```
# raidcom get ldev -ldev_id 200
```

While the delete LDEV operation is in process, the VOL_TYPE is REMOVING. When the volume is deleted correctly, the VOL_TYPE changes from REMOVING to NOT DEFINED. If VOL_TYPE is other than REMOVING or NOT DEFINED, the deletion ended abnormally. Check CSV_Status to take either of the following actions:

- When CSV_Status shows FAILED, see the Troubleshooting Dynamic Provisioning section in the Provisioning Guide for your system.
- When CSV_Status shows a status other than FAILED or does not show any status, execute the raidcom delete ldev command again without specifying the -operation initialize_capacity_saving option.

Deleting a virtual volume by blocking, initializing, and then deleting the volume

Use the following procedure to delete a virtual volume by blocking, initializing, and then deleting the volume. The command examples in this procedure use LDEV number 200 for the virtual volume being deleted.

Procedure

1. Block the volume by executing the **raidcom modify ldev** command.

```
# raidcom modify ldev -status blk -ldev_id 200
```

2. Verify that the block LDEV command completed normally by executing the **raidcom get command_status** command. If the command completed normally, the value "0" is returned.

```
# raidcom get command_status
```

3. Initialize the volume by executing the **raidcom initialize ldev** command.

```
# raidcom initialize ldev -operation fmt -ldev_id 200
```

4. Verify that the initialize LDEV command completed normally by executing the **raidcom get command_status** command. If the command completed normally, the value "0" is returned.

```
# raidcom get command_status
```

5. Check the status of the volume by executing the **raidcom get ldev** command.

```
# raidcom get ldev -ldev_id 200
```

When the volume is initialized correctly, the VOL_TYPE is OPEN-V-CVS and the CSV_Status is DISABLED.

6. Delete the volume by executing the `raidcom delete ldev` command.

```
# raidcom delete ldev -ldev_id 200
```

7. Verify that the delete LDEV command completed normally by executing the `raidcom get command_status` command. If the command completed normally, the value "0" is returned.

```
# raidcom get command_status
```

Virtual volume (Dynamic Provisioning for Mainframe) operations

Creating virtual volumes (Dynamic Provisioning for Mainframe)

To create LDEVs of virtual volumes (Dynamic Provisioning for Mainframe) and make the LDEVs available to the host, perform the following Provisioning operations.

Step	Operation overview	Description	Executed command
1	Setting SSID (arbitrarily)	Configures the SSID unless it is configured. Set (register) the SSID by specifying undefined LDEV numbers in the area in which SSIDs are not defined.	<code>raidcom modify ldev -ldev_id<ldev#> -ssid<value></code>
2	Creating LDEVs	Creates LDEVs by specifying parity groups. Specifies only 3390-V for the emulation type.	<code>raidcom add ldev -parity_grp_id <gno- sgno> -ldev_id <ldev#> {-capacity <size> -offset_capacity <size> -cylinder <size>} -emulation 3390-V -location <lba>] [-mp_blade_id <mp#>]</code>
3	Formatting LDEVs	Formats created LDEVs.	<code>raidcom initialize ldev -ldev_id <ldev#> -operation <type></code>

Step	Operation overview	Description	Executed command
4	Creating LDEV nicknames (arbitrarily)	Creates LDEV nicknames. This operation is optional.	<pre>raidcom modify ldev -ldev_id <ldev#> -ldev_name <ldev naming></pre>
5	Configuring MP blades of LDEVs	Configures MP blades of created LDEVs.	<pre>raidcom modify ldev -ldev_id <ldev#> -mp_blade_id <mp#></pre>
6	Displaying a LDEV information	Displays an information of created LDEV, and confirms an execution result of the command.	<pre>raidcom get ldev -ldev_id <ldev#> ... [-cnt <count>] [-key <keyword>]</pre>
7	Creating the pool (for the Hitachi Dynamic Provisioning for mainframe)	Creates the pool for the Hitachi Dynamic Provisioning for mainframe.	<pre>raidcom add dp_pool {{-pool_id <pool ID#> [-pool_name <pool naming>] -pool_name <pool naming> [-pool_id <pool ID#>}} -pool_id <pool ID#> -pool_name <pool naming>} {- ldev_id <ldev#> ...[-cnt <count>] -grp_opt <group option> -device_grp_name <device group name> [<device name>]} [- user_threshold <threshold_1> [<threshold_2>]]</pre>
8	Creating LDEV (V-VOL)	Specifies the pool and creates LDEV (V-VOL).	<pre>raidcom add ldev -pool {<pool ID#> <pool naming> snap} - ldev_id <ldev#> {-capacity <size> -offset_capacity <size></pre>

Step	Operation overview	Description	Executed command
			-cylinder <size>} [-emulation <emulation type>][-location <lba>] [-mp_blade_id <mp#>]
9	Creating LDEV (V-VOL) nicknames (arbitrarily)	Creates LDEV (V-VOL) nicknames. This operation is optional.	raidcom modify ldev -ldev_id <ldev#> -ldev_name <ldev naming>
10	Configuring MP blades of LDEVs (V-VOL)	Configures MP blades of created LDEVs (V-VOL).	raidcom modify ldev -ldev_id <ldev#> -mp_blade_id <mp#>
11	Displaying a LDEV (V-VOL) information	Displays an information of created LDEV (V-VOL), and confirms an execution result of the command.	raidcom get ldev -ldev_id <ldev#> [-cnt <count>] [-key <keyword>]

Script examples of virtual volume (Dynamic Provisioning for Mainframe) operation

The following shows the script examples of virtual volume (Dynamic Provisioning for Mainframe) operation.

Script examples of virtual volume operation (Dynamic Provisioning for Mainframe) (1/2)

```

raidcom -login USER01 PASS01                ;Log in with the user ID: USER01 and the
                                             ;password: PASS01.
raidcom lock resource -resource_grp_name    ;Lock the resource group: meta_resource.
meta_resource                               ;
                                             ;
for /l %%i in (0,1,9) do (                  ;Create each 10 of 483078 cylinder LDEV to
raidcom add ldev -parity_grp_id 1-1 -emulation 3390-V -cylinder 483078 -ldev_id %%i ;Parity_grp_id 1-1 (LDEV: 0 to 9)
)                                             ;
raidcom get command_status                  ;
raidcom reset command_status                ;
                                             ;
for /l %%i in (0,1,9) do (                  ;Execute the quick format to LDEV:0 to 9.
raidcom initialize ldev -ldev_id %%i -operation qfmt
)                                             ;
raidcom get command_status                  ;
raidcom reset command_status                ;
                                             ;
for /l %%i in (0,1,9) do (                  ;Give a nickname to LDEV:0 to 9.
raidcom modify ldev -ldev_id %%i -device_name my_volume_%%i
)                                             ;
                                             ;
for /l %%i in (0,1,9) do (                  ;Set the LDEV MP Blade ID of LDEV: 0 to 9 to
raidcom modify ldev -ldev_id %%i -mp_blade_id 2
)                                             ;
                                             ;
raidcom get ldev -ldev_id 0 -cnt 10         ;Display the information of LDEV: 0 to
                                             ;9(Internal VOL).
                                             ;
raidcom add dp_pool -pool_id 1 -ldev_id 0 -cnt 10
raidcom get command_status                  ;
raidcom reset command_status                ;
                                             ;
for /l %%i in (10,1,19) do(                 ;Create 10 of 5420 cylinder VWOL to
raidcom add ldev -ldev_id %%i -emulation 3390-A -cylinder 5420 -pool 1
)                                             ;
                                             ;
raidcom get command_status                  ;
raidcom reset command_status                ;
                                             ;
for /l %%i in (10,1,29) do (                 ;Give a nickname to VWOL: 10 to 29.
raidcom modify ldev -ldev_id %%i -device_name my_virtual_volume_%%i
)

```

Script examples of virtual volume operation (Dynamic Provisioning for Mainframe) (2/2)

```

for /l %%i in (10,1,29) do (
    raidcom modify ldev -ldev_id %%i -mp_blade_id 2 ;Set the WOL MP Blade ID of WVOL:10 to 29 to
) ;2.
;
;
raidcom get ldev -ldev_id 10 -cnt 20 ;Display the information of WVOL: 10 to
;29(virtual VOL).
;
;
raidcom unlock resource -resource_grp_name meta_resource ;Unlock the resource group: meta_resource.
meta_resource
;
;
raidcom get resource ;Display the resource group information.
;
;
raidcom -logout ;Log out.

```

Virtual volume (Dynamic Tiering) operations

Operational flow

When using the V-VOL (Dynamic Tiering), tiers of pools must be created after creating pools, and then the performance of pools must be monitored before the operation. If the performance of pools are insufficient, extend the capacity of pool volumes (addition of pool volumes) and of the V-VOL.

The following diagram shows the workflow for configuring a virtual volume (Dynamic Tiering) and the corresponding GUI (Device Manager - Storage Navigator) and CLI (CCI) tasks.

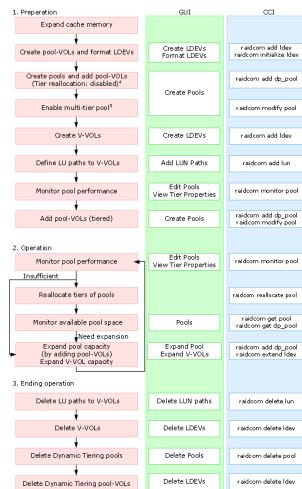

Notes:

1. The multi-tier pool is disabled when a pool is created byCCI. Multiple media cannot be registered as a pool volume when a pool is created. Execute tiering after changing the multi-tier pool to the enabled status.
2. If you use the GUI, you need to create a pool volume and format LDEVs before creating a pool. Perform this step from the Create LDEV wizard or the Format LDEVs wizard.

In addition, if you create a pool using an external volume, you need to create a pool volume and format the LDEVs before performing this step.
3. When the multi-tier pool is enabled, the tiering control is set to "Manual" automatically. To change the setting to "Auto", it is required to use.
4. If you use Device Manager - Storage Navigator for this operation, you need to delete pool volumes after deleting a pool from the Delete LDEVs window.



Note: Before creating a pool, it is required to create a virtual volume management area on the cache memory. The virtual volume management area is created automatically when cache memory is added. For information about adding cache memory, please contact customer support.



Caution: The operations explained here are executable by the storage administrator only.

Creating virtual volumes (Dynamic Tiering)

Use the following operations to create LDEVs of virtual volumes (Dynamic Tiering) and making the LDEVs available to the host.

Table 2 Operations and descriptions

Step	Operation overview	Description	Executed command
1	Setting port	Make enabled the LUN security of port. Modify setting such as port topology and data transfer speed as needed.	raidcom modify port -port <port#> -security_switch y
2	Creating host group	Specify port and create host group.	raidcom add host_grp -port <port#> -host_grp_name <host group name>
3	Setting host mode	Specify port and set host mode for host group.	raidcom modify host_grp -port <port#> [<host group name>] -host_mode <host mode> [-host_mode_opt <host mode option> ...]

Step	Operation overview	Description	Executed command
4	Displaying host group information	Display host group information and confirm result of executing command.	raidcom get host_grp -port <port#> [<host group name>]
5	Adding host to host group	Register host to host group of the port.	raidcom add hba_wwn -port <port#> [<host group name>] -hba_wwn <WWN strings>
6	Displaying WWN information	Display WWN of connection host registered to the host group and confirm the result of executing the command.	raidcom get hba_wwn {-port <port#> [<host group name>]}
7	Creating LDEV	Specify a parity group and create LDEV.	raidcom add ldev {-parity_grp_id <gno-sgno> -ldev_id <ldev#> {-capacity <size> -offset_capacity <size> -cylinder <size>} [-emulation <emulation type>]} [-location <lba>] [-mp_blade_id <mp#>]
8	Formatting LDEV	Format created LDEV.	raidcom initialize ldev -ldev_id <ldev#> -operation <type>
9	Creating LDEV nickname (arbitrary)	Create LDEV nickname. This operation is arbitrary.	raidcom modify ldev -ldev_id <ldev#> -ldev_name <ldev naming>
10	Setting MP blade of LDEV	Set MP blade of created LDEV.	raidcom modify ldev -ldev_id <ldev#> -mp_blade_id <mp#>
11	Displaying LDEV information	Display information of created LDEV and confirm the result of executing the command.	raidcom get ldev -ldev_id <ldev#> ... [-cnt <count>] [-key <keyword>]
12	Creating pool (for Dynamic Provisioning)	Create pool (for Dynamic Provisioning).	raidcom add dp_pool {{-pool_id <pool ID#> [-pool_name <pool naming>] -pool_name <pool naming> [-pool_id <pool ID#>]} -pool_id <pool ID#> -pool_name <pool naming>}} -ldev_id <ldev#> ... [-cnt count] [-user_threshold <%>]

Step	Operation overview	Description	Executed command
13	Setting pool option	Modify pool for Dynamic Provisioning to pool for Dynamic Tiering.	raidcom modify pool -pool {<pool ID#> <pool naming>} -pool_attribute dt_manual
14	Adding different media to pool volume	Add a pool volume of different media to a pool for Dynamic Tiering.	raidcom add dp_pool {{-pool_id <pool ID#> [-pool_name <pool naming>] -pool_name <pool naming> [-pool_id <pool ID#>]} -pool_id <pool ID#> -pool_name <pool naming>} -ldev_id <ldev#> ...[-cnt <count>] [-user_threshold <threshold_1> [<threshold_2>]]
15	Creating LDEV (V-VOL)	Specify pool and create LDEV (V-VOL).	raidcom add ldev -pool {<pool ID#> <pool naming> snap} -ldev_id <ldev#> -capacity <size> [-emulation <emulation type>][-location <lba>] [-mp_blade_id <mp#>]
16	Creating LDEV (V-VOL) nickname (arbitrary)	Create nickname for created LDEV (V-VOL). This operation is arbitrary.	raidcom modify ldev -ldev_id <ldev#> -ldev_name <ldev naming>
17	Setting MP blade of LDEV (V-VOL)	Set MP blade of created LDEV (V-VOL).	raidcom modify ldev -ldev_id <ldev#> -mp_blade_id <mp#>
18	Displaying LDEV (V-VOL) information	Display information of created LDEV (V-VOL) and confirm the result of executing the command.	raidcom get ldev -ldev_id <ldev#> ... [-cnt <count>] [-key <keyword>]
19	Creating LU path	Specify port, map LDEV to LUN and create an LU path.	raidcom add lun -port <port#> [host group name] -ldev_id <ldev#> [-lun_id <lun#>]
20	Displaying LU path information	Display LU path information and confirm the result of executing the command.	raidcom get lun -port <port#> [<host group name>]

Step	Operation overview	Description	Executed command
21	Starting performance monitoring of a pool for Dynamic Tiering	Start the performance monitoring of a pool for Dynamic Tiering.	raidcom monitor pool -pool {<pool ID#> <pool naming>} -operation start
22	Stopping performance monitoring of a pool for Dynamic Tiering	Stop the performance monitoring of a pool for Dynamic Tiering.	raidcom monitor pool -pool {<pool ID#> <pool naming>} -operation stop
23	Instructing reallocation of pool for Dynamic Tiering	Perform instruction of reallocation of pool for Dynamic Tiering.	raidcom reallocate pool -pool {<pool ID#> <pool naming>} -operation <type>

Script examples cript examples of virtual volume (Dynamic Tiering) operation

The following shows the script examples of virtual volume (Dynamic Tiering) operation.

Script examples of virtual volume operation (Dynamic Tiering) (1/3)

```

raidcom -login USER01 PASS01           :Log on with the user ID : USER01
                                        and :password: PASS01.
raidcom lock resource -resource_grp_name :Lock the resource group:meta_resource.
meta_resource                          :
                                        :
raidcom modify port -port CL1-A -security :Turn ON the security switch of PortCL1-A
_switch y                               :and PortCL2-A.
raidcom modify port -port CL2-A -security :
_switch y                               :
                                        :
raidcom add host_grp -port CL1-A-0 -     :Set the host group #0, host group name: HP-
host_grp_name HP-UX-P                   :UX-P to the PortCL1-A, and the host group
raidcom add host_grp -port CL2-A-0 -     :#0, host group name: HP-UX-S to the
host_grp_name HP-UX-S                   :PortCL2-A.
                                        :
raidcom modify host_grp -port CL1-A-0 -  :Set the host mode: HP-UX to the host group
host_mode HP-UX                         :#0 of PortCL1-A and PortCL2-A.
raidcom modify host_grp -port CL2-A-0 -  :
host_mode HP-UX                         :
                                        :
raidcom get host_grp -port CL1-A        :Display the host group information that is
raidcom get host_grp -port CL2-A        :set to the PortCL1-A and the PortCL2-A.
                                        :
                                        :
raidcom add hba_wwn -port CL1-A HP-UX-P - :Set the connection host
hba_wwn 210000e0.8b0256f8               :WWN:210000e0.8b0256f8 to the PortCL1-A,
raidcom add hba_wwn -port CL2-A HP-UX-S - :host group HP-UX-P, and the connection host
hba_wwn 210000e0.8b0256f9               :WWN:210000e0.8b0256f9 to the PortCL2-A,
                                        :host group HP-UX-S.
                                        :
                                        :
raidcom get hba_wwn -port CL1-A HP-UX-P :Display the connection host WWN that is set
raidcom get hba_wwn -port CL2-A HP-UX-S :to the PortCL1-A, host group HP-UX-P, and
                                        :the connection host WWN that is set to the
                                        :PortCL2-A, host group HP-UX-S.

```

Script examples of virtual volume operation (Dynamic Tiering) (2/3)

```

for /l %%i in (0,1,4) do (                                :Create 5 of 10G LDEV to Parity_grp_id 1-1
raidcom add ldev -ldev_id %%i -capacity 10g             :(LDEV:0 to 4) Low speed media
-parity_grp_id 1-1
)
for /l %%i in (5,1,9) do (                                :Create 5 of 10G LDEV to Parity_grp_id 1-2
raidcom add ldev -ldev_id %%i -capacity 10g             :(LDEV: 5 to 9) High speed media
-parity_grp_id 1-2
)
raidcom get command_status
raidcom reset command_status

for /l %%i in (0,1,9) do (                                :LDEV: Execute Quick format to 0 to 9
raidcom initialize ldev -ldev_id %%i -operation          :qfmt
)
raidcom get command_status
raidcom reset command_status

for /l %%i in (0,1,9) do (                                :Give an nickname to LDEV: 0 to 9
raidcom modify ldev -ldev_id %%i -device_name           :(my_volume 0 ot 9)
my_volume_%%i
)

for /l %%i in (0,1,9) do (                                :Set to 2 the LDEV owner MP blade of LDEV:
raidcom modify ldev -ldev_id %%i -mp_blade_id 2         :0 to 9
)
raidcom get ldev -ldev_id 0 -cnt 10                       :Display the information of LDEV: 0 to 9
                                                         :(Internal VOL)

raidcom add dp_pool -pool_id 1 -ldev_id 0 -cnt 5          :Use LDEV: 0 to 4, then create pool:1
raidcom get command_status
raidcom reset command_status

raidcom modify pool -pool 1 -pool_attribute              :Change the setting of pool:1,
dt_manual                                                 :from Dynamic Provisioning pool to
                                                         :Dynamic Tiering pool.

raidcom add dp_pool -pool_id 1 -ldev_id 5 -cnt           :
5                                                         :Add a pool volume of different media to
                                                         :pool:1 (LDEV: 5 to 9)

for /l %%i in (10,1,19) do (                               :
raidcom add ldev -ldev_id %%i -capacity 10g -           :
pool 1                                                    :Create each 10 of 10G VVOL to Pool_id 1
)                                                         :(LDEV:10 to 19, 20 to 29)

for /l %%i in (20,1,29) do (                               :
raidcom add ldev -ldev_id %%i -capacity 10g -           :
pool 1                                                    :
)                                                         :
raidcom get command_status
raidcom reset command_status

for /l %%i in (10,1,29) do (                               :Give a nickname to VVOL: 10 to 29
raidcom modify ldev -ldev_id %%i -device_name           :(my_virtual_volume 10 to 29)
my_virtual_volume_%%i
)                                                         :

for /l %%i in (10,1,29) do (                               :Set to 2 the VVOL owner MP blade of
raidcom modify ldev -ldev_id %%i -mp_blade_id 2         :VVOL:10 to 29
)                                                         :

```

Script examples of virtual volume operation (Dynamic Tiering) (3/3)

```

raidcom get ldev -ldev_id 10 -cnt 20           ;Display the information of VVOL:10 to
                                                ;29(virtual VOL)
                                                ;
for /l %%i in (10,1,19) do (
raidcom add device_grp -device_grp_name grp1  ;Give the device name: data0 to 19 to VVOL:
data%%i -ldev_id %%i                          ;10 to 29, and add it to Device group name
)                                                ;grp1(data0 to 9) and grp2(data10 to 19).
                                                ;
for /l %%i in (20,1,29) do (
raidcom add device_grp -device_grp_name grp2  ;
data%%i -ldev_id %%i                          ;
)                                                ;
raidcom get command_status                    ;
raidcom reset command_status                  ;

raidcom get device_grp -device_grp_name grp1  ;Display the device group information: grp1
raidcom get device_grp -device_grp_name grp2  ;and grp2.
                                                ;
raidcom add copy_grp -copy_grp_name ora grp1  ;Create a copy group (ora) at the device
grp2                                           ;group (grp1 and grp2).
                                                ;
raidcom get command_status                    ;
raidcom reset command_status                  ;

raidcom get copy_grp                          ;Display the copy group information.
                                                ;
for /l %%i in (10,1,19) do (
raidcom add lun -port CL1-A HP-UX-P -ldev_id  ;Execute the path definition of VVOL:10 to
%%i                                           ;19 to Port CL1-A host group HP-UX-P.
)                                                ;Execute the path definition of VVOL:20 to
for /l %%i in (20,1,29) do (
raidcom add lun -port CL2-A HP-UX-S -ldev_id  ;29 to Port CL2-A host group HP-UX-S.
%%i                                           ;Give an LU number automatically.
)                                                ;
                                                ;
raidcom get lun -port CL1-A HP-UX-P           ;Display the path information that is set to
raidcom get lun -port CL2-A HP-UX-S           ;PortCL1-A, host group HP-UX-P, and
                                                ;the path information that is set to
                                                ;PortCL2-A, host group HP-UX-S.
                                                ;
raidcom unlock resource -resource_grp_name    ;Unlock the resource group:meta_resource.
meta_resource                                  ;
                                                ;
raidcom get resource                          ;Display the resource group information.
                                                ;
raidcom monitor pool -pool 1 -operation start ;Start monitoring of Pool:1
raidcom monitor pool -pool 1 -operation stop  ;Stop monitoring of Pool:1
                                                ;
raidcom reallocate pool -pool 1 -operation    ;Start reallocation processing of Pool:1
start                                          ;
                                                ;
raidcom -logout                               ;Log out

```

Configuring iSCSI virtual ports

You can use CCI to enable and disable the iSCSI virtual port mode and set and delete virtual port numbers for iSCSI ports.

Setting an iSCSI virtual port

The following procedure describes how to enable the virtual port mode for the iSCSI port (CL4-E) and then set the virtual port number (15) and IPv4 address for the port.

Procedure

1. Check the current status of the iSCSI port (CL4-E).

```
# raidcom get port -port CL4-E -key opt
PORT : CL4-E
TCP_OPT : IPV6_D : SACK_E : DACK_E : INS_D : VTAG_D
:
IPV4_ADDR : 192.168.0.181
IPV4_SMSK : 255.255.255.0
:
VLAN_ID : -
ISCSI_VP_MODE : D
```

2. Enable the virtual port mode for the iSCSI port (CL4-E).

```
# raidcom modify port -port CL4-E -iscsi_virtual_port_mode enable
```

3. Set the virtual port number (15) and IPv4 address (192.168.4.100) for the iSCSI port (CL4-E).

```
# raidcom modify port -port CL4-E -add_iscsi_virtual_port 15 -
ip6_mode disable -ipv4_address 192.168.4.100 -ipv4_subnetmask
255.255.255.0
```

4. Confirm that the virtual port mode is enabled (ISCSI_VP_MODE : E), then make sure that the information for the virtual port number (15) is set correctly.

```
# raidcom get port -port CL4-E -key opt
PORT : CL4-E
TCP_OPT : IPV6_D : SACK_E : DACK_E : INS_D : VTAG_D
:
IPV4_ADDR : 192.168.0.181
IPV4_SMSK : 255.255.255.0
:
ISCSI_VP_MODE : E
ISCSI_VP_ID : 0 15
```

5. Confirm that the IPv4 address (192.168.4.100) is set for the virtual port.

```
# raidcom get port -port CL4-E -key opt -iscsi_virtual_port_id 15
PORT : CL4-E
ISCSI_VP_ID : 15
TCP_OPT : IPV6_D : SACK_E : DACK_E : INS_D : VTAG_D
:
IPV4_ADDR : 192.168.4.100
IPV4_SMSK : 255.255.255.0
```

Deleting an iSCSI virtual port

The following procedure describes how to delete the virtual port number (15) and then disable the virtual port mode for the iSCSI port (CL4-E).

Procedure

1. Check the current status of the iSCSI port (CL4-E).

```
#raidcom get port -port CL4-E -key opt
PORT : CL4-E
TCP_OPT : IPV6_D : SACK_E : DACK_E : INS_D : VTAG_D
:
ISCSI_VP_MODE : E
ISCSI_VP_ID : 0 15
```

2. Delete the virtual port number (15) set for the iSCSI port (CL4-E).

```
# raidcom modify port -port CL4-E -delete_iscsi_virtual_port 15
```

3. Confirm that the virtual port number (15) is deleted.

```
# raidcom get port -port CL4-E -key opt
PORT : CL4-E
TCP_OPT : IPV6_D : SACK_E : DACK_E : INS_D : VTAG_D
:
IPV4_ADDR : 192.168.0.181
IPV4_SMSK : 255.255.255.0
:
ISCSI_VP_MODE : E
ISCSI_VP_ID : 0
```

4. Disable the virtual port mode for the iSCSI port (CL4-E).

```
# raidcom modify port -port CL4-E -iscsi_virtual_port_mode disable
```

5. Confirm that the virtual port mode is disabled (ISCSI_VP_MODE : D).

```
# raidcom get port -port CL4-E -key opt
TCP_OPT : IPV6_D : SACK_E : DACK_E : INS_D : VTAG_D
:
IPV4_ADDR : 192.168.0.181
IPV4_SMSK : 255.255.255.0
:
ISCSI_VP_MODE : D
```

External volume operations

Creating external volumes (Fibre Channel)

Use the following provisioning operations to create LDEVs of external volumes and make the LDEVs available from the host.

Step	Operation overview	Description	Executed command
1	Setting port attribute of local storage system	Set port attribute of local storage system to External (ELUN) port	<code>raidcom modify port -port <port#> -port_attribute ELUN</code>
2	Searching external storage	Display port information on the external storage connected to the External port.	<code>raidcom discover external_storage -port <port#></code>
3	Searching external volume	Display a list of external volumes that can be mapped from External port.	<code>raidcom discover lun -port <port#> -external_wnn <wnn strings></code>
4	Creating external volume	Create external volume.	<code>raidcom add ldev - external_grp_id <gno-sgno> -ldev_id <ldev#> -capacity <size> [-emulation <emulation type>][-location <lba>] [-mp_blade_id <mp#>]</code>
5	Modifying external volume option	Modify external volume option (cache mode, inflow mode, and MP blade setting).	<code>raidcom modify external_grp -external_grp_id <gno-sgno> {-cache_mode < y n > -cache_inflow < y n > -mp_blade_id <mp#>}</code>
6	Checking external volume information	Display external volume information and confirm result of executing command.	<code>raidcom get external_grp [-external_grp_id <gno-sgno>]</code>
7	Setting external path	Set external path. Execute the required number of commands.	<code>raidcom add path - path_grp <path group#> -port <port#> -external_wnn <wnn strings></code>

Step	Operation overview	Description	Executed command
8	Displaying external path information	Display external path information for and confirm the result of executing the command.	<code>raidcom get path [-path_grp <path group#>]</code>
9	Setting port of external storage system	Make enabled the LUN security of port. Modify setting such as port topology and data transfer speed as needed.	<code>raidcom modify port -port <port#> -security_switch y</code>
10	Creating host group	Specify port, map LDEV to LUN and create an LU path.	<code>raidcom add host_grp -port <port#> -host_grp_name <host group name></code>
11	Setting host mode and host mode option	Specify port and set host mode and host mode option for host group.	<code>raidcom modify host_grp -port <port#> [<host group name>] -host_mode <host mode> [-host_mode_opt <host mode option> ...]</code>
12	Displaying host group information	Display host group information and confirm result of executing command.	<code>raidcom get host_grp -port <port#> [<host group name>]</code>
13	Adding host to host group	Register host to host group of the port.	<code>raidcom add hba_wnn -port <port#> [<host group name>] -hba_wnn <WWN strings></code>
14	Displaying WWN information	Display WWN of connection host registered to the host group and confirm the result of executing the command.	<code>raidcom get hba_wnn -port <port#> [<host group name>]</code>
15	Creating LDEV	Specify external volume group and create LDEV.	<code>raidcom add ldev - external_grp_id</code>

Step	Operation overview	Description	Executed command
			<pre><gno-sgno> -ldev_id <ldev#> {-capacity <size> -offset_capacity <size> -cylinder <size>} [-emulation <emulation type>][-location <lba>] [-mp_blade_id <mp#>]</pre>
16	Creating LDEV nickname (arbitrary)	Create nickname of created LDEV. This operation is arbitrary.	<pre>raidcom modify ldev -ldev_id <ldev#> -ldev_name <ldev naming></pre>
17	Setting MP blade of LDEV	Set MP blade of created LDEV.	<pre>raidcom modify ldev -ldev_id <ldev#> -mp_blade_id <mp#></pre>
18	Displaying LDEV information	Display information of created LDEV and confirm the result of executing the command.	<pre>raidcom get ldev -ldev_id <ldev#> ... [-cnt <count>] [-key <keyword>]</pre>
19	Creating LU path	Specify port, map LDEV to LUN and create an LU path.	<pre>raidcom add lun -port <port#> [<host group name>] -ldev_id <ldev#> [-lun_id<lun#>]</pre>
20	Displaying LU path information	Display LU path information and confirm the result of executing the command.	<pre>raidcom get lun -port <port#> [<host group name>]</pre>

Creating external volumes (iSCSI)

Use the following provisioning operations to create LDEVs of external volumes using iSCSI and make the LDEVs available from the host.

Step	Operation overview	Description	Executed command
1	Setting the port attribute of the local storage system	Set the port attribute of the local storage system to the External (ELUN) port.	<pre>raidcom modify port -port <port#> -port_attribute ELUN</pre>
2	Searching the iSCSI target of an external storage system	Display information about the iSCSI target of the external storage system that has the specified IP address and is connected to the External (ELUN) port.	<pre>raidcom discover external_iscsi_name -port <port#> -address <external IP address></pre>
3	Registering the iSCSI name of the iSCSI target for an external storage system	Register the iSCSI target to connect as an external storage system.*	<pre>raidcom add external_iscsi_name -port <port#> -iscsi_name <external iscsi name> -address <external IP address></pre>
4	Setting CHAP authentication information for connecting to the iSCSI target of an external storage system	When CHAP authentication is used for connection to external storage systems, set the CHAP user name and a password (secret) used by the iSCSI target of an external storage system for authenticating the External (ELUN) port of the local storage system.	<pre>raidcom modify initiator_chap_user -port <port#> [-chap_user <username>] [-secret]</pre>
5	Setting CHAP authentication information for connecting to the iSCSI target of an external storage system (for CHAP two-way authentication)	When CHAP authentication is used for connection to external storage systems, set the CHAP user name and a password (secret) used by the External (ELUN) port of the local storage system for authenticating the iSCSI target of an external storage system.	<pre>raidcom modify external_chap_user -port <port#> -iscsi_name <external iscsi name> -address <external IP address> [-chap_user <user name>] [-secret]</pre>

Step	Operation overview	Description	Executed command
6	Testing login to the iSCSI target	Attempt to log in to the iSCSI target of the external storage system registered in the local storage system, and display the result.*	raidcom check external_iscsi_name [-port <port#>]
7	Searching external storage systems	Display information of the port on the external storage system connected to the External (ELUN) port.	raidcom discover external_storage -port <port#>
8	Searching external volumes	List the external volumes that can be mapped from the External (ELUN) port.	raidcom discover lun - port <port#> -external_iscsi_name <external iscsi name> -external_address <IP address>
9	Mapping external volume groups	Map the volume in the external storage system to the external volume group.	raidcom add external_grp -path_grp <path group#> -external_grp_id <gno- sgno> -port <port#> -external_iscsi_name <externaliscsi name> -external_address <IP address> -lun_id <lun#> [-emulation <emulation type>] [-clpr <clpr#>] [-external_attribute migration] [-data_direct_mapping enable]
10	Creating external volumes	Create an external volume.	raidcom add ldev -external_grp_id <gno- sgno> -ldev_id <ldev#> -capacity <size> [-emulation <emulation type>]

Step	Operation overview	Description	Executed command
			<pre>[-location <lba>] [-mp_blade_id <mp#>]</pre>
11	Modifying external volume options	Modify external volume options (cache mode, inflow mode, and MP blade settings).	<pre>raidcom modify external_grp -external_grp_id <gno- sgno> {-cache_mode { y n } -cache_inflow {y n } -mp_blade_id <mp#>}</pre>
12	Checking external volume information	Display external volume information and confirm the result of executing the command.	<pre>raidcom get external_grp [-external_grp_id <gno- sgno>]</pre>
13	Setting external path	Set external path. Execute the required number of commands.	<pre>raidcom add path -path_grp <path group#> -port <port#> -external_iscsi_name <external iscsi name> -external_address <IP address></pre>
14	Displaying external path information	Display external path information and confirm the result of executing the command.	<pre>raidcom get path [-path_grp <path group#>]</pre>
15	Setting the local storage system port	<p>Enable LUN security settings of the port.</p> <p>Change the IP address or the MTU size of the port if necessary.</p>	<pre>raidcom modify port -port <port#> -security_switch y</pre>
16	Creating host groups	Specify the port to create a host group (iSCSI target).	<pre>raidcom add host_grp -port <port#> -host_grp_name <host group name> [-iscsi_name <target iscsi name>]</pre>

Step	Operation overview	Description	Executed command
17	Setting the host mode and host mode option	Specify the port to set the host mode and host mode option for the host group.	<pre>raidcom modify host_grp -port <port#> [<host group name>] -host_mode < host mode> [-host_mode_opt <host mode option> ...]</pre>
18	Displaying host group information	Display host group information and confirm the result of executing the command.	<pre>raidcom get host_grp -port <port#> [<host group name>]</pre>
19	Adding a host to a host group	Register the host to the host group of the port.	<pre>raidcom add hba_iscsi -port <port#> [<host group name>] -hba_iscsi_name <initiator iscsi name></pre>
20	Displaying iSCSI name information	Display the iSCSI name of the connected host registered in the host group, and confirm the result of executing the command.	<pre>raidcom get hba_iscsi -port <port#> [<host group name>]</pre>
21	Creating LDEVs	Specify the external volume group to create an LDEV.	<pre>raidcom add ldev -external_grp_id <gno- sgno> -ldev_id <ldev#> {-capacity <size> -offset_capacity <size> -cylinder <size>} [-emulation <emulation type>] [-location <lba>] [-mp_blade_id <mp#>]</pre>
22	Setting LDEV nicknames (arbitrary)	Set a nickname of the created LDEV. This operation is arbitrary.	<pre>raidcom modify ldev -ldev_id <ldev#> -ldev_name <ldev naming></pre>

Step	Operation overview	Description	Executed command
23	Setting the MP blade of an LDEV	Set the MP blade of the created LDEV.	<pre>raidcom modify ldev -ldev_id <ldev#> -mp_blade_id <mp#></pre>
24	Displaying LDEV information	Display information of the created LDEV and confirm the result of executing the command.	<pre>raidcom get ldev -ldev_id <ldev#> ... [-cnt <count>] [-key <keyword>]</pre>
25	Creating an LU path	Specify the port, map the LDEV to the LUN, and create an LU path.	<pre>raidcom add lun -port <port#> [<host group name>] -ldev_id <ldev#> [-lun_id<lun#>]</pre>
26	Displaying LU path information	Display LU path information, and confirm the result of executing the command.	<pre>raidcom get lun -port <port#> [<host group name>]</pre>
<p>*After registering the iSCSI name of the iSCSI target for an external storage system, perform the login test to check if you can log in to the iSCSI target correctly. If iSCSI targets to which you cannot log in correctly due to a security setting error are registered, attempts to check connections are made while external volumes are being searched. As a result, external volumes and networks are loaded, and recognizing an external volume might fail. For all iSCSI targets for which login test fails, change the CHAP authentication information for connecting to the iSCSI target of the external storage system, or check external storage system settings. After that, perform the login test again to make sure that the test is successful. In addition, delete unnecessary iSCSI targets using raidcom delete external_iscsi_name.</p>			

Script examples of external volume operations

The following shows the script examples of external volume operations.

Script Examples of External Volume Operation (1/3)

```

raidcom -login USER01 PASS01           ;Log in with user ID: USER01, and password:
                                       ;PASS01.
raidcom lock resource -resource_grp_name meta_resource ;Lock the resource group: meta_resource
meta_resource                          ;
                                       ;
raidcom modify port -port CL3-A -port_attribute ELUN ;Change the attribute of Port CL3-A to Port
                                       ;External (ELUN) and of Port CL4-A to
raidcom modify port -port CL4-A -port_attribute ELUN ;External (ELUN)
ELUN                                    ;
                                       ;
raidcom discover external_storage -port CL3-A ;Display the port on the external storage
                                       ;from port:CL3-A.
raidcom discover lun -port CL3-A -external_wwn 50060e80,1611a870 ;Display LU that is defined to the port on
                                       ;the external port: 50060e80,1611a870 and
                                       ;connected to the port:CL3-A(External port)
                                       ;
                                       ;
raidcom add external_grp -path_grp 1 -external_grp_id 1-1 -port CL3-A -external_wwn 50060e80,1611a870 -lun_id 0 ;Map LU:0 that is defined to the port on the
                                       ;external port: 50060e80,1611a870 and
                                       ;connected to the port:CL3-A (External port)
                                       ;with the external volume group #1-1, path
                                       ;group #1.
raidcom get command_status
raidcom reset command_status

```

Script Examples of External Volume Operation (2/3)

```

raidcom modify external_grp -external_grp_id 1-1 -cache_mode y ;Turn ON the cache mode of External volume
1 -cache_mode y ;group #1-1.
:
raidcom get external_grp -external_grp_id 1-1 ;Specify the external volume group and
;display the external volume information.
raidcom add path -path_grp 1 -port CL4-A - ;Add paths of External port CL4-A and the
external_wwn 50060e80,05fa0f36 ;port 50060e80 and 05fa0f36 on the side of
raidcom get command_status ;External storage ;to the path group:1.
raidcom reset command_status ;
;
raidcom get path -path_grp 1 ;Display the information of Path Group: 1.
:
raidcom modify port -port CL1-A -security ;Turn ON the security switches of PortCL1-A
_switch y ;and PortCL2-A.
raidcom modify port -port CL2-A -security ;
_switch y ;
:
raidcom add host_grp -port CL1-A-0 - ;Set the host group#0, host group name:
host_grp_name HP-UX-P ;HP-UX-P to PortCL1-A and host group#0,
raidcom add host_grp -port CL2-A-0 - ;host group name: HP-UX-S to PortCL2-A.
host_grp_name HP-UX-S ;
:
raidcom modify host_grp -port CL1-A-0 - ;Set the host mode: HP-UX to host group #0
host_mode HP-UX ;of PortCL1-A and PortCL2-A.
raidcom modify host_grp -port CL2-A-0 - ;
host_mode HP-UX ;
:
raidcom get host_grp -port CL1-A ;Display the host group information set to
raidcom get host_grp -port CL2-A ;PortCL1-A and PortCL2-A.
:
raidcom add hba_wwn -port CL1-A HP-UX-P - ;Set the connection host WWN:210000e0,
hba_wwn 210000e0,8b0256f8 ;8b0256f8 to PortCL1-A, host group :HP-UX-P
raidcom add hba_wwn -port CL2-A HP-UX-S - ;and the connection host WWN:210000e0,
hba_wwn 210000e0,8b0256f9 ;8b0256f9 to PortCL2-A, host group HP-UX-S.
:
raidcom get hba_wwn -port CL1-A HP-UX-P ;Display the connection host WWNs set to
raidcom get hba_wwn -port CL2-A HP-UX-S ;PortCL1-A, host group HP-UX-P and to
;PortCL2-A, host group HP-UX-S.
:
for /l %%i in (0,1,19) do ( ;Create each 10 of 10G Ldev to
raidcom add ldev -ldev_id %%i -capacity external_grp_id 1-1 (LDEV:0 to 9, 10 to
10g -external_grp_id 1-1 ;19).
) ;
raidcom get command_status ;
raidcom reset command_status ;
:
for /l %%i in (0,1,19) do ( ;Give a nickname to LDEV: 0 to 19
raidcom modify ldev -ldev_id %%i -device_name ;(my_volume 0 to 19)
my_volume_%%i ;
) ;
;Set the LDEV MP Blade ID of LDEV: 0 to 19
for /l %%i in (0,1,19) do ( ;to 2.
raidcom modify ldev -ldev_id %%i -mp_blade_id 2 ;
) ;
:
raidcom get ldev -ldev_id 0 -cnt 20 ;Display the information of LDEV: 0 to 19
;(internal VOL).
:
for /l %%i in (0,1,9) do ( ;Give a device name: data 0 to 19 to LDEV:
raidcom add device_grp -device_grp_name grp1 ;0 to 19, and add it to device group name:
data%%i -ldev_id %%i ;grp1(data0 to 9) and grp2(data10 to 19).
) ;

```

Script Examples of External Volume Operation (3/3)

```

for /I %%i in (10,1,19) do (
raidcom add device_grp -device_grp_name grp2
data%%i -ldev_id %%i
)
raidcom get command_status
raidcom reset command_status

raidcom get device_grp -device_grp_name grp1
raidcom get device_grp -device_grp_name grp2

raidcom add copy_grp -copy_grp_name ora grp1
grp2
raidcom get command_status
raidcom reset command_status

raidcom get copy_grp

for /I %%i in (0,1,9) do (
raidcom add lun -port CL1-A HP-UX-P -ldev_id
%%i
)
for /I %%i in (10,1,19) do (
raidcom add lun -port CL2-A HP-UX-S -ldev_id
%%i
)

raidcom get lun -port CL1-A HP-UX-P
raidcom get lun -port CL2-A HP-UX-S

raidcom unlock resource -resource_grp_name
meta_resource

raidcom get resource

raidcom -logout

```

```

:
:
:
:Display the device group information:
:grp1, grp2.
:
:
:Create copy group (ora) with the device
:group (grp1, grp2).
:
:
:Display the copy group information.
:
:Defining paths of LDEV: 0 to 9 to Port:
:CL1-A host group HP-UX-P.
:Defining path of LDEV: 10 to 19 to Port:
:CL2-A host group HP-UX-S.
:Give an LU number automatically.
:
:
:Display the path information that is set
:to PortCL1-A, host group HP-UX-P and
:PortCL2-A, host group HP-UX-S.
:
:
:Unlock the resource group: meta_resource.
:
:
:Display the resource group information.
:
:
:Log out.

```

Virtual Partition Manager operations

Virtual Partition Manager operations using CCI include migrating LDEVs, parity groups, and external volume groups to other CLPRs.

- For information about Virtual Partition Manager operations, including important warnings and restrictions, see the *Hitachi Virtual Partition Manager User Guide for USP VVM* or the *Hitachi Virtual Partition Manager User Guide for VSP*.
- For details about the CCI commands for Virtual Partition Manager operations, see the *Command Control Interface Command Reference*.

Performing Virtual Partition Manager operations

The following table shows the procedure for migrating LDEVs, parity groups, and external volume groups to other CLPRs.

Step	Operation overview	Description	Command
1	Confirming the CLPR configuration.	Check the status of the CLPRs.	<code>raidcom get clpr</code>

Step	Operation overview	Description	Command
2	Migrating one of the following to other CLPRs: <ul style="list-style-type: none"> ▪ LDEV ▪ parity group ▪ external volume group 	Specify the LDEV number, parity group number, or external volume group number.	<pre>raidcom modify clpr -clpr <clpr#> { -ldev_id <ldev#> -parity_grp_id <gno-sgno> - external_grp_id <gnosgno>}</pre>
3	Verifying the CLPR migration.	For parity group migration, check the status of the parity group.	<pre>raidcom get parity_grp</pre>

Displaying CLPR information

The `raidcom get clpr` command lists and displays the status of the CLPRs in the storage system. If no CLPRs have been created, CLPR0 is displayed as entire cache.

Display example:

```
# raidcom get clpr
```

```
CLPR CLPR_NAME      TC_CAP (MB)  TU_CAP (MB)  WP_CAP (MB)  SF_CAP (MB)  U (%)
W (%) S (%)
000 Oracle_DB        40000       20000       4000         0           50   30   0
001 Oracle_DB_PROD  20000       10000       2000         0           50   10   0
003 Oracle_DB_BACK  10000       5000        500          0           50   5    0
```

Migrating parity groups in a CLPR

This section explains operations from checking the parity group information to moving the parity group.

Displaying parity group information

The `raidcom` check the status, display the information about the parity group. See the following example.

Display example:

```
# raidcom get parity_grp
```

T	GROUP	Num_LDEV	U(%)	AV_CAP(GB)	R_LVL	R_TYPE	SL	CL	DRIVE_TYPE
R	32-16	4	45	140000	RAID1	2D+2D	0	0	DKS2C-K072FC
R	32-17	4	45	140000	RAID1	2D+2D	0	0	DKS2C-K072FC
R	33-16	4	45	140000	RAID1	2D+2D	0	0	DKS2C-K072FC
R	33-17	4	45	140000	RAID1	2D+2D	0	3	DKS2C-K072FC

Moving parity groups

If you change the allocation of parity groups, parity groups are moved from another CLPR. In this case, plural parity groups which configure the distributed parity group have to be allocated the same CLPR. Parity groups including LDEVs where cache area of Cache Residency is defined cannot be moved to another CLPR. For the restrictions on the CLPR's transfer, see the *Performance Guide*. The following shows examples of parity groups transfer in CLPR.

Example for moving parity group 32-17 to the CLPR number 1

```
# raidcom modify clpr -clpr 1 -parity_grp_id 32-17
```

When you move parity groups by specifying their LDEV numbers, use LDEV numbers for virtual volumes of Dynamic Provisioning, Copy-on-Write Snapshot, or Thin Image. When you move other volumes, specify a parity group number or external volume group number. The following shows an example of moving a virtual volume of Dynamic Provisioning, Copy-on-Write Snapshot, or Thin Image.

Example for moving the virtual volume of LDEV number: 02:00 to CLPR ID: 2

```
# raidcom modify clpr -clpr 2 -ldev_id 0x0200
```

Checking result of CLPR transfer

By displaying the information about parity groups, check the result of CLPR transfer. See the following example.

Display example:

```
# raidcom get parity_grp
```

T	GROUP	Num_LDEV	U(%)	AV_CAP(GB)	R_LVL	R_TYPE	SL	CL	DRIVE_TYPE
R	32-16	4	45	140000	RAID1	2D+2D	0	0	DKS2C-K072FC
R	32-17	4	45	140000	RAID1	2D+2D	0	1	DKS2C-K072FC
R	33-16	4	45	140000	RAID1	2D+2D	0	3	DKS2C-K072FC
R	33-17	4	45	140000	RAID1	2D+2D	0	3	DKS2C-K072FC

Server Priority Manager operations

Server Priority Manager enables you to prioritize host I/O operations to provide high-speed processing for specified hosts. The host is identified by the WWN or iSCSI name of the host bus adapter. Server Priority Manager has two settings: prioritized and non-prioritized. Set the prioritized option for hosts that require high-speed processing, and the non-prioritized option for the other hosts.

The following methods are used to set the priority level, but only one of them can be used in a single storage system:



Note: The WWN of a host bus adapter connected to a port is required when specifying the port with CCI and setting SPM. Since the WWN of an HBA connected to a NAS Platform port cannot be obtained, the SPM setting with specifying these port types is not available.

- **Specifying ports and WWNs of host bus adapters:**

- Using SPM without registering host groups to the SPM group
- Using SPM by registering host groups in the SPM group (VSP only)

For details, see [Configuring Server Priority Manager by specifying ports and WWNs of HBAs \(on page 238\)](#).

- **Specifying an LDEV and a WWN of the host bus adapter:**

For details, see [Configuring Server Priority Manager by specifying LDEVs and WWNs or iSCSI names of HBAs \(on page 252\)](#).

- **Specifying an LDEV and an iSCSI name of a host bus adapter:**

For details, see [Configuring Server Priority Manager by specifying LDEVs and WWNs or iSCSI names of HBAs \(on page 252\)](#).

Configuring Server Priority Manager by specifying ports and WWNs of HBAs

This section describes operations for configuring Server Priority Manager by specifying a port and a WWN of a host bus adapter.

- [Controlling the priority of I/O operations in storage systems on servers \(on page 239\)](#)
- [Using and managing Server Priority Manager \(on page 239\)](#)
- [Setting SPM names for WWNs and registering them to the SPM group \(on page 240\)](#)
- [Configuring Server Priority Manager by specifying ports and WWNs of HBAs \(on page 241\)](#)
- [Cautions about using Server Priority Manager \(on page 248\)](#)
- [Cautions when using host groups after registering them in SPM groups \(VSP only\) \(on page 251\)](#)

Controlling the priority of I/O operations in storage systems on servers

To control server performance, specify the I/O operation priority (prioritized or non-prioritized), the threshold (one value for each storage system), and the upper limit (one value for each non-prioritized WWN) for host bus adapters on a host. Set a host bus adapter with higher priority as a prioritized WWN, and set a host bus adapter with lower priority as a non-prioritized WWN. By adjusting the upper limit or threshold to an appropriate value, you can maintain the number of accesses or the amount of data to be transferred to a storage system at a higher level on a prioritized server.

Priority to be set by specifying a port and a WWN of an HBA, and control of server performance

Priority	Server performance
Non-prioritized	<p>Controls server performance based on the upper limit. The upper limit is set for each non-prioritized WWN.</p> <p>The upper limit suppresses the number of accesses to a storage system, or the amount of data to be transferred. Monitoring information can be displayed according to the combination of a port and a WWN of a host bus adapter.</p>
Prioritized	<p>Controls server performance based on the threshold. One threshold is set for each storage system, but it cannot be set for each prioritized WWN.</p> <p>If the amount of traffic goes down to the threshold, the control of the upper limit is disabled automatically.</p> <p>Monitoring information can be displayed according to the combination of a port and a WWN of a host bus adapter.</p>

Using and managing Server Priority Manager

You can give a nickname (SPM name) to each host WWN to assist in managing the hosts. You can also manage WWN and the SPM name per group. The groups to which WWN and the SPM name are registered are managed uniquely. The following table lists the details for the Server Priority Manager operations and the management unit.

SPM Operation	Management per port	Management per system
raidcom modify spm_wwn	<p>prioritized or non-prioritized</p> <p>upper limit</p> <p>WWN or SPM name</p>	threshold
raidcom modify spm_group	<p>prioritized or non-prioritized</p> <p>upper limit</p>	threshold

SPM Operation	Management per port	Management per system
	SPM group name	
raidcom add spm_wwn	-	SPM name
raidcom add spm_group	-	SPM group name
raidcom delete spm_wwn	-	SPM name (SPM information per port is also deleted.)
raidcom delete spm_group	-	SPM group name (SPM information per port is also deleted.)
raidcom get spm_wwn	prioritized or non-prioritized upper limit WWN or SPM name SPM group name	threshold
raidcom get spm_group	prioritized or non-prioritized upper limit SPM group name	threshold
raidcom monitor spm_wwn	performance of server (IOps/ KBps)	control mode of SPM
raidcom monitor spm_group	performance of server (IOps/ KBps)	control mode of SPM

Setting SPM names for WWNs and registering them to the SPM group

The following figure shows the workflow of setting SPM names for WWNs and registering them in the SPM group.

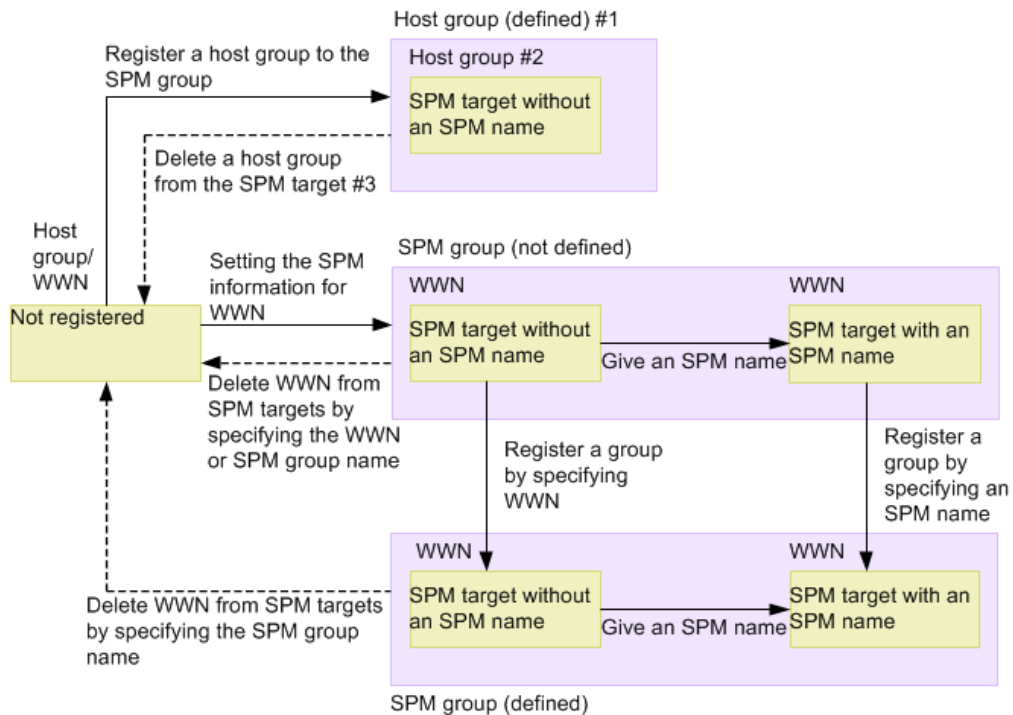

- #1: Associated with the host group.
- #2: All WWNs belonging to the host group are the SPM target.
- #3: Migrated if all WWNs are deleted from the host group.

Configuring Server Priority Manager by specifying ports and WWNs of HBAs

This section describes how to use Server Priority Manager when setting a port and a WWN of a host bus adapter. For VSP models, the procedure varies depending on whether the host groups is registered in the SPM group. Only VSP models can register host groups to the SPM group.

Controlling server performance when the host group is not registered in the SPM group

The following table shows the procedure when the host group is not registered in the SPM group.

Step	Operation overview	Description	Executed command
1	Setting the SPM information for WWN	Set the priority (prioritized or non-prioritized option) for the SPM controlling by specifying the number of port to which the host bus adapter is connected and WWN of the host bus adapter.	<pre>raidcom modify spm_wwn -port <port#> [-spm_priority <y/n>] {-limit_io -limit_kb -limit_mb } <value> {- hba_wwn <wwn_strings> -spm_name <nick_name>}</pre>
2	Giving a nickname (SPM name).	Give a nickname to WWN for the SPM controlling to make the host bus adapter distinguishable.	<pre>raidcom add spm_wwn -port <port#> -spm_name <nick_name> -hba_wwn <wwn_strings></pre>
3	Registering WWN for SPM to SPM group	Specifying WWN: To operate per group, group multiple WWNs for SPM control into one group.	<pre>raidcom add spm_group -port <port#> -spm_group <group_name> -hba_wwn <wwn_strings></pre>
		Specifying nickname: To operate per group, group multiple WWNs for SPM control into one group.	<pre>raidcom add spm_group -port <port#> -spm_group <group_name> <nick_name></pre>
4	Checking the SPM information	Display the setting state of SPM by specifying WWN or the SPM name.	<pre>raidcom get spm_wwn -port <port#> [-hba_wwn <wwn_strings> -spm_name <nick_name>]</pre>
		Display the SPM information by specifying the SPM group name.	<pre>raidcom get spm_group -port <port#> -spm_group <group_name></pre>
5	Displaying the monitoring information of the prioritized	Display the monitoring information by specifying WWN or the SPM name.	<pre>raidcom monitor spm_wwn {-hba_wwn <wwn_strings> -spm_name <nick_name>}</pre>

Step	Operation overview	Description	Executed command
	WWN or the non-prioritized WWN	Display the monitoring information by specifying the SPM group name.	<pre>raidcom monitor spm_group -spm_group <group_name></pre>
6	Changing the threshold or the upper limit value of the non-prioritized WWN	Change the threshold or the upper limit value of the non-prioritized WWN by specifying WWN or the SPM name.	<pre>raidcom modify spm_wnn -port <port#> [-spm_priority <y/n>] {-limit_io -limit_kb -limit_mb } <value> {-hba_wnn <wnn_strings> -spm_name <nick_name>}</pre>
		Change the threshold or the upper limit value of the non-prioritized WWN by specifying the SPM group name.	<pre>raidcom modify spm_group -port <port#> [-spm_priority <y/n>] {-limit_io -limit_kb -limit_mb } <value> -spm_group <group_name></pre>
7	Deleting WWN from the SPM targets	Delete WWN from the SPM targets by specifying WWN or the SPM name.	<pre>raidcom delete spm_wnn -port <port#> [-hba_wnn <wnn_strings> -spm_name <nick_name>]</pre>
		Delete WWN from the SPM targets by specifying the SPM group name.	<pre>raidcom delete spm_group -port <port#> -spm_group <group_name></pre>

Controlling server performance when the host group is registered in the SPM group (VSP only)

The following table shows the procedure when the host group is registered in the SPM group.



Note: For cautions when registering host groups to the SPM group and operating them (VSP only), see Cautions when using host groups after registering them in SPM groups (VSP only).

Step	Operation overview	Description	Executed command
1	Registering the host group that contains WWN controlled by SPM to the SPM group	Specify the host group to which WWN of the host bus adapter is registered and register the host group to the SPM.	<pre>raidcom add spm_group -spm_group <group name> -port <port#> [<host group name>] -spm_host_grp</pre>
2	Changing the threshold or the maximum value of nonpreferred WWN.	Specify the host group to change the threshold or the maximum value of the nonpreferred WWN.	<pre>raidcom modify spm_group -port <port#> [<host group name>] -spm_host_grp [-spm_priority <y/n>] { - limit_io -limit_kb -limit_mb } <value></pre>
3	Checking the SPM information	Specify the WWN name to display the SPM setting status.	<pre>raidcom get spm_wnn -port <port#> [-hba_wnn <wnn_strings>]</pre>
4		Specify the host group to display the SPM setting status.	<pre>raidcom get spm_group -port <port#> [<host group name>] -spm_host_grp</pre>
5		Specify the SPM group name to display the SPM setting status.	<pre>raidcom get spm_group -port <port#> -spm_group <group_name></pre>
6	Displaying monitoring information of preferred or nonpreferred WWN	Specify the WWN name to display monitoring information.	<pre>raidcom monitor spm_wnn {-hba_wnn <wnn_strings> }</pre>
7		Specify the SPM group name to display monitoring information.	<pre>raidcom monitor spm_group -spm_group <group_name></pre>

Step	Operation overview	Description	Executed command
8	Registering WWN to the host group registered in the SPM group, and setting the WWN as the SPM target	Register the WWN to the host group registered in the SPM group to set the WWN as the SPM target.	<code>raidcom add hba_wnn -port <port#> [<host group name>] -hba_wnn <WWN strings></code>
9	Deleting from the SPM targets	Specify the host group to delete it from the SPM target.	<code>raidcom delete spm_group -port <port#> [<host group name>] -spm_host_grp</code>
10		Delete the host group to delete it from the SPM target.	<code>raidcom delete host_grp -port <port#> [<host group name>]</code>
11		Delete WWN from the host group to delete it from the SPM target.	<code>raidcom delete hba_wnn -port <port#> [<host group name>] -hba_wnn <WWN strings></code>

Displaying the WWN of host bus adapters

Displays the WWN of the host bus adapters that are registered in host groups.

Display example:

```
# raidcom get hba_wnn -port CL4-E-0
PORT  GID  GROUP_NAME  HWWN                Serial#  NICK_NAME
CL4-E  0    Linux_x86   210000e08b0256f8    63528   ORA_NODE0_CTL_0
CL4-E  0    Linux_x86   210000e08b039c15    63528   ORA_NODE1_CTL_1
```

Setting the priority on host bus adapters

Display example: Set the host bus adapter (WWN: 210000e0,8b0256f8) to the non-prioritized WWN, and set 5000 [IOPS] as the upper limit.

```
# raidcom modify spm_wnn -port CL4-E -spm_priority
n -limit_io 5000 -hba_wnn 210000e0,8b0256f8
```

Display example: Set the host bus adapter (WWN: 210000e0,8b039c15) to the prioritized WWN, and set 3000 [IOPS] as the threshold.

```
# raidcom modify spm_wnn -port CL4-E -spm_priority  
y -limit_io 3000 -hba_wnn 210000e0,8b039c15
```

-limit_io 3000 shown in the example of the priority setting is the threshold value of the entire system.

Displaying the status of the prioritized WWN and the non-prioritized WWN settings

Display the status of the prioritized WWN and the non-prioritized WWN settings and check it. Display examples of the status of the prioritized WWN and the non-prioritized WWN settings are shown below.

Example for displaying the status of settings of the prioritized WWN and the non-prioritized WWN assigned under the specified port (CL4-E)

```
# raidcom get spm_wnn -port CL4-E
```

PORT	SPM_MD	SPM_WWN	NICK_NAME	GRP_NAME	Serial#
CL4-E	WWN	210000e08b0256f8	-	-	63528
CL4-E	WWN	210000e08b039c15	-	-	63528

Example for displaying the status of setting to specify the WWN (210000e08b0256f8)

```
# raidcom get spm_wnn -port CL4-E -hba_wnn 210000e0,8b0256f8
```

PORT	SPM_MD	PRI	IOps	KBps	Serial#
CL4-E	WWN	N	5000	-	63528

Example for displaying the status of setting to specify the WWN (210000e08b039c15)

```
# raidcom get spm_wnn -port CL4-E -hba_wnn 210000e0,8b039c15
```

PORT	SPM_MD	FRI	IOps	KBps	Serial#
CL4-E	WWN	Y	3000	-	63528

The threshold value displayed for the prioritized WWN by using the get spm_wnn command is set for the entire system.

Setting SPM names for host bus adapters

The host bus adapters can be identified by checking the WWNs, but using SPM names might make it easier to identify the host bus adapters. Display examples of setting the SPM name of the host bus adapter are shown below.

Display example: Set the SPM name (ORA_NODE0_CTL_0) for the WWN (210000e08b0256f8)

```
# raidcom add spm_wnn -port CL4-E -spm_name
ORA_NODE0_CTL_0 -hba_wnn 210000e0,8b0256f8
```

Display example: Set the SPM name (ORA_NODE1_CTL_1) for the WWN (210000e08b039c15)

```
# raidcom add spm_wnn -port CL4-E -spm_name
ORA_NODE1_CTL_1 -hba_wnn 210000e0,8b039c15
```

SPM names are managed uniquely in the entire system.

Grouping multiple host bus adapters into one group

You can group the host bus adapters into SPM groups, and then use the SPM groups to change the priorities of multiple host bus adapters at the same time. You can also set the same upper limit value for all host bus adapters in an SPM group at the same time.

Examples of setting the SPM group:

Display example: Set the SPM name (ORA_NODE0_CTL_0) for the SPM group name (WWN_GRP_LINUX0)

```
# raidcom add spm_group -port CL4-E -spm_group WWN_GRP_LINUX0
ORA_NODE0_CTL_0
```

Display example: Set the WWN (210000e08b039c15) for the SPM group name (WWN_GRP_LINUX1)

```
# raidcom add spm_group -port CL4-E -spm_group
WWN_GRP_LINUX1 -hba_wnn 210000e0,8b039c15
```

SPM group names are managed uniquely in the entire system.

Obtaining monitoring information of the prioritized WWN and the non-prioritized WWN

You can use the monitoring function to check whether the performance of the prioritized WWN can be secured by setting the upper limit. Example of acquiring the monitoring information:

Acquires the monitoring information by specifying the WWN (210000e08b039c15).

Display example:

```
# raidcom monitor spm_wwn -hba_wwn 210000e0,8b039c15
PORT   SPM_MD  IOps  KBps   Serial#
CL4-E  WWN      5000  5000000 63528
```

Stopping performance control of server by using SPM function

To stop controlling the performance of the server by using the SPM function, delete the SPM name from the SPM targets.

Example of deleting from the SPM targets:

Delete the SPM name ("ORA_NODE0_CTL_0") from the SPM targets.

Display example:

```
# raidcom delete spm_wwn -port CL4-E -spm_name ORA_NODE0_CTL_0
```

Cautions about using Server Priority Manager

The following table describes the cautions about using Server Priority Manager.

Caution	Description
Exclusive access control with Storage Navigator	<p>Server Priority Manager settings are exclusive for CCI operations and Storage Navigator operations:</p> <ul style="list-style-type: none"> ▪ If you set Server Priority Manager using CCI, you cannot set Server Priority Manager from Storage Navigator. You need to delete all Server Priority Manager settings made using CCI, and then use Server Priority Manager on Storage Navigator to make the Server Priority Manager settings. ▪ If you set Server Priority Manager using Storage Navigator, you cannot set Server Priority Manager using CCI. You need to delete all Server Priority Manager settings made using Storage Navigator (for instructions see the <i>Performance Guide</i>), and then use Server Priority Manager from CCI to make the Server Priority Manager settings.
Performance Monitor of Device Manager - Storage Navigator	<p>If you set Server Priority Manager using CCI, you cannot use a part of Performance Monitor of Device Manager - Storage Navigator. For details, see the <i>Performance Guide</i>.</p>

Caution	Description
Maintenance	<p>When you perform the following operations, the upper limit value control might be disabled for about two minutes:</p> <ul style="list-style-type: none"> ▪ Adding, replacing, or removing cache memory ▪ Changing the system configuration ▪ Updating the firmware ▪ VSP Gx00 models and VSP Fx00 models: Replacing the controller (CTL) ▪ VSP Gx00 models and VSP Fx00 models: Adding, replacing, or removing front-end module (CHB) ▪ VSP G1x00 and VSP F1500: Replacing MP blades ▪ VSP G1x00 and VSP F1500: Adding, replacing, or removing front-end directors (CHAs) ▪ Powering on and off the storage system <div style="background-color: #e0f2f1; padding: 10px; margin-top: 10px;"> <p> Note:</p> <p>The upper limit value control might be disabled when an abnormal condition that causes the login or logout of the host occurs, such as a network failure or damage on the HBA or Fibre cable. Resolve the cause of the unexpected login/logout behavior, and then enable the upper limit value control.</p> </div>
When specifying ports and WWNs of HBAs: Deleting SPM names or SPM group names	<p>If you delete a combination of the specified port and the WWN of the HBA from the SPM targets by using the SPM name, the SPM setting and SPM name under the specified port are deleted. If the same SPM name is set to another port, only the SPM setting of the specified port is deleted.</p> <p>If you delete a combination of the specified port and the WWN of the HBA from the SPM targets by using the SPM group name, the SPM setting and the group under the specified port are deleted. If the same SPM group name is set to another port, only the SPM setting of the specified port is deleted.</p>
When specifying ports and WWNs of HBAs: Resource group function and restrictions for Server Priority Manager	<p>When you use the resource group function, the range of operation is limited per port of resource group by Server Priority Manager. The threshold value, the SPM name, and the SPM group name, which are managed in the entire system, are common among the resource groups.</p>

Caution	Description
	<p>When you perform Server Priority Manager operations using the resource group function, share the threshold value that the storage administrator determines among users of resource groups. Determine rules for SPM names and SPM group names including port names to avoid redundant names between ports.</p>
<p>When specifying WWN or iSCSI name of LDEVs and HBAs: DKCMAIN microcode version and storage models</p>	<p>For microcode 80-04-xx-xx/00 or earlier in VSP G1x00 and VSP F1500 or firmware 83-03-0x-xx/00 or earlier in VSP Gx00 models and VSP Fx00 models, if SPM information is set or referenced, behavior is not guaranteed.</p> <p>The following errors might occur:</p> <ul style="list-style-type: none"> ▪ Server performance cannot be controlled according to the specified upper limit value. ▪ No detailed error message appears when an error occurs. ▪ No error message appears if an invalid upper limit value is set. ▪ The same error as when an invalid WWN is specified occurs. For details about the errors, see the row below. <p>Behavior when SPM information is set for or referenced by VSP or HUS VM models cannot be guaranteed. If SPM information is set or referenced, the following errors might occur:</p> <ul style="list-style-type: none"> ▪ Server performance cannot be controlled according to the specified upper limit value. ▪ No detailed error message appears when an error occurs. ▪ No error message appears if an invalid upper limit value is set.
<p>When specifying WWN or iSCSI name of LDEVs and HBAs: Invalid WWNs</p>	<p>Behavior is not guaranteed when an invalid WWN (not in the format defined by IEEE) is specified.</p> <p>In VSP G1x00 and VSP F1500, if you specify SPM information for an invalid WWN, you might not be able to set SPM information with an iSCSI name specified.</p> <p>In VSP Gx00 models and VSP Fx00 models with DKCMAIN firmware 83-03-0x or earlier, if you specify SPM information for an invalid WWN and then update the firmware to 83-03-2x or later, the following errors might occur:</p> <ul style="list-style-type: none"> ▪ Invalid WWNs with SPM information specified are deleted from the SPM target. ▪ SPM information is set for the iSCSI name of which SPM information is not specified.

Caution	Description
When specifying WWN or iSCSI name of LDEVs and HBAs: I/Os issued to non-prioritized LDEVs	When the number of I/Os issued to a non-prioritized LDEV reaches the upper limit, I/Os exceeding the upper limit are retained in the storage system. By this method, host process might be consumed, and I/O performance of prioritized LDEVs or non-prioritized LDEVs that have I/Os below the upper limit might be affected. If I/O performance of other LDEVs becomes lower than expected due to the host process number limit, review the queue depth settings or alternate path policy settings of the host.

Cautions when using host groups after registering them in SPM groups (VSP only)

The following limitations apply when you register host groups in SPM groups (VSP only):

1. You cannot register host groups that contain WWNs for which SPM information is set in step 1 of [Controlling server performance when the host group is not registered in the SPM group \(on page 241\)](#).
2. You cannot register host groups in SPM groups in which WWNs (SPM targets) are registered in step 3 of [Controlling server performance when the host group is not registered in the SPM group \(on page 241\)](#).

You can register host groups described in limitation 1 above in SPM groups that were not specified in step 3 of [Controlling the priority of I/O operations in storage systems on servers \(on page 239\)](#) if the WWNs that belong to the host group meet the following requirements:

- The WWNs are not already registered as SPM targets using another port number by performing step 1 of [Controlling the priority of I/O operations in storage systems on servers \(on page 239\)](#).
- The WWNs belong to SPM groups that were specified in step 3 of [Controlling server performance when the host group is not registered in the SPM group \(on page 241\)](#).

After registering a host group in an SPM group, Server Priority Manager sets the SPM information as follows:

- When the SPM group is associated with the host group, Server Priority Manager sets the same priority (prioritized or non-prioritized) as the SPM group. Then, for the prioritized host group Server Priority Manager sets the threshold, or for the non-prioritized host group Server Priority Manager sets the upper limit of non-prioritized WWNs.
- When the SPM group is not associated with the host group, Server Priority Manager sets the priority setting to prioritized without changing the threshold.

For how to register host groups in SPM groups, see [Controlling server performance when the host group is registered in the SPM \(VSP only\)](#).

Configuring Server Priority Manager by specifying LDEVs and WWNs or iSCSI names of HBAs

To control the I/O priority for volumes in a storage system on the server, you can configure Server Priority Manager by specifying an LDEV and a WWN or iSCSI name of a host bus adapter.

For the combination of a volume (LDEV) and a host (WWN or iSCSI name), specify the I/O priority (prioritized or non-prioritized). When the priority is non-prioritized, set the upper limit value to control the server performance. Set the prioritized priority to the host with higher priority, and the non-prioritized priority to the host with lower priority. By adjusting the upper limit value to an appropriate value, you can maintain the number of accesses and the amount of data to be transferred from a prioritized host to a storage system at a higher level.

Requirements for using Server Priority Manager by specifying the LDEV, the WWN or iSCSI name of the host bus adapter

Item	Range
Number of LDEVs that can be registered for each storage system	1 to 16,384 ¹
Number of WWNs that can be registered for each storage system	1 to 2,048 ²
Number of iSCSI names that can be registered for each storage system	1 to 2,048 ²
Number of WWNs that can be registered for each LDEV	1 to 32 ³
Number of iSCSI names that can be registered for each LDEV	1 to 32 ³
<p>Notes:</p> <ol style="list-style-type: none"> 1. When the maximum number of LDEVs for a storage system is less than 16,384, the maximum number of LDEVs that can be registered is the maximum number of total LDEVs for a storage system. 2. The sum of the number of WWNs and the number of iSCSI names. This sum should be a maximum of 2,048 for each storage system. 3. The sum of the number of WWNs and the number of iSCSI names. This sum should be a maximum of 32 for each LDEV. 	



Note:

- When there are 4,096 or more LDEVs with SPM configured, if you configure SPM in another LDEV, host I/O response in the LDEV is slower than the existing LDEVs with SPM configured. To improve the host I/O response, delete the SPM information in the new LDEV with SPM configured, then delete the existing SPM information to decrease the number of LDEVs with SPM configured to 4,095 or fewer, and then configure SPM in the new LDEV again.

Priority to be set by specifying a port and a WWN or iSCSI name of an HBA, and control of server performance

Priority	Server performance
Non-prioritized	<p>Controls server performance based on the upper limit. The upper limit is set for each non-prioritized WWN or non-prioritized iSCSI name.</p> <p>The upper limit suppresses the number of accesses from a host bus adapter to an LDEV, or the amount of data to be transferred.</p> <p>Monitoring information can be displayed according to the combination of an LDEV and a WWN or iSCSI name of a host bus adapter.</p>
Prioritized	<p>Does not control server performance of a prioritized WWN or prioritized iSCSI name.</p> <p>Monitoring information can be displayed according to the combination of an LDEV and a WWN or iSCSI name of a host bus adapter.</p>



Note: Unlike the case of configuring Server Priority Manager by specifying a port and a WWN of a host bus adapter, the function for enabling or disabling control of the upper limit automatically according to the traffic amount is not supported.

Server Priority Manager operations when an LDEV and a WWN or iSCSI name of an HBA is specified

Step	Operation overview	Description	Executed command
1	Setting SPM information for an LDEV and a WWN or iSCSI name	Specify the LDEV number, and the WWN or iSCSI name of the host bus adapter to set the priority (prioritized or non-prioritized) as the SPM target. To set the non-prioritized option, set the upper limit as well. Normally, set the prioritized option in step 1, and check the monitoring information in step 3. And then, if necessary, change the priority to non-priority in step 4, and set the upper limit.	<pre>raidcom modify spm_ldev - ldev_id <ldev#> {-hba_wwn <wwn strings> - hba_iscsi_name <initiator iscsi name>} [- spm_priority <y/n>] [{- limit_io -limit_kb - limit_mb} <value>]</pre>
2	Checking SPM information	Display the setting status of SPM.	<pre>raidcom get spm_ldev [- ldev_id <ldev#> - hba_wwn <wwn strings> - hba_iscsi_name <initiator iscsi name>]</pre>
3	Displaying monitoring information of the prioritized or non-prioritized WWN	Display monitoring information.	<pre>raidcom monitor spm_ldev - ldev_id <ldev#> {-hba_wwn <wwn strings> - hba_iscsi_name <initiator iscsi name>}</pre>
4	Changing the upper limit of the prioritized and non-prioritized WWNs	If necessary, determine the priority and the upper limit based on the monitoring information, and then change the priority. When the non-prioritized option is set, set the upper limit as well.	<pre>raidcom modify spm_ldev - ldev_id <ldev#> {- hba_wwn <wwn strings> - hba_iscsi_name <initiator iscsi name>} [- spm_priority <y/n>] [{- limit_io -limit_kb - limit_mb} <value>]</pre>

Step	Operation overview	Description	Executed command
5	Deleting from the SPM target	Specify the LDEV number and the WWN or iSCSI name of the host bus adapter to delete them from the SPM target.	<code>raidcom delete spm_ldev -ldev_id <ldev#> {-hba_wwn <wwn strings> -hba_iscsi_name <initiator iscsi name>}</code>

Virtual storage machine operations

- [Creating host groups in a virtual storage machine \(on page 255\)](#)
- [Adding LDEVs to a virtual storage machine \(on page 256\)](#)
- [Removing the virtual storage machine \(on page 256\)](#)

Creating host groups in a virtual storage machine

Use the following provisioning operations to create host groups in a virtual storage machine and to assign virtualized LDEV to LU.

Step	Operation overview	Description	Executed command
1	Reserving host group IDs	Reserve ports and host group IDs to the resource groups in the virtual storage machine. Be sure to execute the command before creating host groups.	<code>raidcom add resource -resource_name <resource group name> -port <port#> -<HG#></code>
2	Creating host groups	Create host groups by specifying the reserved port and host group ID to the resource group.	<code>raidcom add host_grp -port <port#> -<HG#> -host_grp_name <host group name></code>
3	Specifying the host mode and host mode options	Specify the host mode to the created host group. Also, specify the host mode options if necessary.	<code>raidcom modify host_grp -port <port#> [<host group name>] - host_mode < host mode> [- host_mode_opt <host mode option> ...]</code>

Step	Operation overview	Description	Executed command
4	Adding hosts to the host group	Register hosts to the host group.	<pre>raidcom add hba_wwn -port <port#> [<host group name>] -hba_wwn <WWN strings></pre>

Adding LDEVs to a virtual storage machine

Use the following provisioning operations to add LDEVs to a virtual storage machine and to use LDEVs from hosts.

Step	Operation overview	Description	Executed command
1	Delete the virtual LDEV ID set by default	Specify an LDEV ID to delete the virtual LDEV ID set by default. By default, the virtual LDEV ID is the same as the real LDEV ID.	<pre>raidcom unmap resource -ldev_id <ldev#> -virtual_ldev_id <ldev#></pre>
2	Add the LDEV to the resource group	Add the LDEV of which the virtual LDEV ID was deleted to the resource group in the virtual storage machine.	<pre>raidcom add resource -resource_name <resource group name> -ldev_id <ldev#></pre>
3	Virtualize LDEVs	Set a virtual LDEV ID to the specified LDEV. Also, specify the product ID and SSID if necessary.	<pre>raidcom map resource -ldev_id <ldev#> -virtual_ldev_id <ldev#> [-ssid<ssid> -emulation <emulation type>]</pre>
4	Create LU path	To create LU path, assign LDEVs to the host group that belongs to the resource group in the virtual storage machine.	<pre>raidcom add lun -port <port#> [<host group name>] -ldev_id <ldev#> [-lun_id<lun#>]</pre>

Removing the virtual storage machine

Use the following provisioning operations to remove resources from the virtual storage machine and to remove the virtual storage machine.

Step	Operation overview	Description	Executed command
1	Remove the LU path	Remove the LU path from the LDEV in the virtual storage machine.	<code>raidcom delete lun -port <port#> [<host group name>] {-lun_id <lun#> -ldev_id <ldev#> -grp_opt <group option> -device_grp_name <device group name> [<device name>]}</code>
2	Remove the virtual LDEV ID	Remove the virtual LDEV ID from the LDEV in the virtual storage machine.	<code>raidcom unmap resource -ldev_id <ldev#> -virtual_ldev_id <ldev#></code>
3	Remove the LDEV from the resource group	Remove the LDEV from the resource group in the virtual storage machine	<code>raidcom delete resource -resource_name <resource group name> -ldev_id <ldev#></code>
4	Invalidate the LDEV virtualization	Specify the virtual LDEV ID that is the same as the real LDEV ID in order to invalidate the LDEV virtualization.	<code>raidcom map resource -ldev_id <ldev#> -virtual_ldev_id <ldev#></code>
5	Delete the host group	Delete the host group in the virtual storage machine.	<code>raidcom delete host_grp -port <port#> [<host group name>]</code>
6	Remove the host group ID from the resource group	Remove the host group ID that belongs to the resource group in the virtual storage machine	<code>raidcom delete resource -resource_name <resource group name> -port <port#> -<HG#></code>
7	Remove the resource from the resource group	Remove the resource from the resource group in the virtual storage machine.	<code>raidcom delete resource -resource_name <resource group name> [-ldev_id <ldev#> -port <port#> [<host group name>] -parity_grp <gno-sgno> -external_grp_id <gno-sgno> -grp_opt <group option> -device_grp_name</code>

Step	Operation overview	Description	Executed command
			<pre><device group name> [<device name>]]</pre>
8	Remove the virtual storage machine	Delete all resource groups in the virtual storage machine in order to remove the virtual storage machine.	<pre>raidcom delete resource -resource_name <resource group name></pre>

Chapter 6: Data replication operations with CCI

This chapter describes data replication operations with CCI.

About data replication operations

The data replication features of the RAID storage systems include:

- Local replication:
 - ShadowImage
 - ShadowImage for Mainframe
 - Thin Image
 - Copy-on-Write Snapshot
- Remote replication:
 - TrueCopy
 - TrueCopy for Mainframe
 - TrueCopy Async
 - Universal Replicator
 - Universal Replicator for Mainframe
 - global-active device
- Mainframe replication:
 - Compatible XRC
 - Compatible FlashCopy® V2
 - Business Continuity Manager

For detailed information about any of these features, see the applicable user guide (for example, *Hitachi ShadowImage® User Guide*).

Features of paired volumes

Paired logical volumes are often handled independently by servers. When CCI is used, the paired volumes can be managed by the replication functions (for example, ShadowImage, TrueCopy, Universal Replicator, global-active device) as combined or separated pairs. The replication functions regard the two volumes being combined or separated as a uniquely paired logical volume used by the servers. Paired volumes can also be handled as groups, grouping them by units of server software or units of databases and their attributes.

For detailed information about volume pairs (for example, maximum number of pairs per storage system, maximum P-VOL size), see the user guide for your storage system and copy function (for example, *Hitachi ShadowImage® User Guide*).

See the following figure depicting the concept of paired volume.

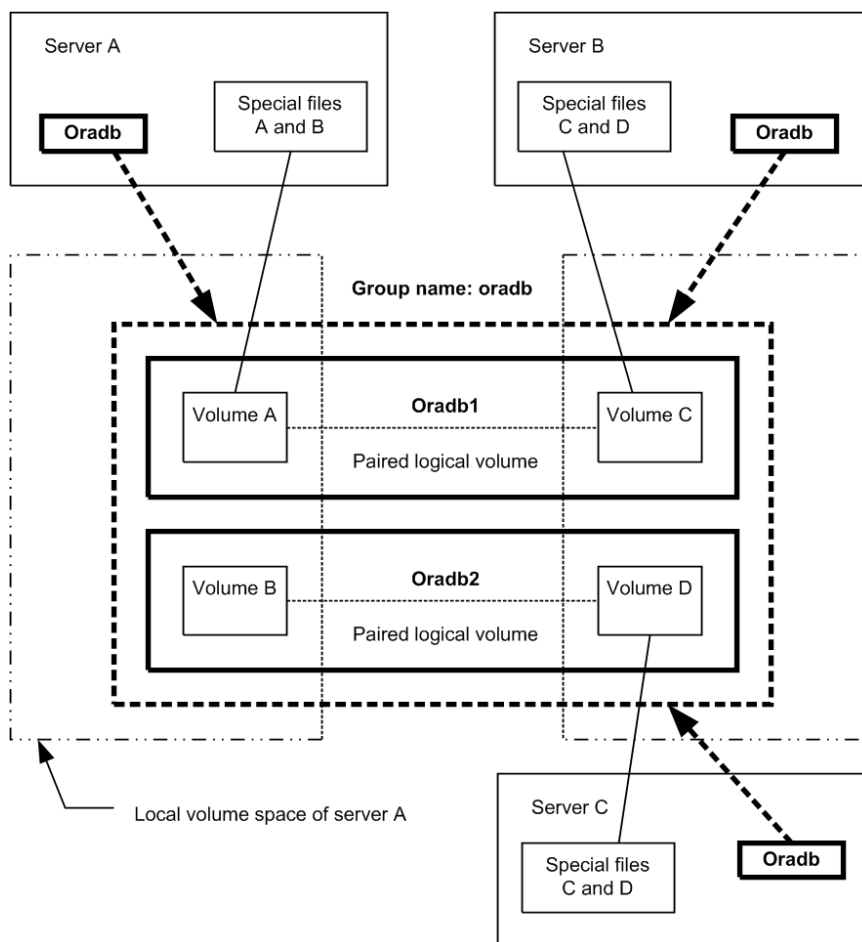

Addressing paired logical volumes: The correspondence of paired logical volumes to their physical volumes is defined by describing the paired logical volume names and group names in the configuration definition files of each server. It is possible to define a server for the paired logical volumes in units of group name. Each paired logical volume must belong to a group in order to determine the corresponding server.

Specification of volumes by commands: Volume names to be used by the CCI commands must be referenced via the paired logical volume names or the group names.

Using CCI with ShadowImage and TrueCopy

CCI allows you to perform ShadowImage and TrueCopy operations by issuing ShadowImage and TrueCopy commands from the UNIX/PC server host to the RAID storage system. ShadowImage and TrueCopy operations are nondisruptive and allow the primary volume of each volume pair to remain online to all hosts for both read and write operations. Once established, ShadowImage and TrueCopy operations continue unattended to provide continuous data backup.

There are specific requirements for using ShadowImage and TrueCopy in high-availability (HA) configurations. UNIX/PC servers in HA configurations normally support disk duplication functions to enhance disk reliability (for example, mirroring provided by the LVM or device driver, RAID5 or an equivalent function provided by the LVM). UNIX/PC servers also feature hot standby and mutual hot standby functions in case of failures on the server side. However, mutual hot standby for disaster recovery has not yet been achieved since it requires the remote mirroring function.

ShadowImage provides the mirroring function within the storage system. For detailed information about ShadowImage operations, please see the *Hitachi ShadowImage® User Guide* for your storage system.

TrueCopy provides remote mirroring functionality, linkage functionality with failover switching, and remote backup operations among servers, all of which are required by UNIX/PC servers in HA configurations for disaster recovery. For detailed information about TrueCopy operations, please see the *Hitachi TrueCopy® User Guide* for your storage system.

Using CCI with Thin Image

CCI allows you to perform Hitachi Thin Image operations by issuing `raidcom` commands (for example, `raidcom add snapshot`) to the RAID storage system. Hitachi Thin Image stores snapshots in storage system. Creating a Thin Image pair changes the status to "PAIR" and stores snapshot data as a copy of the data on the Thin Image P-VOL. A Thin Image pair consists of a P-VOL, one or more S-VOLs that are virtual volumes (V-VOLs), and one or more pool-VOLs that are LDEVs. P-VOL differential data is stored as snapshot data in the pool-VOLs. If your storage system experiences a data storage failure, you can restore the data using the snapshot data in the pool. Splitting a Thin Image pair saves a snapshot and stops the copying of replaced data in the pool.

Consistency groups and snapshot groups are groups of pairs for which you can simultaneously perform pair tasks on all pairs within the group. You can use CCI `raidcom` commands to create consistency groups and snapshot groups and to split pairs to store the snapshot data for the groups.

- A consistency group can include HTI, SI, and Slz pairs. Splitting the pairs using the group assures data consistency at the time the storage system receives the request.
- A snapshot group is a group of only Thin Image pairs. Use consistency or snapshot groups to perform Thin Image tasks on all of the pairs within the group. You define Thin Image pairs to a snapshot group when you create the pairs.

 **Note:** When you use the CCI to define multiple Thin Image pairs in a consistency group, you can only specify one consistency group for a group defined in the CCI configuration definition file.

The configuration definition file for CCI is a group that is not a consistency group.

Creating a new pair and defining the pairs in a consistency group for a group you defined using the CCI configuration definition file and the pair is already defined in a consistency group defines the pair in the same consistency group, even if you try to create a new pair and assign it to a different consistency group.

For details about Hitachi Thin Image, see the *Hitachi Thin Image User Guide* for your storage system.

Using CCI with global-active device

The CCI software is installed on the host servers and used for global-active device operations. The CCI command devices and CCI configuration definition files are required for global-active device operations. You can execute CCI commands for global-active device using the in-band or out-of-band method of CCI command execution.

For details about global-active device, see the *Global-Active Device User Guide*. For details about the CCI command options and display results for global-active device operations (for example, PHY_LDEV, VIR_LDEV), see the *Command Control Interface Command Reference*.

 **Note:** If you set the S-VOL Disable attribute of Data Retention Utility to a GAD secondary volume, GAD pair operations from CCI are restricted. Release the S-VOL Disable attribute of the GAD secondary volume, and then perform the GAD pair operations.

ShadowImage operations

The ShadowImage commands also support the functionality that links the system operation for the purpose of volume backup among UNIX servers managed by the operating system. For detailed information about the operational requirements and specifications for ShadowImage, see the *Hitachi ShadowImage® User Guide* for your storage system.

Following is a list of sample ShadowImage functions that can be executed using CCI commands:

- **Pair creation:** Creates a new volume pair. Volume pairs can be created in units of volumes or groups.
- **Pair splitting:** Splits a volume pair and allows read and write access to the secondary volume.

- **Pair resynchronization:** Resynchronizes a split volume pair based on the primary volume. The primary volume remains accessible during resynchronization.
- **Pair resynchronization with restore option:** Resynchronizes a split pair based on the secondary volume (reverse resync). The primary volume is not accessible during resync with restore option.
- **Event waiting:** Used for waiting for the completion of a volume pair creation or resynchronization to check the pair status.
- **Pair status display and configuration confirmation:** Displays the pair status and configuration of the volume pairs; this can also be used for checking the completion of a pair creation or pair resynchronization. The figure given below illustrates a ShadowImage system configuration.

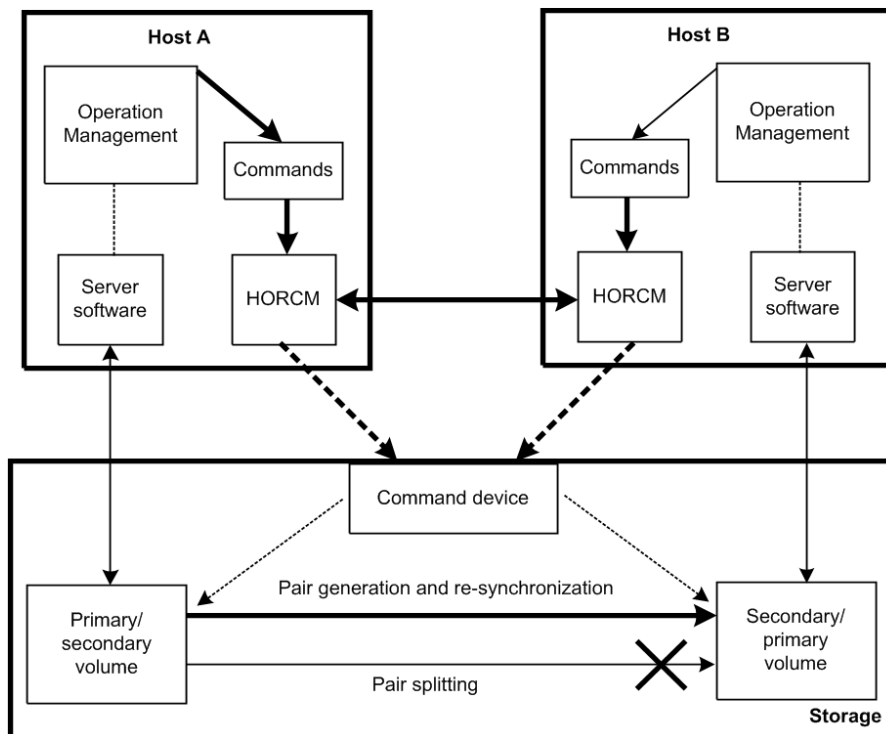

ShadowImage duplicated mirroring

Duplicated mirroring of a single primary volume is possible when the ShadowImage feature is used. Duplicated mirror volumes can be specified up to the maximum quantity 3. The duplicated mirror volumes of the P-VOL are expressed as virtual volumes using the mirror descriptors (MU#0-2) in the configuration diagram as shown below.

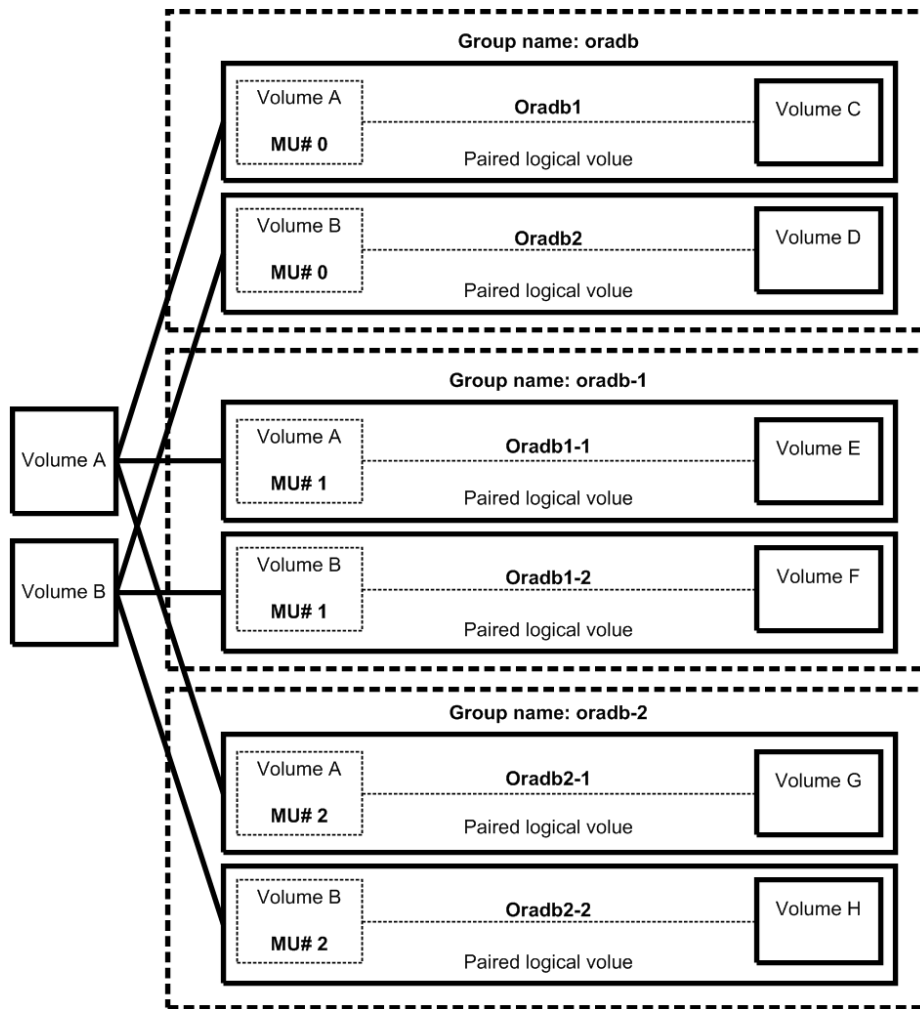

ShadowImage cascading pairs

ShadowImage provides a cascading function for the ShadowImage S-VOL. Cascading mirror volumes can be specified up to the maximum quantity 2. The cascading mirrors of the S-VOL are expressed as virtual volumes using the mirror descriptors (MU#1-2) in the configuration diagram as shown below. The MU#0 of a mirror descriptor is used for connection of the S-VOL.

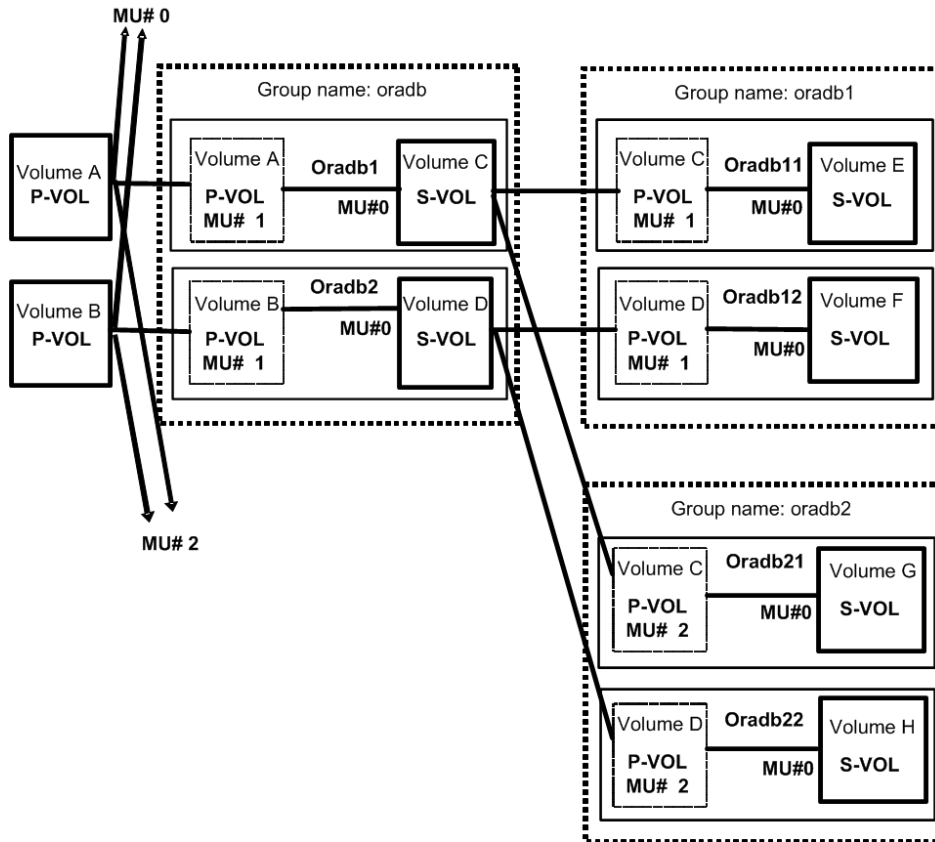

Restrictions for ShadowImage cascading volumes

Pair Creation:

Pair creation of S-VOL (oradb1) can only be performed after the pair creation of S/P-VOL (oradb). If you create the oradb1 pair first without creating the oradb, the subsequent oradb creation will be rejected with EX_CMDRJE or EX_CMDIOE.

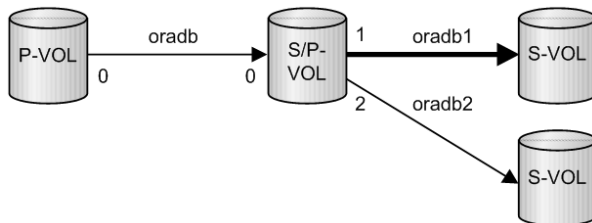

Pair splitting:

Pair splitting of S-VOL (oradb1) can only be performed after the S/P-VOL (oradb) is in a SMPL or PSUS state, since ShadowImage copies are asynchronous. If pair splitting of the S-VOL (oradb1) is attempted while the S/P-VOL (oradb) is in a COPY or PAIR state, the `pairsplit` command is rejected with EX_CMDRJE or EX_CMDIOE.

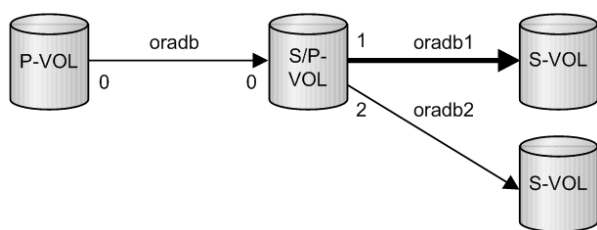

Pair restore:

Pair restore (resync from S-VOL (oradb1) to S/P-VOL) can only be performed when the S-VOL (oradb) and the P-VOL (oradb2) on the S/P-VOL are in the SMPL and PSUS states. If the pair restore of S-VOL (oradb1) is performed while either the S-VOL (oradb) or P-VOL (oradb2) on the S/P-VOL are in a COPY, PAIR or PSUS state, the `pairresync -restore` command is rejected with EX_CMDRJE or EX_CMDIOE.

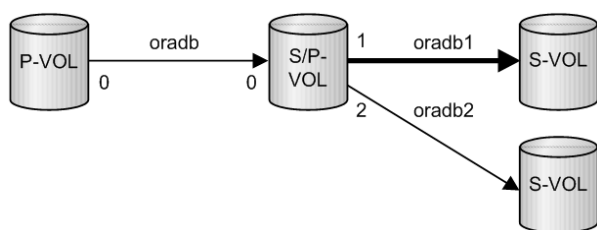

Restriction for TrueCopy/ShadowImage cascading volumes

Pair restore (resynchronization from S-VOL (oradb1) to S/P-VOL) can only be performed when the TrueCopy S-VOL (oradb) and the P-VOL (oradb2) on the S/P-VOL are in the SMPL or PSUS(SSUS) state. If pairresync of S-VOL (oradb1) is performed when the S/P-VOL (oradb or oradb2) is in any other state, the `pairresync -restore` option command is rejected with EX_CMDRJE or EX_CMDIOE.

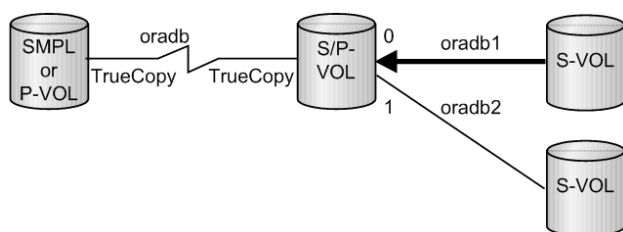

TrueCopy operations

CCI TrueCopy commands operate in conjunction with the software on the UNIX/PC servers and the TrueCopy functions of the RAID storage systems. The CCI software provides failover and other functions such as backup commands to allow mutual hot standby in cooperation with the failover product on the UNIX/PC server (for example, MC/ServiceGuard, FirstWatch, HACMP).

Note: For proper maintenance of TrueCopy operations, it is important to determine if there are any faults in paired volumes, recover the volumes from the failures as soon as possible, and continue operation in the original system.

Note: For information about the operational requirements and specifications for TrueCopy, please see the *Hitachi TrueCopy® User Guide* for your storage system.

TrueCopy takeover commands

The figure given below illustrates a high-availability (HA) environment. When a server software error or a node error is detected, the HA failover software causes the cluster manager (CM) to monitor server programs and causes the CM of the standby node to automatically activate the HA control script of the corresponding server program. The HA control script usually contains database recovery procedures, server program activation procedures, and other related recovery procedures. The TrueCopyCCI takeover commands are also activated by the HA control script.

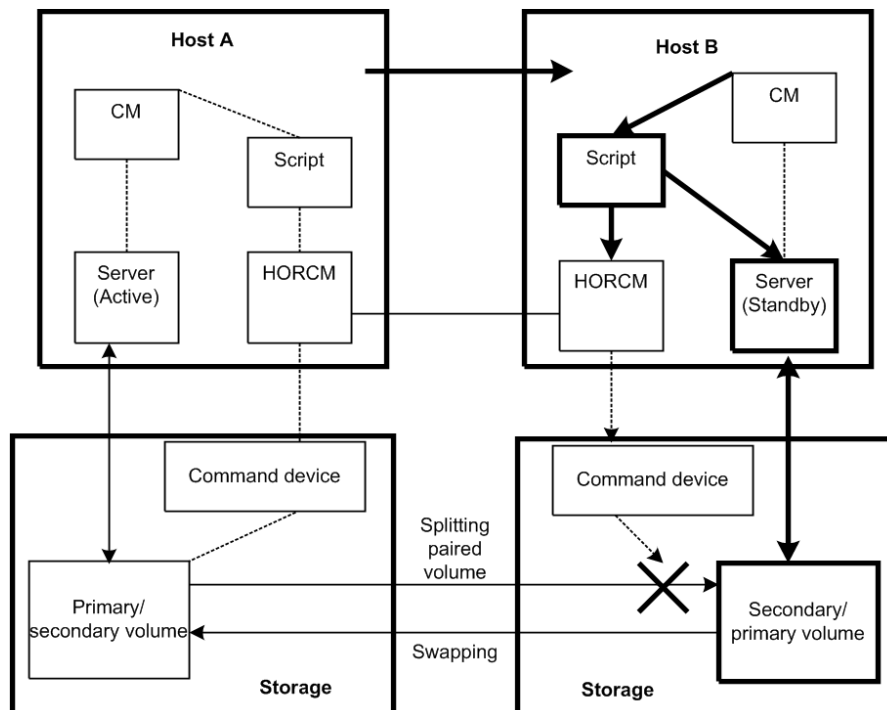

Legend

- CM (Cluster Manager): Demon process that keeps the consistency of the cluster by monitoring the node and server program in the cluster.
- Script: Shell script that automatically performs takeover process when CM detects the server failure.

In an HA environment, a package is a group of applications that are scripted to run on the secondary host in the event of a primary host failure. When using the HA software (for example, MC/ServiceGuard), the package can be transferred to the standby node as an operation executed by the system administrator (see the figure given below for package transfer on high availability (HA) software).

Note: If the operation is performed when CCI and TrueCopy are being used, the volume is switched from primary to secondary as if an error had occurred, even though data consistency is assured. When restoral of the original node occurs along with its original package (group of applications), it is necessary to copy the data on the secondary volume onto the primary volume; this operation can take as much time as the initial copy operation for the pair. In actual operation, no package can be transferred when TrueCopy is being used. The secondary package is switched to the primary package, and vice versa, when the primary volume is switched to the secondary volume. Therefore, the primary and secondary TrueCopy volumes should be switched depending on the package state.

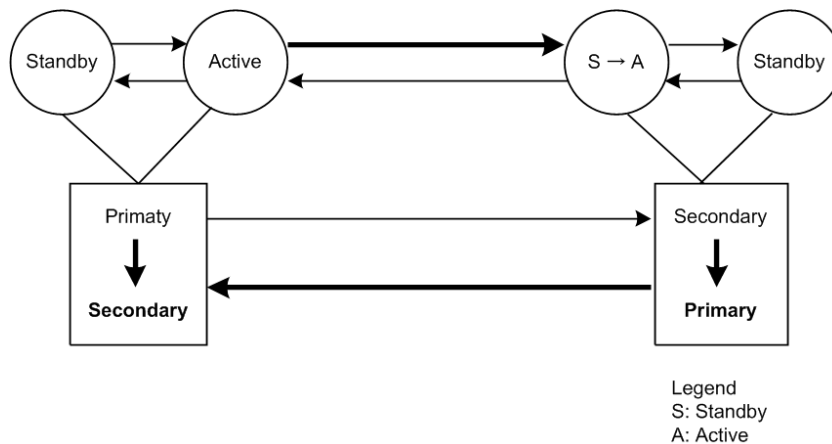

The swap option of the takeover command allows swapping of the primary and secondary volume designations, so if the primary and secondary volume are switched due to a server error or package transfer, pair operation can be continued using the reversed volumes. When control is handed back over to the original node, swapping the volume designations again eliminates the need of copying them. In addition, the takeover command has the option to allow the secondary volume to be logically separated (for the purpose of recovery from a disaster at the original operating site). The takeover command has four functions designed for HA software operation: Takeoverswitch, swap-takeover, SVOL-takeover, and PVOL-takeover. This command is not available for ShadowImage.

Takeover-switch function

The control scripts activated by HA software are used by all nodes of a cluster in exactly the same manner so they have no discrimination between primary and secondary pair volumes (they just know the near and far disk in a pair). Thus, the takeover command, when activated by a control script, must check the combination of attributes of volumes possessed by the local and remote nodes and determine the proper takeover action. The table below shows the takeover actions, like Near/Local and Far/Remote Volume Attributes and Takeover ActionsNear/Local and Far/Remote Volume Attributes and Takeover Actions.

Local node (Takeover node)		Remote node		Takeover action
Volume attribute	Fence and status	Volume attribute	P-VOL status	
SMPL	-	SMPL	-	Reject
		P-VOL	-	Nop-takeover ¹
		S-VOL	-	Unconformable
		Unknown	-	Reject
P-VOL (primary)	Fence == Data or Status && pair status == PSUE or PDUB or MINAP == 0	SMPL	-	Reject
		P-VOL	-	Unconformable
		S-VOL	-	PVOL-Takeover ²
		Unknown	-	PVOL-Takeover ²
	Others	SMPL	-	Reject
		P-VOL	-	Unconformable
		S-VOL	-	Nop-takeover ¹
		Unknown	-	Nop-takeover ¹
S-VOL (secondary)	Status == SSWS (After SVOL_SSUStakeover)	-	-	Nop-takeover ¹
		Other than SSWS	SMPL	-
	Other than SSWS	P-VOL	PAIR or PFUL	Swap-takeover ²
			Others	SVOL-takeover ²
	Other than SSWS	S-VOL	-	Unconformable
		Unknown	-	SVOL-takeover ²
Notes:				

Local node (Takeover node)		Remote node		Takeover action
Volume attribute	Fence and status	Volume attribute	P-VOL status	
<ol style="list-style-type: none"> 1. No action needed to allow local writes. 2. Required to allow local writes. 				

Nop-takeover

No operation is done to allow local writes, though the takeover command is accepted. Personality swaps must be accomplished in another way.

Unconformable

A pair of volumes are not conformable to each other as a pair (that is, one P-VOL, one S-VOL). The takeover command execution terminates abnormally.

Reject

The takeover command is rejected, and the operation terminates abnormally.

Unknown

The attribute of the remote node is unknown and cannot be identified. This means that the remote node system has gone down or cannot communicate over the LAN.

SSWS

Since the SSWS state is referring to a Suspend for Swapping with S-VOL Side only, the SSWS state is displayed as SSUS (SVOL_PSUS) by all commands except the `-fc` option of the `pairdisplay` command.

Swap-takeover function

The P-VOL status at the remote node is PAIR or PFUL (TrueCopy Async and over high-water mark) and the S-VOL has mirroring consistency. In such a state, it is possible to swap the primary and secondary volume designations to continue operation. The takeover command internally executes the operating commands (explained later) step by step, to swap the primary and secondary volume designations. Swapping can be specified at the granularity of volume pair, consistency group, or volume group.

The swap-takeover function does not use Simplex and No Copy mode for Swapping in order to guarantee mirror consistence more surely, and it is included as a function of SVOL-takeover.

1. As the preliminary step of swap-takeover, the command orders a Suspend for Swapping (SSWS) for the local volume (S-VOL). If this step fails, the swap-takeover function is disabled and it will be returned at an error.

2. The command orders a Resync for Swapping for switch to the primary volume that the local volume (S-VOL) is swapped as the NEW_PVOL and re-synchronizes the NEW_SVOL based on the NEW_PVOL. As for the number of simultaneous copy tracks, if the remote host is known then the command will use the value of P-VOL specified at paircreate time, else (remote host is Unknown) the command will use a default of 3 as the number of tracks for Resync for Swapping.

If this step fails, the swap-takeover function will be returned at SVOL-SSUS-takeover, and the local volume (S-VOL) is maintained in SSUS(PSUS) state which permits WRITE and maintaining delta data (BITMAP) for the secondary volume. Also this special state is displayed as SWS state using -fc option of pairedisplay command.

TrueCopy Async/Universal Replicator specific behavior for swap-takeover:

The S-VOL side CCI will issue a Suspend for Swapping to the S-VOL side storage system. Non-transmitted data which remains in the FIFO queue (sidefile) of the primary volume will be copied to the S-VOL side and a Resync for Swapping operation will be performed (after the copy process). The Swap operation is required to copy Nontransmitted P-VOL data within a given timeout value (specified by the -t <timeout> option).

SVOL-takeover function

The function makes it so the takeover node alone can use the secondary volume (except in COPY state) in SSUS(PSUS) state (i.e., reading and writing are enabled), on the assumption that the remote node (possessing the primary volume) cannot be used.

The data consistency of the secondary volume is judged by its status and fence level. If this check proves that data is not consistent, the SVOL-takeover function fails. If this check proves that data is consistent then this function will try to switch the S-VOL to a primary volume using a Resync for Swapping, and if it succeeds then this function will return Swap-takeover, else this function will return SVOL-SSUS-takeover as the return value of horctakeover command. In case of a Host failure, this function will be returned as Swap-takeover. In case of a FICON or P-VOL site failure, this function will be returned as SVOL-SSUS-takeover. A SVOL-takeover can be specified by the granularity of a paired logical volume, consistency group, or volume group. If a SVOL-takeover is specified for a volume group, a data consistency check is executed for all volumes in the group. Inconsistent volumes are picked out and displayed in the execution log file as shown below:

Example

```
Group Pair vol Port targ# lun# LDEV#...Volstat Status Fence To be...
oradb1 ora001 CL1-A 1 5 145...S-VOL PAIR NEVER Analyzed
oradb1 ora002 CL1-A 1 6 146...S-VOL PSUS STATUS Suspected
```

Even so, the SVOL-takeover function enables the secondary volume to be used (i.e., reading and writing are enabled) since it assumes that the remote node (possessing the primary volume) cannot be used.

TrueCopy Async/Universal Replicator specific behavior for SVOL-takeover:

The S-VOL side CCI will issue a Suspend for Swapping to the S-VOL side storage system. Non-transmitted P-VOL data will be copied to the S-VOL and a Resync for Swapping operation will be performed (after the copy process).

In case of a Host failure, this data synchronize operation will be accomplished and the SVOL-takeover function will return as Swaptakeover after attempting a Resync for Swapping.

In case of a FICON or P-VOL site failure, this data synchronization operation might fail. Even so, the SVOL-takeover function will do Suspend for Swapping, and enable the secondary volume to be used.

As a result, this function will return as SVOL-SSUS-takeover. Through this behavior, you will be able to judge that non-transmitted data of the primary volume was not transmitted completely when a SVOL-takeover returns SVOL-SSUS-takeover.



Caution: The SVOL-takeover operation is required to copy Nontransmitted P-VOL data within a given timeout value (specified by the `-t <timeout>` option).

If the timeout occurs (before the SVOL-takeover operation has completed all S-VOL changes to a SSWS state), the horctakeover command will fail with EX_EWSTOT. If the horctakeover has failed due to a timeout then you need to try for a recovery as shown below.

- Wait until the S-VOL state becomes SSWS' via `pairdisplay -g <group> -l -fc` command, and try to the start-up again for the HA Control Script.
- Make an attempt to re-synchronize the original P-VOL based on the S-VOL using `pairresync -g <group> -swaps -c <size>` for a Fast Failback operation.

If this operation fails with [EX_CMDRJE] or [EX_CMDIOE], this is due to a FICON link down or site failure. After a recovery from the failure, perform the operation again.

Therefore this timeout value should be a greater than (or equal) to the start-up timeout value for the MC & CC Control Script.

PVOL-takeover function

A PVOL-takeover relinquishes the pair state for a volume or group in order to make the P-VOL writable following some type of error (for example, link down with DATA fence). This function makes it so the takeover node alone can use the primary volume (that is, reading and writing are enabled), on the assumption that the remote node (possessing the secondary volume) cannot be used.

The PVOL-takeover function has two functions: PVOL-PSUE-takeover, and PVOL-SMPL-takeover. A PVOL-PSUE-takeover forces the primary volume to suspend (PSUE, PSUS) state which permits WRITES to all primary volumes of the group (even if the fence level is data). Therefore PSUE and/or PSUS are intermingled in the volume group through the action of this PVOL-PSUE-takeover. This intermingled pair status creates PSUE as the group status, therefore the `pairvolchk` command results give precedence to PSUE (PDUB) status over PSUS for the group.

This special state returns back to its original state by issuing the pairresync command. A PVOL-SMPL-takeover forces the primary volume to simplex (SMPL) state so the pair is destroyed. At first, PVOL-takeover executes PVOL-PSUE-takeover. If PVOL-PSUE-takeover fails, it then executes PVOL-SMPL-takeover. PVOL-takeover can be specified per paired logical volume or per volume group.

TrueCopy Async/Universal Replicator specific behavior for PVOL-takeover:

PVOL-takeover will not be executed. It will become a Nop-Takeover, since the fence level will be Async which is equal to Never so it is not needed to allow P-VOL writes.

TrueCopy remote commands

The CCI TrueCopy remote commands assist the system operation with volume backups among UNIX servers and their operating system management functions. The TrueCopy remote pair commands are also used to copy volumes in server failover configurations and to restore the volumes to their original state after a server failover has been recovered.

- **Pair creation command:** Creates a new volume pair. Volume pairs can be created in units of volume or group.
- **Pair splitting command:** Splits a volume pair and allows read and write access to the secondary volume.
- **Pair resynchronization command:** Resynchronizes a split volume pair based on the primary volume. The primary volume remains accessible during resynchronization.
 - Swaps(p) option (TrueCopy only). Swaps volume from the S-VOL(P-VOL) to the P-VOL(S-VOL) when the S-VOL(P-VOL) is in the suspended state and resynchronizes the NEW_SVOL based on the NEW_PVOL. At the result of this operation, the volume attributes of the host of reference (local host) are used as the attributes for the NEW_PVOL(SVOL).
- **Event waiting command:** Used to wait for the completion of volume pair creation or resynchronization and to check the pair status.
- **Pair status display and configuration confirmation command:** Displays the pair status and configuration of the volume pairs and is used for checking the completion of pair creation or pair resynchronization.

The following figure illustrates a TrueCopy remote system configuration.

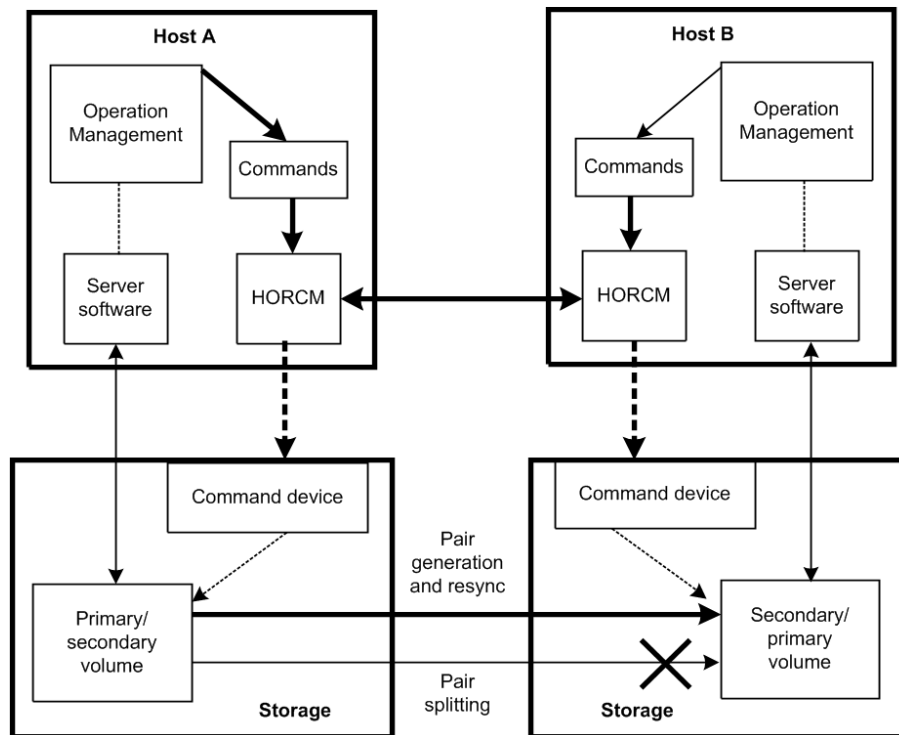

Legend

- HORCM: The manager is a demon process, executes multiple commands, charges to a storage system through itself. Among the managers are connected by UDP, remotely execute a command among the servers mutually.
- Command: A command provisioned by CCI.

TrueCopy local commands

The CCI TrueCopy local commands assist the system operation with volume backups among UNIX servers and their operating system management functions. The TrueCopy local commands perform the same functions as the remote commands but within the same RAID storage system instead of between two RAID storage systems.

The following figure illustrates a TrueCopy local system configuration.

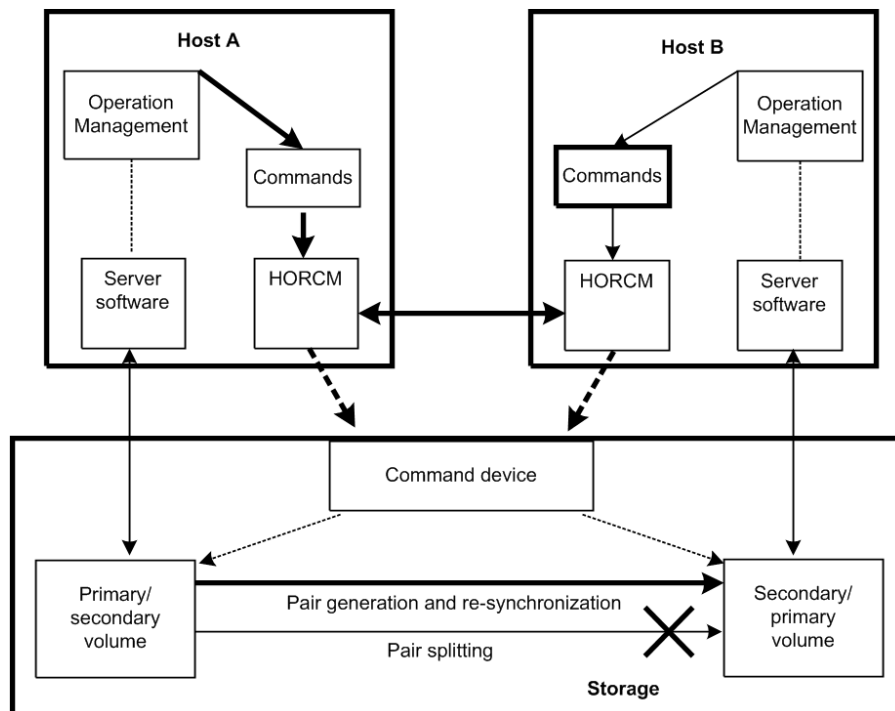

TrueCopy, ShadowImage, and Universal Replicator operations

TrueCopy/ShadowImage volumes

TrueCopy commands allow you to create volume pairs consisting of one primary volume (P-VOL) and one secondary volume (S-VOL). The TrueCopy P-VOL and S-VOL can be in different storage systems. TrueCopy provides synchronous and asynchronous copy modes. TrueCopy Async can only be used between separate storage systems (not within one storage system). For details on TrueCopy specifications, volumes and operations, please see the *Hitachi TrueCopy® User Guide* for your storage system.

ShadowImage commands allow you to create volume pairs consisting of one P-VOL and up to nine S-VOLs using the ShadowImage cascade function. ShadowImage pairs are contained within the same storage system and are maintained using asynchronous update copy operations. For details on ShadowImage specifications volumes and operations, please see the *Hitachi ShadowImage® User Guide* for your storage system.

Each volume pair that you want to create must be registered in the CCI configuration file. ShadowImage volume pairs must include a MU (mirrored unit) number assigned to the S-VOL. The MU number indicates that the pair is a ShadowImage pair and not a TrueCopy pair. Once the correspondence between the paired logical volumes has been defined in the HORCM_DEV section of the configuration file, you can use the configuration file to group the paired volumes into volume groups that can be managed by the host operating system's LVM (logical volume manager).

The host's LVM allows you to manage the TrueCopy/ShadowImage volumes as individual volumes or by volume group. TrueCopy/ShadowImage commands can specify individual logical volumes or group names. For LUSE volumes, you must enter commands for each volume (LDEV) within the expanded LU. If you define volume groups and you want to issue commands to those volume groups, you must register the volume groups in the configuration file. For further information about the server LVM, see the user documentation for your corresponding operating system.

TrueCopy/ShadowImage/Universal Replicator pair status

Each TrueCopy pair consists of one P-VOL and one S-VOL, and each ShadowImage pair consists of one P-VOL and up to nine S-VOLs when the cascade function is used. The P-VOL controls the pair status for the primary and secondary volumes. The major pair statuses are SMPL, PAIR, PSUS/PSUE, and COPY/RCPY. Read and write requests from the host are accepted or rejected depending on the pair status of the volume.

The pair status can change when a CCI command is executed. The validity of the specified operation is checked according to the status of the volume (primary volume).

See the tables below for the relationship between pair status and TrueCopy/Universal Replicator command acceptance, pair status and ShadowImage command acceptance and pair status and Copy-on-Write Snapshot command acceptance.

For details on pair status of TrueCopy for Mainframe, ShadowImage for Mainframe, and Universal Replicator for Mainframe, see Pair operations with mainframe volumes.

TrueCopy and ShadowImage pair status

Status	TrueCopy Pair Status	ShadowImage Pair Status	Primary	Secondary
SMPL	Unpaired volume	Unpaired volume	R/W enabled	R/W enabled
PAIR	Paired volume. Initial copy is complete. Updates are processed synchronously or asynchronously.	Paired volume. Initial copy is complete. Updates are processed asynchronously.	R/W enabled	R enabled
COPY	In paired state, but initial copy, pairsplit, or resync operation is not complete. Includes COPY(PD), COPY(SP), and COPY(RS) status.	In paired state, but initial copy, pairsplit, or resync operation is not complete. Includes COPY(PD), COPY(SP), and COPY(RS) status.	R/W enabled	R enabled
RCPY	Not used for TrueCopy	In paired state, but reverse resync operation is not complete. Includes COPY(RS-R) status.	R enabled	R enabled

Status	TrueCopy Pair Status	ShadowImage Pair Status	Primary	Secondary
PSUS (split) SSUS (split)	In paired state, but updates to the S-VOL data are suspended due to user-requested pairsplit. The RAID storage system keeps track of P-VOL and S-VOL updates while the pair is split.	In paired state, but updates to the S-VOL data are suspended due to user-requested pairsplit. The RAID storage system keeps track of P-VOL and S-VOL updates while the pair is split.	R/W enabled	R/W enabled when using write enable pairsplit option
PSUE (error) or PFUS	In paired state, but updates to the S-VOL data are suspended due to an error condition. (PSUE is PSUS due to internal error. PFUS is PSUS due to sidefile full.)	In paired state, but updates to the S-VOL volume data are suspended due to an error condition. When a PSUE pair is resynchronized, the RAID storage system copies the entire P-VOL to the S-VOL (same as initial copy).	R/W enabled if no error occurs in the primary volume	R enabled
PDU B	Used only for TrueCopy LUSE pairs. In paired state, but updates to one or more LDEVs within the LUSE pair are suspended due to an error condition.	Not used for ShadowImage	R/W enabled if no error occurs in the primary volume	R enabled

Universal Replicator pair status

Status	Universal Replicator Pair Status	Primary	Secondary
SMP L	Unpaired volume	R/W enabled	R/W enabled
PAIR	The pair is synchronized. Updates to the P-VOL are duplicated on the S-VOL.	R/W enabled	R enabled
COPY	In paired state, but initial copy, pairsplit, or resync operation is not complete. Includes COPY(PD), COPY(SP), and COPY(RS) status.	R/W enabled	R enabled

Stat us	Universal Replicator Pair Status	Primary	Secondary
PSUS (split) SSUS (split)	<p>The user has split the pair or released the pair; the pair is no longer synchronized.</p> <ul style="list-style-type: none"> ▪ The primary and secondary systems keep track of journal data discarded during the pairsplit operation. ▪ When the operation is performed at the primary system, the status of both the P-VOL and S-VOL changes to PSUS. ▪ When the operation is performed at the secondary system, the status of the S-VOL changes to PSUS; the primary system detects this (if path status is normal) and changes P-VOL status to PSUS. ▪ When a pair is released from the secondary system, the secondary system changes the status of the S-VOL to SMPL. The primary system detects this (if path status is normal) and changes P-VOL status to PSUS. (The pair must be released from the primary system to change P-VOL status to SMPL.) 	R/W enabled	R/W enabled when using write enable pairsplit option
PSUE	<p>The pair is suspended due to an error; the pair is not synchronized.</p> <ul style="list-style-type: none"> ▪ The primary and secondary systems keep track of any journal data that are discarded during the suspension operation. ▪ The primary system keeps track of P-VOL tracks that are updated while the pair is suspended. ▪ When a UR suspension condition is detected, the primary system changes P-VOL and S-VOL status to PSUE. If the secondary system detects the condition, it changes the S-VOL status to PSUE; the primary system detects this and changes P-VOL status to PSUS. 	R/W enabled if no error occurs in the primary volume	R enabled

Stat us	Universal Replicator Pair Status	Primary	Secondary
PFUS	<p>If the Data Overflow Watch period is exceeded, pair status changes from PFUL to PFUS, and the pair is suspended.</p> <ul style="list-style-type: none"> The PFUS status is displayed by CCI and Storage Navigator as PSUS. If a virtual volume of Dynamic Provisioning (DP-VOL) is used as a UR S-VOL, and the capacity of a pool-VOL is nearly full, UR status becomes PFUS and the pair is suspended. 	R/W enabled	Read Only, unless write option is enabled.
SSW S	<p>After Takeover, SSWS is the status of the S-VOL. With this status, data can be written to the S-VOL.</p> <ul style="list-style-type: none"> SSWS is displayed by CCI, from which the horctakover command is issued. Storage Navigator displays this status as PSUS or PSUE. 	R enabled	R/W enabled
PFUL	<p>If data in the journal volume exceeds 80%, pair status changes to PFUL. The write data that inflows then is monitored during the Data Overflow Watch.</p> <p>PFUL status is displayed by CCI. Storage Navigator displays this status as PAIR.</p>	R/W enabled	R enabled

Pair status versus TrueCopy/Universal Replicator commands

		TrueCopy/Universal Replicator command					
		paircreate		pairsplit			pairresyn c
#	Statu s	Copy	Nocopy	-r or -rw option	-P option	-S option	Resync
1	SMPL	Accepted 2	Accepted 3	Rejected	Rejected	Acceptabl e	Rejected
2	COPY	Acceptabl e	Acceptabl e	Accepted 4	Rejected	Accepted 1	Acceptabl e
3	PAIR	Acceptabl e	Acceptabl e	Accepted 4	Accepted 4	Accepted 1	Acceptabl e

		TrueCopy/Universal Replicator command					
		paircreate		pairsplit			pairresync
#	Status	Copy	Nocopy	-r or -rw option	-P option	-S option	Resync
4	PSUS	Rejected	Rejected	Acceptable	Acceptable	Accepted 1	Accepted 2*
5	PSUE	Rejected	Rejected	Acceptable	Acceptable	Accepted 1	Accepted 2*
6	PDUB	Rejected	Rejected	Rejected	Rejected	Accepted 1	Accepted 2*

Legend:

Accepted = Accepted and executed. When the operation terminates normally, the status changes to the indicated number.

Acceptable = Accepted but no operation is executed.

Rejected = Rejected and operation terminates abnormally.

Pairsplit of a TrueCopy Async volume is returned after verification of state transition that waits until delta data is synchronized from P-VOL to S-VOL.



Note: In the case of the SSWS status after SVOL-SSUS-takeover execution, the **pairresync** command (from P-VOL to S-VOL) is rejected because the delta data for S-VOL becomes dominant, and its status is expected to be using the **-swaps (p)** option of **pairresync**. If the **pairresync** command (from P-VOL to S-VOL) is rejected, confirm this special status using the **-fc** option of the **pairdisplay** command.

Pair status versus ShadowImage commands

The following table shows the relation of command acceptances for paired status and ShadowImage.

		ShadowImage command					
		paircreate		pairsplit			pairresync
Pair Status		No -split	-split	-E option	-C option	-S option	Resync
1	SMPL	Accepted 2	Accepted 2 to 4	Rejected	Rejected	Acceptable	Rejected

-		ShadowImage command					
		paircreate		pairsplit			pairresync
Pair Status		No -split	-split	-E option	-C option	-S option	Resync
2	COPY RCPY	Acceptable	Accepted [1] 2 to 4	Accepted 5	Accepted [1] 2 to 4	Accepted 1	Acceptable
3	PAIR	Acceptable	Accepted [2] 2 to 4	Accepted 5	Accepted [2] 2 to 4	Accepted 1	Acceptable
4	PSUS	Rejected	Acceptable	Accepted 5	Acceptable	Accepted 1	Accepted 2
5	PSUE	Rejected	Acceptable	Acceptable	Acceptable	Accepted 1	Accepted 2

Legend:

Accepted = Accepted and executed. When the operation terminates normally, the status changes to the indicated number.

Acceptable = Accepted but no operation is executed.

Rejected = Rejected and operation terminates abnormally.

In the following descriptions, when the pair statuses of P-VOL and S-VOL are different, PVOL_ or SVOL_ are applied to show which volume is indicated.



Note: If the P-VOL does not have Write in the PAIR state, then data identical with an S-VOL is guaranteed. Therefore, when using the S-VOL with the SMPL state, after stopping Write to the P-VOL, generate a paired volume, and then split the paired volume after confirming that the paired volume has the PAIR status. In the PSUE state, ShadowImage does not manage differential data at the P-VOL or S-VOL. Therefore, **pairresync** issued to a pair in the PSUE state is all copy performance, but the copy progress rate returned by the `-fc` option of the **pairdisplay** command indicates "0%".

[1]: The (2 to 4) state change is effective for only the COPY state that is changed without specification of `-split` for **paircreate** command.

[2]: The (2 to 4) state change appears as P-VOL_PSUS & S-VOL_COPY (see example below), and reading and writing are enabled for S-VOL in SVOL_COPY state.

```
# pairsplit -g oradb
```

```
# pairdisplay -g oradb -fc
```

```
Group   PairVol(L/R) (Port#,TID,LU-M), Seq#, LDEV#.P/S, Status, % , P-
LDEV# M
```

```
oradb   oradev3(L)   (CL2-N , 3, 4-0) 8071 28..P-VOL PSUS, 100 29
W
```

```
oradb   oradev3(R)   (CL2-N , 3, 5-0) 8071 29..S-VOL COPY, 97 28
-
```

PVOL_PSUS & SVOL_COPY is the non-reflected PSUS state that data is still being copied from the P-VOL to the S-VOL, and this state has the following specific behavior.

- If you attempt to read non-reflected data on S-VOL in PVOL_PSUS & SVOL_COPY state, then ShadowImage copies non-reflected data from P-VOL to S-VOL, and returns the correct data after copied. This will bring the performance degradation (1/6 to 1/15 with IOPS) to read on the S-VOL.
- If you attempt to write non-reflected data on S-VOL in PVOL_PSUS & SVOL_COPY state, then ShadowImage copies non-reflected data from P-VOL to S-VOL, and writing data is managed as delta data for S-VOL after copied. This will bring the performance degradation(1/6 to 1/8 with IOPS) to write on the S-VOL.
- If you attempt to write to the data on P-VOL that does not still reflected the data to S-VOL, then ShadowImage copies non-reflected data from P-VOL to S-VOL, and writing data is managed as delta data for P-VOL. This will bring the performance degradation(1/6 to 1/8 with IOPS) to write on the P-VOL.
- The state changes for **pairsplit** are (WD = Write Disable, WE = Write Enable):

If P-VOL has non-reflected data in PAIR state:

Behavior of OLD pairsplit at T0	Behavior of first pairsplit at T0
T0: PVOL_PAIR from/to SVOL_PAIR(WD)	PVOL_PAIR from/to SVOL_PAIR(WD)
T1: PVOL_COPY from/to SVOL_COPY(WD)	PVOL_PSUS from/to SVOL_COPY(WE)
T2: PVOL_PSUS from/to SVOL_SSUS(WE)	PVOL_PSUS from/to SVOL_SSUS(WE)

If P-VOL has been reflected all data to S-VOL in PAIR state:

Behavior of OLD pairsplit at T0	Behavior of First pairsplit at T0
T0: PVOL_PAIR from/to SVOL_PAIR(WD)	PVOL_PAIR from/to SVOL_PAIR(WD)
T1: PVOL_PSUS from/to SVOL_SSUS(WE)	PVOL_PSUS from/to SVOL_SSUS(WE)

- The state changes for **paircreate -split** are:

Behavior of OLD paircreate -split at T0	Behavior of First paircreate -split at T0
T0: SMPL from/to SMPL	SMPL from/to SMPL
T1: PVOL_COPY from/to SVOL_COPY(WD)	PVOL_PSUS from/to SVOL_COPY(WE)
T2: PVOL_PSUS from/to SVOL_SSUS(WE)	PVOL_PSUS from/to SVOL_SSUS(WE)

- If you attempt the **pairevtwait -s psus** in PVOL_PSUS & SVOL_COPY state, then **pairevtwait** will return immediately even if the S-VOL is still in SVOL_COPY state because P-VOL is already in PVOL_PSUS state. If you want to wait the "SVOL_SSUS" state, and then you must check the status of the S-VOL becomes "SVOL_PSUS" via the return code using **pairvolchk -ss** command on S-VOL side or **pairvolchk -ss -c** command on P-VOL side. Or you can use **pairevtwait -ss ssus** on both P-VOL and S-VOL, **pairevtwait -ss ssus -l** on S-VOL locally.
- If you attempt the **pairresync -restore** or **pairsplit -s** in PVOL_PSUS & SVOL_COPY state, then ShadowImage will reject this command due to unable to perform. In this case, you need to wait until the S-VOL state becomes SVOL_SSUS.

Pair status versus Copy-on-Write Snapshot commands

Pair Status		Copy-on-Write Snapshot Command					
		paircreate		pairsplit			pairresync
		No -split	-split	-E option	-C option	-S option	Resync
1	SMPL	Accepted 2	Rejected	Rejected	Rejected	Acceptable	Rejected

Pair Status		Copy-on-Write Snapshot Command					
		paircreate		pairsplit			pairresync
		No -split	-split	-E option	-C option	-S option	Resync
2	COPY RCPY	Acceptable	Rejected	Rejected	Rejected	Rejected	Acceptable
3	PAIR	Acceptable	Accepted* 4	Rejected	Accepted 4	Accepted 1	Acceptable
4	PSUS (PFUS)	Rejected	Acceptabl e	Rejected	Acceptabl e	Accepted 1	Accepted* 2
5	PSUE	Rejected	Rejected	Acceptable	Rejected	Accepted 1	Accepted* 2

Accepted: The command is accepted and executed. When the operation ends normally, the status changes to the shown number.

Accepted*: The command is accepted and issued. Whether this command is executed or not is determined by the microcode version of the storage system.

Acceptable: The command is accepted, but not executed.

Rejected: The command is rejected and the operation terminates abnormally.



Note:

- pairsplit ("simplex -S") of Copy-on-Write Snapshot volume is returned without verification of state transition that waits until SMPL state. In SMPL state, the volume that was S-VOL becomes R/W disable and data is discarded.
- In the "PSUE" state, Copy-on-Write Snapshot does not manage for differential data between the primary volume and secondary volume.

TrueCopy Async, TrueCopy Sync, Universal Replicator, and global-active device volumes

TrueCopy Async and Universal Replicator provide paired volumes that use asynchronous transfer to ensure the sequence of writing data between the primary volume and secondary volume. The sequence of writing data between the primary and secondary volumes is guaranteed within each consistency group (CTG). The following figure illustrates TrueCopy Async consistency group.

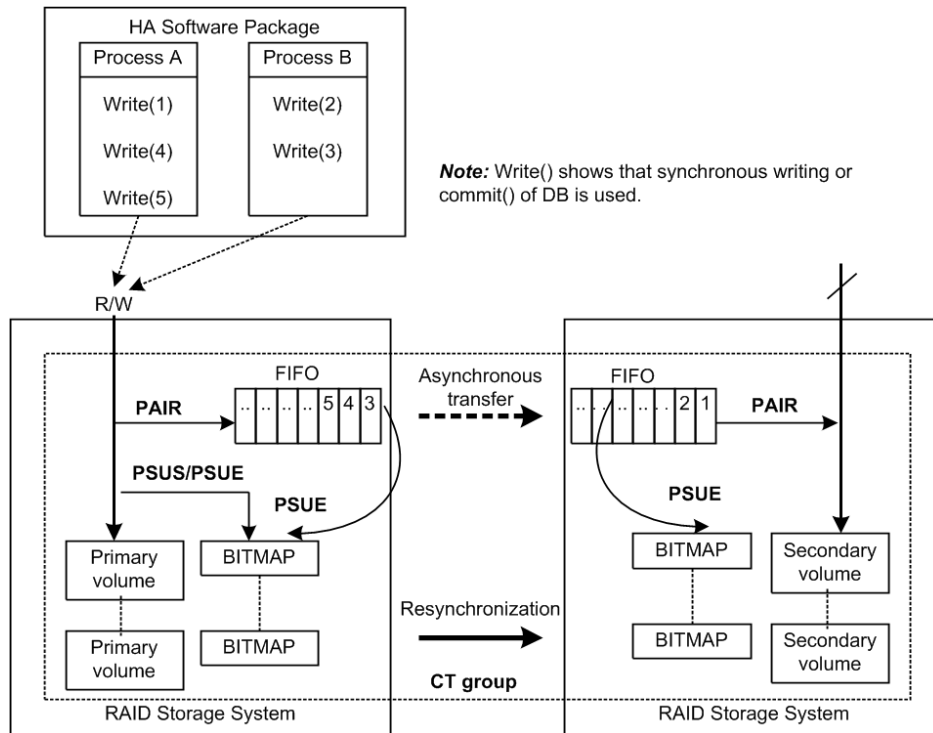

Restrictions

- **Group definition of TrueCopy Async/Universal Replicator/TrueCopy Sync/global-active device volume:** All volumes in a group must be contained within the same storage system. If two or more groups of CCI include the same consistency group (CTG), then pair operation of the group is applied to the entire CTG.
- **Registration of CTG ID number and limitations:** CCI registers CTG IDs to the RAID disk array automatically when paired volumes are created by the `paircreate` command, and groups of configuration definition files are mapped to CTG ID. The maximum number of consistency groups is as follows:
 - HUS VM, VSP, USP V/VM, and Universal Storage Platform/TagmaStore NSC: 256 (CTG ID 0 - CTG ID 255)
 - VSP G800, VSP F800, and 9900V: 128 (CTG ID 0 - CTG ID 127)
 - VSP G400, G600 and VSP F400, F600: 64 (CTG ID 0 - CTG ID 63)
 - VSP G200: 16 (CTG ID 0 - CTG ID 15)

TrueCopy Async/Universal Replicator/global-active device pair command is terminated with EX_ENOCTG when the maximum number of consistency groups is exceeded.

- **Relationships between CTG ID and Journal ID:** The consistency group numbers from 0 to 127 are assigned to TrueCopy Async and TrueCopy Sync, and from 0 to 255 are assigned to Universal Replicator and global-active device. The consistency group numbers for Universal Replicator are mapped to the journal. See the table given below for the assignment of consistency group IDs (CTG IDs).

CTG ID	Assignment	
0 to 127	TrueCopy Asynchronous TrueCopy	CTG 0 to 127
	Universal Replicator Global-active device	CTG 0 to 127
128 to 255	Universal Replicator Global-active device	CTG 128 to 255

- **Pair split with the TrueCopy Sync CTG specified:** The operation for making data consistency is only supported by the following option:

```
pairsplit -g <group> ... [-r]
```

```
pairsplit -g <group> ... -rw
```

TrueCopy Async and Universal Replicator volume characteristics

TrueCopy Async/Universal Replicator volumes have the following characteristics:

- **PAIR state:** A TrueCopy Async pair changes to the PAIR status as soon as all pending recordsets have been placed in the queue at the primary volume, without waiting for the updates to complete in the secondary volume.
- **Pair splitting:** When a TrueCopy Async pair is split or deleted, all pending recordsets at the primary volume are sent to the secondary volume, then the pair status changes to PSUS or SMPL. With the `pairsplit` command only, updates for the primary volume that occur during and after the pairsplit operation are marked on the bitmap of the primary volume.
- **Pair resynchronization:** The `pairresync` command resynchronizes the secondary volume based on the primary volume. This resynchronization does not guarantee the sequenced data transfer.
- **Error suspension:** Pending recordsets that have not yet been sent to the secondary volume are marked on the bitmap of the primary volume, then deleted from the queue, and then the pair status changes to PSUE.
- **Group operations:** TrueCopy Async automatically registers the CTG IDs with the storage system when paired volumes are created using the `paircreate` command, and groups in the configuration file are mapped to their corresponding CTG IDs. If more than one group, defined in the configuration definition file, is assigned to the same CTG ID, then pair operations on the group specificity apply to the entire consistency group.

Sidefile cache for TrueCopy Async

The first-in-first-out (FIFO) queue of each consistency group is placed in an area of cache called the sidefile. The sidefile is used for transferring TrueCopy Async recordsets to the RCU. The sidefile is not a fixed area in cache but has variable capacity for write I/Os for the primary volume. If the host write I/O rate is high and the MCU cannot transfer the TrueCopy Async recordsets to the RCU fast enough, then the sidefile capacity expands gradually. The sidefile has a threshold to control the quantity of data transfer of host side write I/O. Host side write I/Os are controlled by delaying response when the sidefile exceeds the constant quantity limit on cache in the storage system. See the figure below for sidefile quantity limit.

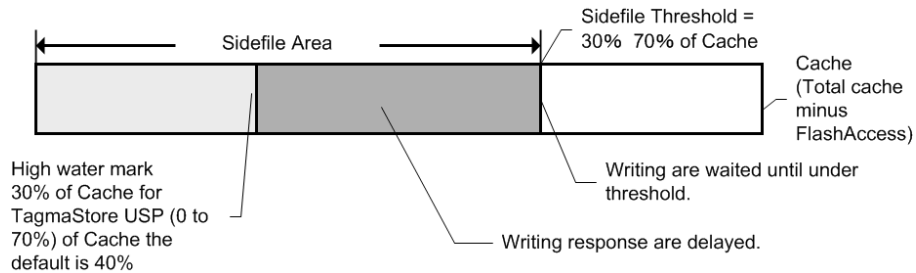

Legend

- **Sidefile area:** Sidefile area = 30% to 70% of cache as set on Storage Navigator (default sidefile = 50% for USP V/VM, ; 40% for TagmaStore USP/TagmaStore NSC).
- **Write I/O control via the high-water mark (HWM):** When the quantity of data in the sidefile reaches 30% of cache, the TrueCopy Async pair status is HWM of PAIR state, and the host write I/Os receive a delayed response in the range of 0.5 seconds to 4 seconds. Following is an arithmetic expression of the HWM at 100% of a sidefile space:
$$\text{HWM}(\%) = \text{High water mark}(\%) / \text{Sidefile threshold (30 to 70)} * 100$$
- **Write I/O control via the sidefile threshold:** When the quantity of data in the sidefile occupies the maximum defined sidefile area, host write I/Os are delayed until there is enough sidefile space to store the next new write data. The copy pending timeout group option is defined using Storage Navigator and specifies the maximum delay between the M-VOL update and the corresponding R-VOL update. The range for the copy pending timeout option is 1-255 seconds (600 seconds for Universal Replicator), and default value is 90 seconds (60 seconds for UR). If the timeout occurs during this wait state, the pair status changes from PAIR to PSUS (sidefile full), and host write I/Os continue with updates being managed by the cylinder bitmap.



Important: The copy pending timeout value should be less than the I/O timeout value of the host system.

TrueCopy Async transition states and sidefile control

TrueCopy Async volumes have special states for sidefile control during status transitions. The table below shows the transition states for TrueCopy and TrueCopy Async volumes.

The suspending and deleting states are temporary internal states within the RAID storage system. CCI cannot detect these transition states, because these states are reported on the previous state of the storage system. These states are therefore concealed inside the **pairsplit** command. After the **pairsplit** command is accepted, host write I/Os for the P-VOL are managed by the cylinder bitmap (normal), non-transmitted data remaining in the P-VOL's FIFO queue is transferred to the S-VOL's FIFO queue, and the pair status is then set to PSUS [SMPL] state when all data in the P-VOL's FIFO queue has been transmitted.

PFUL If the quantity of data in sidefile cache exceeds 30% of cache storage, the internal status of the RAID storage system is PFUL, and host write I/Os receive delayed response in the range of 0.5 seconds (minimum) to 4 seconds (maximum).

PFUS If the quantity of data in sidefile cache exceeds the user-defined sidefile area (30%-70%), then host write I/Os must wait for enough sidefile space to become available for storing the next new write data. If a copy pending timeout occurs during this waiting state, then the pair status changes from PAIR to PFUS, host write I/Os are accepted, and write data is managed by bitmap.

The CCI software can detect and report the PFUL and PFUS states as follows:

- As a return code of the **pairvolchk** command
- As the status code displayed to code item by the **pairmon** command
- As the paired status displayed to status item using -fc option of **pairdisplay** command

State table for TrueCopy Sync vs. TrueCopy Async

The following table describes pair statuses of TrueCopy Sync and TrueCopy Async volumes.

CCI state	Storage system internal state	Description			Writing control on TC async volume		Transfer data via ESCON
		TrueCopy Sync	TrueCopy Async		Writing data	Response	
SMPL	SMPL	SMPL	Same		Normal	Usual	None
COPY	COPY	COPY	Same		Via Sidefile	Usual*	Sidefile & bitmap
	Deleting	N/A	Deleting from COPY using [pairsplit -S]		Normal	Usual	Sidefile
	Suspending	N/A	Suspending from COPY by using [pairsplit]		Via Bitmap	Usual	Sidefile
PAIR	PAIR	Synchronized	Async sidefile in use	Less than HWM	Via Sidefile	Usual	Sidefile

CCI state	Storage system internal state	Description		Writing control on TC async volume		Transfer data via ESCON	
		TrueCopy Sync	TrueCopy Async	Writing data	Response		
	PFUL	N/A		HWM to Threshold	Via Sidefile	Delayed	Sidefile
				Over Threshold	Via Sidefile	Wait until under threshold	Sidefile
	Deleting	N/A	Deleting from PAIR using [pairsplit -S]	Normal	Usual	Sidefile	
	Suspending	N/A	Suspending from PAIR	Using [pairsplit]	Via Bitmap	Usual	Sidefile
Timeout of over threshold							
PSUS	PSUS	PSUS	Same	Via Bitmap	Usual	None	
	PFUS	None	Timeout Over Threshold	Via Bitmap	Usual	None	
PSUE	PSUE	PSUE	Same (link down, etc.)	Via Bitmap	Usual	None	
PDUB	PDUB	PDUB	Same	Via Bitmap	Usual	None	
<p>* If the host has more write I/Os in COPY state, then host write I/Os are delayed until there is enough space in the sidefile.</p> <p>Legend:</p> <p>Bitmap: Host write data is managed via a cylinder BITMAP of delta data.</p> <p>Normal: Host write data is not managed by BITMAP or sidefile.</p> <p>Usual: Host side writing response is not delayed.</p> <p>HWM (High Water Mark): Sidefile quantity is over 30% of cache storage.</p>							

TrueCopy Async/Universal Replicator error state

In the case of an ESCON or fibre-channel (FC) failure, the S-VOL FIFO queue is missing a data block that was transferred from the P-VOL FIFO queue. The RCU waits to store the next sequenced data block in the S-VOL FIFO queue until the TrueCopy Async copy pending timeout occurs (defined using TrueCopy). In addition, the timeout value can be specified at Device Manager - Storage Navigator. The default value is set to 5 minutes. If the timeout occurs during this waiting state, the pair status changes from PAIR to PSUE, and non-sequenced data blocks are managed by the S-VOL bitmap. The missing data block can be recovered using the `pairresync` command, which merges the S-VOL bitmap with the P-VOL bitmap. The figure below shows this situation on the secondary side.

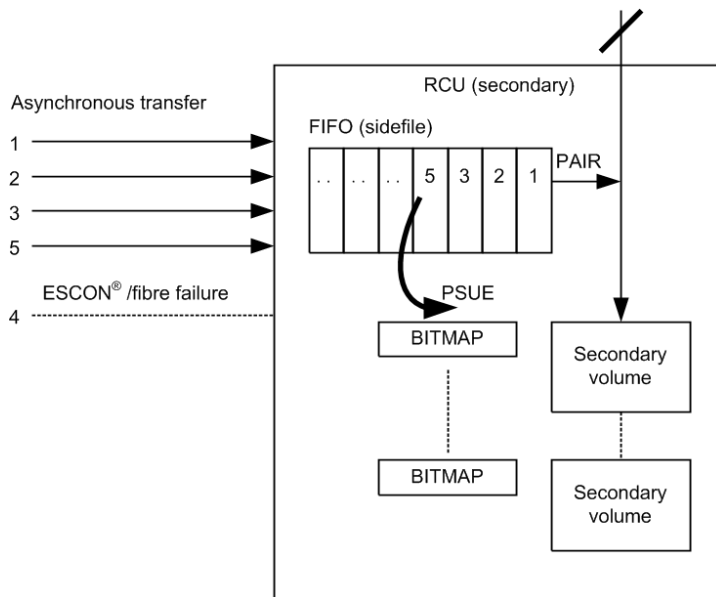

TrueCopy Sync/TrueCopy Async and Universal Replicator/global-active device fence level settings

TrueCopy volume pairs are assigned a fence level for write I/Os to ensure mirroring consistency of critical volumes. When the secondary volume takes over from the primary volume, the takeover action is determined according to the pair status and fence level of the corresponding secondary volume. The table below shows the relationship between TrueCopy pair statuses and fence levels.

The fence level for TrueCopy is Data, Status, Never. The fence level for TrueCopy Async and Universal Replicator is always Async. The fence level for global-active device is always Never.

- Mirror consistency = Identity and sequence of data is assured via error notification after an I/O completion.
- Data consistency = Sequence of data is assured in I/O order based on host.

Relationship between TrueCopy pair statuses and fence levels

TrueCopy pair status of volume	Fence level and write response			
	Data ¹	Status ²	Never ³	Async ⁴
<p>Write response</p> <p>Primary volume Secondary volume</p>	OK	OK	OK	OK
<p>Write response</p> <p>Primary volume Secondary volume</p>	ERROR	OK	OK	OK
<p>Write response</p> <p>Primary volume Secondary volume</p>	ERROR	ERROR	OK	OK

Notes:

- When the fence level is data: Mirroring consistency is assured, since a write error is returned if mirror consistency with the remote S-VOL is lost. The secondary volume can continue operation, regardless of the status. Note: A P-VOL write that discovers a link down situation will, in addition to returning an error to the host, likely be recorded on [only] the P-VOL side.
- When the fence level is status: If there is a mirror consistency problem (that is, PSUE) and it is possible to set the S-VOL to PSUE, the P-VOL write completes OK. If the S-VOL cannot be set to PSUE for any reason, the P-VOL write completes with an error. The mirror consistency of the S-VOL depends on its status:
 - PSUE:** The secondary volume is dubious.
 - PAIR:** The secondary volume can continue operation.
- When the fence level is never: Writing to the P-VOL is still enabled in the state where mirror consistency to the S-VOL is lost, regardless of whether the secondary volume status is updated or not. Thus, the secondary could have these states:
 - PSUE:** The secondary volume is dubious.

TrueCopy pair status of volume	Fence level and write response			
	Data ¹	Status ²	Never ³	Async ⁴
<p>PAIR: The secondary volume is substantially dubious, since it can continue operation and is also dubious. The P-VOL status must be checked to confirm the mirroring consistency.</p> <p>4. When the fence level is async: TrueCopy Async/UR uses asynchronous transfers to ensure the sequence of write data between the P-VOL and S-VOL. Writing to the P-VOL is enabled, regardless of whether the S-VOL status is updated or not. Thus the mirror consistency of the secondary volume is dubious (similar to the "Never" fence):</p> <ul style="list-style-type: none"> ▪ PSUE: The S-VOL mirroring consistency is not assured, but the PSUE suspended state ensures the sequence of data for the consistency group; thus, data consistency is also assured during a PSUE state. At a PSUE state, the P-VOL writes still complete and are also noted in a bitmap for future transfer. Due to the use of a bitmap in the suspend state, data consistency is not assured during a copy state resync. ▪ PAIR: If the P-VOL and S-VOL are both in a PAIR state, mirror consistency is not assured (might be behind) but data consistency is assured (what has reached the S-VOL is in the proper order). 				

Setting the fence level

Data fence level

The figure below shows the relationship between redo log files (journal) and data files. If the S-VOL takes over from the P-VOL in the status shown in the figure (where two errors have occurred), the secondary host leaves data (V) unprocessed in the roll-back processing and cannot be recovered completely. Therefore, the fence level of a redo log file must be defined as data. Once the fence level is set to data, the P-VOL returns an error if data might possibly be inconsistent when a write request is issued by the host. Since writing to the data file is not executed due to a write error of the redo log file, the log file stays consistent with the data file. However, when the fence level is set to data, a write I/O error occurs even in the case where operation is suspended due to an error in the S-VOL. Accordingly, duplication becomes meaningless when the S-VOL takes over. Thus, applications using paired volumes with the data fence level should be able to handle write I/O errors properly. For example, the Oracle application creates multiple redo log files by itself (three by default). The fence level can be set to data in this case in which disk errors are permissible by creating multiple files.

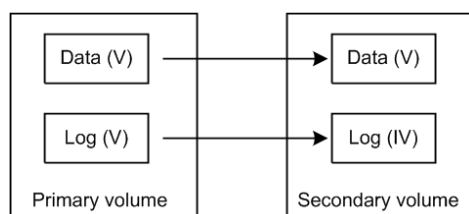

Never fence level

Because most UNIX file systems (excluding JFS and VxFS) have no journal files, the fence level should be defined as Never. When a takeover by the S-VOL occurs, fsck is executed on the volume and the file system is cleaned up, even if the S-VOL is undefined at the secondary host. The data that is lost depends on how much differential data is contained in the P-VOL when the S-VOL is suspended. During operation, error recovery should be performed when the suspended status (PSUE or PDUB) is detected (when one error occurs).

Copy-on-Write Snapshot operations

Copy-on-Write Snapshot normally creates virtual volumes for copying on write without specifying LUNs as S-VOLs. However, to use a Copy-on-Write Snapshot volume via the host, it is necessary to map the Copy-on-Write Snapshot S-VOL to a LUN. Therefore, CCI provides a combined command to enable the user or application to use the same CCI command in order to maintain ShadowImage compatibility.

Copy-on-Write Snapshot uses two techniques, one called "V-VOL mapping" (or virtual volume mapping) and the other is "Snapshot using copy on write" or "Copy-on-write snapshot." Copy-on-Write Snapshot volumes are also put into pooling volumes called a "Snapshot pool," and a Snapshot pool is specified as a pool ID when a Snapshot is made. Copy-on-Write Snapshot and volume mapping is illustrated in the figure given below.

The following figure illustrates Copy-on-Write Snapshot volume mapping.

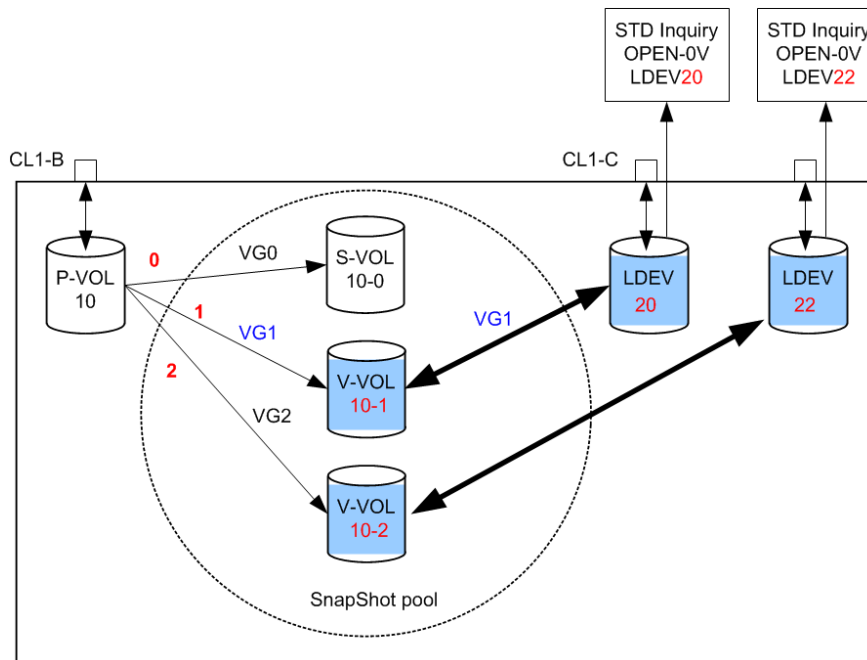

Copy-on-Write Snapshot volumes

The specifications for Copy-on-Write Snapshot volumes are:

- Allowable type of paired volume: The supported volume type is OPEN-V only for P VOL, and OPEN-0V for S VOL.
- Number of volumes (Copy-on-Write Snapshot) can be paired: This depends on P VOL capacity, Copy-on-Write Snapshot pool capacity, and shared memory capacity on the RAID storage system.
- Duplicated writing mode: Copying on write.
- Number of mirror volumes:
 - Thin Image: Up to 1,024 secondary volumes can be defined for each P VOL.
 - Copy-on-Write Snapshot: Up to 64 secondary volumes can be defined for each P VOL.

For details on Thin Image or Copy-on-Write Snapshot specifications such as maximum number of mirrored volumes, volumes and operations, please see the *Hitachi Thin Image User Guide* or *Hitachi Copy-on-Write Snapshot User Guide* for your storage system.

Pair operations and commands for Copy-on-Write Snapshot and Thin Image

The following table shows the pair operations and commands that can be used for Copy-on-Write Snapshot and Thin Image pairs.

Command	Copy-on-Write Snapshot	Thin Image	Thin Image (cascade pairs, pairs with the clone attribute)
paircreate	Yes	Yes*	No
pairsplit	Yes	Yes*	No
pairresync	Yes	Yes*	No
paireventwait	Yes	Yes*	No
pairmon	Yes	Yes*	No
pairvolchk	Yes	Yes*	No
pairdisplay	Yes	Yes*	No
raidscan	Yes	Yes*	No
raidcom	No	Yes	Yes
*The MU numbers that can be used and referenced are from 0 to 63.			

Creating a Copy-on-Write Snapshot pair

The CCI command for creating a Thin Image or Copy-on-Write Snapshot pair is the same as for ShadowImage. However, Thin Image pair can only operate up to 64 S-VOLs. Therefore, use `raidcom` command if you want to operate more than 64 S-VOLs.

The RAID storage system determines whether it is a ShadowImage pair or a Thin Image/ Copy-on-Write Snapshot pair by the attribute of the S-VOL. The RAID storage system also determines whether it is a Thin Image pair or a Copy-on-Write Snapshot pair by the type of the pool to be used.

A Thin Image pair is generated in the following two cases:

- When a V-VOL (OPEN-0V) is specified as an S-VOL.
- When a pool for Thin Image is specified as the pool type.

A Copy-on-Write Snapshot pair is generated in the following two cases:

- When a V-VOL (OPEN-0V) is specified as an S-VOL.
- When a pool for Copy-on-Write Snapshot is specified as the pool type.

A V-VOL has the following characteristics:

- It appears as "OPEN-0V" to identify a V-VOL easily via the SCSI Inquiry or CCI.
- A V-VOL unmapped to the S-VOL of a Copy-on-Write Snapshot will reply to a SCSI Inquiry, but Reading and/or Writing is not allowed. LDEV will reply the capacity setting as an LU to SCSI Read Capacity.
- A V-VOL that has become the S-VOL of a Copy-on-Write Snapshot will reply to a SCSI Inquiry, and Reading and/or Writing is allowed.

Copy-on-Write Snapshot pair status

Each paired volume consists of a primary volume (P-VOL) and a secondary volume (S-VOL). Each volume has the status for controlling the pair state.

The P-VOL controls the pair state that is reflected on the status of the S-VOL. The major pair statuses are "SMPL", "PAIR", "PSUS", "COPY", and "RCPY". The status is changed when the CCI command is issued. A read or write request from the host is allowed or rejected according to the status.

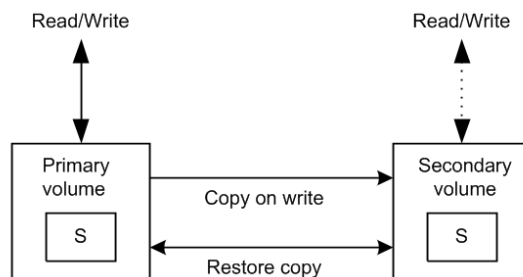

See the table below for Copy-on-Write Snapshot pairing status.

P-VOL Status	Pairing Status	Primary	Secondary
SMPL	Unpaired (Copy-on-Write Snapshot) volume	R/W enabled	R/W disable ¹
PAIR (PFUL)	The Copy-on-Write Snapshot available state allocated the resource.	R/W enabled	R/W disable
COPY	The preparing state allocates the resource for the Copy-on-Write Snapshot.	R/W enabled	R/W disable
RCPY	The copying state from Copy-on-Write Snapshot to the primary volume by using restore option.	R/W enabled	R/W disable
PSUS (PFUS)	The differences of the updated data of the primary and secondary volume are controlled with copying on write.	R/W enabled	R/W enabled
PSUE (Error)	"PSUS" status due to an internal failure. The differences of the updated data for the Copy-on-Write Snapshot volume are not controlled.	R/W enabled ²	R/W disable
Notes: <ol style="list-style-type: none"> 1. V-VOL unmapped to the S-VOL of a Copy-on-Write Snapshot will reply to a SCSI Inquiry, but Reading and/or Writing is not allowed. 2. Reading and writing are enabled, as long as no failure occurs in the primary volume. 			

Pair status relationship to Copy-on-Write Snapshot commands

The pair status relationship to Copy-on-Write Snapshot commands table applies to a Copy-on-Write Snapshot context. It explains:

1. What a pair status can be prior to any CCI command execution.
2. What the result will be after giving a CCI command.
3. What the pair status can be if the CCI command is accepted.

		Copy-on-Write Snapshot Command					
		paircreate		pairsplit			pairresync
Pair Status		No -split	-split	-E option	-C option	-S option	Resync
1	SMPL	Accepted 2	Rejected	Rejected	Rejected	Acceptable	Rejected
2	COPY RCPY	Acceptable	Rejected	Rejected	Accepted*	Accepted 1	Acceptable

-		Copy-on-Write Snapshot Command					
		paircreate		pairsplit			pairresync
Pair Status		No -split	-split	-E option	-C option	-S option	Resync
3	PAIR	Acceptable	Accepted* 4	Rejected	Accepted*	Accepted 1	Acceptable
4	PSUS (PFUS)	Rejected	Acceptabl e	Rejected	Accepted*	Accepted 1	Accepted* 2
5	PSUE	Rejected	Rejected	Rejected	Rejected	Accepted 1	Accepted* 2

Accepted: The command is accepted and executed. When the operation ends normally, the status changes to the shown number.

Accepted*: The command is accepted and issued. Whether this command is executed or not is determined by the microcode version of the storage system.

Acceptable: The command is accepted, but not executed.

Rejected: The command is rejected and the operation terminates abnormally.

**Note:**

- `pairsplit -S` of a Copy-on-Write Snapshot volume is returned without verification of the state transition that waits until SMPL state. In a SMPL state, note that the volume that was an S-VOL becomes R/W disabled and data is discarded.
- In the "PSUE" state, Copy-on-Write Snapshot does not manage differential data between the primary volume and secondary volume.

Controlling Volume Migration

Volume Migration, including external volumes, must be controlled using CLI in a Data Lifecycle Management (DLCM) solution. It is possible to support volume migration (Volume Migration function) and the external connection by operating the current ShadowImage and VDEV mapping of the external connection.

Also, it is important to consider the support of Volume Migration on the compatibility based on the current CLI interface, because CCI is supporting ShadowImage and the external connection. For this purpose, CCI makes the CLI interface that works by minimum compatible of the application by specifying the COPY mode for Volume Migration to the CLI of CCI.

Specifications for Volume Migration

CCI must be mapped to the port for pooling of RAID in order to control the volume of the external connection. Therefore, the external volume needs to be mapped previously to the RAID port without connecting to the host. Following is an execution example of the volume migration executed for LDEV#18.

The following figure shows the Volume Migration configurations.

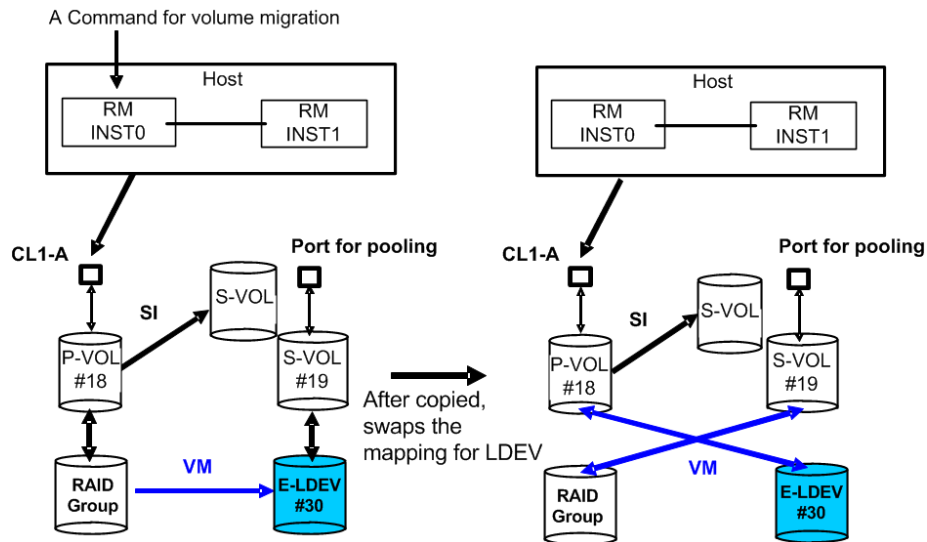

Volume Migration functions

(1) Command specification

CCI operates the volume migration by specifying to the `horcm*.conf` as same SI and TC, because the volume migration using CCI is necessary to be defined the mapping for the target volume.

MU# (of SMPL as SI) that is not used because SI is used for Volume Migration operation.

An original volume for the migration is defined as P-VOL. A target volume for the migration is defined as S-VOL. In other words, an original volume is migrated from P-VOL to S-VOL, and the mapping between LDEV and VDEV is swapped after copied.

(2) Mapping specification

The mapping between LUN and LDEV is maintained for the replying of SCSI-Inquiry in order to make recognize as identical LUN through the host after mapping changes.

The way to know whether the mapping is changed or not is possible to use `-fe` option of `pairedisplay` and/or `raidscan` command that shows the connection for the external volumes.

Also LU of the external connection and LU of RAID Group intermingle on the port for pooling, but can confirm this with the above option of the `raidscan` command.

(3) Group operation

It is possible to execute the Volume Migration as a group by describing it to the `horcm*.conf`, however LU(LDEV), which was mapped to S-VOL after command execution, does not maintain the consistency of the group. In other words, you must consider the volume mapped to the S-VOL after execution as the discarded volume.

When HORCM demon is KILLED or the host has crash during group operation, the group aborting the execution of the command has LUN mixed with the external connection and RAID Group as the group. In this case, CCI skips the executed LU and issues the CC (Volume Migration) command to the un-executed LU, and an identical command is executed once again.

(4) Using MU#

CCI manages the status of TC/SI using MU#, so CCI uses the empty MU# that is managed for SI. Therefore, execute the command of the volume migration in the environment for SI having `HORCC_MRCF` environment variable. An example is shown below.

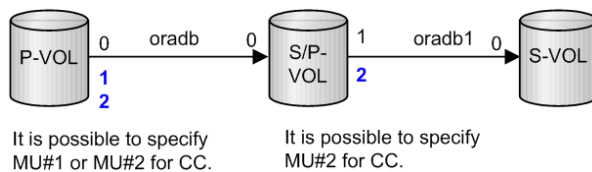

(5) HORCM instance

It is possible to describe the original and target volume for the volume migration to MU# as another group in `horcm*.conf` for HORCM instance of SI and /or TC. Also, it is possible to define the original and target volume for the volume migration in the `horcm*.conf` as HORCM instance independent from SI/TC.

Commands to control Volume Migration

(1) Command for Volume Migration

CCI supports the volume migration by adding an option (`-m cc`) to the `paircreate` command.

```
paircreate -g <group> -d <pair vol> ... -m <mode> -vl[r] -c <size>
```

`-m <mode>` mode = `cc` (can only be specified for ShadowImage)

This option is used to specify the Volume Migration mode.



Note: This option cannot be specified with "-split" option in the same command.

`-vl[r]`

The `-vl` option specifies "local", and copies from the local instance LU (P-VOL) to the remote instance LU (S-VOL), an original volume as the local instance LU is migrated from P-VOL to S-VOL, and the physical volume mapping between P-VOL and S-VOL is swapped after copied

The `-vr` option specifies "remote", and copies from the remote instance LU (P-VOL) to the local instance LU (S-VOL), an original volume as the remote instance LU is migrated from P-VOL to S-VOL, and the physical volume mapping between P-VOL and S-VOL is swapped after copied.

`-c <size>`: This option is used to specify a track size of the case that copies paired volume at 1-15 extents. In case of stopping Write to P-VOL and copying in a short time, the maximum value 15 is specified. When this option is omitted, it uses a default value of (3) is used for track size.

(2) Command for discovering an external volume

It is possible to discover the external volumes by using "-fe" option of the `raidscan` command.

```
raidscan -p <port#> -fe
-fe
```

This option is used to display the serial# and LDEV# of the external LUNs only mapped to the LDEV.

If the external LUN mapped to the LDEV on a specified port does not exist, then this option will do nothing. Also if this option is specified, `-f [f] [g] [d]` option is not allowed.

Display example:

```
# raidscan -p cl1-a-0 -fe -CLI
```

PORT#	/ALPA/C	TID#	LU#	Seq#	Num	LDEV#	P/S	Status	Fence	E-Seq#	E-LDEV#
CL1-A-0	ef	0	0	8	62496	1	19 SMPL	-	-	30053	30
CL1-A-0	ef	0	0	9	62496	1	21 SMPL	-	-	30053	32
CL1-A-0	ef	0	0	10	62496	1	22 SMPL	-	-	30053	33

E-Seq#

Displays the production (serial) number of the external LUN.

E-LDEV#

Displays the LDEV# of the external LUN.

(3) Command for confirming the status

It is possible to confirm the status for Volume Migration by using "-fe" option of the `pairdisplay` command.

```
pairdisplay -g <group> -fe
-fe
```

This option is used to display the serial# and LDEV# of the external LUNs mapped to the LDEV and additional information for the pair volume.

This option displays the information above by adding to last column, and then ignores the format of 80 column.

This option is invalid if the cascade options (-m all,-m cas) are specified.

Display example:

Before execution of Volume Migration command:

```
# pairdisplay -g horc0 -fe
```

```
Group ... Seq#,LDEV#.P/S,Status, Seq#,P-LDEV# M CTG CM EM E-Seq# E-LDEV#
horc0 ... 62496 18.SMPL ---,----- --- - - - - - -
horc0 ... 62496 19.SMPL ---,----- --- - - - H 30053 30
```

```
# paircreate -g horc0 -vl -m cc
```

During execution of Volume Migration command, the progress is displayed in the copy %:

```
# pairdisplay -g horc0 -fe
```

```
Group ... Seq#,LDEV#.P/S,Status, Seq#,P-LDEV# M CTG CM EM E-Seq# E-LDEV#
horc0 ... 62496 18.P VOL COPY,62496 19 - - C - - -
horc0 ... 62496 19.S VOL COPY,----- 18 - - C H 30053 30
```

After completion of Volume Migration command:

```
Group ... Seq#,LDEV#.P/S,Status, Seq#,P-LDEV# M CTG CM EM E-Seq# E-LDEV#
horc0 ... 62496 18.P VOL PSUS,62496 19 - - C V 30053 30
horc0 ... 62496 19.S VOL SSUS,----- 18 - - C - - -
```

CM

Displays the following copy modes:

- N: Non Snapshot
- S: Snapshot. For SMPL state, this shows that pair-volume will be created as Copy-on-Write Snapshot.
- C: Volume Migration

EM

Displays the following external connection modes:

- H: Mapped E-lun as hidden from the host.
- V: Mapped E-lun as visible to the host ' - ': Unmapped to the E-lun.
- BH: Mapped E-lun as hidden from the host, but LDEV blockading.
- BV: Mapped E-lun as visible to the host, but LDEV blockading.
- B: Unmapped to the E-lun, but LDEV blockading

E-Seq#

Displays the production (serial) number of the external LUN. Unknown is shown as '-'.
 ' '.

E-LDEV#

Displays the LDEV# of the external LUN. 'Unknown' is shown as '-'.
 ' '.

(4) Command for discovering an external volume via the device file

It is possible to discover the external volumes by using the **in RAID** command.

Example in Linux:

```
# ls /dev/sd* |./in RAID -CLI
```

DEVICE_FILE	PORT	SERIAL	LDEV	CTG	H/M/12	SSID	R:Group	
PRODUCT_ID								
sdh	CL2-G	63528	15360	-	s/s/ss	0100	5:01-09	OPEN-V
sdu	CL2-G	63528	2755	-	s/s/ss	000B	S:00001	OPEN-
0V								
sdv	CL2-G	63528	2768	-	s/s/ss	000B	U:00000	OPEN-
0V								
sdw	CL2-G	63528	2769	-	s/s/ss	000B	E:16384	OPEN-V

R:Group

This displays the physical position of an LDEV according to mapping of LDEV in the RAID storage system.

LDEV mapping	R:	Group
RAID Group	RAID Level 1: RAID1 5: RAID5 6: RAID6	RAID Group number - Sub number
Copy-on-Write Snapshot S-VOL	S	PoolID number
Unmapped	U	00000
External LUN	E	External Group number

Example in Linux:

```
# ls /dev/sd* |./inraid
/dev/sdh -> CHNO = 0 TID = 1 LUN = 1
          [SQ] CL2-G Ser = 63528 LDEV =15360 [HITACHI ] [OPEN-V
]
          HORC = SMPL HOMRCF[MU#0 = SMPL MU#1 = SMPL MU#2 = SMPL]
          RAID5[Group 1- 9] SSID = 0x0100
/dev/sdu -> CHNO = 0 TID = 1 LUN = 14
          [[SQ] CL2-G Ser = 63528 LDEV =2755 [HITACHI ] [OPEN-V
]
          HORC = SMPL HOMRCF[MU#0 = SMPL MU#1 = SMPL MU#2 = SMPL]
          E-LUN[Group 00001] SSID = 0x000B
          SNAPS[PoolID 0001] SSID = 0x000B
/dev/sdv -> CHNO = 0 TID = 1 LUN = 15
          [[SQ] CL2-G Ser = 63528 LDEV =2768 [HITACHI ] [OPEN-V
]
          HORC = SMPL HOMRCF[MU#0 = SMPL MU#1 = SMPL MU#2 = SMPL]
          E-LUN[Group 08191] SSID = 0x000B
          UNMAP[Group 00000] SSID = 0x000B
/dev/sdw -> CHNO = 0 TID = 1 LUN = 16
          [[SQ] CL2-G Ser = 63528 LDEV =2769 [HITACHI ] [OPEN-V
]
          HORC = SMPL HOMRCF[MU#0 = SMPL MU#1 = SMPL MU#2 = SMPL]
          E-LUN[Group 16384] SSID = 0x000B
          E-LUN[Group 16384] SSID = 0x000B
```

Group

This item shows physical position of an LDEV according to mapping of LDEV in the RAID storage system.

LDEV Mapping	Display Formats
RAID Group	RAID1[Group Group number - Sub number]

LDEV Mapping	Display Formats
	RAID5[Group Group number - Sub number] RAID6[Group Group number - Sub number]
Copy-on-Write Snapshot S-VOL	SNAPS[PoolID poolID number]
Unmapped	UNMAP[Group 00000]
External LUN	E-LUN[Group External Group number]

Relations between "cc" command issues and migration volume status

The migration volumes can be handled by issuing the CCI commands (pair creation and pair splitting commands). The validity of the specified operation is checked according to the status of the paired volume (primary volume).

The table shows the relations between the migration volume statuses and command acceptances.

Command	Pair Creation	Pair Splitting
Pairing Status CC	-m cc	Simplex -S
(1) SMPL	Accepted (2) to (3) (2) to (4)	Acceptable
(2) COPY	Acceptable	Accepted (1)
(3) PSUS	Rejected	Accepted (1)
(4) PSUE PDUB	Rejected	Accepted (1)
<p>Legend:</p> <p>Accepted: A command is accepted and executed. When the command execution succeeds, the status changes to that of the shown number.</p> <p>Acceptable: No operation is executed, though a command is accepted.</p> <p>Rejected: Command execution is rejected and the operation terminates abnormally.</p> <p>Other commands and options (for example, pairresync...) for operating a paired volume are rejected.</p> <p>The "-m cc" option cannot be specified with "-split" option in the same command.</p>		

Restrictions for Volume Migration

Volume Migration must be used within the following restrictions:

- **ShadowImage (HOMRCF):** The operation for the volume migration must be operated at the "SMPL" or "PAIR" state. If not, `paircreate -m cc` command is rejected with EX_CMDRJE or EX_CMDIOE. Also ShadowImage cannot be operated to CC_SVOL moving in Volume Migration. In copying CC_SVOL, the copy operation for the volume migration is stopped, if the ShadowImage `pairsplit` command is executed.

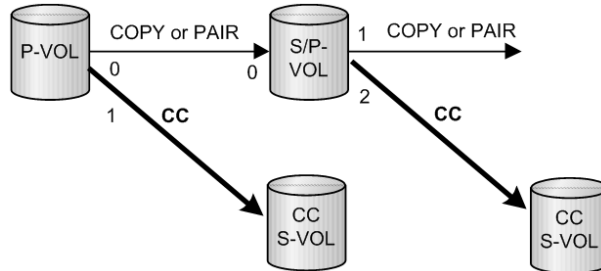

- **TrueCopy (HORC):** The operation for the volume migration must be performed at the "SMPL" or "PSUS" state. If not, `paircreate -m cc` command is rejected with EX_CMDRJE or EX_CMDIOE. Also HORC cannot be operated to CC_SVOL copying in Volume Migration. On one hand, in copying CC_SVOL, the copy operation for the volume migration is stopped, if `pairresync` command for of HORC is executed.

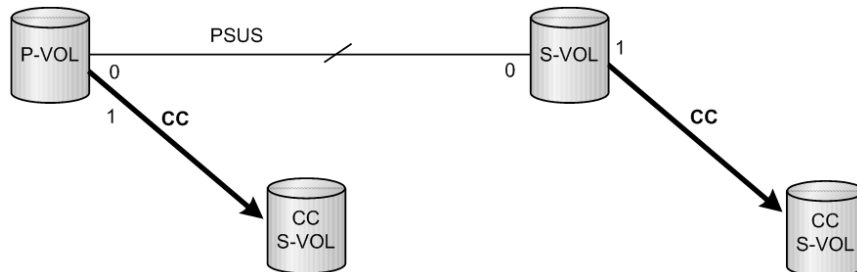

- **LDEV type for Volume Migration:** The volume of the external connection for the volume migration must be mapped to an LDEV as OPEN-V.

Universal Replicator MxN configuration and control

Overview

Universal Replicator supports 4X4 by using sysplex timers on the mainframe. However, open systems do not have an equivalent of sysplex timers on the mainframe, because the SCSI protocol does not have timestamps.

If the open system (CCI) has the timestamp as an equivalent of sysplex timers, Universal Replicator supports 4X4 on the open system.

- CCI: delivers the timestamp(CTQ-Marker) to the consistency group
- Storage system (RCU): arbitrates the timestamp (CTQ-Marker) across multiple storage systems connected remote command devices, and then commits the journal data.

In this architecture, CCI needs to be running. If CCI has stopped, the storage system (RCU) function does not appear to exist. Therefore, the better architecture is to include the storage system (RCU) function into CCI.

CCI already supports the group control across multiple storage systems in the TC_Sync group. This means that CCI can support Universal Replicator MxN on the open system if CCI is capable of delivering the timestamps and committing the Journal data with a CTQ-Marker.

Thus, CCI supports UR MxN for open systems in the four ways described in the policy.

Policy

All data consistency of the consistency group across multiple storage systems is maintained by CCI. The storage system supports only basic functions; there is no relation between storage systems in order to simplify testing and configurations.

CCI supports Universal Replicator MxN in the following ways.

(1) Delivering the timestamp (CTQ-Marker)

CCI (HORCM daemon process) makes a table for the groups registered to the horcm.conf as HORCM_CTQM with startup, and makes the threads for each group that delivers the same timestamp with an increment to the multiple storage systems configured in a group. The thread for a group delivers the same timestamp with increments, as far as a group configured Universal Replicator in the PAIR status.

The timestamp is delivered by using Freeze/Q-Marker & Run way as default. The timestamp is maintained in each storage system. CCI includes this timestamp with startup, and then delivers the same timestamp with increments to each storage system.

(2) Arbitrating/committing the journal data with CTQ-Marker

The thread for a group on HORCM compares the timestamp of S-JNL on each storage system (RCU) as far as a group configured Universal Replicator in PAIR state. Once HORCM detects a matching point of the timestamp (CTQ-Marker) on all storage systems (RCU), it issues an order to commit the Journal data with CTQ-Marker to each storage system (RCU).

(3) Propagating Error suspend

The thread for a group on HORCM delivers the same timestamp with increments as far as a group configured Universal Replicator in PAIR state. If the PSUE/PFUS state detects at least one storage system, then it notifies another storage system to suspend PSUS in order to keep the state consistent in the consistency group. Then the thread stops to deliver the timestamp, and keeps monitoring its consistency group with interval of HORCM_CTQM until it becomes PAIR state by next pair-resync.

(4) Committing the Journal data inside the `pairsplit` command

The `pairsplit` command makes a suspending state on PAIR state, and inherits to compare the timestamp of S-JNL on each storage system (RCU). If it detects a matching point of the timestamp (CTQ-Marker) on all storage systems (RCUs), then it issues an order to commit the Journal data with Q-Marker to each storage system (RCU), and repeats it until it detects an EOM (End Of Marker) of CTQ-Marker with the `pairsplit` command.

Configuration definition file (horcm.conf)

CCI supports TC_Sync group across multiple storage systems, but it does not allow TrueCopy Async (UR) group across multiple storage systems. Therefore, CCI needs to add the group definition (HORCM_CTQM) in order to allow making TrueCopy Async(UR) group across multiple storage systems. Then the HORCM daemon process delivers the timestamps (called CTQ-Marker), and commits S-VOL Journal data with CTQ-Marker to the defined group.

(1) Definition to control UR MxN

CCI supports a way to specify CTQ-Marker to the specified group by adding "HORCM_CTQM" as a keyword in horcm.conf (see the example below).

```
HORCM CTQM
#groupinterval (10ms)mode(optional
oradb300
```

group

Defines the groups to be allowed as a group across multiple storage systems.

interval

Defines the interval for the CTQ-Marker, recommended as a few second.

mode

This is the run mode for the CTQ-Marker (timestamp). The default run mode is freeze/run. This does not normally need to be specified. If "run" is specified, then the timestamp is issued without freeze.

(2) Specifying different JID for consistency groups

In order to support the MxN configuration, it is necessary to specify a different journal ID (JID) for a consistency group corresponding to a CCI group. Thus CCI adds an option to specify Journal ID in horcm.conf.

```
HORCM_LDEV
```

#dev_group	dev_name	Serial#	CU:LDEV (LDEV#)	MU#
oradb	dev1	30095:1	02:40	
oradb	dev2	30095:1	02:41	

```
oradb      dev3      30095:2   02:42
oradb      dev4      30095:2   02:43
```

 **Note:** The number at the end of the serial number (for example, :1 or :2) specifies the Journal ID.

If JID (Journal ID) is specified on horcm.conf as mentioned above, then the **paircreate** command need not specify Journal ID (-jp <jid> -js <jid>) option.

If JID (Journal ID) is not specified on horcm.conf, then Journal ID (-jp <jid> -js <jid>) option of the **paircreate** command is used.

Command specifications

CCI does not change the command options for supporting Universal Replicator MxN Open. However the output of the command is added so that the command can display the consistency group and Q-Marker for each storage system, because the consistency group and Q-Marker are managed on each storage system.

pairdisplay command

The output of **pairdisplay -v ctg** and **pairdisplay -v jnl[t]** are supported so that the option can display consistency group information for each storage system.

Example for UR 2x2:

```
# pairdisplay -g ora -v ctg
CTG  P/S   Status AP  U(%) Q-Marker  QM-Cnt  SF(%)  Seq#  IFC  OT/s  CT/m  RT/m
000  P-VOL PAIR   1   0  00000032      18   50    64034 ON   60   -
-
000  S-VOL PAIR   1   0  00000020      -   70    64035 -    -   -
-
000  P-VOL PAIR   1   0  00000031      15   50    64045 ON   60   -
-
000  S-VOL PAIR   1   0  00000022      -   70    64046 -    -   -
-
```

```
# pairdisplay -g ora -v jnl
JID MU CTG  JNLS AP  U(%)  Q-Marker  Q-CNT  D-SZ (BLK)  Seq#  Num  LDEV#
001 1  0  PJNN 1  0  00000049  2  1633672703  64034
2  5376
002 1  0  SJNN 1  0  00000047  0  1633672703  64035
2  5378
001 1  0  PJNN 1  0  00000049  20  211506164  64045
13 12388
```

```
002 1 0 SJNN 1 0 00000035 20 260319089 64046
16 12544
```

```
# pairdisplay -g ora -v jnl
JID MU CTG JNLS AP U(%) Q-Marker Q-CNT D-SZ (BLK) Seq# DOW PBW APW
001 1 0 PJNN 1 0 00000c76 20 1633672703 64034
60 300 40
002 1 0 SJNN 1 0 00000c62 20 1633672703 64035
60 300 40
001 1 0 PJNN 1 0 00000c3a 7 211506164 64045
60 300 40
002 1 0 SJNN 1 0 00000c33 7 260319089 64046
60 300 40
```

```
# pairdisplay -g horc0 -v jnl -fe
JID MU CTG JNLS AP U(%) Q-Marker Q-CNT D-SZ (BLK) Seq#
Num LDEV# CTQM
016 2 0 PJSN 1 0 0000bb1b 0 198578688 64014
1 32768 -
018 2 0 SJSN 1 0 0000bb1b 0 99283968 64014
1 32770 0000187f
017 2 0 PJSN 1 0 00000011 0 198578688 64014
1 32769 -
019 2 0 SJSN 1 0 00000011 0 99283968 64014
1 32771 0000187f
```



Note: CTQM displays the last CTQ-Marker that was committed on S-VOL.

pairsplit command

The **pairsplit** command does not change the command options for supporting UR MxN Open. However, internal behavior is different from 1x1 UR or TrueCopy Async.

(1) pairsplit -r or -rw option

- Issues Freeze to consistency group on each MCU
- Issues Suspend & Run to make a suspending state for consistency group on each MCU
- Searches/commits a minimum matching point of the CTQ-Marker on RCU via MCU (in other words, do Journal Restore with CTQ-Marker)
- Repeats above until detecting an EOM (End Of Marker) marked on MCU on all RCU via MCU
- Issues End of Suspend to terminate a suspending state, after committed with EOM (End Of Marker) marked on MCU on all RCU

Exception: If an uncommitted state (that is, link failure) is detected while executing its operation, then the operation of committing is aborted on keeping current CTQ-Marker level, and a suspending state terminates without waiting for the EOM (End Of Marker).

(2) pairsplit -P option

- Issues Freeze to consistency group on each MCU
- Issues Suspend & Run to make a suspending state for consistency group on each MCU
- Searches/commits a minimum matching point of the CTQ-Marker on RCU via MCU (in other words, do Journal Restore with CTQ-Marker)
- Repeats above until detecting an EOM (End Of Marker) marked on MCU on all RCU via MCU
- Issues End of Suspend to terminate a suspending state

Exception: If an uncommitted state (that is, link failure) is detected while executing its operation, then the operation of committing is aborted on keeping current CTQ-Marker level, and a suspending state terminates without waiting for the EOM (End Of Marker).

(3) pairsplit -S option

- Issues Freeze to consistency group on each MCU
- Issues Delete & Run to make a deleting state for consistency group on each MCU
- Searches/commits a minimum matching point of the CTQ-Marker on RCU via MCU (in other words, do Journal Restore with CTQ-Marker)
- Repeats above until detecting an EOM (End Of Marker) marked on MCU on all RCU via MCU
- Issues End of Delete to terminate a deleting state, after committed with EOM (End Of Marker) on all RCU

Exception: If an uncommitted state(that is, link failure) is detected while executing its operation, then the operation of committing is aborted on keeping current CTQ-Marker level, and a deleting state terminates without waiting for an EOM (End Of Marker).

(4) pairsplit -RS option

In the case of PAIR state (NO failure):

- Issues SwapSuspend to make a suspending state for consistency group on each RCU
- Searches/commits a minimum matching point of the CTQ-Marker on RCU via RCU (in other words, do Journal Restore with CTQ-Marker)
- Repeats above until detecting an EOM (End Of Marker) marked on MCU on all RCU via RCU
- Issues End of Suspend to terminate a suspending state, after committed with an EOM (End Of Marker) on all RCU

Exception: If an uncommitted state (that is, link failure) is detected while executing its operation, then the operation of committing is aborted on keeping current CTQ-Marker level, and a suspending state terminates with detecting at least one EOM (End Of Marker).

In the case of Failure (PSUE/PSUS):

- Issues SwapSuspend to make a suspending state for consistency group on each RCU
- Searches/commits a minimum matching point of the CTQ-Marker on RCU via RCU (in other words, do Journal Restore with CTQ-Marker)
- Repeats above until detecting an EOM(End Of Marker) marked on all RCU via RCU
- Issues End of Suspend to terminate a suspending state

(5) pairsplit -R option

In the case of PAIR state (NO failure):

- Issues Delete to make a deleting state for consistency group on each RCU
- Searches/commits a minimum matching point of the CTQ-Marker on RCU via RCU (in other words, do Journal Restore with CTQ-Marker)
- Repeats above until detecting an EOM (End Of Marker) marked on MCU on all RCU via RCU
- Issues End of Delete to terminate a deleting state, after committed with an EOM (End Of Marker) on all RCU

Exception: If an uncommitted state (that is, link failure) is detected while executing its operation, then the operation of committing is aborted on keeping current CTQ-Marker level, and a deleting state terminates with detecting at least one EOM (End Of Marker).

In the case of Failure(PSUE/PSUS):

- Issues Delete to make a deleting state for consistency group on each RCU
- Searches/commits a minimum matching point of the CTQ-Marker on RCU via RCU (in other words, do Journal Restore with CTQ-Marker)
- Repeats above until detecting an EOM(End Of Marker) marked on all RCU via RCU
- Issues End of Delete to terminate a deleting state

Notice on system operation

CCI does not change the command options for supporting Universal Replicator MxN Open. However, the output of the command is added so that the command can display the consistency group and Q-Marker for each storage system, because the consistency group and Q-Marker are managed on each storage system.

(1) Consistency group ID and journal ID for UR

The consistency group ID must be assigned/used as the unique identifier across multiple storage systems. Therefore, the **paircreate** command makes a group volume having the same consistency group ID across multiple storage systems.

(2) Cascading operation

The "-FHORC" option for cascading operation does not perform with CTQ-Marker Mode. Hence the cascading volume must not be specified UR MxN volume when using the "-FHORC" option.

(3) Running HORCM daemon

HORCM daemon process delivers the timestamps (called the consistency Q-Marker) to the defined consistency group. Therefore if HORCM daemon is stopped, then UR will stop to delta (commit) and will suspend because of Journal Full state.

Thus HORCM daemon must be running to keep the PAIR state.

(4) Separating a command device IO from application IO

The HORCM daemon process issues IOs to the command device in order to deliver the timestamps to the defined consistency group. Therefore, it is recommended to separate the command device path from the application IO path.

(5) About waiting application IO

The HORCM daemon process delivers the timestamps to the defined consistency group while freezing IO for each journal.

Waiting Rate = $0.5\text{ms} * \text{Number of journal} / \text{Interval (ms)} * 100$

(Note that 0.5 ms depends on the OS platform.)

Therefore it is recommended to limit within four journal per consistency group and 8192 LDEVs per consistency group. In the case of multiple consistency groups per HORCM, it is recommended to limit within 256 LDEVs per consistency group.

(6) HOST IO on pairsplit -RS, -R, horctakeover, pairresync -swapp(s)

The `pairsplit -RS, -R` operation cannot be frozen and Split HOST IO from RCU in Link Normal state. In other words this option does not support At-time Split, hence these operations are required to stop HOST IO in order to keep Data Consistency on S-VOL. This is the same restriction as TC_Sync.

(7) Suspending/deleting status

To commit S-VOL Journal data with CTQ-Marker, the internal status of the storage system must be suspending or deleting. These statuses are controlled by CCI commands.

If a CCI command is aborted for some reason (KILL, etc.) or EX_EWSTOT, the storage system keeps that status (suspending/deleting).

To terminate this status restart CCI, and then close it after "JNL Consistency Restore".

(8) Detecting inconsistent CTQ-Marker

The `pairsplit` command checks data consistency with CTQ-Marker across multiple storage systems. If an inconsistent CTQ-Marker is detected, then it returns with EX_VOLCUR after changed to suspend status.

This error needs to confirm if CTQMs are the same on S-VOL on each storage system using the "pairdisplay -v jnl -fe" option.

```
# pairdisplay -g horc0 -v jnl -fe
```

JID Num	MU LDEV#	CTG	JNLS CTQM	AP	U(%)	Q-Marker	Q-CNT	D-SZ (BLK)	Seq#
---------	----------	-----	-----------	----	------	----------	-------	------------	------

016	2	0	PJSN	1	0	0000bb1b	0	198578688	64014
1	32768		-						

018	2	0	SJSN	1	0	0000bb1b	0	99283968	64014
1	32770	0000187f							

017	2	0	PJSN	1	0	00000011	0	198578688	64014
1	32769		-						

019	2	0	SJSN	1	0	00000011	0	99283968	64014
1	32771	0000187f							

(9) About pairsyncwait command

Using the Q-Marker with the **pairsyncwait** command is managed on each Journal including the target device. Therefore the **pairsyncwait** command must specify a target device (-g <group> -d <pair vol>, or -d <device file>, or -d <serial#> <ldev#>). For example:

```
# pairsyncwait -g horc0 -d dev-002 -t 500
```

UnitID	CTGID	Q-Marker	Status	Q-Num
--------	-------	----------	--------	-------

1	0	0000003de8	DONE	0
---	---	------------	------	---

If group (-g <group>) is specified, then the first dev_name on the specified group is used.

Explanation of terms:

JNL Consistency Restore

Commits up as far as MAX CTQ-Marker.

JNL Full Restore

Commits up to EOM (End of marker for split).

JNL Consistency Suspend

Suspends after "JNL Consistency Restore".

JNL Full Suspend

Suspends after "JNL Full Restore".

Configuration examples

CCI does not change the command options for supporting Universal Replicator MxN Open. However the output of the command is added so that the command can display the consistency group and Q-Marker for each storage system, because the consistency group and Q-Marker are managed on each storage system.

(1) UR 2x2

```

#/****** HORCM0 on production *****/
HORCM_MON
#ip_address service poll(10ms) timeout(10ms)
NONE      horcm0    1000 3000

#/****** For HORCM_CMD *****/
HORCM_CMD
#dev_name
#UnitID #0(Serial# 64034), #1(Serial# 64045)
\\.\CMD-64034:/dev/rdisk
\\.\CMD-64045:/dev/rdisk

#/****** For HORCM_LDEV *****/
HORCM_LDEV
#dev_group dev_name Serial# LDEV# MU#
ora      data0      64034 400
ora      data1      64034 401
ora      data2      64045 400
ora      data3      64045 401

#/****** For HORCM_INST *****/
HORCM_INST
#dev_group ip_address service
ora      RHOST      horcm0

#/****** For UR of multiple DKC *****/
HORCM_CTQM
#dev_group interval(10ms) mode
ora      300
    
```

```

#/****** HORCM0 on Remote *****/
HORCM_MON
#ip_address service poll(10ms) timeout(10ms)
NONE      horcm0    1000 3000

#/****** For HORCM_CMD *****/
HORCM_CMD
#dev_name
#UnitID #0(Serial# 64035), #1(Serial# 64046)
\\.\CMD-64035:/dev/rdisk
\\.\CMD-64046:/dev/rdisk

#/****** For HORCM_LDEV *****/
HORCM_LDEV
#dev_group dev_name Serial# LDEV# MU#
ora      data0      64035 400
ora      data1      64035 401
ora      data2      64046 400
ora      data3      64046 401

#/****** For HORCM_INST *****/
HORCM_INST
#dev_group ip_address service
ora      PHOST      horcm0

#/****** For UR of multiple DKC *****/
HORCM_CTQM
#dev_group interval(10ms) mode
ora      300
    
```

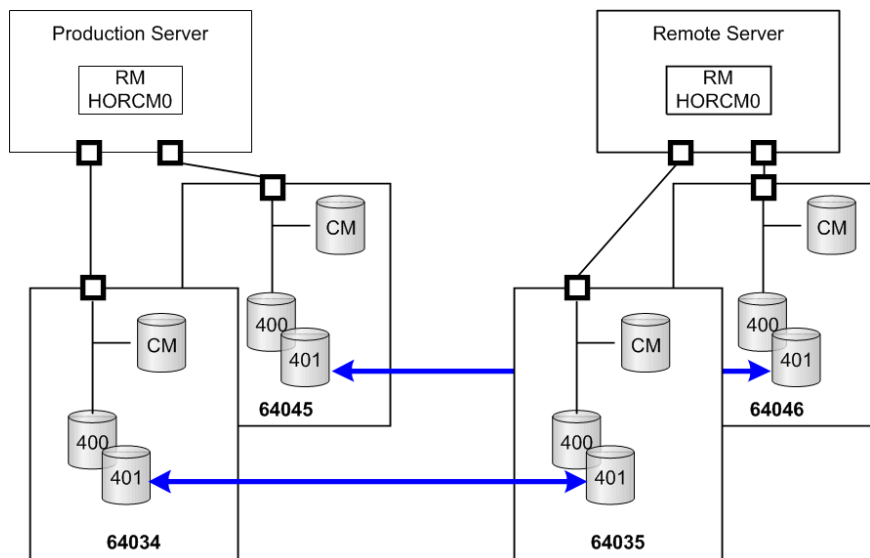

(2) UR 2x1

```

#/****** HORCM0 on production *****/
HORCM_MON
#ip_address service poll(10ms) timeout(10ms)
NONE horcm0 1000 3000

#/****** For HORCM_CMD *****/
HORCM_CMD
#dev_name
#UnitID #0(Serial# 64034), #1(Serial# 64045)
\\.\CMD-64034:/dev/rdisk
\\.\CMD-64045:/dev/rdisk

#/****** For HORCM_LDEV *****/
HORCM_LDEV
#dev_group dev_name Serial# LDEV# MU#
ora data0 64034:1 400
ora data1 64034:1 401
ora data2 64045:1 400
ora data3 64045:1 401

#/****** For HORCM_INST *****/
HORCM_INST
#dev_group ip_address service
ora RHOST horcm0

#/****** For UR of multiple DKC *****/
HORCM_CTQM
#dev_group interval(10ms) mode
ora 300
    
```

```

#/****** HORCM0 on Remote *****/
HORCM_MON
#ip_address service poll(10ms) timeout(10ms)
NONE horcm0 1000 3000

#/****** For HORCM_CMD *****/
HORCM_CMD
#dev_name
#UnitID #0(Serial# 64046)
\\.\CMD-64046:/dev/rdisk

#/****** For HORCM_LDEV *****/
HORCM_LDEV
#dev_group dev_name Serial# LDEV# MU#
ora data0 64046:1 400
ora data1 64046:1 401
ora data2 64046:2 402
ora data3 64046:2 403

#/****** For HORCM_INST *****/
HORCM_INST
#dev_group ip_address service
ora PHOST horcm0

#/****** For UR of multiple DKC *****/
HORCM_CTQM
#dev_group interval(10ms) mode
ora 300
    
```

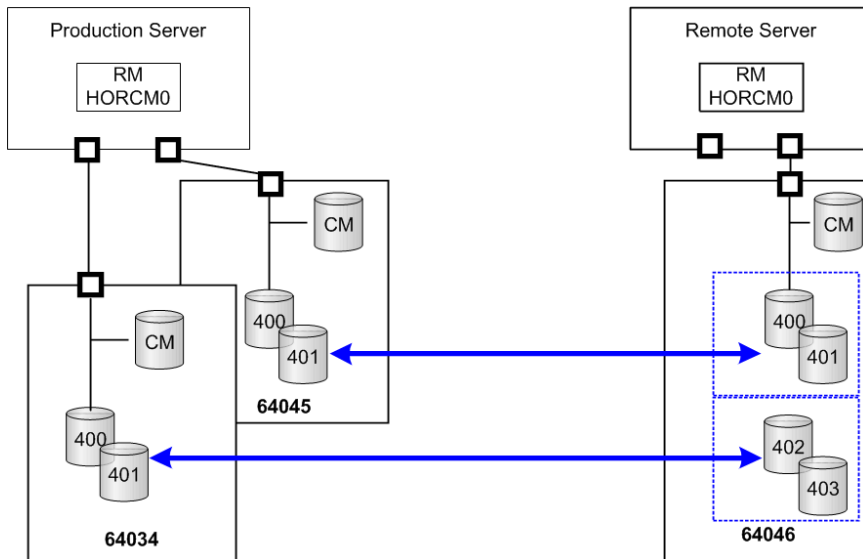

Duplication of CCI applications

⚠ Caution: You must read Requirements for duplication of CCI before you duplicate CCI applications.

When a failure occurs on the CCI application (for example, failure of the server on which CCI is installed) in the MxN configuration of Universal Replicator, the data consistency in the consistency group that spans multiple storage systems will not be able to be maintained. Duplication of the CCI application is a function to use a second CCI application to maintain the data consistency in the consistency group when a failure occurs in the first CCI application.

You can use up to two CCI applications per one consistency group for each site. The following figure illustrates the typical MxN configuration.

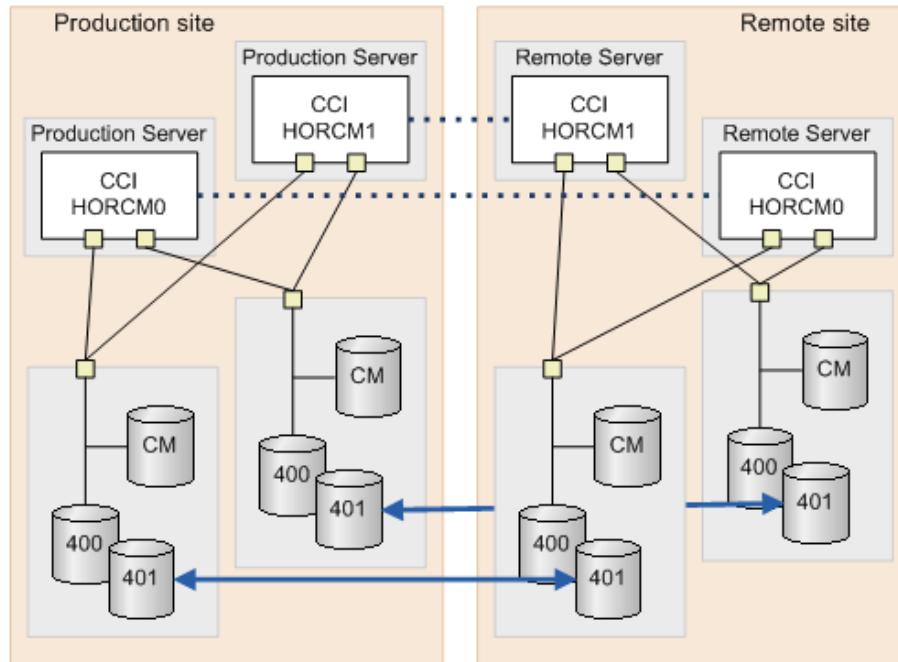

When you specify the command device to the HORCM_CMD in the configuration definition file, you must make the definition sequence of storage system match within the site, as shown in the following definition file examples.

```

#/****** HORCM0 on production *****/
HORCM_MON
#ip_address service poll(10ms) timeout(10ms)
NONE horcm0 1000 3000

#/****** For HORCM_CMD *****/
HORCM_CMD
#dev_name
#UnitID #0(Serial# 64034), #1(Serial# 64045)
\\.\CMD-64034:/dev/rdisk
\\.\CMD-64045:/dev/rdisk

#/****** For HORCM_LDEV *****/
HORCM_LDEV
#dev_group dev_name Serial# LDEV# MU#
ora data0 64034 400
ora data1 64034 401
ora data2 64045 400
ora data3 64045 401

#/****** For HORCM_INST *****/
HORCM_INST
#dev_group
ora
#/****** For HORCM_CTQM *****/
HORCM_CTQM
#dev_group
ora

```

```

#/****** HORCM1 on production *****/
HORCM_MON
#ip_address service poll(10ms) timeout(10ms)
NONE horcm1 1000 3000

#/****** For HORCM_CMD *****/
HORCM_CMD
#dev_name
#UnitID #0(Serial# 64034), #1(Serial# 64045)
\\.\CMD-64034:/dev/rdisk
\\.\CMD-64045:/dev/rdisk

#/****** For HORCM_LDEV *****/
HORCM_LDEV
#dev_group dev_name Serial# LDEV# MU#
ora data0 64034 400
ora data1 64034 401
ora data2 64045 400
ora data3 64045 401

#/****** For HORCM_INST *****/
HORCM_INST
#dev_group ip_address service
ora RHOST horcm1

#/****** For UR of multiple DKC *****/
HORCM_CTQM
#dev_group interval(10ms) mode
ora 300

```

Match the definition sequence of units.

```

#/****** HORCM0 on Remote *****/
HORCM_MON
#ip_address service poll(10ms) timeout(10ms)
NONE horcm0 1000 3000

#/****** For HORCM_CMD *****/
HORCM_CMD
#dev_name
#UnitID #0(Serial# 64035), #1(Serial# 64046)
\\.\CMD-64035:/dev/rdsk
\\.\CMD-64046:/dev/rdsk

#/****** For HORCM_LDEV *****/
HORCM_LDEV
#dev_group dev_name Serial# LDEV# MU#
ora data0 64035 400
ora data1 64035 401
ora data2 64046 400
ora data3 64046 401

#/****** For HORCM_INST *****/
HORCM_INST
#dev_group
ora
#/****** For HORCM_CTQM *****/
HORCM_CTQM
#dev_group
ora

```

```

#/****** HORCM1 on Remote *****/
HORCM_MON
#ip_address service poll(10ms) timeout(10ms)
NONE horcm1 1000 3000

#/****** For HORCM_CMD *****/
HORCM_CMD
#dev_name
#UnitID #0(Serial# 64035), #1(Serial# 64046)
\\.\CMD-64035:/dev/rdsk
\\.\CMD-64046:/dev/rdsk

#/****** For HORCM_LDEV *****/
HORCM_LDEV
#dev_group dev_name Serial# LDEV# MU#
ora data0 64035 400
ora data1 64035 401
ora data2 64046 400
ora data3 64046 401

#/****** For HORCM_INST *****/
HORCM_INST
#dev_group ip_address service
ora PHOST horcm1

#/****** For UR of multiple DKC *****/
HORCM_CTQM
#dev_group interval(10ms) mode
ora 300

```

Match the definition sequence of units.

Requirements for duplication of CCI

All of the following requirements must be met in order to use multiple CCI applications. If any of these requirements is not met, the duplication of CCI makes data inconsistent on the RCU.

- **CCI version:** 01-31-03/08 or later
- **Platform on which both CCI applications are installed:** other than OpenVMS

- **Storage system:**
 - Hitachi Virtual Storage Platform (VSP)
 - Hitachi Virtual Storage Platform G1x00 and Hitachi Virtual Storage Platform F1500 (VSP G1x00 and VSP F1500)
 - Hitachi Virtual Storage Platform G200, G400, G600, G800 (VSP Gx00 models)
 - Hitachi Virtual Storage Platform F400, F600, F800 (VSP Fx00 models)
 - Hitachi Unified Storage VM (HUS VM)
- **DKCMAIN microcode version:**
 - VSP: 70-06-20-00/00 or later
 - VSP G1000: 80-03-00-00/03 or later
 - VSP G1500 and VSP F1500: 80-05-00-xx/xx or later
 - VSP Gx00 models and VSP Fx00 models: 83-03-00-xx/xx or later
 - HUS VM: 73-03-48-x0/00 or later

Note for duplication of CCI

When a failure does not occur in CCI, the running CCI application handles the processing to keep the data consistency in the consistency group, for example CTQ-Marker, and the other CCI application stands by in case of a failure. If the stand-by CCI application issues the `pairsplit` command, an error (EX_INVVOL) might occur. If this error occurs, issue the `pairsplit` command from the other CCI application.

Remote volume discovery

In the configuration separating "Storage admin server (CCI server)" and each production server, it is difficult to verify/check the volumes on the production servers and the volumes described to the `horcm.conf` on CCI server.

In this configuration, you cannot use the following CCI capabilities:

- Command device security
- `pairdisplay -fd` option that displays the device file on the production host view
- `raidscan -find verify`

To solve this configuration problem, CCI supports a way to discover the volume information on the remote server by exporting the volume information with the `inraid` command, and by importing its output with the `raidscan -find` command.

The following figure illustrates volume discovery.

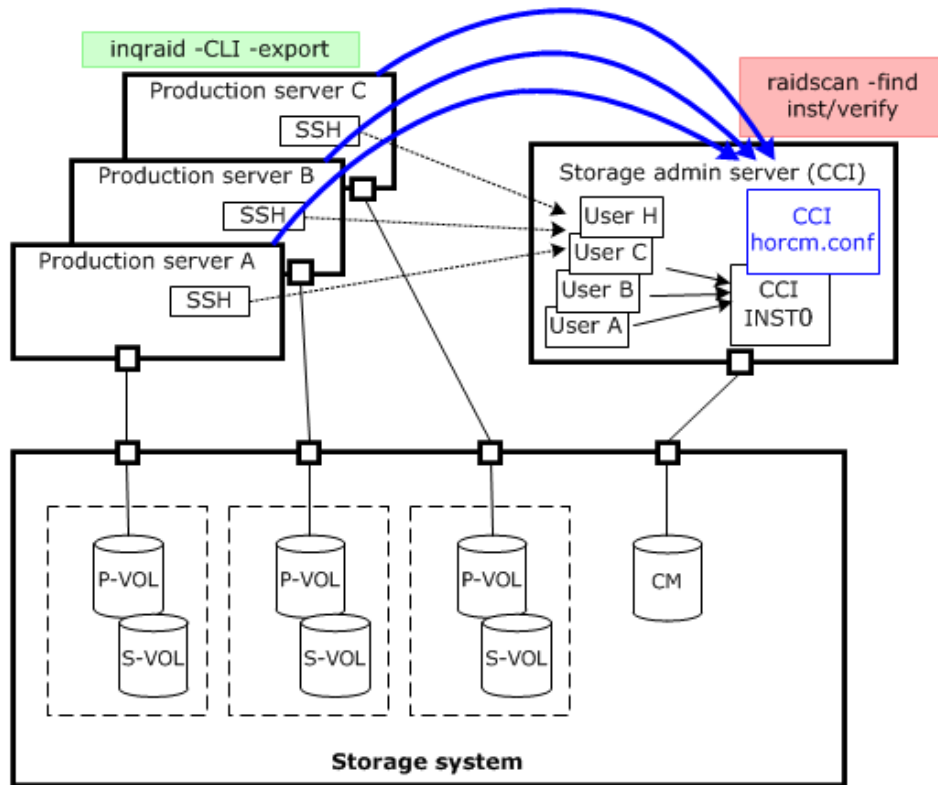

Discovering a remote volume

The volume information discovered on the production servers is exported by specifying the **inqraid** command with the **-CLI** option and **-export** option. The volume information includes "Keyword, Serial#, Ldev#, Device file name..". The **raidscan -find inst** command on CCI server imports the volume information, and registers it into the HORCM daemon.

The **inqraid** command is needed only for discovering LUNs on the production server.

Example of exporting by **inqraid** command (Solaris):

```
# ls /dev/rdisk/clt* | inqraid -CLI -export
INQRAID:@CL4-G@64015@0@124@OPEN-V-CM@/dev/rdisk/clt0d0s2
INQRAID:@CL4-G@64015@1@124@OPEN-V-CM@/dev/rdisk/clt0d1s2
INQRAID:@CL4-G@64015@2@95@OPEN-V@/dev/rdisk/clt0d2s2
INQRAID:@CL4-G@64015@3@95@OPEN-V@/dev/rdisk/clt0d3s2
INQRAID:@CL4-G@64015@4@95@OPEN-V@/dev/rdisk/clt0d4s2
INQRAID:@CL4-G@64015@5@95@OPEN-V@/dev/rdisk/clt0d5s2
INQRAID:@CL4-G@64015@7@95@OPEN-V@/dev/rdisk/clt0d7s2
```

Example for exporting/importing to CCI server using pipe & SSH (Solaris):

```
# ls /dev/rdisk/clt* | inqraid -CLI -export | ssh
<CCI host> raidscan -find inst
DEVICE_FILE          Group      PairVol    PORT     TARG  LUN M  SERIAL
```



```
LDEV
/dev/rdisk/c1t0d2s2      G1      G1-000      CL4-G-1  57      2  0
64015      2
/dev/rdisk/c1t0d2s2      G1      G1-000      CL4-G-1  57      2  -
64015      2
/dev/rdisk/c1t0d3s2      G1      G1-001      CL4-G-1  57      3  0
64015      3
```

Example for verifying the imported volume information (Solaris):

```
# ls /dev/rdisk/c1t* | inqraid -CLI -export | ssh <CCI
host> raidscan -find verify
DEVICE_FILE          Group    PairVol    PORT     TARG     LUN M
SERIAL  LDEV
/dev/rdisk/c1t0d0s2  -        -          -        -        -  -
64015    0
/dev/rdisk/c1t0d1s2  -        -          -        -        -  -
64015    1
/dev/rdisk/c1t0d2s2  G1      G1-000     CL4-G-1  57      2  -
64015    2
/dev/rdisk/c1t0d3s2  G1      G1-001     CL4-G-1  57      3  -
64015    3
/dev/rdisk/c1t0d4s2  -        -          -        -        -  -
64015    4
/dev/rdisk/c1t0d5s2  -        -          -        -        -  -
64015    5
/dev/rdisk/c1t0d7s2  -        -          -        -        -  -
64015    7
```

Import method by the startup of CCI (horcmstart.sh) on the remote host

The following is the method to import the volume information by exporting the volume information which is discovered on the production server and starting up the CCI on the remote host.

Procedure

1. Export the volume information from the local host (Production server) to /etc/horcmperm*.conf of CCI on the remote host. (* = instance number)

Example of exporting the volume information:

```
# ls /dev/rdisk/c1t* | inqraid -CLI -export | ssh <CCI host> cat > /etc/
horcmperm*.conf
```

2. Import the volume information. This volume information is imported automatically by starting up CCI on the remote host.

Example of importing automatically by starting up CCI:

```
# horcmstart.sh *
```

(* = instance number)

3. Verify the imported volume information on the CCI server.

Example for verifying the imported volume information:

```
# cat /etc/horcmperm*.conf | raidscan -find verify
DEVICE_FILE      Group  PairVol  PORT    TARG  LUN  M  SERIAL  LDEV
/dev/rdisk/c1t0d0s2  -      -        -       -     -    -   64015   0
/dev/rdisk/c1t0d1s2  -      -        -       -     -    -   64015   1
/dev/rdisk/c1t0d2s2  G1     G1-000  CL4-G-1  57    2    -   64015   2
/dev/rdisk/c1t0d3s2  G1     G1-001  CL4-G-1  57    3    -   64015   3
/dev/rdisk/c1t0d4s2  -      -        -       -     -    -   64015   4
/dev/rdisk/c1t0d5s2  -      -        -       -     -    -   64015   5
/dev/rdisk/c1t0d7s2  -      -        -       -     -    -   64015   7
```

Chapter 7: Data protection operations with CCI

This chapter describes data protection operations using CCI.

Data protection operations

User data files are normally placed on a disk through a software layer such as a file system, LVM, disk driver, SCSI protocol driver, bus adapter, and SAN switching fabric. Data corruption can happen due to software layer bugs or human error. CCI Data Protection Facility does not prevent these types of errors. On the other hand, the purpose of data protection is to prevent writing to volumes that the RAID storage system is guarding.

Data protection functions include:

- Data Retention Utility
- Volume Retention Manager
- Volume Security
- Encryption License Key
- Database Validator

Data Retention Utility

The purpose of the Data Retention Utility is to prevent writing to volumes that the RAID storage system is guarding. Similar to the command that supports Database Validator, Data Retention Utility sets a protection attribute for the specified LU.

- **Hide from Inquiry command.** The RAID storage system conceals the target volumes from the SCSI Inquiry command by responding "unpopulated volume" (0x7F) to the device type.
- **SIZE 0 volume.** The RAID storage system replies with "SIZE 0" to the target volumes through the SCSI Read capacity command.
- **Read protection.** The RAID storage system protects reading from the target volumes by responding with the "Illegal function" check condition (SenseKey = 0x05, SenseCode = 0x2200).

- **Write protection.** The RAID storage system replies with "Write Protect" in the mode sense header, and protects from writing the target volumes by responding with the "Write Protect" check condition (SenseKey=0x07, SenseCode=0x2700).
- **S-VOL disabling.** The RAID storage system rejects the command execution of the copy series program product for not to be overwritten the secondary (target) volume by the copy process of copy series program product (TrueCopy, Universal Replicator, ShadowImage, Copy-on-Write Snapshot, global-active device), and protects the target volume. This option can be used with the other Data Retention Utility options in parallel. For example, if you want to protect from the writing by the both copy series program product and the host accessing, set the both write protection option and this option. Only the setting of write protection option cannot protect the target volume from the writing executed by the copy processing of the copy series program product.

Restrictions on Data Retention Utility volumes

- **File systems using Data Retention Utility**
 - When setting DRU to the UNIX file system volumes, the volumes must be mounted with the Read Only option after the volumes are unmounted. If DRU is set to the volumes as they are in the mounted status, unexpected behavior or errors might occur in the system.
 - When using a file system for Write Protect Mode set disk on Windows Server 2003/Windows Server 2008/Windows Server 2012, use the "-x mount" and "-x umount" CCI command options with the above mentioned procedures.
 - Data Retention Utility volumes set to Write Protect Mode (Read ONLY) cannot be used for the Windows NT/Windows 2000 file system (NTFS, FAT).
 - In a configuration with NAS modules installed, do not set Data Retention Utility in a file system volume used by a NAS module. If you do, unexpected behavior or errors might occur in the system.
- **LVM(VxVM) on Data Retention Utility**
 - If changing LVM configuration including Data Retention Utility, use the `raidvchset -vg` command for setting the status of the target volume checking prohibited temporarily. Also, after the completion of LVM configuration change, set again the status as checking.
- **Data Retention Utility in HA Cluster Server**
 - If HA Cluster software writes to the metadata at regular intervals to confirm whether its disks are available or not, then Data Retention Utility should not be used in HA environments.
- **Dynamic disk on Windows systems**
 - Data Retention Utility volumes cannot be used for the dynamic disk, because the dynamic disk does not handle the volumes set to Write Protect Mode (Read ONLY). Data Retention Utility volumes must be used for basic disks only.
- **LUN#0**
 - Some operating systems cannot recognize LUNs over LUN#1 if LUN#0 has the Data Retention Utility "inv" attribute set. This is because some HBA drivers do not scan all LUNs on a port if LUN#0 is invisible.

Database Validator

Database Validator prevents data corruption in an Oracle database by checking Oracle data validation before an Oracle data block is written on a disk.

- **Data Block corruption:** This occurs when Oracle data is corrupted by some intervening software layer and/or hardware components. The RAID storage system can check the validity of the data block before the Oracle data block is written to disk.
- **Data block address corruption:** The OS (file system, LVM, Disk driver) might write blocks to the wrong location. The RAID storage system can check the validity of the data block address to verify that the Oracle data block is written to the correct location on disk.
- **Protection of Oracle volume:** Oracle data files might be overwritten by a non-Oracle application or by human operation using a command. The RAID storage system can protect volumes storing Oracle files by preventing the volumes from being modified by another application or by human error.

Restrictions on Database Validator

- **Oracle® tablespace location**
 - File system-based Oracle files are not supported by Database Validator. All Oracle database files must be placed on raw volumes (including LVM raw volumes) directly.
 - If host-based striping is used on raw volumes, then the stripe size must be an exact multiple of the Oracle block size.
 - Oracle redo log files (including archive logs) must be on separate volumes with respect to the data files (including control files). In other words, Oracle redo log files and the data files must not be mixed on the same LU.
- **Restoring Oracle® files**
 - Before restoring Oracle data files from a backup, data validation might need to be temporarily turned off for those data files that were backed up prior to the Oracle checksum being enabled.

Old blocks can exist on disk without checksum information in them if the database was running without checksum enabled in the past.

- **Oracle® on LVM(VxVM)**

- LVM block size must be a multiple of the Oracle block size. The Oracle block size must be less than or equal to the minimum of the LVM stripe size and the largest block size at which LVM will not fracture (known as "Logical Track Group" in LVM), which is 256 KB in LVM.
- When adding new physical volumes (PVs) to a logical volume (LV) to be used as an Oracle data file, control file, or online log, the data validation should be re-enabled in order to have HARD checking take effect on those new PVs.

Similarly, in order to have HARD checking no longer performed on PVs that have been removed from an LV that had previously been used by Oracle, HARD checking should be explicitly disabled on the device corresponding to the PV.

- If host-based mirroring is used such as LVM mirroring, all component PV mirrors must be HARD-enabled, otherwise the entire logical volume (LV) is exposed. That is, if a user takes an unmirrored HARD-enabled LV, then makes it mirrored on the fly without HARD-enabling all sides of the mirror, that entire LV is exposed to data corruption.
- LVM bad block relocation is not allowed on PVs that are HARD-enabled.

- **Oracle® and LVM (VxVM) on HA Cluster Server**

- If HA Cluster software writes to LVM metadata at regular intervals to confirm whether its disks are available or not, change the check area which is set for the target LU (except management area) by using the "-vs <bsize> SLBA ELBA" option.

Protection parameters and operations

The RAID storage systems have protection checking parameters for each LU, and these parameters are set through CCI and its command device. CCI supports the following commands to set and verify the parameters for protection checking for each LU:

- **raidvchkset**: Sets the protection checking parameter for the specified volumes.
- **raidvchkdsp**: Shows the protection checking parameter for the specified volumes based on the CCI configuration definition file.
- **raidvchkscan**: This command has three different uses depending on the options used with the command.
 - Shows the port, target ID, LDEV, and validation checking parameters for the specified volumes based on the **raidscan** command.
 - Shows the journal volume list setting and information for the journal volume.
 - Shows the Copy-on-Write Snapshot pool setting and information for the Copy-on-Write Snapshot pool.

Data Protection facility

The Data Protection Facility permits main operations to volumes that you can see on the host, and prevents wrong operations. CCI controls protected volumes at the result of recognition of protection. CCI recognizes only volumes that the host shows. For that purpose LUN Security is provided for the CCI environment.

The Data Protection Facility ON/OFF is controlled by the security setting for the command device, as shown in the following table.

Command device setting			Security to be set
Security	User authentication	Group information acquisition	
0	0	0	No security
0	0	1	Only HORCM_DEV allowed ¹
0	1	0	User authentication required ²
0	1	1	User authentication required ² Only HORCM_DEV allowed ¹
1	0	0	CMD security ³
1	0	1	CMD security ³ Only HORCM_DEV allowed ¹
1	1	0	CMD security ³ User authentication required ²
1	1	1	CMD security ³ User authentication required ² Only HORCM_DEV allowed ¹

Notes:

1. The operation can be performed only for paired logical volumes described at HORCM_DEV.
2. Only the commands issued by the authorized users can be executed.
3. Only the devices recognizable from the host can be operated

The Data Protection Facility uses an enhanced command device that you define using the LUN Manager software (or SNMP). When you define the command device, the Data Protection Facility is turned ON or OFF to each command device, which has an attributes to enable the Data Protection Facility. CCI distinguishes the ON from OFF attribute when CCI recognizes the command device. The figure given below shows the definition of protected volumes.

Note: If the command device is set to enable protection mode, there is no impact on CCI operations. CCI controls pairs under current specification. For details about the command operations when the Data Protection Facility is turned ON, see Target commands for protection.

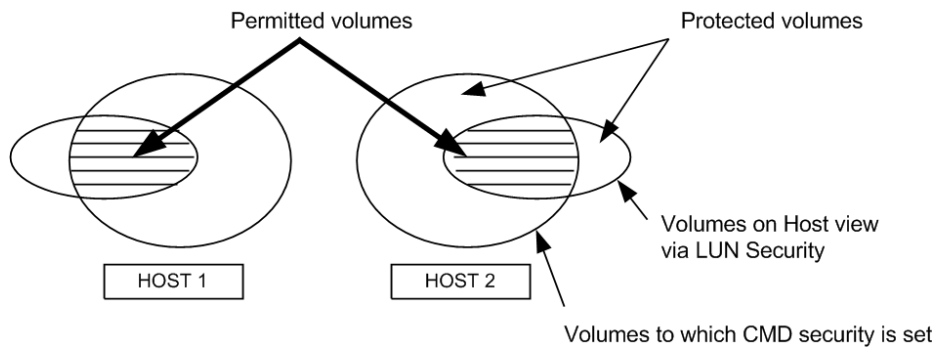

Data Protection Facility specifications

Only the permitted volumes can be registered in `horcm.conf`. When creating the `horcm.conf` file, describe volumes only from the view that the host shows. CCI manages mirror descriptors (TrueCopy, ShadowImage/MU#0/1/2) as a unit.

The Data Protection Facility has two specifications: one must be a volume that you can see from the host such as the Inquiry tool, and the other must be a mirror descriptor volume that was registered in `horcm.conf`. The following table shows the registration for the mirror descriptor.

Volume s in <code>horcm.conf</code>	Mirror Descriptor in <code>horcm.conf</code>							
	TrueCopy		ShadowImage					
			MU#0		MU#1		MU#2	
	E	none	E	none	E	none	E	none
Unkno wn	-	-	-	-	-	-	-	-
/dev/ rdsk/ c0t0d0	permitt ed volume s	-	permitt ed volume s	-	permitt ed volume s	-	permitt ed volume s	-

Volume s in horcm. conf	Mirror Descriptor in horcm.conf							
	TrueCopy		ShadowImage					
			MU#0		MU#1		MU#2	
	E	none	E	none	E	none	E	none
Unkno wn	-	-	-	-	-	-	-	-
Legend: E: Mirror descriptor volume to be registered in <code>horcm.conf</code> . Unknown: Volumes that own host cannot recognize, even though volumes were registered in <code>horcm.conf</code> .								

- CCI permits operation after the **permission** command at startup of HORCM. The target is volume that was registered in the `horcm.conf` file.
- The **permission** command is necessary to permit the protected volume at first. The **permission** command compares an identification for volumes of `horcm.conf` to all of own host volumes, and the result is registered within HORCM. And HORCM makes tables for protected volume and permitted volumes from `horcm.conf` and Inquiry result. Inquiry result is based on configuration of Data Retention Utility. When controlling pair volumes, requests to protected volumes are rejected with error code EX_ENPERM.
- The Data Protection Facility is based on the host side view at the result of Data Retention Utility. You need to configure Data Retention Utility before CCI operation. CCI checks Data Retention Utility by Inquiry within CCI.
- The Data Protection Facility can be enabled separately for each command device. If you want to use protection and non-protection modes in the same storage system at the same time, you can define two (or more) command devices: one with protection ON, one with protection OFF. Protection mode is enabled for the host that has Data Retention Utility and ON command device.

Examples for configuration and protected volumes

Case (1): Two Hosts (See the figure given below for two host configuration). In protect mode, Ora2 are rejected to operate the paired volume, because of Unknown for Grp4 on HOST2.

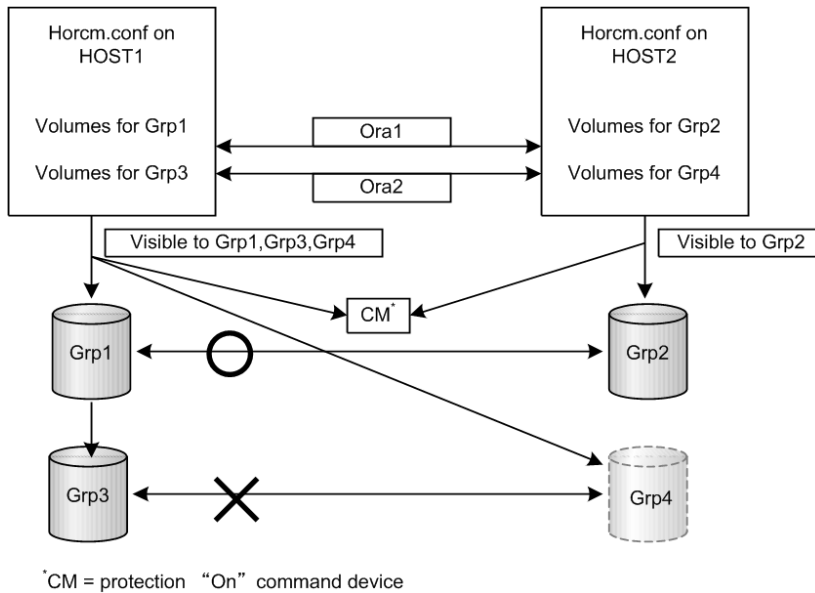

Case (2): One Host (See the figure given below for one host configuration). In protect mode, Ora1 and Ora2 are rejected to operate the paired volume, because of Unknown for Grp2 and Grp4 on HOST1. If HOST1 has a protection OFF command device, then Ora1 and Ora2 are permitted to operate the paired volume.

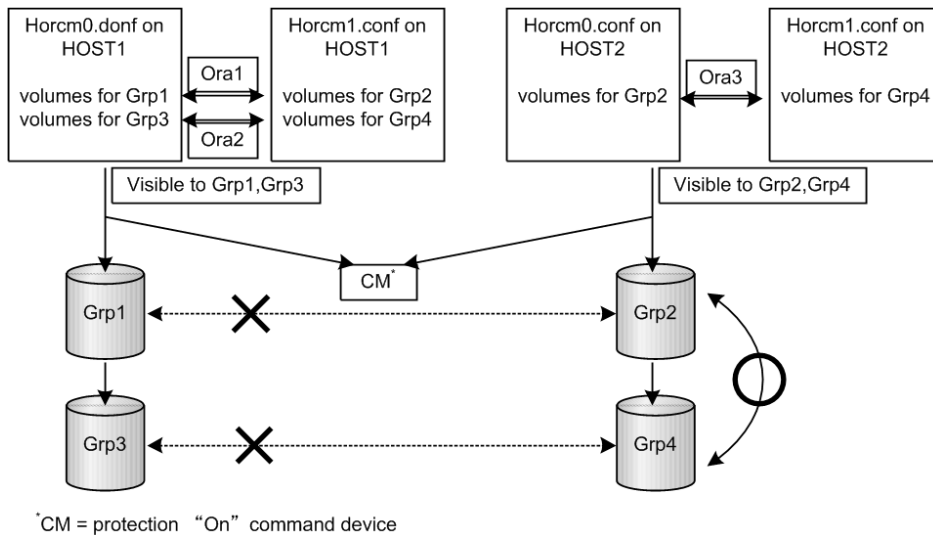

Note: The Data Protection Facility is implemented by only CCI. CCI needs to know the protection attribute for the command device whether should be permitted the operation for paired volume. If HORCM has protection ON command device at its time, then HORCM checks a permission for a paired volume.

Operation authority with CMD security enabled

If the CMD security is enabled, you have the operation authority for the LU which meets both of the following requirements.

- The connection to the host has been recognized when you start CCI.
- The LU is the target of the pair operation specified with MU# which is defined in the configuration definition file.

For the volumes that you do not have the operation authority, "****" is displayed as the LDEV#, and "----" is displayed as the status. If you perform the pair operations, CCI rejects the request with the error code "EX_ENPERM" (**pairdisplay** is not included).

If you specify 0, 1 2... for the MU#, your operation authority is limited on the LUs for the local copy program products (ShadowImage, ShadowImage for Mainframe and Copy-on-Write Snapshot). If you specify h0, h1 or h2 for the MU#, your operation authority is limited on the LUs for the remote copy operations (TrueCopy, TrueCopy for Mainframe, TrueCopy Async, Universal Replicator, Universal Replicator for Mainframe, and global-active device). If you specify nothing for the MU#, you have the operation authority on MU#0 for the local copy and the remote copy operations.

Target commands for protection

The following commands are controlled by the Data Protection Facility: **horctakeover**, **paircurchk**, **paircreate**, **pairsplit**, **pairresync**, **pairvolchk**, **pairevtwait**, **pairsyncwait**, **raidvchkset**, **raidvchkdsp**, **pairdisplay**. When the command is issued to non-permitted volumes, CCI rejects the request with error code "EX_ENPERM" (**pairdisplay** is not included).

- The **pairdisplay** command shows all volumes, so that you can confirm non-permitted volumes. Non-permitted volumes are shown without LDEV# information. As shown below, the LDEV# information is "****" (-CLI is "-").

Example

```
# pairdisplay -g oradb
```

```
Group   PairVol (L/R) (Port#,TID,LU-M),Seq#, LDEV#.P/S,Status, Seq#,P-
LDEV# M
oradb   oradev1 (L)   (CL1-D , 3, 0-0) 35013 ****.- -,- -
oradb   oradev1 (R)   (CL1-D , 3, 1-0) 35013 ****.- -,- -
```

- The **raidscan** command shows all volumes same as current specification, because it does not need HORCM_DEV and HORCM_INST on **horcm.conf**. If you want to know permitted volumes at **raidscan**, use **raidscan -find**. The **-find** option shows device file name and storage system information by using internal Inquiry result. You can use **raidscan -find** to make **horcm.conf**, because only permitted volumes are shown with host side view. Following is an example for HP-UX systems:

Example

```
# ioscan -fun | grep rdisk | raidscan -find
```

```
DEVICE_FILE      UID  S/F PORT  TARG  LUN   SERIAL  LDEV
PRODUCT_ID
/dev/rdsk/c0t3d0  0    F  CL1-D   3     0    35013   17  OPEN-3
/dev/rdsk/c0t3d1  0    F  CL1-D   3     1    35013   18  OPEN-3
```

permission command

CCI recognizes permitted volumes at the result of the **permission** command. The **permission** command is the **-find inst** option of **raidscan**. This option issues an inquiry to a specified device file to get Ser# and LDEV# from the RAID storage system, and checks an identification for volumes of **horcm.conf** to all of own host volumes, then stores the result within HORCM of the instance. This **permission** command is started by **/etc/horcmgr** automatically.

The following example shows the relation between the device file and `horcm.conf` for a manual operation on an HP-UX system. All volumes of `ioscan` are permitted.

Example

```
# ioscan -fun | grep rdsk | raidscan -find inst
```

DEVICE_FILE LDEV	Group	PairVol	PORT	TARG	LUN M	SERIAL
/dev/rdsk/c0t3d0 17	oradb	oradev1	CL1-D	3	0 -	35013
/dev/rdsk/c0t3d0 17	oradb	oradev1	CL1-D	3	0 0	35013

New options for security

raidscan -find inst

This option registers the device file name to all mirror descriptors of the LDEV map table for CCI and permits the matching volumes on `horcm.conf` in protection mode. It is started from `/etc/horcmgr` automatically. You will not normally need to use this option. This option issues an Inquiry to a device file from the result of STDIN. Then CCI gets Ser# and LDEV# from the RAID storage system. Subsequently, CCI compares the Inquiry result to the contents of `horcm.conf`, and the result is stored within HORCM for the instance. At the same time CCI shows the result of this option about the relation. This option will also be terminated to avoid wasteful scanning after registration based on `horcm.conf`, because HORCM does not need the registration any more.

Example

```
# ioscan -fun | grep rdsk | raidscan -find inst
```

DEVICE_FILE LDEV	Group	PairVol	PORT	TARG	LUN M	SERIAL
/dev/rdsk/c0t3d0 17	oradb	oradev1	CL1-D	3	0 -	35013
/dev/rdsk/c0t3d0 17	oradb	oradev1	CL1-D	3	0 0	35013



Note: When multiple device files share the same LDEV, the first device file is registered to the LDEV map table.

raidscan -find verify [MU#]

This option shows the relation between group on `horcm.conf` and Device_File registered to the LDEV map tables from DEVICE_FILE of STDIN.

Example

```
# ioscan -fun | grep rdsk | raidscan -find verify -fd
```

DEVICE_FILE	Group	PairVol	Device_File	M	SERIAL
LDEV					
/dev/rdsk/c0t3d0 17	oradb	oradev1	c0t3d0	0	35013
/dev/rdsk/c0t3d1 18	oradb	oradev2	Unknown	0	35013
/dev/rdsk/c0t3d2 19	-	-	-	0	35013



Note: It shows shared LDEV among multiple device files, if there is a difference between DEVICE_FILE and Device_File. You can also use this option to the command device that specified non-protection mode. It is used for the purpose to see the relation between DEVICE_FILE and the group of horcm.conf.

raidscan -f[d]

This option shows the Device_File that was registered on the group of HORCM, based on the LDEV (as defined in the local instance configuration definition file).

Example

```
# raidscan -p cl1-d -fd
```

Port#	,TargetID#	,Lun#..Num(LDEV#....)	...P/S	Status	Fence	LDEV#	Device_File
CL1-D	,	3,	0...1(17)SMPL	-	-	-,c0t3d0
CL1-D	,	3,	1...1(18)SMPL	-	-	-,c0t3d1

pairedisplay -f[d]

This option shows the relation between the Device_File and the paired volumes (protected volumes and permitted volumes), based on the group, even though this option does not have any relation with protection mode.

Example

```
# pairedisplay -g oradb -fd
```

Group	PairVol (L/R)	Device_File	M	,Seq#	,LDEV#	.P/S	Status	Seq#	P-LDEV#
oradb	oradev1 (L)	c0t3d0	0	35013	17	..P-VOL	COPY,	35013	18

```

-
oradb  oradev1 (R)  c0t3d1          0 35013  18..S-VOL COPY, 35013  17
-

```

If either the local or the remote host (instance) has not been shown the Device_File, then pair operations are rejected (except the local option such as "-l") in protection mode because of Unknown volume, as shown in the following example.

Example

```
# pairdisplay -g oradb -fd
```

```

Group  PairVol (L/R) Device_File  M ,Seq#,LDEV#.P/S,Status, Seq#,P-LDEV#
M
oradb  oradev1 (L)  c0t3d0          0 35013  17..P-VOL COPY, 35013  18
-
oradb  oradev1 (R)  Unknown        0 35013  ****..- -, - - -

```

Permitting protected volumes

Protection mode needs recognition step to check accessible volumes and the `horcm.conf` at the startup of HORCM on protection mode. The protected volumes must be registered to enable the Data Protection Facility at each startup of HORCM, so that this registration process is executed automatically by `/etc/horcmgr`.

With a \$HORCMPerm file

The following is executed for registration of permitted volume file (\$HORCMPerm file), if \$HORCMPerm file exists and there are permitted volumes. To permit only the volumes specified, then the volume list must be defined in the \$HORCMPerm file.

Naming of \$HORCMPerm file on UNIX systems

\$HORCMPerm is `/etc/horcmperm.conf` or `/etc/horcmperm*.conf` (* = instance number) by default. For example, on HP-UX systems:

```

cat $HORCMPerm | /HORCM/usr/bin/raidscan -find inst
# The following are an example to permit the LVM Volume groups.
# For MU# 0
vg00 /dev/rdisk/c0t3d0 /dev/rdisk/c0t3d1
vg00 /dev/rdisk/c0t3d2 /dev/rdisk/c0t3d3
# For MU# 1
vg01 /dev/rdisk/c0t3d0 /dev/rdisk/c0t3d1
vg01 /dev/rdisk/c0t3d2 /dev/rdisk/c0t3d3

```

Verifying a group for vg01: The following are examples how to verify whether a LVM volume group is mapped to group (MU#1 for ShadowImage) in the `horcm.conf` file correctly.

```
# export HORCC_MRCF=1
# cat /etc/horcmperm.conf | grep vg01 | raidscan -find verify 1 -fd
```

OR

```
# vgdisplay -v /dev/vg01|grep dsk|sed 's/\/*\dsk\\/\rdsk\\/'
g'|raidscan -find verify 1 -fd
DEVICE_FILE          Group    PairVol    Device_File    M    SERIAL
LDEV
/dev/rdsk/c0t3d0      oradb1   oradev1    c0t3d0         1
35013    17
/dev/rdsk/c0t3d1      oradb1   oradev2    c0t3d1         1
35013    18
/dev/rdsk/c0t3d2      oradb    oradev3    c0t3d2         1
35013    19
/dev/rdsk/c0t3d3      -        -          -              1
35013    20
```

Naming of \$HORCMPerm file on Windows systems

\$HORCMPerm is `%windir%\horcmperm.conf` or `%windir%\horcmperm*.conf` (* = instance number) by default.

```
type $HORCMPerm | x:\HORCM\etc\raidscan.exe -find inst
# The following are an example to permit the DB Volumes.
# Note: a numerical value is interpreted as Harddisk#.
# DB0 For MU# 0
Hd0-10
harddisk12 harddisk13 harddisk17
# DB1 For MU# 1
hd20-23
```

Verifying a group for DB1: The following is an example of how to verify whether a DB volume group is mapped to a group (MU#1 for ShadowImage) in the `horcm.conf` file correctly.

```
D:\HORCM\etc> set HORCC_MRCF=1
D:\HORCM\etc> echo hd20-23 | raidscan -find verify 1 -fd
DEVICE_FILE          Group    PairVol    Device_File    M    SERIAL
LDEV
Harddisk20           oradb1   oradev1    Harddisk20     1    35013
17
Harddisk21           oradb1   oradev2    Harddisk21     1    35013
18
Harddisk22           oradb    oradev3    Harddisk22     1    35013
19
```

Harddisk23	-	-	-	1	35013
20					

Without a \$HORCMPerm file: Commands to run on different operating systems

If NO \$HORCMPerm file exists, run a command on the host to permit all volumes on the host. The following table shows the command to run on each operating system.

System	Command
HP-UX	echo /dev/rdisk/* /dev/rdisk/* /dev/rcdisk/* /HORCM/usr/bin/raidscan -find inst
Linux	ls /dev/sd* /HORCM/usr/bin/raidscan -find inst
zLinux	ls /dev/sd* /dev/dasd* /HORCM/usr/bin/raidscan -find inst
Solaris	ls /dev/rdisk/* /HORCM/usr/bin/raidscan -find inst
AIX	lsdev -C -c disk grep hdisk /HORCM/usr/bin/raidscan -find inst
Tru64 UNIX	ls /dev/rdisk/dsk* /HORCM/usr/bin/raidscan -find inst
Digital UNIX	ls /dev/rrz* /HORCM/usr/bin/raidscan -find inst
DYNIX/ptx	/etc/dumpconf -d grep sd /HORCM/usr/bin/raidscan -find inst
IRIX64	ls /dev/rdisk/*vol /dev/rdisk/*/*vol/* /HORCM/usr/bin/raidscan -find inst
OpenVMS	/HORCM/usr/bin/raidscan -pi '\$1\$DGA0-10000 DKA0-10000 DGA0-10000' -find inst
Windows	X:\HORCM\etc\raidscan.exe -pi \$PhysicalDrive -find inst



Note: This registration process has risk because it is executed automatically by /etc/horcmgr without judgment for protection mode in order to validate the `-fd` option. This registration brings a degradation in horcmstart.sh, but HORCM daemon has been running as usual, and it will depend on how many devices a host has. To start faster at HORCM faster in non-protection mode, create the \$HORCMPerm file of "SIZE 0 byte" as a dummy file or to set HORCMPerm=MGRNOINST. At this time, the `-fd` option shows Device_File name as Unknown, and after you can use `raidscan -find inst` to validate the `-fd` option.

Environment variables

\$HORCMPROMOD

This environment variable turns protection mode ON as specified in the following table depicting the relation between HORCMPROMOD and command device. If your command device is set for non-protection mode, this parameter sets it to protection mode.

Command Device	HORCMPROMOD	Mode
Protection mode	Don't care	Protection mode
Non-protection mode	Not specified	Non-protection mode
	Specified	Protection mode

\$HORCMPerm

This variable is used to specify the HORCM permission file name. If no file name is specified, `/etc/horcmperm.conf` or `/etc/horcmperm*.conf` (* = instance number) is the default.

- If a HORCM permission file exists, then `/etc/horcmgr` executes the following command to permit the volumes specified.

Example for UNIX systems:

```
cat $HORCMPerm | /HORCM/usr/bin/raidscan -find inst
```

Example for Windows systems:

```
type $HORCMPerm | x:\HORCM\etc\raidscan.exe -find inst
```

- If no HORCM permission file exists, then `/etc/horcmgr` executes a built-in command to permit all volumes of a host. See [Without a \\$HORCMPerm file: Commands to run on different operating systems](#) for examples of commands run on an operating basis.
- `/etc/horcmgr` does not execute the built-in command if the following is defined for \$HORCMPerm. This is used to execute a system command to permit the volumes specified from a user's shell script.

```
HORCMPerm=MGRNOINST.
```

Determining the protection mode command device

The inquiry page is not changed for a command device with protection mode ON. Therefore, CCI provides how to find the protection mode command device. To determine the currently used command device, use the `horcctl -D` command. This command shows the protection mode command device by adding an asterisk (*) to the device file name.

Example for HP-UX systems:

```
# horcctl -D  
Current control device = /dev/rdisk/c0t0d0*  
- * indicates protection ON.
```

Chapter 8: Examples of using CCI commands

This chapter provides examples of typical tasks performed using CCI commands.

Group version control for mixed storage system configurations

Before executing each option of a command, CCI checks the facility version of the storage system internally to verify that the same version is installed on mixed storage system configuration. If the configuration includes older storage systems (for example, 9900V), this method might not meet the requirements for the mixed storage system environment, because the older storage system limits the availability enhancements in later facility versions. If the facility versions of the storage systems are different, you cannot use TagmaStore USP/TagmaStore NSC-specific facility, because CCI applies the minimum version to all storage systems. To expand the capability for mixed storage system configurations and avoid problems such as this, CCI supports the following group version control to manage a version for each group.

- CCI (HORCM daemon) makes a facility version for each group based on a configuration file at the startup of HORCM.
- In a mixed storage system configuration, if the facility version of the storage systems (for example, USP V/VM and TagmaStore USP/TagmaStore NSC) is different on a group, CCI will apply the minimum version for each group (see the following figure showing the definition of the group version).

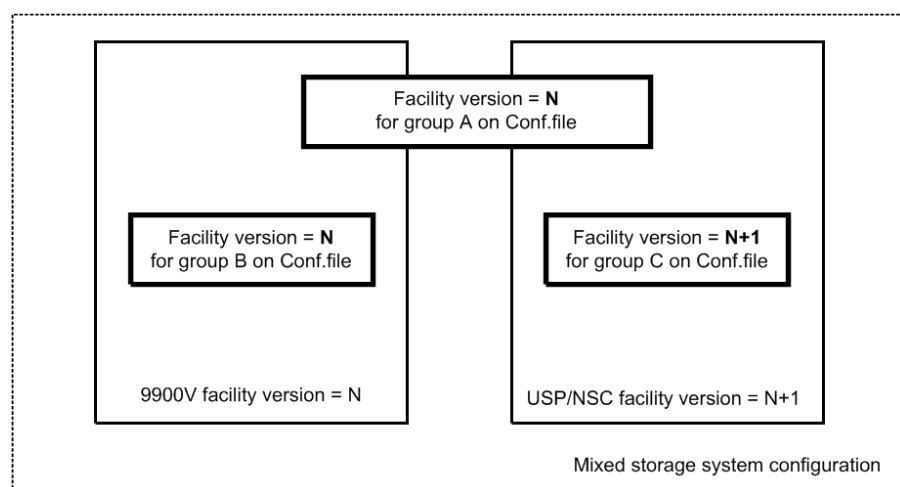

LDM volume discovery and flushing for Windows

Windows systems support the Logical Disk Manager (LDM) (such as VxVM), and a logical drive letter is typically associated with an LDM volume (\Device\HarddiskVolumeX). Therefore, you cannot know the relationship between LDM volumes and the physical volumes of the RAID storage system. Therefore, you need to create the CCI configuration file, and you need to know the relationship that is illustrated in the figure given below.

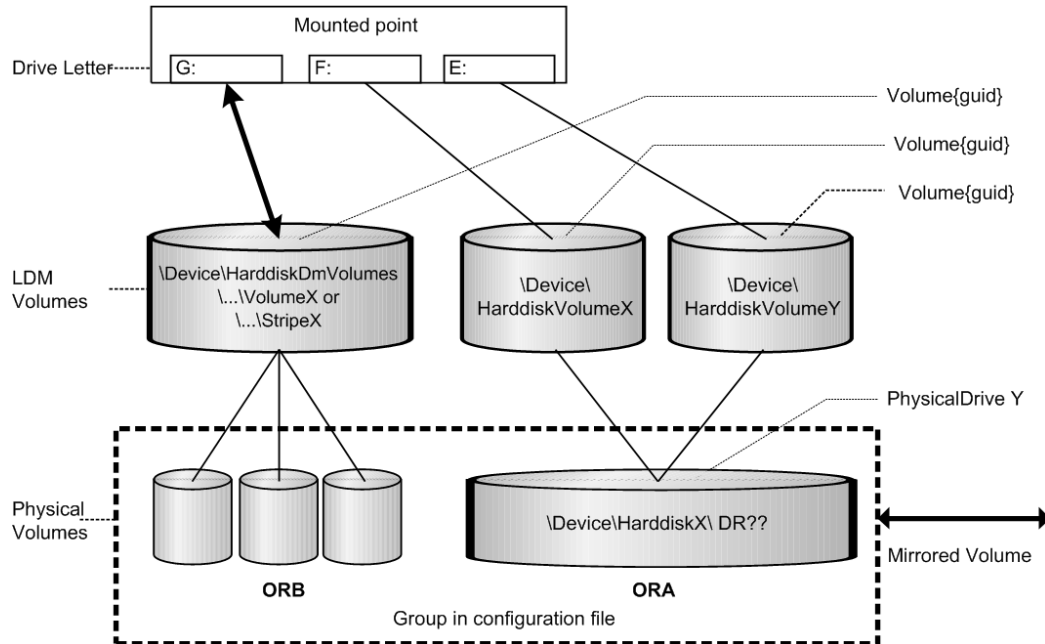

Volume discovery function

CCI supports the volume discovery function on three levels showing the relationship between LDM volumes and the physical volumes.

- **Physical level:** CCI shows the relationship between PhysicalDrive and LDEV by giving \$Physical as a KEY WORD for the discovery.
- **LDM volume level:** CCI shows the relationship between [LDM volume and PhysicalDrives] and LDEV by given \$Volume as KEY WORD for the discovery.
- **Drive letter level:** CCI shows the relationship between [Drive letter and LDM volume and PhysicalDrives] and LDEV by given \$LETALL as KEY WORD for the discovery.

The KEY WORD (**\$Physical**, **\$Volume**, **\$LETALL**) can be used with **raidscan -find**, **inraid**, **mkconf** commands.

In Windows, DOS devices (for example, C:, Volume{ }) are linked to a Device Object Name (\Device\...). CCI indicates as the following by abbreviating a long Device Object Name.

- Device Object Name of the LDM for Windows:
 \Device\HarddiskVolumeX for Partition : \VolX\DskY

DskY shows that VolX are configured through HarddiskY.

- Device Object Name of the LDM for Windows 2003/2000:

\Device\HarddiskDmVolumes\ ... \VolumeX for spanned volume : \DmsX\DskYs

\Device\HarddiskDmVolumes\ ... \StripeX for striped volume : \DmtX\DskYs

\Device\HarddiskDmVolumes\ ... \RaidX for Raid-5 volume : \DmrX\DskYs

DskYs shows that DmsX(DmtX,Dmr) volumes are configured through bundling multiple HarddiskY1 Y2....

- Device Object Name of the PhysicalDrive for Windows:

\Device\HarddiskX\DR?? : HarddiskX

You can determine the relationship between LDM volumes and LDEV by given a KEY WORD to the **inqraid** command.

Example 1

```
inqraid $LETALL -CLI
DEVICE_FILE      PORT      SERIAL    LDEV CTG   H/M/12  SSID R:Group  PRODUCT_ID
D:\Vol2\Dsk4     -         -         -    -     -       -     -       -   DDRS-34560D
E:\Vol44\Dsk0    CL2-K     61456     194  -     s/s/ss  0004 1:01-10 OPEN-3
F:\Vol45\Dsk0    CL2-K     61456     194  -     s/s/ss  0004 1:01-10 OPEN-3
G:\Dmt1\Dsk1     CL2-K     61456     256  -     s/s/ss  0005 1:01-11 OPEN-3
G:\Dmt1\Dsk2     CL2-K     61456     257  -     s/s/ss  0005 1:01-11 OPEN-3
G:\Dmt1\Dsk3     CL2-K     61456     258  -     s/s/ss  0005 1:01-11 OPEN-3
```

Example 2

```
inqraid $Volume -CLI
DEVICE_FILE      PORT      SERIAL    LDEV CTG   H/M/12  SSID R:Group  PRODUCT_ID
\Vol2\Dsk4       -         -         -    -     -       -     -       -   DDRS-34560D
\Vol44\Dsk0      CL2-K     61456     194  -     s/s/ss  0004 1:01-10 OPEN-3
\Vol45\Dsk0      CL2-K     61456     194  -     s/s/ss  0004 1:01-10 OPEN-3
\Dmt1\Dsk1       CL2-K     61456     256  -     s/s/ss  0005 1:01-11 OPEN-3
\Dmt1\Dsk2       CL2-K     61456     257  -     s/s/ss  0005 1:01-11 OPEN-3
\Dmt1\Dsk3       CL2-K     61456     258  -     s/s/ss  0005 1:01-11 OPEN-3
```

Example 3

```
inqraid $Phy -CLI
DEVICE_FILE      PORT      SERIAL    LDEV CTG   H/M/12  SSID R:Group  PRODUCT_ID
Harddisk0        CL2-K     61456     194  -     s/s/ss  0004 1:01-10 OPEN-3
Harddisk1        CL2-K     61456     256  -     s/s/ss  0005 1:01-11 OPEN-3
Harddisk2        CL2-K     61456     257  -     s/s/ss  0005 1:01-11 OPEN-3
```

```

Harddisk3      CL2-K      61456    258    -    s/s/ss    0005    1:01-11    OPEN-3
Harddisk4      -          -        -      -      -          -        -          -    DDRS-34560D

```

- Device Object Name of the Partition for Windows NT
 - \Device\HarddiskX\PartitionY : \DskX\pY
- Device Object Name of the PhysicalDrive for Windows NT
 - \Device\HarddiskX\Partition0 : HarddiskX

Example 4

```

inqraid $LETALL -CLI
DEVICE_FILE    PORT      SERIAL    LDEV CTG    H/M/12    SSID R:Group    PRODUCT_ID
D:\Dsk0\p1     -         -         -    -      -         -         -          -    DDRS-34560D
E:\Dsk1\p1     CL2-K     61456     194  -    s/s/ss    0004    1:01-10    OPEN-3
F:\Dsk1\p2     CL2-K     61456     194  -    s/s/ss    0004    1:01-10    OPEN-3

```

Example 5

```

inqraid $Phy -CLI
DEVICE_FILE    PORT      SERIAL    LDEV CTG    H/M/12    SSID R:Group    PRODUCT_ID
Harddisk0      -         -         -    -      -         -         -          -    DDRS-34560D
Harddisk1      CL2-K     61456     194  -    s/s/ss    0005    1:01-11    OPEN-3

```

You want to know the relationship between LDM volumes and a group of the configuration files, and then find a group of the configuration file by giving a KEY WORD to **raidscan -find verify** command.

Example 6

```

raidscan -pi $LETALL -find verify
DEVICE_FILE          Group    PairVol    PORT    TARG    LUN M    SERIAL
LDEV
E:\Vol44\Dsk0        ORA      ORA_000    CL2-K    7      2 -    61456
194
F:\Vol45\Dsk0        ORA      ORA_000    CL2-K    7      2 -    61456
194
G:\Dmt1\Dsk1        ORB      ORB_000    CL2-K    7      4 -    61456
256
G:\Dmt1\Dsk2        ORB      ORB_001    CL2-K    7      5 -    61456
257
G:\Dmt1\Dsk3        ORB      ORB_002    CL2-K    7      6 -    61456
258

```

Example 7

```

raidscan -pi $LETALL -find
DEVICE_FILE          UID    S/F    PORT    TARG    LUN    SERIAL    LDEV    PRODUCT_ID
E:\Vol44\Dsk0        0      F      CL2-K    7      2      61456    194    OPEN-3
F:\Vol45\Dsk0        0      F      CL2-K    7      2      61456    194    OPEN-3

```

```
G:\Dmt1\Dsk1      0  F  CL2-K    7   4   61456   256  OPEN-3
G:\Dmt1\Dsk2      0  F  CL2-K    7   5   61456   257  OPEN-3
G:\Dmt1\Dsk3      0  F  CL2-K    7   5   61456   258  OPEN-3
```

Mountvol attached to Windows 2012/2008/2003/2000 systems

Pay attention to the **mountvol /D** command attached to a Windows system, such that it does not flush the system buffer associated with the specified logical drive. The **mountvol** command shows the volume mounted as Volume{guid} as follows:

Example

```
mountvol
Creates, deletes, or lists a volume mount point.
.
.
MOUNTVOL [drive:]path VolumeName
MOUNTVOL [drive:]path /D
MOUNTVOL [drive:]path /L
  \\?\Volume{56e4954a-28d5-4824-a408-3ff9a6521e5d}\
  G:\
  \\?\Volume{bf48a395-0ef6-11d5-8d69-00c00d003b1e}\
  F:\
```

You can determine what `\\?\Volume{guid}\` is configured, as follows:

Example

```
inraid $Volume{bf48a395-0ef6-11d5-8d69-00c00d003b1e} -CLI
DEVICE_FILE      PORT      SERIAL  LDEV CTG  H/M/12  SSID R:Group PRODUCT_ID
\Vol146\Dsk1     CL2-K     61456   193  -   S/s/ss  0004 1:01-10 OPEN-3
raidscan -pi $Volume{bf48a395-0ef6-11d5-8d69-00c00d003b1e} -find
DEVICE_FILE      UID  S/F PORT  TARG  LUN   SERIAL  LDEV  PRODUCT_ID
\Vol146\Dsk1     0    F  CL2-K    7     1     61456   193  OPEN-3
```

System buffer flushing function

The logical drive to be flushed can be specified by the following two methods. One method is that the logical drive (for example, G:\hd1 drive, as below) is specified immediately, but this method must know about the logical drive corresponding to a group before executing the **sync** command. Also the volume is mounting by a directory and this method requires finding its volume name. To solve such a complication, CCI supports a method that flushes the system buffer associated with a logical drive through finding a volume{guid} corresponding to a group of the configuration file. This method does not depend on mounted point, so that it is possible to flush the volume mounted by a directory. This method is supported to be specified a group to the **raidscan -find sync** command. The figure given below shows the LDM volume flushing operation.

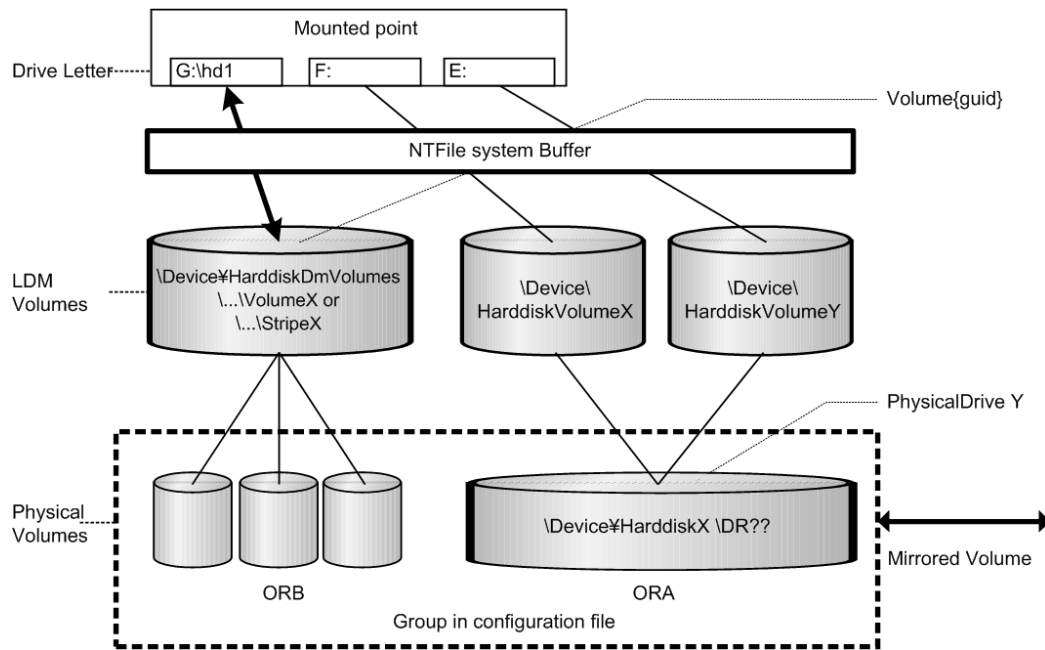

The following example flushes the system buffer associated with the ORB group through \$Volume.

Example

```

raidscan -pi $Volume -find sync -g ORB
[SYNC] : ORB ORB_000[-] -> \Dmt1\Dsk1 : Volume{bf48a395-0ef6-11d5
8d69-00c00d003b1e}
[SYNC] : ORB ORB_001[-] -> \Dmt1\Dsk2 : Volume{bf48a395-0ef6-11d5
8d69-00c00d003b1e}
[SYNC] : ORB ORB_002[-] -> \Dmt1\Dsk3 : Volume{bf48a395-0ef6-11d5
8d69-00c00d003b1e}

```

The following example flushes the system buffer associated with all groups for the local instance.

Example

```

raidscan -pi $Volume -find sync
[SYNC] : ORA ORA_000[-] -> \Vol144\Dsk0 : Volume{56e4954a-28d5
4824-a408-3ff9a6521e5d}
[SYNC] : ORA ORA_000[-] -> \Vol145\Dsk0 : Volume{56e4954a-28d5
4824-a408-3ff9a6521e5e}
[SYNC] : ORB ORB_000[-] -> \Dmt1\Dsk1 : Volume{bf48a395-0ef6
11d5-8d69-00c00d003b1e}
[SYNC] : ORB ORB_001[-] -> \Dmt1\Dsk2 : Volume{bf48a395-0ef6
11d5-8d69-00c00d003b1e}
[SYNC] : ORB ORB_002[-] -> \Dmt1\Dsk3 : Volume{bf48a395-0ef6
11d5-8d69-00c00d003b1e}

```



Note: Windows NT does not support the LDM volume, so specify \$LETALL instead of \$Volume.

Offline backup using `raidscan -find sync` for Windows file system:

The `raidscan -find sync` command flushes the system buffer associated with a logical drive through finding a Volume{guid} corresponding to a group of the configuration file, without using the `-x mount` and `-x umount` commands. The following examples are for group ORB.

P-VOL Side	S-VOL Side
<p>Close all logical drives on the P-VOL by application.</p> <ul style="list-style-type: none"> ▪ Flush the system buffer for P-VOL using <code>raidscan -pi \$Volume -find sync -g ORB</code>. ▪ Split the paired volume using <code>pairsplit -g ORB</code> with r/w mode. ▪ Open all logical drives on the P-VOL by application. ▪ Resynchronize the paired volume using <code>pairresync -g ORB</code>. 	<ul style="list-style-type: none"> ▪ Flush the system buffer for NEW S-VOL data using <code>raidscan -pi \$Volume -find sync -g ORB</code>. ▪ Back up the S-VOL data. ▪ Flush the system buffer for S-VOL updates using <code>raidscan -pi \$Volume -find sync -g ORB</code> when the backup is finished.

Online backup using `raidscan -find sync` for Windows file system:

The `raidscan -find sync` command flushes the system buffer associated with a logical drive through finding a Volume{guid} corresponding to a group of the configuration file, without using the `-x mount` and `-x umount` commands. The following examples are for group ORB.

P-VOL Side	S-VOL Side
<p>Freeze DB on opening P-VOL by application.</p> <ul style="list-style-type: none"> ▪ Flush the system buffer for P-VOL using <code>raidscan -pi \$Volume -find sync -g ORB</code>. ▪ Splits the paired volume using <code>pairsplit -g ORB</code> with r/w mode. ▪ Unfreeze DB on opening P-VOL by application. ▪ Resynchronize the paired volume using <code>pairresync -g ORB</code>. 	<ul style="list-style-type: none"> ▪ Flush the system buffer for NEW S-VOL data using <code>raidscan -pi \$Volume -find sync -g ORB</code>. ▪ Back up the S-VOL data. ▪ Flush the system buffer for S-VOL updates using <code>raidscan -pi \$Volume -find sync -g ORB</code> when the backup is finished.

Offline backup using raidscan -find sync for Windows NT file system:

The **raidscan -find sync** command flushes the system buffer through finding a logical drive corresponding to a group of the configuration file, without using the **-x mount** and **-x umount** commands. The following examples are for group ORB.

P-VOL Side	S-VOL Side
<p>Close all logical drives on the P-VOL by application.</p> <ul style="list-style-type: none"> ▪ Flush the system buffer for P-VOL using <code>raidscan -pi \$LETALL -find sync -g ORB</code>. ▪ Split the paired volume using <code>pairsplit -g ORB</code> with r/w mode. ▪ Open all logical drives on the P-VOL by application. ▪ Resynchronize the paired volume using <code>pairresync -g ORB</code>. 	<ul style="list-style-type: none"> ▪ Back up the S-VOL data. ▪ Flush the system buffer for S-VOL updates using <code>raidscan -pi \$LETALL -find sync -g ORB</code> when the backup is finished.

Online backup using raidscan -find sync for Windows NT file system:

The **raidscan -find sync** command flushes the system buffer through finding a logical drive corresponding to a group of the configuration file, without using the **-x mount** and **-x umount** commands. The following examples are for group ORB.

P-VOL Side	S-VOL Side
<p>Freeze DB on opening P-VOL by application.</p> <ul style="list-style-type: none"> ▪ Flush the system buffer for P-VOL using the <code>raidscan -pi \$LETALL -find sync -g ORB</code>. ▪ Splits the paired volume using <code>pairsplit -g ORB</code> with r/w mode. ▪ Unfreeze DB on opening P-VOL by application. ▪ Resynchronize the paired volume using <code>pairresync -g ORB</code>. 	<ul style="list-style-type: none"> ▪ Back up the S-VOL data. ▪ Flush the system buffer for S-VOL updates using <code>raidscan -pi \$LETALL -find sync -g ORB</code> when the backup is finished.

**Note:**

- P-VOL side must stop the WRITE IO to the logical drive corresponding to a [-g name] before issuing the `raidscan -find sync` command.
- S-VOL side must close the logical drive corresponding to a [-g name] before issuing the `raidscan -find sync` command.

Special facilities for Windows systems

CCI provides the following special facilities for Windows systems:

- [Signature changing facility for Windows systems \(on page 348\)](#)
- [GPT disk for Windows \(on page 351\)](#)

Signature changing facility for Windows systems

Consider the following Microsoft Cluster Server (MSCS) configuration in which a MSCS P-VOL is shared from MSCS Node1 and Node2, and the copied volume of S-VOL is used for backup on Node2. If the Node2 has reboot on standby state, then MSCS of Node2 has a problem to assign drive letter of S-VOL with previous P-VOL drive letter. This problem will happen on Node2 on MSCS environment as shown in the following figure. The conditions are:

- Node1 is active.
- Node2 is standby state where P-VOL on Node2 is hidden by MSCS, and reboots the Node2.

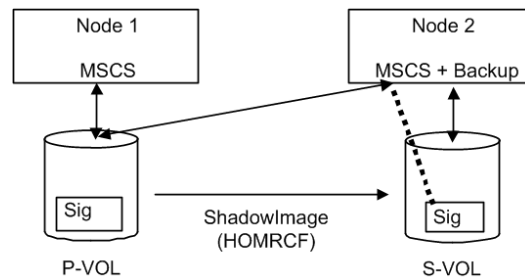

MSCS on Node2 will misunderstand the S-VOL as MSCS cluster resource, because the signature of S-VOL and P-VOL is the same due to copied. The reason is that MSCS cluster resources are managed with the signature only. Therefore S-VOL of Node2 will unable to backup so that MSCS of Node2 carry away the S-VOL. This is a problem of MSCS service because Windows system does change the signature through reboot if the same signature is detected on NO MSCS service. MSCS will not accommodate LUNs with duplicate signatures and partition layout. The best way to avoid such problems is to transport to another host outside the cluster, but this enforces to set up a backup server, so CCI supports a facility to put back the signature as a second way.

The signature can be changed by using the `dumpcfg.exe` command attached to Windows resource kits, but if the S-VOL is created with the `Noread` option and the system is rebooted, then the `dumpcfg.exe` command will fail to change the signature, because the system does not know the signature and volume layout information for S-VOL.

CCI adopts the following way with this point in view:

- You must save the signature and volume layout information to the system disk by using the `inqraid -gvinf` command, after an S-VOL has set the signature and new partition by the Windows disk management.
- You can put back the signature by setting the signature and volume layout information to an S-VOL that was saved to the system disk by using the `inqraid -svinf` command, after splitting the S-VOL. If the S-VOL is created with the `Noread` option and the system is rebooted, then the system cannot create a device object (`\Device\HarddiskVolume#`) and `Volume{guid}` for S-VOL, but the `-svinf` option will create a Device object (`\Device\HarddiskVolume#`) and `Volume{guid}` without using the Windows disk management.



Note: The Cluster Disk Driver does not allow using the Noread volume as [Device is not ready] at the boot time, since the Cluster Disk Driver is a Non-Plug and Play Driver. Verify this situation using the **inqraid** command as follows:

```
inqraid $Phy -CLI
DEVICE_FILE      PORT      SERIAL  LDEV CTG  H/M/12  SSID R:Group
PRODUCT_ID
Harddisk0        -          -       -    -    -        -    -
Harddisk1        -          -       -    -    -        -    -
```

In this case, do the following to disable the Cluster Disk Driver:

1. In the **Computer Management** window, double-click System Tools, and then click Device Manager.
2. On the View menu, click Show Hidden Devices. Non-Plug and Play Drivers appear in the list in the right pane.
3. Open Non-Plug and Play Drivers, right-click Cluster Disk, and then click Disable. When prompted to confirm whether to disable the cluster disk, click Yes. When prompted to restart the computer, click Yes.
4. Verify that you can see the Noread volume using **inqraid** command as follows.

```
inqraid $Phy -CLI
DEVICE_FILE      PORT      SERIAL  LDEV CTG  H/M/12  SSID
R:Group PRODUCT_ID
Harddisk0        CL2-K     61456   194  -    s/S/ss  0004 1:01-
10 OPEN-3
Harddisk1        CL2-K     61456   256  -    s/S/ss  0005 1:01-
11 OPEN-3
```

5. After starting up CCI and splitting the S-VOL, put back the signature by using the **inqraid -svinf** command.
6. Again, in the **Computer Management** window, enable the Cluster Disk Driver, and restart the computer.

GPT disk for Windows

Windows supports the basic disk called GPT disk using GUID partition instead of the Signature. The GPT disk also can be used as an S-VOL of ShadowImage. Therefore, CCI supports saving/restoring the GUID DiskId of the GPT Basic disk to the **inqraid** command.

- **gvinfex option (Windows 2012 only):**

This option retrieves the LUN signature and volume layout information by way of a raw device file provided via STDIN or arguments, and saves it in a system disk file with the following format:

```
\WindowsDirectory\VOLssss_l1111.ini
```

where

```
ssss = serial#
```

```
l1111 = LDEV#
```

Normally, this option is used to save the Disk signature/GUID DiskId and volume layout information once, after it has been written on a potential (and before its **paircreate**). You do not need to directly view these host files.

For example, saves the volume information for all physical drives:

Example

```
D:\HORCM\etc>inqraid $Phys -gvinfex -CLI
\\.\PhysicalDrive10:
# Harddisk10 -> [VOL61459_448_DA7C0D91] [OPEN-V          ]
\\.\PhysicalDrive11:
# Harddisk11 -> [VOL61459_449_D4CB5F17-2ADC-4FEE-8650
D3628379E8F5] [OPEN-V          ]
\\.\PhysicalDrive12:
# Harddisk12 -> [VOL61459_450_9ABDCB73-3BA1-4048-9E94
22E3798C3B61] [OPEN-V          ]
```

- **-svinfex[=PTN] option (Windows 2003 only):**

This option writes LUN signature/GUID DiskId and volume layout information (that had previously been saved in a system disk file) by way of a raw device file provided via STDIN or arguments.

This option gets the serial# and LDEV# of the RAID storage system for the target device using SCSI Inquiry, and writes the signature/GUID DiskId and volume layout information from the VOLssss_l1111.ini file to the target device.

This option will work correctly (even if Harddisk# changes due to configuration changes) because the signature/GUID DiskId and volume layout information is associated the array serial# and LDEV# (not Harddisk#).

- **[=PTN]:**

This option specifies a string pattern usable to select only the pertinent output lines being provide from STDIN. If used as shown, only the **pairdisplay** output lines containing Harddisk would be used to cause signature writing.

Example

```
D:\HORCM\etc>pairdisplay -l -fd -g URA | inqraid -svinfex=Harddisk
[VOL61459_448_DA7C0D91] -> Harddisk10          [OPEN-V          ]
[VOL61459_449_D4CB5F17-2ADC-4FEE-8650-D3628379E8F5] ->
Harddisk11          [OPEN-V          ]
[VOL61459_450_9ABDCB73-3BA1-4048-9E94-22E3798C3B61] ->
Harddisk12          [OPEN-V          ]
```

- **-gp1baex option (Windows 2012/2008 only):**

This option is used for displaying usable LBA on a Physical drive in units of 512 bytes, and is used to specify [slba] [elba] options for **raidvchksset** command.

Example

```
C:\HORCM\Tool>inqraid -CLI -gp1baex hd10,13
Harddisk10   : SLBA = 0x0000003f ELBA = 0x013fe5d9 PCNT = 1 [OPEN-V
]
Harddisk11   : SLBA = 0x00000022 ELBA = 0x013fffd9 PCNT = 2 [OPEN-V
]
Harddisk12   : SLBA = 0x00000022 ELBA = 0x013fffd9 PCNT = 3 [OPEN-V
]
```

SLBA

Displays usable starting LBA in units of 512 bytes

ELBA

Displays usable ending LBA (ELBA -1) in units of 512 bytes

PCNT

Displays the number of partitions

Directory mount facility for Windows systems

The attached **mountvol** command into Windows supports the directory mount, but it does not support the directory mount function that flushes the system buffer associated to a logical drive such as in UNIX systems. The directory mount structure on Windows is only symbolical link between a directory and Volume{guid}, illustrated in the figure given below. As such, CCI supports the function to discover the mounted volumes by a directory, and supports the operation to mount/unmount with the subcommand option.

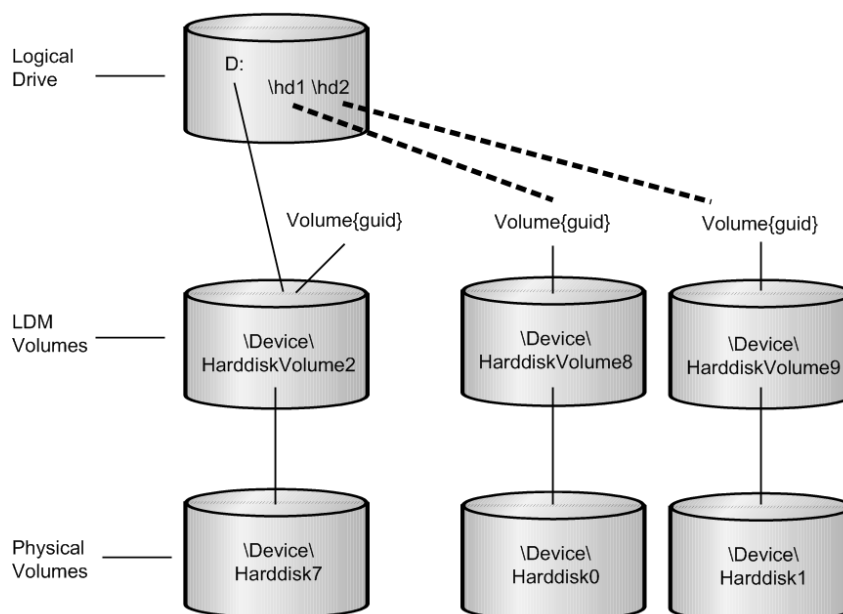

Volume discovery for directory mounted volume:

CCI can discover the directory mounted volume by using \$LETALL that shows the relationship between logical drive and the physical volumes. The KEY WORD (\$LETALL) can also be used with the **raidscan -find** and **mkconf** commands.

Example

```
D:\HORCM\etc>in RAID $LETALL -CLI
DEVICE_FILE      PORT      SERIAL    LDEV CTG  H/M/12  SSID R:Group  PRODUCT_ID
D:\Vol2\Dsk7     -         -         -    -    -        -        -        DDRS-34560D
D:\hd1\Vol8\Dsk0 CL2-F     61459     448  -    s/s/ss  0005 1:01-01  OPEN-3
D:\hd2\Vol9\Dsk1 CL2-F     61459     449  -    s/s/ss  0005 1:01-01  OPEN-3
G:\Dms1\Dsk2     CL2-K     61456     256  -    s/s/ss  0005 1:01-11  OPEN-3
G:\Dms1\Dsk3     CL2-K     61456     257  -    s/s/ss  0005 1:01-11  OPEN-3
G:\Dms1\Dsk4     CL2-K     61456     258  -    s/s/ss  0005 1:01-11  OPEN-3
```

Subcommand for directory mounted volume:

CCI supports the directory mount with the **-x mount**, **-x unmount**, **-x sync** option so that the directory mount can be used to mount/unmount the S-VOL.

Mount and Sync used Volume{GUID} for Windows:

CCI supports the **mount** command option specified in the device object name, such as `\Device\Harddiskvolume X`. Windows changes the device number for the device object name after recovering from a failure of the `PhysicalDrive`. As a result, the **mount** command specified in the device object name might fail. Therefore, CCI supports a **mount** command option that specifies a `Volume{GUID}` as well as the device object name.

- **Mount**

- The **mount** command option specifies a `Volume{GUID}` as well as the device object name.
- If a `Volume{GUID}` is specified, then it is executed by converting a `Volume{GUID}` to a device object name.
- Discover the `Volume{GUID}`s by using `inqraid $Volu -fv` command option.

Example

```
C:\HORCM\etc>inqraid -CLI $Vol -fv
DEVICE_FILE          PORT    SERIAL  LDEV
CTG  H/M/12  SSID R:Group  PRODUCT_ID
Volume{cec25efe-d3b8-11d4-aead-00c00d003b1e}\Vol13\Dsk0      CL2-D
62496  256  -      -      -      -  OPEN-3-CVS-CM
```

- **[Mount used DefineDosDevice()]**



Note: This might forcibly dismount the mounted volume due to LOG-OFF of Windows. For example:

Example

```
C:\HORCM\etc>raidscan -x mount E: Volume{cec25efe-d3b8-11d4-aead-00c00d003b1e}
E: <+> HarddiskVolume3
```

- **[Mount used Directory mount]**



Note: This prevents the forcible removal of a volume due to LOG-OFF of Windows. For example:

Example

```
C:\HORCM\etc>raidscan -x mount E:\ Volume{cec25efe-d3b8-11d4-aead-00c00d003b1e}
E:\ <+> HarddiskVolume3
```

- **sync**
 - The **sync** command option will also be able to specify a Volume{GUID} as well as the device object name.
 - If a Volume{GUID} is specified, then it is executed by converting a Volume{GUID} to a device object name.

Example

```
C:\HORCM\etc>raidscan -x sync Volume{cec25efe-d3b8-11d4-aead-00c00d003b1e}
[SYNC] Volume{cec25efe-d3b8-11d4-aead-00c00d003b1e}
```

Host group control

The RAID storage systems have the defined host group in the port and can allocate a host LU for every host group. CCI does not use this host LU, and specifies an absolute LUN in the port. To eliminate confusion that LUN of the CCI notation does not correspond to LUN on the host view and Storage Navigator, CCI supports specifying a host group and LUN on the host view.

Specifying a host group

(1) Defining the formats

The addition of arguments for the host group to the **raidscan** command and the configuration file means that it is not compatible with conventional CLI. Therefore, CCI provides a way to support CLI by specifying a host group in the port strings as follows.

- CL1-A-GRP# (GRP# can be up to 127)

Specifying the host group for the **raidscan** command:

```
raidscan -p CL1-A-5
```

Specifying the host group for the configuration file:

#dev_group	dev_name	port#	TargetID	LU#	MU#
ORA	ORA_000	CL2-D-1	4	1	0
ORA	ORA_001	CL2-D-1	4	2	0

If the port including a host group is specified to the port name, then a maximum of 255 LUNs can be specified.

(2) Specifiable port strings

As a result, CCI supports four kinds of forms for the port name.

- Specifying the port name without a host group

CL1-A

CL1-An where n: unit ID for multiple RAID

- Specifying the port name with a host group

CL1-A-g where g: host group

CL1-An-g where n-g: host group=g on CL1-A in unit ID=n

Commands and options including a host group

(1) Specifiable command for host group

The following commands can specify a host group with the port strings:

- **raidscan -p <port#>, raidar -p <port#>, raidvchkscan -p <port#>**

```
# raidscan -p CL2-D-1
PORT# /ALPA/C,TID#,LU#.Num(LDEV#....)...P/S, Status,Fence,LDEV#,P-Seq#,P-
LDEV#
CL2-D-1 /da/ 0, 4, 0.1(256).....SMPL ---- - - - - - , - - - - -
-
CL2-D-1 /da/ 0, 4, 1.1(257).....SMPL ---- - - - - - , - - - - -
-
CL2-D-1 /da/ 0, 4, 2.1(258).....SMPL ---- - - - - - , - - - - -
-
```

(2) Command option including a host group

CCI supports new option for the following commands in order to show a LUN on the host view by finding a host group via the specified device.

- **raidscan -pdg <device>, raidar -pdg <device>, raidvchkscan -pdg <device>**

```
# raidscan -pdg /dev/rdisk/c57t4d1
PORT# /ALPA/C,TID#,LU#.Num(LDEV#....)...P/S, Status,Fence,LDEV#,P-Seq#,P-
LDEV#
CL2-D-1 /da/ 0, 4, 0.1(256).....SMPL ---- - - - - - , - - - - -
-
CL2-D-1 /da/ 0, 4, 1.1(257).....SMPL ---- - - - - - , - - - - -
-
CL2-D-1 /da/ 0, 4, 2.1(258).....SMPL ---- - - - - - , - - - - -
-
Specified device(hgrp=1) is LDEV# 0257
```

- **raidscan -findg**

```
# ls /dev/rdisk/c57* | raidscan -findg
DEVICE_FILE      UID  S/F PORT  TARG  LUN   SERIAL  LDEV
PRODUCT_ID
/dev/rdisk/c57t4d0  0    F  CL2-D-1  4    0    62500  256  OPEN3-
CVS-CM
/dev/rdisk/c57t4d1  0    F  CL2-D-1  4    1    62500  257  OPEN3-CVS
/dev/rdisk/c57t4d2  0    F  CL2-D-1  4    2    62500  258  OPEN3-CVS
```

- **raidscan -findg conf, mkconf -gg**

```
# ls /dev/rdisk/c57* | raidscan -findg conf 0 -g ORA
HORCM_DEV
#dev_group      dev_name      port#      TargetID    LU#      MU#
# /dev/rdisk/c57t4d1  SER =      62500  LDEV =    257 [ FIBRE FCTBL = 4 ]
ORA             ORA_000      CL2-D-1    4           1        0
# /dev/rdisk/c57t4d2  SER =      62500  LDEV =    258 [ FIBRE FCTBL = 4 ]
ORA             ORA_001      CL2-D-1    4           2        0
```

- **inqraid -fg**

```
# ls /dev/rdisk/c57* | ./inqraid -CLI -fg
DEVICE_FILE     PORT      SERIAL  LDEV CTG  H/M/12  SSID R:Group
PRODUCT_ID
c57t4d0         CL2-D-1   62500   256  -    -      -      - OPEN-3-
CVS-CM
c57t4d1         CL2-D-1   62500   257  -    s/P/ss  0005 1:01-02 OPEN-3-
CVS
c57t4d2         CL2-D-1   62500   258  -    s/P/ss  0005 1:01-02 OPEN-3-
CVS
```

Using CCI SLPR security

The Virtual Partition Manager feature of the RAID storage systems (USP V/VM and TagmaStore USP/TagmaStore NSC) supports storage logical partitioning (SLPR), a feature that partitions the ports and volumes of the RAID storage system. If CCI does not have SLPR security, then it can operate the target volumes crossing SLPR through the command device. The purpose of CCI SLPR security is to prevent CCI from operating the volumes on another SLPR (SLPR#N) through the command device from the SLPR (SLPR#M) that is assigned to its Host. You can use CCI SLPR Security by defining the command device through the Virtual Partition Manager feature, so that CCI can protect the target volume.

The following example represents the SLPR protection facility. The figure given below shows an example of protection of the command device that has the SLPR attribute.

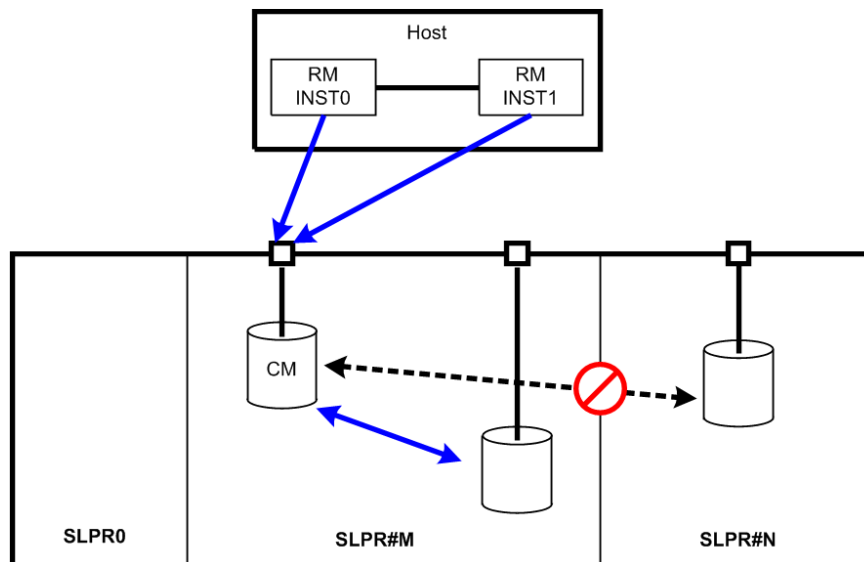

Legend:

SLPR

Split of storage

SLPR#M

Split number M of storage

Specifying the SLPR protection facility

When you want to access certain SLPRs on a single Host, use the CCI protection facility so that the Host can access multiple SLPRs through a single command device. The following outline reviews the setup tasks for the SLPR protection facility.

Procedure

1. **Setting SLPR on the command device:** The command device has an SLPR number and an associated bitmap so you can set multiple SLPRs. You accomplish this by sharing a command device (using ports connected to different SLPRs) by setting the command device through SLPR#0 (called Storage Administrator) on Storage Navigator.

For example, if the command device is shared with the port on SLPR#1 and SLPR#2, then the command device will automatically set the bitmap corresponding to SLPR#1 and SLPR#2.

2. **Testing SLPR:** CCI verifies whether or not the command device can access a target within SLPR. So, if the command device belongs to SLPR#0, or CCI has no SLPR function, then the SLPR protection is ignored.

However, if the command device is shared with the port on SLPR#1 and SLPR#2, CCI allows you to operate the volume on SLPR#1 and SLPR#2.

3. Rejecting commands: If access is denied on the specified port (or target volume), CCI rejects the following commands and outputs an error code, EX_ESPERM:

- `horctakeover`, `paircurchk`, `paircreate`, `pairsplit`, `pairresync`, `pairvolchk`, `pairevtwait`, `pairsyncwait`
- `raidscan` (except `-find verify`, `-find inst`), `raidar`, `pairdisplay`
- `raidvchkset`, `raidvchkscan` (except `-v jnl`), `raidvchkdsp`

```
[EX_ESPERM]      Permission denied with the SLPR
[Cause ] : A specified command device does not have a
permission to access other SLPR.
[Action] : Please make the SLPR so that the target port and
the command device belongs to the same SLPR.
```

SLPR configuration examples

Single host

The figure given below for SLPR configuration on a single host provides an example of when control is denied to the `paircreate` and `raidscan` commands in the following cases:

- The volume described on RMINST1 is different from the SLPR of the command device, so the `paircreate` command cannot control the paired volume.
- The specified port is different from the SLPR of the command device, so the `raidscan -p CL3-A` command cannot scan any ports that are defined as SLPR#N.

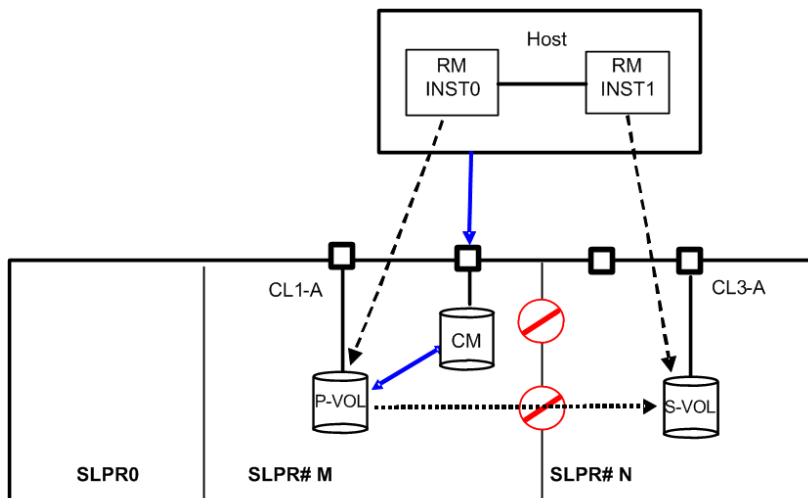

To operate SLPR#N, assign the command device. If RMINST1 has been assigned to a command device for SLPR#N, the `paircreate` command is permitted. However, the `raidscan -p CL3-A` command (via RMINST0) is unable to scan a port, because the specified port is different than the SLPR of the command device. In this case, `-p CL3-A` must be operated via RMINST1, as shown in the following example for operation across SLPRs using two command devices on a single host.

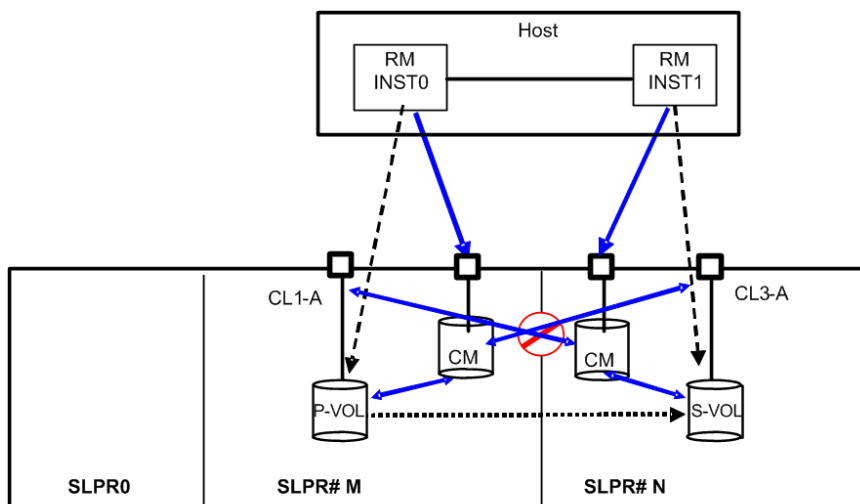

To operate SLPR#N, share the command device. If RMINST1 has a shared command device for SLPR#N, the `paircreate` command is permitted. Additionally, the `raidscan -p CL3-A` command (via RMINST0), is permitted to scan a port, because the shared command device has the Bitmap settings SLPR#M and SLPR#N.

See the following example for operation across SLPRs using a shared command device on a single host.

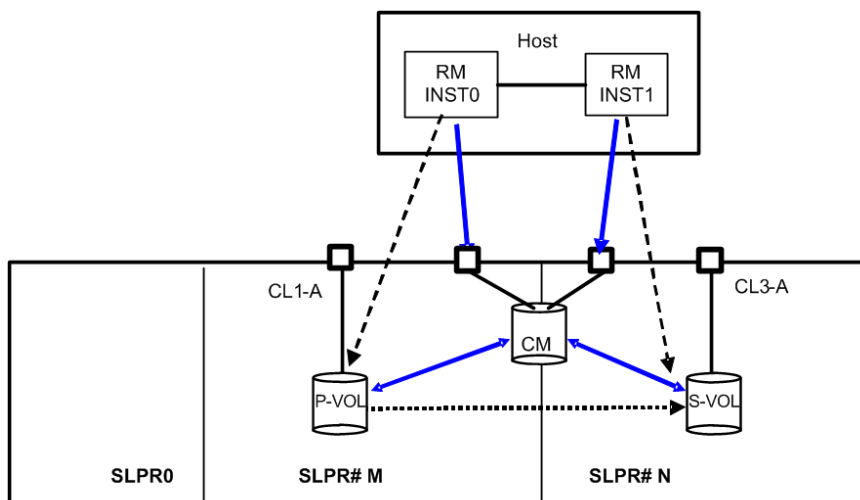

Dual Hosts

In the following example for SLPR configuration on dual hosts, the `paircreate` command is unable to operate the paired volume because the volume described on HostB is different than the SLPR of the command device. Also, the `raidscan -p CL3-A` command (via both Hosts), is unable to scan a port because the specified port is different than the SLPR of the command device.

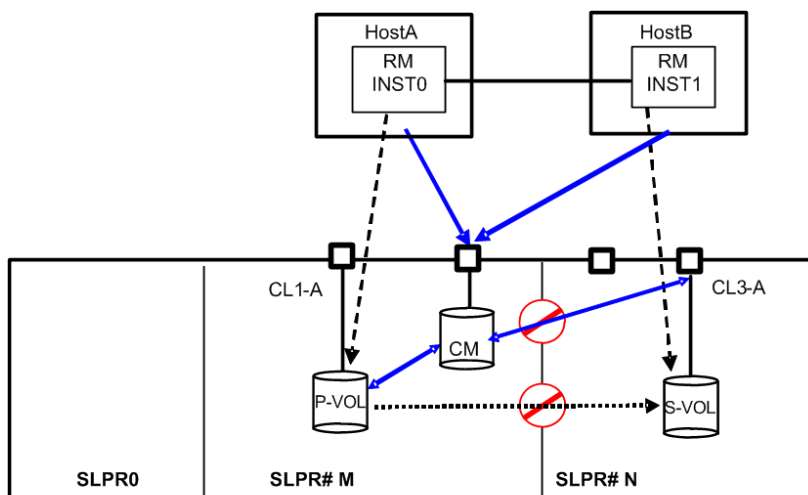

To operate SLPR#N, assign the command device. If HostB has a command device for SLPR#N, the `paircreate` command is permitted. However, the `raidscan -p CL3-A` command via HostA is unable to scan a port because the specified port is different than the SLPR of the command device. In this case, `raidscan -p CL3-A` command must be operated via HostB.

See the following example for operation across SLPRs using two command devices on dual hosts.

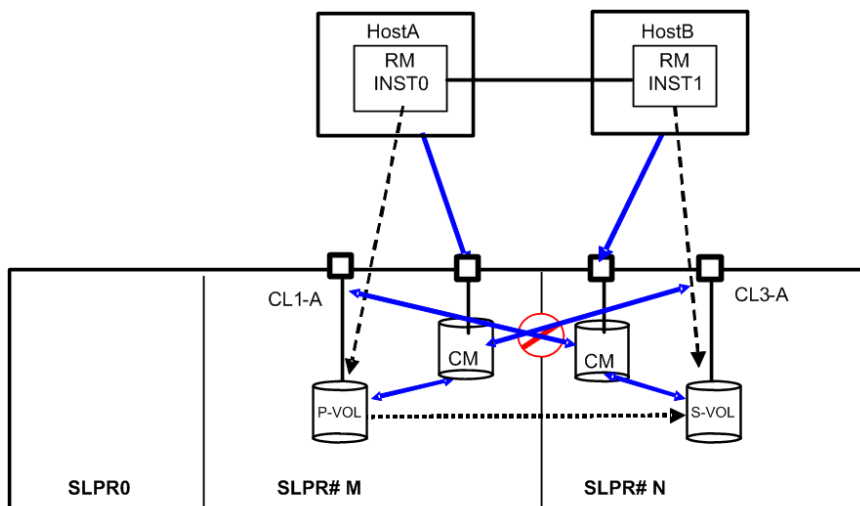

To operate SLPR#N, share the command device. If HostB has a shared command device for SLPR#N, the `paircreate` command is permitted. Also, the `raidscan -p CL3-A` command (via HostA), is allowed to scan a port because the shared command device has the Bitmap settings SLPR#M and SLPR#N.

See the following example for operating SLPR#N by sharing the command device.

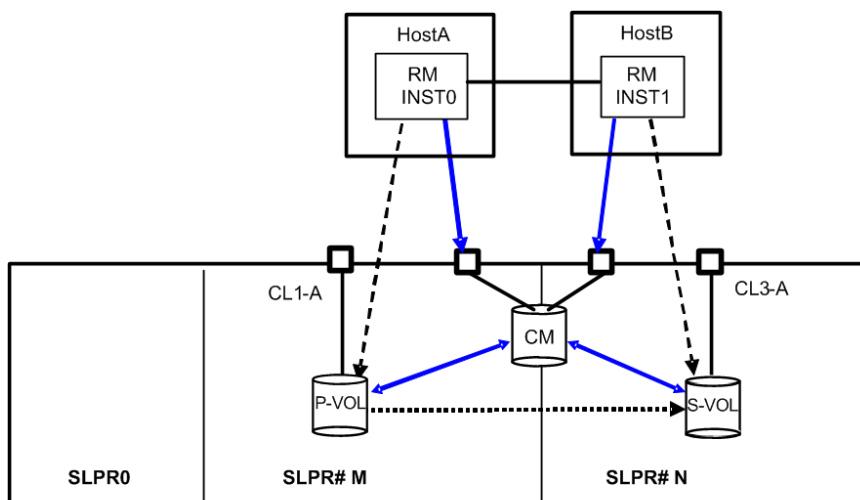

TrueCopy using dual hosts

In the following example, the `pair-operation` command (except the `-l` option) determines whether the operation for paired volumes should be permitted at a remote site. The result is that the `paircreate` command is not allowed to operate the paired volume, because the volume described on HostB differs from the SLPR of the command device. Also, the `raidscan -p CL3-A` command (on HostB) is not allowed to scan a port.

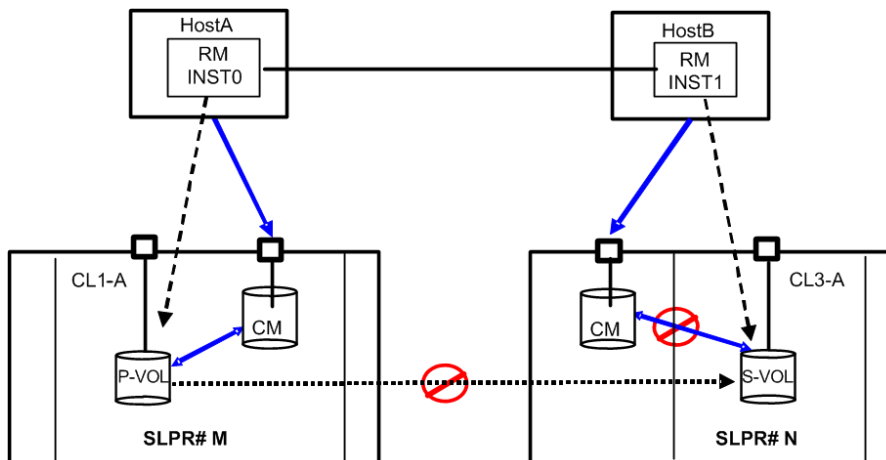

Chapter 9: Troubleshooting

This chapter provides troubleshooting information for CCI.

General troubleshooting

If you have a problem with the CCI software, first make sure that the problem is not being caused by the UNIX/PC server hardware or software, and try restarting the server.

Problem	Recommended action
Deprecated SCSI ioctl The following message is output to syslog file(/var/log/messages) with every ioctl(): program horcmgr is using a deprecated SCSI ioctl, please convert it to SG_IO	CCI currently uses the ioctl(SCSI_IOCTL_SEND_COMMAND) for sending the control command to the command device. However, in RHEL 4.0 using kernel 2.6.9.xx, the following message is output to syslog file(/var/log/messages) with every ioctl(): program horcmgr is using a deprecated SCSI ioctl, please convert it to SG_IO

Problem	Recommended action
	<p>This can originate from the following kernel code in drivers/scsi/scsi_ioctl.c as way of warning that ioctl(SCSI_IOCTL_...) of kernel 2.6.9.xx does not properly handle an error of the HBA driver.</p> <pre> ----- ----- /* Check for deprecated ioctls ... all the ioctls that do not follow the new unique numbering scheme are deprecated */ switch (cmd) { case SCSI_IOCTL_SEND_COMMAND: case SCSI_IOCTL_TEST_UNIT_READY: case SCSI_IOCTL_BENCHMARK_COMMAND: case SCSI_IOCTL_SYNC: case SCSI_IOCTL_START_UNIT: case SCSI_IOCTL_STOP_UNIT: printk(KERN_WARNING "program %s is using a deprecated SCSI " "ioctl, please convert it to SG_IO\n", current->comm); ----- ----- </pre>

Problem	Recommended action
	<p>Thus, CCI supports a way to change to the <code>ioctl(SG_IO)</code> automatically, if Linux kernel supports the <code>ioctl(SG_IO)</code> for <code>horcmgr</code> and <code>inqraid</code> command. However, CCI might encounter Linux kernel that does not support the <code>ioctl(SG_IO)</code> fully, so CCI also supports by defining either following environment variable or <code>"/HORCM/etc/USE_OLD_IOCTL"</code> file(size=0) that uses the <code>ioctl(SCSI_IOCTL_SEND_COMMAND)</code> forcibly. For example:</p> <pre>export USE_OLD_IOCTL=1</pre> <pre>horcmstart.sh 10</pre> <p>HORCM/etc:</p> <pre>-rw-r--r-- 1 root root 0 Nov 11 11:12 USE_OLD_IOCTL</pre> <pre>-r--r--r-- 1 root sys 32651 Nov 10 20:02 horcm.conf</pre> <pre>-r-xr--r-- 1 root sys 282713 Nov 10 20:02 horcmgr</pre>
CCI cannot be started because <code>horcmstart</code> command fails	<p>If you have changed the configuration definition file settings: make sure that the configuration definition file you changed is correct.</p> <p>If you have changed the settings of the storage system: make sure that the settings you changed are correct, and if necessary, change the configuration definition file settings.</p> <p>Even if there are no problems in these files and settings, but if you cannot run CCI, get all log files under the specified directory by <code>HORCM_LOG</code> (the default setting: <code>/horcm/log/</code>), and then contact customer support.</p>
The following messages are output to the standard error output with every command I/O:	<p>These messages are output if the path for the PA-RISC version shared library (<code>libcl.sl</code>) is not set when you use CCI on HP-UX (IA64).</p> <p>Set the path of the <code>libcl.sl</code> to the <code>LD_PRELOAD</code> environment variable.</p> <p>Example: <code># export LD_PRELOAD=/path/libcl.sl</code></p> <p>Enter the absolute path for specifying the directory where <code>libcl.sl</code> is stored into <i>path</i>.</p>

Problem	Recommended action
<pre>"/usr/lib/ dld.sl: Can't shl_load() a library containing Thread Local Storage: /us r/lib/ libcl.sl" "/usr/lib/ dld.sl: Exec format error"</pre>	
<p>When you attempt to remove RM Shadow Copy Provider, the installer displays a message indicating that a file cannot be deleted because it is used by another program.</p>	<p>Perform the following steps to delete the file:</p> <ol style="list-style-type: none"> 1. Check the information about the program that is using the file indicated by the installer. 2. Stop the removal of RM Shadow Copy Provider. 3. Close the program you found out in step 1. 4. Try to remove RM Shadow Copy Provider again. 5. Repeat steps 1 through 4 until you can remove RM Shadow Copy Provider successfully.

Operational notes and restrictions for CCI operations

For maintenance of volumes used by CCI and the Hitachi Vantara features it supports, if a volume failure occurs, it is important to find the failure in the paired volumes, recover the volumes, and continue operation on the original system. When a CCI (HORCM) or Hitachi Vantara feature failure is detected, please collect the data in the error log file and trace data (all files in HORCM_LOG directory), and report the failure to your Hitachi Vantara representative.

Items	Notes and restrictions
Startup restrictions	When the server starts up, sometimes a volume group (VG) is activated by the LVM, or a file system is mounted automatically, and the host writes to the S-VOL. When this happens, if the S-VOL does not permit writing, data cannot be written and the operation fails. To avoid this failure, change the S-VOL to PSUS (R/W enable) or to the SMPL state and restart the server.
Hot standby operations	<p>Note the following when executing hot standby operations using industry-standard failover products (for example, MC/ServiceGuard, HACMP, FirstWatch[®]) and TrueCopy/ TrueCopy Async/ Universal Replicator.</p> <ul style="list-style-type: none"> ▪ Do not split a single volume using partitions and share it among different server programs. If you do so, the takeover command is executed for the volume when failover of a server program happens, and that might affect other servers that share the volume. ▪ If you are using the LVM, do not create LDEVs for different LVM within the same volume. If you do so, the takeover command is executed for the volume when failover of a server program happens, and that might affect other servers that share the volume.
Coexistence of LVM mirror and TrueCopy	When the LVM mirror and TrueCopy volumes are used together, the LVM mirror handles write errors and changes the volumes. Thus, the fence level of the volumes used by the LVM mirror must be set to data.
Using paired volume in a single host	<p>When constructing paired volume in a single host, it is necessary to activate two or more CCI instances. To activate two or more CCI instances, instance numbers must be assigned using the environment variable HORCMINST. The HORCM and TrueCopy/ShadowImage commands must possess this environment variable.</p> <p>A configuration definition file and a log directory is set for each instance. For sharing command devices over 17 instances, use LU path among the storage system ports to share the command devices.</p>
Sharing volumes in a hot standby configuration	When paired volume is used for the disk shared by the hosts in hot standby configuration using HA software, use the primary volume as the shared disk and describe the corresponding hosts using the paired volume in the configuration definition file as shown below. In the HA configuration, if a TrueCopy command issued by host C fails in host B (because host B has gone down and/or IO_ERROR of the command device), host A is connected and the command execution is retried.

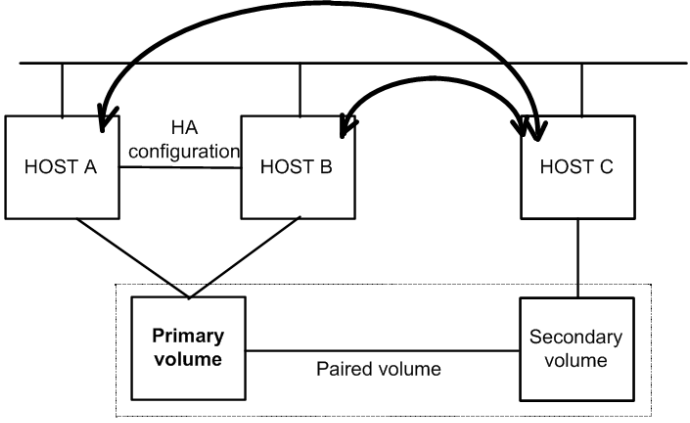
Items	Notes and restrictions
	 <p>The diagram illustrates a high-availability (HA) configuration for three hosts (HOST A, HOST B, and HOST C) connected to a network. HOST A and HOST B are connected to a Primary volume, and HOST C is connected to a Secondary volume. The Primary and Secondary volumes are connected as Paired volumes. Arrows indicate HA configuration between HOST A and HOST B, and HA configuration between HOST B and HOST C.</p>
Linkage with HA software	<p>The HORC Manager must not be an object of the process monitoring by the HA software (cluster manager), because HORCM should run in the same level as the cluster manager. Cooperation with HA software is done by activating the takeover command from the shell script activated by the cluster manager in units of the package software.</p> <p>Note: Cannot use a pair volume for the cluster lock disk that HA software uses for election.</p>
Maintenance	<p>Restart of HORCM is required if the storage system configuration is changed (for example, microcode exchange, cache memory install/uninstall).</p> <p>TrueCopy only: In the case of an error (for example, single error in cache memory) which made the pair volume is accompanied by maintenance work, the pairresync or paircreate command cannot execute copy rejection.</p>
SVP/GUM microcode exchange	<p>In out-of-band method using SVP, if the microcode exchange of the SVP is performed, the timeout on command occurs. Execute the command again after finishing the microcode exchange.</p> <p>In out-of-band method using GUM, if the maintenance on the controller with GUM is performed, the timeout on command might occur. Switch the command device so that the other virtual command device of GUM can be used before the maintenance. For details about the alternate command device function, see Alternate command device function.</p>

Items	Notes and restrictions
Command device	Each TrueCopy/ShadowImage command is executed by issuing a command to the command device. The TrueCopy/ShadowImage command is read or written from/into the specific block area of the command device. Therefore, the command device cannot be used. In addition, this device must not belong to an LVM volume group. For Windows systems, do not assign a drive letter to the command device to prevent utilization by general users.
SCSI alternate path restrictions	If the P-VOL and S-VOL are on the same server, alternate path from P-VOL to S-VOL cannot be used. Use of SCSI alternate path to a volume pair in the pair status is limited to among primary (secondary) volumes. Alternate path using Path Manager (Safe Path) is limited to primary volumes.
horctakeover (Swap-Takeover)	When executing horctakeover on a standby server manually, I/O on the active server must be stopped. When the package software goes for a standby server a failover by HA software, the HA software must guarantee an I/O insulation of the active server.
HORCM failure to activate	After a new system has been constructed, a failure to activate HORCM might occur due to improper environment setting and/or configuration definition. Refer to the HORCM activation log, and correct the settings.
Abnormal termination of command	Refer to the command log file and HORCM log file to identify the cause of the error. If a command terminates abnormally because of a remote server failure, recover the server from the failure, then re-execute the command. If HORCM has shut down, restart HORCM. If an unrecoverable error occurs, obtain the log files and contact customer support.
Error in paired volume operation	<p>TrueCopy only: If an error occurs in duplicated writing in paired volumes (that is, pair suspension), the server software using the volumes might detect the error by means of the fence level of the paired volume. In such a case, check the error notification command or syslog file to identify a failed paired volume.</p> <p>The system administrator can confirm that duplicated writing in a paired volume is suspended due to a failure and the system runs in regressed state using the error notification command of the TrueCopy. HORCM monitors failures in paired volumes at regular intervals. When it detects a failure, it outputs it to the host's syslog file. Thus, the system administrator can detect the failure by checking the syslog file. Concerning the operation of the RAID storage system, the failure can also be found on Storage Navigator (or SVP) provided.</p>

Items	Notes and restrictions
	Issue the TrueCopy commands manually to the identified failed paired volume to try to recover it. If the secondary volume is proved to be the failed volume, issue the pair resynchronization command to recover it. If the primary volume fails, delete the paired volume (pair splitting simplex) and use the secondary volume as the substitute volume.
About "/" HORCM/.uds" directory	CCI uses "/HORCM/.uds" as the directory for the UNIX domain socket for IPC (Inter Process Communication), and makes the directory and files as "/HORCM/.uds/.lcm*" in CCI version 01-17-03/01 or later. Caution: This "/HORCM/.uds/.lcm*" should not be removed while HORCM is running.

Error messages and error codes

System log messages

The following table lists and describes the HORCM system log messages and provides recommended actions for resolving the error conditions.

Message ID	Condition	Cause	Recommended action
HORCM_001	The HORCM log file cannot be opened.	The file cannot be created in the HORCM directory.	Create space on the disk on which the root directory resides.
HORCM_002	The HORCM trace file cannot be opened.	The file cannot be created in the HORCM directory.	Create space on the disk on which the root directory resides.
HORCM_003	The HORCM daemon process cannot create a child process due to an error.	HORCM daemon attempted to create more processes than the maximum allowable number.	Terminate unnecessary programs or daemon processes running simultaneously.
HORCM_004	HORCM assertion failed, resulting in a fatal internal error in the HORCM.	An internal error that could not be identified by the HORCM occurred.	Restart the system, and contact customer support.

Message ID	Condition	Cause	Recommended action
HORCM_005	The CCI software failed to create the end point for remote communication.	HORCM failed to create a socket, or an error exists in the format or a parameter in the HORCM configuration definition file (\$HORCM_CONF).	Refer to the HORCM startup log to identify the cause of the error.
HORCM_006	HORCM memory allocation failed.	HORCM memory could not be secured.	Increase the system virtual memory, or close any unnecessary programs.
HORCM_007	An error exists in the parameter value in the HORCM setup file.	An error exists in the parameter value setting in the HORCM setup file.	Refer to the startup log and reset the parameters.
HORCM_008	HORCM configuration definition file parameters reading fails.	An error exists in the format or parameters of the HORCM configuration definition file (\$HORCM_CONF).	Refer to the HORCM startup log to identify the cause of the error.
HORCM_009	TrueCopy/ShadowImage connection to the CCI software failed.	System devices are improperly connected, or an error exists in the device parameter in the HORCM configuration definition file.	Refer to the HORCM startup log to identify the cause of the error.
HORCM_101	TrueCopy/ShadowImage and the CCI software communication fails.	A system I/O error occurred or an error exists in the device parameter in the HORCM configuration definition file (\$HORCM_CONF).	Refer to the HORCM startup log to identify the cause of the error.
HORCM_102	The volume is suspended.	The pair status was suspended due to code XXXX.	Contact customer support.

Message ID	Condition	Cause	Recommended action
HORCM_103	Detected a validation check error on this volume (xxxx unit#x,ldev#x): CfEC=n, MNEC=n, SCEC=n, BNEC=n	A validation error occurs on the database volume, or validation parameters for this volume are illegal.	Please confirm the following items, and use raidvchkdsp -v <op> command for verifying the validation parameters. (1)Check if the block size (-vs <size>) is an appropriate size. (2)Check if the type for checking (-vt <type>) is an appropriate type. (3)Check if the data validations are disabled for LVM configuration changes. (4)Check if the data validations are not shared on file system. (5)Check if the redo log and data file are separated among the volumes.

Command error messages

The following table lists and describes the command error messages and their return values and provides recommended action for resolving the error conditions.

The messages below are typical command error messages. Check the command log file for details of the error. For details about the command log file, see CCI log files.

Error code	Error message	Condition	Recommended action	Returned Value
EX_COMERR	Can't be communicate with HORCM Manager	This command failed to communicate with the CCI software.	Confirm whether HORCM is enabled. If HORCM is not activated yet, start HORCM. If HORCM ended abnormally despite being activated, verify the disk capacity has 3000 KB or more free space. Free up disk space, and then restart HORCM. If the problem persists, contact customer support.	255

Error code	Error message	Condition	Recommended action	Returned Value
EX_REQ ARG	Required Arg list	Arguments for the command are not sufficient, or the command syntax is not correct.	Please designate the correct option using the -h option.	254
EX_INVA RG	Invalid argument	An option or arguments of an option are incorrect.	Please designate the correct option using the -h option.	253
EX_UNW OPT	Unknown option	Designated an unknown option.	Please designate the correct option using the -h option.	252
EX_ATTH OR	Can't be attached to HORC Manager	Could not connect with HORCM.	Please verify that HORCM is running and/or that HORCMINST is set correctly.	251
EX_ATTD BG	Can't be attached to a Debug layer	Failed to communicate with HORCM, or cannot make a log directory file.	Verify that HORCM is running by using UNIX commands [ps - ef grep horcm].	250
EX_INVN AM	Invalid name of option	The name specified in an argument of an option is not appropriate.	Please designate the correct name using the -h option.	249
EX_OPTI NV	A specified option is invalid	Detected contradiction in information that RAID reported.	Contact customer support.	248
EX_ENO ENT	No such device or group	The designated device or group name does not exist in the configuration definition file.	Verify the device or group name and add it to the configuration definition file of the remote and local hosts.	247
EX_ENO DEV	No such device	The designated device name does not exist in the configuration definition file.	Verify the device name and add it to the configuration definition file of the remote and local hosts.	246

Error code	Error message	Condition	Recommended action	Returned Value
EX_ENO UNT	No such RAID unit	The designated RAID unit ID does not exist in the configuration definition file.	Verify the RAID unit ID and add it to the configuration definition file of the remote and local hosts.	219
EX_ENQ SER	Unmatched Serial# vs RAID unitID	The group designated by ShadowImage paircreate does not have the same RAID unit, or the unitID is not identical to the unit ID in the same RAID serial# (Seq#).	Confirm the serial# (Seq#) of the storage system using the pairdisplay command, or confirm that the serial# (Seq#) and the unit ID of storage system are the same among hosts using the raidqry -r command.	218
EX_ENO MEM	Not enough core	Insufficient memory exists.	Increase the virtual memory capacity of the system, or close any unnecessary programs and/or daemon processes.	245
EW_ENE SCR	Cannot execute script file	The script file specified by the -zt option cannot be performed.	Confirm the execution right, permission the extension, the execution path of the script file.	131
EX_ERA NGE	Result too large	Your entry is one of the following statuses. <ul style="list-style-type: none"> ▪ The value was entered beyond the maximum. ▪ The result value is beyond the maximum. ▪ The unit you set is invalid. 	Refer to the error message, and designate an appropriate value or confirm whether you specified the unit correctly.	244
EX_ENA MLG	File name too long	Undefined error.	Contact customer support.	243

Error code	Error message	Condition	Recommended action	Returned Value
EX_ENORMT	No remote host alive for remote commands or remote HORCM might be blocked (sleeping) on an existing I/O	A timeout occurred on remote communication, and HORC Manager failed to re-execute.	Please confirm that the HORC Manager in the remote host is running. If the IP address of the host has been changed, restart the HORCM instance. If the HORCM still does not restart, increase the value of the timeout in the configuration definition file.	242
EX_INVMOD	Invalid RAID command mode	Detected a contradiction for a command.	Contact customer support.	241
EX_INVCMD	Invalid RAID command	Detected a contradiction for a command.	Contact customer support.	240
EX_ENOGRP	No such group	The designated device or group name does not exist in the configuration definition file, or the network address for remote communication does not exist.	Verify the device or group name and add it to the configuration definition file of the remote and local hosts.	239
EX_UNWCOD	Unknown function code	Detected a contradiction for a command.	Retry your operation after restart of the instance for CCI. Contact customer support if the operation fails because of same error again.	238
EX_CMDIOE	Control command I/O error	A read/write to the command device failed with an I/O error.	This error might occur due to a device failure. Check device condition, then retry the command after recovery from the failure. If the error occurs even after the retry, refer to the host syslog file, and investigate the cause of the error.	237

Error code	Error message	Condition	Recommended action	Returned Value
			If the problem persists, collect the log information of HORCM (\$HORCM_LOG), and contact customer support.	
EX_CMDRJE	An order to the control/command device was rejected	<p>The request to the command device failed or was rejected.</p> <p>Note: This error code is sometimes caused by the operating system and reported as EX_CMDIOE instead of EX_CMDRJE (see next row).</p>	<p>Verify the program products, such as TrueCopy and ShadowImage, are installed.</p> <p>Verify ports are set.</p> <p>Verify CU paths have been established by Device Manager - Storage Navigator, CCI, or other methods.</p> <p>Verify that the target volume is available.</p> <p>CCI displays "SSB" in the output of the commands so a service representative can identify the cause of EX_CMDRJE (except for Tru64, DYNIX).</p> <p>Example:</p> <pre># paircreate -g G1 -f never -v1 -nocopy</pre> <pre>paircreate: [EX_CMDRJE] An order to the control/command device was rejected</pre> <p>Refer to the command log (/HORCM/log10/horcc_u1-1.log) for details.</p> <p>It was rejected due to SKEY=0x05, ASC=0x26, SSB=0xB9BF,0xB9C7 on Serial#(63502).</p>	221

Error code	Error message	Condition	Recommended action	Returned Value
EX_CMD IOE	Control command I/O error or rejected	A read/write to the command device failed with an I/O error or was rejected.	<p>This error might occur due to a device failure. Check device condition, then retry the command after recovery from the failure. If the error occurs even after the retry, refer to the host syslog file, and investigate the cause of the error. If the cause is "Illegal Request (0x05)" Sense Key, please confirm the following items.</p> <p>Verify the program products, such as TrueCopy and ShadowImage, are installed.</p> <p>Verify ports are set.</p> <p>Verify CU paths have been established by Device Manager - Storage Navigator, CCI, or other methods.</p> <p>Verify that the volume which is the target of the pair operation is in the appropriate status for issuing the concerned command.</p>	237

Error code	Error message	Condition	Recommended action	Returned Value
			<p>Verify that the status of the volume which is the target of the pair operation changed to the intended status after 160 or more seconds have passed since the concerned command issued.</p> <ul style="list-style-type: none"> ▪ When the status has changed as you intended: The command executed normally. The communication delay or other errors may happen. Confirm the path between the storage systems. ▪ When the status has not changed: Issue the concerned command again. If the phenomenon happens again, contact customer support. ▪ Other than above: Contact customer support. <p>If the problem persists, contact customer support.</p>	
EX_ENQ VOL	Unmatched volume status within the group	The volume attribute or the fence level within a group is not identical.	Confirm status using the pairdisplay command. Make sure all volumes in the group have the same fence level and volume attributes.	236
EX_EVOL CE	Pair Volume combination error	Combination of a volume is unsuitable between the remote and local host.	Confirm volume status using the pairdisplay command, and change the combination of volumes properly.	235
EX_EWS USE	Pair suspended at WAIT state	Detected a suspended status (PSUE) for the paired volume, before it made it to the designated status.	Please issue the pairresync command manually to the identified failed paired volume to try to recover it. If the problem persists, contact customer support.	234

Error code	Error message	Condition	Recommended action	Returned Value
EX_EWS TOT	Timeout waiting for specified status	Detected a time out, before it made it to the designated status.	Please increase the value of the timeout using the -t option. For details, refer to the troubleshooting information in the relevant user document. When this error occurs during execution of the pairsplit command, contact customer support.	233
EX_EWS LTO	Timeout waiting for specified status on the local host	Timeout error because the remote did not notify about expected status in time.	Please confirm that HORC Manager on the remote host is running.	232
EX_EST MON	HORCM Monitor stopped	HORC Manager monitoring was refused.	Please confirm the value of "poll" in the configuration definition file.	231
EX_UNW CMD	Unknown command	An unknown command was attempted.	Please confirm the command name.	230
EX_INCS TG	Inconsistent status in group	The pair status of a volume within a group is not identical to the status of the other volumes in the group.	Please confirm the pair status using the pairdisplay command.	229
EX_INVS TP	Invalid pair status	The pair status of the target volume is not appropriate.	Please confirm the pair status using the pairdisplay command.	228
EX_INVV OL	Invalid volume status	The volume status of the target volume is not appropriate.	Please confirm the volume status using the pairdisplay -1 or the raidvchkdsp -v aou command.	222

Error code	Error message	Condition	Recommended action	Returned Value
EX_INVNUM	Invalid mu# with HORC/UR or HOMRCF	The MU# of the volume to be operated is not appropriate.	Please confirm the MU# (MU #1/2 cannot be used for TrueCopy and must be P-VOL for ShadowImage.) for the specified group using the pairdisplay command. And also confirm the command execution environment to be set as HOMRCF.	220
EX_ENLDEV	No such LDEV within the RAID	A device defined in the configuration definition file does not have a mapping to a real LUN and target ID within the RAID storage system.	Please confirm that the Port, Target ID, LUN are defined correctly under HORCM_DEV in the configuration definition file.	227
EX_INVRC	Invalid return code	Wrong return code.	Contact customer support.	226
EX_VOLCUR	S-VOL currency error	Currency check error for S-VOL. Cannot guarantee identical data on S-VOL.	Check the volume list to see if an operation was directed to the wrong S-VOL.	225
EX_VOLCUE	Local volume currency error	The volume specified with the S-VOL-takeover command is not the same as the P-VOL.	Please confirm the pair status of the local volume using the pairdisplay command.	224
EX_VOLCRE	Local and remote volume currency error	The combination of the volumes specified with Swap-takeover is unsuitable.	Please confirm the pair status of remote and local volumes using the pairdisplay command.	223
EX_UNWERR	Unknown error code.	Wrong error code.	Contact customer support.	--

Error code	Error message	Condition	Recommended action	Returned Value
EX_ENOCTG	Not enough CT groups in RAID	<p>The specified CTG ID cannot be used when the volume for TrueCopy, Universal Replicator, global-active device or ShadowImage pair is created, because the specified CTG ID is used by the other program product in the storage system. Otherwise, CTG ID cannot be registered because the number of the consistency groups exceeds the maximum number.</p> <p>For details about the maximum number of the consistency groups, see TrueCopy, Universal Replicator, and global-active device volumes.</p>	When the specified CTG ID is used by the other program product, use the other CTG ID which is not used by the other program product in the storage system.	217

Error code	Error message	Condition	Recommended action	Returned Value
			When the number of the consistency groups exceeds the maximum number, execute one of the following actions:	

Error code	Error message	Condition	Recommended action	Returned Value
			<ul style="list-style-type: none"> ▪ To create the TC, UR, GAD or SI pair after reducing the consistency groups: <ol style="list-style-type: none"> 1. Select consistency group which can be deleted in the existing consistency groups. 2. Find the configuration definition file in which the name of the consistency group to be deleted is written at <code>dev_group</code>. 3. Execute the pairsplit -S command specifying the <code>dev_group</code> name of the consistency group to be deleted by the HORCM instance which matches the configuration definition file found at step 2 (split the pair). 4. Delete the <code>dev_group</code> which matches the consistency group to be deleted from the configuration definition file found in step 2 (delete both P-VOL and S-VOL which configures the split pair). 5. Restart the HORCM instance which matches the configuration definition file found at step 2, reflecting the editing results of the configuration definition file. 6. Add the device to the <code>dev_group</code> which matches the consistency group to be added using new or existing configuration definition file (add P-VOL and S-VOL which configures the pair to be added). 7. Start or restart the HORCM instance which matches the configuration definition file used at step 6. 	

Error code	Error message	Condition	Recommended action	Returned Value
			<p>8. Execute the paircreate command specifying the <code>dev_group</code> name of the consistency group in which the pair is added by the HORCM instance which matches the configuration definition file used at step 6 as follows.</p> <p>In case of TC, UR, or GAD:</p> <pre>paircreate -g <dev_group name> -f[g] <fence> [CTGID]</pre> <p>In case of SI:</p> <pre>paircreate -g <dev_group name> -m grp [CTGID]</pre> <p>Confirm the CTG ID of the existing consistency group by pairvolchk command.</p> <p>When the <code>-fg</code> option is specified and <code>CTGID</code> is omitted in the paircreate command, unused CTG ID is set automatically.</p>	

Error code	Error message	Condition	Recommended action	Returned Value
			<ul style="list-style-type: none"> ▪ To add the TC, UR, GAD or SI pair to the existing consistency group that is used by the same program product: <ol style="list-style-type: none"> 1. Select an existing consistency group to which the pair can be added. 2. Find the configuration definition file in which the name of the consistency group to which the pair is added is written at <code>dev_group</code>. 3. Add the device to the <code>dev_group</code> in the configuration definition file found at step 2 which matches the consistency group to which the pair is added (add P-VOL and S-VOL which configures the pair to be added). 4. Restart the HORCM instance which matches the configuration definition file found at step 2, reflecting the editing results of the configuration definition file. 5. Execute the paircreate command specifying the <code>dev_group</code> name of the consistency group to which the pair is added by the HORCM instance which matches the configuration definition file found at step 2 as follows. <p style="margin-left: 20px;">In case of TC, UR, or GAD:</p> <pre style="margin-left: 40px;">paircreate -g <dev_group name> -f[g] <fence> [CTGID]</pre> <p style="margin-left: 20px;">In case of SI:</p> <pre style="margin-left: 40px;">paircreate -g <dev_group name> -m grp [CTGID]</pre> 	

Error code	Error message	Condition	Recommended action	Returned Value
			<p>Confirm the CTG ID of the existing consistency group by pairvolchk command.</p> <p>When the -fg option is specified and CTGID is omitted in the paircreate command, unused CTG ID is set automatically.</p>	
EX_EXCTG	Extended CT group across RAIDs	A TrueCopy, Universal Replicator, global-active device, or ShadowImage volume is defined in the configuration definition file (HORCM_CONF) as a group that extends across storage systems.	Please confirm the serial # of the volumes by using the pairedisplay command to verify that the consistency group is contained completely within one RAID storage system.	216
EX_ENXCTG	No CT groups left for OPEN Vol use.	An available consistency group for OPEN Volume does not exist.	Please confirm whether all consistency groups are already used by mainframe volumes.	215
EX_ENQCTG	Unmatched CTGID within the group	The consistency group references within a group do not have an identical CTG ID.	Please confirm the CTG ID using the pairvolchk command and confirm that group references within the configuration definition file (HORCM_CONF) refer to the same consistency group.	214
EX_ENPE RM	Permission denied with the LDEV	A device mentioned in the configuration definition file does not have a permission for a pair-operation.	Please confirm whether pair-operation is permitted on the device by using the pairedisplay or raidscan -find verify command.	213
EX_ENQSIZ	Unmatched volume size for pairing	Size of a volume is unsuitable between the remote and local volume.	Please confirm volume size or number of LUSE volume using the 'raidscan -f' command, and make sure the volume sizes are identical.	212

Error code	Error message	Condition	Recommended action	Returned Value
EX_ERPERM	Permission denied with the RAID	A storage system (RAID) mentioned in the configuration file does not have a permission for CCI.	Please confirm if the type of storage system is permitted for a CCI by using the inqraid -CLI and raidqry -h commands.	211
EX_ESVOL	S-VOL denied due to be disabling	A specified target volume for S-VOL is denied to become S-VOL by the setting of Data Retention Utility.	Please confirm whether a target volume is setting to S-VOL disabling by using inqraid -fl or raidvchkscan -v gflag command.	209
EX_ENOSUP	Microcode not supported	The storage system does not support a function for CCI.	Please confirm the storage system model name and microcode version by using the raidqry -l command.	210
EX_EXPORT	Mode changes denied due to retention time	A target volume is denied to be changing due to retention time via LDEV guarding.	Please confirm the retention time for a target volume that is set to Data Retention Utility by using raidvchkscan -v gflag command.	208
EX_ESPERM	Permission denied with the SLPR	A specified command device does not have a permission to access other SLPR.	Please make the SLPR so that the target port and the command device belongs to the same SLPR.	207
EX_ENOPOL	Not enough Pool in RAID	Could not retain the pool for executing a command due to be exceeded the threshold rate.	Please release the pair of older generations paired volume, or re-synchronize the pair of split status paired volume.	206
EX_ENOBJ	No such Object in the RAID	The specified object is not installed. There are port, LDEV, and Hostgroup in the object.	Specify the appropriate object. Check the status of one of the following. <ul style="list-style-type: none"> ▪ The specified port is not installed. ▪ The value of the specified port is invalid. ▪ LU path is defined. ▪ A logical path between MCU and RCU remain. ▪ LDEV is not installed. 	205

Error code	Error message	Condition	Recommended action	Returned Value
			<ul style="list-style-type: none"> ▪ The attribute of the port is not Target (TAR) or RCU Target (RCU). ▪ LUN security is invalid. ▪ The specified host group is not installed. ▪ The specified virtual port ID is not correct. 	
EX_EPPE RM	Permission denied with the privilege	The specified command device does not have an authority to execute this command.	Check the operation authentication.	203
EX_ENQ CLP	Unmatched CLPR with JNL and Volume	The specified command device does not have an authority to execute this command.	Check the operation authentication.	204
EX_CTXC HK	Context check error	An error is detected by the Context Checking.	Check if the operation by the command executes a proper procedures and has the consistency or not.	199
EX_EACC ES	Access denied with Lock/Unlock	The resource that you specified to lock or unlock has already been used by another user.	Check if the specified resource is used by such as Storage Navigator or Device Manager - Storage Navigator or not.	200
EX_ENA UTH	Authentication failed with User	User authentication failed at the authentication command device.	Check the user ID and password.	202
EW_INV ARG	Invalid argument	Invalid option or an argument of the option.	User -h option to check the correct option, and specify it.	253
EW_INV OPA	Invalid option argument	Invalid argument of an option	Use -h option to check the correct option and use it.	131

Error code	Error message	Condition	Recommended action	Returned Value
EW_INV OPT	Invalid option	Invalid option.	Use -h option to check the correct option and use it.	131
EW_LNG ARG	Argument too long	The number of character for action, object, option or argument of option exceeded the maximum.	Specify the number of characters of action, object, option, an argument of option, or the total number of characters are to be appropriate number of characters.	131
EW_MAX ARG	Maximum argument	The total number of option or the argument of option exceeded the maximum.	Check the total number of option or argument of option.	131
EW_ENFILE	No such file	The specified file does not exist.	Check if the specified file exist or not, and specify the correct file.	131
EW_REQ CMD	Required action/object list	The number of action or the argument of object is insufficient.	Use -h option and specify the correct action or object.	131
EW_REQ OPT	Required option list	The number of option or the argument of option is insufficient.	Use -h option and specify the correct option.	131
EW_UN WCMD	Unknown command	The command action or an object is undefined.	Check the issued command action and object.	230
EW_UN WOPT	raidcom: [EW_UN WOPT] Unknown option	Specifies an undefined option.	Use -h option and specify the correct option.	252
EW_SYS ERR	System error	An invalid internal error has detected.	Contact customer support.	131
EW_ENO MEM	Not enough core	Memory to execute a command cannot be allocated in HORCM.	Add more virtual memory of a whole system, or terminate unnecessary programs or daemons that are executed in parallel.	245

Error code	Error message	Condition	Recommended action	Returned Value
EX_CHG OBJ	Objects was changed while referring	The object is in operation.	Issue the command again after the operation of the object is complete.	198
EX_EGPERM	Permission denied with the Resource Group	You do not have the operation authority to operate the target resource group.	Specify the resource group that is allocated to the user group as the operation target or set the operation authority to the user group in order to operate the target resource group.	201
EX_IDEXHA	There is no available request ID.	There are no request IDs that can be used for the storage system.	Release the request IDs that are no longer used.	194

Generic error codes (*horctakeover* and *pair* commands)

The following table lists the generic error codes returned by the following commands:

- **horctakeover**
- **paircurchk, paircreate, pairsplit, pairresync, pairevtwait, pairvolchk, pairsyncwait, pairdisplay**

In this table, "Unrecoverable" indicates errors that cannot be recovered by reexecuting the command, and "Recoverable" indicates errors that can be recovered by reexecuting the command.

Category	Error code	Error message	Return Value
Syntax for Argument (Unrecoverable)	EX_REQARG	Required Arg list	254
	EX_INVARG	Invalid argument	253
	EX_INVNAM	Invalid name of option	249
	EX_UNWOPT	Unknown option	252
	EX_UNWCOD	Unknown function code	238

Category	Error code	Error message	Return Value
	EX_UNWCMD	Unknown command	230
	EX_ERANGE	Result too large	244
	EX_ENAMLG	File name too long	243
	EX_INVRCD	Invalid return code	226
Configuration (Unrecoverable)	EX_ENOGRP	No such group	239
	EX_ENOENT	No such device or group	247
	EX_ENODEV	No such device	246
	EX_ENLDEV	No such LDEV within the RAID	227
	EX_ENOUNT	No such RAID unit	219
	EX_INVMUN	Invalid mu# with HORC or HOMRCF	220
	EX_ENQSER	Unmatched Serial# vs RAID unitID	218
	EX_EXTCTG	Extended CTgroup across RAIDs	216
	EX_ENQCTG	Unmatched CTGID within the group	214
	EX_ENPERM	Permission denied with the LDEV	213
	EX_ERPERM	Permission denied with the RAID	211
	EX_ESPERM	Permission denied with the SLPR	207
Command I/O to RAID (Recoverable)	EX_CMDRJE	An order to the control/command was rejected	221
	EX_CMDIOE	Control command I/O error, or rejected	237
	EX_OPTINV	A specified option is invalid	248
	EX_INVMOD	Invalid RAID command mode	241
	EX_INVCMD	Invalid RAID command	240
Communication for HORCM (Recoverable)	EX_ATTJOR	Cannot be attached to HORC manager	251
	EX_ATTDBG	Cannot be attached to a Debug layer	250
	EX_COMERR	Cannot be communicate with HORC manager	255

Category	Error code	Error message	Return Value
Recoverable	EX_ENORMT	No remote host alive for remote commands, or Remote CCI might be blocked (sleeping) on an existing I/O.	242
Resource (Unrecoverable)	EX_ENOMEM	Not enough core	245

Generic error codes (raidscan, raidqry, raidar, horcctl)

The following table lists the generic error codes returned by the following commands:

- **raidscan**
- **raidqry**
- **raidar**
- **horcctl**

In this table, "Unrecoverable" indicates errors that cannot be recovered by reexecuting the command, and "Recoverable" indicates errors that can be recovered by reexecuting the command.

Category	Error code	Error message	Value
Syntax for Argument (Unrecoverable)	EX_REQARG	Required Arg list	254
	EX_INVARG	Invalid argument	253
	EX_INVNAM	Invalid name of option	249
	EX_UNWOPT	Unknown option	252
	EX_UNWCOD	Unknown function code	238
	EX_UNWCMD	Unknown command	230
	EX_ERANGE	Result too large	244
	EX_ENAMLG	File name too long	243
Configuration (Unrecoverable)	EX_INVRCO	Invalid return code	226
	EX_ENLDEV	No such LDEV within the RAID	227
	EX_ENOUNT	No such RAID unit	219

Category	Error code	Error message	Value
	EX_INVNUM	Invalid mu# with HORC or HOMRCF	220
	EX_ERPERM	Permission denied with the RAID	211
	EX_ENOSUP	Microcode not supported	210
	EX_ESPERM	Permission denied with the SLPR	207
Command I/O to RAID (Recoverable)	EX_CMDIOE	Control command I/O error	237
	EX_OPTINV	A specified option is invalid	248
	EX_INVMOD	Invalid RAID command mode	241
	EX_INVCMD	Invalid RAID command	240
Communication for HORCM (Recoverable)	EX_ATHOR	Can't be attached to HORC manager	251
	EX_ATTDBG	Can't be attached to a Debug layer	250
	EX_COMERR	Can't be communicated with HORC manager	255
Resource (Unrecoverable)	EX_ENOMEM	Not enough core	245

Specific error codes

The following table lists the specific error codes returned by the following commands:

- **horctakeover**
- **paircurchk, paircreate, pairsplit, pairresync, pairevwait, pairvolchk, pairsyncwait, raidvchkset**

In this table, "Unrecoverable" indicates errors that cannot be recovered by reexecuting the command, and "Recoverable" indicates errors that can be recovered by reexecuting the command.

See the *Command Control Interface Command Reference* for more information on error codes for each command.

Category	Error code	Error message	Value
Volume Status (Unrecoverable)	EX_ENQVOL	Unmatched volume status within the group	236
	EX_INCSTG	Inconsistent status in group	229

Category	Error code	Error message	Value
	EX_INVVOL	Invalid volume status	222
	EX_EVOLCE	Pair Volume combination error	235
	EX_INVSTP	Invalid pair status	228
	EX_VOLCUR	S-VOL currency error	225
	EX_VOLCUE	Local Volume currency error	224
	EX_VOLCRE	Local and Remote Volume currency error	223
	EX_EWSUSE	Pair suspended at WAIT state	234
	EX_ENQSIZ	Unmatched volume size for pairing	212
	EX_ESVOLD	S-VOL denied due to be disabling	209
	EX_EPRORT	Mode changes denied due to retention time	208
Timer (Recoverable)	EX_EWSTOT	Timeout waiting for specified status	233
	EX_EWSLTO	Timeout waiting for specified status on the local host	232
Resource (Unrecoverable)	EX_ENOCTG	Not enough CT groups in the RAID	217
	EX_ENXCTG	No CT groups left for OPEN Vol use.	215
	EX_ENOPOL	Not enough Pool in RAID	206

SSB codes

An SSB code is error information that is output when an error occurs by executing a CCI command. The SSB code is output to the CCI execution log file or to the console. Identify the SSB code from an error code as follows:

- SSB code that is output to the CCI execution log file.

The following shows an example of a SSB code that is output to the CCI execution log file.

Example:11:06:03-37897-10413- SSB = 0xb9a0,2089

The alphanumeric characters after the equal sign shows an error code. The last four digits of alphanumeric characters on the left side of the comma (,) is SSB1 (for example, b9a0), and the alphanumeric characters on the right side is SSB2 (for example, 2089).

- SSB code that is output on the console.

It was rejected due to SKEY=0x05, ASC=0x20, SSB=0xB9E1,0xB901 on Serial#(64015)
<div style="display: flex; justify-content: space-around; width: 100%;"> <div style="text-align: center;"> ↓ SSB1 </div> <div style="text-align: center;"> ↓ SSB2 </div> </div>

The following shows an example of an SSB code that is output to the console.

The alphanumeric characters after the "SSB=" show an error code. The last four digits of alphanumeric characters on the left side of comma (,) is SSB1 (for example, B9E1), and the last four digits of alphanumeric characters on the right side is SSB2 (for example, B901).

The following describes the SSB codes returned by the replication commands and the configuration setting command (raidcom).

SSB codes returned by the replication commands

When a replication command returns an SSB code, refer to the troubleshooting information in the user document for the product as follows:

Command	Product returning the SSB code
<ul style="list-style-type: none"> paircreate pairresync pairsplit horctakeover horctakeoff 	Hitachi TrueCopy®
<ul style="list-style-type: none"> paircreate pairresync pairsplit 	Universal Replicator

Command	Product returning the SSB code
<ul style="list-style-type: none"> ▪ horctakeover ▪ horctakeoff 	
<ul style="list-style-type: none"> ▪ paircreate ▪ pairresync ▪ pairsplit ▪ horctakeover ▪ horctakeoff 	global-active device
<ul style="list-style-type: none"> ▪ paircreate ▪ pairresync ▪ pairsplit 	Hitachi ShadowImage®
<ul style="list-style-type: none"> ▪ paircreate ▪ pairsplit 	Hitachi Volume Migration
<ul style="list-style-type: none"> ▪ paircreate ▪ pairresync ▪ pairsplit 	Hitachi Thin Image
<ul style="list-style-type: none"> ▪ raidvchkset -vt ▪ raidvchkset -vs 	Database Validator
<ul style="list-style-type: none"> ▪ raidvchkset -vg 	Data Retention Utility
<ul style="list-style-type: none"> ▪ raidvchkset -vext 	Hitachi Dynamic Provisioning

The following tables provide information about the SSB codes returned by the replication commands. If you see an error not described in the tables, contact customer support.

SSB codes returned by the paircreate command

paircreate				
Error message	Executing/ Async	Error code		Description
		SSB1	SSB2	
CMDRJE	Executing	B980	B901	The command was rejected because the specified port is for NAS Platform (System LU).

paircreate				
Error message	Executing/ Async	Error code		Description
		SSB1	SSB2	
CMDRJE	Executing	B980	B903	The command was rejected because the selected resource belongs to NAS_Platform_System_RSG.

SSB codes returned by the pairsplit command

pairsplit				
Error message	Executing/ Async	Error code		Description
		SSB1	SSB2	
CMDRJE	Executing	B980	B901	The command was rejected because the specified port is for NAS Platform (System LU).

SSB codes returned by the pairsplit -S command

pairsplit -S				
Error message	Executing/ Async	Error code		Description
		SSB1	SSB2	
CMDRJE	Executing	B980	B901	The command was rejected because the specified port is for NAS Platform (System LU).

SSB codes returned by the configuration setting command (raidcom)

Executing the configuration setting command (**raidcom** command) can return an SSB code. An error can occur whether the command is executed synchronously or asynchronously. For an asynchronous error, the error information is displayed on the console by executing **raidcom get command_status** command. When the error message shows "CMDRJE" or "Get Command Status", check the contents of SSB1 and SSB2. You can verify a content of an error by the **raidcom get error_message** command. When you specify the SSB code with the **raidcom get error_message** command, make sure not to specify a wrong SSB code.

The following tables provide information about each SSB code returned by the configuration setting command (**raidcom** command). If you see an error not described in the tables, contact customer support.

Common				
Error message	Executing/ Async	Error code		Description
		SSB1	SSB2	
CMDRJE Get Command Status	Executing/ Async	2E10	8000	The operation cannot be performed because Storage Navigator or Device Manager - Storage Navigator is in progress, another application is in progress on the SVP, or the configuration is being changed. Wait a while, and then retry the operation.
CMDRJE	Executing	2E11	2205	The resource group to which the operation object belongs is locked by another user (or another session). Check the lock status of the resource group. If maintenance personnel is performing maintenance operations, retry the command after confirming the completion of the operations.
CMDRJE	Executing	2E11	2206	You do not have the operation authority for the target resource group. Specify the resource group that is allocated to the user group as the operation target, or set the operation authority to the user group in order to operate the target resource group.
CMDRJE	Executing	2E11	2207	The system is locked by another user (or another session). Wait a while, then retry the command. If maintenance personnel is performing maintenance operations, retry the command after confirming the completion of the operations..
CMDRJE Get Command Status	Executing/ Async	2E11	8303	The command cannot be executed because there is blocked part in the system.
CMDRJE	Executing	2E11	9400	The command cannot be accepted. Wait a while, then retry the command.
CMDRJE	Executing	2E31	9100	The command cannot be executed because the user authentication is not performed.
CMDRJE Get Command Status	Executing/ Async	2E3F	8000	The specified operation is not supported in the current microcode version.
CMDRJE	Executing	2EBE	9E01	The specified parameter is invalid. Check the <i>Command Control Interface Command Reference</i> .

Common				
Error message	Executing/ Async	Error code		Description
		SSB1	SSB2	
CMDRJE	Executing	2EF3	9300	The specified command cannot be executed due to the following reasons: <ul style="list-style-type: none"> The command cannot be accepted because it is not supported. The command is not supported in the current CCI version.
CMDRJE	Executing	2EF3	9F02	The specified operation is not supported in the current microcode version.
CMDRJE	Executing	2EF4	0026	The virtual storage machine with the specified serial number is not found.
CMDRJE	Executing	2EFF	FF00	The specified operation is not supported in the current microcode version.
CMDRJE	Executing	B90F	B90F	The specified operation is not supported in the current microcode version.
CMDRJE	Executing	B954	FF5F	The specified operation is not supported in the current microcode version.
CMDRJE	Executing	B9EC	B9EC	The specified operation is not supported in the current microcode version.
CMDRJE	Executing	B9EE	B9EE	The specified operation is not supported in the current microcode version.
CMDRJE	Executing	B9FD	B90A	The specified operation is not supported in the current microcode version.
CMDRJE	Executing	B9FD	B90C	The specified operation is not supported in the current microcode version.

SSB codes returned by `raidcom add external_grp`

raidcom add external_grp				
Error message	Executing/ Async	Error code		Description
		SSB1	SSB2	
CMDRJE	Executing	2E00	000D	Invalid emulation type.

raidcom add external_grp				
Error message	Executing/ Async	Error code		Description
		SSB1	SSB2	
Get Command Status	Async	2E00	0013	There are not enough cache management devices.
CMDRJE	Executing	2E00	4100	The external volume group is not in a effective range.
Get Command Status	Async	2E00	4104	The command cannot be executed by receiving the multiple operations for the same external volume group.
Get Command Status	Async	2E00	4108	The external volume group exists already.
Get Command Status	Async	2E00	410B	The specified CLPR does not exist.
CMDRJE	Executing	2E00	410D	The volume cannot be mapped for online data migration because the emulation type is not OPEN-V.
CMDRJE	Executing	2E00	410E	The specified external volume group attribute is invalid.
CMDRJE Get Command Status	Executing Async	2E00	4111	This command does not support the specified emulation type.
CMDRJE	Executing	2E00	4500	The path group is not in a effective range.
CMDRJE	Executing	2E00	8400	The value of the specified port is not valid.
CMDRJE	Executing	2E00	9B01	The specified iSCSI name is invalid.
Get Command Status	Async	2E02	4101	The iSCSI target cannot be specified because the emulation type is for mainframe.
CMDRJE	Executing	2E02	8403	The specified virtual port number is out of range.
Get Command Status	Async	2E10	4200	LUN of the specified external storage port does not exist.
Get Command Status	Async	2E10	4201	The external volume cannot be created because the specified external LU is a command device.

raidcom add external_grp				
Error message	Executing/ Async	Error code		Description
		SSB1	SSB2	
Get Command Status	Async	2E10	4203	The volume cannot be mapped as a remote command device because the specified external LU is not a command device.
Get Command Status	Async	2E10	4400	The WWN on the side of the specified external storage does not connected to a External port. This message may be output if the migration source storage system is USP V/VM and the host mode option 2 is not set to the port that connects to the migration target storage system.
CMDRJE	Executing	2E10	8404	The iSCSI virtual port mode for the specified port is disabled.
Get Command Status	Async	2E11	4106	The specified external LU cannot create a external volume because the transition of data is required.
Get Command Status	Async	2E11	4200	The specified path group cannot be operated because a path between other devices exists.
Get Command Status	Async	2E11	800F	The operation cannot be performed because the unsupported microcode version exists in the system.
CMDRJE	Executing	2E11	8010	The storage system is in internal process, or the configuration changing processes are conflicting.
CMDRJE	Executing	2E11	9400	The command cannot be accepted. After a while, execute the same command.
Get Command Status	Async	2E20	4102	Package for Mainframe is required when you specify the emulation type of mainframe.
Get Command Status	Async	2E20	8300	The specified MP Blade is not installed.
CMDRJE	Executing	2E20	8401	The specified virtual port is not defined.
CMDRJE Get Command Status	Executing/ Async	2E21	9008	The program product of Universal Volume Manager is not installed.

raidcom add external_grp				
Error message	Executing/ Async	Error code		Description
		SSB1	SSB2	
CMDRJE Get Command Status	Executing/ Async	2E21	9013	The program product of nondisruptive migration is not installed.
Get Command Status	Async	2E22	4100	The external volume group exists already.
CMDRJE	Executing	2E22	4100	The external volume group exists already.
Get Command Status	Async	2E23	0201	The operation cannot be performed because the number of remote command devices that can be created in the system exceeds the maximum number.
Get Command Status	Async	2E23	4102	Exceeded the number of mapping that can be set per 1 port.
Get Command Status	Async	2E23	4303	The operation cannot be performed because the number of path in the path group exceeds 8.
Get Command Status	Async	2E30	4119	The external volume cannot be added because the number of virtual volumes that can be created in the system exceeded the maximum number.
Get Command Status	Async	2E30	411B	The external volume having the Data Direct Mapping attribute cannot be created because the size of the specified external LU is less than 8GB.
Get Command Status	Async	2E30	4201	The specified external LU has mapped already.
CMDRJE	Executing	2E30	8400	The port attribute is not External.
CMDRJE	Executing	2E30	840E	The command cannot be executed with the specified port attribute.
Get Command Status	Async	2E31	4000	The specified external storage LU is the device of not supported.
Get Command Status	Async	2E31	4001	The specified external storage system is not supported.
Get Command Status	Async	2E31	4002	The specified external volume does not support nondisruptive migration.

raidcom add external_grp				
Error message	Executing/ Async	Error code		Description
		SSB1	SSB2	
Get Command Status	Async	2E31	9000	The usage capacity exceeds the license capacity of the program product.
CMDRJE	Executing	2EDA	00EE	The command cannot be accepted. After a while, execute the same command.
Get Command Status	Async	2EDA	41FA	An internal error occurred.
CMDRJE	Executing	2EF3	4102	The specified parameter is invalid. Check the <i>Command Control Interface Command Reference</i> .
CMDRJE	Executing	B980	B901	The command was rejected because the specified port is for NAS Platform (System LU).
CMDRJE	Executing	B980	B902	The command was rejected because the selected port is for NAS Platform (User LU).

SSB codes returned by raidcom check_ext_storage external_grp

raidcom check_ext_storage external_grp				
Error message	Executing/ Async	Error code		Description
		SSB1	SSB2	
CMDRJE	Executing	2E00	4100	The external volume group is not in the effective range.
CMDRJE	Executing	2E10	4301	The specified external volume has already disconnected the path, or is in the process of checking path.
CMDRJE	Executing	2E11	001B	The target LDEV is blocked.
CMDRJE	Executing	2E11	4000	The path for the specified external path is in the state of disconnected.
CMDRJE	Executing	2E11	4302	All the paths for the specified external path are blocked.
CMDRJE	Executing	2E20	4100	There is no external volume group.
CMDRJE	Executing	2E20	4300	There is no external path.
CMDRJE	Executing	2E30	001E	Online from the mainframe host.

raidcom check_ext_storage external_grp				
Error message	Executing/ Async	Error code		Description
		SSB1	SSB2	
Get Command Status	Async	2EDA	0905	An internal error occurred by the operation of external path. Call customer support.
CMDRJE	Executing	2EDA	0905	An internal error occurred by the operation of external volume. Call customer support.

SSB codes returned by raidcom delete external_grp

raidcom delete external_grp				
Error message	Executing/ Async	Error code		Description
		SSB1	SSB2	
CMDRJE	Executing	2E00	4100	The external volume group # is in the effective range.
Get Command Status	Async	2E10	0012	LDEVs in the external volume group are devices that have a CC/XRC attributes.
CMDRJE	Executing	2E11	0153	The specified external volume group is used in another operation.
Get Command Status	Async	2E11	4103	Destage is not executed.
Get Command Status	Async	2E11	4104	The external volume is used as Compatible FlashCopy® V2.
Get Command Status	Async	2E11	4105	The specified external volume cannot be deleted because audit logs for the system disk are being used.
Get Command Status	Async	2E11	8004	The operation cannot be performed because the internal processing is in progress.
CMDRJE	Executing	2E11	8010	The storage system is in internal process, or the configuration changing processes are conflicting.
Get Command Status	Async	2E11	8108	The operation cannot be performed because there is blocked part in the system.

raidcom delete external_grp				
Error message	Executing/ Async	Error code		Description
		SSB1	SSB2	
CMDRJE	Executing	2E11	9400	The command cannot be accepted. After a while, execute the same command.
CMDRJE	Executing	2E20	4100	There is no external volume group.
CMDRJE	Executing	2E30	0007	LU path is defined to LDEV in the external volume group.
Get Command Status	Async	2E30	0057	The external volume is used as a system disk.
Get Command Status	Async	2E30	4101	The external volume is used as LUSE.
Get Command Status	Async	2E30	4102	The external volume is used as a TrueCopy pair volume.
Get Command Status	Async	2E30	4103	The external volume is used as a TrueCopy pair volume.
Get Command Status	Async	2E30	4104	The specified volume is used as a ShadowImage pair volume, a Thin Image pair volume, or a FICON® Data Migration volume.
Get Command Status	Async	2E30	4105	The specified volume is used as a ShadowImage pair volume, a Thin Image pair volume, or a FICON® Data Migration volume.
Get Command Status	Async	2E30	4106	There is the volume that has path definition.
Get Command Status	Async	2E30	4107	The external volume is used as a ShadowImage reserved VOL.
Get Command Status	Async	2E30	4108	The external volume is used as aVolume Migration reserved VOL.
Get Command Status	Async	2E30	4109	There is a mainframe path group setting in the external volume.
Get Command Status	Async	2E30	410A	There is a Data Retention Utility setting in the external volume.
Get Command Status	Async	2E30	410B	There is a mainframe LDEV Guard setting in the external volume.
Get Command Status	Async	2E30	410C	There is a Volume Security setting in the external volume.

raidcom delete external_grp				
Error message	Executing/ Async	Error code		Description
		SSB1	SSB2	
Get Command Status	Async	2E30	410D	The external volume is used as a Universal Replicator pair volume.
Get Command Status	Async	2E30	410E	The external volume is used as a Universal Replicator journal volume.
Get Command Status	Async	2E30	410F	The external volume is used as a pool-VOL.
Get Command Status	Async	2E30	4110	The external volume is used as a pool-VOL.
Get Command Status	Async	2E30	4111	The external volume is used as aVolume Migration VOL.
Get Command Status	Async	2E30	4112	The external volume is used as aVolume Migration VOL.
Get Command Status	Async	2E31	0001	The target external group cannot be deleted because a quorum disk exists in it.
CMDRJE	Executing	2EDA	00EE	The command cannot be accepted. After a while, execute the same command.
Get Command Status	Async	2EE8	FFFB	An internal error occurred. Call customer support.
Get Command Status	Async	2EFF	41FF	An internal error occurred. Call customer support.

SSB codes returned by raidcom check_ext_storage path

raidcom check_ext_storage path				
Error message	Executing/ Async	Error code		Description
		SSB1	SSB2	
CMDRJE	Executing	2E00	4500	The path group is not in the enabled range.
CMDRJE	Executing	2E00	8400	The value of the port is not enabled.
CMDRJE	Executing	2E02	8403	The specified virtual port number is out of range.

raidcom check_ext_storage path				
Error message	Executing/ Async	Error code		Description
		SSB1	SSB2	
Get Command Status	Async	2E10	4301	The specified external volume has already disconnected the path, or is in the process of checking path.
CMDRJE	Executing	2E10	8404	The iSCSI virtual port mode for the specified port is disabled.
Get Command Status	Async	2E11	001B	The target LDEV is blocked.
Get Command Status	Async	2E11	4000	The path for the specified external path is in the state of disconnected.
Get Command Status	Async	2E11	4302	All the paths for the specified external path are blocked.
CMDRJE	Executing	2E11	9400	The command cannot be accepted. After a while, execute the same command.
Get Command Status	Async	2E20	4100	There is no specified external volume.
Get Command Status CMDRJE	Async/ Executing	2E20	4300	There is no specified path.
CMDRJE	Executing	2E20	4400	WWN is not registered.
CMDRJE	Executing	2E20	4500	This command cannot be operated due to one of the following reasons: <ul style="list-style-type: none"> ▪ There is no path group. ▪ external_wwn is not defined.
CMDRJE	Executing	2E20	8401	The specified virtual port is not defined.
Get Command Status	Async	2E30	001E	Online from the mainframe host.
CMDRJE	Executing	2E30	8400	The port attribute is not External (ELUN).
CMDRJE	Executing	2E30	840E	The command cannot be executed with the specified port attribute.
CMDRJE	Executing	2EDA	00EE	The command cannot be accepted. After a while, execute the same command.

raidcom check_ext_storage path				
Error message	Executing/ Async	Error code		Description
		SSB1	SSB2	
Get Command Status	Async	2EDA	0905	An internal error occurred by the operation of external path. Call customer support.
CMDRJE	Executing	B980	B901	The command was rejected because the specified port is for NAS platform (System LU).
CMDRJE	Executing	B980	B902	The command was rejected because the specified port is for NAS platform (User LU).

SSB codes returned by raidcom disconnect external_grp

raidcom disconnect external_grp				
Error message	Executing/ Async	Error code		Description
		SSB1	SSB2	
CMDRJE	Executing	2E00	4100	The external volume group is not in the effective range.
CMDRJE	Executing	2E10	0000	The specified LDEV is used for a ShadowImage pair.
CMDRJE	Executing	2E10	0001	It is used as a TrueCopy or Universal Replicator pair.
CMDRJE	Executing	2E10	0003	A ShadowImage pair, a Thin Image/Copy-on-Write Snapshot pair or a Compatible FlashCopy® V2 relationship or in status of splitting or pending exists.
CMDRJE	Executing	2E10	0004	The specified LDEV is used for a Thin Image pair or a Copy-on-Write Snapshot pair.
CMDRJE	Executing	2E10	0008	It is used as a system disk.
CMDRJE	Executing	2E10	0012	It is used as a concurrent copy or XRC.
CMDRJE	Executing	2E10	0062	The specified LDEV is used as the primary volume of a global-active device (GAD) pair.
CMDRJE	Executing	2E10	0063	The specified LDEV is used as the secondary volume of aGAD pair.

raidcom disconnect external_grp				
Error message	Executing/ Async	Error code		Description
		SSB1	SSB2	
CMDRJE	Executing	2E10	4100	The specified external volume group is in the state of disconnected.
CMDRJE	Executing	2E10	4102	The specified external device is in the state of disconnected.
CMDRJE	Executing	2E10	4301	The specified external volume has already disconnected the path, or is in the process of checking path.
CMDRJE	Executing	2E11	0007	It is in the state of shredding.
CMDRJE	Executing	2E11	001B	The target LDEV is blocked.
CMDRJE	Executing	2E11	4000	The path for the specified external path is in the state of disconnected.
CMDRJE	Executing	2E11	410D	The DP-VOL with the Data Direct Mapping attribute which is allocated to the specified external volume is not blocked.
CMDRJE	Executing	2E11	4302	All the paths for the specified external path are blocked.
CMDRJE	Executing	2E11	6005	The specified external volume belongs to a Thin Image or Copy-on-Write Snapshot where the pair in the PSUS status exists.
CMDRJE	Executing	2E11	800E	The operation cannot be performed because the internal processing is in progress. Wait for a while, then retry the operation.
CMDRJE	Executing	2E20	4100	There is no specified external volume.
CMDRJE	Executing	2E20	4300	There is no specified path.
CMDRJE	Executing	2E30	000A	It is included the Hitachi Dynamic Provisioning volume that is associated with a pool.
CMDRJE	Executing	2E30	000C	The specified LDEV is used as a quorum disk.
CMDRJE	Executing	2E30	000E	It is used as a pool volume.
CMDRJE	Executing	2E30	000F	It is used as a journal volume.
CMDRJE	Executing	2E30	0014	It is used as a reserved volume of Volume Migration.
CMDRJE	Executing	2E30	001A	Volume Security is set.

raidcom disconnect external_grp				
Error message	Executing/ Async	Error code		Description
		SSB1	SSB2	
CMDRJE	Executing	2E30	001C	It is used as a remote command device.
CMDRJE	Executing	2E30	001E	Online from the mainframe host.
CMDRJE	Executing	2E30	004E	This is a volume that the Data Retention Utility is set.
CMDRJE	Executing	2E30	0061	The Dynamic Provisioning volume not in the blocked state is included in the Dynamic Provisioning that is associated with the pool to which the pool volume is belongs.
CMDRJE	Executing	2EDA	0000	An internal error occurred by the operation of disconnecting the external volume. Call customer support.
CMDRJE	Executing	2EDA	0905	An internal error occurred by the operation of external volume. Call customer support.

SSB codes returned by raidcom modify external_grp

raidcom modify external_grp				
Error message	Executing/ Async	Error code		Description
		SSB1	SSB2	
CMDRJE	Executing	2E00	4100	The external volume group is not in the effective range.
CMDRJE	Executing	2E00	410F	The specified value of the load balance mode is invalid.
CMDRJE	Executing	2E00	4110	The specified value of the ALUA mode is invalid.
CMDRJE	Executing	2E00	8301	MP Blade ID is not in the effective range.
CMDRJE	Executing	2E10	4202	The operation cannot be performed because the volume used for data migration is reserved from the host.
CMDRJE	Executing	2E10	8300	The specified MP Blade is blocked.

raidcom modify external_grp				
Error message	Executing/ Async	Error code		Description
		SSB1	SSB2	
CMDRJE	Executing	2E11	4107	The attribute cannot be changed because Volume Migration is being executed.
CMDRJE	Executing	2E11	4303	The load balance mode cannot be changed because the alternative path mode is set to Single.
CMDRJE	Executing	2E11	800F	The load balance mode cannot be changed because microcodes of multiple versions are in the storage system.
CMDRJE	Executing	2E20	4100	There is no external volume group.
CMDRJE	Executing	2E20	8300	The specified MP Blade is not installed.
CMDRJE	Executing	2E30	4104	The attribute cannot be changed because the external volume is used as a ShadowImage pair volume.
CMDRJE	Executing	2E30	410D	The external volume is used as a Universal Replicator pair volume.
CMDRJE	Executing	2E30	411A	The external volume is used as a TrueCopy volume.
CMDRJE	Executing	2E30	411C	The operation cannot be performed because the external volume is being used as a global-active device pair.
CMDRJE	Executing	2E31	000C	Cache mode cannot be changed because there is an LDEV that Cache Residency Manager bind mode is set.
CMDRJE	Executing	2E31	4101	Cache mode cannot be changed because the specified external volume includes a pool volume or an LDEV that is used by LUSE.
CMDRJE	Executing	2E31	4107	The cache mode cannot be changed because the specified external volume is one of the following. <ul style="list-style-type: none"> ▪ A pool volume in the pool that consists of both external volumes and internal volumes. ▪ A pool volume in the pool whose multi-tier pool option is enabled.

raidcom modify external_grp				
Error message	Executing/ Async	Error code		Description
		SSB1	SSB2	
CMDRJE	Executing	2E31	4108	The attribute of the external volume cannot be changed from the current cache mode to the specified cache mode.
CMDRJE	Executing	2E31	4109	The attribute cannot be changed because the external volume group is not mapped for online data migration.
CMDRJE	Executing	2EDA	00F1	The specified command cannot be accepted because the command is not supported.
CMDRJE	Executing	2EDA	0905	An internal error occurred on the changing of an external volume option. Call customer support.
CMDRJE	Executing	2EF3	0002	The specified parameter is incorrect. Check the <i>Command Control Interface Command Reference</i> .

SSB codes returned by raidcom modify port -loop_id

raidcom modify port -loop_id				
Error message	Executing/ Async	Error code		Description
		SSB1	SSB2	
CMDRJE	Executing	B955	0404	An LU path or a logical path has been defined.
CMDRJE	Executing	B955	040F	An internal error occurred.
CMDRJE	Executing	B955	044C	The specified AL-PA is invalid.
CMDRJE	Executing	B955	054E	The specified topology is invalid.
CMDRJE	Executing	B955	05A6	The other than "fabric on" cannot be specified when specifying a topology of the package for Fibre Channel over Ethernet.
CMDRJE	Executing	B955	05A7	The other than "P-to-P (point to point)" cannot be specified when specifying a topology of the package for Fibre Channel over Ethernet.
CMDRJE	Executing	B955	1039	The command device being used at the local CCI exists under the port.

raidcom modify port -loop_id				
Error message	Executing/ Async	Error code		Description
		SSB1	SSB2	
CMDRJE	Executing	B955	104F	The program product is not installed.
CMDRJE	Executing	B955	113D	Invalid host speed is set for the 4Gbps fibre adapter. The available host speeds are AUTO, 1G, 2G, and 4G only.
CMDRJE	Executing	B955	113F	Invalid host speed is set for the 8Gbps fibre adapter. The available host speeds are AUTO, 2G, 4G, and 8G only.
CMDRJE	Executing	B955	11A5	The other than "10G" cannot be specified when specifying a host speed of the package for Fibre Channel over Ethernet.
CMDRJE	Executing	B980	B901	The command was rejected because the specified port is for NAS Platform (System LU).
CMDRJE	Executing	B980	B902	The command was rejected because the selected port is for NAS Platform (User LU).

SSB codes returned by raidcom modify port -topology

raidcom modify port -topology				
Error message	Executing/ Async	Error code		Description
		SSB1	SSB2	
CMDRJE	Executing	B955	0404	An LU path or a logical path has been defined.
CMDRJE	Executing	B955	040F	An internal error occurred.
CMDRJE	Executing	B955	044C	The specified AL-PA is invalid.
CMDRJE	Executing	B955	054E	The specified topology is invalid.
CMDRJE	Executing	B955	05A6	The other than "fabric on" cannot be specified when specifying a topology of the package for Fibre Channel over Ethernet.
CMDRJE	Executing	B955	05A7	The other than "P-to-P (point to point)" cannot be specified when specifying a topology of the package for Fibre Channel over Ethernet.

raidcom modify port -topology				
Error message	Executing/ Async	Error code		Description
		SSB1	SSB2	
CMDRJE	Executing	B955	1039	The command device being used at the local CCI exists under the port.
CMDRJE	Executing	B955	104F	The program product is not installed.
CMDRJE	Executing	B955	113D	Invalid host speed is set for the 4Gbps fibre adapter. The available host speeds are AUTO, 1G, 2G, and 4G only.
CMDRJE	Executing	B955	113F	Invalid host speed is set for the 8Gbps fibre adapter. The available host speeds are AUTO, 2G, 4G, and 8G only.
CMDRJE	Executing	B955	11A5	The other than "10G" cannot be specified when specifying a host speed of the package for Fibre Channel over Ethernet.
CMDRJE	Executing	B955	12AF	The combination of the specified topology FC-AL and the host speed set for the fibre channel adapter is not supported. See the <i>Provisioning Guide</i> of your system for supported combinations of data transfer speed and type of connection.
CMDRJE	Executing	B980	B901	The command was rejected because the specified port is for NAS Platform (System LU).
CMDRJE	Executing	B980	B902	The command was rejected because the selected port is for NAS Platform (User LU).

SSB codes returned by raidcom modify port -security_switch

raidcom modify port -security_switch				
Error message	Executing/ Async	Error code		Description
		SSB1	SSB2	
CMDRJE	Executing	B955	0404	An LU path or a logical path has been defined.
CMDRJE	Executing	B955	040F	An internal error occurred.
CMDRJE	Executing	B955	044C	The specified AL-PA is invalid.
CMDRJE	Executing	B955	054E	The specified topology is invalid.

raidcom modify port -security_switch				
Error message	Executing/ Async	Error code		Description
		SSB1	SSB2	
CMDRJE	Executing	B955	05A6	The other than "fabric on" cannot be specified when specifying a topology of the package for Fibre Channel over Ethernet.
CMDRJE	Executing	B955	05A7	The other than "P-to-P (point to point)" cannot be specified when specifying a topology of the package for Fibre Channel over Ethernet.
CMDRJE	Executing	B955	1039	The command device being used at the local CCI exists under the port.
CMDRJE	Executing	B955	104F	The program product is not installed.
CMDRJE	Executing	B955	113D	Invalid host speed is set for the 4Gbps fibre adapter. The available host speeds are AUTO, 1G, 2G, and 4G only.
CMDRJE	Executing	B955	113F	Invalid host speed is set for the 8Gbps fibre adapter. The available host speeds are AUTO, 2G, 4G, and 8G only.
CMDRJE	Executing	B955	11A5	The other than "10G" cannot be specified when specifying a host speed of the package for Fibre Channel over Ethernet.
CMDRJE	Executing	B980	B901	The command was rejected because the specified port is for NAS Platform (System LU).
CMDRJE	Executing	B980	B902	The command was rejected because the selected port is for NAS Platform (User LU).

SSB codes returned by raidcom add ldev

raidcom add ldev				
Error message	Executing/ Async	Error code		Description
		SSB1	SSB2	
CMDRJE	Executing	2E00	0000	The LDEV number is out of settable range.
CMDRJE Get Command Status	Executing/ Async	2E00	0002	The specified capacity is not in the effective range.

raidcom add ldev				
Error message	Executing/ Async	Error code		Description
		SSB1	SSB2	
CMDRJE	Executing	2E00	0003	SSID is not in the effective range.
CMDRJE	Executing	2E00	000D	The value of the specified emulation type is invalid.
CMDRJE Get Command Status	Executing/ Async	2E00	000E	The specified emulation type is not supported in this command.
Get Command Status	Async	2E00	0010	The operation cannot be performed because the specified LDEV number is already used.
Get Command Status	Async	2E00	0013	The operation cannot be performed because there are not enough cache management devices.
Get Command Status	Async	2E00	0014	Cannot create because the specified capacity is invalid.
CMDRJE	Executing	2E00	0019	The capacity in the case of specifying a emulation type of the mainframe series must be dividable by the cylinder.
CMDRJE	Executing	2E00	001A	The capacity when 3390-V emulation type is specified must be divisible by page unit.
CMDRJE	Executing	2E00	001C	When you specify emulation type for open system, you cannot specify the size by the cylinder.
CMDRJE Get Command Status	Executing/ Async	2E00	0025	The following external volume cannot be created because the capacity which is specified with LBA is not same as the size of the external volume group. <ul style="list-style-type: none"> ▪ An external volume for the online data migration. ▪ An external volume having the Data Direct Mapping attribute.
CMDRJE	Executing	2E00	0026	The capacity must be specified because LDEVs are in the parity group (or the external volume group).
CMDRJE	Executing	2E00	0027	The capacity must be specified.

raidcom add ldev				
Error message	Executing/ Async	Error code		Description
		SSB1	SSB2	
Get Command Status	Async	2E00	002D	The emulation type of the mainframe cannot be specified because the virtual volume is set for the specified LDEV.
CMDRJE	Executing	2E00	002F	The specified value of the Full Allocation is invalid.
Get Command Status	Async	2E00	0030	Full Allocation cannot be specified to the specified LDEV because the emulation type is not supported.
CMDRJE	Executing	2E00	0101	The parity group number or the external group number is not in the effective range.
Get Command Status	Async	2E00	1005	Failed to restore the LDEV that is created to external volume group.
CMDRJE	Executing	2E00	6000	The specified pool ID is not in the effective range.
CMDRJE	Executing	2E00	7000	The specified CLPR ID is not in the effective range.
CMDRJE	Executing	2E00	8301	MP Blade ID is not in the effective range.
CMDRJE	Executing	2E02	0201	The specified protection type is not supported.
Get Command Status	Async	2E02	0203	The specified operation cannot be performed because it is an external volume.
Get Command Status	Async	2E02	0204	The operation cannot be performed because the specified capacity is less than 8 GB.
Get Command Status	Async	2E02	0205	Full Allocation cannot be performed because the pool uses the LDEV belonging to a parity group with accelerated compression enabled.
CMDRJE Get Command Status	Executing/ Async	2E02	A601	The operation cannot be performed because either of the following applies: <ul style="list-style-type: none"> ▪ The specified request ID is invalid. ▪ A request ID managed by another session is specified.
CMDRJE	Executing	2E10	0003	The specified LDEV is used as a Compatible FlashCopy® V2 relationship.

raidcom add ldev				
Error message	Executing/ Async	Error code		Description
		SSB1	SSB2	
Get Command Status	Async	2E10	001F	The operation cannot be performed because the total capacity of virtual volumes for Dynamic Tiering or active flash in the system exceeds the maximum.
Get Command Status	Async	2E10	002D	The operation cannot be performed because the specified LDEV is a journal volume.
Get Command Status	Async	2E10	005A	The operation cannot be performed because the following information of the migration source and the migration target does not match. <ul style="list-style-type: none"> ▪ serial number ▪ product ID ▪ emulation type ▪ SSID ▪ LUSE ▪ CVS configuration ▪ LDEV number
Get Command Status	Async	2E10	0064	The specified pool volume is already linked with the virtual volume having the Data Direct Mapping attribute.
Get Command Status	Async	2E10	0100	The volumes cannot be added because the encryption value of the key number that is set to encryption ECC is invalid.
Get Command Status	Async	2E10	0101	The volumes cannot be added because the check sum of the encryption key does not match.
Get Command Status	Async	2E10	020E	The specified LDEV is not in the status where the capacity saving setting can be enabled.
Get Command Status	Async	2E10	6014	The operation cannot be performed because the specified pool status is incorrect.
Get Command Status	Async	2E10	601B	The free space in the specified pool is insufficient.
Get Command Status	Async	2E10	601C	Full Allocation cannot be performed because the pool volume is being deleted.

raidcom add ldev				
Error message	Executing/ Async	Error code		Description
		SSB1	SSB2	
Get Command Status	Async	2E10	6020	The deduplication function cannot be used in the specified pool.
Get Command Status	Async	2E10	6021	The deduplication system data volume defined for the specified pool is not in the normal status.
Get Command Status	Async	2E10	6022	The operation cannot be performed because the deduplication system data volume of the pool linked with the specified LDEV is blocked.
Get Command Status	Async	2E11	0003	An LDEV that is in the state of shredding is included in the parity group of the target LDEV.
Get Command Status	Async	2E11	0004	An LDEV that is in the state of formatting is included in the parity group of the target LDEV.
Get Command Status	Async	2E11	0005	An LDEV that is in the state of executing quick format is included in the parity group of the target LDEV.
Get Command Status	Async	2E11	001B	The specified LDEV is blocked.
CMDRJE	Executing	2E11	0053	The specified LDEV is used in another operation.
Get Command Status	Async	2E11	0102	The parity group of the target LDEV is in the state of correction copy.
CMDRJE	Executing	2E11	0153	The parity group or the external volume group that the specified LDEV is belongs to is used in another operation.
Get Command Status	Async	2E11	0205	The operation cannot be performed because the total capacity of provisioning virtual volumes and deduplication system data volumes defined in the specified pool exceeds the maximum of reserved pool capacity.
Get Command Status	Async	2E11	0209	The operation cannot be performed due to a cache memory failure or maintenance work being performed.
CMDRJE Get Command Status	Executing/ Async	2E11	2208	The operation cannot be performed because you do not have the resource group authority.

raidcom add ldev				
Error message	Executing/ Async	Error code		Description
		SSB1	SSB2	
CMDRJE Get Command Status	Executing/ Async	2E11	2209	The operation cannot be performed because there is no LDEV ID that can be used in a system or resource group.
Get Command Status	Async	2E11	6007	The operation cannot be performed because the specified pool volume is blocked.
Get Command Status	Async	2E11	6008	The operation cannot be performed because the pool linked with the specified LDEV is in the unusable status.
Get Command Status	Async	2E11	8004	The operation cannot be performed because the internal processing is in progress.
CMDRJE	Executing	2E11	8010	The storage system is in internal process, or the configuration changing processes are conflicting.
Get Command Status	Async	2E11	8105	Cache segment size is incorrect.
Get Command Status	Async	2E11	8108	The operation cannot be performed because there is blocked part in the system.
CMDRJE	Executing	2E11	9400	The command cannot be accepted. After a while, execute the same command.
CMDRJE Get Command Status	Executing/ Async	2E11	A602	The operation cannot be performed because the internal processing is in progress. After a while, perform the operation again.
CMDRJE	Executing	2E20	0000	The specified LDEV is not defined.
CMDRJE Get Command Status	Executing/ Async	2E20	0007	The specified CLPR does not exist.
CMDRJE	Executing	2E20	0100	There is no parity group.
CMDRJE Get Command Status	Executing/ Async	2E20	6000	Pool ID is invalid.
Get Command Status	Async	2E20	8300	The specified MP Blade is not installed.

raidcom add ldev				
Error message	Executing/ Async	Error code		Description
		SSB1	SSB2	
Get Command Status	Async	2E21	6003	There is not enough free shared memory space.
Get Command Status	Async	2E21	8103	The operation cannot be performed because the capacity of shared memory is insufficient.
Get Command Status	Async	2E21	810A	The shared memory is not installed.
Get Command Status	Async	2E21	8300	Package for Mainframe is required when you specify the emulation type of mainframe.
Get Command Status	Async	2E21	9000	The program product is not installed.
CMDRJE	Executing	2E21	9001	The program product is not installed.
CMDRJE	Executing	2E21	9002	The program product is not installed.
CMDRJE/Get Command Status	Executing/ Async	2E21	9004	The program product is not installed.
CMDRJE	Executing	2E21	900E	Hitachi Compatible Software for IBM® FlashCopy® SE program product is not installed.
CMDRJE	Executing	2E22	0001	LDEV is already defined.
CMDRJE	Executing	2E22	000F	You cannot create the volume because the size of the specified external volume group exceeds the maximum capacity of the external volume for online data migration.
CMDRJE Get Command Status	Executing/ Async	2E23	0001	The number exceeds the maximum number of LDEV that can be created in the current system configuration.
Get Command Status	Async	2E30	0006	The specified LDEV is used in the FICON® Data Migration.
CMDRJE	Executing	2E30	0020	The specified SSID is already used in another CU.
CMDRJE	Executing	2E30	0021	The SSID is allocated to the CU already.
Get Command Status	Async	2E30	0025	The specified volume is used as an alias device in Compatible PAV.

raidcom add ldev				
Error message	Executing/ Async	Error code		Description
		SSB1	SSB2	
Get Command Status	Async	2E30	0026	An LDEV of another emulation type is allocated in the range where the number is divided into each 32LDEVs.
CMDRJE	Executing	2E30	004C	The emulation type that cannot be mixed with is specified.
CMDRJE	Executing	2E30	004D	The number of LDEVs exceeds the maximum number of LDEVs that can be created in the parity group or the external volume group.
CMDRJE	Executing	2E30	0098	The volume which is specified as a pool volume must have a Data Direct Mapping attribute.
Get Command Status	Async	2E30	0099	The specified LDEV is a volume for which the Data Direct Mapping attribute is enabled.
Get Command Status	Async	2E30	009A	The page reservation cannot be set for the specified LDEV with the specified operation.
Get Command Status	Async	2E30	009B	The operation cannot be performed because the page reservation is set for the specified LDEV.
CMDRJE	Executing	2E30	0104	There is not enough amount of free space that is specified in the parity group or the external volume group.
CMDRJE	Executing	2E30	0105	The location is out of the range that can be specified.
CMDRJE	Executing	2E30	0106	Volume whose emulation type is 3390-V cannot be created in RAID1 parity group.
CMDRJE Get Command Status	Executing/ Async	2E30	4119	The virtual volume cannot be added because the number of virtual volumes that can be created in the system exceeded the maximum number.
CMDRJE Get Command Status	Executing/ Async	2E30	6003	The specified pool is the pool for Thin Image or Copy-on-Write Snapshot.
Get Command Status	Async	2E30	6012	The operation cannot be performed because the specified pool is used for Data Direct Mapping.

raidcom add ldev				
Error message	Executing/ Async	Error code		Description
		SSB1	SSB2	
Get Command Status	Async	2E30	6014	The operation cannot be performed because the specified pool is for active flash.
Get Command Status	Async	2E31	6003	The operation cannot be performed with the specified pool type.
CMDRJE	Executing	2E31	6007	TSE-VOL cannot be created because of the following conditions. <ul style="list-style-type: none"> ▪ The specified pool is other than HDPz pool. ▪ The specified emulation type is other than 3390-A.
CMDRJE	Executing	2E31	6008	TSE-VOL cannot be created in combination with the specified pool ID and the CU number of LDEV. You must specify the even CU number for the pool of even pool ID, and the odd CU number for the pool of odd pool ID.
Get Command Status	Async	2E31	6009	A TSE-VOL cannot be created in the specified pool for Dynamic Tiering or active flash.
CMDRJE Get Command Status	Executing/ Async	2E3F	8000	The specified operation is not supported in the current microcode version.
CMDRJE Get Command Status	Executing/ Async	2EBE	9E01	The specified parameter is invalid.
CMDRJE	Executing	2EE8	00EE	The command cannot be accepted. After a while, execute the same command.
Get Command Status	Async	2EE8	FFFB	An internal error occurred. Call customer support.
CMDRJE	Executing	2EF3	0002	The specified parameter is invalid. Check the <i>Command Control Interface Command Reference</i> .
CMDRJE	Executing	B980	B903	The command was rejected because the selected resource belongs to NAS_Platform_System_RSG.

raidcom add ldev				
Error message	Executing/ Async	Error code		Description
		SSB1	SSB2	
ERANGE Result too large	Executing	-	-	The value of the capacity is invalid.

SSB codes returned by raidcom delete journal

raidcom delete journal				
Error message	Executing/ Async	Error code		Description
		SSB1	SSB2	
CMDRJE	Executing	2E00	0000	The number of specified LDEV is invalid.
Get Command Status	Async	2E00	0023	The specified volume capacity is too small.
CMDRJE	Executing	2E00	5000	The specified journal ID is exceeds the range.
Get Command Status	Async	2E10	0011	The specified volume is not installed or cannot be used.
Get Command Status	Async	2E10	0053	The specified volume is used in maintenance operation.
Get Command Status	Async	2E10	5000	The specified operation failed because the journal or mirror is not in the operable status.
Get Command Status	Async	2E10	5010	The journal volume cannot be deleted with the specified journal status.
Get Command Status	Async	2E11	800B	The operation cannot be performed because it is in the state of start-up.
Get Command Status	Async	2E11	800E	The operation cannot be performed because the internal processing is in progress. Wait for a while, then retry the operation.
CMDRJE	Executing	2E11	9400	The command cannot be accepted. After a while, execute the same command.
CMDRJE	Executing	2E13	5002	The specified LDEV is not in the journal.
CMDRJE	Executing	2E20	5000	The specified journal ID is not registered.
Get Command Status	Async	2E21	5000	The operation failed because the specified journal is not registered.

raidcom delete journal				
Error message	Executing/ Async	Error code		Description
		SSB1	SSB2	
Get Command Status	Async	2E21	8104	The journal volume cannot be added, or the journal cannot be added to the extended consistency group due to insufficient capacity of the shared memory.
CMDRJE	Executing	2E21	8105	The shared memory for Universal Replicator is not installed.
CMDRJE	Executing	2E23	0008	The number of specified LDEVs is invalid.
Get Command Status	Async	2E30	0062	The specified volume cannot be used as a journal volume because it is an external volume that can execute the I/O suppression mode.
Get Command Status	Async	2E30	5002	The specified journal cannot be deleted because there are data volumes.
CMDRJE	Executing	2EE4	08E6	The command cannot be accepted. After a while, execute the same command.
Get Command Status	Async	2EE4	50EE	An internal error occurred. Call customer support.
CMDRJE	Executing	B980	B903	The command was rejected because the selected resource belongs to NAS_Platform_System_RSG.

SSB codes returned by raidcom add journal

raidcom add journal				
Error message	Executing/ Async	Error code		Description
		SSB1	SSB2	
CMDRJE	Executing	2E00	0000	The value of LDEV number is invalid.
CMDRJE	Executing	2E00	0018	A new journal volume cannot be registered because the number of journal volume exceeds the maximum that can be registered.
Get Command Status	Async	2E00	0023	The specified volume capacity is too small.

raidcom add journal				
Error message	Executing/ Async	Error code		Description
		SSB1	SSB2	
CMDRJE	Executing	2E00	8301	The specified MP Blade ID is invalid.
CMDRJE Get Command Status	Executing/ Async	2E10	0000	The specified volume is already used by another program product.
CMDRJE Get Command Status	Executing/ Async	2E10	0011	The specified volume is not installed or cannot be used.
Get Command Status	Async	2E10	001A	The specified volume is connected from the mainframe host.
CMDRJE Get Command Status	Executing/ Async	2E10	001B	There is a PIN slot in the journal volume.
CMDRJE Get Command Status	Executing/ Async	2E10	001C	The specified volume cannot be registered as a journal volume because it is in shredding. Wait until the shredding operation is completed, then retry the operation.
Get Command Status	Async	2E10	0053	The specified volume is used in maintenance operation.
Get Command Status	Async	2E10	0056	The specified volume cannot be used as the journal volume because the virtual LDEV ID is deleted.
Get Command Status	Async	2E10	0057	The specified volume cannot be used as the journal volume because it is the virtual volume.
Get Command Status	Async	2E10	5000	The specified operation failed because the journal or mirror is not in the operable status.
Get Command Status	Async	2E11	800B	The operation cannot be performed because it is in the state of start-up.
Get Command Status	Async	2E11	800E	The operation cannot be performed because the internal processing is in progress. Wait for a while, then retry the operation.
CMDRJE Get Command Status	Executing/ Async	2E11	810A	Abnormal cache status.

raidcom add journal				
Error message	Executing/ Async	Error code		Description
		SSB1	SSB2	
CMDRJE	Executing	2E11	9400	The command cannot be accepted. After a while, execute the same command.
CMDRJE	Executing	2E20	0000	The specified LDEV is not defined.
CMDRJE	Executing	2E20	8300	The specified MP Blade is not installed.
Get Command Status	Async	2E21	5000	The operation failed because the specified journal is not installed.
Get Command Status	Async	2E21	8104	The journal volume cannot be added, or the journal cannot be added to the extended consistency group due to insufficient capacity of the shared memory.
CMDRJE	Executing	2E21	8105	The shared memory for Universal Replicator is not installed.
Get Command Status	Async	2E21	9000	A journal volume cannot be registered, or a journal cannot be added to the extended consistency group because the program product of Universal Replicator or Hitachi Universal Replicator software for Mainframe is not installed.
Get Command Status	Async	2E23	0005	A new journal volume cannot be registered, or the number of selected volumes is too many.
CMDRJE	Executing	2E23	0008	The number of specified LDEVs is invalid.
Get Command Status	Async	2E23	003E	The operation failed because the multiple LDKC numbers cannot be mixed in the journal.
Get Command Status	Async	2E23	5000	The operation failed because the number of journals in the journal or the extended consistency group exceeds the maximum.
CMDRJE Get Command Status	Executing/ Async	2E30	0005	The specified volume cannot be used as a journal volume because it is set by Cache Residency Manager or Cache Residency Manager for Mainframe.
CMDRJE Get Command Status	Executing/ Async	2E30	0006	The specified volume cannot be used because it is used in FICON(R) Data Migration.

raidcom add journal				
Error message	Executing/ Async	Error code		Description
		SSB1	SSB2	
CMDRJE Get Command Status	Executing/ Async	2E30	0007	A path is defined in the specified volume.
CMDRJE Get Command Status	Executing/ Async	2E30	000C	The operation failed because the specified volume is a quorum disk.
CMDRJE Get Command Status	Executing/ Async	2E30	000D	The specified volume cannot be used as a journal volume because it is a system disk.
Get Command Status	Async	2E30	000E	The operation failed because the specified volume is a pool volume of Dynamic Provisioning.
Get Command Status CMDRJE	Async/ Executing	2E30	000F	The specified volume is already used as a journal volume or a data volume.
CMDRJE Get Command Status	Executing/ Async	2E30	0010	The specified volume is used as a command device.
CMDRJE Get Command Status	Executing/ Async	2E30	0013	The specified volume cannot be used as a journal volume because it is a LUSE volume.
CMDRJE Get Command Status	Executing/ Async	2E30	0019	The specified volume cannot be used as a journal volume because it is set by Data Retention Utility or .
CMDRJE Get Command Status	Executing/ Async	2E30	001A	Using the specified volume is prohibited by Volume Security.
CMDRJE	Executing	2E30	0035	The internal volumes and external volumes exist in the specified journal.
Get Command Status	Async	2E30	0040	The emulation type of the specified volume is not supported. Or, the combination of an emulation type of the journal volume is incorrect.

raidcom add journal				
Error message	Executing/ Async	Error code		Description
		SSB1	SSB2	
Get Command Status	Async	2E30	0041	The volume cannot be registered as a journal volume because the CLPR ID of the specified volume differs from the CLPR ID of the registered journal volume.
CMDRJE	Executing	2E30	005F	The specified LDEV is a remote command device.
CMDRJE Get Command Status	Executing/ Async	2E30	0062	The specified volume cannot be used as a journal volume because it is an external volume that can execute the I/O suppression mode.
CMDRJE Get Command Status	Executing/ Async	2E30	0064	The specified volume is a reserved volume of a mainframe host.
CMDRJE Get Command Status	Executing/ Async	2E30	0065	The specified volume is used by XRC.
CMDRJE Get Command Status	Executing/ Async	2E30	0067	The specified volume is a volume of Just in Time (On-demand) function.
Get Command Status	Async	2E30	0068	The specified volume cannot be used as a journal volume because it is used by Compatible PAV.
CMDRJE Get Command Status	Executing/ Async	2E30	0070	The resource group ID of the specified volume cannot be registered because the resource group ID is different from the resource group ID of the other journal volume in the specified journal group.
CMDRJE Get Command Status	Executing/ Async	2E30	0074	The specified LDEV cannot be operated because it is an external volume mapped for online data migration.
Get Command Status	Async	2E30	0084	The specified LDEV cannot be used as a journal volume because the size of the LDEV is less than the minimum capacity of journal volume.

raidcom add journal				
Error message	Executing/ Async	Error code		Description
		SSB1	SSB2	
CMDRJE Get Command Status	Executing/ Async	2E30	0086	The operation cannot be performed because the specified volume is not the Dynamic Provisioning V-VOL.
Get Command Status	Async	2E30	0208	The operation cannot be performed because the specified LDEV is a volume for which capacity saving setting is enabled or a deduplication system data volume.
CMDRJE	Executing	2EE4	08E6	The command cannot be accepted. After a while, execute the same command.
CMDRJE Get Command Status	Executing/ Async	2EE4	50EE	An internal error occurred. Call customer support.
CMDRJE Get Command Status	Executing/ Async	2EE4	FEEC	An internal error occurred. Call customer support.
CMDRJE	Executing	2EF3	5002	The specified parameter is invalid. Check the <i>Command Control Interface Command Reference</i> .
CMDRJE	Executing	B980	B903	The command was rejected because the selected resource belongs to NAS_Platform_System_RSG.

SSB codes returned by raidcom modify journal

raidcom modify journal				
Error message	Executing/ Async	Error code		Description
		SSB1	SSB2	
CMDRJE Get Command Status	Executing/ Async	2E00	0000	The specified volume number is out of effective range.
CMDRJE	Executing	2E00	0023	The specified volume capacity is too small.
CMDRJE	Executing	2E00	5000	The specified journal ID exceeds the range.

raidcom modify journal				
Error message	Executing/ Async	Error code		Description
		SSB1	SSB2	
CMDRJE	Executing	2E00	500B	The specified path blocked path monitoring is not in the valid range.
CMDRJE	Executing	2E00	8301	The specified MP Blade ID is invalid.
CMDRJE Get Command Status	Executing/ Async	2E02	5201	The specified mirror ID is out of effective range.
CMDRJE Get Command Status	Executing/ Async	2E10	0011	The specified volume is not installed or cannot be used.
Get Command Status	Async	2E10	021C	The specified remote command device cannot be operated because it is blocked.
Get Command Status	Async	2E10	021D	No more mirrors can be assigned to the specified remote command device.
Get Command Status	Async	2E10	021E	The operation cannot be performed because the number of remote command devices that can be assigned to the mirror exceeds the maximum.
CMDRJE	Executing	2E10	5000	The specified operation failed because the journal or mirror is not in the operable status.
CMDRJE	Executing	2E10	5006	The specified operation failed because the mirror of journal is not in the operable status.
CMDRJE	Executing	2E10	8300	The specified MP Blade is blocked.
Get Command Status	Async	2E11	4306	The operation cannot be performed due to a temporary path failure.
Get Command Status	Async	2E11	5201	Another remote command device is already assigned to the specified mirror.
Get Command Status	Async	2E11	5202	The operation cannot be performed because the mirror of the journal is not in the operable status.
Get Command Status	Async	2E11	5203	The operation cannot be performed because the specified mirror is not available.

raidcom modify journal				
Error message	Executing/ Async	Error code		Description
		SSB1	SSB2	
Get Command Status	Async	2E11	5204	The operation cannot be performed because the remote command device is not assigned to the specified mirror.
Get Command Status	Async	2E11	5205	The assignment of the remote command device failed because the Universal Replicator pair in the specified mirror is cooperating with the global-active device pair.
CMDRJE Get Command Status	Executing/ Async	2E11	800B	The operation cannot be performed because it is in the state of start-up.
Get Command Status	Async	2E11	800E	The operation cannot be performed because the internal processing is in progress. Wait a while, then retry the operation.
Get Command Status	Async	2E11	8801	The operation cannot be performed because the remote command device does not match the serial number of the mirror.
CMDRJE	Executing	2E11	9400	The operation cannot be accepted. Wait a while, then execute the command again.
Get Command Status	Async	2E13	5003	The operation cannot be performed because the specified journal is not in a 3DC cascade or 3DC multi target configuration.
CMDRJE	Executing	2E20	0000	The specified volume is not installed.
CMDRJE	Executing	2E20	5000	The specified journal ID is not registered.
CMDRJE Get Command Status	Executing/ Async	2E21	5000	The operation failed because the specified journal is not registered.
CMDRJE Get Command Status	Executing/ Async	2E21	8104	The journal volume cannot be added, or the journal cannot be added to the extended consistency group due to insufficient capacity of the shared memory.
CMDRJE	Executing	2E23	0008	The number of specified LDEVs is invalid.
Get Command Status	Async	2E30	0062	The specified volume cannot be used as a journal volume because it is an external volume that can execute the I/O suppression mode.

raidcom modify journal				
Error message	Executing/ Async	Error code		Description
		SSB1	SSB2	
Get Command Status	Async	2E30	020A	The operation cannot be performed because the specified volume is not a remote command device.
CMDRJE	Executing	2E30	5001	The timer type cannot be changed because the specified journal belongs to the extended consistency group.
CMDRJE	Executing	2E30	5003	The parameter of inflow control cannot be changed because the specified journal is not a primary journal.
CMDRJE	Executing	2E30	5005	The cache mode option or the data overflow monitoring time cannot be changed because the specified journal is used by both the primary and the secondary journals.
CMDRJE Get Command Status	Executing/ Async	2EE4	50EE	An internal error occurred. Call customer support.
CMDRJE Get Command Status	Executing/ Async	2EE4	FEEC	An internal error occurred. Call customer support.
Get Command Status	Async	2EF3	3001	The remote storage system does not support configuration operation for remote command devices.

SSB codes returned by raidcom modify ldev

raidcom modify ldev				
Error message	Executing/ Async	Error code		Description
		SSB1	SSB2	
CMDRJE	Executing	B980	B903	The command was rejected because the selected resource belongs to NAS_Platform_System_RSG.

raidcom modify ldev				
Error message	Executing/ Async	Error code		Description
		SSB1	SSB2	
CMDRJE	Executing	B980	B906	An LDEV for which an LU path is set in NAS Platform (User LU) cannot have the Command Device attribute.

SSB codes returned by raidcom modify ldev -alua

raidcom modify ldev -alua				
Error message	Executing/ Async	Error code		Description
		SSB1	SSB2	
CMDRJE	Executing	2E00	0000	The LDEV number is out of settable range.
CMDRJE	Executing	2E11	0059	The status of the GAD pair is not able to change ALUA.
CMDRJE	Executing	2E11	800F	The operation cannot be performed because the unsupported microcode version exists in the system.
CMDRJE	Executing	2E20	0000	The specified LDEV is not installed.
CMDRJE	Executing	2E23	1001	The number of the host groups which can be set by ALUA exceeded the maximum.
CMDRJE	Executing	2EE8	FEEC	An internal error occurred.

SSB codes returned by raidcom modify ldev -mp_blade_id

raidcom modify ldev -mp_blade_id				
Error message	Executing/ Async	Error code		Description
		SSB1	SSB2	
CMDRJE	Executing	2E00	0000	The LDEV number is out of settable range.
CMDRJE	Executing	2E00	8301	MP Blade ID is not in the effective range.
CMDRJE	Executing	2E10	8300	The specified MP Blade is blocked.
CMDRJE	Executing	2E20	0000	LDEV is not installed.

raidcom modify ldev -mp_blade_id				
Error message	Executing/ Async	Error code		Description
		SSB1	SSB2	
CMDRJE	Executing	2E20	8300	The specified MP Blade is not installed.

SSB codes returned by raidcom delete device_grp

raidcom delete device_grp				
Error message	Executing/ Async	Error code		Description
		SSB1	SSB2	
CMDRJE	Executing	2E00	0000	The LDEV number is out of settable range.
CMDRJE	Executing	2E20	0000	LDEV is not installed.
CMDRJE	Executing	2E20	0002	LDEV is not registered in the device group.
CMDRJE	Executing	2E20	2100	A device group is not installed.
CMDRJE	Executing	2E22	000E	The number of LDEVs that can be deleted in a operation exceeds the maximum. The number of LDEVs that can be deleted includes the number of LDEVs of a LUSE.
CMDRJE	Executing	2E23	0008	The number of specified LDEVs is invalid.

SSB codes returned by raidcom add device_grp

raidcom add device_grp				
Error message	Executing/ Async	Error code		Description
		SSB1	SSB2	
CMDRJE	Executing	2E00	0000	The LDEV number is out of settable range.
CMDRJE	Executing	2E20	0000	LDEV is not installed.
CMDRJE	Executing	2E22	0009	The number of device name in the system has reached the maximum.
CMDRJE	Executing	2E22	000A	The device name of an LDEV is duplicated in the system.

raidcom add device_grp				
Error message	Executing/ Async	Error code		Description
		SSB1	SSB2	
CMDRJE	Executing	2E22	000E	The number of LDEVs that can be registered in a operation exceeds the maximum. The number of LDEVs that can be registered includes the number of LDEVs of a LUSE.
CMDRJE	Executing	2E23	0008	The number of specified LDEVs is invalid.
CMDRJE	Executing	2E23	2100	It exceeds the number of device group in the system.
CMDRJE	Executing	2E30	0051	The LDEV to be allocated to the device group is not set the device name.
CMDRJE	Executing	2E30	0072	The specified resource group ID of the LDEV cannot be registered because it is different from other resource group ID of the LDEV in the specified device group.
CMDRJE	Executing	2EEA	FEEC	An internal error occurred. Call customer support.

SSB codes returned by raidcom modify ldev -ldev_name

raidcom modify ldev -ldev_name				
Error message	Executing/ Async	Error code		Description
		SSB1	SSB2	
CMDRJE	Executing	2E00	0000	The LDEV number is out of settable range.
CMDRJE	Executing	2E00	0007	LDEV nickname is not specified.
CMDRJE	Executing	2E20	0000	LDEV is not installed.
Invalid Character	Executing	-	-	Unavailable character is included in LDEV nickname.

SSB codes returned by raidcom initialize ldev

raidcom initialize ldev				
Error message	Executing/ Async	Error code		Description
		SSB1	SSB2	
CMDRJE	Executing	2E00	0000	The LDEV number is out of settable range.
Get Command Status	Async	2E10	0000	The specified LDEV is used for a ShadowImage pair.
Get Command Status	Async	2E10	0001	The specified LDEV is used for a TrueCopy pair or a Universal Replicator pair.
Get Command Status	Async	2E10	0003	The specified LDEV is used as a Compatible FlashCopy® V2 relationship.
Get Command Status	Async	2E10	0004	The specified LDEV is used for a Thin Image pair or a Copy-on-Write Snapshot pair.
Get Command Status	Async	2E10	0008	The specified LDEV is used on the system disk.
Get Command Status	Async	2E10	0010	LDEV is not blocked.
Get Command Status	Async	2E10	0012	The specified LDEV is a CC/XRC attribute device.
Get Command Status	Async	2E10	0062	The specified LDEV is used as the primary volume of aGAD pair.
Get Command Status	Async	2E10	0063	The specified LDEV is used as the secondary volume of aGAD pair.
Get Command Status	Async	2E10	0100	The formatting operation cannot be performed because the encryption value of the key number that is set to encryption ECC is invalid.
Get Command Status	Async	2E10	0101	The formatting operation cannot be performed because the check sum of the encryption key is not coincident.
Get Command Status	Async	2E10	0210	The specified LDEV cannot be operated because capacity saving status is Failed.
Get Command Status	Async	2E10	6022	The operation cannot be performed because the deduplication system data volume of the pool linked with the specified LDEV is blocked.
Get Command Status	Async	2E11	0007	The LDEV is in shredding.

raidcom initialize ldev				
Error message	Executing/ Async	Error code		Description
		SSB1	SSB2	
Get Command Status	Async	2E11	0009	The operation cannot be performed because LDEV is now expanding.
Get Command Status	Async	2E11	001E	The operation cannot be performed because the virtual disk space is blocked.
CMDRJE	Executing	2E11	0053	The specified LDEV is used in another operation.
CMDRJE Get Command Status	Executing/ Async	2E11	0060	The operation failed because accelerated compression of the parity group to which the specified LDEV belongs is enabled.
Get Command Status	Async	2E11	0102	The parity group of the target LDEV is in the state of correction copy.
CMDRJE	Executing	2E11	0153	The parity group or the external volume group to which the specified LDEV belongs is used in another operation.
CMDRJE	Executing	2E11	0201	The operation cannot be performed because the parity group format is not done for the parity group to which the specified LDEV belongs.
Get Command Status	Async	2E11	6004	The operation of Dynamic Provisioning V-VOL cannot be performed because there is a blocked pool.
Get Command Status	Async	2E11	6006	The operation of Dynamic Provisioning V-VOL cannot be performed because there is a blocked pool volume.
Get Command Status	Async	2E11	8004	The operation cannot be performed because the internal processing is in progress.
Get Command Status	Async	2E11	8010	The operation cannot be performed because the internal processing is in progress.
CMDRJE	Executing	2E11	9400	The command cannot be accepted. After a while, execute the same command.
Get Command Status	Async	2E14	0000	The processing stopped because aborting processing is required.
CMDRJE	Executing	2E20	0000	LDEV is not installed.

raidcom initialize ldev				
Error message	Executing/ Async	Error code		Description
		SSB1	SSB2	
CMDRJE	Executing	2E21	9011	The program product is not installed.
Get Command Status	Async	2E22	0100	The quick format cannot be performed because the total number of parity groups in which the LDEVs in quick formatting or the LDEVs blocked while quick formatting are implemented exceeds the maximum number that can be performed at the same time.
Get Command Status	Async	2E30	000A	The specified LDEV is used for a Dynamic Provisioning.
Get Command Status	Async	2E30	000C	The specified LDEV is used as a quorum disk.
CMDRJE Get Command Status	Executing/ Async	2E30	000E	The specified LDEV is used as a pool volume.
Get Command Status	Async	2E30	000F	The specified LDEV is used as a journal volume.
Get Command Status	Async	2E30	001A	Volume Security is set to the specified LDEV.
Get Command Status	Async	2E30	002D	Quick format cannot be performed because the target LDEV is not an internal volume.
Get Command Status	Async	2E30	004E	The specified LDEV is a Data Retention Utility/ Volume Retention Manager attribute device.
Get Command Status	Async	2E30	0061	The specified LDEV is a pool volume and the pool volume include the Dynamic Provisioning volume that is not in the blocked status.
Get Command Status	Async	2E30	0074	The specified LDEV cannot be operated because it is an external volume mapped for online data migration.
CMDRJE	Executing	2E30	0075	The specified ldev is used as the TSE-VOL.
CMDRJE Get Command Status	Executing/ Async	2E30	0206	The operation cannot be performed because the specified LDEV is a deduplication system data volume.

raidcom initialize ldev				
Error message	Executing/ Async	Error code		Description
		SSB1	SSB2	
CMDRJE	Executing	2E30	0209	The operation cannot be performed because the specified LDEV is a volume for which capacity saving setting is enabled.
Get Command Status	Async	2E31	0001	Maintenance work cannot be performed because the target LDEV is a quorum disk.
Get Command Status	Async	2E31	0017	LDEV cannot be formatted because there is no normal external path.
CMDRJE	Executing	2EE8	00EE	The command cannot be accepted. After a while, execute the same command.
Get Command Status	Async	2EE8	0A18	An internal error occurred.
CMDRJE Get Command Status	Executing/ Async	2EE8	FEEC	An internal error occurred. Call customer support.
CMDRJE Get Command Status	Executing/ Async	2EE8	FFFF	An internal error occurred. Call customer support.
CMDRJE	Executing	2EF3	0002	The specified parameter is incorrect. Check the <i>Command Control Interface Command Reference</i> .
CMDRJE	Executing	B980	B903	The command was rejected because the selected resource belongs to NAS_Platform_System_RSG.

SSB codes returned by raidcom modify ldev -command_device

raidcom modify ldev -command_device				
Error message	Executing/ Async	Error code		Description
		SSB1	SSB2	
CMDRJE	Executing	2E10	0000	The command device cannot be set to the specified LDEV because of the following causes. <ul style="list-style-type: none"> The LDEV is used for a ShadowImage pair. The reserve attribute of a ShadowImage is configured.
CMDRJE	Executing	2E10	0001	The specified LDEV is used for a TrueCopy pair.
CMDRJE	Executing	2E10	0002	The specified LDEV is used for a Universal Replicator pair or a journal.
CMDRJE	Executing	2E10	0004	The specified volume cannot be set because it is used by a Thin Image pair or a Copy-on-Write Snapshot pair.
CMDRJE	Executing	2E10	0062	The specified LDEV is used as the primary volume of aGAD pair.
CMDRJE	Executing	2E10	0063	The specified LDEV is used as the secondary volume of aGAD.
CMDRJE	Executing	2E10	0201	The operation failed because the T10 PI attribute of the specified LDEV is enabled.
CMDRJE	Executing	2E20	0000	The specified LDEV is not defined.
CMDRJE	Executing	2E21	9000	The following settings cannot be performed because the program product of LUN Manager is not installed. <ul style="list-style-type: none"> Command device settings Command security settings
CMDRJE	Executing	2E30	0004	The emulation type of the specified volume is not OPEN volume.
CMDRJE	Executing	2E30	0008	The command device cannot be set because LDEV is used as a virtual volume of Thin Image or Copy-on-Write Snapshot.
CMDRJE	Executing	2E30	000C	The specified volume cannot be set because it is a quorum disk.

raidcom modify ldev -command_device				
Error message	Executing/ Async	Error code		Description
		SSB1	SSB2	
CMDRJE	Executing	2E30	000D	The specified volume cannot be set because it is a system disk.
CMDRJE	Executing	2E30	000E	The specified volume cannot be set because it is a pool volume.
CMDRJE	Executing	2E30	0012	The specified LDEV cannot be released because it is command device that is being used.
CMDRJE	Executing	2E30	0013	The specified volume cannot be set because it is a LUSE volume.
CMDRJE	Executing	2E30	0014	The command device cannot be set to the specified LDEV because of the following causes. <ul style="list-style-type: none"> ▪ It is used as aVolume Migration. ▪ The reserve attribute of aVolume Migration is configured.
CMDRJE	Executing	2E30	0019	The specified volume cannot be used as a command device because it is set by a Data Retention Utility.
CMDRJE	Executing	2E30	0074	The specified LDEV cannot be operated because it is an external volume mapped for online data migration.
CMDRJE	Executing	2E30	0096	The specified LDEV is used as an ALU.
Get Command Status	Async	2E30	0206	The operation cannot be performed because the specified LDEV is a deduplication system data volume.
CMDRJE	Executing	2EE8	FEEC	An internal error occurred. Call customer support.

SSB codes returned by raidcom modify ldev -ssid

raidcom modify ldev -ssid				
Error message	Executing/ Async	Error code		Description
		SSB1	SSB2	
CMDRJE	Executing	2E11	0023	SSID cannot be changed because there are LDEVs in the boundary where the specified LDEV belongs.
CMDRJE	Executing	2E22	7201	The specified SSID is used for the other boundary.
CMDRJE	Executing	2EE8	FECC	An internal error occurred. Call customer support.
CMDRJE	Executing	2EF3	0002	The specified parameter is invalid. Check the <i>Command Control Interface Command Reference</i> .

SSB codes returned by raidcom modify ldev -status nml

raidcom modify ldev -status nml				
Error message	Executing/ Async	Error code		Description
		SSB1	SSB2	
CMDRJE	Executing	2E00	0000	The LDEV number is out of settable range.
Get Command Status	Async	2E10	0000	The specified LDEV is used for a ShadowImage pair.
Get Command Status	Async	2E10	0001	The specified LDEV is used for a TrueCopy pair or a Universal Replicator pair.
Get Command Status	Async	2E10	0003	The specified LDEV is used as a Compatible FlashCopy® V2 relationship.
Get Command Status	Async	2E10	0004	The specified LDEV is used for a Thin Image pair or a Copy-on-Write Snapshot pair.
Get Command Status	Async	2E10	0008	The specified LDEV is used as a system disk.
CMDRJE	Executing	2E10	0010	LDEV is not blocked.
Get Command Status	Async	2E10	0012	The specified LDEV is a CC/XRC attribute device.

raidcom modify ldev -status nml				
Error message	Executing/ Async	Error code		Description
		SSB1	SSB2	
Get Command Status	Async	2E10	001E	The specified LDEV is not formatted after it is used as the journal volume.
Get Command Status	Async	2E10	0062	The specified LDEV is used as the primary volume of aGAD pair.
Get Command Status	Async	2E10	0063	The specified LDEV is used as the secondary volume of aGAD pair.
Get Command Status	Async	2E10	600B	The pool is blocked.
Get Command Status	Async	2E11	0009	The operation cannot be performed because LDEV is not expanding.
Get Command Status	Async	2E11	001E	The operation cannot be performed because the virtual disk space is blocked.
CMDRJE	Executing	2E11	0053	The specified LDEV is used in another operation.
CMDRJE	Executing	2E11	0153	The parity group or the external group to which the specified LDEV belongs is used in another operation.
Get Command Status	Async	2E11	6006	The operation of Dynamic Provisioning V-VOL cannot be performed because there is a blocked pool volume.
Get Command Status	Async	2E11	8004	The operation cannot be performed because the internal processing is in progress.
CMDRJE	Executing	2E11	9400	The command cannot be accepted. After a while, execute the same command.
CMDRJE	Executing	2E20	0000	The specified LDEV is not installed.
Get Command Status	Async	2E30	000A	The specified LDEV is used for a Dynamic Provisioning.
Get Command Status	Async	2E30	000C	The specified LDEV is used as a quorum disk.
Get Command Status	Async	2E30	000E	The specified LDEV is used as a pool volume.
Get Command Status	Async	2E30	0014	The specified LDEV is used as a reserved volume of Volume Migration.

raidcom modify ldev -status nml				
Error message	Executing/ Async	Error code		Description
		SSB1	SSB2	
Get Command Status	Async	2E30	001A	Volume Security is set to the specified LDEV.
Get Command Status	Async	2E30	002C	The specified LDEV cannot be restored because the shredding or the formatting operation has not been performed.
Get Command Status	Async	2E30	004E	The specified LDEV is a Data Retention Utility/ Volume Retention Manager attribute device.
Get Command Status	Async	2E31	0017	LDEV cannot be restored because there is no connection path to the normal external path.
CMDRJE	Executing	2EE8	00EE	The command cannot be accepted. After a while, execute the same command.

SSB codes returned by raidcom modify ldev -status blk

raidcom modify ldev -status blk				
Error message	Executing/ Async	Error code		Description
		SSB1	SSB2	
CMDRJE	Executing	2E00	0000	The LDEV number is out of settable range.
Get Command Status	Async	2E10	0000	The specified LDEV is used for a pair of ShadowImage/Thin Image/Copy-on-Write Snapshot/Volume Migration or as a relationship of Compatible FlashCopy [®] V2/Hitachi Compatible Software for IBM [®] FlashCopy [®] SE.
Get Command Status	Async	2E10	0001	The specified LDEV is used for a pair of TrueCopy or Universal Replicator.
Get Command Status	Async	2E10	0003	The specified LDEV is used as a Compatible FlashCopy [®] V2 relationship.
Get Command Status	Async	2E10	0004	The specified LDEV is used for a Thin Image pair or a Copy-on-Write Snapshot pair.
Get Command Status	Async	2E10	0008	The specified LDEV is used as a system disk.

raidcom modify ldev -status blk				
Error message	Executing/ Async	Error code		Description
		SSB1	SSB2	
CMDRJE	Executing	2E10	0011	LDEV is not installed, or LDEV is not in the state of Normal.
Get Command Status	Async	2E10	0012	The specified LDEV is used at the concurrent copy or XRC.
Get Command Status	Async	2E10	0062	The specified LDEV is used as the primary volume of aGAD pair.
Get Command Status	Async	2E10	0063	The specified LDEV is used as the secondary volume of aGAD pair.
Get Command Status	Async	2E11	0009	The operation cannot be performed because LDEV is now expanding.
Get Command Status	Async	2E11	001E	The operation cannot be performed because the virtual disk space is blocked.
CMDRJE	Executing	2E11	0053	The specified LDEV is used in another operation.
CMDRJE	Executing	2E11	0153	The parity group or the external group to which the specified LDEV belongs is used in another operation.
Get Command Status	Async	2E11	8004	The operation cannot be performed because the internal processing is in progress.
CMDRJE	Executing	2E11	9400	The command cannot be accepted. After a while, execute the same command.
CMDRJE	Executing	2E20	0000	The specified LDEV is not installed.
Get Command Status	Async	2E30	000A	The specified LDEV is used for a Dynamic Provisioning.
Get Command Status	Async	2E30	000C	The specified LDEV is used as a quorum disk.
Get Command Status	Async	2E30	000E	The specified LDEV is used as a pool volume.
CMDRJE	Executing	2E30	000F	It is used as a journal.
Get Command Status	Async	2E30	0014	The specified LDEV is used as a reserved volume of Volume Migration.

*SSB codes returned by raidcom modify ldev -status enable_reallocation/disable_reallocation/
new_page_allocation/enable_relocation_policy*

raidcom modify ldev -status blk				
Error message	Executing/ Async	Error code		Description
		SSB1	SSB2	
Get Command Status	Async	2E30	001A	Volume Security is set to the specified LDEV.
Get Command Status	Async	2E30	001C	It is used as a remote command device.
Get Command Status	Async	2E30	004E	It is a volume that the Data Retention Utility is set.
Get Command Status	Async	2E30	004E	The specified LDEV is a Data Retention Utility/ Volume Retention Manager attribute device.
Get Command Status	Async	2E30	0060	It is used as a command device that is used at extended consistency group.
Get Command Status	Async	2E30	0061	DP volume that is not in the blocked state is included in the DP volume associated with a pool that the pool volume is belongs to.
Get Command Status	Async	2E31	0001	Maintenance work cannot be performed because the target LDEV is a quorum disk.
Get Command Status	Async	2E31	0017	LDEV cannot be blocked because there is no connection path to the normal external path.
Get Command Status	Async	2EE8	0A18	An internal error occurred.

*SSB codes returned by raidcom modify ldev -status enable_reallocation/
disable_reallocation/new_page_allocation/enable_relocation_policy*

raidcom modify ldev -status enable_reallocation/disable_reallocation/new_page_allocation/ enable_relocation_policy				
Error message	Executing/ Async	Error code		Description
		SSB1	SSB2	
CMDRJE	Executing	2E00	0000	Invalid LDEV number.
CMDRJE	Executing	2E00	6101	The tiering policy is not in the effective range.
CMDRJE	Executing	2E00	6102	The new page assignment tier is invalid.
CMDRJE	Executing	2E20	0000	The specified LDEV is not installed.

raidcom modify ldev -status enable_reallocation/disable_reallocation/new_page_allocation/enable_relocation_policy				
Error message	Executing/Async	Error code		Description
		SSB1	SSB2	
CMDRJE	Executing	2E21	8102	The shared memory for Dynamic Tiering or active flash is not installed.
CMDRJE	Executing	2E30	000B	The specified LDEV is not a virtual volume of Dynamic Provisioning, Dynamic Tiering, or active flash.
CMDRJE	Executing	2E30	0073	The specified LDEV is not a virtual volume of Dynamic Tiering or active flash.
CMDRJE	Executing	2E30	0209	The operation cannot be performed because the specified LDEV is a volume for which the capacity saving setting is enabled.
CMDRJE	Executing	2EE8	0014	The specified LDEV is not a virtual volume of Dynamic Tiering or active flash.

SSB codes returned by `raidcom modify ldev -status discard_zero_page/stop_discard_zero_page`

raidcom modify ldev -status discard_zero_page/stop_discard_zero_page				
Error message	Executing/Async	Error code		Description
		SSB1	SSB2	
CMDRJE	Executing	2E10	0000	The specified LDEV is used for a ShadowImage pair.
CMDRJE	Executing	2E10	0001	The specified LDEV is used for a TrueCopy pair.
CMDRJE	Executing	2E10	0002	The specified LDEV is used for a Universal Replicator pair.
CMDRJE	Executing	2E10	0003	The specified LDEV is used as a Compatible FlashCopy® V2 relationship.
CMDRJE	Executing	2E10	0004	The specified LDEV is used for a Thin Image pair or a Copy-on-Write Snapshot pair.
CMDRJE	Executing	2E10	0005	The specified LDEV is used for aVolume Migration pair.
CMDRJE	Executing	2E10	0011	The specified LDEV is blocked.

raidcom modify ldev -status discard_zero_page/stop_discard_zero_page				
Error message	Executing/ Async	Error code		Description
		SSB1	SSB2	
CMDRJE	Executing	2E10	600B	The associated pool is blocked.
CMDRJE	Executing	2E11	0054	The page cannot be discarded because the pool volume is being deleted or the Tier is being reallocated.
CMDRJE	Executing	2E11	0055	The operation cannot be performed because the system pool volume is blocked.
CMDRJE	Executing	2E11	8003	The operation cannot be performed because the power supply is switched off.
CMDRJE	Executing	2E14	0001	The page cannot be discarded because of the non-operable status.
CMDRJE	Executing	2E20	0000	The specified LDEV is not installed.
CMDRJE	Executing	2E20	000A	The operation cannot be performed because the specified volume is being formatted.
CMDRJE	Executing	2E30	000B	The specified LDEV is not a virtual volume of Dynamic Provisioning, Dynamic Tiering, or active flash.
CMDRJE	Executing	2E30	000F	The specified LDEV is used as a journal volume.
CMDRJE	Executing	2E30	0033	It is not associated to a pool.
CMDRJE	Executing	2E30	0065	The specified volume is used by XRC.
CMDRJE	Executing	2E30	0075	The page cannot be discarded because the specified LDEV is a TSE-VOL.
CMDRJE	Executing	2E30	0099	The specified LDEV is a volume of which Data Direct Mapping attribute is enabled.
Get Command Status	Async	2E30	0206	The operation cannot be performed because the specified LDEV is a deduplication system data volume.
CMDRJE	Executing	2E31	001B	The page of DP-VOL cannot be discarded because the LU path to the host group whose host mode option 97 is enabled is defined to the specified LDEV.
CMDRJE	Executing	2EE8	00E7	An internal error occurred. Call customer support.

raidcom modify ldev -status discard_zero_page/stop_discard_zero_page				
Error message	Executing/ Async	Error code		Description
		SSB1	SSB2	
CMDRJE	Executing	2EF3	9F02	The specified operation cannot be performed because it is not supported.

SSB codes returned by `raidcom modify ldev -status enable_fullallocation/disable_fullallocation`

raidcom modify ldev -status enable_fullallocation/disable_fullallocation				
Error message	Executing/ Async	Error code		Description
		SSB1	SSB2	
CMDRJE	Executing	2E00	0000	The LDEV number is out of settable range.
CMDRJE	Executing	2E00	002F	The specified value of the Full Allocation is invalid.
CMDRJE	Executing	2E00	0030	Full Allocation cannot be specified to the specified LDEV because the emulation type is not supported.
CMDRJE	Executing	2E10	0065	The operation failed because the specified LDEV is a DP-VOL that belongs to the pool of which accelerated compression is enabled.
CMDRJE	Executing	2E10	600B	The associated pool is blocked.
CMDRJE	Executing	2E10	600D	The operation cannot be performed because a pool volume is being deleted.
CMDRJE	Executing	2E10	601B	The free space in the specified pool is insufficient.
CMDRJE	Executing	2E10	8000	The operation cannot be performed because Storage Navigator or Device Manager - Storage Navigator is in progress, another application is in progress on the SVP, or the configuration is being changed. Wait a while, and then retry the operation.
CMDRJE	Executing	2E11	001B	The specified LDEV is blocked.
CMDRJE	Executing	2E20	0000	LDEV is not installed.
CMDRJE	Executing	2E30	000B	The specified LDEV is not DP-VOL.

raidcom modify ldev -status enable_fullallocation/disable_fullallocation				
Error message	Executing/ Async	Error code		Description
		SSB1	SSB2	
CMDRJE	Executing	2E30	0099	The specified LDEV is a volume of which Data Direct Mapping attribute is enabled.
Get Command Status	Async	2E30	0206	The operation cannot be performed because the specified LDEV is a deduplication system data volume.
Get Command Status	Async	2E30	0209	The operation cannot be performed because the specified LDEV is a volume for which the capacity saving setting is enabled.
CMDRJE	Executing	2EE8	00EE	The command cannot be accepted because the DKC is busy. After a while, execute the same command.
CMDRJE	Executing	2EE8	FEEC	An internal error occurred.
CMDRJE	Executing	2EF3	9F02	The specified operation cannot be performed because it is not supported.

SSB codes returned by raidcom modify ldev -quorum_enable

raidcom modify ldev -quorum_enable				
Error message	Executing/ Async	Error code		Description
		SSB1	SSB2	
CMDRJE	Executing	2E00	0000	The LDEV number is out of settable range.
CMDRJE	Executing	2E00	8000	The device type is invalid.
CMDRJE	Executing	2E00	8001	The serial number is invalid.
CMDRJE	Executing	2E00	A001	The quorum disk ID is out of settable range.
Get Command Status	Async	2E10	0005	The specified LDEV is used for Volume Migration.
Get Command Status	Async	2E10	0057	The specified LDEV cannot be configured because the LDEV is a virtual volume.
Get Command Status	Async	2E10	0201	The operation failed because the T10 PI attribute of the specified LDEV is enabled.

raidcom modify ldev -quorum_enable				
Error message	Executing/ Async	Error code		Description
		SSB1	SSB2	
Get Command Status	Async	2E10	0202	The specified volume belongs to the resource group of NAS_Platform_System_RSG.
Get Command Status	Async	2E10	A001	The specified quorum disk ID is being used.
Get Command Status	Async	2E10	A003	The specified quorum disk is in processing.
Get Command Status	Async	2E10	A005	The specified quorum disk is used as the quorum disk of the different device.
Get Command Status	Async	2E10	A006	The specified LDEV is used as the quorum disk.
Get Command Status	Async	2E10	A007	The operation failed because the quorum disk was inaccessible.
Get Command Status	Async	2E11	001B	The specified LDEV is blocked.
CMDRJE	Executing	2E11	0053	The specified LDEV is used for other operation.
Get Command Status	Async	2E11	410B	The external volume is inaccessible.
Get Command Status	Async	2E11	410C	An unformatted external volume is used. Format the external volume, then retry the operation.
Get Command Status	Async	2E11	8014	The command cannot be accepted. After a while, execute the same command.
Get Command Status	Async	2E13	0001	The specified LDEV is not the first LDEV that belongs to the external volume group.
CMDRJE	Executing	2E20	0000	LDEV is not installed.
Get Command Status	Async	2E20	000E	The specified LDEV is not an external volume.
Get Command Status	Async	2E21	810A	A shared memory is not installed.
Get Command Status	Async	2E30	0005	Cache Residency Manager is set to the specified volume.

raidcom modify ldev -quorum_enable				
Error message	Executing/ Async	Error code		Description
		SSB1	SSB2	
Get Command Status	Async	2E30	0007	A path is defined to the specified volume.
Get Command Status	Async	2E30	000E	The specified LDEV is used as a pool volume.
Get Command Status	Async	2E30	000F	The specified LDEV is used as a journal volume.
Get Command Status	Async	2E30	0010	The specified volume is used as a command device.
Get Command Status	Async	2E30	004E	Data Retention Utility is set to the specified volume.
Get Command Status	Async	2E30	0074	The specified LDEV cannot be operated because it is an external volume mapped for online data migration.
Get Command Status	Async	2E30	008E	The emulation type of the specified LDEV is not OPEN-V.
Get Command Status	Async	2E30	0092	The specified LDEV cannot be used because the size of LDEV is less than the minimum capacity of the quorum disk.
Get Command Status	Async	2E30	0099	The specified LDEV is a volume of which Data Direct Mapping attribute is enabled.
CMDRJE Get Command Status	Executing/ Async	2EE8	FEEC	Internal error occurred.

SSB codes returned by raidcom modify ldev -quorum_disable

raidcom modify ldev -quorum_disable				
Error message	Executing/ Async	Error code		Description
		SSB1	SSB2	
CMDRJE	Executing	2E00	0000	The LDEV number is out of settable range.

raidcom modify ldev -quorum_disable				
Error message	Executing/ Async	Error code		Description
		SSB1	SSB2	
Get Command Status	Async	2E10	A002	The specified LDEV is not a quorum disk.
Get Command Status	Async	2E10	A003	The specified quorum disk is in processing.
Get Command Status	Async	2E10	A004	The pair using the specified quorum disk exists.
Get Command Status	Async	2E10	A007	<p>The setting of the quorum disk was released but the operation failed.</p> <p>If you display the ldev information using raidcom get ldev command, "QRD" (that means the disk is the quorum disk) is not displayed on VOL_ATTR because the quorum disk setting was released. But the management information possibly remains in the external volume.</p> <p>If you define again an external volume in which the management information remains as a quorum disk, an error may occur. When you reuse an external volume which was used as a quorum disk after removing it, format the external volume.</p>
CMDRJE	Executing	2E11	0053	The specified LDEV is being used for other operation.
CMDRJE	Executing	2E20	0000	LDEV is not installed.
Get Command Status	Async	2E21	810A	A shared memory is not installed.
CMDRJE Get Command Status	Executing	2EE8	FEEC	Internal error occurred.

SSB codes returned by raidcom delete lun

raidcom delete lun				
Error message	Executing/ Async	Error code		Description
		SSB1	SSB2	
CMDRJE	Executing	B958	0155	The other than multiplatform volume or OPEN volume is included in the specified LDEV.
CMDRJE	Executing	B958	015D	An used LDEV exists in the specified LDEV.
CMDRJE	Executing	B958	0202	It cannot be deleted because it is the last path of a TrueCopy or GAD pair.
CMDRJE	Executing	B958	0203	It cannot be deleted because it is the last path of ShadowImage.
CMDRJE	Executing	B958	020A	It cannot be deleted because it is the last path of Thin Image or Copy-on-Write Snapshot.
CMDRJE	Executing	B958	020B	It cannot be deleted because it is the last path of Universal Replicator.
CMDRJE	Executing	B958	020F	The specified LDEV is not installed.
CMDRJE	Executing	B958	0233	It cannot be deleted because the operation object LU is executing host I/O.
CMDRJE	Executing	B958	0234	It cannot be deleted because the operation object LU is reserved.
CMDRJE	Executing	B958	0239	The command device is being used in the local Command Control Interface.
CMDRJE	Executing	B958	0240	A command device is being set.
CMDRJE	Executing	B958	028E	It cannot be deleted because of the ALU path definition.
CMDRJE	Executing	B958	0927	The command cannot be operated because the virtual LDEV is not defined yet.
CMDRJE	Executing	B958	0944	The value of LUN exceeds the maximum.
CMDRJE	Executing	B958	0945	The value of LDEV exceeds the maximum.
CMDRJE	Executing	B958	0956	The value of host group ID exceeds the maximum.
CMDRJE	Executing	B958	0957	The program product is not installed.
CMDRJE	Executing	B958	0959	Host group is not installed.

raidcom delete lun				
Error message	Executing/ Async	Error code		Description
		SSB1	SSB2	
CMDRJE	Executing	B958	095D	An invalid LDEV exists in the specified LDEVs.
CMDRJE	Executing	B958	098C	Multiple LDEVs cannot be specified.
CMDRJE	Executing	B958	098D	When the host mode option 60 is set, the LU path of LUN0 cannot be set or released.
CMDRJE	Executing	B958	0996	The LU path cannot be deleted because the virtual LDEV ID of the specified volume was deleted.
CMDRJE	Executing	B958	099F	The specified port is not mounted.
CMDRJE	Executing	B958	09A1	Another LDEV is already mapped in the specified LUN.
Executing	B980	B901	The comm and was rejected because the specified port is for NAS Platform (System LU).	

raidcom delete lun				
Error message	Executing/ Async	Error code		Description
		SSB1	SSB2	
Executing	B980	B902	The command was rejected because the specified port is for NAS Platform (User LU).	
Executing	B980	B903	The command was rejected because the selected resource belongs to NAS_Platform_System_RSG.	

SSB codes returned by raidcom add lun

raidcom add lun				
Error message	Executing/ Async	Error code		Description
		SSB1	SSB2	
CMDRJE	Executing	2EF6	0014	An invalid LDEV exists in the specified LDEVs.
Get Command Status	Executing	B958	0101	The LU path cannot be set because it is reserved for Volume Migration.
Get Command Status	Executing	B958	010C	The LU path cannot be set because the volume is a deduplication system data volume.
CMDRJE	Executing	B958	014A	When an ISCSI is used, the LU path cannot be set in the LDEV other than the OPEN volume.
CMDRJE	Executing	B958	0150	The attribute of the specified port is Initiator or External.
CMDRJE	Executing	B958	0155	The other than HMDE volume or OPEN volume is included in the specified LDEV.
Get Command Status	Executing	B958	015A	An LU path has already been defined in the target LDEV.
CMDRJE	Executing	B958	015D	An invalid LDEV exists in the specified LDEVs.
Get Command Status	Executing	B958	015E	It exceeds the maximum LUN under the port.
Get Command Status	Executing	B958	0178	LDEV is set as a pool volume.
CMDRJE	Executing	B958	017B	The LU path cannot be set because the LDEV is a system disk.
Get Command Status	Executing	B958	017C	The LU path cannot be set because the LDEV is a journal volume.
CMDRJE	Executing	B958	017D	The LU path cannot be set because the access attribute of LDEV Data Retention Utility is reserved.
CMDRJE	Executing	B958	017E	The LU path cannot be set because the access attribute of LDEV Data Retention Utility is different from "Read/Write".
Get Command Status	Executing	B958	018E	The LU path cannot be set because the LDEV has an ALU attribute.

raidcom add lun				
Error message	Executing/ Async	Error code		Description
		SSB1	SSB2	
CMDRJE	Executing	B958	01A3	When the host mode is Universal Volume Manager(0x4C), the LU path cannot be set in other than the external volume.
Get Command Status	Executing	B958	01C1	The LU path cannot be defined because the volume is used as a quorum disk.
Get Command Status	Executing	B958	01DC	The number of the host groups which can be set by ALUA exceeded the maximum.
Get Command Status	Executing	B958	01DE	The operation cannot be performed because the specified LDEV is the external volume having the Data Direct Mapping attribute.
Get Command Status	Executing	B958	01DF	The LU path cannot be defined because the LDEV belongs to the parity group of which accelerated compression is enabled.
Get Command Status	Executing	B958	01F2	The host group and the LDEV that configure the LU path do not exist in the same virtual storage machine.
CMDRJE	Executing	B958	01F3	The LU path cannot be defined because the virtual LDEV information of the specified LDEV is not defined yet.
Get Command Status	Executing	B958	01F4	The path of the external volume which has an NDM attribute cannot be defined
Get Command Status	Executing	B958	01F9	The LU path cannot be added because the setting of the T10 PI attribute on the specified port or on the specified LDEV is not correct. Enable the T10 PI attribute on the specified port. Otherwise, disable the T10 PI attribute on the specified LDEV.
Get Command Status	Executing	B958	01FA	The operation failed because the T10 PI attribute of the specified LDEV is enabled.
CMDRJE	Executing	B958	0601	The command device cannot be set because it is reserved for Volume Migration.
CMDRJE	Executing	B958	0606	The command device cannot be set because it is a ShadowImage pair or it is reserved.
CMDRJE	Executing	B958	060F	The specified LDEV is not installed.

raidcom add lun				
Error message	Executing/ Async	Error code		Description
		SSB1	SSB2	
CMDRJE	Executing	B958	0639	The command device cannot be operated because it is used at the local CCI.
CMDRJE	Executing	B958	064A	A command device cannot be set because LDEV is other than the OPEN volume.
CMDRJE	Executing	B958	065D	The specified LDEV is not installed.
CMDRJE	Executing	B958	0679	A command device cannot be set because LDEV is the virtual volume of Thin Image or Copy-on-Write Snapshot.
CMDRJE	Executing	B958	06C0	The specified LDEV is being used as a volume of aGAD pair.
CMDRJE	Executing	B958	06C1	The specified LDEV is used as a quorum disk.
CMDRJE	Executing	B958	06C2	The specified LDEV is used for a TrueCopy pair or a Universal Replicator pair.
Get Command Status	Executing/ Async	B958	090F	An internal error occurred. Call customer support.
CMDRJE	Executing	B958	0927	The command cannot be operated because the virtual LDEV is not defined yet.
CMDRJE	Executing	B958	0944	The value of LUN exceeds the maximum.
CMDRJE	Executing	B958	0945	The value of LDEV exceeds the maximum.
CMDRJE	Executing	B958	0947	Another LDEV is already mapped to the specified LUN.
CMDRJE	Executing	B958	0956	The value of Host group ID exceeds the maximum.
Get Command Status	Executing	B958	0957	The program product is not installed.
Get Command Status	Executing	B958	0959	The specified host group is not installed.
Get Command Status	Executing	B958	095D	An invalid LDEV exists in the specified LDEVs.
CMDRJE	Executing	B958	098C	The multiple LDEV cannot be specified.

raidcom add lun				
Error message	Executing/ Async	Error code		Description
		SSB1	SSB2	
CMDRJE	Executing	B958	098D	When the host mode option 60 is set, the LU path of LUN0 cannot be set or released.
CMDRJE	Executing	B958	0994	An invalid LDEV exists in the specified LDEVs.
CMDRJE	Executing	B958	0996	The LU path cannot be added because the virtual LDEV ID of the specified volume was deleted.
CMDRJE	Executing	B958	099C	The number of paths exceeds the maximum.
CMDRJE	Executing	B958	099D	Only one path is set for NAS Platform (User LU).
CMDRJE	Executing	B958	099E	The same port number is specified more than once.
Get Command Status	Executing	B958	099F	The specified port is not mounted.
Get Command Status	Executing	B958	09F8	The LU path cannot be set because the specified LDEV is being deleted.
Get Command Status	Async	B958	1307	The operation cannot be performed because there is no free common LU path number in the specified host group.
Executing/Async	B958	2116	The operation cannot be performed because the specified port is used by Storage Advisor or Embedded.	

raidcom add lun				
Error message	Executing/ Async	Error code		Description
		SSB1	SSB2	
Executing	B980	B901	The command was rejected because the specified port is for NAS Platform (System LU).	
Executing	B980	B902	The command was rejected because the specified port is for NAS Platform (User LU).	

raidcom add lun				
Error message	Executing/ Async	Error code		Description
		SSB1	SSB2	
Executing	B980	B903	The command was rejected because the selected resource belongs to NAS_Platform_System_RSG.	
Executing	B980	B905	The LU path cannot be set in Command Device because Port is NAS Platform (User LU).	

SSB codes returned by raidcom modify lun

raidcom modify lun				
Error message	Executing/ Async	Error code		Description
		SSB1	SSB2	
CMDRJE	Executing	2E02	1000	The value of host group ID exceeds the maximum.
CMDRJE	Executing	2E02	1102	The value of LUN exceeds the maximum.
CMDRJE	Executing	2E02	8404	The value of the specified port is invalid.
CMDRJE	Executing	2E11	2206	You do not have the operation authority to operate the target resource group. Specify the resource group that is allocated to the user group as the operation target or set the operation authority to the user group in order to operate the target resource group.
CMDRJE	Executing	2E20	1003	The specified host group is not installed.
CMDRJE	Executing	2E20	1102	The LU path definition does not exist in the host group.
CMDRJE	Executing	2E20	1103	The path is not defined for the specified LUN.
Get Command Status	Async	2EA9	FECC	An internal error occurred. Call customer support.
CMDRJE	Executing	B958	5021	The PCB type of the port to which the host group belongs is out of operation target.
CMDRJE	Executing	B958	5046	The LU path definition does not exist in the host group.
CMDRJE	Executing	B958	5056	The value of host group ID exceeds the maximum.
CMDRJE	Executing	B958	5059	Host group is not installed.
CMDRJE	Executing	B958	50DD	The specified ALUA path priority is invalid.
CMDRJE	Executing	B958	50F7	Unavailable to operate because another application is in progress on Storage Navigator, Device Manager - Storage Navigator, or SVP.

SSB codes returned by raidcom discover lun

raidcom discover lun				
Error message	Executing/ Async	Error code		Description
		SSB1	SSB2	
CMDRJE	Executing	2E00	9B01	The specified iSCSI name is invalid.
CMDRJE	Executing	2E02	8403	The specified virtual port number is out of range.
CMDRJE	Executing	2E10	8404	The iSCSI virtual port mode for the specified port is disabled.
CMDRJE	Executing	2E20	8401	The specified virtual port is not defined.

SSB codes returned by raidcom modify pool

raidcom modify pool				
Error message	Executing/ Async	Error code		Description
		SSB1	SSB2	
CMDRJE	Executing	2E00	0000	The LDEV number is out of the valid range.
CMDRJE	Executing	2E00	0003	The SSID is out of the valid range.
Get Command Status	Async	2E00	0010	The specified LDEV number is already used.
Get Command Status	Async	2E00	0013	There are not enough cache management devices.
Get Command Status	Async	2E00	0016	The command cannot be executed by receiving multiple operations for the same pool ID.
CMDRJE	Executing	2E00	002F	The specified attribute is invalid.
CMDRJE	Executing	2E00	6000	The value of pool ID is invalid.
CMDRJE	Executing	2E00	6001	The specified pool is for Thin Image or Copy-on-Write Snapshot.
CMDRJE	Executing	2E00	6002	The specified maximum reserve rate is not in the effective range.
CMDRJE	Executing	2E00	6003	The specified Tier Range value is invalid.

raidcom modify pool				
Error message	Executing/ Async	Error code		Description
		SSB1	SSB2	
CMDRJE	Executing	2E00	6004	Relations between the specified lower limit of Tier Range and the Delta value is invalid.
CMDRJE	Executing	2E00	6006	The specified Tier capacity threshold value is out of range.
CMDRJE	Executing	2E00	6009	The threshold of the specified High water mark is out of range.
CMDRJE	Executing	2E00	600A	The operation cannot be performed because the specified threshold of Warning is larger than the threshold of the specified High water mark.
CMDRJE	Executing	2E00	6100	The specified tier number is out of range.
CMDRJE	Executing	2E02	0202	The threshold value cannot be changed to the specified value, because the specified pool is used for Data Direct Mapping.
CMDRJE Get Command Status	Executing/ Async	2E10	001F	The operation cannot be performed because the total capacity of virtual volumes for Dynamic Tiering or active flash in the system exceeds the maximum.
CMDRJE	Executing	2E10	600B	The specified pool is in the state of blocked.
Get Command Status	Async	2E10	600C	The setting of the threshold value is less than the pool usage value.
CMDRJE	Executing	2E10	600D	The operation cannot be performed because it is in the state of shrinking.
CMDRJE	Executing	2E10	6011	The operation cannot be performed because it is being discarded pages.
Get Command Status	Async	2E10	6012	Pool cannot be restored because the usage rate of pool is 100%.
Get Command Status	Async	2E10	6014	The operation cannot be performed because the specified pool status is incorrect.
CMDRJE	Executing	2E10	6015	The operation cannot be performed because the Tier is being deterred reallocation.
CMDRJE	Executing	2E10	6017	The operation cannot be performed because collecting the performance monitoring data is being prepared.

raidcom modify pool				
Error message	Executing/ Async	Error code		Description
		SSB1	SSB2	
CMDRJE	Executing	2E10	601D	The specified pool cannot be changed to the pool for Data Direct Mapping, because the threshold value of High water mark is fixed.
CMDRJE Get Command Status	Executing/ Async	2E10	601F	The deduplication function is set to be enabled for the specified pool.
Get Command Status	Async	2E10	6020	The deduplication function cannot be used in the specified pool.
CMDRJE Get Command Status	Executing/ Async	2E10	8000	The operation cannot be performed because Storage Navigator or Device Manager - Storage Navigator is in progress, another application is in progress on the SVP, or the configuration is being changed. Wait a while, and then retry the operation.
CMDRJE Get Command Status	Executing/ Async	2E11	0205	The operation cannot be performed because the total capacity of provisioning virtual volumes and deduplication system data volumes defined in the specified pool exceeds the maximum of reserved pool capacity.
CMDRJE	Executing	2E11	6003	The pool is not in the status where the pool option can be set.
Get Command Status	Async	2E11	8004	The operation cannot be performed because of the internal processing.
CMDRJE	Executing	2E11	800F	The operation cannot be performed because the unsupported microcode version exists in the system.
Get Command Status	Async	2E11	8010	The storage system is in the internal processing or the configuration change processes are conflicting.
Get Command Status	Async	2E11	8105	The cache segment size is incorrect.
Get Command Status	Async	2E11	8108	The operation cannot be performed because there is a blocked part in the storage system.
CMDRJE	Executing	2E11	9400	The command cannot be accepted. Wait a while, and then execute the same command.

raidcom modify pool				
Error message	Executing/ Async	Error code		Description
		SSB1	SSB2	
CMDRJE	Executing	2E13	6000	The Dynamic Tiering or active flash operations cannot be performed to the pool because the specified pool contains RAID 1 pool VOLs.
CMDRJE	Executing	2E13	6002	The specified pool for Dynamic Provisioning cannot be changed to a pool for Dynamic Tiering because the pool is related to TSE-VOL.
CMDRJE	Executing	2E13	6005	The setting cannot be performed because the microcode does not support active flash.
CMDRJE	Executing	2E13	6007	The operation cannot be performed because the specified pool is already linked with the virtual volume of Dynamic Provisioning.
CMDRJE	Executing	2E13	6008	The operation cannot be performed because the pool volume having the Data Direct Mapping attribute is included in the specified pool.
Get Command Status	Async	2E13	600A	The operation cannot be performed because the specified pool is linked with an LDEV for which the deduplication function is enabled.
Get Command Status	Async	2E13	600B	The operation cannot be performed because the specified pool is linked with an LDEV that has deduplication data.
Get Command Status	Async	2E13	600C	The operation cannot be performed because the specified pool is linked with a volume for which capacity saving function is enabled.
CMDRJE	Executing	2E20	6000	Pool ID is not installed.
CMDRJE	Executing	2E20	6101	The specified Tier number is invalid.
Get Command Status	Async	2E20	8300	The specified MP blade or MP unit is not installed.
CMDRJE	Executing	2E21	8101	The shared memory for Dynamic Provisioning is not installed.
CMDRJE	Executing	2E21	8102	The shared memory for Dynamic Tiering or active flash is not installed.
Get Command Status	Async	2E21	8103	The operation cannot be performed because of the insufficient capacity of shared memory.

raidcom modify pool				
Error message	Executing/ Async	Error code		Description
		SSB1	SSB2	
Get Command Status	Async	2E21	810A	The shared memory is not installed.
Get Command Status	Async	2E21	9000	The program product is not installed.
CMDRJE	Executing	2E21	9014	Data Retention Utility program product is not installed.
CMDRJE Get Command Status	Executing/ Async	2E22	0001	The specified LDEV is already defined.
Get Command Status	Async	2E23	0001	The number exceeds the maximum number of LDEVs that can be created in the current system configuration.
CMDRJE Get Command Status	Executing/ Async	2E23	0008	The number of specified deduplication system data volumes exceeds the maximum limit.
CMDRJE	Executing	2E23	7201	The specified SSID number exceeds the maximum limit.
Get Command Status	Async	2E30	0020	The specified SSID is already used in the another CU.
Get Command Status	Async	2E30	0021	The SSID is already allocated to the CU.
Get Command Status	Async	2E30	0025	The specified volume is used as an alias device in Compatible PAV.
Get Command Status	Async	2E30	0026	An LDEV of another emulation type is allocated in the range where the number is divided into each 32 LDEVs.
CMDRJE	Executing	2E30	006E	The Dynamic Tiering or active flash operation cannot be performed to the pool because the specified pool contains the external volumes whose cache mode is invalid.
CMDRJE Get Command Status	Executing/ Async	2E30	0071	A pool volume cannot be operated because the LDEV of the resource group different from the resource group of the pool volume belonging to the specified pool is specified.

raidcom modify pool				
Error message	Executing/ Async	Error code		Description
		SSB1	SSB2	
Get Command Status	Async	2E30	009A	The page reservation cannot be set on the specified LDEV with the specified operation.
Get Command Status	Async	2E30	4119	The operation cannot be performed because the number of V-VOLs that can be created in the system exceeds the maximum number.
CMDRJE	Executing	2E30	6000	The threshold value 1 is out of range.
CMDRJE	Executing	2E30	6003	The specified pool is for Thin Image or Copy-on-Write Snapshot.
CMDRJE	Executing	2E30	6005	The specified pool must be assigned two user-defined thresholds to.
CMDRJE	Executing	2E30	600D	On the specified pool, Tier Reallocation is not enabled.
CMDRJE	Executing	2E30	600F	The specified operation cannot be performed because the specified pool is not for Dynamic Provisioning.
CMDRJE	Executing	2E30	6010	Active flash cannot be enabled because an SSD medium does not exist on Tier 1 of Dynamic Provisioning.
CMDRJE	Executing	2E30	6011	Active flash cannot be enabled or disabled because the pool is for Dynamic Provisioning.
CMDRJE	Executing	2E30	6012	The operation of Dynamic Tiering cannot be performed because the specified pool is used for Data Direct Mapping.
Get Command Status	Async	2E30	6014	The operation cannot be performed because the specified pool is for active flash.
Get Command Status	Async	2E31	6003	The operation cannot be performed because the specified pool is for Dynamic Provisioning for Mainframe.
CMDRJE	Executing	2E31	6004	The specified pool includes the different RAID levels of volumes although the pool cannot include those volumes together.
CMDRJE	Executing	2E31	6005	The specified pool includes external volumes although the pool cannot include those volumes together.

raidcom modify pool				
Error message	Executing/ Async	Error code		Description
		SSB1	SSB2	
CMDRJE	Executing	2E31	6006	The specified pool cannot be used for a Dynamic Tiering or active flash.
CMDRJE	Executing	2E31	9000	The capacity that can be used by the installed program products exceeds the maximum.
CMDRJE	Executing	2E31	9001	The program product is not installed.
CMDRJE	Executing	2E3F	8000	The specified operation is not supported in the current microcode version.
CMDRJE	Executing	2EE7	0001	Pool ID is not installed.
CMDRJE	Executing	2EE7	0011	An internal error occurred at the pool operation. Call customer support.
CMDRJE	Executing	2EE7	00EE	The command cannot be accepted. After a while, execute the same command.
CMDRJE	Executing	2EE7	00F0	The specified command cannot be accepted because the command is not supported.
CMDRJE	Executing	2EE7	FEEC	An internal error occurred in the pool operation. Call customer support.
CMDRJE	Executing	2EF3	9F02	The specified operation cannot be performed because it is not supported.

SSB codes returned by raidcom rename pool

raidcom rename pool				
Error message	Executing/ Async	Error code		Description
		SSB1	SSB2	
CMDRJE	Executing	2E00	6000	The value of pool ID is out of range.
CMDRJE	Executing	2E10	6016	The pool name cannot be changed because the pool configuration is being changed.
CMDRJE	Executing	2E20	6000	Invalid pool ID.

raidcom rename pool				
Error message	Executing/ Async	Error code		Description
		SSB1	SSB2	
CMDRJE	Executing	2E31	6001	The pool name is duplicated with another pool.
CMDRJE	Executing	2EE7	FECC	An internal error occurred. Call customer support.

SSB codes returned by raidcom delete pool

raidcom delete pool				
Error message	Executing/ Async	Error code		Description
		SSB1	SSB2	
CMDRJE	Executing	2E00	0000	The LDEV number is out of settable range.
CMDRJE	Executing	2E00	6000	The value of pool ID is out of range.
Get Command Status	Async	2E00	600B	All pool volumes associated to a pool cannot be deleted.
Get Command Status	Async	2E10	0009	The specified LDEV is in the state of blocked.
CMDRJE	Executing	2E10	600D	This pool cannot be deleted because a pool volume is being deleted.
Get Command Status	Async	2E10	600E	The operation cannot be performed because the pool usage rate exceeds the threshold value of the pool usage.
Get Command Status	Async	2E10	600F	The operation cannot be performed because the current capacity rate exceeds the value of maximum reserved capacity rate.
Get Command Status	Async	2E10	6010	It cannot be deleted because the pool volume is set in the state of being deterred deleting.
Get Command Status	Async	2E10	6011	Deleting operation cannot be performed because it is being discarded pages.
Get Command Status	Async	2E10	601F	The deduplication function is set to be enabled for the specified pool.
Get Command Status	Async	2E10	8002	The specified operation is not supported in the current microcode version.

raidcom delete pool				
Error message	Executing/ Async	Error code		Description
		SSB1	SSB2	
Get Command Status	Async	2E11	001F	The operation cannot be performed because a Thin Image pair or a Copy-on-Write Snapshot pair remains or the association with a Dynamic Provisioning virtual volume exists.
Get Command Status	Async	2E11	0020	The operation cannot be performed because a Thin Image pair or a Copy-on-Write Snapshot pair is being deleted or a Dynamic Provisioning virtual volume is being deleted.
Get Command Status	Async	2E11	0021	The operation cannot be performed because a pool volume of a specified pool is being formatted.
CMDRJE Get Command Status	Executing/ Async	2E11	6003	The pool is not in the status where the pool can be deleted or a pool volume can be deleted.
Get Command Status	Async	2E11	8003	The operation cannot be performed because the power supply is switched off.
CMDRJE	Executing	2E11	9400	The command cannot be accepted. After a while, execute the same command.
Get Command Status	Async	2E13	0002	The operation cannot be performed because the specified LDEV is linked with the virtual volume having the Data Direct Mapping attribute.
Get Command Status	Async	2E13	6006	The last SSD medium on Tier 1 of active flash cannot be deleted.
Get Command Status	Async	2E13	6009	The operation cannot be performed because the pool capacity is insufficient for Data Direct Mapping.
CMDRJE	Executing	2E20	0003	The specified LDEV is not registered to the pool.
Get Command Status	Async	2E20	0003	The operation cannot be performed because the pool volume is not of a specified pool.
CMDRJE Get Command Status	Executing/ Async	2E20	6000	Pool ID is not installed.

raidcom delete pool				
Error message	Executing/ Async	Error code		Description
		SSB1	SSB2	
Get Command Status	Async	2E21	8106	The operation cannot be performed because the shared memory is not initialized.
CMDRJE	Executing	2E23	0008	The number of specified LDEVs is invalid.
CMDRJE	Executing	2E30	0052	The specified LDEV cannot be deleted because it is a top VOL of the pool.
CMDRJE	Executing	2E30	6003	The specified pool is a pool for Thin Image or Copy-on-Write Snapshot.
CMDRJE	Executing	2EE7	00EE	The command cannot be accepted. After a while, execute the same command.
CMDRJE	Executing	2EE7	00F9	Pool ID is not installed.
CMDRJE	Executing	2EE7	FEEC	An internal error occurred. Call customer support.
CMDRJE	Executing	2EF3	6002	The specified parameter is invalid. Check the <i>Command Control Interface Command Reference</i> .
CMDRJE	Executing	B980	B903	The command was rejected because the selected resource belongs to NAS_Platform_System_RSG.

SSB codes returned by raidcom add snap_pool

raidcom add snap_pool				
Error message	Executing/ Async	Error code		Description
		SSB1	SSB2	
Get Command Status	Async	2E00	0000	The LDEV number is out of settable range.
CMDRJE	Executing	2E00	6000	Pool ID is out of range.
CMDRJE	Executing	2E00	6001	The type of pool is invalid.
CMDRJE	Executing	2E00	6002	The maximum reserve ratio for V-VOL is out of range.

raidcom add snap_pool				
Error message	Executing/ Async	Error code		Description
		SSB1	SSB2	
Get Command Status	Async	2E10	000C	The operation cannot be performed because a SATA-E drive in the state of quick formatting is in the specified LDEV.
Get Command Status	Async	2E10	0009	The specified LDEV is in the state of blocked.
CMDRJE	Executing	2E10	0011	The specified LDEV is in the state of blocked, or not installed.
Get Command Status	Async	2E10	0050	Thin Image cannot be used because there are not enough cache management devices to create pairs.
Get Command Status	Async	2E10	0102	The pool cannot be created because there are not enough resources (VDEV) depending on cache management devices.
Get Command Status	Async	2E10	600D	The operation cannot be performed because the pool volume is being deleted.
Get Command Status	Async	2E11	005F	The operation failed because accelerated compression of the parity group to which the specified LDEV belongs is enabled and the other LDEV in the parity group is being used for the other pool.
Get Command Status	Async	2E11	0108	The specified LDEV is the LDEV configuring the RAID configuration which cannot be used for the pool volume.
CMDRJE Get Command Status	Executing/ Async	2E11	6003	The pool is not in the status where the pool volume can be added.
Get Command Status	Async	2E11	8003	The operation cannot be performed because the power supply is switched off.
CMDRJE	Executing	2E11	9400	The command cannot be accepted. After a while, execute the same command.
Get Command Status	Async	2E20	0000	The specified LDEV is not installed.
Get Command Status	Async	2E21	8103	The operation cannot be performed because the memory capacity of the shared memory is insufficient.

raidcom add snap_pool				
Error message	Executing/ Async	Error code		Description
		SSB1	SSB2	
Get Command Status	Async	2E21	8106	The operation cannot be performed because the shared memory for Thin Image or Copy-on-Write Snapshot is not initialized.
CMDRJE	Executing	2E21	9007	Thin Image or Copy-on-Write Snapshot program product is not installed.
Get Command Status	Async	2E22	0005	Exceeded the number of pool volume that can be registered in a pool.
Get Command Status	Async	2E22	000D	The larger number of drive types than the supported configuration cannot be added to the specified pool.
Get Command Status	Async	2E22	6100	Pool volume cannot be registered because the drive type of the specified LDEV is different from the other pool volume type, or the drive type in the pool exceeds the three.
CMDRJE	Executing	2E23	0008	The number of specified LDEVs is invalid.
Get Command Status	Async	2E30	0000	The emulation type of the specified LDEV cannot be used as a pool VOL.
Get Command Status	Async	2E30	0007	The specified LDEV has the LU path definition.
Get Command Status	Async	2E30	000C	The specified LDEV is used as a quorum disk.
Get Command Status	Async	2E30	000D	The specified LDEV is used as a system disk.
Get Command Status	Async	2E30	000E	The specified LDEV is already used as a pool volume.
Get Command Status	Async	2E30	0010	The specified LDEV is a command device.
Get Command Status	Async	2E30	0038	It cannot be used as a pool volume because the size of the specified LDEV is less than 8GB.
Get Command Status	Async	2E30	0039	Creating a pool or adding a pool volume cannot be performed because CLPR is mixed in the specified pool.
Get Command Status	Async	2E30	005C	The specified LDEV is used as a V-VOL.

raidcom add snap_pool				
Error message	Executing/ Async	Error code		Description
		SSB1	SSB2	
Get Command Status	Async	2E30	005E	The specified LDEV is used in another program product.
CMDRJE	Executing	2E30	006C	An LDEV, whose emulation type is not available to be mixed, is in the specified LDEVs.
CMDRJE	Executing	2E30	006D	The emulation type of the specified volume is not OPEN-V.
Get Command Status	Async	2E30	006E	The operation cannot be performed for the following reasons: <ul style="list-style-type: none"> ▪ The pool volumes include external volumes whose cache modes are invalid. ▪ The pool includes both external volumes whose cache modes are invalid and internal volumes.
CMDRJE Get Command Status	Executing/ Async	2E30	0071	A pool volume cannot be added because the LDEV of the resource group different from the resource group of the pool volume to which the specified pool belongs is specified.
Get Command Status	Async	2E30	0074	The specified LDEV cannot be operated because it is an external volume mapped for online data migration.
Get Command Status	Async	2E30	0085	The specified volume cannot be used as a pool volume.
Get Command Status	Async	2E30	0099	The specified LDEV is a volume of which Data Direct Mapping attribute is enabled.
CMDRJE	Executing	2E30	6000	The threshold value 1 is out of range.
Get Command Status	Async	2E30	6004	The specified pool attribute differs from the pool attribute of existed pool.
Get Command Status	Async	2E31	0015	The RAID level of the specified LDEV is different from the RAID level of the other pool volumes.
Get Command Status	Async	2E31	0016	There is a blocked pool volume.
Get Command Status	Async	2E31	0018	External volumes whose cache modes are different are included.

raidcom add snap_pool				
Error message	Executing/ Async	Error code		Description
		SSB1	SSB2	
CMDRJE	Executing	2E31	6001	The POOL Name is duplicated with another pool.
Get Command Status	Async	2E31	6004	The pool cannot include volumes in different RAID levels because the pool cannot include those volumes. Or the pool cannot include the RAID 1 volumes and the volumes of other RAID levels together.
Get Command Status	Async	2E31	6005	The pool cannot include both internal volumes and external volumes because the pool is not set to Mixable.
Get Command Status	Async	2E31	9000	The usage capacity exceeds the license capacity of program product.
CMDRJE Get Command Status	Executing Async	2EE7	FEEC	An internal error occurred. Call customer support.
Get Command Status	Async	2EE7	FFFF	An internal error occurred. Call customer support.
CMDRJE	Executing	2EF3	0002	The specified parameter is invalid. Check the <i>Command Control Interface Command Reference</i> .
CMDRJE	Executing	B980	B903	The command was rejected because the selected resource belongs to NAS_Platform_System_RSG.

SSB codes returned by raidcom add snapshot

raidcom add snapshot				
Error message	Executing/ Async	Error code		Description
		SSB1	SSB2	
CMDRJE	Executing	2E00	0000	The LDEV number is out of settable range.
CMDRJE	Executing	2E00	0013	A pair cannot be created because there are not enough cache management devices.

raidcom add snapshot				
Error message	Executing/ Async	Error code		Description
		SSB1	SSB2	
CMDRJE	Executing	2E00	0028	The command ends abnormally because the volume whose LDEV number is out of range is specified as the P-VOL of a Thin Image pair or a Copy-on-Write Snapshot pair.
CMDRJE	Executing	2E00	0029	The command ends abnormally because the volume whose LDEV number is out of range is specified as the S-VOL of a Thin Image pair or a Copy-on-Write Snapshot pair.
CMDRJE	Executing	2E00	6000	The specified pool ID is out of the range.
CMDRJE	Executing	2E00	9701	There are not enough required input parameters.
CMDRJE	Executing	2E10	0020	A pair cannot be created because the volume that has the size exceeding the supported size is specified as the P-VOL of a Thin Image pair or a Copy-on-Write Snapshot pair.
CMDRJE	Executing	2E10	0021	A pair cannot be created because the volume exceeded the support size is specified as the S-VOL of a Thin Image pair or a Copy-on-Write Snapshot pair.
CMDRJE	Executing	2E10	0022	A pair cannot be created because the V-VOL is specified as the P-VOL of a Thin Image pair or a Copy-on-Write Snapshot pair.
CMDRJE	Executing	2E10	0023	A pair cannot be created because the pool-VOL is specified as the P-VOL of a Thin Image pair or a Copy-on-Write Snapshot pair.
CMDRJE	Executing	2E10	0024	A pair cannot be created because the journal volume of Universal Replicator is specified as the P-VOL of a Thin Image pair or a Copy-on-Write Snapshot pair.
CMDRJE	Executing	2E10	0025	The command ends abnormally because the LUSE volumes of different structure are specified as the P-VOL and the S-VOL.
CMDRJE	Executing	2E10	0026	A pair cannot be created because the volume in which the VMA is set is specified as the P-VOL.

raidcom add snapshot				
Error message	Executing/ Async	Error code		Description
		SSB1	SSB2	
CMDRJE	Executing	2E10	0027	A pair cannot be created because the external volume is specified as the S-VOL of a Thin Image pair or a Copy-on-Write Snapshot pair.
CMDRJE	Executing	2E10	0028	A pair cannot be created because the volume other than V-VOL is specified as the S-VOL of a Thin Image pair or a Copy-on-Write Snapshot pair.
CMDRJE	Executing	2E10	0029	A pair cannot be created because the pool-VOL is specified as the S-VOL of a Thin Image pair or a Copy-on-Write Snapshot pair.
CMDRJE	Executing	2E10	002A	A pair cannot be created because the volume (the data volume or the journal volume) of the Universal Replicator pair that is in the intermediate site of the 3DC cascading configuration is specified as the S-VOL of a Thin Image pair or a Copy-on-Write Snapshot pair.
CMDRJE	Executing	2E10	002B	A pair cannot be created because the P-VOL of a Universal Replicator pair is specified as the S-VOL of a Thin Image pair or a Copy-on-Write Snapshot pair.
CMDRJE	Executing	2E10	002C	A pair cannot be created because the S-VOL of a Universal Replicator pair is specified as the S-VOL of a Thin Image pair or a Copy-on-Write Snapshot pair.
CMDRJE	Executing	2E10	002D	A pair cannot be created because the journal volume of the Universal Replicator is specified as the S-VOL of a Thin Image pair or a Copy-on-Write Snapshot pair.
CMDRJE	Executing	2E10	002E	The command ends abnormally because the volume to which S-VOL Disable option is set is specified as the S-VOL of a Thin Image pair or a Copy-on-Write Snapshot pair.
CMDRJE	Executing	2E10	002F	A pair cannot be created because the volume to which VMA is set is specified as the S-VOL of a Thin Image pair or a Copy-on-Write Snapshot pair.

raidcom add snapshot				
Error message	Executing/ Async	Error code		Description
		SSB1	SSB2	
CMDRJE	Executing	2E10	0030	The command ends abnormally because the volumes of different Max LBA size are specified as the P-VOL and S-VOL of a Thin Image pair or a Copy-on-Write Snapshot pair.
CMDRJE	Executing	2E10	0031	The command ends abnormally because the volumes whose the number of slots is different are specified as the P-VOL and S-VOL of a Thin Image pair or a Copy-on-Write Snapshot pair.
CMDRJE	Executing	2E10	0032	A pair cannot be created because the Dynamic Provisioning V-VOL is specified as the S-VOL of a Thin Image pair or the specified Thin Image pair does not exist.
CMDRJE	Executing	2E10	0033	The command ends abnormally because the ShadowImage reserved volume is specified as the P-VOL of a Thin Image pair or a Copy-on-Write Snapshot pair.
CMDRJE	Executing	2E10	0034	The command ends abnormally because the Volume Migration source volume is specified as the P-VOL of a Thin Image pair or a Copy-on-Write Snapshot pair.
CMDRJE	Executing	2E10	0035	The command ends abnormally because the Volume Migration target volume is specified as the P-VOL of a Thin Image pair or a Copy-on-Write Snapshot pair.
CMDRJE	Executing	2E10	0036	The command ends abnormally because the Volume Migration reserved volume is specified as the P-VOL of a Thin Image pair or a Copy-on-Write Snapshot pair.
CMDRJE	Executing	2E10	0037	The command ends abnormally because the P-VOL of a ShadowImage pair is specified as the S-VOL of a Thin Image pair or a Copy-on-Write Snapshot pair.
CMDRJE	Executing	2E10	0038	The command ends abnormally because the S-VOL of a ShadowImage pair is specified as the S-VOL of a Thin Image pair or a Copy-on-Write Snapshot pair.

raidcom add snapshot				
Error message	Executing/ Async	Error code		Description
		SSB1	SSB2	
CMDRJE	Executing	2E10	0039	The command ends abnormally because the ShadowImage reserved volume is specified as the S-VOL of a Thin Image pair or aCopy-on-Write Snapshot pair.
CMDRJE	Executing	2E10	003A	The command ends abnormally because the Volume Migration source volume is specified as the S-VOL of a Thin Image pair or aCopy-on-Write Snapshot pair.
CMDRJE	Executing	2E10	003B	The command ends abnormally because the Volume Migration target volume is specified as the S-VOL of a Thin Image pair or aCopy-on-Write Snapshot pair.
CMDRJE	Executing	2E10	003C	The command ends abnormally because the Volume Migration reserved volume is specified as the S-VOL of a Thin Image pair or aCopy-on-Write Snapshot pair.
CMDRJE	Executing	2E10	003D	A Thin Image pair or aCopy-on-Write Snapshot pair cannot be created because the volume of Universal Replicator for the delta resync is specified as the P-VOL of a Thin Image pair or aCopy-on-Write Snapshot pair.
CMDRJE	Executing	2E10	003E	A Thin Image pair or aCopy-on-Write Snapshot pair cannot be created because the volume of Universal Replicator pair for the delta resync operation is specified as the S-VOL of a Thin Image pair or a Copy-on-Write Snapshot pair.
CMDRJE	Executing	2E10	003F	The command ends abnormally because the quorum disk is specified as the P-VOL of a Thin Image pair or a Copy-on-Write Snapshot pair.
CMDRJE	Executing	2E10	0040	The command ends abnormally because the quorum disk is specified as the S-VOL of a Thin Image pair or a Copy-on-Write Snapshot pair.
CMDRJE	Executing	2E10	0041	A Thin Image pair or a Copy-on-Write Snapshot pair cannot be created because the Dynamic Provisioning V-VOL in capacity expanding is specified as the P-VOL of a Thin Image pair or a Copy-on-Write Snapshot pair.

raidcom add snapshot				
Error message	Executing/ Async	Error code		Description
		SSB1	SSB2	
CMDRJE	Executing	2E10	0042	A pair cannot be created because the page discard (reclaim zero pages) is being executed by a SCSI command from the Host to the specified P-VOL.
CMDRJE	Executing	2E10	0045	A pair cannot be created because the P-VOL of a TrueCopy pair is specified as the S-VOL of a Thin Image pair or a Copy-on-Write Snapshot pair.
CMDRJE	Executing	2E10	0046	A pair cannot be created because the S-VOL of a TrueCopy pair is specified as the S-VOL of a Thin Image pair or a Copy-on-Write Snapshot pair.
CMDRJE	Executing	2E10	0049	The command ends abnormally because the ShadowImage pair is being resynchronized when the volume is shared between the P-VOL of a Thin Image/Copy-on-Write Snapshot pair and the P-VOL of a ShadowImage pair.
CMDRJE	Executing	2E10	004A	The command ends abnormally because the ShadowImage pair status is other than PSUS when the volume is shared between P-VOL of a Thin Image/Copy-on-Write Snapshot pair and the S-VOL of a ShadowImage pair.
CMDRJE	Executing	2E10	004E	The operation cannot be performed because the P-VOL of the ShadowImage pair on which the Quick Restore is being operated is specified as the P-VOL of a Thin Image pair or a Copy-on-Write Snapshot pair.
CMDRJE	Executing	2E10	0051	The pair operation cannot be performed because the volume which specifies the volume using two mirrors cannot accept the specified command in the following configurations using three Universal Replicator sites. <ul style="list-style-type: none"> ▪ 3DC multi target configuration ▪ 3DC cascade configuration ▪ Delta resync configuration

raidcom add snapshot				
Error message	Executing/ Async	Error code		Description
		SSB1	SSB2	
CMDRJE	Executing	2E10	0052	A Thin Image pair cannot be created because the pair status of all Thin Image pairs sharing the specified P-VOL is PSUE.
CMDRJE	Executing	2E10	0056	The specified volume cannot be used for the Thin Image pair operation because the virtual LDEV ID is deleted.
CMDRJE	Executing	2E10	005B	The Thin Image pair operation cannot be performed because the virtual storage machine of the specified P-VOL is different from the virtual storage machine of the specified S-VOL.
CMDRJE	Executing	2E10	005C	A Thin Image pair cannot be operated because changing the model and the serial number in the virtual storage machine of the specified P-VOL is in progress.
CMDRJE	Executing	2E10	005D	A Thin Image pair cannot be operated because changing the model and the serial number in the virtual storage machine of the specified S-VOL is in progress.
CMDRJE	Executing	2E10	0203	The operation failed because the setting of the T10 PI attribute is not match between the specified P-VOL and the specified S-VOL.
CMDRJE	Executing	2E10	0205	A pair cannot be created because the page discard (reclaim zero pages) is being executed by a SCSI command from the Host to the specified S-VOL.
CMDRJE	Executing	2E10	0206	A Thin Image pair cannot be created because the Dynamic Provisioning V-VOL in capacity expanding is specified as the S-VOL of a Thin Image pair.
CMDRJE	Executing	2E10	0211	The command ends abnormally because the volume which is being deleted is specified.

raidcom add snapshot				
Error message	Executing/ Async	Error code		Description
		SSB1	SSB2	
CMDRJE	Executing	2E10	2300	A Thin Image pair or a Copy-on-Write Snapshot pair with the specified consistency group ID cannot be created due to one of the following reasons: <ul style="list-style-type: none"> ▪ The specified consistency group ID is used by the ShadowImage. ▪ The number of pairs that can be defined in a consistency group exceeds the maximum. ▪ The pair created by using the same P-VOL already exists in the specified consistency group.
CMDRJE	Executing	2E10	2302	A Thin Image pair specifying CTG mode cannot be created because the maximum number of consistency groups has already been defined.
CMDRJE	Executing	2E10	6018	A Thin Image pair cannot be created due to one of the following reasons: <ul style="list-style-type: none"> ▪ The pool usage value exceeds the threshold value. ▪ The specified pool is blocked.
CMDRJE	Executing	2E10	8100	A Thin Image pair or a Copy-on-Write Snapshot pair cannot be created because there are not enough pair tables.
CMDRJE	Executing	2E10	8101	A Thin Image pair or a Copy-on-Write Snapshot pair cannot be created because there are not enough differential tables.
CMDRJE	Executing	2E10	8102	A pair cannot be created because there is not enough free shared memory space.
CMDRJE	Executing	2E10	9701	The command ends abnormally because the pair is in the state of unacceptable the command.
CMDRJE	Executing	2E10	9705	A Thin Image pair or a Copy-on-Write Snapshot pair cannot be created because the number of Thin Image pairs or Copy-on-Write Snapshot pairs has already reached the maximum.

raidcom add snapshot				
Error message	Executing/ Async	Error code		Description
		SSB1	SSB2	
CMDRJE	Executing	2E10	9706	A Thin Image pair cannot be created because the maximum number of Snapshot IDs (MU numbers) has already been in use for the specified P-VOL.
CMDRJE	Executing	2E10	9707	A Thin Image pair cannot be created because the maximum number of Snapshot groups has already been defined, or the maximum number of Thin Image pairs has already been defined in the specified Snapshot group.
CMDRJE	Executing	2E10	9708	A Thin Image pair cannot be created because the DP pool is being initialized.
CMDRJE	Executing	2E10	970D	The pair cannot be created because the number of pair layers in the cascade configuration exceeds the maximum number.
CMDRJE	Executing	2E10	970E	The pair cannot be created because the number of clone attribute pair layers exceeds the maximum number.
CMDRJE	Executing	2E10	970F	When the pair status is other than PAIR or PSUS, you cannot create a pair by specifying the S-VOL of a Thin Image pair.
CMDRJE	Executing	2E10	9712	Thin Image pairs that can be cascaded or cloned and Thin Image pairs that cannot be cascaded or cloned cannot be contained in a snapshot tree.
CMDRJE	Executing	2E10	9713	The operation cannot be performed because the snapshot tree is being deleted.
CMDRJE	Executing	2E10	9800	An error occurred at the operation of Thin Image due to one of the following reasons: <ul style="list-style-type: none"> ▪ The LDEV number specified for the P-VOL or the S-VOL is incorrect. ▪ The LDEV specified as the P-VOL or the S-VOL is not paired. ▪ The pair of the specified P-VOL or the S-VOL is not ready to perform the specified operation.

raidcom add snapshot				
Error message	Executing/ Async	Error code		Description
		SSB1	SSB2	
				<ul style="list-style-type: none"> ▪ The specified Snapshot ID (MU number) is wrong. ▪ The specified Snapshot ID (MU number) is already used. ▪ The specified pool is not in the usable status. ▪ The license capacity has exceeded the maximum. ▪ The control table for Thin Image is depleted. ▪ The number of pairs that can be created in a snapshot tree has exceeded the maximum.
CMDRJE	Executing	2E11	8003	The operation cannot be performed because power-off is in progress.
CMDRJE	Executing	2E11	800F	The operation failed because multiple versions of DKCMAIN microcode are included.
CMDRJE	Executing	2E11	9701	A pair cannot be created because the specified snapshot group contains Thin Image pairs with the clone attribute and without the clone attribute.
CMDRJE	Executing	2E11	9702	A pair cannot be created in the same consistency group as the Thin Image pair which uses the specified P-VOL as an S-VOL.
CMDRJE	Executing	2E13	0000	A Thin Image pair or a Copy-on-Write Snapshot pair cannot be created because the specified P-VOL is a LUSE volume.
CMDRJE	Executing	2E13	6003	A pair cannot be created because there is a pair in the specified primary volume, which is using a different pool number from the specified pool number.
CMDRJE	Executing	2E13	6004	The specified pair operation cannot be performed for the specified pool.

raidcom add snapshot				
Error message	Executing/ Async	Error code		Description
		SSB1	SSB2	
CMDRJE	Executing	2E13	9900	The consistency group to be used in the specified Snapshot Group is in one of the following status: <ul style="list-style-type: none"> The number of pairs that can be defined in a consistency group exceeds the maximum. The pair created by using the same P-VOL already exists in the specified consistency group.
CMDRJE	Executing	2E20	0000	The specified LDEV is not defined.
CMDRJE	Executing	2E20	0008	The command ends abnormally because an unmounted volume is specified as the P-VOL of a Thin Image pair or a Copy-on-Write Snapshot pair.
CMDRJE	Executing	2E20	0009	The command ends abnormally because the blocked volume is specified as the P-VOL of a Thin Image pair or a Copy-on-Write Snapshot pair.
CMDRJE	Executing	2E20	000A	The command ends abnormally because the volume in formatting is specified as the P-VOL of a Thin Image pair or a Copy-on-Write Snapshot pair.
CMDRJE	Executing	2E20	000B	The command ends abnormally because an unmounted volume is specified as the S-VOL of a Thin Image pair or a Copy-on-Write Snapshot pair.
CMDRJE	Executing	2E20	000C	The command ends abnormally because the blocked volume is specified as the S-VOL of a Thin Image pair or a Copy-on-Write Snapshot pair.
CMDRJE	Executing	2E20	000D	The command ends abnormally because the volume in formatting is specified as the S-VOL of a Thin Image pair or a Copy-on-Write Snapshot pair.
CMDRJE	Executing	2E20	0201	When you create a pair with the clone attribute, you must specify the S-VOL.

raidcom add snapshot				
Error message	Executing/ Async	Error code		Description
		SSB1	SSB2	
CMDRJE	Executing	2E21	8107	The command ends abnormally because the shared memory (FC, TPF, or Extension1) is not added for necessary capacity or maintenance work is being performed.
CMDRJE	Executing	2E21	8108	The shared memory for Thin Image or Copy-on-Write Snapshot is not installed.
CMDRJE	Executing	2E21	8109	A Thin Image pair or a Copy-on-Write Snapshot pair cannot be created due to one of the following reasons: <ul style="list-style-type: none"> The shared memory is not expanded for necessary capacity. It is in the initializing process.
CMDRJE	Executing	2E21	810A	The shared memory is not installed.
CMDRJE	Executing	2E21	9010	The program product is not installed.
CMDRJE	Executing	2E21	9306	The virtual LDEV ID for a virtual storage machine is not defined on the specified LDEV.
CMDRJE	Executing	2E21	930A	The virtual storage machine with the specified serial number is not found.
CMDRJE	Executing	2E30	000C	The specified LDEV is used as a quorum disk.
CMDRJE	Executing	2E30	0076	A pair cannot be created because the volume is already used in the S-VOL of a Thin Image pair or a Copy-on-Write Snapshot pair is specified as the P-VOL.
CMDRJE	Executing	2E30	0077	A pair cannot be created because the volume is already used as the P-VOL of a Thin Image pair or a Copy-on-Write Snapshot pair is specified as the S-VOL.
CMDRJE	Executing	2E30	0078	A pair cannot be created because the volume is already used as the S-VOL of a Thin Image pair or a Copy-on-Write Snapshot pair is specified as the S-VOL.
CMDRJE	Executing	2E30	007A	The command ends abnormally because the volume other than OPEN-V is specified as the P-VOL of a Thin Image pair or a Copy-on-Write Snapshot pair.

raidcom add snapshot				
Error message	Executing/ Async	Error code		Description
		SSB1	SSB2	
CMDRJE	Executing	2E30	007B	A pair cannot be created because the volume whose command device is set is specified as the P-VOL of a Thin Image pair or a Copy-on-Write Snapshot pair.
CMDRJE	Executing	2E30	007C	The command ends abnormally because the volume other than OPEN-V is specified as the S-VOL of a Thin Image pair or a Copy-on-Write Snapshot pair.
CMDRJE	Executing	2E30	007D	A pair cannot be created because the volume whose command device is set is specified as the S-VOL of a Thin Image pair or a Copy-on-Write Snapshot pair.
CMDRJE	Executing	2E30	007E	The command ends abnormally because the volume having no path definition is specified as the P-VOL of a Thin Image pair or the specified Thin Image pair does not exist.
CMDRJE	Executing	2E30	007F	The command ends abnormally because the volume having no path definition is specified as the S-VOL of a Thin Image pair or the specified Thin Image pair does not exist.
CMDRJE	Executing	2E30	0080	The command ends abnormally because the external volume mapped for the online data migration is specified as the P-VOL of a Thin Image pair or a Copy-on-Write Snapshot pair.
CMDRJE	Executing	2E30	0081	The command ends abnormally because the external volume mapped for the online data migration is specified as the S-VOL of a Thin Image pair or a Copy-on-Write Snapshot pair.
CMDRJE	Executing	2E30	0090	The pair operation is rejected because the specified volume as the primary volume is a reserved volume for GAD, or a volume for the GAD pair which is in the invalid status.
CMDRJE	Executing	2E30	0091	The pair operation is rejected because the specified volume as the secondary volume is a reserved volume for GAD, or a volume for aGAD pair.

raidcom add snapshot				
Error message	Executing/ Async	Error code		Description
		SSB1	SSB2	
CMDRJE	Executing	2E30	0099	The specified LDEV is a volume of which Data Direct Mapping attribute is enabled.
CMDRJE	Executing	2E30	0201	The specified LDEV is an external volume of which Data Direct Mapping attribute is enabled.
CMDRJE	Executing	2E30	0202	The specified LDEV is a virtual volume of which Data Direct Mapping attribute is enabled.
CMDRJE	Executing	2E30	0206	The operation cannot be performed because the specified LDEV is a deduplication system data volume.
CMDRJE	Executing	2E30	600E	<p>A pair cannot be created because the attribute of the pool is other than Thin Image or Copy-on-Write Snapshot.</p> <p>A pair for which a snapshot group was specified cannot be created because the specified pool is one of the following:</p> <ul style="list-style-type: none"> ▪ A pool for which Data Direct Mapping attribute is enabled. ▪ A pool for HDT. ▪ A pool for mainframe.
CMDRJE	Executing	2E31	9002	A pair cannot be created because the capacity exceeds the licensed capacity.
CMDRJE	Executing	2E31	9701	For creation of a pair with the cascade or clone attribute, a Dynamic Provisioning V-VOL is not specified for the S-VOL.
CMDRJE	Executing	2E31	9702	A pair cannot be created in the specified pool due to restrictions of the system.
CMDRJE	Executing	2E3F	8000	The specified operation is not supported in the current microcode version.
CMDRJE	Executing	2EC6	FEEC	An internal error occurred. Call customer support.
CMDRJE	Executing	B980	B903	The command was rejected because the selected resource belongs to NAS_Platform_System_RSG.

SSB codes returned by raidcom modify snapshot

raidcom modify snapshot				
Error message	Executing/ Async	Error code		Description
		SSB1	SSB2	
CMDRJE	Executing	2E00	0000	The LDEV number is out of settable range.
CMDRJE	Executing	2E00	000B	The MU number exceeds the maximum.
CMDRJE	Executing	2E00	0028	The command ends abnormally because the volume whose LDEV number is out of range is specified as the P-VOL of a Thin Image pair or a Copy-on-Write Snapshot pair.
CMDRJE	Executing	2E02	9701	The command cannot be executed because the clone specification of the input parameter and the clone attribute of a Thin Image pair to be operated do not match.
CMDRJE	Executing	2E10	0033	The command ends abnormally because the ShadowImage reserved volume is specified as the P-VOL of a Thin Image pair or a Copy-on-Write Snapshot pair.
CMDRJE	Executing	2E10	0034	The command ends abnormally because the Volume Migration source volume is specified as the P-VOL of a Thin Image pair or a Copy-on-Write Snapshot pair.
CMDRJE	Executing	2E10	0035	The command ends abnormally because the Volume Migration target volume is specified as the P-VOL of a Thin Image pair or a Copy-on-Write Snapshot pair.
CMDRJE	Executing	2E10	0036	The command ends abnormally because the Volume Migration reserved volume is specified as the P-VOL of a Thin Image pair or a Copy-on-Write Snapshot pair.
CMDRJE	Executing	2E10	003F	The command ends abnormally because the quorum disk is specified as the P-VOL of a Thin Image pair or a Copy-on-Write Snapshot pair.
CMDRJE	Executing	2E10	0043	The Thin Image pair or the Copy-on-Write Snapshot pair cannot be restored because the TrueCopy pair status is other than PSUS or PSUE when the volume is shared between the P-VOL of a Thin Image/Copy-on-Write Snapshot pair and the P-VOL of a TrueCopy pair.

raidcom modify snapshot				
Error message	Executing/ Async	Error code		Description
		SSB1	SSB2	
CMDRJE	Executing	2E10	0044	A Thin Image pair or a Copy-on-Write Snapshot pair cannot be restored because the Universal Replicator pair status is other than PSUS or PSUE when the volume is shared between the P-VOL of a Thin Image/Copy-on-Write Snapshot pair and the P-VOL of a Universal Replicator pair.
CMDRJE	Executing	2E10	0047	A Snapshot data cannot be obtained because the TrueCopy pair status is COPY when the volume is shared between the P-VOL of a Thin Image/Copy-on-Write Snapshot pair and the S-VOL of a TrueCopy pair.
CMDRJE	Executing	2E10	0048	A Snapshot data cannot be obtained because the Universal Replicator pair status is COPY when the volume is shared between the P-VOL of a Thin Image/Copy-on-Write Snapshot pair and the S-VOL of a Universal Replicator pair.
CMDRJE	Executing	2E10	0049	The command ends abnormally because the ShadowImage pair is being resynchronized when the volume is shared between the P-VOL of a Thin Image/Copy-on-Write Snapshot pair and the P-VOL of a ShadowImage pair.
CMDRJE	Executing	2E10	004A	The command ends abnormally because the ShadowImage pair status is other than PSUS when the volume is shared between P-VOL of a Thin Image/Copy-on-Write Snapshot pair and the S-VOL of a ShadowImage pair.
CMDRJE	Executing	2E10	004B	The Thin Image pair or the Copy-on-Write Snapshot pair cannot be restored because the Thin Image pair or the Copy-on-Write Snapshot pair status is other than PSUS or PSUE when the volume is shared between the P-VOL of a Thin Image/Copy-on-Write Snapshot pair and the P-VOL of a ShadowImage pair.

raidcom modify snapshot				
Error message	Executing/ Async	Error code		Description
		SSB1	SSB2	
CMDRJE	Executing	2E10	004C	The Thin Image pair or the Copy-on-Write Snapshot pair cannot be restored because the Thin Image pair or the Copy-on-Write Snapshot pair status is other than PSUS when the volume is shared between the P-VOL of a Thin Image/ Copy-on-Write Snapshot pair and the S-VOL of a ShadowImage pair.
CMDRJE	Executing	2E10	004D	A Snapshot data cannot be obtained because the TrueCopy asynchronous pair status is other than PSUS or PSUE when the volume is shared between the P-VOL of a Thin Image/Copy-on-Write Snapshot pair and the S-VOL of a TrueCopy asynchronous pair.
CMDRJE	Executing	2E10	004E	The operation cannot be performed because the P-VOL of the ShadowImage pair on which the Quick Restore is being operated is specified as the P-VOL of a Thin Image pair or a Copy-on-Write Snapshot pair.
CMDRJE	Executing	2E10	0051	The pair operation cannot be performed because the volume which specifies the volume using two mirrors cannot accept the specified command in the following configurations using three Universal Replicator sites. <ul style="list-style-type: none"> ▪ 3DC multi target configuration ▪ 3DC cascade configuration ▪ Delta resync configuration
CMDRJE	Executing	2E10	0052	A Thin Image pair operation cannot be performed because the pair status of all Thin Image pairs sharing the specified P-VOL is PSUE.
CMDRJE	Executing	2E10	0056	The specified volume cannot be used for the Thin Image pair operation because the virtual LDEV ID is deleted.
CMDRJE	Executing	2E10	005B	The Thin Image pair operation cannot be performed because the virtual storage machine of the specified P-VOL is different from the virtual storage machine of the specified S-VOL.

raidcom modify snapshot				
Error message	Executing/ Async	Error code		Description
		SSB1	SSB2	
CMDRJE	Executing	2E10	0061	The Thin Image pair operation cannot be performed because the virtual LDEV ID of the specified volume is deleted.
CMDRJE	Executing	2E10	6018	A Thin Image pair cannot be created due to one of the following reasons: <ul style="list-style-type: none"> ▪ The pool usage value exceeds the threshold value. ▪ The specified pool is blocked.
CMDRJE	Executing	2E10	6019	A Snapshot data cannot be obtained because the pool or the pool-VOL is blocked.
CMDRJE	Executing	2E10	8100	A Thin Image pair or a Copy-on-Write Snapshot pair cannot be created because there are not enough pair tables.
CMDRJE	Executing	2E10	8101	A Thin Image pair or a Copy-on-Write Snapshot pair cannot be created because there are not enough differential tables.
CMDRJE	Executing	2E10	8102	A pair cannot be created because there is not enough free shared memory space.
CMDRJE	Executing	2E10	9700	The command ends abnormally because other than the raidcom add snapshot command is issued for the volume other than the Thin Image pair or the Copy-on-Write Snapshot pair.
CMDRJE	Executing	2E10	9701	The command ends abnormally because the pair is in the state of unacceptable the command.
CMDRJE	Executing	2E10	9702	The Thin Image pair or the Copy-on-Write Snapshot pair cannot be restored because the volume is shared between the P-VOL of a Thin Image/Copy-on-Write Snapshot pair and the S-VOL of a TrueCopy pair.
CMDRJE	Executing	2E10	9703	The Thin Image pair or the Copy-on-Write Snapshot pair cannot be restored because the volume is shared between the P-VOL of a Thin Image/Copy-on-Write Snapshot pair and the S-VOL of a Universal Replicator pair.

raidcom modify snapshot				
Error message	Executing/ Async	Error code		Description
		SSB1	SSB2	
CMDRJE	Executing	2E10	9704	<p>The Thin Image pair or the Copy-on-Write Snapshot pair cannot be restored due to one of the following reasons:</p> <ul style="list-style-type: none"> ▪ Snapshot data of a restore target Thin Image pair or Copy-on-Write Snapshot pair is being obtained per consistency group. ▪ Snapshot data of a different pair whose primary volume is the restore target P-VOL of a Thin Image pair or a Copy-on-Write Snapshot pair is being obtained per consistency group.
CMDRJE	Executing	2E10	9710	The clone attribute of the specified Thin Image pair is enabled.
CMDRJE	Executing	2E10	9713	The operation cannot be performed because the snapshot tree is being deleted.
CMDRJE	Executing	2E10	9714	The specified snapshot group name cannot be changed because it is already registered.
CMDRJE	Executing	2E10	9800	<p>An error occurred at the operation of Thin Image due to one of the following reasons:</p> <ul style="list-style-type: none"> ▪ The LDEV number specified for the P-VOL or the S-VOL is incorrect. ▪ The LDEV specified as the P-VOL or the S-VOL is not paired. ▪ The pair of the specified P-VOL or the S-VOL is not ready to perform the specified operation. ▪ The specified Snapshot ID (MU number) is wrong. ▪ The specified Snapshot ID (MU number) is already used. ▪ The specified pool is not in the usable status. ▪ The license capacity has exceeded the maximum.

raidcom modify snapshot				
Error message	Executing/ Async	Error code		Description
		SSB1	SSB2	
				<ul style="list-style-type: none"> ▪ The control table for Thin Image is depleted. ▪ The snapshot group name cannot be changed.
CMDRJE	Executing	2E11	8003	The operation cannot be performed because power-off is in progress.
CMDRJE	Executing	2E11	9703	The pair operation cannot be performed because the status of the pair that uses the specified P-VOL as an S-VOL is not PSUS.
CMDRJE	Executing	2E11	9705	The command was rejected because pairs in the status other than PAIR exist under the specified pair.
CMDRJE	Executing	2E20	0000	The specified LDEV is not defined.
CMDRJE	Executing	2E20	0008	The command ends abnormally because an unmounted volume is specified as the P-VOL of a Thin Image pair or a Copy-on-Write Snapshot pair.
CMDRJE	Executing	2E20	0009	The command ends abnormally because the blocked volume is specified as the P-VOL of a Thin Image pair or a Copy-on-Write Snapshot pair.
CMDRJE	Executing	2E20	000A	The command ends abnormally because the volume in formatting is specified as the P-VOL of a Thin Image pair or a Copy-on-Write Snapshot pair.
CMDRJE	Executing	2E21	8107	The command ends abnormally because the shared memory (FC, TPF, or Extension1) is not added for necessary capacity or maintenance work is being performed.
CMDRJE	Executing	2E21	8108	The shared memory for Thin Image or Copy-on-Write Snapshot is not installed.
CMDRJE	Executing	2E21	810A	The shared memory is not installed.
CMDRJE	Executing	2E21	9010	The program product is not installed.
CMDRJE	Executing	2E21	9306	The virtual LDEV ID for a virtual storage machine is not defined on the specified LDEV.

raidcom modify snapshot				
Error message	Executing/ Async	Error code		Description
		SSB1	SSB2	
CMDRJE	Executing	2E21	930A	The virtual storage machine with the specified serial number is not found.
CMDRJE	Executing	2E30	000C	The specified LDEV is used as a quorum disk.
CMDRJE	Executing	2E30	0079	The Thin Image pair or the Copy-on-Write Snapshot pair cannot be restored because the volume that is set the S-VOL Disable is specified as the P-VOL.
CMDRJE	Executing	2E30	007A	The command ends abnormally because the volume other than OPEN-V is specified as the P-VOL of a Thin Image pair or a Copy-on-Write Snapshot pair.
CMDRJE	Executing	2E30	0081	The command ends abnormally because the external volume mapped for the online data migration is specified as the S-VOL of a Thin Image pair or a Copy-on-Write Snapshot pair.
CMDRJE	Executing	2E30	0090	The pair operation is rejected because the specified volume as the primary volume is a reserved volume for GAD, or the volume for the GAD pair which is in the invalid status.
CMDRJE	Executing	2E30	0091	The pair operation is rejected because the specified volume as the secondary volume is a reserved volume for GAD, or the volume for the GAD pair.
CMDRJE	Executing	2E30	0099	The specified LDEV is a volume of which Data Direct Mapping attribute is enabled.
CMDRJE	Executing	2E30	0201	The specified LDEV is an external volume of which Data Direct Mapping attribute is enabled.
CMDRJE	Executing	2E30	0202	The specified LDEV is a virtual volume of which Data Direct Mapping attribute is enabled.
CMDRJE	Executing	2E3F	8000	The specified operation is not supported in the current microcode version.
CMDRJE	Executing	2EC6	FECC	An internal error occurred. Call customer support.
CMDRJE	Executing	2EF3	0002	The specified parameter is invalid. Check the <i>Command Control Interface Command Reference</i> .

raidcom modify snapshot				
Error message	Executing/ Async	Error code		Description
		SSB1	SSB2	
CMDRJE	Executing	B980	B903	The command was rejected because the selected resource belongs to NAS_Platform_System_RSG.

SSB codes returned by raidcom get snapshot

raidcom get snapshot				
Error message	Executing/ Async	Error code		Description
		SSB1	SSB2	
CMDRJE	Executing	2EC5	FEEC	An internal error occurred. Call customer support.

SSB codes returned by raidcom delete snapshot

raidcom delete snapshot				
Error message	Executing/ Async	Error code		Description
		SSB1	SSB2	
CMDRJE	Executing	2E00	0000	The LDEV number is out of settable range.
CMDRJE	Executing	2E00	000B	The MU number exceeds the maximum.
CMDRJE	Executing	2E00	0028	The command ends abnormally because the volume whose LDEV number is out of range is specified as the P-VOL of a Thin Image pair or a Copy-on-Write Snapshot pair.
CMDRJE	Executing	2E10	0033	The command ends abnormally because the ShadowImage reserved volume is specified as the P-VOL of a Thin Image pair or a Copy-on-Write Snapshot pair.
CMDRJE	Executing	2E10	0034	The command ends abnormally because the Volume Migration source volume is specified as the P-VOL of a Thin Image pair or a Copy-on-Write Snapshot pair.

raidcom delete snapshot				
Error message	Executing/ Async	Error code		Description
		SSB1	SSB2	
CMDRJE	Executing	2E10	0035	The command ends abnormally because the Volume Migration target volume is specified as the P-VOL of a Thin Image pair or a Copy-on-Write Snapshot pair.
CMDRJE	Executing	2E10	0036	The command ends abnormally because the Volume Migration reserved volume is specified as the P-VOL of a Thin Image pair or a Copy-on-Write Snapshot pair.
CMDRJE	Executing	2E10	0049	The command ends abnormally because the ShadowImage pair is being resynchronized when the volume is shared between the P-VOL of a Thin Image/Copy-on-Write Snapshot pair and the P-VOL of a ShadowImage pair.
CMDRJE	Executing	2E10	004A	The command ends abnormally because the ShadowImage pair status is other than PSUS when the volume is shared between P-VOL of a Thin Image/Copy-on-Write Snapshot pair and the S-VOL of a ShadowImage pair.
CMDRJE	Executing	2E10	004D	A Snapshot data cannot be obtained because the TrueCopy asynchronous pair status is other than PSUS or PSUE when the volume is shared between the P-VOL of a Thin Image/Copy-on-Write Snapshot pair and the S-VOL of a TrueCopy asynchronous pair.
CMDRJE	Executing	2E10	004E	The operation cannot be performed because the P-VOL of the ShadowImage pair on which the Quick Restore is being operated is specified as the P-VOL of a Thin Image pair or a Copy-on-Write Snapshot pair.
CMDRJE	Executing	2E10	0056	The specified volume cannot be used for the Thin Image pair operation because the virtual LDEV ID is deleted.
CMDRJE	Executing	2E10	005B	The Thin Image pair operation cannot be performed because the virtual storage machine of the specified P-VOL is different from the virtual storage machine of the specified S-VOL.

raidcom delete snapshot				
Error message	Executing/ Async	Error code		Description
		SSB1	SSB2	
CMDRJE	Executing	2E10	0061	The specified volume cannot be used for the Thin Image pair operation because the virtual LDEV ID is deleted.
CMDRJE	Executing	2E10	0204	The operation failed because the specified LDEV which is holding the attribute of SLU is bind to the LDEV which is holding the attribute of ALU.
CMDRJE	Executing	2E10	6019	A Snapshot data cannot be obtained because the pool or the pool-VOL is blocked.
CMDRJE	Executing	2E10	9700	The command ends abnormally because other than the raidcom add snapshot command is issued for the volume other than the Thin Image pair or the Copy-on-Write Snapshot pair.
CMDRJE	Executing	2E10	9701	The command ends abnormally because the pair is in the state of unacceptable the command.
CMDRJE	Executing	2E10	9800	An error occurred at the operation of Thin Image due to one of the following reasons: <ul style="list-style-type: none"> ▪ The LDEV number specified for the P-VOL or the S-VOL is incorrect. ▪ The LDEV specified as the P-VOL or the S-VOL is not paired. ▪ The pair of the specified P-VOL or the S-VOL is not ready to perform the specified operation. ▪ The specified Snapshot ID (MU number) is wrong. ▪ The specified Snapshot ID (MU number) is already used. ▪ The specified pool is not in the usable status. ▪ The license capacity has exceeded the maximum. ▪ The control table for Thin Image is depleted.
CMDRJE	Executing	2E11	2206	You do not have the operation authority to operate the target resource group.

raidcom delete snapshot				
Error message	Executing/ Async	Error code		Description
		SSB1	SSB2	
				Specify the resource group that is allocated to the user group as the operation target, or set the operation authority to the user group in order to operate the target resource group.
CMDRJE	Executing	2E11	8003	The operation cannot be performed because power-off is in progress.
CMDRJE	Executing	2E11	9704	The operation cannot be performed because a pair exists under the specified pair.
CMDRJE	Executing	2E11	9706	The operation cannot be performed because the specified volume is not a root volume of a pair with the cascade or clone attribute, or the volume is an S-VOL in another snapshot tree.
CMDRJE	Executing	2E20	0000	The specified LDEV is not defined.
CMDRJE	Executing	2E20	0008	The command ends abnormally because an unmounted volume is specified as the P-VOL of a Thin Image pair or a Copy-on-Write Snapshot pair.
CMDRJE	Executing	2E20	0009	The command ends abnormally because the blocked volume is specified as the P-VOL of a Thin Image pair or a Copy-on-Write Snapshot pair.
CMDRJE	Executing	2E21	8107	The command ends abnormally because the shared memory (FC, TPF, or Extension2) is not added for necessary capacity or maintenance work is being performed.
CMDRJE	Executing	2E21	8108	The shared memory for Thin Image or Copy-on-Write Snapshot is not installed.
CMDRJE	Executing	2E21	9306	The virtual LDEV ID for a virtual storage machine is not defined on the specified LDEV.
CMDRJE	Executing	2E21	930A	The virtual storage machine with the specified serial number is not found.
CMDRJE	Executing	2EC6	FEEC	An internal error occurred. Call customer support.

raidcom delete snapshot				
Error message	Executing/ Async	Error code		Description
		SSB1	SSB2	
CMDRJE	Executing	B980	B903	The command was rejected because the selected resource belongs to NAS_Platform_System_RSG.

SSB codes returned by raidcom map snapshot

raidcom map snapshot				
Error message	Executing/ Async	Error code		Description
		SSB1	SSB2	
CMDRJE	Executing	2E00	0028	The command ends abnormally because the volume whose LDEV number is out of range is specified as the P-VOL of a Thin Image pair or a Copy-on-Write Snapshot pair.
CMDRJE	Executing	2E00	0029	The command ends abnormally because the volume whose LDEV number is out of range is specified as the S-VOL of a Thin Image pair or a Copy-on-Write Snapshot pair.
CMDRJE	Executing	2E10	0020	The command ends abnormally because the volume that has the size exceeding the supported size is specified as the P-VOL of a Thin Image pair or a Copy-on-Write Snapshot pair.
CMDRJE	Executing	2E10	0025	The command ends abnormally because the LUSE volumes of different structure are specified as the P-VOL and the S-VOL.
CMDRJE	Executing	2E10	0027	The command ends abnormally because the external volume is specified as the S-VOL of a Thin Image pair or a Copy-on-Write Snapshot pair.
CMDRJE	Executing	2E10	0028	The command ends abnormally because the volume other than V-VOL is specified as the S-VOL of a Thin Image pair or a Copy-on-Write Snapshot pair.

raidcom map snapshot				
Error message	Executing/ Async	Error code		Description
		SSB1	SSB2	
CMDRJE	Executing	2E10	0029	The command ends abnormally because the pool-VOL is specified as the S-VOL of a Thin Image pair or a Copy-on-Write Snapshot pair.
CMDRJE	Executing	2E10	002A	The command ends abnormally because the volume (the data volume or the journal volume) of the Universal Replicator pair that is in the intermediate site of the 3DC cascading configuration is specified as the S-VOL of a Thin Image pair or a Copy-on-Write Snapshot pair.
CMDRJE	Executing	2E10	002B	The command ends abnormally because the P-VOL of a Universal Replicator pair is specified as the S-VOL of a Thin Image pair or a Copy-on-Write Snapshot pair.
CMDRJE	Executing	2E10	002C	The command ends abnormally because the S-VOL of a Universal Replicator pair is specified as the S-VOL of a Thin Image pair or a Copy-on-Write Snapshot pair.
CMDRJE	Executing	2E10	002D	The command ends abnormally because the journal volume of the Universal Replicator is specified as the S-VOL of a Thin Image pair or a Copy-on-Write Snapshot pair.
CMDRJE	Executing	2E10	002E	The command ends abnormally because the volume to which S-VOL Disable option is set is specified as the S-VOL of a Thin Image pair or a Copy-on-Write Snapshot pair.
CMDRJE	Executing	2E10	002F	The command ends abnormally because the volume to which VMA is set is specified as the S-VOL of a Thin Image pair or a Copy-on-Write Snapshot pair.
CMDRJE	Executing	2E10	0030	The command ends abnormally because the volumes of different Max LBA size are specified as the P-VOL and S-VOL of a Thin Image pair or a Copy-on-Write Snapshot pair.
CMDRJE	Executing	2E10	0031	The command ends abnormally because the volumes whose the number of slots is different are specified as the P-VOL and S-VOL of a Thin Image pair or a Copy-on-Write Snapshot pair.

raidcom map snapshot				
Error message	Executing/ Async	Error code		Description
		SSB1	SSB2	
CMDRJE	Executing	2E10	0032	A pair cannot be created because the Dynamic Provisioning V-VOL is specified as the S-VOL of a Thin Image pair or the specified Thin Image pair does not exist.
CMDRJE	Executing	2E10	0037	The command ends abnormally because the P-VOL of a ShadowImage pair is specified as the S-VOL of a Thin Image pair or a Copy-on-Write Snapshot pair.
CMDRJE	Executing	2E10	0038	The command ends abnormally because the S-VOL of a ShadowImage pair is specified as the S-VOL of a Thin Image pair or a Copy-on-Write Snapshot pair.
CMDRJE	Executing	2E10	003A	The command ends abnormally because the Volume Migration source volume is specified as the S-VOL of a Thin Image pair or a Copy-on-Write Snapshot pair.
CMDRJE	Executing	2E10	003B	The command ends abnormally because the Volume Migration target volume is specified as the S-VOL of a Thin Image pair or a Copy-on-Write Snapshot pair.
CMDRJE	Executing	2E10	003E	The command ends abnormally because the volume of Universal Replicator pair for the delta resync operation is specified as the S-VOL of a Thin Image pair or a Copy-on-Write Snapshot pair.
CMDRJE	Executing	2E10	0045	The command ends abnormally because the P-VOL of a TrueCopy pair is specified as the S-VOL of a Thin Image pair or a Copy-on-Write Snapshot pair.
CMDRJE	Executing	2E10	0046	The command ends abnormally because the S-VOL of a TrueCopy pair is specified as the S-VOL of a Thin Image pair or a Copy-on-Write Snapshot pair.
CMDRJE	Executing	2E10	0056	The specified volume cannot be used for the Thin Image pair operation because the virtual LDEV ID is deleted.

raidcom map snapshot				
Error message	Executing/ Async	Error code		Description
		SSB1	SSB2	
CMDRJE	Executing	2E10	005B	The Thin Image pair operation cannot be performed because the virtual storage machine of the specified P-VOL is different from the virtual storage machine of the specified S-VOL.
CMDRJE	Executing	2E10	005F	The command ends abnormally because the specified S-VOL is assigned to a Thin Image pair.
CMDRJE	Executing	2E10	0203	The operation failed because the setting of the T10 PI attribute is not match between the specified P-VOL and the specified S-VOL.
CMDRJE	Executing	2E10	0211	The command ends abnormally because the volume which is being deleted is specified.
CMDRJE	Executing	2E10	9709	The command ends abnormally because the specified Thin Image pair does not exist.
CMDRJE	Executing	2E10	970B	The command ends abnormally because the specified Thin Image pair is assigned to an S-VOL.
CMDRJE	Executing	2E10	9713	The operation cannot be performed because the snapshot tree is being deleted.
CMDRJE	Executing	2E11	800F	The operation failed because multiple versions of DKCMAIN microcode are included.
CMDRJE	Executing	2E20	0000	The specified LDEV is not defined.
CMDRJE	Executing	2E20	0008	The command ends abnormally because an unmounted volume is specified as the P-VOL of a Thin Image pair or a Copy-on-Write Snapshot pair.
CMDRJE	Executing	2E20	000B	The command ends abnormally because an unmounted volume is specified as the S-VOL of a Thin Image pair or a Copy-on-Write Snapshot pair.
CMDRJE	Executing	2E20	000C	The command ends abnormally because the blocked volume is specified as the S-VOL of a Thin Image pair or a Copy-on-Write Snapshot pair.

raidcom map snapshot				
Error message	Executing/ Async	Error code		Description
		SSB1	SSB2	
CMDRJE	Executing	2E20	000D	The command ends abnormally because the volume in formatting is specified as the S-VOL of a Thin Image pair or a Copy-on-Write Snapshot pair.
CMDRJE	Executing	2E21	8107	The command ends abnormally because the shared memory (FC, TPF, or Extension1) is not added for necessary capacity or maintenance work is being performed.
CMDRJE	Executing	2E21	8108	The shared memory for Thin Image or Copy-on-Write Snapshot is not installed.
CMDRJE	Executing	2E21	9010	The program product is not installed.
CMDRJE	Executing	2E21	9306	The virtual LDEV ID for a virtual storage machine is not defined on the specified LDEV.
CMDRJE	Executing	2E21	930A	The virtual storage machine with the specified serial number is not found.
CMDRJE	Executing	2E30	0077	The command ends abnormally because the volume is already used as the P-VOL of a Thin Image pair or a Copy-on-Write Snapshot pair is specified as the S-VOL.
CMDRJE	Executing	2E30	0078	The command ends abnormally because the volume is already used as the S-VOL of a Thin Image pair or a Copy-on-Write Snapshot pair is specified as the S-VOL.
CMDRJE	Executing	2E30	007C	The command ends abnormally because the volume other than OPEN-V is specified as the S-VOL of a Thin Image pair or a Copy-on-Write Snapshot pair.
CMDRJE	Executing	2E30	007D	The command ends abnormally because the volume whose command device is set is specified as the S-VOL of a Thin Image pair or a Copy-on-Write Snapshot pair.
CMDRJE	Executing	2E30	007F	The command ends abnormally because the volume having no path definition is specified as the S-VOL of a Thin Image pair or the specified Thin Image pair does not exist.

raidcom map snapshot				
Error message	Executing/ Async	Error code		Description
		SSB1	SSB2	
CMDRJE	Executing	2E30	0081	The command ends abnormally because the external volume mapped for the online data migration is specified as the S-VOL of a Thin Image pair or a Copy-on-Write Snapshot pair.
CMDRJE	Executing	2E30	008F	The command ends abnormally because the specified P-VOL is not a P-VOL of a Thin Image pair.
CMDRJE	Executing	2E30	0099	The specified LDEV is a volume of which Data Direct Mapping attribute is enabled.
CMDRJE	Executing	2E30	0201	The specified LDEV is an external volume of which Data Direct Mapping attribute is enabled.
CMDRJE	Executing	2E30	0202	The specified LDEV is a virtual volume of which Data Direct Mapping attribute is enabled.
CMDRJE	Executing	2E30	0206	The operation cannot be performed because the specified LDEV is a deduplication system data volume.
CMDRJE	Executing	2E30	0207	The operation cannot be performed because the specified volume is a DP-VOL with the SLU attribute.
CMDRJE	Executing	2E30	2E30	The specified LDEV is a V-VOL for which the Data Direct Mapping attribute is enabled.
CMDRJE	Executing	2E31	9701	For mapping pairs with the cascade or clone attribute, the Dynamic Provisioning V-VOL is not specified as an S-VOL.
CMDRJE	Executing	2E3F	8000	The specified operation is not supported in the current microcode version.
CMDRJE	Executing	B980	B903	The operation cannot be performed because the selected resource belongs to NAS_Platform_System_RSG.

SSB codes returned by raidcom replace snapshot

raidcom replace snapshot				
Error message	Executing/ Async	Error code		Description
		SSB1	SSB2	
CMDRJE	Executing	2E00	0029	The command ends abnormally because the volume whose LDEV number is out of range is specified as the S-VOL of a Thin Image pair or a Copy-on-Write Snapshot pair.
CMDRJE	Executing	2E10	0020	The command ends abnormally because the volume that has the size exceeding the supported size is specified as the P-VOL of a Thin Image pair or a Copy-on-Write Snapshot pair.
CMDRJE	Executing	2E10	0025	The command ends abnormally because the LUSE volumes of different structure are specified as the P-VOL and the S-VOL.
CMDRJE	Executing	2E10	0027	The command ends abnormally because the external volume is specified as the S-VOL of a Thin Image pair or a Copy-on-Write Snapshot pair.
CMDRJE	Executing	2E10	0028	The command ends abnormally because the volume other than V-VOL is specified as the S-VOL of a Thin Image pair or a Copy-on-Write Snapshot pair.
CMDRJE	Executing	2E10	0029	The command ends abnormally because the pool-VOL is specified as the S-VOL of a Thin Image pair or a Copy-on-Write Snapshot pair.
CMDRJE	Executing	2E10	002A	The command ends abnormally because the volume (the data volume or the journal volume) of the Universal Replicator pair that is in the intermediate site of the 3DC cascading configuration is specified as the S-VOL of a Thin Image pair or a Copy-on-Write Snapshot pair.
CMDRJE	Executing	2E10	002B	The command ends abnormally because the P-VOL of a Universal Replicator pair is specified as the S-VOL of a Thin Image pair or a Copy-on-Write Snapshot pair.

raidcom replace snapshot				
Error message	Executing/ Async	Error code		Description
		SSB1	SSB2	
CMDRJE	Executing	2E10	002C	The command ends abnormally because the S-VOL of a Universal Replicator pair is specified as the S-VOL of a Thin Image pair or a Copy-on-Write Snapshot pair.
CMDRJE	Executing	2E10	002D	The command ends abnormally because the journal volume of the Universal Replicator is specified as the S-VOL of a Thin Image pair or a Copy-on-Write Snapshot pair.
CMDRJE	Executing	2E10	002E	The command ends abnormally because the volume to which S-VOL Disable option is set is specified as the S-VOL of a Thin Image pair or a Copy-on-Write Snapshot pair.
CMDRJE	Executing	2E10	002F	The command ends abnormally because the volume to which VMA is set is specified as the S-VOL of a Thin Image pair or a Copy-on-Write Snapshot pair.
CMDRJE	Executing	2E10	0030	The command ends abnormally because the volumes of different Max LBA size are specified as the P-VOL and S-VOL of a Thin Image pair or a Copy-on-Write Snapshot pair.
CMDRJE	Executing	2E10	0031	The command ends abnormally because the volumes whose the number of slots is different are specified as the P-VOL and S-VOL of a Thin Image pair or a Copy-on-Write Snapshot pair.
CMDRJE	Executing	2E10	0032	A pair cannot be created because the Dynamic Provisioning V-VOL is specified as the S-VOL of a Thin Image pair or the specified Thin Image pair does not exist.
CMDRJE	Executing	2E10	0037	The command ends abnormally because the P-VOL of a ShadowImage pair is specified as the S-VOL of a Thin Image pair or a Copy-on-Write Snapshot pair.
CMDRJE	Executing	2E10	0038	The command ends abnormally because the S-VOL of a ShadowImage pair is specified as the S-VOL of a Thin Image pair or a Copy-on-Write Snapshot pair.

raidcom replace snapshot				
Error message	Executing/ Async	Error code		Description
		SSB1	SSB2	
CMDRJE	Executing	2E10	003A	The command ends abnormally because the Volume Migration source volume is specified as the S-VOL of a Thin Image pair or a Copy-on-Write Snapshot pair.
CMDRJE	Executing	2E10	003B	The command ends abnormally because the Volume Migration target volume is specified as the S-VOL of a Thin Image pair or a Copy-on-Write Snapshot pair.
CMDRJE	Executing	2E10	003E	The command ends abnormally because the volume of Universal Replicator pair for the delta resync operation is specified as the S-VOL of a Thin Image pair or a Copy-on-Write Snapshot pair.
CMDRJE	Executing	2E10	0045	The command ends abnormally because the P-VOL of a TrueCopy pair is specified as the S-VOL of a Thin Image pair or a Copy-on-Write Snapshot pair.
CMDRJE	Executing	2E10	0046	The command ends abnormally because the S-VOL of a TrueCopy pair is specified as the S-VOL of a Thin Image pair or a Copy-on-Write Snapshot pair.
CMDRJE	Executing	2E10	0056	The specified volume cannot be used for the Thin Image pair operation because the virtual LDEV ID is deleted.
CMDRJE	Executing	2E10	005B	The Thin Image pair operation cannot be performed because the virtual storage machine of the specified P-VOL is different from the virtual storage machine of the specified S-VOL.
CMDRJE	Executing	2E10	0060	The command ends abnormally because the specified S-VOL is not assigned to a Thin Image pair.
CMDRJE	Executing	2E10	0061	The specified volume cannot be used for the Thin Image pair operation because the virtual LDEV ID is deleted.
CMDRJE	Executing	2E10	0204	The operation failed because the specified LDEV which is holding the attribute of SLU is bind to the LDEV which is holding the attribute of ALU.

raidcom replace snapshot				
Error message	Executing/ Async	Error code		Description
		SSB1	SSB2	
CMDRJE	Executing	2E10	9709	The command ends abnormally because the specified Thin Image pair is not exist.
CMDRJE	Executing	2E10	970B	The command ends abnormally because the specified Thin Image pair is assigned to an S-VOL.
CMDRJE	Executing	2E10	970C	The command ends abnormally because the specified Thin Image pair is not assigned to an S-VOL.
CMDRJE	Executing	2E10	9710	The clone attribute of the specified Thin Image pair is enabled.
CMDRJE	Executing	2E10	9711	The operation cannot be performed because the S-VOL is the node volume.
CMDRJE	Executing	2E10	9713	The operation cannot be performed because the snapshot tree is being deleted.
CMDRJE	Executing	2E11	800F	The operation failed because multiple versions of DKCMAIN microcode are included.
CMDRJE	Executing	2E20	0000	The specified LDEV is not defined.
CMDRJE	Executing	2E20	000B	The command ends abnormally because an unmounted volume is specified as the S-VOL of a Thin Image pair or a Copy-on-Write Snapshot pair.
CMDRJE	Executing	2E20	000C	The command ends abnormally because the blocked volume is specified as the S-VOL of a Thin Image pair or a Copy-on-Write Snapshot pair.
CMDRJE	Executing	2E20	000D	The command ends abnormally because the volume in formatting is specified as the S-VOL of a Thin Image pair or a Copy-on-Write Snapshot pair.
CMDRJE	Executing	2E21	8107	The command ends abnormally because the shared memory (FC, TPF, or Extension1) is not added for necessary capacity or maintenance work is being performed.
CMDRJE	Executing	2E21	8108	The shared memory for Thin Image or Copy-on-Write Snapshot is not installed.

raidcom replace snapshot				
Error message	Executing/ Async	Error code		Description
		SSB1	SSB2	
CMDRJE	Executing	2E21	9010	The program product is not installed.
CMDRJE	Executing	2E21	9306	The virtual LDEV ID for a virtual storage machine is not defined on the specified LDEV.
CMDRJE	Executing	2E21	930A	The virtual storage machine with the specified serial number is not found.
CMDRJE	Executing	2E30	0077	The command ends abnormally because the volume is already used as the P-VOL of a Thin Image pair or a Copy-on-Write Snapshot pair is specified as the S-VOL.
CMDRJE	Executing	2E30	0078	The command ends abnormally because the volume is already used as the S-VOL of a Thin Image pair or a Copy-on-Write Snapshot pair is specified as the S-VOL.
CMDRJE	Executing	2E30	007C	The command ends abnormally because the volume other than OPEN-V is specified as the S-VOL of a Thin Image pair or a Copy-on-Write Snapshot pair.
CMDRJE	Executing	2E30	007D	The command ends abnormally because the volume whose command device is set is specified as the S-VOL of a Thin Image pair or a Copy-on-Write Snapshot pair.
CMDRJE	Executing	2E30	007F	The command ends abnormally because the volume having no path definition is specified as the S-VOL of a Thin Image pair or the specified Thin Image pair does not exist.
CMDRJE	Executing	2E30	0081	The command ends abnormally because the external volume mapped for the online data migration is specified as the S-VOL of a Thin Image pair or a Copy-on-Write Snapshot pair.
CMDRJE	Executing	2E30	0099	The specified LDEV is a volume of which Data Direct Mapping attribute is enabled.
CMDRJE	Executing	2E30	0201	The specified LDEV is an external volume of which Data Direct Mapping attribute is enabled.
CMDRJE	Executing	2E30	0202	The specified LDEV is a virtual volume of which Data Direct Mapping attribute is enabled.

raidcom replace snapshot				
Error message	Executing/ Async	Error code		Description
		SSB1	SSB2	
CMDRJE	Executing	2E31	9701	For replacement of pairs with the cascade or clone attribute, a Dynamic Provisioning V-VOL is not specified for the S-VOL.
CMDRJE	Executing	2E3F	8000	The specified operation is not supported in the current microcode version.
CMDRJE	Executing	B980	B903	The operation cannot be performed because the selected resource belongs to NAS_Platform_System_RSG.

SSB codes returned by raidcom unmap snapshot

raidcom unmap snapshot				
Error message	Executing/ Async	Error code		Description
		SSB1	SSB2	
CMDRJE	Executing	2E00	0028	The command ends abnormally because the volume whose LDEV number is out of range is specified as the P-VOL of a Thin Image pair or a Copy-on-Write Snapshot pair.
CMDRJE	Executing	2E00	0029	The command ends abnormally because the volume whose LDEV number is out of range is specified as the S-VOL of a Thin Image pair or a Copy-on-Write Snapshot pair.
CMDRJE	Executing	2E10	0028	The command ends abnormally because the volume other than V-VOL is specified as the S-VOL of a Thin Image pair or a Copy-on-Write Snapshot pair.
CMDRJE	Executing	2E10	0056	The specified volume cannot be used for the Thin Image pair operation because the virtual LDEV ID is deleted.
CMDRJE	Executing	2E10	005B	The Thin Image pair operation cannot be performed because the virtual storage machine of the specified P-VOL is different from the virtual storage machine of the specified S-VOL.

raidcom unmap snapshot				
Error message	Executing/ Async	Error code		Description
		SSB1	SSB2	
CMDRJE	Executing	2E10	0060	The command ends abnormally because the specified S-VOL is not assigned to a Thin Image pair.
CMDRJE	Executing	2E10	0061	The specified volume cannot be used for the Thin Image pair operation because the virtual LDEV ID is deleted.
CMDRJE	Executing	2E10	0204	The operation failed because the specified LDEV which is holding the attribute of SLU is bind to the LDEV which is holding the attribute of ALU.
CMDRJE	Executing	2E10	9709	The command ends abnormally because the specified Thin Image pair is not exist.
CMDRJE	Executing	2E10	970C	The command ends abnormally because the specified Thin Image pair is not assigned to an S-VOL.
CMDRJE	Executing	2E10	9710	The clone attribute of the specified Thin Image pair is enabled.
CMDRJE	Executing	2E10	9711	The operation cannot be performed because the S-VOL is the node volume.
CMDRJE	Executing	2E10	9713	The operation cannot be performed because the snapshot tree is being deleted.
CMDRJE	Executing	2E11	800F	The operation failed because multiple versions of DKCMAIN microcode are included.
CMDRJE	Executing	2E20	0000	The specified LDEV is not defined.
CMDRJE	Executing	2E20	0008	The command ends abnormally because an unmounted volume is specified as the P-VOL of a Thin Image pair or a Copy-on-Write Snapshot pair.
CMDRJE	Executing	2E20	000B	The command ends abnormally because an unmounted volume is specified as the S-VOL of a Thin Image pair or a Copy-on-Write Snapshot pair.

raidcom unmap snapshot				
Error message	Executing/ Async	Error code		Description
		SSB1	SSB2	
CMDRJE	Executing	2E20	000C	The command ends abnormally because the blocked volume is specified as the S-VOL of a Thin Image pair or a Copy-on-Write Snapshot pair.
CMDRJE	Executing	2E21	8107	The command ends abnormally because the shared memory (FC, TPF, or Extension1) is not added for necessary capacity or maintenance work is being performed.
CMDRJE	Executing	2E21	8108	The shared memory for Thin Image or Copy-on-Write Snapshot is not installed.
CMDRJE	Executing	2E21	9010	The program product is not installed.
CMDRJE	Executing	2E21	9306	The virtual LDEV ID for a virtual storage machine is not defined on the specified LDEV.
CMDRJE	Executing	2E21	930A	The virtual storage machine with the specified serial number is not found.
CMDRJE	Executing	2E30	008F	The command ends abnormally because the specified P-VOL is not a P-VOL of a Thin Image pair.
CMDRJE	Executing	2E30	0099	The specified LDEV is a volume of which Data Direct Mapping attribute is enabled.
CMDRJE	Executing	2E30	0201	The specified LDEV is an external volume of which Data Direct Mapping attribute is enabled.
CMDRJE	Executing	2E30	0202	The specified LDEV is a virtual volume of which Data Direct Mapping attribute is enabled.
CMDRJE	Executing	2E3F	8000	The specified operation is not supported in the current microcode version.
CMDRJE	Executing	B980	B903	The operation cannot be performed because the selected resource belongs to NAS_Platform_System_RSG.

SSB codes returned by raidcom add ssid

raidcom add ssid				
Error message	Executing/ Async	Error code		Description
		SSB1	SSB2	
CMDRJE	Executing	2E00	3001	The CU number of the RCU exceeds the effective value.
CMDRJE	Executing	2E00	3008	The command cannot be executed because the parameter of the specified RCU is invalid.
CMDRJE	Executing	2E00	7100	The CU number is out of effective range.
CMDRJE	Executing	2E11	8004	The operation cannot be performed because the microcode is being changed.
CMDRJE	Executing	2E20	3000	The serial number, product ID, or SSID of the target storage system is incorrect.
CMDRJE	Executing	2E20	3001	The command cannot be executed because the specified RCU is not registered.
CMDRJE	Executing	2E22	3002	The operation cannot be performed due to one of the following reasons: <ul style="list-style-type: none"> ▪ The number of RCUs registered in MCU or RCU is more than four. ▪ The number of RCUs registered in the system is more than 64 in the case of specifying the cu free.
CMDRJE	Executing	2E23	3301	The number of the specified SSIDs is invalid.
CMDRJE	Executing	2E31	3001	The command cannot be executed because the RCU identification code of a path is invalid.
CMDRJE	Executing	2ED6	00EF	An internal error occurred. Call customer support.
CMDRJE	Executing	2ED6	3300	The SSID is invalid.
CMDRJE	Executing	2EF3	3002	The specified parameter is invalid. Check the <i>Command Control Interface Command Reference</i> .

SSB codes returned by raidcom delete ssid

raidcom delete ssid				
Error message	Executing/ Async	Error code		Description
		SSB1	SSB2	
CMDRJE	Executing	2E00	3001	The CU number of the RCU exceeds the effective value.
CMDRJE	Executing	2E00	3008	The command cannot be executed because the parameter of the specified RCU is invalid.
CMDRJE	Executing	2E00	7100	The CU number is out of effective range.
CMDRJE	Executing	2E11	8004	The operation cannot be performed because the microcode is being changed.
CMDRJE	Executing	2E20	3000	The serial number, the product ID, or the SSID of the remote storage system is invalid.
CMDRJE	Executing	2E20	3001	The command cannot be executed because the specified RCU is not registered.
CMDRJE	Executing	2E23	3301	The number of the specified SSIDs is invalid.
CMDRJE	Executing	2ED6	00EF	An internal error occurred. Call customer support.
CMDRJE	Executing	2ED6	3300	The SSID is invalid.
CMDRJE	Executing	2EF3	3002	The specified parameter is invalid. Check the <i>Command Control Interface Command Reference</i> .

SSB codes returned by raidcom add dp_pool

raidcom add dp_pool				
Error message	Executing/ Async	Error code		Description
		SSB1	SSB2	
Get Command Status	Async	2E00	0000	The LDEV number is out of settable range.
CMDRJE	Executing	2E00	6000	The value of pool ID is out of range.
CMDRJE	Executing	2E00	6001	The type of pool is invalid.

raidcom add dp_pool				
Error message	Executing/ Async	Error code		Description
		SSB1	SSB2	
CMDRJE	Executing	2E00	6002	The maximum reserve ratio of V-VOL is out of range.
CMDRJE	Executing	2E00	6009	The threshold of the specified High water mark is out of range.
CMDRJE	Executing	2E00	600A	The operation cannot be performed because the specified threshold of Warning is larger than the threshold of the specified High water mark.
Get Command Status	Async	2E10	0009	The specified LDEV is in the state of blocked.
Get Command Status	Async	2E10	000C	The operation cannot be performed because a SATA-E drive in the state of quick formatting is in the specified LDEV.
CMDRJE	Executing	2E10	0011	The specified LDEV is in the state of blocked, or not installed.
Get Command Status	Async	2E10	0102	The pool cannot be created because there are not enough resources (VDEV) depending on cache management devices.
Get Command Status	Async	2E10	600D	The operation cannot be performed because the pool volume is being deleted.
Get Command Status	Async	2E10	6029	The lowest tier cannot be added because either of the following applies to the specified pool: <ul style="list-style-type: none"> ▪ The pool contains a volume for which capacity saving is enabled. ▪ The deduplication function is enabled.
Get Command Status	Async	2E10	8002	The specified operation is not supported in the current microcode version.
Get Command Status	Async	2E11	005F	The operation failed because accelerated compression of the parity group to which the specified LDEV belongs is enabled and the other LDEV in the parity group is being used for the other pool.
Get Command Status	Async	2E11	0108	The specified LDEV is the LDEV configuring the RAID configuration which cannot be used for the pool volume.

raidcom add dp_pool				
Error message	Executing/ Async	Error code		Description
		SSB1	SSB2	
CMDRJE Get Command Status	Executing/ Async	2E11	6003	The pool is not in the status where the pool volume can be added.
Get Command Status	Async	2E11	8003	The operation cannot be performed because the power supply is switched off.
Get Command Status	Async	2E11	800F	The operation cannot be performed because the unsupported microcode version exists in the system.
CMDRJE	Executing	2E11	9400	The command cannot be accepted. After a while, execute the same command.
Get Command Status	Async	2E13	6009	The operation cannot be performed because the pool capacity is insufficient for Data Direct Mapping.
Get Command Status	Async	2E20	0000	The specified LDEV is not installed.
Get Command Status	Async	2E21	8103	The operation cannot be performed because the memory capacity of the shared memory is insufficient.
Get Command Status	Async	2E21	8106	The operation cannot be performed because the shared memory is not initialized.
CMDRJE	Executing	2E21	9007	Dynamic Provisioning program product is not installed.
Get Command Status	Async	2E21	9014	Data Retention Utility program product is not installed.
Get Command Status	Async	2E22	0005	Exceeded the number of pool volume that can be registered in a pool.
Get Command Status	Async	2E22	000D	The larger number of drive types than the supported configuration cannot be added to the specified pool.
Get Command Status	Async	2E22	6100	Pool volume cannot be registered because the drive type of the specified LDEV is different from the other pool volume type, or the drive type in the pool exceeds three.
CMDRJE	Executing	2E23	0008	The number of specified LDEVs is invalid.

raidcom add dp_pool				
Error message	Executing/ Async	Error code		Description
		SSB1	SSB2	
CMDRJE Get Command Status	Executing/ Async	2E30	0000	The emulation type of the specified LDEV cannot be used as a pool VOL.
Get Command Status	Async	2E30	0007	The specified LDEV has the LU path definition.
Get Command Status	Async	2E30	000C	The specified LDEV is used as a quorum disk.
Get Command Status	Async	2E30	000D	The specified LDEV is used as a system disk.
Get Command Status	Async	2E30	000E	The specified LDEV is already used as a pool volume.
Get Command Status	Async	2E30	0010	The specified LDEV is a command device.
Get Command Status	Async	2E30	0038	It cannot be used as a pool volume because the size of the specified LDEV is less than 8GB.
Get Command Status	Async	2E30	0039	Creating a pool or adding a pool volume cannot be performed because CLPR is mixed in the specified pool.
Get Command Status	Async	2E30	004D	The number of LDEVs that can be created in the parity group or the external volume exceeds the maximum.
Get Command Status	Async	2E30	005C	The specified LDEV is used as a V-VOL.
Get Command Status	Async	2E30	005D	The specified LDEV is a volume of unsupported Dynamic Tiering or active flash.
Get Command Status	Async	2E30	005E	The specified LDEV is used in another program product.
CMDRJE	Executing	2E30	006C	An LDEV, whose emulation type is not available to be mixed, is in the specified LDEVs.

raidcom add dp_pool				
Error message	Executing/ Async	Error code		Description
		SSB1	SSB2	
Get Command Status	Async	2E30	006E	The operation cannot be performed for the following reasons: <ul style="list-style-type: none"> The pool volumes to be added to the Dynamic Tiering pool or active flash pool include external volumes whose cache modes are invalid. The Dynamic Provisioning pool includes both external volumes whose cache modes are invalid and internal volumes.
CMDRJE Get Command Status	Executing/ Async	2E30	0071	A pool volume cannot be added because the LDEV of the resource group different from the resource group of the pool volume to which the specified pool belongs is specified.
Get Command Status	Async	2E30	0074	The specified LDEV cannot be operated because it is an external volume mapped for online data migration.
Get Command Status	Async	2E30	0085	The specified volume cannot be used as a pool volume.
Get Command Status	Async	2E30	0099	The specified LDEV is a volume of which Data Direct Mapping attribute is enabled.
CMDRJE	Executing	2E30	6000	The threshold value 1 is out of range.
Get Command Status	Async	2E30	6004	The specified pool attribute differs from the pool attribute of existed pool.
Get Command Status	Async	2E30	6013	The LDEV that belongs to the parity group which accelerated compression is enabled cannot be added to the pool with the DP-VOL which is full allocated.
Get Command Status	Async	2E31	0015	The RAID level of the specified LDEV is different with the RAID level of others.
Get Command Status	Async	2E31	0016	There is a blocked pool volume.
Get Command Status	Async	2E31	0018	External volumes whose cache modes are different are included.
CMDRJE	Executing	2E31	6001	The POOL Name is duplicated with another pool.

raidcom add dp_pool				
Error message	Executing/ Async	Error code		Description
		SSB1	SSB2	
Get Command Status	Async	2E31	6004	The pool cannot include volumes in different RAID levels because the pool cannot include those volumes. Or the pool cannot include the RAID 1 volumes and the volumes of other RAID levels together.
Get Command Status	Async	2E31	6005	The pool cannot include both internal volumes and external volumes because the pool is not set to Mixable.
Get Command Status	Async	2E31	9000	The usage capacity exceeds the license capacity of program product.
CMDRJE	Executing	2EE7	00EE	The command cannot be accepted. After a while, execute the same command.
CMDRJE Get Command Status	Executing/ Async	2EE7	FECC	An internal error occurred. Call customer support.
Get Command Status	Async	2EE7	FFFF	An internal error occurred. Call customer support.
CMDRJE	Executing	B980	B903	The command was rejected because the selected resource belongs to NAS_Platform_System_RSG.

SSB codes returned by raidcom modify rcu

raidcom modify rcu				
Error message	Executing/ Async	Error code		Description
		SSB1	SSB2	
CMDRJE	Executing	2E00	3001	CU# of RCU exceed the effective value.
CMDRJE	Executing	2E00	3002	The value of least path number is invalid.
CMDRJE	Executing	2E00	3003	The value of RIO MIH time is invalid.
CMDRJE	Executing	2E00	3004	The value of Round-trip response time is invalid.

raidcom modify rcu				
Error message	Executing/ Async	Error code		Description
		SSB1	SSB2	
CMDRJE	Executing	2E00	3005	Invalid product ID or path registration ID.
CMDRJE	Executing	2E00	3007	Incident that is created by CU is not in the one of followings. - Incident that is sent to MCU host and RCU. - Incident that is sent to RCU.
Get Command Status	Async	2E00	3008	The command cannot be executed because the parameter of the specified RCU is invalid.
Get Command Status	Async	2E00	3009	The command cannot be executed because all the CU numbers in the RCU is not unified at the path that is specified creation or deletion.
CMDRJE	Executing	2E00	7100	The CU number is out of effective range.
CMDRJE	Executing	2E11	8004	The operation cannot be performed because the microcode is being changed.
CMDRJE	Executing	2E20	3000	The serial number, the product ID, or the SSID of the target storage system is incorrect.
CMDRJE	Executing	2E20	3001	The attribute of the RCU cannot be changed because the specified RCU is not registered.
Get Command Status	Async	2E21	7101	The specified CU number is not defined, or an LDEV is not defined under the CU number.
CMDRJE	Executing	2E23	3101	The operation cannot be performed because the number of paths becomes less than the least path number.
Get Command Status	Async	2E31	3001	The command cannot be executed because the RCU identification code of a path is invalid.
CMDRJE	Executing	2ED6	00EF	An internal error occurred. Call customer support.
CMDRJE	Executing	2ED6	3300	The value of SSID for the remote storage system is invalid.

SSB codes returned by raidcom delete rcu_path

raidcom delete rcu_path				
Error message	Executing/ Async	Error code		Description
		SSB1	SSB2	
CMDRJE	Executing	2E00	3001	The CU# of RCU exceeds the effective value.
CMDRJE	Executing	2E00	3005	The product ID or the path registration ID is invalid.
Get Command Status	Async	2E00	3008	The command cannot be executed because the parameter of the specified RCU is invalid.
CMDRJE	Executing	2E00	3200	The specified port # on the side of RCU is invalid.
CMDRJE Get Command Status	Executing/ Async	2E00	7100	The CU number is out of effective range.
CMDRJE Get Command Status	Executing/ Async	2E00	8400	The value of the specified port is invalid.
Get Command Status	Async	2E10	3101	Failed to establish a path or the deletion operation. The following factor can be thought. <ul style="list-style-type: none"> ▪ Input parameter is invalid. ▪ Port status or the MP Blade status is in the state of abnormal. ▪ Cable is not connected correctly. ▪ Port is specified incorrectly.
Get Command Status	Async	2E11	8004	The operation cannot be performed because the microcode is being changed.
CMDRJE	Executing	2E11	9400	The command cannot be accepted. After a while, execute the same command.
Get Command Status	Async	2E20	3001	A logical path cannot be deleted because the specified RCU is not registered.
Get Command Status	Async	2E21	7101	The specified CU number is not defined, or an LDEV is not defined under the CU number.
Get Command Status	Async	2E23	3101	The operation cannot be performed because the number of paths becomes less than the least path number.

raidcom delete rcu_path				
Error message	Executing/ Async	Error code		Description
		SSB1	SSB2	
CMDRJE	Executing	2E30	840A	The port attribute is not Initiator (MCU).
CMDRJE	Executing	2E30	840E	The command cannot be executed with the specified port attribute.
Get Command Status	Async	2E31	3001	The command cannot be executed because the RCU identification code of a path is invalid.
Get Command Status	Async	2E31	3101	The command cannot be executed because the serial number is not unified in the specified path.
CMDRJE	Executing	2ED6	00EE	The command cannot be accepted because the DKC is busy. After a while, execute the same command.
Get Command Status	Async	2ED6	3005	An internal error occurred. Call customer support.
CMDRJE	Executing	2EF3	3002	The specified parameter is invalid. Check the <i>Command Control Interface Command Reference</i> .
CMDRJE	Executing	B980	B901	The command was rejected because the specified port is for NAS Platform (System LU).
CMDRJE	Executing	B980	B902	The command was rejected because the specified port is for NAS Platform (User LU).

SSB codes returned by raidcom add rcu_path

raidcom add rcu_path				
Error message	Executing/ Async	Error code		Description
		SSB1	SSB2	
CMDRJE	Executing	2E00	3001	CU# of RCU exceeds the effective value.
CMDRJE	Executing	2E00	3005	Invalid product ID or path registration ID.
Get Command Status	Async	2E00	3008	The command cannot be executed because the parameter of the specified RCU is invalid.

raidcom add rcu_path				
Error message	Executing/ Async	Error code		Description
		SSB1	SSB2	
Get Command Status	Async	2E00	3009	The command cannot be executed because all the CU numbers in the RCU is not unified at the path that is specified creation or deletion.
CMDRJE	Executing	2E00	3200	The value of port # on the side of RCU is invalid.
CMDRJE Get Command Status	Executing /Async	2E00	7100	The CU number is out of effective range.
CMDRJE Get Command Status	Executing/ Async	2E00	8400	The value of the specified port is invalid.
Get Command Status	Async	2E10	3101	Failed to establish a path or the deletion operation. The following factor can be thought. <ul style="list-style-type: none"> ▪ Input parameter is invalid. ▪ Port status or the MP Blade status is in the state of abnormal. ▪ Cable is not connected correctly. ▪ Port is specified incorrectly.
Get Command Status	Async	2E11	8004	The operation cannot be performed because the microcode is being changed.
CMDRJE	Executing	2E11	9400	The command cannot be accepted. After a while, execute the same command.
Get Command Status	Async	2E20	3000	The serial number, the product ID, or the SSID of the target storage system is incorrect.
Get Command Status	Async	2E20	3001	A logical path cannot be added because the specified RCU is not registered.
Get Command Status	Async	2E21	7101	The specified CU number is not defined, or an LDEV is not defined under the CU number.
Get Command Status	Async	2E23	3100	An RCU path cannot be added because the number of valid paths exceeds the maximum.
Get Command Status	Async	2E23	3101	The operation cannot be performed because the number of paths becomes less than the least path number.

raidcom add rcu_path				
Error message	Executing/ Async	Error code		Description
		SSB1	SSB2	
CMDRJE	Executing	2E30	840A	The port attribute is not Initiator (MCU).
CMDRJE	Executing	2E30	840E	The command cannot be executed with the specified port attribute.
Get Command Status	Async	2E31	3001	The command cannot be executed because the RCU identification code of a path is invalid.
Get Command Status	Async	2E31	3101	The command cannot be executed because the serial number is not unified in the specified path.
CMDRJE	Executing	2ED6	00EE	The command cannot be accepted because the DKC is busy. After a while, execute the same command.
Get Command Status	Async	2ED6	3005	An internal error occurred. Call customer support.
CMDRJE	Executing	2ED6	3300	The value of SSID on the remote storage system is invalid.
CMDRJE	Executing	2EF3	3002	The specified parameter is invalid. Check the <i>Command Control Interface Command Reference</i> .
CMDRJE	Executing	B980	B901	The command was rejected because the specified port is for NAS Platform (System LU).
CMDRJE	Executing	B980	B902	The command was rejected because the specified port is for NAS Platform (User LU).

SSB codes returned by raidcom delete rcu

raidcom delete rcu				
Error message	Executing/ Async	Error code		Description
		SSB1	SSB2	
CMDRJE	Executing	2E00	3001	CU# on the RCU exceeds the effective range.
CMDRJE	Executing	2E00	3005	Invalid product ID or path registration ID.
Get Command Status	Async	2E00	3008	The command cannot be executed because the parameter of the specified RCU is invalid.

raidcom delete rcu				
Error message	Executing/ Async	Error code		Description
		SSB1	SSB2	
CMDRJE	Executing	2E00	3200	The value of the specified port# on the RCU side is invalid.
Get Command Status	Async	2E00	7100	The CU number is out of effective range.
CMDRJE Get Command Status	Executing/ Async	2E00	8400	The value of the specified port is invalid.
Get Command Status	Async	2E11	8004	The operation cannot be performed because the microcode is being changed.
CMDRJE	Executing	2E11	9400	The command cannot be accepted. After a while, execute the same command.
Get Command Status	Async	2E20	3000	The serial number, the product ID, or the SSID of the target storage system is incorrect.
Get Command Status	Async	2E20	3001	The specified RCU cannot be deleted because the RCU is not registered.
Get Command Status	Async	2E21	7101	The specified CU number is not defined, or an LDEV is not defined under the CU number.
Get Command Status	Async	2E22	3101	The path cannot be deleted because there is a pair of TrueCopy/Universal Replicator, or a journal volume is in the target CU.
Get Command Status	Async	2E31	3001	The command cannot be executed because the RCU identification code of a path is invalid.
CMDRJE	Executing	2ED6	00EE	The command cannot be accepted because the DKC is busy. After a while, execute the same command.
Get Command Status	Async	2ED6	3005	An internal error occurred. Call customer support.
CMDRJE	Executing	2ED6	3300	The value of SSID on the remote storage system is invalid.
CMDRJE	Executing	2EDE	00D1	RCU storage system does not exist.
CMDRJE	Executing	2EF3	3002	The specified parameter is invalid. Check the <i>Command Control Interface Command Reference</i> .

SSB codes returned by raidcom add rcu

raidcom add rcu				
Error message	Executing/ Async	Error code		Description
		SSB1	SSB2	
CMDRJE	Executing	2E00	3001	The value of CU# on the RCU exceeds the effective range.
CMDRJE	Executing	2E00	3005	Invalid product ID or path registration ID.
Get Command Status	Async	2E00	3008	The command cannot be executed because the parameter of the specified RCU is invalid.
Get Command Status	Async	2E00	3009	The command cannot be executed because all the CU numbers in the RCU is not unified at the path that is specified creation or deletion.
CMDRJE	Executing	2E00	3200	The value of port# on the side of RCU is invalid.
CMDRJE Get Command Status	Executing/ Async	2E00	7100	The CU number is out of effective range.
CMDRJE Get Command Status	Executing/ Async	2E00	8400	The value of the specified port is invalid.
Get Command Status	Async	2E10	3101	Failed to establish a path or the deletion operation. The following factor can be thought. <ul style="list-style-type: none"> ▪ Input parameter is invalid. ▪ Port status or the MP Blade status is in the state of abnormal. ▪ Cable is not connected correctly. ▪ Port is specified incorrectly.
Get Command Status	Async	2E11	8004	The operation cannot be performed because the microcode is being changed.
CMDRJE	Executing	2E11	9400	The command cannot be accepted. After a while, execute the same command.
Get Command Status	Async	2E20	3000	The serial number, the product ID, or the SSID of the target storage system is incorrect.
Get Command Status	Async	2E21	7101	The specified CU number is not defined, or an LDEV is not defined under the CU number.

raidcom add rcu				
Error message	Executing/ Async	Error code		Description
		SSB1	SSB2	
Get Command Status	Async	2E22	3001	The specified RCU is already registered to another product ID.
Get Command Status	Async	2E22	3002	The operation cannot be performed due to one of the following reasons: <ul style="list-style-type: none"> ▪ The number of RCUs registered in MCU or RCU is more than four. ▪ The number of RCUs registered in the system is more than 64 in the case of specifying the cu free.
Get Command Status	Async	2E22	3300	The specified SSID is already registered to another RCU.
Get Command Status	Async	2E23	3000	The specified RCU is cannot be registered because there is no free RCU.
Get Command Status	Async	2E23	3101	The operation cannot be performed because the number of paths becomes less than the least path number.
CMDRJE	Executing	2E30	840A	The port attribute is not Initiator (MCU).
CMDRJE	Executing	2E30	840E	The command cannot be executed with the specified port attribute.
Get Command Status	Async	2E31	3001	The command cannot be executed because the RCU identification code of a path is invalid.
Get Command Status	Async	2E31	3002	The operation cannot be performed because the remote storage system does not support the path between CUs.
Get Command Status	Async	2E31	3101	The command cannot be executed because the serial number is not unified in the specified path.
CMDRJE	Executing	2ED6	00EE	The command cannot be accepted because the DKC is busy. After a while, execute the same command.
Get Command Status	Async	2ED6	3005	An internal error occurred. Call customer support.
CMDRJE	Executing	2ED6	3300	The value of SSID on the remote storage system is invalid.

raidcom add rcu				
Error message	Executing/ Async	Error code		Description
		SSB1	SSB2	
CMDRJE	Executing	2EF3	3002	The specified parameter is invalid. Check the <i>Command Control Interface Command Reference</i> .
CMDRJE	Executing	B980	B901	The command was rejected because the specified port is for NAS Platform (System LU).
CMDRJE	Executing	B980	B902	The command was rejected because the specified port is for NAS Platform (User LU).

SSB codes returned by raidcom delete ldev

raidcom delete ldev				
Error message	Executing/ Async	Error code		Description
		SSB1	SSB2	
CMDRJE	Executing	2E00	0000	The LDEV number is out of settable range.
Get Command Status	Async	2E00	000E	This command does not support the emulation type of the specified LDEV.
Get Command Status	Async	2E00	0016	The command cannot be executed by receiving multiple operations for the same LDEV.
Get Command Status	Async	2E10	0000	The specified LDEV is used for a pair of ShadowImage/Thin Image/Copy-on-Write Snapshot/Volume Migration or as a relationship of Compatible FlashCopy [®] V2/Hitachi Compatible Software for IBM [®] FlashCopy [®] SE.
Get Command Status	Async	2E10	0001	The specified LDEV is used for a TrueCopy pair, a Universal Replicator pair or a command device defined by Business Continuity Manager.
Get Command Status	Async	2E10	0002	The specified LDEV is used for a Universal Replicator pair or a journal.
Get Command Status	Async	2E10	0003	The specified LDEV is used as a Compatible FlashCopy [®] V2 relationship.
Get Command Status	Async	2E10	0004	The specified LDEV is used for a Thin Image pair or a Copy-on-Write Snapshot pair.

raidcom delete ldev				
Error message	Executing/ Async	Error code		Description
		SSB1	SSB2	
Get Command Status	Async	2E10	0005	The specified LDEV is used for aVolume Migration.
Get Command Status	Async	2E10	0008	The specified LDEV is used as a system disk.
Get Command Status	Async	2E10	0012	The specified LDEV is used as a CC/XRC attribute device.
Get Command Status	Async	2E10	0062	The specified LDEV is used as the primary volume for the GAD pair.
Get Command Status	Async	2E10	0063	The specified LDEV is used as the secondary volume for the GAD pair.
Get Command Status	Async	2E10	020B	The specified LDEV cannot be operated because the deduplication function is set.
Get Command Status	Async	2E10	020C	The specified LDEV cannot be operated because deduplicated data exists.
Get Command Status	Async	2E10	020D	The specified LDEV cannot be operated because it is in the status where the capacity saving setting cannot be disabled.
Get Command Status	Async	2E10	0212	The operation cannot be performed because a page is allocated to the specified LDEV. To delete the volume, specify the -operation initialize_capacity_saving option, or perform any one of the following before the deletion: <ul style="list-style-type: none"> ▪ Format the LDEV. ▪ Disable the capacity saving setting of the LDEV. ▪ Initialize the deduplication system data volume of the pool and the volume that contains deduplicated data.
CMDRJE Get Command Status	Executing/ Async	2E10	0217	The specified LDEV cannot be operated because it is a volume for which capacity saving setting is disabled.
Get Command Status	Async	2E10	600B	The pool is blocked.

raidcom delete ldev				
Error message	Executing/ Async	Error code		Description
		SSB1	SSB2	
Get Command Status	Async	2E10	6022	The operation cannot be performed because the deduplication system data volume of the pool linked with the specified LDEV is blocked.
Get Command Status	Async	2E10	6026	The specified virtual volume cannot be operated because the used capacity of the pool associated with the specified virtual volume exceeds the depletion threshold.
Get Command Status	Async	2E11	0004	An LDEV that is in the state of formatting is included in the parity group of the target LDEV.
Get Command Status	Async	2E11	0005	An LDEV that is in the state of executing quick format is included in the parity group of the target LDEV.
Get Command Status	Async	2E11	001B	The specified LDEV is blocked.
CMDRJE	Executing	2E11	0053	The specified LDEV is used in another operation.
Get Command Status	Async	2E11	0102	The parity group of the target LDEV is in the state of correction copy.
CMDRJE	Executing	2E11	0153	The parity group or the external volume group that the specified LDEV is belongs to is used in another operation.
Get Command Status	Async	2E11	0202	The external volume group with the Data Direct Mapping attribute which is allocated to the specified LDEV is not in the state of disconnected.
Get Command Status	Async	2E11	6004	The operation cannot be performed because pools are blocked.
Get Command Status	Async	2E11	6008	The operation cannot be performed because the pool linked with the specified LDEV is in the unusable status.
Get Command Status	Async	2E11	8004	The operation cannot be performed because the internal processing is in progress.
Get Command Status	Async	2E11	800F	The operation failed because multiple versions of DKCMAIN microcode are included.

raidcom delete ldev				
Error message	Executing/ Async	Error code		Description
		SSB1	SSB2	
CMDRJE	Executing	2E11	8010	The storage system is in internal process, or the configuration changing processes are conflicting.
Get Command Status	Async	2E11	8108	The operation cannot be performed because there is blocked part in the system.
CMDRJE	Executing	2E11	9400	The command cannot be accepted. After a while, execute the same command.
CMDRJE Get Command Status	Executing/ Async	2E20	0000	LDEV is not installed.
CMDRJE	Executing	2E30	0007	An LU path has been defined.
Get Command Status	Async	2E30	000A	The specified LDEV is used for a Dynamic Provisioning.
Get Command Status	Async	2E30	000C	The specified LDEV is used as a quorum disk.
Get Command Status	Async	2E30	000E	The specified LDEV is used as a pool volume.
Get Command Status	Async	2E30	000F	The specified LDEV is used as a journal volume.
Get Command Status	Async	2E30	0006	The specified LDEV is used in the FICON® Data Migration.
Get Command Status	Async	2E30	0010	The specified LDEV is a command device.
CMDRJE Get Command Status	Executing/ Async	2E30	0013	The specified volume cannot be deleted because it is a LUSE volume.
Get Command Status	Async	2E30	0014	The specified LDEV is used as a reserved volume of Volume Migration.
Get Command Status	Async	2E30	0018	This is a volume that the Data Retention Utility is set.
Get Command Status	Async	2E30	001A	Volume Security is set to the specified LDEV.

raidcom delete ldev				
Error message	Executing/ Async	Error code		Description
		SSB1	SSB2	
Get Command Status	Async	2E30	001E	The specified LDEV cannot be deleted because of online from the mainframe host.
Get Command Status	Async	2E30	002C	The specified LDEV cannot be operated because it has not been formatted.
Get Command Status	Async	2E30	004E	The specified LDEV is a Data Retention Utility/ Volume Retention Manager attribute device.
Get Command Status	Async	2E30	0053	This is a volume that the Volume Retention Manager is set.
Get Command Status	Async	2E30	0054	The specified LDEV is used as a Compatible FlashCopy [®] V2 or a Hitachi Compatible Software for IBM [®] FlashCopy [®] SE relationship.
Get Command Status	Async	2E30	0055	The specified LDEV is used for aVolume Migration.
Get Command Status	Async	2E30	0056	The specified LDEV is used for aVolume Migration
Get Command Status	Async	2E30	0057	The specified LDEV is used as a system disk.
Get Command Status	Async	2E30	0058	The specified LDEV is used as a system disk.
Get Command Status	Async	2E30	0060	The specified LDEV is a command device.
Get Command Status	Async	2E30	0074	The specified LDEV cannot be operated because it is an external volume mapped for online data migration.
Get Command Status	Async	2E30	0096	The specified LDEV is used as an ALU.
Get Command Status	Async	2E30	0097	The specified LDEV is used as an SLU.
Get Command Status	Async	2E30	0206	The operation cannot be performed because the specified LDEV is a deduplication system data volume.
Get Command Status	Async	2E30	4102	The specified volume is used as a TrueCopy.

raidcom delete ldev				
Error message	Executing/ Async	Error code		Description
		SSB1	SSB2	
Get Command Status	Async	2E30	4103	The specified volume is used as a TrueCopy.
Get Command Status	Async	2E30	4104	The specified volume is used as a ShadowImage pair volume, a Thin Image pair volume, or a FICON® Data Migration volume.
Get Command Status	Async	2E30	4105	The specified volume is used as a ShadowImage pair volume, a Thin Image pair volume, or a FICON® Data Migration volume.
Get Command Status	Async	2E30	4107	The specified volume is used as a ShadowImage.
Get Command Status	Async	2E30	4108	The specified LDEV is used as a reserved volume of Volume Migration.
Get Command Status	Async	2E31	0001	The target LDEV is a quorum disk and cannot be deleted.
CMDRJE	Executing	2EE8	00EE	The command cannot be accepted. After a while, execute the same command.
CMDRJE	Executing	2EE8	00F0	The specified command cannot be accepted because the command is not supported.
Get Command Status	Async	2EE8	0A18	An internal error occurred.
CMDRJE Get Command Status	Executing/ Async	2EE8	FEEC	An internal error occurred. Call customer support.
Get Command Status	Async	2EE8	FFFB	An internal error occurred. Call customer support.
CMDRJE	Executing	B980	B903	The command was rejected because the selected resource belongs to NAS_Platform_System_RSG.

SSB codes returned by raidcom delete hba_wwn

raidcom delete hba_wwn				
Error message	Executing/ Async	Error code		Description
		SSB1	SSB2	
CMDRJE	Executing	B957	404F	The program product is not installed.
CMDRJE	Executing	B957	4087	The host group ID exceeds the maximum value.
CMDRJE	Executing	B957	4089	The specified host group is not installed.
CMDRJE	Executing	B957	408A	The attribute of the specified port is Initiator or External.
CMDRJE	Executing	B957	408F	The specified command is not supported for the iSCSI port.
Executing	B980	B901	The command was rejected because the specified port is for NAS Platform (System LU).	

raidcom delete hba_wwn				
Error message	Executing/ Async	Error code		Description
		SSB1	SSB2	
Executing	B980	B902	The command was rejected because the specified port is for NAS Platform (User LU).	

SSB codes returned by `raidcom add hba_wwn`

raidcom add hba_wwn				
Error message	Executing/ Async	Error code		Description
		SSB1	SSB2	
CMDRJE	Executing	B957	404F	The program product is not installed.
CMDRJE	Executing	B957	4081	The value of hba_wwn is invalid.
CMDRJE	Executing	B957	4087	The value of host group ID exceeds the maximum.
CMDRJE	Executing	B957	4089	The host group is not installed.
CMDRJE	Executing	B957	408A	The attribute of the specified port is Initiator or External.
CMDRJE	Executing	B957	408F	The specified command is not supported for the iSCSI port.
CMDRJE	Executing	B957	4184	The number of WWN reached the maximum.
CMDRJE	Executing	B957	4188	HBA WWN is already registered.

raidcom add hba_wwn				
Error message	Executing/ Async	Error code		Description
		SSB1	SSB2	
Executing	B980	B901	The command was rejected because the specified port is for NAS Platform (System LU).	
CMDRJE	Executing	B980	B902	The command was rejected because the specified port is for NAS Platform (User LU).

SSB codes returned by raidcom set hba_wwn

raidcom set hba_wwn				
Error message	Executing/ Async	Error code		Description
		SSB1	SSB2	
CMDRJE	Executing	B957	404F	The program product is not installed.
CMDRJE	Executing	B957	4087	The value of host group ID exceeds the maximum.
CMDRJE	Executing	B957	4089	The host group is not installed.
CMDRJE	Executing	B957	408A	The attribute of the specified port is Initiator or External.
CMDRJE	Executing	B957	4385	The specified WWN does not exist.
CMDRJE	Executing	B957	438B	The specified WWN nickname is already used in the same port.

raidcom set hba_wwn				
Error message	Executing/ Async	Error code		Description
		SSB1	SSB2	
CMDRJE	Executing	B980	B901	The command was rejected because the specified port is for NAS Platform (System LU).
CMDRJE	Executing	B980	B902	The command was rejected because the specified port is for NAS Platform (User LU).

SSB codes returned by raidcom reset hba_wwn

raidcom reset hba_wwn				
Error message	Executing/ Async	Error code		Description
		SSB1	SSB2	
CMDRJE	Executing	B957	404F	The program product is not installed.
CMDRJE	Executing	B957	4087	The value of Host group ID exceeds the maximum.
CMDRJE	Executing	B957	4089	The host group is not installed.
CMDRJE	Executing	B957	408A	The attribute of the specified port is Initiator or External.
CMDRJE	Executing	B957	4385	The specified WWN does not exist.
CMDRJE	Executing	B980	B901	The command was rejected because the specified port is for NAS Platform (System LU).
CMDRJE	Executing	B980	B902	The command was rejected because the specified port is for NAS Platform (User LU).

SSB codes returned by raidcom add copy_grp

raidcom add copy_grp				
Error message	Executing/ Async	Error code		Description
		SSB1	SSB2	
CMDRJE	Executing	2E00	000B	The number of MU# exceeds the maximum.
CMDRJE	Executing	2E00	2100	Invalid device number.

raidcom add copy_grp				
Error message	Executing/ Async	Error code		Description
		SSB1	SSB2	
CMDRJE	Executing	2E00	5000	The specified journal ID exceeds the range.
CMDRJE	Executing	2E20	2100	A device group is not installed.
CMDRJE	Executing	2E22	2000	There is a copy group.
CMDRJE	Executing	2E23	2000	The number of copy groups in the system reached the maximum.
CMDRJE	Executing	2E30	2100	The specified device group is already defined in the other copy group.
CMDRJE	Executing	2E31	0012	There is an LDEV in the device group that has an undefined device name.
CMDRJE	Executing	2E31	0013	The same device names of LDEV are in the device group.
CMDRJE	Executing	2E31	0014	The same LDEVs are in the copy group.
Invalid Character	Executing	-	-	Unavailable character is included in the name of copy group.

SSB codes returned by raidcom delete copy_grp

raidcom delete copy_grp				
Error message	Executing/ Async	Error code		Description
		SSB1	SSB2	
CMDRJE	Executing	2E20	2000	The copy group is not installed.
Invalid Character	Executing	-	-	Unavailable character is included in the name of copy group.

SSB codes returned by raidcom modify port -port_speed

raidcom modify port -port_speed				
Error message	Executing/ Async	Error code		Description
		SSB1	SSB2	
CMDRJE	Executing	B955	0404	An LU path or a logical path has been defined.
CMDRJE	Executing	B955	040F	An internal error occurred.
CMDRJE	Executing	B955	044C	The specified AL-PA is invalid.
CMDRJE	Executing	B955	054E	The specified topology is invalid.
CMDRJE	Executing	B955	05A6	The other than "fabric on" cannot be specified when specifying a topology of the package for Fibre Channel over Ethernet.
CMDRJE	Executing	B955	05A7	The other than "P-to-P (point to point)" cannot be specified when specifying a topology of the package for Fibre Channel over Ethernet.
CMDRJE	Executing	B955	1039	The command device being used at the local CCI exists under the port.
CMDRJE	Executing	B955	104F	The program product is not installed.
CMDRJE	Executing	B955	113D	Invalid host speed is set for 4Gbps fibre adapter. The available host speeds are AUTO, 1G, 2G, and 4G only.
CMDRJE	Executing	B955	113E	Invalid host speed is set for the specified fibre adapter.
CMDRJE	Executing	B955	113F	Invalid host speed is set for 8Gbps fibre adapter. The available host speeds are AUTO, 2G, 4G, and 8G only.
CMDRJE	Executing	B955	11A5	The other than "10G" cannot be specified when specifying a host speed of the package for Fibre Channel over Ethernet.
CMDRJE	Executing	B955	11AE	Invalid host speed is set for 16Gbps fibre adapter. The available host speeds are AUTO, 2G, 4G, and 8G only.

raidcom modify port -port_speed				
Error message	Executing/ Async	Error code		Description
		SSB1	SSB2	
CMDRJE	Executing	B955	12AF	The combination of the specified host speed and the topology FC-AL set for the fibre channel adapter is not supported. See the <i>Provisioning Guide</i> of your system for supported combinations of data transfer speed and type of connection.
CMDRJE	Executing	B980	B901	The command was rejected because the specified port is for NAS Platform (System LU).
CMDRJE	Executing	B980	B902	The command was rejected because the specified port is for NAS Platform (User LU).

SSB codes returned by `raidcom modify port -port_attribute`

raidcom modify port -port_attribute				
Error message	Executing/ Async	Error code		Description
		SSB1	SSB2	
Get Command Status	Async	2E00	8404	The target channel adapter or the channel board does not support the specified port attribute.
CMDRJE	Executing	2E10	8001	The operation cannot be performed because another application, for example Storage Navigator, Device Manager - Storage Navigator, and SVP is used.
CMDRJE	Executing	2E10	8400	The specified port is blocked.
CMDRJE	Executing	2E10	8402	There is a pair for TrueCopy/Universal Replicator that is using the specified port.
CMDRJE	Executing	2E10	8403	There is a pair for TrueCopy/Universal Replicator that is using the specified port.
CMDRJE	Executing	2E11	800D	The storage system is in the state of start-up. Wait for a while, then retry the operation.
CMDRJE	Executing	2E13	8401	The port attribute cannot be changed because it is used for the iSCSI path of the remote replication.

raidcom modify port -port_attribute				
Error message	Executing/ Async	Error code		Description
		SSB1	SSB2	
CMDRJE	Executing	2E13	8402	iSNS is set for the specified port.
CMDRJE	Executing	2E20	8400	The specified port is not installed.
CMDRJE	Executing	2E30	8403	There is a path for TrueCopy/Universal Replicator in the specified port.
CMDRJE	Executing	2E30	8406	There is an external VOL path in the specified port.
CMDRJE	Executing	2E30	8407	There is a path for TrueCopy/Universal Replicator in the specified port.
CMDRJE	Executing	2E30	8408	There is a path for TrueCopy/Universal Replicator in the specified port.
CMDRJE	Executing	2E30	8409	An LU path has been defined.
CMDRJE	Executing	2ED0	84FC	An internal error occurred. Call customer support.
CMDRJE	Executing	B980	B901	The command was rejected because the specified port is for NAS Platform (System LU).
CMDRJE	Executing	B980	B902	The command was rejected because the specified port is for NAS Platform (User LU).

SSB codes returned by raidcom modify port -delayed_ack_mode

raidcom modify port -delayed_ack_mode				
Error message	Executing/ Async	Error code		Description
		SSB1	SSB2	
CMDRJE	Executing	B955	1039	The command device being used at the local CCI exists under the port.
CMDRJE	Executing	B955	120E	The command cannot be executed because the iSCSI virtual port mode is ON.

SSB codes returned by raidcom modify port -ipv4_address

raidcom modify port -ipv4_address				
Error message	Executing/ Async	Error code		Description
		SSB1	SSB2	
CMDRJE	Executing	B955	1039	The command device being used at the local CCI exists under the port.
CMDRJE	Executing	B955	10B3	The network address, loop-back address, broadcast address or the IP address beginning with 255 cannot be used as the IP address for IPv4.
CMDRJE	Executing	B955	120E	The command cannot be executed because the iSCSI virtual port mode is ON.

SSB codes returned by raidcom modify port -ipv4_subnetmask

raidcom modify port -ipv4_subnetmask				
Error message	Executing/ Async	Error code		Description
		SSB1	SSB2	
CMDRJE	Executing	B955	1039	The command device being used at the local CCI exists under the port.
CMDRJE	Executing	B955	10DB	The subnet mask cannot be set because the specified value is invalid.
CMDRJE	Executing	B955	120E	The command cannot be executed because the iSCSI virtual port mode is ON.

SSB codes returned by raidcom modify port -ipv4_gateway_address

raidcom modify port -ipv4_gateway_address				
Error message	Executing/ Async	Error code		Description
		SSB1	SSB2	
CMDRJE	Executing	B955	1039	The command device being used at the local CCI exists under the port.

raidcom modify port -ipv4_gateway_address				
Error message	Executing/ Async	Error code		Description
		SSB1	SSB2	
CMDRJE	Executing	B955	120E	The command cannot be executed because the iSCSI virtual port mode is ON.

SSB codes returned by `raidcom modify port -ipv6_gateway_address`

raidcom modify port -ipv6_gateway_address				
Error message	Executing/ Async	Error code		Description
		SSB1	SSB2	
CMDRJE	Executing	B955	1039	The command device being used at the local CCI exists under the port.
CMDRJE	Executing	B955	10B9	The multicast address or the loop-back address cannot be set as the default gateway for IPv6.
CMDRJE	Executing	B955	10C9	The same IPv6 address cannot be set to the same port redundantly.
CMDRJE	Executing	B955	120E	The command cannot be executed because the iSCSI virtual port mode is ON.

SSB codes returned by `raidcom modify port -ipv6_global_address`

raidcom modify port -ipv6_global_address				
Error message	Executing/ Async	Error code		Description
		SSB1	SSB2	
CMDRJE	Executing	B955	1039	The command device being used at the local CCI exists under the port.
CMDRJE	Executing	B955	10B8	The multicast address or the loop-back address cannot be set as global address 1 for IPv6.
CMDRJE	Executing	B955	10C9	The same IPv6 address cannot be set to the same port redundantly.
CMDRJE	Executing	B955	120E	The command cannot be executed because the iSCSI virtual port mode is ON.

SSB codes returned by raidcom modify port -ipv6_global_address2

raidcom modify port -ipv6_global_address2				
Error message	Executing/ Async	Error code		Description
		SSB1	SSB2	
CMDRJE	Executing	B955	1039	The command device being used at the local CCI exists under the port.
CMDRJE	Executing	B955	10C9	The same IPv6 address cannot be set to the same port redundantly.
CMDRJE	Executing	B955	10FD	If global address 1 for IPv6 is not set, you cannot set global address 2 for IPv6 manually.
CMDRJE	Executing	B955	10FE	The multicast address or the loop-back address cannot be set as global address 2 for IPv6.
CMDRJE	Executing	B955	120E	The command cannot be executed because the iSCSI virtual port mode is ON.

SSB codes returned by raidcom modify port -ipv6_local_address

raidcom modify port -ipv6_local_address				
Error message	Executing/ Async	Error code		Description
		SSB1	SSB2	
CMDRJE	Executing	B955	1039	The command device being used at the local CCI exists under the port.
CMDRJE	Executing	B955	10B6	The invalid value is specified for the link local address of IPv6.
CMDRJE	Executing	B955	10C9	The same IPv6 address cannot be set to the same port redundantly.
CMDRJE	Executing	B955	120E	The command cannot be executed because the iSCSI virtual port mode is ON.

SSB codes returned by raidcom modify port -ipv6_mode

raidcom modify port -ipv6_mode				
Error message	Executing/ Async	Error code		Description
		SSB1	SSB2	
CMDRJE	Executing	B955	1039	The command device being used at the local CCI exists under the port.
CMDRJE	Executing	B955	10C8	To disable IPv6, delete the remote path for avoiding the failure of remote copy.
CMDRJE	Executing	B955	120E	The command cannot be executed because the iSCSI virtual port mode is ON.

SSB codes returned by raidcom modify port -isns_mode

raidcom modify port -isns_mode				
Error message	Executing/ Async	Error code		Description
		SSB1	SSB2	
CMDRJE	Executing	B955	1039	The command device being used at the local CCI exists under the port.
CMDRJE	Executing	B955	10FC	The attribute of the specified port is Initiator or External.
CMDRJE	Executing	B955	120E	The command cannot be executed because the iSCSI virtual port mode is ON.

SSB codes returned by raidcom modify port -isns_port

raidcom modify port -isns_port				
Error message	Executing/ Async	Error code		Description
		SSB1	SSB2	
CMDRJE	Executing	B955	1039	The command device being used at the local CCI exists under the port.
CMDRJE	Executing	B955	120E	The command cannot be executed because the iSCSI virtual port mode is ON.

SSB codes returned by `raidcom modify port -isns_server_address`

raidcom modify port -isns_server_address				
Error message	Executing/ Async	Error code		Description
		SSB1	SSB2	
CMDRJE	Executing	B955	1039	The command device being used at the local CCI exists under the port.
CMDRJE	Executing	B955	10C5	The specified IP address of the iSNS server is incorrect by the following reasons: <ul style="list-style-type: none"> ▪ The loop-back address, broadcast address or the IP address beginning with 255 has been set as the IPv4 address. ▪ The multicast address or the loop-back address has been set as the IPv6 address, or the address has not been specified yet.
CMDRJE	Executing	B955	120E	The command cannot be executed because the iSCSI virtual port mode is ON.

SSB codes returned by `raidcom modify port -keep_alive_timer`

raidcom modify port -keep_alive_timer				
Error message	Executing/ Async	Error code		Description
		SSB1	SSB2	
CMDRJE	Executing	B955	1039	The command device being used at the local CCI exists under the port.
CMDRJE	Executing	B955	10BE	The invalid value is specified for the Keep Alive timer.
CMDRJE	Executing	B955	10FB	The attribute of the specified port is Initiator or External.
CMDRJE	Executing	B955	120E	The command cannot be executed because the iSCSI virtual port mode is ON.

SSB codes returned by raidcom modify port -mtu

raidcom modify port -mtu				
Error message	Executing/ Async	Error code		Description
		SSB1	SSB2	
CMDRJE	Executing	B955	1039	The command device being used at the local CCI exists under the port.
CMDRJE	Executing	B955	10B0	The invalid value is specified for the Ethernet MTU size.
CMDRJE	Executing	B955	120E	The command cannot be executed because the iSCSI virtual port mode is ON.

SSB codes returned by raidcom modify port -selective_ack_mode

raidcom modify port -selective_ack_mode				
Error message	Executing/ Async	Error code		Description
		SSB1	SSB2	
CMDRJE	Executing	B955	1039	The command device being used at the local CCI exists under the port.
CMDRJE	Executing	B955	120E	The command cannot be executed because the iSCSI virtual port mode is ON.

SSB codes returned by raidcom modify port -tcp_port

raidcom modify port -tcp_port				
Error message	Executing/ Async	Error code		Description
		SSB1	SSB2	
CMDRJE	Executing	B955	1039	The command device being used at the local CCI exists under the port.
CMDRJE	Executing	B955	120E	The command cannot be executed because the iSCSI virtual port mode is ON.

SSB codes returned by `raidcom modify port -add_vlan_id`

raidcom modify port -add_vlan_id				
Error message	Executing/ Async	Error code		Description
		SSB1	SSB2	
CMDRJE	Executing	B955	1039	The command device being used at the local CCI exists under the port.
CMDRJE	Executing	B955	10B2	The invalid value is specified for the VLAN ID.
CMDRJE	Executing	B955	10CB	The number of VLANs exceeds the maximum.
CMDRJE	Executing	B955	120E	The command cannot be executed because the iSCSI virtual port mode is ON.

SSB codes returned by `raidcom modify port -delete_vlan_id`

raidcom modify port -delete_vlan_id				
Error message	Executing/ Async	Error code		Description
		SSB1	SSB2	
CMDRJE	Executing	B955	1039	The command device being used at the local CCI exists under the port.
CMDRJE	Executing	B955	10B2	The invalid value is specified for the VLAN ID.
CMDRJE	Executing	B955	120E	The command cannot be executed because the iSCSI virtual port mode is ON.

SSB codes returned by `raidcom modify port -modify_vlan_id`

raidcom modify port -modify_vlan_id				
Error message	Executing/ Async	Error code		Description
		SSB1	SSB2	
CMDRJE	Executing	B955	1039	The command device being used at the local CCI exists under the port.
CMDRJE	Executing	B955	10B2	The invalid value is specified for the VLAN ID.
CMDRJE	Executing	B955	10CD	The command cannot be executed because the specified VLAN ID is already used.

raidcom modify port -modify_vlan_id				
Error message	Executing/ Async	Error code		Description
		SSB1	SSB2	
CMDRJE	Executing	B955	120E	The command cannot be executed because the iSCSI virtual port mode is ON.

SSB codes returned by `raidcom modify port -vlan_tagging_mode`

raidcom modify port -vlan_tagging_mode				
Error message	Executing/ Async	Error code		Description
		SSB1	SSB2	
CMDRJE	Executing	B955	1039	The command device being used at the local CCI exists under the port.
CMDRJE	Executing	B955	10BF	The VLAN tagging mode cannot be set because the VLAN ID has not been entered yet.
CMDRJE	Executing	B955	120E	The command cannot be executed because the iSCSI virtual port mode is ON.

SSB codes returned by `raidcom modify port -window_size`

raidcom modify port -window_size				
Error message	Executing/ Async	Error code		Description
		SSB1	SSB2	
CMDRJE	Executing	B955	1039	The command device being used at the local CCI exists under the port.
CMDRJE	Executing	B955	120E	The command cannot be executed because the iSCSI virtual port mode is ON.

SSB codes returned by raidcom modify port -t10pi (VSP Gx00 models, VSP Fx00 models)

raidcom modify port -t10pi				
Error message	Executing/ Async	Error code		Description
		SSB1	SSB2	
CMDRJE Get Command Status	Executing Async	2E00	8400	The value of the specified port is invalid.
CMDRJE Get Command Status	Executing Async	2E00	8404	The channel board of the object is not supported.
Get Command Status	Async	2E10	8000	The operation cannot be performed because Storage Navigator or Device Manager - Storage Navigator is in progress, another application is in progress on the SVP, or the configuration is being changed. Wait a while, and then retry the operation.
CMDRJE Get Command Status	Executing Async	2E10	8400	The specified port is blocked.
CMDRJE	Executing	2E11	9400	The command cannot be accepted. After a while, execute the same command.
CMDRJE Get Command Status	Executing Async	2E20	8400	The specified port is not installed.
Get Command Status	Executing Async	2E30	840F	LU path of the specified port or LU path of the port in the same group is defined, the T10 PI attribute of the port cannot be changed.
CMDRJE	Executing	2E3F	8000	The specified operation is not supported in the current microcode version.
CMDRJE Get Command Status	Executing Async	2ED0	FEEC	An internal error occurred.

SSB codes returned by raidcom modify port -add_iscsi_virtual_port

raidcom modify port -add_iscsi_virtual_port				
Error message	Executing/ Async	Error code		Description
		SSB1	SSB2	
CMDRJE	Executing	B955	1039	The command device being used at the local CCI exists under the port.
CMDRJE	Executing	B955	10B0	The invalid value is specified for the Ethernet MTU size.
CMDRJE	Executing	B955	10B2	The invalid value is specified for the VLAN ID.
CMDRJE	Executing	B955	10B3	This command cannot be set due to one of the following reasons: <ul style="list-style-type: none"> ▪ The network address, loop-back address, broadcast address, or the IP address beginning with 255 is set as the IPv4 address. ▪ No option is set when a virtual port in IPv4 mode was added. See the <i>Command Control Interface Command Reference</i>.
CMDRJE	Executing	B955	10B8	The multicast address or the loop-back address cannot be set as global address 1 for IPv6.
CMDRJE	Executing	B955	10B9	The multicast address or the loop-back address cannot be set as the default gateway for IPv6.
CMDRJE	Executing	B955	10BE	The invalid value is specified for the Keep Alive timer.
CMDRJE	Executing	B955	10BF	The VLAN tagging mode cannot be set because the VLAN ID has not been entered yet.
CMDRJE	Executing	B955	10C8	To disable IPv6, delete the remote path for avoiding the failure of remote copy.
CMDRJE	Executing	B955	10C9	The same IPv6 address cannot be set to the same port redundantly.
CMDRJE	Executing	B955	10CB	The number of VLANs exceeds the maximum.
CMDRJE	Executing	B955	10CD	The command cannot be executed because the specified VLAN ID is already used.

raidcom modify port -add_iscsi_virtual_port				
Error message	Executing/ Async	Error code		Description
		SSB1	SSB2	
CMDRJE	Executing	B955	10DB	This command cannot be set due to one of the following reasons: <ul style="list-style-type: none"> The specified value is invalid. No option is set when a virtual port in IPv4 mode was added. See the <i>Command Control Interface Command Reference</i>.
CMDRJE	Executing	B955	10FB	The attribute of the specified port is Initiator or External.
CMDRJE	Executing	B955	1201	The command cannot be executed because the invalid virtual port number has been entered.
CMDRJE	Executing	B955	1202	The command cannot be executed because the iSCSI virtual port mode is OFF.
CMDRJE	Executing	B955	1203	The same IPv6 address cannot be set to the same virtual port redundantly.
CMDRJE	Executing	B955	1204	The IPv6 global address 2 cannot be set for the ports other than virtual port 0.
CMDRJE	Executing	B955	1205	The command cannot be executed because the RCU port or the iSCSI name of the iSCSI target for the external storage system is registered for the specified virtual port.
CMDRJE	Executing	B955	120A	An internal error occurred.
CMDRJE	Executing	B955	120B	The specified port is not a port of the package for iSCSI.
CMDRJE	Executing	B955	120C	The specified virtual port does not exist.
CMDRJE	Executing	B955	120D	The storage system is in the internal processing, or the configuration change processes are conflicting.
CMDRJE	Executing	B955	120F	The command cannot be executed because the information of the virtual port is already set for the specified port.
CMDRJE	Executing	B955	1210	The command cannot be executed because both IPv4 mode and IPv6 mode are disabled.

raidcom modify port -add_iscsi_virtual_port				
Error message	Executing/ Async	Error code		Description
		SSB1	SSB2	
CMDRJE	Executing	B955	1211	The command cannot be executed for ports that are not registered as targets.
CMDRJE	Executing	B955	1212	iSNS cannot be set for virtual ports.
CMDRJE	Executing	B955	1214	The command cannot be set because the same VLAN IDs are conflicting in the physical port.
CMDRJE	Executing	B955	1215	The command cannot be executed because the virtual ports with the same VLAN IDs and the same IPv4 addresses are conflicting in the physical port.

SSB codes returned by raidcom modify port -modify_iscsi_virtual_port

raidcom modify port -modify_iscsi_virtual_port				
Error message	Executing/ Async	Error code		Description
		SSB1	SSB2	
CMDRJE	Executing	B955	1039	The command device being used at the local CCI exists under the port.
CMDRJE	Executing	B955	10B0	The invalid value is specified for the Ethernet MTU size.
CMDRJE	Executing	B955	10B2	The invalid value is specified for the VLAN ID.
CMDRJE	Executing	B955	10B3	This command cannot be set due to one of the following reasons: <ul style="list-style-type: none"> ▪ The network address, loop-back address, broadcast address, or the IP address beginning with 255 is set as the IPv4 address. ▪ No option is set when the port is changed to IPv4 mode. See the <i>Command Control Interface Command Reference</i>.
CMDRJE	Executing	B955	10B8	The multicast address or the loop-back address cannot be set as global address 1 for IPv6.

raidcom modify port -modify_iscsi_virtual_port				
Error message	Executing/ Async	Error code		Description
		SSB1	SSB2	
CMDRJE	Executing	B955	10B9	The multicast address or the loop-back address cannot be set as the default gateway for IPv6.
CMDRJE	Executing	B955	10BE	The invalid value is specified for the Keep Alive timer.
CMDRJE	Executing	B955	10BF	The VLAN tagging mode cannot be set because the VLAN ID has not been entered yet.
CMDRJE	Executing	B955	10C8	To disable IPv6, delete the remote path for avoiding the failure of remote copy.
CMDRJE	Executing	B955	10C9	The same IPv6 address cannot be set to the same port redundantly.
CMDRJE	Executing	B955	10CB	The number of VLANs exceeds the maximum.
CMDRJE	Executing	B955	10DB	This command cannot be set due to one of the following reasons: <ul style="list-style-type: none"> ▪ The specified value is invalid. ▪ No option is set when the port is changed to IPv4 mode. See the <i>Command Control Interface Command Reference</i>.
CMDRJE	Executing	B955	10FB	The attribute of the specified port is Initiator or External.
CMDRJE	Executing	B955	10FD	If global address 1 for IPv6 is not set, you cannot set global address 2 for IPv6 manually.
CMDRJE	Executing	B955	10FE	The multicast address or the loop-back address cannot be set as global address 2 for IPv6.
CMDRJE	Executing	B955	1201	The command cannot be executed because the invalid virtual port number has been entered.
CMDRJE	Executing	B955	1202	The command cannot be executed because the iSCSI virtual port mode is OFF.
CMDRJE	Executing	B955	1203	The same IPv6 address cannot be set to the same virtual port redundantly.
CMDRJE	Executing	B955	1204	The IPv6 global address 2 cannot be set for the ports other than virtual port 0.

raidcom modify port -modify_iscsi_virtual_port				
Error message	Executing/ Async	Error code		Description
		SSB1	SSB2	
CMDRJE	Executing	B955	1205	The command cannot be executed because the RCU port or the iSCSI name of the iSCSI target for the external storage system is registered for the specified virtual port.
CMDRJE	Executing	B955	1206	The command cannot be executed for virtual port 0.
CMDRJE	Executing	B955	120A	An internal error occurred.
CMDRJE	Executing	B955	120B	The specified port is not a port of the package for iSCSI.
CMDRJE	Executing	B955	120C	The specified virtual port does not exist.
CMDRJE	Executing	B955	120D	The storage system is in the internal processing, or the configuration change processes are conflicting.
CMDRJE	Executing	B955	1210	The command cannot be executed because both IPv4 mode and IPv6 mode are disabled.
CMDRJE	Executing	B955	1211	The command cannot be executed for ports that are not registered as targets.
CMDRJE	Executing	B955	1212	iSNS cannot be set for virtual ports.
CMDRJE	Executing	B955	1213	The command cannot be executed for the ports other than virtual port 0.
CMDRJE	Executing	B955	1214	The command cannot be set because the same VLAN IDs are conflicting in the physical port.
CMDRJE	Executing	B955	1215	The command cannot be executed because the virtual ports with the same VLAN IDs and the same IPv4 addresses are conflicting in the physical port.

SSB codes returned by raidcom modify port -delete_iscsi_virtual_port

raidcom modify port -delete_iscsi_virtual_port				
Error message	Executing/ Async	Error code		Description
		SSB1	SSB2	
CMDRJE	Executing	B955	1039	The command device being used at the local CCI exists under the port.
CMDRJE	Executing	B955	1201	The command cannot be executed because the invalid virtual port number has been entered.
CMDRJE	Executing	B955	1202	The command cannot be executed because the iSCSI virtual port mode is OFF.
CMDRJE	Executing	B955	1206	The command cannot be executed for virtual port 0.
CMDRJE	Executing	B955	120A	An internal error occurred.
CMDRJE	Executing	B955	120B	The specified port is not a port of the package for iSCSI.
CMDRJE	Executing	B955	120C	The specified virtual port does not exist.
CMDRJE	Executing	B955	120D	The storage system is in the internal processing, or the configuration change processes are conflicting.

SSB codes returned by raidcom modify port -iscsi_virtual_port_mode

raidcom modify port -iscsi_virtual_port_mode				
Error message	Executing/ Async	Error code		Description
		SSB1	SSB2	
CMDRJE	Executing	2E00	8400	The value of the specified port is invalid.
CMDRJE	Executing	2E11	800F	The operation failed because multiple versions of DKCMAIN microcode are included.
CMDRJE	Executing	2E11	8010	The storage system is in internal process, or the configuration changing processes are conflicting.
CMDRJE	Executing	2E11	810A	Abnormal cache status.

raidcom modify port -iscsi_virtual_port_mode				
Error message	Executing/ Async	Error code		Description
		SSB1	SSB2	
CMDRJE	Executing	2E11	8403	The operation cannot be performed because iSNS is set for the specified port or a port of the same group.
CMDRJE	Executing	2E11	8404	The operation cannot be performed because a virtual port is registered for the specified port or a port of the same group.
CMDRJE	Executing	2E20	8400	The specified port is not installed.
CMDRJE	Executing	2E31	8301	The specified port is not a port of the package for iSCSI.
CMDRJE	Executing	2E3F	8000	The specified operation is not supported in the current microcode version.
CMDRJE	Executing	2ED0	FEEC	An internal error occurred.

SSB codes returned by raidcom delete host_grp

raidcom delete host_grp				
Error message	Executing/ Async	Error code		Description
		SSB1	SSB2	
CMDRJE	Executing	B956	302C	The host group cannot be deleted because the host mode option 61 or 72 is set.
CMDRJE	Executing	B956	304F	The program product is not installed.
CMDRJE	Executing	B956	3071	The value of host group ID exceeds the maximum.
CMDRJE	Executing	B956	3077	The attribute of the specified port is Initiator or External.
CMDRJE	Executing	B956	30FD	The attribute of the specified port is Initiator or External.
CMDRJE	Executing	B956	3203	Deletion cannot be executed because the last path of ShadowImage is included in the host group.

raidcom delete host_grp				
Error message	Executing/ Async	Error code		Description
		SSB1	SSB2	
CMDRJE	Executing	B956	320A	Deletion cannot be executed because the last path of Thin Image or Copy-on-Write Snapshot is included in the host group.
CMDRJE	Executing	B956	3234	Deletion cannot be executed because the LU which is the target of the operation is in the reserved status.
CMDRJE	Executing	B956	3239	The command device being used at the local CCI exists under the host group.
	Executing	B980	B901	The command was rejected because the specified port is for NAS Platform (System LU).
	Executing	B980	B902	The command was rejected because the specified port is for NAS Platform (User LU).

SSB codes returned by `raidcom add host_grp`

raidcom add host_grp				
Error message	Executing/ Async	Error code		Description
		SSB1	SSB2	
CMDRJE	Executing	B956	304F	The program product is not installed.
CMDRJE	Executing	B956	3071	The value of host group ID exceeds the maximum.
CMDRJE	Executing	B956	3077	The attribute of the specified port is Initiator or External.
CMDRJE	Executing	B956	30FD	The attribute of the specified port is Initiator or External.
CMDRJE	Executing	B956	3173	The same host group name is already installed in the specified port.
CMDRJE	Executing	B956	3174	The default host group name cannot be registered for the host group ID is other than 0.
CMDRJE	Executing	B956	31D0	The character or the number of characters of the iSCSI target name is invalid.

raidcom add host_grp				
Error message	Executing/ Async	Error code		Description
		SSB1	SSB2	
CMDRJE	Executing	B956	31D5	The character or the number of characters of the iSCSI target alias is invalid.
CMDRJE	Executing	B956	31D7	The specified iSCSI target alias is already assigned to the same port.
CMDRJE	Executing	B956	31D8	The specified iSCSI target alias cannot be registered because the iSCSI target alias is reserved for the iSCSI target ID 00.
CMDRJE	Executing	B956	31D9	The specified iSCSI target name is already used for the same port.
CMDRJE	Executing	B956	31DA	The specified iSCSI target name cannot be registered because the iSCSI target name is reserved for the iSCSI target ID 00.
CMDRJE	Executing	B956	3204	An LU path or a logical path has been defined.
CMDRJE	Executing	B980	B903	The command was rejected because the selected resource belongs to NAS_Platform_System_RSG.

SSB codes returned by raidcom modify host_grp

raidcom modify host_grp				
Error message	Executing/ Async	Error code		Description
		SSB1	SSB2	
CMDRJE	Executing	B956	304F	The program product is not installed.
CMDRJE	Executing	B956	30FD	The attribute of the specified port is Initiator or External.
CMDRJE	Executing	B956	3204	An LU path or a logical path has been defined.
CMDRJE	Executing	B958	032F	You cannot cancel the host mode option because the specified host group is associated with the LDEV in another virtual storage machine by the path definition.
CMDRJE	Executing	B958	0339	The command device being used at the local CCI exists under the host group.

raidcom modify host_grp				
Error message	Executing/ Async	Error code		Description
		SSB1	SSB2	
CMDRJE	Executing	B958	0350	Changing of the host mode/ host mode option cannot be executed for the port of Initiator or External.
CMDRJE	Executing	B958	0354	The invalid host mode is specified.
CMDRJE	Executing	B958	092C	The cancellation of the host mode option 61 or 72 was suppressed.
CMDRJE	Executing	B958	0956	The host group ID exceeds the maximum.
CMDRJE	Executing	B958	0957	The program product is not installed.
CMDRJE	Executing	B958	0959	The specified host group is not installed.
CMDRJE	Executing	B958	098E	When using 8FC16 or 16FE10 channel package, you cannot configure the host mode option 51 (Round Trip Set Up Option) for the host group because the host mode option 51 is not supported.
Executing	B980	B901	The command was rejected because the specified port is for NAS Platform (System LU).	

raidcom modify host_grp				
Error message	Executing/ Async	Error code		Description
		SSB1	SSB2	
Executing	B980	B902	The command was rejected because the specified port is for NAS Platform (User LU).	
Executing	B980	B903	The command was rejected because the selected resource belongs to NAS_Platform_System_RS G.	

SSB codes returned by raidcom disconnect path

raidcom disconnect path				
Error message	Executing/ Async	Error code		Description
		SSB1	SSB2	
CMDRJE	Executing	2E00	4500	The path group is out of the enabled range.
CMDRJE	Executing	2E00	8400	The value of the specified port is invalid.
CMDRJE	Executing	2E02	8403	The specified virtual port number is out of range.
Get Command Status	Async	2E10	4301	The specified external path has already disconnected the path, or is in the process of checking path.
CMDRJE	Executing	2E10	8404	The iSCSI virtual port mode for the specified port is disabled.
Get Command Status	Async	2E11	001B	The target LDEV is blocked.
Get Command Status	Async	2E11	4000	The path for the specified external path is in the state of disconnected.
Get Command Status	Async	2E11	4302	This command cannot be operated due to one of the following reasons: <ul style="list-style-type: none"> ▪ All the paths to the external volumes are blocked. ▪ There will be no normal paths.
CMDRJE	Executing	2E11	9400	The command cannot be accepted. After a while, execute the same command.
Get Command Status CMDRJE	Executing/ Async	2E20	4100	There is no specified external volume.
Get Command Status CMDRJE	Executing/ Async	2E20	4300	There is no connection path to an external volume.
CMDRJE	Executing	2E20	4400	WWN is not registered.

raidcom disconnect path				
Error message	Executing/ Async	Error code		Description
		SSB1	SSB2	
CMDRJE	Executing	2E20	4500	This command cannot be operated due to one of the following reasons: <ul style="list-style-type: none"> There is no path group. external_wwn is not defined.
CMDRJE	Executing	2E20	8401	The specified virtual port is not defined.
Get Command Status	Async	2E30	001E	Online from the mainframe host.
CMDRJE	Executing	2E30	8400	The attribute of a port is not External(ELUN).
CMDRJE	Executing	2E30	840E	The command cannot be executed with the specified port attribute.
CMDRJE	Executing	2EDA	00EE	The command cannot be accepted. After a while, execute the same command.
Get Command Status	Async	2EDA	0905	An internal error occurred by the operation of a path for an external path. Call customer support.
CMDRJE	Executing	B980	B901	The command was rejected because the specified port is for NAS platform (System LU).
CMDRJE	Executing	B980	B902	The command was rejected because the specified port is for NAS platform (User LU).

SSB codes returned by raidcom delete path

raidcom delete path				
Error message	Executing/ Async	Error code		Description
		SSB1	SSB2	
CMDRJE	Executing	2E00	4500	The path group is not in a effective range.
CMDRJE	Executing	2E00	8400	The value of the specified port is incorrect.
CMDRJE	Executing	2E02	8403	The specified virtual port number is out of range.

raidcom delete path				
Error message	Executing/ Async	Error code		Description
		SSB1	SSB2	
Get Command Status	Async	2E10	4303	The path operations cannot be performed for the following reasons: <ul style="list-style-type: none"> The target of the specified path group is TagmaStore USP/TagmaStore NSC. The specified path group contains an external volume for which the reserve attribute is set by the host.
CMDRJE	Executing	2E10	8404	The iSCSI virtual port mode for the specified port is disabled.
Get Command Status	Async	2E11	8011	The operation cannot continue because the microcode is being replaced.
CMDRJE	Executing	2E11	9400	The command cannot be accepted. After a while, execute the same command.
CMDRJE	Executing	2E20	4100	There is no external volume group.
CMDRJE	Executing	2E20	4300	There is no external connection path.
CMDRJE	Executing	2E20	4400	WWN is not registered.
CMDRJE Get Command Status	Executing/ Async	2E20	4500	There is no path group.
CMDRJE	Executing	2E20	8401	The specified virtual port is not defined.
CMDRJE Get Command Status	Executing/ Async	2E23	4300	Paths cannot be deleted because there are no normal paths.
CMDRJE	Executing	2E30	8400	The port attribute is not External (ELUN).
CMDRJE	Executing	2E30	840E	The command cannot be executed with the specified port attribute.
CMDRJE	Executing	2EDA	00EE	The command cannot be accepted. After a while, execute the same command.
Get Command Status	Async	2EDA	FECC	An internal error occurred. Call customer support.

raidcom delete path				
Error message	Executing/ Async	Error code		Description
		SSB1	SSB2	
Get Command Status	Async	2EDA	FFFF	An internal error occurred. Call customer support.
CMDRJE	Executing	B980	B901	The command was rejected because the specified port is for NAS platform (System LU).
CMDRJE	Executing	B980	B902	The command was rejected because the specified port is for NAS platform (User LU).

SSB codes returned by raidcom -logout

raidcom -logout				
Error message	Executing/ Async	Error code		Description
		SSB1	SSB2	
CMDRJE	Executing	2E01	2200	Failed to release the resource lock.

SSB codes returned by raidcom monitor pool

raidcom monitor pool				
Error message	Executing/ Async	Error code		Description
		SSB1	SSB2	
CMDRJE	Executing	2E00	6000	The value of pool ID is out of range.
CMDRJE	Executing	2E10	6004	Monitor cannot be started because the performance monitor is in the collecting status.
CMDRJE	Executing	2E10	6005	Monitor cannot be stopped because the performance monitor is stopped.
CMDRJE	Executing	2E10	6006	Monitor cannot start because the performance monitor is in use. Retry the operation after completing or stopping the reallocation of Tier.
CMDRJE	Executing	2E10	6007	There is not enough time after collecting performance monitor.

raidcom monitor pool				
Error message	Executing/ Async	Error code		Description
		SSB1	SSB2	
CMDRJE	Executing	2E11	6003	The pool is not in the state of specifying the performance monitor to start or stop.
CMDRJE	Executing	2E20	6000	The pool ID is not installed.
CMDRJE	Executing	2E21	8101	A shared memory for Dynamic Provisioning is not installed.
CMDRJE	Executing	2E21	8102	A shared memory for Dynamic Tiering or active flash is not installed.
CMDRJE	Executing	2E21	9000	The program product of Dynamic Tiering or active flash is not installed.
CMDRJE	Executing	2E30	6002	Start or stop of performance monitor by hand cannot be performed because it is a pool for Dynamic Provisioning or it is automatic execution mode.
CMDRJE	Executing	2E30	6003	The specified pool is the one for Thin Image or Copy-on-Write Snapshot.
CMDRJE	Executing	2EE7	FEEC	An internal error occurred. Call customer support.

SSB codes returned by raidcom reallocate pool

raidcom reallocate pool				
Error message	Executing/ Async	Error code		Description
		SSB1	SSB2	
CMDRJE	Executing	2E00	6000	The value of pool ID is out of range.
CMDRJE	Executing	2E10	6007	There is not enough time after collecting performance monitor.
CMDRJE	Executing	2E10	6008	Tier reallocation cannot be started because the state of performance monitor information is not enabled. Start the performance monitor again.
CMDRJE	Executing	2E10	6009	Reallocation cannot be started because it is reallocating.

raidcom reallocate pool				
Error message	Executing/ Async	Error code		Description
		SSB1	SSB2	
CMDRJE	Executing	2E10	600A	Reallocation cannot be stopped because it is not reallocating.
CMDRJE	Executing	2E10	6011	The operation cannot be performed because it is being discarded pages.
CMDRJE	Executing	2E10	6015	The operation cannot be performed because the Tier is being deterred reallocation.
CMDRJE	Executing	2E11	6003	The pool is not in the status of specifying the reallocation to start or stop.
CMDRJE	Executing	2E20	6000	The pool ID is not installed.
CMDRJE	Executing	2E21	8101	A shared memory for Dynamic Provisioning is not installed.
CMDRJE	Executing	2E21	8102	A shared memory for Dynamic Tiering or active flash is not installed.
CMDRJE	Executing	2E21	9000	The program product of Dynamic Tiering or active flash is not installed.
CMDRJE	Executing	2E30	6002	Start or stop of performance monitor by hand cannot be performed because it is a pool for Dynamic Provisioning or it is automatic execution mode.
CMDRJE	Executing	2E30	6003	The specified pool is the one for Thin Image or Copy-on-Write Snapshot.
CMDRJE	Executing	2E31	6000	Reallocation cannot be performed because there is only one Tier in the pool group.
CMDRJE	Executing	2EE7	FECC	An internal error occurred. Call customer support.

SSB codes returned by raidcom extend ldev

raidcom extend ldev				
Error message	Executing/ Async	Error code		Description
		SSB1	SSB2	
CMDRJE	Executing	-	-	See the troubleshooting topics in the <i>Provisioning Guide</i> for the storage system.

SSB codes returned by raidcom delete resource

raidcom delete resource				
Error message	Executing/ Async	Error code		Description
		SSB1	SSB2	
CMDRJE	Executing	2E00	2201	The specified resource group cannot be operated.
CMDRJE	Executing	2E10	2201	The specified resource groups cannot be deleted because the resource groups are locked by another user (or another session). Check the lock status of the resource groups. If maintenance personnel is performing maintenance operations, retry the command after confirming the completion of the operations..
CMDRJE	Executing	2E10	2202	The LDEV and the host group cannot be set to the different virtual storage machine.
CMDRJE	Executing	2E20	0100	There is no parity group.
CMDRJE	Executing	2E20	2200	A resource group cannot be deleted because the specified resource group is undefined.
CMDRJE	Executing	2E20	4100	There is no external volume group.
CMDRJE	Executing	2E21	9305	The information for the virtual storage machine is set in the specified resource.
CMDRJE	Executing	2E22	2202	A resource group cannot be deleted because a resource belongs to the specified resource group.

raidcom delete resource				
Error message	Executing/ Async	Error code		Description
		SSB1	SSB2	
CMDRJE	Executing	2E22	2203	A resource cannot be deleted from the resource group because the specified LDEV number is not the top LDEV number in the LUSE volume.
CMDRJE	Executing	2E30	2201	The operation to resource group 0 (meta_resource) cannot be performed.
CMDRJE	Executing	2ECA	FEEC	An internal error occurred. Call customer support.
CMDRJE	Executing	B980	B903	The command was rejected because the selected resource belongs to NAS_Platform_System_RSG.
CMDRJE	Executing	B980	B904	The command was rejected because the selected resource group belongs to NAS_Platform_System_RSG.

SSB codes returned by raidcom add resource

raidcom add resource				
Error message	Executing/ Async	Error code		Description
		SSB1	SSB2	
CMDRJE	Executing	2E00	2200	The specified resource group name is against the naming rules.
CMDRJE	Executing	2E00	2201	The specified resource group cannot be operated.
CMDRJE	Executing	2E00	2202	The resource ID and the sub-resource ID are out of the effective range.
CMDRJE	Executing	2E00	8000	The machine type is invalid.
CMDRJE	Executing	2E00	8001	The serial number is invalid.
CMDRJE	Executing	2E00	8400	The value of the specified port is invalid.
CMDRJE	Executing	2E10	2202	The LDEV and the host group cannot be set to the different virtual storage machine.

raidcom add resource				
Error message	Executing/ Async	Error code		Description
		SSB1	SSB2	
CMDRJE	Executing	2E20	0100	There is no parity group.
CMDRJE	Executing	2E20	2200	You cannot execute this command because of either reason below. <ul style="list-style-type: none"> ▪ A resource cannot be added to the resource group because the specified resource group is undefined. ▪ A resource group name cannot be changed because the specified resource group is undefined.
CMDRJE	Executing	2E20	4100	There is no external volume group.
CMDRJE	Executing	2E20	8400	The specified port is not installed.
CMDRJE	Executing	2E21	900D	The program products of Resource Partition Manager are not installed.
CMDRJE	Executing	2E21	9305	The information for the virtual storage machine is set in the specified resource.
CMDRJE	Executing	2E21	930B	A virtual storage machine cannot be created because the virtual storage machine with the specified serial number already exists.
CMDRJE	Executing	2E22	2200	You cannot execute this command because of either reason below. <ul style="list-style-type: none"> ▪ A resource group cannot be created because the specified resource group name is duplicated. ▪ A resource group name cannot be changed because the specified resource group name is duplicated.
CMDRJE	Executing	2E22	2201	A resource cannot be added to a resource group because the specified resource belongs to the resource group.
CMDRJE	Executing	2E22	2203	A resource cannot be added to the resource group because the specified LDEV number is not the top LDEV number in the LUSE volume.
CMDRJE	Executing	2E23	2200	Any more resource groups cannot be created because the registered number of resource groups has reached the maximum.

raidcom add resource				
Error message	Executing/ Async	Error code		Description
		SSB1	SSB2	
CMDRJE	Executing	2E23	2201	A virtual storage machine cannot be created because the number of registered virtual storage machines has reached the maximum.
CMDRJE	Executing	2E30	2201	The operation to resource group 0 (meta_resource) cannot be performed.
CMDRJE	Executing	2E30	8402	The attribute of the specified port is Initiator or External.
CMDRJE	Executing	2ECA	FEEC	An internal error occurred. Call customer support.
CMDRJE	Executing	2EF3	2202	The specified operation cannot be performed because it is not supported.
CMDRJE	Executing	B980	B903	The command was rejected because the selected resource belongs to NAS_Platform_System_RSG.
CMDRJE	Executing	B980	B904	The command was rejected because the selected resource group belongs to NAS_Platform_System_RSG.

SSB codes returned by raidcom get resource

raidcom get resource				
Error message	Executing/ Async	Error code		Description
		SSB1	SSB2	
CMDRJE	Executing	2EF0	FEEC	An internal error occurred. Call customer support.

SSB codes returned by raidcom map resource

raidcom map resource				
Error message	Executing/ Async	Error code		Description
		SSB1	SSB2	
CMDRJE	Executing	2E00	0000	The specified LDEV number or the LDEV number for the virtual volume is out of the range.
CMDRJE	Executing	2E00	0003	SSID is not with in the valid range.
CMDRJE	Executing	2E00	000E	The specified emulation type of the LDEV is not supported in this command.
CMDRJE	Executing	2E00	002B	The specified attribute of the virtual LDEV is not supported.
CMDRJE	Executing	2E00	002C	The specified attribute of the virtual LDEV is invalid.
CMDRJE	Executing	2E00	2205	You cannot execute the command because a parameter required for the virtualization was not specified.
CMDRJE	Executing	2E00	9301	The specified emulation type is invalid.
CMDRJE	Executing	2E10	0055	The specified LDEV cannot be operated because it belongs to the default virtual storage machine.
CMDRJE	Executing	2E10	0059	The specified volume cannot be operated because the LDEV number of the specified volume does not match the LDEV number of the virtual volume.
CMDRJE	Executing	2E10	8000	The operation cannot be performed because Storage Navigator or Device Manager - Storage Navigator is in progress, another application is in progress on the SVP, or the configuration is being changed. Wait a while, and then retry the operation.
CMDRJE	Executing	2E21	9305	The information of the virtual storage machine is already set in the specified resource.
CMDRJE	Executing	2E21	9307	The specified virtual LDEV number is already exist in the virtual storage machine to which the specified LDEV belongs.

raidcom map resource				
Error message	Executing/ Async	Error code		Description
		SSB1	SSB2	
CMDRJE	Executing	2E21	9308	You cannot operate the LDEV that has the LU path definition.
CMDRJE	Executing	2E22	0001	The specified LDEV is already defined.
CMDRJE	Executing	2E30	0013	The specified volume cannot be set because it is a LUSE volume.
CMDRJE	Executing	2E30	0088	The specified LDEV cannot be operated because it has an attribute.
CMDRJE	Executing	2E30	0089	The specified LDEV cannot be operated because the ldev has a reserve attribute for GAD.
CMDRJE	Executing	2E30	008A	The specified LDEV is used for aGAD pair.
CMDRJE	Executing	2E30	008C	The specified LDEV cannot be set the information of the virtual volume because it is not virtualized.
CMDRJE	Executing	2ECA	FECC	An internal error occurred. Call customer support.
CMDRJE	Executing	2EF3	2202	The specified operation cannot be performed because it is not supported.

SSB codes returned by raidcom unmap resource

raidcom unmap resource				
Error message	Executing/ Async	Error code		Description
		SSB1	SSB2	
CMDRJE	Executing	2E10	0000	The specified LDEV number or the LDEV number for the virtual volume is out of the range.
CMDRJE	Executing	2E10	004F	The specified LDEV for the virtual storage machine is not defined in the specified LDEV.
CMDRJE	Executing	2E10	005E	The specified LDEV is used by the TrueCopy pair or the Universal Replicator pair.

raidcom unmap resource				
Error message	Executing/ Async	Error code		Description
		SSB1	SSB2	
CMDRJE	Executing	2E10	8000	The operation cannot be performed because Storage Navigator or Device Manager - Storage Navigator is in progress, another application is in progress on the SVP, or the configuration is being changed. Wait a while, and then retry the operation.
CMDRJE	Executing	2E21	9012	The Resource Partition Manager is not installed.
CMDRJE	Executing	2E21	9306	The information of the virtual storage machine is not set in the specified resource.
CMDRJE	Executing	2E21	9308	You cannot operate the LDEV that has the LU path definition.
CMDRJE	Executing	2E30	000C	The specified LDEV is used as a quorum disk.
CMDRJE	Executing	2E30	000F	The specified LDEV is used as a journal volume.
CMDRJE	Executing	2E30	008A	The specified LDEV is used for aGAD pair.
CMDRJE	Executing	2E30	008B	The specified LDEV cannot be operated because it is the external volume for the online data migration.
CMDRJE	Executing	2E30	008D	The specified volume cannot be operated because it is the mainframe volume.
CMDRJE	Executing	2E30	0096	The specified LDEV is used as an ALU.
CMDRJE	Executing	2E30	0097	The specified LDEV is used as an SLU.
CMDRJE	Executing	2ECA	FEEC	An internal error occurred. Call customer support.
CMDRJE	Executing	2EF3	2202	The specified operation cannot be performed because it is not supported.

SSB codes returned by raidcom modify resource

raidcom modify resource				
Error message	Executing/ Async	Error code		Description
		SSB1	SSB2	
CMDRJE	Executing	2EF3	2202	The specified operation cannot be performed because it is not supported.

SSB codes returned by raidcom set resource

raidcom set resource				
Error message	Executing/ Async	Error code		Description
		SSB1	SSB2	
CMDRJE	Executing	2EF3	2202	The specified operation cannot be performed because it is not supported.

SSB codes returned by raidcom reset resource

raidcom reset resource				
Error message	Executing/ Async	Error code		Description
		SSB1	SSB2	
CMDRJE	Executing	2EF3	2202	The specified operation cannot be performed because it is not supported.

SSB codes returned by raidcom modify clpr

raidcom modify clpr				
Error message	Executing/ Async	Error code		Description
		SSB1	SSB2	
CMDRJE	Executing	2E00	0000	The LDEV number is out of settable range.
CMDRJE	Executing	2E00	002A	The specified LDEV is not subject to processing.

raidcom modify clpr				
Error message	Executing/ Async	Error code		Description
		SSB1	SSB2	
CMDRJE	Executing	2E00	0101	The parity group number or the external volume group number is not in the effective range.
CMDRJE	Executing	2E00	0102	The specified group type is not correct.
CMDRJE	Executing	2E00	0107	The combined parity group cannot be set across multiple CLPRs.
CMDRJE	Executing	2E00	1300	The item cannot be migrated to another CLPR because of either reason below. <ul style="list-style-type: none"> ▪ The specified parity group or external volume group has an LUSE volume. ▪ The specified volume is an LUSE volume.
CMDRJE	Executing	2E00	7000	The specified CLPR ID is invalid.
CMDRJE	Executing	2E11	810A	Abnormal cache status.
CMDRJE	Executing	2E13	0101	The CLPR cannot be migrated because the specified parity group or the external volume group includes the pool volume that is used in the pool for Thin Image or Copy-on-Write Snapshot.
CMDRJE	Executing	2E20	0000	LDEV is not installed.
CMDRJE	Executing	2E20	0100	There is no parity group.
CMDRJE	Executing	2E20	4100	There is no external volume group.
CMDRJE Get Command Status	Executing/ Async	2E20	7001	The specified CLPR is not installed.
CMDRJE	Executing	2E30	0005	CLPR cannot be transferred by either one of the following two reasons. <ul style="list-style-type: none"> ▪ Cache Residency Manager is set for the specified volume. ▪ The specified parity group includes the volumes for which Cache Residency Manager are set.
CMDRJE	Executing	2E30	000F	The specified LDEV is used as a journal volume.

raidcom modify clpr				
Error message	Executing/ Async	Error code		Description
		SSB1	SSB2	
CMDRJE	Executing	2E30	0083	The specified parity group includes HDEV with the journal attribute.
CMDRJE	Executing	2EE8	00F0	The specified command cannot be accepted because the command is not supported.
CMDRJE	Executing	2EE8	FEEC	An internal error occurred. Call customer support.
CMDRJE	Executing	2EF3	0102	The specified parameter is invalid. Check the <i>Command Control Interface Command Reference</i> .
CMDRJE	Executing	2EF3	9F02	The specified operation cannot be performed because it is not supported.
CMDRJE	Executing	2EF6	FEEC	An internal error occurred. Call customer support.

SSB codes returned by raidcom add spm_group

raidcom add spm_group				
Error message	Executing/ Async	Error code		Description
		SSB1	SSB2	
CMDRJE	Executing	B9D4	B9D0	The command cannot be executed due to one of the following reasons: <ul style="list-style-type: none"> Server Priority Manager is being used by Storage Navigator or Device Manager - Storage Navigator. Delete all settings of Server Priority Manager using Storage Navigator or Device Manager - Storage Navigator. Server Priority Manager information for the port WWN already exists in the system. Delete Server Priority Manager information from Performance Monitor.
CMDRJE	Executing	B9D4	B9D4	Server Priority Manager program product is not installed.

raidcom add spm_group				
Error message	Executing/ Async	Error code		Description
		SSB1	SSB2	
CMDRJE	Executing	B9D4	B9D6	The number of Server Priority Manager groups exceeds the maximum.

SSB codes returned by raidcom delete spm_group

raidcom delete spm_group				
Error message	Executing/ Async	Error code		Description
		SSB1	SSB2	
CMDRJE	Executing	B980	B901	The command was rejected because the specified port is for NAS Platform (System LU).
CMDRJE	Executing	B9D4	B9D0	The command cannot be executed due to one of the following reasons: <ul style="list-style-type: none"> Server Priority Manager is being used by Storage Navigator or Device Manager - Storage Navigator. Delete all settings of Server Priority Manager using Storage Navigator or Device Manager - Storage Navigator. Server Priority Manager information for the port WWN already exists in the system. Delete Server Priority Manager information from Performance Monitor.
CMDRJE	Executing	B9D4	B9D2	The specified WWN or nickname does not exist.
CMDRJE	Executing	B9D4	B9D4	Server Priority Manager program product is not installed.

SSB codes returned by raidcom modify spm_group

raidcom modify spm_group				
Error message	Executing/ Async	Error code		Description
		SSB1	SSB2	
CMDRJE	Executing	B980	B901	The command was rejected because the specified port is for NAS Platform (System LU).
CMDRJE	Executing	B9D4	B9D0	The command cannot be executed due to one of the following reasons: <ul style="list-style-type: none"> ▪ Server Priority Manager is being used by Storage Navigator or Device Manager - Storage Navigator. Delete all settings of Server Priority Manager using Storage Navigator or Device Manager - Storage Navigator. ▪ Server Priority Manager information for the port WWN already exists in the system. Delete Server Priority Manager information from Performance Monitor.
CMDRJE	Executing	B9D4	B9D3	The specified WWN or upper limit is invalid.
CMDRJE	Executing	B9D4	B9D4	Server Priority Manager program product is not installed.

SSB codes returned by raidcom add spm_wwn

raidcom add spm_wwn				
Error message	Executing/ Async	Error code		Description
		SSB1	SSB2	
CMDRJE	Executing	B9D4	B9D0	The command cannot be executed due to one of the following reasons: <ul style="list-style-type: none"> Server Priority Manager is being used by Storage Navigator or Device Manager - Storage Navigator. Delete all settings of Server Priority Manager using Storage Navigator or Device Manager - Storage Navigator. Server Priority Manager information for the port WWN already exists in the system. Delete Server Priority Manager information from Performance Monitor.
CMDRJE	Executing	B9D4	B9D2	The specified WWN does not exist.
CMDRJE	Executing	B9D4	B9D4	Server Priority Manager program product is not installed.
CMDRJE	Executing	B9D4	B9D7	The specified SPM name has already existed.

SSB codes returned by raidcom delete spm_wwn

raidcom delete spm_wwn				
Error message	Executing/ Async	Error code		Description
		SSB1	SSB2	
CMDRJE	Executing	B980	B901	The command was rejected because the specified port is for NAS Platform (System LU).

raidcom delete spm_wwn				
Error message	Executing/ Async	Error code		Description
		SSB1	SSB2	
CMDRJE	Executing	B9D4	B9D0	The command cannot be executed due to one of the following reasons: <ul style="list-style-type: none"> Server Priority Manager is being used by Storage Navigator or Device Manager - Storage Navigator. Delete all settings of Server Priority Manager using Storage Navigator or Device Manager - Storage Navigator. Server Priority Manager information for the port WWN already exists in the system. Delete Server Priority Manager information from Performance Monitor.
CMDRJE	Executing	B9D4	B9D2	The configuration WWN or nickname does not exist.
CMDRJE	Executing	B9D4	B9D4	Server Priority Manager program product is not installed.

SSB codes returned by raidcom modify spm_wwn

raidcom modify spm_wwn				
Error message	Executing/ Async	Error code		Description
		SSB1	SSB2	
CMDRJE	Executing	B980	B901	The command was rejected because the specified port is for NAS Platform (System LU).

raidcom modify spm_wwn				
Error message	Executing/ Async	Error code		Description
		SSB1	SSB2	
CMDRJE	Executing	B9D4	B9D0	The command cannot be executed due to one of the following reasons: <ul style="list-style-type: none"> Server Priority Manager is being used by Storage Navigator or Device Manager - Storage Navigator. Delete all settings of Server Priority Manager using Storage Navigator or Device Manager - Storage Navigator. Server Priority Manager information for the port WWN already exists in the system. Delete Server Priority Manager information from Performance Monitor.
CMDRJE	Executing	B9D4	B9D1	The number of WWNs exceeds the maximum that can be set in the system.
CMDRJE	Executing	B9D4	B9D3	The specified WWN or upper limit is invalid.
CMDRJE	Executing	B9D4	B9D4	Server Priority Manager program product is not installed.
CMDRJE	Executing	B9D4	B9D5	The number of WWNs exceeds the maximum that can be set to the port.

SSB codes returned by raidcom modify spm_idev

raidcom modify spm_idev				
Error message	Executing/ Async	Error code		Description
		SSB1	SSB2	
CMDRJE	Executing	2E00	9B01	The specified iSCSI name is incorrect.
CMDRJE	Executing	2E11	9400	The command cannot be accepted. After a while, execute the same command.
CMDRJE	Executing	2E21	8301	The specified operation cannot be performed because of no iSCSI package.

raidcom modify spm_idev				
Error message	Executing/ Async	Error code		Description
		SSB1	SSB2	
CMDRJE	Executing	2E22	9B04	The iSCSI name cannot be registered because the number of iSCSI names that can be registered in the system exceeded the maximum number.
CMDRJE	Executing	2E3F	8000	The specified operation is not supported in the current microcode version.
CMDRJE	Executing	B9D3	B9D0	The operation cannot be performed because internal processing is in progress. Wait a while, and then retry the command. If maintenance personnel is performing maintenance operations, retry the command after confirming the completion of the maintenance operations.
CMDRJE	Executing	B9D3	B9D1	The Server Priority Manager information for the port WWN already exists in the system.
CMDRJE	Executing	B9D3	B9D2	The LDEV cannot be registered because the number of LDEVs that can be registered in the system exceeded the maximum number.
CMDRJE	Executing	B9D3	B9D3	The WWN cannot be registered because the number of WWNs that can be registered in the system exceeded the maximum number.
CMDRJE	Executing	B9D3	B9D4	The WWN cannot be registered because the number of WWNs that can be registered in the LDEV exceeded the maximum number.
CMDRJE	Executing	B9D3	B9D5	The specified LDEV is not defined.
CMDRJE	Executing	B9D3	B9D7	Server Priority Manager is being used by Storage Navigator or Device Manager - Storage Navigator.
CMDRJE	Executing	B9D3	B9D8	The iSCSI name cannot be registered because an invalid WWN is registered. Invalid WWNs are WWNs which are not in the WWN format defined by IEEE. See Cautions about using Server Priority Manager for details.
CMDRJE	Executing	B9D3	B9D9	The specified operation cannot be performed because of no iSCSI package.

raidcom modify spm_ldev				
Error message	Executing/ Async	Error code		Description
		SSB1	SSB2	
CMDRJE	Executing	B9D7	B9D7	The specified WWN, iSCSI name, or upper limit is incorrect.
CMDRJE	Executing	B9D8	B9D8	The specified LDEV does not have the WWN or iSCSI name.
CMDRJE	Executing	B9D9	B9D9	The Server Priority Manager program product is not installed.

SSB codes returned by raidcom delete spm_ldev

raidcom delete spm_ldev				
Error message	Executing/ Async	Error code		Description
		SSB1	SSB2	
CMDRJE	Executing	2E00	9B01	The specified iSCSI name is incorrect.
CMDRJE	Executing	2E11	9400	The command cannot be accepted. After a while, execute the same command.
CMDRJE	Executing	2E3F	8000	The specified operation is not supported in the current microcode version.
CMDRJE	Executing	B9D3	B9D0	The operation cannot be performed because internal processing is in progress. Wait a while, and then retry the command. If maintenance personnel is performing maintenance operations, retry the command after confirming the completion of the maintenance operations.
CMDRJE	Executing	B9D3	B9D9	The specified operation cannot be performed because of no iSCSI package.
CMDRJE	Executing	B9D7	B9D7	The specified WWN or iSCSI name is incorrect.
CMDRJE	Executing	B9D8	B9D8	The specified LDEV does not have the WWN or iSCSI name.

SSB codes returned by raidcom monitor spm_ldev

raidcom monitor spm_ldev				
Error message	Executing/ Async	Error code		Description
		SSB1	SSB2	
CMDRJE	Executing	2E00	9B01	The specified iSCSI name is incorrect.
CMDRJE	Executing	2E11	9400	The command cannot be accepted. After a while, execute the same command.
CMDRJE	Executing	2E3F	8000	The specified operation is not supported in the current microcode version.
CMDRJE	Executing	B9D3	B9D0	The operation cannot be performed because internal processing is in progress. Wait a while, and then retry the command. If maintenance personnel is performing maintenance operations, retry the command after confirming the completion of the maintenance operations.
CMDRJE	Executing	B9D7	B9D7	The specified WWN or iSCSI name is incorrect.

SSB codes returned by raidcom get spm_ldev

raidcom get spm_ldev				
Error message	Executing/ Async	Error code		Description
		SSB1	SSB2	
CMDRJE	Executing	2E00	9B01	The specified iSCSI name is incorrect.
CMDRJE	Executing	2E11	9400	The command cannot be accepted. After a while, execute the same command.
CMDRJE	Executing	2E3F	8000	The specified operation is not supported in the current microcode version.
CMDRJE	Executing	B9D3	B9D0	The operation cannot be performed because internal processing is in progress. Wait a while, and then retry the command. If maintenance personnel is performing maintenance operations, retry the command after confirming the completion of the maintenance operations.

raidcom get spm_ldev				
Error message	Executing/ Async	Error code		Description
		SSB1	SSB2	
CMDRJE	Executing	B9D7	B9D7	The specified WWN or iSCSI name is incorrect.

SSB codes returned by `raidcom modify ldev -capacity_saving/-capacity_saving_mode`

raidcom modify ldev -capacity_saving/-capacity_saving_mode				
Error message	Executing/ Async	Error code		Description
		SSB1	SSB2	
CMDRJE	Executing	2E00	0000	The LDEV number is out of the valid range.
Get Command Status	Async	2E00	0013	The operation cannot be performed because there are not enough cache management devices.
Get Command Status	Async	2E10	002D	The operation cannot be performed because the specified LDEV is a journal volume.
Get Command Status	Async	2E10	0207	The specified LDEV cannot be operated because it is a Universal Replicator P-VOL and is being copied.
Get Command Status	Async	2E10	0208	The specified LDEV cannot be operated because its pages are being released.
Get Command Status	Async	2E10	020B	The specified LDEV cannot be operated because the deduplication function is enabled.
Get Command Status	Async	2E10	020C	The specified LDEV cannot be operated because deduplicated data exists.
Get Command Status	Async	2E10	020D	The specified LDEV cannot be operated because it is in the status where the capacity saving setting cannot be disabled.
Get Command Status	Async	2E10	020E	The specified LDEV is not in the status where the capacity saving setting can be enabled.
Get Command Status	Async	2E10	020F	The specified LDEV is not in the status where the capacity saving setting can be changed.

raidcom modify ldev -capacity_saving/-capacity_saving_mode				
Error message	Executing/ Async	Error code		Description
		SSB1	SSB2	
Get Command Status	Async	2E10	0214	The operation cannot be performed because the specified volume is being used by Volume Migration.
Get Command Status	Async	2E10	0215	The operation cannot be performed because the specified volume is being used by Quick Restore of ShadowImage.
Get Command Status	Async	2E10	0219	The tiering policy is enabled for the specified LDEV.
Get Command Status	Async	2E10	6020	The deduplication function cannot be used in the pool linked with the specified LDEV.
Get Command Status	Async	2E10	6022	The operation cannot be performed because the deduplication system data volume of the pool linked with the specified LDEV is blocked.
Get Command Status	Async	2E10	6026	The specified virtual volume cannot be operated because the used capacity of the pool associated with the specified virtual volume exceeds the depletion threshold.
Get Command Status	Async	2E11	001B	The specified LDEV is blocked.
Get Command Status	Async	2E11	0209	The operation cannot be performed due to a cache memory failure or maintenance work being performed.
Get Command Status	Async	2E11	6008	The operation cannot be performed because the pool linked with the specified LDEV is in unusable status.
CMDRJE	Executing	2E11	9400	The command cannot be accepted. Wait a while, and issue the same command.
CMDRJE Get Command Status	Executing/ Async	2E20	0000	The specified LDEV is not installed.
Get Command Status	Async	2E21	8103	The operation cannot be performed because the capacity of shared memory is insufficient.
Get Command Status	Async	2E21	810A	The shared memory is not installed.

raidcom modify ldev -capacity_saving/-capacity_saving_mode				
Error message	Executing/ Async	Error code		Description
		SSB1	SSB2	
Get Command Status	Async	2E21	9000	The program product is not installed.
Get Command Status	Async	2E30	0086	The operation cannot be performed because the specified volume is not a DP-VOL.
Get Command Status	Async	2E30	0099	The specified LDEV is set that the Data Direct Mapping attribute is enabled.
Get Command Status	Async	2E30	009B	The operation cannot be performed because the page reservation is set for the specified LDEV.
Get Command Status	Async	2E30	0206	The operation cannot be performed because the specified LDEV is a deduplication system data volume.
Get Command Status	Async	2E30	6014	The operation cannot be performed because the pool linked with the specified LDEV is for active flash.
Get Command Status	Async	2E3F	8000	The specified operation is not supported in the current microcode version.
CMDRJE	Executing	2EBE	9E01	The specified parameter is incorrect.
CMDRJE Get Command Status	Executing/ Async	2EE8	FEEC	An internal error occurred. Contact customer support.

SSB codes returned by raidcom replace quorum

raidcom replace quorum				
Error message	Executing/ Async	Error code		Description
		SSB1	SSB2	
CMDRJE	Executing	2E00	0000	The LDEV number is out of settable range.
CMDRJE	Executing	2E00	A001	The quorum disk ID is out of settable range.
CMDRJE	Executing	2E10	0005	The specified LDEV is used for Volume Migration.

raidcom replace quorum				
Error message	Executing/ Async	Error code		Description
		SSB1	SSB2	
CMDRJE	Executing	2E10	0057	The specified LDEV cannot be configured because the LDEV is a virtual volume.
CMDRJE	Executing	2E10	0201	The operation failed because the T10 PI attribute of the specified LDEV is enabled.
CMDRJE	Executing	2E10	0202	The specified volume belongs to the resource group of NAS_Platform_System_RSG.
CMDRJE	Executing	2E10	A003	The specified quorum disk is in processing.
CMDRJE	Executing	2E10	A006	The specified LDEV is used as the quorum disk.
CMDRJE	Executing	2E10	A008	The operation cannot be performed because the LDEV set for the quorum disk is not blocked.
CMDRJE	Executing	2E11	001B	The specified LDEV is blocked.
CMDRJE	Executing	2E11	800F	The operation failed because multiple versions of DKCMAIN microcode are included.
CMDRJE	Executing	2E13	0001	The specified LDEV is not the first LDEV that belongs to the external volume group.
CMDRJE	Executing	2E20	000E	The specified LDEV is not an external volume.
CMDRJE	Executing	2E20	A001	The specified quorum disk is not defined.
CMDRJE	Executing	2E21	810A	The shared memory is not installed.
CMDRJE	Executing	2E30	0005	Cache Residency Manager is set to the specified volume.
CMDRJE	Executing	2E30	0007	A path is defined to the specified volume.
CMDRJE	Executing	2E30	000E	The specified LDEV is used as a pool volume.
CMDRJE	Executing	2E30	000F	The specified LDEV is used as a journal volume.
CMDRJE	Executing	2E30	0010	The specified volume is used as a command device.
CMDRJE	Executing	2E30	004E	Data Retention Utility is set to the specified volume.
CMDRJE	Executing	2E30	0074	The specified LDEV cannot be operated because it is an external volume mapped for online data migration.

raidcom replace quorum				
Error message	Executing/ Async	Error code		Description
		SSB1	SSB2	
CMDRJE	Executing	2E30	008E	The emulation type of the specified LDEV is not OPEN-V.
CMDRJE	Executing	2E30	0092	The specified LDEV cannot be used because the size of the LDEV is less than the minimum capacity of the quorum disk.
CMDRJE	Executing	2E30	0099	The specified LDEV is a volume of which Data Direct Mapping attribute is enabled.
CMDRJE	Executing	2EB9	FECC	An internal error occurred. Contact customer support.

SSB codes returned by raidcom modify quorum

raidcom modify quorum				
Error message	Executing/ Async	Error code		Description
		SSB1	SSB2	
CMDRJE	Executing	2E00	A001	The specified quorum disk ID is out of the valid range.
CMDRJE	Executing	2E00	A002	The specified value for Read Response Guaranteed Time When Quorum Disk Blocked is not in the valid range.
CMDRJE	Executing	2E20	A001	The specified quorum disk is not defined.
CMDRJE	Executing	2EE8	FECC	An internal error occurred.
CMDRJE	Executing	2EF3	9F02	The specified operation cannot be performed because it is not supported.

SSB codes returned by raidcom add hba_iscsi

raidcom add hba_iscsi				
Error message	Executing/ Async	Error code		Description
		SSB1	SSB2	
CMDRJE	Executing	B957	404F	The program product is not installed.
CMDRJE	Executing	B957	408F	The specified command is not supported for the FC port.
CMDRJE	Executing	B957	40FD	The attribute of the specified port is Initiator or External.
CMDRJE	Executing	B957	44E0	The invalid character or the invalid number of characters is specified for the initiator iSCSI name.
CMDRJE	Executing	B957	44E4	The specified iSCSI target is not registered.
CMDRJE	Executing	B957	44E7	The iSCSI name cannot be added because the number of iSCSI names that can be used for this port has already reached the maximum value.
Executing	B980	B901	The command was rejected because the specified port is for NAS platform (System LU).	

raidcom add hba_iscsi				
Error message	Executing/ Async	Error code		Description
		SSB1	SSB2	
Executing	B980	B902	The command was rejected because the specified port is for NAS platform (User LU).	

SSB codes returned by raidcom delete hba_iscsi

raidcom delete hba_iscsi				
Error message	Executing/ Async	Error code		Description
		SSB1	SSB2	
CMDRJE	Executing	B957	404F	The program product is not installed.
CMDRJE	Executing	B957	408F	The specified command is not supported for the FC port.
CMDRJE	Executing	B957	40FD	The attribute of the specified port is Initiator or External.
CMDRJE	Executing	B957	44E0	The invalid character or the invalid number of characters is specified for the initiator iSCSI name.
CMDRJE	Executing	B957	44E4	The specified iSCSI target is not registered.

raidcom delete hba_iscsi				
Error message	Executing/ Async	Error code		Description
		SSB1	SSB2	
Executing	B980	B901	The command was rejected because the specified port is for NAS platform (System LU).	
Executing	B980	B902	The command was rejected because the specified port is for NAS platform (User LU).	

SSB codes returned by raidcom set hba_iscsi

raidcom set hba_iscsi				
Error message	Executing/ Async	Error code		Description
		SSB1	SSB2	
CMDRJE	Executing	B957	404F	The program product is not installed.
CMDRJE	Executing	B957	408F	The specified command is not supported for the FC port.
CMDRJE	Executing	B957	40FD	The attribute of the specified port is Initiator or External.
CMDRJE	Executing	B957	45E0	The character or the number of characters that cannot be specified for the initiator iSCSI name is specified.
CMDRJE	Executing	B957	45E2	The character or the number of characters that cannot be specified for the initiator iSCSI nickname is specified.
CMDRJE	Executing	B957	45E3	The specified iSCSI name is not registered.
CMDRJE	Executing	B980	B901	The command was rejected because the specified port is for NAS platform (System LU).
CMDRJE	Executing	B980	B902	The command was rejected because the specified port is for NAS platform (User LU).

SSB codes returned by raidcom reset hba_iscsi

raidcom reset hba_iscsi				
Error message	Executing/ Async	Error code		Description
		SSB1	SSB2	
CMDRJE	Executing	B980	B901	The command was rejected because the specified port is for NAS platform (System LU).
CMDRJE	Executing	B980	B902	The command was rejected because the specified port is for NAS platform (User LU).

SSB codes returned by raidcom add chap_user

raidcom add chap_user				
Error message	Executing/ Async	Error code		Description
		SSB1	SSB2	
CMDRJE	Executing	B957	404F	The program product is not installed.
CMDRJE	Executing	B957	408F	The specified command is not supported for the FC port.
CMDRJE	Executing	B957	40FD	The attribute of the specified port is Initiator or External.
CMDRJE	Executing	B957	46E4	The specified iSCSI target is not registered.
CMDRJE	Executing	B957	46E8	The character used for the user ID, or the number of characters is invalid.
CMDRJE	Executing	B957	46EB	The specified CHAP user name is already used for the same port.
CMDRJE	Executing	B957	46EF	The CHAP user ID cannot be added because the number of CHAP user IDs that can be set for this port has already reached the maximum value.
CMDRJE	Executing	B980	B901	The command was rejected because the specified port is for NAS platform (System LU).
CMDRJE	Executing	B980	B902	The command was rejected because the specified port is for NAS platform (User LU).

SSB codes returned by raidcom delete chap_user

raidcom delete chap_user				
Error message	Executing/ Async	Error code		Description
		SSB1	SSB2	
CMDRJE	Executing	B957	404F	The program product is not installed.
CMDRJE	Executing	B957	408F	The specified command is not supported for the FC port.
CMDRJE	Executing	B957	40FD	The attribute of the specified port is Initiator or External.

raidcom delete chap_user				
Error message	Executing/ Async	Error code		Description
		SSB1	SSB2	
CMDRJE	Executing	B957	46E4	The specified iSCSI target is not registered.
CMDRJE	Executing	B957	46E8	The character used for the user ID, or the number of characters is invalid.
CMDRJE	Executing	B957	46EC	The specified CHAP user name is not registered.
CMDRJE	Executing	B980	B901	The command was rejected because the specified port is for NAS platform (System LU).
CMDRJE	Executing	B980	B902	The command was rejected because the specified port is for NAS platform (User LU).

SSB codes returned by raidcom set chap_user

raidcom set chap_user				
Error message	Executing/ Async	Error code		Description
		SSB1	SSB2	
CMDRJE	Executing	B957	404F	The program product is not installed.
CMDRJE	Executing	B957	408F	The specified command is not supported for the FC port.
CMDRJE	Executing	B957	40FD	The attribute of the specified port is Initiator or External.
CMDRJE	Executing	B957	47E4	The specified iSCSI target is not registered.
CMDRJE	Executing	B957	47E8	The character used for the user ID, or the number of characters is invalid.
CMDRJE	Executing	B957	47EA	The specified password for CHAP authentication is incorrect.
CMDRJE	Executing	B957	47EC	The specified CHAP user name is not registered.
CMDRJE	Executing	B957	47EE	The iSCSI target cannot be set because the user authentication of the iSCSI target is invalid.
CMDRJE	Executing	B980	B901	The command was rejected because the specified port is for NAS platform (System LU).

raidcom set chap_user				
Error message	Executing/ Async	Error code		Description
		SSB1	SSB2	
CMDRJE	Executing	B980	B902	The command was rejected because the specified port is for NAS platform (User LU).

SSB codes returned by raidcom reset chap_user

raidcom reset chap_user				
Error message	Executing/ Async	Error code		Description
		SSB1	SSB2	
CMDRJE	Executing	B957	404F	The program product is not installed.
CMDRJE	Executing	B957	408F	The specified command is not supported for the FC port.
CMDRJE	Executing	B957	40FD	The attribute of the specified port is Initiator or External.
CMDRJE	Executing	B957	47E4	The specified iSCSI target is not registered.
CMDRJE	Executing	B957	47E8	The character used for the user ID, or the number of characters is invalid.
CMDRJE	Executing	B957	47EC	The specified CHAP user name is not registered.
CMDRJE	Executing	B957	47EE	The iSCSI target cannot be set because the user authentication of the iSCSI target is invalid.
CMDRJE	Executing	B980	B901	The command was rejected because the specified port is for NAS platform (System LU).
CMDRJE	Executing	B980	B902	The command was rejected because the specified port is for NAS platform (User LU).

SSB codes returned by raidcom send ping

raidcom send ping				
Error message	Executing/ Async	Error code		Description
		SSB1	SSB2	
CMDRJE	Executing	2E00	8400	The value of the specified port is invalid.
CMDRJE	Executing	2E02	8403	The specified virtual port number is out of range.
CMDRJE	Executing	2E10	8400	The specified port is blocked.
CMDRJE	Executing	2E10	8404	The iSCSI virtual port mode for the specified port is disabled.
CMDRJE	Executing	2E10	8405	The IP version of the specified IP address is not enabled.
CMDRJE	Executing	2E11	8004	The operation cannot be performed because the internal processing is in progress.
CMDRJE	Executing	2E11	9400	The command cannot be accepted. After a while, execute the same command.
CMDRJE	Executing	2E20	8400	The specified port is not installed.
CMDRJE	Executing	2E20	8401	The specified virtual port is not defined.
CMDRJE	Executing	2E3F	8000	The specified operation is not supported in the current microcode version.

SSB codes returned by raidcom add rcu_iscsi_port

raidcom add rcu_iscsi_port				
Error message	Executing/ Async	Error code		Description
		SSB1	SSB2	
CMDRJE	Executing	2E00	3005	The product ID is invalid.
CMDRJE	Executing	2E02	9C01	The specified IP address is invalid.
CMDRJE	Executing	2E20	3000	The serial number or product ID of the target storage system is incorrect.
CMDRJE	Executing	2E21	810A	The shared memory is not installed.
CMDRJE	Executing	2E22	3202	The specified RCU port is already registered.

raidcom add rcu_iscsi_port				
Error message	Executing/ Async	Error code		Description
		SSB1	SSB2	
CMDRJE	Executing	2E22	9B02	The total number of registered iSCSI targets and RCU ports in the storage system reached the maximum.
CMDRJE	Executing	2E22	9B03	The total number of registered iSCSI targets and RCU ports per port reached the maximum.
CMDRJE	Executing	2E30	840A	The port attribute is not Initiator (MCU).
CMDRJE	Executing	2E31	8301	The specified port is not a port of the package for iSCSI.
CMDRJE	Executing	B980	B901	The command was rejected because the specified port is for NAS Platform (System LU).
CMDRJE	Executing	B980	B902	The command was rejected because the specified port is for NAS Platform (User LU).

SSB codes returned by raidcom delete rcu_iscsi_port

raidcom delete rcu_iscsi_port				
Error message	Executing/ Async	Error code		Description
		SSB1	SSB2	
CMDRJE	Executing	2E20	3000	The serial number, product ID, or SSID of the target storage system is incorrect.
CMDRJE	Executing	2E20	3201	The specified RCU port is not registered.
CMDRJE	Executing	2E21	3201	Deletion cannot be executed because the RCU path is defined.
CMDRJE	Executing	B980	B901	The command was rejected because the specified port is for NAS Platform (System LU).
CMDRJE	Executing	B980	B902	The command was rejected because the specified port is for NAS Platform (User LU).

SSB codes returned by `raidcom add external_iscsi_name`

raidcom add external_iscsi_name				
Error message	Executing/ Async	Error code		Description
		SSB1	SSB2	
CMDRJE	Executing	2E00	9B01	The specified iSCSI name is invalid.
CMDRJE	Executing	2E02	8403	The specified virtual port number is out of range.
CMDRJE	Executing	2E02	9C01	The specified IP address is invalid.
CMDRJE	Executing	2E10	8404	The iSCSI virtual port mode for the specified port is disabled.
CMDRJE	Executing	2E20	8401	The specified virtual port is not defined.
CMDRJE	Executing	2E21	810A	The shared memory is not installed.
CMDRJE	Executing	2E22	8401	The specified target information is registered for another virtual port under the specified physical port.
CMDRJE	Executing	2E22	9B01	The specified iSCSI target is already registered.
CMDRJE	Executing	2E22	9B02	The total number of registered iSCSI target and RCU port in the storage system reached the maximum.
CMDRJE	Executing	2E22	9B03	The total number of registered iSCSI targets and RCU ports per port reached the maximum.
CMDRJE	Executing	2E30	8400	The port attribute is not External (ELUN).
CMDRJE	Executing	2E31	8301	The specified port is not a port of the package for iSCSI.

SSB codes returned by `raidcom check external_iscsi_name`

raidcom check external_iscsi_name				
Error message	Executing/ Async	Error code		Description
		SSB1	SSB2	
CMDRJE	Executing	2E02	8403	The specified virtual port number is out of range.

raidcom check external_iscsi_name				
Error message	Executing/ Async	Error code		Description
		SSB1	SSB2	
CMDRJE	Executing	2E10	8404	The iSCSI virtual port mode for the specified port is disabled.
CMDRJE	Executing	2E20	8401	The specified virtual port is not defined.
CMDRJE	Executing	2E20	9B01	The specified iSCSI target is not registered.

SSB codes returned by raidcom delete external_iscsi_name

raidcom delete external_iscsi_name				
Error message	Executing/ Async	Error code		Description
		SSB1	SSB2	
CMDRJE	Executing	2E02	8403	The specified virtual port number is out of range.
CMDRJE	Executing	2E10	8404	The iSCSI virtual port mode for the specified port is disabled.
CMDRJE	Executing	2E20	8401	The specified virtual port is not defined.
CMDRJE	Executing	2E20	9B01	The specified iSCSI target is not registered.
CMDRJE	Executing	2E11	4304	The operation cannot be performed because the specified iSCSI target is defined to the external path.

SSB codes returned by raidcom discover external_iscsi_name

raidcom discover external_iscsi_name				
Error message	Executing/ Async	Error code		Description
		SSB1	SSB2	
CMDRJE	Executing	2E02	8403	The specified virtual port number is out of range.
CMDRJE	Executing	2E10	8404	The iSCSI virtual port mode for the specified port is disabled.

raidcom discover external_iscsi_name				
Error message	Executing/ Async	Error code		Description
		SSB1	SSB2	
CMDRJE	Executing	2E11	9B01	Failed to search the iSCSI target. Check the setting of input parameter or the network connection.
CMDRJE	Executing	2E14	9B01	The processing failed because multiple searches for the iSCSI target were executed.
CMDRJE	Executing	2E20	8401	The specified virtual port is not defined.
CMDRJE	Executing	2E30	8400	The port attribute is not External (ELUN).
CMDRJE	Executing	2E31	8301	The specified port is not a port of the package for iSCSI.

SSB codes returned by raidcom modify external_chap_user

raidcom modify external_chap_user				
Error message	Executing/ Async	Error code		Description
		SSB1	SSB2	
CMDRJE	Executing	2E00	9B02	The specified CHAP user or CHAP secret is invalid.
CMDRJE	Executing	2E02	8403	The specified virtual port number is out of range.
CMDRJE	Executing	2E02	9C01	The specified IP address is invalid.
CMDRJE	Executing	2E10	8404	The iSCSI virtual port mode for the specified port is disabled.
CMDRJE	Executing	2E20	8401	The specified virtual port is not defined.
CMDRJE	Executing	2E20	9B01	The specified iSCSI target is not registered.
CMDRJE	Executing	2E21	810A	The shared memory is not installed.
CMDRJE	Executing	2E30	8400	The port attribute is not External (ELUN).

SSB codes returned by raidcom modify initiator_chap_user

raidcom modify initiator_chap_user				
Error message	Executing/ Async	Error code		Description
		SSB1	SSB2	
CMDRJE	Executing	2E00	9B02	The specified CHAP user or CHAP secret is invalid.
CMDRJE	Executing	2E11	4305	The operation cannot be performed because the specified port is defined to the external path.
CMDRJE	Executing	2E21	810A	The shared memory is not installed.
CMDRJE	Executing	2E31	8301	The specified port is not a port of the package for iSCSI.

SSB codes returned by raidcom initialize parity_grp

raidcom initialize parity_grp				
Error message	Executing/ Async	Error code		Description
		SSB1	SSB2	
CMDRJE	Executing	2E00	0101	The parity group number is not in the effective range.
CMDRJE	Executing	2E00	0102	The operation cannot be performed because it is not a parity group.
Get Command Status	Async	2E10	0000	LDEV is used as a ShadowImage pair volume.
Get Command Status	Async	2E10	0001	LDEV is used as a TrueCopy pair volume or Universal Replicator pair volume.
Get Command Status	Async	2E10	0003	LDEV is used as a Compatible FlashCopy [®] V2 relationship.
Get Command Status	Async	2E10	0004	LDEV is used as a Thin Image pair volume or a Copy-on-Write Snapshot pair volume.
Get Command Status	Async	2E10	0008	LDEV is used as a system disk.
Get Command Status	Async	2E10	0010	LDEV is not blocked.

raidcom initialize parity_grp				
Error message	Executing/ Async	Error code		Description
		SSB1	SSB2	
Get Command Status	Async	2E10	0062	LDEV is used as the primary volume of a global-active device (GAD) pair.
Get Command Status	Async	2E10	0063	LDEV is used as the secondary volume of a global-active device (GAD) pair.
Get Command Status	Async	2E10	0100	The formatting operation cannot be performed because the encryption value of the key number that is set to encryption ECC is invalid.
Get Command Status	Async	2E10	0101	The formatting operation cannot be performed because the checksum of the encryption key does not match.
Get Command Status	Async	2E10	0210	The operation cannot be performed because the capacity saving status of LDEV is Failed.
Get Command Status	Async	2E10	6022	The operation cannot be performed because the deduplication system data volume of the pool linked with an LDEV is blocked.
Get Command Status	Async	2E11	0007	LDEV is in shredding.
Get Command Status	Async	2E11	0009	The operation cannot be performed because LDEV is now expanding.
Get Command Status	Async	2E11	001E	The operation cannot be performed because the virtual disk space is blocked.
Get Command Status	Async	2E11	010A	The target parity group is in the state of correction copy.
Get Command Status	Async	2E11	6004	The operation of Dynamic Provisioning V-VOL cannot be performed because there is a blocked pool.
Get Command Status	Async	2E11	6006	The operation of Dynamic Provisioning V-VOL cannot be performed because there is a blocked pool volume.
Get Command Status	Async	2E11	8004	The operation cannot be performed because the internal processing is in progress.
Get Command Status	Async	2E11	8010	The operation cannot be performed because the internal processing is in progress.

raidcom initialize parity_grp				
Error message	Executing/ Async	Error code		Description
		SSB1	SSB2	
CMDRJE	Executing	2E11	9400	The command cannot be accepted. After a while, execute the same command.
CMDRJE Get Command Status	Executing Async	2E13	0102	The operation cannot be performed because there is no LDEV in the parity group.
Get Command Status	Async	2E14	0000	The processing stopped because aborting processing is required.
Get Command Status	Async	2E20	0000	LDEV is not installed.
CMDRJE Get Command Status	Executing Async	2E20	0100	There is no parity group.
Get Command Status	Async	2E30	000A	LDEV is used as a Dynamic Provisioning.
Get Command Status	Async	2E30	000C	LDEV is used as a quorum disk.
Get Command Status	Async	2E30	000E	LDEV is used as a pool volume.
Get Command Status	Async	2E30	000F	LDEV is used as a journal volume.
Get Command Status	Async	2E30	001A	Volume Security is set to LDEV.
Get Command Status	Async	2E30	004E	The Data Retention Utility/Volume Retention Manager attribute of LDEV is enabled.
Get Command Status	Async	2E30	0061	LDEV is a pool volume and the pool volume include the Dynamic Provisioning volume that is not in the blocked status.
Get Command Status	Async	2E30	0074	LDEV cannot be operated because it is an external volume mapped for online data migration.
Get Command Status	Async	2E30	0206	The operation cannot be performed because the LDEV is a deduplication system data volume.

raidcom initialize parity_grp				
Error message	Executing/ Async	Error code		Description
		SSB1	SSB2	
Get Command Status	Async	2E31	0001	Maintenance work cannot be performed because the LDEV is a quorum disk.
CMDRJE Get Command Status	Executing Async	2ECF	FEEC	An internal error occurred. Call customer support.
CMDRJE	Executing	2EF3	0102	The specified parameter is invalid. Check the <i>Command Control Interface Command Reference</i> .

SSB codes returned by raidcom get parity_grp

raidcom get parity_grp				
Error message	Executing/ Async	Error code		Description
		SSB1	SSB2	
CMDRJE	Executing	2ECF	00F1	The operation cannot be executed because the operation is not supported.

SSB codes returned by raidcom modify parity_grp

raidcom modify parity_grp				
Error message	Executing/ Async	Error code		Description
		SSB1	SSB2	
CMDRJE Get Command Status	Executing/ Async	2E00	0101	The parity group number or the external volume group number is not within a valid range.
CMDRJE	Executing	2E00	0102	The specified group type is not correct.
Get Command Status	Async	2E10	0103	The specified operation cannot be performed because the collection copy is in process.
Get Command Status	Async	2E10	0104	The specified operation cannot be performed because the dynamic sparing is in process.

raidcom modify parity_grp				
Error message	Executing/ Async	Error code		Description
		SSB1	SSB2	
Get Command Status	Async	2E10	0105	The specified operation cannot be performed because the copy back is in process.
Get Command Status	Async	2E10	0107	The specified operation cannot be performed because the collection access is in process.
Get Command Status	Async	2E10	0108	The specified parity group is a RAID configuration which cannot be used as the pool vol.
Get Command Status	Async	2E10	010A	The specified operation cannot be performed because the parity group does not support accelerated compression.
Get Command Status	Async	2E10	010B	The operation cannot be performed because data remains in a expanded space of the parity group. Format parity groups.
Get Command Status	Async	2E10	010C	The specified operation cannot be performed because the encryption is enabled.
Get Command Status	Async	2E10	8500	The specified operation cannot be performed because the drive copy is in process.
Get Command Status	Async	2E10	8501	The specified operation cannot be performed because the drive is blocked.
Get Command Status	Async	2E10	8506	The specified operation cannot be performed because the drive's firmware does not support accelerated compression.
Get Command Status	Async	2E11	0057	The specified operation cannot be performed because the LDEV is under format, shredding, or quick format.
Get Command Status	Async	2E11	005A	The specified operation cannot be performed because the pool is used as the pool which is full allocated.
Get Command Status	Async	2E11	005B	The specified operation cannot be performed because the LDEV in the parity group is dispersed in several pools.
Get Command Status	Async	2E11	005C	There is a volume which Data Retention Utility is set in the specified parity group.

raidcom modify parity_grp				
Error message	Executing/ Async	Error code		Description
		SSB1	SSB2	
Get Command Status	Async	2E11	005D	The specified operation cannot be performed because the LDEV is created in the expanded space of the parity group.
Get Command Status	Async	2E11	005E	The specified operation cannot be performed because the LDEV belongs in the blocked pool.
Get Command Status	Async	2E11	0208	The operation cannot be performed because the specified parity group contains an LDEV that is not a pool volume.
Get Command Status	Async	2E11	800F	The operation failed because the DKCMAIN microcode version is mixed.
CMDRJE	Executing	2E11	9400	The command cannot be accepted. After a while, execute the same command.
CMDRJE Get Command Status	Executing/ Async	2E20	0100	There is no parity group.
Get Command Status	Async	2E30	0005	The volume which Cache Residency Manager is configured is available in the specified parity group.
Get Command Status	Async	2E30	0007	The LDEV of which path is defined is available.
Get Command Status	Async	2E30	000F	The LDEV in the specified parity group is used as the journal volume.
Get Command Status	Async	2E30	0038	The LDEV of which size is smaller than the possible value that can be registered to the pool is in the specified parity group.
Get Command Status	Async	2E31	0001	The LDEV in the specified parity group is used as the quorum disk.
Get Command Status	Async	2E31	0201	The LDEV in the specified parity group is used as the pair volume.
Get Command Status	Async	2E31	0202	The LDEV in the specified parity group is mapped for the online data migration.
CMDRJE	Executing/ Async	2ECF	FECC	Internal error occurred. Contact customer support.

raidcom modify parity_grp				
Error message	Executing/ Async	Error code		Description
		SSB1	SSB2	
Get Command Status				
CMDRJE	Executing	2EF3	0102	The specified operation cannot be performed because the operation is not supported.

SSB codes returned by raidcom get local_replica_opt

raidcom get local_replica_opt				
Error message	Executing/ Async	Error code		Description
		SSB1	SSB2	
CMDRJE	Executing	2E3F	8000	The specified operation is not supported in the current microcode version.
CMDRJE	Executing	2EBD	FECC	Internal error occurred.

SSB codes returned by raidcom modify local_replica_opt

raidcom modify local_replica_opt				
Error message	Executing/ Async	Error code		Description
		SSB1	SSB2	
CMDRJE	Executing	2E02	9D01	Multiple option IDs cannot be specified.
CMDRJE	Executing	2E02	9D02	The specified option ID is out of the effective range.
CMDRJE	Executing	2E10	8000	The operation cannot be performed because Storage Navigator or Device Manager - Storage Navigator is in progress, another application is in progress on the SVP, or the configuration is being changed. Wait a while, and then retry the operation.
CMDRJE	Executing	2E11	8019	Shadow Initialize is running.
CMDRJE	Executing	2E21	810A	A shared memory is not installed.

raidcom modify local_replica_opt				
Error message	Executing/ Async	Error code		Description
		SSB1	SSB2	
CMDRJE	Executing	2E3F	8000	The specified operation is not supported in the current microcode version.
CMDRJE	Executing	2EBD	FEEC	Internal error occurred. Contact customer support.
CMDRJE	Executing	2EBE	9E01	The specified parameter is invalid.

SSB codes returned by raidcom add license (VSP Gx00 models and VSP Fx00 models)

raidcom add license				
Error message	Executing/ Async	Error code		Description
		SSB1	SSB2	
CMDRJE	Executing	2EC0	0009	No program product is supported.
CMDRJE	Executing	2EC0	0030	The program product cannot be installed because the history of the trial for the Temporary key remains.
CMDRJE	Executing	2EC0	0051	To install this program product, install or enable the related program products first.
CMDRJE	Executing	2EC0	0052	This program product cannot be installed because it is pre-installed.
CMDRJE	Executing	2EC0	0060	The program product is already installed.
CMDRJE	Executing	2EC0	0081	The specified program product ID is invalid.
CMDRJE	Executing	2EC0	0090	The specified license key code is invalid.
CMDRJE	Executing	2EC0	0091	The serial number is not correct.
CMDRJE	Executing	2EC0	0101	The current DKCMAIN firmware version does not support this program product.
CMDRJE	Executing	2EC0	0102	This program product requires a higher-version hardware product.

SSB codes returned by raidcom delete license (VSP Gx00 models and VSP Fx00 models)

raidcom add license				
Error message	Executing/ Async	Error code		Description
		SSB1	SSB2	
CMDRJE	Executing	2EC0	0103	To use this program product, increase the shared memory allocation, and enable the program product.
CMDRJE	Executing	2EC0	0108	This program product requires another type of DKC.
CMDRJE	Executing	2EC0	010D	The specified program product is not supported.
CMDRJE	Executing	2EC0	0130	The model information for the license key code is not correct.
CMDRJE	Executing	2EC0	0200	The specified number of extended days is shorter than the number of trial days.
CMDRJE	Executing	2EC0	0201	The program product cannot be enabled because the license capacity is insufficient.
CMDRJE	Executing	2EC0	0204	The license capacity is insufficient. The program product is installed, but it will be invalid if the license capacity is not increased before the contract period expires.
CMDRJE	Executing	2EC0	0206	The status of the specified license is already changed or incorrect.
CMDRJE	Executing	2EC0	050C	With the current DKCMAIN firmware version, the program product cannot be installed.
CMDRJE	Executing	2EC0	2E01	The specified operation is not supported in the current microcode version.

SSB codes returned by raidcom delete license (VSP Gx00 models and VSP Fx00 models)

raidcom delete license				
Error message	Executing/ Async	Error code		Description
		SSB1	SSB2	
CMDRJE	Executing	2EC1	0009	No program product is supported.

raidcom delete license				
Error message	Executing/ Async	Error code		Description
		SSB1	SSB2	
CMDRJE	Executing	2EC1	0051	To remove this program product, remove or disable the related program products first.
CMDRJE	Executing	2EC1	0081	The specified program product ID is invalid.
CMDRJE	Executing	2EC1	0104	To remove this program product, the configuration must be changed.
CMDRJE	Executing	2EC1	0105	This program product cannot be removed because it is being used.
CMDRJE	Executing	2EC1	0106	To remove this program product, another program product must be removed or disabled first.
CMDRJE	Executing	2EC1	0107	To remove this program product, another program product must be removed or disabled first.
CMDRJE	Executing	2EC1	010C	Data Retention Utility cannot be deleted because secondary volume rejection or reservation settings remain.
CMDRJE	Executing	2EC1	010D	The specified program product is not supported.
CMDRJE	Executing	2EC1	0206	The status of the specified license is already changed or incorrect.
CMDRJE	Executing	2EC1	0501	The specified program product is already removed.
CMDRJE	Executing	2EC1	050C	With the current DKCMAIN firmware version, the program product cannot be removed.

SSB codes returned by raidcom modify license (VSP Gx00 models and VSP Fx00 models)

raidcom modify license				
Error message	Executing/ Async	Error code		Description
		SSB1	SSB2	
CMDRJE	Executing	2EC2	0009	No program product is supported.

raidcom modify license				
Error message	Executing/ Async	Error code		Description
		SSB1	SSB2	
CMDRJE	Executing	2EC2	0051	To enable or disable this program product, enable or disable the related program products first.
CMDRJE	Executing	2EC2	0081	The specified program product ID is invalid.
CMDRJE	Executing	2EC2	0101	The current DKCMAIN firmware version does not support this program product.
CMDRJE	Executing	2EC2	0102	This program product requires a higher-version hardware product.
CMDRJE	Executing	2EC2	0103	To use this program product, increase the shared memory allocation, and enable the program product.
CMDRJE	Executing	2EC2	0105	This program product cannot be removed because it is being used.
CMDRJE	Executing	2EC2	0106	To disable this program product, another program product must be removed or disabled first.
CMDRJE	Executing	2EC2	0107	To disable this program product, another program product must be removed or disabled first.
CMDRJE	Executing	2EC2	0108	This program product requires another type of DKC.
CMDRJE	Executing	2EC2	010C	Data Retention Utility cannot be deleted because secondary volume rejection or reservation settings remain.
CMDRJE	Executing	2EC2	010D	The specified program product is not supported.
CMDRJE	Executing	2EC2	0205	The program product was removed because the Term license had expired.
CMDRJE	Executing	2EC2	0206	The status of the specified license is already changed or incorrect.
CMDRJE	Executing	2EC2	0503	The specified operation cannot be performed because the key type is incorrect.
CMDRJE	Executing	2EC2	050C	The current DKCMAIN firmware version cannot enable or disable the program product.

SSB codes returned by raidcom initialize pool

raidcom initialize pool				
Error message	Executing/ Async	Error code		Description
		SSB1	SSB2	
CMDRJE	Executing	2E00	6000	The value of the specified ID is out of range.
Get Command Status	Async	2E10	0001	The volume defined in specified pool is used as a TrueCopy pair.
Get Command Status	Async	2E10	0002	The volume defined in specified pool is used as a Universal Replicator pair.
Get Command Status	Async	2E10	0004	The volume defined in specified pool is used as a Thin Image pair.
Get Command Status	Async	2E10	0005	The volume defined in specified pool is used as a Volume Migration volume.
Get Command Status	Async	2E10	0213	The volume defined in specified pool is used as a global-active device (GAD) pair.
Get Command Status	Async	2E10	0216	The volume defined in specified pool is used as a ShadowImage pair.
Get Command Status	Async	2E10	600B	The specified pool is blocked.
Get Command Status	Async	2E10	600D	The specified pool is shrinking.
Get Command Status	Async	2E10	6020	The specified pool is in deduplication disabled.
Get Command Status	Async	2E10	6023	The specified pool is being created or expanded.
Get Command Status	Async	2E10	6024	The specified pool is being deleted.
Get Command Status	Async	2E11	0204	The deduplication system data volume defined in the specified pool or the volume for which the deduplication function is enabled is not blocked.
CMDRJE	Executing	2E11	9400	The command cannot be accepted. Wait a while and issue the same command.
CMDRJE	Executing / Async	2E20	6000	The specified pool is not installed.

raidcom initialize pool				
Error message	Executing/ Async	Error code		Description
		SSB1	SSB2	
Get Command Status				
Get Command Status	Async	2E21	8101	The control memory or shared memory for Dynamic Provisioning is not installed.
Get Command Status	Async	2E30	000F	The volume defined in specified pool is used as a journal volume.
CMDRJE	Executing	2EE7	00F0	The specified command cannot be accepted because the command is not supported.
CMDRJE Get Command Status	Executing / Async	2EE7	FEEC	The internal error occurs. Contact customer support.

SSB codes returned by `raidcom add parity_grp` (VSP Gx00 models, VSP Fx00 models)

raidcom add parity_grp				
Error message	Executing/ Async	Error code		Description
		SSB1	SSB2	
CMDRJE Get Command Status	Executing/ Async	2E00	000D	The emulation type is incorrect.
CMDRJE Get Command Status	Executing/ Async	2E00	0101	The parity group number is not in the effective range.
CMDRJE Get Command Status	Executing/ Async	2E00	0108	The RAID type of the specified parity group is not correct.
CMDRJE Get Command Status	Executing/ Async	2E00	7000	The specified CLPR ID is out of the range.
CMDRJE	Executing	2E00	8500	The specified drive box or drive is not correct.

raidcom add parity_grp				
Error message	Executing/ Async	Error code		Description
		SSB1	SSB2	
Get Command Status	Async	2E02	0101	A parity group in which encryption and accelerated compression are enabled cannot be created.
Get Command Status	Async	2E02	8501	The specified drive has different drive type codes.
Get Command Status	Async	2E10	0109	The parity group cannot be created because the parity group which is specified to be combined contains parity groups that do not support accelerated compression.
Get Command Status	Async	2E10	010A	The specified operation cannot be performed because the parity group does not support accelerated compression.
Get Command Status	Async	2E10	8003	The specified operation cannot be performed because the storage system is being turned off.
Get Command Status	Async	2E10	8500	The specified operation cannot be performed because the drive copy is in process.
Get Command Status	Async	2E10	8501	The specified operation cannot be performed because the drive is blocked.
Get Command Status	Async	2E10	8503	The specified drive is already used.
Get Command Status	Async	2E10	8505	The parity group cannot be created because some of the specified drives do not support accelerated compression.
Get Command Status	Async	2E10	8506	The specified operation cannot be performed because the drive's firmware version does not support accelerated compression.
Get Command Status	Async	2E11	0001	The specified operation cannot be performed because the LDEV is being verified.
Get Command Status	Async	2E11	0056	The specified operation cannot be performed because data in the cache is corrupted.
Get Command Status	Async	2E11	0057	The specified operation cannot be performed because the LDEV is under format, shredding, or quick format.

raidcom add parity_grp				
Error message	Executing/ Async	Error code		Description
		SSB1	SSB2	
Get Command Status	Async	2E11	0109	The entered parity group ID is already used.
Get Command Status	Async	2E11	8012	The specified operation cannot be performed because the power condition of the drive box is abnormal.
Get Command Status	Async	2E11	8013	The specified operation cannot be performed because storage system is in process.
Get Command Status	Async	2E11	8102	The specified operation cannot be performed because cache memory is blocked.
Get Command Status	Async	2E11	810A	The specified operation cannot be performed because the cache status is abnormal.
Get Command Status	Async	2E11	8200	The specified operation cannot be performed because the MP unit status is being changed.
Get Command Status	Async	2E11	8201	The specified operation cannot be performed because the MP unit is blocked.
Get Command Status	Async	2E11	8301	The specified operation cannot be performed because DKB is being transferred.
Get Command Status	Async	2E11	8302	The specified operation cannot be performed because CHB is being transferred.
Get Command Status	Async	2E11	8311	The specified operation cannot be performed because DKB is blocked.
Get Command Status	Async	2E11	8312	The specified operation cannot be performed because CHB is blocked.
Get Command Status	Async	2E11	8400	The specified operation cannot be performed because the port is blocked.
Get Command Status	Async	2E11	9400	The command cannot be accepted. After a while, execute the same command.
Get Command Status	Async	2E11	9A00	The encryption key cannot be obtained from the key management server.
Get Command Status	Async	2E11	9A01	The specified operation cannot be performed because the unused encryption keys have run out.

raidcom add parity_grp				
Error message	Executing/ Async	Error code		Description
		SSB1	SSB2	
Get Command Status	Async	2E20	7001	The specified CLPR is not installed.
Get Command Status	Async	2E20	8501	The specified drive is not installed.
CMDRJE Get Command Status	Executing/ Async	2EC4	FECC	An internal error occurred. Contact customer support.

SSB codes returned by raidcom delete parity_grp (VSP Gx00 models and VSP Fx00 models)

raidcom delete parity_grp				
Error message	Executing/ Async	Error code		Description
		SSB1	SSB2	
CMDRJE Get Command Status	Executing/ Async	2E00	0101	The parity group number is not within the valid range.
Get Command Status	Async	2E10	0000	The specified parity group contains LDEVs used by another program product.
Get Command Status	Async	2E10	0001	The specified parity group contains an LDEV used as a TrueCopy or Universal Replicator pair.
Get Command Status	Async	2E10	0062	The specified parity group contains an LDEV used as the P-VOL of a GAD pair.
Get Command Status	Async	2E10	0063	The specified parity group contains an LDEV used as the S-VOL of a GAD pair.
Get Command Status	Async	2E02	0100	The specified operation cannot be performed because the encryption value of the key number that is set to encryption ECC is invalid.
Get Command Status	Async	2E10	0101	The specified operation cannot be performed because the checksum of the encryption key is not coincident.

raidcom delete parity_grp				
Error message	Executing/ Async	Error code		Description
		SSB1	SSB2	
Get Command Status	Async	2E10	8003	The specified operation cannot be performed because the storage system is being turned off.
Get Command Status	Async	2E10	8500	The specified operation cannot be performed because the drive copy is in process.
Get Command Status	Async	2E10	8501	The specified operation cannot be performed because the drive is blocked.
Get Command Status	Async	2E11	0001	The specified operation cannot be performed because the LDEV is being verified.
Get Command Status	Async	2E11	0056	The specified operation cannot be performed because data in the cache is corrupted.
Get Command Status	Async	2E11	0057	The specified operation cannot be performed because the LDEV is under format, shredding, or quick format.
Get Command Status	Async	2E11	0058	The specified operation cannot be performed because the specified parity group is using a spare drive.
Get Command Status	Async	2E11	2206	You do not have the operation authority to operate the target resource group. Specify the resource group that is allocated to the user group as the operation target, or set the operation authority to the user group in order to operate the target resource group.
Get Command Status	Async	2E11	8012	The specified operation cannot be performed because the power condition of the drive box is abnormal.
Get Command Status	Async	2E11	8013	The specified operation cannot be performed because storage system is in process.
Get Command Status	Async	2E11	8102	The specified operation cannot be performed because cache memory is blocked.
Get Command Status	Async	2E11	810A	The specified operation cannot be performed because the cache status is abnormal.
Get Command Status	Async	2E11	8200	The specified operation cannot be performed because the MP unit status is being changed.

raidcom delete parity_grp				
Error message	Executing/ Async	Error code		Description
		SSB1	SSB2	
Get Command Status	Async	2E11	8201	The specified operation cannot be performed because the MP unit is blocked.
Get Command Status	Async	2E11	8301	The specified operation cannot be performed because DKB is being transferred.
Get Command Status	Async	2E11	8302	The specified operation cannot be performed because CHB is being transferred.
Get Command Status	Async	2E11	8311	The specified operation cannot be performed because DKB is blocked.
Get Command Status	Async	2E11	8312	The specified operation cannot be performed because CHB is blocked.
Get Command Status	Async	2E11	8400	The specified operation cannot be performed because the port is blocked.
Get Command Status	Async	2E11	9400	The command cannot be accepted. After a while, execute the same command.
Get Command Status	Async	2E11	9A00	The encryption key cannot be obtained from the key management server.
Get Command Status	Async	2E11	9A01	The specified operation cannot be performed because the unused encryption keys have run out.
Get Command Status	Async	2E14	0101	The operation cannot be continued because an error occurred while the command for deleting a parity group was being executed. Check if the parity group is deleted. If it is not deleted, execute the command again. If this problem occurs again, contact customer support.
Get Command Status	Async	2E20	0100	The parity group is not found.
Get Command Status	Async	2E30	0007	The specified parity group contains LDEVs for which LU path is already defined.
Get Command Status	Async	2E30	000E	The operation failed because the specified parity group contains a pool volume of Dynamic Provisioning.

SSB codes returned by the raidcom add clpr command (VSP Gx00 models and VSP Fx00 models)

raidcom delete parity_grp				
Error message	Executing/ Async	Error code		Description
		SSB1	SSB2	
Get Command Status	Async	2E30	000F	The specified parity group contains an LDEV which is already used as a journal volume or a data volume.
Get Command Status	Async	2E30	004E	The specified parity group contains a Data Retention Utility/Volume Retention Manager attribute device.
Get Command Status	Async	2E30	0060	The LDEV in the specified parity group is used as a command device that is used in the extended consistency group.
Get Command Status	Async	2E30	0095	The specified parity group cannot be deleted because it contains the remote command device which is used for the mirror of the journal group.
CMDRJE Get Command Status	Executing/ Async	2EC4	FECC	An internal error occurred. Contact customer support.

SSB codes returned by the raidcom add clpr command (VSP Gx00 models and VSP Fx00 models)

raidcom add clpr				
Error message	Executing/ Async	Error code		Description
		SSB1	SSB2	
CMDRJE	Executing	2E02	7001	CLPR 0 is specified.
Get Command Status	Executing/ Async	2E02	7002	The number of characters of the specified CLPR name is invalid.
Get Command Status	Executing/ Async	2E02	7003	The specified CLPR name contains characters other than alphanumeric characters.
Get Command Status	Executing/ Async	2E02	7004	The CLPR capacity of CLPR0 is out of the range.
Get Command Status	Executing/ Async	2E02	7005	The value set for the specified CLPR capacity is out of the range.

raidcom add clpr				
Error message	Executing/ Async	Error code		Description
		SSB1	SSB2	
Get Command Status	Executing/ Async	2E02	7006	The specified CLPR name is reserved for the storage system.
Get Command Status	Executing/ Async	2E11	7001	The specified CLPR name is duplicated.
Get Command Status	Executing/ Async	2E11	7002	The number of characters of the specified CLPR name is invalid.
Get Command Status	Executing/ Async	2E11	7003	The capacity of the CLPR is being changed.
Get Command Status	Executing/ Async	2E11	7004	The resource of the CLPR is being moved.

SSB codes returned by `raidcom reset command_status` command

raidcom reset command_status				
Error message	Executing/ Async	Error code		Description
		SSB1	SSB2	
CMDRJE Get Command Status	Executing/ Async	2EF1	000C	The operation cannot be performed because the internal processing is in progress. After a while, perform the operation again.
CMDRJE Get Command Status	Executing/ Async	2EF1	000E	The specified request ID is invalid.
CMDRJE Get Command Status	Executing/ Async	2EF1	000F	The operation cannot be performed because a request ID managed by another session is specified.
CMDRJE Get Command Status	Executing/ Async	2EF1	0010	The operation cannot be performed because the specified request ID is being executed.

SSB codes returned by the raidcom add clpr command (VSP Gx00 models and VSP Fx00 models)

raidcom add clpr				
Error message	Executing/ Async	Error code		Description
		SSB1	SSB2	
CMDRJE	Executing	2E02	7001	CLPR 0 is specified.
Get Command Status	Executing/ Async	2E02	7002	The number of characters of the specified CLPR name is invalid.
Get Command Status	Executing/ Async	2E02	7003	The specified CLPR name contains characters other than alphanumeric characters.
Get Command Status	Executing/ Async	2E02	7004	The CLPR capacity of CLPR0 is out of the range.
Get Command Status	Executing/ Async	2E02	7005	The value set for the specified CLPR capacity is out of the range.
Get Command Status	Executing/ Async	2E02	7006	The specified CLPR name is reserved for the storage system.
Get Command Status	Executing/ Async	2E11	7001	The specified CLPR name is duplicated.
Get Command Status	Executing/ Async	2E11	7002	The number of characters of the specified CLPR name is invalid.
Get Command Status	Executing/ Async	2E11	7003	The capacity of the CLPR is being changed.
Get Command Status	Executing/ Async	2E11	7004	The resource of the CLPR is being moved.

SSB codes returned by the raidcom delete clpr command (VSP Gx00 models and VSP Fx00 models)

raidcom delete clpr				
Error message	Executing/ Async	Error code		Description
		SSB1	SSB2	
CMDRJE	Executing	2E02	7001	CLPR 0 is specified.
Get Command Status	Executing/ Async	2E02	7002	The number of characters of the specified CLPR name is invalid.

raidcom delete clpr				
Error message	Executing/ Async	Error code		Description
		SSB1	SSB2	
Get Command Status	Executing/ Async	2E02	7003	The specified CLPR name contains characters other than alphanumeric characters.
Get Command Status	Executing/ Async	2E11	7002	The number of characters of the specified CLPR name is invalid.
Get Command Status	Executing/ Async	2E11	7003	The capacity of the CLPR is being changed.
Get Command Status	Executing/ Async	2E11	7004	The resource of the CLPR is being moved.
Get Command Status	Executing/ Async	2E13	7001	A parity group or virtual volume is allocated to the specified CLPR.
Get Command Status	Executing/ Async	2E20	7002	The specified CLPR is not installed.
Get Command Status	Executing/ Async	2E20	7002	The specified CLPR is already installed.
Get Command Status	Executing/ Async	2E23	7001	The number of CLPRs that can be installed is exceeded.

Other SSB codes indicating internal errors

The error codes (SSB1) listed below in the table indicate internal errors. For your confirmation, contact customer support.

Error codes		Description
SSB1	SSB2	
2EBB	XXXX	An internal error occurred. Contact customer support.
2EBD	XXXX	An internal error occurred. Contact customer support.
2EBE	XXXX	An internal error occurred. Contact customer support.
2EBF	XXXX	An internal error occurred. Contact customer support.
2EC3	XXXX	An internal error occurred. Contact customer support.
2EC4	XXXX	An internal error occurred. Contact customer support.

Error codes		Description
SSB1	SSB2	
2EC5	XXXX	An internal error occurred. Contact customer support.
2EC6	XXXX	An internal error occurred. Contact customer support.
2EC8	XXXX	An internal error occurred. Contact customer support.
2EC9	XXXX	An internal error occurred. Contact customer support.
2ECA	XXXX	An internal error occurred. Contact customer support.
2ECC	XXXX	An internal error occurred. Contact customer support.
2ECD	XXXX	An internal error occurred. Contact customer support.
2ECE	XXXX	An internal error occurred. Contact customer support.
2ECF	XXXX	An internal error occurred. Contact customer support.
2ED0	XXXX	An internal error occurred. Contact customer support.
2ED6	XXXX	An internal error occurred. Contact customer support.
2EDA	XXXX	An internal error occurred. Contact customer support.
2EDB	XXXX	An internal error occurred. Contact customer support.
2EE4	XXXX	An internal error occurred. Contact customer support.
2EE6	XXXX	An internal error occurred. Contact customer support.
2EE7	XXXX	An internal error occurred. Contact customer support.
2EE8	XXXX	An internal error occurred. Contact customer support.
2EEA	XXXX	An internal error occurred. Contact customer support.
2EEC	XXXX	An internal error occurred. Contact customer support.
2EEE	XXXX	An internal error occurred. Contact customer support.
2EEF	XXXX	An internal error occurred. Contact customer support.
2EF0	XXXX	An internal error occurred. Contact customer support.
2EF6	XXXX	An internal error occurred. Contact customer support.
2EXX	FECC	An internal error occurred. Contact customer support.

Calling customer support

If you need to contact customer support, please provide as much information about the problem as possible, including:

- The circumstances surrounding the error or failure.
- The exact content of any error messages displayed on the host systems.
- The exact content of any error messages displayed by Storage Navigator.
- The Storage Navigator configuration information (use the Dump Tool).
- The data in the CCI error log file and trace data (all files in the HORCM_LOG directory).
- The service information messages (SIMs), including reference codes and severity levels, displayed by Storage Navigator.

The Hitachi Vantara customer support staff is available 24 hours a day, seven days a week. To contact technical support, log on to Hitachi Vantara Support Connect for contact information: https://support.hitachivantara.com/en_us/contact-us.html

Glossary

Index

A

- alternate command device
 - defining 36
- asynchronous commands
 - list of provisioning 177
 - processing 23, 176
- authorities for commands and operations 101

C

- cascading connections
 - and configuration files 67
 - configuration files 69
- cascading pairs 264
- cascading volumes
 - restrictions 265
- CCI functions 22
- cluster manager 267
- command device
 - alternate 35
 - guarding 33
 - instance number 34
- command execution modes 116
- command parameter, HORCM_CMD (in-band 48
- command parameter, HORCM_CMD (out-of-band 53
- commands
 - authorities 101
 - error logging for audit 82
 - error messages and troubleshooting 372
 - examples 340
 - execution modes 23
 - in-band execution 90
 - out-of-band execution 90
 - processing asynchronously 176
 - processing synchronously 176
- configuration check 125
- configuration definition file
 - examples 43
- configuration definition file settings
 - cascading connections 67, 69
 - HORCM_ALLOW_INST 62

- configuration definition file settings (*continued*)
 - HORCM_CMD (in-band 48
 - HORCM_CMD (out-of-band 53
 - HORCM_DEV 56
 - HORCM_INST 59
 - HORCM_INSTP 62
 - HORCM_LDEV 60
 - HORCM_LDEVG 61
 - HORCM_MON 47
- configuration file
 - parameters 43
- configuration file parameters 43
- configuration setting commands, raidcom 23
- consistency groups 284
- copy groups
 - defining 136
 - deleting 140
 - deleting LDEV 139

D

- data protection
 - command compatibility 332
 - configuration examples 329
 - defining command device 338
 - environment variables 338
 - facility 327
 - parameters 326
 - permission command 332
 - permitting protected volumes 335
 - specifications 328
- data protection operations 323
- data replication operations 259
- Data Retention Utility
 - how it works 323
 - restrictions on volumes 324
- Database Validator
 - how it works 325
 - restrictions 325
- definition file, configuration
 - parameters 43
- definition file, configuration parameters 43

- device groups
 - definition methods 130
 - deleting 135
 - settings and read operations 130
- device parameter, HORCM_DEV 56
- discovering remote volumes 319
- dual pathing on Solaris 32
- duplicated mirroring 263

E

- endian
 - little vs big 42
- environment variables for data protection 338
- environment variables for log directories 79
- error codes
 - horctakeover and pair
 - commands:troubleshooting 390
 - raidscan, raidqry, raidar, horcctl:troubleshooting 392
 - troubleshooting 370, 393
- error messages
 - troubleshooting 370
- examples
 - directory mound for Windows 352
 - GPT disk for Windows 351
 - group version control for mixed storage system configurations 340
 - LDM volume discovery and flushing for Windows 341
 - mountvol attached to Windows 344
 - signature changing facility for Windows 348
 - SLPR configuration 359
 - specify host group 355
 - system buffer flushing 344
 - volume discovery 341
- external volumes
 - creating using Fibre Channel 224
 - creating using iSCSI 227
 - operations 224

F

- fence level settings 290, 292
- fibre channel failure 290
- files
 - log and trace files 79
 - OpenVMS 77
 - UNIX 72
 - user-created scripts 88, 89
 - Windows 74

H

- HORCM_ALLOW_INST 62
- HORCM_CMD (in-band) 48
- HORCM_CMD (out-of-band) 53
- HORCM_DEV 56
- HORCM_INST 59
- HORCM_INSTP 62
- HORCM_LDEV 60
- HORCM_LDEVG 61
- HORCM_MON 47
- horcm.conf file 307
- host components
 - and pairing 42
 - HORCM 39
 - instance configurations 40
- host group check 123

I

- in-band
 - command execution 90
- in-system replication 29
- instance number 34
- instance parameter, HORCM_INST 59
- internal volumes
 - creating 197, 202
 - operations 197
- iSCSI virtual port mode
 - disabling 223
 - enabling 222
- iSCSI virtual port number
 - deleting 223
 - setting 222

L

- LDEV
 - adding 133
 - check 118
 - deleting 134
- LDEV group function 127
- LDEV group parameter, HORCM_LDEVG 61
- LDEV grouping 28
- LDEV nickname 28, 180
- LDEV parameter, HORCM_LDEV 60
- line-by-line mode 23, 116
- log and trace files
 - command error logging for audit 82
- log files
 - environment variables for log directories 79
 - names and locations 79

logging command errors for audit 82

M

mirror descriptors

and volumes 328

configuration file correspondence 63

mirroring

duplicated 263

monitor parameter, HORCM_MON 47

MxN configuration and control 305

O

OpenVMS

files 77

starting up one instance 170

starting up two instances 171

Oracle

protection of volume 325

restrictions with Database Validator 325

out-of-band

command execution 90

P

pairedisplay examples on HOST1 and HOST2 69

paired volumes 260

parameters, configuration 43

permission command and data protection 332

port check 121

precheck 24

provisioning operations 175

R

raidcom command

configuration setting command 23

remote command device

defining 36

replication 305

remote replication 30

remote volume discovery 319

replication

cascading pairs 264

cascading volumes 265

duplicated mirroring 263

in-system 29

local system configuration 274

operations 259, 275

pair status 276

paired volumes 284

replication (*continued*)

remote 30

remote system configuration 273

requirements 261

sidefile cache 287

volume status 276

resource group locking 29

resource lock function 115

restrictions

cascading volumes 265

CCI operations 366

Data Retention Utility 324

Database Validator 325

replication 284

Volume Migration 305

S

script files

content checking 118

SCSI command interface

command competition 38

command flow 38

LDEVs 38

SCSI commands 37

sidefile

cache 287

SLPR

configuration examples 359

security 357

security:specify SLPR protection facility 358

Solaris

dual pathing 32

SSB codes

troubleshooting 395

starting

as a service on Windows 172

one instance on OpenVMS 170

one instance on UNIX 168

one instance on Windows 169

two instance on OpenVMS 171

two instances on UNIX 168

two instances on Windows 170

synchronous commands

processing 176

system log messages

troubleshooting 370

T

takeover commands 267

trace control command 82

- trace files
 - trace control command [82](#)
- transaction mode [23](#), [24](#), [116](#)
- troubleshooting
 - command error codes [372](#)
 - error messages and error codes [370](#)
 - general [363](#)
 - generic error codes (horctakeover and pair commands) [390](#), [395](#)
 - generic error codes (raidscan, raidqry, raidar, horcctl) [392](#)
 - notes and restrictions [366](#)
 - specific codes [393](#)
 - system log messages [370](#)

U

- UNIX
 - files [72](#)
 - starting up one instance [168](#)
 - starting up two instances [168](#)
- user authentication
 - command operation [97](#)

V

- virtual port mode
 - disabling [223](#)
 - enabling [222](#)
- virtual port number
 - deleting [223](#)
 - setting [222](#)
- virtual volumes
 - creating [204](#), [216](#)
 - operations [204](#), [215](#)
- volume migration
 - commands [299](#)
 - configurations [298](#)
 - controlling [297](#)
 - specifications [298](#)
- volumes
 - restrictions using Data Retention Utility [324](#)

W

- Windows
 - files [74](#)
 - starting as a service [172](#)
 - starting up one instance [169](#)
 - starting up two instances [170](#)

Hitachi Vantara Corporation



Corporate Headquarters

2845 Lafayette Street

Santa Clara, CA 95050-2639 USA

www.HitachiVantara.com | community.HitachiVantara.com

Regional Contact Information

Americas: +1 866 374 5822 or info@hitachivantara.com

Europe, Middle East, and Africa: +44 (0) 1753 618000 or info@emea@hitachivantara.com

Asia Pacific: + 852 3189 7900 or info.marketing.apac@hitachivantara.com