

COMPUTERS & STRUCTURES, INC.

STRUCTURAL AND EARTHQUAKE ENGINEERING SOFTWARE

SAP2000® version
19
Integrated Solution for
Structural Analysis and Design

Concrete Frame Design Manual

Eurocode 2-2004 with 8-2004





Concrete Frame Design Manual

Eurocode 2-2004

with

Eurocode 8-2004

For SAP2000®

COPYRIGHT

Copyright © Computers and Structures, Inc., 1978-2017
All rights reserved.

The CSI Logo® and CSiBridge® are registered trademarks of Computers and Structures, Inc. Watch & Learn™ is a trademark of Computers and Structures, Inc.

The computer program CSiBridge® and all associated documentation are proprietary and copyrighted products. Worldwide rights of ownership rest with Computers and Structures, Inc. Unlicensed use of these programs or reproduction of documentation in any form, without prior written authorization from Computers and Structures, Inc., is explicitly prohibited.

No part of this publication may be reproduced or distributed in any form or by any means, or stored in a database or retrieval system, without the prior explicit written permission of the publisher.

Further information and copies of this documentation may be obtained from:

Computers and Structures, Inc.

www.csiamerica.com

info@csiamerica.com (for general information)

support@csiamerica.com (for technical support questions)

DISCLAIMER

CONSIDERABLE TIME, EFFORT AND EXPENSE HAVE GONE INTO THE DEVELOPMENT AND TESTING OF THIS SOFTWARE. HOWEVER, THE USER ACCEPTS AND UNDERSTANDS THAT NO WARRANTY IS EXPRESSED OR IMPLIED BY THE DEVELOPERS OR THE DISTRIBUTORS ON THE ACCURACY OR THE RELIABILITY OF THIS PRODUCT.

THIS PRODUCT IS A PRACTICAL AND POWERFUL TOOL FOR STRUCTURAL DESIGN. HOWEVER, THE USER MUST EXPLICITLY UNDERSTAND THE BASIC ASSUMPTIONS OF THE SOFTWARE MODELING, ANALYSIS, AND DESIGN ALGORITHMS AND COMPENSATE FOR THE ASPECTS THAT ARE NOT ADDRESSED.

THE INFORMATION PRODUCED BY THE SOFTWARE MUST BE CHECKED BY A QUALIFIED AND EXPERIENCED ENGINEER. THE ENGINEER MUST INDEPENDENTLY VERIFY THE RESULTS AND TAKE PROFESSIONAL RESPONSIBILITY FOR THE INFORMATION THAT IS USED.

Contents

Chapter 1	Introduction	
	1.1 Organization	1-2
	1.2 Recommended Reading/Practice	1-2
Chapter 2	Design Prerequisites	
	2.1 Design Load Combinations	2-1
	2.2 Design and Check Stations	2-3
	2.3 Identifying Beams and Columns	2-3
	2.4 Design of Beams	2-3
	2.5 Design of Columns	2-4
	2.6 P-Delta Effects	2-5
	2.7 Element Unsupported Lengths	2-5
	2.8 Choice of Input Units	2-6
Chapter 3	Design Process	
	3.1 Notation	3-1

3.2	Assumptions / Limitations	3-4
3.3	Design Load Combinations	3-5
3.4	Column Design	3-8
3.4.1	Generation of Biaxial Interaction Surface	3-9
3.4.2	Calculate Column Capacity Ratio	3-12
3.4.3	Design Longitudinal Reinforcement	3-18
3.4.4	Design Column Shear Reinforcement	3-18
3.5	Beam Design	3-22
3.5.1	Design Beam Flexural Reinforcement	3-22
3.5.2	Design Beam Shear Reinforcement	3-30
3.5.3	Design Beam Torsion Reinforcement	3-33
Chapter 4	Seismic Provisions	
4.1	Notations	4-2
4.2	Design Preferences	4-3
4.3	Overwrites	4-3
4.4	Supported Framing Types	4-4
4.5	Member Design	4-4
4.5.1	Ductility Class High – Moment-Resisting Frames	4-4
4.5.2	Ductility Class Medium – Moment-Resisting Frames	4-20
4.5.3	Ductility Class Low – Moment-Resisting Frames	4-24
4.5.4	Special Consideration for Seismic Design	4-25
Appendix A	Second Order P-Delta Effects	
Appendix B	Member Unsupported Lengths and Computation of β-Factors	
Appendix C	Concrete Frame Design Preferences	
Appendix D	Concrete Frame Overwrites	
Appendix E	Error Messages and Warnings	
Appendix F	Nationally Determined Parameters (NDPs)	
	References	

Chapter 1

Introduction

The design of concrete frames is seamlessly integrated within the program. Initiation of the design process, along with control of various design parameters, is accomplished using the Design menu.

Automated design at the object level is available for any one of a number of user-selected design codes, as long as the structure has first been modeled and analyzed by the program. Model and analysis data, such as material properties and member forces, are recovered directly from the model database, and no additional user input is required if the design defaults are acceptable.

The design is based on a set of user-specified loading combinations. However, the program provides default load combinations for each design code supported. If the default load combinations are acceptable, no definition of additional load combinations is required.

In the design of columns, the program calculates the required longitudinal and shear reinforcement. However, the user may specify the longitudinal steel, in which case a column capacity ratio is reported. The column capacity ratio gives an indication of the load condition with respect to the capacity of the column.

The biaxial column capacity check is based on the generation of consistent three-dimensional interaction surfaces. It does not use any empirical formulations that extrapolate uniaxial interaction curves to approximate biaxial action.

Interaction surfaces are generated for user-specified column reinforcing configurations. The column configurations may be rectangular, square, or circular, with similar reinforcing patterns. The calculation of second order moments, unsupported lengths, and material partial factors is automated in the algorithm.

Every beam member is designed for flexure, shear, and torsion at output stations along the beam span.

Input and output data can be presented graphically on the model, in tables, or on the calculation sheet prepared for each member. For each presentation method, the data is in a format that allows the engineer to quickly study the stress conditions that exist in the structure and, in the event the member reinforcing is not adequate, aids the engineer in taking appropriate remedial measures, including altering the design member without rerunning the entire analysis.

1.1 Organization

This manual is designed to help you quickly become productive with the concrete frame design options of Eurocode 2-2004. Chapter 2 provides detailed descriptions of the Design Prerequisites used for Eurocode 2-2004. Chapter 3 provides detailed descriptions of the code-specific process used for Eurocode 2-2004. Chapter 4 provides a detailed description of the algorithms related to seismic provisions in the design/check of structures in accordance with EN 1998-1:2004 – Eurocode 8. The appendices provide details on certain topics referenced in this manual.

1.2 Recommended Reading/Practice

It is strongly recommended that you read this manual and review any applicable “Watch & Learn” Series™ tutorials, which can be found on our web site, www.csiamerica.com, before attempting to design a concrete frame. Additional information can be found in the on-line Help facility available from within the program’s main menu.

Chapter 2

Design Prerequisites

This chapter provides an overview of the basic assumptions, design preconditions, and some of the design parameters that affect the design of concrete frames.

In writing this manual it has been assumed that the user has an engineering background in the general area of structural reinforced concrete design and familiarity with the Eurocode 2-2004 design code and the seismic provisions in the design/check of structures in accordance with EN 1998-1:2004 Eurocode 8.

2.1 Design Load Combinations

The design load combinations are used for determining the various combinations of the load cases for which the structure needs to be designed/checked. The load combination factors to be used vary with the selected design code. The load combination factors are applied to the forces and moments obtained from the associated load cases and are then summed to obtain the factored design forces and moments for the load combination.

For multi-valued load combinations involving response spectrum, time history, moving loads and multi-valued combinations (of type enveloping, square-root of the sum of the squares or absolute) where any correspondence between interacting quantities is lost, the program automatically produces multiple sub

combinations using maxima/minima permutations of interacting quantities. Separate combinations with negative factors for response spectrum cases are not required because the program automatically takes the minima to be the negative of the maxima for response spectrum cases and the previously described permutations generate the required sub combinations.

When a design combination involves only a single multi-valued case of time history or moving load, further options are available. The program has an option to request that time history combinations produce sub combinations for each time step of the time history. Also, an option is available to request that moving load combinations produce sub combinations using maxima and minima of each design quantity but with corresponding values of interacting quantities.

For normal loading conditions involving static dead load, live load, wind load, and earthquake load, or dynamic response spectrum earthquake load, the program has built-in default loading combinations for each design code. These are based on the code recommendations and are documented for each code in the corresponding manual.

For other loading conditions involving moving load, time history, pattern live loads, separate consideration of roof live load, snow load, and so on, the user must define design loading combinations either in lieu of or in addition to the default design loading combinations.

The default load combinations assume all static load cases declared as dead load to be additive. Similarly, all cases declared as live load are assumed additive. However, each static load case declared as wind or earthquake, or response spectrum cases, is assumed to be non additive with each other and produces multiple lateral load combinations. Also, wind and static earthquake cases produce separate loading combinations with the sense (positive or negative) reversed. If these conditions are not correct, the user must provide the appropriate design combinations.

The default load combinations are included in the design if the user requests them to be included or if no other user-defined combinations are available for concrete design. If any default combination is included in design, all default combinations will automatically be updated by the program any time the design code is changed or if static or response spectrum load cases are modified.

Live load reduction factors can be applied to the member forces of the live load case on an element-by-element basis to reduce the contribution of the live load to the factored loading.

The user is cautioned that if moving load or time history results are not requested to be recovered in the analysis for some or all of the frame members, the effects of those loads will be assumed to be zero in any combination that includes them.

2.2 Design and Check Stations

For each load combination, each element is designed or checked at a number of locations along the length of the element. The locations are based on equally spaced output stations along the clear length of the element. The number of output stations in an element is requested by the user before the analysis is performed. The user can refine the design along the length of an element by requesting more output stations.

2.3 Identifying Beams and Columns

In the program, all beams and columns are represented as frame elements, but design of beams and columns requires separate treatment. Identification for a concrete element is accomplished by specifying the frame section assigned to the element to be of type beam or column. If any brace member exists in the frame, the brace member also would be identified as a beam or a column element, depending on the section assigned to the brace member.

2.4 Design of Beams

In the design of concrete beams, in general, the program calculates and reports the required areas of reinforcing steel for flexure, shear, and torsion based on the beam moments, shears, load combination factors, and other criteria, which are described in detail in Chapter 3 and 4 (seismic). The reinforcement requirements are calculated at a user-defined number of stations along the beam span.

All beams are designed for major direction flexure, shear, and torsion only. Effects resulting from any axial forces and minor direction bending that may exist in the beams must be investigated independently by the user.

In designing the flexural reinforcement for the major moment at a particular station of a particular beam, the steps involve the determination of the maximum factored moments and the determination of the reinforcing steel. The beam section is designed for the maximum positive and maximum negative factored moment envelopes obtained from all of the load combinations. Negative beam moments produce top steel. In such cases, the beam is always designed as a rectangular section. Positive beam moments produce bottom steel. In such cases, the beam may be designed as a rectangular beam or a T-beam. For the design of flexural reinforcement, the beam is first designed as a singly reinforced beam. If the singly reinforced beam is not adequate, the required compression reinforcement is calculated.

In designing the shear reinforcement for a particular beam for a particular set of loading combinations at a particular station because of beam major shear, the steps involve the determination of the factored shear force, the determination of the shear force that can be resisted by concrete, and the determination of any reinforcement steel required to carry the balance.

2.5 Design of Columns

In the design of the columns, the program calculates the required longitudinal steel, or if the longitudinal steel is specified, the column stress condition is reported in terms of a column capacity ratio, which is a factor that gives an indication of the load condition of the column with respect to the capacity of the column. The design procedure for the reinforced concrete columns of the structure involves the following steps:

- Generate axial force-biaxial moment interaction surfaces for all of the different concrete section types in the model.
- Check the capacity of each column for the factored axial force and bending moments obtained from each loading combination at each end of the column. This step is also used to calculate the required steel reinforcement (if none was specified) that will produce a column capacity ratio of 1.0.

The generation of the interaction surface is based on the assumed strain and stress distributions and other simplifying assumptions. These stress and strain distributions and the assumptions are documented in Chapter 3.

The shear reinforcement design procedure for columns is very similar to that for beams, except that the effect of the axial force on the concrete shear capacity is considered.

2.6 P-Delta Effects

The program design process requires that the analysis results include P-Delta effects. For the individual member stability effects, the first order analysis moments are increased with additional second order moments, as documented in Chapter 3. As an alternative, the user can turn off the calculation of second order moments for individual member stability effects. If this calculation is turned off, the user should apply another method, such as equivalent lateral loading or P-Delta analysis with vertical members divided into at least two segments, to capture the member stability effects in addition to the global P-Delta effects.

Users of the program should be aware that the default analysis option is that P-Delta effects are not included. The user can include P-Delta analysis and set the maximum number of iterations for the analysis. The default number of iteration for P-Delta analysis is 1. Further details about P-Delta analysis are provided in Appendix A of this design manual.

2.7 Element Unsupported Lengths

To account for column slenderness effects, the column unsupported lengths are required. The two unsupported lengths are l_{33} and l_{22} . These are the lengths between support points of the element in the corresponding directions. The length l_{33} corresponds to instability about the 3-3 axis (major axis), and l_{22} corresponds to instability about the 2-2 axis (minor axis).

Normally, the unsupported element length is equal to the length of the element, i.e., the distance between END-I and END-J of the element. The program, however, allows users to assign several elements to be treated as a single member for design. This can be accomplished differently for major and minor bending, as documented in Appendix B.

The user has options to specify the unsupported lengths of the elements on an element-by-element basis.

2.8 Choice of Input Units

Imperial, as well as SI and MKS metric units can be used for input and output. The codes are based on a specific system of units. The Eurocode 2-2004 design code is published in Newton-millimeter-second units and all equations and descriptions presented in the “Design Process” chapter correspond to these units. However, any system of units can be used to define and design a structure in the program.

Chapter 3 Design Process

This chapter provides a detailed description of the code-specific algorithms used in the design of concrete frames when the Eurocode 2-2004 code has been selected. For simplicity, all equations and descriptions presented in this chapter correspond to Newton-millimeter-second units unless otherwise noted. It also should be noted that this section describes the implementation of the CEN Default version of Eurocode 2-2004, without a country specific National Annex. Where Nationally Determined Parameters [NDPs] are to be considered, this is highlighted in the respective section by the notation [*NDP*].

3.1 Notation

The various notations used in this chapter are described herein:

A_c	Area of concrete used to determine shear stress, mm ²
A_g	Gross area of concrete, mm ²
A_k	Area enclosed by centerlines of connecting walls for torsion, mm ²
A_s	Area of tension reinforcement, mm ²
A'_s	Area of compression reinforcement, mm ²

A_{sl}	Area of longitudinal torsion reinforcement, mm ²
A_t/s	Area of transverse torsion reinforcement (closed stirrups) per unit length of the member, mm ² /mm
A_{sw}/s	Area of shear reinforcement per unit length of the member, mm ² /mm
E_c	Modulus of elasticity of concrete, MPa
E_s	Modulus of elasticity of reinforcement, assumed as 200 GPa
I_g	Moment of inertia of gross concrete section about centroidal axis, neglecting reinforcement, mm ⁴
M_{01}	Smaller factored end moment in a column, N-mm
M_{02}	Larger factored end moment in a column, N-mm
M_{Ed}	Design moment, including second order effects to be used in design, N-mm
M_{0Ed}	Equivalent first order end moment (EC2 5.8.8.2), N-mm
M_2	Second order moment from the Nominal Curvature method (EC2 5.8.8), N-mm
M_{22}	First order factored moment at a section about 2-axis, N-mm
M_{33}	First order factored moment at a section about 3-axis, N-mm
N_B	Buckling load, N
N_{Ed}	Factored axial load at a section, N
T_{Ed}	Factored torsion at a section, N-mm
V_{Ed}	Factored shear force at a section, N
$V_{Rd,c}$	Design shear resistance without shear reinforcement, N
$V_{Rd,max}$	Shear force that can be carried without crushing of the notional concrete compressive struts, N
a	Depth of compression block, mm
a_{max}	Maximum allowed depth of compression block, mm
b	Width of member, mm

b_f	Effective width of flange (T-beam section), mm
b_w	Width of web (T-beam section), mm
d	Distance from compression face to tension reinforcement, mm
d'	Concrete cover-to-center of reinforcing, mm
d_s	Thickness of slab/flange (T-beam section), mm
e_2	Deflection due to curvature for the Nominal Curvature method (EC2 5.8.8), mm
e_i	Eccentricity to account for geometric imperfections (EC2 5.2), mm
e_{\min}	Minimum eccentricity (EC2 6.1), mm
f_{cd}	Design concrete compressive strength (EC 3.1.6), MPa
f_{cm}	Mean value of axial tensile strength of concrete, MPa
f_{yd}	Design yield strength of reinforcement (EC2 3.2), MPa
h	Overall depth of a column section, mm
l_0	Member effective length, mm
l_u	Member unsupported length, mm
r	Radius of gyration of column section, mm
t_{ef}	Effective wall thickness for torsion, mm
u	Outer perimeter of cross-section, mm
u_k	Outer perimeter of area A_k , mm
x	Depth to neutral axis, mm
α_{cc}	Material coefficient taking account of long-term effects on the compressive strength (EC2 3.1.6)
α_{ct}	Material coefficient taking account of long-term effects on the tensile strength (EC2 3.1.6)
α_{lcc}	Light-weight material coefficient taking account of long-term effects on the compressive strength (EC2 11.3.5)

α_{1ct}	Light-weight material coefficient taking account of long-term effects on the tensile strength (EC2 11.3.5)
ε_c	Strain in concrete
ε_{cu2}	Ultimate strain allowed in extreme concrete fiber (0.0035 mm/mm)
ε_s	Strain in reinforcing steel
γ_c	Material partial factor for concrete (EC2 2.4.2.4)
γ_s	Material partial factor for steel (EC2 2.4.2.4)
λ	Factor defining effective height of concrete stress block (EC2 3.1.7)
η	Factor defining effective strength of concrete stress block (EC2 3.1.7)
θ	Angle between concrete compression strut and member axis perpendicular to the shear force
θ_i	Inclination due to geometric imperfections (EC2 5.2), ratio
θ_o	Basic inclination for geometric imperfections (EC2 5.2), ratio

3.2 Assumptions / Limitations

The following general assumptions and limitations exist for the current implementation of Eurocode 2-2004 within the program. Limitations related to specific parts of the design are discussed in their relevant sections.

- Design of plain or lightly reinforced concrete sections is not handled.
- Design of prestressed or post-tensioned sections currently is not handled.
- The serviceability limit state currently is not handled.
- Design for fire resistance currently is not handled.
- By default, the Persistent & Transient design situation (EC2 Table 2.1N) is considered. Other design situations can be considered and may require modification of some of the concrete design preference values.

- It is assumed that the structure being designed is a building type structure. Special design requirements for special structure types (such as bridges, pressure vessels, offshore platforms, liquid-retaining structures, and the like) currently are not handled.
- It is assumed that the load actions are based on Eurocode 1.
- The program works with cylinder strength as opposed to cube strength.
- The program does not check depth-to-width ratios (EC2 5.3.1) or effective flange widths for T-beams (EC2 5.3.2). The user needs to consider these items when defining the sections.
- It is assumed that the user will consider the maximum concrete strength limit, C_{\max} , specified in the design code (EC2 3.1.2(3)).
- It is assumed that the cover distances input by the user satisfy the minimum cover requirements (EC2 4.4.1.2).
- The design value of the modulus of elasticity of steel reinforcement, E_s , is assumed to be 200 GPa (EC2 3.2.7(4)).

3.3 Design Load Combinations

The design load combinations are the various combinations of the prescribed load cases for which the structure is to be checked. The program creates a number of default design load combinations for a concrete frame design. Users can add their own design load combinations as well as modify or delete the program default design load combinations. An unlimited number of design load combinations can be specified.

To define a design load combination, simply specify one or more load patterns, each with its own scale factor. The scale factors are applied to the forces and moments from the load cases to form the design forces and moments for each design load combination. There is one exception to the preceding. For spectral analysis modal combinations, any correspondence between the signs of the moments and axial loads is lost. The program uses eight design load combinations for each such loading combination specified, reversing the sign of axial loads and moments in major and minor directions.

As an example, if a structure is subjected to dead load, D, and live load, L, only, the Eurocode 2-2004 design check would require two design load combinations only. However, if the structure is subjected to wind, earthquake, or other loads, numerous additional design load combinations may be required.

The program allows live load reduction factors to be applied to the member forces of the reducible live load case on a member-by-member basis to reduce the contribution of the live load to the factored responses.

The design load combinations are the various combinations of the load cases for which the structure needs to be checked. Eurocode 0-2002 allows load combinations to be defined based on EC0 Eq. 6.10 or the less favorable EC0 Eqs. 6.10a and 6.10b [NDP].

$$\sum_{j \geq 1} \gamma_{G,j} G_{k,j} + \gamma_P P + \gamma_{Q,1} Q_{k,1} + \sum_{i > 1} \gamma_{Q,i} \Psi_{0,i} Q_{k,i} \quad (\text{EC0 Eq. 6.10})$$

$$\sum_{j \geq 1} \gamma_{G,j} G_{k,j} + \gamma_P P + \gamma_{Q,1} \Psi_{0,1} Q_{k,1} + \sum_{i > 1} \gamma_{Q,i} \Psi_{0,i} Q_{k,i} \quad (\text{EC0 Eq. 6.10a})$$

$$\sum_{j \geq 1} \xi_j \gamma_{G,j} G_{k,j} + \gamma_P P + \gamma_{Q,1} Q_{k,1} + \sum_{i > 1} \gamma_{Q,i} \Psi_{0,i} Q_{k,i} \quad (\text{EC0 Eq. 6.10b})$$

Load combinations considering seismic loading are automatically generated based on EC0 Eq. 6.12b.

$$\sum_{j \geq 1} G_{k,j} + P + A_{Ed} + \sum_{i > 1} \Psi_{2,i} Q_{k,i} \quad (\text{EC0 Eq. 6.12b})$$

For this code, if a structure is subjected to dead (D), live (L), wind (W), and earthquake (E) loads, and considering that wind and earthquake forces are reversible, the following load combinations need to be considered if equation 6.10 is specified for generation of the load combinations (EC0 6.4.3):

$$\gamma_{Gj,\text{sup}} D \quad (\text{EC0 Eq. 6.10})$$

$$\gamma_{Gj,\text{sup}} D + \gamma_{Q,1} L \quad (\text{EC0 Eq. 6.10})$$

$$\gamma_{Gj,\text{inf}} D \pm \gamma_{Q,1} W \quad (\text{EC0 Eq. 6.10})$$

$$\gamma_{Gj,\text{sup}} D \pm \gamma_{Q,1} W \quad (\text{EC0 Eq. 6.10})$$

$$\gamma_{Gj,\text{sup}} D + \gamma_{Q,1} L \pm \gamma_{Q,i} \psi_{0,i} W \quad (\text{EC0 Eq. 6.10})$$

$$\gamma_{Gj,\text{sup}} D \pm \gamma_{Q,1} W + \gamma_{Q,i} \psi_{0,i} L \quad (\text{EC0 Eq. 6.10})$$

$$D \pm 1.0E \quad (\text{EC0 Eq. 6.12b})$$

$$D \pm 1.0E + \psi_{2,i} L$$

If the load combinations are specified to be generated from the maximum of EC0 Eqs. 6.10a and 6.10b, the following load combinations from both equations are considered in the program.

$$\gamma_{Gj,\text{sup}} D \quad (\text{EC0 Eq. 6.10a})$$

$$\xi \gamma_{Gj,\text{sup}} D \quad (\text{EC0 Eq. 6.10b})$$

$$\gamma_{Gj,\text{sup}} D + \gamma_{Q,1} \psi_{0,1} L \quad (\text{EC0 Eq. 6.10a})$$

$$\xi \gamma_{Gj,\text{sup}} D + \gamma_{Q,1} L \quad (\text{EC0 Eq. 6.10b})$$

$$\gamma_{Gj,\text{inf}} D \pm \gamma_{Q,1} \psi_{0,1} W \quad (\text{EC0 Eq. 6.10a})$$

$$\gamma_{Gj,\text{sup}} D \pm \gamma_{Q,1} \psi_{0,1} W \quad (\text{EC0 Eq. 6.10a})$$

$$\gamma_{Gj,\text{inf}} D \pm \gamma_{Q,1} W \quad (\text{EC0 Eq. 6.10b})$$

$$\xi \gamma_{Gj,\text{sup}} D \pm \gamma_{Q,1} W \quad (\text{EC0 Eq. 6.10b})$$

$$\gamma_{Gj,\text{sup}} D + \gamma_{Q,1} \psi_{0,1} L \pm \gamma_{Q,i} \psi_{0,i} W \quad (\text{EC0 Eq. 6.10a})$$

$$\gamma_{Gj,\text{sup}} D \pm \gamma_{Q,1} \psi_{0,1} W + \gamma_{Q,i} \psi_{0,i} L \quad (\text{EC0 Eq. 6.10a})$$

$$\xi \gamma_{Gj,\text{sup}} D + \gamma_{Q,1} L \pm \gamma_{Q,i} \psi_{0,i} W \quad (\text{EC0 Eq. 6.10b})$$

$$\gamma_{Gj,\text{sup}} D \pm \gamma_{Q,1} W + \gamma_{Q,i} \psi_{0,i} L \quad (\text{EC0 Eq. 6.10b})$$

$$D \pm 1.0E \quad (\text{EC0 Eq. 6.12b})$$

$$D \pm 1.0E + \psi_{2,i} L$$

For both sets of load combinations, the variable values for the CEN Default version of the load combinations are defined in the list that follows. Values for other countries, as determined from their National Annex, are included in Appendix E.

$$\gamma_{Gj,\text{sup}} = 1.35 \quad (\text{EC0 Table A1.2(B)})$$

$$\gamma_{Gj,\text{inf}} = 1.00 \quad (\text{EC0 Table A1.2(B)})$$

$$\gamma_{Q,1} = 1.5 \quad (\text{EC0 Table A1.2(B)})$$

$$\psi_{0,i} = 0.7 \text{ (live load, assumed not to be storage)} \quad (\text{EC0 Table A1.1})$$

$$\psi_{0,i} = 0.6 \text{ (wind load)} \quad (\text{EC0 Table A1.1})$$

$$\xi = 0.85 \quad (\text{EC0 Table A1.2(B)})$$

$$\psi_{2,i} = 0.3 \text{ (assumed to be office/residential space)} \quad (\text{EC0 Table A1.1})$$

Depending on the selection made in the design preferences, one of the preceding two sets of load combinations also makes up the default design load combinations in the program whenever the Eurocode 2-2004 design code is used. The user should apply other appropriate design load combinations if roof live load is separately treated, or if other types of loads are present. PLL is the live load multiplied by the Pattern Live Load Factor. The Pattern Live Load Factor can be specified in the Preferences.

When using the Eurocode 2-2004 design code, the program design assumes that a P-Delta analysis has been performed.

3.4 Column Design

The program can be used to check column capacity or to design columns. If the geometry of the reinforcing bar configuration of the concrete column section has been defined, the program can check the column capacity. Alternatively, the program can calculate the amount of reinforcing required to design the column based on a provided reinforcing bar configuration. The reinforcement requirements are calculated or checked at a user-defined number of output stations along the column height. The design procedure for reinforced concrete columns involves the following steps:

- Generate axial force-biaxial moment interaction surfaces for all of the different concrete section types of the model. A typical biaxial interaction diagram is shown in Figure 3-1. For reinforcement to be designed, the program generates the interaction surfaces for the range of allowable reinforcement from a minimum of 0.2 percent [*NDP*] to a maximum of 4 percent [*NDP*] (EC2 9.5.2).

- Calculate the capacity ratio or the required reinforcement area for the factored axial force and biaxial (or uniaxial) bending moments obtained from each load combination at each output station of the column. The target capacity ratio is taken as the Utilization Factor Limit when calculating the required reinforcing area.
- Design the column shear reinforcement.

The following four sections describe in detail the algorithms associated with this process.

3.4.1 Generation of Biaxial Interaction Surfaces

The column capacity interaction volume is numerically described by a series of discrete points that are generated on the three-dimensional interaction failure surface. In addition to axial compression and biaxial bending, the formulation allows for axial tension and biaxial bending considerations. A typical interaction surface is shown in Figure 3-1.

The coordinates of the points on the failure surface are determined by rotating a plane of linear strain in three dimensions on the column section, as shown in Figure 3-2. The linear strain diagram limits the maximum concrete strain, ϵ_c , at the extremity of the section to 0.0035 (EC2 Table 3.1).

The formulation is based consistently upon the general principles of ultimate strength design (EC2 6.1).

The stress in the steel is given by the product of the steel strain and the steel modulus of elasticity, $\epsilon_s E_s$, and is limited to the yield stress of the steel, f_{yd} (EC2 3.2.7). The area associated with each reinforcing bar is assumed to be placed at the actual location of the center of the bar, and the algorithm does not assume any further simplifications with respect to distributing the area of steel over the cross-section of the column, as shown in Figure 3-2.

The concrete compression stress block is assumed to be rectangular, with an effective strength of ηf_{cd} (EC2 3.1.7) and effective height of λx , as shown in Figure 3-3, where η is taken as:

$$\eta = 1.0 \text{ for } f_{ck} \leq 50 \text{ MPa} \quad (\text{EC2 Eq. 3.21})$$

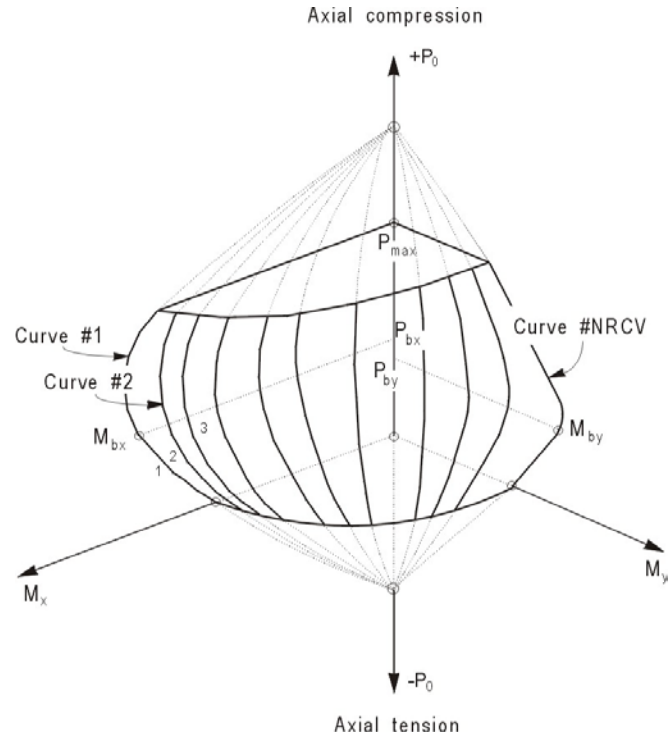

Figure 3-1 A typical column interaction surface

$$\eta = 1.0 - (f_{ck} - 50)/200 \text{ for } 50 < f_{ck} \leq 90 \text{ MPa} \quad (\text{EC2 Eq. 3.22})$$

and λ is taken as:

$$\lambda = 0.8 \text{ for } f_{ck} \leq 50 \text{ MPa} \quad (\text{EC2 Eq. 3.19})$$

$$\lambda = 0.8 - (f_{ck} - 50)/400 \text{ for } 50 < f_{ck} \leq 90 \text{ MPa} \quad (\text{EC2 Eq. 3.20})$$

The interaction algorithm provides correction to account for the concrete area that is displaced by the reinforcement in the compression zone. The depth of the equivalent rectangular block is further referred to as a , such that:

$$a = \lambda x \quad (\text{EC2 3.1.7})$$

where x is the depth of the stress block in compression, as shown in Figure 3-3.

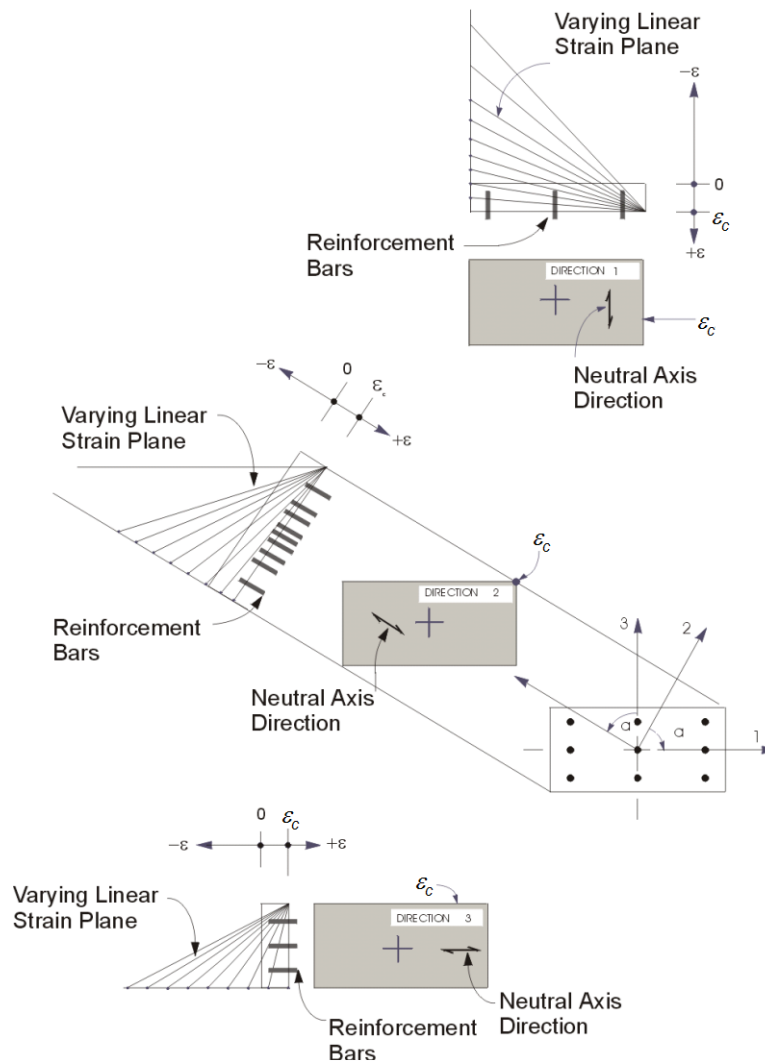

Figure 3-2 Idealized strain distribution for generation of interaction surface

The effect of the material partial factors, γ_c and γ_s [NDPs], and the material coefficients, α_{cc} , α_{ct} , α_{lcc} , and α_{lct} [NDPs], are included in the generation of the interaction surface (EC2 3.1.6).

Default values for γ_c , γ_s , α_{cc} , α_{ct} , α_{lcc} , and α_{lct} are provided by the program but can be overwritten using the Preferences.

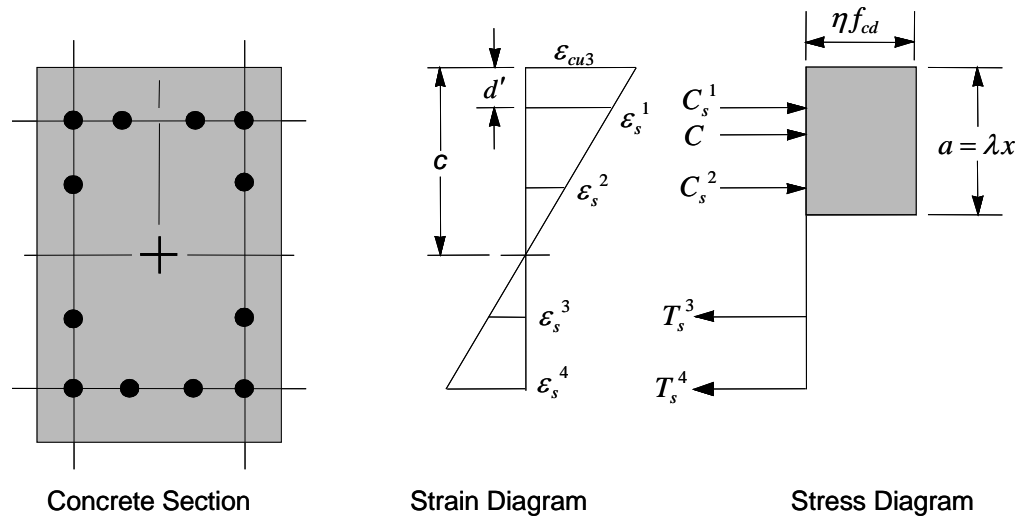

Figure 3-3 Idealization of stress and strain distribution in a column section

3.4.2 Calculate Column Capacity Ratio

The column capacity ratio is calculated for each design load combination at each output station of each column. The following steps are involved in calculating the capacity ratio of a particular column, for a particular design load combination, at a particular location:

- Determine the factored first order moments and forces from the load cases and the specified load combination factors to give N_{ed} , M_{22} , and M_{33} .
- Determine the second order moment based on the chosen Second Order Method [NDP], which can be either “Nominal Stiffness” (EC2 5.8.7) or “Nominal Curvature” (EC2 5.8.8) and can be changed using the Preferences. There is also a “None” option if the user wants to explicitly ignore second order effects within the design calculations. This may be desirable if the second order effects have been simulated with equivalent loads or if a P-Delta analysis has been undertaken and each column member is divided into at least two elements, such that M_{22} and M_{33} already account for the second order effects.
- Add the second order moments to the first order moments if the column is determined to be slender (EC2 5.8.3.1). Determine whether the point,

defined by the resulting axial load and biaxial moment set, lies within the interaction volume.

The following three sections describe in detail the algorithms associated with this process.

3.4.2.1 Determine Factored Moments and Forces

The loads for a particular design load combination are obtained by applying the corresponding factors to all of the load cases, giving N_{Ed} , M_{22} , and M_{33} . These first order factored moments are further increased to account for geometric imperfections (EC2 5.2). The eccentricity to account for geometric imperfections, e_i , is defined as:

$$e_i = \theta_i l_0 / 2 \quad (\text{EC2 Eq. 5.2})$$

where l_0 is the effective length of the member and θ_i is an inclination, defined as a ratio as:

$$\theta_i = \theta_0 \alpha_h \alpha_m \quad (\text{EC2 Eq. 5.1})$$

where α_m is a reduction factor for the number of members, taken as 1 in the program for isolated members, α_h is a reduction factor for length, taken as $2/\sqrt{l}$, and θ_0 [NDP] is the basic inclination, defined as a ratio, and can be overwritten in the Preferences. The resulting geometric imperfection moments, are calculated as:

$$M_{i2} = e_{i2} N_{Ed}$$

$$M_{i3} = e_{i3} N_{Ed}$$

where e_i shall be taken greater than or equal to the code specified minimum eccentricity e_{\min} (EC2 6.2). The minimum eccentricity, e_{\min} , is defined as:

$$e_{\min} = h/30 \geq 20 \text{ mm} \quad (\text{EC2 6.1})$$

The moment generated because of the geometric imperfection eccentricity, or the min eccentricity if greater, is considered only in a single direction at a time.

3.4.2.2 Second Order Moments

The design algorithm assumes that the moments M_{22} and M_{32} are obtained from a second order elastic ($P-\Delta$) analysis or by applying fictitious, magnified horizontal forces following the recommendations of EC2 Annex H. For more information about $P-\Delta$ analysis, refer to Appendix A.

The computed moments are further increased for individual column stability effects, $P-\delta$ (EC2 5.8.5), by computing a moment magnification factor based on the Nominal Stiffness method (EC2 5.8.7) or computing a nominal second order moment based on the Nominal Curvature method (EC2 5.8.8).

3.4.2.2.1 Nominal Stiffness Method

The overall design moment, M_{Ed} , based on the Nominal Stiffness method is computed as:

$$M_{Ed} = M_{0Ed} \text{ (factor)} \quad \text{(EC2 Eq. 5.31)}$$

where M_{0Ed} is defined as:

$$M_{0Ed} = M_{0e} + M_i$$
$$M_{0e} = 0.6 M_{02} + 0.4 M_{01} \geq 0.4 M_{02} \quad \text{(EC2 Eq. 5.32)}$$

M_{02} and M_{01} are the moments at the ends of the column, and M_{02} is numerically larger than M_{01} . M_{01}/M_{02} is positive for single curvature bending and negative for double curvature bending. The preceding expression of M_{0e} is valid if there is no transverse load applied between the supports.

The moment magnification factor associated with the major or minor direction of the column is defined as:

$$\text{factor} = 1 + \beta / \left[(N_B / N_{Ed}) - 1 \right] \quad \text{(EC2 Eq. 5.28)}$$

The factor β depends on the distribution of the first and second order moments and is defined as:

$$\beta = \pi^2 / c_0, \quad \text{(EC2 Eq. 5.29)}$$

where c_0 is a coefficient that depends on the distribution of the first order moment and is taken equal to 8, which is consistent with a constant first order moment. The term N_B is the buckling load and is computed as:

$$N_B = \frac{\pi^2 EI}{(\beta_l l_u)^2}$$

where β_l is conservatively taken as 1; however, the program allows the user to overwrite this value. The unsupported length of the column for the direction of bending considered is defined as l_u . The two unsupported lengths are l_{22} and l_{33} , corresponding to instability in the minor and major directions of the object, respectively, as shown in Figure B-1 in Appendix B. These are the lengths between the support points of the object in the corresponding directions.

Refer to Appendix B for more information about how the program automatically determines the unsupported lengths. The program allows the user to overwrite the unsupported length ratios, which are the ratios of the unsupported lengths for the major and minor axis bending to the overall member length.

When using the stiffness method, the EI associated with a particular column direction is considered in the design as:

$$EI = 0.3EI_g$$

This value neglects creep effects and may be unconservative if significant creep effects exist.

The additional moment from the Nominal Stiffness method must be a positive number. Therefore, N_{Ed} must be greater than N_B . If N_{Ed} is found to be less than or equal to N_B , a failure condition is declared.

3.4.2.2.2 Nominal Curvature Method

The overall design moment, M_{Ed} , based on the Nominal Curvature method is computed as:

$$M_{Ed} = M_{0Ed} + M_2 \quad (\text{EC2 Eq. 5.31})$$

where M_{0Ed} is defined as:

$$M_{0Ed} = M_{0e} + M_i$$

$$M_{0e} = 0.6 M_{02} + 0.4 M_{01} \geq 0.4 M_{02} \quad (\text{EC2 Eq. 5.32})$$

M_{02} and M_{01} are the moments at the ends of the column, and M_{02} is numerically larger than M_{01} . M_{01}/M_{02} is positive for single curvature bending and negative for double curvature bending. The preceding expression of M_{0e} is valid if no transverse load is applied between the supports.

The additional second order moment associated with the major or minor direction of the column is defined as:

$$M_2 = N_{Ed} e_2 \quad (\text{EC2 Eq. 5.33})$$

where N_{Ed} is the design axial force, and e_2 , the deflection due to the curvature, is defined as:

$$e_2 = (1/r) l_o^2 / c \quad (\text{EC2 5.8.8.2(3)})$$

The effective length, l_o , is taken equal to $\beta_1 l_u$. The factor c depends on the curvature distribution and is taken equal to 8, corresponding to a constant first order moment. The term $1/r$ is the curvature and is defined as:

$$1/r = K_r K_\phi 1/r_0 \quad (\text{EC2 Eq. 5.34})$$

The correction factor, K_r , depends on the axial load and is taken as 1 by default. The factor K_ϕ is also taken as 1, which represents the situation of negligible creep. Both of these factors can be overwritten on a member-by-member basis. The term $1/r_0$ is defined as:

$$1/r_0 = \varepsilon_{yd} / (0.45d) \quad (\text{EC2 5.8.8.3(1)})$$

The preceding second order moment calculations are performed for major and minor directions separately.

The additional second order moment, M_2 is ignored when the slenderness, λ is less than the limiting slenderness specified by the code.

$$\lambda_{\text{lim}} = \frac{20 \cdot A \cdot B \cdot C}{\sqrt{n}} \quad (\text{EC2 5.8.3.1(1)})$$

3.4.2.3 Determine Capacity Ratio

As a measure of the load condition of the column, a capacity ratio is calculated. The capacity ratio is a factor that gives an indication of the load condition of the column with respect to the load capacity of the column.

Before entering the interaction diagram to check the column capacity, the second order moments are added to the first order factored loads to obtain N_{Ed} , M_{Ed2} , and M_{Ed3} . The point $(N_{Ed}, M_{Ed2}, M_{Ed3})$ is then placed in the interaction space shown as point L in Figure 3-4. If the point lies within the interaction volume, the column capacity is adequate. However, if the point lies outside the interaction volume, the column is overloaded.

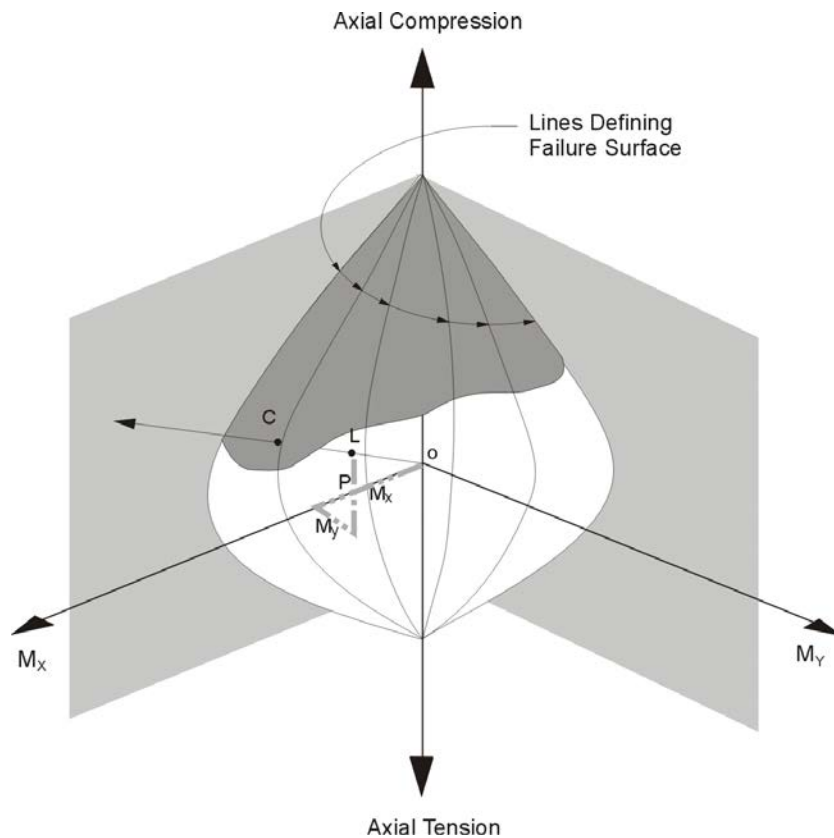

Figure 3-4 Geometric representation of column capacity ratio

This capacity ratio is achieved by plotting the point L and determining the location of point C . Point C is defined as the point where the line OL (if extended

outwards) will intersect the failure surface. This point is determined by three-dimensional linear interpolation between the points that define the failure surface, as shown in Figure 3-4. The capacity ratio, CR , is given by the ratio OL/OC .

- If $OL = OC$ (or $CR = 1$), the point lies on the interaction surface and the column is loaded to capacity.
- If $OL < OC$ (or $CR < 1$), the point lies within the interaction volume and the column capacity is adequate.
- If $OL > OC$ (or $CR > 1$), the point lies outside the interaction volume and the column is overloaded.

The maximum of all the values of CR calculated from each design load combination is reported for each check station of the column, along with the controlling N_{Ed} , M_{Ed2} , and M_{Ed3} set and associated design load combination name.

3.4.3 Design Longitudinal Reinforcement

If the reinforcing area is not defined, the program computes the required reinforcement that will give a column capacity ratio equal to the Utilization Factor Limit, which is set to 0.95 by default.

3.4.4 Design Column Shear Reinforcement

The shear reinforcement is designed for each design combination in the major and minor directions of the column. The following steps are involved in designing the shear reinforcing for a particular column, for a particular design load combination resulting from shear forces in a particular direction:

- Determine the design forces acting on the section, N_{Ed} and V_{Ed} . Note that N_{Ed} is needed for the calculation of $V_{Rd,c}$.
- Determine the design shear resistance of the member without shear reinforcement, $V_{Rd,c}$.
- Determine the maximum design shear force that can be carried without crushing of the notional concrete compressive struts, $V_{Rd,max}$.

- Determine the required shear reinforcement as area per unit length, A_{sw}/s .

The following four sections describe in detail the algorithms associated with this process.

3.4.4.1 Determine Design Shear Force

In the design of the column shear reinforcement of concrete frames, the forces for a particular design load combination, namely, the column axial force, N_{Ed} , and the column shear force, V_{Ed} , in a particular direction are obtained by factoring the load cases with the corresponding design load combination factors.

3.4.4.2 Determine Design Shear Resistance

Given the design force set N_{Ed} and V_{Ed} , the shear force that can be carried without requiring design shear reinforcement, $V_{Rd,c}$, is calculated as:

$$V_{Rd,c} = [C_{Rd,c} k (100 \rho_l f_{ck})^{1/3} + k_l \sigma_{cp}] b_w d \quad (\text{EC2 Eq. 6.2.a})$$

with a minimum of:

$$V_{Rd,c} = (v_{\min} + k_l \sigma_{cp}) b_w d \quad (\text{EC2 Eq. 6.2.b})$$

where f_{ck} is in MPa, and k , ρ_l , and σ_{cp} are calculated as:

$$k = 1 + \sqrt{\frac{200}{d}} \leq 2.0 \quad (d \text{ is in mm}) \quad (\text{EC2 6.2.2(1)})$$

$$\rho_l = \frac{A_s}{b_w d} \leq 0.02 \quad (\text{EC2 6.2.2(1)})$$

$$\sigma_{cp} = N_{Ed} / A_c < 0.2 f_{cd} \quad (\text{in MPa}) \quad (\text{EC2 6.2.2(1)})$$

The effective shear area, A_c , is shown shaded in Figure 3-6. For circular columns, A_c is taken to be equal to the gross area of the section. The factor $k_l = 0.15$ [NDP] and the values of $C_{Rd,c}$ [NDP] and v_{\min} [NDP] are determined as:

$$C_{Rd,c} = 0.18 / \gamma_c \quad (\text{EC2 6.2.2(1)})$$

$$v_{\min} = 0.035 k^{3/2} f_{ck}^{1/2} \quad (\text{EC2 Eq. 6.3N})$$

3.4.4.3 Determine Maximum Design Shear Force

To prevent crushing of the concrete compression struts, the design shear force V_{Ed} is limited by the maximum sustainable design shear force, $V_{Rd,max}$. If the design shear force exceeds this limit, a failure condition occurs. The maximum sustainable shear force is defined as:

$$V_{Rd,max} = \alpha_{cw} b_w z v_1 f_{cd} / (\cot\theta + \tan\theta) \quad (\text{EC2 Eq. 6.9})$$

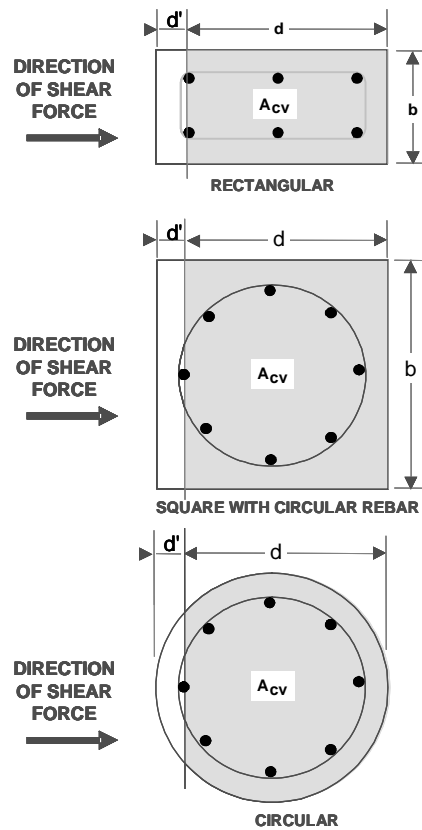

Figure 3-6 Shear stress area, A_{cv}

The coefficient α_{cw} [NDP] takes account of the state of stress in the compression chord and is taken equal to 1, which is recommended for non-prestressed structures. The strength reduction factor for concrete cracked in shear, v_1 [NDP], is defined as:

$$v_1 = 0.6[1 - f_{ck}/250] \quad (f_{ck} \text{ is in MPa}) \quad (\text{EC2 Eq. 6.6N})$$

The inner lever arm distance, z , is approximated as $0.9d$. The angle between the concrete compression strut and the column axis perpendicular to the shear force is defined as θ and taken as 45 degrees. EC2 allows θ to be taken between 21.8 and 45 degrees. The program assumes the conservative value of 45 degrees.

3.4.4.4 Determine Required Shear Reinforcement

If V_{Ed} is greater than $V_{Rd,c}$ and less than $V_{Rd,max}$, the required shear reinforcement in the form of stirrups or ties per unit spacing, A_{sw}/s , is calculated as:

$$\frac{A_{sw}}{s} = \frac{V_{Ed}}{z f_{ywd} \cot \theta} \quad (\text{EC2 Eq. 6.8})$$

In the preceding expressions, for a rectangular section, b_w is the width of the column, d is the effective depth of the column, and A_c is the effective shear area, which is equal to $b_w d$. For a circular section, b_w is replaced with D , which is the external diameter of the column, d is replaced with $0.8D$, and A_c is replaced with the gross area $\pi D^2/4$.

The maximum of all of the calculated A_{sw}/s values, obtained from each design load combination, is reported for the major and minor directions of the column, along with the controlling combination name.

The column shear reinforcement requirements reported by the program are based purely on shear strength consideration. Any minimum stirrup requirements to satisfy spacing considerations or transverse reinforcement volumetric considerations must be investigated independently by the user.

3.5 Beam Design

In the design of concrete beams, the program calculates and reports the required areas of steel for flexure and shear based on the beam moments, shear forces, torsions, design load combination factors, and other criteria described in the text that follows. The reinforcement requirements are calculated at a user-defined number of output stations along the beam span.

All beams are designed for major direction flexure, shear, and torsion only. Effects resulting from any axial forces and minor direction bending that may exist in the beams must be investigated independently by the user.

The beam design procedure involves the following steps:

- Design flexural reinforcement
- Design shear reinforcement
- Design torsion reinforcement

3.5.1 Design Beam Flexural Reinforcement

The beam top and bottom flexural reinforcement is designed at output stations along the beam span. The following steps are involved in designing the flexural reinforcement for the major moment for a particular beam, at a particular section:

- Determine the maximum factored moments
- Determine the required reinforcing steel

3.5.1.1 Determine Factored Moments

In the design of flexural reinforcement of concrete beams, the factored moments for each design load combination at a particular beam section are obtained by factoring the corresponding moments for different load cases with the corresponding design load combination factors.

The beam section is then designed for the factored moments obtained from each of the design load combinations. Positive moments produce bottom steel. In such cases, the beam may be designed as a rectangular or a T-beam section.

Negative moments produce top steel. In such cases, the beam is always designed as a rectangular section.

3.5.1.2 Determine Required Flexural Reinforcement

In the flexural reinforcement design process, the program calculates both the tension and compression reinforcement. Compression reinforcement is added when the applied design moment exceeds the maximum moment capacity of a singly reinforced section. The user can avoid the need for compression reinforcement by increasing the effective depth, the width, or the grade of concrete.

The design procedure is based on a simplified rectangular stress block, as shown in Figure 3-7 (EC2 3.1.7(3)). When the applied moment exceeds the moment capacity, the area of compression reinforcement is calculated on the assumption that the additional moment will be carried by compression and additional tension reinforcement.

The design procedure used by the program for both rectangular and flanged sections (T-beams) is summarized in the following subsections. It is assumed that the design ultimate axial force is negligible, hence all beams are designed ignoring axial force.

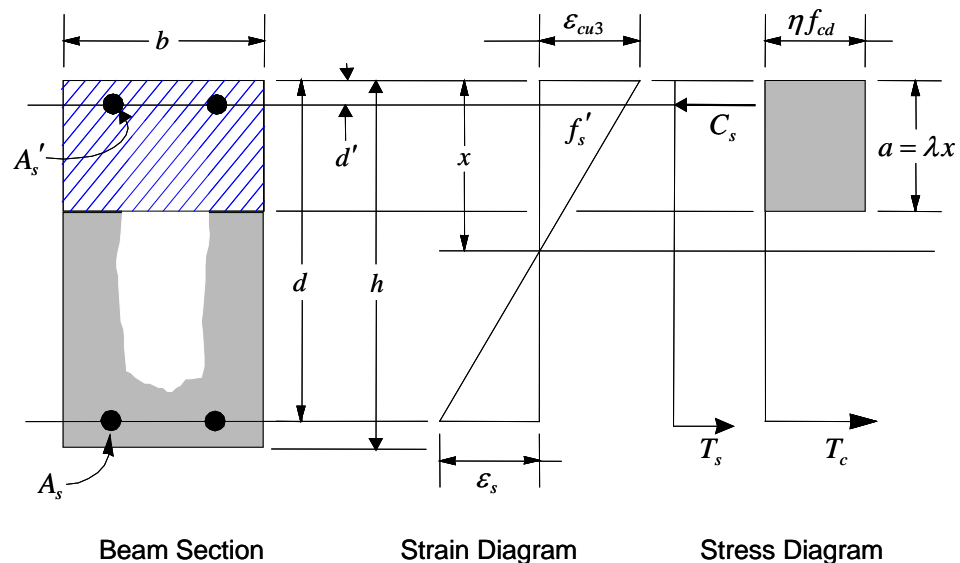

Figure 3-7 Rectangular beam design

In designing for a factored negative or positive moment, M_{Ed} (i.e., designing top or bottom steel), the effective strength and depth of the compression block are given by ηf_{cd} and λx (see Figure 3-7) respectively, where:

$$\lambda = 0.8 \text{ for } f_{ck} \leq 50 \text{ MPa,} \quad (\text{EC2 Eq. 3.19})$$

$$\lambda = 0.8 - \left[(f_{ck} - 50) / 400 \right] \text{ for } 50 < f_{ck} \leq 90 \text{ MPa,} \quad (\text{EC2 Eq. 3.20})$$

$$\eta = 1.0 \text{ for } f_{ck} \leq 50 \text{ MPa,} \quad (\text{EC2 Eq. 3.21})$$

$$\eta = 1.0 - \left[(f_{ck} - 50) / 200 \right] \text{ for } 50 < f_{ck} \leq 90 \text{ MPa,} \quad (\text{EC2 Eq. 3.22})$$

where x is the depth of the neutral axis, λ is a factor defining the effective height of the compression zone, and η is a factor defining the effective strength.

The limiting value of the ratio of the neutral axis depth at the ultimate limit state to the effective depth, $(x/d)_{lim}$, is expressed as a function of the ratio of the redistributed moment to the moment before redistribution, δ , as follows:

$$(x/d)_{lim} = (\delta - k_1) / k_2 \text{ for } f_{ck} \leq 50 \text{ MPa} \quad (\text{EC2 Eq. 5.10a})$$

$$(x/d)_{lim} = (\delta - k_3) / k_4 \text{ for } f_{ck} > 50 \text{ MPa} \quad (\text{EC2 Eq. 5.10b})$$

No redistribution is assumed, such that δ is assumed to be 1. The four factors, k_1 , k_2 , k_3 , and k_4 [NDPs], are defined as:

$$k_1 = 0.44 \quad (\text{EC2 5.5(4)})$$

$$k_2 = 1.25(0.6 + 0.0014/\varepsilon_{cu2}) \quad (\text{EC2 5.5(4)})$$

$$k_3 = 0.54 \quad (\text{EC2 5.5(4)})$$

$$k_4 = 1.25(0.6 + 0.0014/\varepsilon_{cu2}) \quad (\text{EC2 5.5(4)})$$

where the ultimate strain, ε_{cu2} [NDP], is determined from EC2 Table 3.1 as:

$$\varepsilon_{cu2} = 0.0035 \text{ for } f_{ck} < 50 \text{ MPa} \quad (\text{EC2 Table 3.1})$$

$$\varepsilon_{cu2} = 2.6 + 35 \left[(90 - f_{ck}) / 100 \right]^4 \text{ for } f_{ck} \geq 50 \text{ MPa} \quad (\text{EC2 Table 3.1})$$

3.5.1.2.1 Rectangular Beam Flexural Reinforcement

For rectangular beams, the normalized moment, m , and the normalized section capacity as a singly reinforced beam, m_{lim} , are determined as:

$$m = \frac{M}{bd^2\eta f_{cd}}$$

$$m_{lim} = \lambda \left(\frac{x}{d} \right)_{lim} \left[1 - \frac{\lambda}{2} \left(\frac{x}{d} \right)_{lim} \right]$$

The reinforcing steel area is determined based on whether m is greater than, less than, or equal to m_{lim} .

- If $m \leq m_{lim}$, a singly reinforced beam will be adequate. Calculate the normalized steel ratio, ω , and the required area of tension reinforcement, A_s , as:

$$\omega = 1 - \sqrt{1 - 2m}$$

$$A_s = \omega \left[\frac{\eta f_{cd} bd}{f_{yd}} \right]$$

This area of reinforcing steel is to be placed at the bottom if M_{Ed} is positive, or at the top if M_{Ed} is negative.

- If $m > m_{lim}$, compression reinforcement is required. Calculate the normalized steel ratios, ω' , ω_{lim} , and ω , as:

$$\omega_{lim} = \lambda \left(\frac{x}{d} \right)_{lim} = 1 - \sqrt{1 - 2m_{lim}}$$

$$\omega' = \frac{m - m_{lim}}{1 - d'/d}$$

$$\omega = \omega_{lim} + \omega'$$

where d' is the depth to the compression steel, measured from the concrete compression face.

Calculate the required area of compression and tension reinforcement, A_s' and A_s , as:

$$A_s' = \omega' \left[\frac{\eta f_{cd} b d}{f_s'} \right]$$

$$A_s = \omega \left[\frac{\eta f_{cd} b d}{f_{yd}} \right]$$

where f_s' , the stress in the compression steel, is calculated as:

$$f_s' = E_s \varepsilon_c \left[1 - \frac{d'}{x_{iim}} \right] \leq f_{yd}$$

A_s is to be placed at the bottom and A_s' is to be placed at the top if M_{Ed} is positive, and A_s' is to be placed at the bottom and A_s is to be placed at the top if M_{Ed} is negative.

3.5.1.2.2 T-Beam Flexural Reinforcement

In designing a T-beam, a simplified stress block, as shown in Figure 3-8, is assumed if the flange is in compression, i.e., if the moment is positive. If the moment is negative, the flange is in tension, and therefore ignored. In that case, a simplified stress block, similar to that shown in Figure 3-8, is assumed on the compression side.

Flanged Beam Under Negative Moment

In designing for a factored negative moment, M_{Ed} (i.e., designing top steel), the calculation of the reinforcing steel area is exactly the same as described for a rectangular beam, i.e., no specific T-beam data is used.

Flanged Beam Under Positive Moment

In designing for a factored positive moment, M_{Ed} , the program analyzes the section by considering the depth of the stress block. If the depth of the stress block is less than or equal to the flange thickness, the section is designed as a

rectangular beam with a width b_f . If the stress block extends into the web, additional calculation is required.

For T-beams, the normalized moment, m , and the normalized section capacity as a singly reinforced beam, m_{lim} , are calculated as:

$$m = \frac{M}{b_f d^2 \eta f_{cd}}$$

$$m_{\text{lim}} = \lambda \left(\frac{x}{d} \right)_{\text{lim}} \left[1 - \frac{\lambda}{2} \left(\frac{x}{d} \right)_{\text{lim}} \right]$$

Calculate the normalized steel ratios ω_{lim} and ω , as:

$$\omega_{\text{lim}} = \lambda \left(\frac{x}{d} \right)_{\text{lim}}$$

$$\omega = 1 - \sqrt{1 - 2m}$$

Calculate the maximum depth of the concrete compression block, a_{max} , and the effective depth of the compression block, a , as:

$$a_{\text{max}} = \omega_{\text{lim}} d$$

$$a = \omega d$$

The reinforcing steel area is determined based on whether m is greater than, less than, or equal to m_{lim} . The maximum allowable depth of the rectangular compression block, a_{max} , is given by:

- If $a \leq h_f$, the subsequent calculations for A_s are exactly the same as previously defined for rectangular beam design. However, in this case, the width of the beam is taken as b_f , as shown in Figure 3-8. Compression reinforcement is required if $a > a_{\text{max}}$.
- If $a > h_f$, the calculation for A_s has two parts. The first part is for balancing the compressive force from the flange, and the second part is for balancing the compressive force from the web, as shown in Figure 3-8.

- The required reinforcing steel area, A_{s2} , and corresponding resistive moment, M_2 , for equilibrating compression in the flange outstands are calculated as:

$$A_{s2} = \frac{(b_f - b_w)h_f \eta f_{cd}}{f_{yd}}$$

$$M_2 = A_{s2} f_{yd} \left(d - \frac{h_f}{2} \right)$$

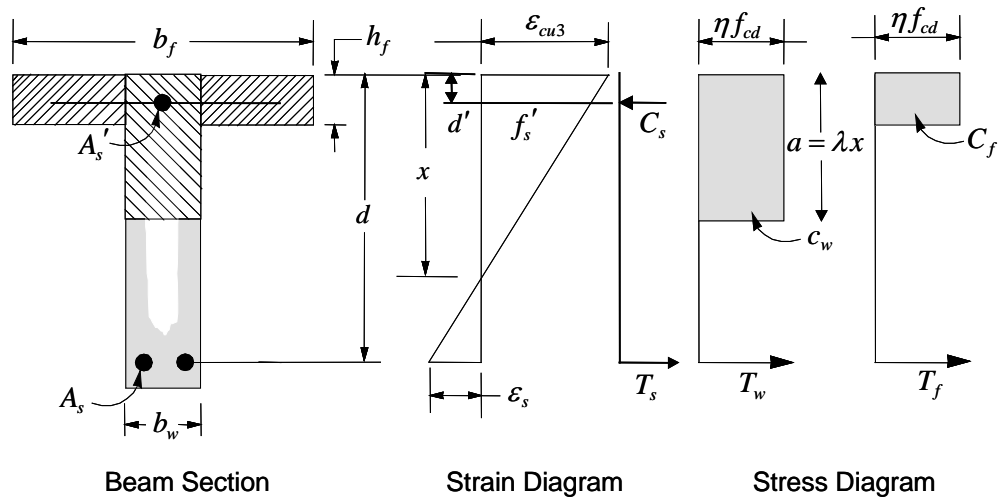

Figure 3-8 T-beam design

Now calculate the required reinforcing steel area A_{s1} for the rectangular section of width b_w to resist the remaining moment $M_1 = M_{Ed} - M_2$. The normalized moment, m_1 is calculated as:

$$m_1 = \frac{M_1}{b_w d^2 \eta f_{cd}}$$

The reinforcing steel area is determined based on whether m_1 is greater than, less than, or equal to m_{lim} .

- If $m_l \leq m_{lim}$, a singly reinforced beam will be adequate. Calculate the normalized steel ratio, ω_l , and the required area of tension reinforcement, A_{s_l} , as:

$$\omega_l = 1 - \sqrt{1 - 2m}$$

$$A_{s_l} = \omega_l \left[\frac{\eta f_{cd} b d}{f_{yd}} \right]$$

- If $m_l > m_{lim}$, compression reinforcement is required. Calculate the normalized steel ratios, ω' , ω_{lim} , and ω , as:

$$\omega_{lim} = \lambda \left(\frac{x}{d} \right)_{lim}$$

$$\omega' = \frac{m - m_{lim}}{1 - d'/d}$$

$$\omega_l = \omega_{lim} + \omega'$$

where d' is the depth to the compression steel, measured from the concrete compression face.

Calculate the required area of compression and tension reinforcement, A_s' and A_s , as:

$$A_s' = \omega' \left[\frac{\eta f_{cd} b d}{f_s'} \right]$$

$$A_{s_l} = \omega_l \left[\frac{\eta f_{cd} b d}{f_{yd}} \right]$$

where f_s' , the stress in the compression steel, is calculated as:

$$f_s' = E_s \varepsilon_c \left[1 - \frac{d'}{x_{lim}} \right] \leq f_{yd}$$

The total tensile reinforcement is $A_s = A_{s1} + A_{s2}$, and the total compression reinforcement is A_s' . A_s is to be placed at the bottom and A_s' is to be placed at the top of the section.

3.5.1.3 Minimum and Maximum Tensile Reinforcement

The minimum flexural tensile steel reinforcement, $A_{s,min}$ [NDP], required in a beam section is given as the maximum of the following two values:

$$A_{s,min} = 0.26 \left(f_{cm} / f_{yk} \right) b_t d \quad (\text{EC2 Eq. 9.1N})$$

$$A_{s,min} = 0.0013 b_t d$$

where b_t is the mean width of the tension zone, equal to the web width for T-beams, and f_{cm} is the mean value of axial tensile strength of the concrete, calculated as:

$$f_{cm} = 0.30 f_{ck}^{(2/3)} \quad \text{for } f_{ck} \leq 50 \text{ MPa} \quad (\text{EC2 Table 3.1})$$

$$f_{cm} = 2.12 \ln(1 + f_{cm}/10) \quad \text{for } f_{ck} > 50 \text{ MPa} \quad (\text{EC2 Table 3.1})$$

$$f_{cm} = f_{ck} + 8 \text{ MPa}$$

The maximum flexural steel reinforcement, $A_{s,max}$ [NDP], permitted as either tension or compression reinforcement is defined as:

$$A_{s,max} = 0.04 A_c \quad (\text{EC2 9.2.1.1(3)})$$

where A_c is the gross cross-sectional area.

3.5.2 Design Beam Shear Reinforcement

The required beam shear reinforcement is calculated for each design load combination at each output station along the beam length. The following assumptions are made for the design of beam shear reinforcement:

- The beam section is assumed to be prismatic. The shear capacity is based on the beam width at the output station and therefore a variation in the width of the beam is neglected in the calculation of the concrete shear capacity at each particular output station.

- All shear reinforcement is assumed to be perpendicular to the longitudinal reinforcement. Inclined shear steel is not handled.

The following steps are involved in designing the shear reinforcement for a particular output station subjected to beam major shear:

- Determine the design value of the applied shear force, V_{Ed} .
- Determine the design shear resistance of the member without shear reinforcement, $V_{Rd,c}$.
- Determine the maximum design shear force that can be carried without crushing of the notional concrete compressive struts, $V_{Rd,max}$.
- Determine the required shear reinforcement as area per unit length, A_{sw}/s .

The following four sections describe in detail the algorithms associated with this process.

3.5.2.1 Determine Design Shear Force

In the design of the beam shear reinforcement, the shear forces and moments for a particular design load combination at a particular beam section are obtained by factoring the associated shear forces and moments with the corresponding design load combination factors.

3.5.2.2 Determine Design Shear Resistance

The shear force that can be carried without requiring design shear reinforcement, $V_{Rd,c}$, is calculated as:

$$V_{Rd,c} = \left[C_{Rd,c} k (100 \rho_l f_{ck})^{1/3} + k_1 \sigma_{cp} \right] b_w d \quad (\text{EC2 Eq. 6.2.a})$$

with a minimum of:

$$V_{Rd,c} = (v_{\min} + k_1 \sigma_{cp}) b_w d \quad (\text{EC2 Eq. 6.2.b})$$

where f_{ck} is in MPa, and k , ρ_l , and σ_{cp} are calculated as:

$$k = 1 + \sqrt{\frac{200}{d}} \leq 2.0 \quad (d \text{ is in mm}) \quad (\text{EC2 6.2.2(1)})$$

$$\rho_l = \frac{A_s}{b_w d} \leq 0.02 \quad (\text{EC2 6.2.2(1)})$$

$$\sigma_{cp} = N_{Ed}/A_c < 0.2f_{cd} \quad (\text{in MPa}) \quad (\text{EC2 6.2.2(1)})$$

The effective shear area, A_c (see Figure 3-6), is taken as $b_w d$. The factor $k_l = 0.15$ [NDP] and the values of $C_{Rd,c}$ [NDP] and v_{\min} [NDP] are determined as:

$$C_{Rd,c} = 0.18/\gamma_c \quad (\text{EC2 6.2.2(1)})$$

$$v_{\min} = 0.035 k^{3/2} f_{ck}^{1/2} \quad (\text{EC2 Eq. 6.3N})$$

3.5.2.3 Determine Maximum Design Shear Force

To prevent crushing of the concrete compression struts, the design shear force V_{Ed} is limited by the maximum sustainable design shear force, $V_{Rd,max}$. If the design shear force exceeds this limit, a failure condition occurs. The maximum sustainable shear force is defined as:

$$V_{Rd,max} = \alpha_{cw} b_w z v_1 f_{cd} / (\cot\theta + \tan\theta) \quad (\text{EC2 Eq. 6.9})$$

The coefficient α_{cw} [NDP] takes account of the state of stress in the compression chord and is taken equal to 1, which is recommended for non-prestressed structures. The strength reduction factor for concrete cracked in shear, v_1 [NDP] is defined as:

$$v_1 = 0.6 \left[1 - f_{ck}/250 \right] \quad (f_{ck} \text{ is in MPa}) \quad (\text{EC2 Eq. 6.6N})$$

The inner lever arm distance, z , is approximated as $0.9d$.

The angle between the concrete compression strut and the beam axis perpendicular to the shear force is defined as θ . If torsion is significant i.e., $T_{Ed} > T_{cr}$ where T_{cr} is defined as:

$$T_{cr} = T_{Rd,c} \left(1 - \frac{|V_{Ed}|}{V_{Rd,c}} \right) \quad (\text{EC2 Eq. 6.31})$$

and if the load combination include seismic, the value of θ is taken as 45° . However, for other cases θ is optimized using the following relationship:

$$(\cot\theta + \tan\theta) = 0.9\alpha_{cw}v_1f_{cd}/v_{Ed}$$

where

$$21.8^\circ \leq \theta \leq 45^\circ$$

3.5.2.4 Determine Required Shear Reinforcement

If V_{Ed} is greater than $V_{Rd,c}$ and less than $V_{Rd,max}$, the required shear reinforcement in the form of stirrups or ties per unit spacing, A_{sw}/s , is calculated as:

$$\frac{A_{sw}}{s} = \frac{V_{Ed}}{z f_{ywd} \cot \theta} \quad (\text{EC2 Eq. 6.8})$$

The computation of θ is given in preceding section.

The maximum of all the calculated A_{sw}/s values, obtained from each design load combination, is reported for the beam, along with the controlling combination name. The calculated shear reinforcement must be greater than the minimum reinforcement ratio of:

$$\rho_{w,min} = (0.08\sqrt{f_{ck}})/f_{yk} \quad (\text{EC2 Eq. 9.5N})$$

The beam shear reinforcement requirements reported by the program are based purely on shear strength considerations. Any minimum stirrup requirements to satisfy spacing and volumetric consideration must be investigated independently of the program by the user.

3.5.3 Design Beam Torsion Reinforcement

The torsion reinforcement is designed for each design load combination at a user-defined number of output stations along the beam span. The following steps are involved in designing the longitudinal and shear reinforcement for a particular station due to beam torsion:

- Determine the factored torsion, T_{Ed} .

- Determine torsion section properties.
- Determine the torsional cracking moment.
- Determine the reinforcement steel required.

3.5.3.1 Determine Factored Torsion

In the design of torsion reinforcement of any beam, the factored torsions for each design load combination at a particular design station are obtained by factoring the corresponding torsion for different load cases with the corresponding design load combination factors.

3.5.3.2 Determine Torsion Section Properties

For torsion design, special torsion section properties, including A_k , t_{ef} , u , u_k , and z_i , are calculated. These properties are described as follows (EC2 6.3).

A_k = Area enclosed by centerlines of the connecting walls, where the centerline is located a distance of $t_{ef}/2$ from the outer surface

t_{ef} = Effective wall thickness

u = Outer perimeter of the cross-section

u_k = Perimeter of the area A_k

z_i = Side length of wall i , defined as the distance between the intersection points of the wall centerlines

For torsion design of T-beam sections, it is assumed that placing torsion reinforcement in the flange area is inefficient. With this assumption, the flange is ignored for torsion reinforcement calculation. However, the flange is considered during calculation of the torsion section properties. With this assumption, the special properties for a Rectangular beam section are given as follows:

$$A = bh$$

$$A_k = (b - t_{ef})(h - t_{ef})$$

$$u = 2b + 2h$$

$$u_k = 2(b - t_{ef}) + 2(h - t_{ef})$$

where, the section dimensions b , h , and t_{ef} are shown in Figure 3-9. Similarly, the special section properties for a T-beam section are given as follows:

$$A = b_w h + (b_f - b_w) d_s$$

$$A_k = (b_f - t_{ef})(h - t_{ef})$$

$$u = 2b_f + 2h$$

$$u_k = 2(b_f - t_{ef}) + 2(h - t_{ef})$$

where the section dimensions b_f , b_w , h , and d_s for a T-beam are shown in Figure 3-9.

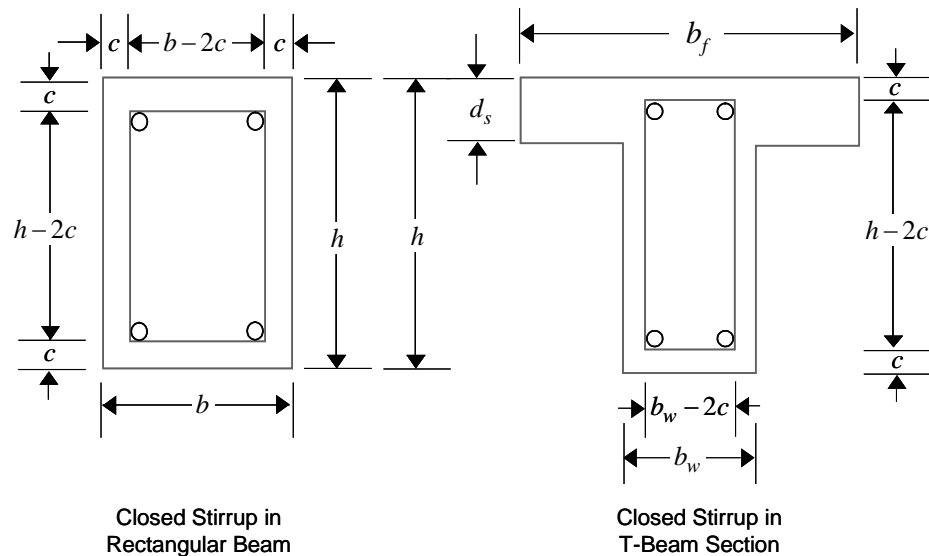

Figure 3-9 Closed stirrup and section dimensions for torsion design

3.5.3.3 Determine Torsional Cracking Moment

The torsion in the section can be ignored with only minimum shear reinforcement (EC2 9.2.1.1) necessary if the following condition is satisfied:

$$T_{Ed}/T_{Rd,c} + V_{Ed}/V_{Rd,c} \leq 1.0 \quad (\text{EC2 Eq. 6.31})$$

where $T_{Rd,c}$ is the torsional cracking moment, determined as:

$$T_{Rd,c} = f_{ctd} t_{ef} 2A_k$$

where t_{ef} , and f_{ctd} , the design tensile strength, are defined as:

$$t_{ef} = A/u \quad (\text{EC2 6.3.2(1)})$$

$$f_{ctd} = \alpha_{ct} f_{ctk0.05} / \gamma_c \quad (\text{EC2 Eq. 3.16})$$

where A is the gross cross-section area, u is the outer circumference of the cross-section, α_{ct} [NDP] is a coefficient, taken as 1.0, taking account of long-term effects on the tensile strength, and $f_{ctk0.05}$ is defined as:

$$f_{ctk0.05} = 0.7f_{cm} \quad (\text{EC2 Table 3.1})$$

3.5.3.4 Determine Torsion Reinforcement

If EC2 Eq. 6.31, as previously defined, is satisfied, torsion can be safely ignored (EC2 6.3.2(5)). In that case, the program reports that no torsion shear reinforcement is required. However, if the equation is not satisfied, it is assumed that the torsional resistance is provided by closed stirrups, longitudinal bars, and compression diagonals.

If torsion reinforcement in the form of closed stirrups is required, the shear due to this torsion, V_t , is first calculated, followed by the required stirrup area, as:

$$V_t = 2(h - t_{ef}) [(T_{Ed} - T_{con}) / 2A_k]$$

where,

$$T_{con} = \left(1 - \frac{V_{Ed}}{V_{Rd,c}} \right) T_{Rd,c} \quad (\text{EC2 6.3.2(5)})$$

$$\frac{A_t}{s} = \frac{V_t}{z f_{ywd} \cot \theta}$$

The required longitudinal reinforcement area for torsion is defined as:

$$A_{sl} = \frac{T_{Ed}}{2A_k} \cot \theta \frac{u_k}{f_{yd}} \quad (\text{EC2 Eq. 6.28})$$

where θ is the angle of the compression struts, as previously defined for beam shear. In the preceding expressions, θ is taken as 45° . The code allows any value between 21.8° and 45° (EC2 6.2.3(2)), while the program assumes the conservative value of 45° .

An upper limit of the combination of V_{Ed} and T_{Ed} that can be carried by the section without exceeding the capacity of the concrete struts also is checked using the following equation.

$$\frac{T_{Ed}}{T_{Rd,max}} + \frac{V_{Ed}}{V_{Rd,max}} \leq 1.0 \quad (\text{EC2 Eq. 6.29})$$

where, $T_{Rd,max}$, the design torsional resistance moment is defined as:

$$T_{Rd,max} = 2\nu\alpha_{cw}f_{cd}A_k t_{ef} \sin\theta \cos\theta \quad (\text{EC2 Eq. 6.30})$$

The value ν is defined by EC2 Eq. 6.6N. If the combination of V_{Ed} and T_{Ed} exceeds this limit, a failure message is declared. In that case, the concrete section should be increased in size.

The maximum of all the calculated A_{st} and A_t/s values obtained from each design load combination is reported along with the controlling combination names.

The beam torsion reinforcement requirements reported by the program are based purely on strength considerations. Any minimum stirrup requirements and longitudinal rebar requirements to satisfy spacing considerations must be investigated independently of the program by the user.

Chapter 4 Seismic Provisions

This chapter provides a detailed description of the algorithms related to seismic provisions in the design/check of structures in accordance with the "EN 1998-1:2004 — Eurocode 8: Design of Structures for Earthquake Resistance" (EC 8 2004). The code option "Eurocode 2-2004" covers these provisions. The implementation covers load combinations from "Eurocode 2-2004," which is described in the section "Design Loading Combination" of Chapter 3. The loading based on "Eurocode 8-2004" has been described in a separate document entitled "CSI Lateral Load Manual" (CSI 2009).

For referring to pertinent sections of the corresponding code, a unique prefix is assigned for each code.

- Reference to the Eurocode EN 1990:2001 code is identified with the prefix "**EC0.**"
- Reference to the Eurocode EN 1992-1-1:2004 code is identified with the prefix "**EC2.**"
- Reference to the Eurocode EN 1998-1:2004 code is identified with the prefix "**EC8.**"

4.1 Notations

The following notations are used in this chapter.

A_{sh}	Total area of horizontal hoops in a beam-column joint, mm ²
$A_{sv,i}$	Total area of column vertical bars between corner bars in one direction through a joint, mm ²
ΣM_{Rb}	Sum of design values of moments of resistance of the beams framing into a joint in the direction of interest, N-mm
ΣM_{Rc}	Sum of design values of the moments of resistance of the columns framing into a joint in the direction of interest, N-mm
$M_{i,d}$	End moment of a beam or column for the calculation of its capacity design shear, N-mm
$M_{Rb,i}$	Design value of beam moment of resistance at end i , N-mm
$M_{Rc,i}$	Design value of column moment of resistance at end i , N-mm
$V_{Ed,max}$	Maximum acting shear force at the end section of a beam from capacity design calculation, N
$V_{Ed,min}$	Minimum acting shear force at the end section of a beam from capacity design calculation, N
h	Cross-section depth, mm
h_c	Cross-sectional depth of the column in the direction of interest, mm
h_{jc}	Distance between extreme layers of the column reinforcement in a beam-column joint, mm
h_{jw}	Distance between beam top and bottom reinforcement, mm
l_{cl}	Clear length of a beam or a column, mm
q_o	Basic value of the behavior factor
α_o	Prevailing aspect ratio of the walls of the structural design

α_1	Multiplier of the horizontal design seismic action at formation of the first plastic hinge in the system
α_u	Multiplier of the horizontal seismic design action at formation of the global plastic mechanism
γ_{Rd}	Model uncertainty factor on the design value of resistance in the estimation of the capacity design action effects, accounting for various sources of overstrength
ξ	Ratio, $V_{Ed,min}/V_{Ed,max}$, between the minimum and maximum acting shear forces at the end section of a beam
μ_ϕ	Curvature ductility factor
μ_δ	Displacement ductility factor
ρ	Tension reinforcement ratio

4.2 Design Preferences

The concrete frame design Preferences are basic assignments that apply to all of the concrete frame members. The following steel frame design Preferences are relevant to the special seismic provisions.

- Framing Type
- Ignore Seismic Code?

4.3 Overwrites

The concrete frame design Overwrites are basic assignments that apply only to those elements to which they are assigned. The following steel frame design overwrite is relevant to the special seismic provisions.

- Frame Type

4.4 Supported Framing Types

The code (Eurocode 8:2004) now recognizes the following types of framing systems (EC8 5.2.1(4)). With regard to these framing types, the program has implemented specifications for the types of framing systems listed.

Framing Type	References
DCH MRF (Ductility Class High – Moment-Resisting Frame)	EC8 5.5
DCM MRF (Ductility Class Medium – Moment-Resisting Frame)	EC8 5.4
DCL MRF (Ductility Class Low – Moment-Resisting Frame)	EC8 5.3
Secondary	

The program default frame type is Ductility Class High – Moment-Resisting Frame (DCH MRF). However, that default can be changed in the Preference for all frames or in the Overwrites on a member-by-member basis. If a frame type Preference is revised in an existing model, the revised frame type does not apply to frames that have already been assigned a frame type through the Overwrites; the revised Preference applies only to new frame members added to the model after the Preference change and to the old frame members that were not assigned a frame type through the Overwrites.

4.5 Member Design

This section describes the special requirements for designing a member.

4.5.1 Ductility Class High – Moment-Resisting Frames (DCH MRF)

For this framing system ($q_o = 4.5\alpha_u/\alpha_1$, $\alpha_u/\alpha_1 = 1.1-1.3$) (EC8 5.2.2.2(5), Table 5.1), the following additional requirements are checked or reported (EC8 5.5).

NOTE: The geometrical constraints and material requirements given in EC8 Section 5.5.1 should be checked independently by the user because the program does not perform those checks.

4.5.1.1 Design Forces

4.5.1.1.1 Beams

The design values of bending moments and axial forces are obtained from the analysis of the structure for the seismic design situation in accordance with EC0 section 6.4.3.4, taking into account second order effects in accordance with EC0 4.4.2.2 and the capacity design requirements of 5.2.3.3(2) (EC8 5.5.2). The design values for shear forces of primary seismic beams and columns are determined in accordance with EC8 5.5.2.1 and EC8 5.5.2.2, respectively.

In primary seismic beams, the design shear forces are determined in accordance with the capacity design rule, on the basis of the equilibrium of the beam under (a) the transverse load acting on it in the seismic design situation and (b) end moments $M_{i,d}$ (with $i = 1,2$ denoting the end sections of the beam), corresponding to plastic hinge formation for positive and negative directions of seismic loading. The plastic hinges should be taken to form at the ends of the beams or (if they form there first) in the vertical elements connected to the joints into which the beam ends frame (see Figure 4-1) (EC8 5.5.2.1, 5.4.2.2(1)P).

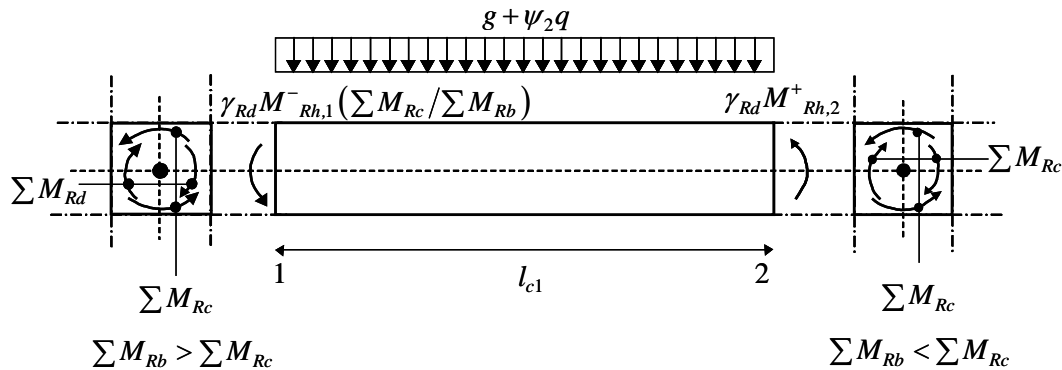

Figure 4-1 Capacity Design Shear Force for beams

The above condition has been implemented as follows (EC8 5.5.2.1, 5.4.2.2(2)P, 5.4.2.2(3)P).

- a) At end section i , two values of the acting shear force should be calculated, i.e. the maximum $V_{Ed,max,i}$ and the minimum $V_{Ed,min,i}$ corresponding to the maximum positive and the maximum negative end moments $M_{i,d}$ that can develop at ends 1 and 2 of the beam.

$$\max V_{i,d} = \frac{\gamma_{Rd} \left[M_{Rd,bi}^- \min \left(1, \frac{\sum M_{Rd,c}}{\sum M_{Rd,b}} \right)_i + M_{Rd,bj}^+ \min \left(1, \frac{\sum M_{Rd,c}}{\sum M_{Rd,b}} \right)_j \right]}{l_{cl}} + V_{g+\psi_2q,o}$$

$$\min V_{i,d} = \frac{\gamma_{Rd} \left[M_{Rd,bi}^+ \min \left(1, \frac{\sum M_{Rd,c}}{\sum M_{Rd,b}} \right)_i + M_{Rd,bj}^- \min \left(1, \frac{\sum M_{Rd,c}}{\sum M_{Rd,b}} \right)_j \right]}{l_{cl}} + V_{g+\psi_2q,o}$$

As the moments and shears on the right-hand side of equations presented above are positive, the outcome may be positive or negative. If it is positive, the shear at any section will not change the sense of action despite the cyclic nature of seismic loading; if it is negative, the shear does change sense. The ratio

$$\xi_i = \frac{\min V_{i,d}}{\max V_{i,d}}$$

is used in the dimensioning of shear reinforcement of DCH beams as a measure of reversal of the shear force at end i (similarly at end j).

- b) End moments $M_{i,d}$ is determined as follows:

$$M_{i,d} = \gamma_{Rd} M_{Rb,i} \min \left(1, \frac{\sum M_{Rc}}{\sum M_{Rb}} \right) \quad (\text{EC8 Eq. 5.8})$$

where

γ_{Rd} is the factor accounting for possible overstrength because of steel strain hardening, which in the case of DCH beams is taken as equal to 1.2;

$M_{Rb,i}$ is the design value of the beam moment of resistance at end i in the sense of the seismic bending moment under the considered sense of the seismic action;

ΣM_{Rc} and ΣM_{Rb} are the sum of the design values of the moments of resistance of the columns and the sum of the design values of the moments of resistance of the beams framing into the joint, respectively. The value of ΣM_{Rc} should correspond to the column axial force(s) in the seismic design situation for the considered sense of the seismic action.

- c) At a beam end where the beam is supported indirectly by another beam instead of framing into a vertical member, the beam end moment, $M_{i,d}$, may be taken as equal to the acting moment at the beam end section in a seismic design situation.

4.5.1.1.2 Columns

In primary seismic columns, the design values of shear forces are determined in accordance with the capacity design rule, on the basis of the equilibrium of the column under end moments $M_{i,d}$ (with $i=1,2$ denoting the end stations of the column), corresponding to plastic hinge formation for positive and negative directions of seismic loading. The plastic hinges should be taken to form at the ends of the beams connected to the joints into which the column end frames, or (if they form there first) at the ends of the columns (see Figure 4-2).

$$\max V_{CD,c} = \frac{\gamma_{Rd} \left[M_{Rd,c1} \min \left(1, \frac{\sum M_{Rd,b}}{\sum M_{Rd,c}} \right)_i + M_{Rd,c2} \min \left(1, \frac{\sum M_{Rd,b}}{\sum M_{Rd,c}} \right)_j \right]}{l_{cl}}$$

End moments $M_{i,d}$ is determined as follows:

$$M_{i,d} = \gamma_{Rd} M_{Rc,i} \min \left(1, \frac{\sum M_{Rb}}{\sum M_{Rc}} \right) \quad (\text{EC8 Eq. 5.9})$$

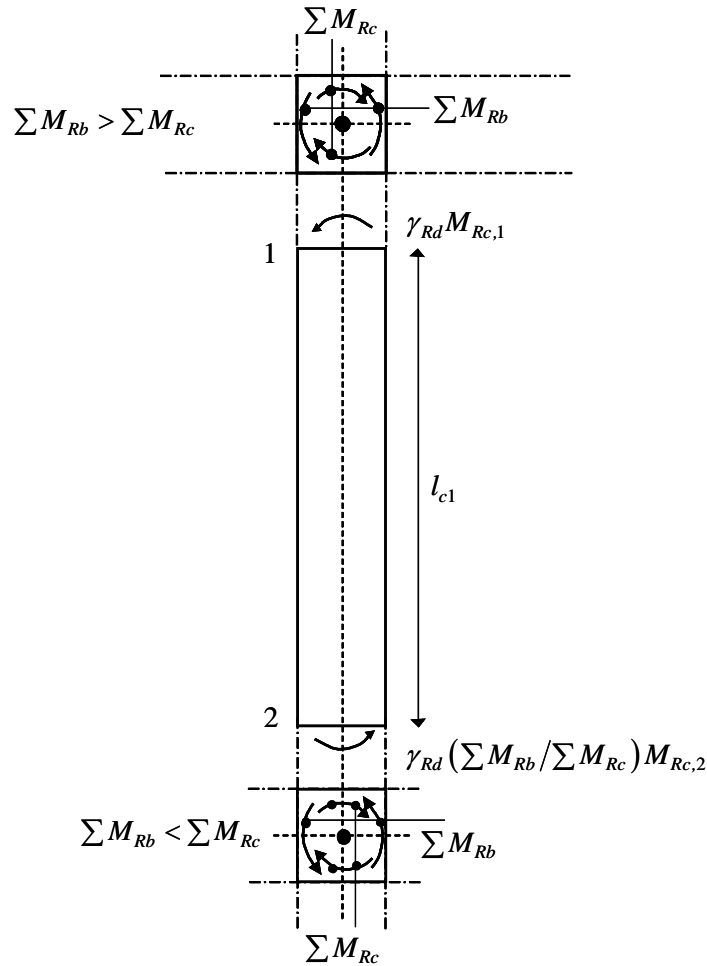

Figure 4-2 Capacity Design Shear Force for Columns

where

γ_{Rd} is the factor accounting for possible overstrength due to steel strain hardening, which in the case of DCH beams is taken as equal to 1.3;

$M_{Rc,i}$ is the design value of the column moment of resistance at end i in the sense of the seismic bending moment under the considered sense of the seismic action;

ΣM_{Rc} and ΣM_{Rb} are the sum of the design values of the moments of resistance of the columns and the sum of the design values of the moments of resistance of the beams framing into the joint, respectively.

The value of ΣM_{Rc} should correspond to the column axial force(s) in the seismic design situation for the considered sense of the seismic action.

4.5.1.2 Design Resistance

The beam and column bending resistance is computed in accordance with EN 1992-1-1:2004 (EC8 5.5.3.1.1(1)P).

The beam shear resistance is computed in accordance with EN 1992-1-1:2004 with the following exceptions (EC8 5.5.3.1.1):

- (1) In the critical regions of primary seismic beams, the strut inclination, θ , in the truss model is 45° .
- (2) With regard to the arrangement of shear reinforcement within the critical region at an end of a primary seismic beam where the beam frames into a column, the following cases should be distinguished, depending on the algebraic value of the ratio:

$\zeta = V_{Ed,min}/V_{Ed,max}$ ratio between the minimum and maximum acting shear forces, as derived in accordance with EC8 section 5.5.2.1(3).

- (a) If $\zeta \geq -0.5$, the shear resistance provided by the reinforcement should be computed in accordance with EN 1992-1-1:2004.
- (b) If $\zeta < -0.5$, i.e. when an almost full reversal of shear forces is expected, then:

- (i) if $|V_E|_{\max} \leq (2 + \xi) f_{ctd} b_w d$ (EC8 Eqn. 5.27)

where f_{ctd} is the design value of the concrete tensile strength from EN 1992-1-1:2004, the same rule as in (a) of this section applies.

(ii) if $|V_E|_{\max}$ exceeds the limit value in expression (EC8 Eqn. 5.27), inclined reinforcement should be provided in two directions, either at $\pm 45^\circ$ to the beam axis or along the two diagonals of the beam in elevation, and half of $|V_E|_{\max}$ should be resisted by stirrups and half by inclined reinforcement.

- In such a case, the verification is carried out by means of the condition:

$$0.5V_{E\max} \leq 2A_s f_{yd} \sin \alpha \quad (\text{EC8 Eqn. 5.28})$$

where,

A_s is the area of the inclined reinforcement in one direction, crossing the potential sliding plane (i.e. the beam end section);

α is the angle between the inclined reinforcement and the beam axis (normally $\alpha = 45^\circ$, or $\tan \alpha \approx (d - d')/l_b$).

NOTE: Inclined stirrups are not designed at this time (EC8 5.5.3.1.2(3)). Only vertical stirrups are designed for case EC8 5.5.3.1.2(b) for the full shear force.

The column shear resistance is computed in accordance with EN 1992-1-1:2004, with the following exceptions (EC8 5.5.3.2.1):

In primary seismic columns, the value of the normalized axial force v_d should not exceed 0.55 (EC8 5.5.3.2.1(3)P). Otherwise the program generates a warning message.

$$v_d = \frac{N_{Ed}}{f_{cd} A_g} \quad (\text{EC8 5.5.3.3(3)})$$

4.5.1.3 Joint Design

To ensure that the beam-column joint of a Ductility Class High Moment Resisting Frame (DCH MRF) possesses adequate shear strength, the program performs a rational analysis of the beam-column panel zone to determine the

shear forces that are generated in the joint. The program then checks this against design shear strength.

Only joints having a column below the joint are checked. The material properties of the joint are assumed to be the same as those of the column below the joint.

The joint analysis is completed in the major and the minor directions of the column. The joint design procedure involves the following steps:

- Determine the panel zone design shear force, V_{jhd}
- Determine the effective area of the joint
- Design panel zone shear rebar/stirrup

The algorithms associated with these three steps are described in detail in the following three sections.

4.5.1.3.1 Determine the Panel Zone Shear Force

Figure 4-3 illustrates the free body stress condition of a typical beam-column intersection for a column direction, major or minor.

The force V_{jhd} is the horizontal panel zone shear force that is to be calculated. The forces that act on the joint are N_{Ed} , V_C , M_{Ed}^L , and M_{Ed}^R . The forces N_{Ed} and V_C are the design axial force and design shear force, respectively, from the column framing into the top of the joint. The moments M_{Ed}^L and M_{Ed}^R are obtained from the beams framing into the joint. The program calculates the joint shear force V_{jhd} by resolving the moments into C and T forces. Noting that $T_L = C_L$ and $T_R = C_R$,

$$V_{jhd} = T_L + T_R - V_C$$

The location of C or T forces is determined by the direction of the moment. The magnitude of C or T forces is conservatively determined using basic principles of ultimate strength theory.

The program resolves the moments and the C and T forces from beams that frame into the joint in a direction that is not parallel to the major or minor directions of the column along the direction that is being investigated, thereby contributing force components to the analysis. Also, the program calculates the C and T for the positive and negative moments, considering the fact that the concrete cover may be different for the direction of moment.

In the design of Ductility Class High Moment Resisting Frames (DCH MRF), the evaluation of the design shear force is based on the moment capacities (with a reinforcing steel overstrength factor due to steel strain hardening, γ_{rd} , which in the case of DCH MRF beams is taken as equal to 1.2 (EC8 5.5.2.3 (2))). The C and T force are based on those moment capacities. The program calculates the column shear force V_C from the beam moment capacities, as follows (see Figure 4-3):

$$V_C = \frac{M_{Ed}^L + M_{Ed}^R}{H}$$

It should be noted that the points of inflection shown on Figure 4-3 are taken as midway between actual lateral support points for the columns. If no column exists at the top of the joint, the shear force from the top of the column is taken as zero.

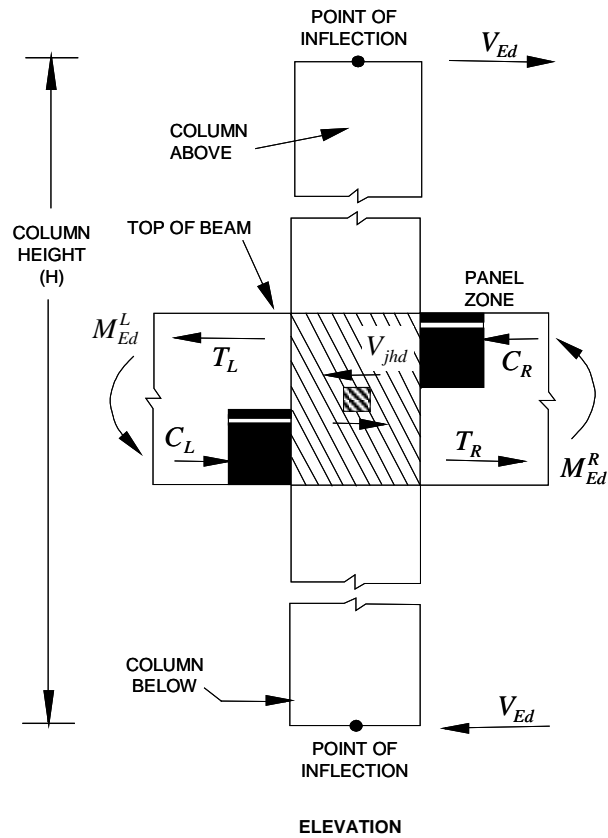

Figure 4-3 Column shear force V_C

The effects of load reversals, as illustrated in Case 1 and Case 2 of Figure 4-4, are investigated and the design is based on the maximum of the joint shears obtained from the two cases.

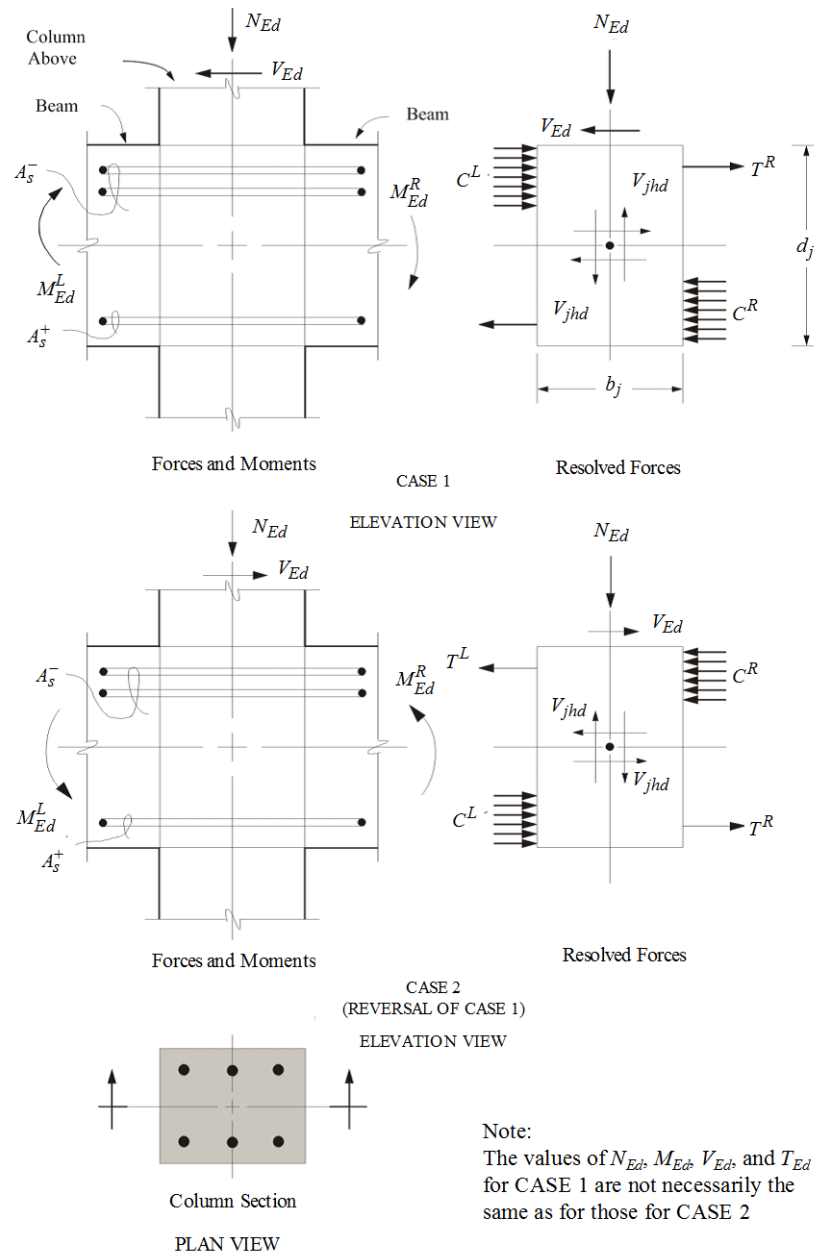

Figure 4-4 Beam-column joint analysis

4.5.1.3.2 Determine the Effective Area of Joint

The joint area that resists the shear forces is assumed always to be rectangular in plan view. The dimensions of the rectangle correspond to the major and minor dimensions of the column below the joint, except if the beam framing into the joint is very narrow. The effective width of the joint area to be used in the calculation is limited as follows:

$$\text{If } b_c > b_w, \quad b_j = \min \{ b_c, (b_w + 0.5h_c) \}; \quad (\text{EC8 Eqn. 5.34a, 5.5.3.3(2)})$$

$$\text{If } b_c < b_w, \quad b_j = \min \{ b_w, (b_c + 0.5h_c) \}; \quad (\text{EC8 Eqn. 5.34a, 5.5.3.3(2)})$$

where

b_c = cross-sectional dimension of column,

b_w = width of web of a beam, and

h_c = cross-sectional depth of column in the direction of interest.

The joint area for joint shear along the major and minor directions is calculated separately (EC8 5.5.3.3).

It should be noted that if the beam frames into the joint eccentrically, the preceding assumptions may not be conservative and the user should investigate the acceptability of the particular joint.

4.5.1.3.3 Check Panel Zone Shear Force

The panel zone shear force is evaluated by comparing it with the following design shear strengths (EC85.5.3.3(2)).

$$V_{jhd} \leq \begin{cases} \eta f_{cd} \sqrt{1 - \frac{v_d}{\eta}} b_j h_{jc} & \text{for interior joints,} \\ 0.8 \eta f_{cd} \sqrt{1 - \frac{v_d}{\eta}} b_j h_{jc} & \text{for exterior joints,} \end{cases} \quad (\text{EC8 Eq. 5.33})$$

where,

$$\eta = 0.6(1 - f_{ck}/250)$$

h_{jc} is the distance between extreme layers of column reinforcement;

b_j is as defined by EC8 equation 5.34a and 5.34 b;

v_d is the normalized axial force in the column above the joint; and

f_{ck} is given in MPa.

4.5.1.4 Design Panel Zone Confinement Reinforcing

The panel zone confinement reinforcing (horizontal hoops) is computed as follows (EC8 5.3.3(3)).

$$A_{sh} = \left[\frac{\left(\frac{V_{jhd}}{b_j h_{jc}} \right)^2}{f_{ctd} + v_d f_{cd}} - f_{ctd} \right] \frac{b_j h_{jw}}{f_{ywd}} \quad (\text{EC8 Eqn. 5.35})$$

where,

A_{sh} is the total area of the horizontal hoops;

V_{jhd} is the horizontal shear force acting on the concrete core of the joint

h_{jw} is the distance between the top and the bottom reinforcement of the beam;

h_{jc} is the distance between the extreme layers of column reinforcement;

b_j is as defined in EC8 equation 5.34a and 5.34b;

v_d is the normalized design axial force of the column above

$$(v_d = N_{Ed} / A_c f_{cd})$$

The horizontal hoops should be uniformly distributed within the depth h_{jw} between the top and bottom bars of the beam. In exterior joints, they should enclose the ends of beam bars bent toward the joint (EC85.5.3.3(5)).

Additional requirements for horizontal confinement reinforcement in joints of primary seismic beam with columns as stipulated in EC8 sections 5.5.3.3(7), 5.4.3.3(1) and 5.4.3.2.2(8)-(11) are NOT enforced by program.

4.5.1.5 Beam-Column Flexural Capacity Ratios

The program calculates the ratio of the sum of the beam moment capacities to the sum of the column moment capacities. For Ductility Class High Moment Resisting Frames (DCH MRF), at a particular joint for a particular column direction, major or minor (EC8 5.2.3.3(2)):

$$\frac{\sum 1.3M_b}{\sum M_c} \leq 1.0 \quad (\text{EC8 4.4.2.3(4), 5.2.3.3(2)})$$

$\sum M_c$ = Sum of nominal flexural strengths of columns framing into the joint, evaluated at the faces of the joint. Individual column flexural strength is calculated for the associated factored axial force.

$\sum M_b$ = Sum of nominal flexural strengths of the beams framing into the joint, evaluated at the faces of the joint.

The capacities are calculated with no reinforcing overstrength factor due to steel strain hardening. The beam capacities are calculated for reversed situations (Cases 1 and 2) as illustrated in Figure 4-3, and the maximum summation obtained is used.

The moment capacities of beams that frame into the joint in a direction that is not parallel to the major or minor direction of the column are resolved along the direction that is being investigated, and the resolved components are added to the summation.

The column capacity summation includes the column above and the column below the joint. For each load combination, the axial force, N_{Ed} , in each of the

columns is calculated from the program design load combinations. For each design load combination, the moment capacity of each column under the influence of the corresponding axial load is then determined separately for the major and minor directions of the column, using the uniaxial column interaction diagram; see Figure 4-5. The moment capacities of the two columns are added to give the capacity summation for the corresponding design load combination. The maximum capacity summations obtained from all of the design load combinations is used for the beam-column capacity ratio.

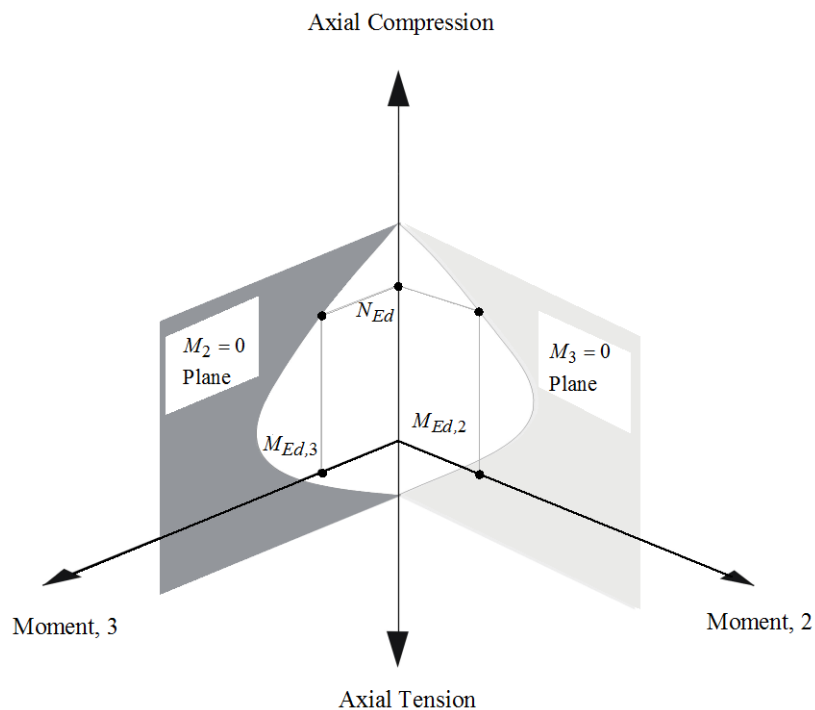

Figure 4-5 Moment capacity M_{Ed} at a given axial load N_{Ed}

The beam-column capacity ratio is determined for a beam-column joint only when the following conditions are met:

- the frame is a Ductility Class High Moment Resisting Frame (DCH MRF)
- when a column exists above the beam-column joint, the column is concrete
- all of the beams framing into the column are concrete beams

- the connecting member design results are available
- the load combo involves seismic load

If this ratio is greater than 1.0, a warning message is printed in the output.

4.5.1.6 Minimum and Maximum Tensile Reinforcement

The minimum flexural tensile reinforcement ratio in a beam section is limited to the following minimum value (EC8 5.5.3.1.3(5)):

$$\rho_{\min} = 0.5 \left(\frac{f_{ctm}}{f_{yk}} \right) \quad (\text{EC8 5.5.3.1.3(5), 5.4.3.1.2(5)})$$

The maximum flexural tensile reinforcement ratio in a beam section within plastic hinge is limited to the following maximum values (EC8 5.5.3.1.3(3)):

$$\rho_{\max} = \rho' + \frac{0.0018 f_{cd}}{\mu_{\varphi} \varepsilon_{sy,d} f_{yd}} \quad (\text{EC8 5.5.3.1.3(3), 5.4.3.1.2 (4)})$$

where,

$$\mu_{\varphi} = 2q_o - 1 \text{ if } T_1 \geq T_c \quad (\text{EC8 5.2.3.4(3), Eqn. 5.4})$$

$$\mu_{\varphi} = 1 + (2q_o - 1)T_c/T_1 \text{ if } T_1 < T_c \quad (\text{EC8 5.2.3.4(3), Eqn. 5.5})$$

However, the preceding limit is NOT enforced in the program. The user must manually check the preceding limit at potential hinge locations.

The minimum and maximum flexural tensile reinforcement ratio required in a column section is limited to the following (EC8 5.5.3.2.2(3), 5.4.3.2.2(3)):

The total longitudinal reinforcement ratio, ρ_1 , is limited as follows:

$$\rho_{\min} = 0.01 \quad (\text{EC8 5.4.3.2.2(1)})$$

$$\rho_{\max} = 0.04 \quad (\text{EC8 5.4.3.2.2(1)})$$

4.5.2 Ductility Class Medium – Moment-Resisting Frames (DCM MRF)

For this framing system ($q_o = 3.0\alpha_u/\alpha_1$, $\alpha_u/\alpha_1 = 1.1-1.3$) (EC8 5.2.2.2(5), Table 5.1), the additional requirements described in the sections that follow are checked or reported (EC8 5.5).

NOTE: The geometrical constraints and material requirements given in EC8 Section 5.4.1 should be independently checked by the user because the program does not perform those checks.

4.5.2.1 Design Forces

4.5.2.1.1 Beams

The design values of bending moments and axial forces are obtained from the analysis of the structure for the seismic design situation in accordance with EN 1990:2001 section 6.4.3.4, taking into account second order effects in accordance with section 4.4.2.2 and the capacity design requirements of section 5.2.3.3(2) (EC8 5.5.2). The design values of shear forces of primary seismic beams and columns are determined in accordance with sections 5.4.2.1 and 5.4.2.2, respectively.

In primary seismic beams, the design shear forces are determined in accordance with the capacity design rule, on the basis of the equilibrium of the beam under: (a) the transverse load acting on it in the seismic design situation and (b) end moments $M_{i,d}$ (with $i = 1,2$, denoting the end sections of the beam), corresponding to plastic hinge formation for positive and negative directions of seismic loading. The plastic hinges should be taken to form at the ends of the beams or (if they form there first) in the vertical elements connected to the joints into which the beam ends frame (see Figure 4-1) (EC8 5.4.2.2(1)P).

The above condition should be implemented as follows (EC8 5.4.2.2(2)P, 5.4.2.2(3)P).

- a) At end section i , two values of the acting shear force should be calculated, i.e. the maximum $V_{Ed,max,i}$ and the minimum $V_{Ed,min,i}$ corresponding to the maximum positive and the maximum negative end moments $M_{i,d}$ that can develop at ends 1 and 2 of the beam.

$$\max V_{i,d} = \frac{\gamma_{Rd} \left[M_{Rd,bi}^- \min \left(1, \frac{\sum M_{Rd,c}}{\sum M_{Rd,b}} \right)_i + M_{Rd,bj}^+ \min \left(1, \frac{\sum M_{Rd,c}}{\sum M_{Rd,b}} \right)_j \right]}{l_{cl}} + V_{g+\psi 2q,o}$$

$$\min V_{i,d} = \frac{\gamma_{Rd} \left[M_{Rd,bi}^+ \min \left(1, \frac{\sum M_{Rd,c}}{\sum M_{Rd,b}} \right)_i + M_{Rd,bj}^- \min \left(1, \frac{\sum M_{Rd,c}}{\sum M_{Rd,b}} \right)_j \right]}{l_{cl}} + V_{g+\psi 2q,o}$$

b) End moments $M_{i,d}$ is determined as follows:

$$M_{i,d} = \gamma_{Rd} M_{Rb,i} \min \left(1, \frac{\sum M_{Rc}}{\sum M_{Rb}} \right) \quad (\text{EC8 Eq. 5.8})$$

where

γ_{Rd} is the factor accounting for possible overstrength due to steel strain hardening, which in the case of DCM beams is taken as equal to 1.0;

$M_{Rb,i}$ is the design value of the beam moment of resistance at end i in the sense of the seismic bending moment under the considered sense of the seismic action;

$\sum M_{Rc}$ and $\sum M_{Rb}$ are the sum of the design values of the moments of resistance of the columns and the sum of the design values of the moments of resistance of the beams framing into the joint, respectively. The value of $\sum M_{Rc}$ should correspond to the column axial force(s) in the seismic design situation for the considered sense of the seismic action.

c) At a beam end where the beam is supported indirectly by another beam, instead of framing into a vertical member, the beam end moment $M_{i,d}$ may be taken as equal to the acting moment at the beam end section in the seismic design situation.

4.5.2.1.2 Columns

In primary seismic columns the design values of shear forces is determined in accordance with the capacity design rule, on the basis of the equilibrium of the column under end moments $M_{i,d}$ (with $i = 1,2$ denoting the end sections of the column), corresponding to plastic hinge formation for positive and negative directions of seismic loading. The plastic hinges should be taken to form at the ends of the beams connected to the joints into which the column end frames, or (if they form there first) at the ends of the columns (see Figure 4-2).

$$\max V_{CD,c} = \frac{\gamma_{Rd} \left[M_{Rd,c1} \min \left(1, \frac{\sum M_{Rd,b}}{\sum M_{Rd,c}} \right)_i + M_{Rd,c2} \min \left(1, \frac{\sum M_{Rd,b}}{\sum M_{Rd,c}} \right)_j \right]}{l_{cl}}$$

End moments $M_{i,d}$ is determined as follows:

$$M_{i,d} = \gamma_{Rd} M_{Rc,i} \min \left(1, \frac{\sum M_{Rb}}{\sum M_{Rc}} \right) \quad (\text{EC8 Eqn. 5.9})$$

where

γ_{Rd} is the factor accounting for possible overstrength due to steel strain hardening, which in the case of DCM beams is taken as equal to 1.1;

$M_{Rc,i}$ is the design value of the column moment of resistance at end i in the sense of the seismic bending moment under the considered sense of the seismic action;

$\sum M_{Rc}$ and $\sum M_{Rb}$ are the sum of the design values of the moments of resistance of the columns and the sum of the design values of the moments of resistance of the beams framing into the joint, respectively.

The value of $\sum M_{Rc}$ should correspond to the column axial force(s) in the seismic design situation for the considered sense of the seismic action.

4.5.2.2 Design Resistance

The beam and column bending resistance and beam shear is computed in accordance with EN 1992-1-1:2004 (EC8 5.4.3.1.1(1)P).

The column shear resistance is computed in accordance with EN 1992-1-1:2004 with the following exception (EC8 5.4.3.2.1):

In primary seismic columns the value of the normalized axial force v_d should not exceed 0.65 (EC8 5.4.3.2.1(3)P). Otherwise, the program generates a warning message.

4.5.2.3 Beam-Column Flexural Capacity Ratios

The program calculates the ratio of the sum of the beam moment capacities to the sum of the column moment capacities. For Ductility Class Medium Moment Resisting Frames (DCM MRF), at a particular joint for a particular column direction, major or minor (EC8 5.2.3.3(2)):

$$\frac{\sum 1.3M_b}{\sum M_c} \leq 1.0 \quad (\text{EC8 4.4.2.3(4), 5.2.3.3(2)})$$

$\sum M_c$ = Sum of nominal flexural strengths of columns framing into the joint, evaluated at the faces of the joint. Individual column flexural strength is calculated for the associated factored axial force.

$\sum M_b$ = Sum of nominal flexural strengths of the beams framing into the joint, evaluated at the faces of the joint.

The capacities are calculated with no reinforcing overstrength factor due to steel strain hardening. The beam capacities are calculated for reversed situations (Cases 1 and 2) as illustrated in Figure 4-3, and the maximum summation obtained is used. Refer to Section 4.5.1.5 of this chapter for further details on computing the Beam-Column Flexural capacity Ratio for DCM MRF.

4.5.2.4 Minimum and Maximum Tensile Reinforcement

The minimum flexural tensile reinforcement ratio in a beam section is limited to the following minimum value (EC8 5.4.3.1.3(5)):

$$\rho_{\min} = 0.5 \left(\frac{f_{ctm}}{f_{yk}} \right) \quad (\text{EC8 5.4.3.1.2(5)})$$

The maximum flexural tensile reinforcement ratio in a beam section within a plastic hinge is limited to the following maximum values (EC8 5.4.3.1.3(4)):

$$\rho_{\max} = \rho' + \frac{0.0018 f_{cd}}{\mu_{\phi} \varepsilon_{sy,d} f_{yd}} \quad (\text{EC8 5.4.3.1.2 (4)})$$

where,

$$\mu_{\phi} = 2q_o - 1 \text{ if } T_1 \geq T_c \quad (\text{EC8 5.2.3.4(3)})$$

$$\mu_{\phi} = 1 + (2q_o - 1)T_c/T_1 \text{ if } T_1 < T_c \quad (\text{EC8 5.2.3.4(3)})$$

However, the preceding limit is NOT enforced in the program. The user must manually check the preceding limit at the potential hinge locations.

The minimum and maximum flexural tensile reinforcement ratio required in a column section is limited to the following (EC8 5.5.3.2.2(3), 5.4.3.2.2(3)):

The total longitudinal reinforcement ratio, ρ_l , is limited as follows:

$$\rho_{\min} \geq 0.01 \quad (\text{EC8 5.4.3.2.2(1)})$$

$$\rho_{\max} \leq 0.04 \quad (\text{EC8 5.4.3.2.2(1)})$$

4.5.3 Ductility Class Low – Moment-Resisting Frames (DCL MRF)

Seismic design for Ductility Class Low Moment Resisting Frames (DCL MRF) is completed in accordance with EN 1992-1-1:2004 without any additional requirements other than EC8 section 5.3.2. Reinforcing class B or C in EN 1992-1-1:2004, Table C.1 is permitted for DCL MRF (EC8 5.3.2). The program does not perform any special check when DCL MRF is specified.

4.5.4 Special Consideration for Seismic Design

For Special Moment Resisting Concrete Frames (seismic design), the beam design satisfies the following additional conditions (see also Table 4-1):

Table 4-1: Design Criteria

Type of Check/Design	Ductility Class Low Moment Resisting Frames (DCL MRF)	Ductility Class Medium Moment Resisting Frames (DCM MRF)	Ductility Class High Moment Resisting Frames (DCH MRF)
Column Check (interaction)	Specified Combinations	Specified Combinations	Specified Combinations
Column Design (interaction)	Specified Combinations $0.2\% < \rho < 4\%$	Specified Combinations $1\% < \rho < 4\%$	Specified Combinations $1\% < \rho < 4\%$
Column Shears	Specified Combinations	Specified Combinations Column Capacity Shear $\gamma_{Rd} = 1.1$	Specified Combinations Column Capacity Shear $\gamma_{Rd} = 1.3$
Beam Design Flexure	Specified Combinations $\rho_{\min} \geq \max \begin{cases} 0.26 \left(\frac{f_{ctm}}{f_{yk}} \right) \\ 0.0013 \end{cases}$ $\rho_{\max} \leq 0.004$	Specified Combinations $\rho_{\min} \geq 0.5 \left(\frac{f_{ctm}}{f_{yk}} \right)$	Specified Combinations $\rho_{\min} \geq 0.5 \left(\frac{f_{ctm}}{f_{yk}} \right)$
Beam Min. Moment Override Check	No Requirement	$M_{u,\text{end}}^+ \geq \frac{1}{2} M_{u,\text{end}}^-$ $M_{\text{span}}^- \geq \frac{1}{2} \max \{ M^+, M^- \}_{\text{max}}$	$M_{u,\text{end}}^+ \geq \frac{1}{2} M_{u,\text{end}}^-$ $M_{\text{span}}^+ \geq \frac{1}{4} \max \{ M^+, M^- \}_{\text{end}}$ $M_{\text{span}}^- \geq \frac{1}{2} \max \{ M^+, M^- \}_{\text{end}}$

Table 4-1: Design Criteria

Type of Check/Design	Ductility Class Low Moment Resisting Frames (DCL MRF)	Ductility Class Medium Moment Resisting Frames (DCM MRF)	Ductility Class High Moment Resisting Frames (DCH MRF)
Beam Design Shear	Specified Combinations	Specified Combinations Beam Capacity Shear (V_e) $\gamma_{Rd} = 1.0$	Specified Combinations Beam Capacity Shear (V_e) $\gamma_{Rd} = 1.2$
Joint Design	No Requirement	No Requirement	Checked for shear
Beam/Column Capacity Ratio	No Requirement	Checked	Checked

- At any end (support) of the beam, the beam positive moment capacity (i.e., associated with the bottom steel) in DCH MRF and DCM MRF would not be less than 1/2 of the beam negative moment capacity (i.e., associated with the top steel) at that end (EC8 5.4.3.1.2(4)).
- Neither the negative moment capacity nor the positive moment capacity at any of the sections within the beam in DCH MRF would be less than 1/4 of the maximum of positive or negative moment capacities of any of the beam end (support) stations (EC8 5.5.3.1.3(5)).

APPENDICES

Appendix A

Second Order P-Delta Effects

Typically, design codes require that second order P-Delta effects be considered when designing concrete frames. These effects are the global lateral translation of the frame and the local deformation of members within the frame.

Consider the frame object shown in Figure A-1, which is extracted from a story level of a larger structure. The overall global translation of this frame object is indicated by Δ . The local deformation of the member is shown as δ . The total second order P-Delta effects on this frame object are those caused by both Δ and δ .

The program has an option to consider P-Delta effects in the analysis. When P-Delta effects are considered in the analysis, the program does a good job of capturing the effect due to the Δ deformation shown in Figure A-1, but it does not typically capture the effect of the δ deformation (unless, in the model, the frame object is broken into multiple elements over its length).

Consideration of the second order P-Delta effects is generally achieved by computing the flexural design capacity using a formula similar to that shown in the following equation.

$$M_{CAP} = aM_{nt} + bM_{lt} \quad \text{where,}$$

$$M_{CAP} = \text{Flexural design capacity required}$$

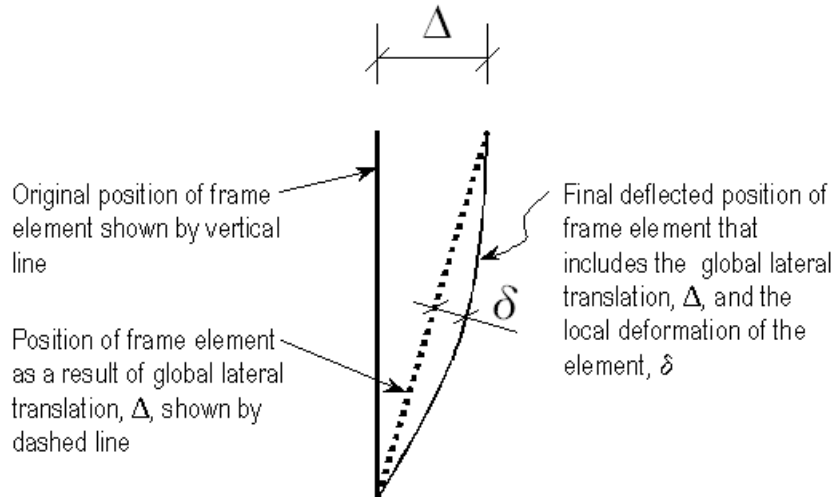

Figure A-1 The total second order P-delta effects on a frame element caused by both Δ and δ

- M_{nt} = Required flexural capacity of the member assuming there is no joint translation of the frame (i.e., associated with the δ deformation in Figure A-1)
- M_{lt} = Required flexural capacity of the member as a result of lateral translation of the frame only (i.e., associated with the Δ deformation in Figure A-1)
- a = Unitless factor multiplying M_{nt}
- b = Unitless factor multiplying M_{lt} (assumed equal to 1 by the program; see the following text)

When the program performs concrete frame design, it assumes that the factor b is equal to 1 and calculates the factor a . That $b = 1$ assumes that P-Delta effects have been considered in the analysis, as previously described. Thus, in general, when performing concrete frame design in this program, **consider P-Delta effects in the analysis before running the program.**

Appendix B

Member Unsupported Lengths and Computation of β -Factors

The column unsupported lengths are required to account for column slenderness effects. The program automatically determines the unsupported length ratios, which are specified as a fraction of the frame object length. Those ratios times the frame object length give the unbraced lengths for the members. Those ratios also can be overwritten by the user on a member-by-member basis, if desired, using the overwrite option.

There are two unsupported lengths to consider. They are l_{33} and l_{22} , as shown in Figure B-1. These are the lengths between support points of the member in the corresponding directions. The length l_{33} corresponds to instability about the 3-3 axis (major axis), and l_{22} corresponds to instability about the 2-2 axis (minor axis).

In determining the values for l_{22} and l_{33} of the members, the program recognizes various aspects of the structure that have an effect on those lengths, such as member connectivity, diaphragm constraints and support points. The program automatically locates the member support points and evaluates the corresponding unsupported length.

It is possible for the unsupported length of a frame object to be evaluated by the program as greater than the corresponding member length. For example, assume

a column has a beam framing into it in one direction, but not the other, at a floor level. In that case, the column is assumed to be supported in one direction only at that story level, and its unsupported length in the other direction will exceed the story height.

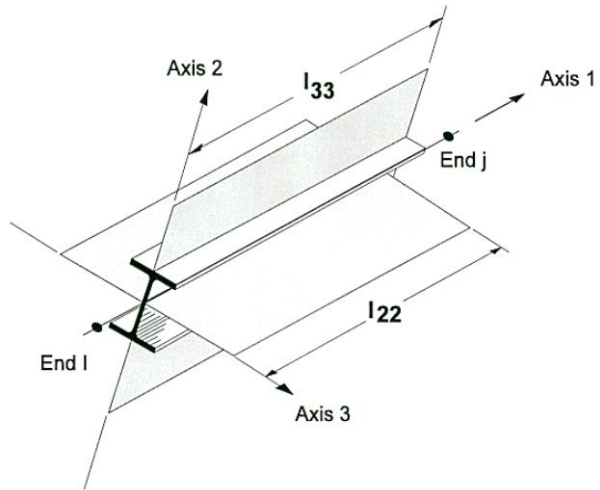

Figure B-1 Axis of bending and unsupported length

Appendix C

Concrete Frame Design Preferences

The Concrete Frame Design Preferences are basic assignments that apply to all of the concrete frame members. Table C-1 lists the Concrete Frame Design Preferences for the Eurocode 2-2004 code Default values are provided for all preference items. Thus, it is not necessary to specify or change any of the preferences. However, at least review the default values to ensure they are acceptable. Some of the preference items also are available as member specific overwrite items. The Overwrites are described in Appendix D. Overwritten values take precedence over the preferences.

Table C-1 Preferences

Item	Possible Values	Default Value	Description
Country	CEN Default United Kingdom	CEN Default	Toggle to choose the country for which the Nationally Determined Parameters [NDPs] should be used. The various NDPs and their associated values for each country are described in Appendix F.
Combinations Equation	Eq. 6.10 Max of Eq. 6.10a/6.10b	Eq. 6.10	Toggle to choose which equation is used to generate automatic load combinations.

Item	Possible Values	Default Value	Description
Second Order Method	Nominal Stiffness Nominal Curvature None	Nominal Curvature	Toggle to choose the method to be used to calculate isolated member P- δ effects. If None is chosen, these effects should be captured by alternative methods.
Time History Design	Envelopes, Step-by-Step	Envelopes	Toggle for design load combinations that include a time history designed for the envelope of the time history, or designed step-by-step for the entire time history. If a single design load combination has <i>more than one</i> time history case in it, that design load combination is designed for the envelopes of the time histories, regardless of what is specified here.
Number of Interaction Curves	Multiple of 4 ≥ 4	24	Number of equally spaced interaction curves used to create a full 360-degree interaction surface (this item should be a multiple of four). We recommend 24 for this item.
Number of Interaction Points	Any odd value ≥ 5	11	Number of points used for defining a single curve in a concrete frame; should be odd.
Consider Minimum Eccentricity	No, Yes	Yes	Toggle to specify if minimum eccentricity is considered in design.
Theta0 (ratio)	> 0	0.005	Inclination angle for imperfections.
GammaS (steel)	> 0	1.15	Partial safety factor for steel.
GammaC (concrete)	> 0	1.5	Partial safety factor for concrete.
AlphaCC (compression)	> 0	1	Material coefficient taking account of long-term effects on the concrete compressive strength and unfavorable effects from the load application.

Appendix C – Concrete Frame Design Preferences

Item	Possible Values	Default Value	Description
AlphaCT (tension)	> 0	1	Material coefficient taking account of long-term effects on the concrete tensile strength and unfavorable effects from the load application.
AlphaLCC (Light-weight compression)	> 0	0.85	Light-weight material coefficient taking account of long-term effects on the concrete compressive strength and unfavorable effects from the load application.
AlphaLCT (Lightweight tension)	> 0	0.85	Light-weight material coefficient taking account of long-term effects on the concrete tensile strength and unfavorable effects from the load application.
Pattern Live Load Factor	≥ 0	0.75	The live load factor for automatic generation of load combinations involving pattern live loads and dead loads.
Utilization Factor Limit	> 0	0.95	Stress ratios that are less than or equal to this value are considered acceptable.

Appendix D Concrete Frame Overwrites

The concrete frame design overwrites are basic assignments that apply only to those elements to which they are assigned. Table D-1 lists concrete frame design overwrites for Eurocode 2-2004. Default values are provided for all overwrite items. Thus, it is not necessary to specify or change any of the overwrites. However, at least review the default values to ensure they are acceptable. When changes are made to overwrite items, the program applies the changes only to the elements to which they are specifically assigned.

Table D-1 Overwrites

Item	Possible Values	Default Value	Description
Current Design Section	Any defined concrete section	Analysis section	The design section for the selected frame objects.
Element Type	Sway Nonsway	From Reference	Frame type defined as sway (unbraced) or nonsway (braced).
Live Load Reduction Factor	≥ 0	Calculated	The reduced live load factor. A reducible live load is multiplied by this factor to obtain the reduced live load for the frame object. Specifying 0 means the value is program determined.

Item	Possible Values	Default Value	Description
Unbraced Length Ratio (Major)	≥ 0	Calculated	Unbraced length factor for buckling about the frame object major axis. This item is specified as a fraction of the frame object length. Multiplying this factor times the frame object length gives the unbraced length for the object. Specifying 0 means the value is program determined.
Unbraced Length Ratio (Minor)	≥ 0	0.60	Unbraced length factor for buckling about the frame object minor axis. Multiplying this factor times the frame object length gives the unbraced length for the object. Specifying 0 means the value is program determined. This factor also is used in determining the length for lateral-torsional buckling.
Effective Length Factor (β Major)	> 0	Calculated	EC2 does not specify this, but it is included to allow the user to overwrite the program determined effective length. Effective length factor for buckling about the frame object major axis. This item is specified as a fraction of the frame object length.
Effective Length Factor (β Minor)	> 0	Calculated	EC2 does not specify this, but it is included to allow the user to overwrite the program determined effective length. Effective length factor for buckling about the frame object minor axis. This item is specified as a fraction of the frame object length.
Correction Factor, K_r	> 0	1.0	Correction factor depending on axial load that is used by the Nominal Curvature method for computing additional moments.
Creep Factor, K_{Φ}	> 0	1.0	Creep factor that is used by the Nominal Curvature method for computing additional moments.

Appendix E Error Messages and Warnings

Table E-1 provides a complete list of Concrete Errors messages and Warnings.

Table E-1 Error Messages

Error Number	Description
1	Beam concrete compression failure
2	Reinforcing required exceeds maximum allowed
3	Shear stress exceeds maximum allowed
4	Column design moments cannot be calculated
5	Column factored axial load exceeds Euler Force
6	Required column concrete area exceeds maximum
7	Flexural capacity could not be calculated for shear design
8	Concrete column supports non-concrete beam/column

Error Number	Description
9	$k * L/r > 115$, $\zeta_2 < 0$, $\eta < 1.0$ (GB50010 7.3.10)
10	Column is overstressed for P-M-M
11	Axial compressive capacity for concrete exceeded (TBM 6.4.2)
12	Beam frames into column eccentrically (11.6.3)
13	Torsion exceeds maximum allowed
14	Reinforcing provided is below minimum required
15	Reinforcing provided exceeds maximum allowed
16	Tension reinforcing provided is below minimum required
17	$k * L/r > 30$ (GB 7.3.10)
21	The column is not ductile. Beam/column capacity ratio is not needed.
22	The load is not seismic. Beam/column capacity ratio is not needed.
23	There is no beam on top of column. Beam/column capacity ratio is not needed.
24	At least one beam on top of column is not of concrete. Beam/column capacity ratio is not calculated.
25	The column on top is not concrete. Beam/column capacity ratio is not calculated.
26	The station is not at the top of the column. Beam/column capacity ratio is not needed.
27	The column is not ductile. Joint shear ratio is not needed.

Error Number	Description
28	The load is not seismic. Joint shear ratio is not needed.
29	There is no beam on top of column. Joint shear ratio is not needed.
30	At least one beam on top of column is not concrete. Joint shear ratio is not calculated.
31	The column on top is not concrete. Joint shear ratio is not needed.
32	The station is not at the top of the column. Joint shear ratio is not needed.
33	Beam/column capacity ratio exceeds limit.
34	Joint shear ratio exceeds limit.
35	Capacity ratio exceeds limit.
36	All beams around the joint have not been designed. Beam/column capacity ratio is not calculated.
37	At least one beam around the joint has failed. Beam/column capacity ratio is not calculated.
38	The column above the joint has not been designed. Beam/column capacity ratio is not calculated.
39	The column above the joint has failed. Beam/column capacity ratio is not calculated.
40	All beams around the joint have not been designed. Joint shear ratio is not calculated.
41	At least one beam around the joint has failed. Joint shear ratio is not calculated.
42	The column above the joint has not been designed. Joint shear

Error Number	Description
	ratio is not calculated.
43	The column above the joint has failed. Joint shear ratio is not calculated.
45	Shear stress due to shear force and torsion together exceeds maximum allowed.

Appendix F Nationally Determined Parameters (NDPs)

The Comité Européen de Normalisation (CEN) version of Eurocode 2-2004 specifies a set of clauses in the design code, for which Nationally Determined Parameters (NDPs) are permitted to be adjusted by each member country within their National Annex. Variations in these parameters between countries are considered in the program by choosing the desired country in the Preferences. This appendix lists the NDPs as adopted in the program for the CEN Default version of the design code. Additional tables are provided that list the NDPs that differ from the CEN Default values for each country supported in the program.

Table F-1 CEN Default NDPs

NDP	Clause	Value
γ_c	2.4.2.4(1)	1.5
γ_s	2.4.2.4(1)	1.15
α_{cc}	3.1.6(1)	1.0
α_{ct}	3.1.6(2)	1.0
$\max f_{yk}$	3.2.2(3)	600MPa

Table F-1 CEN Default NDPs

NDP	Clause	Value
Load Combinations	5.1.3(1)	Combinations from Eq. 6.10
θ_0	5.2(5)	0.005
k_1	5.5(4)	0.44
k_2	5.5(4)	$1.25(0.6 + 0.0014/\epsilon_{cu2})$
k_3	5.5(4)	0.54
k_4	5.5(4)	$1.25(0.6 + 0.0014/\epsilon_{cu2})$
λ_{lim}	5.8.3.1(1)	$20 \cdot A \cdot B \cdot C / \sqrt{n}$
Second Order Analysis Method	5.8.5(1)	Nominal Curvature
$C_{Rd,c}$	6.2.2(1)	$0.18/\gamma_c$
ν_{min}	6.2.2(1)	$0.035k^{3/2}f_{ck}^{1/2}$
k_1	6.2.2(1)	0.15
Cot θ	6.2.3(2)	$1 \leq \text{Cot}\theta \leq 2.5$
ν_1	6.2.3(3)	$0.6 \left[1 - \frac{f_{ck}}{250} \right]$
α_{cw}	6.2.3(3)	1.0
Beam $A_{s,min}$	9.2.1.1(1)	$0.26 \frac{f_{cm}}{f_{yk}} b, d \geq 0.0013b, d$
Beam $A_{s,max}$	9.2.1.1(3)	$0.04A_c$
Beam $\rho_{w,min}$	9.2.2(5)	$(0.08\sqrt{f_{ck}}) / f_{yk}$

Table F-1 CEN Default NDPs

NDP	Clause	Value
Column $A_{s,min}$	9.5.2(2)	$\frac{0.10N_{Ed}}{f_{yd}} \geq 0.002A_c$
Column $A_{s,max}$	9.5.2(3)	$0.04A_c$
α_{cc}	11.3.5(1)	0.85
α_{ct}	11.3.5(2)	0.85
$C_{Ird,c}$	11.6.1(1)	$0.15/\gamma_c$
$v_{l,min}$	11.6.1(1)	$0.30k^{3/2}f_{ck}^{1/2}$
k_1	11.6.1(1)	0.15
v_1	11.6.2(1)	$0.5\eta_1(1 - f_{ck}/250)$

Table F-2 United Kingdom NDPs

NDP	Clause	Value
$\psi_{0,i}$ (wind load)	EC0 Combos	0.5
α_{cc}	3.1.6(1)	0.85
k_1	5.5(4)	0.4
k_2	5.5(4)	$0.6 + 0.0014/\epsilon_{cu2}$
k_3	5.5(4)	0.4
k_4	5.5(4)	$0.6 + 0.0014/\epsilon_{cu2}$

Table F-2 United Kingdom NDPs

NDP	Clause	Value
$v_{l,min}$	11.6.1(1)	$0.30k^{3/2}f_{ck}^{1/2}$

Table F-3 Slovenia NDPs

NDP	Clause	Value
Column $A_{s,min}$	9.5.2(2)	$\frac{0.15N_{Ed}}{f_{yd}} \geq 0.003A_c$

Table F-4 Norway NDPs

NDP	Clause	Value
α_{cc}	3.1.6(1)	0.85
α_{ct}	3.1.6(2)	0.85
λ_{lim}	5.8.3.1(1)	$13(2 - r_m)A_f$
k_1	6.2.2(1)	0.15 for compression 0.3 for tension
Beam $\rho_{w,min}$	9.2.2(5)	$(0.1\sqrt{f_{ck}}) / f_{yk}$
Column $A_{s,min}$	9.5.2(2)	$\frac{0.2A_c f_{cd}}{f_{yd}} \leq \frac{0.5N_{Ed}}{f_{yd}}$ but not less than $0.01A_c$
Column $A_{s,max}$	9.5.2(3)	$0.08A_c$
$v_{l,min}$	11.6.1(1)	$0.028k^{3/2}f_{ck}^{1/2}$

Table F-4 Norway NDPs

NDP	Clause	Value
k_1	11.6.1(1)	0.15 for compression 0.3 for tension
v_1	11.6.2(1)	$0.5(1 - f_{tck}/250)$

Table F-5 Singapore NDPs

NDP	Clause	Value
α_{cc}	3.1.6(1)	0.85
k_1	5.5(4)	0.4
k_2	5.5(4)	$0.6 + 0.0014/\epsilon_{cu2}$
k_3	5.5(4)	0.54
k_4	5.5(4)	$0.6 + 0.0014/\epsilon_{cu2}$
v_{lim}	5.8.3.1(1)	$0.30k^{3/2}f_{tck}^{1/2}$

Table F-6 Sweden NDPs

NDP	Clause	Value
Beam $A_{s,max}$	9.2.1.1(3)	Unlimited
Column $A_{s,min}$	9.5.2(2)	$0.002A_c$
Column $A_{s,max}$	9.5.2(3)	Unlimited

Table F-6 Sweden NDPs

NDP	Clause	Value
α_{cc}	11.3.5(1)	1.0
α_{ct}	11.3.5(2)	1.0

Table F-7 Finland NDPs

NDP	Clause	Value
α_{cc}	3.1.6(1)	0.85
Max f_{yk}	3.2.2(3)	700MPa
Load Combinations	5.1.3(1)	Combinations from Eq. 6.10a/b
k_2	5.5(4)	1.10
Beam $A_{s,max}$	9.2.1.1(3)	Unlimited
Column $A_{s,max}$	9.5.2(3)	0.06A _c

Table F-8 Denmark NDPs

NDP	Clause	Value
γ_c	2.4.2.4(1)	1.45
γ_s	2.4.2.4(1)	1.20
Max f_{yk}	3.2.2(3)	650MPa
Load Combinations	5.1.3(1)	Combinations from Eq. 6.10a/b

Table F-8 Denmark NDPs

NDP	Clause	Value
λ_{lim}	5.8.3.1(1)	$20 \cdot \sqrt{\frac{A_c f_{cd}}{N_{Ed}}}$
Second Order Analysis Method	5.8.5(1)	Nominal Stiffness
Beam $\rho_{w,min}$	9.2.2(5)	$(0.063\sqrt{f_{ck}}) / f_{yk}$
α_{cc}	11.3.5(1)	1.0
α_{ct}	11.3.5(2)	1.0
$v_{l,min}$	11.6.1(1)	$0.03k^{3/2}f_{ck}^{1/2}$

Table F-9 Portugal NDPs

NDP	Clause	Value
Max f_{yk}	3.2.2(3)	500MPa

Table F-10 Germany NDPs

NDP	Clause	Value
α_{cc}	3.1.6(1)	0.85
α_{ct}	3.1.6(2)	0.85
max f_{yk}	3.2.2(3)	500MPa
θ_0	5.2(5)	$0 \leq \alpha_h \leq 1.0$

Table F-10 Germany NDPs

NDP	Clause	Value
k_1	5.5(4)	0.64
k_2	5.5(4)	0.8
k_3	5.5(4)	0.72
k_4	5.5(4)	0.8
λ_{lim}	5.8.3.1(1)	$25 \text{ for } n \geq 0.41$ $16/\sqrt{n} \text{ for } n < 0.41$
Second Order Analysis Method	5.8.5(1)	Nominal Stiffness
$C_{Rd,c}$	6.2.2(1)	$0.15/\gamma_c$
ν_{min}	6.2.2(1)	$(0.0525/\gamma_c)k^{3/2}f_{ck}^{1/2} \text{ for } d \leq 600\text{mm}$ $(0.0375/\gamma_c)k^{3/2}f_{ck}^{1/2} \text{ for } d > 800\text{mm}$
k_1	6.2.2(1)	0.12
Cot θ	6.2.3(2)	$1 \leq \text{Cot}\theta \leq 3.0$
ν_1	6.2.3(3)	$0.75 \nu_2$ where $\nu_2 = (1.1 \cdot f_{ck}/500) \leq 1.0$
Beam $A_{s,max}$	9.2.1.1(3)	$0.08A_c$
Beam $\rho_{w,min}$	9.2.2(5)	$0.16f_{ctm}/f_{yk}$
Column $A_{s,min}$	9.5.2(2)	$0.15 N_{Ed} / f_{yd}$
α_{cc}	11.3.5(1)	0.75
$\nu_{l,min}$	11.6.1(1)	$(0.0525/\gamma_c)k^{3/2}f_{lck}^{1/2} \text{ for } d \leq 600\text{mm}$ $(0.0375/\gamma_c)k^{3/2}f_{lck}^{1/2} \text{ for } d > 800\text{mm}$

Table F-10 Germany NDPs

NDP	Clause	Value
k_1	11.6.1(1)	0.12
v_1	11.6.2(1)	$0.75\eta_1$

Table F-11 Poland NDPs

NDP	Clause	Value
γ_c	2.4.2.4(1)	1.4
Cot θ	6.2.3(2)	$1 \leq \text{Cot}\theta \leq 2.0$
Column $A_{s,\min}$	9.5.2(2)	$0.15 N_{Ed} / f_{yd} \geq 0.003A_c$

Table F-12 Ireland NDPs

NDP	Clause	Value
α_{cc}	3.1.6(1)	0.85
k_1	5.5(4)	0.4
k_2	5.5(4)	$0.6 + 0.0014/\epsilon_{cu2}$
k_3	5.5(4)	0.4
k_4	5.5(4)	$0.6 + 0.0014/\epsilon_{cu2}$
$v_{l,\min}$	11.6.1(1)	$0.028k^{3/2}f_{lck}^{1/2}$

References

- EC0, 2001. Eurocode 0: Basis of Structural Design (EN 1990:2000), European Committee for Standardization, rue de Stassart, 36, B-1050 Brussels.
- EC2, 2004. Eurocode 2: Design of Concrete Structures – Part 1-1: General Rules and Rules for Buildings (EN 1992-1-1), European Committee for Standardization, rue de Stassart, 36, B-1050 Brussels.
- EC8, 2004. Eurocode 8: Design of structures for earthquake resistance – Part 1: General rules, seismic actions and rules for buildings (EN 1998-1:2004), European Committee for Standardization, rue de Stassart, 36, B-1050 Brussels.
- CSI, 2008. CSI Analysis Reference Manual, Computers and Structures, Inc., Berkeley, California.
- CSI, 2009. CSI Lateral Load Manual. Computers and Structures, Inc., 1995 University Avenue, Berkeley, California, 94704.