

CLP-8301

Barcode Label Printer

User's Manual

CITIZEN®

FCC COMPLIANCE STATEMENT FOR AMERICAN USERS

This equipment has been tested and found to comply with the limits for a Class A digital device, pursuant to Part 15 of the FCC Rules. These limits are designed to provide reasonable protection against harmful interference when the equipment is operated in a commercial environment. This equipment generates, uses, and can radiate radio frequency energy and, if not installed and used in accordance with the instruction manual, may cause harmful interference to radio communications. Operation of this equipment in a residential area is likely to cause harmful interference in which case the user will be required to correct the interference at his own expense.

CE DECLARATION FOR EUROPEAN USERS

CE marking shows conformity to the following criteria and provisions:

Low Voltage Directive (73/23/EEC)/EN60950

EMC Directive (89/336/EEC)/EN55022, EN55024, EN61000-3-2

& EN61000-3-3

EMI COMPLIANCE STATEMENT FOR CANADIAN USERS

This equipment generates and uses radio frequency energy and if not installed and used properly, that is, in strict accordance with the manufacturer's instructions, may cause interference to radio and television reception. This digital apparatus does not exceed the Class A limits for radio noise emissions from digital apparatus set out in the Radio Interference Regulations of the Canadian Department of Communications. This equipment is designed to provide reasonable protection against such interference in a residential installation. However, there is no guarantee that interference will not occur in a particular installation. If this equipment does cause interference to radio or television reception, which can be determined by turning the equipment off and on, the user is encouraged to try to correct the interference by one or more of the following measures:

- Reorient or relocate the receiving antenna.
- Increase the separation between the equipment and receiver.
- Connect the equipment into an outlet on a circuit different from that to which the receiver is connected.
- Consult the dealer or an experienced radio/TV technician for help.

CAUTION: Use shielded cables to connect this device to computers.

Any changes or modifications not expressly approved by the grantee of this device could void the user's authority to operate the equipment.

ETAT DE CONFORMITE EMI A L'USAGE DES UTILISATEURS CANADIENS

Cet équipement produit et utilise l'énergie à radiofréquences et s'il n'est pas installé et utilisé correctement, c'est à dire en accord strict avec les instructions du fabricant, il risque de provoquer des interférences avec la réception de la radio et de la télévision.

Le présent appareil numérique n'émet pas de bruits radioélectriques dépassant les limites applicables aux appareils numériques de la classe A prescrites dans le Règlement sur le brouillage radioélectrique édicté par le ministère des Communications du Canada.

Cet équipement est conçu pour fournir une protection satisfaisante contre de telles interférences dans une installation résidentielle. Cependant, il n'y a pas de garantie contre les interférences avec les réceptions radio ou télévision, provoquées par la mise en et hors circuit de l'équipement; aussi, il est demandé à l'utilisateur d'essayer de corriger l'interférence par l'une ou plus des mesures suivantes:

- Réorienter l'antenne de réception.
- Installer l'ordinateur autre part, par égard pour le récepteur.
- Brancher l'ordinateur dans une prise de courant différente de façon à ce que l'ordinateur et le récepteur soient branchés sur des circuits différents.

Important Safety Instructions

1. Read all of these instructions and save them for later reference.
2. Follow all warnings and instructions marked on the product.
3. Unplug this product from the wall outlet before cleaning. Do not use liquid or aerosol cleaners. Use a damp cloth for cleaning.
4. Do not use this product near water.
5. Do not place this product on an unstable cart, stand or table. The product may fall, causing serious damage to the product.
6. Slots and openings on the cabinet and the back or bottom are provided for ventilation.
To ensure reliable operation of the product and to protect it from overheating, do not block or cover these openings. The openings should never be blocked by placing the product on a bed, sofa, rug or other similar surface. This product should never be placed near or over a radiator or heat register. This product should not be placed in a built-in installation unless proper ventilation is provided.
7. This product should be operated from the type of power source indicated on the marking label. If you are not sure of the type of power available, consult your dealer or local power company.
8. This product is equipped with a three-pronged plug, a plug having a third (grounding) pin. This plug will only fit into a grounding-type power outlet. This is a safety feature. If you are unable to insert the plug into the outlet, contact your electrician to replace your obsolete outlet. Do not defeat the safety purpose of the grounding-type plug.
9. Do not allow anything to rest on the power cord. Do not locate this product where the cord will be walked on.
10. If an extension cord is used with this product, make sure that the total of the ampere ratings on the products plugged into the extension cord do not exceed the extension cord ampere rating. Also, make sure that the total of all products plugged into the wall outlet does not exceed 15 amperes for 120V outlet and 7.5 amperes for 220V–240V outlet.
11. Never push objects of any kind into this product through cabinet slots as they may touch dangerous voltage points or short out parts that could result in a risk of fire or electric shock. Never spill liquid of any kind on the product.
12. Except as explained elsewhere in this manual, don't attempt to service this product yourself. Opening and removing those covers that are marked "Do Not Remove" may expose you to dangerous voltage points or other risks. Refer all servicing on those compartments to service personnel.
13. The mains plug on this equipment must be used to disconnect mains power. Please ensure that the socket outlet is installed near the equipment and shall be easily accessible.
14. Unplug this product from the wall outlet and refer servicing to qualified service personnel under the following conditions:
 - A. When the power cord or plug is damaged or frayed.
 - B. If liquid has been spilled into the product.
 - C. If the product has been exposed to rain or water.
 - D. If the product does not operate normally when the operating instructions are followed. Adjust only those controls that are covered by the operating instructions since improper adjustment of other controls may result in damage and will often require extensive work by a qualified technician to restore the product to normal operation.
 - E. If the product has been dropped or the cabinet has been damaged.
 - F. If the product exhibits a distinct change in performance, indicating a need for service.

Notice

1. Before use, be sure to read this manual. And keep it handy for reference when needed.
2. The contents of this manual may change without prior notice.
3. Reproduction, transfer, or transmission of the contents of this manual without prior consent is strictly prohibited.
4. We are not liable for any damage resulting from the use of the information contained herein, regardless of errors, omissions, or misprints.
5. We are not liable for any problems resulting from the use of optional products and consumable supplies other than the designated products contained herein.
6. Do not handle, disassemble or repair the parts other than those specified in this manual.
7. We are not liable for any damage caused by user's erroneous use of the printer and inadequate environment.
8. Data residing in the printer is temporary. Therefore, all data will be lost if power is lost. We are not liable for any damage or loss of profits caused by data loss due to failures, repairs, inspections, etc.
9. Please contact us if there are any mistakes or ambiguities within this manual.
10. If there are missing or incorrectly collated pages in this manual, contact us to obtain a new manual.

Trademark Acknowledgement

Contains UFST from Agfa Monotype Corporation

- * Trademarks or registered trademarks of other companies and products are included in this manual.

Introduction

Thank you for purchasing a Citizen CLP series barcode label printer. This manual is designed to help you quickly understand the basic operations of this printer.

Features

This printer accurately prints clear bar codes and various character fonts on media such as labels and tags at high speeds. Both direct thermal and thermal transfer printing is possible.

- **Wide media, yet small installation space**

Wide media up to 9" (228.6 mm) can be used in this printer, and yet only a small installation space is needed, thanks to an innovative interior and exterior design.

- **Easy operation control panel**

Printing operations such as printer setup, print position and interface configuration can be performed with the six keys on the control panel. Even an untrained operator can easily operate this printer by following the instructions on the LCD (Display).

- **Easy access to media and ribbon**

The wide-opening printhead allows for easy access to the media and ribbon so loading is quick and easy.

- **Minimum maintenance**

The printhead, platen, tear bar etc are thoughtfully designed to facilitate easy maintenance. The consumable mechanical items can be easily exchanged in minutes.

- **Interfacing to a computer**

The printer is equipped with the RS-232C serial and parallel interfaces as standard. Other interfaces such as USB, Ethernet and IEEE1284ECP are also optionally available.

Table of Contents

FCC Compliance Statement for American Users	i
CE Declaration for European Users	i
EMI Compliance Statement for Canadian Users.....	ii
Important Safety Instructions	iii
Notice	iv
Trademark Acknowledgement	iv
Introduction.....	v
Features	v
Table of Contents.....	vi
Chapter 1 Unpacking.....	1
1.1 Printer accessories	2
Chapter 2 Safety Precautions.....	3
● Safety signs	3
● Installation precautions	8
Chapter 3 Names and Functions of Printer Parts.....	9
3.1 Printer main body	9
3.2 Control panel	12
Chapter 4 Media (Paper) and Ribbon.....	15
4.1 Types of media.....	15
4.2 Media size.....	18
4.3 Loading media (paper)	19
4.4 Loading ribbon	23
Ribbon tension adjustments	27
Ribbon winding torque adjustments.....	27
4.5 Printhead adjustments.....	28
Guide to media thickness ranges.....	28
4.6 Media sensor adjustments	29
Positioning the sensor	29
Selecting Media Sensor and AutoCal Mode	30
4.7 Avoiding wrinkling of the ribbon	31
Removing slack on winding side of ribbon (in front of printhead).....	31
Removing slack on feeding side of ribbon (behind printhead)	32

Chapter 5 Power ON and Using the Control Panel.....	33
5.1 Connecting to a power outlet	33
5.2 Turning the printer ON.....	34
5.3 Ready Mode and Menu Mode.....	35
5.4 Navigating the Menu System.....	36
5.5 Changing Menu Values	37
5.6 Permanently Saving Printer Settings	38
5.7 Producing a Test or Configuration Print	39
5.8 Turning the printer OFF.....	40
Chapter 6 Configuring Your Printer Using the Menus.....	41
6.1 The Group Menu	41
6.2 Page Setup Menu	42
6.3 System Setup Menu.....	43
6.4 After Print Menu.....	45
6.5 Interface Setup Menu.....	46
6.6 Permanently Saving Settings Menu.....	47
6.7 Test Mode Menu	47
6.8 Menu Mode Description	48
Chapter 7 Troubleshooting.....	51
7.1 Items to check in case of trouble	51
7.2 Error messages and corrective actions	53
Chapter 8 Maintenance.....	55
8.1 Printer care.....	55
8.2 Cleaning method	56
Chapter 9 Specifications.....	57
9.1 General specifications	57
9.2 Interfaces	58
9.3 PCMCIA Memory Card (factory-installed option)	61
9.4 Print width.....	62
9.5 Movable sensors	63
9.6 Environmental requirements	64

Chapter 1

Unpacking

First open the carton and take out the top foam damper, then lift the printer main body out of the carton, holding the bottom of the printer firmly.

Also keep the carton and packing materials as the printer must be packed with those materials for future shipment.

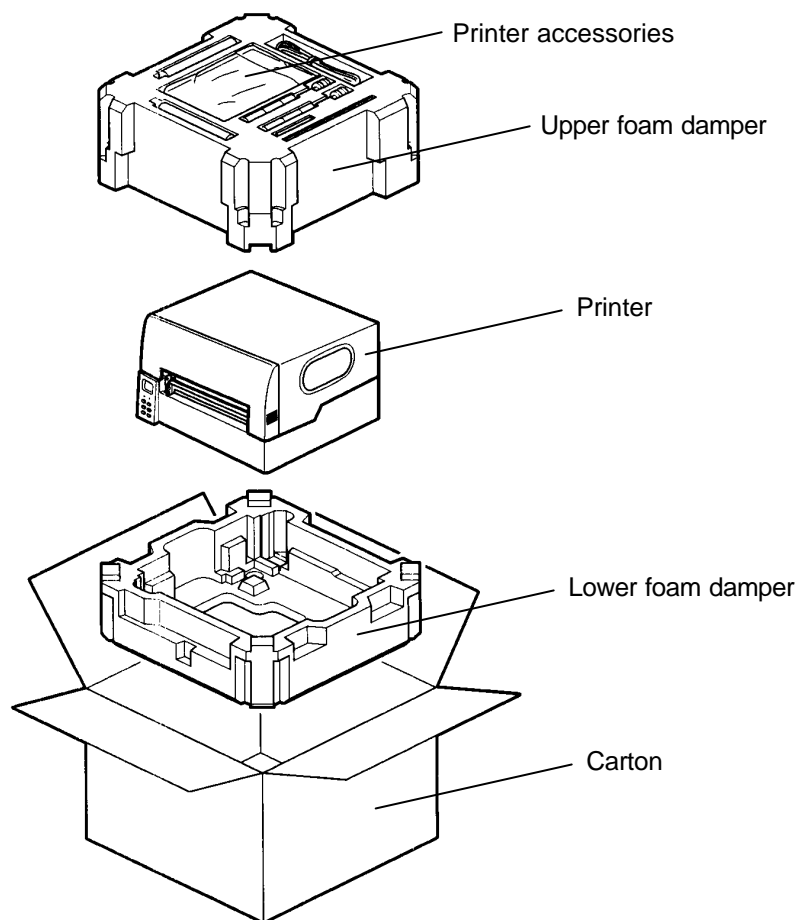

CAUTION

- When taking the printer out of the carton, prepare ample space to set the printer down. To ensure safety, no fewer than two persons should lift the printer main body at this time.
- Do not hold the foam damper when lifting the printer main body.

1.1 Printer accessories

First, you should check that all of the following accessories are put in the carton. If any are missing, please contact your supplier.

- Power cord 1 piece
- Ribbon takeup core 1 piece
- Media holder shaft 1 piece
- Media holder disks 2 pieces
- Label media 1 piece
- Ribbon 1 piece
- Thermal head cleaner 1 piece
- Ribbon mandrels 2 pieces
- User's manual 1 copy

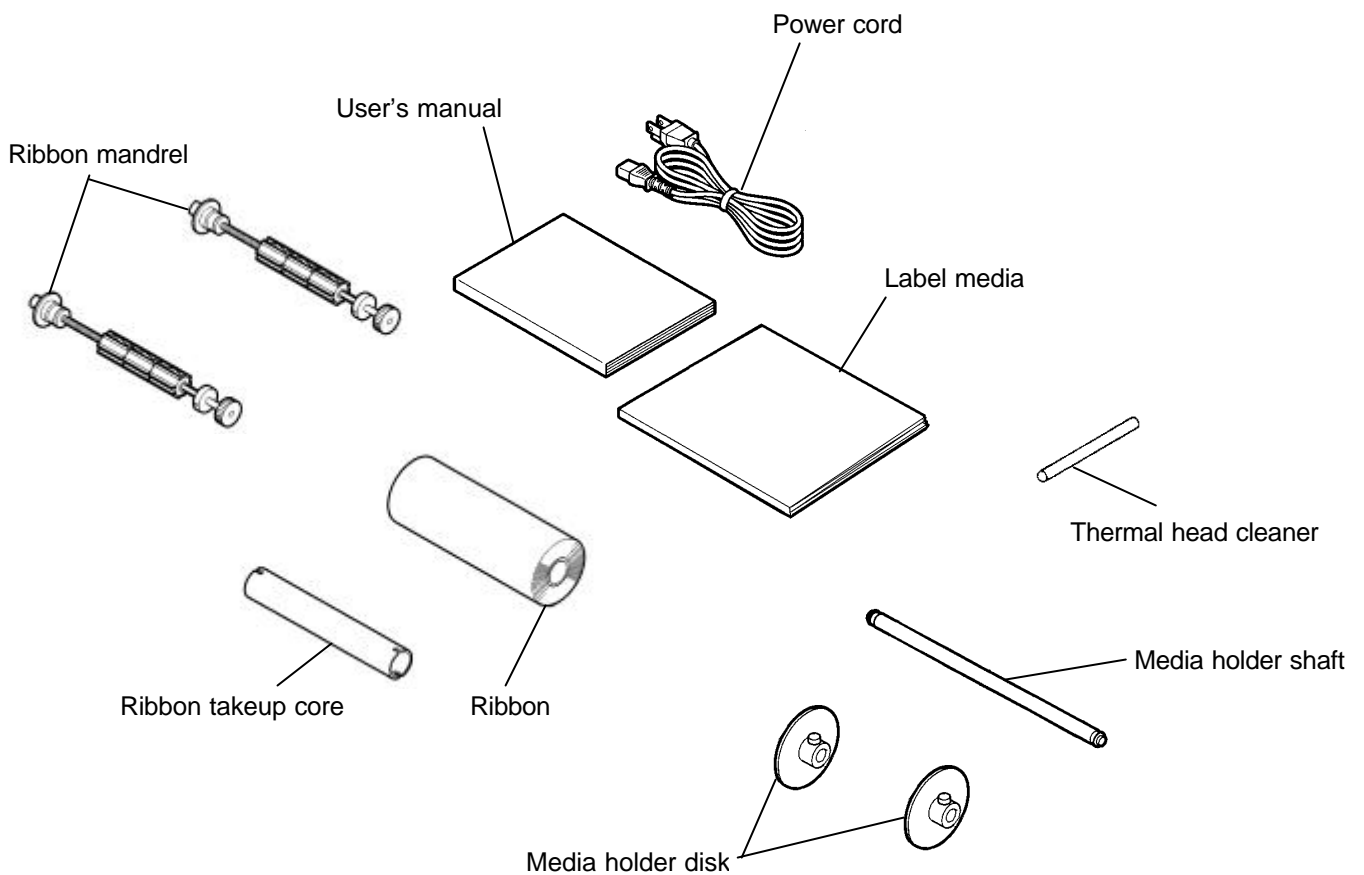

Chapter 2

Safety Precautions

This chapter describes safety precautions when using the printer. Please read and understand the precautions in this chapter before using the printer.

● Safety signs

The various safety signs included in this manual and pasted on the printer are intended to inform you of the correct and safe handling of this printer and protect against personal injury and property damage. Please familiarize yourselves with the following safety signs and their meanings.



WARNING

Indicates a situation which, if not observed and handled properly, could result in death or serious injury.



CAUTION

Indicates a situation which, if not observed and handled properly, could result in personal injury or property damage.

Examples



Symbol \triangle : Attention! The actual warning is portrayed in the drawing (for example, the sign on the left calls attention to electrical shock).



Symbol \otimes : Operation prohibited. The prohibited operation is portrayed in the drawing (for example, the sign on the left indicates that disassembling is prohibited).



Symbol \bullet : Operation required. The required operation is portrayed in the drawing (for example, the sign on the left indicates that the plug must be removed from the outlet).



WARNING



Avoid unsafe places

Avoid unsafe places such as the top of a shaky desk, an uneven surface or any area subject to vibration. Failure to observe this precaution may cause the printer to fall or turn over, resulting in injury.



Do not put water-filled containers nearby

Do not put containers filled with water or chemical liquids such as vases and cups near the printer. If a liquid spills or enters the printer, turn off the power switch immediately, remove the plug of the power cord from the outlet, and contact our service personnel. Continued use without corrective action may result in fire or electrical shock.



Do not allow any foreign matter to enter

Do not allow any metallic objects or flammable material to enter or fall into the printer through the openings (such as the cable port and fanfold media insertion slot). If foreign matter enters, turn off the power switch immediately, remove the plug of the power cord from the outlet, and contact our service personnel. Continued use without corrective action may result in fire or electrical shock.



Do not use an improper power voltage

Do not use a power voltage other than the specified in the rating label on the rear of the printer. Failure to observe this precaution may result in fire or electrical shock.



Connect the ground wire

Make sure that the ground wire to the printer is properly connected to the earth. Failure to do so may result in electrical shock.

Power cord

Do not damage, break or modify the power cord. Putting heavy objects on the power cord or heating or pulling it may cause damages, leading to fire and electrical shock.



If the power cord is damaged (e.g., the core is exposed or the wire broken), contact our service personnel. Continued use without corrective action may result in fire or electrical shock.



When using, do not bend, twist, or pull the power cord. Failure to observe this precaution may result in fire or electrical shock.

If the printer is dropped or damaged

If you accidentally drop or damage the printer, turn off the power switch immediately, remove the plug of the power cord from the outlet, and contact our service personnel. Continued use without corrective action may result in fire or electrical shock.



Avoid using the printer in abnormal conditions

Do not use the printer in abnormal conditions, for example, when it is smoking or smells unpleasant. If you notice an abnormal condition, turn off the power switch immediately, remove the plug of the power cord from the outlet, and contact our service personnel. Failure to observe this precaution may result in fire or electrical shock. To avoid serious danger, never try to carry out repairs by yourself.



Do not disassemble

Do not disassemble or modify the printer. Failure to observe this precaution may result in fire or electrical shock. For checking, adjusting, or repairing parts inside the printer, contact our service personnel.



Thermal head cleaner

The thermal head cleaner is inflammable. Never heat it or throw it into the fire, and keep it away from children.





CAUTION

Avoid high-humidity areas



Do not put the printer in areas with high-humidity or heavy condensation. If moisture has condensed on the printer, turn off the power switch immediately and leave the printer for a while until the moisture dries up. Using the printer when damp may result in electrical shock.

Carrying



Before carrying the printer, be sure to remove the plug from the outlet and the connecting cable to the outer equipment. If left connected, the power cord and connecting cable may be damaged, leading to fire and electrical shock.



Do not transport the printer while loaded with media. If media is loaded, it may drop out, leading to injury.



When placing the printer on a floor or desk, be careful not to catch your fingers and hands under the feet of the printer.

Power



Never operate the power switch or insert/remove the power cord or interface cable with wet fingers. Failure to observe this precaution may result in electrical shock.

Power cord



Do not put a heater near the power cord. A nearby heater can melt the power cord casing, resulting in fire or electrical shock.



When removing the plug of the power cord from the outlet, be sure to grip the plug, not the cord, when pulling it out. Pulling the cord may expose the core or break the wire, leading to fire or electrical shock.

**Opening/closing the top cover**

When opening/closing the top cover, be careful not to catch your fingers between the cover and chassis.

**Printhead**

The printhead remains at a high temperature immediately after printing. Therefore, be careful to avoid contact with the printhead when replacing the ribbon or media or cleaning the printer immediately after printing. Failure to observe this precaution may result in burning.



The edge of the printhead can injure your bare hands and the printhead itself can give you an electrical shock. To replace the printhead, contact our service personnel. Never try replacement by yourself.

**Loading the media and ribbon**

When loading the media and ribbon, be careful not to catch your fingers in the mechanism.

**No use for long periods**

When the printer is not used for long periods, the plug of the power cord should be removed from the outlet to ensure safety.

**Printer care and cleaning**

Whilst performing maintenance and cleaning, the plug of the power cord should be removed from the outlet to ensure safety.



Do not use benzine, thinner, alcohol, etc. to wipe the dirt off the printer. Failure to do so may cause discoloration or deformation. If the dirt is too large, soak a cloth in a thin neutral detergent and squeeze out and wipe with it, and finally wipe with a dry, soft cloth.

● Installation precautions

After reading and understanding the safety signs, install the printer, observing the following precautions:



Avoid dust

Dust can stop the printer from cleanly printing a document. It can also cause breakdowns and shorten the printer life.



Install away from high power-consuming equipment such as compressors and generators

High power-consuming equipment such as compressors or generators can cause power voltage drops or generate power noises, resulting in printer malfunction or breakdown. Therefore, be sure to keep the printer away from this kind of equipment.



Avoid direct sunlight

This printer includes optical sensors that may malfunction if exposed to direct sunlight. When printing, close the cover firmly.

Chapter 3

Names and Functions of Printer Parts

This chapter describes the names and functions of each part of the printer.

3.1 Printer main body

1. Top cover

The top cover is the upper part of the whole cabinet of the printer. To open lift evenly from both sides using the embossed patterns on the surface to help grip the cover and open it all the way until it stops at hinge stops. To close it, just return slowly to the original position.

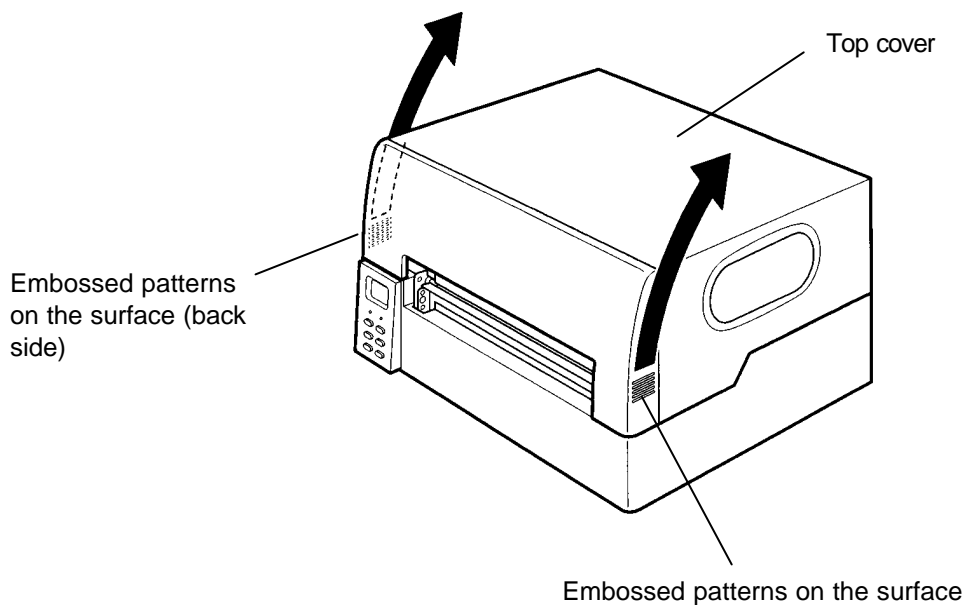

2. Inside the Printer

- | | |
|---|---|
| 1 Tear bar | 11 Media holder disk |
| 2 Platen | 12 Media guide (on both sides) |
| 3 Control panel | 13 Media holder supporting plate |
| 4 Transparent sensor (upper media sensor) | 14 Media holder shaft |
| 5 Transparent sensor guide | 15 Media guide lock screw |
| 6 Printhead | 16 Printhead adjustment lever |
| 7 Media guide roller | 17 Transparent sensor guide release lever |
| 8 Reflective sensor (lower media sensor) | 18 Printhead release lever |
| 9 Interface box | 19 Ribbon guide plate |
| 10 Top cover | 20 Ribbon mandrel holder |

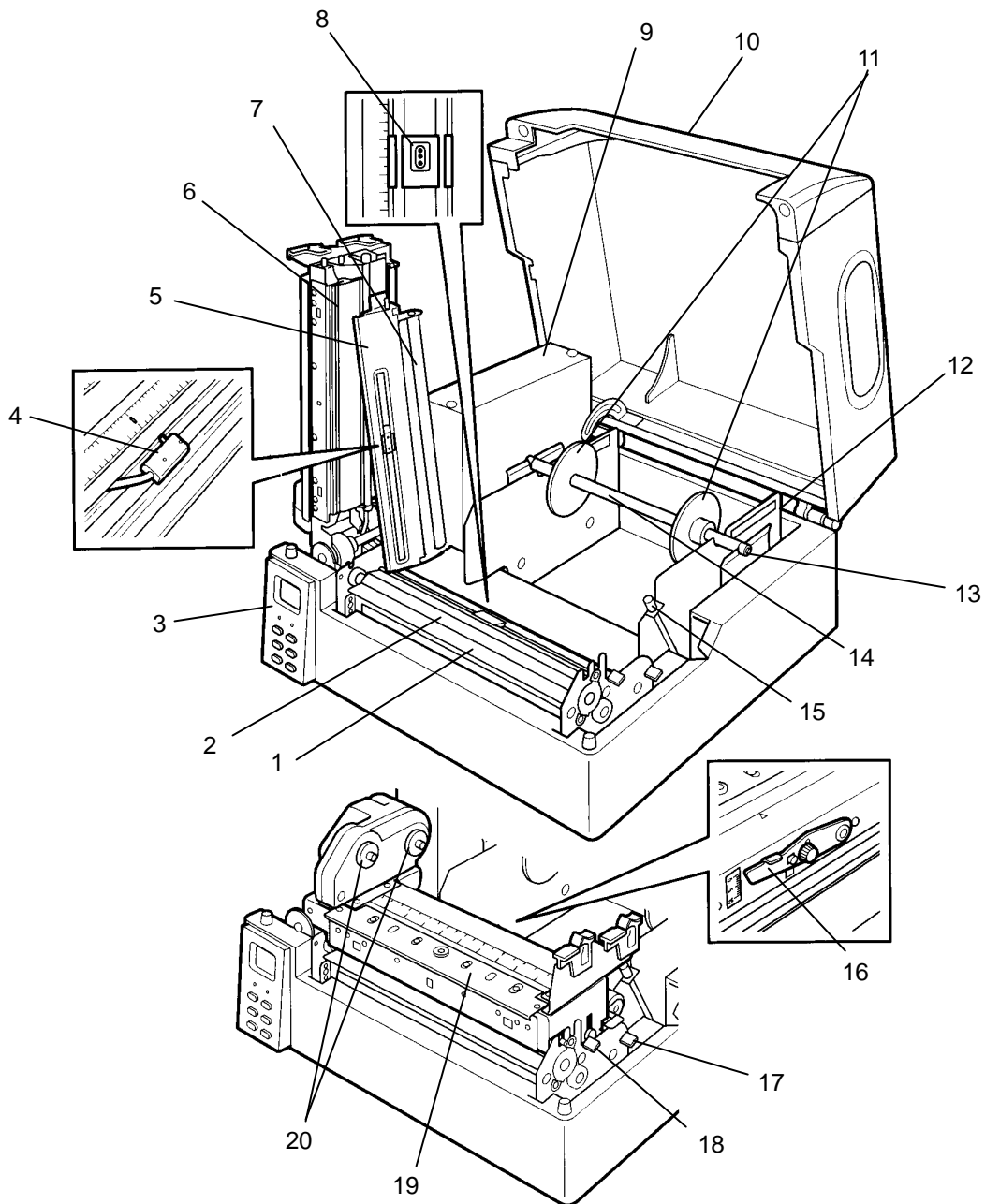

3. Rear and side of printer

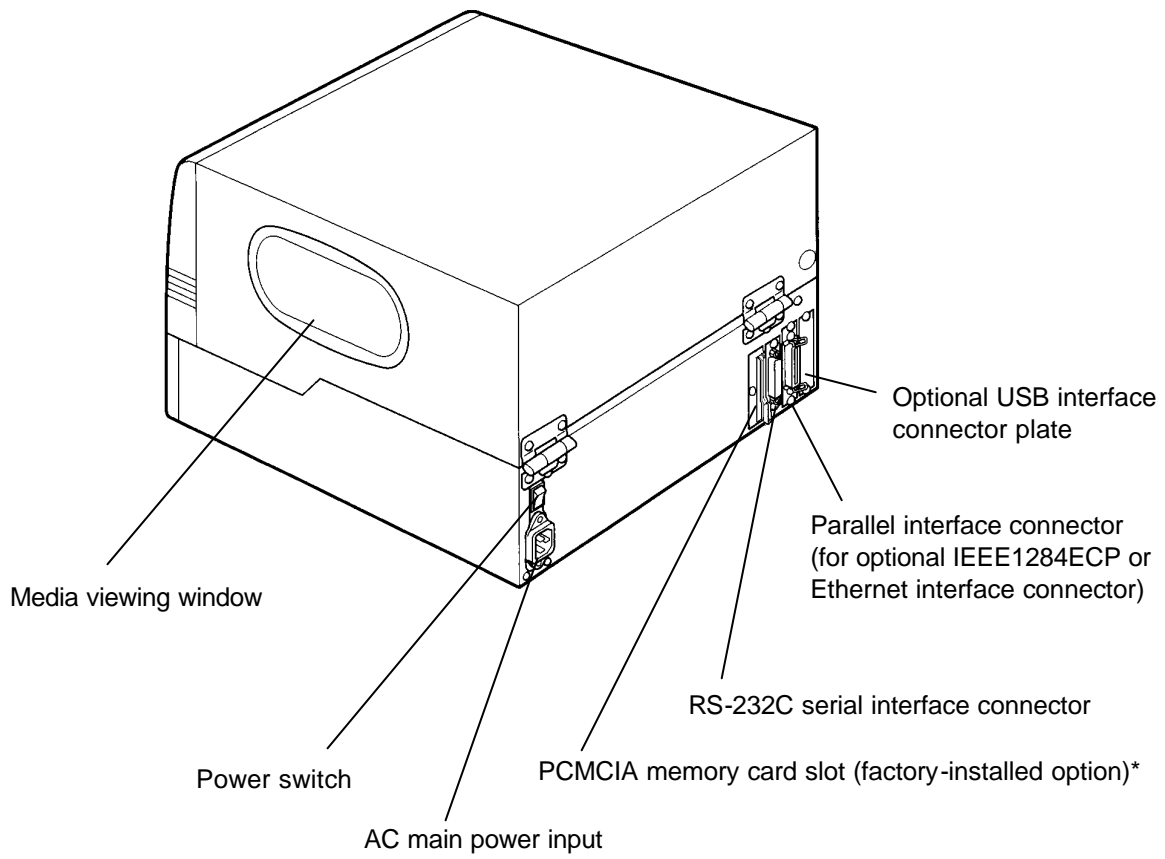

* Please contact your supplier to discuss this option.

3.2 Control panel

The control panel consists of an LCD displaying two lines of eight characters, two LEDs and six control keys. **Two functions** are assigned to **each key** except the MODE key.

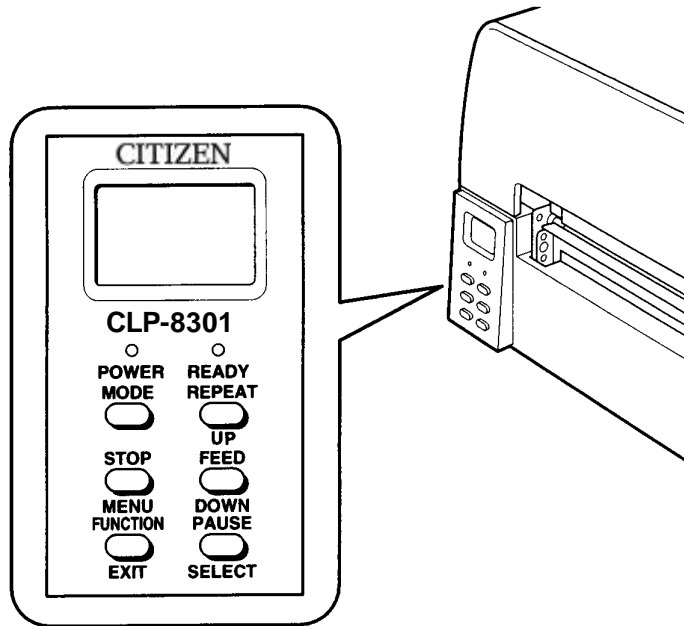

● Indications

LCD (Display)

Shows the current printer status by a message on the display.

POWER LED

Lights up when the printer power is turned on.

READY LED

- Lights up when the printer is placed into the print ready state.
When the PAUSE key is pressed, the READY LED goes out and "Pause" is shown on the LCD (Display). By pressing the PAUSE key again, the READY LED lights up.

● Control keys

On the control panel legend, in Ready mode, the text written ABOVE each key shows the key's function. In Menu mode, the text written BELOW each key shows the key's function.

MODE key

When the MODE key is pressed, the printer is placed into the Ready mode. When the MODE key is pressed again, the printer is placed into the Menu mode. Each time the MODE key is pressed, the printer toggles between the **Ready mode** and **Menu mode**. (See P35)

■ Key functions in the Ready mode

STOP key

- Shows "JobClear" on the LCD (Display) if data is stored in print buffer.
- Completes printing midway through the print job or data processing and shows "JobClear Yes/No" on the LCD (Display).
- Pressing STOP again changes the selection of "Yes/No" under the display of "Job Clear".
- Places the printer into paused state if it is waiting to receive data from the host computer.

FEED key

- Feeds one sheet of label when this key is pressed after TOF (top-of-form) positioning has been performed.
- Performs TOF (top-of-form) positioning if the printer is part way through a label or page.
Note: Sometimes the media may be set at irregular position when it is being loaded or the power to the printer is turned on. If this occurs, press the FEED key to advance the media to the top of the next label or page.

PAUSE key

- Completes current page printing midway through the print job and places the printer into paused status. To resume printing, press the PAUSE key again.
- Places the printer into paused state if it is waiting to receive data from the host computer.

FUNCTION key

This is a reserved key; no operation is performed.

REPEAT key

- Reprints one job of the last printed label each time this key is pressed if the last print data is stored in print buffer and is not printed yet.
- Performs no operation if no print data is stored in print buffer or printer is in printing state.

MODE key

Printer enters the Menu mode, and the '* Page Setup' menu is shown on the LCD (Display).

■ **Key functions in the Menu mode**

MENU key

Selects the next Group Menu or Menu Item. (See P35-37)

UP key

- Selects the next Group Menu or Menu Item. (See P35-37)
- Selects the next Value of the Menu Item. (See P35-37)

DOWN key

- Selects the previous Group Menu or Menu Item. (See P35-37)
- Selects the previous Value of the Menu Item. (See P35-37)

SELECT key

- Enters the Menu Item from the Group Menu. (See P35-37)
- Enters or exits the Value from the Menu Item. (See P35-37)
- Executes current setting of the Value, for example, "Printing Sample" in Test mode.
(See P39)

EXIT key

Return to the Menu Item or Group Menu. (See P35-37)

MODE key

Return to the Ready mode and the 'READY' is shown on the LCD (Display). (See P35, 36)

Chapter 4

Media (Paper) and Ribbon

This chapter describes all of the types of media available for this printer and how to load the media and ribbon. Unless otherwise specified, the term 'media,' 'paper,' 'page,' 'labels,' or 'tags' is referring to any media that is being printed using the printer.

4.1 Types of media

We recommend the use of CITIZEN media for optimal print quality.

Types of media available for this printer:

- Center-punched hole tag
- Black mark tag
- Notched tag
- Labels with inter-label gap
- Black mark label

● Tag

Media without adhesive material on the back are referred to as tags, which are often used by cutting pieces. The holes are usually arranged on the cut-off line.

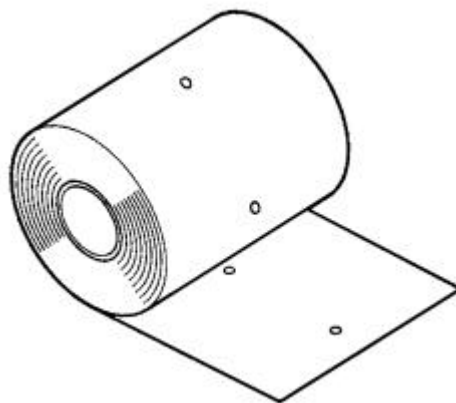

.. **Center-punched hole tag**

Holes (2.5mm diameter) are perforated lengthwise along the central line of the tag.

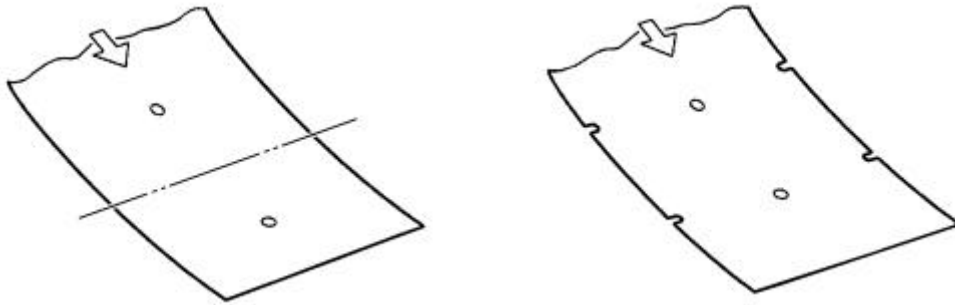

.. **Black mark tag**

Black marks are printed on the back of the tag at the center or on the right side in the direction of feed.

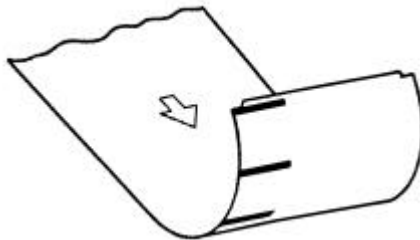

.. **Notched tag**

The cuts on the edge of this tag are deeper than the cuts on center-hole tag.

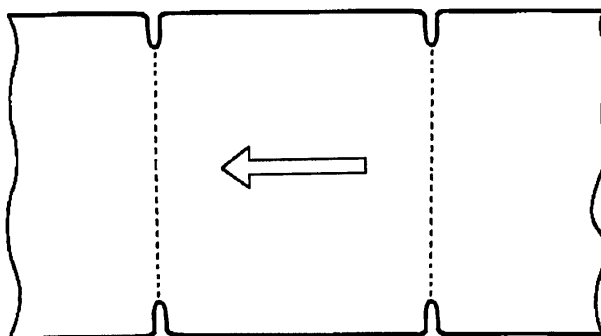

● **Label**

Media with adhesive material on the back are referred to as labels. Labels are peeled off the liner piece by piece and stuck to a product or item.



◆ **Labels with inter-label gap**

There are gaps between labels.

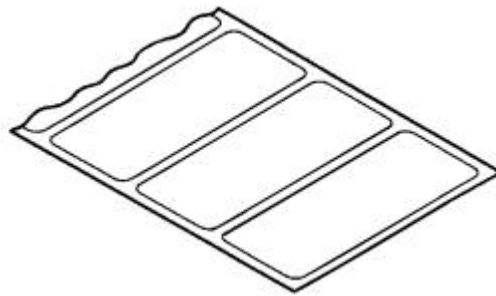

◆ **Black mark label**

Black marks are printed on the back of the label line on the central line or right side in the direction of feed.

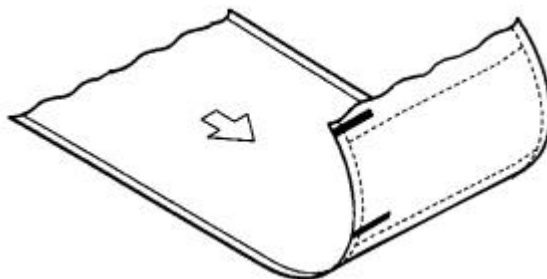

4.2 Media size

		Minimum value mm (in)	Maximum value mm (in)
A	Label width	76.2 (3)	228.6 (9)
B	Liner width	76.2 (3)	228.6 (9)
C	Label left edge position	0.00	2.54 (0.10)
D	Gap between labels	2.0 (0.079)	508.0 (20)
E	Label length	12.7 (0.5)	508.0 (20)
F	Label pitch	12.7 (0.5)	508.0 (20)
G	Liner thickness	0.06 (0.0024)	0.089 (0.0035)
H	Media total thickness	0.14 (0.0055)	0.254 (0.01)
I	Notch right end position	3.76 (0.148)	140.0 (5.51)
J	Notch length	3.76 (0.148)	—
K	Notch width	2.0 (0.079)	3.0 (0.118)
L	Black mark right end position	6.0 (0.236)	140.0 (5.51)
M	Black mark length	6.0 (0.236)	—
N	Black mark width	3.0 (0.118)	4.0 (0.157)

- Note**
- If media has both gap and black mark, use the transparent sensor.
 - For fanfold, use the transparent sensor.

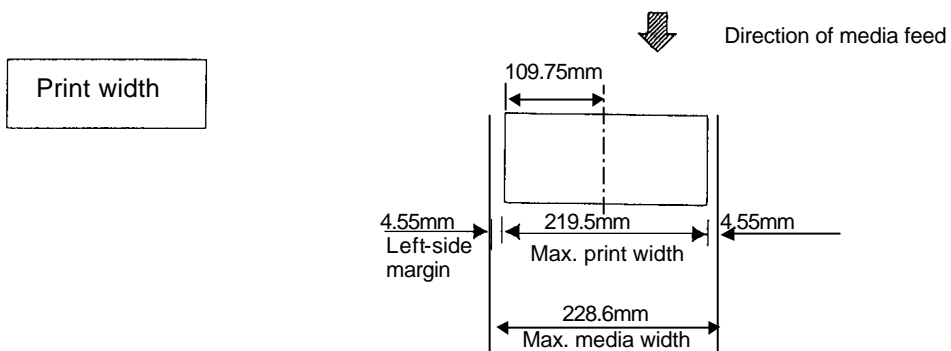
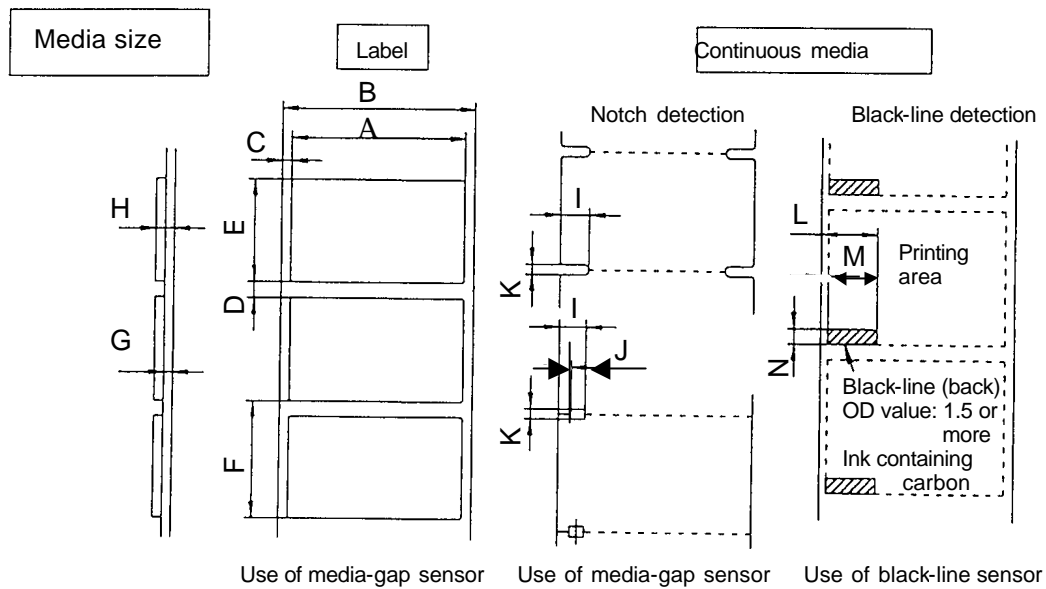

4.3 Loading media (paper)

This printer is designed to align the center of the media (paper) with the center of the printhead, regardless of media (paper) width. Refer to the scale on the media guide plate (see P30) for aligning media (paper) or ribbon. And for reference, the center of the gear of the media guide drive mechanism, which is located on the bottom of the printer main body, is the center of the media (paper).

Roll media

- 1 Put both media holder disks on the media holder shaft to make the media holder assembly. Adjust both disks according to the width of the roll media so that they are the same distance from the center of the media holder shaft and inside the media core.

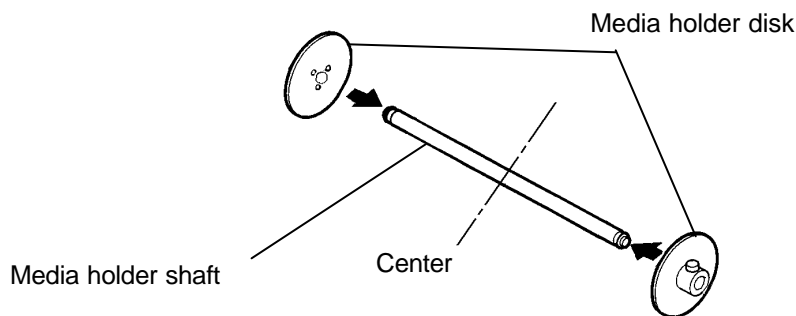

- 2 Insert the media holder assembly into the media core.

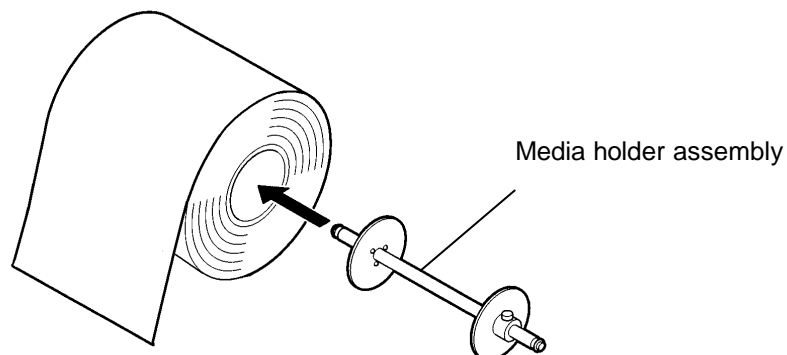

- 3 Load the media into the printer by referring to the diagram and the following sequence:
 - (1) Open the top cover all the way until it stops at hinges.
 - (2) Unlock the printhead assembly by pushing the printhead release lever and raise it until it stops and stands upright. At the same time unlock the transparent sensor guide by pushing the transparent sensor guide release lever and raise it until it stops.

- (3) Unlock the media guide lock screw and move both side media guides to their maximum outward position.

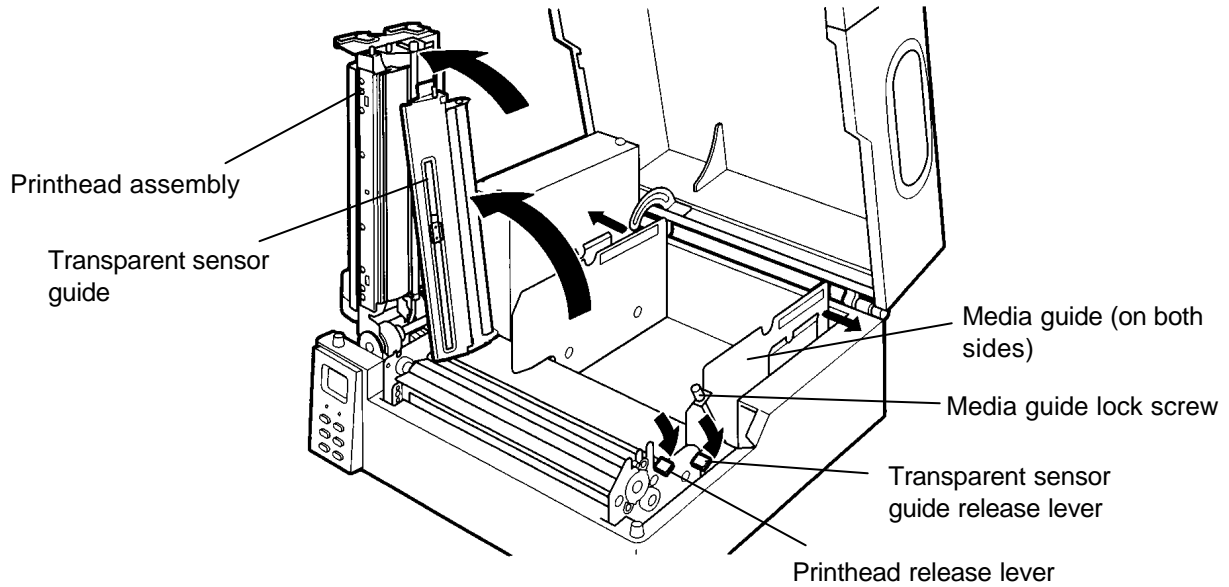

4 Install the roll media as follows:

- (1) Place the media holder shaft onto the round notches on the media guides and media holder shaft supporting plates.
- (2) Move both media guides by using both hands so that they come into contact with the edges of the roll so that no clearance is left between media guide and media.
- (3) Lock the media guides with the media guide lock screw turned clockwise.

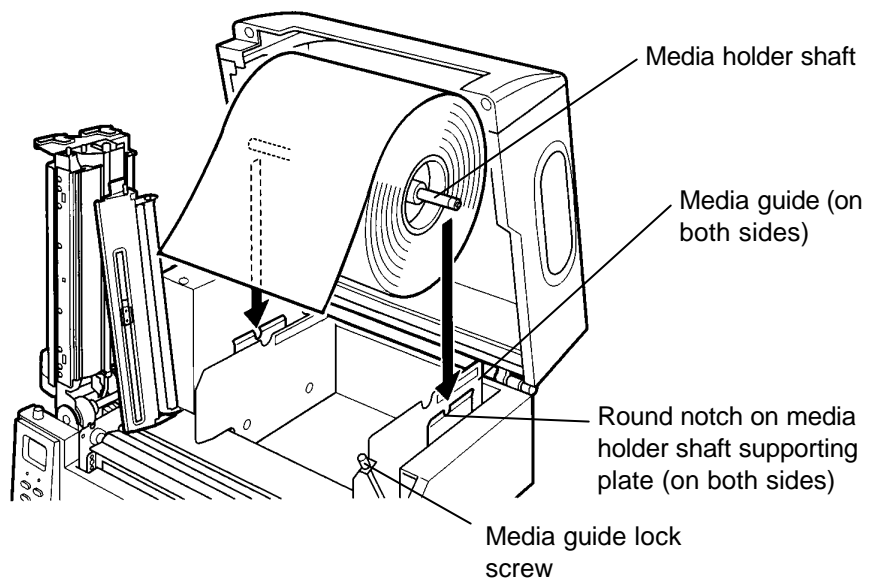

5 Route the roll media over the platen out to the front of the printer.

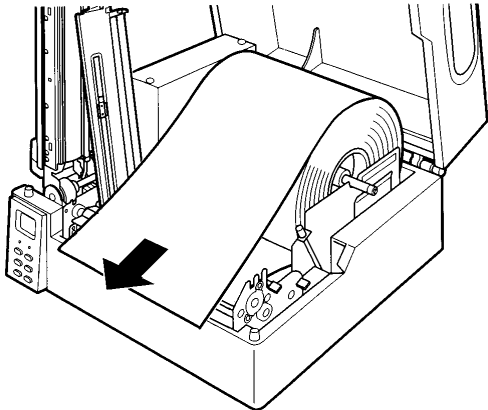

6 First lower the transparent sensor guide and push down gently to lock. Then lower the printhead assembly fully and push down firmly on the top edge by the ribbon holders to lock in place.

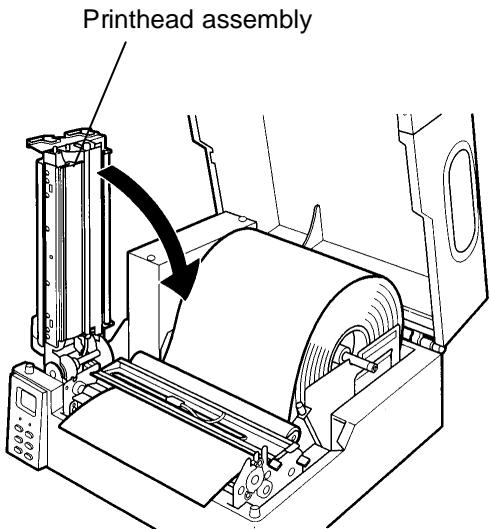
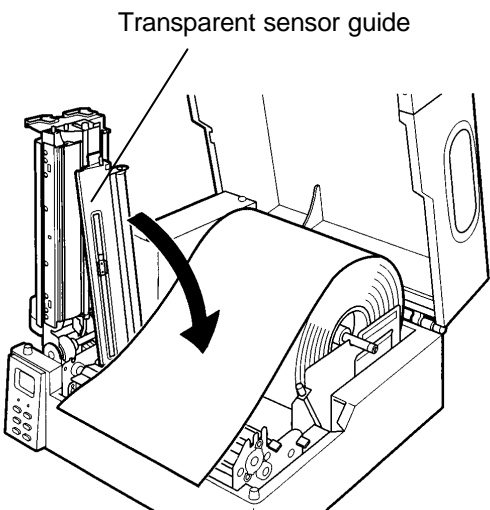

Path of outward-wound roll media

Path of inward-wound roll media

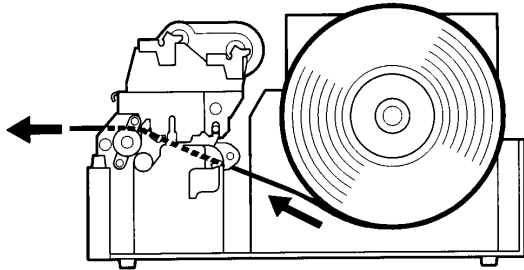
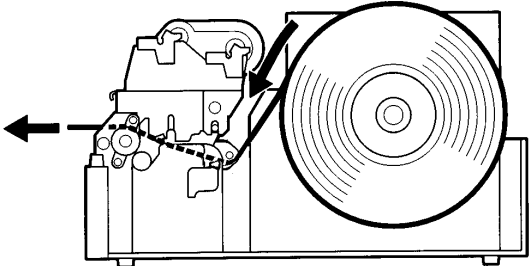

Note: For media sensor adjustments, see P29. For loading ribbon, see P23.

- 7 The roll media is now loaded. Lastly close the top cover.

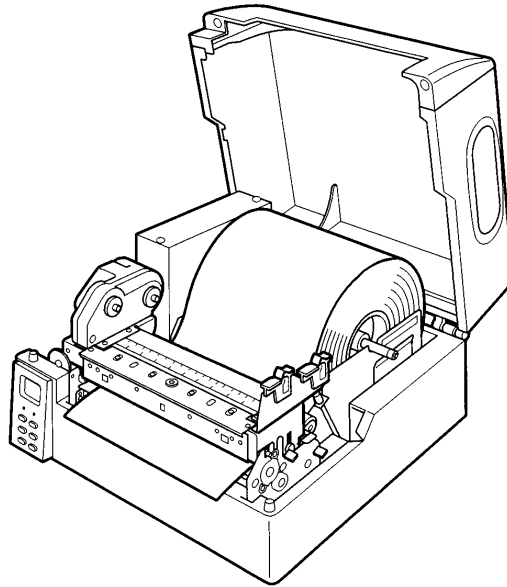

Fanfold media

- 1 Remove ribbon holder disks (two) from the ribbon holder assembly. Place the media holder shaft onto the round notches on the media guides and media holder shaft supporting plates on both sides.
- 2 Place the fanfold media on firm, level surface in the back of the printer and route it through the opening between top and lower bottom covers on the back of the printer, over the media holder shaft and platen out to the top of the printer. Other loading procedures are same as for roll media (see P19-22).

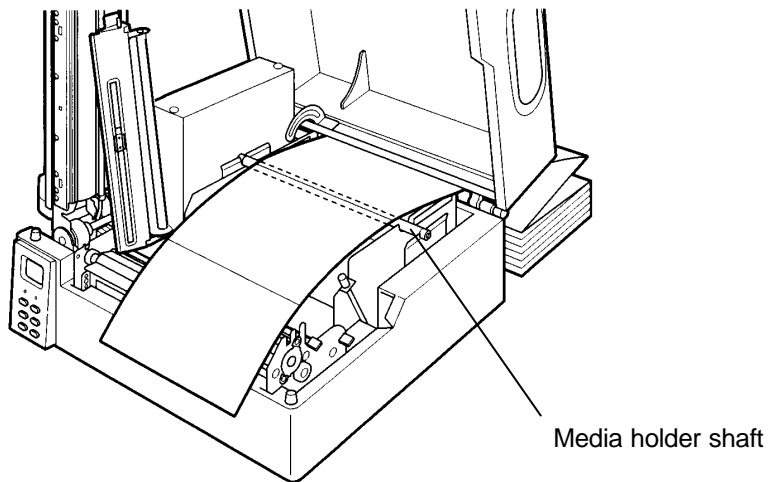

4.4 Loading ribbon

We recommend the use of CITIZEN Thermal Transfer Ribbon for optimal print quality.

This printer is designed to align the center of the media (paper) with the center of the printhead, regardless of media width. Refer to the scale on the tear bar for aligning media (paper) or ribbon.

And for reference, the center of the gear of the media guide drive mechanism, which is located on the bottom of the printer main body, is the center of the media.

1 To align the ribbon with the media (paper) being used, adjust the flange as follows:

- 1) First turn the Lock Nut on the ribbon mandrel counterclockwise, then turn the Ribbon Positioning Nut counterclockwise to move the Flange towards the center of the ribbon mandrel and to align it with the edge of the media being loaded.

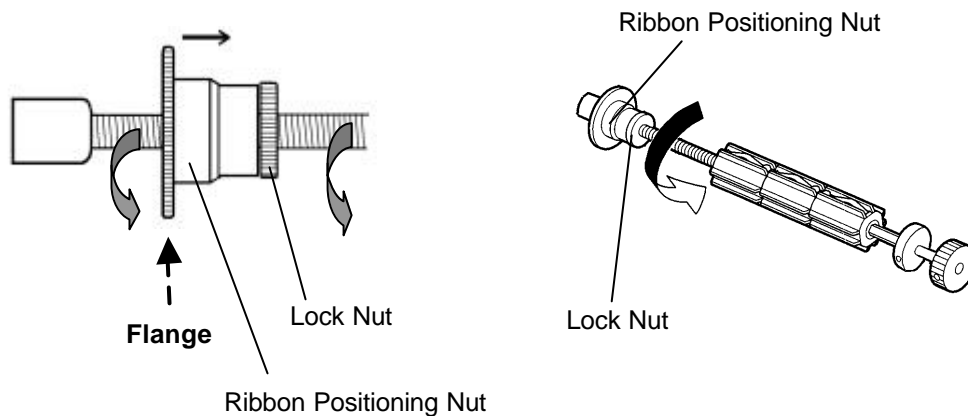

- 2) Referring to the scale on the tear bar, adjust the flange so that the ribbon is put in the center of the media. The value of half the ribbon width being used is the actual value on the scale.

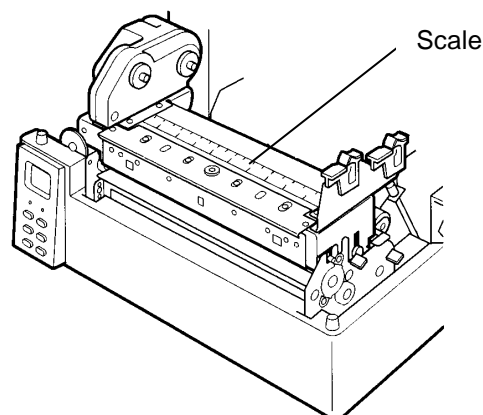

- 3) Check to see that the ribbon is positioned properly and fix the ribbon positioning nut by turning the lock nut clockwise.
- 4) Repeat the procedure for the second ribbon mandrel.

- 2 Two ribbon mandrels are used for loading ribbon; one is inserted in the supply (unused) ribbon core and the other is inserted the ribbon takeup core. Wind the ribbon from the takeup mandrel until most wrinkles are no longer visible.

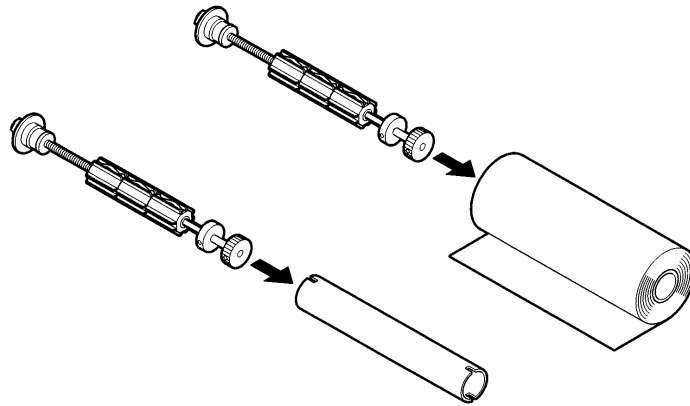

NOTE

The following procedure may help in loading the ribbon. First insert the mandrels into the supply and takeup ribbon cores, affix a small piece of adhesive tape at the end of the ribbon and then wind the ribbon around the takeup mandrel until the tape is hidden. Finally, install the ribbon by passing it through the lower side of the printhead assembly.

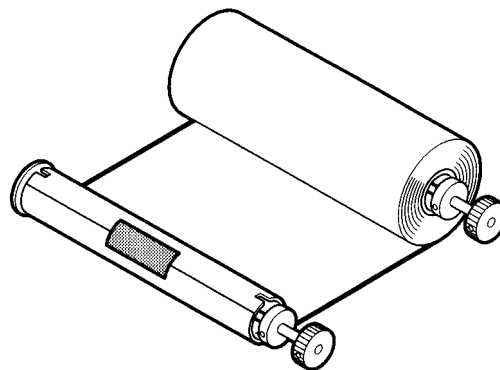

CAUTION

Be sure to wind the ribbon sufficiently over the adhesive clear tape fastened to the end of the ribbon.

- 3 Perform the following sequence; open the top cover all the way until it stops at hinges, and unlock the printhead assembly by pushing the printhead release lever and raise it until it stops and stands upright.

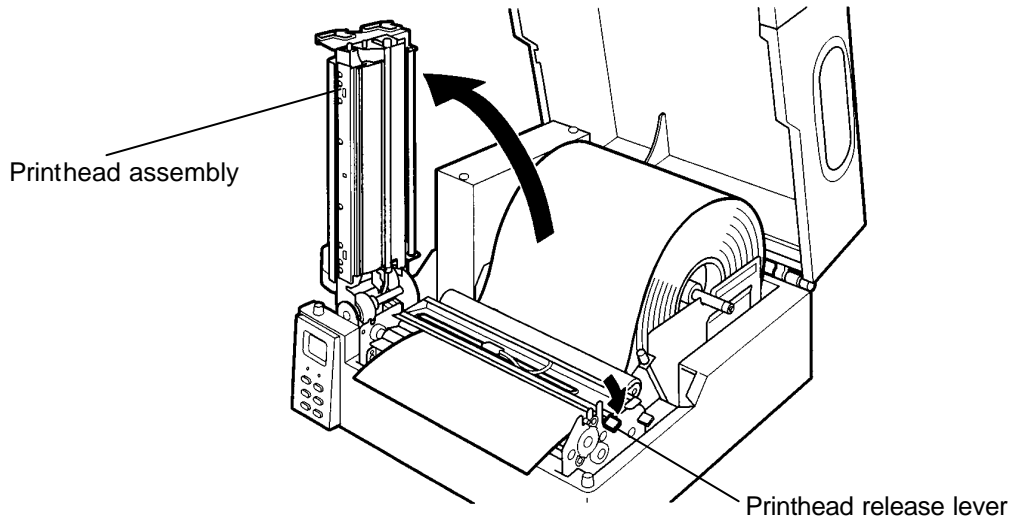

- 4 Hold by both hands the ribbon with a length of about 300 mm (1 ft) unwound between mandrels; the left hand grips the ribbon supply mandrel and the right hand grips the takeup mandrel.

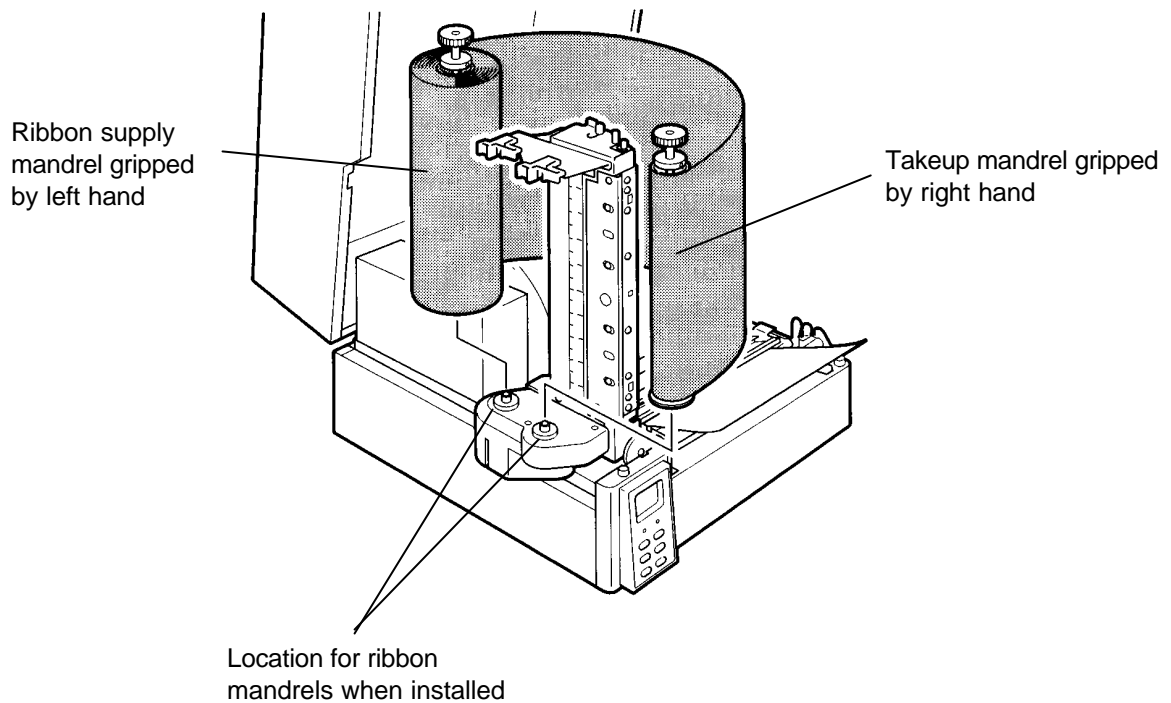

- 5 Temporarily winding the ribbon with a length of about 300 mm (1 ft) unwound between mandrels around the lower, bottom side of the printhead assembly, first fit both sockets of the ribbon takeup and supply mandrels, then snap into place both knobs of the ribbon takeup and supply mandrels.

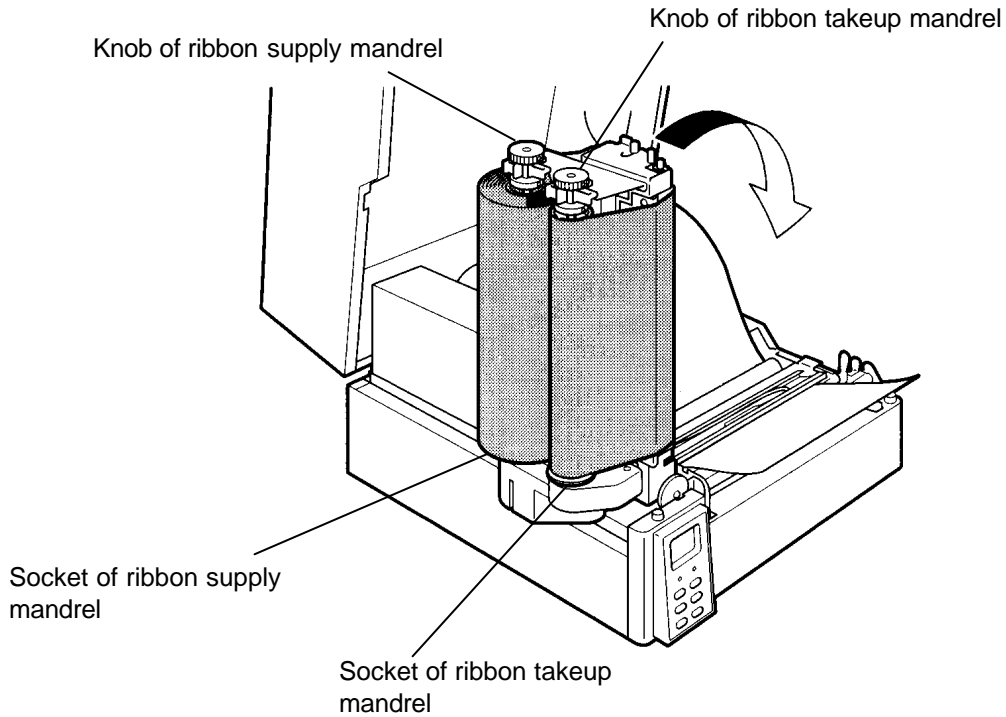

- 6 Remove any slack and wrinkles by turning the knob of the ribbon takeup mandrel clockwise, making sure that the ribbon is wound evenly between two mandrels.
- 7 Lower the printhead assembly with ribbon and push down firmly to lock. The ribbon is now loaded. Lastly close the top cover.

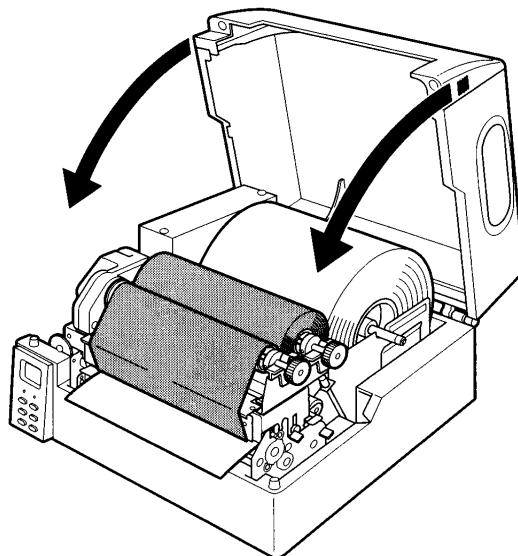

Ribbon tension adjustments

The ribbon tension should be adjusted as needed according to the media (paper) width to prevent ribbon from wrinkling. To increase tension torque, turn the ribbon supply mandrel (the deeper side viewed from the front of the printer) knob clockwise until the required number is obtained on the scale, while stopping the gear with a coin inserted in the slit on the ribbon mandrel support and held down. Generally, the wider the ribbon, the greater the ribbon tension required.

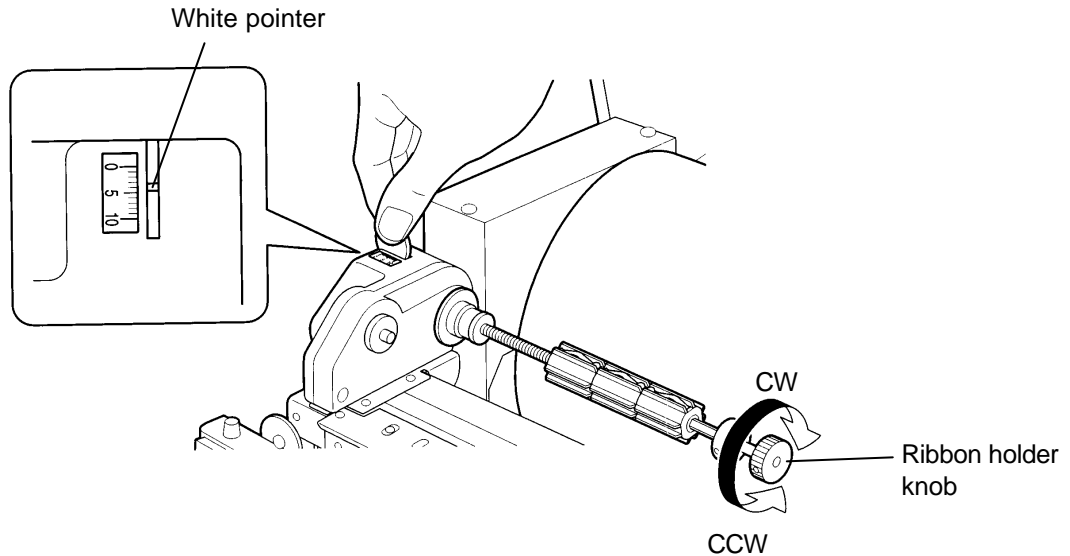

Scale	Ribbon width	Knob turning direction
— 0	3 in	Counterclockwise
— 5	↕	↕
— 10	8 in	Clockwise

Ribbon winding torque adjustments

If there are smudges on the print, adjust the ribbon winding torque from the control panel. Full details of using the control panel are shown later in the manual:



From the menu system, select “*Page Setup” of the Group Menu. Choose “Ribbon Torque” from the list of menu items. The default setting is Torque 3 so select Torque 4 or 5 to see that there are no smudges on the printout. To save the settings permanently after power off (if required) use the “*Save Settings” of the Group Menu. (See P47)

4.5 Printhead adjustments

Printhead adjustments should be made according to the type of media (paper), using the printhead adjustment lever located on the back of the printhead assembly.

Generally, for media with moderate stiffness (labels), position the printhead adjustment lever to the middle of the range to put the printhead in middle position, and for media with greater stiffness (tags or card), lower the adjustment lever to the lower level to put the printhead in forward position. For media with little stiffness, raise the adjustment lever to the upper level to put the printhead in a rearward position.

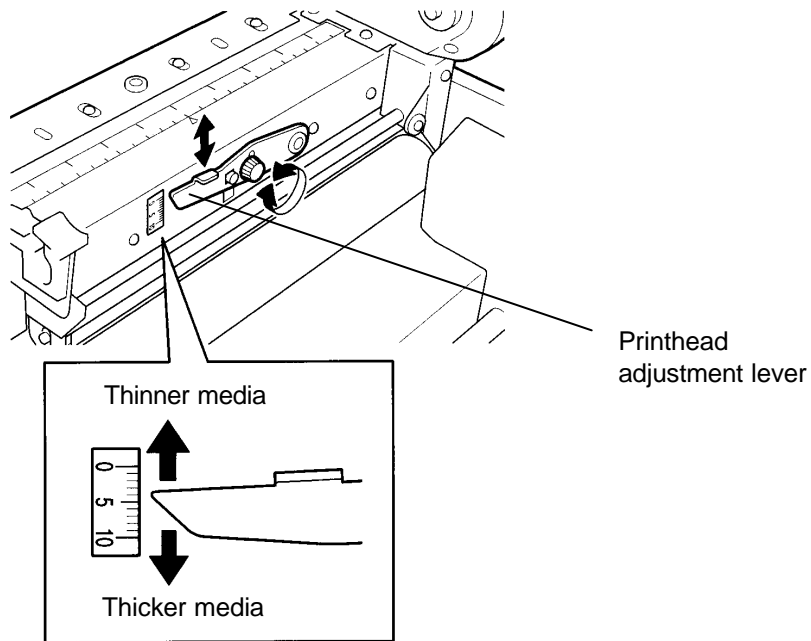

Guide to media thickness ranges

Scale	Tag/Card	Label
— 0		↕
— 5	↕	↕
— 10		

4.6 Media sensor adjustments

The printer is equipped with the upper and lower media sensors that are moved separately.

Both media sensors detect the presence of media and top of form of media except continuous roll media.

The media should be positioned for the media sensors as described in the following table.

Media	Using media sensor	Sensor position mark
Black mark tag	Lower sensor	Directly over the black mark
Die-cut label	Lower and upper sensors	The middle of media
Center-punched hole tag	Lower and upper sensors	Directly over the hole
Notched tag	Lower and upper sensors	Directly over the notch

Positioning the sensor

To adjust the media sensor position, perform the following operation:

- 1 Open the top cover all the way until it stops at hinges, unlock the printhead assembly by pushing the printhead release lever and open it towards the left side of the printer all the way until it stops and stands upright and at the same time unlock the transparent sensor guide by pushing the release lever and open it towards the left side of the printer all the way until it stops.
- 2 When the media is a black mark tag, align the black mark with the lower sensor position mark 'R.' Then lower the transparent sensor guide fully to the end and push it to lock and route the media over the platen out to the front of the printer.

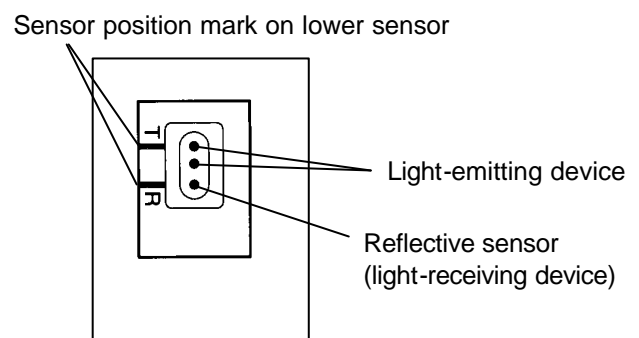
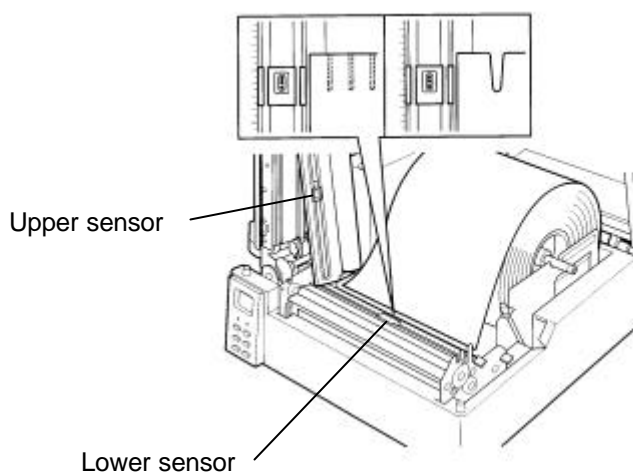

- When the media is a center-punched hole or notched tag, first align the hole or notch with the lower sensor position mark 'T.' At this point, read the value of the scale on the media guide plate pointing the 'T' mark. And set the lower sensor guide fully and push it down gently to lock. Then move the pointer of the upper sensor to the same scale position as the lower sensor position mark 'T.'

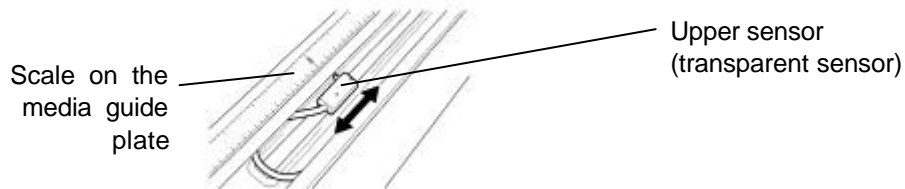

- The media sensor adjustments are now completed. Lastly return the printhead assembly and top cover to their original position.

Note:

You can see the level of the signal being produced by the media sensors using the “Sensor Monitor” from the “*System Setup” menu. (See P43, 48) With the Sensor Monitor on the LCD screen, you can manually adjust the position of the media sensors after opening the printhead. This will aid in obtaining more accurate alignment of the media sensors.

Selecting Media Sensor and AutoCal Mode

The media sensor and AutoCal Mode selection should be made before printing for the first time or after changing the media. This is performed from the control panel. (For full details, see Chapter 6.)

From the menu system, select the “System Setup” of the Group Menu. Choose the “Media Sensor” from the list of menu items and select the sensor type to match the media used (see P43).



From the same Group Menu “System Setup,” choose the “AutoCal Mode” and select “Yes” when any media sensor has already been selected from the “Media Sensor” above (see P44). This allows the printer to detect most media without calibration.



Note: Load the media and execute AutoCal Mode.

However, if the media is not detected properly, first check the sensing levels using the “Sensor Monitor,” then select the optimum value from the “Sensor Level.” For example, when the label with liner (or the tag with black marks) is used, place the liner and non-liner portions of the label (or the black mark and non-black mark portions of the tag) between the sensors and read the values of the sensing levels respectively from the “Sensor Monitor.” The average value of the measured sensing levels should be selected for the sensor level.



4.7 Avoiding wrinkling of the ribbon

If the ribbon wrinkles, the ribbon tension on either side of the ribbon will not be even. Remove slack on the ribbon in the following order:

Removing slack on winding side of ribbon (in front of printhead)

- 1 Open the top cover all the way until it stops at hinges and unlock the printhead assembly by pushing the printhead release lever and open it towards the left side of the printer all the way until it stops and stands upright.
- 2 Loosen ribbon guide plate thumbscrews on both ends of the ribbon guide plate. Do NOT remove them — just loosen them one turn. Never loosen screws other than these.
You should be able to make adjustments to the ribbon guide plate with the ribbon installed. However, it may be easier to detach mandrels from the ribbon mandrel holders. This will depend on the ribbon width being used
- 3 Remove slack and wrinkles on both sides.
 - When they are found on the right side of the ribbon (viewed from the front of the printer), move the right end of the ribbon guide plate towards you,
 - And when they are found on the left side of the ribbon (viewed from the front of the printer), move the left end of the ribbon guide plate towards you — the plate can turn on the center set screw as the rigid point of support.
- 4 Check to see that slack and wrinkles on the ribbon are removed completely, and lastly tighten the guide plate thumbscrews on both ends.

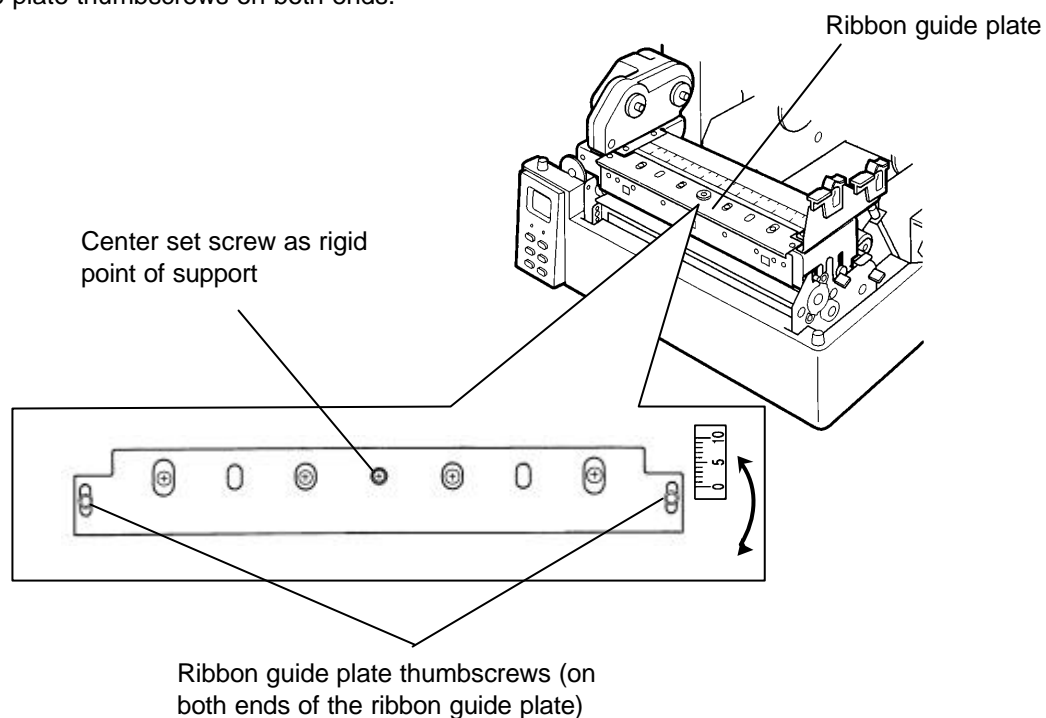

Removing slack on feeding side of ribbon (behind printhead)

- 1 Open the top cover all the way until it stops at hinges and unlock the printhead assembly by pushing the printhead release lever and open it towards the left side of the printer all the way until it stops and stands upright.
- 2 Loosen the thumbscrew with the ribbon guide shaft a little (but not completely) and move it vertically to remove slack and wrinkles on both sides.
 - When they are found on the right side of the ribbon (viewed from the front of the printer), lower the thumbscrew towards the value of 10 on the scale,
 - And when they are found on the left side of the ribbon (viewed from the front of the printer), raise the thumbscrew towards the value of 0 (zero) on the scale.
- 3 Check to see that slack and wrinkles on the ribbon are removed completely, and lastly tighten the thumbscrew.

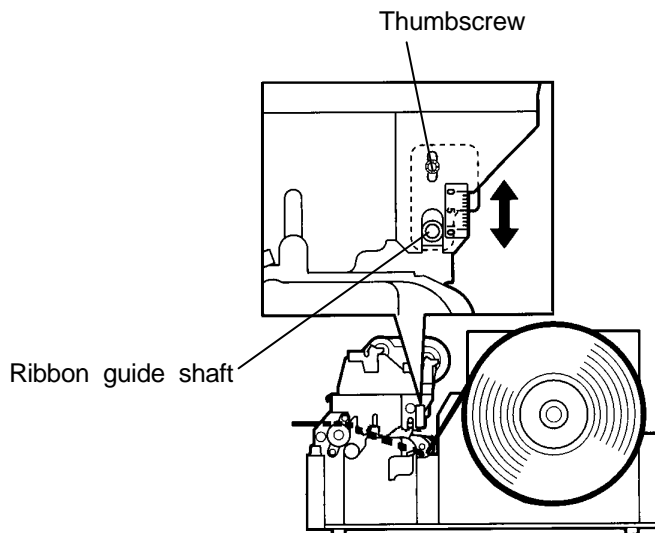

Chapter 5

Power ON and Using the Control Panel

After loading the media and ribbon, connect the power cord and turn your printer on.

5.1 Connecting to a power outlet

First plug the power cord into the AC power input on the back of the printer, then plug the other end of the power cord into the AC power outlet.

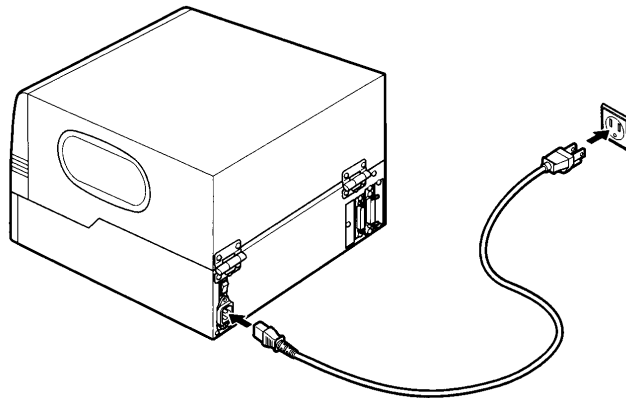

5.2 Turning the printer ON

Turn ON the power switch.

- Press “I” for ON.
- Press “O” to turn off the printer.

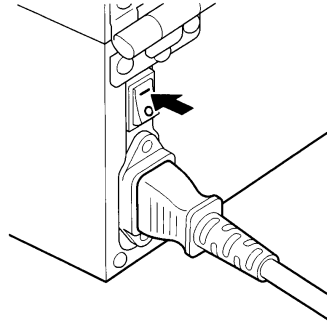

Once the power is turned ON, the following initial messages are displayed on the screen for about three seconds.

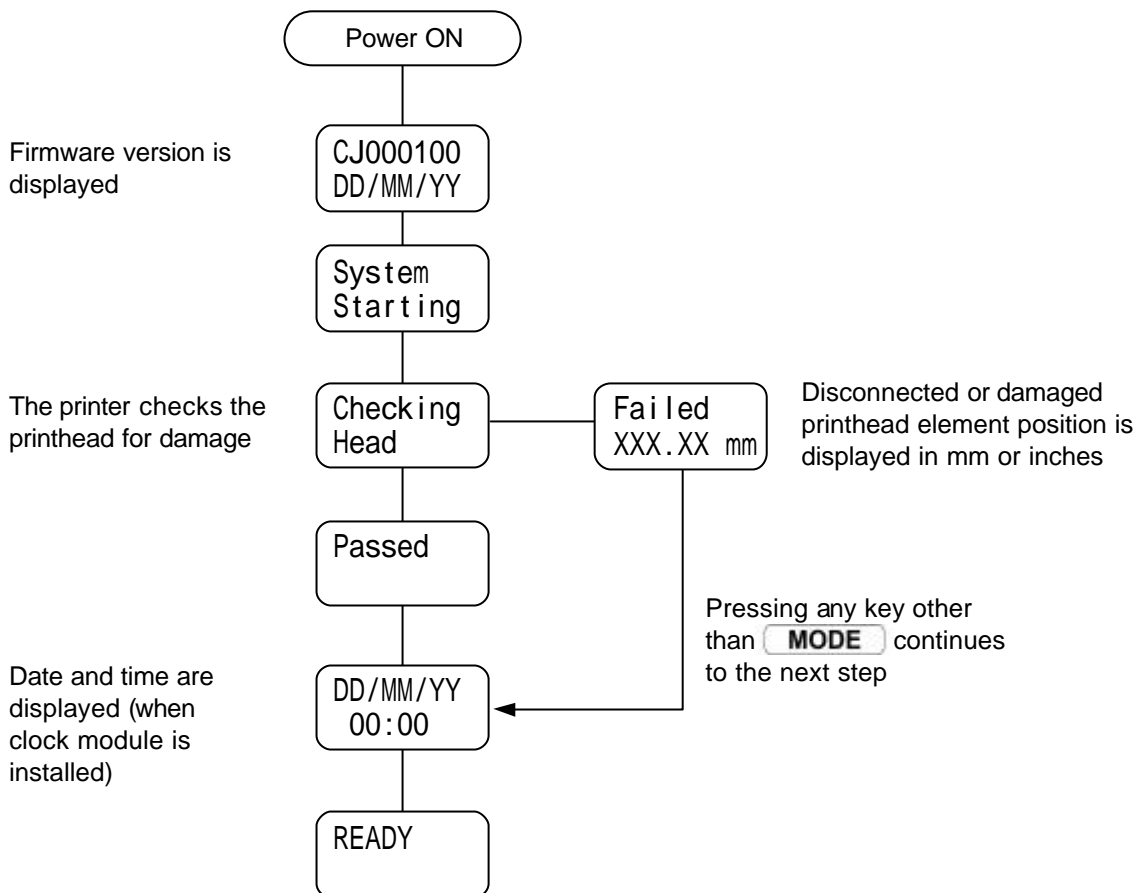

5.3 Ready Mode and Menu Mode

This section describes the operation flow of the **Ready mode** and **Menu mode**. This printer can be easily operated using the six keys on the control panel.

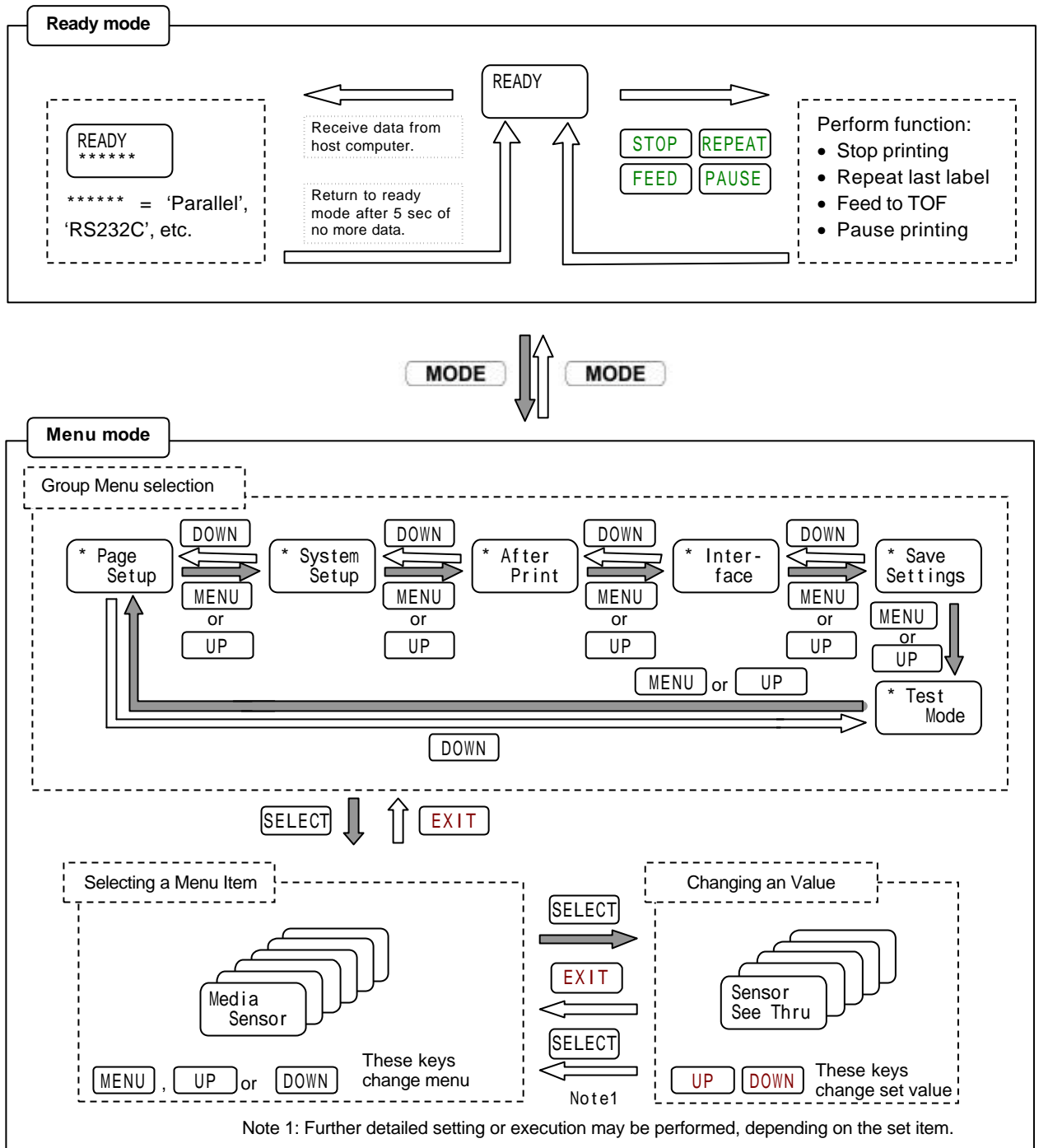

Ready mode

READY

The printer is in Ready mode after power is switched on and the self-test is performed. The LCD (Display) shows “READY” and the READY LED is lit. In this state, you can perform the media feed, printing stop/restart etc using the keys on the control panel. (See P12)

READY Parallel

The display shows the name of the receiving interface when data is received from the host computer. In this state, the printer receives and processes the information accordingly.

READY RS-232C

If no data is received for 5 seconds, the printer returns to Ready mode with no interface selected and continues to scan all installed interfaces for incoming data.

Menu mode

* Page Setup

The printer enters the Menu mode when the **MODE** key is pressed. In this state, you can access the menu system and set the printer configuration and print attributes using the keys on the control panel. Pressing **MODE** again returns to Ready mode.

5.4 Navigating the Menu System

The printer uses the same operating procedure to set various print attributes and configuration settings. This section describes the relationship between the different menu levels as well as the functions of the **MENU**, **UP**, **DOWN**, **SELECT** and **EXIT** keys on the control panel.

The **Group Menu** is the highest level of the menu tree and consists of six options as shown in the diagram below. Beneath each **Group Menu** are a number of **Menu Items** from which a desired **Value** can be selected, increased or decreased.

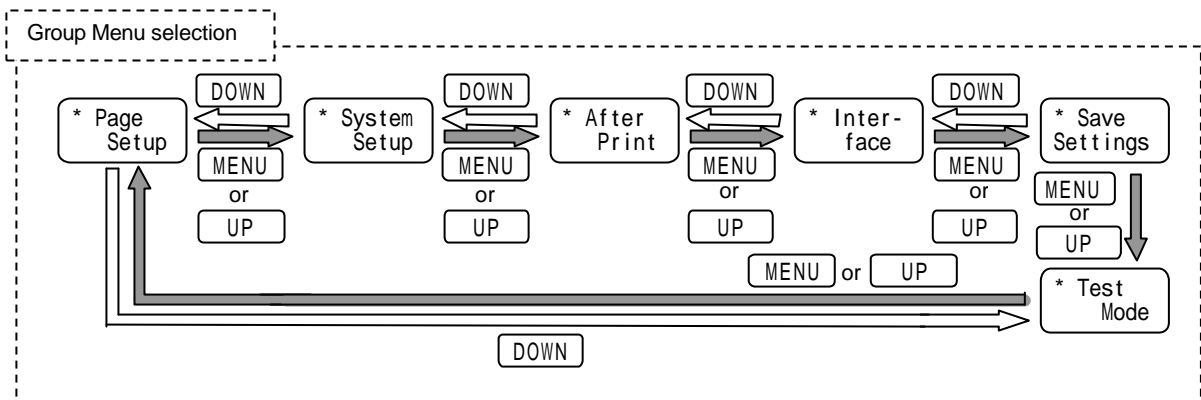

Pressing the **MENU** key moves to the next **Group Menu** available. Pressing the **SELECT** key displays the first **Menu Item** within a **Group Menu** group. Pressing the **EXIT** key returns to the **Group Menu** selection.

5.5 Changing Menu Values

With a **Menu Item** displayed on the LCD (such as Print Speed, Darkness or Baud Rate), pressing the **SELECT** key allows you to adjust or select the **Value** of the **Menu Item**.

The **UP** and **DOWN** keys are used to increase or decrease a Value, such as the print speed or printing position. If the **Menu Item** is an option that has a fixed set of values, such as the type of media used, then pressing the **UP** and **DOWN** keys will cycle through the values in turn.

The action of the **SELECT** key while you are changing a **Value** depends on the particular **Menu Item**:

- If the **Menu Item** is a **Value** pressing the **SELECT** or **EXIT** key stores the value and returns to the previous Menu Item.
- If the Menu Item is an action, such as a test print or head check, pressing the **SELECT** key executes the action. Pressing the **EXIT** key returns to the previous Menu Item without executing the action.

● Example: changing the print density

The best way to learn how the menu system works is to go through an example. In the example given here, the print density is changed to 15. The print density has been factory-set to 10. Follow the procedure below to change this. For more about the print density, see Chapter 6.

Group Menu: *Page Setup
 Menu Item: Print Darkness
 Value: 00 – 30 (Note: When language DDP-N3 is used, the maximum value is 20.)

Turn the power switch ON.

- The various system checks will be performed
- After the checks, the 'READY' display is shown on the LCD.

READY

Press **MODE** to bring up the first **Group Menu**.

- '* Page Setup' will be displayed.

* Page Setup

Show the Menu Items within the Page Setup menu.

- Press **SELECT** to bring up the first Menu Item of the Page Setup menu 'Label width.'

Label Width

Select the Print Darkness Menu Item.

- Press **MENU** twice to bring up the Print Darkness function.

Print
Darkness

Show the Print Darkness current value.

- Press **SELECT** to bring up the current Print Darkness value.

Darkness
10

Change the setting to "15"

- Press and hold **UP** to increase the Value from "10" to "15"
- Press **SELECT** to save the new value and printer returns to the Menu Item.

Darkness
15

When **EXIT** is pressed, the display goes back to '* Page Setup.'

- Press the **MODE** key to return the printer to Ready Mode.

Ready

5.6 Permanently Saving Printer Settings

The menu and configuration settings will be lost when the power is switched off. However, to save them when the printer is switched off, you must use the 'Save Settings' function.

Press **MODE** to ensure you are in Menu Mode.

- Press **MENU** to select the '* Save Settings' Group Menu.

* Save
Settings

Press **SELECT** to enter the Save Settings Menu.

- The display will show 'Save Yes/No.'

Save
Yes/No

Press the **UP** or **DOWN** key to move the cursor under the 'Yes.'

- Press **SELECT** to save settings to the printer's memory.

Save
Yes/No

Press **EXIT** once the settings have been saved.

- Press **MODE** to return to Ready Mode.

Settings
Saved !

5.7 Producing a Test or Configuration Print

When the Test Mode is selected from the Group Menu, test and configuration prints, head element check and Hex Dump mode can be selected. The two test print patterns and two configuration printouts are available.

● Example: producing a test pattern print

Press the **MODE** key to display the **Group Menu** display.

* Page
Setup

Select the '* Test Mode' menu from the Group Menu

- Press the **MENU** key to move the display to '* Test Mode.'

* Test
Mode

Show the Menu Items within Test Mode menu

- Press **SELECT** to bring up the Test Mode Menu Items
- The display will show 'Print Pattern.'

Print
Pattern

Show the values for the possible Test Patterns.

- Press **SELECT** to bring up the Test Pattern values.
- The display will move to 'Current Settings.'

Current
Settings

Change Current Settings to Pattern Sample.

- Press **DOWN** to change from 'Current Settings' to 'Pattern Sample.'

Pattern
Sample

To print the selected pattern.

- Press **SELECT** to 'execute' the request and print the pattern.
- When the sample has printed, press **EXIT** to return to the previous menu.

Printing

5.8 Turning the printer OFF

Do not turn the printer OFF suddenly. If the printer is printing, press the **STOP** or **PAUSE** key and wait for the printer to stop printing before turning the power switch OFF.

Chapter 6

Configuring Your Printer Using the Menus

This chapter explains all the possible menu options for configuring the barcode printer. Refer to Chapter 5 for information on the operation of the menus system and which keys perform which actions.

6.1 The Group Menu

The printer has two modes of operation: Ready mode and Menu mode. To switch between the modes, press the **MODE** key. The **Group Menu** is the first level of menus after entering the Menu Mode from Ready Mode. Each of the subsequent sections explains the individual menu options.

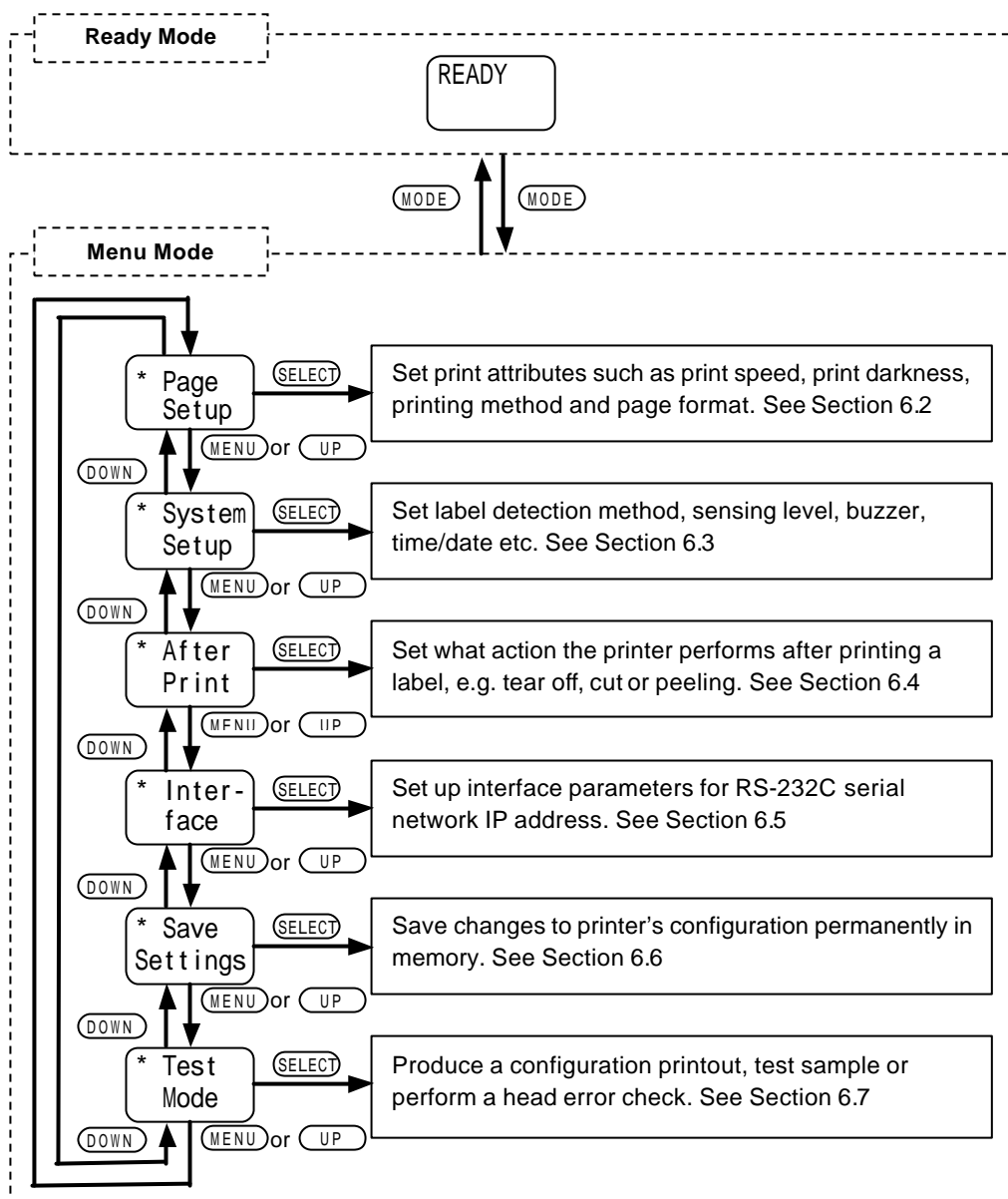

6.2 Page Setup Menu

The Page Setup Menu allows the setting of items such as print speed, print darkness, direct or thermal transfer printing and horizontal and vertical position adjustments.

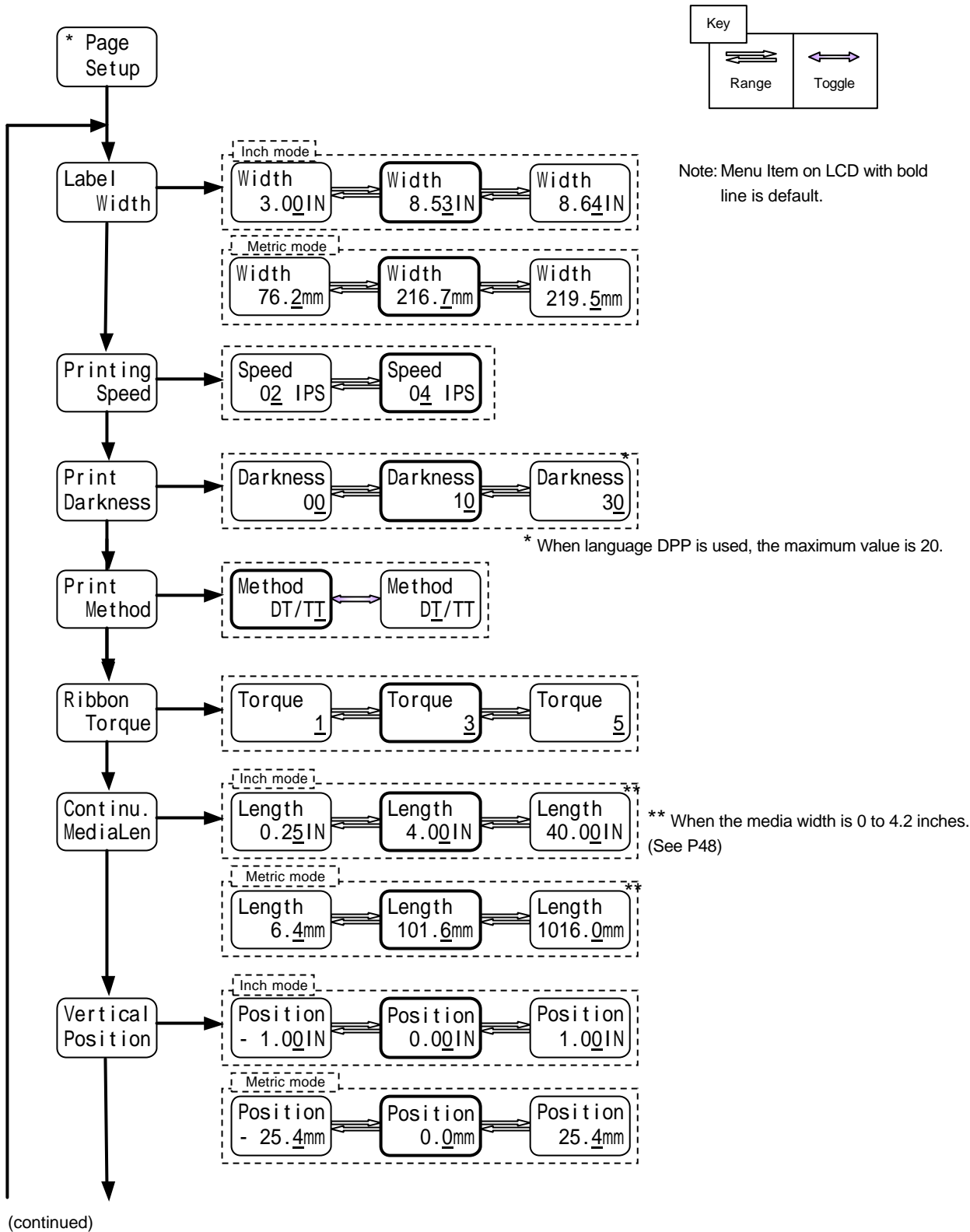

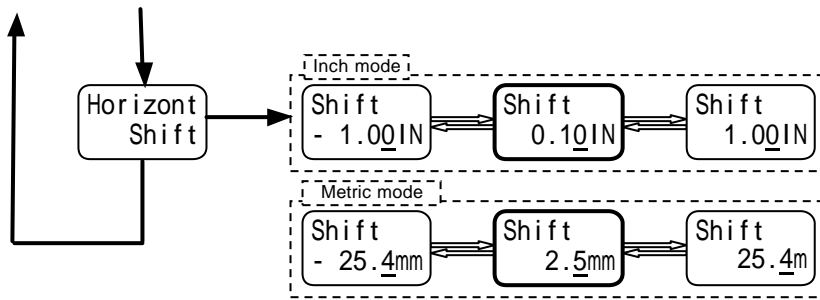

6.3 System Setup Menu

The System Setup Menu provides access to configure the hardware settings within the printer such as the type of media sensor used and the threshold for gap detection, metric or imperial (inches) selection and print resolution. It also allows for user access to the control panel and settings to be locked out to avoid inadvertent changes.

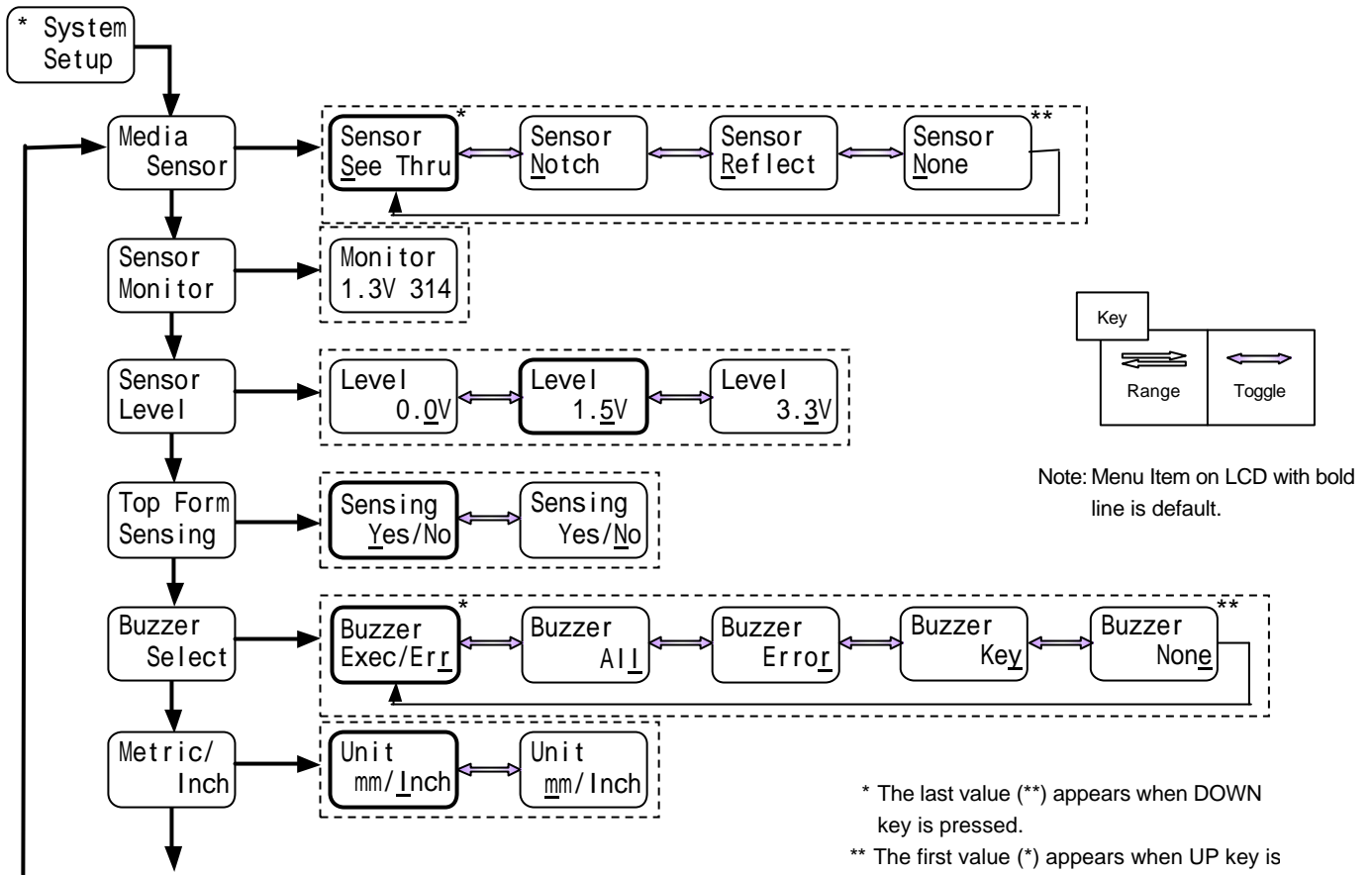

(continued)

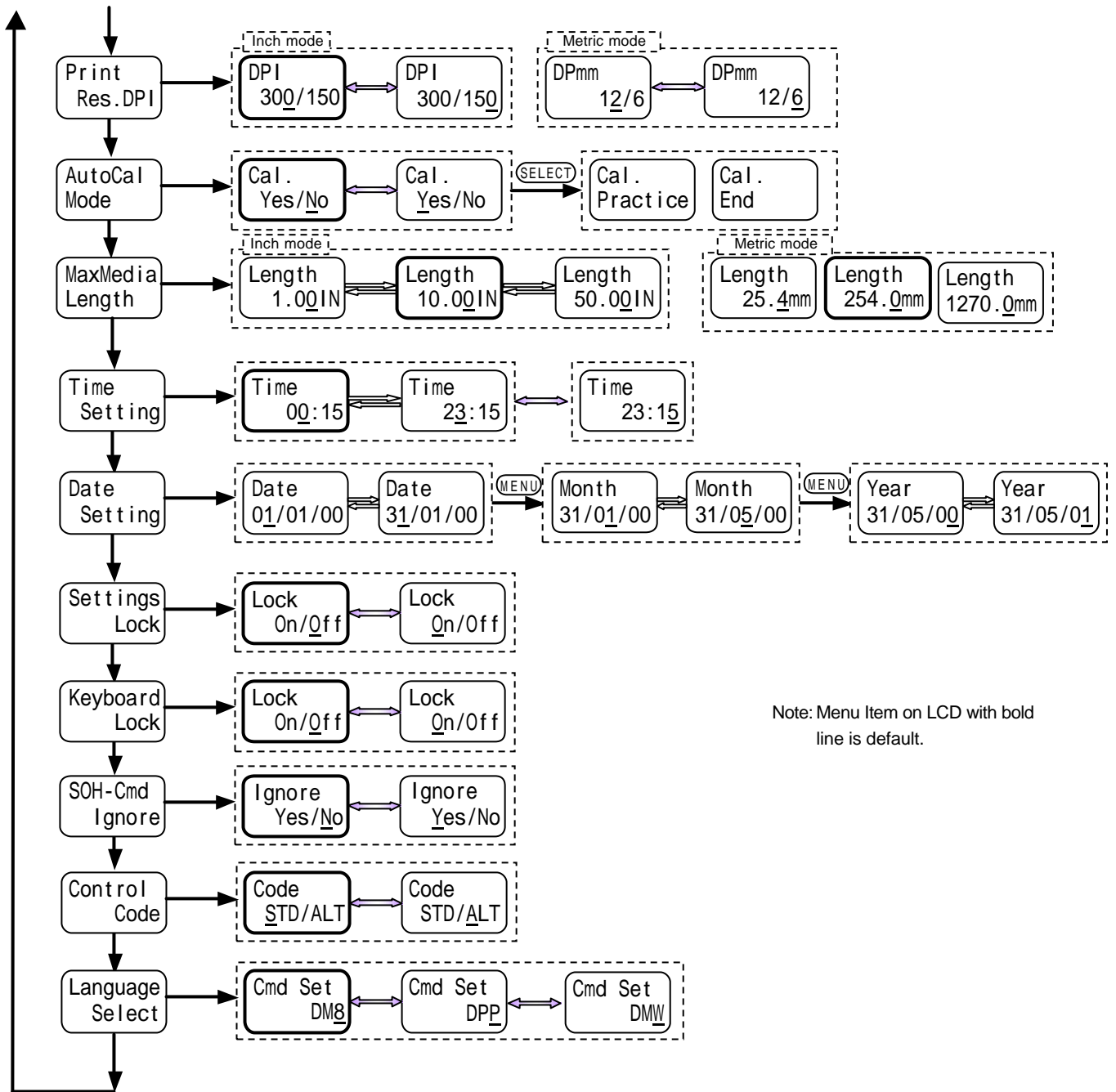

6.4 After Print Menu

The After Print Menu allows you to configure what the printer does once the label has been printed, including whether the printer feeds to the tear position after a batch of labels, whether the printer cuts the labels.

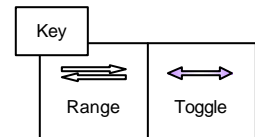
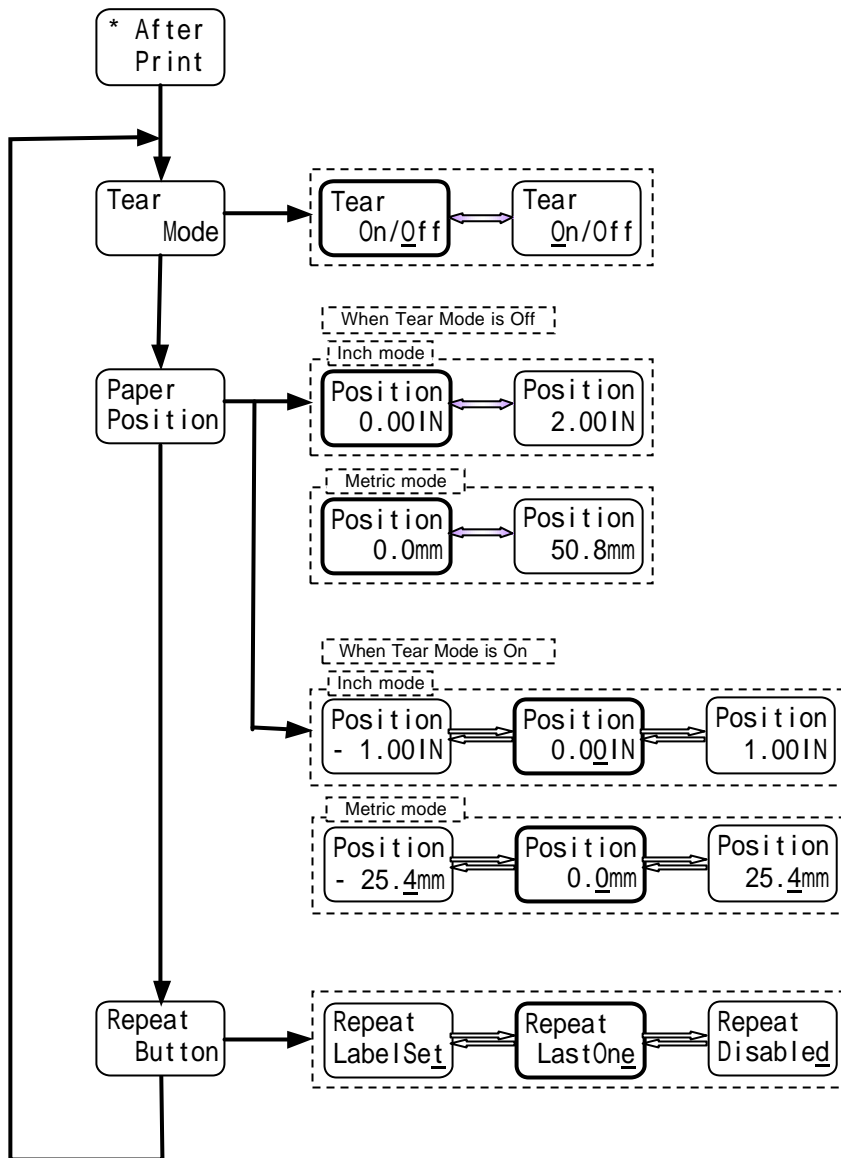

Note: Menu Item on LCD with bold line is default.

6.5 Interface Setup Menu

The Interface Setup Menu configures the baud rate, parity, data length, protocols and stop bits for the standard serial interface. It also allows for the configuration of the optional network interface, including IP address, subnet mask and gateway addresses.

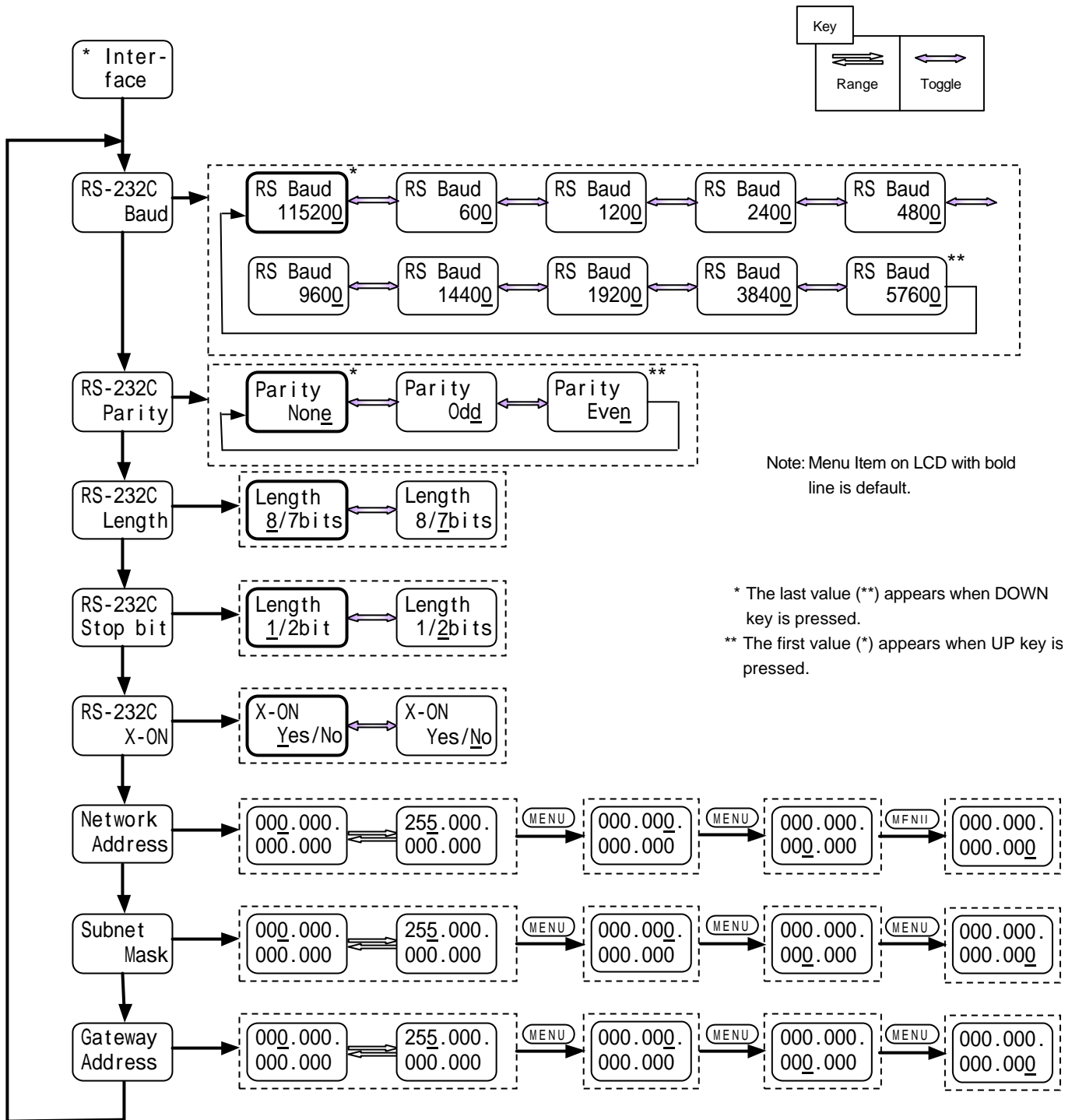

6.6 Permanently Saving Settings Menu

Settings made within the menu system of the printer are saved in standard memory. When the printer is switched off, these settings will be lost unless they are save to the non-volatile memory inside the printer. The Permanently Saving Settings Menu has just one option.

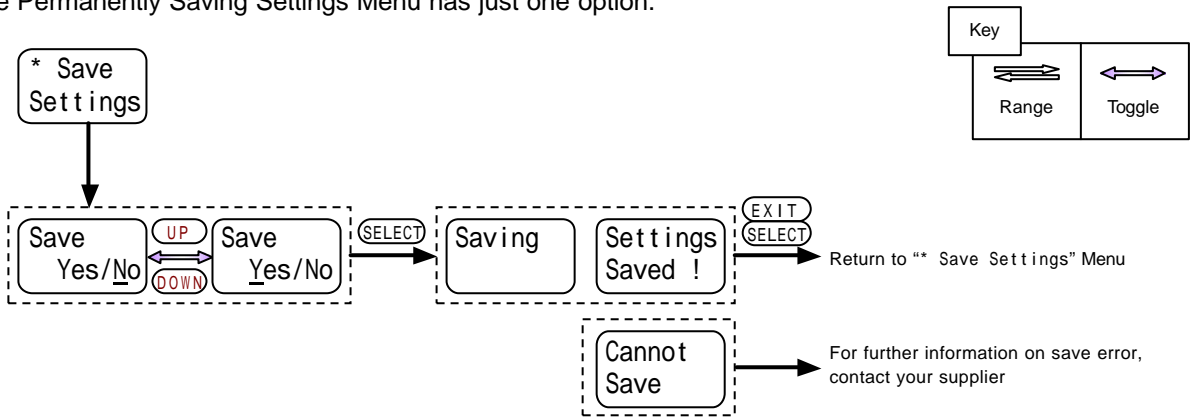

6.7 Test Mode Menu

The Test Mode Menu allows the printer to produce configuration prints for current settings, machine information such as distance counter and test samples. It also allows for head checks, resetting the non-volatile memory to factory default values and a hex dump mode.

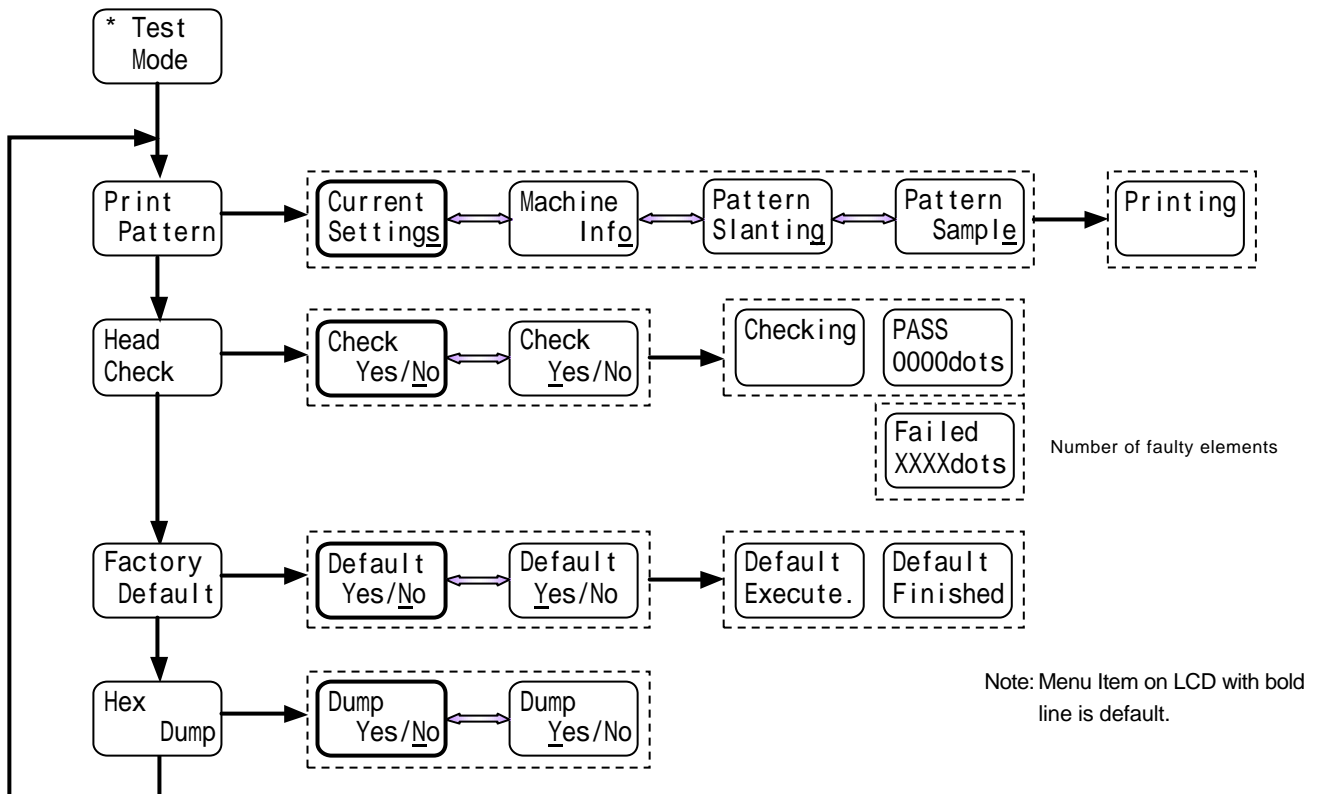

6.8 Menu Mode Description

Group Menu	Menu Item	Default Value	Range of Values	Description
*Page Setup	Label Width	8.53in 216.7mm	3.00 – 8.64in 76.2 – 219.5mm	Set the maximum limit for the printable width. Image or data beyond this limit will not be printed.
	Note: The actual printable area is split equally either side of the centerline of the media, e.g. 8.20" would print from 4.1" to the left of center to "4.1" to right of the centerline.			
	Printing Speed	04 IPS	02 – 04 IPS	Set print speed.
	Print Darkness	10	00 – 30	Set print darkness by controlling printhead heat.
	Note: When language is "DPP," the maximum value is 20.			
	Print Method	TT	DT / Direct Thermal TT / Thermal Transfer	Set printing method.
	Ribbon Torque	3	1 – 5	Set ribbon winding torque.
	Note: If smudge occurs, increase the value. When a small width of label is used, decrease the value.			
	Continu. MediaLen	4.00in 101.6mm	0.25 – 40.00in 6.4 – 1016.0mm	Set media length for print in Sensor None mode.
	Note: The maximum media length will be changed by using the "Label Width" value due to allocation of RAM memory space for print data. When media widths are 0 – 4.2in, 4.21 – 6.2in and 6.21in or more, the values are 40in (1016mm), 30in (762mm) and 20in (508mm) respectively.			
Vertical Position	0.00in 0.00mm	- 1.00 – 1.00in -25.4 – 25.4mm	Adjust print start position in vertical direction.	
Horizont Shift	0.10in 2.5mm	- 1.00 – 1.00in -25.4 – 25.4mm	Adjust print start position in horizontal direction	
* System Setup	Media Sensor	See Thru	See Thru Notch Reflect None	Select label sensor. See Thru: Transparent GAP sensor. Notch: Transparent HOLE sensor. Reflect: Reflective sensor. None: No use of sensor (continuous media)
	Sensor Monitor	—	x.xV adc	LCD display shows media sensing level while setting media in the sensor position. When None, See Thru (Gap) sensor sensing level is monitored.
	Note: a) Before performing Sensor Monitor, ensure that Media Sensor selection is matched correctly with media. b) The average sensor value between the label and liner area is recommended to use for setting the "Sensor Level" (see below). c) When Media Sensor is set to None, See Thru (Gap) sensor is monitored.			
	Sensor Level	1.5V/1.7V	0.0V – 3.3V	Set threshold value for media sensor by changing Up or Down key.
Note: For reflective sensor, if black marks on the liner are not detected because of small reflection factor, decrease the sensor level. For transparent sensor, if notches or gaps between labels are not detected because of small transparency factor, decrease the sensor level. The Sensor Monitor menu will be useful for setting Sensor Level.				

(continued)

Group Menu	Menu Item	Default Value	Range of Values	Description	
* System Setup	Top Form Sensing	Yes	Yes No	Select Top-Of-Form (TOF) sensing. Printer will feed to top-of-form before first print after power on.	
	Buzzer Select	Exec/Err	Exec/Err All Error Key None	Select condition for buzzer. Exec/Err: Sounds when setting and execution are completed or error occurs. All: Sounds in all situations. Error: Sounds only in error. Key: Sounds in key operation. None: No sound.	
	Metric/Inch	Inch	Inch mm	Set basic unit of measurement to millimeters or inches.	
	Print Res. DPI (Print Res. DPmm)	300	300DPI (12 dot/mm) 150DPI (6 dot/mm)	Set print resolution. Values in parentheses are in metric system.	
	AutoCal Mode	—	Yes No	Perform sensor calibration with setting media when “Yes” is selected by pressing the SELECT key.	
	Note: When AutoCal mode is executed, ensure that a media sensor is selected and media is loaded.				
	MaxMedia Length	10.00in 254.0mm	1.00 – 50.00in 25.4mm – 1270.0mm	When media length is over 5 inches (127mm), set MaxMedia Length to a length that is more than two times of media length.	
	Note: This function detects over what distance a “media end” or “paper jam” event is detected. The printer looks for the gap between each section of media and, if it does not see a signal after the maximum media length, it stops with a “Paper Jam” error. If the value is less than the label length, the printer will always think there is a paper jam. We recommend setting the value of MaxMedia Length to approximately double the label length being used.				
	Time Setting	—	—	Set time (hours and minutes).	
	Date Setting	—	—	Set date (day, month and year).	
	Settings Lock	Off	On Off	When “On,” commands sent from the host system that attempt to change the menu settings are ignored.	
	Note: When Setting Lock is ON, it is still possible to change settings from the control panel.				
	Keyboard Lock	Off	On Off	Disable key operation when On is selected.	
	Note: In Menu mode, UP and DOWN keys do not operate. In Ready mode, STOP, PAUSE, FEED and REPEAT keys do not operate.				
	SOH-Cmd Ignore	No	Yes No	This menu determines how the SOH command (0x01) is treated. “Yes” means that command is acted upon and “No” means the command is ignored.	
Control Code	STD	STD ALT	Some systems cannot send “unprintable characters” which are used to control the printer. This menu substitutes these for printable versions and is often referred to as “AS400” mode. ALT = AS400 mode. <u>STD</u> <u>ALT</u> SOH (0x01) ^ (0x5E) STX (0x02) ~ (0x7E) ^ (0x5E) @ (0x40)		
Language Select	DM8	DMW DM8 DPP	Select compatible emulation for label printing application software.		

(continued)

Group Menu	Menu Item	Default Value	Range of Values	Description
* After Print	Tear Mode	Off	Off On	Set Tear Mode.
	Paper Position	0.00in 0.0mm	When Tear Mode is On - 1.00 – 1.00in - 25.4 – 25.4mm When Tear Mode is Off 0.00 – 2.00in 0.0 – 50.8mm	Adjust the tear off position when media is fed from the printer after performing tear off operation. This adjustment is performed if necessary.
	Repeat Button	LastOne	LabelSet LastOne Disabled	Select repeat printing method. LabelSet: Reprint the number of duplications that are set in the label format. LastOne: Reprint the last label from the most recently printed batch. (One Label) Disabled: Disable Repeat key.
* Interface	RS-232C Baud	115200	115200 600 1200 2400 4800 9600 14400 19200 38400 57600	Set serial interface baud rate. New value is valid after power is turned off and on gain or a reset command is issued.
	RS-232C Parity	None	None Odd Even	Set serial interface communication parity.
	RS-232C Length	8 bits	8 bits 7 bits	Set serial interface character length.
	RS-232C Stop bit	1 bit	1 bit 2 bits	Set serial interface stop bits.
	RS-232C X-ON	Yes	No Yes	Enable or disable serial interface X-ON flow control.
	Network Address	000.000. 000.000	000.000.000.000 – 255.255.255.255	Set network IP address.
	Subnet Mask	000.000. 000.000	000.000.000.000 – 255.255.255.255	Set subnet mask.
	Gateway Address	000.000. 000.000	000.000.000.000 – 255.255.255.255	Set gateway address.
* Save Settings	—	—	—	Permanently save configuration values in non-volatile memory.
* Test Mode	Print Pattern	Current setting	Current setting Machine Info Pattern Slanting Pattern Sample	Choose and execute a test print. The test pattern or configuration print can only be produced when there is no print job is in buffer.
	Head Check	No	Yes No	LCD display shows the number of faulty element(s) on the printhead, when Yes is selected.
	Factory Default	No	Yes No	Return to factory default setting values.
	Hex Dump	No	Yes No	Data sent from host PC is printed as HEX dump data for checking the software program when Yes is selected.

Chapter 7

Troubleshooting

When an error occurs, an error message is displayed on the LCD panel. This chapter describes corrective actions to be taken when error message is received or problems or difficulties are experienced.

7.1 Items to check in case of trouble

If problems or difficulties are experienced during the operation of the printer, please check the following table to try and resolve your problem.







Symptom	Check	Remedy
The LCD stays blank when the printer power is turned ON.	<ol style="list-style-type: none"> 1. Is the socket end of the power cord plugged properly into an AC outlet? 2. Is the other end of the power cord plugged properly into the main power input port on the printer? 3. Is the power cord damaged or broken? 4. Is there electricity in the power outlet used to power the printer? 5. Have the main fuses in the fuse box for the building blown? Is the circuit breaker turned off? 	<ol style="list-style-type: none"> 1. Plug the socket end of the power cord properly into an AC outlet. 2. Plug the other end of the power cord properly into the main power input port on the printer. 3. Replace the power cord. Use the dedicated power cord for this printer. Contact our service personnel to obtain a replacement. CAUTION: Do not use a power cord other than the dedicated power cord for this printer. 4. Check the main power source to the outlet. If there is no problem, check whether electricity is supplied to the building. Also, check for the possibility of a power failure. 5. Replace the main fuses for the building and turn on the circuit breaker again. For replacement, contact a qualified electrician.
Media can feed but nothing is printed.	<ol style="list-style-type: none"> 1. Is the printhead dirty? Is a label stuck? 2. Are you using a genuine CITIZEN ribbon or its equivalent? 	<ol style="list-style-type: none"> 1. If the printhead is dirty, wipe it off with the head cleaning pen supplied. If a label is stuck, remove it. CAUTION: Avoid using metallic tools to remove labels stuck inside the printer. (Metallic tools may damage the printhead.) If label adhesive material is stuck to the printhead, wipe it off with ethyl alcohol. 2. Use a genuine CITIZEN ribbon or its equivalent.

(continued)

Symptom	Check	Remedy
Text is not printed cleanly.	<ol style="list-style-type: none"> 1. Is the media and ribbon loaded properly? 2. Is the print density too dark or faint? 3. Is the platen dirty or deformed? 4. Is the printhead dirty? Is a label stuck? 5. Are you using a genuine CITIZEN ribbon or its equivalent? 6. Is the printhead position proper for the media being used? 	<ol style="list-style-type: none"> 1. Load the media and ribbon properly. 2. Set the proper print density via the menu or control software. 3. If the platen is dirty, remove the dirt using ethyl alcohol. If the platen is deformed, contact our service personnel for replacement. 4. If the printhead is dirty, wipe it off with the head cleaning pen. If a label is stuck, remove it. CAUTION: Avoid using metallic tools to remove labels stuck inside the printer. (Metallic tools may damage the printhead.) If label adhesive material is stuck to the printhead, wipe it off with ethyl alcohol. 5. Use a genuine CITIZEN ribbon or its equivalent. 6. Adjust the printhead position, using the printhead adjustment lever.
Print position changes.	<ol style="list-style-type: none"> 1. Is the media and ribbon loaded properly? 2. Is the platen dirty or deformed? 3. Are you using a genuine CITIZEN ribbon or its equivalent? 4. Are the contents of the data and signals from the computer proper? 5. Are the values of the Menu set proper? 6. Is the media sensor level proper for the media being used? 	<ol style="list-style-type: none"> 1. Load the media and ribbon properly. 2. If the platen is dirty, remove the dirt using ethyl or isopropyl alcohol. If the platen is deformed, contact our service personnel for replacement. 3. Use a genuine CITIZEN ribbon or its equivalent. 4. If a message of "ERROR RS-232C" etc is displayed on the LCD, check the contents of the software and the communication conditions set on the computer. 5. Set the proper values of the Menu set from the control panel or your PC. 6. Incorrect sensor level may cause the printer to miss some or all of the end-of-label marks on the media.
Ribbon wrinkles.	<ol style="list-style-type: none"> 1. Is the ribbon tension proper for the media being used? 2. Is the ribbon guide plate guiding the ribbon evenly? 3. Is the ribbon guide shaft guiding the ribbon evenly? 	<ol style="list-style-type: none"> 1. Adjust the ribbon tension properly (see P27). 2. Adjust the setting angle of the ribbon guide plate (see P31). 3. Adjust the setting angle of the ribbon guide shaft (see P32).
Ribbon Smudge	<ol style="list-style-type: none"> 1. Is the ribbon torque proper for the media being used? 	<ol style="list-style-type: none"> 1. Adjust the ribbon torque properly (see P27, 42, and 48).

7.2 Error messages and corrective actions

The printer will be placed in error status and an error message will be displayed on the LCD (Display) if the printer has not been prepared properly for printing or printer setup conditions are not correct. Check error messages and take corrective actions to clear error. If a message other than the following is displayed, please contact our service personnel.

Cause	Corrective action	LEDs/Buzzer	LCD (Display)
Sensor error (when printing)	<ul style="list-style-type: none"> Place media straight Set type of sensor to match media being used. Adjust sensor position. Adjust sensor sensing level. Make sure printer "MaxMedia Length" is longer than actual label length. 	 0.3sec Sounds 0.3sec twice	Paper Jam
Media end (when printing)	<ul style="list-style-type: none"> Load new media. 	 0.5sec Sounds 0.5sec twice	Paper End
Ribbon end (when printing)	<ul style="list-style-type: none"> Load new ribbon. 	 0.5sec Sounds 0.5sec twice	Ribbon End
Printhead up (just before printing)	<ul style="list-style-type: none"> Set printhead properly by lowering printhead lever. 	 0.5sec Sounds 0.5sec once	Head Open
Printhead disconnected (when turning power on or resetting)	<ul style="list-style-type: none"> Contact our service personnel. 	 1sec Sounds 1sec once	Failed X.XXinch
Interface error	<ul style="list-style-type: none"> Check interface cable connection. Check interface setup. 	 0.3sec Sounds 0.3sec once	ERROR XXXXXXXX*
Command error	<ul style="list-style-type: none"> * This occurs due to misscript or improper RS-232C setup. This is cleared automatically as it is interpreted as a normal command. LED goes off for 0.3 second and blinks and LCD shows a message for 0.3 second. 	 0.3sec Sounds 0.3sec once	READY Cmd Err

Light up  blink 

- Clear an error with a control key (other than MODE key) or command (in case of command error) and an initial message "Ready xxxxxxx" will be shown if data is received from the host computer (see P35, 36).

* XXXXXXXX: the contents of the interface error.

Chapter 8

Maintenance

Since this printer uses a thermal head and a carbon ink ribbon, thermal paper dust etc may adhere to the printhead or other related parts. In this case, printing errors or failure of the printhead may occur.

If paper dust or ribbon material adheres to the printhead, irregular printer movements, paper jams or poor print quality may occur. Therefore, be sure to clean the printhead, platen and media path periodically. The amount of cleaning will depend on the volume of media being printed and the quality of the consumables and media used in the printer. Genuine Citizen consumables will be you the best performance.

If a defect should occur under normal use, it will be repaired free of charge during the warranty period. However, the printhead, platen and pinch roller will be regarded as consumable supplies.

8.1 Printer care

Observe the following when caring for the printer.

- Use a cotton swab or soft cloth to clean each part of the printer.
- Hard or square tools such as screwdrivers can scratch any part of the printer. Never clean the printhead with such tools.
- Before deaning, make sure that the power to the printer is turned OFF and the power cord is disconnected from the mains supply.



CAUTION

Do not use benzine, thinner, alcohol etc to wipe the dirt off the printer. Failure to do so may cause discoloration or deformation. If the dirt is too large, soak a cloth in a thin neutral detergent and squeeze out and wipe with it, and finally wipe with a dry, soft cloth.

8.2 Cleaning method

Remove dirt, paper dust, adhesive materials for labels etc upon completion of printing.

Cleaning tools



Soft cloth



Ethyl or isopropyl alcohol (do not use solvent like thinner)

Printhead and platen

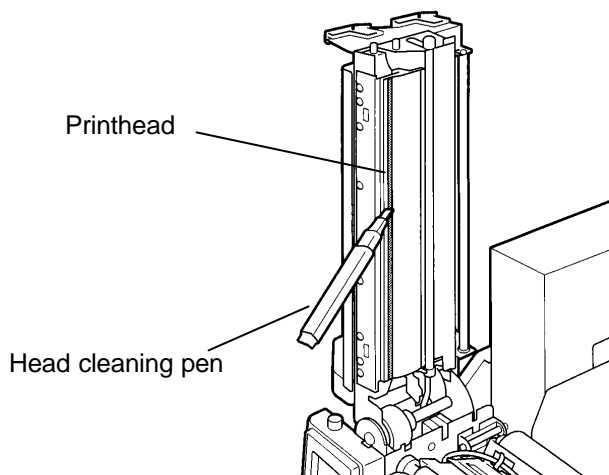

Tension roller and its surroundings

Chapter 9

Specifications

9.1 General specifications

Item	CLP-8301
Printing method	Thermal Transfer/Direct Thermal
Printhead resolution	300 DPI (11.81 dots/mm)
Maximum print width	219.5 mm (8.64")
Print length	Print length: Media width: 1016 mm (40") 0 – 106 mm (0 – 4.2") 762 mm (30") 107 – 157 mm (4.21 – 6.2") 508 mm (20") 158 – 219 mm (6.21 – 8.64")
Print speed	2 – 4 IPS
Media	Max. roll media outer diameter: 203 mm (8") Max. media width: 228.6 mm (9")
Media Sensor	Adjustable transparent and reflective sensors
Ribbon	Max. ribbon outer diameter: 78 mm (3.07") Max. ribbon length: 450 m (1,476 feet)* *The length of ribbon may vary, depending on the thickness of the ribbon.
Barcodes	Code 39/93/128 (A/B/C), EAN 8/13, UPC-A/E, UPC-2&5-Digit Codabar (NW-7), Interleaved 2 of 5, UCC/EAN 128 PDF-417, UPS MaxiCode, DataMatrix, Telepen
Indicators	LCD: 8-character x 2 rows. LEDs: POWER and READY
Control keys	Setup keys (six): MODE, MENU, SELECT, EXIT, UP and DOWN Execution keys (four): STOP, FEED, PAUSE and REPEAT
Graphic data	7-bit ASCII, 8-bit HEX, PCX and BMP
Interfaces	Standard: RS-232C serial (max: 115.2 kbps) and Centronics parallel Optional: Ethernet, USB and IEEE 1284 ECP
A/C Input	100V – 240V (-10%+6%), 1.6 – 3.2A, 50/60HZ
Power consumption	Typical operating: 200VA, Standby: 30VA
Operating temperature and humidity	5 – 40°C (41 – 104°F), Relative Humidity 25 – 85% (non-condensing)
Outer dimensions	395mm W x 260mm H x 415mm D (15.5" W x 10.2" H x 16.3" D)
Weight	18 kg (39.68 lb) approx. excluding media and ribbon
Standards	120V: UL1950 CSA: No. 950 FCC: Class A 220V – 240V: EN60950, EN55022, EN55024, EN61000-3-2, EN61000-3-3

9.2 Interfaces

1 Serial interface

Specifications

Transfer method: Start stop synchronous dual communication system

Signal level: RS-232C

Baud rate: 2400, 4800, 9600, 14400, 19200, 38400, 57600, 115200 bps

Data bits: 7 or 8

Start bits: 1

Stop bits: 1 or 2

Parity: Even, odd, or none

Connector: D-SUB 25PIN 17LE-13250-27(D41)(DDK) or its equivalent

XON/XOFF protocol

XON code output requirements:

- Communication is enabled after power is turned ON.
- Residual capacity of the buffer is 1K bytes or more after sending XOFF code.
- Paused state is cleared.
- XOFF code is output due to error and printer returns to normal conditions.

XOFF code output requirements:

- Printer is in error.
- Printer is in paused state.
- Receive buffer has less than 128 bytes available.

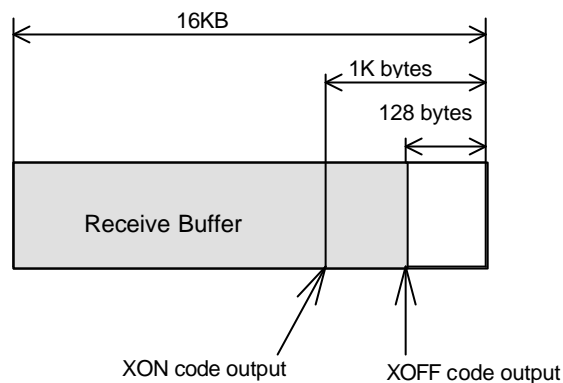

DTR protocol

DTR signal “Ready (High)” level requirements:

The following must be satisfied:

- Printer is on line.
- Receive buffer has more than 128 bytes available.

Note: When receive buffer has less than 128 bytes available, DTR signal becomes “Busy (Low)” level and this “Busy (Low)” level is kept until receive buffer has at least 1K bytes available.

DTR signal “Busy (Low)” level requirements:

The following must be satisfied:

- Printer is in error.
- Printer is in paused state.
- Receive buffer has less than 128 bytes available.

Pin assignment

Pin No.	Signal	Input/Output	Description
1	FG	Output	Frame ground
7	SGND	Output	Signal ground
2	TXD	Output	Signal to transmit data
3	RXD	Input	Signal to receive data
4	RTS	Output	Transmission request signal. Pull up to +12V with 3.3Kohm
6	DSR	Input	Signal active when host computer ready to interface with printer
20	DTR	Output	Signal active when printer ready to interface with host computer
25	VCC	Output	(Factory use)

2 Parallel interface

Specifications

Transfer method:	8-bit parallel (compatibility mode)
Synchronous:	Strobe pulse
Handshaking:	ACKNLG and BUSY signals
Signal level:	TTL
Printer side:	36-pin non-phenol type

Pin assignment

Pin No.	Signal	Input/Output	Description
1	$\overline{\text{STROBE}}$	Input	Strobe signal to read 8-bit data
2–9	$\overline{\text{DATA1-8}}$	Input	8-bit parallel data signal
10	$\overline{\text{ACKNLG}}$	Output	8-bit parallel data request signal
11	BUSY	Output	Signal to indicate printer 'Busy'
12	PERROR	Output	Signal to indicate media out
13	SELECT	Output	Signal to indicate printer on line or off line
14	N.C	–	Not used
15	NC	–	Not used
16	GND	–	Ground
17	F.GND	–	Frame ground
18	N.C	–	Not used
19–30	GND	–	GND
31	$\overline{\text{INIT}}$	Input	Printer reset
32	$\overline{\text{FAULT}}$	Output	Signal to indicate printer error
33–35	N.C	–	Not used
36	N.C	–	Not used

Timing chart

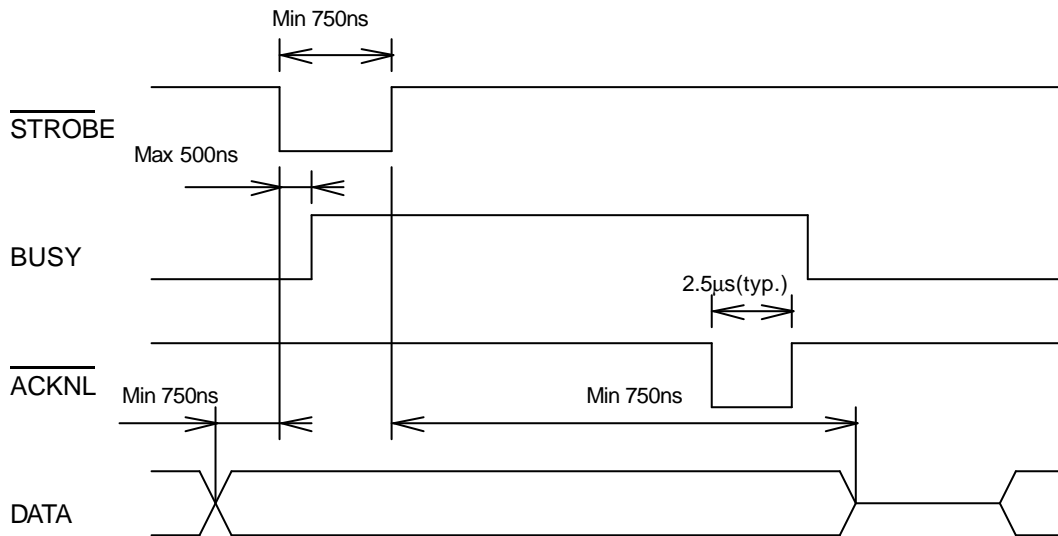

ACKNLG “Low” shows that the printer requests the computer to send data. BUSY “High” shows that the printer cannot receive data and BUSY “Low” shows that the printer now can receive data from the computer.

9.3 PCMCIA Memory Card

<ul style="list-style-type: none"> • Card type 	PCMCIA Type II flash memory card
<ul style="list-style-type: none"> • PCMCIA memory card application 	<ul style="list-style-type: none"> a) Storing print format files: Data in the field register area can be stored and loaded. b) Storing graphic data: Bitmap graphic images can be stored and recalled from the PCMCIA memory card and can combined with field data and printed. c) Storing fonts: Downloadable fonts can be stored.

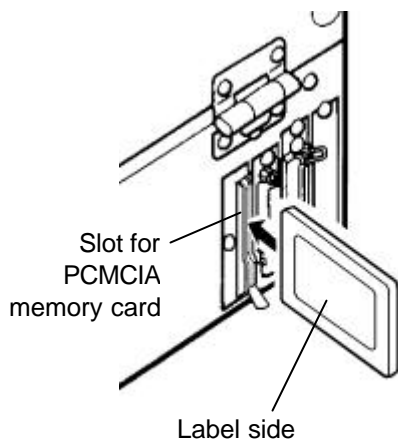

CAUTION

- Do not insert or remove the PCMCIA memory card before the power to the printer is turned off.
- Before use, carefully read and understand the instructions regarding the PCMCIA memory card.

PLEASE NOTE: The slot for PCMCIA memory card is a factory-installed option. The printer already has flash memory on the motherboard to accept downloaded fonts and images. Please contact your supplier to discuss this option.

9.4 Print width

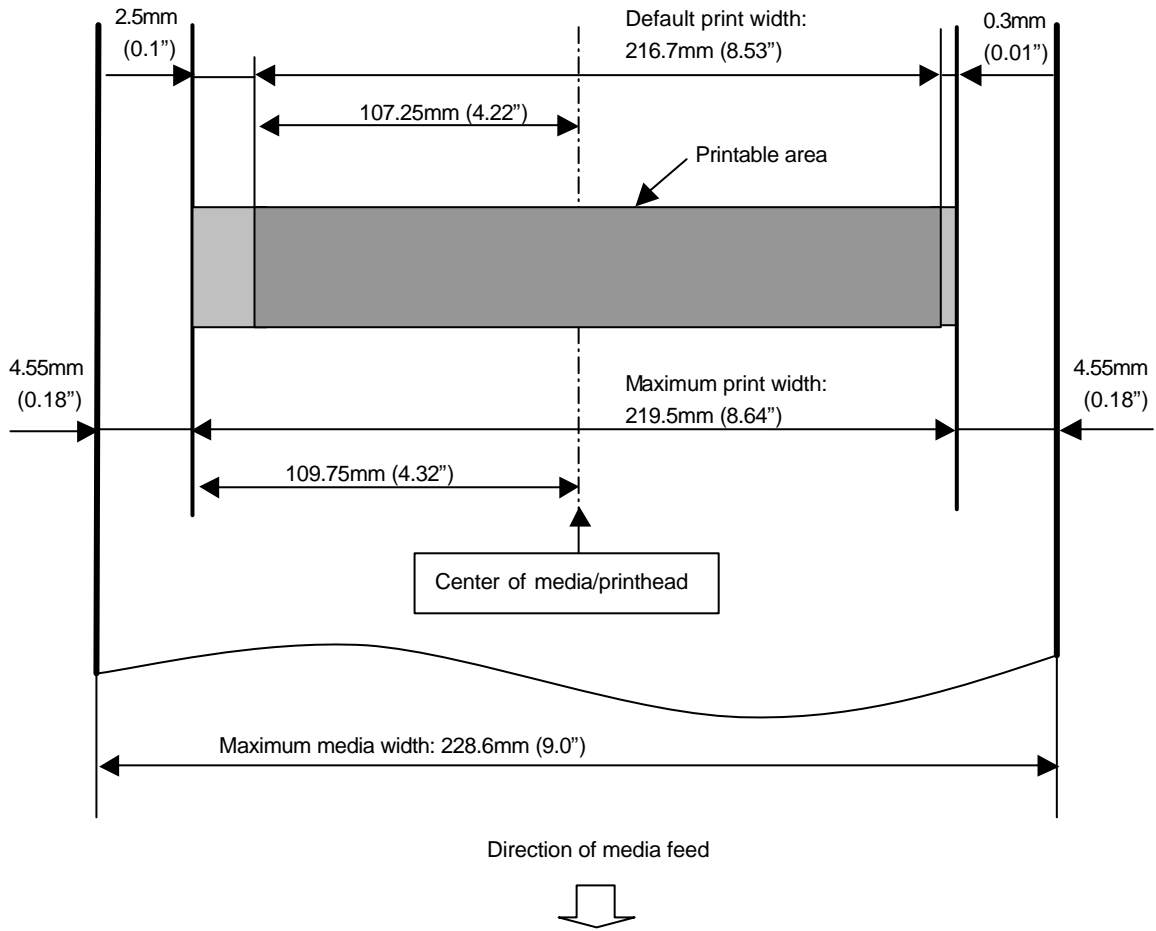

9.5 Movable sensors

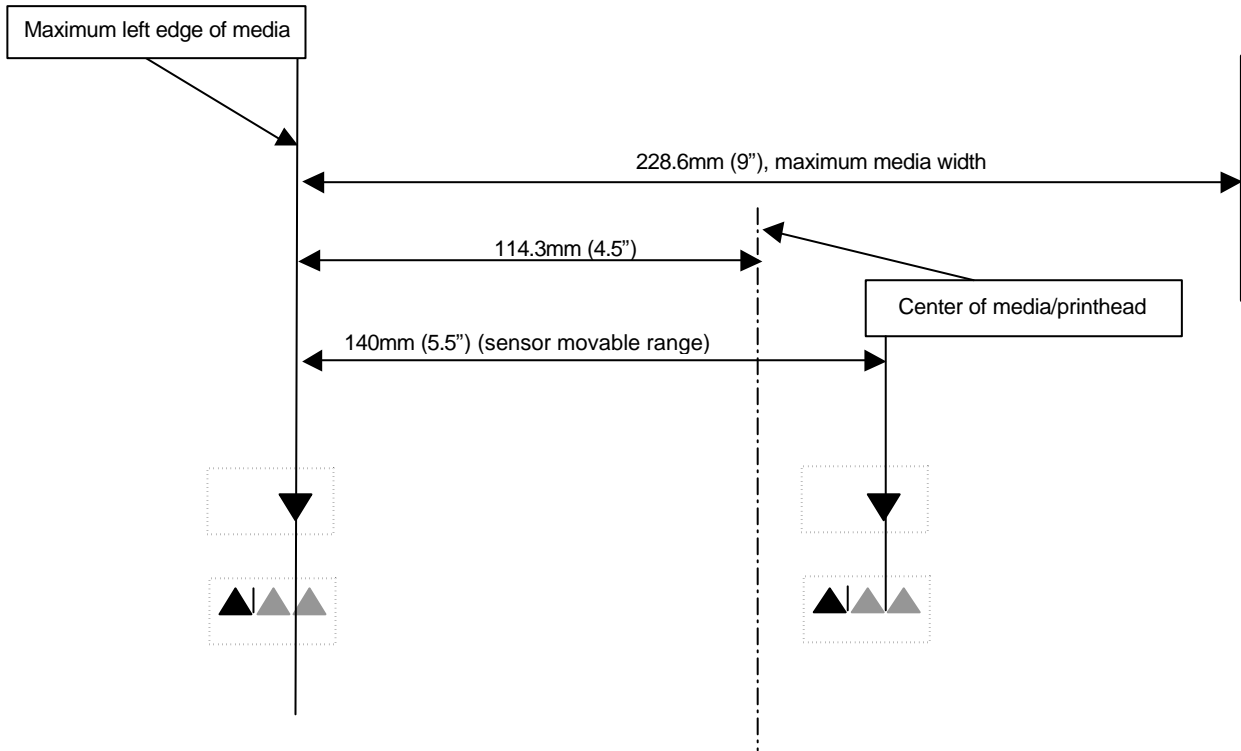

Media	Mark A/D Voltage	Setup Guide	Setup Voltage	Voltage Level	Variable Voltage
Black Mark	Low	No Mark area	2.1V	1.7V or less	0.0V – 3.3V
Gap	High	No Gap area	1.05V	1.5V or more	
Hole (including corner 'R')	High	No Paper	2.5V	1.5V or more	

9.6 Environmental requirements

1 Printer operating conditions for ensuring print quality

Operating temperature: 5°C – 40°C

Humidity: 25% – 85% RH (non-condensing)

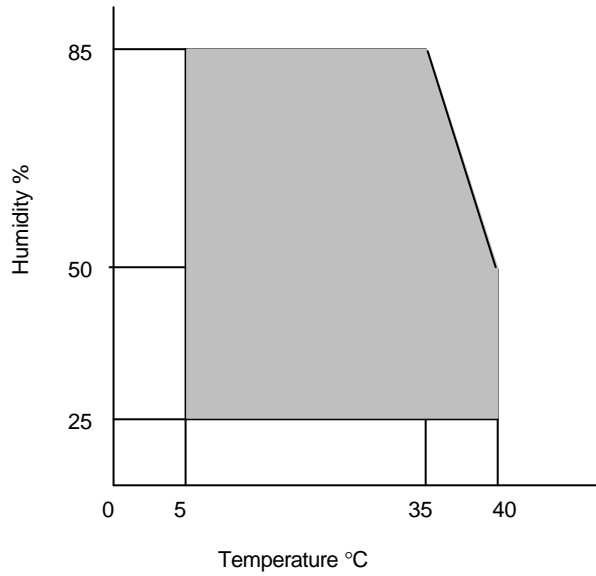

2 Printer storage conditions

Storage temperature: -20°C – 60°C

Humidity: 25% – 85% RH (non-condensing)

(Printer should be stored in a condition that the printhead is up and no media and ribbon are loaded.)

