



Electronic Service Manuals

This electronic document is provided as a service to our customers. We do not create the contents of the information contained in this document. Should you have detailed questions pertaining to the information contained in this document, you may contact Michco, or the manufacturer which provided the original information in this electronic deliverable. Michco's only part in this electronic deliverable was the electronic assembly process.

You may contact Michco through the following methods:
Phone (517) 484-9312 or (800) 331-3339 MI, OH, IN only
2011 N. High St. -- Lansing, Michigan -- 48906
Fax: (517) 484-9836
Email: CustServ@Michco.com
Web site: www.Michco.Com
Parts Web site: www.FloorMachineParts.Com

Order Parts on Line at:
www.FloorMachineParts.Com

Directly to Parts & Service:
By Email: **Shop@Michco.com**
By Fax: (517) 702-2041
By Voice: Use numbers above.

Serving the Cleaning Industry Since 1922

Notice: All copyrighted material remains property of original owners, all trademarks are property of respective owners. Manuals are subject to Manufacturer's reproduction limitations. Originals or reproductions were provided by manufacturers through a request. We make no warranty as to the correctness of information provided in this document and you assume all risk.

CMAX™ 28ST

BA 750ST / BA 850ST

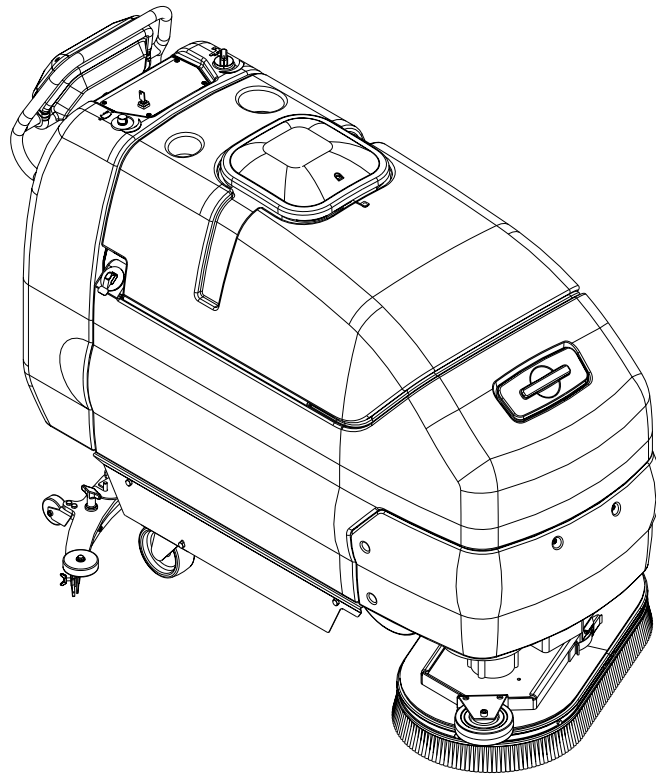

PARTS LIST

Advance MODEL 56396010

Nilfisk MODELS 56396011, 56396012



**Nilfisk
Advance**

setting standards

2/02 revised 10/04 FORM NO. 56042423

BOOK E SECTION 11.6.1

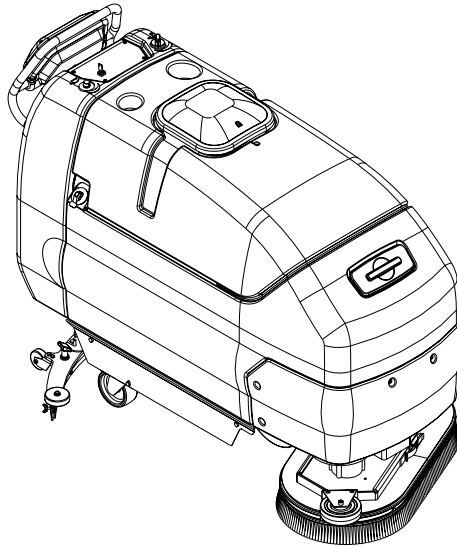

DESCRIPTION	PLAN
CHASSIS SYSTEM	E-11.6.1-3
CONTROL / ELECTRICAL SYSTEM-1	E-11.6.1-5
CONTROL / ELECTRICAL SYSTEM-2	E-11.6.1-7
HANDLE PADDLE ASSEMBLY	E-11.6.1-9
DECAL SYSTEM	E-11.6.1-11
RECOVERY SYSTEM	E-11.6.1-13
SCRUB SYSTEM	E-11.6.1-15
SCRUB SYSTEM SKIRTS	E-11.6.1-17
SOLUTION SYSTEM	E-11.6.1-19
SQUEEGEE SYSTEM	E-11.6.1-21
SQUEEGEE ASSEMBLY-CMAX 28ST / BA 750ST	E-11.6.1-23
SQUEEGEE ASSEMBLY-BA 850ST	E-11.6.1-25
SCHEMATIC	E-11.6.1-27
BRUSH CLICK-OFF KIT	E-11.6.1-29
PARKING BRAKE KIT	E-11.6.1-31
INDUSTRIAL BUMPER KIT	E-11.6.1-33
OPTIONAL KITS AND ACCESSORIES	E-11.6.1-34
BRUSH / DISC SELECTOR GUIDE	E-11.6.1-35

WHEN ORDERING PARTS

- * Use the 8 digit numbers from the "Ref. No." columns in this parts list.
- * Specify the model and serial number of the machine.
- * Use the space below to record the model and serial number for future reference.

Model _____ Serial No. _____

FRONT

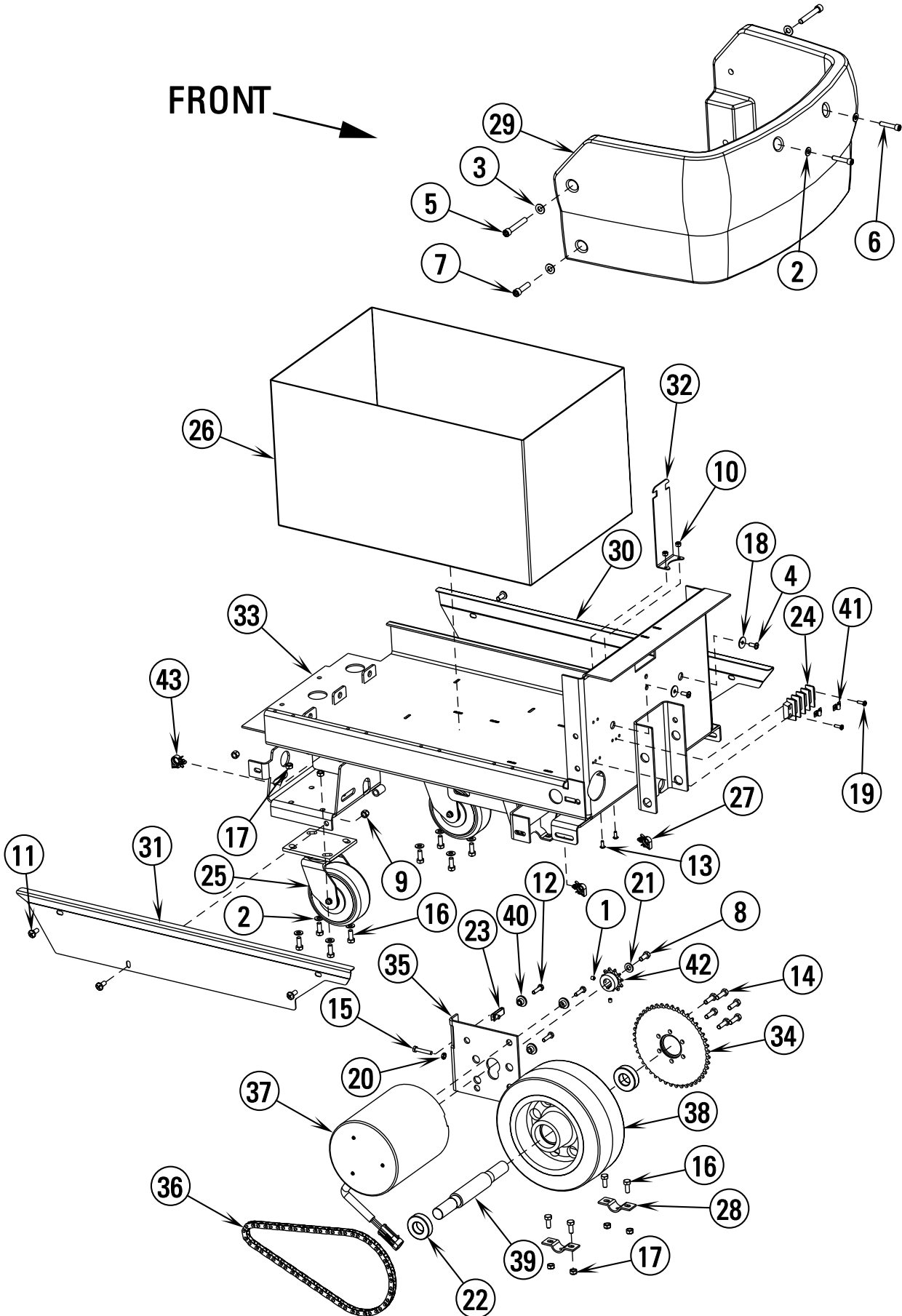

02-2	CHASSIS SYSTEM	BOOK E		
02-8	CMAX™ 28ST / BA 750ST / BA 850ST	E	11.6.1	3

Item	Ref. No.	Qty	Description
1	56001841	2	Scr, Soc Set Loc 1/4-20 x .25
2	56001939	10	Wsh, Flt SAE 5/16
3	56002063	4	Wsh, Flt SAE 3/8
4	56002066	2	Scr, Pan Phil 1/4-20 x .62
5	56002196	2	Scr, Soc Hd 3/8-16 x 2.50
6	56002201	2	Scr, Soc Hd 5/16-18 x 1.50
7	56002316	2	Scr, Soc Hd 3/8-16 x 1.50
8	56002667	1	Scr, Hex Hd 5/16-18 x .75
9	56002701	6	Nut, Hex Nyl Loc 5/16-18
10	56002768	2	Nut, Hex Nyl Loc 10-24
11	56002793	6	Scr, Pan Phil 5/16-18 x .75
12	56002883	3	Scr, Hex Hd SS 1/4-20 x 1.00
13	56002900	2	Scr, Pan Phil SS 10-24 x .50
14	56003073	6	Scr, Hex Hd Loc 5/16-18 x 1.00
15	56003125	1	Scr, Hex Thd To Hd SS 1/4-20 x 1.50
16	56003179	12	Scr, Hex Thd To Hd M8-1.25 x 20mm
17	56003389	12	Nut, Hex Nyl Loc M8-1.25
18	56009002	2	Wsh, Flt .266 x .906 x .060
19	56009042	2	Scr, Pan Phil Thd Form 10-24 x .62
20	56009087	1	Nut, Hex Jam 1/4-20
21	56009214	1	Wsh, Flt .406 x .750 x .090
22	56479430	2	Bearing, Ball
23	56009289	1	Nut, U Multi-Thread 1/4-20
24	56026111	1	Term. Block, 4 Term. 50 Amp
25	56055658	2	Caster, Swivel
26	56056727	1	Box, Battery Molded
27	56386407	2	Clip, Conduit
28	56396039	2	Clamp, Axle
29	56396083	1	Panel, Front (CMAX 28ST / BA 750ST)
	56396084	1	Panel, Front (BA 850ST)
30	56396115	1	Panel, Left
31	56396118	1	Panel, Right
32	56396200	1	Bracket, Vac Exhaust Hose
33	56396263	1	Weldment, Chassis
34	56396022	1	Sprocket
35	56396267	1	Bracket, Tension-Traction Drive
36	56396276	1	Chain, #40
37	56396311	1	Motor, 24VDC 1/2 HP
*	56039276	4	Carbon Brushes
38	56396350	1	Wheel, 10.00 x 4.00
39	56396351	1	Axle
40	56397085	3	Bushing
41	56397184	2	Plate, Jumper
42	56741122	1	Sprocket
43	56900756	2	Clip, Conduit
**	56396301	1	Kit, Brush Click-Off 24V (All Models)
**	56396302	1	Kit, Parking Brake (All Models)
**	56396307	1	Kit, Industrial Bumper (CMAX 28ST)

* = Not Shown

** = Optional

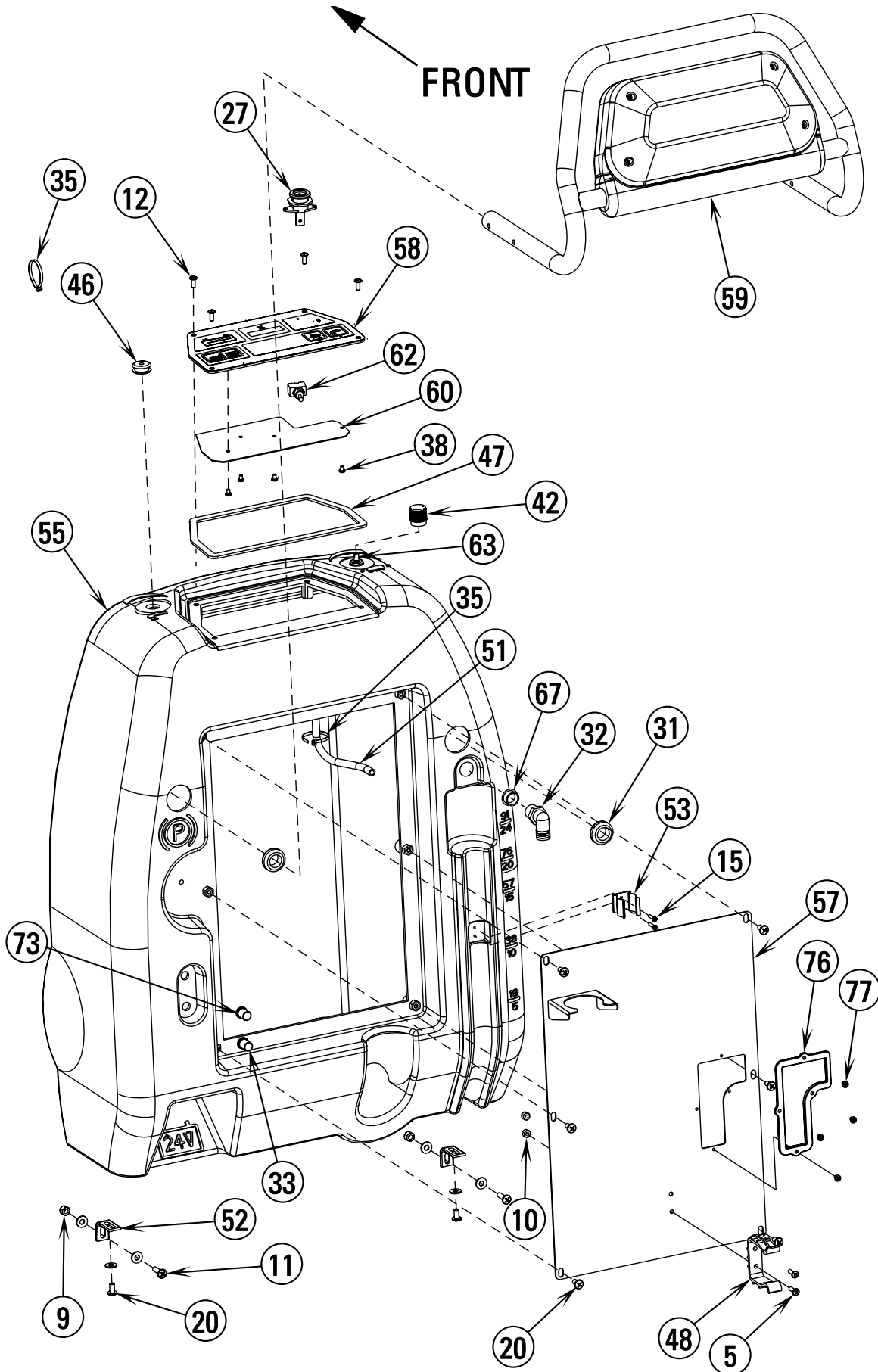

02-2	CONTROL / ELECTRICAL SYSTEM-1	BOOK E		
04-8	C MAX™ 28ST / BA 750ST / BA 850ST	E	11.6.1	5

Item	Ref. No.	Qty	Description
5	56002124	2	Scr, Pan Phil 10-24 x .62
9	56002708	5	Nut, Hex Nyl Loc 1/4-20
10	56002768	2	Nut, Hex Nyl Loc 10-24
11	56002785	2	Scr, Pan Phil 1/4-20 x .88
12	56002831	4	Scr, Pan Phil Blk 10-24 x .50
15	56003197	2	Scr, Pan Phil Plastite 6-18 x .62
20	56009069	12	Scr, Pan Phil Loc 1/4-20 x .50
27	56393325	1	Bracket, Keylock
*	56393415	A/R	Replacement Key
31	56418199	2	Grommet
32	56456802	1	Barb, 90 Elbow 11/16 x 3/4NPT
33	56459369	1	Boot, Reset Button
35	56478246	1	Tie, Cable
38	56009386	4	Scr, Pan Phil Metric Blue M4 x 6
42	56056596	1	Knob
46	56396149	1	Grommet
47	56396151	1	Gasket
48	56396199	1	Clamp, Plastic
51	56396204	1	Hose, PVC 1/4 x 3/8 x 48
52	56396218	2	Bracket, Panel
53	56396252	1	Clip, Spring
55	56396281	1	Cover, Rear
57	56396288	1	Weldment, Rear Panel TSBUS2002-830
58	56396297	1	Display Panel Assy
59	56396298	1	Paddle, Handle Assy
60	56396300	1	Control PCB Assy TSBUS2004-870
62	56396305	1	Switch, SPST Toggle (Main)
63	56397123	1	Potentiometer, 25K (Speed Limit)
67	56900041	1	Plug, Cap
73	56459367	1	Boot, Reset Button
76	56396331	1	Wear Strip
77	56009036	4	Scr, Pan Phil Thd Form 8-32 x .25

* = Not Shown

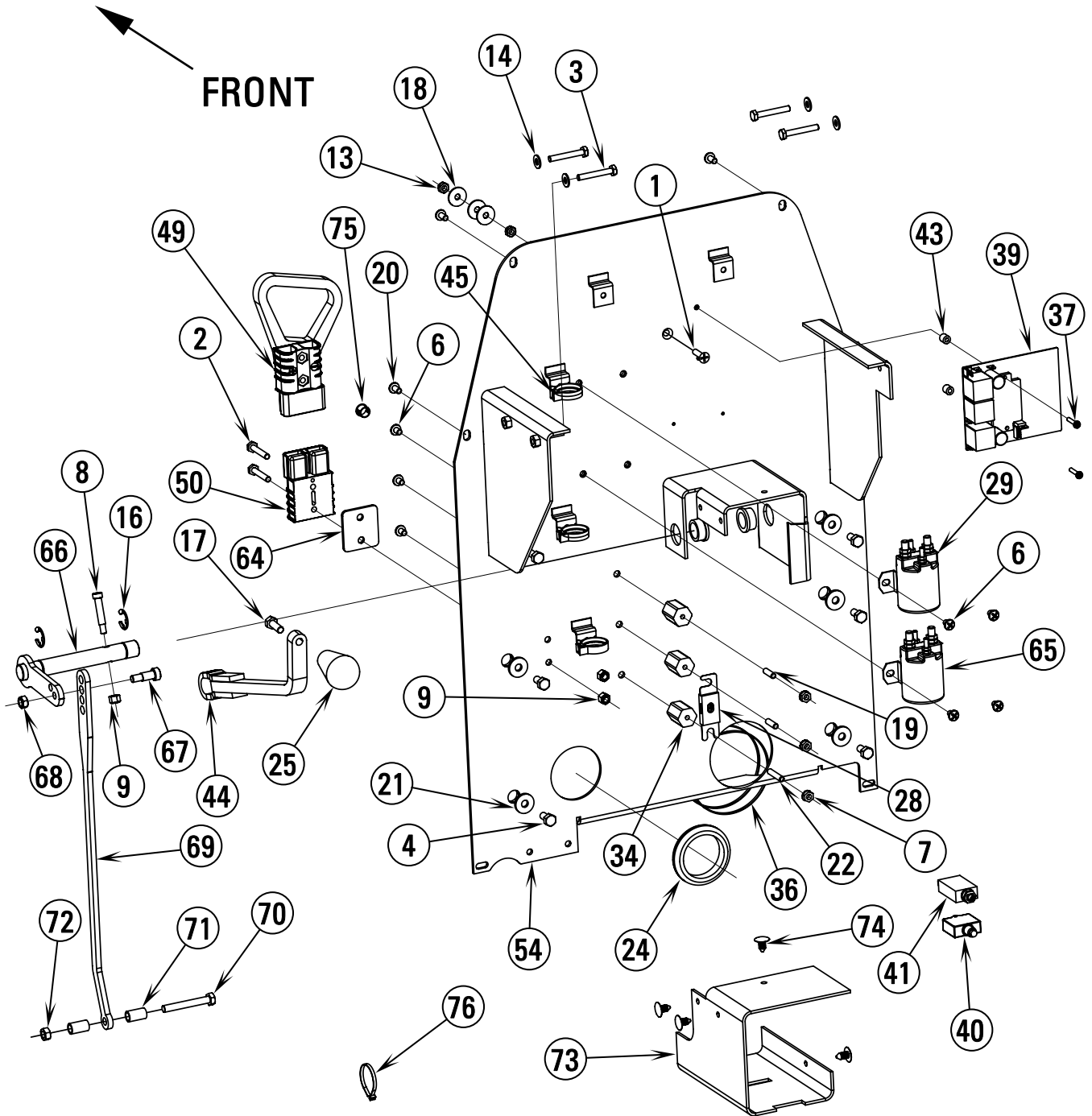

02-2	CONTROL / ELECTRICAL SYSTEM-2	BOOK E		
04-8	C MAX™ 28ST / BA 750ST / BA 850ST	E	11.6.1	7

Item	Ref. No.	Qty	Description
1	56001832	1	Scr, Flt Phil 1/4-20 x 1.00
2	56001833	2	Scr, Hex Hd 1/4-20 x 1.50
3	56001967	4	Scr, Hex Hd 1/4-20 x 1.75
4	56002035	6	Scr, Hex Hd 5/16-18 x .62
6	56002462	7	Scr, Pan Phil 1/4-20 x .38
7	56002561	3	Nut, Hex W/SHPRF 1/4-20
8	56002619	1	Scr, Soc Shd .31 x 1.25 x 1/4-20
9	56002708	5	Nut, Hex Nyl Loc 1/4-20
13	56002840	2	Nut, Hex Nyl Loc-Thin 1/4-20
14	56002859	10	Wsh, Flt SAE SS 1/4
16	56003266	2	Ring, Ret Ext Type E .75 Dia.
17	56003335	1	Scr, Hex Loc SS 5/16-18 x .88
18	56009002	3	Wsh, Flt .266 x .906 x .060
19	56009020	2	Stud
20	56009069	12	Scr, Pan Phil Loc 1/4-20 x .50
21	56009122	6	Wsh, Flt .344 x .938 x .125
22	56009203	1	Stud, 1/4-20
23	56250414	2	Bearing, Flange
24	56262531	1	Grommet
25	56364527	1	Knob
26	56372673	8	Boot, Battery Post (not shown)
28	56412089	1	Fuse, 150 Amp
29	56412179	1	Contactor, 24VDC (Vac Motor)
30	56416445	3	Cable Assy 4 AWG (Battery Interconnect / not shown)
34	56469858	3	Electrical Mount
36	56478523	2	Tie, Cable
37	56009034	2	Scr, Pan Phil Thd Form 8-32 x .88
39	56324023	1	Control, DC Curtis
40	56026198	1	Circuit Breaker, 30 Amp (Wheel Drive)
41	56387328	1	Circuit Breaker, 5 Amp (Controls)
43	56057428	2	Spacer, Aluminum
44	56212035	1	Lift Lever Weldment
45	56212190	3	Clip, Conduit
49	56396202	1	Connector Assembly (TSBUS2003-841) (Connected to Batteries)
50	56396203	1	Connector Assembly (Connected to Machine)
*	56100686	2	#1 Contact
*	56100621	1	Connector Housing
54	56396279	1	Back Panel Weldment
56	56396283	1	Harness, Main (not shown) TSBUS2004-870
61	56396304	1	Cable Assembly 6 AWG x 11.00 (not shown)
64	56397189	1	Spacer
65	56412179	1	Contactor, 24VDC (Brush Motor)
66	56397513	1	Weldment, Lift Shaft
67	56002962	1	Scr, Soc Shd .38 x .62 x 5/16-18
68	56002851	1	Nut, Hex Nyl Loc-Thin SS 5/16-18
69	56397532	1	Link, Squeegee Lift
70	56003464	1	Scr, Hex Hd SS M8-1.25 x 60mm
71	56397286	2	Spacer
72	56003405	1	Nut, Hex Nyl Loc SS M8-1.25
73	56396324	1	Flap, Rubber
74	56212241	4	Clip, Panel
75	56323560	1	Plug, Cap
76	56478246	8	Tie, Cable

* = Not Shown

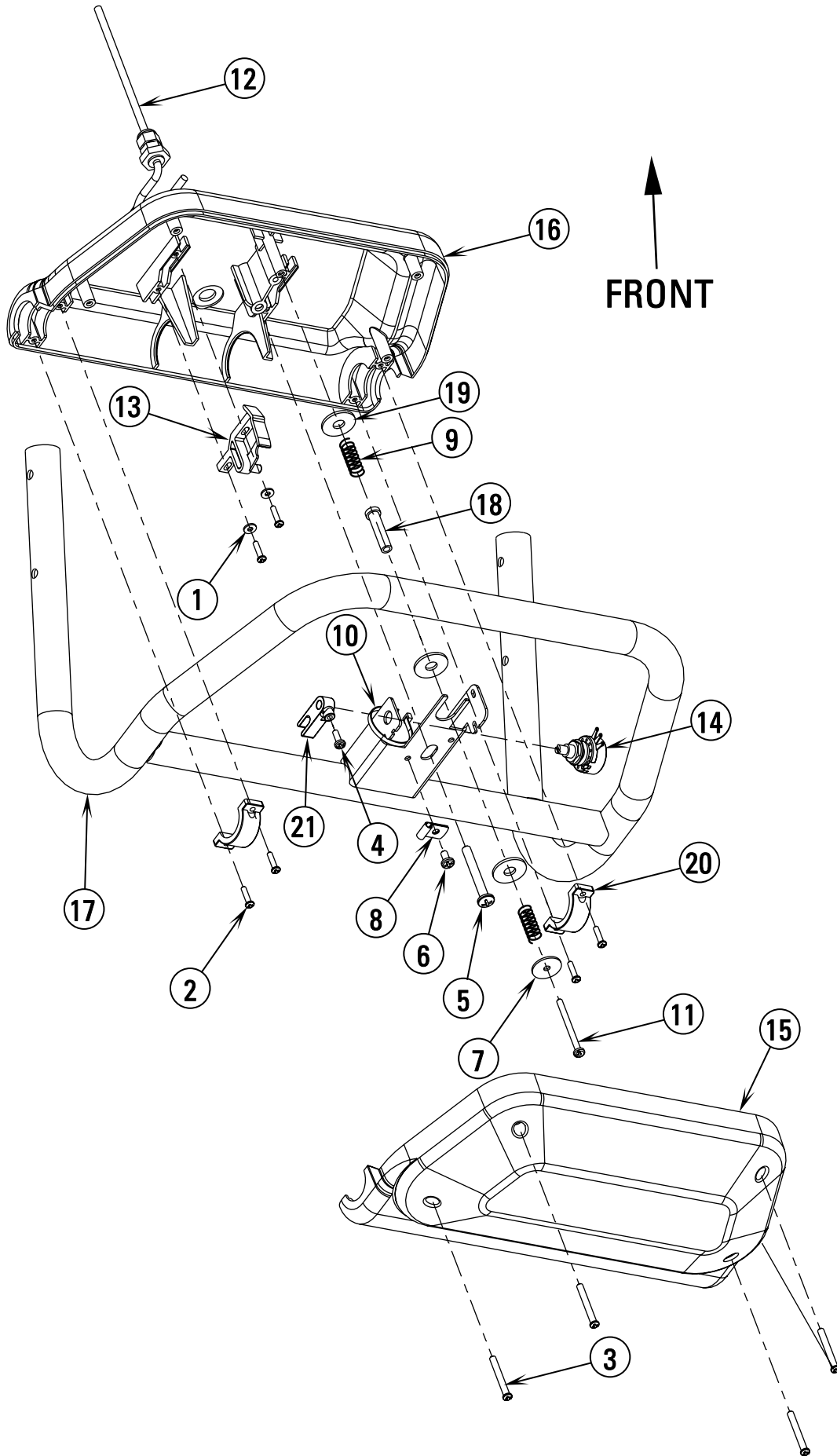

Item	Ref. No.	Qty	Description
	56396298	1	Paddle, Handle Assembly (#1-21)
1	56002006	2	Wsh, Flt SAE #6
2	56003197	6	Scr, Pan Phil Plastite 6-18 x .62
3	56003199	4	Scr, Pan Phil Plastite 8-15 x 1.50
4	56003354	1	Scr, Pan Phil M4 x 12
5	56003527	1	Scr, Pan Phil Plastite 1/4-10 x 2.00
6	56009030	1	Scr, Pan Phil Thd Form 10-24 x .38
7	56009096	1	Wsh, Flt .193 x .875 x .060
8	56220507	1	Clamp, P
9	56325654	2	Spring, Compression
10	56478246	1	Tie, Cable
11	56009287	1	Scr, Pan Phil Type B 8 x 2.00
12	56396299	1	Harness, Handle
13	56397015	1	Cam Controller
14	56397029	1	Potentiometer, 5K
15	56397030	1	Paddle, Front Molded
16	56397031	1	Paddle, Back Molded
17	56397034	1	Weldment, Handle
18	56397109	1	Sleeve
19	56397170	3	Washer, Plastic
20	56397171	2	Clamp
21	56397172	1	Potentiometer Fork

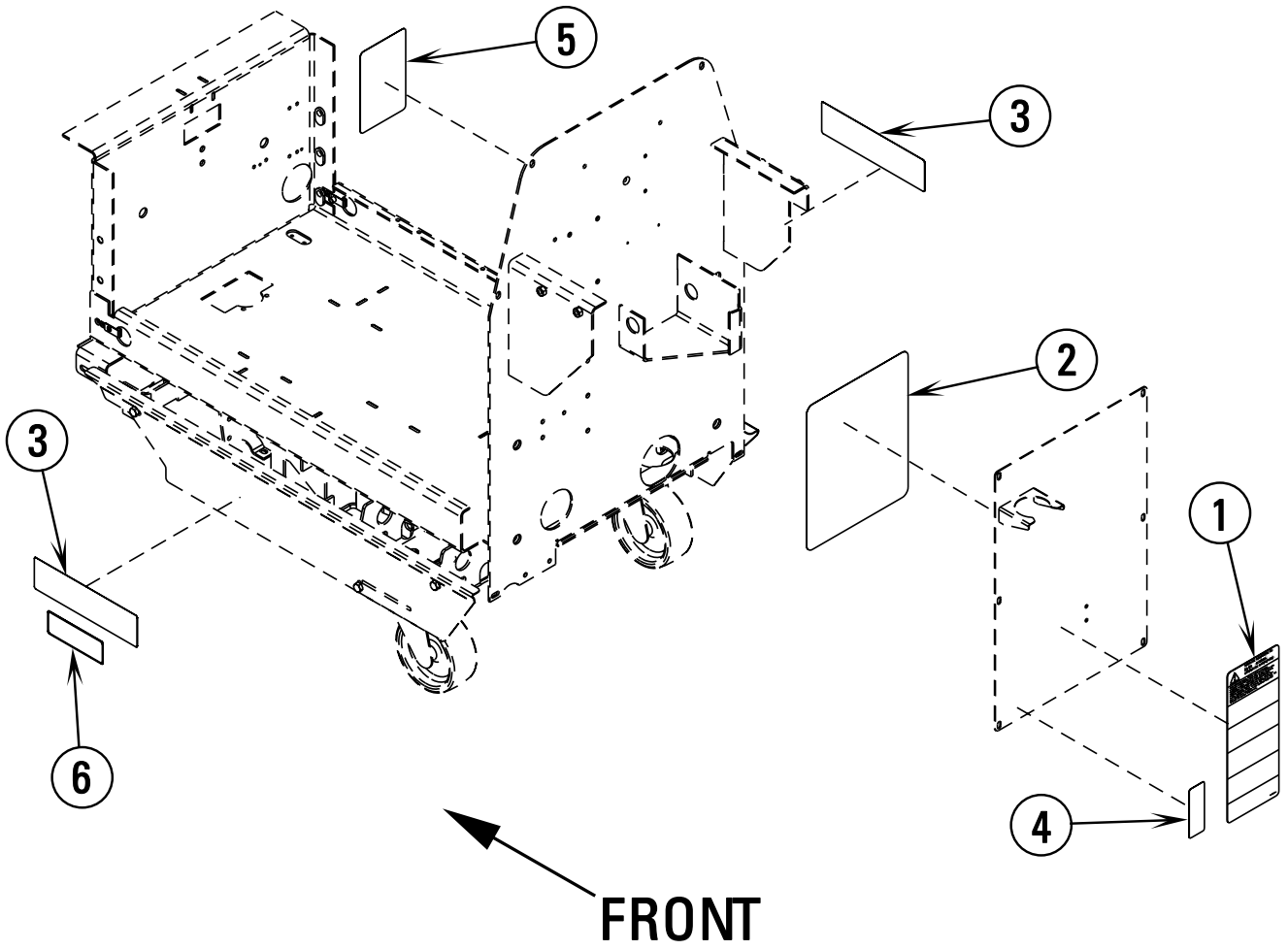

02-2	DECAL SYSTEM	BOOK E		
04-10	CMAX™ 28ST / BA 750ST / BA 850ST	E	11.6.1	11

Item	Ref. No.	Qty	Description
1	56014601	1	Decal, Caution
2	56015048	1	Decal, Electrical Schematic
3	56016682	2	Decal, CMAX 28ST
	56016685	2	Decal, BA 750ST
	56016686	2	Decal, BA 850ST
4	56015065	1	Decal, Circuit Breaker
5	56016486	1	Decal, Battery Wiring
6	56015254	1	Decal, ECO Solutions (Nilfisk)
	56016680	1	Decal, Smart Solutions (Advance)

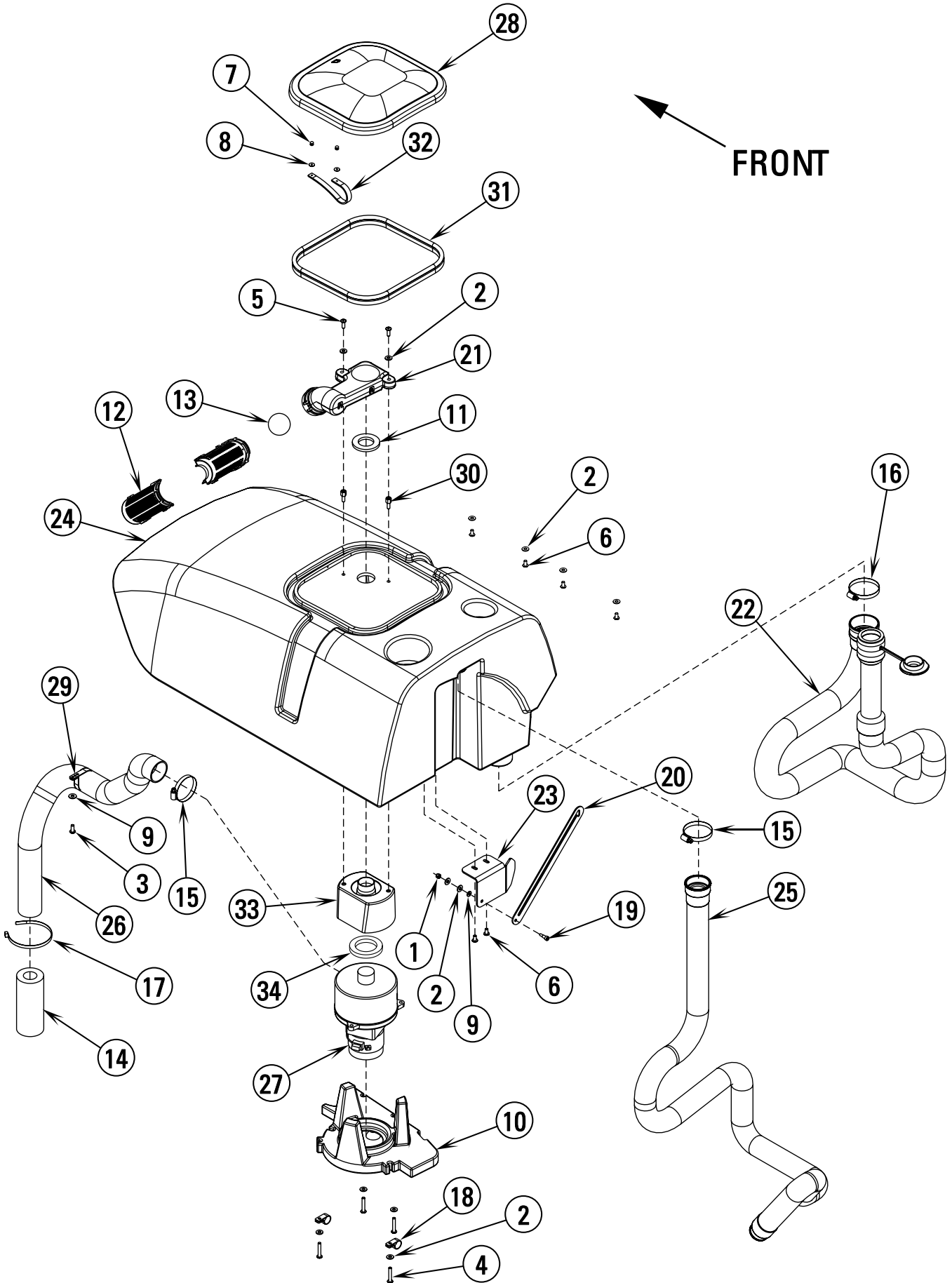

Item	Ref. No.	Qty	Description
1	56002768	1	Nut, Hex Nyl Loc 10-24
2	56002859	12	Wsh, Flt SAE SS 1/4
3	56002900	1	Scr, Pan Phil SS 10-24 x .50
4	56002905	4	Scr, Pan Phil SS 1/4-20 x 1.50
5	56003067	2	Scr, Pan Phil SS 1/4-20 x 1.00
6	56003119	6	Scr, Pan Phil SS 1/4-20 x .50
7	56003293	2	Rivet, Pop A/S .125 x .38 / .50
8	56009098	2	Wsh, Flt SS .125 x .50 x .036
9	56009205	2	Wsh, Flt SS #10
10	56302141	1	Vac Motor Duct
11	56302165	1	Gasket
12	56324497	2	Cage, Float
13	56391690	1	Ball, Float
14	56391807	1	Foam, Acoustical
15	56440213	2	Clamp, Hose SAE #32
16	56456797	1	Clamp, Hose SAE #36
17	56477613	1	Tie, Cable
18	56486112	2	Clamp, P
19	56003537	1	Scr, Soc Shd .25 x .38 x 10-24
20	56057508	1	Bar, Steel
21	56302142	1	Float Duct
22	56396031	1	Drain Hose
23	56396148	1	Bracket, Pivot
24	56396224	1	Tank, Recovery (Advance)
	56396223	1	Tank, Recovery (Nilfisk)
25	56396287	1	Vac Hose Assy
26	56397040	1	Hose, Vac Exhaust
27	56397041	1	Vac Motor Assembly
*	56397098	1	Carbon Brush Set
28	56397045	1	Lid
29	56397095	1	Clamp, Hose
30	56397096	2	Spacer Bolt
31	56397151	1	Gasket
32	56397167	1	Strap, Retaining
33	56397303	1	Spacer, Vac Motor
34	56397307	1	Gasket, Vac

* = Not Shown

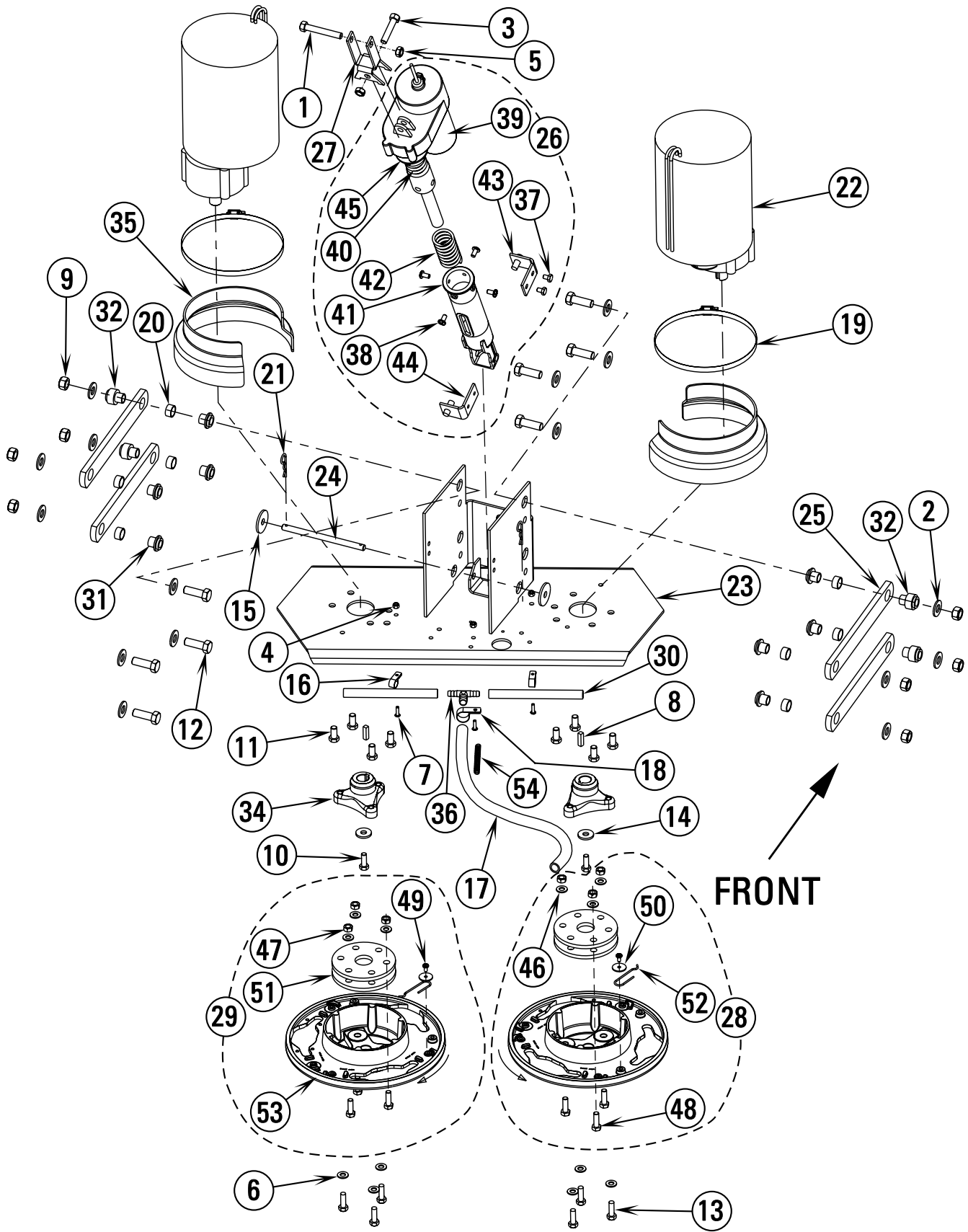

02-2	SCRUB SYSTEM	BOOK E		
04-8	CMAX™ 28ST / BA 750ST / BA 850ST	E	11.6.1	15

Item	Ref. No.	Qty	Description	Item	Ref. No.	Qty	Description
1	56001873	1	Scr, Hex Hd 3/8-16 x 2.50				Lug Assemblies-NOTE #1
2	56001879	16	Wsh, Flt SAE 1/2	46	56002938	3	Wsh, Flt SAE SS 5/16
3	56002684	1	Scr, Hex Hd 3/8-16 x 1.75	47	56003405	3	Nut, Hex Nyl Loc SS M8-1.25
4	56002808	4	Nut, Hex Nyl Loc 8-32	48	56003436	3	Scr, Hex Hd SS M8-1.25 x 25mm
5	56002841	2	Nut, Hex Nyl Loc-Thin 3/8-16	49	56009030	1	Scr, Pan Phil Thd Form 10-24 x .38
6	56002938	6	Wsh, Flt SAE SS 5/16	50	56009096	1	Wsh, Flt .193 x .875 x .060
7	56003001	4	Scr, Pan Phil SS 8-32 x .62	51	56407053	2	Thermoid Disk
8	56003244	2	Key, Sq .25 x .94	52	56397081	1	Spring Retainer
9	56003312	8	Nut, Hex Nyl Loc M12-1.75	53	56314030	1	Brush Holder
10	56003335	2	Scr, Hex Loc SS 5/16-18 x .88	54	56373686	2	Spring, Compression (insert into hose item 17)
11	56003338	8	Scr, Hex Loc SS 3/8-16 x .75				CMAX 28ST / BA 750ST Brushes
12	56003415	8	Scr, Hex M12-1.75 x 35mm	**	56505770	2	Pad Holder
13	56003477	6	Scr, Hex Loc SS M8-1.00 x 25mm	**	56505771	2	MagnaGrit Brush
14	56009107	2	Wsh, Flt SS .378 x 1.00 x .120	**	56505772	2	DynaGrit Brush
15	56009242	2	Wsh, Flt .406 x 1.500 x .125	**	56505773	2	AgLite Grit Brush
16	56152617	2	Clamp, P	**	56505774	2	Prolene Brush
17	56172099	1	Hose, PVC Clear	**	56505775	2	ProLite Brush
18	56328064	2	Clamp, P	**	56505776	2	Union Mix Brush
19	56355488	2	Clamp, Hose SAE #96	**	56505777	2	MidGrit Brush
20	56370878	8	Bearing, Sleeve	**	56505778	2	MidLite Brush
21	56003120	2	Pin, Cotter Hair .0915 x .375	**	56182058	2	Lock Collar, Snap
22	56027153	2	Asm, Motor and Gear Unit, 24V	**	56393567	2	Lock Collar, Thrd
*	56397090	1	Bearing, B.E.	**	56505780	2	BA 850ST Brushes Pad Holder
*	56397135	1	Bearing, F.E.	**	56505781	2	MagnaGrit Brush
*	56397138	4	Brush Spring	**	56505782	2	DynaGrit Brush
*	56039276	4	Carbon Brush	**	56505783	2	AgLite Grit Brush
*	56397048	1	Brush Board	**	56505784	2	Prolene Brush
23	56035313	1	Weld't, Brush Head (CMAX™ 28ST / BA 750ST)	**	56505785	2	ProLite Brush
	56035078	1	Weld't, Brush Head (BA 850ST)	**	56505786	2	Union Mix Brush
24	56056987	1	Shaft, Steel (CMAX™ 28ST / BA 750ST)	**	56505787	2	MidGrit Brush
	56056474	1	Shaft, Steel (BA 850ST)	**	56505788	2	MidLite Brush
25	56396045	4	Arm	**	56182058	2	Lock Collar, Snap
26	56396049	1	Lift Actuator Assy (#37-45)	**	56393567	2	Lock Collar, Thrd
27	56396066	1	Yoke, Actuator				
28	56396080	1	Lug, Counterclockwise (#46-53)				
29	56396081	1	Lug, Clockwise (#46-53)				
30	56396195	2	Hose, PVC (CMAX™ 28ST / BA 750ST)				
	56397301	1	Hose, PVC (BA 850ST)				
31	56396196	8	Bushing (qty of 4 on BA 850ST)				
32	56396198	4	Bushing (BA 850ST only)				
34	56314031	2	Hub, Drive				
35	56397112	2	Shroud, Motor				
36	56397300	1	Tee, Barb				
			Lift Actuator Assembly				
37	56009019	2	Scr, Hex Thd Form 1/4-20 x .38				
38	56009062	4	Scr, Pan Phil Thd Form 1/4-20 x .50				
39	56393303	1	Actuator, Motor TSBUS2004-870				
*	56393790	2	Limit Switch				
*	56470433	1	Carbon Brush Kit				
*	56388520	1	Plastic Nut				
40	56412071	1	Compression Spring				
41	56412262	1	Housing, Spring TSBUS2002-811				
42	56420018	1	Compression Spring				
43	56420019	1	Nut Retainer				
44	56420020	1	Nut Retainer				
45	56396268	1	Spring Housing Guide				

* = Not Shown
** = Not Included (optional)

NOTE #1: All Lug Assembly quantities are for one assembly only.

CMAX 28ST / BA 750ST

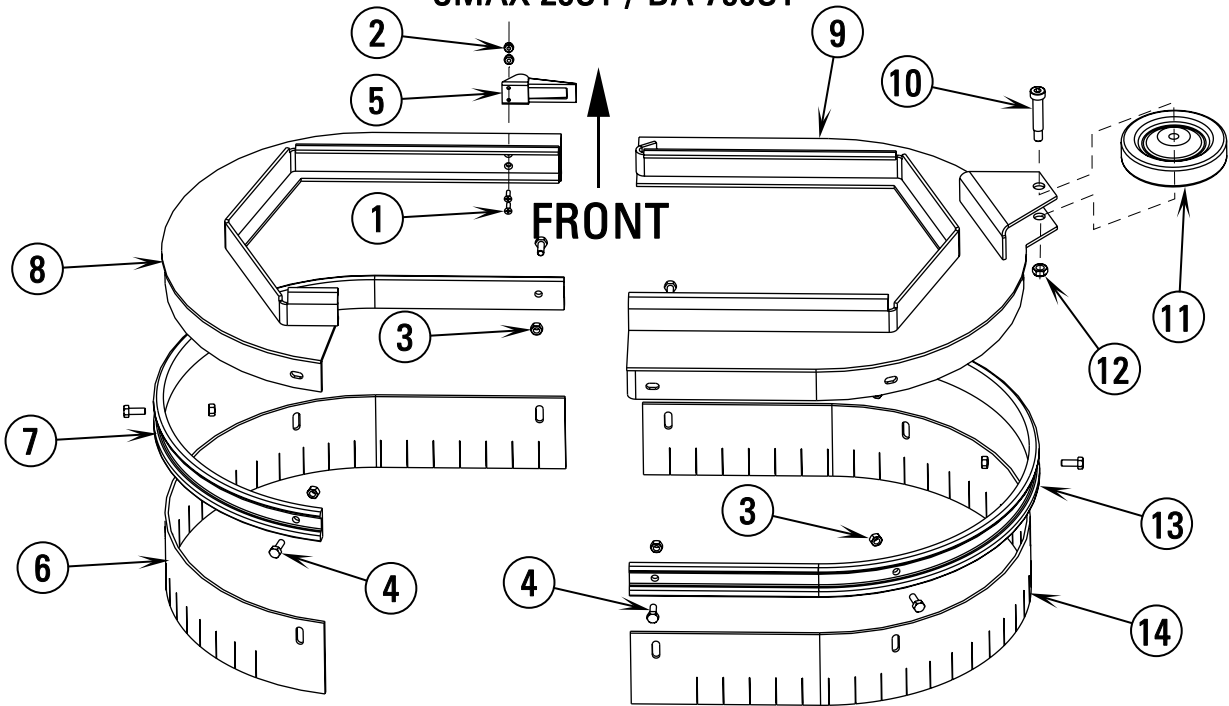

BA 850ST

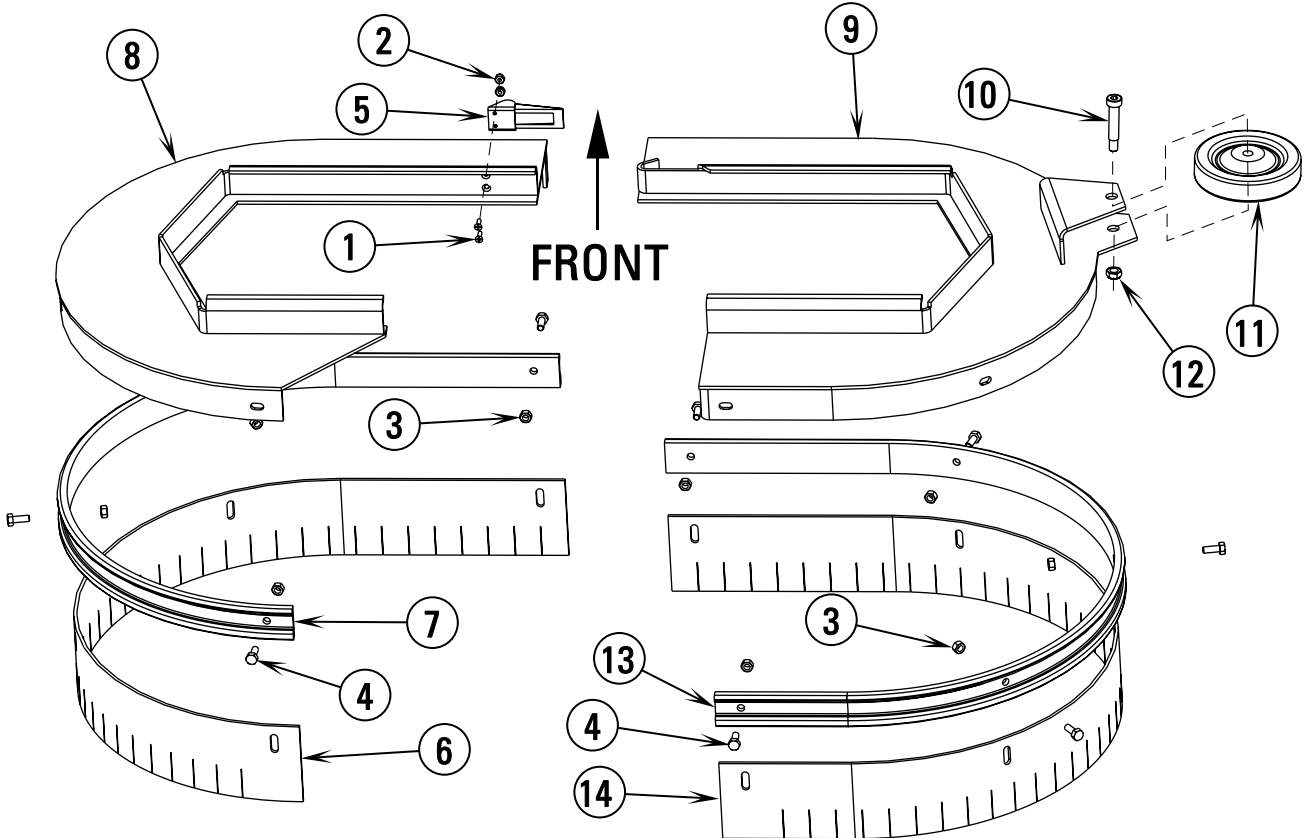

02-2	SCRUB SYSTEM SKIRTS	BOOK E		
04-10	CMAX™ 28ST / BA 750ST / BA 850ST	E	11.6.1	17

Item	Ref. No.	Qty	Description	Item	Ref. No.	Qty	Description
CMAX 28ST / BA 750ST				BA 850ST			
	56396261	1	Assy, Brush Cover, Left (#1-8)	56397510	1	Assy, Brush Cover, Left (#1-8)	
	56396262	1	Assy, Brush Cover, Right (#3, 4 & 9-14)	56397511	1	Assy, Brush Cover, Right (#3, 4 & 9-14)	
1	56002816	2	Scr, Flt Phil 6-32 x .50	1	56002816	2	Scr, Flt Phil 6-32 x .50
2	56002907	2	Nut, Hex Nyl Loc SS 6-32	2	56002907	2	Nut, Hex Nyl Loc SS 6-32
3	56003426	9	Nut, Hex Nyl Loc SS M6-1.00	3	56003426	10	Nut, Hex Nyl Loc SS M6-1.00
4	56003431	9	Scr, Hex Hd SS M6-1.00 x 16mm	4	56003431	10	Scr, Hex Hd SS M6-1.00 x 16mm
5	56471194	1	Latch Assy	5	56471194	1	Latch Assy
6	56396005	1	Blade, Left	6	56397019	1	Blade, Left
7	56396007	1	Channel, Left	7	56397055	1	Channel, Left
8	56396294	1	Weld't, Brush Cover, Left	8	56397531	1	Weld't, Brush Cover, Left
9	56396291	1	Weld't, Brush Cover, Right	9	56397536	1	Weld't, Brush Cover, Right
10	56002625	1	Scr, Soc Shd .38 x 1.50 x 5/16-18	10	56002625	1	Scr, Soc Shd .38 x 1.50 x 5/16-18
11	56228102	1	Wheel	11	56228102	1	Wheel
12	56002826	1	Nut, Hex Nyl Loc-Thin 5/16-18	12	56002826	1	Nut, Hex Nyl Loc-Thin 5/16-18
13	56396006	1	Channel, Right	13	56397044	1	Channel, Right
14	56396004	1	Blade, Right	14	56397014	1	Blade, Right
**	56396008	1	Rubber Blade Kit (#3, 4, 6, 7, 13, 14)	**	56397080	1	Rubber Blade Kit (#3, 4, 6, 7, 13, 14)

** = Optional (not included)

** = Optional (not included)

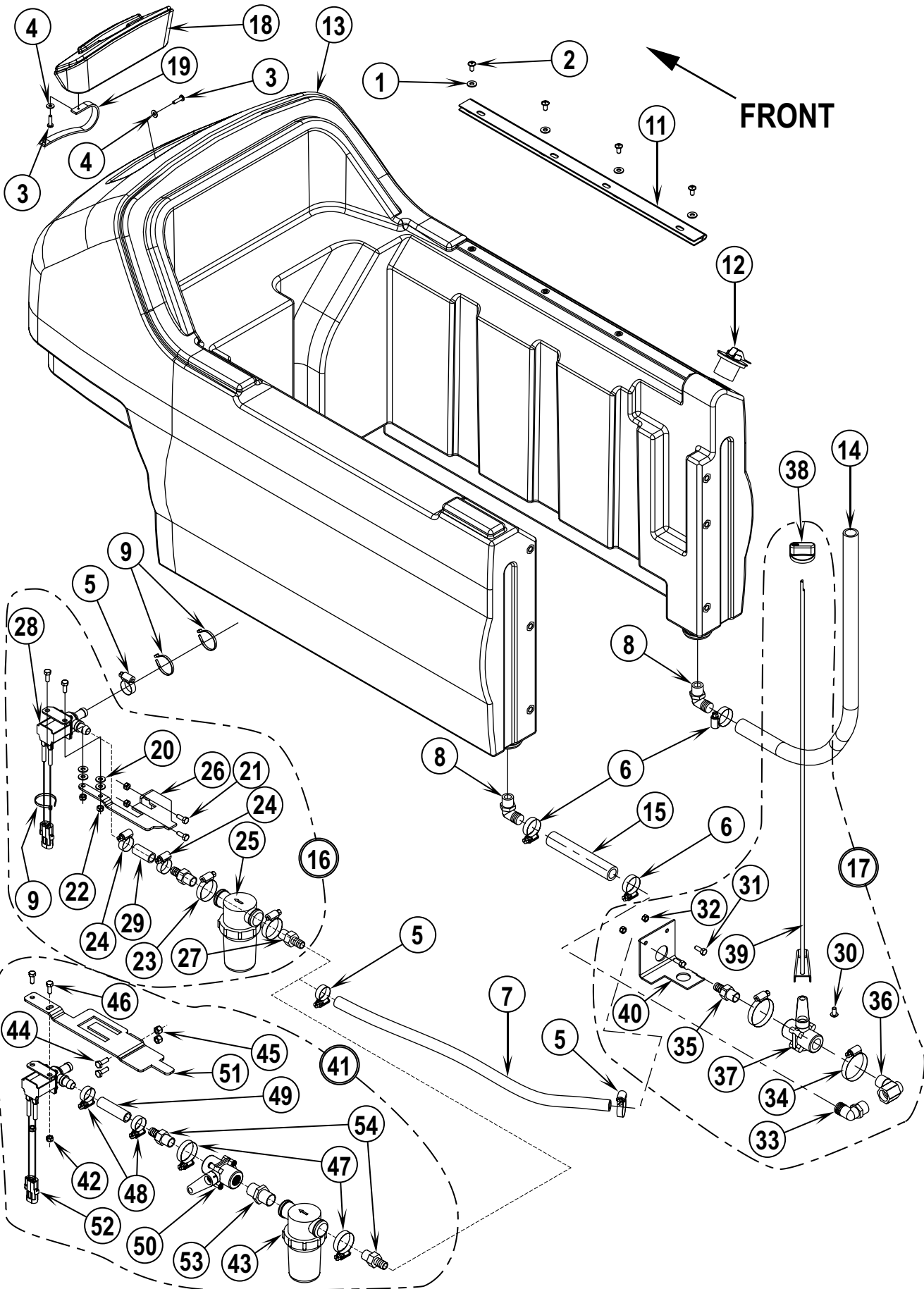

02-2	SOLUTION SYSTEM	BOOK E		
04-3	CMAX™ 28ST / BA 750ST / BA 850ST	E	11.6.1	19

Item	Ref. No.	Qty	Description	Item	Ref. No.	Qty	Description
1	56002859	4	Wsh, Flt SAE SS 1/4	41	56396512	1	Assembly, Filter (#42-54) NOTE 2
2	56003119	4	Scr, Pan Phil SS 1/4-20 x .50	42	56003403	2	Nut, Hex Nyl Loc M6-1.00
3	56009005	2	Scr, Pan Phil SS Type B 10-16 x .75	43	56412173	1	Solution Filter
4	56009205	2	Wsh, Flt SS #10	44	56002155	2	Scr, Hex Hd 1/4-20 x .75
5	56219932	3	Clamp, Hose SAE #6	45	56002708	2	Nut, Hex Nyl Loc 1/4-20
6	56244969	3	Clamp, Hose SAE #12	46	56003174	2	Scr Hex Thd To Hd M6-1.0 x 16mm
7	56324249	1	Hose, Spiral .50 (24") NOTE 1	47	56131601	2	Clamp, Hose SAE #16
	56396513	1	Hose, Spiral .50 (17") NOTE 2	48	56219932	2	Clamp, Hose SAE #6
8	56456802	2	Barb, 90 Elbow 11/16 x 3/4NPT	49	56392347	1	Hose, PVC Clear 2.5 Inch
9	56478246	3	Tie, Cable	50	56396505	1	Valve, Solution
11	56056291	1	Hinge	51	56396511	1	Bracket, Flow Valve
12	56057852	1	Plug, Expansion	52	56397203	1	Solenoid Valve Assy.
13	56396024	1	Tank, Solution	53	56412182	1	Nipple, Hex 3/4-14
14	56396143	1	Hose, .75 Clear PVC	54	56412184	2	Barb, Adapter 1/2 x 1/2 NPT
15	56396266	1	Hose, .75 Clear PVC				
16	56396277	1	Assembly, Filter ST (#20-29) TSBUS2003-835 NOTE 1				
	56396096	1	Assembly, Filter (#20-29) TSBUS2003-835 NOTE 1				
17	56396309	1	Assembly, Ball Valve (#30-40)				
18	56397021	1	Lid, Solution				
19	56397167	1	Strap, Retaining				
			Filter Assembly NOTE 1				
20	56002098	4	Wsh, Flt SAE 1/4				
21	56003174	4	Scr, Hex Thd To Hd M6-1.00 x 16mm				
22	56003403	4	Nut, Hex Nyl Loc M6-1.00				
23	56131601	2	Clamp, Hose SAE #16				
24	56219932	2	Clamp, Hose SAE #6				
25	56260905	1	Strainer TSBUS2003-835				
	56412173	1	Solution Filter TSBUS2003-835				
26	56396068	1	Filter Bracket				
27	56397145	2	Barb, Hose Female TSBUS2003-835				
	56412184	2	Barb, Adapter 1/2 x 1/2NPT TSBUS2003-835				
28	56397203	1	Solenoid Valve Assembly				
29	56396330	1	Hose, PVC Clear TSBUS2003-835				
	56397217	1	Hose, PVC Clear TSBUS2003-835				
			Valve Assembly				
30	56003119	1	Scr, Pan Phil SS 1/4-20 x .50				
31	56003174	2	Scr, Hex Thd To Hd M6-1.00 x 16mm				
32	56003403	2	Nut, Hex Nyl Loc M6-1.00				
33	56244985	1	Barb, 90 Elbow 3/4 x 1/2NPT				
34	56329145	2	Clamp, Hose SAE #24				
35	56412184	1	Barb, Adapter 1/2 x 1/2NPT				
36	56055071	1	Elbow, Street				
37	56057830	1	Valve, Ball				
38	56396201	1	Knob				
39	56396310	1	Flow Valve Weldment				
40	56396314	1	Bracket, Water Valve				

NOTE 1: Items used on (BA 750 ST before SN 1736969, BA 850 ST before SN 1736974, CMAX before SN 1736954).

NOTE 2: Items used on (BA 750 ST after SN 1736968, BA 850 ST after SN 1736973, CMAX after SN 1736953).

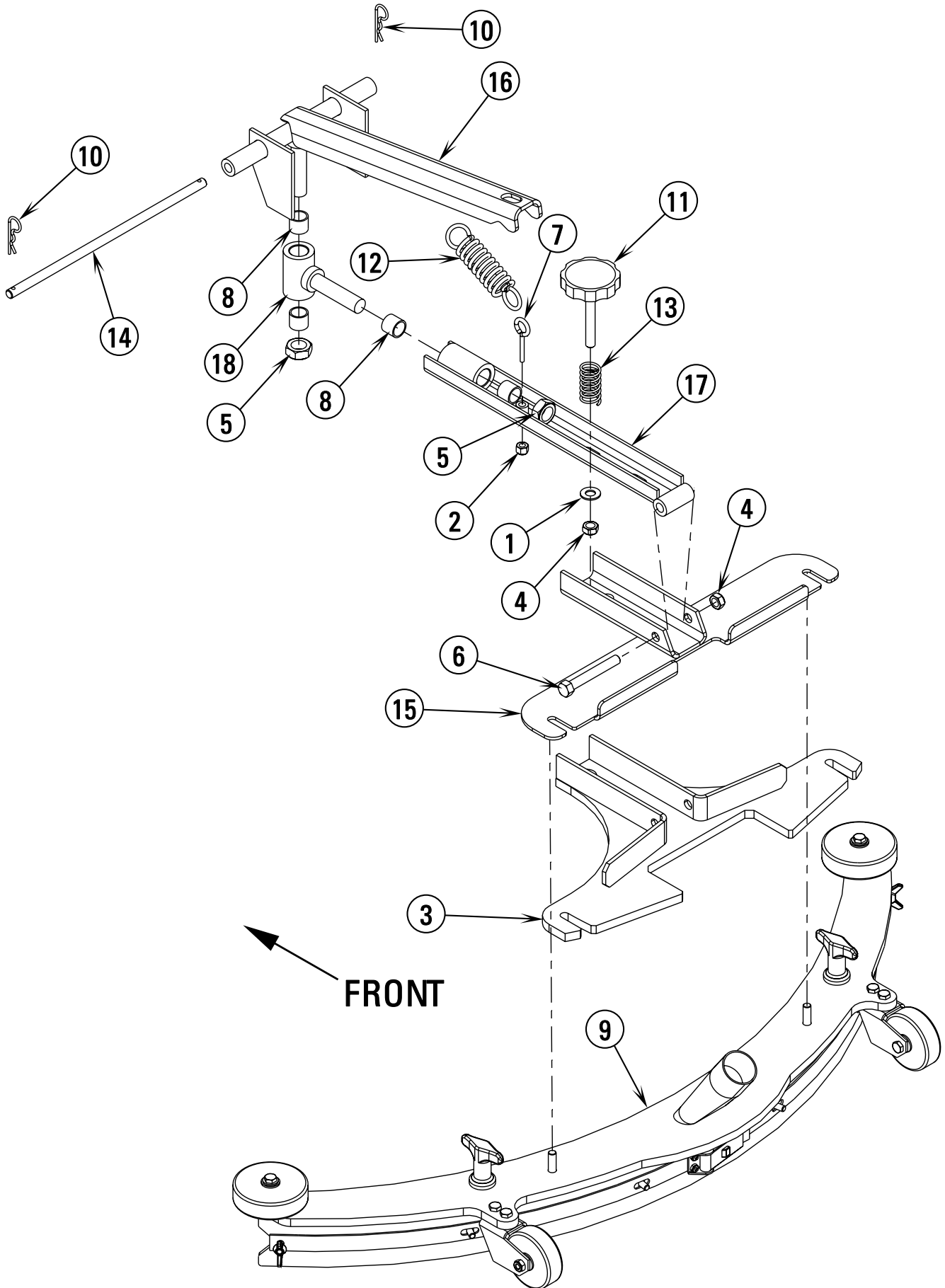

02-2	SQUEEGEE SYSTEM	BOOK E		
02-11	CMAX™ 28ST / BA 750ST / BA 850ST	E	11.6.1	21

Item	Ref. No.	Qty	Description
1	56002910	1	Wsh, Flt SAE SS 3/8
2	56002708	1	Nut, Hex Nyl Loc 1/4-20
3	56397356	1	Weld't, Squeegee Mount (BA 850ST)
4	56002852	2	Nut, Hex Nyl Loc-Thin SS 3/8-16
5	56002855	2	Nut, Hex Nyl Loc-Thin SS 5/8-11
6	56002903	1	Scr, Hex Hd SS 3/8-16 x 2.75
7	56009220	1	Bolt, Eye 1/4-20 x 1.38
8	56367389	4	Bearing, Sleeve
9	56391281	1	Squeegee Assy (CMAX 28ST / BA 750ST)
	56397349	1	Squeegee Assy (BA 850ST)
10	56003120	2	Pin, Cotter Hair .0915 x .375
11	56035163	1	Assy, Knob, Adjustment
12	56051136	1	Spring, Ext.
13	56056585	1	Compression Spring
14	56056977	1	Shaft
15	56396053	1	Weld't, Squeegee Mount (CMAX 28ST / BA 750ST)
16	56396061	1	Weld't, Squeegee Lift
17	56396076	1	Squeegee Bar Weld't.
18	56396085	1	Squeegee Pivot Weld't.

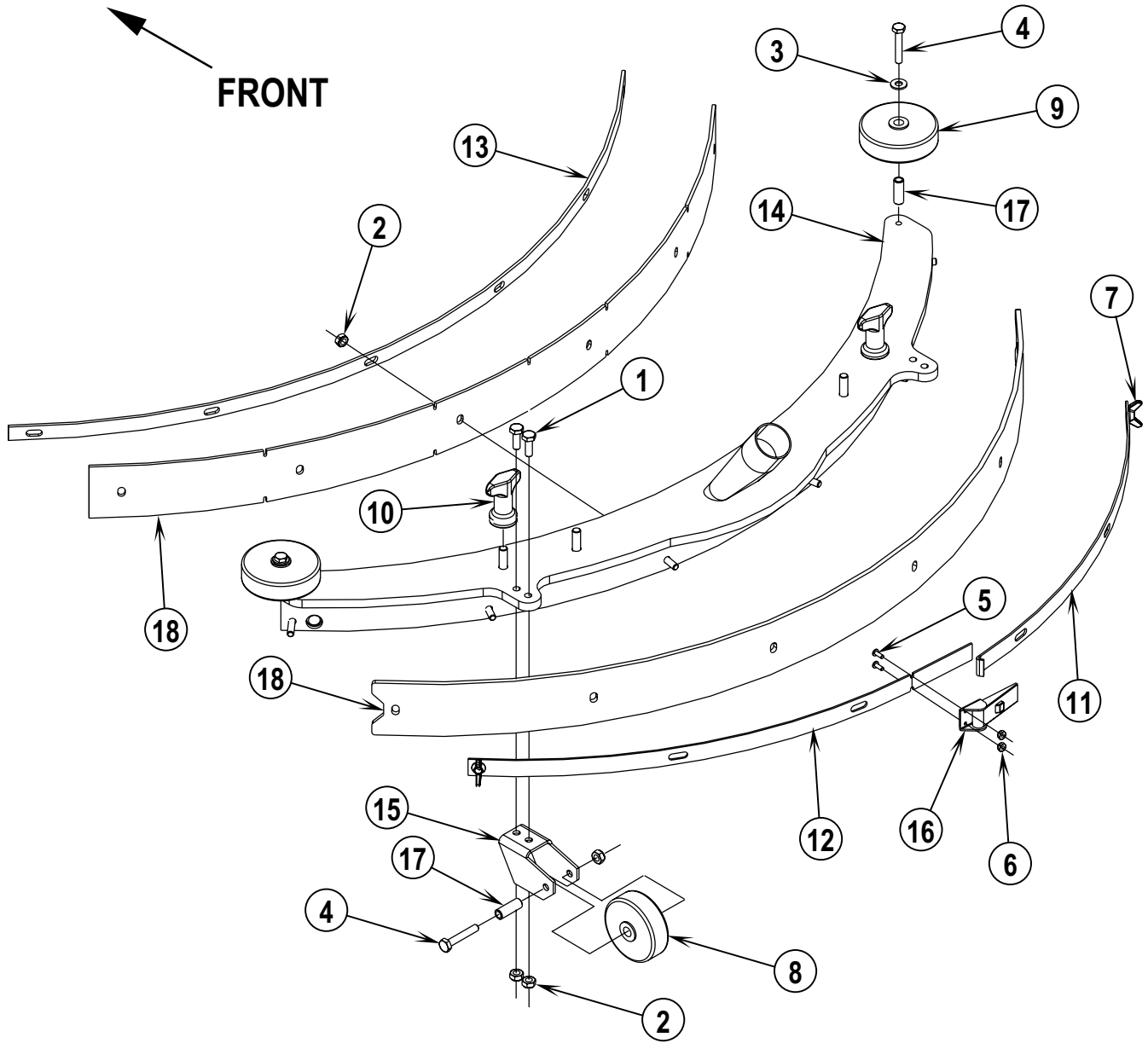

02-2	SQUEEGEE ASSEMBLY-CMAX 28ST/BA 750ST	BOOK E		
04-10	CMAX™ 28ST / BA 750ST / BA 850ST	E	11.6.1	23

Item	Ref. No.	Qty	Description
	56391281	1	Squeegee Assy (CMAX 28ST / BA 750ST)
1	56002807	4	Scr, Hex Hd SS 1/4-20 x .75
2	56002850	12	Nut, Hex Nyl Loc-Thin SS 1/4-20
3	56002859	2	Wsh, Flt SAE SS 1/4
4	56002901	4	Scr, Hex Hd SS 1/4-20 x 1.50
5	56002909	2	Scr, Pan Phil SS 6-32 x .38
6	56002964	2	Nut, Hex Nyl Loc-Thin SS 6-32
7	56009048	2	Nut, Wing Loc 1/4-20
8	56324350	2	Wheel
9	56324499	2	Wheel 3.00
10	56370711	2	Nut, Thumb
11	56391286	1	Strap, Rear Right
12	56391288	1	Strap, Rear Left
13	56391290	1	Strap, Front
14	56391292	1	Tool Weldment
15	56409656	2	Bracket, Wheel
16	56471194	1	Latch
17	56471220	4	Bushing, .25 x .37 x 1.00
18	56391340	1	Blade Kit (Gum Rubber) NOTE #1
**	56391342	1	Oil Resistant Blade Kit (Neoprene) NOTE #1
**	56396172	1	Blade Kit (Linatex) NOTE #1
**	56397325	1	Blade, Front-Tile Gum
**	56397326	1	Blade, Front-Tile Linatex

** = Optional

NOTE #1: All squeegee blade kits contain both front and rear squeegee blades.

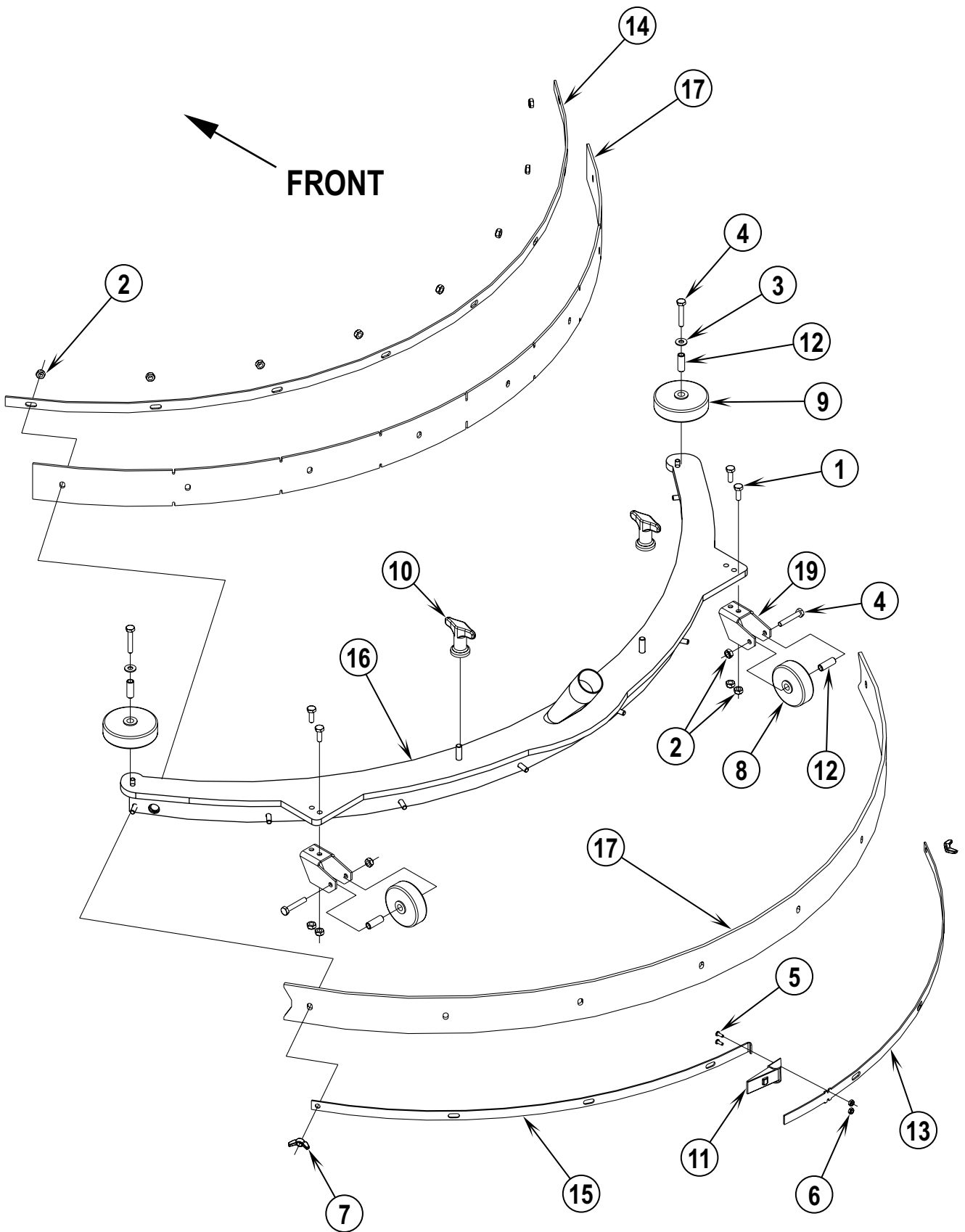

02-2	SQUEEGEE ASSEMBLY-BA 850ST	BOOK E		
04-10	CMAX™ 28ST / BA 750ST / BA 850ST	E	11.6.1	25

Item	Ref. No.	Qty	Description
	56397349	1	Squeegee Assy (BA 850ST)
1	56002807	4	Scr, Hex Hd SS 1/4-20 x .75
2	56002850	14	Nut, Hex Nyl Loc-Thin SS 1/4-20
3	56002859	2	Wsh, Flt SAE SS 1/4
4	56002901	4	Scr, Hex Hd SS 1/4-20 x 1.50
5	56002909	2	Scr, Pan Phil SS 6-32 x .38
6	56002964	2	Nut, Hex Nyl Loc-Thin SS 6-32
7	56009048	2	Nut, Wing Loc 1/4-20
8	56324350	2	Wheel
9	56324499	2	Wheel 3.00
10	56370711	2	Nut, Thumb
11	56471194	1	Latch Assembly
12	56471220	4	Bushing .25 x .37 x 1.0
13	56397353	1	Strap, Rear
14	56397354	1	Strap, Front
15	56397355	1	Strap, Rear
16	56397359	1	Squeegee Tool Weldment
17	56397094	1	Blade Kit (Gum Rubber) NOTE #1
18			Intentionally Omitted
19	56409656	2	Bracket, Wheel
**	56397106	1	Blade Kit (Linatex) NOTE #1
**	56397595	1	Blade Kit (Oil Resistant) NOTE #1
**	56397147	1	Blade, Front-Tile Gum
**	56397148	1	Blade, Front-Tile Linatex

** = Optional

NOTE #1: All squeegee blade kits contain both front and rear squeegee blades.

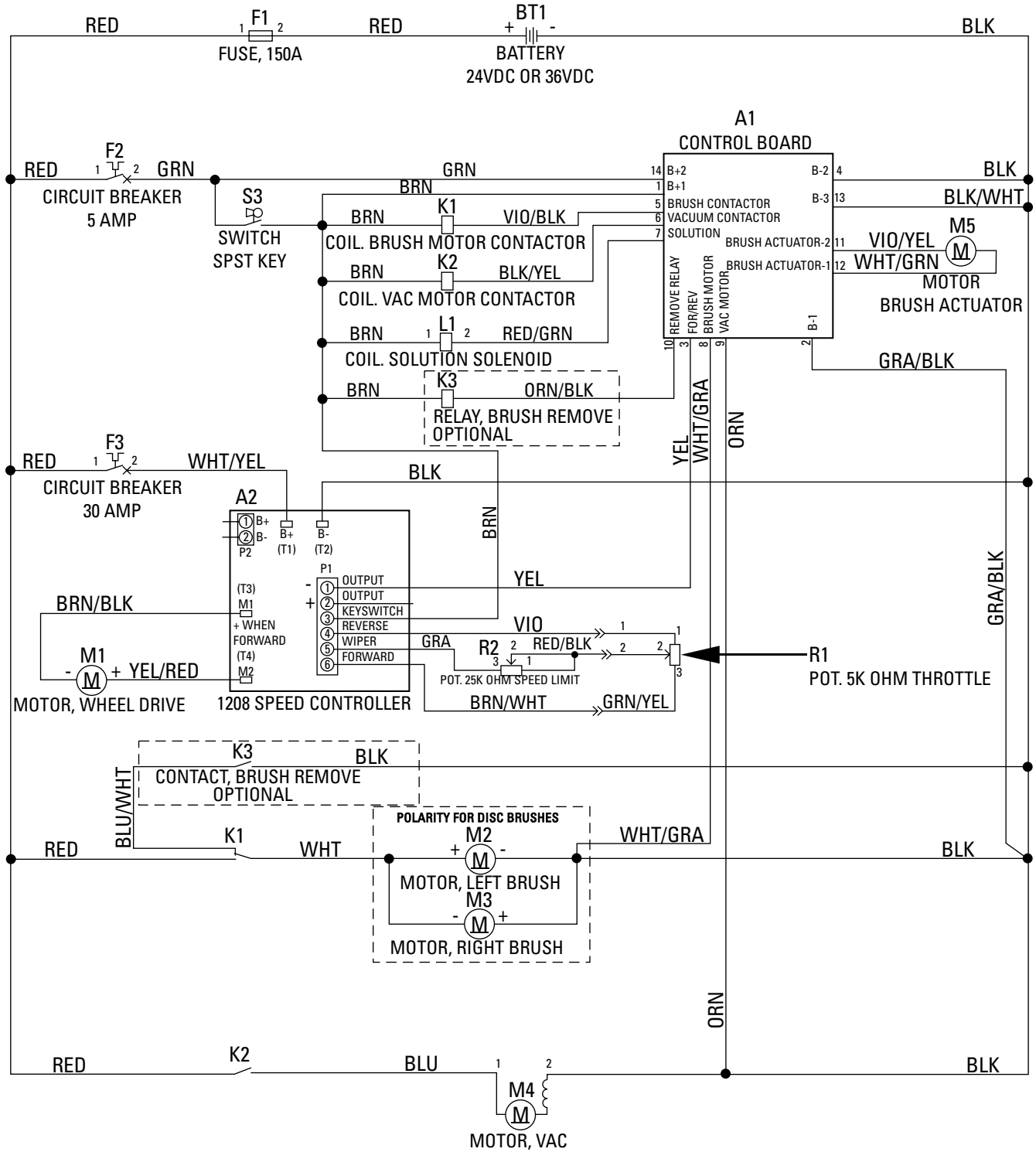

02-2	WIRING DIAGRAM	BOOK E		
04-8	CMAX™ 28ST / BA 750ST / BA 850ST	E	11.6.1	27

Item	Ref. No.	Qty	Description
A1	56396300	1	Control PCB Assy TSBUS2004-870
A2	56324023	1	Control, DC Curtis
BT1	N/A	A/R	Batteries
F1	56412089	1	Fuse, 150A
F2	56387328	1	Circuit Breaker, 5A (Controls)
F3	56026198	1	Circuit Breaker, 30A (Wheel Drive)
K1	56412179	1	Contactor (Brush Motor)
	56397088	1	Contactor (Replaces 56412179 for Brush Remove Option)
K2	56412179	1	Contactor (Vac Motor)
K3	56396286	1	Relay (Brush Remove/Optional)
L1	56397203	1	Solution Solenoid Valve Assy
M1	56396311	1	Motor, 24VDC 1/2 HP (Wheel Drive)
*	56039276	4	Carbon Brushes
M2	56027153	1	Asm, Motor and Gear Unit, 24V (Left Brush)
*	56397090	1	Bearing, B.E.
*	56397135	1	Bearing, F.E.
*	56397138	4	Brush Spring
*	56039276	4	Carbon Brush
*	56397048	1	Brush Board
M3	56027153	1	Asm, Motor and Gear Unit, 24V (Right Brush)
*	56397090	1	Bearing, B.E.
*	56397135	1	Bearing, F.E.
*	56397138	4	Brush Spring
*	56039276	4	Carbon Brush
*	56397048	1	Brush Board
M4	56397041	1	Vac Motor Assembly
*	56397098	1	Carbon Brush Set
M5	56393303	1	Actuator, Motor (Brush Lift) TSBUS2004-870
*	56393790	2	Limit Switch
*	56470433	1	Carbon Brush Kit
*	56388520	1	Plastic Nut
R1	56397029	1	Potentiometer, 5K (Throttle)
R2	56397123	1	Potentiometer, 25K (Speed Limit)
S3	56396305	1	Switch, SPST Toggle (Main Power)
*	56396283	1	Harness, Main TSBUS2004-870
*	56396299	1	Harness, Handle
*	56416445	3	Cable Assy 4 AWG (Battery Interconnect)
*	56396202	1	Connector Assy (TSBUS2003-841) (Connects to Batteries)
*	56396203	1	Connector Assy (Connects to Machine)

* = Not Shown

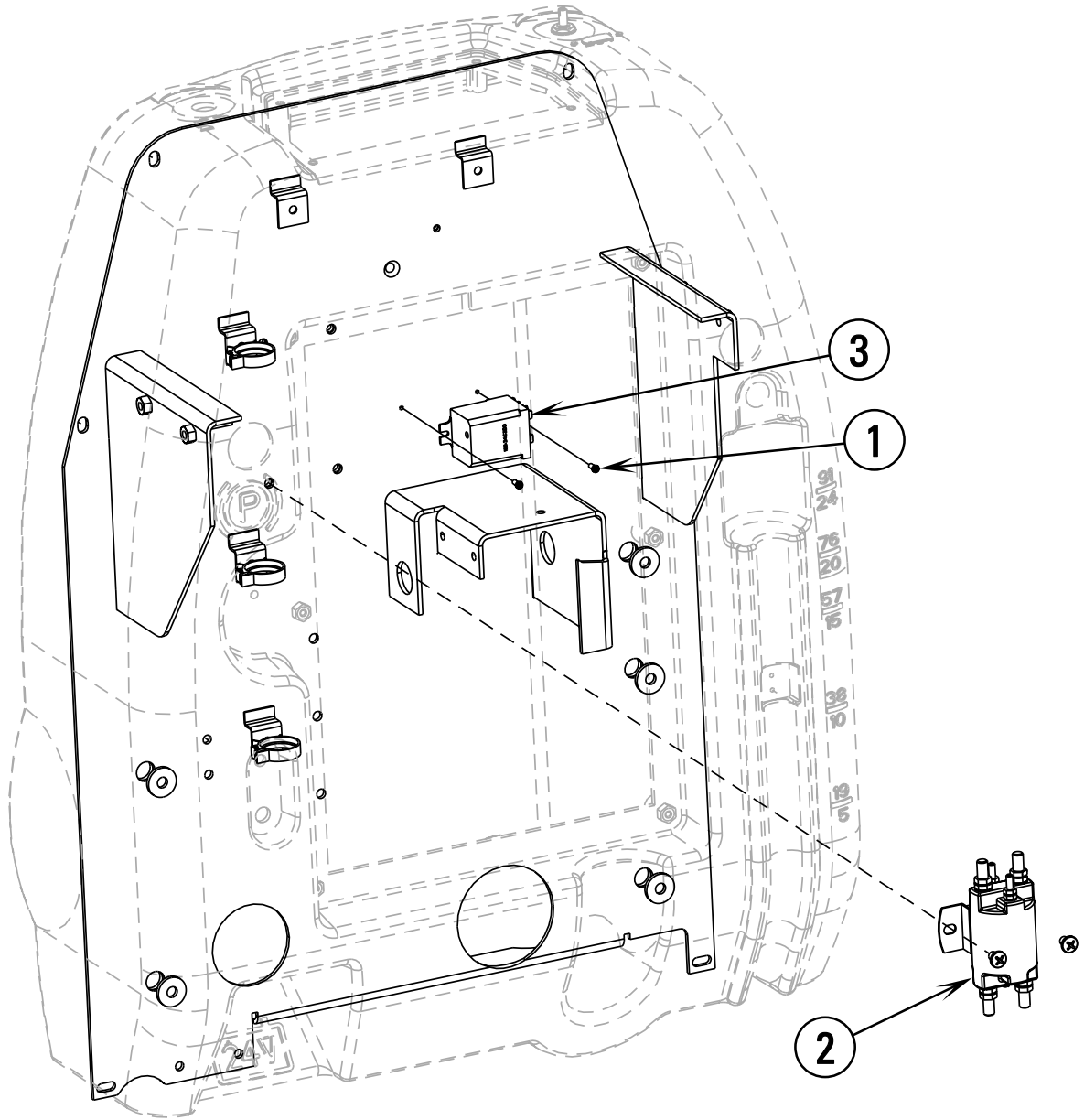

02-2	BRUSH CLICK-OFF KIT	BOOK E		
02-4	CMAX™ 28ST / BA 750ST / BA 850ST	E	11.6.1	29

Item	Ref. No.	Qty	Description
	56396301	1	Kit, Brush Click-Off
1	56002539	2	Scr, Pan Phil Thd Form 6-32 x .31
2	56397088	1	Contactora, 24V, SPDT
3	56396286	1	Relay, 24V, SPST
*	56040762	1	Instruction Sheet

* = Not Shown

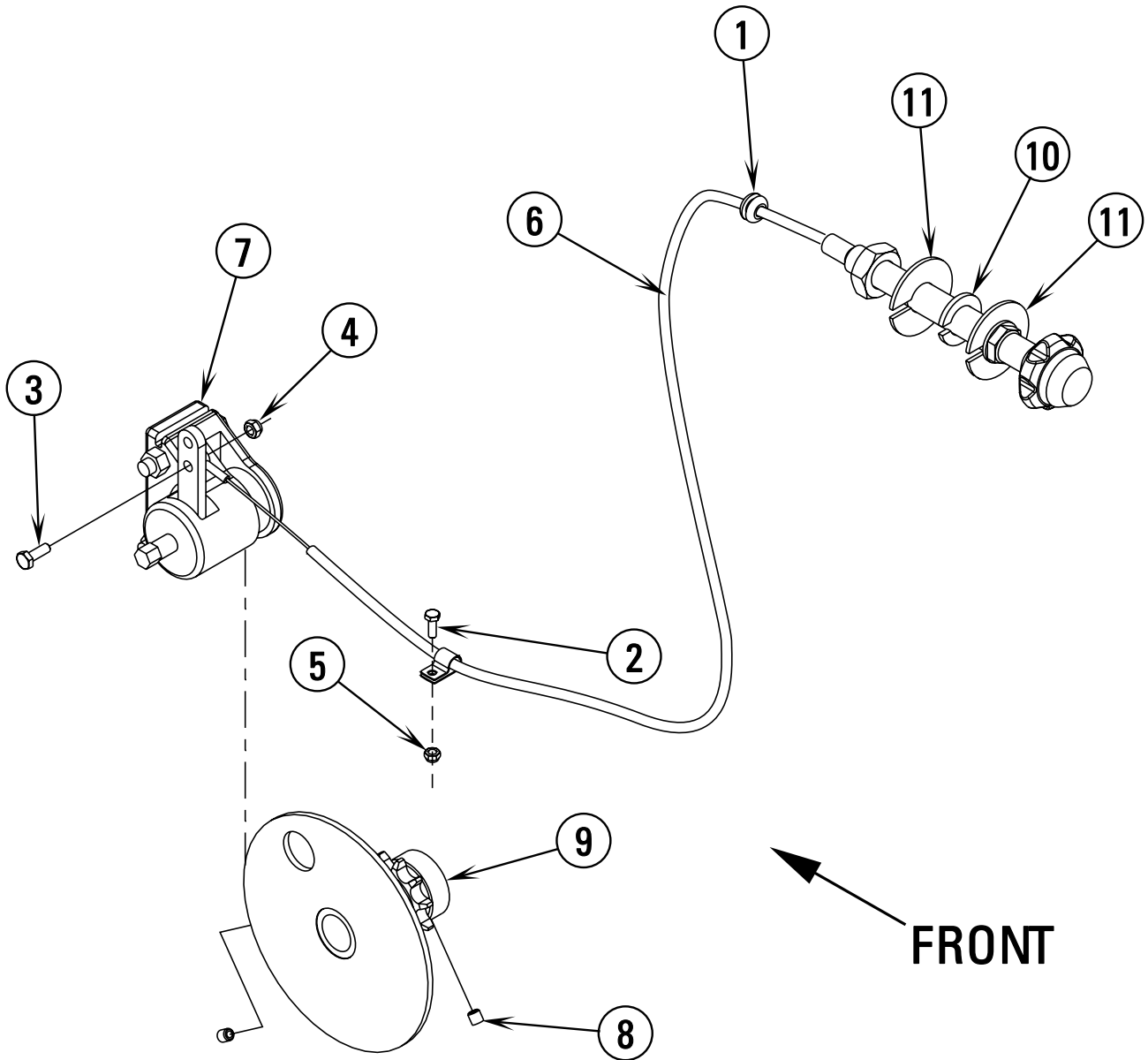

02-2	PARKING BRAKE KIT	BOOK E		
02-4	CMAX™ 28ST / BA 750ST / BA 850ST	E	11.6.1	31

Item	Ref. No.	Qty	Description
	56396302	1	Kit, Parking Brake
1	56321559	1	Grommet
2	56002503	1	Scr, Hex Hd 10-24 x .50
3	56003358	1	Scr, Hex M6-1.00 x 25mm
4	56003403	1	Nut, Hex Nyl Loc M6-1.00
5	56002768	1	Nut, Hex Nyl Loc 10-24
6	56056323	1	Cable, Brake Assembly
7	56056245	1	Brake, Mechanical Caliper
8	56001841	2	Scr, Soc Set Loc 1/4-20 x .25
9	56396326	1	Sprocket Weldment
10	56396329	1	Plate, Brake Align
11	56396328	2	Plate, Brake Mount
*	56040763	1	Instruction Sheet

* = Not Shown

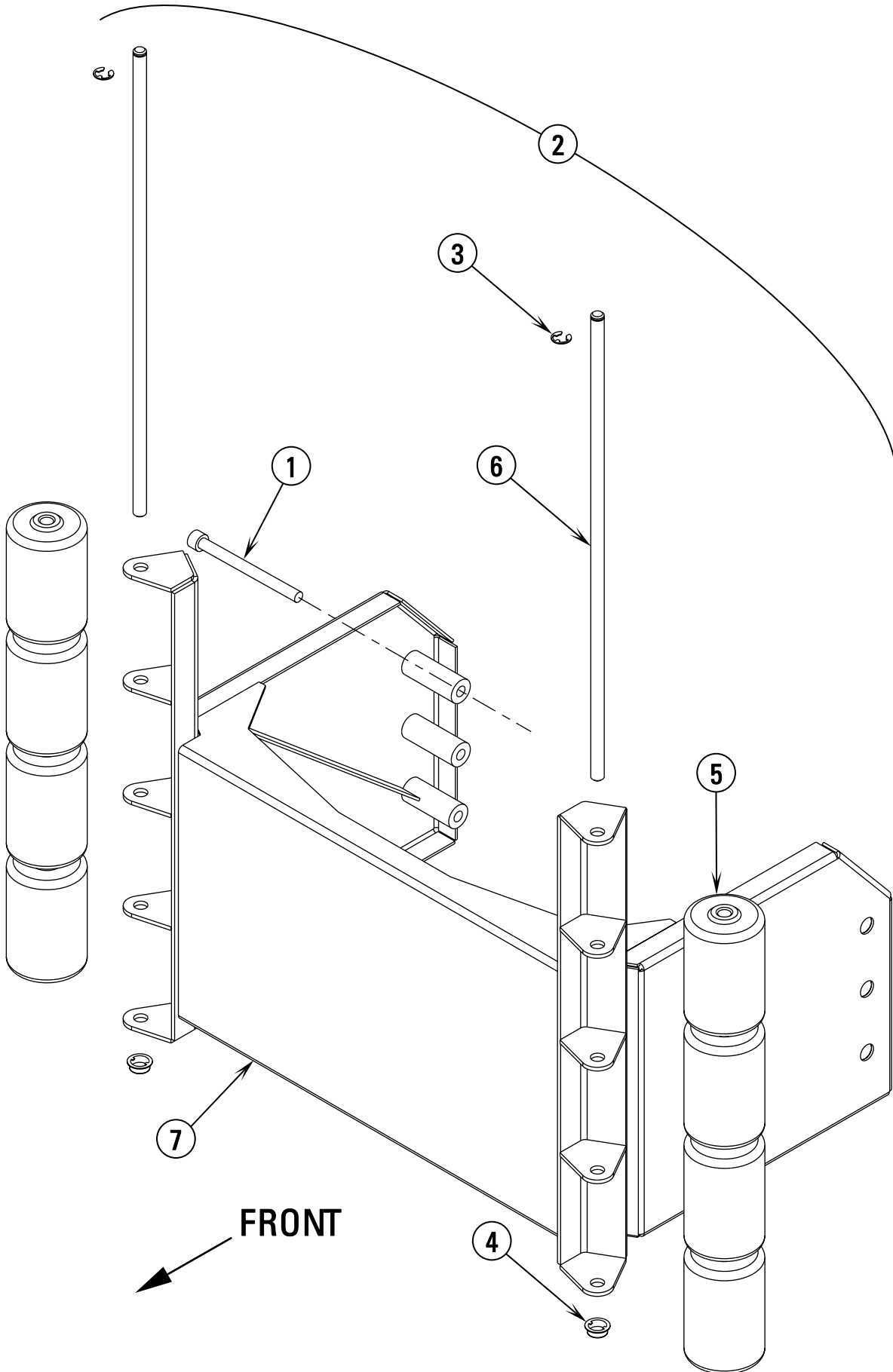

02-2	INDUSTRIAL BUMPER KIT	BOOK E		
02-4	CMAX™ 28ST / BA 750ST / BA 850ST	E	11.6.1	33

Item	Ref. No.	Qty	Description
	56396307	1	Kit, Industrial Bumper
1	56003542	6	Scr, Soc Hd 3/8-16 x 3.00
2	56396134	1	Assembly, Industrial Bumper (#3-7)
3	56003264	2	Ring, Ret Ext Type E .50 dia
4	56009097	2	Nut, Push Cap 1/2
5	56392102	8	Roller
6	56392809	2	Rod
7	56396133	1	Weldment, Bumper Industrial
*	56040764	1	Instruction Sheet

* = Not Shown

Ref. No.	Qty	Description
Optional Kits		
** 56396301	1	Kit, Brush Click-Off 24V (All Models)
** 56396302	1	Kit, Parking Brake (All Models)
** 56396307	1	Kit, Industrial Bumper (CMAX 28ST)
** 56397450	1	Hose / Wand Kit
28" Squeegee Blade Kits		
** 56391340	1	Blade Kit (Gum Rubber) NOTE #1
** 56391342	1	Oil Resistant Blade Kit (Neoprene) NOTE #1
** 56396172	1	Blade Kit (Linatex) NOTE #1
32" Squeegee Blade Kits		
** 56397094	1	Blade Kit (Gum Rubber) NOTE #1
** 56397106	1	Blade Kit (Linatex) NOTE #1
** 56397595	1	Blade Kit (Oil Resistant) NOTE #1
Accessories		
** 56397453	4	Indicator, Battery Level (1 per battery)
Optional Batteries		
** 56391391	4	Battery, 6V 305AH
** 56206079	4	Battery, 6V 238AH
** 56206117	4	Battery, 6V 195AH
Optional Battery Chargers		
** 56388109	A/R	Charger, 24V 25A 110V
** 56031409	A/R	Charger, 24V, 36A 110V

** = Optional, Not Included

NOTE #1: All squeegee blade kits include both front and rear squeegee blades.

We provide brushes and pad holders that will give you the best possible performance between machine and floor. Following are descriptions of the materials and their applications.

- Union Mix:** Medium grade natural fibers for polishing finished floors with standard-speed equipment. Recommended for use in place of white pads.
- ProLite:** Bristles are made from light-duty polypropylene for general scrubbing when you do not want to scratch or remove finish from the floor. Recommended for use in place of red pads.
- Prolene:** Polypropylene material for medium-duty scrubbing on concrete, terrazzo and vinyl floor tile. Recommended for use in place of green or blue pads.
- Magna Grit:** For extreme heavy-duty scrubbing or stripping of floors. This brush has extra large diameter silicon carbide grit impregnated synthetic bristles. Recommended for use in place of black pads.
- Dyna Grit:** For aggressive, heavy-duty scrubbing or stripping of floors. Recommended for use in place of brown pads.
- MidLite Grit:** For general purpose scrubbing of sealed or unsealed concrete, stone, terrazzo, quarry tile and other resilient hard floor surfaces. Recommended for use in place of green or blue pads.
- MidGrit:** For general purpose scrubbing when you need a lighter action for sealed or unsealed concrete, stone, terrazzo, quarry tile and other resilient hard floor surfaces. Recommended for use in place of green or blue pads.
- AgLite Grit:** For light scrubbing when used wet; buffing or polishing when used dry on urethane coated, sealed concrete or other resilient hard surface floors. Recommended for use in place of red or white pads.
- Short Trim Pad Holder:** Made with a structural foam block and center ring for correct pad centering. It has a "shower feed" design for getting solution to the floor.

Ref. No.: CMAX 28ST / BA 750ST BRUSHES

- 56505770 - Pad Holder
 56505771 - Magna Grit
 56505772 - Dyna Grit
 56505773 - AgLite Grit
 56505774 - Prolene
 56505775 - ProLite
 56505776 - Union Mix
 56505777 - Mid Grit
 56505778 - MidLite Grit

Ref. No.: BA 850ST BRUSHES

- 56505780 - Pad Holder
 56505781 - Magna Grit
 56505782 - Dyna Grit
 56505783 - AgLite Grit
 56505784 - Prolene
 56505785 - ProLite
 56505786 - Union Mix
 56505787 - Mid Grit
 56505788 - MidLite Grit

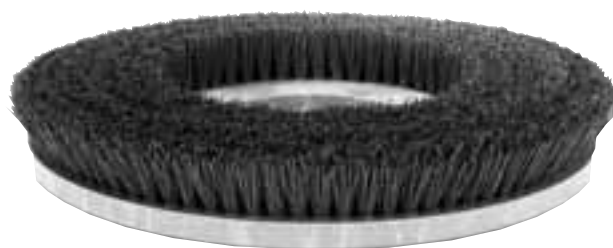

Austria (Sales Sub)

Nilfisk-Advance GmbH	Phone: +43
Voralberger Allee 46	1616 58 30 22
A-1230 Wien	Fax: +43
info@nilfisk-advance.at	1616 58 30 40
www.nilfisk-advance.at	

Belgium (Sales Sub)

Nilfisk-Advance NV/SA	Phone: +32
Doornveld Sphere Business Park	(0)2467 60 50
Industrie Asse 3, No. 11	Fax: +32
B-1731 Zellik-Asse	(0)2463 44 16
www.nilfisk-advance.be	

Czech Republic (Sales Sub)

Nilfisk-Advance s.r.o.	Phone: +420
Lysinská 44/1863	2 44 09 09 12
143 00 Praha - Modrany	+420
Czech Republic	2 44 09 09 21 4
	Fax: +420
	2 44 40 23 93

Denmark

Nilfisk-Advance A/S	Phone: +45
Sognevej 25	43 23 81 00
DK-2605 Brøndby	Fax: +45
mail@nilfisk-advance.dk	43 43 77 00
www.nilfisk-advance.com	

Denmark (Prod. Sub)

Gerni A/S	Phone: +45
Myntevej 2	89 12 22 00
DK-8900 Randers	Fax: +45
www.gerni.com	86 43 14 81

Denmark (Sales Sub)

Nilfisk-Advance Nordic A/S	Phone: +45
Sognevej 25A	43 23 40 50
Postbox 344	Fax: +45
DK-2605 Brøndby	43 23 40 60
kundeservice@nilfisk-advance.dk	
www.nilfisk-advance.dk	

France (Sales Sub)

Nilfisk-Advance S.A.	Phone: +33
27 avenue de la Baltique	1695 98 700
Villebon sur Yvette	Fax: +33
P.B. 246	1695 98 701
F-91944 Courtaboeuf Cedex	
info@nilfisk-advance.fr	
www.nilfisk-advance.fr	

Germany (Sales Sub)

Nilfisk-Advance AG	Phone: +49
Siemensstrasse 25-27	4101 3990
Postfach 1361	Fax: +49
D-25462 Rellingen	4101 39 91 91
info@nilfisk-advance.de	
www.nilfisk-advance.de	

Greece (Sales Sub)

Nilfisk-Advance A.E.	Tel.: +30
8, Thoukididou Str.	210 963 3443
Argioupoli	Fax: +30
Gr - 164 52 Athens	210 965 0975
Greece	

Holland (Sales Sub)

Nilfisk-Advance B.V.	Phone: +31
Camerastraat 9 (2e verdieping)	36 546 07 00
1322 BB Almere	Fax: +31
Postbus 60112	36 523 51 48
1320 AC Almere	
www.nilfisk-advance.nl	

Ireland (Sales Sub)

Nilfisk-Advance Limited	Phone: +35
28 Sandyford Office Park	3 12 94 38 38
Sandyford, Dublin 18	Fax: +35
Ireland	3 12 94 38 45

Italy (Prod & Sales Sub)

CFM SpA	Phone: +39
Nilfisk-Advance Div. Guardamiglio	0377 /414021
Localita Novella III	/45 1124
I-26862 Guardamiglio (Mi)	Fax: +39
	0377 51 443

Italy (Prod & Sales Sub)

CFM S.p.A.	Phone: +39
Via Porrettana 1991	059 973 0000
I-41059 Zocca (Modena)	Fax: +39
cfm@cfm.it	059 973 0099

Norway (Sales Sub)

Nilfisk-Advance AS	Phone: +47
Ulvenveien 89C	23 06 75 00
N-0581 Oslo	Fax: +47
	23 06 75 01

Poland (Sales Sub)

Nilfisk-Advance Sp.Z.O.O.	Phone: +48
05-800 Pruszków	22 738 37 50
ul. 3-go MAJA 8	Fax: +48
Poland	22 738 37 51

Portugal (Sales Sub)

Nilfisk-Advance, Lda.	Phone: +35
Sintra Business Park	121 911 2670
Zona Industrial Da Abrunheira	Fax: +35
Edificio 1, 1o A	121 911 2679
P-2710-089 Sintra	

Russia (Sales Sub)

Nilfisk-Advance LLC	Phone: 7
Vyatskaya str. 27, bld. 7	095 783 9602
127015 Moscow	Fax: +7
Russia	095 783 9603

Spain (Sales Sub)

Nilfisk-Advance S.A.	Phone: +34
Torre D'Ara	93 741 2400
Passeig del Rengle, 5 Pl.10	Fax: +34
E-08302 Mataró (Barcelona)	93 757 8020
nilfisk@nilfisk-advance.es	

Sweden (Sales Sub)

Nilfisk -Advance A/S	Phone: +46
Sjöbjörnsvägen 5	8555 94400
Box 44045	Fax: +46
S-100 73 Stockholm	8555 94430
info@nilfisk-advance.se	
www.nilfisk-advance.se	

Sweden (Prod.)

Nilfisk-Advance A/S Phone: +46
Åmål Branch 5321 7500
Strömsbergsgatan Fax: +46
Box 127 5321 7595
S-662 23 Åmål

Switzerland (Sales Sub)

Nilfisk-Advance AG Phone: +41
Ringsstrasse 19 71 92 38 444
Kirchberg/Industrie Stelzl Fax: +41
CH-9500 Wil 71 92 35 283
www.nilfisk-advance.ch

UK (Sales Sub)

Nilfisk-Advance Limited Phone: +44
Newmarket Road 1284 763163
Bury St. Edmunds Fax: +44
UK-Suffolk IP33 3SR 1284 750 562

USA (Prod.)

Nilfisk-Advance Inc. Phone: +1 763
14600 21.st Avenue North 745 3500
Plymouth, MN 55447-3408 Fax: +1 763
www.mn.nilfisk-advance.com 745 3718

USA (Sales Sub)

Nilfisk-Advance America Inc. Phone: +1 610
300 Technology Drive 647 6420
Malvern, PA 19355 Fax: +1 610
www.pa.nilfisk-advance.com 647 6427

Canada (Sales Sub)

Nilfisk-Advance Canada Comp. Phone: +1 905
396 Watline Avenue 712 3260
Mississauga, Ontario L4Z 1X2 Fax: +1 905
712 3255

Australia (Sales Sub)

Nilfisk-Advance Pty. Ltd. Phone: +61(0)2
48 Egerton Street 9648 2700
Silverwater, NSW 2128 Fax: +61(0)2
Postal adresse: 9648 2711
PO Box 6046
Silverwater. NSW 1811
info@nilfisk-advance.com.au
www.nilfisk-advance.com.au

China (Shenzhen)

Nilfisk-Advance (Shenzhen) Ltd Phone: +86 755
Blok 3, Unit 130, 1001 Honghua Road 8359 7937 el.
Int. Commercial & Trade Center 8359 7939-42
Fuitian Free Trade Zone Fax: +86 755
518038 **Shenzhen** 8359 1063
P.R. China

China (Suzhou)

Nilfisk-Advance Professional Phone: +86 512
Cleaning Equipment (Suzhou) Co. Ltd. 8918 5656
306 Su Hong Zhong Road, Build. 2 Fax: +86 512
Suzhou Industrial Park 8918 5666
215021 **Suzhou**
P.R. China

Hong Kong (Sales Sub)

Nilfisk-Advance Ltd. Phone: +852
2001 HK Worsted Mills Ind'l Bldg., 2427 5951
31-39 Wo Tong Tsui St. Fax: +852
Kwai Chung, Hong Kong 2487 5828

Japan (Sales Sub)

Nilfisk-Advance Inc. Phone: +8145
3-17-40-101 Chigasaki Higashi 942 7741
Tsuzuki-ku, Yokohama 224-0033 Fax: +8145
Japan 942 6545

Malaysia (Sales Sub)

Nilfisk-Advance Sdn Bhd Phone: +60 3
No. 21, Jalan SS 25/41 7956 8188
Mayang Industrial Park Fax: +60 3
47301 Petaling Jaya 7966 6828
Selangor, Malaysia

New Zealand (Sales Sub)

Nilfisk-Advance Limited Phone: +64(0)9
Danish House 525 0092
6 Rockridge Avenue Fax: +64(0)9
Penrose 92-829 525 6440
Auckland1135
Postal adresse:
Private Bag 92 825
Auckland
New Zealand

Singapore (Sales Sub)

Nilfisk-Advance Pte. Ltd. Phone: + 65
22, Woodlands Industrial Park E1 6 7599100
Singapore 757740 Fax: +65
sales@nilfisk-advance.com.sg 7599133

Taiwan, ROC (Sales Sub)

Nilfisk-Advance Ltd. Phone: +886
Taiwan Branch (H.K.) 2 2239 8812
1F, No. 193, Sec.2 Fax: +886
Xing Long Rd., Taipei 2 2239 8832
Taiwan, R.O.C.

Thailand (Sales Sub)

Nilfisk-Advance Co. Ltd. Phone: +66 2
89 Soi Chokechai-Ruammitr 275-5630
Viphavadee-Rangsit Road Fax: +66 2
Ladyao, Jatuchak, Bangkok 10900 691-4079
Thailand



www.nilfisk-advance.com

© 2004 Printed in USA