

HITACHI

SERVICE MANUAL

SM0541

CP-S235W(C10SM2)

Warning

The technical information and parts shown in this manual are not to be used for the development, design, production, storage or use of nuclear, chemical, biological or missile weapons or other weapons of mass destruction; or military purposes; or purposes that endanger global safety and peace. Moreover, do not sell, give or export these items or grant permission for use to parties with such objectives. Forward all inquiries to Hitachi Ltd.

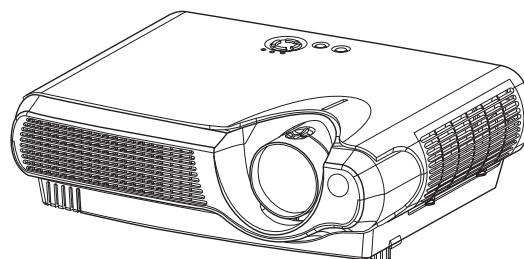

Caution

Be sure to read this manual before servicing. To assure safety from fire, electric shock, injury harmful radiation and materials, various measures are provided in this Hitachi Multimedia LCD Projector. Be sure to read cautionary items described in the manual to maintain safety before servicing.

Service Warning

1. When replacing the lamp, avoid burns to your fingers. The lamp becomes very hot.
2. Never touch the lamp bulb with a finger or anything else. Never drop it or give it a shock. This may cause bursting of the bulb.
3. This projector is provided with a high voltage circuit for the lamp. Do not touch the electric parts of power unit (main) when the projector is turned on.
4. Do not touch the exhaust fan during operation.
5. The LCD module assembly is easily damaged. When replacing the LCD LENS/PRISM assembly, do not hold the FPC of the LCD module assembly.
6. Use only the cables included with the projector or specified.

Contents

| | | | |
|--------------------------|----|---------------------------------------|----|
| 1. Features | 2 | 8. Assembly diagram..... | 35 |
| 2. Specifications | 2 | 9. Replacement parts list | 38 |
| 3. Part names | 3 | 10.RS-232C communication | 39 |
| 4. Adjustment | 5 | 11.Block diagram | 47 |
| 5. Troubleshooting | 11 | 12.Connector connection diagram | 48 |
| 6. Service notes | 16 | 13.Basic circuit diagrams | 49 |
| 7. Wiring diagram | 30 | | |

SPECIFICATIONS AND PARTS ARE SUBJECT TO CHANGE FOR IMPROVEMENT.

Multimedia LCD Projector

March 2004 Digital Media Division

CP-S235 (C10SM2)

1. Features

- ▶ Ultra high brightness
- ▶ Whisper mode equipped
- ▶ User memory function
- ▶ Partial magnification function
- ▶ Keystone distortion correction

2. Specifications

| | | |
|---|------------------|--|
| Liquid Crystal Panel | Drive system | TFT active matrix |
| | Panel size | 1.4cm (0.55type) |
| | Number of pixels | 800 (H) × 600 (V) |
| Lamp | | 160W UHB |
| Video Input | System | NTSC, PAL (BGDHI), SECAM, PAL-M, PAL-N, NTSC4.43, PAL60 |
| | Level | Composite 1.0 ±0.1Vp-p (75Ω termination) |
| | | S-Video Y : 1.0 ±0.1Vp-p (75Ω termination) C : 0.286 ±0.1Vp-p (NTSC burst signal, 75Ω termination) 0.3 ±0.1Vp-p (PAL/SECAM burst signal, 75Ω termination) |
| Component Y: 1.0 ±0.1Vp-p (75Ω termination) C _B /P _B : 0.7 ±0.1Vp-p (75Ω termination) C _R /P _R : 0.7 ±0.1Vp-p (75Ω termination) | | |
| RGB input / output | Analog RGB | 0.7Vp-p (75Ω termination) |
| | Sync. | TTL level |
| Audio Input | | 200mVrms, 50KΩ |
| Speaker output | | 1.0W (mono) |
| Power supply | | 100~120VAC / 2.6A, 220~240VAC / 1.4A |
| Power consumption | | 240W |
| Dimensions | | 332(W) × 92(H) × 254(D) mm (No including protruding parts) |
| Weight | | 3.0Kg |
| Temperature | | Operation : 0~35°C Storage : -20~60°C |
| Accessories | | Remote control transmitter × 1 Battery × 2 RGB cable × 1 Soft case × 1 (Power cord) User's manual operating guide (Book × 2 or CD-ROM × 1) Strap for lens cap × 1 User's manual quick guide (Book × 1) Rivet for lens cap × 1 User's manual safety guide (Book × 1) |

CP-S235 (C10SM2)

3. Part names

● Projector

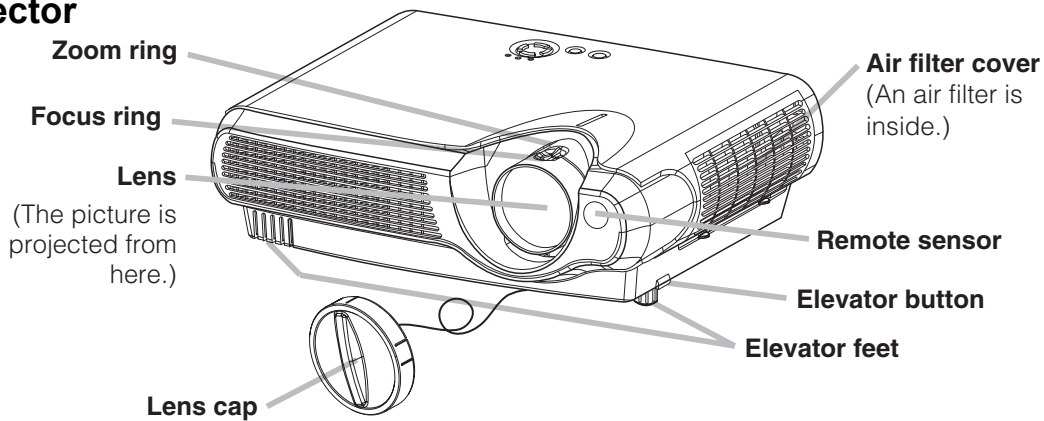

Projector (Front/Right)

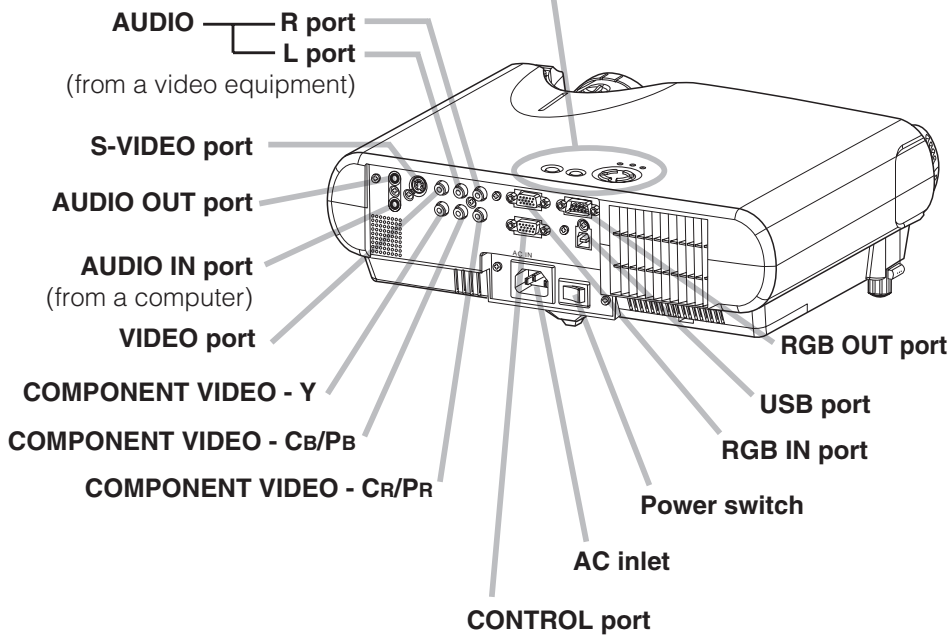
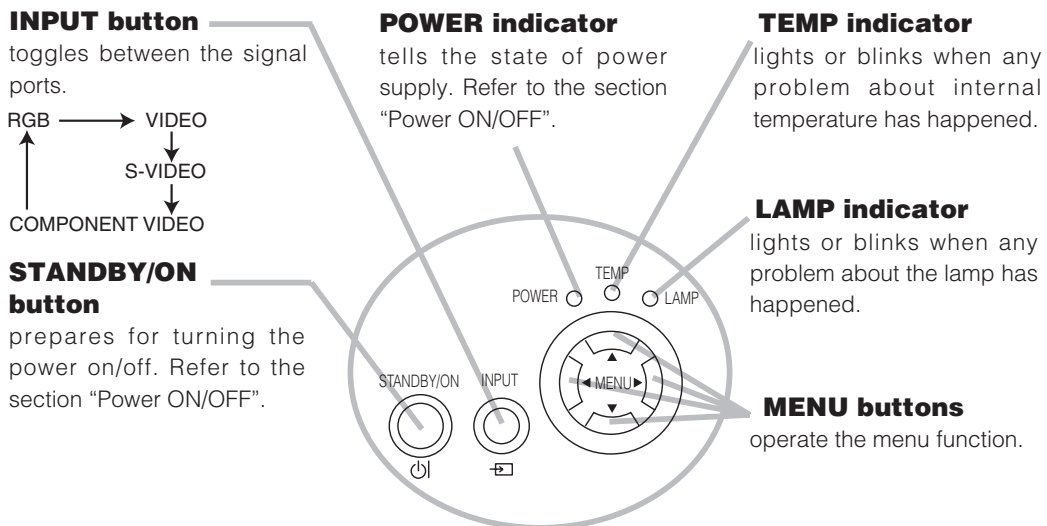

Projector (Rear/Left)

CP-S235 (C10SM2)

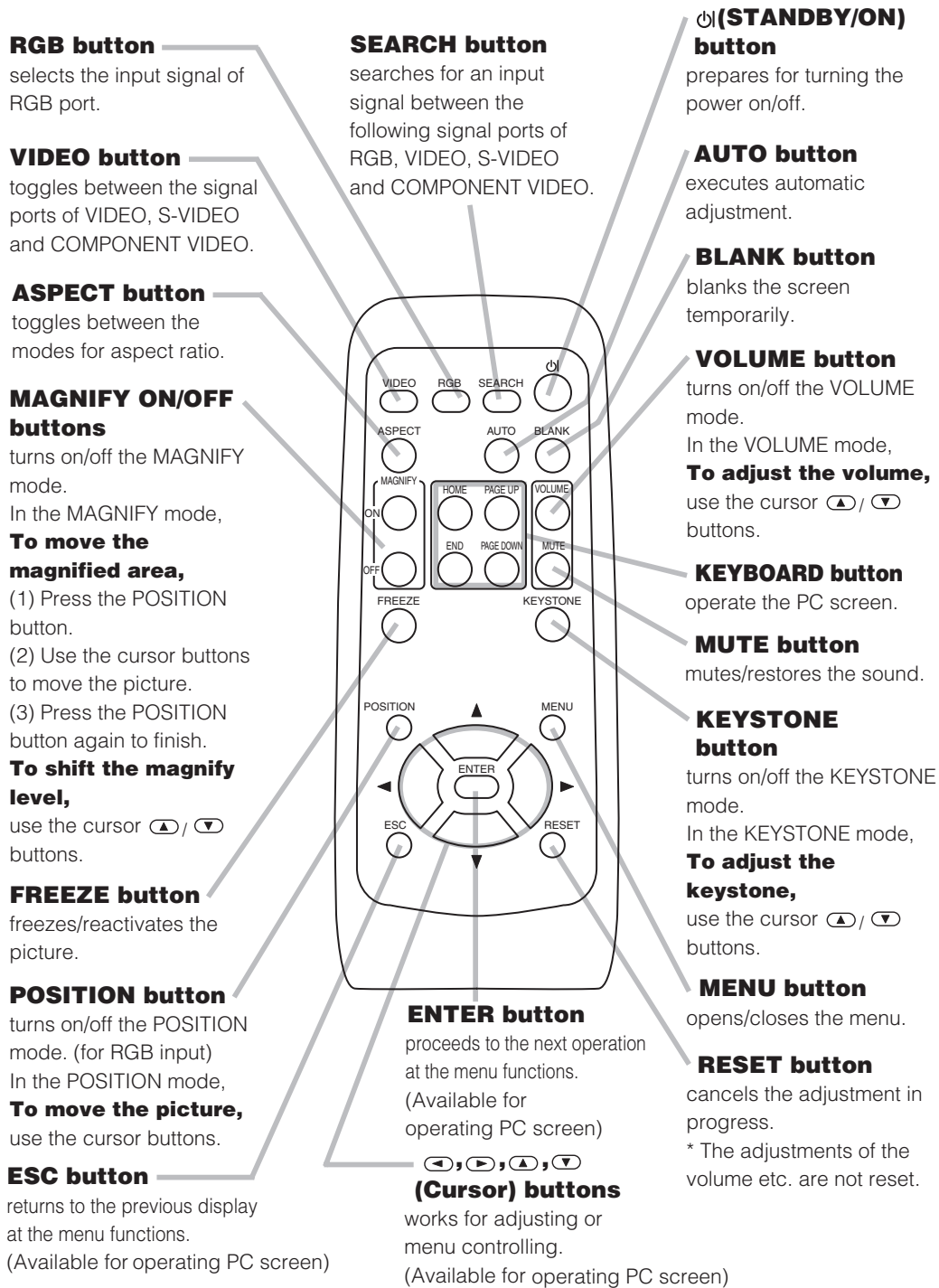

Remote control transmitter

4. Adjustment

4-1 Before adjusting

4-1-1 Selection of adjustment

When any parts in the table 4-1 are changed, choose the proper adjusting items with the chart.

Table 4-1: Relation between the replaced part and adjustment

| Replaced part | Adjustment | | | | | |
|-------------------------|------------------|--------------------|-----------------|--------------------------|------------------------------|-----------------------|
| | Ghost (Chap.4-2) | Flicker (Chap.4-3) | NRSH (Chap.4-4) | White balance (Chap.4-5) | Colour uniformity (Chap.4-6) | AIR SENSOR (Chap.4-7) |
| Dichroic optics unit | ○ | ○ | × | △ | △ | ○ |
| LCD/LENS prism assembly | ○ | ○ | ○ | ○ | ○ | △ |
| Main Board | ○ | ○ | ○ | ○ | ○ | ○ |
| Lamp unit assembly | △ | △ | × | △ | △ | × |
| Sensor Board | × | × | × | × | × | ○ |

○ : means need for adjustment. × : means not need for adjustment.
△ : means recommended.

4-1-2 Setting of condition before adjustment

1. Before starting adjustment, warm up the projector for about 10 minutes. (Blank white)
2. Set Zoom Wide to Max. And project an image with more than 1m (40 type) in diagonal size.
3. Normalising the video adjustment.
(Press the [MENU] button of the Remote control transmitter to display the MAIN menu. After pressing the [▶] key, use the [▲] or [▼] key to select [RESET]. Next, open MAIN menu and press the [▼] key to display the PICTURE1 menu. Choose RESET and perform EXECUTE by the same operation described above.

*note :The MAIN and PICTURE1 menu is not reset with no signal.

4. Set the NORMAL at GAMMA in the PICTURE1 menu.
5. Perform all adjustments from the FACTORY MENU. Perform the following operations to display the FACTORY MENU.
 - a. Press the [MENU] button on the Remote control transmitter (the MAIN menu will appear).
 - b. Select the [RESET] in the MAIN menu, and then press the [▶] button.
 - c. Next, press the [RESET] button one time. And hold the [RESET] button for 3 seconds or more (the FACTORY MENU will appear).

4-2 Ghost adjustment

Signals for internal adjustment

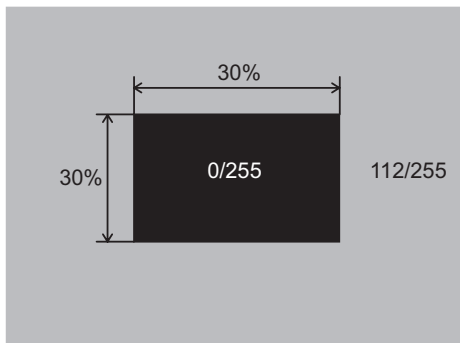

Adjustment procedure

1. Use DAC-P - GHOST - R: in the FACTORY MENU to adjust so that R colour ghost is at a minimum. (Set the adjustment value to default, and then raise the value. When a ghost appears to the left of a vertical line, reduce the value by 4 steps.)
2. In the same way, use DAC-P - GHOST-G: in the FACTORY MENU to adjust so that G colour ghost is at a minimum.
3. In the same way, use DAC-P - GHOST-B: in the FACTORY MENU to adjust so that B colour ghost is at a minimum.

4-3 Flicker adjustment (V.COM adjustment)

Signals for internal adjustment



Adjustment procedure

1. Make this adjustment after completing the adjustment in 4-2 Ghost adjustment.
2. Use DAC-P - V.COM - R: in the FACTORY MENU to adjust so that the flicker at the centre of the screen is less than the flicker at the periphery. (When the flicker is about the same across the whole screen, adjust so that the flicker at the centre of the screen is somewhat less than elsewhere.)
3. In the same way, use DAC-P - V.COM-G: in the FACTORY MENU to adjust the G colour flicker.
4. In the same way, use DAC-P - V.COM-B: in the FACTORY MENU to adjust the B colour flicker.

4-4 NRSH adjustment (vertical stripe adjustment)

Signals for internal adjustment

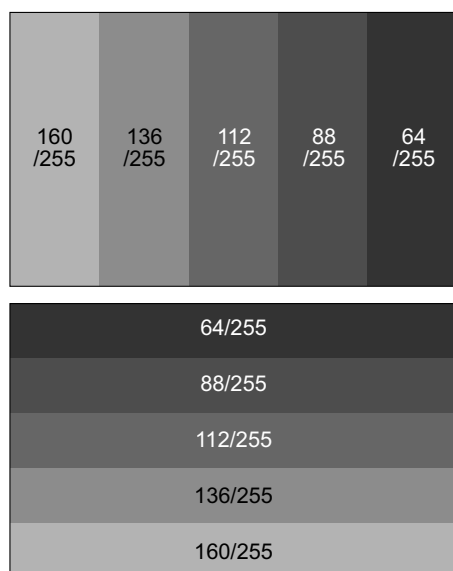

Adjustment procedure

1. Either of adjustment patterns as shown on the left appears, which depends on the firmware version. If any other pattern is displayed, press the [ENTER] key on the remote control.
2. Use the DAC-P - NRSH - R: in the FACTORY MENU to adjust so that the vertical stripes with one pixel width every 6 pixels are as inconspicuous as possible. (Note that when the adjustment value is lowered, stripes with 6 pixels width every 12 pixels may appear on the right side of the darkest or the 2nd darkest tone. Should this happen, make as inconspicuous stripes as possible on the whole screen.)
3. In the same way, use DAC-P - NRSH - G: in the FACTORY MENU to adjust vertical stripes of G colour.

4-5 White balance adjustment (visual inspection)

Preparations

1. Perform these adjustments after the NRSH adjustment described in Section 4-4.

Adjustment procedure

1. First, adjust the G colour.
2. Select GAMMA, SUB-CNT, and G: in the FACTORY MENU. If the background is white solid, press the [ENTER] key on the Remote control transmitter to change to [G] monochrome in the 29-tone greyscale.
3. Adjust GAMMA, SUB-CNT, and G: in the FACTORY MENU so that brightness of 29 steps is best.
4. Don't adjust GAMMA, SUB-BRT, and G: in the FACTORY MENU. Because we want to keep the best contrast ratio.
5. Then adjust colours R and B.

2. Reset gamma correction before adjustment.
 - Place the cursor on [GAMMA] in the FACTORY MENU, press the [RESET] key and select [DEFAULT].
6. Select GAMMA, SUB-CNT, and G: in the FACTORY MENU. If the background is white solid, press the [ENTER] key on the Remote control transmitter to change to [W] monochrome in the 29-tone greyscale.
7. Adjust GAMMA, SUB-BRT, R: and B: in the FACTORY MENU so that low-brightness white balance is best.
8. Adjust GAMMA, SUB-CNT, R: and B: in the FACTORY MENU so that middle-brightness white balance is best.
9. Repeat steps 7 to 8 above, and adjust so that brightness white balance of 29 steps is best.

4-6 Colour uniformity adjustment

Preparations

- Perform these adjustments after the white balance adjustment described in Section 4-5.
- Make a colour uniformity adjustment for the following four tones.
 - MIN tone (approx. 3% input signal)
 - MID-L tone (approx. 13% input signal)
 - MID-H tone (approx. 22% input signal)
 - MAX tone (approx. 50% input signal)
- Place the cursor on [C.UNIF.] in the FACTORY MENU and press the [▶] key. This displays the Adjust Tone menu at the bottom of the screen. To choose the tone to be adjusted, press the [▶] key and then use the [▲] or [▼] key. Select the major adjustment lattice point No. and color, and then adjust them.
- The major adjustment lattice point numbers (a total of 17 points) corresponds to the major adjustment lattice point positions in the diagram on the right. The colour uniformity of the entire screen can be adjusted by adjusting the white balance for each of the points starting in order from the low numbers.
- Adjustment point No.1 should not be adjusted, because it controls the brightness of the entire screen.
- To temporarily turn correction off, place the cursor on [C.UNIF.] in the Adjust Tone menu and press the [▼] key. The ON/OFF menu appears. Place the cursor on [ON] with the [▶] key and press the [▼] key. To turn it on again, place the cursor on [OFF] and press the [▲] key.
- Although this adjustment can also be made using internal signals, we will here use the [ENTER] key on the Remote control transmitter to select the following two signals.
 - Solid monochrome adjustment colour (use G colour adjustment when a colour differential meter is used).
 - Solid white (use for adjustment other than above).
- Reset colour-shading correction before adjustment.
 - When 4 tones and all colours are to be reset, place the cursor on [C.UNIF.] in the FACTORY MENU, press the [RESET] key and select [DEFAULT].
 - When only 1 tone is to be reset, place the cursor on the tone to be reset, press the [RESET] key and select [DEFAULT].
 - Single tone and monochrome resets cannot be performed.

FACTORY MENU

| |
|----------|
| VID-AD |
| C. UNIF. |
| DAC-P |
| GAMMA |
| STRIPE |

Adjust tone menu

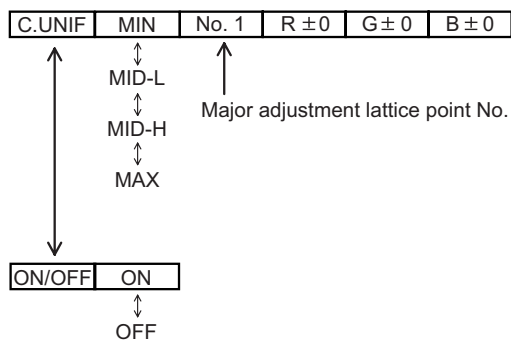

Major adjustment lattice point position

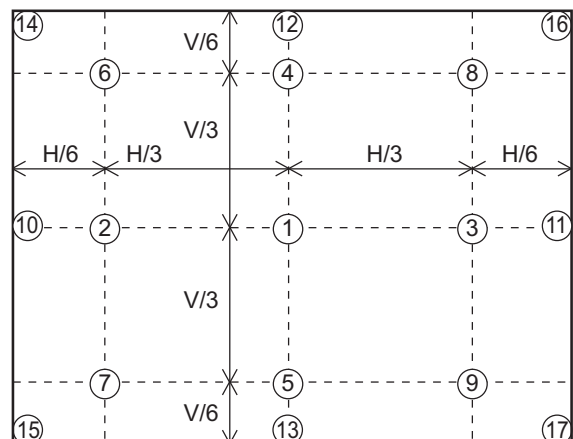

CP-S235 (C10SM2)

Adjustment procedure 1

(when a colour differential meter is used)

1. First adjust [MID-L] tone [G:].
2. Select adjustment point [No.2][G:].
When the background is not [G] monochrome, press the [ENTER] key on the Remote control transmitter to change to solid [G] monochrome.
3. Measure the illumination at adjustment points No. 2, No.3, No.10 and No.11.
The values should be:
No.2 = Y2 [lx] No.10 = Y10 [lx]
No.3 = Y3 [lx] No.11 = Y11 [lx]
4. No.2 and No.3 adjustment point have the average of Y2 and Y3.
 $Y2 = (Y2 + Y3) / 2 \pm 2 [\%]$
 $Y3 = (Y2 + Y3) / 2 \pm 2 [\%]$
5. No.10 and No.11 adjustment point have the average of Y10 and Y11.
 $Y10 = (Y10 + Y11) / 2 \pm 2 [\%]$
 $Y11 = (Y10 + Y11) / 2 \pm 2 [\%]$
6. Then adjust [MID-L] tone [R] and [B].
When the background is [G] monochrome, press the [ENTER] key on the Remote control transmitter to change to solid white.
7. Measure the colour co-ordinates of adjustment point [No.1] and make a note of them.
Assume that they are $x = x1$, $y = y1$.
Note: When the CL-100 colour and colour difference meter is used, the Δ (delta) mode is convenient. When adjustment point [No.1] colour co-ordinate has been selected, set the slide switch on the side to Δ (delta) while holding down the [F] button on the front panel. The measurement shown after this displays the deviation from measurement point 1.
8. Measure the colour co-ordinates of measurement point [No.2] and adjust [No.2][R:] and [B:] so that the co-ordinates are as follows.
 $x = x1 \pm 0.005$, $y = y1 \pm 0.010$
9. Similarly, measure adjustment points [No.3] to [No.17] and adjust their colour co-ordinates starting in order from the small number points.
This completes adjustments required for [MIN].
Note: Since excessive correction may lead to a correction data overview during internal calculations, use the following values for reference.
[No.2] to [No.5] ± 40 or less
[No.6] to [No.9] ± 50 or less
[No.10] to [No.13] ± 70 or less
[No.14] to [No.17] ± 120 or less
10. Then adjust [MIN] tone [G] so that the adjustment data set two times as much as [MID-L] tone [G].
This completes [G] colour adjustments.
11. Then adjust [MIN] tone [R] and [B].
Select [No.2] [B:] and press the [ENTER] key on the Remote control transmitter to change to solid white.
12. Measure the colour co-ordinates of adjustment point [No.1] and make a note of them.
Assume that they are $x = x1$, $y = y1$.
13. Now measure the colour co-ordinates of measurement point [No.2] and adjust [No.2][R:] and [B:] so that the co-ordinates are as follows.
 $x = x1 \pm 0.005$, $y = y1 \pm 0.010$ (Target)
 $x = x1 \pm 0.020$, $y = y1 \pm 0.040$
14. Similarly, measure adjustment points [No.3] to [No.17] and adjust their colour co-ordinates starting in order from the small number points.
This completes [MIN] tone adjustments.
15. Now make similar adjustments for [MID-H] tone.
(Adjust [MID-H] tone [G] so that the adjustment data set half as many as [MID-L] tone [G].)
16. Now make similar adjustments for [MAX] tone.
(Adjust [MAX] tone [G] so that the adjustment data set half as many as [MID-L] tone [G].)

CP-S235 (C10SM2)

Adjustment procedure 2 (visual inspection)

1. First adjust [MIN] tone [G:].
2. Select [No.2] [G:].
If the background is [G] monochrome, press the [ENTER] key on the Remote control transmitter to change to solid white.
3. View measurement point [No.2] and [No.3].
Lower the [G] colour intensity only of the colour point whose [G] colour is more intense than measurement point [No.1].
4. View measurement point [No.10] and [No.11].
Lower the [G] colour intensity only of the colour point whose [G] colour is more intense than measurement point [No.1], and raise the intensity of the point whose colour intensity is lower than measurement point [No.1].
5. Now adjust the [MIN] tone for colours [R] and [B].

6. View measurement points [No.2], [No.3], [No.10] and [No.11]. Adjust the [R] and [B] of each measurement point so that they have the same color as measurement point [No.1].

Adjustment technique:

First, adjust [B:] of the point whose colour is to be adjusted so that it approximates that of [No.1]. If [R:] is low at this time, the image will have cyan cast, in which case [R:] is increased. On the other hand, if [R:] is excessive, the image will have a magenta cast, in which case [R:] is decreased. Overall, a cyan cast makes it easy to see colour shading.

7. Next, view measurement points [No.4], [No.5], [No.12], [No.13] and make similar adjustments.
8. Then adjust measurement points [No.6], [No.7], [No.8], [No.9], [No.14], [No.15], [No.16] and [No.17].
This completes the [MIN] tone adjustments.
9. Make similar another three tones as described in steps 1 to 8 above.

No. 2 deviation range

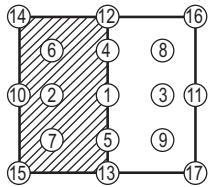

No. 10 deviation range

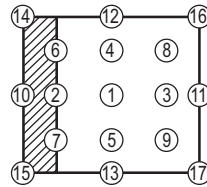

No. 3 deviation range

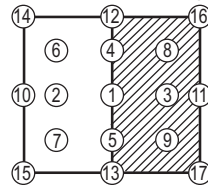

No. 11 deviation range

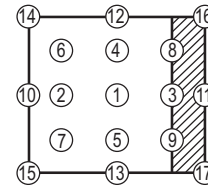

No. 4 deviation range

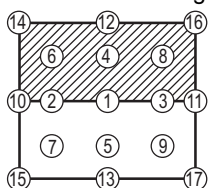

No. 12 deviation range

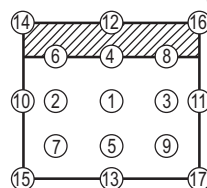

No. 5 deviation range

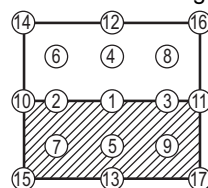

No. 13 deviation range

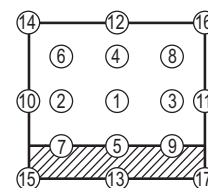

No. 6 deviation range

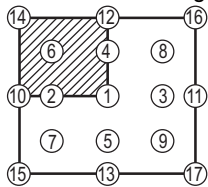

No. 7 deviation range

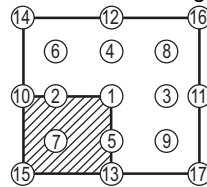

No. 8 deviation range

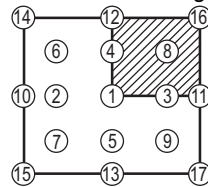

No. 9 deviation range

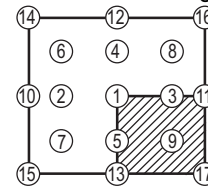

No. 14 deviation range

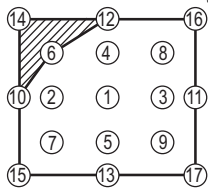

No. 15 deviation range

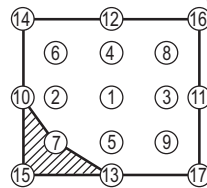

No. 16 deviation range

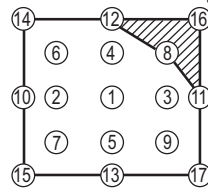

No. 17 deviation range

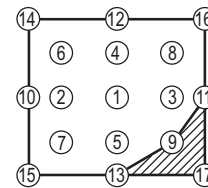

CP-S235 (C10SM2)

4-7 AIR-SENSOR adjustment

When the MAIN board or the SENSOR board is replaced, perform this adjustment after completing reassembling the projector.

1. Open SERVICE MENU and choose AIR-SENSOR by using ▼ button.
Service menu comes up by following operation. Set the cursor on the OPTION menu and press the MAGNIFY OFF button on the Remote controller. Next hold the MAGNIFY OFF button for 3 seconds or more.
2. Press the ► button. Next press the [▲] button to select EXECUTE. The adjustment program runs automatically.
3. After the message of "END" is displayed, check the Offset value displayed according to the following spec
Spec. : $150 \leq \text{Offset} \leq 227$
4. If out of spec, confirm the below conditions Then retry the same adjustment.

| | Description |
|-----|--|
| (a) | Installing the air filter correctly. |
| (b) | No obstruction and dust on air filter. (If not good condition, clean or replace the air filter.) |
| (c) | Using the proper type of air filter. |
| (d) | Installing the SENSOR board correctly. |
| (e) | Connecting the proper wires to E7A1 and E981 firmly. |
| (f) | The component I7A2 on the MAIN board stands vertically |
| (g) | The component D981 on the SENSOR board stands vertically |

5. If the all conditions above is okay, replace the MAIN board.

5. Troubleshooting

Check points

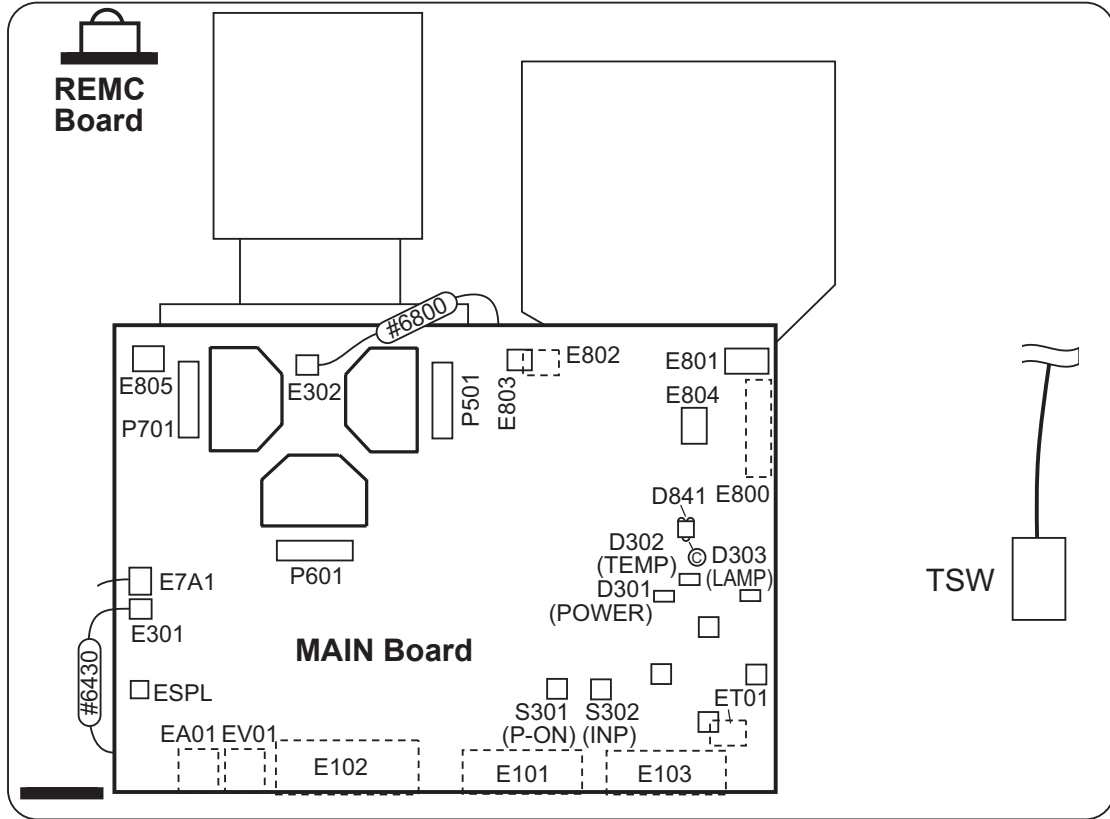

SENSOR Board

Rear view

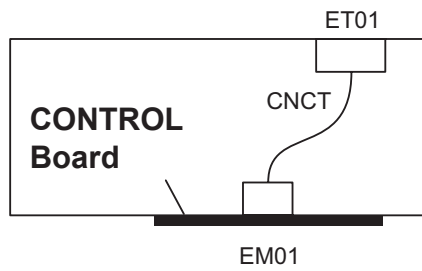

CP-S235 (C10SM2)

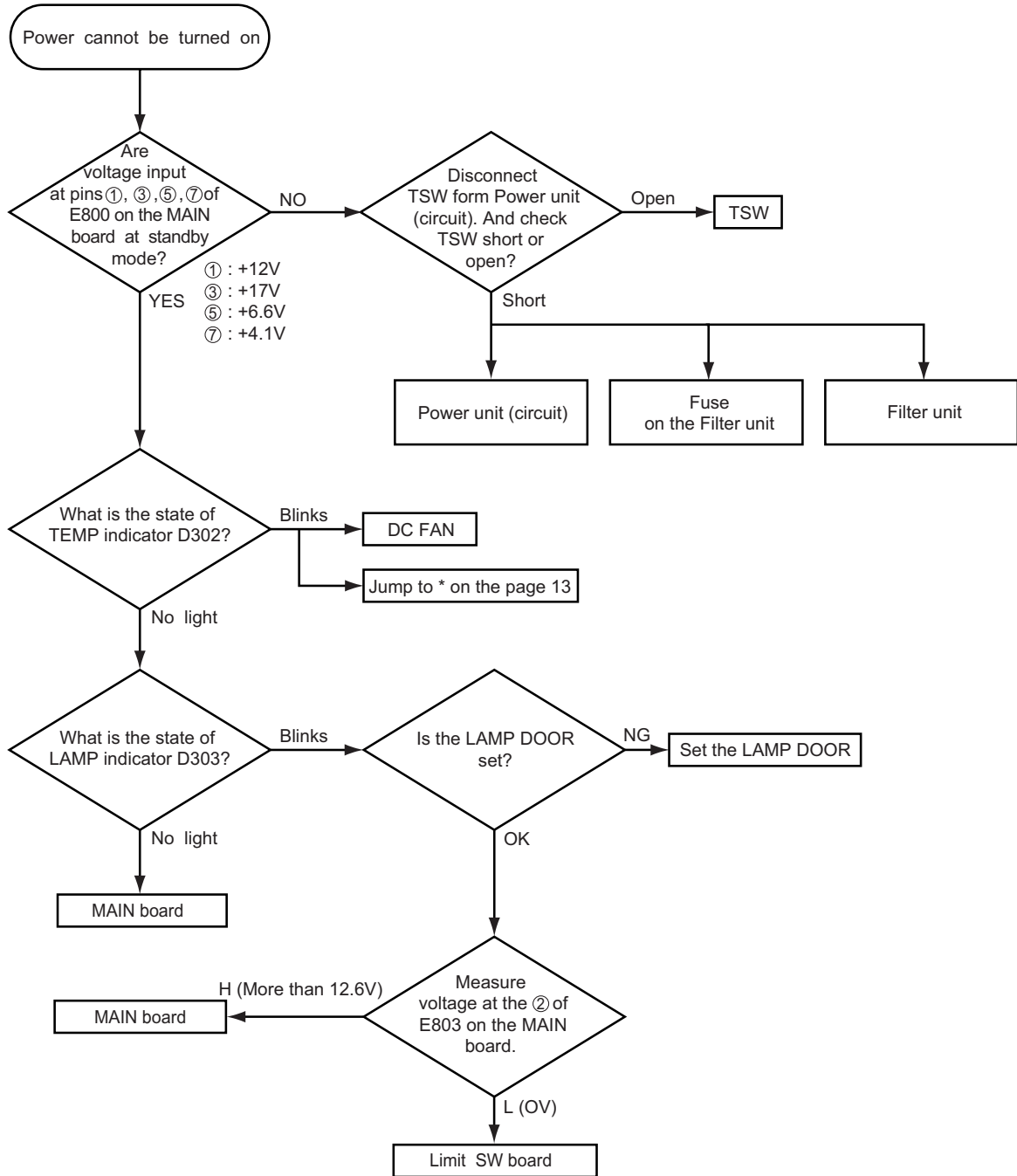

CP-S235 (C10SM2)

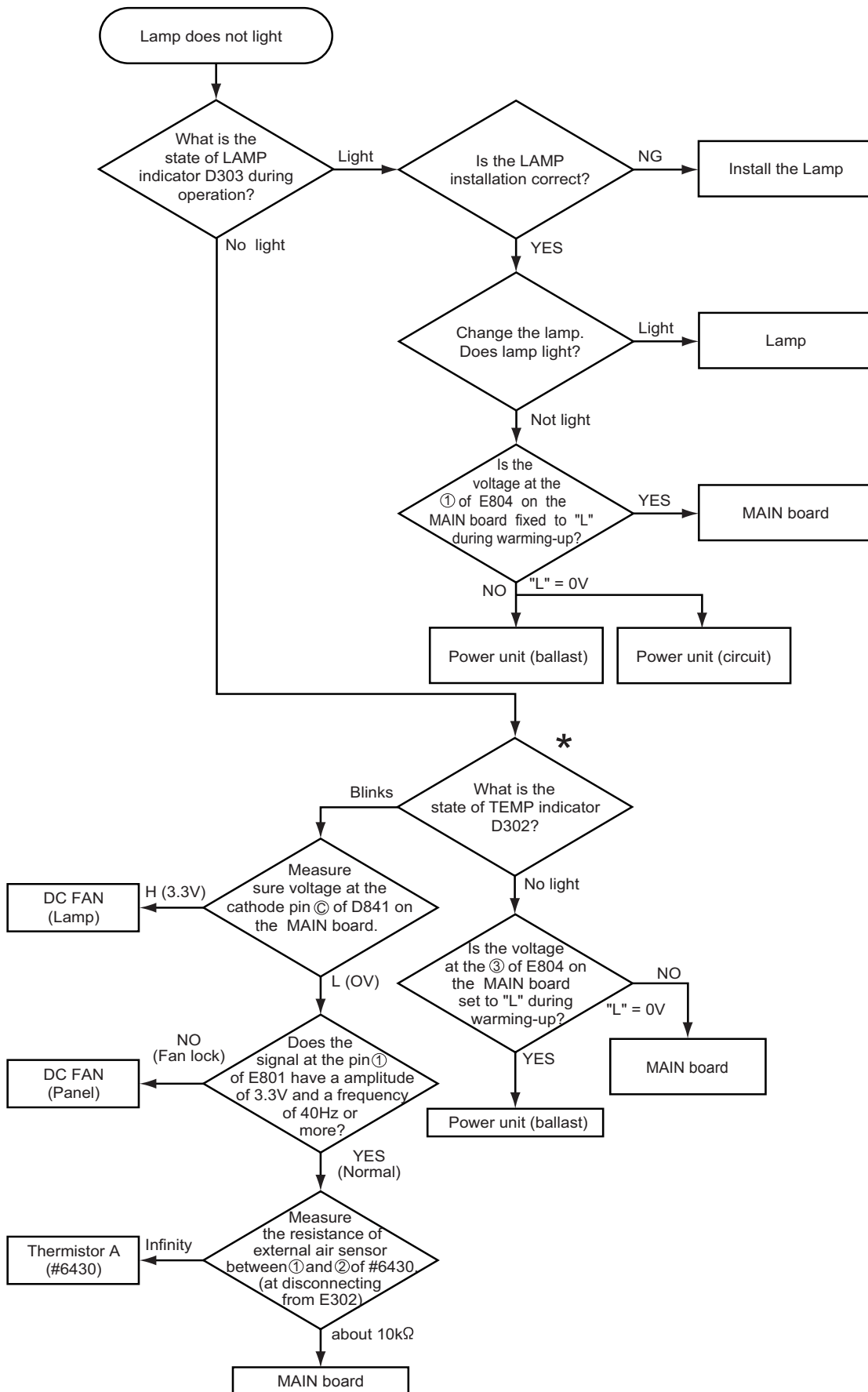

CP-S235 (C10SM2)

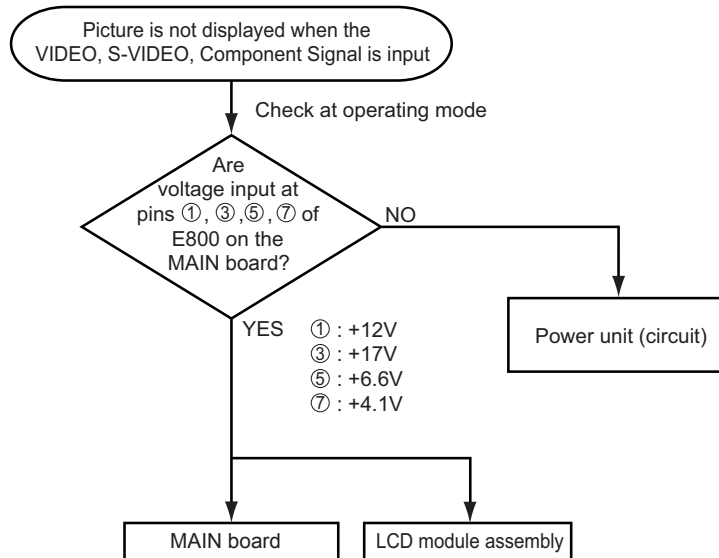
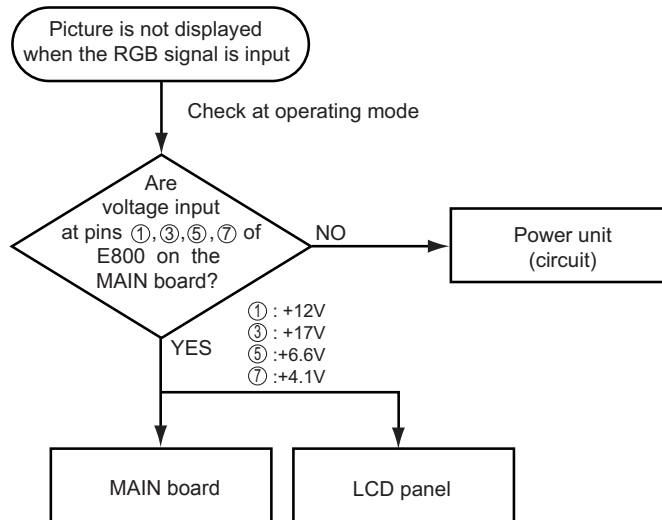

CP-S235 (C10SM2)

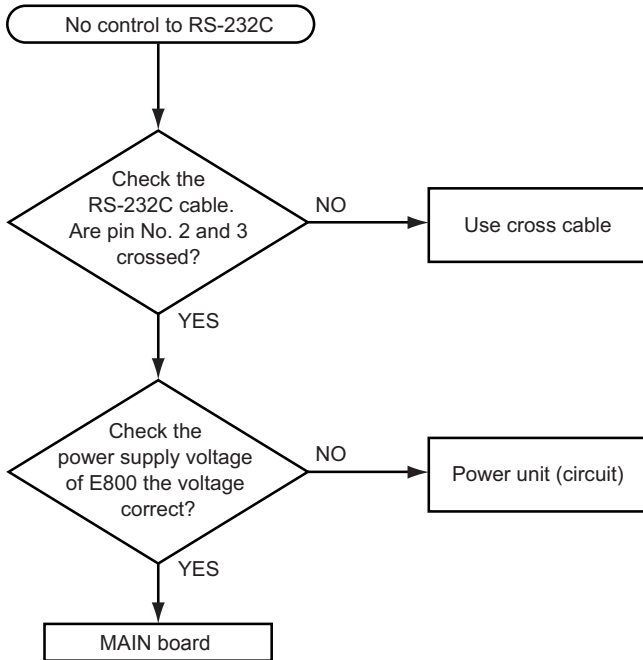
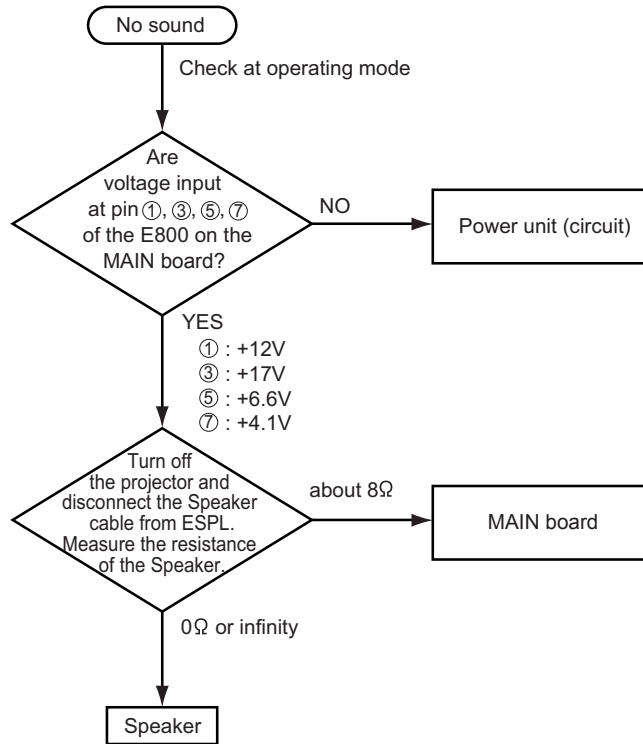

The check after parts change

1. PC power supply OFF
 2. Connection of cable
 3. Projector starting
 4. PC starting
- *When not operating :
PC set up change of cable.

6. Service notes

6-1 Lead-free solder [CAUTION]

This product uses lead-free solder (unleaded) to help preserve the environment. Please read these instructions before attempting any soldering work.

⚠ CAUTION

Always wear safety glasses to prevent fumes or molten solder from getting into the eyes. Lead-free solder can splatter at high temperatures (600°C).

■ Lead-free solder indicator

Printed circuit boards using lead-free solder are engraved with an "F."

■ Properties of lead-free solder

The melting point of lead-free solder is 40-50°C higher than leaded solder.

■ Servicing solder

Solder with an alloy composition of Sn-3.0Ag-0.5Cu or Sn-0.7Cu is recommended.

Although servicing with leaded solder is possible, there are a few precautions that have to be taken. (Not taking these precautions may cause the solder to not harden properly, and lead to consequent malfunctions.)

Precautions when using leaded solder

- Remove all lead free solder from soldered joints when replacing components.
- If leaded solder should be added to existing lead free joints, mix in the leaded solder thoroughly after the lead-free solder has been completely melted (do not apply the soldering iron without solder).

■ Servicing soldering iron

A soldering iron with a temperature setting capability (temperature control function) is recommended.

The melting point of lead-free solder is higher than leaded solder. Use a soldering iron that maintains a high stable temperature (large heat capacity), and that allows temperature adjustment according to the part being serviced, to avoid poor servicing performance.

Recommended soldering iron:

- Soldering iron with temperature control function (temperature range: 320-450°C)

Recommended temperature range per part:

| Part | Soldering iron temperature |
|---------------------------------|----------------------------|
| Mounting (chips) on mounted PCB | 320 ±30°C |
| Mounting (chips) on empty PCB | 380 ±30°C |
| Chassis, metallic shield, etc. | 420 ±30°C |

The boards using lead-free solder

- | | |
|------------------|------------------------|
| ① MAIN board | ⑤ POWER UNIT (BALLAST) |
| ② SENSOR board | ⑥ POWER UNIT (CIRCUIT) |
| ③ REMC board | ⑦ FILTER UNIT |
| ④ COVER SW board | |

CP-S235 (C10SM2)

6-2 Cautions when removing the MAIN board

When removing the MAIN board, there is danger of damaging the connector connecting cables.

- 1) Disconnect 11 cables and remove 4 screws.

⚠ ATTENTION

Handling FPC cable

Be careful not to add strong load, such as pulling or twisting the FPC cable.

If load is added to FPC cable, convergence may shift.

In case FPC cable is being removing, or when attaching, or when opening a intake LID, or when closing, please carry out carefully and slowly so that load is not added to FPC cable.

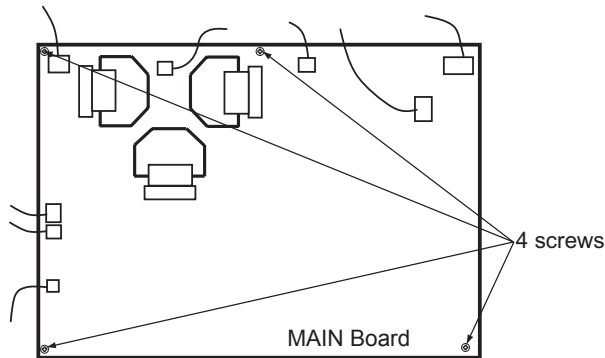

- 2) Remove 2 screw.

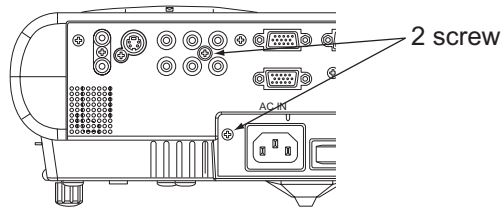

- 3) Lift the rear of the MAIN board to the front.

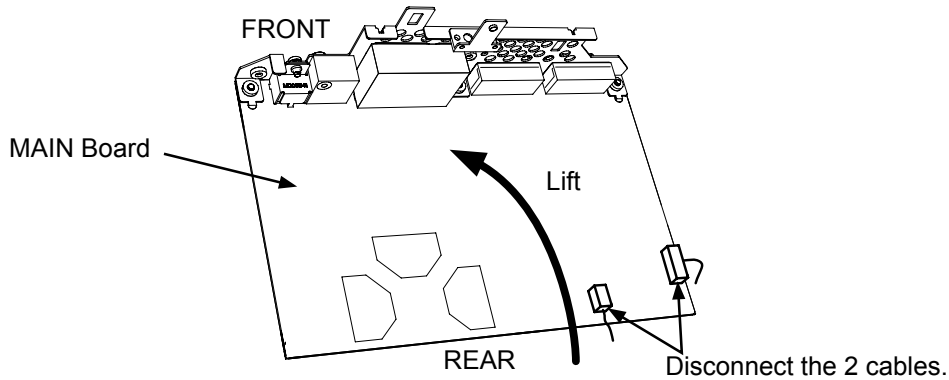

6-3 Cautions when removing the power unit (BALLAST)

When removing the cable (CNBAR) connected to Power Unit (BALLAST), there is danger of damaging the small PCB connecting cables.

-  Disconnect the CNBAR from connector CN200, while pressing the sub-board (to prevent the stress on the sub-board).

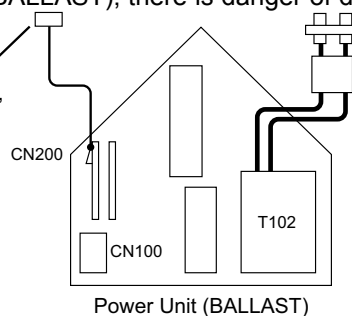

CP-S235 (C10SM2)

6-4 Before replacing the LCD/Lens prism

You should not separately replace the parts of the liquid crystal LCD/Lens prism because they only work properly when used together. Therefore, you can either replace the LCD/Lens prism assembly or send the whole LCD/Lens prism assembly unit back to HITACHI where we will replace the malfunctioning part, recondition the device and send it back to you.

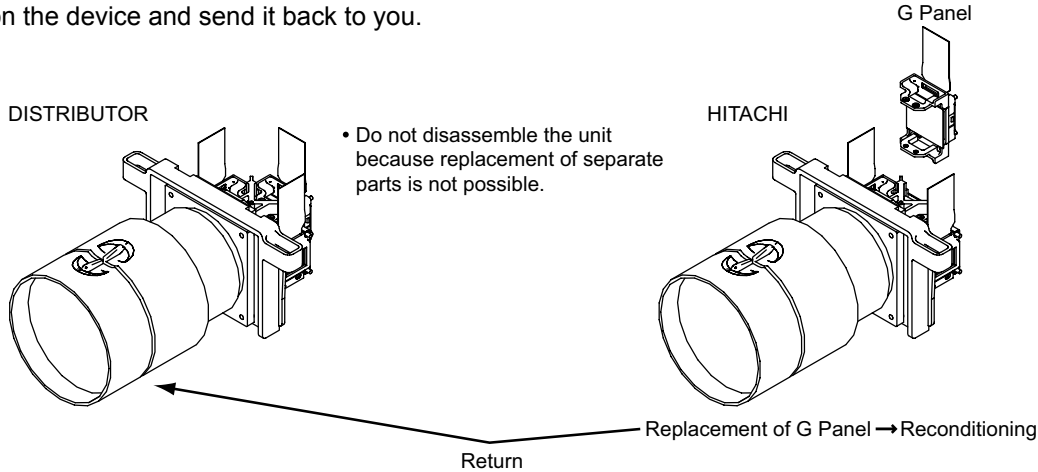

6-5 Cleaning dust from panels and optical filters

1. Preparation

Prepare cleaning tools and materials as follows. Work in a relatively clean room so as to remove additional dust while in removal operation.

- (1) Swab for cleaning P#: NX08061, "Cotton stick L147"
- (2) Air duster (Dust blower, spray can)
- (3) Vacuum cleaner

2. Disassemble and open the maintenance hole.

- (1) Turn off the projector, and unplug the power cord.
- (2) Remove the top cover, according to the disassembling diagram of chapter 8.
- (3) Remove the MAIN board, according to the Chapter 6-2.
- (4) Remove the intake LID.

⚠ ATTENTION

Handling FPC cable

Be careful not to add strong load, such as pulling or twisting the FPC cable.

If load is added to FPC cable, Convergence may shift.

When the FPC cable is being removed, attached, when opening or closing a intake LID, perform the operation carefully and slowly so that load is not added to FPC cable.

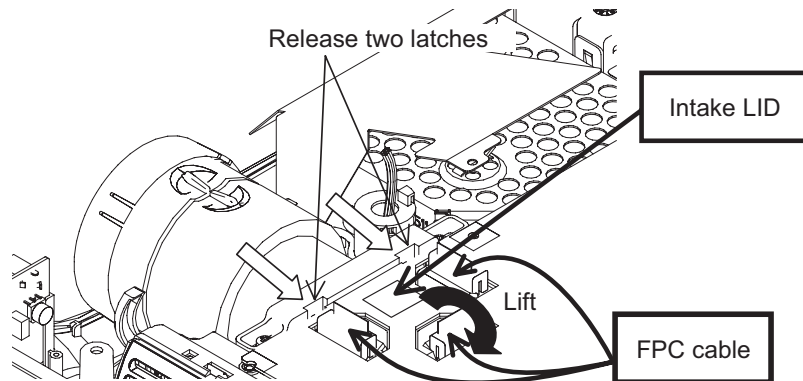

- (5) Re-assemble the MAIN board and re-connect all the connectors.

CP-S235 (C10SM2)

3. Maintenance point

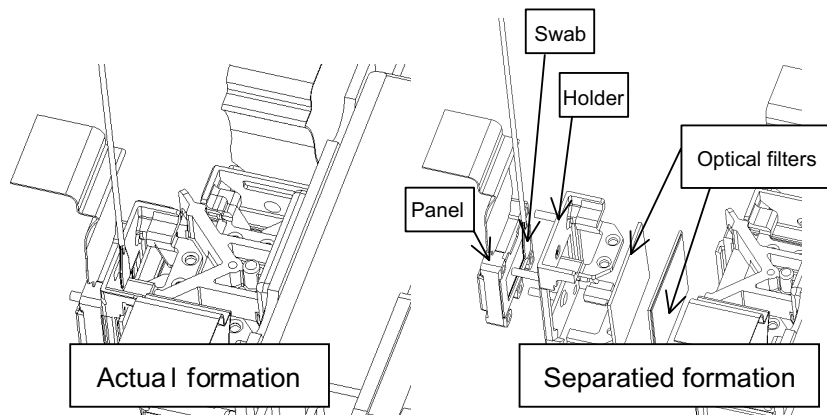

Each colour part has same construction.

By using swab and air duster, you can easily remove dust from panel and optical filters.

4. Cleaning the panels and optical filters

- (1) Turn on the set and lit on the lamp.
- (2) Set blank screen to black or white.
- (3) By using swab and air duster, remove the dust. While cleaning you can check the dust on screen.

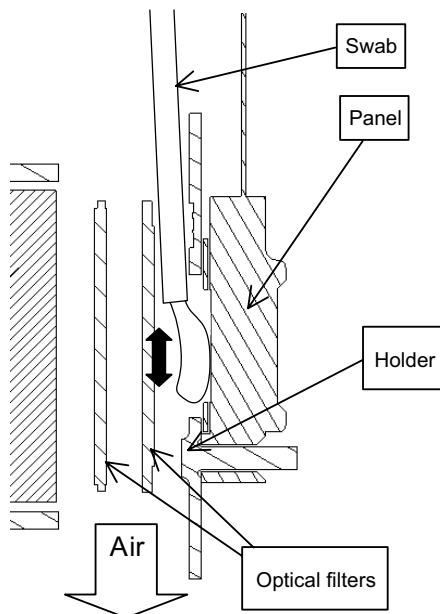

- While removing the dust, separated dust will be blown off by air cooling system.
- Please pay attention not to damage panel and filters.

5. Re-assembly

- (1) Turn off the set and remove the MAIN board.
- (2) Set the intake LID.
- (3) Re-assemble the MAIN board.
- (4) Re-assemble the set.
- (5) While re-assembling, clean the intake LID and intake filter and filter cover using a vacuum cleaner.

6-5 Putting batteries

CAUTION

Always handle the batteries with care and use them only as directed. Improper use may result in battery cracking or leakage, which could result in fire, injury and/or pollution of the surrounding environment.

- Keep the battery away from children and pets.
- Be sure to use only the batteries specified for use with the remote control. Do not mix new batteries with used ones.
- When inserting batteries, verify that the plus and minus terminals are aligned correctly (as indicated in the remote control).
- When you dispose the battery, you should obey the law in the relative area or country.

1. Remove the battery cover.

Slide back and remove the cover in the direction of the arrow.

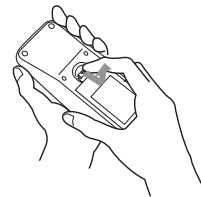

2. Insert the batteries.

Align and insert the two AA batteries according to their plus and minus terminals.
(as indicated in the remote control.)

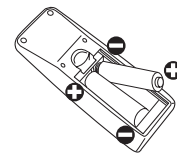

3. Close the battery cover.

Replace the cover in the direction of the arrow and snap it back into place.

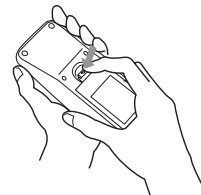

6-6 Air filter

The air filter should be cleaned about every 100 hours. If the indicators or a message prompts you to clean the air filter, clean the air filter as soon as possible. If the air filter becomes clogged by dust or the like, internal temperature rises and could cause malfunction.





⚠ WARNING

- Please carefully read the "User's Manual - Safety Guide".
- Before replacing the air filter, make sure the power switch is off and the power cable is not plugged in.
- Use the air filter of the specified type only. **Type number: NJ08292**
- Do not use the projector with the air filter and filter cover removed. The use without the air filter could result in damage.

⚠ CAUTION

- Do not reset the filter timer without cleaning or replacing the air filter.
- If the air filter becomes clogged by dust or the like, internal temperature rises and could cause malfunction. The power is automatically turned off in order to prevent the projector from overheating internally.
- When you replace the lamp, please replace also the air filter. The air filter may be attached to the replacement lamp.



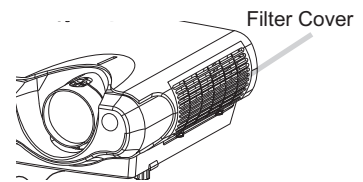

● Caring for the air filter

1. Turn off the projector and unplug the power cord.
2. Apply a vacuum cleaner to the top of the filter cover to clean the air filter.
3. Reset the filter timer, according to following "Reset The Filter Timer".
 - (1) Turn on the projector. While the projector running, press the MENU button to open the menu.
 - (2) Choose the "OPTION" on the menu using the  button, then press the  button or ENTER button.
 - (3) Choose the "FILTER TIME" using the  button, then press and hold the  button of projector or the RESET button of remote control for 3 seconds.
 - (4) Choose the "RESET" using the  button.



● Replacing the air filter

If the soiling will not come off the air filter or it becomes damaged, then it needs to be replaced. Please replace the air filter as soon as possible.

1. Turn off the projector and unplug the power cord.
2. Contact your local dealer to prepare a new air filter. Tell the dealer your air filter type number.
3. After making sure that the projector has cooled adequately, remove the filter cover. Hold the release buttons of the filter cover while pulling up it.
4. Hold the release buttons of the air filter while pulling down it.
5. Insert a new air filter and replace the filter cover.
6. Reset the filter timer, according to following "Reset The Filter Timer".
 - (1) Turn on the projector. While the projector running, press the MENU button to open the menu.
 - (2) Choose the "OPTION" on the menu using the  button, then press the  button or ENTER button.
 - (3) Choose the "FILTER TIME" using the  button, then press and hold the  button of projector or the RESET button of remote control for 3 seconds.
 - (4) Choose the "RESET" using the  button.

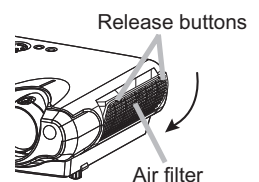
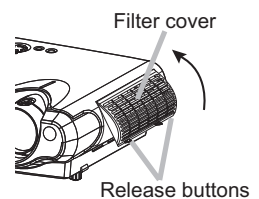

CP-S235 (C10SM2)

6-5 Lamp

WARNING



HIGH VOLTAGE



HIGH TEMPERATURE



HIGH PRESSURE

The projector uses a high-pressure mercury glass lamp. The lamp can **break with a loud bang, or burn out**, if jolted or scratched, handled while hot or worn-out over time.

Note that each lamp has a different lifetime and some may burst or burn out soon after you start using them.

In addition, when the bulb bursts, it is possible for **shards of glass** to fly into the lamp housing and for **gas containing mercury** to escape from the projector's vent holes.

About disposal of a lamp • This product contains a mercury lamp; do not put in trash. Dispose of in accord with environmental laws.

For lamp recycling, go to www.lamprecycle.org. (in USA)

For product disposal, contact your local government agency or www.eiae.org (in the US) or www.epsc.ca (in Canada).

For more information, call your dealer.



Disconnect the plug from the power outlet

- If the lamp should break (it will make a loud bang when it does), unplug the power cord from the outlet and make sure to request a replacement lamp from your local dealer. Note that shards of glass could damage the projector's internals or cause injury during handling, so please do not try to clean the projector or replace the lamp yourself.
- If the lamp should break (it will make a loud bang when it does), ventilate the room well and make sure not to breathe the gas that comes out of the projector vents or get it in your eyes or mouth.
- Before replacing the lamp, make sure the power switch is off and the power cable is not plugged in, then wait at least 45 minutes for the lamp to cool sufficiently. Handling the lamp while hot can cause burns as well as damaging the lamp.



- Do not open the lamp cover while the projector is suspended from above. This is dangerous, since if the lamp's bulb has broken, the shards will fall out when the cover is opened. In addition, working in high places is dangerous so ask your local dealer to have the lamp replaced even if the bulb is not broken.
- Do not use the projector with the lamp cover removed. When replacing the lamp, make sure that the screws are screwed in firmly. Loose screws could result in damage or injury.



- Use only the lamp of the specified type: **DT00621**
- If the lamp breaks soon after the first time it is used, it is possible that there are electrical problems elsewhere besides the lamp. If this happens, contact your local dealer or a service representative.
- Handle with care: jolting or scratching could cause the lamp bulb to burst during use.
- If the indicators or a message prompts you to replace the lamp (see the section "Related Messages" and "Regarding the indicator Lamps"), replace the lamp as soon as possible. Using the lamp for long periods of time or past the replacement date could cause it to burst. Do not use old (used) lamps; this is a cause of breakage.

CP-S235 (C10SM2)

● Replacing the lamp

If the indicators or a message prompts you to replace the lamp, replace the lamp as soon as possible. Using the lamp for long periods of time, or past the replacement date, could cause it to burst.

WARNING





- Please carefully read the "User's Manual - Safety Guide".

CAUTION

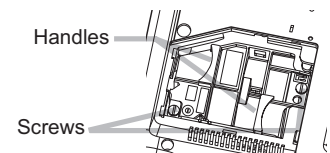
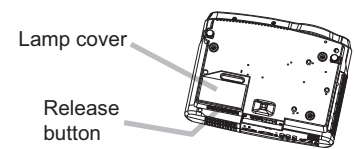
- Do not reset the lamp timer without replacing the lamp.
- When you replace the lamp, please replace also the air filter. The air filter may be attached when you buy a replacement lamp for this projector. Please ask your dealer.

1. Turn off the projector and unplug the power cord. Allow the lamp bulb to cool for at least 45 minutes and prepare a new lamp.
2. After making sure that the projector has cooled adequately, slowly flip over the projector so that the bottom is facing up.
3. Hold the release button while sliding and taking the lamp cover up.
4. Unscrew the 2 screws and slowly pick up the lamp by the handles.
5. Insert the new lamp and tighten the 2 screws firmly to lock it in place.
6. Slide the lamp cover into place until it locks into position.
7. Slowly turn the projector so that the top is facing up.
8. Turn on the projector and reset the lamp timer. When the lamp has been replaced after the message of "THE POWER WILL TURN OFF AFTER 0hr." is displayed, complete the following operation within 10 minutes of switching power on.



- (1) While the projector running, press the MENU button to open the menu.
- (2) Choose the "OPTION" on the menu using the  button, then press the  button or ENTER button
- (3) Choose the "LAMP TIME" using the  button, then press and hold the  button of projector or the RESET button of remote control for 3 seconds.
- (4) Choose the "RESET" using the  button.

6-8 Notice of AUTO adjustment

Use of AUTO adjustment with the image through RGB input optimises V_POSI, H_POSI, H_SIZE and H_PHASE automatically.

In case that projected image has dark tone around its peripheral, AUTO operation sometimes makes artifacts in the image, shifts capture area and so on. Those failures are caused by period of image data is not exactly distinguished to period of blanking on signal processing.

To avoid such phenomena, AUTO function should be used with the full size picture that has bright tone on its peripheral.



Image when AUTO operates correctly



Image when AUTO fails.

- Noting image of top or bottom lines.
- Shift of the image to East or West.
- Artifacts on image. Etc.

NOTE

- The phenomenon at the failure of AUTO adjustment depends on resolution of input source, scene of picture etc.
- There is no failure above in AUTO with video source through VIDEO, S-VIDEO or COMPONENT input. The reason is why recognition of input signal's standard does not need to search the capture range from input signal itself.

CP-S235 (C10SM2)

6-9 PIN LOCK System

If the following PIN BOX menu appears after power on the projector, the PIN LOCK system has been activated. Under such a condition, key operations and signal displaying are inhibited. To open the PIN LOCK system, 4 correct PIN CODE digits need to be input. If correct PIN CODE is not input in 5 min., the lamp will be automatically turned off.



PIN BOX

Returning repaired unit

Use the Master PIN code. See the paragraph of Releasing the PIN LOCK system inactivation.

Swap unit/Returned unit

Inactivate the PIN LOCK system. See the paragraph of the PIN LOCK system inactivation.

Releasing the PIN LOCK System

When the PIN BOX menu is displayed, sequentially enter the codes with remote controller as follows. In accordance with remote controller button entry, “*” mark appears in the PIN BOX menu.

Master PIN codes

- 1st entry code: Press the “MENU” button.
- 2nd entry code: Press the “▼” button.
- 3rd entry code: Press the “KEYSTONE” button.
- 4th entry code: Press the “▲” button.

Note: The Master PIN codes can be used up to 30 times. The codes cannot be used thereafter. If the Master PIN codes cannot be used, see the following paragraph.

The PIN LOCK System inactivation

1. When the PIN BOX menu is displayed, press “RESET” for 3 seconds or more in order to get the ID Inquiring Code.

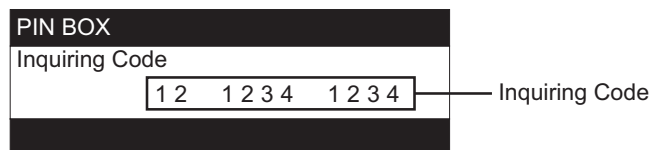

PIN BOX (ID Inquiring Code)

2. Send the HITACHI sales company the Inquiring code (10 digits) to receive the correct PIN code.
3. With the PIN BOX menu displayed, input the correct PIN code. Enter the correct PIN CODE that has been received.
4. Open the menu and select “TURN OFF” from the PIN LOCK items in the OPTION menu. Then the PIN BOX menu appears.
5. Input the correct PIN code in the PIN BOX menu.
6. The OPTION menu then appears.

After the PIN LOCK system is inactivated, the PIN BOX is no longer displayed in the OPTION menu.

If the PIN LOCK items keep displaying, the PIN LOCK system is not inactivated. Input the correct PIN CODE again.

CP-S235 (C10SM2)

6-10 Related messages

When the unit's power is ON, messages such as those shown below may be displayed. When any such message is displayed on the screen, please respond as described below.

| Message | Description |
|--|---|
| CHANGE THE LAMP AFTER REPLACING LAMP, RESET THE LAMP TIMER. (*1) | Lamp usage time is approaching 2000 hours. (*2) Preparation of a new lamp and an early lamp change is recommended. After you have changed the lamp, please be sure to reset the lamp timer. |
| CHANGE THE LAMP AFTER REPLACING LAMP, RESET THE LAMP TIMER. THE POWER WILL TURN OFF AFTER ** hr. (*1) | Lamp usage time is approaching 2000 hours. (*2) A lamp change within ** hours is recommended. When lamp usage reaches 2000 hours, the power will automatically be turned OFF. Please change the lamp by referring to the "Lamp" section of this manual. After you have changed the lamp, please be sure to reset the lamp timer. |
| CHANGE THE LAMP AFTER REPLACING LAMP, RESET THE LAMP TIMER. THE POWER WILL TURN OFF AFTER 0 hr. | As lamp use has reached 2000 hours (*2), the power will soon be automatically turned OFF. Please immediately turn the power off and change the lamp by referring to the "Lamp" section of this manual. After you have changed the lamp, please be sure to reset the lamp timer. |
| NO INPUT IS DETECTED ON *** | There is no input signal. Please confirm the signal input connection and the status of the signal source. |
| SYNC IS OUT OF RANGE ON *** [H] *****kHz [V] *****Hz | The horizontal or vertical wavelength of the inputted signal is outside of the response parameters of this unit. Please confirm the specs for this unit or the signal source specs. |
| CHECK THE AIR FLOW | The internal portion temperature is rising. Please turn the power OFF and allow the unit to cool down at least 20 minutes. After having confirmed the following items, please turn the power ON again. • Is there blockage of the air passage aperture? • Is the air filter dirty? • Does the peripheral temperature exceed 35°C? |
| CLEAN THE AIR FILTER POWER OFF FIRST, THEN CLEAN THE AIR FILTER. AFTER CLEANING THE AIR FILTER, RESET THE FILTER TIMER. | A note of precaution when cleaning the air filter. Please immediately turn the power OFF and clean or change the air filter by referring to the "Air Filter" section of this manual. After you have cleaned or changed the air filter, please be sure to reset the filter timer. If the same message is displayed after the treatment, please clean the transparent area of filter cover and the dust-detecting window, according to the following "Caring Of The Transparent Area Of Filter Cover and The Dust-detecting Window" . |

Note: (*1) • Although this message will automatically disappear after around 3 minutes, it will reappear every time the power is turned ON.

(*2) • Lamps have a finite product life. Lamps are characterised by the fact that, after long hours of usage, a lamp will no longer light or the lamp will break or burst, etc. This unit is equipped with an automatic shut-down function such that the power will automatically be turned OFF when lamp usage time has reached 2,000 hours. Please be aware, however, that among lamp types there are major differences in product lifetimes; a lamp may thus fail to light even prior to the functioning of the automatic shut-down function of this unit.

● Caring of the Transparent Area of filter cover and the dust-detecting window.

The transparent area of filter cover and the dust-detecting window should be cleaned for normal operation of the optical dust detecting system. Pay attention not to leave fibre or fragment from a cleaning cloth inside the duct.

1. Turn off the projector and unplug the power cord.
2. After making sure that the projector has cooled adequately, remove the filter cover.
Hold the release buttons of the filter cover while pulling up it.
3. Wipe the transparent area of the filter cover by using a swab or a soft cloth.
4. Remove the air filter.
Hold the release buttons of the air filter while pulling down it.
5. Wipe the dust-detecting window by using a soft cloth.
6. Replace the air filter and filter cover.

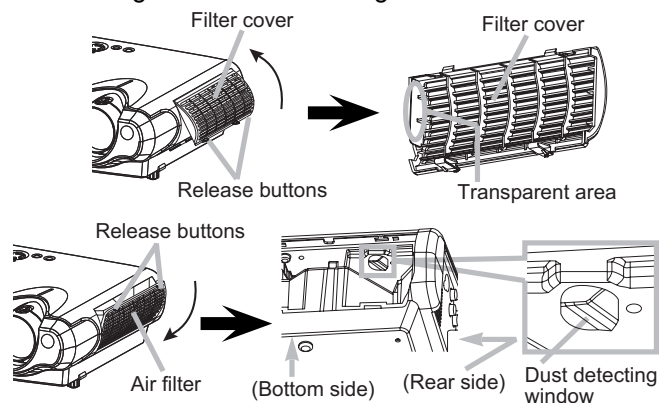

CP-S235 (C10SM2)

6-11 Indicator lamps

ATTENTION

When the interior portion has become overheated, for safety purposes, the power source may be automatically turned off and the indicator lamps may also be turned off. In such a case, press the "○" (OFF) side of the power switch and wait at least 45 minutes. After the unit has sufficiently cooled down, please confirm the attachment state of the lamp and lamp cover then turn the power on again.

Lighting and flashing of the POWER indicator, the LAMP indicator and the TEMP indicator have the meanings as described in the Table below. Please respond in accordance with the instructions within the Table.

| POWER indicator | LAMP indicator | TEMP indicator | Description |
|-------------------------|------------------------------|----------------|--|
| Lights in orange | Turned off | Turned off | The unit is in a standby state. Please refer to the "Power ON/OFF" section of this manual. |
| Flashes in green | Turned off | Turned off | The unit is warming up. Please wait. |
| Lights green | Turned off | Turned off | The unit is in an ON state. Ordinary operations may be performed. |
| Flashes in orange | Turned off | Turned off | The unit is cooling down. Please wait. |
| Blinks in red | - | - | The unit is cooling down. A certain error has been detected. Wait until the POWER indicator has finished flashing and then perform the proper response measure using the item descriptions below as reference. |
| Lights or blinks in red | Lights in red | Turned off | The projector lamp has not been properly fixed (attached), the projector lamp does not light and/or there is a possibility that the interior portion has become heated. Turn the power OFF and wait at least 20 minutes. After the unit has sufficiently cooled down, please make confirmation of the following items and then turn the power ON again. If the same indication is displayed, please change the lamp. <ul style="list-style-type: none"> • Is there blockage of the air passage aperture? • Is the air filter is dirty? • Does the peripheral temperature exceed 35°C? |
| Lights or blinks in red | Blinks in red | Turned off | The lamp cover has not been properly fixed (attached). Turn the power OFF and wait at least 45 minutes. After the unit has sufficiently cooled down, please make confirmation of the attachment state of the lamp and lamp cover and then turn the power ON again. |
| Lights or blanks in red | Turned off | Blinks in red | The cooling fan is not operating. Turn the power OFF and wait at least 20 minutes. After the unit has sufficiently cooled down, please make confirmation of the following item and then resent the power to ON. <ul style="list-style-type: none"> • Is there no foreign matter caught in the cooling fan? |
| Lights or blinks in red | Turned off | Lights in red | There is a possibility that the interior portion has become heated. Turn the power OFF and wait at least 20 minutes. After the unit has sufficiently cooled down, please make confirmation of the following item and then resent the power to ON. <ul style="list-style-type: none"> • Is there blockage of the air passage aperture? • Is the air filter is dirty? • Does the peripheral temperature exceed 35°C? |
| Lights in green | Alternative blinking in red | | There is a possibility that the interior portion has become overcooled. Please use the unit within the usage temperature parameters (0°C to 35°C). After the treatment, resent the power to ON. |
| Lights in green | Simultaneous blinking in red | | It is time to clean the air filter, or there is no air filter. Please immediately turn the power OFF and clean or change the air filter by referring to the "Air Filter" section of this manual. After you have cleaned or changed the lamp, please be sure to reset the filter timer. After the treatment, resent the power to ON. |

CP-S235 (C10SM2)

SERVICE MENU

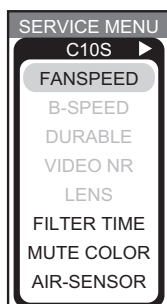

To display the OSD for “SERVICE MENU” set up.

| By the control panel | By the remote control transmitter |
|--|--|
| <ol style="list-style-type: none"> 1. Display the menu by the “MENU” button. 2. Select the “OPTION” on the menu. 3. Continue press the button “◀” first, then press the button “◀” together with “INPUT”, and hold for 3 seconds. | <ol style="list-style-type: none"> 1. Display the menu by the “MENU” button. 2. Select the “OPTION” on the menu. 3. Press the “MAGNIFY OFF” button. Next hold the “MAGNIFY OFF” button for 3 seconds. |

● Setup of cooling fan speed

When using this projector in the place where altitude is high, we recommend you to set a cooling fan’s speed as “HIGH”. It is because the cooling efficiency of a projector falls and the temperature inside a projector rises easily in such a place since the density of air becomes low.

Setting method of cooling fan speed

1. Select the “FAN SPEED” on the OSD using button “▼”.
Next press the “▶” to select “FAN SPEED MENU” by the SERVICE MENU.

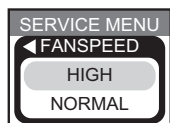

2. Select the “HIGH” on the OSD using the button “▲”. To reset this setup, select the “NORMAL” using the button “▼”.
3. The OSD will be ended by no operation for 10 seconds or change of input signal. To end immediately, use one of buttons except buttons “▲”, “▼”, “◀”, “▶”.

NOTE • The “HIGH” mode makes the fan noisy than “NORMAL” mode.
• The recall of factory setting sets the fan speed to “NORMAL” mode. You must set the fan speed after recall of factory setting if you need “HIGH” mode.

CP-S235 (C10SM2)

● Setup of filter time (“ON” or “OFF”)

1. Select the “FILTER TIME” on the OSD using button “▼” .

Next press the “▶” to select “FILTER TIME MENU” by the SERVICE MENU.

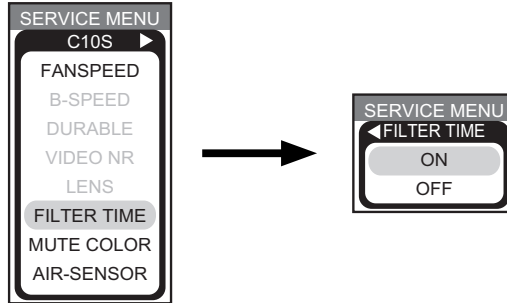

2. ON : Select the “ON” on the OSD using button “▲” .
OFF : Select the “OFF” on the OSD using button “▼” .
3. The OSD will be ended by no operation for 10 seconds or change of input signal. To end immediately, use one of buttons “▲”, “▼”, “◀”, “▶” .

● Set operating time display method (accumulated lamp time display method)

1. Select [Option] from the [Menu] display, then select [Lamp Time].
2. Press the [Reset] button once, then press [Keystone] for 3 seconds or more to display the screen shown below. (The menu will close after 10 seconds if there are no further operations.)
3. Use “▲” or “▼” to select the usage status number. (The usage status is as shown below.)

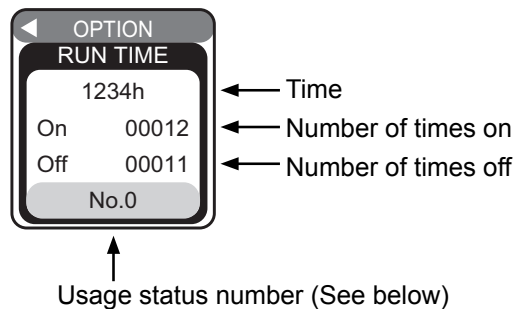

Usage status number

- 0 Total usage status
- 1 Current usage status
- 2 Usage status before first reset
- 3 Usage status before second reset
- ||
- 9 Usage status before seventh reset

Circuit/ballast power board, Control - Main board wiring

- Circuit power board wiring
- (1) Connect TSW.
 - (2) Connect CNPOW and FEB3.
 - (3) Connect FEB2.
 - (4) Connect CN1, CD2, FEB1, and FEB5.

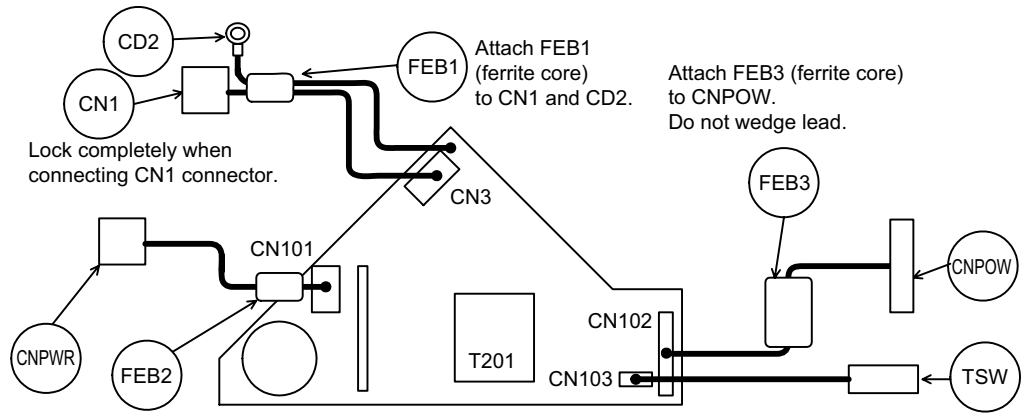

- Lock completely when connecting CNPWR connector to CN101.
- Attach FEB2 (ferrite core) to CNPWR and keep close to board.
- Confirm that CN102 and CN103 are connected properly (confirmation is not possible later).

- Ballast power board wiring
- (1) Connect CNBAR.

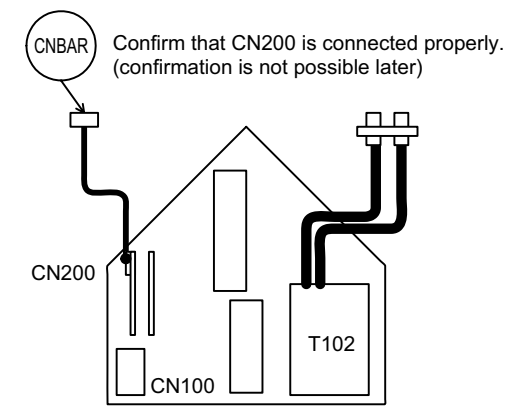

30

Control - Main board wiring

- (1) Connect CNCT.

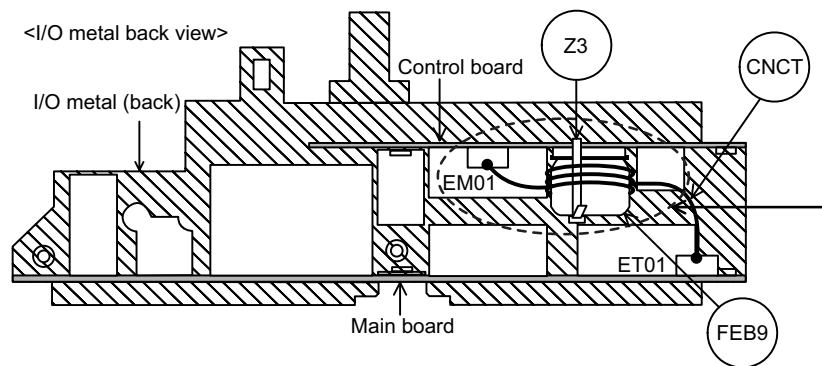

Installation details for the CNCT, FEB9 and Z3 are as per the following diagram.

Place the wiring in the notch that runs along the control board, fasten down the FEB9 that was installed in the CNCT with a Z3 (band) and cut off any excess length.

Then, Wiring the CNCT into the FEB9 brings near to the notch in the Control board and Z3 should be fixed directly to FEB9.

Install the FEB9 (ferrite core) in the CNCT. Wind the CNCT three times around the FEB9 making sure that it passes through it four times.

Wiring diagram 1 (C10SM2)

Power block wiring (board block SUB ASS'Y)

- Attaching ballast power block
- (1) Connect and wire CNPWR.
 - (2) Wire lamp lead.
 - (3) Wire CN1 and CD2.
 - (4) Wire TSW and CNPOW.

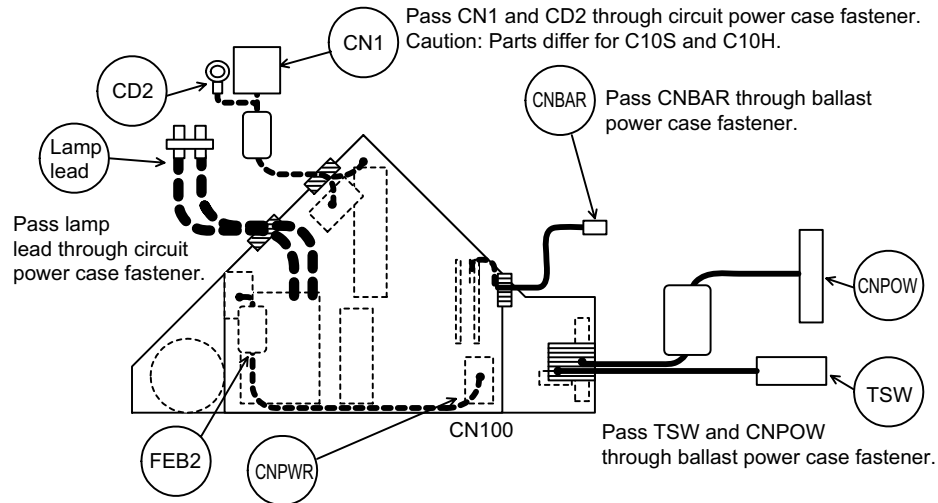

Lock CNPWR completely when connecting the connector to ballast power CN100. Arrange the lead as shown and attach FEB2 close to the circuit power. Do not wedge in cooling wheel or igniter transformer.

Assembly procedure

- (1) Pass CNBAR through ballast power block fastener and lock.
- (2) Pass CN1 and CD2 through circuit power block fastener and lock.
- (3) Connect one end of CNPWR to ballast power.
- (4) Pass lamp lead through circuit power block fastener and lock when attaching ballast power block to circuit power block.
Pass TSW and CNPOW through ballast power block fastener and lock.

After attaching ballast power block
(1) Secure FEB3.

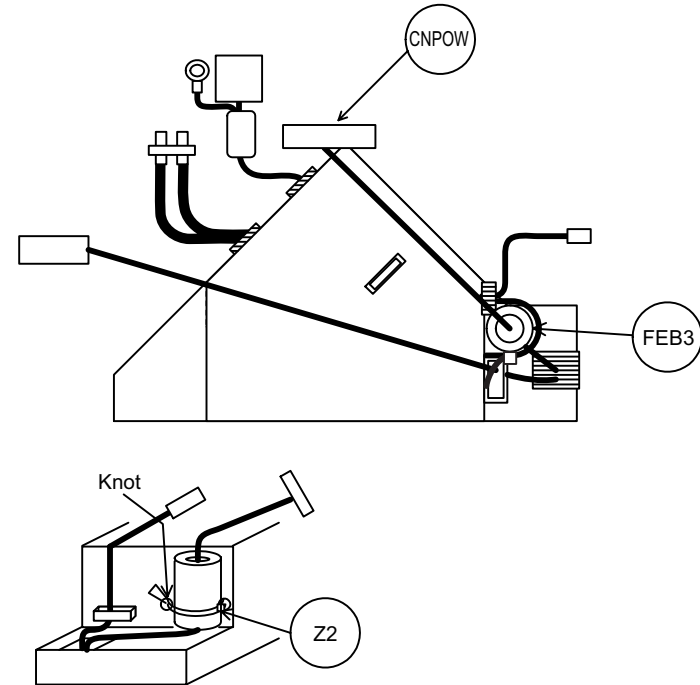

Pass tie band through side hole of ballast power case and secure FEB3. Bind the band on back side of set and crop loose end to minimize hindrance when attaching upper case.

However, if any excess length of the SK binder (Z2) comes into contact with the projector lens, cut the excess off.

Bottom case assembly wiring

Guide leads away from optical unit positions to prevent leads from becoming wedged when mounting optical unit.

Bottom case assembly

(1) Do not wedge wires when mounting optical unit.

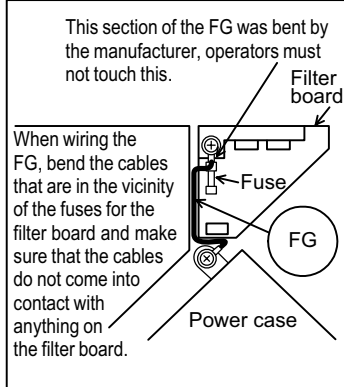

Pass wire between PBS duct and optical unit.

Pass the A83 leads twice through the FEBA.

After fastening down the FEBA to the Z4 on the ribs of the bottom case, cut off any excess length.

Arrange speaker and internal air sensor leads as shown below. Extract the speaker leads from the right hand side of the rear panel. Ensure external air sensor lead is hooked on optical unit hook. (To prevent lead getting caught when attaching main board.)

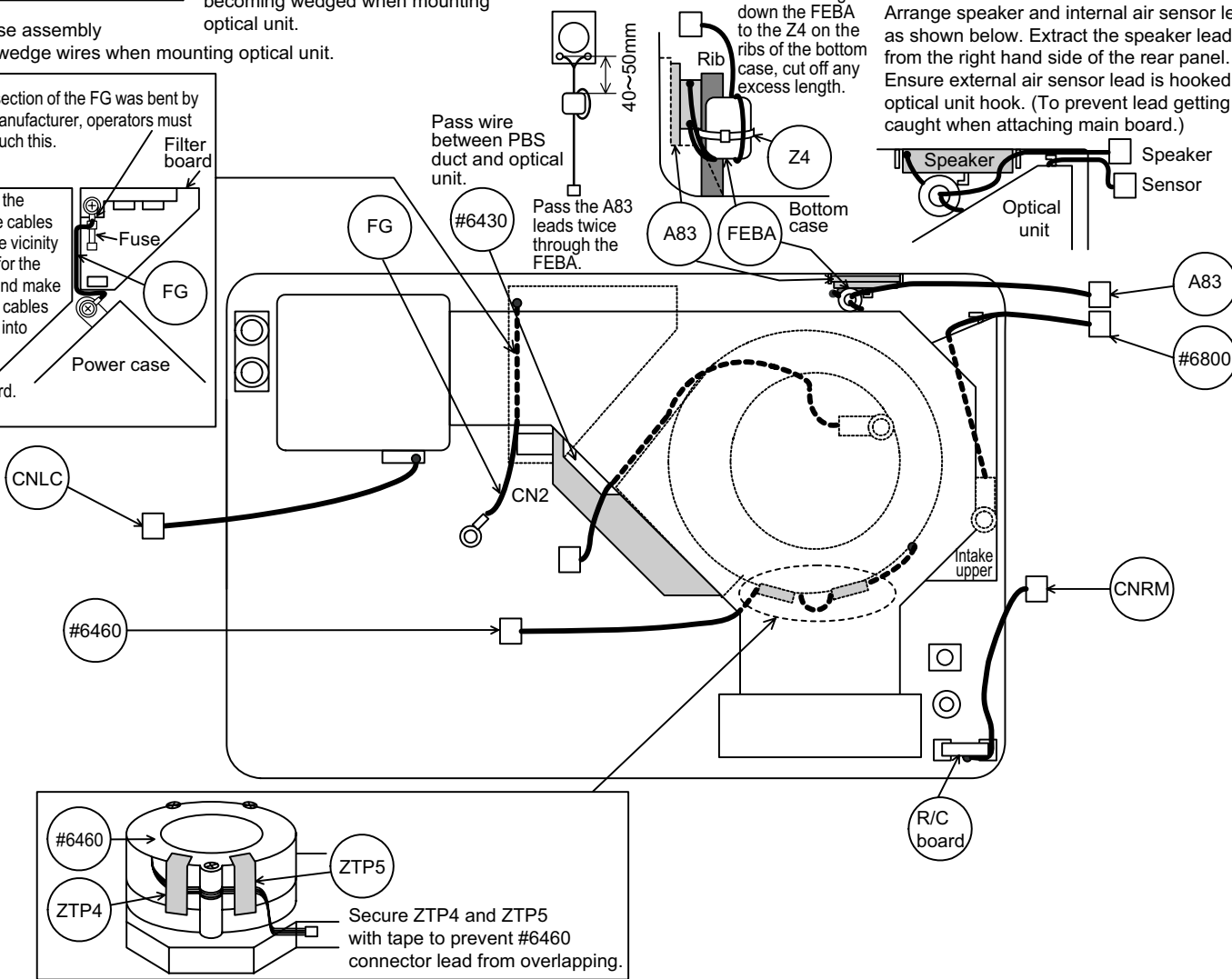

Wiring diagram 3 (C10SM2)

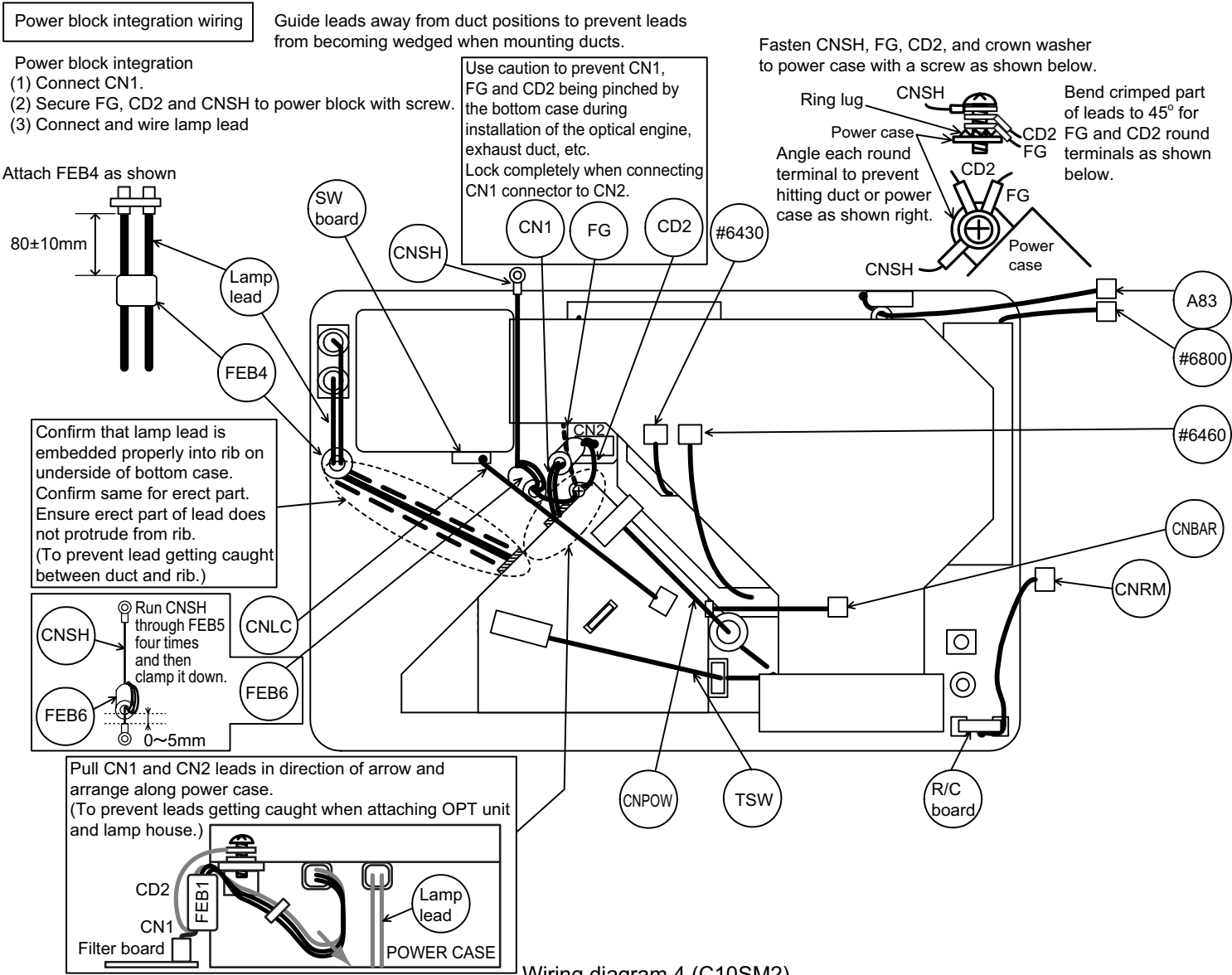

Wiring diagram 4 (C10SM2)

Duct and drive board mounting wiring

1. Mounting duct
 (1) Do not wedge lamp lead.
 (2) Do not wedge CNLC and CN1.
 (3) Attach TSW

Check that TSW marking reads "YS11A90A-**," and assemble with marked surface down.

Arrange CNSH lead between main board and sub board shield (to prevent wedging between main board and upper case).

Arrange #6460 lead eliminating slack and secure with fastener located on top of power block (to prevent interference with projection lens).

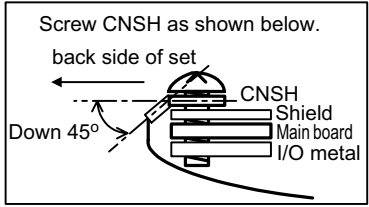

LED board
 A83 Pass CNME, #6430, and A83 leads below LED board fitting and arrange in groove located at top of ventilation duct.
 #6800 Pull lead toward front of set as shown and maintain slack. (To prevent lead getting caught in upper case rib.)
 CNME

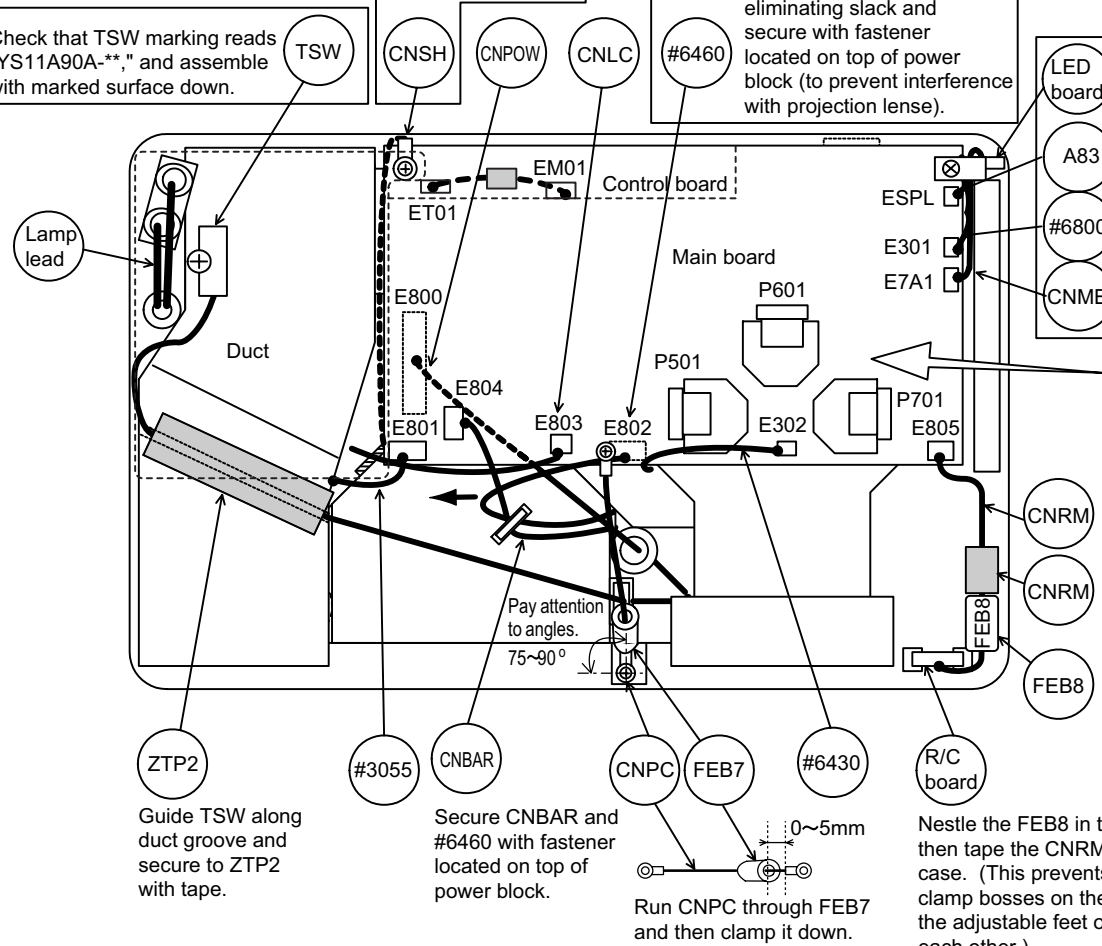
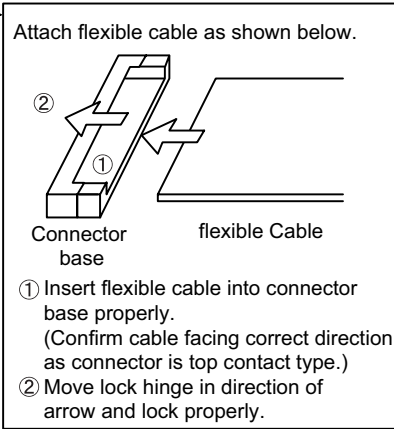

Guide TSW along duct groove and secure to ZTP2 with tape.

Secure CNBAR and #6460 with fastener located on top of power block.

Run CNPC through FEB7 and then clamp it down.

Nestle the FEB8 in the remote control board so that it will not move, then tape the CNRM leads to the ZTP1 on the insides of the bottom case. (This prevents the leads from getting pinched by the screw clamp bosses on the upper and bottom cases and also prevents the adjustable feet on the cases from coming into contact with each other.)

2. Mounting drive board
 (1) Connect CNPOW and #6460 (Underside of board: exercise caution).
 (2) Connect CNBAR, CNLC, A83, #6800, #6430, CNRM, CNME, #3055, and CNSH connectors.
 (3) Connect LCD panel cable.

Wiring diagram 5 (C10SM2)

CP-S235 (C10SM2)

8. Disassembly diagram

M: Machine screw
T: Tapping screw

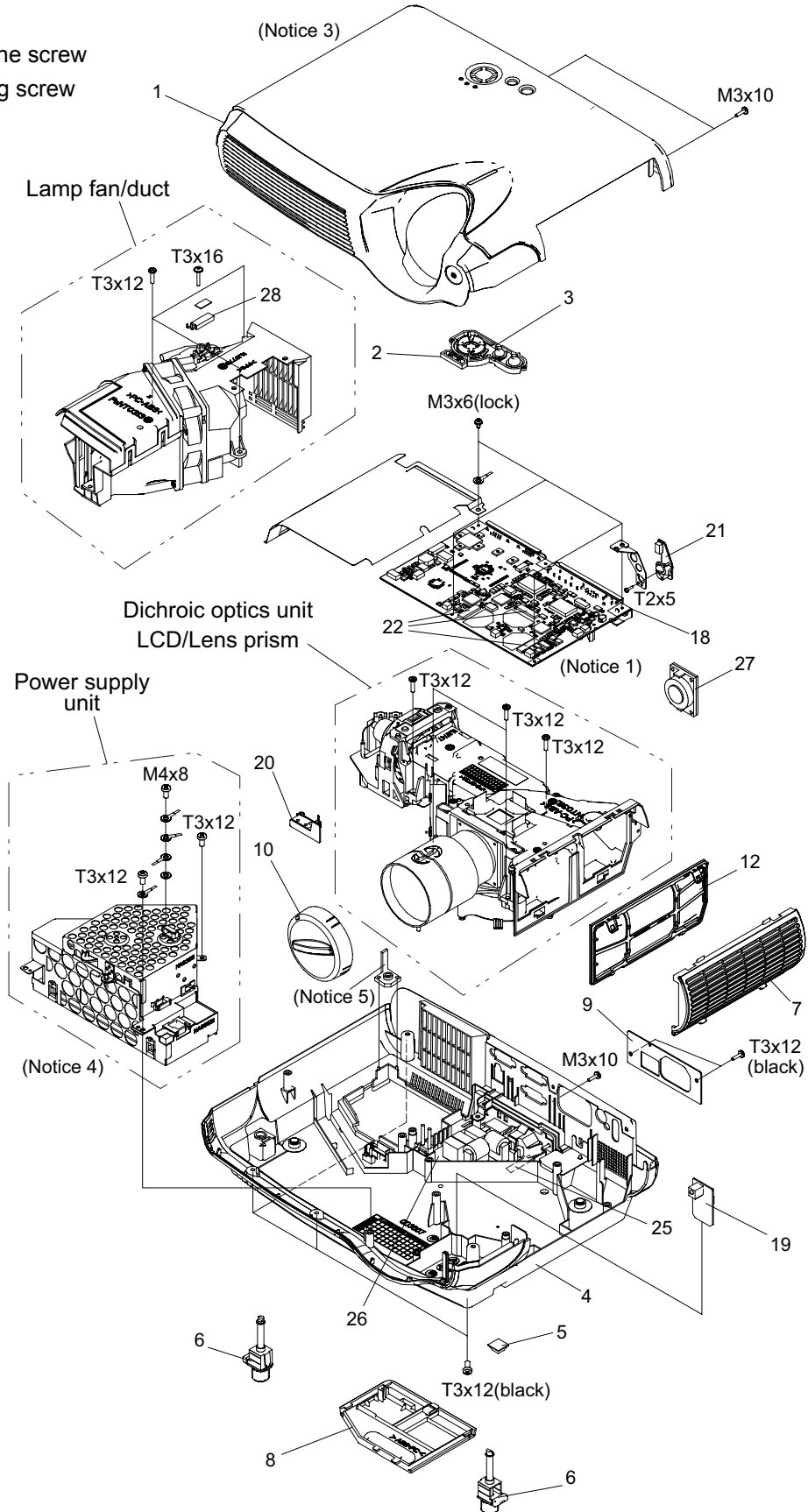

CP-S235 (C10SM2)

M: Machine screw

T: Tapping screw

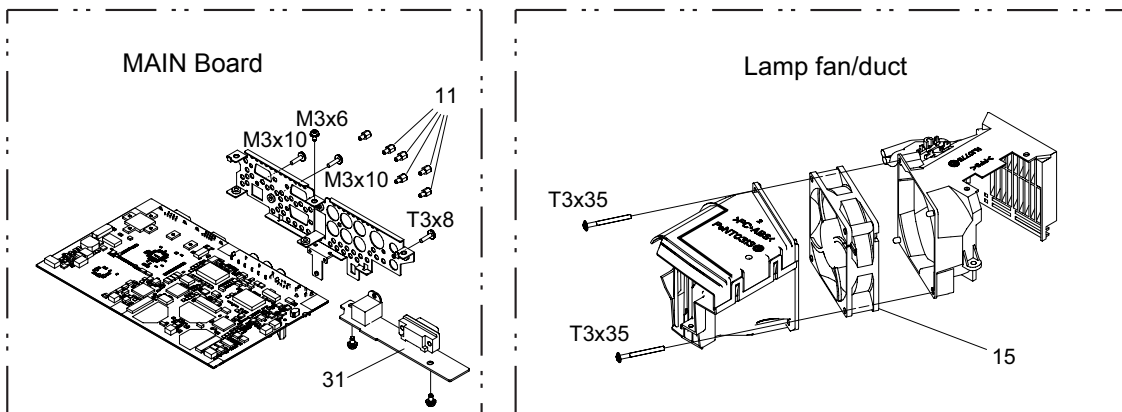
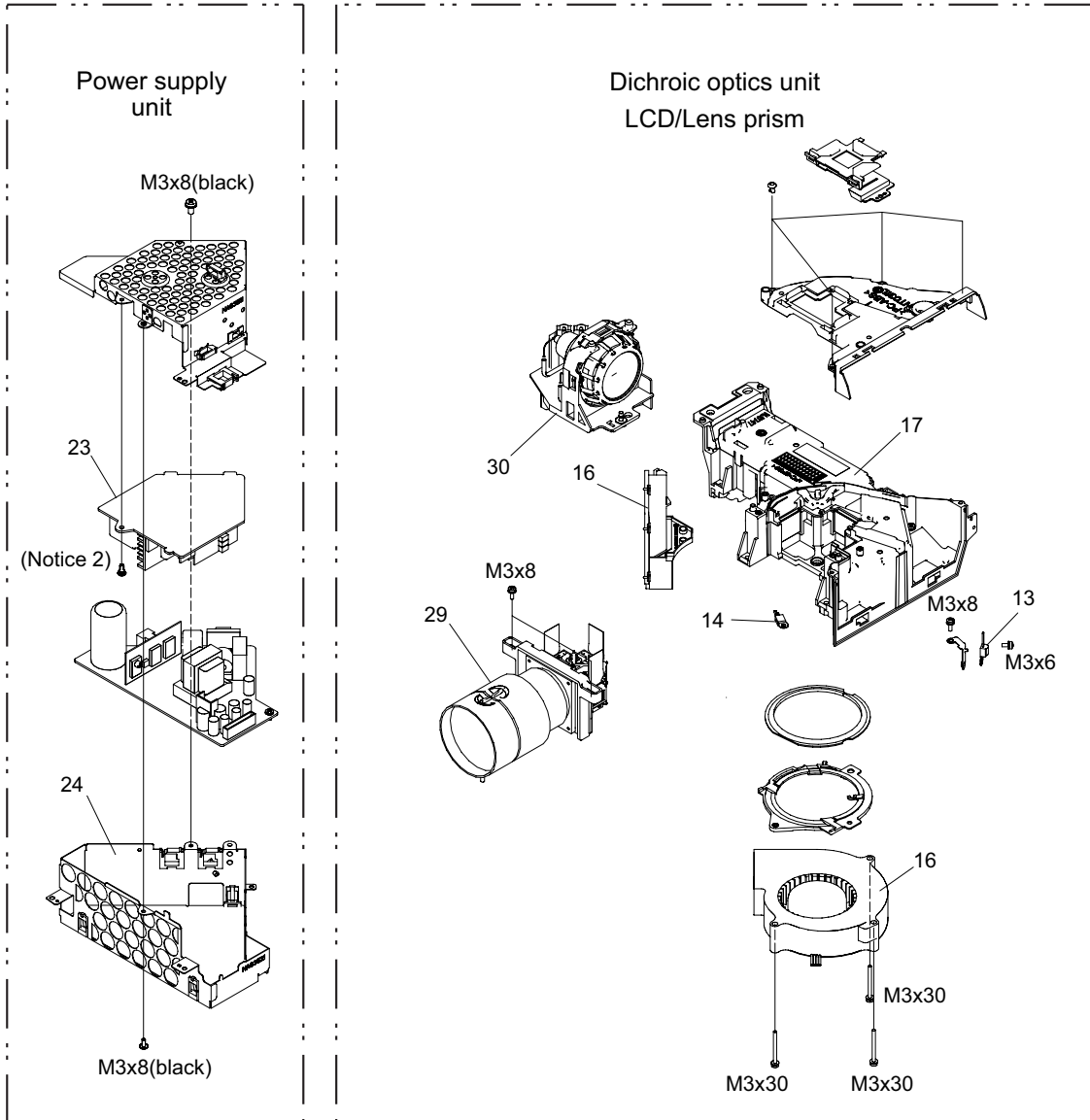

Notice

1. After attaching MAIN board assembly to case with M3x6 lock screws, tighten screws on back of bottom case.
2. To remove power board from shield case, push board in direction of arrow, and unlock catches (a) and (b) on board holders with screwdriver. (Lift board toward (d).) Unlock catch (c) with screwdriver and remove holding (e).

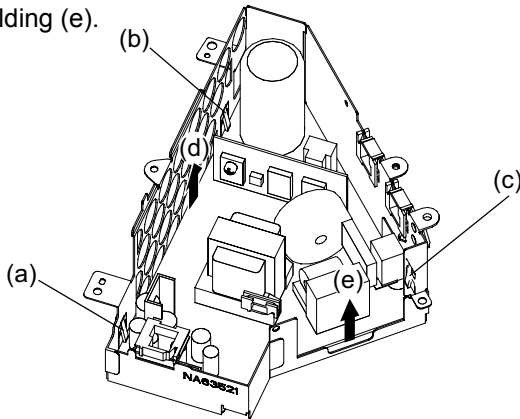

3. Swivel case as shown below when attaching or dismantling upper case.

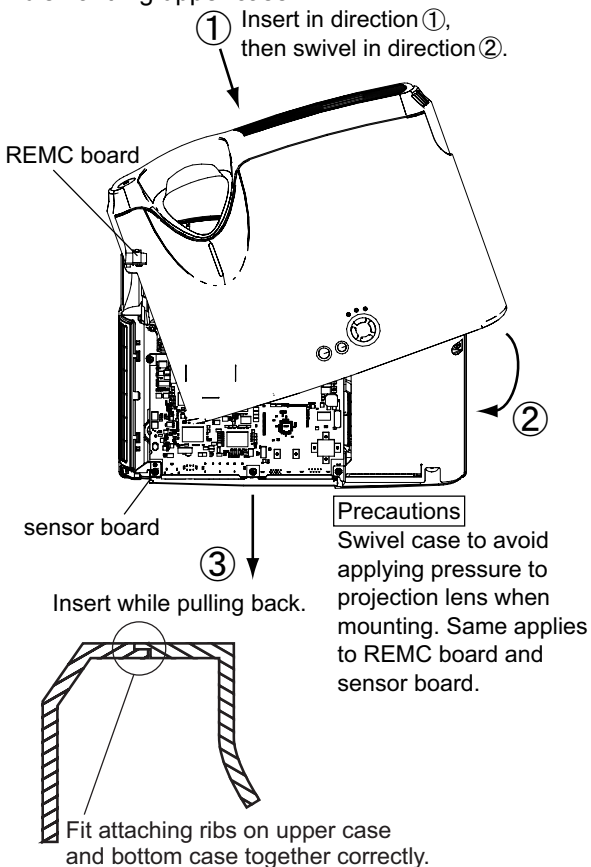

4. Align shield case joints.

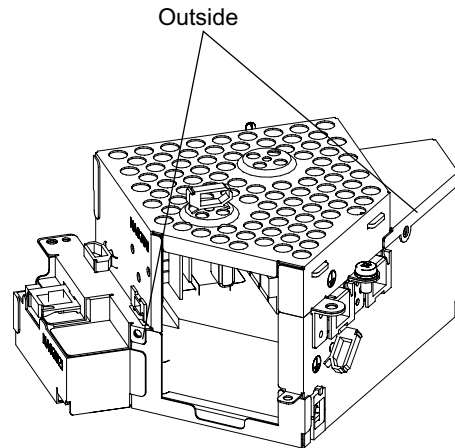
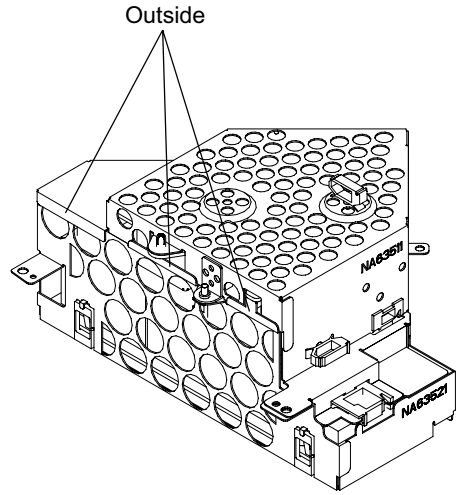

5. Attach lamp case bracket as shown below after removing dichroic optics unit and duct assembly.

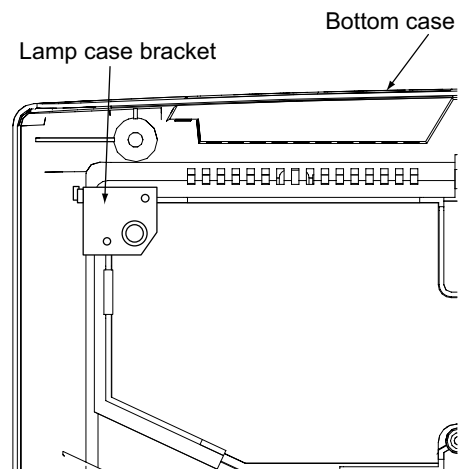

9. Replacement Parts list

**THE UPDATED PARTS LIST
FOR THIS MODEL IS
AVAILABLE ON ESTA**

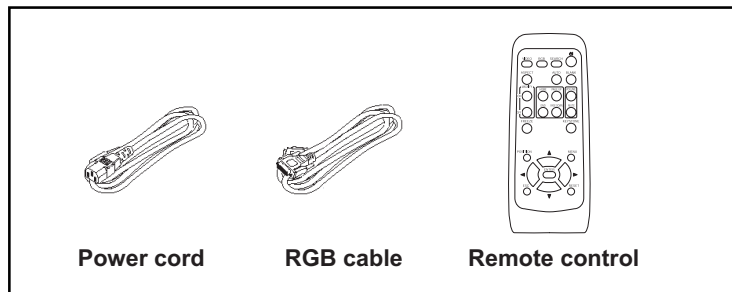

10. RS-232C communication

● Connecting the cable

- (1) Turn off the projector and the computer power supplies.
- (2) Connect the CONTROL port of the projector with a RS-232C port of the computer by a RS-232C cable. Use the cable that fulfills the specification shown in the following figure.
- (3) Turn on the computer power supply and after the computer has started up, turn on the projector power supply.

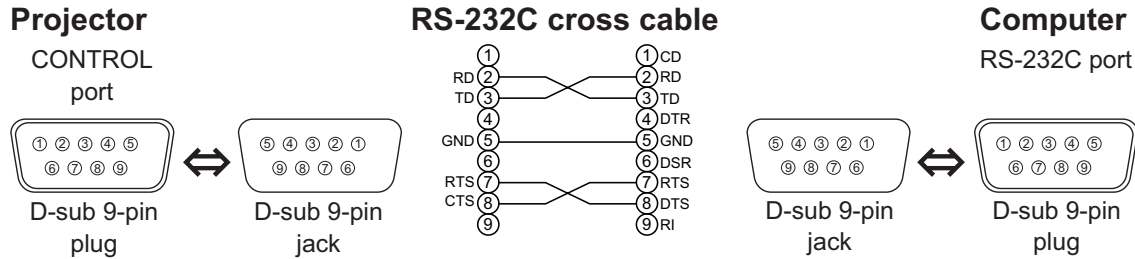

● Communications setting

19200bps, 8N1

1. Protocol

Consist of header (7 bytes) + command data (6 bytes).

2. Header

BE + EF + 03 + 06 + 00 + CRC_low + CRC_high

CRC_low : Lower byte of CRC flag for command data

CRC_high : Upper byte of CRC flag for command data

3. Command data

Command data chart

| byte_0 | byte_1 | byte_2 | byte_3 | byte_4 | byte_5 |
|--------|--------|--------|--------|--------------|--------|
| Action | | Type | | Setting code | |
| low | high | low | high | low | high |

Action (byte_0 - 1)

| Action | Classification | Content |
|--------|----------------|--------------------------------------|
| 1 | SET | Change setting to desired value. |
| 2 | GET | Read projector internal setup value. |
| 4 | INCREMENT | Increment setup value by 1. |
| 5 | DECREMENT | Decrement setup value by 1. |
| 6 | EXECUTE | Run a command. |

CP-S235 (C10SM2)

Requesting projector status (Get command)

- (1) Send the request code Header + Command data ('02H'+ '00H'+ type (2 bytes)+ '00H'+ '00H') from the computer to the projector.
- (2) The projector returns the response code '1DH'+ data (2 bytes) to the computer.

Changing the projector settings (Set command)

- (1) Send the setting code Header + Command data ('01H'+ '00H'+ type (2 bytes) + setting code (2 bytes)) from the computer to the projector.
- (2) The projector changes the setting based on the above setting code.
- (3) The projector returns the response code '06H' to the computer.

Using the projector default settings (Reset Command)

- (1) The computer sends the default setting code Header + Command data ('06H'+ '00H'+ type (2 bytes) + '00H'+ '00H') to the projector.
- (2) The projector changes the specified setting to the default value.
- (3) The projector returns the response code '06H' to the computer.

Increasing the projector setting value (Increment command)

- (1) The computer sends the increment code Header + Command data ('04H'+ '00H'+ type (2 bytes) + '00H'+ '00H') to the projector.
- (2) The projector increases the setting value on the above setting code.
- (3) The projector returns the response code '06H' to the computer.

Decreasing the projector setting value (Decrement command)

- (1) The computer sends the decrement code Header + Command data ('05H'+ '00H'+ type (2 bytes) + '00H'+ '00H') to the projector.
- (2) The projector decreases the setting value on the above setting code.
- (3) The projector returns the response code '06H' to the computer.

When the projector cannot understand the received command.

When the projector cannot understand the received command, the error code '15H' is sent back to the computer. Sometimes the projector cannot properly receive the command. In such a case, the command is not executed and the error code '15H' is sent back to the computer. If this error code is returned, send the same command again.

When the projector cannot execute the received command.

When the projector cannot execute the received command, the error code '1cH' + 'xxxxH' is sent back to the computer. When the data length is greater than indicated by the data length code, the projector ignore the excess data code.

Conversely when the data length is shorter than indicated by the data length code, an error code will be returned to the computer.

- NOTE** • Operation cannot be guaranteed when the projector receives an undefined command or data.
- Provide an interval of at least 40ms between the response code and any other code.
 - The projector outputs test data when the power supply is switched ON, and when the lamp is lit. Ignore this data.
 - Commands are not accepted during warm-up.

CP-S235 (C10SM2)

● Command data chart

| Names | Operation type | Header | | | Command data | | | | |
|------------------|----------------|-------------|-------|-------|--------------|--------|-------|--------------|-------|
| | | | | | CRC | Action | Type | Setting code | |
| Keystone | Get | BE EF | 03 | 06 00 | B9 D3 | 02 00 | 07 20 | 00 00 | |
| | Increment | BE EF | 03 | 06 00 | DF D3 | 04 00 | 07 20 | 00 00 | |
| | Decrement | BE EF | 03 | 06 00 | 0E D2 | 05 00 | 07 20 | 00 00 | |
| Keystone Reset | Execute | BE EF | 03 | 06 00 | 08 D0 | 06 00 | 0C 70 | 00 00 | |
| Brightness | Get | BE EF | 03 | 06 00 | 89 D2 | 02 00 | 03 20 | 00 00 | |
| | Increment | BE EF | 03 | 06 00 | EF D2 | 04 00 | 03 20 | 00 00 | |
| | Decrement | BE EF | 03 | 06 00 | 3E D3 | 05 00 | 03 20 | 00 00 | |
| Brightness Reset | Execute | BE EF | 03 | 06 00 | 58 D3 | 06 00 | 00 70 | 00 00 | |
| Contrast | Get | BE EF | 03 | 06 00 | FD D3 | 02 00 | 04 20 | 00 00 | |
| | Increment | BE EF | 03 | 06 00 | 9B D3 | 04 00 | 04 20 | 00 00 | |
| | Decrement | BE EF | 03 | 06 00 | 4A D2 | 05 00 | 04 20 | 00 00 | |
| Contrast Reset | Execute | BE EF | 03 | 06 00 | A4 D2 | 06 00 | 01 70 | 00 00 | |
| Aspect | Set | 4:3 | BE EF | 03 | 06 00 | 9E D0 | 01 00 | 08 20 | 00 00 |
| | | 16:9 | BE EF | 03 | 06 00 | 0E D1 | 01 00 | 08 20 | 01 00 |
| | | 15:9 | BE EF | 03 | 06 00 | 6E D0 | 01 00 | 08 20 | 03 00 |
| | | 32:15 | BE EF | 03 | 06 00 | 5E D2 | 01 00 | 08 20 | 04 00 |
| | | WIDE | BE EF | 03 | 06 00 | CE D3 | 01 00 | 08 20 | 05 00 |
| | | ZOOM | BE EF | 03 | 06 00 | 3E D3 | 01 00 | 08 20 | 06 00 |
| | Get | BE EF | 03 | 06 00 | AD D0 | 02 00 | 08 20 | 00 00 | |
| Whisper | Set | NORMAL | BE EF | 03 | 06 00 | 3B 23 | 01 00 | 00 33 | 00 00 |
| | | WHISPER | BE EF | 03 | 06 00 | AB 22 | 01 00 | 00 33 | 01 00 |
| | Get | BE EF | 03 | 06 00 | 08 23 | 02 00 | 00 33 | 00 00 | |
| Mirror | Set | Normal | BE EF | 03 | 06 00 | C7 D2 | 01 00 | 01 30 | 00 00 |
| | | H Inverse | BE EF | 03 | 06 00 | 57 D3 | 01 00 | 01 30 | 01 00 |
| | | V Inverse | BE EF | 03 | 06 00 | A7 D3 | 01 00 | 01 30 | 02 00 |
| | | H&V Inverse | BE EF | 03 | 06 00 | 37 D2 | 01 00 | 01 30 | 03 00 |
| | Get | BE EF | 03 | 06 00 | F4 D2 | 02 00 | 01 30 | 00 00 | |

CP-S235 (C10SM2)

| Names | Operation type | | Header | | | Command data | | | |
|--------------------|----------------|------------|--------|-------|-------|--------------|--------|-------|--------------|
| | | | | | | CRC | Action | Type | Setting code |
| Language | Set | English | BE EF | 03 | 06 00 | F7 D3 | 01 00 | 05 30 | 00 00 |
| | | FRANÇAIS | BE EF | 03 | 06 00 | 67 D2 | 01 00 | 05 30 | 01 00 |
| | | Deutsch | BE EF | 03 | 06 00 | 97 D2 | 01 00 | 05 30 | 02 00 |
| | | ESPAÑOL | BE EF | 03 | 06 00 | 07 D3 | 01 00 | 05 30 | 03 00 |
| | | Italiano | BE EF | 03 | 06 00 | 37 D1 | 01 00 | 05 30 | 04 00 |
| | | Norsk | BE EF | 03 | 06 00 | A7 D0 | 01 00 | 05 30 | 05 00 |
| | | Nederlands | BE EF | 03 | 06 00 | 57 D0 | 01 00 | 05 30 | 06 00 |
| | | PORTUGUÊS | BE EF | 03 | 06 00 | C7 D1 | 01 00 | 05 30 | 07 00 |
| | | 日本語 | BE EF | 03 | 06 00 | 37 D4 | 01 00 | 05 30 | 08 00 |
| | | 中文 | BE EF | 03 | 06 00 | A7 D5 | 01 00 | 05 30 | 09 00 |
| | | 한글 | BE EF | 03 | 06 00 | 57 D5 | 01 00 | 05 30 | 0A 00 |
| | | SVENSKA | BE EF | 03 | 06 00 | C7 D4 | 01 00 | 05 30 | 0B 00 |
| | | РУССКИЙ | BE EF | 03 | 06 00 | F7 D6 | 01 00 | 05 30 | 0C 00 |
| | SUOMI | BE EF | 03 | 06 00 | 67 D7 | 01 00 | 05 30 | 0D 00 | |
| POLSKI | BE EF | 03 | 06 00 | 97 D7 | 01 00 | 05 30 | 0E 00 | | |
| | Get | BE EF | 03 | 06 00 | C4 D3 | 02 00 | 05 30 | 00 00 | |
| Gamma | Set | NORMAL | BE EF | 03 | 06 00 | C7 F0 | 01 00 | A1 30 | 00 00 |
| | | CINEMA | BE EF | 03 | 06 00 | 57 F1 | 01 00 | A1 30 | 01 00 |
| | | DYNAMIC | BE EF | 03 | 06 00 | A7 F1 | 01 00 | A1 30 | 02 00 |
| | | CUSTOM | BE EF | 03 | 06 00 | 07 FD | 01 00 | A1 30 | 10 00 |
| | | Get | BE EF | 03 | 06 00 | F4 F0 | 02 00 | A1 30 | 00 00 |
| Custom Gamma | Get | BE EF | 03 | 06 00 | 08 F1 | 02 00 | A0 30 | 00 00 | |
| | Increment | BE EF | 03 | 06 00 | 6E F1 | 04 00 | A0 30 | 00 00 | |
| | Decrement | BE EF | 03 | 06 00 | BF F0 | 05 00 | A0 30 | 00 00 | |
| Custom Colour Temp | Set | USER | BE EF | 03 | 06 00 | 3B F8 | 01 00 | B0 30 | 10 00 |
| | | HIGH | BE EF | 03 | 06 00 | 0B F5 | 01 00 | B0 30 | 03 00 |
| | | MIDDLE | BE EF | 03 | 06 00 | 9B F4 | 01 00 | B0 30 | 02 00 |
| | | LOW | BE EF | 03 | 06 00 | 6B F4 | 01 00 | B0 30 | 01 00 |
| | | Get | BE EF | 03 | 06 00 | C8 F5 | 02 00 | B0 30 | 00 00 |
| Custom User R | Set | 50 | BE EF | 03 | 06 00 | 57 F7 | 01 00 | B1 30 | 05 00 |
| | | 60 | BE EF | 03 | 06 00 | C7 F6 | 01 00 | B1 30 | 04 00 |
| | | 70 | BE EF | 03 | 06 00 | F7 F4 | 01 00 | B1 30 | 03 00 |
| | | 80 | BE EF | 03 | 06 00 | 67 F5 | 01 00 | B1 30 | 02 00 |
| | | 90 | BE EF | 03 | 06 00 | 97 F5 | 01 00 | B1 30 | 01 00 |
| | | 100 | BE EF | 03 | 06 00 | 07 F4 | 01 00 | B1 30 | 00 00 |
| | | Get | BE EF | 03 | 06 00 | 34 F4 | 02 00 | B1 30 | 00 00 |
| Custom User G | Set | 50 | BE EF | 03 | 06 00 | 13 F7 | 01 00 | B2 30 | 05 00 |
| | | 60 | BE EF | 03 | 06 00 | 83 F6 | 01 00 | B2 30 | 04 00 |
| | | 70 | BE EF | 03 | 06 00 | B3 F4 | 01 00 | B2 30 | 03 00 |
| | | 80 | BE EF | 03 | 06 00 | 23 F5 | 01 00 | B2 30 | 02 00 |
| | | 90 | BE EF | 03 | 06 00 | D3 F5 | 01 00 | B2 30 | 01 00 |
| | | 100 | BE EF | 03 | 06 00 | 43 F4 | 01 00 | B2 30 | 00 00 |
| | | Get | BE EF | 03 | 06 00 | 70 F4 | 02 00 | B2 30 | 00 00 |

CP-S235 (C10SM2)

| Names | Operation type | | Header | | | | Command data | | |
|------------------------|----------------|-------|--------|-------|-------|-------|--------------|--------|-------|
| | | | | | | | CRC | Action | Type |
| Custom User B | Set | 50 | BE EF | 03 | 06 00 | EF F6 | 01 00 | B3 30 | 05 00 |
| | | 60 | BE EF | 03 | 06 00 | 7F F7 | 01 00 | B3 30 | 04 00 |
| | | 70 | BE EF | 03 | 06 00 | 4F F5 | 01 00 | B3 30 | 03 00 |
| | | 80 | BE EF | 03 | 06 00 | DF F4 | 01 00 | B3 30 | 02 00 |
| | | 90 | BE EF | 03 | 06 00 | 2F F4 | 01 00 | B3 30 | 01 00 |
| | | 100 | BE EF | 03 | 06 00 | BF F5 | 01 00 | B3 30 | 00 00 |
| | Get | BE EF | 03 | 06 00 | 8C F5 | 02 00 | B3 30 | 00 00 | |
| Colour Balance R | Get | BE EF | 03 | 06 00 | 01 D2 | 02 00 | 05 20 | 00 00 | |
| | Increment | BE EF | 03 | 06 00 | 67 D2 | 04 00 | 05 20 | 00 00 | |
| | Decrement | BE EF | 03 | 06 00 | B6 D3 | 05 00 | 05 20 | 00 00 | |
| Colour Balance R Reset | Execute | BE EF | 03 | 06 00 | 94 D3 | 06 00 | 05 70 | 00 00 | |
| Colour Balance G | Get | BE EF | 03 | 06 00 | B5 D7 | 02 00 | 12 20 | 00 00 | |
| | Increment | BE EF | 03 | 06 00 | D3 D7 | 04 00 | 12 20 | 00 00 | |
| | Decrement | BE EF | 03 | 06 00 | 02 D6 | 05 00 | 12 20 | 00 00 | |
| Colour Balance G Reset | Execute | BE EF | 03 | 06 00 | 04 DB | 06 00 | 29 70 | 00 00 | |
| Colour Balance B | Get | BE EF | 03 | 06 00 | 45 D2 | 02 00 | 06 20 | 00 00 | |
| | Increment | BE EF | 03 | 06 00 | 23 D2 | 04 00 | 06 20 | 00 00 | |
| | Decrement | BE EF | 03 | 06 00 | F2 D3 | 05 00 | 06 20 | 00 00 | |
| Colour Balance B Reset | Execute | BE EF | 03 | 06 00 | D0 D3 | 06 00 | 06 70 | 00 00 | |
| Sharpness | Get | BE EF | 03 | 06 00 | F1 72 | 02 00 | 01 22 | 00 00 | |
| | Increment | BE EF | 03 | 06 00 | 97 72 | 04 00 | 01 22 | 00 00 | |
| | Decrement | BE EF | 03 | 06 00 | 46 73 | 05 00 | 01 22 | 00 00 | |
| Sharpness Reset | Execute | BE EF | 03 | 06 00 | C4 D0 | 06 00 | 09 70 | 00 00 | |
| Colour | Get | BE EF | 03 | 06 00 | B5 72 | 02 00 | 02 22 | 00 00 | |
| | Increment | BE EF | 03 | 06 00 | D3 72 | 04 00 | 02 22 | 00 00 | |
| | Decrement | BE EF | 03 | 06 00 | 02 73 | 05 00 | 02 22 | 00 00 | |
| Colour Reset | Execute | BE EF | 03 | 06 00 | 80 D0 | 06 00 | 0A 70 | 00 00 | |
| Tint | Get | BE EF | 03 | 06 00 | 49 73 | 02 00 | 03 22 | 00 00 | |
| | Increment | BE EF | 03 | 06 00 | 2F 73 | 04 00 | 03 22 | 00 00 | |
| | Decrement | BE EF | 03 | 06 00 | FE 72 | 05 00 | 03 22 | 00 00 | |
| Tint Reset | Execute | BE EF | 03 | 06 00 | 7C D1 | 06 00 | 0B 70 | 00 00 | |
| My Memory Load | Set | 1 | BE EF | 03 | 06 00 | 0E D7 | 01 00 | 14 20 | 00 00 |
| | | 2 | BE EF | 03 | 06 00 | 9E D6 | 01 00 | 14 20 | 01 00 |
| | | 3 | BE EF | 03 | 06 00 | 6E D6 | 01 00 | 14 20 | 02 00 |
| | | 4 | BE EF | 03 | 06 00 | FE D7 | 01 00 | 14 20 | 03 00 |
| My Memory Save | Set | 1 | BE EF | 03 | 06 00 | F2 D6 | 01 00 | 15 20 | 00 00 |
| | | 2 | BE EF | 03 | 06 00 | 62 D7 | 01 00 | 15 20 | 01 00 |
| | | 3 | BE EF | 03 | 06 00 | 92 D7 | 01 00 | 15 20 | 02 00 |
| | | 4 | BE EF | 03 | 06 00 | 02 D6 | 01 00 | 15 20 | 03 00 |

CP-S235 (C10SM2)

| Names | Operation type | Header | | | | Command data | | | |
|------------------|----------------|-------------|-------|-------|-------|--------------|-------|--------------|-------|
| | | | | | CRC | Action | Type | Setting code | |
| V Position | Get | BE EF | 03 | 06 00 | 0D 83 | 02 00 | 00 21 | 00 00 | |
| | Increment | BE EF | 03 | 06 00 | 6B 83 | 04 00 | 00 21 | 00 00 | |
| | Decrement | BE EF | 03 | 06 00 | BA 82 | 05 00 | 00 21 | 00 00 | |
| V Position Reset | Execute | BE EF | 03 | 06 00 | E0 D2 | 06 00 | 02 70 | 00 00 | |
| H Position | Get | BE EF | 03 | 06 00 | F1 82 | 02 00 | 01 21 | 00 00 | |
| | Increment | BE EF | 03 | 06 00 | 97 82 | 04 00 | 01 21 | 00 00 | |
| | Decrement | BE EF | 03 | 06 00 | 46 83 | 05 00 | 01 21 | 00 00 | |
| H Position Reset | Execute | BE EF | 03 | 06 00 | 1C D3 | 06 00 | 03 70 | 00 00 | |
| H Phase | Get | BE EF | 03 | 06 00 | 49 83 | 02 00 | 03 21 | 00 00 | |
| | Increment | BE EF | 03 | 06 00 | 2F 83 | 04 00 | 03 21 | 00 00 | |
| | Decrement | BE EF | 03 | 06 00 | FE 82 | 05 00 | 03 21 | 00 00 | |
| H Size | Get | BE EF | 03 | 06 00 | B5 82 | 02 00 | 02 21 | 00 00 | |
| | Increment | BE EF | 03 | 06 00 | D3 82 | 04 00 | 02 21 | 00 00 | |
| | Decrement | BE EF | 03 | 06 00 | 02 83 | 05 00 | 02 21 | 00 00 | |
| H Size Reset | Execute | BE EF | 03 | 06 00 | 68 D2 | 06 00 | 04 70 | 00 00 | |
| Over Scan | Get | BE EF | 03 | 06 00 | 91 70 | 02 00 | 09 22 | 00 00 | |
| | Increment | BE EF | 03 | 06 00 | F7 70 | 04 00 | 09 22 | 00 00 | |
| | Decrement | BE EF | 03 | 06 00 | 26 71 | 05 00 | 09 22 | 00 00 | |
| Over Scan Reset | Execute | BE EF | 03 | 06 00 | EC D9 | 06 00 | 27 70 | 00 00 | |
| Colour Space | Set | AUTO | BE EF | 03 | 06 00 | 0E 72 | 01 00 | 04 22 | 00 00 |
| | | RGB | BE EF | 03 | 06 00 | 9E 73 | 01 00 | 04 22 | 01 00 |
| | | SMPTE240 | BE EF | 03 | 06 00 | 6E 73 | 01 00 | 04 22 | 02 00 |
| | | REC709 | BE EF | 03 | 06 00 | FE 72 | 01 00 | 04 22 | 03 00 |
| | | REC601 | BE EF | 03 | 06 00 | CE 70 | 01 00 | 04 22 | 04 00 |
| | Get | BE EF | 03 | 06 00 | 3D 72 | 02 00 | 04 22 | 00 00 | |
| Component | Set | COMPONENT | BE EF | 03 | 06 00 | 4A D7 | 01 00 | 17 20 | 00 00 |
| | | SCART RGB | BE EF | 03 | 06 00 | DA D6 | 01 00 | 17 20 | 01 00 |
| | Get | BE EF | 03 | 06 00 | 79 D7 | 02 00 | 17 20 | 00 00 | |
| Video Format | Set | AUTO | BE EF | 03 | 06 00 | 9E 75 | 01 00 | 00 22 | 0A 00 |
| | | NTSC | BE EF | 03 | 06 00 | FE 71 | 01 00 | 00 22 | 04 00 |
| | | PAL | BE EF | 03 | 06 00 | 6E 70 | 01 00 | 00 22 | 05 00 |
| | | SECAM | BE EF | 03 | 06 00 | 6E 75 | 01 00 | 00 22 | 09 00 |
| | | NTSC 4.43 | BE EF | 03 | 06 00 | 5E 72 | 01 00 | 00 22 | 02 00 |
| | | M-PAL | BE EF | 03 | 06 00 | FE 74 | 01 00 | 00 22 | 08 00 |
| | | N-PAL | BE EF | 03 | 06 00 | 0E 71 | 01 00 | 00 22 | 07 00 |
| | Get | BE EF | 03 | 06 00 | 0D 73 | 02 00 | 00 22 | 00 00 | |
| Frame Lock | Set | TURN OFF | BE EF | 03 | 06 00 | CB D6 | 01 00 | 14 30 | 00 00 |
| | | TURN ON | BE EF | 03 | 06 00 | 5B D7 | 01 00 | 14 30 | 01 00 |
| | Get | BE EF | 03 | 06 00 | F8 D6 | 02 00 | 14 30 | 00 00 | |
| 3D-YCS | Set | TURN OFF | BE EF | 03 | 06 00 | E6 70 | 01 00 | 0A 22 | 00 00 |
| | | NORMAL | BE EF | 03 | 06 00 | 76 71 | 01 00 | 0A 22 | 01 00 |
| | | STILL IMAGE | BE EF | 03 | 06 00 | 86 71 | 01 00 | 0A 22 | 02 00 |
| | Get | BE EF | 03 | 06 00 | D5 70 | 02 00 | 0A 22 | 00 00 | |

CP-S235 (C10SM2)

| Names | Operation type | | Header | | | | Command data | | | | | | | | |
|-----------------------|----------------|-----------|--------|----|----|-----|--------------|------|--------------|----|----|----|----|----|----|
| | | | | | | CRC | Action | Type | Setting code | | | | | | |
| Video NR | Set | LOW | BE | EF | 03 | 06 | 00 | 26 | 72 | 01 | 00 | 06 | 22 | 01 | 00 |
| | | MIDDLE | BE | EF | 03 | 06 | 00 | D6 | 72 | 01 | 00 | 06 | 22 | 02 | 00 |
| | | HIGH | BE | EF | 03 | 06 | 00 | 46 | 73 | 01 | 00 | 06 | 22 | 03 | 00 |
| | | Get | BE | EF | 03 | 06 | 00 | 85 | 73 | 02 | 00 | 06 | 22 | 00 | 00 |
| Progressive | Set | Turn off | BE | EF | 03 | 06 | 00 | 4A | 72 | 01 | 00 | 07 | 22 | 00 | 00 |
| | | TV | BE | EF | 03 | 06 | 00 | DA | 73 | 01 | 00 | 07 | 22 | 01 | 00 |
| | | Film | BE | EF | 03 | 06 | 00 | 2A | 73 | 01 | 00 | 07 | 22 | 02 | 00 |
| | | Get | BE | EF | 03 | 06 | 00 | 79 | 72 | 02 | 00 | 07 | 22 | 00 | 00 |
| S2-Aspect | Set | TURN OFF | BE | EF | 03 | 06 | 00 | 1A | 71 | 01 | 00 | 0B | 22 | 00 | 00 |
| | | TURN ON | BE | EF | 03 | 06 | 00 | 8A | 70 | 01 | 00 | 0B | 22 | 01 | 00 |
| | | Get | BE | EF | 03 | 06 | 00 | 29 | 71 | 02 | 00 | 0B | 22 | 00 | 00 |
| Auto Adjust | | Execute | BE | EF | 03 | 06 | 00 | 91 | D0 | 06 | 00 | 0A | 20 | 00 | 00 |
| Auto off | | Get | BE | EF | 03 | 06 | 00 | 08 | 86 | 02 | 00 | 10 | 31 | 00 | 00 |
| | | Increment | BE | EF | 03 | 06 | 00 | 6E | 86 | 04 | 00 | 10 | 31 | 00 | 00 |
| | | Decrement | BE | EF | 03 | 06 | 00 | BF | 87 | 05 | 00 | 10 | 31 | 00 | 00 |
| Auto Search | Set | TURN OFF | BE | EF | 03 | 06 | 00 | B6 | D6 | 01 | 00 | 16 | 20 | 00 | 00 |
| | | TURN ON | BE | EF | 03 | 06 | 00 | 26 | D7 | 01 | 00 | 16 | 20 | 01 | 00 |
| | | Get | BE | EF | 03 | 06 | 00 | 85 | D6 | 02 | 00 | 16 | 20 | 00 | 00 |
| Blank Colour | Set | Blue | BE | EF | 03 | 06 | 00 | CB | D3 | 01 | 00 | 00 | 30 | 03 | 00 |
| | | White | BE | EF | 03 | 06 | 00 | 6B | D0 | 01 | 00 | 00 | 30 | 05 | 00 |
| | | Black | BE | EF | 03 | 06 | 00 | 9B | D0 | 01 | 00 | 00 | 30 | 06 | 00 |
| | | Get | BE | EF | 03 | 06 | 00 | 08 | D3 | 02 | 00 | 00 | 30 | 00 | 00 |
| Blank on/off | Set | TURN OFF | BE | EF | 03 | 06 | 00 | FB | D8 | 01 | 00 | 20 | 30 | 00 | 00 |
| | | TURN ON | BE | EF | 03 | 06 | 00 | 6B | D9 | 01 | 00 | 20 | 30 | 01 | 00 |
| | | Get | BE | EF | 03 | 06 | 00 | C8 | D8 | 02 | 00 | 20 | 30 | 00 | 00 |
| Startup | Set | TURN ON | BE | EF | 03 | 06 | 00 | 0B | D2 | 01 | 00 | 04 | 30 | 00 | 00 |
| | | TURN OFF | BE | EF | 03 | 06 | 00 | 9B | D3 | 01 | 00 | 04 | 30 | 01 | 00 |
| | | Get | BE | EF | 03 | 06 | 00 | 38 | D2 | 02 | 00 | 04 | 30 | 00 | 00 |
| Menu Position V | | Get | BE | EF | 03 | 06 | 00 | 40 | D7 | 02 | 00 | 16 | 30 | 00 | 00 |
| | | Increment | BE | EF | 03 | 06 | 00 | 26 | D7 | 04 | 00 | 16 | 30 | 00 | 00 |
| | | Decrement | BE | EF | 03 | 06 | 00 | F7 | D6 | 05 | 00 | 16 | 30 | 00 | 00 |
| Menu Position V Reset | | Execute | BE | EF | 03 | 06 | 00 | A8 | C7 | 06 | 00 | 44 | 70 | 00 | 00 |
| Menu Position H | | Get | BE | EF | 03 | 06 | 00 | 04 | D7 | 02 | 00 | 15 | 30 | 00 | 00 |
| | | Increment | BE | EF | 03 | 06 | 00 | 62 | D7 | 04 | 00 | 15 | 30 | 00 | 00 |
| | | Decrement | BE | EF | 03 | 06 | 00 | B3 | D6 | 05 | 00 | 15 | 30 | 00 | 00 |
| Menu Position H Reset | | Execute | BE | EF | 03 | 06 | 00 | DC | C6 | 06 | 00 | 43 | 70 | 00 | 00 |
| Message | Set | TURN OFF | BE | EF | 03 | 06 | 00 | 8F | D6 | 01 | 00 | 17 | 30 | 00 | 00 |
| | | TURN ON | BE | EF | 03 | 06 | 00 | 1F | D7 | 01 | 00 | 17 | 30 | 01 | 00 |
| | | Get | BE | EF | 03 | 06 | 00 | BC | D6 | 02 | 00 | 17 | 30 | 00 | 00 |

CP-S235 (C10SM2)

| Names | Operation type | Header | | | | Command data | | | |
|-------------------|----------------|---------------------|--------------|------------------|------------------|--------------|----------------|------------------|-------|
| | | | | | CRC | Action | Type | Setting code | |
| Volume | Get | BE EF | 03 | 06 00 | 31 D3 | 02 00 | 01 20 | 00 00 | |
| | Increment | BE EF | 03 | 06 00 | 57 D3 | 04 00 | 01 20 | 00 00 | |
| | Decrement | BE EF | 03 | 06 00 | 86 D2 | 05 00 | 01 20 | 00 00 | |
| MUTE | Set | TURN ON | BE EF | 03 | 06 00 | 46 D3 | 01 00 | 02 20 | 00 00 |
| | | TURN OFF | BE EF | 03 | 06 00 | D6 D2 | 01 00 | 02 20 | 01 00 |
| | Get | BE EF | 03 | 06 00 | 75 D3 | 02 00 | 02 20 | 00 00 | |
| Screen type | Set | 4:3 | BE EF | 03 | 06 00 | 7A D6 | 01 00 | 13 20 | 00 00 |
| | | 16:9- Top | BE EF | 03 | 06 00 | EA D7 | 01 00 | 13 20 | 01 00 |
| | | 16:9- Center | BE EF | 03 | 06 00 | 1A D7 | 01 00 | 13 20 | 02 00 |
| | | 16:9- Bottom | BE EF | 03 | 06 00 | 8A D6 | 01 00 | 13 20 | 03 00 |
| | Get | BE EF | 03 | 06 00 | 49 D6 | 02 00 | 13 20 | 00 00 | |
| Lamp Time | Get | BE EF | 03 | 06 00 | C2 FF | 02 00 | 90 10 | 00 00 | |
| Lamp Time Reset | Execute | BE EF | 03 | 06 00 | 58 DC | 06 00 | 30 70 | 00 00 | |
| Filter Time | Get | BE EF | 03 | 06 00 | C2 F0 | 02 00 | A0 10 | 00 00 | |
| Filter Time Reset | Execute | BE EF | 03 | 06 00 | 98 C6 | 06 00 | 40 70 | 00 00 | |
| Magnify | Get | BE EF | 03 | 06 00 | 7C D2 | 02 00 | 07 30 | 00 00 | |
| | Increment | BE EF | 03 | 06 00 | 1A D2 | 04 00 | 07 30 | 00 00 | |
| | Decrement | BE EF | 03 | 06 00 | CB D3 | 05 00 | 07 30 | 00 00 | |
| Freeze | Set | Normal | BE EF | 03 | 06 00 | 83 D2 | 01 00 | 02 30 | 00 00 |
| | | Freeze | BE EF | 03 | 06 00 | 13 D3 | 01 00 | 02 30 | 01 00 |
| | Get | BE EF | 03 | 06 00 | B0 D2 | 02 00 | 02 30 | 00 00 | |
| Power | Set | TURN OFF | BE EF | 03 | 06 00 | 2A D3 | 01 00 | 00 60 | 00 00 |
| | | TURN ON | BE EF | 03 | 06 00 | BA D2 | 01 00 | 00 60 | 01 00 |
| | Get | | BE EF | 03 | 06 00 | 19 D3 | 02 00 | 00 60 | 00 00 |
| | | (Example Return) | | 00 00 | 01 00 | 02 00 | | | |
| | | | (Off) | (On) | (Cool down) | | | | |
| Input Source | Set | RGB | BE EF | 03 | 06 00 | FE D2 | 01 00 | 00 20 | 00 00 |
| | | Video | BE EF | 03 | 06 00 | 6E D3 | 01 00 | 00 20 | 01 00 |
| | | S-Video | BE EF | 03 | 06 00 | 9E D3 | 01 00 | 00 20 | 02 00 |
| | | Component | BE EF | 03 | 06 00 | AE D1 | 01 00 | 00 20 | 05 00 |
| | Get | BE EF | 03 | 06 00 | CD D2 | 02 00 | 00 20 | 00 00 | |
| Error Status | Get | | BE EF | 03 | 06 00 | D9 D8 | 02 00 | 20 60 | 00 00 |
| | | (Example of Return) | | 00 00 | 01 00 | 02 00 | 03 00 | | |
| | | | (Normal) | (Cover-error) | (Fan-error) | (Lamp-error) | | | |
| | | | 04 00 | 05 00 | 06 00 | 07 00 | 08 00 | 09 00 | |
| | | | (Temp-error) | (Air flow-error) | (Lamp-Time-over) | (Cool-error) | (Filter-Error) | (Filter-Missing) | |

11. Block diagram

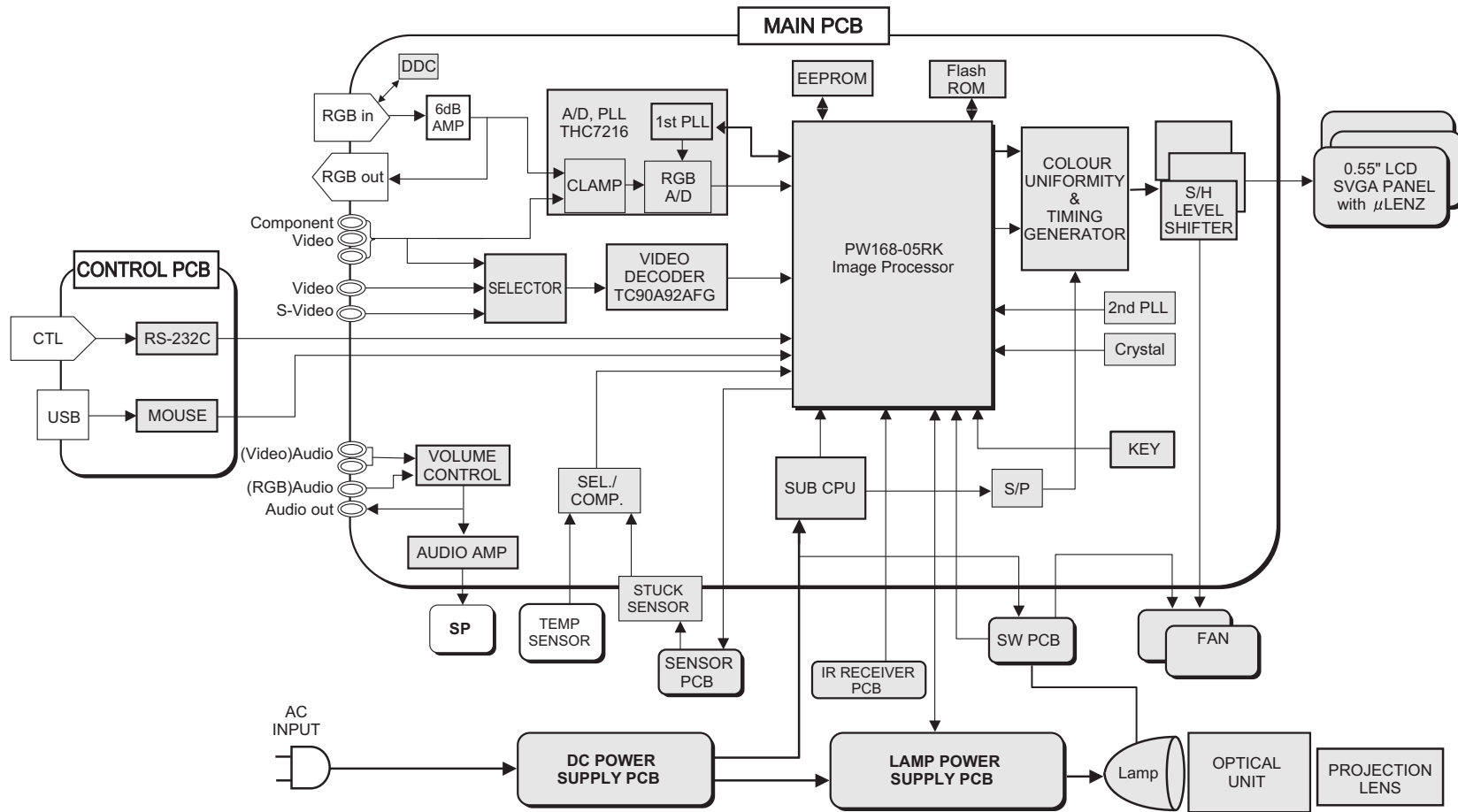

Block diagram (C10SM2)

12. Connector connection diagram

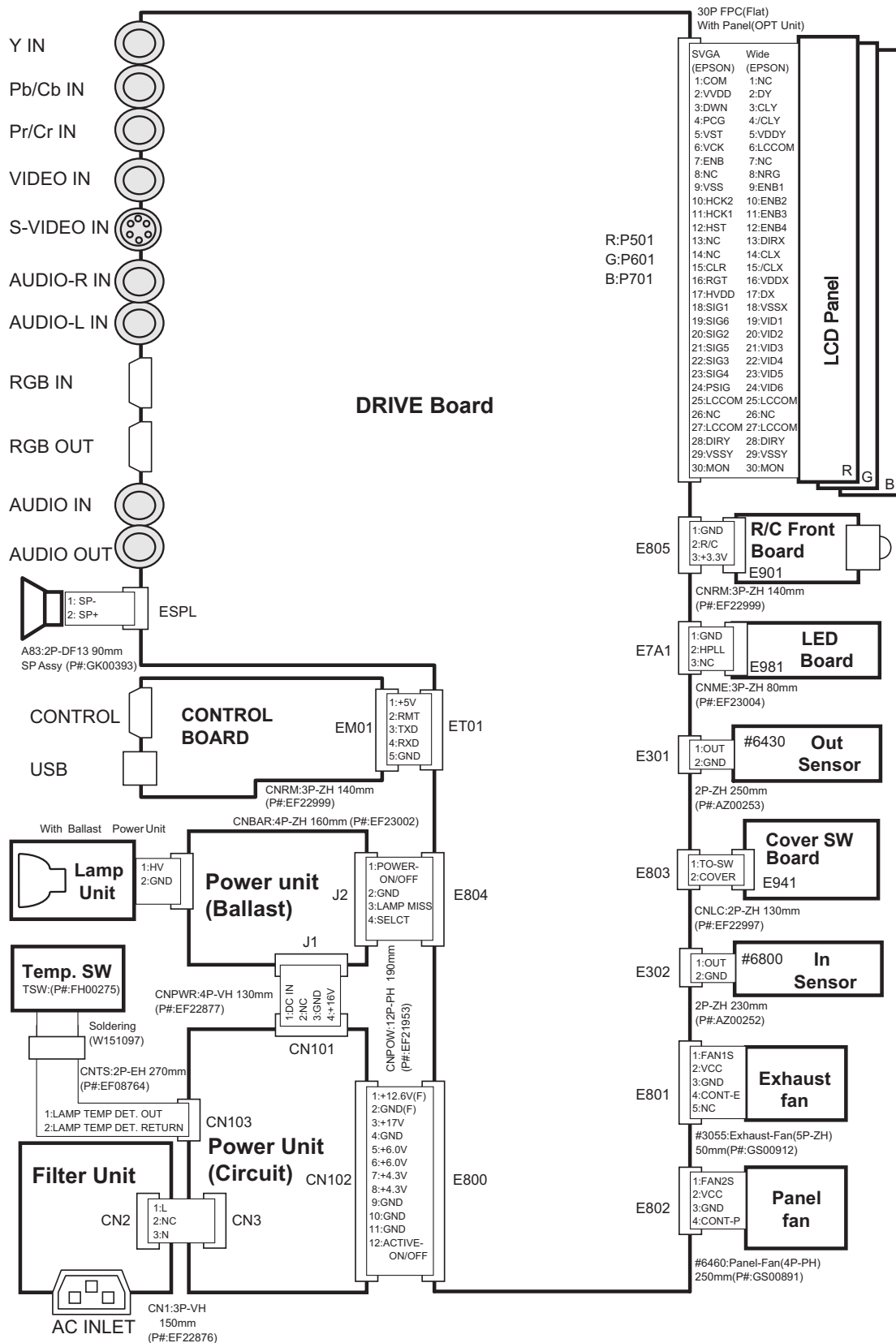

Connector connection diagram (C10SM2)

13. Basic circuit diagrams

Basic circuit diagram list

| | |
|----------------------|---------------|
| SENSOR Board | MAIN Board 3 |
| COVER SWITCH Board | MAIN Board 4 |
| REMOTE CONTROL Board | MAIN Board 5 |
| FILTER UNIT | MAIN Board 6 |
| POWER UNIT CIRCUIT | MAIN Board 7 |
| POWER UNIT BALLAST 1 | MAIN Board 8 |
| POWER UNIT BALLAST 2 | MAIN Board 9 |
| CONTROL Board | MAIN Board 10 |
| MAIN Board 1 | MAIN Board 11 |
| MAIN Board 2 | |

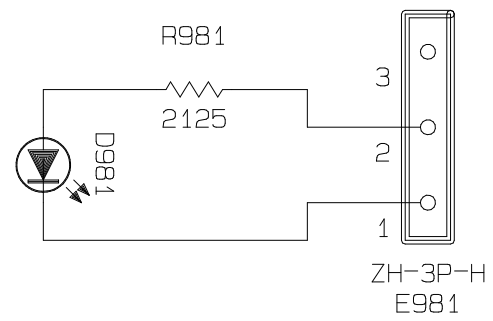

SENSOR BOARD

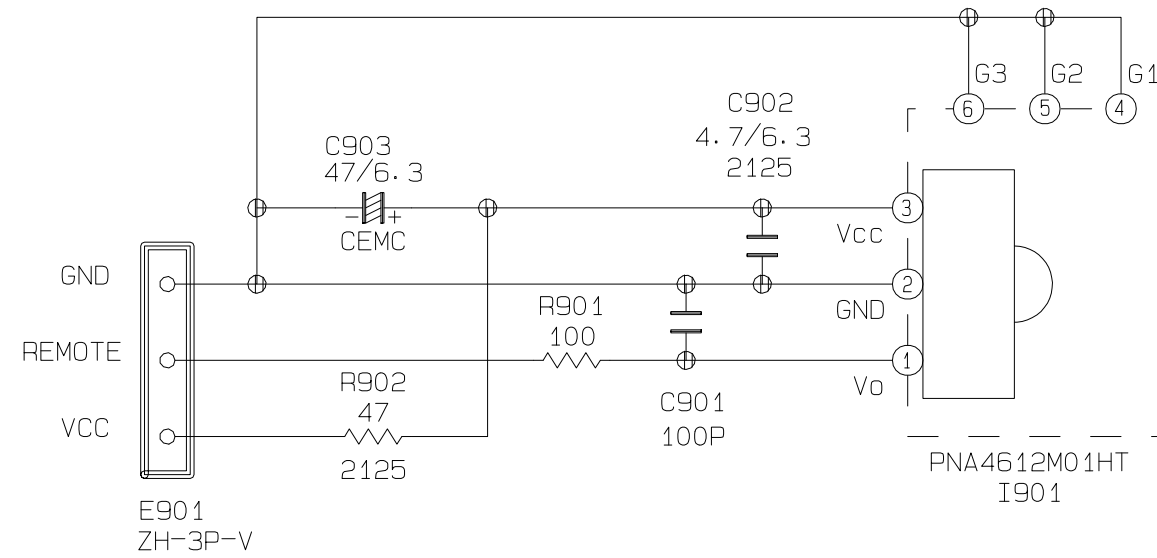

REMOTE CONTROL BOARD

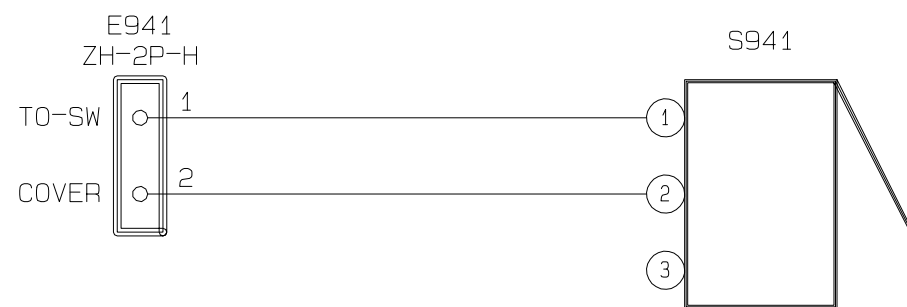

COVER SWITCH BOARD

PARTS WITH HATCHING ARE NOT MOUNTED

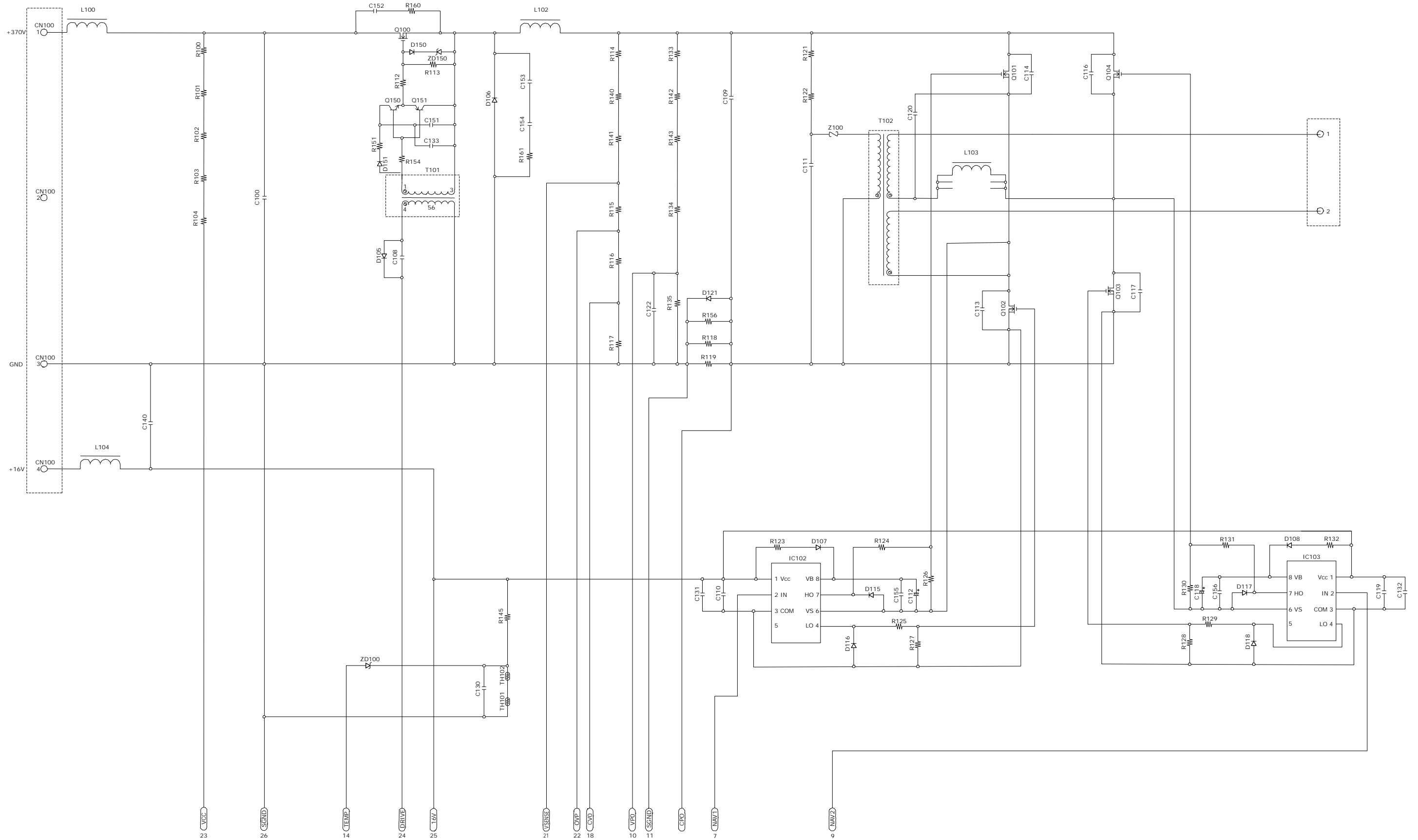

PARTS WITH HATCHING ARE NOT MOUNTED

SM0541

POWER UNIT (BALLAST) 1

HITACHI

USB
MOUSE

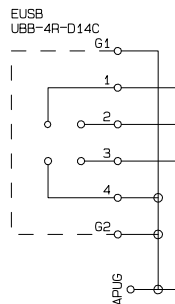

RS232C

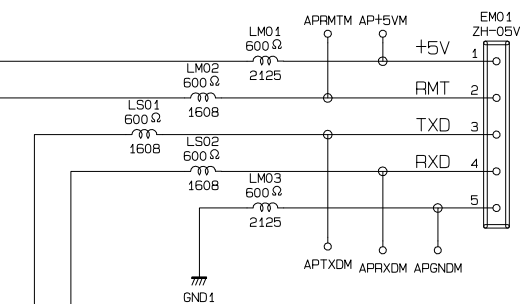
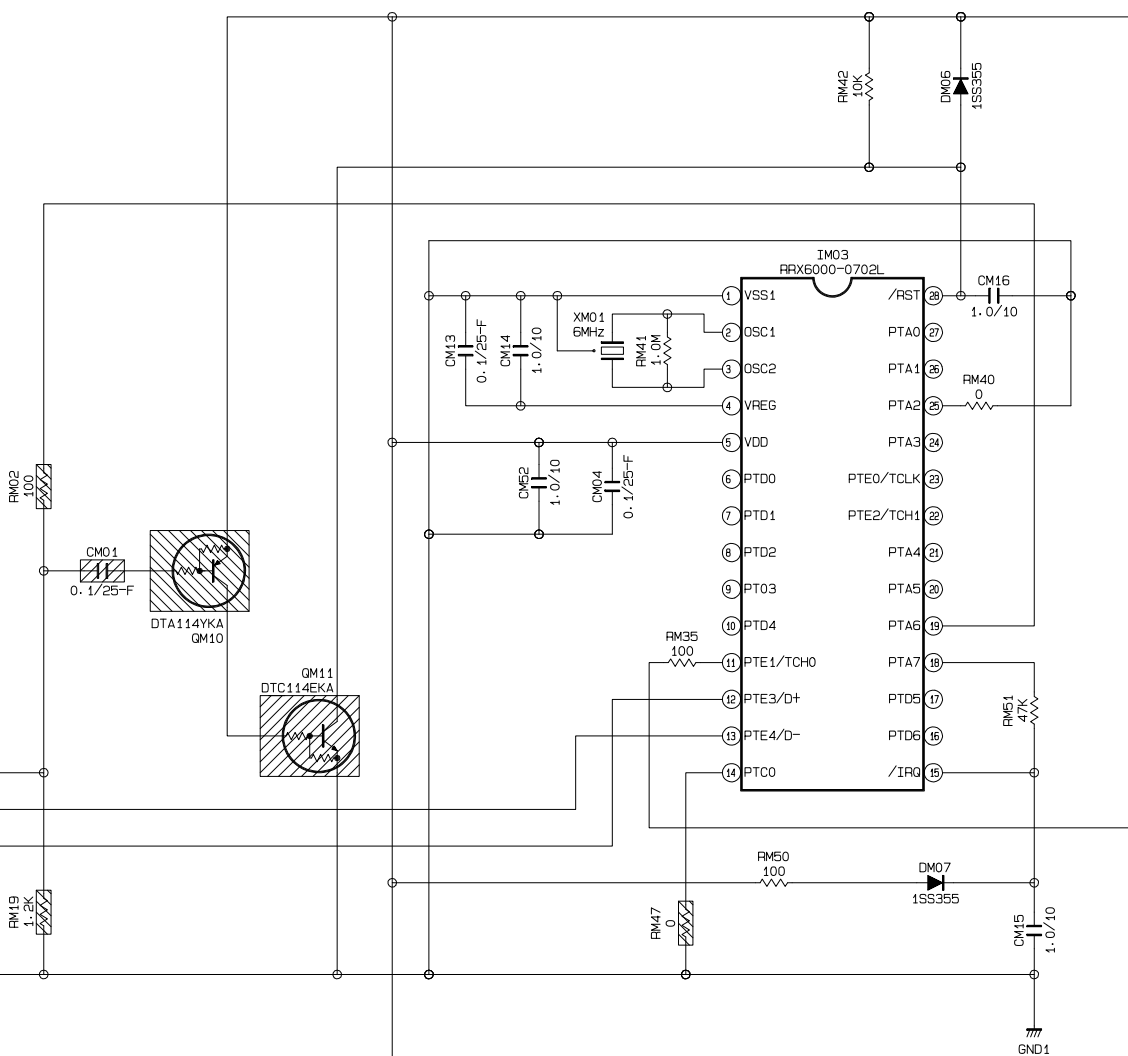
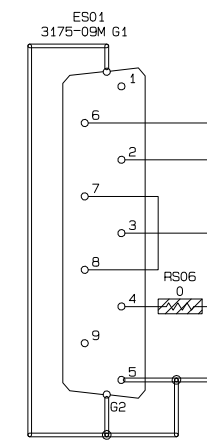

PARTS WITH HATCHING ARE NOT MOUNTED

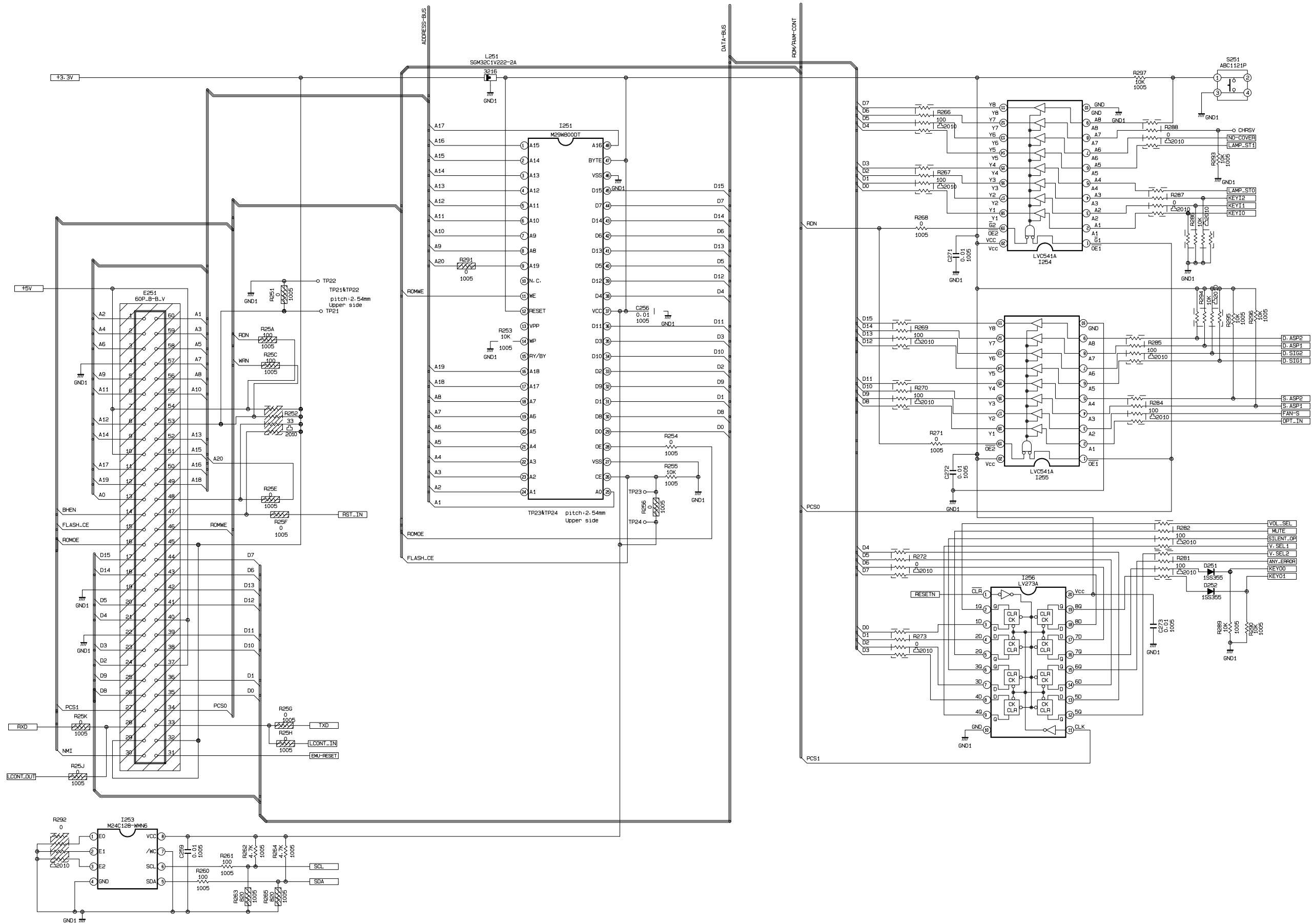

PARTS WITH HATCHING ARE NOT MOUNTED

SM0541

MAIN BOARD 2

HITACHI

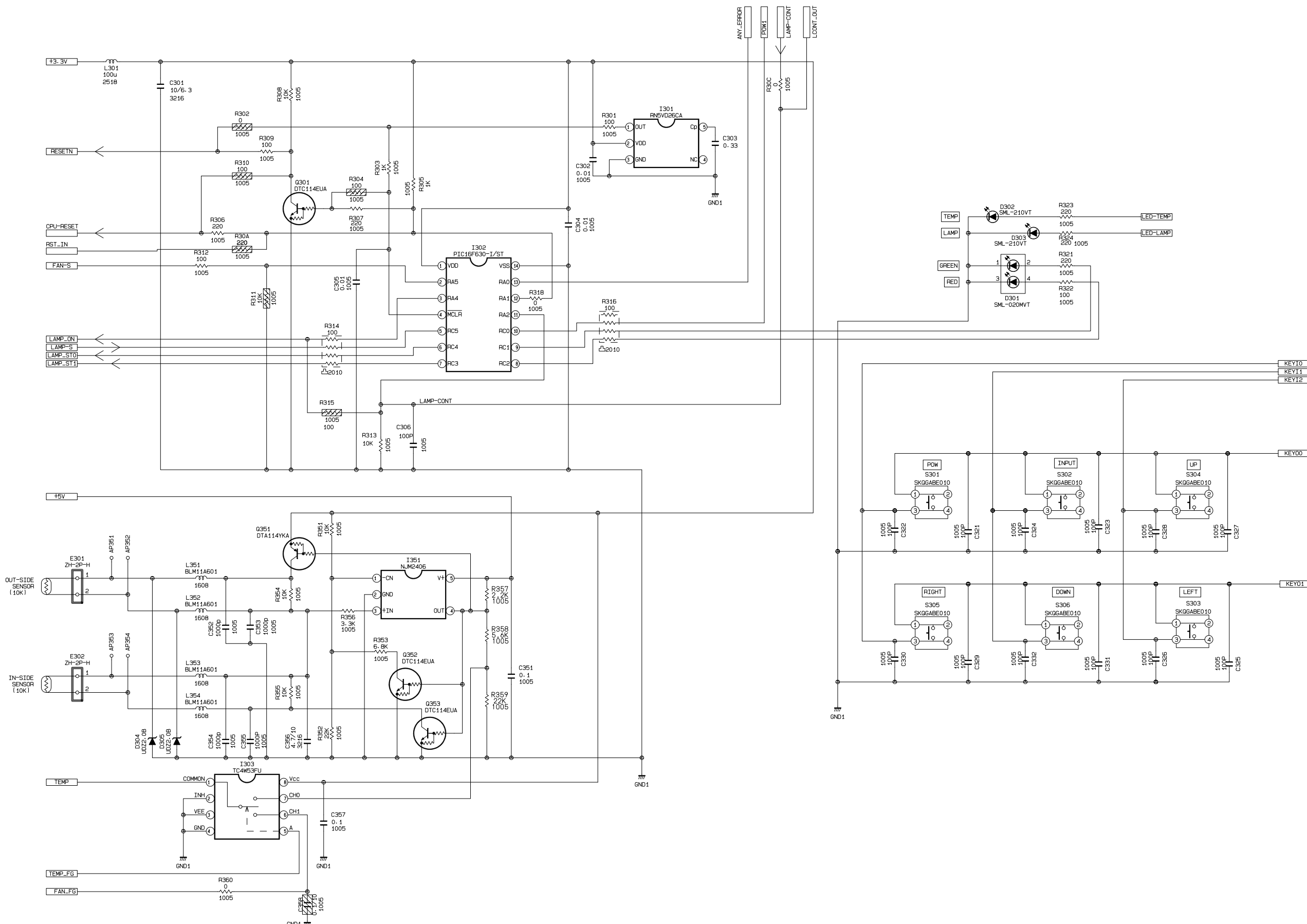

PARTS WITH HATCHING ARE NOT MOUNTED

SM0541

MAIN BOARD 3

HITACHI

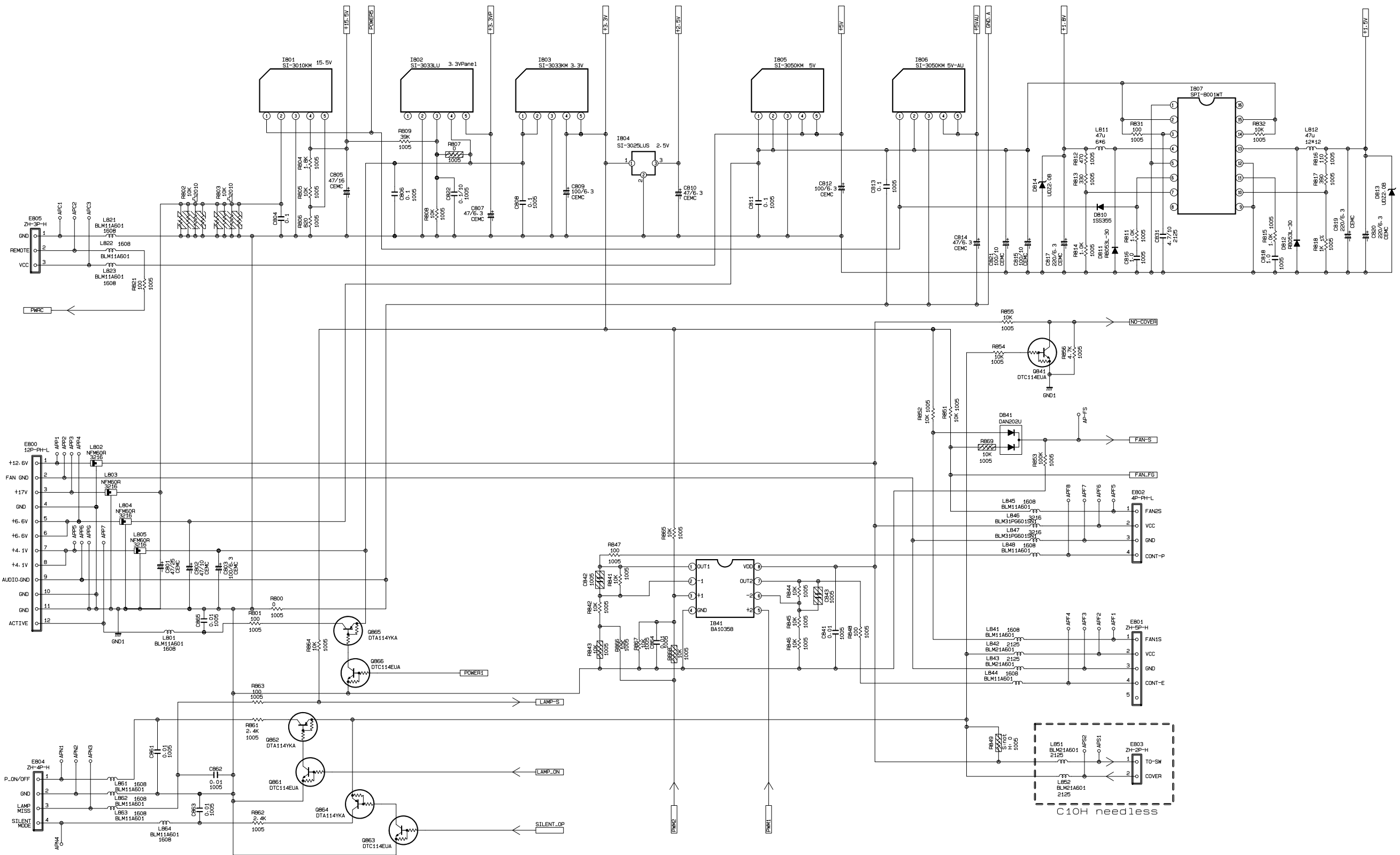

PARTS WITH HATCHING ARE NOT MOUNTED

SM0541

MAIN BOARD 4

HITACHI

R Panel Part

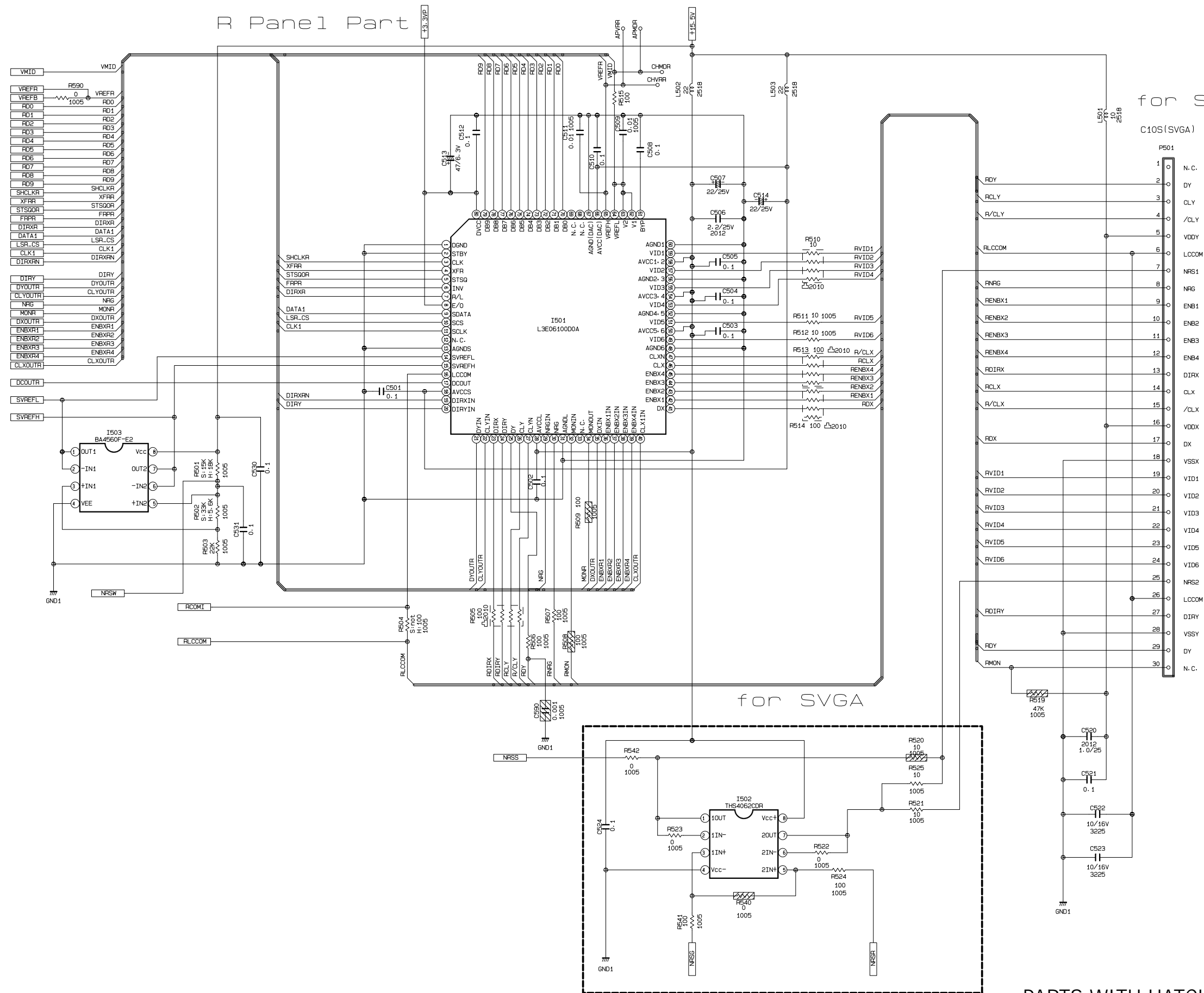

for SVGA PANEL

C10S(SVGA)

- | P501 | Signal |
|------|--------|
| 1 | N.C. |
| 2 | DY |
| 3 | CLY |
| 4 | /CLY |
| 5 | VDDY |
| 6 | LCCOM |
| 7 | NFS1 |
| 8 | NFG |
| 9 | ENB1 |
| 10 | ENB2 |
| 11 | ENB3 |
| 12 | ENB4 |
| 13 | DIRX |
| 14 | CLX |
| 15 | /CLX |
| 16 | VDDX |
| 17 | DX |
| 18 | VSSX |
| 19 | VID1 |
| 20 | VID2 |
| 21 | VID3 |
| 22 | VID4 |
| 23 | VID5 |
| 24 | VID6 |
| 25 | NFS2 |
| 26 | LCCOM |
| 27 | DIRY |
| 28 | VSSY |
| 29 | DY |
| 30 | N.C. |

for SVGA

PARTS WITH HATCHING ARE NOT MOUNTED

G Panel Part

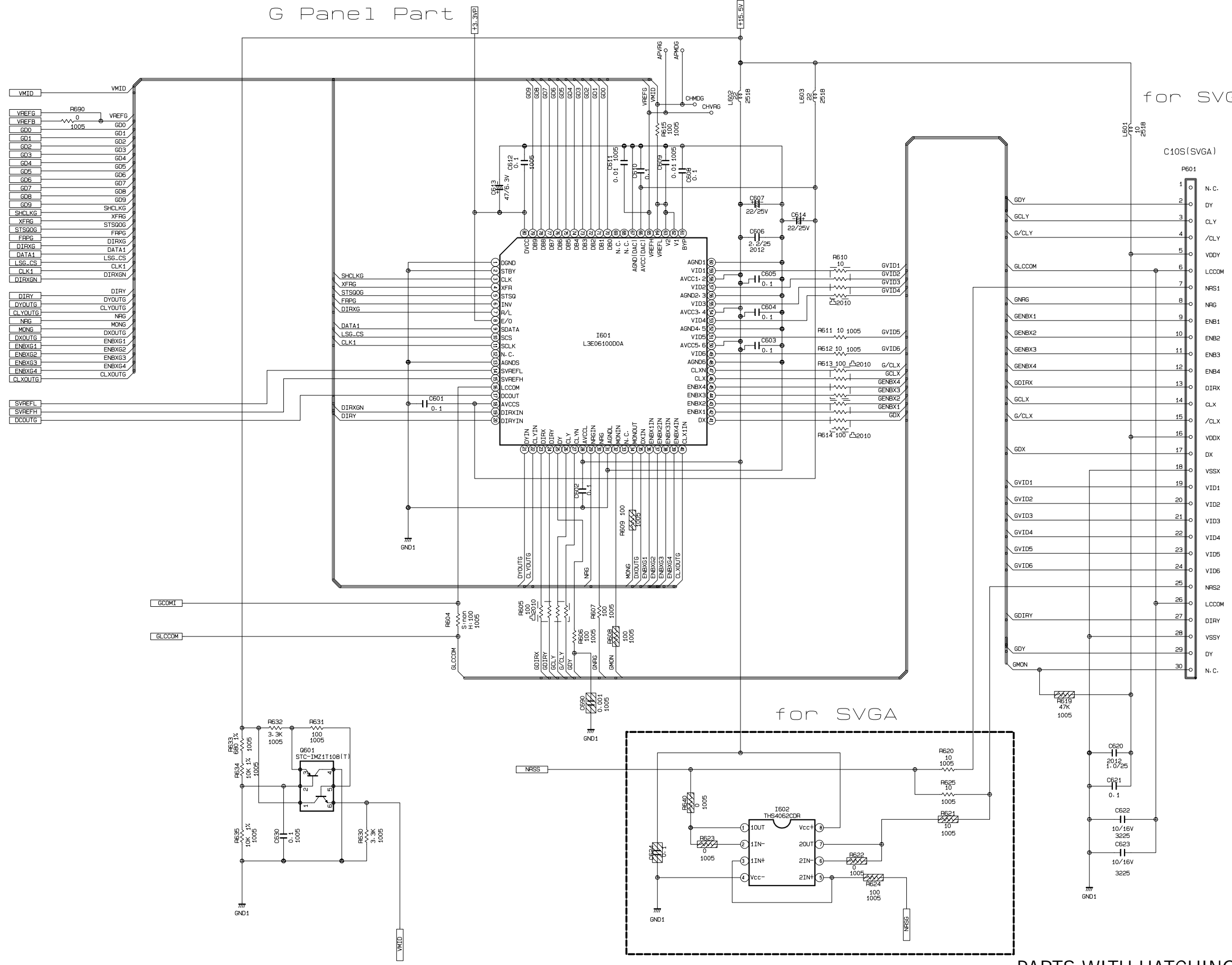

| | | | | | |
|---|---|--------|---|---|--------|
| 1 | 2 | SIGNAL | 1 | 2 | ASPECT |
| L | L | 750p | L | L | 16 : 9 |
| L | H | 1125i | L | H | LETTER |
| H | L | 525P | H | H | 4 : 3 |
| H | H | 525I | H | L | N. C. |

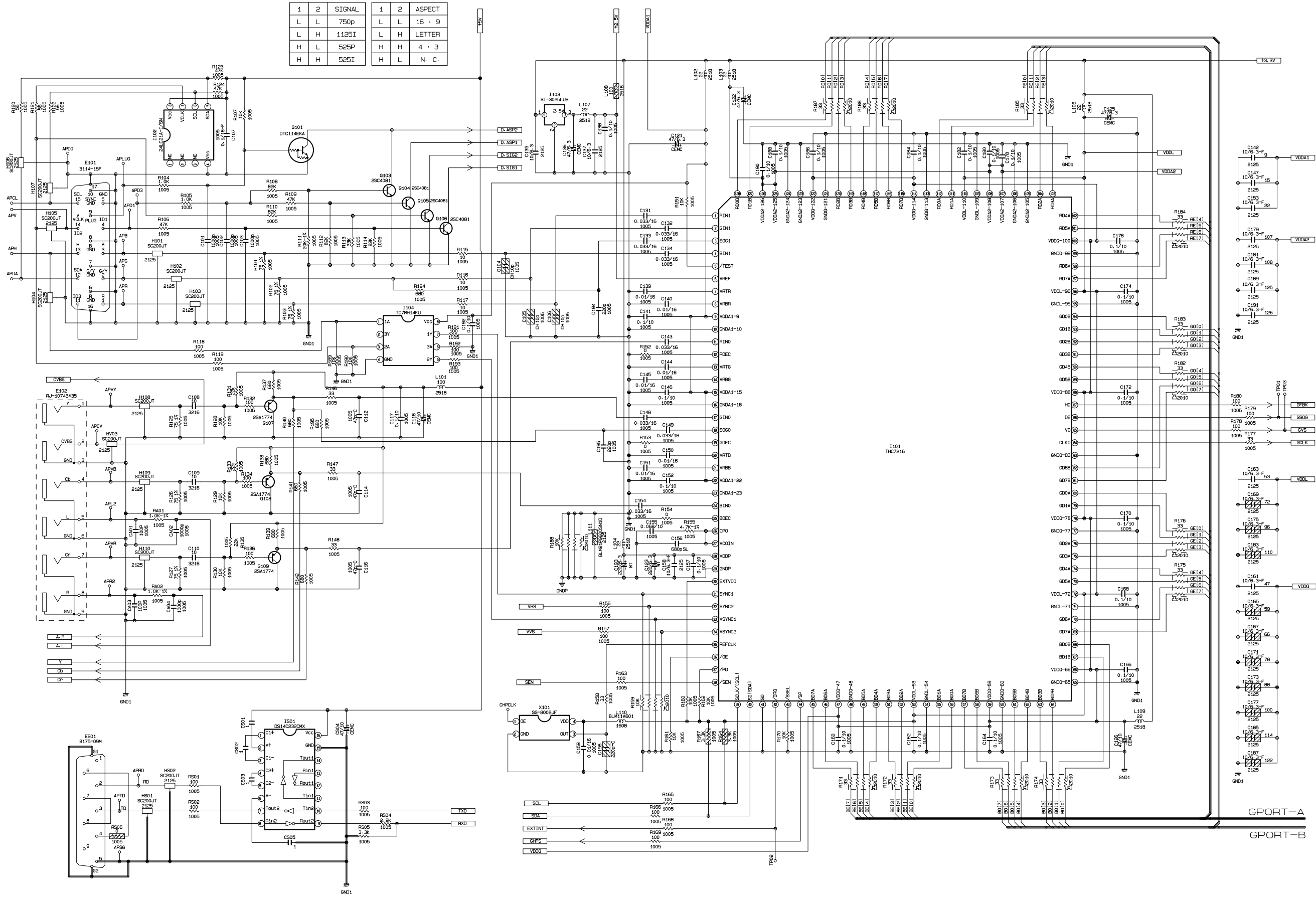

1101
THC7216

GPORT-A
GPORT-B

PARTS WITH HATCHING ARE NOT MOUNTED

SM0541

MAIN BOARD 9

HITACHI

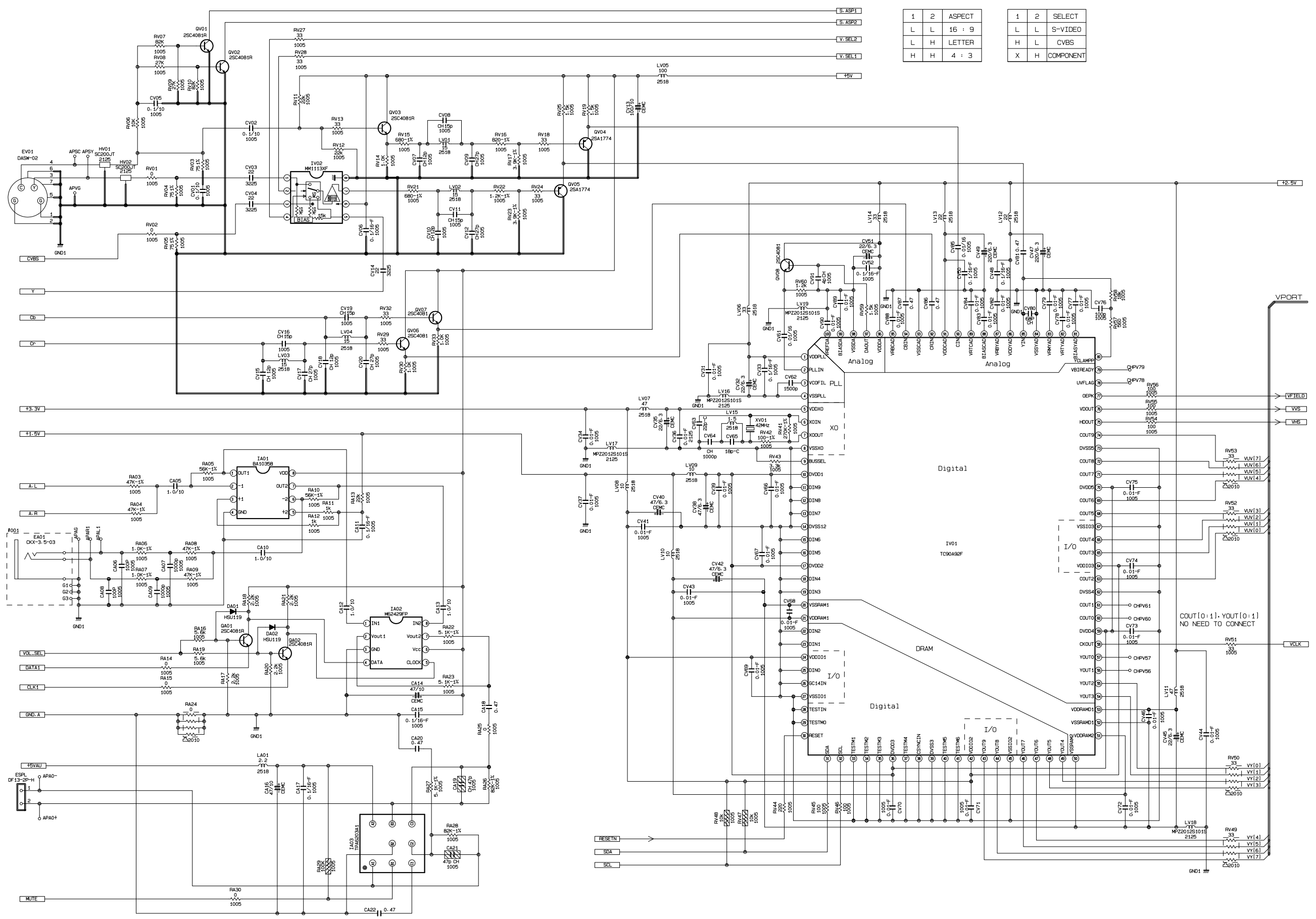

| | | |
|---|---|--------|
| 1 | 2 | ASPECT |
| L | L | 16 : 9 |
| L | H | LETTER |
| H | H | 4 : 3 |

| | | |
|---|---|-----------|
| 1 | 2 | SELECT |
| L | L | S-VIDEO |
| H | L | CVBS |
| X | H | COMPONENT |

SM0541

MAIN BOARD 10

PARTS WITH HATCHING ARE NOT MOUNTED

HITACHI

RGB IN

RGB OUT

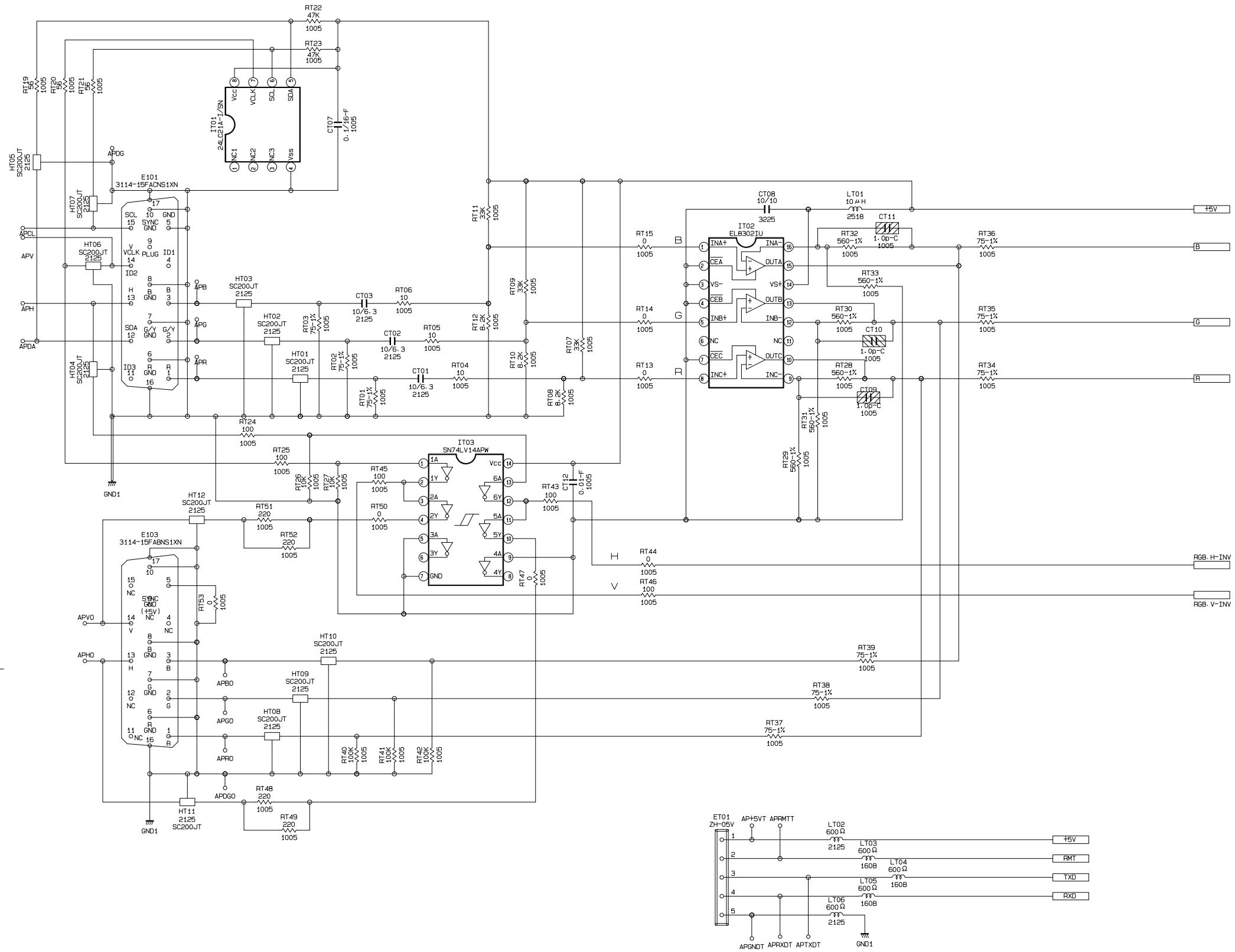

PARTS WITH HATCHING ARE NOT MOUNTED

SM0541

MAIN BOARD 11

HITACHI

HITACHI

Hitachi, Ltd. Tokyo, Japan
International Sales Division
THE HITACHI ATAGO BUILDING,
No. 15-12 Nishi Shinbashi, 2 - Chome,
Minato - Ku, Tokyo 105-8430, Japan.
Tel: 03 35022111

HITACHI EUROPE LTD,

Whitebrook Park
Lower Cookham Road
Maidenhead
Berkshire
SL6 8YA

UNITED KINGDOM

Tel: 01628 643000
Fax: 01628 643400
Email: consumer-service@hitachi-eu.com

HITACHI EUROPE S.A.

364 Kifissias Ave. & 1, Delfon Str.
152 33 Chalandri
Athens

GREECE

Tel: 1-6837200
Fax: 1-6835964
Email: service.hellas@hitachi-eu.com

HITACHI EUROPE GmbH

Munich Office
Dornacher Strasse 3
D-85622 Feldkirchen bei München

GERMANY

Tel: +49-89-991 80-0
Fax: +49-89-991 80-224
Hotline: +49-180-551 25 51 (12ct/min)
Email: HSE-DUS.service@hitachi-eu.com

HITACHI EUROPE S.A.

Gran Via Carlos III, 86, planta 5
Edificios Trade - Torre Este
08028 Barcelona

SPAIN

Tel: 93 409 2550
Fax: 93 491 3513
Email: atencion.cliente@hitachi-eu.com

HITACHI EUROPE srl

Via Tommaso Gulli N.39, 20147
Milano, Italia

ITALY

Tel: +39 02 487861
Tel: +39 02 38073415 Servizio Clienti
Fax: +39 02 48786381/2
Email: customerservice.italy@hitachi-eu.com

HITACHI Europe AB

Box 77 S-164 94 Kista

SWEDEN

Tel: +46 (0) 8 562 711 00
Fax: +46 (0) 8 562 711 13
Email: csgswe@hitachi-eu.com

HITACHI EUROPE S.A.S

Lyon Office
B.P. 45, 69671 BRON CEDEX

FRANCE

Tel: 04 72 14 29 70
Fax: 04 72 14 29 99
Email: france.consommateur@hitachi-eu.com

HITACHI EUROPE LTD (Norway) AB

STRANDVEIEN 18

1366 Lysaker

NORWAY

Tel: 67 5190 30
Fax: 67 5190 32
Email: csgnor@hitachi-eu.com

HITACH EUROPE AB

Egebækgård
Egebækvej 98
DK-2850 Nærum

DENMARK

Tel: +45 43 43 6050
Fax: +45 43 60 51
Email: csgnor@hitachi-eu.com

HITACHI EUROPE AB

Neopoli / Niemenkatu 73
FIN-15140 Lahti

FINLAND

Tel : +358 3 8858 271
Fax: +358 3 8858 272
Email: csgnor@hitachi-eu.com

Hitachi Europe Ltd

Bergensesteenweg 421
1600 Sint-Pieters-Leeuw

BELGIUM

Tel: +32 2 363 99 01
Fax: +32 2 363 99 00
Email: sofie.van.bom@hitachi-eu.com

HITACHI EUROPE LTD

Na Sychrove 975/8
101 27 Praha 10 - Bohdalec

CZECH REPUBLIC

Tel: +420 267 212 383
Fax: +420 267 212 385
Email: csgnor@hitachi-eu.com