



Card Stock & Label Guide

Laser Printers

Edition notice

July 2014

The following paragraph does not apply to any country where such provisions are inconsistent with local law: LEXMARK INTERNATIONAL, INC., PROVIDES THIS PUBLICATION "AS IS" WITHOUT WARRANTY OF ANY KIND, EITHER EXPRESS OR IMPLIED, INCLUDING, BUT NOT LIMITED TO, THE IMPLIED WARRANTIES OF MERCHANTABILITY OR FITNESS FOR A PARTICULAR PURPOSE. Some states do not allow disclaimer of express or implied warranties in certain transactions; therefore, this statement may not apply to you.

This publication could include technical inaccuracies or typographical errors. Changes are periodically made to the information herein; these changes will be incorporated in later editions. Improvements or changes in the products or the programs described may be made at any time.

References in this publication to products, programs, or services do not imply that the manufacturer intends to make these available in all countries in which it operates. Any reference to a product, program, or service is not intended to state or imply that only that product, program, or service may be used. Any functionally equivalent product, program, or service that does not infringe any existing intellectual property right may be used instead. Evaluation and verification of operation in conjunction with other products, programs, or services, except those expressly designated by the manufacturer, are the user's responsibility.

For Lexmark technical support, visit <http://support.lexmark.com>.

For information on supplies and downloads, visit www.lexmark.com.

© 2014 Lexmark International, Inc.

All rights reserved.

Trademarks

Lexmark, Lexmark with diamond design, MarkVision, Optra, and *Prebate* are trademarks of Lexmark International, Inc., registered in the United States and/or other countries.

Diamond Fine and WinWriter are trademarks of Lexmark International, Inc.

All other trademarks are the property of their respective owners.

GOVERNMENT END USERS

The Software Program and any related documentation are "Commercial Items," as that term is defined in 48 C.F.R. 2.101, "Computer Software" and "Commercial Computer Software Documentation," as such terms are used in 48 C.F.R. 12.212 or 48 C.F.R. 227.7202, as applicable. Consistent with 48 C.F.R. 12.212 or 48 C.F.R. 227.7202-1 through 227.7207-4, as applicable, the Commercial Computer Software and Commercial Software Documentation are licensed to the U.S. Government end users (a) only as Commercial Items and (b) with only those rights as are granted to all other end users pursuant to the terms and conditions herein.

Contents

- Edition notice.....2**
- Overview.....7**
 - Introduction.....7
- General information.....8**
 - Paper and label industry.....8
 - Printing volumes.....8
 - Testing print material.....8
 - Design factors.....9
 - Pick roller technology.....11
 - Maintenance procedures.....14
 - Troubleshooting.....14
- Card stock.....16**
 - Weight.....16
 - Grain orientation.....17
 - Coatings.....18
 - Offset powders.....19
- Labels.....20**
 - Label characteristics.....20
 - Printing on labels.....20
 - Duplexing paper labels.....20
 - Primary rib pattern design guidelines for reference edge alignment.....22
 - Label components.....23
 - Label design guidelines.....25
- Printer specifications.....32**
 - Lexmark C500n.....32
 - Lexmark C510.....33
 - Lexmark C520, C522, and C524.....34
 - Lexmark C530, C532, and C534.....36
 - Lexmark C540, C543, C544, and C546dtn.....38
 - Lexmark C720.....39

Lexmark C734 and C736.....	41
Lexmark C746 and C748.....	43
Lexmark C750.....	45
Lexmark C752.....	47
Lexmark C760 and C762.....	49
Lexmark C770, C772, C780, and C782.....	51
Lexmark C792e, C792de, C792dte, and C792dhe.....	53
Lexmark C910.....	54
Lexmark C912.....	56
Lexmark C920.....	57
Lexmark C925.....	59
Lexmark C935.....	60
Lexmark C950.....	62
Lexmark CS310n, CS310dn, CS410n, CS410dn, and CS510de.....	63
Lexmark CX310n, CX310dn, CX410e, CX410de, CX410dte, CX510de, CX510dhe, and CX510dthe.....	65
Lexmark E120.....	66
Lexmark E220.....	67
Lexmark E230, E232, E234(n), E330, and E332n.....	68
Lexmark E238, E240, E240n, E340, and E342n.....	69
Lexmark E250, E350, and E450n.....	70
Lexmark E260, E260d, E260dn, E360d, E360dn, E460dn, E460dw, and E462dtn.....	71
Lexmark E320, E322.....	72
Lexmark E321, E323.....	73
Lexmark MS310d, MS310dn, MS312dn, MS315dn, MS410d, MS410dn, MS415dn, MS510dn, MS610dn, and MS610de.....	74
Lexmark MS710 and MS711.....	76
Lexmark MS810, MS811, and MS812.....	78
Lexmark MS911.....	81
Lexmark MX310dn, MX410de, MX510de, MX511de, MX511dhe, MX610de, MX611de, and MX611dhe.....	82
Lexmark MX710, MX711, MX810, MX811, and MX812.....	84
Lexmark MX910, MX911, and MX912.....	87
Lexmark T420.....	88
Lexmark T430.....	90
Lexmark T520, T522.....	92
Lexmark T620, T622.....	94
Lexmark T630, T632, T634.....	97

Lexmark T640, T642, T644.....	100
Lexmark T650, T652, T654, and T656dne.....	102
Lexmark W812.....	105
Lexmark W820.....	106
Lexmark W840.....	107
Lexmark W850.....	109
Lexmark X203n and X204n.....	110
Lexmark X215.....	112
Lexmark X264dn, X363dn, X364dn, and X364dw.....	114
Lexmark X422.....	115
Lexmark X463de, X464de, X466dte, and X466dtwe.....	117
Lexmark X500 and X502n.....	118
Lexmark X543, X544, and X546dtn.....	119
Lexmark X548.....	121
Lexmark X560.....	122
Lexmark X642e.....	123
Lexmark X644e, X646e.....	126
Lexmark X651de, X652de, X654de, X656de, and X658de.....	128
Lexmark X734, X736, and X738.....	131
Lexmark X746 and X748.....	133
Lexmark X782.....	135
Lexmark X792de, X792dte, X792dtfe, X792dtpe, X792dtme, and X792dtse.....	137
Lexmark X850, X852e, and X854e.....	139
Lexmark X860e, X862e, and X864e.....	141
Lexmark X925.....	143
Lexmark X940 and X945.....	145
Lexmark X950.....	146
Optra plus, 4039, 4029, 4019, WinWriter 600 printers.....	147
Optra C.....	150
Optra C710.....	151
Optra Color 1200.....	152
Optra E, Ep.....	153
Optra E310, E312.....	154
Optra Es special media printer.....	155
Optra K 1220.....	156
Optra M410, M412.....	157
Optra N.....	159

Optra S.....160
Optra SC 1275.....162
Optra T.....163
Optra W810.....166

Glossary.....168

Index.....172

Overview

Introduction

This document provides guidelines to help you select appropriate print materials for the following Lexmark laser printers.

Series	Printer models
4019	All
4029	All
4039 10 plus	All
4039 12C	All
C series	C500, C510, C520, C522, C524, C530, C532, C534, C540, C546dtn, C543, C544, C720, C734, C736, C746, C748, C750, C752, C760, C762, C770, C772, C780, C782, C792e, C792de, C792dte, C792dhe, C910, C912, C920, C925, C935, C950, CS310n, CS310dn, CS410n, CS410dn, CS510de, CX310n, CX310dn, CX410e, CX410de, CX410dte, CX510de, CX510dhe, CX510dthe
E series	E120, E220, E230, E232, E234(n), E238, E240, E250, E260, E320, E321, E322, E323, E330, E332n, E340, E342n, E350, E360, E450, E460, E462dtn
M series	MS310d, MS310dn, MS312dn, MS315dn, MS410d, MS410dn, MS415dn, MS510dn, MS610dn, MS610de, MS710, MS711, MS810, MS811, MS812, MS911, MX310dn, MX410de, MX510de, MX610de, MX611de, MX611dhe, MX710, MX711, MX810, MX811, MX812, MX910, MX911, MX912
Optra™	All
T series	T420, T430, T520, T522, T620, T622, T630, T632, T634, T640, T642, T644, T650, T652, T654, T656dne
W series	W812, W820, W840, W850
WinWriter™ 600	4035 5W
X series	X203, X204, X215, X264, X363, X364, X422, X463, X464, X466, X500, X502, X543, X544, X546dtn, X548, X560(n), X642e, X644e, X646e, X651, X652, X654, X656, X658, X734, X736, X738, X746, X748, X782, X792de, X792dte, X792dtfe, X792dtpe, X792dtme, X792dtse, X850, X852e, X854e, X860e, X862e, X864e, X925, X940, X945, X950

The information supplied here supersedes other information relating to card stock and labels included with your printer. See other printer documentation for detailed information about the paper, envelopes, and transparencies suitable for your printer.

In addition to printer-specific media recommendations, this document also explains design factors to consider when purchasing all types of print materials. For definitions of industry terms, see [“Glossary” on page 168](#). If you have specific stock or design questions, then contact your print materials supplier.

See your printer documentation for general printing information and terms. For technical assistance contact numbers, see the printer registration card, information on the printer CD, or visit the Lexmark Web site at

<http://support.lexmark.com>.

Note: *Always test print materials thoroughly before buying large quantities.* Doing so helps you avoid unexpected problems when you begin regular printing.

General information

Paper and label industry

The paper and label industry includes manufacturers, converters, and distributors.

- *Manufacturers* produce the base stock. If the base is for labels, then manufacturers may ship it on large rolls or in a cut-sheet form.
- *Converters* take the base stock and convert it into cut-sheet products. Converters may work from rolls with or without the adhesive applied. They may also take a base stock and convert it to meet their customers' specifications. The conversion process includes, but is not limited to, cutting the stock to size, perforating the stock, die-cutting, and applying inks and topcoats. Converters work with their customers to convert the base material into a cut-sheet product designed for use in laser printers.
- *Distributors* are generally the direct link to the customer.

As needs and prices change, distributors may work with different converters and converters may work with different manufacturers. Most businesses follow accepted industry conventions, but specifications, standards, formulations, and processes may vary with time or with different companies.

As a result, labels or paper that worked well in the past may suddenly create printing problems because of a change in material or process.

Some large businesses perform all three functions, from manufacturing to distribution. These companies may offer greater expertise and product consistency than companies that concentrate on one facet of the process.

Printing volumes

Printing numerous sheets of card stock or labels in a short period of time can create printing problems. Continuous printing on labels, for example, may result in more frequent service calls. The glue on the labels can be squeezed out by the rollers in the printer and contaminate other printer parts. Most labels and card stock have cuts or perforations that can be abrasive if not ironed or flattened.

Special media, in general, have rough coatings and are thicker.

Proper printer maintenance can help you avoid these problems. For information about maintaining your printer, see [“Maintenance procedures” on page 14](#).

Testing print material

Consider the following factors when choosing print materials:

- Physical characteristics of the base stock and the manufacturing processes, which are dependent on the vendor, may change over time.
- The quality of print materials can also affect printer reliability and downtime. Using materials from converters or vendors who are unfamiliar with laser printing may result in unsatisfactory print quality or other printing problems.

Once a design is finalized, test the print material before placing a large order to avoid costly mistakes.

Your print materials supplier should be able to help develop your application or solve a problem you have with an existing application. In addition, Lexmark has worked with several suppliers and has business partners in this field. For technical assistance contact numbers, see the printer registration card, information on the printer CD, or visit the Lexmark Web site at <http://support.lexmark.com>.

Design factors

Print materials all have measurable characteristics that you need to consider when selecting or designing forms for your particular application.

Basis weight

Basis weight is a term used to describe the weight in pounds of 500 sheets of paper (one ream). However, the weight is determined based on the standard size of the paper, which may not be the purchased size. For example, the standard size of 20-lb bond paper is 17 x 22 inches, and a ream of 17 x 22-inch 20-lb bond paper weighs 20 pounds. If the 17 x 22-inch 20-lb bond paper was cut, creating four reams of 8.5 x 11-inch paper, each ream would be labeled 20-lb bond paper but would only weigh five pounds.

If the same paper weighed 24 pounds, it would be called 24-lb bond. The 24-lb bond paper is thicker, heavier, and more dense than the 20-lb bond. Thicker paper means less paper can be placed in a tray, and paper that is heavier and more dense may cause paper jams or feed reliability problems in some printers. Check the supported paper weights table located in the printer documentation to verify that the paper basis weight being used is acceptable.

Not all basis weights are related to the same standard sheet size: for example, 70-lb material can be lighter than 40-lb material if it is based on larger base size paper. The metric measurement of grams per square meter (g/m^2) is a more consistent way to compare weights and has been standardized by the International Organization for Standardization (ISO). For more information, locate your printer in the “Printer specifications” chapter.

Your printer can accept a wide range of stock weights, but materials either too light or too heavy can cause printing problems. Heavy and/or thicker materials may not heat quickly enough in the fuser, resulting in poor print quality. They may also feed less reliably or skew due to their weight or rigidity. Conversely, lighter materials can wrinkle and jam in the printer due to low beam strength (stiffness).

Depending on the orientation of the stock as it feeds through the printer, you may need to request that heavier materials be cut grain short or grain long to provide flexibility in paper path turns. For more precise recommendations, locate your printer in the “Printer specifications” chapter.

Dimensions

All printers have print material dimension limitations. See the printer documentation that came with your printer for details. You can sometimes redesign forms to overcome these limitations. For example, if you use forms that are shorter than the minimum length supported by your printer, you may be able to link two forms together when printing multiple forms. An optional Universally Adjustable Tray designed for the Opra S, Opra T, and Lexmark T printer families prints on a range of paper sizes including A6 and 3 x 5-inch index cards, 3 x 7-inch punch cards, and 4 x 6-inch postcards.

Environment

Lexmark printers meet or exceed all industry emission regulations and standards. Continuous printing on some papers or other media may create fumes that are not a problem with occasional printing. Make sure your printer is located in a well-ventilated area.

Temperature and humidity can have a major impact on printing. Even small changes (such as from day to night) can greatly affect feed reliability if the print material is just within the range of acceptability.

We recommend that you *condition* stock while it is still in the original wrapper. To condition stock, store it in the same environment as the printer for 24–48 hours before printing to let the stock stabilize at the new conditions. You may need to extend this time by several days if the storage or transportation environment is very different from the printer environment. Thick stock may also require a longer conditioning period because of the mass of the material.

If you remove the wrapper from the stock before you are ready to load it in the printer, the stock may develop uneven moisture content that can cause curl. Prior to loading your stock, we recommend that curl not exceed 3 mm (0.125 in.). Lighter materials, such as paper labels and some integrated forms, are more likely to have printing problems if curl is present.

Most label manufacturers recommend printing in a temperature range of 18–24°C (65–75°F) with relative humidity of 40–60%. Lexmark printers are designed to operate in a temperature range of 15.5–32°C (60 to 90°F) with relative humidity of 8 to 80%. Printing in an environment outside these recommendations may cause jams, feeding problems, reduced print quality, and predisping (peeling) labels.

Inks (preprinted stock)

Preprinted stock introduces semi-liquid and volatile components to the high temperatures and pressure used in the laser printing process. Preprinted inks and colorations must withstand a fuser temperature up to 225°C (437°F) and pressure up to 25 psi without contaminating the printer or creating hazardous fumes.

Thermography inks are *not* recommended. Thermography inks have a waxy feel and the printed image appears raised above the surface of the print material. These inks can melt and damage the fuser assembly.

Preprinted inks must also be abrasion resistant to reduce ink dust and ink contamination in the printer. If you are printing over a preprinted area, the ink must be receptive to toner to ensure adequate fusing.

All preprinted inks must be thoroughly dry before using printed materials. However, we do *not* recommend using offset powders or other foreign materials to speed drying. Check with your converter, or the manufacturer or vendor of the ink you plan to use, to determine if the ink is compatible with laser printers that heat the ink to 225°C (437°F).

Perforations and die-cuts

If your form has perforations, the perforation line should stop 1.6 mm (0.06 in.) from each edge of the form to avoid separating the form in the printer path, resulting in a jam. The location of the perforation affects initial pick strength. Perforations closer to the edge may increase the number of jams. For pressure-sensitive materials such as labels, minimize the number of perforations that go through the backing material, or liner, since these can also affect the strength of the form.

Perforations should be ironed so the print material lies flat, reducing nesting of forms. Edges should be smooth and clean with no roll-over. *Laser-perfs* (also known as *micro-perfs* or *data-perfs*) provide greater stability and are preferred. These smaller perforations do not normally nest or create excessive paper dust and debris. Make sure paper chaff and dust created during the conversion process are removed before packaging.

If perforations *tent*, or crease at the perforation line, the perfs may break, causing a paper jam. Tenting may increase skew, cause double-sheet feeding, or smear the toner on the print material before fusing, resulting in poor print quality. To reduce tenting, use micro-perfs. If the print material is lightly snapped as it moves through the printer, the perforations should hold without breaking.

Die-cutting is used to create shapes in a label or a card stock design. When designing labels, round all corners to prevent delamination of the labels, and avoid cuts through the liner (*anvil cuts*). Back splits and pop-out windows are also not recommended.

If perforations or die-cuts are part of the design of the print material, ties are recommended. These small uncut areas (approximately 1.6 mm or 0.06 in.) help stabilize the form and prevent tearing at perforations and die-cuts during printing.

For areas with die-cuts or perforations that create a small end product, or where die-cuts or perforations intersect, ties on the corners of the design provide added stability. Ties may be located anywhere along perforations or die-cuts. For pressure-sensitive products, ties help prevent the labels from peeling off the liner while in the printer. Ties cannot, however, be used to compensate for inadequate release strength of the adhesive in label designs.

For specific perforation and die-cut guidelines for your printer, locate your printer in the “Printer specifications” chapter.

Debossing and embossing

Avoid debossing and embossing materials. Embossing leads to nesting and double-sheet feeds, and the fusing process significantly reduces the height of the raised image. Printing too close to embossments results in poor print quality and poor fuse grade.

Metallics

We do *not* recommend using metallics in forms, whether in inks or other materials, due to their conductivity and their ability to bleed charge. This can interfere with toner transfer and cause poor print quality.

Basic form design

When designing forms, include a non-print area of 8.38 mm (0.33 in.) at the top and bottom of the form and 6.35 mm (0.25 in.) on both sides of the form.

In general, portrait orientation is the preferred layout, especially if you are printing bar codes. If your forms require landscape orientation, be aware that variations in paper path speed may produce spacing variations when printing bar codes.

Note: We do *not* warrant uninterrupted or error-free operation of a product. Warranty service does *not* include repair of failures caused by:

- modification or attachments
- accidents or misuse
- unsuitable physical or operating environment
- maintenance by any unauthorized (non-Lexmark) servicer
- operation of a product beyond the limit of its duty cycle
- failure to have installed a maintenance kit as specified (if applicable)
- use of printing media outside of Lexmark specifications
- use of non-Lexmark supplies (such as toner cartridges and/or inkjet cartridges)
- use of non-Lexmark product or component

Pick roller technology

Some printers have an auto compensator which feeds paper more reliably than the corner buckler system used by earlier printer models. The auto compensator has two rollers that touch the media. Avoid placing deep perforations in these areas since the media may nest, causing multiple sheets to feed. Perforations that could cause nesting and tenting should fall outside the pick roller area on the leading edge of the media. This is different from the 0.50-inch space we recommend leaving at the top of the form for printers with a corner buckler system. You may want to use micro-perfs to avoid nesting problems. For more information, see [“Perforations and die-cuts” on page 10](#).

For the following printers, make sure perforations fall outside the 0.3–0.79-inch area on the leading edge of the media:
Optra S, Optra T, T520, T522, T620, T622, T630, T632, T634, T640, T642, T644, T650, T652, T654, T656dne, X203, X204, X264, X363, X364, X463, X464, X466, X543, X544, X546dtn, X560n, X642e, X644e, X646e, X651, X652, X654, X656, X658, X734, X736, X738.

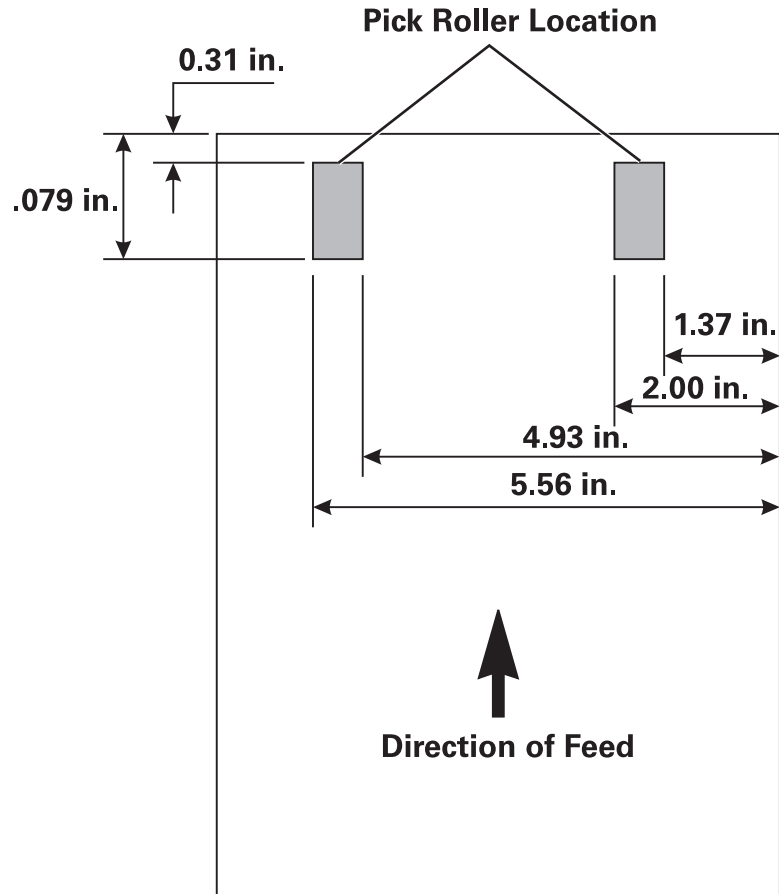

For the following printers, make sure perforations fall outside the 0.31–1.05-inch area on the leading edge of the media:
 C520, C522, C524, C530, C532, C534, C540, C543, C544, C546dtn, C734, C736, C750, C752, C760, C762, C770, C772,
 C780, C782, C792e, C792de, C792dte, C792dhe, CS310n, CS310dn, CS410n, CS410dn, CS510de, CX310n, CX310dn,
 CX410e, CX410de, CX410dte, CX510de, CX510dhe, CX510dthe, X792de, X792dte, X792dtfe, X792dtpe, X792dtme, and
 X792dtse.

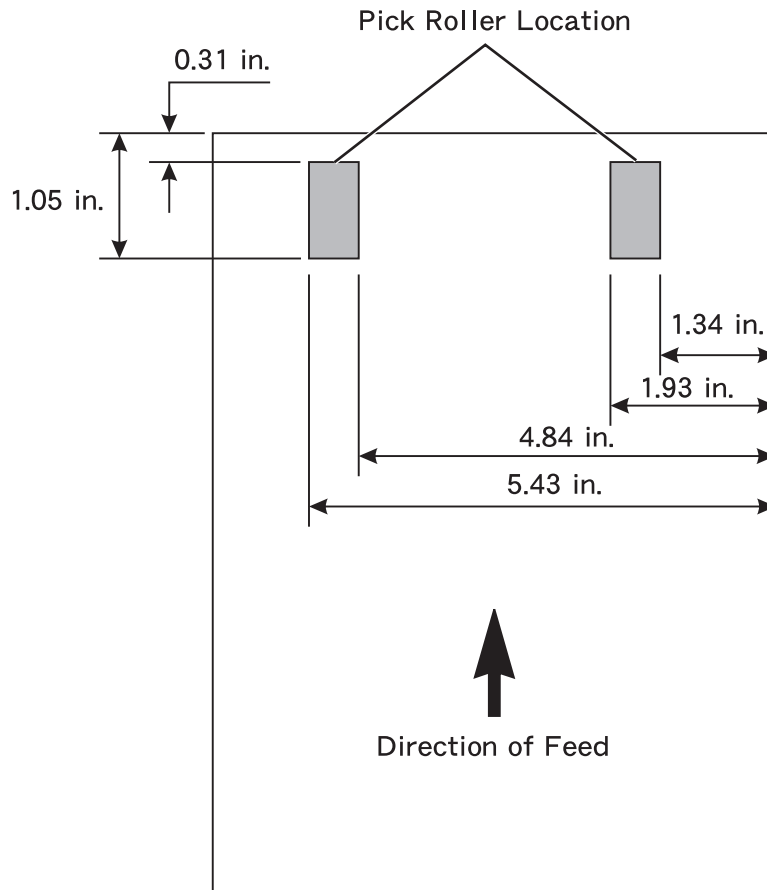

For the following printers, make sure perforations fall outside the 0.12–0.91-inch area on the leading edge of the media: MS710, MS711, MS810, MS811, MS812, MX710, MX711, MX810, MX811, and MX812.

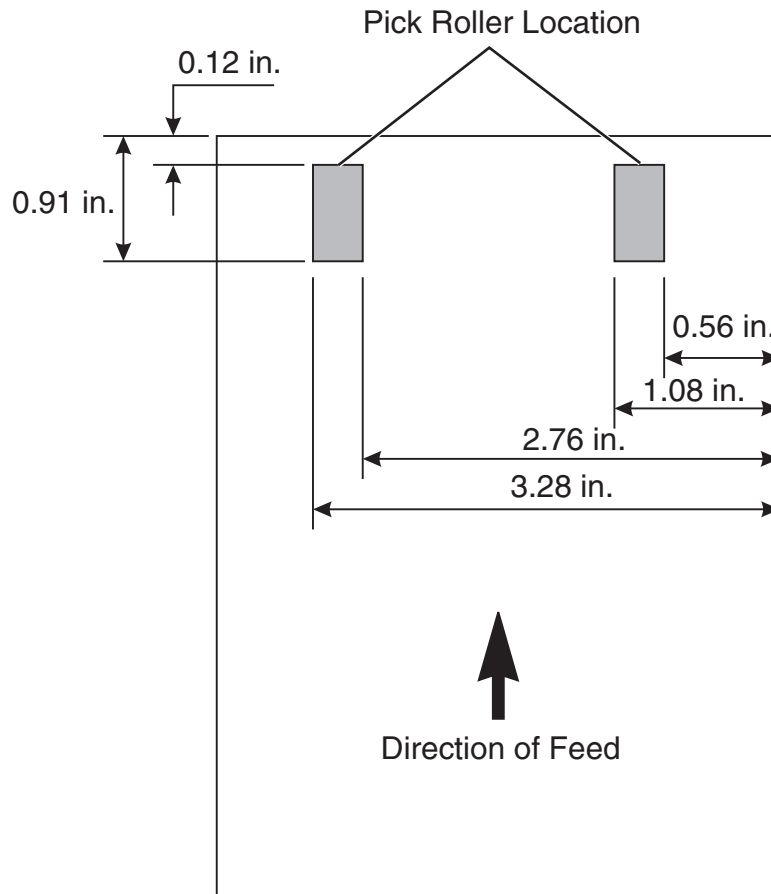

Maintenance procedures

Note: These procedures apply only to mono laser printers.

If print quality begins to degrade when printing on vinyl labels, then do the following:

- 1 Print on five sheets of paper.
- 2 Wait approximately five seconds.
- 3 Print on five more sheets of paper.

To maintain printer feeding reliability, repeat this cleaning process every time you replace the toner cartridge.

Note: Failure to follow maintenance procedures for your printer could cause jams, poor print quality, feeding problems, and fuser problems.

Troubleshooting

The following table provides solutions to some common card stock and label problems. For more troubleshooting information, see your printer documentation.

Problem	Solution
Print on heavy stock is blurred or out of focus.	Make sure the Paper Type setting is correct for your print material. Note: Card stock in excess of 203 g/m ² (54-lb bond) may not produce acceptable print results.
	Print on five sheets of paper, wait for approximately five seconds, and then print five more sheets of paper to remove any toner that may have accumulated.
Toner rubs off the page.	Make sure the Paper Type setting is correct for your print material.
	Use material that is lighter than 300 g/m ² .
	Print on five sheets of paper, wait for approximately five seconds, and then print five more sheets of paper to remove any toner that may have accumulated.
Printing shows voids.	Change the Paper Type to Plain Paper.
	Print on five sheets of paper, wait for approximately five seconds, and then print five more sheets of paper to remove any toner that may have accumulated.

Card stock

Card stock is a rigid, stiff material that can have a wide variety of constructions. Orientation of paper fibers (grain direction), moisture content, thickness, texture, and other properties can significantly impact printing, as can preprinting, perforation, creasing, and other features common to forms. For example, preprinting introduces semi-liquid, volatile components that must withstand the high temperatures used in laser printing. Perforation and creasing may cause nesting, or interlocking, which can cause paper jams and double-sheet feeds.

In general, we recommend a single-ply construction of 100% chemically-pulped wood with a vellum finish. Before purchasing large quantities of card stock, make sure you test samples of the print material in your printer.

Weight

The weight of card stock significantly affects the print quality and feed reliability of the stock. Specify the correct basis weight of a stock. For more information, see [“Basis weight” on page 9](#).

Basis weight is the weight in pounds of one ream, or 500 sheets, of paper. Since the sheet size varies from one type of stock to another, basis weights are not always easily comparable. For example, an office supply store has 8.5 x 11-size cover stock (80 lb Bristol) and 8.5 x 11-size card stock (90 lb Index) side by side on the shelf. Both papers are manufactured by the same company, and a basis weight comparison indicates the card stock (90 lb Index) is heavier than the cover stock (80 lb Bristol). In this case, however, the cover stock (80 lb Bristol) is actually heavier than the card stock (90 lb Index).

Before the two types of paper were cut into 8.5 x 11-size pages, the card stock was a larger sheet size than the sheet size of the cover stock. When the papers were cut during the manufacturing process into 8.5 x 11-size pages, more reams (500 sheets) of paper were received from the card stock sheets than from the cover stock sheets. This makes the weight of the cover stock heavier than the weight of the card stock.

It is easier to compare the cover stock metric weight (g/m²) against card stock metric weight (g/m²). If you look at the metric weights of the two stocks in the previous example, it is immediately evident that 80 lb Bristol cover stock (176 g/m²) is heavier than 90 lb Index card stock (163 g/m²).

Not all printers are able to print on cover stock. This is because cover stock is usually thicker and not able to make the turns in the printer paper path. This causes paper jams and sometimes causes the paper to feed incorrectly. Also, when using a laser printer, toner is pulled onto the paper through an electrical charge. If the paper is too thick, then there may not be enough voltage to pull the toner onto the paper properly, resulting in poor print quality.

To determine if your printer supports cover stock, see the section for your printer in the "Printer specifications" chapter and review the supported paper type information. You can also view the supported paper types in the documentation that came with your printer.

Use the following table to compare the weights of various types of card stock.

Metric equivalent (g/m ²)	Basis weight (lbs/ream)					
	Bond 431.8 x 558.8 mm (17 x 22 in.)	Offset 635 x 965.2 mm (25 x 38 in.)	Cover 508 x 660.4 mm (20 x 26 in.)	Printing Bristol 571.5 x 889 mm (22.5 x 35 in.)	Index Bristol 647.7 x 774.7 mm (25.5 x 30.5 in.)	Tag 609.6 x 914.4 mm (24 x 36 in.)
75	20	50	—	—	—	50
90	24	60	—	—	—	—

Card stock weights may vary ± 5%.

Metric equivalent (g/m ²)	Basis weight (lbs/ream)					
	Bond 431.8 x 558.8 mm (17 x 22 in.)	Offset 635 x 965.2 mm (25 x 38 in.)	Cover 508 x 660.4 mm (20 x 26 in.)	Printing Bristol 571.5 x 889 mm (22.5 x 35 in.)	Index Bristol 647.7 x 774.7 mm (25.5 x 30.5 in.)	Tag 609.6 x 914.4 mm (24 x 36 in.)
105	28	70	—	—	—	—
108	29	—	40	—	—	—
118	31	80	—	—	—	—
120	32	—	—	—	67	74
131	35	90	—	—	—	—
135	36	—	50	—	—	—
148	39	100	—	—	—	—
163	43	—	60	—	90	100
176	47	120	65	—	—	—
199	53	—	—	110	110	—
203	54	—	—	—	—	125

Card stock weights may vary \pm 5%.

Depending on the printer, material thicker than 0.30 mm (0.012 in.) may present feed reliability problems, and material thicker than 0.17 mm (0.007 in.) may reduce print quality. Contact your supplier to determine the weight of any card stock you currently use.

See the individual printer specifications in this document for more information about the card stock weights your printer supports.

Grain orientation

Grain refers to the alignment of the paper fibers in a sheet of paper. Grain is either *grain short*, running the width of the paper, or *grain long*, running the length of the paper.

The orientation of the grain contributes to the rigidity of card stock and affects feed reliability. The recommended grain orientation depends on the weight of the stock and whether the printer feeds the stock short edge first or long edge first. For lighter card stocks, *grain long* is recommended to reduce potential curl problems. Curl may decrease the ability of the form to move reliably through the printer.

Most printers feed paper short edge first. If your printer supports larger paper sizes, such as 11 x 17 in. or A3, it may feed some paper sizes long edge first. See your printer documentation for more information.

For materials fed *short edge* first:

Grain short is recommended for stock heavier than 135 g/m² Grain long is recommended for stock lighter than 135 g/m²

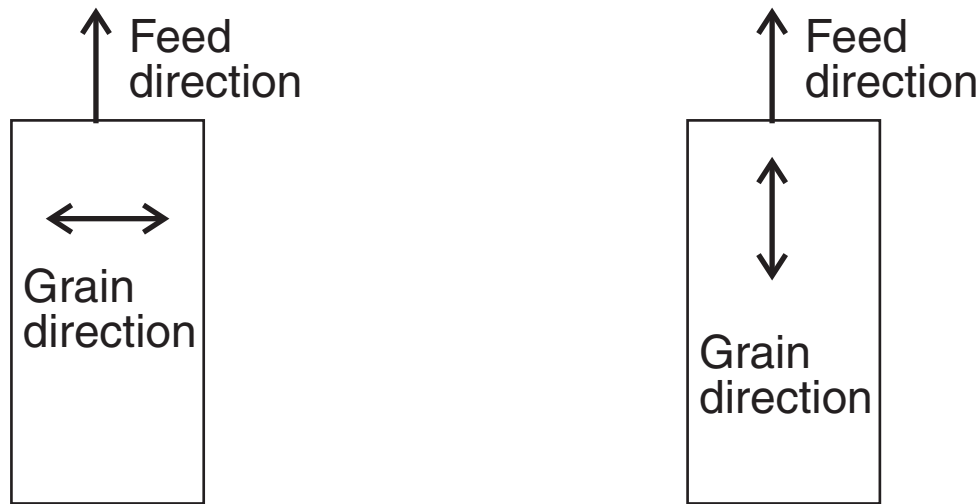

For materials fed *long edge* first:

Grain long is recommended for stock heavier than 135 g/m² Grain short is recommended for stock lighter than 135 g/m²

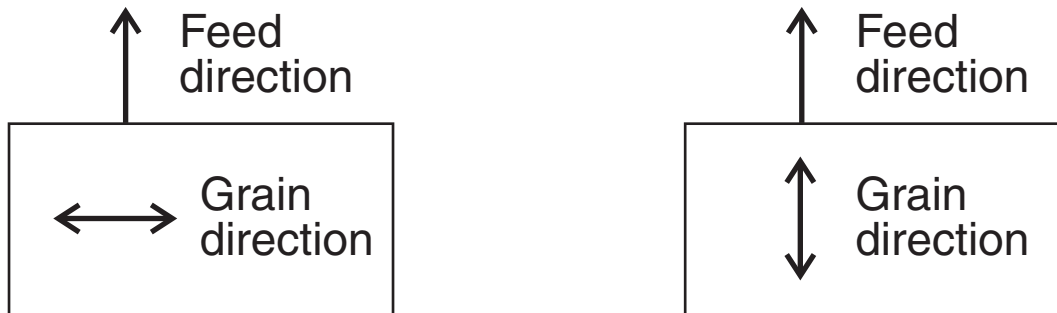

See the individual printer specifications in [“Printer specifications” on page 32](#) for more information about the recommended grain direction for card stock you use with your printer.

Coatings

Surface texture and coatings on card stock significantly affect toner adhesion (fuse grade), print quality, and feed reliability. We recommend a vellum finish for the best printing performance. We do *not* recommend glossy coatings and slick surfaces or surfaces that mimic laid finishes (glossy paper, not glossy card stock, is acceptable for some printers). Paper smoothness also affects print quality. If the paper is too rough, the toner does not fuse to the paper properly; if the paper is too smooth, it can affect feed reliability. We recommend smoothness to be between 100 and 400 Sheffield points (150–250 is optimal). Using media higher than 300 Sheffield could result in printing degradation.

Offset powders

We do *not* recommend using offset powders or other foreign materials to speed drying. Offset powders are used by print shops to prevent printed pages from sticking together. Powder is usually sprayed on the printed page right before it reaches the stacker on the offset printing press. This powder provides an intermediate layer between two sheets of paper, preventing ink from transferring from one sheet to another.

Labels

Labels, or pressure-sensitive materials, are multi-ply materials that contain various combinations of face sheets (printable stock), adhesives, and removable protective backings (liners). These layers can result in thick materials that are difficult to handle.

Labels are among the most difficult print materials for any printer to reliably feed and print. Factors such as heat, pressure, and paper path could make printing on labels quite challenging. For example, temperatures near 225°C (437°F) [temperatures vary between printers; check the section for your specific printer] and pressures to 25 psi can be necessary for the fusing process. Heavy label stock can absorb heat, which in turn affects toner adhesion and print quality and causes problems such as delamination.

Note: To prevent labels from peeling off or delaminating, make sure the release strength of the labels is sufficient to withstand the temperature and pressure extremes generated during printing.

Label characteristics

The materials used to construct labels have a wide range of properties that can affect printing. Volatile components are in the label materials and in the adhesive itself. We recommend that volatile emissions from the label, up to 160°C (320°F), should be a minimal amount. The volatile components, which have low boiling point, produce emissions when heated in the fuser and could emit vapors that can damage the printer.

Preprinted inks can also cause printer contamination, and may be present on one or both sides of the label sheet.

Follow the recommended label design guidelines to prevent labels from peeling off, which could cause jams. The label or adhesive could also melt if the sheet is jammed in the fuser.

Review label designs with a converter or a vendor who has extensive knowledge about labels and laser printers to ensure that you are using the proper type of labels.

Before purchasing large quantities of labels, make sure you extensively test the labels with your printer.

Printing on labels

Print on full label sheets only. Sheets with missing labels could peel off during printing and result in a paper jam. Partial sheets can also leave adhesive marks on the printer and cartridge, which could void the printer and cartridge service warranties.

Do *not* feed labels through the printer more than once. Doing so may contaminate the cartridge and other components with adhesive.

Depending on your printer model and the number of labels being printed, printing labels may require special printer maintenance. For specific maintenance information, see the documentation that came with your printer.

For more information about printing on labels, see the section for your printer in the “Printer specifications” chapter.

Duplexing paper labels

Labels are not typically duplexed because of their special construction. However, printing on both sides of the label sheet may be possible if certain design, construction, and usage guidelines are followed.

When developing a paper label for duplexing, the converter should make sure that the label is designed to protect against contamination or buildup. Contamination could result in paper feed problems and paper jams.

We recommend the use of label sheets that have a non-adhesive border around the label area. Make sure that the release strength is enough to withstand temperatures of 225°C (437°F) and pressure up to 25 psi. The ability to withstand these factors is important because the label sheet will be subjected to these twice.

Use label ties whenever possible. These small uncut areas (approximately 1.6 mm or 0.06 in.) help stabilize the label sheet and prevent tearing at perforations and die-cuts during printing. Label ties also prevent labels from predispending in the printer.

The slits and cuts in the labels expose the adhesives to the printer. For best results when duplexing labels, position the label sheet so the slits and cuts are *not* aligned with the ribs in the duplex or redrive areas of the printer. This eliminates any contact points between the label adhesive and the printer, thereby preventing any adhesive contamination in the printer. The following graphics show the rib locations for the Optra S, Optra T, and Lexmark T, respectively.

Optra S rib locations (rib width = 2 mm):

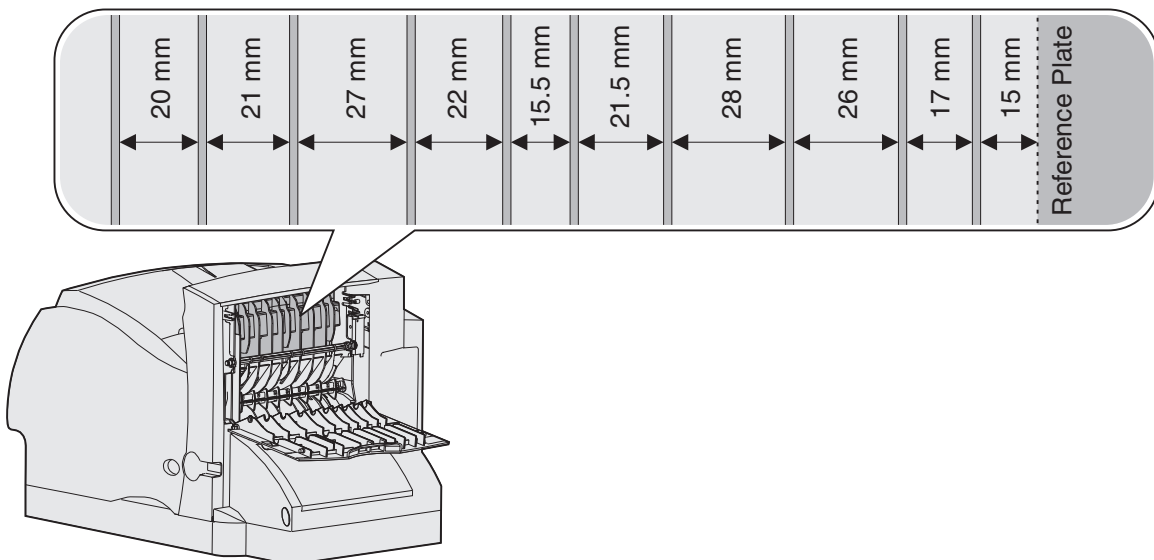

Optra T and Lexmark T rib locations (rib width = 2 mm):

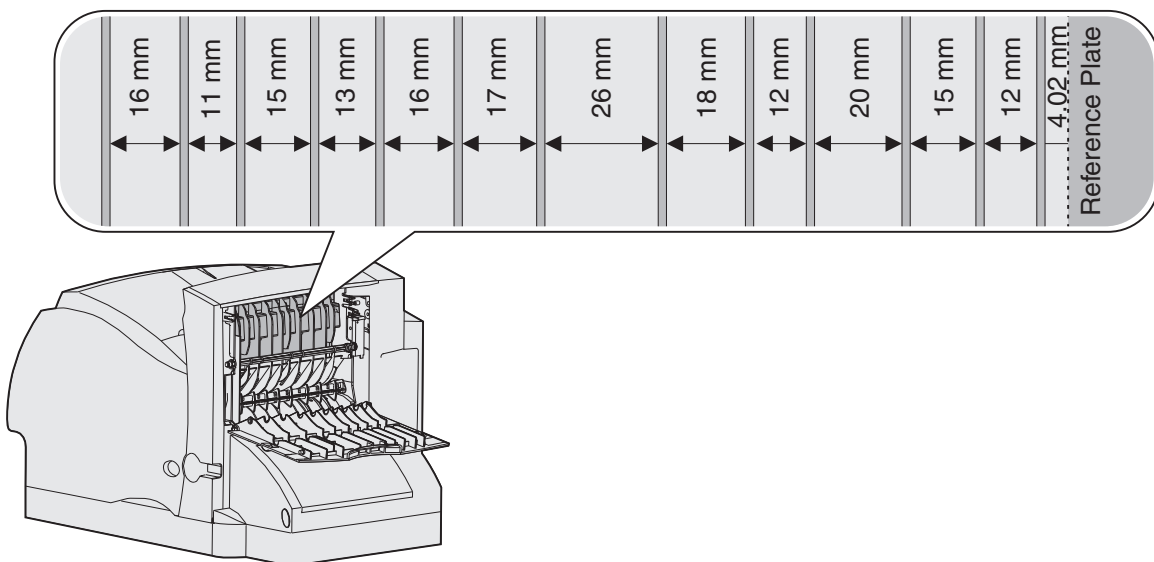

Load label sheets with the label end first. Use grain long paper instead of grain short paper, which tends to curl easily. If a converter develops a grain short label sheet for duplexing, then test the sheet first to make sure it works satisfactorily.

Note: We recommend testing any material with your application and printer before purchasing large quantities.

To use the duplex label application, you *must* install a special fuser wiper.

Printer	Fuser wiper part number
S1855, T612, T614, T520, and T522	99A1082
T620 and T622	18A1467
T630, T632 and T634	56P2109
T64x, X644e, and X646e	40X2666
T65x and X65x	40X2666

The wiper makes it possible to print on both sides of paper labels specifically designed for duplexing. You may also use the wiper when using the printer to print on one side of a label sheet or both sides of a sheet of paper. When ordering a new cartridge, be sure to order the cartridge that includes the correct fuser wiper.

Primary rib pattern design guidelines for reference edge alignment

The function of the primary rib pattern is to provide the best support to the media during transport. If it is known that the media will be touching a certain surface, then that surface must contain the primary rib pattern.

The feed path should guide the leading edge of the media into the primary guide surface and not the secondary surface. This provides a determinate location for the leading edge of the media on the guide surface that provides the best support.

The incidence angle of the leading edge of the media as it touches the primary guide surface should be no more than 30°. This eliminates media stubbing on the guides and reduces the amount of energy input into the media by the guide.

The primary rib pattern is to have the rib support extending out to between 3 to 10 mm from the edge of the paper and 2 to 10 mm from the edge of the envelopes. This keeps the corners of the media stiff so that it cannot fold and catch other surfaces in the printer. It also prevents the corners of the media from catching the inside surface of a paper path rib.

The primary rib pattern should not have any ribs closer than 3 mm to the outside edge of paper and envelopes. This keeps the media from stubbing into a rib that is too close to the edge of the media.

The maximum rib spacing of the primary rib pattern should not be greater than 20 mm. This keeps the leading edge of the media flat as it moves through the system.

The following are the rib locations for the Lexmark MS710, MS711, MS810, MS811, MS812, MX710, MX711, MX810, MX811, and MX812 printer models.

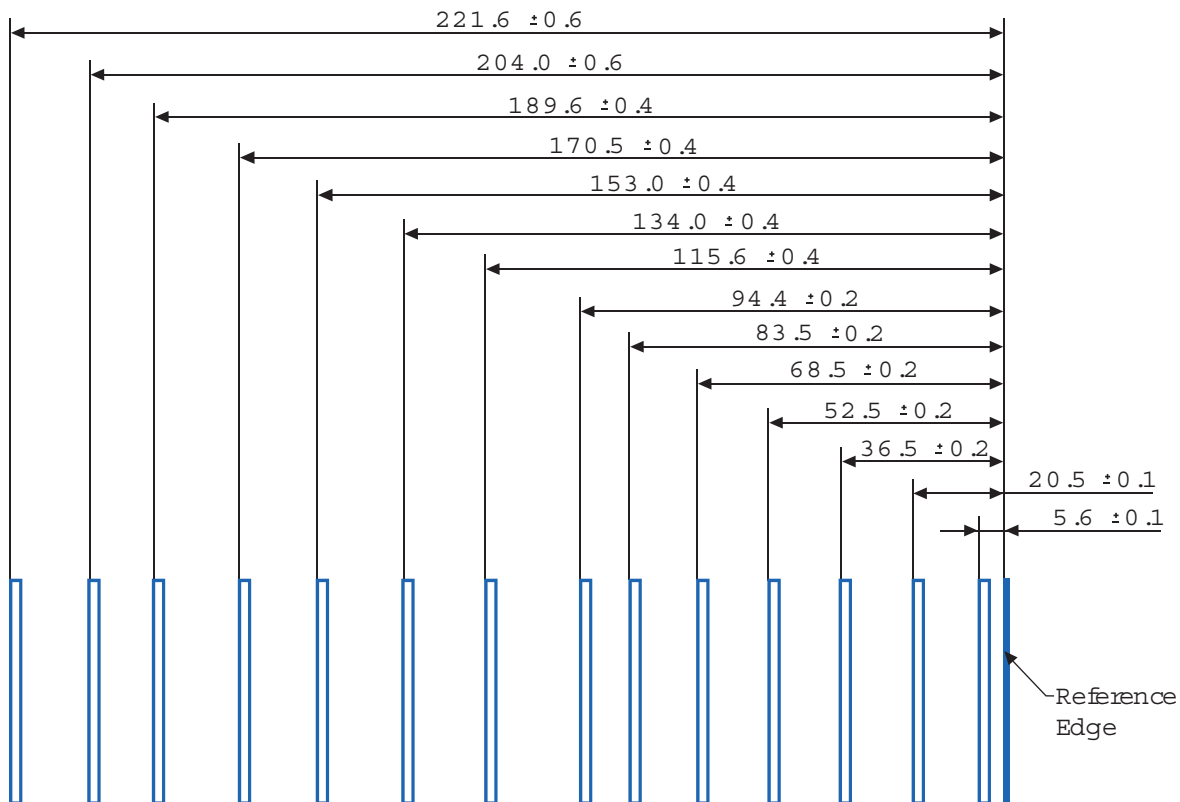

Label components

Labels are composed of three basic parts: the liner, the adhesive, and the face sheet. Labels may also have topcoats that affect printing. Choosing appropriate materials for each of these label components will help ensure reliable printing.

Liners

The *liner*, also known as the *carrier* or *backing*, is the material onto which the label is attached. The liner carries the label through the printer and directly affects feed reliability. Liner weights and construction vary based on the printable face stock used. For more information, see [“Face sheet \(printable stock\)” on page 25](#).

Tissue-backed, plain bond, or bond-like, porous, lay-flat liners are preferred. Liners constructed for use with high-speed laser printers (50 or more pages per minute) may not produce acceptable results.

A liner should bend easily and go back to its original flat state when released. If the form remains bent, then it may cause paper jams or damage to the edge of the sheet, particularly in earlier printer models using a corner buckler rather than an auto compensator to separate the sheets. The following table shows which printers use a corner buckler and which use an auto compensator.

Note: If your printer is not listed here, then contact your Lexmark representative to verify which method your printer uses to separate sheets of labels.

Printers using a corner buckler	Printers using an auto compensator
<ul style="list-style-type: none"> • 4019, 4029, 4039, 4049 • Lexmark E220, E320, E321, E322, E323, T420, W820, X422 • Optra 12L, 12R, Lxi, Lx, Rx • Optra R+, Rt+, Lx+, Lxi+ • Optra C, Optra Color 1200, Optra N • Optra M410, M412, W810 • C910, C912, C920 	<ul style="list-style-type: none"> • Lexmark E230, E232, E234(n), E330, E332n, E260, E360, E460, C510, C520, C522, C524, C530, C532, C534, C540, C734, C736, C750, C752, C760, C762, C770, C772, C780, C782, C792e, C792de, C792dte, C792dhe, C935, CS310n, CS310dn, CS410n, CS410dn, CS510de, CX310n, CX310dn, CX410e, CX410de, CX410dte, CX510de, CX510dhe, CX510dthe, T520, T522, T620, T622, T630, T632, T634, T640, T642, T644, T650, T652, T654, T656dne, X203, X204, X215, X264, X363, X364, X463, X464, X466, X540, X642e, X644e, X646e, X651, X652, X654, X656, X658, X734, X736, X738, X792de, X792dte, X792dtfe, X792dtpe, X792dtme, X792dtse, W840 • Optra S 1250, S 1650, S 2450 • Optra S 1255, S 1625, S 1855, S 2455 • Optra Se 3455 • Optra T610(n), T612(n), T614(n), T616(n)

Some liner materials used in pressure-sensitive constructions are called *label papers*. Label papers are either machine finish (MF) or English finish (EF) papers that are calendered, supercalendered, or coated on one side. An MF has varying degrees of surface smoothness. The smoothness is determined by the number of times the paper passes through the rollers (wet or dry) during manufacturing. An EF is uncoated and low gloss in appearance. Label papers may also be used as the face sheet for pressure-sensitive paper products, such as the materials used in dual web forms construction.

Supercalendering produces high gloss surfaces that may be slick. Some supercalendered liners are difficult for printers to pick and feed reliably. We do *not* recommend using supercalendered liners designed for high-speed laser printers (50 or more pages per minute).

Some pressure-sensitive constructions use Kraft liners or bleached Kraft liners. Kraft liners are made from sulfate pulp and are MF or machine glazed (MG). Most MG papers have a high gloss appearance. High gloss, glazed surfaces may increase skew and are more difficult for the printer feed mechanism to handle reliably. Some Kraft liners may produce acceptable results; however, we strongly recommend extensive testing of pressure-sensitive constructions using Kraft liners.

Tissue-backed or plain bond liners reduce toner contamination inside the printer and improve feed performance. Slick, non-porous liners are harder to feed and increase toner buildup in the fuser and on the backup roll. Rough backings, on the other hand, can increase paper path friction, which can cause skew and paper jams. The face material of the liner needs to have a melt temperature that can also withstand the fuser temperatures of nearly 225°C (437°F). Since there is a stripped area of a maximum of 3 mm, this can expose the face material to these temperatures and could cause melting or contamination in the fuser.

Excessive paper dust or chaff associated with the liner may affect print quality. If a liner material produces excessive paper dust or chaff during the conversion process, some of this debris may be packaged with the material and end up in the printer. Liner materials that produce excessive paper dust or chaff as they feed through the printer may also affect print quality.

Your forms supplier can provide additional information on liners.

Adhesives

There are three basic types of label adhesives: removable, permanent, and semi-permanent (cold temp). All types, with proper design, can be used with your printer. Acrylic-based adhesives are generally preferred for cut-sheet label printers.

The major adhesive-related printing problem is printer and cartridge contamination. The adhesives are semi-liquid and may contain volatile components. If the sheet jams in the fuser, the adhesive can melt, thereby contaminating parts of the printer or releasing fumes. To avoid exposing adhesive to the paper path guides, drive rollers, charge roller, photoconductor drum, transfer roller, and detack fingers, use full label sheets.

Zone coating means placing the adhesive only where needed. Paper labels and integrated forms typically use zone coating. In addition, a non-adhesive border of 1 mm (0.04 inches) around the outside edge of the label sheet generates good results. Check with your adhesive manufacturer or forms supplier for more information about designing labels for your printer.

A *stripped edge matrix* along the outer border of the stock, combined with adhesive that does not ooze, helps prevent adhesive contamination. This design requires a stiffer backing material to prevent damage when the sheet is aligned on the reference edge. Generally, vinyl and polyester labels are well-suited for this design. Paper and dual web designs may require testing to determine which backing produces good results. For more information on matrices, see [“Label design guidelines” on page 25](#).

Make sure the *release strength* is adequate so labels stay attached to the liner and do not peel off in the printer. Adhesives must be able to withstand pressures to 25 psi and fuser temperatures of 225°C (437°F) without delaminating, creating hazardous fumes, or oozing around edges of labels, perforations, or die-cuts. Shear strength should be strong enough to prevent adhesive stringers. For more information, contact your forms supplier.

Face sheet (printable stock)

Paper, vinyl, and polyester are the most common materials used for printable stock. Your forms supplier can provide information on whether the printable stock you want to use can withstand temperatures up to 225°C (437°F) and pressures up to 25 psi. Carefully test the stock to make sure it functions satisfactorily with your printer.

Note: Temperatures vary by printer. For more information, see the section for your printer.

Topcoats

Topcoats for non-paper labels may be either water-based or solvent-based. Avoid topcoats containing chemicals that emit hazardous fumes when heated or exposed to pressure. Topcoats affect the print quality, feed reliability, and adhesion of toner to the face sheet. Topcoats must be able to withstand temperatures up to 225°C (437°F) and pressures up to 25 psi for 100 milliseconds to prevent fuser damage.

Note: Temperatures vary by printer. For more information, see the section for your printer.

Water-based topcoats tend to be more conductive than solvent-based topcoats and are more difficult to fuse. With some water-based topcoats and heavy liners, the fuse grade may fall below acceptable levels. Solvent-based topcoats tend to be lower in conductivity than water-based topcoats. With some solvent-based topcoats, fuse grade is within acceptable levels when heavier liners are used.

Print quality may degrade when using topcoats on labels with heavier liners. Using a lighter liner may reduce the appearance of splatter. Carefully test the forms to make sure the topcoat functions satisfactorily with your printer.

Label design guidelines

Labels with a *stripped edge matrix* do not have the area around the outer edge of the cut sheet. Labels with a *total strip matrix* do not have the die-cut stock around and between the labels. This makes it easy to peel the labels from the backing.

Butt cut labels are cut flush to one another, with no extra area between them. Avoid using butt cut labels without a stripped edge matrix.

Die-cut labels are cut with a non-print area between each label. For best results, do not print within 2.3 mm (0.090 in.) of the edge of the label, of the perforations, or of the die-cuts of the label.

If you are using a butt cut or die-cut label, then make sure adhesive contamination does not occur. Labels use varying levels and types of adhesive, as well as a variety of liner materials and facestock papers. Adhesive can ooze from all label stocks. Make sure die-cuts are free of adhesive stringers. To prevent adhesive contaminations, use zone coating or pattern adhesive with a non-adhesive border of about 1-mm (0.04-in.) or larger.

If zone coating is not used, then we recommend a stripped edge matrix. The stripped edge matrix varies with the type of face stock, liner, and adhesive materials. See the following table for stripped edge matrix guidelines. Measurements may vary ±0.5 mm.

Face type	Total weight of label	Edge matrix removal	Location of strip
Paper* (cut sheet or dual web)	140–180 g/m ²	1.6 mm (0.0625 in.) 1.6 mm (0.0625 in.)	215.9 mm (8.5 in.) at leading edge 279.4 mm (11 in.) at driver edge
Vinyl	265–300 g/m ²	1.6 mm (0.0625 in.) 1.6 mm (0.0625 in.)	215.9 mm (8.5 in.) at leading edge 279.4 mm (11 in.) at driver edge
Polyester and other face materials	Varies	1.6 mm (0.0625 in.) 1.6 mm (0.0625 in.)	215.9 mm (8.5 in.) at leading edge 279.4 mm (11 in.) at driver edge

* Use a non-oozing adhesive.

Using cut sheet labels with adhesive applied to the edge of the sheet will contaminate your printer and your cartridge and could void your printer and cartridge warranties.

When using pressure-sensitive materials without zone coating, choose butt cut labels without any stringers and with a stripped edge matrix. If a total strip matrix is in the design for the final product, then print before removing the matrix. If the matrix must be removed before printing, then round all corners and make sure adhesive is not exposed.

The following diagram shows a recommended label design for Optra plus printers, 4039, 4029, and 4019, as well as the T610, T520, T620, and T630 laser printers.

Note: The non-print area may vary depending on the printer model.

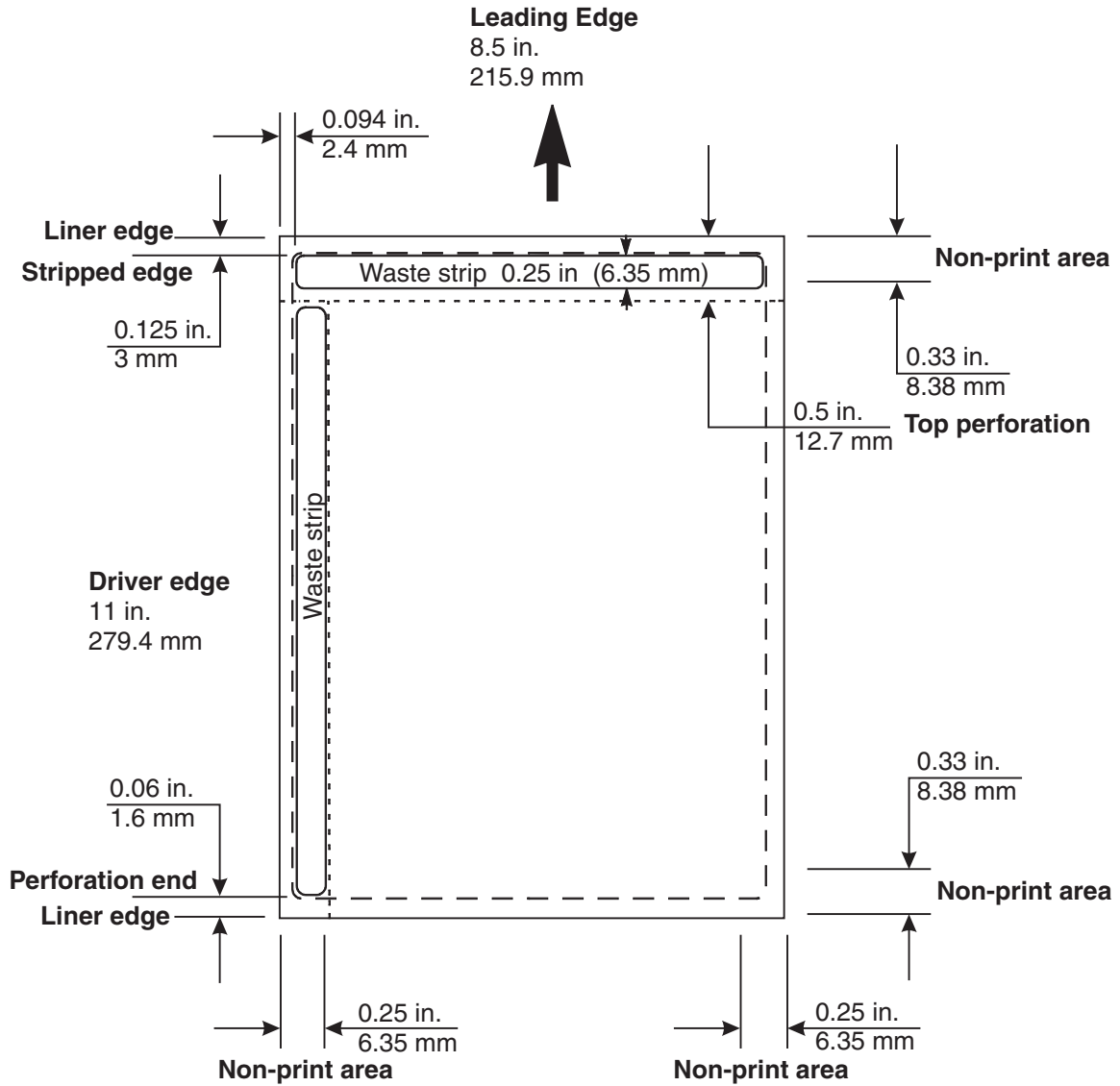

(Not drawn to scale)

The following diagram shows a recommended label design for the T640 and T650 laser printers.

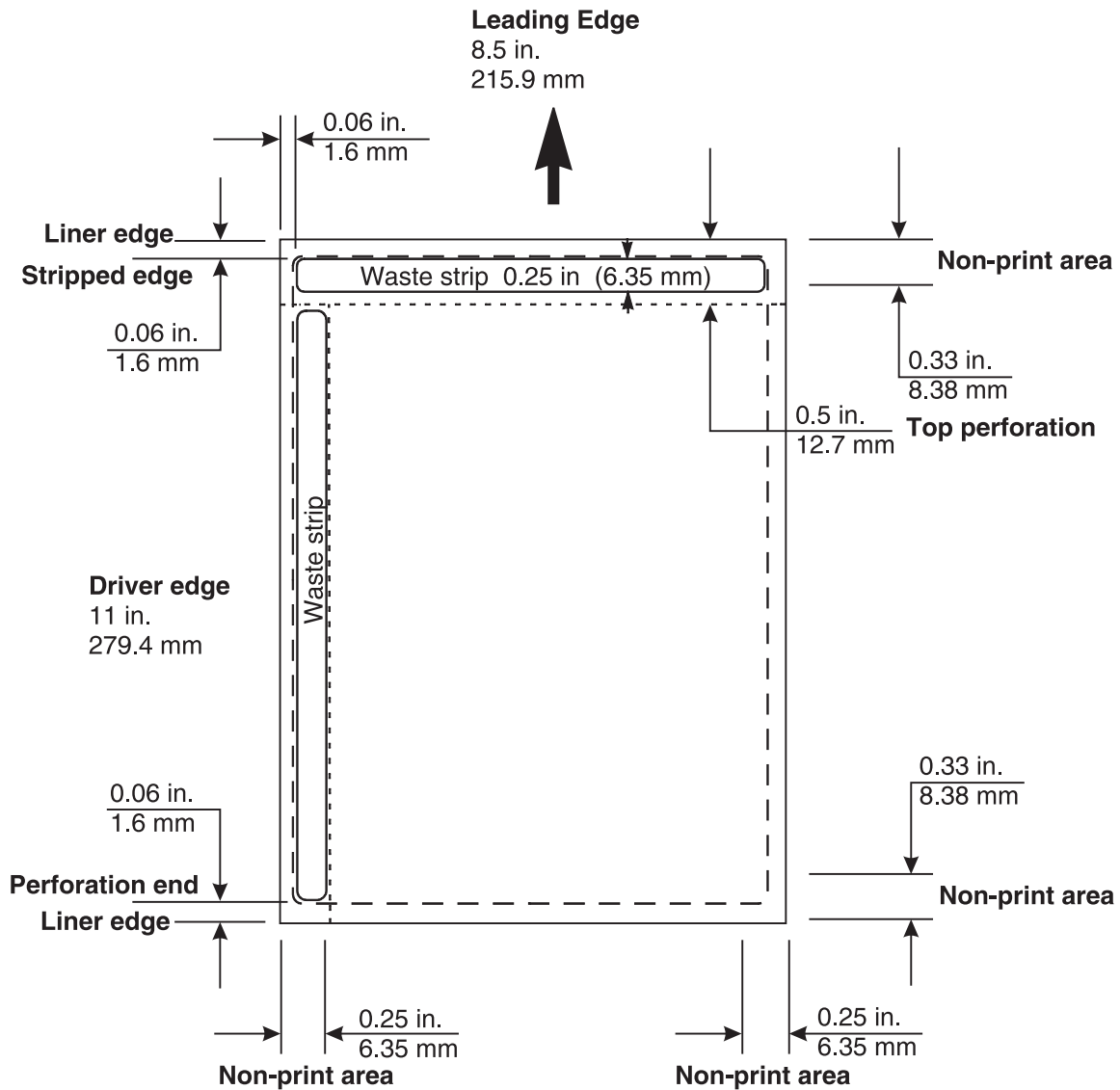

(Not drawn to scale)

The following diagram shows a recommended label design for laser printers, which use a different paper picking mechanism.

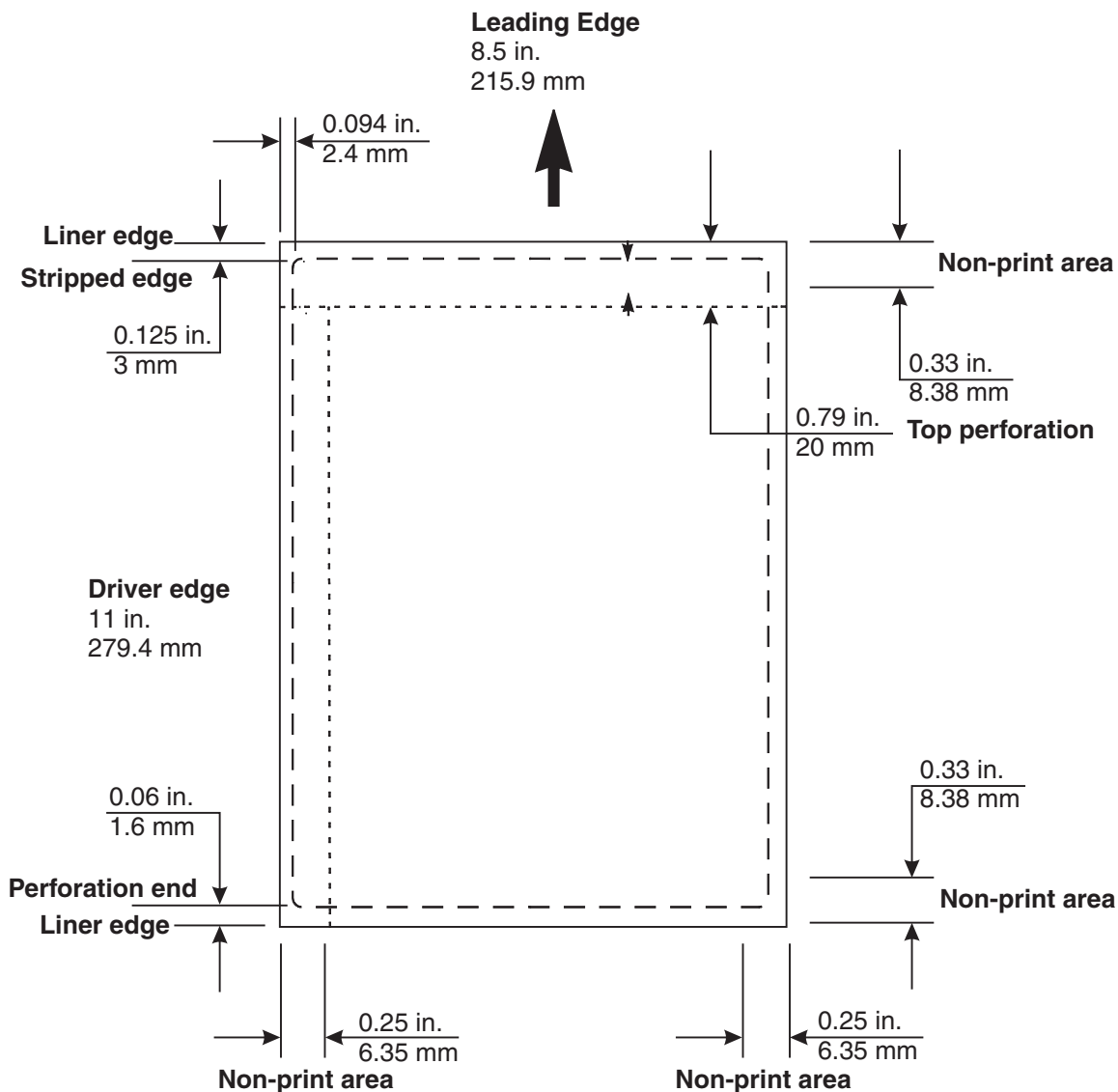

(Not drawn to scale)

Cut sheet paper labels

- Generally, cut sheet paper labels work well with your printer.
- Coating or *sizing* to make the paper liquid-resistant decreases toner adhesion and increases the risk of toner contaminating the fuser. At a minimum, paper labels should be equivalent in weight and rigidity to a 20-lb xerographic bond paper.

Dual web forms

- Constructing dual web forms involves joining together rolls of two different materials (usually pressure-sensitive paper and bond paper) and then converting to a cut sheet product.
- This construction requires a stripped edge matrix. The liner must be rigid enough to withstand the pick force of the printer.

- The two materials must be thin enough for the sheet to lie flat in the paper tray. The differences in thickness may cause the materials to curl down towards the leading edge of the form which can negatively affect feeding. For more robust feeding, it is recommended that the leading label edge should be as thick as or slightly thicker than the dual web overlap thickness to make sure the sheet lies flat in the tray. The form should be placed with the label facedown in the tray. Orient the form in the tray so that the pressure-sensitive area feeds into the printer first. The form should have no adhesive exposed in the overlay area or anywhere along the front or back of the form.
- We recommend designing a non-adhesive strip with a minimum width of 1 mm (0.04 in.) along the edges of the overlay.
- To help prevent material from slipping in the fuser, we recommend *knurling*, which roughens up the exposed silicon area at the glue joint.
- The face sheet of a dual web form is usually a paper pressure-sensitive product; therefore, the guidelines for paper labels are applicable to dual web forms.
- The following diagram shows the recommended dual web form design. The non-print area may vary depending on the printer model.

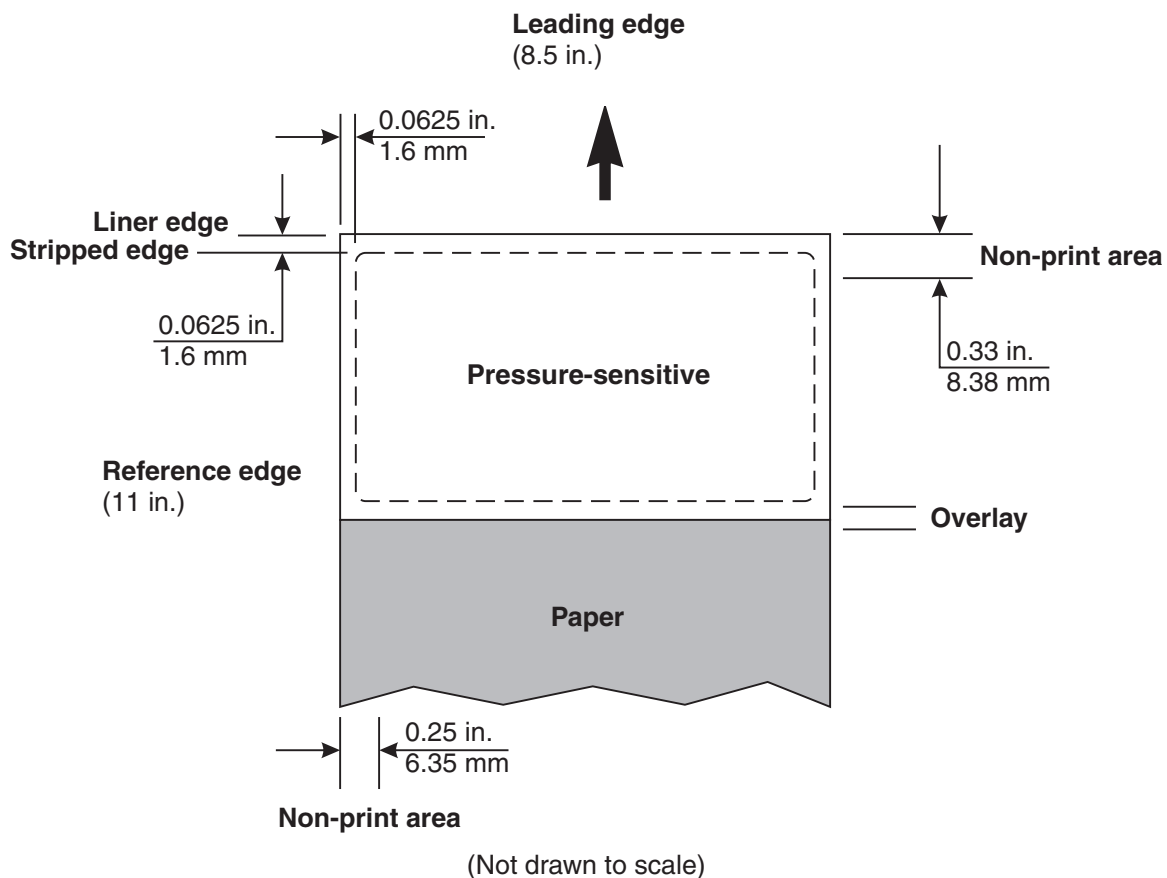

Vinyl and polyester labels

- Vinyl labels work well within specified design parameters. Vinyls are heat-sensitive, so the liners need to be thick enough to absorb excess heat and prevent melting. A total strip matrix may cause adhesive contamination.
- Thin liners or weak pull strength may lead to labels peeling off the form inside the printer, which will require printer servicing. For more information on recommended label designs, see [“Label design guidelines” on page 25](#).

- For Optra S, Optra T, and Lexmark T printers, a leading and trailing edge stripped area is recommended to be a maximum of 3 mm. This area is recommended to prevent adhesive being close to the edge, which can contaminate your printer.
- Certain materials used in label construction, which have liner face melt temperatures lower than the fuser temperature, may require the leading and trailing edge stripped areas to be 1.6 mm maximum due to feeding problems.
- It is preferred that the liner face be constructed with material that can withstand our fuser temperatures, which eliminates the need for changing the stripped areas from 3 mm to 1.6 mm.
- If a 1.6-mm stripped area is used, it is very important that the 1.6-mm tolerance be held tightly. With a stripped area of less than 1.6 mm, it is highly possible that adhesive contamination will occur.
- Vinyls are non-absorbing, which leads to toner build-up in the fuser that requires special maintenance. See the documentation that came with your printer for specific information about maintaining your printer. Vinyls may require a topcoat to ensure good toner adhesion.
- Polyester labels are less heat-sensitive but are also non-absorbing. Backings for polyester labels can be thinner, but requirements for coatings and cleaning are similar to vinyl labels.
- It is recommended that when you run vinyl labels, you install a special oil fuser cleaner, P/N 99A0725 or 40X2665. When you order a new cartridge, be sure to order the cartridge that will include the correct fuser cleaner.

Integrated forms

- To create *integrated forms*, the converter uses hot melt adhesives to apply the label adhesive and liner to a base material (generally paper).
- *Oil bleed*, recognizable by a discolored face sheet, can be a problem with these forms. Oil may also migrate from the top of the liner to the back surface of the liner while it is on the roll, before the conversion process takes place.
- The forms created from this material may then be slick, and the pick mechanism of your printer may be unable to successfully move all the sheets from the tray into the printer. Jamming and misfeeds increase when oil is present on the back of the liner.
- The adhesive on these forms is commonly patterned on two or four sides (that is, the forms have a non-adhesive border on either two or four edges). We recommend designing a 1-mm (0.04-in.) non-adhesive border (zone coated) on all four edges.
- When printing on integrated forms with a grain long base material, orient the form in the tray so the paper portion of the form feeds into the printer first. Orient the pressure-sensitive portion of the form toward the portrait left edge.
- For integrated forms with a grain short base material, orient the form in the tray so the pressure-sensitive portion feeds into the printer first.
- Due to the unique construction of integrated forms, you may experience stacking problems in the output bin. Contact your Lexmark marketing representative if you experience stacking problems with these forms.

Note: Test some forms before purchasing large quantities.

Printer specifications

Lexmark C500n

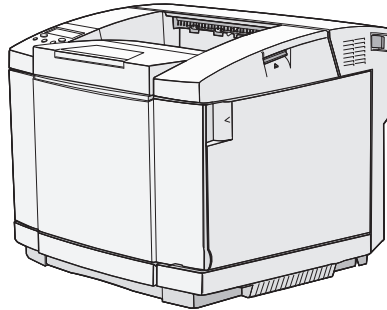

Limit label printing to occasional use of paper office labels designed for laser printers. The Lexmark C500n does *not* support vinyl or polyester labels.

The Lexmark C500n supports 90–210-g/m² (24–55-lb) stock. Card stock and labels are supported from Tray 1 and Tray 2. Tray 1 supports approximately 120 sheets of card stock and Tray 2 supports up to 250 sheets of card stock. The following table lists the maximum weights supported.

Paper source	Card stock (Grain short is preferred for papers over 135 g/m ²)			Labels*
	Index Bristol	Tag	Cover	Paper
Tray 1 (standard tray)	90–210 g/m ²	90–210 g/m ²	90–210 g/m ²	180 g/m ²
Tray 2 (optional tray)	90–210 g/m ²	90–210 g/m ²	90–210 g/m ²	180 g/m ²

* Vinyl labels are *not* supported.

Labels	Width:	76.2–216 mm (3–8.5 in.)
	Length:	123.8–355.6 mm (4.88–14 in.)
	Weight:	180 g/m ² (48 lb)
	Thickness:	0.13–0.20 mm (0.005–0.008 in.)
	Smoothness:	100–400 Sheffield*

* 150–250 Sheffield is optimal. Using media higher than 300 Sheffield could result in printing degradation.

Card Stock	Weight:	163-g/m ² (90-lb) Index Bristol
		163-g/m ² (100-lb) Tag
		Up to 210-g/m ² (78-lb) Cover

For more information on the supported media sizes, see the printer *User's Guide* on the publications CD.

Lexmark C510

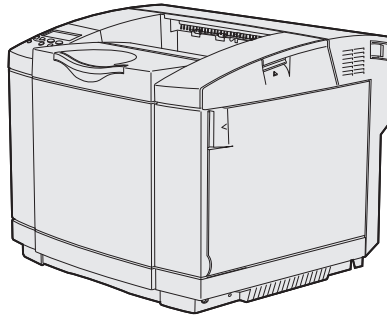

Limit label printing to occasional use of paper office labels designed for laser printers. The Lexmark C510 does *not* support vinyl or polyester labels.

The Lexmark C510 supports stocks up to 176 g/m². Feed labels from the standard tray only, which holds up to 80 sheets of labels or up to 120 sheets of card stock.

The following table lists the maximum weights supported.

Paper source	Card stock			Labels	
	Index Bristol	Tag	Cover	Paper	Vinyl
Tray 1 (standard tray)	163 g/m ²	163 g/m ²	176 g/m ²	—	—
Tray 2 (optional tray)	163 g/m ²	163 g/m ²	176 g/m ²	—	—
Multipurpose feeder	163 g/m ²	163 g/m ²	176 g/m ²	131 g/m ²	—

Labels	Width:	105–216 mm (4.1–8.5 in.)
	Length:	220–297 mm (8.7–11.7 in.)
	Weight:	120–163 g/m ²
	Thickness:	0.13–0.20 mm (0.005–0.008 in.)
	Smoothness:	100–400 Sheffield*

* 150–250 Sheffield is optimal. Using media higher than 300 Sheffield could result in printing degradation.

Card stock	Weight:	Up to 163 g/m ² Index Bristol (90 lb)
		Up to 163 g/m ² Tag (100 lb)

Cover stock	Weight:	Up to 176 g/m ² (65 lb)
--------------------	---------	------------------------------------

Card stock and label guidelines

When printing on labels:

- Feed labels from Tray 1 only.
- Use only paper labels. Do *not* use vinyl labels.

- Use only label sheets that have no gaps between the labels.

Acceptable labels

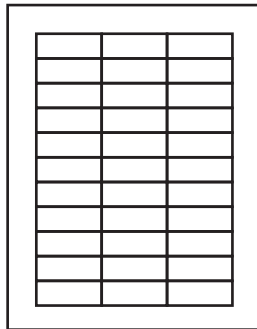

Unacceptable labels

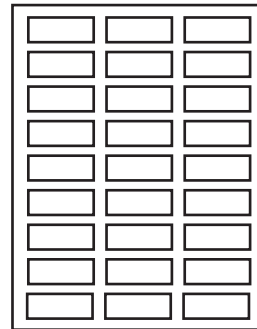

- Recommended labels are Avery 5260.
- From the operator panel or from MarkVision™ Professional, set the Paper Type to Labels.
- Do *not* print a large number of labels continuously.
- Do *not* use labels that have coating or sizing applied to make the labels liquid-resistant.
- Do *not* use labels that have exposed adhesive on the label sheets.

When printing on card stock:

- Feed card stock from Tray 1 only.
- We recommend using Springhill Index Plus 90 lb card stock.
- For the best print quality, always set the Paper Type to Card Stock.

Lexmark C520, C522, and C524

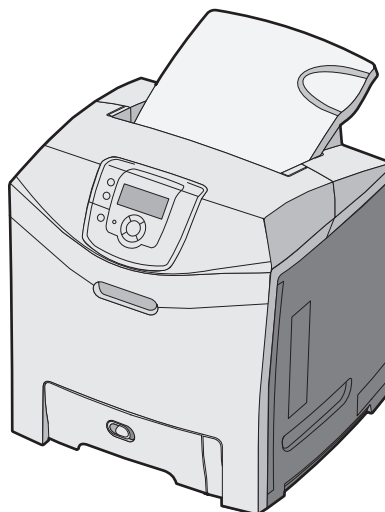

Limit label printing to occasional use of paper office labels designed for laser printers. The Lexmark C520, C522, and C524 do *not* support vinyl or polyester labels.

The Lexmark C520, C522, and C524 support stocks up to 176 g/m². Card stock is supported from Tray 1, Tray 2, the manual feed slot, and the multipurpose feeder. Labels are supported only from the multipurpose feeder and the manual feed slot.

Tray 1 supports approximately 120 sheets of card stock and Tray 2 supports approximately 250 sheets of card stock. The multipurpose feeder supports approximately 50 sheets of card stock or labels, and the manual feed slot accepts single sheets only. The following table lists the maximum weights supported.

Paper source	Card stock						Labels*
	Index Bristol		Tag		Cover		Paper
	grain long	grain short	grain long	grain short	grain long	grain short	
Tray 1 (standard tray)	120 g/m ²	163 g/m ²	120 g/m ²	163 g/m ²	135 g/m ²	176 g/m ²	—
Tray 2 (optional tray)	120 g/m ²	163 g/m ²	120 g/m ²	163 g/m ²	135 g/m ²	176 g/m ²	—
Multipurpose feeder Manual feed slot	120 g/m ²	163 g/m ²	120 g/m ²	163 g/m ²	135 g/m ²	176 g/m ²	135 g/m ²

* Vinyl labels are *not* supported.

Labels

Width: 105–216 mm (4.1–8.5 in.)

Length: 220–297 mm (8.7–11.7 in.)

Weight: 120–163 g/m² (32–43 lb)

Thickness: 0.13–0.20 mm (0.005–0.008 in.)

Smoothness: 50–300 Sheffield*

* 50–150 Sheffield is optimal. This printer may support labels with smoothness of less than 50 Sheffield such as coated paper, polyester, vinyl, or other synthetic facestock paper. Using media higher than 200 Sheffield could result in print quality degradation.

Card stock

Weight: Up to 163 g/m² Index Bristol (90 lb)
Up to 163 g/m² Tag (100 lb)

Cover stock

Weight: Up to 176 g/m²

For more information on the supported media sizes, see the printer *User's Guide* on the publications CD.

Card stock and label guidelines

When printing on labels:

- Use only paper labels. Do *not* use vinyl labels.
- Use only label sheets that have no gaps between the labels.

Acceptable labels

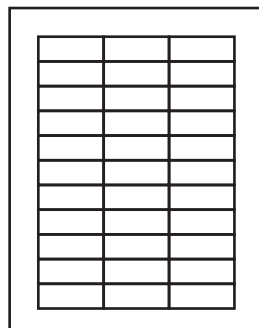

Unacceptable labels

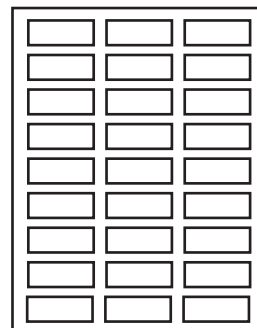

- Recommended labels are Avery 5260.

- From the printer control panel or from MarkVision Professional, set Paper Type to Labels.
- Do *not* print a large number of labels continuously.
- Do *not* use labels that have coating or sizing applied to make the labels liquid-resistant.
- Do *not* use labels that have exposed adhesive on the label sheets.

When printing on card stock:

- We recommend using Springhill Index Plus 90 lb card stock.
- For the best print quality, always set Paper Type to Card Stock.

For more information, see [“Pick roller technology” on page 11](#).

Lexmark C530, C532, and C534

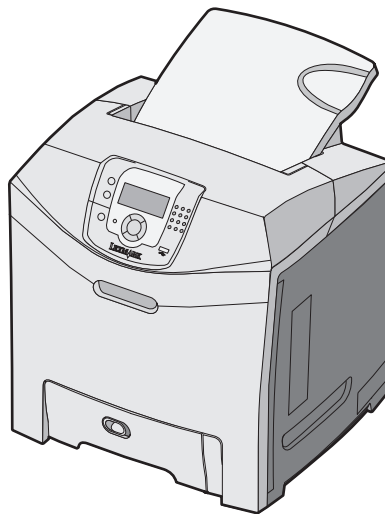

Limit label printing to occasional use of paper office labels designed for laser printers. The Lexmark C530, C532, and C534 do *not* support vinyl or polyester labels.

The Lexmark C530, C532, and C534 support stocks up to 176 g/m². Card stock and labels are supported from Tray 1, Tray 2, the manual feed slot, and the multipurpose feeder.

Tray 1 supports approximately 120 sheets of card stock, and Tray 2 supports approximately 250 sheets of card stock. The multipurpose feeder supports approximately 50 sheets of card stock or labels and the manual feed slot accepts single sheets only. The following table lists the maximum weights supported.

Paper source	Card stock						Labels*
	Index Bristol		Tag		Cover		Paper
	grain long	grain short	grain long	grain short	grain long	grain short	
Tray 1 (standard tray)	120 g/m ²	163 g/m ²	120 g/m ²	163 g/m ²	135 g/m ²	176 g/m ²	131 g/m ²
Tray 2 (optional tray)	120 g/m ²	163 g/m ²	120 g/m ²	163 g/m ²	135 g/m ²	176 g/m ²	131 g/m ²
Multipurpose feeder	120 g/m ²	163 g/m ²	120 g/m ²	163 g/m ²	135 g/m ²	176 g/m ²	131 g/m ²
Manual feeder							

* Vinyl labels are *not* supported.

Labels	Width:	76.2–216 mm (3–8.5 in.)
	Length:	123.8–355.6 mm (4.88–14 in.)
	Weight:	131 g/m ² (35 lb)
	Thickness:	0.13–0.20 mm (0.005–0.008 in.)
	Smoothness:	50–300 Sheffield*

* 50–150 Sheffield is optimal. This printer may support labels with smoothness of less than 50 Sheffield such as coated paper, polyester, vinyl, or other synthetic facestock paper. Using media higher than 200 Sheffield could result in print quality degradation.

Card stock	Weight:	Up to 163 g/m ² Index Bristol (90 lb)
		Up to 163 g/m ² Tag (100 lb)

Cover stock	Weight:	Up to 176 g/m ²
--------------------	---------	----------------------------

For more information on the supported media sizes, see the printer *User's Guide* on the publications CD.

Card stock and label guidelines

When printing on labels:

- Use only paper labels. Do *not* use vinyl labels.
- Use only label sheets that have no gaps between the labels.

Acceptable labels

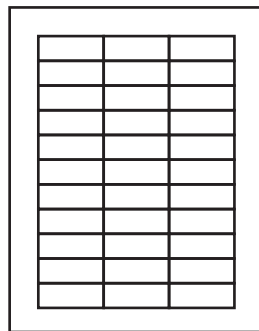

Unacceptable labels

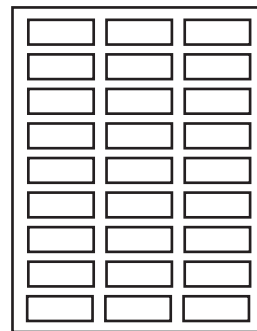

- We recommend using Avery 5260.
- From the printer control panel or from MarkVision Professional, set Paper Type to Labels.
- Do *not* print a large number of labels continuously.
- Do *not* use labels that have coating or sizing applied to make the labels liquid-resistant.
- Do *not* use labels that have exposed adhesive on the label sheets.

When printing on card stock:

- We recommend using Springhill Index Plus 90 lb card stock.
- For the best print quality, always set Paper Type to Card Stock.

For more information, see [“Pick roller technology” on page 11](#).

Lexmark C540, C543, C544, and C546dtn

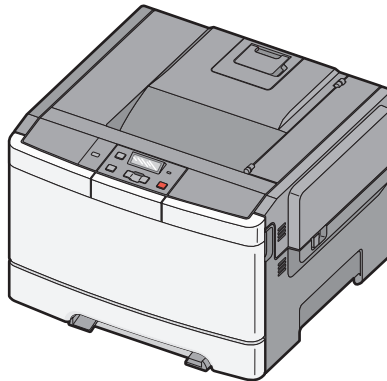

Notes:

- Your printer may not have a 650-sheet duo drawer with an integrated multipurpose feeder.
- The 250-sheet tray (Tray 1) and the 650-sheet duo drawer support the same paper sizes and types.
- Not all models are pictured.

Limit label printing to occasional use of paper office labels designed for laser printers. The Lexmark C540, C543, C544, and C546dtn do *not* support vinyl or polyester labels.

The Lexmark C540, C543, C544, and C546dtn support card stock weights up to 176 g/m². Card stock and labels are supported from Tray 1, Tray 2, the manual feeder, and the multipurpose feeder.

Tray 1 supports approximately 100 sheets of card stock or labels, and Tray 2 supports approximately 200 sheets of card stock or labels. The multipurpose feeder supports approximately 50 sheets of card stock or labels, and the manual feeder accepts single sheets only. Capacity varies depending on label material and construction. The following table lists the maximum weights supported.

Paper source	Grain direction	Card stock			Labels
		Index Bristol	Tag	Cover	Paper
Standard and optional 250-sheet tray	grain long	120 g/m ²	120 g/m ²	135 g/m ²	131 g/m ²
	grain short	163 g/m ²	163 g/m ²	176 g/m ²	
Tray 2 (optional tray/drawer)	grain long	120 g/m ²	120 g/m ²	135 g/m ²	131 g/m ²
	grain short	163 g/m ²	163 g/m ²	176 g/m ²	
Multipurpose and manual feeder*	grain long	120 g/m ²	120 g/m ²	135 g/m ²	131 g/m ²
	grain short	163 g/m ²	163 g/m ²	176 g/m ²	

* The multipurpose feeder may not support labels with certain design characteristics.

Labels	Width:	105–216 mm (4.1–8.5 in.)
	Length:	148–356 mm (5.8–14 in.)
	Weight:	131 g/m ² (35 lb bond)
	Thickness:	0.102–0.254 mm (0.004–0.010 in.)
	Smoothness:	50–300 Sheffield*

* 50–150 Sheffield is optimal. This printer may support labels with smoothness of less than 50 Sheffield, such as coated paper, polyester, vinyl or other synthetic facestock paper. Using media higher than 200 Sheffield could result in print quality degradation.

For more information on the supported media sizes, see the printer *User's Guide* on the publications CD.

Card stock and label guidelines

When printing on labels:

- Use only paper labels. Do *not* use vinyl labels.
- Use only label sheets that have no gaps between the labels.

Acceptable labels

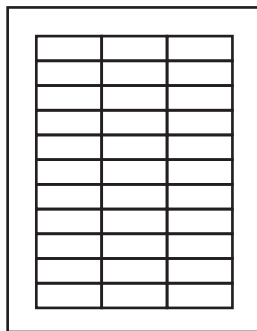

Unacceptable labels

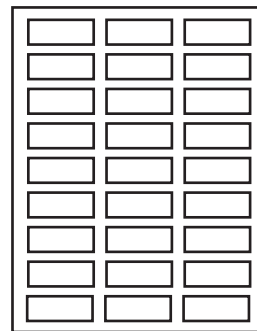

- For optimal printing, use Avery laser labels.
- From the printer control panel or from MarkVision Professional, set Paper Type to Labels.
- Do *not* print a large number of labels continuously.
- Do *not* use labels that have coating or sizing applied to make the labels liquid-resistant.
- Do *not* use labels that have exposed adhesive on the label sheets.

When printing on card stock:

- For optimal printing, use a 90-lb Index card stock.
- For the best print quality, always set Paper Type to Card Stock.

For more information, see [“Pick roller technology” on page 11](#).

Lexmark C720

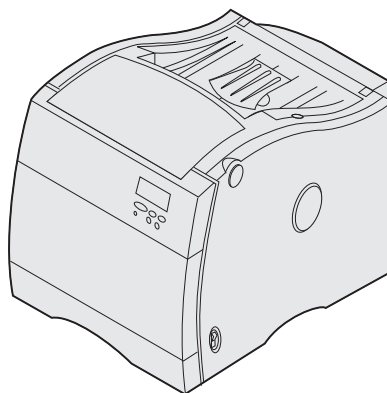

Limit label printing to occasional use of paper office labels designed for laser printers. The Lexmark C720 does *not* support vinyl or polyester labels.

The Lexmark C720 supports stocks up to 43 lb (163 g/m²). Feed labels from the standard tray only, which holds up to 80 sheets of labels or up to 120 sheets of card stock.

The following table lists the maximum weights supported.

Paper source	Card stock			Labels	
	Index Bristol	Tag	Cover	Paper	Vinyl
Tray 1 (standard tray)	163 g/m ²	163 g/m ²	—	163 g/m ²	—

For paper and transparency specifications, see the printer *User's Guide*.

- Labels**
- Width: 105–216 mm (4.1–8.5 in.)
 - Length: 220–297 mm (8.7–11.7 in.)
 - Weight: 120–163 g/m² (32–43 lb)
 - Thickness: 0.13–0.20 mm (0.005–0.008 in.)
 - Smoothness: 100–400 Sheffield*
- * 150–250 Sheffield is optimal. Using media higher than 300 Sheffield could result in printing degradation.

- Card stock**
- Weight: Up to 163 g/m² Index Bristol (90 lb)
Up to 163 g/m² Tag (100 lb)

Card stock and label guidelines

When printing on labels:

- Feed labels from Tray 1 only.
- Use only paper labels. Do *not* use vinyl labels.
- Use only label sheets that have no gaps between the labels.

Acceptable labels

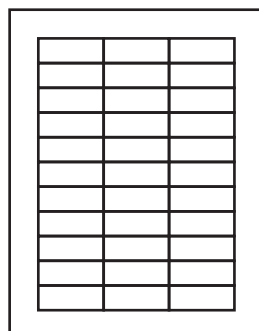

Unacceptable labels

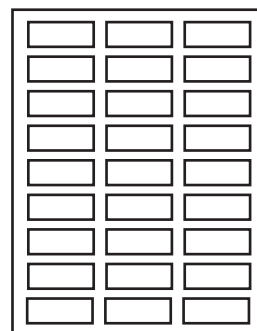

- Recommended labels are Avery 5260.
- From the operator panel or from MarkVision Professional, set the Paper Type to Labels.
- Do *not* print a large number of labels continuously.
- Do *not* use labels that have coating or sizing applied to make the labels liquid-resistant.
- Do *not* use labels that have exposed adhesive on the label sheets.

When printing on card stock:

- Feed card stock from Tray 1 only.
- We recommend using Springhill Index Plus 90 lb card stock.
- For the best print quality, always set the Paper Type to Card Stock.

Lexmark C734 and C736

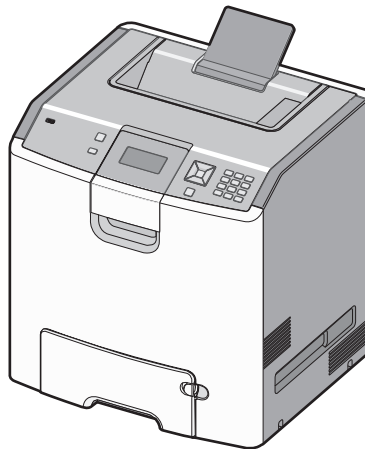

Lexmark C734 and C736 support card stock and labels from the standard 550-sheet tray, an optional 550-sheet tray, the multipurpose tray, and an optional 550-sheet specialty media drawer.

Note: The optional 2,000-sheet tray does not support card stock or labels.

Tray 1 supports approximately 120 sheets of card stock, and the optional 550-sheet tray supports approximately 250 sheets of card stock. The multipurpose feeder supports approximately 50 sheets of card stock or labels. The following tables list the maximum weights supported.

Paper source	Card stock					
	Index Bristol		Tag		Cover	
	grain long	grain short	grain long	grain short	grain long	grain short
Standard 550-sheet tray (Tray 1)	163 g/m ²	199 g/m ²	163 g/m ²	203 g/m ²	163 g/m ²	216 g/m ²
Optional 550-sheet tray Optional 550-sheet specialty media drawer	163 g/m ²	199 g/m ²	163 g/m ²	203 g/m ²	163 g/m ²	216 g/m ²
Multipurpose tray	163 g/m ²	199 g/m ²	163 g/m ²	203 g/m ²	163 g/m ²	216 g/m ²

Paper source	Labels		
	Dual Web/Paper	Polyester	Vinyl
Standard 550-sheet tray (Tray 1)	180 g/m ²	220 g/m ²	300 g/m ²
Optional 550-sheet tray Optional 550-sheet specialty media drawer	180 g/m ²	220 g/m ²	300 g/m ²
Multipurpose tray	180 g/m ²	220 g/m ²	300 g/m ²

Labels	Width:	76.2–216 mm (3–8.5 in.)
	Length:	123.8–355.6 mm (4.88–14 in.)
	Weight:	180–300 g/m ² (48–92 lb)
	Thickness:	0.13–0.20 mm (0.005–0.008 in.)
	Smoothness:	50–300 Sheffield*

* 50–150 Sheffield is optimal. This printer may support labels with smoothness of less than 50 Sheffield such as coated paper, polyester, vinyl, or other synthetic facestock paper. Using media higher than 200 Sheffield could result in print quality degradation.

Card stock	Weight:	Up to 199 g/m ² Index Bristol (110 lb)
		Up to 203 g/m ² Tag (125 lb)

Cover stock	Weight:	Up to 216 g/m ² (80 lb)
--------------------	---------	------------------------------------

For more information on the supported media sizes, see the printer *User's Guide* on the publications CD.

Card stock and label guidelines

When printing on labels:

- Print samples on the labels being considered for use before buying large quantities.
- Use only label sheets that have no gaps between the labels.

Acceptable labels

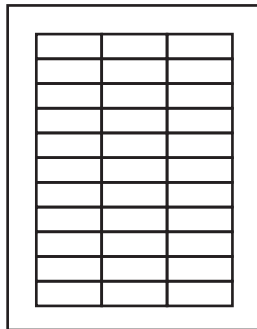

Unacceptable labels

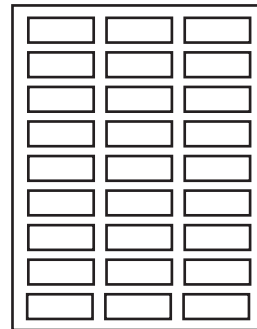

- From the printer control panel or from MarkVision Professional, set Paper Type to Labels.
- Do *not* print a large number of labels continuously.
- Do *not* use labels that have coating or sizing applied to make the labels liquid-resistant.
- Do *not* use labels that have exposed adhesive on the label sheets.

When printing on card stock:

- Select the appropriate paper texture setting.
- For the best print quality, always set Paper Type to Card Stock.
- Use grain short card stock when possible.
- Do not use preprinted card stock manufactured with chemicals that may contaminate the printer.
- Be aware that preprinting, perforation, and creasing may significantly affect the print quality and cause jams or other paper-handling problems.

For more information, see [“Pick roller technology” on page 11](#).

Lexmark C746 and C748

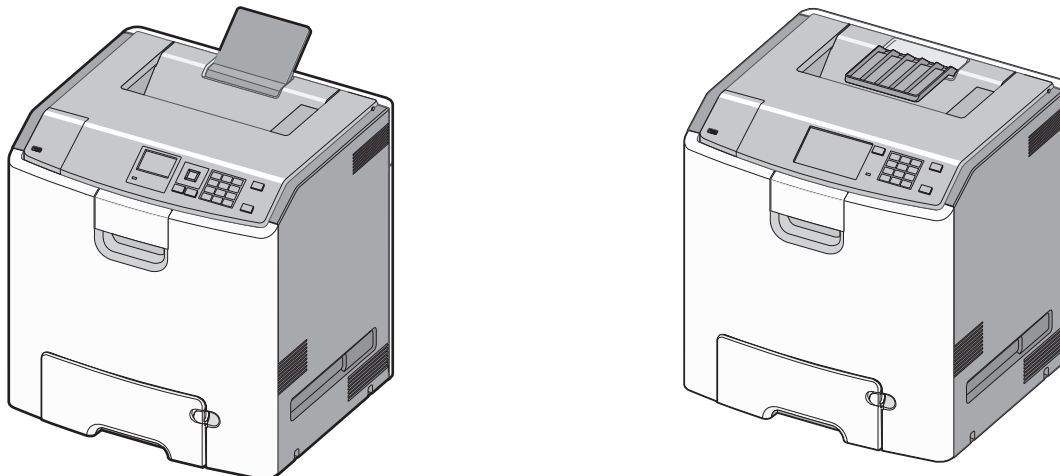

The Lexmark C746 and C748 printer models support card stock and labels from the standard 550-sheet tray, an optional 550-sheet tray, the multipurpose feeder, and the optional 550-sheet specialty media tray.

Note: The optional 2,000-sheet tray does not support card stock or labels.

Tray 1, the optional 550-sheet tray, and the specialty media tray support approximately 250 sheets of card stock or labels. The following table lists the maximum weights supported.

Paper source	Grain direction	Card stock			Labels			
		Index Bristol	Tag	Cover	Paper	Dual-web paper	Polyester	Vinyl
Standard and optional 550-sheet tray	grain long	199 g/m ²	163 g/m ²	176 g/m ²	180 g/m ²	180 g/m ²	220 g/m ²	300 g/m ²
	grain short	199 g/m ²	203 g/m ²	216 g/m ²				
Multipurpose feeder	grain long	199 g/m ²	163 g/m ²	176 g/m ²	180 g/m ²	180 g/m ²	220 g/m ²	300 g/m ²
	grain short	199 g/m ²	203 g/m ²	216 g/m ²				

* The multipurpose feeder may not support labels with certain design characteristics.

Labels	Width:	76–216 mm (3–8.5 in.) ¹
	Length:	124–356 mm (4.88–14 in.) ¹
	Weight:	Up to 180 g/m ² Paper (48 lb) Up to 180 g/m ² Dual Web Paper (48 lb) Up to 220 g/m ² Polyester (59 lb) Up to 300 g/m ² Vinyl (92 lb)
	Thickness:	0.13–0.20 mm (0.005–0.008 in.)
	Smoothness:	50–300 Sheffield ²

¹ The minimum size for labels supported in the multipurpose feeder is 76 x 124 mm (3 x 4.88 in.). The minimum size for labels supported in the standard and optional trays is 148 x 210 mm (5.82 x 8.26 in.)

² 50–150 Sheffield is optimal. This printer may support labels with smoothness of less than 50 Sheffield such as coated paper, polyester, vinyl, or other synthetic facestock paper. Using media higher than 200 Sheffield could result in print quality degradation.

Card stock	Weight:	Up to 199 g/m ² Index Bristol (110 lb)
		Up to 203 g/m ² Tag (125 lb)
		Up to 216 g/m ² Cover (80 lb)

For more information on the supported media sizes, see the printer *User's Guide on the Software and Documentation CD*.

Card stock and label guidelines

When printing on labels:

- Print samples on the labels being considered for use before buying large quantities.
- Use only label sheets that have no gaps between the labels.

Acceptable labels

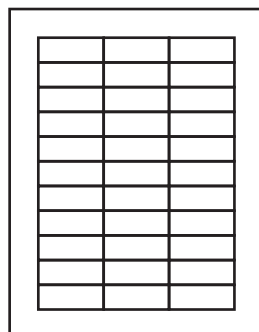

Unacceptable labels

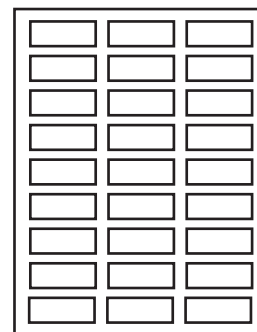

- From the printer control panel or from MarkVision Professional, set Paper Type to Labels.
- Do *not* print a large number of labels continuously.
- Do *not* use labels that have coating or sizing applied to make the labels liquid-resistant.
- Do *not* use labels that have exposed adhesive on the label sheets.
- Run the labels only once through the printer as this may contaminate the printer.

When printing on card stock:

- Select the appropriate Paper Texture setting.
- For the best print quality, always set Paper Type to Card Stock.
- Use grain short card stock when possible.
- Do not use preprinted card stock manufactured with chemicals that may contaminate the printer.
- Be aware that preprinting, perforation, and creasing may significantly affect the print quality and cause jams or other paper-handling problems.

For more information, see [“Pick roller technology” on page 11](#).

Lexmark C750

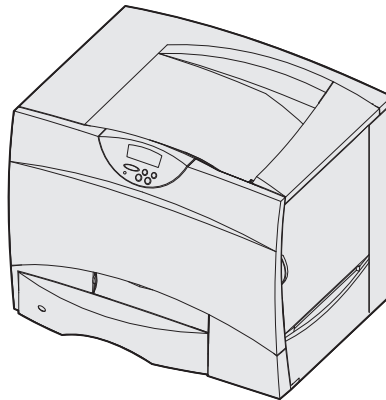

The Lexmark C750 prints on many labels designed for use with laser printers.

The following table lists the maximum weights supported by the trays and the multipurpose feeder.

The Lexmark C750 paper feeding mechanism uses advanced technology that enhances feeding reliability. The Lexmark C750 trays, which hold approximately 500 sheets of 75 g/m² paper, reliably feed all supported media.

Note: The optional 2000-sheet drawer supports paper only.

Print material		Range or maximum weight supported	
		500-sheet tray and optional 500-sheet drawer	Multipurpose feeder
Paper ¹ (grain direction ²)	Xerographic or business paper	60–176 g/m ² (16–47 lb bond)	60–176 g/m ² (16–47 lb bond)
Card Stock (grain long ²)	Index Bristol	163 g/m ² (90 lb)	163 g/m ² (90 lb)
	Tag	163 g/m ² (100 lb)	163 g/m ² (100 lb)
	Cover	176 g/m ² (65 lb)	176 g/m ² (65 lb)
Card Stock (grain short ²)	Index Bristol	199 g/m ² (110 lb)	199 g/m ² (110 lb)
	Tag	203 g/m ² (125 lb)	203 g/m ² (125 lb)
	Cover	216 g/m ² (80 lb)	216 g/m ² (80 lb)
Labels	Paper	180 g/m ² (48 lb bond)	199 g/m ² (53 lb bond)
	Dual-web paper	180 g/m ² (48 lb bond)	199 g/m ² (53 lb bond)
	Vinyl ³	300 g/m ² (92 lb liner)	260 g/m ² (78 lb liner)
	Polyester	220 g/m ² (59 lb bond)	220 g/m ² (59 lb bond)

¹ Paper less than 75 g/m² is supported only when the relative humidity is less than 60% and is *not* supported in duplex.

² See [“Grain orientation” on page 17](#) for specific recommendations.

³ Vinyl labels are supported only when printing environment and media are 20–32°C (68–90°F).

⁴ Pressure-sensitive area must enter the printer first.

Print material		Range or maximum weight supported	
		500-sheet tray and optional 500-sheet drawer	Multipurpose feeder
Integrated forms	Pressure-sensitive area ⁴	140–175 g/m ²	140–175 g/m ²
	Paper base (grain long)	75–135 g/m ² (20–36 lb bond)	75–135 g/m ² (20–36 lb bond)

¹ Paper less than 75 g/m² is supported only when the relative humidity is less than 60% and is *not* supported in duplex.
² See [“Grain orientation” on page 17](#) for specific recommendations.
³ Vinyl labels are supported only when printing environment and media are 20–32°C (68–90°F).
⁴ Pressure-sensitive area must enter the printer first.

For paper and transparency specifications, see the *Lexmark C750 Publications CD*.

The following table indicates the paper sizes each tray supports.

Source	Standard sizes (width x length)		Universal sizes (width x length)	
	Minimum	Maximum	Minimum	Maximum
Standard tray 500-sheet drawer	148 x 210 mm (5.83 x 8.27 in.)	215.9 x 355.6 mm (8.5 x 14 in.)	139.7 x 210 mm (5.5 x 8.27 in.)	215.9 x 355.6 mm (8.5 in. x 14 in.)
Multipurpose feeder*	148 x 210 mm (5.83 x 8.27 in.)	215.9 x 355.6 mm (8.5 x 14 in.)	69.85 x 127 mm (2.75 in. x 5 in.)	229 x 355.6 mm (9.01 x 14 in.)

* If you load paper that is narrower than 148 mm (5.83 in.) in the multipurpose feeder (for example, 3 x 5-inch index cards), set the MP Feeder Size menu item to Universal.

Labels Thickness: 0.102–0.305 mm (0.004–0.012 in.)

 Smoothness: 100–400* Sheffield

* 150–250 Sheffield is optimal. Using media higher than 300 Sheffield could result in printing degradation.

Card stock and label guidelines

Labels are one of the most difficult print materials for laser printers. A fuser equipped with a web oiler may be required for label applications to optimize feed reliability. Contact your local service representative for ordering information.

If you print large quantities of labels or other glossy print media, replace the fuser housing with a web oiler field upgrade kit (P/N 12G6307 for a 115 V printer, P/N 12G6308 for a 220 V printer).

When printing on labels:

- Using the printer operator panel, set the Paper Type to Labels in the Paper Menu. For vinyl and other heavy labels, set the Labels Weight (under the Paper Weight menu) to Heavy, and set the Labels Texture (under the Paper Texture menu) to Smooth.
- Do *not* load labels together with paper or transparencies in the same paper tray. Combining print materials can cause feeding problems.
- Use full label sheets. Partial sheets may cause labels to peel off during printing, resulting in a paper jam. Adhesive material may contaminate your printer. It could also void your printer and cartridge warranties.

When feeding labels, the number of labels per sheet can affect registration more than basis weight. Typically, the more labels per sheet, the better the registration.

When printing on card stock:

- Set the Paper Type to Card Stock in the Paper Menu.
- Do *not* use card stock that is creased. It may cause paper jams.

For more information, see the following:

- [“Pick roller technology” on page 11](#)
- [“Grain orientation” on page 17](#)
- [“Maintenance procedures” on page 14](#)
- [“Troubleshooting” on page 14](#)

Lexmark C752

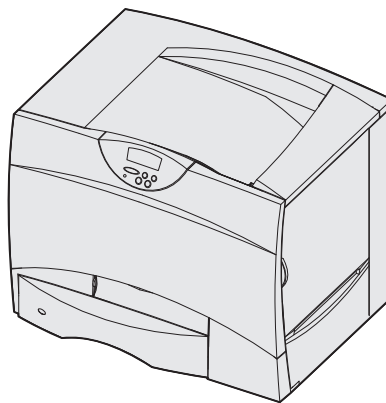

The Lexmark C752 prints on many labels designed for use with laser printers.

The Lexmark C752 trays, which hold approximately 500 sheets of 75 g/m² paper, reliably feed all supported media.

The following table lists the maximum weights supported by the trays and the multipurpose feeder.

Note: The optional 2000-sheet drawer supports paper only

Print material		Range or maximum weight supported	
		500-sheet tray and optional 500-sheet drawer	Multipurpose feeder
Paper ¹ (grain direction ²)	Xerographic or business paper	60–176 g/m ² (16–47 lb bond)	60–176 g/m ² (16–47 lb bond)
Card stock (grain long ²)	Index Bristol	163 g/m ² (90 lb)	163 g/m ² (90 lb)
	Tag	163 g/m ² (100 lb)	163 g/m ² (100 lb)
	Cover	176 g/m ² (65 lb)	176 g/m ² (65 lb)

¹ Paper less than 75 g/m² is supported only when the relative humidity is less than 60% and is *not* supported in duplex.

² See [“Grain orientation” on page 17](#) for specific recommendations.

³ Vinyl labels are supported only when printing environment and media are 20–32°C (68–90°F).

⁴ Pressure-sensitive area must enter the printer first.

Print material		Range or maximum weight supported	
		500-sheet tray and optional 500-sheet drawer	Multipurpose feeder
Card stock (grain short ²)	Index Bristol	199 g/m ² (110 lb)	199 g/m ² (110 lb)
	Tag	203 g/m ² (125 lb)	203 g/m ² (125 lb)
	Cover	216 g/m ² (80 lb)	216 g/m ² (80 lb)
Labels	Paper	180 g/m ² (48 lb bond)	199 g/m ² (53 lb bond)
	Dual-web paper	180 g/m ² (48 lb bond)	199 g/m ² (53 lb bond)
	Vinyl ³	300 g/m ² (92 lb liner)	260 g/m ² (78 lb liner)
	Polyester	220 g/m ² (59 lb bond)	220 g/m ² (59 lb bond)
Integrated forms	Pressure-sensitive area ⁴	140–175 g/m ²	140–175 g/m ²
	Paper base (grain long)	75–135 g/m ² (20–36 lb bond)	75–135 g/m ² (20–36 lb bond)

¹ Paper less than 75 g/m² is supported only when the relative humidity is less than 60% and is *not* supported in duplex.

² See [“Grain orientation” on page 17](#) for specific recommendations.

³ Vinyl labels are supported only when printing environment and media are 20–32°C (68–90°F).

⁴ Pressure-sensitive area must enter the printer first.

For paper and transparency specifications, see the *Lexmark C752 Publications CD*.

The following table indicates the paper sizes each tray supports.

Source	Standard sizes (width x length)		Universal sizes (width x length)	
	Minimum	Maximum	Minimum	Maximum
Standard tray 500-sheet drawer	148 x 210 mm (5.83 x 8.27 in.)	215.9 x 355.6 mm (8.5 x 14 in.)	139.7 x 210 mm (5.5 x 8.27 in.)	215.9 x 355.6 mm (8.5 in. x 14 in.)
Multipurpose feeder*	148 x 210 mm (5.83 x 8.27 in.)	215.9 x 355.6 mm (8.5 x 14 in.)	69.85 x 127 mm (2.75 in. x 5 in.)	229 x 355.6 mm (9.01 x 14 in.)

* If you load paper that is narrower than 148 mm (5.83 in.) in the multipurpose feeder (for example, 3 x 5-inch index cards), set the MP Feeder Size menu item to Universal.

Labels Thickness: 0.102–0.305 mm (0.004–0.012 in.)
 Smoothness: 100–400* Sheffield

* 150–250 Sheffield is optimal. Using media higher than 300 Sheffield could result in printing degradation.

Card stock and label guidelines

Labels are one of the most difficult print materials for laser printers. A fuser equipped with a web oiler may be required for label applications to optimize feed reliability. Contact your local service representative for ordering information.

If you print large quantities of labels or other glossy print media, replace the fuser housing with a web oiler (P/N 56P1555 for a 115 V printer or P/N 56P1556 for a 220 V printer).

When printing on labels:

- Using the printer operator panel, set the Paper Type to Labels in the Paper Menu. For vinyl and other heavy labels, set the Labels Weight (under the Paper Weight menu) to Heavy, and set the Labels Texture (under the Paper Texture menu) to Smooth.
- Do *not* load labels together with paper or transparencies in the same paper tray. Combining print materials can cause feeding problems.
- Use full label sheets. Partial sheets may cause labels to peel off during printing, resulting in a paper jam. Adhesive material may contaminate your printer. It could also void your printer and cartridge warranties.

When feeding labels, the number of labels per sheet can affect registration more than basis weight. Typically, the more labels per sheet, the better the registration.

When printing on card stock:

- Set the Paper Type to Card Stock in the Paper Menu.
- Do *not* use card stock that is creased. It may cause paper jams.

For more information, see the following:

- [“Pick roller technology” on page 11](#)
- [“Grain orientation” on page 17](#)
- [“Maintenance procedures” on page 14](#)
- [“Troubleshooting” on page 14](#)

Lexmark C760 and C762

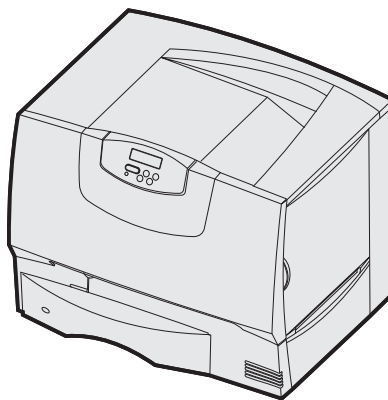

Lexmark C760 and C762 print on many labels designed for use with laser printers.

The following table lists the maximum weights supported by the trays and the multipurpose feeder.

Note: The optional 2,000-sheet drawer supports paper only.

Print material		Range or maximum weight supported	
		500-sheet tray and optional 500-sheet drawer	Multipurpose feeder
Paper ¹ (grain direction ²)	Xerographic or business paper	60–176 g/m ² (16–47 lb bond)	60–176 g/m ² (16–47 lb bond)
Card stock (grain long ²)	Index Bristol	163 g/m ² (90 lb)	163 g/m ² (90 lb)
	Tag	163 g/m ² (100 lb)	163 g/m ² (100 lb)
	Cover	176 g/m ² (65 lb)	176 g/m ² (65 lb)
Card stock (grain short ²)	Index Bristol	199 g/m ² (110 lb)	199 g/m ² (110 lb)
	Tag	203 g/m ² (125 lb)	203 g/m ² (125 lb)
	Cover	216 g/m ² (80 lb)	216 g/m ² (80 lb)
Labels	Paper	180 g/m ² (48 lb bond)	199 g/m ² (53 lb bond)
	Dual-web paper	180 g/m ² (48 lb bond)	199 g/m ² (53 lb bond)
	Vinyl ³	300 g/m ² (92 lb liner)	260 g/m ² (78 lb liner)
	Polyester	220 g/m ² (59 lb bond)	220 g/m ² (59 lb bond)
Integrated forms	Pressure-sensitive area ⁴	140–175 g/m ²	140–175 g/m ²
	Paper base (grain long)	75–135 g/m ² (20–36 lb bond)	75–135 g/m ² (20–36 lb bond)

¹ Paper less than 75 g/m² is supported only when the relative humidity is less than 60% and is *not* supported in duplex.

² See [“Grain orientation” on page 17](#) for specific recommendations.

³ Vinyl labels are supported only when printing environment and media are 20–32°C (68–90°F).

⁴ Pressure-sensitive area must enter the printer first.

For paper and transparency specifications, see the printer publications CD.

The following table indicates the paper sizes each tray supports.

Labels	Thickness:	0.102–0.305 mm (0.004–0.012 in.)
	Smoothness:	50–300 Sheffield*

* 50–150 Sheffield is optimal. This printer may support labels with smoothness of less than 50 Sheffield such as coated paper, polyester, vinyl, or other synthetic facestock papers. Using media higher than 200 Sheffield could result in printing degradation.

Card stock and label guidelines

Labels are one of the most difficult print materials for laser printers. A fuser equipped with a web oiler may be required for label applications to optimize feed reliability. Contact your local service representative for ordering information.

If you print large quantities of labels or other glossy print media, replace the fuser housing with a web oiler (P/N 56P1555 for a 115 V printer or P/N 56P1556 for a 220 V printer).

When printing on labels:

- Using the printer operator panel, set Paper Type to Labels in the Paper Menu. For vinyl and other heavy labels, set Labels Weight (under the Paper Weight menu) to Heavy, and set Labels Texture (under the Paper Texture menu) to Smooth.
- Do *not* load labels together with paper or transparencies in the same paper tray. Combining print materials can cause feeding problems.
- Use full label sheets. Partial sheets may cause labels to peel off during printing, resulting in a paper jam. Adhesive material may contaminate your printer. It could also void your printer and cartridge warranties.

Print on sheets with more number of labels to improve registration.

When printing on card stock:

- Set Paper Type to Card Stock in the Paper Menu.
- Do *not* use creased card stock. It may cause paper jams.

For more information, see the following:

- [“Pick roller technology” on page 11](#)
- [“Grain orientation” on page 17](#)
- [“Maintenance procedures” on page 14](#)
- [“Troubleshooting” on page 14](#)

Lexmark C770, C772, C780, and C782

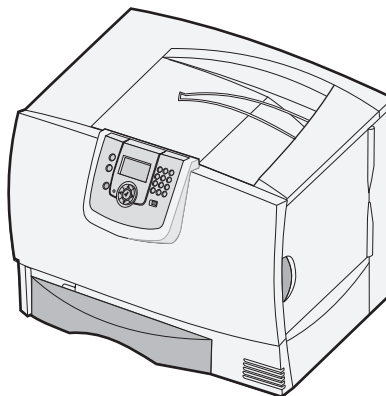

The Lexmark C770, C772, C780, and C782 print on many labels designed for use with laser printers.

The following tables list the maximum weights supported by the trays and the multipurpose feeder.

Note: The optional 2000-sheet drawer supports plain and glossy paper.

Paper source	Card stock (grain long/grain short)					
	Index Bristol		Tag		Cover	
	grain long	grain short	grain long	grain short	grain long	grain short
500-sheet drawers	163 g/m ²	199 g/m ²	163 g/m ²	203 g/m ²	176 g/m ²	216 g/m ²
Multipurpose feeder	163 g/m ²	199 g/m ²	163 g/m ²	203 g/m ²	176 g/m ²	216 g/m ²

Paper source	Labels			
	Paper	Dual-web paper	Polyester	Vinyl ^{1, 2}
500-sheet drawers	180 g/m ²	180 g/m ²	220 g/m ²	300 g/m ²
Multipurpose feeder	199 g/m ²	199 g/m ²	220 g/m ²	260 g/m ²

¹ Vinyl labels are supported only when the printing environment and media are 20–32.2°C (68–90°F).

² The skew performance of heavy vinyl labels may be enhanced by feeding from an optional 500-sheet drawer if placement of the image is critical.

For paper and transparency specifications, see the printer publications CD.

Labels	Thickness:	0.102–0.305 mm (0.004–0.012 in.)
	Smoothness:	50–300 Sheffield*

* 50–150 Sheffield is optimal. This printer may support labels with smoothness of less than 50 Sheffield such as coated paper, polyester, vinyl, or other synthetic facestock paper. Using media higher than 200 Sheffield could result in print quality degradation.

Card stock and label guidelines

Labels are one of the most difficult print materials for laser printers. A fuser equipped with a dry web cleaner may be required for label applications to optimize feed reliability. If you print large quantities of labels or other glossy print media, then install a dry web cleaner upgrade kit (P/N 40X1856). Contact your local service representative for ordering information.

When printing on labels:

- From the printer control panel, set Paper Type to Labels in the Paper Menu. For vinyl and other heavy labels, set Labels Weight (under the Paper Weight menu) to Heavy, and set Labels Texture (under the Paper Texture menu) to Smooth.
- Do *not* load labels together with paper or transparencies in the same paper tray. Combining print materials can cause feeding problems.
- Use full label sheets. Partial sheets may cause labels to peel off during printing, resulting in a paper jam. Adhesive material may contaminate your printer. It could also void your printer and cartridge warranties.

Print on sheets with more number of labels to improve registration.

When printing on card stock:

- Set Paper Type to Card Stock in the Paper Menu.
- Do *not* use creased card stock. It may cause paper jams.

For more information, see the following:

- [“Pick roller technology” on page 11](#)
- [“Maintenance procedures” on page 14](#)
- [“Troubleshooting” on page 14](#)

Lexmark C792e, C792de, C792dte, and C792dhe

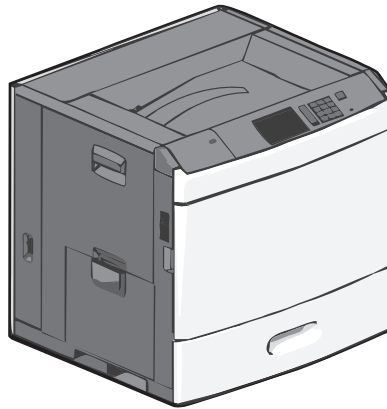

The Lexmark C792e, C792de, C792dte, and C792dhe printer models print on many labels designed for use with laser printers.

The following tables list the maximum weights supported by the trays and the multipurpose feeder.

Overview of card stock support

Paper source	Card stock (grain long/grain short)					
	Index Bristol		Tag		Cover	
	grain long	grain short	grain long	grain short	grain long	grain short
Standard and optional 550-sheet trays	163 g/m ²	199 g/m ²	163 g/m ²	203 g/m ²	176 g/m ²	216 g/m ²
Multipurpose feeder	163 g/m ²	199 g/m ²	163 g/m ²	203 g/m ²	176 g/m ²	216 g/m ²

Overview of label support

Paper source	Labels			
	Paper	Dual-web paper	Polyester	Vinyl ^{1, 2}
Standard and optional 550-sheet trays	180 g/m ²	180 g/m ²	220 g/m ²	300 g/m ²
Multipurpose feeder	199 g/m ²	199 g/m ²	220 g/m ²	260 g/m ²

¹ Vinyl labels are supported only when the printing environment and media are 20–32.2°C (68–90°F).

² The skew performance of heavy vinyl labels may be enhanced by feeding from an optional 500-sheet drawer if placement of the image is critical.

For paper and transparency specifications, see the printer publications CD.

Media specifications

Labels	Thickness:	0.102–0.305 mm (0.004–0.012 in.)
	Smoothness:	50–300* Sheffield

* 50–150 Sheffield is optimal. This printer may support labels with smoothness of less than 50 Sheffield such as coated paper, polyester, vinyl, or other synthetic facestock paper. Using media higher than 200 Sheffield could result in print quality degradation.

Card stock and label guidelines

Labels are one of the most difficult print materials for laser printers. A fuser equipped with a dry web cleaner may be required for label applications to optimize feed reliability. If you print large quantities of labels or other glossy print media, then install a dry web cleaner upgrade kit (P/N 40X1856). Contact your local service representative for ordering information.

When printing on labels:

- From the printer control panel, set Paper Type to Labels in the Paper Menu. For vinyl and other heavy labels, set Labels Weight (under the Paper Weight menu) to Heavy, and set Labels Texture (under the Paper Texture menu) to Smooth.
- Do *not* load labels together with paper or transparencies in the same paper tray. Combining print materials can cause feeding problems.
- Use full label sheets. Partial sheets may cause labels to peel off during printing, resulting in a paper jam. Adhesive material may contaminate your printer. It could also void your printer and cartridge warranties.

Print on sheets with more number of labels to improve registration.

When printing on card stock:

- Set Paper Type to Card Stock in the Paper Menu.
- Do *not* use creased card stock. It may cause paper jams.

For more information, see the following:

- [“Pick roller technology” on page 11](#)
- [“Maintenance procedures” on page 14](#)
- [“Troubleshooting” on page 14](#)

Lexmark C910

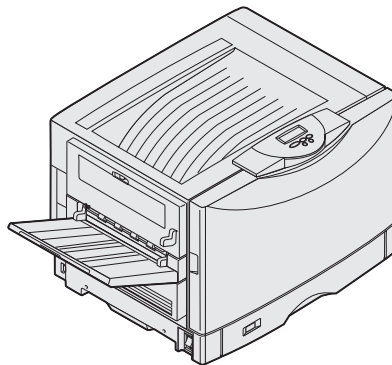

Limit label printing to occasional use of paper office labels designed for laser printers. We do *not* recommend using vinyl or polyester labels.

The Lexmark C910 supports stocks up to 163 g/m² (90 lb).

The following table lists the maximum weights supported by the heavy media tray and the multipurpose feeder.

Paper source	Card stock			Labels	
	Index Bristol	Tag	Cover	Paper	Vinyl
Heavy media tray	—	—	—	180 g/m ²	—
Multipurpose feeder	163 g/m ²	163 g/m ²	—	180 g/m ²	—

For paper and transparency specifications, see the *Lexmark C910 Publications CD*.

- Labels**
- Width: 210–216 mm (8.3–8.5 in.)
 - Length: 279–297 mm (11–11.7 in.)
 - Weight: 120–180 g/m² (32– 43 lb)
 - Thickness: 0.13–0.20 mm (0.005–0.008 in.)
 - Smoothness: 100–400 Sheffield*
- * 150–250 Sheffield is optimal. Using media higher than 300 Sheffield could result in printing degradation.

- Card stock**
- Weight: Up to 163 g/m² Index Bristol (90 lb)
 - Up to 163 g/m² Tag (100 lb)

Card stock and label guidelines

When printing on labels:

- Use only label sheets that have no gaps between the labels.

Acceptable labels

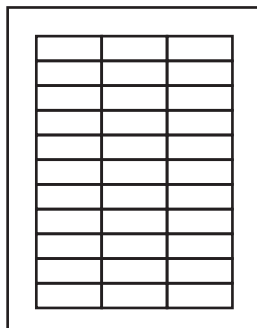

Unacceptable labels

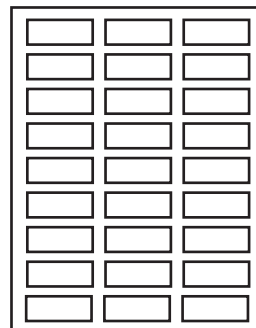

- From the operator panel or from MarkVision Professional, set the Paper Type to Labels in the Paper Menu.
- Do *not* print a large number of labels continuously.
- Do *not* use labels that have coating or sizing applied to make the labels liquid-resistant.
- Do *not* use labels that have exposed adhesive on the label sheets.
- We recommend using Avery paper labels.

When printing on card stock:

- We recommend using Springhill Index Plus 90 lb card stock.
- For the best print quality, always set the Paper Type to Card Stock in the Paper Menu.

Lexmark C912

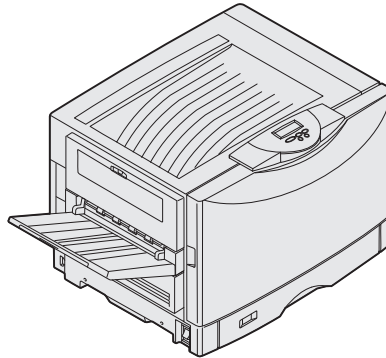

Limit label printing to occasional use of paper office labels designed for laser printers. We do not recommend using vinyl or polyester labels.

The Lexmark C912 supports stocks up to 216 g/m².

The following table lists the maximum weights supported by the standard tray and the multipurpose feeder.

Paper source	Card stock	Labels	
	Index Bristol	Paper	Vinyl
Standard tray	—	180 g/m ²	—
Multipurpose feeder	216 g/m ²	180 g/m ²	300 g/m ²

Labels	Width:	210–216 mm (8.3–8.5 in.)
	Length:	279–297 mm (11–11.7 in.)
	Weight:	180 g/m ²
	Thickness:	0.13–0.20 mm (0.005–0.008 in.)
	Smoothness:	100–400 Sheffield*

* 150–250 Sheffield is optimal. Using media higher than 300 Sheffield could result in printing degradation.

Card stock	Weight:	Up to 216 g/m ²
-------------------	---------	----------------------------

For paper and transparency specifications, refer to the printer publications CD.

Card stock and label guidelines

When printing on labels:

- Use only label sheets that have no gaps between the labels.

Acceptable labels

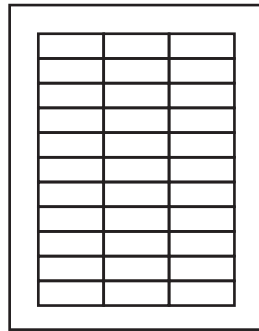

Unacceptable labels

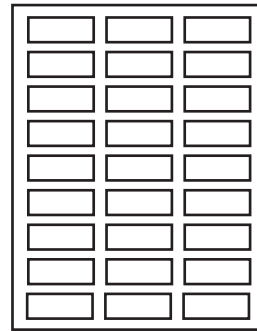

- From the operator panel or from MarkVision Professional, set the Paper Type to Labels in the Paper Menu.
- Do not print a large number of labels continuously.
- Do not use labels that have coating or sizing applied to make the labels liquid-resistant.
- Do not use labels that have exposed adhesive on the label sheets.
- We recommend using Avery paper labels.

When printing on vinyl labels:

- From the operator panel or from MarkVision Professional, set the Paper Type to Card Stock in the Paper Menu. Set the CardStock Weight (under the Paper Weight menu) to Heavy.
- Download the vinyl file, vinyl8ppm.npa, from our FTP site and send it to the printer (copy the file to the printer port).

When printing on card stock:

- We recommend using Springhill Index Plus 90 lb card stock.
- For the best print quality, always set the Paper Type to Card Stock in the Paper Menu.

Lexmark C920

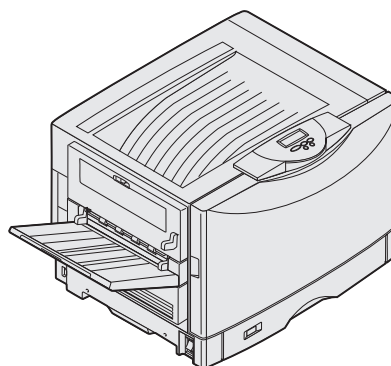

Limit label printing to occasional use of paper office labels designed for laser printers. We do *not* recommend using vinyl or polyester labels.

The Lexmark C920 supports stocks up to 216 g/m².

The following table lists the maximum weights supported by the standard tray and the multipurpose feeder.

Paper source	Card stock	Labels	
	Index Bristol	Paper	Vinyl
Standard tray	—	180 g/m ²	—
Multipurpose feeder	216 g/m ²	180 g/m ²	300 g/m ²

- Labels**
- Width: 210–216 mm (8.3–8.5 in.)
 - Length: 279–297 mm (11–11.7 in.)
 - Weight: 180 g/m²
 - Thickness: 0.13–0.20 mm (0.005–0.008 in.)
 - Smoothness: 100–400 Sheffield*
- * 150–250 Sheffield is optimal. Using media higher than 300 Sheffield could result in printing degradation.

- Card stock**
- Weight: Up to 216 g/m²

Card stock and label guidelines

When printing on labels:

- Use only label sheets that have no gaps between the labels.

Acceptable labels

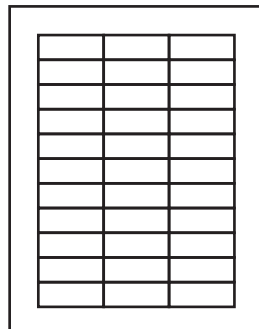

Unacceptable labels

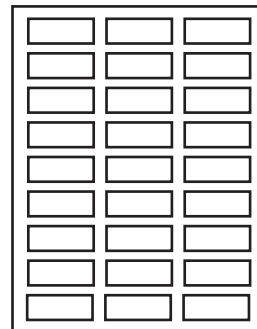

- Set the Paper Type to Labels in the Paper Menu.
- Do *not* print a large number of labels continuously.
- Do *not* use labels that have coating or sizing applied to make the labels liquid-resistant.
- Do *not* use labels that have exposed adhesive on the label sheets.
- We recommend using Avery paper labels.

When printing on card stock:

- We recommend using Springhill Index Plus 90 lb card stock.
- For the best print quality, always set the Paper Type to Card Stock in the Paper Menu.

Lexmark C925



Limit label printing to occasional use of A4- or letter-size paper office labels designed for laser printers. We do *not* recommend using vinyl or polyester labels.

The trays and the multipurpose feeder support card stock. The multipurpose feeder supports card stocks up to 256 g/m². *Always* feed labels from the standard 150-sheet tray or the multipurpose feeder.

The standard 250- and optional 550-sheet trays do not support labels.

The following table lists the maximum weights supported by the trays and the multipurpose feeder.

Paper source	Card stock (grain long/grain short)					
	Index Bristol		Tag		Cover	
	grain long	grain short	grain long	grain short	grain long	grain short
Standard 150-sheet tray	120 g/m ²	163 g/m ²	120 g/m ²	163 g/m ²	135 g/m ²	176 g/m ²
Standard 250- and optional 550-sheet trays	120 g/m ²	157 g/m ²	120 g/m ²	157 g/m ²	135 g/m ²	157 g/m ²
Multipurpose feeder	120 g/m ²	256 g/m ²	120 g/m ²	256 g/m ²	135 g/m ²	256 g/m ²

Paper source	Labels	
	Paper	Vinyl
Standard 150-sheet tray	131 g/m ²	Not applicable
Multipurpose feeder	131 g/m ²	Occasional use up to 256 g/m ²

- Labels**
- Width: 210–216 mm (8.3–8.5 in.)
 - Length: 279–356 mm (11–11.7 in.)
 - Weight: 120–128 g/m²
 - Thickness: 0.13–0.20 mm (0.005–0.008 in.)
 - Smoothness: 100–400 Sheffield*

* 150–250 Sheffield is optimal. Using media higher than 300 Sheffield could result in print quality degradation.

Card stock	Width:	210–216 mm (8.3–8.5 in.)
	Length:	279–356 mm (11–11.7 in.)
	Weight:	Up to 216 g/m ²

Card stock and label guidelines

When printing on labels:

- From the printer control panel, set Paper Type to Labels in the Paper Menu.
- Do *not* use label sheets with a slick backing material.
- Do *not* print within 1 mm (0.04 in.) of the die-cut, the edge of the label or the perforations, or between the die-cuts.
- Use full label sheets. Partial sheets may cause labels to peel off during printing, resulting in a paper jam.
- Do *not* use label sheets that have adhesive to the edge of the sheet. We recommend zone coating of the adhesive at least 1 mm (0.04 in.) away from the edges. Adhesive material may contaminate your printer and could void your warranty.

When printing on card stock:

- From the printer control panel, set Paper Type to Card Stock.
- Do *not* use creased card stock. It may cause paper jams.
- We recommend the use of grain long card stock.

Lexmark C935

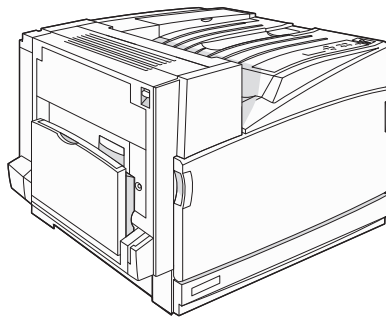

Limit label printing to occasional use of A4- or letter-size paper office labels designed for laser printers. We do *not* recommend using vinyl or polyester labels.

Lexmark C935 supports card stock up to 220 g/m².

The following table lists the maximum weights supported by the trays and the multipurpose feeder.

	Tray 1	Trays 2 and 3	Multipurpose feeder
Labels	Not applicable	Not applicable	220 g/m ²
Card stock	105 g/m ²	220 g/m ²	220 g/m ²

Labels	Width:	210–216 mm (8.3–8.5 in.)
	Length:	279–356 mm (11–11.7 in.)
	Weight:	120–128 g/m ²
	Thickness:	0.13–0.20 mm (0.005–0.008 in.)
	Smoothness:	100–400 Sheffield*
		* 150–250 Sheffield is optimal. Using media higher than 300 Sheffield could result in print quality degradation.
Card stock	Width:	210–216 mm (8.3–8.5 in.)
	Length:	279–356 mm (11–11.7 in.)
	Weight:	Up to 220 g/m ²

Card stock and label guidelines

When printing on labels:

- Load labels only on the multipurpose feeder.
- From the printer control panel, set Paper Type to Labels in the Paper Menu.
- Do *not* use label sheets with a slick backing material.
- Do *not* print within 1 mm (0.04 in.) of the die-cut, the edge of the label or the perforations, or between the die-cuts.
- Use full label sheets. Partial sheets may cause labels to peel off during printing, resulting in a paper jam.
- Do *not* use label sheets that have adhesive to the edge of the sheet. We recommend zone coating of the adhesive at least 1 mm (0.04 in.) away from the edges. Adhesive material may contaminate your printer and could void your warranty.

When printing on card stock:

- From the printer control panel, set Paper Type to Card Stock.
- Do *not* use creased card stock. It may cause paper jams.
- We recommend the use of grain long card stock.

Lexmark C950

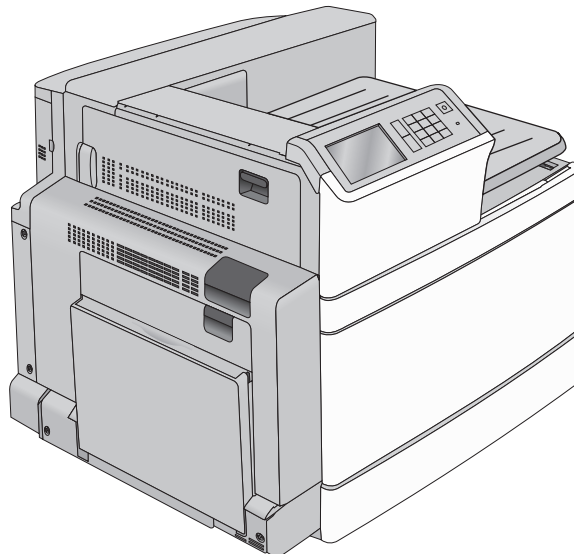

Limit label printing to occasional use of A4- or letter-size paper office labels designed for laser printers. We do *not* recommend using vinyl or polyester labels.

Lexmark C950 supports card stock up to 300 g/m².

The following table lists the maximum weights supported by the trays and the multipurpose feeder.

	Trays 1–4	Multipurpose feeder	High-capacity feeder
Labels	60–256 g/m ²	60–300 g/m ²	60–216 g/m ²
Card stock	60–256 g/m ²	60–300 g/m ²	60–216 g/m ²

Labels	Width:	140–320 mm (5.5–12.6 in.)
	Length:	182–457 mm (7.2–18 in.)
	Weight:	60–256 g/m ²
	Smoothness:	100–200 Sheffield
Card stock	Width:	140–320 mm (5.5–12.6 in.)
	Length:	182–457 mm (7.2–18 in.)
	Weight:	60–256 g/m ²

Card stock and label guidelines

When printing on labels:

- From the printer control panel, set the paper size, type, texture, and weight in the Paper menu to match the labels loaded in the tray.
- Do *not* use label sheets with a slick backing material.
- Do *not* print within 1 mm (0.04 in.) of the die-cut, the edge of the label or the perforations, or between the die-cuts.
- Use full label sheets. Partial sheets may cause labels to peel off during printing, resulting in a jam. Partial sheets also contaminate the printer and the cartridge with adhesive, and could void the printer and toner cartridge warranties.

When printing on card stock:

- From the printer control panel, set the paper size, type, texture, and weight in the Paper menu to match the card stock loaded in the tray.
- Do *not* use creased card stock. It may cause paper jams.
- We recommend the use of grain long card stock.

Lexmark CS310n, CS310dn, CS410n, CS410dn, and CS510de

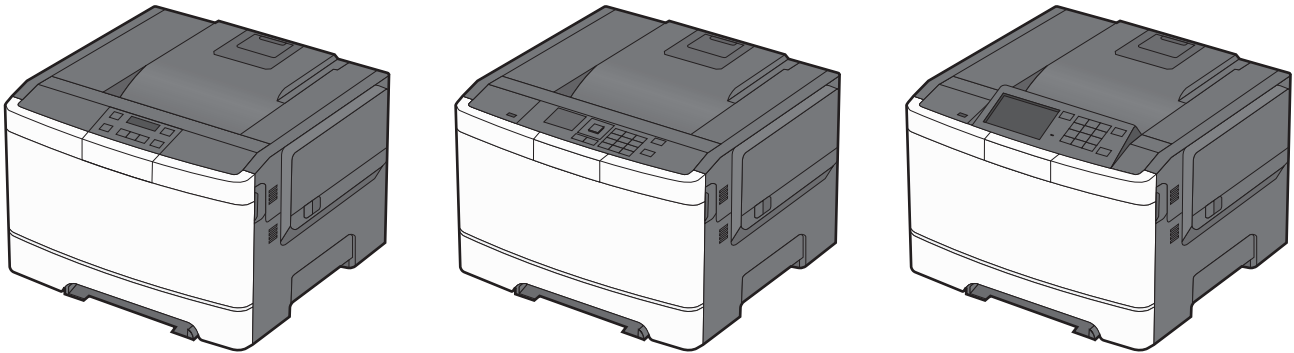

Notes:

- Your printer may not have a 650-sheet duo tray with an integrated multipurpose feeder.
- The 250-sheet tray (Tray 1), 550-sheet tray, and the 650-sheet duo tray support the same paper sizes and types.

Limit label printing to occasional use of paper office labels designed for laser printers. The Lexmark CS310n, CS310dn, CS410n, CS410dn, and CS510de printer models do *not* support vinyl or polyester labels.

The Lexmark CS310n, CS310dn, CS410n, CS410dn, and CS510de printer models support card stock weights up to 176 g/m². Card stock and labels are supported from the 250-sheet tray, 550-sheet tray, 650-sheet duo tray, the manual feeder, and the multipurpose feeder.

The 250-sheet tray supports approximately 100 sheets of card stock or labels, and the optional 550-sheet tray supports approximately 200 sheets of card stock or labels. The multipurpose feeder supports approximately 50 sheets of card stock or labels, and the manual feeder accepts single sheets only. Capacity varies depending on label material and construction.

The following table lists the maximum weights supported.

Paper source	Grain direction	Card stock			Labels
		Index Bristol	Tag	Cover	Paper
Standard 250-sheet tray	grain long	120 g/m ²	120 g/m ²	135 g/m ²	131 g/m ²
	grain short	163 g/m ²	163 g/m ²	176 g/m ²	
Standard or optional 550-sheet tray	grain long	120 g/m ²	120 g/m ²	135 g/m ²	131 g/m ²
	grain short	163 g/m ²	163 g/m ²	176 g/m ²	
Multipurpose and manual feeder*	grain long	120 g/m ²	120 g/m ²	135 g/m ²	131 g/m ²
	grain short	163 g/m ²	163 g/m ²	176 g/m ²	

* The multipurpose feeder may not support labels with certain design characteristics.

Labels	Width:	76.2–215.9 mm (3–8.5 in.)
	Length:	127–355.6 mm (5–14 in.)
	Weight:	131 g/m ² (35 lb bond)
	Thickness:	0.102–0.254 mm (0.004–0.010 in.)
	Smoothness:	50–300 Sheffield*

* 50–150 Sheffield is optimal. This printer may support labels with smoothness of less than 50 Sheffield such as coated paper, polyester, vinyl, or other synthetic facestock paper. Using media higher than 200 Sheffield could result in print quality degradation.

Card stock	Weight:	Up to 163 g/m ² Index Bristol (90 lb)
		Up to 163 g/m ² Tag (100 lb)
		Up to 176 g/m ² Cover (65 lb)

For more information on the supported media sizes, see the printer *User's Guide* on the *Software and Documentation* CD.

Card stock and label guidelines

When printing on labels:

- Use only paper labels. Do *not* use vinyl labels.
- Use only label sheets that have no gaps between the labels.

Acceptable labels

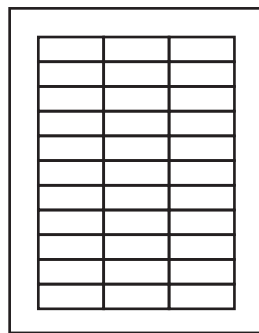

Unacceptable labels

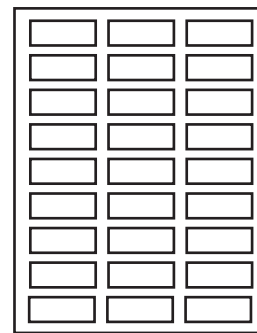

- For optimal printing, use Avery laser labels.
- From the printer control panel or from MarkVision Professional, set Paper Type to Labels.
- Do *not* print a large number of labels continuously.
- Do *not* use labels that have coating or sizing applied to make the labels liquid-resistant.
- Do *not* use labels that have exposed adhesive on the label sheets.

When printing on card stock:

- For optimal printing, use a 90-lb Index card stock.
- For the best print quality, always set Paper Type to Card Stock.
- Set Card Stock Weight to Normal or Heavy.
- Do *not* use creased card stock. It may cause paper jams.

For more information, see [“Pick roller technology” on page 11](#).

Lexmark CX310n, CX310dn, CX410e, CX410de, CX410dte, CX510de, CX510dhe, and CX510dthe

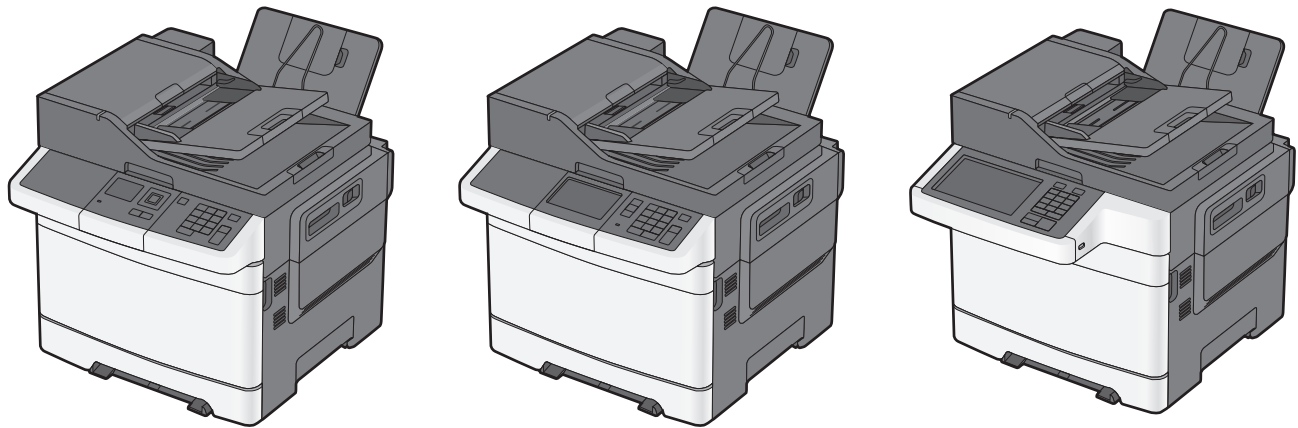

Notes:

- Your printer may not have a 650-sheet duo tray with an integrated multipurpose feeder.
- The 250-sheet tray (Tray 1), 550-sheet tray, and the 650-sheet duo tray support the same paper sizes and types.
- The automatic document feeder (ADF) does not support card stock or labels.

Limit label printing to occasional use of paper office labels designed for use with laser printers. The Lexmark CX310n, CX310dn, CX410e, CX410de, CX410dte, CX510de, CX510dhe, and CX510dthe printer models do *not* support vinyl or polyester labels.

The following table lists the maximum weights supported by the trays and the multipurpose feeder.

Paper source	Grain direction	Card stock			Labels
		Index Bristol	Tag	Cover	Paper
Standard 250-sheet tray	grain long	120 g/m ²	120 g/m ²	135 g/m ²	131 g/m ²
	grain short	163 g/m ²	163 g/m ²	176 g/m ²	
Standard or optional 550-sheet tray	grain long	120 g/m ²	120 g/m ²	135 g/m ²	131 g/m ²
	grain short	163 g/m ²	163 g/m ²	176 g/m ²	
Multipurpose feeder* and manual feeder	grain long	120 g/m ²	120 g/m ²	135 g/m ²	131 g/m ²
	grain short	163 g/m ²	163 g/m ²	176 g/m ²	

* The multipurpose feeder may not support labels with certain design characteristics.

Labels	Width:	76.2–215.9 mm (3–8.5 in.)
	Length:	127–355.6 mm (5–14 in.)
	Weight:	131 g/m ² (35 lb bond)
	Thickness:	0.102–0.254 mm (0.004–0.010 in.)
	Smoothness:	50–300 Sheffield*

* 50–150 Sheffield is optimal. This printer may support labels with smoothness of less than 50 Sheffield such as coated paper, polyester, vinyl, or other synthetic facestock paper. Using media higher than 200 Sheffield could result in print quality degradation.

Card stock	Weight:	Up to 163 g/m ² Index Bristol (90 lb)
		Up to 163 g/m ² Tag (100 lb)
		Up to 176 g/m ² Cover (65 lb)

Card stock and label guidelines

When printing on labels:

- Use only paper labels. Do *not* use vinyl labels.
- Use only label sheets that have no gaps between the labels.

Acceptable labels

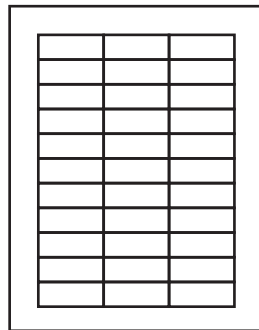

Unacceptable labels

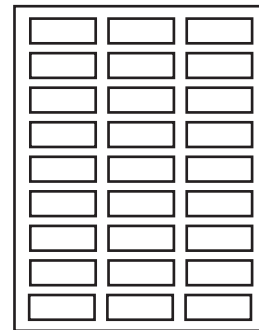

- From the printer control panel, set Paper Type to Labels in the Paper Menu.
- Do *not* load labels together with paper or transparencies in the same paper tray. Combining print materials can cause feeding problems.
- Use only letter-, A4-, or legal-size full label sheets. Partial sheets may cause labels to peel off during printing, resulting in a paper jam. Adhesive material may contaminate your printer. It could also void your printer and cartridge warranties.

When printing on card stock:

- From the printer control panel, set Paper Type to Card Stock in the Paper Menu.
- Set Card Stock Weight to Normal or Heavy.
- Do *not* use creased card stock. It may cause paper jams.

Lexmark E120

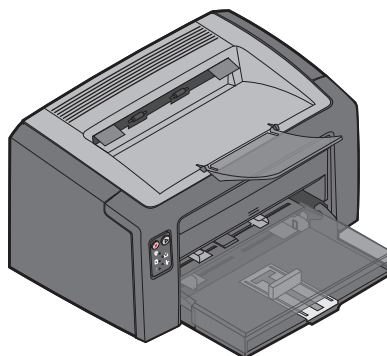

Limit label printing to occasional use of paper office labels designed for laser printers. We do *not* recommend using vinyl or polyester labels.

The Lexmark E120 supports stocks up to 163 g/m² (43 lb). The automatic paper feeder can hold up to 10 sheets of card stock or labels.

The following table lists the maximum weights supported by Tray 1 and the manual sheet feeder.

Paper source	Card stock	Labels	
	Index Bristol	Paper	Vinyl
Tray 1	135–163 g/m ² (up to 90 lb)	60–163 g/m ² (16–43 lb)	—
Manual feed	135–163 g/m ² (up to 90 lb)	60–163 g/m ² (16–43 lb)	—

For paper and transparency specifications, see the *Lexmark E220 Publications CD*.

Labels	Width:	210–216 mm (8.3–8.5 in.)
	Length:	279–297 mm (11–11.7 in.)
	Weight:	Up to 163 g/m ² (43 lb)
	Thickness:	Up to 0.25 mm (0.01 in.)
	Smoothness:	100–400* Sheffield

* 150–250 Sheffield is optimal. Using media higher than 300 Sheffield could result in printing degradation.

Card stock	Weight:	Up to 163 g/m ² Index Bristol (90 lb)
		Up to 163 g/m ² Tag (100 lb)

Note: To minimize curl, use the top exit when printing on card stock and labels.

For more information, see [“Maintenance procedures” on page 14](#).

Lexmark E220

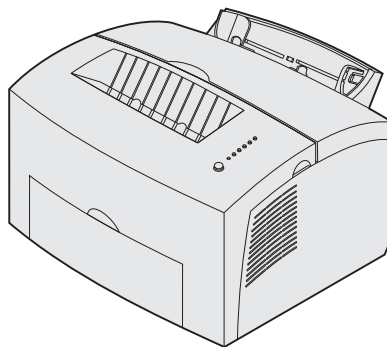

Limit label printing to occasional use of paper office labels designed for laser printers. We do *not* recommend using vinyl or polyester labels.

The Lexmark E220 supports stocks up to 163 g/m² (43 lb). The automatic paper feeder can hold up to 10 sheets of card stock or labels.

The following table lists the maximum weights supported by Tray 1 and the manual sheet feeder.

Paper source	Card stock			Labels	
	Index Bristol	Tag	Cover	Paper	Vinyl
Tray 1	163 g/m ²	163 g/m ²	—	163 g/m ²	—
Manual feed	163 g/m ²	163 g/m ²	—	163 g/m ²	—

For paper and transparency specifications, see the *Lexmark E220 Publications CD*.

Labels	Width:	210–216 mm (8.3–8.5 in.)
	Length:	279–297 mm (11–11.7 in.)
	Weight:	Up to 163 g/m ² (43 lb)
	Thickness:	Up to 0.25 mm (0.01 in.)
	Smoothness:	100–400* Sheffield

* 150–250 Sheffield is optimal. Using media higher than 300 Sheffield could result in printing degradation.

Card stock	Weight:	Up to 163 g/m ² Index Bristol (90 lb)
		Up to 163 g/m ² Tag (100 lb)

Note: To minimize curl, use the top exit when printing on card stock and labels.

For more information, see [“Maintenance procedures” on page 14](#).

Lexmark E230, E232, E234(n), E330, and E332n

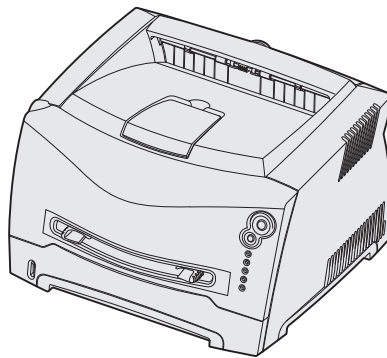

Limit label printing to occasional use of paper office labels designed for laser printers. We do *not* recommend using vinyl or polyester labels.

The Lexmark E230, E232, E234(n), E330, and E332n support paper and label stock from 60–90 g/m² (24 lb) and card stock up to 163 g/m² (43 lb). The automatic paper feeder can hold up to 50 sheets of paper labels.

The following table lists the maximum weights supported by Tray 1 and the manual sheet feeder.

Paper source	Card stock			Labels	
	Index Bristol	Tag	Cover	Paper	Vinyl
Tray 1	—	—	—	90 g/m ²	—
Manual feed	163 g/m ²	163 g/m ²	—	90 g/m ²	—

For paper and transparency specifications, see the *Lexmark E230/E232/E234(n)/E330/E332n Publications CDs*.

Labels	Width:	210–216 mm (8.3–8.5 in.)
	Length:	279–297 mm (11–11.7 in.)
	Weight:	Up to 90 g/m ² (24 lb)
	Thickness:	Up to 0.25 mm (0.01 in.)
	Smoothness:	100–400* Sheffield
		*150–250 Sheffield is optimal. Using media higher than 300 Sheffield could result in printing degradation.
Card stock	Weight:	Up to 163 g/m ² Index Bristol (90 lb)
		Up to 163 g/m ² Tag (100 lb)

Note: To minimize curl, use the rear exit when printing on card stock and labels.

For more information, see [“Maintenance procedures” on page 14.](#)

Lexmark E238, E240, E240n, E340, and E342n

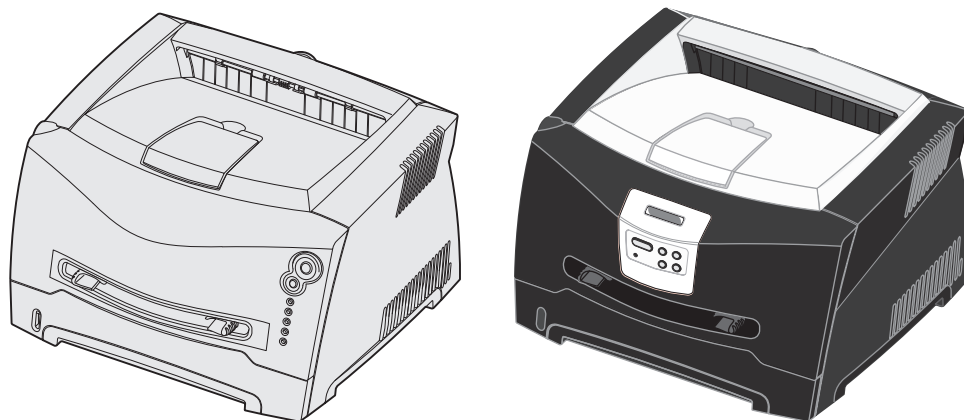

Limit label printing to occasional use of paper office labels designed for laser printers. We do *not* recommend using vinyl or polyester labels.

The printer supports stocks up to 163 g/m² (43 lb). You can load up to 50 label sheets in Tray 1. Card stock must be sent through the manual feeder one sheet at a time.

The following table lists the maximum weights supported by Tray 1, Tray 2, and the manual sheet feeder.

Paper source	Card Stock			Labels	
	Index Bristol	Tag	Cover	Paper	Vinyl
Tray 1	—	—	—	90 g/m ²	—
Tray 2	—	—	—	90 g/m ²	—
Manual Feed	163 g/m ²	163 g/m ²	—	163 g/m ²	—

Note: The E238 printer does not support a second drawer option.

For paper and transparency specifications, refer to the printer publications CD.

Labels	Width:	89–216 mm (3.5–8.5 in.)
	Length:	210–356 mm (8.27–14 in.)
	Weight:	Up to 163 g/m ² (43 lb)
	Thickness:	Up to 0.25 mm (0.01 in.)
	Smoothness:	100–400* Sheffield
	*150–250 Sheffield is optimal. Using media higher than 300 Sheffield could result in printing degradation.	
Card stock	Weight:	Up to 163 g/m ² Index Bristol (90 lb)
		Up to 163 g/m ² Tag (100 lb)

Note: To minimize curl, use the rear exit when printing on card stock and labels.

For more information, see [“Maintenance procedures” on page 14.](#)

Lexmark E250, E350, and E450n

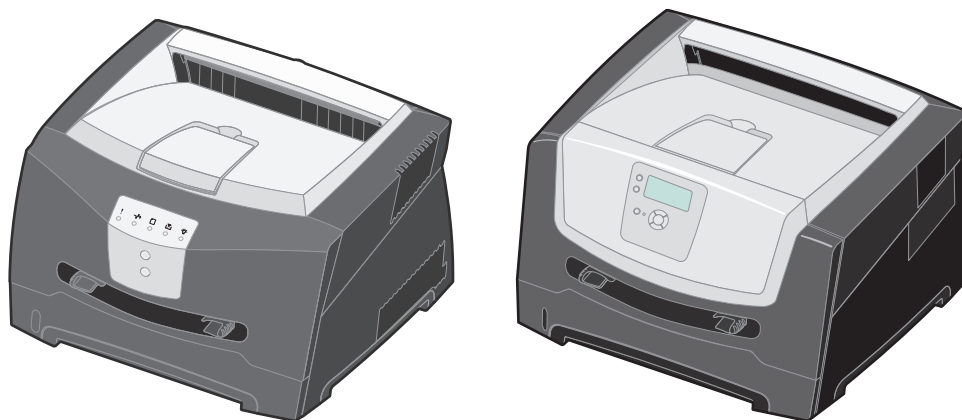

Limit label printing to occasional use of paper office labels designed for laser printers. We do *not* recommend using vinyl or polyester labels.

The printer supports paper and label stock from 60–90 g/m² and index card stock up to 163 g/m² (43 lb). You can load up to 50 label sheets in Tray 1. Card stock must be sent through the manual feeder one sheet at a time.

The following table lists the maximum weights supported by Tray 1, Tray 2, and the manual sheet feeder.

Paper source	Card Stock			Labels	
	Index Bristol	Tag	Cover	Paper	Vinyl
Tray 1	—	—	—	90 g/m ²	—
Tray 2	—	—	—	90 g/m ²	—
Manual Feed	163 g/m ²	163 g/m ²	—	90 g/m ²	—

Card stock should be grain short and set to exit the rear door.

For paper and transparency specifications, refer to the printer publications CD.

Labels	Width:	210–216 mm (8.3–8.5 in.)
	Length:	279–297 mm (11–11.7 in.)
	Weight:	Up to 90 g/m ² (24 lb)
	Thickness:	Up to 0.25 mm (0.01 in.)
	Smoothness:	100–400* Sheffield

*150–250 Sheffield is optimal. Using media higher than 300 Sheffield could result in printing degradation.

Card stock	Weight:	Up to 163 g/m ² Index Bristol (90 lb)
		Up to 163 g/m ² Tag (100 lb)

Note: To minimize curl, use the rear exit when printing on card stock and labels.

For more information, see [“Maintenance procedures” on page 14.](#)

Lexmark E260, E260d, E260dn, E360d, E360dn, E460dn, E460dw, and E462dtn

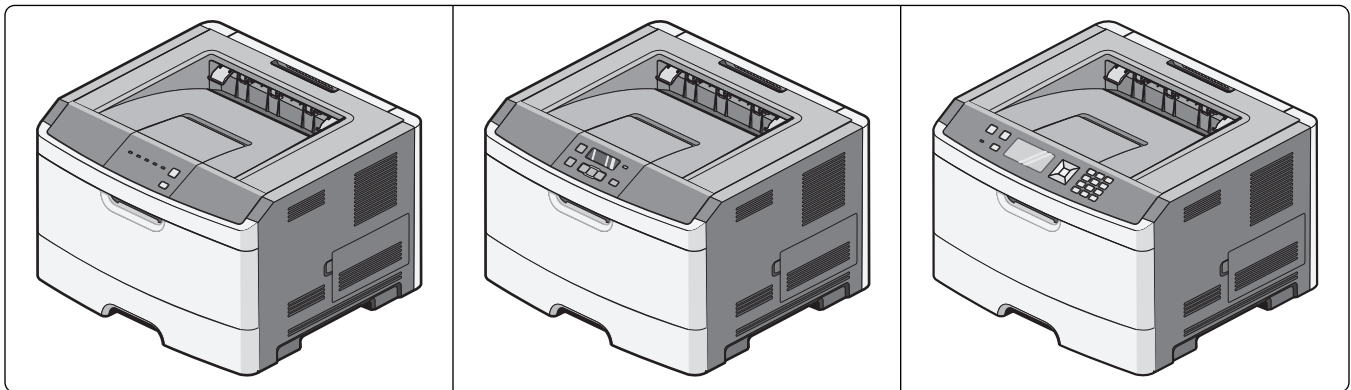

Limit label printing to occasional use of paper office labels designed for laser printers. We do *not* recommend using vinyl or polyester labels.

The printer supports paper and label stock from 60–90 g/m² and index card stock up to 163 g/m² (43 lb). You can load up to 50 label sheets in Tray 1. Card stock must be sent through the manual feeder one sheet at a time.

The following table lists the maximum weights supported by Tray 1, Tray 2, and the manual sheet feeder.

Paper source	Card Stock			Labels
	Index Bristol	Tag	Cover	Paper
Tray 1	—	—	—	90 g/m ²
Tray 2	—	—	—	90 g/m ²
Manual Feed	163 g/m ²	163 g/m ²	—	90 g/m ²

Card stock should be grain short and set to exit the rear door.

For paper and transparency specifications, see the printer publications CD.

Labels	Width:	210–216 mm (8.3–8.5 in.)
	Length:	279–297 mm (11–11.7 in.)
	Weight:	Up to 90 g/m ² (24 lb)
	Thickness:	Up to 0.25 mm (0.01 in.)
	Smoothness:	100–200* Sheffield
		*150–200 Sheffield is optimal. Using media higher than 300 Sheffield could result in printing degradation.
Card stock	Weight:	Up to 163 g/m ² Index Bristol (90 lb)
		Up to 163 g/m ² Tag (100 lb)

Note: To minimize curl, use the rear exit when printing on card stock and labels.

For more information, see [“Maintenance procedures” on page 14](#).

Lexmark E320, E322

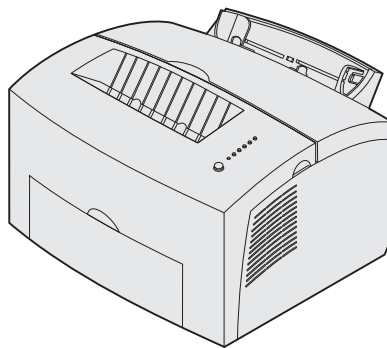

Limit label printing to occasional use of paper office labels designed for laser printers. We do *not* recommend using vinyl or polyester labels.

The Lexmark E320 and Lexmark E322 support stocks up to 163 g/m² (43 lb). The automatic paper feeder can hold up to 10 sheets of card stock or labels.

The following table lists the maximum weights supported by Tray 1 and the manual sheet feeder.

Paper source	Card stock			Labels	
	Index Bristol	Tag	Cover	Paper	Vinyl
Tray 1	163 g/m ²	163 g/m ²	—	163 g/m ²	—
Manual feed	163 g/m ²	163 g/m ²	—	163 g/m ²	—

For paper and transparency specifications, see the *Lexmark E320/E322 Publications CD*.

Labels	Width:	210–216 mm (8.3–8.5 in.)
	Length:	279–297 mm (11–11.7 in.)
	Weight:	Up to 163 g/m ² (43 lb)
	Thickness:	Up to 0.25 mm (0.01 in.)
	Smoothness:	100–400* Sheffield

Lexmark MS310d, MS310dn, MS312dn, MS315dn, MS410d, MS410dn, MS415dn, MS510dn, MS610dn, and MS610de

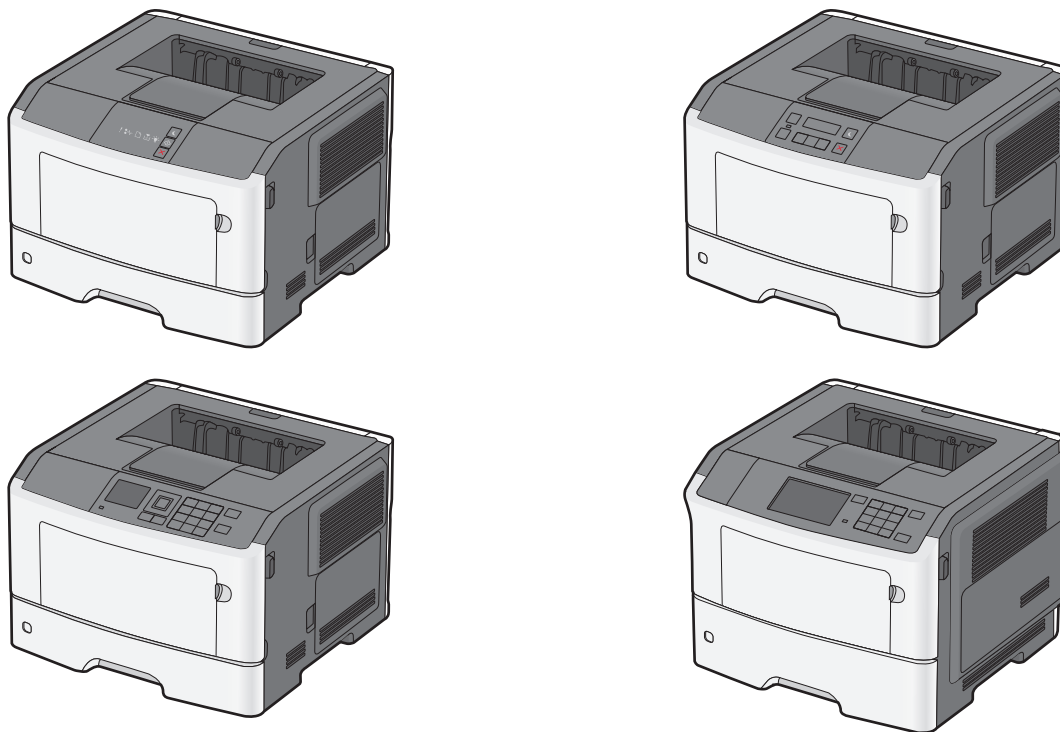

Notes:

- Use labels that are designed specifically for laser printers. We recommend printing only up to 20 pages of paper labels per month.
- Vinyl, pharmacy, or polyester labels are not supported. Paper office labels are for occasional use only.
- The printer and duplex path support 60–90 g/m² (16–24 lb) paper weights. The multipurpose feeder supports 60–163 g/m² (16–43 lb) paper weights.

Maximum weights supported by the trays and feeders

Paper source	Card Stock			Labels
	Index Bristol	Tag	Cover	Paper
Standard tray	—	—	—	60–90 g/m ²
Optional 250-sheet tray Optional 550-sheet tray	—	—	—	60–120 g/m ²

- Notes:**
- For the MS31x and MS41x printer models, you can load paper labels up to 50 sheets in the standard tray and up to the full capacity of the optional trays. You can load up to 15 paper labels and up to 10 sheets of card stock in the multipurpose feeder.
 - For the MS51x and MS61x printer models, you can load paper labels up to the full capacity of the standard and optional trays. You can load up to 30 paper labels and up to 20 sheets of card stock in the multipurpose feeder.

Paper source	Card Stock			Labels
	Index Bristol	Tag	Cover	Paper
Manual feeder Multipurpose feeder	60–163 g/m ²	60–163 g/m ²	—	60–163 g/m ²
Notes:				
<ul style="list-style-type: none"> For the MS31x and MS41x printer models, you can load paper labels up to 50 sheets in the standard tray and up to the full capacity of the optional trays. You can load up to 15 paper labels and up to 10 sheets of card stock in the multipurpose feeder. For the MS51x and MS61x printer models, you can load paper labels up to the full capacity of the standard and optional trays. You can load up to 30 paper labels and up to 20 sheets of card stock in the multipurpose feeder. 				

Labels	Width:	210–216 mm (8.3–8.5 in.)
	Length:	279–297 mm (11–11.7 in.)
	Weight:	Up to 163 g/m ² (43 lb)
	Thickness:	Up to 0.25 mm (0.01 in.)
	Smoothness:	100–400* Sheffield
Card stock	Weight:	Up to 163 g/m ² Index Bristol (90 lb)
		Up to 163 g/m ² Tag (100 lb)

*150–250 Sheffield is optimal. Using media higher than 300 Sheffield could result in printing degradation.

When printing on labels

- Check with the manufacturer or vendor to ensure that the labels can withstand temperatures up to 210°C (410°F) without sealing, curling excessively, wrinkling, or releasing hazardous emissions.
- Check with the manufacturer or vendor to ensure that the labels can withstand 25 psi (172 kPa) pressure without delaminating, oozing around the edges, or releasing hazardous fumes.
- Do not use labels with slick backing material.
- Use full label sheets. Partial sheets may cause labels to peel off during printing, resulting in a jam.
- Do not use labels with exposed adhesive.
- Do not print within 1.5 mm (0.06 in.) of the edge of the label, of the perforations, or between die-cuts on the label if the label is loaded in Tray 1, Tray 2, or the multipurpose feeder. If the label is loaded in Tray 3 or Tray 4, then do not print within 2.5 mm (0.10 in.).
- Be sure adhesive backing does not reach to the sheet edge. Zone coating of the adhesive at least 1 mm (0.04 in.) away from the edges is recommended. Adhesive material contaminates the printer and could void the warranty.
- If zone coating of the adhesive is not possible, remove a 1.6 mm (0.06 in.) strip on the leading and driver edge, and use a non-oozing adhesive.
- Portrait orientation works best, especially when printing bar codes.

When printing on card stock

- Make sure that the Paper Type is Card Stock.
- Select the Paper Texture setting.
- Be aware that preprinting, perforation, and creasing may significantly affect the print quality and cause jams or other paper handling problems.

- Check with the manufacturer or vendor to ensure the card stock can withstand temperatures up to 210°C (410°F) without releasing hazardous emissions.
- Do not use preprinted card stock manufactured with chemicals that may contaminate the printer.
- Use grain short card stock when possible.

For more information, see [“Maintenance procedures” on page 14.](#)

Lexmark MS710 and MS711

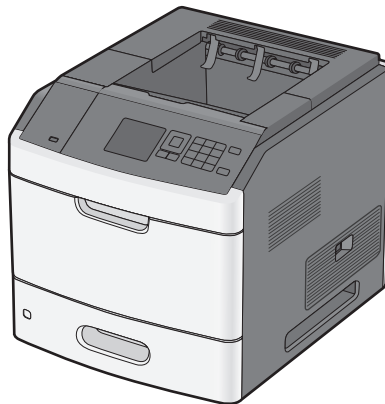

The Lexmark MS710 and MS711 printer models print on many labels, which includes vinyl and polyester, designed for use with laser printers.

The following table lists the maximum weights supported by the trays and the multipurpose feeder.

Paper source	Card stock ¹			Labels			
	Index Bristol	Tag	Cover	Paper	Dual-web paper	Polyester	Vinyl
Standard and optional 250- and 550-sheet trays	199 g/m ²	203 g/m ²	176 g/m ²	180 g/m ²	180 g/m ²	220 g/m ²	300 g/m ²
Multipurpose feeder ²	199 g/m ²	203 g/m ²	176 g/m ²	180 g/m ²	180 g/m ²	220 g/m ²	260 g/m ²

¹ See [“Grain orientation” on page 17](#) for specific recommendations.

² Due to label design characteristics, unacceptable feeding may be experienced from the multipurpose feeder.

Labels	Thickness:	0.102–0.305 mm (0.004–0.012 in.)
	Smoothness:	100–400* Sheffield
		*150–250 Sheffield is optimal. Using media higher than 300 Sheffield could result in printing degradation.
Card stock	Weight:	Up to 199 g/m ² Index Bristol (110 lb)
		Up to 203 g/m ² Tag (125 lb)
		Up to 176 g/m ² Cover (65 lb)

Card stock and label guidelines

Labels are one of the most difficult print materials for laser printers. A special fuser cleaner should be used for label applications to optimize feed reliability.

Printing labels on the Lexmark MS710 and MS711 requires a special label fuser cleaner that prevents duplexing.

It is recommended that when you run labels, you install a special oil fuser cleaner, P/N 40X8579. When you order a new cartridge, make sure the cartridge includes the correct fuser cleaner.

It is possible to duplex certain labels that have been specifically designed for this application. To duplex labels, consult the Lexmark "Converter Lists" to see which converters have successfully developed this type of label, and you must install a special fuser wiper. The wax wiper that is used with the Lexmark MS710 and MS711 is P/N 40X8581. Cartridges designed for duplex label printing contain two wax wipers. Change the wax wiper at the halfway point of your normal cartridge usage to provide additional cleaning and optimize performance. Contact your Supplies and Label Specialist for information on oil and wax vinyl label cartridges.

Note: Wax wipers are not recommended when using vinyl labels.

Tray fill line information

Depending on construction, labels and card stock can sometimes be difficult to pick and feed reliably. Performance can be improved by controlling the number of sheets of media loaded in the tray. There are two fill lines in the tray. The solid line is the maximum paper fill indicator. No media should be loaded in the tray above this line or paper jams could occur. The dashed line is the alternate paper fill indicator and should be used if any feed or reliability issues are noted with specialty media, including labels and card stock. If paper jams occur when completely filling the tray, load the specialty media only up to the alternate paper fill indicator.

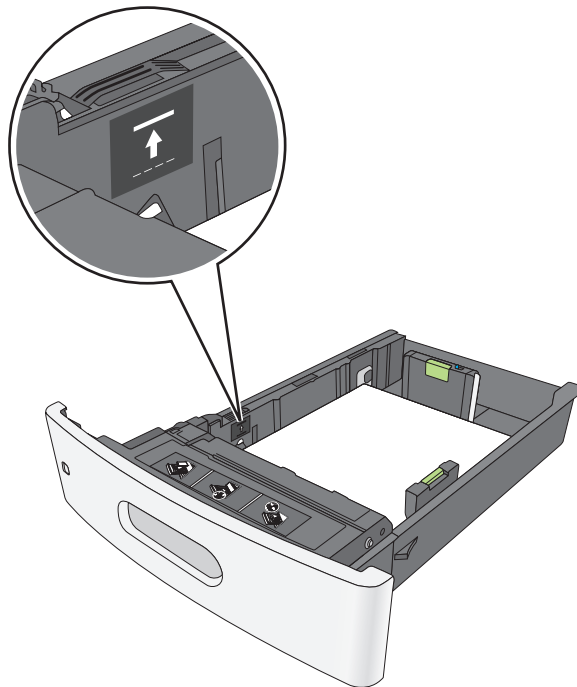

For more information on the printer models and feeding different types of media, contact your Lexmark sales representative.

When printing on labels:

- From the printer control panel, set the paper size, type, texture, and weight in the Paper menu to match the labels loaded in the tray.
- Do *not* load labels together with paper or transparencies in the same paper tray. Combining print materials can cause feeding problems.
- Use full label sheets. Partial sheets may cause labels to peel off during printing, resulting in a paper jam. Adhesive material may contaminate your printer. It could also void your printer and cartridge warranties.

When feeding labels, the number of labels per sheet can affect registration more than basis weight. Typically, the more labels per sheet, the better the registration.

When printing on card stock:

- From the printer control panel, set the paper size, type, texture, and weight in the Paper menu to match the card stock loaded in the tray.
- Do *not* use card stock that is creased. It may cause paper jams.

For more information, see the following:

- [“Pick roller technology” on page 11](#)
- [“Grain orientation” on page 17](#)
- [“Maintenance procedures” on page 14](#)
- [“Troubleshooting” on page 14](#)
- [“Primary rib pattern design guidelines for reference edge alignment” on page 22](#)

Lexmark MS810, MS811, and MS812

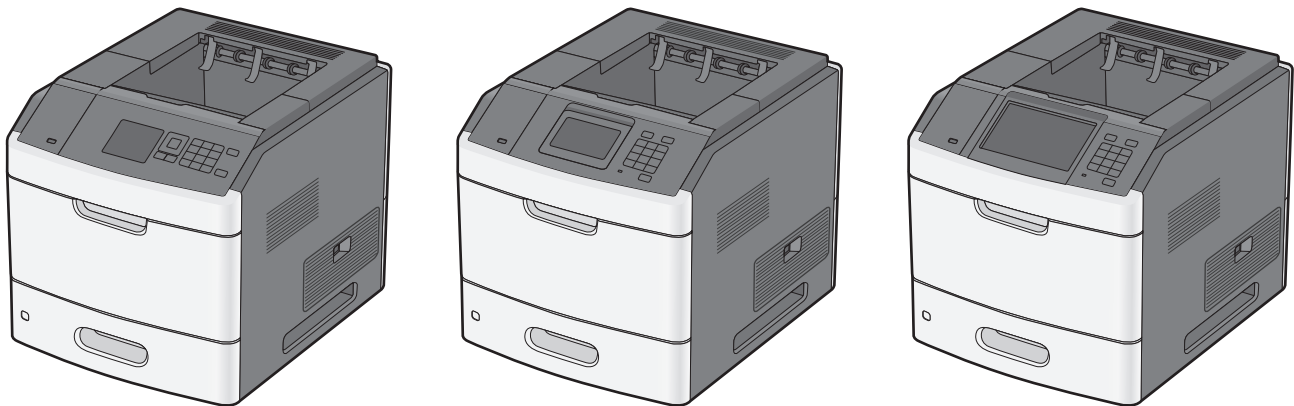

The Lexmark MS810, MS811, and MS812 printer models print on many labels designed for use with laser printers. However the MS81x and MS71x printer models have been specifically designed for slightly different media applications.

The MS81x printer models should *not* be used in the following customer applications:

- Vinyl and Polyester labels

For applications where these labels are run, the MS71x printer models are recommended.

- Narrow Media Batch Jobs

The MS810 printer model supports many standard and custom paper sizes. When printing on paper less than 210 mm (8.3 inches) wide, the printer speed may decrease. If you print large jobs on narrow paper regularly, consider the MS71x printer models, which are designed to print batches of 10 or more pages of narrow paper at a faster speed.

Note: For the MS81x printer models, A5 default orientation is Landscape, which is also called as LEF, and thus A5 is not considered as narrow media.

If vinyl labels are printed on the MS81x printer models, this can lead to print quality problems and printer damage. If narrow media batch jobs are printed, printer throughput could be substantially reduced. If either of these applications are being considered for the MS81x printer models, then contact your Lexmark sales representative for more information about the MS71x printer models.

The following table lists the maximum weights supported by the trays and the multipurpose feeder:

Paper source	Card stock ¹			Labels	
	Index Bristol	Tag	Cover	Paper	Dual-web paper
Standard and optional 250- and 550-sheet trays	199 g/m ²	203 g/m ²	176 g/m ²	180 g/m ²	180 g/m ²
Multipurpose feeder ²	199 g/m ²	203 g/m ²	176 g/m ²	180 g/m ²	180 g/m ²

¹ See [“Grain orientation” on page 17](#) for specific recommendations.

² Due to label design characteristics, unacceptable feeding may be experienced from the multipurpose feeder.

Labels	Thickness:	0.102–0.305 mm (0.004–0.012 in.)
	Smoothness:	100–400* Sheffield
		*150–250 Sheffield is optimal. Using media higher than 300 Sheffield could result in printing degradation.
Card stock	Weight:	Up to 199 g/m ² Index Bristol (110 lb)
		Up to 203 g/m ² Tag (125 lb)
		Up to 176 g/m ² Cover (65 lb)

Card stock and label guidelines

Tray fill line information

Depending on construction, labels and card stock can sometimes be difficult to pick and feed reliably. Performance can be improved by controlling the number of sheets of media loaded in the tray. There are two fill lines in the tray. The solid line is the maximum paper fill indicator. No media should be loaded in the tray above this line or paper jams could occur. The dashed line is the alternate paper fill indicator and should be used if any feed or reliability issues are noted with specialty media, including labels and card stock. If paper jams occur when completely filling the tray, load the specialty media only up to the alternate paper fill indicator.

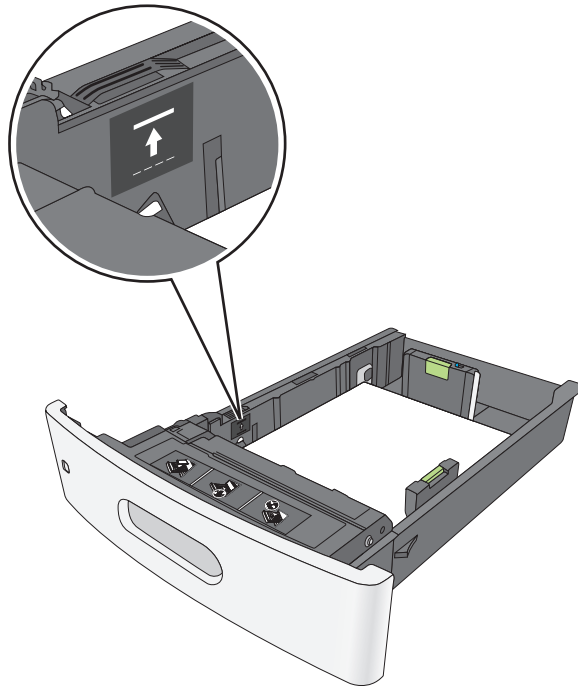

When printing on labels:

- From the printer control panel, set the paper size, type, texture, and weight in the Paper menu to match the labels loaded in the tray.
- Do *not* load labels together with paper or transparencies in the same paper tray. Combining print materials can cause feeding problems.
- Use full label sheets. Partial sheets may cause labels to peel off during printing, resulting in a paper jam. Adhesive material may contaminate your printer. It could also void your printer and cartridge warranties.

When feeding labels, the number of labels per sheet can affect registration more than basis weight. Typically, the more labels per sheet, the better the registration.

When printing on card stock:

- From the printer control panel, set the paper size, type, texture, and weight in the Paper menu to match the card stock loaded in the tray.
- Do *not* use card stock that is creased. It may cause paper jams.

For more information, see the following:

- [“Pick roller technology” on page 11](#)
- [“Grain orientation” on page 17](#)
- [“Maintenance procedures” on page 14](#)
- [“Troubleshooting” on page 14](#)
- [“Primary rib pattern design guidelines for reference edge alignment” on page 22](#)

Lexmark MS911

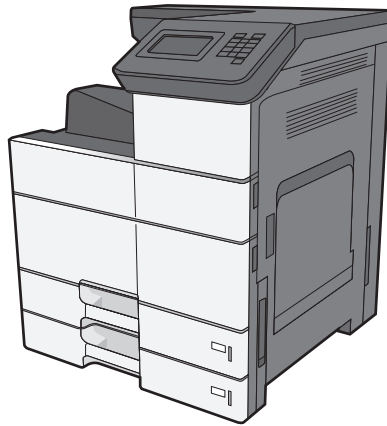

Notes:

- Use only labels that are designed specifically for laser printers.
- Vinyl or polyester labels are not supported. Paper office labels are for occasional use only.
- You can load up to 75 paper labels and up to 81 sheets of card stock in the multipurpose feeder.

Typical weights supported by the trays and the multipurpose feeder

Paper source	Card stock	Labels
2 x 500-sheet tray	158–256 g/m ²	—
2500-sheet tray*	158–256 g/m ²	—
3000-sheet tray*	158–256 g/m ²	—
Multipurpose feeder	158–256 g/m ²	60–256 g/m ²

* The 2500- and 3000-sheet trays only support A4- or Letter-size media depending on geography.

Labels

Width:	139.7–320 mm (5.5–12.6 in.)
Length:	182–457.2 mm (7.2–18 in.)
Weight:	60–256 g/m ²

Card stock

Width:	139.7–320 mm (5.5–12.6 in.)
Length:	182–457.2 mm (7.2–18 in.)
Weight:	158–256 g/m ²

Card stock and label guidelines

- Flexibility of the media in the feed direction is critical, and this sometimes varies tremendously regardless of the media basis weight. Be sure to test or get guarantee from your media supplier for particularly thin or thick media.
- From the control panel, set the paper size, type, texture, and weight in the Paper menu to match the card stock or labels loaded in the tray or feeder.
- Do not use creased card stock.

- Do not use label sheets with a slick backing material.
- Use full label sheets. Partial sheets may cause labels to peel off during printing, resulting in a jam. Partial sheets also contaminate the printer and the cartridge with adhesive, and could void the printer and toner cartridge warranties.

Lexmark MX310dn, MX410de, MX510de, MX511de, MX511dhe, MX610de, MX611de, and MX611dhe

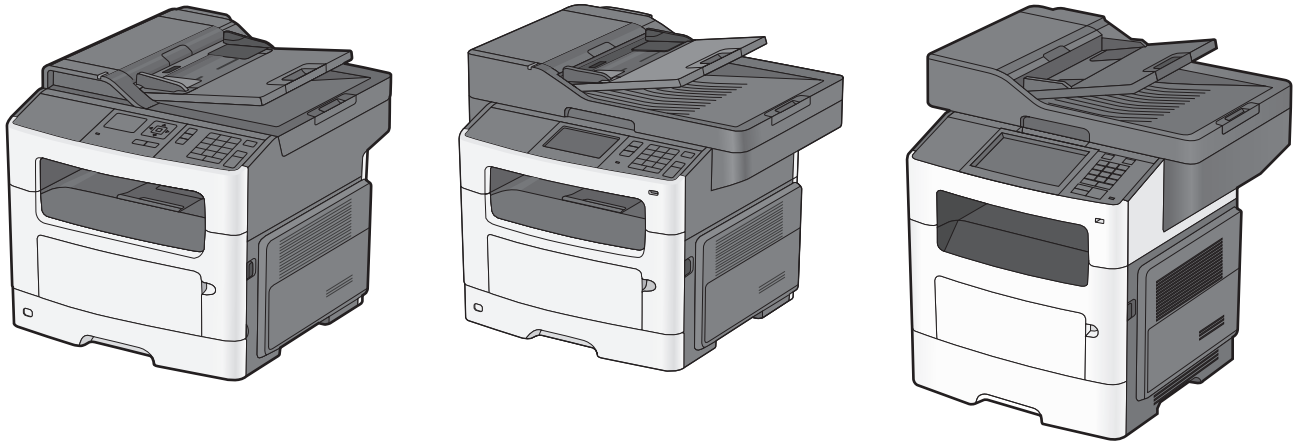

Limit label printing to occasional use of paper office labels designed for laser printers. The Lexmark MX310dn, MX410de, MX510de, MX511de, MX511dhe, MX610de, MX611de, and MX611dhe printer models do *not* support vinyl, pharmacy, or polyester labels. It is recommended to print no more than 20 pages of paper labels a month.

The printer and duplex path support 60–90 g/m² (16–24 lb) paper weights. The multipurpose feeder supports 60–163 g/m² (16–43 lb) paper weights.

For the MX31x and MX41x printer models, you can load paper labels up to 50 sheets in the standard tray and up to the full capacity of the optional trays. You can load up to 15 paper labels and up to 10 sheets of card stock in the multipurpose feeder.

For the MX51x and MX61x printer models, you can load paper labels up to the full capacity of the standard tray and optional trays. You can load up to 30 paper labels and up to 20 sheets of card stock in the multipurpose feeder.

The following table lists the maximum weights supported by the standard tray, optional 250- and 550-sheet trays, and multipurpose and manual feeders.

Paper source	Card Stock			Labels
	Index Bristol	Tag	Cover	Paper
Standard tray	—	—	—	60–90 g/m ²
Optional 250-sheet tray Optional 550-sheet tray	—	—	—	60–120 g/m ²
Manual feeder Multipurpose feeder	60–163 g/m ²	60–163 g/m ²	—	60–163 g/m ²

Labels	Width:	210–216 mm (8.3–8.5 in.)
	Length:	279–297 mm (11–11.7 in.)
	Weight:	Up to 163 g/m ² (43 lb)
	Thickness:	Up to 0.25 mm (0.01 in.)
	Smoothness:	100–400* Sheffield
		*150–250 Sheffield is optimal. Using media higher than 300 Sheffield could result in printing degradation.
Card stock	Weight:	Up to 163 g/m ² Index Bristol (90 lb)
		Up to 163 g/m ² Tag (100 lb)

When printing on labels:

- Check with the manufacturer or vendor to ensure the labels can withstand temperatures up to 210°C (410°F) without sealing, curling excessively, wrinkling, or releasing hazardous emissions.
- Check with the manufacturer or vendor to ensure the labels can withstand 25 psi (172 kPa) pressure without delaminating, oozing around the edges, or releasing hazardous fumes.
- Do not use labels with slick backing material.
- Use full label sheets. Partial sheets may cause labels to peel off during printing, resulting in a jam.
- Do not use labels with exposed adhesive.
- Do not print within 1 mm (0.04 in.) of the edge of the label, of the perforations, or between die-cuts on the label.
- Be sure adhesive backing does not reach to the sheet edge. Zone coating of the adhesive at least 1 mm (0.04 in.) away from the edges is recommended. Adhesive material contaminates the printer and could void the warranty.
- If zone coating of the adhesive is not possible, remove a 1.6 mm (0.06 in.) strip on the leading and driver edge, and use a non-oozing adhesive.
- Portrait orientation works best, especially when printing bar codes.

When printing on card stock:

- Make sure the Paper Type is Card Stock.
- Select the Paper Texture setting.
- Be aware that preprinting, perforation, and creasing may significantly affect the print quality and cause jams or other paper handling problems.
- Check with the manufacturer or vendor to ensure the card stock can withstand temperatures up to 210°C (410°F) without releasing hazardous emissions.
- Do not use preprinted card stock manufactured with chemicals that may contaminate the printer.
- Use grain short card stock when possible.

For more information, see [“Maintenance procedures” on page 14](#).

Lexmark MX710, MX711, MX810, MX811, and MX812

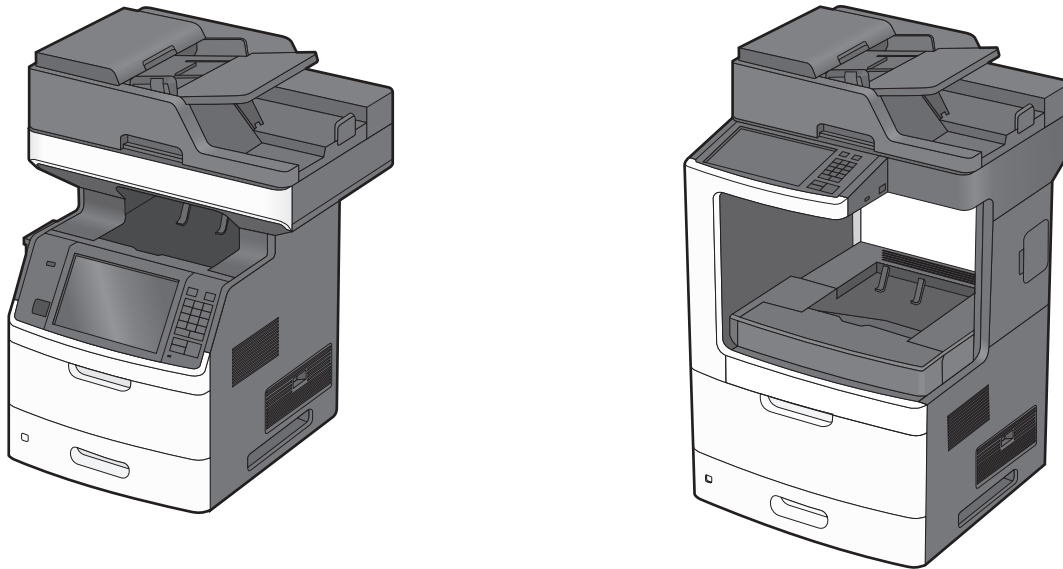

The Lexmark MX710, MX711, MX810, MX811, and MX812 printer models print on many labels designed for use with laser printers. However the MX71x, MX81x, and MS71x printer models have been specifically designed for slightly different media applications.

The MX81x printer models should *not* be used in the following customer applications:

- Vinyl and Polyester labels

For applications where these labels are run, the MS71x printer models are recommended.

- Narrow Media Batch Jobs

The MX810 printer model supports many standard and custom paper sizes. When printing on paper less than 210 mm (8.3 inches) wide, the printer speed may decrease. If you print large jobs on narrow paper regularly, then consider the MS71x printer models, which are designed to print batches of 10 or more pages of narrow paper at a faster speed.

Note: For the MX81x printer models, A5 default orientation is Landscape, which is also called as LEF, and thus A5 is not considered as narrow media.

If vinyl labels are printed on the MX71x or MX81x printer models, this can lead to print quality problems and printer damage. If narrow media batch jobs are printed, printer throughput could be substantially reduced. If either of these applications are being considered for the MX71x or MX81x printer models, then contact your Lexmark sales representative for more information about the MS71x printer models.

The following table lists the maximum weights supported by the trays and the multipurpose feeder.

Note: Scanning labels through the ADF is *not* recommended.

Paper source	Card stock ¹			Labels	
	Index Bristol	Tag	Cover	Paper	Dual-web paper
Standard and optional 250- and 550-sheet trays	199 g/m ²	203 g/m ²	176 g/m ²	180 g/m ²	180 g/m ²
Multipurpose feeder ²	199 g/m ²	203 g/m ²	176 g/m ²	180 g/m ²	180 g/m ²

¹ See [“Grain orientation” on page 17](#) for specific recommendations.

² Due to label design characteristics, unacceptable feeding may be experienced from the multipurpose feeder.

Labels	Thickness:	0.102–0.305 mm (0.004–0.012 in.)
	Smoothness:	100–400* Sheffield
		* 150–250 Sheffield is optimal. Using media higher than 300 Sheffield could result in printing degradation.
Card stock	Weight:	Up to 199 g/m ² Index Bristol (110 lb)
		Up to 203 g/m ² Tag (125 lb)
		Up to 176 g/m ² Cover (65 lb)

Card stock and label guidelines

Tray fill line information

Depending on construction, labels and card stock can sometimes be difficult to pick and feed reliably. Performance can be improved by controlling the number of sheets of media loaded in the tray. There are two fill lines in the tray. The solid line is the maximum paper fill indicator. No media should be loaded in the tray above this line or paper jams could occur. The dashed line is the alternate paper fill indicator and should be used if any feed or reliability issues are noted with specialty media, including labels and card stock. If paper jams occur when completely filling the tray, load the specialty media only up to the alternate paper fill indicator.

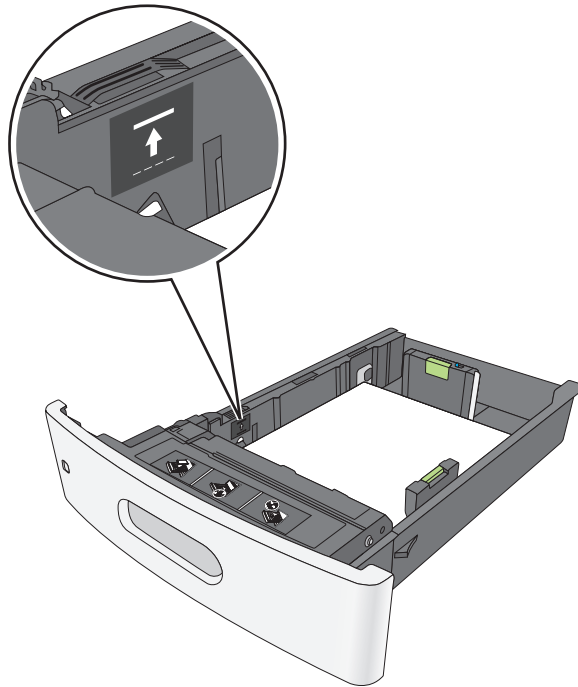

When printing on labels:

- From the printer control panel, set the paper size, type, texture, and weight in the Paper menu to match the labels loaded in the tray.
- Do *not* load labels together with paper or transparencies in the same paper tray. Combining print materials can cause feeding problems.
- Use full label sheets. Partial sheets may cause labels to peel off during printing, resulting in a paper jam. Adhesive material may contaminate your printer. It could also void your printer and cartridge warranties.

When feeding labels, the number of labels per sheet can affect registration more than basis weight. Typically, the more labels per sheet, the better the registration.

When printing on card stock:

- From the printer control panel, set the paper size, type, texture, and weight in the Paper menu to match the card stock loaded in the tray.
- Do *not* use card stock that is creased. It may cause paper jams.

For more information, see the following:

- [“Pick roller technology” on page 11](#)
- [“Grain orientation” on page 17](#)
- [“Maintenance procedures” on page 14](#)
- [“Troubleshooting” on page 14](#)
- [“Primary rib pattern design guidelines for reference edge alignment” on page 22](#)

Lexmark MX910, MX911, and MX912

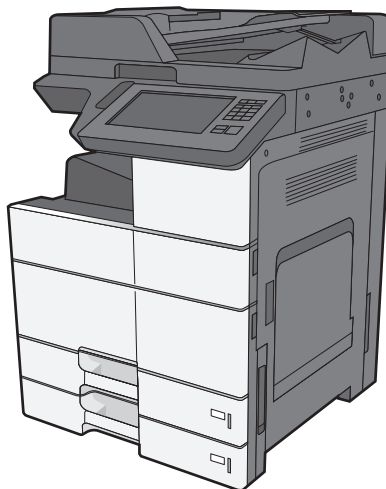

Notes:

- Use only labels that are specifically designed for laser printers.
- Vinyl or polyester labels are not supported. Paper office labels are for occasional use only.
- You can load up to 75 paper labels and up to 81 sheets of card stock in the multipurpose feeder.

Typical weights supported by the trays and the multipurpose feeder

Paper source	Card stock	Labels
2 x 500-sheet tray	158–256 g/m ²	—
2500-sheet tray*	158–256 g/m ²	—
3000-sheet tray*	158–256 g/m ²	—
Multipurpose feeder	158–256 g/m ²	60–256 g/m ²

* The 2500- and 3000-sheet trays only support A4- or Letter-size media depending on geography.

Labels

- Width: 139.7–320 mm (5.5–12.6 in.)
- Length: 182–457.2 mm (7.2–18 in.)
- Weight: 60–256 g/m²

Card stock

- Width: 139.7–320 mm (5.5–12.6 in.)
- Length: 182–457.2 mm (7.2–18 in.)
- Weight: 158–256 g/m²

Card stock and label guidelines

- Flexibility of the media in the feed direction is critical, and this sometimes varies tremendously regardless of the media basis weight. Be sure to test or get guarantee from your media supplier for particularly thin or thick media.
- From the control panel, set the paper size, type, texture, and weight in the Paper menu to match the card stock or labels loaded in the tray or feeder.

- Do not use creased card stock.
- Do not use label sheets with a slick backing material.
- Use full label sheets. Partial sheets may cause labels to peel off during printing, resulting in a jam. Partial sheets also contaminate the printer and the cartridge with adhesive, and could void the printer and toner cartridge warranties.

Lexmark T420

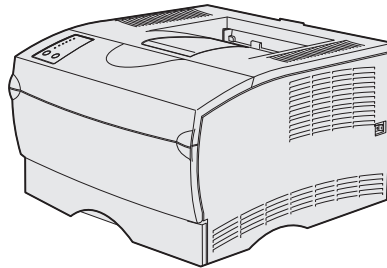

The Lexmark T420 prints on many labels designed for use with laser printers.

The Lexmark T420 supports stocks up to 60-199 g/m² (16–53 lb). The standard tray is designed to handle 100 sheets of heavy labels, but its capacity may be reduced due to the thickness of some labels. The multipurpose feeder can feed up to 30 sheets of dual-web or integrated labels and 10 sheets of card stock.

The following tables list the maximum weights supported by Tray 1 and the multipurpose feeder.

Paper source	Card stock		
	Index Bristol	Tag	Cover
Tray 1	—	—	—
Multipurpose feeder*	60–199 g/m ² (16–53 lb)		—

* Card stock can only be fed from the multipurpose feeder and must always exit to the rear output bin.

Label type	Print media source		
	Standard tray	Multipurpose feeder	Optional trays
Paper	✓	X	X
Integrated	X	✓	X
Dual web	✓	✓	X
Vinyl	X	X	X

✓ - indicates support

X - indicates no support

Note: Do *not* place over 100 label sheets in the standard tray or over 30 label sheets in the multipurpose feeder.

Warning—Potential Damage: Feeding labels from print media sources that are not supported may damage your printer.

For paper and transparency specifications, see the *Lexmark T420 Publications CD*.

Labels	Width:	76.2–216 mm (3.0–8.5 in.)
	Length:	127–355.6 mm (5–14 in.)
	Weight:	Up to 199 g/m ² (53 lb)
	Thickness:	Up to 0.25 mm (0.01 in.)
	Smoothness:	100–400* Sheffield
		* 150–250 Sheffield is optimal. Using media higher than 300 Sheffield could result in printing degradation.
Card stock	Weight:	Up to 163 g/m ² Index Bristol (90 lb)
		Up to 163 g/m ² Tag (100 lb)

Note: Always use the rear exit when printing on card stock. To minimize curl, use the rear exit when printing on labels.

Card stock and label guidelines

When printing on labels:

- Set the Paper Type to Labels from the printer driver, the Local Printer Setup Utility, or MarkVision.
- Do *not* load labels together with paper or transparencies in the same paper source.
- Do *not* use label sheets with a slick backing material.
- Do *not* print within 1 mm (0.040 in.) of the die-cut.
- Use full label sheets. Partial sheets may cause labels to peel off during printing, resulting in a paper jam. Partial sheets will also contaminate the printer and the cartridge with adhesive, and could void the printer and cartridge warranties.
- Use labels that can withstand temperatures of 205°C (401°F) without sealing, excessive curling, wrinkling, or releasing hazardous emissions.
- Use labels that can withstand pressure of 25 pounds per square inch (psi).
- Do *not* print within 1 mm (0.040 in.) of the edge of the label, of the perforations, or between die-cuts of the label.
- Do *not* use labels that have adhesive to the edge of the sheet. We recommend zone coating of the adhesive at least 1 mm (0.040 in.) from the edges. Adhesive material will contaminate the printer and could void the warranty.
- If zone coating of the adhesive is not possible, a 3-mm (0.125-in.) strip should be removed on the leading and driver edge, and a non-oozing adhesive should be used.
- Remove a 3-mm (0.125-in.) strip from the leading edge to prevent labels from peeling inside the printer.
- Portrait orientation is preferred, especially when printing bar codes.
- Do *not* use labels that have exposed adhesive.
- For the multipurpose feeder, load labels with the recommended print side faceup and the top edge going in first. For the tray, load labels with the recommended print side facedown.

When printing on card stock:

- Set the Paper Type to Card Stock from the printer driver, the Local Printer Setup Utility, or MarkVision.
- Do *not* use preprinted card stock manufactured with chemicals that may contaminate the printer. Preprinting introduces semi-liquid and volatile components into the printer.
- Do *not* use card stock that is creased. It may cause paper jams.
- We recommend the use of grain short card stock.
- Load card stock with the recommended print side faceup and the top edge going in first.

For more information, see [“Maintenance procedures” on page 14](#).

Lexmark T430

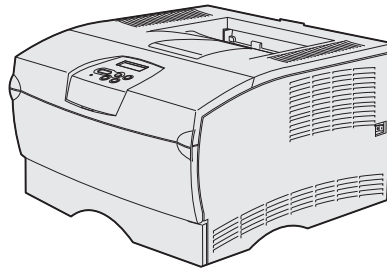

The Lexmark T430 prints on paper office labels designed for laser printers. Limit label printing to occasional use. We do *not* recommend using vinyl or polyester labels.

The Lexmark T430 supports stocks from 60–163 g/m² (16–43 lb). The multipurpose feeder can feed up to 30 sheets of dual-web or integrated labels and 10 sheets of card stock.

The following tables list the maximum weights supported by Tray 1 and the multipurpose feeder.

Paper source	Index Bristol	Tag	Cover
Tray 1	—	—	—
Multipurpose Feeder*	60–163 g/m ² (16–43 lb)		—

* Card stock can only be fed from the multipurpose feeder and must always exit to the rear output bin.

Label type	Standard tray	Multipurpose feeder	Optional trays
Paper	X	✓	X
Integrated	X	✓	X
Dual web	X	✓	X

✓ - indicates support
 X - indicates no support
Note: Do *not* place over 100 label sheets in the standard tray or over 30 label sheets in the multipurpose feeder.
Warning—Potential Damage: Feeding labels from print media sources that are not supported may damage your printer.

Labels

Width: 76.2–216 mm (3.0–8.5 in.)

Length: 127–355.6 mm (5–14 in.)

Weight: Up to 199 g/m² (53 lb)

Thickness: Up to 0.25 mm (0.01 in.)

Smoothness: 100–400* Sheffield

* 150 - 250 Sheffield is optimal. Using media higher than 300 Sheffield could result in printing degradation.

Card stock

Weight: Up to 163 g/m² Index Bristol (90 lb)

Up to 163 g/m² Tag (100 lb)

Note: Always use the rear exit when printing on card stock. To minimize curl, use the rear exit when printing on labels.

Card stock and label guidelines

When printing on labels:

- Set the Paper Type to Labels from the printer driver, the Local Printer Setup Utility, or MarkVision.
- Do *not* load labels together with paper or transparencies in the same paper source.
- Do *not* use label sheets with a slick backing material.
- Do *not* print within 1 mm (0.040 in.) of the die-cut.
- Use full label sheets. Partial sheets may cause labels to peel off during printing, resulting in a paper jam. Partial sheets will also contaminate your printer and your cartridge with adhesive, and could void your printer and cartridge warranties.
- Use labels that can withstand temperatures of 205°C (401°F) without sealing, excessive curling, wrinkling, or releasing hazardous emissions.
- Use labels that can withstand pressure of 25 pounds per square inch (psi).
- Do *not* print within 1 mm (0.040 in.) of the edge of the label, of the perforations, or between die-cuts of the label.
- Do *not* use label sheets that have adhesive to the edge of the sheet. We recommend zone coating of the adhesive at least 1 mm (0.040 in.) away from edges. Adhesive material will contaminate your printer and could void your warranty.
- If zone coating of the adhesive is not possible, a non-oozing adhesive should be used. Unlike other printers, do *not* remove the leading or driver edge.
- The perforation locations may impact printer reliability.
Note: Test any perforated card stock or paper before purchasing large quantities.
- Portrait orientation is preferred, especially when printing bar codes.
- Do *not* use labels that have exposed adhesive.
- For the multipurpose feeder, load labels with the recommended print side faceup and the top edge going in first. For the tray, load labels with the recommended print side facedown.

When printing on card stock:

- Set the Paper Type to Card Stock from the printer driver, the Local Printer Setup Utility, or MarkVision.
- Do *not* use preprinted card stock manufactured with chemicals that may contaminate the printer. Preprinting introduces semi-liquid and volatile components into the printer.
- Do *not* use card stock that is creased. It may cause paper jams.
- We recommend the use of grain short card stock.
- Load card stock with the recommended print side faceup and the top edge going in first.

For more information, see [“Maintenance procedures” on page 14](#).

Lexmark T520, T522

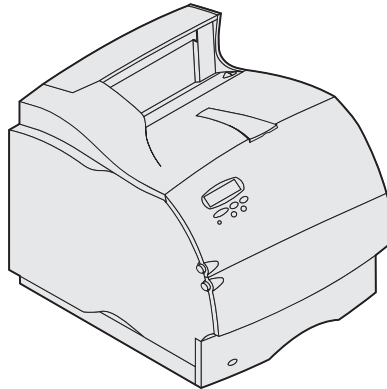

The Lexmark T520 and T522 print on many labels designed for use with laser printers.

The following table lists the maximum weights supported by the trays and the multipurpose feeder.

Print material		Range or maximum weight supported	
		Integrated tray and optional 500-sheet drawer	Multipurpose feeder ³ and optional 250-sheet drawer
Paper (grain direction ¹)	Xerographic or business paper	60–176 g/m ² (16–47 lb bond)	60–135 g/m ² (16–36 lb bond)
Card Stock (grain direction ¹)	Index Bristol	199 g/m ² (110 lb)	163 g/m ² (90 lb)
	Tag	203 g/m ² (125 lb)	163 g/m ² (100 lb)
	Cover	216 g/m ² (80 lb)	176 g/m ² (65 lb)
Labels	Paper	180 g/m ² (48 lb bond)	163 g/m ² (43 lb bond)
	Dual-web paper	180 g/m ² (48 lb bond)	163 g/m ² (43 lb bond)
	Vinyl	300 g/m ² (92 lb liner)	260 g/m ² (78 lb liner)
	Polyester	220 g/m ² (59 lb bond)	220 g/m ² (59 lb bond)
Integrated forms	Pressure sensitive area ²	140–175 g/m ²	140–175 g/m ²
	Paper base (grain long)	75–135 g/m ² (20–36 lb bond)	75–135 g/m ² (20–36 lb bond)

¹ See [“Grain orientation” on page 17](#) for specific recommendations.

² Pressure-sensitive area must enter the printer first for grain short paper.

³ Due to label design characteristics, unacceptable feeding may be experienced from the multipurpose feeder.

For paper and transparency specifications, see the printer publications CD.

The following table indicates the paper sizes each tray supports.

Source	Standard sizes (width x length)		Universal sizes (width x length)	
	Minimum	Maximum	Minimum	Maximum
Standard tray, 250-sheet drawer, 500-sheet drawer	148 x 210 mm (5.83 x 8.27 in.)	215.9 x 355.6 mm (8.5 x 14 in.)	139.7 x 210 mm (5.5 x 8.27 in.)	215.9 x 355.6 mm (8.5 in. x 14 in.)
Multipurpose feeder*	148 x 210 mm (5.83 x 8.27 in.)	215.9 x 355.6 mm (8.5 x 14 in.)	69.85 x 127 mm (2.75 in. x 5 in.)	229 x 355.6 mm (9.01 x 14 in.)

* If you load paper that is narrower than 148 mm (5.83 in.) in the multipurpose feeder (for example, 3 x 5-inch index cards), set the MP Feeder Size menu item to Universal.

Labels	Thickness:	0.102–0.305 mm (0.004–0.012 in.)
	Smoothness:	100–400* Sheffield
		* 150–250 Sheffield is optimal. Using media higher than 300 Sheffield could result in printing degradation.
Card stock	Weight:	Up to 199 g/m ² Index Bristol (90 lb)
		Up to 203 g/m ² Tag (100 lb)

Standard trays and special media trays

The Lexmark T520 and T522 paper feeding mechanism uses advanced technology that enhances feeding reliability. The standard Lexmark T520 and T522 tray, which holds 250 or 500 sheets of 20-lb xerographic paper, reliably feeds all media tested according to the guidelines specified under [“Dimensions” on page 9](#).

For those difficult-to-print sizes, such as 3 x 5-inch index cards, Lexmark offers a variety of special media trays and drawers.

Note: Optional 250-sheet Universally Adjustable Trays can be used to print forms with a minimum length of 5 inches using a T520, when installed either in the integral tray location or in a 250-sheet drawer under a 250-sheet integral tray. Optional 250-sheet Universally Adjustable Trays support forms with a minimum length of 7 inches on a T522. Optional 400-sheet Universally Adjustable Trays support forms with a minimum length of 7 inches on both the T520 and T522.

Source	Part number
250-Sheet Special Media Tray	11K1572
250-Sheet Special Media Drawer	11K1573
250-Sheet Universally Adjustable Tray	11K1574
250-Sheet Universally Adjustable Drawer	11K1878
500-Sheet Special Media Tray	11K1921
500-Sheet Special Media Tray + Drawer	11K1922
400-Sheet Universally Adjustable Tray	11K1941
400-Sheet Universally Adjustable Tray + Drawer	11K1942

Card stock and label guidelines

Labels are one of the most difficult print materials for laser printers. A special fuser cleaner should be used for label applications to optimize feed reliability. See your printer documentation for information on ordering additional label fuser cleaners.

When printing on labels:

- Using the printer operator panel, set the Paper Type to Labels in the Paper Menu. For vinyl and other heavy labels, set the Labels Weight (under the Paper Weight menu) to Heavy, and set the Labels Texture (under the Paper Texture menu) to Smooth.
- Do *not* load labels together with paper or transparencies in the same paper tray. Combining print materials can cause feeding problems.
- Use full label sheets. Partial sheets may cause labels to peel off during printing, resulting in a paper jam. Adhesive material may contaminate your printer. It could also void your printer and cartridge warranties.

When feeding labels, the number of labels per sheet can affect registration more than basis weight. Typically, the more labels per sheet, the better the registration.

When printing on card stock:

- Set the Paper Type to Card Stock in the Paper Menu.
- Do *not* use card stock that is creased. It may cause paper jams.

For more information, see the following:

- [“Pick roller technology” on page 11](#)
- [“Grain orientation” on page 17](#)
- [“Maintenance procedures” on page 14](#)
- [“Troubleshooting” on page 14](#)

Lexmark T620, T622

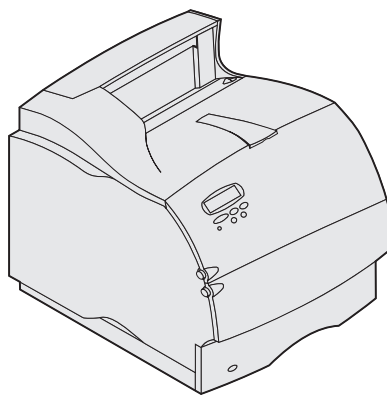

The Lexmark T620 and T622 print on many labels designed for use with laser printers.

The following table lists the maximum weights supported by the trays and the multipurpose feeder.

Print Material		Range or maximum weight supported	
		250-sheet and 500-sheet trays	Multipurpose feeder ⁴ and optional 250-sheet drawer
Paper (grain long)	Xerographic or business paper	60–176 g/m ² (16–47 lb bond)	60–135 g/m ² (16–36 lb bond)
Card stock (grain long ¹)	Index Bristol	163 g/m ² (90 lb)	120 g/m ² (67 lb)
	Tag	163 g/m ² (100 lb)	120 g/m ² (74 lb)
	Cover	176 g/m ² (65 lb)	135 g/m ² (50 lb)
Card stock (grain short ¹)	Index Bristol	199 g/m ² (110 lb)	163 g/m ² (90 lb)
	Tag	203 g/m ² (125 lb)	163 g/m ² (100 lb)
	Cover	216 g/m ² (80 lb)	176 g/m ² (65 lb)
Labels	Paper	180 g/m ² (48 lb bond)	163 g/m ² (43 lb bond)
	Dual-Web Paper	180 g/m ² (48 lb bond)	163 g/m ² (43 lb bond)
	Vinyl ²	300 g/m ² (92 lb liner)	260 g/m ² (78 lb liner)
	Polyester	220 g/m ² (59 lb bond)	220 g/m ² (59 lb bond)
Integrated forms	Pressure sensitive area ³	140–175 g/m ²	140–175 g/m ²
	Paper base (grain long)	75–135 g/m ² (20–36 lb bond)	75–135 g/m ² (20–36 lb bond)

¹ See [“Grain orientation” on page 17](#) for specific recommendations.

² The Lexmark T622 does not support vinyl labels.

³ Pressure-sensitive area must enter the printer first for grain short paper.

⁴ Due to label design characteristics, unacceptable feeding may be experienced from the multipurpose feeder.

For paper and transparency specifications, see the publications CD.

The following table indicates the paper sizes each tray supports.

Source	Standard sizes (width x length)		Universal sizes (width x length)	
	Minimum	Maximum	Minimum	Maximum
Standard tray, 250-sheet drawer, 500-sheet drawer	148 x 210 mm (5.83 x 8.27 in.)	215.9 x 355.6 mm (8.5 x 14 in.)	139.7 x 210 mm (5.5 x 8.27 in.)	215.9 x 355.6 mm (8.5 in. x 14 in.)
Multipurpose feeder*	148 x 210 mm (5.83 x 8.27 in.)	215.9 x 355.6 mm (8.5 x 14 in.)	69.85 x 127 mm (2.75 in. x 5 in.)	229 x 355.6 mm (9.01 x 14 in.)

* If you load paper that is narrower than 148 mm (5.83 in.) in the multipurpose feeder (for example, 3 x 5-inch index cards), set the MP Feeder Size menu item to Universal.

Labels Thickness: 0.102–0.305 mm (0.004–0.012 in.)
 Smoothness: 100–400* Sheffield

* 150–250 Sheffield is optimal. Using media higher than 300 Sheffield could result in printing degradation.

Card stock	Weight:	Up to 199 g/m ² Index Bristol (90 lb)
		Up to 203 g/m ² Tag (100 lb)

Standard trays and special media trays

The Lexmark T620 and T622 paper feeding mechanism uses advanced technology that enhances feeding reliability. The standard Lexmark T620 and T622 tray, which holds 500 sheets of bond paper, reliably feeds all media tested according to the guidelines specified under [“Dimensions” on page 9](#).

For those difficult-to-print sizes, such as 3 x 7-inch forms, Lexmark offers a variety of special media trays and drawers.

Note: Optional 250-sheet Universally Adjustable Trays support forms with a minimum length of 7 inches on both the T620 and T622. Optional 400-sheet Universally Adjustable Trays support forms with a minimum length of 7 inches on both the T620 and T622.

Source	Part number
250-Sheet Special Media Tray	11K1572
250-Sheet Special Media Drawer	11K1573
250-Sheet Universally Adjustable Tray	11K1574
250-Sheet Universally Adjustable Drawer	11K1878
500-Sheet Special Media Tray	11K1921
500-Sheet Special Media Tray + Drawer	11K1922
400-Sheet Universally Adjustable Tray	11K1941
400-Sheet Universally Adjustable Tray + Drawer	11K1942

Card stock and label guidelines

Labels are one of the most difficult print materials for laser printers. A special fuser cleaner should be used for label applications to optimize feed reliability. See your printer documentation for information on ordering additional label fuser cleaners.

Printing labels on the T620 and T622 requires a special label fuser cleaner that prevents duplexing.

It is recommended that when you run vinyl labels, you install a special oil fuser cleaner, P/N 99A0725. When you order a new cartridge, be sure to order the cartridge that will include the correct fuser cleaner.

It is possible to duplex certain labels that have been specifically designed for this application. To duplex labels, consult the Lexmark “Converter Lists” to see which converters have successfully developed this type of label, and you must install a special fuser wiper. The wax wiper that is used with the T620 and T622 is P/N 18A1467.

When printing on labels:

- Using the printer operator panel, set the Paper Type to Labels in the Paper Menu. For vinyl and other heavy labels, set the Labels Weight (under the Paper Weight menu) to Heavy, and set the Labels Texture (under the Paper Texture menu) to Smooth.
- Do not load labels together with paper or transparencies in the same paper tray. Combining print materials can cause feeding problems.
- Use full label sheets. Partial sheets may cause labels to peel off during printing, resulting in a paper jam. Adhesive material may contaminate your printer. It could also void your printer and cartridge warranties.

Note: The Lexmark T622 does not support vinyl labels.

When feeding labels, the number of labels per sheet can affect registration more than basis weight. Typically, the more labels per sheet, the better the registration.

When printing on card stock:

- Set the Paper Type to Card Stock in the Paper Menu.
- Do not use card stock that is creased. It may cause paper jams.

For more information, see the following:

- [“Pick roller technology” on page 11](#)
- [“Grain orientation” on page 17](#)
- [“Maintenance procedures” on page 14](#)
- [“Troubleshooting” on page 14](#)

Lexmark T630, T632, T634

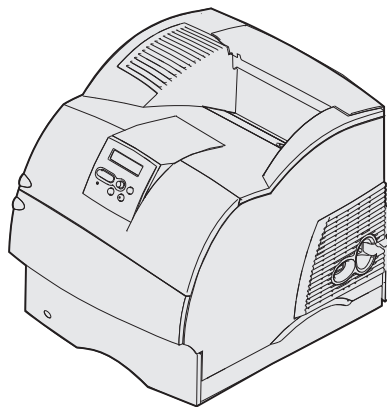

The Lexmark T630, T632, and T634 print on many labels designed for use with laser printers.

The following table lists the maximum weights supported by the trays and the multipurpose feeder.

Print material		Range or maximum weight supported	
		250-sheet and 500-sheet trays	Multipurpose feeder ³ and optional 250-sheet drawer
Paper (grain long)	Xerographic or business paper	60–176 g/m ² (16–47 lb bond)	60–135 g/m ² (16–36 lb bond)
	Card stock (grain long ¹)	Index Bristol	120 g/m ² (67 lb)
	Tag	163 g/m ² (100 lb)	120 g/m ² (74 lb)
	Cover	176 g/m ² (65 lb)	135 g/m ² (50 lb)

¹ See [“Grain orientation” on page 17](#) for specific recommendations.

² Due to label design characteristics, unacceptable feeding may be experienced from the multipurpose feeder.

³ Pressure-sensitive area must enter the printer first for grain short paper.

Print material		Range or maximum weight supported	
		250-sheet and 500-sheet trays	Multipurpose feeder ³ and optional 250-sheet drawer
Card stock (grain short ¹)	Index Bristol	199 g/m ² (110 lb)	163 g/m ² (90 lb)
	Tag	203 g/m ² (125 lb)	163 g/m ² (100 lb)
	Cover	216 g/m ² (80 lb)	176 g/m ² (65 lb)
Labels	Paper	180 g/m ² (48 lb bond)	163 g/m ² (43 lb bond)
	Dual-Web Paper	180 g/m ² (48 lb bond)	163 g/m ² (43 lb bond)
	Vinyl ²	300 g/m ² (92 lb liner)	260 g/m ² (78 lb liner)
	Polyester	220 g/m ² (59 lb bond)	220 g/m ² (59 lb bond)
Integrated forms	Pressure-sensitive area ³	140–175 g/m ²	140–175 g/m ²
	Paper base (grain long)	75–135 g/m ² (20–36 lb bond)	75–135 g/m ² (20–36 lb bond)

¹ See [“Grain orientation” on page 17](#) for specific recommendations.

² Due to label design characteristics, unacceptable feeding may be experienced from the multipurpose feeder.

³ Pressure-sensitive area must enter the printer first for grain short paper.

For paper and transparency specifications, see the publications CD.

The following table indicates the paper sizes each tray supports.

Source	Standard sizes (width x length)		Universal sizes (width x length)	
	Minimum	Maximum	Minimum	Maximum
Standard tray, 250-sheet drawer, 500-sheet drawer	148 x 210 mm (5.83 x 8.27 in.)	215.9 x 355.6 mm (8.5 x 14 in.)	139.7 x 210 mm (5.5 x 8.27 in.)	215.9 x 355.6 mm (8.5 x 14 in.)
Multipurpose feeder*	148 x 210 mm (5.83 x 8.27 in.)	215.9 x 355.6 mm (8.5 x 14 in.)	69.85 x 127 mm (2.75 x 5 in.)	229 x 355.6 mm (9.01 x 14 in.)

* If you load paper that is narrower than 148 mm (5.83 in.) in the multipurpose feeder (for example, 3 x 5-inch index cards), set the MP Feeder Size menu item to Universal.

- Labels**
- Thickness: 0.102–0.305 mm (0.004–0.012 in.)
 - Smoothness: 100–400* Sheffield
 - * 150–250 Sheffield is optimal. Using media higher than 300 Sheffield could result in printing degradation.
- Card stock**
- Weight: Up to 199 g/m² Index Bristol (90 lb)
 - Up to 203 g/m² Tag (100 lb)

Standard trays and special media trays

The Lexmark T630, T632, and T634 paper feeding mechanism uses advanced technology that enhances feeding reliability. The standard Lexmark T630, T632, and T634 tray, which holds 250 or 500 sheets of bond paper, reliably feeds all media tested according to the guidelines specified under [“Dimensions” on page 9](#).

For those difficult-to-print sizes, such as 3 x 5-inch index cards, Lexmark offers a variety of special media trays and drawers.

Note: Optional 250-sheet Universally Adjustable Trays can be used to print forms with a minimum length of 5 inches using a T630 when installed either in the integral tray location or in a 250-sheet drawer under a 250-sheet integral tray. Optional 250-sheet Universally Adjustable Trays support forms with a minimum length of 7 inches on a T632. Optional 400-sheet Universally Adjustable Trays support forms with a minimum length of 7 inches on the T630, T632 and T634.

Source	Part number
250-Sheet Special Media Tray	11K1572
250-Sheet Special Media Drawer	11K1573
250-Sheet Universally Adjustable Tray	11K1574
250-Sheet Universally Adjustable Drawer	11K1878
500-Sheet Special Media Tray	11K1921
500-Sheet Special Media Tray + Drawer	11K1922
400-Sheet Universally Adjustable Tray	11K1941
400-Sheet Universally Adjustable Tray + Drawer	11K1942

Card stock and label guidelines

Labels are one of the most difficult print materials for laser printers. A special fuser cleaner should be used for label applications to optimize feed reliability. See your printer documentation for information on ordering label fuser cleaners.

Printing labels on the T630, T632 and T634 requires a special label fuser cleaner that prevents duplexing.

It is recommended that when you run vinyl labels, you install a special oil fuser cleaner, P/N 56P1415. When you order a new cartridge, be sure to order the cartridge that will include the correct fuser cleaner.

It is possible to duplex certain labels that have been specifically designed for this application. To duplex labels, consult the Lexmark “Converter Lists” to see which converters have successfully developed this type of label, and you must install a special fuser wiper. The wax wiper that is used with the T630, T632, and T634 is P/N 56P2109. (Cartridges designed for duplex label printing contain two wax wipers. Change the wax wiper at the halfway point of your normal cartridge usage to provide additional cleaning and optimize performance.)

When printing on labels:

- Using the printer operator panel, set the Paper Type to Labels in the Paper Menu. For vinyl and other heavy labels, set the Labels Weight (under the Paper Weight menu) to Heavy, and set the Labels Texture (under the Paper Texture menu) to Smooth.

Note: When Paper Type is set to Labels, and Labels Weight is set to Heavy, the printer reduces the printing speed to 30 ppm, to ensure acceptable printing.

- Do *not* load labels together with paper or transparencies in the same paper tray. Combining print materials can cause feeding problems.

- Use full label sheets. Partial sheets may cause labels to peel off during printing, resulting in a paper jam. Adhesive material may contaminate your printer. It could also void your printer and cartridge warranties.

When feeding labels, the number of labels per sheet can affect registration more than basis weight. Typically, the more labels per sheet, the better the registration.

When printing on card stock:

- Set the Paper Type to Card Stock in the Paper Menu.
- Do *not* use card stock that is creased. It may cause paper jams.

For more information, see the following:

- [“Pick roller technology” on page 11](#)
- [“Grain orientation” on page 17](#)
- [“Maintenance procedures” on page 14](#)
- [“Troubleshooting” on page 14](#)

Lexmark T640, T642, T644

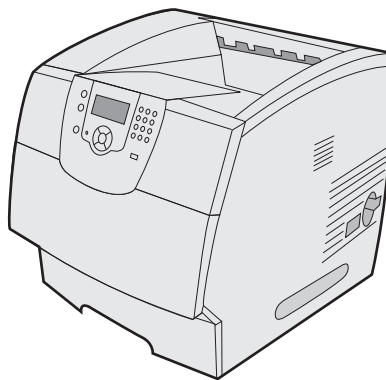

The Lexmark T640, T642, and T644 print on many labels designed for use with laser printers.

The following table lists the maximum weights supported by the trays and the multipurpose feeder.

Paper source	Grain direction	Card stock			Labels			
		Index Bristol	Tag	Cover	Paper	Dual-web paper	Polyester	Vinyl
Integrated tray	grain long	163 g/m ²	163 g/m ²	176 g/m ²	180 g/m ²	180 g/m ²	220 g/m ²	300 g/m ²
	grain short	199 g/m ²	203 g/m ²	216 g/m ²				
Optional 250-sheet drawer	grain long	120 g/m ²	120 g/m ²	135 g/m ²	163 g/m ²	163 g/m ²	220 g/m ²	260 g/m ²
	grain short	163 g/m ²	163 g/m ²	176 g/m ²				
Optional 500-sheet drawer	grain long	163 g/m ²	163 g/m ²	176 g/m ²	180 g/m ²	180 g/m ²	220 g/m ²	300 g/m ²
	grain short	199 g/m ²	203 g/m ²	216 g/m ²				
Multipurpose feeder*	grain long	120 g/m ²	120 g/m ²	135 g/m ²	163 g/m ²	163 g/m ²	220 g/m ²	260 g/m ²
	grain short	163 g/m ²	163 g/m ²	176 g/m ²				

* Due to label design characteristics, unacceptable feeding may be experienced from the multipurpose feeder.

Labels	Thickness:	0.102–0.305 mm (0.004–0.012 in.)
	Smoothness:	100–400* Sheffield
		* 150–250 Sheffield is optimal. Using media higher than 300 Sheffield could result in printing degradation.
Card stock	Weight:	Up to 199 g/m ² Index Bristol (90 lb)
		Up to 203 g/m ² Tag (100 lb)

Standard trays and special trays

The Lexmark T640, T642, and T644 paper feeding mechanism uses advanced technology that enhances feeding reliability. The standard Lexmark T640, T642, and T644 tray holds 250 or 500 sheets of bond paper and reliably feeds all media tested according to the guidelines specified under [“Dimensions” on page 9](#).

For those difficult-to-print sizes, such as 3 x 5-inch index cards, Lexmark offers a variety of special media trays and drawers.

Note: Optional 250-sheet Universally Adjustable Trays can be used to print forms with a minimum length of 5 inches when installed either in the integral tray location or in a 250-sheet drawer under a 250-sheet integral tray. Forms less than 7 inches long are *not* supported from a 400-sheet universally adjustable tray.

Source	Part number
250-Sheet Mild Special Media Tray	20G1237
250-Sheet Aggressive Special Media Tray	20G1230
250-Sheet Mild Special Media Drawer	20G1236
250-Sheet Aggressive Special Media Drawer	20G1229
250-Sheet Universally Adjustable Tray	20G1224
250-Sheet Universally Adjustable Drawer	20G1223
500-Sheet Mild Special Media Tray	20G1240
500-Sheet Mild Special Media Tray + Drawer	20G1239
500-Sheet Aggressive Special Media Tray	20G1227
500-Sheet Aggressive Special Media Tray + Drawer	20G1226
400-Sheet Universally Adjustable Tray	20G1217
400-Sheet Universally Adjustable Tray + Drawer	20G1218

Card stock and label guidelines

Labels are one of the most difficult print materials for laser printers. A special fuser cleaner should be used for label applications to optimize feed reliability. See your printer documentation for information on ordering additional label fuser cleaners.

Printing labels on the T640, T642, and T644 requires a special label fuser cleaner that prevents duplexing.

It is recommended that when you run vinyl labels, you install a special oil fuser cleaner, P/N 40X2665. When you order a new cartridge, be sure to order the cartridge that will include the correct fuser cleaner.

It is possible to duplex certain labels that have been specifically designed for this application. To duplex labels, consult the Lexmark "Converter Lists" to see which converters have successfully developed this type of label, and you must install a special fuser wiper. The wax wiper that is used with the T640, T642, and T644 is P/N 40X2666. (Cartridges designed for duplex label printing contain two wax wipers. Change the wax wiper at the halfway point of your normal cartridge usage to provide additional cleaning and optimize performance.)

When printing on labels:

- Set the Paper Type to Labels in the Paper Menu. For vinyl and other heavy labels, set the Paper Type to Vinyl Labels.

Note: When Paper Type is set to Vinyl Labels, the printer reduces the printing speed to ensure acceptable printing.

- Do *not* load labels together with paper or transparencies in the same paper tray. Combining print materials can cause feeding problems.
- Use full label sheets. Partial sheets may cause labels to peel off during printing, resulting in a paper jam. Adhesive material may contaminate your printer. It could also void your printer and cartridge warranties.

When feeding labels, the number of labels per sheet can affect registration more than basis weight. Typically, the more labels per sheet, the better the registration.

When printing on card stock:

- Set the Paper Type to Card Stock in the Paper Menu.
- Do *not* use card stock that is creased. It may cause paper jams.

For more information, see the following:

- ["Pick roller technology" on page 11](#)
- ["Grain orientation" on page 17](#)
- ["Maintenance procedures" on page 14](#)
- ["Troubleshooting" on page 14](#)

Lexmark T650, T652, T654, and T656dne

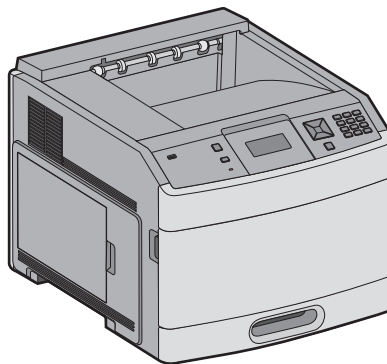

The Lexmark T650, T652, T654, and T656dne print on many labels designed for use with laser printers. The following table lists the maximum weights supported by the trays and the multipurpose feeder.

Paper source	Grain direction	Card stock			Labels			
		Index Bristol	Tag	Cover	Paper	Dual-web paper	Polyester	Vinyl
Integrated tray	grain long	163 g/m ²	163 g/m ²	176 g/m ²	180 g/m ²	180 g/m ²	220 g/m ²	300 g/m ²
	grain short	199 g/m ²	203 g/m ²	216 g/m ²				
Optional 250-sheet drawer	grain long	120 g/m ²	120 g/m ²	135 g/m ²	163 g/m ²	163 g/m ²	220 g/m ²	260 g/m ²
	grain short	163 g/m ²	163 g/m ²	176 g/m ²				
Optional 550-sheet drawer	grain long	163 g/m ²	163 g/m ²	176 g/m ²	180 g/m ²	180 g/m ²	220 g/m ²	300 g/m ²
	grain short	199 g/m ²	203 g/m ²	216 g/m ²				
Multipurpose feeder*	grain long	120 g/m ²	120 g/m ²	135 g/m ²	163 g/m ²	163 g/m ²	220 g/m ²	260 g/m ²
	grain short	163 g/m ²	163 g/m ²	176 g/m ²				

* Due to label design characteristics, unacceptable feeding may be experienced from the multipurpose feeder.

Labels Thickness: 0.102–0.305 mm (0.004–0.012 in.)
Smoothness: 100–400* Sheffield
*150–250 Sheffield is optimal. Using media higher than 300 Sheffield could result in printing degradation.

Card stock Weight: Up to 199 g/m² Index Bristol (90 lb)
Up to 203 g/m² Tag (100 lb)
Up to 216 g/m² Cover (80 lb)

Standard trays and special trays

The Lexmark T650, T652, T654, and T656dne paper feeding mechanism uses advanced technology that enhances feeding reliability. The standard Lexmark T650, T652, T654, and T656dne tray holds 250 and 550 sheets of bond paper and reliably feeds all media tested according to the guidelines specified under [“Dimensions” on page 9](#).

For difficult-to-print sizes, such as 3 x 5-inch index cards, Lexmark offers a variety of special media trays and drawers.

Note: Optional 200-sheet Universally Adjustable Trays can be used to print forms with a minimum length of five inches when installed either in the integral tray location or in a 200-sheet drawer under a 200-sheet integral tray. Forms less than seven inches long are *not* supported from a 400-sheet universally adjustable tray.

Source	Part number
200-Sheet Aggressive Special Media Tray	30G0932
200-Sheet Aggressive Special Media Tray + Drawer	30G0933
200-Sheet Lockable Universally Adjustable Tray + Drawer	30G0836
200-Sheet Mild Special Media Tray	30G0890
200-Sheet Mild Special Media Tray + Drawer	30G0891
200-Sheet Universally Adjustable Tray	30G0872
200-Sheet Universally Adjustable Tray + Drawer	30G0871
400-Sheet Lockable Universally Adjustable Tray + Drawer	30G0859

Source	Part number
400-Sheet Mild Special Media Tray	30G0934
400-Sheet Mild Special Media Tray + Drawer	30G0935
400-Sheet Aggressive Special Media Tray	30G0892
400-Sheet Aggressive Special Media Tray + Drawer	30G0893
400-Sheet Universally Adjustable Tray	30G0861
400-Sheet Universally Adjustable Tray + Drawer	30G0860
550-Sheet Lockable Tray + Drawer	30G0849

Card stock and label guidelines

Labels are one of the most difficult print materials for laser printers. A special fuser cleaner should be used for label applications to optimize feed reliability. See your printer documentation for information on ordering additional label fuser cleaners.

Printing labels on the T650, T652, T654, and T656dne requires a special label fuser cleaner that prevents duplexing.

It is recommended that when you run labels, you install a special oil fuser cleaner, P/N 40X2665. When you order a new cartridge, be sure to order the cartridge that will include the correct fuser cleaner.

It is possible to duplex certain labels that have been specifically designed for this application. To duplex labels, consult the Lexmark "Converter Lists" to see which converters have successfully developed this type of label, and you must install a special fuser wiper. The wax wiper that is used with the T650, T652, T654, and T656dne is P/N 40X2666. (Cartridges designed for duplex label printing contain two wax wipers. Change the wax wiper at the halfway point of your normal cartridge usage to provide additional cleaning and optimize performance.) Contact your Supplies and Label Specialist for information on oil and wax vinyl label cartridges.

Note: Wax wipers are not recommended when using vinyl labels.

When printing on labels:

- Set the Paper Type to Labels in the Paper Menu. For vinyl and other heavy labels, set the Paper Type to Vinyl Labels.
 - Note:** When Paper Type is set to Vinyl Labels, the printer reduces the printing speed to ensure acceptable printing.
- Do *not* load labels together with paper or transparencies in the same paper tray. Combining print materials can cause feeding problems.
- Use full label sheets. Partial sheets may cause labels to peel off during printing, resulting in a paper jam. Adhesive material may contaminate your printer. It could also void your printer and cartridge warranties.

When feeding labels, the number of labels per sheet can affect registration more than basis weight. Typically, the more labels per sheet, the better the registration.

When printing on card stock:

- Set the Paper Type to Card Stock in the Paper Menu.
- Do *not* use card stock that is creased. It may cause paper jams.

For more information, see the following:

- [“Pick roller technology” on page 11](#)
- [“Grain orientation” on page 17](#)

- [“Maintenance procedures” on page 14](#)
- [“Troubleshooting” on page 14](#)

Lexmark W812

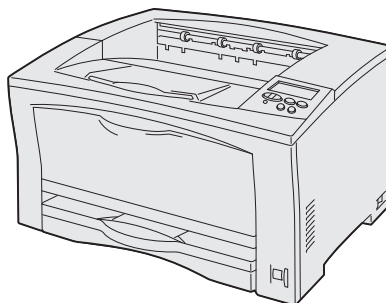

The Lexmark W812 prints on many labels designed for use with laser printers.

The following table lists the maximum weights supported by the trays and the multipurpose feeder.

Paper source	Card stock			Labels	
	Index Bristol	Tag	Cover	Paper	Vinyl
250-sheet Tray 1*	—	—	—	—	—
Multipurpose feeder	111 g/m ²	123 g/m ²	74 g/m ²	200 g/m ²	—
250 sheet option	111 g/m ²	123 g/m ²	74 g/m ²	200 g/m ²	—
500 sheet option*	—	—	—	—	—

* The standard 250-sheet tray (Tray 1) and 500-sheet option do *not* support card stock or labels.

For paper and transparency specifications, see the publication CD that came with your printer.

Labels	Width–Multipurpose feeder:	87–297 mm (3.43–11.69 in.)
	Length–Multipurpose feeder:	98–508 mm (3.86–20 in.)
	Width & Length–Optional 250-sheet trays:	<i>Standard sizes:</i> A3, A4, A5, JIS B4, JIS B5, letter, legal, 8.5 x 13, 11 x 17
	Weight:	64–200 g/m ²
	Thickness:	0.13–0.20 mm (0.005–0.008 in.)
Card stock	Smoothness:	100–400 Sheffield*
		* 150–250 Sheffield is optimal. Using media higher than 300 Sheffield could result in printing degradation.
	Width:	210–216 mm (8.3–8.5 in.)
	Length:	279–356 mm (11–11.7 in.)
	Weight:	Up to 163 g/m ²

Lexmark W820

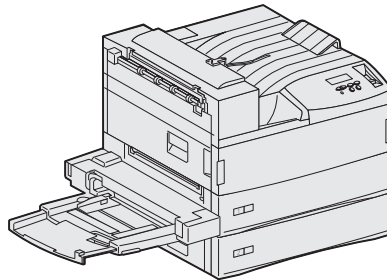

Limit label printing to occasional use of A4- or letter-size paper office labels designed for laser printers. We do *not* recommend using vinyl or polyester labels.

The Lexmark W820 supports stocks up to 163 g/m². *Always* feed labels and card stock from Tray 1, 2, or 3, each of which can hold up to 250 sheets of labels or card stock.

The following table lists the maximum weights supported by the trays and the multipurpose feeder.

Paper source	Media types	Weight
Tray 1	Paper, Bond, Card stock, Labels, Transparencies	60–163 g/m ²
Trays 2, 3	Paper, Bond, Card stock, Labels	60–163 g/m ²
Trays 4, 5	Paper, Bond	60–105 g/m ²
Multipurpose Feeder	Paper, Bond, Card stock, Labels, Transparencies, Envelopes	120–128 g/m ²

For paper and transparency specifications, see the printer publications CD.

Labels	Width:	210–216 mm (8.3–8.5 in.)
	Length:	279–356 mm (11–11.7 in.)
	Weight:	120–128 g/m ²
	Thickness:	0.13–0.20 mm (0.005–0.008 in.)
	Smoothness:	100–400 Sheffield*
* 150–250 Sheffield is optimal. Using media higher than 300 Sheffield could result in printing degradation.		

Card stock	Width:	210–216 mm (8.3–8.5 in.)
	Length:	279–356 mm (11–11.7 in.)
	Weight:	Up to 163 g/m ²

Card stock and label guidelines

When printing on labels:

- Set the Paper Type to Labels in the Paper Menu.
- Do *not* use label sheets with a slick backing material.
- Do *not* print within 1 mm (0.04 in.) of the die-cut, the edge of the label or the perforations, or between the die-cuts.

- Use full label sheets. Partial sheets may cause labels to peel off during printing, resulting in a paper jam.
- Do *not* use label sheets that have adhesive to the edge of the sheet. We recommend zone coating of the adhesive at least 1 mm (0.04 in.) away from the edges. Adhesive material may contaminate your printer and could void your warranty.

When printing on card stock:

- Set the Paper Type to Card Stock.
- Do *not* use card stock that is creased. It may cause paper jams.
- We recommend the use of grain long card stock.

Lexmark W840

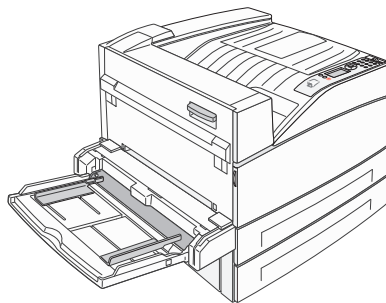

Limit label printing to occasional use of A4- or letter-size paper office labels designed for laser printers. We do *not* recommend using vinyl or polyester labels.

The Lexmark W840 supports stocks up to 216 g/m². *Always* feed labels and card stock from Tray 1, 2, or the multipurpose feeder.

The following table lists the maximum weights supported by the trays and the multipurpose feeder.

	Tray 1	Tray 2	Multipurpose feeder
Labels	64–105 g/m ²	64–216 g/m ²	64–216 g/m ²
Card stock	64–105 g/m ²	64–216 g/m ²	64–216 g/m ²

Labels	Width:	89–297 mm (3.5–11.7 in.)
	Length:	99–432 mm (3.9–17 in.)
	Weight:	64–216 g/m ²
	Thickness:	Up to 0.25 mm
	Smoothness:	100–400 Sheffield*
* 150–250 Sheffield is optimal. Using media higher than 300 Sheffield could result in printing degradation.		
Card stock	Width:	89–297 mm (3.5–11.7 in.)
	Length:	99–432 mm (3.9–17 in.)
	Weight:	Up to 216 g/m ²

Card stock and label guidelines

When printing on labels:

- Set the Paper Type to Labels from the printer driver.
- Use standard-size products (either A4 or Letter).
- Do *not* use label sheets with a slick backing material.
- Do *not* print within 1 mm (0.040 in.) of the die-cut.
- Use full label sheets. Partial sheets may cause labels to peel off during printing, resulting in a paper jam. Partial sheets will also contaminate your printer and your cartridge with adhesive, and could void your printer and cartridge warranties.
- Use labels that can withstand temperatures of 180°C (356°F) without sealing, excessive curling, wrinkling, or releasing hazardous emissions.
- Verify that your label adhesive material can tolerate a fusing temperature of 180°C (356°F) for 0.1 second.
- Use labels that can withstand pressure of 25 pounds per square inch (psi).
- Do *not* print within 1 mm (0.040 in.) of the edge of the label, of the perforations, or between die-cuts of the label.
- Do *not* use label sheets that have adhesive to the edge of the sheet. We recommend zone coating of the adhesive at least 1 mm (0.040 in.) away from edges. Adhesive material will contaminate your printer and could void your warranty.
- If zone coating of the adhesive is not possible, a 3-mm (0.125-in.) strip should be removed on the leading and driver edge, and a non-oozing adhesive should be used.
- Remove a 3-mm (0.125-in.) strip from the leading edge to prevent labels from peeling inside the printer.
- Portrait orientation is preferred, especially when printing bar codes.
- Do *not* use labels that have exposed adhesive.
- Do *not* use labels that are separating from the backing sheet or are wrinkled, bubbled, or otherwise damaged.
- Do *not* load a sheet of labels through the machine more than once.
- Load labels into the manual bypass feeder with the recommended print side faceup and the top edge going in first.

When printing on card stock:

- Set the Paper Type to Card Stock from the printer driver.
- Do *not* use preprinted card stock manufactured with chemicals that may contaminate the printer. Preprinting introduces semi-liquid and volatile components into the printer.
- Do *not* use card stock that is creased. It may cause paper jams.
- We recommend the use of grain short card stock.
- Load card stock into the manual bypass feeder with the recommended print side faceup and the top edge going in first.

Lexmark W850

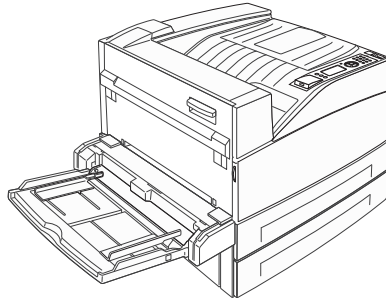

Limit label printing to occasional use of A4- or letter-size paper office labels designed for laser printers. We do *not* recommend using vinyl or polyester labels.

The Lexmark W850 supports stocks up to 216 g/m². *Always* feed labels and card stock from Tray 1, 2 or the multipurpose feeder.

The following table lists the maximum weights supported by the trays and the multipurpose feeder.

Paper source	Media types	Weight
Tray 1	Paper, Labels, Transparencies	64-105 g/m ²
Tray 2	Paper, Card stock, Labels, Transparencies	64-216 g/m ²
Multipurpose feeder	Paper, Card stock, Envelopes, Labels, Transparencies	64-216 g/m ²

Labels	Width:	89–297 mm (3.5–11.7 in.)
	Length:	99–432 mm (3.9–17 in.)
	Weight:	64-216 g/m ²
	Thickness:	Up to 0.25 mm
	Smoothness:	100–400 Sheffield*

* 150–250 Sheffield is optimal. Using media higher than 300 Sheffield could result in printing degradation.

Card stock	Width:	89–297 mm (3.5–11.7 in.)
	Length:	99–432 mm (3.9–17 in.)
	Weight:	Up to 216 g/m ²

Card stock and label guidelines

When printing on labels:

- Set the Paper Type to Labels from the printer driver.
- Use standard-size products (either A4 or Letter).
- Do *not* use label sheets with a slick backing material.
- Do *not* print within 1 mm (0.040 in.) of the die-cut.
- Use full label sheets. Partial sheets may cause labels to peel off during printing, resulting in a paper jam. Partial sheets will also contaminate your printer and your cartridge with adhesive, and could void your printer and cartridge warranties.

- Use labels that can withstand temperatures of 180°C (356°F) without sealing, excessive curling, wrinkling, or releasing hazardous emissions.
- Verify that your label adhesive material can tolerate a fusing temperature of 180°C (356°F) for 0.1 second.
- Use labels that can withstand pressure of 25 pounds per square inch (psi).
- Do *not* print within 1 mm (0.040 in.) of the edge of the label, of the perforations, or between die-cuts of the label.
- Do *not* use label sheets that have adhesive to the edge of the sheet. We recommend zone coating of the adhesive at least 1 mm (0.040 in.) away from edges. Adhesive material will contaminate your printer and could void your warranty.
- If zone coating of the adhesive is not possible, a 3-mm (0.125-in.) strip should be removed on the leading and driver edge, and a non-oozing adhesive should be used.
- Remove a 3-mm (0.125-in.) strip from the leading edge to prevent labels from peeling inside the printer.
- Portrait orientation is preferred, especially when printing bar codes.
- Do *not* use labels that have exposed adhesive.
- Do *not* use labels that are separating from the backing sheet or are wrinkled, bubbled, or otherwise damaged.
- Do *not* load a sheet of labels through the machine more than once.
- Load labels into the manual bypass feeder with the recommended print side faceup and the top edge going in first.

When printing on card stock:

- Set the Paper Type to Card Stock from the printer driver.
- Do *not* use preprinted card stock manufactured with chemicals that may contaminate the printer. Preprinting introduces semi-liquid and volatile components into the printer.
- Do *not* use card stock that is creased. It may cause paper jams.
- We recommend the use of grain short card stock.
- Load card stock into the manual bypass feeder with the recommended print side faceup and the top edge going in first.

Lexmark X203n and X204n

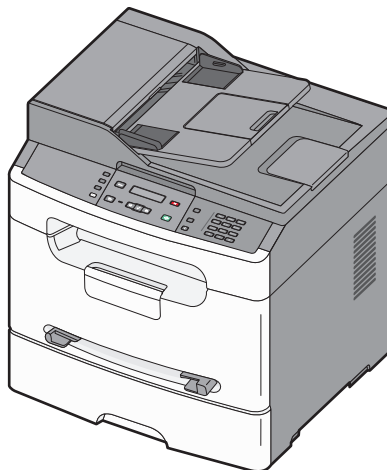

Limit label printing to occasional use of paper office labels designed for laser printers. We do *not* recommend printing more than 20 pages of labels a month. For best results, feed labels from the paper tray.

The Lexmark X203n and X204n printer models support stocks up to 90 g/m² (24 lb).

Note: The smallest supported Universal size is 76 x 127 mm (3 x 5 in.); the largest is 216 x 356 mm (8.5 x 14 in.).

The following table lists the maximum weights supported by the paper tray and the manual feeder.

Paper source	Card stock			Labels
	Index Bristol	Tag	Cover	Paper
Paper tray	163 g/m ²	163 g/m ²	—	163 g/m ²
Manual feeder	163 g/m ²	163 g/m ²	—	163 g/m ²

Note: The manual feeder can feed only one sheet at a time.

Labels	Width:	210–216 mm (8.3–8.5 in.)
	Length:	216–356 mm (8.5–14 in.)
	Weight:	Up to 163 g/m ² (43 lb)
	Thickness:	Up to 0.25 mm (0.01 in.)
	Smoothness:	100–300* Sheffield
		* 150–200 Sheffield is optimal. Using media higher than 300 Sheffield could result in printing degradation.
Card stock	Weight:	Up to 163 g/m ² Index Bristol (90 lb)
		Up to 163 g/m ² Tag (100 lb)

When printing on labels:

- Use labels only in the paper tray or manual feeder. Do not use labels in the ADF.
- Do not use labels with slick backing material.
- Use full label sheets. Partial sheets may cause labels to peel off during printing, resulting in a jam. Partial sheets also contaminate the printer and the cartridge with adhesive, and could void the printer and cartridge warranties.
- Do not use labels with exposed adhesive.
- Use labels designed specifically for laser printers. Check with the manufacturer or vendor to verify that the labels can withstand temperatures up to 225°C (437°F) without sealing, excessive curling, wrinkling, or releasing hazardous emissions.
- Do not print within 1 mm (0.04 in.) of the edge of the label, of the perforations, or between die-cuts of the label.
- Portrait orientation works best, especially when printing bar codes.
- Be sure adhesive backing does not reach to the sheet edge. Zone coating of the adhesive at least 1 mm (0.04 in.) away from edges is recommended. Adhesive material contaminates the printer and could void the warranty. If zone coating of the adhesive is not possible, remove a 1.6 mm (0.06 in.) strip on the leading and driver edge, and use a non-oozing adhesive.

When printing on card stock:

- Make sure the Paper Type is Card Stock.
- Select the appropriate Paper Texture setting.
- Be aware that preprinting, perforation, and creasing may significantly affect the print quality and cause jams or other paper handling problems.
- Check with the manufacturer or vendor to ensure the card stock can withstand temperatures up to 210°C (410°F) without releasing hazardous emissions.

- Do not use preprinted card stock manufactured with chemicals that may contaminate the printer. Preprinting introduces semi-liquid and volatile components into the printer.
- Use grain short card stock when possible.

Note: To minimize curl, us the rear exit when printing on card stock and labels.

For more information, see [“Maintenance procedures” on page 14.](#)

Lexmark X215

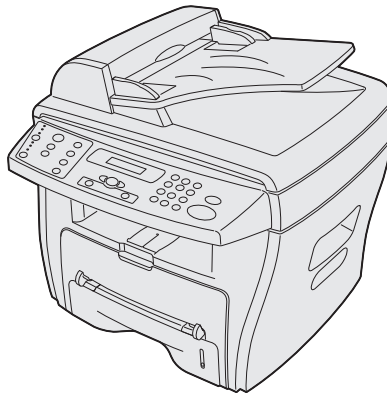

The Lexmark X215 prints on paper office labels designed for use with laser printers.

Labels can be fed only from the manual bypass feeder. Card stock and labels must be fed one sheet at a time through the manual bypass feeder.

The following table lists the maximum weights supported by the manual bypass feeder.

Paper source	Card stock		
	Index Bristol	Tag	Cover
Manual bypass feeder*	Up to 163 g/m ² (90 lb)	Up to 163 g/m ² (100 lb)	—

* Card stock can be fed only from the manual bypass feeder.

For paper and transparency specifications, see the *Lexmark X215 User's Guide*.

Labels	Width:	210–216 mm (8.3–8.5 in.)
	Length:	279–297 mm (11–11.7 in.)
	Weight:	Up to 163 g/m ² (43 lb bond)
	Thickness:	Up to 0.25 mm (0.01 in.)
	Smoothness:	100–400* Sheffield
		* 150–250 Sheffield is optimal. Using media higher than 300 Sheffield could result in printing degradation.
Card stock	Weight:	Up to 163 g/m ² Index Bristol (90 lb)
		Up to 163 g/m ² Tag (100 lb)

Card stock and label guidelines

Use only materials recommended for use with laser printers.

To prevent specialty media sheets from sticking together, remove each sheet from the output bin as it is printed.

When printing on labels:

- Set the Paper Type to Labels from the printer driver.
- Use standard-size products (either A4 or Letter).
- Do *not* use label sheets with a slick backing material.
- Do *not* print within 1 mm (0.040 in.) of the die-cut.
- Use full label sheets. Partial sheets may cause labels to peel off during printing, resulting in a paper jam. Partial sheets will also contaminate your printer and your cartridge with adhesive, and could void your printer and cartridge warranties.
- Use labels that can withstand temperatures of 180°C (356°F) without sealing, excessive curling, wrinkling, or releasing hazardous emissions.
- Verify that your label adhesive material can tolerate a fusing temperature of 180°C (356°F) for 0.1 second.
- Use labels that can withstand pressure of 25 pounds per square inch (psi).
- Do *not* print within 1 mm (0.040 in.) of the edge of the label, of the perforations, or between die-cuts of the label.
- Do *not* use label sheets that have adhesive to the edge of the sheet. We recommend zone coating of the adhesive at least 1 mm (0.040 in.) away from edges. Adhesive material will contaminate your printer and could void your warranty.
- If zone coating of the adhesive is not possible, a 3-mm (0.125-in.) strip should be removed on the leading and driver edge, and a non-oozing adhesive should be used.
- Remove a 3-mm (0.125-in.) strip from the leading edge to prevent labels from peeling inside the printer.
- Portrait orientation is preferred, especially when printing bar codes.
- Do *not* use labels that have exposed adhesive.
- Do *not* use labels that are separating from the backing sheet or are wrinkled, bubbled, or otherwise damaged.
- Do *not* load a sheet of labels through the machine more than once.
- Load labels into the manual bypass feeder with the recommended print side faceup and the top edge going in first.

When printing on card stock:

- Set the Paper Type to Card Stock from the printer driver.
- Do *not* use preprinted card stock manufactured with chemicals that may contaminate the printer. Preprinting introduces semi-liquid and volatile components into the printer.
- Do *not* use card stock that is creased. It may cause paper jams.
- We recommend the use of grain short card stock.
- Load card stock into the manual bypass feeder with the recommended print side faceup and the top edge going in first.

Lexmark X264dn, X363dn, X364dn, and X364dw



Limit label printing to occasional use of paper office labels designed for laser printers. We do *not* recommend using vinyl, pharmacy, or polyester labels. It is recommended to print no more than 20 pages of paper labels a month.

The printer and duplex path support paper and label stock from 60–90 g/m² (16-24 lb). The multipurpose and manual feeders support card stock up to 163 g/m² (43 lb). You can load up to 50 label sheets in the standard tray. Card stock must be sent through the manual feeder one sheet at a time.

The following table lists the maximum weights supported by the standard tray, optional 250- and 550-sheet trays, and multipurpose and manual feeders.

Paper source	Card Stock			Labels
	Index Bristol	Tag	Cover	Paper
Standard tray	—	—	—	90 g/m ²
Optional 250-sheet tray Optional 550-sheet tray	—	—	—	90 g/m ²
Manual feeder Multipurpose feeder	163 g/m ²	163 g/m ²	—	90 g/m ²

Card stock should be grain short and set to exit the rear door.

For paper and transparency specifications, see the printer publications CD.

Labels	Width:	210–216 mm (8.3–8.5 in.)
	Length:	279–297 mm (11–11.7 in.)
	Weight:	Up to 90 g/m ² (24 lb)
	Thickness:	Up to 0.25 mm (0.01 in.)
	Smoothness:	100–300* Sheffield
		*150–200 Sheffield is optimal. Using media higher than 300 Sheffield could result in printing degradation.
Card stock	Weight:	Up to 163 g/m ² Index Bristol (90 lb)
		Up to 163 g/m ² Tag (100 lb)

Note: To minimize curl, use the rear exit when printing on card stock and labels.

When printing on labels:

- Check with the manufacturer or vendor to ensure the labels can withstand temperatures up to 210°C (410°F) without sealing, curling excessively, wrinkling, or releasing hazardous emissions.
- Check with the manufacturer or vendor to ensure the labels can withstand 25 psi (172 kPa) pressure without delaminating, oozing around the edges, or releasing hazardous fumes.
- Do not use labels with slick backing material.
- Use full label sheets. Partial sheets may cause labels to peel off during printing, resulting in a jam.
- Do not use labels with exposed adhesive.
- Do not print within 1 mm (0.04 in.) of the edge of the label, of the perforations, or between die-cuts on the label.
- Be sure adhesive backing does not reach to the sheet edge. Zone coating of the adhesive at least 1 mm (0.04 in.) away from the edges is recommended. Adhesive material contaminates the printer and could void the warranty.
- If zone coating of the adhesive is not possible, remove a 1.6 mm (0.06 in.) strip on the leading and driver edge, and use a non-oozing adhesive.
- Portrait orientation works best, especially when printing bar codes.

When printing on card stock:

- Make sure the Paper Type is Card Stock.
- Select the Paper Texture setting.
- Be aware that preprinting, perforation, and creasing may significantly affect the print quality and cause jams or other paper handling problems.
- Check with the manufacturer or vendor to ensure the card stock can withstand temperatures up to 210°C (410°F) without releasing hazardous emissions.
- Do not use preprinted card stock manufacturer with chemicals that may contaminate the printer.
- Use grain short card stock when possible.

For more information, see [“Maintenance procedures” on page 14](#).

Lexmark X422

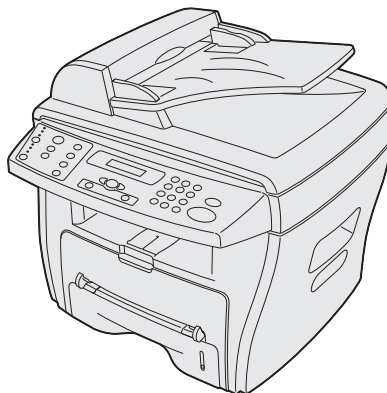

The Lexmark X422 prints on many labels designed for use with laser printers.

Card stock is supported from the multipurpose feeder, and labels are supported from the standard tray.

The following table lists the maximum weights supported.

Note: Scanning large quantities of labels is *not* recommended.

Paper source	Card stock	Paper labels
Tray 1 (standard)	—	60–90 g/m ²
Multipurpose feeder	60–199 g/m ²	—

Card stock and label guidelines

Use only materials recommended for use with laser printers.

To prevent specialty media sheets from sticking together, remove each sheet from the output bin as it is printed.

When printing on labels:

- Set the Paper Type to Labels from the printer driver.
- Use standard-size products (either A4 or Letter).
- Do *not* use label sheets with a slick backing material.
- Do *not* print within 1 mm (0.040 in.) of the die-cut.
- Use full label sheets. Partial sheets may cause labels to peel off during printing, resulting in a paper jam. Partial sheets will also contaminate your printer and your cartridge with adhesive, and could void your printer and cartridge warranties.
- Use labels that can withstand temperatures of 180°C (356°F) without sealing, excessive curling, wrinkling, or releasing hazardous emissions.
- Verify that your label adhesive material can tolerate a fusing temperature of 180°C (356°F) for 0.1 second.
- Use labels that can withstand pressure of 25 pounds per square inch (psi).
- Do *not* print within 1 mm (0.040 in.) of the edge of the label, of the perforations, or between die-cuts of the label.
- Do *not* use label sheets that have adhesive to the edge of the sheet. We recommend zone coating of the adhesive at least 1 mm (0.040 in.) away from edges. Adhesive material will contaminate your printer and could void your warranty.
- If zone coating of the adhesive is not possible, a 3-mm (0.125-in.) strip should be removed on the leading and driver edge, and a non-oozing adhesive should be used.
- Remove a 3-mm (0.125-in.) strip from the leading edge to prevent labels from peeling inside the printer.
- Portrait orientation is preferred, especially when printing bar codes.
- Do *not* use labels that have exposed adhesive.
- Do *not* use labels that are separating from the backing sheet or are wrinkled, bubbled, or otherwise damaged.
- Do *not* load a sheet of labels through the machine more than once.
- Load labels into the standard tray with the recommended print side faceup and the top edge going in first.

When printing on card stock:

- Set the Paper Type to Card Stock from the printer driver.
- Do *not* use preprinted card stock manufactured with chemicals that may contaminate the printer. Preprinting introduces semi-liquid and volatile components into the printer.
- Do *not* use card stock that is creased. It may cause paper jams.
- We recommend the use of grain short card stock.
- Load card stock into the multipurpose feeder with the recommended print side faceup and the top edge going in first.

Lexmark X463de, X464de, X466dte, and X466dtwe



Limit label printing to occasional use of paper office labels designed for laser printers. We do *not* recommend using vinyl, pharmacy, or polyester labels. It is recommended to print no more than 20 pages of paper labels a month.

The printer and duplex path support 60–90 g/m² (16–24 lb) paper weights. The multipurpose feeder supports 60–163 g/m² (16–43 lb) paper weights. You can load up to 50 label sheets in the standard tray and optional trays. You can load up to 15 paper labels and up to 10 sheets of card stock in the multipurpose feeder.

The following table lists the maximum weights supported by the standard tray, optional 250- and 550-sheet trays, and multipurpose and manual feeders.

Paper source	Card Stock			Labels
	Index Bristol	Tag	Cover	Paper
Standard tray	—	—	—	90 g/m ²
Optional 250-sheet tray Optional 550-sheet tray	—	—	—	90 g/m ²
Manual feeder Multipurpose feeder	163 g/m ²	163 g/m ²	—	90 g/m ²

Card stock should be grain short and set to exit the rear door.

For paper and transparency specifications, see the printer publications CD.

Labels	Width:	210–216 mm (8.3–8.5 in.)
	Length:	279–297 mm (11–11.7 in.)
	Weight:	Up to 90 g/m ² (24 lb)
	Thickness:	Up to 0.25 mm (0.01 in.)
	Smoothness:	100–300* Sheffield

*150–200 Sheffield is optimal. Using media higher than 300 Sheffield could result in printing degradation.

Card stock	Weight:	Up to 163 g/m ² Index Bristol (90 lb)
		Up to 163 g/m ² Tag (100 lb)

Note: To minimize curl, use the rear exit when printing on card stock and labels.

When printing on labels:

- Check with the manufacturer or vendor to ensure the labels can withstand temperatures up to 210°C (410°F) without sealing, curling excessively, wrinkling, or releasing hazardous emissions.
- Check with the manufacturer or vendor to ensure the labels can withstand 25 psi (172 kPa) pressure without delaminating, oozing around the edges, or releasing hazardous fumes.
- Do not use labels with slick backing material.
- Use full label sheets. Partial sheets may cause labels to peel off during printing, resulting in a jam.
- Do not use labels with exposed adhesive.
- Do not print within 1 mm (0.04 in.) of the edge of the label, of the perforations, or between die-cuts on the label.
- Be sure adhesive backing does not reach to the sheet edge. Zone coating of the adhesive at least 1 mm (0.04 in.) away from the edges is recommended. Adhesive material contaminates the printer and could void the warranty.
- If zone coating of the adhesive is not possible, remove a 1.6 mm (0.06 in.) strip on the leading and driver edge, and use a non-oozing adhesive.
- Portrait orientation works best, especially when printing bar codes.

When printing on card stock:

- Make sure the Paper Type is Card Stock.
- Select the Paper Texture setting.
- Be aware that preprinting, perforation, and creasing may significantly affect the print quality and cause jams or other paper handling problems.
- Check with the manufacturer or vendor to ensure the card stock can withstand temperatures up to 210°C (410°F) without releasing hazardous emissions.
- Do not use preprinted card stock manufactured with chemicals that may contaminate the printer.
- Use grain short card stock when possible.

For more information, see [“Maintenance procedures” on page 14](#).

Lexmark X500 and X502n



Limit label printing to occasional use of paper office labels designed for laser printers. The Lexmark X500 and X502n do *not* support vinyl or polyester labels.

The Lexmark X500 and X502n support 90–210 g/m² (24–55 lb) stock. Card stock and labels are supported from Tray 1 and Tray 2.

Tray 1 supports approximately 120 sheets of card stock and Tray 2 supports up to 250 sheets of card stock. The following table lists the maximum weights supported.

Paper source	Card stock ¹			Labels ²
	Index Bristol	Tag	Cover	Paper
Tray 1 (standard tray)	90–210 g/m ²	90–210 g/m ²	90–210 g/m ²	180 g/m ²
Tray 2 (optional tray)	90–210 g/m ²	90–210 g/m ²	90–210 g/m ²	180 g/m ²

¹ Grain short is preferred for papers over 135 g/m².

² Vinyl labels are *not* supported.

Labels	Width:	76.2–216 mm (3–8.5 in.)
	Length:	123.8–355.6 mm (4.88–14 in.)
	Weight:	180 g/m ² (48 lb)
	Thickness:	0.13–0.20 mm (0.005–0.008 in.)
	Smoothness:	100–400 Sheffield*
		* 150–250 Sheffield is optimal. Using media higher than 300 Sheffield could result in printing degradation.
Card Stock	Weight:	163 g/m ² Index Bristol (90 lb)
		163 g/m ² Tag (100 lb)
Cover Stock	Weight:	Up to 210 g/m ²

For more information on the supported media sizes, see the printer *User's Guide* on the publications CD.

Lexmark X543, X544, and X546dtn

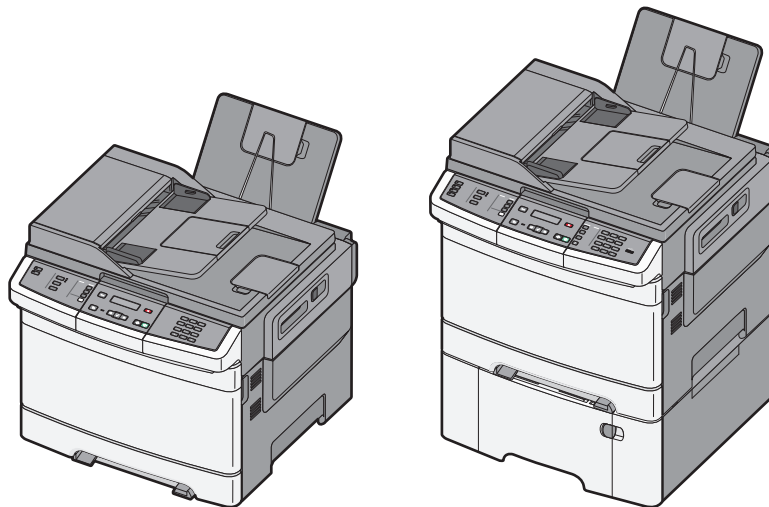

Limit label printing to occasional use of paper office labels designed for use with laser printers. Lexmark X543, X544, and X546dtn do *not* support vinyl or polyester labels.

The following table lists the maximum weights supported by the trays and the multipurpose feeder.

Note: Scanning large quantities of labels is *not* recommended.

Paper source	Grain direction	Card stock			Labels
		Index Bristol	Tag	Cover	Paper
Standard and optional 250-sheet tray	grain long	120 g/m ²	120 g/m ²	135 g/m ²	131 g/m ²
	grain short	163 g/m ²	163 g/m ²	176 g/m ²	
Optional 550-sheet tray	grain long	120 g/m ²	120 g/m ²	135 g/m ²	131 g/m ²
	grain short	163 g/m ²	163 g/m ²	176 g/m ²	
Multipurpose feeder* and manual slot	grain long	120 g/m ²	120 g/m ²	135 g/m ²	131 g/m ²
	grain short	163 g/m ²	163 g/m ²	176 g/m ²	

* The multipurpose feeder may not support labels with certain design characteristics.

Labels	Thickness:	0.102–0.254 mm (0.004–0.010 in.)
	Smoothness:	50–300 Sheffield*
	* 50–150 Sheffield is optimal. This printer may support labels with smoothness of less than 50 Sheffield such as coated paper, polyester, vinyl, or other synthetic facestock paper. Using media higher than 200 Sheffield could result in print quality degradation.	
Card stock	Weight:	Up to 163 g/m ² Index Bristol (90 lb)
		Up to 163 g/m ² Tag (100 lb)
		Up to 176 g/m ² Cover (65 lb)

Card stock and label guidelines

When printing on labels:

- From the printer control panel, set Paper Type to Labels in the Paper Menu.
- Do *not* load labels together with paper or transparencies in the same paper tray. Combining print materials can cause feeding problems.
- Use only letter-, A4-, or legal-size full label sheets. Partial sheets may cause labels to peel off during printing, resulting in a paper jam. Adhesive material may contaminate your printer. It could also void your printer and cartridge warranties.

When printing on card stock:

- From the printer control panel, set Paper Type to Card Stock in the Paper Menu.
- Set Paper Weight to Card Stock Weight in the Paper Menu.
- Set Card Stock Weight to Normal or Heavy.
- Do *not* use creased card stock. It may cause paper jams.

Lexmark X548

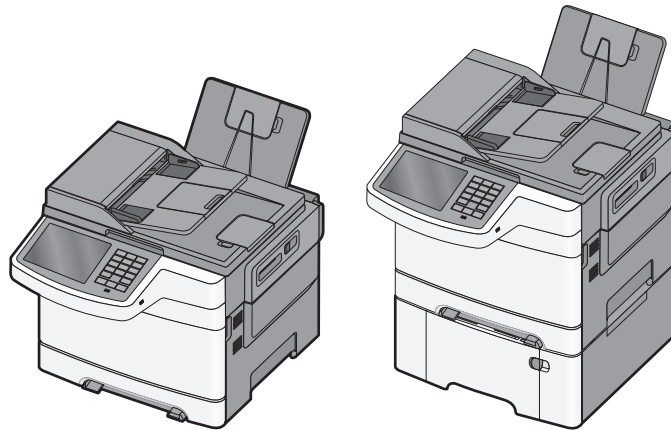

Limit label printing to occasional use of paper office labels designed for use with laser printers. Lexmark X548 does *not* support vinyl or polyester labels.

Note: Printing large quantities of labels is *not* recommended.

Paper source	Grain direction	Card stock			Labels
		Index Bristol	Tag	Cover	Paper
Standard and optional 250-sheet tray	grain long	120 g/m ²	120 g/m ²	135 g/m ²	131 g/m ²
	grain short	163 g/m ²	163 g/m ²	176 g/m ²	
Standard and optional 550-sheet tray	grain long	120 g/m ²	120 g/m ²	135 g/m ²	131 g/m ²
	grain short	163 g/m ²	163 g/m ²	176 g/m ²	
Multipurpose feeder* and manual slot	grain long	120 g/m ²	120 g/m ²	135 g/m ²	131 g/m ²
	grain short	163 g/m ²	163 g/m ²	176 g/m ²	

* The multipurpose feeder may not support labels with certain design characteristics.

Labels

Thickness: 0.102–0.254 mm (0.004–0.010 in.)

Smoothness: 50–300 Sheffield*

* 50–150 Sheffield is optimal. This printer may support labels with smoothness of less than 50 Sheffield such as coated paper, polyester, vinyl, or other synthetic facestock paper. Using media higher than 200 Sheffield could result in print quality degradation.

Card stock

Weight:

- Up to 163 g/m² Index Bristol (90 lb)
- Up to 163 g/m² Tag (100 lb)
- Up to 176 g/m² Cover (65 lb)

Card stock and label guidelines

When printing on labels:

- From the printer control panel, set the paper size, type, texture, and weight in the Paper menu to match the labels loaded in the tray.
- Do *not* load labels together with other types of paper to avoid jams.

- Use full label sheets. Partial sheets may cause labels to peel off during printing, resulting in a jam. Partial sheets also contaminate the printer and the cartridge with adhesive, and could void the printer and toner cartridge warranties.

When printing on card stock:

- From the printer control panel, set the paper size, type, texture, and weight in the Paper menu to match the card stock loaded in the tray.
- Do *not* use creased card stock to avoid jams.

Lexmark X560



The Lexmark X560 prints on many labels designed for use with laser printers.

The following table lists the maximum weights supported by the trays and the multipurpose feeder.

Note: Scanning large quantities of labels is *not* recommended.

Paper source	Grain direction	Card stock			Labels
		Index Bristol	Tag	Cover	Paper
Integrated Tray 2	grain long	163 g/m ²	163 g/m ²	176 g/m ²	180 g/m ²
	grain short	199 g/m ²	203 g/m ²	216 g/m ²	
Optional 550-sheet tray (Tray 3)	grain long	163 g/m ²	163 g/m ²	176 g/m ²	180 g/m ²
	grain short	199 g/m ²	203 g/m ²	216 g/m ²	
Multipurpose feeder* (Tray 1)	grain long	163 g/m ²	163 g/m ²	176 g/m ²	180 g/m ²
	grain short	199 g/m ²	203 g/m ²	216 g/m ²	

* Due to label design characteristics, unacceptable feeding may be experienced from the multipurpose feeder.

Labels	Thickness:	0.102–0.305 mm (0.004–0.012 in.)
	Smoothness:	30–50* Sheffield
	Weight:	180 g/m ² (48 lb bond)

* Using media higher than 300 Sheffield could result in printing degradation.

Card stock	Weight:	Up to 199 g/m ² Index Bristol (110 lb)
		Up to 203 g/m ² Tag (125 lb)
		Up to 216 g/m ² Cover (80 lb)

Card stock and label guidelines

When printing on labels:

- From Print Properties or the printer control panel, set the Paper type to Labels.
- Do *not* load labels together with paper or transparencies in the same paper tray. Combining print materials can cause feeding problems.
- Use only letter-, A4-, and legal-size label sheets.
- Use full label sheets. Partial sheets may cause labels to peel off during printing, resulting in a paper jam. Adhesive material may contaminate your printer. It could also void your printer and cartridge warranties.
- Do not use vinyl labels.

When printing on card stock:

- From Print Properties or the printer control panel, set the Paper type to Thin Card Stock or Thick Card Stock.
- Do *not* use card stock that is creased. It may cause paper jams.

Lexmark X642e

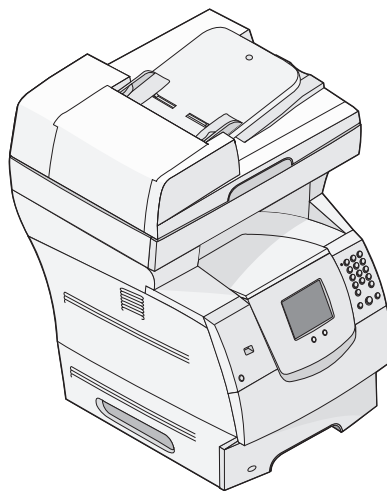

The Lexmark X642e prints on many labels designed for use with laser printers.

The following table lists the maximum weights supported by the trays and the multipurpose feeder.

Note: Scanning large quantities of labels is *not* recommended.

Source	Part number
500-Sheet Aggressive Special Media Tray	20G1227
500-Sheet Aggressive Special Media Tray + Drawer	20G1226
400-Sheet Universally Adjustable Tray	20G1217
400-Sheet Universally Adjustable Tray + Drawer	20G1218

Card stock and label guidelines

Labels are one of the most difficult print materials for laser printers. A special fuser cleaner should be used for label applications to optimize feed reliability. See your printer documentation for information on ordering additional label fuser cleaners.

When feeding labels, the number of labels per sheet can affect registration more than basis weight. Typically, the more labels per sheet, the better the registration.

Printing labels on the X642e, requires a special label fuser cleaner that prevents duplexing.

It is recommended that when you run vinyl labels, you install a special oil fuser cleaner, P/N 40X2665. When you order a new label cartridge, order the X644H01A high yield return print cartridge or X644X01A extra high yield print cartridge.

It is possible to duplex certain labels that have been specifically designed for this application. To duplex labels, consult the Lexmark "Converter Lists" to see which converters have successfully developed this type of label, and you must install a special fuser wiper. The wax wiper that is used with the X642e is P/N 40X2666 (Cartridges designed for duplex label printing contain two wax wipers. Change the wax wiper at the halfway point of your normal cartridge usage to provide additional cleaning and optimize performance.)

When printing on labels:

- Set the Paper Type to Labels in the Paper Menu. For vinyl and other heavy labels, set the Paper Type to Vinyl Labels.

Note: When Paper Type is set to Vinyl Labels, the printer reduces the printing speed to ensure acceptable printing.

- Do *not* load labels together with paper or transparencies in the same paper tray. Combining print materials can cause feeding problems.
- Use full label sheets. Partial sheets may cause labels to peel off during printing, resulting in a paper jam. Adhesive material may contaminate your printer. It could also void your printer and cartridge warranties.

When printing on card stock:

- Set the Paper Type to Card Stock in the Paper Menu.
- Do *not* use card stock that is creased. It may cause paper jams.

For more information, see the following:

- [“Pick roller technology” on page 11](#)
- [“Grain orientation” on page 17](#)
- [“Maintenance procedures” on page 14](#)
- [“Troubleshooting” on page 14](#)

Lexmark X644e, X646e

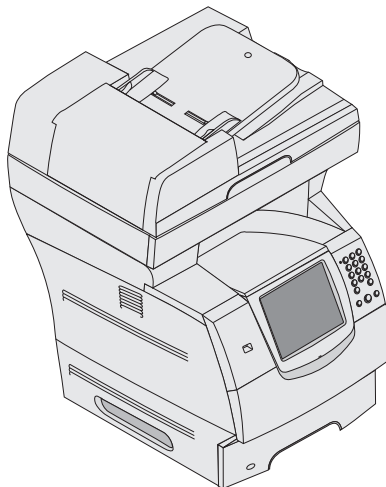

The Lexmark X644e and X646e print on many labels designed for use with laser printers.

The following table lists the maximum weights supported by the trays and the multipurpose feeder.

Note: Scanning large quantities of labels is *not* recommended.

Paper source	Grain direction	Card stock			Labels			
		Index Bristol	Tag	Cover	Paper	Dual-web paper	Polyester	Vinyl
Integrated tray	grain long	163 g/m ²	163 g/m ²	176 g/m ²	180 g/m ²	180 g/m ²	220 g/m ²	300 g/m ²
	grain short	199 g/m ²	203 g/m ²	216 g/m ²				
Optional 250-sheet drawer	grain long	120 g/m ²	120 g/m ²	135 g/m ²	163 g/m ²	163 g/m ²	220 g/m ²	260 g/m ²
	grain short	163 g/m ²	163 g/m ²	176 g/m ²				
Optional 500-sheet drawer	grain long	163 g/m ²	163 g/m ²	176 g/m ²	180 g/m ²	180 g/m ²	220 g/m ²	300 g/m ²
	grain short	199 g/m ²	203 g/m ²	216 g/m ²				
Multipurpose feeder*	grain long	120 g/m ²	120 g/m ²	135 g/m ²	163 g/m ²	163 g/m ²	220 g/m ²	260 g/m ²
	grain short	163 g/m ²	163 g/m ²	176 g/m ²				

* Due to label design characteristics, unacceptable feeding may be experienced from the multipurpose feeder.

- Labels**
- Thickness: 0.102–0.305 mm (0.004–0.012 in.)
 - Smoothness: 100–400* Sheffield
 - * 150–250 Sheffield is optimal. Using media higher than 300 Sheffield could result in printing degradation.
- Card stock**
- Weight: Up to 199 g/m² Index Bristol (90 lb)
 - Up to 203 g/m² Tag (100 lb)

Standard trays and special trays

The Lexmark X644e and X646e paper feeding mechanism uses advanced technology that enhances feeding reliability. The standard Lexmark X644e and X646e trays hold 250 or 500 sheets of bond paper and reliably feed all media tested according to the guidelines specified under [“Dimensions” on page 9](#).

For those difficult-to-print sizes, such as 3 x 5-inch index cards, Lexmark offers a variety of special media trays and drawers.

Note: Optional 250-sheet Universally Adjustable Trays can be used to print forms with a minimum length of 5 inches when installed either in the integral tray location or in a 250-sheet drawer under a 250-sheet integral tray. Forms less than 7 inches in length are *not* supported from a 400-sheet universally adjustable tray.

Source	Part number
250-Sheet Mild Special Media Tray	20G1237
250-Sheet Aggressive Special Media Tray	20G1230
250-Sheet Mild Special Media Drawer	20G1236
250-Sheet Aggressive Special Media Drawer	20G1229
250-Sheet Universally Adjustable Tray	20G1224
250-Sheet Universally Adjustable Drawer	20G1223
500-Sheet Mild Special Media Tray	20G1240
500-Sheet Mild Special Media Tray + Drawer	20G1239
500-Sheet Aggressive Special Media Tray	20G1227
500-Sheet Aggressive Special Media Tray + Drawer	20G1226
400-Sheet Universally Adjustable Tray	20G1217
400-Sheet Universally Adjustable Tray + Drawer	20G1218

Card stock and label guidelines

Labels are one of the most difficult print materials for laser printers. A special fuser cleaner should be used for label applications to optimize feed reliability. See your printer documentation for information on ordering additional label fuser cleaners.

Printing labels on the X644e and X646e requires a special label fuser cleaner that prevents duplexing.

It is recommended that when you run vinyl labels, you install a special oil fuser cleaner, P/N 40X2665. When you order a new label cartridge, order the X644H01A high yield return print cartridge or X644X01A extra high yield print cartridge.

It is possible to duplex certain labels that have been specifically designed for this application. To duplex labels, consult the Lexmark "Converter Lists" to see which converters have successfully developed this type of label, and you must install a special fuser wiper. The wax wiper that is used with the X644e and X646e is P/N 40X2666 (Cartridges designed for duplex label printing contain two wax wipers. Change the wax wiper at the halfway point of your normal cartridge usage to provide additional cleaning and optimize performance.)

When printing on labels:

- Set the Paper Type to Labels in the Paper Menu. For vinyl and other heavy labels, set the Paper Type to Vinyl Labels.

Note: When Paper Type is set to Vinyl Labels, the printer reduces the printing speed to ensure acceptable printing.

- Do *not* load labels together with paper or transparencies in the same paper tray. Combining print materials can cause feeding problems.
- Use full label sheets. Partial sheets may cause labels to peel off during printing, resulting in a paper jam. Adhesive material may contaminate your printer. It could also void your printer and cartridge warranties.

When feeding labels, the number of labels per sheet can affect registration more than basis weight. Typically, the more labels per sheet, the better the registration.

When printing on card stock:

- Set the Paper Type to Card Stock in the Paper Menu.
- Do *not* use card stock that is creased. It may cause paper jams.

For more information, see the following:

- [“Pick roller technology” on page 11](#)
- [“Grain orientation” on page 17](#)
- [“Maintenance procedures” on page 14](#)
- [“Troubleshooting” on page 14](#)

Lexmark X651de, X652de, X654de, X656de, and X658de

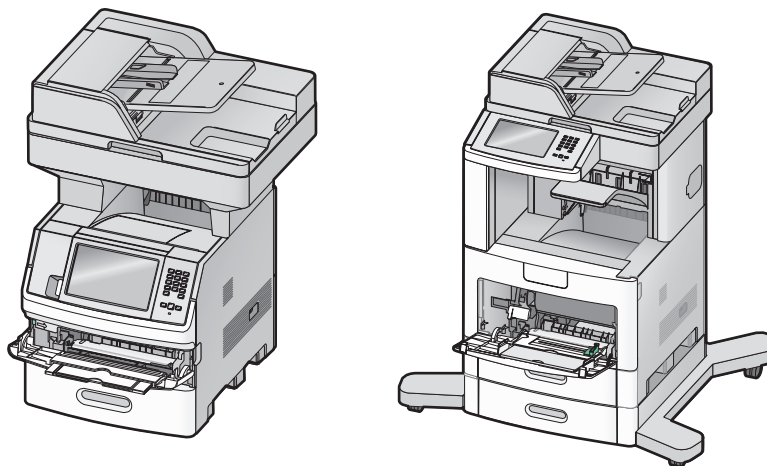

The Lexmark X651de, X652de, X654de, X656de, and X658de print on many labels designed for use with laser printers.

The following table lists the maximum weights supported by the trays and the multipurpose feeder.

Note: Scanning labels through the ADF is *not* recommended.

Source	Part number
200-Sheet Universally Adjustable Tray + Drawer	30G0871
200-Sheet Universally Adjustable Tray	30G0872
400-Sheet Lockable Universally Adjustable Tray + Drawer	30G0859
400-Sheet Mild Special Media Tray	30G0934
400-Sheet Mild Special Media Tray + Drawer	30G0935
400-Sheet Aggressive Special Media Tray	30G0892
400-Sheet Aggressive Special Media Tray + Drawer	30G0893
400-Sheet Universally Adjustable Tray + Drawer	30G0860
400-Sheet Universally Adjustable Tray	30G0861
550-Sheet Lockable Tray + Drawer	30G0849

Card stock and label guidelines

Labels are one of the most difficult print materials for laser printers. Printing labels on the X651de, X652de, X654de, X656de, and X658de requires a special fuser cleaner that prevents duplexing. It is recommended that you install a special oil fuser cleaner, P/N 40X2665, when you run labels. When you order a new cartridge, be sure the cartridge includes the correct fuser cleaner.

It is possible to duplex certain labels that have been specifically designed for this application. To duplex labels, consult the Lexmark “Converter Lists” to see which converters have successfully developed this type of label. You must install a special fuser wiper. The wax wiper that is used with the X651de, X652de, X654de, and X656de printers is P/N 40X2666 (cartridges designed for duplex label printing contain two wax wipers). Change the wax wiper at the halfway point of your normal cartridge usage to provide additional cleaning and optimize performance. Contact your Supplies and Label Specialist for information on oil and wax vinyl label cartridges.

Note: We do not recommend using wax wipers with vinyl labels.

When printing on labels:

- Set the Paper Type to Labels in the Paper Menu. For vinyl and other heavy labels, set the Paper Type to Vinyl Labels.

Note: When Paper Type is set to Vinyl Labels, the printer reduces the printing speed to ensure acceptable printing.

- Do *not* load labels together with paper or transparencies in the same paper tray. Combining print materials can cause feeding problems.
- Use full label sheets. Partial sheets may cause labels to peel off during printing, resulting in a paper jam. Adhesive material may contaminate your printer. It could also void your printer and cartridge warranties.

When feeding labels, the number of labels per sheet can affect registration more than basis weight. Typically, the more labels per sheet, the better the registration.

When printing on card stock:

- Set the Paper Type to Card Stock in the Paper Menu.
- Do *not* use card stock that is creased. It may cause paper jams.

For more information, see the following:

- [“Pick roller technology” on page 11](#)
- [“Grain orientation” on page 17](#)

- [“Maintenance procedures” on page 14](#)
- [“Troubleshooting” on page 14](#)

Lexmark X734, X736, and X738

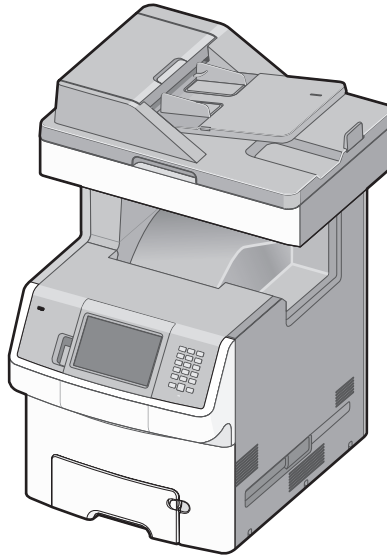

Lexmark X734, X736, and X738 printer models support card stock and labels from the standard 550-sheet tray, an optional 550-sheet tray, the multipurpose tray, and the optional 550-sheet specialty media drawer.

Note: The optional 2,000-sheet tray does not support card stock or labels.

Tray 1, the optional 550-sheet tray, and the specialty media tray support approximately 250 sheets of card stock or labels. The following tables list the maximum weights supported.

Paper source	Card stock (grain long/grain short)		
	Index Bristol	Tag	Cover
Standard 550-sheet tray (Tray 1)	163–199 g/m ²	163–203 g/m ²	163–216 g/m ²
Optional 550-sheet tray Optional 550-sheet specialty media drawer	163–199 g/m ²	163–203 g/m ²	163–216 g/m ²
Multipurpose tray	163–199 g/m ²	163–203 g/m ²	163–216 g/m ²

Paper source	Labels		
	Dual Web/Paper	Polyester	Vinyl
Standard 550-sheet tray (Tray 1)	180 g/m ²	220 g/m ²	300 g/m ²
Optional 550-sheet tray Optional 550-sheet specialty media drawer	180 g/m ²	220 g/m ²	300 g/m ²
Multipurpose tray	180 g/m ²	220 g/m ²	300 g/m ²

Labels	Width:	76–216 mm (3–8.5 in.)
	Length:	124–356 mm (4.88–14 in.)
	Weight:	180–300 g/m ² (48–92 lb)
	Thickness:	0.13–0.20 mm (0.005–0.008 in.)
	Smoothness:	50–300 Sheffield*

* 50–150 Sheffield is optimal. This printer may support labels with smoothness of less than 50 Sheffield such as coated paper, polyester, vinyl, or other synthetic facestock paper. Using media higher than 200 Sheffield could result in print quality degradation.

Card stock	Weight:	Up to 199 g/m ² Index Bristol (110 lb)
		Up to 203 g/m ² Tag (125 lb)

Cover stock	Weight:	Up to 216 g/m ² (80 lb)
--------------------	---------	------------------------------------

For more information on the supported media sizes, see the printer *User's Guide* on the publications CD.

Card stock and label guidelines

When printing on labels:

- Print samples on the labels being considered for use before buying large quantities.
- Use only label sheets that have no gaps between the labels.

Acceptable labels

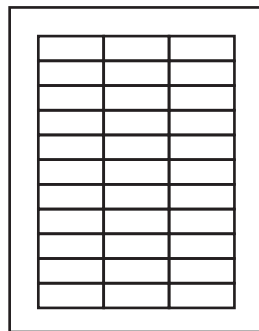

Unacceptable labels

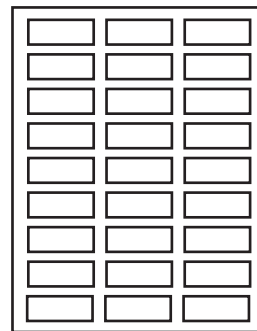

- From the printer control panel or from MarkVision Professional, set Paper Type to Labels.
- Do *not* print a large number of labels continuously.
- Do *not* use labels that have coating or sizing applied to make the labels liquid-resistant.
- Do *not* use labels that have exposed adhesive on the label sheets.

When printing on card stock:

- Select the appropriate Paper Texture setting.
- For the best print quality, always set Paper Type to Card Stock.
- Use grain short card stock when possible.
- Do not use preprinted card stock manufactured with chemicals that may contaminate the printer.
- Be aware that preprinting, perforation, and creasing may significantly affect the print quality and cause jams or other paper-handling problems.

For more information, see [“Pick roller technology” on page 11](#).

Lexmark X746 and X748

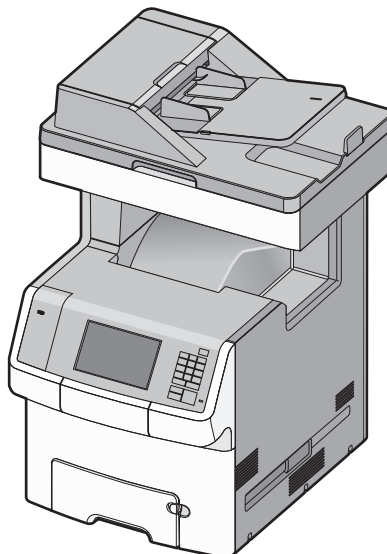

The Lexmark X746 and X748 printer models support card stock and labels from the standard 550-sheet tray, an optional 550-sheet tray, the multipurpose feeder, and the optional 550-sheet specialty media tray.

Note: The optional 2,000-sheet tray does not support card stock or labels.

Tray 1, the optional 550-sheet tray, and the specialty media tray support approximately 250 sheets of card stock or labels. The following table lists the maximum weights supported.

Paper source	Grain direction	Card stock			Labels			
		Index Bristol	Tag	Cover	Paper	Dual-web paper	Polyester	Vinyl
Standard and optional 550-sheet tray	grain long	199 g/m ²	163 g/m ²	176 g/m ²	180 g/m ²	180 g/m ²	220 g/m ²	300 g/m ²
	grain short	199 g/m ²	203 g/m ²	216 g/m ²				
Multipurpose feeder	grain long	199 g/m ²	163 g/m ²	176 g/m ²	180 g/m ²	180 g/m ²	220 g/m ²	300 g/m ²
	grain short	199 g/m ²	203 g/m ²	216 g/m ²				

* The multipurpose feeder may not support labels with certain design characteristics.

Labels	Width:	76–216 mm (3–8.5 in.) ¹
	Length:	124–356 mm (4.88–14 in.) ¹
	Weight:	Up to 180 g/m ² Paper (48 lb)
		Up to 180 g/m ² Dual Web Paper (48 lb)
		Up to 220 g/m ² Polyester (59 lb)
	Up to 300 g/m ² Vinyl (92 lb)	
Thickness:	0.13–0.20 mm (0.005–0.008 in.)	
Smoothness:	50–300 Sheffield ²	

¹ The minimum size for labels supported in the multipurpose feeder is 76 x 124 mm (3 x 4.88 in.). The minimum size for labels supported in the standard and optional trays is 148 x 210 mm (5.82 x 8.26 in.)

² 50–150 Sheffield is optimal. This printer may support labels with smoothness of less than 50 Sheffield such as coated paper, polyester, vinyl, or other synthetic facestock paper. Using media higher than 200 Sheffield could result in print quality degradation.

Card stock	Weight:	Up to 199 g/m ² Index Bristol (110 lb)
		Up to 203 g/m ² Tag (125 lb)
		Up to 216 g/m ² Cover (80 lb)

For more information on the supported media sizes, see the printer *User's Guide on the Software and Documentation CD*.

Card stock and label guidelines

When printing on labels:

- Print samples on the labels being considered for use before buying large quantities.
- Use only label sheets that have no gaps between the labels.

Acceptable labels

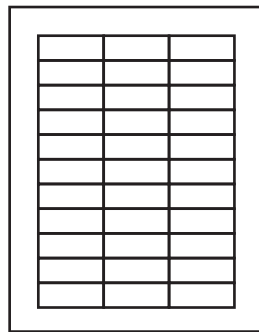

Unacceptable labels

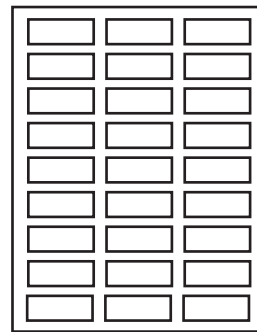

- From the printer control panel or from MarkVision Professional, set Paper Type to Labels.
- Do *not* print a large number of labels continuously.
- Do *not* use labels that have coating or sizing applied to make the labels liquid-resistant.
- Do *not* use labels that have exposed adhesive on the label sheets.
- Run the labels only once through the printer as this may contaminate the printer.

When printing on card stock:

- Select the appropriate Paper Texture setting.
- For the best print quality, always set Paper Type to Card Stock.
- Use grain short card stock when possible.
- Do not use preprinted card stock manufactured with chemicals that may contaminate the printer.
- Be aware that preprinting, perforation, and creasing may significantly affect the print quality and cause jams or other paper-handling problems.

For more information, see [“Pick roller technology” on page 11](#).

Lexmark X782



The Lexmark X782 can print on many labels designed for use with laser printers.

The following tables list the maximum weights supported by the trays and the multipurpose feeder.

Note: The optional 2000-sheet drawer supports plain and glossy paper.

Paper source	Card stock (grain long/grain short)					
	Index Bristol		Tag		Cover	
	grain long	grain short	grain long	grain short	grain long	grain short
500-sheet drawers	163 g/m ²	199 g/m ²	163 g/m ²	203 g/m ²	176 g/m ²	216 g/m ²
Multipurpose feeder	163 g/m ²	199 g/m ²	163 g/m ²	203 g/m ²	176 g/m ²	216 g/m ²

Paper source	Labels			
	Paper	Dual-web paper	Polyester	Vinyl ^{1, 2}
500-sheet drawers	180 g/m ²	180 g/m ²	220 g/m ²	300 g/m ²
Multipurpose feeder	199 g/m ²	199 g/m ²	220 g/m ²	260 g/m ²

¹ Vinyl labels are supported only when the printing environment and media are 20–32.2°C (68–90°F).

² The skew performance of heavy vinyl labels may be enhanced by feeding from an optional 500-sheet drawer if placement of the image is critical.

For paper and transparency specifications, see the printer *User's Guide* on the publications CD.

Labels	Thickness:	0.102–0.305 mm (0.004–0.012 in.)
	Smoothness:	50–300* Sheffield

* 50–150 Sheffield is optimal. This printer may support labels with smoothness of less than 50 Sheffield such as coated paper, polyester, vinyl, or other synthetic facestock papers. Using media higher than 200 Sheffield could result in print quality degradation.

Card stock and label guidelines

Labels are one of the most difficult print materials for laser printers. A fuser equipped with a dry web cleaner may be required for label applications to optimize feed reliability. If you print large quantities of labels or other glossy print media, then install a dry web cleaner upgrade kit (P/N 40X1856). Contact your local service representative for ordering information.

When printing on labels:

- From the printer control panel, set Paper Type to Labels in the Paper Menu. For vinyl and other heavy labels, set Labels Weight (under the Paper Weight menu) to Heavy, and set Labels Texture (under the Paper Texture menu) to Smooth.
- Do *not* load labels together with paper or transparencies in the same paper tray. Combining print materials can cause feeding problems.
- Use full label sheets. Partial sheets may cause labels to peel off during printing, resulting in a paper jam. Adhesive material may contaminate your printer. It could also void your printer and cartridge warranties.

Print on sheets with more number of labels to improve registration.

When printing on card stock:

- From the printer control panel, set Paper Type to Card Stock in the Paper Menu.
- Do *not* use creased card stock. It may cause paper jams.

For more information, see the following:

- [“Pick roller technology” on page 11](#)
- [“Maintenance procedures” on page 14](#)
- [“Troubleshooting” on page 14](#)

Lexmark X792de, X792dte, X792dtfe, X792dtpe, X792dtme, and X792dtse

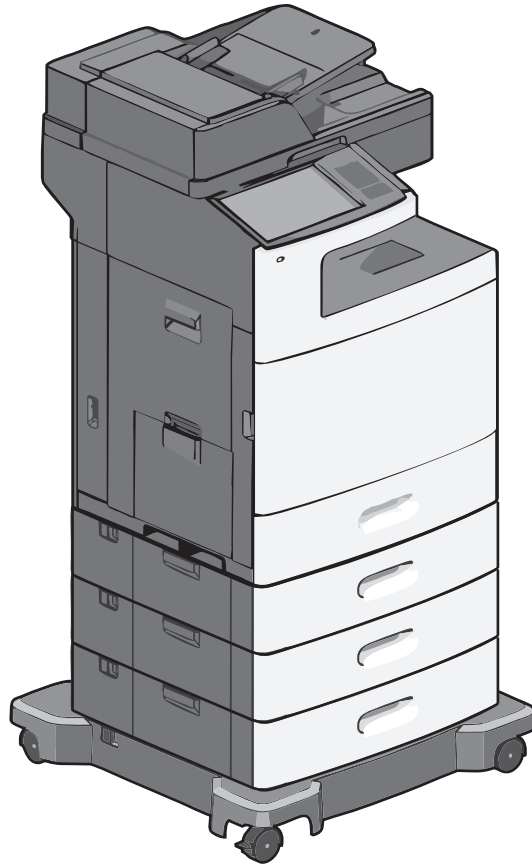

The Lexmark X792de, X792dte, X792dtfe, X792dtpe, X792dtme, and X792dtse printer models support card stock and labels from the standard 550-sheet tray, an optional 550-sheet tray, and the multipurpose feeder.

Note: The optional 2000-sheet drawer does not support card stock or labels.

Overview of card stock support

Paper source	Card stock (grain long/grain short)					
	Index Bristol		Tag		Cover	
	grain long	grain short	grain long	grain short	grain long	grain short
Standard and optional 550-sheet trays	163 g/m ²	199 g/m ²	163 g/m ²	203 g/m ²	176 g/m ²	216 g/m ²
Multipurpose feeder	163 g/m ²	199 g/m ²	163 g/m ²	203 g/m ²	176 g/m ²	216 g/m ²

Overview of label support

Paper source	Labels			
	Paper	Dual-web paper	Polyester	Vinyl ^{1, 2}
Standard and optional 550-sheet trays	180 g/m ²	180 g/m ²	220 g/m ²	300 g/m ²
Multipurpose feeder	199 g/m ²	199 g/m ²	220 g/m ²	260 g/m ²

¹ Vinyl labels are supported only when the printing environment and media are 20–32.2°C (68–90°F).

² The skew performance of heavy vinyl labels may be enhanced by feeding from an optional 500-sheet drawer if placement of the image is critical.

Media specifications

Labels	Width:	76.2–139.7 mm (3–8.5 in.)
	Length:	127–355.6 mm (5–14 in.)
	Weight:	160–220 g/m ² 160–300 g/m ² (Vinyl)
	Thickness:	Up to 0.25 mm
	Smoothness:	50–300 Sheffield*
		* 50–150 Sheffield is optimal. This printer may support labels with smoothness of less than 50 Sheffield such as coated paper, polyester, vinyl, or other synthetic facestock paper. Using media higher than 200 Sheffield could result in print quality degradation.
Card stock	Width:	76.2–139.7 mm (3–8.5 in.)
	Length:	127–355.6 mm (5–14 in.)
	Weight:	Up to 216 g/m ²

Use only materials recommended for use with laser printers.

To prevent specialty media sheets from sticking together, remove each sheet from the bin as it is printed.

Card stock and label guidelines

When printing on labels:

- Set Paper Type to Labels from the printer driver.
- Use A4- or letter-size paper.
- Do *not* use label sheets with a slick backing material.
- Do *not* print within 1 mm (0.040 inch) of the die-cut.
- Use full label sheets. Partial sheets may cause labels to peel off during printing, resulting in a paper jam. Partial sheets will also contaminate your printer and your cartridge with adhesive, and could void your printer and cartridge warranties.
- Use labels that can withstand temperatures of 180°C (356°F) without sealing, excessive curling, wrinkling, or releasing hazardous emissions.
- Verify that the adhesive material of the label can tolerate a fusing temperature of 180°C (356°F) for 0.1 second.
- Use labels that can withstand pressure of 25 pounds per square inch (psi).
- Do *not* print within 1 mm (0.040 inch) of the edge of the label, of the perforations, or between die-cuts of the label.

- Do *not* use label sheets that have adhesive to the edge of the sheet. We recommend zone coating of the adhesive at least 1 mm (0.040 inch) away from edges. Adhesive material will contaminate your printer and could void your warranty.
- If zone coating of the adhesive is not possible, a 3-mm (0.125-inch) strip should be removed on the leading and driver edge, and a non-oozing adhesive should be used.
- Remove a 3-mm (0.125-inch) strip from the leading edge to prevent labels from peeling inside the printer.
- Portrait orientation is preferred, especially when printing bar codes.
- Do *not* use labels that have exposed adhesive.
- Do *not* use labels that are separating from the backing sheet or are wrinkled, bubbled, or otherwise damaged.
- Do *not* load a sheet of labels through the machine more than once.
- Load labels into the multipurpose feeder with the recommended print side faceup and the top edge entering the printer first.

When printing on card stock:

- Set Paper Type to Card Stock from the printer driver.
- Do *not* use preprinted card stock manufactured with chemicals that may contaminate the printer. Preprinting introduces semi-liquid and volatile components into the printer.
- Do *not* use creased card stock. It may cause paper jams.
- We recommend the use of grain short card stock.
- Load card stock into the multipurpose feeder with the recommended print side faceup and the top edge entering the printer first.

Lexmark X850, X852e, and X854e

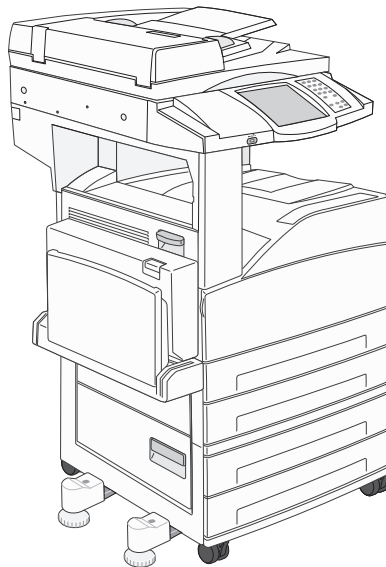

Limit label printing to occasional use of paper office labels designed for laser printers. Paper labels are supported in Tray 1, Tray 2, and the manual bypass feeder.

The following table lists the maximum weights supported.

Note: Scanning large quantities of labels is *not* recommended.

	Tray 1	Tray 2	Multipurpose feeder
Labels	64–105 g/m ²	64–216 g/m ²	64–216 g/m ²
Card stock	64–105 g/m ²	64–216 g/m ²	64–216 g/m ²

Labels	Width:	89–297 mm (3.5–11.7 in.)
	Length:	99–432 mm (3.9–17 in.)
	Weight:	64–216 g/m ²
	Thickness:	Up to 0.25 mm
	Smoothness:	100–400 Sheffield*
* 150–250 Sheffield is optimal. Using media higher than 300 Sheffield could result in printing degradation.		
Card stock	Width:	89–297 mm (3.5–11.7 in.)
	Length:	99–432 mm (3.9–17 in.)
	Weight:	Up to 216 g/m ²

Use only materials recommended for use with laser printers.

To prevent specialty media sheets from sticking together, remove each sheet from the output bin as it is printed.

Card stock and label guidelines

When printing on labels:

- Set the Paper Type to Labels from the printer driver.
- Use standard-size products (either A4 or Letter).
- Do *not* use label sheets with a slick backing material.
- Do *not* print within 1 mm (0.040 in.) of the die-cut.
- Use full label sheets. Partial sheets may cause labels to peel off during printing, resulting in a paper jam. Partial sheets will also contaminate your printer and your cartridge with adhesive, and could void your printer and cartridge warranties.
- Use labels that can withstand temperatures of 180°C (356°F) without sealing, excessive curling, wrinkling, or releasing hazardous emissions.
- Verify that your label adhesive material can tolerate a fusing temperature of 180°C (356°F) for 0.1 second.
- Use labels that can withstand pressure of 25 pounds per square inch (psi).
- Do *not* print within 1 mm (0.040 in.) of the edge of the label, of the perforations, or between die-cuts of the label.
- Do *not* use label sheets that have adhesive to the edge of the sheet. We recommend zone coating of the adhesive at least 1 mm (0.040 in.) away from edges. Adhesive material will contaminate your printer and could void your warranty.
- If zone coating of the adhesive is not possible, a 3-mm (0.125-in.) strip should be removed on the leading and driver edge, and a non-oozing adhesive should be used.
- Remove a 3-mm (0.125-in.) strip from the leading edge to prevent labels from peeling inside the printer.
- Portrait orientation is preferred, especially when printing bar codes.
- Do *not* use labels that have exposed adhesive.
- Do *not* use labels that are separating from the backing sheet or are wrinkled, bubbled, or otherwise damaged.

- Do *not* load a sheet of labels through the machine more than once.
- Load labels into the manual bypass feeder with the recommended print side faceup and the top edge going in first.

When printing on card stock:

- Set the Paper Type to Card Stock from the printer driver.
- Do *not* use preprinted card stock manufactured with chemicals that may contaminate the printer. Preprinting introduces semi-liquid and volatile components into the printer.
- Do *not* use card stock that is creased. It may cause paper jams.
- We recommend the use of grain short card stock.
- Load card stock into the manual bypass feeder with the recommended print side faceup and the top edge going in first.

Lexmark X860e, X862e, and X864e

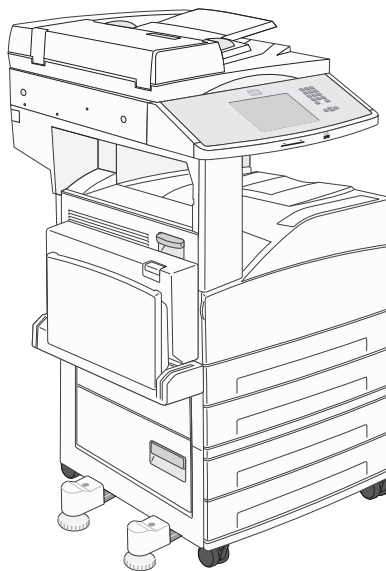

Limit label printing to occasional use of A4- or letter-size paper office labels designed for laser printers. We do *not* recommend using vinyl or polyester labels.

The Lexmark X860e, X862e, and X864e support stocks up to 216 g/m². *Always* feed labels and card stock from Tray 1, 2 or the multipurpose feeder.

The following table lists the maximum weights supported by the trays and the multipurpose feeder.

Paper source	Media types	Weight
Tray 1	Paper, Labels, Transparencies	64-105 g/m ²
Tray 2	Paper, Card stock, Labels, Transparencies	64-216 g/m ²
Multipurpose feeder	Paper, Card stock, Envelopes, Labels, Transparencies	64-216 g/m ²

Labels	Width:	89–297 mm (3.5–11.7 in.)
	Length:	99–432 mm (3.9–17 in.)
	Weight:	64–216 g/m ²
	Thickness:	Up to 0.25 mm
	Smoothness:	100–400 Sheffield*
		* 150–250 Sheffield is optimal. Using media higher than 300 Sheffield could result in printing degradation.
Card stock	Width:	89–297 mm (3.5–11.7 in.)
	Length:	99–432 mm (3.9–17 in.)
	Weight:	Up to 216 g/m ²

Card stock and label guidelines

When printing on labels:

- Set the Paper Type to Labels from the printer driver.
- Use standard-size products (either A4 or Letter).
- Do *not* use label sheets with a slick backing material.
- Do *not* print within 1 mm (0.040 in.) of the die-cut.
- Use full label sheets. Partial sheets may cause labels to peel off during printing, resulting in a paper jam. Partial sheets will also contaminate your printer and your cartridge with adhesive, and could void your printer and cartridge warranties.
- Use labels that can withstand temperatures of 180°C (356°F) without sealing, excessive curling, wrinkling, or releasing hazardous emissions.
- Verify that your label adhesive material can tolerate a fusing temperature of 180°C (356°F) for 0.1 second.
- Use labels that can withstand pressure of 25 pounds per square inch (psi).
- Do *not* print within 1 mm (0.040 in.) of the edge of the label, of the perforations, or between die-cuts of the label.
- Do *not* use label sheets that have adhesive to the edge of the sheet. We recommend zone coating of the adhesive at least 1 mm (0.040 in.) away from edges. Adhesive material will contaminate your printer and could void your warranty.
- If zone coating of the adhesive is not possible, a 3-mm (0.125-in.) strip should be removed on the leading and driver edge, and a non-oozing adhesive should be used.
- Remove a 3-mm (0.125-in.) strip from the leading edge to prevent labels from peeling inside the printer.
- Portrait orientation is preferred, especially when printing bar codes.
- Do *not* use labels that have exposed adhesive.
- Do *not* use labels that are separating from the backing sheet or are wrinkled, bubbled, or otherwise damaged.
- Do *not* load a sheet of labels through the machine more than once.
- Load labels into the manual bypass feeder with the recommended print side faceup and the top edge going in first.

When printing on card stock:

- Set the Paper Type to Card Stock from the printer driver.
- Do *not* use preprinted card stock manufactured with chemicals that may contaminate the printer. Preprinting introduces semi-liquid and volatile components into the printer.
- Do *not* use card stock that is creased. It may cause paper jams.

- We recommend the use of grain short card stock.
- Load card stock into the manual bypass feeder with the recommended print side faceup and the top edge going in first.

Lexmark X925

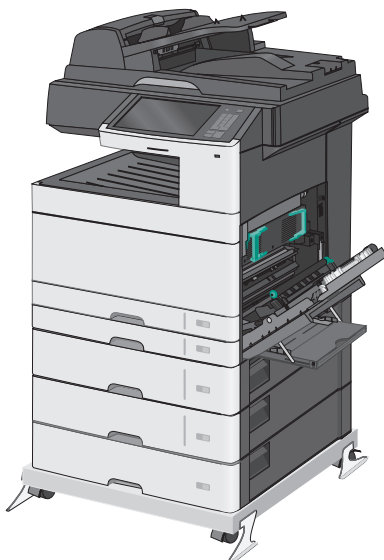

Limit label printing to occasional use of A4- or letter-size paper office labels designed for laser printers. We do *not* recommend using vinyl or polyester labels.

Trays and the multipurpose feeder support card stock. The multipurpose feeder supports card stocks up to 256 g/m².

Always feed labels from the standard 150-sheet tray or the multipurpose feeder.

The standard 250- and optional 550-sheet trays do not support labels.

The following table lists the maximum weights supported by the trays and the multipurpose feeder.

Paper source	Card stock (grain long/grain short)					
	Index Bristol		Tag		Cover	
	grain long	grain short	grain long	grain short	grain long	grain short
Standard 150-sheet tray	120 g/m ²	163 g/m ²	120 g/m ²	163 g/m ²	135 g/m ²	176 g/m ²
Standard 250- and optional 550-sheet trays	120 g/m ²	157 g/m ²	120 g/m ²	157 g/m ²	135 g/m ²	157 g/m ²
Multipurpose feeder	120 g/m ²	256 g/m ²	120 g/m ²	256 g/m ²	135 g/m ²	256 g/m ²

Paper source	Labels	
	Paper	Vinyl
Standard 150-sheet tray	131 g/m ²	Not applicable
Multipurpose feeder	131 g/m ²	Occasional use up to 256 g/m ²

Labels	Width:	210–216 mm (8.3–8.5 in.)
	Length:	279–356 mm (11–11.7 in.)
	Weight:	120–128 g/m ²
	Thickness:	0.13–0.20 mm (0.005–0.008 in.)
	Smoothness:	100–400 Sheffield*

* 150–250 Sheffield is optimal. Using media higher than 300 Sheffield could result in print quality degradation.

Card stock	Width:	210–216 mm (8.3–8.5 in.)
	Length:	279–356 mm (11–11.7 in.)
	Weight:	Up to 216 g/m ²

Card stock and label guidelines

When printing on labels:

- From the printer control panel, set Paper Type to Labels in the Paper Menu.
- Do *not* use label sheets with a slick backing material.
- Do *not* print within 1 mm (0.04 in.) of the die-cut, the edge of the label or the perforations, or between the die-cuts.
- Use full label sheets. Partial sheets may cause labels to peel off during printing, resulting in a paper jam.
- Do *not* use label sheets that have adhesive to the edge of the sheet. We recommend zone coating of the adhesive at least 1 mm (0.04 in.) away from the edges. Adhesive material may contaminate your printer and could void your warranty.

When printing on card stock:

- Use grain long card stock, and set Paper Type to Card Stock.
- Do *not* use creased card stock. It may cause paper jams.

Lexmark X940 and X945

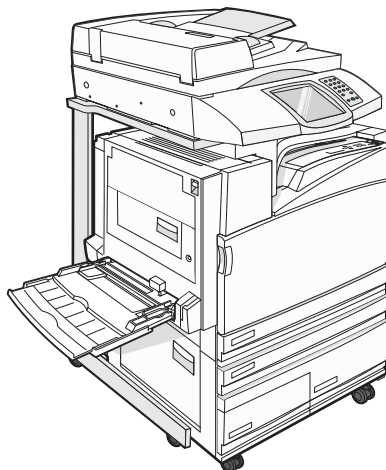

Limit label printing to occasional use of A4- or letter-size paper office labels designed for laser printers. We do *not* recommend using vinyl or polyester labels.

Lexmark X940 and X945 support stocks up to 220 g/m². *Always* feed labels and card stock from Tray 1, 2, or 3. We recommend printing on grain long card stock.

The following table lists the maximum weights supported by the trays and the multipurpose feeder.

Note: Scanning large quantities of labels is *not* recommended.

	Tray 1	Tray 2 and 3	Multipurpose feeder
Labels	105 g/m ²	220 g/m ²	220 g/m ²
Card stock	105 g/m ²	220 g/m ²	220 g/m ²

Labels

Width: 210–216 mm (8.3–8.5 in.)

Length: 279–356 mm (11–11.7 in.)

Weight: 120–128 g/m²

Thickness: 0.13–0.20 mm (0.005–0.008 in.)

Smoothness: 100–400 Sheffield*

* 150–250 Sheffield is optimal. Using media higher than 300 Sheffield could result in print quality degradation.

Card stock

Width: 210–216 mm (8.3–8.5 in.)

Length: 279–356 mm (11–11.7 in.)

Weight: Up to 220 g/m²

Card stock and label guidelines

When printing on labels:

- Set the paper type to Labels in the Paper Menu.
- Do *not* use label sheets with a slick backing material.

- Do *not* print within 1 mm (0.04 in.) of the die-cut, the edge of the label or the perforations, or between the die-cuts.
- Use full label sheets. Partial sheets may cause labels to peel off during printing and result in a paper jam.
- Do *not* use label sheets that have adhesive to the edge of the sheet. We recommend zone coating of the adhesive at least 1 mm (0.04 in.) away from the edges. Adhesive material may contaminate your printer and could void your warranty.

When printing on card stock:

- Use grain long card stock, and set the paper type to Card Stock.
- Do *not* use creased card stock. It may cause paper jams.

Lexmark X950

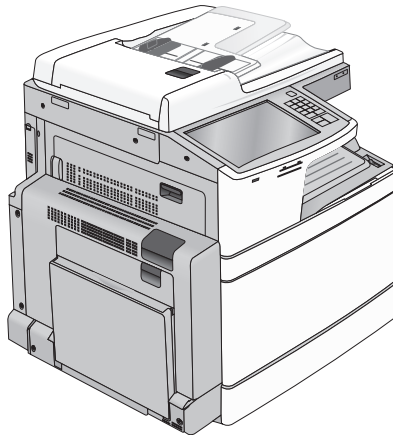

Limit label printing to occasional use of A4- or letter-size paper office labels designed for laser printers. We do *not* recommend using vinyl or polyester labels.

Lexmark X950 supports card stock up to 300 g/m².

The following table lists the maximum weights supported by the trays and the multipurpose feeder.

	Trays 1–4	Multipurpose feeder	High-capacity feeder
Labels	60–256 g/m ²	60–300 g/m ²	60–216 g/m ²
Card stock	60–256 g/m ²	60–300 g/m ²	60–216 g/m ²

Labels	Width:	140–320 mm (5.5–12.6 in.)
	Length:	182–457 mm (7.2–18 in.)
	Weight:	60–256 g/m ²
	Smoothness:	100–200 Sheffield
Card stock	Width:	140–320 mm (5.5–12.6 in.)
	Length:	182–457 mm (7.2–18 in.)
	Weight:	60–256 g/m ²

Card stock and label guidelines

When printing on labels:

- From the printer control panel, set the paper size, type, texture, and weight in the Paper menu to match the labels loaded in the tray.
- Do *not* use label sheets with a slick backing material.
- Do *not* print within 1 mm (0.04 in.) of the die-cut, the edge of the label or the perforations, or between the die-cuts.
- Use full label sheets. Partial sheets may cause labels to peel off during printing, resulting in a jam. Partial sheets also contaminate the printer and the cartridge with adhesive, and could void the printer and toner cartridge warranties.

When printing on card stock:

- From the printer control panel, set the paper size, type, texture, and weight in the Paper menu to match the card stock loaded in the tray.
- Do *not* use creased card stock. It may cause paper jams.
- We recommend the use of grain long card stock.

Optra plus, 4039, 4029, 4019, WinWriter 600 printers

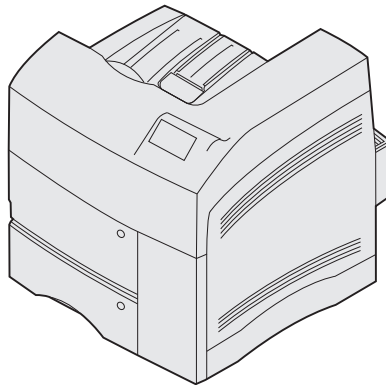

The following table lists the maximum weights supported by each of the special card stock and label trays, as well as the manual feed tray.

Paper source	Card stock			Labels	
	Index Bristol	Tag	Cover	Paper	Vinyl
200-sheet heavy duty tray	163 g/m ²	163 g/m ²	176 g/m ²	150 g/m ²	265 g/m ²
500-sheet tray (450 grams)	90 g/m ²	—	—	—	—
500-sheet tray (550 grams)	135 g/m ²	135 g/m ²	135 g/m ²	165 g/m ²	—
500-sheet tray (650 grams)	163 g/m ²	163 g/m ²	176 g/m ²	175 g/m ²	300 g/m ²
500-sheet tray (750 grams)	199 g/m ²	203 g/m ²	216 g/m ²	180 g/m ²	300 g/m ²
Manual feed tray	253 g/m ²	241 g/m ²	285 g/m ²	263 g/m ²	300 g/m ²

For paper and transparency specifications, see your printer *User's Guide*.

As the following table indicates, the paper tray capacities vary depending on the print material construction. See your printer documentation for additional specifications.

Label material	200-sheet heavy duty tray	500-sheet card stock & label tray
Paper, dual web	125 sheets	250 sheets
Vinyl, polyester	70 sheets	200 sheets

The following table lists the print material specifications for the special card stock and label trays, as well as guidelines for the tray position (upper or lower drawer). This information is intended to convey general guidelines for tray and drawer selection. We recommend that you test your selected print material to determine the best tray and drawer selection for your application. The material type, rigidity, sizing, perforations, die-cuts, and surface influence printing reliability. Contact your point of purchase for more information on the optional trays available for your printer.

Note: If you use materials with a weight over 135 g/m² (36 lb bond), print registration and skew may be unpredictable.

Media	Paper/card stock ¹	Pressure-sensitive paper labels ²	Pressure-sensitive vinyl labels ²
200-sheet heavy duty tray	75–163 g/m ² (20–43 lb bond)	120–150 g/m ² (32–40 lb bond)	260–265 g/m ² 82 lb Liner
500-sheet tray (450 grams)	60–90 g/m ² (16–24 lb bond)	NA	NA
500-sheet tray (550 grams)	75–135 g/m ² (20–36 lb bond)	140–165 g/m ² (37–44 lb bond)	NA
500-sheet tray (650 grams)	120–163 g/m ² (32–43 lb bond)	150–175 g/m ² (40–47 lb bond)	260–300 g/m ² 82–92 lb Liner
500-sheet tray (750 grams)	163–203 g/m ² (43–54 lb bond)	165–180 g/m ² (44–48 lb bond)	265–300 g/m ² 92 lb Liner
Valid tray positions (upper and lower)	Upper: 60–163 g/m ² Lower: All supported media	Upper: 120–150 g/m ² Lower: 140–180 g/m ²	Upper: 260–265 g/m ² Lower: 260–300 g/m ²

¹ You can manually feed card stock with a weight up to 285 g/m².

² For pressure-sensitive materials under 131 g/m², grain long is recommended. For pressure-sensitive materials over 131 g/m², grain short is recommended.

Media	Dual web forms ¹ Pressure-sensitive area Paper base	Integrated forms ¹ Pressure-sensitive area Paper base ²
200-sheet heavy duty tray	140–175 g/m ² 75–135 g/m ² (20–36 lb bond)	140–175 g/m ² 75–135 g/m ² (20–36 lb bond)
500-sheet tray (450 grams)	— —	— 75–90 g/m ² (20–24 lb bond)

¹ Select the appropriate tray according to the part of the form (pressure-sensitive area or paper base) that enters the printer first when feeding from the tray.

² Grain long is recommended.

Media	Dual web forms ¹ Pressure-sensitive area Paper base	Integrated forms ¹ Pressure-sensitive area Paper base ²
500-sheet tray (550 grams)	140–175 g/m ² 75–131 g/m ² (20–35 lb bond)	140–170 g/m ² 75–135 g/m ² (20–36 lb bond)
500-sheet tray (650 grams)	— —	170–175 g/m ² NA
500-sheet tray (750 grams)	— —	— —
Valid tray positions (upper and lower)	Upper and Lower: All supported media	Upper and Lower: All supported media
¹ Select the appropriate tray according to the part of the form (pressure-sensitive area or paper base) that enters the printer first when feeding from the tray. ² Grain long is recommended.		

Labels	Thickness:	0.102–0.254 mm (0.004–0.01 in.)
	Smoothness:	100–400* Sheffield
		* 150–250 Sheffield is optimal. Using media higher than 300 Sheffield could result in printing degradation.
Card stock	Weight:	Up to 163 g/m ² Index Bristol (90 lb)
		Up to 163 g/m ² Tag (100 lb)

Maintenance procedures

For reliable printer performance when feeding card stock and labels, follow the appropriate maintenance procedures outlined in the following sections.

General maintenance

If the print quality begins to degrade when printing sheets of vinyl labels, we suggest you follow the three cleaning steps below:

- 1** Print 5 sheets of paper.
- 2** Wait approximately 5 seconds.
- 3** Print 5 more sheets of paper.

To maintain printer feeding reliability, repeat this cleaning process every time you replace the print cartridge, more often with some media. Failure to follow maintenance procedures could cause jamming, poor print quality, feeding problems, and fuser problems.

Additional maintenance for Optra plus, Optra, 4039 12C (with serial numbers after BC143), and 4039 10 plus printers

- If your laser printer has a fuser cleaner, we recommend that you change it when you replace the print cartridge. If you are printing on labels or card stock, you may need to change the fuser cleaner more frequently. Check the fuser cleaner every 2,000 pages, and replace it if it is crusty or stiff. See your printer documentation for information about ordering additional fuser cleaners. Using a substitute cleaner may result in degraded print quality and may void your printer warranty.
- Use a 4039 print cartridge (P/N 1380850 or 1380950) in Optra and Optra plus laser printers that are dedicated to printing labels. Machine engine code level 43.74 or later is required to use the 4039 cartridges in your Optra and Optra plus printer. Print the menu page from the Tests Menu to determine the level of engine code installed in your printer. Contact Lexmark customer support if you need assistance upgrading to a higher level.
- Always use the fuser cleaners that come with the 4039 print cartridges. If you need additional fuser cleaners, order P/N 1380785. This particular fuser cleaner has oil in the pad to lubricate the fuser and prolong fuser life. It also lessens toner buildup on some labels, ensuring good print quality.
- We recommend using the fuser cleaner shipped with Diamond Fine™ toner cartridges (P/N 1382100 or 1382150) when duplexing.
- Note that 4039 print cartridges are not recommended for general use in Optra printers, since they cannot provide the 1200 dpi quality desirable for graphics and gray scaling. *Using third party, non-Lexmark cartridges and fuser cleaners can void the printer warranty.* Using refilled non-Lexmark cartridges can result in toner build-up in the printer, which increases the potential of toner contamination.
- Some card stock and labels generate a large amount of paper dust, debris, and chaff. To remove excess dust and debris, you may need to clean the inside of the printer frequently, possibly daily. Consult your printer documentation for specific instructions on how to properly clean your printer. Removing debris helps improve paper feeding and fuse grade.
- See your printer documentation for other maintenance procedures to maintain the print quality and reliability of your printer.

For more information, see [“Troubleshooting” on page 14](#).

Optra C

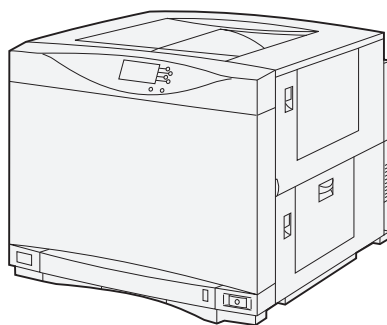

We do *not* recommend using card stock or labels with this printer.

Card stock and labels are *not supported* from any of the paper trays.

For paper and transparency specifications, see the printer *User's Guide*.

Optra C710

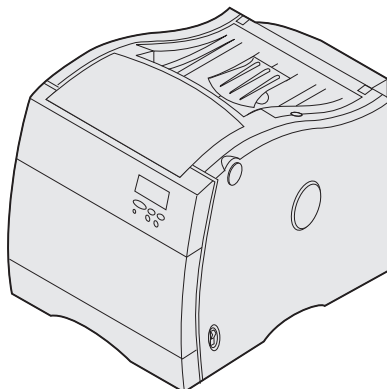

Limit label printing to occasional use of paper office labels designed for laser printers. We do *not* recommend using vinyl or polyester labels.

The Optra C710 supports stocks up to 163 g/m² (90 lb). Feed labels from the multipurpose feeder only, which holds up to 30 sheets of card stock or labels.

The following table lists the maximum weights supported by the multipurpose feeder.

Paper source	Card stock			Labels	
	Index Bristol	Tag	Cover	Paper	Vinyl
Multipurpose feeder	163 g/m ²	163 g/m ²	—	163 g/m ²	—

For paper and transparency specifications, see the printer *User's Guide*.

- Labels**
- Width: 210–216 mm (8.3–8.5 in.)
 - Length: 279–297 mm (11–11.7 in.)
 - Weight: 120–163 g/m² (32–43 lb)
 - Thickness: 0.13–0.20 mm (0.005–0.008 in.)
 - Smoothness: 100–400 Sheffield*
- * 150–250 Sheffield is optimal. Using media higher than 300 Sheffield could result in printing degradation.
- Card stock**
- Weight: Up to 163 g/m² Index Bristol (90 lb)
 - Up to 163 g/m² Tag (100 lb)

Card stock and label guidelines

When printing on labels:

- Use only label sheets that have no gaps between the labels.

Acceptable labels

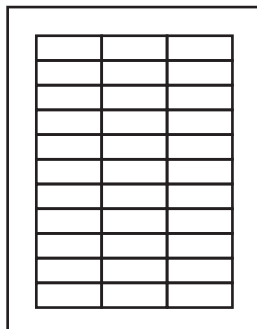

Unacceptable labels

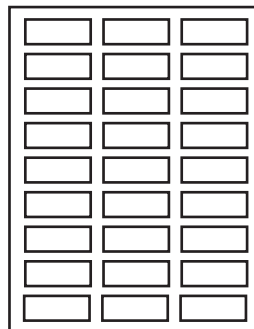

- From the operator panel or from MarkVision Professional, set the Paper Type to Labels.
- Do *not* print a large number of labels continuously.
- Do *not* use labels that have coating or sizing applied to make the labels liquid-resistant.
- Do *not* use labels that have exposed adhesive on the label sheets.

When printing on card stock:

- We recommend using Springhill Index Plus 90 lb card stock.
- For the best print quality, always set the Paper Type to Card Stock.

Optra Color 1200

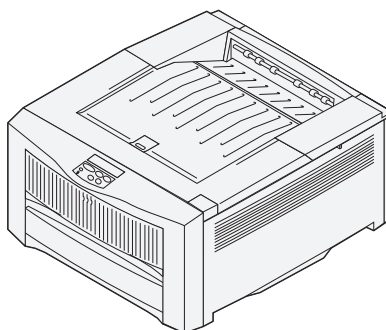

Limit label printing to occasional use of paper office labels designed for laser printers. We do *not* recommend using vinyl or polyester labels.

The Optra Color 1200 supports stock up to 163 g/m² (43 lb).

Always feed labels and card stock from the multipurpose feeder. The multipurpose feeder holds up to 50 sheets of labels or card stock.

The following table lists the maximum weights supported by the multipurpose feeder.

Paper source	Card stock			Labels	
	Index Bristol	Tag	Cover	Paper	Vinyl
Multipurpose feeder	163 g/m ²	163 g/m ²	—	135 g/m ²	—

For paper and transparency specifications, see the printer *User's Guide*.

Labels	Width:	210–216 mm (8.3–8.5 in.)
	Length:	279–356 mm (11–14 in.)
	Weight:	60–135 g/m ²
Card stock	Weight	Up to 163 g/m ² Index Bristol (90 lb)
		Up to 163 g/m ² Tag (100 lb)

Optra E, Ep

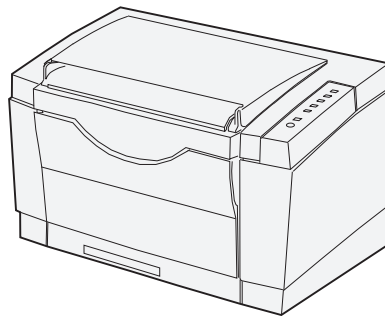

Limit label printing to occasional use of paper office labels designed for laser printers. We do *not* recommend using vinyl or polyester labels.

The Optra E and Optra Ep support stocks up to 163 g/m² (43 lb). Tray 1 can hold up to 10 sheets of card stock or labels.

The following table lists the maximum weights supported by Tray 1 and the manual feed slot.

Paper source	Card stock			Labels	
	Index Bristol	Tag	Cover	Paper	Vinyl
Tray 1	163 g/m ²	163 g/m ²	—	150 g/m ²	—
Manual feed slot	163 g/m ²	163 g/m ²	—	150 g/m ²	—

For paper and transparency specifications, see the printer *User's Guide*.

Labels	Width:	210–216 mm (8.3–8.5 in.)
	Length:	279–297 mm (11–11.7 in.)
	Weight:	120–150 g/m ² (32–39 lb)
	Thickness:	0.13–0.25 mm (0.005–0.01 in.)
	Smoothness:	100–400 Sheffield*

* 150–250 Sheffield is optimal. Using media higher than 300 Sheffield could result in printing degradation.

Optra Es special media printer

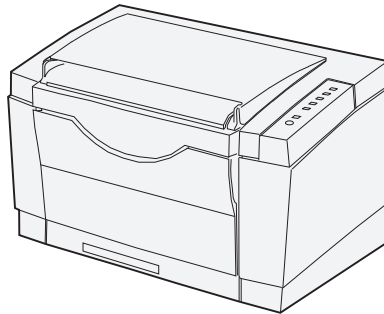

The Optra Es printer has highly precise print registration and excellent feeding reliability. It was designed to handle a wide range of paper and card stock weights, as well as continuous printing of labels.

The following table lists the maximum weights supported by Tray 1 and the manual feed slot.

Paper source	Card stock			Labels	
	Index Bristol	Tag	Cover	Paper	Vinyl
Tray 1	199 g/m ²	163 g/m ²	176 g/m ²	180 g/m ²	300 g/m ²
Manual feed slot	199 g/m ²	163 g/m ²	176 g/m ²	180 g/m ²	300 g/m ²

For paper and transparency specifications, see the printer *User's Guide*.

Selecting and loading media

Your printer can accept a wide range of paper or card stock weights, but materials either too light or too heavy can cause paper handling and print quality problems. Heavier weight materials can cause fusing problems because of the mass of material the fuser must heat quickly. Heavy materials may also feed less reliably or skew because of their weight or stiffness. Lighter materials can wrinkle or jam.

When you use preprinted forms, make sure the ink on the forms can withstand the printer fuser temperature of 200°C (392°F); otherwise, you risk contaminating the printer or creating hazardous fumes.

When you select the correct Paper Type (Normal, Rough Paper, Card Stock, Transparency, Labels) from MarkVision Professional, your printer automatically optimizes print quality and toner adhesion.

Feed labels, card stock, transparencies, and envelopes from Tray 1 or the manual feed slot. Reserve Tray 2 for 20–24 lb bond paper. Do *not* load labels together with other media in the same paper tray; combining different print media can cause feeding problems. To avoid curl, do *not* leave labels in the tray overnight.

When feeding labels from Tray 1, push the label lever to the left. When printing on other media, push the lever to the right.

To improve feed reliability, flex the print media before placing it in the paper tray.

Source	Print media		Maximum stack height	Input capacity	Output capacity
Tray 1	Paper	20 lb bond	15 mm (0.6 in.)	150 sheets	100 sheets
		24 lb bond	15 mm (0.6 in.)	100 sheets	100 sheets
	Labels	Paper	13 mm (0.5 in.)	70 sheets	70 sheets
		Vinyl	13 mm (0.5 in.)	35–50 sheets	35–50 sheets
		Dual Web Forms Integrated Forms	13 mm (0.5 in.)	50–60 sheets	50–60 sheets
	Card stock ^{1,2}	Index 163 g/m ² (90 lb)	7 mm (0.3 in.)	35 sheets	35 sheets
		Index 199 g/m ² (110 lb)	7 mm (0.3 in.)	30 sheets	1 sheet
		Tag 163 g/m ² (100 lb)	7 mm (0.3 in.)	30 sheets	30 sheets
	Envelopes (20 lb)		13 mm (0.5 in.)	10 envelopes	10 envelopes
	Transparencies		2.5 mm (0.1 in.)	10 sheets	10 sheets
Tray 2	Paper	20 lb bond	25 mm (1 in.)	250 sheets	250 sheets
		24 lb bond	25 mm (1 in.)	150 sheets	150 sheets
Manual	All supported media		—	1 sheet	1 sheet

¹ Card stock weights may vary \pm 5%.

² 110 lb Index recommended for applications using only solid black lines, text, or area fills. Applications using gray scales may have unpredictable results.

For more information, see [“Maintenance procedures” on page 14.](#)

Optra K 1220

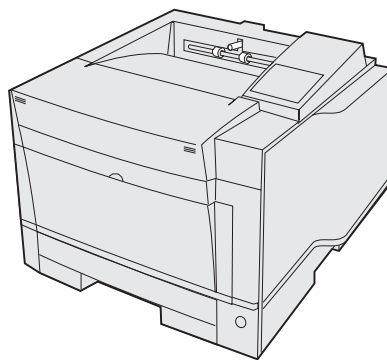

Limit label printing to occasional use of paper office labels designed for laser printers. We do *not* recommend using vinyl or polyester labels or any card stock with the Optra K 1220 printer.

Always feed labels from the manual feed tray or the optional multipurpose feeder. The multipurpose feeder can hold up to 30 sheets of labels.

The following table lists the maximum weights supported.

Paper source	Card stock			Labels	
	Index Bristol	Tag	Cover	Paper	Vinyl
Multipurpose feeder	—	—	—	150 g/m ²	—
Manual feed tray	—	—	—	150 g/m ²	—

For paper and transparency specifications, see the printer *User's Guide*.

Labels	Width:	210–216 mm (8.3–8.5 in.)
	Length:	279–356 mm (11–14 in.)
	Weight:	120–150 g/m ² (32–40 lb)

Label guidelines

When printing on labels:

- From the operator panel or from MarkVision, set the Paper Type to Labels. Set the Paper Weight to either Normal or Heavy for optimum print quality.
- To minimize curl, make sure the rear exit bin is open so the labels feed straight out the back of the printer.
- Do *not* print a large number of labels continuously.
- Do *not* use labels that have exposed adhesive on the label sheets.

Optra M410, M412

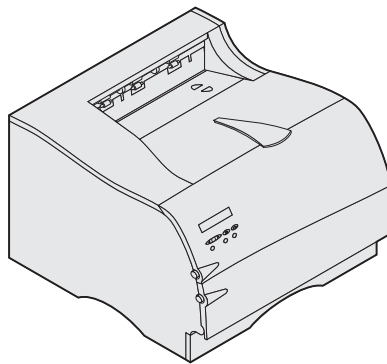

The Optra M410 and Optra M412 print on card stock and many labels designed for use with laser printers.

The following tables list the weights supported by the multipurpose feeder and the 250-sheet label tray, P/N 4K00293.

Paper source	Card stock		
	Index Bristol	Tag	Cover
Multipurpose feeder	Up to 199 g/m ²	Up to 163 g/m ²	Up to 176 g/m ²
250-sheet label tray	—	—	—

Paper source	Labels			
	Paper	Vinyl	Dual web	Integrated
Multipurpose feeder	120–180 g/m ²	260–300 g/m ²	140–180 g/m ²	140–175 g/m ²
250-sheet label tray	120–180 g/m ²	260–300 g/m ²	140–180 g/m ²	140–175 g/m ²

The 250-sheet label tray option accommodates plain paper, transparencies, simple paper labels, dual web paper labels, and vinyl labels. Lightweight plain paper (less than 20 lb. bond) is not supported.

To reliably feed lightweight plain paper and some lightweight labels, use the standard 250-sheet input tray that comes with your printer.

The label tray can hold up to 100 labels.

The optional 500-sheet drawer should only be used to feed paper; it does not support card stock and label printing.

You can try occasional label printing from Tray 1, but we recommend you use the multipurpose feeder.

For paper and transparency specifications, see the printer *User's Guide*.

Source	Print media	Capacity
Multipurpose feeder	Labels	30 labels
	Card stock	10 sheets card stock
250-sheet label tray	Labels	100 labels

Card stock and label guidelines

When printing on labels:

- From the operator panel or MarkVision Professional, set the Paper Type to Labels.
- Do *not* load labels together with paper or transparencies in the same paper source.
- To minimize curl, make sure the rear exit bin is open so the labels feed straight out the back of the printer.
- Do *not* use label sheets with a slick backing material.
- Do *not* print within 1 mm (0.040 in.) of the die-cut.
- Use full label sheets. Partial sheets may cause labels to peel off during printing, resulting in a paper jam. Partial sheets will also contaminate your printer and your cartridge with adhesive, and could void your printer and cartridge warranties.
- Do *not* print within 1 mm (0.040 in.) of the edge of the label, of the perforations, or between die-cuts of the label.
- Do *not* use label sheets that have adhesive to the edge of the sheet. We recommend zone coating of the adhesive at least 1 mm (0.040 in.) away from edges. Adhesive material will contaminate your printer and could void your warranty.
- If zone coating of the adhesive is not possible, a 3-mm (0.125-in.) strip should be removed on the leading and driver edge, and a non-oozing adhesive should be used.
- Remove a 3-mm (0.125-in.) strip from the leading edge to prevent labels from peeling inside the printer.
- Portrait orientation is preferred, especially when printing bar codes.
- Do *not* use labels that have exposed adhesive.
- For best results when using the multipurpose feeder, dual web and integrated labels should be fed paper-end first.
- For best results when using the 250-sheet label tray, dual web and integrated labels should be fed label-end first.

When printing on card stock:

- From the operator panel or MarkVision Professional, set the Paper Type to Card Stock.
- Do *not* use preprinted card stock manufactured with chemicals that may contaminate the printer.
- Do *not* use card stock that is creased. It may cause paper jams.
- To minimize curl, make sure the rear exit bin is open so the card stock feeds straight out the back of the printer.
- We recommend the use of grain short card stock.

For more information, see [“Maintenance procedures” on page 14](#).

Optra N

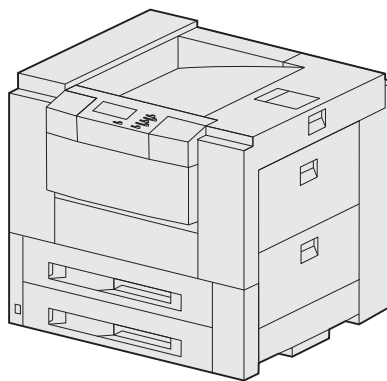

Limit label printing to occasional use of paper office labels designed for laser printers. We do *not* recommend using vinyl or polyester labels.

Always feed labels from the multipurpose tray. The multipurpose tray can hold up to 50 sheets of labels.

The Optra N supports print materials up to 128 g/m² (34 lb).

The following table lists the maximum weights supported by the multipurpose tray.

Paper source	Card stock			Labels	
	Index Bristol	Tag	Cover	Paper	Vinyl
Multipurpose Tray	—	—	—	128 g/m ²	—

For paper and transparency specifications, see the printer *User's Guide*.

Labels	Width:	210–216 mm (8.3–8.5 in.)
	Length:	279–356 mm (11–14 in.)
	Weight:	120–128 g/m ² (32–34 lb)
	Thickness:	0.13–0.20 mm (0.005–0.008 in.)
	Smoothness:	100–400 Sheffield*

* 150–250 Sheffield is optimal. Using media higher than 300 Sheffield could result in printing degradation.

Optra S

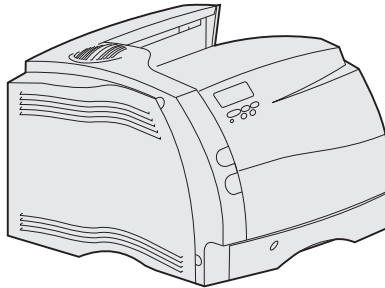

Optra S 1250, S 1255, S 1620, S 1625, S 1650, S 1855, S 2420, S 2450, S 2455, Se 3455

The following table lists the maximum weights supported by each of the printer trays.

Print material		Range or maximum weight supported	
		250-sheet and 500-sheet trays	Multipurpose feeder and optional 250-sheet drawer
Paper (grain long)	Xerographic or business paper	60–176 g/m ² (16–47 lb bond)	60–135 g/m ² (16–36 lb bond)
Card stock (grain long ¹)	Index Bristol	163 g/m ² (90 lb)	120 g/m ² (67 lb)
	Tag	163 g/m ² (100 lb)	120 g/m ² (74 lb)
	Cover	176 g/m ² (65 lb)	135 g/m ² (50 lb)
Card stock (grain short ¹)	Index Bristol	199 g/m ² (110 lb)	163 g/m ² (90 lb)
	Tag	203 g/m ² (125 lb)	163 g/m ² (100 lb)
	Cover	216 g/m ² (80 lb)	176 g/m ² (65 lb)
Labels	Paper	180 g/m ² (48 lb bond)	163 g/m ² (43 lb bond)
	Dual-Web Paper	180 g/m ² (48 lb bond)	163 g/m ² (43 lb bond)
	Vinyl	300 g/m ² (92 lb liner)	260 g/m ² (78 lb liner)
	Polyester	220 g/m ² (59 lb bond)	220 g/m ² (59 lb bond)
Integrated forms	Pressure sensitive area ²	140–175 g/m ²	140 to 175 g/m ²
	Paper base (grain long)	75–135 g/m ² (20–36 lb bond)	75–135 g/m ² (20–36 lb bond)

¹ See [“Grain orientation” on page 17](#) for specific recommendations.

² Pressure-sensitive area must enter the printer first for grain short paper.

For paper and transparency specifications, see the printer *User's Guide*.

Labels	Thickness:	0.102–0.305 mm (0.004–0.012 in.)
	Smoothness:	100–400* Sheffield

The information in the specification tables is intended to convey general guidelines for tray and drawer selection. The material type, rigidity, sizing, perforations, die-cuts, and surface influence the performance reliability.

The duplex option supports all paper weights and types that the printer supports, except for transparencies and envelopes. Duplexing of specially designed labels is supported in the Optra S1855 printer.

You may notice skew or print registration problems if you feed materials over 135 g/m² from the multipurpose feeder or the optional 250-sheet drawer. You may notice similar problems if you feed materials over 176 g/m² from the primary 250-sheet tray or the optional 500-sheet drawer.

When feeding labels, the number of labels per sheet can affect registration more than basis weight. Typically, the more labels per sheet, the better the registration.

Ordering special supplies for label printing

Labels are one of the most difficult print materials for laser printers to handle. To optimize printer performance, use the special label fuser cleaner for printers dedicated to label printing.

To get the special label oil fuser cleaner (to use with simplex labels and vinyl labels), order print cartridge P/N 1382929. If you need additional label fuser cleaners of this type (packaged separately from the print cartridge), order P/N 43H0814. If you are duplexing other jobs, do *not* use the special label fuser cleaner that comes with this cartridge.

Duplexing of specially designed duplex labels is only supported in the S1855. You must also use a specially designed wax fuser cleaner (P/N 99A1082) with this application. The cartridge containing this special wax fuser cleaner should be ordered when cartridge replacements are needed.

Print cartridge part number	Yield (average)	Coverage (approximate)
1382929 <i>Prebate</i> [™] (cartridge for special label machine use)	17,600 pages	5%

For more information, see the following:

- [“Pick roller technology” on page 11](#)
- [“Maintenance procedures” on page 14](#)
- [“Troubleshooting” on page 14](#)

Optra SC 1275

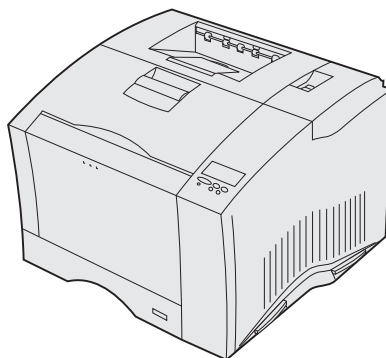

Limit label printing to occasional use of paper office labels designed for laser printers. We do *not* recommend using vinyl or polyester labels.

Card stock	Weight:	Up to 199 g/m ² Index Bristol (90 lb)
		Up to 203 g/m ² Tag (100 lb)

Standard trays and special media trays

The Optra T paper feeding mechanism uses advanced technology that enhances feeding reliability. The standard Optra T tray, which holds 250 or 500 sheets of bond paper, reliably feeds all media tested according to the guidelines specified under [“Dimensions” on page 9](#).

For those difficult-to-print sizes, such as 3 x 5-inch index cards, Lexmark offers a variety of special media trays and drawers.

Note: Optional 250-sheet Universally Adjustable Trays designed for the Lexmark T printer family support forms with a minimum length of 5 inches when installed either in the integral tray location or in a 250-sheet drawer under a 250-sheet integral tray. The 250-sheet Universally Adjustable Tray does not support forms shorter than 7 inches on a T522, T620, T622, T630, or T632. Optional 500-sheet Universally Adjustable Trays support forms with a minimum length of 7 inches.

Source	Part number
250-Sheet Special Media Tray	11K1572
250-Sheet Special Media Drawer	11K1573
250-Sheet Universally Adjustable Tray	11K1574
250-Sheet Universally Adjustable Drawer	11K1878
500-Sheet Special Media Tray	11K1921
500-Sheet Special Media Tray + Drawer	11K1922
400-Sheet Universally Adjustable Tray	11K1941
400-Sheet Universally Adjustable Tray + Drawer	11K1942

Card stock and label guidelines

Labels are one of the most difficult print materials for laser printers. A special fuser cleaner should be used for label applications to optimize feed reliability. See your printer documentation for information on ordering additional label fuser cleaners.

Printing labels on the Optra T requires a special label fuser cleaner that prevents duplexing.

It is recommended that when you run vinyl labels, you install a special oil fuser cleaner, P/N 99A0725. When you order a new cartridge, be sure to order the cartridge that will include the correct fuser cleaner.

It is possible to duplex certain labels that have been specifically designed for this application. To duplex labels, consult the Lexmark “Converter Lists” to see which converters have successfully developed this type of label, and you must install a special fuser wiper. The wax wiper that is used with the Optra T is P/N 99A1082.

When printing on labels:

- Using the printer operator panel, set the Paper Type to Labels in the Paper Menu. For vinyl and other heavy labels, set the Labels Weight (under the Paper Weight menu) to Heavy, and set the Labels Texture (under the Paper Texture menu) to Smooth.
- Do *not* load labels together with paper or transparencies in the same paper tray. Combining print materials can cause feeding problems.

- Use full label sheets. Partial sheets may cause labels to peel off during printing, resulting in a paper jam. Adhesive material may contaminate your printer. It could also void your printer and cartridge warranties.

When printing on card stock:

- Set the Paper Type to Card Stock in the Paper Menu.
- Do *not* use card stock that is creased. It may cause paper jams.

When feeding labels, the number of labels per sheet can affect registration more than basis weight. Typically, the more labels per sheet, the better the registration.

For more information, see the following:

- [“Pick roller technology” on page 11](#)
- [“Grain orientation” on page 17](#)
- [“Maintenance procedures” on page 14](#)
- [“Troubleshooting” on page 14](#)

Optra W810

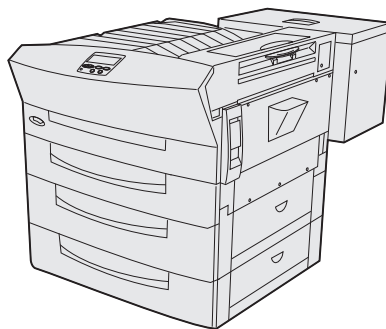

Limit label printing to occasional use of A4- or letter-size paper labels designed for laser printers. We do *not* recommend using vinyl or polyester labels.

The Optra W810 supports stocks up to 163 g/m² (43 lb). *Always* feed labels and card stock from Tray 1, which holds up to 50 sheets of labels or card stock.

The following table lists the maximum weights supported by Tray 1.

Paper source	Card stock			Labels	
	Index Bristol	Tag	Cover	Paper	Vinyl
Tray 1	163 g/m ²	163 g/m ²	—	163 g/m ²	—

For paper and transparency specifications, see the printer *User's Guide*.

Labels	Width:	210–216 mm (8.3–8.5 in.)
	Length:	279–356 mm (11–11.7 in.)
	Weight:	120–128 g/m ² (32–34 lb.)
	Thickness:	0.13–0.20 mm (0.005–0.008 in.)
	Smoothness:	100–400 Sheffield*

* 150–250 Sheffield is optimal. Using media higher than 300 Sheffield could result in printing degradation.

Card stock	Width:	210–216 mm (8.3–8.5 in.)
	Length:	279–356 mm (11–11.7 in.)
	Weight:	Up to 163 g/m ² Index Bristol (90 lb)

Card stock and label guidelines

When printing on labels:

- Set the Paper Type to Labels in the Paper Menu.
- Do *not* use label sheets with a slick backing material.
- Do *not* print within 1 mm (0.040 in.) of the die-cut, the edge of the label, the perforations, or between the die-cuts.
- Use full label sheets. Partial sheets may cause labels to peel off during printing, resulting in a paper jam.
- Do *not* use label sheets that have adhesive to the edge of the sheet. We recommend zone coating of the adhesive at least 1 mm (0.040 in.) away from the edges. Adhesive material may contaminate your printer and could void your warranty.

When printing on card stock:

- Set the Paper Type to Plain Paper. The Optra W810 treats card stock the same as Plain Paper. It does not adjust the print speed or fuser temperature when the Paper Type is set to Card Stock.
- Do *not* use card stock that is creased. It may cause paper jams.
- We recommend the use of grain long card stock.

Glossary

Adhesive contamination	Migration of adhesive away from a label, which can cause printer contamination. Also known as <i>glue contamination</i> .
Anvil cuts	Cuts that penetrate both the face stock and the liner of a label.
Auto compensator	A gear-driven pick arm suspended by a counterbalance spring that allows the printer to automatically adjust the pick force necessary for different types of print materials.
Back splits	Also known as <i>back slits</i> or <i>liner cuts</i> . Cuts through the backside of the liner. Back splits increase the potential for <i>adhesive contamination</i> .
Backup roll contamination	Toner contamination of the fuser's backup roll. Particularly applies to vinyl, plastic, and paper labels. Slick backings are harder to feed and increase toner buildup in the fuser.
Basis weight	Weight in pounds of a specific number of sheets of paper or stock in a standard size for that particular material.
Beam strength	Also known as <i>column strength</i> . Refers to how well the material is able to support itself and remain flat and straight during the printing process.
Butt cut	Cut flush to one another, with no extra area between. This cut does not extend through the liner. Butt cut labels may or may not have an edge matrix removed.
Calendering	The process of moving paper through metal rolls during manufacturing to smooth and gloss the surface of the paper.
Clipping	Also known as <i>buckler damage</i> . A notching or slight folding of the corner of the stock placed under the corner buckler of the paper tray.
Conversion	The process that turns base stock into cut-sheet products designed for specific applications. Conversion includes cutting the base stock to size, perforating the stock, die-cutting, and applying inks and topcoats.
Converters	Print material suppliers who take the base stock from the manufacturer and convert it into cut sheet products.
Corner buckler	The metal tab at the corner of a paper tray that helps the printer separate one sheet of paper from the stack during the pick process.
Curl	Waviness or curvature at the edge of the material that is generally moisture related.
Cut sheet	Single piece (page) of paper or label stock.
Debossing	Process of pressing an image down into the surface of the label or card stock. See “Embossing” on page 169 .
Delamination	The peeling of labels off the backing during the printing process.
Die-cut	Labels: Cut of material (face stock) to form individual labels on sheet. Cuts do not penetrate the liner. Card Stock: Cuts made with dies to create the shapes wanted in the stock. Cuts may or may not go completely through the stock. See “Ties” on page 170 .

Driver edge	For printers that use a fixed reference for feeding paper through the paper path (as opposed to printers that center paper in the path), the edge of the print material that is positioned next to the hardware reference and that is driven by the rollers in the printer. For most Lexmark printers, the driver edge is the left edge of a portrait page.
Embossing	Process of raising the surface of the base material by stamping an image or design with an embossing machine. The machine has a roll with a raised image on the surface. As the print material passes through the machine, the image is pressed into the material. See “Debossing” on page 168 .
Feed	How well the stock moves out of the paper tray and through the printer.
Fiber content	The material used to manufacture the paper. Most high-quality xerographic paper is made from 100% chemically pulped wood. This content provides the paper with a high degree of stability resulting in fewer paper feeding problems and better print quality. Paper containing fibers such as cotton have characteristics that can result in degraded paper feeding.
Fuse grade	Qualitative measurement of the adhesion of toner to the printed sheet.
Fusing	Printer process of melting toner and adhering it to the print material.
Glue contamination	See “Adhesive contamination” on page 168 .
Grain	The orientation of the fibers in the print material. <i>Grain short</i> indicates the fibers run the width of the paper. <i>Grain long</i> indicates the fibers run the length of the paper.
Ink contamination	Transfer of ink from a form to the printer's pick mechanism or fuser assembly, which can cause printer contamination.
Ironing	A mechanical process used during conversion to flatten stock.
Laser ink	Inks that can withstand fuser temperatures of 225°C (437°F) and pressures to 25 psi without contaminating the printer or releasing hazardous fumes.
Laser-perfs	Small perforations (20 to 30 perfs per inch) that create little paper dust and debris and do not normally cause nesting. Also known as micro-perfs or data-perfs.
Leading edge	The edge of the print material that enters the printer paper path first.
Matrix	Unneeded portions of die-cut stock around labels. A <i>stripped matrix</i> is one that is removed to make it easier to peel labels from the liner.
Micro-perfs	See “Laser-perfs” on page 169 .
Moisture content	The amount of moisture in the paper, which affects both print quality and paper feeding. Leave paper in its original wrapper until you are ready to use it. This limits the exposure of the paper to moisture changes that can damage the paper.
Nesting	To fit compactly together; to interlock; to stick together.
Offset powder	A powder applied during some printing processes to help dry inks.
Oil bleed	Migration of materials from the substrate or the adhesive out to the face. This generally occurs in aged materials or materials exposed to extreme temperature changes. Also known as <i>penetration</i> , <i>bleed through</i> , and <i>bleed</i> .
Ooze	Migration of adhesive away from labels, which can cause printer contamination.
Perforation	Line of very small holes or slots punched to facilitate tearing. See also “Laser-perfs” on page 169 .

Pick	The mechanical action the printer performs to remove one sheet of material from the tray.
Pick roller	The roller that assists in picking a sheet of material from the tray.
Pull strength	See “Release” on page 170 .
Release	The ability of adhesive to resist label peeling during the printing process.
Rollback	The lifting of labels from the backing during the printing process. Also known as <i>butterflying</i> .
Roll-over	Bending of the paper edge during conversion due to a dull cutting knife.
Semi-liquid	Having characteristics of both liquid and solid.
Shear strength	Cohesive strength of the adhesive.
Shelf talkers	Small signs that hang over or next to a regular shelf label. Shelf talkers may be constructed of a pressure-sensitive material or card stock.
Sizing	Additives applied to paper (internally or externally) that improve offset printing qualities and resistance to liquids.
Skew	Slant of printed lines in reference to the edge of the paper; due to paper moving through the printer in something other than a straight path.
Smoothness	The degree of smoothness of the print material. If the paper is too rough, the toner does not fuse to the paper properly, resulting in poor print quality. If the paper is too smooth, it can cause paper feeding problems in the printer. Smoothness is measured in Sheffield points; lower values indicate smoother paper.
Splatter	The appearance of black specks around a printed image. Generally related to printing on stock that is too heavy or has a surface that repels toner.
Stacking	How well the paper stacks in the output bin.
Stringers	Small bits of adhesive found on top of a pressure-sensitive material at the die-cut and perforated areas. Stringers are indications of a dull blade and are related to the shear strength of the adhesive.
Stripped edge matrix	Labels with a portion of the area around the outer edge of the cut sheet removed.
Supercalendering	A process where paper passes through heated, polished steel and compressed cotton rolls that "iron" the material to a high gloss, polished finish.
Talkers	Printed or handwritten signs used to advertise specials or to draw attention to a particular product.
Tenting	The creasing of perforated material when it is flexed.
Thermography	A printing process that raises the ink image or design above the surface of the base material. Also known as <i>electro-thermography</i> .
Ties	Small areas along perforations or die-cuts in the face material of a label (pressure-sensitive material), or in card stock, which are not cut through. Ties help stabilize the form and prevent tearing at the perforations and die-cuts.
Toner	The material that adheres to the paper or print material to create the printed image.
Total strip matrix	Labels that have the unneeded portion of the die-cut stock around the labels, including a portion between the labels, removed to make it easier to peel labels from the backing.

Vellum finish	A finish with a rough surface similar to eggshell and antique finishes. A vellum finish is relatively absorbent, providing good ink penetration.
Wash boarding	Waviness in the stock that gives a rippled appearance to the material; generally moisture related.
Zone coating	Placing adhesive in selected areas only. Allows no adhesive areas along edge of labels. Also known as <i>patterned adhesive</i> , <i>pattern coated</i> , <i>dry lap</i> , <i>separator</i> , <i>strip coated</i> .

Index

A

adhesives
contamination 20, 23, 25
integrated forms 25
label component 23

B

backing 23
bar codes 11
basis weight 9, 16
butt cut labels 25

C

card stock
coatings 18
design factors 9
grain orientation 17
recommendations 16
thickness 16
weights 9, 16
carrier 23
chaff 23, 150
coatings 18
contamination 20, 23, 25
converters 8
curl 10, 17
cut sheet paper labels 25

D

debossing 11
designing labels 9, 25
die-cut labels 25
die-cuts 10
dimensions 9
distributors 8
dual web forms 25
duplexing labels 20

E

embossing 9
environmental factors 9

F

face sheet 23
fiber content 169
finishes 18, 23

form design 11, 9
fumes 9, 25
fuser cleaner
Optra Plus and 4039 printers 150
Optra S 162

G

grain orientation 17

H

humidity 9

I

industry 8
inks (preprinted stock) 10
integrated forms 31
ironing 10

L

label characteristics 20
label components
adhesives 24
face sheets 25
liners 23
topcoats 25
label fuser cleaner (Optra S) 162
labels
construction 23, 20
design 25, 20
dual web forms 29
duplexing 20
integrated forms 31
printer maintenance 20
printing 20
vinyl and polyester labels 30
labels, printing on 20
laser printers 7
liners 23

M

maintenance procedures 14
manufacturers 8
matrix
defined 169
stripped edge 25
total strip 26, 25
metallics 11

moisture content 169

N

notices 2

O

oil bleed 31
orientation 11

P

paper and label industry 8
paper dust 24, 150
perforations 10
pick roller 11
polyester labels 30
preprinted stock 10
primary rib pattern design
guidelines 22
print is blurred or out of focus 14
print volumes 8
printing on labels 20
printing shows voids 14

R

reference edge alignment 22

S

sizing 29
smoothness 24
stacking in output bin 31
stripped edge matrix 23, 25
supercalendering 24
supported laser printers 7

T

technical assistance 7, 9
temperature 9
testing print material 8
thermography inks 10
toner rubs off 14
topcoats 25
troubleshooting 14

V

vinyl labels 25
volume printing 8

W

weight, basis 9
weights, card stock
comparison 0

Z

zone coating
adhesives 25
integrated forms 31
labels 26