

# COOLING AND LUBRICATION SYSTEM

## CONTENTS

ENGINE COOLANT .....	6- 2
COOLING CIRCUIT .....	6- 3
COOLING CIRCUIT INSPECTION .....	6- 3
RADIATOR AND WATER HOSE .....	6- 4
RADIATOR REMOVAL .....	6- 4
RADIATOR CAP INSPECTION .....	6- 6
RADIATOR INSPECTION AND CLEANING .....	6- 6
RADIATOR INSTALLATION .....	6- 6
WATER HOSE INSPECTION .....	6- 7
RADIATOR RESERVOIR TANK .....	6- 7
COOLING FAN .....	6- 8
REMOVAL .....	6- 8
INSTALLATION .....	6- 9
INSPECTION .....	6- 9
COOLING FAN RELAY INSPECTION .....	6-10
ECT SENSOR .....	6-10
REMOVAL .....	6-10
INSPECTION .....	6-10
INSTALLATION .....	6-11
THERMOSTAT .....	6-12
REMOVAL .....	6-12
INSPECTION .....	6-12
INSTALLATION .....	6-13
WATER PUMP .....	6-14
REMOVAL AND DISASSEMBLY .....	6-14
INSPECTION .....	6-16
REASSEMBLY AND INSTALLATION .....	6-17
OIL TANK, OIL RETURN TANK AND HOSES .....	6-20
CONSTRUCTION .....	6-20
OIL TANK .....	6-21
OIL RETURN TANK .....	6-23
LUBRICATION SYSTEM .....	6-24
OIL PRESSURE .....	6-24
OIL FILTER .....	6-24
OIL STRAINER .....	6-24
OIL PUMP .....	6-24
ENGINE LUBRICATION SYSTEM CHART .....	6-25

## ENGINE COOLANT

At the time of manufacture, the cooling system is filled with a 50:50 mixture of distilled water and ethylene glycol anti-freeze. This 50:50 mixture will provide the optimum corrosion protection and excellent heat protection, and will protect the cooling system from freezing at temperatures above  $-31\text{ }^{\circ}\text{C}$  ( $-24\text{ }^{\circ}\text{F}$ ).

If the vehicle is to be exposed to temperatures below  $-31\text{ }^{\circ}\text{C}$  ( $-24\text{ }^{\circ}\text{F}$ ), this mixing ratio should be increased up to 55% or 60% according to the figure.

Anti-freeze density	Freezing point
50%	$-30\text{ }^{\circ}\text{C}$ ( $-24\text{ }^{\circ}\text{F}$ )
55%	$-40\text{ }^{\circ}\text{C}$ ( $-44\text{ }^{\circ}\text{F}$ )
60%	$-55\text{ }^{\circ}\text{C}$ ( $-67\text{ }^{\circ}\text{F}$ )

### CAUTION

- \* Use a high quality ethylene glycol base anti-freeze, mixed with distilled water. Do not mix an alcohol base anti-freeze and different brands of anti-freeze.
- \* Do not put in 60% and more anti-freeze or 50% and less. (Refer to below figure.)
- \* Do not use a radiator anti-leak additive.

50% Engine coolant including reserve tank capacity

Anti-freeze	700 ml (1.5/1.2 US/lmp.pt)
Water	700 ml (1.5/1.2 US/lmp.pt)

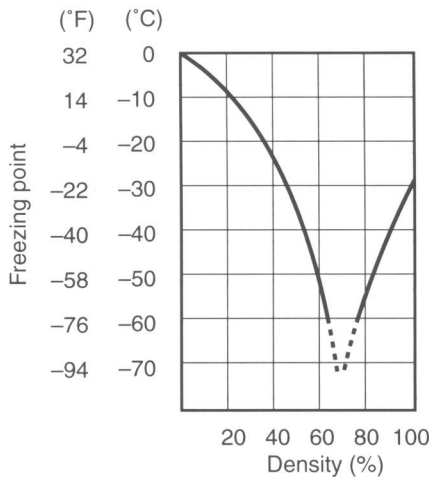

Fig. 1 Engine coolant density-freezing point curve

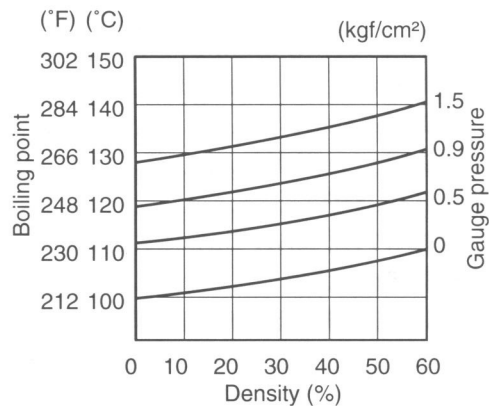
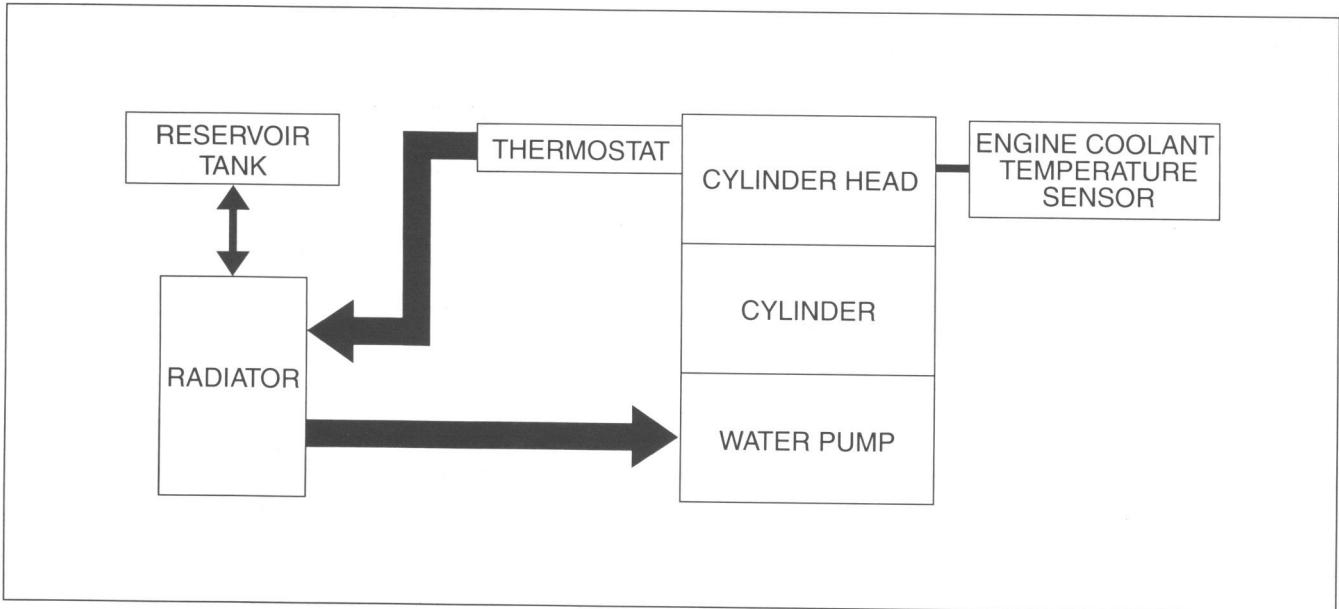

Fig. 2 Engine coolant density-boiling point curve

### WARNING

- \* You can be injured by scalding fluid or steam if you open the radiator cap when the engine is hot. After the engine cools, wrap a thick cloth around cap and carefully remove the cap by turning it a quarter turn to allow pressure to escape and then turn the cap all the way off.
- \* The engine must be cool before servicing the cooling system.
- \* Coolant is harmful;
  - If it comes in contact with skin or eyes, flush with water.
  - If swallowed accidentally, induce vomiting and call physician immediately.
  - Keep it away from children.

## COOLING CIRCUIT



## COOLING CIRCUIT INSPECTION

Before removing the radiator and draining the engine coolant, inspect the cooling circuit for tightness.

- Remove the side cover (R). (7-6)
- Remove the radiator cap ① and connect the tester ② to the filler.

### ⚠ WARNING

**Do not remove the radiator cap when the engine is hot.**

- Give a pressure of about 120 kPa (1.2 kgf/cm<sup>2</sup>, 17 psi) and see if the system holds this pressure for 10 seconds.
- If the pressure should fall during this 10-second interval, it means that there is a leaking point in the system. In such a case, inspect the entire system and replace the leaking component or part.

### ⚠ WARNING

**When removing the radiator cap tester, put a rag on the filler to prevent spouting of engine coolant.**

### CAUTION

**Do not allow the pressure to exceed the radiator cap release pressure, or the radiator can be damaged.**

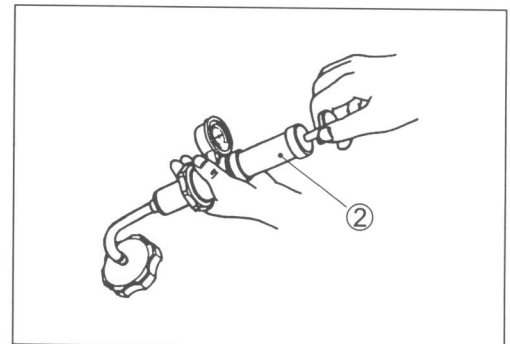
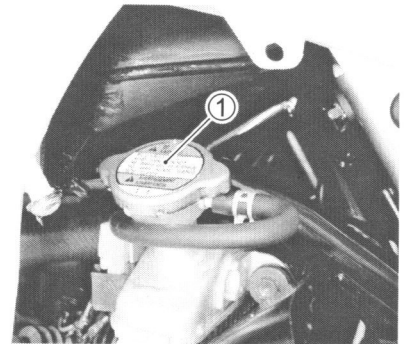

## RADIATOR AND WATER HOSE

### RADIATOR REMOVAL

- Remove the front fender. (☞ 7-6)
- Drain engine coolant. (☞ 2-15)
- Remove the oil return tank. (☞ 6-23)
- Remove the fuel tank and fuel tank lower cover. (☞ 5-4)
- Remove the cooling fan. (☞ 6-8)
- Remove the radiator reservoir tank. (☞ 6-7)
- Remove the battery holder. (☞ 6-21)
- Remove the cooling fan fuse ① from the radiator.
- Disconnect the inlet hose ②.
- Disconnect the outlet hose ③.
- Disconnect the rear brake switch coupler ④.
- Remove the rear brake switch wire harness from the clamp.
- Remove the main harness ⑤ from the clamp.
- Remove the radiator cover mounting bolts.

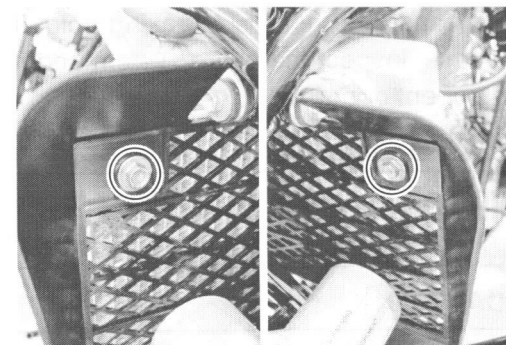
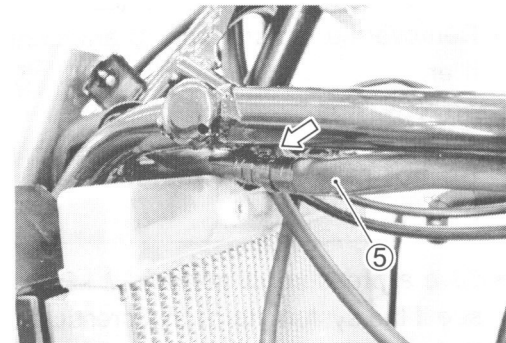
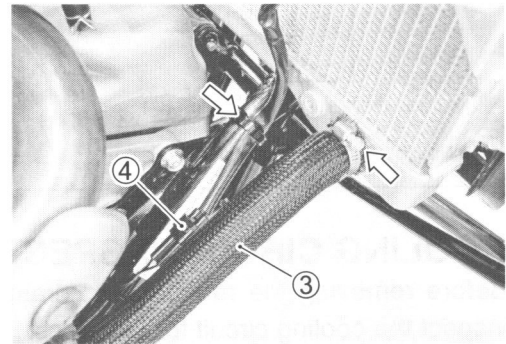
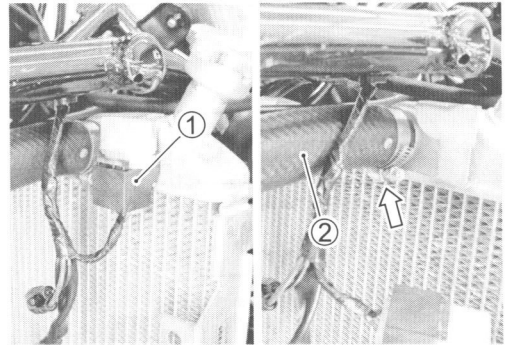



- Remove the radiator mounting bolts, and then radiator ⑥ from the body of a vehicle.

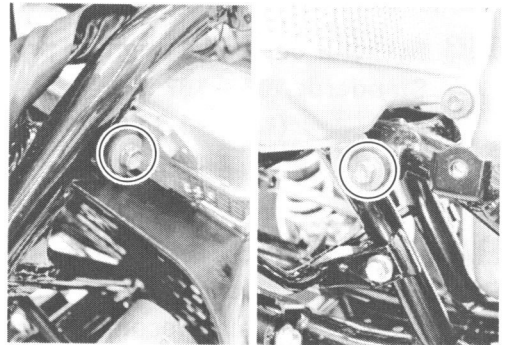
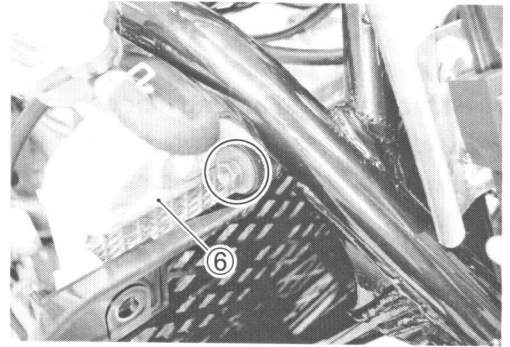

- Remove the radiator cover ⑦ from the body of a vehicle.

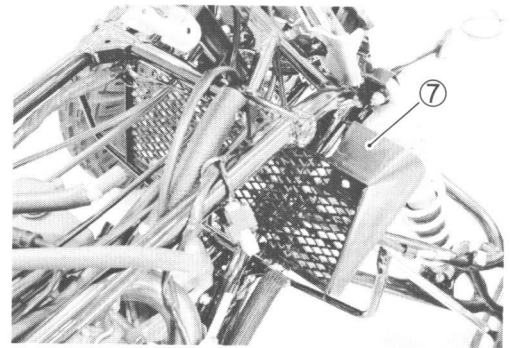

- Disconnect the siphon hose ⑧.

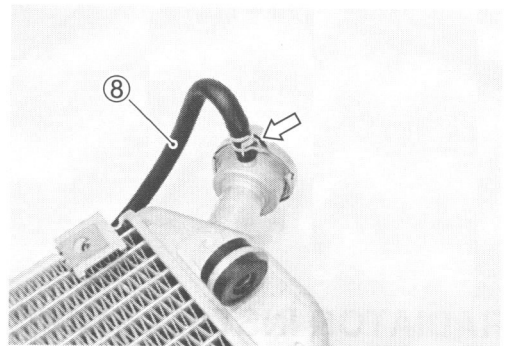

## RADIATOR CAP INSPECTION

- Remove the radiator cap ① from the radiator.
- Fit the cap ① to the radiator cap tester ②.
- Build up pressure slowly by operating the tester. Make sure that the pressure build-up stops at 108 – 137 kPa (1.08 – 1.37 kgf/cm<sup>2</sup>, 15.4 – 19.5 psi) and that, with the tester held standstill, the cap is capable of holding that pressure for at least 10 seconds.
- Replace the cap if it is found not to satisfy either of these two requirements.

### **DATA** Radiator cap valve opening pressure

**Standard: 108 – 137 kPa**

**(1.08 – 1.37 kgf/cm<sup>2</sup>, 15.4 – 19.5 psi)**

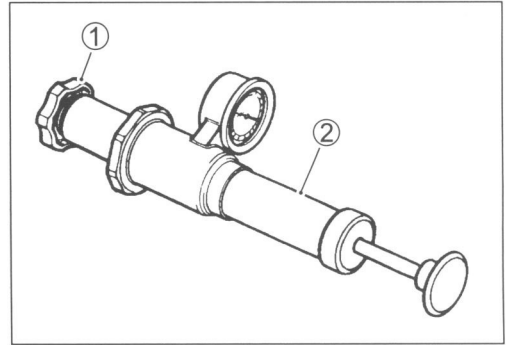

## RADIATOR INSPECTION AND CLEANING

Road dirt or trash stuck on the fins must be removed. Use of compressed air is recommended for this cleaning.

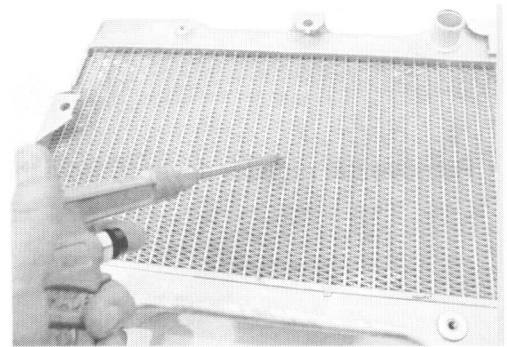

Fins bent down or dented can be repaired by straightening them with the blade of a small screwdriver.

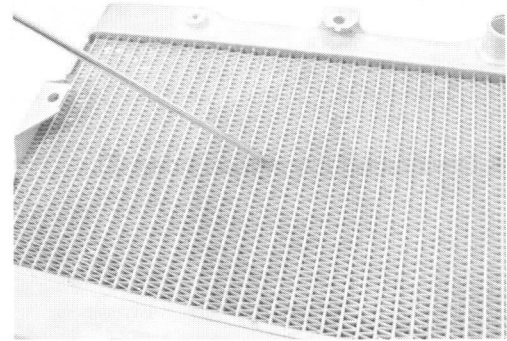

## RADIATOR INSTALLATION

Install the radiator in the reverse order of removal. Pay attention to the following points:

- Align the grooves on the radiator covers with the boss on the radiator.
- Install the radiator cover to the radiator.
- Install the radiator.
- Route the siphon hose and radiator hoses. (☞ 9-20)
- Pour engine coolant. (☞ 2-13)

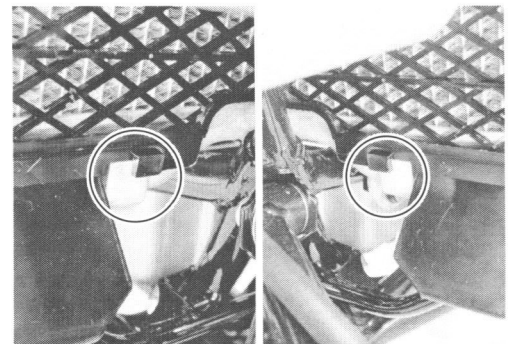

## WATER HOSE INSPECTION

- Remove the side covers (R & L). (☞ 7-6)
- Any water hose found in a cracked condition or flattened must be replaced.
- Any leakage from the connecting section should be corrected by proper tightening.

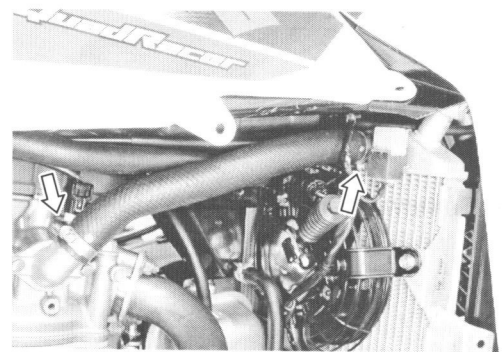
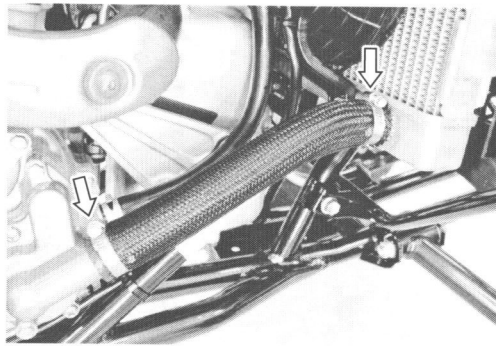
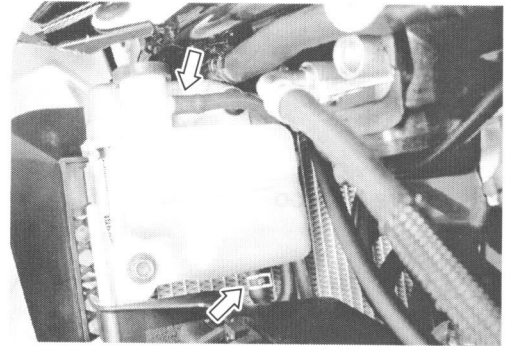
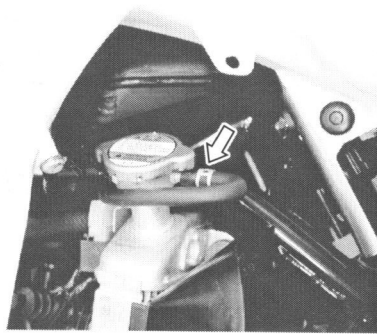

## RADIATOR RESERVOIR TANK REMOVAL/REMOUNTING

- Remove the side cover (L). (☞ 7-6)
- Remove the reservoir tank mounting bolts and disconnect the siphon hose from the reservoir tank and drain engine coolant.
- Install the reservoir tank in the reverse order of removal.
- Pour engine coolant. (☞ 2-15)

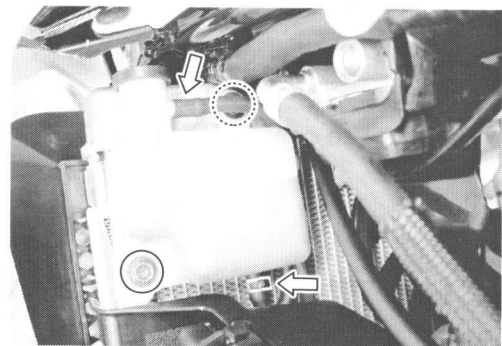

## COOLING FAN

### REMOVAL

- Remove the front fender. (☞ 7-6)
- Remove the fuel tank and fuel tank lower cover. (☞ 5-4)
- Disconnect the cooling fan motor lead wire coupler ①.
- Remove the rear brake switch wire harness ② from the clamp.

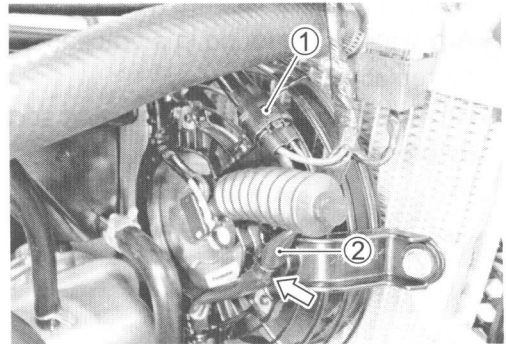

- Remove the cooling fan unit ③.

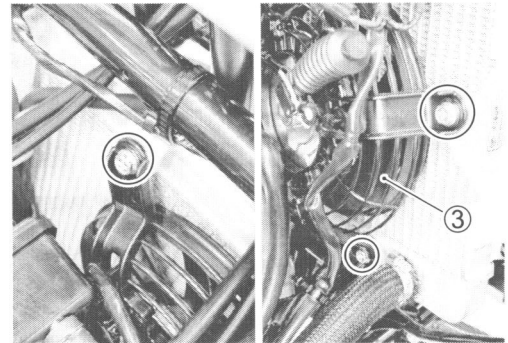

- Remove the cushion ④.

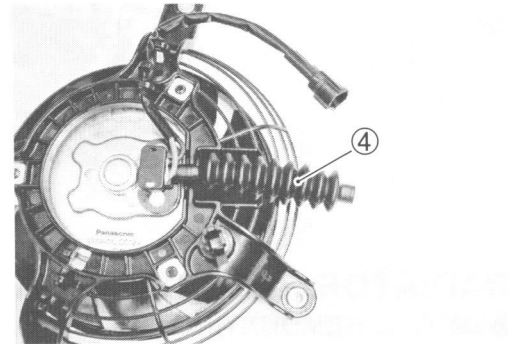

- Remove the cooling fan ⑤.

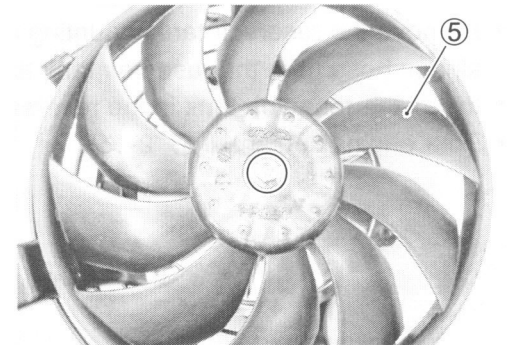

- Remove the cooling fan motor ⑥.

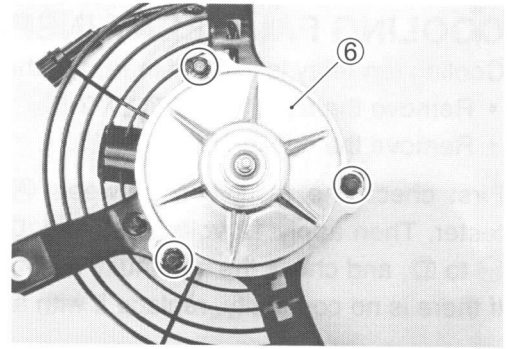

## INSTALLATION

Install the cooling fan unit in the reverse order of removal. Pay attention to the following points:

- Apply a small quantity of the THREAD LOCK SUPER “1303” on the cooling fan motor shaft.
- Tighten the cooling fan nut.

 99000-32030: THREAD LOCK SUPER “1303”

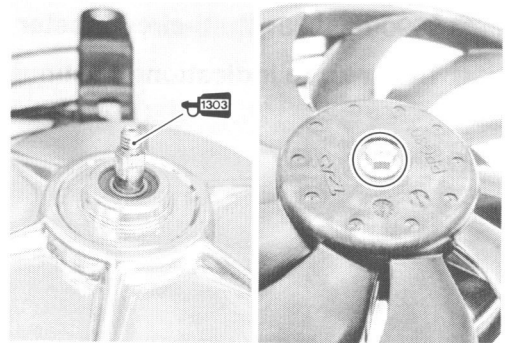

## INSPECTION

- Remove the front fender. (☞ 7-6)
- Disconnect the cooling fan coupler ①.
- Test the cooling fan motor for load current with an ammeter connected as shown in the illustration.

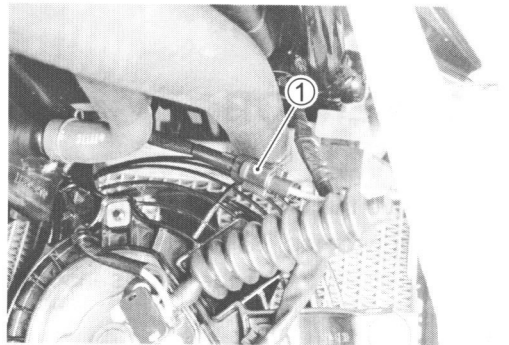

- The voltmeter is for making sure that the battery ② applies 12 volts to the cooling fan motor ③. With the cooling fan motor with electric motor fan running at full speed, the ammeter ④ should be indicating not 5 amperes and more.
- If the fan motor does not turn, replace the motor assembly with a new one.

### NOTE:

When making above test, it is not necessary to remove the cooling fan unit.

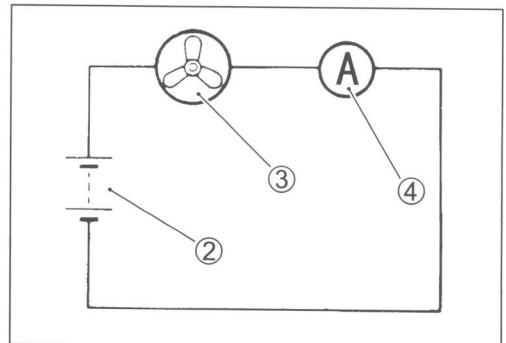

## COOLING FAN RELAY INSPECTION

Cooling fan relay is located in rear of the headlight assembly.

- Remove the front fender. (☞ 7-6)
- Remove the cooling fan relay ①.

First check the insulation between (A) and (B) terminals with tester. Then apply 12 volts to (C) and (D) terminals, (+) to (C) and (-) to (D), and check the continuity between (A) and (B).

If there is no continuity, replace it with a new one.

 **09900-25008: Multi-circuit tester set**

 **Tester knob indication: Continuity test (•••)**

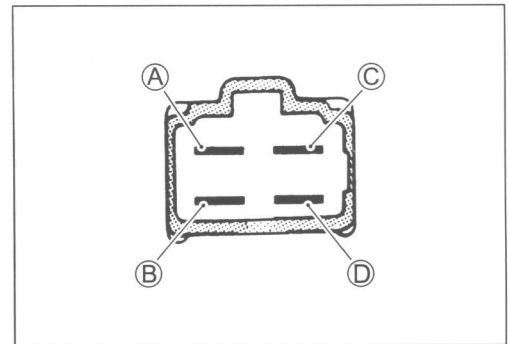
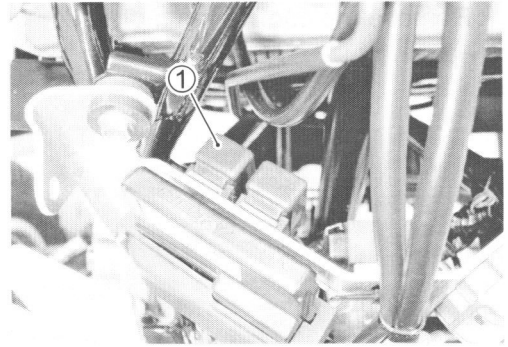

## ECT SENSOR

### REMOVAL

- Remove the fuel tank and fuel tank lower cover. (☞ 5-4)
- Disconnect the ECT sensor coupler ①.
- Place a rag under the ECT sensor and remove the ECT sensor.

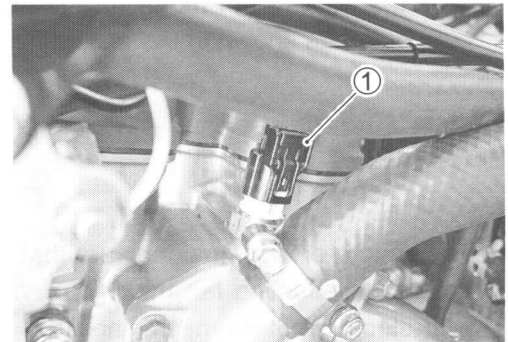

### INSPECTION

- Check the ECT sensor by testing it at the bench as shown in the figure. Connect the ECT sensor ① to a circuit tester and place it in the oil ② contained in a pan, which is placed on a stove.
- Heat the oil to raise its temperature slowly and read the column thermometer ③ and the ohmmeter.

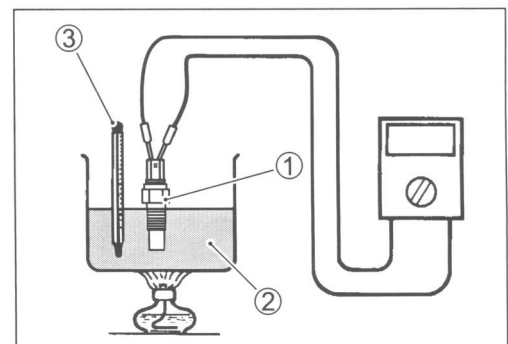

- If the ECT sensor ohmic value does not change in the proportion indicated, replace it with a new one.

#### **DATA** Temperature sensor specification

Temperature	Standard resistance
20 °C (68 °F)	Approx. 2.6 kΩ
50 °C (122 °F)	Approx. 0.772 kΩ
80 °C (176 °F)	Approx. 0.279 kΩ
110 °C (230 °F)	Approx. 0.118 kΩ

#### **DATA** Cooling fan operating temperature:

**Standard (OFF→ON): Approx. 98 °C (208 °F)**

**(ON→OFF): Approx. 93 °C (199 °F)**

If the resistance is noted to show infinity or too much different resistance value, replace the ECT sensor with a new one.

#### **CAUTION**

- \* Take special care when handling the ECT sensor. It may cause damage if it gets a sharp impact.
- \* Do not contact the ECT sensor and the column thermometer with a pan.

## INSTALLATION

- Apply engine coolant to the O-ring.
- Tighten the ECT sensor to the specified torque.

**ECT sensor: 12 N·m (1.2 kgf-m, 8.5 lb-ft)**

#### **CAUTION**

**Take special care when handling the ECT sensor. It may cause damage if it gets a sharp impact.**

- Connect the ECT sensor coupler.
- Install the fuel tank lower cover and fuel tank.
- Check the engine coolant level. (☞ 2-15)

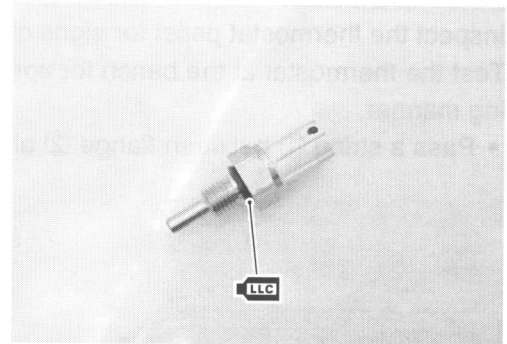



## THERMOSTAT

### REMOVAL

- Drain the engine coolant. (☞ 2-15)
- Place a rag under the thermostat case.
- Remove the thermostat case ①.

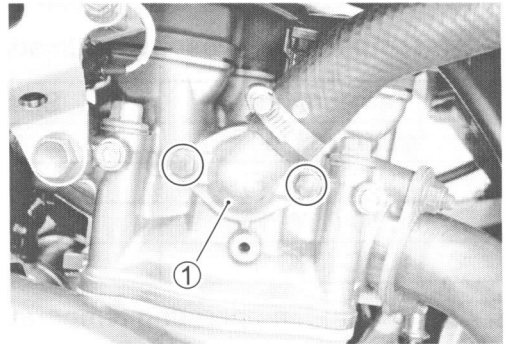

- Remove the thermostat ②.

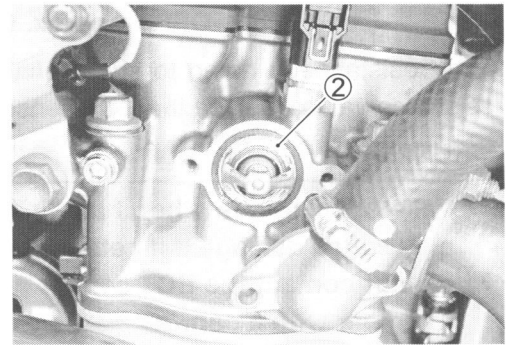

### INSPECTION

Inspect the thermostat pellet for signs of cracking.

Test the thermostat at the bench for control action, in the following manner.

- Pass a string ① between flange ② of thermostat, as shown.

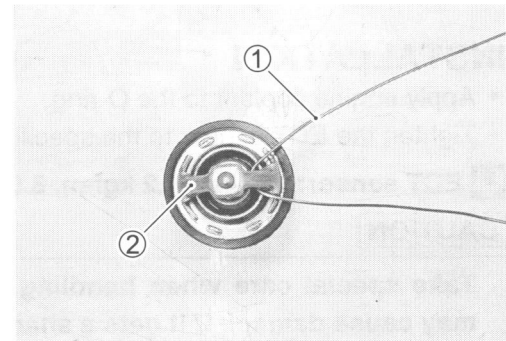

- Immerse the thermostat in the water contained in a beaker, as shown in the illustration. Note that the immersed thermostat is in suspension. Heat the water ③ by placing the beaker on a stove ④ and observe the rising temperature on a thermometer ⑤.
- Read the thermometer just when opening the thermostat. This reading, which is the temperature level at which the thermostat valve begins to open, should satisfy the standard value.

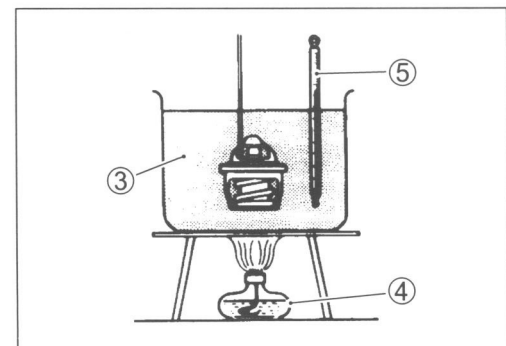

**DATA** Thermostat valve opening temperature  
Standard: Approx. 76.5 °C (169.7 °F)

- Keep on heating the water to raise its temperature.
- Just when the water temperature reaches specified value, the thermostat valve should have lifted by at least 4.5 mm (0.18 in).

**DATA** Thermostat valve lift <sup>(A)</sup>**Standard:****4.5 mm and over at 90 °C (0.18 in and over at 194 °F)**

- A thermostat failing to satisfy either of the two requirements (start-to-open temperature and valve lift) must be replaced.

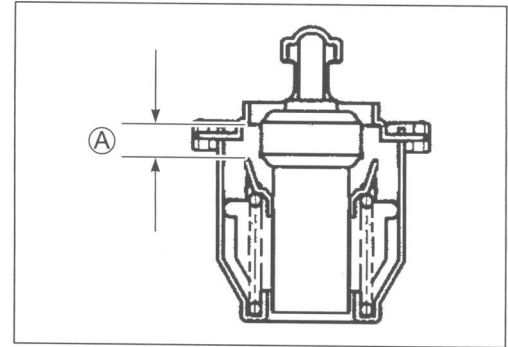
**INSTALLATION**

Install the thermostat in the reverse order of removal.

- Apply engine coolant to the rubber seal on the thermostat.
- After installing the thermostat and thermostat case, be sure to add engine coolant. (↩ 2-15)

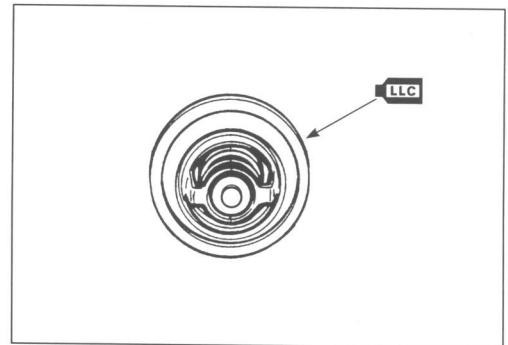

## WATER PUMP

### REMOVAL AND DISASSEMBLY

**NOTE:**

Before draining engine oil and engine coolant, inspect engine oil and coolant leakage between the water pump and crankcase. If engine oil is leaking, visually inspect the oil seal and O-ring. If engine coolant is leaking, visually inspect the mechanical seal and seal washer. (☞ 6-16)

- Drain engine coolant. (☞ 2-15)
- Drain engine oil. (☞ 2-13)
- Disconnect the radiator hose ① and breather hose ②.
- Remove the rear brake switch ③ and brake pedal ④. (☞ 7-67)

- Remove the right oil tank hose.

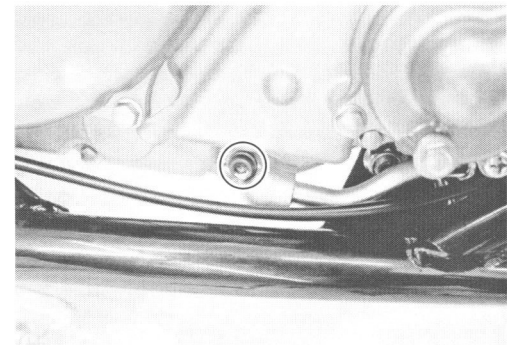
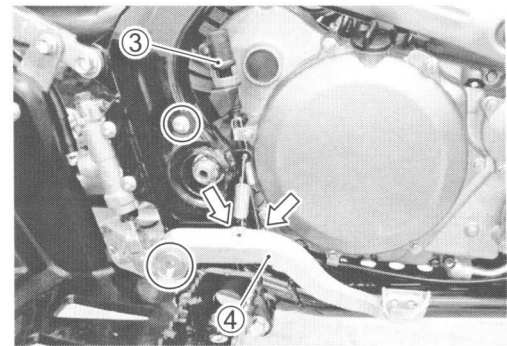
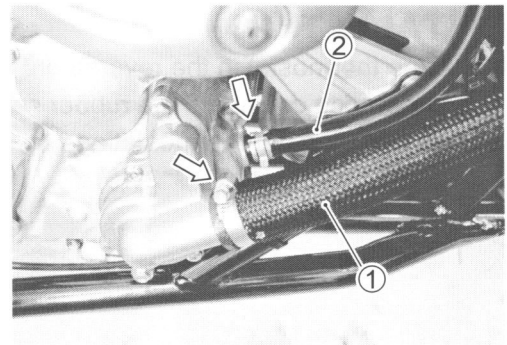
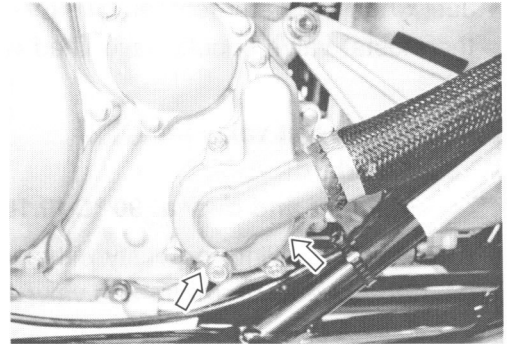

- Remove the clutch cover ⑤.

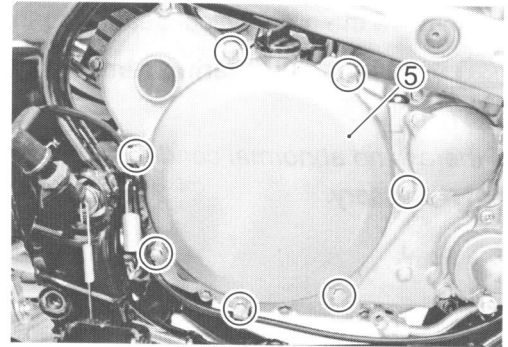

- Remove the right crankcase cover ⑥.

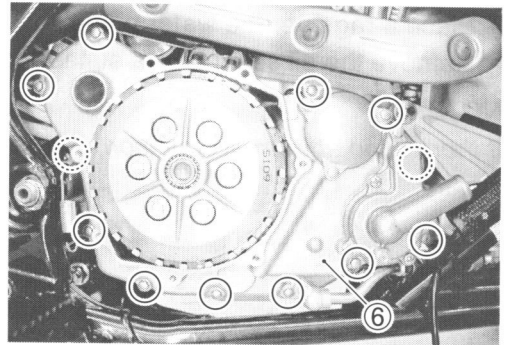

- Remove the water pump cover ⑦.

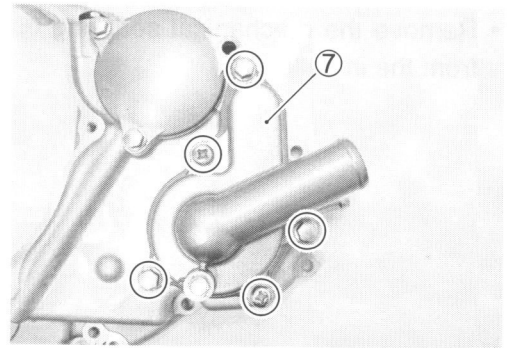

- Remove the snap ring ⑧, water pump driven gear ⑨, pin ⑩ and washer ⑪.

**TOOL** 09900-06107: Snap ring pliers

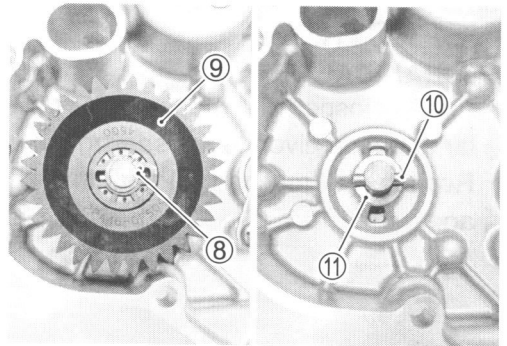

- Remove the impeller ⑫ and water pump body ⑬.
- Remove the O-ring ⑭ and ⑮.

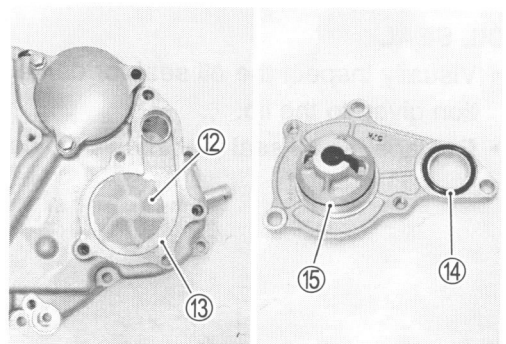

- Remove the mechanical seal using the special tool.

**TOOL 09921-20240: Bearing remover set**

**NOTE:**

*If there is no abnormal condition, the mechanical seal removal is not necessary.*

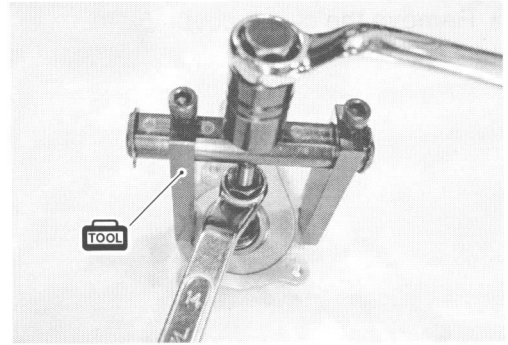

- Place a rag over the water pump.
- Remove the oil seal using a suitable bar.

**NOTE:**

*If there is no abnormal condition, the oil seal removal is not necessary.*

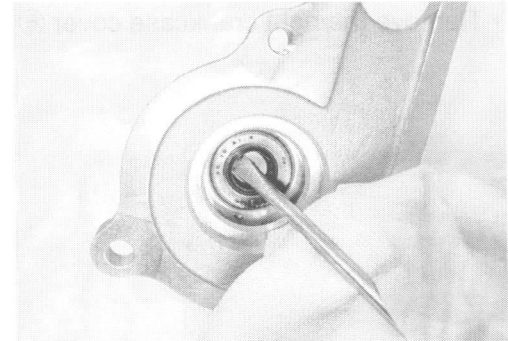

- Remove the mechanical seal ring ⑯ and the rubber seal ⑰ from the impeller.

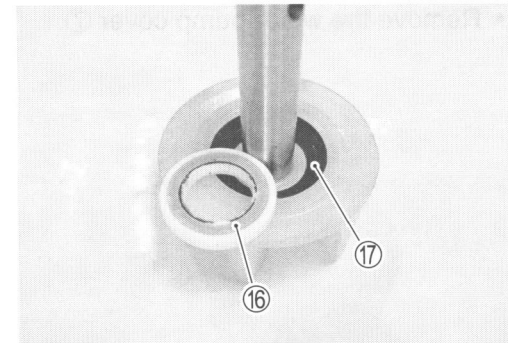

## INSPECTION

### MECHANICAL SEAL

- Visually inspect the mechanical seal for damage, with particular attention given to the sealing face.
- Replace the mechanical seal that shows indications of leakage.

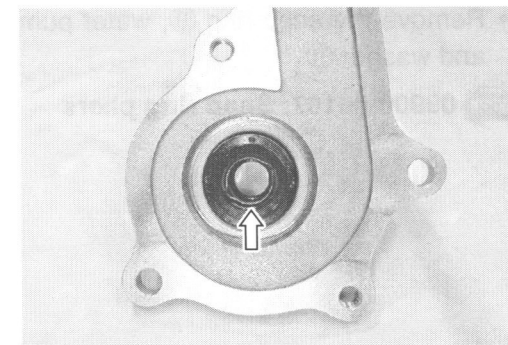

### OIL SEAL

- Visually inspect the oil seal for damage, with particular attention given to the lip.
- Replace the oil seal that shows indications of leakage.

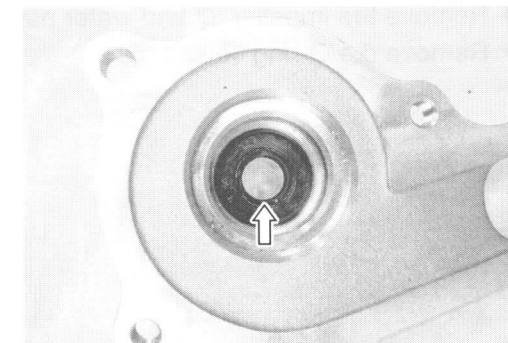

**IMPELLER SHAFT JOURNAL**

- Visually inspect the journal for damage or scratch.
- Replace the water pump body if necessary.

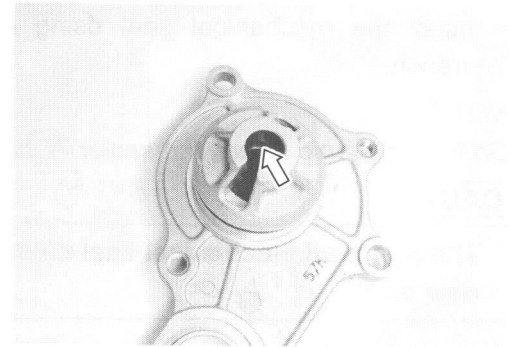
**IMPELLER**

- Visually inspect the impeller and its shaft for damage.

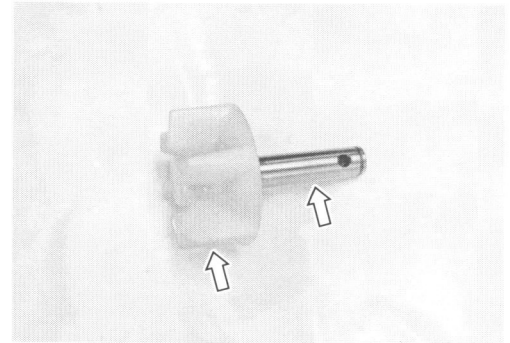
**REASSEMBLY AND INSTALLATION**

- Install the oil seal using the special tool.

**TOOL** 09913-70210: Bearing installer set

**NOTE:**

*The stamped mark on the oil seal faces outside.*

**CAUTION**

**The removed oil seal must be replaced with a new one.**

- Apply a small quantity of the SUZUKI SUPER GREASE "A" to the oil seal lip.

**TAH** 99000-25010: SUZUKI SUPER GREASE "A"  
(or equivalent grease)

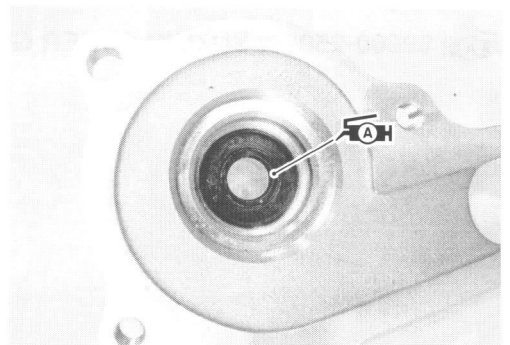
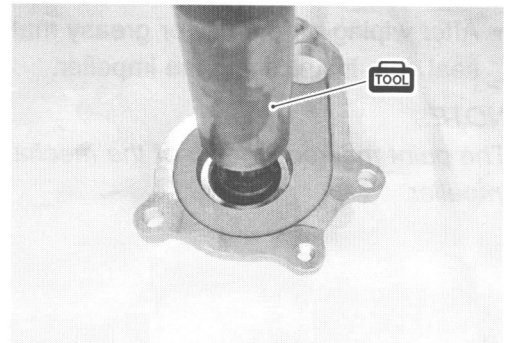



- Install the mechanical seal using a suitable size socket wrench.

**NOTE:**

On the mechanical seal, the sealer (A) has been applied.

**CAUTION**

The removed mechanical seal must be replaced with a new one.

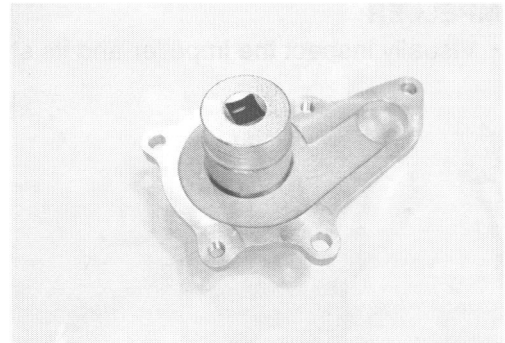
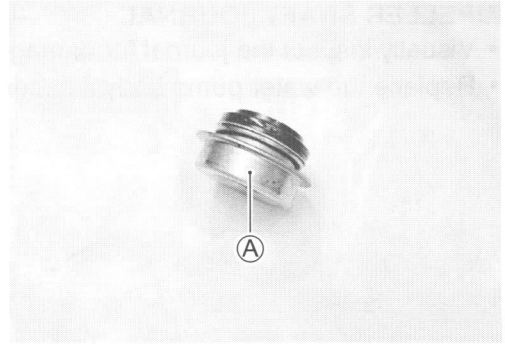

- Install the rubber seal (1) into the impeller.
- After wiping off the oily or greasy matter from the mechanical seal ring, install it into the impeller.

**NOTE:**

The paint marked side (B) of the mechanical seal ring faces the impeller.

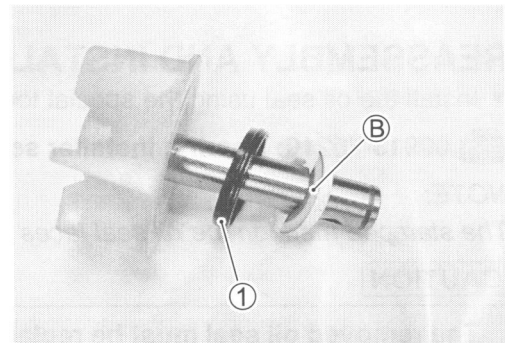

- Apply grease to the impeller shaft.

 99000-25010: SUZUKI SUPER GREASE "A"  
(or equivalent grease)

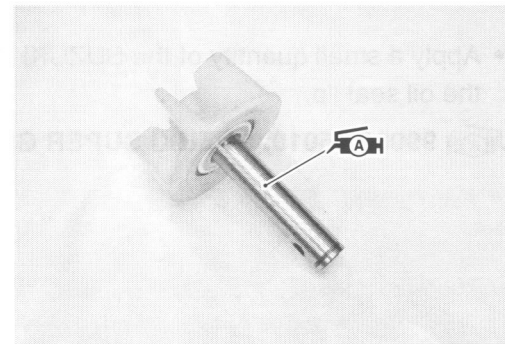

- Apply grease to the O-rings.
- Install the O-rings (2) and (3).

 99000-25010: SUZUKI SUPER GREASE "A"  
(or equivalent grease)

**CAUTION**

The removed O-rings must be replaced with new ones.

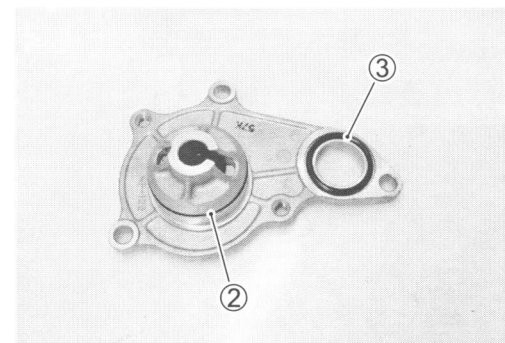



- Install the impeller shaft to the water pump body.
- Install the water pump body with the impeller to the clutch cover.

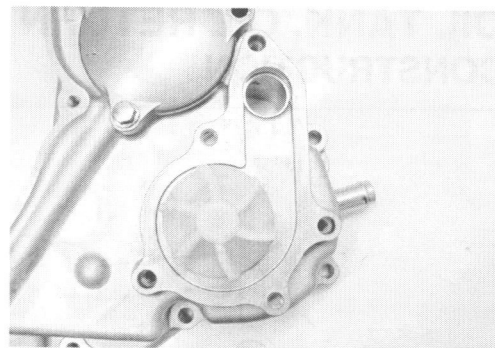

- Install the washer ④, pin ⑤, water pump driven gear ⑥ and snap ring ⑦.

**TOOL** 09900-06107: Snap ring pliers

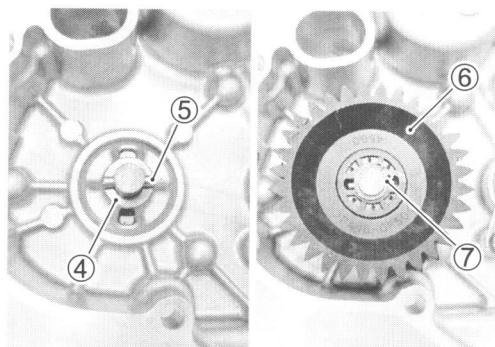

- Apply engine coolant to the O-ring.
- Install the O-ring to the water pump cover.

#### CAUTION

The removed O-ring must be replaced with a new one.

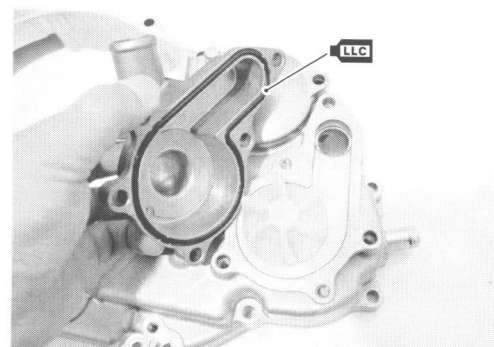

- Install the water pump cover ⑧ to the right crankcase cover.

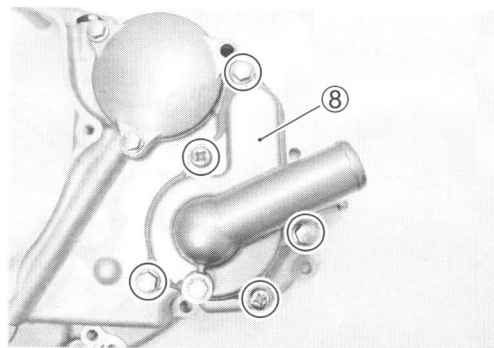

- Install the right crankcase cover. (☞ 3-70)
- Install the clutch cover. (☞ 3-70)
- Install the right oil tank hose. (☞ 6-23)
- Install the brake pedal (☞ 7-67) and rear brake switch.
- Connect the breather hose and radiator hose.
- Pour engine oil. (☞ 2-13)
- Pour engine coolant. (☞ 2-15)
- Adjust the brake pedal. (☞ 2-19)
- Adjust the rear brake switch. (☞ 2-19)

# OIL TANK, OIL RETURN TANK AND HOSES CONSTRUCTION

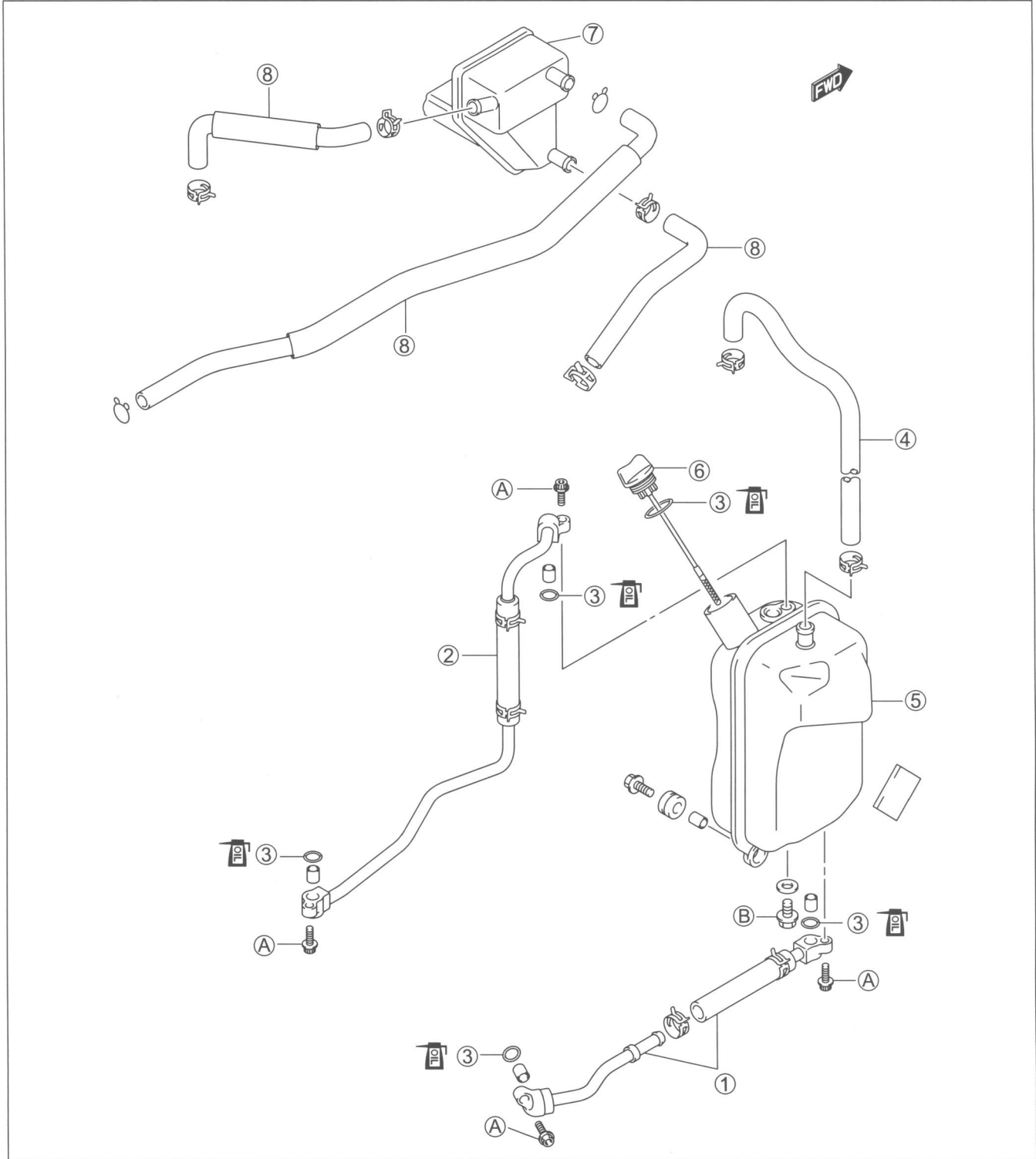

①	Oil tank hose (R)	⑥	Oil level gauge
②	Oil tank hose (L)	⑦	Oil return tank
③	O-ring	⑧	Breather hose
④	Oil tank over-flow hose	(A)	Oil tank hose mounting bolt
⑤	Oil tank	(B)	Drain plug

ITEM	N·m	kgf·m	lb·ft
(A)	10	1.0	7.0
(B)	12	1.2	8.5

## OIL TANK

### REMOVAL

- Remove the front fender. (☞ 7-6)
- Drain engine oil. (☞ 2-13)
- Remove the oil return tank. (☞ 6-23)
- Remove the fuel tank and fuel tank lower cover. (☞ 5-4)
- Remove the battery. (☞ 8-3)
- Remove the oil return tank bracket ①.

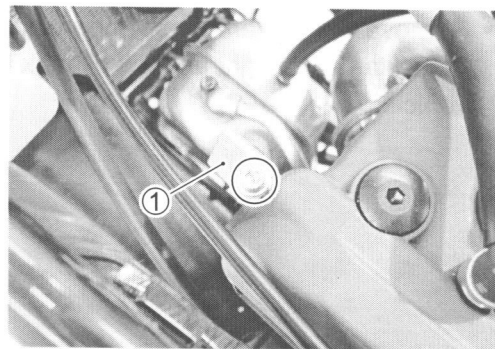

- Remove the battery holder ②.

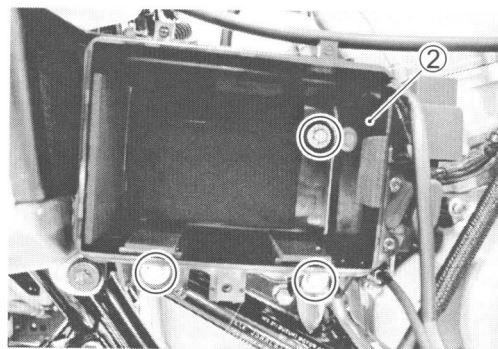

- Disconnect the oil tank over-flow hose.

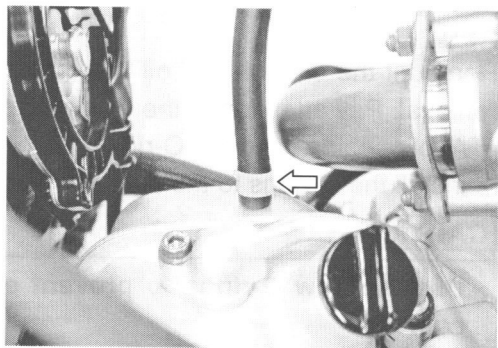

- Remove the oil return tank mounting bolts.

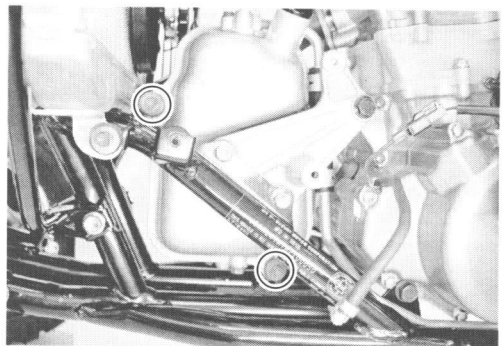

- Remove the oil tank hose mounting bolts, and then remove the oil tank and right and left oil tank hoses from the body of a vehicle.

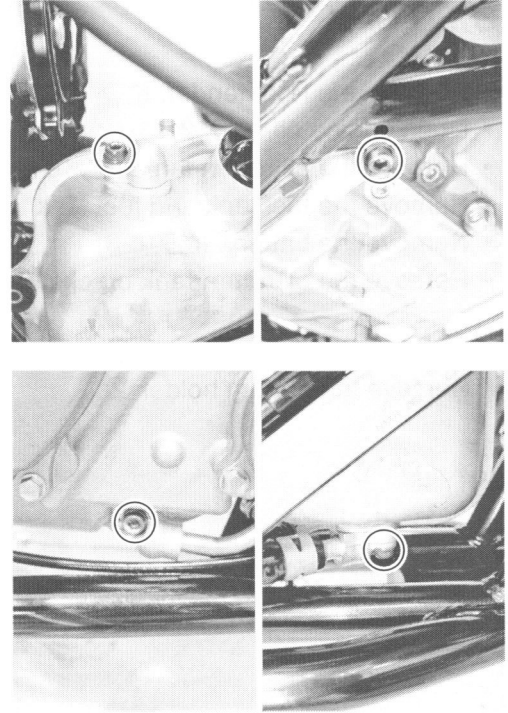

### REMOUNTING

Remount the oil tank and oil tank hoses in the reverse order of removal. Pay attention to the following points.

- Apply engine oil to the O-rings.
- Install the O-rings to the right and left hoses.

### CAUTION

Use the new O-rings to prevent engine coolant leakage.

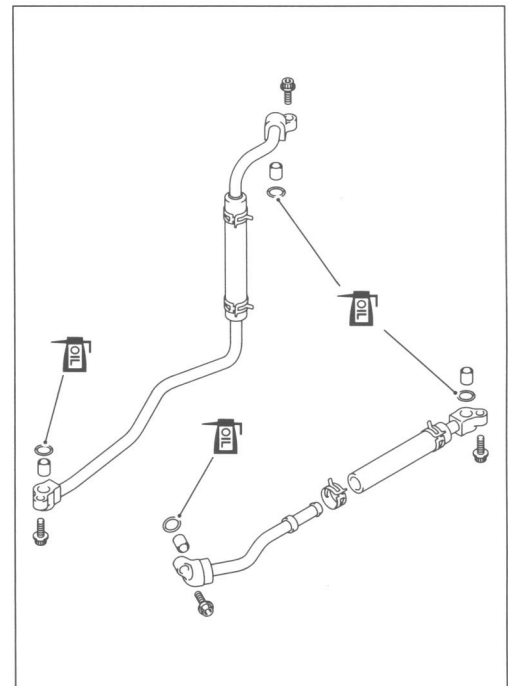

- Tighten the oil tank hose mounting bolts to the specified torque.

 **Oil tank hose mounting bolt:**

**10 N·m (1.0 kgf-m, 7.0 lb-ft)**

- Install the oil tank.
- Pour engine oil. ( 2-13)

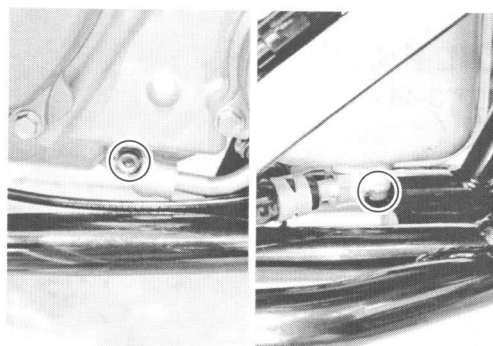
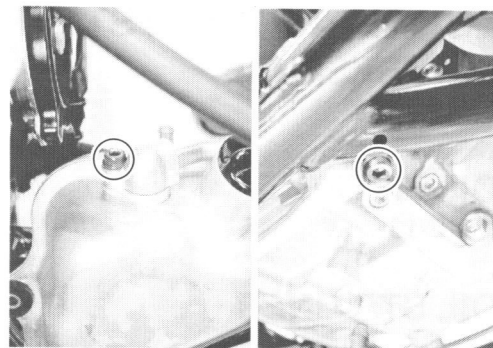

## OIL RETURN TANK REMOVAL AND DISASSEMBLY

- Remove the oil return tank mounting bolt.

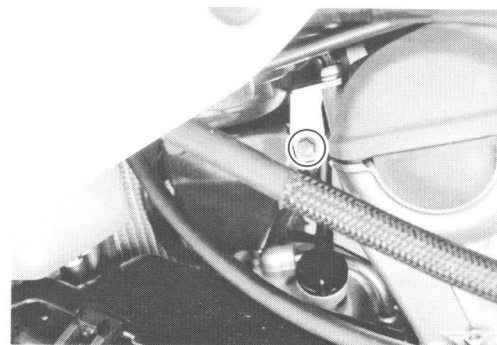

- Disconnect the breather hoses ①, ② and ③ and then, remove the oil return tank ④.

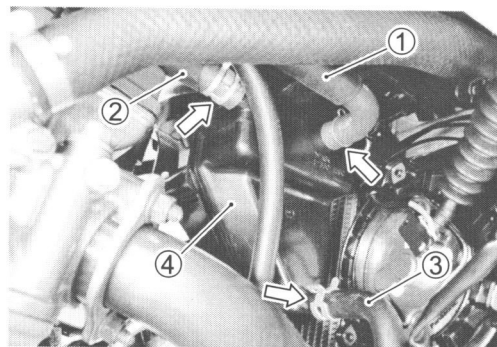

### INSPECTION

Inspect the oil return tank for damage.  
Clean the oil return tank.

### INSTALLATION

Install the oil return tank in the reverse order of removal.

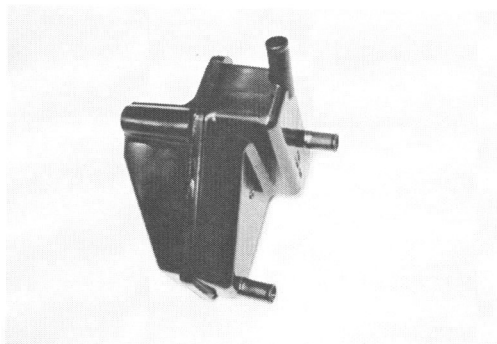

## LUBRICATION SYSTEM

### OIL PRESSURE

 2-35

### OIL FILTER

 2-13

### OIL STRAINER

 3-51

### OIL PUMP

 3-44

# ENGINE LUBRICATION SYSTEM CHART

