



Cinema Reference

Dolby Digital® & DTS®
Audio•Video Preamplifier
with THX® Enhancements

Operations & Installation Manual

For the Cinema Reference with Version 1.70 Software

© Copyright 1998, Audio Design Associates, Inc., All Rights Reserved.



Contents

AC Connections	3
Power Amplifier (& Powered Subwoofer) Connections	4
Introduction - Front Panel Controls & Displays	5
Power On, Mute, Off, & Master Volume Control	6
Input Selection - Dialing in the desired component.	7
Mode Indicators & How They Function	8
Mode Selection & Dolby Digital Mode Descriptions	9
Dolby Digital Modes (AC-3)	9
DTS Modes	11
Pro Logic & Auto Modes	12
Stereo, Phantom, & Music Modes	13
3 Channel, Quad, Stereo Enhance, and Mono Enhance	14
Record Selector	15
Rear Panel Inputs & Outputs	16
Out Of The Box Setup	17
Laser Disc or Combination Laser Disc/DVD Player	19
Laser Disc Player without a Digital Output (or 2nd Laser)	21
DVD Player	23
VCR	25
DSS or Satellite Receiver	26
Cable or TV Tuner	27
CD Player	28
Tuner	29
Cassette	30
Auxiliary Input	31
Record Output Connections	32
Connection To Your TV, Projector, or Line-Doubler	33
Audio Setup	34
Custom Setup - A/V Linking	37
Custom Setup - AC-3 RF Inputs & Auto Mode	38
Custom Setup - Labeling Inputs	40
Custom Setup - Turn-On Input	41
Custom Setup - Default Mode	42
Custom Setup - Turn On Volume	43
Custom Setup - Vector Scope On/Off	44
Custom Setup - Display Illumination Level	45
Pro Setup - Enter At Your Own Risk	46
Pro Setup - Delay Setup	47
Pro Setup - Network Bus	50
Pro Setup - Final Input	51
Pro Setup - System Setup - Bass Management	52
Pro Setup - IR Receiver On & Off Control	53
Pro Setup - Bass Limiter	54
Pro Setup - HDR & LDR Scale Factors	55
Pro Setup - THX - Re-EQ, Timbre Match, & Decorrelate	56
Pro Setup - Auto-Balance	57
Pro Setup - Repeat Count	58
Pro Setup - Analog Gain Control	59
Pro Setup - PCM Scale Factors	60
Pro Setup - Input Format	61
Pro Setup - Auxiliary DC Triggers	62
Pro Setup - Effect Delay	63
Pro Setup - Effect Level	64
Appendix A - Solo Channel Test	65

Safety Instructions & Electrical Warning

READ INSTRUCTIONS - All the safety and operating instructions should be read before the appliance is operated.

RETAIN INSTRUCTIONS - The operating instructions should be retained for future reference.

HEED WARNING - All warnings on the appliance and in the operating instructions should be adhered to.

FOLLOW INSTRUCTIONS - All operating and use instructions should be followed.

WATER AND MOISTURE - The appliance should not be used near water - for example, near a bathtub, washbowl, kitchen sink, laundry tub, in a wet basement, or near a swimming pool, etc.

LOCATION - The appliance should be installed in a stable location.

WALL OR CEILING MOUNT - The appliance should not be mounted to a wall or ceiling.

VENTILATION - The appliance should be situated so that its location or position does not interfere with its proper ventilation. For example, the appliance should not be situated on a bed, sofa, rug or similar surface that may block the ventilation openings.

HEAT - The appliance should be situated away from heat sources such as radiators, heat registers, stoves, or other appliances that produce heat.

POWER SOURCES - The appliance should be connected to a power supply only of the type described in the operating instructions or as marked on the appliance.

GROUNDING - Make sure that this unit is always connected to a standard three-prong grounded outlet (the circular pin is ground). When operating this unit at a higher voltage with a different power cord configuration, consult your dealer for the proper power cord/outlet combination to use before operating this unit.

POWER CORD PROTECTION - Power supply cords should be routed so that they are not likely to be walked on or pinched by items placed upon or against them, paying particular attention to cords at plugs, convenience receptacles, and the point where they exit from the appliance.

CLEANING - The appliance should be cleaned only with a polishing cloth or a soft dry cloth. Never clean with furniture wax, benzene, insecticides or other volatile liquids since they may corrode the face plate.

POWER LINES - An outdoor antenna should be located away from power lines.

NONUSE PERIODS - The power cord of the appliance should be unplugged from the outlet when left unused for a long period of time.

OBJECT AND LIQUID ENTRY - Care should be taken so that objects do not fall and liquids are not spilled into the enclosure through openings.

DAMAGE REQUIRING SERVICE - The appliance should be serviced by an authorized service center or qualified service personnel when:

- The power supply cord or plug has been damaged; or
- Objects have fallen, or liquid has been spilled into the appliance; or
- The appliance has been exposed to rain; or
- The appliance does not appear to operate normally or exhibits a marked change in performance; or
- The appliance has been dropped; or the enclosure has been damaged.

SERVICING - The user should not attempt to service the appliance beyond that described in the operating instructions. For all other service requirements, the user should contact an Authorized Dealer or Service Center.

WARNING:

TO REDUCE THE RISK OF FIRE OR ELECTRICAL SHOCK, DO NOT EXPOSE THIS APPLIANCE TO RAIN OR MOISTURE. REPLACE FUSE ONLY AS MARKED.

CAUTION:

TO PREVENT ELECTRIC SHOCK, DO NOT PLUG THIS UNIT INTO ANY OUTLET OR EXTENSION CORD WITHOUT THE STANDARD THREE-PRONG CONFIGURATION, WHERE THE CIRCULAR HOLE IS USED FOR THE GROUND PLUG. ANY UNITS NOT SOLD IN THE UNITED STATES OR CANADA ARE NOT SUPPLIED WITH A POWER CORD. THEREFORE, AN AUDIO DESIGN ASSOCIATES DEALER SHOULD BE CONSULTED BEFORE CONNECTING THIS UNIT TO ANY POWER SOURCE.

LINE VOLTAGE SELECTOR SWITCH AND REMOVABLE POWER CORD:

THIS UNIT IS EQUIPPED WITH A VOLTAGE SELECTOR SWITCH. IN MOST CASES, THIS SWITCH WILL REMAIN IN THE 115V POSITION (SEE PICTURE BELOW), WHICH IS HOW THE UNIT LEAVES THE FACTORY. HOWEVER, IF YOU WANT TO OPERATE THE UNIT IN AN AREA THAT USES THE 230V SETTING, CONSULT YOUR DEALER BEFORE PLUGGING THE UNIT IN. IN A CASE WHERE THE 230V SETTING WOULD BE NEEDED, AUDIO DESIGN ASSOCIATES WILL NOT PROVIDE A POWER CORD FOR THE UNIT. THEREFORE, THE USER MUST CONSULT AN AUTHORIZED DEALER OR ADA TO OBTAIN THE PROPER POWER CORD, AS WELL. **MAKE SURE THAT THE VOLTAGE SELECTOR SWITCH IS IN THE PROPER POSITION AND THAT YOU HAVE THE CORRECT POWER CORD BEFORE THIS UNIT IS PLUGGED IN AND OPERATED!**

Page 2

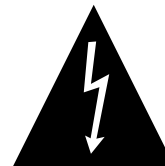

The lightning flash with the arrow-head, within an equilateral triangle, is intended to alert the user of the presence of uninsulated "dangerous voltage" within the product's enclosure that may be of sufficient magnitude to constitute a risk of electrical shock to persons.

IMPORTANT

CAUTION
RISK OF ELECTRIC SHOCK
DO NOT OPEN

CAUTION: TO PREVENT RISK OF ELECTRICAL SHOCK, DO NOT REMOVE COVER (OR BACK). NO USER-SERVICEABLE PARTS INSIDE. REFER SERVICING TO QUALIFIED SERVICE PERSONNEL.



The exclamation point within the equilateral triangle is intended to alert the user of the presence of important operating and maintenance (servicing) instruction in the literature accompanying the appliance.

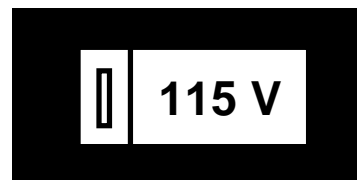

AC Connections

AC Connection

Before you plug your Cinema Reference into an AC outlet, make certain that the voltage selector switch is set to the proper position. Since ADA tests each unit prior to shipping, if the Voltage Selector Switch is in the correct position, the Cinema Reference's safety fuse will also be the correct value.

If you are altering the Voltage Selector Switch, you will also most likely need to change the safety fuse. Both the Voltage Selector Switch and the Safety Fuse are located on the Cinema Reference's left side (when viewed from the front.)

AC Connection

For customers who are using the U.S. standard AC receptacle, you will use the EIC AC Power Cord provided with the Cinema Reference. Simply plug this AC cord into an operative AC outlet. For customers who are using a non-U.S. standard AC receptacle, you will need to acquire an EIC AC Power Cord with the appropriate receptacle connector. ADA only provides AC Power Cords with the U.S. standard AC prongs.

Before You Begin

As you remove the Cinema Reference from its packaging, inspect the condition of the component prior to proceeding with the following steps for AC connection. In the event that the Cinema Reference appears to have suffered cosmetic damage due to shipping, please contact your Authorized ADA Dealer immediately and do not proceed to plug the unit into an AC outlet.

Caution

Before plugging your Cinema Reference into an AC outlet, check the Voltage Selector Switch setting, located on the units left side (when looking at the Cinema Reference from the front) and make certain that the selector is set to your appropriate voltage position. For U.S. customers, this setting should be 115V. For international customers, you may need to set this switch to 230V.

Fuse Values

For U.S. customers or international customers also operating on a 115V AC system, the fuse value of the Cinema Reference should be a 1 Amp Slow Blow fuse. For international customers operating on a 230V AC system, the fuse value should be 1/2 Amp Slow Blow. The safety fuse is located next to the Voltage selector switch on the Cinema Reference's left side (when viewing it from the front.) Typically, if you receive the Cinema Reference with the voltage selector already set correctly for your local voltage system, the corresponding fuse value has also been inserted to match the voltage setting. If you are altering the Voltage Selector Switch setting, you will need to also replace the fuse with the appropriate value fuse.

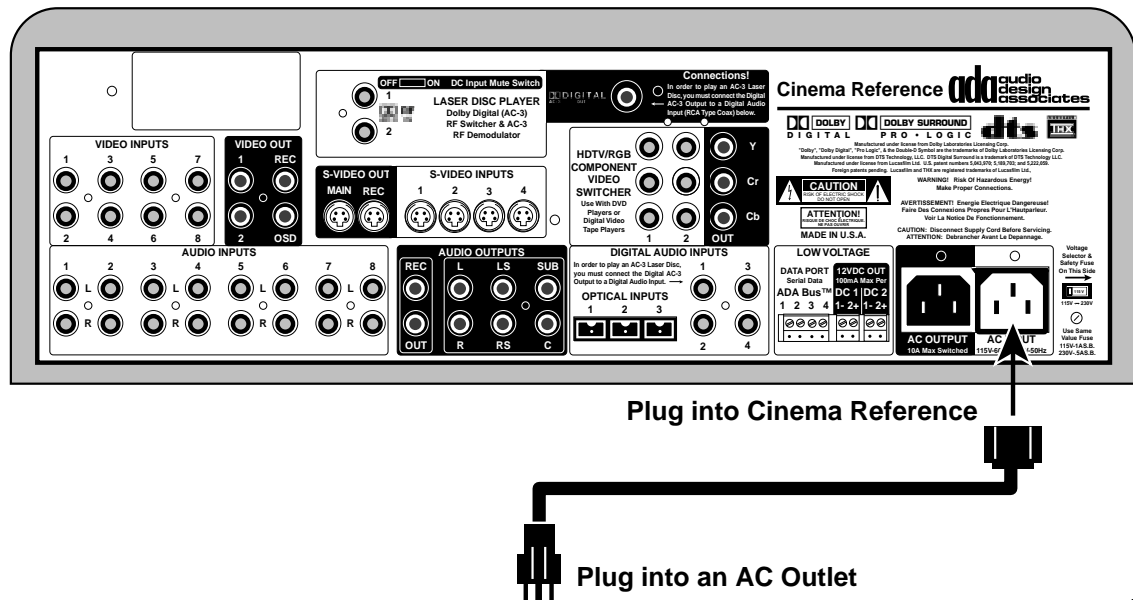

Power Amplifier (& Powered Subwoofer) Connections

Audio Connections

The Cinema Reference's Audio Outputs are clearly marked in a white field on the back of the Cinema Reference. ADA strongly suggests not using directional interconnects that lift the grounds. If you are connecting the audio outputs to a six channel power amplifier (which will also power the subwoofer), use the diagram below. This diagram includes ADA's critically acclaimed PTM-6150 Six Channel THX Power Amplifier. While you may decide to vary the input arrangement if you are using a PTM-6150, the following input arrangement will cause the amplifier's front panel LED display to spread outward from Channel 3, the center channel speaker. If you are using a self-powered subwoofer, you will connect the Cinema Reference's SUB Output directly to the subwoofer. If you are using a self powered subwoofer with the PTM-6150, you may opt to "Y" split the SUB output so as to illuminate channel six of the PTM-6150.

Amplifier AC Connections

The Cinema Reference incorporates a switched AC outlet which is rated at 10 Amps. This is powerful enough for ADA's PTM-6150 Six Channel THX Power Amplifier. Several other power amplifiers could also be plugged directly into this switched AC outlet. However, if the power amplifier is going to draw more than 10 Amps (such as ADA's MPA-500 Five Channel THX High-Power Amplifier), you will want to avoid using this switched AC outlet. To connect the power amplifier to the Cinema Reference, you will need to use an EIC Male to EIC Female AC Cord. These AC cords are also used for computers and computer monitors and are available in stores that support computer and AC products.

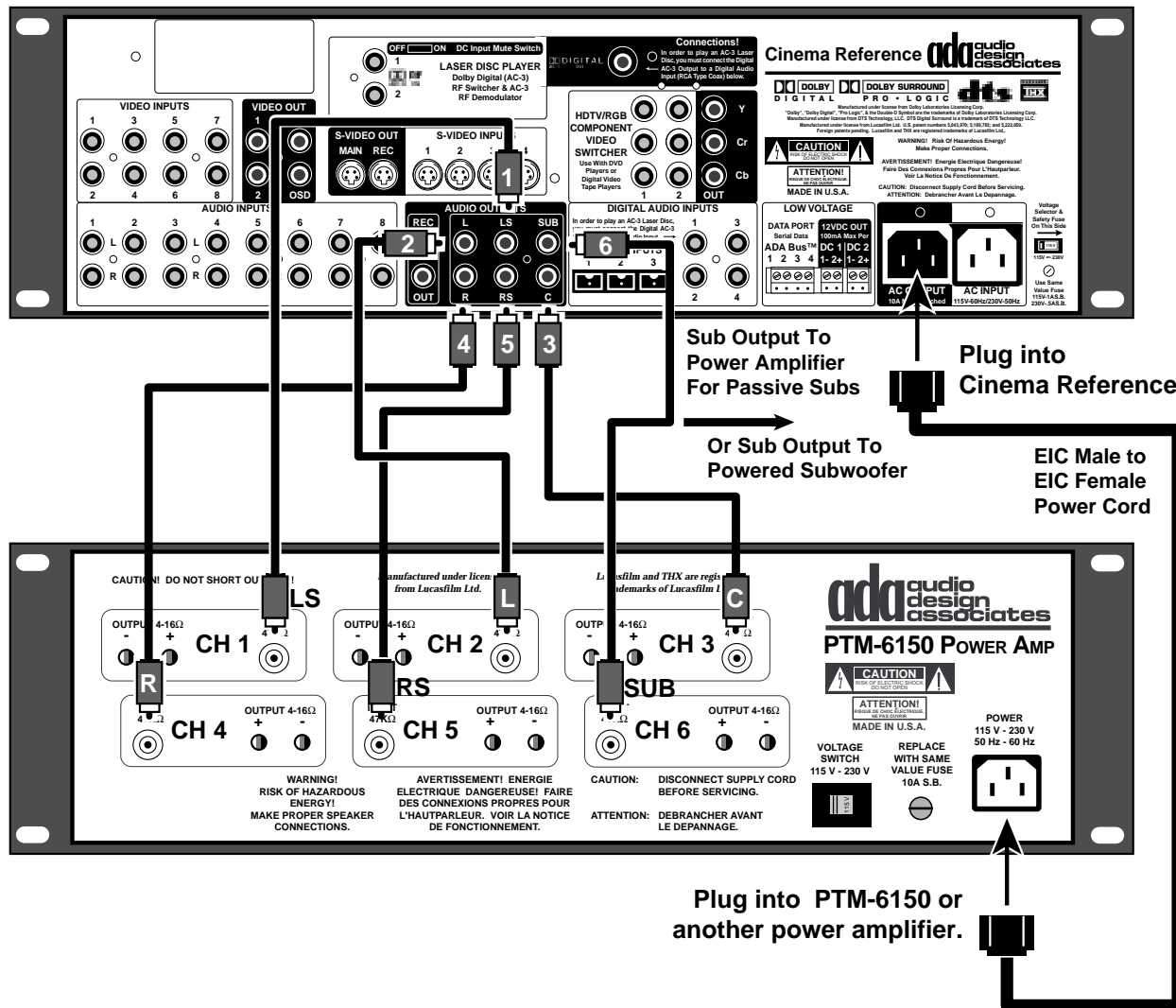

Introduction - Front Panel Controls & Displays

Overview

The Cinema Reference is factory set for optimum operation. This section details the front panel features of the Cinema Reference. All component functions can be operated through the five control knobs located on the units front panel. The three front panel displays are also explained in this section.

Welcome

The Cinema Reference is the world's most advanced audio video surround sound preamplifier. **It is also configured "Out Of The Box" for optimum operation.** While it is designed to be easy to setup and operate, ADA strongly recommends spending some time familiarizing yourself with the units many functions and features. For those who wish to customize their home theater system, the Cinema Reference is also equipped to be configured to operate ideally in almost any environment and with many varying source components. While the connection of components and accessories are discussed in the following sections, this area will explain the front panel features and basic operation commands of the Cinema Reference's front panel. The text found in italic type in this manual's margins will act as a quick reference when reviewing these materials.

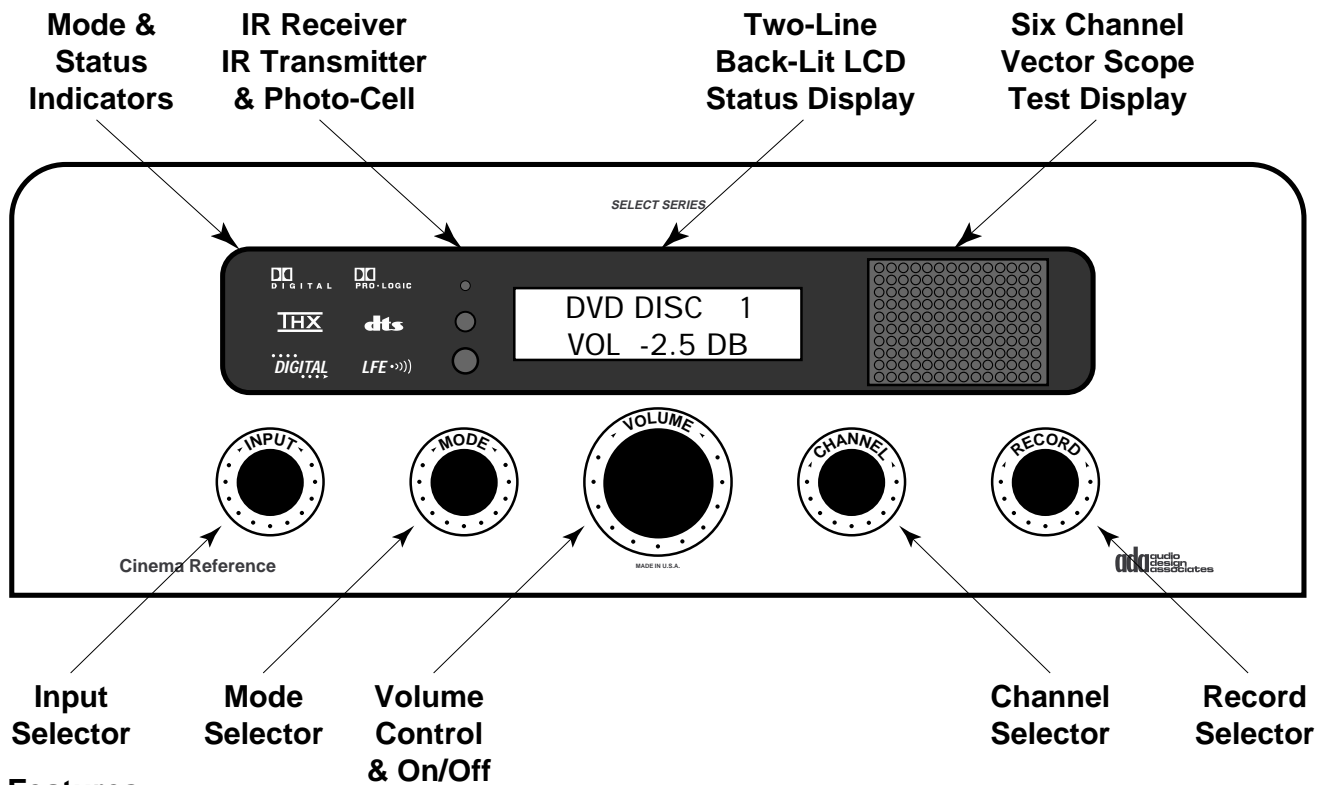

Features

The Cinema Reference acts as both an input selector and surround sound decoder. It is capable of decoding Dolby Pro Logic, Dolby Digital (AC-3), and DTS encoded formats and also providing Lucasfilm THX enhancements and filters to Dolby Digital & Pro Logic. While the Cinema Reference can automatically detect between Dolby Digital, DTS, Dolby Pro Logic, and Dolby Digital/Dolby Pro Logic (both decoding formats are used when playing two-channel encoded DVD discs {typically older movies available on DVD that are not mixed in six channels}), the option to engage either full THX enhancements or only THX Re-EQ must be manually set on the Cinema Reference. The Cinema Reference also provides several additional modes ideal for music playback. There are additional settings that permit the Cinema Reference to also operate in home theaters where a full six channel speaker array may only be partially implemented (i.e. no subwoofer and/or no center channel). Furthermore, the Cinema Reference also permits each channel to be set to its own volume level with respect to all other channels as well as have its own delay setting. These features and more are discussed in the upcoming sections.

Power On, Mute, Off, & Master Volume Control

When the Cinema Reference is off, turning any knob or pushing any knob other than the Volume knob will cause the Cinema Reference's center LCD display to indicate:

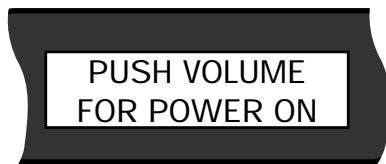

To turn on the Cinema Reference, providing the unit is not in Mute, press the Volume knob once. Pressing of the Volume knob performs only three functions.

If the unit is off, pressing it will turn it on.
If the unit is on, pressing it once will engage Mute.
If the unit is in Mute, pressing it again will turn it off.

(To regain the audio (exit Mute), turn any of one of the five knobs or press any knob other than the Volume knob).

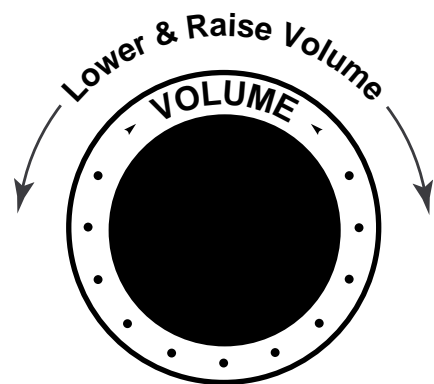

Front View

Once the Cinema Reference is on, turning the Volume knob will only raise or lower the system's volume level. This is considered the Master Volume Control as it will adjust all six channels of volume, maintaining the balance of levels that are preset between channels.

Volume Reference

Since the home theater could have as many as six different volume levels, one for each of the six channels, ADA uses the

highest volume level of the five main channels (not the sub) as the reference level on the display. For example, if the volume levels for Left, Left Surround, Right, and Right Surround are set to -10dB, the subwoofer is set to -2dB, and the Center channel is set at -5dB, the Volume level for ALL will indicate -5dB.

Upper Volume Limit

As the Cinema Reference closes in on the upper volume limit of +10.0dB, all channels will raise to that limit stopping when the first of the main five channels ceilings out at +10.0dB.

Lower Volume Limit

When the first channel reaches the lower volume limit of -96dB, all other channels will stop lowering in volume level. Hitting either the lower or upper volume limits will not alter the balance between channels.

Power On

Press the Cinema Reference's Volume knob to engage power on.

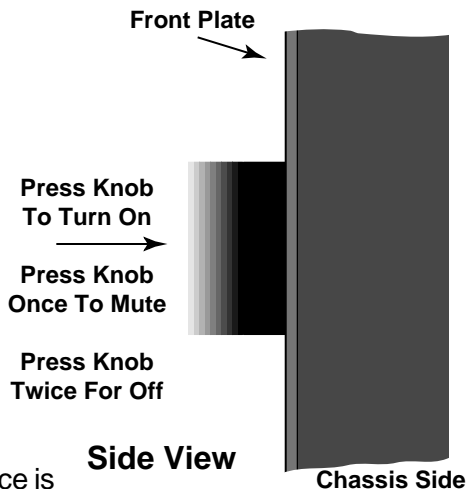

Side View

Mute

While the Cinema Reference is on, pressing it's Volume knob once will mute all channels.

Power Off

While the Cinema Reference is in Mute, pressing the Volume knob a second time will turn the Cinema Reference off.

Un-Mute

While the Cinema Reference is in Mute, turning any knob or pressing any knob other than the Volume knob, will regain audio.

Power On/Off Via AC Control

If the Cinema Reference is on when it is unplugged or when power is removed through the use of an AC Controller, it will also automatically turn back on when power is restored.

Input Selection - Dialing in the desired component.

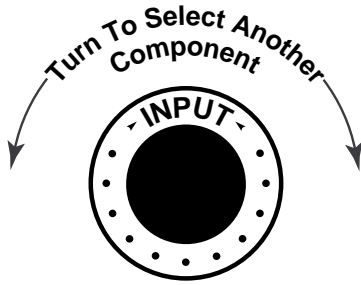

The Cinema Reference permits you to scroll to the next input without having all of the components you are passing actively process through the Cinema Reference. This prevents the clicking that is commonly associated with changing TV channels up and down. To best access another component from the front of the Cinema Reference, turn the Input Selector knob. As you turn this knob, you will notice that the top row of the LCD display will not change, still indicating the current component in use (in this example, DVD DISC). The second line of the LCD display will advance through the input names until the desired component is displayed.

Front View

1. Dial In New Input
Turn the Input Selector knob until the second line of the LCD display reads the component you wish to select. As you turn the knob, you will notice that the top line of the display still indicates the current source in play. Also, this component is still being routed and processed by the Cinema Reference.

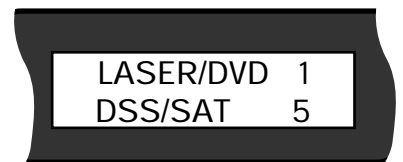
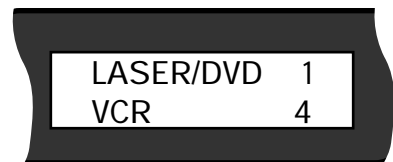
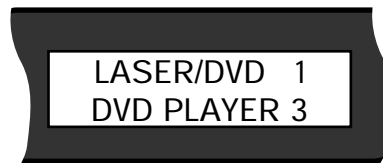
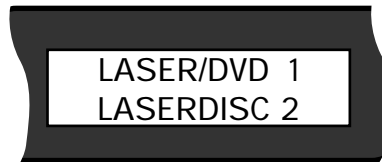
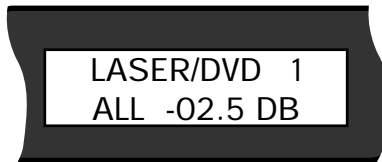

2. Engage New Input
Once the second line of the display indicates the next component you wish to access, press the Input Selector knob to engage this input. This method permits you to select an input without switching all of the inputs you are scrolling through.

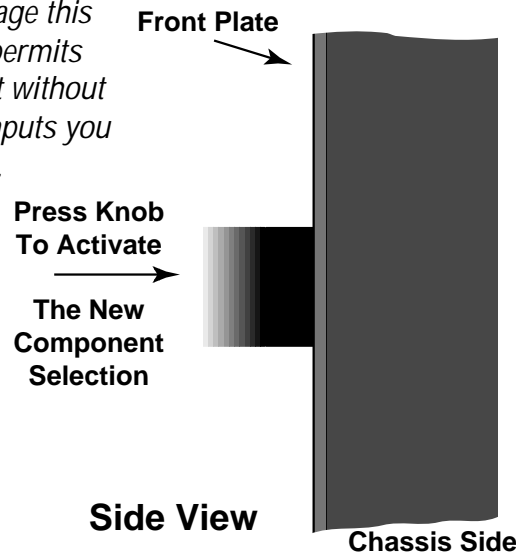

Once the desired component is displayed on the LCD's second row, press the Input Selector knob to engage that component. The display will then return to read the new selection (i.e. DSS TV) along with the Volume Level.

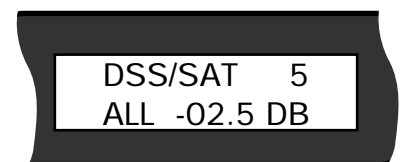

Mode Indicators & How They Function

The Cinema Reference features six indicators on the left side of its front panel. They provide a visual indication of decoding mode, the presence of an LFE (“1” of “5.1”), and if a digital input is accessed. While you can manually select modes, these indicators are an ideal way to determine status when the Cinema Reference is in the “Auto-Mode Detection” state.

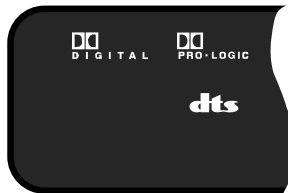
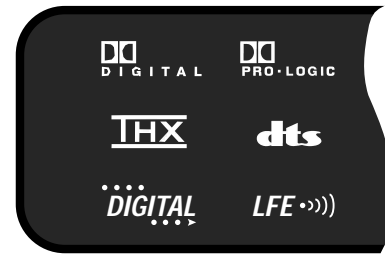

Three of the indicators are used to provide status of the decoding mode, Dolby Pro Logic, Dolby Digital (AC-3), or DTS. Typically, only one of these indicators is on at any one time. If a mode other than a Dolby or DTS mode is selected, none of the indicators will be lit.

In the event you are playing a two-channel digital source that was encoded in AC-3 (i.e. an older movie on a DVD), the Cinema Reference will engage both Dolby Digital decoding to extract the from the DVD and then Dolby Pro Logic to decode the two channel mix for playback. Both indicators will be on in this case.

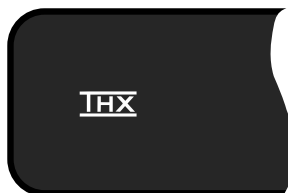
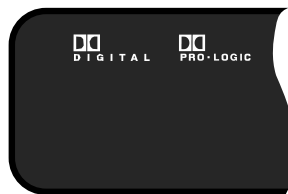

The Cinema Reference also permits the addition of full-blown THX enhancements to Dolby Digital, DTS, or Dolby Pro Logic decoding formats. When THX is selected to enhance these modes, the indicator will be lit.

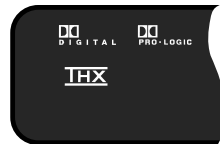
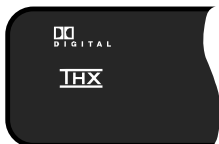

Please note, the Cinema Reference does not detect the presence of THX as it is not an encoded process but rather a filtering process. THX certification to video tapes, laser discs, and DVDs is intended to ensure that the material was properly mixed and transferred and does not directly relate to the THX certification of the Cinema Reference. To engage either full-blown THX or THX Re-EQ, you must do so manually on the Cinema Reference.

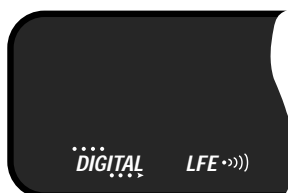

The Cinema Reference has two additional indicators that detail information for digital sources. The Digital indicator will illuminate when a digital input is accessed. The LFE indicator will light up if the digital source material has an independent six channel encoded in it for bass or “Low Frequency Effects” (LFE). If a source material (i.e. AC-3 or DTS CD, Laserdisc or DVD), is truly “5.1” (“1” being the LFE or subwoofer signal), the LFE indicator will light up.

Mode Indicators

The Cinema Reference features three mode indicators that illuminate when either Dolby Digital (AC-3), Dolby Pro Logic, or DTS decoding formats are engaged. Typically, only one of these three indicators are on at any one time. However, when playing a digitally formatted source material (i.e. DVD) of an older movie that is only mixed with two-channel audio, both the Dolby Digital and Dolby Pro Logic will illuminate indicating that both decoding formats are being implemented. If a decoding mode other than DTS, Pro Logic, or Dolby Digital is selected, none of the indicators will be on.

THX Enhancements

The THX indicator will illuminate only when THX has been selected in conjunction with Dolby Digital, DTS, or Dolby Pro Logic modes. THX is not auto-detected but must be intentionally engaged.

Digital & LFE Indicators

The Digital indicator will be lit when a digital input is selected. The LFE indicator will be lit when a digital input contains a distinct subwoofer signal (only in DTS & AC-3).

Mode Selection & Dolby Digital Mode Descriptions

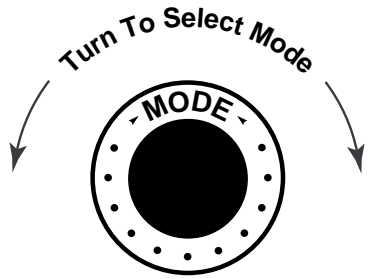

1. Dial In New Mode
Turn the Mode Selector knob until the second line of the LCD display reads the mode you wish to select. As you turn the knob, you will notice that the top line of the display indicates the current source in play and the second line indicates the modes available. The Cinema Reference will not engage the new mode until Step 2 is accessed.

2. Engage New Mode
Once the second line of the display indicates the next mode you wish to access, press the Mode Selector knob to engage this mode.

AC3 ULTRA Mode

This is the most dynamic or all Dolby Digital AC-3 modes. In the AC-3 Ultra mode, the dialogue normalization takes place in the Cinema Reference's analog domain and not in the digital domain. Other AC-3 modes provide dialogue normalization in the digital domain by discarding bits of data.

The Cinema Reference provides 22 modes for film, television, and music playback. This section will detail these modes and their functions. Because the Cinema Reference can also automatically detect the encoding method of the selected source, it will automatically engage the best possible decoding mode for the selected components output. While the Cinema Reference can automatically switch between Dolby Digital, DTS, and Dolby Pro Logic, enhancement features such as THX, Re-EQ, and other Dolby Digital options will need to be engaged using the Mode Selector.

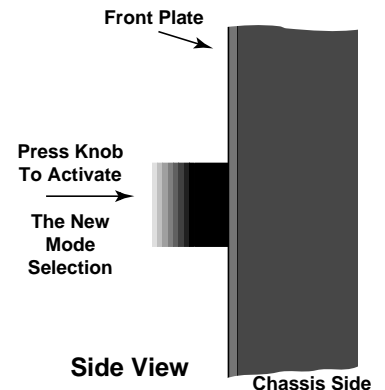

Dolby Digital Modes (AC-3)

Line Mode & RF Mod Mode - Dolby Digital AC-3 applies dynamic range compression in one of two forms, Line Mode or RF Mod Mode. Only AC-3 Night mode utilizes the RF Mod Mode for dynamic range compression. Both AC-3 Standard and AC-3 Max modes utilize the Line Mode for dynamic range compression. The difference between these two modes the preset HDR and LDR scaling factors. The AC-3 Ultra mode does not use either the RF Mod or Line modes for dynamic range compression.

HDR & LDR Scale Factors - Dolby Digital AC-3 decoding has the option to engage a high level dynamic range (HDR) and low level dynamic range (LDR). The range of the scale is from "0" or Full Off to "1" or Full On in increments of ".05". As the LDR (low level scale) setting is increased, the softer sounds (lower) are raised, such as whispers. As the HDR (high level scale) is increased the louder sounds (higher) are lowered. Thus, setting these scales up or to Full On (settings of "1"), will narrow the volume range such that the explosions are not too loud and the whispers are not too soft.

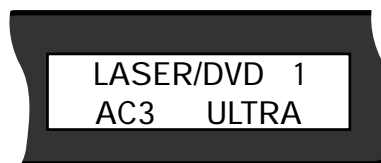

Ultra Maximum Dynamic Range

- This is the most dynamic of all the AC-3 modes in that dialogue normalization takes place in the Cinema Reference's analog domain rather than the digital domain. When dialogue normalization takes place in the digital domain, it is processed by discarding bits of data which may not be optimal. AC-3 Ultra mode reads information flags contained in the DVD or laser disc and uses these software specific parameters to set the dialogue normalization after digital processing takes place. The HDR and LDR scales are preset at "0" (Full Off) but can be scaled individually.

Dolby Digital Modes (AC-3) - cont.

Normal Dynamic Range - This mode engages the AC-3 "Line Mode" coupled with the High Level (HDR) and Low Level (LDR) resolution factors preset to "255" or Full On. While the option of Line Mode is fixed, the HDR & LDR factors can be scaled.



LASER/DVD 1
AC3 STANDARD

AC3 STANDARD Mode

This mode offers normal dialogue normalization coupled with full on/variable HDR & LDR scaling.

Maximum Dynamic Range - This mode uses the AC-3 Line Mode setting as found in AC3 Standard, however the HDR and LDR factors are fixed at "0" or Full Off. For play back of films, this mode may be preferred over AC3 Ultra in that some compression schemes are designed to recreate the movie theater environment in the home.

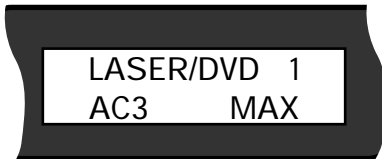

LASER/DVD 1
AC3 MAX

AC3 MAX Mode

This mode offers maximum dynamic range for dialogue normalization taking place in the digital domain.

Minimum Dynamic Range - This mode uses the AC-3 RF Mod Mode setting. Also, the HDR and LDR factors are fixed at "255" or Full On. This mode is ideal when viewing a film at a time where the bangs may be too loud or the softer sounds too low. In AC3 Night, the audio range is narrowed between loud and soft sounds.

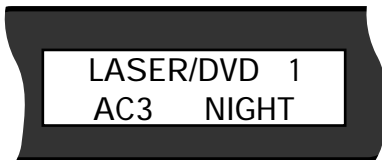

LASER/DVD 1
AC3 NIGHT

AC3 NIGHT Mode

The least dynamic of all AC-3 modes, AC3 Night mode is ideal for viewing movies when loud bangs or other impact related sounds would normally be too loud.

Full THX Enhancements - This mode engages all of the THX related filters including re-equalization, timbre match, and decorrelation.

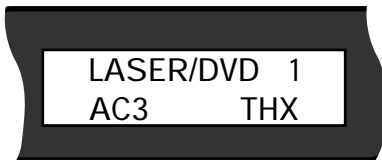

LASER/DVD 1
AC3 THX

AC3 THX Mode

This mode provides full THX enhancements.

THX Re-Equalization Only - This mode is used to provide partial THX enhancements focused on the adjustment of sound levels for the front three channels. Typically, films are mixed with the front three channels adjusted to compensate for the film screen they need to project through. Re-EQ compensates for this factor in the home.

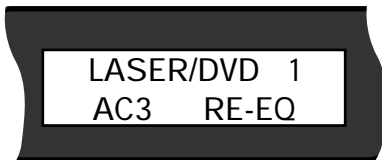

LASER/DVD 1
AC3 RE-EQ

AC3 RE-EQ

This mode offers only THX Re-equalization for the front channels.

AC-3 Mono Mode - This mode down mixes AC-3 into the center channel. While this may not be ideal for motion pictures and broadcasts encoded in 5.1 channels, it may be used for older movies that were recorded in mono.

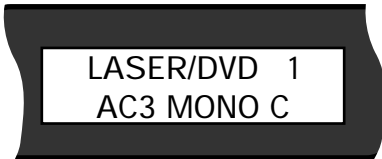

LASER/DVD 1
AC3 MONO C

AC3 MONO Mode

This mode combines all five channels of audio information into the center channel.

DTS Modes

DTS DIRECT Mode

This mode is the standard DTS decoding mode without any delay and bass management level settings.

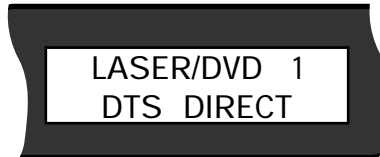

DTS Direct Mode - Much like Dolby Digital AC-3, DTS is a 5.1 digitally encoded matrix. This mode provides DTS decoding. Please note, that most DTS software, in the form of CDs and Laser Discs, do not contain any standard two channel audio tracks. If you are playing DTS software and are getting nothing but noise, you are most likely not in a DTS decoding mode. Please note, in the Pro Setup Menu, the delays, bass limiter, and THX enhancements are disabled and are controlled by the main processor. This mode is the purist of all DTS modes as it was designed to deliver 5.1 playback as DTS has intended.

DTS CINEMA Mode

This is the enhanced DTS decoding mode coupled with the Delay and Bass Management Settings found under the Cinema Reference's Pro Setup.

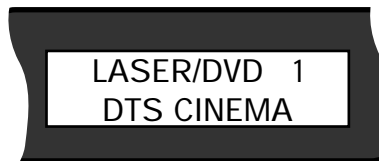

DTS Cinema Mode - This mode provides DTS decoding with the enhancements from the Cinema Reference's delay and bass management settings. Please note, most DTS software that is encoded onto PCM audio channels (DTS CD's and Laser Discs) do not contain any standard two channel audio tracks. If you are playing DTS software and are getting nothing by noise, you are most likely not in a DTS decoding mode.

DTS THX Mode

This mode offers full THX Enhancements to DTS, in addition to the features available with the DTS Cinema mode.

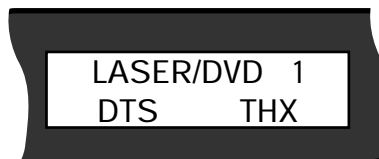

DTS THX Mode - This mode is the same as the DTS Cinema mode with THX Enhancements added to the surround processing.

DTS RE-EQ Mode

This setting is offers only THX RE-EQ to the DTS Mode in addition to the features available with the DTS Cinema Mode.

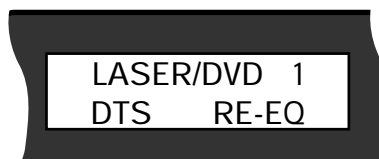

DTS RE-EQ Mode - This mode is the same at the DTS Cinema mode with only RE-EQ added to the surround mix. RE-EQ is one of the aspects of the full THX Enhancements.

Pro Logic & Auto Modes

Dolby Pro Logic Mode - This mode is used for most film or TV source materials that are not encoded in either Dolby Digital or DTS. Pro Logic uses a 2-channel audio mix and plays back a center channel mix and surround channel mix in addition to the right and left audio channels.

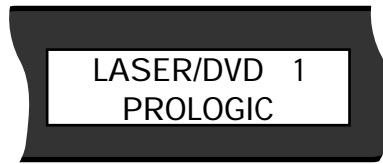

PRO LOGIC Mode

This mode is used for most current TV, Cable and Satellite broadcasts as well as playback of video tapes and non-AC-3/DTS laser discs.

Pro Logic THX Mode - This mode provides full THX enhancements to source materials encoded in Dolby Surround. With Dolby Surround encoded materials, timbre match and decorrelation assist in providing some degree of channel separation to the surround speakers.

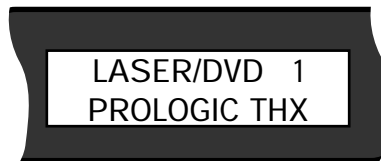

PROLOGIC THX Mode

This mode provides full THX enhancements to Dolby Pro Logic.

THX Re-Equalization Only - This mode is used to provide partial THX enhancements focused on the adjustment of sound levels for the front three channels. Typically, films are mixed with the front three channels adjusted to compensate for the film screen they need to project through. Re-EQ compensates for this factor in the home.

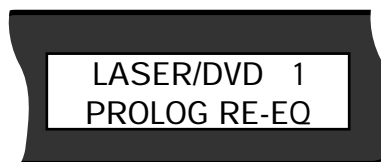

PROLOG RE-EQ

This mode offers only THX Re-equalization for the front channels to Dolby Pro Logic.

Auto Mode On - The Auto Mode is not so much a mode but rather a state in which the Cinema Reference checks for Dolby Digital, DTS, or Dolby Pro Logic playback. Since there are several mode options for each, AC-3, DTS, and Pro Logic, the Cinema Reference will engage the last version of these modes used when auto-detecting.

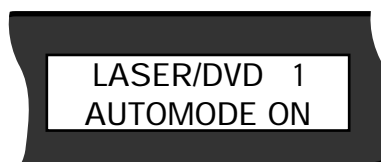

AUTOMODE ON

This setting is engaged for devices that can play either AC-3, DTS, or PCM software (Laser Disc, CD, and DVD Players). When the Auto Mode is On, the Cinema Reference will seek automatically switch between AC-3, DTS, and Pro Logic.

Auto Mode Off - When Auto Mode is off, no detection is used.

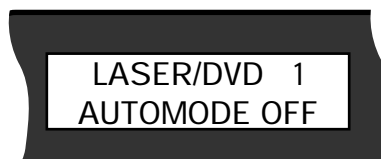

AUTOMODE OFF

No Auto Detection in this setting.

Stereo, Phantom, & Music Modes

STEREO Mode

This mode offers two-channel stereo playback with the subwoofer active. The Subwoofer can also be deactivated.

LASER/DVD 1
STEREO

Stereo Mode- The Stereo mode engages only the front right and left speakers. The audio path provides for stereo separation. The subwoofer is also active providing that the subwoofer is active in the Bass Management setting found in the Pro Setup menu.

STEREO RE-EQ Mode

This mode provides two-channel stereo playback with THX Re-Equalization.

LASER/DVD 1
STEREO RE-EQ

Stereo RE-EQ - This mode will add THX RE-EQ to the stereo channels. This is not a full THX mode.

PHANTOM Mode

This mode redirects the center channel information to the front right and left speakers and is used when no center channel speaker is used.

LASER/DVD 1
PHANTOM

The Phantom Mode - This mode takes the center channels information and combines it with the signal front right and left channels. This mode is ideal for systems not incorporating a center channel.

PHANTOM EHN Mode

This Phantom mode engages THX Enhancements.

LASER/DVD 1
PHANTOM ENH

Phantom ENH Mode - Phantom Enhance Mode provides the same surround sound decoding as the Phantom mode but with full THX Enhancements.

PHANTOM RE-EQ Mode

This Phantom mode only engages THX RE-EQ.

LASER/DVD 1
PHANTOM REEQ

Phantom RE-EQ - This mode provides the same redirection of the center channel information as the Phantom mode. This mode also adds THX RE-EQ to the surround sound mix.

PHANTOM PLUS Mode

This Phantom mode provides full range audio to the surround channels..

LASER/DVD 1
PHANTOM PLUS

Phantom Plus Mode - Phantom Plus Mode will divert the center channel information while providing decorrelation to the surround channels.

MUSIC Mode

This mode can be used for music playback as it provides some level of steering encoded sound tracks.

LASER/DVD 1
MUSIC

Music Mode - This mode enables some level of decoding, thus passing audio to all speaker channels. Sounding like Dolby Pro Logic, this mode does not engage any noise reduction, resulting in a sound that delivers additional highs.

MUSIC PLUS Mode

This mode adds decorrelation to the surround channels of the standard MUSIC Mode.

LASER/DVD 1
MUSIC PLUS

Music Plus Mode - The Music Plus mode in addition to Music Mode also provides decorrelation to the surround channels.

3 Channel, Quad, Stereo Enhance, and Mono Enhance

3 Channel Mode- This mode only engages the front three speaker, providing Pro Logic steering across these channels with the surrounds completely muted. The subwoofer is active in this mode assuming it is set to be active for this input in the Bass Management section under Pro Setup.

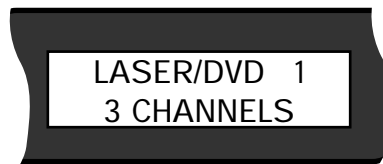

3 CHANNELS Mode

This mode provides Pro Logic decoding with only the three front channels and the subwoofer active.

3 Channel Re-EQ Mode- This mode is like the 3 Channels mode with the addition of THX Re-EQ.

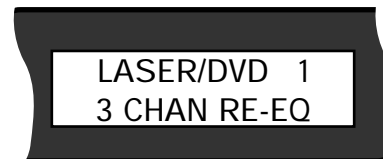

3 CHANN RE-EQ Mode

This 3 channel mode adds re-equalization to the three front channels.

Quad Bypass Mode- Ideal for music playback, the right channel information is sent to the right surround channel and the left channel information is sent to the left surround channel. The center channel (if active, see System Setup in Pro Setup) is sent a mix of the right and left channels, with the mix lowered by 3db.

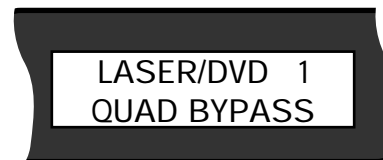

QUAD BYPASS Mode

This mode is designed to utilize the entire speaker array for two channel music playback. All four right and left speakers receive R/L information and the center gets a mix of the two.

QUAD BYP ENH Mode - The Quad Bypass Enhanced mode operates just like the Quad Bypass mode but adds full THX Enhancements to the surround sound mix.

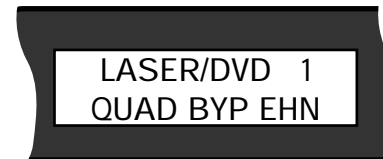

QUAD BYP EHN Mode

This mode adds THX Enhancements to the Quad Bypass mode.

STEREO ENH Mode - The Stereo Enhanced Mode is ideal for two channel mixes with limited stereo separation. TV broadcasts and poorly mixed video tapes will playback with a fuller use of the speaker array in this mode. Stereo Enhance couples increased stereo separation without destroying the mono mix. This proprietary mode uses delay settings to enhance the surround sound effect. The effect level and delay can be adjusted in the Pro Setup menu.

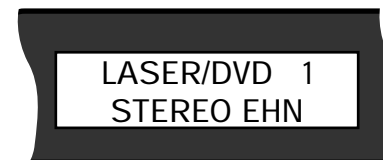

STEREO ENH Mode

This is a proprietary mode ideal for playback of signals with limited stereo separation such as TV broadcasts and poorly mixed video tapes.

MONO ENH Mode - The Mono Enhance Mode is similar in design to the Stereo Enhance mode but is ideal for non-stereo mixes. Thus old movies and mono TV broadcasts emanate not just from the center speaker, but rather, utilize the entire speaker array. Even the worst audio mixes are spatially enhanced. This mode is also adjustable by setting the effect level and delay in the Pro Setup Menu.

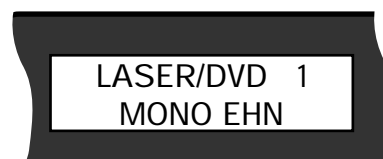

MONO EHN Mode

This mode is ideal for playback of mono only mixes as it will utilize the entire speaker array.

Record Selector

The Record Selector operates independently from the main output providing the ability to record, view, or play (in another room) a component other than the one selected in the home theater.

To determine which device is currently selected, press the Record Selector knob. To change components:

- 1. Dial In New Device**
Turn the Record Selector knob until the second line of the LCD display reads the component you wish to select.
- 2. Engage New Device**
Once the second line of the display indicates the next component you wish to access, press the Input Record knob to engage this input.



Front View

The Cinema Reference incorporates a record selector that operates independently from the actual source component selected for the home theater room. This record selector can be used in several ways.

- 1 Use the Record Selector to send audio and video signals from a particular component to a recording device (i.e. VCR)
- 2 Use the Record Selector to send a video signals to a second monitor or TV set. Ideal for the sports fanatic, this option would permit a second TV to display a broadcast from on tuning mechanism (i.e. DSS receiver, TV tuner, or VCR TV tuner). While the primary viewing surface would be set to display a particular channel from one device (i.e. DSS receiver), the additional TV or monitor could be set to display the image of the TV Tuner in the VCR.
- 3 Use the Record Selector to determine the image inserted into a TV's PIP (Picture In Picture). This would provide the same effect as described in option 2 (above) using the PIP function in place of a second TV or monitor.
- 4 Use the Record Selector to send the audio and video signal of a particular device to a whole-house multi-room audio video system. This setup would cause the Record Selector to act as a separate zone from the actual home theater.

Record Selector Functions

To determine what component the Record Selector is currently set to, press the Record Selector knob. The display will read as follows where the second line of the display indicates the component selected.

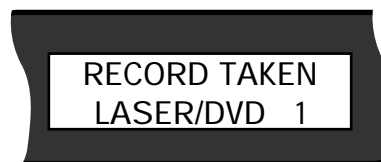

To Select another source component for recording, display to a second monitor (TV or PIP), or for distribution through the house, turn the Record Selector knob until the new component appears in the display.



Then press the Record Selector knob to engage this device.

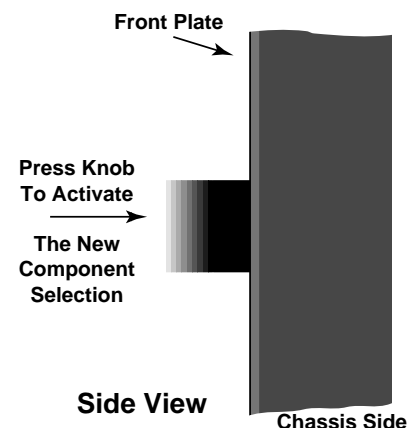

Side View

Rear Panel Inputs & Outputs

The Cinema Reference's rear panel connections provide ample component connectors (inputs) for a wide variety of equipment. The following pages show the factory default "Out Of The Box" input settings for the Cinema Reference. When proceeding to connect your components to the Cinema Reference, ADA suggests using these settings, however, you may also select to customize your Cinema Reference to provide any type of input combination. As a reminder, the Cinema Reference is preprogrammed for optimum operation right "Out Of The Box".

All rear panel connections are clearly marked such that all inputs are situated in a black field which is bordered and labeled in white and all outputs are on a white field labeled in black. Each type of area is designated by input type.

Before you proceed, it will be useful to determine what type of components you intend to connect to the Cinema Reference. Once you have selected the components, you will want to determine what connectors these devices feature and how to best connect them to the Cinema Reference. If you are uncertain as to what jacks to use, ADA suggests contacting your local Authorized ADA Retailer or Custom Installation Professional for technical support. Should you have any questions on the Cinema Reference, you can receive factory support by calling Audio Design Associates, Inc. at 1-800-43-AUDIO (1-800-432-8346), between the hours of 9am-5pm, eastern time, Monday-Friday.

As a starting point, ADA suggests using the "Out Of The Box" configuration to begin making your source connections. If the "Out Of The Box" setup needs further modification to perfectly customize your home theater system, the Cinema Reference also permits "Custom Setup" that allows for hundreds of potential setups.

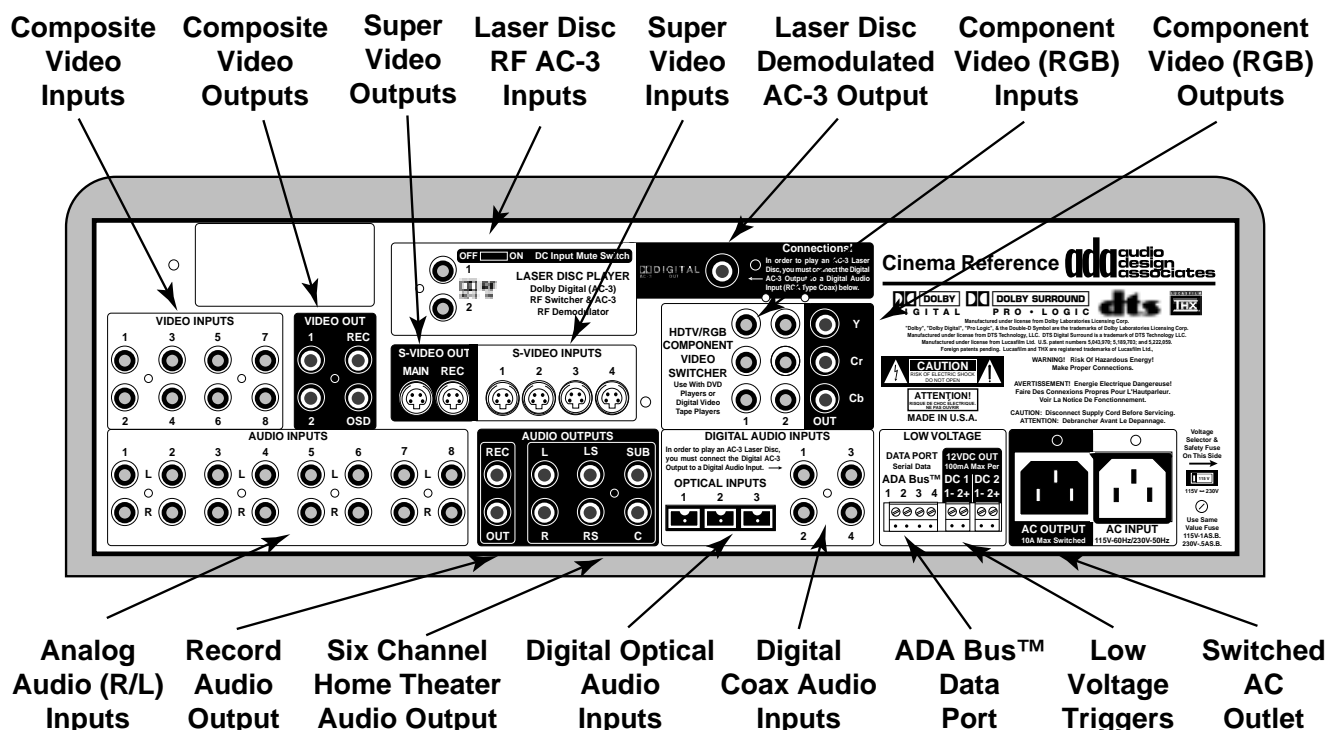

Out Of The Box Setup

The "Out Of The Box" Setup uses the Cinema Reference's default setup program. Since not all source components have the same audio outputs, this section offers different connection possibilities to take into consideration the many component connections.

To best proceed with the connection of your components, simply examine the units that you have and compare the component's output jack to the illustration.

Please note, that the Cinema Reference's "Out Of The Box" setup is designed for quick and easy connection of the most common source components used in today's home theater systems. Thus, this setup does not optimize all of the audio inputs since a CD player, second laser disc player, or DSS receiver may feature a digital output. If all three devices offered a digital output, you would be able to bypass these components analog connections noted in the "Out Of The Box" setup and have three additional analog inputs available for other devices. If the video game or computer were to also offer a digital output, you could then connect as many as fifteen devices to the cinema reference.

The chart on the following page details the "Out Of The Box" Setup.

The Cinema Reference is preprogrammed to permit quick and easy connection of your audio and video components. This section details the options available taking into consideration that not all source components have each and every output jack present. Since the Cinema Reference is fully equipped with an abundance of audio inputs of varying types: 8 Analog R&L Stereo (RCA) Inputs, 4 Digital Coax (RCA), 3 TOS-Link Digital Optical Inputs, and 2 Laser Disc AC-3 RF Inputs (RCA), the "Out Of The Box" configuration should cover most any home theater system.

Please note, the Cinema Reference is also fully programmable. Should you care to customize your system, you can do so by following the items in the section titled "Custom Setup".

The Cinema Reference offers fifteen "Input Labels". An Input Label is the name of the component followed by a sequence number (i.e. *LASER/DVD 1, LASERDISC 2, DVD PLAYER 3*). Each input label is capable of being customized including the way the components name appears in the display. Again, you can customize the way the Input Labels read in the "Custom Setup" section of this manual. During a typical "Out of the Box" setup, you will most likely use only a portion of the Input Labels that are preprogrammed in the factory. The input labels appear as follows:

<i>LASER/DVD</i>	<i>1</i>	Used for combination LD/DVD Player.
<i>LASERDISC</i>	<i>2</i>	Used for a second laser disc player or a laser disc without a digital out.
<i>DVD PLAYER</i>	<i>3</i>	Used for a DVD Player.
<i>VCR</i>	<i>4</i>	Used for VCR.
<i>DSS/SAT</i>	<i>5</i>	Used for a DSS or Satellite Receiver.
<i>CABLE/TV</i>	<i>6</i>	Used for cable box or TV's audio output.
<i>CD PLAYER</i>	<i>7</i>	Used for a CD player.
<i>TUNER</i>	<i>8</i>	Used for a radio tuner.
<i>CASSETTE</i>	<i>9</i>	Used for a cassette deck.
<i>AUXILIARY</i>	<i>10</i>	Used for any A/V component.
<i>CAMCORDER</i>	<i>11</i>	Used for a Camcorder.
<i>VIDEOGAME</i>	<i>12</i>	Used for video games.
<i>COMPUTER</i>	<i>13</i>	Used for a computers output.
<i>PREAMP</i>	<i>14</i>	Used for connection of an existing preamp.
<i>MULTIROOM</i>	<i>15</i>	Used for connection of the audio output from a multi-room audio system.

The Cinema Reference in its "Out Of The Box" setup, will only permit the connection of ten (10) components. Inputs 10-15 are preprogrammed to the same audio and video input and as such, only one such device can be connected without going into the "Custom Setup".

In the "Out Of The Box" setup, the Input Labels show a nine character component name followed by a number. The first 8 inputs correspond to buttons 1-8 on a One-For-All Six IR remote control that may be shipped with some units.

Laser Disc or Combination Laser Disc/DVD Player

The "Out Of The Box" setup presumes that your combination laser disc/DVD player has the following outputs:

*Digital Audio PCM/AC-3
Coax (RCA) Type Output*

AC-3•RF Output (LD)

*Video Output
(Composite RCA Type)*

Your combi-player may also include a super video output. Please note, the Cinema Reference does not cross mix video signals. As such, if you wish to use a component's S-Video output, you will need to connect an S-Video cable from the Cinema Reference to the TV or Projector.

Use the diagram on the following page to make your combi-player connections. ADA suggests using a quality 75Ω Coaxial cable. In the event that none are available, you can use standard RCA interconnects.

If your combi-player does not have an RCA Type Digital Audio PCM/AC-3 Coax output but rather has only an Optical Digital PCM/AC-3 output, you will need to change the programming for this input. These steps are discussed at the bottom of the following page.

The Cinema Reference is preprogrammed to permit you to easily connect a combination laser disc & DVD player. You will need to make two audio connections in for this unit to play the following:

Dolby Digital Laser Discs, Pro Logic Laser Discs, DTS Laser Discs, Dolby Digital DVDs, 2 Channel Dolby Digital DVDs, Stereo CDs, and DTS CDs.

All connections should use a 75 Ohm coaxial cable. If none are available, standard RCA video interconnects will work.

Connection 1 - Laser Disc Player's AC-3 RF Output - You will need to connect the combi-players "AC-3•RF Output" (LD for Laser Disc) to the Cinema Reference's Laser Disc Player #1 "RF IN". This connects the laser disc's AC-3 RF output to the Cinema Reference's internal AC-3 RF Demodulator.

Connection 2 - Cinema Reference's RF Demodulator's Output - You will need to connect the Cinema Reference's Laser Disc Player's Digital Output (Black RCA Connector) to the Cinema Reference's #4 Digital Audio Input (Orange RCA Connector). This "Laser Disc AC-3 Loop Cable" passes the demodulated laser disc AC-3 signal to a digital audio input which will then decode it.

Connection 3 - Laser Disc Player's PCM/AC-3 Digital Output - You will need to connect the combi-players digital output that is marked by both PCM and AC-3 to the Cinema Reference's #1 Digital Audio Input (Orange RCA Connector). This input will pass audio for all AC-3 playback from a laser disc.

Connection 4 - Laser Disc Player's Video Output - You will need to connect the laser disc player's video output (Composite Video) to the Cinema Reference's #1 Video Input.

Connection 5 (Optional) - Laser Disc Player's S-Video Output - You may also choose to connect the S-Video (Super Video) output of the laser disc player to the Cinema Reference S-Video #1 input. This will require a special super video cable. Please note, if your projector or TV does not have a super video input, you will not need to make this connection as the Cinema Reference does not cross convert S-Video to Composite Video.

The diagram to the right details all of these connections. If your combi-player does not have an RCA style digital audio output for PCM/AC-3, it may have an optical digital audio output for PCM/AC-3 playback. In this case you will need to alter the *LASER/DVD 1* input. The steps to change the input from a digital to an optical input is discussed at the bottom of the following page.

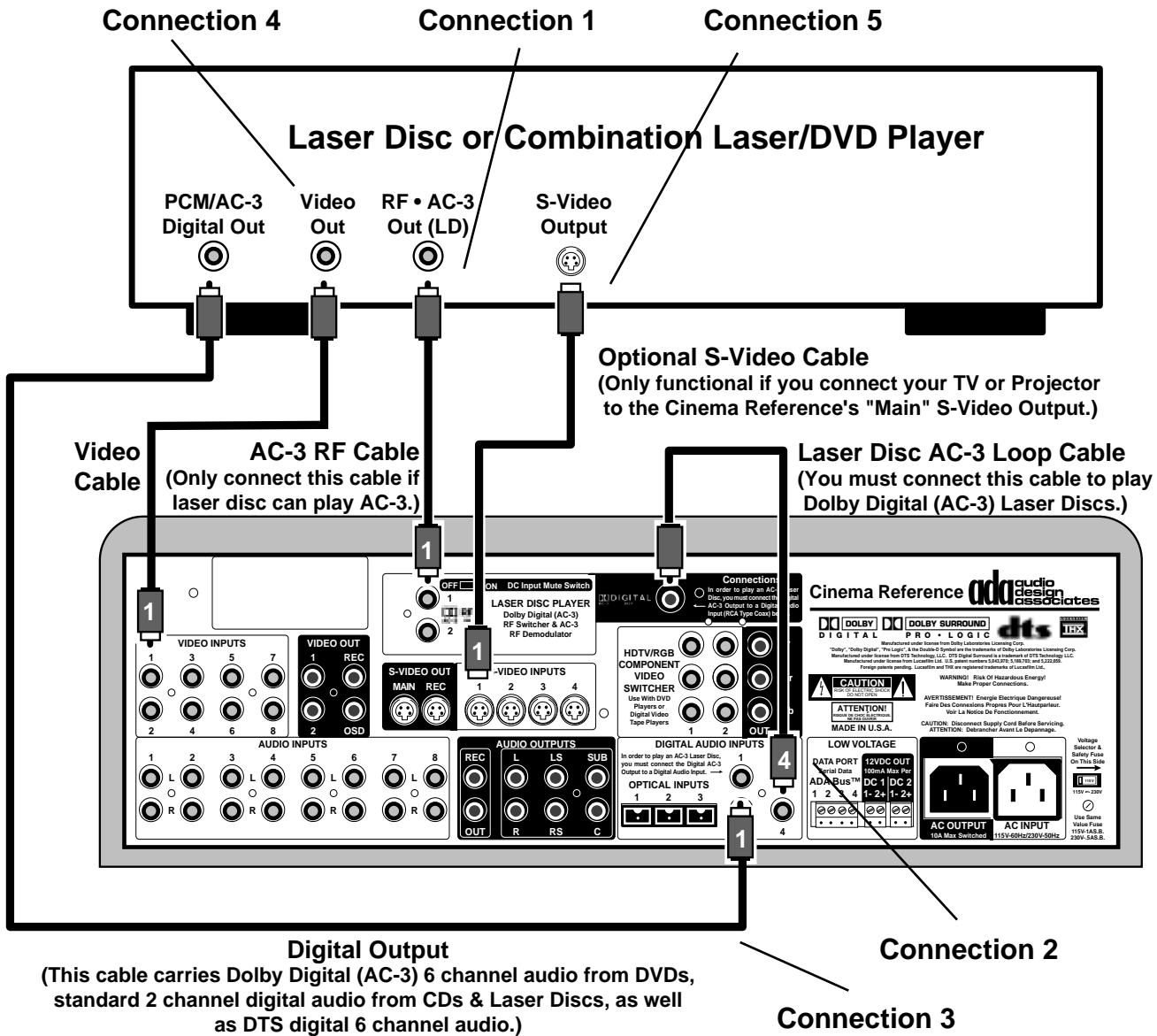

Changing the Cinema Reference's Audio Input

If you are using a combi-player which only has an optical digital PCM/AC-3 output, you will need to use an optical TOS-Link type cable to connect the combi-player to Optical #1 on the Cinema Reference. Then follow these steps.

- 1 Turn the Input knob to LASER/DVD 1 and press the knob.
- 2 Turn the Mode knob clockwise to SETUP MODE and press the knob.
- 3 Turn the Mode knob to AUDIO INPUT and press the knob. Once the knob is pressed the will read "DIGITAL IN 1".
- 4 Turn the mode knob until the display reads OPTICAL IN 1 and press the knob.

You have now altered the LASER/DVD input to access Optical Input 1.

Laser Disc Player without a Digital Output (or 2nd Laser)

*The "Out Of The Box" setup presumes that for the **LASERDISC** input, you wish to connect a laser disc player that does not have either a digital coax or digital optical audio output. You can also use this input for a second laser disc player that has a digital audio output however you will need to custom program this input using the steps discussed on the bottom of the following page. For laser disc players that do not have a digital audio output, you will use the following laser disc outputs*

Stereo Audio (R&L) Output

*AC-3•RF Output (LD)
(May or May Not Exist)*

*Video Output
(Composite RCA Type)*

Your laser disc player may also include an S-Video output. Please note, the Cinema Reference does not cross mix video signals. As such, if you wish to use a component's S-Video output, you will need to connect an S-Video cable from the Cinema Reference to the TV or Projector.

Use the diagram on the following page to make your laser disc player connections. ADA suggests using a quality 75Ω Coaxial cable. In the event that none are available, you can use standard RCA interconnects.

The Cinema Reference is preprogrammed to permit you to easily connect a laser disc player that does not have a digital audio output. This laser disc may or may not have an AC-3 RF output. If it does have an AC-3 RF output, you will need to make two audio connections in for this unit to play the following:

Dolby Digital Laser Discs, Pro Logic Laser Discs, and Stereo CDs.

If you are using this input for a second laser disc that has a digital audio output (to also play DTS laser discs and CDs), you will need to custom configure this input. This is discussed at the bottom of the following page.

All connections should use a 75 Ohm coaxial cable. If none are available, standard RCA video interconnects will work.

Connection 1 - Laser Disc Player's Stereo Audio Output - You will need to connect the laser disc player's stereo (analog) audio output (R&L RCA type) to the Cinema Reference's Audio Input #2.

Connection 2 - Laser Disc Player's Video Output - You will need to connect the laser disc player's video output (Composite Video) to the Cinema Reference's #2 Video Input.

Connection 3 (Optional) - Laser Disc Player's AC-3 RF Output - You will need to connect the Laser disc players "AC-3•RF Output" (LD for Laser Disc) to the Cinema Reference's Laser Disc Player #2 "RF IN". This connects the laser disc's AC-3 RF output to the Cinema Reference's internal AC-3 RF Demodulator.

Connection 4 (Must Accompany Step 3, May already be in place if you also connected a laser disc or combi-player as described on the previous page) - Cinema Reference's RF Demodulator's Output - You will need to connect the Cinema Reference's Laser Disc Player's Digital Output (Black RCA Connector) to the Cinema Reference's #4 Digital Audio Input (Orange RCA Connector). This "Laser Disc AC-3 Loop Cable" passes the demodulated laser disc AC-3 signal to a digital audio input which will then decode it.

If this is a second laser disc player, chances are it may have a digital audio input, either Coax (RCA) or optical (TOS-Link). You will most likely wish to connect this laser disc player to either Digital Input #2 or Optical Input #2 on the Cinema Reference. This would free up one analog audio input for an eleventh component as the "Out Of The Box" setup permits for connection of only ten devices (without going into the "Custom Setup".)

Follow the steps on the bottom of the next page to alter the audio input from Analog 2 to either Digital 2 or Optical 2.

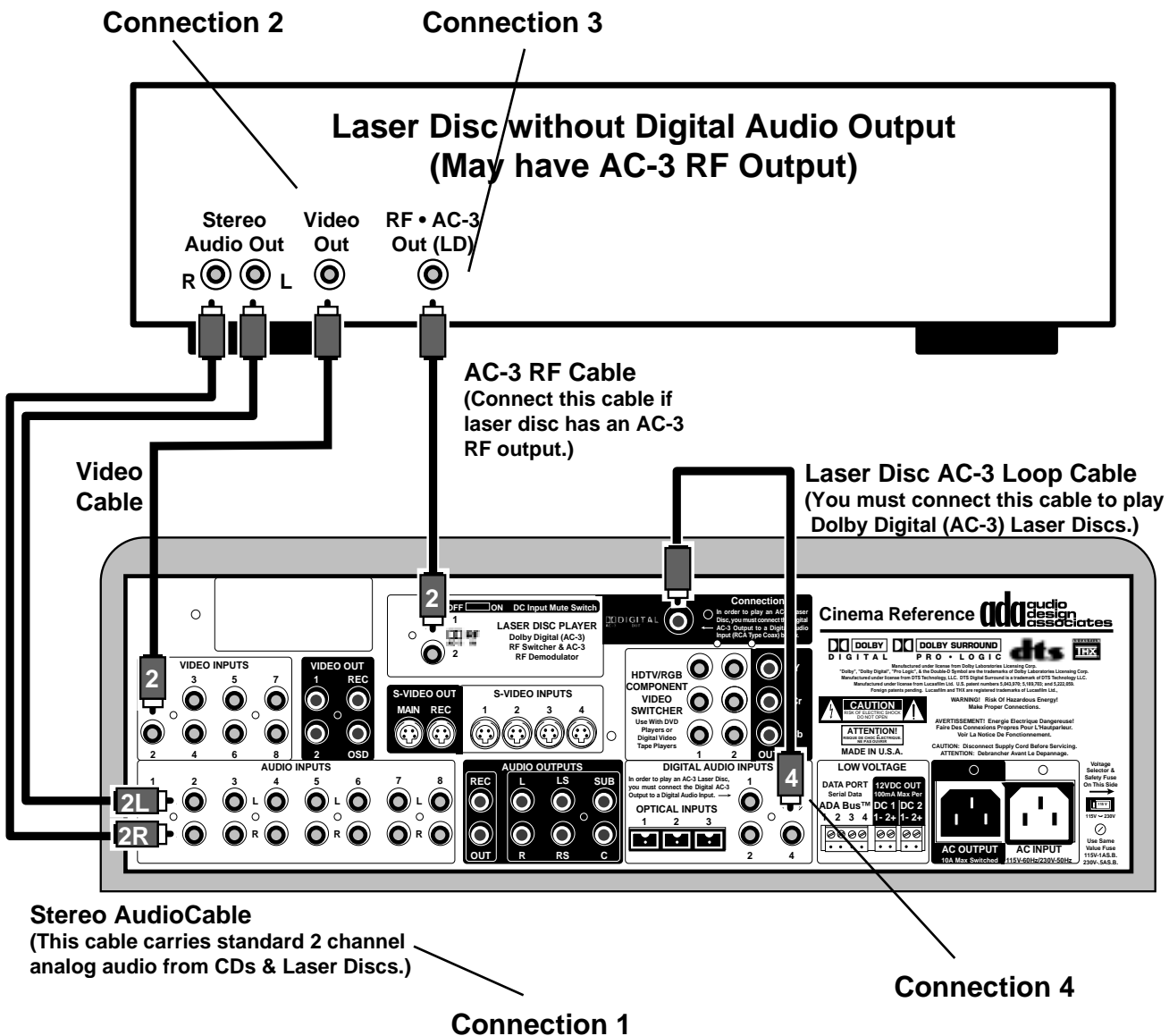

Changing the Cinema Reference's Audio Input to Accommodate A Second Laser Disc

If you are using a laser disc player which only has either a digital coax audio output or an optical digital audio output, you will need to use either a 75Ω coax to connect it to Digital Input #3 or an optical TOS-Link type cable to connect the laser disc to Optical #3 on the Cinema Reference. Then follow these steps.

- 1 Turn the Input knob to LASERDISC 2 and press the knob.
- 2 Turn the Mode knob clockwise to SETUP MODE and press the knob.
- 3 Turn the Mode knob to AUDIO INPUT and press the knob. Once the knob is pressed the will read "ANALOG IN 1".
- 4 Turn the mode knob until the display reads either DIGITAL IN 2 or OPTICAL IN 2 (based on your configuration) and press the knob.

You have now altered the LASERDISC 2 input to access either Digital Input 2 or Optical Input 2.

DVD Player

The "Out Of The Box" setup presumes that your DVD player has the following outputs:

*Digital Audio PCM/AC-3
Coax (RCA) Type Output*

*Video Output
(Composite RCA Type)*

Your DVD Player may also include a super video output. Please note, the Cinema Reference does not cross mix video signals. As such, if you wish to use a component's S-Video output, you will need to connect an S-Video cable from the Cinema Reference to the TV or Projector.

Your DVD Player may also offer Component Video output which is the video passed in an RGB configuration (Y, Cr, Cb). Component Video, while offering superior video quality, cannot be played on all TV's or Projectors. As the Cinema Reference provides no on-board video cross mixing, you will only need to make these connections if you are using a line doubler, TV or projector that is capable of displaying a component video image.

Use the diagram on the following page to make your DVD player connections. ADA suggests using a quality 75Ω Coaxial cable. In the event that none are available, you can use standard RCA interconnects.

The Cinema Reference is preprogrammed to permit you to easily connect a DVD player. You will need to make only one audio connection to play:

Dolby Digital AC-3 DVDs and Stereo CDs.

All connections should use a 75 Ohm coaxial cable. If none are available, standard RCA video interconnects will work. In the event that your DVD player does not have a digital PCM/AC-3 coax (RCA Type) output, but rather only has an optical TOS-Link output for PCM/AC-3 playback, you will need to customize the setup using the steps found at the bottom of the following page.

Connection 1 - DVD Player's Digital PCM/AC-3 Audio Output - You will need to connect the DVD player's digital PCM/AC-3 audio output (coax RCA type) to the Cinema Reference's Digital Audio Input #3.

Connection 2 - DVD Player's Video Output - You will need to connect the DVD player's video output (Composite Video) to the Cinema Reference's #3 Video Input.

Connection 3 (Optional) - DVD Player's S-Video Output - You may also choose to connect the S-Video (Super Video) output of the DVD player to the Cinema Reference's #3 S-Video Input. This will require a special super video cable. Please note, if your projector or TV does not have a super video input, you will not need to make this connection as the Cinema Reference does not cross convert S-Video to Composite Video.

Connection 4 (Optional) - DVD Player's Component Video Output - You may also choose to connect the DVD player's component video output to the Cinema Reference. Please note, that not all DVD player's offer this type of output. Furthermore, not all TV's and projectors have this type of input. You will only wish to make this connection if you are using a line-doubler or a TV/Projector that offers a component video input. Please note, all three connections, Y, Cr, and Cb, need to be in place for a proper picture.

If your DVD player does not have an RCA Type Digital Audio PCM/AC-3 Coax output but rather has only an Optical Digital PCM/AC-3 output, you will need to change the programming for this input. These steps are discussed at the bottom of the following page. If you are going to connect the DVD player using an optical input, you should proceed to connect the DVD's optical output to the Cinema Reference's #3 Optical Input. Then proceed with the instructions on the following page.

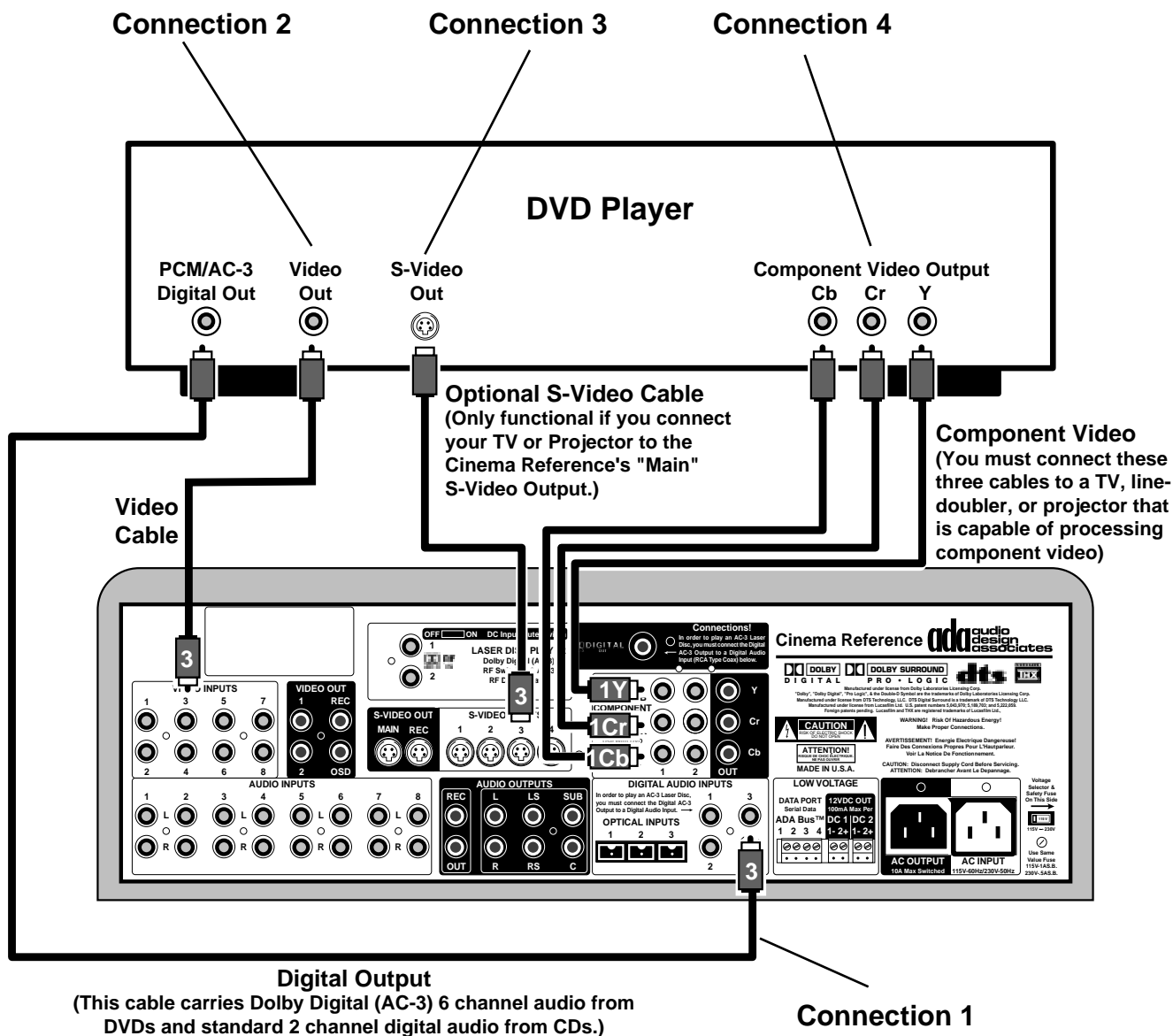

Changing the Cinema Reference's Audio Input for a DVD with only an Optical Output

If you are using a DVD player which only has an optical digital audio output, you will need to use an optical TOS-Link type cable to connect the laser disc to Optical #2 on the Cinema Reference. Then follow these steps.

- 1 Turn the Input knob to DVD PLAYER 3 and press the knob.
- 2 Turn the Mode knob clockwise to SETUP MODE and press the knob.
- 3 Turn the Mode knob to AUDIO INPUT and press the knob. Once the knob is pressed the display will read "DIGITAL IN 3".
- 4 Turn the mode knob until the display reads either OPTICAL IN 3 and press the knob.

You have now altered the DVD PLAYER 3 input to access Optical Input 3.

VCR

The "Out Of The Box" setup for your VCR permits you connect R&L Stereo Audio as well as both composite video and super video.

Your VCR may also include a super video output. Please note, the Cinema Reference does not cross mix video signals. As such, if you wish to use a component's S-Video output, you will need to connect an S-Video cable from the Cinema Reference to the TV or Projector.

The Cinema Reference is preprogrammed to permit you to easily connect a VCR. You will need to make only one audio connection to play video tapes.

Standard RCA interconnects are used for the audio connection while a 75Ω coax cable is used for the video connection.

Connection 1 - VCR Audio Output - You will need to connect the VCR's audio output (stereo RCA type) to the Cinema Reference's Audio Input #4.

Connection 2 - VCR Player's Video Output - You will need to connect the VCR's video output (Composite Video) to the Cinema Reference's #4 Video Input.

Connection 3 (Optional) - VCR's S-Video Output - You may also choose to connect the S-Video (Super Video) output of the VCR to the Cinema Reference's #4 S-Video Input. This will require a special super video cable. Please note, if your projector or TV does not have a super video input, you will not need to make this connection as the Cinema Reference does not cross convert S-Video to Composite Video.

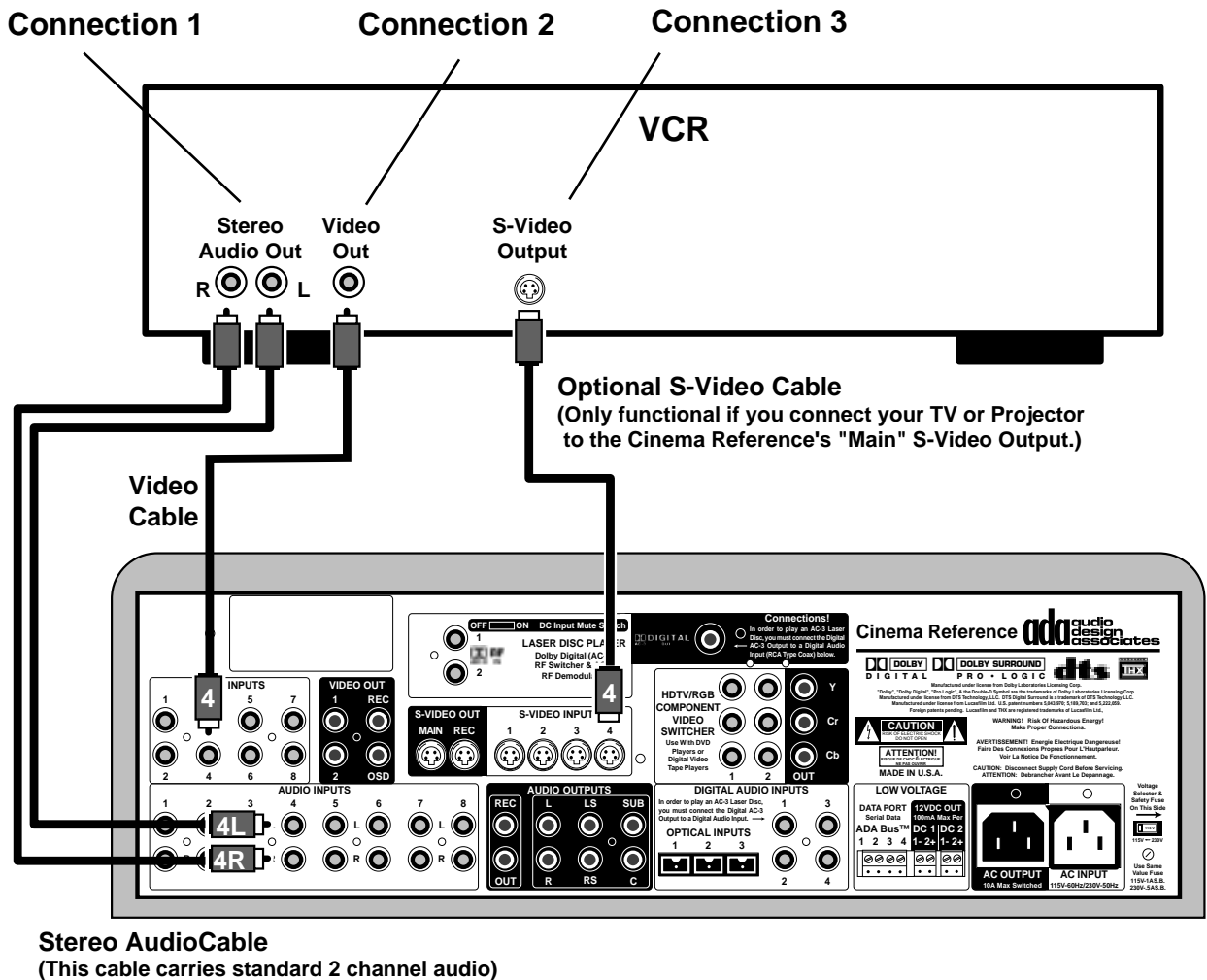

DSS or Satellite Receiver

The Cinema Reference is preprogrammed to permit you to easily connect a DSS or Satellite Receiver.

Standard RCA interconnects are used for the audio connection while a 75Ω coax cable is used for the video connection.

Connection 1 - DSS Audio Output - You will need to connect the DSS's audio output (stereo RCA type) to the Cinema Reference's Audio Input #5.

Connection 2 - DSS Receiver's Video Output - You will need to connect the DSS's video output (Composite Video) to the Cinema Reference's #5 Video Input.

Connection 3 (Optional) - DSS's S-Video Output - You may also choose to connect the S-Video (Super Video) output of the DSS to the Cinema Reference's #2 S-Video Input. This will require a special super video cable. Please note, if your projector or TV does not have a super video input, you will not need to make this connection as the Cinema Reference does not cross convert S-Video to Composite Video.

For DSS or SAT Receivers that sport a Digital output, you may select to alter the Cinema Reference's "Out Of The Box" setup to switch the audio for the DSS/SAT Receiver to a digital input that is not used.

1 Turn the Input knob to DSS/SAT 6 and press the knob.

2 Turn the Mode knob clockwise to SETUP MODE and press the knob.

3 Turn the Mode knob to AUDIO INPUT and press the knob. Once the knob is pressed the display will read "ANALOG IN 5".

4 Turn the mode knob until the display reads the corresponding digital input that you have connected your DSS to and press the knob.

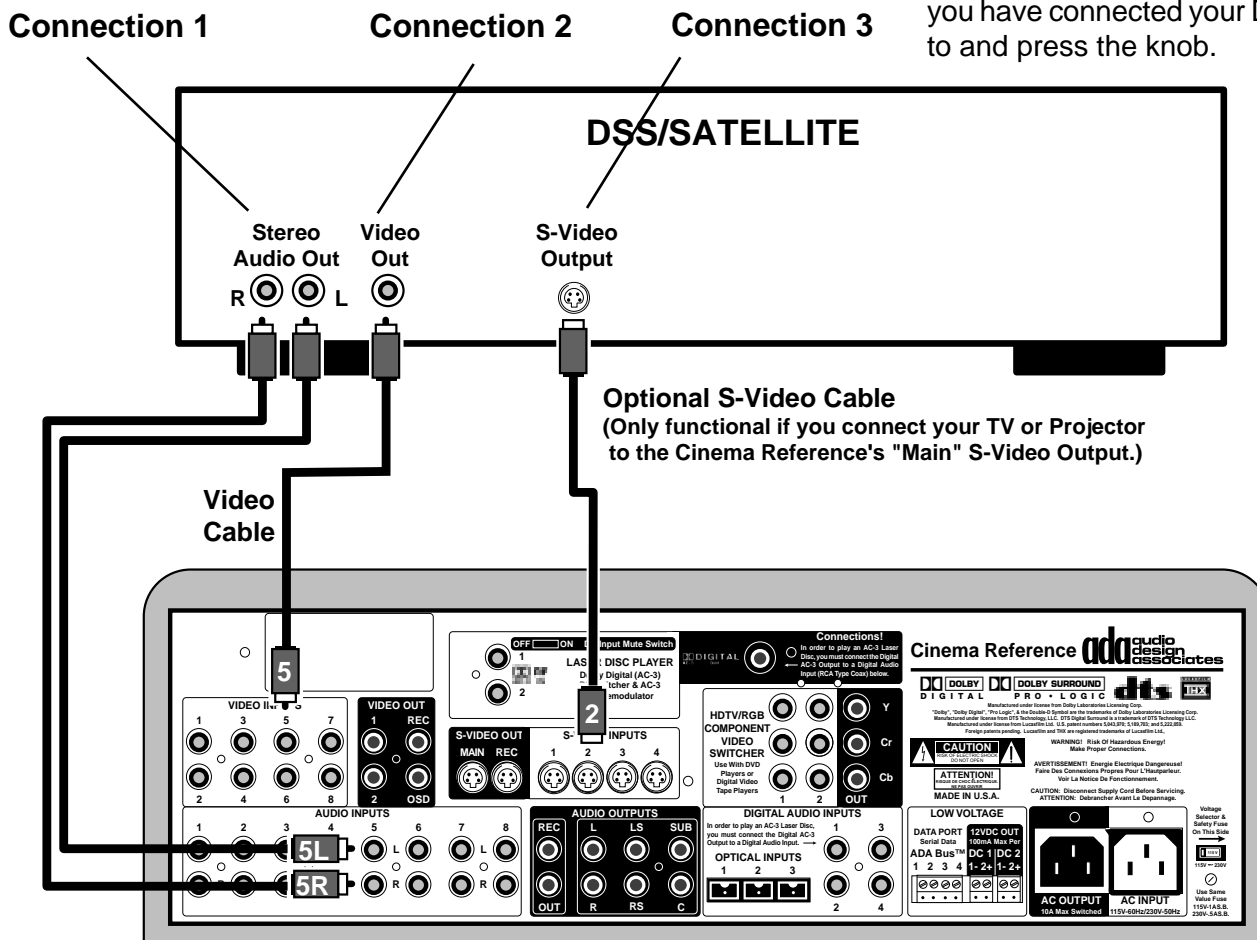

Stereo Audio Cable
(This cable carries standard 2 channel audio)

Cable or TV Tuner

Your Cable Box or TV Tuner can be directly connected to the Cinema Reference. In order for your cable box to be connected as a component to the Cinema Reference, it will need to be a cable box which supports a stereo (R&L) analog audio output (RCA Type) as well as a composite video output. If your cable box or cable convertor does not support these outputs (it only has an RF output), you will need to modulate it through a tuner on either channel 3 or channel 4.

The Cinema Reference is preprogrammed to permit you to easily connect a VCR.

Standard RCA interconnects are used for the audio connection while a 75Ω coax cable is used for the video connection.

Connection 1 - Cable Box or TV Tuner Audio Output - You will need to connect the tuner's audio output (stereo RCA type) to the Cinema Reference's Audio Input #6.

Connection 2 - Cable Box or TV Tuner's Video Output - You will need to connect the tuner's video output (Composite Video) to the Cinema Reference's #6 Video Input.

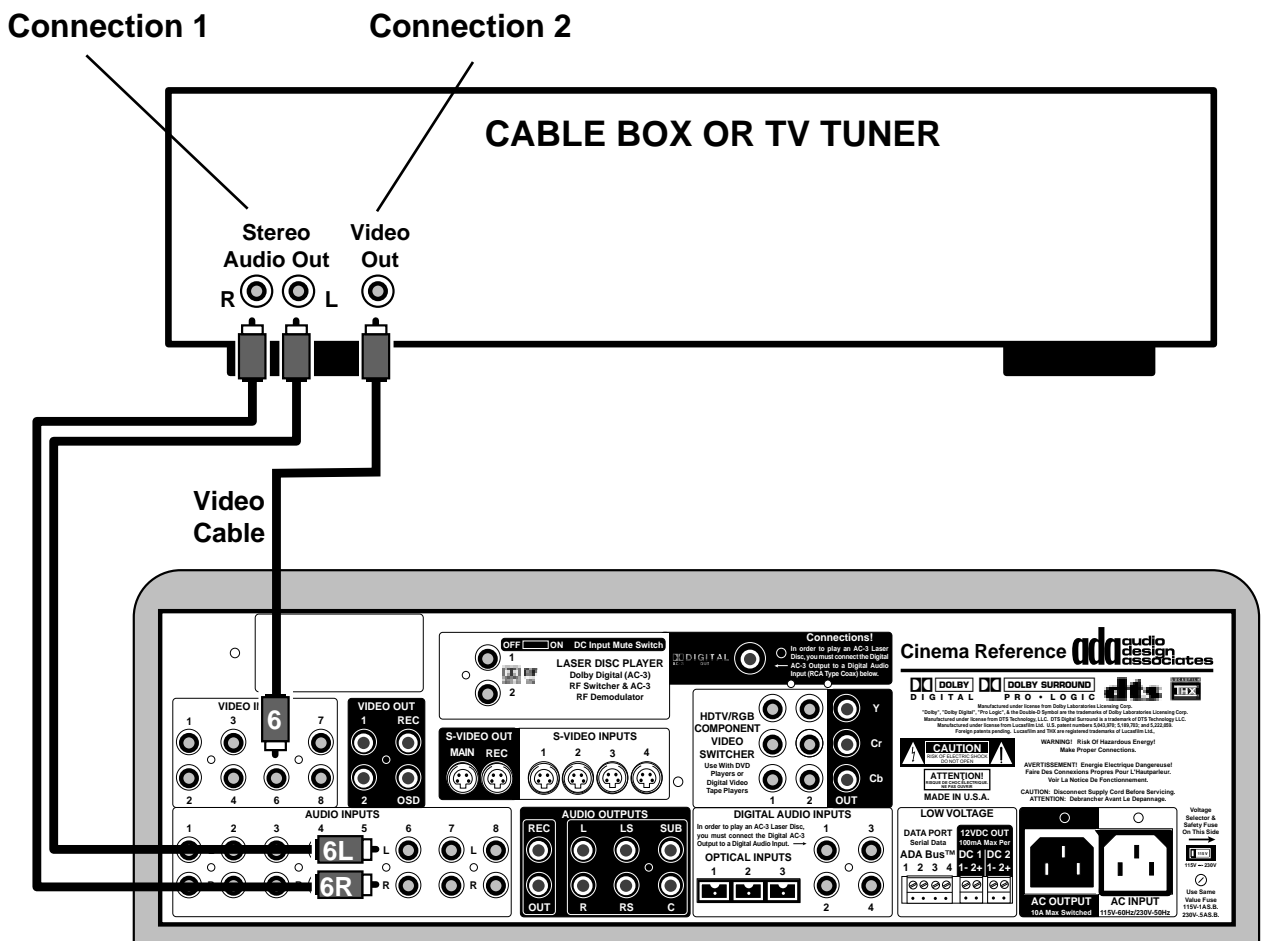

Stereo AudioCable
(This cable carries standard 2 channel audio)

CD Player

The Cinema Reference is preprogrammed to permit you to easily connect a CD.

Standard RCA interconnects are used for the audio connection while a 75Ω coax cable is used for the video connection.

Connection 1 - CD Audio Output - You will need to connect the CD's audio output (stereo RCA type) to the Cinema Reference's Audio Input #7.

Connection 2 (Optional) - CD Player's Video Output - You will need to connect the CD's video output (Composite Video) to the Cinema Reference's #7 Video Input.

Please note, not all CD players offer a video output and as such, the Cinema Reference's #7 Video Output can be used with an audio input that is not used. To custom configure your Cinema Reference, see the section titled "Custom Setup".

For CD Players that sport a Digital output, you may select to alter the Cinema Reference's "Out Of The Box" setup to switch the audio for the CD Player to a digital input that is not used.

- 1 Turn the Input knob to CD PLAYER 7 and press the knob.
- 2 Turn the Mode knob clockwise to SETUP MODE and press the knob.
- 3 Turn the Mode knob to AUDIO INPUT and press the knob. Once the knob is pressed the display will read "ANALOG IN 7".
- 4 Turn the mode knob until the display reads the corresponding digital input that you have connected your CD Player to and press the knob.

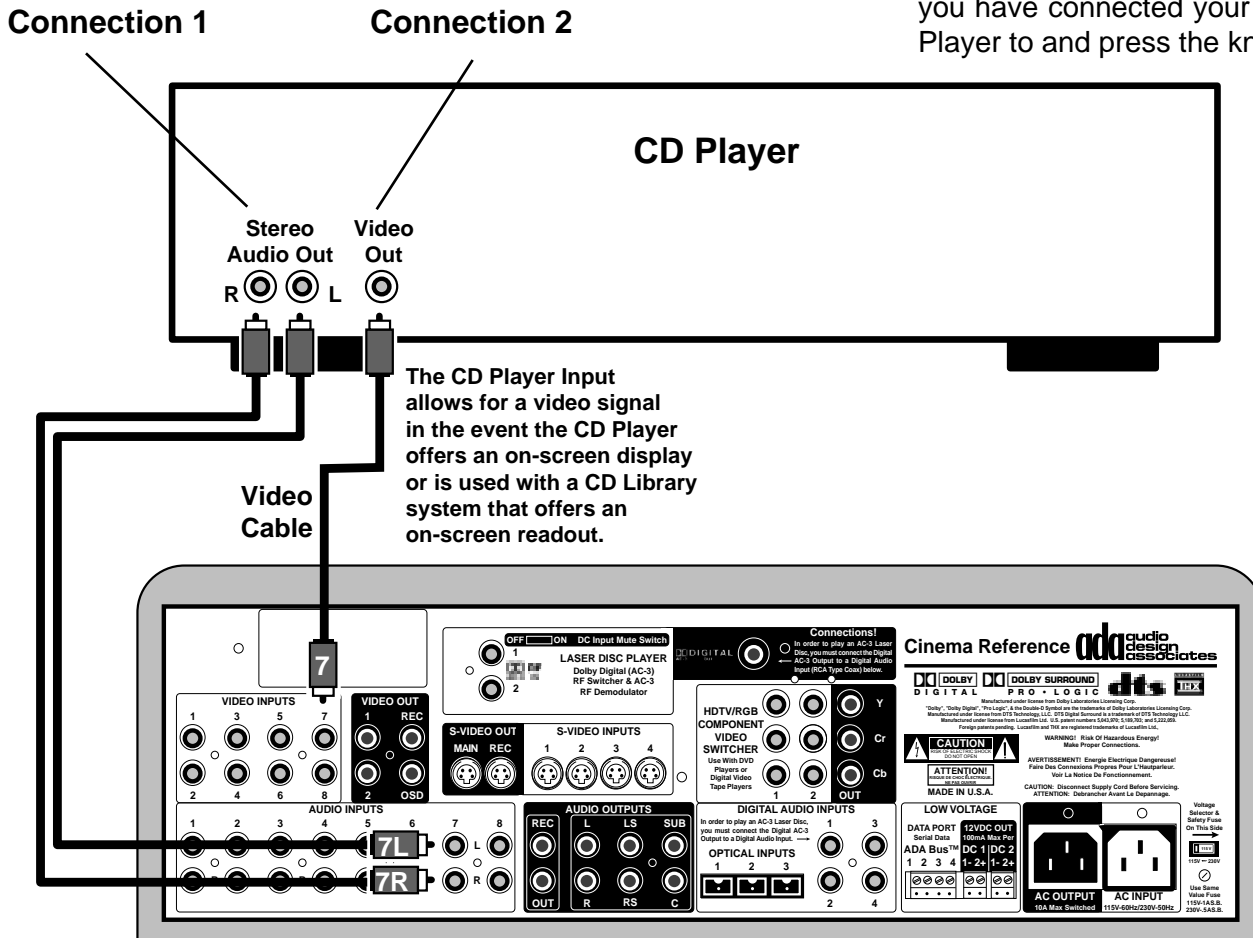

Stereo Audio Cable
(This cable carries standard 2 channel audio)

Tuner

A Tuner can be directly connected to the Cinema Reference's #8 Analog Audio Input.

The Cinema Reference is preprogrammed to permit you to easily connect a Tuner.

Standard RCA interconnects are used for the audio connection.

Connection 1 - Tuner Audio Output - You will need to connect the tuner's audio output (stereo RCA type) to the Cinema Reference's Audio Input #8.

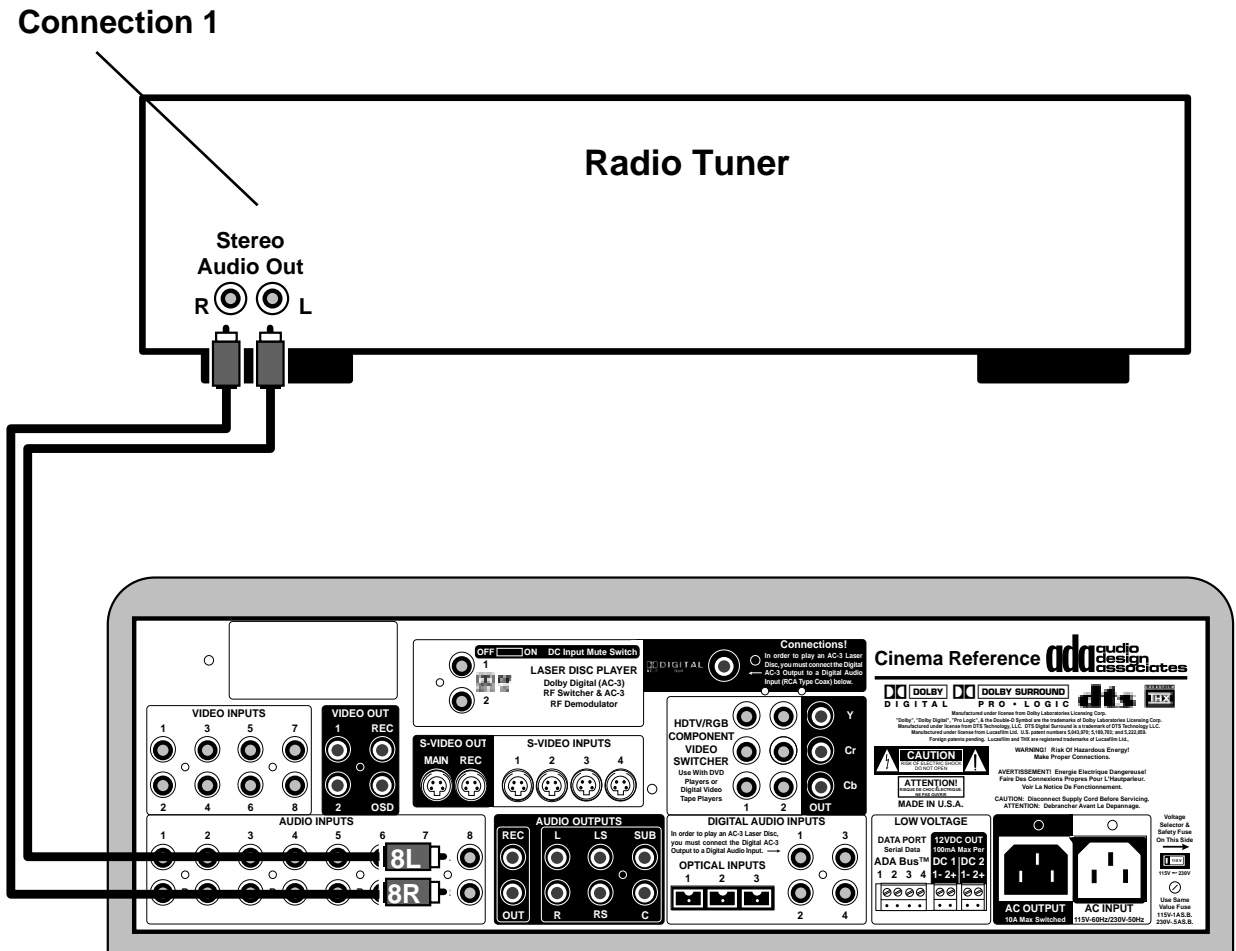

Stereo Audio Cable
(This cable carries standard 2 channel audio)

Cassette

The Cinema Reference is preprogrammed to permit you to easily connect a Cassette.

Standard RCA interconnects are used for the audio connection.

Connection 1 - Cassette Audio Output - You will need to connect the cassette's audio output (stereo RCA type) to the Cinema Reference's Audio Input #1.

A Cassette Player can be directly connected to the Cinema Reference's #1 Analog Audio Input.

Connection 1

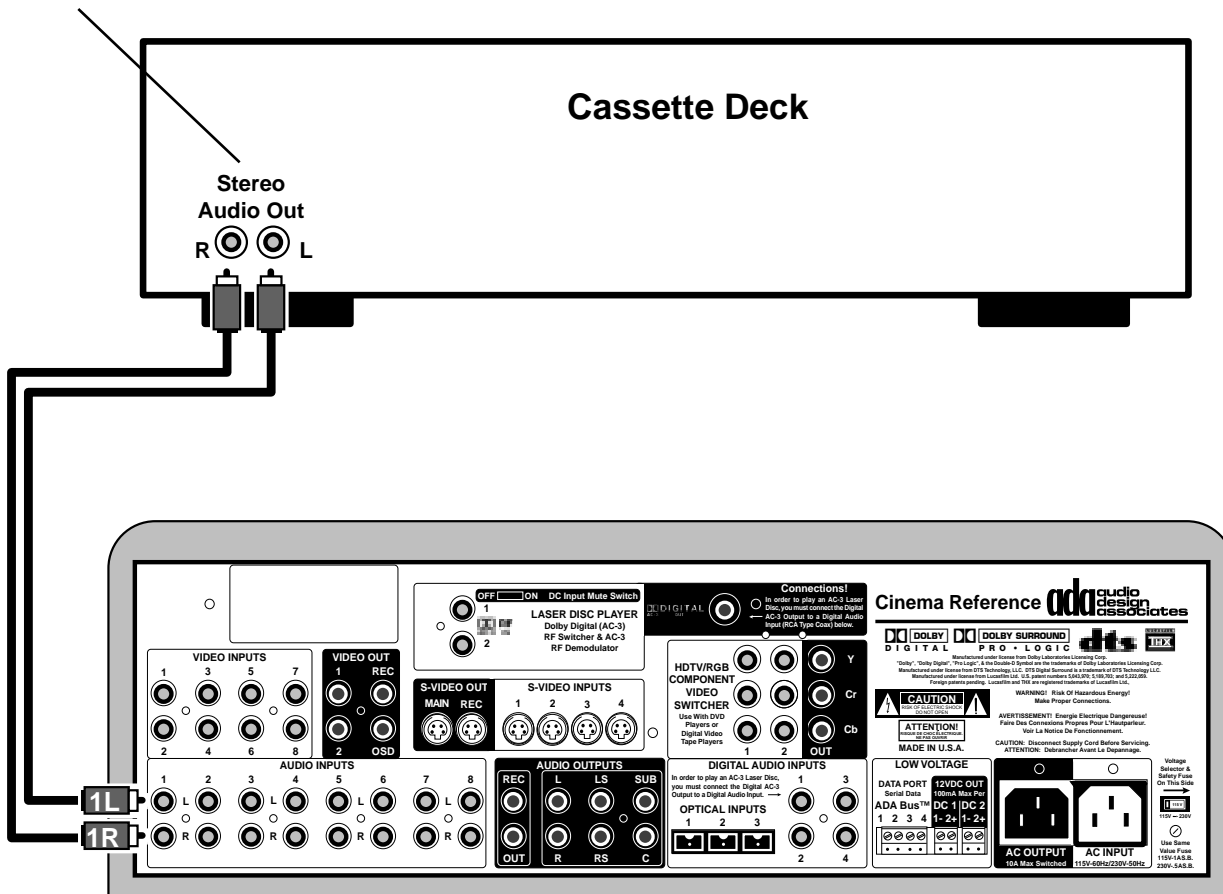

Stereo Audio Cable
(This cable carries standard 2 channel audio)

Auxiliary Input

Your last available input on a Cinema Reference can be automatically tied to one of the following device input labels:

- AUXILIARY
- CAMCORDER
- VIDEOGAME
- COMPUTER
- PREAMP
- MULTIROOM

Please note, that you can only use one of the Input Labels for a single component. If you wish to use more than one of these input labels, you will need to proceed with the "Custom Setup" instructions.

The Cinema Reference is preprogrammed to permit you to easily connect a tenth component. ADA has provided the "Out Of The Box" setup with six input label that access Analog Input 3 and Video Input 8. If you wish to connect either a:

- Camcorder or
- Video Game or
- Computer or
- Preamplifier or
- Multi-Room System

If your tenth component does not match any of the above Input Label names, ADA suggests using the Auxiliary Input Label name.

Simply connect one of these items using standard RCA interconnects are used for the audio connection while a 75Ω coax cable is used for the video connection.

Connection 1 - To the Cinema Reference's Audio Input #3.

Connection 2 - To the Cinema Reference's #6 Video Input.

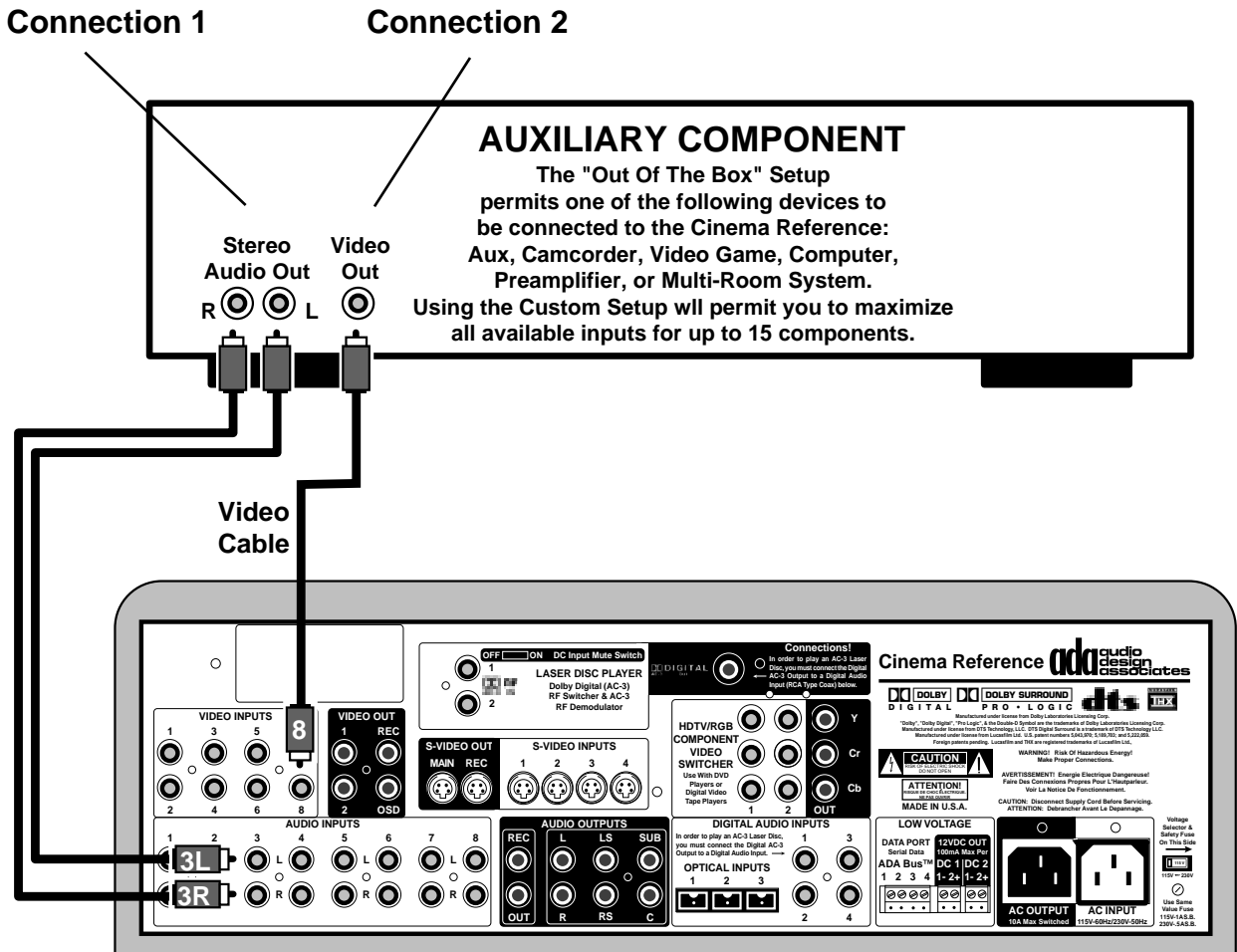

Record Output Connections

Typically, you will use the diagram below to connect the Cinema Reference's Record Output to either a VCR or Cassette (or other type of) Recorder. If you wish to pass audio and video to the VCR and audio only to the Cassette, you will need to provide RCA "Y" Splitters which will then enable both connection of the VCR and Cassette. Some components may not be properly grounded. When these devices are connected to other devices using "Y" splitters, you may begin to hear some background hum or noise. If this is the case, you may wish to proceed with the connection of only one of the recording devices. Otherwise, please consult with your Authorized ADA Dealer.

The Cinema Reference features a "Record Output" that can select a component independently from the main theater's component selection. Thus it is possible to record from one component to another (i.e. DSS to VCR) while you are viewing a third component (i.e. DVD).

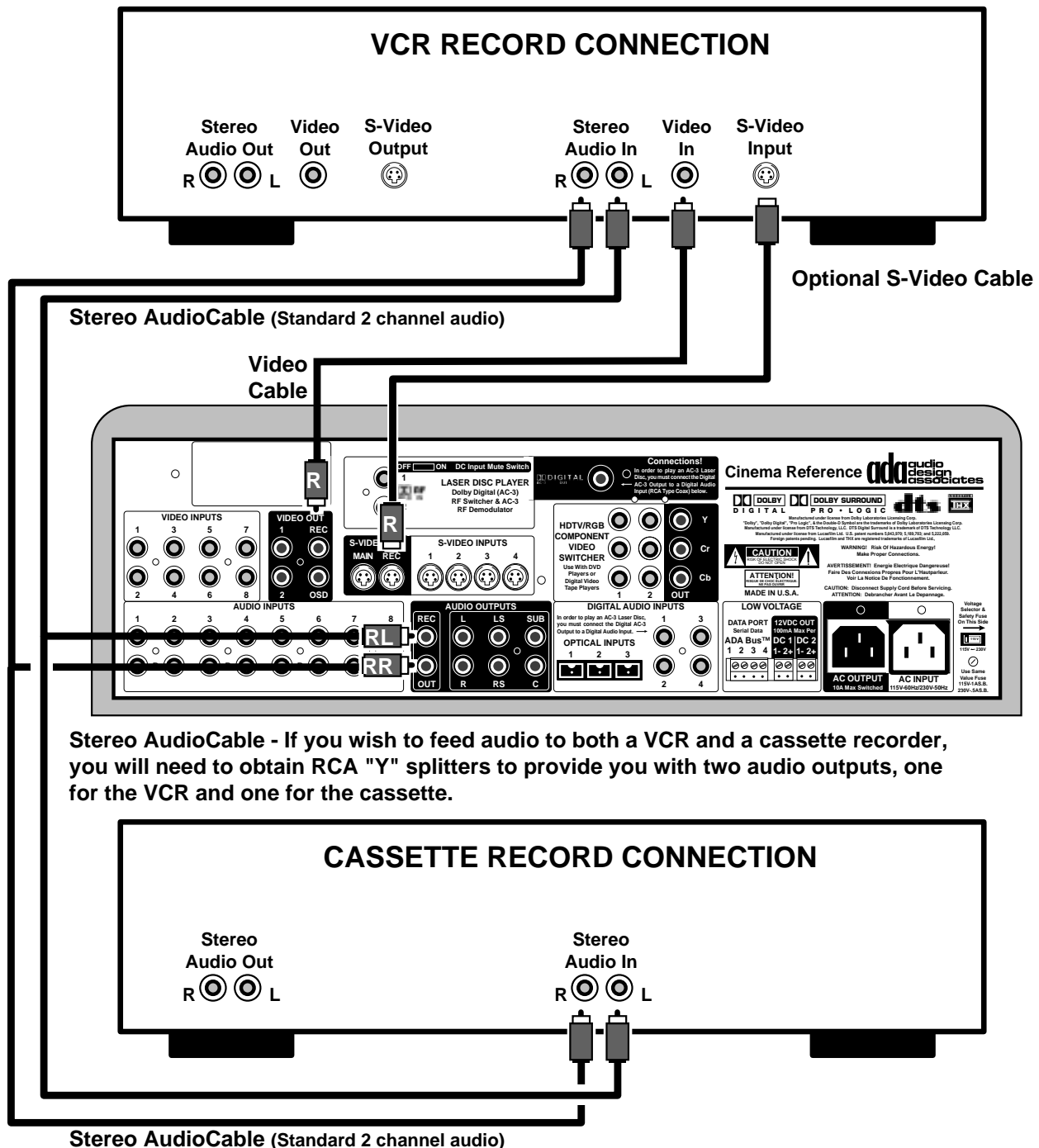

Connection To Your TV, Projector, or Line-Doubler

The Cinema Reference offers several video outputs. If your video display device (TV) or display system (projector, line doubler) offers a component or RGB type of input, you may connect the Cinema Reference's Component Video Output in addition to at the Composite Video and Super Video Outputs. Please note, the Cinema Reference does not provide cross video mixing and as such, each type of video input requires its own video output connection to your display device.

When connecting the Cinema Reference to your display device, you will need to make these connections in order of priority: 1st - Composite (RCA) Video, 2nd S-Video, and 3rd Component Video (RGB)

Composite Video

The Cinema Reference has three main Video Outputs (RCA Composite). VIDEO OUT 1 & 2 are identical and provide standard composite video. The OSD VIDEO OUT offers, in addition to standard composite video (like 1 & 2), an on-screen-display overlay that appears when a function is selected on the Cinema Reference. This OSD readout is useful during setup and when the Cinema Reference is out of visual range from the seating area.

S-Video

If you wish to view super video, you will need to make this connection to your TV or Projector.

Component Video (RGB or HDTV)

Component Video is currently only available on better model DVD players. The video signal consists of Y, Cr, and Cb. If your TV, monitor, projector, or line doubler (tripler or quadrupler) offer an RGB or Component Video input, you can proceed to make these connections.

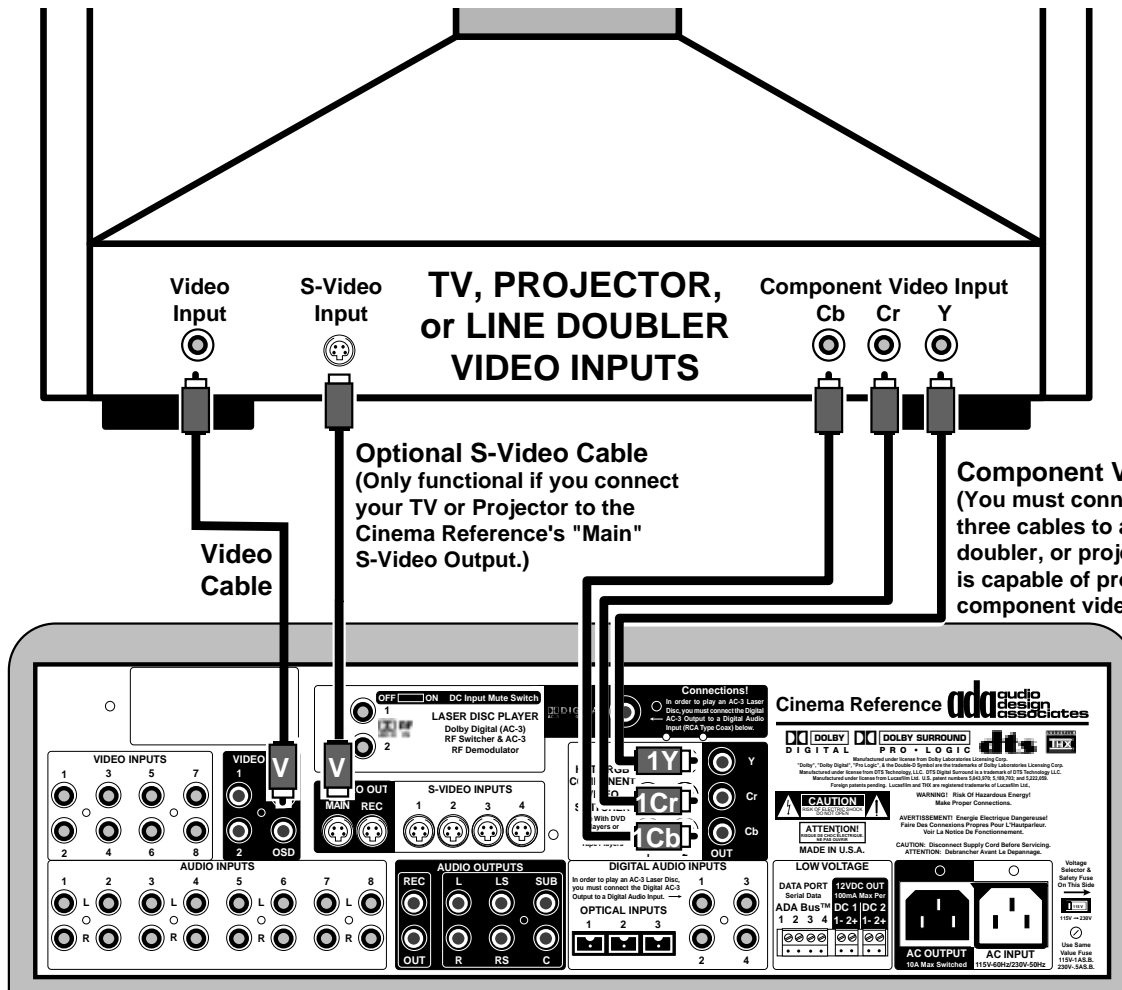

Audio Setup

The Cinema Reference has been calibrated in the factory for optimum operation. Thus you can at this time decide to run your system with just minor adjustments to the Master Volume Control (center knob).

However, since not all speaker configurations and rooms are the same, you may desire to alter the channel balance and delay settings to better suit your home theater system. If you are unfamiliar with the process of home theater level calibration and the use of an SPL meter (Sound Pressure Level meter), ADA strongly suggests contacting an Authorized ADA Dealer for assistance prior to proceeding.

The Cinema Reference features an internal Pink Noise generator which is used to determine signal level to each speaker. In order to best proceed with the remainder of this page's setup instructions, it is recommended that you use an SPL meter.

The Cinema Reference incorporates two Volume Presets. Both presets are loaded with ADA's factory default settings for all channels and all inputs set to -25.0 dB. This level is not too high and you can always alter the level by simply raising the Master Volume control. To best calibrate your system:

- 1 Turn the CHANNEL knob until the display reads VOL RECALL 1 and press the CHANNEL knob.
- 2 Turn on your SPL meter to the 70-80 dB range, Slow, C Weighted setting.
- 3 Turn the CHANNEL knob until the display reads NOISE TEST and press the CHANNEL knob. The top line of the display should read NOISE ALL and the second line should read ALL -25.0 dB. You should also hear very light pink noise from all of the speakers.
- 4 Press the CHANNEL knob. Using your SPL meter, slowly turn the CHANNEL knob clockwise, raising the level of the pink noise test until the SPL meter reads approximately 75 dB.
- 5 Press the CHANNEL knob again. Turn the CHANNEL knob clockwise one click until the display reads NOISE LEFT and then press the CHANNEL knob.
- 6 Raise (clockwise) or lower (counter clockwise) the left channel's pink noise level to approximately 75 dB and then press the CHANNEL knob.

The Cinema Reference comes preprogrammed "Out Of The Box" ready to play. Unless you are going to use an SPL meter to calibrate your system, proceed with the setup as described on page 33 - step 14.

If you are using an SPL meter, you will first want to set the pink noise level for all of the channels to 75 dB.

You will then look to lower your master volume to a safe level as 0.0 dB may be too bright. ADA suggests reducing the master Volume to at least -15 dB.

At this time you will want to load the current volume level and the individual channel levels to each other, into Volume Preset 1. This will preserve the balance of the individual speakers.

Audio Setup - Continued

As you proceed to go through pink noise sweeps, the only knob you will need to work is the Cinema Reference's Channel knob. This knob not only selects noise modes but also noise channels and then the adjustment of the channels. Jumping to the master Volume control will take you out of the noise mode.

- 7 Turn the CHANNEL knob clockwise one click until the display reads NOISE CENTER and then press the CHANNEL knob. Raise (clockwise) or lower (counter clockwise) the center channel's pink noise level to approximately 75 dB and then press the CHANNEL knob.
- 8 Turn the CHANNEL knob clockwise one click until the display reads NOISE RIGHT and then press the CHANNEL knob. Raise (clockwise) or lower (counter clockwise) the right channel's pink noise level to approximately 75 dB and then press the CHANNEL knob.
- 9 Turn the CHANNEL knob clockwise one click until the display reads NOISE R SURR and then press the CHANNEL knob. Raise (clockwise) or lower (counter clockwise) the right surround channel's pink noise level to approximately 75 dB and then press the CHANNEL knob.
- 10 Turn the CHANNEL knob clockwise one click until the display reads NOISE L SURR and then press the CHANNEL knob. Raise (clockwise) or lower (counter clockwise) the left surround channel's pink noise level to approximately 75 dB and then press the CHANNEL knob.
- 11 Turn the CHANNEL knob clockwise one click until the display reads NOISE L/R SR and then press the CHANNEL knob. Raise (clockwise) or lower (counter clockwise) both surround channel's pink noise level to approximately 75 dB and then press the CHANNEL knob.
- 12 Turn the CHANNEL knob clockwise one click until the display reads NOISE SUB and then press the CHANNEL knob. Raise (clockwise) or lower (counter clockwise) the subwoofer channel's pink noise level to approximately 75 dB and then press the CHANNEL knob.

At this time you have calibrated the pink noise to THX specifications and the Cinema Reference's channel calibration should read near 0.0 dB for all of the channels. Please note, that this volume level is extremely high and may be too loud for your comfort and enjoyment. At this time, ADA suggests turning the Master VOLUME control down to at least -15.0 dB.

- 13 To preserve the levels that you have just tuned, turn the CHANNEL knob to VOL RECALL 1. Press and Hold the CHANNEL knob until the display flashes VOL STORED 1.

Audio Setup - Continued

- 14 Turn the INPUT knob to a component that is typically hotter than other components (i.e. a DVD disc, laser disc, or CD) and begin to play that component. Raise or lower the master VOLUME knob to suit your listening level. When you have reached a desired level, turn the CHANNEL knob to VOL RECALL 1 and press and hold the CHANNEL knob until the display reads VOL STORED 1.

At this time you have programmed the Cinema Reference's Volume Preset #1 to levels that are consistent with the pink noise test sweeps (if done) and this preset corresponds to a listening level comfortable with respect to your listening environment.

Bass Volume Presets - While the five main channels should be set to the same level as you select from one source to another, ADA has experienced that the subwoofer level for different components and decoding modes can be significantly different. As such, a bass level for one input might need to be lower for another input. The Cinema Reference is equipped to handle this issue as each input can have its own bass level setting stored into VOL PRESET 1. To set the bass level for all other inputs, you will need to select each input one at a time, adjust the bass level to taste and load it into the preset.

- 15 Turn the INPUT knob to the next device and engage the component into play.
- 16 Turn the CHANNEL knob until the second line of the display reads SUB and a number. Press the CHANNEL knob.
- 17 Raise and lower the CHANNEL knob and the subwoofer will go up and down in volume. When you have a desired subwoofer level, press the CHANNEL knob.
- 18 Turn the CHANNEL knob until the display reads VOL RECALL 1. Press and hold the CHANNEL knob until the display reads VOL STORED 1.
- 19 Proceed with steps 15-18 until all active inputs have been calibrated.

The Cinema Reference is capable of setting different bass levels for each one your components. While the main five channels levels remain the same, each input would engage a different bass level. This permits you to contour the bass sound based on the source component, the decoding mode, and the software. As different decoding modes and their software have varying levels of bass, you will find this feature very useful.

Note:

In order to load in a bass level for each one of your components, you will need to select that component and then adjust its bass level while the unit is in play. After you have set a bass level you like, you will need to load the current volume setting into the Volume Preset #1, using the same steps that were required to load the preset on the previous pages.

Custom Setup - A/V Linking

The Cinema Reference can be custom configured, permitting you to link any Analog, Video, S-Video, Component Video, and LASER AC-3 RF (RF Inputs are discussed on the next page) input jack to a particular Input Label. You can also modify or completely change the name of an Input Label. And finally, under Pro Setup, you can even limit the number of Input Labels that appear as you turn the INPUT knob. While this is discussed further under Pro Setup, if you wish to fully customize your Cinema Reference, such that you only see the number of devices you are using, you will first need to:

A Determine the number of components you are connecting to your Cinema Reference and set the Final Input limit to correspond to this number (see Pro Setup).

B Now that you have the exact number of Input Labels you need, you will most likely need to alter the Input Labels as some of the names may not be displayed exactly as you wish them to. (See next page - Altering Input Labels)

C Once you have the Input Labels sequencing in order as you wish them to, you may also need to alter the audio and video connections linked to this input label. These steps are discussed in the paragraph to the left (Custom Setup - AV Linking).

At this time you have already connected all or most of your audio video components to the Cinema Reference. If you are satisfied with the component connections to the Cinema Reference, you need not continue with this section. As the Cinema Reference is preprogrammed in the factory for optimum performance, you will not necessarily need to custom program your unit.

In the event that you want to custom program your Cinema Reference, this section will discuss altering audio and video inputs linked to a particular Input Label.

Each Input Label is nothing but a name. Assigned to each name is an audio input, a video input, a super video input, a component video input, and an AC-3 RF input (RF see page 38). Even a radio tuner, that does not have a video output, will have a video output possibly connected to another device, linked to it. As such each Input Label has several Cinema Reference rear panel jacks tied to it. The beauty behind the Cinema Reference, is that these jacks are linked in software and can be easily switched using the steps below. Please note, you can also alter the way the Input Label reads. This is discussed on the next page, Custom Setup - Labeling Inputs.

To alter a components audio and video inputs:

- 1 Select the device you wish to alter by turning the INPUT knob until the second line of the display reads the device name and press the INPUT knob.
- 2 Turn the MODE knob clockwise until the display reads SETUP MODE and then press the MODE knob.
- 3 Turn the MODE knob clockwise to until the display reads the type of input you wish to alter for this component.

If you want to alter an analog input, turn to ANALOG INPUT

If you want to alter a video input, turn to VIDEO INPUT.

If you want to alter an S-Video input, turn to S-VIDEO INPUT.

If you want to alter an component video input, turn to RGB INPUT.

When you have selected the type of input you wish to alter, press the MODE knob.

- 4 Turn the MODE knob until the display reads the new input you are connected to and then press the MODE knob to engage that input.
- 5 Proceed with step three to alter other inputs for this component.
- 6 If you wish to exit this mode, simply turn the INPUT knob.

Custom Setup - AC-3 RF Inputs & Auto Mode

As discussed on the previous page, the Cinema Reference will typically apply an A/V Link to each Input Label. Thus, if you select the TUNER 8 input and leave your TV & VCR on, you will still see the VCR's video image even though you are listening to the radio tuner. With the exception of the RGB Inputs, which have an off setting, each Input Label will have a video and S-video follower. They will also have an AC-3 RF input follower as well. The ability to set the RF inputs is discussed in this section.

The Cinema Reference uses a unique circuit whereby it can auto-detect an AC-3 or DTS signal. This auto detection will permit the Cinema Reference to change its active decoding mode between an AC-3, DTS, or non-5.1 mode depending on the software. Since a single input could auto-mode between as many as three different decoding formats, and since each decoding format has several enhancement and filter options available, ADA has made it very easy to setup the Cinema Reference to play your desired format option automatically.

When you select an input that is programmed to auto-mode, begin playing some software from that component. The Cinema Reference will auto detect the correct decoding format. At that time, you may turn the mode knob to one of the other mode options. When you begin playing software that needs to be decoded in this same format, the Cinema Reference will engage the last selected format option.

As an example, suppose your laser disc player is connected to the Cinema Reference to play AC-3 laser discs, PCM laser discs, DTS laser discs, and DTS CDs. Furthermore, suppose you prefer AC-3 ULTRA decoding for AC-3 software, PRO LOGIC THX for standard laser discs, and DTS DIRECT for DTS laser discs and CDs, all you would do is to place the first piece of software in the laserdisc. If this were an AC-3 laser disc, the auto detection might very well first engage AC-3 THX. You can then turn the mode knob to AC-3 ULTRA and then press the mode knob to secure this mode. Any time you play an AC-3 laser disc from this point forward, the Cinema Reference will auto-mode to AC-3 ULTRA. To further insure proper setup, continue to test the auto-mode circuit with a non-5.1 laser disc. Again, the Cinema Reference will engage a two channel surround mode, typically Pro Logic. Turn the mode knob to PRO LOGIC THX and press it. From this point forward, non-5.1 formatted material will automatically play in Pro Logic THX. Finally, play a DTS CD or laser disc. Once DTS locks in, turn the mode knob to DTS DIRECT and press it. As with AC-3 and two-channel formats, from this point forward, the DTS automode default format will be DTS DIRECT.

Please note, if your default mode is set to any DTS mode, if auto detection occurs for either AC-3 or two-channel software, the Cinema Reference will engage to either AC-3 THX or Pro Logic THX, regardless of the last mode used for that format.

The Cinema Reference incorporates a unique Auto Mode detection circuit for AC-3, DTS, and non-5.1 software. When Auto Mode is set to on for a Laser Disc or DVD component, the Cinema Reference will automatically switch to an appropriate decoding mode.

For Laser Disc Players, this feature is coupled with the Cinema Reference's RF Demodulator. Since the RF Demodulators output connects to the Digital 4 input, not only does the Cinema Reference need to detect and change modes, but also inputs. As such, for full Auto Mode control when playing Laser Discs, you will also need to set the Laser Disc Player's (s) AC-3 RF Input setting to Auto as well.

When an input is set to auto-mode on, it will engage the best possible decoding mode. As each 5.1 and the two channel format have several options, you can select which option you want engaged during an auto-mode detection sequence. As the Cinema Reference will recall the last mode format option used, you can setup your Cinema Reference by simply dialing in a mode for both AC-3 and DTS 5.1 software and a decoding option for two channel software.

For components that are not set to auto-mode on, the Cinema Reference's default mode for this input will return after re-selecting the input or during a restart, even if you alter the mode.

For example, if your CD player is set for Quad Bypass as its Default Mode but for this one CD, you wish to listen to it in Stereo, turn the mode knob to Stereo. If you change inputs or turn the system off, the next time you access your CD player, it will default to the Quad Bypass mode.

For full Auto Mode detection of a Laser Disc or Combination Laser Disc/DVD Player, there are two settings that need to be in place. The first involves setting of the AC-3 RF Inputs on the Cinema Reference. These are adjusted in the SETUP MODE. The AC-3 RF setting options include:

AC3 RF IN 1, AC 3 RF IN 2, AC3 RF AUTO1, & AC3 RF AUTO2

For all non-Laser Disc inputs, you can opt to set these to either AC3 RF IN 1 or AC3 RF IN 2. As these devices will not use the RF Demodulator, the link setting is arbitrary. Please note, the Cinema Reference's "Out Of The Box" setup, defaults LASER/DVD 1 to AC3 RF AUTO1 and LASERDISC 2 to AC3 RF AUTO2. All other inputs are properly set to AC3 RF IN 1. To alter these settings:

- 1 Select the device you wish to alter by turning the INPUT knob until the second line of the display reads the device name and press the INPUT knob.
- 2 Turn the MODE knob clockwise until the display reads SETUP MODE and then press the MODE knob.
- 3 Turn the MODE knob clockwise until the display reads AC3 RF INPUT and press the MODE knob.
- 4 Turn the MODE knob until the display reads the AC3 RF setting you desire.
- 5 Proceed with step three to alter other inputs for this component you can simply turn the Input Knob without leaving the AC3 RF setup mode.
- 6 If you wish to exit this mode, simply press the INPUT knob.

Auto Mode On/Off

The AUTOMODE function is a setting rather than a decoding mode. This setting is intended to permit the Cinema Reference to automatically switch between 5.1 (AC-3 or DTS) decoding modes or a two channel mode depending on the software in play. When combined with an AC3 RF AUTO setting, the AUTOMODE function will allow you to flip between AC-3 laser discs (via RF Demodulator), DTS and 2 channel PCM lasers & CDs, and DTS or AC-3 DVDs.

To turn the AUTOMODE ON or OFF:

- 1 Turn the INPUT knob to the device (capable of playing AC-3 software) you wish to alter and press the INPUT knob.
- 2 Turn the MODE knob clockwise until the display reads AUTOMODE ON or AUTOMODE OFF.
- 3 Press the MODE knob to switch ON to OFF or OFF to ON.

The Cinema Reference's "Out Of The Box" Setup has the LASER/DVD 1 and LASERDISC 2 Input Labels set to AUTOMODE ON. All other Input Labels are set to OFF. If you are using a DVD player on the DVD PLAYER 3 Input Label and you plan to also play standard CDs, you may wish to set the DVD PLAYER Input Label to AUTOMODE ON.

Custom Setup - Labeling Inputs

The Cinema Reference permits you to alter the Input Labels. These are labels that appear for each component as you rotate the Input knob. This is quite useful if you have connected a component that does not appear on the Cinema Reference (i.e. DAT Player). Altering Input Labels is also available when you don't want the numbers to appear on the Cinema Reference's display (i.e. LASER/DVD 1, LASERDISC 2). The front panel display can read a name up to 12 characters in length (alphanumeric). The most significant benefit of altering Input Label names is derived when using the Cinema Reference's "Final Input" Setup Mode (found under Pro Setup). The "Final Input" Setup Mode permits you to limit the number of Input Labels that appear on the Cinema Reference. If you wish to only display only the devices connected to your Cinema Reference, ADA suggests first proceeding to the section entitled "Pro Setup - Final Input". Once you have set the Final Input, then return to this page to change the Input Labels. To alter a components Input Label:

- 1 Select the device you wish to alter by turning the INPUT knob until the second line of the display reads the device name and press the INPUT knob.
- 2 Turn the MODE knob clockwise until the display reads SETUP MODE and then press the MODE knob.
- 3 Turn the MODE knob clockwise to until the display reads INPUT LABELS and then press the MODE knob. The top line of the display will read LABEL INPUTS and the second line of the display will read the Input Label as it currently appears with the first letter of the Input Label flashing (cursor).
- 4 Turn the MODE knob to select a new character for the first letter. If you do not wish to alter the character of the first letter, press the MODE knob to advance to the cursor to the second letter.
- 5 Turn the MODE knob to change this character and press the MODE knob to advance the cursor position to the next character.
- 6 Repeat step 5 until the display reads the new name for this Input Label. ADA suggests leaving the numeric value at the end of each Input Label in place to provide you with a reference as to this Input Label's position to the Cinema Reference's program.
- 7 When you are done relabeling an Input Label, turn the INPUT knob to advance to the next input you wish to relabel. Repeat with steps 4 - 6. When you are done labeling all inputs, turn either Volume, Channel, or Record to exit the

While the Cinema Reference's "Out Of The Box" Setup has pre-labeled connections for most any home theater audio/video component, you may wish to custom label any or all inputs to display to your liking.

The Cinema Reference's built-in character generator allows you to alter the way an Input Label reads when it is displayed. If you prefer to have DSS/SAT 5 input read as simply DSS RECEIVER, you can enter the Cinema Reference's Label Mode to edit and alter this input. While the "Out Of The Box" Setup assigns a sequenced Input Label number to each Input Label (1 -15), you can overwrite these numbers so that they do not appear, but note, these numbers do refer to the direct access input numbers found on the ADA One-For-All Remote.

The ability to alter the way Input Labels read is particularly useful if you are custom configuring your Cinema Reference using the Pro Setup's "Final Input" settings. Since the Final Input Setup allows you to limit the number of Input Labels that are displayed as you rotate the Input Knob, the need to relabel the lower inputs to suit your setup will be important. Prior to proceeding you may wish to review Final Input under Pro Setup.

Custom Setup - Turn-On Input

The Cinema Reference provides you with the ability to select which device you want the Cinema Reference to always turn on to. If you primarily use the Cinema Reference for viewing DSS broadcasts, you will want to alter the Turn On Input.

The Cinema Reference's "Out Of The Box" Turn On Input is set to VCR as most any home theater system includes a VCR. The steps in the paragraph to the right detail how to alter the Cinema Reference's Turn On Input.

While you may opt to have the Cinema Reference turn on to a specific component, you may also opt to have the Cinema Reference always engage to the input last used.

The Cinema Reference is factory set to always turn on to the VCR 4 input. Thus, even if you were watching a movie on DVD last night, when the kids come to turn it on in the morning, the Cinema Reference will always switch to the VCR.

While this ideal for some, you may prefer to have your Cinema Reference to turn on to another device, for example the DSS receiver. You may even prefer to have the Cinema Reference always engage to the component that was last used. Any of these options is easy to access by following these steps.

To alter the Cinema Reference's Turn-On Input:

- 1 Turn the MODE knob clockwise until the display reads SETUP MODE and then press the MODE knob.
- 2 Turn the MODE knob clockwise to until the display reads TURNON INPUT press the MODE knob.
- 3 Turn the MODE knob until the display reads the device you wish to have the Cinema Reference come on to or to the words LAST USED and press the MODE knob to engage that setting.
- 4 If you wish to exit the setup mode, simply turn the INPUT knob.

Custom Setup - Default Mode

Each Input Label can have a mode automatically engaged whenever that input is accessed. This eliminates the confusion of having to figure out what mode to select every time that device is engaged. The “Out Of The Box Setup” has already programmed the Input Labels to engage the most appropriate decoding mode for the various devices. If you wish to alter the Default Mode for one or all of the devices follow these steps.

Please note, that for non-5.1 channel components, the default mode is always engaged when that input is selected. You may still change modes while on this input. If desired, you may also engage the option of “Last Used”.

If you have selected a component that is set to auto-mode (Auto-Mode On), the default mode will have different properties. Since auto-mode will engage one of three decoding formats (AC-3, DTS, or 2-channel) based on the input signal, one single default mode (or preferred) is required. As such, these “defaults” are simply set during the playback of a software segment encoded in that mode. During playback, turn the mode knob to select the desired option for that mode (i.e. DTS DIRECT, DTS THX, DTS REQ, etc.). Every time from this point forward a DTS software segment is played on this input, the last used DTS decoding option will engage (i.e. DTS THX). The same is true for AC-3 modes or two-channel modes. This “last mode type played” default-to feature will always operate if the input’s Default Mode is set to “Last Used”. If you set the Default Mode to either an AC-3 or two-channel mode, when that mode is detected, the Cinema Reference will engage the Default Mode rather than the mode format option that was last used. If you select any DTS mode as the Default Mode, when either an AC-3 or two-channel mix is detected, the Cinema Reference will only engage either AC-3 THX or PRO LOGIC THX, respectively.

To set or alter the Default Mode:

- 1 Turn the INPUT knob until the input that you wish to alter appears on the second line of the display and then press the INPUT knob.
- 2 Turn the MODE knob clockwise until the display reads SETUP MODE and then press the MODE knob.
- 3 Turn the MODE knob clockwise to until the display reads DEFAULT MODE press the MODE knob. The top line of the display will read the current default mode.
- 4 Turn the MODE knob until the display reads the desired default mode or the words LAST USED, or AUTO MODE. Then press the MODE knob to lock in that default mode.
- 5 Turn the INPUT knob to the next input you wish to alter and **Page 42** press the INPUT knob. Then proceed with steps 2-4.

INPUT LABEL	COMPONENT	"OUT OF THE BOX" DEFAULT MODE SETTING
LASER/DVD 1	AC-3 LASER DISC OR COMBINATION PLAYER	AC-3 THX
LASERDISC 2	OLDER LASER DISC OR SECOND LASER DISC	PRO LOGIC THX
DVD PLAYER 3	DVD PLAYER	AC-3 THX
VCR 4	VCR	PRO LOGIC THX
DSS/SAT 5	DSS OR SATELLITE RECEIVER	PRO LOGIC THX
CABLE/TV 6	CABLE BOX OR TV TUNER	PRO LOGIC THX
CD PLAYER 7	CD PLAYER	MUSIC
TUNER 8	RADIO TUNER	MUSIC
CASSETTE 9	CASSETTE DECK	MUSIC
AUXILIARY 10	ANY DEVICE YOU WANT	PRO LOGIC THX
CAMCORDER 11	CAMCORDER	PRO LOGIC THX
VIDEOGAME 12	VIDEO GAME	PRO LOGIC THX
COMPUTER 13	COMPUTER INPUT	PRO LOGIC THX
PREAMP 14	AUDIO OR AUDIO/VIDEO PREAMPLIFIER	MUSIC
MULTIROOM 15	MULTI-ROOM AUDIO OR AUDIO/VIDEO SYSTEM	MUSIC

The Cinema Reference's "Out Of The Box" Setup has assigned Default Modes to each input. If you are altering the Out Of The Box Setup, chances are you will also wish to alter the default modes for the inputs you have changed.

For components set to Auto Mode Off, the Cinema Reference will always engage the specified Default Mode including the option of "Last Used".

For components that are set to Auto Mode On, the default mode will apply as the go to mode, providing a better decoding option is not detected. You may also opt to leave the Default Mode set to LAST USED as in auto mode, the Cinema Reference will automatically engage the last format option for that mode. When DTS is selected as a Default Mode in automode, THX will always be applied to either AC-3 or two channel mixes.

Custom Setup - Turn On Volume

The Cinema Reference's "Out Of The Box" Setup has the Cinema Reference always turning on to VOLUME PRESET #1. Unless you have already locked in a new volume preset under Audio Setup, this level will be -25.0 dB.

You can opt to alter the Turn On Volume to either VOLUME PRESET #2 or the LAST USED volume level. The steps described in the paragraph to the right detail how to change the Cinema Reference's Turn On Volume.

*Note
ADA strongly recommends using a Turn On Volume Preset whose level is not too high. Since the last volume used might be ear shattering, having the Cinema Reference turn on to a preset volume level removes the chance of engaging a system that is ready to sand-blast a room. This is providing that the Volume Preset you select is also of moderate level.*

The Cinema Reference has the ability to recall one of three volume levels when it is turned on. The Out Of The Box Setup has the Cinema Reference always turning onto VOL PRESET 1 which is factory set for all channels and all inputs at -25.0 dB. This level is typically a low or moderate volume level. If you have already completed the section on "Audio Setup", then you may have already locked in a new audio preset on VOL PRESET 1.

Factory Default Note: The Cinema Reference has been preprogrammed in the factory such that both VOL PRESET 1 and VOL PRESET 2 have the same preset level of all channels on all inputs set to -25.0 dB. If you wish to instantly recall the factory settings, simply proceed to recall VOL PRESET 2 by turning the CHANNEL knob until the display reads VOL RECALL 2 and then press the CHANNEL knob. If you wish to reset VOL PRESET 1 to the factory default as to begin again, once you have recalled VOL PRESET 2, simply turn the CHANNEL knob until the display reads VOL RECALL 1 and then press and hold the CHANNEL knob until the display reads VOL STORED 1.

If you want the Cinema Reference to come on to a volume level other than VOL PRESET 1, you can alter it to come on to either VOL PRESET 2 or LAST USED.

To alter the Cinema Reference's Turn On Volume:

- 1 Turn the MODE knob clockwise until the display reads SETUP MODE and then press the MODE knob.
- 2 Turn the MODE knob clockwise to until the display reads TURNON VOL press the MODE knob. The top line of the display will read the current turn on volume setting.
- 3 Turn the MODE knob until the display reads the desired turn on volume. Then press the MODE knob to lock in that turn on volume.

Custom Setup - Vector Scope On/Off

The Six Quadrant Vector Scope on the front of the Cinema Reference is designed to provide you with a testing scope that shows the input signal, after decoding, prior to volume adjustment. As such, you can see if a source signal has any surround channel information (lower right and left quadrants), bass information (vertical movement on the right and left side of the scope),

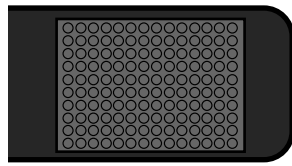

adrasudio
associates

or if the signal is only a mono signal (center channel deflection - straight up). This is useful if you are uncertain as to which mode will provide the best surround effect. It is also useful in the event a speaker or amplifier channel is not functioning properly as if you detect signal to that channel on the scope but hear no audio, you may wish to investigate your connections, etc.

The Vector Scope, unlike the rest of the Cinema Reference's front panel display, is not capable of being dimmed. You can however, turn the scope off if you do not like it.

To turn the Vector Scope on and off on the Cinema Reference:

- 1 Turn the MODE knob clockwise until the display reads SETUP MODE and then press the MODE knob.
- 2 Turn the MODE knob clockwise to until the display reads VECTOR SCOPE press the MODE knob. The top line of the display will read VECTOR SCOPE and the bottom line of the display will read "IS NOW ON" or "IS NOW OFF".
- 3 Turn the MODE knob until the display reads the desired setting, on or off. Then press the MODE knob to lock in that setting.

The Cinema Reference's Six Quadrant Vector Scope is capable of being turned on and off. The Out Of The Box Setup has the scope in the on position. If you choose to, you can turn the scope off using the steps as described in the following page.

Custom Setup - Display Illumination Level

While you can turn the Six Quadrant Vector Scope of the Cinema Reference On and Off, you can actually dim the rest of the Cinema Reference's front panel display to a % level that you prefer.

The Cinema Reference's "Out Of The Box" Setup has the Cinema Reference's front panel intensity level set to 100%. You can dim this display, including the six indicators to the left of the front panel all the way down to 0% (full off).

The Cinema Reference permits you to alter the intensity of the front panel LCD display as well as the six indicators located to the left side of the front panel. If you wish, you can lower the intensity from 100% to 0% (All Off). The Cinema Reference's Out Of The Box Setup is set to full intensity (100% On).



To alter the level:

- 1 Turn the MODE knob clockwise until the display reads SETUP MODE and then press the MODE knob.
- 2 Turn the MODE knob clockwise to until the display reads ILLUMINATION press the MODE knob. The top line of the display will read ILLUMINATION and the second row will read the current %.
- 3 Turn the MODE knob until the display reads the desired level. Then press the MODE knob to lock in that turn on volume. Note, that as you change the level the display increases or decreases in intensity.

Pro Setup - Enter At Your Own Risk

The Cinema Reference permits access to the “One Time” Setup functions only through its “Pro Setup”. The Pro Setup is well protected from accidental access in order to best preserve the Cinema Reference’s “Out Of The Box” factory default parameters. Since the Cinema Reference is designed for optimum operation, these parameters may not need to be adjusted, and as such, under most circumstances, should be left alone.

The features that are available in Pro Setup are:

Delay Settings - Each channels delay (including Sub) can be set in 0.5 dB steps.

Network Bus - The setting of the ADA Bus™ address.

Final Input - Setting the maximum number of Input Labels that appear on the Cinema Reference.

System Setup - All bass management features which are input specific.

IRR On/Off - Turning the Cinema Reference’s front panel IR receiver on and off.

HDR Scale - Setting the High Dynamic Range scale factor for Dolby Digital (AC-3).

LDR Scale - Setting the Low Dynamic Range scale factor for Dolby Digital (AC-3).

Re-Equalize - Turning the THX Re-Equalizer on and off for each input.

Timbre Match - Turning the THX Timbre Match on and off for each input.

Decorrelate - Turning the THX Decorrelation on and off for each input.

Auto-Balance - Turning the Auto-Balance on and off for each input.

Repeat Count - Setting the maximum number of consecutive blocks repeated before muting for Dolby Digital modes.

Analog Gain - Adjusting the gain control from 0 dB to +9 dB, in 3 dB steps per input.

PCM Up Scale - Adjusts the higher end of the PCM scale per AC-3 or non-AC-3 modes.

PCM Dn Scale - Adjusts the lower end of the PCM scale per AC-3 or non-AC-3 modes.

Input Format - Sets the Dolby Digital decoding input format per input.

Output Format - Sets the active speaker output format per input.

Aux DC Trig 1 - Sets the Auxiliary Trigger #1 to engage with specific inputs.

Aux DC Trig 2 - Sets the Auxiliary Trigger #2 to engage with specific inputs.

To enter the Pro Setup Mode:

- 1 Turn the MODE knob clockwise until the display reads SETUP MODE and then press the MODE knob.
- 2 Turn the MODE knob clockwise to until the display reads PRO SETUP and press and hold the MODE knob. The top line of the display will read PRO SETUP and the second line of the display will read T-MINUS 10, T-MINUS 9,.....T-MINUS 1. At this time the display will flash and the top line will return to read PRO SETUP and the second line will now read the first Pro Setup function, NETWORK BUS.
- 3 To exit the Pro Setup Mode, turn any knob other than the mode and input knobs. Turn the mode knob to access the above mentioned parameters.

The Cinema Reference has additional parameters that can be set under the Pro Setup Mode. These parameters are set in the factory for optimum performance.

To protect these factory settings, the ability to access the Pro Setup mode requires the turning of the MODE knob until SETUP MODE appears followed by pressing and holding of the MODE knob for a countdown of ten seconds. When in the Pro Setup Mode, you can still access functions typically limited to the standard Setup Mode.

There is no time-out function while in Pro Setup.

To exit the Pro Setup Mode, simply turn the INPUT knob.

Pro Setup - Delay Setup

The Cinema Reference provides the flexibility to set the delay for each of the six speaker channels including the subwoofer. Unlike conventional delay settings, where the front right and left speakers act as the reference distance, the six channel delay configuration requires that one of the six channels be selected as the reference. Since delay is applied to speakers that are closer than the furthest most speaker, the "Reference Speaker" is the speaker that has the greatest distance to the primary listening position. Delay is then applied to all of the other channels.

The Cinema Reference is capable of delay settings in 0.5 millisecond increments. Since 1 foot is equal to 1 millisecond, you can adjust the delay for each channel to the nearest 1/2 foot (six inches). As such, your measurements need be rounded to the nearest six inches.

The adjustment of the Delay setting can be configured independently for each of the Cinema Reference's six channels (including the subwoofer channel). The goal of setting channel delays is to have the sound from each speaker reach the primary seating position at the same time or perhaps better put, the correct time. Since the Cinema Reference can delay the signal of a channel from reaching that channel's output (and as such, the amplifier, then the speaker, and then your ears), the delay is applied to all speakers that are closer to the listener than the furthest speaker. This speaker, the one at greatest distance from the primary listening/viewing position, for the sake of this section, will be called the "Reference Speaker", because all of the other speakers closer to the listening position, will use this speaker's distance as a reference point.

The process of setting the delays will require the use of a tape measure or some other distance measuring instrument. ADA suggests using the U.S./British standard to measure these distances in feet as sound travels at approximately 1 foot per millisecond (1/100th of a second). If you are using the metric standard to measure your distances, ADA suggests converting all measurements to feet as it will be easier to calibrate the delay time settings (1 foot is approximately equal to 30.5 cm).

The example below details a sample speaker placement where each speaker is located at a different distance from the primary seating position. The chart to the right is filled in with the sample distances from diagram below.

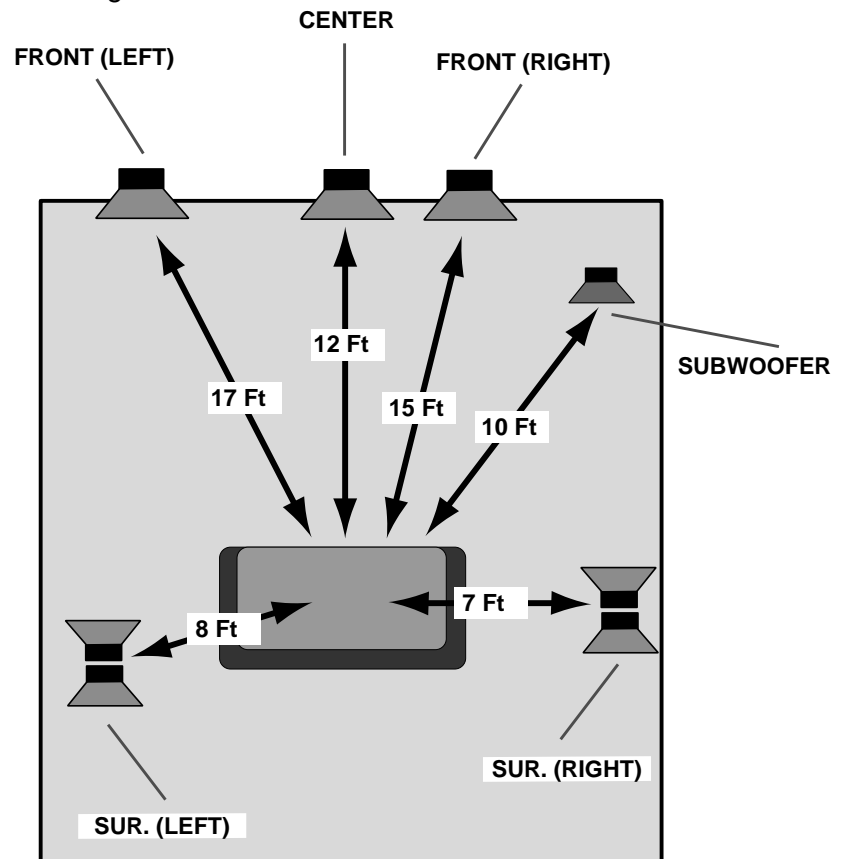

To proceed, you will first determine where your primary listening viewing seating position will be. Next you will want to measure the distance from the primary listening/viewing position each speaker using a tape measure. Your measurements need to be accurate to within 6 Inches (1/2 Foot). Follow these steps:

- 1 Determine the primary seating position and use it as the measuring center point.
- 2 Measure the distance to each speaker and write them on a piece of paper. You can use the blank chart found on page 36 which is identical to the sample chart on the next page.

Most home theaters have the front right and left speakers equal distance from the main seating area. The same is usually true of the surround left and right speakers as it is common that they are also of equal distance from the primary seating position.

	FRONT LEFT	CENTER	FRONT RIGHT	SUBWOOFER	LEFT SURROUND	RIGHT SURROUND	
DISTANCE IN FEET	17	12	15	10	8	7	
ENTER DISTANCE OF FURTHEST FRONT SPEAKER (REFERENCE SPEAKER)	17	17	17	17	17	17	
ENTER DISTANCE OF SPEAKER	17	12	15	10	8	7	
SUBTRACT SPEAKER'S DISTANCE FROM REFERENCE SPEAKER	0	5	2	7	9	10	THESE ARE THE SPEAKER'S DELAY SETTINGS

Please note, as the delay range for 5.1 modes is 0-15 ms, the above delay settings directly apply only to 5.1 decoding modes. For Dolby Pro Logic modes, the delay range is 15-30 ms. Thus for Dolby Pro Logic modes add 15 ms to these numbers

- 3 Determine which of the speakers is furthest away and use this speaker as the "Reference Speaker". In most home theater systems, the front right and left speakers are typically of equal distance from the seating area as are the left and right surround speakers. If more than one speaker's position is equal to the greatest distance from the primary seating position, these speakers will also have no delay.
- 4 Subtract the distance of all of the speakers from the distance of the furthest speaker (Reference Speaker). These numbers will be used as the Delay Settings. The chart above shows the measurements taken from the example diagram on the bottom of the previous page. Since the Front Left speaker is placed the greatest distance from the seating area, it is used as the Reference Speaker and requires no delay (Delay = 0 ms). The difference in the distance of the other speakers from the Reference Speaker are the actual delay settings. The chart above details the math involved.

If the front set of right and left speakers are furthest from the seating area, they would together act as the Reference Speaker and not require any delay. The distance to one of these speakers will be used as a reference and the appropriate delay would then be set for the surround, center, and subwoofer speakers. In this example, all speakers are at different distances.

Delay Setup - Continued

You can use the diagram below to insert the distances you measured for your theater.

	FRONT LEFT	CENTER	FRONT RIGHT	SUBWOOFER	LEFT SURROUND	RIGHT SURROUND	
MEASURED DISTANCE IN FEET							
ENTER DISTANCE OF FURTHEST FRONT SPEAKER (REFERENCE SPEAKER)							
ENTER DISTANCE OF SPEAKER							
SUBTRACT SPEAKER'S DISTANCE FROM REFERENCE SPEAKER'S DISTANCE							THESE ARE THE SPEAKER'S DELAY SETTINGS

The actual delay value for each channel is equal to the distance that is calculated by subtracting that channel's distance from the primary listening position from the distance of the furthest speaker to the primary listening position.

In the example from the previous page, the Reference Speaker is the Left Front speaker and this speaker will not be delayed (0.0 ms). The Center speaker's delay will be set to 5 ms, the Front Right speaker will be set to 2 ms, the Subwoofer will be set to 7 ms, the Left Surround speaker will be set to 9 ms, and the Right Surround Speaker will be set to 10 ms. Note that these delay settings are equal to the distances in feet.

Note: If you are in a non-5.1 mode, you will have to add 15 to each delay setting.

- 5 If you wish to use the figures directly from the chart above without adding 15 to each number, turn the MODE knob to read an AC-3 mode and then press the knob. If the input you are on is set to auto-mode on and you are not playing a 5.1 encoded software segment, the Cinema Reference will not permit you to engage a 5.1 mode. ADA suggests selecting another input and manually engaging AC-3 for this step.
- 6 Turn the MODE knob clockwise until the display reads SETUP MODE and then press the MODE knob.
- 7 Turn the MODE knob clockwise to until the display reads the word DELAY followed by the first channel you wish to adjust, and then press the MODE knob to engage that channel. The top row of the display will read the channel name and the bottom row will read its current delay setting in MS (milliseconds).
- 8 Turn the MODE knob until the display reads the desired delay level and then press the MODE knob to engage that delay. The difference (measured in feet) of the farthest speaker from the selected speaker is also the same value in milliseconds.
- 9 Turn the MODE knob to the next channel who's delay you wish to adjust and press the MODE knob.
- 10 Repeat steps 7 & 8 for all channels that require delay adjustment.
- 11 When you have completed adjusting the delay for all channels, turn the INPUT knob to exit the Setup Mode.

Pro Setup - Network Bus

The Cinema Reference has the ability to be controlled in a network with other ADA Bus™ components, including multiple Cinema References. As such, the Cinema Reference has the ability to be set to as many as 256 addresses. Typically, the factory default address for the Cinema Reference is Bus Address 0. At this address setting, the Cinema Reference operates with its infrared remote control.

When using the Cinema Reference in an ADA Bus™ multi-zone audio/video system, you may need to alter the address setting to have the Cinema Reference also operate in conjunction with that zone's ADA Bus™ keypad.

The Cinema Reference also has a setting whereby the bi-directional control option via the ADA Bus™ jack is completely off. To select this feature, set the Network Bus Address to "255".

To change the Bus Address:

- 1 While in the Pro Setup mode, turn the MODE knob until the display reads NETWORK BUS and then press the MODE knob.
- 2 Turn the MODE knob until you have set the Network Bus to the desired address setting (from 0 {default standard} to 254 - 255 turns the bidirectional control/feedback option off).
- 3 When you have the desired address setting on the Cinema Reference's display, press the MODE knob to engage the address.
- 4 To exit the Network Bus Setup Mode without leaving the Pro Setup Mode, press the MODE knob. If you wish to exit the Setup Mode completely, turn any of the knobs other than MODE or INPUT.

The Cinema Reference can be set to one of 255 ADA Bus™ Address settings. The standard factory default address is "0". This address permits the Cinema Reference to be controlled by its infrared remote control.

Pro Setup - Final Input

The Cinema Reference provides a total of fifteen Input Labels, all of which are accessible in the "Out Of The Box" configuration. However, while this setup permits easy connection of almost any number of components without complex programming, it also means that the Cinema Reference will display device names which may not necessarily be on your system.

ADA has provided a means by which you can limit the number of Input Labels that appear on the Cinema Reference's display by locking in the Final Input. This has been discussed briefly under Labeling Inputs. When you set the Final Input, the Cinema Reference will no longer scroll through all Input Labels beyond the Final Input. While this does permit you to limit the number of devices displayed, you will most likely need to re-configure the audio and video inputs as well as their Input Labels for some of your components.

The Cinema Reference provides you with the ability to custom configure the way its display appears. Through the use of the Label Inputs option, you can rename an Input Label to appear as you wish it read. Through the Audio/Video Setup, you can alter the links to the Cinema Reference's input jacks for any Input Label. But if you wish to have the Cinema Reference scroll through Input Labels for only the devices you have connected to it, you will first need to limit the number of Input Labels the Cinema Reference will display using the Final Input Setup Mode.

As the Cinema Reference has a total of fifteen Input Labels in its factory default "Out Of The Box" setup, you may not necessarily be connecting a total of fifteen devices to the Cinema Reference. If for example, you are connecting only six devices to the Cinema Reference, you can limit the number of Input Labels that appear on the Cinema Reference to only six.

Please note, that when the Cinema Reference sets a limit to the higher Input Label names, it does so by, in this example, not displaying Input Labels 7-15. You cannot selectively omit Input Label names from displaying (i.e. Input Labels 3, 4, 8, 9-15). Thus, when you set a limit to the number of Input Label names that are accessible, you will also most likely need to alter the names of certain labels as well as the audio/video links to those labels.

To set the Final Input limit:

- 1 While in the Pro Setup Mode, turn the MODE knob clockwise until the display reads FINAL INPUT and then press the MODE knob.
- 2 Turn the MODE knob until the display reads the last input you wish to access. If you have not altered any Input Labels up to this point, the Input Label name should also appear with a number after it and you can use these as a guide.
- 3 When you have the last Input Label you wish to display on the screen, press the MODE knob to engage this final input.
- 4 To exit the Final Input Setup Mode without leaving the Pro Setup Mode, press the MODE knob. If you wish to exit the Setup Mode completely, turn any of the knobs other than MODE or INPUT.

Pro Setup - System Setup - Bass Management

The Cinema Reference incorporates several bass management features which are also featured under Pro Setup. These bass management options are capable of being set differently for each Input Label. Since the Cinema Reference's "Out Of The Box" Setup is designed for optimum system operation, you may not need to alter these settings. The standard default setting is BASS CONFIG = 0, which, as described on the chart below, engages the High Pass Filter for all speakers, combining the LFE channels information with a sum of the bass information contained in the other speaker channels. This is the default setting for a THX Home Cinema.

The Cinema Reference's "Out Of The Box" Setup is defaulted to the THX standard where the High Pass Filter is active on all speakers with their subwoofer information summed to with the LFE channel.

BASS CONFIGURATION CODE #	LEFT & RIGHT FRONT CHANNELS (L R)	CENTER CHANNEL (C)	LEFT & RIGHT SURROUND CHANNELS (S)	SUBWOOFER (LFE)	BASS MIX
0	HIGH PASS FILTER	HIGH PASS FILTER	HIGH PASS FILTER	YES	LFE + LR,C,S TO SUB
1	FULL RANGE	FULL RANGE	FULL RANGE	YES	LFE TO SUB
2	FULL RANGE	FULL RANGE	FULL RANGE	NO	LFE TO LR,S
3	FULL RANGE	FULL RANGE	HIGH PASS FILTER	YES	LFE + S TO SUB
4	FULL RANGE	FULL RANGE	HIGH PASS FILTER	NO	LFE + S TO LR
5	FULL RANGE	HIGH PASS FILTER	FULL RANGE	YES	LFE + C TO SUB
6	FULL RANGE	HIGH PASS FILTER	FULL RANGE	YES	LFE TO SUB/C TO LR
7	FULL RANGE	HIGH PASS FILTER	FULL RANGE	NO	LFE TO LR,S/C TO LR
8	FULL RANGE	HIGH PASS FILTER	HIGH PASS FILTER	YES	LFE + C + S TO SUB
9	FULL RANGE	HIGH PASS FILTER	HIGH PASS FILTER	NO	LFE + C + S TO LR
10	HIGH PASS FILTER	HIGH PASS FILTER	FULL RANGE	YES	LFE + LR, C TO LFE
11	HIGH PASS FILTER	FULL RANGE	HIGH PASS FILTER	YES	LFE + LR, S TO SUB
12	HIGH PASS FILTER	FULL RANGE	FULL RANGE	YES	LFE + LR TO SUB

To change the Bass Configuration:

- 1 While in the Pro Setup mode, turn the MODE knob until the display reads SYSTEM SETUP and then press the MODE knob. The display will read BASS CONFIG on the top line and the second line will read the Bass Configuration # for the Input Label currently selected.
- 2 Select the input you wish to change the Bass Configuration setting for by turning the INPUT knob (In the BASS CONFIG Setup Mode, turning the INPUT knob does not eject you from the Pro Setup). The top line of the display will momentarily display the input you have selected (turned to) and the display will then indicate this input's BASS CONFIG #.
- 3 Turn the MODE knob until you have set the BASS CONFIG # to the desired setting (from 0 {default standard} to 12). You do not need to press the MODE knob to engage the bass configuration and if you wish, you can listen to the different configurations as you dial through them.
- 4 If you wish to alter the Bass Configuration for any or all other inputs, repeat steps 2 & 3. To exit the Bass Configuration Setup Mode without leaving the Pro Setup Mode, press the MODE knob. If you wish to exit the Setup Mode completely, turn any of the knobs other than MODE or INPUT.

If you are using full range speakers in your home theater system, you can alter the bass management aspect of the Cinema Reference.

Please note, that the Bass Configuration setting is input specific. As such, you will need to alter the Bass Configuration setting for each input.

If you are using full range speakers (speakers capable of handling bass information) either for all five main speakers or just some of the five main speakers, you will need to use the chart to determine which Bass Configuration # best applies to your speaker array.

Pro Setup - IR Receiver On & Off Control

The Cinema Reference permits you to turn off the front panel IR receiver via software. This is useful if the Cinema Reference is being touch screen controlled as some installations will cause the front panel IR to reflect data transfers and prevent control.

The Cinema Reference provides you with the ability to turn its front panel infrared receiver on and off via software. If you are using the Cinema Reference in an environment which is flooded by other infrared signals (from high intensity light bulbs, high frequency lamps, IR motion detectors, sunlight, etc.), you may opt to turn the Cinema Reference's front panel infrared receiver off. You may also want to turn this IR receiver off if you are controlling the Cinema Reference from a computer controlled touch screen or ADA keypad as, in some instances, this IR receiver will prevent component control due to data reflection.

The Cinema Reference's "Out Of The Box" setup has the IR receiver in the On position. To turn the IR receiver off or on:

- 1 While in the Pro Setup Mode, turn the MODE knob clockwise until the display reads IRR CONTROL and then press the MODE knob. The Cinema Reference's display will read IRR CONTROL on the top line and the second line will read "IS NOW ON" or "IS NOW OFF".
- 2 Turn the MODE knob until the display reads the correct setting for the IR Receiver, ON or OFF.
- 3 To exit the IRR Control Setup Mode without leaving the Pro Setup Mode, press the MODE knob. If you wish to exit the Setup Mode completely, turn any of the knobs other than MODE or INPUT.

Pro Setup - Bass Limiter

The Cinema Reference provides you with the ability to engage a bass limiter that operates in a range from 0 dB (decibels) to -24 dB. The function of the bass limiter is to reduce the possibility of overloading the subwoofer in cases of extreme volume and/or software that provides extremely dynamic bass information. If your subwoofer is capable of providing a large level of bass without bottoming out, you may not need to engage the bass limiter at all. If however, you play your system a volume levels that on occasion will cause your subwoofer to play distorted audio segments, you will wish to engage the bass limiter.

The Cinema Reference's "Out Of The Box" setup has the Bass Limiter set to 0 dB. To adjust the Bass Limiter setting:

- 1 While in the Pro Setup Mode, turn the MODE knob clockwise until the display reads BASS LIMITER and then press the MODE knob. The Cinema Reference's display will read BASS LIMITER on the top line and the second line will read a level (i.e. 0 DB LIMIT).
- 2 Turn the MODE knob until the display reads the desired setting for the Bass Limiter (0 to -24 dB).
- 3 To exit the BASS LIMITER Setup Mode without leaving the Pro Setup Mode, press the MODE knob. If you wish to exit the Setup Mode completely, turn any of the knobs other than MODE or INPUT.

The Cinema Reference permits you to engage a Bass Limiter which will prevent the subwoofer from distorting when playing the system at high volume levels that the subwoofer cannot properly process.

To best apply this feature, operate your home theater system at a level slightly louder than you would normally play it at. Try using software that is dynamic, something that includes scenes with explosions might be appropriate. Determine if your subwoofer is beginning to "bottom out" or distort. If this is the case, slowly increase the value of the bass limiter from 0 dB to -24 dB. As the Cinema Reference permits you to sample the changes live, you can determine the limiter setting where the bass no longer distorts.

Pro Setup - HDR & LDR Scale Factors

The HDR (High Dynamic Range) and LDR (Low Dynamic Range) Scale Factors permit the playback of AC-3 formatted source material with compression of both the low and high levels. As such, the bangs and booms are never too loud and whispers never too soft. This narrowing of the Dynamic Range takes place when listening to the AC-3 Night mode. However, the Cinema Reference can also adjust these factors for the AC-3 Ultra and AC-3 Standard modes. If you make adjustments to the AC-3 Ultra mode, these changes will then also apply to AC-3 THX and AC-3 Re-EQ as they are linked together. Conversely, if you modify either AC-3 THX or AC-3 Re-EQ, the other linked modes are also affected.

The Cinema Reference's "Out Of The Box" Setup has the HDR and LDR Scale Factors set to "0" or Full Off. These scale factors are engaged in the AC-3 Night mode automatically and need not be adjusted to access AC-3 Night.

The Cinema Reference offers several mode settings when decoding a Dolby Digital (AC-3) signal. One of these modes is AC-3 NIGHT mode which provides compression of the low level and high level signals, such that, the bangs and booms are reduced and the whispers are accentuated. This, in effect narrows the volume range to permit comfortable listening without the worry of disturbing others during an explosion or other loud dramatic sound effect. To accomplish this compression, the Cinema Reference, when in AC-3 NIGHT Mode, engages both the HDR (High Dynamic Range) Scale and the LDR (Low Dynamic Range) Scale to "255" or Full On. These scale factors are also set to "255" or Full On during the AC-3 STANDARD mode. While the Cinema Reference's "Out Of The Box" Setup has the HDR and LDR scale factors set to "0" or Full Off (no compression), you can selectively set these scales to a point between (and including) 0 and 255. These scale factors are specific to the AC-3 modes and as such, can be set differently for either AC-3 ULTRA mode and AC-3 STANDARD MODE (Please note that AC-3 THX and AC-3 RE-EQ will also be affected with any change to the AC-3 ULTRA mode in that these modes are tied together).

Prior to proceeding with the HDR and LDR scale factor, you will first need to select an AC-3 Input Label. Turn the mode knob to AUTOMODE OFF (or ON) is displayed. If the display is reading AUTOMODE ON, press the MODE button to turn it to AUTOMODE OFF. If Automode is already set to off, turn the mode knob to either AC-3 ULTRA or AC-3 STANDARD (which ever one you wish to adjust the HDR and/or LDR scale) and press the MODE button to engage that mode. You will then need to enter the Pro Setup mode.

- 1 While in the Pro Setup mode, turn the MODE knob until the display reads either HDR UP SCALE or LDR DN SCALE and then press the MODE knob. The display will read HDR UP SCALE (or LDR DN SCALE) on the top line and the second line will read the current scale factor and the mode name (ULTRA, STANDARD, THX, or RE-EQ). If this input is set to AC-3 NIGHT, AC-3 MAX, or a non-AC-3 mode, the display will read FIXED SCALE. While in either the HDR or LDR Setup mode, you can turn the INPUT knob to see the settings on other inputs.
- 2 Turn the MODE knob until you have set the HDR (or LDR) scale set to the desired setting (from 0 {default standard - Full Off} to 255 {Full On}). You do not need to press the MODE knob to engage this setting. While in either the HDR or LDR Setup mode, you can turn the INPUT knob to see the settings on other inputs with other modes.
- 3 If you wish to alter the HDR or LDR scales for any or all other modes, repeat steps 2 & 3. To exit the HDR (or LDR) Setup Mode without leaving the Pro Setup Mode, press the MODE knob. If you wish to exit the Setup Mode completely, turn any of the knobs other than MODE or INPUT.

Pro Setup - THX - Re-EQ, Timbre Match, & Decorrelate

There are three distinct aspects to the THX enhancements, Re-Equalization, Timbre Match, and Decorrelation. These enhancements can be applied to either Dolby Digital (AC-3) or Dolby Pro Logic modes. Furthermore, they can be applied in part or in full (THX).

When you select the AC-3 THX or PROLOGIC THX modes, all three enhancements are active (On). When you select the AC-3 RE-EQ or PROLOG RE-EQ modes, the re-equalizer is active (On) and the Timbre Match and Decorrelation filters are off.

While these fixed modes permit instant access to certain THX enhancements, the Cinema Reference also permits you to customize inputs set to either an AC-3 or Pro Logic mode. Thus, you can selectively turn the Re-EQ, Timbre Match, and Decorrelation enhancements to on or off, individually, when in the Pro Setup mode.

If you are interested in dabbling with the effects of Re-EQ, Timbre Match, and Decorrelation, you can do so following the steps below.

- 1 While in the Pro Setup Mode, turn the MODE knob until the display reads either RE-EQUALIZE, TIMBRE MATCH, or DECORRELATE and then press the MODE knob. The Cinema Reference's display will read RE-EQUALIZE (TIMBRE MATCH or DECORRELATE) on the top line and the second line will read "IS NOW ON" or "IS NOW OFF".
- 2 Turn the MODE knob until the display reads the correct setting for the particular THX enhancement, ON or OFF. Since each Input has its own default mode, you can set the THX enhancement to on or off for other Input Labels by turning the INPUT knob and scrolling through all inputs. Please note, some modes will not allow you to turn on and off certain THX enhancements.
- 3 To exit the RE-EQUALIZE, TIMBRE MATCH, or DECORRELATE Setup Modes without leaving the Pro Setup Mode, press the MODE knob. If you wish to exit the Setup Mode completely, turn any of the knobs other than MODE or INPUT.

The Cinema Reference permits you to turn selectively engage the Re-Equalization, Timbre Match, and Decorrelation filters individually. These enhancements, when all three are on, are equal to full THX. Thus, you can more simply turn all three enhancements to on by simply selecting either the AC-3 THX or PROLOGIC THX modes using the MODE knob.

You can also directly select the AC-3 RE-EQ or PROLOG RE-EQ modes using the MODE knob. Please note, that these enhancements are only available on a Dolby Digital (AC-3) mode or Dolby Pro Logic mode.

If you wish to alter either one of these three enhancement filters, you can do so under the Pro Setup.

Pro Setup - Auto-Balance

The Cinema Reference's "Out Of The Box" Setup has the Auto Balance in the On position. You can selectively set the Auto Balance to On or Off for Inputs set to a Dolby mode.

The Cinema Reference also permits you to turn off the Auto Balance circuit. When the Auto Balance is on, the Cinema Reference will compensate for discrepancies in the left and right channels, when in an analog domain. The Cinema Reference's "Out Of The Box" Setup has the Auto Balance in the On position.

- 1 While in the Pro Setup mode, turn the MODE knob until the display reads AUTO BALANCE and then press the MODE knob. The display will read AUTO BALANCE on the top line and the second line will read the current scale factor and the mode name IS NOW ON or IS NOW OFF.
- 2 Turn the MODE knob to turn the Auto Balance On or Off. You can turn the INPUT knob to see the settings on other inputs with other modes.
- 3 To exit the AUTO BALANCE Setup Mode without leaving the Pro Setup Mode, press the MODE knob. If you wish to exit the Setup Mode completely, turn any of the knobs other than MODE or INPUT.

Pro Setup - Repeat Count

The Repeat count is used on Dolby Digital (AC-3) modes and can be set independently per input, which is set to an AC-3 mode. The Cinema Reference's "Out Of The Box" Setup has the Repeat Count set to "1". If you wish to alter this setting, you can increase the Repeat Count as high as 8.

- 1 While in the Pro Setup Mode, turn the MODE knob until the display reads REPEAT COUNT and then press the MODE knob. The Cinema Reference's display will read REPEAT COUNT on the top line and the second line will read a number (1) followed by the word COUNT.
- 2 Turn the MODE knob until the display reads the desired setting for the Repeat Count (1-8). Since each Input that is on an AC-3 mode has its own Repeat Count, you can set the Repeat Count for other Input Labels by turning the INPUT knob, thus scrolling through all inputs.
- 3 To exit the REPEAT COUNT Setup Modes without leaving the Pro Setup Mode, press the MODE knob. If you wish to exit the Setup Mode completely, turn any of the knobs other than MODE or INPUT.

The REPEAT COUNT is a function that is directly related to the Dolby Digital (AC-3) Surround Mode. The Repeat Count setting indicates the maximum number of consecutive block repeats before muting the output. The Out Of The Box setup for repeat count is set to 1. The maximum setting is 8.

Pro Setup - Analog Gain Control

The Cinema Reference is designed to provide an ideal listening environment for all of your source components. Digital audio components, such as CD players, DVDs, laser disc players, and DSS receivers typically have very good gain drive, there is no need to compensate their output levels. However, for analog audio components, you may wish to raise their analog gain so that, as you change from one input to the next, the output levels (the sound level in the room) remains somewhat constant. The Cinema Reference is fully equipped to lower the gain levels for all analog inputs independently.

The Cinema Reference's "Out Of The Box" Setup has the Analog Gain levels set to 0 dB for all Analog Inputs. You can selectively raise the Analog Gain for each analog audio input in 3 dB steps up to 9 dB. The Cinema Reference will display the input gain level, providing the component is putting out audio, and will indicate when clipping begins to occur.

The Cinema Reference also permits you to adjust the gain individually for all analog inputs. The Cinema Reference's "Out Of The Box" Setup has all analog inputs set to 0 dB or no Analog Gain. You can raise the gain for the analog inputs from 0 dB to 3 dB, 6 dB, or as high as 9 dB of gain. This is quite useful for components that have lower gain drive such as radio tuners, VCRs, and phonographs (phono preamplified output). Digital devices such as CDs, DVDs, Laser Disc players, DSS receivers, etc., typically have a higher drive. Therefore, you can adjust each analog audio input to an appropriate level such that, as you switch inputs, the output levels are steady.

- 1 While in the Pro Setup mode, turn the MODE knob until the display reads ANALOG GAIN and then press the MODE knob. The display will read level arrows (<<<<>>>) on the top line and the second line will read IN = 00.0 dB (or some other number if you have already altered the factory defaults).
- 2 Turn the MODE knob to raise or lower the Analog Gain Control from 0 dB through 9 dB (in 3 dB steps). Note that the level arrows will raise as you raise the Analog Gain. If the level arrows reach the edges of the display (<<<<<<<<>>>>>>>), you have raised the analog gain too far as clipping is occurring. ADA suggests raising the Analog Gain level cautiously. Since other inputs may also require Analog Gain adjustment, you can turn the INPUT knob to see the settings on other analog inputs and continue to adjust their gain.
- 3 To exit the ANALOG GAIN Setup Mode without leaving the Pro Setup Mode, press the MODE knob. If you wish to exit the Setup Mode completely, turn any of the knobs other than MODE or INPUT.

Pro Setup - PCM Scale Factors

The Cinema Reference also permits you to adjust the PCM Scale for audio inputs. This scale has two settings, one for AC-3 Modes and another for Pro Logic Modes.

The PCM scale ranges from 0 to 255, with the factory default (Out Of The Box Setup) set to 127.

ADA strongly suggests that you do not change these scales.

Adjusting the PCM Scales will lower the level of each input. This is not the ideal method of level scaling as the levels are being reduced by the discarding of bits of data. However, if you wish to adjust either the Upper PCM Scale or the Downward PCM Scale the following steps detail how this is accomplished.

- 1 While in the Pro Setup Mode, turn the MODE knob until the display reads either PCM SCALE and then press the MODE knob. The Cinema Reference's display will read PCM SCALE on the top line and the second line will read a number followed by the words FOR AC-3 or FOR PROL (Pro Logic).
- 2 Turn the MODE knob until the display reads the desired setting for the PCM Scale that you have selected. Since each Input that is on an either an AC-3 mode or a Pro Logic mode has its own PCM scale setting, you can set the PCM Scales for other Input Labels by turning the INPUT knob, thus scrolling through all inputs.
- 3 To exit the PCM Scale Setup Modes without leaving the Pro Setup Mode, press the MODE knob. If you wish to exit the Setup Mode completely, turn any of the knobs other than MODE or INPUT.

The Cinema Reference provides you with the ability to alter the PCM Scales for each input set to either an AC-3 or Pro Logic mode. The effect of altering the PCM scale is the lowering of a devices audio level. This adjustment to the audio level does come with a drawback as the audio level is reduced by discarding bits of data. As such it is not ideal.

ADA strongly suggests not altering the factory default (Out Of The Box) settings for the PCM scales.

Pro Setup - Input Format

The Cinema Reference has the ability to alter its Input Format which only applies to AC-3 decoding. The standard Input Format for Dolby AC-3 decoding from a laser disc or DVD is "SIF S/PDIF". The current alternate setting is "SIF NONFORM" and is for future AC-3 decoding options that may come with HDTV off-air or satellite broadcasts.

At this time, ADA strongly suggests not altering the Input Format.

The Cinema Reference is also prepared to decode other AC-3 formats, most of which are intended for AC-3 broadcast with HDTV by way of off-air or satellite reception. As these are future decoding formats, ADA strongly suggests not altering these settings.

However, should you need to alter these settings, the following describes the procedure to do so.

- 1 While in the Pro Setup mode, turn the MODE knob until the display reads INPUT FORMAT and then press the MODE knob. The display will read INPUT FORMAT on the top line and the second line will read SIF S/PDIF (or some other number if you have already altered the factory defaults).
- 2 Turn the MODE knob to alter between the SIF S/PDIF and SIF NONFORM (non-formatted) settings. Since other inputs can also have their own Input Format setting, provided they are set to AC-3 modes, you can turn the INPUT knob to see the settings on other inputs and continue to alter their Input Format.
- 3 To exit the INPUT FORMAT Setup Mode without leaving the Pro Setup Mode, press the MODE knob. If you wish to exit the Setup Mode completely, turn any of the knobs other than MODE or INPUT.

Pro Setup - Auxiliary DC Triggers

The Cinema Reference has two low voltage outputs which can be used to trigger other components or devices. These triggers can be used to perform several different operations such as:

- a Engaging a projector, screen, and curtains for only video devices.
- b Turning on a power amplifier using an external AC switcher (ADA ACC-3) if the amplifier will draw more than 10 amps current (Cinema Reference's Switched AC Outlet maximum).
- c Alternate speaker drivers between music and film playback.
- d Provide a basic trigger to other components to engage their sequence.

The Cinema Reference sports two such triggers and both of these triggers are input specific. The Out Of The Box setup is as follows:

AUX DC TRIG 1 = Engages with all inputs.

AUX DC TRIG 2 = Engages with only the Video Inputs:

LASER/DVD 1, LASERDISC 2, DVD PLAYER 3, VCR 4, DSS/SAT 5, CABLE/TV 6, AUXILIARY 10, CAMCORDER 11, VIDEO GAME 12, and COMPUTER 13.

Since most home theaters using this feature will involve some level of professional setup, you can alter the Aux DC Triggers using the following steps. If you are planning on adjusting the Final Input or Input Labels, ADA suggests first making these adjustments prior to proceeding with the Aux DC Trigger setup.

To setup and verify the Aux DC Triggers:

- 1 While in the Pro Setup mode, turn the MODE knob until the display reads either AUX DC TRIG 1 or AUX DC TRIG 2 and then press the MODE knob. The display will read Input Label that is currently selected on the top line and the second line will read DC TRIG1 ON or DC TRIG1 OFF (when adjusting Aux DC Trig 1).
- 2 Turn the MODE knob to switch between DC TRIG1 ON or DC TRIG1 OFF. Since other inputs may also need to be set to this particular auxiliary DC trigger, you can turn the INPUT knob to see the settings on other inputs and continue to alter their status from on to off or off to on. Thus, you can quickly setup an auxiliary trigger by just turning the INPUT knob to the next input and then turning the MODE knob to set the trigger on or off.
- 3 To exit the AUX DC TRIGGER Setup Mode without leaving the Pro Setup Mode, press the MODE knob. If you wish to exit the Setup Mode completely, turn any of the knobs other than MODE or INPUT.

The Cinema Reference features two auxiliary DC outputs or triggers. These triggers are set in software and the two triggers operate independently of each other. Furthermore, the Aux DC Triggers track each input and determine whether they should be on for that input.

As such, you can have one trigger activate a projector, screen, curtain when only video devices are selected and another trigger activate speaker drivers when switching from a music source to a film source.

The Cinema Reference's Out Of The Box Setup has Aux DC Trigger 1 engaging with any input as to power up an auxiliary AC switcher which in turn, powers up a power amplifier. While the Cinema Reference has a switched outlet rated at 10 Amps, this trigger can be used in conjunction with ADA's ACC-3 AC Switcher (15 Amps) when powering up ADA's High Power MPA-500 Five Channel Power Amplifier and BPA-500 Bass Amplifier. Aux DC Trigger 2 is set to engage with only video components.

Pro Setup - Effect Delay

The Cinema Reference has two modes that are developed exclusively by ADA. The Stereo Enhance mode permits quality surround sound playback of two-channel mixes, even if the separation between the two channels is minimal. The Mono Enhance mode applies some of the same theories of Stereo Enhancement to mono-only signals, again providing a full surround sound array to a mono only signal.

The Effect Delay sets up the delay level between right and left channels that makes the surround effect of these two modes more pronounced. Please note, even slight adjustment of the Effect Delay will have an effect on how these modes sound.

The Cinema Reference has two proprietary ADA modes, Stereo Enhance and Mono Enhance. These modes are applied to two-channel or one channel mixes respectively. These modes, when selected have two variables, one of which is the Effect Delay. The Effect Delay works in different ways depending on which of the two modes are selected. When Stereo Enhance is engaged, the Effect Delay setting (0-20 ms range) is applied to the left channel, leaving the right channel untouched, all prior to Pro Logic decoding. In the Mono Enhance mode, used typically, for mono-only software, where the right and left channel information are identical. In this mode, the two channels are first mixed mono together, then the stereo enhancement feature is applied, with the delay set to the left channel (after mixing down to mono) and prior to the Pro Logic decoding. This permits the Mono Enhance mode to deliver surround sound with depth and feel, even though the input signal is mono and during standard Dolby Pro Logic playback, would only provide audio out of the center channel.

To set the desired Effect Delay setting:

- 1 While in the Pro Setup mode, turn the MODE knob until the display reads EFFECT DELAY and then press the MODE knob. The display will read EFFECT DELAY on the top row and a delay setting on the bottom row (i.e. 0 ms).
- 2 Turn the MODE knob to change the delay setting in the range from 0 to 20 ms (milliseconds). Please note, this control option provides real-time feedback but the turning of the Mode knob to increment through the steps is a slow process.
- 3 To exit the EFFECT DELAY Setup Mode without leaving the Pro Setup Mode, press the MODE knob. If you wish to exit the Setup Mode completely, turn any of the knobs other than MODE or INPUT.

Pro Setup - Effect Level

The Cinema Reference has two proprietary ADA modes, Stereo Enhance and Mono Enhance. These modes are applied to two-channel or one channel mixes respectively. These modes, when selected have two variables, one of which is the Effect Level. The Effect Level is best described as throttle for the decoding circuit. When the Effect Level is set to OFF, the decoding circuit is least active, providing the flattest surround sound field. When the level is set to -0 dB, the surround sound decoding circuit is processing the audio signal at its maximum decoding level. You can decrease this decoding level in 1 dB steps to -20 dB or also OFF. Please note, this feature applies to both Stereo Enhance and Mono Enhance modes, and like the Effect Level, only needs to be set once. Like all major Cinema Reference features, you may sample the results of this setting as you adjust it. Furthermore, a slight adjustment may make a big difference in the sound you hear. As such, this control moves slowly. Please note, that ADA suggests a setting somewhere between -4 dB and -8 dB.

To set the desired Effect Level setting:

- 1 While in the Pro Setup mode, turn the MODE knob until the display reads EFFECT LEVEL and then press the MODE knob. The display will read EFFECT LEVEL on the top row and a level setting on the bottom row (i.e. - 0 DB).
- 2 Turn the MODE knob to change the delay setting in the range from -0 to -20 dB (decibels), or OFF. Please note, this control option provides real-time feedback but the turning of the Mode knob to increment through the steps is a slow process.
- 3 To exit the EFFECT LEVEL Setup Mode without leaving the Pro Setup Mode, press the MODE knob. If you wish to exit the Setup Mode completely, turn any of the knobs other than MODE or INPUT.

The Cinema Reference has two modes that are developed exclusively by ADA. The Stereo Enhance mode permits quality surround sound playback of two-channel mixes, even if the separation between the two channels is minimal. The Mono Enhance mode applies some of the same theories of Stereo Enhancement to mono-only signals, again providing a full surround sound array to a mono only signal.

The Effect Level is a unique feature whereby you can actually adjust the power of the decoding circuit. Much like a gas pedal, at -0 dB the decoding circuit is operating at its fullest. At -20 dB, the decoding circuit is operating a significantly lower rate. At OFF, it's features are not noticeable at all.

Appendix A - Solo Channel Test

The Cinema Reference is also capable of playing only one channel at a time when in the Solo Test mode. This is ideal for testing a particular channel's output or an individual speaker.

The Solo Test mode is also ideal if you wish to determine the information coming out of a particular channel.

The Cinema Reference has a unique channel test feature called Solo Test. When in the Solo Test mode, you can switch between channels while playing an audio track. Thus, you can actually listen to either all channels, or selectively to one channel. Typically, on other processors, this would involve lowering all channels until they could not be heard, then raising the volume of one channel. The Cinema Reference permits you to engage one channel at a time by just turning a knob. Furthermore, you can also raise and lower each channel or all channels while directly in the Solo Test Mode.

This feature is ideal when you are trying to test a particular channel output or speaker. It is also unique when toying around with six channel encoded material. As such, you can instantly see for yourself, the effect one particular channel has with respect to the overall sound field.

Software Note:

The DTS CD of the *Eagles* "Hell Freezes Over" album, contains a bonus cut of "Seven Bridges Road". While this cut does feature some instruments, the unique aspect of the recording is that each vocalist is assigned to one of the five speaker channels. When playing this recording, the harmonies are actually mixing in the open space of your home theater system, not in the recording studio. Use the Solo Test mode to select one channel at a time and try to figure out which voice is coming from which speaker. You need not be an *Eagles* fan to enjoy this test.

To access the Cinema Reference's Solo Test Mode:

- 1 Turn the CHANNEL knob until the second line of the display reads SOLO TEST and press the CHANNEL knob.
- 2 At this time, the Cinema Reference is in the Solo Test mode. You can now turn the CHANNEL knob to selectively access individual channels. There is even a SOLO SEQ option which will cause the Cinema Reference to automatically sequence through all channels while in the Solo Test mode.
- 3 While in the Solo Test mode, if you wish to raise or lower a particular channel's volume level, pressing of the CHANNEL knob while locked into a channel, engages the volume controller. Use the CHANNEL knob to raise and lower volume levels.
- 4 To exit the Solo Test mode, simply turn any knob other than the CHANNEL knob.