

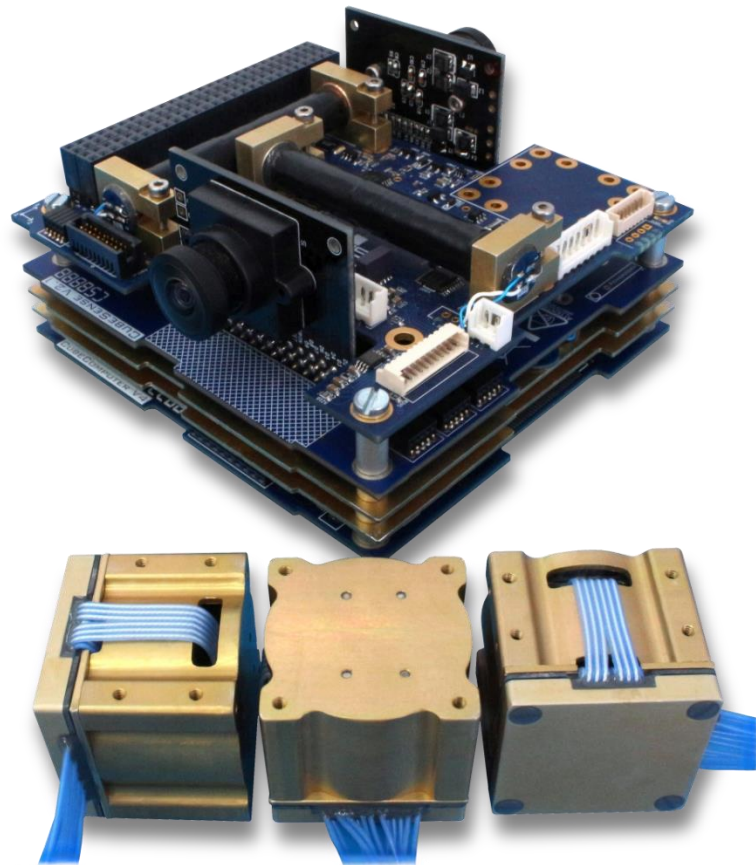

CUBEADCS

THE COMPLETE ADCS SOLUTION



REFERENCE MANUAL



Contact Us

Phone : +27 21 808 9499
E-mail : info@cubespace.co.za
Web : www.cubespace.co.za
Facebook : [/CubeSpaceADCS](https://www.facebook.com/CubeSpaceADCS)
Twitter : [@CubeSpace_ADCS](https://twitter.com/CubeSpace_ADCS)

Physical Address

CubeSpace
The LaunchLab
Hammanhand Road
Stellenbosch, 7600
South Africa





Document	CubeADCS Reference Manual
Version	3.10
Domain	Public
Date modified	29 March 2018
Approved by	Name: Mike-Alec Kearney
	Signature: 

Document Version History

Version	Responsible person(s)	Pages	Date	Description of change
3.0	MK	ALL	20/03/2017	V3 First draft
3.02	WHS	ALL	28/06/2017	V3 Second draft
3.03	MK	ALL	13/07/2017	V3 Third draft (Minor formatting)
3.04	MK	ALL	27/07/2017	Accept/Reject team changes
3.05	HWJ	24, 28, 67, 78, 84 - 88, 106-111, 140	17/10/2017	Added default configuration telecommand and corrected download package size. Added scrub settings tlm and tcm. Updated ADCS state, Communication status tlm packets
3.06	WHS	31,32	16/01/2018	Update Control Modes
3.07	CJG + HWJ	24, 26, 68, 84 - 88	09/02/2018	Removed command 70, added JPG conversion telecommand and telemetry and the CubeACP status telemetry
3.08	CJG	21	12/02/2018	Added a description for SPI
3.09	WHS		21/02/2018	Corrections to magnetometer selection TC and TLM enums. Cam1 and Cam2 designations.
3.10	LV	21 - 166	9/03/2018	Removed commands and telemetries specific to the bootloader Added links to tables Added 'save unix time to flash' command and telemetry pair. Updated all telecommand and telemetry definitions from node definition XML documents

List of Acronyms/Abbreviations

ACP	ADCS Control Program
ADCS	Attitude Determination and Control System
CSS	Coarse Sun Sensor
ESD	Electrostatic Discharge
I ² C	Inter-Integrated Circuit
MCU	Microcontroller Unit
MEMS	Microelectromechanical System
OBC	Onboard Computer
PCB	Printed Circuit Board
RTC	Real-Time Clock
SBC	Satellite Body Coordinate
SPI	Serial Peripheral Interface
TC	Telecommand
TLM	Telemetry
UART	Universal Asynchronous Receiver/Transmitter

Relevant reference documents

This document is to be used in combination with the following documents

Reference	Document name	Document version
Ref 1	CubeADCS - ICD	V3.0 or higher
Ref 2	CubeADCS – User Manual	V3.0 or higher

Relevant CubeACP version

This document serves as reference to the CubeACP with the following version numbers

	Version
Software version	3.11
Node type identifier	10
Interface version	3

Table of Contents

1.	Introduction.....	6
2.	ADCS Hardware.....	7
2.1	Sensor accuracies.....	7
2.2	ADCS Hardware Stack.....	7
2.3	CubeComputer (ADCS OBC).....	8
2.4	CubeControl.....	9
2.5	CubeWheels.....	12
2.6	CubeSense Module.....	12
3.	Example ADCS Simulation.....	14
3.1	Control Stage 1.....	15
3.2	Control Stage 2.....	16
3.3	Control Stage 3.....	18
4.	Software Interface.....	20
4.1	UART.....	20
4.2	I ² C.....	20
4.3	CAN.....	21
4.4	SPI.....	21
4.5	Telecommands and Telemetries.....	21

1. Introduction

This document serves as source of information to refer to when using the User Manual, Commissioning Manual, and other CubeADCS documentation. The document contains complete listings of TCs and TLMs, communications examples, and other reference examples to assist in designing a system which will interface with the ADCS.

2. ADCS Hardware

This section provides an overview of the hardware that is contained within the ADCS unit.

2.1 Sensor accuracies

The accuracies and strengths of the sensors and actuators contained in the ADCS are shown in the table below.

Table 1 - ADCS Sensors and Actuators

Sensors & Actuators	Type	Range/FOV	Accuracy (RMS)
Magnetometer	3-axis MagR	$\pm 60 \mu\text{T}$	$< 40 \text{ nT}$
Sun Sensor	2-axis CMOS	Hemisphere	$< 0.2^\circ$
Nadir Sensor	2-axis CMOS	$\pm 45^\circ$	$< 0.2^\circ$
Coarse Sun Sensor	6 Photodiodes	Full Sphere	$< 10^\circ$
Rate sensor	3-axis MEMS	$\pm 20^\circ/\text{sec}$	$< 0.01^\circ/\text{sec}$
Star Tracker	2-axis APS	$52^\circ \times 27^\circ$	$< 0.01^\circ$ bore sight $< 0.03^\circ$ rotate
CubeWheel Small	BLDC Motor	$\pm 1.7 \text{ mNm}$ $\pm 0.2 \text{ mNm}$	$< 0.0004 \text{ mNm}$ $< 0.001 \text{ mNm}$
Magnetorquer Rod	3-axis Ferro-magnetic coils	$\pm 0.24 \text{ Am}^2$	$< 0.0012 \text{ Am}^2$

2.2 ADCS Hardware Stack

The ADCS hardware stack depends on the components and options that have been selected. The figure below shows complete stack with all of the ADCS components.

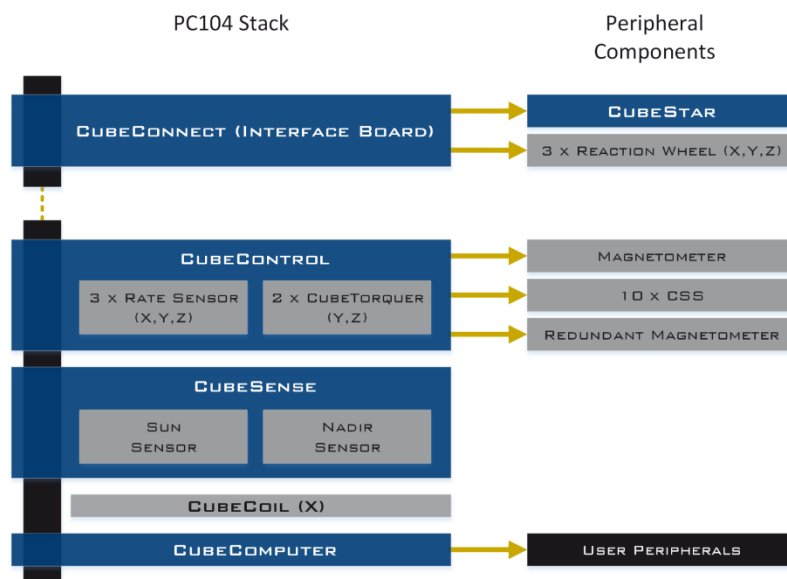

Figure 1 - ADCS stack

Figure 2 below shows examples of disassembled ADCS stacks.

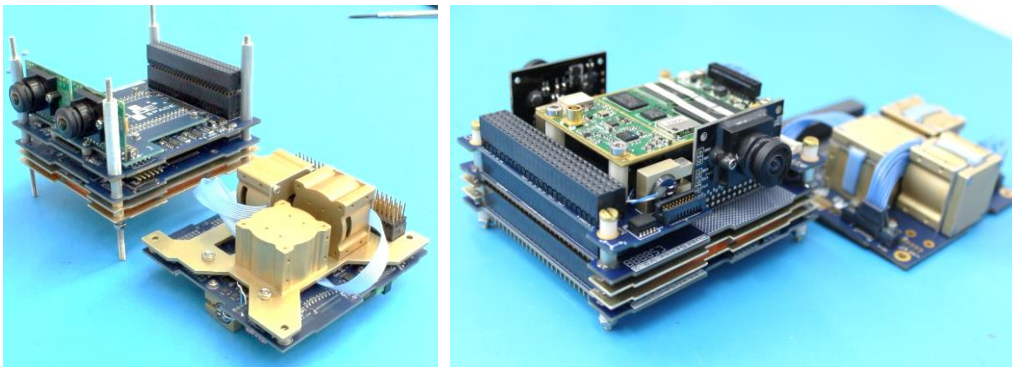

Figure 2 - ADCS Hardware Stack Examples

2.3 CubeComputer (ADCS OBC)

The controlling unit in the ADCS stack is the CubeComputer OBC. CubeComputer uses a high performance, low power 32-bit ARM Cortex-M3 based MCU with floating point support. The computer was developed for ADCS processing and to be used as a general purpose OBC. The OBC features the following functions as standard:

- An integrated RTC and an internal and external watchdog
- A 32 kB EEPROM is used for the firmware (boot loader)
- A 4 MB Flash for the code and in-flight reprogramming
- A FPGA for flow-through EDAC and SEU protection
- Current monitoring for SEL (latch-up) protection and power cycling ability
- A MicroSD card for 2 GB of data storage
- I2C, CAN, UART interfaces to another OBC

The basic physical specifications of the board are shown below:

Table 2 – CubeComputer Physical Specifications

Mass	64g
Average power when running ADCS	120mW
Peak power when running ADCS	180mW

Figure 3 shows a photo of CubeComputer.



Figure 3 - CubeComputer V4.1

2.4 CubeControl

All attitude sensors and control actuators are accessed at 1 Hz by CubeComputer through the ADCS actuator module called CubeControl. A block diagram of this module is shown in Figure 4 below.

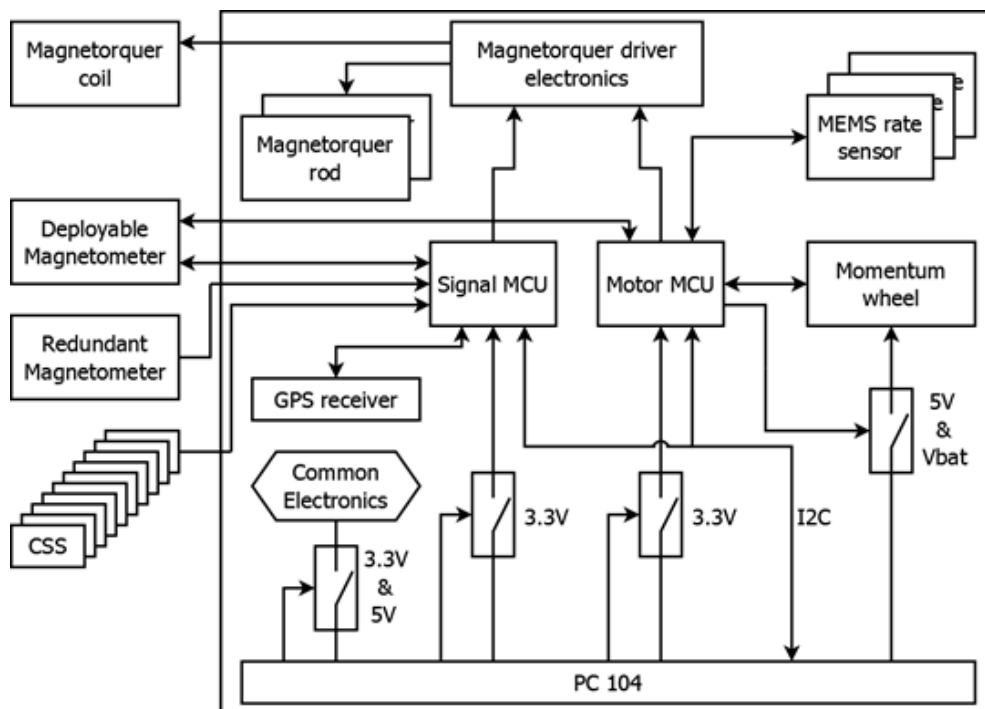

Figure 4 - CubeControl hardware layout

The digital processing of the module consists of two low power micro-controllers with several I/O ports, Analog to Digital inputs and a I²C communication bus. The I²C bus is connected to CubeComputer and CubeSense. Figure 5 shows a photo of CubeControl.

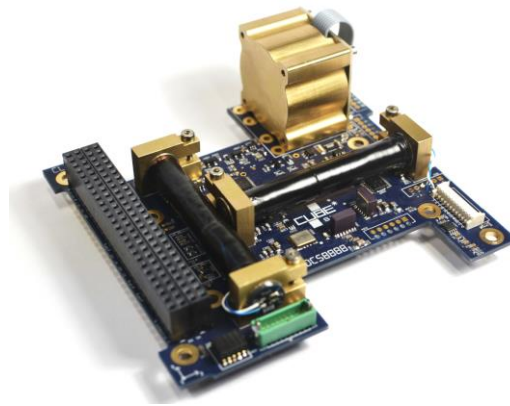

Figure 5 - CubeControl Module

The peripheral sensors that connect to CubeControl are discussed below.

2.4.1 Coarse sun sensors:

Ten planar photodiodes are mounted on various outside facets of the CubeSat structure. The short circuit current from these diodes is roughly proportional to the cosine of the sun vector angle to the photodiode surface's normal. A current to voltage amplifier is used for each photodiode to obtain a signal large enough for a 10-bit analogue to digital (A/D) conversion. The sun vector direction can then be extracted from the largest three photodiode measurements – assuming no shadowing from any deployed satellite structures. The earth albedo will contaminate the measurements and reduce the sun vector direction accuracy to a RMS value of roughly 10^0 .



Figure 6 – Coarse Sun Sensors

2.4.2 Magnetometer:

A magneto-resistive 3-axis magnetic field sensor is used as magnetic sensor. A deployable and redundant non-deployable option is offered. The deployment of the magnetometer is done to reduce magnetic noise that the internal subsystems of the satellite may cause. The three analogue output channels of the magnetometer are low pass filtered and 16-bit A/D converted on the CubeControl module. Figure 7 shows the magnetometer in stowed and deployed configuration, also shows the redundant version.



Figure 7 - Stowed, deployed and redundant magnetometer

2.4.3 MEMS Rate Sensor

Three MEMS type rate sensors are used to measure the X/Y/Z-spin rate during detumbling. This sensor is mounted on the CubeControl module.

2.4.4 Magnetorquers (CubeTorquers & Cubecoil)

Two magnetorquer rods (CubeTorquers) are used to generate a controlled magnetic moment in the Y- and Z-body axes. These rods are mounted on the CubeControl module. In the X-body axis a torquer coil (CubeCoil) will be used. The coil is mounted between two PC104 modules. By pulse width modulation (PWM) of the magnetorquer currents a magnetic moment vector in a desired direction and size can be obtained. Figure 8 shows the 28 gram CubeTorquer of length 60 mm and 10 mm diameter. The torquers are manufactured using a low remanence ferromagnetic core. A nominal magnetic moment of 0.2 Am^2 is obtained using 2.1 V at 70 mA current (147 mW). This nominal value is obtained using a 42% PWM duty cycle from the 5 V regulated bus.

Figure 9 shows the CubeCoil of 46 gram with PC104 form factor. The maximum magnetic moment is 0.13 Am^2 from 5V at 310 mW.



Figure 8 - CubeTorquer Magnetorquer Rod

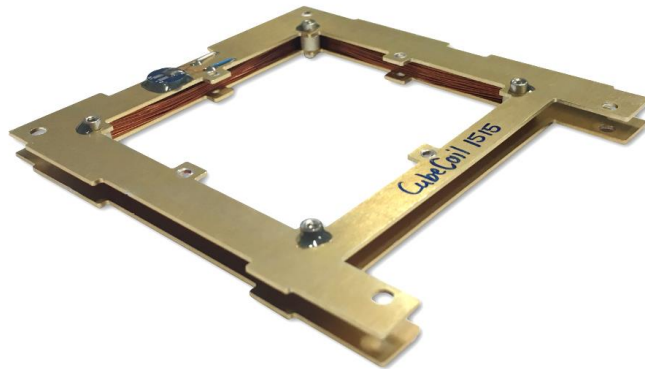

Figure 9 - CubeTorquer Magnetorquer Coil

2.5 CubeWheels

CubeWheels come in three sizes (Small, Medium and Large) as shown in Figure 10. These wheels have integrated digital processing electronics as well as motor drivers. Reference speeds are sent to the wheels by CubeComputer over the I2C bus. The wheels are either mounted on a supplied CubeConnect board, or mounted by the user.

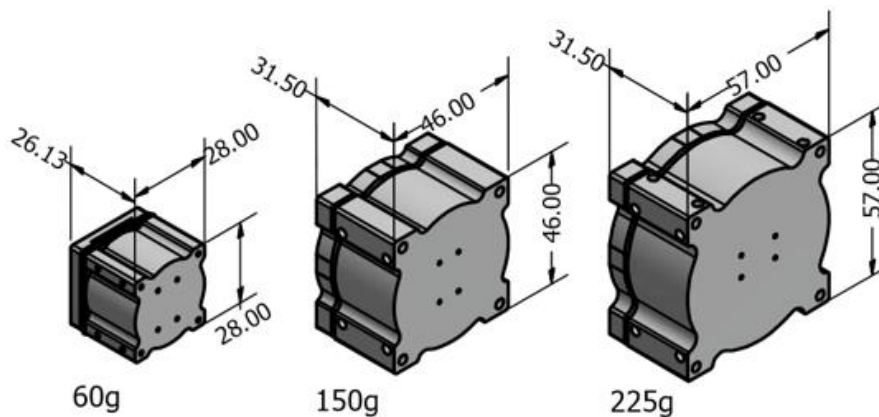

Figure 10: Small/Medium/Large CubeWheel Unit

2.6 CubeSense Module

CubeSense is a dual camera sensor. CubeSense uses low power CMOS camera modules with resolution of 1024x1024 pixels, fitted with a fisheye lens with an effective field of view of 180°. Each of the two CubeSense cameras can be used as either a sun sensor or a nadir sensor. If configured as a sun sensor, the camera is fitted with a neutral density filter to reduce the sun intensity on the image sensor. Both the sun and Nadir sensors does image processing to determine the center points of the sun and earth, and ultimately to determine accurate vectors to these bodies.

CubeSense uses an FPGA to read images from the camera into SRAM. A low-power microcontroller (MCU) then performs image processing on this stored image to determine the sun and nadir vectors. Both cameras are connected to both FPGAs to provide redundancy in case of failure of one of the FPGAs or SRAMs. CubeComputer reads the calculated vectors from CubeSense at 1Hz. Figure 11 shows a block diagram of the hardware layout of CubeSense. Figure 12 shows a picture of a typical CubeSense unit. The dual (sun and nadir) cameras can be board-mounted with boresights in opposite or orthogonal directions, but can also be mounted on a harness for custom placement.

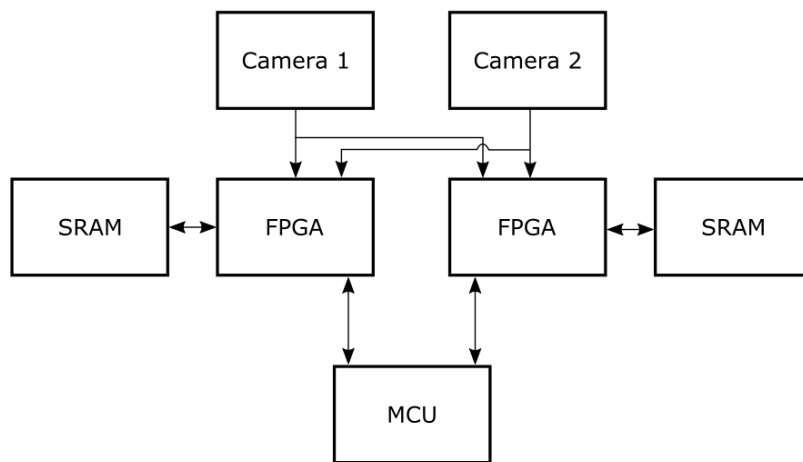

Figure 11 - Block Diagram of *CubeSense*

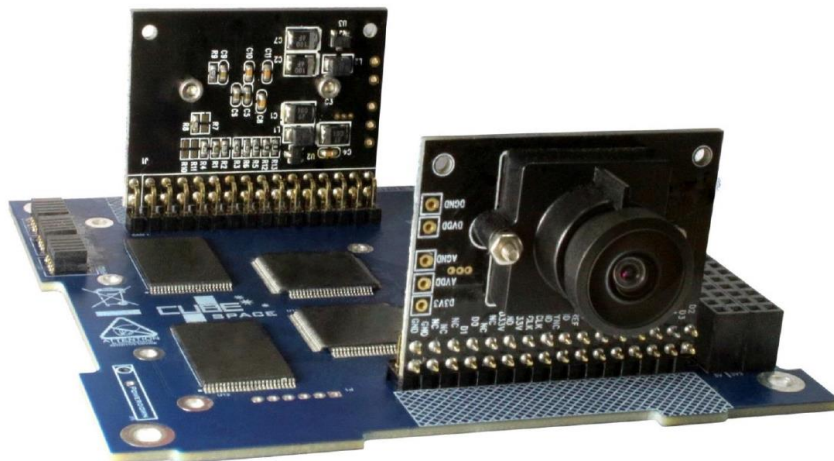

Figure 12 - CubeSense Module with Sun and Nadir Cameras

3. Example ADCS Simulation

The orbit used for the simulation tests is a 500 km circular sun-synchronous orbit. The orbit elements used are presented in Table 3. The simulation was executed using a sample period of one second for all models, controllers and estimators. In practice the sampling period of the onboard control loop can be increased to at least ten seconds, without any noticeable degradation in performance (due to the slow open and closed loop dynamics). However, for the simulation accuracy of the numeric integrators it was decided to implement the simulation loop at 1 Hz.

An SGP4 model was used to simulate the satellite’s orbit in combination with an accurate sun orbit model. The geomagnetic field was simulated using a 10th order IGRF spherical harmonic model.

Table 3 - Orbit used for the 3U CubeSat ADCS Testing

Orbit Parameter	Value
<i>Semi-major axis</i>	6992 km
<i>Initial Inclination</i>	97.98°
<i>Orbital Period</i>	5818 sec
<i>Eccentricity</i>	0.0011
<i>Sun-synchronicity</i>	LTDN 10h25

All the ADCS sensors were modelled with realistic measurement noise and slow varying offset errors where applicable. The ADCS actuators were modelled with their saturation and quantization limits.

Table 4 shows the inertia tensor values of the 3U CubeSat as used in the simulations. The remainder of this section will present graphical simulation results of the ADCS of a satellite starting with typical initial conditions for the various control stages.

Table 4 - 3U CubeSat MOI & POI values

Inertia Parameter	Value (kgm ²)
I_{xx}	0.007
I_{yy}	0.04
I_{zz}	0.038
I_{xy}	0.000097
I_{xz}	-0.000068
I_{yz}	0.000055

3.1 Control Stage 1

The satellite is detumbled using a BDot controller and MEMS rate sensor for direct measurement of the body Y_B angular rate. The initial roll, pitch and yaw angles are 0° , 0° and 45° respectively. The initial angular rate vector (orbit referenced) is: $\omega_{B/O} = [5 \ 10 \ 0]^T$ $^\circ/\text{sec}$. The magnetic controller is enabled after 0.5 orbits. Figure 13 shows the results of Control Stage 1 from detumble into Y-Thomson stabilization. It is clear how the X_B and Z_B orbit referenced (ORC) body rates are quickly dumped after the first controlled orbit. The Y_B body rate is controlled to a reference rate of -2 $^\circ/\text{sec}$. The attitude angles are controlled finally into an almost perfect pitch rotation for a Y-Thomson spin.

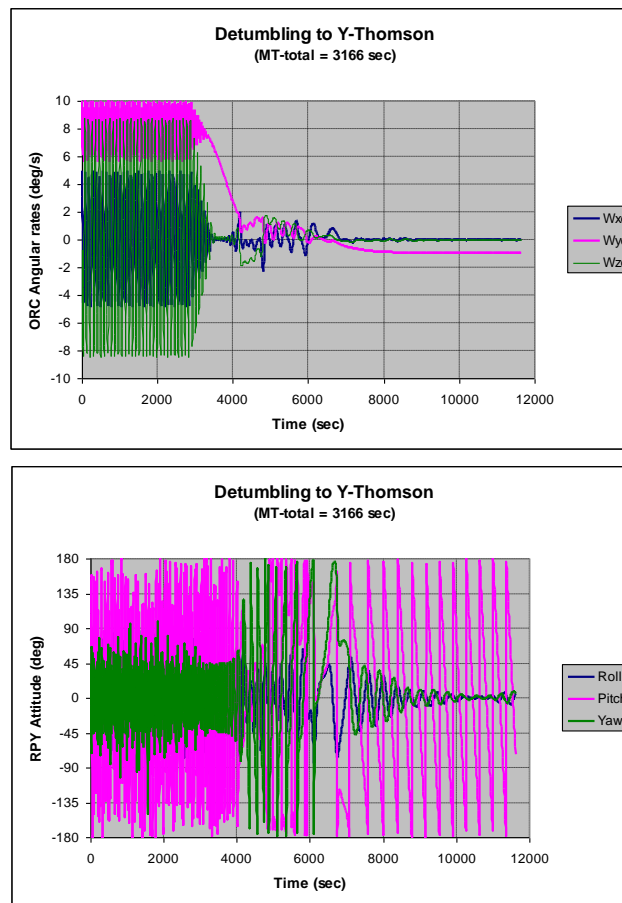

Figure 13: Detumbling to Y-Thomson in Control Stage 1

3.2 Control Stage 2

The next simulation starts in a Y-Thomson spin and is left for 0.5 orbits before the Y-wheel momentum controller is enabled. The Y-wheel momentum is maintained at -0.001 Nms, using a Cross-product magnetic controller. After 0.5 orbits the Y-wheel controller is also enabled to 3-axis stabilize the attitude angles to zero values (see Figure 14). A pitch attitude maneuver to $+90^\circ$ and back to 0° can also be seen. These controllers make use of the estimated rate and quaternion values of the EKF estimator, using only magnetometer measurements and the CubeSense sensor for sun and nadir measurement vectors, the latter sensor can only supply measurements during the sunlit part of an orbit.

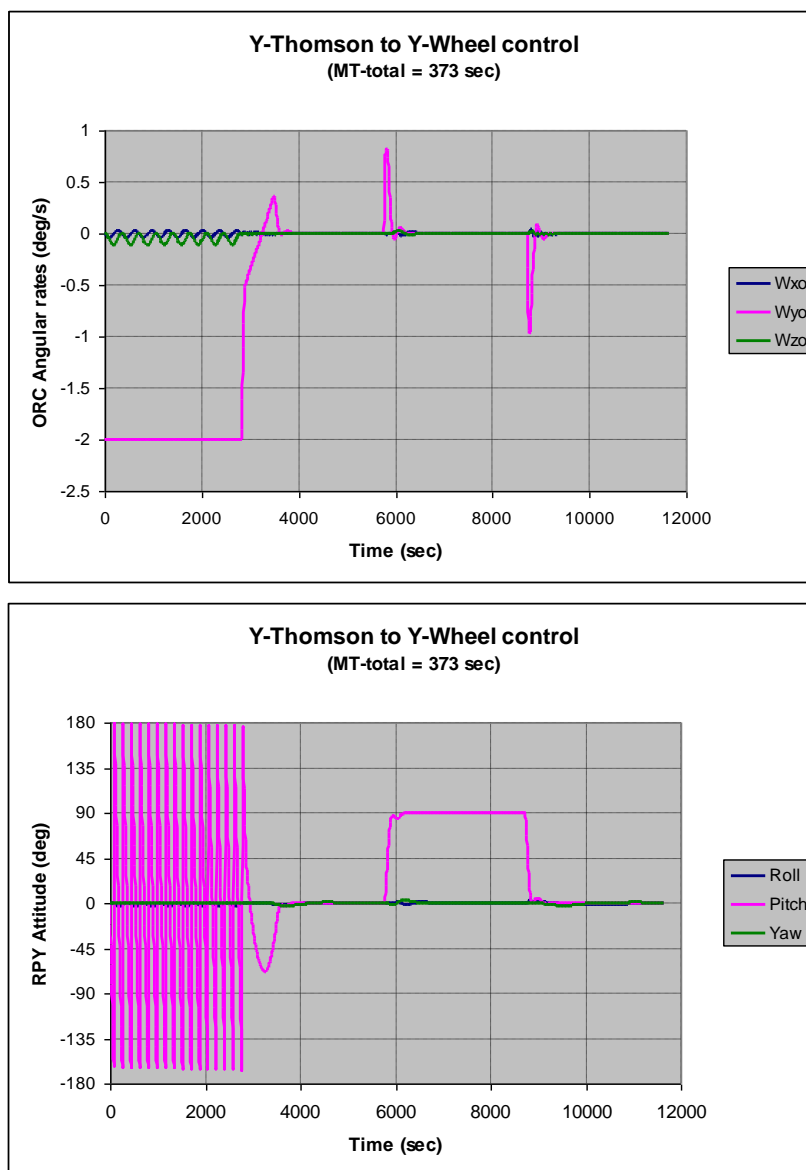

Figure 14: Y-Thomson to Y-Momentum wheel in Control Stage 2

The last simulation for Control Stage 2 presents the nutation damping performance and the pitch tracking performance using only the Y-wheel and the Cross-Product magnetic controller. The initial roll, pitch and yaw angles are 10° , 0° and 5° respectively and the controllers are only enabled after 0.5 orbits. The roll and yaw nutation can clearly be seen in Figure 15 for the Y-wheel momentum of -0.001 Nms. When the controllers are enabled, the nutation angles are damped within 0.5 orbits and the pitch angle controlled to zero. Figure 18 also shows a 10° pitch rotation maneuver. The maximum attitude RMS errors in the sunlit part of the orbit is less than 0.4° and in eclipse less than 1° .

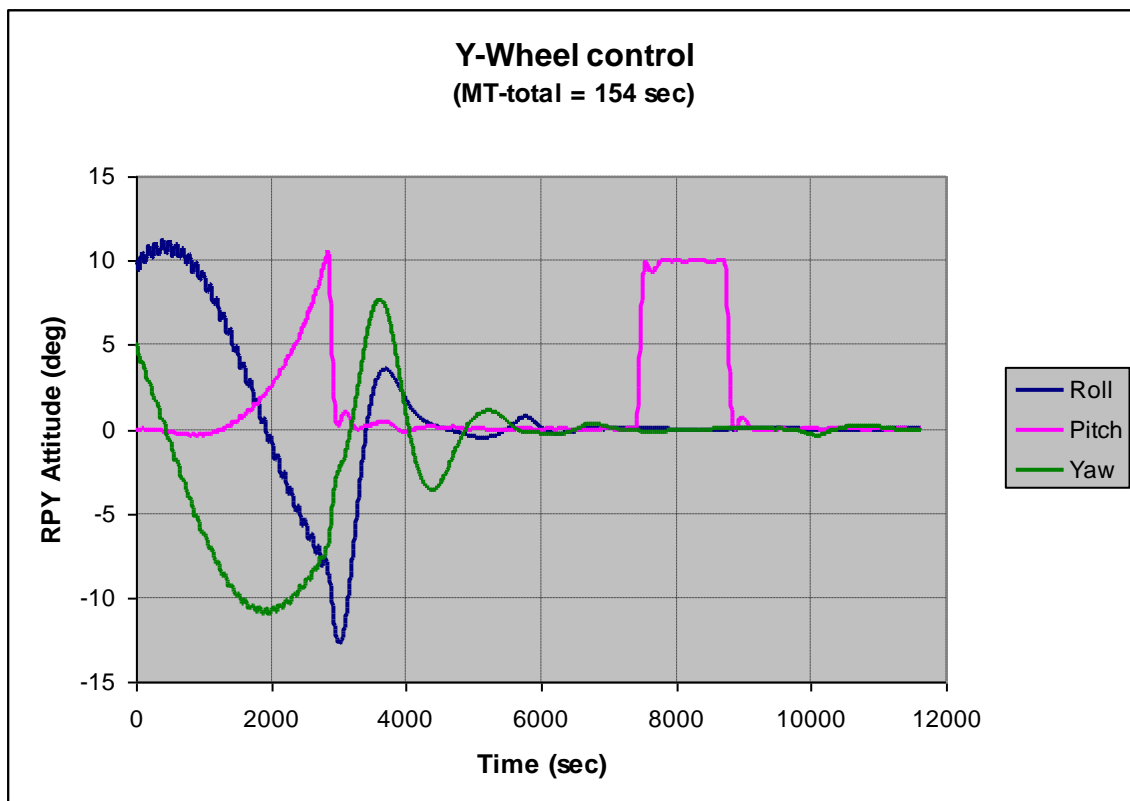

Figure 15: Y-Momentum wheel control performance in *Control Stage 2*

3.3 Control Stage 3

The last couple of simulations show the performance that can be expected with the zero bias 3-axis quaternion feedback reaction wheel controller and the momentum dumping Cross-Product magnetic controller. The initial roll, pitch and yaw angles are 10° , 0° and 5° respectively and the Y-wheel also has an initial angular momentum of -0.001 Nms. The controllers are enabled after 0.5 orbits (same as previously). Figure 16 shows the performance when the 3-axis reaction wheel controller is enabled. The roll, pitch and yaw angles are quickly controlled to below 2° within the 60 second settling time of the controller. The Y-wheel momentum is dumped to zero by the magnetic controller within 30 minutes.



Figure 16: Reaction wheel control performance in Control Stage 3 without CubeStar

The reason for the initial RPY attitude deviations after the controllers are enabled, has to do with EKF estimation errors caused by eclipse (when the controllers are enabled there is no availability of sun and nadir vector measurements) and the Y-wheel momentum that needs to be dumped. After the end of eclipse (around 4800 seconds) the attitude RMS errors quickly reduce to about 0.25° in the sunlit part of the orbit and 1° in eclipse). Figure 16 also shows a 10° roll, -10° pitch and 5° yaw rotation maneuver and thereafter a maneuver back to zero attitude at 8500 seconds.

Figure 17 shows the performance when the 3-axis reaction wheel controller is enabled with CubeStar vector measurements included in the EKF. The roll, pitch and yaw angles are quickly controlled to below 1° within the 60 second settling time of the controller. The Y-wheel momentum is dumped to zero by the magnetic controller within 30 minutes. Thereafter the RPY attitude RMS errors are reduced to below 0.02° . Figure 17 also shows a 10° roll, -10° pitch

and 5° yaw rotation maneuver and thereafter a maneuver back to zero attitude at 8500 seconds.

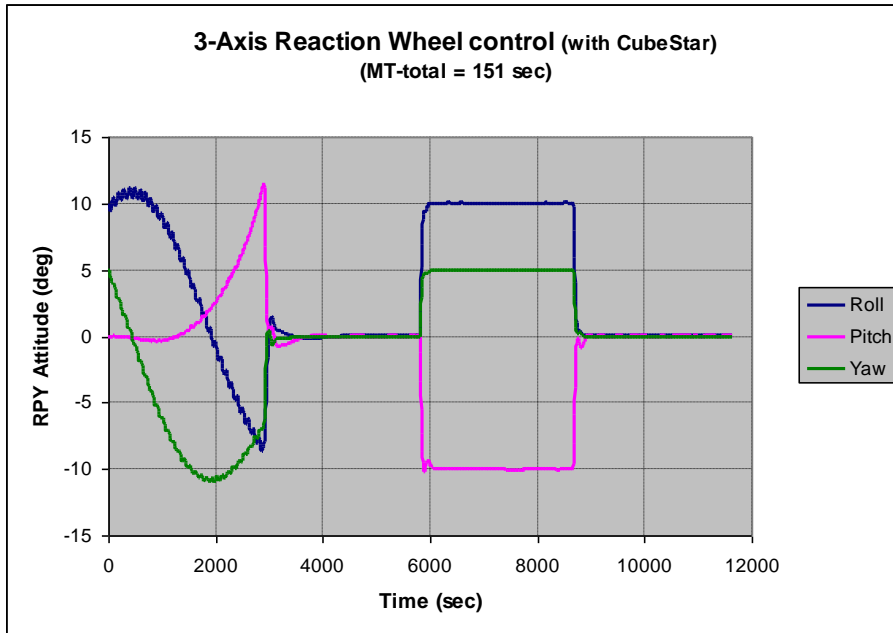

Figure 17: Reaction wheel control performance in *Control Stage 3* with *CubeStar*

4. Software Interface

4.1 UART

The standard specifications of the CubeADCS UART interfaces are given in Table 5. These specifications are however customisable if CubeComputer is the main OBC of the satellite.

Table 5 – Standard UART specifications for CubeComputer

Parameter	Value
Baud rate	115200
Data bits	8
Parity	None
Stop bits	1

The UART protocol makes use of start-of-message (SOM 0x7F) and end-of-message (EOM 0xFF) identifiers to mark the beginning and end of a transmission. An escape character (ESC 0x1F) precedes the SOM and EOM identifiers. When decoding a UART message, on reception of the escape character, the byte following the escape character has the following implications:

Table 6 – UART message decoding

Byte received after ESC character	Meaning
0x7F	Start of message
0xFF	End of message
0x1F	Data byte 0x1F
other	Should not occur - error

More information regarding the UART protocol can be found in the CubeADCS User Manual and in Section 4.5.

4.2 I²C

If CubeComputer is not used as the main OBC of the satellite (therefore it is only the ADCS OBC), it acts as a slave on the system I²C bus with 7-bit addressing. The default 8-bit write and read addresses of CubeComputer are shown in Table 7. This is the first byte of the I²C transaction.

Table 7 – CubeComputer (slave node) I²C addresses

Function	I ² C address
Write	0xAE
Read	0xAF

More details regarding the communications interface (including protocols for TCs, TLM requests, and file downloading) can be found in the CubeADCS User Manual and in Section 4.5.

4.3 CAN

The CubeADCS unit can act as a slave or a master on a 1 Mbps CAN bus.

The combination of a CAN transceiver and a CAN controller module on CubeComputer allows CubeADCS unit to interface at CAN bus voltage levels of 3.3 V or 5 V. A termination resistor between the CANH and CANL lines can be populated if required by the user.

More information regarding the CAN protocol can be found in the CubeADCS ICD.

4.4 SPI

The CubeComputer has an open SPI module which can be connected to the PC104 header. This optional SPI connection intended use is for an Unlocked ACP (See [Ref 2]). This SPI bus will allow the CubeComputer to be connected to slave nodes.

The ACP is supplied with a board support package which contains examples of SPI drivers. The user can make use of these examples to customize the SPI driver to suit their specific needs.

Please note that unlike the I2C, UART and CAN, the SPI cannot be used as a means to communicate with CubeComputer (ACP). It is provided to expand the CubeComputer's capabilities for users who intend to use an Unlocked version of the ACP.

4.5 Telecommands and Telemetries

4.5.1 Telemetry and Telecommand IDs

The first byte of a message will determine whether the message is a telecommand or telemetry request, and also contain the ID of the telecommand or telemetry request. The most significant bit determines whether it is a telecommand or telemetry request, and the lower 7 bits contain the ID.

Table 8: Telecommand or telemetry frame ID

Bit(s)	Data
7	0 = telecommand, 1 = telemetry request
0:6	Telecommand or telemetry frame ID

When considering the full byte identifier, telecommands will have values in the range 0-127 and telemetry requests in the range 128-255 because of the value of the most significant bit.

The format of the message varies for each telecommand and telemetry ID. The length and content of all the telemetry frames for the ACP are detailed in the tables in section 4.5.7, while the telecommands are detailed in section 4.5.8.

The commands and telemetry definitions in these table apply to the 3-Axis CubeACP program. Other versions of the ADCS firmware might have different definitions.

4.5.2 I2C Telemetry request format

Telemetry is requested from the ADCS over the system I2C bus by either performing a combined read-write operation (repeated start condition) or a separate master write to select the TLM register, followed by a master read operation. The first write following the start condition is the address of the node (0xAE). This is followed by the telemetry frame identifier. In the case of a separate write and read, a stop condition will follow and the master will then issue another start condition. In the case of the combined write-then-read operation, the master will issue a repeated start condition (without a preceding stop condition).

The second start condition will be followed by the node read address (0xAF). The master then issues a number of read cycles depending on the length of the telemetry frame.

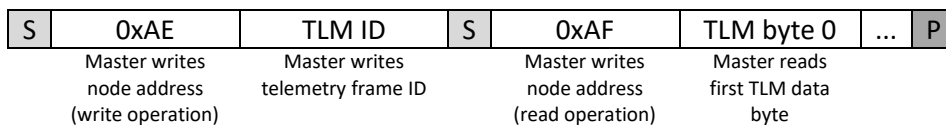

Figure 18: I2C Telemetry request using I2C repeated start condition

Because the master determines the number of bytes that are read, it is possible to read past the end of a telemetry frame or to read an incomplete telemetry frame. The ADCS will set an error flag if an incorrect number of bytes are read for a given TLM ID. This flag is stored in the *Communication Status* frame (TLMID 144), and can be read using a telemetry request. The flag will remain set until the *Clear Latched Error Flags* (TCID 12) is issued.

4.5.3 I2C Telecommand format

Telecommands are sent by performing a master write to the module. The first data byte (after the address byte) is the telecommand identifier, followed by the telecommand parameters.

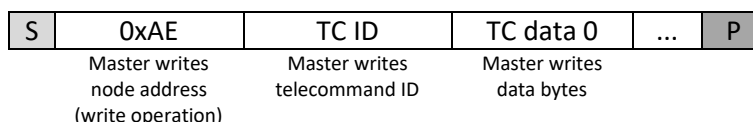

Figure 19: I2C Telecommand

Because the ADCS is an I2C slave, it cannot acknowledge telecommands by performing an I2C write transaction. The telecommand acknowledge status must therefore be polled via a telemetry request (TLMID 240).

It is not a requirement that the telecommand acknowledge status has to be read following a telecommand, but an error will occur if another telecommand is sent before the Telecommand Processed flag (contained in the *Telecommand Acknowledge* frame) has been set. In this case the telecommand buffer will be overwritten while the first telecommand is being processed, leading to corrupt telecommand data.

The *Processed* flag is not an indication of the telecommand execution status. The *Processed* flag is only an indication that the module is ready for another telecommand to be sent.

The *Telecommand Acknowledge* frame also contains a *TC Error* flag. This flag will be set if an invalid telecommand ID was received for the last telecommand, or if the number of data bytes were incorrect or contained invalid data.

The following sequence illustrates the actions that the master has to take to ensure proper telecommand execution:

1. Send telecommand.
2. Poll *Telecommand Acknowledge Telemetry Format* until the *Processed* flag equals 1.
3. Confirm telecommand validity by checking the *TC Error* flag of the last read *Telecommand Acknowledge Telemetry Format*.
4. Back to step 1 (if another telecommand is to be sent)

4.5.4 UART Telemetry request format

A telemetry request via the UART will have the following form:

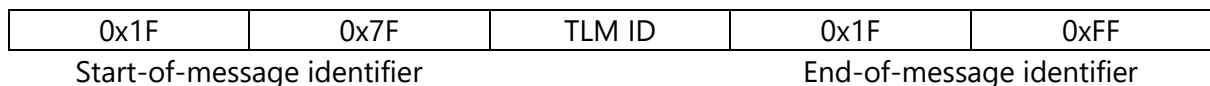

Figure 20: UART Telemetry request

The reply will then have the following form:

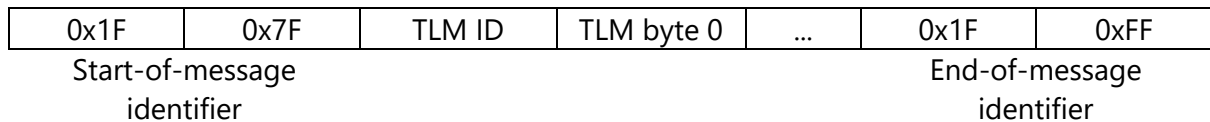

Figure 21: UART Telemetry reply

4.5.5 UART Telecommand format

A telecommand via the UART will have the following form:

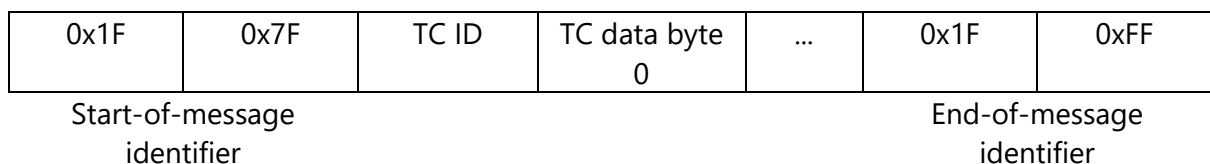

Figure 22: UART Telecommand

An acknowledge message will be sent as reply to the telecommand.

0x1F	0x7F	TC ID	TC Error flag	0x1F	0xFF
Start-of-message identifier			0 = no error 1 = invalid TC ID 2 = invalid parameters	End-of-message identifier	

Figure 23: UART Telecommand acknowledge

The reply will contain two data bytes, the last one being the *TC Error* flag. The receipt of the telecommand acknowledge will indicate that another telecommand may be sent. Sending another telecommand before the acknowledge will corrupt the telecommand buffer.

4.5.6 Telemetry logging

The CubeACP can save telemetry frames to a log file on the SD card, and also output “unsolicited” telemetry on the UART. In both cases, the telemetry frames that are selected for logging, are specified using a 10-byte mask. The bits in the mask each represent a specific telemetry frame (with specific ID). Not all telemetry frames can be logged. The frames which can be logged, their IDs and respective bit-position in the 10-byte mask can be found in section 4.5.9.

Telemetry log frames which are output on the UART have the following format. The message identifier is always 255 (0xFF). This is followed by the 10-byte mask which further determines which telemetry frames follow.

byte offset	0	1	2	3	4	5	6	7	8	9	10	11	12	13	14	16	17	18	19	20	21	22	23	...
contents	255	Bit selection										TLM frame 1						TLM frame 2						...

Content	Log ID (0xFF)	Mask	TLM frame 1	TLM frame 2	...	TLM frame N
Offset (bytes)	0	1	11	17	...	11 + (N-1)*6
Len (bytes)	1	10	6	6	...	6

Figure 24 Contents of UART log unsolicited telemetry transmissions

The mask is a 10-byte array, where each bit in the mask identifies a unique 6-byte telemetry packet. For every bit that is set in the mask there will be a corresponding 6-byte telemetry frame appended to the UART transmission. The total length of the message is 11+N*6 bytes where N is the number of bits that are set in the mask.

4.5.7 Telecommands

Table 9: List of Telecommands

ID	Name	Description	Length (bytes)
General			
1	Reset	Perform a reset - Table 10: Reset Command Format	1
2	Current Unix Time	Current Unix Time - Table 11: Current Unix Time Command Format	6
3	Cache enabled state	Cache enabled state - Table 12: Cache enabled state Command Format	1
4	Reset Log Pointer	Reset pointer to log buffer (from where LastLogEvent TLM is returned) - Table 13: Reset Log Pointer Command Format	0
5	Advance Log Pointer	Advance pointer to log buffer (from where LastLogEvent TLM is returned) - Table 14: Advance Log Pointer Command Format	0
6	Reset Boot Registers	Reset Boot Registers - Table 15: Reset Boot Registers Command Format	0
7	Deploy Magnetometer Boom	Deploy magnetometer boom - Table 16: Deploy Magnetometer Boom Command Format	1
8	SRAM Scrub Parameters	SRAM scrubbing size - Table 17: SRAM Scrub Parameters Command Format	2
9	Unix Time Save to Flash	Configuration settings for unixtime flash memory persistence - Table 18: Unix Time Save to Flash Command Format	2
10	ADCS Run Mode	Set ADCS enabled state & control loop behaviour - Table 19: ADCS Run Mode Command Format	1
11	ADCS Power Control	Control power to selected components - Table 21: ADCS Power Control Command Format	3
12	Clear Errors	Clear Latched Error Flags - Table 23: Clear Errors Command Format	1
13	Set Attitude Control Mode	Set attitude control mode - Table 24: Set Attitude Control Mode Command Format	4
14	Set Attitude Estimation Mode	Set attitude estimation mode - Table 26: Set Attitude Estimation Mode Command Format	1

15	Commanded Attitude Angles	Commanded attitude angles - Table 28: Commanded Attitude Angles Command Format	6
16	Set Magnetorquer Output	Set magnetorquer output (only valid if Control Mode is None) - Table 29: Set Magnetorquer Output Command Format	6
17	Set Wheel Speed	Set wheel speed (only valid if Control Mode is None) - Table 30: Set Wheel Speed Command Format	6
18	Trigger ADCS Loop	Trigger ADCS to perform one iteration of the control loop (only valid when ADCS Run Mode is Triggered) - Table 31: Trigger ADCS Loop Command Format	0
19	Trigger ADCS Loop with Simulated Sensor Data	Trigger ADCS to perform one iteration of the control loop (only valid when ADCS Run Mode is Triggered) - Table 32: Trigger ADCS Loop with Simulated Sensor Data Command Format	90
20	ADCS Configuration	Current configuration - Table 33: ADCS Configuration Command Format	272
21	Set Magnetorquer Configuration	Set magnetorquer configuration parameters - Table 37: Set Magnetorquer Configuration Command Format	3
22	Set Wheel Configuration	Set wheel configuration parameters - Table 38: Set Wheel Configuration Command Format	4
23	Set Rate Gyro Configuration	Set rate gyro configuration parameters - Table 39: Set Rate Gyro Configuration Command Format	3
24	Set CSS Alignment Configuration	Set photodiode pointing directions - Table 40: Set CSS Alignment Configuration Command Format	10
25	Set CSS Scale Factor Configuration	Set photodiode scale factors - Table 41: Set CSS Scale Factor Configuration Command Format	11
26	Set Cam1 Sensor Configuration	Set Cam1 sensor configuration parameters - Table 42: Set Cam1 Sensor Configuration Command Format	15
27	Set Cam2 Sensor Configuration	Set Cam2 sensor configuration parameters - Table 43: Set Cam2 Sensor Configuration Command Format	15

28	Set Nadir Sensor Mask Configuration 1	Set Nadir Sensor Mask Configuration 1 - Table 44: Set Nadir Sensor Mask Configuration 1 Command Format	8
29	Set Nadir Sensor Mask Configuration 2	Set Nadir Sensor Mask Configuration 2 - Table 45: Set Nadir Sensor Mask Configuration 2 Command Format	8
30	Set Nadir Sensor Mask Configuration 3	Set Nadir Sensor Mask Configuration 3 - Table 46: Set Nadir Sensor Mask Configuration 3 Command Format	8
31	Set Nadir Sensor Mask Configuration 4	Set Nadir Sensor Mask Configuration 4 - Table 47: Set Nadir Sensor Mask Configuration 4 Command Format	8
32	Set Nadir Sensor Mask Configuration 5	Set Nadir Sensor Mask Configuration 5 - Table 48: Set Nadir Sensor Mask Configuration 5 Command Format	8
33	Set Magnetometer Mounting Configuration	Set magnetometer mounting configuration parameters - Table 49: Set Magnetometer Mounting Configuration Command Format	6
34	Set Magnetometer Offset and Scaling Configuration	Set Magnetometer Offset and Scaling Configuration - Table 50: Set Magnetometer Offset and Scaling Configuration Command Format	12
35	Set Magnetometer Sensitivity Configuration	Set Magnetometer Sensitivity Configuration - Table 51: Set Magnetometer Sensitivity Configuration Command Format	12
36	Set Rate Sensor Configuration	Set Rate Sensor Offsets - Table 52: Set Rate Sensor Configuration Command Format	7
37	Set Star Tracker Configuration	Set configurations of CubeStar - Table 53: Set Star Tracker Configuration Command Format	26
38	Set Detumbling Control Parameters	Set controller gains and reference values for Detumbling control mode - Table 54: Set Detumbling Control Parameters Command Format	14
39	Set Y-Wheel Control Parameters	Set controller gains and reference value for Y-wheel control mode - Table 55: Set Y-Wheel Control Parameters Command Format	20
40	Set Reaction Wheel Control Parameters	Set controller gains and reference value for reaction wheel control mode - Table 56: Set Reaction Wheel Control Parameters Command Format	8
41	Set Moments of Inertia	Set satellite moments of inertia - Table 57: Set Moments of Inertia Command Format	12

42	Set Products of Inertia	Set satellite products of inertia - Table 58: Set Products of Inertia Command Format	12
43	Set Estimation Parameters 1	Set estimation noise covariance and sensor mask 1 - Table 59: Set Estimation Parameters 1 Command Format	16
44	Set Estimation Parameters 2	Set estimation noise covariance and sensor mask 2 - Table 60: Set Estimation Parameters 2 Command Format	14
45	SGP4 Orbit Parameters	SGP4 Orbit Parameters - Table 61: SGP4 Orbit Parameters Command Format	64
46	Set SGP4 Orbit Inclination	Set SGP4 Orbit Inclination - Table 63: Set SGP4 Orbit Inclination Command Format	8
47	Set SGP4 Orbit Eccentricity	Set SGP4 Orbit Eccentricity - Table 64: Set SGP4 Orbit Eccentricity Command Format	8
48	Set SGP4 Orbit RAAN	Set SGP4 Orbit RAAN - Table 65: Set SGP4 Orbit RAAN Command Format	8
49	Set SGP4 Orbit Argument of Perigee	Set SGP4 Orbit Argument of Perigee - Table 66: Set SGP4 Orbit Argument of Perigee Command Format	8
50	Set SGP4 Orbit B-Star Drag term	Set SGP4 Orbit B-Star Drag term - Table 67: Set SGP4 Orbit B-Star Drag term Command Format	8
51	Set SGP4 Orbit Mean Motion	Set SGP4 Orbit Mean Motion - Table 68: Set SGP4 Orbit Mean Motion Command Format	8
52	Set SGP4 Orbit Mean Anomaly	Set SGP4 Orbit Mean Anomaly - Table 69: Set SGP4 Orbit Mean Anomaly Command Format	8
53	Set SGP4 Orbit Epoch	Set SGP4 Orbit Epoch - Table 70: Set SGP4 Orbit Epoch Command Format	8
54	Set Tracking Controller Gain Parameters	Set controller gains for tracking control mode - Table 71: Set Tracking Controller Gain Parameters Command Format	12
55	Tracking Controller Target Reference	Target reference for tracking control mode - Table 72: Tracking Controller Target Reference Command Format	12
56	Set Mode of Magnetometer Operation	Use of main or redundant magnetometer - Table 73: Set Mode of Magnetometer Operation Command Format	1
57	Convert to JPG file	Convert raw or bmp files to JPG - Table 74: Convert to JPG file Command Format	3
60	Default Configuration	Retrieves default configuration and saves it to flash - Table 75: Default Configuration Command Format	0

63	Save Configuration	Save current configuration to flash memory - Table 76: Save Configuration Command Format	0
64	Save Orbit Parameters	Save current orbit parameters to flash memory - Table 77: Save Orbit Parameters Command Format	0
80	Save Image	Save and capture image from one of CubeSense cameras or CubeStar camera to SD card - Table 78: Save Image Command Format	2
104	SD Log1 Configuration	Log selection and period for LOG1 - Table 81: SD Log1 Configuration Command Format	13
105	SD Log2 Configuration	Log selection and period for LOG2 - Table 83: SD Log2 Configuration Command Format	13
106	UART Log Configuration	Log selection and period for UART (unsolicited TLM) - Table 84: UART Log Configuration Command Format	12
108	Erase File	Erase File - Table 85: Erase File Command Format	3
112	Load File Download Block	Fill download buffer with file contents - Table 87: Load File Download Block Command Format	8
113	Advance File List Read Pointer	Advance File List Read Pointer - Table 88: Advance File List Read Pointer Command Format	0
114	Initiate File Upload	Initiate File Upload - Table 89: Initiate File Upload Command Format	2
115	File Upload Packet	File Upload Packet - Table 91: File Upload Packet Command Format	22
116	Finalize Upload Block	Finalize Uploaded File Block - Table 92: Finalize Upload Block Command Format	7
117	Reset Upload Block	Reset HoleMap for Upload Block - Table 93: Reset Upload Block Command Format	0
118	Reset File List Read Pointer	Reset File List Read Pointer - Table 94: Reset File List Read Pointer Command Format	0
119	Initiate Download Burst	Initiate Download Burst - Table 95: Initiate Download Burst Command Format	2
120	Hole Map 1	File Upload Hole Map 1 - Table 96: Hole Map 1 Command Format	16
121	Hole Map 2	File Upload Hole Map 2 - Table 97: Hole Map 2 Command Format	16
122	Hole Map 3	File Upload Hole Map 3 - Table 98: Hole Map 3 Command Format	16

123	Hole Map 4	File Upload Hole Map 4 - Table 99: Hole Map 4 Command Format	16
124	Hole Map 5	File Upload Hole Map 5 - Table 100: Hole Map 5 Command Format	16
125	Hole Map 6	File Upload Hole Map 6 - Table 101: Hole Map 6 Command Format	16
126	Hole Map 7	File Upload Hole Map 7 - Table 102: Hole Map 7 Command Format	16
127	Hole Map 8	File Upload Hole Map 8 - Table 103: Hole Map 8 Command Format	16

Table 10: Reset Command Format

ID	1		Parameters Length (bytes)	1	
Description	Perform a reset				
Parameters	Offset (bits)	Length (bits)	Name	Data Type	Description
	0	8	Magic number	UINT	Magic number to make sure it is a valid reset command. Should equal 0x5A

Table 11: Current Unix Time Command Format

ID	2		Parameters Length (bytes)	6	
Description	Current Unix Time				
Parameters	Offset (bits)	Length (bits)	Name	Data Type	Description
	0	32	Current Unix Time	UINT	Time in s since 01/01/1970, 00:00. (Unit of measure is [s])
	32	16	Milliseconds	UINT	Current millisecond count. (Unit of measure is [ms])

Table 12: Cache enabled state Command Format

ID	3		Parameters Length (bytes)	1	
Description	Cache enabled state				
Parameters	Offset (bits)	Length (bits)	Name	Data Type	Description
	0	1	Enabled state	BOOL	Enabled state

Table 13: Reset Log Pointer Command Format

ID	4	Parameters Length (bytes)	0
Description	Reset pointer to log buffer (from where LastLogEvent TLM is returned)		

Table 14: Advance Log Pointer Command Format

ID	5	Parameters Length (bytes)	0
Description	Advance pointer to log buffer (from where LastLogEvent TLM is returned)		

Table 15: Reset Boot Registers Command Format

ID	6	Parameters Length (bytes)	0
Description	Reset Boot Registers		

Table 16: Deploy Magnetometer Boom Command Format

ID	7	Parameters Length (bytes)	1		
Description	Deploy magnetometer boom				
Parameters	Offset (bits)	Length (bits)	Name	Data Type	Description
	0	8	Timeout	UINT	Deployment actuation timeout value. (Unit of measure is [s])

Table 17: SRAM Scrub Parameters Command Format

ID	8	Parameters Length (bytes)	2		
Description	SRAM scrubbing size				
Parameters	Offset (bits)	Length (bits)	Name	Data Type	Description
	0	16	Scrub Size	UINT	Scrub Size

Table 18: Unix Time Save to Flash Command Format

ID	9	Parameters Length (bytes)	2		
Description	Configuration settings for unixtime flash memory persistence				
Parameters	Offset (bits)	Length (bits)	Name	Data Type	Description
	0	1	Save Now	BOOL	Save current unixtime to flash memory

	1	1	Save On Update	BOOL	Save unixtime to flash memory whenever there is a command to update the unixtime
	2	1	Save Periodic	BOOL	Save unixtime to flash memory periodically
	8	8	Period	UINT	Interval at which to save unixtime to flash memory. (Unit of measure is [s])

Table 19: ADCS Run Mode Command Format

ID	10	Parameters Length (bytes)			1
Description	Set ADCS enabled state & control loop behaviour				
Parameters	Offset (bits)	Length (bits)	Name	Data Type	Description
	0	8	Enabled	ENUM	Set ADCS enabled state. When disabled the CubeACP will not use the ADCS I2C bus. Possible values are in Table 20: AdcsRunMode Enumeration Values

Table 20: AdcsRunMode Enumeration Values

Numeric Value	Name	Description
0	Off	ADCS loop is inactive
1	Enabled	ADCS 1Hz loop is active
2	Triggered	ADCS will execute control loop only when triggered
3	Simulation	ADCS is in simulation mode

Table 21: ADCS Power Control Command Format

ID	11	Parameters Length (bytes)			3
Description	Control power to selected components				
Parameters	Offset (bits)	Length (bits)	Name	Data Type	Description
	0	2	CubeControl Signal Power Selection	ENUM	Control power to electronics of CubeControl Signal PIC. Possible values are in Table 22: PowerSelect Enumeration Values

	2	2	CubeControl Motor Power Selection	ENUM	Control power to electronics of CubeControl Motor PIC. Possible values are in Table 22: PowerSelect Enumeration Values
	4	2	CubeSense Power Selection	ENUM	Control power to the CubeSense. Possible values are in Table 22: PowerSelect Enumeration Values
	6	2	CubeStarPower Power Selection	ENUM	Control power to the CubeStar. Possible values are in Table 22: PowerSelect Enumeration Values
	8	2	CubeWheel1Power Power Selection	ENUM	Control power to the CubeWheel1. Possible values are in Table 22: PowerSelect Enumeration Values
	10	2	CubeWheel2Power Power Selection	ENUM	Control power to the CubeWheel2. Possible values are in Table 22: PowerSelect Enumeration Values
	12	2	CubeWheel3Power Power Selection	ENUM	Control power to the CubeWheel3. Possible values are in Table 22: PowerSelect Enumeration Values
	14	2	Motor Power	ENUM	Control power to Motor electronics. Possible values are in Table 22: PowerSelect Enumeration Values
	16	2	GPS Power	ENUM	Control power to GPS LNA. Possible values are in Table 22: PowerSelect Enumeration Values

Table 22: PowerSelect Enumeration Values

Numeric Value	Name	Description
0	Permanently Off	Permanently Off
1	Permanently On	Permanently On
2	Power state depends on current control mode	Power state depends on current control mode
3	Simulated Auto Mode	Simulate power control - Nodes are not actually enabled, but the ACP behaves as if they are. This setting is used for HIL simulations

Table 23: Clear Errors Command Format

ID	12	Parameters Length (bytes)			1
Description	Clear Latched Error Flags				
Parameters	Offset (bits)	Length (bits)	Name	Data Type	Description
	0	1	ADCS Error Flags	BOOL	Clear ADCS error flags
	1	1	HK Error Flags	BOOL	Clear HK Error flags

Table 24: Set Attitude Control Mode Command Format

ID	13	Parameters Length (bytes)			4
Description	Set attitude control mode				
Parameters	Offset (bits)	Length (bits)	Name	Data Type	Description
	0	8	Control Mode	ENUM	Attitude control mode. Possible values are in Table 25: ConModeSelect Enumeration Values
	8	1	Override flag	BOOL	Ignore current state and force control mode (if this flag is not set, certain control transitions will not be allowed)
	16	16	Timeout	UINT	Control timeout duration. Control will revert to None when timer reaches zero. 0xFFFF for infinite timeout. (Unit of measure is [s])

Table 25: ConModeSelect Enumeration Values

Numeric Value	Name	Description
0	No control	No control
1	Detumbling control	Detumbling control
2	Y-Thomson spin	Y-Thomson spin
3	Y-Wheel momentum stabilized - Initial Pitch Acquisition	Y-Wheel momentum stabilized - Initial Pitch Acquisition
4	Y-Wheel momentum stabilized - Steady State	Y-Wheel momentum stabilized - Steady State
5	XYZ-Wheel control	XYZ-Wheel control
6	Rwheel sun tracking control	Rwheel sun tracking control
7	Rwheel target tracking control	Rwheel target tracking control

8	Very Fast-spin Detumbling control	10Hz Detumbling control within CubeControl
9	Fast-spin Detumbling control	Fast Detumbling control
10	User Defined Control Mode 1	User defined, or custom control mode 1
11	User Defined Control Mode 2	User defined, or custom control mode 2
12	Stop R-wheels	Stop all R-wheels
13	User Coded Control Mode	User coded control mode

Table 26: Set Attitude Estimation Mode Command Format

ID	14	Parameters (bytes)	Length	1	
Description	Set attitude estimation mode				
Parameters	Offset (bits)	Length (bits)	Name	Data Type	Description
	0	8	Attitude Estimation Mode	ENUM	Attitude estimation mode. Possible values are in Table 27: EstimModeSelect Enumeration Values

Table 27: EstimModeSelect Enumeration Values

Numeric Value	Name	Description
0	No attitude estimation	No attitude estimation
1	MEMS rate sensing	MEMS rate sensing
2	Magnetometer rate filter	Magnetometer rate filter
3	Magnetometer rate filter with pitch estimation	Magnetometer rate filter with pitch estimation
4	Magnetometer and Fine-sun TRIAD algorithm	Magnetometer and Fine-sun TRIAD algorithm
5	Full-state EKF	Full-state EKF
6	MEMS gyro EKF	MEMS gyro EKF

Table 28: Commanded Attitude Angles Command Format

ID	15	Parameters Length (bytes)	6		
Description	Commanded attitude angles				
Parameters	Offset (bits)	Length (bits)	Name	Data Type	Description
	0	16	Commanded Roll Angle	INT	Commanded roll angle. Raw parameter value is obtained

					using the formula: (raw parameter) = (formatted value)*100.0 (formatted value is in [deg] units)
	16	16	Commanded Pitch Angle	INT	Commanded pitch angle. Raw parameter value is obtained using the formula: (raw parameter) = (formatted value)*100.0 (formatted value is in [deg] units)
	32	16	Commanded Yaw Angle	INT	Commanded yaw angle. Raw parameter value is obtained using the formula: (raw parameter) = (formatted value)*100.0 (formatted value is in [deg] units)

Table 29: Set Magnetorquer Output Command Format

ID	16	Parameters Length (bytes)	6		
Description	Set magnetorquer output (only valid if Control Mode is None)				
Parameters	Offset (bits)	Length (bits)	Name	Data Type	Description
	0	16	Commanded X Magnetorquer duty cycle	INT	Commanded X-torquer duty cycle. Raw parameter value is obtained using the formula: (raw parameter) = (formatted value)*1000.0
	16	16	Commanded Y Magnetorquer duty cycle	INT	Commanded Y-torquer duty cycle. Raw parameter value is obtained using the formula: (raw parameter) = (formatted value)*1000.0
	32	16	Commanded Z Magnetorquer duty cycle	INT	Commanded Z-torquer duty cycle. Raw parameter value is obtained using the formula: (raw parameter) = (formatted value)*1000.0

Table 30: Set Wheel Speed Command Format

ID	17	Parameters Length (bytes)	6		
Description	Set wheel speed (only valid if Control Mode is None)				

Parameters	Offset (bits)	Length (bits)	Name	Data Type	Description
	0	16	Commanded X speed	INT	Commanded X-wheel speed. (Unit of measure is [rpm])
	16	16	Commanded Y speed	INT	Commanded Y-wheel speed. (Unit of measure is [rpm])
	32	16	Commanded Z speed	INT	Commanded Z-wheel speed. (Unit of measure is [rpm])

Table 31: Trigger ADCS Loop Command Format

ID	18	Parameters Length (bytes)	0
Description	Trigger ADCS to perform one iteration of the control loop (only valid when ADCS Run Mode is Triggered)		

Table 32: Trigger ADCS Loop with Simulated Sensor Data Command Format

ID	19	Parameters Length (bytes)	90		
Description	Trigger ADCS to perform one iteration of the control loop (only valid when ADCS Run Mode is Triggered)				
Parameters	Offset (bits)	Length (bits)	Name	Data Type	Description
	0	32	Unix Time	UINT	Unix time for iteration. (Unit of measure is [s])
	32	16	Css Raw 1	UINT	CSS1 raw measurement
	48	16	Css Raw 2	UINT	CSS2 raw measurement
	64	16	Css Raw 3	UINT	CSS3 raw measurement
	80	16	Css Raw 4	UINT	CSS4 raw measurement
	96	16	Css Raw 5	UINT	CSS5 raw measurement
	112	16	Css Raw 6	UINT	CSS6 raw measurement
	128	16	Css Raw 7	UINT	CSS7 raw measurement
	144	16	Css Raw 8	UINT	CSS8 raw measurement
	160	16	Css Raw 9	UINT	CSS9 raw measurement
	176	16	Css Raw 10	UINT	CSS10 raw measurement
	192	16	Cam1 Raw X	INT	Cam1 sensor raw X angle
	208	16	Cam1 Raw Y	INT	Cam1 sensor raw Y angle
	224	8	Cam1 Busy	UINT	Cam1 sensor capture status
	232	8	Cam1 Result	UINT	Cam1 sensor detection result
	240	16	Cam2 Raw X	INT	Cam2 sensor raw X angle
	256	16	Cam2 Raw Y	INT	Cam2 sensor raw Y angle
	272	8	Cam2 Busy	UINT	Cam2 sensor capture status

280	8	Cam2 Result	UINT	Cam2 sensor detection result
288	16	Mag Raw X	INT	Raw magnetometer X measurement
304	16	Mag Raw Y	INT	Raw magnetometer Y measurement
320	16	Mag Raw Z	INT	Raw magnetometer Z measurement
336	16	Rate Raw X	INT	Raw X rate sensor measurement
352	16	Rate Raw Y	INT	Raw Y rate sensor measurement
368	16	Rate Raw Z	INT	Raw Z rate sensor measurement
384	16	Wheel Raw X	INT	Raw X wheel speed measurement. (Unit of measure is [rpm])
400	16	Wheel Raw Y	INT	Raw Y wheel speed measurement. (Unit of measure is [rpm])
416	16	Wheel Raw Z	INT	Raw Z wheel speed measurement. (Unit of measure is [rpm])
432	16	Star1CameraX	INT	Star1 camera X-vector
448	16	Star1CameraY	INT	Star1 camera Y-vector
464	16	Star1CameraZ	INT	Star1 camera Z-vector
480	16	Star1InertialX	INT	Star1 inertial X-vector
496	16	Star1InertialY	INT	Star1 inertial Y-vector
512	16	Star1InertialZ	INT	Star1 inertial Z-vector
528	16	Star2CameraX	INT	Star2 camera X-vector
544	16	Star2CameraY	INT	Star2 camera Y-vector
560	16	Star2CameraZ	INT	Star2 camera Z-vector
576	16	Star2InertialX	INT	Star2 inertial X-vector
592	16	Star2InertialY	INT	Star2 inertial Y-vector
608	16	Star2InertialZ	INT	Star2 inertial Z-vector
624	16	Star3CameraX	INT	Star3 camera X-vector
640	16	Star3CameraY	INT	Star3 camera Y-vector
656	16	Star3CameraZ	INT	Star3 camera Z-vector
672	16	Star3InertialX	INT	Star3 inertial X-vector
688	16	Star3InertialY	INT	Star3 inertial Y-vector
704	16	Star3InertialZ	INT	Star3 inertial Z-vector

Table 33: ADCS Configuration Command Format

ID	20	Parameters Length (bytes)	272
-----------	----	----------------------------------	-----

Description	Current configuration				
Parameters	Offset	Length	Name	Data	Description
	(bits)	(bits)		Type	
	0	8	Magnetorquer 1 Configuration	ENUM	Magnetorquer 1 Configuration. Possible values are in Table 34: AxisSelect Enumeration Values
	8	8	Magnetorquer 2 Configuration	ENUM	Magnetorquer 2 Configuration. Possible values are in Table 34: AxisSelect Enumeration Values
	16	8	Magnetorquer 3 Configuration	ENUM	Magnetorquer 3 Configuration. Possible values are in Table 34: AxisSelect Enumeration Values
	24	8	RW1 Configuration	ENUM	RW1 Configuration. Possible values are in Table 34: AxisSelect Enumeration Values
	32	8	RW2 Configuration	ENUM	RW2 Configuration. Possible values are in Table 34: AxisSelect Enumeration Values
	40	8	RW3 Configuration	ENUM	RW3 Configuration. Possible values are in Table 34: AxisSelect Enumeration Values
	48	8	RW4 Configuration	ENUM	RW4 Configuration. Possible values are in Table 34: AxisSelect Enumeration Values
	56	8	Gyro1 Configuration	ENUM	Gyro1 Configuration. Possible values are in Table 34: AxisSelect Enumeration Values
	64	8	Gyro2 Configuration	ENUM	Gyro2 Configuration. Possible values are in Table 34: AxisSelect Enumeration Values
	72	8	Gyro3 Configuration	ENUM	Gyro3 Configuration. Possible values are in Table 34: AxisSelect Enumeration Values
	80	8	CSS1 Configuration	ENUM	CSS1 Configuration. Possible values are in Table 34: AxisSelect Enumeration Values
	88	8	CSS2 Configuration	ENUM	CSS2 Configuration. Possible values are in Table 34: AxisSelect Enumeration Values
	96	8	CSS3 Configuration	ENUM	CSS3 Configuration. Possible values are in Table 34: AxisSelect Enumeration Values

	104	8	CSS4 Configuration	ENUM	CSS4 Configuration. Possible values are in Table 34: AxisSelect Enumeration Values
	112	8	CSS5 Configuration	ENUM	CSS5 Configuration. Possible values are in Table 34: AxisSelect Enumeration Values
	120	8	CSS6 Configuration	ENUM	CSS6 Configuration. Possible values are in Table 34: AxisSelect Enumeration Values
	128	8	CSS7 Configuration	ENUM	CSS7 Configuration. Possible values are in Table 34: AxisSelect Enumeration Values
	136	8	CSS8 Configuration	ENUM	CSS8 Configuration. Possible values are in Table 34: AxisSelect Enumeration Values
	144	8	CSS9 Configuration	ENUM	CSS9 Configuration. Possible values are in Table 34: AxisSelect Enumeration Values
	152	8	CSS10 Configuration	ENUM	CSS10 Configuration. Possible values are in Table 34: AxisSelect Enumeration Values
	160	8	CSS1 Relative Scale	UINT	CSS1 Relative Scaling Factor. Raw parameter value is obtained using the formula: (raw parameter) = (formatted value)*100.0
	168	8	CSS2 Relative Scale	UINT	CSS2 Relative Scaling Factor. Raw parameter value is obtained using the formula: (raw parameter) = (formatted value)*100.0
	176	8	CSS3 Relative Scale	UINT	CSS3 Relative Scaling Factor. Raw parameter value is obtained using the formula: (raw parameter) = (formatted value)*100.0
	184	8	CSS4 Relative Scale	UINT	CSS4 Relative Scaling Factor. Raw parameter value is obtained using the formula: (raw parameter) = (formatted value)*100.0
	192	8	CSS5 Relative Scale	UINT	CSS5 Relative Scaling Factor. Raw parameter value is obtained

					using the formula: (raw parameter) = (formatted value)*100.0
	200	8	CSS6 Relative Scale	UINT	CSS6 Relative Scaling Factor. Raw parameter value is obtained using the formula: (raw parameter) = (formatted value)*100.0
	208	8	CSS7 Relative Scale	UINT	CSS7 Relative Scaling Factor. Raw parameter value is obtained using the formula: (raw parameter) = (formatted value)*100.0
	216	8	CSS8 Relative Scale	UINT	CSS8 Relative Scaling Factor. Raw parameter value is obtained using the formula: (raw parameter) = (formatted value)*100.0
	224	8	CSS9 Relative Scale	UINT	CSS9 Relative Scaling Factor. Raw parameter value is obtained using the formula: (raw parameter) = (formatted value)*100.0
	232	8	CSS10 Relative Scale	UINT	CSS10 Relative Scaling Factor. Raw parameter value is obtained using the formula: (raw parameter) = (formatted value)*100.0
	240	8	CSS Threshold	UINT	CSS Threshold
	248	16	Cam1 Sensor Mounting Transform Alpha Angle	INT	Cam1 Sensor Mounting Transform Alpha Angle. Raw parameter value is obtained using the formula: (raw parameter) = (formatted value)*100.0 (formatted value is in [deg] units)
	264	16	Cam1 Sensor Mounting Transform Beta Angle	INT	Cam1 Sensor Mounting Transform Beta Angle. Raw parameter value is obtained using the formula: (raw parameter) = (formatted value)*100.0 (formatted value is in [deg] units)

	280	16	Cam1 Sensor Mounting Transform Gamma Angle	INT	Cam1 Sensor Mounting Transform Gamma Angle. Raw parameter value is obtained using the formula: (raw parameter) = (formatted value)*100.0 (formatted value is in [deg] units)
	296	8	Cam1 detection threshold	UINT	
	304	1	Cam1 sensor auto adjust mode	BOOL	0 = disabled and 1 = enabled
	312	16	Cam1 sensor exposure time	UINT	exposure time register value
	328	16	Cam1 Boresight X	UINT	X Pixel location of Cam1 boresight. Raw parameter value is obtained using the formula: (raw parameter) = (formatted value)*100.0 (formatted value is in [pixels] units)
	344	16	Cam1 Boresight Y	UINT	Y Pixel location of Cam1 boresight. Raw parameter value is obtained using the formula: (raw parameter) = (formatted value)*100.0 (formatted value is in [pixels] units)
	360	1	Cam1 Shift	BOOL	Use Cam2 processing chain for Cam1 detection
	368	16	Cam2 Sensor Mounting Transform Alpha Angle	INT	Cam2 Sensor Mounting Transform Alpha Angle. Raw parameter value is obtained using the formula: (raw parameter) = (formatted value)*100.0 (formatted value is in [deg] units)
	384	16	Cam2 Sensor Mounting Transform Beta Angle	INT	Cam2 Sensor Mounting Transform Beta Angle. Raw parameter value is obtained using the formula: (raw parameter) = (formatted value)*100.0 (formatted value is in [deg] units)
	400	16	Cam2 Sensor Mounting	INT	Cam2 Sensor Mounting Transform Gamma Angle. Raw

			Transform Gamma Angle		parameter value is obtained using the formula: (raw parameter) = (formatted value)*100.0 (formatted value is in [deg] units)
	416	8	Cam2 detection threshold	UINT	Cam2 detection threshold
	424	1	Cam2 sensor auto adjust mode	BOOL	0 = disabled and 1 = enabled
	432	16	Cam2 sensor exposure time	UINT	exposure time register value
	448	16	Cam2 Boresight X	UINT	X Pixel location of Cam2 boresight. Raw parameter value is obtained using the formula: (raw parameter) = (formatted value)*100.0 (formatted value is in [pixels] units)
	464	16	Cam2 Boresight Y	UINT	Y Pixel location of Cam2 boresight. Raw parameter value is obtained using the formula: (raw parameter) = (formatted value)*100.0 (formatted value is in [pixels] units)
	480	1	Cam2 Shift	BOOL	Use Sun processing chain for Cam2 detection
	488	16	Minimum X of area 1	UINT	Minimum X of Area 1
	504	16	Maximum X of area 1	UINT	Maximum X of Area 1
	520	16	Minimum Y of area 1	UINT	Minimum Y of Area 1
	536	16	Maximum Y of area 1	UINT	Maximum Y of Area 1
	552	16	Minimum X of area 2	UINT	Minimum X of Area 2
	568	16	Maximum X of area 2	UINT	Maximum X of Area 2
	584	16	Minimum Y of area 2	UINT	Minimum Y of Area 2
	600	16	Maximum Y of area 2	UINT	Maximum Y of Area 2

	616	16	Minimum X of area 3	UINT	Minimum X of Area 3
	632	16	Maximum X of area 3	UINT	Maximum X of Area 3
	648	16	Minimum Y of area 3	UINT	Minimum Y of Area 3
	664	16	Maximum Y of area 3	UINT	Maximum Y of Area 3
	680	16	Minimum X of area 4	UINT	Minimum X of Area 4
	696	16	Maximum X of area 4	UINT	Maximum X of Area 4
	712	16	Minimum Y of area 4	UINT	Minimum Y of Area 4
	728	16	Maximum Y of area 4	UINT	Maximum Y of Area 4
	744	16	Minimum X of area 5	UINT	Minimum X of Area 5
	760	16	Maximum X of area 5	UINT	Maximum X of Area 5
	776	16	Minimum Y of area 5	UINT	Minimum Y of Area 5
	792	16	Maximum Y of area 5	UINT	Maximum Y of Area 5
	808	16	Magnetometer Mounting Transform Alpha Angle	INT	Magnetometer Mounting Transform Alpha Angle. Raw parameter value is obtained using the formula: (raw parameter) = (formatted value)*100.0 (formatted value is in [deg] units)
	824	16	Magnetometer Mounting Transform Beta Angle	INT	Magnetometer Mounting Transform Beta Angle. Raw parameter value is obtained using the formula: (raw parameter) = (formatted value)*100.0 (formatted value is in [deg] units)
	840	16	Magnetometer Mounting Transform Gamma Angle	INT	Magnetometer Mounting Transform Gamma Angle. Raw parameter value is obtained using the formula: (raw

					parameter) = (formatted value)*100.0 (formatted value is in [deg] units)
	856	16	Magnetometer Channel 1 Offset	INT	Magnetometer Channel 1 Offset. Raw parameter value is obtained using the formula: (raw parameter) = (formatted value)*1000.0
	872	16	Magnetometer Channel 2 Offset	INT	Magnetometer Channel 2 Offset. Raw parameter value is obtained using the formula: (raw parameter) = (formatted value)*1000.0
	888	16	Magnetometer Channel 3 Offset	INT	Magnetometer Channel 3 Offset. Raw parameter value is obtained using the formula: (raw parameter) = (formatted value)*1000.0
	904	16	Magnetometer Sensitivity Matrix S11	INT	Magnetometer Sensitivity Matrix S11. Raw parameter value is obtained using the formula: (raw parameter) = (formatted value)*1000.0
	920	16	Magnetometer Sensitivity Matrix S22	INT	Magnetometer Sensitivity Matrix S22. Raw parameter value is obtained using the formula: (raw parameter) = (formatted value)*1000.0
	936	16	Magnetometer Sensitivity Matrix S33	INT	Magnetometer Sensitivity Matrix S33. Raw parameter value is obtained using the formula: (raw parameter) = (formatted value)*1000.0
	952	16	Magnetometer Sensitivity Matrix S12	INT	Magnetometer Sensitivity Matrix S12. Raw parameter value is obtained using the formula: (raw parameter) = (formatted value)*1000.0
	968	16	Magnetometer Sensitivity Matrix S13	INT	Magnetometer Sensitivity Matrix S13. Raw parameter value is obtained using the formula: (raw parameter) = (formatted value)*1000.0

	984	16	Magnetometer Sensitivity Matrix S21	INT	Magnetometer Sensitivity Matrix S21. Raw parameter value is obtained using the formula: (raw parameter) = (formatted value)*1000.0
	1000	16	Magnetometer Sensitivity Matrix S23	INT	Magnetometer Sensitivity Matrix S23. Raw parameter value is obtained using the formula: (raw parameter) = (formatted value)*1000.0
	1016	16	Magnetometer Sensitivity Matrix S31	INT	Magnetometer Sensitivity Matrix S31. Raw parameter value is obtained using the formula: (raw parameter) = (formatted value)*1000.0
	1032	16	Magnetometer Sensitivity Matrix S32	INT	Magnetometer Sensitivity Matrix S32. Raw parameter value is obtained using the formula: (raw parameter) = (formatted value)*1000.0
	1048	16	X-Rate Sensor Offset	INT	X-Rate Sensor Offset. Raw parameter value is obtained using the formula: (raw parameter) = (formatted value)*1000.0 (formatted value is in [deg/s] units)
	1064	16	Y-Rate Sensor Offset	INT	Y-Rate Sensor Offset. Raw parameter value is obtained using the formula: (raw parameter) = (formatted value)*1000.0 (formatted value is in [deg/s] units)
	1080	16	Z-Rate Sensor Offset	INT	Z-Rate Sensor Offset. Raw parameter value is obtained using the formula: (raw parameter) = (formatted value)*1000.0 (formatted value is in [deg/s] units)
	1096	8	RateSensorMult	UINT	Multiplier of rate sensor measurement
	1104	16	StarTracker Mounting	INT	StarTracker Mounting Transform Alpha Angle. Raw parameter value is obtained using the

		Transform Alpha Angle		formula: (raw parameter) = (formatted value)*100.0 (formatted value is in [deg] units)
1120	16	StarTracker Mounting Transform Beta Angle	INT	StarTracker Mounting Transform Beta Angle. Raw parameter value is obtained using the formula: (raw parameter) = (formatted value)*100.0 (formatted value is in [deg] units)
1136	16	StarTracker Mounting Transform Gamma Angle	INT	StarTracker Mounting Transform Gamma Angle. Raw parameter value is obtained using the formula: (raw parameter) = (formatted value)*100.0 (formatted value is in [deg] units)
1152	16	StarTracker exposure time	UINT	exposure time register value
1168	8	StarTracker detection threshold	UINT	StarTracker detection threshold
1176	8	StarTracker star threshold	UINT	StarTracker star threshold
1184	8	Maximum Star Matched	UINT	Maximum of stars that the star tracker will match
1192	8	Maximum Star Pixel	UINT	Maximum pixels in a star
1200	8	Maximum Star Noise	UINT	Maximum star pixel noise
1208	8	Minimum Star Pixel	UINT	Minimum pixels in a star
1216	8	Star Tracker Error Margin	UINT	% Error margin of the star identification. Raw parameter value is obtained using the formula: (raw parameter) = (formatted value)*100.0 (formatted value is in [%] units)
1224	32	Star Tracker Centroid X	FLOAT	Pixel centroid X
1256	32	Star Tracker Centroid Y	FLOAT	Pixel centroid Y
1288	16	Star Tracker Focal Length	UINT	Star Tracker Focal Length. Raw parameter value is obtained using the formula: (raw parameter) = (formatted

					value)*10000.0 (formatted value is in [mm] units)
	1304	8	Synch Delay	UINT	Synchronization delay within star Tracker
	1312	32	Detumbling Spin Gain	FLOAT	Detumbling Spin Gain (Ks)
	1344	32	Detumbling Damping Gain	FLOAT	Detumbling Damping Gain (Kd)
	1376	16	Reference spin rate	INT	Reference spin rate (wy-ref). Must always be smaller than 0. Raw parameter value is obtained using the formula: (raw parameter) = (formatted value)*1000.0 (formatted value is in [deg/s] units)
	1392	32	Fast BDot Detumbling Gain	FLOAT	Fast BDot Detumbling Gain (Kdf)
	1424	32	Y-Momentum Control Gain	FLOAT	Y-Momentum Control Gain (Kh)
	1456	32	Y-momentum Nutation Damping Gain	FLOAT	Y-momentum Nutation Damping Gain (Kn)
	1488	32	Y-momentum Proportional Gain	FLOAT	Y-momentum Proportional Gain (Kp1)
	1520	32	Y-momentum Derivative Gain	FLOAT	Y-momentum Derivative Gain (Kd1)
	1552	32	Reference Wheel Momentum	FLOAT	Reference Wheel Momentum (H-ref). Must always be smaller than 0. (Unit of measure is [Nms])
	1584	32	RWheel Proportional Gain	FLOAT	RWheel Proportional Gain (Kp2)
	1616	32	RWheel Derivative Gain	FLOAT	RWheel Derivative Gain (Kd2)
	1648	32	Tracking Proportional Gain	FLOAT	Tracking Proportional Gain (Kp3)
	1680	32	Tracking Derivative Gain	FLOAT	Tracking Derivative Gain (Kd3)
	1712	32	Tracking Integral Gain	FLOAT	Tracking Integral Gain (Ki3)
	1744	32	Moment Of Inertia - Ixx	FLOAT	Moment Of Inertia - Ixx. (Unit of measure is [kg.m^2])

	1776	32	Moment Of Inertia - lyy	FLOAT	Moment Of Inertia - lyy. (Unit of measure is [kg.m ²])
	1808	32	Moment Of Inertia - lzz	FLOAT	Moment Of Inertia - lzz. (Unit of measure is [kg.m ²])
	1840	32	Moment Of Inertia - lxy	FLOAT	Moment Of Inertia - lxy. (Unit of measure is [kg.m ²])
	1872	32	Moment Of Inertia - lxz	FLOAT	Moment Of Inertia - lxz. (Unit of measure is [kg.m ²])
	1904	32	Moment Of Inertia - lyz	FLOAT	Moment Of Inertia - lyz. (Unit of measure is [kg.m ²])
	1936	32	Magnetometer Rate Filter System Noise	FLOAT	Magnetometer Rate Filter System Noise
	1968	32	EKF System Noise	FLOAT	EKF System Noise
	2000	32	CSS Measurement Noise	FLOAT	CSS Measurement Noise
	2032	32	Sun Sensor Measurement Noise	FLOAT	Sun Sensor Measurement Noise
	2064	32	Nadir Sensor Measurement Noise	FLOAT	Nadir Sensor Measurement Noise
	2096	32	Magnetometer Measurement Noise	FLOAT	Magnetometer Measurement Noise
	2128	32	Star Tracker Measurement Noise	FLOAT	Star Tracker Measurement Noise
	2160	1	Use Sun Sensor	BOOL	Use Sun Sensor measurement in EKF
	2161	1	Use Nadir Sensor	BOOL	Use Nadir Sensor measurement in EKF
	2162	1	Use CSS	BOOL	Use CSS measurement in EKF
	2163	1	Use Star Tracker	BOOL	Use Star Tracker measurement in EKF
	2164	2	Magnetometer Mode	ENUM	Mode describing which magnetometer is used for estimation and control. Possible values are in Table 35: MagModeVal Enumeration Values

	2168	8	Cam1 and Cam2 Sampling Period	UINT	Cam1 and Cam2 sensor sampling period. Lower four bits are Cam1 period and upper four bits the Cam2 period. Setting period to zero for sensor will disable sampling of sensor.. (Unit of measure is [s])
--	------	---	-------------------------------	------	---

Table 34: AxisSelect Enumeration Values

Numeric Value	Name	Description
0	Positive X	Positive X
1	Negative X	Negative X
2	Positive Y	Positive Y
3	Negative Y	Negative Y
4	Positive Z	Positive Z
5	Negative Z	Negative Z
6	Not Used	Not Used

Table 35: MagModeVal Enumeration Values

Numeric Value	Name	Description
0	MainMagOnly	Only main magnetometer is sampled and used
1	RedMagOnly	Only redundant magnetometer is sampled and used
2	BothMagMainUsed	Both magnetometers are sampled but main is used
3	BothMagRedUsed	Both magnetometers are sampled but redundant is used

Table 36: Parts of ADCS Configuration command (ID 20), sent using shorter telecommands

ID	Partial Commands	Length (bytes)	Bit offset	Bit length	Overlapping ADCS Configuration Telecommand Parameters
21	Set Magnetorquer Configuration - Table 37: Set Magnetorquer Configuration Command Format	3	0	8	Magnetorquer 1 Configuration
			8	8	Magnetorquer 2 Configuration

			16	8	Magnetorquer 3 Configuration
22	Set Wheel Configuration - Table 38: Set Wheel Configuration Command Format	4	24	8	RW1 Configuration
			32	8	RW2 Configuration
			40	8	RW3 Configuration
			48	8	RW4 Configuration
23	Set Rate Gyro Configuration - Table 39: Set Rate Gyro Configuration Command Format	3	56	8	Gyro1 Configuration
			64	8	Gyro2 Configuration
			72	8	Gyro3 Configuration
24	Set CSS Alignment Configuration - Table 40: Set CSS Alignment Configuration Command Format	10	80	8	CSS1 Configuration
			88	8	CSS2 Configuration
			96	8	CSS3 Configuration
			104	8	CSS4 Configuration
			112	8	CSS5 Configuration
			120	8	CSS6 Configuration
			128	8	CSS7 Configuration
			136	8	CSS8 Configuration
			144	8	CSS9 Configuration
			152	8	CSS10 Configuration
25	Set CSS Scale Factor Configuration - Table 41: Set CSS Scale Factor Configuration Command Format	11	160	8	CSS1 Relative Scale
			168	8	CSS2 Relative Scale
			176	8	CSS3 Relative Scale
			184	8	CSS4 Relative Scale
			192	8	CSS5 Relative Scale
			200	8	CSS6 Relative Scale
			208	8	CSS7 Relative Scale
			216	8	CSS8 Relative Scale

			224	8	CSS9 Relative Scale
			232	8	CSS10 Relative Scale
			240	8	CSS Threshold
26	Set Cam1 Sensor Configuration - Table 42: Set Cam1 Sensor Configuration Command Format	15	248	16	Cam1 Sensor Mounting Transform Alpha Angle
			264	16	Cam1 Sensor Mounting Transform Beta Angle
			280	16	Cam1 Sensor Mounting Transform Gamma Angle
			296	8	Cam1 detection threshold
			304	1	Cam1 sensor auto adjust mode
			312	16	Cam1 sensor exposure time
			328	16	Cam1 Boresight X
			344	16	Cam1 Boresight Y
			360	1	Cam1 Shift
27	Set Cam2 Sensor Configuration - Table 43: Set Cam2 Sensor Configuration Command Format	15	368	16	Cam2 Sensor Mounting Transform Alpha Angle
			384	16	Cam2 Sensor Mounting Transform Beta Angle
			400	16	Cam2 Sensor Mounting Transform Gamma Angle
			416	8	Cam2 detection threshold
			424	1	Cam2 sensor auto adjust mode
			432	16	Cam2 sensor exposure time
			448	16	Cam2 Boresight X
			464	16	Cam2 Boresight Y
			480	1	Cam2 Shift
28	Set Nadir Sensor Mask Configuration 1 - Table 44: Set Nadir Sensor Mask Configuration 1 Command Format	8	488	16	Minimum X of area 1
			504	16	Maximum X of area 1
			520	16	Minimum Y of area 1
			536	16	Maximum Y of area 1

29	Set Nadir Sensor Mask Configuration 2 - Table 45: Set Nadir Sensor Mask Configuration 2 Command Format	8	552	16	Minimum X of area 2
			568	16	Maximum X of area 2
			584	16	Minimum Y of area 2
			600	16	Maximum Y of area 2
30	Set Nadir Sensor Mask Configuration 3 - Table 46: Set Nadir Sensor Mask Configuration 3 Command Format	8	616	16	Minimum X of area 3
			632	16	Maximum X of area 3
			648	16	Minimum Y of area 3
			664	16	Maximum Y of area 3
31	Set Nadir Sensor Mask Configuration 4 - Table 47: Set Nadir Sensor Mask Configuration 4 Command Format	8	680	16	Minimum X of area 4
			696	16	Maximum X of area 4
			712	16	Minimum Y of area 4
			728	16	Maximum Y of area 4
32	Set Nadir Sensor Mask Configuration 5 - Table 48: Set Nadir Sensor Mask Configuration 5 Command Format	8	744	16	Minimum X of area 5
			760	16	Maximum X of area 5
			776	16	Minimum Y of area 5
			792	16	Maximum Y of area 5
33	Set Magnetometer Mounting Configuration - Table 49: Set Magnetometer Mounting	6	808	16	Magnetometer Mounting Transform Alpha Angle

	Configuration Command Format				
			824	16	Magnetometer Mounting Transform Beta Angle
			840	16	Magnetometer Mounting Transform Gamma Angle
34	Set Magnetometer Offset and Scaling Configuration - Table 50: Set Magnetometer Offset and Scaling Configuration Command Format	12	856	16	Magnetometer Channel 1 Offset
			872	16	Magnetometer Channel 2 Offset
			888	16	Magnetometer Channel 3 Offset
			904	16	Magnetometer Sensitivity Matrix S11
			920	16	Magnetometer Sensitivity Matrix S22
			936	16	Magnetometer Sensitivity Matrix S33
35	Set Magnetometer Sensitivity Configuration - Table 51: Set Magnetometer Sensitivity Configuration Command Format	12	952	16	Magnetometer Sensitivity Matrix S12
			968	16	Magnetometer Sensitivity Matrix S13
			984	16	Magnetometer Sensitivity Matrix S21
			1000	16	Magnetometer Sensitivity Matrix S23
			1016	16	Magnetometer Sensitivity Matrix S31
			1032	16	Magnetometer Sensitivity Matrix S32
36	Set Rate Sensor Configuration - Table 52: Set Rate Sensor	7	1048	16	X-Rate Sensor Offset

	Configuration Command Format				
			1064	16	Y-Rate Sensor Offset
			1080	16	Z-Rate Sensor Offset
			1096	8	RateSensorMult
37	Set Star Tracker Configuration - Table 53: Set Star Tracker Configuration Command Format	26	1104	16	StarTracker Mounting Transform Alpha Angle
			1120	16	StarTracker Mounting Transform Beta Angle
			1136	16	StarTracker Mounting Transform Gamma Angle
			1152	16	StarTracker exposure time
			1168	8	StarTracker detection threshold
			1176	8	StarTracker star threshold
			1184	8	Maximum Star Matched
			1192	8	Maximum Star Pixel
			1200	8	Maximum Star Noise
			1208	8	Minimum Star Pixel
			1216	8	Star Tracker Error Margin
			1224	32	Star Tracker Centroid X
			1256	32	Star Tracker Centroid Y
			1288	16	Star Tracker Focal Length
			1304	8	Synch Delay
38	Set Detumbling Control Parameters - Table 54: Set Detumbling Control Parameters Command Format	14	1312	32	Detumbling Spin Gain
			1344	32	Detumbling Damping Gain
			1376	16	Reference spin rate
			1392	32	Fast BDot Detumbling Gain
39	Set Y-Wheel Control Parameters - Table 55: Set Y-Wheel Control Parameters Command Format	20	1424	32	Y-Momentum Control Gain
			1456	32	Y-momentum Nutation Damping Gain

			1488	32	Y-momentum Proportional Gain
			1520	32	Y-momentum Derivative Gain
			1552	32	Reference Wheel Momentum
40	Set Reaction Wheel Control Parameters - Table 56: Set Reaction Wheel Control Parameters Command Format	8	1584	32	RWheel Proportional Gain
			1616	32	RWheel Derivative Gain
54	Set Tracking Controller Gain Parameters - Table 71: Set Tracking Controller Gain Parameters Command Format	12	1648	32	Tracking Proportional Gain
			1680	32	Tracking Derivative Gain
			1712	32	Tracking Integral Gain
41	Set Moments of Inertia - Table 57: Set Moments of Inertia Command Format	12	1744	32	Moment Of Inertia - lxx
			1776	32	Moment Of Inertia - lyy
			1808	32	Moment Of Inertia - lzz
42	Set Products of Inertia - Table 58: Set Products of Inertia Command Format	12	1840	32	Moment Of Inertia - lxy
			1872	32	Moment Of Inertia - lxz
			1904	32	Moment Of Inertia - lyz
43	Set Estimation Parameters 1 - Table 59: Set Estimation Parameters 1 Command Format	16	1936	32	Magnetometer Rate Filter System Noise
			1968	32	EKF System Noise
			2000	32	CSS Measurement Noise
			2032	32	Sun Sensor Measurement Noise
44	Set Estimation Parameters 2 - Table 60: Set Estimation	14	2064	32	Nadir Sensor Measurement Noise

Parameters 2 Command Format	2096	32	Magnetometer Measurement Noise
	2128	32	Star Tracker Measurement Noise
	2160	1	Use Sun Sensor
	2161	1	Use Nadir Sensor
	2162	1	Use CSS
	2163	1	Use Star Tracker
	2164	2	Magnetometer Mode
	2168	8	Cam1 and Cam2 Sampling Period

Table 37: Set Magnetorquer Configuration Command Format

ID	21	Parameters Length (bytes)	3		
Description	Set magnetorquer configuration parameters				
Parameters	Offset (bits)	Length (bits)	Name	Data Type	Description
	0	8	Magnetorquer 1 Configuration	ENUM	Magnetorquer 1 Configuration. Possible values are in Table 34: AxisSelect Enumeration Values
	8	8	Magnetorquer 2 Configuration	ENUM	Magnetorquer 2 Configuration. Possible values are in Table 34: AxisSelect Enumeration Values
	16	8	Magnetorquer 3 Configuration	ENUM	Magnetorquer 3 Configuration. Possible values are in Table 34: AxisSelect Enumeration Values

Table 38: Set Wheel Configuration Command Format

ID	22	Parameters Length (bytes)	4		
Description	Set wheel configuration parameters				
Parameters	Offset (bits)	Length (bits)	Name	Data Type	Description
	0	8	RW1 Configuration	ENUM	RW1 Configuration. Possible values are in Table 34: AxisSelect Enumeration Values
	8	8	RW2 Configuration	ENUM	RW2 Configuration. Possible values are in Table 34: AxisSelect Enumeration Values

	16	8	RW3 Configuration	ENUM	RW3 Configuration. Possible values are in Table 34: AxisSelect Enumeration Values
	24	8	RW4 Configuration	ENUM	RW4 Configuration. Possible values are in Table 34: AxisSelect Enumeration Values

Table 39: Set Rate Gyro Configuration Command Format

ID	23	Parameters Length (bytes)			3
Description	Set rate gyro configuration parameters				
Parameters	Offset (bits)	Length (bits)	Name	Data Type	Description
	0	8	Gyro1 Configuration	ENUM	Gyro1 Configuration. Possible values are in Table 34: AxisSelect Enumeration Values
	8	8	Gyro2 Configuration	ENUM	Gyro2 Configuration. Possible values are in Table 34: AxisSelect Enumeration Values
	16	8	Gyro3 Configuration	ENUM	Gyro3 Configuration. Possible values are in Table 34: AxisSelect Enumeration Values

Table 40: Set CSS Alignment Configuration Command Format

ID	24	Parameters Length (bytes)			10
Description	Set photodiode pointing directions				
Parameters	Offset (bits)	Length (bits)	Name	Data Type	Description
	0	8	CSS1 Configuration	ENUM	CSS1 Configuration. Possible values are in Table 34: AxisSelect Enumeration Values
	8	8	CSS2 Configuration	ENUM	CSS2 Configuration. Possible values are in Table 34: AxisSelect Enumeration Values
	16	8	CSS3 Configuration	ENUM	CSS3 Configuration. Possible values are in Table 34: AxisSelect Enumeration Values
	24	8	CSS4 Configuration	ENUM	CSS4 Configuration. Possible values are in Table 34: AxisSelect Enumeration Values

	32	8	CSS5 Configuration	ENUM	CSS5 Configuration. Possible values are in Table 34: AxisSelect Enumeration Values
	40	8	CSS6 Configuration	ENUM	CSS6 Configuration. Possible values are in Table 34: AxisSelect Enumeration Values
	48	8	CSS7 Configuration	ENUM	CSS7 Configuration. Possible values are in Table 34: AxisSelect Enumeration Values
	56	8	CSS8 Configuration	ENUM	CSS8 Configuration. Possible values are in Table 34: AxisSelect Enumeration Values
	64	8	CSS9 Configuration	ENUM	CSS9 Configuration. Possible values are in Table 34: AxisSelect Enumeration Values
	72	8	CSS10 Configuration	ENUM	CSS10 Configuration. Possible values are in Table 34: AxisSelect Enumeration Values

Table 41: Set CSS Scale Factor Configuration Command Format

ID	25	Parameters Length (bytes)		11	
Description	Set photodiode scale factors				
Parameters	Offset (bits)	Length (bits)	Name	Data Type	Description
	0	8	CSS1 Relative Scale	UINT	CSS1 Relative Scaling Factor. Raw parameter value is obtained using the formula: (raw parameter) = (formatted value)*100.0
	8	8	CSS2 Relative Scale	UINT	CSS2 Relative Scaling Factor. Raw parameter value is obtained using the formula: (raw parameter) = (formatted value)*100.0
	16	8	CSS3 Relative Scale	UINT	CSS3 Relative Scaling Factor. Raw parameter value is obtained using the formula: (raw parameter) = (formatted value)*100.0
	24	8	CSS4 Relative Scale	UINT	CSS4 Relative Scaling Factor. Raw parameter value is obtained

					using the formula: (raw parameter) = (formatted value)*100.0
	32	8	CSS5 Relative Scale	UINT	CSS5 Relative Scaling Factor. Raw parameter value is obtained using the formula: (raw parameter) = (formatted value)*100.0
	40	8	CSS6 Relative Scale	UINT	CSS6 Relative Scaling Factor. Raw parameter value is obtained using the formula: (raw parameter) = (formatted value)*100.0
	48	8	CSS7 Relative Scale	UINT	CSS7 Relative Scaling Factor. Raw parameter value is obtained using the formula: (raw parameter) = (formatted value)*100.0
	56	8	CSS8 Relative Scale	UINT	CSS8 Relative Scaling Factor. Raw parameter value is obtained using the formula: (raw parameter) = (formatted value)*100.0
	64	8	CSS9 Relative Scale	UINT	CSS9 Relative Scaling Factor. Raw parameter value is obtained using the formula: (raw parameter) = (formatted value)*100.0
	72	8	CSS10 Relative Scale	UINT	CSS10 Relative Scaling Factor. Raw parameter value is obtained using the formula: (raw parameter) = (formatted value)*100.0
	80	8	CSS Threshold	UINT	CSS Threshold

Table 42: Set Cam1 Sensor Configuration Command Format

ID	26	Parameters Length (bytes)			15
Description	Set Cam1 sensor configuration parameters				
Parameters	Offset (bits)	Length (bits)	Name	Data Type	Description

	0	16	Cam1 Sensor Mounting Transform Alpha Angle	INT	Cam1 Sensor Mounting Transform Alpha Angle. Raw parameter value is obtained using the formula: (raw parameter) = (formatted value)*100.0 (formatted value is in [deg] units)
	16	16	Cam1 Sensor Mounting Transform Beta Angle	INT	Cam1 Sensor Mounting Transform Beta Angle. Raw parameter value is obtained using the formula: (raw parameter) = (formatted value)*100.0 (formatted value is in [deg] units)
	32	16	Cam1 Sensor Mounting Transform Gamma Angle	INT	Cam1 Sensor Mounting Transform Gamma Angle. Raw parameter value is obtained using the formula: (raw parameter) = (formatted value)*100.0 (formatted value is in [deg] units)
	48	8	Cam1 detection threshold	UINT	
	56	1	Cam1 sensor auto adjust mode	BOOL	0 = disabled and 1 = enabled
	64	16	Cam1 sensor exposure time	UINT	exposure time register value
	80	16	Cam1 Boresight X	UINT	X Pixel location of Cam1 boresight. Raw parameter value is obtained using the formula: (raw parameter) = (formatted value)*100.0 (formatted value is in [pixels] units)
	96	16	Cam1 Boresight Y	UINT	Y Pixel location of Cam1 boresight. Raw parameter value is obtained using the formula: (raw parameter) = (formatted value)*100.0 (formatted value is in [pixels] units)
	112	1	Cam1 Shift	BOOL	Use Cam2 processing chain for Cam1 detection

Table 43: Set Cam2 Sensor Configuration Command Format

ID	27	Parameters Length (bytes)			15
Description	Set Cam2 sensor configuration parameters				
Parameters	Offset (bits)	Length (bits)	Name	Data Type	Description
	0	16	Cam2 Sensor Mounting Transform Alpha Angle	INT	Cam2 Sensor Mounting Transform Alpha Angle. Raw parameter value is obtained using the formula: (raw parameter) = (formatted value)*100.0 (formatted value is in [deg] units)
	16	16	Cam2 Sensor Mounting Transform Beta Angle	INT	Cam2 Sensor Mounting Transform Beta Angle. Raw parameter value is obtained using the formula: (raw parameter) = (formatted value)*100.0 (formatted value is in [deg] units)
	32	16	Cam2 Sensor Mounting Transform Gamma Angle	INT	Cam2 Sensor Mounting Transform Gamma Angle. Raw parameter value is obtained using the formula: (raw parameter) = (formatted value)*100.0 (formatted value is in [deg] units)
	48	8	Cam2 detection threshold	UINT	Cam2 detection threshold
	56	1	Cam2 sensor auto adjust mode	BOOL	0 = disabled and 1 = enabled
	64	16	Cam2 sensor exposure time	UINT	exposure time register value
	80	16	Cam2 Boresight X	UINT	X Pixel location of Cam2 boresight. Raw parameter value is obtained using the formula: (raw parameter) = (formatted value)*100.0 (formatted value is in [pixels] units)
	96	16	Cam2 Boresight Y	UINT	Y Pixel location of Cam2 boresight. Raw parameter value is obtained using the formula: (raw parameter) = (formatted

					value)*100.0 (formatted value is in [pixels] units)
	112	1	Cam2 Shift	BOOL	Use Sun processing chain for Cam2 detection

Table 44: Set Nadir Sensor Mask Configuration 1 Command Format

ID	28	Parameters Length (bytes)			8
Description	Set Nadir Sensor Mask Configuration 1				
Parameters	Offset (bits)	Length (bits)	Name	Data Type	Description
	0	16	Minimum X of area 1	UINT	Minimum X of Area 1
	16	16	Maximum X of area 1	UINT	Maximum X of Area 1
	32	16	Minimum Y of area 1	UINT	Minimum Y of Area 1
	48	16	Maximum Y of area 1	UINT	Maximum Y of Area 1

Table 45: Set Nadir Sensor Mask Configuration 2 Command Format

ID	29	Parameters Length (bytes)			8
Description	Set Nadir Sensor Mask Configuration 2				
Parameters	Offset (bits)	Length (bits)	Name	Data Type	Description
	0	16	Minimum X of area 2	UINT	Minimum X of Area 2
	16	16	Maximum X of area 2	UINT	Maximum X of Area 2
	32	16	Minimum Y of area 2	UINT	Minimum Y of Area 2
	48	16	Maximum Y of area 2	UINT	Maximum Y of Area 2

Table 46: Set Nadir Sensor Mask Configuration 3 Command Format

ID	30	Parameters Length (bytes)			8
Description	Set Nadir Sensor Mask Configuration 3				
Parameters	Offset (bits)	Length (bits)	Name	Data Type	Description

	0	16	Minimum X of area 3	UINT	Minimum X of Area 3
	16	16	Maximum X of area 3	UINT	Maximum X of Area 3
	32	16	Minimum Y of area 3	UINT	Minimum Y of Area 3
	48	16	Maximum Y of area 3	UINT	Maximum Y of Area 3

Table 47: Set Nadir Sensor Mask Configuration 4 Command Format

ID	31	Parameters Length (bytes)			8
Description	Set Nadir Sensor Mask Configuration 4				
Parameters	Offset (bits)	Length (bits)	Name	Data Type	Description
	0	16	Minimum X of area 4	UINT	Minimum X of Area 4
	16	16	Maximum X of area 4	UINT	Maximum X of Area 4
	32	16	Minimum Y of area 4	UINT	Minimum Y of Area 4
	48	16	Maximum Y of area 4	UINT	Maximum Y of Area 4

Table 48: Set Nadir Sensor Mask Configuration 5 Command Format

ID	32	Parameters Length (bytes)			8
Description	Set Nadir Sensor Mask Configuration 5				
Parameters	Offset (bits)	Length (bits)	Name	Data Type	Description
	0	16	Minimum X of area 5	UINT	Minimum X of Area 5
	16	16	Maximum X of area 5	UINT	Maximum X of Area 5
	32	16	Minimum Y of area 5	UINT	Minimum Y of Area 5
	48	16	Maximum Y of area 5	UINT	Maximum Y of Area 5

Table 49: Set Magnetometer Mounting Configuration Command Format

ID	33	Parameters Length (bytes)			6
Description	Set magnetometer mounting configuration parameters				
Parameters	Offset (bits)	Length (bits)	Name	Data Type	Description
	0	16	Magnetometer Mounting Transform Alpha Angle	INT	Magnetometer Mounting Transform Alpha Angle. Raw parameter value is obtained using the formula: (raw parameter) = (formatted value)*100.0 (formatted value is in [deg] units)
	16	16	Magnetometer Mounting Transform Beta Angle	INT	Magnetometer Mounting Transform Beta Angle. Raw parameter value is obtained using the formula: (raw parameter) = (formatted value)*100.0 (formatted value is in [deg] units)
	32	16	Magnetometer Mounting Transform Gamma Angle	INT	Magnetometer Mounting Transform Gamma Angle. Raw parameter value is obtained using the formula: (raw parameter) = (formatted value)*100.0 (formatted value is in [deg] units)

Table 50: Set Magnetometer Offset and Scaling Configuration Command Format

ID	34	Parameters Length (bytes)			12
Description	Set Magnetometer Offset and Scaling Configuration				
Parameters	Offset (bits)	Length (bits)	Name	Data Type	Description
	0	16	Magnetometer Channel 1 Offset	INT	Magnetometer Channel 1 Offset. Raw parameter value is obtained using the formula: (raw parameter) = (formatted value)*1000.0
	16	16	Magnetometer Channel 2 Offset	INT	Magnetometer Channel 2 Offset. Raw parameter value is obtained using the formula: (raw parameter) = (formatted value)*1000.0

	32	16	Magnetometer Channel 3 Offset	INT	Magnetometer Channel 3 Offset. Raw parameter value is obtained using the formula: (raw parameter) = (formatted value)*1000.0
	48	16	Magnetometer Sensitivity Matrix S11	INT	Magnetometer Sensitivity Matrix S11. Raw parameter value is obtained using the formula: (raw parameter) = (formatted value)*1000.0
	64	16	Magnetometer Sensitivity Matrix S22	INT	Magnetometer Sensitivity Matrix S22. Raw parameter value is obtained using the formula: (raw parameter) = (formatted value)*1000.0
	80	16	Magnetometer Sensitivity Matrix S33	INT	Magnetometer Sensitivity Matrix S33. Raw parameter value is obtained using the formula: (raw parameter) = (formatted value)*1000.0

Table 51: Set Magnetometer Sensitivity Configuration Command Format

ID	35	Parameters Length (bytes)			12
Description	Set Magnetometer Sensitivity Configuration				
Parameters	Offset (bits)	Length (bits)	Name	Data Type	Description
	0	16	Magnetometer Sensitivity Matrix S12	INT	Magnetometer Sensitivity Matrix S12. Raw parameter value is obtained using the formula: (raw parameter) = (formatted value)*1000.0
	16	16	Magnetometer Sensitivity Matrix S13	INT	Magnetometer Sensitivity Matrix S13. Raw parameter value is obtained using the formula: (raw parameter) = (formatted value)*1000.0
	32	16	Magnetometer Sensitivity Matrix S21	INT	Magnetometer Sensitivity Matrix S21. Raw parameter value is obtained using the formula: (raw parameter) = (formatted value)*1000.0

	48	16	Magnetometer Sensitivity Matrix S23	INT	Magnetometer Sensitivity Matrix S23. Raw parameter value is obtained using the formula: (raw parameter) = (formatted value)*1000.0
	64	16	Magnetometer Sensitivity Matrix S31	INT	Magnetometer Sensitivity Matrix S31. Raw parameter value is obtained using the formula: (raw parameter) = (formatted value)*1000.0
	80	16	Magnetometer Sensitivity Matrix S32	INT	Magnetometer Sensitivity Matrix S32. Raw parameter value is obtained using the formula: (raw parameter) = (formatted value)*1000.0

Table 52: Set Rate Sensor Configuration Command Format

ID	36	Parameters Length (bytes)	7		
Description	Set Rate Sensor Offsets				
Parameters	Offset (bits)	Length (bits)	Name	Data Type	Description
	0	16	X-Rate Sensor Offset	INT	X-Rate Sensor Offset. Raw parameter value is obtained using the formula: (raw parameter) = (formatted value)*1000.0 (formatted value is in [deg/s] units)
	16	16	Y-Rate Sensor Offset	INT	Y-Rate Sensor Offset. Raw parameter value is obtained using the formula: (raw parameter) = (formatted value)*1000.0 (formatted value is in [deg/s] units)
	32	16	Z-Rate Sensor Offset	INT	Z-Rate Sensor Offset. Raw parameter value is obtained using the formula: (raw parameter) = (formatted value)*1000.0 (formatted value is in [deg/s] units)
	48	8	RateSensorMult	UINT	Multiplier of rate sensor measurement

Table 53: Set Star Tracker Configuration Command Format

ID	37	Parameters Length (bytes)			26
Description	Set configurations of CubeStar				
Parameters	Offset (bits)	Length (bits)	Name	Data Type	Description
	0	16	StarTracker Mounting Transform Alpha Angle	INT	StarTracker Mounting Transform Alpha Angle. Raw parameter value is obtained using the formula: (raw parameter) = (formatted value)*100.0 (formatted value is in [deg] units)
	16	16	StarTracker Mounting Transform Beta Angle	INT	StarTracker Mounting Transform Beta Angle. Raw parameter value is obtained using the formula: (raw parameter) = (formatted value)*100.0 (formatted value is in [deg] units)
	32	16	StarTracker Mounting Transform Gamma Angle	INT	StarTracker Mounting Transform Gamma Angle. Raw parameter value is obtained using the formula: (raw parameter) = (formatted value)*100.0 (formatted value is in [deg] units)
	48	16	StarTracker exposure time	UINT	exposure time register value
	64	8	StarTracker detection threshold	UINT	StarTracker detection threshold
	72	8	StarTracker star threshold	UINT	StarTracker star threshold
	80	8	Maximum Star Matched	UINT	Maximum of stars that the star tracker will match
	88	8	Maximum Star Pixel	UINT	Maximum pixels in a star
	96	8	Maximum Star Noise	UINT	Maximum star pixel noise
	104	8	Minimum Star Pixel	UINT	Minimum pixels in a star
	112	8	Star Tracker Error Margin	UINT	% Error margin of the star identification. Raw parameter value is obtained using the formula: (raw parameter) =

					(formatted value)*100.0 (formatted value is in [%] units)
	120	32	Star Tracker Centroid X	FLOAT	Pixel centroid X
	152	32	Star Tracker Centroid Y	FLOAT	Pixel centroid Y
	184	16	Star Tracker Focal Length	UINT	Star Tracker Focal Length. Raw parameter value is obtained using the formula: (raw parameter) = (formatted value)*10000.0 (formatted value is in [mm] units)
	200	8	Synch Delay	UINT	Synchronization delay within star Tracker

Table 54: Set Detumbling Control Parameters Command Format

ID	38		Parameters Length (bytes)	14	
Description	Set controller gains and reference values for Detumbling control mode				
Parameters	Offset (bits)	Length (bits)	Name	Data Type	Description
	0	32	Detumbling Spin Gain	FLOAT	Detumbling Spin Gain (Ks)
	32	32	Detumbling Damping Gain	FLOAT	Detumbling Damping Gain (Kd)
	64	16	Reference spin rate	INT	Reference spin rate (wy-ref). Must always be smaller than 0. Raw parameter value is obtained using the formula: (raw parameter) = (formatted value)*1000.0 (formatted value is in [deg/s] units)
	80	32	Fast BDot Detumbling Gain	FLOAT	Fast BDot Detumbling Gain (Kdf)

Table 55: Set Y-Wheel Control Parameters Command Format

ID	39		Parameters Length (bytes)	20	
Description	Set controller gains and reference value for Y-wheel control mode				
Parameters	Offset (bits)	Length (bits)	Name	Data Type	Description

	0	32	Y-Momentum Control Gain	FLOAT	Y-Momentum Control Gain (Kh)
	32	32	Y-momentum Nutation Damping Gain	FLOAT	Y-momentum Nutation Damping Gain (Kn)
	64	32	Y-momentum Proportional Gain	FLOAT	Y-momentum Proportional Gain (Kp1)
	96	32	Y-momentum Derivative Gain	FLOAT	Y-momentum Derivative Gain (Kd1)
	128	32	Reference Wheel Momentum	FLOAT	Reference Wheel Momentum (H-ref). Must always be smaller than 0. (Unit of measure is [Nms])

Table 56: Set Reaction Wheel Control Parameters Command Format

ID	40	Parameters Length (bytes)			8
Description	Set controller gains and reference value for reaction wheel control mode				
Parameters	Offset (bits)	Length (bits)	Name	Data Type	Description
	0	32	RWheel Proportional Gain	FLOAT	RWheel Proportional Gain (Kp2)
	32	32	RWheel Derivative Gain	FLOAT	RWheel Derivative Gain (Kd2)

Table 57: Set Moments of Inertia Command Format

ID	41	Parameters Length (bytes)			12
Description	Set satellite moments of inertia				
Parameters	Offset (bits)	Length (bits)	Name	Data Type	Description
	0	32	Moment Of Inertia - Ixx	FLOAT	Moment Of Inertia - Ixx. (Unit of measure is [kg.m ²])
	32	32	Moment Of Inertia - Iyy	FLOAT	Moment Of Inertia - Iyy. (Unit of measure is [kg.m ²])
	64	32	Moment Of Inertia - Izz	FLOAT	Moment Of Inertia - Izz. (Unit of measure is [kg.m ²])

Table 58: Set Products of Inertia Command Format

ID	42	Parameters Length (bytes)			12
Description	Set satellite products of inertia				

Parameters	Offset (bits)	Length (bits)	Name	Data Type	Description
	0	32	Moment Of Inertia - lxy	FLOAT	Moment Of Inertia - lxy. (Unit of measure is [kg.m ²])
	32	32	Moment Of Inertia - lxz	FLOAT	Moment Of Inertia - lxz. (Unit of measure is [kg.m ²])
	64	32	Moment Of Inertia - lyz	FLOAT	Moment Of Inertia - lyz. (Unit of measure is [kg.m ²])

Table 59: Set Estimation Parameters 1 Command Format

ID	43	Parameters Length (bytes)	16		
Description	Set estimation noise covariance and sensor mask 1				
Parameters	Offset (bits)	Length (bits)	Name	Data Type	Description
	0	32	Magnetometer Rate Filter System Noise	FLOAT	Magnetometer Rate Filter System Noise
	32	32	EKF System Noise	FLOAT	EKF System Noise
	64	32	CSS Measurement Noise	FLOAT	CSS Measurement Noise
	96	32	Sun Sensor Measurement Noise	FLOAT	Sun Sensor Measurement Noise

Table 60: Set Estimation Parameters 2 Command Format

ID	44	Parameters Length (bytes)	14		
Description	Set estimation noise covariance and sensor mask 2				
Parameters	Offset (bits)	Length (bits)	Name	Data Type	Description
	0	32	Nadir Sensor Measurement Noise	FLOAT	Nadir Sensor Measurement Noise
	32	32	Magnetometer Measurement Noise	FLOAT	Magnetometer Measurement Noise
	64	32	Star Tracker Measurement Noise	FLOAT	Star Tracker Measurement Noise
	96	1	Use Sun Sensor	BOOL	Use Sun Sensor measurement in EKF

	97	1	Use Nadir Sensor	BOOL	Use Nadir Sensor measurement in EKF
	98	1	Use CSS	BOOL	Use CSS measurement in EKF
	99	1	Use Star Tracker	BOOL	Use Star Tracker measurement in EKF
	100	2	Magnetometer Mode	ENUM	Mode describing which magnetometer is used for estimation and control. Possible values are in Table 35: MagModeVal Enumeration Values
	104	8	Cam1 and Cam2 Sampling Period	UINT	Cam1 and Cam2 sensor sampling period. Lower four bits are Cam1 period and upper four bits the Cam2 period. Setting period to zero for sensor will disable sampling of sensor.. (Unit of measure is [s])

Table 61: SGP4 Orbit Parameters Command Format

ID	45	Parameters Length (bytes)			64
Description	SGP4 Orbit Parameters				
Parameters	Offset (bits)	Length (bits)	Name	Data Type	Description
	0	64	Inclination	DOUBLE	Inclination. (Unit of measure is [deg])
	64	64	Eccentricity	DOUBLE	Eccentricity
	128	64	Right-ascension of the Ascending Node	DOUBLE	Right-ascension of the Ascending Node. (Unit of measure is [deg])
	192	64	Argument of Perigee	DOUBLE	Argument of Perigee. (Unit of measure is [deg])
	256	64	B-Star drag term	DOUBLE	B-Star drag term
	320	64	Mean Motion	DOUBLE	Mean Motion. (Unit of measure is [orbits/day])
	384	64	Mean Anomaly	DOUBLE	Mean Anomaly. (Unit of measure is [deg])
	448	64	Epoch	DOUBLE	Epoch (year.day). (Unit of measure is [year.day])

Table 62: Parts of SGP4 Orbit Parameters command (ID 45), sent using shorter telecommands

ID	Partial Commands	Length (bytes)	Bit offset	Bit length	Overlapping ADCS Configuration Telecommand Parameters
46	Set SGP4 Orbit Inclination - Table 63: Set SGP4 Orbit Inclination Command Format	8	0	64	Inclination
47	Set SGP4 Orbit Eccentricity - Table 64: Set SGP4 Orbit Eccentricity Command Format	8	64	64	Eccentricity
48	Set SGP4 Orbit RAAN - Table 65: Set SGP4 Orbit RAAN Command Format	8	128	64	Right-ascension of the Ascending Node
49	Set SGP4 Orbit Argument of Perigee - Table 66: Set SGP4 Orbit Argument of Perigee Command Format	8	192	64	Argument of Perigee
50	Set SGP4 Orbit B-Star Drag term - Table 67: Set SGP4 Orbit B-Star Drag term Command Format	8	256	64	B-Star drag term
51	Set SGP4 Orbit Mean Motion - Table 68: Set SGP4 Orbit Mean Motion Command Format	8	320	64	Mean Motion
52	Set SGP4 Orbit Mean Anomaly - Table 69: Set SGP4 Orbit Mean Anomaly Command Format	8	384	64	Mean Anomaly
53	Set SGP4 Orbit Epoch - Table 70: Set SGP4 Orbit Epoch Command Format	8	448	64	Epoch

Table 63: Set SGP4 Orbit Inclination Command Format

ID	46	Parameters (bytes)	Length	8	
Description	Set SGP4 Orbit Inclination				
Parameters	Offset (bits)	Length (bits)	Name	Data Type	Description
	0	64	Inclination	DOUBLE	Inclination. (Unit of measure is [deg])

Table 64: Set SGP4 Orbit Eccentricity Command Format

ID	47	Parameters Length (bytes)	8		
Description	Set SGP4 Orbit Eccentricity				
Parameters	Offset (bits)	Length (bits)	Name	Data Type	Description
	0	64	Eccentricity	DOUBLE	Eccentricity

Table 65: Set SGP4 Orbit RAAN Command Format

ID	48	Parameters Length (bytes)	8		
Description	Set SGP4 Orbit RAAN				
Parameters	Offset (bits)	Length (bits)	Name	Data Type	Description
	0	64	Right-ascension of the Ascending Node	DOUBLE	Right-ascension of the Ascending Node. (Unit of measure is [deg])

Table 66: Set SGP4 Orbit Argument of Perigee Command Format

ID	49	Parameters (bytes)	Length	8	
Description	Set SGP4 Orbit Argument of Perigee				
Parameters	Offset (bits)	Length (bits)	Name	Data Type	Description
	0	64	Argument of Perigee	DOUBLE	Argument of Perigee. (Unit of measure is [deg])

Table 67: Set SGP4 Orbit B-Star Drag term Command Format

ID	50	Parameters Length (bytes)	8
-----------	----	----------------------------------	---

Description	Set SGP4 Orbit B-Star Drag term				
Parameters	Offset (bits)	Length (bits)	Name	Data Type	Description
	0	64	B-Star drag term	DOUBLE	B-Star drag term

Table 68: Set SGP4 Orbit Mean Motion Command Format

ID	51	Parameters (bytes)	Length	8	
Description	Set SGP4 Orbit Mean Motion				
Parameters	Offset (bits)	Length (bits)	Name	Data Type	Description
	0	64	Mean Motion	DOUBLE	Mean Motion. (Unit of measure is [orbits/day])

Table 69: Set SGP4 Orbit Mean Anomaly Command Format

ID	52	Parameters (bytes)	Length	8	
Description	Set SGP4 Orbit Mean Anomaly				
Parameters	Offset (bits)	Length (bits)	Name	Data Type	Description
	0	64	Mean Anomaly	DOUBLE	Mean Anomaly. (Unit of measure is [deg])

Table 70: Set SGP4 Orbit Epoch Command Format

ID	53	Parameters (bytes)	Length	8	
Description	Set SGP4 Orbit Epoch				
Parameters	Offset (bits)	Length (bits)	Name	Data Type	Description
	0	64	Epoch	DOUBLE	Epoch (year.day). (Unit of measure is [year.day])

Table 71: Set Tracking Controller Gain Parameters Command Format

ID	54	Parameters Length (bytes)	12		
Description	Set controller gains for tracking control mode				
Parameters	Offset (bits)	Length (bits)	Name	Data Type	Description

	0	32	Tracking Proportional Gain	FLOAT	Tracking Proportional Gain (Kp3)
	32	32	Tracking Derivative Gain	FLOAT	Tracking Derivative Gain (Kd3)
	64	32	Tracking Integral Gain	FLOAT	Tracking Integral Gain (Ki3)

Table 72: Tracking Controller Target Reference Command Format

ID	55	Parameters Length (bytes)			12
Description	Target reference for tracking control mode				
Parameters	Offset (bits)	Length (bits)	Name	Data Type	Description
	0	32	Geocentric longitude of target	FLOAT	Geocentric longitude of target. (Unit of measure is [deg])
	32	32	Geocentric latitude of target	FLOAT	Geocentric latitude of target. (Unit of measure is [deg])
	64	32	Geocentric altitude of target	FLOAT	Geocentric altitude of target. (Unit of measure is [meter])

Table 73: Set Mode of Magnetometer Operation Command Format

ID	56	Parameters Length (bytes)		1	
Description	Use of main or redundant magnetometer				
Parameters	Offset (bits)	Length (bits)	Name	Data Type	Description
	0	8	Magnetometer Mode	ENUM	Mode describing which magnetometer is used for estimation and control. Possible values are in Table 35: MagModeVal Enumeration Values

Table 74: Convert to JPG file Command Format

ID	57	Parameters Length (bytes)			3
Description	Convert raw or bmp files to JPG				
Parameters	Offset (bits)	Length (bits)	Name	Data Type	Description
	0	8	Source File Counter	UINT	Source File Counter
	8	8	Quality Factor	UINT	Quality Factor

	16	8	White Balance	UINT	White Balance
--	----	---	---------------	------	---------------

Table 75: Default Configuration Command Format

ID	60	Parameters Length (bytes)	0
Description	Retrieves default configuration and saves it to flash		

Table 76: Save Configuration Command Format

ID	63	Parameters Length (bytes)	0
Description	Save current configuration to flash memory		

Table 77: Save Orbit Parameters Command Format

ID	64	Parameters Length (bytes)	0
Description	Save current orbit parameters to flash memory		

Table 78: Save Image Command Format

ID	80	Parameters Length (bytes)	2		
Description	Save and capture image from one of CubeSense cameras or CubeStar camera to SD card				
Parameters	Offset (bits)	Length (bits)	Name	Data Type	Description
	0	8	Camera Select	ENUM	Camera Selection. Possible values are in Table 79: CamSelect Enumeration Values
	8	8	Image Size	ENUM	Image size selection. Possible values are in Table 80: ImSize Enumeration Values

Table 79: CamSelect Enumeration Values

Numeric Value	Name	Description
0	Cam1	Cam1 camera
1	Cam2	Cam2 camera
2	Star	Star camera

Table 80: ImSize Enumeration Values

Numeric Value	Name	Description
0	Size 0	1024 x 1024 pixels
1	Size 1	512 x 512 pixels
2	Size 2	256 x 256 pixels
3	Size 3	128 x 128 pixels
4	Size 4	64 x 64 pixels

Table 81: SD Log1 Configuration Command Format

ID	104	Parameters Length (bytes)	13		
Description	Log selection and period for LOG1				
Parameters	Offset (bits)	Length (bits)	Name	Data Type	Description
	0	80	Log Selection	ARRAY	Log Selection - up to 80 flags indicating which telemetry frames should be logged
	80	16	Log Period	UINT	Log period. Set to 0 to disable logging
	96	8	Log Destination	ENUM	Which SD card to use to store log file. Possible values are in Table 82: SdLogSelect Enumeration Values

Table 82: SdLogSelect Enumeration Values

Numeric Value	Name	Description
0	Primary SD Card	Use Primary (on-board) SD card for log file
1	Secondary SD Card	Use Secondary SD card for log file

Table 83: SD Log2 Configuration Command Format

ID	105	Parameters Length (bytes)	13		
Description	Log selection and period for LOG2				
Parameters	Offset (bits)	Length (bits)	Name	Data Type	Description
	0	80	Log Selection	ARRAY	Log Selection - up to 80 flags indicating which telemetry frames should be logged
	80	16	Log Period	UINT	Log period. Set to 0 to disable logging

	96	8	Log Destination	ENUM	Which SD card to use to store log file. Possible values are in Table 82: SdLogSelect Enumeration Values
--	----	---	-----------------	------	---

Table 84: UART Log Configuration Command Format

ID	106	Parameters Length (bytes)		12	
Description	Log selection and period for UART (unsolicited TLM)				
Parameters	Offset (bits)	Length (bits)	Name	Data Type	Description
	0	80	Log Selection	ARRAY	Log Selection - up to 80 flags indicating which telemetry frames should be logged
	80	16	Log Period	UINT	Log period. Set to 0 to disable logging

Table 85: Erase File Command Format

ID	108	Parameters Length (bytes)		3	
Description	Erase File				
Parameters	Offset (bits)	Length (bits)	Name	Data Type	Description
	0	8	File Type	ENUM	File Type. Possible values are in Table 86: FileType Enumeration Values
	8	8	File Counter	UINT	File Counter
	16	1	Erase All	BOOL	Erase All

Table 86: FileType Enumeration Values

Numeric Value	Name	Description
0	Binary	Binary File
1	Event Log	Event Log File
2	Telemetry Log	Telemetry Log File
3	JPG Image	JPG Image File
4	BMP Image	BMP Image File
5	Payload1	Payload1 File
6	Payload2	Payload2 File
7	Payload3	Payload3 File
8	Payload4	Payload4 File

15	Index	Index File
----	-------	------------

Table 87: Load File Download Block Command Format

ID	112		Parameters Length (bytes)	8	
Description	Fill download buffer with file contents				
Parameters	Offset (bits)	Length (bits)	Name	Data Type	Description
	0	8	File Type	ENUM	File Type. Possible values are in Table 86: FileType Enumeration Values
	8	8	Counter	UINT	Counter
	16	32	Offset	UINT	Offset
	48	16	BlockLength	UINT	Block Length

Table 88: Advance File List Read Pointer Command Format

ID	113		Parameters Length (bytes)	0	
Description	Advance File List Read Pointer				

Table 89: Initiate File Upload Command Format

ID	114		Parameters Length (bytes)	2	
Description	Initiate File Upload				
Parameters	Offset (bits)	Length (bits)	Name	Data Type	Description
	0	8	Destination	ENUM	Destination. Possible values are in Table 90: FileUploadDestination Enumeration Values
	8	8	BlockSize	UINT	Block Size

Table 90: FileUploadDestination Enumeration Values

Numeric Value	Name	Description
2	EEPROM	EEPROM
3	Flash program 1	Flash program 1
4	Flash program 2	Flash program 2
5	Flash program 3	Flash program 3
6	Flash program 4	Flash program 4
7	Flash program 5	Flash program 5

8	Flash program 6	Flash program 6
9	Flash program 7	Flash program 7
10	SD User file 1	SD User file 1
11	SD User file 2	SD User file 2
12	SD User file 3	SD User file 3
13	SD User file 4	SD User file 4
14	SD User file 5	SD User file 5
15	SD User file 6	SD User file 6
16	SD User file 7	SD User file 7
17	SD User file 8	SD User file 8

Table 91: File Upload Packet Command Format

ID	115	Parameters Length (bytes)	22		
Description	File Upload Packet				
Parameters	Offset (bits)	Length (bits)	Name	Data Type	Description
	0	16	Packet Number	UINT	Packet Number
	16	160	File Bytes	ARRAY	File Bytes

Table 92: Finalize Upload Block Command Format

ID	116	Parameters Length (bytes)	7		
Description	Finalize Uploaded File Block				
Parameters	Offset (bits)	Length (bits)	Name	Data Type	Description
	0	8	Destination	ENUM	Destination. Possible values are in Table 90: FileUploadDestination Enumeration Values
	8	32	Offset	UINT	Offset into file
	40	16	Block Length	UINT	Length of block

Table 93: Reset Upload Block Command Format

ID	117	Parameters Length (bytes)	0
Description	Reset HoleMap for Upload Block		

Table 94: Reset File List Read Pointer Command Format

ID	118	Parameters Length (bytes)	0
-----------	-----	----------------------------------	---

Description	Reset File List Read Pointer
--------------------	------------------------------

Table 95: Initiate Download Burst Command Format

ID	119	Parameters Length (bytes)	2		
Description	Initiate Download Burst				
Parameters	Offset (bits)	Length (bits)	Name	Data Type	Description
	0	8	Message Length	UINT	Message Length
	8	1	Ignore Hole Map	BOOL	Ignore Hole Map

Table 96: Hole Map 1 Command Format

ID	120	Parameters Length (bytes)	16		
Description	File Upload Hole Map 1				
Parameters	Offset (bits)	Length (bits)	Name	Data Type	Description
	0	128	Hole Map	ARRAY	Hole Map

Table 97: Hole Map 2 Command Format

ID	121	Parameters Length (bytes)	16		
Description	File Upload Hole Map 2				
Parameters	Offset (bits)	Length (bits)	Name	Data Type	Description
	0	128	Hole Map	ARRAY	Hole Map

Table 98: Hole Map 3 Command Format

ID	122	Parameters Length (bytes)	16		
Description	File Upload Hole Map 3				
Parameters	Offset (bits)	Length (bits)	Name	Data Type	Description
	0	128	Hole Map	ARRAY	Hole Map

Table 99: Hole Map 4 Command Format

ID	123	Parameters Length (bytes)	16		
Description	File Upload Hole Map 4				
Parameters	Offset (bits)	Length (bits)	Name	Data Type	Description
	0	128	Hole Map	ARRAY	Hole Map

Table 100: Hole Map 5 Command Format

ID	124	Parameters Length (bytes)			16
Description	File Upload Hole Map 5				
Parameters	Offset (bits)	Length (bits)	Name	Data Type	Description
	0	128	Hole Map	ARRAY	Hole Map

Table 101: Hole Map 6 Command Format

ID	125	Parameters Length (bytes)			16
Description	File Upload Hole Map 6				
Parameters	Offset (bits)	Length (bits)	Name	Data Type	Description
	0	128	Hole Map	ARRAY	Hole Map

Table 102: Hole Map 7 Command Format

ID	126	Parameters Length (bytes)			16
Description	File Upload Hole Map 7				
Parameters	Offset (bits)	Length (bits)	Name	Data Type	Description
	0	128	Hole Map	ARRAY	Hole Map

Table 103: Hole Map 8 Command Format

ID	127	Parameters Length (bytes)			16
Description	File Upload Hole Map 8				
Parameters	Offset (bits)	Length (bits)	Name	Data Type	Description
	0	128	Hole Map	ARRAY	Hole Map

4.5.8 Telemetry

Table 104: List of Telemetry Frames

ID	Name	Description	Length (bytes)
General			
128	Identification	Identification information for this node - Table 105: Identification Telemetry Format	8
129	Unix Time Save to Flash	Configuration settings for unixtime flash memory persistence - Table 106: Unix Time Save to Flash Telemetry Format	2

130	Boot Index and Status	Current selected boot index and status of last boot - Table 107: Boot Index and Status Telemetry Format	2
131	Cache enabled state	Cache enabled state - Table 110: Cache enabled state Telemetry Format	1
132	Boot And Running Program Status	Boot And Running Program Status - Table 111: Boot And Running Program Status Telemetry Format	6
133	JPG Conversion Progress	Conversion progress - Table 114: JPG Conversion Progress Telemetry Format	3
134	SRAM Scrub Parameters	SRAM scrubbing size - Table 116: SRAM Scrub Parameters Telemetry Format	2
135	CubeACP State	Contains flags regarding the state of the ACP - Table 117: CubeACP State Telemetry Format	1
140	Current Unix Time	Current Unix Time - Table 118: Current Unix Time Telemetry Format	6
141	Last Logged Event	Last Logged Event (relative to pointer - adjusted via Advance and Reset TCs (3 & 4) - Table 119: Last Logged Event Telemetry Format	6
142	SRAM Latchup counters	SRAM Latchup counters - Table 120: SRAM Latchup counters Telemetry Format	6
143	EDAC Error Counters	EDAC Error Counters - Table 121: EDAC Error Counters Telemetry Format	6
144	Communication Status	Communication status - includes command and telemetry counters and error flags - Table 122: Communication Status Telemetry Format	6
145	Current ADCS State	Current state of the Attitude Control Processor - Table 123: Current ADCS State Telemetry Format	6
146	Estimated Attitude Angles	Estimated attitude angles - Table 124: Estimated Attitude Angles Telemetry Format	6
147	Estimated Angular Rates	Estimated angular rates relative to orbit reference frame - Table 125: Estimated Angular Rates Telemetry Format	6
148	Satellite Position (ECI)	Satellite position in ECI frame - Table 126: Satellite Position (ECI) Telemetry Format	6
149	Satellite Velocity (ECI)	Satellite velocity in ECI frame - Table 127: Satellite Velocity (ECI) Telemetry Format	6
150	Satellite Position (LLH)	Satellite position in WGS-84 coordinate frame - Table 128: Satellite Position (LLH) Telemetry Format	6

151	Magnetic Field Vector	Measured magnetic field vector - Table 129: Magnetic Field Vector Telemetry Format	6
152	Coarse Sun Vector	Measured coarse sun vector - Table 130: Coarse Sun Vector Telemetry Format	6
153	Fine Sun Vector	Measured fine sun vector - Table 131: Fine Sun Vector Telemetry Format	6
154	Nadir Vector	Measured nadir vector - Table 132: Nadir Vector Telemetry Format	6
155	Rate Sensor Rates	Rate sensor measurements - Table 133: Rate Sensor Rates Telemetry Format	6
156	Wheel Speed	Wheel speed measurement - Table 134: Wheel Speed Telemetry Format	6
157	Magnetorquer Command	Magnetorquer commands - Table 135: Magnetorquer Command Telemetry Format	6
158	Wheel Speed Commands	Wheel speed commands - Table 136: Wheel Speed Commands Telemetry Format	6
159	IGRF Modelled Magnetic Field Vector	IGRF modelled magnetic field vector (orbit frame referenced) - Table 137: IGRF Modelled Magnetic Field Vector Telemetry Format	6
160	Modelled Sun Vector	Modelled sun vector (orbit frame referenced) - Table 138: Modelled Sun Vector Telemetry Format	6
161	Estimated Gyro Bias	Estimated rate sensor bias - Table 139: Estimated Gyro Bias Telemetry Format	6
162	Estimation Innovation Vector	Estimation innovation vector - Table 140: Estimation Innovation Vector Telemetry Format	6
163	Quaternion Error Vector	Quaternion error vector - Table 141: Quaternion Error Vector Telemetry Format	6
164	Quaternion Covariance	Quaternion covariance - Table 142: Quaternion Covariance Telemetry Format	6
165	Angular Rate Covariance	Angular rate covariance - Table 143: Angular Rate Covariance Telemetry Format	6
166	Raw Cam2 Sensor	Cam2 sensor capture and detection result - Table 144: Raw Cam2 Sensor Telemetry Format	6
167	Raw Cam1 Sensor	Cam1 sensor capture and detection result - Table 147: Raw Cam1 Sensor Telemetry Format	6
168	Raw CSS 1 to 6	Raw CSS measurements 1 to 6 - Table 148: Raw CSS 1 to 6 Telemetry Format	6
169	Raw CSS 7 to 10	Raw CSS measurements 7 to 10 - Table 149: Raw CSS 7 to 10 Telemetry Format	6

170	Raw Magnetometer	Raw magnetometer measurements - Table 150: Raw Magnetometer Telemetry Format	6
171	CubeSense Current Measurements	CubeSense current measurements - Table 151: CubeSense Current Measurements Telemetry Format	6
172	CubeControl Current Measurements	CubeControl current measurements - Table 152: CubeControl Current Measurements Telemetry Format	6
173	Wheel Currents	XYZ Wheel current measurement - Table 153: Wheel Currents Telemetry Format	6
174	ADCS Temperatures	Magnetometer + MCU temperature measurements - Table 154: ADCS Temperatures Telemetry Format	6
175	Rate sensor temperatures	Rate sensor temperatures - Table 155: Rate sensor temperatures Telemetry Format	6
176	Raw GPS Status	Raw GPS status - Table 156: Raw GPS Status Telemetry Format	6
177	Raw GPS Time	Raw GPS time - Table 158: Raw GPS Time Telemetry Format	6
178	Raw GPS X	Raw GPS X position and velocity (ECI referenced) - Table 159: Raw GPS X Telemetry Format	6
179	Raw GPS Y	Raw GPS Y position and velocity (ECI referenced) - Table 160: Raw GPS Y Telemetry Format	6
180	Raw GPS Z	Raw GPS Z position and velocity (ECI referenced) - Table 161: Raw GPS Z Telemetry Format	6
181	Star 1 Body Vector	Star 1 Body Vector - Table 162: Star 1 Body Vector Telemetry Format	6
182	Star 2 Body Vector	Star 2 Body Vector - Table 163: Star 2 Body Vector Telemetry Format	6
183	Star 3 Body Vector	Star 3 Body Vector - Table 164: Star 3 Body Vector Telemetry Format	6
184	Star 1 Orbit Vector	Star 1 Orbit Vector - Table 165: Star 1 Orbit Vector Telemetry Format	6
185	Star 2 Orbit Vector	Star 2 Orbit Vector - Table 166: Star 2 Orbit Vector Telemetry Format	6
186	Star 3 Orbit Vector	Star 3 Orbit Vector - Table 167: Star 3 Orbit Vector Telemetry Format	6
187	Star Magnitude	Instrument magnitude of identified stars - Table 168: Star Magnitude Telemetry Format	6

188	Star Performance	Performance parameters of star measurement - Table 169: Star Performance Telemetry Format	6
189	Star Timing	Timing information of star measurement - Table 171: Star Timing Telemetry Format	6
190	ADCS State	Current ADCS state - Table 172: ADCS State Telemetry Format	48
191	ADCS Measurements	Calibrated sensor measurements - Table 174: ADCS Measurements Telemetry Format	72
192	Actuator Commands	Actuator commands - Table 176: Actuator Commands Telemetry Format	12
193	Estimation Data	Estimation meta-data - Table 178: Estimation Data Telemetry Format	42
194	Raw Sensor Measurements	Raw sensor measurements - Table 180: Raw Sensor Measurements Telemetry Format	28
195	Power and Temperature Measurements	Power and temperature measurements - Table 182: Power and Temperature Measurements Telemetry Format	34
196	Adcs Execution Times	Returns information about execution times of ACP functions - Table 184: Adcs Execution Times Telemetry Format	8
197	ADCS Power Control	Control power to selected components - Table 185: ADCS Power Control Telemetry Format	3
198	ADCS Misc Current Measurements	CubeStar and Torquer current measurements - Table 186: ADCS Misc Current Measurements Telemetry Format	6
199	Commanded Attitude Angles	Commanded attitude angles - Table 187: Commanded Attitude Angles Telemetry Format	6
200	Tracking Controller Target Reference	Target reference for tracking control mode - Table 188: Tracking Controller Target Reference Telemetry Format	12
206	ADCS Configuration	Current configuration - Table 189: ADCS Configuration Telemetry Format	272
207	SGP4 Orbit Parameters	SGP4 Orbit Parameters - Table 190: SGP4 Orbit Parameters Telemetry Format	64
210	Raw GPS Measurements	Raw GPS measurements - Table 191: Raw GPS Measurements Telemetry Format	36
211	Raw Star Tracker	Raw Star Tracker Measurement - Table 193: Raw Star Tracker Telemetry Format	36

212	Star 1 Raw Data	Catalogue index and detected coordinates for star 1 - Table 195: Star 1 Raw Data Telemetry Format	6
213	Star 2 Raw Data	Catalogue index and detected coordinates for star 2 - Table 196: Star 2 Raw Data Telemetry Format	6
214	Star 3 Raw Data	Catalogue index and detected coordinates for star 3 - Table 197: Star 3 Raw Data Telemetry Format	6
215	Redundant Magnetometer Raw Measurements	Redundant Magnetometer raw measurements - Table 198: Redundant Magnetometer Raw Measurements Telemetry Format	6
218	Estimated Quaternion	Estimated quaternion set - Table 199: Estimated Quaternion Telemetry Format	6
219	ECEF Position	Satellite position in ECEF coordinates - Table 200: ECEF Position Telemetry Format	6
220	ACP Execution State	Returns information about the ACP loop - Table 201: ACP Execution State Telemetry Format	3
233	Status of Image Capture and Save Operation	Status of Image Capture and Save Operation - Table 203: Status of Image Capture and Save Operation Telemetry Format	2
235	SD Log1 Configuration	Log selection and period for LOG1 - Table 205: SD Log1 Configuration Telemetry Format	13
236	SD Log2 Configuration	Log selection and period for LOG2 - Table 206: SD Log2 Configuration Telemetry Format	13
237	UART Log Configuration	Log selection and period for UART (unsolicited TLM) - Table 207: UART Log Configuration Telemetry Format	12
240	Telecommand Acknowledge	Telemetry frame with acknowledge status of the previously sent command - Table 208: Telecommand Acknowledge Telemetry Format	4
241	File Download Buffer with File Contents	File Download buffer 20-byte packet - Table 210: File Download Buffer with File Contents Telemetry Format	22
242	Download Block Ready	Status about download block preparation - Table 211: Download Block Ready Telemetry Format	5
243	File Information	File Information - Table 212: File Information Telemetry Format	12
244	Initialize Upload Complete	Initialize Upload Complete - Table 213: Initialize Upload Complete Telemetry Format	1

245	Upload Block Complete	Finalize Upload Block Complete - Table 214: Upload Block Complete Telemetry Format	1
246	Block Checksum	File upload Block CRC16 Checksum - Table 215: Block Checksum Telemetry Format	2
247	Hole Map 1	File Upload Hole Map 1 - Table 216: Hole Map 1 Telemetry Format	16
248	Hole Map 2	File Upload Hole Map 2 - Table 217: Hole Map 2 Telemetry Format	16
249	Hole Map 3	File Upload Hole Map 3 - Table 218: Hole Map 3 Telemetry Format	16
250	Hole Map 4	File Upload Hole Map 4 - Table 219: Hole Map 4 Telemetry Format	16
251	Hole Map 5	File Upload Hole Map 5 - Table 220: Hole Map 5 Telemetry Format	16
252	Hole Map 6	File Upload Hole Map 6 - Table 221: Hole Map 6 Telemetry Format	16
253	Hole Map 7	File Upload Hole Map 7 - Table 222: Hole Map 7 Telemetry Format	16
254	Hole Map 8	File Upload Hole Map 8 - Table 223: Hole Map 8 Telemetry Format	16

Table 105: Identification Telemetry Format

ID	128	Frame Length (bytes)	8		
Description	Identification information for this node				
Channels	Offset (bits)	Length (bits)	Name	Data Type	Description
	0	8	Node type	UINT	Node type identifier.
	8	8	Interface version	UINT	Interface version. This field should have a value of 1
	16	8	Firmware version (Major)	UINT	Firmware version (Major)
	24	8	Firmware version (Minor)	UINT	Firmware version (Minor)
	32	16	Runtime (seconds)	UINT	Number of seconds since processor start-up
	48	16	Runtime (milliseconds)	UINT	Number of milliseconds (after the integer second) since processor start-up

Table 106: Unix Time Save to Flash Telemetry Format

ID	129	Frame Length (bytes)			2
Description	Configuration settings for unixtime flash memory persistence				
Channels	Offset (bits)	Length (bits)	Name	Data Type	Description
	0	1	Save Now	BOOL	Save current unixtime to flash memory
	1	1	Save On Update	BOOL	Save unixtime to flash memory whenever there is a command to update the unixtime
	2	1	Save Periodic	BOOL	Save unixtime to flash memory periodically
	8	8	Period	UINT	Interval at which to save unixtime to flash memory. (Unit of measure is [s])

Table 107: Boot Index and Status Telemetry Format

ID	130	Frame Length (bytes)			2
Description	Current selected boot index and status of last boot				
Channels	Offset (bits)	Length (bits)	Name	Data Type	Description
	0	8	Program Index	ENUM	Program Index. Possible values are in Table 108: BootProgramsList Enumeration Values
	8	8	Boot Status	ENUM	Boot Status. Possible values are in Table 109: BootStatus Enumeration Values

Table 108: BootProgramsList Enumeration Values

Numeric Value	Name	Description
0	Bootloader	Bootloader
1	Internal Flash Program	Internal Flash Program
2	EEPROM	EEPROM
3	External Flash Program 1	External Flash Program 1
4	External Flash Program 2	External Flash Program 2
5	External Flash Program 3	External Flash Program 3
6	External Flash Program 4	External Flash Program 4
7	External Flash Program 5	External Flash Program 5

8	External Flash Program 6	External Flash Program 6
9	External Flash Program 7	External Flash Program 7

Table 109: BootStatus Enumeration Values

Numeric Value	Name	Description
0	New Selection	New Selection
1	Boot Success	Boot Success
2	1 Failed boot attempt	1 Failed boot attempt
3	2 Failed boot attempts	2 Failed boot attempts
4	3 Failed boot attempts	3 Failed boot attempts

Table 110: Cache enabled state Telemetry Format

ID	131	Frame Length (bytes)			1
Description	Cache enabled state				
Channels	Offset (bits)	Length (bits)	Name	Data Type	Description
	0	1	Enabled state	BOOL	Enabled state

Table 111: Boot And Running Program Status Telemetry Format

ID	132	Frame Length (bytes)			6
Description	Boot And Running Program Status				
Channels	Offset (bits)	Length (bits)	Name	Data Type	Description
	0	4	Cause of MCU Reset	ENUM	Cause of MCU reset. Possible values are in Table 112: ResetCause Enumeration Values
	4	4	Boot Cause	ENUM	Cause of last reboot. Possible values are in Table 113: BootCause Enumeration Values
	8	16	Boot Counter	UINT	Number of times CubeComputer has booted
	24	8	Boot Program Index	ENUM	Index of current running program in flash programs list. Possible values are in Table 108: BootProgramsList Enumeration Values
	32	8	Firmware version (Major)	UINT	Firmware version (Major)

	40	8	Firmware version (Minor)	UINT	Firmware version (Minor)
--	----	---	--------------------------	------	--------------------------

Table 112: ResetCause Enumeration Values

Numeric Value	Name	Description
0	Power-On Reset	Power-On Reset
1	Brown-Out Detected on Regulated Power	Brown-Out Detected on Regulated Power
2	Brown-Out Detected on Unregulated Power	Brown-Out Detected on Unregulated Power
3	External Watchdog Reset	External Watchdog Reset
4	External Reset	External Reset
5	Watchdog Reset	Watchdog Reset
6	Lockup System Reset	Lockup System Reset
7	Lockup Reset	Lockup Reset
8	System Request Reset	System Request Reset
9	Backup Brown-Out	Backup domain brown-out reset
10	Backup Mode Reset	Backup mode reset
11	Backup Mode RST and Backup Brown-Out Vdd Regulated	Backup Mode reset and Backup domain brown-out on VDD regulated
12	BackupModeRST and Backup Brown-Out Vdd Regulated and Brown-Out Regulated	Backup Mode reset and Backup domain brown-out on VDD regulated and brown out on regulated
13	Backup Mode RST and Watchdog Reset	Backup mode reset and Watchdog reset
14	Backup Brown-Out Buvin and System Request Reset	Backup Domain brown-out on BUVIN and System request reset.
15	Unkown Reset Cause	Unkown Reset Cause

Table 113: BootCause Enumeration Values

Numeric Value	Name	Description
0	Unexpected	Unexpected reset
1	Not Used	
2	Communications Timeout	Timeout due to lack of communications
3	Commanded	Software commanded MCU reset
4	Not Used	
5	SRAM Latchup	Latchup detected in SRAM

Table 114: JPG Conversion Progress Telemetry Format

ID	133	Frame Length (bytes)			3
Description	Conversion progress				
Channels	Offset (bits)	Length (bits)	Name	Data Type	Description
	0	8	Progress Percentage	UINT	Progress %
	8	8	Conversion Result	ENUM	JPG Conversion Result. Possible values are in Table 115: JpgConvertResult Enumeration Values
	16	8	Output File Counter	UINT	Output File Counter

Table 115: JpgConvertResult Enumeration Values

Numeric Value	Name	Description
0	Nothing Converted Yet	Nothing Converted Yet
1	Success	Success
2	File Load Error	File Load Error
3	Busy	Busy

Table 116: SRAM Scrub Parameters Telemetry Format

ID	134	Frame Length (bytes)			2
Description	SRAM scrubbing size				
Channels	Offset (bits)	Length (bits)	Name	Data Type	Description
	0	16	Scrub Size	UINT	Scrub Size

Table 117: CubeACP State Telemetry Format

ID	135	Frame Length (bytes)			1
Description	Contains flags regarding the state of the ACP				
Channels	Offset (bits)	Length (bits)	Name	Data Type	Description
	0	1	ADCS Config Load Error	BOOL	Flag to indicate that the ADCS configuration was not read successfully out of flash
	1	1	Orbit Parameter Load Error	BOOL	Flag to indicate that the Orbit parameters were not read successfully out of flash

Table 118: Current Unix Time Telemetry Format

ID	140	Frame Length (bytes)			6
Description	Current Unix Time				
Channels	Offset (bits)	Length (bits)	Name	Data Type	Description
	0	32	Current Unix Time	UINT	Time in s since 01/01/1970, 00:00. (Unit of measure is [s])
	32	16	Milliseconds	UINT	Current millisecond count. (Unit of measure is [ms])

Table 119: Last Logged Event Telemetry Format

ID	141	Frame Length (bytes)			6
Description	Last Logged Event (relative to pointer - adjusted via Advance and Reset TCs (3 & 4))				
Channels	Offset (bits)	Length (bits)	Name	Data Type	Description
	0	32	Time of Event	UINT	
	32	8	Event ID	UINT	Event ID
	40	8	Event Parameter	UINT	Event Parameter

Table 120: SRAM Latchup counters Telemetry Format

ID	142	Frame Length (bytes)			6
Description	SRAM Latchup counters				
Channels	Offset (bits)	Length (bits)	Name	Data Type	Description
	0	16	SRAM1 latchups	UINT	The number of SRAM1 latchups detected
	16	16	SRAM2 latchups	UINT	The number of SRAM2 latchups detected

Table 121: EDAC Error Counters Telemetry Format

ID	143	Frame Length (bytes)			6
Description	EDAC Error Counters				
Channels	Offset (bits)	Length (bits)	Name	Data Type	Description
	0	16	Single SRAM upsets	UINT	The number of single SRAM upsets (per byte) detected

	16	16	Double SRAM upsets	UINT	The number of double SRAM upsets (per byte) detected
	32	16	Multiple SRAM upsets	UINT	The number of multiple SRAM upsets (per byte) detected

Table 122: Communication Status Telemetry Format

ID	144	Frame Length (bytes)		6	
Description	Communication status - includes command and telemetry counters and error flags				
Channels	Offset (bits)	Length (bits)	Name	Data Type	Description
	0	16	Telecommand counter	UINT	No. of telecommands received
	16	16	Telemetry request counter	UINT	No. of telemetry requests received
	32	1	Telecommand buffer overrun	BOOL	TC buffer was overrun while receiving a telecommand
	33	1	UART protocol error	BOOL	UART protocol error occurred
	34	1	UART incomplete message	BOOL	UART start-of-message identifier was received without a preceding end-of-message
	35	1	I2C telemetry error	BOOL	Number of data clocked out was more than telemetry package
	36	1	I2C telecommand buffer error	BOOL	Telecommand sent exceeds buffer size
	37	1	CAN telecommand buffer error	BOOL	Telecommand sent exceeds buffer size

Table 123: Current ADCS State Telemetry Format

ID	145	Frame Length (bytes)		6	
Description	Current state of the Attitude Control Processor				
Channels	Offset (bits)	Length (bits)	Name	Data Type	Description
	0	4	Attitude Estimation Mode	ENUM	Current attitude estimation mode. Possible values are in Table 27: EstimModeSelect Enumeration Values
	4	4	Control Mode	ENUM	Current attitude control mode. Possible values are in Table 25:

				ConModeSelect Enumeration Values
8	2	ADCS Run Mode	ENUM	Current ADCS Running mode. Possible values are in Table 20: AdcsRunMode Enumeration Values
10	1	CubeControl Signal Enabled	BOOL	CubeControl Signal electronics enabled status
11	1	CubeControl Motor Enabled	BOOL	CubeControl Motor electronics enabled status
12	1	CubeSense Enabled	BOOL	CubeSense enabled status
13	1	CubeWheel1 Enabled	BOOL	CubeWheel1 enabled status
14	1	CubeWheel2 Enabled	BOOL	CubeWheel2 enabled status
15	1	CubeWheel3 Enabled	BOOL	CubeWheel3 enabled status
16	1	CubeStar Enabled	BOOL	CubeStar enabled status
17	1	GPS Receiver Enabled	BOOL	GPS Receiver enabled status
18	1	GPS LNA Power Enabled	BOOL	GPS Antenna LNA enabled status
19	1	Motor Driver Enabled	BOOL	Motor Driver Electronics enabled status
20	1	Sun is Above Local Horizon	BOOL	Sun is above the local horizon (elevation > 0)
21	1	CubeSense Communications Error	BOOL	Communication error occurred with the CubeSense
22	1	CubeControl Signal Communications Error	BOOL	Communication error occurred with the CubeControl Signal MCU
23	1	CubeControl Motor Communications Error	BOOL	Communication error occurred with the CubeControl Motor MCU
24	1	CubeWheel1 Communications Error	BOOL	Communication error occurred with the CubeWheel1
25	1	CubeWheel2 Communications Error	BOOL	Communication error occurred with the CubeWheel2

26	1	CubeWheel3 Communications Error	BOOL	Communication error occurred with the CubeWheel3
27	1	CubeStar Communications Error	BOOL	Communication error occurred with the CubeStar
28	1	Magnetometer Range Error	BOOL	Magnetometer measured magnetic field with size < 100 nT or > 100,000nT
29	1	Cam1 Sensor Overcurrent Detected	BOOL	Cam1 sensor overcurrent detected
30	1	Cam1 Sensor Busy Error	BOOL	Cam1 sensor was not idle at the start of ADCS loop
31	1	Cam1 Sensor Detection Error	BOOL	Cam1 sensor was unable to compute angles (could be not in FOV)
32	1	Sun Sensor Range Error	BOOL	Detected sun angles were outside of +/- 90 deg
33	1	Cam2 Sensor Overcurrent Detected	BOOL	Cam2 sensor overcurrent detected
34	1	Cam2 Sensor Busy Error	BOOL	Cam2 sensor was not idle at the start of ADCS loop
35	1	Cam2 Sensor Detection Error	BOOL	Cam2 sensor was unable to compute angles (could be not in FOV)
36	1	Nadir Sensor Range Error	BOOL	Detected nadir angles were outside of +/- 60 deg
37	1	Rate Sensor Range Error	BOOL	Measured XYZ-body rate is outside of the range +/-20 deg/s
38	1	Wheel Speed Range Error	BOOL	Wheel XYZ speed measurement was outside the range +/-8500 rpm
39	1	Coarse Sun Sensor Error	BOOL	Unable to compute Coarse Sun vector (could be not in FOV)
40	1	StarTracker Match Error	BOOL	Unable to obtain enough matched stars
41	1	Star Tracker Overcurrent Detected	BOOL	Star tracker overcurrent detected

	42	1	Orbit Parameters are Invalid	BOOL	Orbit Parameters are not in allowed bounds (angle exceeding limits etc.). Failed to initialize SGP4 propagator using supplied parameters
	43	1	Configuration is Invalid	BOOL	Magnetorquer Configuration or CSS is invalid. Each principle axis should have a torquer output (1,2, or 3) assigned. At least one CSS per principle axis needed
	44	1	Control Mode Change is not allowed	BOOL	Attempt was made to select control mode without appropriate estimator, or command to set Y-momentum mode while not in steady-state Y-Thomson
	45	1	Estimator Change is not allowed	BOOL	Attempt was made to change to an estimation mode that would be inappropriate for the current control mode
	46	1	Modelled and measured magnetic field differs in size	BOOL	Modelled and measured magnetic field differs in size by more than 5000 nT
	47	1	Node Recovery Error	BOOL	Failed to Recover an ADCS Node by successive resets

Table 124: Estimated Attitude Angles Telemetry Format

ID	146	Frame Length (bytes)		6	
Description	Estimated attitude angles				
Channels	Offset (bits)	Length (bits)	Name	Data Type	Description
	0	16	Estimated Roll Angle	INT	Estimated roll angle. Formatted value is obtained using the formula: (formatted value) [deg] = RAWVAL*0.01
	16	16	Estimated Pitch Angle	INT	Estimated pitch angle. Formatted value is obtained using the formula: (formatted value) [deg] = RAWVAL*0.01
	32	16	Estimated Yaw Angle	INT	Estimated yaw angle. Formatted value is obtained using the

					formula: (formatted value) [deg] = RAWVAL*0.01
--	--	--	--	--	---

Table 125: Estimated Angular Rates Telemetry Format

ID	147	Frame Length (bytes)			6
Description	Estimated angular rates relative to orbit reference frame				
Channels	Offset (bits)	Length (bits)	Name	Data Type	Description
	0	16	Estimated X Angular Rate	INT	Estimated X angular rate. Formatted value is obtained using the formula: (formatted value) [deg/s] = RAWVAL*0.01
	16	16	Estimated Y Angular Rate	INT	Estimated Y angular rate. Formatted value is obtained using the formula: (formatted value) [deg/s] = RAWVAL*0.01
	32	16	Estimated Z Angular Rate	INT	Estimated Z angular rate. Formatted value is obtained using the formula: (formatted value) [deg/s] = RAWVAL*0.01

Table 126: Satellite Position (ECI) Telemetry Format

ID	148	Frame Length (bytes)			6
Description	Satellite position in ECI frame				
Channels	Offset (bits)	Length (bits)	Name	Data Type	Description
	0	16	X position	INT	ECI referenced X coordinate . Formatted value is obtained using the formula: (formatted value) [km] = RAWVAL*0.25
	16	16	Y position	INT	ECI referenced Y coordinate . Formatted value is obtained using the formula: (formatted value) [km] = RAWVAL*0.25
	32	16	Z position	INT	ECI referenced Z coordinate . Formatted value is obtained using the formula: (formatted value) [km] = RAWVAL*0.25

Table 127: Satellite Velocity (ECI) Telemetry Format

ID	149	Frame Length (bytes)			6
Description	Satellite velocity in ECI frame				
Channels	Offset (bits)	Length (bits)	Name	Data Type	Description
	0	16	X Velocity	INT	ECI referenced X velocity . Formatted value is obtained using the formula: (formatted value) [m/s] = RAWVAL*0.25
	16	16	Y Velocity	INT	ECI referenced Y velocity . Formatted value is obtained using the formula: (formatted value) [m/s] = RAWVAL*0.25
	32	16	Z Velocity	INT	ECI referenced Z velocity . Formatted value is obtained using the formula: (formatted value) [m/s] = RAWVAL*0.25

Table 128: Satellite Position (LLH) Telemetry Format

ID	150	Frame Length (bytes)			6
Description	Satellite position in WGS-84 coordinate frame				
Channels	Offset (bits)	Length (bits)	Name	Data Type	Description
	0	16	Latitude	INT	WGS-84 Latitude angle . Formatted value is obtained using the formula: (formatted value) [deg] = RAWVAL*0.01
	16	16	Longitude	INT	Longitude angle. Formatted value is obtained using the formula: (formatted value) [deg] = RAWVAL*0.01
	32	16	Altitude	UINT	WGS-84 altitude. Formatted value is obtained using the formula: (formatted value) [km] = RAWVAL*0.01

Table 129: Magnetic Field Vector Telemetry Format

ID	151	Frame Length (bytes)			6
Description	Measured magnetic field vector				

Channels	Offset (bits)	Length (bits)	Name	Data Type	Description
	0	16	Magnetic Field X	INT	Magnetic Field X. Formatted value is obtained using the formula: (formatted value) [uT] = RAWVAL*0.01
	16	16	Magnetic Field Y	INT	Magnetic Field Y. Formatted value is obtained using the formula: (formatted value) [uT] = RAWVAL*0.01
	32	16	Magnetic Field Z	INT	Magnetic Field Z. Formatted value is obtained using the formula: (formatted value) [uT] = RAWVAL*0.01

Table 130: Coarse Sun Vector Telemetry Format

ID	152	Frame Length (bytes)	6		
Description	Measured coarse sun vector				
Channels	Offset (bits)	Length (bits)	Name	Data Type	Description
	0	16	Coarse Sun X	INT	Coarse Sun X. Formatted value is obtained using the formula: (formatted value) = RAWVAL/10000.0
	16	16	Coarse Sun Y	INT	Coarse Sun Y. Formatted value is obtained using the formula: (formatted value) = RAWVAL/10000.0
	32	16	Coarse Sun Z	INT	Coarse Sun Z. Formatted value is obtained using the formula: (formatted value) = RAWVAL/10000.0

Table 131: Fine Sun Vector Telemetry Format

ID	153	Frame Length (bytes)	6		
Description	Measured fine sun vector				
Channels	Offset (bits)	Length (bits)	Name	Data Type	Description
	0	16	Sun X	INT	Sun X. Formatted value is obtained using the formula:

					(formatted value) = RAWVAL/10000.0
	16	16	Sun Y	INT	Sun Y. Formatted value is obtained using the formula: (formatted value) = RAWVAL/10000.0
	32	16	Sun Z	INT	Sun Z. Formatted value is obtained using the formula: (formatted value) = RAWVAL/10000.0

Table 132: Nadir Vector Telemetry Format

ID	154	Frame Length (bytes)			6
Description	Measured nadir vector				
Channels	Offset (bits)	Length (bits)	Name	Data Type	Description
	0	16	Nadir X	INT	Nadir X. Formatted value is obtained using the formula: (formatted value) = RAWVAL/10000.0
	16	16	Nadir Y	INT	Nadir Y. Formatted value is obtained using the formula: (formatted value) = RAWVAL/10000.0
	32	16	Nadir Z	INT	Nadir Z. Formatted value is obtained using the formula: (formatted value) = RAWVAL/10000.0

Table 133: Rate Sensor Rates Telemetry Format

ID	155	Frame Length (bytes)			6
Description	Rate sensor measurements				
Channels	Offset (bits)	Length (bits)	Name	Data Type	Description
	0	16	X Angular Rate	INT	X Angular Rate. Formatted value is obtained using the formula: (formatted value) [deg/s] = RAWVAL*0.01
	16	16	Y Angular Rate	INT	Y Angular Rate. Formatted value is obtained using the formula:

					(formatted value) [deg/s] = RAWVAL*0.01
	32	16	Z Angular Rate	INT	Z Angular Rate. Formatted value is obtained using the formula: (formatted value) [deg/s] = RAWVAL*0.01

Table 134: Wheel Speed Telemetry Format

ID	156	Frame Length (bytes)			6
Description	Wheel speed measurement				
Channels	Offset (bits)	Length (bits)	Name	Data Type	Description
	0	16	X Wheel Speed	INT	X Wheel Speed. (Unit of measure is [rpm])
	16	16	Y Wheel Speed	INT	Y Wheel Speed. (Unit of measure is [rpm])
	32	16	Z Wheel Speed	INT	Z Wheel Speed. (Unit of measure is [rpm])

Table 135: Magnetorquer Command Telemetry Format

ID	157	Frame Length (bytes)			6
Description	Magnetorquer commands				
Channels	Offset (bits)	Length (bits)	Name	Data Type	Description
	0	16	X Magnetorquer Command	INT	X Magnetorquer Commanded on-time. (Unit of measure is [10ms units])
	16	16	Y Magnetorquer Command	INT	Y Magnetorquer Commanded on-time. (Unit of measure is [10ms units])
	32	16	Z Magnetorquer Command	INT	Z Magnetorquer Commanded on-time. (Unit of measure is [10ms units])

Table 136: Wheel Speed Commands Telemetry Format

ID	158	Frame Length (bytes)			6
Description	Wheel speed commands				

Channels	Offset (bits)	Length (bits)	Name	Data Type	Description
	0	16	X Wheel Speed	INT	X Wheel Speed. (Unit of measure is [rpm])
	16	16	Y Wheel Speed	INT	Y Wheel Speed. (Unit of measure is [rpm])
	32	16	Z Wheel Speed	INT	Z Wheel Speed. (Unit of measure is [rpm])

Table 137: IGRF Modelled Magnetic Field Vector Telemetry Format

ID	159	Frame Length (bytes)	6		
Description	IGRF modelled magnetic field vector (orbit frame referenced)				
Channels	Offset (bits)	Length (bits)	Name	Data Type	Description
	0	16	IGRF Modelled Magnetic Field X	INT	IGRF Modelled Magnetic Field X. Formatted value is obtained using the formula: (formatted value) [uT] = RAWVAL*0.01
	16	16	IGRF Modelled Magnetic Field Y	INT	IGRF Modelled Magnetic Field Y. Formatted value is obtained using the formula: (formatted value) [uT] = RAWVAL*0.01
	32	16	IGRF Modelled Magnetic Field Z	INT	IGRF Modelled Magnetic Field Z. Formatted value is obtained using the formula: (formatted value) [uT] = RAWVAL*0.01

Table 138: Modelled Sun Vector Telemetry Format

ID	160	Frame Length (bytes)	6		
Description	Modelled sun vector (orbit frame referenced)				
Channels	Offset (bits)	Length (bits)	Name	Data Type	Description
	0	16	Modelled Sun Vector X	INT	Modelled Sun Vector X. Formatted value is obtained using the formula: (formatted value) = RAWVAL/10000.0
	16	16	Modelled Sun Vector Y	INT	Modelled Sun Vector Y. Formatted value is obtained using the formula: (formatted value) = RAWVAL/10000.0

	32	16	Modelled Sun Vector Z	INT	Modelled Sun Vector Z. Formatted value is obtained using the formula: (formatted value) = RAWVAL/10000.0
--	----	----	-----------------------	-----	--

Table 139: Estimated Gyro Bias Telemetry Format

ID	161	Frame Length (bytes)			6
Description	Estimated rate sensor bias				
Channels	Offset (bits)	Length (bits)	Name	Data Type	Description
	0	16	Estimated X-gyro Bias	INT	Estimated X-gyro Bias. Formatted value is obtained using the formula: (formatted value) [deg/s] = RAWVAL*0.001
	16	16	Estimated Y-gyro Bias	INT	Estimated Y-gyro Bias. Formatted value is obtained using the formula: (formatted value) [deg/s] = RAWVAL*0.001
	32	16	Estimated Z-gyro Bias	INT	Estimated Z-gyro Bias. Formatted value is obtained using the formula: (formatted value) [deg/s] = RAWVAL*0.001

Table 140: Estimation Innovation Vector Telemetry Format

ID	162	Frame Length (bytes)			6
Description	Estimation innovation vector				
Channels	Offset (bits)	Length (bits)	Name	Data Type	Description
	0	16	Innovation Vector X	INT	Innovation Vector X. Formatted value is obtained using the formula: (formatted value) = RAWVAL*0.0001
	16	16	Innovation Vector Y	INT	Innovation Vector Y. Formatted value is obtained using the formula: (formatted value) = RAWVAL*0.0001
	32	16	Innovation Vector Z	INT	Innovation Vector Z. Formatted value is obtained using the formula: (formatted value) = RAWVAL*0.0001

Table 141: Quaternion Error Vector Telemetry Format

ID	163	Frame Length (bytes)			6
Description	Quaternion error vector				
Channels	Offset (bits)	Length (bits)	Name	Data Type	Description
	0	16	Quaternion Error - Q1	INT	Quaternion Error - Q1. Formatted value is obtained using the formula: (formatted value) = RAWVAL*0.0001
	16	16	Quaternion Error - Q2	INT	Quaternion Error - Q2. Formatted value is obtained using the formula: (formatted value) = RAWVAL*0.0001
	32	16	Quaternion Error - Q3	INT	Quaternion Error - Q3. Formatted value is obtained using the formula: (formatted value) = RAWVAL*0.0001

Table 142: Quaternion Covariance Telemetry Format

ID	164	Frame Length (bytes)			6
Description	Quaternion covariance				
Channels	Offset (bits)	Length (bits)	Name	Data Type	Description
	0	16	Quaternion Covariance - Q1 RMS	INT	Quaternion Covariance - Q1 RMS. Formatted value is obtained using the formula: (formatted value) = RAWVAL*0.001
	16	16	Quaternion Covariance - Q2 RMS	INT	Quaternion Covariance - Q2 RMS. Formatted value is obtained using the formula: (formatted value) = RAWVAL*0.001
	32	16	Quaternion Covariance - Q3 RMS	INT	Quaternion Covariance - Q3 RMS. Formatted value is obtained using the formula: (formatted value) = RAWVAL*0.001

Table 143: Angular Rate Covariance Telemetry Format

ID	165	Frame Length (bytes)			6
Description	Angular rate covariance				
Channels	Offset (bits)	Length (bits)	Name	Data Type	Description
	0	16	X Angular Rate Covariance	INT	X Angular Rate Covariance. Formatted value is obtained using the formula: (formatted value) = RAWVAL*0.001
	16	16	Y Angular Rate Covariance	INT	Y Angular Rate Covariance. Formatted value is obtained using the formula: (formatted value) = RAWVAL*0.001
	32	16	Z Angular Rate Covariance	INT	Z Angular Rate Covariance. Formatted value is obtained using the formula: (formatted value) = RAWVAL*0.001

Table 144: Raw Cam2 Sensor Telemetry Format

ID	166	Frame Length (bytes)			6
Description	Cam2 sensor capture and detection result				
Channels	Offset (bits)	Length (bits)	Name	Data Type	Description
	0	16	Cam2 centroid X	INT	Cam2 azimuth angle
	16	16	Cam2 centroid Y	INT	Cam2 elevation angle
	32	8	Capture status	ENUM	Cam2 capture status. Possible values are in Table 145: CaptureResult Enumeration Values
	40	8	Detection result	ENUM	Cam2 detection result. Possible values are in Table 146: DetectResult Enumeration Values

Table 145: CaptureResult Enumeration Values

Numeric Value	Name	Description
0	Startup	Start-up
1	Pending	Capture pending
2	SuccessOwn	Successfully captured (own SRAM)
3	SuccessShift	Successfully captured (Other SRAM)

4	Timeout	Camera timeout
5	SRAMError	SRAM overcurrent

Table 146: DetectResult Enumeration Values

Numeric Value	Name	Description
0	Startup	Start-up
1	NoDetect	No detection scheduled
2	Pending	Detection pending
3	TooManyEdges	Nadir error - too many detected edges
4	TooFewEdges	Nadir error - not enough edges detected
5	BadFit	Nadir error - bad fit
6	SunNotFound	Sun error - sun not found
7	Success	Successful detection

Table 147: Raw Cam1 Sensor Telemetry Format

ID	167	Frame Length (bytes)	6		
Description	Cam1 sensor capture and detection result				
Channels	Offset (bits)	Length (bits)	Name	Data Type	Description
	0	16	Cam1 centroid X	INT	Cam1 azimuth angle
	16	16	Cam1 centroid Y	INT	Cam1 elevation angle
	32	8	Capture status	ENUM	Cam1 capture status. Possible values are in Table 145: CaptureResult Enumeration Values
	40	8	Detection result	ENUM	Cam1 detection result. Possible values are in Table 146: DetectResult Enumeration Values

Table 148: Raw CSS 1 to 6 Telemetry Format

ID	168	Frame Length (bytes)	6		
Description	Raw CSS measurements 1 to 6				
Channels	Offset (bits)	Length (bits)	Name	Data Type	Description
	0	8	CSS1	UINT	sampled A/D value - corresponds to COS(sun_angle)
	8	8	CSS2	UINT	sampled A/D value - corresponds to COS(sun_angle)

	16	8	CSS3	UINT	sampled A/D value - corresponds to COS(sun_angle)
	24	8	CSS4	UINT	sampled A/D value - corresponds to COS(sun_angle)
	32	8	CSS5	UINT	sampled A/D value - corresponds to COS(sun_angle)
	40	8	CSS6	UINT	sampled A/D value - corresponds to COS(sun_angle)

Table 149: Raw CSS 7 to 10 Telemetry Format

ID	169	Frame Length (bytes)			6
Description	Raw CSS measurements 7 to 10				
Channels	Offset (bits)	Length (bits)	Name	Data Type	Description
	0	8	CSS7	UINT	sampled A/D value - corresponds to COS(sun_angle)
	8	8	CSS8	UINT	sampled A/D value - corresponds to COS(sun_angle)
	16	8	CSS9	UINT	sampled A/D value - corresponds to COS(sun_angle)
	24	8	CSS10	UINT	sampled A/D value - corresponds to COS(sun_angle)

Table 150: Raw Magnetometer Telemetry Format

ID	170	Frame Length (bytes)			6
Description	Raw magnetometer measurements				
Channels	Offset (bits)	Length (bits)	Name	Data Type	Description
	0	16	MagX	INT	sampled A/D value
	16	16	MagY	INT	sampled A/D value
	32	16	MagZ	INT	sampled A/D value

Table 151: CubeSense Current Measurements Telemetry Format

ID	171	Frame Length (bytes)			6
Description	CubeSense current measurements				
Channels	Offset (bits)	Length (bits)	Name	Data Type	Description

	0	16	CubeSense 3V3 Current	UINT	CubeSense 3V3 Current. Formatted value is obtained using the formula: (formatted value) [mA] = RAWVAL*0.1
	16	16	CubeSense Cam2 SRAM Current	UINT	CubeSense Cam2 SRAM Current. Formatted value is obtained using the formula: (formatted value) [mA] = RAWVAL*0.1
	32	16	CubeSense Cam1 SRAM Current	UINT	CubeSense Cam1 SRAM Current. Formatted value is obtained using the formula: (formatted value) [mA] = RAWVAL*0.1

Table 152: CubeControl Current Measurements Telemetry Format

ID	172	Frame Length (bytes)		6	
Description	CubeControl current measurements				
Channels	Offset (bits)	Length (bits)	Name	Data Type	Description
	0	16	CubeControl 3V3 Current	UINT	CubeControl 3V3 Current. Formatted value is obtained using the formula: (formatted value) [mA] = RAWVAL*0.48828125
	16	16	CubeControl 5V Current	UINT	CubeControl 5V Current. Formatted value is obtained using the formula: (formatted value) [mA] = RAWVAL*0.48828125
	32	16	CubeControl Vbat Current	UINT	CubeControl Vbat Current. Formatted value is obtained using the formula: (formatted value) [mA] = RAWVAL*0.48828125

Table 153: Wheel Currents Telemetry Format

ID	173	Frame Length (bytes)		6	
Description	XYZ Wheel current measurement				
Channels	Offset (bits)	Length (bits)	Name	Data Type	Description
	0	16	Wheel1Current	UINT	Wheel1 Current. Formatted value is obtained using the formula:

					(formatted value) [mA] = RAWVAL*0.01
	16	16	Wheel2Current	UINT	Wheel2 Current. Formatted value is obtained using the formula: (formatted value) [mA] = RAWVAL*0.01
	32	16	Wheel3Current	UINT	Wheel3 Current. Formatted value is obtained using the formula: (formatted value) [mA] = RAWVAL*0.01

Table 154: ADCS Temperatures Telemetry Format

ID	174	Frame Length (bytes)			6
Description	Magnetometer + MCU temperature measurements				
Channels	Offset (bits)	Length (bits)	Name	Data Type	Description
	0	16	MCU Temperature	INT	MCU Temperature. (Unit of measure is [C])
	16	16	Magnetometer Temperature	INT	Magnetometer Temperature. Formatted value is obtained using the formula: (formatted value) [C] = RAWVAL/10.0
	32	16	Redundant Magnetometer Temperature	INT	Redundant Magnetometer Temperature. Formatted value is obtained using the formula: (formatted value) [C] = RAWVAL/10.0

Table 155: Rate sensor temperatures Telemetry Format

ID	175	Frame Length (bytes)			6
Description	Rate sensor temperatures				
Channels	Offset (bits)	Length (bits)	Name	Data Type	Description
	0	16	X-Rate Sensor Temperature	INT	X-Rate sensor Temperature. (Unit of measure is [C])
	16	16	Y-Rate Sensor Temperature	INT	Y-Rate sensor Temperature. (Unit of measure is [C])
	32	16	Z-Rate Sensor Temperature	INT	Z-Rate sensor Temperature. (Unit of measure is [C])

Table 156: Raw GPS Status Telemetry Format

ID	176	Frame Length (bytes)			6
Description	Raw GPS status				
Channels	Offset (bits)	Length (bits)	Name	Data Type	Description
	0	8	Gps Solution Status	ENUM	GPS Solution Status. Possible values are in Table 157: GpsSolutionStatus Enumeration Values
	8	8	Number of tracked GPS satellites	UINT	Number of tracked GPS satellites
	16	8	Number of GPS satellites used in solution	UINT	Number of GPS satellites used in solution
	24	8	Counter for XYZ Lof from GPS	UINT	Counter for XYZ Lof from GPS
	32	8	Counter for RANGE log from GPS	UINT	Counter for RANGE log from GPS
	40	8	Response Message for GPS log setup	UINT	Response Message for GPS log setup - p656 of OEMV615 reference manual

Table 157: GpsSolutionStatus Enumeration Values

Numeric Value	Name	Description
0	Solution computed	Solution computed
1	Insufficient observations	Insufficient observations
2	No convergence	No convergence
3	Singularity at parameters matrix	Singularity at parameters matrix
4	Covariance trace exceeds maximum	Covariance trace exceeds maximum
5	Not yet converged from cold start	Not yet converged from cold start
6	Height or velocity limits exceeded	Height or velocity limits exceeded
7	Variance exceeds limits	Variance exceeds limits
8	Large residuals make position unreliable	Large residuals make position unreliable
9	Calculating comparison to user provided	Calculating comparison to user provided
10	The fixed position is invalid	The fixed position is invalid
11	Position type is unauthorized	Position type is unauthorized

Table 158: Raw GPS Time Telemetry Format

ID	177	Frame Length (bytes)			6
Description	Raw GPS time				
Channels	Offset (bits)	Length (bits)	Name	Data Type	Description
	0	16	GPS Reference Week	UINT	GPS Reference Week
	16	32	GPS Time Milliseconds	UINT	GPS Time Milliseconds. (Unit of measure is [ms])

Table 159: Raw GPS X Telemetry Format

ID	178	Frame Length (bytes)			6
Description	Raw GPS X position and velocity (ECI referenced)				
Channels	Offset (bits)	Length (bits)	Name	Data Type	Description
	0	32	ECEF Position X	INT	ECEF Position X. (Unit of measure is [m])
	32	16	ECEF Velocity X	INT	ECEF Velocity X. (Unit of measure is [m/s])

Table 160: Raw GPS Y Telemetry Format

ID	179	Frame Length (bytes)			6
Description	Raw GPS Y position and velocity (ECI referenced)				
Channels	Offset (bits)	Length (bits)	Name	Data Type	Description
	0	32	ECEF Position Y	INT	ECEF Position Y. (Unit of measure is [m])
	32	16	ECEF Velocity Y	INT	ECEF Velocity Y. (Unit of measure is [m/s])

Table 161: Raw GPS Z Telemetry Format

ID	180	Frame Length (bytes)			6
Description	Raw GPS Z position and velocity (ECI referenced)				
Channels	Offset (bits)	Length (bits)	Name	Data Type	Description
	0	32	ECEF Position Z	INT	ECEF Position Z. (Unit of measure is [m])

	32	16	ECEF Velocity Z	INT	ECEF Velocity Z. (Unit of measure is [m/s])
--	----	----	-----------------	-----	---

Table 162: Star 1 Body Vector Telemetry Format

ID	181	Frame Length (bytes)			6
Description	Star 1 Body Vector				
Channels	Offset (bits)	Length (bits)	Name	Data Type	Description
	0	16	Star1BX	INT	Star1 body X-vector. Formatted value is obtained using the formula: (formatted value) = RAWVAL/10000.0
	16	16	Star1BY	INT	Star1 body Y-vector. Formatted value is obtained using the formula: (formatted value) = RAWVAL/10000.0
	32	16	Star1BZ	INT	Star1 body Z-vector. Formatted value is obtained using the formula: (formatted value) = RAWVAL/10000.0

Table 163: Star 2 Body Vector Telemetry Format

ID	182	Frame Length (bytes)			6
Description	Star 2 Body Vector				
Channels	Offset (bits)	Length (bits)	Name	Data Type	Description
	0	16	Star2BX	INT	Star2 body X-vector. Formatted value is obtained using the formula: (formatted value) = RAWVAL/10000.0
	16	16	Star2BY	INT	Star2 body Y-vector. Formatted value is obtained using the formula: (formatted value) = RAWVAL/10000.0
	32	16	Star2BZ	INT	Star2 body Z-vector. Formatted value is obtained using the formula: (formatted value) = RAWVAL/10000.0

Table 164: Star 3 Body Vector Telemetry Format

ID	183	Frame Length (bytes)			6
Description	Star 3 Body Vector				
Channels	Offset (bits)	Length (bits)	Name	Data Type	Description
	0	16	Star3BX	INT	Star3 body X-vector. Formatted value is obtained using the formula: (formatted value) = RAWVAL/10000.0
	16	16	Star3BY	INT	Star3 body Y-vector. Formatted value is obtained using the formula: (formatted value) = RAWVAL/10000.0
	32	16	Star3BZ	INT	Star3 body Z-vector. Formatted value is obtained using the formula: (formatted value) = RAWVAL/10000.0

Table 165: Star 1 Orbit Vector Telemetry Format

ID	184	Frame Length (bytes)			6
Description	Star 1 Orbit Vector				
Channels	Offset (bits)	Length (bits)	Name	Data Type	Description
	0	16	Star1OX	INT	Star1 orbit X-vector. Formatted value is obtained using the formula: (formatted value) = RAWVAL/10000.0
	16	16	Star1OY	INT	Star1 orbit Y-vector. Formatted value is obtained using the formula: (formatted value) = RAWVAL/10000.0
	32	16	Star1OZ	INT	Star1 orbit Z-vector. Formatted value is obtained using the formula: (formatted value) = RAWVAL/10000.0

Table 166: Star 2 Orbit Vector Telemetry Format

ID	185	Frame Length (bytes)			6
Description	Star 2 Orbit Vector				

Channels	Offset (bits)	Length (bits)	Name	Data Type	Description
	0	16	Star2OX	INT	Star2 orbit X-vector. Formatted value is obtained using the formula: (formatted value) = RAWVAL/10000.0
	16	16	Star2OY	INT	Star2 orbit Y-vector. Formatted value is obtained using the formula: (formatted value) = RAWVAL/10000.0
	32	16	Star2OZ	INT	Star2 orbit Z-vector. Formatted value is obtained using the formula: (formatted value) = RAWVAL/10000.0

Table 167: Star 3 Orbit Vector Telemetry Format

ID	186	Frame Length (bytes)	6		
Description	Star 3 Orbit Vector				
Channels	Offset (bits)	Length (bits)	Name	Data Type	Description
	0	16	Star3OX	INT	Star3 orbit X-vector. Formatted value is obtained using the formula: (formatted value) = RAWVAL/10000.0
	16	16	Star3OY	INT	Star3 orbit Y-vector. Formatted value is obtained using the formula: (formatted value) = RAWVAL/10000.0
	32	16	Star3OZ	INT	Star3 orbit Z-vector. Formatted value is obtained using the formula: (formatted value) = RAWVAL/10000.0

Table 168: Star Magnitude Telemetry Format

ID	187	Frame Length (bytes)	6		
Description	Instrument magnitude of identified stars				
Channels	Offset (bits)	Length (bits)	Name	Data Type	Description
	0	16	Magnitude Star 1	UINT	Instrument magnitude of star 1
	16	16	Magnitude Star 2	UINT	Instrument magnitude of star 2

	32	16	Magnitude Star 3	UINT	Instrument magnitude of star 3
--	----	----	------------------	------	--------------------------------

Table 169: Star Performance Telemetry Format

ID	188	Frame Length (bytes)			6
Description	Performance parameters of star measurement				
Channels	Offset (bits)	Length (bits)	Name	Data Type	Description
	0	4	Number of Star Detected	ENUM	Number of stars detected. Possible values are in Table 170: Stars Enumeration Values
	4	4	Number of Stars Identified	ENUM	Number of stars identified. Possible values are in Table 170: Stars Enumeration Values
	8	8	Star Noise	UINT	Noise level of star image
	16	1	Attitude Success	BOOL	Attitude Success
	17	1	Image Capture Success	BOOL	Image Capture Success
	18	1	Detection Success	BOOL	Detection Success
	19	1	Identification Success	BOOL	Identification Success
	20	1	Loop time Error	BOOL	Loop time Error
	21	1	Max Stars Detected	BOOL	Max Stars Detected
	22	1	Less than three stars in FoV	BOOL	Less than three stars in FoV
	23	1	Comms error	BOOL	Comms error
	24	8	Star1 Confidence	UINT	Confidence factor of star 1
	32	8	Star2 Confidence	UINT	Confidence factor of star 2
40	8	Star3 Confidence	UINT	Confidence factor of star 3	

Table 170: Stars Enumeration Values

Numeric Value	Name	Description
0	Zero	Zero
1	One	One
2	Two	Two

Table 171: Star Timing Telemetry Format

ID	189	Frame Length (bytes)			6
Description	Timing information of star measurement				

Channels	Offset (bits)	Length (bits)	Name	Data Type	Description
	0	16	Capture	UINT	Capture. (Unit of measure is [ms])
	16	16	Detection	UINT	Detection. (Unit of measure is [ms])
	32	16	Identification	UINT	Identification. (Unit of measure is [ms])

Table 172: ADCS State Telemetry Format

ID	190	Frame Length (bytes)	48		
Description	Current ADCS state				
Channels	Offset (bits)	Length (bits)	Name	Data Type	Description
	0	4	Attitude Estimation Mode	ENUM	Current attitude estimation mode. Possible values are in Table 27: EstimModeSelect Enumeration Values
	4	4	Control Mode	ENUM	Current attitude control mode. Possible values are in Table 25: ConModeSelect Enumeration Values
	8	2	ADCS Run Mode	ENUM	Current ADCS Running mode. Possible values are in Table 20: AdcsRunMode Enumeration Values
	10	1	CubeControl Signal Enabled	BOOL	CubeControl Signal electronics enabled status
	11	1	CubeControl Motor Enabled	BOOL	CubeControl Motor electronics enabled status
	12	1	CubeSense Enabled	BOOL	CubeSense enabled status
	13	1	CubeWheel1 Enabled	BOOL	CubeWheel1 enabled status
	14	1	CubeWheel2 Enabled	BOOL	CubeWheel2 enabled status
	15	1	CubeWheel3 Enabled	BOOL	CubeWheel3 enabled status
	16	1	CubeStar Enabled	BOOL	CubeStar enabled status
	17	1	GPS Receiver Enabled	BOOL	GPS Receiver enabled status
	18	1	GPS LNA Power Enabled	BOOL	GPS Antenna LNA enabled status

19	1	Motor Driver Enabled	BOOL	Motor Driver Electronics enabled status
20	1	Sun is Above Local Horizon	BOOL	Sun is above the local horizon (elevation > 0)
21	1	CubeSense Communications Error	BOOL	Communication error occurred with the CubeSense
22	1	CubeControl Signal Communications Error	BOOL	Communication error occurred with the CubeControl Signal MCU
23	1	CubeControl Motor Communications Error	BOOL	Communication error occurred with the CubeControl Motor MCU
24	1	CubeWheel1 Communications Error	BOOL	Communication error occurred with the CubeWheel1
25	1	CubeWheel2 Communications Error	BOOL	Communication error occurred with the CubeWheel2
26	1	CubeWheel3 Communications Error	BOOL	Communication error occurred with the CubeWheel3
27	1	CubeStar Communications Error	BOOL	Communication error occurred with the CubeStar
28	1	Magnetometer Range Error	BOOL	Magnetometer measured magnetic field with size < 100 nT or > 100,000nT
29	1	Cam1 Sensor Overcurrent Detected	BOOL	Cam1 sensor overcurrent detected
30	1	Cam1 Sensor Busy Error	BOOL	Cam1 sensor was not idle at the start of ADCS loop
31	1	Cam1 Sensor Detection Error	BOOL	Cam1 sensor was unable to compute angles (could be not in FOV)
32	1	Sun Sensor Range Error	BOOL	Detected sun angles were outside of +/- 90 deg
33	1	Cam2 Sensor Overcurrent Detected	BOOL	Cam2 sensor overcurrent detected

34	1	Cam2 Sensor Busy Error	BOOL	Cam2 sensor was not idle at the start of ADCS loop
35	1	Cam2 Sensor Detection Error	BOOL	Cam2 sensor was unable to compute angles (could be not in FOV)
36	1	Nadir Sensor Range Error	BOOL	Detected nadir angles were outside of +/- 60 deg
37	1	Rate Sensor Range Error	BOOL	Measured XYZ-body rate is outside of the range +/-20 deg/s
38	1	Wheel Speed Range Error	BOOL	Wheel XYZ speed measurement was outside the range +/-8500 rpm
39	1	Coarse Sun Sensor Error	BOOL	Unable to compute Coarse Sun vector (could be not in FOV)
40	1	StarTracker Match Error	BOOL	Unable to obtain enough matched stars
41	1	Star Tracker Overcurrent Detected	BOOL	Star tracker overcurrent detected
42	1	Orbit Parameters are Invalid	BOOL	Orbit Parameters are not in allowed bounds (angle exceeding limits etc.). Failed to initialize SGP4 propagator using supplied parameters
43	1	Configuration is Invalid	BOOL	Magnetorquer Configuration or CSS in invalid. Each principle axis should have a torquer output (1,2, or 3) assigned. At least one CSS per principle axis needed
44	1	Control Mode Change is not allowed	BOOL	Attempt was made to select control mode without appropriate estimator, or command to set Y-momentum mode while not in steady-state Y-Thomson
45	1	Estimator Change is not allowed	BOOL	Attempt was made to change to an estimation mode that would be inappropriate for the current control mode
46	1	Modelled and measured magnetic field differs in size	BOOL	Modelled and measured magnetic field differs in size by more than 5000 nT

	47	1	Node Recovery Error	BOOL	Failed to Recover an ADCS Node by successive resets
	48	16	Estimated Roll Angle	INT	Estimated roll angle. Formatted value is obtained using the formula: (formatted value) [deg] = RAWVAL*0.01
	64	16	Estimated Pitch Angle	INT	Estimated pitch angle. Formatted value is obtained using the formula: (formatted value) [deg] = RAWVAL*0.01
	80	16	Estimated Yaw Angle	INT	Estimated yaw angle. Formatted value is obtained using the formula: (formatted value) [deg] = RAWVAL*0.01
	96	16	Estimated q1	INT	Estimated q1
	112	16	Estimated q2	INT	Estimated q2
	128	16	Estimated q3	INT	Estimated q3
	144	16	Estimated X Angular Rate	INT	Estimated X angular rate. Formatted value is obtained using the formula: (formatted value) [deg/s] = RAWVAL*0.01
	160	16	Estimated Y Angular Rate	INT	Estimated Y angular rate. Formatted value is obtained using the formula: (formatted value) [deg/s] = RAWVAL*0.01
	176	16	Estimated Z Angular Rate	INT	Estimated Z angular rate. Formatted value is obtained using the formula: (formatted value) [deg/s] = RAWVAL*0.01
	192	16	X position	INT	ECI referenced X coordinate . Formatted value is obtained using the formula: (formatted value) [km] = RAWVAL*0.25
	208	16	Y position	INT	ECI referenced Y coordinate . Formatted value is obtained using the formula: (formatted value) [km] = RAWVAL*0.25
	224	16	Z position	INT	ECI referenced Z coordinate . Formatted value is obtained using the formula: (formatted value) [km] = RAWVAL*0.25
	240	16	X Velocity	INT	ECI referenced X velocity . Formatted value is obtained

					using the formula: (formatted value) [m/s] = RAWVAL*0.25
	256	16	Y Velocity	INT	ECI referenced Y velocity . Formatted value is obtained using the formula: (formatted value) [m/s] = RAWVAL*0.25
	272	16	Z Velocity	INT	ECI referenced Z velocity . Formatted value is obtained using the formula: (formatted value) [m/s] = RAWVAL*0.25
	288	16	Latitude	INT	WGS-84 Latitude angle . Formatted value is obtained using the formula: (formatted value) [deg] = RAWVAL*0.01
	304	16	Longitude	INT	Longitude angle. Formatted value is obtained using the formula: (formatted value) [deg] = RAWVAL*0.01
	320	16	Altitude	UINT	WGS-84 altitude. Formatted value is obtained using the formula: (formatted value) [km] = RAWVAL*0.01
	336	16	ECEF Position X	INT	ECEF Position X. (Unit of measure is [m])
	352	16	ECEF Position Y	INT	ECEF Position Y. (Unit of measure is [m])
	368	16	ECEF Position Z	INT	ECEF Position Z. (Unit of measure is [m])

Table 173: Parts of ADCS State telemetry frame (ID 190), requested using shorter telemetry requests

ID	Partial Commands	Length (bytes)	Bit offset	Bit length	Overlapping ADCS Configuration Telecommand Parameters
145	Current ADCS State - Table 123: Current ADCS State Telemetry Format	6	0	4	Attitude Estimation Mode
			4	4	Control Mode
			8	2	ADCS Run Mode
			10	1	CubeControl Signal Enabled
			11	1	CubeControl Motor Enabled

	12	1	CubeSense Enabled
	13	1	CubeWheel1 Enabled
	14	1	CubeWheel2 Enabled
	15	1	CubeWheel3 Enabled
	16	1	CubeStar Enabled
	17	1	GPS Receiver Enabled
	18	1	GPS LNA Power Enabled
	19	1	Motor Driver Enabled
	20	1	Sun is Above Local Horizon
	21	1	CubeSense Communications Error
	22	1	CubeControl Signal Communications Error
	23	1	CubeControl Motor Communications Error
	24	1	CubeWheel1 Communications Error
	25	1	CubeWheel2 Communications Error
	26	1	CubeWheel3 Communications Error
	27	1	CubeStar Communications Error
	28	1	Magnetometer Range Error
	29	1	Cam1 Sensor Overcurrent Detected
	30	1	Cam1 Sensor Busy Error
	31	1	Cam1 Sensor Detection Error
	32	1	Sun Sensor Range Error
	33	1	Cam2 Sensor Overcurrent Detected
	34	1	Cam2 Sensor Busy Error
	35	1	Cam2 Sensor Detection Error
	36	1	Nadir Sensor Range Error
	37	1	Rate Sensor Range Error
	38	1	Wheel Speed Range Error
	39	1	Coarse Sun Sensor Error
	40	1	StarTracker Match Error
	41	1	Star Tracker Overcurrent Detected
	42	1	Orbit Parameters are Invalid
	43	1	Configuration is Invalid
	44	1	Control Mode Change is not allowed
	45	1	Estimator Change is not allowed
	46	1	Modelled and measured magnetic field differs in size
	47	1	Node Recovery Error

146	Estimated Attitude Angles - Table 124: Estimated Attitude Angles Telemetry Format	6	48	16	Estimated Roll Angle
			64	16	Estimated Pitch Angle
			80	16	Estimated Yaw Angle
218	Estimated Quaternion - Table 199: Estimated Quaternion Telemetry Format	6	96	16	Estimated q1
			112	16	Estimated q2
			128	16	Estimated q3
147	Estimated Angular Rates - Table 125: Estimated Angular Rates Telemetry Format	6	144	16	Estimated X Angular Rate
			160	16	Estimated Y Angular Rate
			176	16	Estimated Z Angular Rate
148	Satellite Position (ECI) - Table 126: Satellite Position (ECI) Telemetry Format	6	192	16	X position
			208	16	Y position
			224	16	Z position
149	Satellite Velocity (ECI) - Table 127: Satellite Velocity (ECI) Telemetry Format	6	240	16	X Velocity
			256	16	Y Velocity
			272	16	Z Velocity
150	Satellite Position (LLH) - Table 128: Satellite Position (LLH) Telemetry Format	6	288	16	Latitude
			304	16	Longitude
			320	16	Altitude
219	ECEF Position - Table 200: ECEF Position Telemetry Format	6	336	16	ECEF Position X
			352	16	ECEF Position Y

		368	16	ECEF Position Z
--	--	-----	----	-----------------

Table 174: ADCS Measurements Telemetry Format

ID	191		Frame Length (bytes)	72	
Description	Calibrated sensor measurements				
Channels	Offset (bits)	Length (bits)	Name	Data Type	Description
	0	16	Magnetic Field X	INT	Magnetic Field X. Formatted value is obtained using the formula: (formatted value) [uT] = RAWVAL*0.01
	16	16	Magnetic Field Y	INT	Magnetic Field Y. Formatted value is obtained using the formula: (formatted value) [uT] = RAWVAL*0.01
	32	16	Magnetic Field Z	INT	Magnetic Field Z. Formatted value is obtained using the formula: (formatted value) [uT] = RAWVAL*0.01
	48	16	Coarse Sun X	INT	Coarse Sun X. Formatted value is obtained using the formula: (formatted value) = RAWVAL/10000.0
	64	16	Coarse Sun Y	INT	Coarse Sun Y. Formatted value is obtained using the formula: (formatted value) = RAWVAL/10000.0
	80	16	Coarse Sun Z	INT	Coarse Sun Z. Formatted value is obtained using the formula: (formatted value) = RAWVAL/10000.0
	96	16	Sun X	INT	Sun X. Formatted value is obtained using the formula: (formatted value) = RAWVAL/10000.0
	112	16	Sun Y	INT	Sun Y. Formatted value is obtained using the formula: (formatted value) = RAWVAL/10000.0
	128	16	Sun Z	INT	Sun Z. Formatted value is obtained using the formula:

					(formatted value) = RAWVAL/10000.0
	144	16	Nadir X	INT	Nadir X. Formatted value is obtained using the formula: (formatted value) = RAWVAL/10000.0
	160	16	Nadir Y	INT	Nadir Y. Formatted value is obtained using the formula: (formatted value) = RAWVAL/10000.0
	176	16	Nadir Z	INT	Nadir Z. Formatted value is obtained using the formula: (formatted value) = RAWVAL/10000.0
	192	16	X Angular Rate	INT	X Angular Rate. Formatted value is obtained using the formula: (formatted value) [deg/s] = RAWVAL*0.01
	208	16	Y Angular Rate	INT	Y Angular Rate. Formatted value is obtained using the formula: (formatted value) [deg/s] = RAWVAL*0.01
	224	16	Z Angular Rate	INT	Z Angular Rate. Formatted value is obtained using the formula: (formatted value) [deg/s] = RAWVAL*0.01
	240	16	X Wheel Speed	INT	X Wheel Speed. (Unit of measure is [rpm])
	256	16	Y Wheel Speed	INT	Y Wheel Speed. (Unit of measure is [rpm])
	272	16	Z Wheel Speed	INT	Z Wheel Speed. (Unit of measure is [rpm])
	288	16	Star1BX	INT	Star1 body X-vector. Formatted value is obtained using the formula: (formatted value) = RAWVAL/10000.0
	304	16	Star1BY	INT	Star1 body Y-vector. Formatted value is obtained using the formula: (formatted value) = RAWVAL/10000.0
	320	16	Star1BZ	INT	Star1 body Z-vector. Formatted value is obtained using the

					formula: (formatted value) = RAWVAL/10000.0
	336	16	Star1OX	INT	Star1 orbit X-vector. Formatted value is obtained using the formula: (formatted value) = RAWVAL/10000.0
	352	16	Star1OY	INT	Star1 orbit Y-vector. Formatted value is obtained using the formula: (formatted value) = RAWVAL/10000.0
	368	16	Star1OZ	INT	Star1 orbit Z-vector. Formatted value is obtained using the formula: (formatted value) = RAWVAL/10000.0
	384	16	Star2BX	INT	Star2 body X-vector. Formatted value is obtained using the formula: (formatted value) = RAWVAL/10000.0
	400	16	Star2BY	INT	Star2 body Y-vector. Formatted value is obtained using the formula: (formatted value) = RAWVAL/10000.0
	416	16	Star2BZ	INT	Star2 body Z-vector. Formatted value is obtained using the formula: (formatted value) = RAWVAL/10000.0
	432	16	Star2OX	INT	Star2 orbit X-vector. Formatted value is obtained using the formula: (formatted value) = RAWVAL/10000.0
	448	16	Star2OY	INT	Star2 orbit Y-vector. Formatted value is obtained using the formula: (formatted value) = RAWVAL/10000.0
	464	16	Star2OZ	INT	Star2 orbit Z-vector. Formatted value is obtained using the formula: (formatted value) = RAWVAL/10000.0
	480	16	Star3BX	INT	Star3 body X-vector. Formatted value is obtained using the formula: (formatted value) = RAWVAL/10000.0

	496	16	Star3BY	INT	Star3 body Y-vector. Formatted value is obtained using the formula: (formatted value) = RAWVAL/10000.0
	512	16	Star3BZ	INT	Star3 body Z-vector. Formatted value is obtained using the formula: (formatted value) = RAWVAL/10000.0
	528	16	Star3OX	INT	Star3 orbit X-vector. Formatted value is obtained using the formula: (formatted value) = RAWVAL/10000.0
	544	16	Star3OY	INT	Star3 orbit Y-vector. Formatted value is obtained using the formula: (formatted value) = RAWVAL/10000.0
	560	16	Star3OZ	INT	Star3 orbit Z-vector. Formatted value is obtained using the formula: (formatted value) = RAWVAL/10000.0

Table 175: Parts of ADCS Measurements telemetry frame (ID 191), requested using shorter telemetry requests

ID	Partial Commands	Length (bytes)	Bit offset	Bit length	Overlapping ADCS Configuration Telecommand Parameters
151	Magnetic Field Vector - Table 129: Magnetic Field Vector Telemetry Format	6	0	16	Magnetic Field X
			16	16	Magnetic Field Y
			32	16	Magnetic Field Z
152	Coarse Sun Vector - Table 130: Coarse Sun Vector Telemetry Format	6	48	16	Coarse Sun X
			64	16	Coarse Sun Y
			80	16	Coarse Sun Z
153	Fine Sun Vector - Table 131: Fine Sun Vector Telemetry Format	6	96	16	Sun X

			112	16	Sun Y
			128	16	Sun Z
154	Nadir Vector - Table 132: Nadir Vector Telemetry Format	6	144	16	Nadir X
			160	16	Nadir Y
			176	16	Nadir Z
155	Rate Sensor Rates - Table 133: Rate Sensor Rates Telemetry Format	6	192	16	X Angular Rate
			208	16	Y Angular Rate
			224	16	Z Angular Rate
156	Wheel Speed - Table 134: Wheel Speed Telemetry Format	6	240	16	X Wheel Speed
			256	16	Y Wheel Speed
			272	16	Z Wheel Speed
181	Star 1 Body Vector - Table 162: Star 1 Body Vector Telemetry Format	6	288	16	Star1BX
			304	16	Star1BY
			320	16	Star1BZ
184	Star 1 Orbit Vector - Table 165: Star 1 Orbit Vector Telemetry Format	6	336	16	Star1OX
			352	16	Star1OY
			368	16	Star1OZ
182	Star 2 Body Vector - Table 163: Star 2 Body Vector Telemetry Format	6	384	16	Star2BX
			400	16	Star2BY
			416	16	Star2BZ
185	Star 2 Orbit Vector - Table 166: Star 2 Orbit Vector Telemetry Format	6	432	16	Star2OX
			448	16	Star2OY
			464	16	Star2OZ

183	Star 3 Body Vector - Table 164: Star 3 Body Vector Telemetry Format	6	480	16	Star3BX
			496	16	Star3BY
			512	16	Star3BZ
186	Star 3 Orbit Vector - Table 167: Star 3 Orbit Vector Telemetry Format	6	528	16	Star3OX
			544	16	Star3OY
			560	16	Star3OZ

Table 176: Actuator Commands Telemetry Format

ID	192	Frame Length (bytes)			12
Description	Actuator commands				
Channels	Offset (bits)	Length (bits)	Name	Data Type	Description
	0	16	X Magnetorquer Command	INT	X Magnetorquer Commanded on-time. (Unit of measure is [10ms units])
	16	16	Y Magnetorquer Command	INT	Y Magnetorquer Commanded on-time. (Unit of measure is [10ms units])
	32	16	Z Magnetorquer Command	INT	Z Magnetorquer Commanded on-time. (Unit of measure is [10ms units])
	48	16	X Wheel Speed	INT	X Wheel Speed. (Unit of measure is [rpm])
	64	16	Y Wheel Speed	INT	Y Wheel Speed. (Unit of measure is [rpm])
	80	16	Z Wheel Speed	INT	Z Wheel Speed. (Unit of measure is [rpm])

Table 177: Parts of Actuator Commands telemetry frame (ID 192), requested using shorter telemetry requests

ID	Partial Commands	Length (bytes)	Bit offset	Bit length	Overlapping ADCS Configuration Telecommand Parameters
157	Magnetorquer Command - Table	6	0	16	X Magnetorquer Command

	135: Magnetorquer Command Telemetry Format		16	16	Y Magnetorquer Command
			32	16	Z Magnetorquer Command
			64	16	Y Wheel Speed
158	Wheel Speed Commands - Table 136: Wheel Speed Commands Telemetry Format	6	48	16	X Wheel Speed
			64	16	Y Wheel Speed
			80	16	Z Wheel Speed

Table 178: Estimation Data Telemetry Format

ID	193	Frame Length (bytes)			42
Description	Estimation meta-data				
Channels	Offset (bits)	Length (bits)	Name	Data Type	Description
	0	16	IGRF Modelled Magnetic Field X	INT	IGRF Modelled Magnetic Field X. Formatted value is obtained using the formula: (formatted value) [uT] = RAWVAL*0.01
	16	16	IGRF Modelled Magnetic Field Y	INT	IGRF Modelled Magnetic Field Y. Formatted value is obtained using the formula: (formatted value) [uT] = RAWVAL*0.01
	32	16	IGRF Modelled Magnetic Field Z	INT	IGRF Modelled Magnetic Field Z. Formatted value is obtained using the formula: (formatted value) [uT] = RAWVAL*0.01
	48	16	Modelled Sun Vector X	INT	Modelled Sun Vector X. Formatted value is obtained using the formula: (formatted value) = RAWVAL/10000.0
	64	16	Modelled Sun Vector Y	INT	Modelled Sun Vector Y. Formatted value is obtained using the formula: (formatted value) = RAWVAL/10000.0
	80	16	Modelled Sun Vector Z	INT	Modelled Sun Vector Z. Formatted value is obtained using

					the formula: (formatted value) = RAWVAL/10000.0
	96	16	Estimated X-gyro Bias	INT	Estimated X-gyro Bias. Formatted value is obtained using the formula: (formatted value) [deg/s] = RAWVAL*0.001
	112	16	Estimated Y-gyro Bias	INT	Estimated Y-gyro Bias. Formatted value is obtained using the formula: (formatted value) [deg/s] = RAWVAL*0.001
	128	16	Estimated Z-gyro Bias	INT	Estimated Z-gyro Bias. Formatted value is obtained using the formula: (formatted value) [deg/s] = RAWVAL*0.001
	144	16	Innovation Vector X	INT	Innovation Vector X. Formatted value is obtained using the formula: (formatted value) = RAWVAL*0.0001
	160	16	Innovation Vector Y	INT	Innovation Vector Y. Formatted value is obtained using the formula: (formatted value) = RAWVAL*0.0001
	176	16	Innovation Vector Z	INT	Innovation Vector Z. Formatted value is obtained using the formula: (formatted value) = RAWVAL*0.0001
	192	16	Quaternion Error - Q1	INT	Quaternion Error - Q1. Formatted value is obtained using the formula: (formatted value) = RAWVAL*0.0001
	208	16	Quaternion Error - Q2	INT	Quaternion Error - Q2. Formatted value is obtained using the formula: (formatted value) = RAWVAL*0.0001
	224	16	Quaternion Error - Q3	INT	Quaternion Error - Q3. Formatted value is obtained using the formula: (formatted value) = RAWVAL*0.0001
	240	16	Quaternion Covariance - Q1 RMS	INT	Quaternion Covariance - Q1 RMS. Formatted value is obtained using the formula: (formatted value) = RAWVAL*0.001

	256	16	Quaternion Covariance - Q2 RMS	INT	Quaternion Covariance - Q2 RMS. Formatted value is obtained using the formula: (formatted value) = RAWVAL*0.001
	272	16	Quaternion Covariance - Q3 RMS	INT	Quaternion Covariance - Q3 RMS. Formatted value is obtained using the formula: (formatted value) = RAWVAL*0.001
	288	16	X Angular Rate Covariance	INT	X Angular Rate Covariance. Formatted value is obtained using the formula: (formatted value) = RAWVAL*0.001
	304	16	Y Angular Rate Covariance	INT	Y Angular Rate Covariance. Formatted value is obtained using the formula: (formatted value) = RAWVAL*0.001
	320	16	Z Angular Rate Covariance	INT	Z Angular Rate Covariance. Formatted value is obtained using the formula: (formatted value) = RAWVAL*0.001

Table 179: Parts of Estimation Data telemetry frame (ID 193), requested using shorter telemetry requests

ID	Partial Commands	Length (bytes)	Bit offset	Bit length	Overlapping ADCS Configuration Telecommand Parameters
159	IGRF Modelled Magnetic Field Vector - Table 137: IGRF Modelled Magnetic Field Vector Telemetry Format	6	0	16	IGRF Modelled Magnetic Field X
			16	16	IGRF Modelled Magnetic Field Y
			32	16	IGRF Modelled Magnetic Field Z
160	Modelled Sun Vector - Table 138: Modelled Sun Vector Telemetry Format	6	48	16	Modelled Sun Vector X
			64	16	Modelled Sun Vector Y
			80	16	Modelled Sun Vector Z

161	Estimated Gyro Bias - Table 139: Estimated Gyro Bias Telemetry Format	6	96	16	Estimated X-gyro Bias
			112	16	Estimated Y-gyro Bias
			128	16	Estimated Z-gyro Bias
162	Estimation Innovation Vector - Table 140: Estimation Innovation Vector Telemetry Format	6	144	16	Innovation Vector X
			160	16	Innovation Vector Y
			176	16	Innovation Vector Z
163	Quaternion Error Vector - Table 141: Quaternion Error Vector Telemetry Format	6	192	16	Quaternion Error - Q1
			208	16	Quaternion Error - Q2
			224	16	Quaternion Error - Q3
164	Quaternion Covariance - Table 142: Quaternion Covariance Telemetry Format	6	240	16	Quaternion Covariance - Q1 RMS
			256	16	Quaternion Covariance - Q2 RMS
			272	16	Quaternion Covariance - Q3 RMS
165	Angular Rate Covariance - Table 143: Angular Rate Covariance Telemetry Format	6	288	16	X Angular Rate Covariance
			304	16	Y Angular Rate Covariance
			320	16	Z Angular Rate Covariance

Table 180: Raw Sensor Measurements Telemetry Format

ID	194	Frame Length (bytes)		28	
Description	Raw sensor measurements				
Channels	Offset (bits)	Length (bits)	Name	Data Type	Description
	0	16	Cam2 centroid X	INT	Cam2 azimuth angle

	16	16	Cam2 centroid Y	INT	Cam2 elevation angle
	32	8	Capture status	ENUM	Cam2 capture status. Possible values are in Table 145: CaptureResult Enumeration Values
	40	8	Detection result	ENUM	Cam2 detection result. Possible values are in Table 146: DetectResult Enumeration Values
	48	16	Cam1 centroid X	INT	Cam1 azimuth angle
	64	16	Cam1 centroid Y	INT	Cam1 elevation angle
	80	8	Capture status	ENUM	Cam1 capture status. Possible values are in Table 145: CaptureResult Enumeration Values
	88	8	Detection result	ENUM	Cam1 detection result. Possible values are in Table 146: DetectResult Enumeration Values
	96	8	CSS1	UINT	sampled A/D value - corresponds to COS(sun_angle)
	104	8	CSS2	UINT	sampled A/D value - corresponds to COS(sun_angle)
	112	8	CSS3	UINT	sampled A/D value - corresponds to COS(sun_angle)
	120	8	CSS4	UINT	sampled A/D value - corresponds to COS(sun_angle)
	128	8	CSS5	UINT	sampled A/D value - corresponds to COS(sun_angle)
	136	8	CSS6	UINT	sampled A/D value - corresponds to COS(sun_angle)
	144	8	CSS7	UINT	sampled A/D value - corresponds to COS(sun_angle)
	152	8	CSS8	UINT	sampled A/D value - corresponds to COS(sun_angle)
	160	8	CSS9	UINT	sampled A/D value - corresponds to COS(sun_angle)
	168	8	CSS10	UINT	sampled A/D value - corresponds to COS(sun_angle)
	176	16	MagX	INT	sampled A/D value
	192	16	MagY	INT	sampled A/D value
	208	16	MagZ	INT	sampled A/D value

Table 181: Parts of Raw Sensor Measurements telemetry frame (ID 194), requested using shorter telemetry requests

ID	Partial Commands	Length (bytes)	Bit offset	Bit length	Overlapping ADCS Configuration Telecommand Parameters
166	Raw Cam2 Sensor - Table 144: Raw Cam2 Sensor Telemetry Format	6	0	16	Cam2 centroid X
			16	16	Cam2 centroid Y
			32	8	Capture status
			40	8	Detection result
167	Raw Cam1 Sensor - Table 147: Raw Cam1 Sensor Telemetry Format	6	48	16	Cam1 centroid X
			64	16	Cam1 centroid Y
			80	8	Capture status
			88	8	Detection result
168	Raw CSS 1 to 6 - Table 148: Raw CSS 1 to 6 Telemetry Format	6	96	8	CSS1
			104	8	CSS2
			112	8	CSS3
			120	8	CSS4
			128	8	CSS5
			136	8	CSS6
169	Raw CSS 7 to 10 - Table 149: Raw CSS 7 to 10 Telemetry Format	6	144	8	CSS7
			152	8	CSS8
			160	8	CSS9
			168	8	CSS10
170	Raw Magnetometer - Table 150: Raw Magnetometer Telemetry Format	6	176	16	MagX
			192	16	MagY
			208	16	MagZ

Table 182: Power and Temperature Measurements Telemetry Format

ID	195	Frame Length (bytes)			34
Description	Power and temperature measurements				
Channels	Offset (bits)	Length (bits)	Name	Data Type	Description
	0	16	CubeSense 3V3 Current	UINT	CubeSense 3V3 Current. Formatted value is obtained using the formula: (formatted value) [mA] = RAWVAL*0.1
	16	16	CubeSense Cam2 SRAM Current	UINT	CubeSense Cam2 SRAM Current. Formatted value is obtained using the formula: (formatted value) [mA] = RAWVAL*0.1
	32	16	CubeSense Cam1 SRAM Current	UINT	CubeSense Cam1 SRAM Current. Formatted value is obtained using the formula: (formatted value) [mA] = RAWVAL*0.1
	48	16	CubeControl 3V3 Current	UINT	CubeControl 3V3 Current. Formatted value is obtained using the formula: (formatted value) [mA] = RAWVAL*0.48828125
	64	16	CubeControl 5V Current	UINT	CubeControl 5V Current. Formatted value is obtained using the formula: (formatted value) [mA] = RAWVAL*0.48828125
	80	16	CubeControl Vbat Current	UINT	CubeControl Vbat Current. Formatted value is obtained using the formula: (formatted value) [mA] = RAWVAL*0.48828125
	96	16	Wheel1Current	UINT	Wheel1 Current. Formatted value is obtained using the formula: (formatted value) [mA] = RAWVAL*0.01
	112	16	Wheel2Current	UINT	Wheel2 Current. Formatted value is obtained using the formula: (formatted value) [mA] = RAWVAL*0.01
	128	16	Wheel3Current	UINT	Wheel3 Current. Formatted value is obtained using the formula:

					(formatted value) [mA] = RAWVAL*0.01
	144	16	CubeStarCurrent	UINT	CubeStar Current. Formatted value is obtained using the formula: (formatted value) [mA] = RAWVAL*0.01
	160	16	Magnetorquer Current	UINT	Magnetorquer Current. Formatted value is obtained using the formula: (formatted value) [mA] = RAWVAL*0.1
	176	16	MCU Temperature	INT	MCU Temperature. (Unit of measure is [C])
	192	16	Magnetometer Temperature	INT	Magnetometer Temperature. Formatted value is obtained using the formula: (formatted value) [C] = RAWVAL/10.0
	208	16	Redundant Magnetometer Temperature	INT	Redundant Magnetometer Temperature. Formatted value is obtained using the formula: (formatted value) [C] = RAWVAL/10.0
	224	16	X-Rate Sensor Temperature	INT	X-Rate sensor Temperature. (Unit of measure is [C])
	240	16	Y-Rate Sensor Temperature	INT	Y-Rate sensor Temperature. (Unit of measure is [C])
	256	16	Z-Rate Sensor Temperature	INT	Z-Rate sensor Temperature. (Unit of measure is [C])

Table 183: Parts of Power and Temperature Measurements telemetry frame (ID 195), requested using shorter telemetry requests

ID	Partial Commands	Length (bytes)	Bit offset	Bit length	Overlapping ADCS Configuration Telecommand Parameters
171	CubeSense Current Measurements - Table 151: CubeSense Current Measurements Telemetry Format	6	0	16	CubeSense 3V3 Current
			16	16	CubeSense Cam2 SRAM Current
			32	16	CubeSense Cam1 SRAM Current

172	CubeControl Current Measurements - Table 152: CubeControl Current Measurements Telemetry Format	6	48	16	CubeControl 3V3 Current
			64	16	CubeControl 5V Current
			80	16	CubeControl Vbat Current
173	Wheel Currents - Table 153: Wheel Currents Telemetry Format	6	96	16	Wheel1Current
			112	16	Wheel2Current
			128	16	Wheel3Current
198	ADCS Misc Current Measurements - Table 186: ADCS Misc Current Measurements Telemetry Format	6	144	16	CubeStarCurrent
			160	16	Magnetorquer Current
174	ADCS Temperatures - Table 154: ADCS Temperatures Telemetry Format	6	176	16	MCU Temperature
			192	16	Magnetometer Temperature
			208	16	Redundant Magnetometer Temperature
175	Rate sensor temperatures - Table 155: Rate sensor temperatures Telemetry Format	6	224	16	X-Rate Sensor Temperature
			240	16	Y-Rate Sensor Temperature
			256	16	Z-Rate Sensor Temperature

Table 184: Adcs Execution Times Telemetry Format

ID	196	Frame Length (bytes)		8	
Description	Returns information about execution times of ACP functions				
Channels	Offset (bits)	Length (bits)	Name	Data Type	Description

	0	16	Time to Perform ADCS Update	UINT	Time to perform complete ADCS Update function. (Unit of measure is [ms])
	16	16	Time to Perform Sensor/Actuator Communications	UINT	Time to perform Sensor/actuator communications. (Unit of measure is [ms])
	32	16	Time to Execute SGP4 Propagator	UINT	Time to execute SGP4 propagator. (Unit of measure is [ms])
	48	16	Time to Execute IGRF Model	UINT	Time to execute IGRF computation. (Unit of measure is [ms])

Table 185: ADCS Power Control Telemetry Format

ID	197	Frame Length (bytes)		3	
Description	Control power to selected components				
Channels	Offset (bits)	Length (bits)	Name	Data Type	Description
	0	2	CubeControl Signal Power Selection	ENUM	Control power to electronics of CubeControl Signal PIC. Possible values are in Table 22: PowerSelect Enumeration Values
	2	2	CubeControl Motor Power Selection	ENUM	Control power to electronics of CubeControl Motor PIC. Possible values are in Table 22: PowerSelect Enumeration Values
	4	2	CubeSense Power Selection	ENUM	Control power to the CubeSense. Possible values are in Table 22: PowerSelect Enumeration Values
	6	2	CubeStarPower Power Selection	ENUM	Control power to the CubeStar. Possible values are in Table 22: PowerSelect Enumeration Values
	8	2	CubeWheel1Power Power Selection	ENUM	Control power to the CubeWheel1. Possible values are in Table 22: PowerSelect Enumeration Values
	10	2	CubeWheel2Power Power Selection	ENUM	Control power to the CubeWheel2. Possible values are in Table 22: PowerSelect Enumeration Values

	12	2	CubeWheel3Power Power Selection	ENUM	Control power to the CubeWheel3. Possible values are in Table 22: PowerSelect Enumeration Values
	14	2	Motor Power	ENUM	Control power to Motor electronics. Possible values are in Table 22: PowerSelect Enumeration Values
	16	2	GPS Power	ENUM	Control power to GPS LNA. Possible values are in Table 22: PowerSelect Enumeration Values

Table 186: ADCS Misc Current Measurements Telemetry Format

ID	198	Frame Length (bytes)		6	
Description	CubeStar and Torquer current measurements				
Channels	Offset (bits)	Length (bits)	Name	Data Type	Description
	0	16	CubeStarCurrent	UINT	CubeStar Current. Formatted value is obtained using the formula: (formatted value) [mA] = RAWVAL*0.01
	16	16	Magnetorquer Current	UINT	Magnetorquer Current. Formatted value is obtained using the formula: (formatted value) [mA] = RAWVAL*0.1

Table 187: Commanded Attitude Angles Telemetry Format

ID	199	Frame Length (bytes)		6	
Description	Commanded attitude angles				
Channels	Offset (bits)	Length (bits)	Name	Data Type	Description
	0	16	Commanded Roll Angle	INT	Commanded roll angle. Formatted value is obtained using the formula: (formatted value) [deg] = RAWVAL*0.01
	16	16	Commanded Pitch Angle	INT	Commanded pitch angle. Formatted value is obtained using the formula: (formatted value) [deg] = RAWVAL*0.01

	32	16	Commanded Yaw Angle	INT	Commanded yaw angle. Formatted value is obtained using the formula: (formatted value) [deg] = RAWVAL*0.01
--	----	----	---------------------	-----	---

Table 188: Tracking Controller Target Reference Telemetry Format

ID	200	Frame Length (bytes)		12	
Description	Target reference for tracking control mode				
Channels	Offset (bits)	Length (bits)	Name	Data Type	Description
	0	32	Geocentric longitude of target	FLOAT	Geocentric longitude of target. (Unit of measure is [deg])
	32	32	Geocentric latitude of target	FLOAT	Geocentric latitude of target. (Unit of measure is [deg])
	64	32	Geocentric altitude of target	FLOAT	Geocentric altitude of target. (Unit of measure is [meter])

Table 189: ADCS Configuration Telemetry Format

ID	206	Frame Length (bytes)		272	
Description	Current configuration				
Channels	Offset (bits)	Length (bits)	Name	Data Type	Description
	0	8	Magnetorquer 1 Configuration	ENUM	Magnetorquer 1 Configuration. Possible values are in Table 34: AxisSelect Enumeration Values
	8	8	Magnetorquer 2 Configuration	ENUM	Magnetorquer 2 Configuration. Possible values are in Table 34: AxisSelect Enumeration Values
	16	8	Magnetorquer 3 Configuration	ENUM	Magnetorquer 3 Configuration. Possible values are in Table 34: AxisSelect Enumeration Values
	24	8	RW1 Configuration	ENUM	RW1 Configuration. Possible values are in Table 34: AxisSelect Enumeration Values
	32	8	RW2 Configuration	ENUM	RW2 Configuration. Possible values are in Table 34: AxisSelect Enumeration Values
	40	8	RW3 Configuration	ENUM	RW3 Configuration. Possible values are in Table 34: AxisSelect Enumeration Values

48	8	RW4 Configuration	ENUM	RW4 Configuration. Possible values are in Table 34: AxisSelect Enumeration Values
56	8	Gyro1 Configuration	ENUM	Gyro1 Configuration. Possible values are in Table 34: AxisSelect Enumeration Values
64	8	Gyro2 Configuration	ENUM	Gyro2 Configuration. Possible values are in Table 34: AxisSelect Enumeration Values
72	8	Gyro3 Configuration	ENUM	Gyro3 Configuration. Possible values are in Table 34: AxisSelect Enumeration Values
80	8	CSS1 Configuration	ENUM	CSS1 Configuration. Possible values are in Table 34: AxisSelect Enumeration Values
88	8	CSS2 Configuration	ENUM	CSS2 Configuration. Possible values are in Table 34: AxisSelect Enumeration Values
96	8	CSS3 Configuration	ENUM	CSS3 Configuration. Possible values are in Table 34: AxisSelect Enumeration Values
104	8	CSS4 Configuration	ENUM	CSS4 Configuration. Possible values are in Table 34: AxisSelect Enumeration Values
112	8	CSS5 Configuration	ENUM	CSS5 Configuration. Possible values are in Table 34: AxisSelect Enumeration Values
120	8	CSS6 Configuration	ENUM	CSS6 Configuration. Possible values are in Table 34: AxisSelect Enumeration Values
128	8	CSS7 Configuration	ENUM	CSS7 Configuration. Possible values are in Table 34: AxisSelect Enumeration Values
136	8	CSS8 Configuration	ENUM	CSS8 Configuration. Possible values are in Table 34: AxisSelect Enumeration Values
144	8	CSS9 Configuration	ENUM	CSS9 Configuration. Possible values are in Table 34: AxisSelect Enumeration Values
152	8	CSS10 Configuration	ENUM	CSS10 Configuration. Possible values are in Table 34: AxisSelect Enumeration Values

160	8	CSS1 Relative Scale	UINT	CSS1 Relative Scaling Factor. Formatted value is obtained using the formula: (formatted value) = RAWVAL*0.01
168	8	CSS2 Relative Scale	UINT	CSS2 Relative Scaling Factor. Formatted value is obtained using the formula: (formatted value) = RAWVAL*0.01
176	8	CSS3 Relative Scale	UINT	CSS3 Relative Scaling Factor. Formatted value is obtained using the formula: (formatted value) = RAWVAL*0.01
184	8	CSS4 Relative Scale	UINT	CSS4 Relative Scaling Factor. Formatted value is obtained using the formula: (formatted value) = RAWVAL*0.01
192	8	CSS5 Relative Scale	UINT	CSS5 Relative Scaling Factor. Formatted value is obtained using the formula: (formatted value) = RAWVAL*0.01
200	8	CSS6 Relative Scale	UINT	CSS6 Relative Scaling Factor. Formatted value is obtained using the formula: (formatted value) = RAWVAL*0.01
208	8	CSS7 Relative Scale	UINT	CSS7 Relative Scaling Factor. Formatted value is obtained using the formula: (formatted value) = RAWVAL*0.01
216	8	CSS8 Relative Scale	UINT	CSS8 Relative Scaling Factor. Formatted value is obtained using the formula: (formatted value) = RAWVAL*0.01
224	8	CSS9 Relative Scale	UINT	CSS9 Relative Scaling Factor. Formatted value is obtained using the formula: (formatted value) = RAWVAL*0.01
232	8	CSS10 Relative Scale	UINT	CSS10 Relative Scaling Factor. Formatted value is obtained using the formula: (formatted value) = RAWVAL*0.01
240	8	CSS Threshold	UINT	CSS Threshold
248	16	Cam1 Sensor Mounting	INT	Cam1 Sensor Mounting Transform Alpha Angle.

			Transform Alpha Angle		Formatted value is obtained using the formula: (formatted value) [deg] = RAWVAL*0.01
264	16	Cam1 Sensor Mounting Transform Beta Angle	INT	Cam1 Sensor Mounting Transform Beta Angle. Formatted value is obtained using the formula: (formatted value) [deg] = RAWVAL*0.01	
280	16	Cam1 Sensor Mounting Transform Gamma Angle	INT	Cam1 Sensor Mounting Transform Gamma Angle. Formatted value is obtained using the formula: (formatted value) [deg] = RAWVAL*0.01	
296	8	Cam1 detection threshold	UINT		
304	1	Cam1 sensor auto adjust mode	BOOL	0 = disabled and 1 = enabled	
312	16	Cam1 sensor exposure time	UINT	exposure time register value	
328	16	Cam1 Boresight X	UINT	X Pixel location of Cam1 boresight. Formatted value is obtained using the formula: (formatted value) [pixels] = RAWVAL*0.01	
344	16	Cam1 Boresight Y	UINT	Y Pixel location of Cam1 boresight. Formatted value is obtained using the formula: (formatted value) [pixels] = RAWVAL*0.01	
360	1	Cam1 Shift	BOOL	Use Cam2 processing chain for Cam1 detection	
368	16	Cam2 Sensor Mounting Transform Alpha Angle	INT	Cam2 Sensor Mounting Transform Alpha Angle. Formatted value is obtained using the formula: (formatted value) [deg] = RAWVAL*0.01	
384	16	Cam2 Sensor Mounting Transform Beta Angle	INT	Cam2 Sensor Mounting Transform Beta Angle. Formatted value is obtained using the formula: (formatted value) [deg] = RAWVAL*0.01	
400	16	Cam2 Sensor Mounting Transform Gamma Angle	INT	Cam2 Sensor Mounting Transform Gamma Angle.	

		Transform Gamma Angle		Formatted value is obtained using the formula: (formatted value) [deg] = RAWVAL*0.01
416	8	Cam2 detection threshold	UINT	Cam2 detection threshold
424	1	Cam2 sensor auto adjust mode	BOOL	0 = disabled and 1 = enabled
432	16	Cam2 sensor exposure time	UINT	exposure time register value
448	16	Cam2 Boresight X	UINT	X Pixel location of Cam2 boresight. Formatted value is obtained using the formula: (formatted value) [pixels] = RAWVAL*0.01
464	16	Cam2 Boresight Y	UINT	Y Pixel location of Cam2 boresight. Formatted value is obtained using the formula: (formatted value) [pixels] = RAWVAL*0.01
480	1	Cam2 Shift	BOOL	Use Sun processing chain for Cam2 detection
488	16	Minimum X of area 1	UINT	Minimum X of Area 1
504	16	Maximum X of area 1	UINT	Maximum X of Area 1
520	16	Minimum Y of area 1	UINT	Minimum Y of Area 1
536	16	Maximum Y of area 1	UINT	Maximum Y of Area 1
552	16	Minimum X of area 2	UINT	Minimum X of Area 2
568	16	Maximum X of area 2	UINT	Maximum X of Area 2
584	16	Minimum Y of area 2	UINT	Minimum Y of Area 2
600	16	Maximum Y of area 2	UINT	Maximum Y of Area 2
616	16	Minimum X of area 3	UINT	Minimum X of Area 3
632	16	Maximum X of area 3	UINT	Maximum X of Area 3

648	16	Minimum Y of area 3	UINT	Minimum Y of Area 3
664	16	Maximum Y of area 3	UINT	Maximum Y of Area 3
680	16	Minimum X of area 4	UINT	Minimum X of Area 4
696	16	Maximum X of area 4	UINT	Maximum X of Area 4
712	16	Minimum Y of area 4	UINT	Minimum Y of Area 4
728	16	Maximum Y of area 4	UINT	Maximum Y of Area 4
744	16	Minimum X of area 5	UINT	Minimum X of Area 5
760	16	Maximum X of area 5	UINT	Maximum X of Area 5
776	16	Minimum Y of area 5	UINT	Minimum Y of Area 5
792	16	Maximum Y of area 5	UINT	Maximum Y of Area 5
808	16	Magnetometer Mounting Transform Alpha Angle	INT	Magnetometer Mounting Transform Alpha Angle. Formatted value is obtained using the formula: (formatted value) [deg] = RAWVAL*0.01
824	16	Magnetometer Mounting Transform Beta Angle	INT	Magnetometer Mounting Transform Beta Angle. Formatted value is obtained using the formula: (formatted value) [deg] = RAWVAL*0.01
840	16	Magnetometer Mounting Transform Gamma Angle	INT	Magnetometer Mounting Transform Gamma Angle. Formatted value is obtained using the formula: (formatted value) [deg] = RAWVAL*0.01
856	16	Magnetometer Channel 1 Offset	INT	Magnetometer Channel 1 Offset. Formatted value is obtained using the formula: (formatted value) = RAWVAL*0.001
872	16	Magnetometer Channel 2 Offset	INT	Magnetometer Channel 2 Offset. Formatted value is obtained

					using the formula: (formatted value) = RAWVAL*0.001
888	16	Magnetometer Channel 3 Offset	INT		Magnetometer Channel 3 Offset. Formatted value is obtained using the formula: (formatted value) = RAWVAL*0.001
904	16	Magnetometer Sensitivity Matrix S11	INT		Magnetometer Sensitivity Matrix S11. Formatted value is obtained using the formula: (formatted value) = RAWVAL*0.001
920	16	Magnetometer Sensitivity Matrix S22	INT		Magnetometer Sensitivity Matrix S22. Formatted value is obtained using the formula: (formatted value) = RAWVAL*0.001
936	16	Magnetometer Sensitivity Matrix S33	INT		Magnetometer Sensitivity Matrix S33. Formatted value is obtained using the formula: (formatted value) = RAWVAL*0.001
952	16	Magnetometer Sensitivity Matrix S12	INT		Magnetometer Sensitivity Matrix S12. Formatted value is obtained using the formula: (formatted value) = RAWVAL*0.001
968	16	Magnetometer Sensitivity Matrix S13	INT		Magnetometer Sensitivity Matrix S13. Formatted value is obtained using the formula: (formatted value) = RAWVAL*0.001
984	16	Magnetometer Sensitivity Matrix S21	INT		Magnetometer Sensitivity Matrix S21. Formatted value is obtained using the formula: (formatted value) = RAWVAL*0.001
1000	16	Magnetometer Sensitivity Matrix S23	INT		Magnetometer Sensitivity Matrix S23. Formatted value is obtained using the formula: (formatted value) = RAWVAL*0.001
1016	16	Magnetometer Sensitivity Matrix S31	INT		Magnetometer Sensitivity Matrix S31. Formatted value is obtained using the formula: (formatted value) = RAWVAL*0.001
1032	16	Magnetometer Sensitivity Matrix S32	INT		Magnetometer Sensitivity Matrix S32. Formatted value is obtained using the formula: (formatted value) = RAWVAL*0.001

1048	16	X-Rate Sensor Offset	INT	X-Rate Sensor Offset. Formatted value is obtained using the formula: (formatted value) [deg/s] = RAWVAL*0.001
1064	16	Y-Rate Sensor Offset	INT	Y-Rate Sensor Offset. Formatted value is obtained using the formula: (formatted value) [deg/s] = RAWVAL*0.001
1080	16	Z-Rate Sensor Offset	INT	Z-Rate Sensor Offset. Formatted value is obtained using the formula: (formatted value) [deg/s] = RAWVAL*0.001
1096	8	RateSensorMult	UINT	Multiplier of rate sensor measurement
1104	16	StarTracker Mounting Transform Alpha Angle	INT	StarTracker Mounting Transform Alpha Angle. Formatted value is obtained using the formula: (formatted value) [deg] = RAWVAL*0.01
1120	16	StarTracker Mounting Transform Beta Angle	INT	StarTracker Mounting Transform Beta Angle. Formatted value is obtained using the formula: (formatted value) [deg] = RAWVAL*0.01
1136	16	StarTracker Mounting Transform Gamma Angle	INT	StarTracker Mounting Transform Gamma Angle. Formatted value is obtained using the formula: (formatted value) [deg] = RAWVAL*0.01
1152	16	StarTracker exposure time	UINT	exposure time register value
1168	8	StarTracker detection threshold	UINT	StarTracker detection threshold
1176	8	StarTracker star threshold	UINT	StarTracker star threshold
1184	8	Maximum Star Matched	UINT	Maximum of stars that the star tracker will match
1192	8	Maximum Star Pixel	UINT	Maximum pixels in a star
1200	8	Maximum Star Noise	UINT	Maximum star pixel noise
1208	8	Minimum Star Pixel	UINT	Minimum pixels in a star

1216	8	Star Tracker Error Margin	UINT	% Error margin of the star identification. Formatted value is obtained using the formula: (formatted value) [%] = RAWVAL*0.01
1224	32	Star Tracker Centroid X	FLOAT	Pixel centroid X
1256	32	Star Tracker Centroid Y	FLOAT	Pixel centroid Y
1288	16	Star Tracker Focal Length	UINT	Star Tracker Focal Length. Formatted value is obtained using the formula: (formatted value) [mm] = RAWVAL*0.0001
1304	8	Synch Delay	UINT	Synchronization delay within star Tracker
1312	32	Detumbling Spin Gain	FLOAT	Detumbling Spin Gain (Ks)
1344	32	Detumbling Damping Gain	FLOAT	Detumbling Damping Gain (Kd)
1376	16	Reference spin rate	INT	Reference spin rate (wy-ref). Must always be smaller than 0. Formatted value is obtained using the formula: (formatted value) [deg/s] = RAWVAL*0.001
1392	32	Fast BDot Detumbling Gain	FLOAT	Fast BDot Detumbling Gain (Kdf)
1424	32	Y-Momentum Control Gain	FLOAT	Y-Momentum Control Gain (Kh)
1456	32	Y-momentum Nutation Damping Gain	FLOAT	Y-momentum Nutation Damping Gain (Kn)
1488	32	Y-momentum Proportional Gain	FLOAT	Y-momentum Proportional Gain (Kp1)
1520	32	Y-momentum Derivative Gain	FLOAT	Y-momentum Derivative Gain (Kd1)
1552	32	Reference Wheel Momentum	FLOAT	Reference Wheel Momentum (H-ref). Must always be smaller than 0. (Unit of measure is [Nms])
1584	32	RWheel Proportional Gain	FLOAT	RWheel Proportional Gain (Kp2)
1616	32	RWheel Derivative Gain	FLOAT	RWheel Derivative Gain (Kd2)

1648	32	Tracking Proportional Gain	FLOAT	Tracking Proportional Gain (Kp3)
1680	32	Tracking Derivative Gain	FLOAT	Tracking Derivative Gain (Kd3)
1712	32	Tracking Integral Gain	FLOAT	Tracking Integral Gain (Ki3)
1744	32	Moment Of Inertia - Ixx	FLOAT	Moment Of Inertia - Ixx. (Unit of measure is [kg.m ²])
1776	32	Moment Of Inertia - Iyy	FLOAT	Moment Of Inertia - Iyy. (Unit of measure is [kg.m ²])
1808	32	Moment Of Inertia - Izz	FLOAT	Moment Of Inertia - Izz. (Unit of measure is [kg.m ²])
1840	32	Moment Of Inertia - Ixy	FLOAT	Moment Of Inertia - Ixy. (Unit of measure is [kg.m ²])
1872	32	Moment Of Inertia - Ixz	FLOAT	Moment Of Inertia - Ixz. (Unit of measure is [kg.m ²])
1904	32	Moment Of Inertia - Iyz	FLOAT	Moment Of Inertia - Iyz. (Unit of measure is [kg.m ²])
1936	32	Magnetometer Rate Filter System Noise	FLOAT	Magnetometer Rate Filter System Noise
1968	32	EKF System Noise	FLOAT	EKF System Noise
2000	32	CSS Measurement Noise	FLOAT	CSS Measurement Noise
2032	32	Sun Sensor Measurement Noise	FLOAT	Sun Sensor Measurement Noise
2064	32	Nadir Sensor Measurement Noise	FLOAT	Nadir Sensor Measurement Noise
2096	32	Magnetometer Measurement Noise	FLOAT	Magnetometer Measurement Noise
2128	32	Star Tracker Measurement Noise	FLOAT	Star Tracker Measurement Noise
2160	1	Use Sun Sensor	BOOL	Use Sun Sensor measurement in EKF
2161	1	Use Nadir Sensor	BOOL	Use Nadir Sensor measurement in EKF
2162	1	Use CSS	BOOL	Use CSS measurement in EKF

	2163	1	Use Star Tracker	BOOL	Use Star Tracker measurement in EKF
	2164	2	Magnetometer Mode	ENUM	Mode describing which magnetometer is used for estimation and control. Possible values are in Table 35: MagModeVal Enumeration Values
	2168	8	Cam1 and Cam2 Sampling Period	UINT	Cam1 and Cam2 sensor sampling period. Lower four bits are Cam1 period and upper four bits the Cam2 period. Setting period to zero for sensor will disable sampling of sensor.. (Unit of measure is [s])

Table 190: SGP4 Orbit Parameters Telemetry Format

ID	207	Frame Length (bytes)			64
Description	SGP4 Orbit Parameters				
Channels	Offset (bits)	Length (bits)	Name	Data Type	Description
	0	64	Inclination	DOUBLE	Inclination. (Unit of measure is [deg])
	64	64	Eccentricity	DOUBLE	Eccentricity
	128	64	Right-ascension of the Ascending Node	DOUBLE	Right-ascension of the Ascending Node. (Unit of measure is [deg])
	192	64	Argument of Perigee	DOUBLE	Argument of Perigee. (Unit of measure is [deg])
	256	64	B-Star drag term	DOUBLE	B-Star drag term
	320	64	Mean Motion	DOUBLE	Mean Motion. (Unit of measure is [orbits/day])
	384	64	Mean Anomaly	DOUBLE	Mean Anomaly. (Unit of measure is [deg])
	448	64	Epoch	DOUBLE	Epoch (year.day). (Unit of measure is [year.day])

Table 191: Raw GPS Measurements Telemetry Format

ID	210	Frame Length (bytes)	36
Description	Raw GPS measurements		

Channels	Offset (bits)	Length (bits)	Name	Data Type	Description
	0	8	Gps Solution Status	ENUM	GPS Solution Status. Possible values are in Table 157: GpsSolutionStatus Enumeration Values
	8	8	Number of tracked GPS satellites	UINT	Number of tracked GPS satellites
	16	8	Number of GPS satellites used in solution	UINT	Number of GPS satellites used in solution
	24	8	Counter for XYZ Lof from GPS	UINT	Counter for XYZ Lof from GPS
	32	8	Counter for RANGE log from GPS	UINT	Counter for RANGE log from GPS
	40	8	Response Message for GPS log setup	UINT	Response Message for GPS log setup - p656 of OEMV615 reference manual
	48	16	GPS Reference Week	UINT	GPS Reference Week
	64	32	GPS Time Milliseconds	UINT	GPS Time Milliseconds. (Unit of measure is [ms])
	96	32	ECEF Position X	INT	ECEF Position X. (Unit of measure is [m])
	128	16	ECEF Velocity X	INT	ECEF Velocity X. (Unit of measure is [m/s])
	144	32	ECEF Position Y	INT	ECEF Position Y. (Unit of measure is [m])
	176	16	ECEF Velocity Y	INT	ECEF Velocity Y. (Unit of measure is [m/s])
	192	32	ECEF Position Z	INT	ECEF Position Z. (Unit of measure is [m])
	224	16	ECEF Velocity Z	INT	ECEF Velocity Z. (Unit of measure is [m/s])
	240	8	X-pos Standard Deviation	UINT	X-pos Standard Deviation. Formatted value is obtained using the formula: (formatted value) [m] = RAWVAL*0.1
	248	8	Y-pos Standard Deviation	UINT	Y-pos Standard Deviation. Formatted value is obtained using the formula: (formatted value) [m] = RAWVAL*0.1

	256	8	Z-pos Standard Deviation	UINT	Z-pos Standard Deviation. Formatted value is obtained using the formula: (formatted value) [m] = RAWVAL*0.1
	264	8	X-vel Standard Deviation	UINT	X-vel Standard Deviation. (Unit of measure is [m/s])
	272	8	Y-vel Standard Deviation	UINT	Y-vel Standard Deviation. (Unit of measure is [m/s])
	280	8	Z-vel Standard Deviation	UINT	Z-vel Standard Deviation. (Unit of measure is [m/s])

Table 192: Parts of Raw GPS Measurements telemetry frame (ID 210), requested using shorter telemetry requests

ID	Partial Commands	Length (bytes)	Bit offset	Bit length	Overlapping ADCS Configuration Telecommand Parameters
176	Raw GPS Status - Table 156: Raw GPS Status Telemetry Format	6	0	8	Gps Solution Status
			8	8	Number of tracked GPS satellites
			16	8	Number of GPS satellites used in solution
			24	8	Counter for XYZ Lof from GPS
			32	8	Counter for RANGE log from GPS
			40	8	Response Message for GPS log setup
177	Raw GPS Time - Table 158: Raw GPS Time Telemetry Format	6	48	16	GPS Reference Week
			64	32	GPS Time Milliseconds
178	Raw GPS X - Table 159: Raw GPS X Telemetry Format	6	96	32	ECEF Position X
			128	16	ECEF Velocity X
179	Raw GPS Y - Table 160: Raw GPS Y Telemetry Format	6	144	32	ECEF Position Y
			176	16	ECEF Velocity Y
180	Raw GPS Z - Table 161: Raw GPS Z Telemetry Format	6	192	32	ECEF Position Z

			224	16	ECEF Velocity Z
			240	8	X-pos Standard Deviation
			248	8	Y-pos Standard Deviation
			256	8	Z-pos Standard Deviation
			264	8	X-vel Standard Deviation
			272	8	Y-vel Standard Deviation
			280	8	Z-vel Standard Deviation

Table 193: Raw Star Tracker Telemetry Format

ID	211	Frame Length (bytes)			36
Description	Raw Star Tracker Measurement				
Channels	Offset (bits)	Length (bits)	Name	Data Type	Description
	0	4	Number of Star Detected	ENUM	Number of stars detected. Possible values are in Table 170: Stars Enumeration Values
	4	4	Number of Stars Identified	ENUM	Number of stars identified. Possible values are in Table 170: Stars Enumeration Values
	8	8	Star Noise	UINT	Noise level of star image
	16	1	Attitude Success	BOOL	Attitude Success
	17	1	Image Capture Success	BOOL	Image Capture Success
	18	1	Detection Success	BOOL	Detection Success
	19	1	Identification Success	BOOL	Identification Success
	20	1	Loop time Error	BOOL	Loop time Error
	21	1	Max Stars Detected	BOOL	Max Stars Detected
	22	1	Less than three stars in FoV	BOOL	Less than three stars in FoV
	23	1	Comms error	BOOL	Comms error
	24	8	Star1 Confidence	UINT	Confidence factor of star 1
	32	8	Star2 Confidence	UINT	Confidence factor of star 2
	40	8	Star3 Confidence	UINT	Confidence factor of star 3
	48	16	Magnitude Star 1	UINT	Instrument magnitude of star 1
	64	16	Magnitude Star 2	UINT	Instrument magnitude of star 2
	80	16	Magnitude Star 3	UINT	Instrument magnitude of star 3
	96	16	Catalogue Star 1	UINT	Catalogue number of star 1
	112	16	Centroid X Star 1	INT	X centroid of star 1
	128	16	Centroid Y Star 1	INT	Y centroid of star 1

	144	16	Catalogue Star 2	UINT	Catalogue number of star 2
	160	16	Centroid X Star 2	INT	X centroid of star 2
	176	16	Centroid Y Star 2	INT	Y centroid of star 2
	192	16	Catalogue Star 3	UINT	Catalogue number of star 3
	208	16	Centroid X Star 3	INT	X centroid of star 3
	224	16	Centroid Y Star 3	INT	Y centroid of star 3
	240	16	Capture	UINT	Capture. (Unit of measure is [ms])
	256	16	Detection	UINT	Detection. (Unit of measure is [ms])
	272	16	Identification	UINT	Identification. (Unit of measure is [ms])

Table 194: Parts of Raw Star Tracker telemetry frame (ID 211), requested using shorter telemetry requests

ID	Partial Commands	Length (bytes)	Bit offset	Bit length	Overlapping ADCS Configuration Telecommand Parameters
188	Star Performance - Table 169: Star Performance Telemetry Format	6	0	4	Number of Star Detected
			4	4	Number of Stars Identified
			8	8	Star Noise
			16	1	Attitude Success
			17	1	Image Capture Success
			18	1	Detection Success
			19	1	Identification Success
			20	1	Loop time Error
			21	1	Max Stars Detected
			22	1	Less than three stars in FoV
			23	1	Comms error
			24	8	Star1 Confidence
			32	8	Star2 Confidence
40	8	Star3 Confidence			
187	Star Magnitude - Table 168: Star Magnitude Telemetry Format	6	48	16	Magnitude Star 1
			64	16	Magnitude Star 2
			80	16	Magnitude Star 3

212	Star 1 Raw Data - Table 195: Star 1 Raw Data Telemetry Format	6	96	16	Catalogue Star 1
			112	16	Centroid X Star 1
			128	16	Centroid Y Star 1
213	Star 2 Raw Data - Table 196: Star 2 Raw Data Telemetry Format	6	144	16	Catalogue Star 2
			160	16	Centroid X Star 2
			176	16	Centroid Y Star 2
214	Star 3 Raw Data - Table 197: Star 3 Raw Data Telemetry Format	6	192	16	Catalogue Star 3
			208	16	Centroid X Star 3
			224	16	Centroid Y Star 3
189	Star Timing - Table 171: Star Timing Telemetry Format	6	240	16	Capture
			256	16	Detection
			272	16	Identification

Table 195: Star 1 Raw Data Telemetry Format

ID	212	Frame Length (bytes)		6	
Description	Catalogue index and detected coordinates for star 1				
Channels	Offset (bits)	Length (bits)	Name	Data Type	Description
	0	16	Catalogue Star 1	UINT	Catalogue number of star 1
	16	16	Centroid X Star 1	INT	X centroid of star 1
	32	16	Centroid Y Star 1	INT	Y centroid of star 1

Table 196: Star 2 Raw Data Telemetry Format

ID	213	Frame Length (bytes)		6	
Description	Catalogue index and detected coordinates for star 2				
Channels	Offset (bits)	Length (bits)	Name	Data Type	Description
	0	16	Catalogue Star 2	UINT	Catalogue number of star 2

	16	16	Centroid X Star 2	INT	X centroid of star 2
	32	16	Centroid Y Star 2	INT	Y centroid of star 2

Table 197: Star 3 Raw Data Telemetry Format

ID	214	Frame Length (bytes)		6	
Description	Catalogue index and detected coordinates for star 3				
Channels	Offset (bits)	Length (bits)	Name	Data Type	Description
	0	16	Catalogue Star 3	UINT	Catalogue number of star 3
	16	16	Centroid X Star 3	INT	X centroid of star 3
	32	16	Centroid Y Star 3	INT	Y centroid of star 3

Table 198: Redundant Magnetometer Raw Measurements Telemetry Format

ID	215	Frame Length (bytes)		6	
Description	Redundant Magnetometer raw measurements				
Channels	Offset (bits)	Length (bits)	Name	Data Type	Description
	0	16	MagX	INT	sampled A/D value
	16	16	MagY	INT	sampled A/D value
	32	16	MagZ	INT	sampled A/D value

Table 199: Estimated Quaternion Telemetry Format

ID	218	Frame Length (bytes)		6	
Description	Estimated quaternion set				
Channels	Offset (bits)	Length (bits)	Name	Data Type	Description
	0	16	Estimated q1	INT	Estimated q1
	16	16	Estimated q2	INT	Estimated q2
	32	16	Estimated q3	INT	Estimated q3

Table 200: ECEF Position Telemetry Format

ID	219	Frame Length (bytes)		6	
Description	Satellite position in ECEF coordinates				
Channels	Offset (bits)	Length (bits)	Name	Data Type	Description

	0	16	ECEF Position X	INT	ECEF Position X. (Unit of measure is [m])
	16	16	ECEF Position Y	INT	ECEF Position Y. (Unit of measure is [m])
	32	16	ECEF Position Z	INT	ECEF Position Z. (Unit of measure is [m])

Table 201: ACP Execution State Telemetry Format

ID	220	Frame Length (bytes)			3
Description	Returns information about the ACP loop				
Channels	Offset (bits)	Length (bits)	Name	Data Type	Description
	0	16	Time Since Iteration Start	UINT	Time since the start of the current loop iteration. (Unit of measure is [ms])
	16	8	Current Execution Point	ENUM	Indicates which part of the loop is currently executing. Possible values are in Table 202: ExecutionWaypoints Enumeration Values

Table 202: ExecutionWaypoints Enumeration Values

Numeric Value	Name	Description
0	Init	Busy with initialization
1	Idle	Idle
2	Sensor/Actuator Communications	Sensor/Actuator Communications
3	ADCS Update	ADCS Estimation & Control Update
4	Peripheral Power commands (over I2C)	Peripheral Power commands (over I2C)
5	CPU Temperature Sampling	CPU Temperature Sampling
6	Image Download	Image Download
7	Image Compression	Image Compression
8	Saving Image to SD Card	Saving Image to SD Card
9	Logging	Logging
10	Log File Compression	Log File Compression
11	Saving Log to SD Card	Saving Log to SD Card
12	Writing to flash	Writing to flash memory

Table 203: Status of Image Capture and Save Operation Telemetry Format

ID	233	Frame Length (bytes)			2
Description	Status of Image Capture and Save Operation				
Channels	Offset (bits)	Length (bits)	Name	Data Type	Description
	0	8	Percentage Complete	UINT	Current progress of operation. (Unit of measure is [%])
	8	8	Status	ENUM	Current status of operation. Possible values are in Table 204: ImSaveStatus Enumeration Values

Table 204: ImSaveStatus Enumeration Values

Numeric Value	Name	Description
0	No Error	No Error
1	Timeout waiting for sensor to become available	Timeout waiting for sensor to become available
2	Timeout waiting for next frame to become ready	Timeout waiting for next frame to become ready
3	Checksum mismatch between downloaded frame and unit frame	Checksum mismatch between downloaded frame and unit frame
4	Error writing to SD card	Error writing to SD card

Table 205: SD Log1 Configuration Telemetry Format

ID	235	Frame Length (bytes)			13
Description	Log selection and period for LOG1				
Channels	Offset (bits)	Length (bits)	Name	Data Type	Description
	0	80	Log Selection	ARRAY	Log Selection - up to 80 flags indicating which telemetry frames should be logged
	80	16	Log Period	UINT	Log period. Set to 0 to disable logging
	96	8	Log Destination	ENUM	Which SD card to use to store log file. Possible values are in Table 82: SdLogSelect Enumeration Values

Table 206: SD Log2 Configuration Telemetry Format

ID	236	Frame Length (bytes)			13
Description	Log selection and period for LOG2				
Channels	Offset (bits)	Length (bits)	Name	Data Type	Description
	0	80	Log Selection	ARRAY	Log Selection - up to 80 flags indicating which telemetry frames should be logged
	80	16	Log Period	UINT	Log period. Set to 0 to disable logging
	96	8	Log Destination	ENUM	Which SD card to use to store log file. Possible values are in Table 82: SdLogSelect Enumeration Values

Table 207: UART Log Configuration Telemetry Format

ID	237	Frame Length (bytes)			12
Description	Log selection and period for UART (unsolicited TLM)				
Channels	Offset (bits)	Length (bits)	Name	Data Type	Description
	0	80	Log Selection	ARRAY	Log Selection - up to 80 flags indicating which telemetry frames should be logged
	80	16	Log Period	UINT	Log period. Set to 0 to disable logging

Table 208: Telecommand Acknowledge Telemetry Format

ID	240	Frame Length (bytes)			4
Description	Telemetry frame with acknowledge status of the previously sent command				
Channels	Offset (bits)	Length (bits)	Name	Data Type	Description
	0	8	Last TC ID	UINT	ID of last received TC
	8	1	Processed flag	BOOL	Flag to indicate if the last TC has been processed.
	16	8	TC error status	ENUM	Status of last processed telecommand. Possible values are in Table 209: TcErrorReason Enumeration Values

	24	8	TC parameter error index	UINT	Index of incorrect TC parameter
--	----	---	--------------------------	------	---------------------------------

Table 209: TcErrorReason Enumeration Values

Numeric Value	Name	Description
0	No Error	No error
1	Invalid TC	Invalid telecommand ID
2	Incorrect Length	Incorrect TC parameter length
3	Incorrect Parameter	Incorrect TC parameter value

Table 210: File Download Buffer with File Contents Telemetry Format

ID	241	Frame Length (bytes)	22		
Description	File Download buffer 20-byte packet				
Channels	Offset (bits)	Length (bits)	Name	Data Type	Description
	0	16	Packet counter	UINT	Packet counter of this file download packet
	16	160	File bytes	ARRAY	File 20-byte packet

Table 211: Download Block Ready Telemetry Format

ID	242	Frame Length (bytes)	5		
Description	Status about download block preparation				
Channels	Offset (bits)	Length (bits)	Name	Data Type	Description
	0	1	Ready	BOOL	Ready
	1	1	ParameterError	BOOL	The combination of message length and hole map resulted in invalid array lengths
	8	16	Block CRC16 Checksum	UINT	Block CRC16 Checksum
	24	16	Block Length	UINT	Block length

Table 212: File Information Telemetry Format

ID	243	Frame Length (bytes)	12		
Description	File Information				
Channels	Offset (bits)	Length (bits)	Name	Data Type	Description

	0	4	File Type	ENUM	File Type. Possible values are in Table 86: FileType Enumeration Values
	4	1	Busy Updating	BOOL	
	8	8	File Ctr	UINT	File Counter
	16	32	File Size	UINT	File Size
	48	32	File Data and Time	UINT	File Data and Time (unix). (Unit of measure is [s])
	80	16	File CRC16 Checksum	UINT	File CRC16 Checksum

Table 213: Initialize Upload Complete Telemetry Format

ID	244	Frame Length (bytes)	1		
Description	Initialize Upload Complete				
Channels	Offset (bits)	Length (bits)	Name	Data Type	Description
	0	1	Busy	BOOL	Busy with file initialization (flash erase, etc.)

Table 214: Upload Block Complete Telemetry Format

ID	245	Frame Length (bytes)	1		
Description	Finalize Upload Block Complete				
Channels	Offset (bits)	Length (bits)	Name	Data Type	Description
	0	1	Busy	BOOL	Busy with block finalization
	1	1	Error	BOOL	Error in block finalization

Table 215: Block Checksum Telemetry Format

ID	246	Frame Length (bytes)	2		
Description	File upload Block CRC16 Checksum				
Channels	Offset (bits)	Length (bits)	Name	Data Type	Description
	0	16	Checksum	UINT	Checksum

Table 216: Hole Map 1 Telemetry Format

ID	247	Frame Length (bytes)	16
Description	File Upload Hole Map 1		

Channels	Offset (bits)	Length (bits)	Name	Data Type	Description
	0	128	Hole Map	ARRAY	Hole Map

Table 217: Hole Map 2 Telemetry Format

ID	248	Frame Length (bytes)	16		
Description	File Upload Hole Map 2				
Channels	Offset (bits)	Length (bits)	Name	Data Type	Description
	0	128	Hole Map	ARRAY	Hole Map

Table 218: Hole Map 3 Telemetry Format

ID	249	Frame Length (bytes)	16		
Description	File Upload Hole Map 3				
Channels	Offset (bits)	Length (bits)	Name	Data Type	Description
	0	128	Hole Map	ARRAY	Hole Map

Table 219: Hole Map 4 Telemetry Format

ID	250	Frame Length (bytes)	16		
Description	File Upload Hole Map 4				
Channels	Offset (bits)	Length (bits)	Name	Data Type	Description
	0	128	Hole Map	ARRAY	Hole Map

Table 220: Hole Map 5 Telemetry Format

ID	251	Frame Length (bytes)	16		
Description	File Upload Hole Map 5				
Channels	Offset (bits)	Length (bits)	Name	Data Type	Description
	0	128	Hole Map	ARRAY	Hole Map

Table 221: Hole Map 6 Telemetry Format

ID	252	Frame Length (bytes)	16		
Description	File Upload Hole Map 6				
Channels	Offset (bits)	Length (bits)	Name	Data Type	Description
	0	128	Hole Map	ARRAY	Hole Map

Table 222: Hole Map 7 Telemetry Format

ID	253	Frame Length (bytes)			16
Description	File Upload Hole Map 7				
Channels	Offset (bits)	Length (bits)	Name	Data Type	Description
	0	128	Hole Map	ARRAY	Hole Map

Table 223: Hole Map 8 Telemetry Format

ID	254	Frame Length (bytes)			16
Description	File Upload Hole Map 8				
Channels	Offset (bits)	Length (bits)	Name	Data Type	Description
	0	128	Hole Map	ARRAY	Hole Map

4.5.9 Logging

Table 224: Loggable Telemetry Frames

Mask	Telemetry ID	Telemetry Frame
01 00 00 00 00 00 00 00 00 00	144	Communication Status
02 00 00 00 00 00 00 00 00 00	143	EDAC Error Counters
04 00 00 00 00 00 00 00 00 00	132	Boot And Running Program Status
08 00 00 00 00 00 00 00 00 00	141	Last Logged Event
10 00 00 00 00 00 00 00 00 00	142	SRAM Latchup counters
20 00 00 00 00 00 00 00 00 00	140	Current Unix Time
80 00 00 00 00 00 00 00 00 00	157	Magnetorquer Command
00 01 00 00 00 00 00 00 00 00	158	Wheel Speed Commands
00 02 00 00 00 00 00 00 00 00	151	Magnetic Field Vector
00 04 00 00 00 00 00 00 00 00	152	Coarse Sun Vector
00 08 00 00 00 00 00 00 00 00	153	Fine Sun Vector
00 10 00 00 00 00 00 00 00 00	154	Nadir Vector
00 20 00 00 00 00 00 00 00 00	155	Rate Sensor Rates
00 40 00 00 00 00 00 00 00 00	156	Wheel Speed
00 80 00 00 00 00 00 00 00 00	181	Star 1 Body Vector
00 00 01 00 00 00 00 00 00 00	184	Star 1 Orbit Vector
00 00 02 00 00 00 00 00 00 00	182	Star 2 Body Vector
00 00 04 00 00 00 00 00 00 00	185	Star 2 Orbit Vector
00 00 08 00 00 00 00 00 00 00	183	Star 3 Body Vector
00 00 10 00 00 00 00 00 00 00	186	Star 3 Orbit Vector
00 00 20 00 00 00 00 00 00 00	171	CubeSense Current Measurements
00 00 40 00 00 00 00 00 00 00	172	CubeControl Current Measurements

00 00 80 00 00 00 00 00 00 00	173	Wheel Currents
00 00 00 01 00 00 00 00 00 00	198	ADCS Misc Current Measurements
00 00 00 02 00 00 00 00 00 00	174	ADCS Temperatures
00 00 00 04 00 00 00 00 00 00	175	Rate sensor temperatures
00 00 00 08 00 00 00 00 00 00	145	Current ADCS State
00 00 00 10 00 00 00 00 00 00	146	Estimated Attitude Angles
00 00 00 20 00 00 00 00 00 00	218	Estimated Quaternion
00 00 00 40 00 00 00 00 00 00	147	Estimated Angular Rates
00 00 00 80 00 00 00 00 00 00	148	Satellite Position (ECI)
00 00 00 00 01 00 00 00 00 00	149	Satellite Velocity (ECI)
00 00 00 00 02 00 00 00 00 00	150	Satellite Position (LLH)
00 00 00 00 04 00 00 00 00 00	219	ECEF Position
00 00 00 00 08 00 00 00 00 00	159	IGRF Modelled Magnetic Field Vector
00 00 00 00 10 00 00 00 00 00	160	Modelled Sun Vector
00 00 00 00 20 00 00 00 00 00	161	Estimated Gyro Bias
00 00 00 00 40 00 00 00 00 00	162	Estimation Innovation Vector
00 00 00 00 80 00 00 00 00 00	163	Quaternion Error Vector
00 00 00 00 00 01 00 00 00 00	164	Quaternion Covariance
00 00 00 00 00 02 00 00 00 00	165	Angular Rate Covariance
00 00 00 00 00 04 00 00 00 00	176	Raw GPS Status
00 00 00 00 00 08 00 00 00 00	177	Raw GPS Time
00 00 00 00 00 10 00 00 00 00	178	Raw GPS X
00 00 00 00 00 20 00 00 00 00	179	Raw GPS Y
00 00 00 00 00 40 00 00 00 00	180	Raw GPS Z
00 00 00 00 00 80 00 00 00 00	166	Raw Cam2 Sensor
00 00 00 00 00 00 01 00 00 00	167	Raw Cam1 Sensor
00 00 00 00 00 00 02 00 00 00	168	Raw CSS 1 to 6
00 00 00 00 00 00 04 00 00 00	169	Raw CSS 7 to 10
00 00 00 00 00 00 08 00 00 00	170	Raw Magnetometer
00 00 00 00 00 00 10 00 00 00	188	Star Performance
00 00 00 00 00 00 20 00 00 00	187	Star Magnitude
00 00 00 00 00 00 40 00 00 00	212	Star 1 Raw Data
00 00 00 00 00 00 80 00 00 00	213	Star 2 Raw Data
00 00 00 00 00 00 00 01 00 00	214	Star 3 Raw Data
00 00 00 00 00 00 00 02 00 00	189	Star Timing
00 00 00 00 00 00 00 04 00 00	215	Redundant Magnetometer Raw Measurements