



P/NO : AFN30347559

JUNE, 2006

LG Electronics Inc.

MODELS : DBRH197/DBRH198/DBRH199/D75/D77/DBRH190

SERVICE MANUAL



DVB-T HDD/DVD RECORDER SERVICE MANUAL

**MODELS : DBRH197/DBRH198/
DBRH199/D75/D77/DBRH190**

CAUTION

BEFORE SERVICING THE UNIT, READ THE "SAFETY PRECAUTIONS"
IN THIS MANUAL.

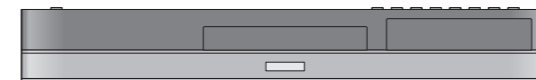

CONTENTS

SECTION 1SUMMARY

SECTION 2CABINET & MAIN CHASSIS

SECTION 3ELECTRICAL

SECTION 4RS-01A LOADER PART

SECTION 5REPLACEMENT PARTS LIST

SECTION 1

SUMMARY

CONTENTS

NEW FUNCTIONS OF HDD/DVD-RECORDER	1-2
PRODUCT SAFETY SERVICING GUIDELINES FOR VIDEO PRODUCTS.....	1-3
SERVICING PRECAUTIONS	1-4
• General Servicing Precautions	
• Insulation Checking Prodedure	
• Electrostatically Sensitive Devices	
SERVICE INFORMATION FOR EEPROM IC SETTING	1-5
SPECIFICATIONS	1-6

NEW FUNCTIONS OF HDD/DVD-RECORDER

• HDMI

HDMI IS THE SPECIFICATION FOR THE HIGH-DEFINITION MULTIMEDIA INTERFACE. HDMI IS PROVIDED FOR TRANSMITTING DIGITAL TELEVISION AUDIOVISUAL SIGNALS FROM HDD-DVD RECORDER TO TELEVISION SETS, OTHER VIDEO DISPLAYS. HDMI CAN CARRY HIGH QUALITY MULTI-CHANNEL AUDIO DATA AND CAN CARRY ALL STANDARD AND HIGH DEFINITION CONSUMER ELECTRONICS VIDEO FORMATS. CONTENT PROTECTION TECHNOLOGY IS AVAILABLE. HDMI CAN ALSO CARRY CONTROL AND STATUS INFORMATION IN BOTH DIRECTIONS.

<< OPERATING >>

AUDIO, VIDEO AND AUXILIARY DATA IS TRANSMITTED ACROSS THE THREE TMDS DATA CHANNELS. THE VIDEO PIXEL CLOCK IS TRANSMITTED ON THE TMDS CLOCK CHANNEL AND IS USED BY THE RECEIVER AS A FREQUENCY REFERENCE FOR DATA RECOVERY ON THE THREE TMDS DATA CHANNELS.

VIDEO DATA IS CARRIED AS A SERIES OF 24-BIT PIXELS ON THE THREE TMDS DATA CHANNELS. TMDS ENCODING CONVERTS THE 8BIT PER CHANNEL INTO THE 10BIT DC-BALANCED.

VIDEO PIXEL RATES CAN RANGE FROM 25MHZ TO 165MHZ. THE VIDEO PIXELS CAN BE ENCODED IN EITHER RGB,YCBCR 4:4:4 OR YCBCR 4:2:2 FORMATS. IN ALL THREE CASES, UP TP 24 BITS PER PIXEL CAN BE TRANSFERRED.

FAST DUBBING

DUBBING MEANS A COPYING FUNCTION BETWEEN HDD TO DVD DISCS.

COPYING BETWEEN HDD TO DVD IS A COMPLETELY DIGITAL PROCESS AND THEREFORE INVOLVES NO LOSS OF QUALITY IN THE AUDIO OR VIDEO. SO THIS MEANS THAT COPYING CAN BE CARRIED OUT AT THE MAXIMUM SPEED POSSIBLE.

<< DUBBING SPEED RATE >>

NORMAL DUBBING : SPEED RATE MAX X1

FAST DUBBING : SPEED RATE MAX X4

WHEN FAST DUBBING FROM HDD TO DVD , THE SPEED OF COPYING DEPENDS ON THE RECORDING MODE AND THE KIND OF USING THE DVD DISC, AND THIS MODE IS NOT AVAILABLE FOR EDITED VIDEO TITLE IN HDD.

WHEN FAST DUBBING FROM DVD TO HDD , ONLY AVAILABLE WHEN COPYING VR MODE DISC(DVD-RW) TO HDD , AND ONLY NORMAL DUBBING AVAILABLE WHEN COPYING VIDEO MODE DISC (DVD+R/RW, DVD-R) TO HDD

PRODUCT SAFETY SERVICING GUIDELINES FOR VIDEO PRODUCTS

IMPORTANT SAFETY NOTICE

This manual was prepared for use only by properly trained audio-video service technicians.

When servicing this product, under no circumstances should the original design be modified or altered without permission from LG Electronics Corporation. All components should be replaced only with types identical to those in the original circuit and their physical location, wiring and lead dress must conform to original layout upon completion of repairs.

Special components are also used to prevent x-radiation, shock and fire hazard. These components are indicated by the letter "x" included in their component designators and are required to maintain safe performance. No deviations are allowed without prior approval by LG Electronics Corporation.

Circuit diagrams may occasionally differ from the actual circuit used. This way, implementation of the latest safety and performance improvement changes into the set is not delayed until the new service literature is printed.

CAUTION: Do not attempt to modify this product in any way. Never perform customized installations without manufacturer's approval. Unauthorized modifications will not only void the warranty, but may lead to property damage or user injury.

Service work should be performed only after you are thoroughly familiar with these safety checks and servicing guidelines.

GRAPHIC SYMBOLS



The exclamation point within an equilateral triangle is intended to alert the service personnel to important safety information in the service literature.



The lightning flash with arrowhead symbol within an equilateral triangle is intended to alert the service personnel to the presence of noninsulated "dangerous voltage" that may be of sufficient magnitude to constitute a risk of electric shock.



The pictorial representation of a fuse and its rating within an equilateral triangle is intended to convey to the service personnel the following fuse replacement caution notice:

CAUTION: FOR CONTINUED PROTECTION AGAINST RISK OF FIRE, REPLACE ALL FUSES WITH THE SAME TYPE AND RATING AS MARKED NEAR EACH FUSE.

SERVICE INFORMATION

While servicing, use an isolation transformer for protection from AC line shock. After the original service problem has been corrected, make a check of the following:

FIRE AND SHOCK HAZARD

1. Be sure that all components are positioned to avoid a possibility of adjacent component shorts. This is especially important on items transported to and from the repair shop.
2. Verify that all protective devices such as insulators, barriers, covers, shields, strain reliefs, power supply cords, and other hardware have been reinstalled per the original design. Be sure that the safety purpose of the polarized line plug has not been defeated.
3. Soldering must be inspected to discover possible cold solder joints, solder splashes, or sharp solder points. Be certain to remove all loose foreign particles.
4. Check for physical evidence of damage or deterioration to parts and components, for frayed leads or damaged insulation (including the AC cord), and replace if necessary.
5. No lead or component should touch a high current device or a resistor rated at 1 watt or more. Lead tension around protruding metal surfaces must be avoided.
6. After reassembly of the set, always perform an AC leakage test on all exposed metallic parts of the cabinet (the channel selector knobs, antenna terminals, handle and screws) to be sure that set is safe to operate without danger of electrical shock. **DO NOT USE A LINE ISOLATION TRANSFORMER DURING THIS TEST.** Use an AC voltmeter having 5000 ohms per volt or more sensitivity in the following manner: Connect a 1500 ohm, 10 watt resistor, paralleled by a .15 mfd 150V AC type capacitor between a known good earth ground water pipe, conduit, etc.) and the exposed metallic parts, one at a time. Measure the AC voltage across the combination of 1500 ohm resistor and .15 mfd capacitor. Reverse the AC plug by using a non-polarized adaptor and repeat AC voltage measurements for each exposed metallic part. Voltage measured must not exceed 0.75 volts RMS. This corresponds to 0.5 milliamp AC. Any value exceeding this limit constitutes a potential shock hazard and must be corrected immediately.

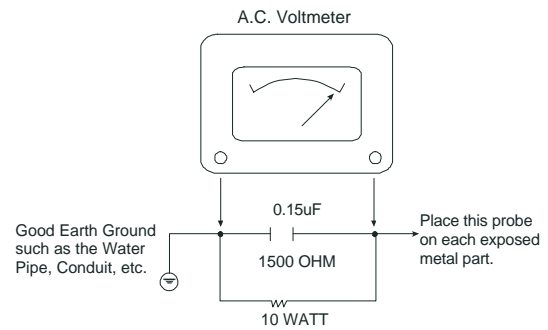

TIPS ON PROPER INSTALLATION

1. Never install any receiver in a closed-in recess, cubbyhole, or closely fitting shelf space over, or close to, a heat duct, or in the path of heated air flow.
2. Avoid conditions of high humidity such as: outdoor patio installations where dew is a factor, near steam radiators where steam leakage is a factor, etc.
3. Avoid placement where draperies may obstruct venting. The customer should also avoid the use of decorative scarves or other coverings that might obstruct ventilation.
4. Wall- and shelf-mounted installations using a commercial mounting kit must follow the factory-approved mounting instructions. A product mounted to a shelf or platform must retain its original feet (or the equivalent thickness in spacers) to provide adequate air flow across the bottom. Bolts or screws used for fasteners must not touch any parts or wiring. Perform leakage tests on customized installations.
5. Caution customers against mounting a product on a sloping shelf or in a tilted position, unless the receiver is properly secured.
6. A product on a roll-about cart should be stable in its mounting to the cart. Caution the customer on the hazards of trying to roll a cart with small casters across thresholds or deep pile carpets.
7. Caution customers against using extension cords. Explain that a forest of extensions, sprouting from a single outlet, can lead to disastrous consequences to home and family.

SERVICING PRECAUTIONS

CAUTION : Before servicing the DVB-T HDD/DVD Recorder covered by this service data and its supplements and addends, read and follow the *SAFETY PRECAUTIONS*. **NOTE :** if unforeseen circumstances create conflict between the following servicing precautions and any of the safety precautions in this publications, always follow the safety precautions.

Remembers Safety First:

General Servicing Precautions

1. Always unplug the DVB-T HDD/DVD Recorder AC power cord from the AC power source before:
 - (1) Removing or reinstalling any component, circuit board, module, or any other assembly.
 - (2) Disconnection or reconnecting any internal electrical plug or other electrical connection.
 - (3) Connecting a test substitute in parallel with an electrolytic capacitor.
Caution : A wrong part substitution or incorrect polarity installation of electrolytic capacitors may result in an explosion hazard.
2. Do not spray chemicals on or near this DVB-T HDD/DVD Recorder or any of its assemblies.
3. Unless specified otherwise in this service data, clean electrical contacts by applying an appropriate contact cleaning solution to the contacts with a pipe cleaner, cotton-tipped swab, or comparable soft applicator. Unless specified otherwise in this service data, lubrication of contacts is not required.
4. Do not defeat any plug/socket B+ voltage interlocks with which instruments covered by this service manual might be equipped.
5. Do not apply AC power to this DVB-T HDD/DVD Recorder and/or any of its electrical assemblies unless all solid-state device heat sinks are correctly installed.
6. Always connect test instrument ground lead to the appropriate ground before connection the test instrument positive lead. Always remove the test instrument ground lead last.

Insulation Checking Procedure

Disconnect the attachment plug from the AC outlet and turn the power on. Connect an insulation resistance meter(500V) to the blades of the attachment plug. The insulation resistance between each blade of the attachment plug and accessible conductive parts (Note 1) should be more than 1M-ohm.

Note 1 : Accessible Conductive Parts including Metal panels, Input terminals, Earphone jacks, etc.

Electrostatically Sensitive (ES) Devices

Some semiconductor (solid state) devices can be damaged easily by static electricity. Such components commonly are called Electrostatically Sensitive (ES) Devices. Examples of typical ES devices are integrated circuits and some field effect transistors and semiconductor chip components.

The following techniques should be used to help reduce the incidence of component damage caused by static electricity.

1. Immediately before handling any semiconductor component or semiconductor-equipped assembly, drain off any electrostatic charge on your body by touching a known earth ground. Alternatively, obtain and wear a commercially available discharging wrist strap device, which should be removed for potential shock reasons prior to applying power to the unit under test.
2. After removing an electrical assembly equipped with ES devices, place the assembly on a conductive surface such as aluminum foil, to prevent electrostatic charge buildup or exposure of the assembly.
3. Use only a grounded-tip soldering iron to solder or unsolder ES devices.
4. Use only an anti-static solder removal device. Some solder removal devices not classified a "anti-static" can generate electrical charges sufficient to damage ES devices.
5. Do not use freon-propelled chemicals. These can generate electrical charge sufficient to damage ES devices.
6. Do not remove a replacement ES device from its protective package until immediately before you are ready to install it. (Most replacement ES devices are packaged with leads electrically shorted together by conductive foam, aluminum foil, or comparable conductive material).
7. Immediately before removing the protective material from the leads of a replacement ES device, touch the protective material to the chassis or circuit assembly into which the device will be installed.

Caution : Be sure no power is applied to the chassis or circuit, and observe all other safety precautions.

8. Minimize bodily motions when handling unpackaged replacement ES devices. (Normally harmless motion such as the brushing together of your clothes fabric or the lifting of your foot from a carpeted floor can generate static electricity sufficient to damage an ES device.)

SERVICE INFORMATION FOR EEPROM IC SETTING

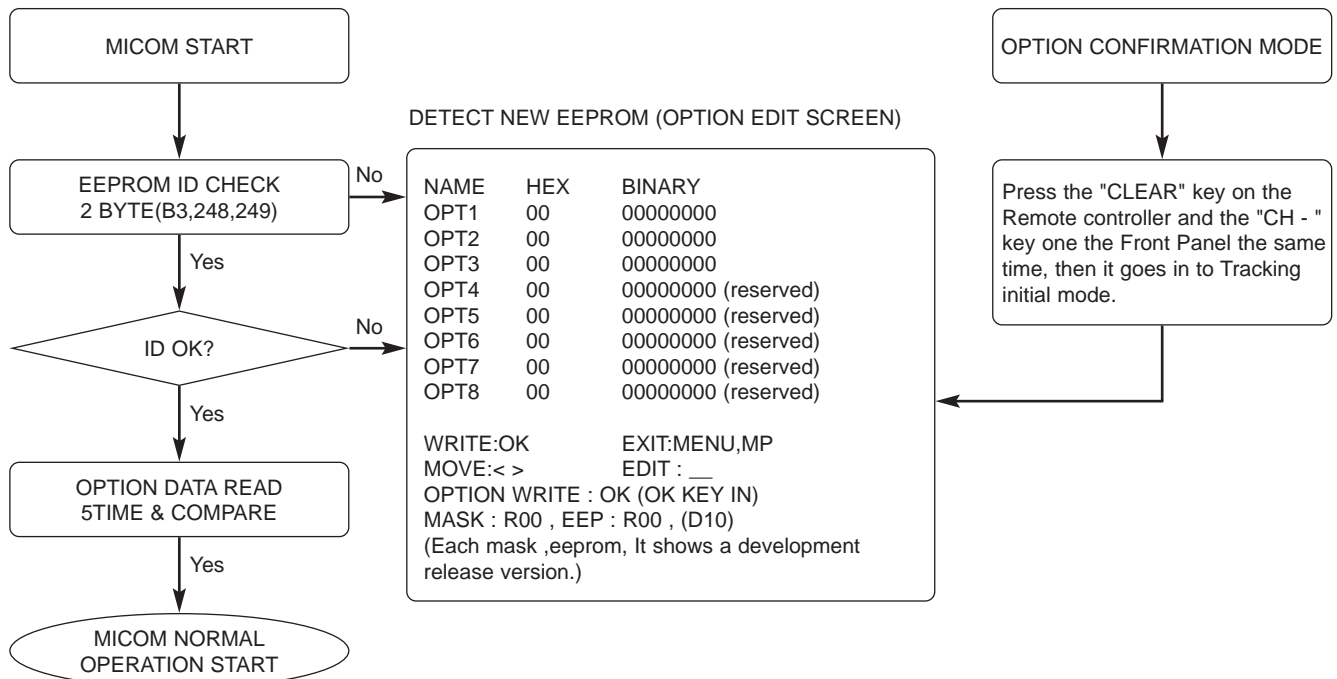

*** EEPROM INITIAL ***

- SETUP is displayed in the field if pressing the Front ch- & ch+ Key with the Remocon number "clear" key pressed in the status of powering on.
- AUTO SEARCH is done since the initial screen of ACMS is serviced if powering on.

SPECIFICATIONS

• GENERAL

Power requirements	AC 200-240V, 50/60 Hz
Power consumption	40W
Dimensions (approx.)	430 X 54 X 340 mm (w x h x d) without foot
Mass (approx.)	4.5 kg
Operating temperature	5°C to 35°C
Operating humidity	5 % to 90 %
Television system	Analog: PAL I, B/G, I/I, SECAM D/K, K1 colour system Digital: DVB-T Standard Compliant
Recording format	PAL
Conditional Access Interface	PCMCIA, 1 Slot Common Interface (DBRH198, DBRH197) SMARTCARD, 2CARD, Conditional Access system (DBRH199)

• RECORDING

Recording format	DVD Video Recording, DVD-VIDEO
Recordable media	HDD (DBRH198: 160GB, DBRH190: 80GB), DVD-ReWritable, DVD-Recordable, DVD+ReWritable, DVD+Recordable, DVD+Recordable (Double Layer)
Recordable time	DVD (4.7GB): Approx. 1 hour (XP mode), 2 hours (SP mode), 4 hours (LP mode), 6 hours (EP mode) DVD+R DL (8.5GB): Approx. 3 hour (XP mode), 3 hours 40 minutes (SP mode), 7 hours 10 minutes (LP mode), 10 hours 30 minutes (EP mode) HDD (80GB/160GB): Approx. 21/43 hours 30 minutes (XP mode), 41/84 hours (SP mode), 81/156 hours (LP mode), 114/233 hours (EP mode)

Video recording format

Sampling frequency	27MHz
Compression format	MPEG 2 (VBR support)

Audio recording format

Sampling frequency	48kHz
Compression format	Dolby Digital

• PLAYBACK

Frequency response	DVD (PCM 48 kHz): 8 Hz to 22 kHz, CD: 8 Hz to 20 kHz DVD (PCM 96 kHz): 8 Hz to 44 kHz
Signal-to-noise ratio	More than 100 dB (AUDIO OUT connector)
Harmonic distortion	Less than 0.008% (AUDIO OUT connector)
Dynamic range	More than 95 dB (AUDIO OUT connector)

• INPUTS

AERIAL IN	Aerial input (Digital and Analog), 75 ohms
VIDEO IN	1.0 Vp-p 75 ohms, sync negative, RCA jack x 2 / SCART x 2
AUDIO IN	2.0 Vrms more than 47 kohms, RCA jack (L, R) x 2 / SCART x 2
S-VIDEO IN	(Y) 1.0 V (p-p), 75 Ω, sync negative, Mini DIN 4-pin x 1 (C) 0.3 V (p-p) 75 Ω
DV IN	4 pin (IEEE 1394 standard)

• OUTPUTS

VIDEO OUT	1 Vp-p 75 Ω, sync negative, RCA jack x 1 / SCART x 2
COMPONENT VIDEO OUT	(Y) 1.0 V (p-p), 75 Ω, sync negative, RCA jack x 1 (Pb)/(Pr) 0.7 V (p-p), 75 Ω, RCA jack x 2
HDMI video/audio output (DBRH198 only)	19 pin (HDMI standard, Type A)
Audio output (digital audio)	0.5 V (p-p), 75 Ω, RCA jack x 1
Audio output (optical audio)	3 V (p-p), 75 Ω, Optical connector x 1
Audio output (analog audio)	2.0 Vrms (1 KHz, 0 dB), 600 Ω, RCA jack (L, R) x 1 / SCART x 2

SECTION 2
CABINET & MAIN CHASSIS

CONTENTS

EXPLODED VIEWS2-2

- 1. CABINET AND MAIN FRAME SECTION2-2**
- 2. DECK MECHANISM SECTION(RS-01A)2-3**
- 3. PACKING ACCESSORY SECTION2-4**

2. DECK MECHANISM SECTION(RS-01A)

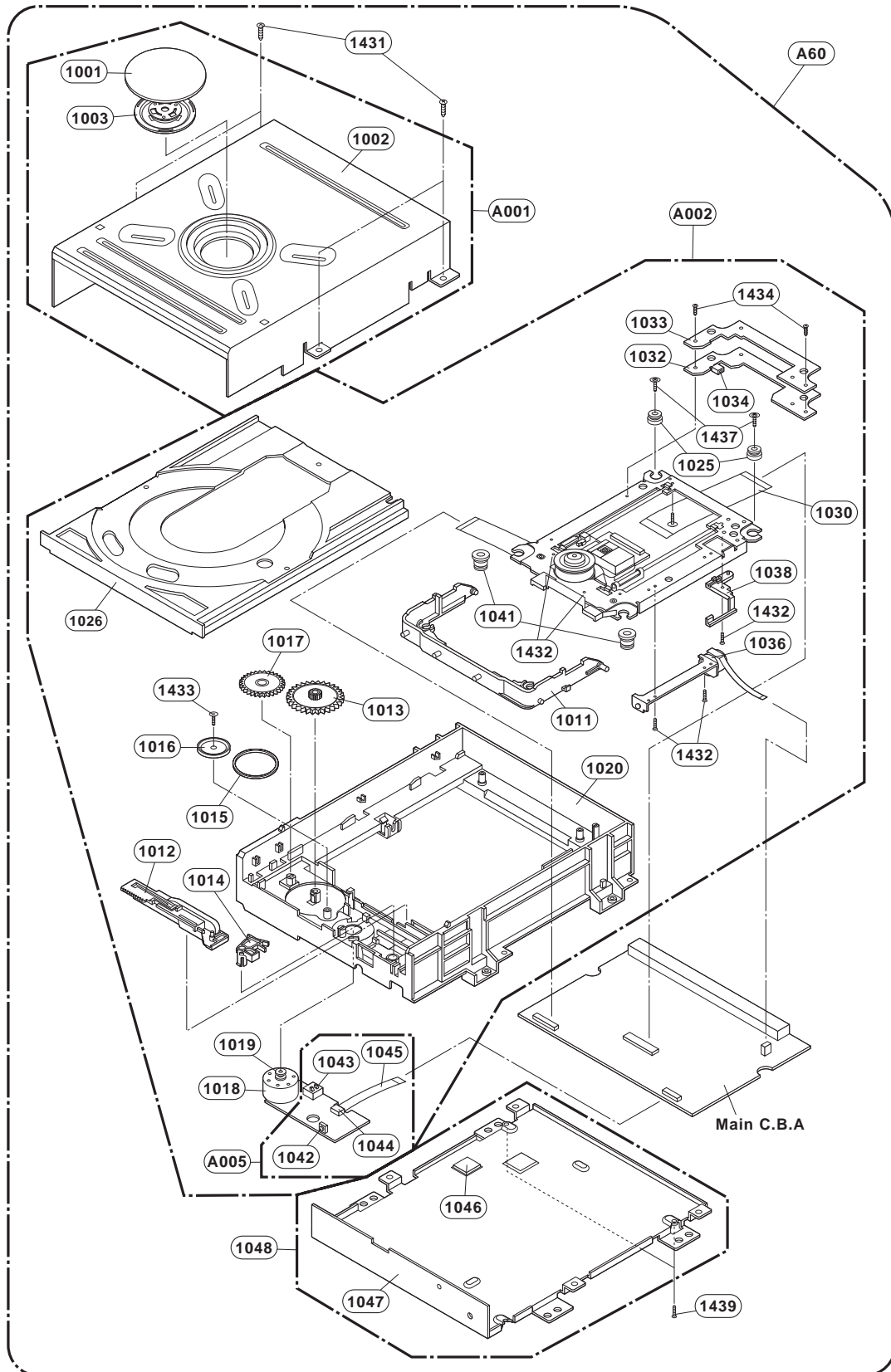

3. PACKING ACCESSORY SECTION

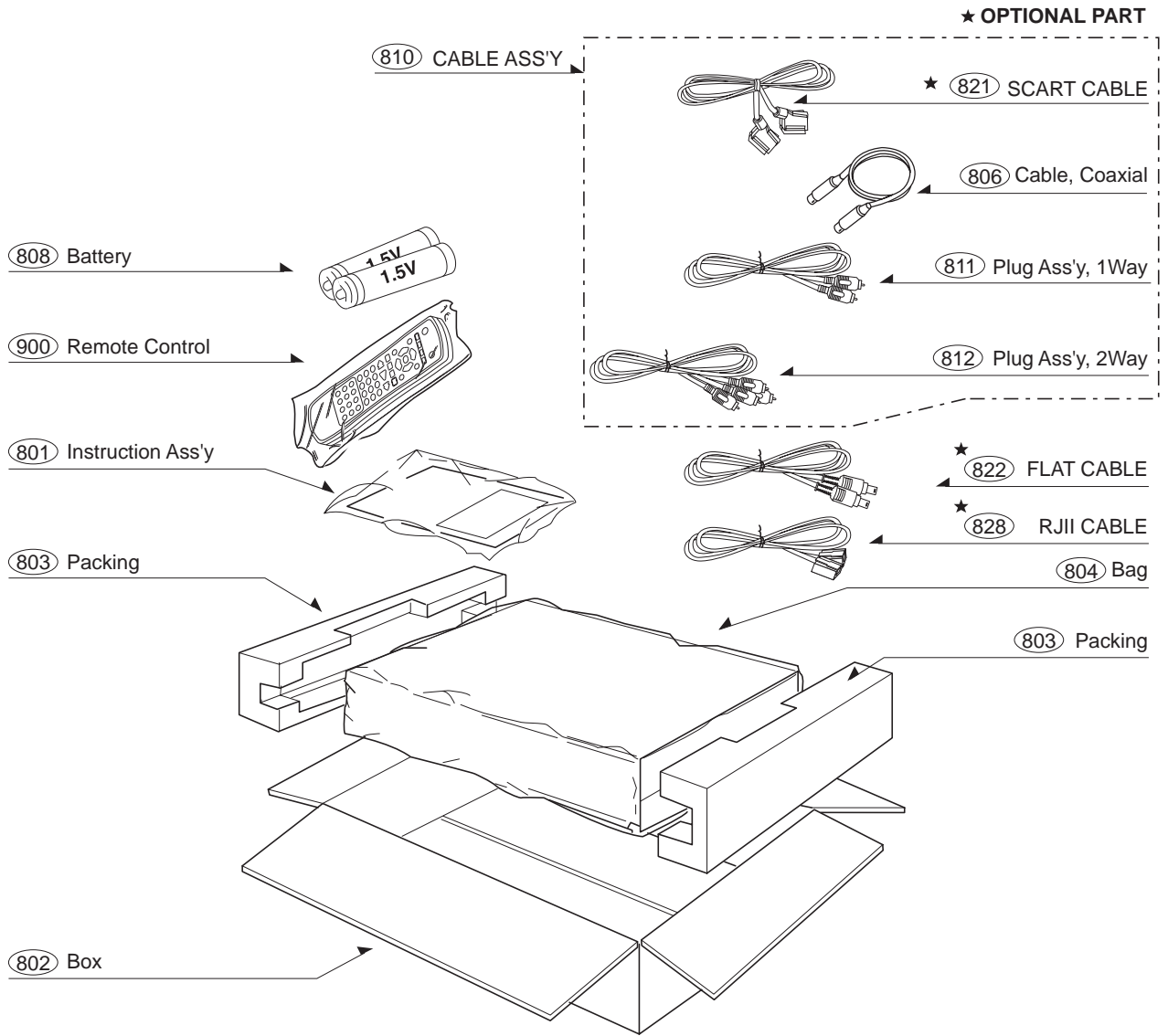

SECTION 3 ELECTRICAL CONTENTS

HDR PART

ELECTRICAL TROUBLESHOOTING GUIDE.....3-2

1. POWER SUPPLY ON SMPS BOARD3-2
2. POWER SUPPLY ON I/O BOARD.....3-4
3. SYSTEM CIRCUIT PART3-6
4. DISC NOT RECOGNIZED3-6
5. WHEN PLAYING DISC, NO AUDIO OUTPUT3-7
6. NO OPTICAL / DIGITAL OUTPUT3-8
7. NO TUNER ANALOG AUDIO OUTPUT3-9
8. NO TUNER DVB_T AUDIO OUTPUT3-10
9. NO EXTERNAL AUDIO INPUT3-11
10. NO RGB / COMPONENT VIDEO
SIGNAL WHEN PLAY DISC.....3-12
11. NO COMPOSITE /
S-VIDEO SIGNAL WHEN PLAY DISC3-12
12. NO TV, EXTERNAL INPUT VIDEO SIGNAL3-13

BLOCK DIAGRAMS3-16

1. OVERALL BLOCK DIAGRAM.....3-16
2. LAYOUT CONNECTION BLOCK DIAGRAM_13-18
3. LAYOUT CONNECTION BLOCK DIAGRAM_23-20
4. SMPS BLOCK DIAGRAM3-22
5. POWER : MAIN BOARD BLOCK DIAGRAM.....3-24
6. POWER : I/O BOARD BLOCK DIAGRAM.....3-26
7. IN/OUT BLOCK DIAGRAM
(SCART MODEL ONLY).....3-28
8. VIDEO BLOCK DIAGRAM3-30
9. VIDEO S/W PATH BLOCK DIAGRAM3-32
10. AUDIO BLOCK DIAGRAM3-34
11. AUDIO S/W PATH BLOCK DIAGRAM3-36
12. FLD / μ -COM / TUNER BLOCK DIAGRAM3-38
13. MAIN BLOCK DIAGRAM
(SCART MODEL ONLY).....3-40
14. TIMER BLOCK DIAGRAM3-42

CIRCUIT DIAGRAMS3-44

1. SMPS 1 CIRCUIT DIAGRAM.....3-44
2. SMPS 2 CIRCUIT DIAGRAM.....3-46
3. MPEG CIRCUIT DIAGRAM
(DBRH197's, DBRH198's ONLY)3-48
4. MPEG CIRCUIT DIAGRAM(DBRH199's ONLY)....3-50
5. FLASH/DDR CIRCUIT DIAGRAM
(DBRH197's, DBRH198's ONLY)3-52
6. FLASH/DDR CIRCUIT DIAGRAM
(DBRH199's ONLY).....3-54
7. RESET & 1394 & JPEG CIRCUIT DIAGRAM
(DBRH197's ONLY).....3-56

8. RESET & 1394 & JPEG CIRCUIT DIAGRAM
(DBRH198's, DBRH199's ONLY)3-58
9. ATAPI & MEMORY CARD CIRCUIT DIAGRAM
(DBRH197's, DBRH198's ONLY)3-60
10. ATAPI & MEMORY CARD CIRCUIT DIAGRAM
(DBRH199's ONLY).....3-62
11. I/O, μ -COM CIRCUIT DIAGRAM.....3-64
12. TUNER/MPX/ADC/DAC/JACK
CIRCUIT DIAGRAM3-66
13. STB SYSTEM CIRCUIT DIAGRAM
(DBRH197's, DBRH198's ONLY)3-68
14. STB SYSTEM CIRCUIT DIAGRAM
(DBRH199's ONLY).....3-70
15. DDR SDRAM CIRCUIT DIAGRAM
(DBRH197's, DBRH198's ONLY)3-72
16. DDR SDRAM CIRCUIT DIAGRAM
(DBRH199's ONLY).....3-74
17. STB, CI INTERFACE CIRCUIT DIAGRAM
(DBRH197's, DBRH198's ONLY)3-76
18. SMART CARD CIRCUIT DIAGRAM
(DBRH199's ONLY).....3-78
19. CI CIRCUIT DIAGRAM(DBRH198's ONLY).....3-80
20. MODEM CIRCUIT DIAGRAM
(DBRH199's ONLY).....3-82
21. SMART CARD TO MAIN INTERFACE
CIRCUIT DIAGRAM(DBRH199's ONLY)3-84
22. KEY CIRCUIT DIAGRAM3-86
23. TIMER CIRCUIT DIAGRAM3-88

• WAVEFORMS3-90

• CIRCUIT VOLTAGE CHART3-92

PRINTED CIRCUIT DIAGRAMS3-100

1. MAIN P.C.BOARD_DBRH197/DBRH198.....3-100
2. MAIN P.C.BOARD_DBRH1993-101
3. I/O P.C.BOARD (TOP VIEW)3-102
4. I/O P.C.BOARD (BOTTOM VIEW)3-104
5. POWER P.C.BOARD3-106
6. KEY P.C.BOARD3-108
7. TIMER P.C.BOARD3-108
8. JUNCTION P.C.BOARD3-109
9. HDMI P.C.BOARD3-110
10. CI P.C.BOARD (DBRH199's ONLY).....3-112
11. SUBBORD P.C.BOARD (DBRH198's ONLY).....3-112
12. SMART CARD P.C.BOARD
(DBRH199's ONLY)3-114

HDR PART

ELECTRICAL TROUBLESHOOTING GUIDE

1. POWER SUPPLY ON SMPS BOARD

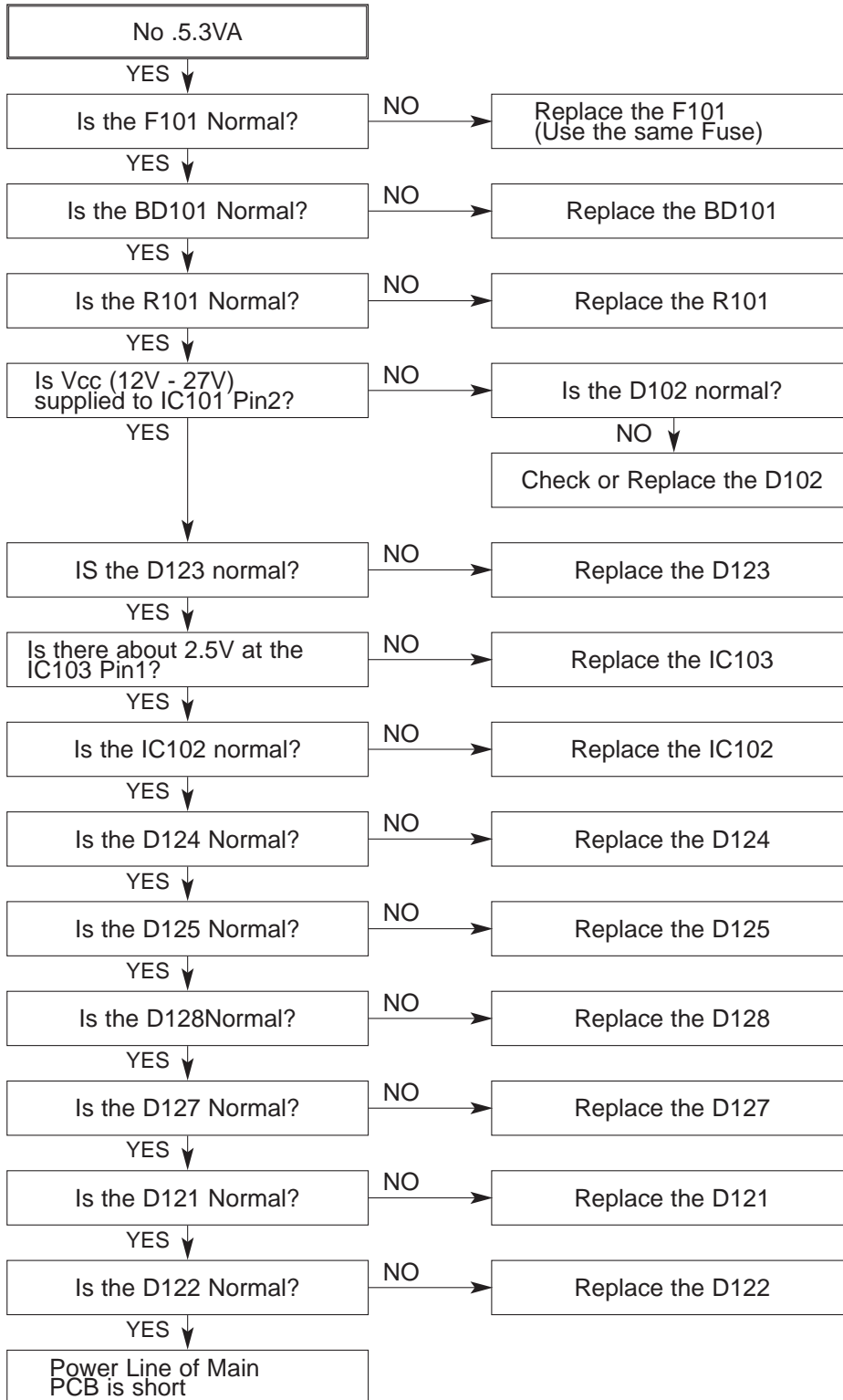

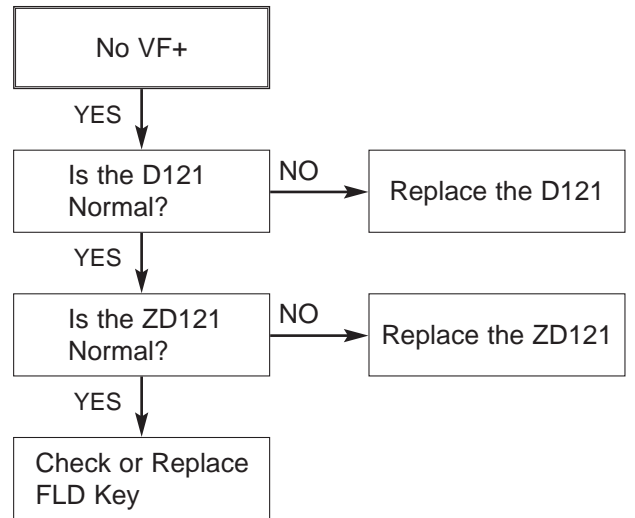
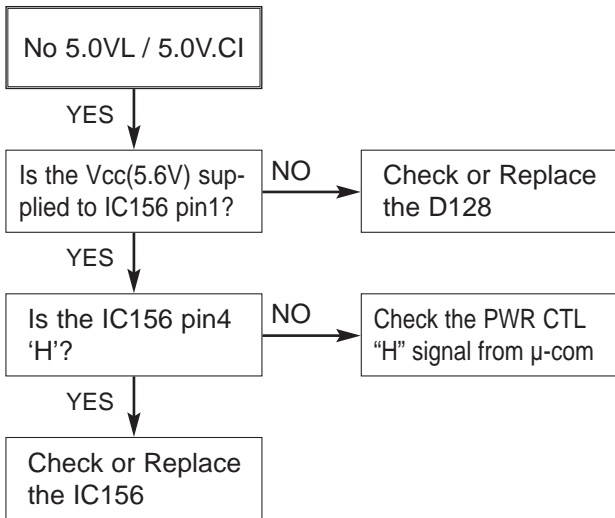
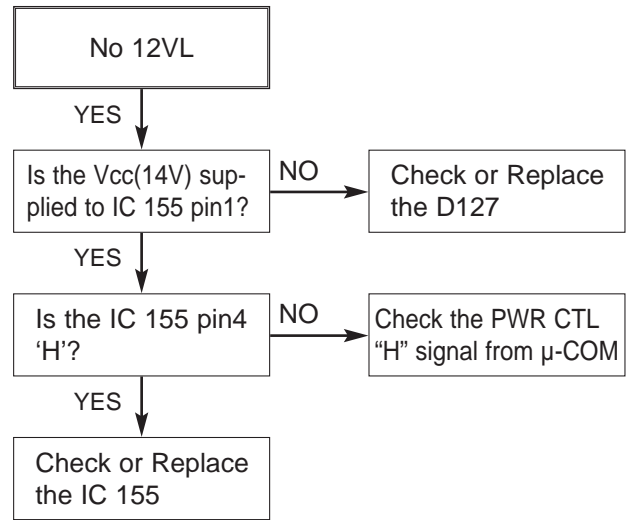
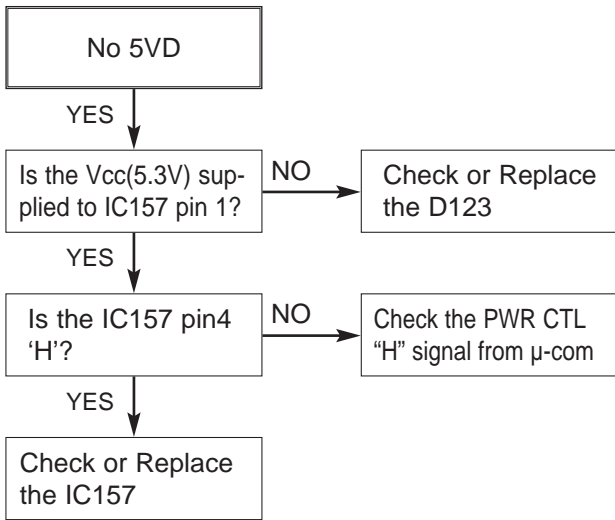

2. POWER SUPPLY ON I/O BOARD

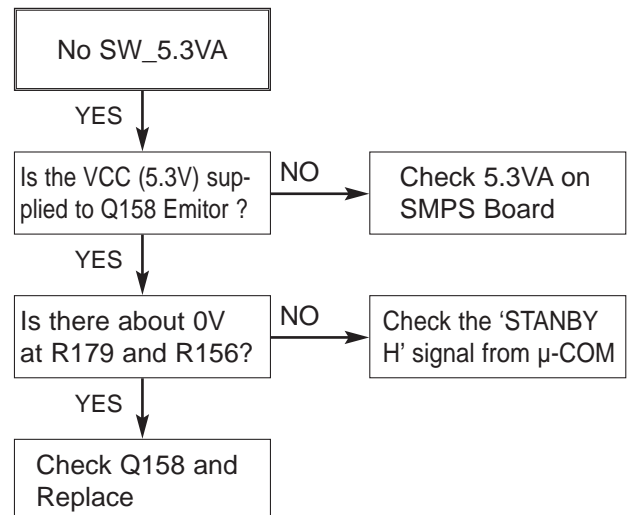
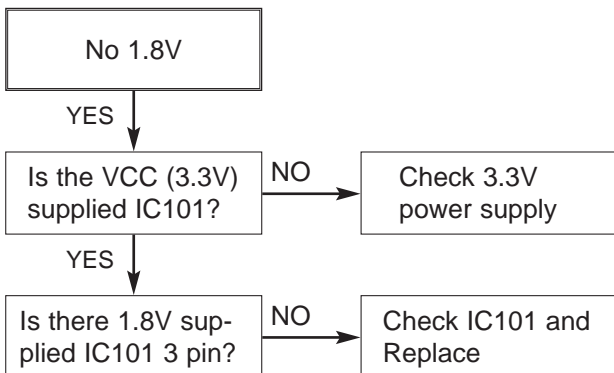
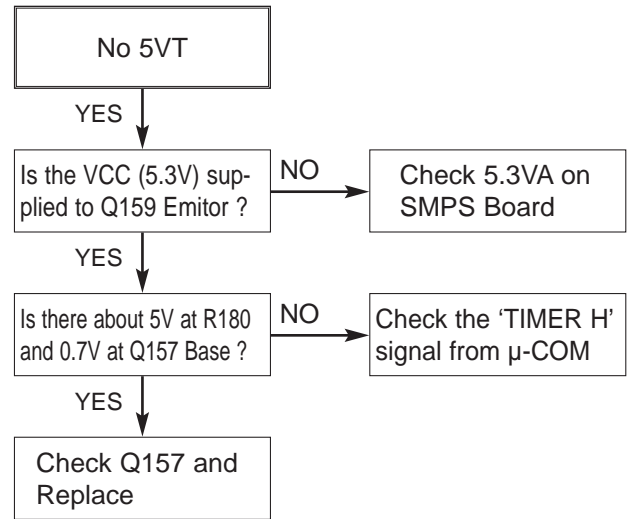
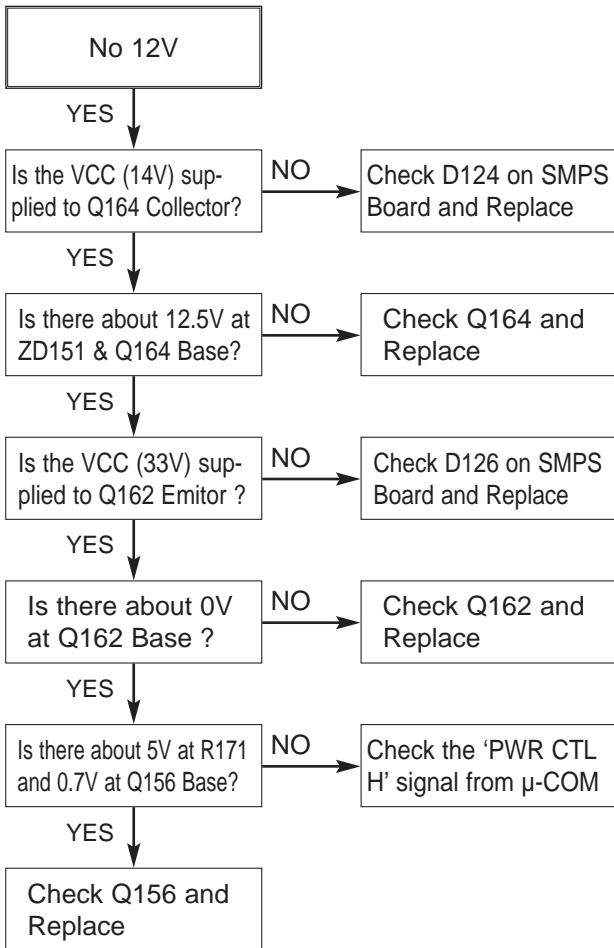

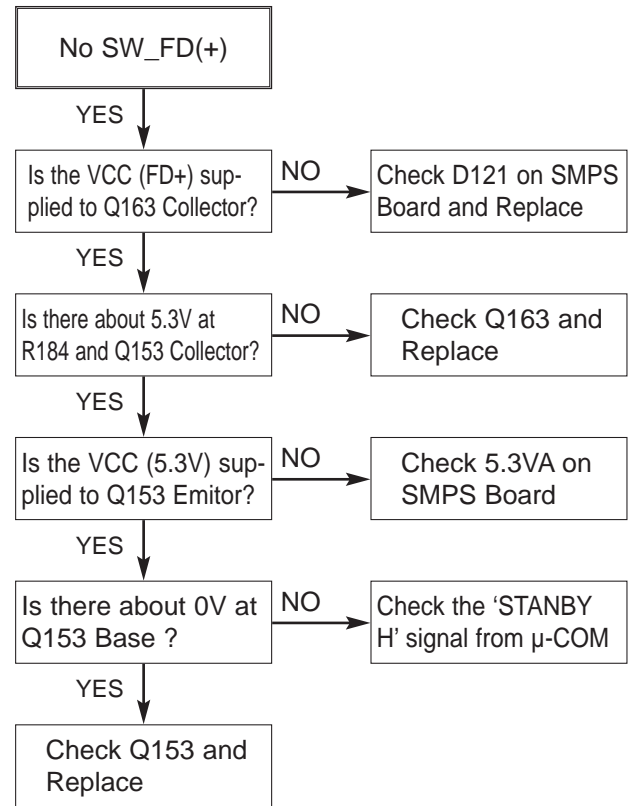
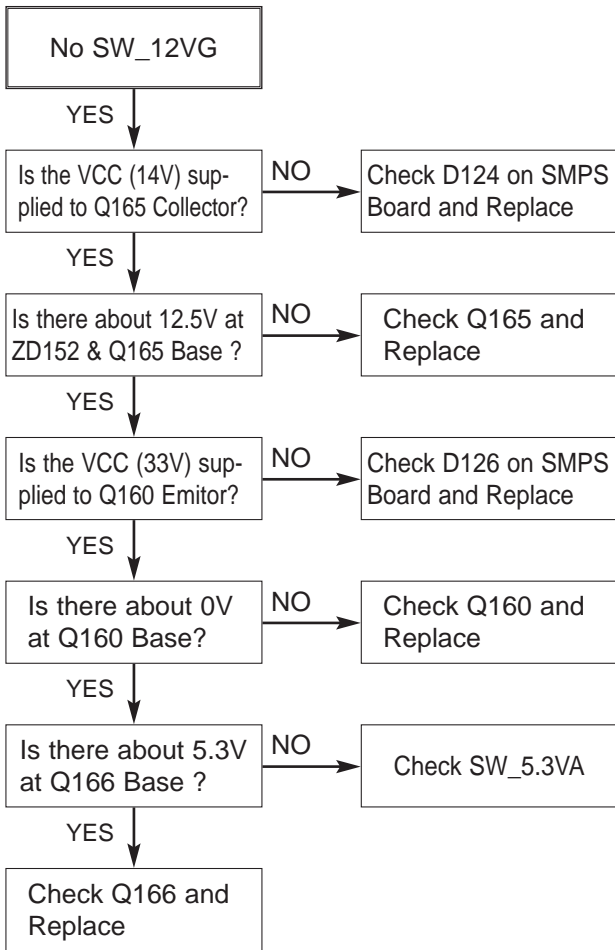

3. SYSTEM CIRCUIT PART

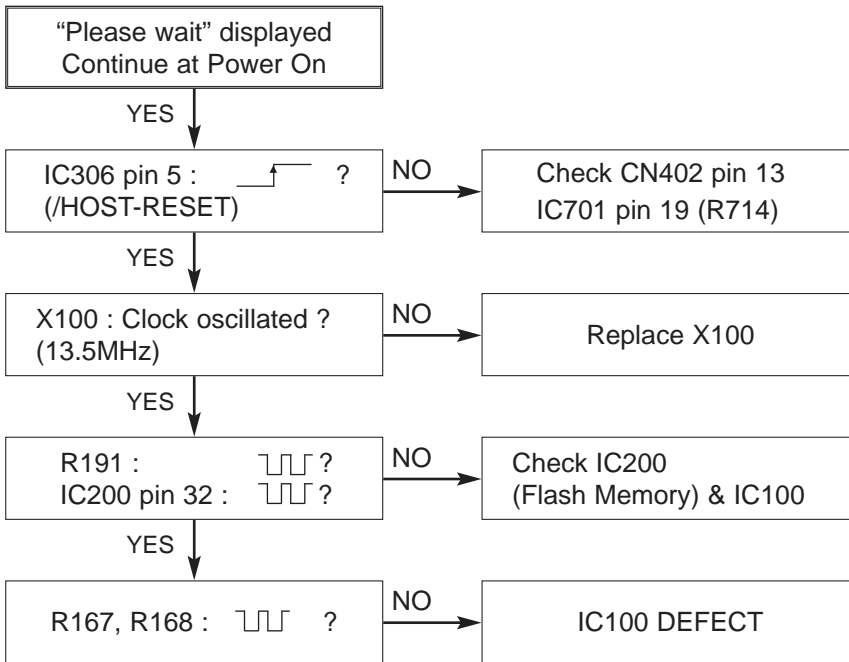

4. DISC NOT RECOGNIZED

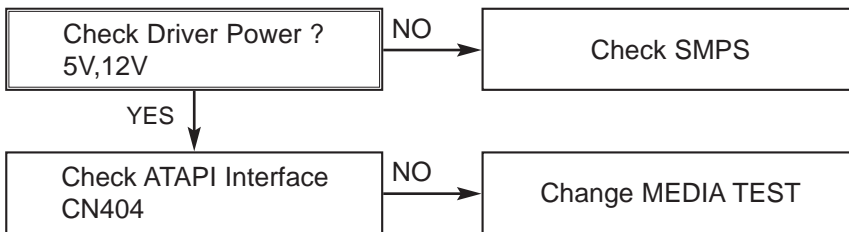

5. WHEN PLAYING DISC, NO AUDIO OUTPUT

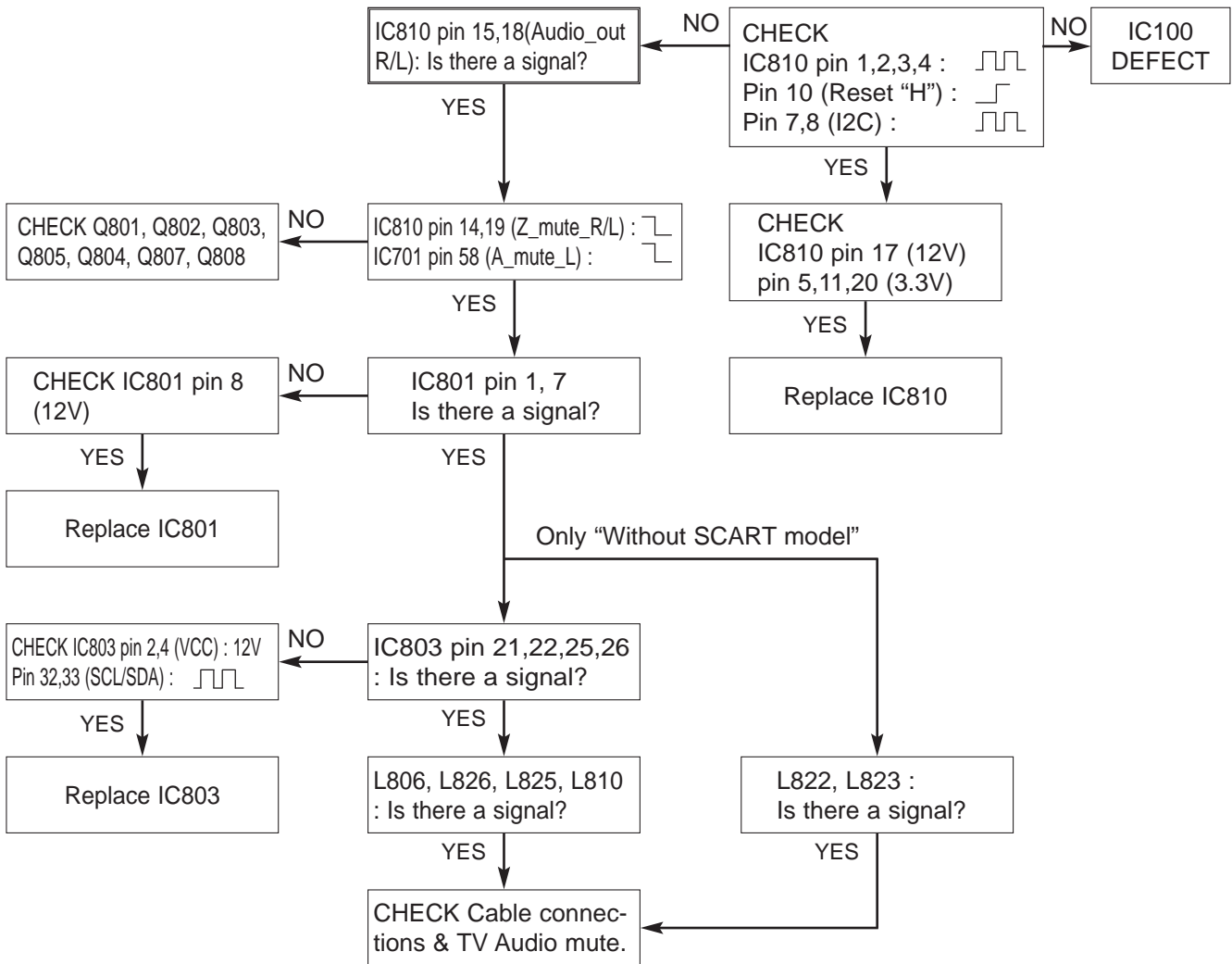

7. NO TUNER ANALOG AUDIO OUTPUT

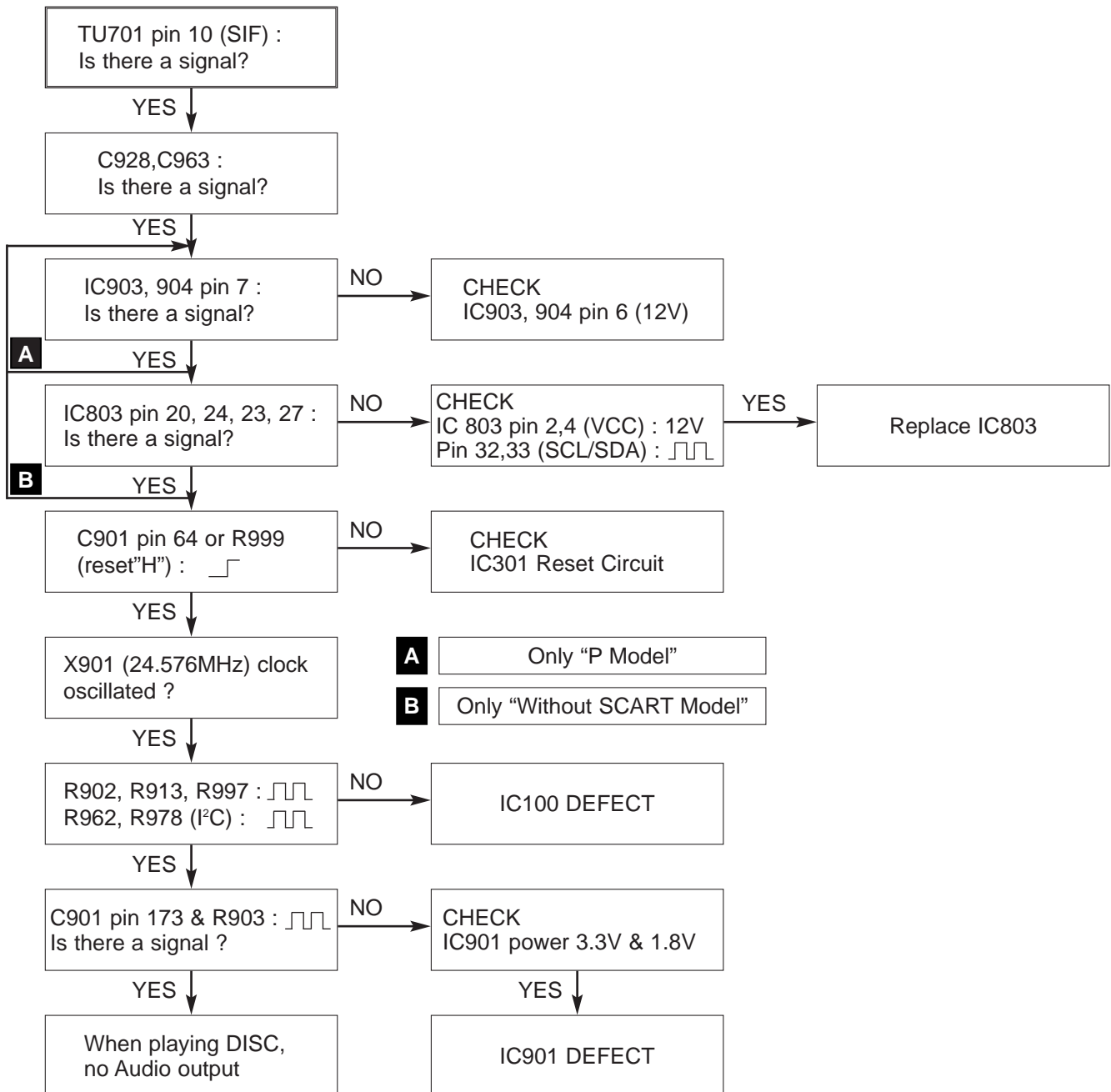

8. NO TUNER DVB_T AUDIO OUTPUT

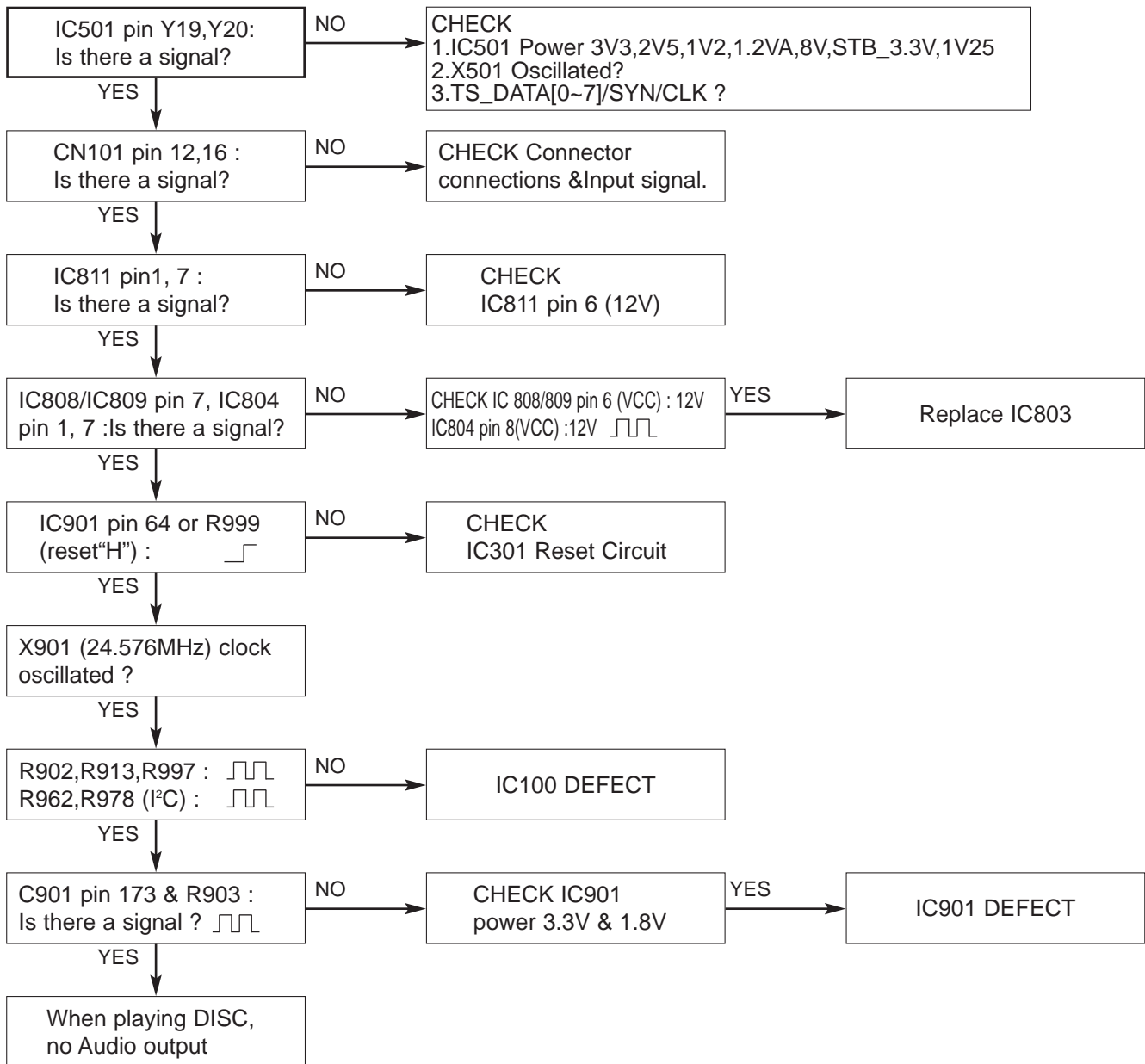

9. NO EXTERNAL AUDIO INPUT

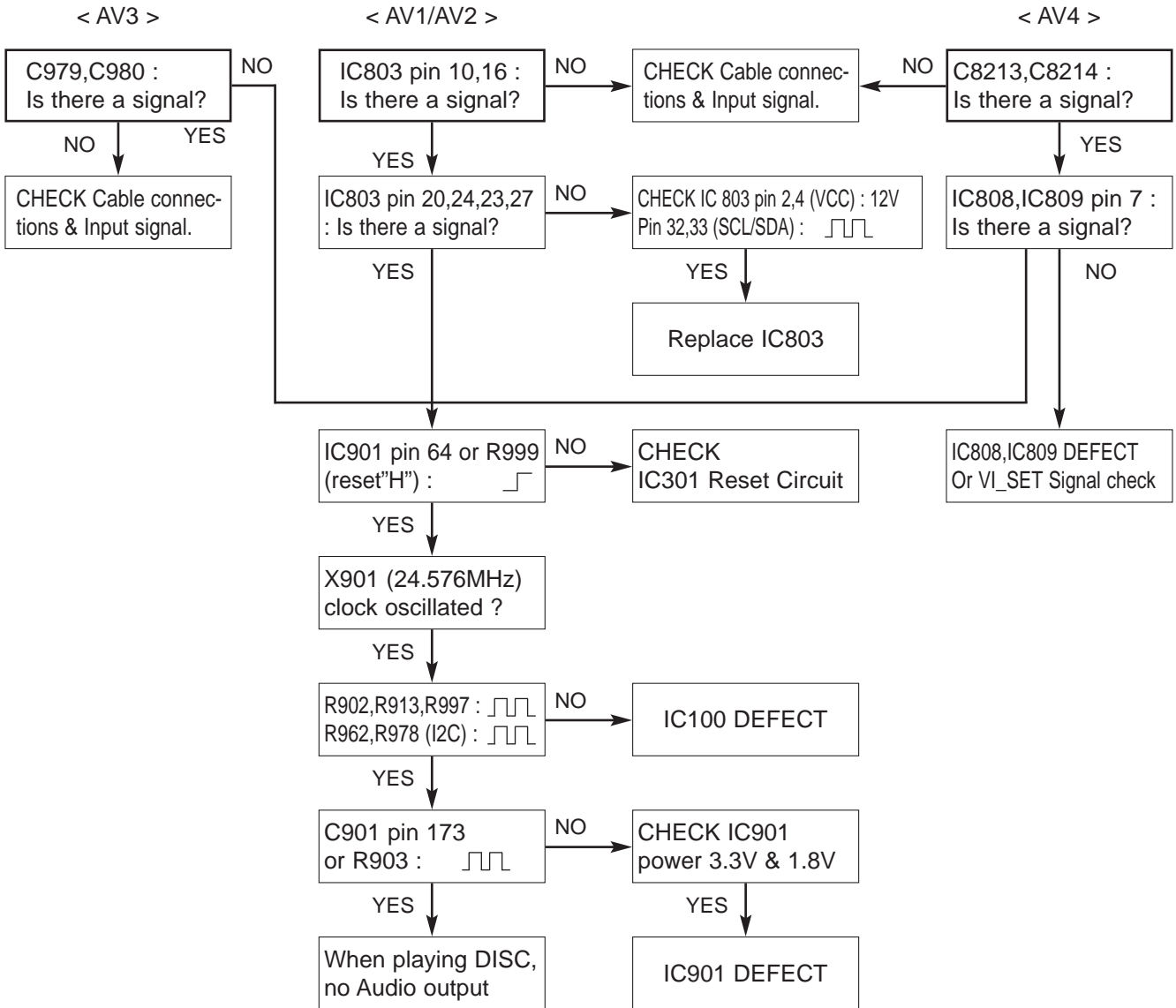

10. NO RGB / COMPONENT VIDEO SIGNAL WHEN PLAY DISC

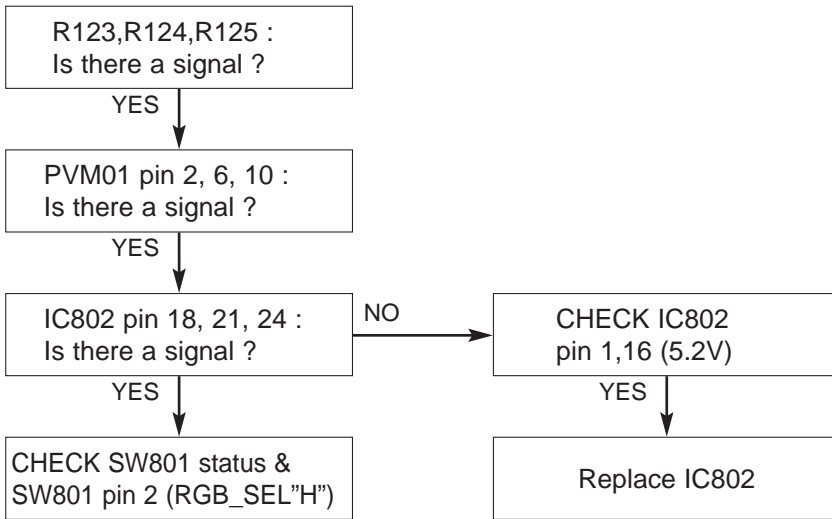

11. NO COMPOSITE / S-VIDEO SIGNAL WHEN PLAY DISC

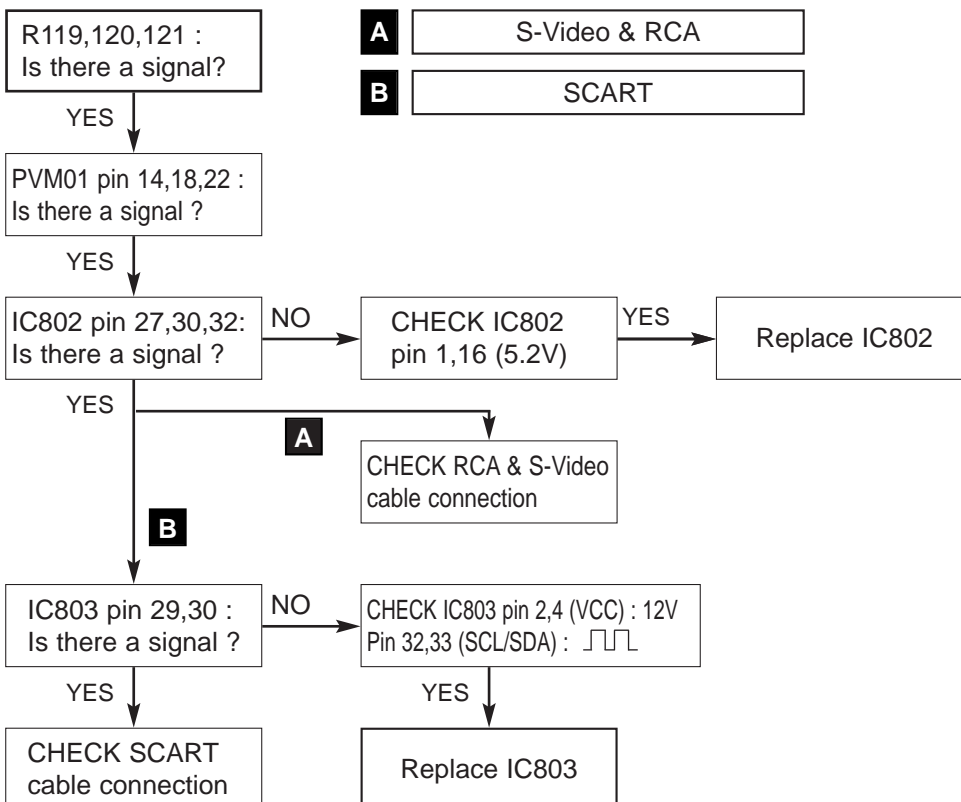

12. NO TV, EXTERNAL INPUT VIDEO SIGNAL

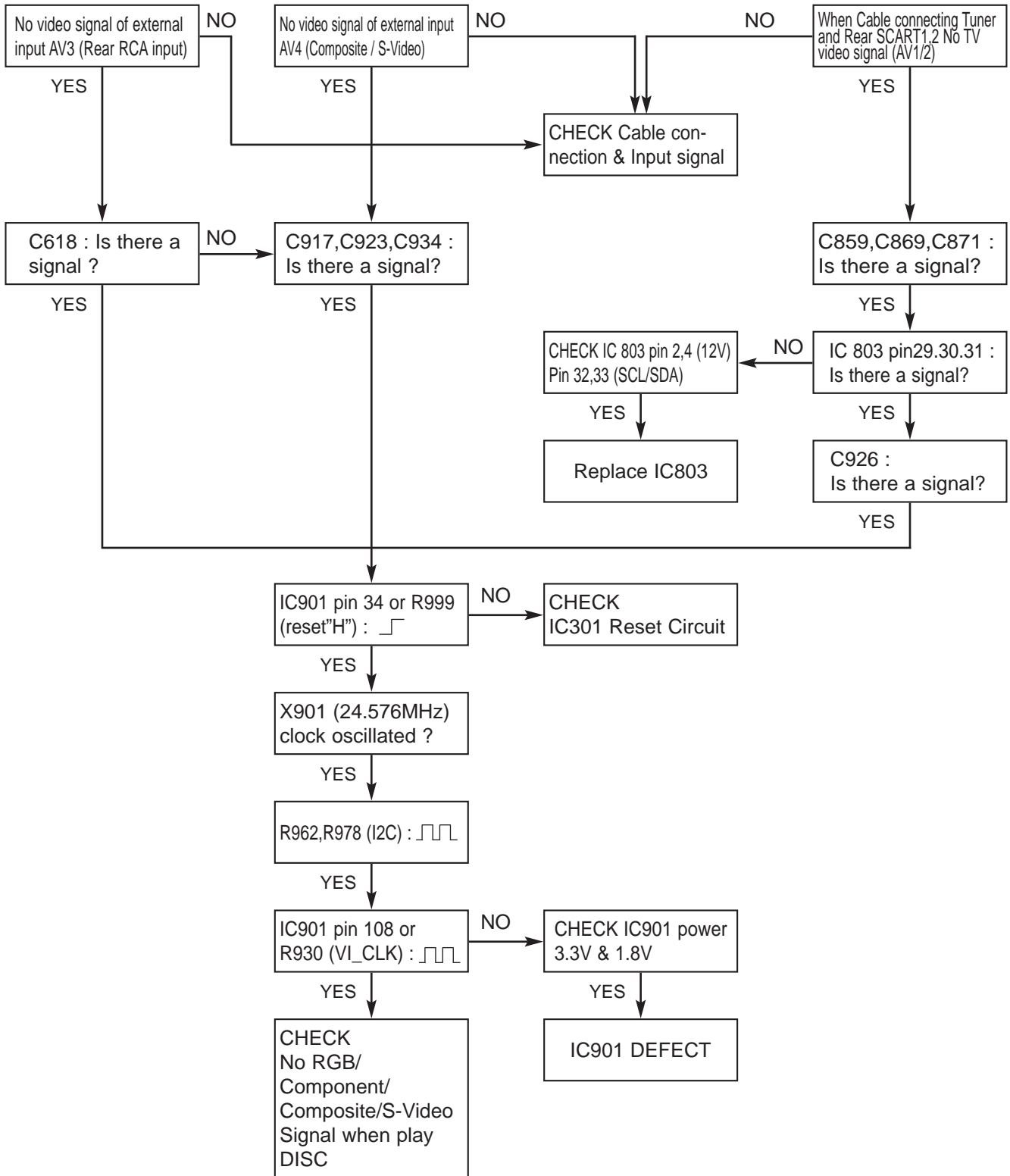

13. NO DVB_T VIDEO OUTPUT

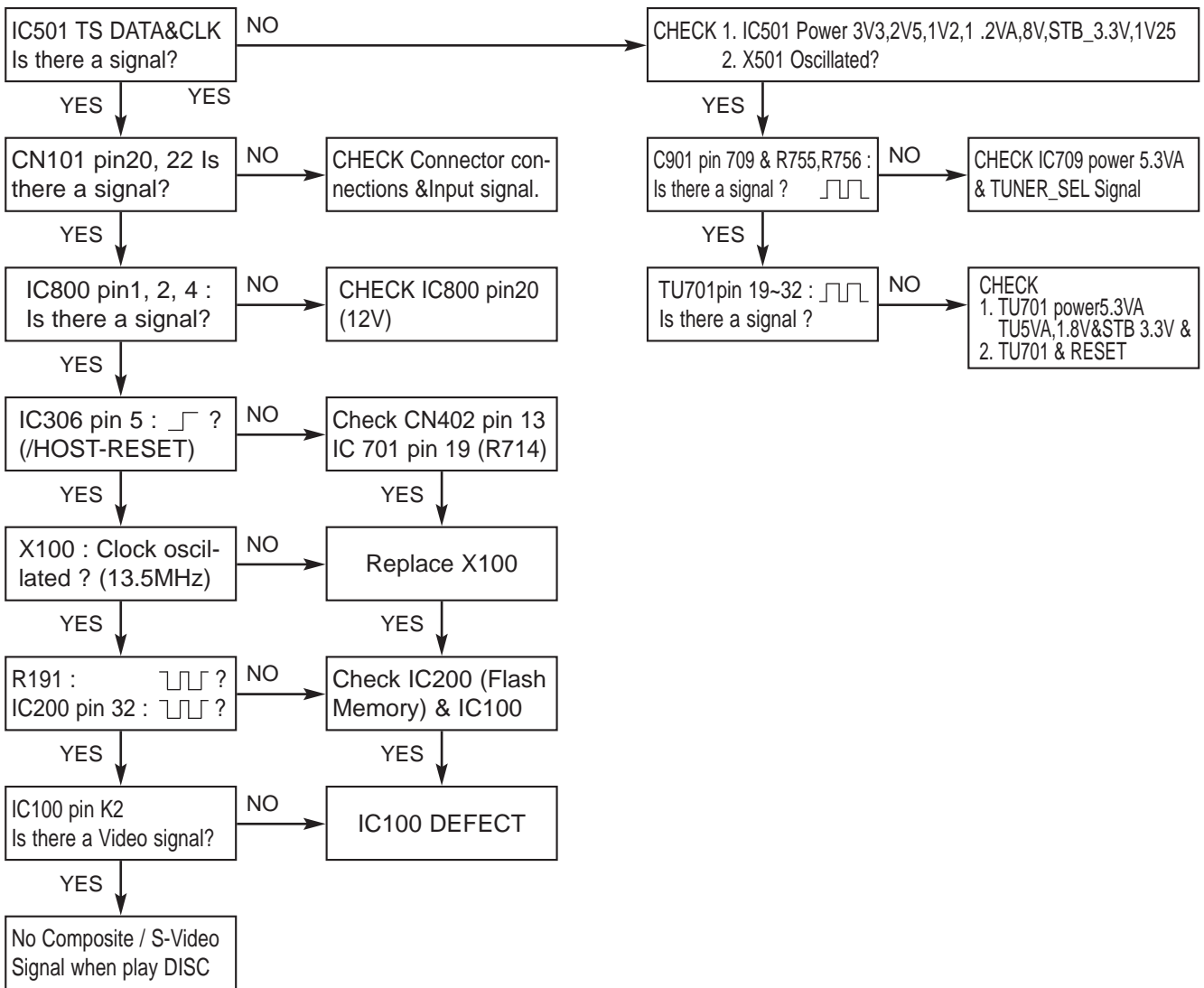

14. NO DV(IEEE 1394) INPUT (VIDEO/AUDIO) SIGNAL

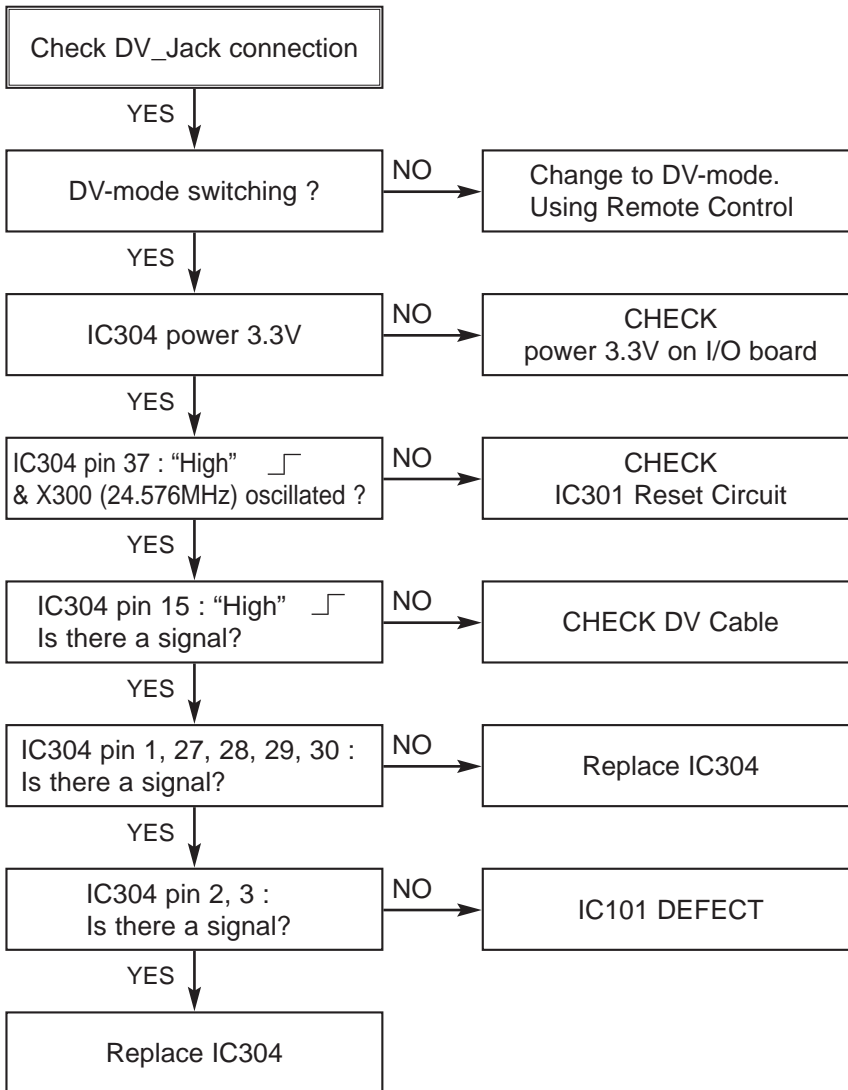

BLOCK DIAGRAMS

1. OVERALL BLOCK DIAGRAM

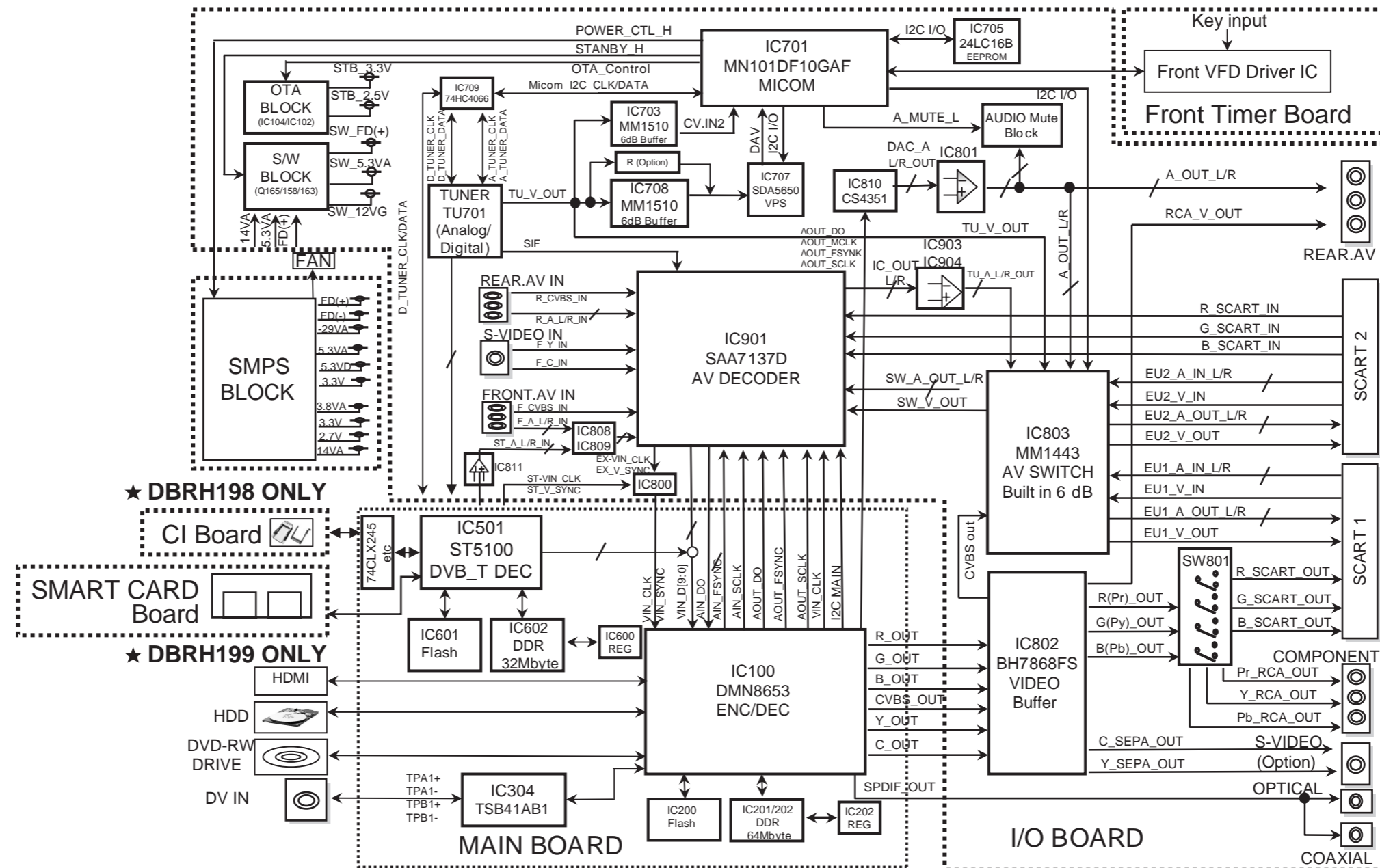

2. LAYOUT CONNECTION BLOCK DIAGRAM_1

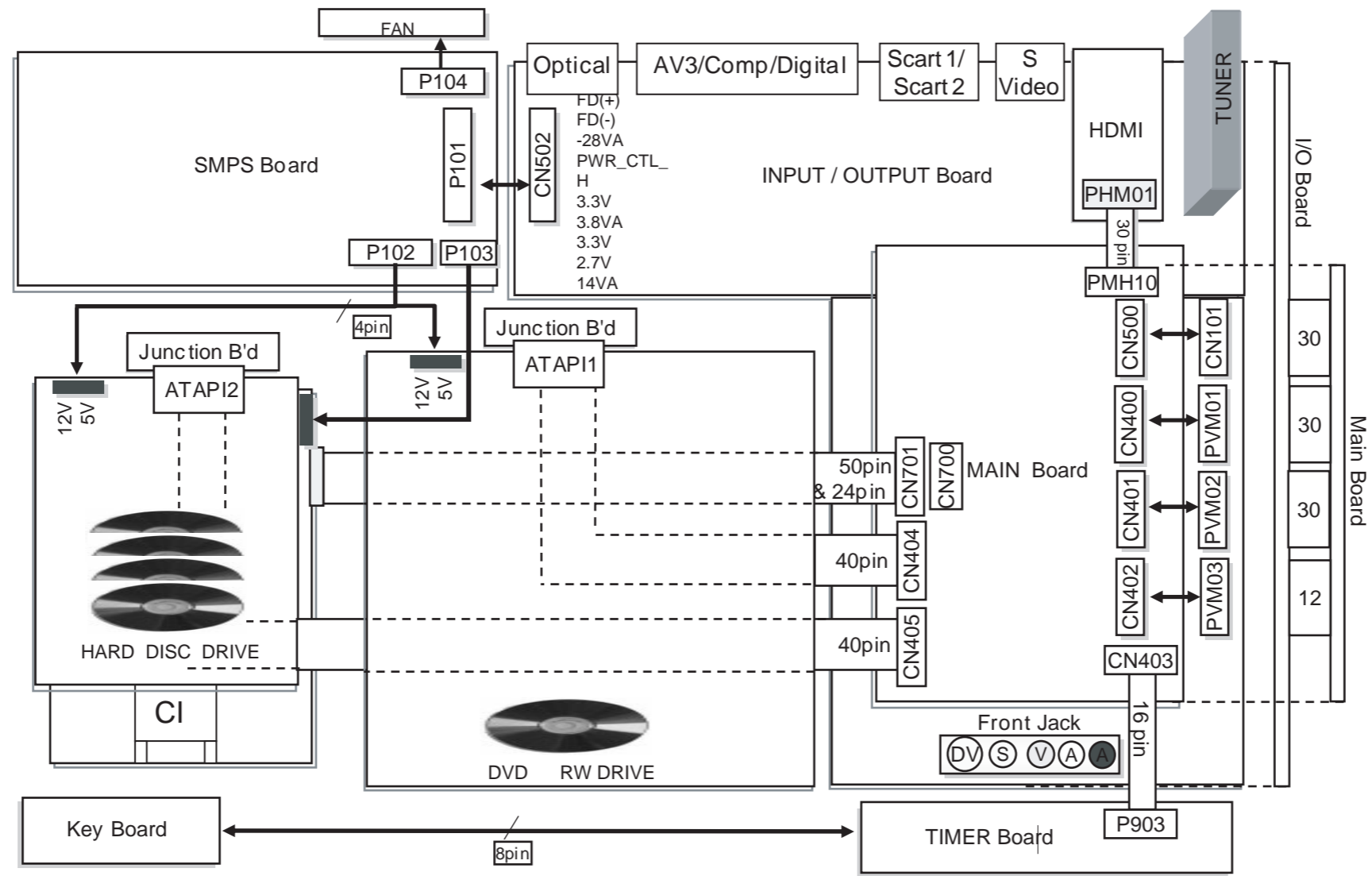

3. LAYOUT CONNECTION BLOCK DIAGRAM_2

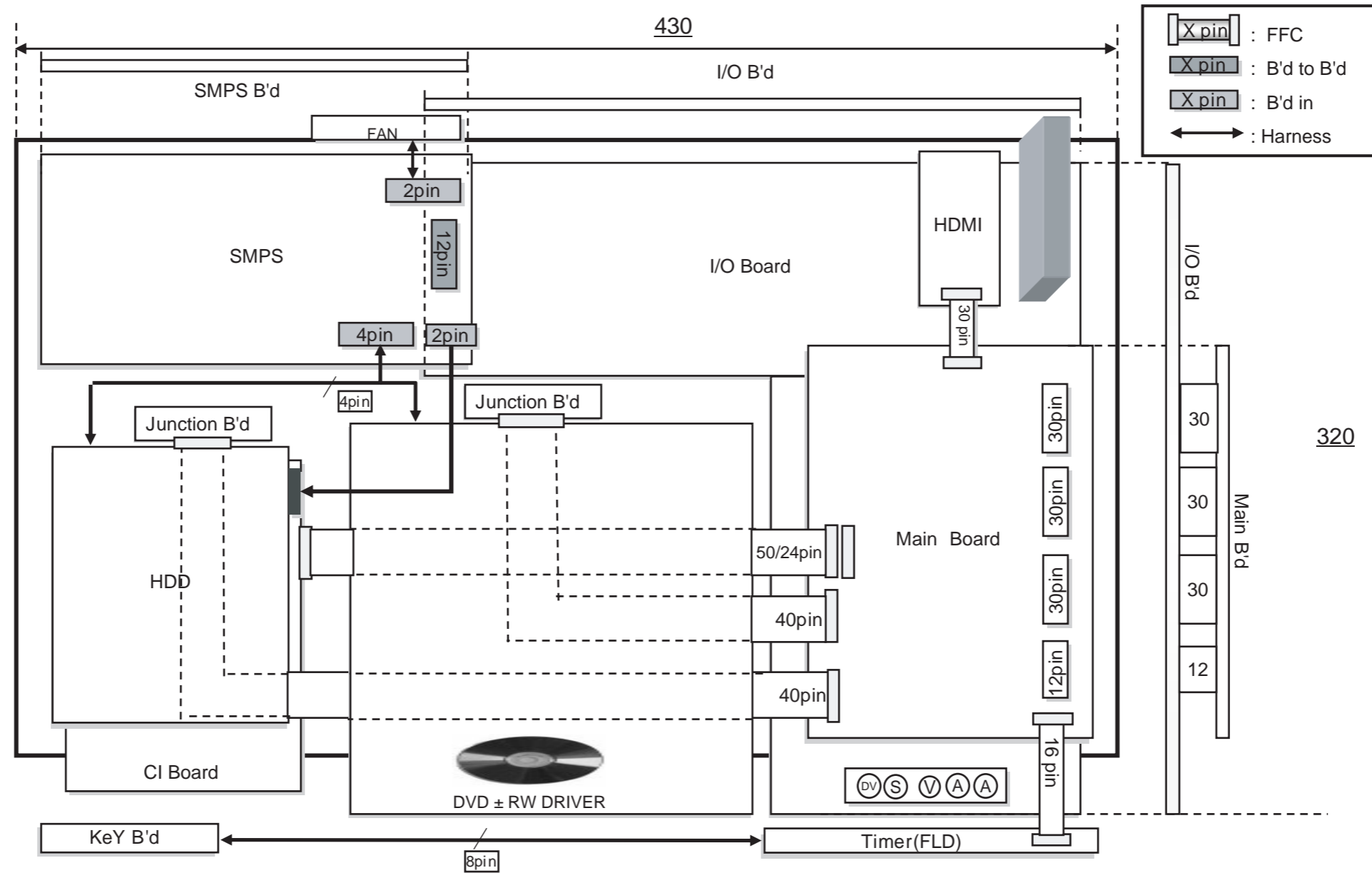

4. SMPS BLOCK DIAGRAM

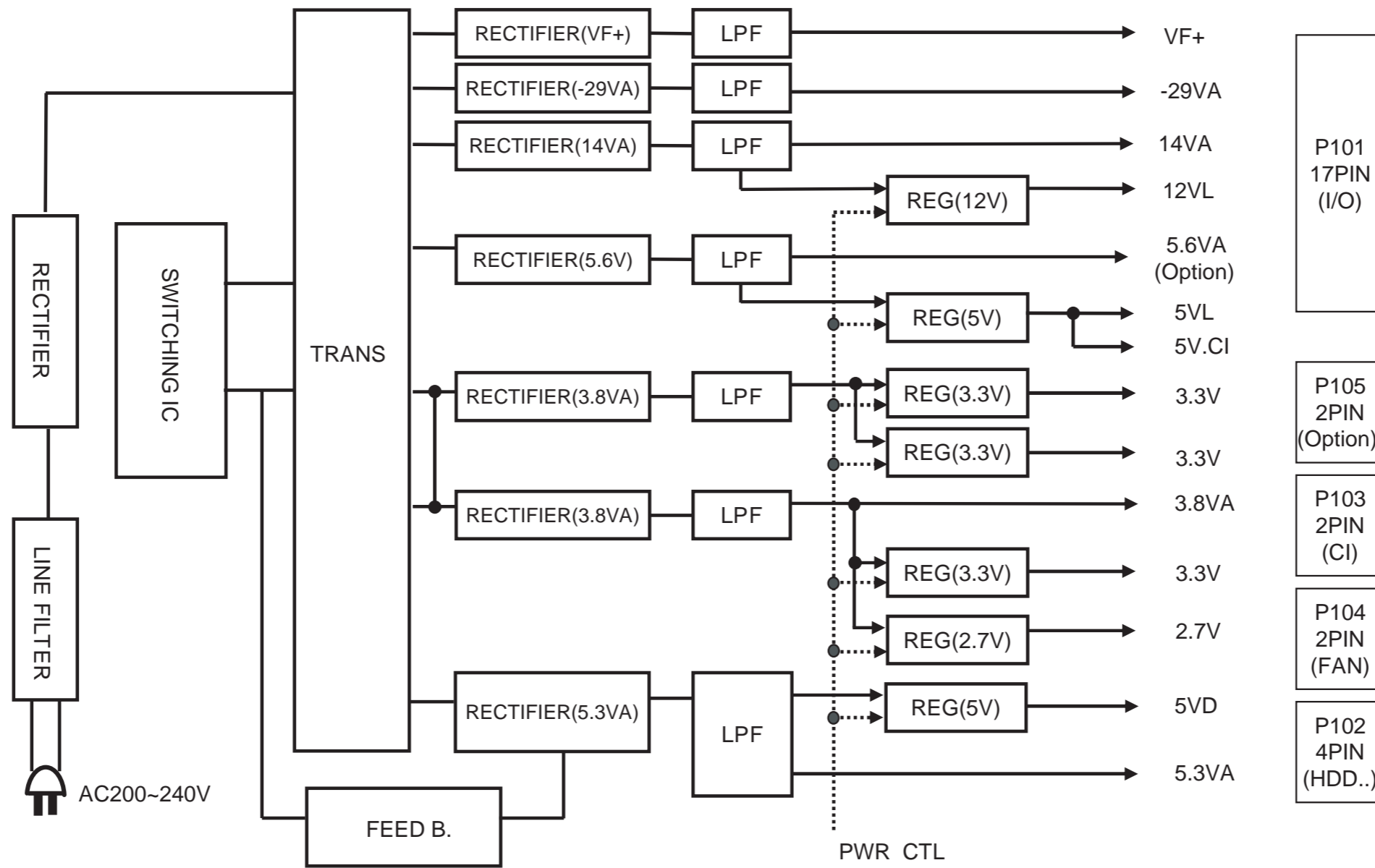

5. POWER : MAIN BOARD BLOCK DIAGRAM

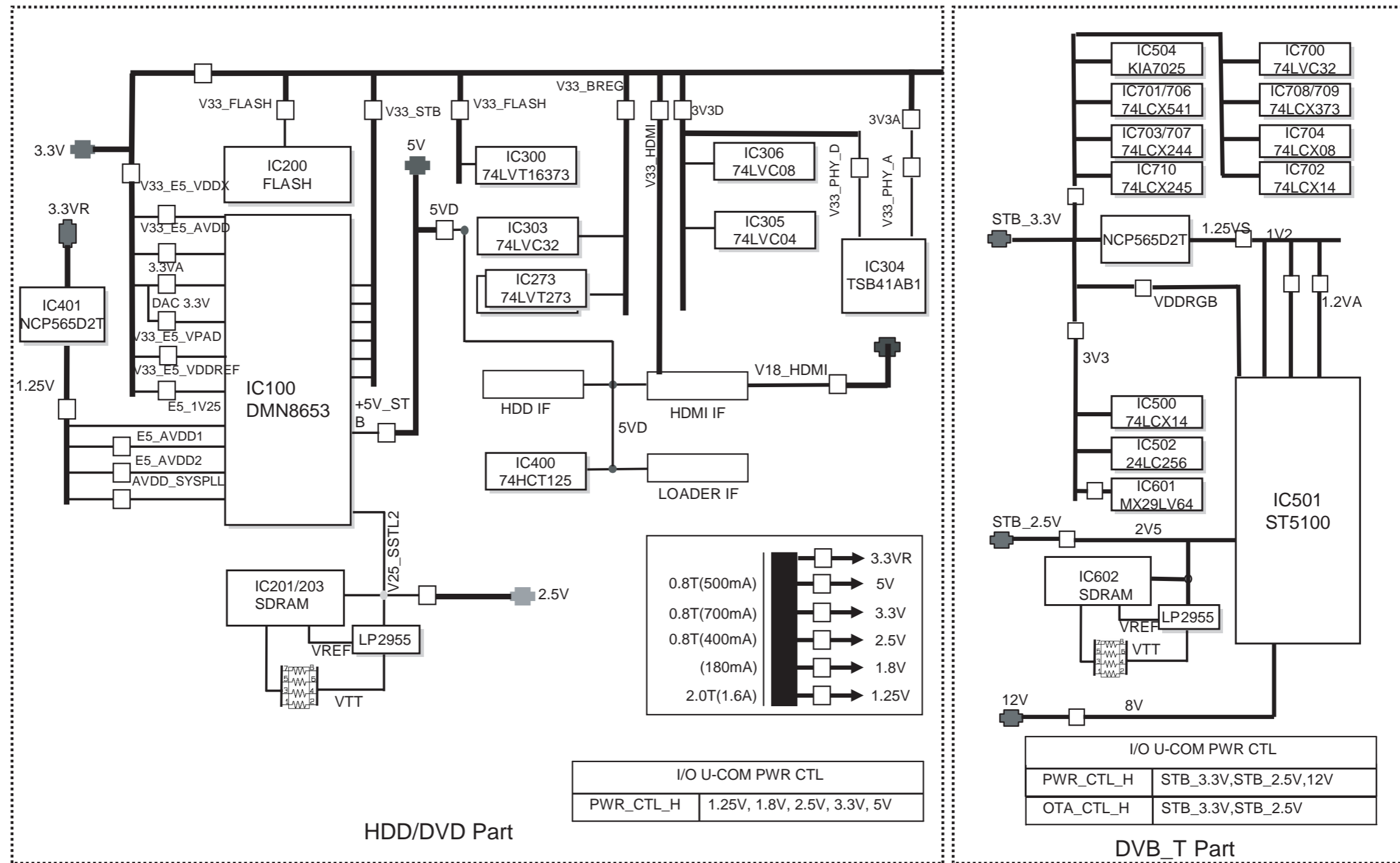

6. POWER : I/O BOARD BLOCK DIAGRAM

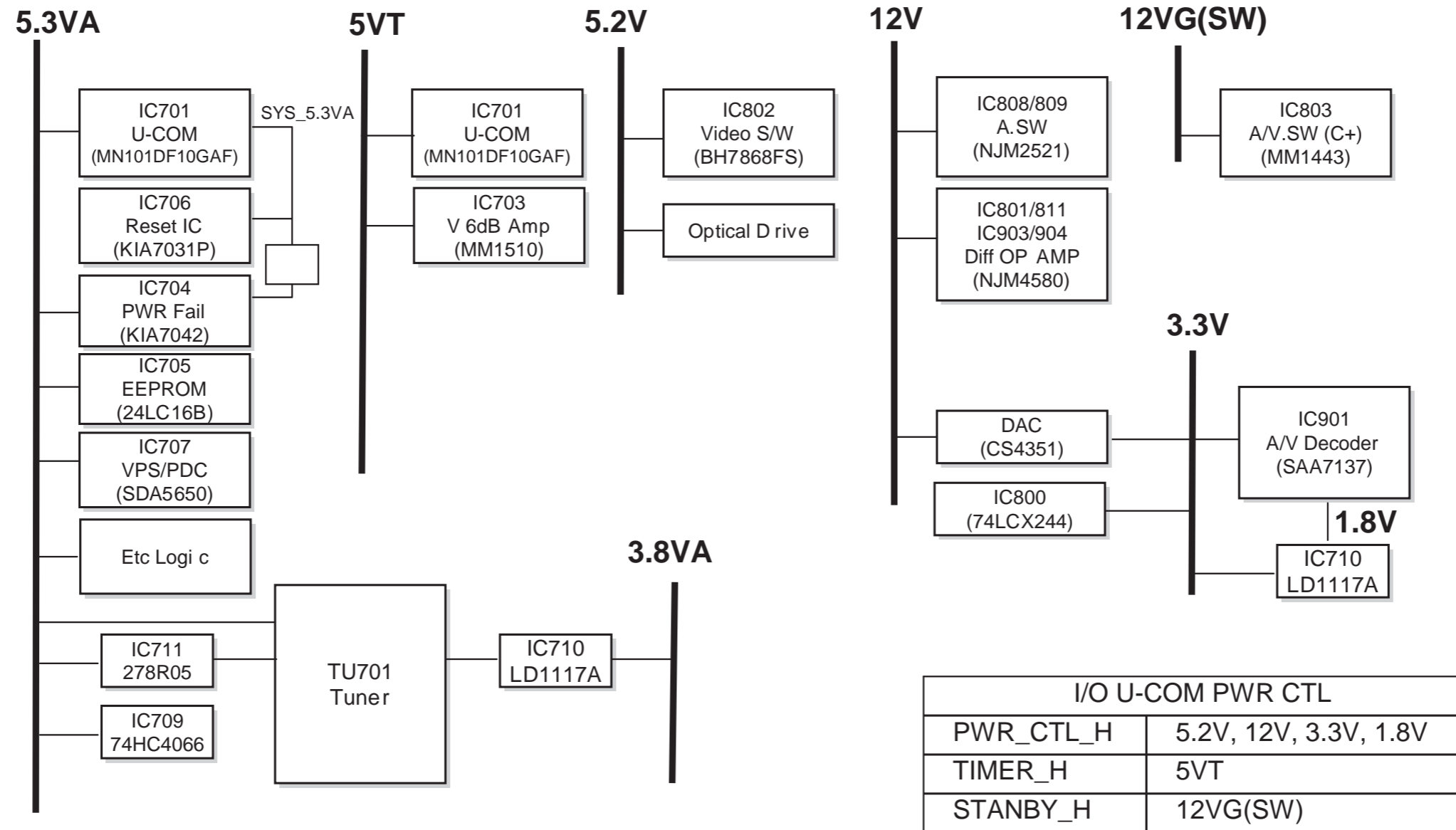

7. IN/OUT BLOCK DIAGRAM (SCART MODEL ONLY)

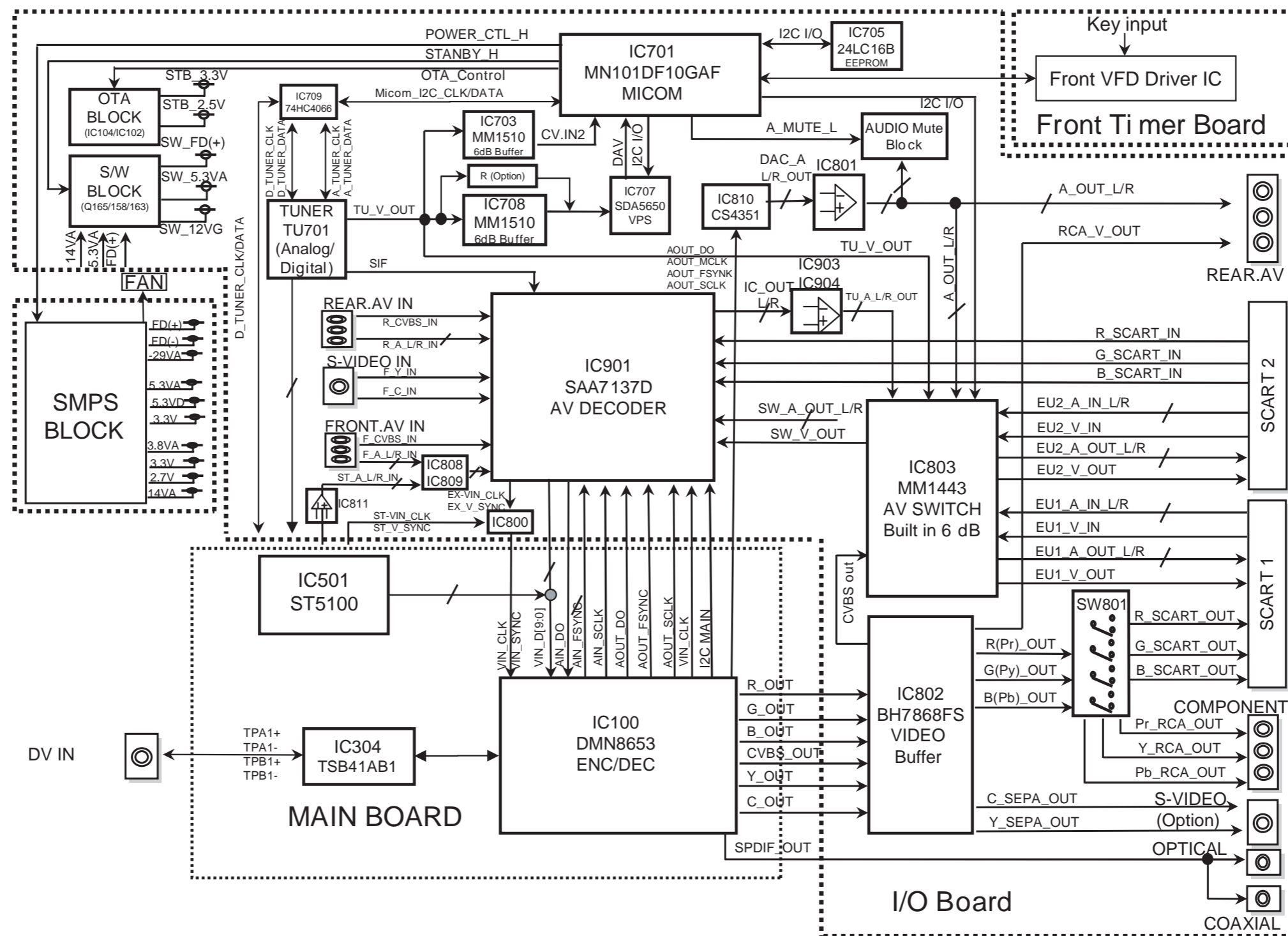

8. VIDEO BLOCK DIAGRAM

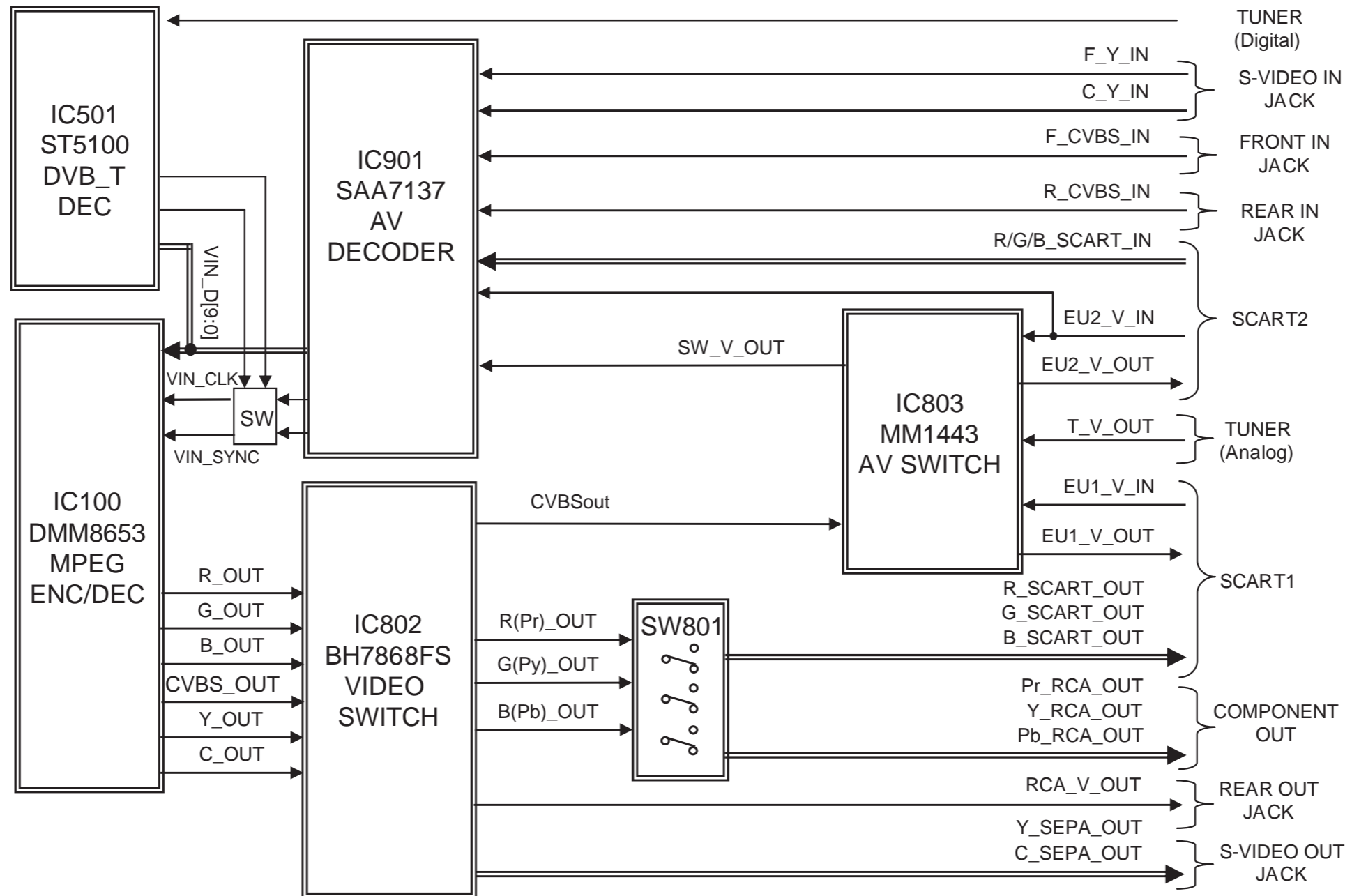

9. VIDEO SW PATH BLOCK DIAGRAM

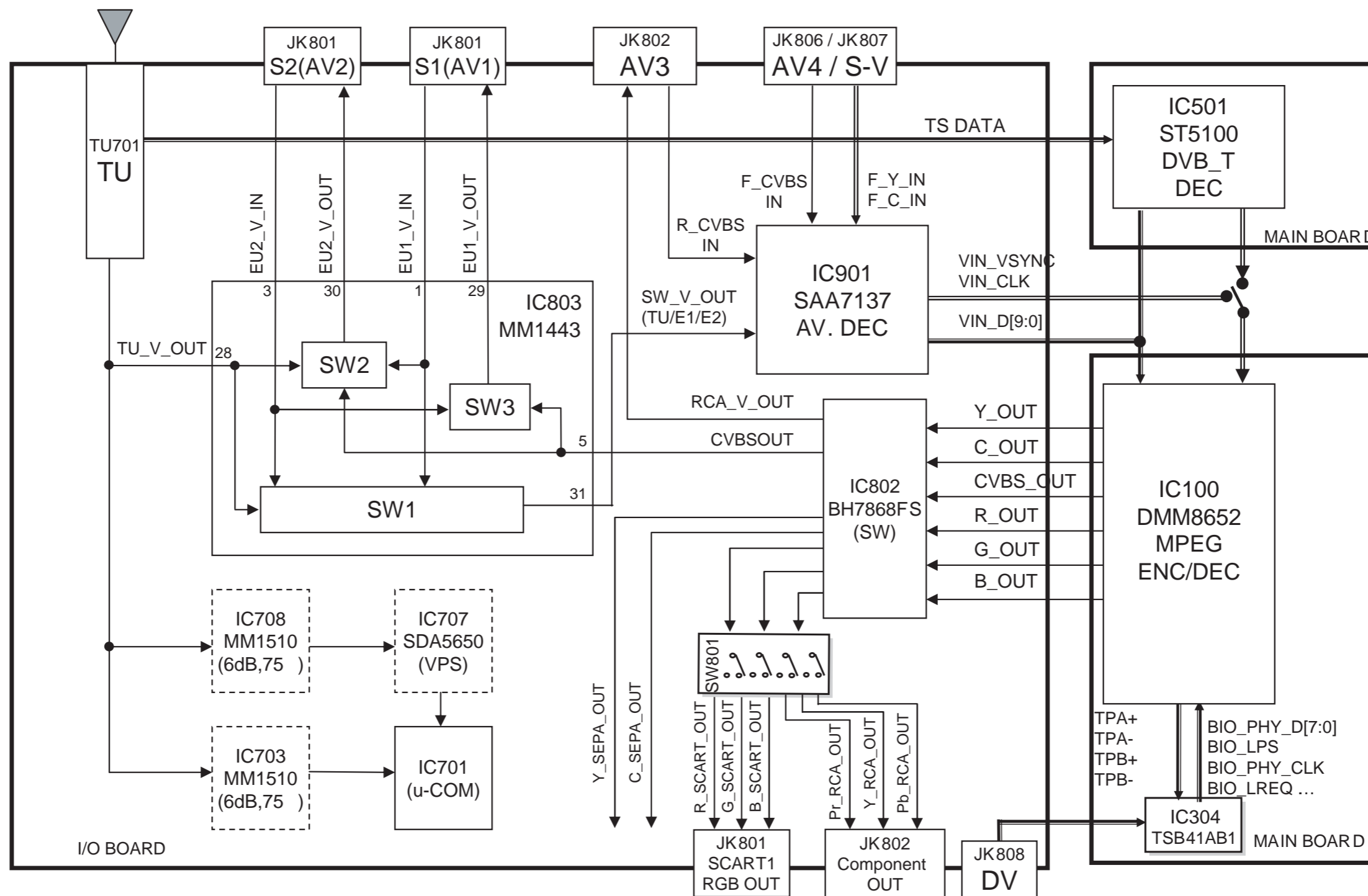

10. AUDIO BLOCK DIAGRAM

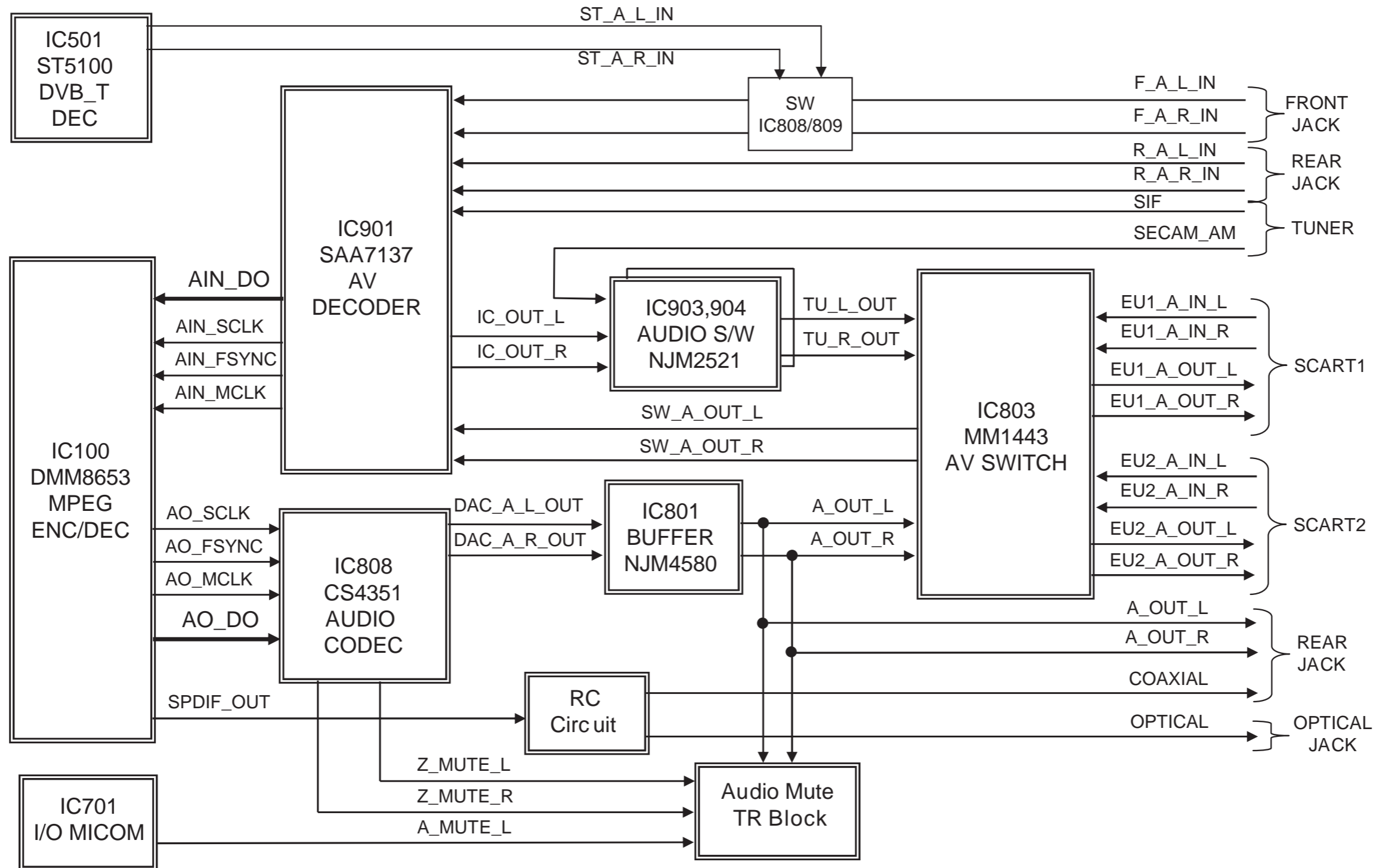

11. AUDIO S/W PATH BLOCK DIAGRAM

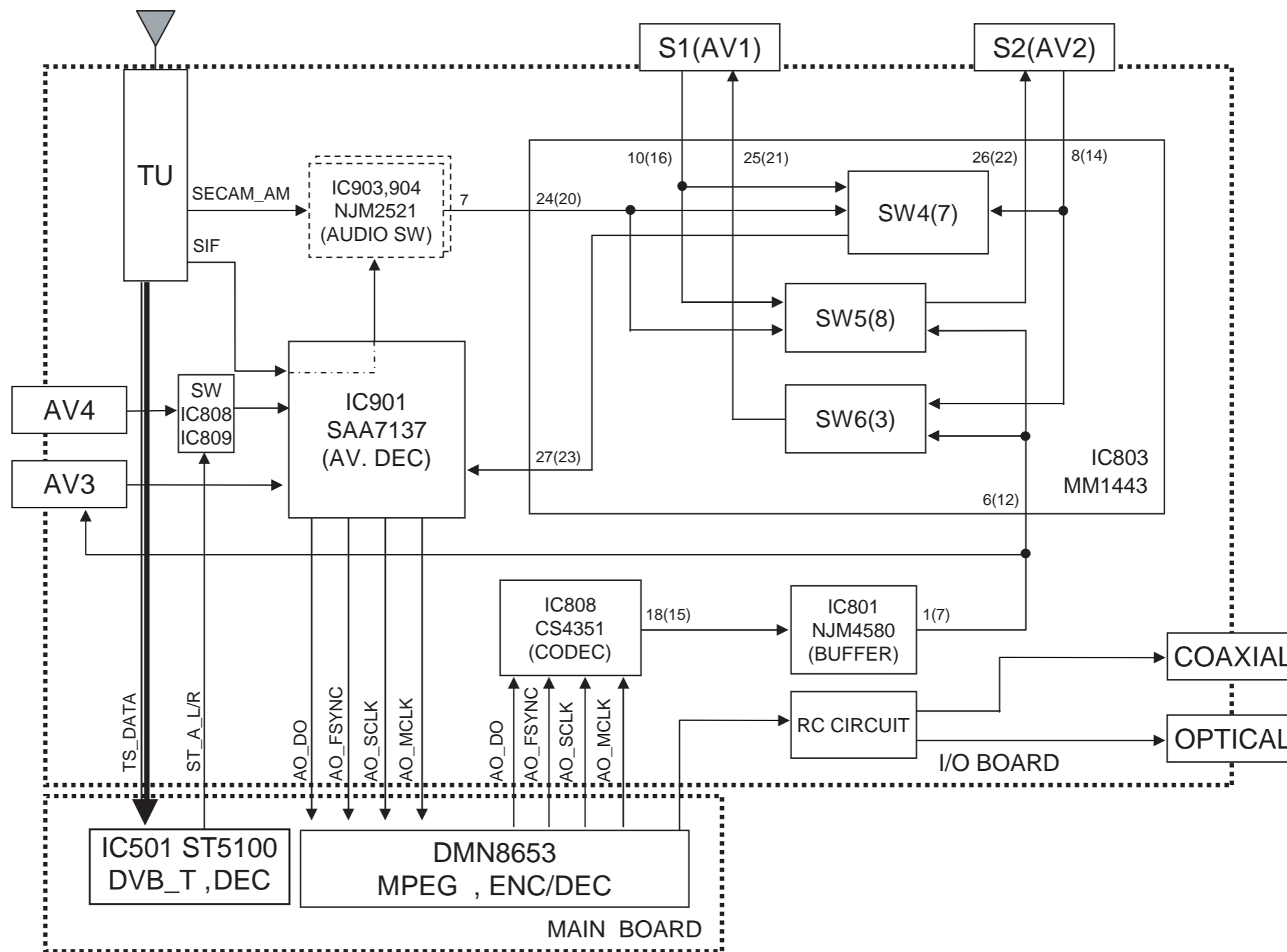

12. FLD / μ -COM / TUNER BLOCK DIAGRAM

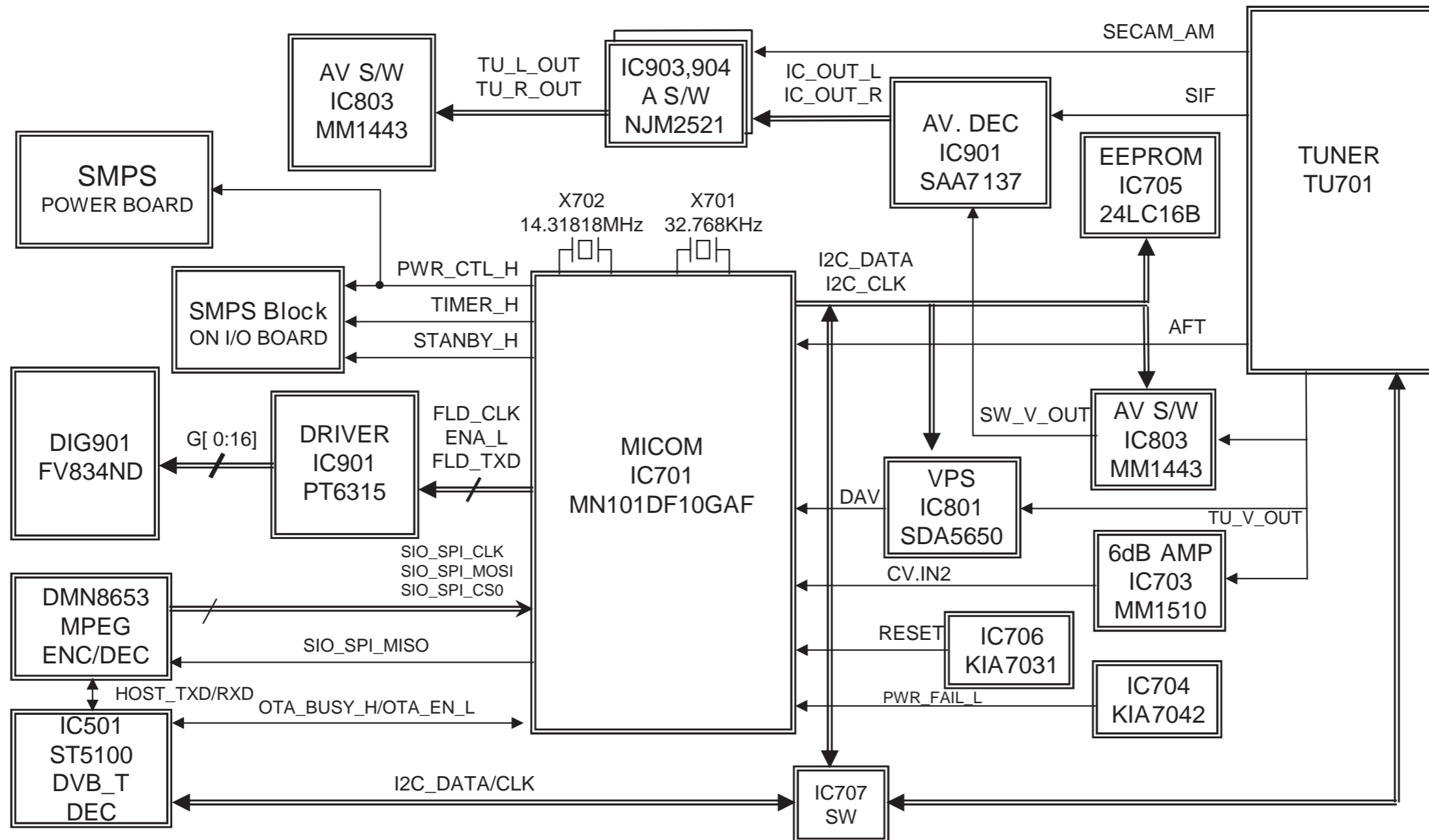

13. MAIN BLOCK DIAGRAM (SCART MODEL ONLY)

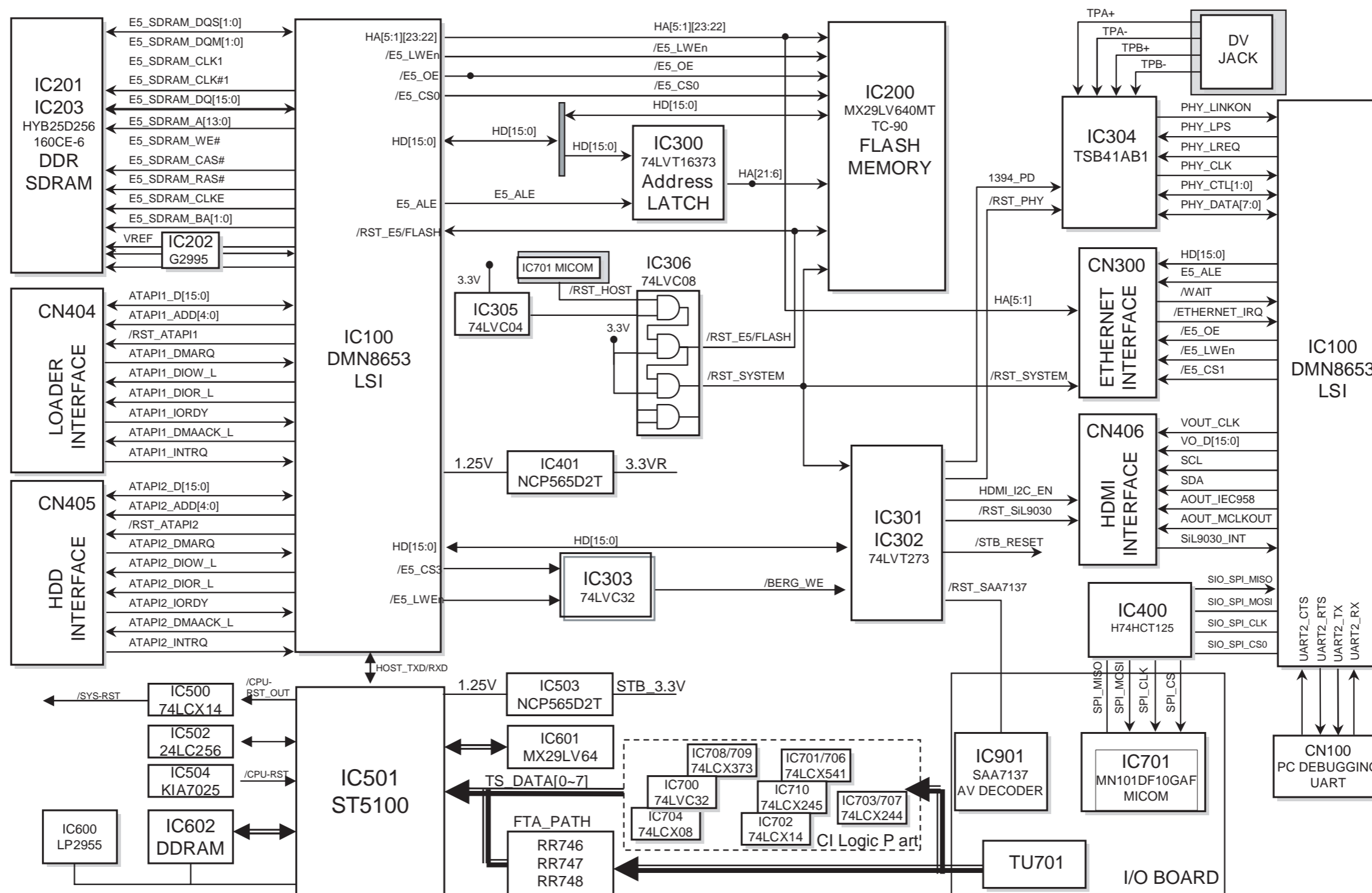

14. TIMER BLOCK DIAGRAM

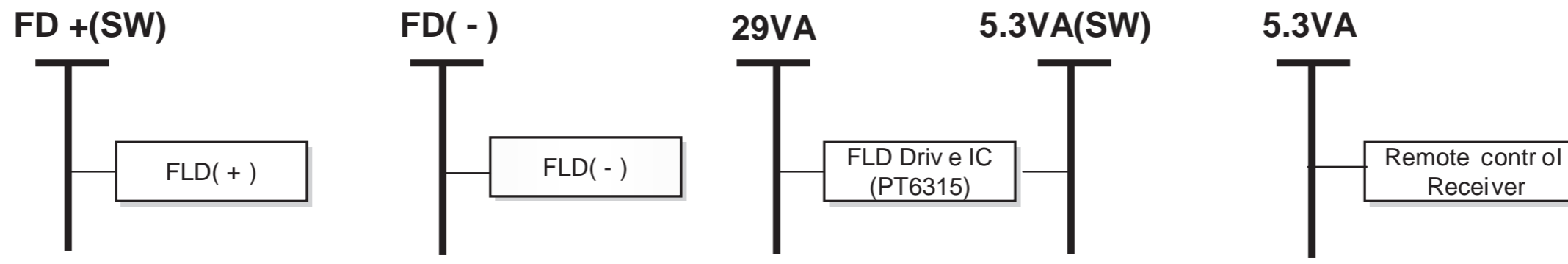

I/O U-COM PWR CTL	
STANBY_H	5.3VA(SW), FD+(SW)

CIRCUIT DIAGRAMS

1. SMPS 1 CIRCUIT DIAGRAM

IMPORTANT SAFETY NOTICE

WHEN SERVICING THIS CHASSIS, UNDER NO CIRCUMSTANCES SHOULD THE ORIGINAL DESIGN BE MODIFIED OR ALTERED WITHOUT PERMISSION FROM THE LG ELECTRONICS CORPORATION. ALL COMPONENTS SHOULD BE REPLACED ONLY WITH TYPES IDENTICAL TO THOSE IN THE ORIGINAL CIR-

CUIT. SPECIAL COMPONENTS ARE SHADED ON THE SCHEMATIC FOR EASY IDENTIFICATION. THIS CIRCUIT DIAGRAM MAY OCCASIONALLY DIFFER FROM THE ACTUAL CIRCUIT USED. THIS WAY, IMPLEMENTATION OF THE LATEST SAFETY AND PERFORMANCE IMPROVEMENT CHANGES INTO THE SET IS NOT DELAYED UNTIL THE NEW SERVICE LITERATURE IS PRINTED.

NOTE :

1. Shaded(■) parts are critical for safety. Replace only with specified part number.
2. Voltages are DC-measured with a digital voltmeter during Play mode.

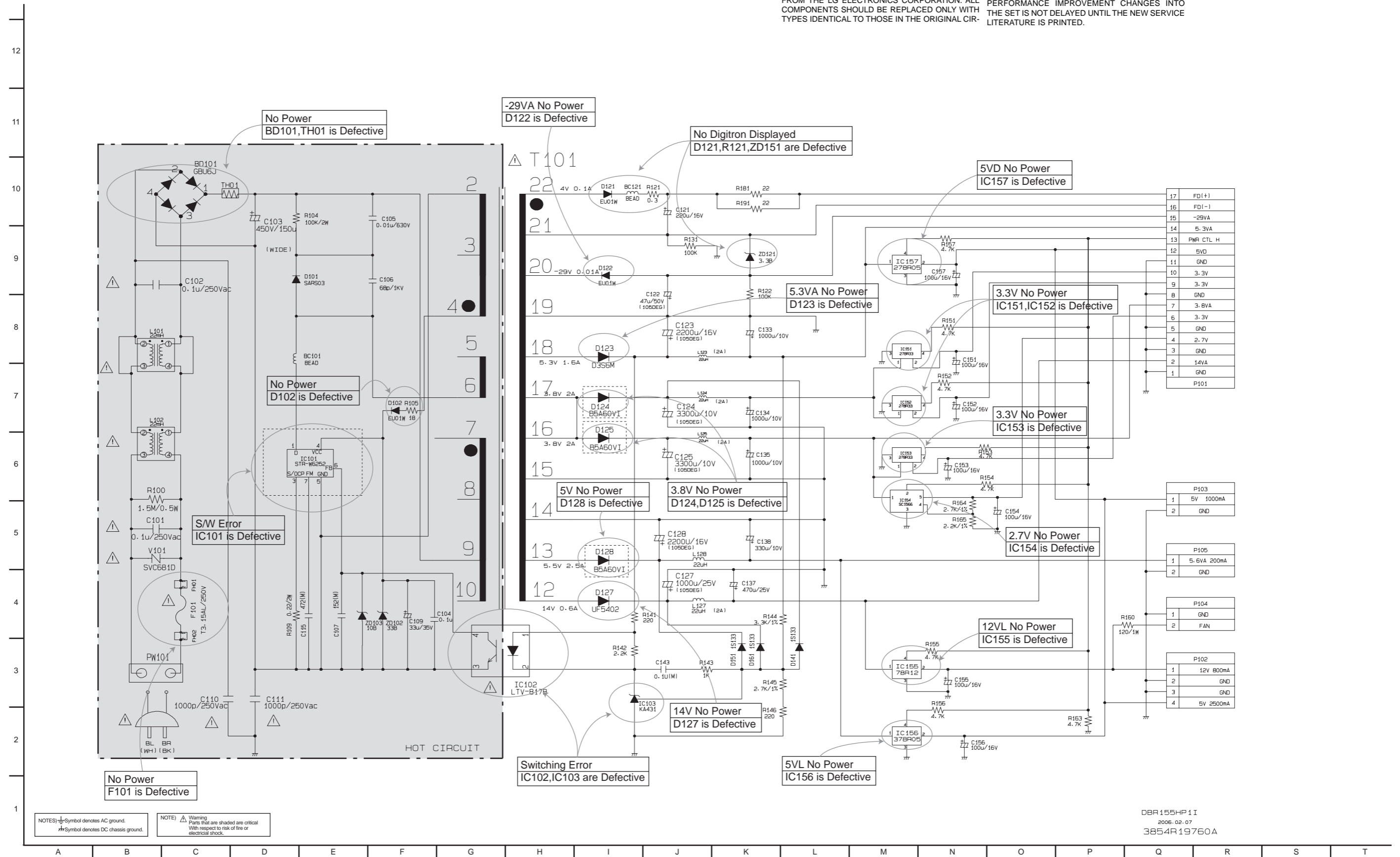

NOTES) \perp Symbol denotes AC ground.
 \perp Symbol denotes DC chassis ground.
 NOTE) \triangle Warning
 Parts that are shaded are critical
 With respect to risk of fire or
 electrical shock.

DBR155HP1 I
 2006.02.07
 3854R19760A

2. SMPS 2 CIRCUIT DIAGRAM

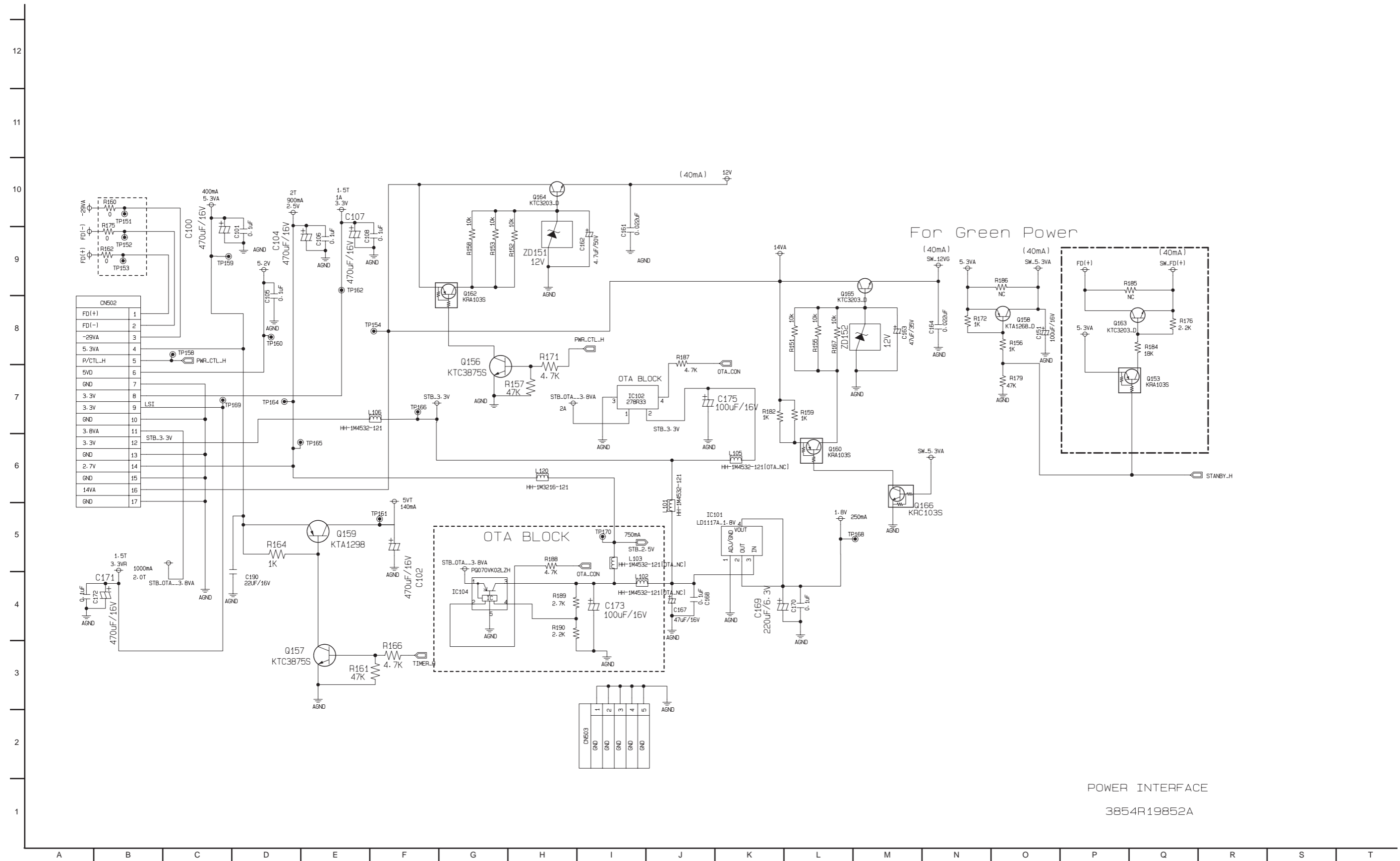

POWER INTERFACE
3854R19852A

3. MPEG CIRCUIT DIAGRAM (DBRH197's, DBRH198's ONLY)

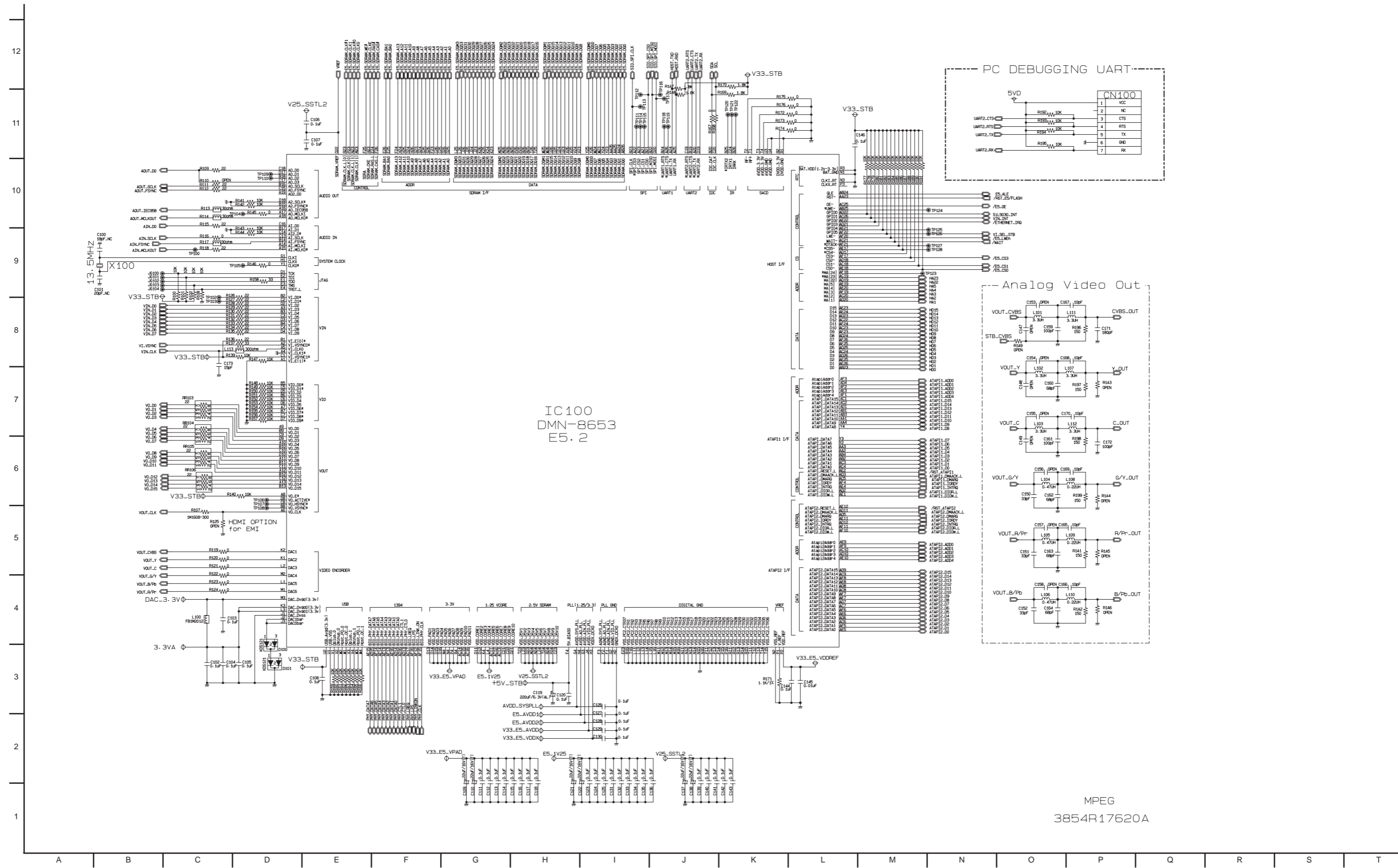

MPEG
3854R17620A

4. MPEG CIRCUIT DIAGRAM(DBRH199's ONLY)

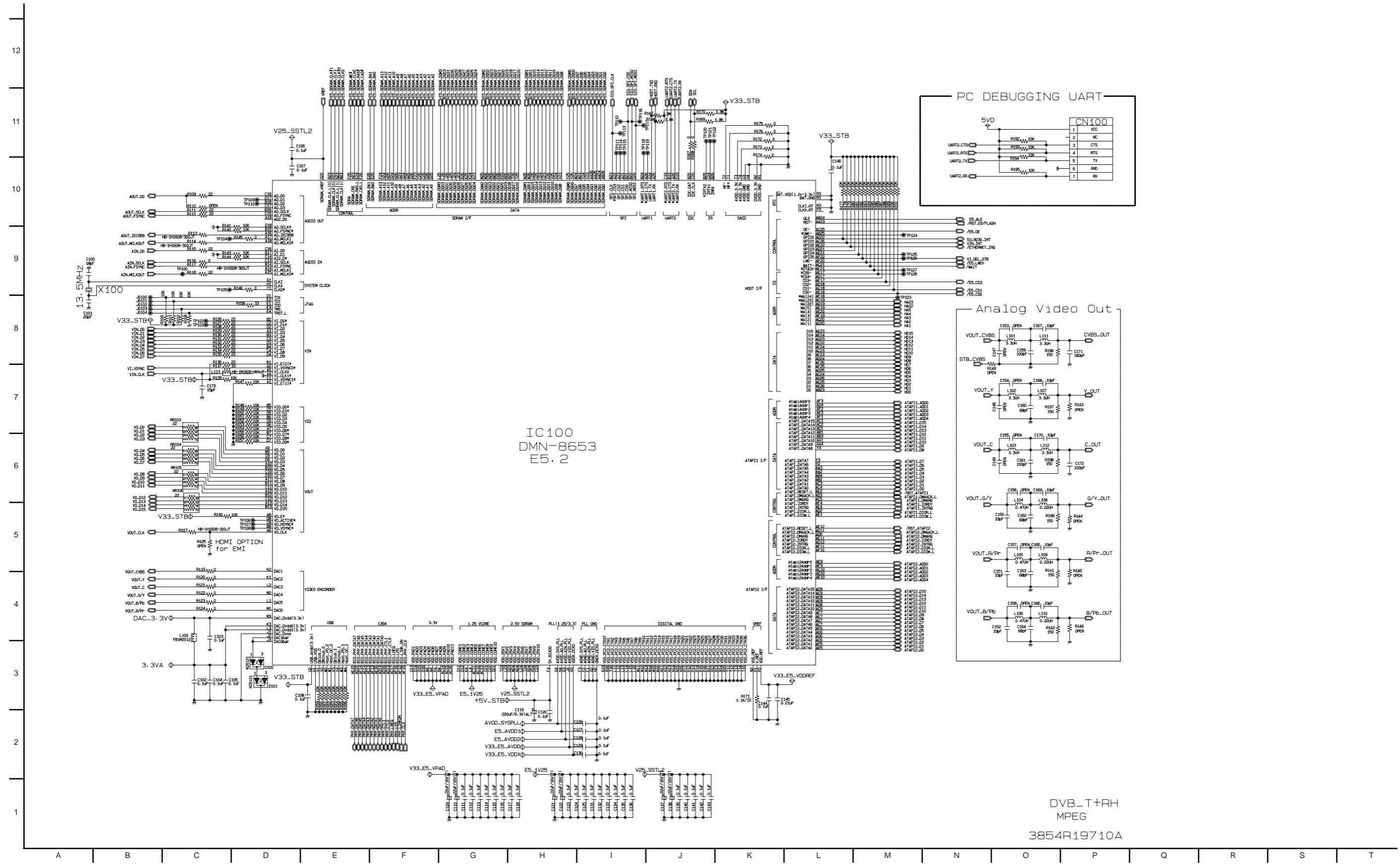

5. FLASH/DDR CIRCUIT DIAGRAM (DBRH197's, DBRH198's ONLY)

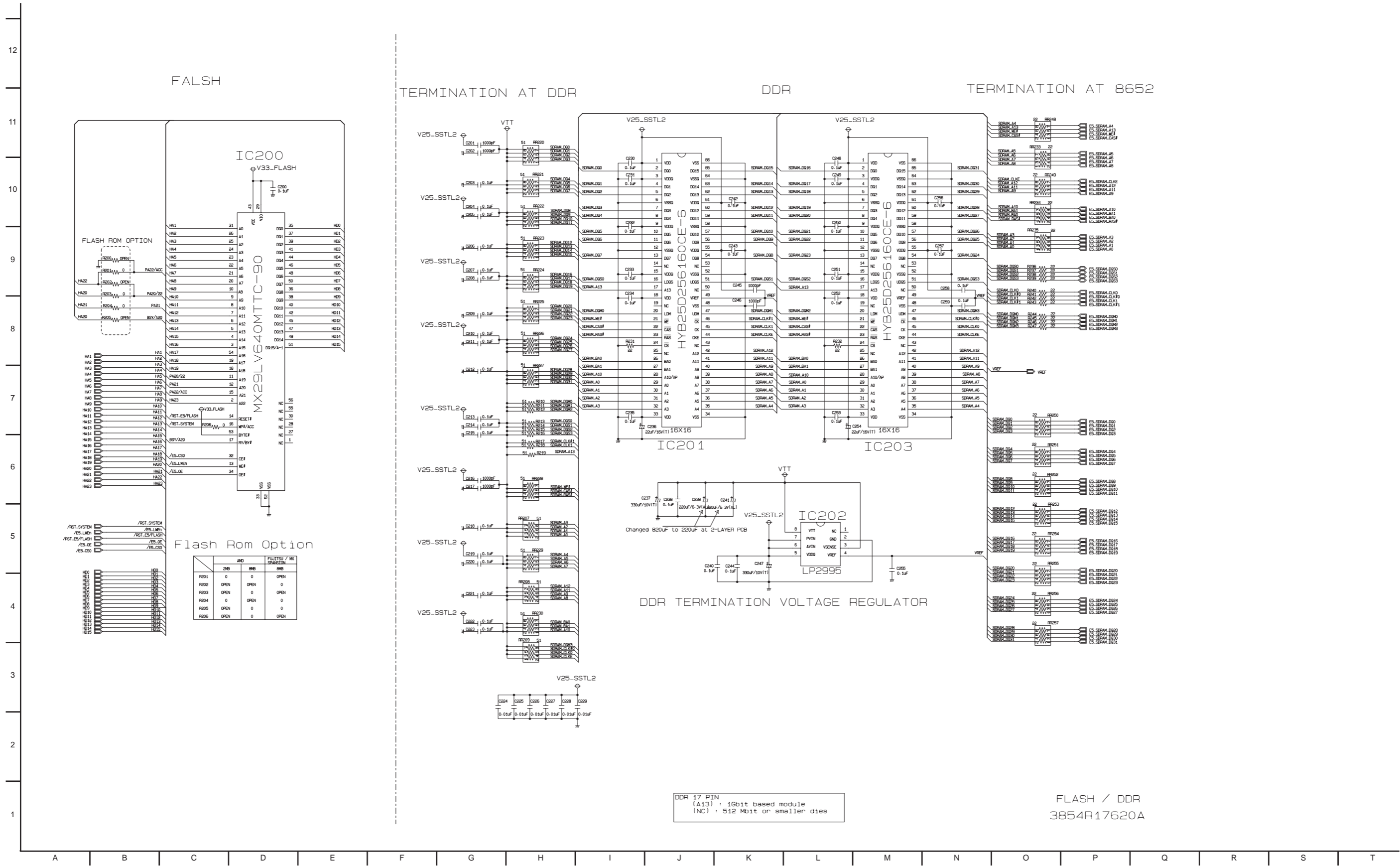

DDR 17 PIN
 (A13) : 1Gbit based module
 (NC) : 512 Mbit or smaller dies

FLASH / DDR
 3854R17620A

6. FLASH/DDR CIRCUIT DIAGRAM (DBRH199's ONLY)

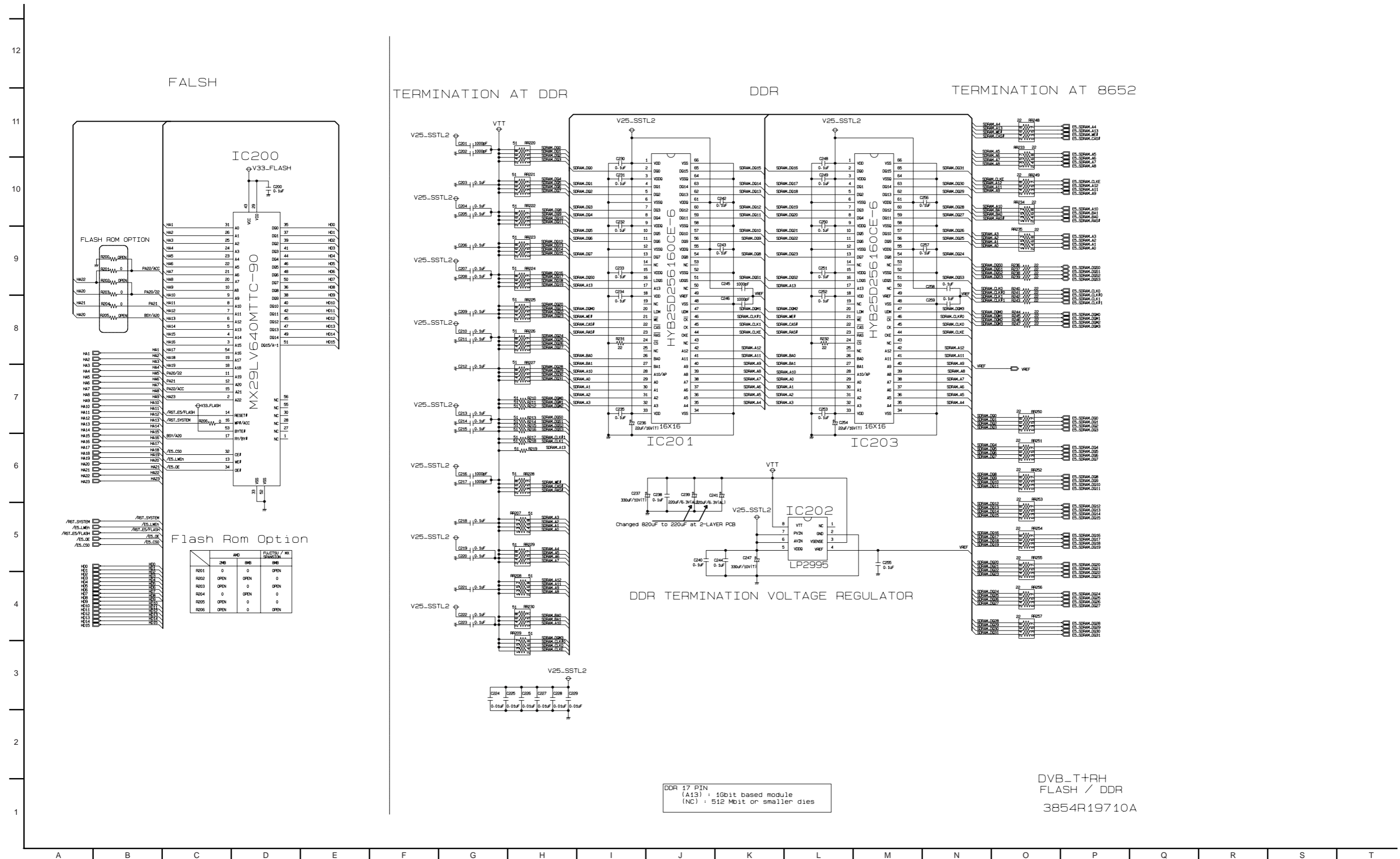

8. RESET & 1394 & JPEG CIRCUIT DIAGRAM(DBRH198's, DBRH199's ONLY)

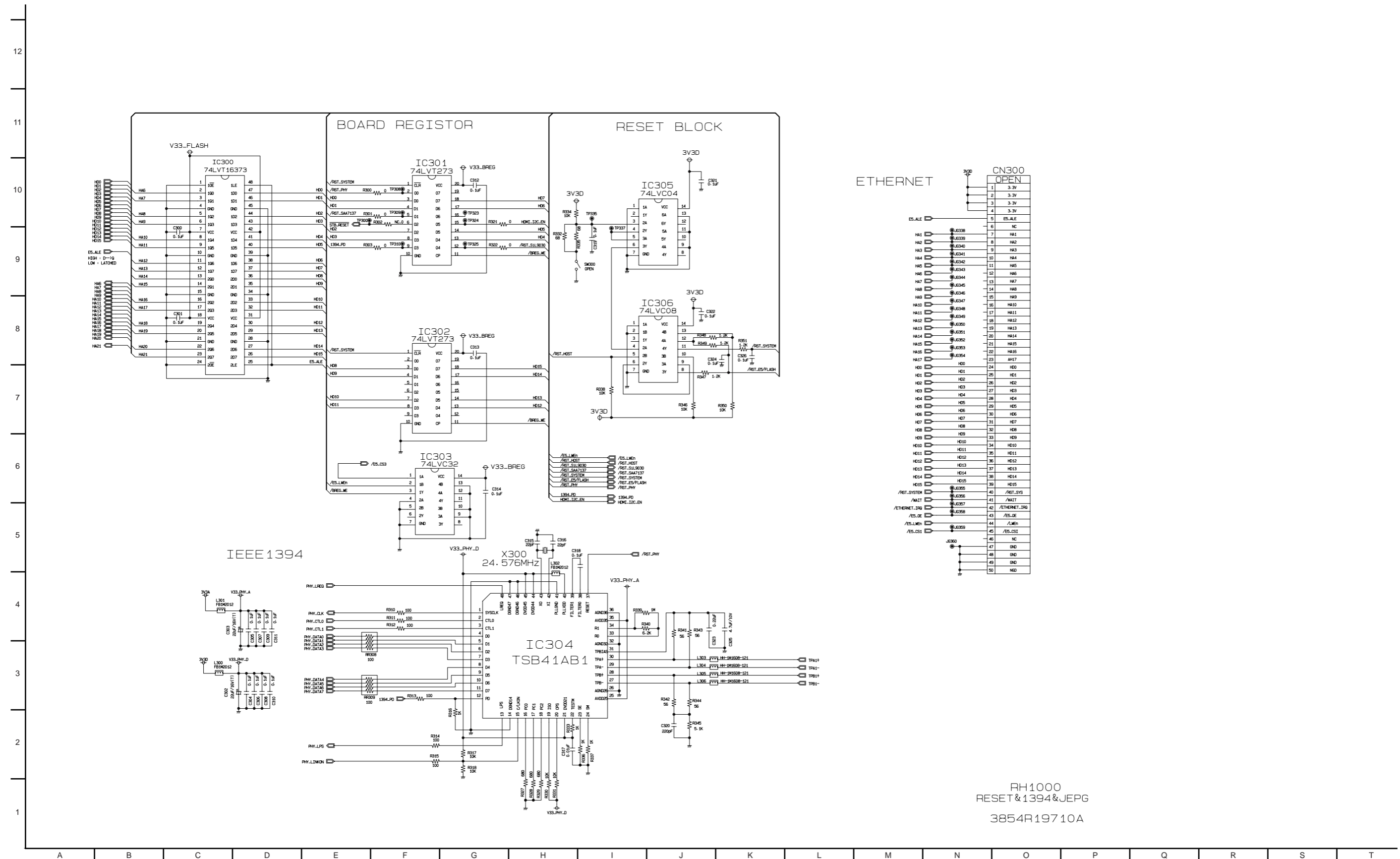

9. ATAPI & MEMORY CARD CIRCUIT DIAGRAM (DBRH197's, DBRH198's ONLY)

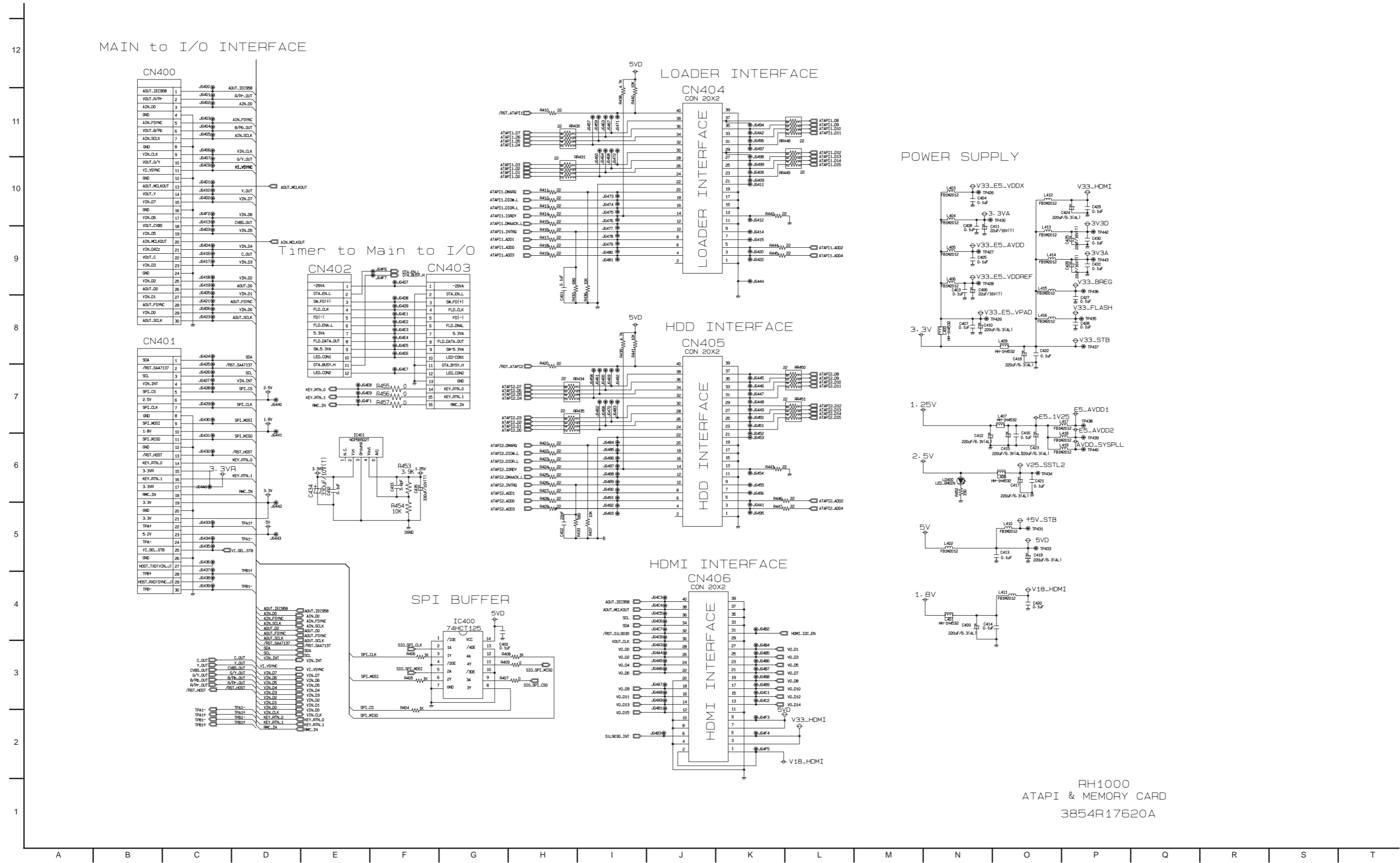

RH1000
ATAPI & MEMORY CARD
3854R17620A

10. ATAPI & MEMORY CARD CIRCUIT DIAGRAM(DBRH199's ONLY)

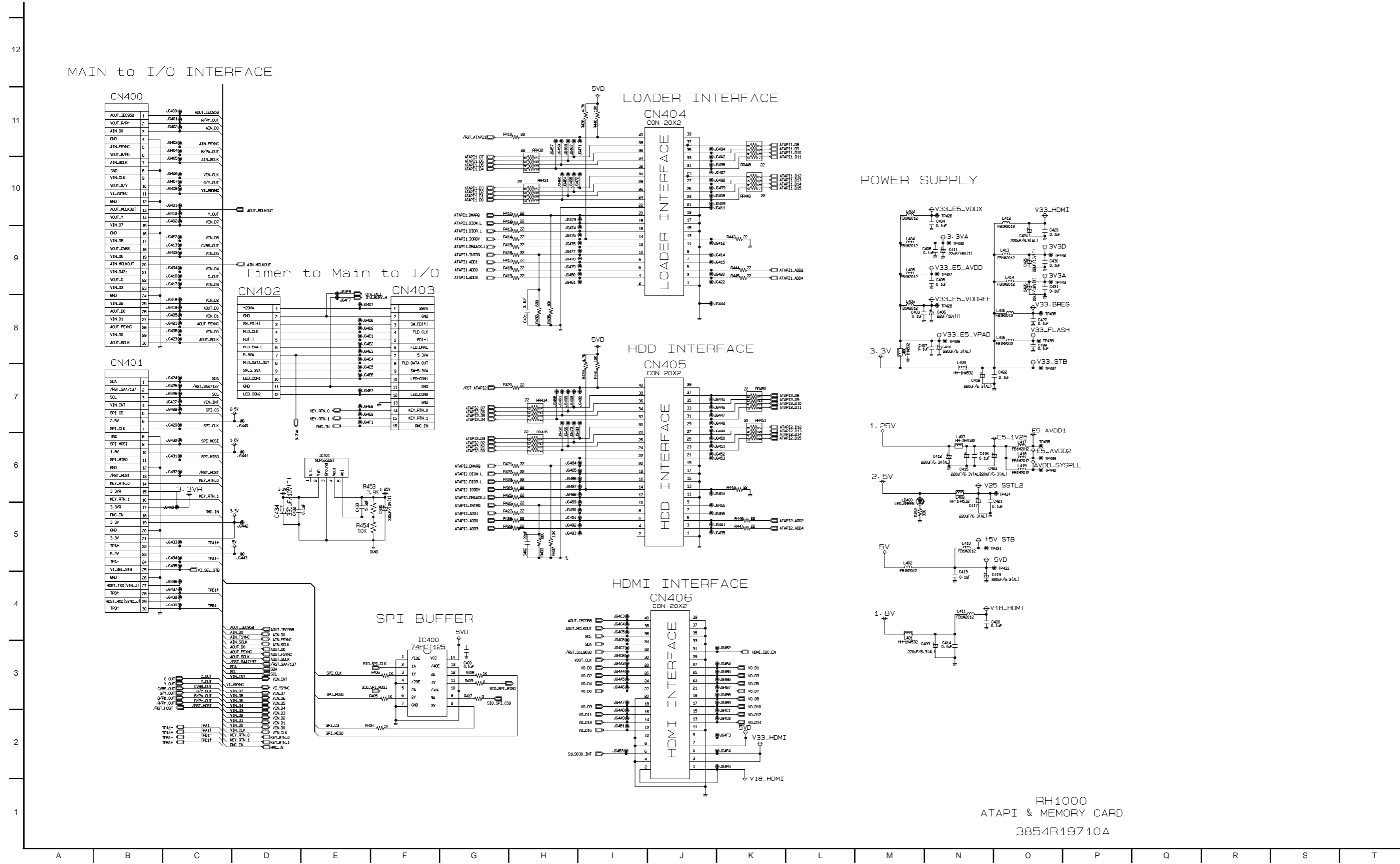

RH1000
ATAPI & MEMORY CARD
3854R19710A

11. I/O, μ-COM CIRCUIT DIAGRAM

12
11
10
9
8
7
6
5
4
3
2
1

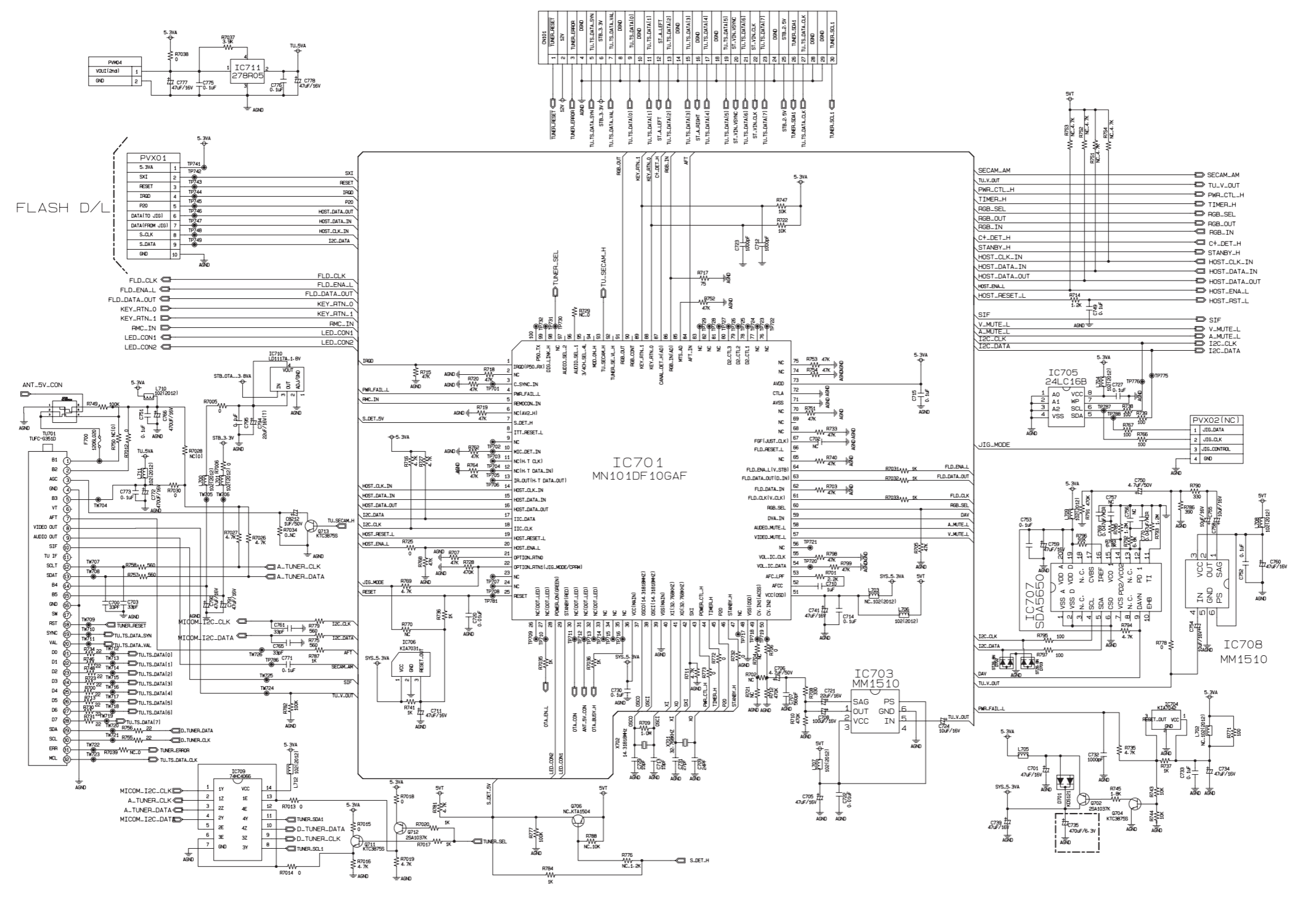

I/O u-COM
3854R19B52A

A B C D E F G H I J K L M N O P Q R S T

12. TUNER/MPX/ADC/DAC/JACK CIRCUIT DIAGRAM

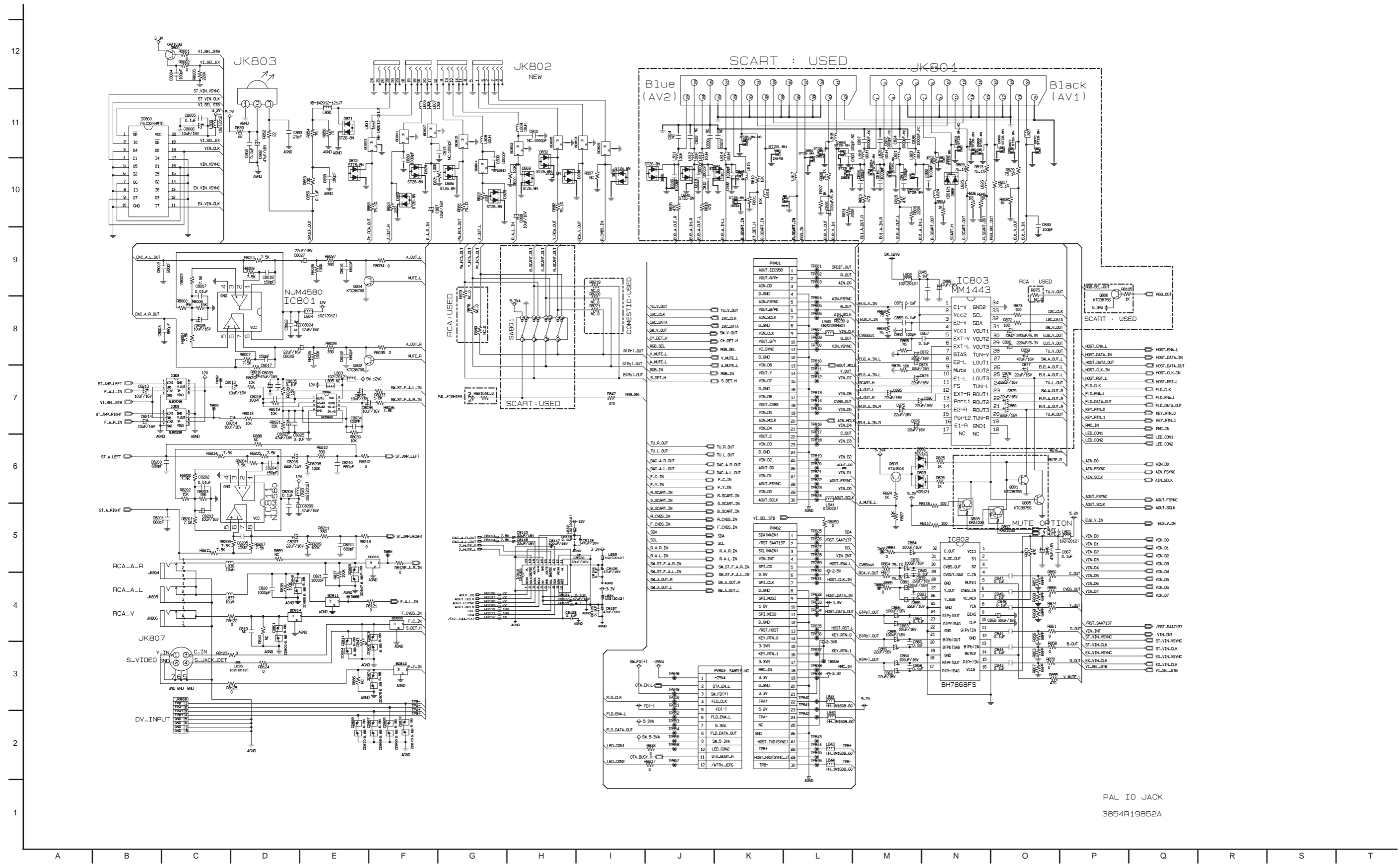

PAL IO JACK
3854R19852A

13. STB SYSTEM CIRCUIT DIAGRAM (DBRH197's, DBRH198's ONLY)

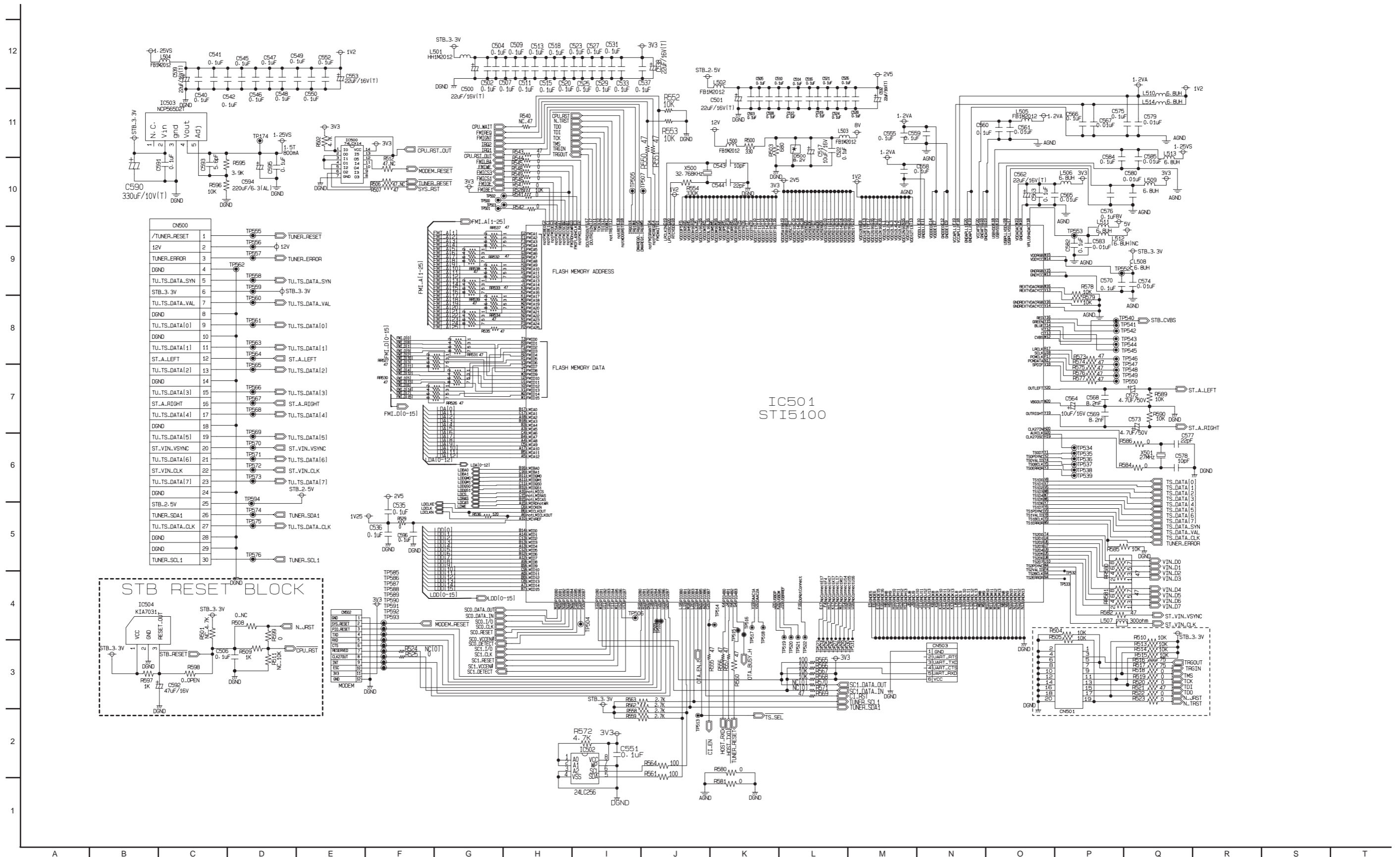

14. STB SYSTEM CIRCUIT DIAGRAM (DBRH199's ONLY)

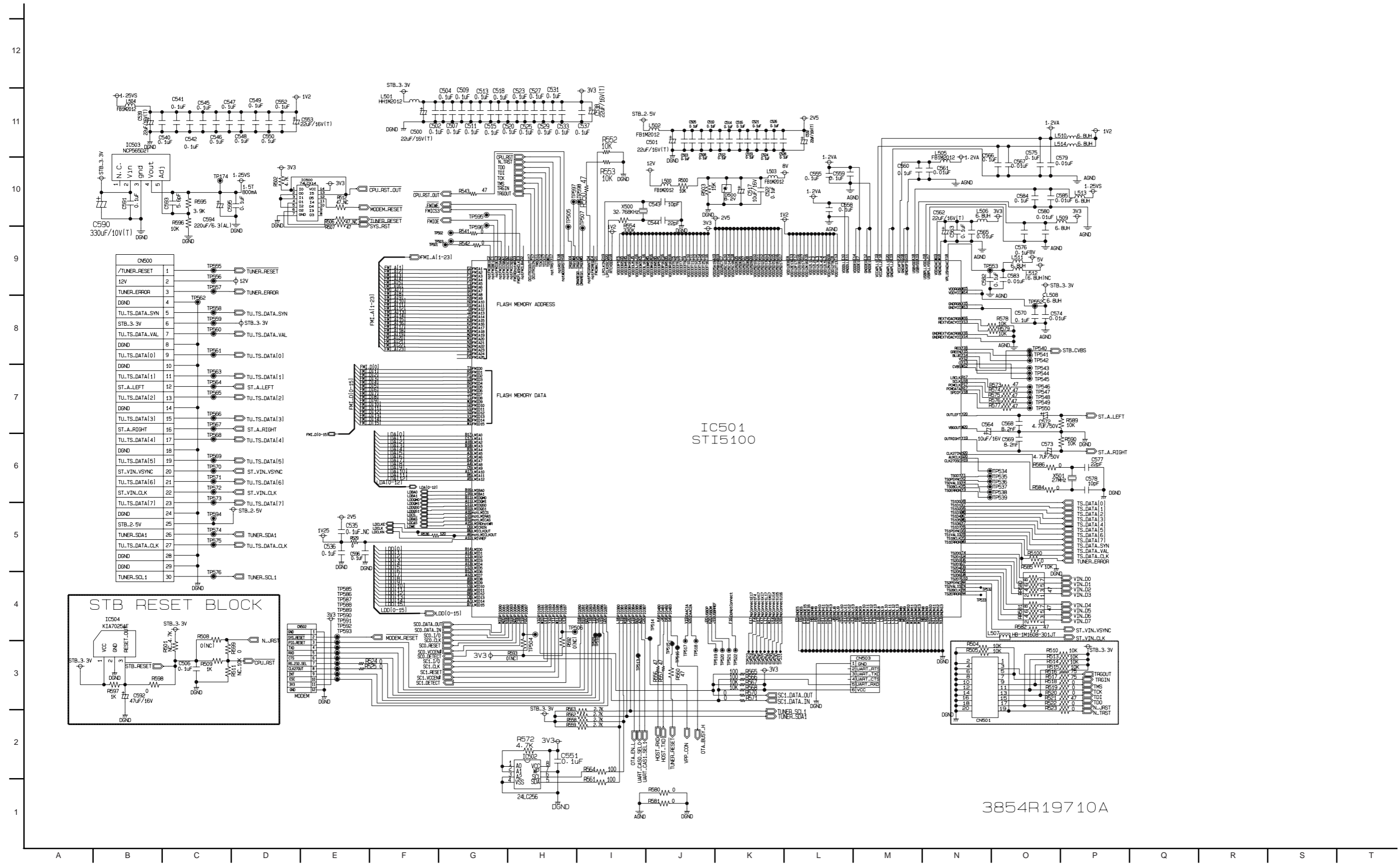

15. DDR SDRAM CIRCUIT DIAGRAM (DBRH197's, DBRH198's ONLY)

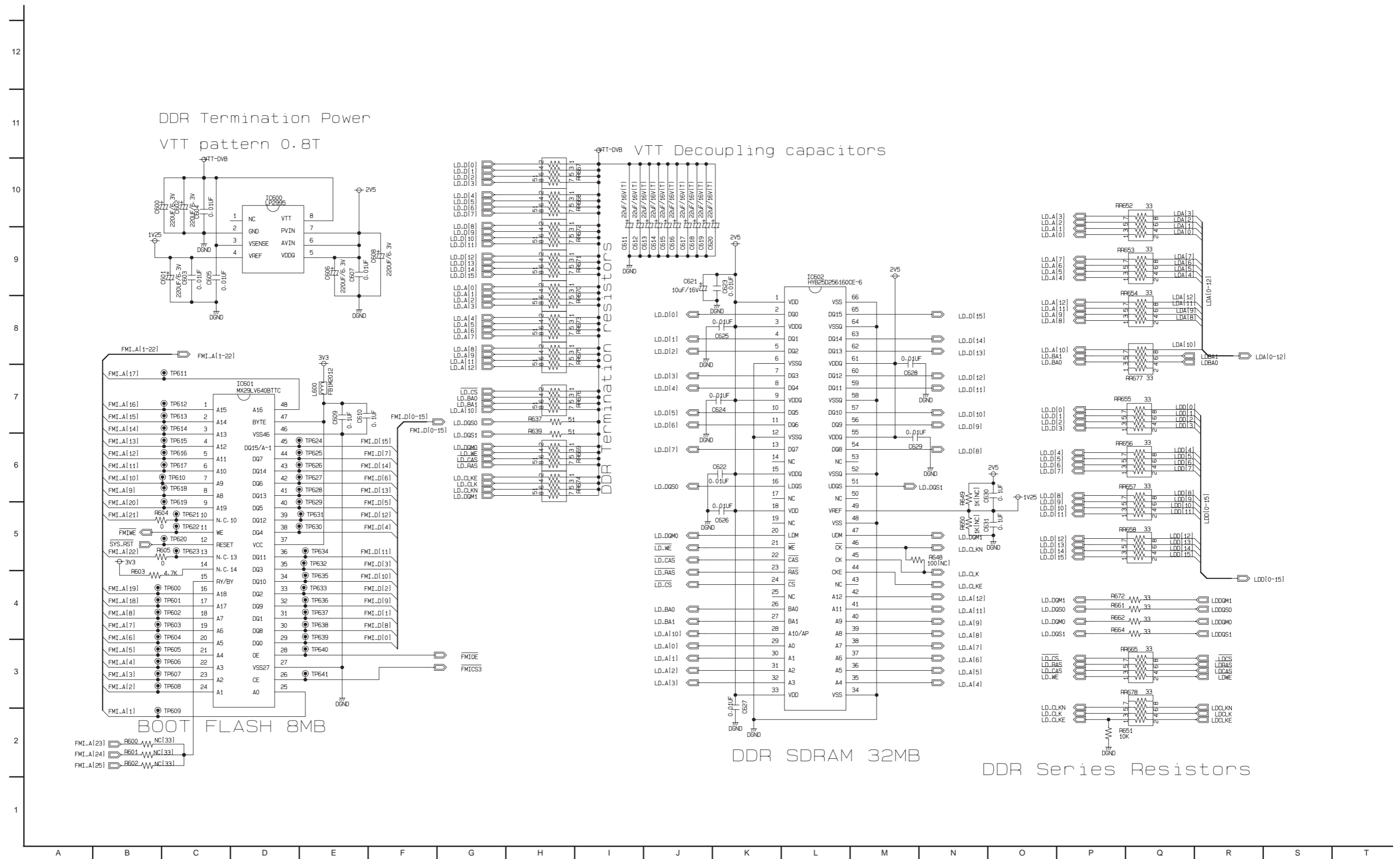

16. DDR SDRAM CIRCUIT DIAGRAM (DBRH199's ONLY)

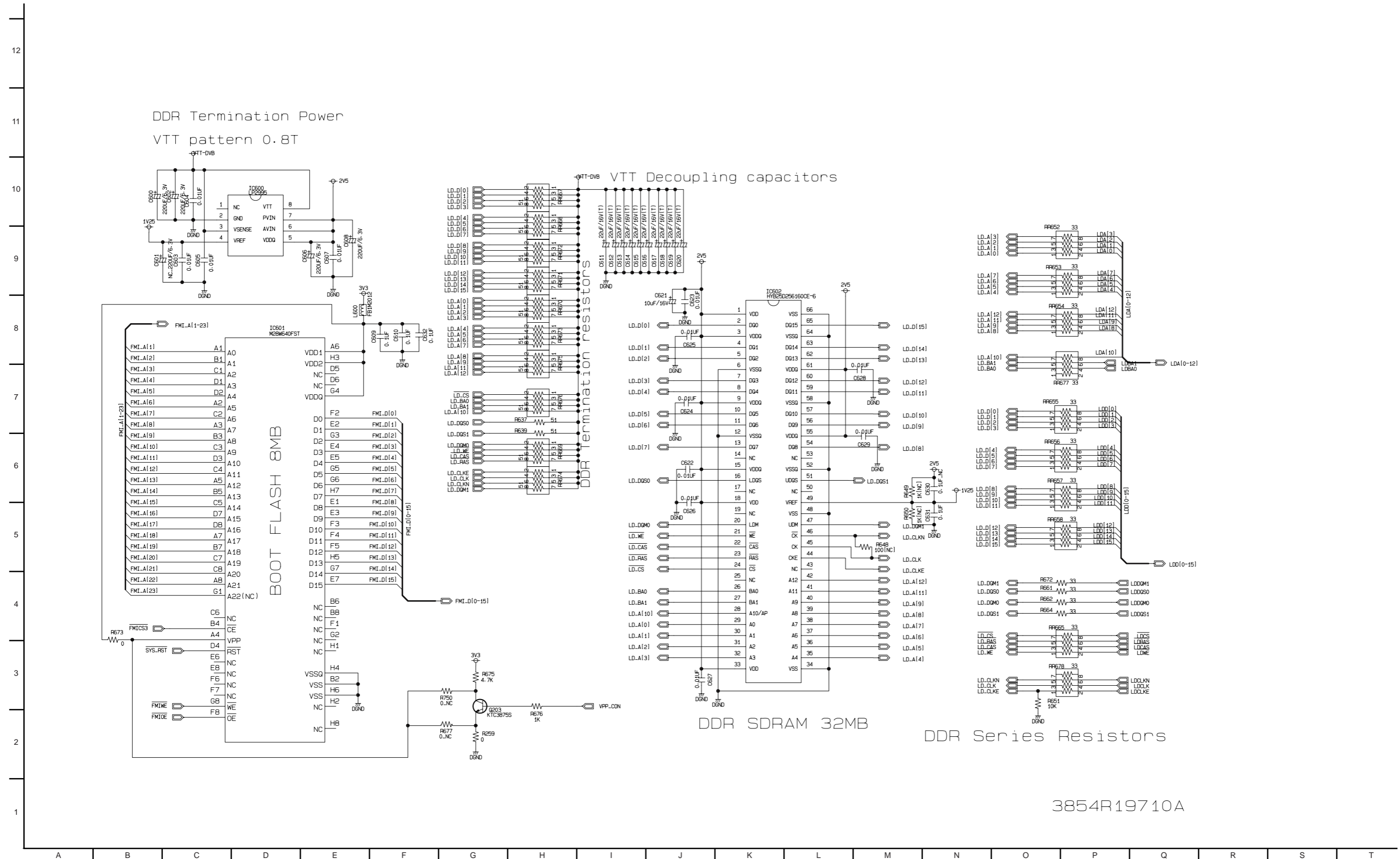

17. STB, CI INTERFACE CIRCUIT DIAGRAM (DBRH197's, DBRH198's ONLY)

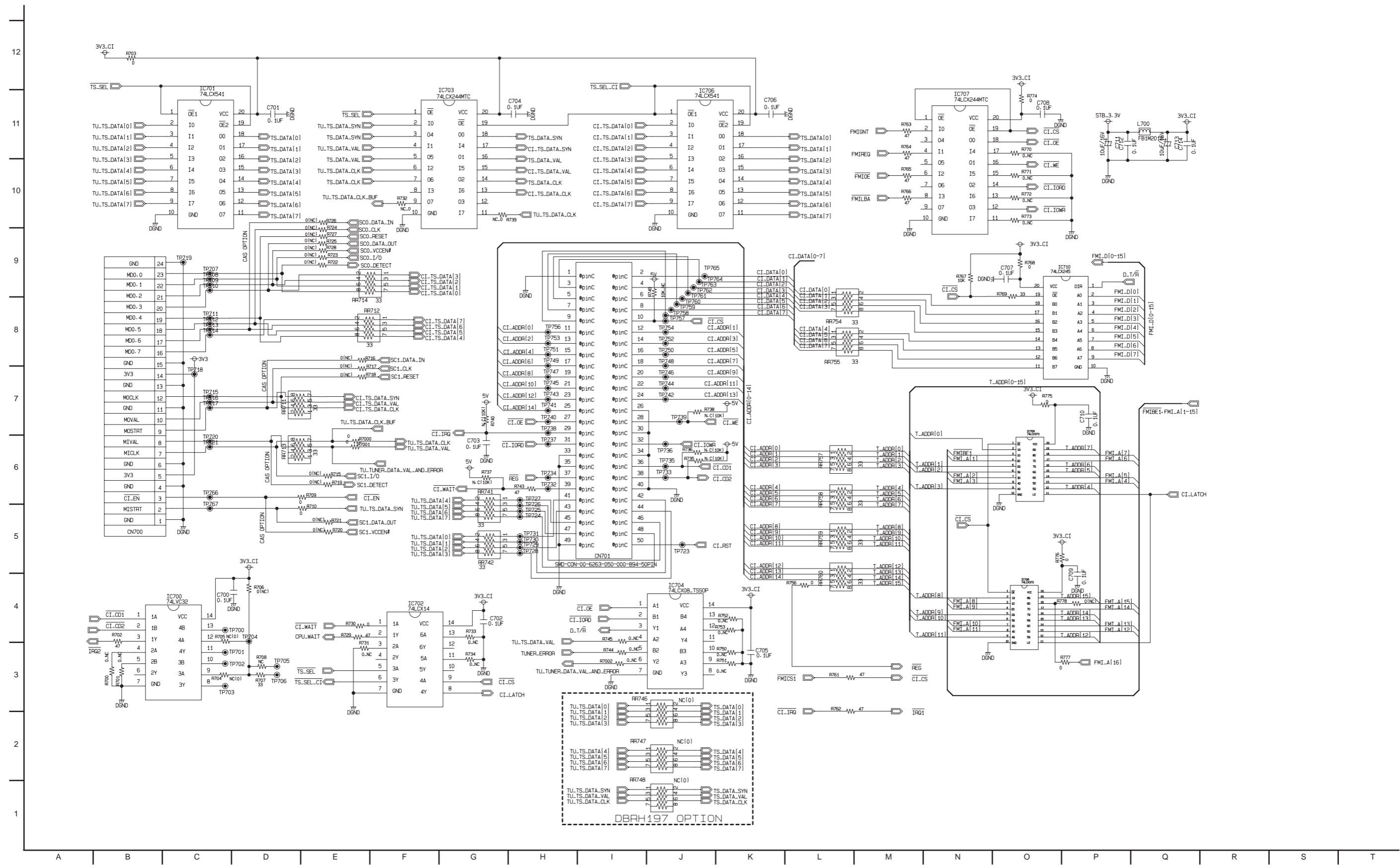

18. SMART CARD CIRCUIT DIAGRAM(DBRH199's ONLY)

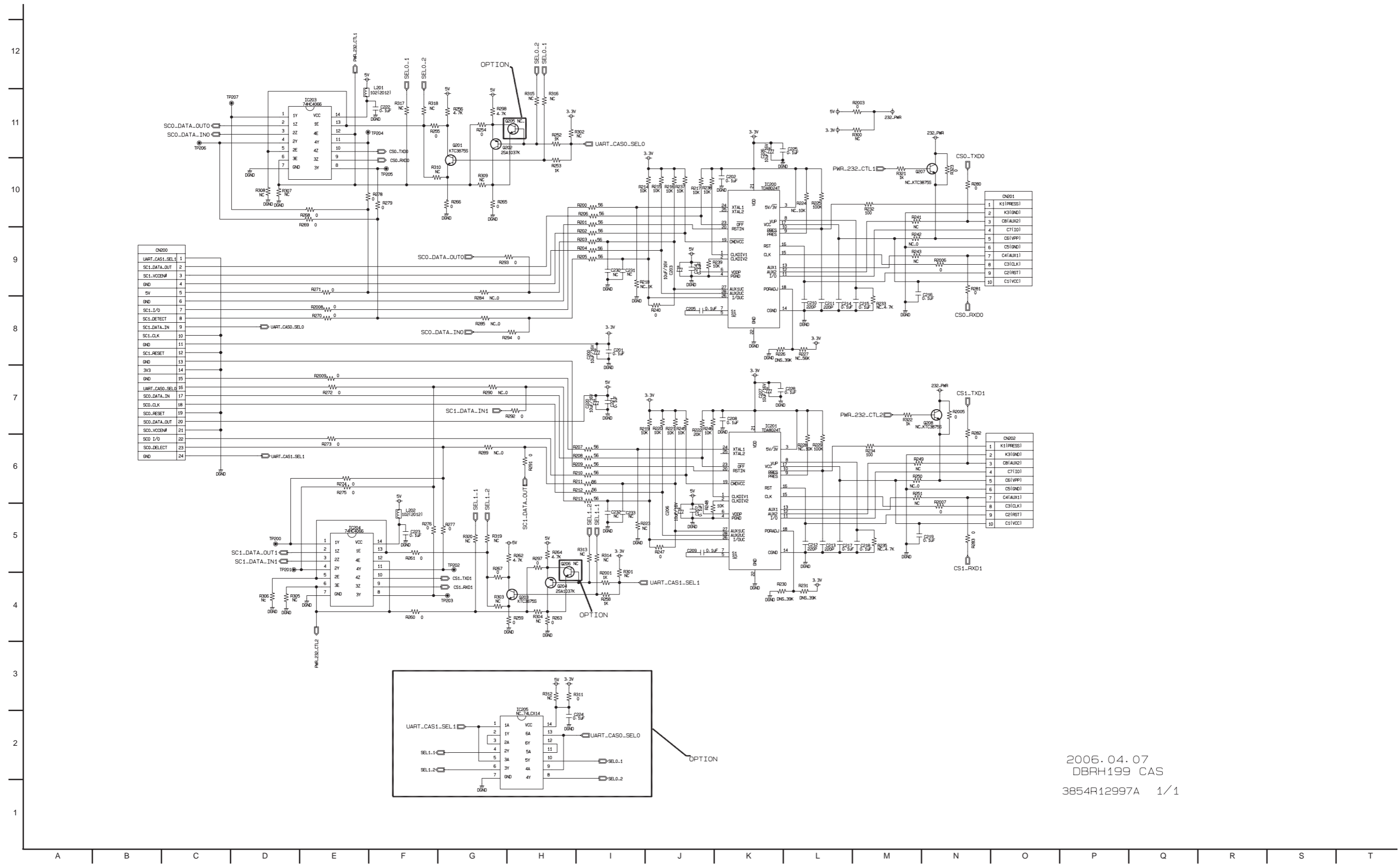

Pin	Signal
1	UART_CAS1_SEL1
2	SC1_DATA_OUT
3	SC1_VOZEN#
4	GND
5	5V
6	GND
7	SC1_I/O
8	SC1_DETECT
9	SC1_DATA_IN
10	SC1_CLK
11	GND
12	SC1_RESET
13	GND
14	3V3
15	GND
16	UART_CASO_SELO
17	SC0_DATA_IN
18	SC0_CLK
19	SC0_RESET
20	SC0_DATA_OUT
21	SC0_VOZEN#
22	SC0_I/O
23	SC0_DELECT
24	GND

Pin	Signal
1	K1(PRESS)
2	K3(GND)
3	C8(AUX2)
4	C7(I/O)
5	C6(VPP)
6	C5(GND)
7	C4(AUX1)
8	C3(CLK)
9	C2(RST)
10	C1(VCC)

Pin	Signal
1	K1(PRESS)
2	K3(GND)
3	C8(AUX2)
4	C7(I/O)
5	C6(VPP)
6	C5(GND)
7	C4(AUX1)
8	C3(CLK)
9	C2(RST)
10	C1(VCC)

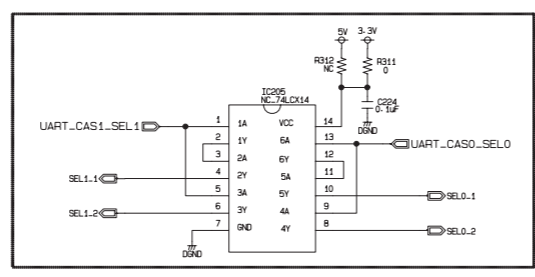

2006.04.07
 DBRH199 CAS
 3854R12997A 1/1

19. CI CIRCUIT DIAGRAM(DBRH198's ONLY)

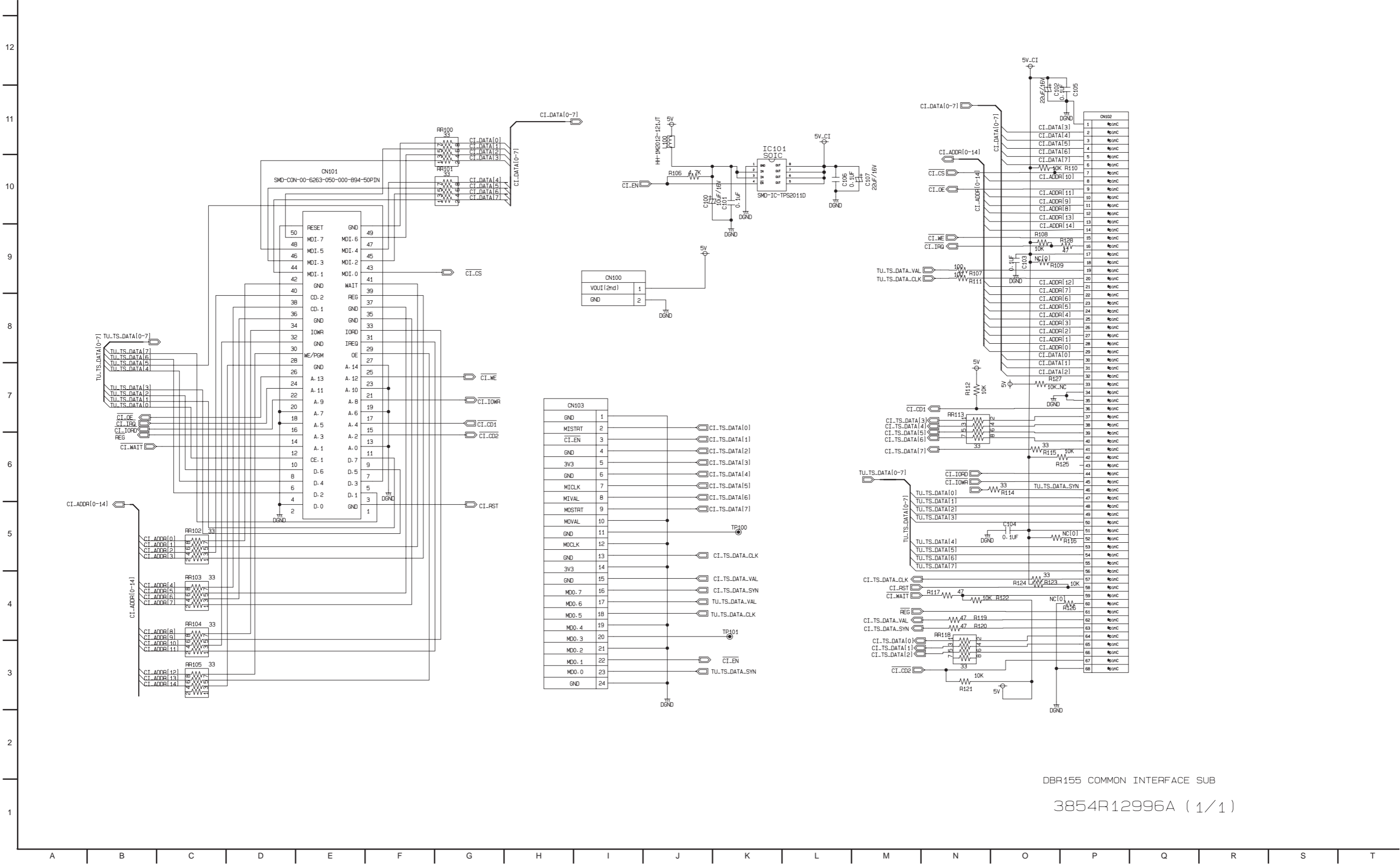

DBR155 COMMON INTERFACE SUB
3854R12996A (1/1)

20. MODEM CIRCUIT DIAGRAM(DBRH199's ONLY)

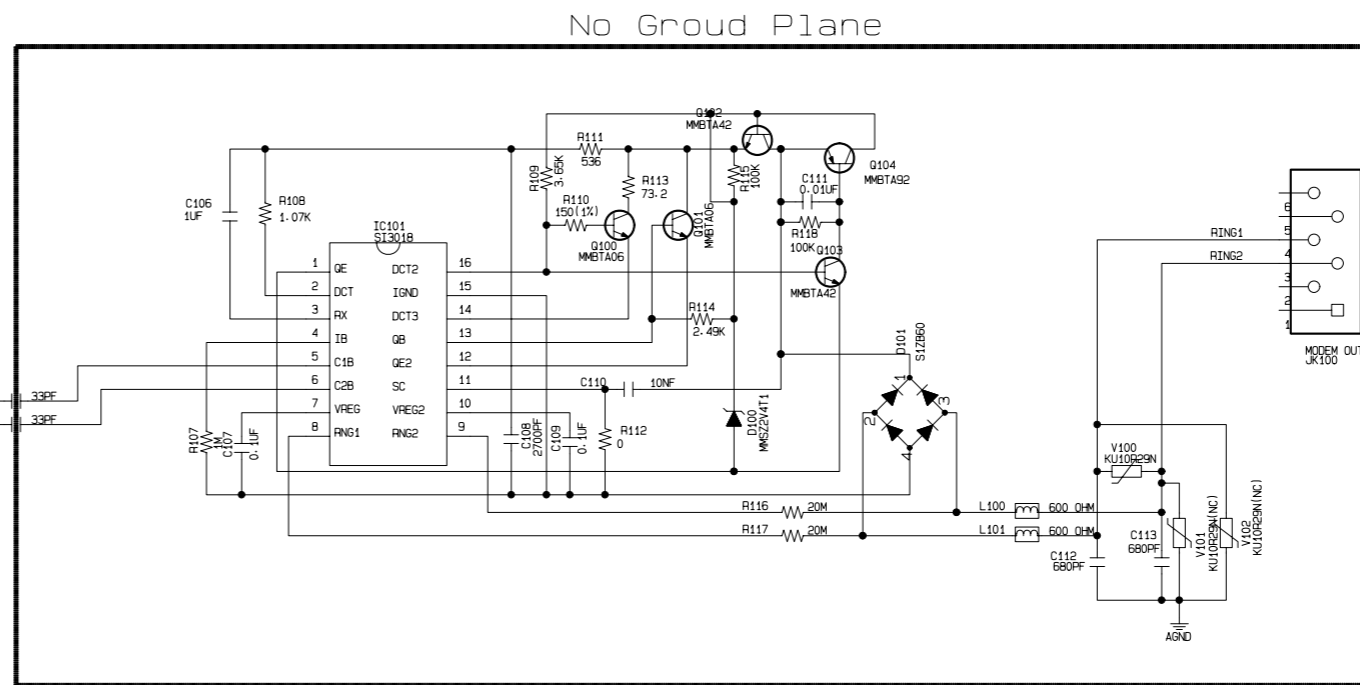
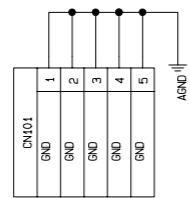
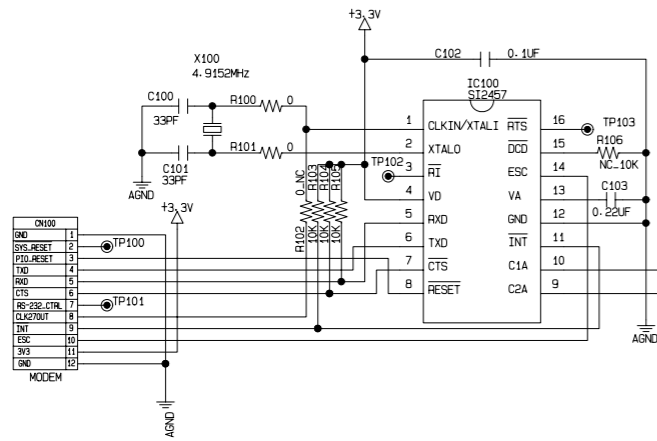

21. SMART CARD TO MAIN INTERFACE CIRCUIT DIAGRAM(DBRH199's ONLY)

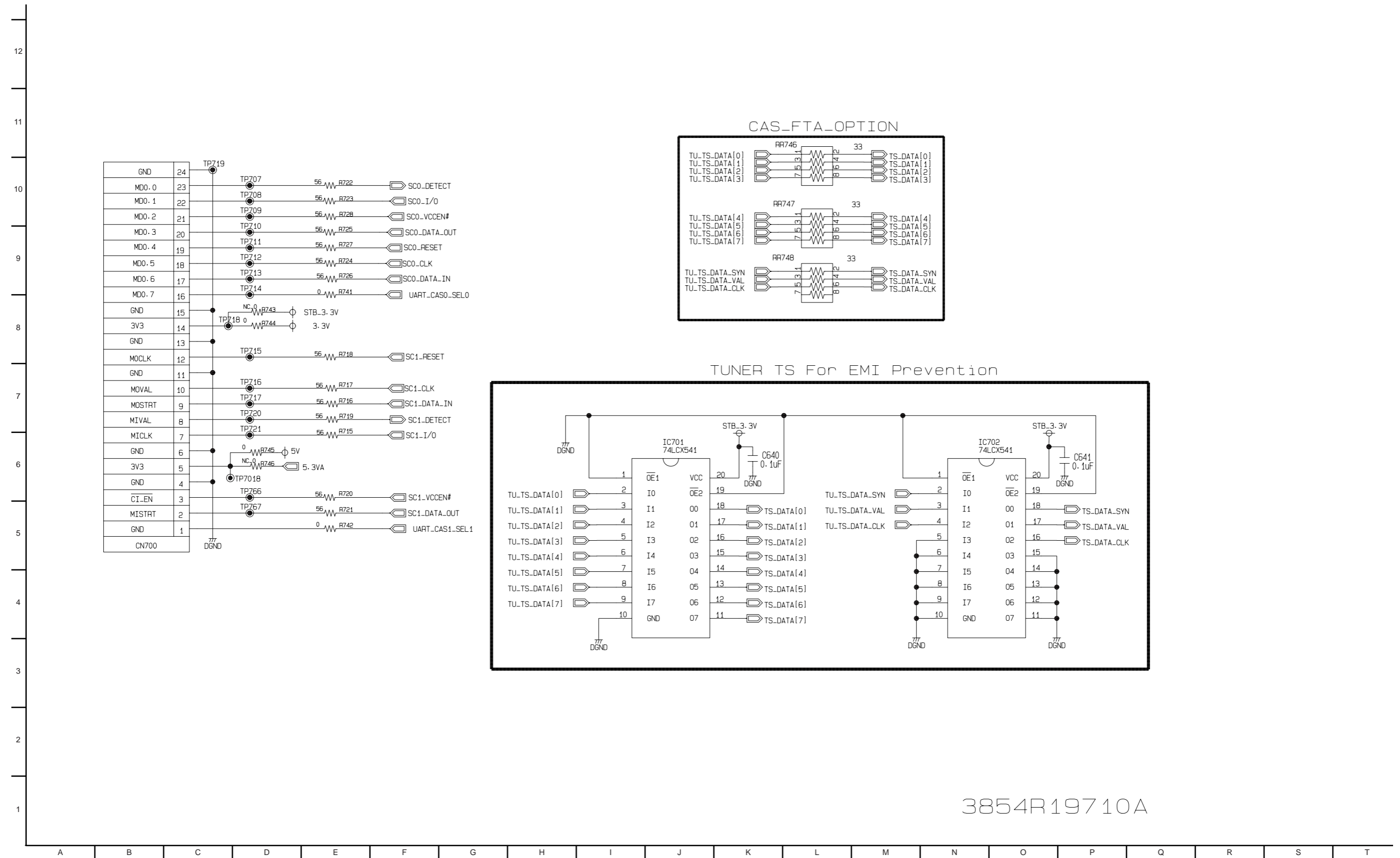

3854R19710A

22. KEY CIRCUIT DIAGRAM

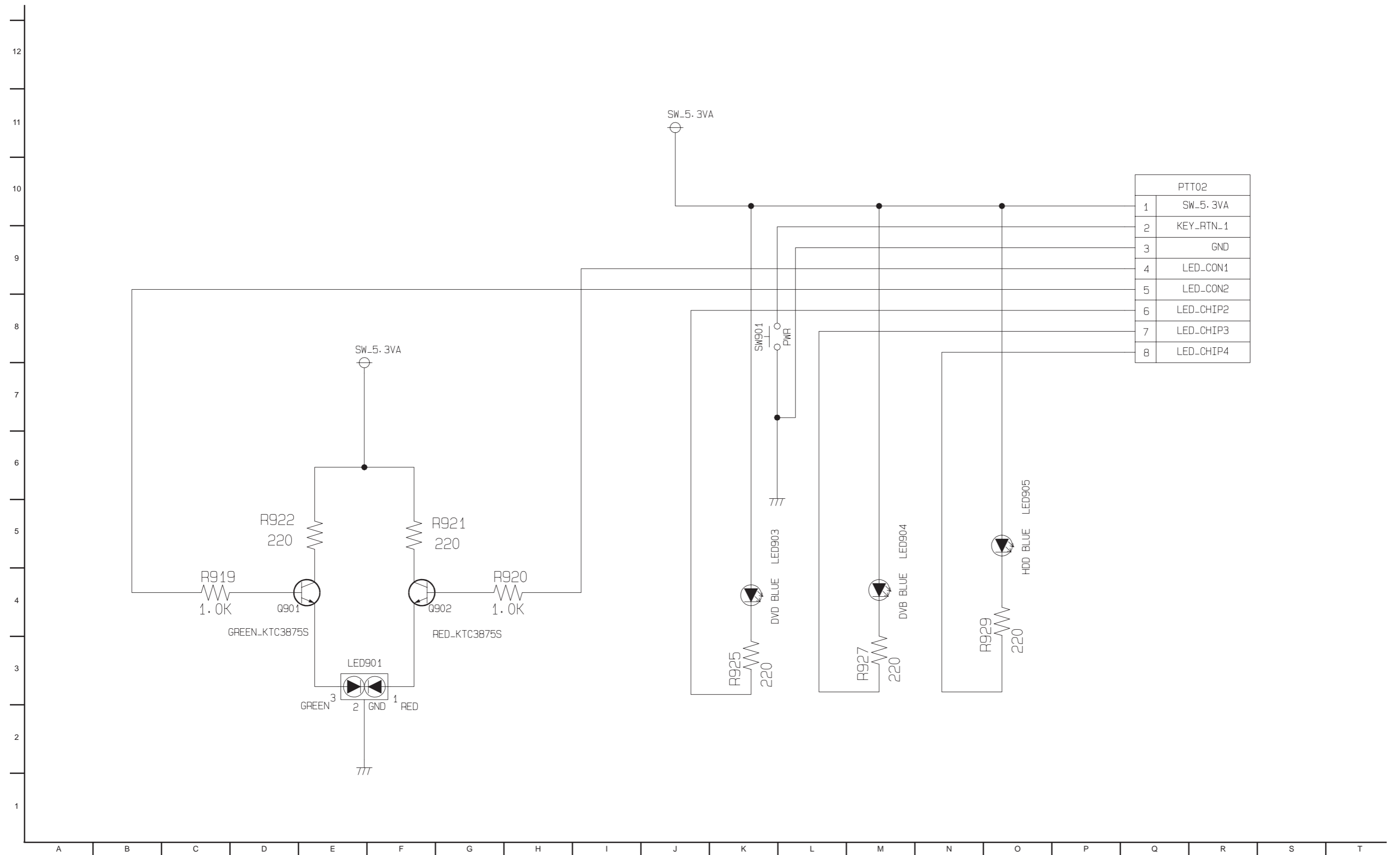

23. TIMER CIRCUIT DIAGRAM

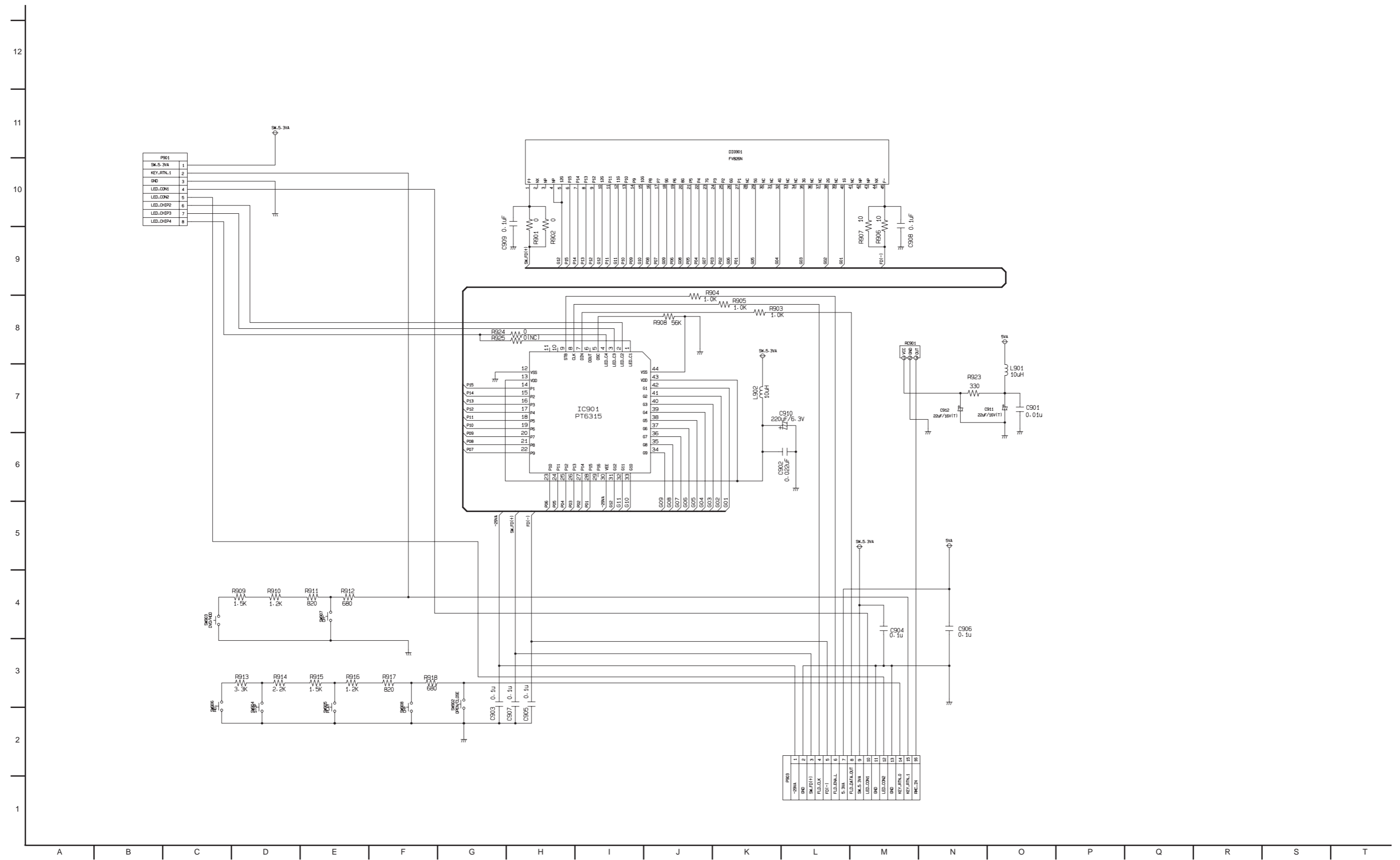

• WAVEFORMS

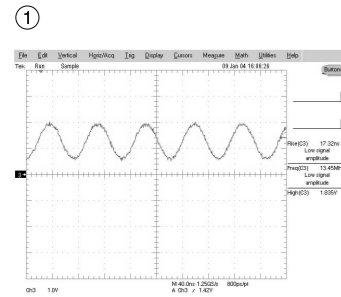

X100
13.5MHZ

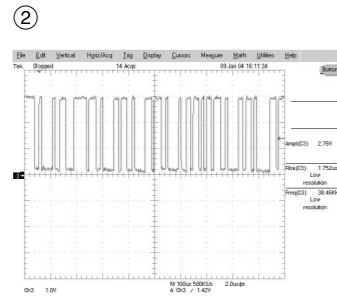

CN401
PIN1:SDA

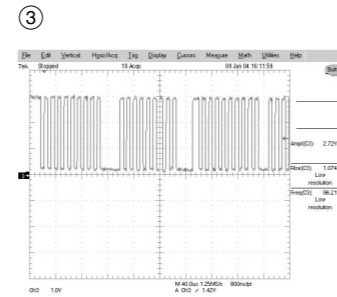

CN401
PIN3:SCL

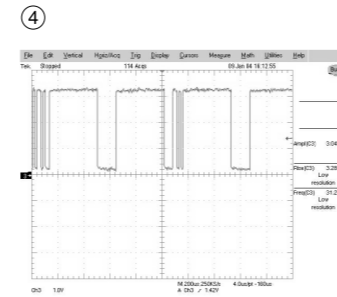

CN401
PIN29:HOST-RXD

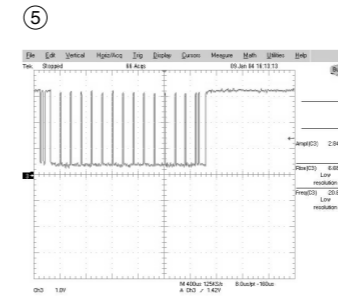

CN401
PIN27:HOST-TXD

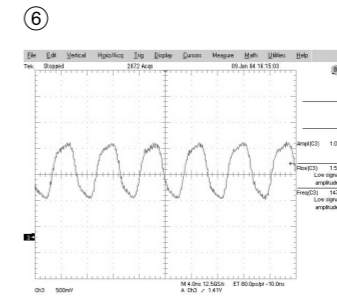

IC201
PIN45:SDRAM_CLK1

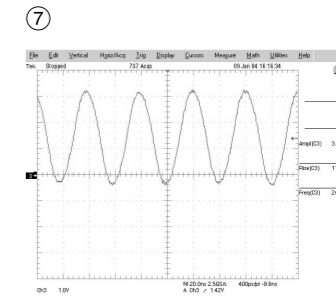

X300
PIN43:24.576MHZ

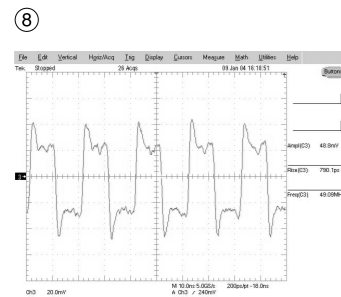

IC304
PIN1:PHY_CLK

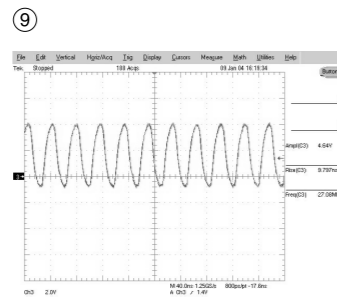

CN400
PIN9:VIN_CLK

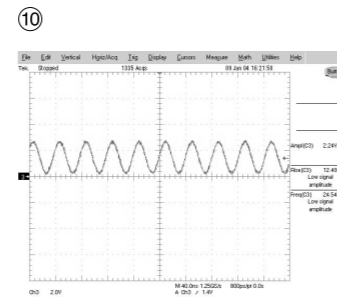

IC901
PIN67:24.576MHZ

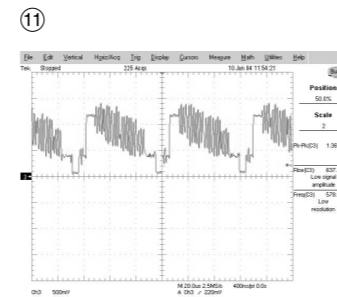

CN400
PIN18:VOUT_CVBS

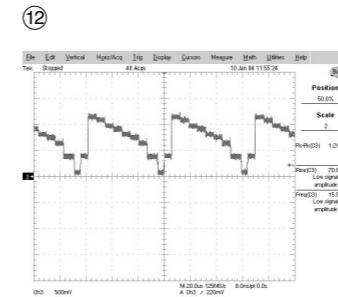

CN400
PIN14:VOUT_Y

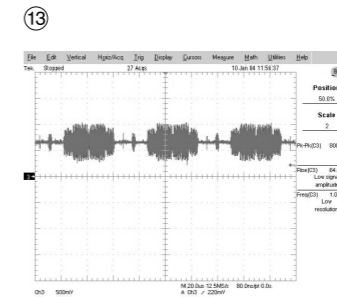

CN400
PIN22:VOUT_C

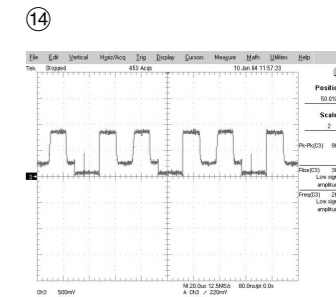

CN400
PIN2:VOUT_R/Pr

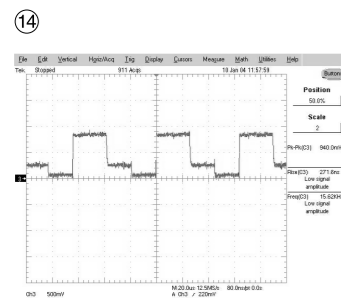

CN400
PIN10:VOUT_G/Y

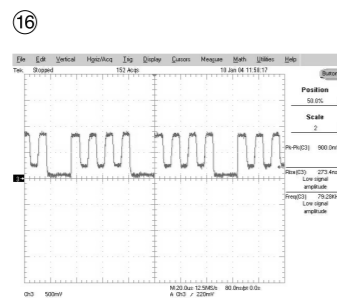

CN400
PIN6:VOUT_B/Pb

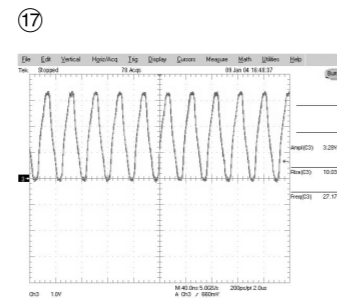

CN901
PIN108:27MHZ

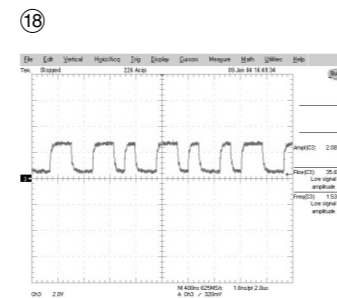

CN400
PIN1:AOUT_ICE958

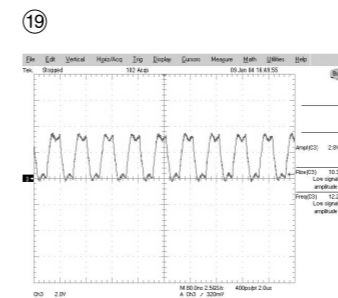

CN401
PIN20:AIN_MCLKOUT

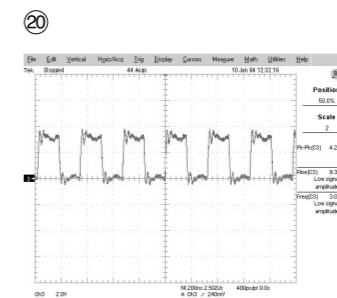

CN401
PIN7:AIN_SCLK

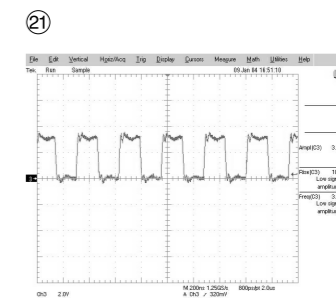

CN401
PIN13:AOUT_MCLKOUT

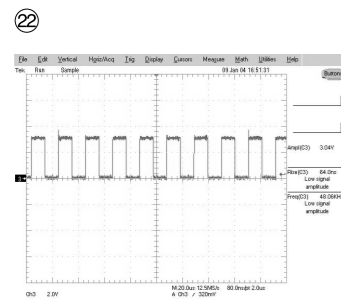

CN400
PIN5:AIN_FSYNC

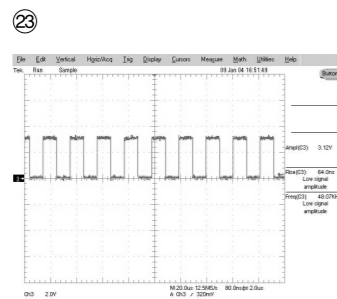

CN400
PIN28:AOUT_FSYNC

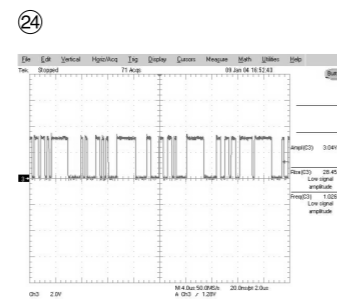

CN400
PIN26:AOUT_DO

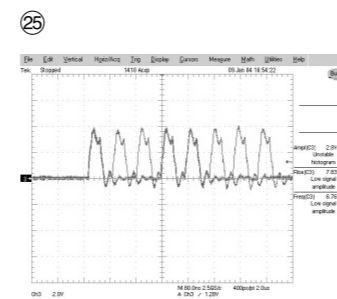

CN400
PIN29:VIN_DO

• CIRCUIT VOLTAGE CHART

MODE PIN NO.	EE	PB	REC
C151 KIA78R25			
1	3.25	3.24	3.23
2	2.52	2.52	2.52
3	0.00	0.00	0.00
4	4.88	4.88	4.88
IC152 KIA78R33			
1	3.64	3.63	3.62
2	3.28	3.28	3.28
3	0.00	0.00	0.00
4	4.43	4.42	4.41
IC153 KIA78R05			
1	5.28	5.28	5.28
2	4.97	4.97	4.97
3	0.00	0.00	0.00
4	4.88	4.88	4.88
IC154 IP1680			
1	3.25	3.25	3.25
2	3.25	3.25	3.25
3	2.55	2.56	2.55
4	1.12	1.12	1.12
5	1.71	1.72	1.71
6	0.00	0.00	0.00
7	1.25	1.25	1.25
8	3.25	3.25	3.25
IC701 MN101DF10GAF			
1	0.00	0.00	0.00
2	5.12	5.12	5.12
3	0.00	0.00	0.00
4	4.80	4.80	4.80
5	4.86	4.86	4.87
6	0.01	0.01	0.01
7	5.13	5.13	5.13
8	5.15	5.15	5.16
9	0.01	0.01	0.01
10	0.00	0.00	0.00
11	5.16	5.16	5.16
12	0.00	0.00	0.00
13	5.15	5.15	5.16
14	4.82	4.83	4.89
15	0.04	0.04	0.04
16	0.12	0.11	0.08
17	5.05	5.05	5.05
18	5.06	5.06	5.06
19	5.10	5.10	5.11
20	4.91	4.90	4.90
21	0.00	0.00	0.00
22	0.01	0.01	0.01
23	0.01	0.01	0.01
24	0.33	0.31	0.14
25	5.16	5.16	5.16
26	0.05	0.05	0.05
27	0.00	0.00	0.22
28	5.16	5.16	5.16
29	0.01	0.01	0.01
30	0.01	0.01	0.01

MODE PIN NO.	EE	PB	REC
31	0.01	0.01	0.01
32	0.01	0.01	0.01
33	0.31	0.32	0.15
34	0.33	0.32	0.16
35	0.01	0.01	0.01
36	5.16	5.16	5.16
37	2.53	2.52	2.54
38	2.43	2.42	2.42
39	0.00	0.00	0.00
40	1.99	1.95	1.95
41	2.55	2.55	2.55
42	0.00	0.00	0.00
43	4.88	4.89	4.89
44	4.89	4.90	4.90
45	0.01	0.01	0.01
46	0.64	0.63	0.63
47	0.01	0.01	0.01
48	0.00	0.00	0.00
49	1.04	1.04	1.04
50	2.78	2.90	2.89
51	5.13	5.13	5.13
52	3.01	3.04	3.05
53	2.54	2.54	2.54
54	5.10	5.10	5.10
55	5.10	5.10	5.10
56	0.01	0.01	0.01
57	5.09	5.09	5.09
58	5.00	5.00	5.01
59	5.25	5.02	5.00
60	0.00	0.00	0.00
61	4.94	4.94	4.93
62	0.00	0.00	0.00
63	0.82	0.81	0.81
64	4.83	4.82	4.82
65	0.00	0.00	0.00
66	0.00	0.00	0.00
67	0.00	0.00	0.00
68	0.00	0.00	0.00
69	0.00	0.00	0.00
70	0.00	0.00	0.00
71	0.00	0.00	0.00
72	0.00	0.00	0.00
73	5.25	5.25	5.25
74	0.00	0.00	0.00
75	0.00	0.00	0.00
76	0.01	0.01	0.00
77	0.01	0.01	0.01
78	0.01	0.01	0.01
79	0.01	0.01	0.01
80	0.01	0.01	0.01
81	0.01	0.01	0.01
82	0.24	0.19	0.14
83	0.24	0.19	0.15
84	1.94	1.92	1.93
85	0.00	0.00	0.00

MODE PIN NO.	EE	PB	REC
86	0.00	0.00	0.00
87	0.00	0.00	0.00
88	5.25	5.25	5.25
89	5.25	5.25	5.25
90	0.01	0.01	0.01
91	0.01	0.01	0.01
92	0.02	0.02	0.02
93	0.01	0.01	0.01
94	0.01	0.01	0.01
95	0.01	0.01	0.01
96	5.16	5.16	5.16
97	0.01	0.01	0.01
98	0.01	0.01	0.01
99	0.01	0.01	0.01
100	5.16	5.16	5.16
IC703 MM1510			
1	2.24	2.24	2.24
2	2.37	2.37	2.38
3	5.13	5.13	5.13
4	1.87	1.87	1.87
5	0.00	0.00	0.00
6	5.13	5.13	5.13
IC704 KIA7042			
1	5.21	5.21	5.21
2	0.00	0.00	0.00
3	4.80	4.80	4.80
IC705 24LC16B			
1	0.00	0.00	0.00
2	0.00	0.00	0.00
3	0.00	0.00	0.00
4	0.00	0.00	0.00
5	5.05	5.05	5.06
6	5.06	5.06	5.06
7	0.00	0.00	0.00
8	5.25	5.25	5.25
IC706 KIA7031			
1	5.17	5.17	5.17
2	0.00	0.00	0.00
3	5.17	5.16	5.16
IC707 SDA5650			
1	0.00	0.00	0.00
2	0.00	0.00	0.00
3	0.00	0.00	0.00
4	5.06	5.06	5.06
5	5.05	5.05	5.06
6	0.00	0.00	0.00
7	0.42	0.42	0.42
8	0.00	0.00	0.00
9	5.25	5.01	5.00
10	2.80	2.79	2.81
11	0.00	0.00	0.00
12	2.47	2.48	2.48
13	0.00	0.00	0.00
14	2.49	2.48	2.49
15	2.47	2.48	2.49

MODE PIN NO.	EE	PB	REC
16	1.57	1.56	1.57
17	1.48	1.54	1.54
18	0.00	0.00	0.00
19	5.25	5.25	5.25
20	5.25	5.25	5.25
IC801 NJM4580			
1	6.06	6.06	6.07
2	6.06	6.06	6.07
3	6.05	6.05	6.05
4	0.00	0.00	0.00
5	6.05	6.05	6.05
6	6.06	6.06	6.06
7	6.06	6.06	6.06
8	12.12	12.12	12.12
IC802 BH7868FS			
1	5.19	5.19	5.19
2	0.05	0.06	0.06
3	0.05	0.06	0.06
4	2.28	2.27	2.27
5	5.00	5.00	5.00
6	1.78	1.60	1.60
7	5.14	5.14	5.15
8	1.78	1.58	1.54
9	2.27	2.27	2.27
10	0.00	0.00	0.00
11	1.77	1.57	1.56
12	0.00	0.00	0.00
13	2.25	2.25	2.25
14	5.00	5.00	5.00
15	2.24	2.27	2.27
16	5.19	5.19	5.20
17	2.31	2.35	2.34
18	2.32	2.37	2.35
19	0.00	0.00	0.00
20	2.32	2.30	2.32
21	2.33	2.32	2.32
22	0.00	0.00	0.00
23	1.90	1.51	1.46
24	2.29	1.79	1.71
25	0.00	0.00	0.00
26	1.91	1.52	1.45
27	2.31	1.81	1.75
28	0.00	0.00	0.00
29	1.98	1.57	1.49
30	2.39	1.85	1.79
31	0.06	0.06	0.06
32	2.39	2.37	2.37
IC803 MM1443			
1	2.74	2.74	2.74
2	12.15	12.15	12.15
3	2.74	2.74	2.74
4	12.15	12.15	12.15
5	3.06	3.22	3.18
6	5.75	5.75	5.75
7	5.76	5.76	5.76

MODE PIN NO.	EE	PB	REC
8	5.70	5.70	5.70
9	0.01	0.01	0.01
10	5.70	5.70	5.70
11	11.55	11.55	11.55
12	5.75	5.75	5.75
13	0.01	0.01	0.01
14	5.70	5.70	5.70
15	0.01	0.01	0.01
16	5.70	5.70	5.70
17	0.00	0.00	0.00
18	0.00	0.00	0.00
19	0.00	0.00	0.00
20	5.70	5.70	5.70
21	5.81	5.81	5.81
22	5.81	5.80	5.80
23	5.74	5.74	5.73
24	5.70	5.70	5.70
25	5.80	5.80	5.80
26	5.80	5.80	5.80
27	5.73	5.73	5.73
28	3.31	3.26	3.33
29	2.47	2.62	2.35
30	2.47	2.62	2.35
31	1.88	1.88	1.80
32	5.05	5.05	5.05
33	5.07	5.07	5.07
34	0.00	0.00	0.00
IC810 CS4351			
1	1.61	1.61	1.62
2	1.62	1.62	1.61
3	1.62	1.62	1.62
4	1.63	1.63	1.63
5	3.17	3.17	3.17
6	0.00	0.00	0.00
7	3.08	3.08	3.08
8	3.03	3.03	3.03
9	3.23	3.23	3.23
10	3.21	3.20	3.20
11	3.22	3.22	3.22
12	1.25	1.25	1.25
13	4.12	4.12	4.12
14	12.12	12.12	12.12
15	4.11	4.11	4.11
16	0.00	0.00	0.00
17	12.13	12.13	12.13
18	4.12	4.12	4.12
19	12.12	12.12	12.12
20	3.23	3.22	3.22
IC901 SAA7317			
1	0.00	0.00	0.00
2	0.00	0.00	0.00
3	1.88	1.87	1.87
4	2.94	2.96	2.95
5	2.94	2.96	2.94
6	2.94	2.96	2.94

MODE PIN NO.	EE	PB	REC
7	2.94	2.96	2.94
8	2.94	2.96	2.94
9	2.94	2.95	2.94
10	1.13	1.13	1.16
11	0.00	0.00	0.00
12	2.95	2.97	2.95
13	0.00	0.00	0.00
14	2.94	2.96	2.93
15	0.17	0.89	0.37
16	0.17	0.75	0.37
17	0.57	1.90	0.59
18	0.57	0.40	0.63
19	0.58	0.78	0.71
20	0.00	0.99	2.36
21	2.94	2.96	2.94
22	0.00	0.00	0.00
23	0.00	0.00	0.00
24	2.94	2.96	2.93
25	0.58	0.60	0.57
26	0.58	0.57	0.57
27	0.57	0.47	0.47
28	1.00	1.00	1.00
29	2.94	2.96	2.93
30	0.00	0.00	0.00
31	1.88	1.87	1.87
32	0.00	0.01	0.01
33	0.00	0.01	0.01
34	2.94	2.96	2.93
35	0.00	0.00	0.00
36	0.00	0.00	0.00
37	0.00	0.00	0.00
38	2.94	2.96	2.93
39	0.57	0.58	0.58
40	0.56	0.58	0.63
41	0		

MODE PIN NO.	EE	PB	REC
117	3.19	2.96	2.93
118	0.21	0.33	1.37
119	0.22	0.32	1.35
120	0.27	0.33	1.37
121	0.22	0.34	1.38
122	0.27	0.37	1.37
123	1.88	1.85	1.85
124	0.02	0.02	0.02
125	2.98	2.96	2.93
126	0.43	0.45	1.35
127	0.42	0.44	1.36
128	0.43	0.44	1.38
129	0.43	0.43	1.36
130	0.43	0.44	1.36
131	2.96	2.96	2.93
132	0.51	0.44	1.33
133	0.52	0.35	1.31
134	0.52	0.50	1.33
135	0.41	0.53	1.42
136	1.44	1.44	1.43
137	2.96	2.96	2.93
138	0.02	0.02	0.02
139	1.31	1.31	1.30
140	1.33	1.32	1.36
141	1.48	1.48	1.49
142	1.49	1.52	1.43
143	1.10	1.11	1.10
144	1.85	1.85	1.88
145	0.02	0.02	0.02
146	2.96	2.96	3.20
147	1.13	1.12	0.37
148	1.51	1.53	0.37
149	0.22	0.20	0.23
150	0.49	0.50	0.37
151	0.49	0.45	0.37
152	3.13	2.96	3.20
153	0.52	0.54	0.37
154	0.53	0.38	0.37
155	0.53	0.41	0.35
156	0.53	0.40	1.44
157	0.59	0.52	1.42
158	3.13	2.97	2.93
159	0.51	0.52	1.53
160	0.51	0.52	1.43
161	0.55	0.52	1.40
162	0.59	0.52	1.45
163	0.62	0.52	1.34
164	3.13	2.97	2.93
165	0.02	0.02	0.02
166	0.60	0.54	1.34
167	0.02	0.02	0.02
168	1.88	1.87	1.05
169	0.02	0.02	0.02
170	1.85	1.85	1.87
171	1.50	1.56	1.88

MODE PIN NO.	EE	PB	REC
172	1.35	1.37	1.68
173	1.27	1.32	1.10
174	1.49	1.49	1.49
175	1.51	1.51	1.49
176	2.98	2.99	2.95
177	2.95	2.95	2.92
178	2.96	2.97	2.93
179	1.50	1.50	1.48
180	1.50	1.51	1.49
181	1.52	1.50	1.48
182	0.02	0.02	0.02
183	0.01	0.01	0.01
184	1.45	1.46	1.46
185	1.45	1.46	1.45
186	2.96	2.97	2.93
187	1.46	1.46	1.45
188	1.46	1.46	1.46
189	0.02	0.02	0.02
190	1.85	1.82	1.85
191	0.00	0.00	0.00
192	0.00	0.00	0.00
193	1.45	1.47	1.44
194	2.96	2.97	2.93
195	0.00	0.00	0.00
196	2.96	2.97	2.93
197	0.00	0.00	0.00
198	1.44	1.44	1.43
199	1.44	1.45	1.43
200	1.44	1.44	1.42
201	1.44	1.45	1.43
202	1.48	1.48	1.46
203	1.44	1.44	1.43
204	1.44	1.44	1.43
205	0.56	1.46	1.16
206	0.57	1.45	1.25
207	0.57	1.46	1.24
208	0.57	1.64	1.12
IC903 NJM2521			
1	7.10	7.09	7.08
2	0.01	0.01	0.01
3	7.22	7.20	7.18
4	0.01	0.01	0.01
5	7.22	7.21	7.19
6	10.70	10.69	10.69
7	7.46	7.45	7.43
8	0.00	0.00	0.00
IC904 NJM2521			
1	7.10	7.09	7.07
2	0.01	0.01	0.01
3	7.22	7.21	7.19
4	0.01	0.01	0.01
5	7.22	7.21	7.19
6	10.70	10.69	10.67
7	7.46	7.45	7.43
8	0.00	0.00	0.00

MODE PIN NO.	EE	PB	REC
IC200			
1	0.00	0.00	0.00
2	0.00	0.00	0.00
3	0.00	0.00	0.00
4	0.00	0.00	0.00
5	0.00	0.00	0.00
6	0.00	0.00	0.00
7	0.00	0.00	0.00
8	0.00	0.00	0.00
9	0.00	0.00	0.00
10	0.00	0.00	0.00
11	3.21	3.22	3.21
12	0.00	0.00	0.00
13	3.23	3.24	3.22
14	3.12	3.13	3.11
15	0.00	0.00	0.00
16	3.22	3.23	3.21
17	0.00	0.00	0.00
18	0.00	0.00	0.00
19	3.21	3.21	3.21
20	0.00	0.00	0.00
21	0.00	0.00	0.00
22	0.00	0.00	0.00
23	0.00	0.00	0.00
24	0.00	0.00	0.00
25	0.00	0.00	0.00
26	0.00	0.00	0.00
27	0.00	0.00	0.00
28	0.00	0.00	0.00
29	3.23	3.23	3.22
30	0.00	0.00	0.00
31	0.00	0.00	0.00
32	3.23	3.24	3.22
33	0.00	0.00	0.00
34	3.23	3.24	3.22
35	0.00	0.00	0.00
36	2.87	2.89	2.87
37	0.00	0.00	0.00
38	0.00	0.00	0.00
39	0.00	0.00	0.00
40	0.00	0.00	0.00
41	0.00	0.00	0.00
42	0.00	0.00	0.00
43	3.23	3.23	3.22
44	0.00	0.00	0.00
45	0.00	0.00	0.00
46	0.00	0.00	0.00
47	0.00	0.00	0.00
48	0.00	0.00	0.00
49	2.87	2.89	2.88
50	0.00	0.00	0.00
51	0.00	0.00	0.00
52	0.00	0.00	0.00
53	3.23	3.24	3.22
54	3.21	3.21	3.21

MODE PIN NO.	EE	PB	REC
55	0.00	0.00	0.00
56	0.00	0.00	0.00
IC201,203			
1	2.39	2.36	2.36
2	1.13	1.05	1.13
3	2.39	2.36	2.36
4	1.13	1.06	1.11
5	1.15	1.06	1.15
6	0.00	0.00	0.00
7	1.14	1.09	1.14
8	1.14	1.12	1.12
9	2.39	2.35	2.34
10	1.14	1.09	1.10
11	1.14	1.09	1.10
12	0.00	0.00	0.00
13	1.14	1.13	1.13
14	0.00	0.00	0.00
15	2.39	2.35	2.35
16	1.18	1.16	1.16
17	1.14	1.11	1.14
18	2.39	2.37	2.36
19	0.00	0.00	0.00
20	0.60	0.60	0.60
21	1.78	1.76	1.75
22	1.78	1.71	1.71
23	1.78	1.75	1.75
24	0.00	0.00	0.00
25	0.00	0.00	0.00
26	1.19	1.19	1.19
27	1.19	1.19	1.19
28	1.15	1.11	1.12
29	1.16	1.12	1.12
30	1.16	1.13	1.13
31	1.16	1.13	1.13
32	1.18	1.17	1.17
33	2.39	2.36	2.36
34	0.00	0.00	0.00
35	1.18	1.17	1.17
36	1.18	1.17	1.17
37	1.17	1.17	1.17
38	1.18	1.17	1.17
39	1.19	1.17	1.17
40	1.18	1.16	1.16
41	1.15	1.11	1.11
42	1.16	1.12	1.14
43	0.00	0.00	0.00
44	1.82	1.80	1.80
45	1.21	1.20	1.20
46	1.18	1.17	1.17
47	0.60	0.59	0.60
48	0.00	0.00	0.00
49	1.19	1.18	1.18
50	0.00	0.00	0.00
51	1.18	1.16	1.16
52	0.00	0.00	0.00

MODE PIN NO.	EE	PB	REC
53	0.00	0.00	0.00
54	1.14	1.06	1.14
55	2.39	2.36	2.36
56	1.15	1.06	1.06
57	1.15	1.05	1.05
58	0.00	0.00	0.00
59	1.14	1.06	1.06
60	1.14	1.06	1.06
61	2.39	2.37	2.36
62	1.16	1.12	1.12
63	1.14	1.04	1.04
64	0.00	0.00	0.00
65	1.15	1.05	1.05
66	0.00	0.00	0.00
IC202			
1	0.00	0.00	0.00
2	0.00	0.00	0.00
3	1.18	1.17	1.17
4	1.18	1.17	1.17
5	2.37	2.34	2.34
6	2.37	2.34	2.34
7	2.37	2.34	2.34
8	1.18	1.17	1.17
IC300			
1	0 (GND)	0 (GND)	0 (GND)
2	0.09	0.09	0.09
3	0.09	0.09	0.09
4	0 (GND)	0 (GND)	0 (GND)
5	0.09	0.09	0.09
6	0.09	0.09	0.09
7	3.24	2.65	3.22
8	0.09	0.09	0.09
9	0.09	0.09	0.09
10	0 (GND)	0 (GND)	0 (GND)
11	0.09	0.09	0.09
12	0.09	0.09	0.09
13	0.09	0.09	0.09
14	0.09	0.09	0.09
15	0 (GND)	0 (GND)	0 (GND)
16	0.09	0.09	0.09
17	0.09	0.09	0.09
18	3.24	3.24	3.22
19	0.09	0.09	0.09
20	0.09	0.09	0.09
21	0 (GND)	0 (GND)	0 (GND)
22	0.09	0.09	0.09
23	0.09	0.09	0.09
24	0 (GND)	0 (GND)	0 (GND)
25	0.00	0.00	0.00
26	0.00	0.00	0.00
27	0.00	0.00	0.00
28	0 (GND)	0 (GND)	0 (GND)
29	0.00	0.00	0.00
30	0.00	0.00	0.00
31	3.24	3.24	3.22

MODE PIN NO.	EE	PB	REC
32	0.00	0.00	0.00
33	0.00	0.00	0.00
34	0 (GND)	0 (GND)	0 (GND)
35	0.00	0.00	0.00
36	0.00	0.00	0.00
37	0.00	0.00	0.00
38	0.00	0.00	0.00
39	0 (GND)	0 (GND)	0 (GND)
40	0.00	0.00	0.00
41	0.00	0.00	0.00
42	3.24	3.24	3.22
43	0.00	0.00	0.00
44	0.00	0.00	0.00
45	0 (GND)	0 (GND)	0 (GND)
46	0.00	0.00	0.00
47	0.00	0.00	0.00
48	0.00	0.00	0.00
C301,302			
1	3.21	3.24	3.23
2	3.21	3.24	3.23
3	0.00	0.00	0.00
4	0.00	0.00	0.00
5	3.22	3.25	3.23
6	0.00	0.00	0.00
7	0.00	0.00	0.00
8	0.00	0.00	0.00
9	0.00	0.00	0.00
10	0 (GND)	0 (GND)	0 (GND)
11	3.22	3.24	3.23
12	0.00	0.00	0.00
13	0.00	0	

MODE PIN NO.	EE	PB	REC
17	1.14	1.11	1.11
18	2.39	2.37	2.36
19	0.00	0.00	0.00
20	0.61	0.59	0.59
21	1.78	1.75	1.75
22	1.78	1.71	1.71
23	1.78	1.75	1.75
24	0.00	0.00	0.00
25	0.00	0.00	0.00
26	1.19	1.19	1.19
27	1.19	1.19	1.19
28	1.15	1.11	1.11
29	1.16	1.13	1.13
30	1.16	1.12	1.12
31	1.16	1.13	1.13
32	1.18	1.17	1.17
33	2.39	2.37	2.36
34	0.00	0.00	0.00
35	1.18	1.17	1.17
36	1.18	1.17	1.17
37	1.18	1.16	1.16
38	1.18	1.17	1.17
39	1.19	1.17	1.17
40	1.18	1.16	1.16
41	1.15	1.11	1.11
42	1.16	1.13	1.13
43	0.00	0.00	0.00
44	1.82	1.80	1.80
45	1.21	1.20	1.20
46	1.18	1.17	1.17
47	0.60	0.59	0.59
48	0.00	0.00	0.00
49	1.19	1.18	1.18
50	0.00	0.00	0.00
51	1.18	1.06	1.06
52	0.00	0.00	0.00
53	0.00	0.00	0.00
54	1.12	1.03	1.03
55	2.39	2.37	2.36
56	1.13	1.06	1.06
57	1.14	1.05	1.05
58	0.00	0.00	0.00
59	1.13	1.05	1.05
60	1.18	1.12	1.12
61	2.39	2.37	2.36
62	1.12	1.05	1.05
63	1.13	1.06	1.06
64	0.00	0.00	0.00
65	1.15	1.12	1.12
66	0.00	0.00	0.00
IC100			
A1	1.17	1.19	1.17
A2	0.00	0.00	0.00
A3	1.37	1.36	1.36
A4	0.00	0.00	0.00

MODE PIN NO.	EE	PB	REC
A5	1.61	1.64	1.64
A6	1.60	1.62	1.62
A7	1.58	1.61	1.59
A8	3.20	3.23	3.21
A9	1.25	0.67	1.25
A10	1.58	1.62	1.60
A11	1.25	0.67	1.25
A12	1.08	0.94	1.06
A13	1.10	1.08	1.10
A14	NC	NC	NC
A15	3.22	3.23	3.20
A16	1.63	1.64	1.62
A17	1.63	1.64	1.98
A18	1.63	1.64	1.63
A19	0.00	0.00	0.00
A20	3.24	3.24	3.23
A21	0.00	0.00	0.00
A22	0.00	0.00	0.00
A23	0.00	0.00	0.00
A24	3.23	3.24	3.22
A25	2.31	2.32	2.30
A26	3.21	3.21	3.21
B1	3.21	3.22	3.21
B2	0.27	0.27	0.27
B3	1.39	1.39	1.39
B4	1.22	1.22	1.21
B5	0.00	0.00	0.00
B6	1.16	1.21	1.18
B7	1.01	1.07	1.01
B8	3.20	3.20	3.19
B9	1.18	1.22	1.18
B10	1.02	1.07	1.02
B11	1.19	1.22	1.18
B12	1.22	1.25	1.24
B13	2.17	2.14	2.17
B14	1.60	1.61	1.59
B15	1.61	1.62	1.60
B16	1.62	1.62	1.61
B17	0.00	0.00	0.00
B18	0.00	0.00	0.00
B19	4.91	4.91	4.91
B20	3.12	3.14	3.14
B21	2.75	2.80	2.84
B22	4.80	4.90	4.82
B23	3.08	3.11	3.10
B24	3.21	3.21	3.21
B25	3.20	3.23	3.21
B26	3.21	3.23	3.21
C1	2.24	2.25	2.25
C2	2.67	2.67	2.66
C3	1.32	1.32	1.32
C4	1.28	1.28	1.27
C5	0.00	0.00	0.00
C6	1.19	0.38	1.17
C7	1.10	1.08	1.10

MODE PIN NO.	EE	PB	REC
C8	2.86	2.86	2.85
C9	1.18	0.38	1.18
C10	1.10	1.08	1.10
C11	1.19	0.38	1.17
C12	1.02	1.07	1.01
C13	1.62	1.63	1.61
C14	0.00	0.00	0.00
C15	1.62	1.63	1.61
C16	1.21	1.21	1.20
C17	0.00	0.00	0.00
C18	1.62	1.64	1.61
C19	0.00	0.00	0.00
C20	3.15	3.18	3.16
C21	1.08	1.05	1.05
C22	1.08	1.05	1.05
C23	2.35	2.29	2.30
C24	3.21	3.23	3.21
C25	1.14	1.10	1.10
C26	1.17	1.16	1.15
D1	2.25	2.25	2.25
D2	1.55	1.55	1.55
D3	1.50	1.50	1.49
D4	1.62	1.62	1.61
D5	1.25	0.66	1.25
D6	1.18	0.94	1.06
D7	1.80	1.77	1.80
D8	2.49	2.49	2.48
D9	1.08	0.94	1.07
D10	1.81	1.78	1.81
D11	1.08	1.05	1.05
D12	1.08	1.05	1.05
D13	3.22	3.24	3.22
D14	3.22	3.24	3.22
D15	3.22	3.24	3.22
D16	3.22	3.24	3.22
D17	0.00	0.00	0.00
D18	1.61	1.61	1.60
D19	4.91	4.91	4.91
D20	3.05	3.05	3.04
D21	1.08	1.05	1.05
D22	1.19	1.17	1.17
D23	2.35	2.29	2.30
D24	1.12	1.08	1.04
D25	1.14	1.09	1.03
D26	1.14	1.09	1.08
E1	0.89	0.40	0.85
E2	2.23	2.24	2.24
E3	2.25	2.26	2.25
E4	0.00	0.00	0.00
E23	0.00	0.00	0.00
E24	2.01	1.97	1.97
E25	1.21	1.18	1.18
E26	1.18	1.18	1.16
F1	0.00	0.00	0.00
F2	0.00	0.00	0.00

MODE PIN NO.	EE	PB	REC
F3	0.00	0.00	0.00
F4	1.05	1.05	1.06
F23	1.19	1.16	1.15
F24	1.18	1.06	1.02
F25	2.03	1.98	1.98
F26	2.08	1.93	1.85
G1	1.48	1.49	1.49
G2	0.00	0.00	0.00
G3	1.05	1.05	1.06
G4	2.35	2.26	2.30
G23	1.17	1.16	1.15
G24	1.18	1.16	1.15
G25	1.17	1.16	1.15
G26	1.16	1.16	1.15
H1	1.69	1.72	1.73
H2	0.00	0.00	0.00
H3	3.23	3.24	3.22
H4	1.06	1.05	1.06
H23	2.10	2.05	2.05
H24	1.14	1.09	1.06
H25	1.12	1.08	1.05
H26	1.17	1.14	1.15
J1	0.00	0.00	0.00
J2	1.58	1.58	1.58
J3	1.58	1.58	1.58
J4	3.23	3.23	3.22
J23	1.18	1.18	1.18
J24	1.11	1.11	1.11
J25	1.11	1.11	1.11
J26	1.11	1.11	1.11
K1	0.63	0.61	0.64
K2	0.64	0.62	0.64
K3	3.21	3.22	3.20
K4	1.08	1.05	1.05
K23	1.11	1.11	1.11
K24	1.13	1.13	1.13
K25	1.12	1.12	1.12
K26	1.11	1.11	1.11
L1	0.72	0.72	0.72
L2	0.73	0.73	0.64
L3	3.21	3.22	3.20
L4	1.08	1.05	1.05
L11	0.00	0.00	0.00
L12	0.00	0.00	0.00
L13	0.00	0.00	0.00
L14	0.00	0.00	0.00
L15	0.00	0.00	0.00
L16	0.00	0.00	0.00
L23	2.35	2.29	2.30
L24	2.35	2.29	2.30
L25	0.35	0.32	0.30
L26	1.16	1.16	1.15
M1	0.72	0.72	0.73
M2	0.64	0.62	0.73
M3	3.21	3.22	3.20

MODE PIN NO.	EE	PB	REC
M4	3.22	3.24	3.22
M11	0.00	0.00	0.00
M12	0.00	0.00	0.00
M13	0.00	0.00	0.00
M14	0.00	0.00	0.00
M15	0.00	0.00	0.00
M16	0.00	0.00	0.00
M23	1.22	1.20	1.20
M24	2.35	2.29	2.30
M25	0.35	0.32	0.30
M26	1.16	1.16	1.15
N1	0.00	0.00	0.00
N2	0.00	0.00	0.00
N3	0.00	0.00	0.00
N4	3.22	3.24	3.22
N11	0.00	0.00	0.00
N12	0.00	0.00	0.00
N13	0.00	0.00	0.00
N14	0.00	0.00	0.00
N15	0.00	0.00	0.00
N16	0.00	0.00	0.00
N23	1.20	1.17	1.16
N24	2.35	2.29	2.30
N25	1.13	1.13	1.13
N26	1.13	1.13	1.13
P1	1.18	1.18	1.18
P2	3.22	3.23	3.22
P3	NC	NC	NC
P4	3.22	3.24	3.22
P11	0.00	0.00	0.00
P12	0.00	0.00	0.00
P13	0.00	0.00	0.00
P14	0.00	0.00	0.00
P15	0.00	0.00	0.00
P16	0.00	0.00	0.00
P23	1.21	1.19	1.19
P24	2.35	2.29	2.30
P25	1.13	1.13	1.13
P26	1.14	1.14	1.14
R1	0.00	0.00	0.00
R2	0.00	0.00	0.00
R3	0.00	0.00	0.00
R4	3.22	3.24	3.22
R11	0.00	0.00	0.00
R12	0.00	0.00	0.00
R13	0.00	0.00	0.00
R14	0.00	0.00	0.00
R15	0.00	0.00	0.00
R16	0.00	0.00	0.00
R23	1.20	1.17	1.17
R24	2.35	2.29	2.30
R25	1.18	1.18	1.18
R26	1.18	1.18	1.18
T1	0.00	0.00	0.00
T2	0.00	0.00	0.00

MODE PIN NO.	EE	PB	REC
T3	0.00	0.00	0.00
T4	0.00	0.00	0.00
T11	0.00	0.00	0.00
T12	0.00	0.00	0.00
T13	0.00	0.00	0.00
T14	0.00	0.00	0.00
T15	0.00	0.00	0.00
T16	0.00	0.00	0.00
T23	2.35	2.29	2.30
T24	2.35	2.29	2.30
T25	1.18	1.18	1.18
T26	1.18	1.18	1.18
U1	0.00	0.00	0.00
U2	NC	NC	NC
U3	0.00	0.00	0.00
U4	0.00	0.00	0.00
U23	1.18	1.18	1.18
U24	1.18	1.18	1.18
U25	1.18	1.18	1.18
U26	1.18	1.18	1.18
V1	NC	NC	NC
V2	NC	NC	NC
V3	NC	NC	NC
V4	NC	NC	NC
V23	1.18	1.18	1.18
V24	1.18	1.18	1.18
V25	1.18	1.18	1.18
V26	1.18	1.18	1.18
W1	0.00	0.00	0.00
W2	NC	NC	NC
W3	NC	NC	NC
W4	0.00	0.00	0.00
W23	1.18	1.18	1.18
W24			

MODE PIN NO.	EE	PB	REC
AD25	0.00	0.00	0.00
AD26	0.00	0.00	0.00
AE1	3.23	3.24	3.22
AE2	3.23	3.24	3.22
AE3	3.23	3.24	3.22
AE4	0.00	0.00	0.00
AE5	1.94	1.91	1.92
AE6	1.92	1.87	1.89
AE7	1.92	1.89	1.91
AE8	1.95	1.92	1.93
AE9	0.00	0.00	0.00
AE10	3.21	3.22	3.21
AE11	4.50	4.50	4.50
AE12	3.23	3.24	3.22
AE13	0.00	0.00	0.00
AE14	0.00	0.00	0.00
AE15	0.00	0.00	0.00
AE16	0.00	0.00	0.00
AE17	3.23	3.24	3.22
AE18	3.22	3.24	3.21
AE19	0.00	0.00	0.00
AE20	0.00	0.00	0.00
AE21	3.23	3.24	3.22
AE22	3.20	3.23	3.21
AE23	0.00	0.00	0.00
AE24	2.87	2.86	2.86
AE25	0.00	0.00	0.00
AE26	0.00	0.00	0.00
AF1	3.22	3.23	3.21
AF2	0.00	0.00	0.00
AF3	0.00	0.00	0.00
AF4	4.60	4.60	4.61
AF5	1.96	1.92	1.94
AF6	1.93	1.89	1.91
AF7	1.95	1.92	1.93
AF8	1.93	1.90	1.91
AF9	0.00	0.00	0.00
AF10	3.23	3.23	3.21
AF11	3.23	3.23	3.21
AF12	0.00	0.00	0.00
AF13	0.00	0.00	0.00
AF14	0.00	0.00	0.00
AF15	1.64	1.66	1.66
AF16	3.21	3.23	3.23
AF17	3.22	3.24	3.21
AF18	0.00	0.00	0.00
AF19	0.00	0.00	0.00
AF20	3.21	3.23	3.21
AF21	3.23	3.24	3.22
AF22	3.23	3.24	3.22
AF23	0.00	0.00	0.00
AF24	0.00	0.00	0.00
AF25	0.00	0.00	0.00
AF26	0.00	0.00	0.00

PRINTED CIRCUIT DIAGRAMS

1. MAIN P.C.BOARD_DBRH197/DBRH198's (TOP VIEW)

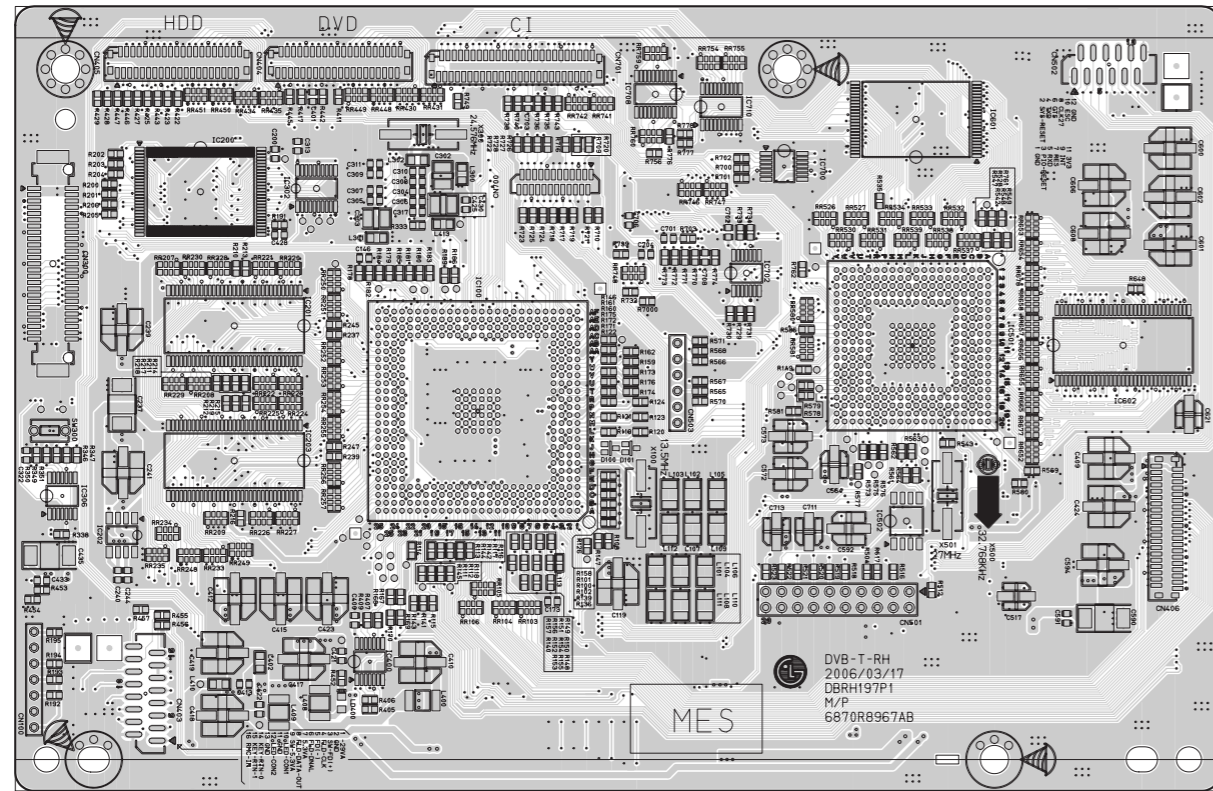

(BOTTOM VIEW)

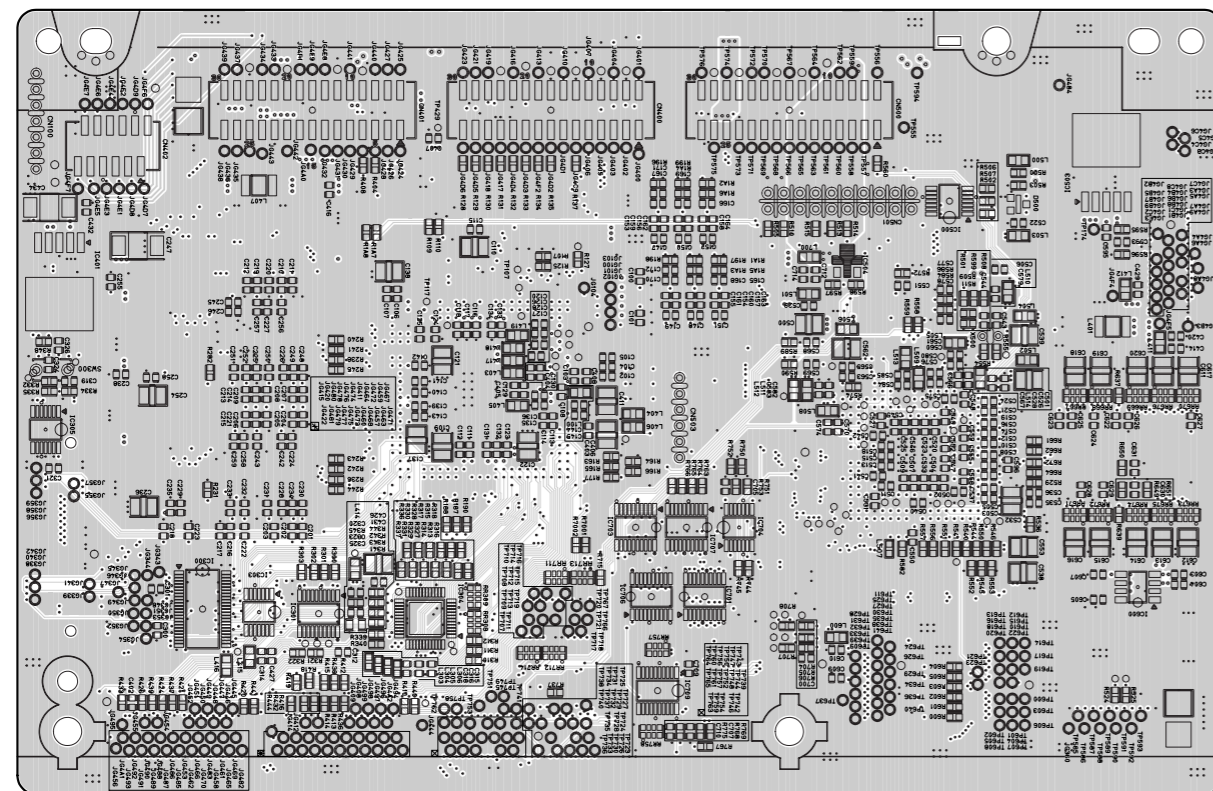

2. MAIN P.C.BOARD_DBRH199's (TOP VIEW)

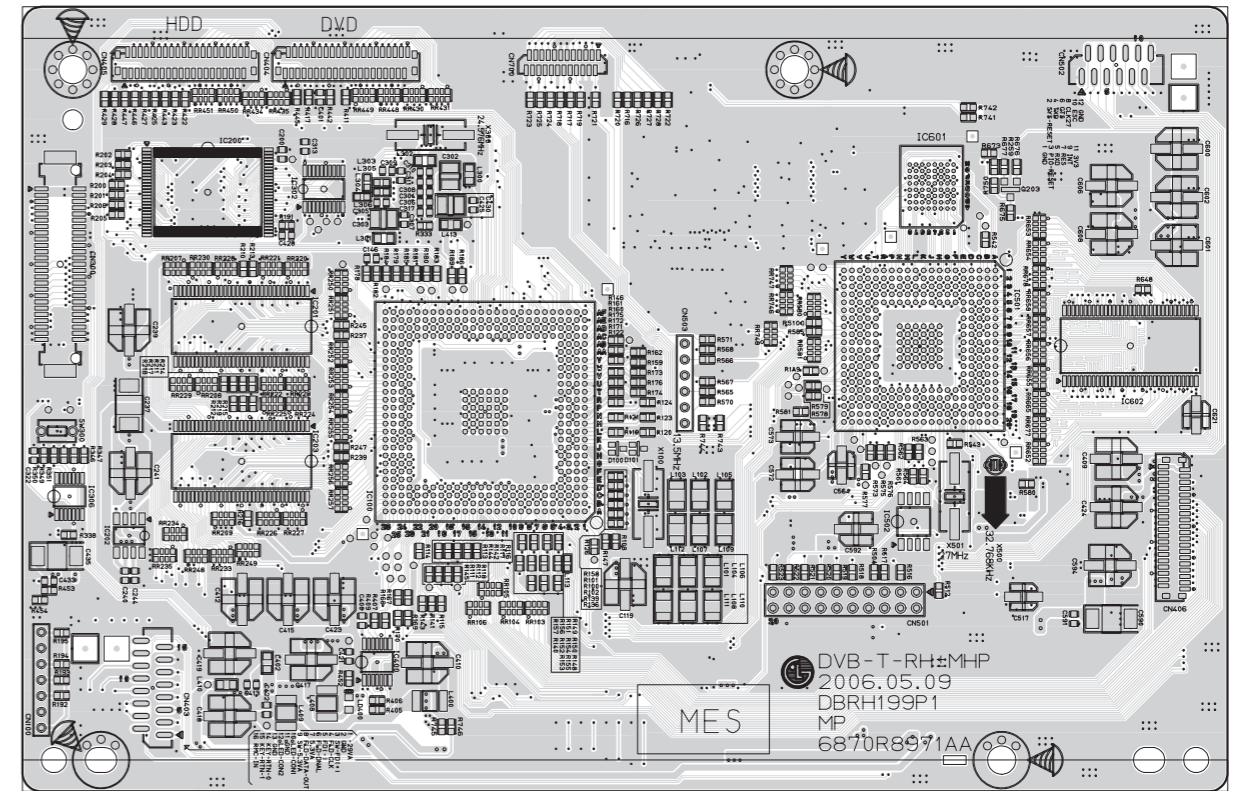

(BOTTOM VIEW)

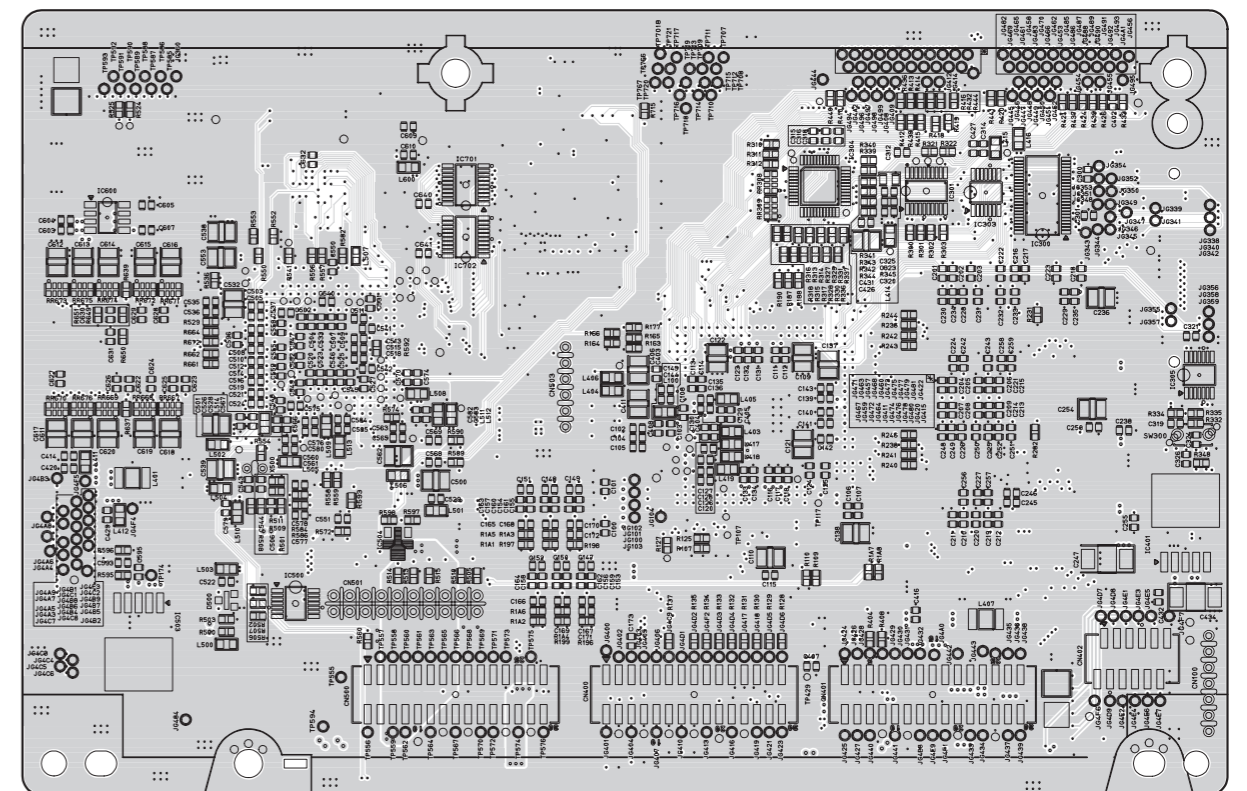

3. I/O P.C.BOARD (TOP VIEW)

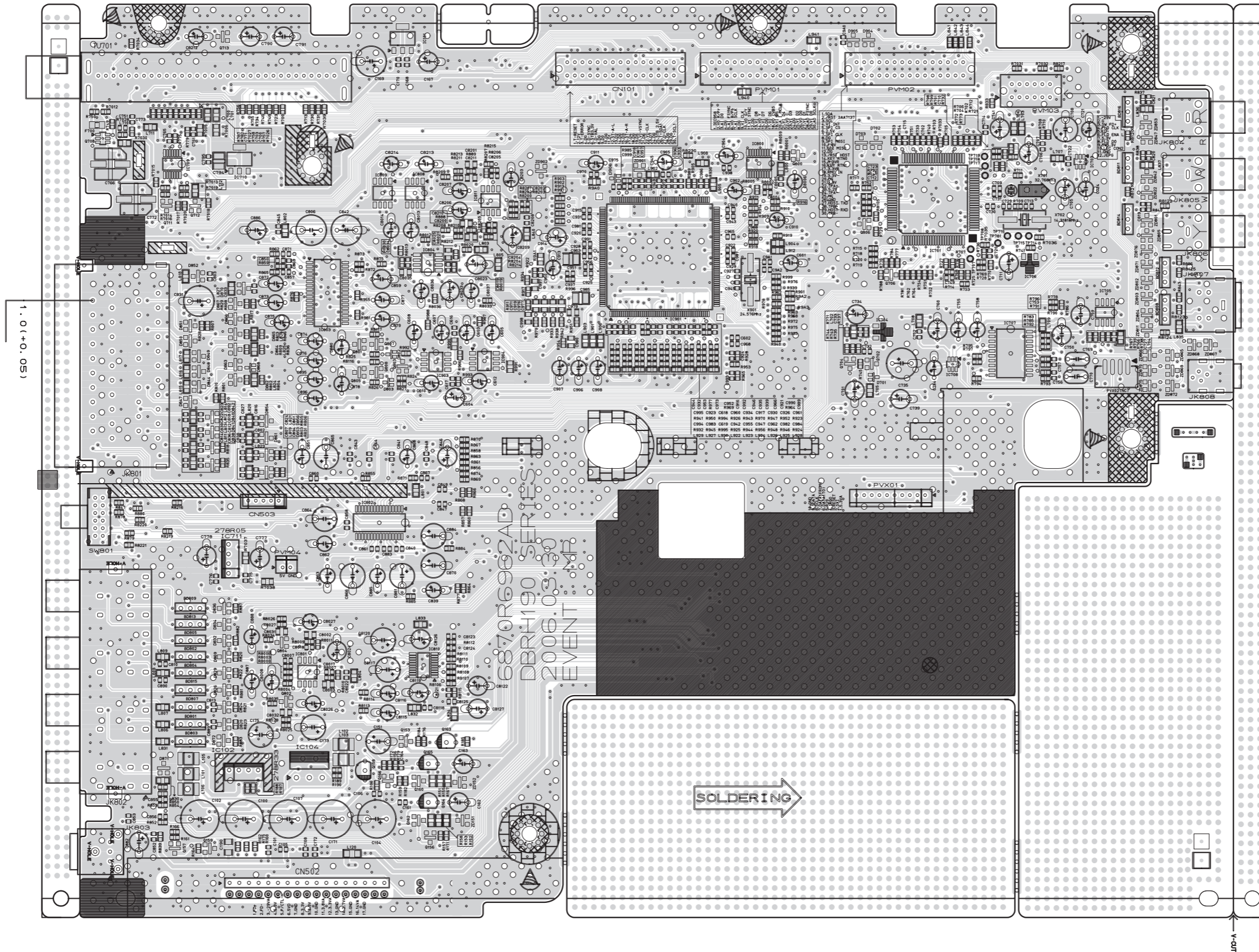

4. I/O P.C.BOARD (BOTTOM VIEW)

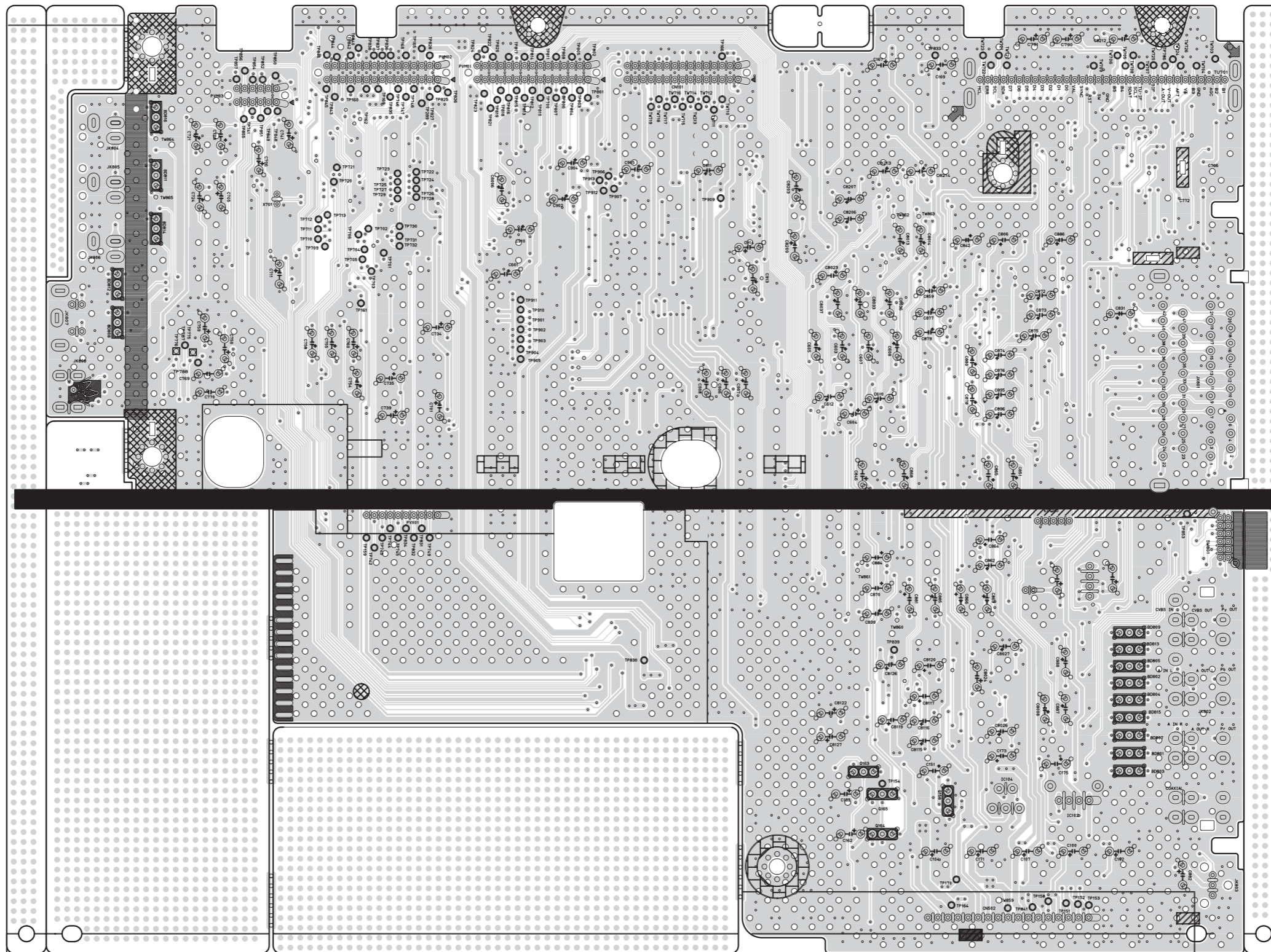

6. KEY P.C.BOARD

(TOP VIEW)

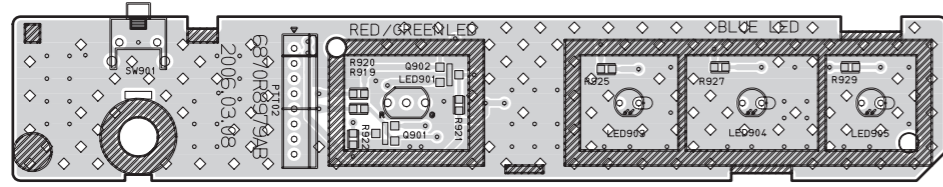

(BOTTOM VIEW)

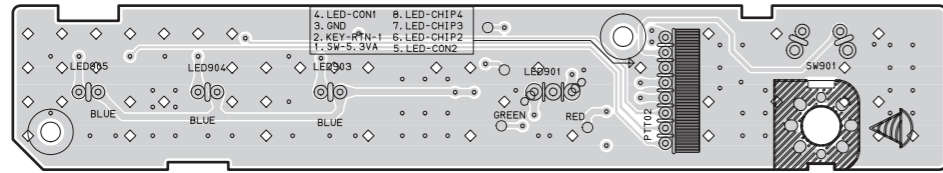

8. JUNCTION P.C.BOARD

(TOP VIEW)

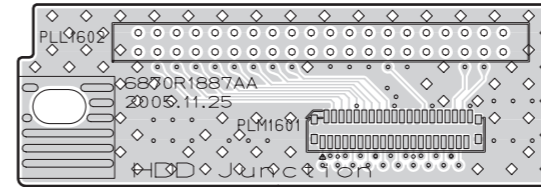

(BOTTOM VIEW)

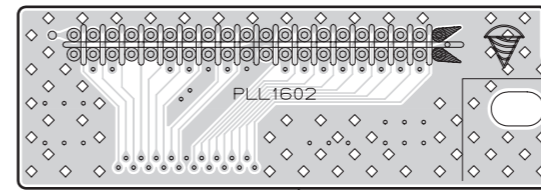

7. TIMER P.C.BOARD

(TOP VIEW)

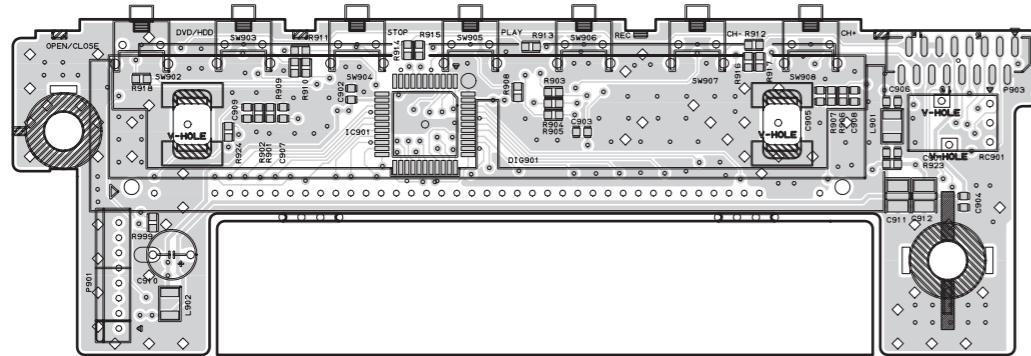

(BOTTOM VIEW)

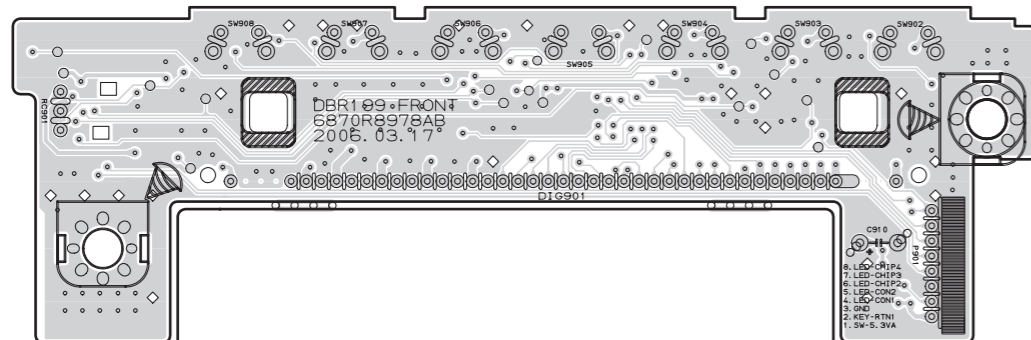

**9. HDMI P.C.BOARD
(TOP VIEW)**

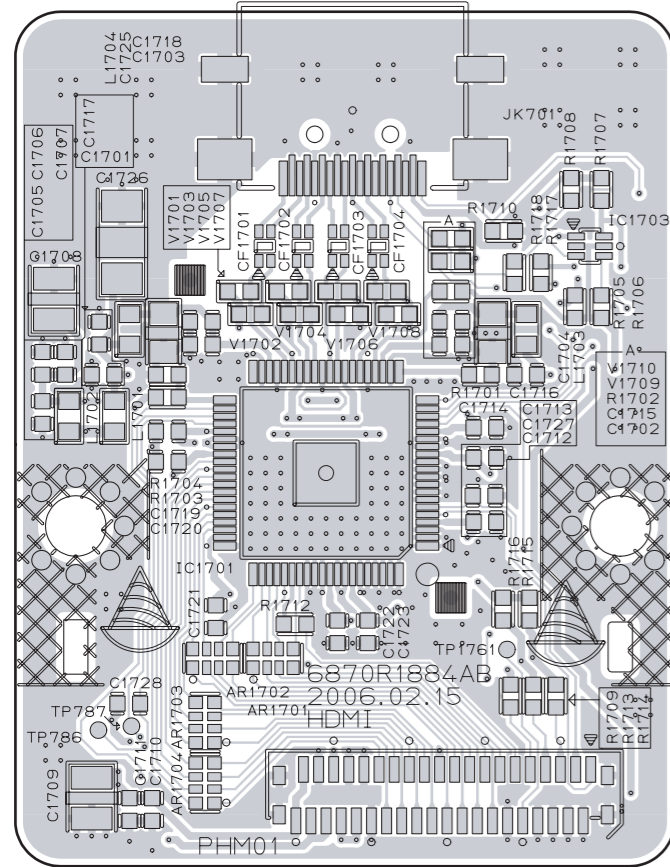

(BOTTOM VIEW)

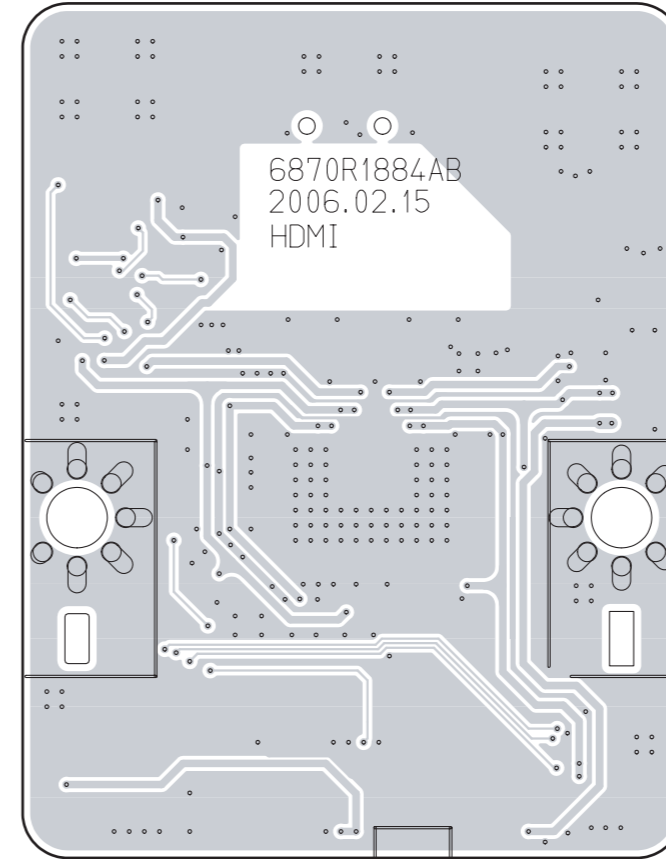

**10. MODEM P.C.BOARD (DBRH199's ONLY)
(TOP VIEW)**

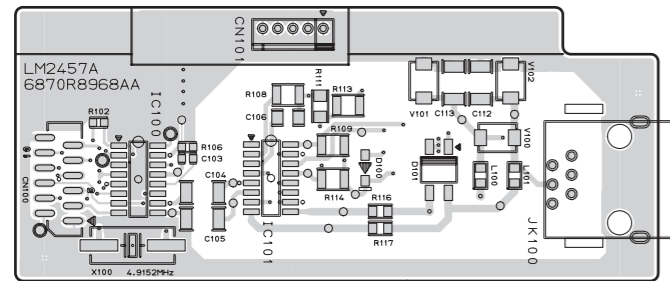

(BOTTOM VIEW)

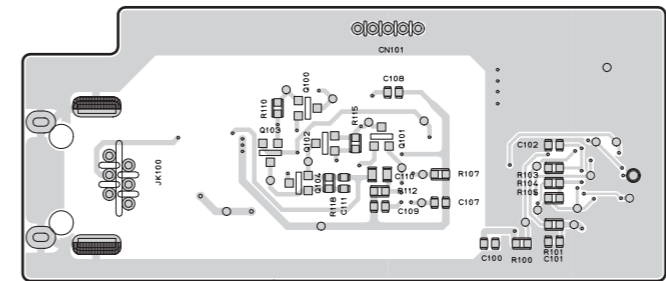

**11. CI P.C.BOARD (DBRH198's ONLY)
(TOP VIEW)**

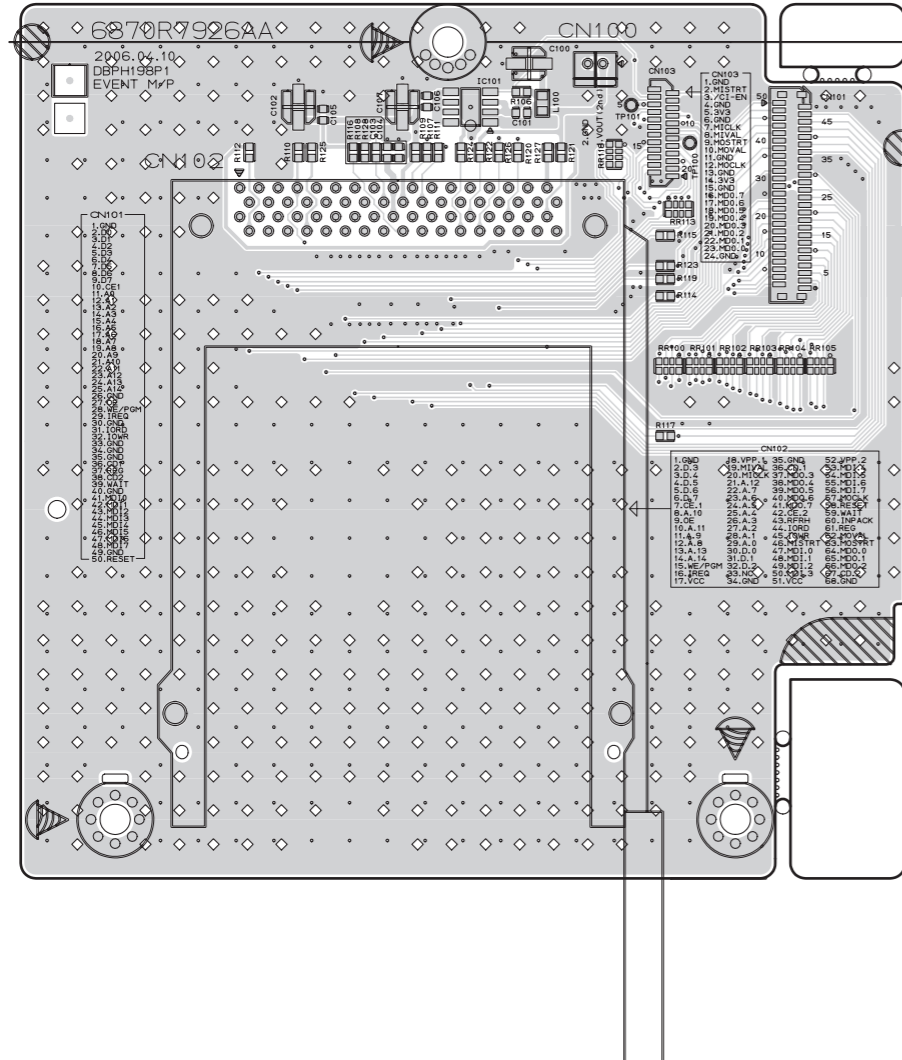

(BOTTOM VIEW)

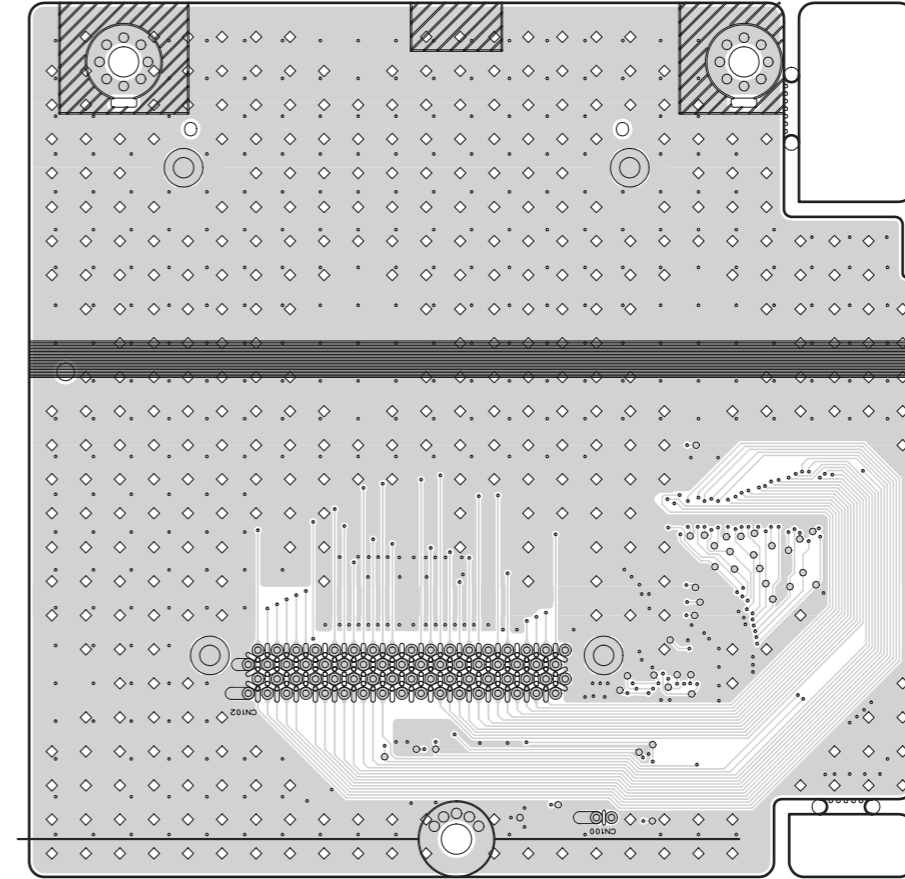

**12. SMART CARD P.C.BOARD (DBRH199's ONLY)
(TOP VIEW)**

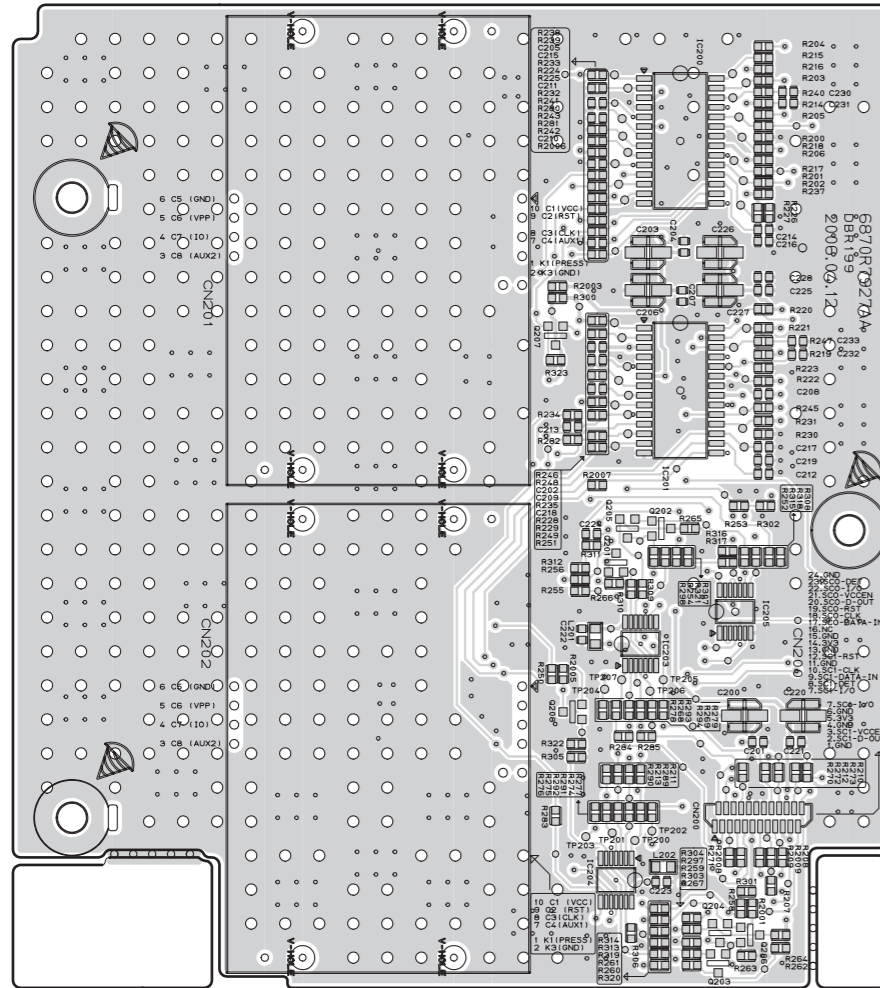

(BOTTOM VIEW)

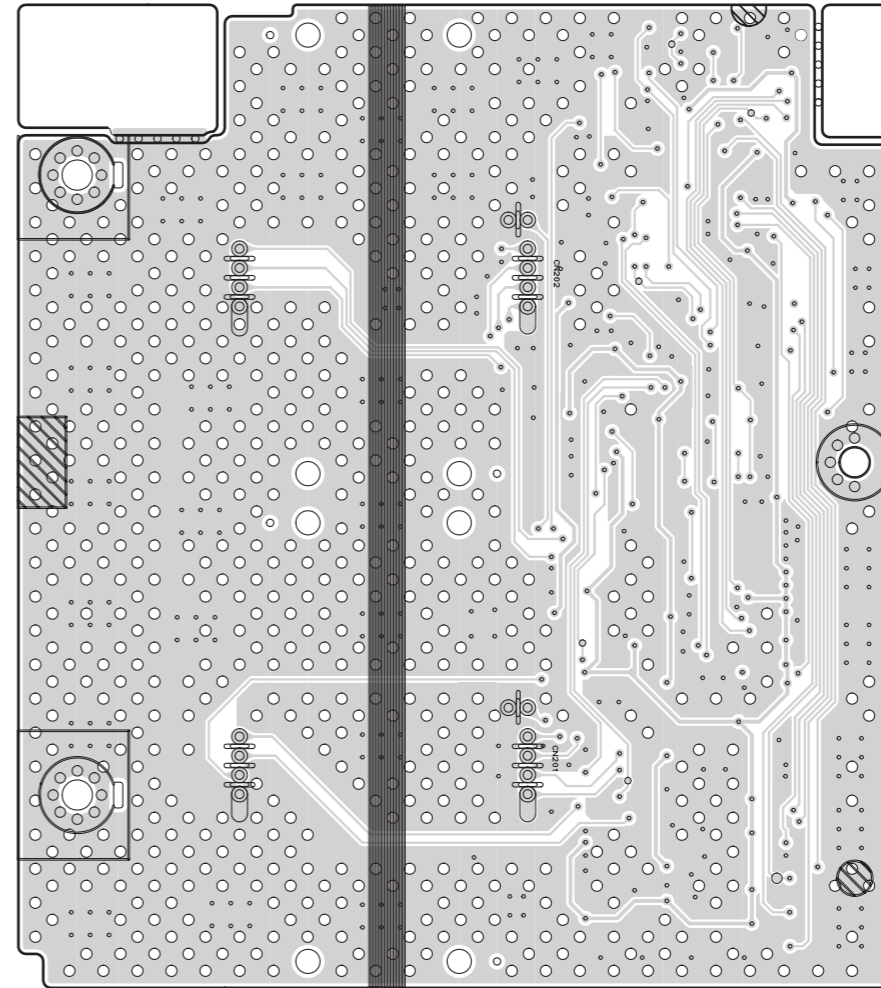

SECTION 4

RS-01A LOADER PART

CONTENTS

ELECTRICAL TROUBLESHOOTING GUIDE	4-2
THE DIFFERENCE OF DVD-R/RW, DVD+R/RW DISCS AND DVD-ROM	4-15
1. RECORDING LAYER	4-15
2. DISC SPECIFICATION	4-16
3. DISC MATERIALS	4-16
4. ORGANIZATION OF THE INNER DRIVE AREA, OUTER DRIVE AREA, LEAD-IN ZONE AND LEAD-OUT ZONE	4-20
HOW TO USE TEST TOOL	4-24
1. ALPC MEASUREMENT SYSTEM	4-24
2. ALPC PROGRAM	4-24
3. EXECUTE ALPC PROGRAM	4-25
4. OPTICAL POWER SETTING	4-27
5. CONFIRM OPTICAL POWER SETTING PARAMETER	4-28
6. OPTICAL POWER SETTING PARAMETER RANGE	4-29
7. ATTACHMENT. OPTICAL POWER MEASUREMENT	4-30
INTERNAL STRUCTURE OF THE PICK-UP	4-31
1. BLOCK DIAGRAM OF THE PICK-UP(LPC-812R)	4-31
2. PICK UP PIN ASSIGNMENT	4-32
3. SIGNAL DETECTION OF THE P/U	4-33
DESCRIPTION OF CIRCUIT	4-34
1. ALPC (AUTOMATIC LASER POWER CONTROL) CIRCUIT	4-34
2. FOCUS/TRACKING/SLED SERVO CIRCUIT	4-35
3. SPINDLE SERVO CIRCUIT	4-37
MAJOR IC INTERNAL BLOCK DIAGRAM	4-38
LIC121 (AN22113A) : FEP(RF) ANALOG SIGNAL PROCESSOR	4-38
IC301 (BD7956FS) : CD-ROM/DVD-ROM 7CH POWER DRIVER	4-41
CIRCUIT DIAGRAMS	4-42
1. DSP CIRCUIT DIAGRAM	4-42
2. RF CIRCUIT DIAGRAM	4-44
3. DRIVE CIRCUIT DIAGRAM	4-46
CIRCUIT VOLTAGE CHART	4-48
PRINTED CIRCUIT DIAGRAMS	4-50
1. MAIN P.C.BOARD(TOP VIEW)	4-50
2. MAIN P.C.BOARD(BOTTOM VIEW)	4-52

ELECTRICAL TROUBLESHOOTING GUIDE

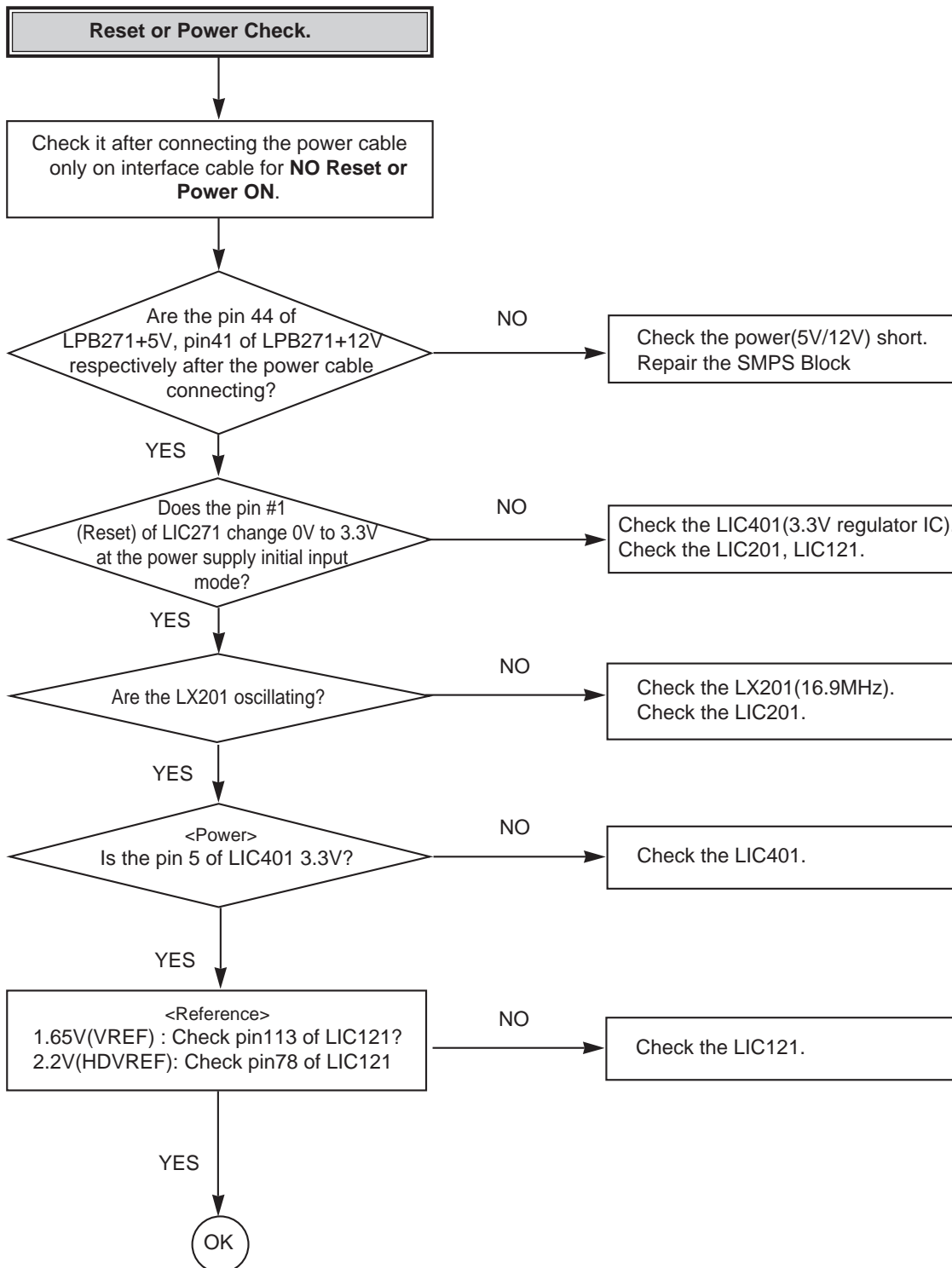

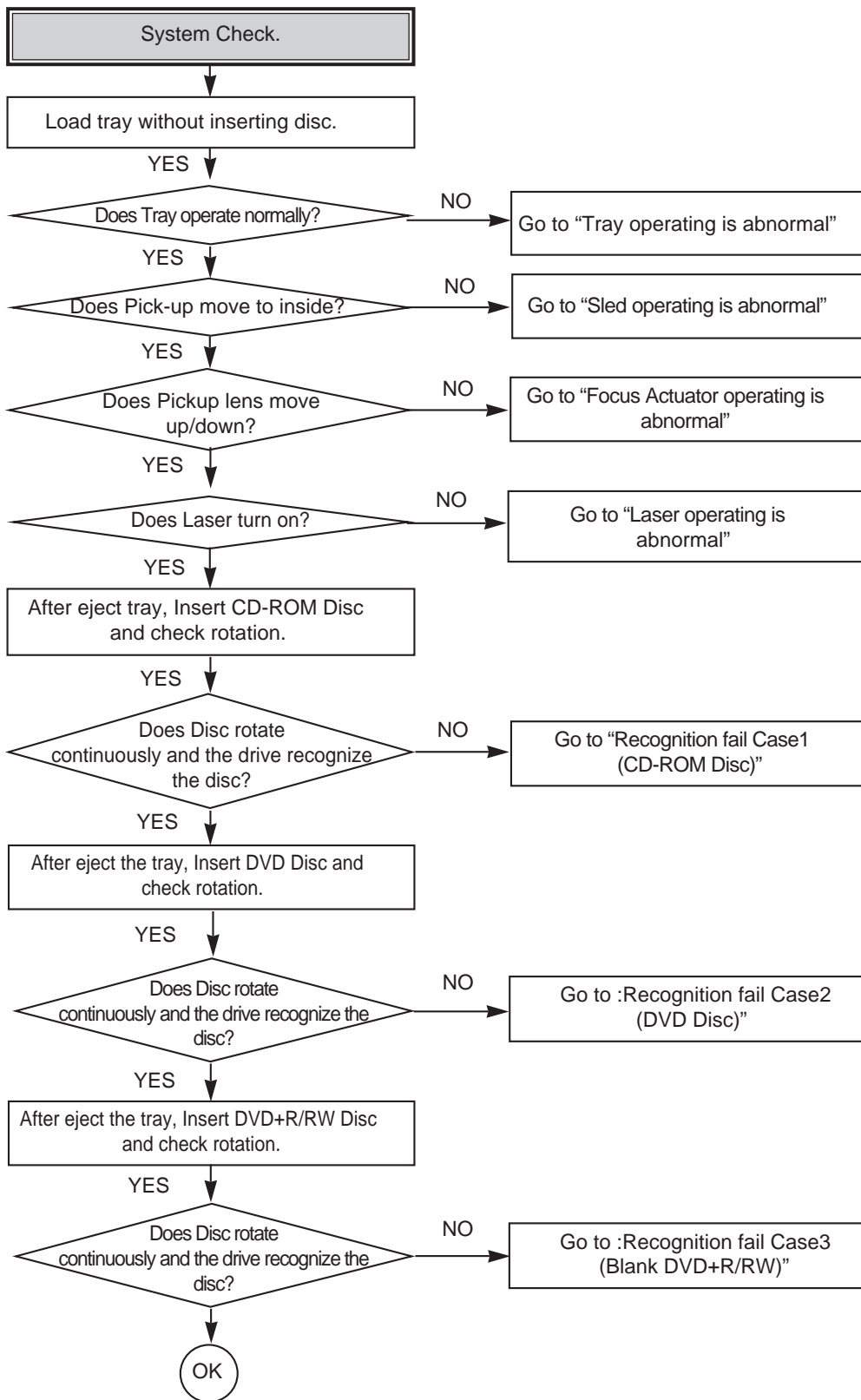

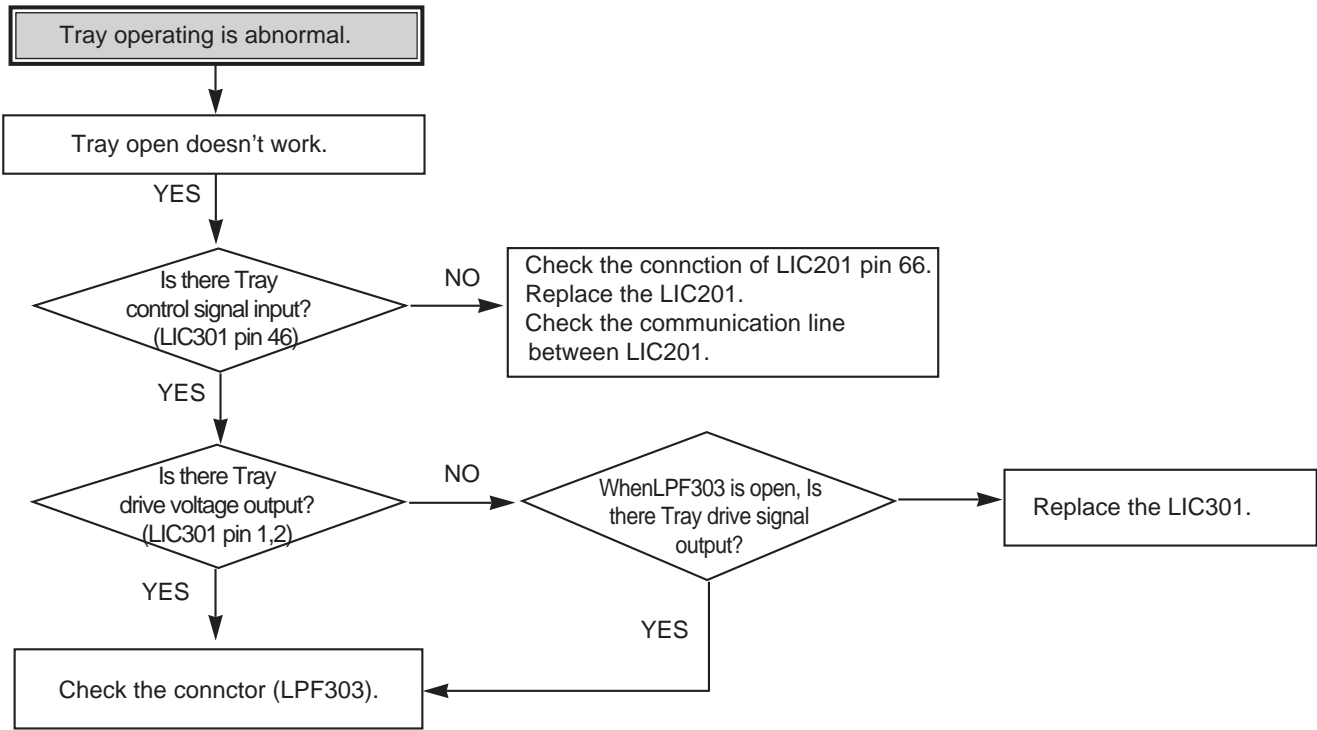

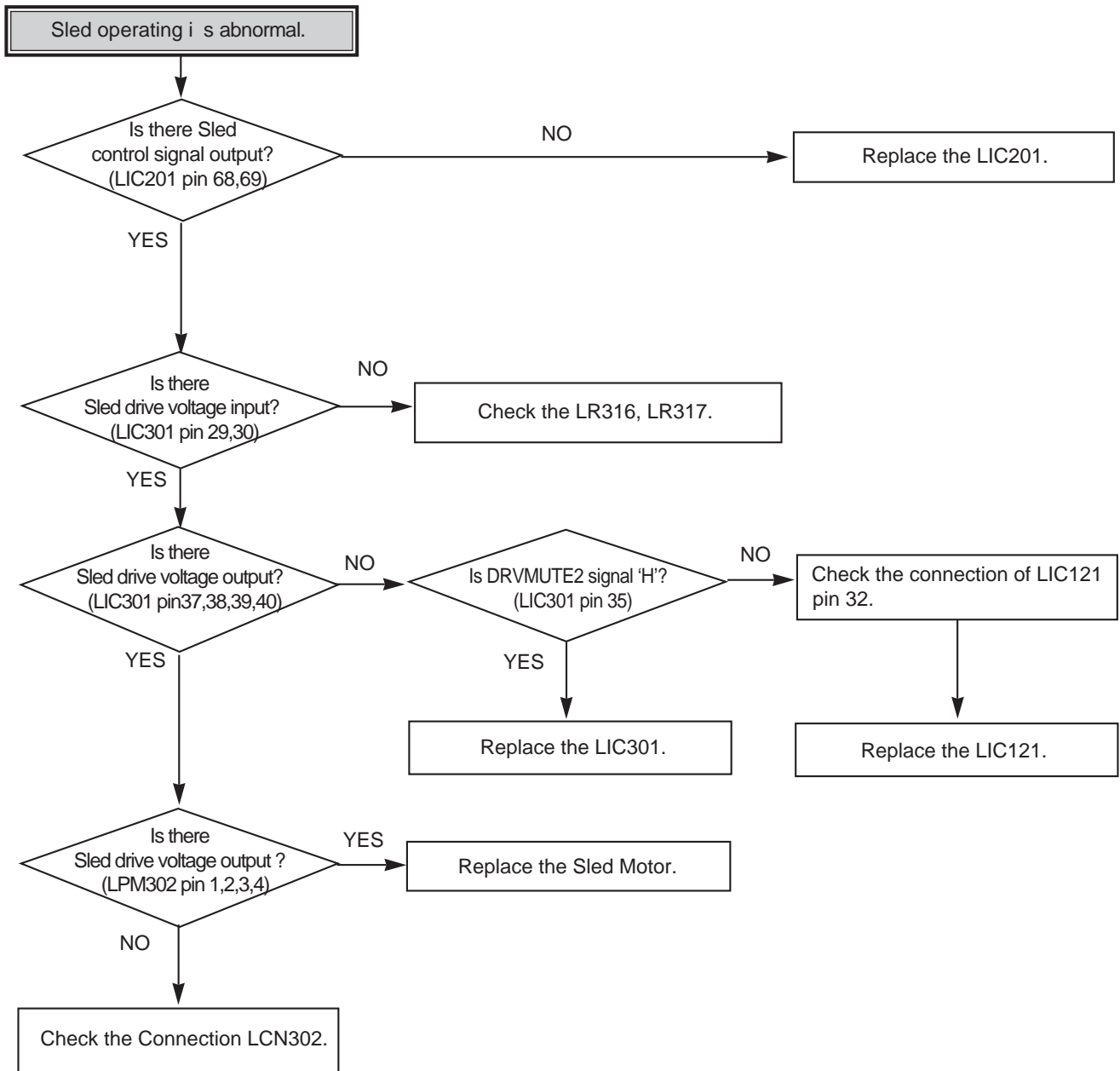

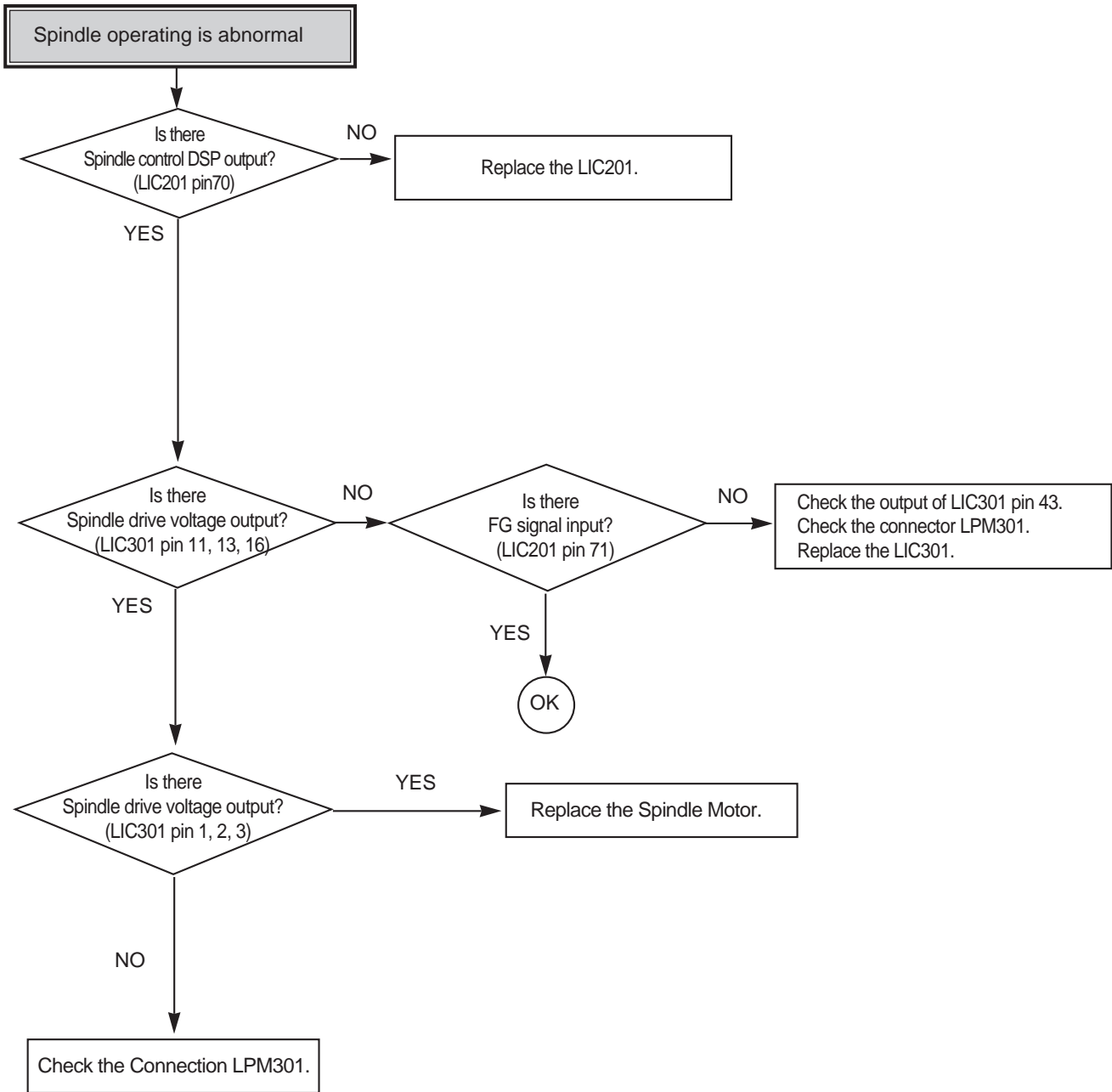

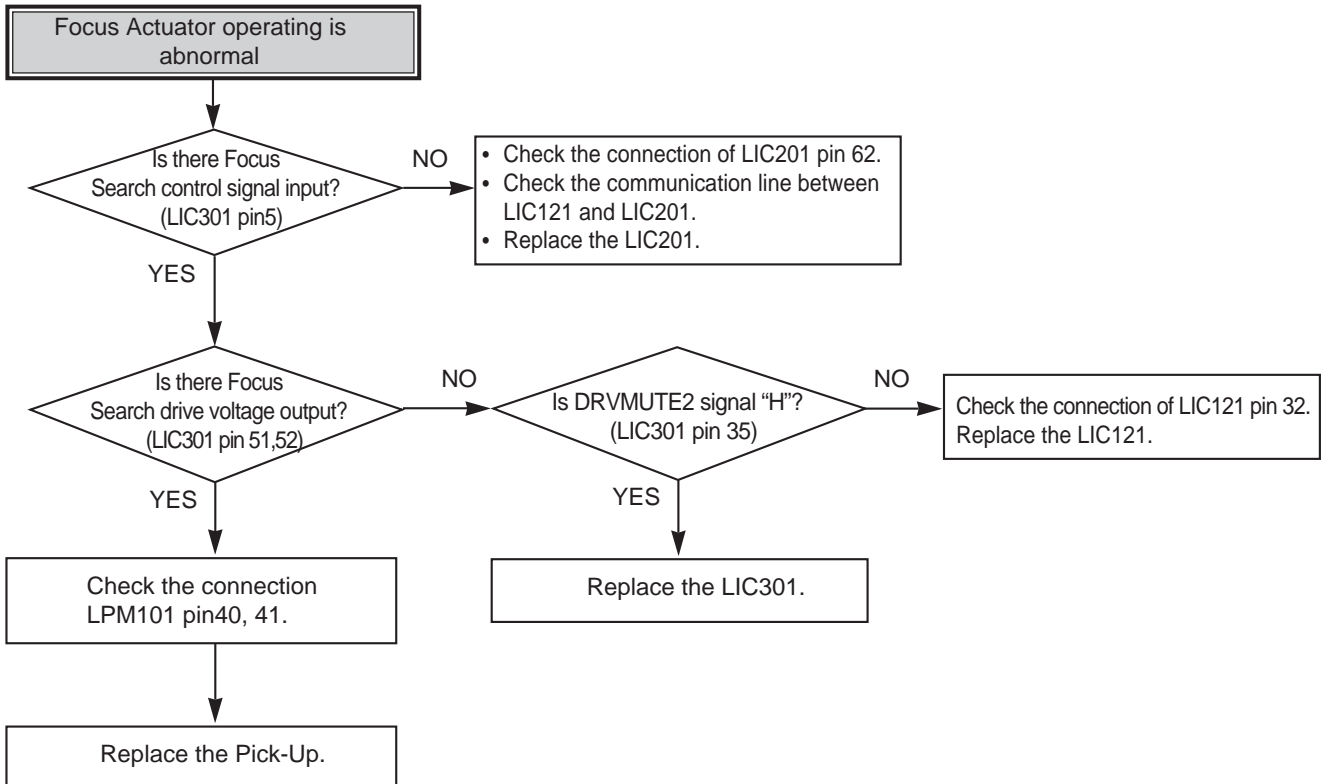
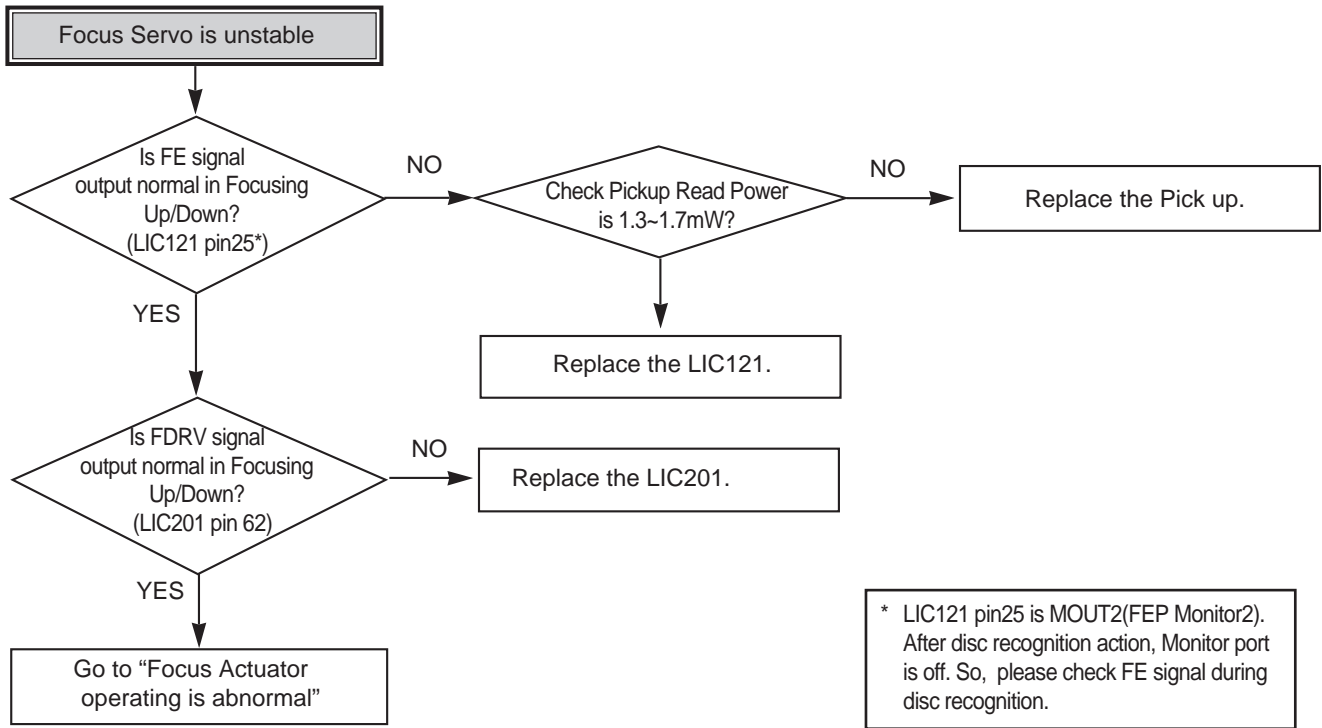

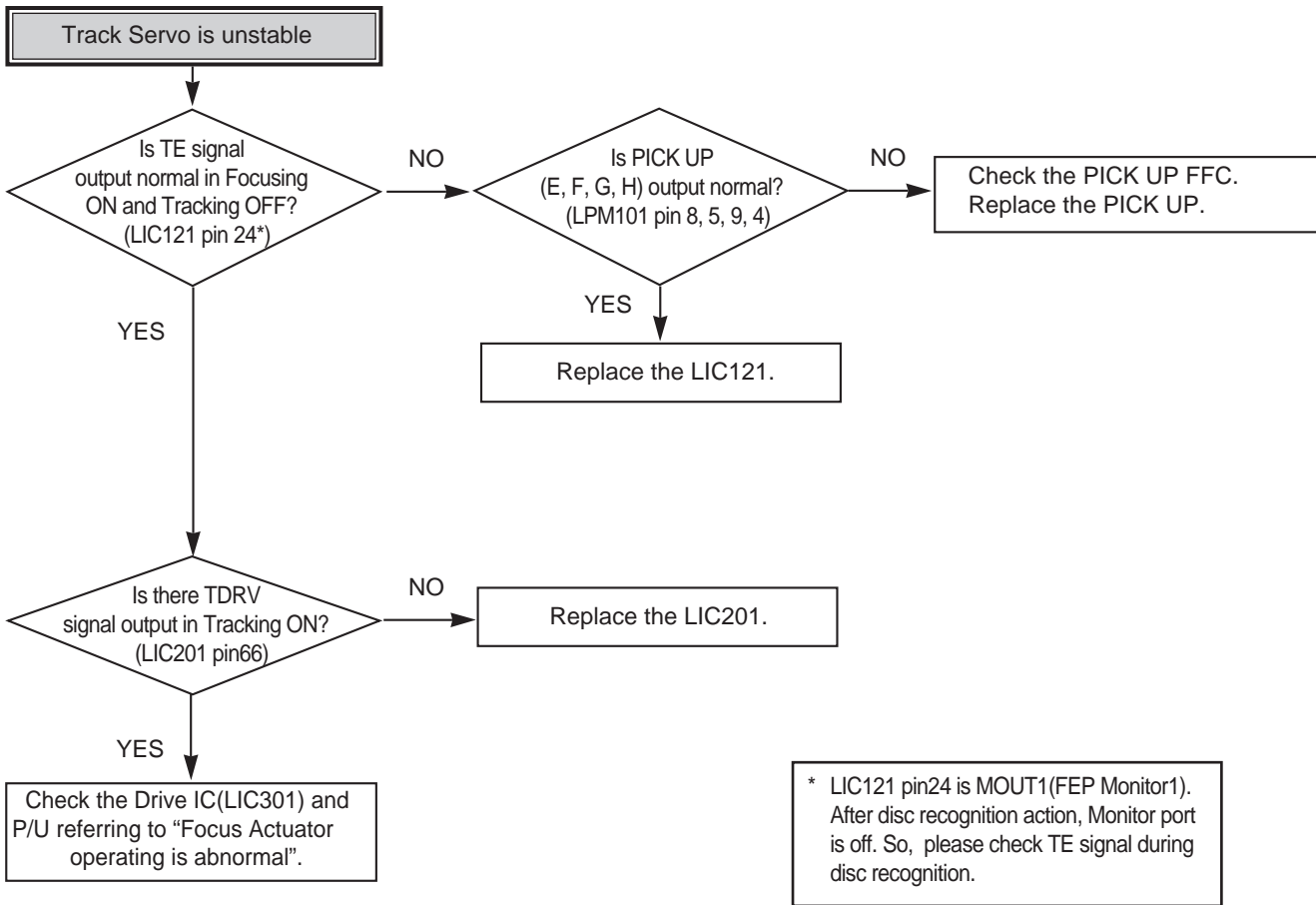

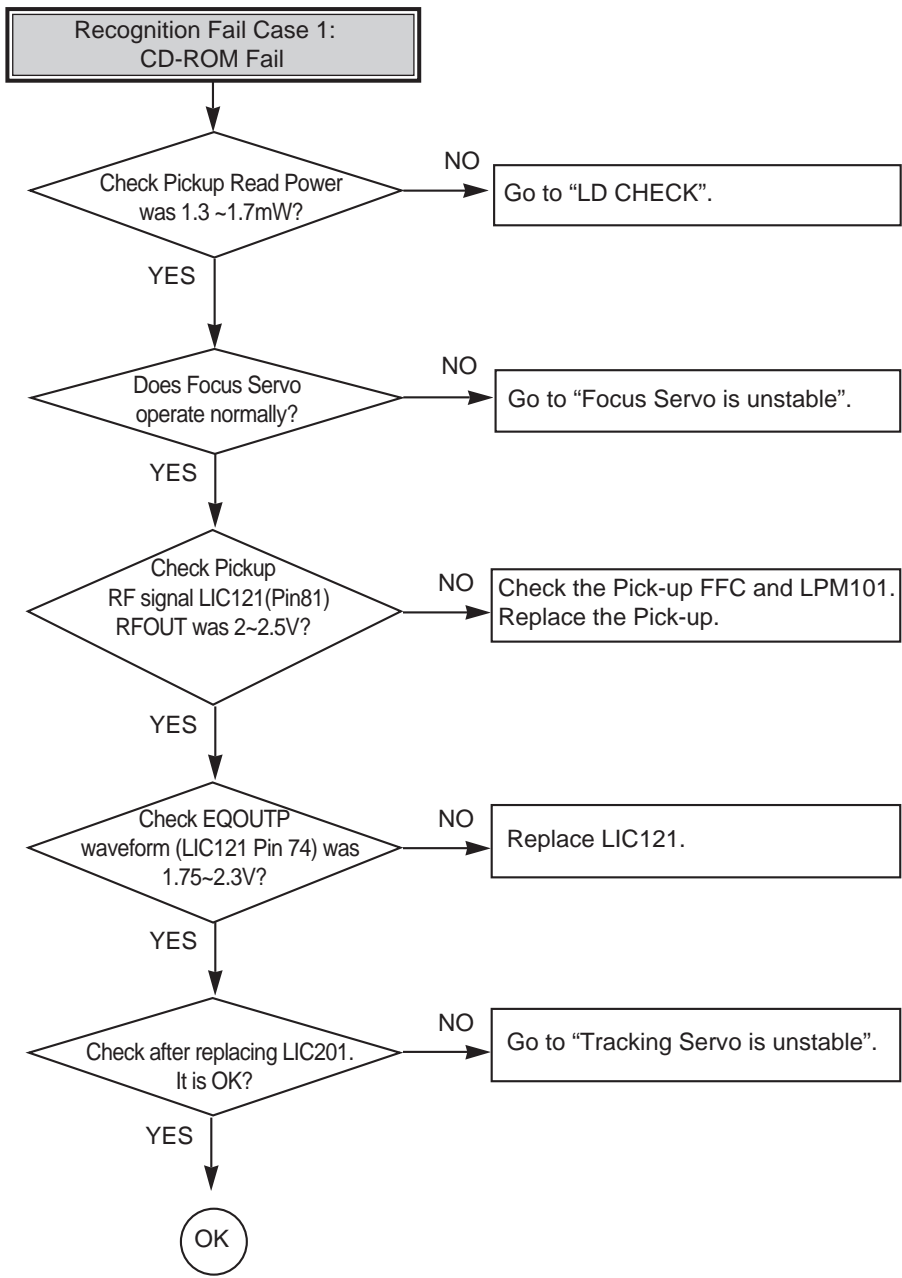

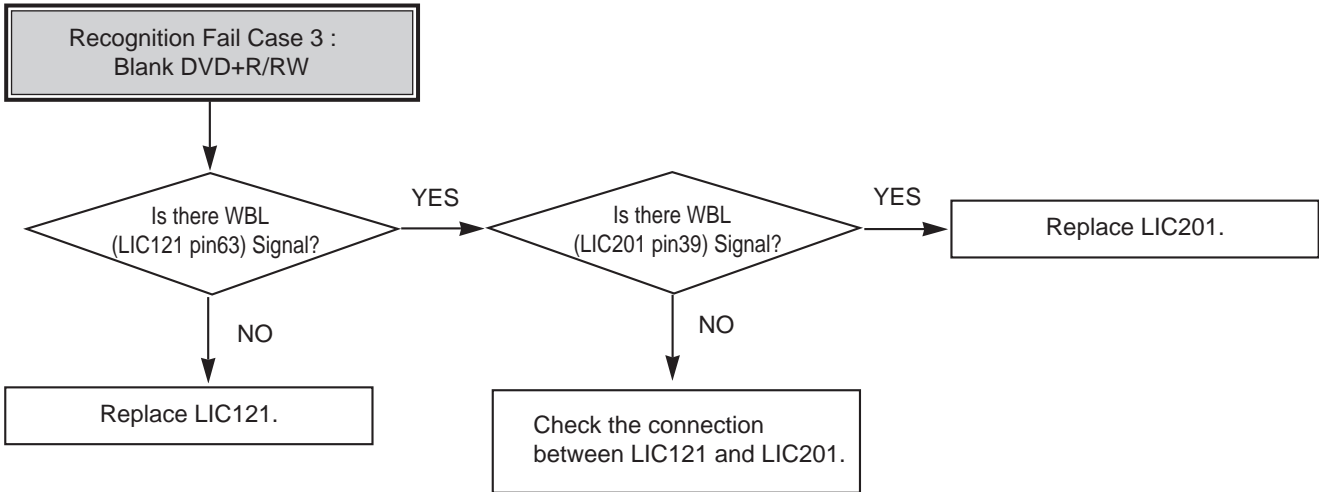
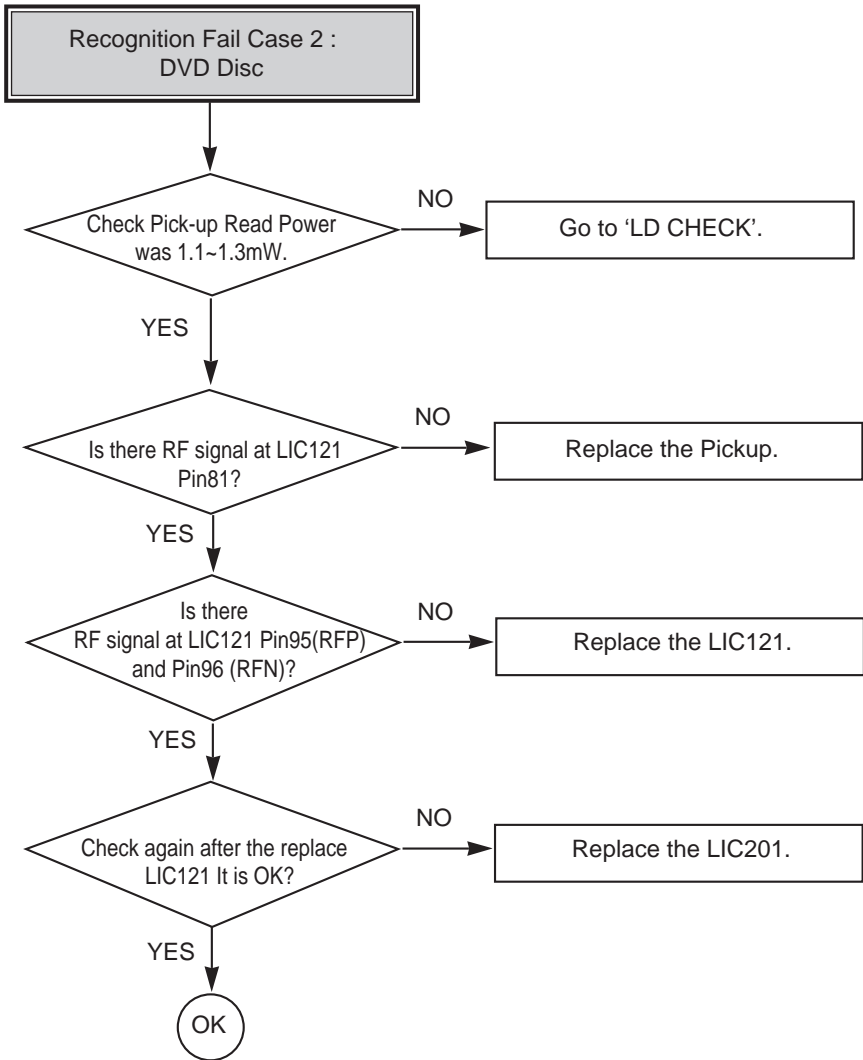

In case of writing fail.

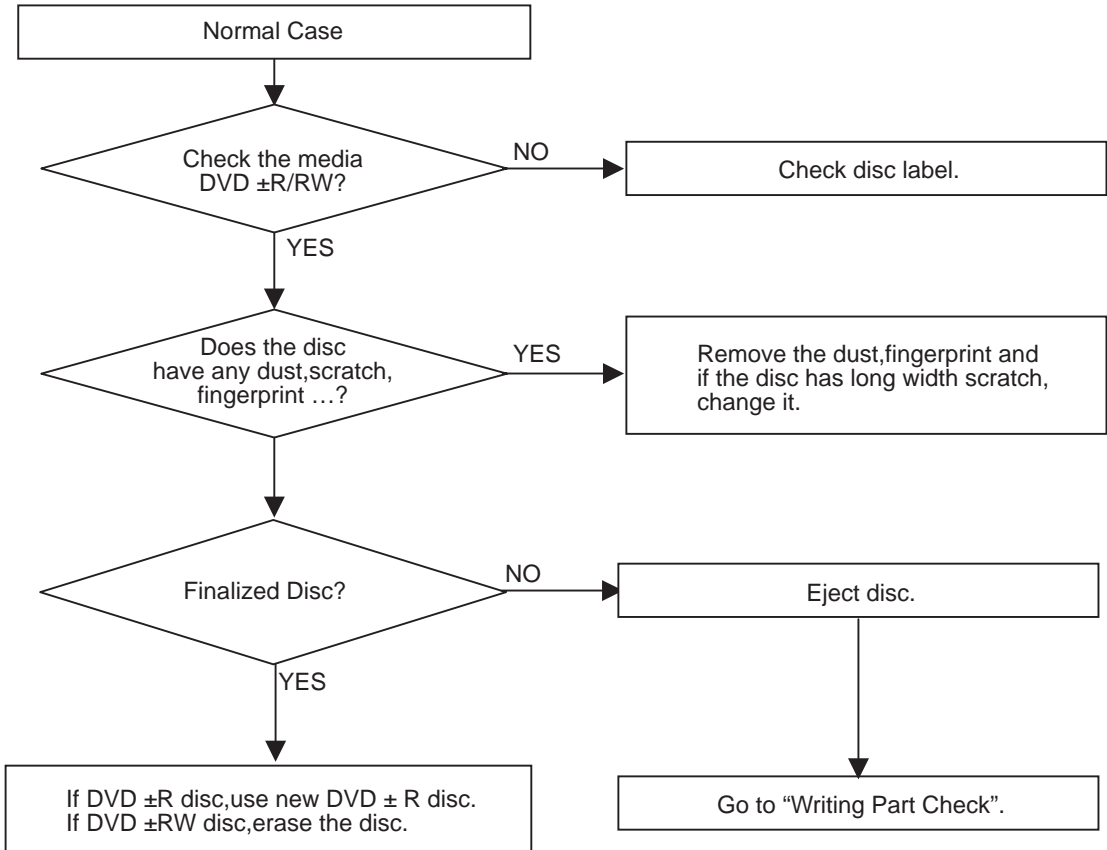

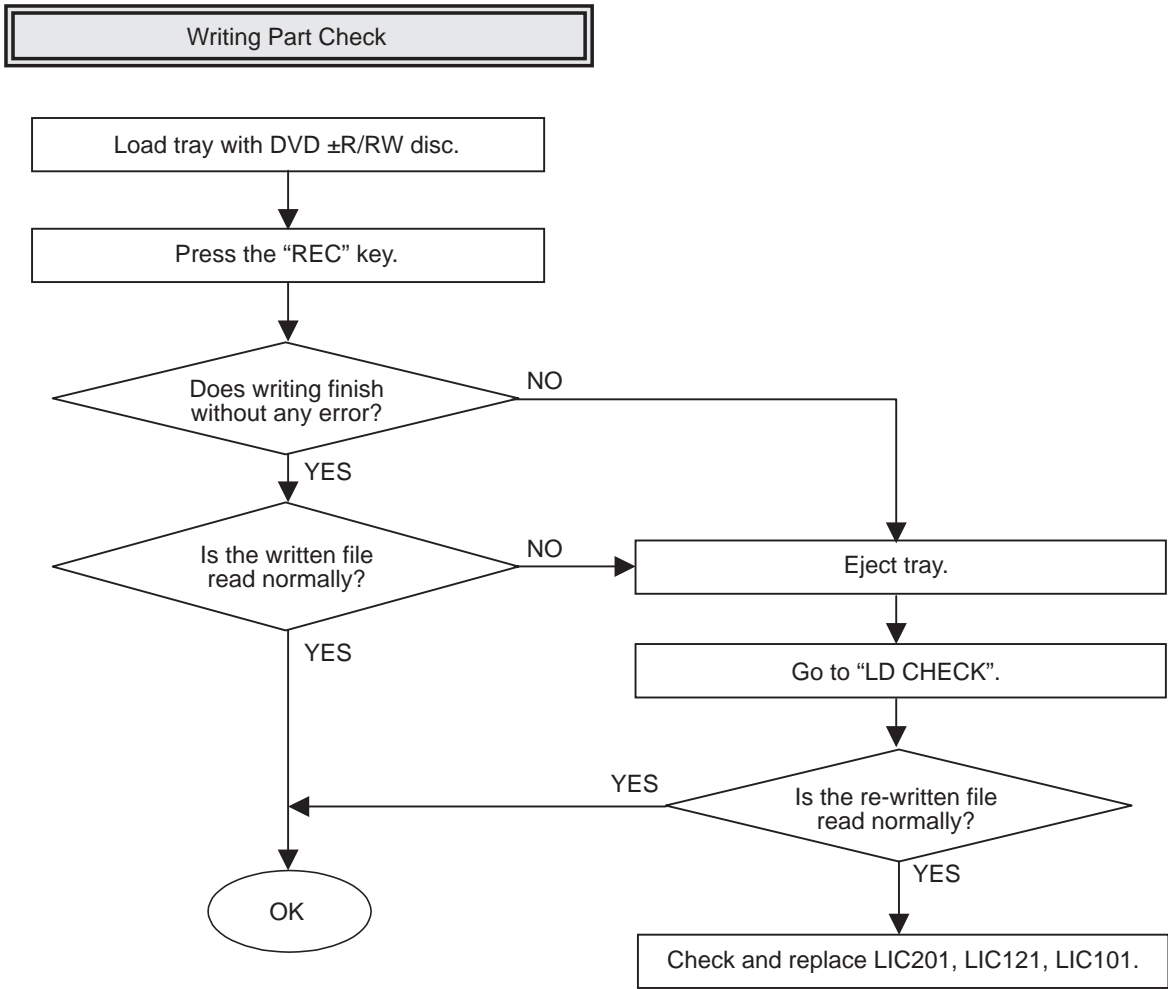

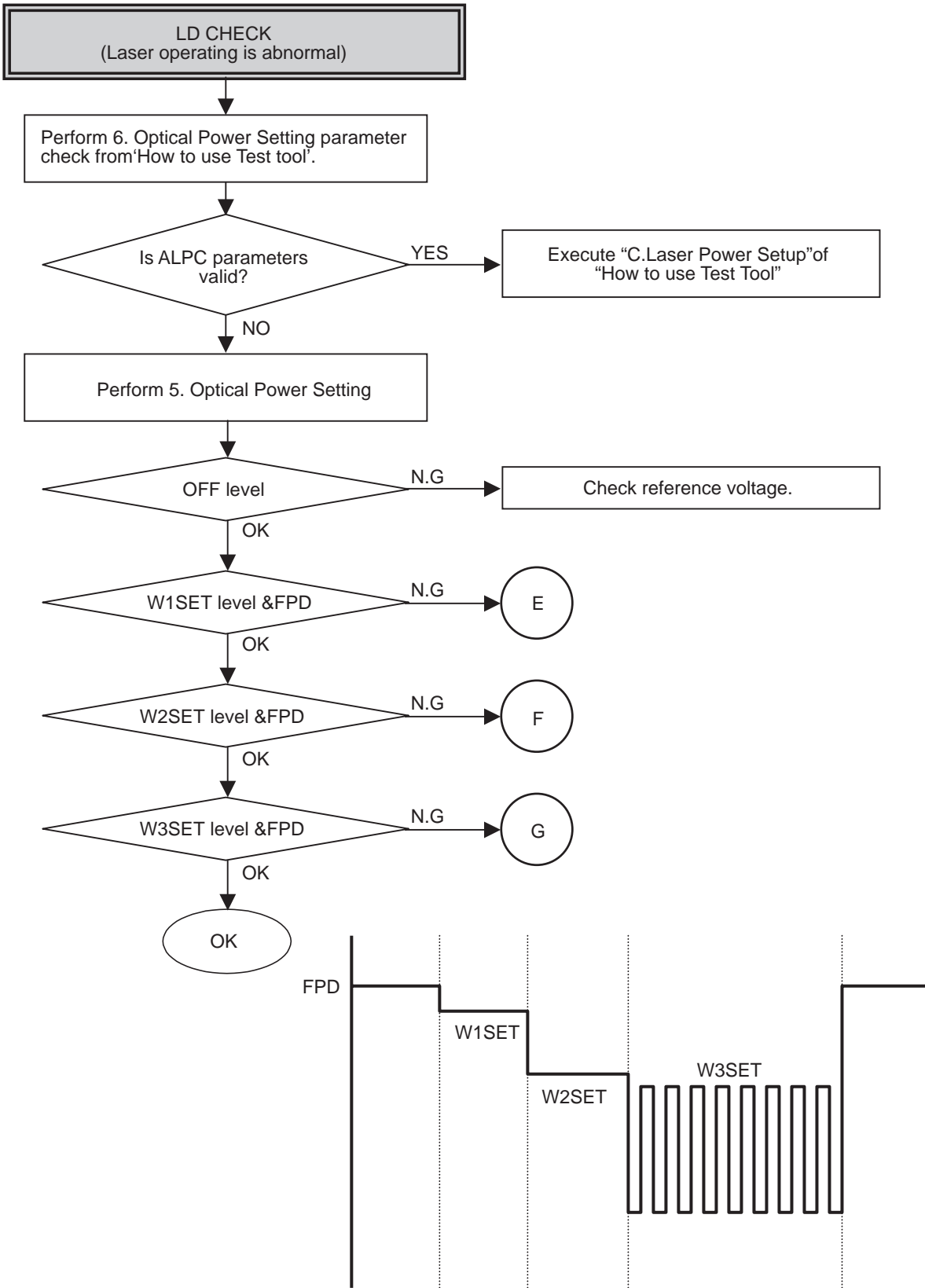

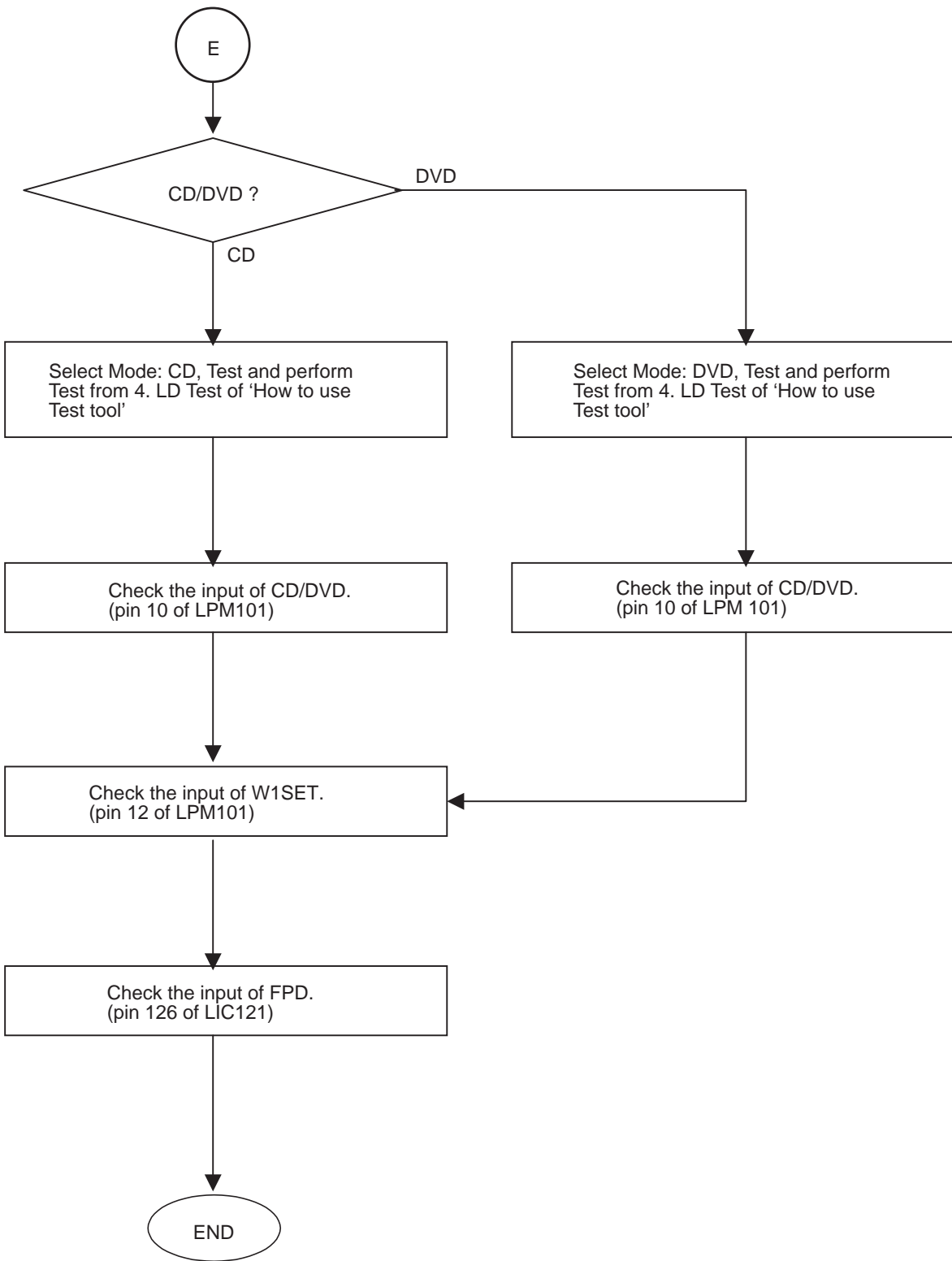



Select Mode: DVD, Test and perform Test from 4. LD Test of 'How to use Test tool'

Check the input of CD/DVD.
(pin 10 of LPM101)

Check the input of W2SET.
(pin 13 of LPM101)

Check the input of recording pulse.
(pin 19, 20, 21, 22,23,24 of LPM101)

Check the input of FPD.
(pin 126 of LIC121)



Select Mode: DVD, Test and perform Test from 4. LD Test of 'How to use Test tool'

Check the input of CD/DVD.
(pin 10 of LPM101)

Check the input of W3SET.
(pin 14 of LPM101)

Check the input of recording pulse.
(pin 19, 20, 21, 22, 23, 24 of LPM101)

Check the input of FPD.
(pin 126 of LIC121)

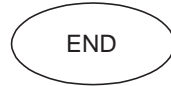

THE DIFFERENCE OF DVD-R/RW, DVD+R/RW DISCS AND DVD-ROM

1. RECORDING LAYER

- DVD-ROM (Read Only Disc)

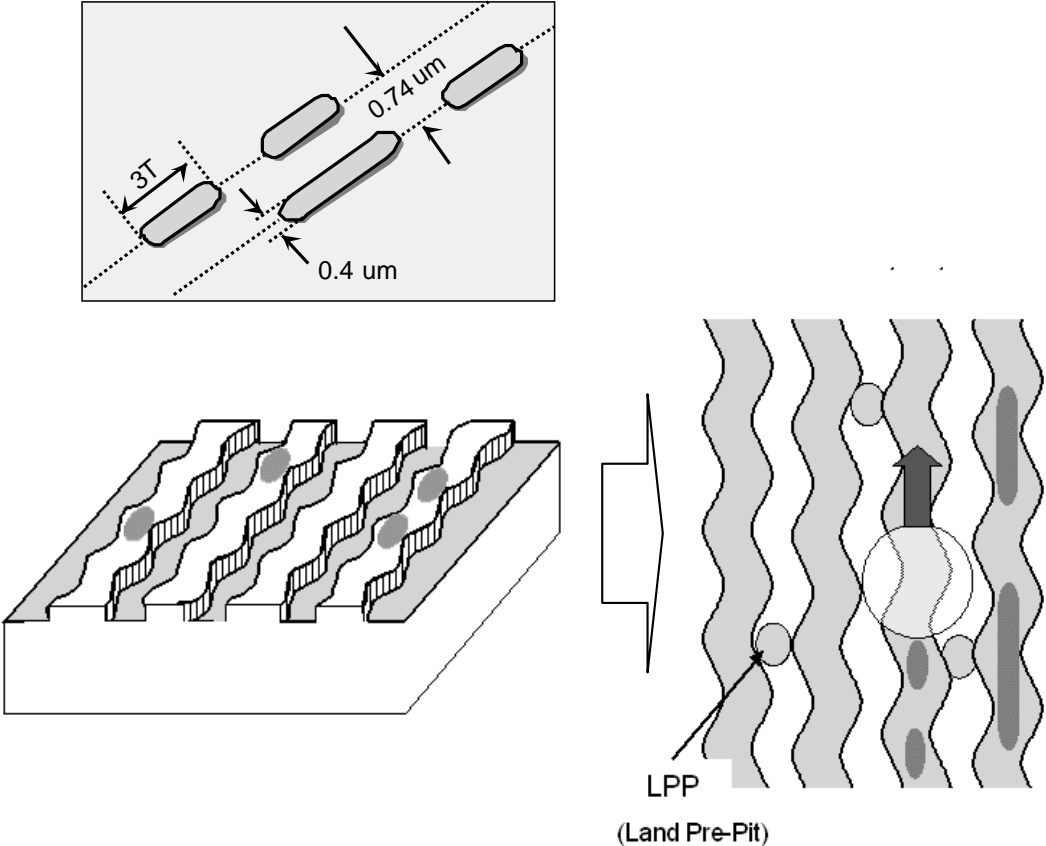

- DVD+R/RW Disc

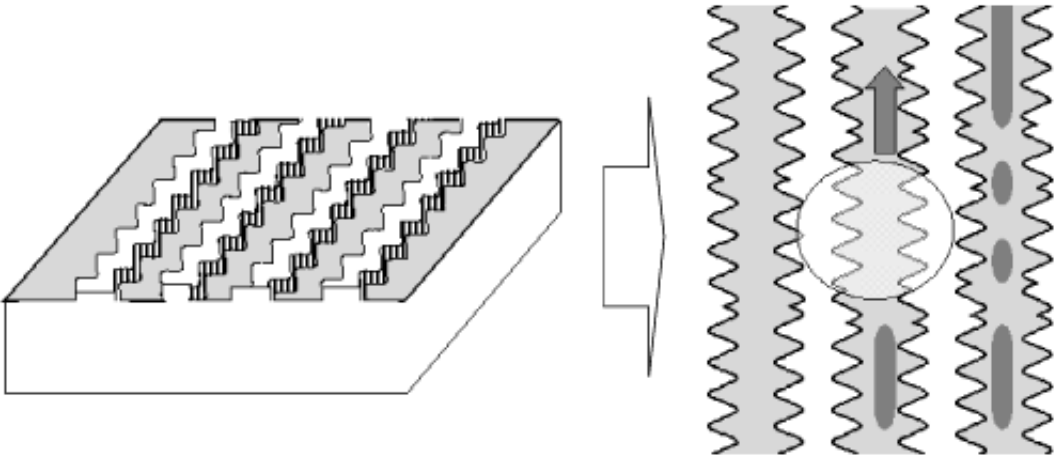

2. DISC SPECIFICATION

	DVD-ROM		DVD-R	DVD-RW	DVD+R	DVD+RW
	Single-Layer	Dual-Layer				
Media Type	Read Only	Read Only	Dye	Phase change	Dye	Phase change
User data capacity	4.7GB	8.54GB	4.7GB	4.7GB	4.7GB	4.7GB
Wavelength	650nm	650nm	650nm	650nm	650nm	650nm
Reflectivity	45~85%	18~30%	45~85%	18~30%	45~85%	18~30%
Track pitch	0.74 μ m	0.74 μ m	0.74 μ m	0.74 μ m	0.74 μ m	0.74 μ m
Minimum pit length	0.4 μ m	0.4 μ m	0.4 μ m	0.4 μ m	0.4 μ m	0.4 μ m
Modulation	>0.6	>0.6	>0.6	>0.6	>0.6	>0.6
Channel bit-rate	26.16MHz	26.16MHz	26.16MHz	26.16MHz	26.16MHz	26.16MHz
Wobble Frequency	–	–	140KHz	140KHz	817.4KHz	817.4KHz
Addressing	26.16MHz	26.16MHz	Wobble & LPP	Wobble & LPP	Wobble(ADIP)	Wobble(ADIP)
Read Power (mW)					0.7 \pm 0.1	0.7 \pm 0.1
Write Power (mW)	–					
Jitter	<8%	<8%	<8%	<8%	<9%	<9%

3. DISC MATERIALS

1) DVD-ROM

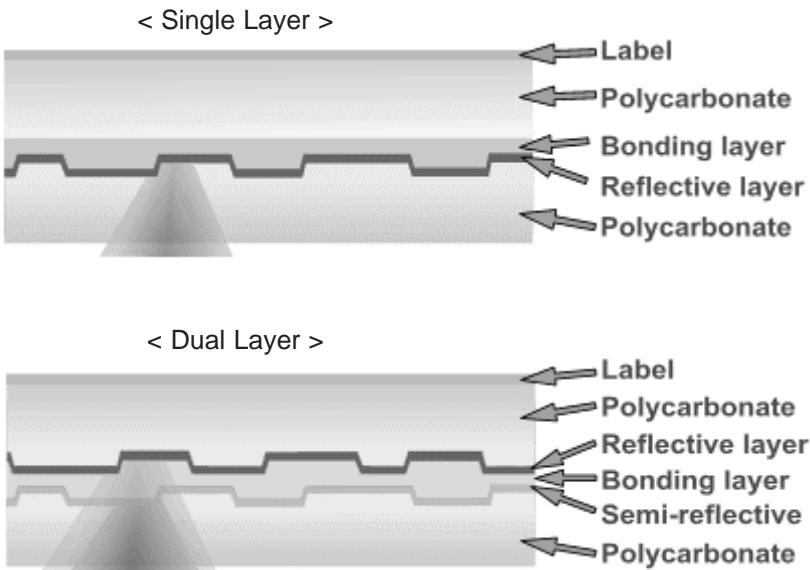

2) Recording format using organic dye material (DVD-R / DVD+R)

The format that records data through the creation of recorded marks by changing the organic dye material with a laser beam.

► Disc structure

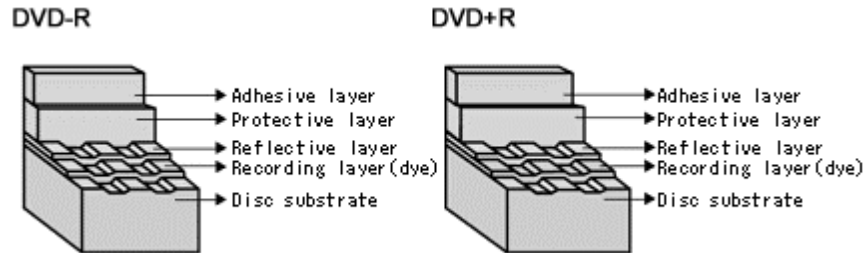

► Recording principles

[Recording]

Recording is done by changing the organic dye layer and the substrate with a laser. When a strong laser is applied to a disc, the temperature of the organic dye material goes up, the dye is decomposed and the substrate changes at the same time. At this time, a durable bit is created as is the case with a CD-ROM.

[Playback]

Signals are read with the differences of the reflection of a laser from pits.

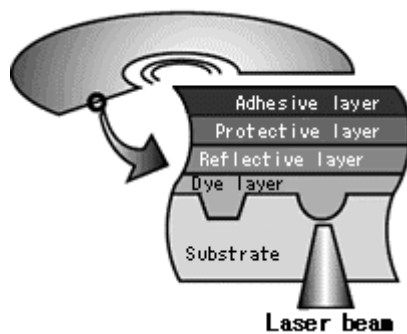

3) Recording format using phase-change recording material (DVD-RW / DVD+RW)

- Data is recorded by changing the recording layer from the amorphous status to the crystalline status, and played back by reading the difference of the reflection coefficient.
Amorphous: Non-crystalline.
- ▶ Disc structure

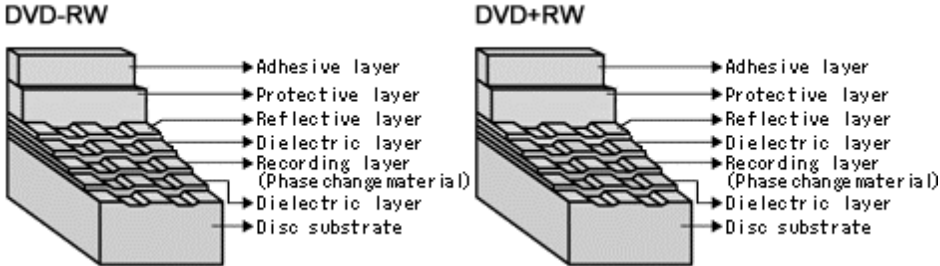

- ▶ Recording principles

[Recording]

When a high-power laser is applied to the recording material, it melts and then becomes amorphous with a low reflection coefficient when it quickly cools off. When a mid-power laser is applied to heat gradually the recording material and then gradually cools it off, it becomes crystal with a high reflection coefficient.

[Playback]

A low-power laser is used for playback. The amount of reflected light depends on the status (amorphous or crystalline) of the recording material. This is detected by an optical sensor.

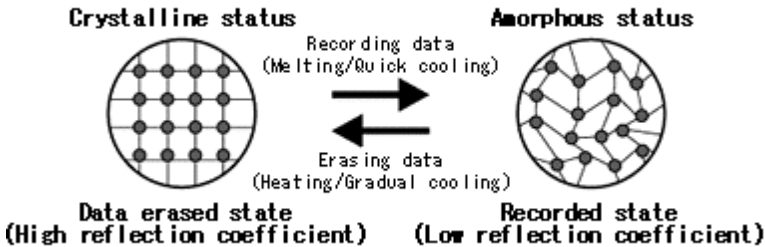
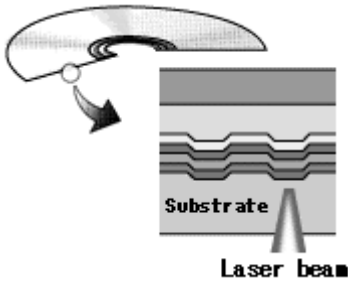

To make recordings, it is necessary to modulate the write pulse, which is called "Write Strategy". There can be many types in Write Strategy. Typically Write Strategy for DVD \pm R has NMP(Non Multi-Pulse) type and MP(Multi-Pulse) type. In NMP type each single mark is created by subsequent separated short pulses. In MP type each single mark is created by one continuous pulse. Write Strategy for DVD \pm RW has Type 1 and Type2. In Type 1 the mark with nT width is created by one top pulse and $(n-2)$ multi-pulses. Thus mark $3T$ is made by one top pulse and one multi-pulse. In Type 2 the mark with nT width is created by one top pulse and $(n-3)$ multi-pulses. Thus mark $3T$ is made by one top pulse only. RL-02A uses MP type Write Strategy for DVD \pm R and Type 1 for DVD \pm RW as shown below.

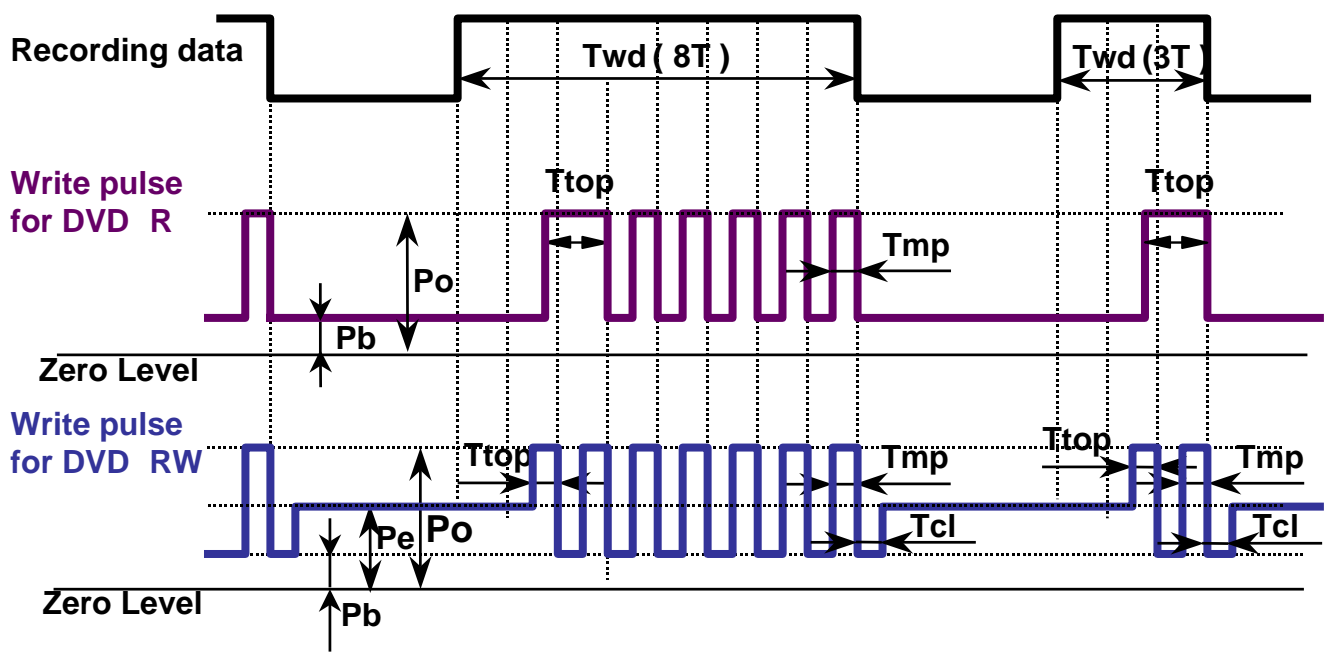

P_o :Write Power (Peak Power)
 P_e :Erase Power
 P_b :Bias Power

4. ORGANIZATION OF THE INNER DRIVE AREA, OUTER DRIVE AREA, LEAD-IN ZONE AND LEAD-OUT ZONE

1) Layout of DVD-R/DL disc

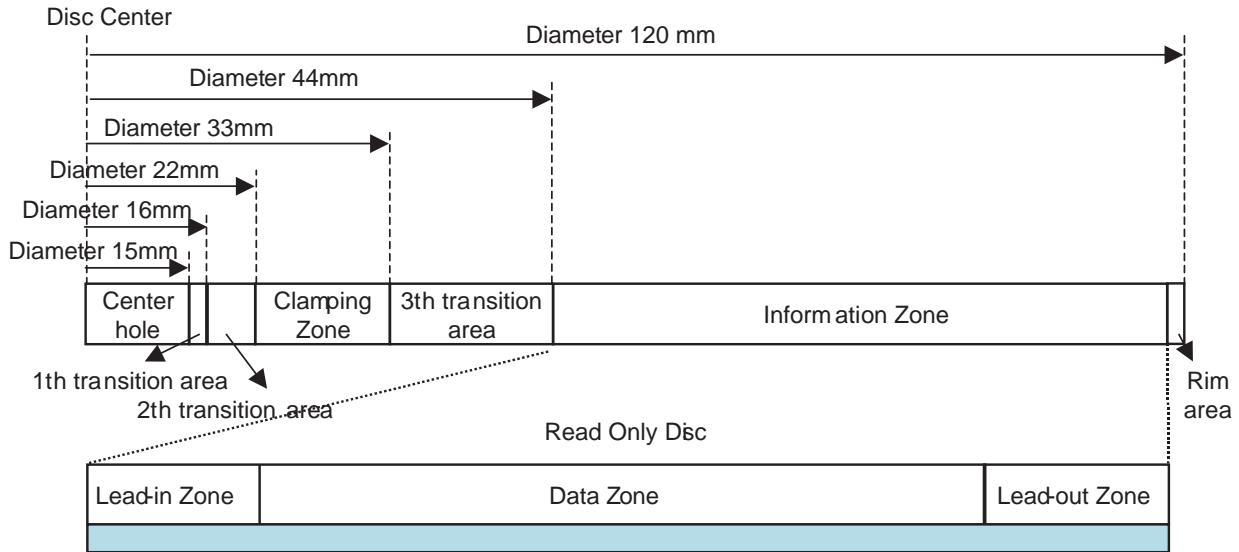

2) Layout of DVD+R disc

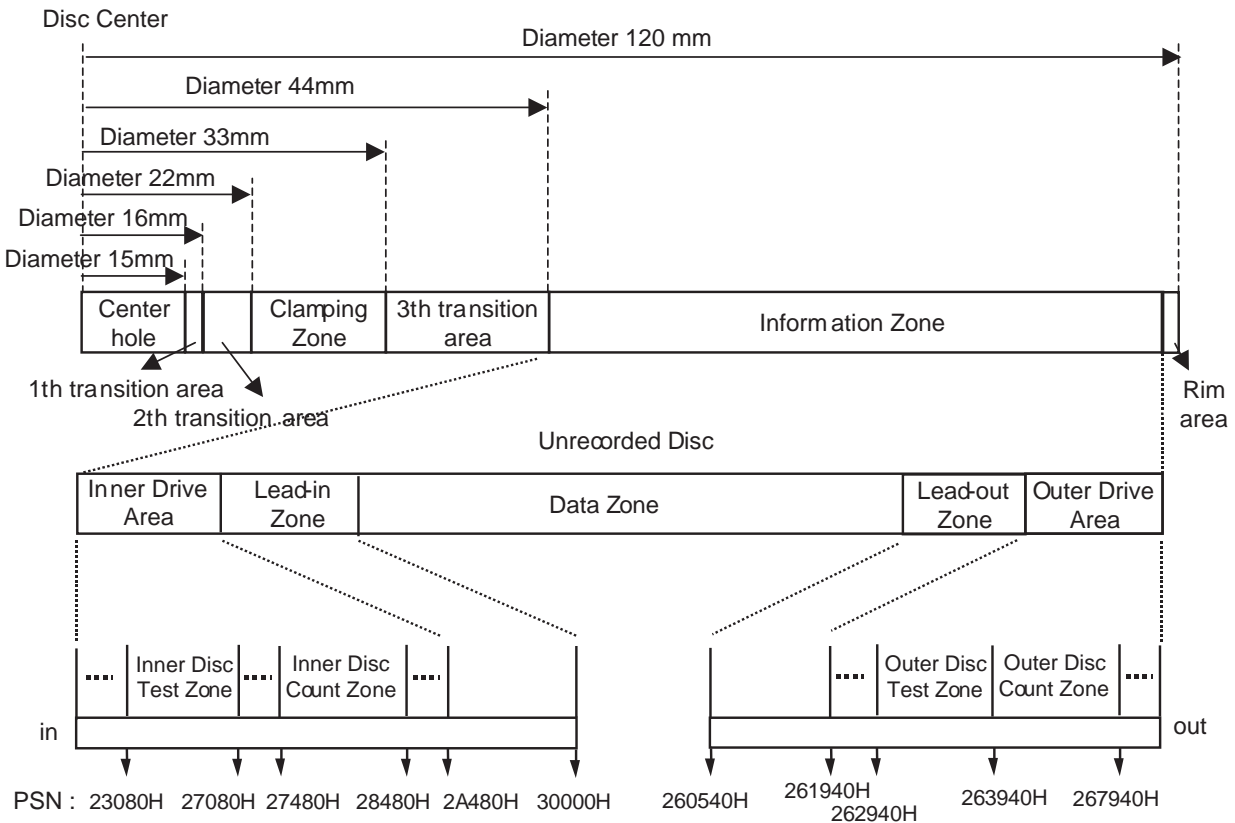

Inner Disc Test Zone : for performing OPC procedures.

Inner Disc Count Zone : For counting the number of OPC algorithm performed in IDT Zone.

Outer Disc Test Zone : for performing OPC procedures.

Outer Disc Count Zone : For counting the number of OPC algorithm performed in IDT Zone.

3) Layout of DVD+RW disc

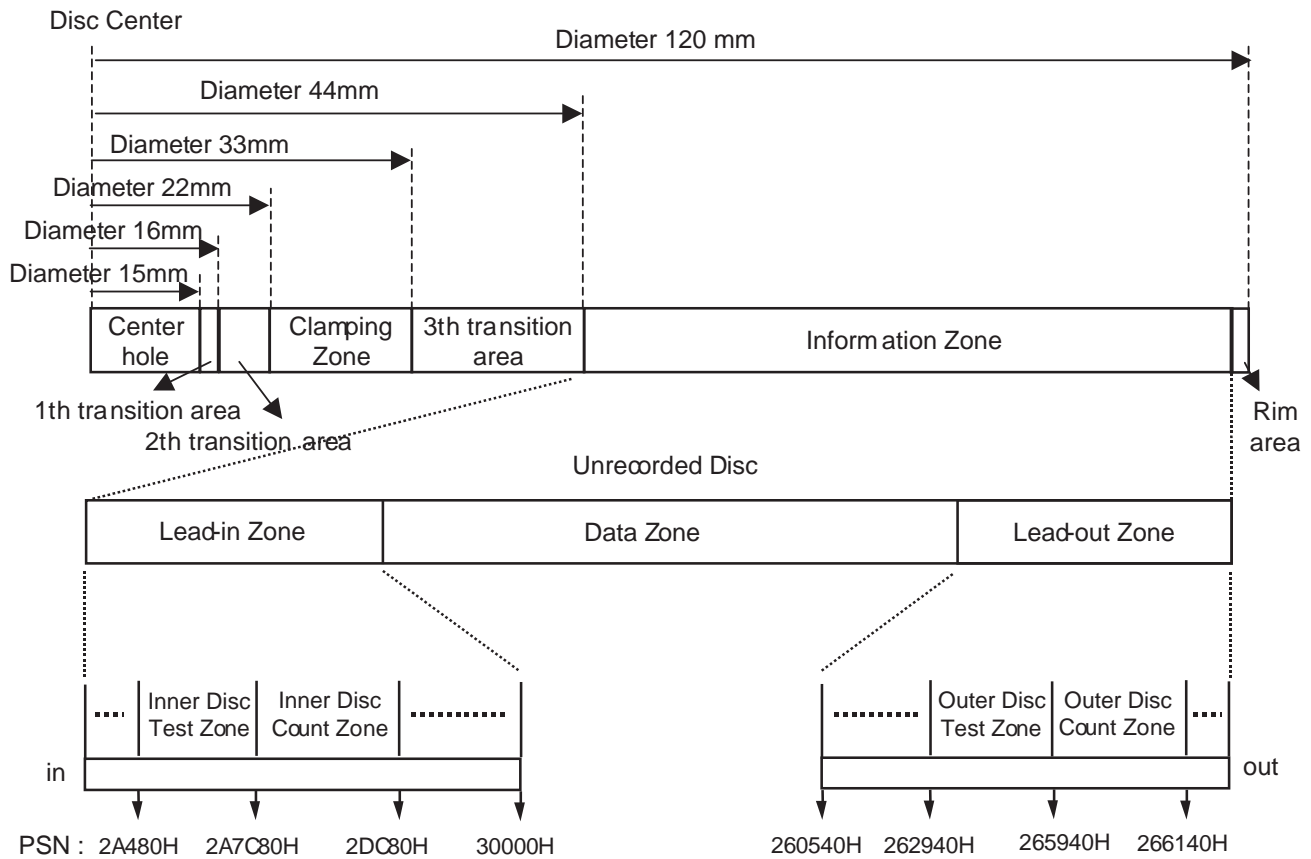

Inner Disc Test Zone : for performing OPC procedures.

Inner Disc Count Zone : For counting the number of OPC algorithm performed in IDT Zone.

Outer Disc Test Zone : for performing OPC procedures.

Outer Disc Count Zone : For counting the number of OPC algorithm performed in IDT Zone.

4) Layout of DVD-R/RW disc

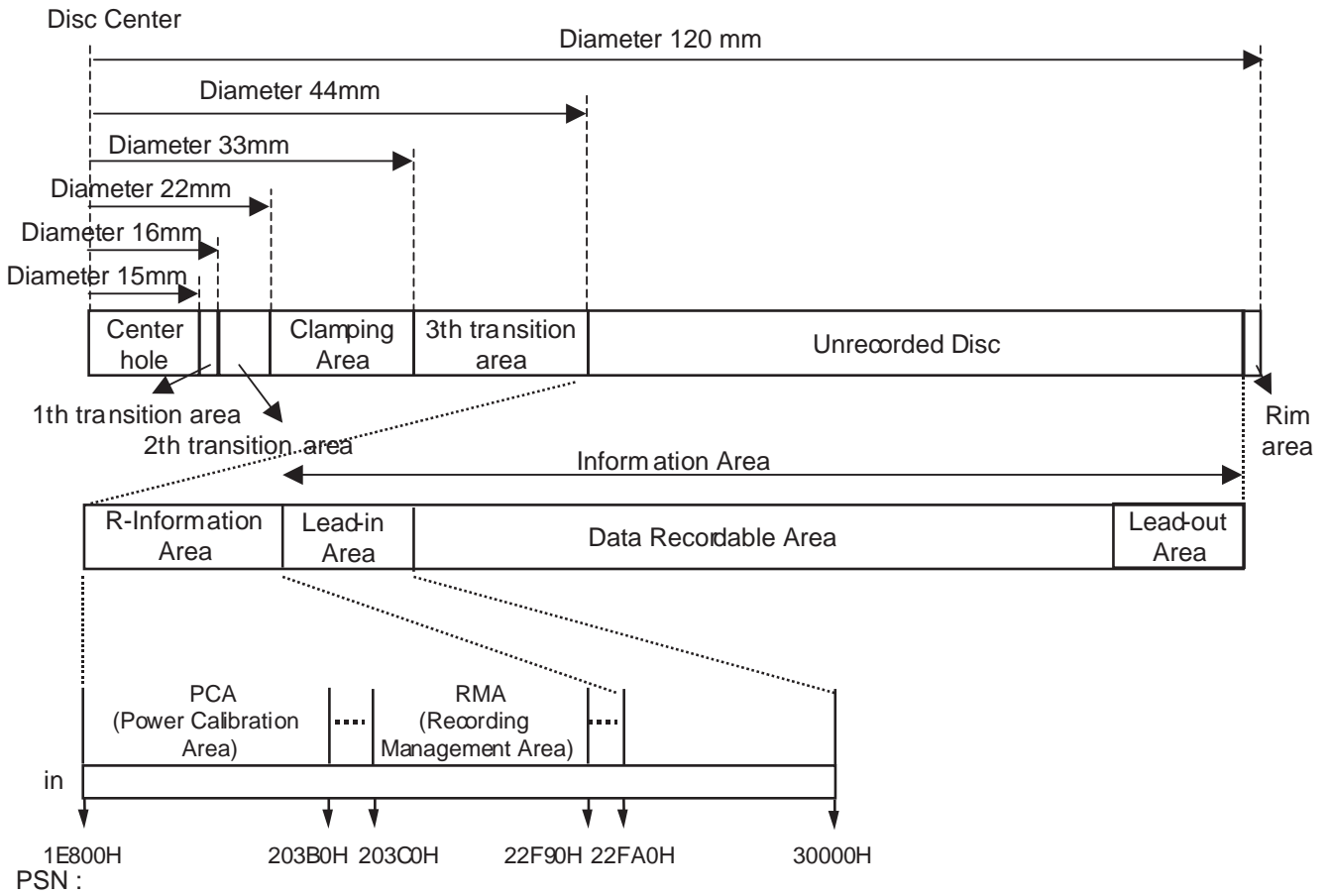

HOW TO USE TEST TOOL

1. ALPC MEASUREMENT SYSTEM

We need basically several measurement instrument to adjust Optical Power of CD and DVD Disc

- **ESSENTIAL INSTRUMENT**

- 1) Optical Power meter & Sensor (ADVANTEST, TQ8230/Q82014A)
- 2) Personal Computer
- 3) Adjustment Program (Dragon or ALPC) --> being recommended ALPC Program in case of SVC

- **OPTIONAL INSTRUMENT**

- 1) USB-ATAPI Interface (if you don't have Notebook which has ATAPI Interface or use PC USB Port)
- 2) Connector-ATAPI Interface Board

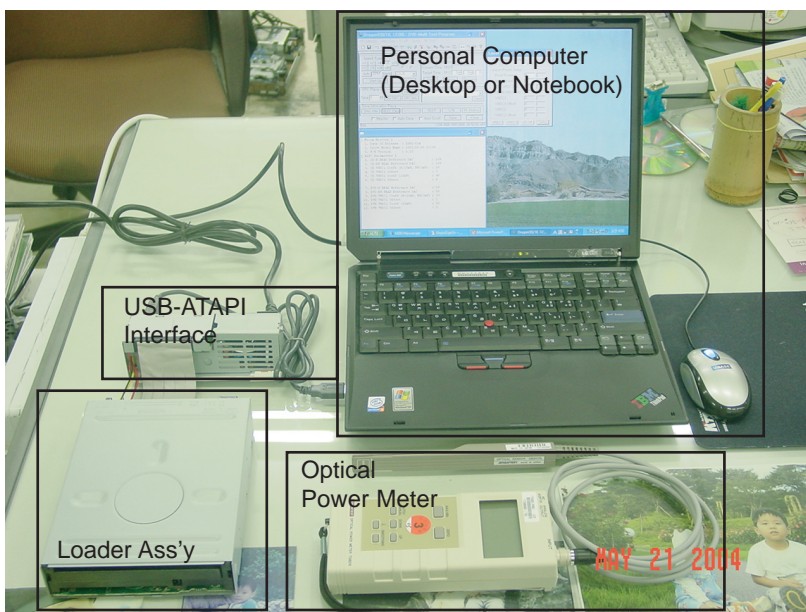

2. ALPC PROGRAM

Use the ALPC program in Dragon tool for Optical power setting. It is consist of total 4 files.

Dragon_JW3P.exe
dragon.cfg
blue.dat
WNASPI32.DLL

Four files must exist in same Directory.

3. EXECUTE ALPC PROGRAM

1) Execute Dragon_JW3P.exe file.

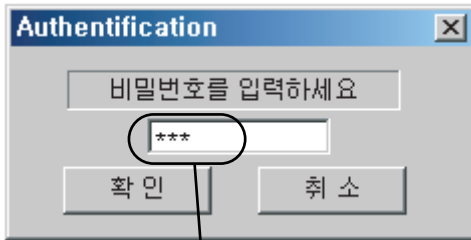

2) Enter the password. It is 'qaz'.
When you enter the password, turn off the 'Caps lock' in your keyboard.

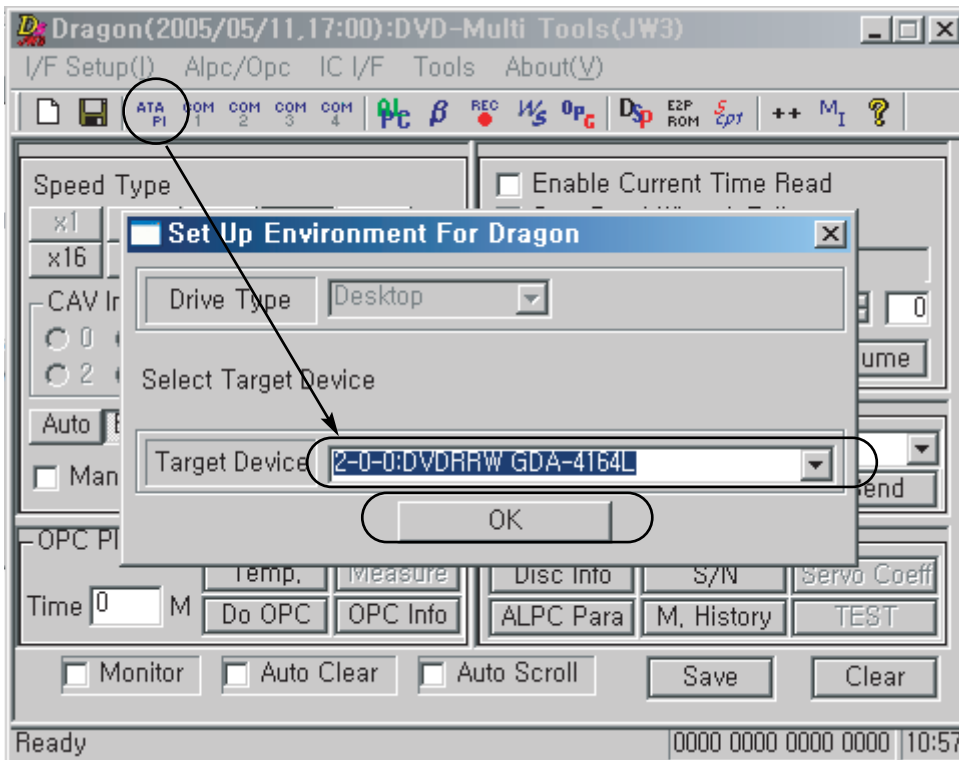

3) Set up the target device.
Press 'ATAPI' button on the main dialog of Dragon tool. And find the target device which is GDA-4164L.

4) If the target device setting is completed, execute the 'Setup Laser Power(Manual)' in the 'Alpc/Opc' menu.

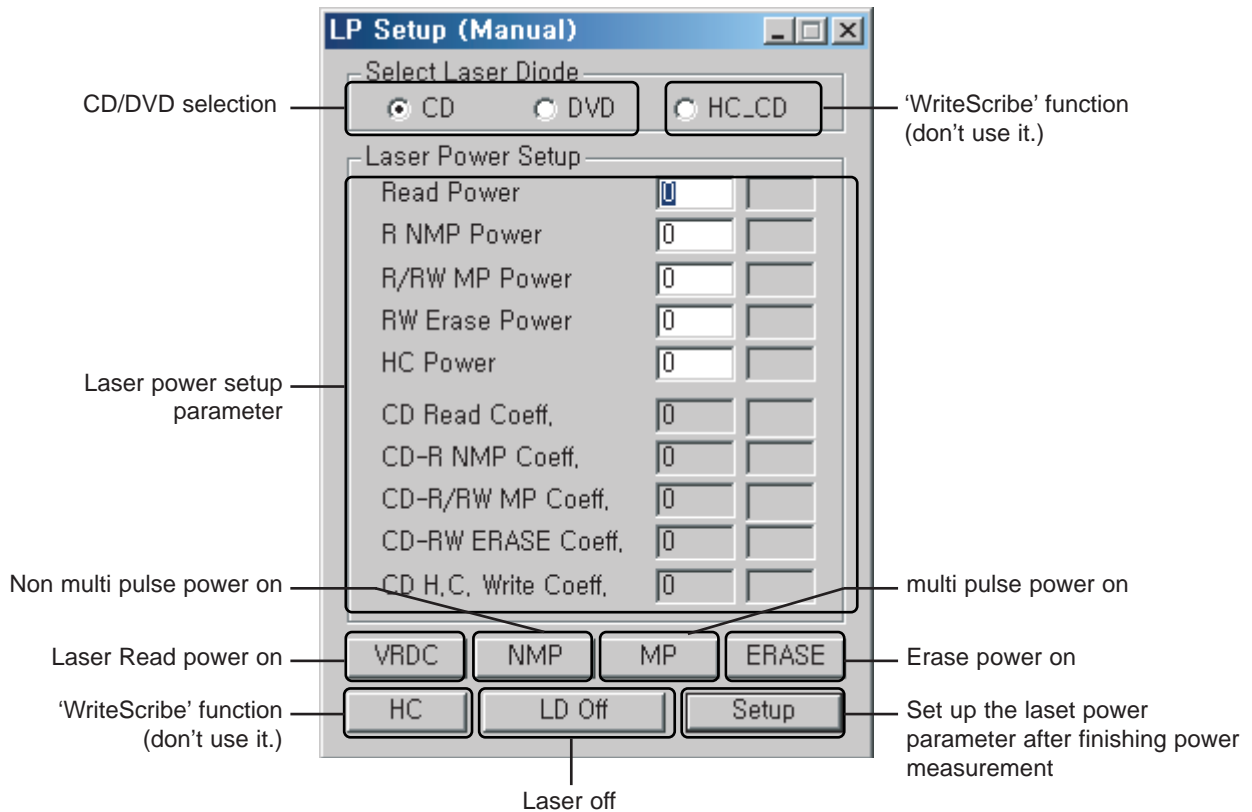
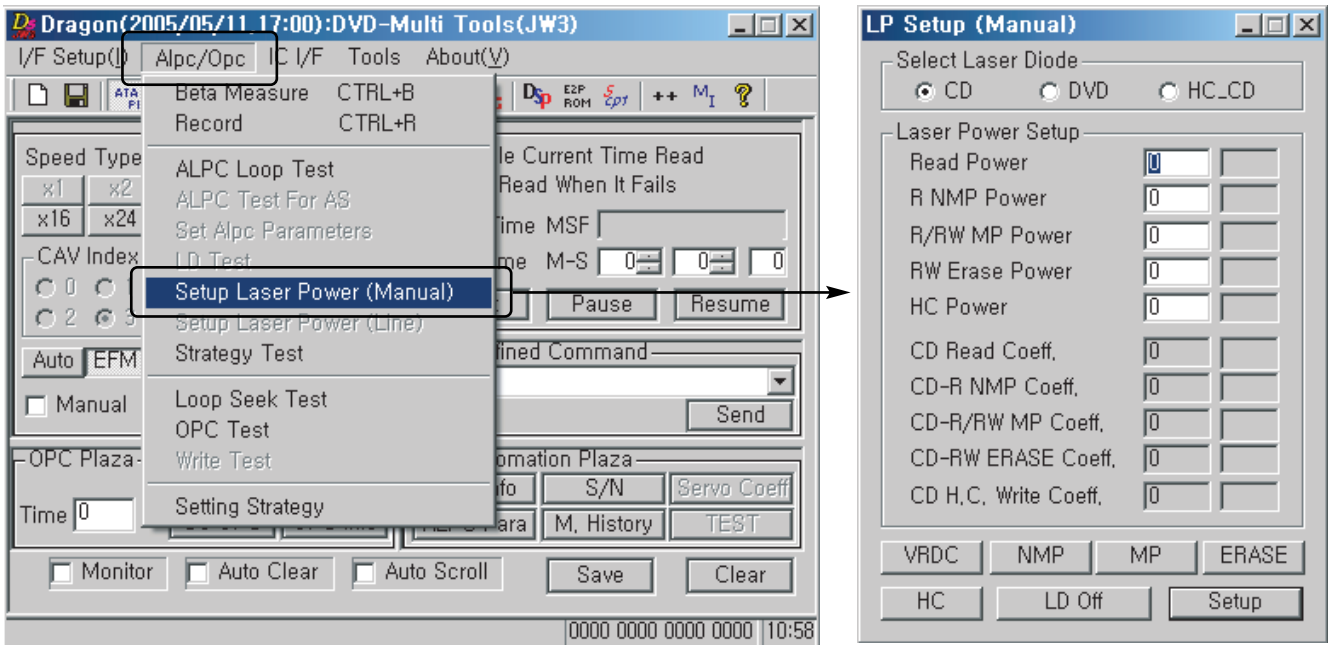

4. OPTICAL POWER SETTING

<Test for checking DVD LD and CD LD>

When you change the Travers ass^oØy(including pick-up) or loader PCB, you must do the laser power setting to match pick-up and loader PCB.

1) DVD LD power setting

- Select the DVD in the 'Select Laser Diode'
- Press **VRDC** (Read Power On, Strong Read light)
- Measure optical read Power.
- Write read power value.
- In case of **NMP** **MP** **ERASE** , you are able to measure the power through same procedure.
- (caution) Don't watch light directly.**
- When you finish optical power measurement, press **LD Off** button(LD Off).
- Press **Setup** button.(save to ERPROM)

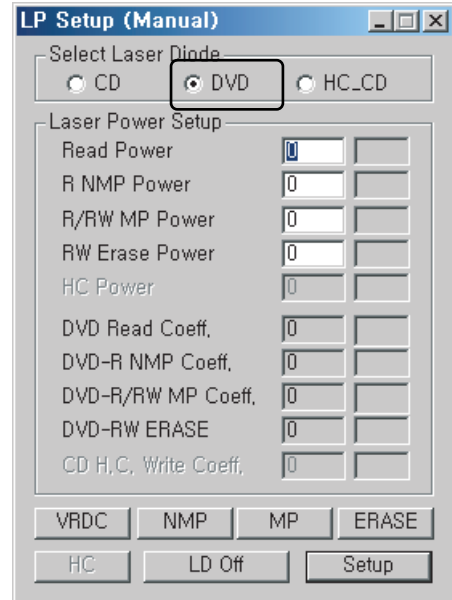

2) CD LD Power Setting

- Select the CD in the 'Select Laser Diode'
 - Press **VRDC** .
 - Measure optical read Power.
 - Write Read Power value.
 - Press **Setup** button(save to ERPROM)
- *** In case of CD power setting of RS-01A, loader don't need to set up write power.
Although NMP, MP, Erase and HC power is N.G when you press setup, please ignore the N.G message.
Because of RS-01A only support reading function about CD-R/RW.

* Look at reference sheet to test Optical Power.

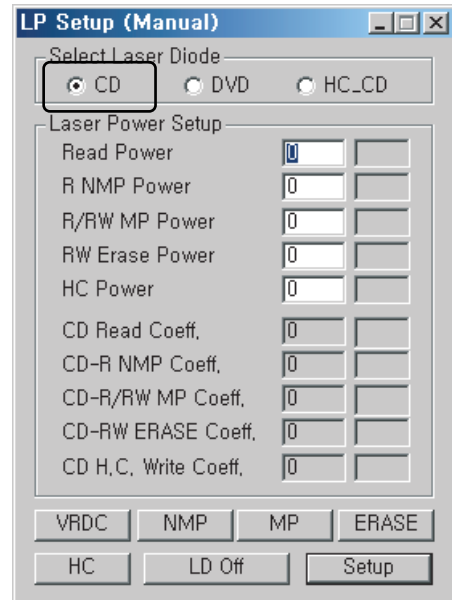

**Power value is β — unit. Value is read power X 100.



5. CONFIRM OPTICAL POWER SETTING PARAMETER

LD Test result is ok, but Loader performance is bad.

1. Check ALPC parameter value

- 1) Press  button to open 'Results Display' dialog.
- 2) Press  button.
 - We can see optical power setting value.
 - Write optical Power Setting value to paper.
 - Adjust power setting again.
 - Compare original parameter to new parameter.
 - if parameter value is different highly, original value is wrong or optical power may change.
 - But pick-up LD test is all ok , just adjust optical power setting again.

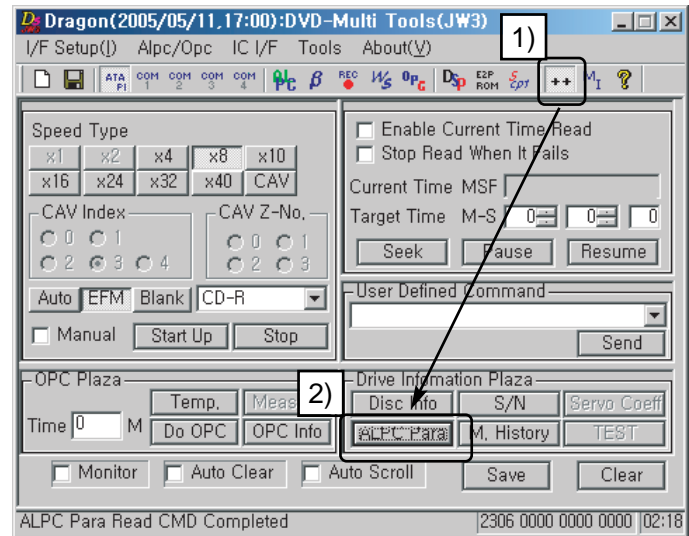

Normal range of ALPC parameter

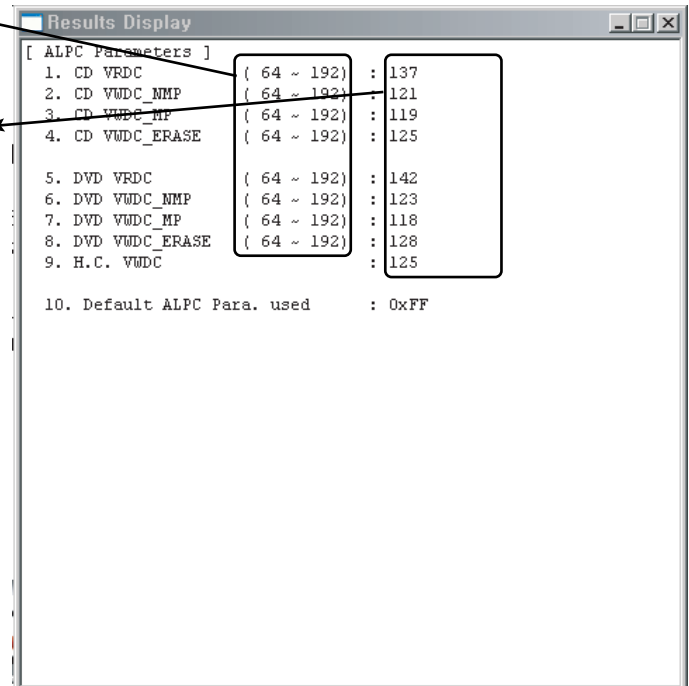

Optical power value which has been saved in the EEPROM

6. OPTICAL POWER SETTING PARAMETER RANGE

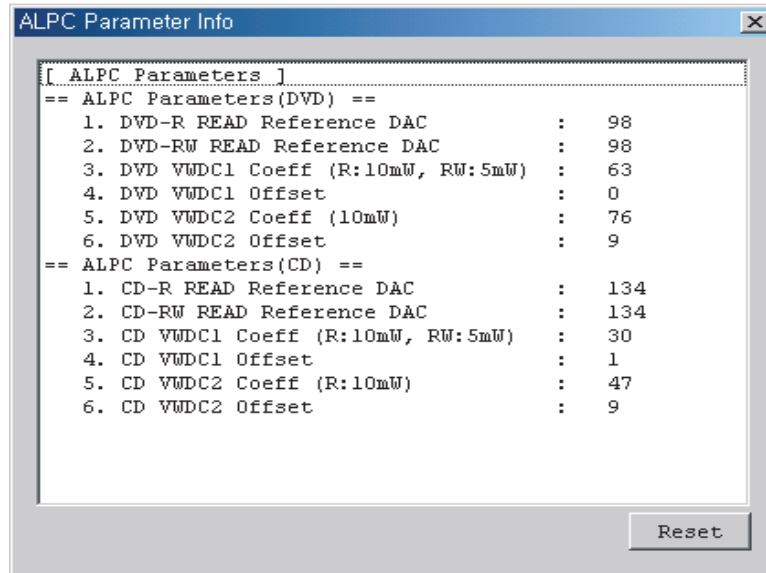

[VALID ALPC Parameters]

< CD >

<DVD>

1) CD-R READ Reference DAC : 30 ~150
 2) CD-RW READ Reference DAC : 80 ~ 250
 3) VWDC1 : 10 ~ 39
 4) VWDC1 Offset : 0 ~ 20
 5) VWDC2 : 20 ~ 57
 6) VWDC2 Offset : 0 ~ 20

1) DVD-R READ Reference DAC : 40 ~145
 2) DVD-RW READ Reference DAC : 40 ~145
 3) VWDC1 : 30 ~ 100
 4) VWDC1 Offset : 0 ~ 20
 5) VWDC2 : 40 ~ 140
 6) VWDC2 Offset : 0 ~ 20

7. ATTACHMENT. OPTICAL POWER MEASUREMENT

Optical Power measurement is to adjust LD power from Pick-up
To measure optical power, LD status is on. Other light affects to optical power.
Avoid other light to measure exact power
Generally headlight power is about $50\mu\text{W}$, Sun power is about 100mW .

Optical Power measurement method

1. Fit optical Power Meter λ (wavelength) value to DVD.(generally 660nm)
2. DVD LD On.
3. Approach power sensor to Pick-up Lens about 3mm vertically. Fix Lens and Sensor \square mark position.
4. Read Monitor value. (move sensor read just a little and read max value.)
(caution) unit is mW.
5. Write monitoring value x 100. Only an integer.
6. Fit optical Power Meter λ (wavelength) value to CD.(generally 780nm)
7. CD LD On.
8. 3 ~ 5 recheck.

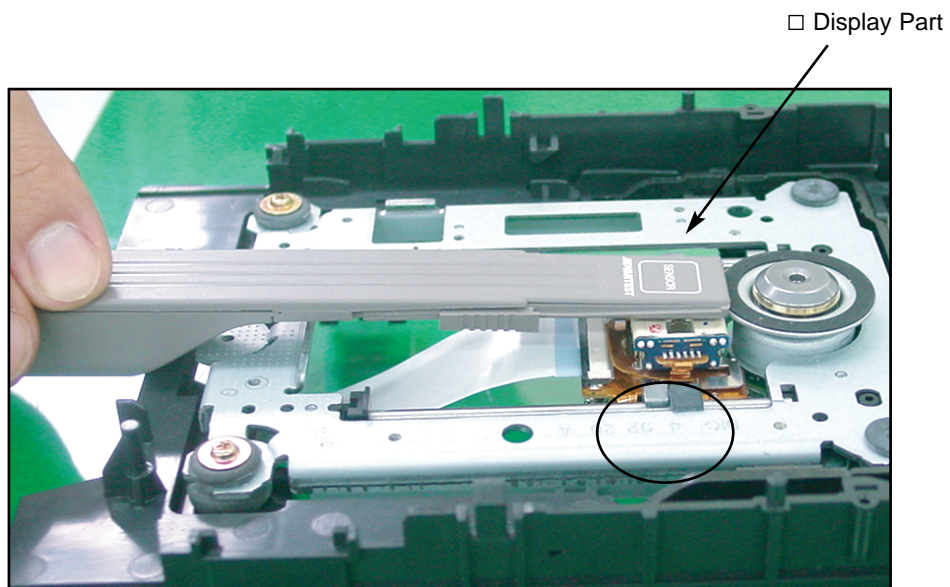

INTERNAL STRUCTURE OF THE PICK-UP

1. BLOCK DIAGRAM OF THE PICK-UP(LPC-812R)

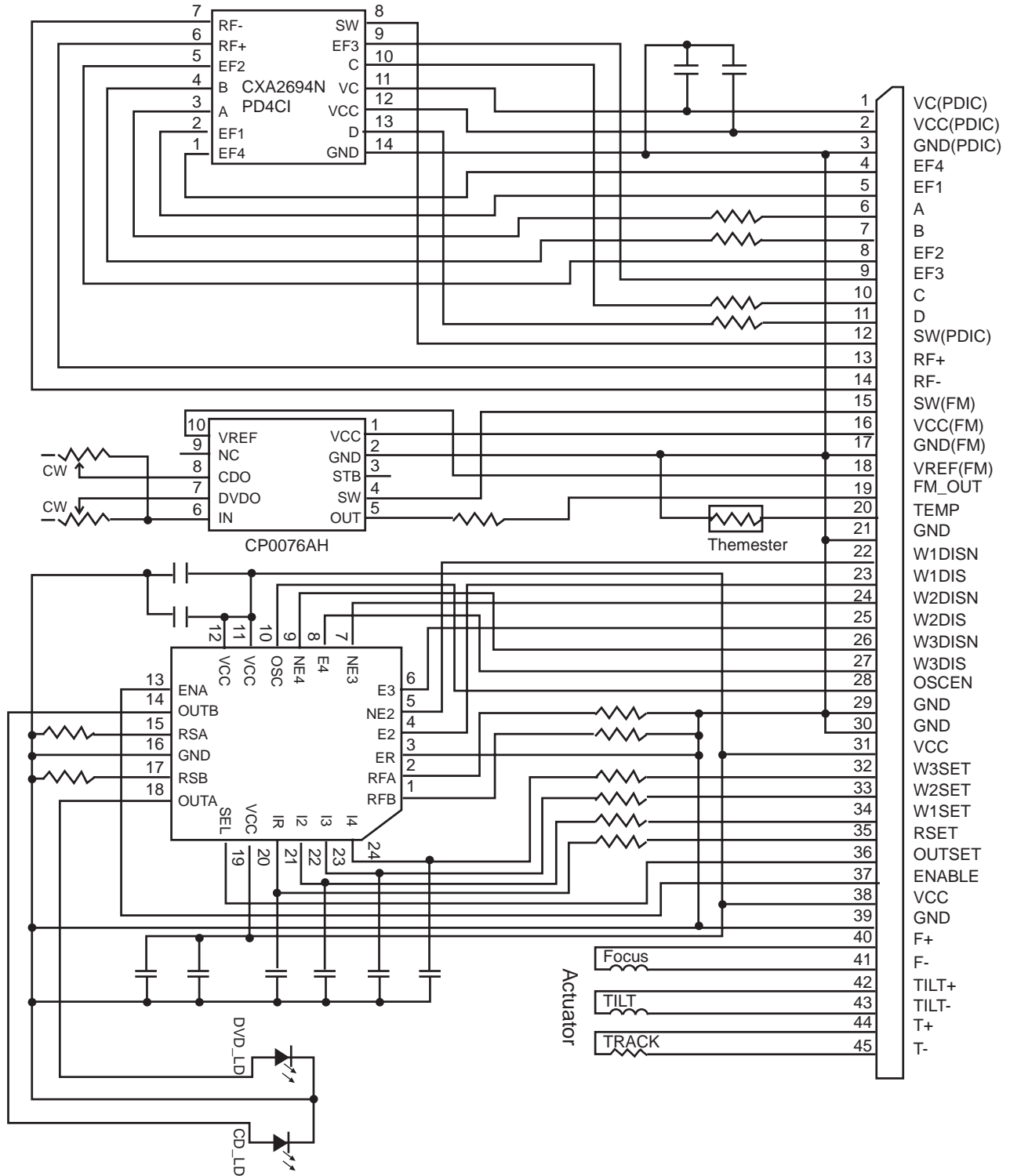

2. PICK UP PIN ASSIGNMENT

No.	Pin Name	Signal Description
45	T-	Tracking Actuator drive signal-
44	T+	Tracking Actuator drive signal+
43	Tilt-	Tilting Actuator drive signal-
42	Tilt+	Tilting Actuator drive signal+
41	F-	Focusing Actuator drive signal-
40	F+	Focusing Actuator drive signal+
39	GND(LDD)	Ground connection for LDD
38	VCC(LDD)	Power supply for LDD
37	ENABLE	Disables output current regardless of OUTEN(ENABLE Low:No lout)
36	OUTSEL	High:selects DVD LD, Low:CD LD
35	RSET	Input voltage for current amplifier
34	W1SET	Input voltage for current amplifier
33	W2SET	Input voltage for current amplifier
32	W3SET	Input voltage for current amplifier
31	VCC(LDD)	Power supply for LDD
30	GND(LDD)	Ground connection for LDD
29	GND(LDD)	Ground connection for LDD
28	OSCEN	TTL control for Oscillator Enable (High Enable)
27	W3DIS	LVDS control for output current (High Enable)
26	W3DISN	LVDS control for output current (Low Enable)
25	W2DIS	LVDS control for output current (High Enable)
24	W2DISN	LVDS control for output current (Low Enable)
23	W1DIS	LVDS control for output current (High Enable)
22	W1DISN	LVDS control for output current (Low Enable)
21	GND(FPD)	Ground connection for PDIC, FPD, TEMP
20	TEMP	Output voltage for controlling temperature
19	FPD-OUT	APC amplifier output
18	VREF(FPD)	APC amplifier reference voltage output
17	GND(TEMP)	Ground connection for PDIC, FPD, TEMP
16	VCC(FPD)	Power supply for FPD
15	SW2(FPD)	FPD output gain Select (High : CD, Low:DVD)
14	RF-	Signal PDIC RF negative differential output
13	RF+	Signal PDIC RF positive differential output
12	SW1(PDIC)	PDIC output gain Select (L/M/H)
11	D	Signal PDIC output D
10	C	Signal PDIC output C
9	EF3	Signal PDIC output EF3
8	EF2	Signal PDIC output EF2
7	B	Signal PDIC output B
6	A	Signal PDIC output A
5	EF1	Signal PDIC output EF1
4	EF4	Signal PDIC output EF4
3	GND(PDIC)	Ground connection for PDIC, FPD, TEMP, LDD
2	VCC(PDIC)	Power supply for PDIC(+5V)
1	VC(PDIC)	Reference voltage input for PDIC)

3. SIGNAL DETECTION OF THE P/U

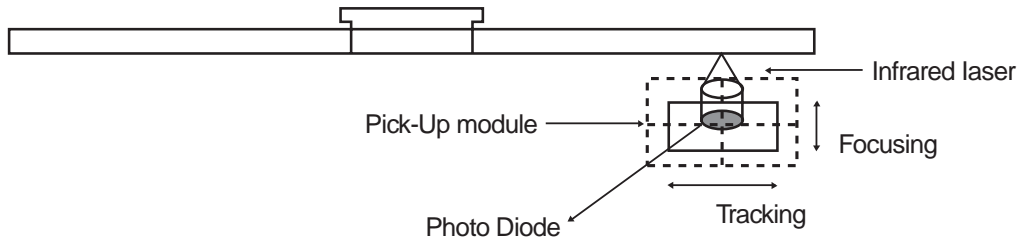

1) Focus Error Signal ==> (A+C)-(B+D)

This signal is generated in RF IC (LIC121 : AN22113A) and controls the pick-up's up and down to focus on Disc.

2) Tracking Error Signal (DPP Method) ==> $\{(A+D)-(B+C)\} - k \times \{(EF_1+EF_4)-(EF_2+EF_3)\}$

This signal is generated in RF IC (LIC121 : AN22113A) and controls the pick-up's left and right shift to find to track on Disc.

3) RF Signal ==> (A+B+C+D)

This signal is converted to DATA signal in DSP IC (LIC201 : MN103SA6G).

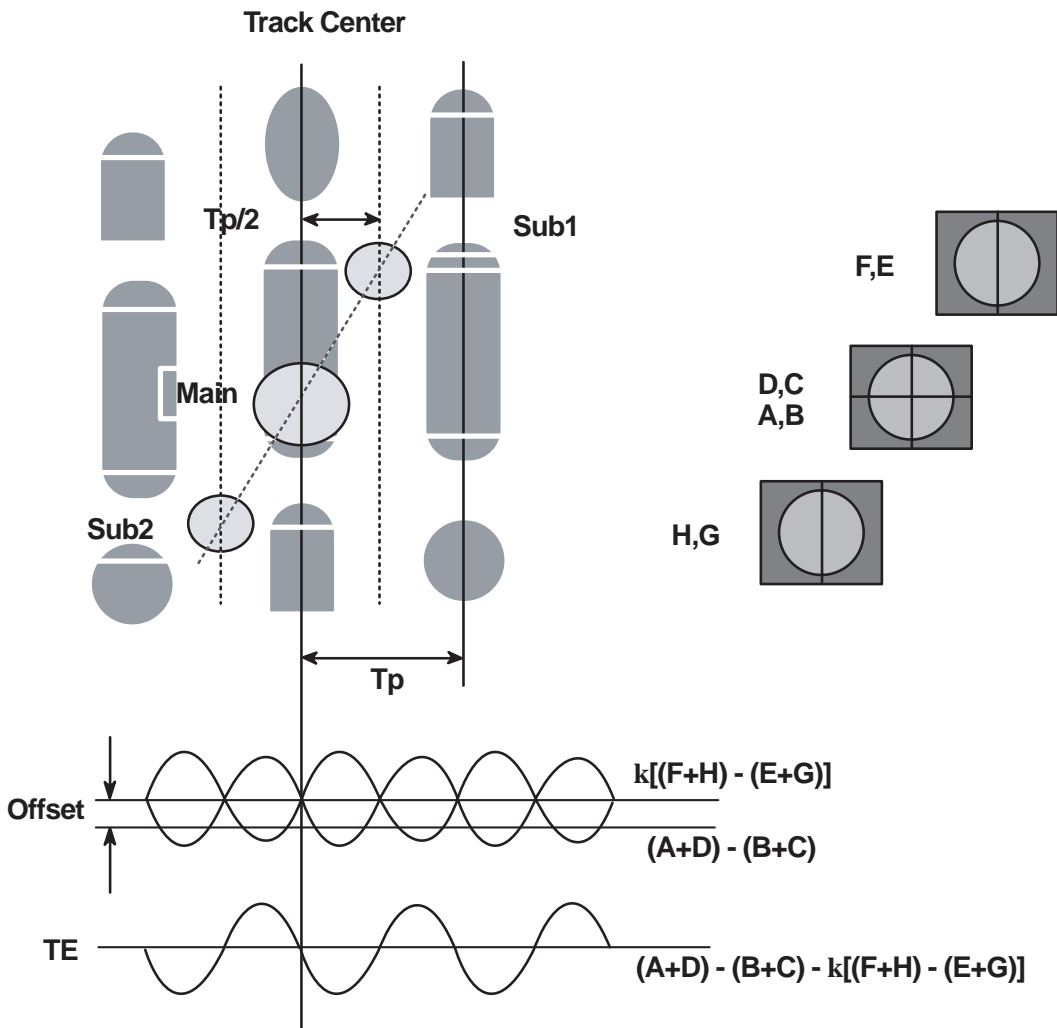

DESCRIPTION OF CIRCUIT

1. ALPC (AUTOMATIC LASER POWER CONTROL) CIRCUIT

1-1. BLOCK DIAGRAM

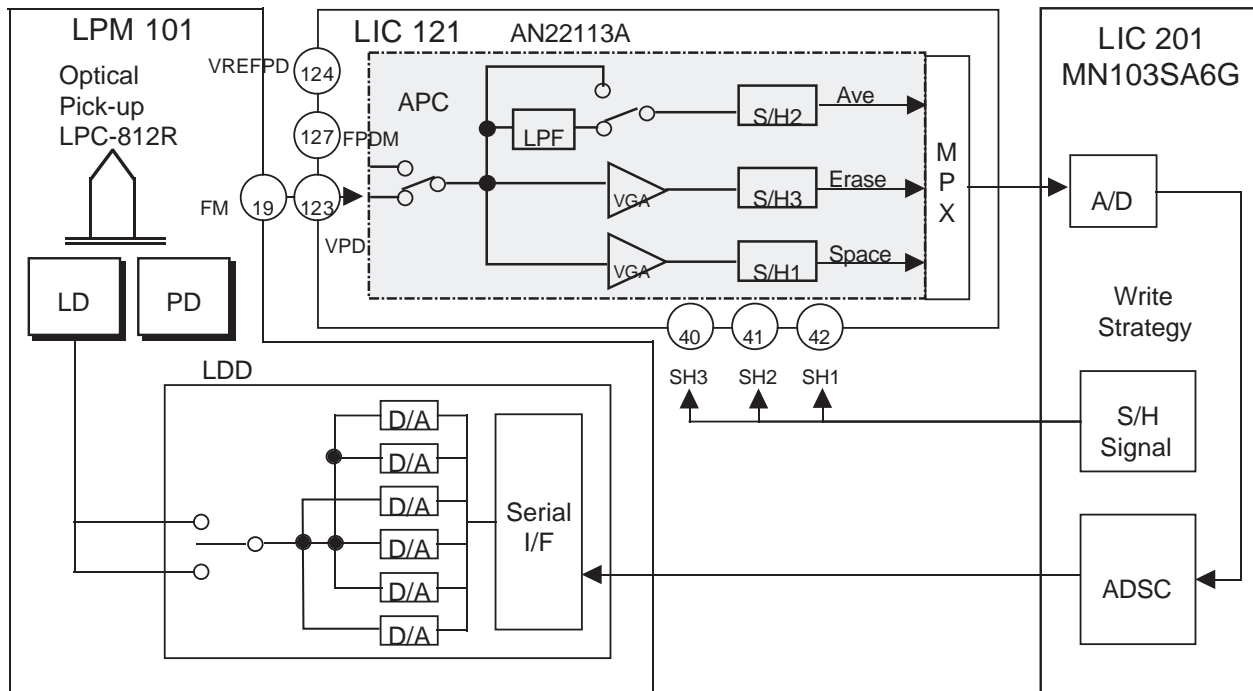

1-2. ALPC (AUTOMATIC LASER POWER CONTROL) CIRCUIT OPERATION

THE ALPC BLOCK DETECTS THE LASER OUTPUT POWER OF THE FRONT MONITOR. THE POWER SIGNAL DETECTED WITH THE PD FOR FRONT MONITOR
DETECTION IS INPUT THE VOLTAGE FROM THE VPD PIN(123PIN) OR THE FPDM PIN(127PIN), THE REFERENCE SIGNAL OF THE INPUT SIGNAL IS
INPUT FROM THE VREFPD PIN(124PIN). THE ALPC BLOCK GENERATES THE SIGNALS FROM THE INPUT LASER POWER SIGNALS IN THE
FOLLOWING DETECTION SYSTEMS. THIS BLOCK HAS FOUR DETECTION PATHS:ALL AVERAGE VALUE PATH, MULTI PULSE AVERAGE/PEAK VALUE
DETECTION PATH, ERASE/BOTTOM VALUE DETECTION PATH, SPACE/PLAYBACK POWER VALUE DETECTION PATH.

2. FOCUS/TRACKING/SLED SERVO CIRCUIT

2-1. FOCUS, TRACKING & SLED SERVO PROCESS

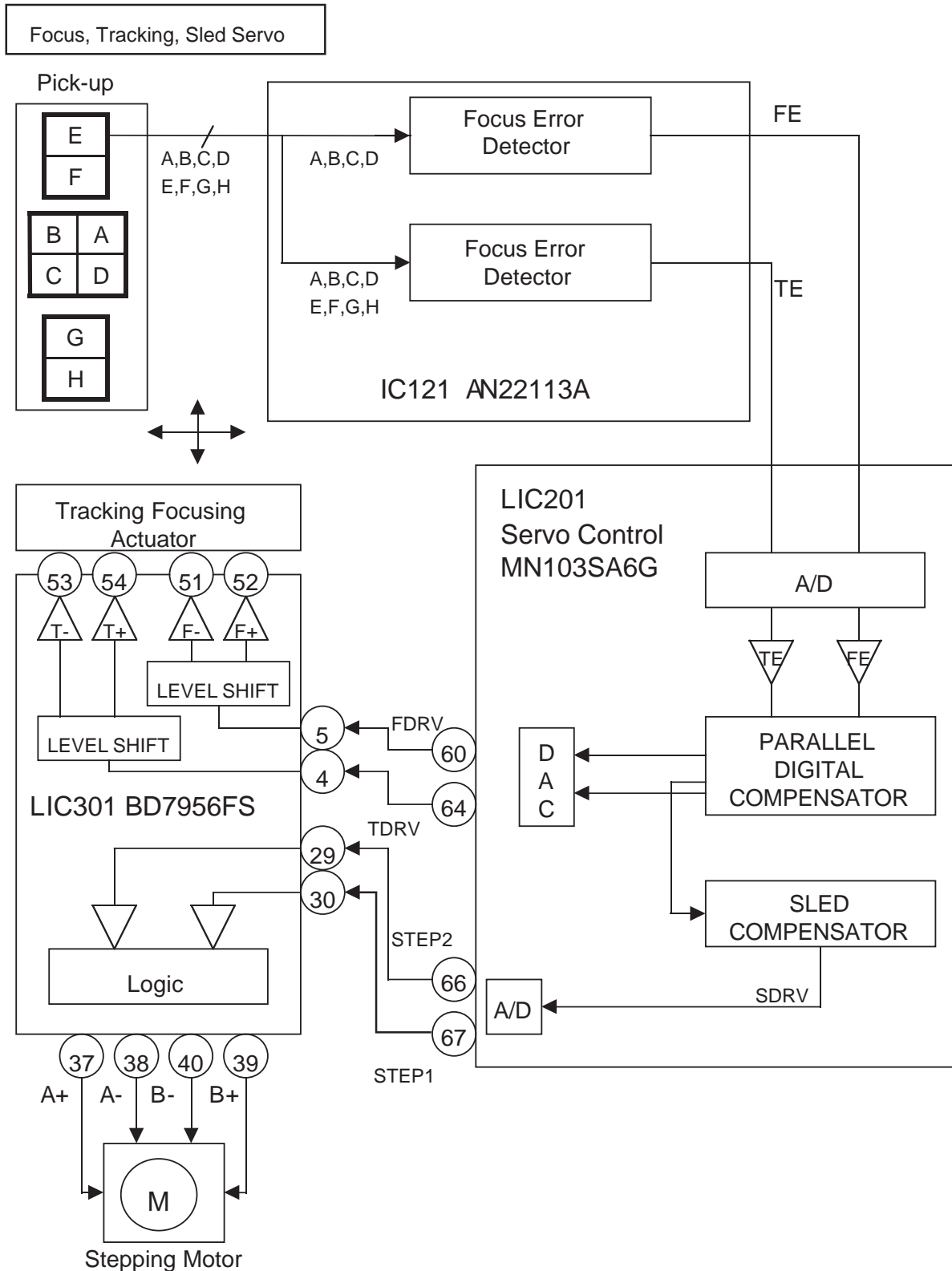

2-1. FOCUS, TRACKING & SLED SERVO PROCESS

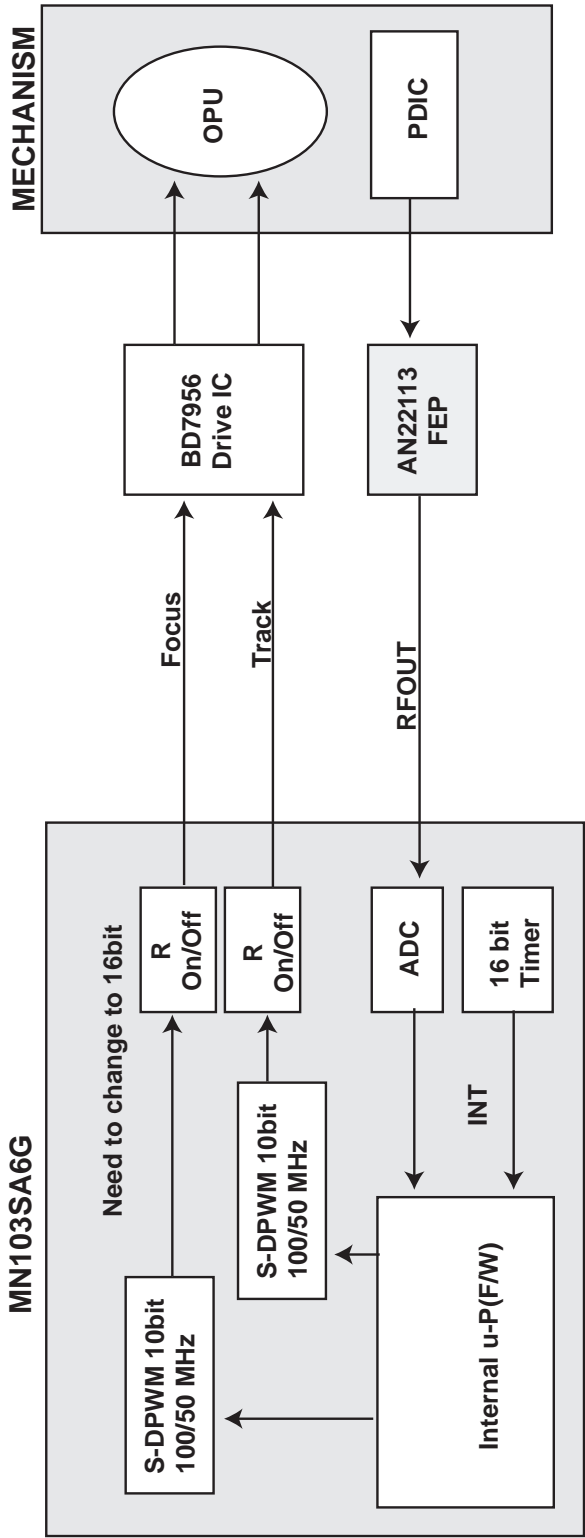

3. SPINDLE SERVO CIRCUIT

3-1. SPINDLE SERVO PROCESS

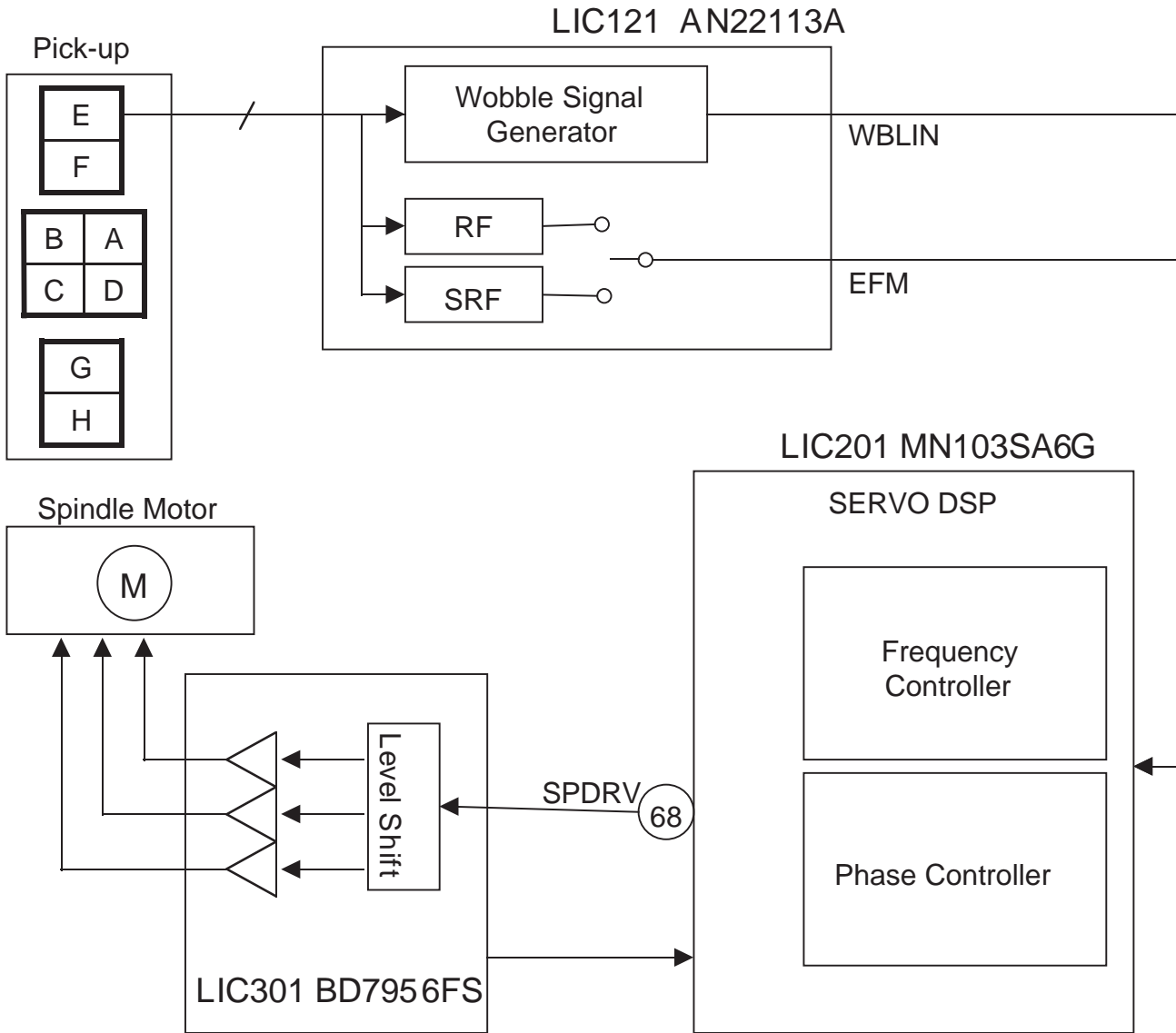

MAJOR IC INTERNAL BLOCK DIAGRAM

LIC121 (AN22113A) : FEP(RF) ANALOG SIGNAL PROCESSOR

• PIN ASSIGNMENT

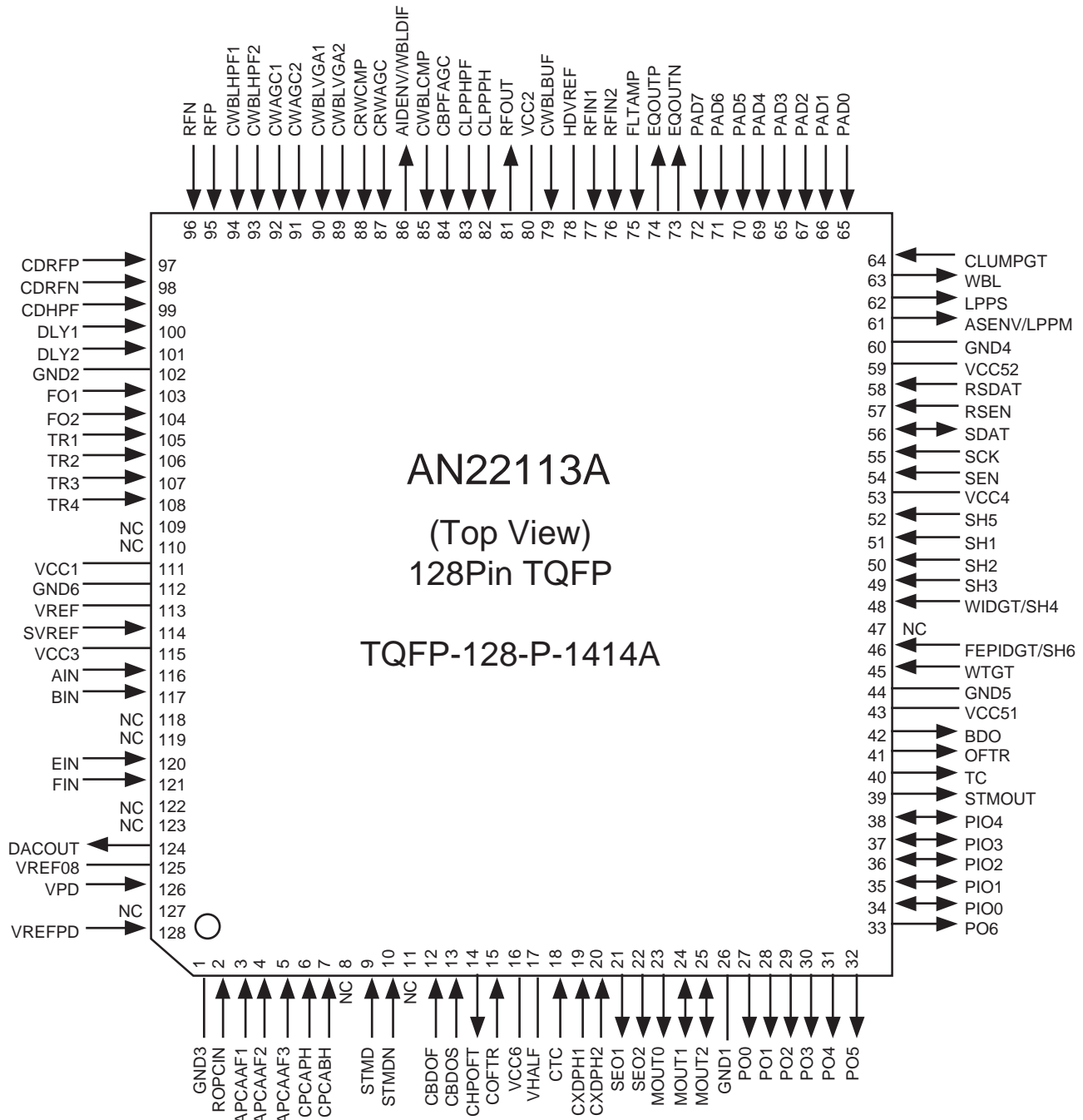

• **BLOCK DIAGRAM**

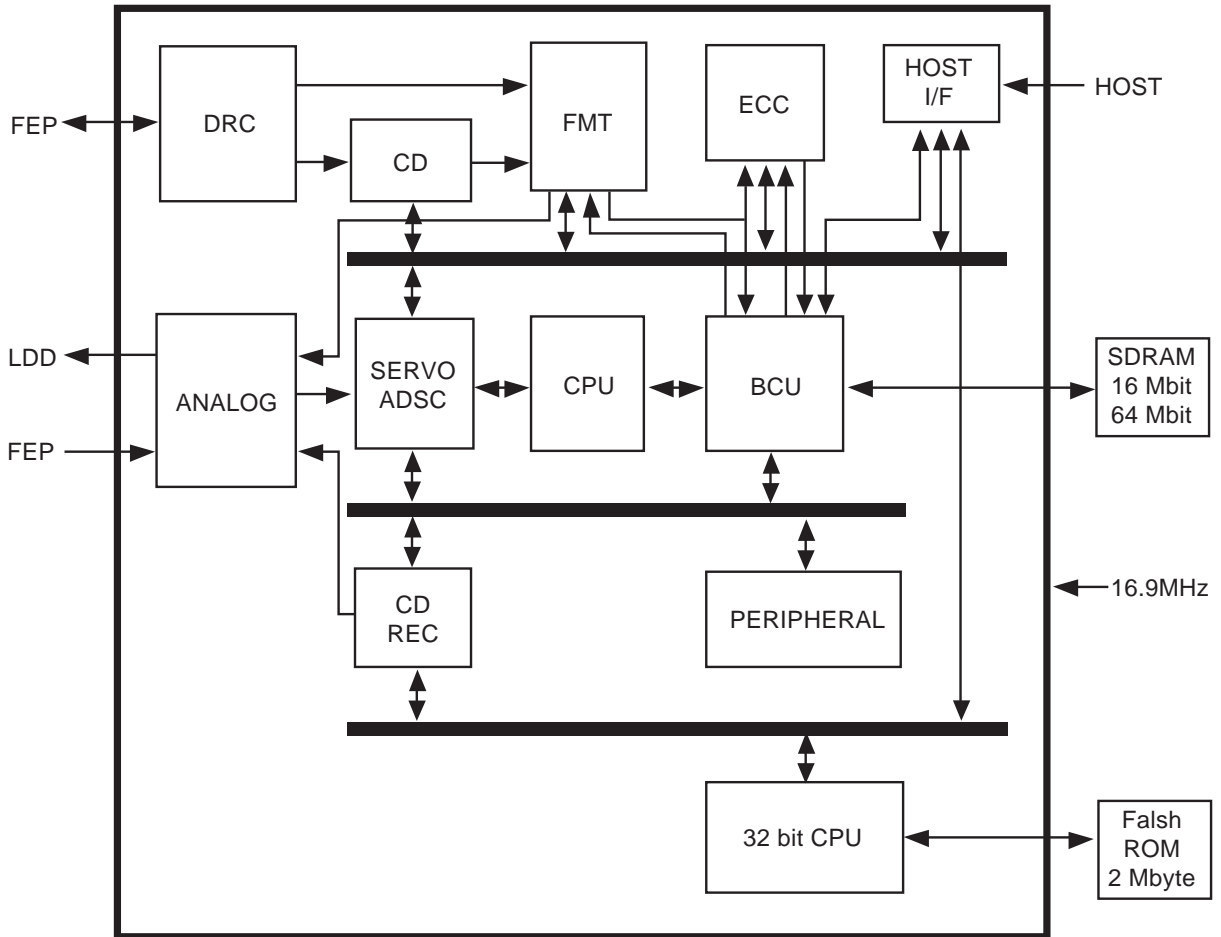

IC301 (BD7956FS) : CD-ROM/DVD-ROM 7CH POWER DRIVER

• BLOCK DIAGRAM

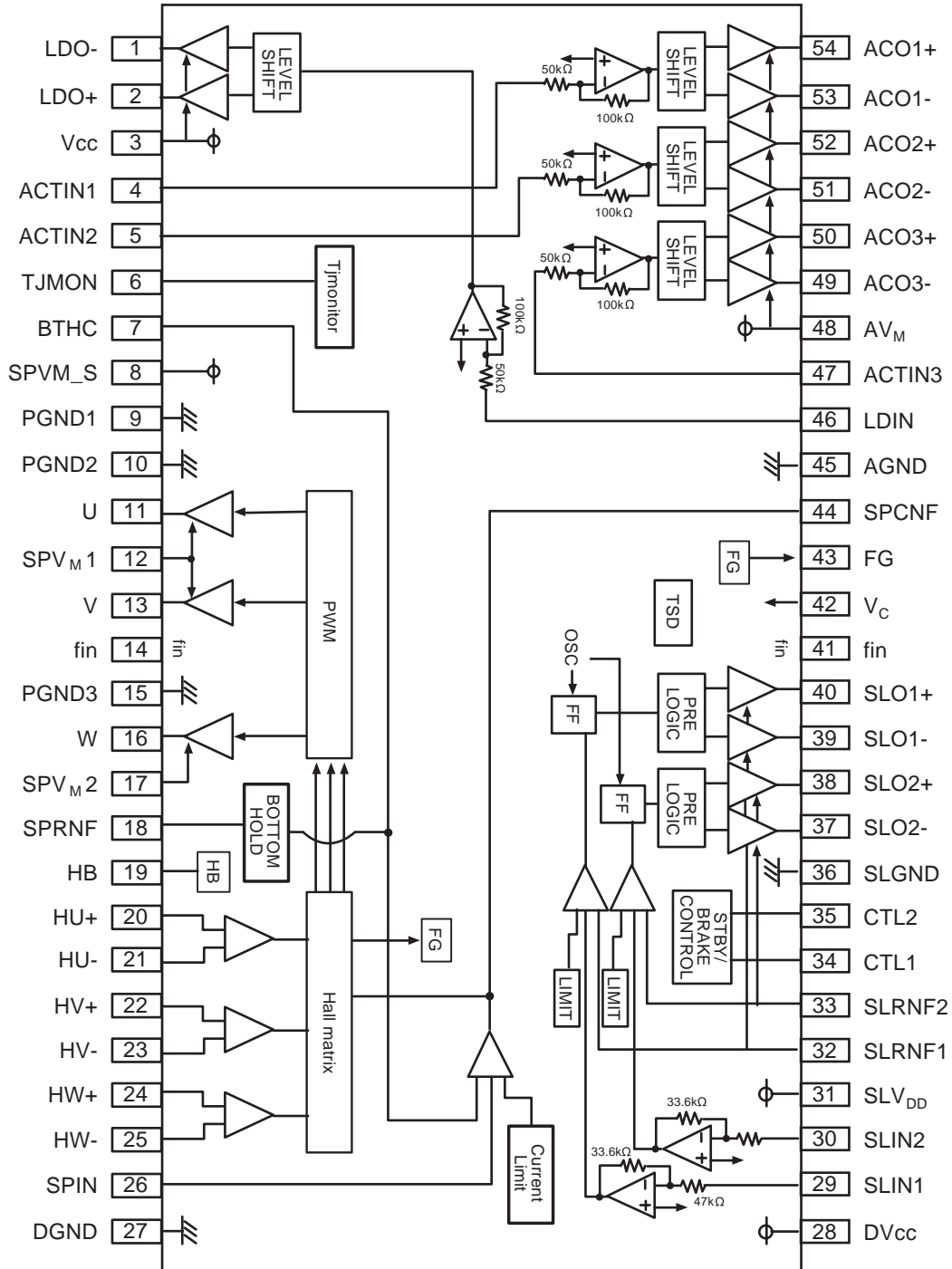

MEMO

A series of horizontal dotted lines for writing.

CIRCUIT DIAGRAMS

1. DSP CIRCUIT DIAGRAM

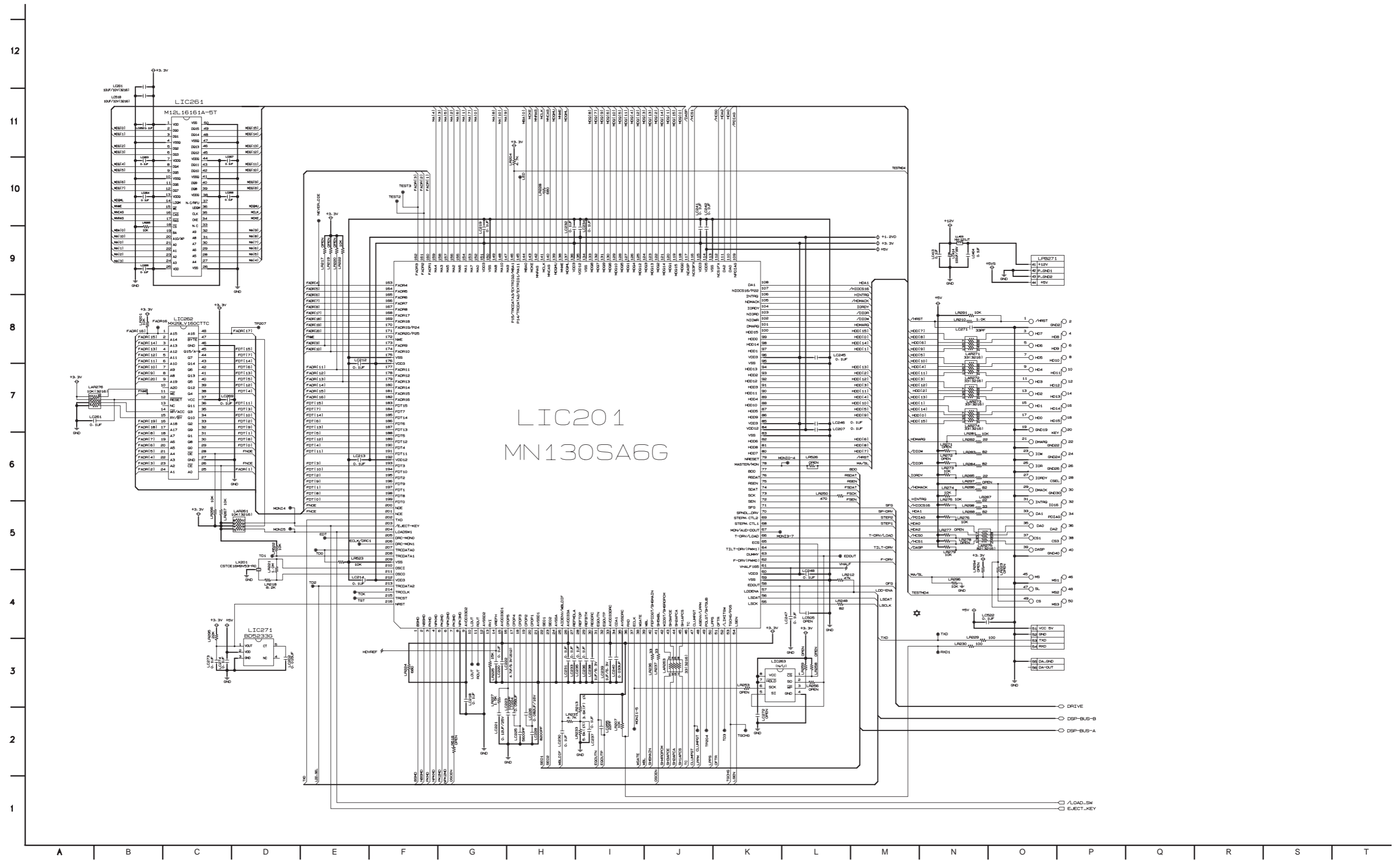

2. RF CIRCUIT DIAGRAM

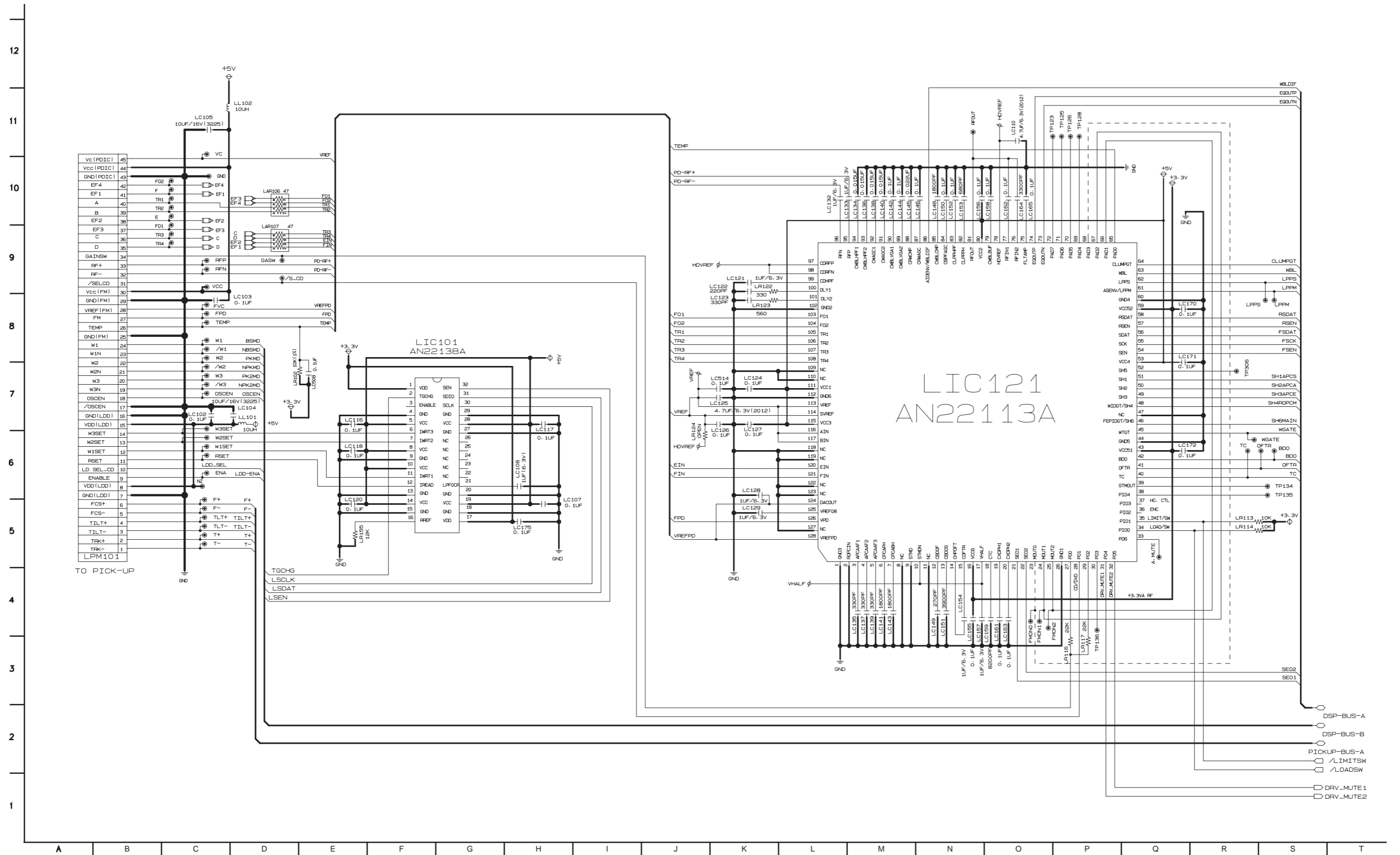

3. DRIVE CIRCUIT DIAGRAM

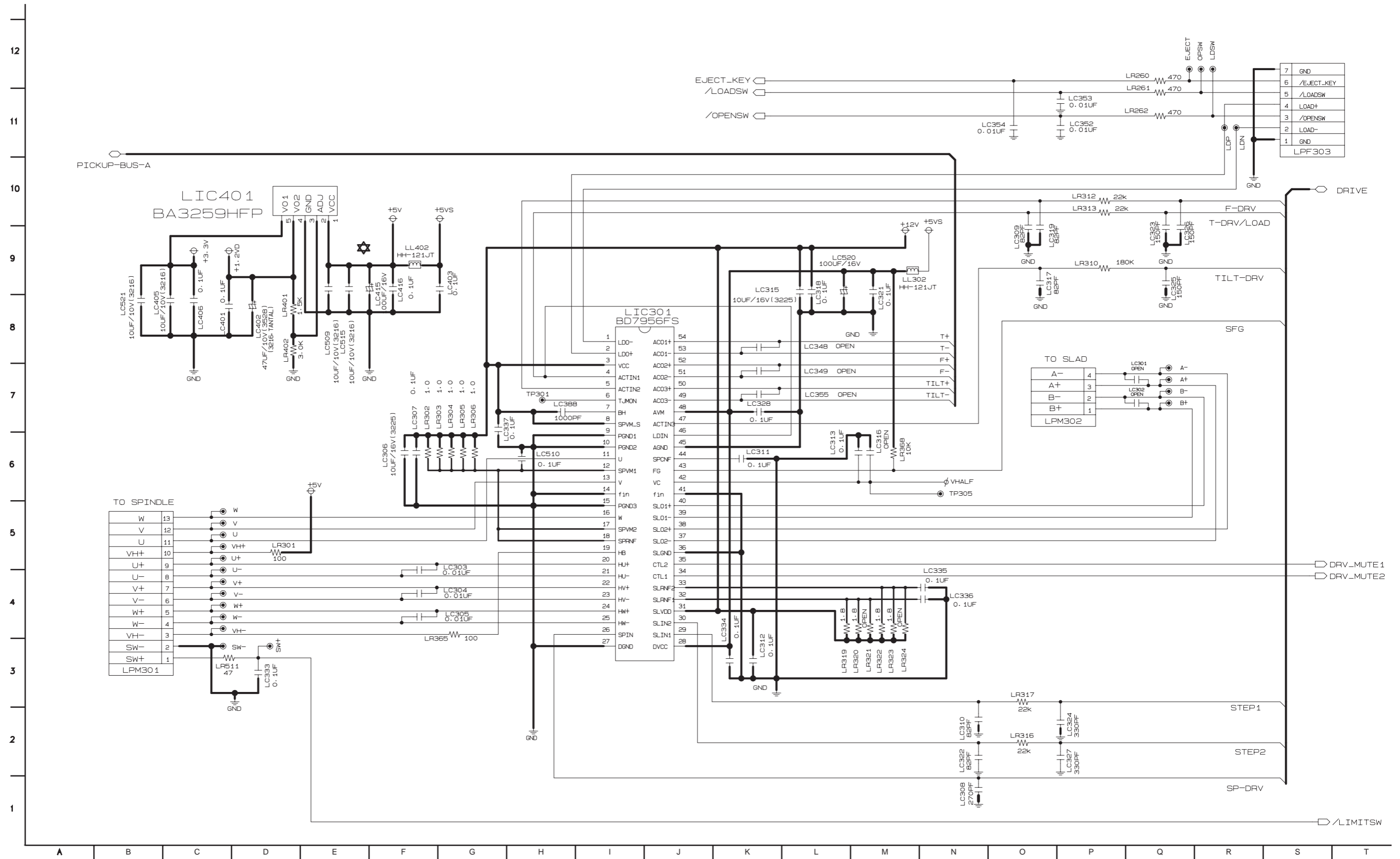

PRINTED CIRCUIT DIAGRAMS

1. MAIN P.C.BOARD (TOP VIEW)

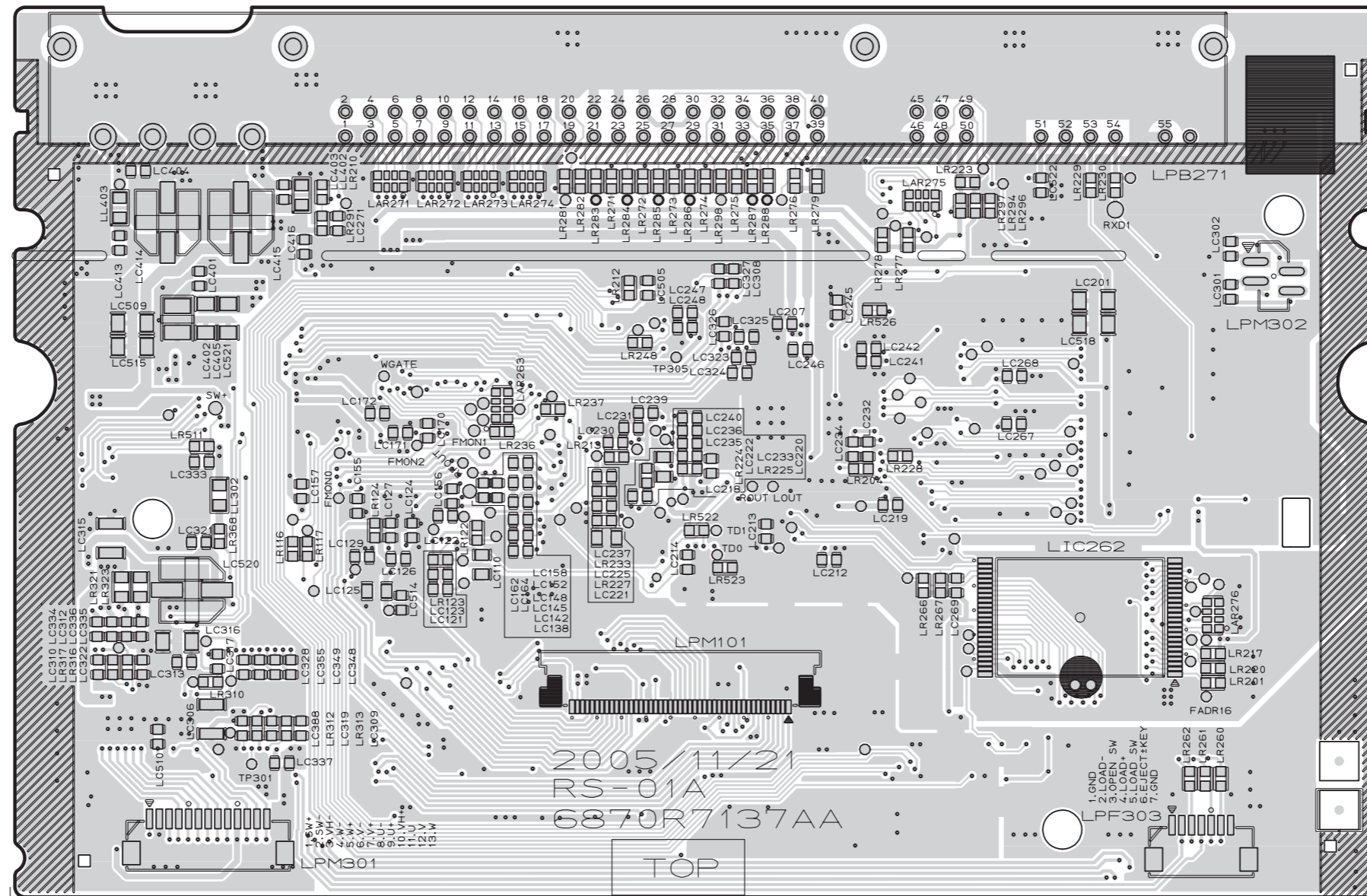

2. MAIN P.C.BOARD (BOTTOM VIEW)

